

# BUCKNER HEAVYLIFT CRANES

## Build Package – Liebherr LR1300 SX– CR3314

Contents	
Sheet	Description
001	Title Page
002	Boom and Luffing Jib Config.
003	Boom Pendant Straps (2)
004	Main Reeving
005	Aux Jib
006	Hook Blocks
007	Erectability Chart 1
008	Erectability Chart 2
009	Load Chart

Note: Crane technician **MUST** verify all information contained in this document matches what is provided by the manufacturer for the specific crane being used. Contact Andy Moore with questions: [andym@bucknerheavylift.com](mailto:andym@bucknerheavylift.com) Cell: 713 705 5726

PROJECT:  
LR 1300 SX 203' ST

LOCATION: -----  
BUCKNER CONTACT: Andy Moore, PE  
AndyM@BucknerHeavylift.com  
LIFT PLAN BY: Andy Moore, PE  
AndyM@BucknerHeavylift.com

DRAWING NOTES:  
Title Page

LR1300 SX	
Operating Mode	MB
Main Boom Length	62m (203')
Luffing Jib Length	N/A
Derrick Length	N/A
Superstructure CWT	273.4k
Carbody CWT	125.7k
Ballast Tray CWT	N/A

FILE: D:\Andy Moore\OneDrive – Buckner Heavylift  
Cranes\Documents –  
Engineering\Drawings\BHL\Buckner\Build Sheets\LR  
1300SX\LR 1300 SX 203' (62m) ST.dwg  
CREATED: 11.08.2023 @ 12:25:55 PM  
EDITING TIME: 17h20m FILE SIZE: 586.43Kb  
PAPER SIZE: ANSI B (17.00 x 11.00 Inches)  
SAVED: 11.08.2023 @ 12:25:41 PM  
PLOTTED: 11.08.2023 @ 12:25:55 PM

### Revisions

All Sheets Same Revision Level

Rev.	Date	Description
000	11.08.2023	Preliminary Planning & Initial Layout
001	----	----
002	----	----
003	----	----
004	----	----
005	----	----
006	----	----
007	----	----
008	----	----
009	----	----
010	----	----

SHEET: 001 OF 009

**BUCKNER**  
HEAVYLIFT CRANES

Assembly and dismantling

Main boom 2821

### 7.5 Main boom 2821

**System-relevant information** for main boom 2821:

- Configuration of main boom
  - Installation position of rope guide (type A)
  - Mid-point suspensions installation positions
- Lengths of mid-point suspensions
- Overview of main boom 2821 steel pendant straps
- Overview of main boom 2821 CF pendant straps
- Reeving diagrams main boom head 2821 (load position 1)
- Reeving diagrams main boom head 2821 in single hook mode with 2 winches
- Reeving diagrams auxiliary jib (36 t (79300 lb)) on main boom head 2821 (load position 2)

#### 7.5.1 Configuration of main boom



**DANGER**

Excess length of main boom!  
Structural breakdown.

▶ Check main boom length in load chart for validity.

Main boom length	Configuration of main boom (symbolic)
20 m 66 ft	
23 m 75 ft	
26 m 85 ft	
29 m 95 ft	
32 m 105 ft	
35 m 115 ft	
38 m 125 ft	
41 m 135 ft	
44 m 144 ft	
47 m 154 ft	
50 m 164 ft	

LWMLR.XLR 1300 SX V02.01/Auslieferung/2014-07-22/en

Assembly and dismantling

Main boom 2821

Main boom length	Configuration of main boom (symbolic)
53 m 174 ft	
56 m 184 ft	
59 m 195 ft	
62 m 203 ft	
65 m 213 ft	
68 m 223 ft	
71 m 233 ft	
74 m 243 ft	
77 m 253 ft	
80 m 262 ft	
83 m 272 ft	
86 m 282 ft	
89 m 292 ft	
92 m 302 ft	
95 m 312 ft	
98 m 322 ft	
101 m 332 ft	
104 m 342 ft	

LWMLR.XLR 1300 SX V02.01/Auslieferung/2014-07-22/en

Tab. 388: Configuration of main boom 2821

- S** - Installation position rope guide (type A)
- X1** - Installation position mid-point suspension 1
- X2** - Installation position mid-point suspension 2

PROJECT:

LR 1300 SX 203' ST

LOCATION: -----

BUCKNER CONTACT: Andy Moore, PE

AndyM@BucknerHeavyLift.com

LIFT PLAN BY: Andy Moore, PE

AndyM@BucknerHeavyLift.com

DRAWING NOTES:

Boom and Luffing Jib Config.

LR1300 SX	
Operating Mode	MB
Main Boom Length	62m (203')
Luffing Jib Length	N/A
Derrick Length	N/A
Superstructure CWT	273.4k
Carbody CWT	125.7k
Ballast Tray CWT	N/A

FILE: D:\Andy Moore\OneDrive - Buckner HeavyLift

Cranes\Documents - Engineering\Drawings\BHL\Buckner\Build Sheets\LR

CREATED: 1300SX\LR 1300 SX 203' (62m) ST.dwg

EDITING TIME: 17h20m FILE SIZE: 586.43Kb

PAPER SIZE: ANSI B (17.00 x 11.00 Inches)

SAVED: 11.08.2023 @ 12:25:41 PM

PLOTTED: 11.08.2023 @ 12:25:58 PM

### Revisions

All Sheets Same Revision Level

Rev.	Date	Description
000	11.08.2023	Preliminary Planning & Initial Layout
001	----	----
002	----	----
003	----	----
004	----	----
005	----	----
006	----	----
007	----	----
008	----	----
009	----	----
010	----	----

SHEET: 002 OF 009



Assembly and dismantling

Main boom 2821

A) Machine with CF pendant straps with boom configuration main boom 2821 + luffing jib 1916: Do not install any mid-point suspensions with main boom lengths 77 m (253 ft) and 80 m (262 ft).

7.5.3 Overview of main boom 2821 steel pendant straps

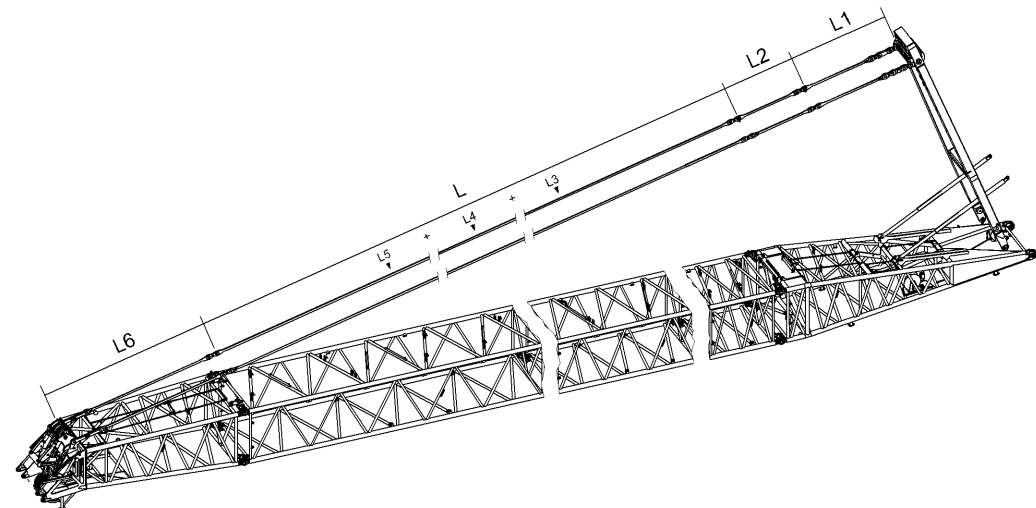

Fig. 2636: Overview of main boom 2821 steel pendant straps

Pendant straps A-frame1 to main boom head 2821

Name	Value
L1 A-frame1 equalizer (For more information see: A-frame1 equalizer, page 65)	3730 mm 12' 3" ft-in
L2 Main boom base section equalizer (For more information see: Equalizer of main boom base section 2821.30, page 165)	2670 mm 8' 9" ft-in
Main boom pendant straps consisting of:	
L L3 Main boom pendant strap 3 m (10 ft) (For more information see: Main boom pendant strap 3 m (10 ft), page 166)	Total L3 +
L4 Main boom pendant strap 6 m (20 ft) (For more information see: Main boom pendant strap 6 m (20 ft), page 168)	Total L4 +
L5 Main boom pendant strap 12 m (40 ft) (For more information see: Main boom pendant strap 12 m (40 ft), page 170)	Total L5

LWMLR.xLR 1300 SX V02.01/Auslieferung/2014-07-22/en

Assembly and dismantling

Main boom 2821

Name	Value
L6 Main boom pendant strap on main boom head 2821 (For more information see: Main boom pendant strap on main boom head 2821.24, page 171)	6300 mm 20' 8" ft-in

Tab. 390: Pendant straps A-frame1 to main boom head 2821

Configuration of main boom pendant straps (L):

Required number of main boom pendant straps 3 m (10 ft) (L3) corresponds to number of main boom sections 3 m (10 ft).

Required number of main boom pendant straps 6 m (20 ft) (L4) corresponds to number of main boom sections 6 m (20 ft).

Required number of main boom pendant straps 12 m (40 ft) (L5) corresponds to number of main boom sections 12 m (40 ft).



Note

► For the admissible number of main boom sections 3 m (10 ft), 6 m (20 ft), 12 m (40 ft), refer to the following table: (For more information see: 7.5.1 Configuration of main boom, page 1056)

7.5.4 Overview of main boom 2821 CF pendant straps

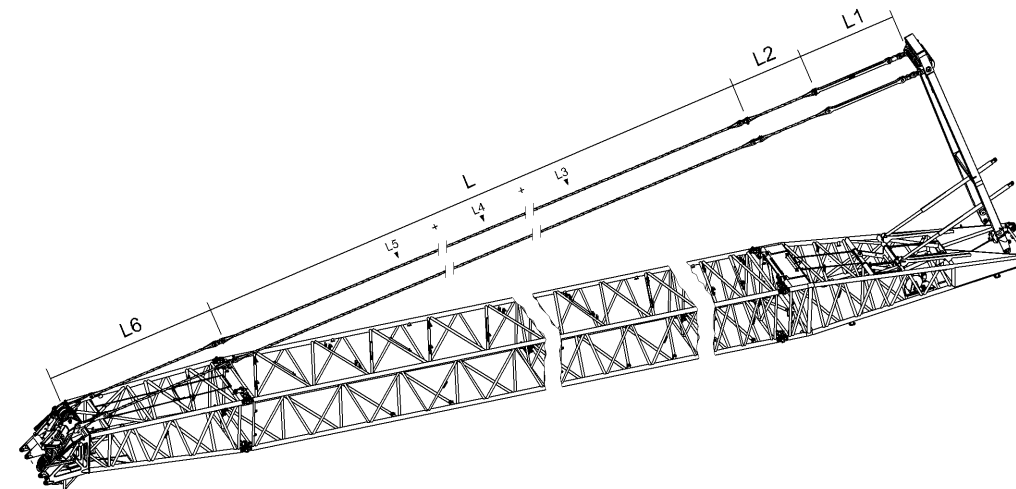

Fig. 2637: Overview of main boom 2821 CF pendant straps

Pendant straps A-frame1 to main boom head 2821

Name	Value
L1 A-frame1 equalizer (For more information see: A-frame1 equalizer, page 66)	3700 mm 12' 2" ft-in

LWMLR.xLR 1300 SX V02.01/Auslieferung/2014-07-22/en

PROJECT:

LR 1300 SX 203' ST

LOCATION: -----  
BUCKNER CONTACT: Andy Moore, PE  
AndyM@BucknerHeavyLift.com  
LIFT PLAN BY: Andy Moore, PE  
AndyM@BucknerHeavyLift.com

DRAWING NOTES:  
Boom Pendant Straps (2)

LR1300 SX	
Operating Mode	MB
Main Boom Length	62m (203')
Luffing Jib Length	N/A
Derrick Length	N/A
Superstructure CWT	273.4k
Carbody CWT	125.7k
Ballast Tray CWT	N/A

FILE: D:\Andy Moore\OneDrive - Buckner HeavyLift  
Cranes\Documents -  
Engineering\Drawings\BHL\Buckner\Build Sheets\LR  
1300SX\LR 1300 SX 203' ST.dwg  
CREATED: 13.08.2023 @ 12:25:58 PM  
EDITING TIME: 17h20m FILE SIZE: 586.43Kb  
PAPER SIZE: ANSI B (17.00 x 11.00 Inches)  
SAVED: 11.08.2023 @ 12:25:41 PM  
PLOTTED: 11.08.2023 @ 12:25:58 PM

Revisions

All Sheets Same Revision Level

Rev.	Date	Description
000	11.08.2023	Preliminary Planning & Initial Layout
001	----	----
002	----	----
003	----	----
004	----	----
005	----	----
006	----	----
007	----	----
008	----	----
009	----	----
010	----	----

SHEET: 003 OF 009



Assembly and dismantling

Main boom 2821

Reeving diagrams for one rope across main boom head 2821 (load position1)

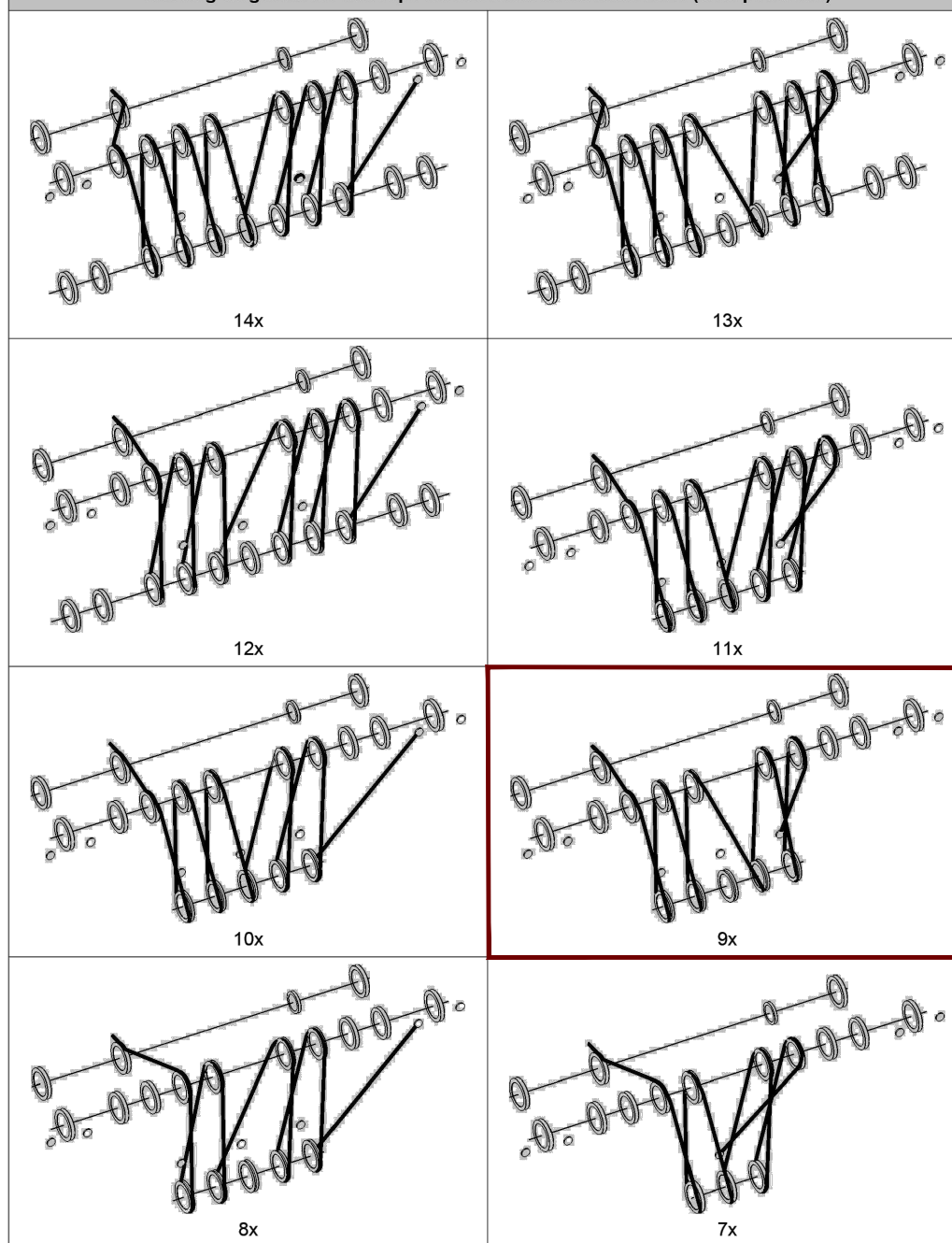

LWNLE.R.v03.04/Auslieferung2015-11-30en

LR 1006.01.06 / V03.04

copyright © Liebherr-Werk Nenzing GmbH 2015  
**LIEBHERR**

1263

PROJECT:

LR 1300 SX 203' ST

LOCATION: -----

BUCKNER CONTACT: Andy Moore, PE  
AndyM@BucknerHeavyLift.com

LIFT PLAN BY: Andy Moore, PE  
AndyM@BucknerHeavyLift.com

DRAWING NOTES:

Main Reeving

LR1300 SX	
Operating Mode	MB
Main Boom Length	62m (203')
Luffing Jib Length	N/A
Derrick Length	N/A
Superstructure CWT	273.4k
Carbody CWT	125.7k
Ballast Tray CWT	N/A

FILE: D:\Andy Moore\OneDrive - Buckner HeavyLift  
Cranes\Documents -  
Engineering\Drawings\BHL\Buckner\Build Sheets\LR  
1300SX\LR 1300 SX 203' (62m) ST.dwg  
CREATED: 13.08.2023 @ 12:25:41 PM  
EDITING TIME: 17h20m FILE SIZE: 586.43Kb  
PAPER SIZE: ANSI B (17.00 x 11.00 Inches)  
SAVED: 11.08.2023 @ 12:25:41 PM  
PLOTTED: 11.08.2023 @ 12:26:04 PM

Revisions

All Sheets Same Revision Level

Rev.	Date	Description
000	11.08.2023	Preliminary Planning & Initial Layout
001	----	----
002	----	----
003	----	----
004	----	----
005	----	----
006	----	----
007	----	----
008	----	----
009	----	----
010	----	----

SHEET: 004 OF 009

**BUCKNER**  
HEAVYLIFT CRANES

Product description

Auxiliary jib\* (36 t (79.300 lb))

### 1.25 Auxiliary jib\* (36 t (79.300 lb))

This auxiliary jib can be attached to any boom head section.

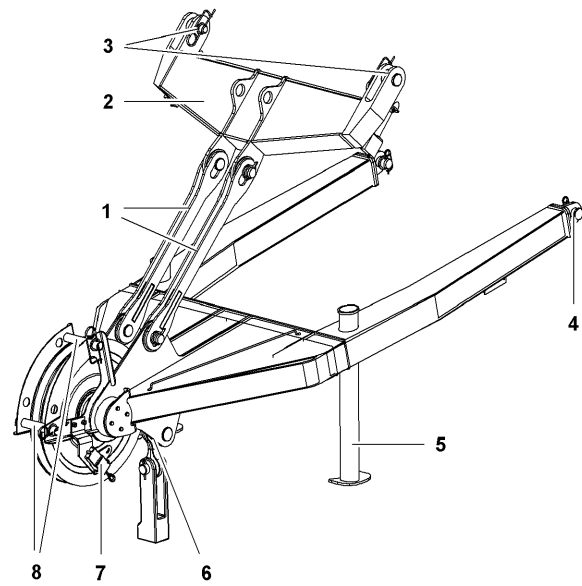

Fig. 403: Auxiliary jib (36 t (79.300 lb)) for the boom head section

- |  |                             |
|--|-----------------------------|
| 1 Pendant strap (2x)                                 | 5 Support base (2x)         |
| 2 Crossbar   | 6 Rope fixation             |
| 3 Top pin connection point (2x) on main boom head    | 7 Hoist limit switch        |
| 4 Bottom pin connection point (2x) on main boom head | 8 Rope protection pipe (2x) |

The auxiliary jib is designed for a maximum load of 36 t (79.300 lb). A second, optional pulley (3-fold reeving) is required if the maximum lifting capacity is to be achieved.

The radius change and the weight increase of the main boom head due to the auxiliary jib are taken into account by the Load moment limiter. Due to this weight increase, it is not possible to erect the main boom to all possible heights.

Recommended values for radius enlargement using the auxiliary jib:

Machine type	Main boom angle			
	15°	20°	45°	86°
LR 1001	1380 mm 4' 6" ft-in	-	1900 mm 6' 3" ft-in	1760 mm 5' 9" ft-in
LR 1002	1210 mm 4' ft-in	-	1890 mm 6' 2" ft-in	2000 mm 6' 7" ft-in

copyright © Liebherr-Werk Nenzing GmbH 2015

**LIEBHERR**

LR 1006.01.06 / V03.04

Product description

Auxiliary jib\* (36 t (79.300 lb))

Machine type	Main boom angle			
	15°	20°	45°	86°
LR 1003	1210 mm 4' ft-in	-	1890 mm 6' 2" ft-in	2000 mm 6' 7" ft-in
LR 1004	1210 mm 4' ft-in	-	1780 mm 5' 10" ft-in	1800 mm 5' 11" ft-in
LR 1006	-	1320 mm 4' 4" ft-in	1780 mm 5' 10" ft-in	1790 mm 5' 10" ft-in

Tab. 251: Guideline values for radius enlargement through auxiliary jib (36 t (79.300 lb)) for main boom head

**NOTICE**

Incorrectly hoisted load with the 2821 main boom and an auxiliary jib attached (L = 1034 mm (3' 5" ft-in)) and main boom angle less than 20°!  
Risk of damage to the rope.

- ▶ Hoist a load with the main boom exclusively when the main boom angle is greater than 20°.

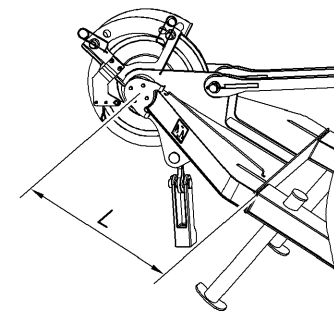

Fig. 404: Dimension L on auxiliary jib (36 t (79.300 lb))

Dimension L on auxiliary jib	Is a load allowed to be hoisted with a 2821 main boom when an auxiliary jib is fit and the main boom angle is less than 20°?
1034 mm 3' 5" ft-in	NO
954 mm 3' 2" ft-in	YES

Tab. 252: Dimension L on auxiliary jib (36 t (79.300 lb))

copyright © Liebherr-Werk Nenzing GmbH 2015

**LIEBHERR**

LR 1006.01.06 / V03.04

PROJECT:

LR 1300 SX 203' ST

LOCATION: -----

BUCKNER CONTACT: Andy Moore, PE  
AndyM@BucknerHeavyLift.com

LIFT PLAN BY: Andy Moore, PE  
AndyM@BucknerHeavyLift.com

DRAWING NOTES:  
Aux Jib 1

LR1300 SX	
Operating Mode	MB
Main Boom Length	62m (203')
Luffing Jib Length	N/A
Derrick Length	N/A
Superstructure CWT	273.4k
Carbody CWT	125.7k
Ballast Tray CWT	N/A

FILE: D:\Andy Moore\OneDrive - Buckner HeavyLift

Cranes\Documents - Engineering\Drawings\BHL\Buckner\Build Sheets\LR

1300SX\LR 1300 SX 203' @ 62m) 37.dwg

CREATED: 17h20m FILE SIZE: 586.43Kb

EDITING TIME: 17h20m FILE SIZE: 586.43Kb

PAPER SIZE: ANSI B (17.00 x 11.00 Inches)

SAVED: 11.08.2023 @ 12:25:41 PM

PLOTTED: 11.08.2023 @ 12:26:01 PM

### Revisions

All Sheets Same Revision Level

Rev.	Date	Description
000	11.08.2023	Preliminary Planning & Initial Layout
001	----	----
002	----	----
003	----	----
004	----	----
005	----	----
006	----	----
007	----	----
008	----	----
009	----	----
010	----	----

SHEET: 005 OF 009

**BUCKNER**  
HEAVYLIFT CRANES

Product description

Auxiliary jib\* (36 t (79.300 lb))

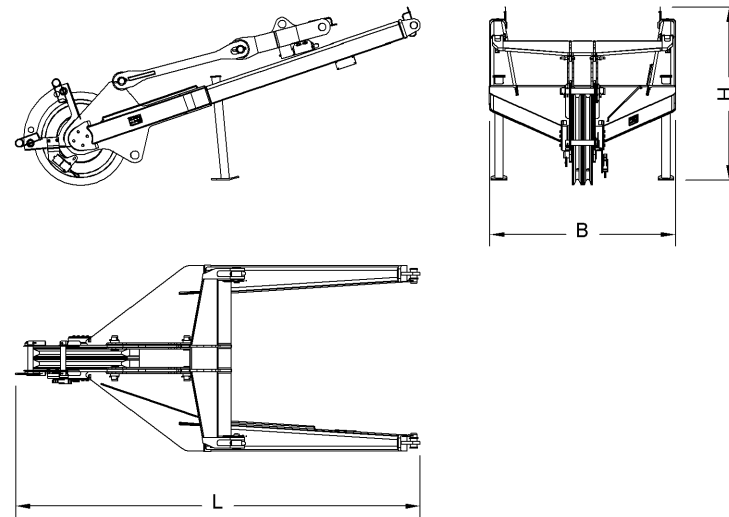

Fig. 405: Dimensions of auxiliary jib (36 t (79.300 lb)) for the boom head section

Designation	Value
L Length	3190 mm 10' 6" ft-in
B Width	1520 mm 5' ft-in
H Height	1400 mm 4' 7" ft-in
Weight	590 kg 1,301 lb

Tab. 253: Technical data for auxiliary jib (36 t (79.300 lb)) for the boom head section

L\WINLR\_x\V03.04\Auslieferung\2015-11-30\en

PROJECT:  
LR 1300 SX 203' ST

LOCATION: -----  
BUCKNER CONTACT: Andy Moore, PE  
AndyM@BucknerHeavylift.com  
LIFT PLAN BY: Andy Moore, PE  
AndyM@BucknerHeavylift.com

DRAWING NOTES:  
Aux Jib 2

LR1300 SX	
Operating Mode	MB
Main Boom Length	62m (203')
Luffing Jib Length	N/A
Derrick Length	N/A
Superstructure CWT	273.4k
Carbody CWT	125.7k
Ballast Tray CWT	N/A

FILE: D:\Andy Moore\OneDrive - Buckner Heavylift  
Cranes\Documents -  
Engineering\Drawings\BHL\Buckner\Build Sheets\LR  
1300SX\LR 1300 SX 203' ST.dwg  
CREATED: 11.08.2023 @ 12:25:58 PM  
EDITING TIME: 17h20m FILE SIZE: 586.43Kb  
PAPER SIZE: ANSI B (17.00 x 11.00 Inches)  
SAVED: 11.08.2023 @ 12:25:41 PM  
PLOTTED: 11.08.2023 @ 12:25:58 PM

Revisions

All Sheets Same Revision Level

Rev.	Date	Description
000	11.08.2023	Preliminary Planning & Initial Layout
001	----	----
002	----	----
003	----	----
004	----	----
005	----	----
006	----	----
007	----	----
008	----	----
009	----	----
010	----	----

SHEET: 005 OF 009



Aux. Hook (Pill)	
Hook 16t (0 Sheave) 28mmØ	
Parts of Line	1
Reeving Cap. (EN 13000)	33 510 lb
Block Wt.	1 984 lb

Main Hook Block	
Hook Block 160t (5 Sheave) 28mmØ	
Parts of Line	9
Reeving Cap. (EN 13000)	288 801 lb
Block Wt.	(With 4 weights) 8 818 lb

Rope reeving	1	2	3	4	5	6	7	8	9
<b>Total boom length</b>	<b>Dead weight of the hook/pulley block</b>								
190 m 623 ft	1150 kg 2,535 lb	2050 kg 4,519 lb							
180 m 590 ft	1100 kg 2,425 lb	1900 kg 4,189 lb	3000 kg 6,614 lb						
170 m 558 ft	1000 kg 2,205 lb	1800 kg 3,968 lb	2800 kg 6,173 lb						
150 m 492 ft	900 kg 1,984 lb	1600 kg 3,527 lb	2500 kg 5,511 lb						
130 m 426 ft	800 kg 1,764 lb	1400 kg 3,086 lb	2150 kg 4,740 lb						
120 m 393 ft	700 kg 1,543 lb	1300 kg 2,866 lb	2000 kg 4,409 lb	2750 kg 6,063 lb					
110 m 360 ft	650 kg 1,433 lb	1200 kg 2,646 lb	1800 kg 3,968 lb	2500 kg 5,511 lb					
100 m 328 ft	600 kg 1,323 lb	1050 kg 2,315 lb	1650 kg 3,638 lb	2300 kg 5,071 lb	2950 kg 6,504 lb				
90 m 295 ft	550 kg 1,213 lb	950 kg 2,094 lb	1500 kg 3,307 lb	2050 kg 4,519 lb	2650 kg 5,842 lb	3300 kg 7,275 lb			
80 m 262 ft	500 kg 1,102 lb	850 kg 1,874 lb	1350 kg 2,976 lb	1850 kg 4,078 lb	2350 kg 5,181 lb	2900 kg 6,393 lb	3500 kg 7,716 lb		
70 m 230 ft	450 kg 992 lb	750 kg 1,653 lb	1200 kg 2,646 lb	1600 kg 3,527 lb	2100 kg 4,630 lb	2550 kg 5,622 lb	3100 kg 6,834 lb	3600 kg 7,937 lb	
60 m 197 ft	350 kg 772 lb	650 kg 1,433 lb	1000 kg 2,205 lb	1400 kg 3,086 lb	1800 kg 3,968 lb	2200 kg 4,850 lb	2650 kg 5,842 lb	3100 kg 6,834 lb	3600 kg 7,937 lb

**MAIN HOOK BLOCK WEIGHT CALC:**

$G=L \times M \times N \times F$   
 $L=203 \text{ ft}$   
 $M=2.65 \text{ lb/ft}$   
 $N=9$   
 $F=1.52$

$G=203 \text{ ft} \times 2.65 \text{ lb/ft} \times 9 \times 1.52 = 7 \text{ 359 lb min. block weight} < 8 \text{ 818 lb so } \underline{O.K.}$

**NOTE:**

When lifting from main hook the weight of the aux. block + boom nose + steel pendants + aux. reeving must be deducted from the gross cap. of the crane. This will vary based on the position of the aux. hook from the boom nose.

PROJECT:  
LR 1300 SX 203' ST

LOCATION: -----  
BUCKNER CONTACT: Andy Moore, PE  
AndyM@BucknerHeavyLift.com  
LIFT PLAN BY: Andy Moore, PE  
AndyM@BucknerHeavyLift.com

DRAWING NOTES:  
Hook Blocks

LR1300 SX	
Operating Mode	MB
Main Boom Length	62m (203')
Luffing Jib Length	N/A
Derrick Length	N/A
Superstructure CWT	273.4k
Carbody CWT	125.7k
Ballast Tray CWT	N/A

FILE: D:\Andy Moore\OneDrive - Buckner HeavyLift  
Cranes\Documents -  
Engineering\Drawings\BHL\Buckner\Build Sheets\LR  
1300SX\LR 1300 SX 203' ST.dwg  
CREATED: 11.08.2023 @ 12:25:41 PM  
EDITING TIME: 17h20m FILE SIZE: 586.43Kb  
PAPER SIZE: ANSI B (17.00 x 11.00 Inches)  
SAVED: 11.08.2023 @ 12:25:41 PM  
PLOTTED: 11.08.2023 @ 12:26:01 PM

Revisions		
All Sheets Same Revision Level		
Rev.	Date	Description
000	11.08.2023	Preliminary Planning & Initial Layout
001	----	----
002	----	----
003	----	----
004	----	----
005	----	----
006	----	----
007	----	----
008	----	----
009	----	----
010	----	----

SHEET: 006 OF 009





### Erectability charts

The erectability charts provide details on the erection capability for all possible boom and ballast configurations.

It should be noted that auxiliary equipment attached to the boom, platforms, as well as ice and snow, can reduce the length of the self-erecting boom.

The load hook/pulley block must always be resting on the ground during erection.

These erectability charts only apply to original LIEBHERR machines and boom components in a new and proper working condition. Any damage, or modification and attachment which has not been approved by LIEBHERR, will affect the erection capabilities described below. Erection is strictly prohibited.

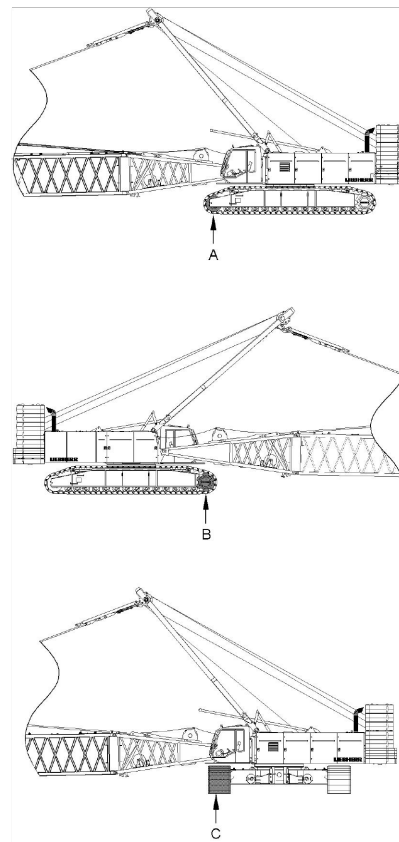

**Erectability A:** The boom is erectable over the **guide wheel**.

**Erectability B:** The boom is erectable over the **turas**.

**Erectability C:** The boom is erectable over the **side**.

PROJECT:  
LR 1300 SX 203' ST

LOCATION: -----  
BUCKNER CONTACT: Andy Moore, PE  
AndyM@BucknerHeavylift.com  
LIFT PLAN BY: Andy Moore, PE  
AndyM@BucknerHeavylift.com

DRAWING NOTES:  
Erectability Chart 1

LR1300 SX	
Operating Mode	MB
Main Boom Length	62m (203')
Luffing Jib Length	N/A
Derrick Length	N/A
Superstructure CWT	273.4k
Carbody CWT	125.7k
Ballast Tray CWT	N/A

FILE: D:\Andy Moore\OneDrive - Buckner Heavylift  
Cranes\Documents -  
Engineering\Drawings\BHL\Buckner\Build Sheets\LR  
1300SX\LR 1300 SX 203' @ 62m\ST.dwg  
CREATED: 11.08.2023 @ 12:25:41 PM  
EDITING TIME: 17h20m FILE SIZE: 586.43Kb  
PAPER SIZE: ANSI B (17.00 x 11.00 Inches)  
SAVED: 11.08.2023 @ 12:25:41 PM  
PLOTTED: 11.08.2023 @ 12:26:01 PM

### Revisions

All Sheets Same Revision Level

Rev.	Date	Description
000	11.08.2023	Preliminary Planning & Initial Layout
001	----	----
002	----	----
003	----	----
004	----	----
005	----	----
006	----	----
007	----	----
008	----	----
009	----	----
010	----	----

SHEET: 007 OF 009







Boom configuration: Main boom  
Ident. no.: /10539958/141906

Main boom 2821-1 Main boom head 2821-2								
2 - Wide track								
Main boom length [ ft ]	Rear counterweight [ 1000 lbs ] Carbody counterweight [ 1000 lbs ]							
	0.0 0.0	0.0 125.7	119.0 0.0	163.1 0.0	207.2 125.7	229.3 125.7	251.3 125.7	273.4 125.7
66	ABC	ABC	ABC	ABC	ABC	ABC	ABC	ABC
75	ABC	ABC	ABC	ABC	ABC	ABC	ABC	ABC
85	AB	ABC	ABC	ABC	ABC	ABC	ABC	ABC
95	AB	ABC	ABC	ABC	ABC	ABC	ABC	ABC
105	-	ABC	ABC	ABC	ABC	ABC	ABC	ABC
115	-	ABC	ABC	ABC	ABC	ABC	ABC	ABC
125	-	AB	ABC	ABC	ABC	ABC	ABC	ABC
135	-	AB	ABC	ABC	ABC	ABC	ABC	ABC
144	-	-	ABC	ABC	ABC	ABC	ABC	ABC
154	-	-	ABC	ABC	ABC	ABC	ABC	ABC
164	-	-	AB	ABC	ABC	ABC	ABC	ABC
174	-	-	AB	ABC	ABC	ABC	ABC	ABC
184	-	-	-	ABC	ABC	ABC	ABC	ABC
194	-	-	-	AB	ABC	ABC	ABC	ABC
203	-	-	-	-	ABC	ABC	ABC	ABC
213	-	-	-	-	ABC	ABC	ABC	ABC
223	-	-	-	-	ABC	ABC	ABC	ABC
233	-	-	-	-	AB	ABC	ABC	ABC
243	-	-	-	-	AB	ABC	ABC	ABC
253	-	-	-	-	-	AB	ABC	ABC
262	-	-	-	-	-	-	AB	AB
272	-	-	-	-	-	-	-	AB

Load hook/pulley block always on ground

**LR1300SX**  
**Erectability charts**

PROJECT:  
LR 1300 SX 203' ST

LOCATION: -----  
BUCKNER CONTACT: Andy Moore, PE  
AndyM@BucknerHeavylift.com  
LIFT PLAN BY: Andy Moore, PE  
AndyM@BucknerHeavylift.com

DRAWING NOTES:  
Erectability Chart 2

LR1300 SX	
Operating Mode	MB
Main Boom Length	62m (203')
Luffing Jib Length	N/A
Derrick Length	N/A
Superstructure CWT	273.4k
Carbody CWT	125.7k
Ballast Tray CWT	N/A

FILE: D:\Andy Moore\OneDrive - Buckner Heavylift  
Cranes\Documents -  
Engineering\Drawings\BHL\Buckner\Build Sheets\LR  
1300SX\LR 1300SX 203' @ 62m) ST.dwg  
CREATED: 11.08.2023 @ 12:25:41 PM  
EDITING TIME: 17h20m FILE SIZE: 586.43Kb  
PAPER SIZE: ANSI B (17.00 x 11.00 Inches)  
SAVED: 11.08.2023 @ 12:25:41 PM  
PLOTTED: 11.08.2023 @ 12:26:00 PM

Revisions

All Sheets Same Revision Level

Rev.	Date	Description
000	11.08.2023	Preliminary Planning & Initial Layout
001	----	----
002	----	----
003	----	----
004	----	----
005	----	----
006	----	----
007	----	----
008	----	----
009	----	----
010	----	----

SHEET: 008 OF 009





**LR1300SX**  
**Loads main boom**

Ident. no.: 11230834/276596/ Main boom base section: 2821-1  
 Swing range: 360 ° Main boom head: 2821-2  
 Foot print: 2 - Wide track  
 Rear counterweight [ 1000 lbs ]: 273.4  
 Carbody counterweight [ 1000 lbs ]: 125.7

Outreach [ ft ]	Main boom angle [ ° ]	Rope pulley height [ ft ]	Load [1000 lbs]
203 ft Main boom, Load fall point Main boom head Main boom head (2821-2)			
30	86	212	79.4
30	85.9	212	79.4
35	84.5	212	79.4
40	83.1	211	79.4
45	81.7	210	79.4
50	80.2	209	79.4
55	78.8	208	79.4
60	77.4	206	79.4
65	75.9	205	79.4
70	74.5	203	79.4
75	73	202	79.4
80	71.5	200	79.4
85	70	198	79.4
90	68.5	196	79.4
95	67	193	79.4
100	65.4	191	79.0
105	63.9	188	73.2
110	62.3	185	68.0
115	60.6	182	63.3
120	59	179	59.0
125	57.3	176	55.1
130	55.6	172	51.5
135	53.8	168	48.2
140	52	164	45.1
145	50.1	159	42.3
150	48.2	154	39.7
155	46.2	149	37.2
160	44.2	144	35.0
165	42.5	140	33.0
170	40.3	133	31.0
175	37.9	126	29.1
180	35.5	119	27.3
185	32.8	111	25.6
190	29.9	102	24.0
195	26.7	91	22.4
200	23	79	20.9
205	18.5	64	19.5

Valid only with preface

30

Liebherr-Werk Nenzing GmbH, Dr. Hans Liebherr Straße 1, 6710 Nenzing, Austria

1.5.2021

Source:a10539989

PROJECT:  
LR 1300 SX 203' ST

LOCATION: -----  
 BUCKNER CONTACT: Andy Moore, PE  
 AndyM@BucknerHeavyLift.com  
 LIFT PLAN BY: Andy Moore, PE  
 AndyM@BucknerHeavyLift.com

DRAWING NOTES:  
Load Chart

LR1300 SX	
Operating Mode	MB
Main Boom Length	62m (203')
Luffing Jib Length	N/A
Derrick Length	N/A
Superstructure CWT	273.4k
Carbody CWT	125.7k
Ballast Tray CWT	N/A

FILE: D:\Andy Moore\OneDrive -- Buckner HeavyLift  
 Cranes\Documents --  
 Engineering\Drawings\BHL\Buckner\Build Sheets\LR  
 1300SX\LR 1300 SX 203' @ 62m\1-37.dwg  
 CREATED: 11.08.2023 @ 12:25:59 PM  
 EDITING TIME: 17h20m FILE SIZE: 586.43Kb  
 PAPER SIZE: ANSI B (17.00 x 11.00 Inches)  
 SAVED: 11.08.2023 @ 12:25:41 PM  
 PLOTTED: 11.08.2023 @ 12:25:59 PM

Revisions

All Sheets Same Revision Level

Rev.	Date	Description
000	11.08.2023	Preliminary Planning & Initial Layout
001	----	----
002	----	----
003	----	----
004	----	----
005	----	----
006	----	----
007	----	----
008	----	----
009	----	----
010	----	----

SHEET: 009 OF 009

