

Ersatzteilkatalog

Spare parts catalogue

Catalogue de pièces de rechange

Catálogo de repuestos

Каталог запасных частей



6.2.2009
025500

LIEBHERR

etk_en_de_074515 LR 1600/2

LIEBHERR RAUPENKRAN LR 1600/2

□ 1 (1/12)

→

LR 1600-2-003

VORBEMERKUNGEN

Dieser Ersatzteilkatalog soll Ihnen die Ermittlung und Bestellung von Ersatzteilen für die Wartung bzw. Reparatur Ihres LIEBHERR-Kranes erleichtern.
Zum schnelleren Auffinden der Ersatzteile sind im Inhaltsverzeichnis die in Ihrem Kran verwendeten Baugruppen aufgeführt.

Inhaltsverzeichnis

Im Inhaltsverzeichnis verweist der Pfeil (⇨) in der zweiten Textzeile der Baugruppenartikelnr. auf die detaillierte Blatt-Nr. mit Artikel-Nr. hin.

Bild- und Textseiten

Die Bild- und Textseiten für die Baugruppen und Einzelteile sind sortiert nach Blatt-Nr.; innerhalb der Blatt-Nr. nach Artikel-Nr. Eine Blatt-Nr. kann aus einer oder mehreren Bild- und / oder Textseiten bestehen.

Jeder weitere Pfeil (⇨) führt zu einer detaillierten Bild- und / oder Textseite des Artikels. Sind Position-Nummern in Klammern (x) gesetzt, handelt es sich um Einzelteile des vorangegangenen Artikels.

Numerischer Index

Der numerische Index ist sortiert nach Artikel-Nr. mit Hinweisen auf Blatt-Nr., Baugruppen-Nr. und Position-Nr.

Alphabetischer Index

Der alphabetische Index ist sortiert nach Bezeichnung mit Hinweisen auf Artikel-Nr., Position-Nr., Blatt-Nr. und Baugruppen-Nr.

Für die sachliche Richtigkeit des Kataloges ist ausschließlich der deutsche Text maßgebend.

PRELIMINARY REMARKS

This spare parts catalog should ease identification and ordering of spare parts of your LIEBHERR crane in respect to maintenance or repair.

In order to locate the spare-parts more quickly, the components used in your crane have been arranged in the table of contents.

Table of contents

In the table of contents the arrow (⇨) in the second text line of the assembly item number indicates the detailed plate number with the item number.

Picture and text pages

The picture and text pages for the assemblies and spare parts are sorted according to page number; within the plate number according to the item number. A page number can consist of one or more picture and / or text pages.

Each further arrow (⇨) leads to a detailed picture and / or text page of item. Should the position number be displayed in brackets (x), individual parts of the preceding item are now being referred to.

Numerical index

The numerical index is sorted according to item no. with notes indicating page no., component no. and position no.

Alphabetical index

The alphabetical index is sorted according to description with notes indicating item no., position no., page no. and component no.

Please note that the German text is binding as far as the correctness of parts list entries is concerned.

REMARQUES PRÉLIMINAIRES

Cette liste des pièces détachées a pour but de vous faciliter la commande de pièces détachées nécessaires à la maintenance ou à la réparation de votre grue LIEBHERR.

Pour permettre de trouver rapidement les pièces détachées, la table des matières reprend les ensembles utilisés sur votre grue.

Table des matières

Dans la table des matières, la flèche (⇨) dans la deuxième ligne de texte du numéro de l'article de l'ensemble indique le n° détaillé de la planche avec le n° de l'article.

Pages de schémas et de textes

Les pages de schémas et de texte pour les ensembles et les pièces individuelles sont triées selon le n° de la planche; dans la planche, elles sont triées selon le n° de l'article. Un n° de planche peut être composé d'une ou plusieurs pages de schémas et / ou de texte.

Toute autre flèche (⇨) conduit à une page de schémas / de texte détaillée concernant l'article. Si les numéros de repère sont entre parenthèses (x), il s'agit de pièces détachées de l'article concerné.

Index numérique

L'index numérique est trié suivant le numéro d'article avec indication du numéro de planche, du numéro d'ensemble et du numéro de repère.

Index alphabétique

L'index alphabétique est trié suivant la désignation avec indication du numéro d'article, du numéro de repère, du numéro de planche et du numéro d'ensemble.

Des erreurs pouvant s'être glissées dans la traduction des désignations, le constructeur ne peut garantir que l'exactitude du texte allemand qui fera foi.

OBSERVACIONES PRELIMINARES

Este catálogo de piezas de repuestos sirve para facilitarle en el pedido de repuestos necesarios para el mantenimiento o reparación de su grúa LIEBHERR. Para encontrar rápidamente las piezas de repuestos, el índice le indica los grupos de componentes utilizados en su grúa.

Indice

En el índice, la flecha (⇨) en la segunda línea de texto del N° de artículo de la unidad de componentes indica el N° de hoja detallada con el N° de artículo.

Página de ilustración y texto

Las páginas de ilustración y texto para la unidad de componentes y las piezas individuales están clasificadas según el N° de la hoja, y en la misma hoja, según el N° del artículo. Un N° de hoja puede contener una una o varias páginas de imágenes y / o texto.

Cualquier otra flecha (⇨) le lleva a una ilustración / texto detallado del artículo. Si los números de posición están entre paréntesis (x), se trata de componentes por unidades del artículo precedente.

Índice numérico

El índice numérico está clasificado según el N° de artículo con indicación del N° de hoja, el N° del grupo de componentes y el N° de posición.

Índice alfabético

El índice alfabético está clasificado según la denominación con indicación del N° de artículo, N° de posición, N° de hoja y N° de grupo de componentes.

En caso que se haya presentado errores en la traducción de designaciones, el constructor garantiza como válido sólo la exactitud del texto alemán.

ПРЕДВАРИТЕЛЬНЫЕ ЗАМЕЧАНИЯ

Данный каталог запасных частей предназначен для поиска, определения и последующего заказа запасных частей, необходимых для технического обслуживания и ремонта кранов фирмы ЛИБХЕРР.

Для быстрого нахождения запасной детали в Оглавлении приведены используемые в Вашем кране узлы.

Оглавление

Стрелка (⇨) в оглавлении, расположенная во второй текстовой строке номера агрегата или узла, указывает на детализированный номер листа с номером артикула.

Иллюстрации и чертежи

Иллюстрации, чертежи и текстовые страницы как по всем агрегатам и узлам, так и по отдельным деталям, отсортированы по номеру страницы, а внутри номера страницы - по номерам деталей. Один номер страницы может состоять из нескольких других иллюстраций и текстов к ним.

Каждая следующая стрелка (⇨) указывает страницу с подробным рисунком и / или текстом по этому изделию. Когда номер позиции заключен в скобки (x), рассматриваются детали предыдущего артикула.

Цифровой индекс

Цифровой индекс сортирован по номеру артикула с указанием номера листа, номера узла и номера позиции.

Буквенный индекс

Буквенный индекс сортирован по обозначению с указанием номера артикула, номера позиции, номера листа и номера узла.

Для правильности заказа и определения детали используйте только немецкий текст.

WIE BESTELLE ICH EIN ERSATZTEIL

Prüfen Sie zunächst, ob der Kran-Typ und die Werk-Nr. auf dem Typenschild Ihres LIEBHERR-Kranes mit dem Kran-Typ und der Werk-Nr. im Ersatzteilkatalog übereinstimmen.

Ihre Bestellung muß folgende Angaben enthalten:

anzugeben:	zu ersehen:	Beispiel:
Krantyp	Typenschild	LTM 1080/1
Werk-Nr.	Typenschild	061044
Bestellmenge	Ihr Bedarf	1 Stück
Artikel-Nr.	Bildseite / Textseite	927708001
Bezeichnung	Bildseite / Textseite	Seilwinde
Versandanschrift	-	-
Versandart	-	-

ACHTUNG:

Bei Aggregaten, für die auch Einzelteile bestellt werden können, weist der Pfeil (⇨) in der zweiten Textzeile der Bezeichnung auf die entsprechende Blatt- und Artikelnummer hin.

Bildseiten der Leitungssysteme (Hydraulik, Pneumatik, Elektrik) beinhalten nicht alle Aggregate.

Diese Aggregate sind auf den Bildseiten zu sehen, die die Einbaulage darstellen.

Für die Lieferung von Ersatzteilen gelten unsere Lieferungs- und Zahlungsbedingungen.

HOW TO ORDER SPARE PARTS

First check that the crane type and works no. on the type plate of your LIEBHERR crane are identical with the crane type and works no. on the spare parts catalog you are consulting.

Your order must contain the following details:

please state:	to be found:	example:
Crane type	Type plate	LTM 1080/1
Works no.	Type plate	061044
Quantity needed	as required	1 piece
Item no.	Picture page / text page	927708001
Description	Picture page / text page	Rope winch
Delivery address	-	-
Delivery method	-	-

CAUTION:

With units to which individual parts can also be ordered, the arrow (⇨) in the second line of the description text indicates the corresponding page and item number.

Picture pages for the line systems (hydraulic, pneumatic, electric) do not include all units.

This units are shown on the picture pages which represent the installation position.

Parts are supplied subject to our terms of delivery and payment.

COMMENT COMMANDER UNE PIECE DETACHEE

S'assurer d'abord que le type de grue et le n° de matricule figurant sur la plaque signalétique de votre grue LIEBHERR correspondent bien au type de grue et au n° de matricule indiqués dans la liste de pièces détachées:

Votre commande doit comporter les renseignements suivants:

renseignement:	où l'obtenir:	exemple:
Type de grue	Plaque signalétique	LTM 1080/1
N° de matricule	Plaque signalétique	061044
Quantité	Selon vos besoins	1 pièce
N° d'article	Page de schémas / page de textes	927708001
Description	Page de schémas / page de textes	Treuil à cable
Adresse	-	-
Mode d'expédition	-	-

ATTENTION:

Pour les composants pour lesquels il est possible de commander des pièces détachées, la flèche (⇨) dans la deuxième ligne de texte de la désignation indique le numéro de la planche et de l'article.

Les pages de schémas des systèmes hydraulique, pneumatique et électrique ne comportent pas tous les composants.

Ces composants sont représentés sur les pages de schémas comportant la position de montage.

La livraison de nos pièces détachées est soumise à nos conditions générales de livraison et de paiement.

¿COMO HACER EL PEDIDO DE REPUESTO?

Primero verificar si el modelo de grúa y el N° de fabricación indicados en la placa de características de su grúa LIEBHERR coincide con el modelo de grúa y de N° de fabricación del catálogo de repuestos.

Su pedido deberá contener las siguientes informaciones:

Informar:	De donde obtener:	Ejemplo:
Modelo de grúa	Placa de características	LTM 1080/1
N° de grúa	Placa de características	061044
Cantidad pedida	según la necesidad del cliente	1 unidad
N° de artículo	Pág. de ilustración / Pág. de texto	927708001
Denominación	Pág. de ilustración / Pág. de texto	Cabrestante de cable
Dirección de expedición	-	-
Modo de expedició	-	-

ATENCION:

Para los componentes, los cuales se puede pedir igualmente en piezas sueltas, la flecha (⇨) indica en la segunda línea de texto, la denominación del número de la página y del artículo.

Las páginas de ilustraciones de los sistemas conductores (sistema hidráulico, neumático, eléctrico) no contienen todos los componentes.

Estos componentes se pueden ver en las páginas de ilustraciones representando la posición de montaje.

El suministro de los repuestos está sometido a nuestras condiciones generales de entrega y pago.

6.2.2009
025505

LIEBHERR

etk_en_de_074515 LR 1600/2

LIEBHERR RAUPENKRAN LR 1600/2

6 (6/12)

⇨

LR 1600-2-003

КАК ЗАКАЗАТЬ НУЖНУЮ ЗАПАСНУЮ ЧАСТЬ

Прежде всего проверьте, соответствует ли каталог запасных частей типу и заводскому номеру крана, нанесенных на фирменную табличку на кране.

Ваш заказ должен содержать следующие необходимые данные:

Данные:	Где искать:	Пример:
Тип крана	Фирменная табличка	LTM 1080/1
Заводской номер	Фирменная табличка	061044
Количество	По потребности	1 шт.
Номер детали	Чертеж / текстовая страница	927708001
Наименование детали	Чертеж / текстовая страница	Канатная лебедка
Адрес получателя	-	-
Вид поставки	-	-

Внимание:

Узлы и агрегаты, для которых возможен заказ отдельных запасных частей, помечены стрелкой (⇨) во второй строке текста наименования детали, стрелка указывает на номер соответствующего чертежа или номер детали. Чертежи отдельных систем (гидравлической, пневматической, электрической) содержат не все входящие в системы агрегаты. Данные агрегаты находятся на чертежах узлов, в которые они входят.

При поставке заказанных запасных частей действуют наши условия оплаты и поставки.

Pos.	Item	Quantity	Description	Bezeichnung	Serie	K
2	91 52 375 08	1	CRAWLER TRACK TRAVEL GEAR CPL. ⇒ 1 100 91 52 375 08	RAUPENFAHRWERK KPL.		
4	91 52 377 08	1	CENTRAL SECTION CRAWLER COMPL. ⇒ 1 130 91 52 377 08	RAUPENMITTELTEIL KPL.		
6	91 52 768 08	2	FLOOR SHEET COMPL. 2.0 M ⇒ 1 300 91 52 768 08	BODENPLATTEN KPL.		
10	91 56 853 08	1	CRAWLER TRACK CARRIER LEFT CPL ⇒ 1 400 91 56 853 08	RAUPENTRAEGER KPL.LI.		
11	91 56 855 08	1	CRAWLER CARRIER RIGHT CPL ⇒ 1 410 300 91 56 855 08	RAUPENTRAEGER KPL.RE.		
13	91 52 386 08	1	FIXING PARTS SLEWING RING QC ⇒ 1 620 91 52 386 08	BEFESTIGUNGSTEILE DREHVE		
15	91 52 387 08	1	HYDRAULIC SUPPORT ⇒ 1 630 91 52 387 08	HYDRAULISCHE ABSTUETZUN		
16	91 52 388 08	1	CATWALK CRAW.TRACK TRAVEL GEAR ⇒ 1 631 100 91 52 388 08	LAUFSTEG RAUPENFAHRWERK		
17	91 52 389 08	1	MECHANICAL SUPPORT ⇒ 1 632 91 52 389 08	MECH.ZUSATZABSTUETZUNG		
20	91 52 392 08	1	CENTRALIZED LUBRICATION SYSTEM ⇒ 1 711 91 52 392 08	ZENTRALSCHMIERUNG RAUPE		
22	91 53 020 08	1	CENTRAL BALLAST 8X7.5T ⇒ 1 740 91 53 020 08	ZENTRALBALLAST		
23	91 53 021 08	1	FIXAGE DU CONTREPOIDS CENTRAL ⇒ 1 742 91 53 021 08	ZENTRALBALLASTBEFESTIGUN		
25	91 52 394 08	1	TOOL ⇒ 1 750 91 52 394 08	WERKZEUG		
28	91 52 505 08	1	ELECTR.FOR CRAWLER CARRIER ⇒ 1 920 300 91 52 505 08	ELEKTRIK RAUPE		
31	91 56 958 08	1	CRAWLER TRACK HYDRAULIC ⇒ 1 970 91 56 958 08	HYDRAULIK RAUPE		
32	91 52 509 08	1	ADD. HYDR. SUPPORTING RAM ⇒ 1 975 006 91 52 509 08	ZUSATZHYDR.ABSTUETZZYLIN		
33	91 52 510 08	1	ROTARY FEED THROUGH ⇒ 1 991 91 52 510 08	DREHDURCHFUEHRUNG		
35	91 52 512 08	1	HOSE LINES CRAWLER ⇒ 1 997 91 52 512 08	SCHLAUCHLEITUNGEN RAUPE		
37	91 52 513 08	1	PIPELINES CRAWLER TYPE UNDERC. MIT ⇒ 1 998 91 52 513 08	ROHRLEITUNGEN RAUPE		
102	91 52 773 08	1	PIN F.S-PIVOT SECTION SA FRAME ⇒ 2 125 91 52 773 08	BOLZEN S-ANLENKST. UND SA-		
103	91 52 503 08	1	WINCH 1 ⇒ 2 310 91 52 503 08	WINDE 1		
104	91 52 504 08	1	WINCH 2 ⇒ 2 320 91 52 504 08	WINDE 2		
106	91 52 774 08	1	ADDITIONAL HYDRAULICS WINCH 1 ⇒ 2 975 700 91 52 774 08	ZUSATZHYDRAULIK WINDE 1		
108	91 52 775 08	1	ADDITIONAL HYDRAULICS WINCH ⇒ 2 975 200 91 52 775 08	ZUSATZHYDRAULIK WINDE 2		
111	91 52 776 08	1	WINCH 4 LUFFING GEAR ⇒ 2 340 91 52 776 08	WINDE 4 EINZIEHWERK		
117	91 52 778 08	1	SLEWING GEAR 2 DREHW. ⇒ 2 350 91 52 778 08	DREHWERK		
118	91 52 780 08	1	ADDITIONAL HYDRAULICS 2 DW ⇒ 2 976 200 91 52 780 08	ZUSATZHYDRAULIK DREHWERK		
119	91 52 782 08	1	ERECTING WINCH ⇒ 2 370 91 52 782 08	MONTAGEWINDE		
120	91 57 881 08	1	ADDNL. HYDR. F. ERECTING WINCH ⇒ 2 975 000 91 57 881 08	ZUSATZHYDRAULIK MONTAGE		
121	91 52 784 08	1	DIESEL ENGINE CPL. ⇒ 2 391 91 52 784 08	DIESELMOTOR KPL.		

6.2.2009

etk_en_de_074515 LR 1600/2

8 (8/12)

LIEBHERR

LIEBHERR RAUPENKRAN LR 1600/2

⇒

LR 1600-2-003

Pos.	Item	Quantity	Description	Bezeichnung	Serie	K
123	91 54 561 08	1	PUMP F.SLEWING GEAR ⇒ 2 212 91 54 561 08	PUMPE F.DREHWERK		
124	91 52 785 08	1	MUFFLER UNIT ⇒ 2 392 91 52 785 08	SCHALLDAEMPFERANLAGE		
125	91 52 787 08	1	AIR FILTER UNIT CPL. ⇒ 2 393 91 52 787 08	LUFTFILTERANLAGE KPL.		
126	91 53 057 08	1	CUP SPRING CLUSTER ⇒ 2 260 91 53 057 08	BATTERIELAGERUNG		
129	91 55 939 08	1	CONTROL STAND ⇒ 2 502 91 55 939 08	STEUERSTAND		
130	91 55 873 08	1	EMERGENCY SEAT ⇒ 2 503 100 91 55 873 08	NOTSITZ		
131	91 52 788 08	1	TURNTABLE PANELLING ⇒ 2 510 91 52 788 08	DREHBUEHNENVERKLEIDUNG		
132	91 56 817 08	1	SLEWING PLATFORM CATWALK ⇒ 2 631 91 56 817 08	LAUFSTEG DREHBUEHNE		
133	91 52 789 08	1	EL.INSTRUMENTS F.CRANE DRIV.CA ⇒ 2 533 91 52 789 08	ELEKTRIK KRANFUEHRERKABIN		
134	91 52 790 08	1	ADD HEATING SUPERSTRUCTURE ⇒ 2 541 91 52 790 08	ZUSATZHEIZUNG OW		
135	91 57 751 08	1	SA FRAME ⇒ 2 550 91 57 751 08	SA-BOCK		
137	91 52 793 08	1	ROLLER SLEWING RING ⇒ 2 620 91 52 793 08	ROLLENDREHVERBINDUNG		
138	91 52 794 08	1	ROLLER BEARING DREHBUEHNE ⇒ 2 652 91 52 794 08	ROLLENLAGERUNG		
139	91 57 656 08	1	MOUNTING EQUIPMENT CRAWLER ⇒ 2 657 91 57 656 08	MONTAGEEINRICHTUNG RAUP		
142	91 52 796 08	1	ADDNL.HYDR.ERECTION DEVICE ⇒ 2 978 100 91 52 796 08	ZUSATZHYDR.MONTAGEEINRIC		
143	91 52 797 08	1	FUEL TANK CPL. ⇒ 2 670 91 52 797 08	KRAFTSTOFFBEHAELTER KPL.		
144	91 52 798 08	1	OIL RESERVOIR, COMPLETE ⇒ 2 671 91 52 798 08	OELBEHAELTER KPL.		
147	91 52 800 08	1	CENT. LUBRIC. SYSTEM SUPERST. ⇒ 2 711 91 52 800 08	ZENTRALSCHMIERANLAGE OW		
148	91 57 283 08	1	SLING GEAR ERECTION CRAWLER ⇒ 2 750 100 91 57 283 08	ANSCHLAGMITTEL MONTAGE		
150	91 52 802 08	1	BASE PLATE SLEWING PLATFORM BA ⇒ 2 730 91 52 802 08	GRUNDPLATTE DREHBUEHNE		
152	91 52 770 08	1	COUNTERWEIGHT 16X7.5T + 6X10T ⇒ 2 740 91 52 770 08	GEGENGEWICHT		
153	91 52 806 08	1	CRANE DRIVER'S CABIN CPL. ⇒ 2 810 91 52 806 08	KRANFUEHRERKABINE KPL.		
156	91 52 807 08	1	BATTERY CHARGER 230V ⇒ 2 835 91 52 807 08	BATTERIELADEGERAET		
159	91 52 809 08	1	SOUND INSULATION ⇒ 2 859 91 52 809 08	GERAEUSCHDAEMMUNG		
163	91 56 833 08	1	ELECTR. SYSTEM F.SLEWING PLATF ⇒ 2 920 91 56 833 08	ELEKTRIK DREHBUEHNE		
165	91 57 750 08	1	BUILT-IN PARTS SWITCH BOX ⇒ 2 932 91 57 750 08	EINBAUTEILE SCHALTSCHRAN		
169	91 56 537 08	1	HYDR ⇒ 2 970 91 56 537 08	HYDRAULIK		
173	91 57 756 08	1	ADDITIONAL HYDR.SLEWING PLATFO ⇒ 2 977 91 57 756 08	ZUSATZHYDRAULIK DREHBUE		
174	91 55 149 08	1	ADDITIONAL HYDR.PUMP/WINCH ⇒ 2 977 200 91 55 149 08	ZUSATZHYDR.PUMPE 5/WINDE		
175	91 52 827 08	1	ADDNL.HYDR.RETAINING DEVICE ⇒ 2 978 100 91 52 827 08	ZUSATZHYDR.D-RUECKHALTES		

6.2.2009

etk_en_de_074515 LR 1600/2

 9 (9/12)

LIEBHERR

LIEBHERR RAUPENKRAN LR 1600/2

⇒

LR 1600-2-003

Pos.	Item	Quantity	Description	Bezeichnung	Serie	K
176	91 54 795 08	1	ADDITIONAL HYDRAULICS PUMP DREHW ⇒ 2 976 700 91 54 795 08	ZUSATZHYDRAULIK PUMPE		
177	91 59 244 08	1	COMPRESSED AIR PLANT ⇒ 2 990 91 59 244 08	DRUCKLUFTANLAGE		
179	91 56 539 08	1	HOSE LINES SUPERSTRUCTURE ⇒ 2 997 91 56 539 08	SCHLAUCHLEITUNGEN OBER		
181	91 56 540 08	1	PIPELINES SUPERSTRUCTURE ⇒ 2 998 91 56 540 08	ROHRLEITUNGEN OBERWAGE		
183	91 52 831 08	1	S OVERRUN PROTECTION ⇒ 3 291 91 52 831 08	S-RUECKHALTESICHERUNG		
184	91 54 843 08	1	ADD.HYDR.S_RETAINING RAM ⇒ 2 978 200 91 54 843 08	ZUSATZHYDR.S-RUECKHALTESI		
190	91 52 834 08	1	ROPE WITH ACCESSORIES 1 ⇒ 2 311 91 52 834 08	SEIL F.WINDE 1		
191	91 52 835 08	1	ROPE WITH ACCESSORIES 2 ⇒ 2 312 91 52 835 08	SEIL F.WINDE 2		
192	91 52 836 08	1	ROPES FOR WINCHES 3 ⇒ 2 313 91 52 836 08	SEIL F.WINDE 3		
193	91 52 837 08	1	ROPE FOR WINCH 4 ⇒ 2 314 91 52 837 08	SEIL F.WINDE 4		
198	91 33 648 08	1	ROPE WITH ACCESSORIES ⇒ 2 372 91 33 648 08	SEIL MONTAGEWINDE M.ZUBEH		
201	91 57 748 08	1	S PIVOT SECTION 10M ⇒ 3 211 91 57 748 08	S-ANLENKSTUECK		
202	91 52 842 08	1	F-CONNECTING HEAD ⇒ 3 213 91 52 842 08	F-ANSCHLUSSKOPF		
203	91 52 843 08	1	SW HEAD SECTION ⇒ 3 214 91 52 843 08	SW-KOPFSTUECK		
204	91 52 846 08	1	ROLLER SET 300T ⇒ 3 215 005 91 52 846 08	ROLLENSATZ		
205	91 52 847 08	1	ROLLER SET 320T ⇒ 3 215 006 91 52 847 08	ROLLENSATZ		
207	91 52 849 08	1	S INTERMEDIATE SECTION 2825.20 6M ⇒ 3 220 500 91 52 849 08	S-ZWISCHENSTUECK		
210	91 52 852 08	2	S INTERMEDIATE SECTION 2825.20 12M ⇒ 3 223 91 52 852 08	S-ZWISCHENSTUECK		
211	91 52 853 08	3	S INTERMEDIATE SECTION 2825.25 12M ⇒ 3 223 010 91 52 853 08	S-ZWISCHENSTUECK		
212	91 54 668 08	1	S INTERMEDIATE SECTION 2825.25 3M ⇒ 3 221 91 54 668 08	S-ZWISCHENSTUECK		
213	91 55 327 08	1	S INTERMEDIATE SECTION 12 M 2825.16Z ⇒ 3 223 100 91 55 327 08	S-ZWISCHENSTUECK		
214	91 52 854 08	1	SL REDUCING SECTION 6.75 M ⇒ 3 225 91 52 854 08	SL-REDUZIERSTUECK		
223	91 52 859 08	1	WINCH 3 ⇒ 3 350 91 52 859 08	WINDE 3		
225	91 52 860 08	1	ADDITIONAL HYDRAULICS WINCH 3 ⇒ 2 975 100 91 52 860 08	ZUSATZHYDRAULIK WINDE 3		
250	91 57 749 08	1	D PIVOT SECTION ⇒ 3 713 91 57 749 08	D-ANLENKSTUECK		
252	91 52 862 08	1	D HEAD SECTION ⇒ 3 714 91 52 862 08	D-KOPFSTUECK		
254	91 52 863 08	1	D INTERMEDIATE SECTION 2420.16 6M ⇒ 3 715 008 91 52 863 08	D-ZWISCHENSTUECK		
256	91 52 864 08	1	D INTERMEDIATE SECTION 2420.20 12M ⇒ 3 716 91 52 864 08	D-ZWISCHENSTUECK		
258	91 52 865 08	1	D OVERRUN PROTECTION ⇒ 3 292 91 52 865 08	D-RUECKHALTESICHERUNG		
268	91 52 870 08	1	L INTERMEDIATE SECTION 2420.10 6M ⇒ 3 226 91 52 870 08	LI-ZWISCHENSTUECK		

6.2.2009

etk_en_de_074515 LR 1600/2

 10 (10/12)
LIEBHERR

LIEBHERR RAUPENKRAN LR 1600/2

⇒

LR 1600-2-003

Pos.	Item	Quantity	Description	Bezeichnung	Serie	K
271	91 53 519 08	1	LI INTERMEDIATE SECT. F-GUYING 2420.9 ⇒ 3 227 200 91 53 519 08	LI-ZWISCHENSTUECK F-ABSP		
272	91 52 872 08	1	L INTERMEDIATE SECTION 2420.10 12M ⇒ 3 227 008 91 52 872 08	LI-ZWISCHENSTUECK		
273	91 52 873 08	1	L INTERMEDIATE SECTION 2420.12 12M ⇒ 3 227 91 52 873 08	LI-ZWISCHENSTUECK		
282	91 52 880 08	1	F-ASSEMBLY UNIT ⇒ 3 205 91 52 880 08	F-MONTAGEEINHEIT		
284	91 52 881 08	1	PIVOT SECTION ⇒ 3 206 91 52 881 08	F-ANLENKSTUECK		
286	91 53 433 08	1	F-GUYING ⇒ 3 207 91 53 433 08	F-ABSPANNUNG		
288	91 52 883 08	1	F-HEAD SECTION ⇒ 3 208 001 91 52 883 08	F-KOPFSTUECK		
294	91 52 896 08	1	ERECTION FRAME ⇒ 3 281 91 52 896 08	FA-BOCK		
296	91 52 897 08	1	OVERRUN PROTECTION ⇒ 3 282 91 52 897 08	F-RUECKHALTESICHERUNG		
314	91 55 528 08	1	HOOK BLOCK 125 DM SPF	HAKENFLASCHE		
317	91 55 527 08	4	ADD WEIGHT 1TO SPF	ZUSATZGEWICHT		
320	91 57 754 08	1	AIR COND. UNIT SUPERSTRUCTURE LR160 ⇒ 2 831 91 57 754 08	KLIMAAANLAGE OW		
322	91 60 728 08	1	CAMERA MONITORING DB ⇒ 2 925 007 91 60 728 08	KAMERAUEBERWACHUNG		
323	91 55 259 08	1	ERG. CAMERA CONTROL ⇒ 2 925 026 91 55 259 08	ERG.KAMERAUEBERWACHUNG		
324	91 60 840 08	1	CAMERA CONTROL WINCH 3 ⇒ 2 925 218 91 60 840 08	KAMERAUEBERWACHUNG WI		
341	91 56 389 08	1	ACOUST. WARN. DISPLACEM. CRAWL ⇒ 2 780 324 91 56 389 08	AKUST.WARNUNG VERFAHREN		
344	91 08 481 08	1	BOLT EXTRACTION ATTACHMENT ⇒ 3 790 91 08 481 08	BOLZENZIEHEINRICHTUNG		
346	91 52 948 08	1	SUSPENDED BALLAST ⇒ 3 745 91 52 948 08	SCHWEBEBALLAST		
350	91 52 950 08	1	CENTERING STANDARD B ⇒ 3 747 91 52 950 08	ZENTRIERUNG STANDARD		
352	91 52 951 08	1	EMERGENCY CUT-OFF CRANE DRIVER ⇒ 2 780 244 91 52 951 08	NOTAUS KRANFUEHRERKABIN		
354	91 24 097 08	1	TELEDIAGNOSIS MODULE 1 ⇒ 2 780 850 91 24 097 08	FERNDIAGNOSE MODUL OW LI		
358	91 05 067 08	1	ACOUST.WARN. SLEWING GEAR ⇒ 2 780 320 91 05 067 08	AKUSTISCHE WARNUNG DRE		
362	91 52 952 08	1	AIR-CRAFT & WIND WARNING ⇒ 3 780 751 91 52 952 08	FLUG-U.WINDWARNUNG		
414	91 52 958 08	1	EXTERNAL FEED 230V-110V ⇒ 2 780 908 91 52 958 08	FREMDEINSPEISUNG		
427	91 57 005 08	1	TRANSPORT KEEPER QC ⇒ 2 790 455 91 57 005 08	TRANSPORTABLAGE		
429	91 57 016 08	1	COVER QC OBERRING ⇒ 2 790 451 91 57 016 08	ABDECKUNG		
430	91 57 017 08	1	COVER QC UNTERRING ⇒ 1 790 503 91 57 017 08	ABDECKUNG		
450	91 55 535 08	1	SUPPLEMENTARY GUYING DEVICE LASC ⇒ 3 830 91 55 535 08	ZUSATZABSPANNUNG		
451	91 55 536 08	1	SUPPLEMENTARY GUYING DEVICE 2M ⇒ 3 832 91 55 536 08	ZUSATZABSPANNUNG		
452	91 55 537 08	1	SUPPLEMENTARY GUYING DEVICE 3M ⇒ 3 832 001 91 55 537 08	ZUSATZABSPANNUNG		
453	91 55 538 08	1	SUPPLEMENTARY GUYING DEVICE 4M ⇒ 3 834 91 55 538 08	ZUSATZABSPANNUNG		

6.2.2009

etk_en_de_074515 LR 1600/2

 11 (11/12)
LIEBHERR

LIEBHERR RAUPENKRAN LR 1600/2

⇒

LR 1600-2-003

Pos.	Item	Quantity	Description	Bezeichnung	Serie	K
454	91 55 539 08	1	SUPPLEMENTARY GUYING DEVICE 5M ⇒ 3 835 000 91 55 539 08	ZUSATZABSPANNUNG		
455	91 55 540 08	1	SUPPLEMENTARY GUYING DEVICE 6M ⇒ 3 836 000 91 55 540 08	ZUSATZABSPANNUNG		
456	91 55 541 08	1	SUPPLEMENTARY GUYING DEVICE 7M ⇒ 3 837 91 55 541 08	ZUSATZABSPANNUNG		
457	91 55 542 08	1	SUPPLEMENTARY GUYING DEVICE 8M ⇒ 3 838 000 91 55 542 08	ZUSATZABSPANNUNG		

6.2.2009

etk_en_de_074515 LR 1600/2

 12 (12/12)

LIEBHERR

LIEBHERR RAUPENKRAN LR 1600/2

⇒

LR 1600-2-003

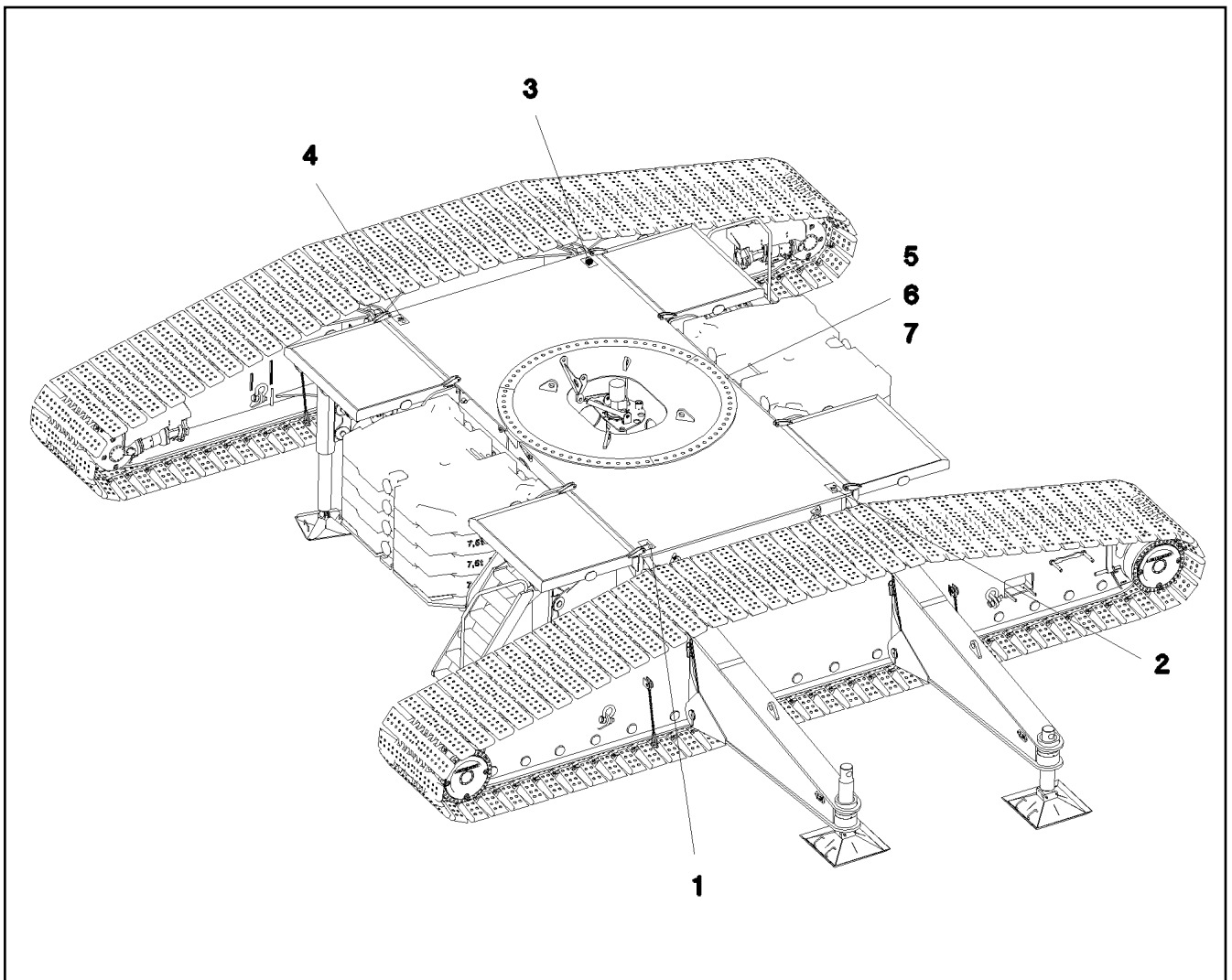

Pos.	Item	Quantity	Description	Bezeichnung	Serie	K
1	95 62 979 08	2	PLATE 2X100X100	BLECH		
2	95 62 980 08	2	PLATE 2X100X100	BLECH		
3	95 62 981 08	2	PLATE 2X100X100	BLECH		
4	95 62 982 08	2	PLATE 2X100X100	BLECH		
5	71 40 008 08	1	SPIRIT LEVEL	LIBELLE		
6	40 01 041 08	3	CYLINDER SCREW DIN 84 M5X35 4.8 VERZ	ZYLINDERSCHRAUBE		
7	41 15 148 08	9	HEX NUT DIN 934 M5 8 VERZ	SECHSKANTMUTTER		

6.2.2009
052365

LIEBHERR

etk_en_de_074515 LR 1600/2

CRAWLER TRACK TRAVEL GEAR CPL.
RAUPENFAHRWERK KPL.

13

⇒ 1 100
91 52 375 08

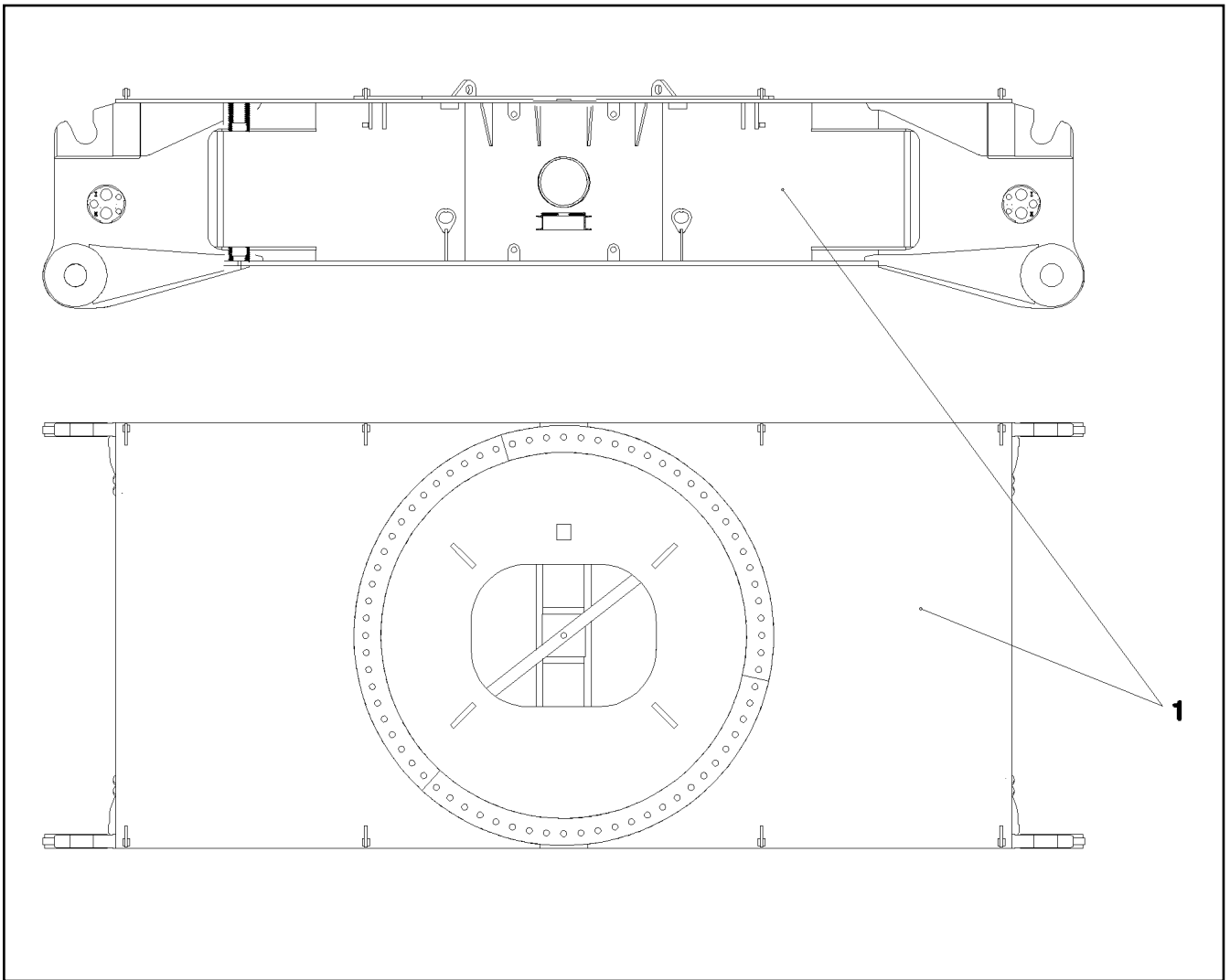

Pos.	Item	Quantity	Description	Bezeichnung	Serie	K
1	96 45 385 08	1	CENTER SECTION WELDED	RAUPENMITTELTEIL SCHWK.		

6.2.2009
055544

LIEBHERR

etk_en_de_074515 LR 1600/2

CENTRAL SECTION CRAWLER COMPL.
RAUPENMITTELTEIL KPL.

14

⇒ 1 130
91 52 377 08

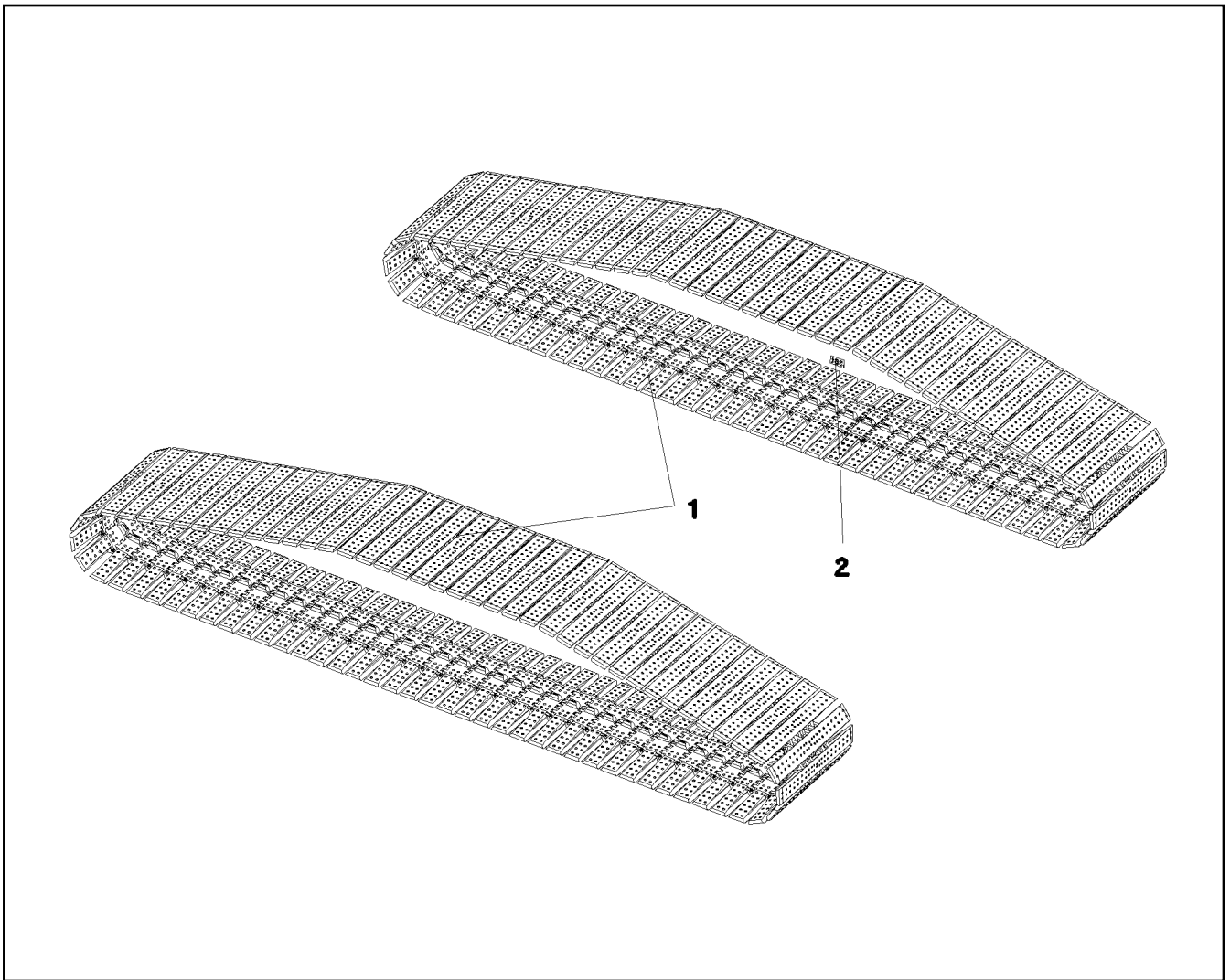

Pos.	Item	Quantity	Description	Bezeichnung	Serie	K
1	96 52 493 08	1	FLOOR PLATES PRE-ASS. ⇒ 1 300 011 96 52 493 08	BODENPLATTEN VORM.		
2	97 81 837 08	2	LABEL 2X208X120	SCHILD		

6.2.2009
054169

LIEBHERR

etk_en_de_074515 LR 1600/2

FLOOR SHEET COMPL.
BODENPLATTEN KPL.

15

⇒ 1 300
91 52 768 08

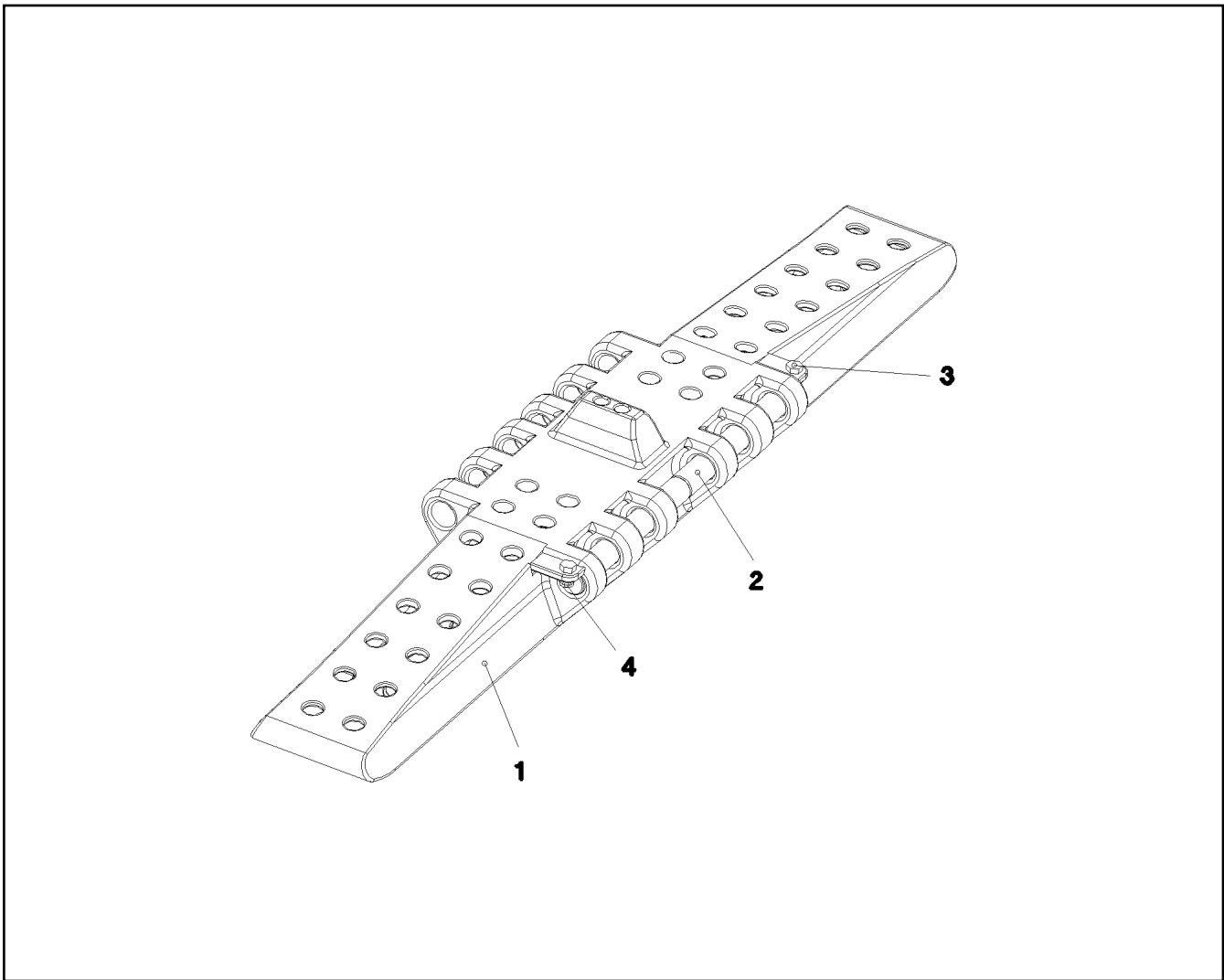

Pos.	Item	Quantity	Description	Bezeichnung	Serie	K
1	97 71 698 08	81	FLOOR PLATE 2.0 M GS-18NIMOCR3 SPF	BODENPLATTE		
2	95 45 849 08	162	ROUND STEEL RD45X364	RUNDSTAHL		
3	49 00 152	162	HEX BOLT ISO 4017 M16X30 8.8 A3C	SECHSKANTSCHRAUBE		
4	41 19 009 08	162	HEX NUT DIN 985 M16 8 VERZ	SECHSKANTMUTTER		

6.2.2009
054170

LIEBHERR

etk_en_de_074515 LR 1600/2

FLOOR PLATES PRE-ASS.
BODENPLATTEN VORM.

16

⇒ 1 300 011
96 52 493 08

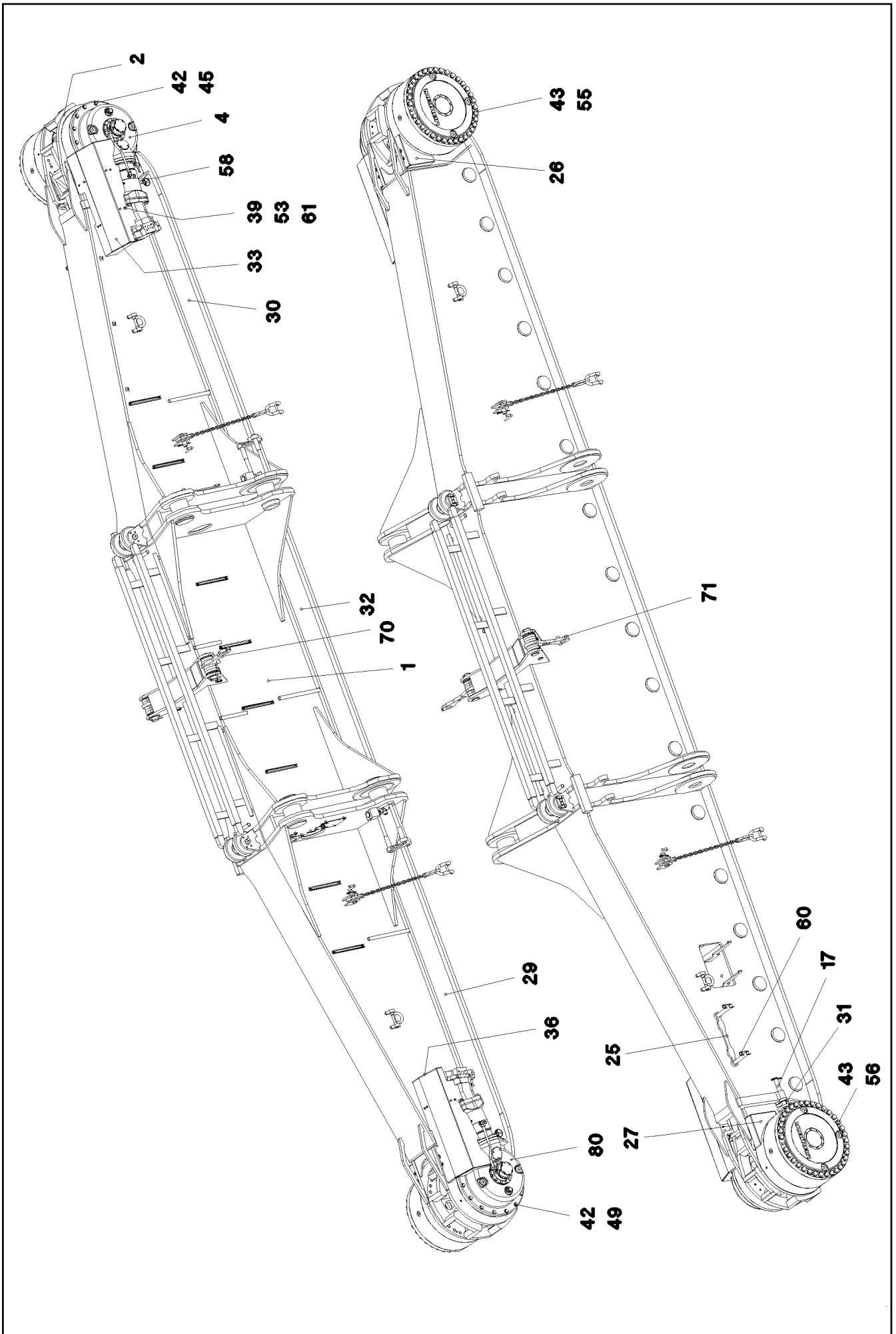

6.2.2009
054171

LIEBHERR

etk_en_de_074515 LR 1600/2

CRAWLER TRACK CARRIER LEFT CPL
RAUPENTRAEGER KPL.LI.

☐ 17 (1/5)

⇒ 1 400
91 56 853 08

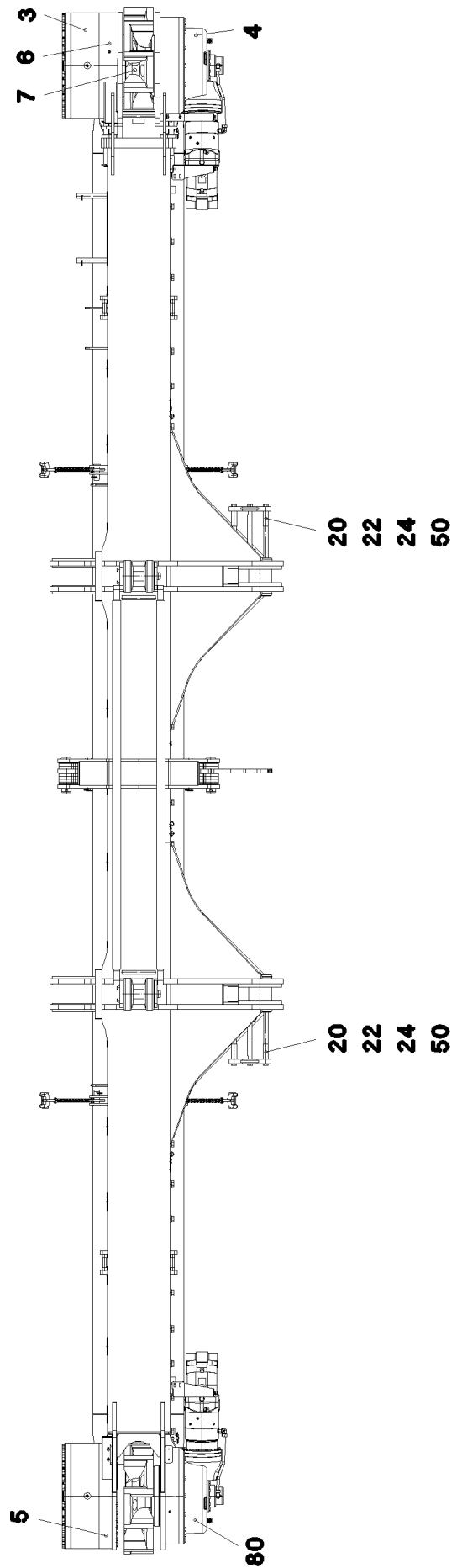
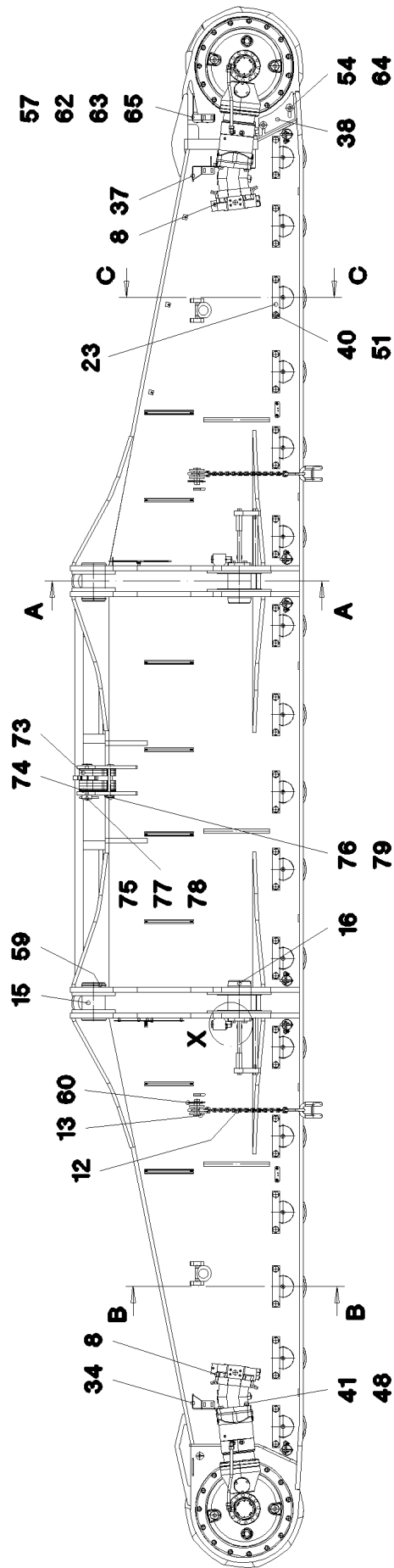

6.2.2009
054172

LIEBHERR

etk_en_de_074515 LR 1600/2

CRAWLER TRACK CARRIER LEFT CPL
RAUPENTRAEGER KPL.LI.

□ 18 (2/5)

⇒ 1 400
91 56 853 08

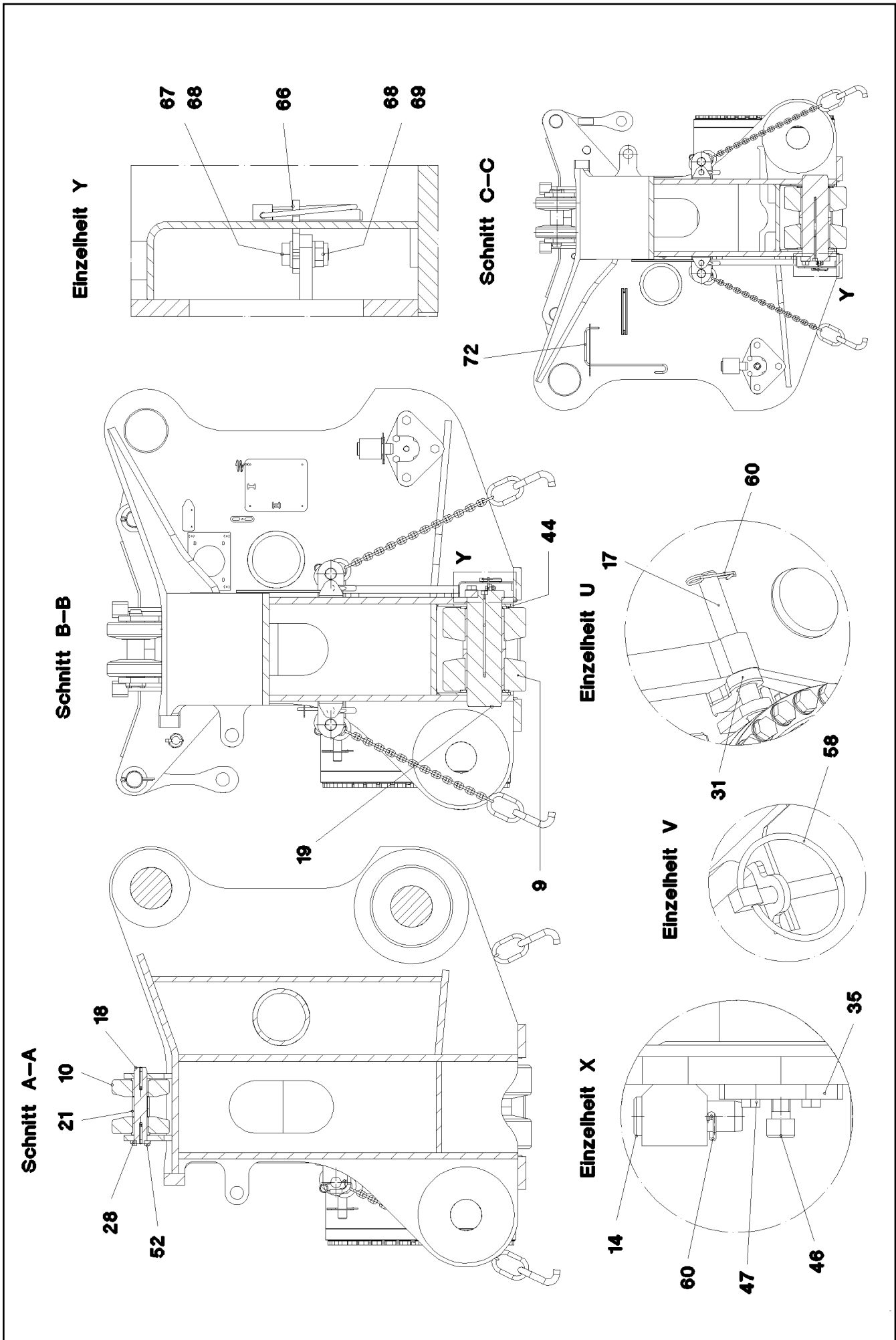

6.2.2009
054173
LIEBHERR

etk_en_de_074515 LR 1600/2
CRAWLER TRACK CARRIER LEFT CPL
RAUPENTRAEGER KPL.LI.

19 (3/5)
⇒ 1 400
91 56 853 08

Pos.	Item	Quantity	Description	Bezeichnung	Serie	K
1	96 53 234 08	1	CRAWLER TRACK CARRIER, LEFT	RAUPENTRAEGER LI.		
(1)	96 53 235 08	1	CRAWLER TRACK CARRIER LEFT	RAUPENTRAEGER SCHWK.LI.		
2	96 45 400 08	1	SLIDING PIECE L STEEL CONSTR.	SCHIEBESTUECK STAHLBAU LI.		
3	93 27 102 01	2	PLANETARY GEAR	PLANETENGETRIEBE		
(2)	76 10 208 03	1	O-RING 600X4 NBR 70	O-RING		
(18)	42 80 119 01	5	LOCKING RING DIN 471 100X4	SICHERUNGSRING		
(28)	42 20 075 08	3	SUPPORTING RING DIN 988 S 170X200X3,5	STUETZSCHEIBE		
(32)	40 01 447	3	LOCKING RING DIN 471 70X4	SICHERUNGSRING		
(37)	46 00 017	4	CYLINDER SCREW ISO 4762 M16X45 8.8 A3	ZYLINDERSCHRAUBE		
(52)	57 16 648 08	1	O-RING 150X3 FPM70	O-RING		
(56)	40 01 696	8	HEX BOLT ISO 4017 M10X20 10.9 A3C	SECHSKANTSCHRAUBE		
(57)	42 39 110 01	8	LOCK WASHER VS 10 VERZ	SICHERUNGSSCHEIBE		
(62)	47 77 048 08	3	PLUG VSTIM42X2ED A3P	STOPFEN		
(68)	46 01 292	1	HEX BOLT ISO 4017 M20X25 8.8 A3C	SECHSKANTSCHRAUBE		
(69)	42 00 021 01	1	WASHER ISO 7089 20 ST VERZ	SCHEIBE		
4	90 00 510 6	1	ANGULAR GEAR	WINKELGETRIEBE		
5	93 95 668 01	1	BEARING	LAGERUNG		
6	93 95 675 01	1	BEARING	LAGERUNG		
7	97 11 958 08	2	TUMBLER GS18NIMOCR36	TURAS		
8	10 42 876 8	2	VARIABLE DISPLACEMENT MOTOR A6VM 2	VERSTELLMOTOR		
9	96 45 287 08	34	ROLLER BODY HALF CPL. ⇒ 1 400 016 96 45 287 08	ROLLENKOERPERHAELFTE KPL		
10	92 51 976 08	4	ROLLER BODY HALF CPL. ⇒ 1 400 017 92 51 976 08	ROLLENKOERPERHAELFTE KPL		
12	74 00 244 08	4	ATTACHMENT CHAIN 0,85M 3T	ANHAENGEKETTE		
13	93 22 268 08	4	PIN RD40X105 30CRNIMO8+QT	BOLZEN		
14	95 19 655 08	2	PIN RD40X130 30CRNIMO8+QT	BOLZEN		
15	97 69 484 08	2	PIN 170.0X260 SPF	BOLZEN		
16	97 69 485 08	2	PIN 170.0X260 SPF	BOLZEN		
17	97 80 530 08	2	PIN 35.0X320 FE//ZN20//C	BOLZEN		
18	97 48 730 08	2	AXLE 55.0X292 SPF	ACHSE		
19	97 68 035 08	17	AXLE 150.0X445 35NICRMOV125 SPF	ACHSE		
20	95 44 784 08	6	THREADED BOLT RD30X365	GEWINDEBOLZEN		
21	95 44 254 08	2	SPACER PIPE RD65X76	DISTANZROHR		
22	95 27 658 08	4	TUBE 38X2,6X105 ST.37.0	ROHR		
23	94 83 965 08	17	AXLE HOLDER 25X50X290	ACHSHALTER		
24	95 44 783 08	2	PLATE 30X180X290	BLECH		
25	97 12 071 08	8	PLATE 20X512X62	BLECH		
26	97 14 450 08	1	PLATE 4X358X405	BLECH		
27	97 17 777 08	1	PLATE 4X369X509	BLECH		
28	97 48 729 08	2	PLATE 12X111X76	BLECH		
29	97 69 487 08	1	PLATE 5X3017X259	BLECH		
30	97 69 488 08	1	PLATE 5X3017X259	BLECH		
31	97 69 489 08	4	PLATE 5X512X62	BLECH		
32	97 69 490 08	1	PLATE 5X2668X259	BLECH		
33	97 69 692 08	1	PLATE 4X1322X633	BLECH		
34	97 69 492 08	1	PLATE 4X389X287	BLECH		
35	95 44 785 08	2	PLATE 20X160X290	BLECH		
36	97 69 693 08	1	PLATE 4X1320X547	BLECH		
37	97 69 495 08	1	PLATE 4X389X287	BLECH		
38	97 69 586 08	2	PLATE 15X303X246	BLECH		
39	42 00 012 08	18	WASHER DIN 125 A8X16 ST VERZ	SCHEIBE		
40	42 00 024 08	34	WASHER DIN 125 A 25 ST VERZ	SCHEIBE		
41	42 00 021 08	4	WASHER ISO 7089 A 21 ST A3C	SCHEIBE		
42	42 15 002 08	26	WASHER DIN 6916 17 C45 VERZ	SCHEIBE		
43	42 15 004 08	70	WASHER DIN 6916 25 C45 VERZ	SCHEIBE		
44	97 68 042 08	34	WASHER 8X185X185	SCHEIBE		
45	40 62 181 08	13	HEX BOLT ISO 4014 M16X200 10.9 FLZN SP	SECHSKANTSCHRAUBE		
46	40 42 242 08	2	CYLINDER SCREW DIN 912 M24X45 8.8 A3C	ZYLINDERSCHRAUBE		
47	40 66 030 08	8	HEX BOLT ISO 4017 M16X40 10.9 FLZN SPF	SECHSKANTSCHRAUBE		

6.2.2009

etk_en_de_074515 LR 1600/2

☐ 20 (4/5)

LIEBHERRCRAWLER TRACK CARRIER LEFT CPL
RAUPENTRAEGER KPL.LI.⇒ 1 400
91 56 853 08

Pos.	Item	Quantity	Description	Bezeichnung	Serie	K
48	40 66 043 08	8	HEX BOLT ISO 4017 M20X70 10.9 A3C	SECHSKANTSCHRAUBE		
49	40 62 051 08	13	HEX BOLT ISO 4014 M16X160 10.9 FLZN SP	SECHSKANTSCHRAUBE		
50	46 00 097	6	HEX BOLT ISO 4017 M20X55 8.8 A3C	SECHSKANTSCHRAUBE		
51	40 65 232 01	34	HEX BOLT ISO 4017 M24X55 8.8 A3C	SECHSKANTSCHRAUBE		
52	49 00 161	8	HEX BOLT ISO 4017 M12X30 8.8 A3C	SECHSKANTSCHRAUBE		
53	49 00 188	18	HEX BOLT ISO 4017 M8X16 8.8 A2C	SECHSKANTSCHRAUBE		
54	49 00 123	4	HEX BOLT ISO 4017 M16X35 8.8 A3C	SECHSKANTSCHRAUBE		
55	10 04 097 9	35	HEX BOLT ISO 4014 M24X370 12.9 FLZN SP	SECHSKANTSCHRAUBE		
56	10 41 289 2	35	HEX BOLT ISO 4014 M24X400 12.9 FLZN SP	SECHSKANTSCHRAUBE		
57	49 00 128	2	HEX BOLT ISO 4017 M8X25 8.8 A2C	SECHSKANTSCHRAUBE		
58	43 32 011 08	6	HINGED CONNECTOR 10,5X70	KLAPPSTECKER		
59	42 80 085 08	2	LOCKING RING DIN 471 160X4	SICHERUNGSRING		
60	43 31 012 08	12	RETAINING SPRING 4X68 VERZ	SICHERUNGSFEDER		
61	41 30 032 08	12	CAGE NUT M8	KAFIGMUTTER		
62	41 19 005 08	2	HEX NUT DIN 985 M8 8 VERZ	SECHSKANTMUTTER		
63	42 18 009 08	2	WASHER DIN 9021 A 8.4 VERZ	SCHEIBE		
64	42 18 013 08	4	WASHER DIN 9021 A 17 ST VERZ	SCHEIBE		
65	97 75 410 08	1	PLATE 4X419X242 S315MC	BLECH		
66	97 76 596 08	6	PLATE 5X90X57	BLECH		
67	40 00 828	12	HEX BOLT ISO 4017 M10X30 8.8 A3C	SECHSKANTSCHRAUBE		
68	50 09 175 08	24	WASHER DIN 125 A 10.5 A2	SCHEIBE		
69	41 19 006 08	12	HEX NUT DIN 985 M10 8 VERZ	SECHSKANTMUTTER		
70	96 53 262 08	1	BRACKET WITH BOARD 0.34 M	LASCHE MIT SCHILD		
71	96 53 263 08	1	BRACKET WITH BOARD 0.34 M	LASCHE MIT SCHILD		
72	97 83 897 08	1	GRIP 10.0X750 S235JRG2 FE//ZN20//C	GRIFF		
73	97 83 633 08	10	PLATE 20X311X106	BLECH		
74	97 83 634 08	12	PLATE 5X311X106	BLECH		
75	95 50 681 08	2	PIN RD65X232	BOLZEN		
76	45 30 300 08	2	PIN DIN 1444 30H11X220X210 30CRNIMO8	BOLZEN		
77	94 33 992 08	2	WASHER 100X2	SCHEIBE		
78	43 30 106 08	2	SPLIT PIN DIN 94 10X100 ST VERZ	SPLINT		
79	43 32 003 08	2	HINGED CONNECTOR DIN 11023 8X42 VER	KLAPPSTECKER		
80	90 00 521 4	1	ANGULAR GEAR	WINKELGETRIEBE		

6.2.2009

etk_en_de_074515 LR 1600/2

21 (5/5)

LIEBHERRCRAWLER TRACK CARRIER LEFT CPL
RAUPENTRAEGER KPL.LI.⇒ 1 400
91 56 853 08

Schnitt A-A

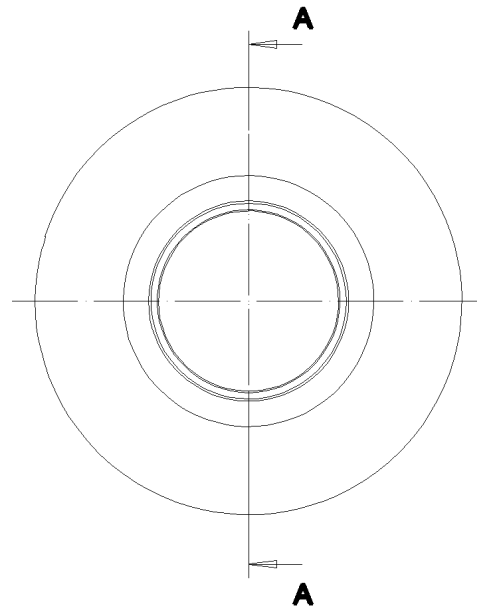
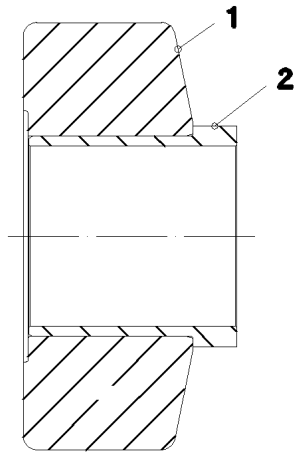

Pos.	Item	Quantity	Description	Bezeichnung	Serie	K
1	97 67 848 08	1	ROLLER CORE HALF 34CRNIMO6 SPF	ROLLENKOERPERHAELFTE		
2	97 67 849 08	1	BUSHING SLEEVE 165X156 GZ-CUZN25AL5	LAUFBUCHSE		

6.2.2009
052366

LIEBHERR

etk_en_de_074515 LR 1600/2

ROLLER BODY HALF CPL.
ROLLENKOERPERHAELFTE KPL.

22

⇒ 1 400 016
96 45 287 08

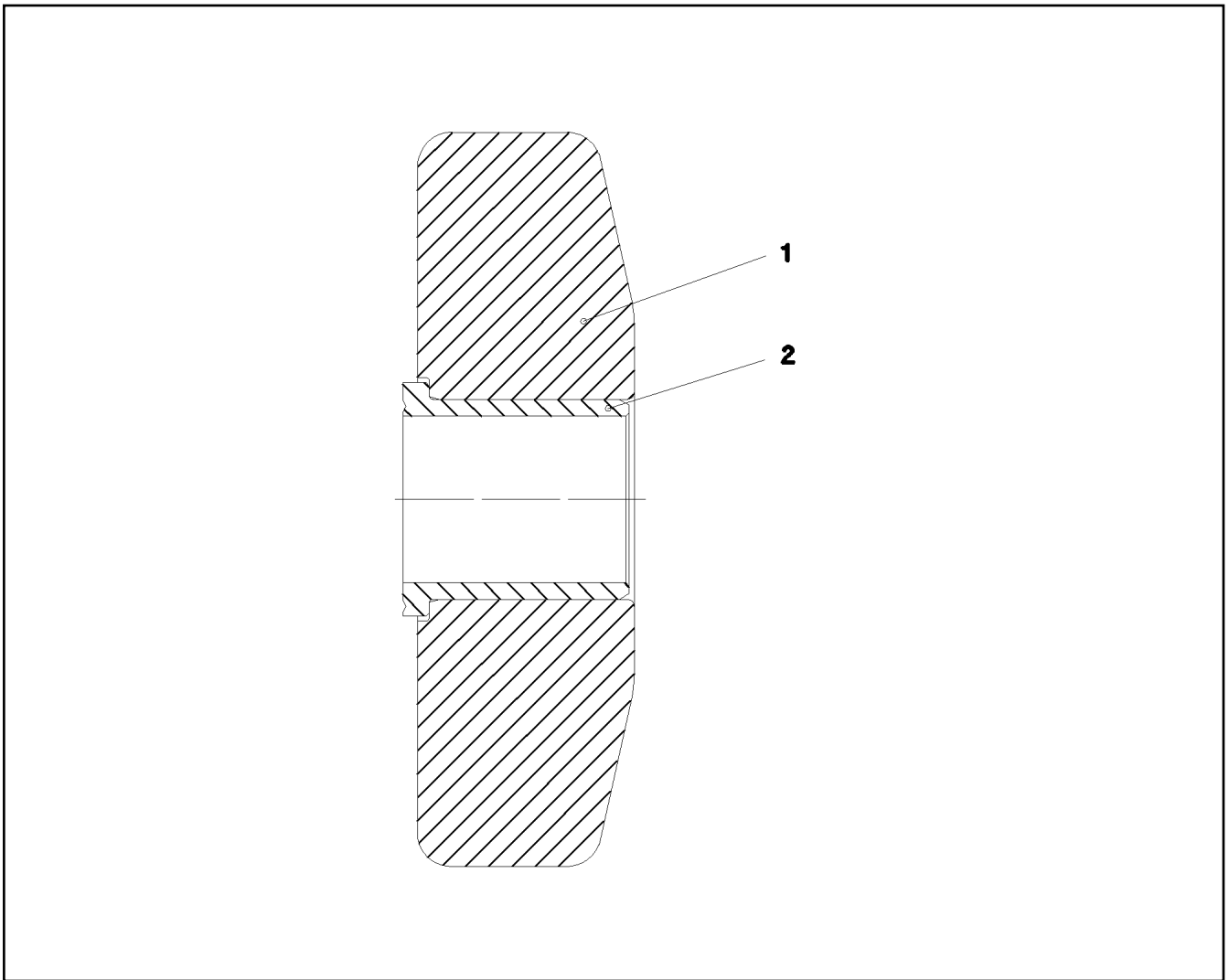

Pos.	Item	Quantity	Description	Bezeichnung	Serie	K
1	95 44 255 08	1	ROLLER CORE RD230X70	ROLLENKOERPER		
2	70 43 316 08	1	BUSHING SLEEVE RD70X68 GZ-CUZN25AL	LAUFBUCHSE		

6.2.2009
142097

LIEBHERR

etk_en_de_074515 LR 1600/2

ROLLER BODY HALF CPL.
ROLLENKOERPERHAELFTE KPL.

23

⇒ 1 400 017
92 51 976 08

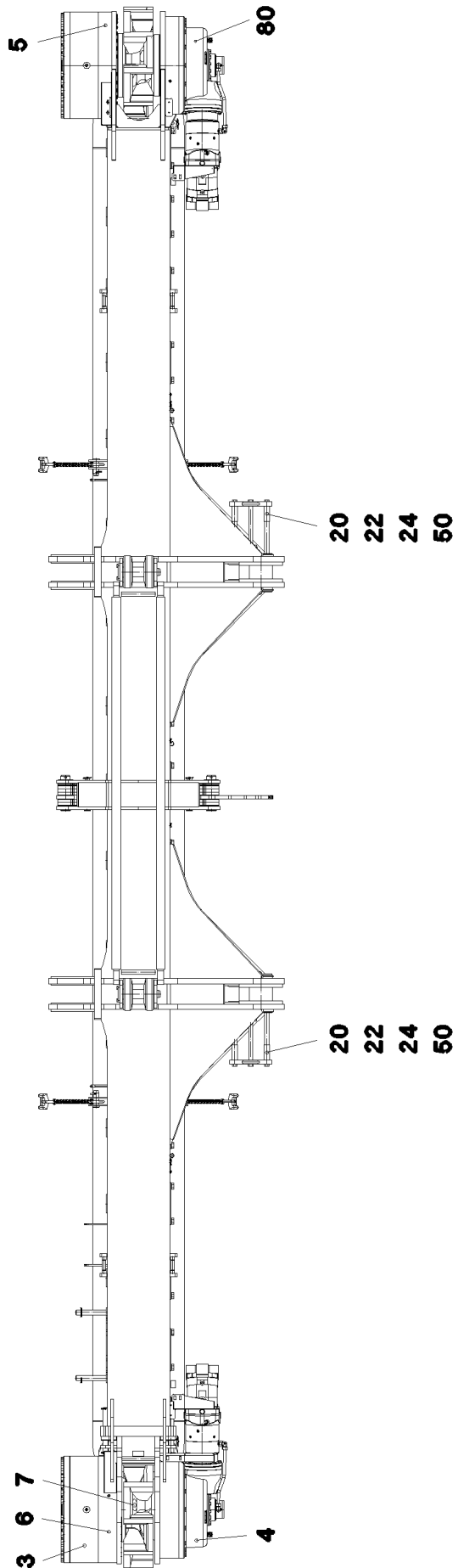
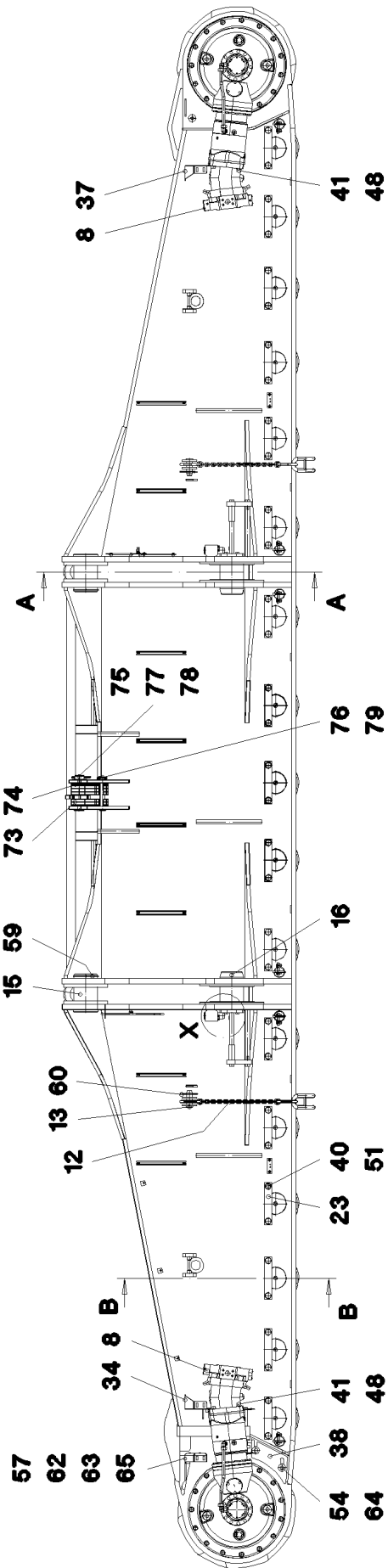

6.2.2009
054175

LIEBHERR

etk_en_de_074515 LR 1600/2

CRAWLER CARRIER RIGHT CPL
RAUPENTRAEGER KPL.RE.

□ 25 (2/5)

⇒ 1 410 300
91 56 855 08

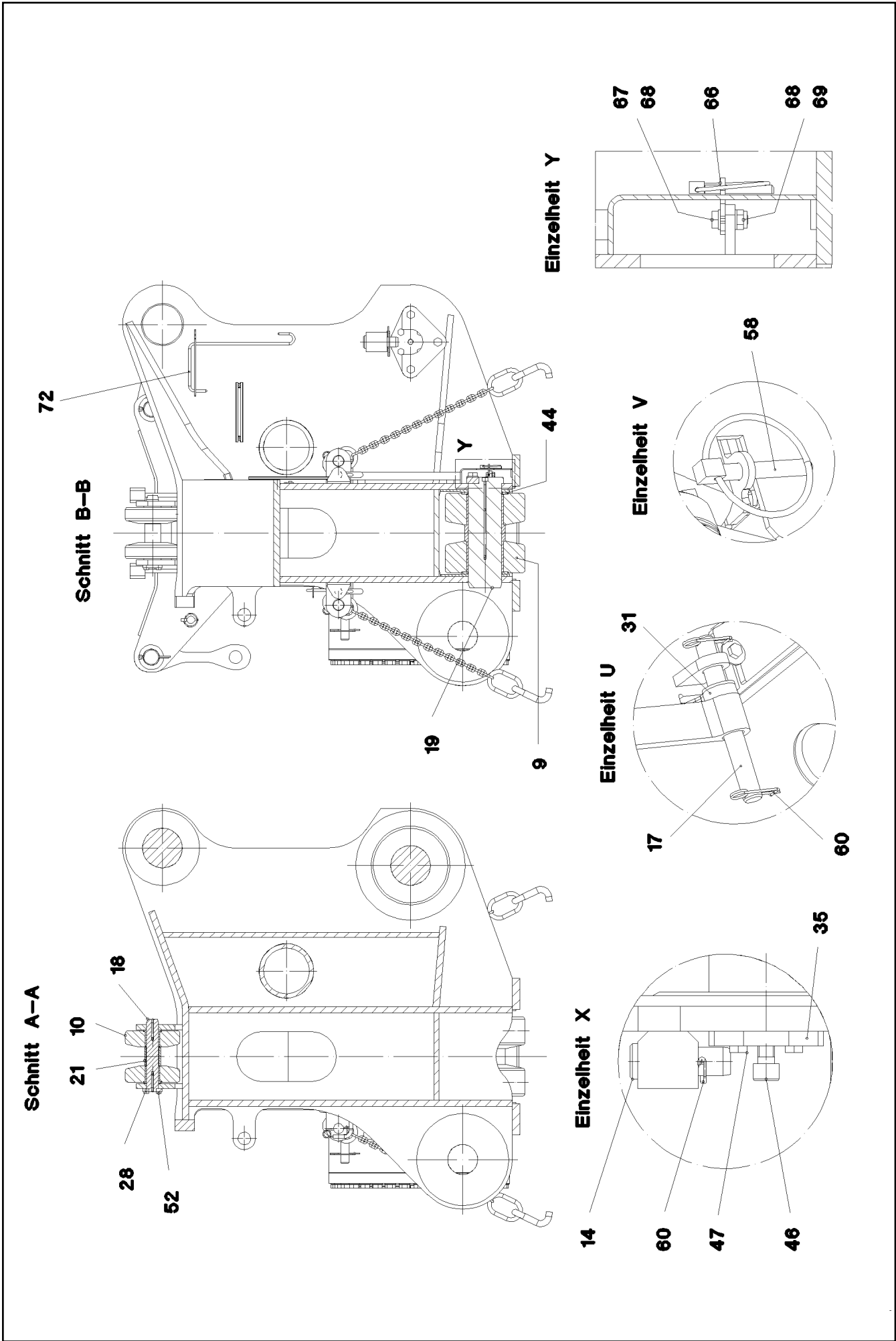

6.2.2009
054176

LIEBHERR

etk_en_de_074515 LR 1600/2

CRAWLER CARRIER RIGHT CPL
RAUPENTRAEGER KPL.RE.

□ 26 (3/5)

⇒ 1 410 300
91 56 855 08

Pos.	Item	Quantity	Description	Bezeichnung	Serie	K
1	96 53 258 08	1	CRAWLER TRACK CARRIER, RIGHT	RAUPENTRAEGER RE.		
(1)	96 53 259 08	1	CRAWLER TRACK CARRIER, RIGHT	RAUPENTRAEGER SCHWK.RE.		
2	96 45 401 08	1	SLIDING PIECE STEEL CONSTR. R	SCHIEBESTUECK STAHLBAU RE		
3	93 27 102 01	2	PLANETARY GEAR	PLANETENGETRIEBE		
4	90 00 521 4	1	ANGULAR GEAR	WINKELGETRIEBE		
5	93 95 668 01	1	BEARING	LAGERUNG		
6	93 95 675 01	1	BEARING	LAGERUNG		
7	97 11 958 08	2	TUMBLER GS18NIMOCR36	TURAS		
8	10 42 876 8	2	VARIABLE DISPLACEMENT MOTOR A6VM 2	VERSTELLMOTOR		
9	96 45 287 08	34	ROLLER BODY HALF CPL. ⇒ 1 400 016 96 45 287 08	ROLLENKOERPERHAELFTE KPL		
10	92 51 976 08	4	ROLLER BODY HALF CPL. ⇒ 1 400 017 92 51 976 08	ROLLENKOERPERHAELFTE KPL		
11	51 23 682 08	1	MOUNTING - PISTON W. PUMP SPF ⇒ 5 123 682 08 51 23 682 08	MONTAGEZYLINDER		
12	74 00 244 08	4	ATTACHMENT CHAIN 0,85M 3T	ANHAENGEKETTE		
13	93 22 268 08	4	PIN RD40X105 30CRNIMO8+QT	BOLZEN		
14	95 19 655 08	2	PIN RD40X130 30CRNIMO8+QT	BOLZEN		
15	97 69 484 08	2	PIN 170.0X260 SPF	BOLZEN		
16	97 69 485 08	2	PIN 170.0X260 SPF	BOLZEN		
17	97 80 530 08	2	PIN 35.0X320 FE//ZN20//C	BOLZEN		
18	97 48 730 08	2	AXLE 55.0X292 SPF	ACHSE		
19	97 68 035 08	17	AXLE 150.0X445 35NICRMOV125 SPF	ACHSE		
20	95 44 784 08	6	THREADED BOLT RD30X365	GEWINDEBOLZEN		
21	95 44 254 08	2	SPACER PIPE RD65X76	DISTANZROHR		
22	95 27 658 08	4	TUBE 38X2,6X105 ST.37.0	ROHR		
23	94 83 965 08	17	AXLE HOLDER 25X50X290	ACHSHALTER		
24	95 44 783 08	2	PLATE 30X180X290	BLECH		
25	97 12 071 08	8	PLATE 20X512X62	BLECH		
26	97 14 596 08	1	PLATE 4X358X405	BLECH		
27	97 17 950 08	1	PLATE 4X369X509	BLECH		
28	97 48 729 08	2	PLATE 12X111X76	BLECH		
29	97 69 487 08	1	PLATE 5X3017X259	BLECH		
30	97 69 488 08	1	PLATE 5X3017X259	BLECH		
31	97 69 489 08	4	PLATE 5X512X62	BLECH		
32	97 69 490 08	1	PLATE 5X2668X259	BLECH		
33	97 69 491 08	1	PLATE 4X1322X633	BLECH		
34	97 69 492 08	1	PLATE 4X389X287	BLECH		
35	95 44 785 08	2	PLATE 20X160X290	BLECH		
36	97 69 494 08	1	PLATE 4X1322X547	BLECH		
37	97 69 495 08	1	PLATE 4X389X287	BLECH		
38	97 69 586 08	2	PLATE 15X303X246	BLECH		
39	42 00 012 08	18	WASHER DIN 125 A8X16 ST VERZ	SCHEIBE		
40	42 00 024 08	34	WASHER DIN 125 A 25 ST VERZ	SCHEIBE		
41	42 00 021 08	4	WASHER ISO 7089 A 21 ST A3C	SCHEIBE		
42	42 15 002 08	26	WASHER DIN 6916 17 C45 VERZ	SCHEIBE		
43	42 15 004 08	70	WASHER DIN 6916 25 C45 VERZ	SCHEIBE		
44	97 68 042 08	34	WASHER 8X185X185	SCHEIBE		
45	40 62 181 08	13	HEX BOLT ISO 4014 M16X200 10.9 FLZN SP	SECHSKANTSCHRAUBE		
46	40 42 242 08	2	CYLINDER SCREW DIN 912 M24X45 8.8 A3C	ZYLINDERSCHRAUBE		
47	40 66 030 08	8	HEX BOLT ISO 4017 M16X40 10.9 FLZN SPF	SECHSKANTSCHRAUBE		
48	40 66 043 08	8	HEX BOLT ISO 4017 M20X70 10.9 A3C	SECHSKANTSCHRAUBE		
49	40 62 051 08	13	HEX BOLT ISO 4014 M16X160 10.9 FLZN SP	SECHSKANTSCHRAUBE		
50	46 00 097	6	HEX BOLT ISO 4017 M20X55 8.8 A3C	SECHSKANTSCHRAUBE		
51	40 65 232 01	34	HEX BOLT ISO 4017 M24X55 8.8 A3C	SECHSKANTSCHRAUBE		
52	49 00 161	8	HEX BOLT ISO 4017 M12X30 8.8 A3C	SECHSKANTSCHRAUBE		
53	49 00 188	18	HEX BOLT ISO 4017 M8X16 8.8 A2C	SECHSKANTSCHRAUBE		
54	49 00 123	4	HEX BOLT ISO 4017 M16X35 8.8 A3C	SECHSKANTSCHRAUBE		
55	10 04 097 9	35	HEX BOLT ISO 4014 M24X370 12.9 FLZN SP	SECHSKANTSCHRAUBE		
56	10 41 289 2	35	HEX BOLT ISO 4014 M24X400 12.9 FLZN SP	SECHSKANTSCHRAUBE		

6.2.2009

etk_en_de_074515 LR 1600/2

□ 27 (4/5)

LIEBHERRCRAWLER CARRIER RIGHT CPL
RAUPENTRAEGER KPL.RE.⇒ 1 410 300
91 56 855 08

Pos.	Item	Quantity	Description	Bezeichnung	Serie	K
57	49 00 128	2	HEX BOLT ISO 4017 M8X25 8.8 A2C	SECHSKANTSCHRAUBE		
58	43 32 011 08	6	HINGED CONNECTOR 10,5X70	KLAPPSTECKER		
59	42 80 085 08	2	LOCKING RING DIN 471 160X4	SICHERUNGSRING		
60	43 31 012 08	12	RETAINING SPRING 4X68 VERZ	SICHERUNGSFEDER		
61	41 30 032 08	12	CAGE NUT M8	KAFIGMUTTER		
62	41 19 005 08	2	HEX NUT DIN 985 M8 8 VERZ	SECHSKANTMUTTER		
63	42 18 009 08	2	WASHER DIN 9021 A 8.4 VERZ	SCHEIBE		
64	42 18 013 08	4	WASHER DIN 9021 A 17 ST VERZ	SCHEIBE		
65	97 75 411 08	1	PLATE 4X419X242 S315MC	BLECH		
66	97 76 596 08	6	PLATE 5X90X57	BLECH		
67	40 00 828	12	HEX BOLT ISO 4017 M10X30 8.8 A3C	SECHSKANTSCHRAUBE		
68	50 09 175 08	24	WASHER DIN 125 A 10.5 A2	SCHEIBE		
69	41 19 006 08	12	HEX NUT DIN 985 M10 8 VERZ	SECHSKANTMUTTER		
70	96 53 262 08	1	BRACKET WITH BOARD 0.34 M	LASCHE MIT SCHILD		
71	96 53 263 08	1	BRACKET WITH BOARD 0.34 M	LASCHE MIT SCHILD		
72	97 83 897 08	1	GRIP 10.0X750 S235JRG2 FE//ZN20//C	GRIFF		
73	97 83 633 08	10	PLATE 20X311X106	BLECH		
74	97 83 634 08	12	PLATE 5X311X106	BLECH		
75	95 50 681 08	2	PIN RD65X232	BOLZEN		
76	45 30 300 08	2	PIN DIN 1444 30H11X220X210 30CRNIMO8	BOLZEN		
77	94 33 992 08	2	WASHER 100X2	SCHEIBE		
78	43 30 106 08	2	SPLIT PIN DIN 94 10X100 ST VERZ	SPLINT		
79	43 32 003 08	2	HINGED CONNECTOR DIN 11023 8X42 VER	KLAPPSTECKER		
80	90 00 510 6	1	ANGULAR GEAR	WINKELGETRIEBE		

6.2.2009

etk_en_de_074515 LR 1600/2

28 (5/5)

LIEBHERR

CRAWLER CARRIER RIGHT CPL
RAUPENTRAEGER KPL.RE.

⇒ 1 410 300
91 56 855 08

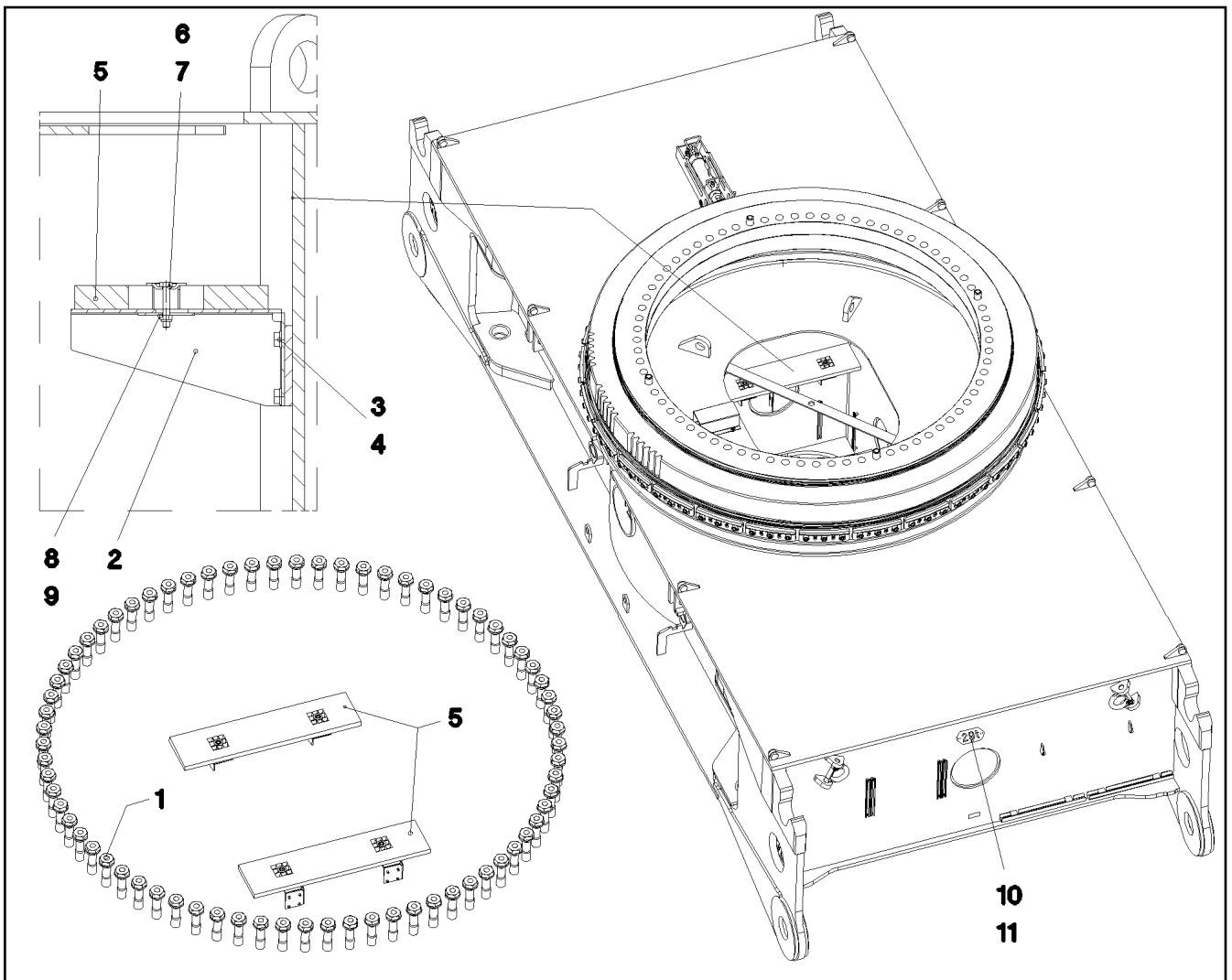

Pos.	Item	Quantity	Description	Bezeichnung	Serie	K
1	40 98 296 08	72	EXPANSION BOLT M48X170 30CRNIMO8 SP	DEHNSCHRAUBE		
2	97 10 255 08	4	PLATE 4X369X224	BLECH		
3	49 00 090	16	HEX BOLT ISO 4017 M10X16 8.8 A3C	SECHSKANTSCHRAUBE		
4	42 00 013 08	16	WASHER ISO 7089 A 10.5 A3C	SCHEIBE		
5	72 58 067 08	2	GRIDIRON T1020X240X30/2 S235JR TZN K	GITTERROST-P		
6	10 10 062 1	4	DISH MOUNTING	TELLERBEFESTIGUNG		
7	40 01 461	4	HEX BOLT ISO 4014 M8X50 8.8 A2C	SECHSKANTSCHRAUBE		
8	41 19 005 08	4	HEX NUT DIN 985 M8 8 VERZ	SECHSKANTMUTTER		
9	94 11 381 08	4	WASHER 70X3	SCHEIBE		
10	97 86 328 08	2	PLATE 2X215X100 FE//Zn20//C	BLECH		
11	10 41 285 4	4	OVAL HEAD FLAT SCREW AEHNL.ISO7380	LINSENFLACHKOPFSCHRAUBE		

6.2.2009
052640

LIEBHERR

etk_en_de_074515 LR 1600/2

FIXING PARTS SLEWING RING
BEFESTIGUNGSTEILE DREHVERBIND.

29

⇒ 1 620
91 52 386 08

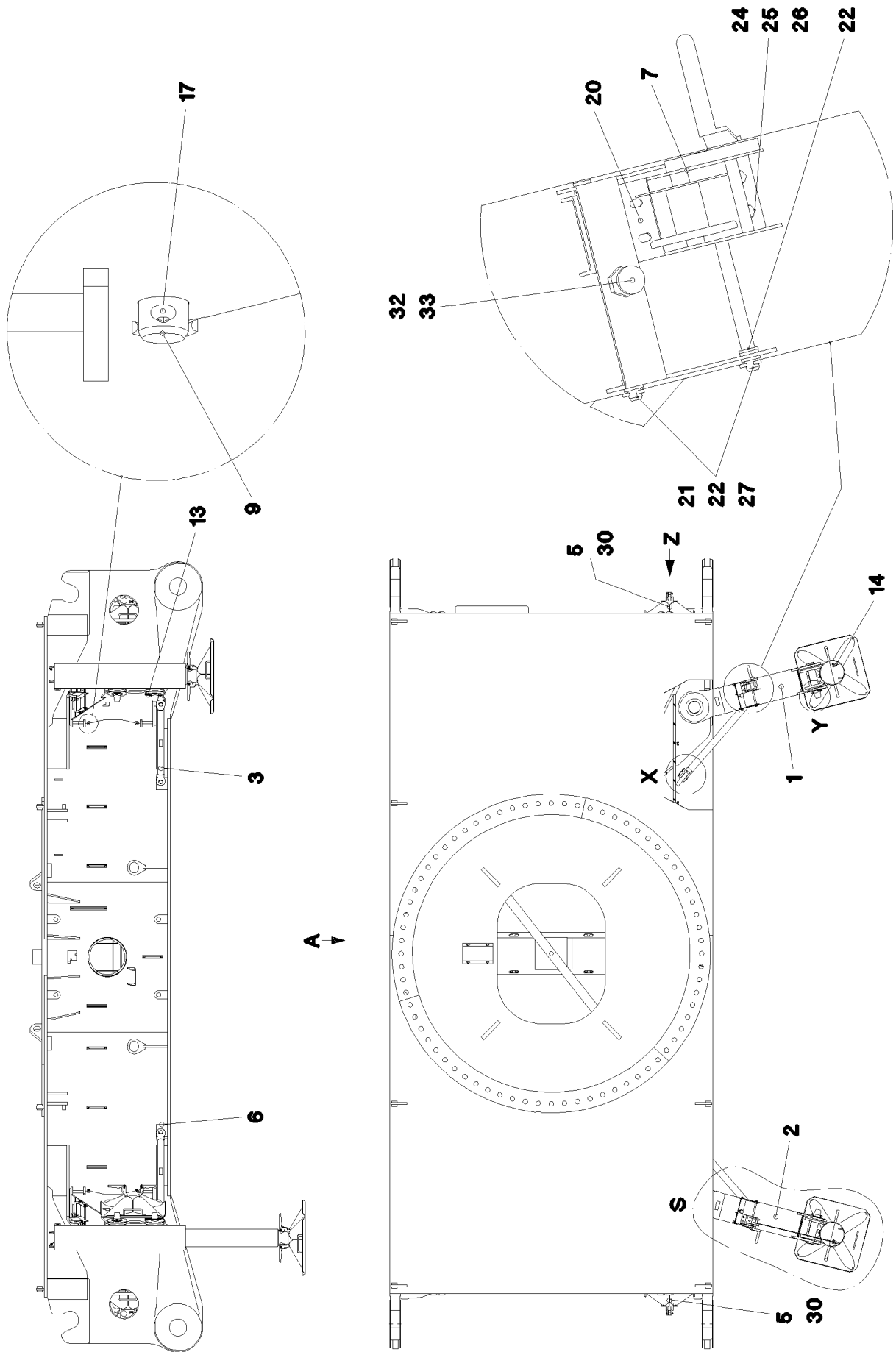

6.2.2009
053048

LIEBHERR

etk_en_de_074515 LR 1600/2

HYDRAULIC SUPPORT
HYDRAULISCHE ABSTUETZUNG

☐ 30 (1/3)

⇒ 1 630
91 52 387 08

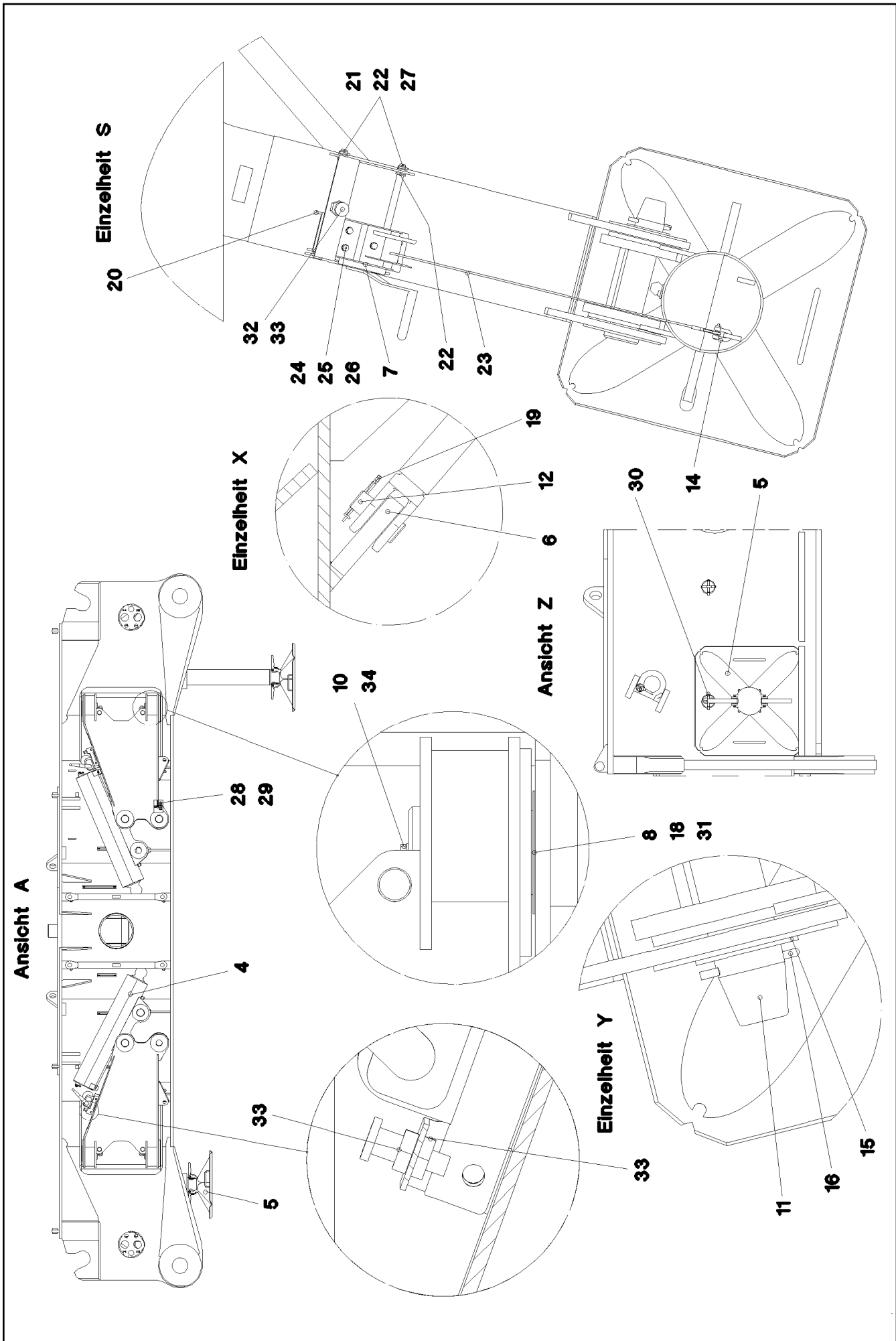

6.2.2009
053049

LIEBHERR

etk_en_de_074515 LR 1600/2

HYDRAULIC SUPPORT
HYDRAULISCHE ABSTUETZUNG

31 (2/3)

→ 1 630
91 52 387 08

Pos.	Item	Quantity	Description	Bezeichnung	Serie	K
1	96 45 817 08	2	HYDR. SUPPORT WELDMENT	HYDRAULISCHE ABSTUETZUNG		
2	96 45 818 08	2	HYDR. SUPPORT WELDMENT	HYDRAULISCHE ABSTUETZUNG		
3	96 45 819 08	4	ROD	STANGE SCHWK.		
4	10 41 080 3	4	STRUT CYLINDER 190/160-850 SPF	ABSTUETZZYLINDER		
5	92 53 053 08	4	SUPPORT PLATE COMPL. ⇒ 1 641 014 92 53 053 08	ABSTUETZPLATTE KPL.		
6	97 69 697 08	4	PLATE 30X150X100	BLECH		
7	54 00 018 08	4	ROPE WINCH	SEILWINDE		
8	97 69 855 08	8	PIN 120.0X222 SPF	BOLZEN		
9	45 30 318 08	8	PIN DIN 1444 30H11X260X250 30CRNIMO8	BOLZEN		
10	49 00 120	8	HEX BOLT ISO 4017 M12X20 8.8 A3C	SECHSKANTSCHRAUBE		
11	93 33 460 08	8	PIN 80.0X328 SPF	BOLZEN		
12	94 56 112 08	8	PIN RD35X85 30CR	BOLZEN		
13	43 31 009 08	4	RETAINING SPRING 4,5 VERZ	SICHERUNGSFEDER		
14	77 39 335 08	4	SHACKLE DIN 82101 A 0,25 0,25T ST VERZ	SCHAEKEL		
15	93 14 640 08	4	WASHER 3X100X100 FE//ZN20//C	SCHEIBE		
16	43 30 097 08	4	SPLIT PIN DIN 94 8X100 ST VERZ	SPLINT		
17	43 30 088 08	8	SPLIT PIN DIN 94 8X50 ST VERZ	SPLINT		
18	97 69 902 08	16	PLATE 2X160X160	BLECH		
19	43 31 028 08	8	RETAINING SPRING 3 VERZ	SICHERUNGSFEDER		
20	97 79 246 08	4	PLATE 4X215X167	BLECH		
21	97 79 357 08	8	PIN 20.0X255 T ZN O	BOLZEN		
22	95 35 616 08	40	WASHER RD22X3	SCHEIBE		
23	10 45 067 1	4	ROPE DIN 3055 4MM 1,3M VERZINKT	SEIL		
24	49 00 128	12	HEX BOLT ISO 4017 M8X25 8.8 A2C	SECHSKANTSCHRAUBE		
25	42 00 012 08	24	WASHER DIN 125 A8X16 ST VERZ	SCHEIBE		
26	41 15 141 08	12	HEX NUT DIN 934 M8 8 A2C	SECHSKANTMUTTER		
27	43 30 050 08	8	SPLIT PIN DIN 94 4X25 ST VERZ	SPLINT		
28	46 01 349	8	HEX BOLT ISO 4017 M14X65 10.9 A3C	SECHSKANTSCHRAUBE		
29	41 15 083 08	16	HEX NUT DIN 934 M14 8 VERZ	SECHSKANTMUTTER		
30	43 32 011 08	4	HINGED CONNECTOR 10,5X70	KLAPPSTECKER		
31	97 79 371 08	8	PLATE 1X160X160	BLECH		
32	70 42 326 08	4	SPRING-LOADED LOCK VERZ	FEDERRIEGEL		
33	41 17 209 08	4	HEX NUT DIN 936 M20X1,5 8 VERZ	SECHSKANTMUTTER		
34	42 00 016 08	8	WASHER ISO 7089 A 13 ST A3C	SCHEIBE		

6.2.2009

etk_en_de_074515 LR 1600/2

32 (3/3)

LIEBHERRHYDRAULIC SUPPORT
HYDRAULISCHE ABSTUETZUNG⇒ 1 630
91 52 387 08

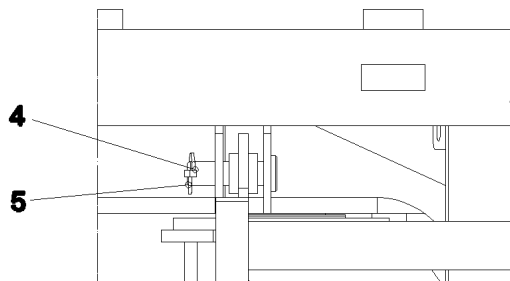
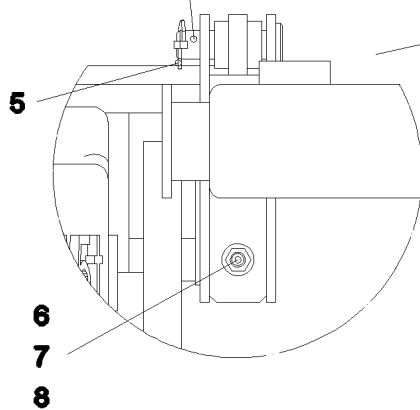
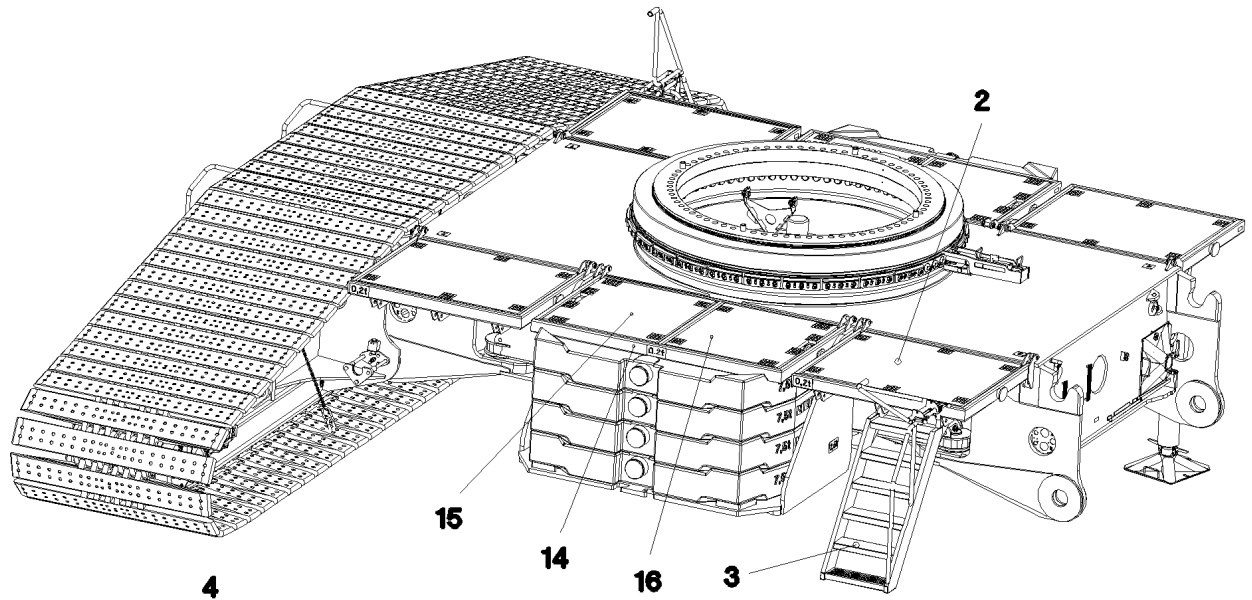

Schnitt A-A

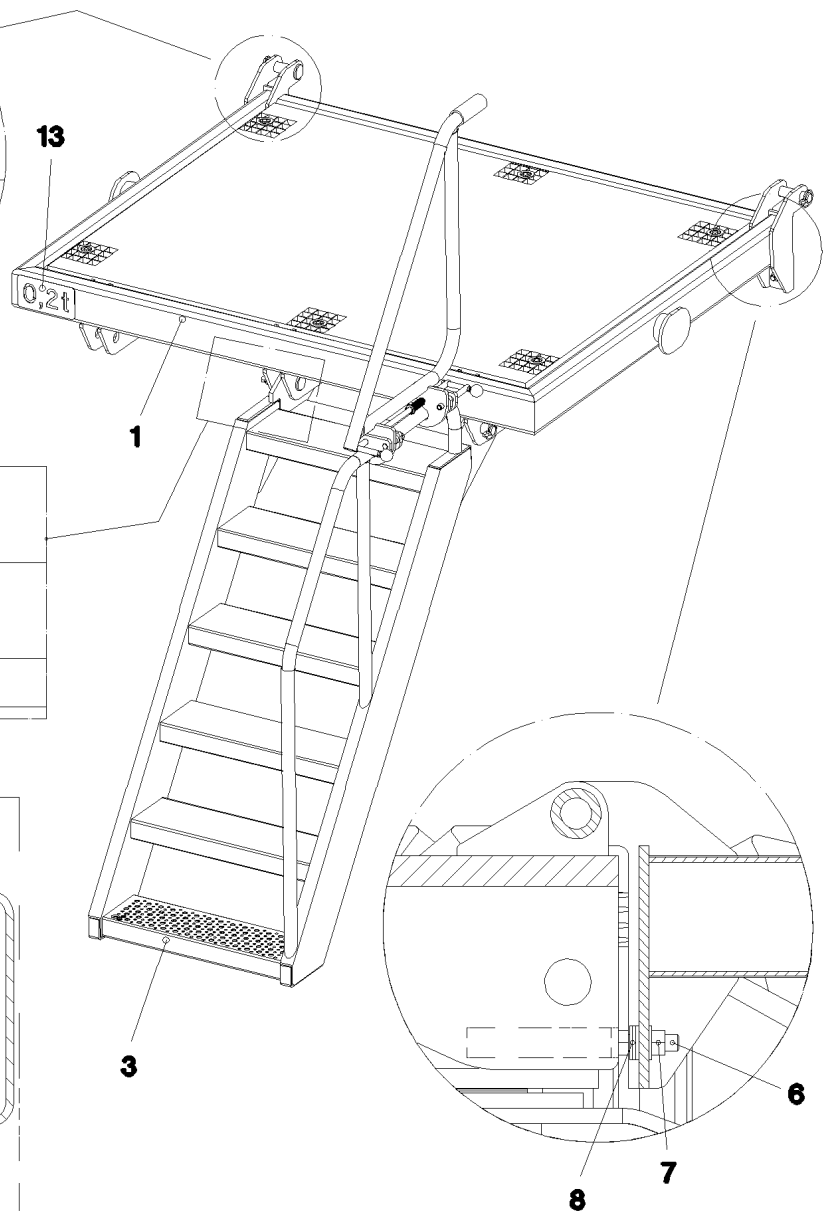
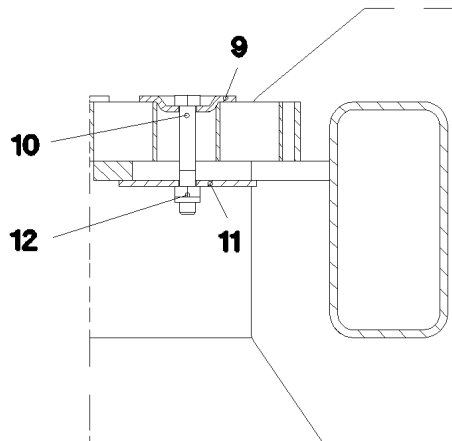

6.2.2009
052641

LIEBHERR

etk_en_de_074515 LR 1600/2

CATWALK CRAW TRACK TRAVEL GEAR
LAUFSTEG RAUPENFAHRWERK

□ 33 (1/2)

⇒ 1 631 100
91 52 388 08

Pos.	Item	Quantity	Description	Bezeichnung	Serie	K
1	96 46 540 08	4	FRAME WELDED T ZN O	RAHMEN SCHWK.		
2	72 58 549 08	4	GRIDIRON T1595X1260X30/2 S235JR TZN K	GITTERROST-P		
3	97 70 589 08	2	ACCESS ALUMINIUM	AUFSTIEG		
4	45 14 308 08	20	PIN DIN 1436 30H11X105X97 30CRNIMO8 GA	BOLZEN		
5	43 32 002 08	20	HINGED CONNECTOR DIN 11023 6X42 VER	KLAPPSTECKER		
6	46 00 189	12	HEX BOLT ISO 4017 M16X50 8.8 A3C	SECHSKANTSCHRAUBE		
7	41 15 145 08	12	HEX NUT DIN 934 M16 8 VERZ	SECHSKANTMUTTER		
8	42 00 020 08	60	WASHER DIN 125 A 19 ST VERZ	SCHEIBE		
9	10 10 062 1	48	DISH MOUNTING	TELLERBEFESTIGUNG		
10	40 61 024	48	HEX BOLT ISO 4014 M8X55 8.8 A2C	SECHSKANTSCHRAUBE		
11	94 11 381 08	48	WASHER 70X3	SCHEIBE		
12	41 19 005 08	48	HEX NUT DIN 985 M8 8 VERZ	SECHSKANTMUTTER		
13	97 42 123 08	6	LABEL 2X190X100	SCHILD		
14	96 55 027 08	2	FRAME WELDED T ZN O	RAHMEN SCHWK.		
15	97 79 271 08	2	GRIDIRON T1140X1260X30/2 S235JR TZN K	GITTERROST-P		
16	97 86 742 08	2	GRIDIRON T1140X1260X30/2 S235JR TZN K	GITTERROST-P		

6.2.2009

etk_en_de_074515 LR 1600/2

34 (2/2)

LIEBHERR

CATWALK CRAW.TRACK TRAVEL GEAR
LAUFSTEG RAUPENFAHRWERK

⇒ 1 631 100
91 52 388 08

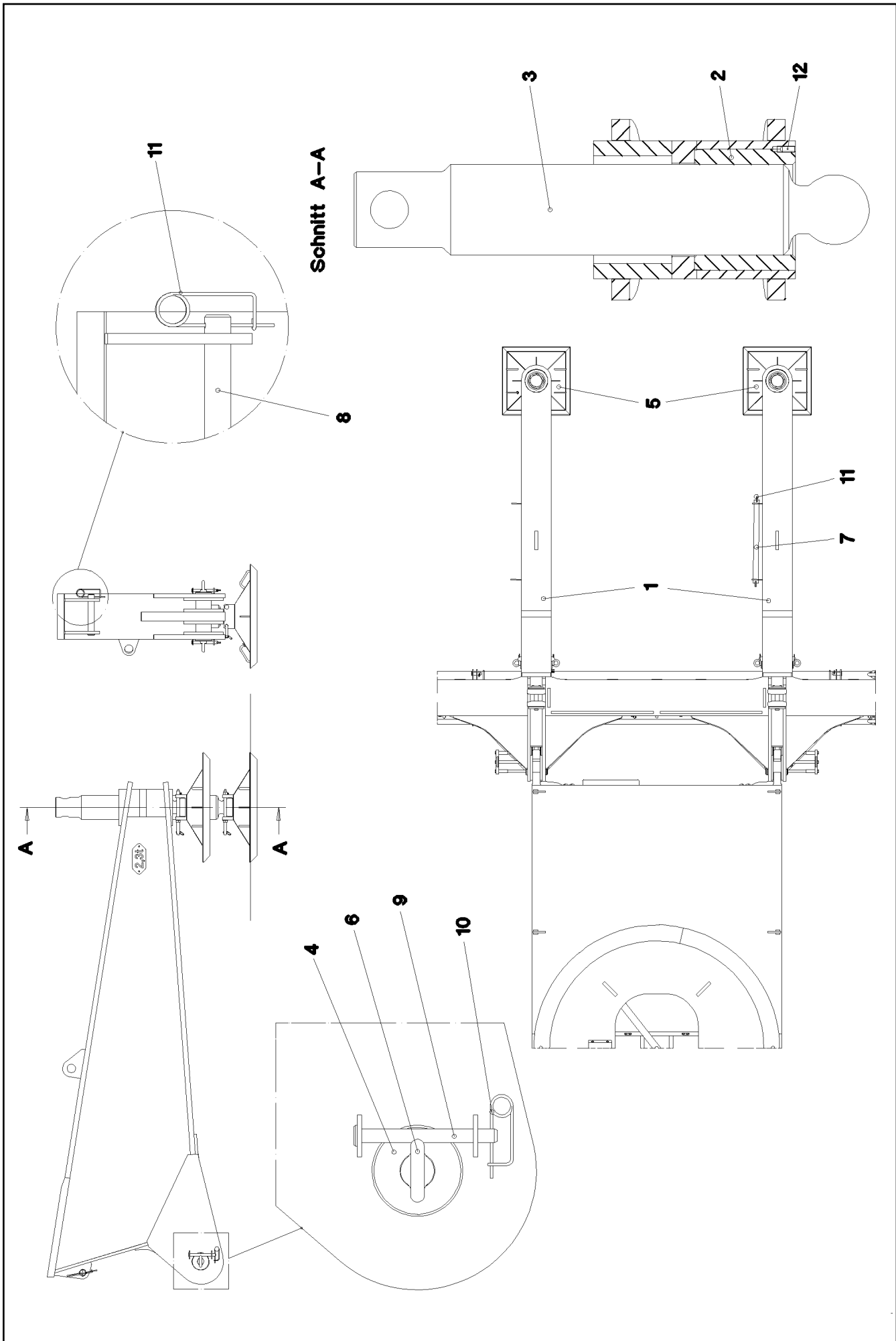

6.2.2009
053047

LIEBHERR

etk_en_de_074515 LR 1600/2

MECHANICAL SUPPORT
MECH.ZUSATZABSTUETZUNG

□ 35 (1/2)

⇒ 1 632
91 52 389 08

Pos.	Item	Quantity	Description	Bezeichnung	Serie	K
1	96 44 950 08	2	MECHANIC ADDITIONAL SUPPORT	MECH.ZUSATZABSTUETZUNG S		
2	93 81 367 08	2	THREADED BUSH RD240X200	GEWINDEBUCHSE		
3	97 17 087 08	2	SPINDLE 180.0X1019	SPINDEL		
4	97 68 667 08	4	PIN 130.0X190 SPF	BOLZEN		
5	96 20 093 08	2	SUPPORT PLATE COMPL. ⇒ 1 632 032 96 20 093 08	ABSTUETZPLATTE KPL.		
6	40 26 007 08	4	RING BOLT DIN 580 M24 C15E A2K	RINGSCHRAUBE		
7	97 41 664 08	1	TUBE 60.3X10 00	ROHR		
8	95 28 924 08	2	PIN RD50X300	BOLZEN		
9	45 30 213 08	4	PIN DIN 1444 20H11X200X192 42CRMO4 GA	BOLZEN		
10	43 31 012 08	4	RETAINING SPRING 4X68 VERZ	SICHERUNGSFEDER		
11	43 31 050 08	4	RETAINING SPRING 6 A3C	SICHERUNGSFEDER		
12	40 46 047 08	2	GRUB SCREW DIN 914 M12X30 45 H VERZ	GEWINDESTIFT		

6.2.2009

etk_en_de_074515 LR 1600/2

☐ 36 (2/2)

LIEBHERR

MECHANICAL SUPPORT
MECH.ZUSATZABSTUETZUNG

⇒ 1 632
91 52 389 08

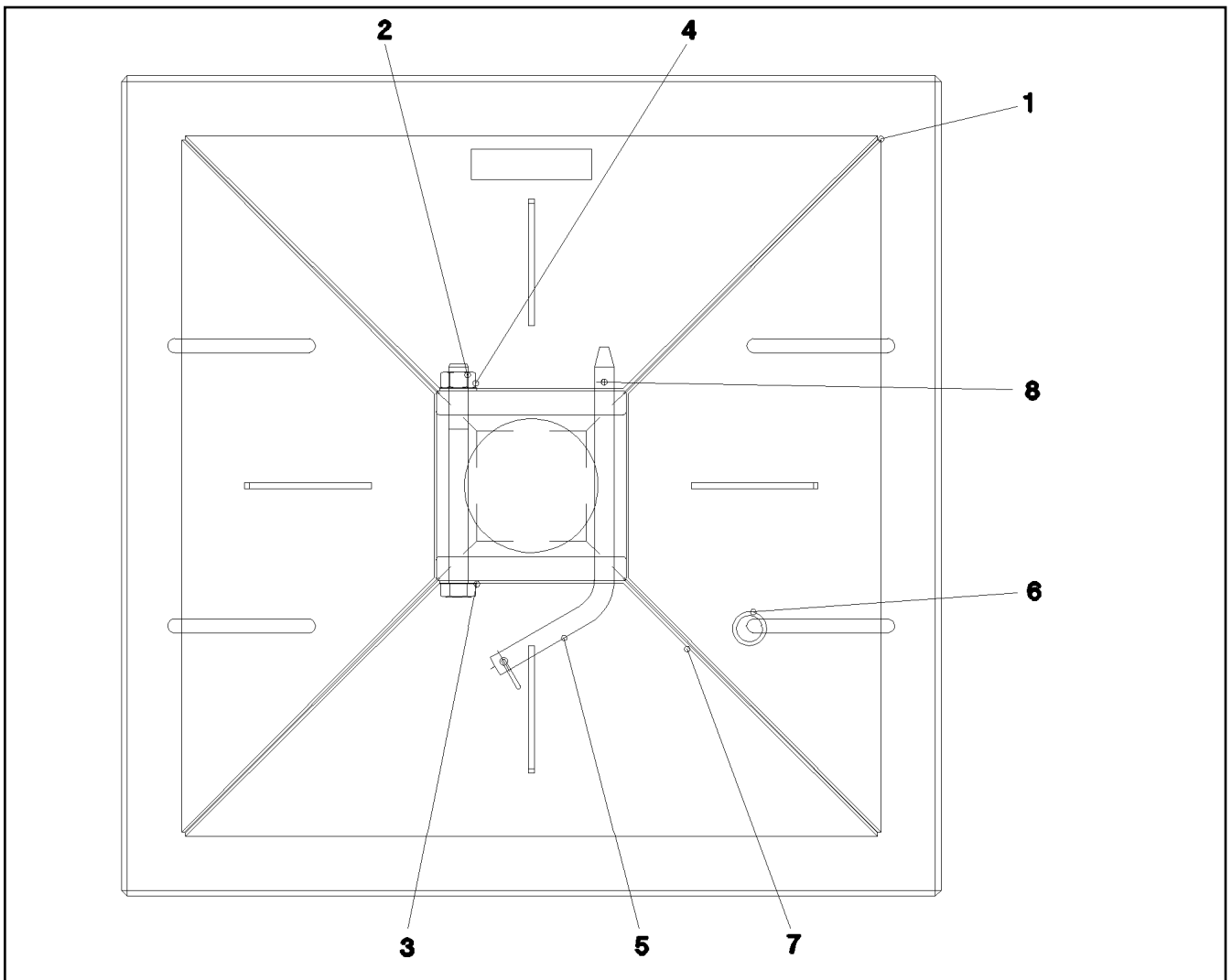

Pos.	Item	Quantity	Description	Bezeichnung	Serie	K
1	96 20 102 08	1	SUPPORT PLATE WELDED	ABSTUETZPLATTE SCHWK.		
2	40 61 246 01	1	HEX BOLT ISO 4014 M20X220 8.8 A3C	SECHSKANTSCHRAUBE		
3	42 00 021 08	2	WASHER ISO 7089 A 21 ST A3C	SCHEIBE		
4	41 15 147 08	1	HEX NUT DIN 934 M20 8 VERZ	SECHSKANTMUTTER		
5	93 03 581 08	1	PLUG RD20X378	STECKER		
6	93 06 259 08	2	WIRE RING RD30X4	DRAHTRING		
7	74 00 008 08	0.25	KNOTTED-LINK CHAIN DIN 5686 1,8X25	KNOTENKETTE		
8	43 32 062 08	1	SPRING PLUG 4 VERZ	FEDERSTECKER		

6.2.2009
029328

LIEBHERR

etk_en_de_074515 LR 1600/2

SUPPORT PLATE COMPL.
ABSTUETZPLATTE KPL.

37

⇒ 1 632 032
96 20 093 08

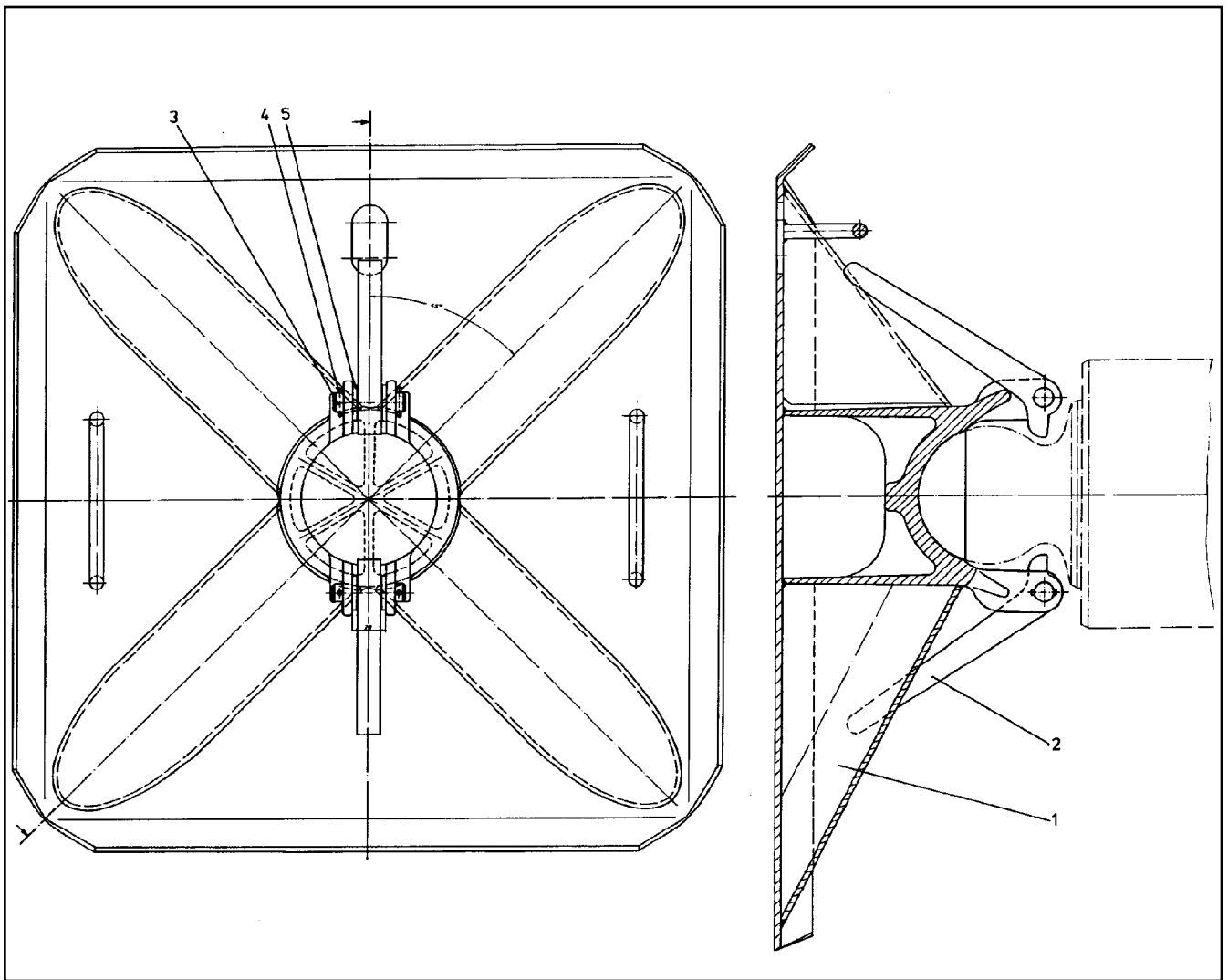

Pos.	Item	Quantity	Description	Bezeichnung	Serie	K
1	92 53 054 08	1	BRACE PLATE	ABSTUETZPLATTE		
2	94 54 958 08	2	LOCKING BAR 20X46X169	RIEGEL		
3	45 00 191 08	2	PIN DIN 1433 16X60X50 ST.50K FE//ZN20//C	BOLZEN		
4	43 20 025 08	4	DOWEL PIN ISO 8752 4X28	SPANNSTIFT		
5	42 00 019 08	4	WASHER DIN 125 A 17 VERZ	SCHEIBE		

6.2.2009
130282

LIEBHERR

etk_en_de_074515 LR 1600/2

SUPPORT PLATE COMPL.
ABSTUETZPLATTE KPL.

38

⇒ 1 641 014
92 53 053 08

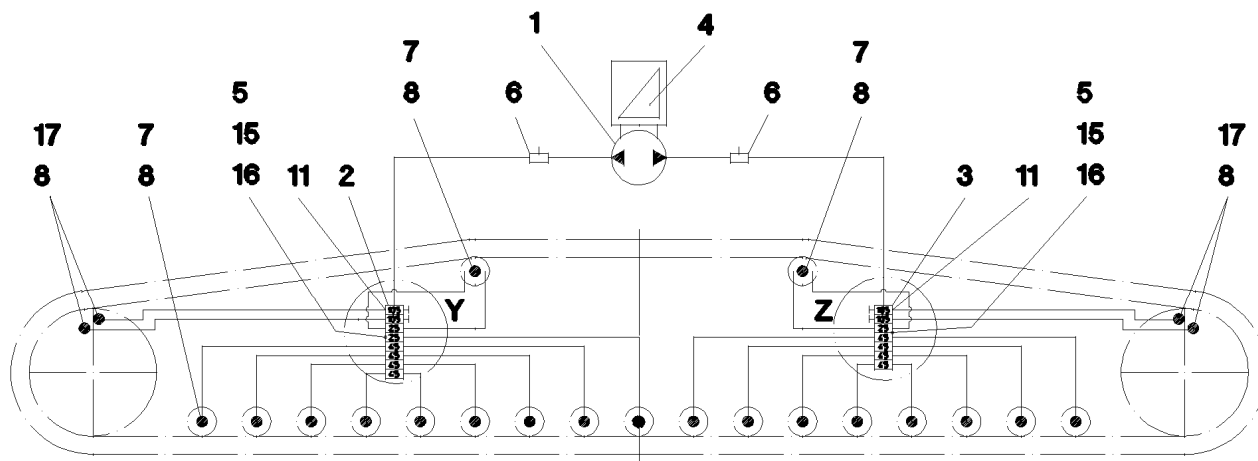

Einzelheit Y

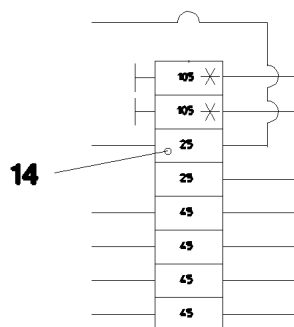

Einzelheit Z

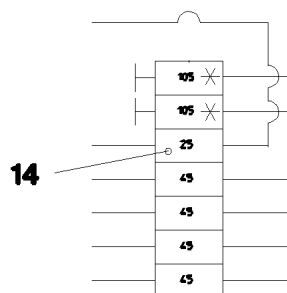

Pos. 9
Pos. 10

Pos.	Item	Quantity	Description	Bezeichnung	Serie	K
1	77 43 728 08	2	PUMP RETURN FLOW	PUMPENRUECKLAUF		
2	10 47 037 0	2	DISTRIBUTION BLOCK 8/13	VERTEILERKOMBINATION		
3	10 47 036 8	2	DISTRIBUTION BLOCK 7/12	VERTEILERKOMBINATION		
4	77 43 566 08	2	ELECTRIC PUMP	ELEKTROPUMPE		
			⇒ 7 743 566 08 77 43 566 08			
5	40 42 025 08	8	CYLINDER SCREW DIN 912 M5X35 8.8 A2C	ZYLINDERSCHRAUBE		
6	77 43 751 08	4	PASSAGE NIPPLE BLOCK	DURCHGANGSNIPPELBLOCK		
(1)	57 15 786 08	1	GREASE NIPPLE	SCHMIERNIPPEL		
7	77 43 734 08	46	EXTENSION M10X1	VERLAENGERUNG		
8	77 43 738 08	50	FLANGE JOINT WE6-M10X1R	VERSCHRAUBUNG		
9	77 43 737 08	120	TUBE 6X1,5 POLYAMID	ROHR		
10	77 43 835 08	14	TUBING COIL	ROHRWENDEL		
11	77 43 765 08	8	FLANGE JOINT GEM10X1K	VERSCHRAUBUNG		
14	77 43 752 08	4	GRUB SCREW M4	GEWINDESTIFT		
15	41 15 148 08	8	HEX NUT DIN 934 M5 8 VERZ	SECHSKANTMUTTER		
16	42 00 008 08	8	WASHER DIN 125 A 5.3 VERZ	SCHEIBE		
17	77 43 832 08	8	CONNECTION PIECE M14X1,5/M10X1	ANSCHLUSSSTUECK		

6.2.2009
052806

LIEBHERR

etk_en_de_074515 LR 1600/2

CENTRALIZED LUBRICATION SYSTEM
ZENTRALSCHMIERUNG RAUPE

39

⇒ 1 711
91 52 392 08

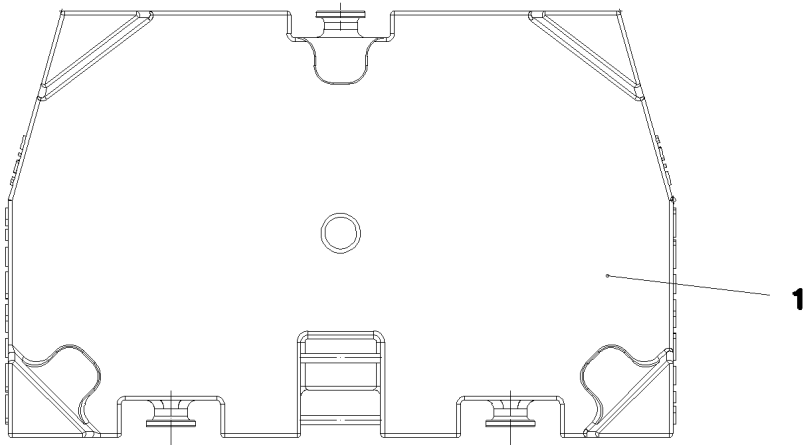
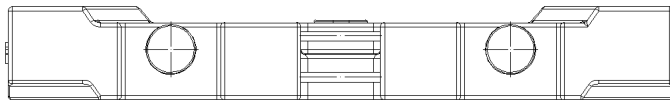

Pos.	Item	Quantity	Description	Bezeichnung	Serie	K
1	97 66 580 08	8	COUNTERWEIGHT SPF	GEGENGEWICHT		

6.2.2009
054177

LIEBHERR

etk_en_de_074515 LR 1600/2

CENTRAL BALLAST
ZENTRALBALLAST

40

⇒ 1 740
91 53 020 08

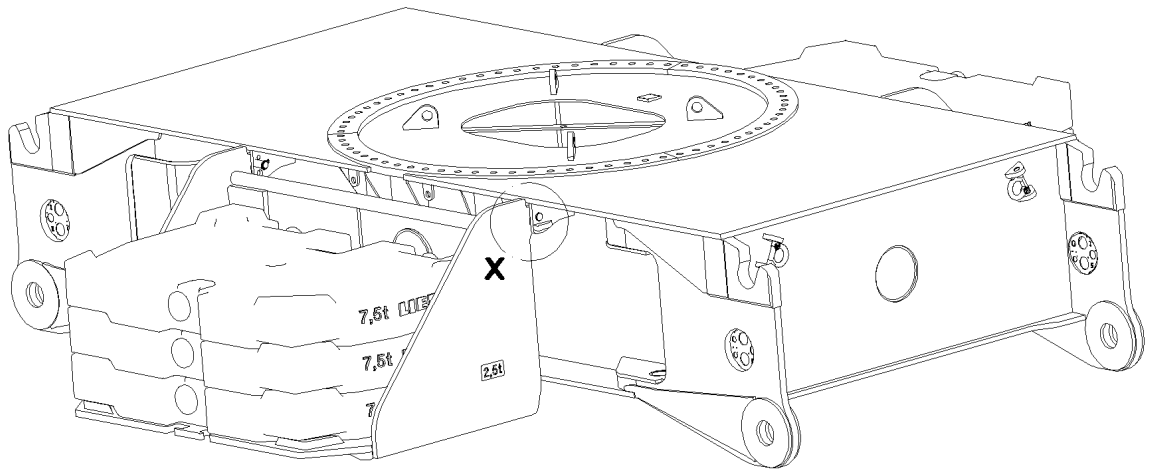

Einzelheit X

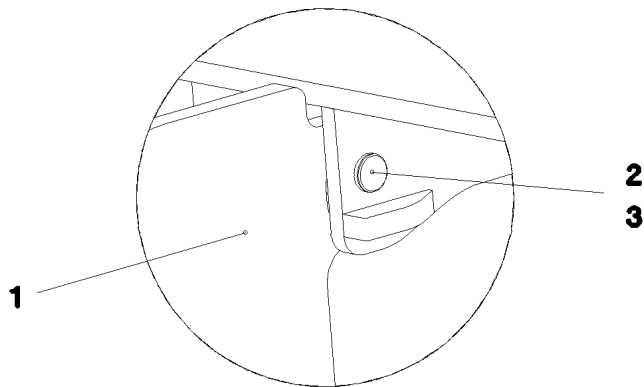

Pos.	Item	Quantity	Description	Bezeichnung	Serie	K
1	96 45 748 08	2	BRACKET WELDED CONST.	KONSOLE SCHWK.		
2	94 99 163 08	4	PIN RD45X177	BOLZEN		
3	43 32 004 08	4	SAFETY PLUG W HINGE-LID 9,5X77 VERZ	SICHERHEITSKLAPPSTECKER		

6.2.2009
052371

LIEBHERR

etk_en_de_074515 LR 1600/2

FIXAGE DU CONTREPOIDS CENTRAL
ZENTRALBALLASTBEFESTIGUNG

41

⇒ 1 742
91 53 021 08

Pos.	Item	Quantity	Description	Bezeichnung	Serie	K
3	79 00 079 08	1	DOUBLE-HEADED SPANNER DIN 3110	DOPPELMAULSCHLUESSEL		
4	79 00 039 08	1	DOUBLE-HEADED SPANNER DIN 3110 46X5	DOPPELMAULSCHLUESSEL		
5	88 51 322 08	1	SINGLE-END SPANNER DIN 894 55	EINMAULSCHLUESSEL		
6	79 00 046 08	1	SINGLE-END SPANNER DIN 894 60	EINMAULSCHLUESSEL		
7	79 00 126 08	1	DOUBLE RING SPANNER DIN 838	DOPPELRINGSCHLUESSEL		
8	79 00 236 08	1	ALLAN KEY DIN 911	INBUSSCHLUESSEL		
9	79 00 303 08	1	HAND HAMMER 500G	HANDHAMMER		
10	79 00 301 08	1	HAND HAMMER DIN 1041 1500G	HANDHAMMER		
11	88 50 341 08	1	SLEDGE HAMMER 5KG	VORSCHLAGHAMMER		
12	79 00 315 08	1	COMBI PLIERS DIN 5244 180	KOMBIZANGE		
13	79 00 320 08	1	SCREW DRIVER 3,5	SCHRAUBENDREHER		
14	88 52 004 08	1	SCREW DRIVER 4,5	SCHRAUBENDREHER		
15	79 00 323 08	1	SCREW DRIVER 5,5	SCHRAUBENDREHER		
16	79 00 444 08	1	FUNNEL RD200 WEISSBLECH	TRICHTER		
17	79 00 249 08	1	SOCKET WRENCH GR.11/3	STECKSCHLUESSEL		
18	79 00 420 08	1	HAND LEVER PRESS VERZ.	HANDHEBELPRESSE		
19	79 00 429 08	1	REINFORCED RUBBER HOSE 300 RH-30 M1	GUMMIPANZERSCHLAUCH		
24	60 71 040 08	1	WORKING LAMP	MONTAGELEUCHE		
26	51 05 696 08	1	PLUG SOCKET	STECKTUELLE		
27	47 10 310 08	1	FLANGE JOINT XGE15-LR-ED A3P	VERSCHRAUBUNG		
28	60 27 011 08	1	CABLE SOCK 25	KABELSTRUMPF		
29	60 27 099 08	1	CABLE SOCK 30	KABELSTRUMPF		
30	75 00 011 08	1	PRESSURE GAUGE 63	MANOMETER		
31	75 00 018 08	2	PRESSURE GAUGE 63	MANOMETER		
32	47 09 008 08	3	PRESSURE GAUGE CONNECTION MAV G1	MANOMETERANSCHLUSS		
33	47 09 018 08	3	MEASURING HOSE DN5 1000	MESSSCHLAUCH		
34	47 09 019 08	2	MEASURING HOSE DN5 2000	MESSSCHLAUCH		
35	77 39 284 08	4	SHACKLE DIN 82101 12T VERZ	SCHAEKEL		
37	77 39 091 08	1	ROPE CLAMP 24-26 GR.1"	SEILKLEMME		
(1)	57 04 059 08	1	PIN	BOLZEN		
38	77 39 118 08	1	ROPE CLAMP DIN 1142 S26 VERZ	SEILKLEMME		
39	77 33 137 08	4	SLING ROPE DIN 3088 7,7T-12M SPF	ANSCHLAGSEIL		
40	88 51 828 08	1	ARTICULATED HOOK WRENCH 155/6	GELENKHAKENSCHLUESSEL		
41	10 03 229 7	1	OIL DRAINING HOSE COMPL. 1,5M	OELABLASSSCHLAUCH KPL.		
42	91 25 249 08	1	MAGNETIC LAMP	MAGNETLAMPE		
			⇒ 1 933 100 91 25 249 08			
44	77 39 401 08	1	ROPE LOCK 28 SPF	SEILSCHLOSS		
45	77 39 132 08	1	ROPE CLAMP DIN 1142 S30 VERZ	SEILKLEMME		
46	81 00 354 08	1	ANGLE SCREW DRIVER GR.3	WINKELSCHRAUBENDREHER		

6.2.2009

etk_en_de_074515 LR 1600/2

□ 42

LIEBHERRTOOL
WERKZEUG⇒ 1 750
91 52 394 08

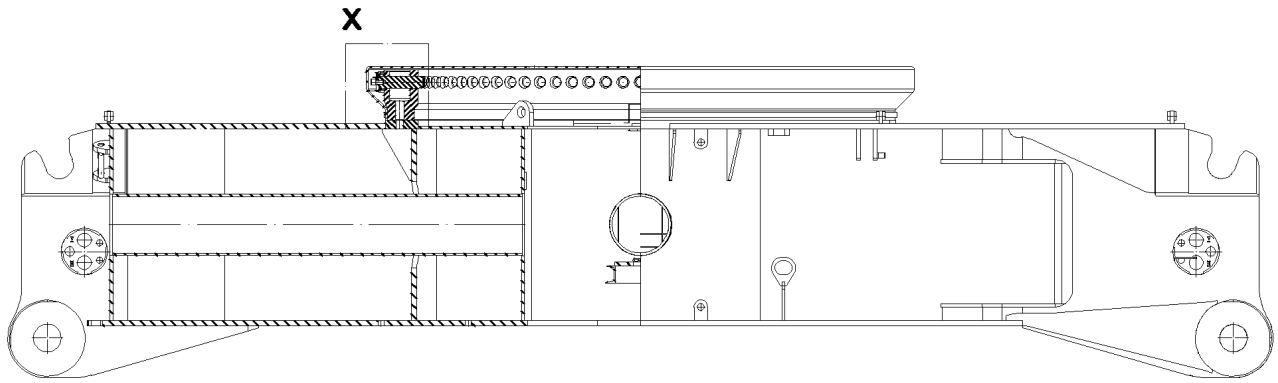

Einzelheit X

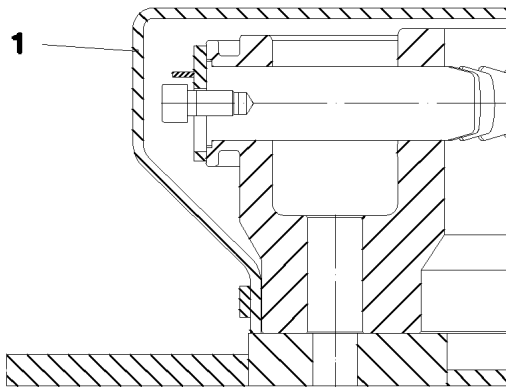

Pos.	Item	Quantity	Description	Bezeichnung	Serie	K
1	97 38 043 08	1	COVER QC LOWER BAND LR 1750	ABDECKUNG QC UNTERRING		

6.2.2009
054021

LIEBHERR

etk_en_de_074515 LR 1600/2

COVER
ABDECKUNG

43

⇒ 1 790 503
91 57 017 08

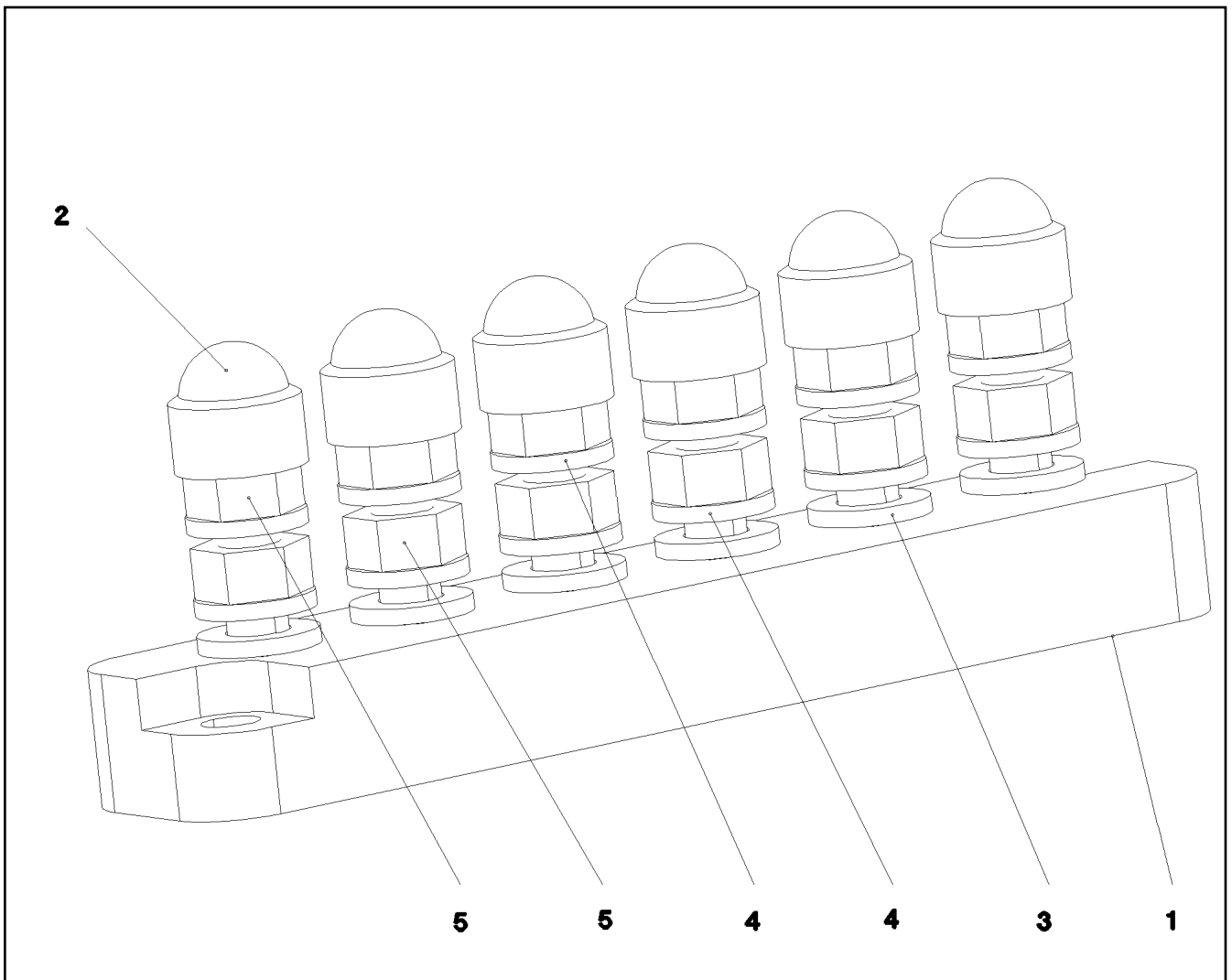

Pos.	Item	Quantity	Description	Bezeichnung	Serie	K
1	60 44 124 08	1	CLAMPING BOARD 6XM6	KLEMMBRETT		
2	77 90 201 08	6	PROTECTING CAP	SCHUTZKAPPE		
3	42 00 009 08	6	WASHER ISO 7089 A 6.4 VERZ	SCHEIBE		
4	42 52 210 08	12	SERRATED LOCK WASHER DIN 6798 J 6,4	FAECHERSCHEIBE		
5	41 15 140 08	12	HEX NUT DIN 934 M6 8 VERZ	SECHSKANTMUTTER		

6.2.2009
022644

LIEBHERR

etk_en_de_074515 LR 1600/2

TERMINAL BOARD PRE-ASS.
KLEMMBRETT VORM.

☐ 44

⇒ 1 830 102
92 26 483 08

Pos.	Item	Quantity	Description	Bezeichnung	Serie	K
2	96 48 383 08	1	ELECTR.FOR CENTER SECTION ⇒ 1 920 307 96 48 383 08	ELEKTRIK MITTELSTUECK		
3	96 48 384 08	1	ELECTR.CRAWLER SUPPORT LEFT ⇒ 1 920 308 96 48 384 08	ELEKTRIK RAUPENTRAEGER LI		
4	96 48 385 08	1	ELECTR.CRAWLER SUPPORT RIGHT ⇒ 1 920 309 96 48 385 08	ELEKTRIK RAUPENTRAEGER R		

6.2.2009

etk_en_de_074515 LR 1600/2

45

LIEBHERR

ELECTR.FOR CRAWLER CARRIER
ELEKTRIK RAUPE

⇒ 1 920 300
91 52 505 08

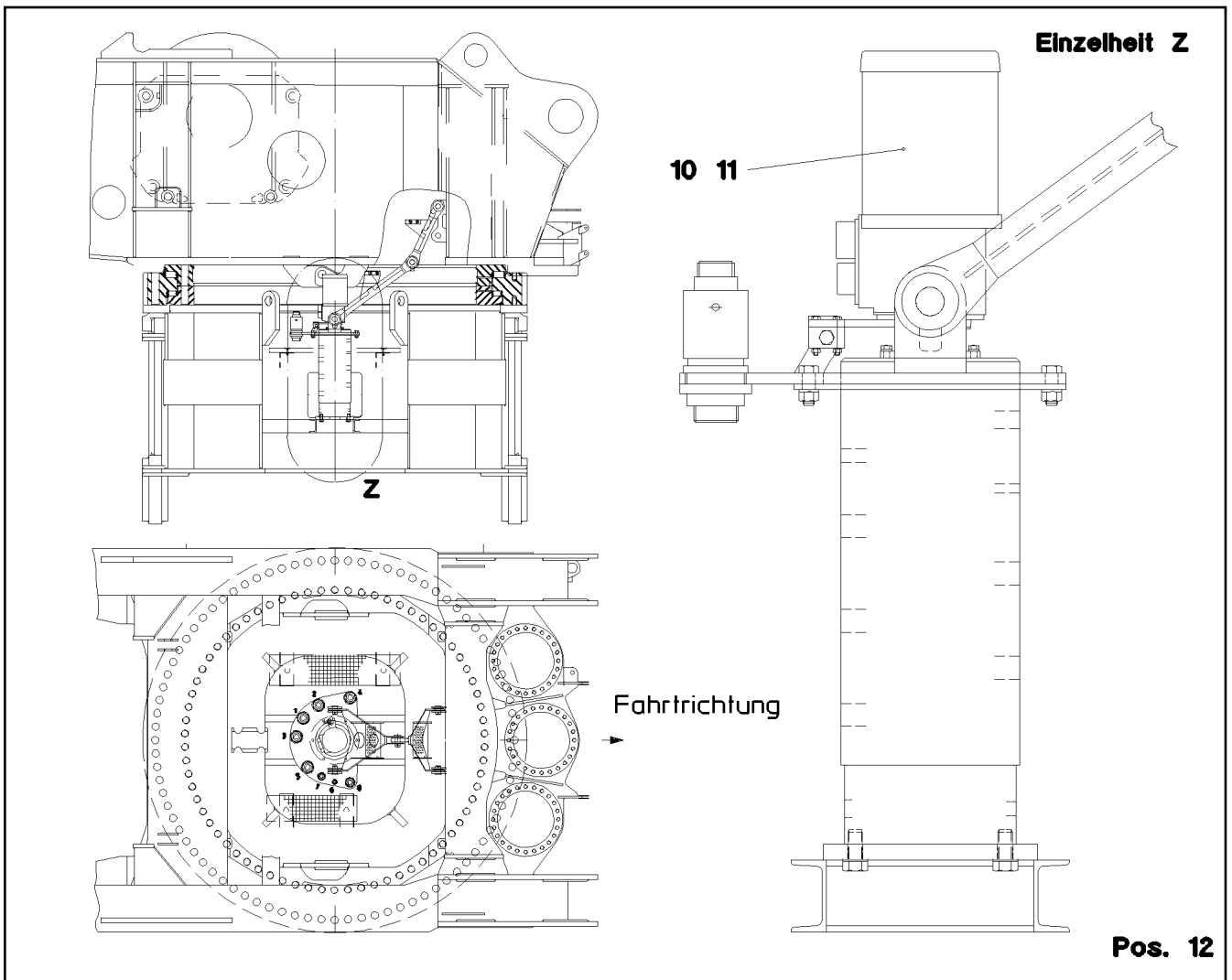

Pos.	Item	Quantity	Description	Bezeichnung	Serie	K
10	69 09 010 08	1	COLLECTING RING 24V SPF ⇒ 6 909 010 08 69 09 010 08	SCHLEIFRINGUEBERTRAEGER		
11	69 23 091 08	1	ROTARY ENCODER OPTISCH 360° SPF	DREHGEBER		
12	28 81 762 08	1	SHEET 15X30X50 PA6G	PLATTE		

6.2.2009
023303

LIEBHERR

etk_en_de_074515 LR 1600/2

INSTALLAT.ROTOR+SLIPRING ASSY.
EINBAU SCHLEIFRINGKOERPER

46

⇒ 1 920 305
92 15 300 08

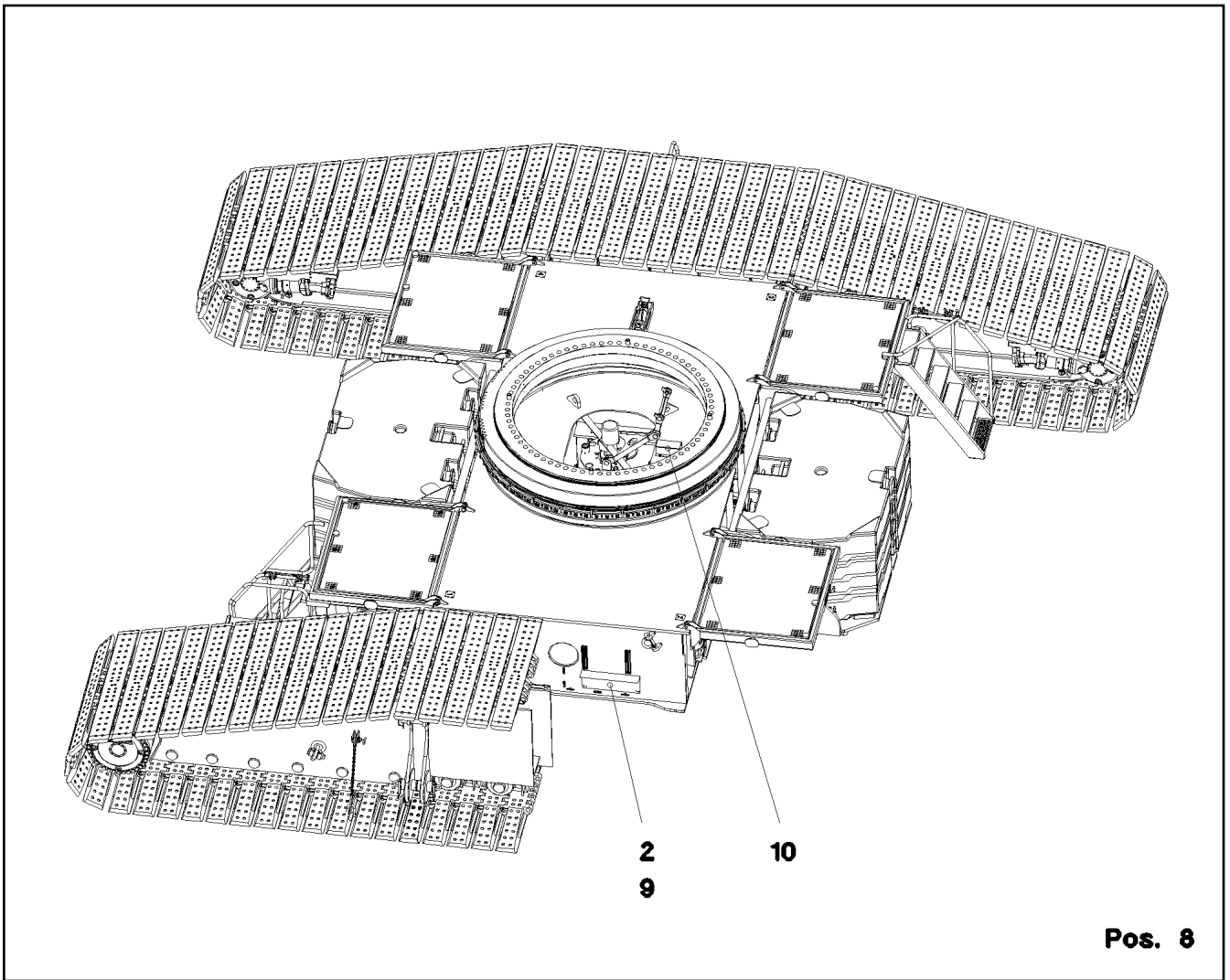

Pos. 8

Pos.	Item	Quantity	Description	Bezeichnung	Serie	K
2	96 48 687 08	1	TERMINAL BOX CPL. S200 ⇒ 1 920 418 96 48 687 08	KLEMMKASTEN KPL.		
8	97 04 309 08	2	PLATE 3x48x75	BLECH		
9	97 15 435 08	1	PLATE 4X680X383	BLECH		
10	69 23 081 08	1	INCLINATION TRANSMITTER SPF	NEIGUNGSGEBER		

6.2.2009
052825

LIEBHERR

etk_en_de_074515 LR 1600/2

ELECTR.FOR CENTER SECTION
ELEKTRIK MITTELSTUECK

□ 47

⇒ 1 920 307
96 48 383 08

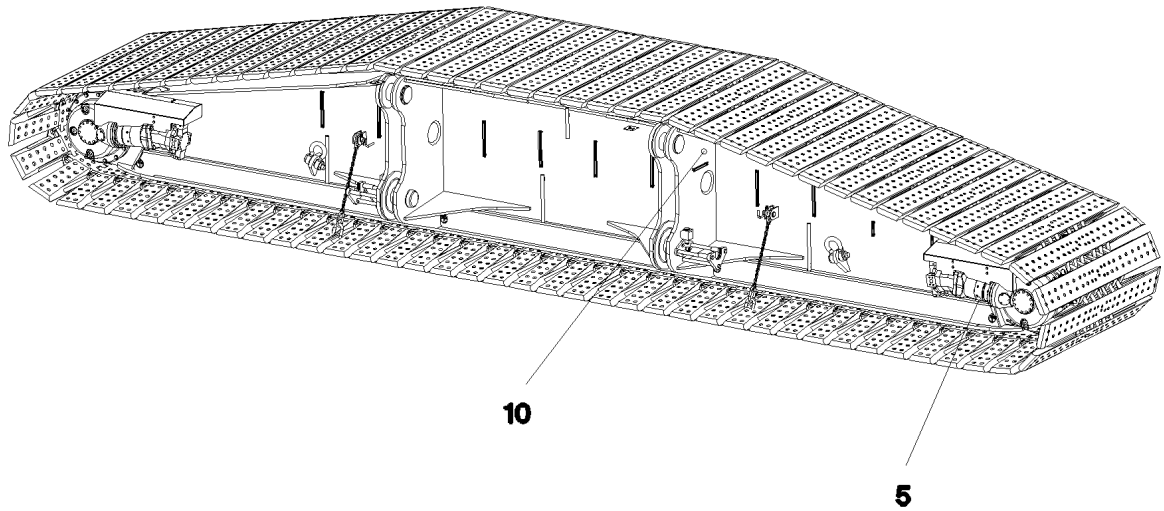

Pos. 20

Pos.	Item	Quantity	Description	Bezeichnung	Serie	K
5	69 27 015 08	2	PROXIMITY SWITCH INDUKTIV SPF	NAEHERUNGSSCHALTER		
10	96 48 703 08	1	TERMINAL BOX CPL. S240 4X FAHRAN. ⇒ 1 920 417 96 48 703 08	KLEMMKASTEN KPL.		
20	95 57 495 08	1	PLATE 4X165X225	BLECH		

6.2.2009
052826

LIEBHERR

etk_en_de_074515 LR 1600/2

ELECTR.CRAWLER SUPPORT LEFT
ELEKTRIK RAUPENTRAEGER LINKS

48

⇒ 1 920 308
96 48 384 08

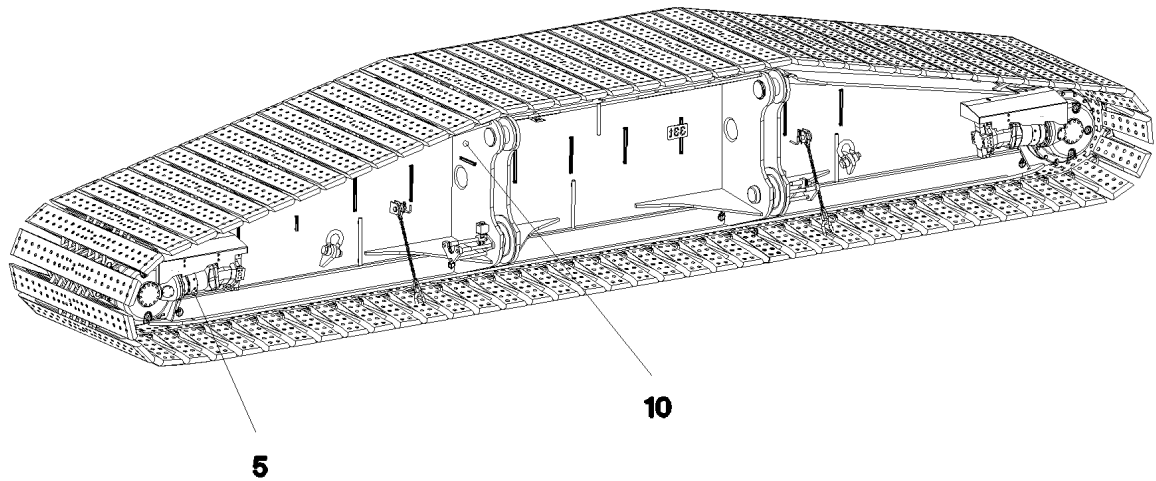

Pos. 20

Pos.	Item	Quantity	Description	Bezeichnung	Serie	K
5	69 27 015 08	2	PROXIMITY SWITCH INDUKTIV SPF	NAEHERUNGSSCHALTER		
10	96 48 707 08	1	TERMINAL BOX CPL. S220 4X FAHRANT. ⇒ 1 920 403 96 48 707 08	KLEMMKASTEN KPL.		
20	95 57 495 08	1	PLATE 4X165X225	BLECH		

6.2.2009
052827

LIEBHERR

etk_en_de_074515 LR 1600/2

ELECTR.CRAWLER SUPPORT RIGHT
ELEKTRIK RAUPENTRAEGER RECHTS

□ 49

⇒ 1 920 309
96 48 385 08

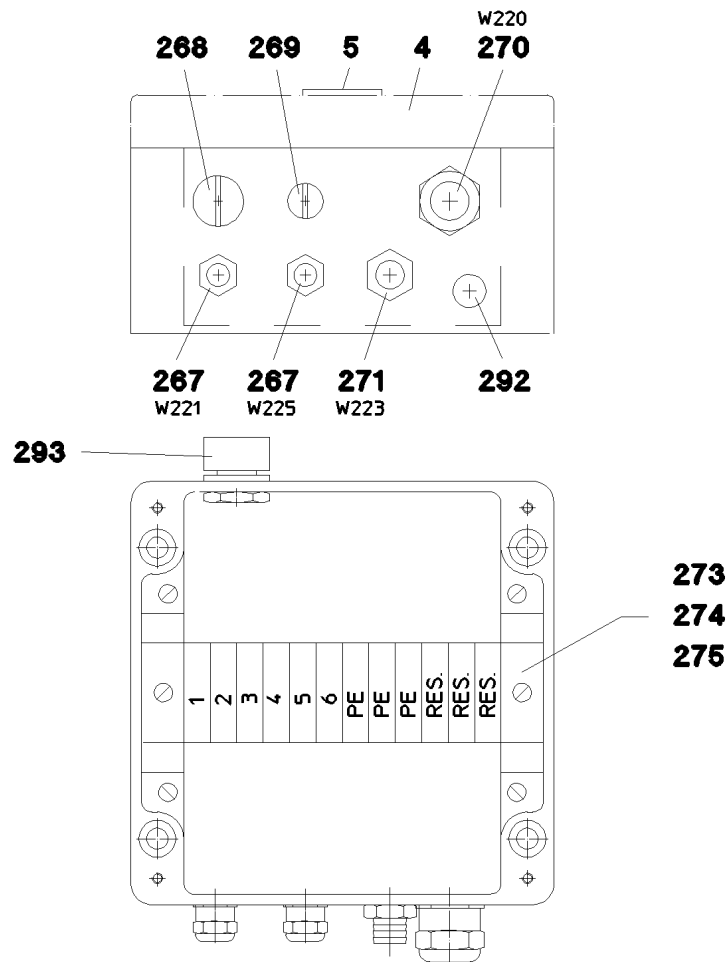

Pos.	Item	Quantity	Description	Bezeichnung	Serie	K
1	96 49 121 08	1	WIRING HARNESS W225	KABELSTRANG		
2	96 48 749 08	1	WIRING HARNESS W223	KABELSTRANG		
3	96 48 750 08	1	WIRING HARNESS W220	KABELSTRANG		
4	97 14 073 08	1	EMPTY CASING 160X160X90X0	LEERGEHAEUSE		
5	97 75 070 08	1	LABEL S220 LEXAN	SCHILD		
10	96 48 719 08	1	LEAD W221	LEITUNG		
267	60 24 241 08	2	THREADED CABLE GLAND M16X1,5 MS	KABELVERSCHRAUBUNG		
268	60 24 250 08	1	SCREW PLUG M20X1,5 MS	VERSCHLUSSSCHRAUBE		
269	60 24 249 08	1	SCREW PLUG M16X1,5 MS	VERSCHLUSSSCHRAUBE		
270	60 24 243 08	1	THREADED CABLE GLAND M25X1,5 MS	KABELVERSCHRAUBUNG		
271	60 24 414 08	1	HOSE UNION JOINT M20X1,5 MS	SCHLAUCHVERSCHRAUBUNG		
273	60 21 067 08	0.15	TOP HAT RAIL 35X27X7,3X1	HUTSCHIENE		
274	10 28 635 4	12	TERMINAL/CLAMP	KLEMME		
275	60 27 417 08	6	CRAMP	KRAMPE		
292	60 25 012 08	1	WATER DRAIN PLUG PA6G SPF	ENTWAESSERUNGSSTOPFEN		
293	60 25 013 08	1	VENTILATION SCREW G1/2"X30 POLYAMID	ENTLUEFTUNGSSCHRAUBE		

6.2.2009
052816

LIEBHERR

etk_en_de_074515 LR 1600/2

TERMINAL BOX CPL.
KLEMMKASTEN KPL.

50

⇒ 1 920 403
96 48 707 08

Ansicht A

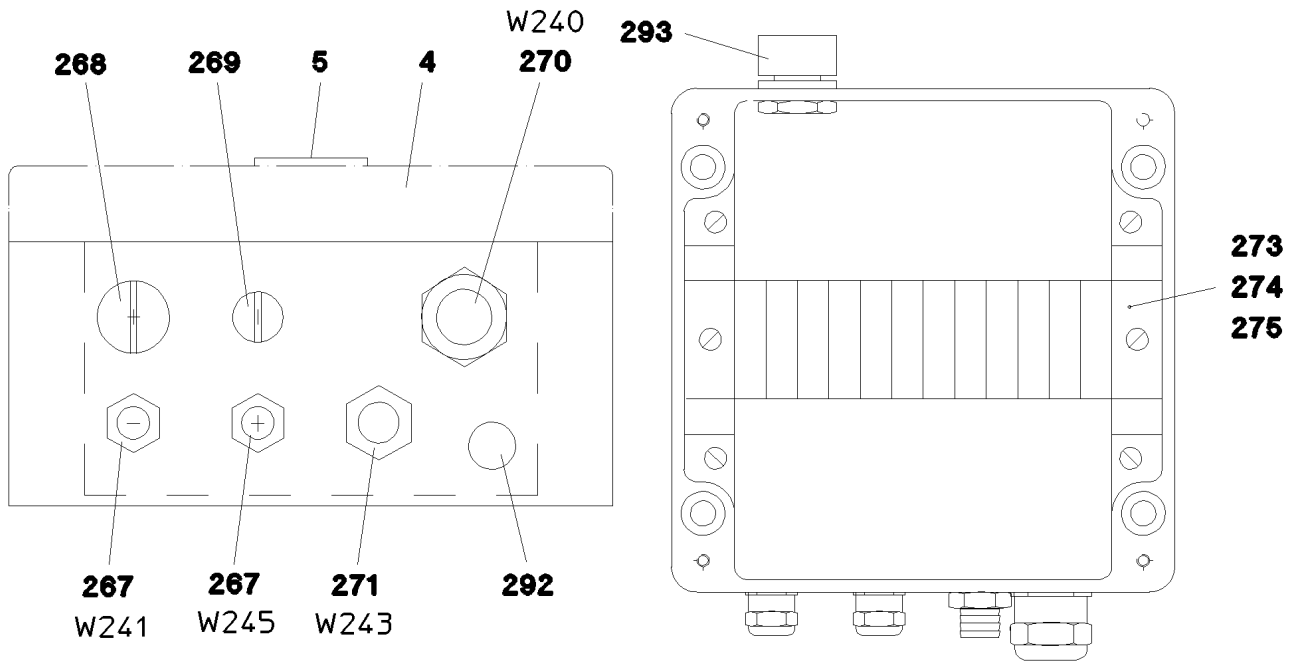

↑
A

Pos. 1
Pos. 2
Pos. 3
Pos. 10

Pos.	Item	Quantity	Description	Bezeichnung	Serie	K
1	96 49 120 08	1	WIRING HARNESS W245	KABELSTRANG		
2	96 48 747 08	1	WIRING HARNESS W243	KABELSTRANG		
3	96 48 748 08	1	WIRING HARNESS W240	KABELSTRANG		
4	97 14 073 08	1	EMPTY CASING 160X160X90X0	LEERGEHAEUSE		
5	97 75 008 08	1	LABEL S240 LEXAN	SCHILD		
10	96 48 718 08	1	LEAD W241	LEITUNG		
267	60 24 241 08	2	THREADED CABLE GLAND M16X1,5 MS	KABELVERSCHRAUBUNG		
268	60 24 250 08	1	SCREW PLUG M20X1,5 MS	VERSCHLUSSSCHRAUBE		
269	60 24 249 08	1	SCREW PLUG M16X1,5 MS	VERSCHLUSSSCHRAUBE		
270	60 24 243 08	1	THREADED CABLE GLAND M25X1,5 MS	KABELVERSCHRAUBUNG		
271	60 24 414 08	1	HOSE UNION JOINT M20X1,5 MS	SCHLAUCHVERSCHRAUBUNG		
273	60 21 067 08	0.15	TOP HAT RAIL 35X27X7,3X1	HUTSCHIENE		
274	10 28 635 4	12	TERMINAL/CLAMP	KLEMME		
275	60 27 417 08	6	CRAMP	KRAMPE		
292	60 25 012 08	1	WATER DRAIN PLUG PA6G SPF	ENTWAESSERUNGSSTOPFEN		
293	60 25 013 08	1	VENTILATION SCREW G1/2"X30 POLYAMID	ENTLUEFTUNGSSCHRAUBE		

6.2.2009
053797

LIEBHERR

etk_en_de_074515 LR 1600/2

TERMINAL BOX CPL.
KLEMMKASTEN KPL.

51

⇒ 1 920 417
96 48 703 08

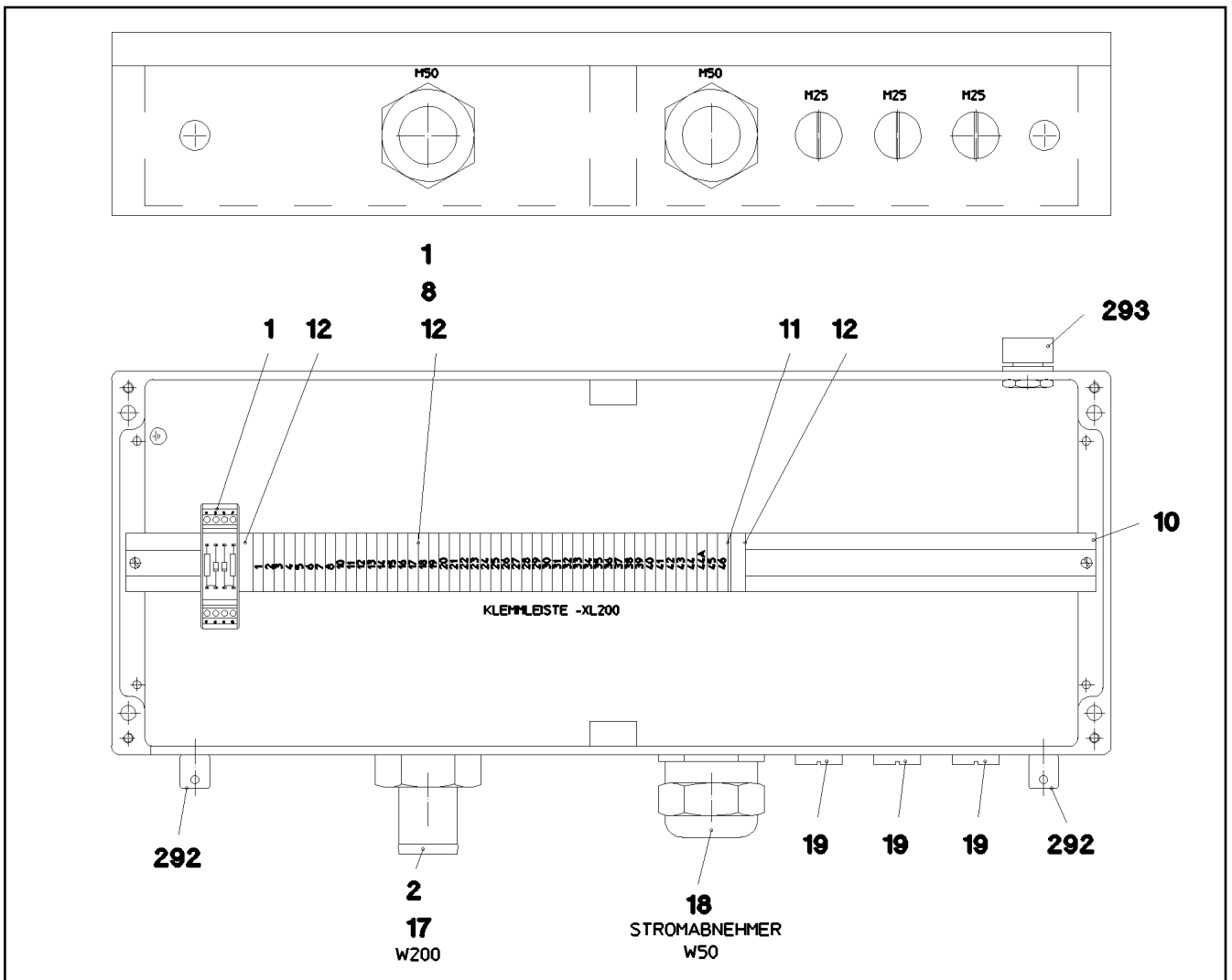

Pos.	Item	Quantity	Description	Bezeichnung	Serie	K
1	96 48 693 08	1	WIRES TERMINAL BOX CPL. S200	DRAEHTE KLEMMKASTEN KPL.		
(2)	96 51 072 08	1	WIRES PRE-ASS. S200	DRAEHTE VORM.		
(151)	10 28 635 4	47	TERMINAL/CLAMP	KLEMME		
(152)	96 48 302 08	1	CUSTOM CIRCUIT MODULE 2	BESTUECKUNGSMODUL 2		
2	96 48 688 08	1	WIRING HARNESS W200	KABELSTRANG		
3	97 13 661 08	1	EMPTY CASING DRILLED 230X600X110X0 A	LEERGEHAEUSE GEBOHLT		
5	97 74 996 08	1	LABEL S200 LEXAN	SCHILD		
10	60 21 067 08	0.585	TOP HAT RAIL 35X27X7,3X1	HUTSCHIENE		
11	10 28 635 3	1	LID	DECKEL		
12	60 27 946 08	2	END ANGLE	ENDWINKEL		
17	60 24 413 08	1	HOSE UNION JOINT M50X1,5 MS	SCHLAUCHVERSCHRAUBUNG		
18	60 24 246 08	1	THREADED CABLE GLAND M50X1,5 MS	KABELVERSCHRAUBUNG		
19	60 24 251 08	3	SCREW PLUG M25X1,5 MS	VERSCHLUSSSCHRAUBE		
261	60 32 003 08	10	CABLE TIE 3,6X150	KABELBINDER		
292	60 25 012 08	2	WATER DRAIN PLUG PA6G SPF	ENTWAESSERUNGSSTOPFEN		
293	60 25 013 08	1	VENTILATION SCREW G1/2"X30 POLYAMID	ENTLUEFTUNGSSCHRAUBE		

6.2.2009
052814

LIEBHERR

etk_en_de_074515 LR 1600/2

TERMINAL BOX CPL.
KLEMMKASTEN KPL.

52

⇒ 1 920 418
96 48 687 08

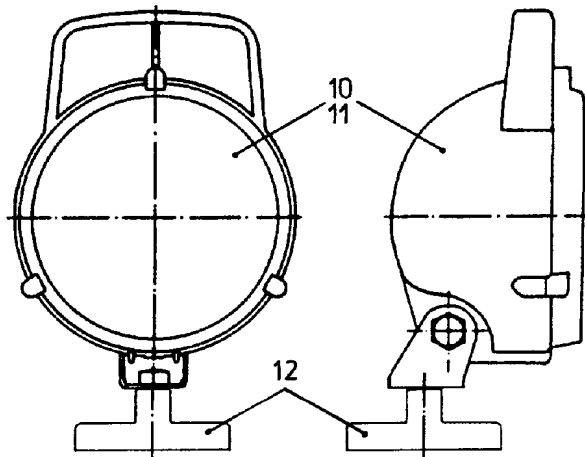
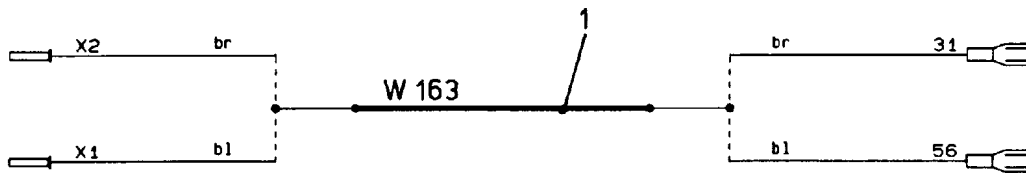

Pos.	Item	Quantity	Description	Bezeichnung	Serie	K
1	92 69 930 08	1	LEAD W163	LEITUNG		
10	60 71 318 08	1	SEARCHLIGHT	SCHEINWERFER		
11	60 70 091 08	1	LIGHT BULB 35W 24V	GLUEHLAMPE		
12	61 70 000 08	1	FERRIMAGNET FERRIT	FLACHGREIFER		

6.2.2009
150945

LIEBHERR

etk_en_de_074515 LR 1600/2

MAGNETIC LAMP
MAGNETLAMPE

53

⇒ 1 933 100
91 25 249 08

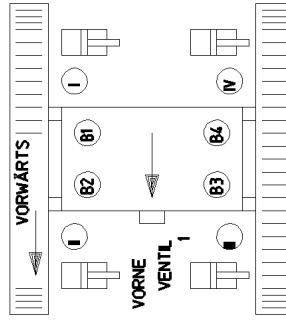
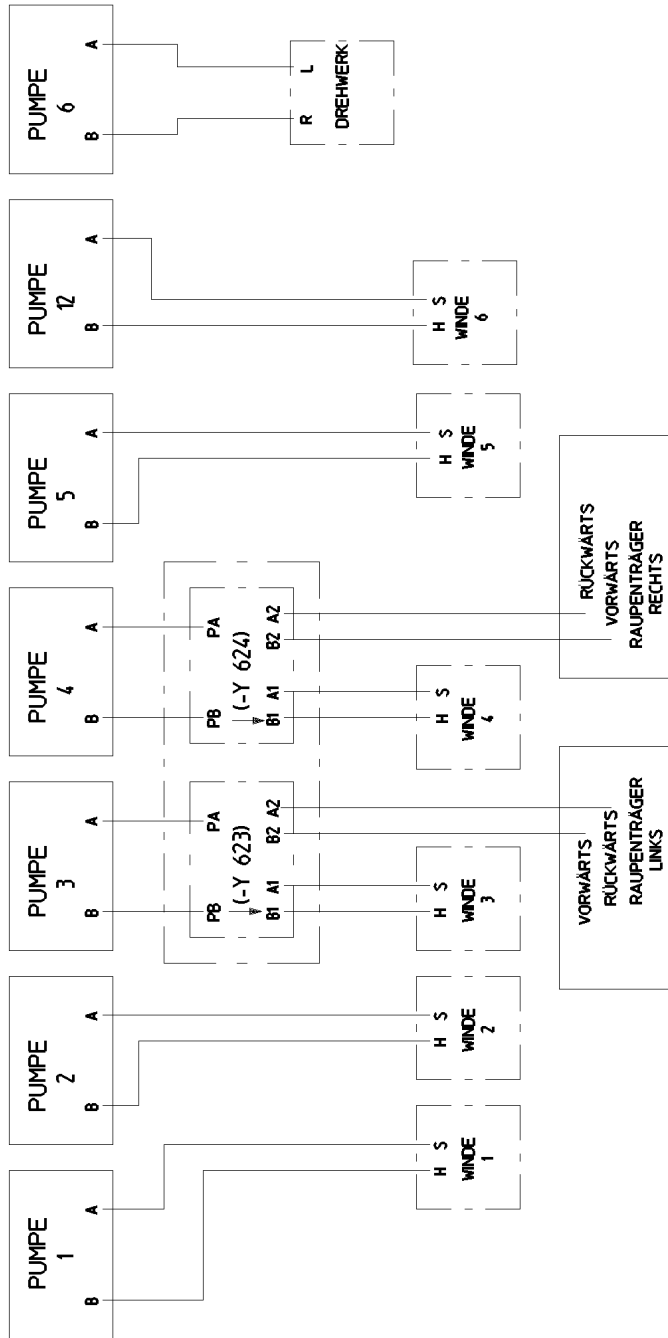

* **1 997**

1 976 050

1 976 006

* **1 998**

1 976 006

VERBOLZUNG
MITTELSTÜCK / RAUPENTRÄGER
UNTEN

ZYLINDER

81 82 83 84

ABSTUETZZYLINDER ==> 1 2 3 4

Pos. 2

6.2.2009
054178

LIEBHERR

etk_en_de_074515 LR 1600/2

CRAWLER TRACK HYDRAULIC
HYDRAULIK RAUPE

54 (1/8)

⇒ 1 970
91 56 958 08

2 977

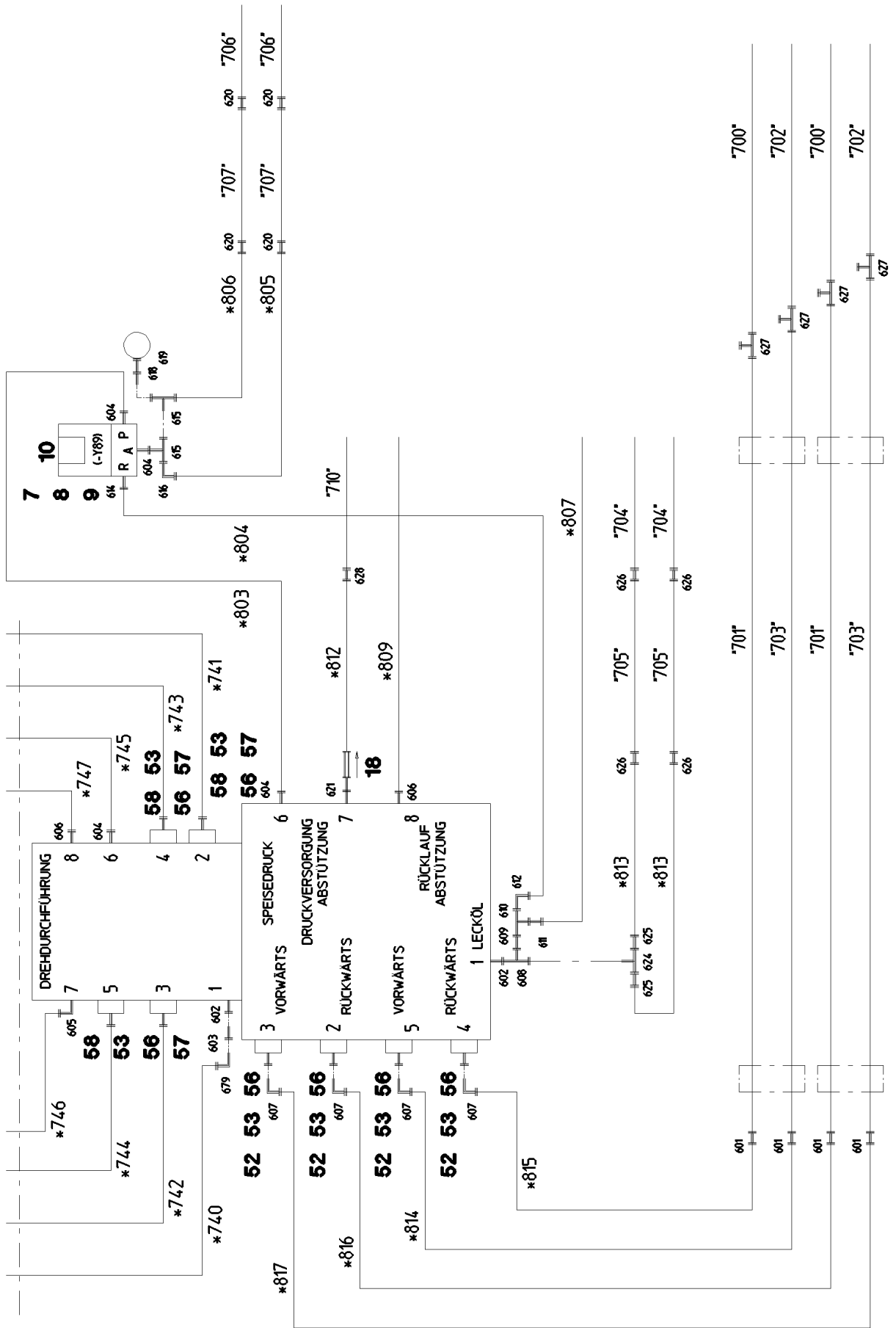

6.2.2009
054179

LIEBHERR

etk_en_de_074515 LR 1600/2

CRAWLER TRACK HYDRAULIC
HYDRAULIK RAUPE

□ 55 (2/8)

⇒ 1 970
91 56 958 08

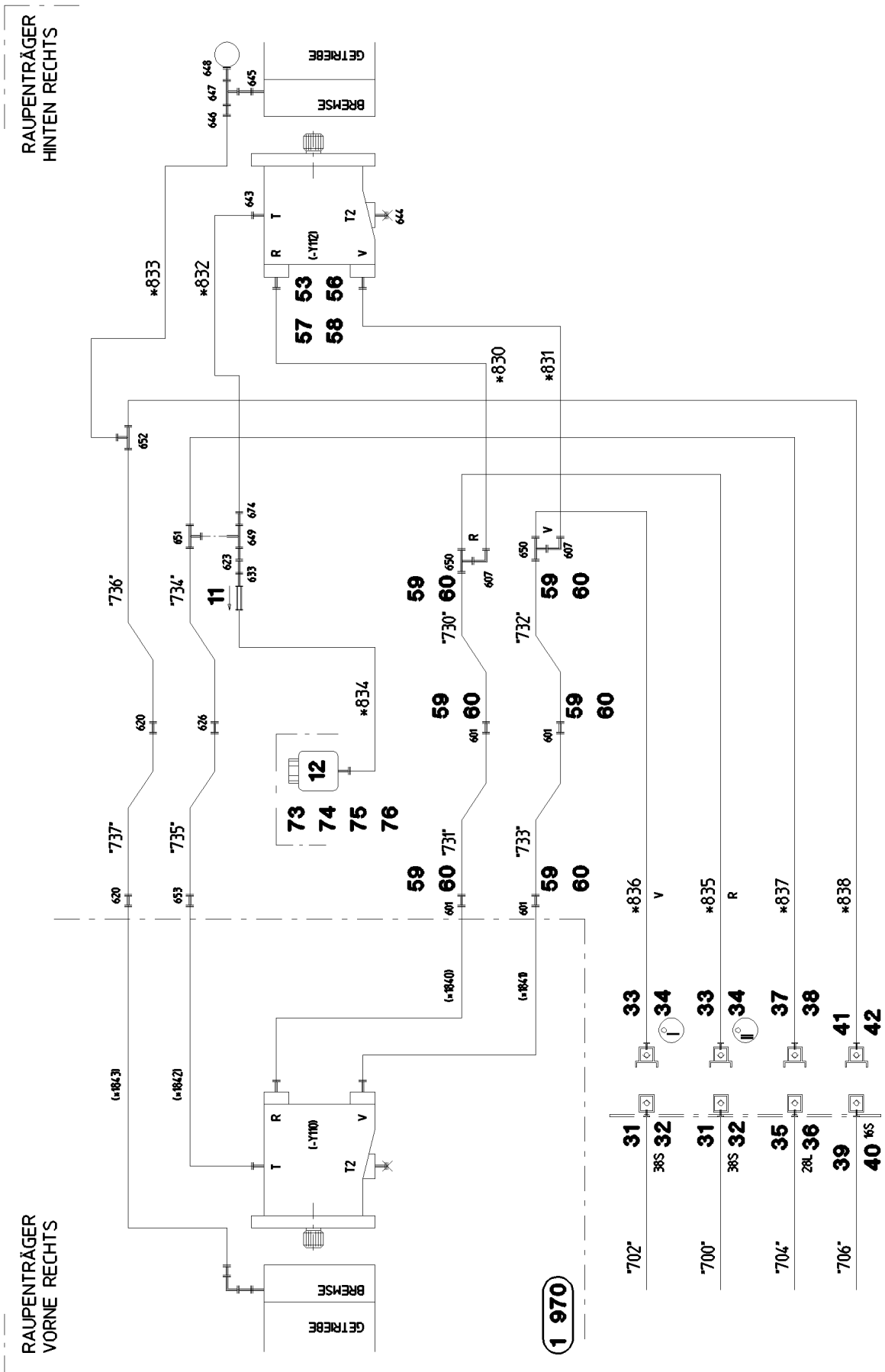

6.2.2009
054181

LIEBHERR

etk_en_de_074515 LR 1600/2

CRAWLER TRACK HYDRAULIC
HYDRAULIK RAUPE

□ 57 (4/8)

⇒ 1 970
91 56 958 08

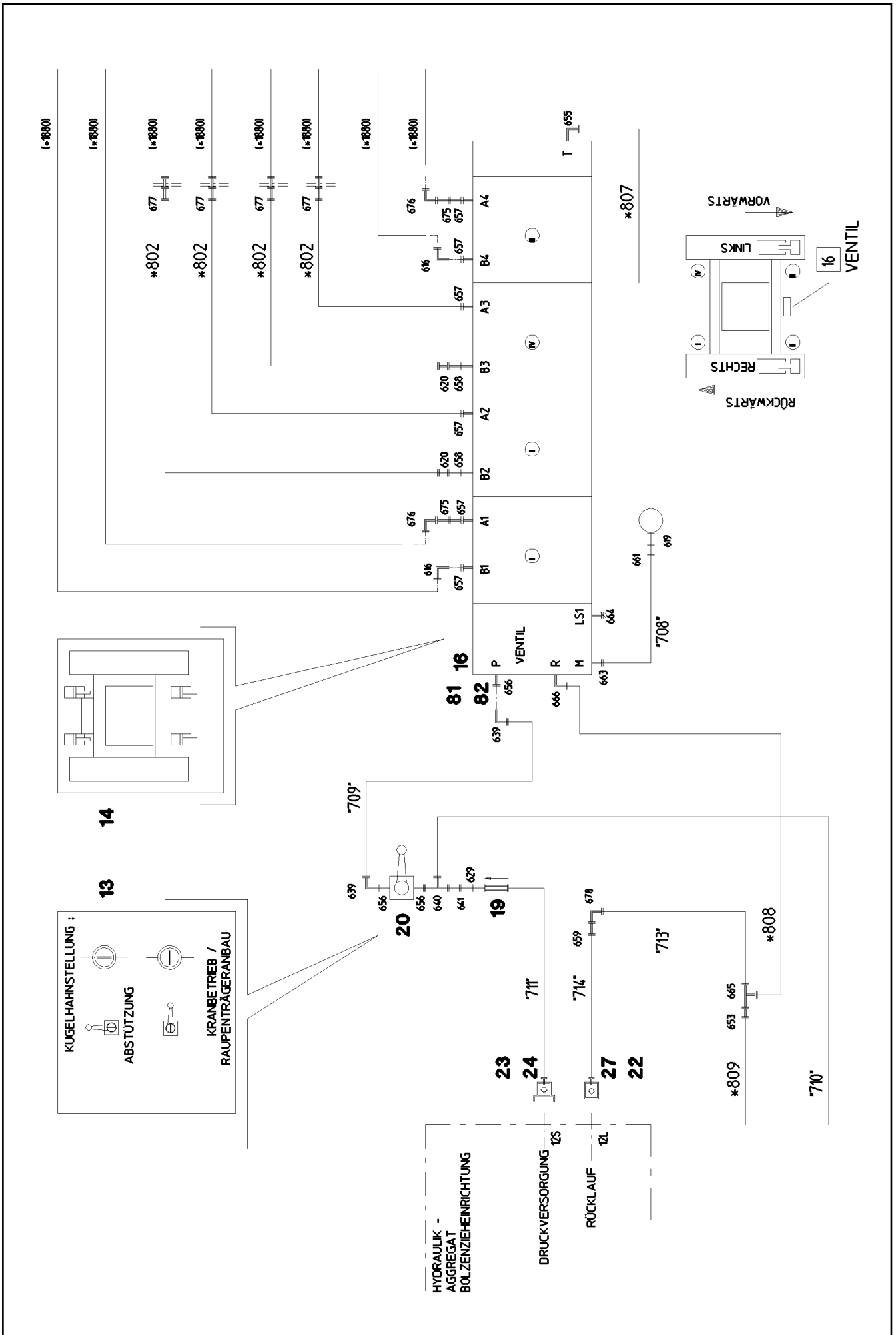

6.2.2009
054182

LIEBHERR

etk_en_de_074515 LR 1600/2

CRAWLER TRACK HYDRAULIC
HYDRAULIK RAUPE

58 (5/8)

1970
91 56 958 08

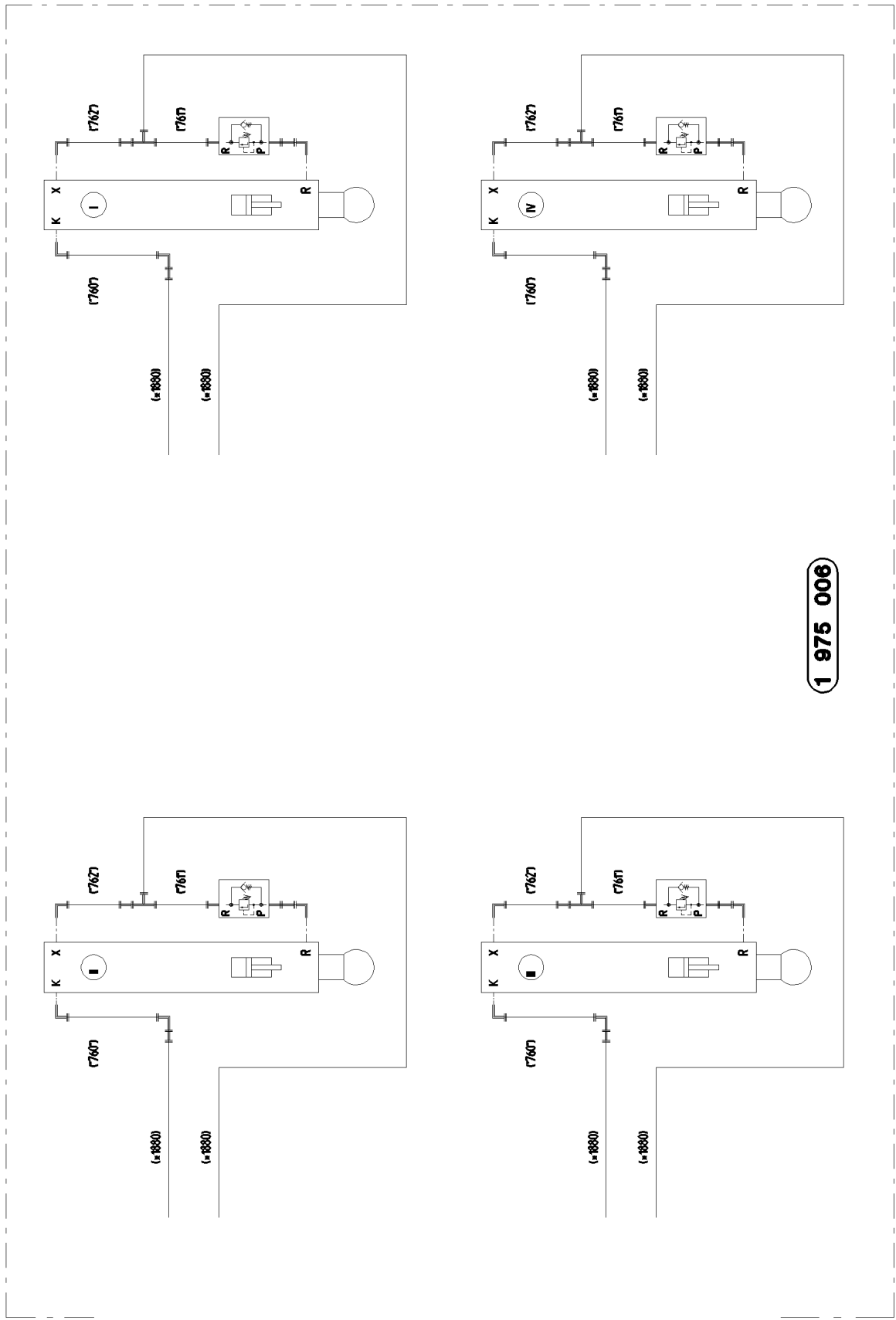

1 975 006

6.2.2009
054183

LIEBHERR

etk_en_de_074515 LR 1600/2

CRAWLER TRACK HYDRAULIC
HYDRAULIK RAUPE

59 (6/8)

⇒ 1 970
91 56 958 08

Pos.	Item	Quantity	Description	Bezeichnung	Serie	K
2	96 50 706 08	1	AUX.HYDR.CR.TRACK CARR.4 MOUNT ⇒ 1 970 161 96 50 706 08	ZUSATZHYDR.RAUPENTRAEG		
7	95 05 282 08	1	PLATE 4X50X95	BLECH		
8	40 65 136	2	HEX BOLT ISO 4017 M8X12 8.8 A2C	SECHSKANTSCHRAUBE		
9	42 40 007 08	2	CIRCLIP DIN 127 A 8 VERZ	FEDERRING		
10	51 14 651 08	1	DIRECTIONAL CONTROL VALVE ⇒ 5 114 651 08 51 14 651 08	WEGEVENTIL		
11	51 14 815 08	2	NON-RETURN VALVE	RUECKSCHLAGVENTIL		
12	50 28 073 08	2	EQUALIZING RESERVOIR	AUSGLEICHSBEHAELTER		
13	97 92 603 08	1	LABEL 100X70X1 AL-BL	SCHILD		
14	97 08 391 08	1	LABEL	SCHILD		
16	51 13 090 08	1	SLIDE VALVE BLOCK 4-FACH SPF ⇒ 5 133 090 08 51 13 090 08	WEGESCHIEBERBLOCK		
18	51 04 121 08	1	NON-RETURN VALVE	RUECKSCHLAGVENTIL		
19	51 04 129 08	1	NON-RETURN VALVE	RUECKSCHLAGVENTIL		
20	51 06 923 08	1	BALL VALVE BKH3/4" A3C	KUGELHAHN		
22	51 15 040 08	1	HEX CAP NUT	VERSCHLUSSMUTTER		
23	51 15 013 08	1	COUPLING PLUG 12-S	KUPPLUNGSSTECKER		
(1)	57 10 830 08	1	SHEET GASKET VITON	DICHTSCHEIBE		
(2)	57 10 826 08	1	O-RING 17X2 FPM70	O-RING		
(3)	57 10 828 08	1	SUPPORTING RING	STUETZRING		
24	10 46 691 0	1	SCREW PLUG RD32X3 SPF	VERSCHLUSSSCHRAUBE		
27	51 15 058 08	1	COUPLING SLEEVE 12-L	KUPPLUNGSMUFFE		
31	51 15 122 08	4	COUPLING SLEEVE 38-S	KUPPLUNGSMUFFE		
32	51 05 456 08	4	HEX CAP NUT	VERSCHLUSSMUTTER		
33	51 15 123 08	4	COUPLING PLUG 38-S	KUPPLUNGSSTECKER		
34	51 05 455 08	4	SCREW PLUG	VERSCHLUSSSCHRAUBE		
35	51 15 010 08	2	COUPLING SLEEVE 28-L	KUPPLUNGSMUFFE		
36	51 05 458 08	2	HEX CAP NUT	VERSCHLUSSMUTTER		
37	51 15 011 08	2	COUPLING PLUG 28-L	KUPPLUNGSSTECKER		
38	10 46 691 2	2	SCREW PLUG RD54X4 SPF	VERSCHLUSSSCHRAUBE		
39	51 15 059 08	2	COUPLING SLEEVE 16-S	KUPPLUNGSMUFFE		
(1)	57 10 819 08	1	SHEET GASKET VITON	DICHTSCHEIBE		
(2)	57 10 820 08	1	O-RING 20X2 FPM70	O-RING		
(3)	57 10 821 08	1	O-RING 26X1,5 FPM70	O-RING		
(4)	57 10 822 08	1	SUPPORTING RING	STUETZRING		
(5)	57 10 823 08	1	NUT	MUTTER		
40	51 05 453 08	2	HEX CAP NUT	VERSCHLUSSMUTTER		
41	51 15 086 08	2	COUPLING PLUG 16-S	KUPPLUNGSSTECKER		
(1)	57 10 824 08	1	SHEET GASKET VITON	DICHTSCHEIBE		
(2)	57 10 820 08	1	O-RING 20X2 FPM70	O-RING		
(3)	57 10 822 08	1	SUPPORTING RING	STUETZRING		
42	10 46 691 1	2	SCREW PLUG RD36X3 SPF	VERSCHLUSSSCHRAUBE		
52	51 15 178 08	4	FLANGE STUB PIPE 38-S	FLANSCHSTUTZEN		
53	51 05 867 08	12	O-RING ARP 568 37,69X3,53 NBR90	O-RING		
56	40 42 152 08	32	CYLINDER SCREW DIN 912 M14X45 8.8 A3C	ZYLINDERSCHRAUBE		
57	40 65 145 01	8	HEX BOLT ISO 4017 M14X45 8.8 A3C	SECHSKANTSCHRAUBE		
58	51 05 866 08	16	FLANGE HALF A3P	FLANSCHHAELFTE		
59	71 02 004 08	4	SOFT GASKET PERBUNAN	WEICHDICHTUNG		
60	47 74 010 08	4	BOX NUT DIN 3870 AS38	UEBERWURFMUTTER		
62	10 41 285 4	8	OVAL HEAD FLAT SCREW AEHNL.ISO7380	LINSENFLACHKOPFSCHRAUBE		
63	40 65 136	8	HEX BOLT ISO 4017 M8X12 8.8 A2C	SECHSKANTSCHRAUBE		
64	42 00 012 08	8	WASHER DIN 125 A8X16 ST VERZ	SCHEIBE		
65	40 43 028 08	16	CYLINDER SCREW DIN 912 M5X50 10.9 SPF	ZYLINDERSCHRAUBE		
66	40 00 829	8	HEX BOLT ISO 4017 M6X20 8.8 A2C	SECHSKANTSCHRAUBE		
67	41 15 140 08	8	HEX NUT DIN 934 M6 8 VERZ	SECHSKANTMUTTER		
73	49 00 605	8	HEX BOLT ISO 4017 M6X12 8.8 A2C	SECHSKANTSCHRAUBE		
74	42 00 009 08	8	WASHER ISO 7089 A 6.4 VERZ	SCHEIBE		
75	41 15 140 08	8	HEX NUT DIN 934 M6 8 VERZ	SECHSKANTMUTTER		
76	10 41 285 4	40	OVAL HEAD FLAT SCREW AEHNL.ISO7380	LINSENFLACHKOPFSCHRAUBE		

6.2.2009

etk_en_de_074515 LR 1600/2

☐ 60 (7/8)

LIEBHERRCRAWLER TRACK HYDRAULIC
HYDRAULIK RAUPE⇒ 1 970
91 56 958 08

Pos.	Item	Quantity	Description	Bezeichnung	Serie	K
81	40 65 136	4	HEX BOLT ISO 4017 M8X12 8.8 A2C	SECHSKANTSCHRAUBE		
82	42 00 012 08	4	WASHER DIN 125 A8X16 ST VERZ	SCHEIBE		
601	47 00 331 08	12	FLANGE JOINT XG38-S A3P	VERSCHRAUBUNG		
602	47 10 347 08	2	FLANGE JOINT XGE42-LR-ED A3P	VERSCHRAUBUNG		
603	47 54 367 08	1	FLANGE JOINT REDSD42/35-L A3P	VERSCHRAUBUNG		
604	47 10 332 08	4	FLANGE JOINT XGE16-SR-ED A3P	VERSCHRAUBUNG		
605	47 32 314 08	1	FLANGE JOINT RSWS20-SR-WD A3P	VERSCHRAUBUNG		
606	47 10 316 08	2	FLANGE JOINT XGE28-LR-ED A3P	VERSCHRAUBUNG		
607	47 25 318 08	8	FLANGE JOINT EWSD38-S A3P	VERSCHRAUBUNG		
608	47 23 311 08	1	FLANGE JOINT ELSD42-L A3P	VERSCHRAUBUNG		
609	47 54 317 08	1	FLANGE JOINT REDSD42/18-L A3P	VERSCHRAUBUNG		
610	47 23 305 08	1	FLANGE JOINT ELSD18-L A3P	VERSCHRAUBUNG		
611	47 54 303 08	1	FLANGE JOINT REDSD18/10-L A3P	VERSCHRAUBUNG		
612	47 25 304 08	1	FLANGE JOINT EWSD18-L A3P	VERSCHRAUBUNG		
614	47 10 312 08	1	FLANGE JOINT XGE18-LR-ED A3P	VERSCHRAUBUNG		
615	47 24 315 08	2	FLANGE JOINT ETSD16-S A3P	VERSCHRAUBUNG		
616	47 25 313 08	3	FLANGE JOINT EWSD16-S A3P	VERSCHRAUBUNG		
618	47 54 331 08	1	FLANGE JOINT REDSD16/6-S A3P	VERSCHRAUBUNG		
619	47 56 015 08	2	MEASURING CONNECTION BMA3 6S	MESSANSCHLUSS		
620	47 00 327 08	10	FLANGE JOINT XG16-S A3P	VERSCHRAUBUNG		
621	47 19 007 08	1	FLANGE JOINT EGESD20-SR-WD A3P	VERSCHRAUBUNG		
623	47 54 357 08	2	FLANGE JOINT REDSDN28/12-L A3P	VERSCHRAUBUNG		
624	47 24 311 08	1	FLANGE JOINT ETSD42-L A3P	VERSCHRAUBUNG		
625	47 54 313 08	2	FLANGE JOINT REDSDN42/28-L A3P	VERSCHRAUBUNG		
626	47 00 308 08	6	FLANGE JOINT XG28-L A3P	VERSCHRAUBUNG		
627	47 56 034 08	4	MEASURING CONNECTION GMA3 38S CR6	MESSANSCHLUSS		
628	47 00 328 08	1	FLANGE JOINT XG20-S A3P	VERSCHRAUBUNG		
629	47 00 103 08	1	FLANGE JOINT SNV12-S A3P	VERSCHRAUBUNG		
633	47 00 113 08	2	FLANGE JOINT SNV12-L A3P	VERSCHRAUBUNG		
639	47 25 314 08	2	FLANGE JOINT EWSD20-S A3P	VERSCHRAUBUNG		
640	47 23 316 08	1	FLANGE JOINT ELSD20-S A3P	VERSCHRAUBUNG		
641	47 54 348 08	1	FLANGE JOINT REDSD20/12-S A3P	VERSCHRAUBUNG		
643	47 10 313 08	2	FLANGE JOINT XGE22-LM-ED A3P	VERSCHRAUBUNG		
644	47 77 051 08	2	PLUG VSTIM18X1,5ED A3P	STOPFEN		
645	47 19 020 08	2	FLANGE JOINT EGESD6-LM-WD A3P	VERSCHRAUBUNG		
646	47 50 303 08	2	FLANGE JOINT GR 15/6L CR6-FREI	VERSCHRAUBUNG		
647	47 20 323 08	3	FLANGE JOINT ELSD6-L A3P	VERSCHRAUBUNG		
648	47 56 014 08	2	MEASURING CONNECTION BMA3 6L	MESSANSCHLUSS		
649	47 24 307 08	2	FLANGE JOINT ETSD28-L A3P	VERSCHRAUBUNG		
650	47 04 330 08	4	FLANGE JOINT XT38-S A3P	VERSCHRAUBUNG		
651	47 04 308 08	2	FLANGE JOINT XT28-L A3P	VERSCHRAUBUNG		
652	47 04 325 08	2	FLANGE JOINT T 16S CR6-FREI	VERSCHRAUBUNG		
653	47 50 318 08	3	FLANGE JOINT XGR28/22-L A3P	VERSCHRAUBUNG		
655	47 32 305 08	1	FLANGE JOINT RSWS10-LR-WD A3P	VERSCHRAUBUNG		
656	47 10 334 08	3	FLANGE JOINT XGE20-SR-ED A3P	VERSCHRAUBUNG		
657	47 10 331 08	6	FLANGE JOINT XGE16-SR-ED3/4" A3P	VERSCHRAUBUNG		
658	47 19 019 08	2	FLANGE JOINT EGESD16-SR-WD A3P	VERSCHRAUBUNG		
659	47 54 361 08	1	FLANGE JOINT REDSD22/12-L A3P	VERSCHRAUBUNG		
661	47 00 310 08	1	FLANGE JOINT XG6-S A3P	VERSCHRAUBUNG		
663	47 10 321 08	1	FLANGE JOINT XGE6-SR-ED A3P	VERSCHRAUBUNG		
664	47 77 040 08	1	STOPPER PLUG VST11/4"ED A3P	BLINDSTOPFEN		
665	47 23 306 08	1	FLANGE JOINT ELSD22-L A3P	VERSCHRAUBUNG		
666	47 33 002 08	1	FLANGE JOINT RSWS22-LR-WD A3P	VERSCHRAUBUNG		
674	47 54 305 08	2	FLANGE JOINT REDSD28/22-L A3P	VERSCHRAUBUNG		
675	47 00 108 08	2	FLANGE JOINT SNV16-S A3P	VERSCHRAUBUNG		
676	47 02 326 08	2	FLANGE JOINT XW16-S A3P	VERSCHRAUBUNG		
677	47 40 326 08	4	FLANGE JOINT XSV16-S A3P	VERSCHRAUBUNG		
678	47 02 307 08	1	FLANGE JOINT XW22-L A3P	VERSCHRAUBUNG		
679	47 25 309 08	1	FLANGE JOINT EWSD35-L A3P	VERSCHRAUBUNG		

6.2.2009

etk_en_de_074515 LR 1600/2

61 (8/8)

LIEBHERRCRAWLER TRACK HYDRAULIC
HYDRAULIK RAUPE

⇒ 1 970

91 56 958 08

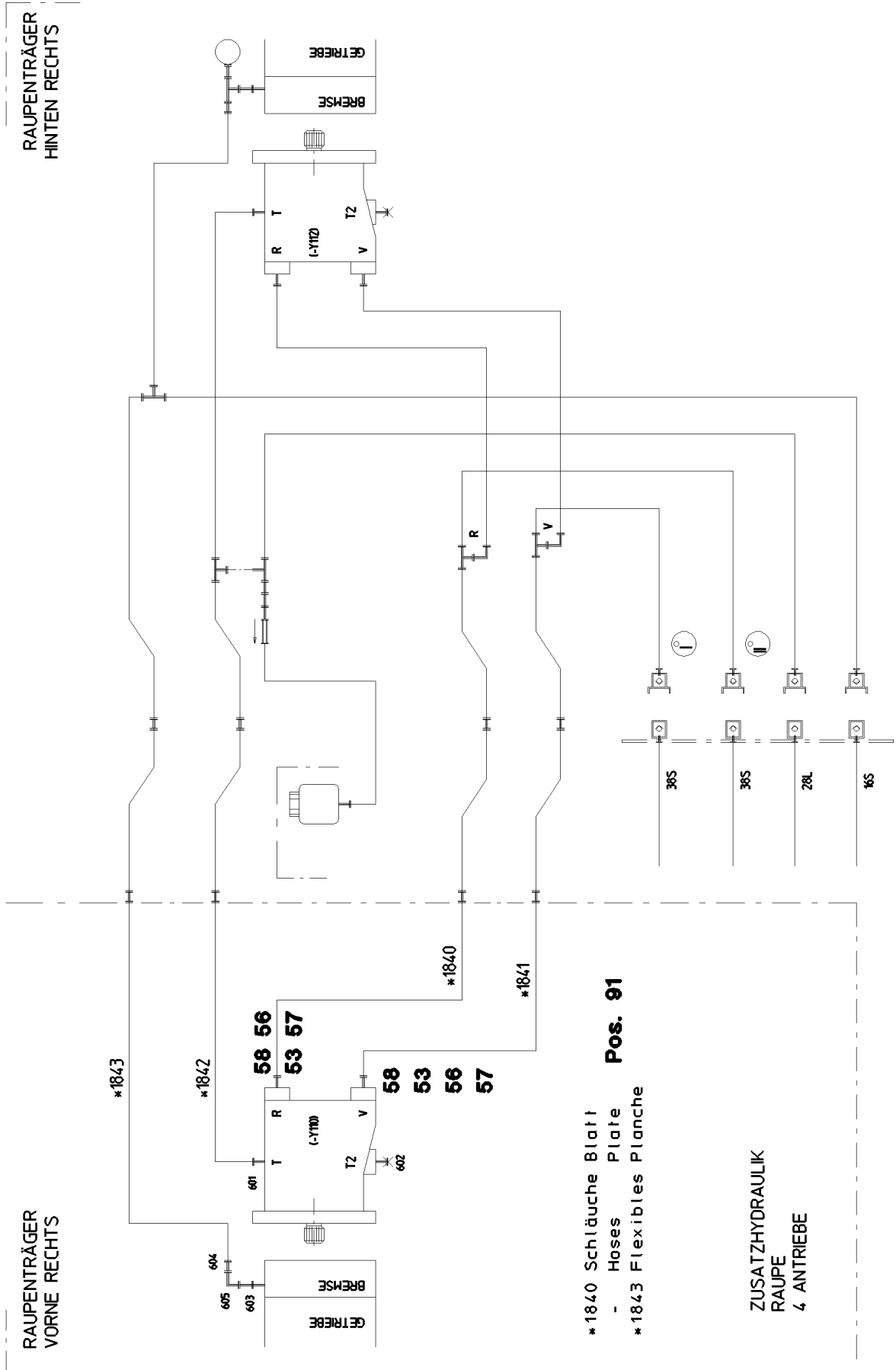

RAUPENTRÄGER
HINTEN RECHTS

RAUPENTRÄGER
VORNE RECHTS

Pos. 91

- *1840 Schläuche Blatt
- Hoses Plate
- *1843 Flexibles Plancher

ZUSATZHYDRAULIK
RAUPE
4 ANTRIEBE

6.2.2009
052499



etk_en_de_074515 LR 1600/2

AUX.HYDR.CR.TRACK CARR.4 MOUNT
ZUSATZHYDR.RAUPENTRAEGER 4 AN.

62 (1/2)

⇒ 1 970 161
96 50 706 08

Pos.	Item	Quantity	Description	Bezeichnung	Serie	K
53	51 05 867 08	4	O-RING ARP 568 37,69X3,53 NBR90	O-RING		
56	40 42 152 08	8	CYLINDER SCREW DIN 912 M14X45 8.8 A3C	ZYLINDERSCHRAUBE		
57	40 65 145 01	8	HEX BOLT ISO 4017 M14X45 8.8 A3C	SECHSKANTSCHRAUBE		
58	51 05 866 08	8	FLANGE HALF A3P	FLANSCHHAELFTE		
91	96 50 707 08	1	HOSES CRAWLER 4 DRIVES ZUSATZ- SCHL ⇒ 1 976 050 96 50 707 08	SCHLAUCHLEITUNGEN RAUPE		
601	47 10 313 08	2	FLANGE JOINT XGE22-LM-ED A3P	VERSCHRAUBUNG		
602	47 77 051 08	2	PLUG VSTIM18X1,5ED A3P	STOPFEN		
603	47 19 020 08	2	FLANGE JOINT EGESD6-LM-WD A3P	VERSCHRAUBUNG		
604	47 50 303 08	3	FLANGE JOINT GR 15/6L CR6-FREI	VERSCHRAUBUNG		
605	47 25 300 08	2	FLANGE JOINT EWSD6-L A3P	VERSCHRAUBUNG		

6.2.2009

etk_en_de_074515 LR 1600/2

63 (2/2)

LIEBHERR

AUX.HYDR.CR.TRACK CARR.4 MOUNT
ZUSATZHYDR.RAUPENTRAEGER 4 AN.

⇒ 1 970 161
96 50 706 08

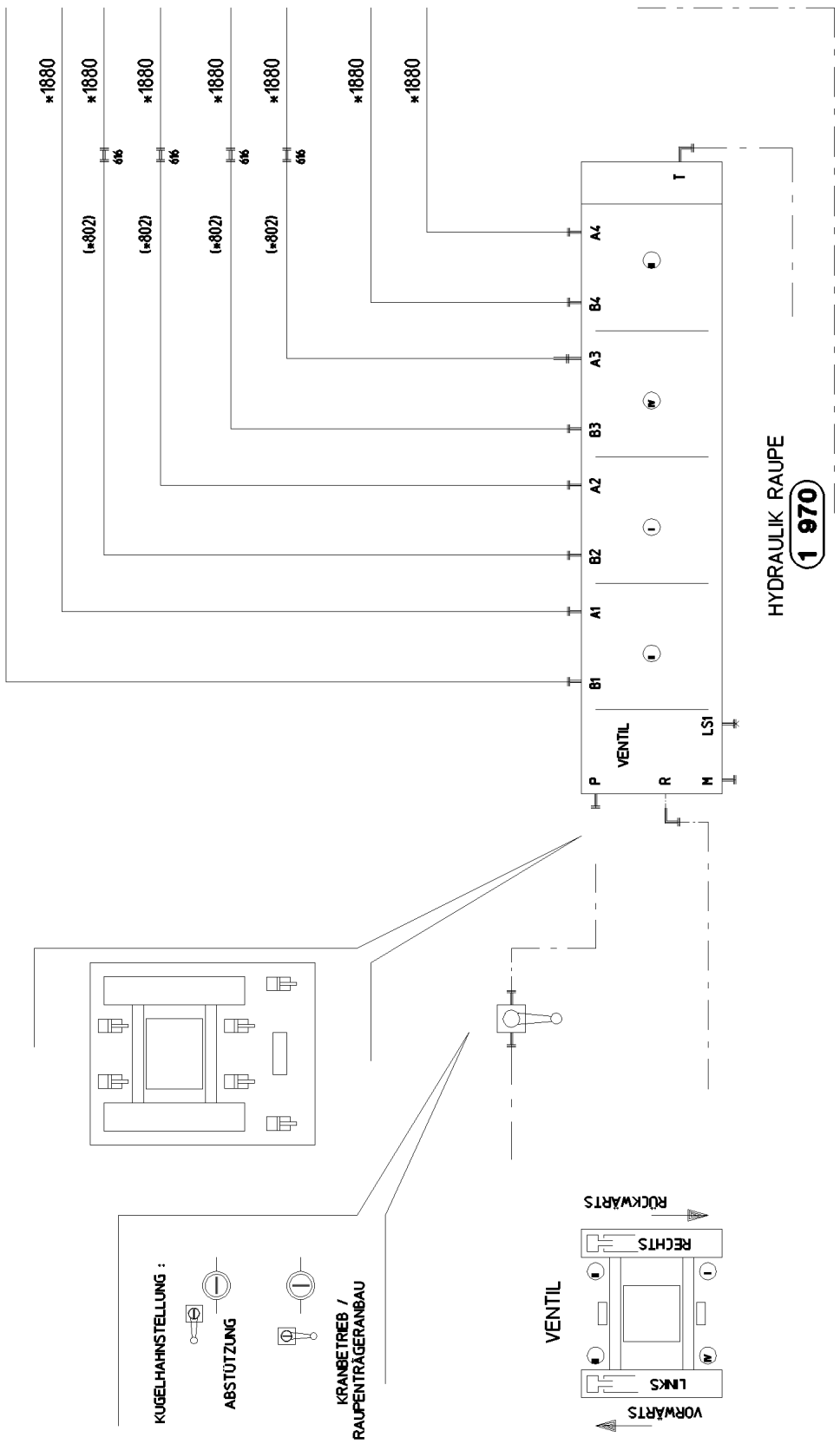

6.2.2009
052807

LIEBHERR

etk_en_de_074515 LR 1600/2

ADD. HYDR. SUPPORTING RAM
ZUSATZHYDR.ABSTUETZZYLINDER

64 (1/3)

⇒ 1 975 006
91 52 509 08

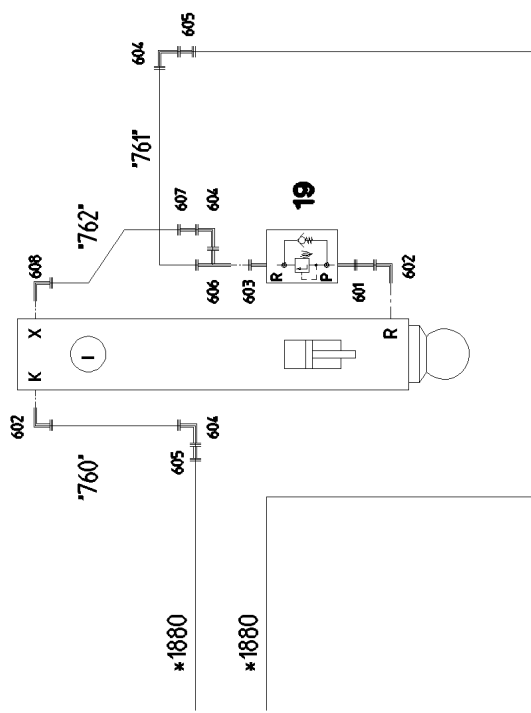

*1880

*1880

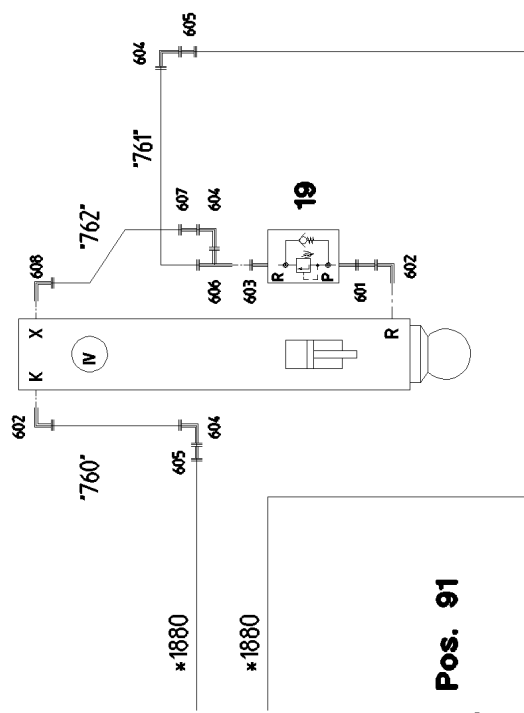

*1880

*1880

Pos. 91
 *1880 Schläuche Blatt
 Hoses
 Plate
 Flexibles Planché

Pos. 93
 *760" Rohre
 - Pipes
 *762" Tuyaux
 Blatt
 Plate
 Planché

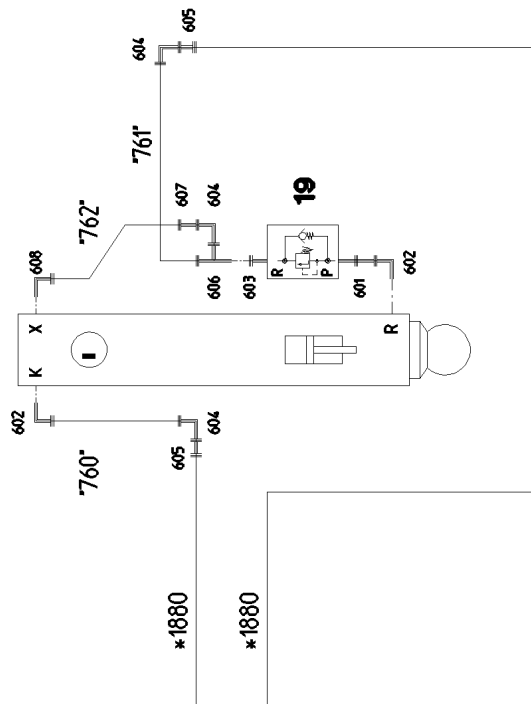

*1880

*1880

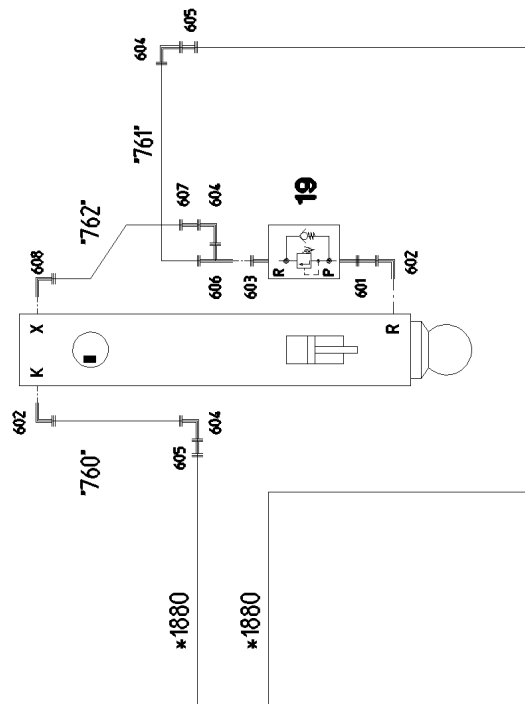

*1880

*1880

6.2.2009
 052808

LIEBHERR

etk_en_de_074515 LR 1600/2

ADD. HYDR. SUPPORTING RAM
 ZUSATZHYDR.ABSTUETZZYLINDER

65 (2/3)

⇒ 1 975 006
 91 52 509 08

Pos.	Item	Quantity	Description	Bezeichnung	Serie	K
19	10 46 788 6	4	PRETENSIONING VALVE 30BAR 40L/MIN SP	VORSPANNVENTIL		
91	96 47 504 08	1	HOSE LINES SUPPORTING RAM	SCHLAUCHLEITUNGEN ABSTUE		
(1)	60 27 603 08	8	NAME PLATE 25,4X165,1	BEZEICHNUNGSSCHILD		
(1880)	92 87 562 08	8	HOSE ASS CPL. 2755 3,8M	SCHLAUCH KPL.		
93	96 47 505 08	1	PIPELINES SUPPORTING RAM	ROHRLEITUNGEN ABSTUETZZY		
(760)	96 48 896 08	4	PIPE COMPL. 12X1,5X622	ROHR KPL.		
(761)	96 48 897 08	4	PIPE COMPL. 12X1,5X103	ROHR KPL.		
(762)	96 48 898 08	4	PIPE COMPL. 6X1X773	ROHR KPL.		
601	47 19 018 08	4	FLANGE JOINT EGE 12S G1/2A CR6-FREI	VERSCHRAUBUNG		
602	47 66 115 08	8	FLANGE JOINT RSWS12-SR-WD A3P	VERSCHRAUBUNG		
603	47 10 326 08	4	FLANGE JOINT GE 12S G1/2A CR6-FREI	VERSCHRAUBUNG		
604	47 25 312 08	12	FLANGE JOINT EWSD12-S A3P	VERSCHRAUBUNG		
605	47 50 325 08	8	FLANGE JOINT XGR16/12-S A3P	VERSCHRAUBUNG		
606	47 23 314 08	4	FLANGE JOINT ELSD12-S A3P	VERSCHRAUBUNG		
607	47 54 329 08	4	FLANGE JOINT REDSD12/6-S A3P	VERSCHRAUBUNG		
608	47 32 306 08	4	FLANGE JOINT RSWS6-SR-WD A3P	VERSCHRAUBUNG		
616	47 40 326 08	4	FLANGE JOINT XSV16-S A3P	VERSCHRAUBUNG		

6.2.2009

etk_en_de_074515 LR 1600/2

66 (3/3)

LIEBHERR

ADD. HYDR. SUPPORTING RAM
ZUSATZHYDR.ABSTUETZZYLINDER

⇒ 1 975 006
91 52 509 08



Schlauchnummer
Hose number
Numéro de flexible
Número de flexible
Номера шланга

Die Schlauchnummern auf den Schläuchen entsprechen den Positionen in der Schlauchliste.

The hose numbers from the hoses are in accordance with the items in the hose list.

Les numéros indiqués sur les flexibles correspondent aux repères de la nomenclature des flexibles.

Los números indicados en los flexibles corresponden a las posiciones de la lista de flexibles.

Нанесенные на шлангах номера соответствуют позициям в перечне.

Pos.	Item	Quantity	Description	Bezeichnung	Serie	K
1	60 27 601 08	2	NAME PLATE 25,4X101,6	BEZEICHNUNGSSCHILD		
2	60 27 603 08	6	NAME PLATE 25,4X165,1	BEZEICHNUNGSSCHILD		
1840	96 49 551 08	2	HOSE ASS CPL. GH466 1,8M	SCHLAUCH KPL.		
1841	96 49 553 08	2	HOSE ASS CPL. GH466 2,0M	SCHLAUCH KPL.		
1842	92 93 167 08	2	HOSE ASS CPL. 2TE 2,6M	SCHLAUCH KPL.		
1843	92 71 131 08	2	HOSE ASS CPL. 2TE 2,8M	SCHLAUCH KPL.		

6.2.2009
133089

LIEBHERR

etk_en_de_074515 LR 1600/2

HOSES CRAWLER 4 DRIVES
SCHLAUCHLEITUNGEN RAUPE 4.ANTR

67

⇒ 1 976 050
96 50 707 08

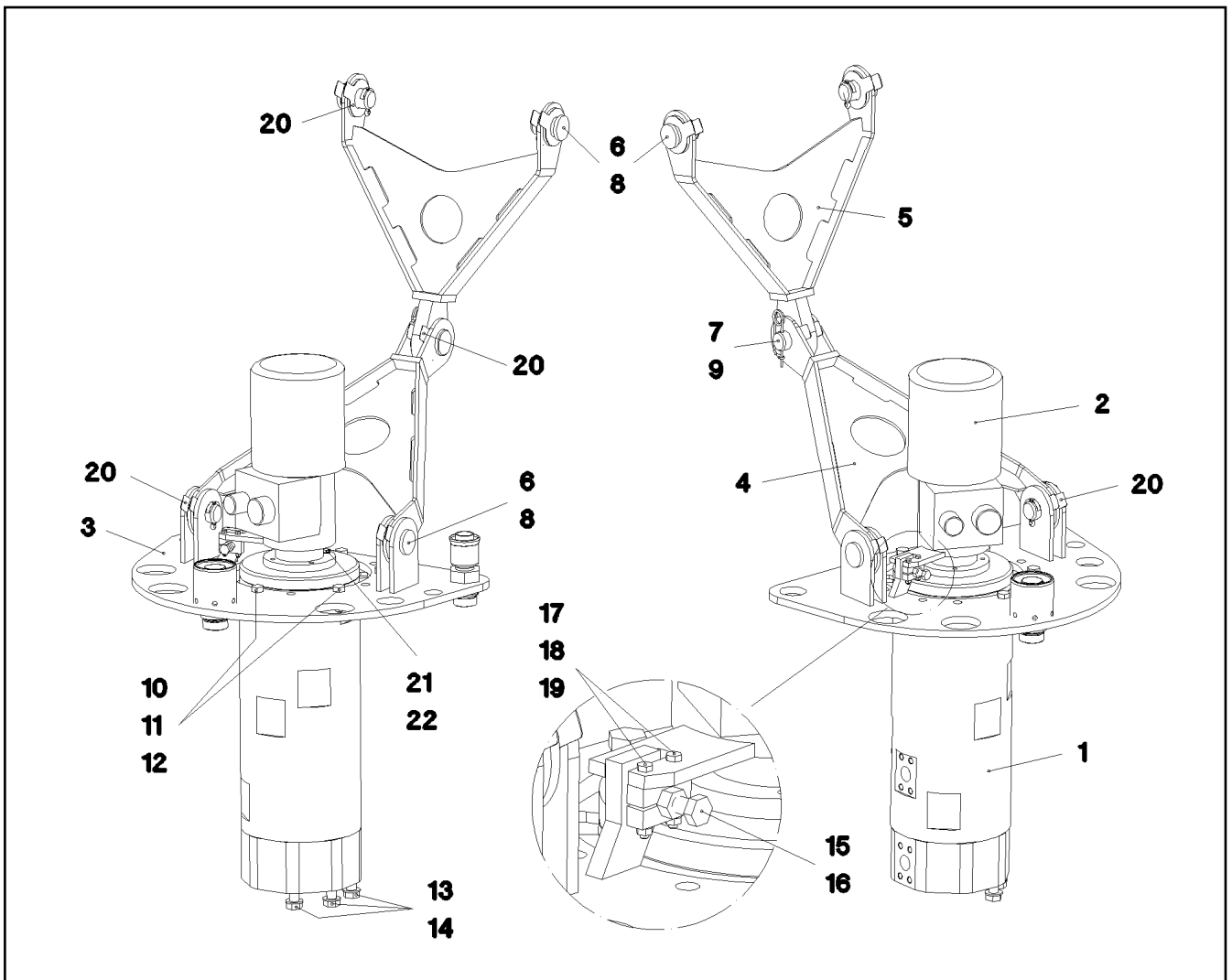

Pos.	Item	Quantity	Description	Bezeichnung	Serie	K
1	10 04 262 0	1	ROTARY FEED THROUGH SPF	DREHDURCHFUEHRUNG		
2	92 15 300 08	1	INSTALLAT. ROTOR+SLIPRING ASSY. ⇒ 1 920 305 92 15 300 08	EINBAU SCHLEIFRINGKOEERPE		
3	92 90 527 08	1	ACTUATOR WELDED	MITNEHMER SCHWK.		
4	96 17 270 08	1	DRAWBAR WELDED	DEICHSEL SCHWK.		
5	92 51 224 08	1	DRAWBAR WELDED	DEICHSEL SCHWK.		
6	45 12 372 08	4	PIN DIN 1435 40H11X60X50 ST.50-2K VERZ	BOLZEN		
7	45 12 375 08	1	PIN DIN 1435 40D10X80X68 ST.50-2K VERZ	BOLZEN		
8	43 30 090 08	4	SPLIT PIN DIN 94 8X63 ST VERZ	SPLINT		
9	43 31 012 08	1	RETAINING SPRING 4X68 VERZ	SICHERUNGSFEDER		
10	46 00 016	6	HEX BOLT ISO 4017 M16X45 8.8 A3C	SECHSKANTSCHRAUBE		
11	41 15 145 08	6	HEX NUT DIN 934 M16 8 VERZ	SECHSKANTMUTTER		
12	42 00 019 08	6	WASHER DIN 125 A 17 VERZ	SCHEIBE		
13	46 00 020	8	HEX BOLT ISO 4017 M20X45 8.8 A3C	SECHSKANTSCHRAUBE		
14	42 00 021 08	8	WASHER ISO 7089 A 21 ST A3C	SCHEIBE		
15	46 00 158	1	HEX BOLT ISO 4017 M12X45 8.8 A3C	SECHSKANTSCHRAUBE		
16	41 15 143 08	1	HEX NUT DIN 934 M12 8 VERZ	SECHSKANTMUTTER		
17	46 00 532	2	HEX BOLT ISO 4017 M6X50 8.8 A2C	SECHSKANTSCHRAUBE		
18	41 15 140 08	2	HEX NUT DIN 934 M6 8 VERZ	SECHSKANTMUTTER		
19	42 00 009 08	2	WASHER ISO 7089 A 6.4 VERZ	SCHEIBE		
20	97 09 048 08	10	PLATE 1X80X110	BLECH		
21	49 00 128	4	HEX BOLT ISO 4017 M8X25 8.8 A2C	SECHSKANTSCHRAUBE		
22	42 00 012 08	4	WASHER DIN 125 A8X16 ST VERZ	SCHEIBE		

6.2.2009
052381

LIEBHERR

etk_en_de_074515 LR 1600/2

ROTARY FEED THROUGH
DREHDURCHFUEHRUNG

68

⇒ 1 991
91 52 510 08

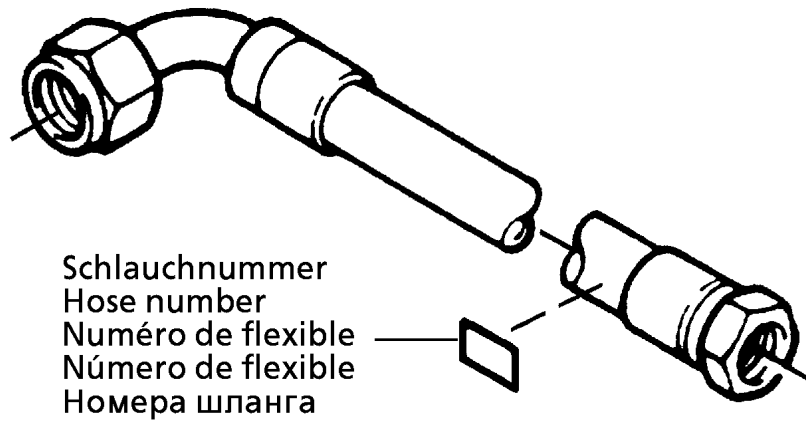

Die Schlauchnummern auf den Schläuchen entsprechen den Positionen in der Schlauchliste.

The hose numbers from the hoses are in accordance with the items in the hose list.

Les numéros indiqués sur les flexibles correspondent aux repères de la nomenclature des flexibles.

Los números indicados en los flexibles corresponden a las posiciones de la lista de flexibles.

Нанесенные на шлангах номера соответствуют позициям в перечне.

Pos.	Item	Quantity	Description	Bezeichnung	Serie	K
1	60 27 601 08	15	NAME PLATE 25,4X101,6	BEZEICHNUNGSSCHILD		
2	60 27 603 08	33	NAME PLATE 25,4X165,1	BEZEICHNUNGSSCHILD		
740	92 93 381 08	1	HOSE ASS CPL. 1SN 1,55M	SCHLAUCH KPL.		
741	96 52 049 08	1	HOSE ASS CPL. GH466 0,88M	SCHLAUCH KPL.		
742	96 36 000 08	1	HOSE ASS CPL. GH466 1,75M	SCHLAUCH KPL.		
743	96 52 049 08	1	HOSE ASS CPL. GH466 0,88M	SCHLAUCH KPL.		
744	96 49 545 08	1	HOSE ASS CPL. GH466 1,85M	SCHLAUCH KPL.		
745	92 87 505 08	1	HOSE ASS CPL. 2TE 0,48M	SCHLAUCH KPL.		
746	92 40 956 08	1	HOSE ASS CPL. 2755 1,3M	SCHLAUCH KPL.		
747	92 15 736 08	1	HOSE ASS CPL. 1SN 0,2M	SCHLAUCH KPL.		
802	96 20 654 08	4	HOSE ASS CPL. 2755 3,4M	SCHLAUCH KPL.		
803	92 76 977 08	1	HOSE ASS CPL. 2TE 1,3M	SCHLAUCH KPL.		
804	92 60 465 08	1	HOSE ASS CPL. 2TE 1,3M	SCHLAUCH KPL.		
805	96 49 535 08	1	HOSE ASS CPL. 2TE 0,4M	SCHLAUCH KPL.		
806	92 76 750 08	1	HOSE ASS CPL. 2TE 1,85M	SCHLAUCH KPL.		
807	92 63 791 08	1	HOSE ASS CPL. 1SC 0,96M	SCHLAUCH KPL.		
808	92 96 106 08	1	HOSE ASS CPL. 2TE 0,52M	SCHLAUCH KPL.		
809	92 66 115 08	1	HOSE ASS CPL. 1SN 2,1M	SCHLAUCH KPL.		
812	92 18 746 08	1	HOSE ASS CPL. 2755 2,2M	SCHLAUCH KPL.		
813	92 97 467 08	2	HOSE ASS CPL. 1SN 1,0M	SCHLAUCH KPL.		
814	96 49 546 08	1	HOSE ASS CPL. GH466 1,0M	SCHLAUCH KPL.		
815	96 49 547 08	1	HOSE ASS CPL. GH466 1,36M	SCHLAUCH KPL.		
816	96 44 763 08	1	HOSE ASS CPL. GH466 0,78M	SCHLAUCH KPL.		
817	96 49 548 08	1	HOSE ASS CPL. GH466 1,12M	SCHLAUCH KPL.		
830	96 49 549 08	2	HOSE ASS CPL. GH466 1,5M	SCHLAUCH KPL.		
831	96 49 550 08	2	HOSE ASS CPL. GH466 1,7M	SCHLAUCH KPL.		
832	92 61 222 08	2	HOSE ASS CPL. 2TE 2,15M	SCHLAUCH KPL.		
833	96 49 541 08	2	HOSE ASS CPL. 2TE 2,5M	SCHLAUCH KPL.		
834	96 17 203 08	2	HOSE ASS CPL. 2TE 0,86M	SCHLAUCH KPL.		
835	96 39 243 08	2	HOSE ASS CPL. GH466 2,05M	SCHLAUCH KPL.		
836	96 31 973 08	2	HOSE ASS CPL. GH466 2,35M	SCHLAUCH KPL.		
837	92 75 709 08	2	HOSE ASS CPL. 1SN 2,6M	SCHLAUCH KPL.		
838	96 32 001 08	2	HOSE ASS CPL. 2SN 2,65M	SCHLAUCH KPL.		
870	92 09 034 08	2	HOSE ASS CPL. HPC 5,9M	SCHLAUCH KPL.		
871	92 93 211 08	2	HOSE ASS CPL. HPC 2,5M	SCHLAUCH KPL.		

6.2.2009

etk_en_de_074515 LR 1600/2

70 (2/2)

LIEBHERR

HOSE LINES CRAWLER
SCHLAUCHLEITUNGEN RAUPE

⇒ 1 997
91 52 512 08

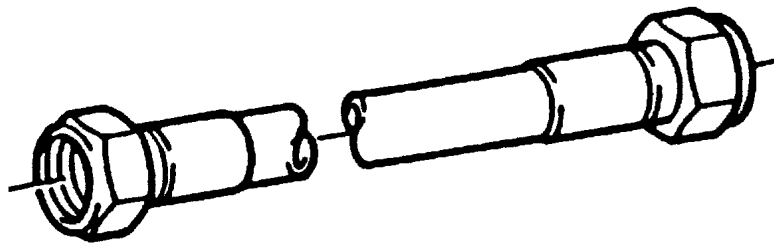

Die Positionsnummern der Rohre auf den Bildtafeln entsprechen den Positionen in der Rohrliste.

The pipe numbers from the illustrations are in accordance with the items in the pipe list.

Les numéros des tuyaux sur les illustrations correspondent aux repères de la nomenclature des tuyaux.

Los números de tubos en las ilustraciones corresponden a las posiciones de la lista de tubos.

Номера позиций труб на изображениях соответствуют позициям в перечне труб.

Pos.	Item	Quantity	Description	Bezeichnung	Serie	K
700	96 48 922 08	2	PIPE COMPL. 38X4X1049	ROHR KPL.		
701	96 48 923 08	2	PIPE COMPL. 38X4X2779	ROHR KPL.		
702	96 48 924 08	2	PIPE COMPL. 38X4X1050	ROHR KPL.		
703	96 48 925 08	2	PIPE COMPL. 38X4X2783	ROHR KPL.		
704	96 48 926 08	2	PIPE COMPL. 28X2X946	ROHR KPL.		
705	96 48 927 08	2	PIPE COMPL. 28X2X2882	ROHR KPL.		
706	96 48 931 08	2	PIPE COMPL. 16X2X1058	ROHR KPL.		
707	96 48 932 08	2	PIPE COMPL. 16X2X2894	ROHR KPL.		
708	96 48 933 08	1	PIPE COMPL. 6X1X216	ROHR KPL.		
709	96 48 934 08	1	PIPE COMPL. 20X2,5X302	ROHR KPL.		
710	96 48 935 08	1	PIPE COMPL. 20X2,5X1072	ROHR KPL.		
711	96 48 936 08	1	PIPE COMPL. 12X1,5X596	ROHR KPL.		
713	96 48 938 08	1	PIPE COMPL. 22X2,5X904	ROHR KPL.		
714	96 48 939 08	1	PIPE COMPL. 12X1,5X451	ROHR KPL.		
730	96 48 907 08	2	PIPE COMPL. 38X4X2447	ROHR KPL.		
731	96 48 908 08	2	PIPE COMPL. 38X4X2224	ROHR KPL.		
732	96 48 909 08	2	PIPE COMPL. 38X4X2035	ROHR KPL.		
733	96 48 910 08	2	PIPE COMPL. 38X4X2308	ROHR KPL.		
734	96 48 911 08	2	PIPE COMPL. 28X2X2256	ROHR KPL.		
735	96 48 912 08	2	PIPE COMPL. 28X2X2015	ROHR KPL.		
736	96 48 913 08	2	PIPE COMPL. 16X2X2014	ROHR KPL.		
737	96 48 914 08	2	PIPE COMPL. 16X2X2265	ROHR KPL.		

6.2.2009
133088

LIEBHERR

etk_en_de_074515 LR 1600/2

PIPELINES CRAWLER TYPE UNDERC.
ROHRLEITUNGEN RAUPE

71

⇒ 1 998
91 52 513 08

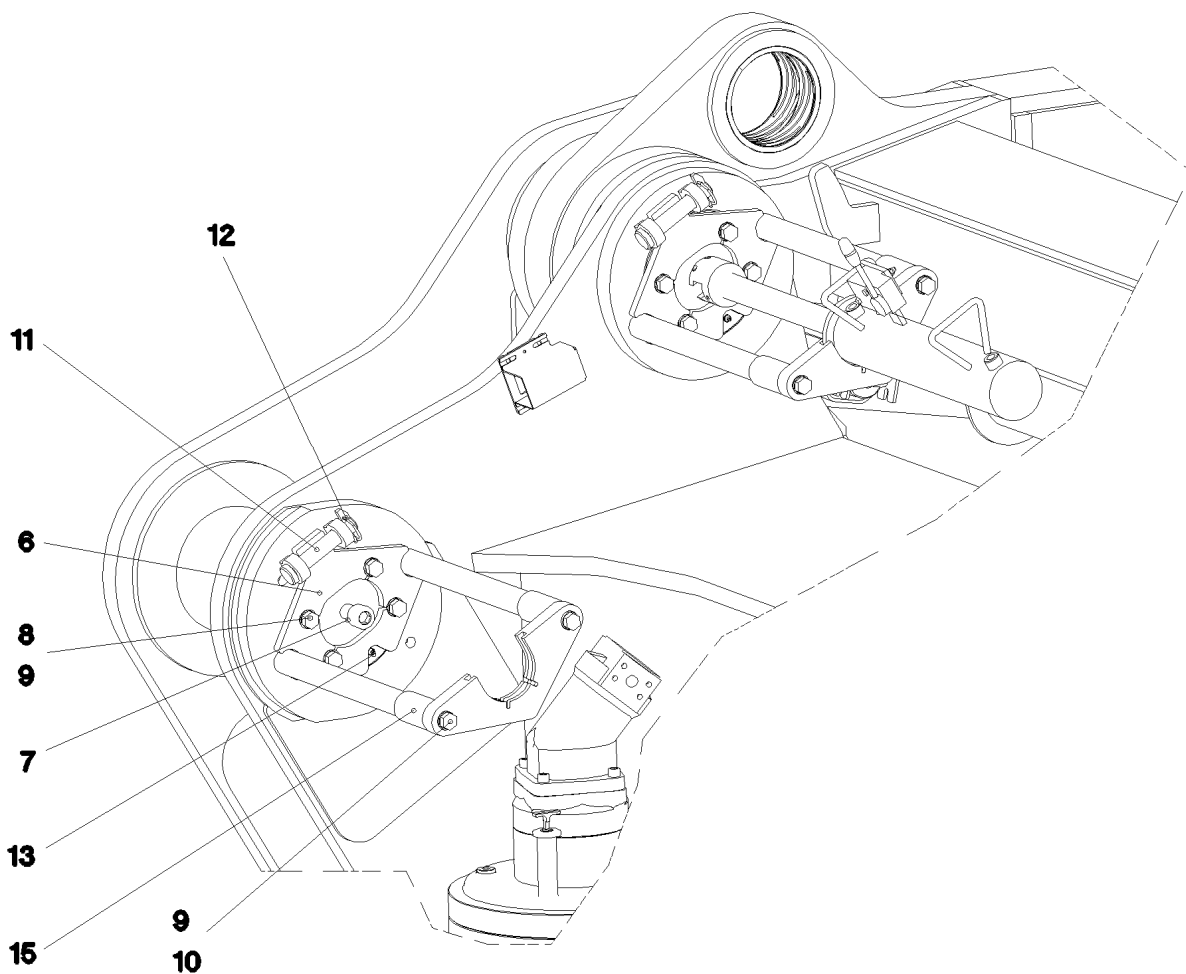
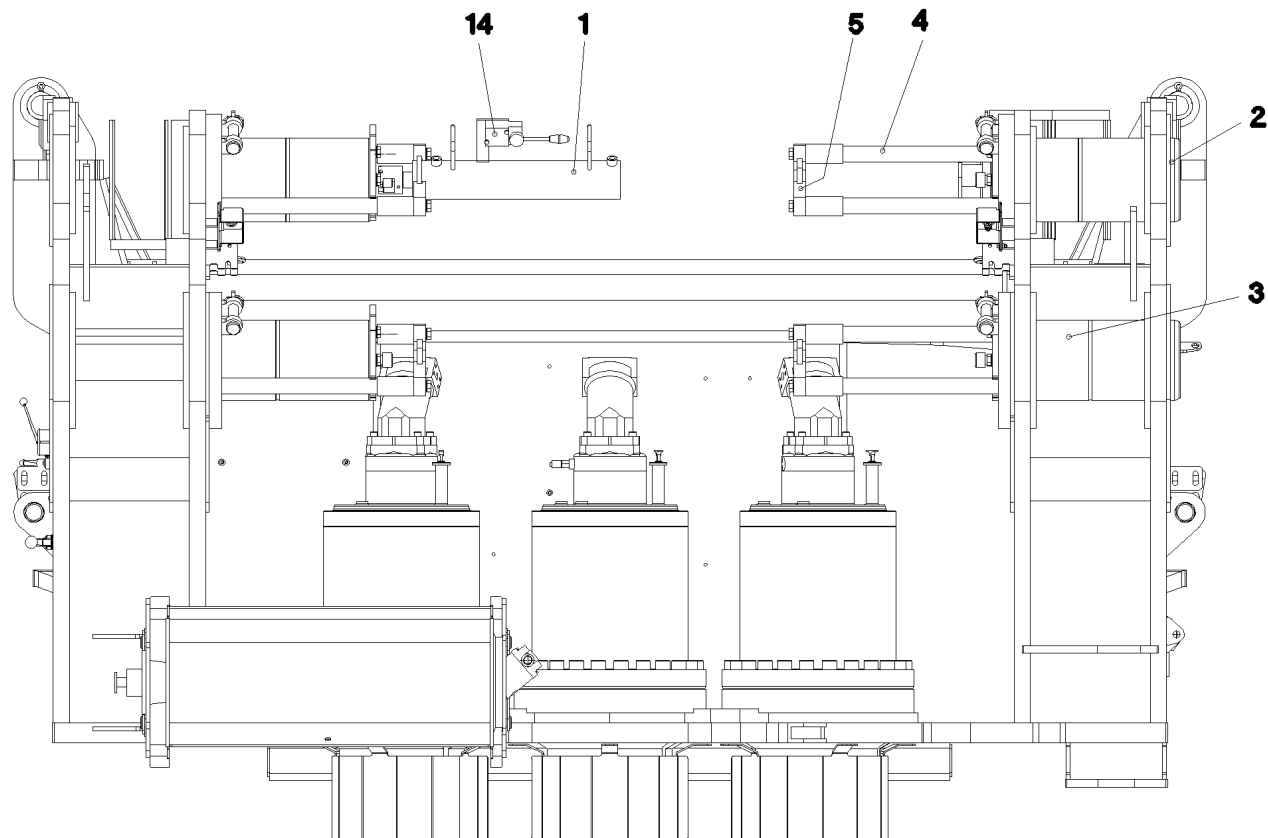

6.2.2009
052619

LIEBHERR

etk_en_de_074515 LR 1600/2

PIN F.S-PIVOT SECTION SA FRAME
BOLZEN S-ANLENKST. UND SA-BOCK

72 (1/2)

⇒ 2 125
91 52 773 08

Pos.	Item	Quantity	Description	Bezeichnung	Serie	K
1	10 41 102 2	1	HYDRO CYLINDER 80/40-400 SPF	HYDROZYLINDER		
2	97 73 402 08	2	PIN 220.0X455 SPF	BOLZEN		
3	97 73 403 08	2	PIN 220.0X455 SPF	BOLZEN		
4	97 73 406 08	8	THREADED BOLT 40.0X505	GEWINDEBOLZEN		
5	97 73 409 08	4	PLATE 30X310X119	BLECH		
6	97 73 410 08	4	PLATE 15X257X235	BLECH		
7	40 42 143 05	4	CYLINDER SCREW ISO 4762 M24X60 8.8 A3	ZYLINDERSCHRAUBE		
8	49 00 153	16	HEX BOLT ISO 4017 M16X40 8.8 A3C	SECHSKANTSCHRAUBE		
9	42 00 019 08	24	WASHER DIN 125 A 17 VERZ	SCHEIBE		
10	46 00 206	8	HEX BOLT ISO 4017 M16X60 8.8 A3C	SECHSKANTSCHRAUBE		
11	97 10 780 08	4	PIN 35.0X14 0 30CRNIMO8+QT	BOLZEN		
12	43 32 002 08	4	HINGED CONNECTOR DIN 11023 6X42 VER	KLAPPSTECKER		
13	77 43 040 08	4	GREASE NIPPLE DIN 71412 A M10X1	SCHMIERNIPPEL		
14	96 50 495 08	1	ADDL.HYDR.F.PIN PULLING DEVICE ⇒ 2 970 081 96 50 495 08	ZUSATZHYDR.BOLZENZIEHZYL		
15	97 78 986 08	8	TUBE 48.3X92	ROHR		

6.2.2009

etk_en_de_074515 LR 1600/2

73 (2/2)

LIEBHERR

PIN F.S-PIVOT SECTION SA FRAME
BOLZEN S-ANLENKST. UND SA-BOCK

⇒ 2 125
91 52 773 08

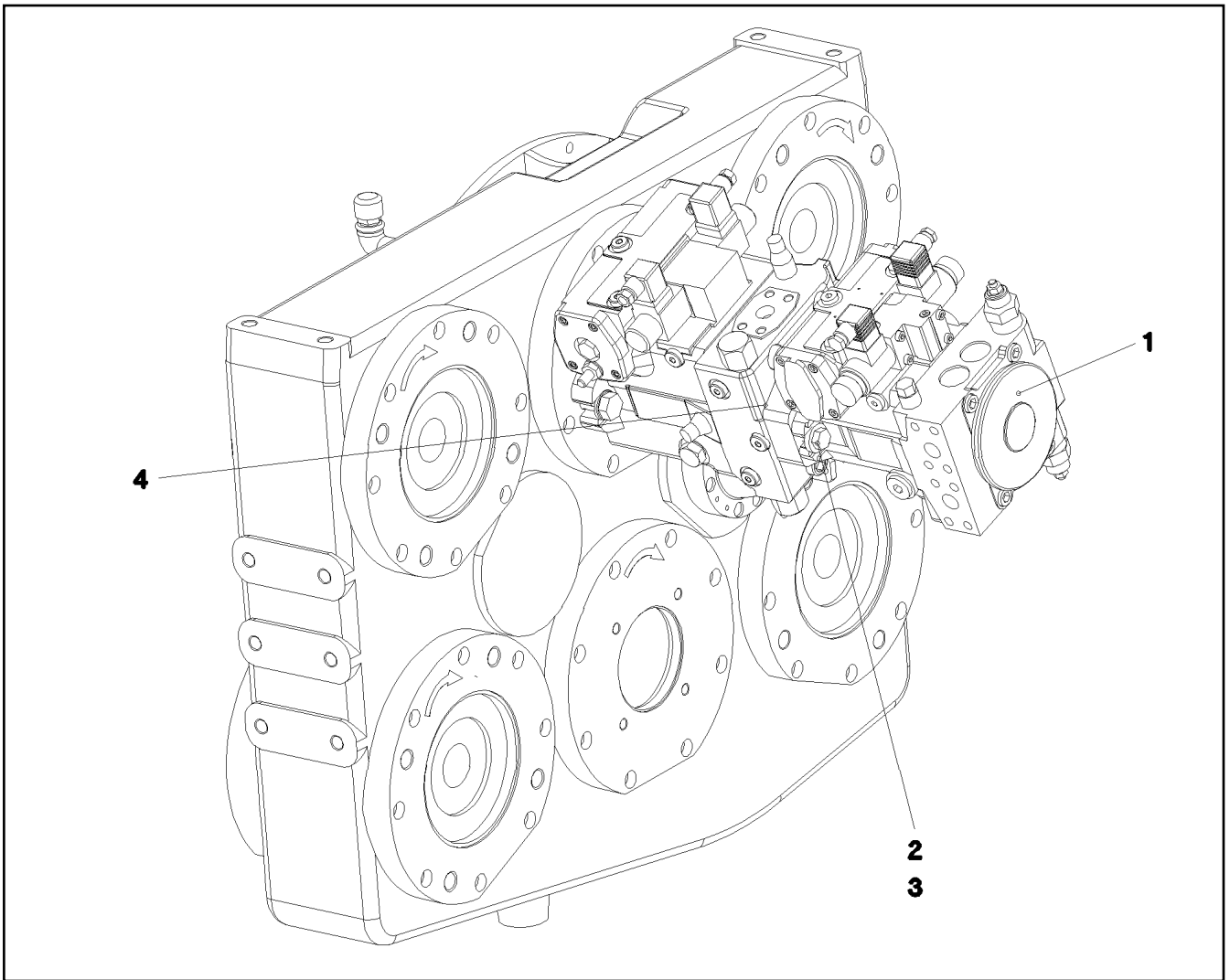

Pos.	Item	Quantity	Description	Bezeichnung	Serie	K
1	10 35 924 9	1	VARIABLE PUMP A4VG/28 LI SPF ⇒ X10359249 10 35 924 9	VERSTELLPUMPE		
2	49 00 204	2	HEX BOLT ISO 4017 M12X35 8.8 A3C	SECHSKANTSCHRAUBE		
3	42 16 007 08	2	WASHER DIN 7349 13 ST VERZ	SCHEIBE		
4	57 19 055 08	1	HUB	NABE		

6.2.2009
052618

LIEBHERR

etk_en_de_074515 LR 1600/2

PUMP F.SLEWING GEAR
PUMPE F.DREHWERK

74

⇒ 2 212
91 54 561 08

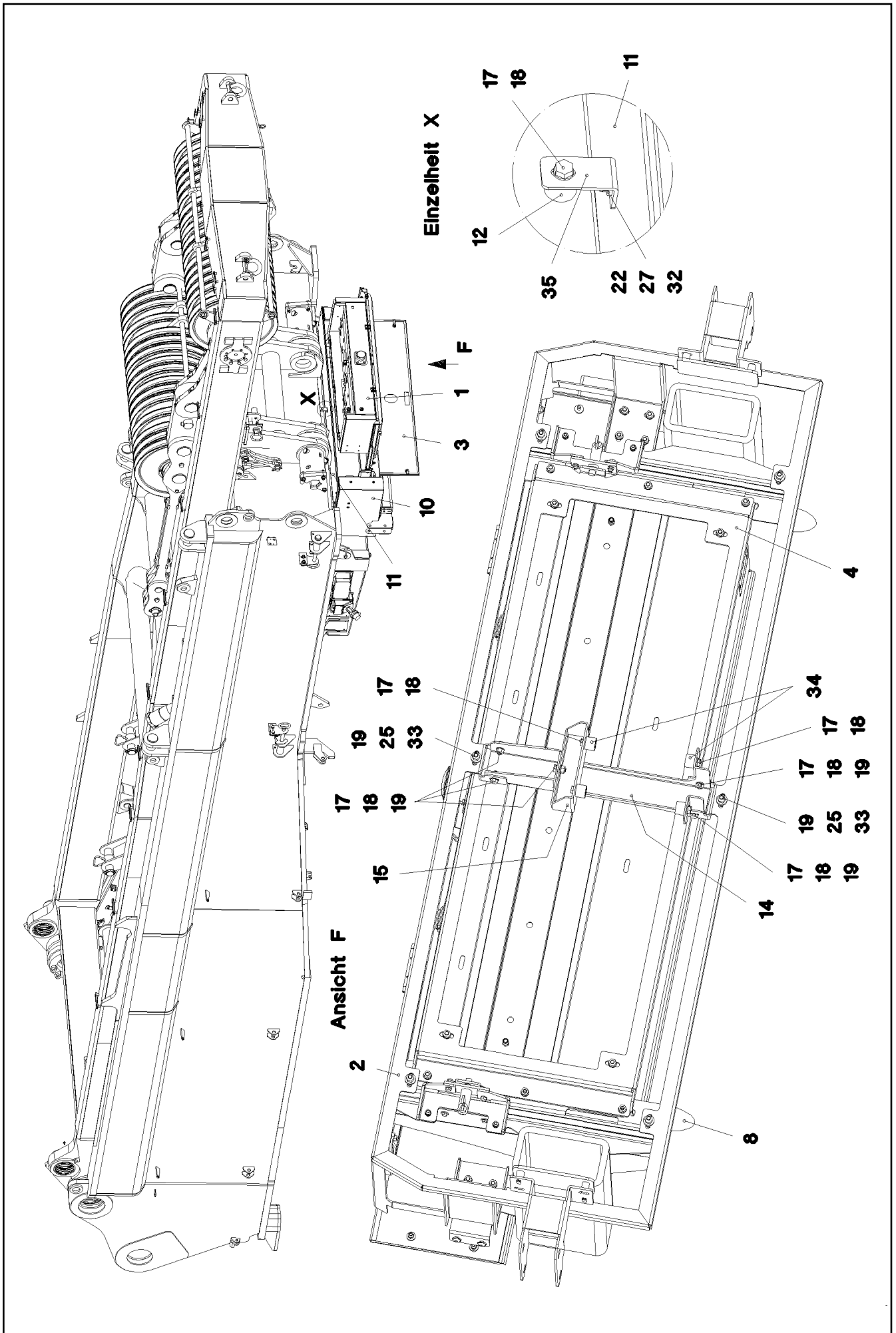

6.2.2009
052386

LIEBHERR

etk_en_de_074515 LR 1600/2

CUP SPRING CLUSTER
BATTERIELAGERUNG

☐ 75 (1/3)

⇒ 2 260
91 53 057 08

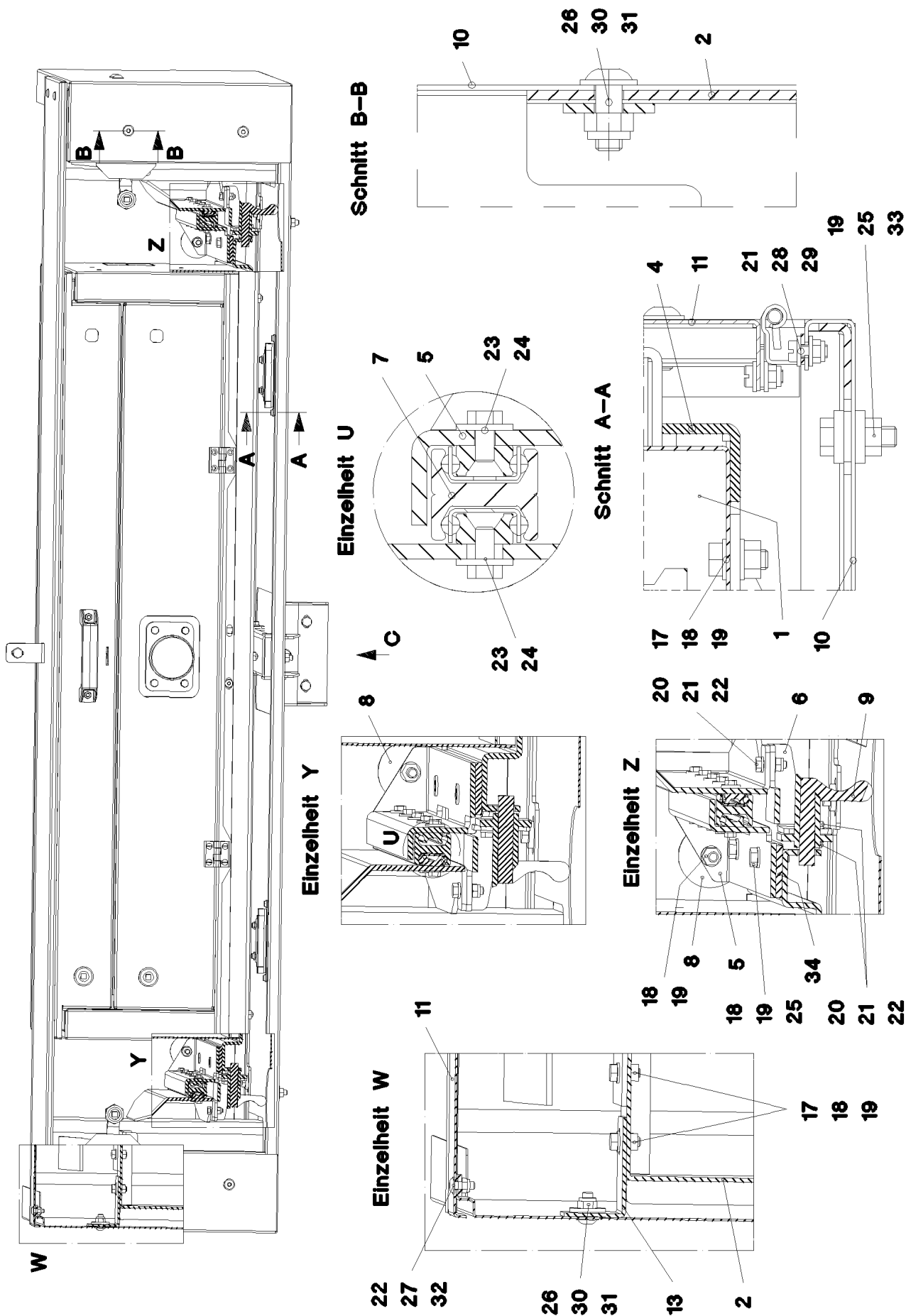

6.2.2009
052387

LIEBHERR

etk_en_de_074515 LR 1600/2

CUP SPRING CLUSTER
BATTERIELAGERUNG

☐ 76 (2/3)

⇒ 2 260
91 53 057 08

Pos.	Item	Quantity	Description	Bezeichnung	Serie	K
1	96 46 501 08	1	BATTERY BOX, PRE-ASSEMBLED ⇒ 2 260 006 96 46 501 08	BATTERIEKASTEN VORM.		
2	96 46 971 08	1	FRAME WELDED	RAHMEN SCHWK.		
3	96 46 972 08	1	FLAP PRE-ASS. ⇒ 2 260 009 96 46 972 08	KLAPPE VORM.		
4	97 52 147 08	1	PLATE 4X1390X487	BLECH		
5	97 70 505 08	2	PLATE 4X611X119	BLECH		
6	97 70 506 08	2	PLATE 4X254X126	BLECH		
7	10 41 235 8	2	TELESCOPE GUIDE RAIL 530X28X26 ST GE	TELESKOPSCHIENE		
8	72 66 158 08	2	RUBBER-METAL STOP BUFFER 50X61-M8 N	MEGI-ANSCHLAGPUFFER		
9	70 42 089 08	2	SPRING-LOADED LOCK VERZ	FEDERRIEGEL		
10	97 71 095 08	1	PLATE 1.5X2576X755	BLECH		
11	97 71 096 08	1	PLATE 1.5X1812X294	BLECH		
12	95 38 734 08	5	SLEEVE	HUELSE		
13	97 71 098 08	2	PLATE 3X121X79	BLECH		
14	97 71 099 08	1	PLATE 3X437X272	BLECH		
15	97 71 100 08	1	PLATE 3X235X155	BLECH		
17	46 00 334	24	HEX BOLT ISO 4017 M8X18 8.8 A2C	SECHSKANTSCHRAUBE		
18	42 00 012 08	57	WASHER DIN 125 A8X16 ST VERZ	SCHEIBE		
19	41 15 141 08	33	HEX NUT DIN 934 M8 8 A2C	SECHSKANTMUTTER		
20	40 00 829	8	HEX BOLT ISO 4017 M6X20 8.8 A2C	SECHSKANTSCHRAUBE		
21	42 00 009 08	24	WASHER ISO 7089 A 6.4 VERZ	SCHEIBE		
22	41 19 004 08	13	HEX NUT DIN 985 M6 8 VERZ	SECHSKANTMUTTER		
23	40 65 060	28	HEX BOLT ISO 4017 M5X10 8.8 A2C	SECHSKANTSCHRAUBE		
24	42 18 006 08	28	WASHER DIN 9021 A 5,3 ST VERZ	SCHEIBE		
25	49 00 128	10	HEX BOLT ISO 4017 M8X25 8.8 A2C	SECHSKANTSCHRAUBE		
26	40 97 041 08	8	PAN-HEAD SCREW M8X20	FLACHKOPFSCHRAUBE		
27	10 41 285 1	5	OVAL HEAD FLAT SCREW AEHNL. ISO 7380	LINSENFLACHKOPFSCHRAUBE		
28	40 01 033 08	4	CYLINDER SCREW DIN 84 M5X12 5.8 VERZ	ZYLINDERSCHRAUBE		
29	41 19 003 08	4	HEX NUT DIN 985 M5 8 VERZ	SECHSKANTMUTTER		
30	41 19 010 08	8	HEX NUT DIN 985 M8 10 VERZ	SECHSKANTMUTTER		
31	42 06 042 08	8	WASHER DIN 440 V 9 ST VERZ	SCHEIBE		
32	42 16 004 08	5	WASHER DIN 7349 6,4 ST VERZ	SCHEIBE		
33	42 16 005 08	12	WASHER DIN 7349 8,4 ST VERZ	SCHEIBE		
34	97 78 350 08	2	PLATE 5X410X41	BLECH		
35	97 78 351 08	1	ANGLE 3X85X30	WINKEL		

6.2.2009

etk_en_de_074515 LR 1600/2

77 (3/3)

LIEBHERRCUP SPRING CLUSTER
BATTERIELAGERUNG⇒ 2 260
91 53 057 08

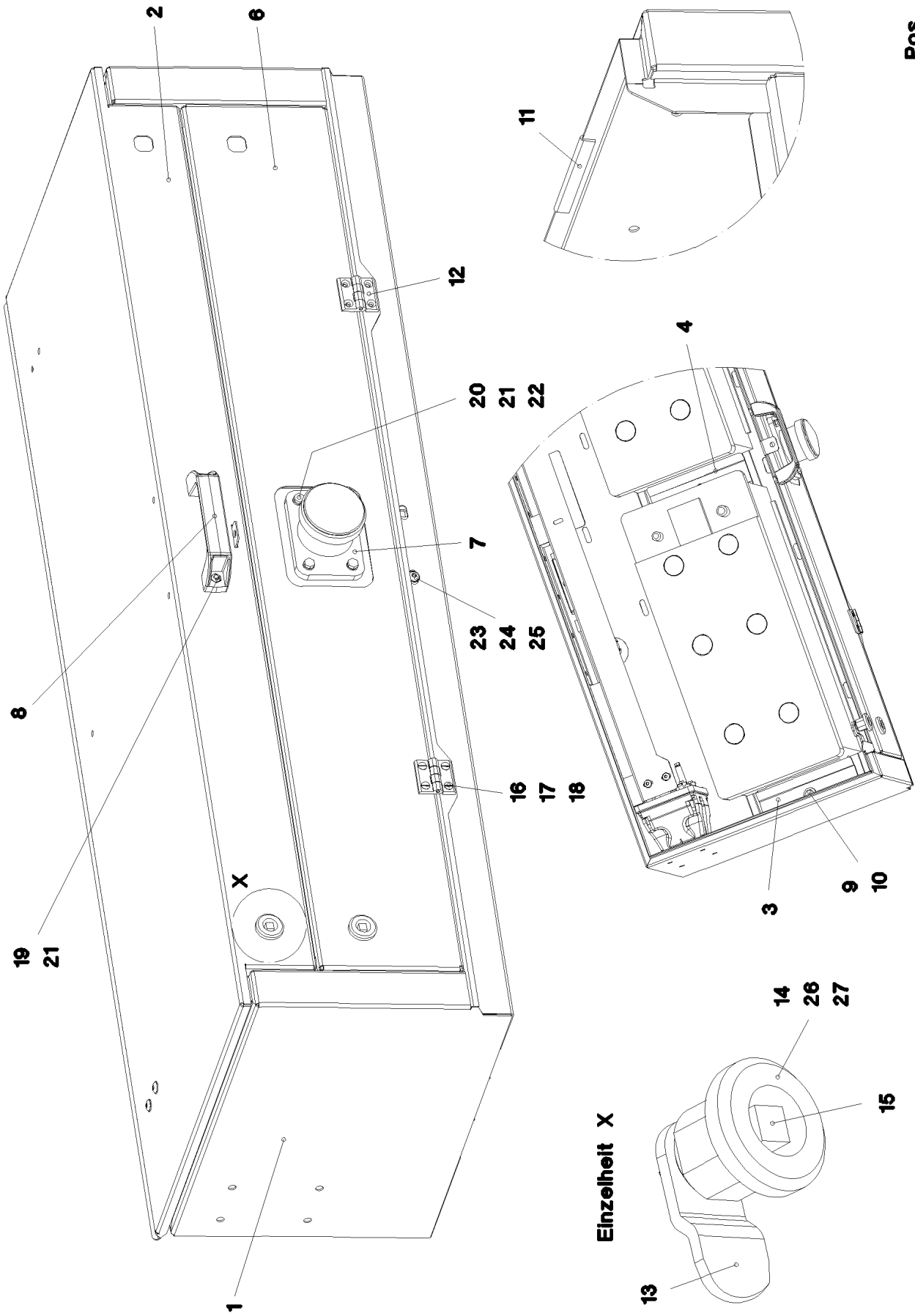

6.2.2009
052448

LIEBHERR

etk_en_de_074515 LR 1600/2

BATTERY BOX, PRE-ASSEMBLED
BATTERIEKASTEN VORM.

□ 78 (1/2)

⇒ 2 260 006
96 46 501 08

Pos.	Item	Quantity	Description	Bezeichnung	Serie	K
1	96 34 249 08	1	BATTERY BOX WELDED SPF	BATTERIEKASTEN SCHWK.		
2	96 23 055 08	1	COVER/LID/CAP, PRE-ASSEMBLED SPF ⇒ 2 391 036 96 23 055 08	DECKEL VORM.		
3	97 02 119 08	2	PLATE 4X174X74	BLECH		
4	97 02 120 08	1	PLATE 4X174X72	BLECH		
5	96 48 319 08	1	ELECTRIC FOR BATTERY BOX ⇒ 2 920 083 96 48 319 08	ELEKTRIK BATTERIEKASTEN		
6	97 23 317 08	1	PLATE 1.5X1140X231	BLECH		
7	97 23 319 08	1	PLATE 3X192X187	BLECH		
8	70 42 545 08	1	GRIP KUNSTSTOFF	GRIFF		
9	49 00 128	3	HEX BOLT ISO 4017 M8X25 8.8 A2C	SECHSKANTSCHRAUBE		
10	42 16 005 08	3	WASHER DIN 7349 8,4 ST VERZ	SCHEIBE		
11	26 21 039 08	3.6	EDGE PROTECTION	KANTENSCHUTZ		
12	70 42 582 08	2	HINGE	SCHARNIER		
13	70 42 535 08	4	TONGUE	ZUNGE		
14	70 42 533 08	4	HOUSING	GEHAEUSE		
15	70 42 534 08	4	ACTUATION SPIKE	BETAETIGUNGSDORN		
16	42 00 008 08	8	WASHER DIN 125 A 5.3 VERZ	SCHEIBE		
17	40 04 016 08	8	COUNTERSUNK SCREW DIN 963 M5X16 5.8	SENKSCHRAUBE		
18	41 15 148 08	8	HEX NUT DIN 934 M5 8 VERZ	SECHSKANTMUTTER		
19	40 65 099	2	HEX BOLT ISO 4017 M6X16 8.8 A2C	SECHSKANTSCHRAUBE		
20	42 00 009 08	6	WASHER ISO 7089 A 6.4 VERZ	SCHEIBE		
21	41 19 004 08	4	HEX NUT DIN 985 M6 8 VERZ	SECHSKANTMUTTER		
22	40 00 829	4	HEX BOLT ISO 4017 M6X20 8.8 A2C	SECHSKANTSCHRAUBE		
23	10 41 285 1	2	OVAL HEAD FLAT SCREW AEHNL. ISO 7380	LINSENFLACHKOPFSCHRAUBE		
24	42 00 012 08	2	WASHER DIN 125 A8X16 ST VERZ	SCHEIBE		
25	41 15 141 08	8	HEX NUT DIN 934 M8 8 A2C	SECHSKANTMUTTER		
26	70 42 749 08	4	FLAT GASKET	FLACHDICHTUNG		
27	70 42 749 08	4	FLAT GASKET	FLACHDICHTUNG		

6.2.2009

etk_en_de_074515 LR 1600/2

79 (2/2)

LIEBHERRBATTERY BOX, PRE-ASSEMBLED
BATTERIEKASTEN VORM.⇒ 2 260 006
96 46 501 08

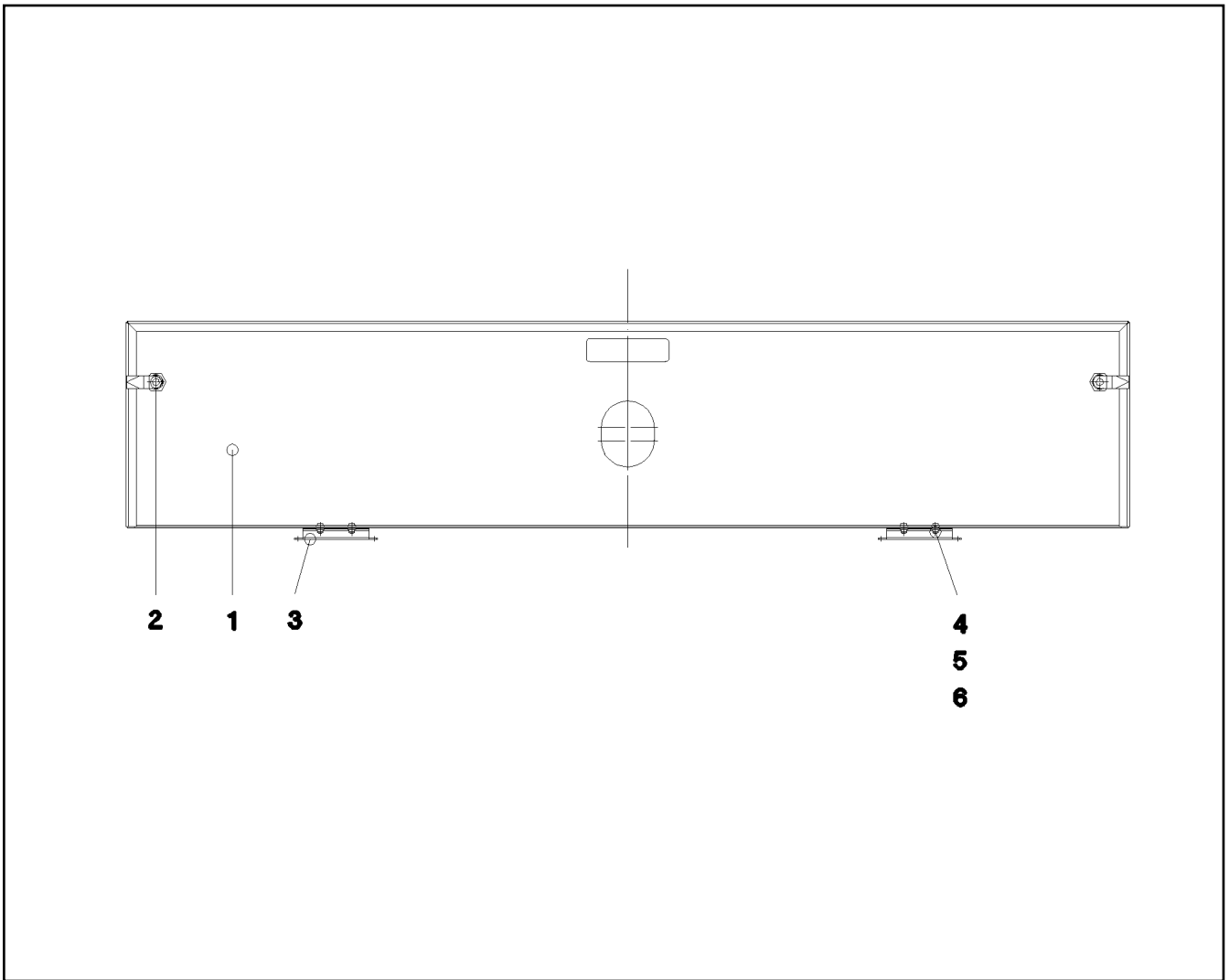

Pos.	Item	Quantity	Description	Bezeichnung	Serie	K
1	97 71 093 08	1	PLATE 1.5X1577X366	BLECH		
2	70 42 710 08	2	SASH LOCK SPF	VORREIBER		
3	70 42 637 08	2	HINGE F6-1 STAHL	SCHARNIER		
4	40 01 033 08	4	CYLINDER SCREW DIN 84 M5X12 5.8 VERZ	ZYLINDERSCHRAUBE		
5	41 19 003 08	4	HEX NUT DIN 985 M5 8 VERZ	SECHSKANTMUTTER		
6	42 00 009 08	8	WASHER ISO 7089 A 6.4 VERZ	SCHEIBE		

6.2.2009
052450

LIEBHERR

etk_en_de_074515 LR 1600/2

FLAP PRE-ASS.
KLAPPE VORM.

80

⇒ 2 260 009
96 46 972 08

Einzelheit U

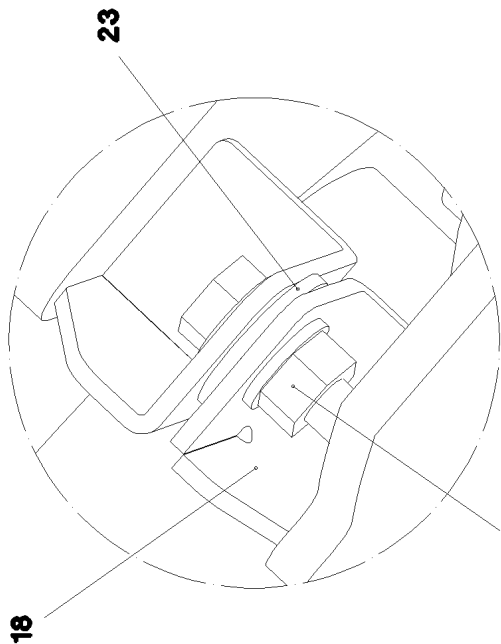

Einzelheit V

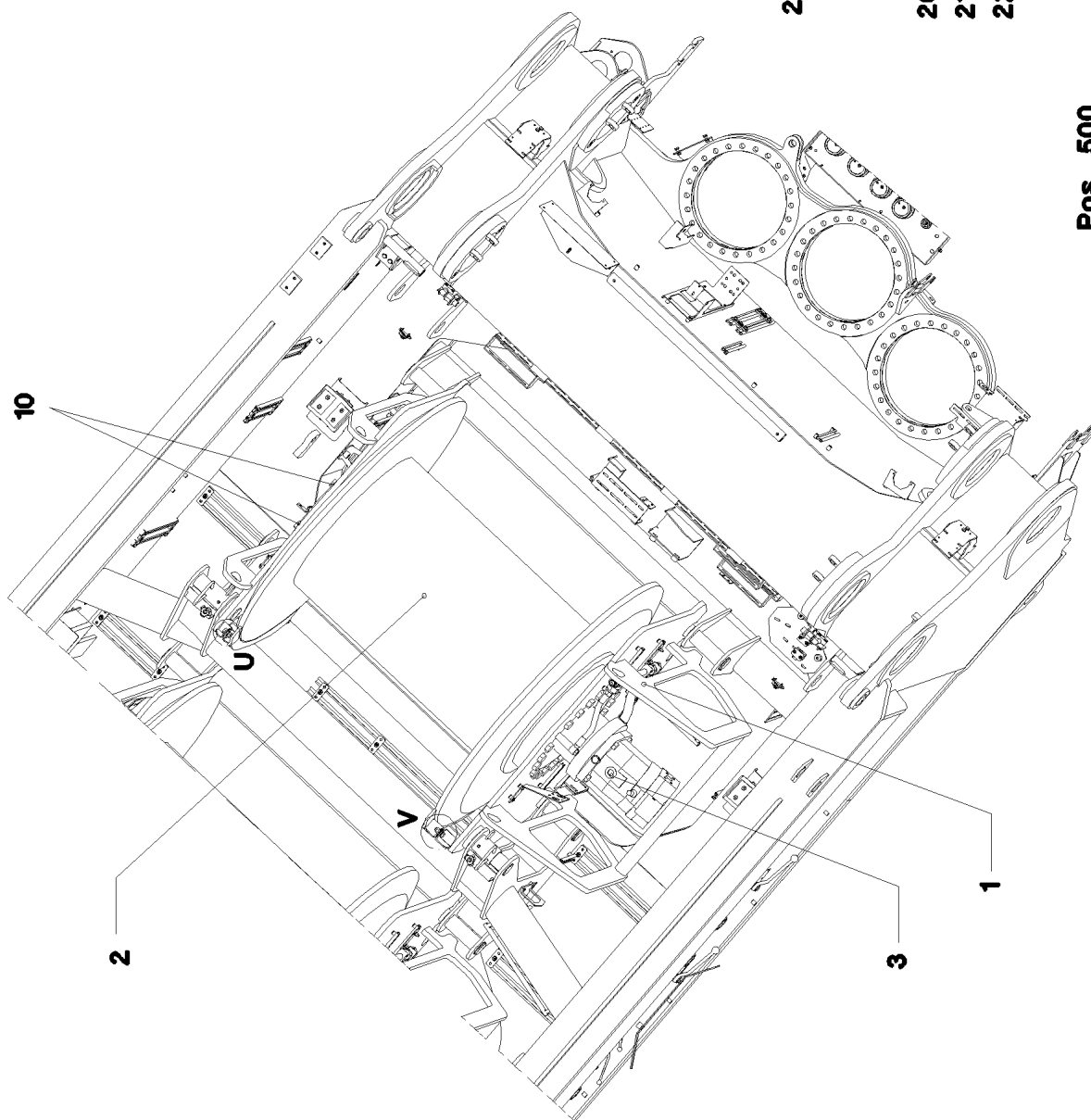
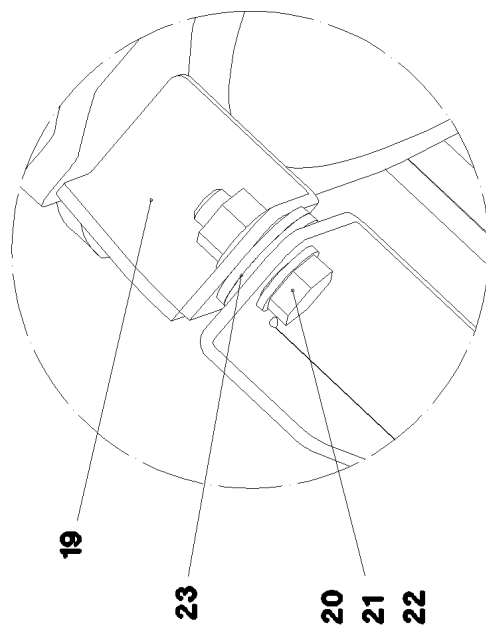

Pos. 500

6.2.2009
052372

LIEBHERR

etk_en_de_074515 LR 1600/2

WINCH 1
WINDE 1

☐ 81 (1/3)

⇒ 2 310
91 52 503 08

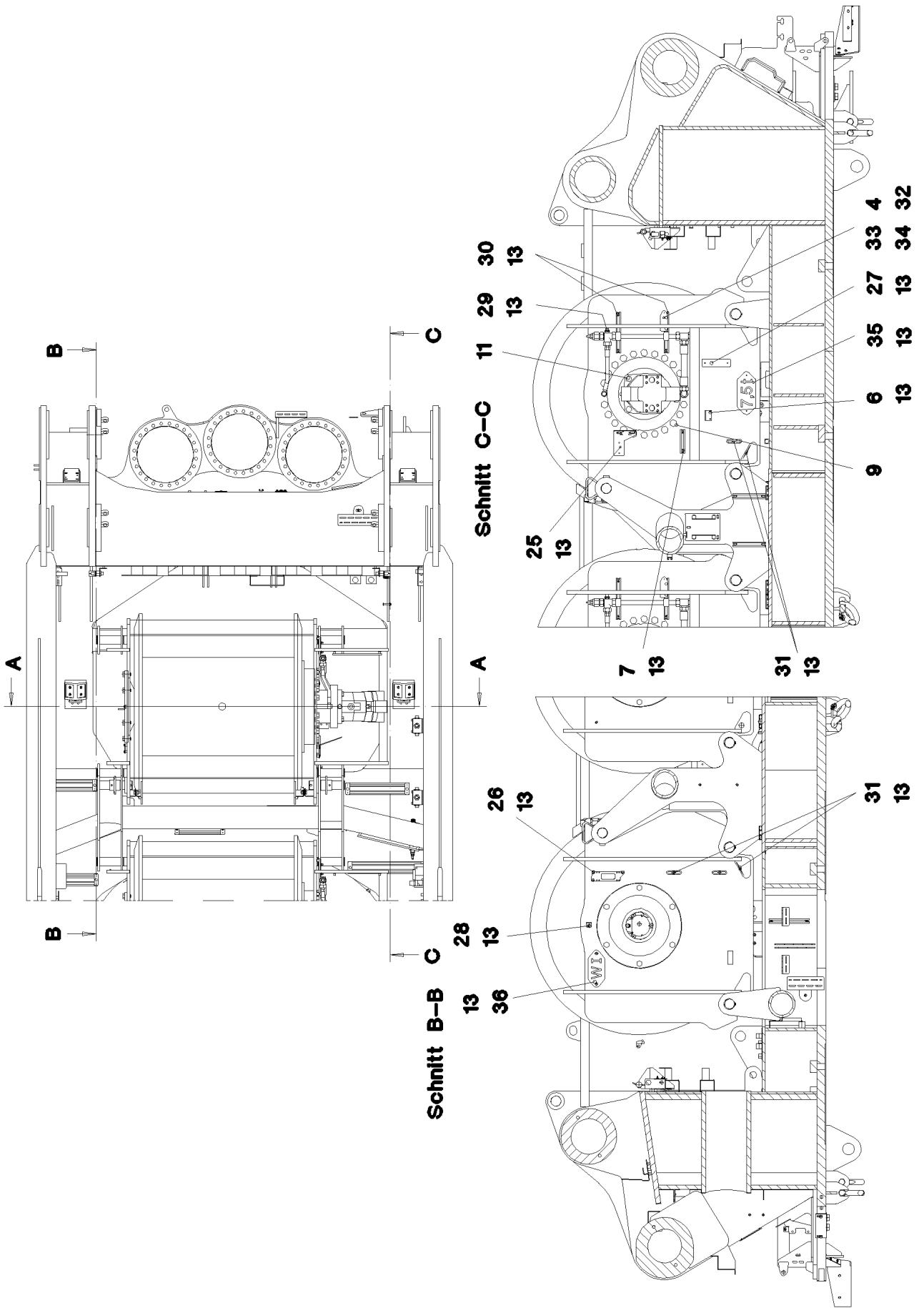

6.2.2009
052373

LIEBHERR

etk_en_de_074515 LR 1600/2

WINCH 1
WINDE 1

82 (2/3)

⇒ 2 310
91 52 503 08

Pos.	Item	Quantity	Description	Bezeichnung	Serie	K
1	96 43 852 08	1	WINCH BEARING	WINDENLAGERUNG SCHWK.		
2	10 35 411 4	1	HOISTING WINCH ZHP 4.29 SPF ⇒ X10354114 10 35 411 4	HUBWINDE		
3	10 35 482 8	1	VARIABLE DISPLACEMENT MOTOR A6VM	VERSTELLMOTOR		
4	95 37 609 08	1	PLATE 3X45X120	BLECH		
6	97 15 061 08	1	PLATE 4X60X103	BLECH		
7	95 41 173 08	1	CARRIER RAIL 140	TRAGSCHIENE		
9	40 66 057 08	22	HEX BOLT ISO 4017 M24X50 10.9 A3C	SECHSKANTSCHRAUBE		
10	46 00 020	6	HEX BOLT ISO 4017 M20X45 8.8 A3C	SECHSKANTSCHRAUBE		
11	40 65 211 01	4	HEX BOLT ISO 4017 M20X60 8.8 A3C	SECHSKANTSCHRAUBE		
13	10 41 285 4	30	OVAL HEAD FLAT SCREW AEHNL.ISO7380	LINSENFLACHKOPFSCHRAUBE		
18	96 44 241 08	1	PROTECTION PLATE WELDED	SCHUTZBLECH SCHWK.		
19	96 44 242 08	1	PROTECTION PLATE WELDED	SCHUTZBLECH SCHWK.		
20	49 00 204	4	HEX BOLT ISO 4017 M12X35 8.8 A3C	SECHSKANTSCHRAUBE		
21	42 00 016 08	8	WASHER ISO 7089 A 13 ST A3C	SCHEIBE		
22	41 15 143 08	4	HEX NUT DIN 934 M12 8 VERZ	SECHSKANTMUTTER		
23	42 18 011 08	8	WASHER ISO 7093-1 A 13 ST A3C	SCHEIBE		
25	97 80 349 08	1	PLATE 4X256X130	BLECH		
26	95 56 681 08	1	PLATE X0	BLECH		
27	97 55 008 08	1	PLATE 3X150X40	BLECH		
28	97 03 501 08	1	PLATE 4x73x30 S235JRG2	BLECH		
29	95 41 175 08	1	CARRIER RAIL 340	TRAGSCHIENE		
30	95 41 174 08	2	CARRIER RAIL 240	TRAGSCHIENE		
31	95 36 500 08	8	CABLE HOLDER 2X22X90	KABELHALTER		
32	40 97 070 08	2	HAMMER HEAD BOLT M8X20 4.6 A2K SPF	HAMMERKOPFSCHRAUBE		
33	42 00 012 08	2	WASHER DIN 125 A8X16 ST VERZ	SCHEIBE		
34	41 15 141 08	2	HEX NUT DIN 934 M8 8 A2C	SECHSKANTMUTTER		
35	97 86 711 08	1	PLATE 2X228X100	BLECH		
36	97 92 102 08	1	PLATE 2X220X100	BLECH		
500	96 44 536 08	1	ELECTRIC FOR WINCH 1 ⇒ 2 920 200 96 44 536 08	ELEKTRIK WINDE 1		

6.2.2009

etk_en_de_074515 LR 1600/2

83 (3/3)

LIEBHERRWINCH 1
WINDE 1⇒ 2 310
91 52 503 08

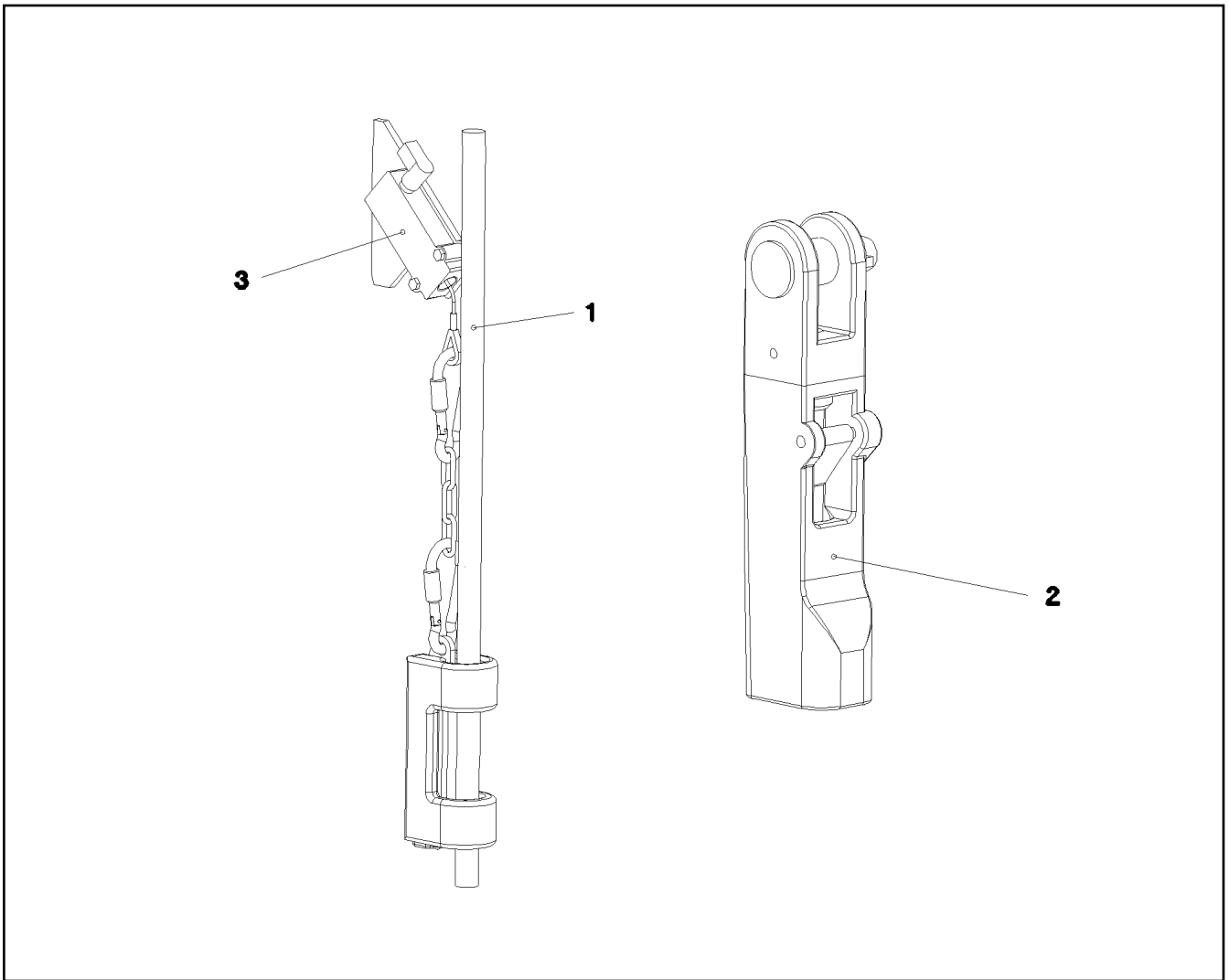

Pos.	Item	Quantity	Description	Bezeichnung	Serie	K
1	10 41 082 0	1	ROPE 28MM 1050M -40°C SPF	SEIL		
2	77 39 399 08	1	POCKET LOCK 27-29 SPF	TASCHENSCHLOSS		
3	96 25 639 08	1	HOIST LIM.SWITCH PLUMMET CPL ⇒ 2 311 001 96 25 639 08	HUBENDSCHALTER GEWICHT K		

6.2.2009
052769

LIEBHERR

etk_en_de_074515 LR 1600/2

ROPE WITH ACCESSORIES 1
SEIL F.WINDE 1

84

⇒ 2 311
91 52 834 08

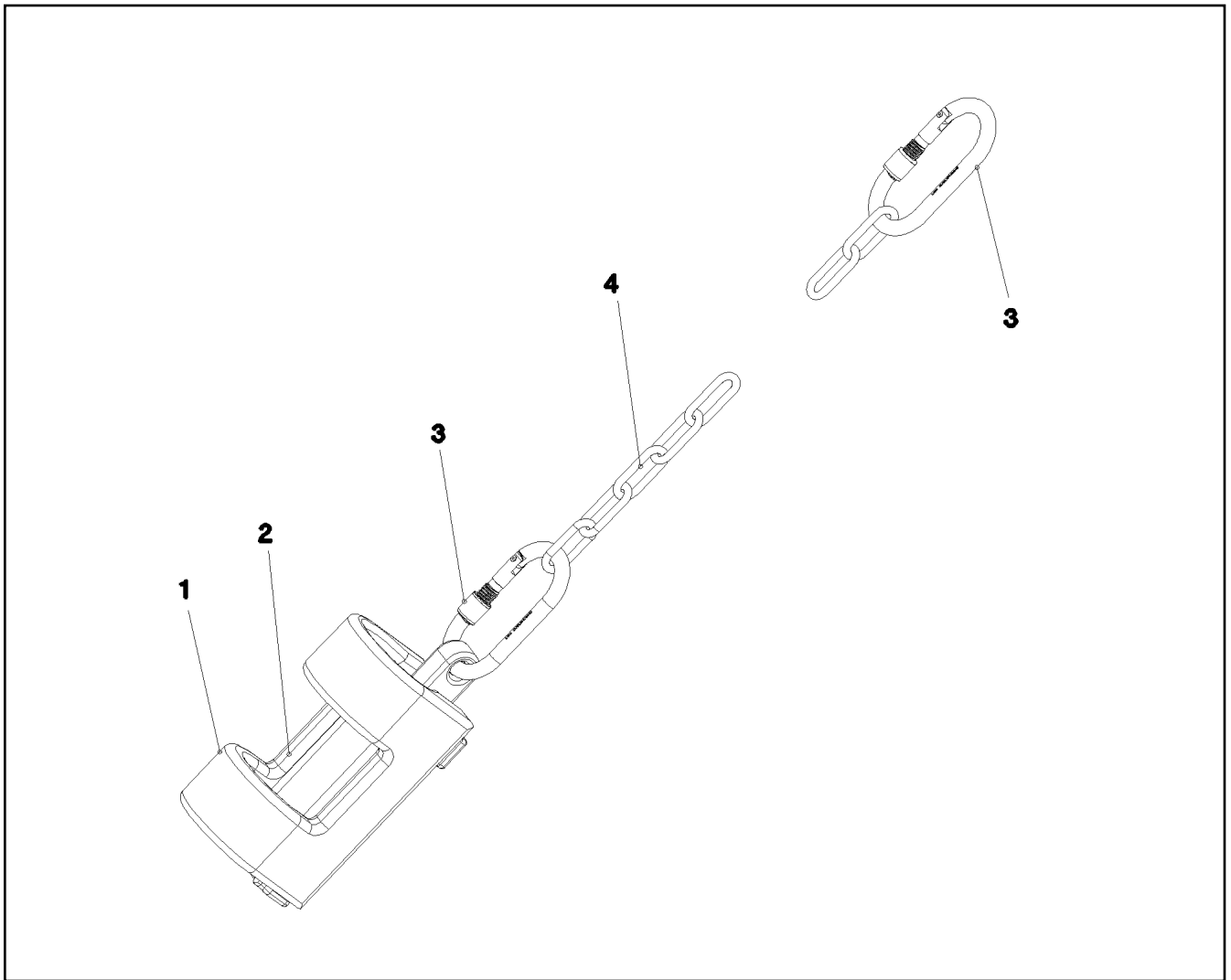

Pos.	Item	Quantity	Description	Bezeichnung	Serie	K
1	38 82 832 08	1	WEIGHT 43X70X245 EN-GJS400-18 VERZ.	GEWICHT		
2	38 82 831 08	1	WEIGHT EN-GJS400-18 FE//ZN20//B	GEWICHT		
3	10 47 304 0	2	SCREW CARABINER OVAL 130X70X12 S35	SCHRAUBKARABINER		
4	74 00 002 08	2	CHAIN DIN 763 6X42 0.2t UST 35-2 GALV. V	KETTE		

6.2.2009
031387

LIEBHERR

etk_en_de_074515 LR 1600/2

HOIST LIM.SWITCH PLUMMET CPL
HUBENDSCHALTER GEWICHT KPL.

85

⇒ 2 311 001
96 25 639 08

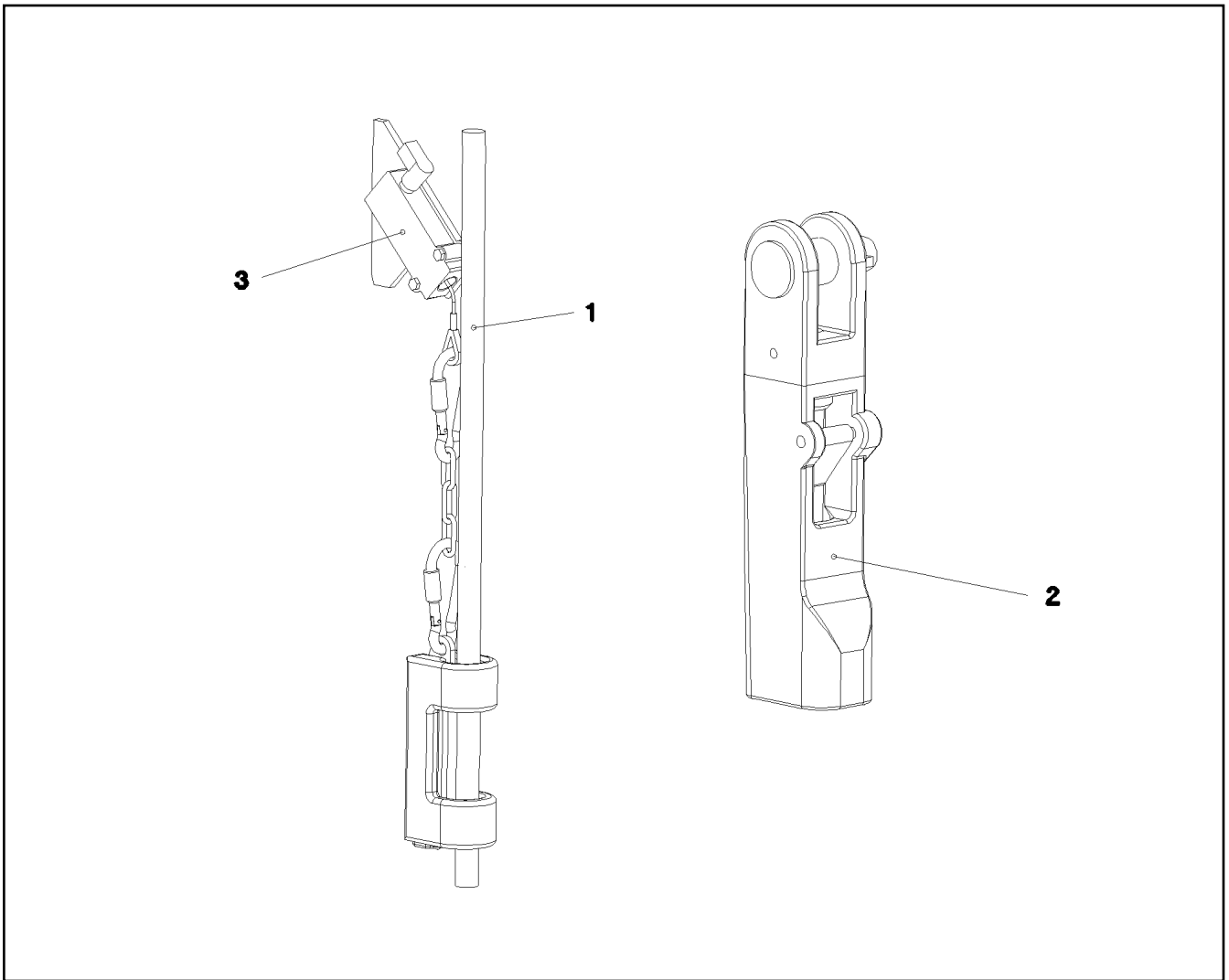

Pos.	Item	Quantity	Description	Bezeichnung	Serie	K
1	10 41 082 0	1	ROPE 28MM 1050M -40°C SPF	SEIL		
2	77 39 399 08	1	POCKET LOCK 27-29 SPF	TASCHENSCHLOSS		
3	96 25 639 08	1	HOIST LIM.SWITCH PLUMMET CPL ⇒ 2 311 001 96 25 639 08	HUBENDSCHALTER GEWICHT K		

6.2.2009
052771

LIEBHERR

etk_en_de_074515 LR 1600/2

ROPE WITH ACCESSORIES 2
SEIL F.WINDE 2

86

⇒ 2 312
91 52 835 08

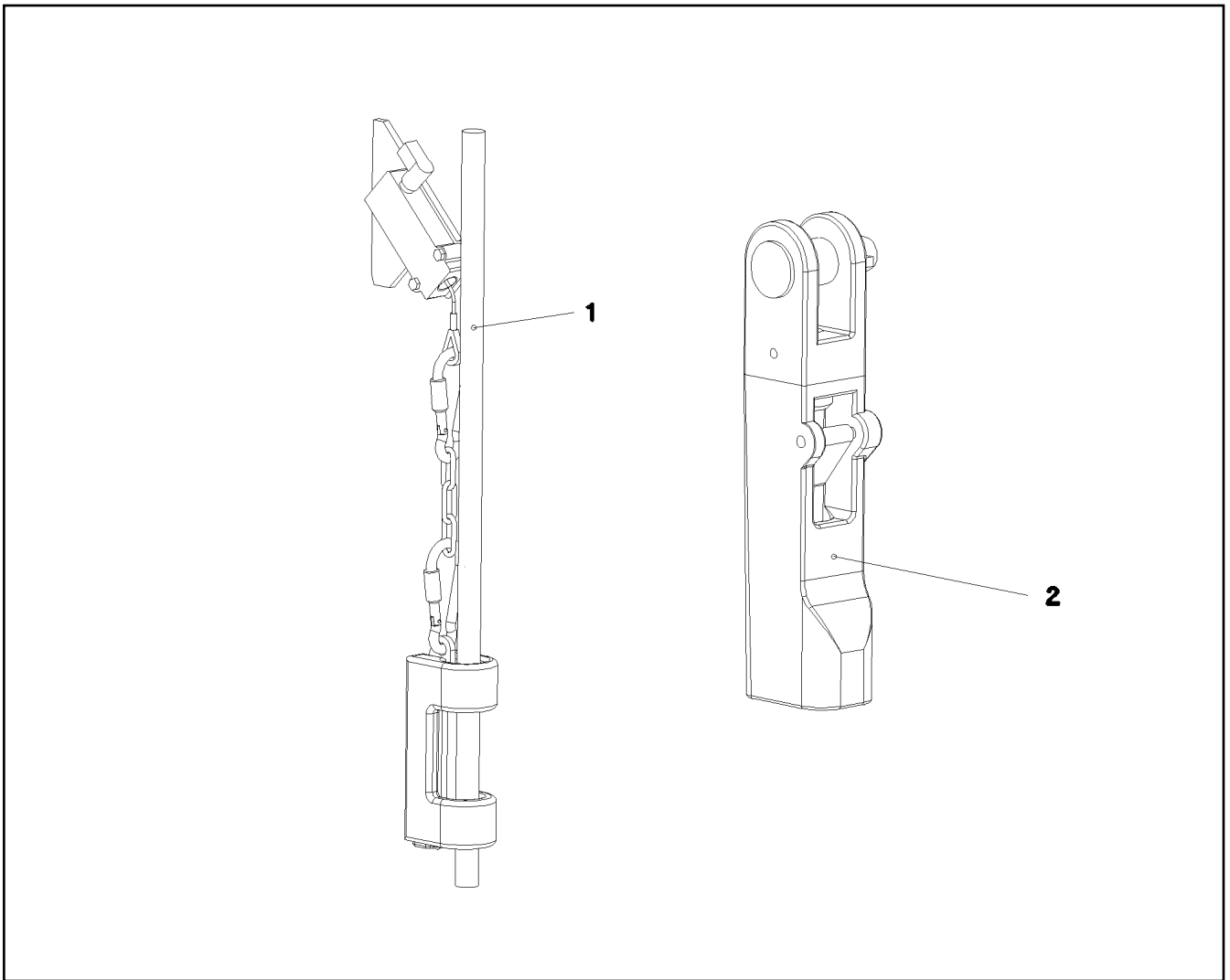

Pos.	Item	Quantity	Description	Bezeichnung	Serie	K
1	10 41 082 4	1	ROPE 28MM 1200M -40°C SPF	SEIL		
2	77 39 399 08	1	POCKET LOCK 27-29 SPF	TASCHENSCHLOSS		

6.2.2009
054253

LIEBHERR

etk_en_de_074515 LR 1600/2

ROPES FOR WINCHES 3
SEIL F.WINDE 3

87

⇒ 2 313
91 52 836 08

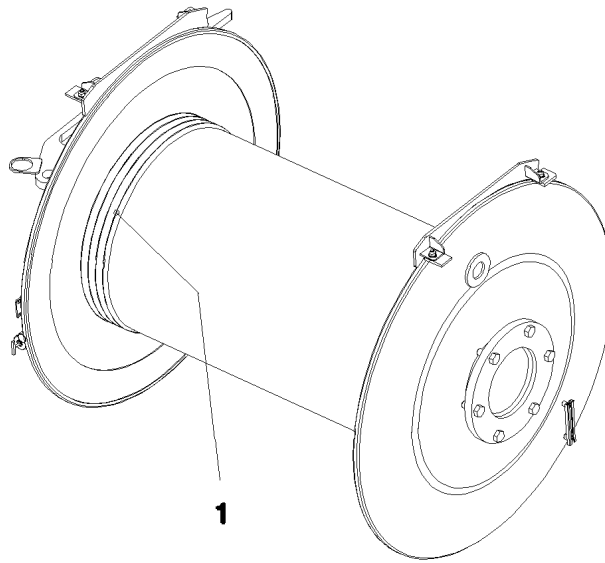

Pos.	Item	Quantity	Description	Bezeichnung	Serie	K
1	10 41 082 9	1	ROPE 28MM 700M -40°C SPF	SEIL		

6.2.2009
052770

LIEBHERR

etk_en_de_074515 LR 1600/2

ROPE FOR WINCH 4
SEIL F.WINDE 4

88

⇒ 2 314
91 52 837 08

Einzelheit X

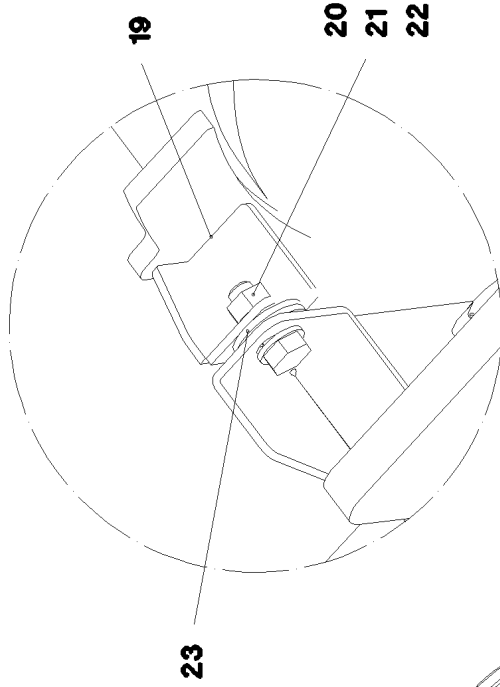

Pos. 500

Einzelheit Y

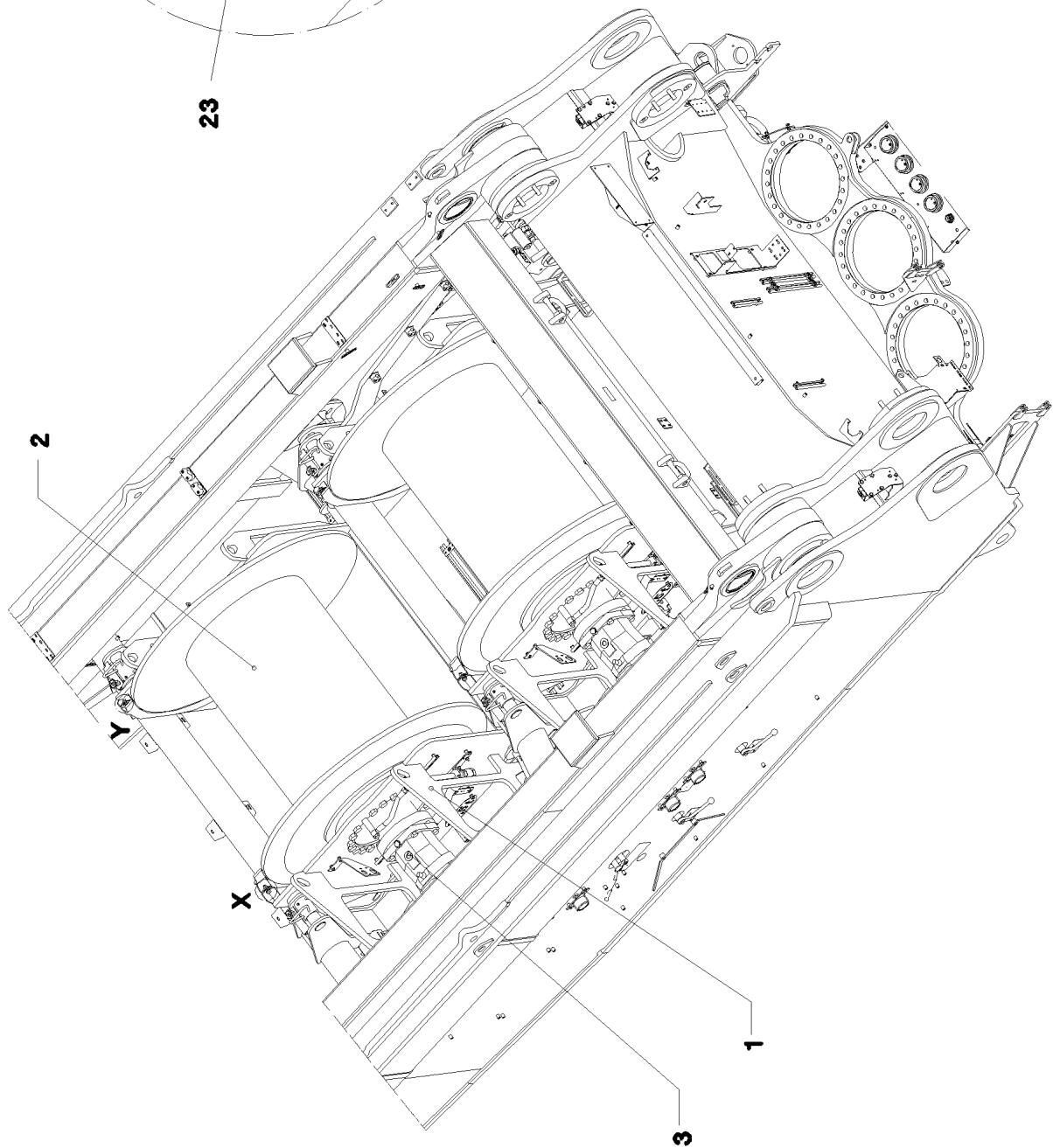
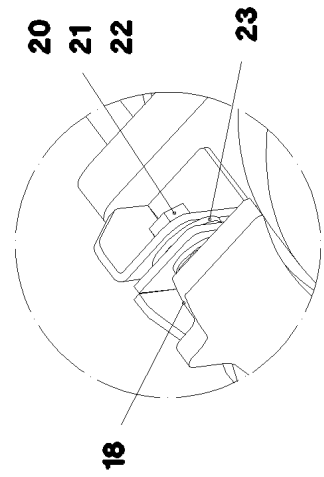

6.2.2009
052374

LIEBHERR

etk_en_de_074515 LR 1600/2

WINCH 2
WINDE 2

89 (1/3)

⇒ 2 320
91 52 504 08

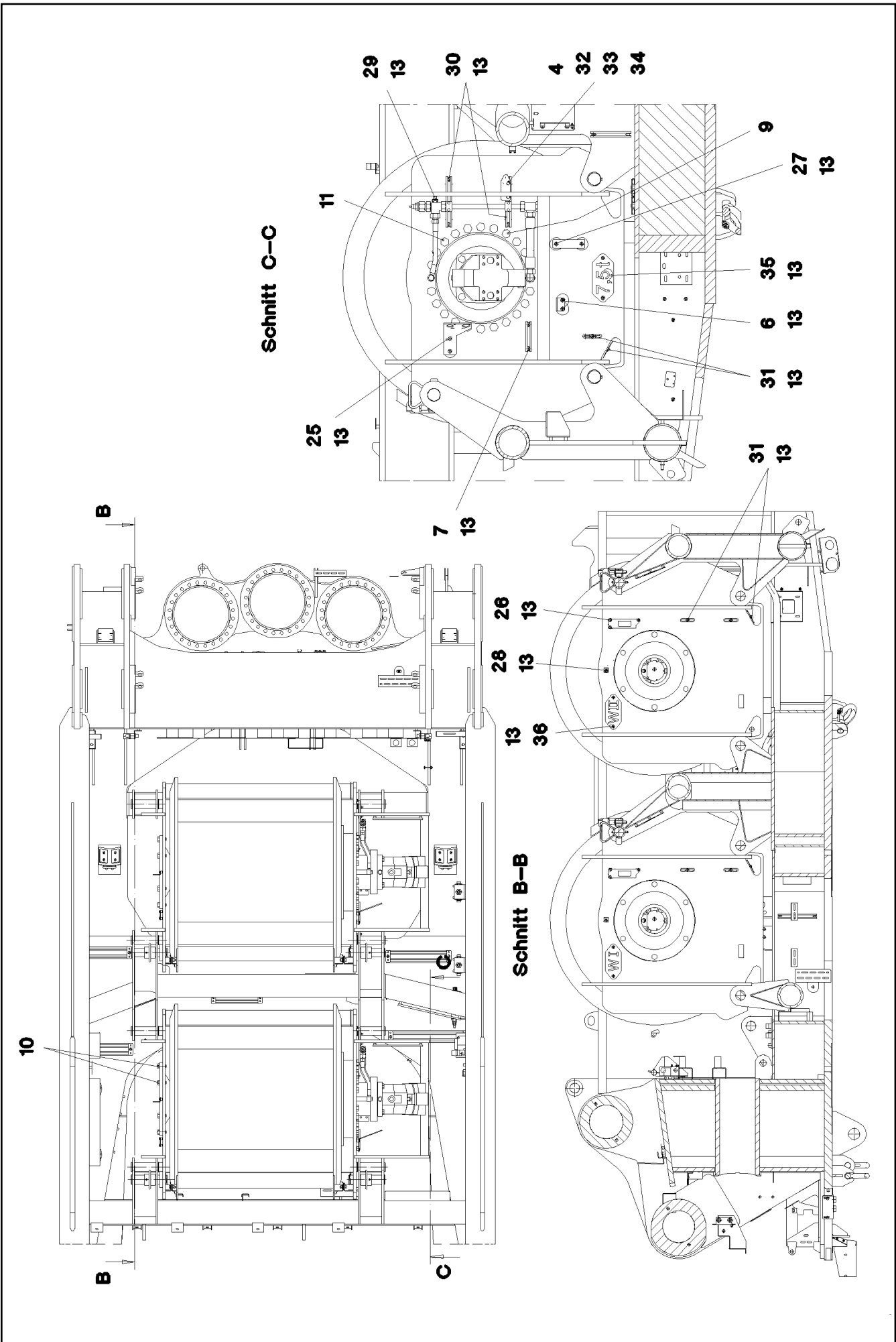

6.2.2009
052375

LIEBHERR

etk_en_de_074515 LR 1600/2

WINCH 2
WINDE 2

90 (2/3)

⇒ 2 320
91 52 504 08

Pos.	Item	Quantity	Description	Bezeichnung	Serie	K
1	96 43 852 08	1	WINCH BEARING	WINDENLAGERUNG SCHWK.		
2	10 35 411 4	1	HOISTING WINCH ZHP 4.29 SPF ⇒ X10354114 10 35 411 4	HUBWINDE		
3	10 35 482 8	1	VARIABLE DISPLACEMENT MOTOR A6VM	VERSTELLMOTOR		
4	95 37 609 08	1	PLATE 3X45X120	BLECH		
6	97 15 061 08	1	PLATE 4X60X103	BLECH		
7	95 41 173 08	1	CARRIER RAIL 140	TRAGSCHIENE		
9	40 66 057 08	22	HEX BOLT ISO 4017 M24X50 10.9 A3C	SECHSKANTSCHRAUBE		
10	46 00 020	6	HEX BOLT ISO 4017 M20X45 8.8 A3C	SECHSKANTSCHRAUBE		
11	40 65 211 01	4	HEX BOLT ISO 4017 M20X60 8.8 A3C	SECHSKANTSCHRAUBE		
13	10 41 285 4	30	OVAL HEAD FLAT SCREW AEHNL.ISO7380	LINSENFLACHKOPFSCHRAUBE		
18	96 44 241 08	1	PROTECTION PLATE WELDED	SCHUTZBLECH SCHWK.		
19	96 44 242 08	1	PROTECTION PLATE WELDED	SCHUTZBLECH SCHWK.		
20	49 00 204	4	HEX BOLT ISO 4017 M12X35 8.8 A3C	SECHSKANTSCHRAUBE		
21	42 00 016 08	8	WASHER ISO 7089 A 13 ST A3C	SCHEIBE		
22	41 15 143 08	4	HEX NUT DIN 934 M12 8 VERZ	SECHSKANTMUTTER		
23	42 18 011 08	8	WASHER ISO 7093-1 A 13 ST A3C	SCHEIBE		
25	97 80 349 08	1	PLATE 4X256X130	BLECH		
26	95 56 681 08	1	PLATE X0	BLECH		
27	97 55 008 08	1	PLATE 3X150X40	BLECH		
28	97 03 501 08	1	PLATE 4x73x30 S235JRG2	BLECH		
29	95 41 175 08	1	CARRIER RAIL 340	TRAGSCHIENE		
30	95 41 174 08	2	CARRIER RAIL 240	TRAGSCHIENE		
31	95 36 500 08	8	CABLE HOLDER 2X22X90	KABELHALTER		
32	40 97 070 08	2	HAMMER HEAD BOLT M8X20 4.6 A2K SPF	HAMMERKOPFSCHRAUBE		
33	42 00 012 08	2	WASHER DIN 125 A8X16 ST VERZ	SCHEIBE		
34	41 15 141 08	2	HEX NUT DIN 934 M8 8 A2C	SECHSKANTMUTTER		
35	97 86 711 08	1	PLATE 2X228X100	BLECH		
36	97 92 276 08	1	PLATE 2X220X100	BLECH		
500	96 44 537 08	1	ELECTRIC FOR WINCH 2 ⇒ 2 920 260 96 44 537 08	ELEKTRIK WINDE 2		

6.2.2009

etk_en_de_074515 LR 1600/2

☐ 91 (3/3)

LIEBHERRWINCH 2
WINDE 2⇒ 2 320
91 52 504 08

Pos. 500

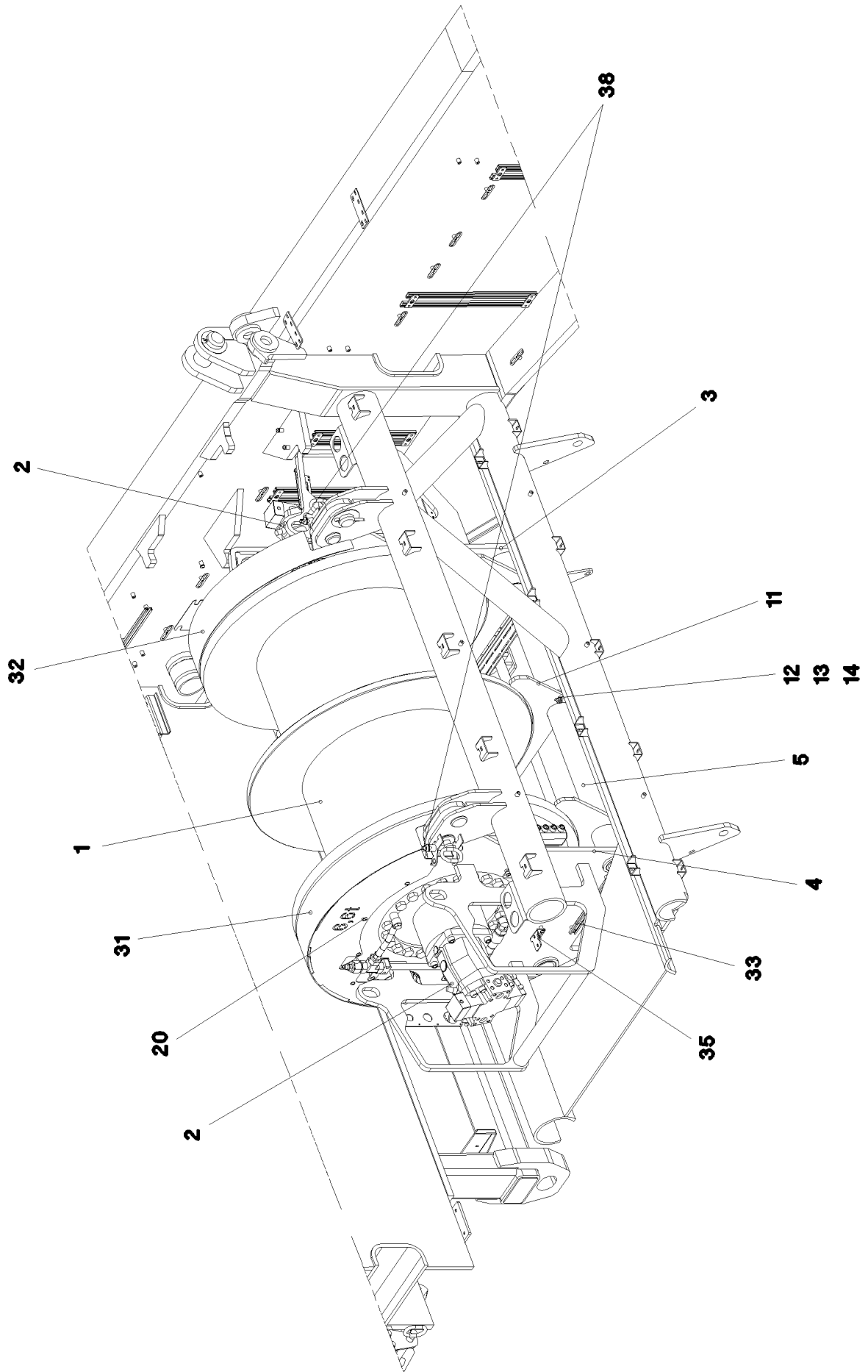

6.2.2009
054024

LIEBHERR

etk_en_de_074515 LR 1600/2

WINCH 4 LUFFING GEAR
WINDE 4 EINZIEHWERK

□ 92 (1/4)

⇒ 2 340
91 52 776 08

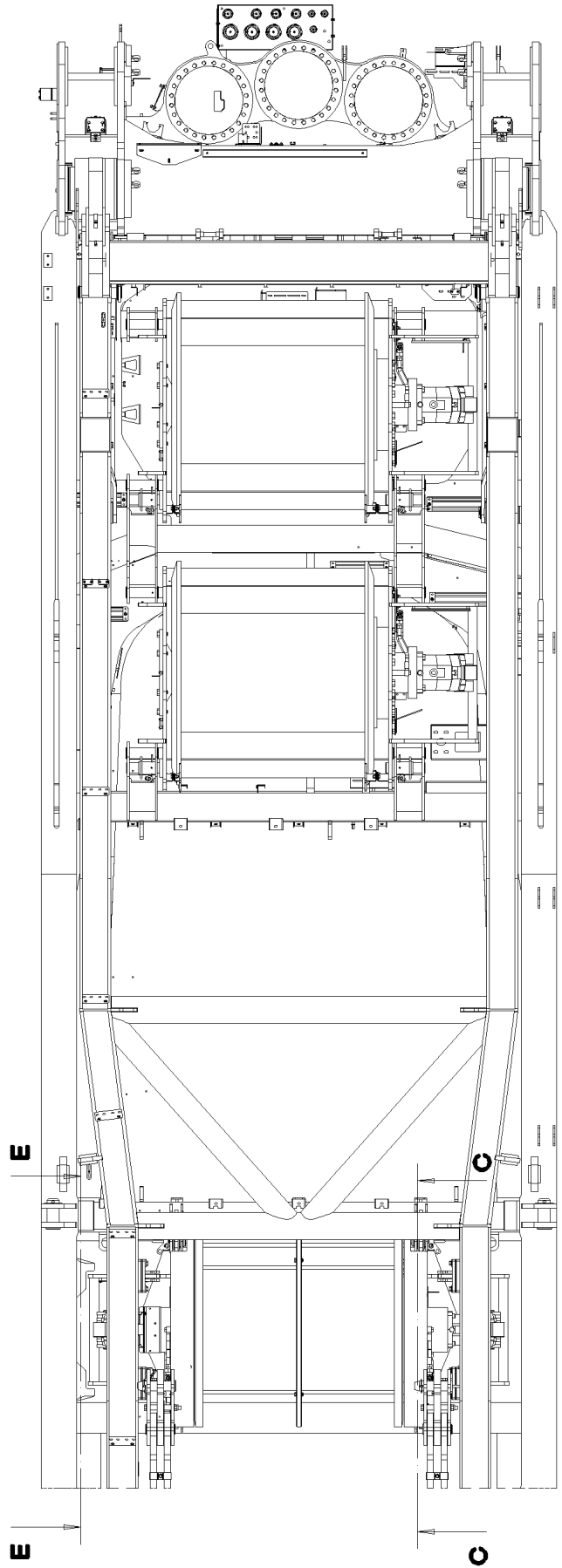
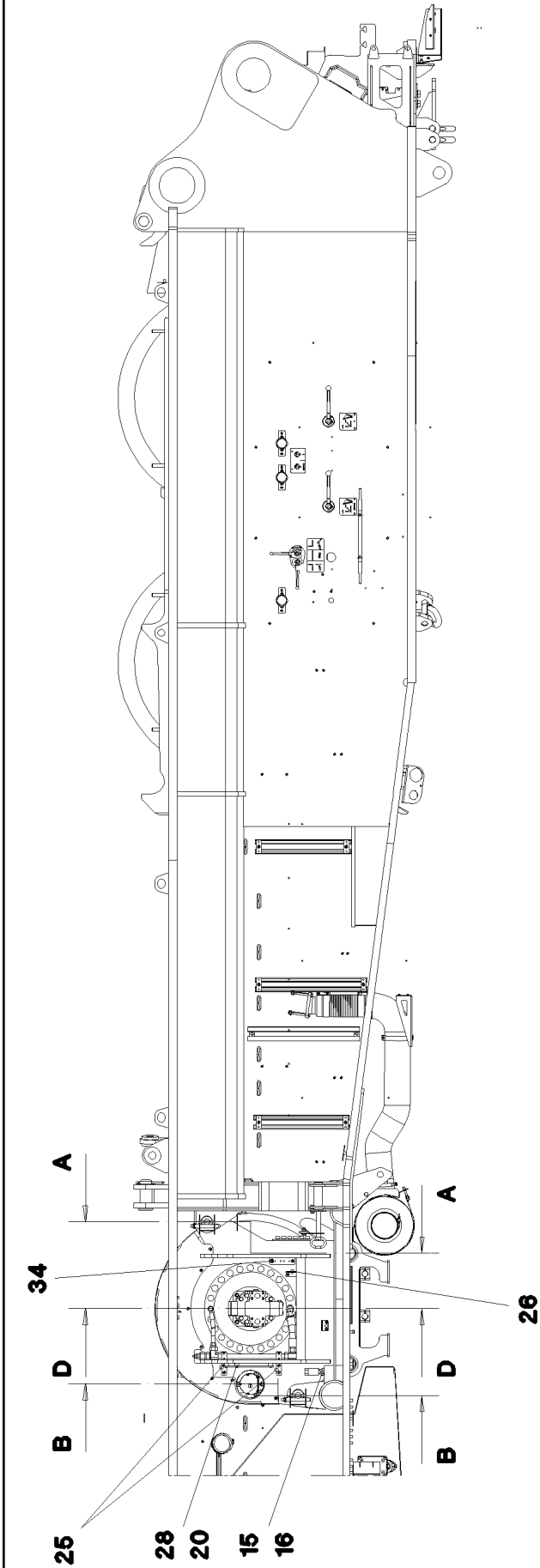

6.2.2009
054025

LIEBHERR

etk_en_de_074515 LR 1600/2

WINCH 4 LUFFING GEAR
WINDE 4 EINZIEHWERK

□ 93 (2/4)

⇒ 2 340

91 52 776 08

Schnitt A-A

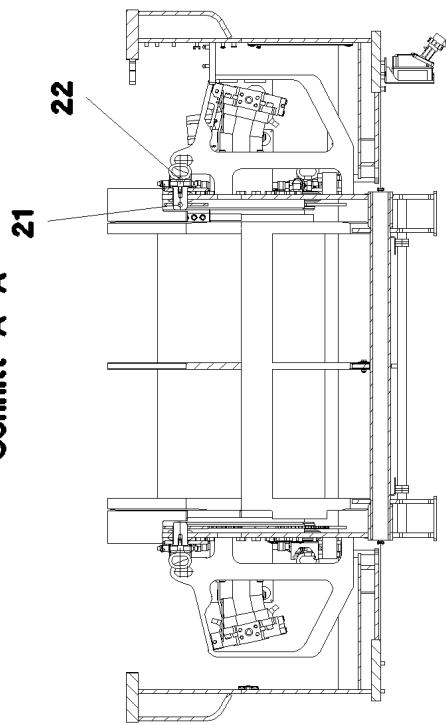

Schnitt D-D

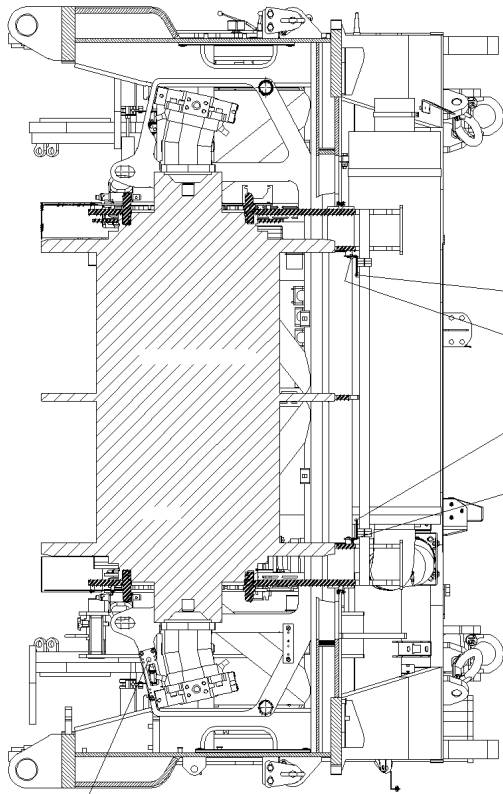

Schnitt B-B

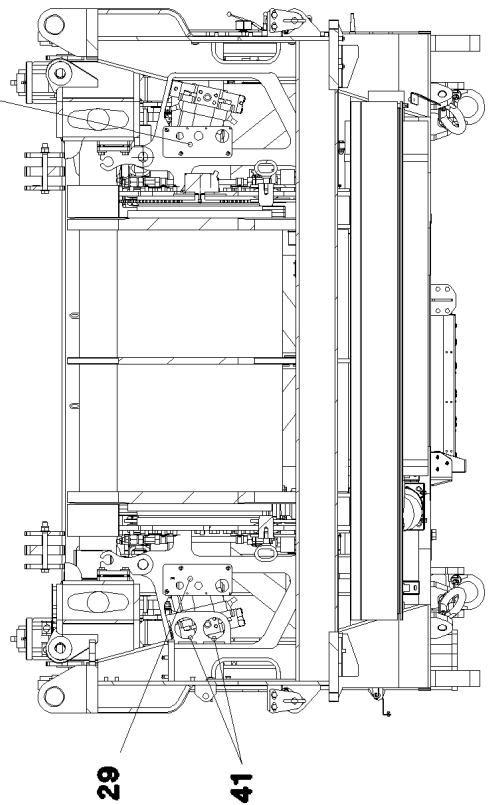

Schnitt E-E

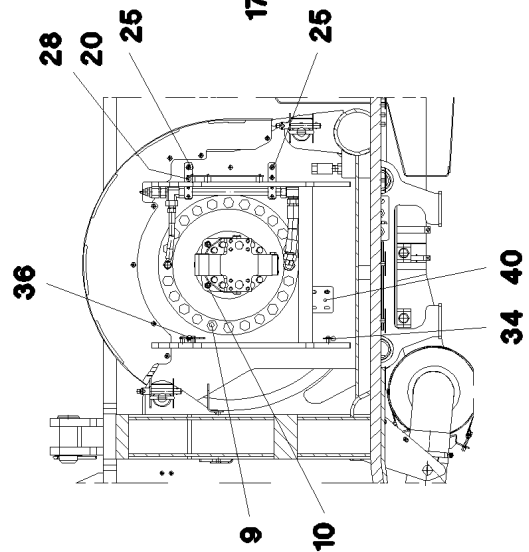

Schnitt C-C

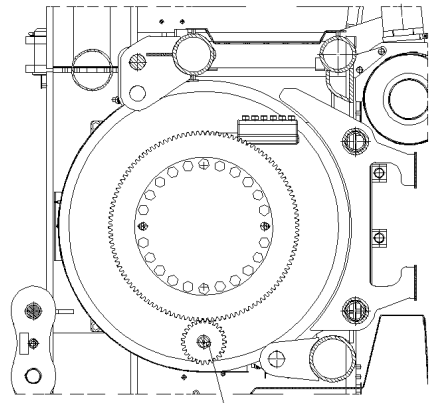

6.2.2009
054026

LIEBHERR

etk_en_de_074515 LR 1600/2

WINCH 4 LUFFING GEAR
WINDE 4 EINZIEHWERK

94 (3/4)

→ 2 340

91 52 776 08

Pos.	Item	Quantity	Description	Bezeichnung	Serie	K
1	10 35 433 2	1	ROPE WINCH ZHP 4.29 SPF	SEILWINDE		
2	10 42 876 6	2	VARIABLE DISPLACEMENT MOTOR A6VM 1	VERSTELLMOTOR		
3	96 44 562 08	1	SIDE PLATE WELDED CONSTR. LINKS	SEITENSCHIEBE SCHWK.		
4	96 44 563 08	1	SIDE PLATE WELDED CONSTR.RIGHT	SEITENSCHIEBE SCHWK.RE.		
5	96 44 583 08	2	PIPE WELDED	ROHR SCHWK.		
9	40 66 056 08	44	HEX BOLT ISO 4017 M24X45 10.9 FLZN SPF	SECHSKANTSCHRAUBE		
10	46 00 237	8	CYLINDER SCREW ISO 4762 M16X50 8.8 A3	ZYLINDERSCHRAUBE		
11	97 66 746 08	1	PLATE 15X930X362	BLECH		
12	46 00 158	2	HEX BOLT ISO 4017 M12X45 8.8 A3C	SECHSKANTSCHRAUBE		
13	42 00 016 08	2	WASHER ISO 7089 A 13 ST A3C	SCHEIBE		
14	41 19 007 08	2	HEX NUT DIN 985 M12 8 A3C	SECHSKANTMUTTER		
15	40 65 140 05	2	HEX BOLT ISO 4017 M24X100 8.8 A3C	SECHSKANTSCHRAUBE		
16	41 15 149 08	2	HEX NUT DIN 934 M24 8 A3C	SECHSKANTMUTTER		
17	96 89 130 01	1	SPUR WHEEL PA6G	STIRNRAD		
20	10 41 285 4	47	OVAL HEAD FLAT SCREW AEHNL.ISO7380	LINSENFLACHKOPFSCHRAUBE		
21	97 78 941 08	4	PIN 70.0X97 SPF	BOLZEN		
22	96 50 603 08	4	HANDLE WELD.CONST.	GRIFF SCHWK.		
25	97 79 264 08	4	PLATE 4X140X30	BLECH		
26	97 79 296 08	1	PLATE 4X98X115	BLECH		
28	95 38 734 08	10	SLEEVE	HUELSE		
29	97 79 331 08	1	PLATE 4X290X130	BLECH		
30	97 79 332 08	1	PLATE 4X290X130	BLECH		
31	96 50 778 08	1	PROTECTION PLATE WELDED RECHTS	SCHUTZBLECH SCHWK.		
32	96 50 779 08	1	PROTECTION PLATE WELDED LINKS	SCHUTZBLECH SCHWK.		
33	95 41 175 08	2	CARRIER RAIL 340	TRAGSCHIENE		
34	97 55 008 08	2	PLATE 3X150X40	BLECH		
35	95 51 525 08	1	PLATE 4X60X103	BLECH		
36	95 56 681 08	1	PLATE X0	BLECH		
37	97 79 887 08	2	PLATE 4X492X116	BLECH		
38	10 45 165 0	4	QUICK RELEASE PIN 20X100 NIROSTA	KUGELSPERRBOLZEN		
40	97 02 204 08	1	PLATE 10x100x100	BLECH		
41	97 49 680 08	4	WASHER 5X120X120	SCHEIBE		
500	96 44 539 08	1	ELECTRIC FOR WINCH 4	ELEKTRIK WINDE 4		
			⇒ 2 920 350 96 44 539 08			

6.2.2009

etk_en_de_074515 LR 1600/2

☐ 95 (4/4)

LIEBHERR

WINCH 4 LUFFING GEAR
WINDE 4 EINZIEHWERK

⇒ 2 340
91 52 776 08

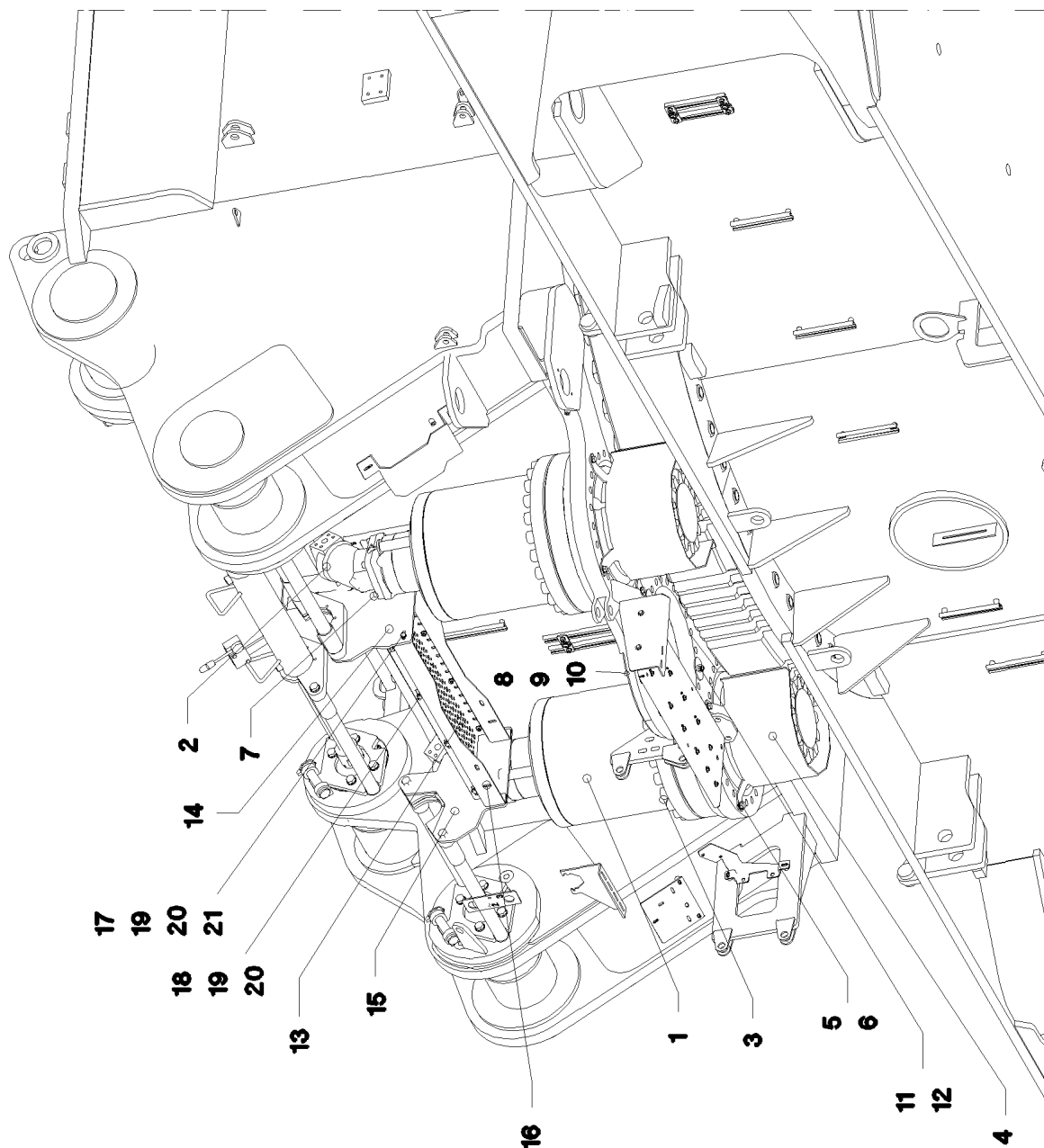

6.2.2009
052377

LIEBHERR

etk_en_de_074515 LR 1600/2

SLEWING GEAR
DREHWERK

□ 96 (1/2)

⇒ 2 350
91 52 778 08

Pos.	Item	Quantity	Description	Bezeichnung	Serie	K
1	96 97 916 01	2	SLEWING GEAR DAT 450/1441 ⇒ 9 697 916 01 96 97 916 01	DREHWERK		
2	51 02 354 08	2	HYDRO MOTOR SPF ⇒ 5 102 354 08 51 02 354 08	HYDROMOTOR		
3	49 01 989	48	CYLINDER SCREW ISO 4762 M24X160 10.9	ZYLINDERSCHRAUBE		
4	97 65 557 08	2	PROTECTION PLATE 4X307X778	SCHUTZBLECH		
5	40 65 164	6	HEX BOLT ISO 4017 M10X25 8.8 A3C	SECHSKANTSCHRAUBE		
6	50 09 175 08	6	WASHER DIN 125 A 10.5 A2	SCHEIBE		
7	40 42 120 08	8	CYLINDER SCREW DIN 912 M12X40 8.8 A3C	ZYLINDERSCHRAUBE		
8	97 66 383 08	1	LID 5X490X490	DECKEL		
9	46 00 310	3	HEX BOLT ISO 4014 M8X100 8.8 A2C	SECHSKANTSCHRAUBE		
10	42 18 009 08	3	WASHER DIN 9021 A 8.4 VERZ	SCHEIBE		
11	94 11 381 08	3	WASHER 70X3	SCHEIBE		
12	41 19 005 08	3	HEX NUT DIN 985 M8 8 VERZ	SECHSKANTMUTTER		
13	97 85 607 08	1	TREAD	TRITT		
14	97 85 716 08	1	PLATE 8X369X382	BLECH		
15	97 85 717 08	1	PLATE 8X369X382	BLECH		
16	97 85 718 08	2	PLATE 4X883X130	BLECH		
17	40 66 042	4	HEX BOLT ISO 4017 M8X25 10.9 A2C	SECHSKANTSCHRAUBE		
18	49 00 089	8	HEX BOLT ISO 4017 M8X20 8.8 A2C	SECHSKANTSCHRAUBE		
19	41 15 141 08	12	HEX NUT DIN 934 M8 8 A2C	SECHSKANTMUTTER		
20	42 00 012 08	24	WASHER DIN 125 A8X16 ST VERZ	SCHEIBE		
21	42 18 009 08	4	WASHER DIN 9021 A 8.4 VERZ	SCHEIBE		
500	96 47 474 08	1	ELECTR.FOR SLEWING GEAR	ELEKTRIK DREHWERK		
(1)	69 27 015 08	2	PROXIMITY SWITCH INDUKTIV SPF	NAEHERUNGSSCHALTER		

6.2.2009

etk_en_de_074515 LR 1600/2

☐ 97 (2/2)

LIEBHERR

SLEWING GEAR
DREHWERK

⇒ 2 350
91 52 778 08

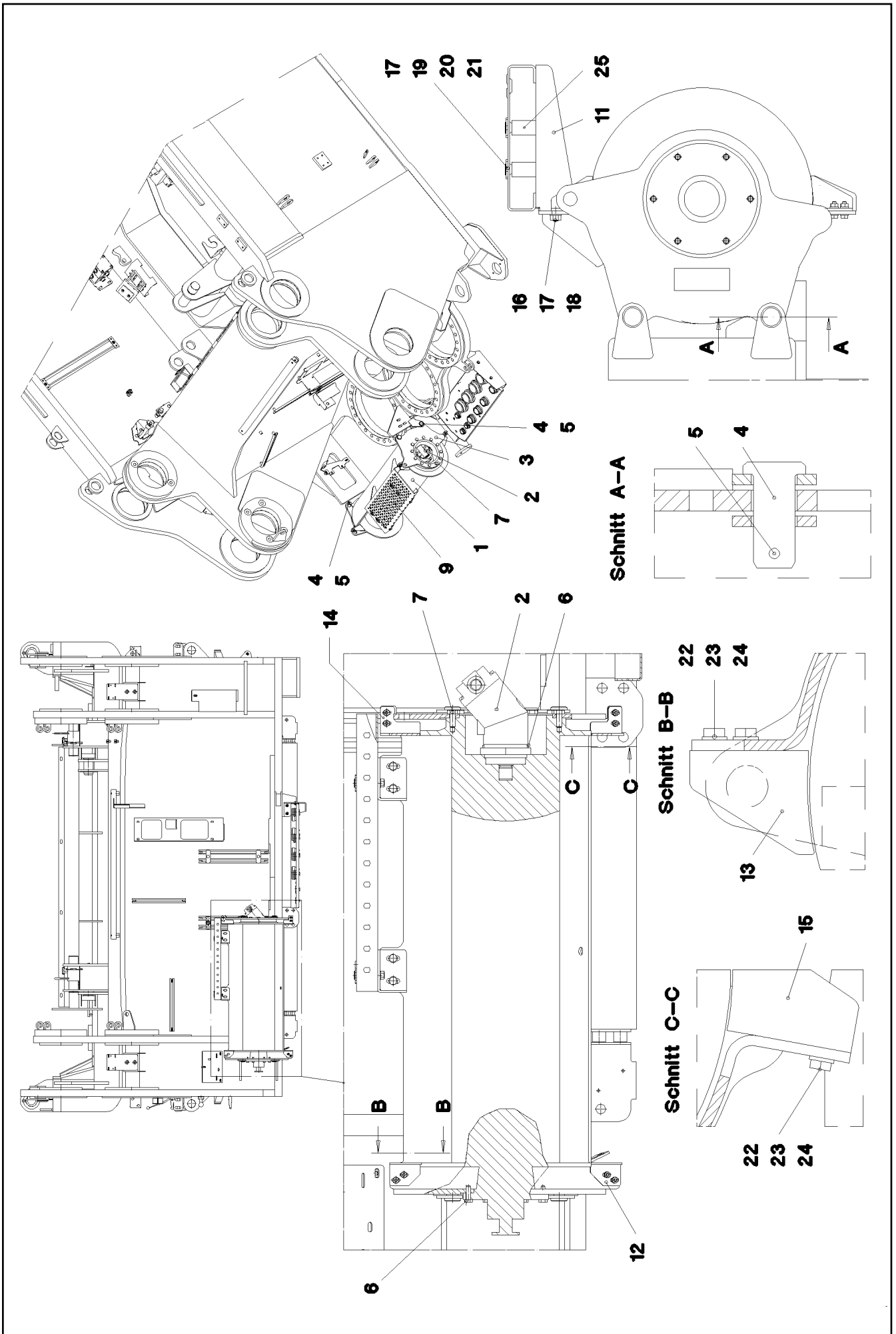

6.2.2009
052282

LIEBHERR

etk_en_de_074515 LR 1600/2

ERECTING WINCH
MONTAGEWINDE

☐ 98 (1/2)

⇒ 2 370
91 52 782 08

Pos.	Item	Quantity	Description	Bezeichnung	Serie	K
1	54 00 565 08	1	ROPE WINCH ZHP 4.13 SPF ⇒ 5 400 565 08 54 00 565 08	SEILWINDE		
2	51 02 306 08	1	HYDRO MOTOR SPF ⇒ 5 102 306 08 51 02 306 08	HYDROMOTOR		
3	96 54 448 08	1	BEARING WELDED	LAGERUNG SCHWK.		
4	45 12 222 08	4	PIN DIN 1435 20H11X45X38 ST.50 VERZ	BOLZEN		
5	43 30 052 08	4	SPLIT PIN DIN 94 4X32 ST VERZ	SPLINT		
6	49 00 128	10	HEX BOLT ISO 4017 M8X25 8.8 A2C	SECHSKANTSCHRAUBE		
7	40 65 164	12	HEX BOLT ISO 4017 M10X25 8.8 A3C	SECHSKANTSCHRAUBE		
9	97 85 605 08	1	TREAD	TRITT		
11	97 85 781 08	2	PLATE 4X283X127	BLECH		
12	97 85 872 08	1	PLATE 4X86X60	BLECH		
13	97 85 873 08	1	PLATE 4X85X60	BLECH		
14	97 85 874 08	1	PLATE 4X97X77	BLECH		
15	97 85 875 08	1	PLATE 4X97X65	BLECH		
16	49 00 089	4	HEX BOLT ISO 4017 M8X20 8.8 A2C	SECHSKANTSCHRAUBE		
17	42 00 012 08	12	WASHER DIN 125 A8X16 ST VERZ	SCHEIBE		
18	41 15 141 08	4	HEX NUT DIN 934 M8 8 A2C	SECHSKANTMUTTER		
19	78 89 018 08	4	FIXING OR FASTENING PART KUNSTSTOF	BEFESTIGUNGSSTUECK		
20	40 86 049 08	4	COUNTERSUNK SCREW DIN 7991 M8X70 8.	SENKSCHRAUBE		
21	41 15 046 08	4	HEX NUT DIN 934 M8 10 VERZ	SECHSKANTMUTTER		
22	40 00 829	8	HEX BOLT ISO 4017 M6X20 8.8 A2C	SECHSKANTSCHRAUBE		
23	42 00 009 08	16	WASHER ISO 7089 A 6.4 VERZ	SCHEIBE		
24	41 15 140 08	8	HEX NUT DIN 934 M6 8 VERZ	SECHSKANTMUTTER		
25	97 88 595 08	4	TUBE 20.0X33	ROHR		

6.2.2009

etk_en_de_074515 LR 1600/2

☐ 99 (2/2)

LIEBHERR

ERECTING WINCH
MONTAGEWINDE

⇒ 2 370
91 52 782 08

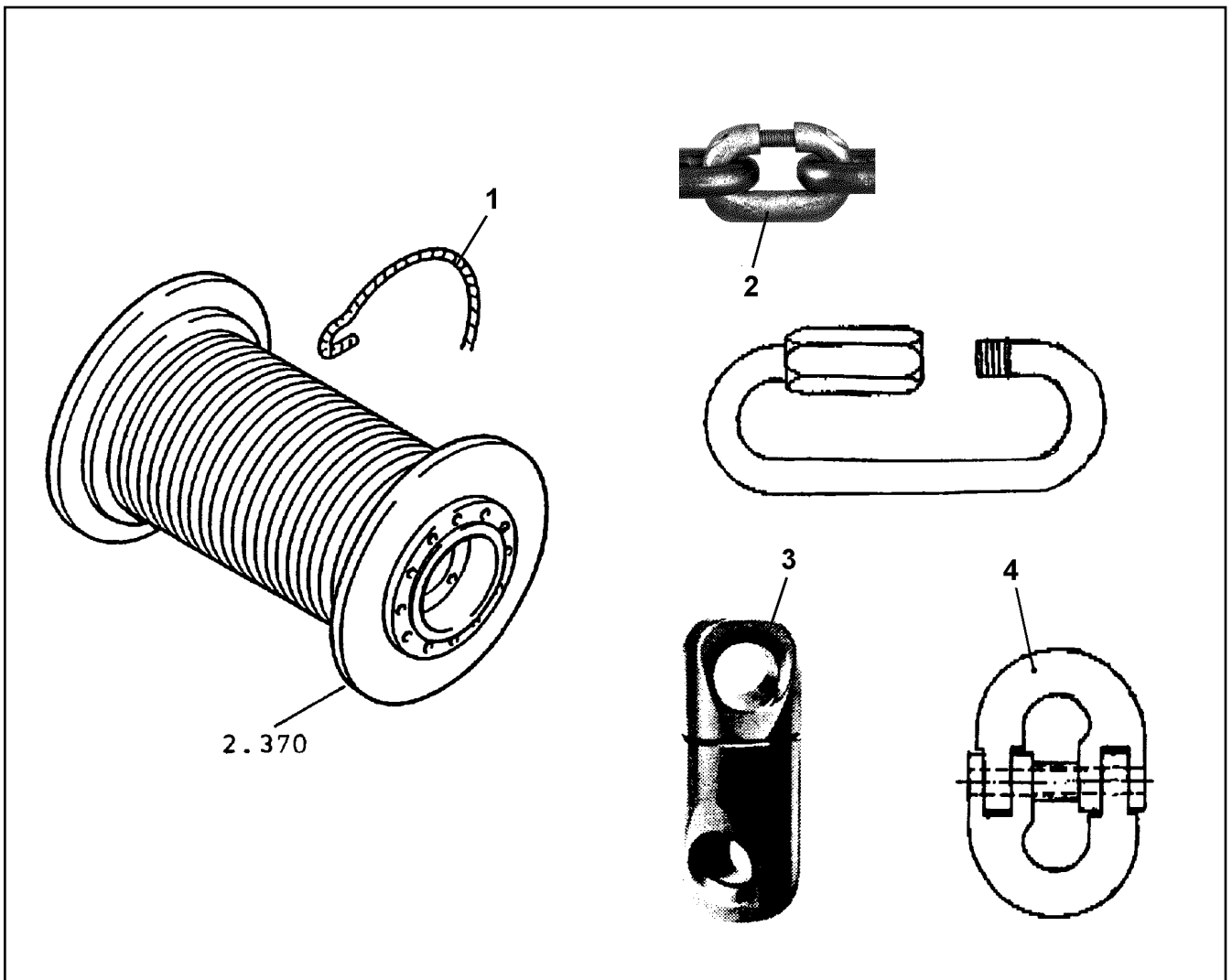

Pos.	Item	Quantity	Description	Bezeichnung	Serie	K
1	10 03 825 9	1	ROPE 8MM 400M	SEIL		
2	10 33 216 1	2	CONNECTING ELEMENT SPF	VERBINDUNGSGLIED		
3	77 39 466 08	1	TWIST STOPPER	DRALLFAENGER		
4	74 00 026 08	2	UNIVERSAL CONNECTING LINK CW6	UNIVERSALVERBINDUNGSGLIE		

6.2.2009
135387

LIEBHERR

etk_en_de_074515 LR 1600/2

ROPE WITH ACCESSORIES
SEIL MONTAGEWINDE M.ZUBEHOER

☐ 100

⇒ 2 372
91 33 648 08

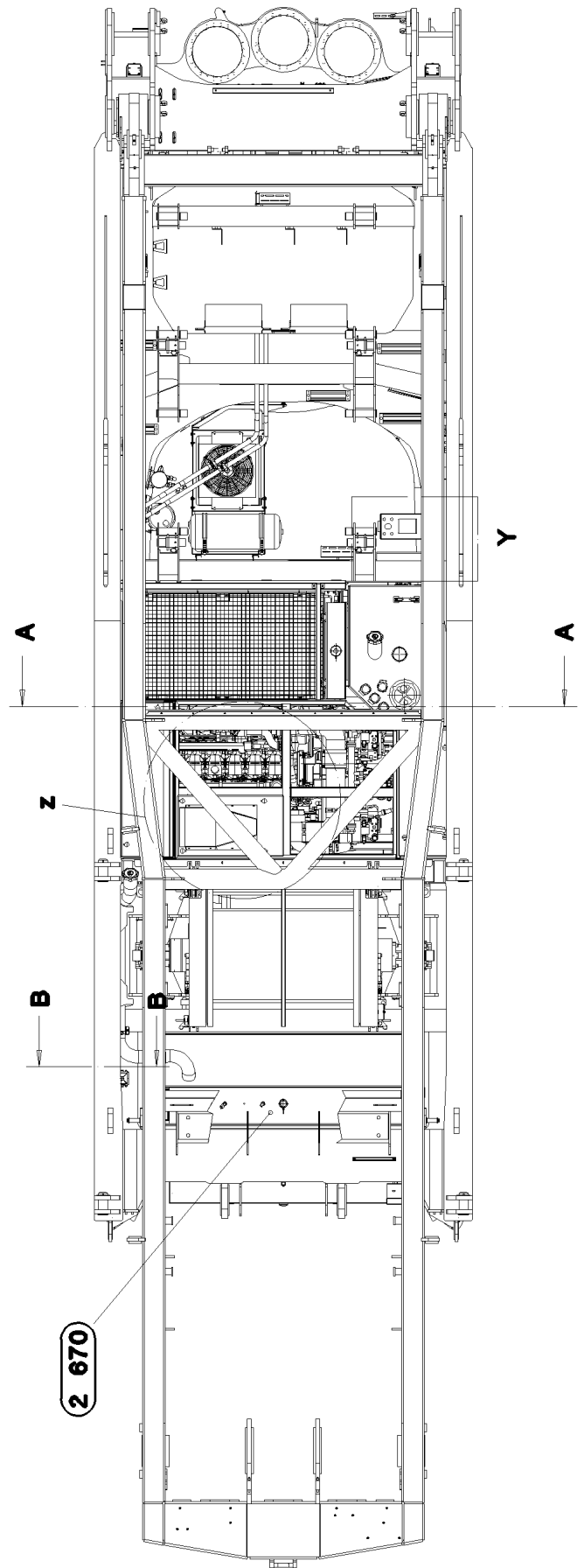
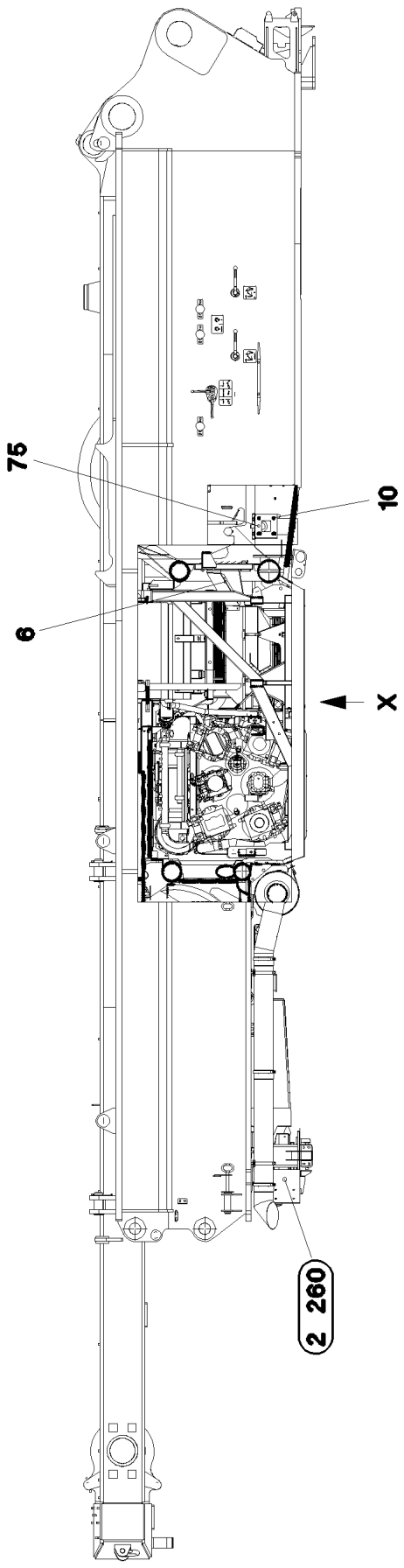

6.2.2009
053050

LIEBHERR

etk_en_de_074515 LR 1600/2

DIESEL ENGINE CPL.
DIESELMOTOR KPL.

101 (1/3)

⇒ 2 391
91 52 784 08

Schnitt B-B

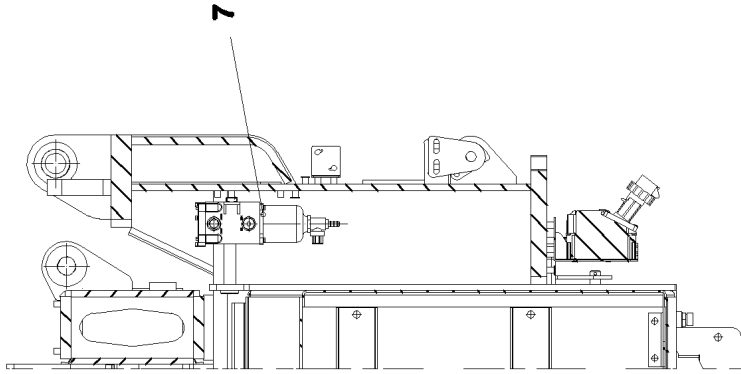

Einzelheit Y

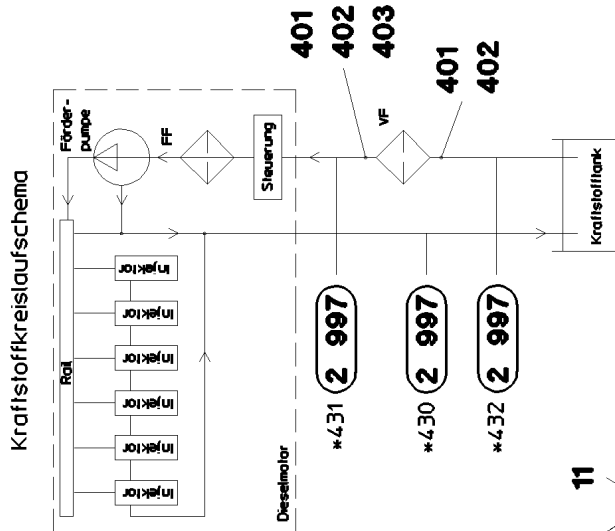
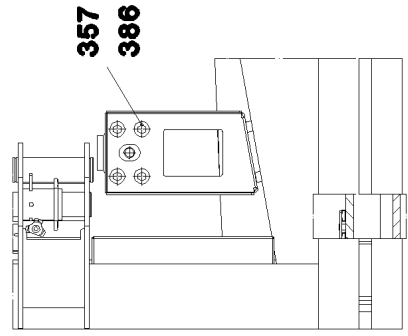

Einzelheit z

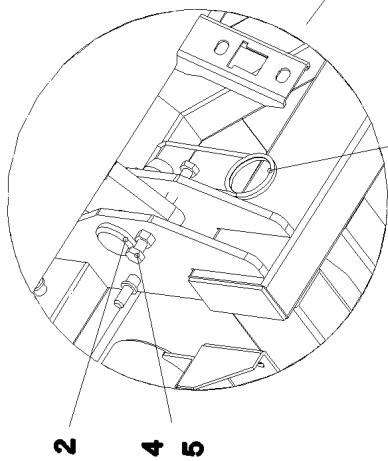
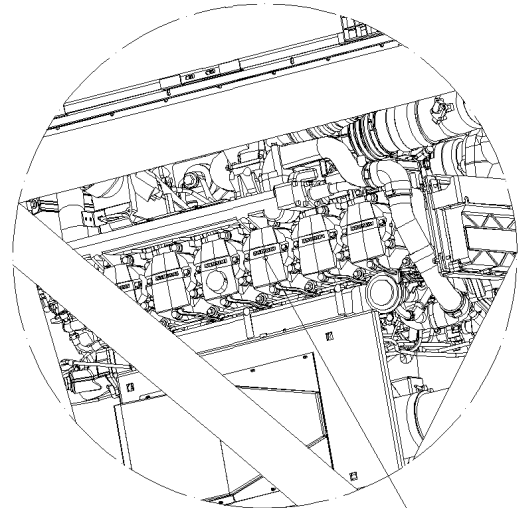

Ansicht X

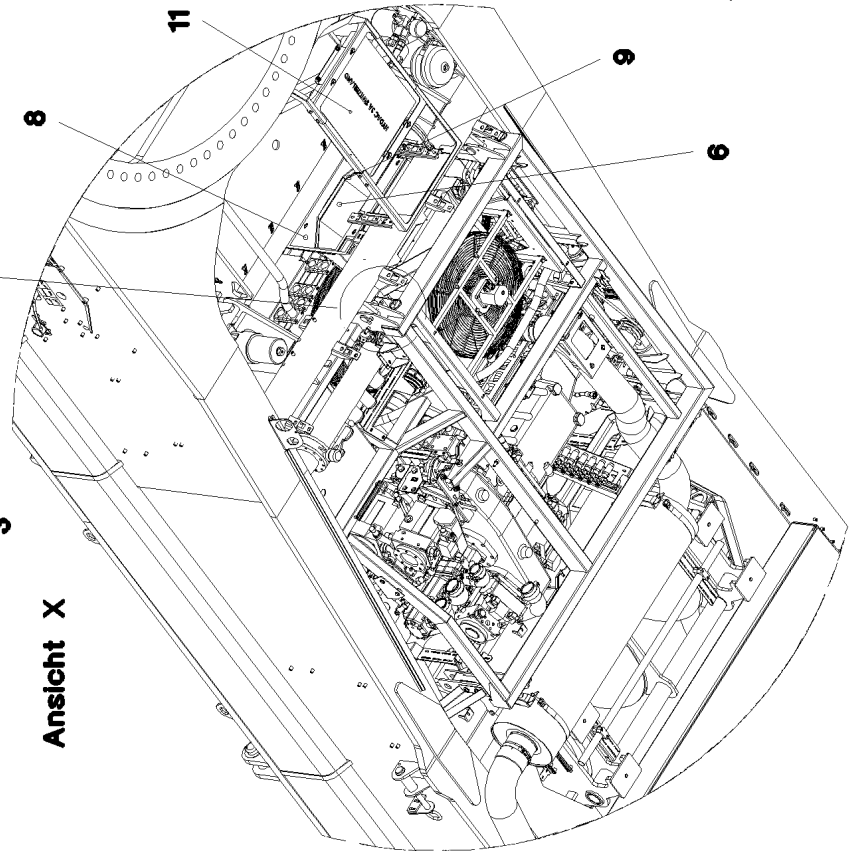

6.2.2009
054192

LIEBHERR

etk_en_de_074515 LR 1600/2

DIESEL ENGINE CPL.
DIESELMOTOR KPL.

102 (2/3)

⇒ 2 391
91 52 784 08

Pos.	Item	Quantity	Description	Bezeichnung	Serie	K
1	96 45 719 08	1	DIESEL ENGINE, PRE-ASSEMBLED ⇒ 2 391 001 96 45 719 08	DIESELMOTOR VORM.		
2	94 51 057 08	4	PIN RD35X105 42CR	BOLZEN		
3	43 31 025 08	4	RETAINING SPRING 5 VERZ	SICHERUNGSFEDER		
4	46 00 156	8	HEX BOLT ISO 4017 M12X50 8.8 A3C	SECHSKANTSCHRAUBE		
5	41 15 143 08	8	HEX NUT DIN 934 M12 8 VERZ	SECHSKANTMUTTER		
6	96 50 616 08	1	COVER CPL ⇒ 2 391 039 96 50 616 08	HUTZE KPL		
7	70 27 481 03	1	WATER SEPARATOR ⇒ 7 027 481 03 70 27 481 03	WASSERABSCHEIDER		
8	97 79 370 08	1	PLATE 2X749X420	BLECH		
9	26 21 039 08	1.75	EDGE PROTECTION	KANTENSCHUTZ		
10	95 38 734 08	4	SLEEVE	HUELSE		
11	96 56 360 08	1	RADIATOR ⇒ 2 391 102 96 56 360 08	ZUSATZKUEHLER VORM.		
75	97 84 521 08	1	PLATE 4X555X617	BLECH		
357	49 00 120	4	HEX BOLT ISO 4017 M12X20 8.8 A3C	SECHSKANTSCHRAUBE		
386	42 18 011 08	4	WASHER ISO 7093-1 A 13 ST A3C	SCHEIBE		
401	47 10 503 08	2	FLANGE JOINT GEO18-LM A3P	VERSCHRAUBUNG		
402	47 25 304 08	2	FLANGE JOINT EWSD18-L A3P	VERSCHRAUBUNG		
403	47 54 356 08	1	FLANGE JOINT REDSD18/15-L A3P	VERSCHRAUBUNG		

6.2.2009	etk_en_de_074515 LR 1600/2	<input type="checkbox"/> 103 (3/3)
LIEBHERR	DIESEL ENGINE CPL. DIESELMOTOR KPL.	⇒ 2 391 91 52 784 08

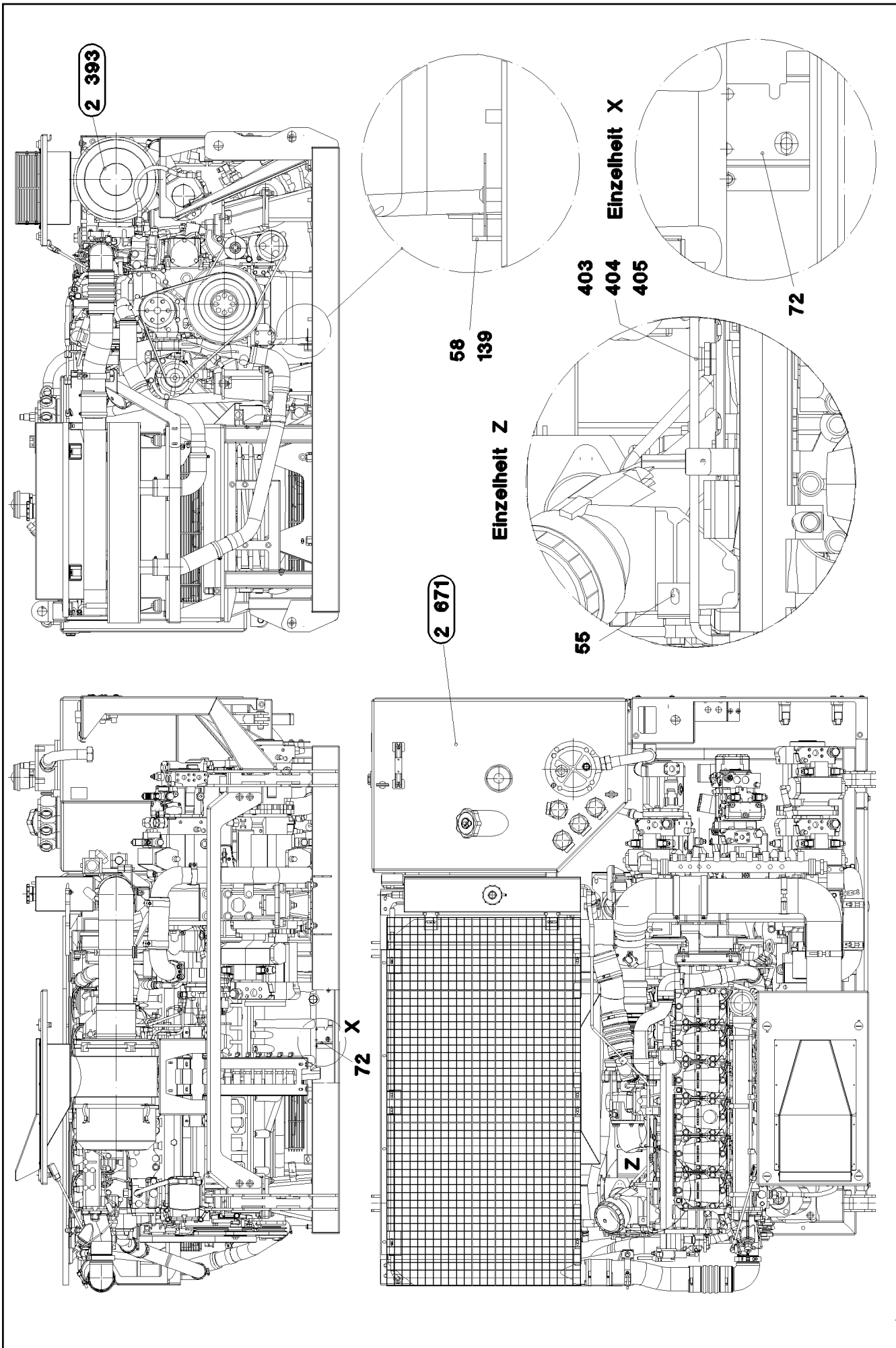

6.2.2009
053055

LIEBHERR

etk_en_de_074515 LR 1600/2

DIESEL ENGINE, PRE-ASSEMBLED
DIESELMOTOR VORM.

104 (1/9)

⇒ 2 391 001
96 45 719 08

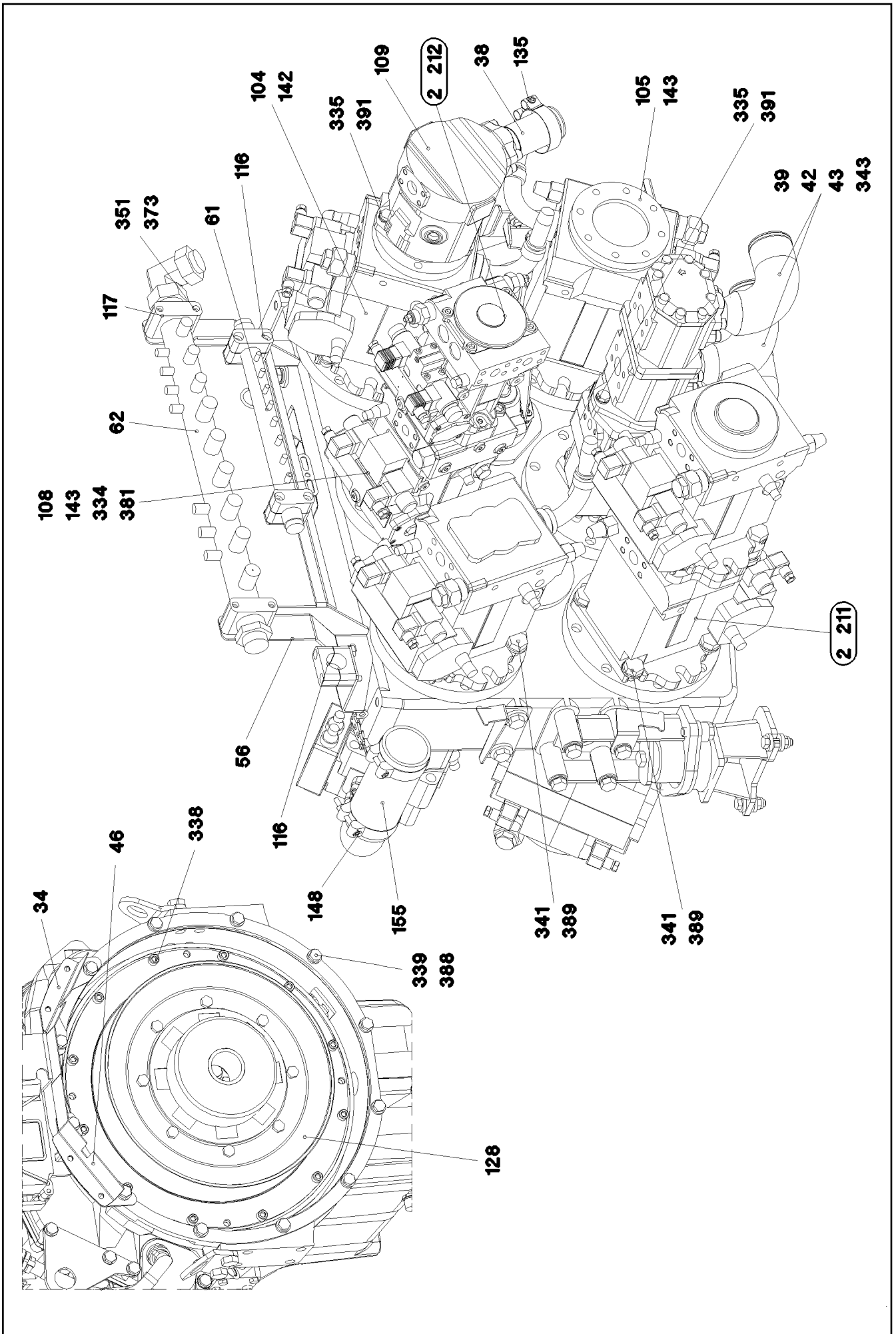

6.2.2009
053056

LIEBHERR

etk_en_de_074515 LR 1600/2

DIESEL ENGINE, PRE-ASSEMBLED
DIESELMOTOR VORM.

105 (2/9)

→ 2 391 001
96 45 719 08

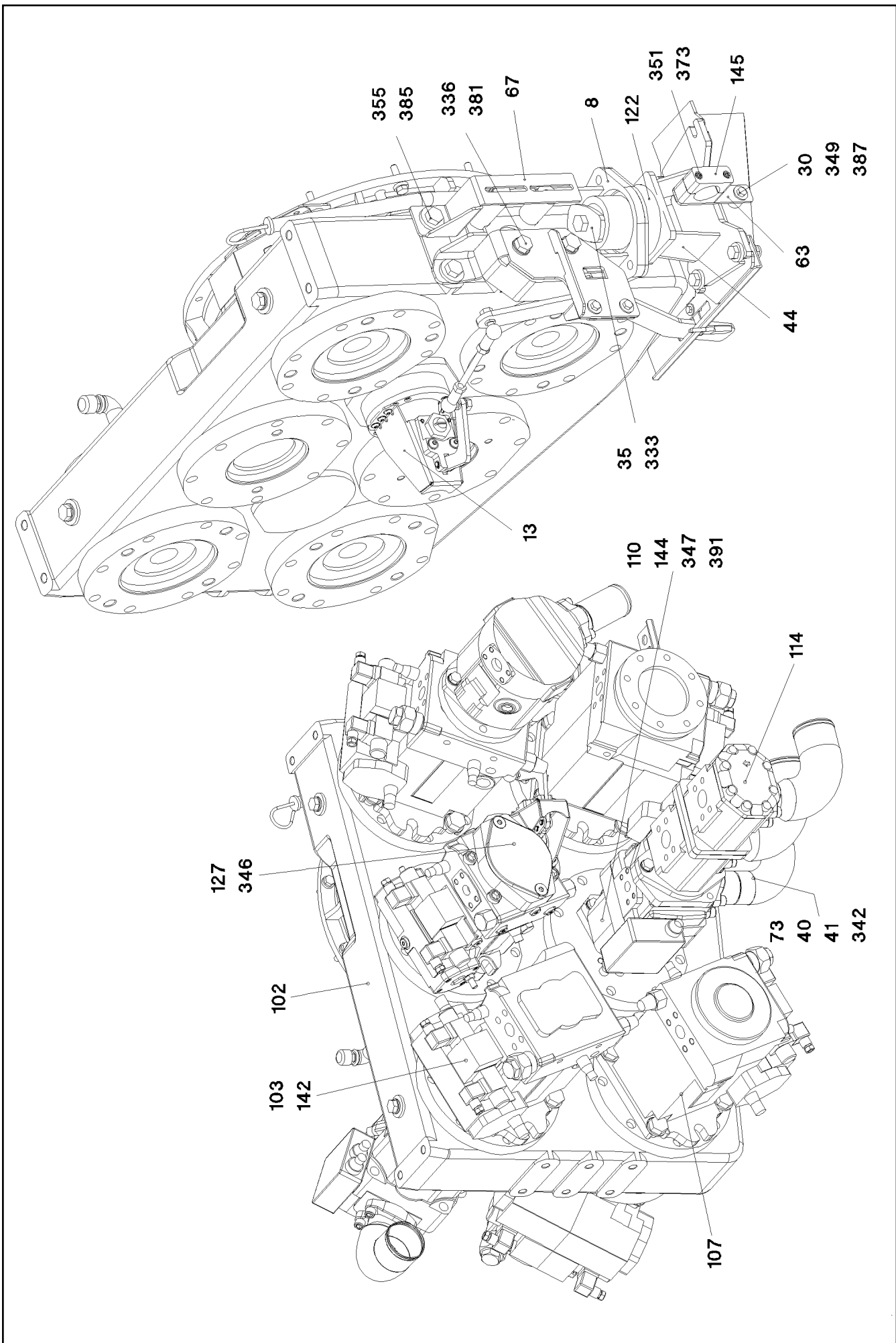

6.2.2009
053057

LIEBHERR

etk_en_de_074515 LR 1600/2

DIESEL ENGINE, PRE-ASSEMBLED
DIESELMOTOR VORM.

□ 106 (3/9)

→ 2 391 001
96 45 719 08

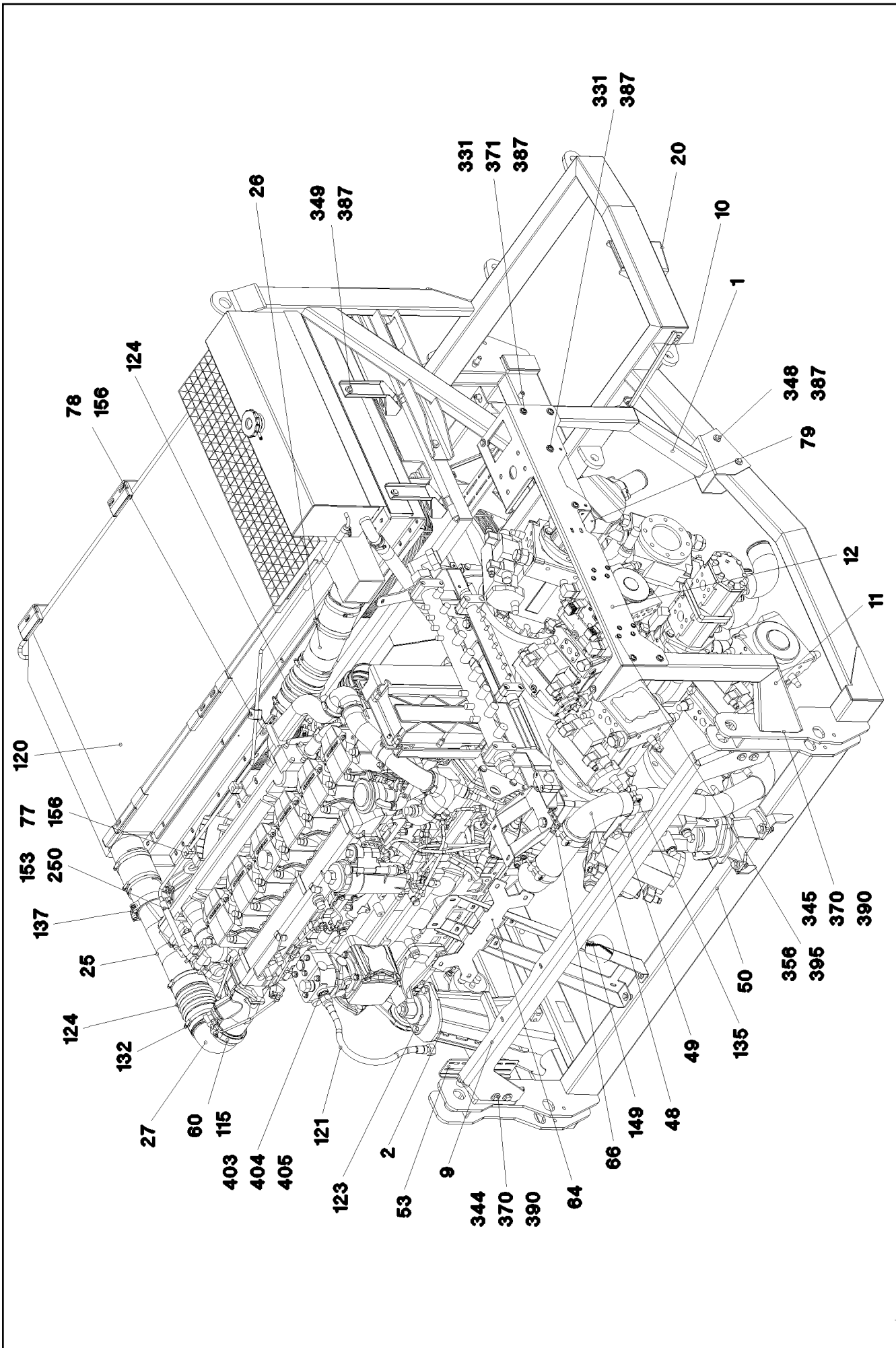

6.2.2009
053058

LIEBHERR

etk_en_de_074515 LR 1600/2

DIESEL ENGINE, PRE-ASSEMBLED
DIESELMOTOR VORM.

□ 107 (4/9)

→ 2 391 001
96 45 719 08

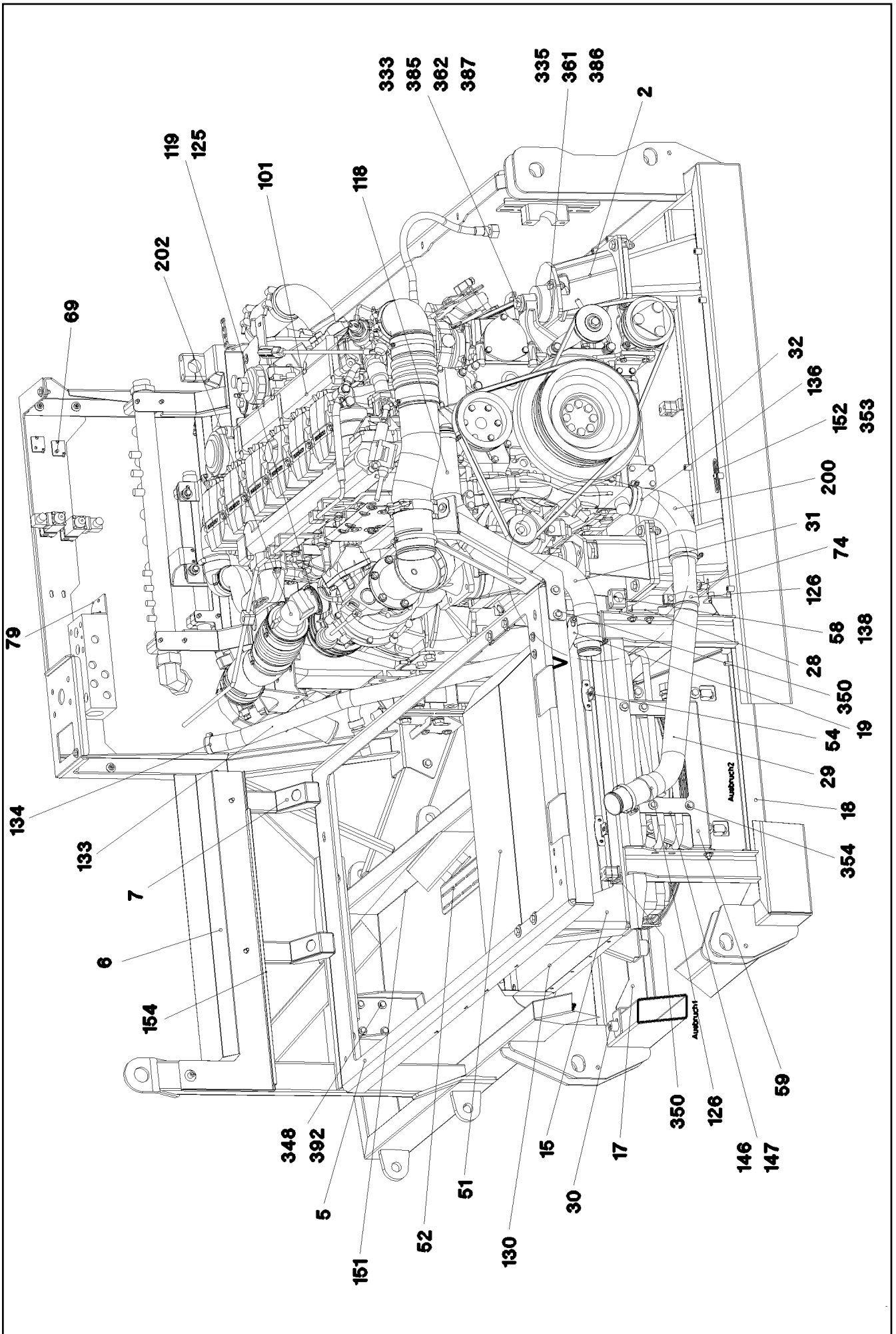

6.2.2009
053059

LIEBHERR

etk_en_de_074515 LR 1600/2

DIESEL ENGINE, PRE-ASSEMBLED
DIESELMOTOR VORM.

108 (5/9)

→ 2 391 001
96 45 719 08

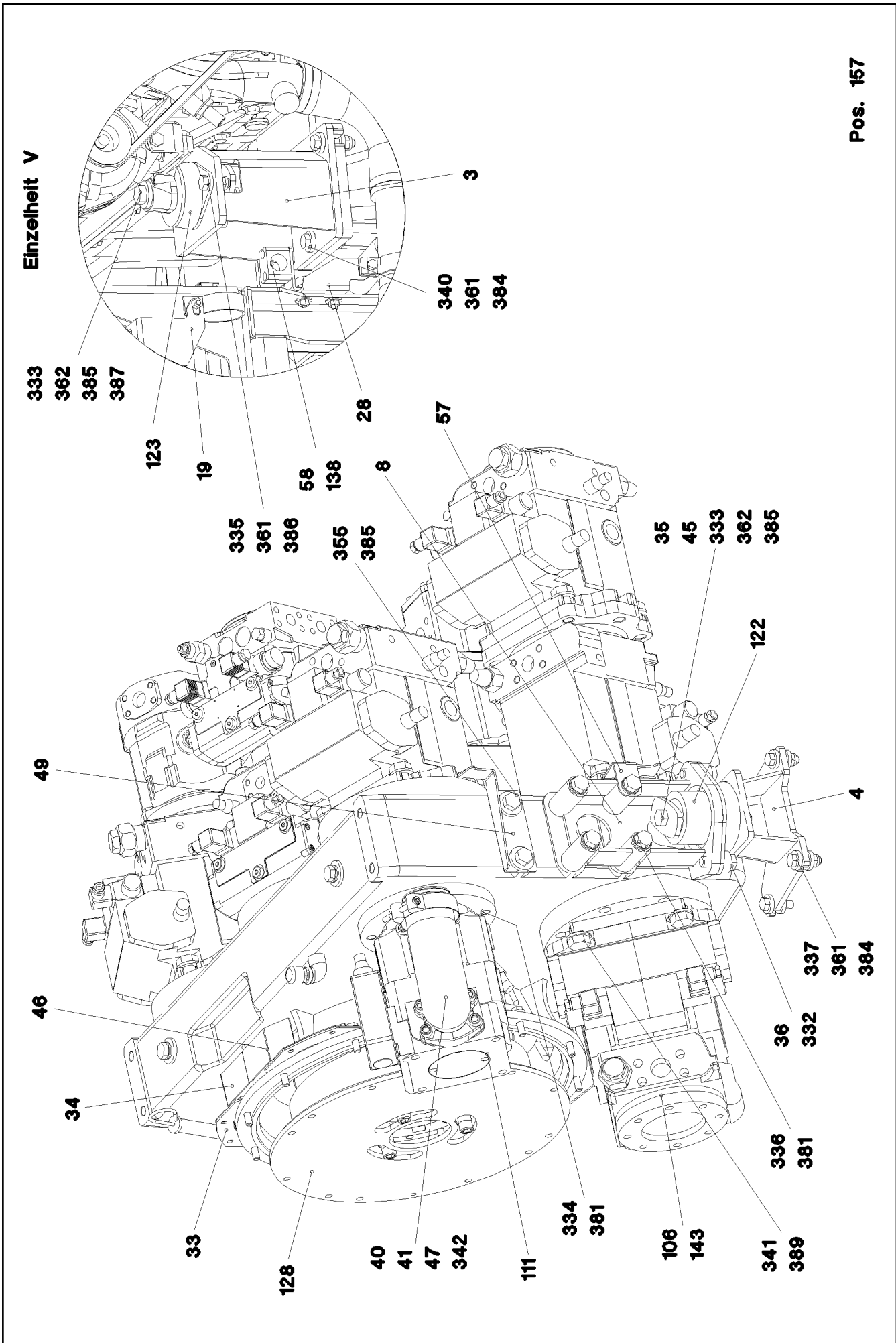

Einzelheit V

6.2.2009
053060
LIEBHERR

etk_en_de_074515 LR 1600/2
DIESEL ENGINE, PRE-ASSEMBLED
DIESELMOTOR VORM.

□ 109 (6/9)
⇒ 2 391 001
96 45 719 08

Pos.	Item	Quantity	Description	Bezeichnung	Serie	K
1	96 48 491 08	1	SUPPORT	STUETZE SCHWK.		
2	96 48 468 08	1	ENGINE BRACKET LEFT	MOTORKONSOLE LI.		
3	96 48 457 08	1	ENGINE BRACKET RIGHT	MOTORKONSOLE RE.		
4	96 48 449 08	1	MOTOR BRACKET	MOTORKONSOLE		
5	97 73 392 08	1	PLATE 5X1799X963	BLECH		
6	96 48 170 08	1	SHEET CPL.	BLECH KPL.		
7	97 73 394 08	2	PLATE 3X380X225	BLECH		
8	96 43 477 08	2	ENGINE BRACKET WELDED	MOTORKONSOLE SCHWK.		
9	97 73 395 08	1	PLATE 5X1762X282	BLECH		
10	97 73 396 08	1	PLATE 4X618X343	BLECH		
11	97 73 397 08	1	PLATE 4X219X1068	BLECH		
12	97 73 398 08	1	PLATE 4X1010X384	BLECH		
13	96 53 645 08	1	CLUTCH ACTUATOR	KUPPLUNGSSTELLER		
			⇒ 2 391 040 96 53 645 08			
15	97 73 421 08	1	PLATE 5X1183X338	BLECH		
17	97 73 423 08	1	PLATE 4X1087X134	BLECH		
18	97 73 424 08	1	PLATE 4X1087X134	BLECH		
19	97 73 425 08	1	PLATE 4X100X145	BLECH		
20	97 73 532 08	1	PLATE 4X227X202	BLECH		
25	96 48 500 08	1	CHARGE AIR PIPE SPF	LADELUFTROHR		
26	96 48 501 08	1	CHARGE AIR PIPE SPF	LADELUFTROHR		
27	97 25 170 08	1	CHARGED AIR TUBE BEND SPF	LADELUFT ROHRBOGEN		
28	97 66 574 08	1	PLATE 4X110X89	BLECH		
29	96 48 528 08	1	WATER PIPE	WASSERROHR SCHWK.		
30	95 38 734 08	11	SLEEVE	HUELSE		
31	96 48 606 08	1	PIPE WELDED	ROHR SCHWK.		
32	97 74 929 08	1	PLATE 4X498X192	BLECH		
33	97 75 000 08	2	PLATE 3X159X113	BLECH		
34	97 75 001 08	1	PLATE 1.5X219X84	BLECH		
35	97 64 835 08	4	PLATE 8X83X83	BLECH		
36	94 99 872 08	4	TUBE 33,7X8X15	ROHR		
38	96 49 134 08	1	SUCTION STUB PIPE WELDED	SAUGSTUTZEN SCHWK.		
39	96 17 591 08	2	AIR INTAKE	SAUGSTUTZEN		
40	72 64 216 08	2	O-RING ARP 568 56,74X3,53 NBR70	O-RING		
41	51 15 167 08	4	FLANGE HALF 2"	FLANSCHHAELFTE		
42	51 15 026 08	6	SAE FLANGE 11/2"	SAE-FLANSCH		
43	51 05 879 08	3	O-RING ARP 568 47,22X3,53 NBR90	O-RING		
44	96 49 935 08	1	MOTOR BRACKET	MOTORKONSOLE		
45	94 78 115 08	2	TUBE 25X3,2X100	ROHR		
46	97 77 539 08	1	PLATE 1.5X219X84	BLECH		
47	96 50 514 08	1	SUCTION STUB PIPE WELDED	SAUGSTUTZEN SCHWK.		
48	96 50 520 08	1	SUCTION PIPE WELDED	SAUGROHR SCHWK.		
49	97 78 727 08	2	PLATE 3X207X105	BLECH		
50	96 46 563 08	1	EQUIPMENT CARRIER WELDED	AGGREGATETRAEGER SCHWK.		
51	96 50 546 08	1	COVER CPL	HUTZE KPL		
52	97 79 824 08	1	PLATE 4X470X271	BLECH		
53	97 79 826 08	1	PLATE 4X260X98	BLECH		
54	97 78 751 08	4	PLATE 2.5X80X48	BLECH		
55	94 73 392 08	1	ANGLE 3X40X94	WINKEL		
56	96 51 071 08	1	SHEET CPL.	BLECH KPL.		
57	97 79 878 08	1	PLATE 3X110X93	BLECH		
58	95 14 733 08	7	HOLDER 4X30X95	HALTER		
59	97 80 168 08	1	PLATE 3X450X252	BLECH		
60	51 05 993 08	1	O-RING ARP 568 85,32X3,53 NBR70	O-RING		
61	92 79 826 08	1	COLLECTING PIPE	SAMMELROHR		
62	92 57 933 08	1	COLLECTING PIPE WELDED	SAMMELROHR SCHWK.		
63	97 80 169 08	1	PLATE 4X140X30	BLECH		
64	97 80 256 08	1	PLATE 4X189X430	BLECH		
66	95 28 598 08	3	PLATE 4X103X20 S235JRG2	BLECH		
67	97 81 060 08	1	PLATE 4X335X109	BLECH		

6.2.2009

etk_en_de_074515 LR 1600/2

□ 110 (7/9)

LIEBHERRDIESEL ENGINE, PRE-ASSEMBLED
DIESELMOTOR VORM.⇒ 2 391 001
96 45 719 08

Pos.	Item	Quantity	Description	Bezeichnung	Serie	K
69	97 61 821 08	4	PLATE 4X40X35	BLECH		
72	97 07 719 08	1	PLATE 3X144X80	BLECH		
73	96 52 448 08	1	SUCTION STUB PIPE WELDED	SAUGSTUTZEN SCHWK.		
74	73 00 009 08	1	VALVE DIN 71401 C M14X1,5	VENTIL		
77	97 85 175 08	2	PLATE 4X178X30	BLECH		
78	97 85 357 08	1	PLATE 3X90X103	BLECH		
79	97 85 358 08	1	PLATE 3X100X90	BLECH		
101	97 39 400	1	DIESEL ENGINE D846 A7 ⇒ 9 739 400 97 39 400	DIESELMOTOR		
102	10 35 659 9	1	DISTRIBUTOR GEARBOX SPF	VERTEILERGETRIEBE		
103	10 35 924 1	1	VARIABLE PUMP A4VG/90 LI SPF ⇒ X10359241 10 35 924 1	VERSTELLPUMPE		
104	10 35 924 2	1	VARIABLE PUMP A4VG/90 LI SPF ⇒ X10359242 10 35 924 2	VERSTELLPUMPE		
105	10 35 924 3	1	VARIABLE PUMP A4VG/125LI SPF ⇒ X10359243 10 35 924 3	VERSTELLPUMPE		
106	10 35 924 4	1	VARIABLE PUMP A4VG/125RE SPF ⇒ X10359244 10 35 924 4	VERSTELLPUMPE		
107	10 35 925 0	1	VARIABLE PUMP A4VG/90 LI SPF ⇒ X10359250 10 35 925 0	VERSTELLPUMPE		
108	10 35 924 6	1	VARIABLE PUMP A4VG/56 LI SPF ⇒ X10359246 10 35 924 6	VERSTELLPUMPE		
109	10 35 925 1	1	VARIABLE PUMP PA10VO/45 LI SPF ⇒ X10359251 10 35 925 1	VERSTELLPUMPE		
110	10 35 924 7	1	VARIABLE PUMP A11VO/40LI SPF ⇒ X10359247 10 35 924 7	VERSTELLPUMPE		
111	10 35 924 8	1	VARIABLE PUMP A11VO/60RE SPF ⇒ X10359248 10 35 924 8	VERSTELLPUMPE		
114	51 21 370 08	1	DOUBLE GEAR PUMP SPF	DOPPELZAHNRADPUMPE		
115	10 45 120 6	1	PROFIL CLAMP 108/25 A2-70	PROFILSCHELLE		
116	60 20 091 08	4	CLAMP-HALF DIN 3015-1 L 5 R 35 PP SW	KLEMMHAELFTE		
117	74 13 103	4	CLAMP-HALF DIN 3015-1 L6R 50,8 PP SW	KLEMMHAELFTE		
118	97 47 495 08	1	FORM HOSE NW60X30GRAD SPF	FORMSCHLAUCH		
119	77 42 856 08	1	RETAINER CLIP 77/20 ST	SPANNSCHELLE		
120	96 45 720 08	1	RADIATOR, PRE-ASSEMBLED ⇒ 2 391 023 96 45 720 08	KUEHLER VORM.		
121	51 05 010 08	1	HOSE	SCHLAUCH		
122	55 04 515 08	2	VIBRATION DAMPER	SCHWINGUNGSDAEMPFER		
123	55 04 516 08	2	VIBRATION DAMPER	SCHWINGUNGSDAEMPFER		
124	55 17 025 08	2	CHARGE AIR CORRUGATED HOSE 100X19	LADELUFTWELLSCHLAUCH		
125	10 01 192 1	1	O RING 63X2,5 FPM1-70-GN	RUNDDICHRING		
126	55 20 506 08	4	PIPE CLAMP DIN 71555 60,5 A3C	ROHRSCHELLE		
127	10 22 566 6	1	LID SAE-B	DECKEL		
128	10 42 823 9	1	COUPLING SILIKON 60SH	KUPPLUNG		
130	96 47 931 08	1	OIL COOLER, PRE-ASSEMBLED ⇒ 2 391 038 96 47 931 08	OELKUEHLER VORM.		
132	55 08 494 08	8	HOSE CLAMP 100-120 W3	SCHLAUCHSCHELLE		
133	77 42 307 08	2	COOLING WATER HOSE DN32 Rolle40m	KUEHLWASSERSCHLAUCH		
134	55 08 495 08	2	HOSE CLAMP 32-50 W3	SCHLAUCHSCHELLE		
135	10 65 265 7	6	HOSE CLAMP 70/68-73/25 ST	SCHLAUCHSCHELLE		
136	77 42 143 08	8	HOSE CLAMP 60-80 W3	SCHLAUCHSCHELLE		
137	77 42 229 08	1	RETAINER CLIP 102-100 ST	SPANNSCHELLE		
138	70 05 052	10	CLAMP-HALF DIN 3015-1 L 3 R 25 PP SW	KLEMMHAELFTE		
139	60 20 022 08	4	CLAMP-HALF DIN 3015-1 18 AL	KLEMMHAELFTE		
142	51 85 781 08	5	O-RING 150X3 NBR70	O-RING		
143	72 64 260 08	2	O-RING 125X3 NBR70	O-RING		
144	72 64 351 08	1	O-RING 100X2,5 NBR70	O-RING		
145	60 20 094 08	1	CLAMP-HALF DIN 3015-1 L5R 42 PP SW	KLEMMHAELFTE		
146	60 20 014 08	4	CLAMP-HALF 4X18	KLEMMHAELFTE		
147	60 20 015 08	2	LID PLATE 30X5X178/2 ST D9 ZNC	DECKPLATTE		

6.2.2009

etk_en_de_074515 LR 1600/2

111 (8/9)

LIEBHERRDIESEL ENGINE, PRE-ASSEMBLED
DIESELMOTOR VORM.⇒ 2 391 001
96 45 719 08

Pos.	Item	Quantity	Description	Bezeichnung	Serie	K
148	77 42 279 08	8	HOSE CLAMP 86-91X25 ST	SCHLAUCHSCHELLE		
149	97 03 448 08	1	CARRIER RAIL	TRAGSCHIENE		
151	95 41 174 08	1	CARRIER RAIL 240	TRAGSCHIENE		
152	95 36 500 08	2	CABLE HOLDER 2X22X90	KABELHALTER		
153	77 42 086 08	2	HOSE CLAMP DIN 3017-1 21,5/16-27/12 W3	SCHLAUCHSCHELLE		
154	26 21 047 08	0.85	SEALING PROFILE	DICHTPROFIL		
155	10 34 353 0	4	SIPHON PIPE 76X6 NBR SPF	SAUGSCHLAUCH		
156	60 20 078 08	2	CLAMP-HALF DIN 3015-1 10 PP SW	KLEMMHAELFTE		
157	10 10 075 2	2.2	HOSE GUARD SPIRAL 26,5 ST VERZ.	SCHLAUCHSCHUTZSPIRALE		
200	55 08 984 08	1	ELBOW DN60 GUMMI	KRUEMMER		
202	10 01 242 0	1	AIR ELBOW	LADELUFTKRUEMMER		
250	77 42 306 08	2	COOLING WATER HOSE 10X4,5	KUEHLWASSERSCHLAUCH		
331	10 41 286 1	4	OVAL HEAD FLAT SCREW AEHNL.ISO7380	LINSENFLACHKOPFSCHRAUBE		
332	46 00 016	4	HEX BOLT ISO 4017 M16X45 8.8 A3C	SECHSKANTSCHRAUBE		
333	40 62 049 08	4	HEX BOLT ISO 4014 M16X150 10.9 FLZN SP	SECHSKANTSCHRAUBE		
334	46 00 189	4	HEX BOLT ISO 4017 M16X50 8.8 A3C	SECHSKANTSCHRAUBE		
335	49 00 204	10	HEX BOLT ISO 4017 M12X35 8.8 A3C	SECHSKANTSCHRAUBE		
336	46 00 038	8	HEX BOLT ISO 4014 M16X100 8.8 A3C	SECHSKANTSCHRAUBE		
337	46 00 158	8	HEX BOLT ISO 4017 M12X45 8.8 A3C	SECHSKANTSCHRAUBE		
338	49 00 195	12	CYLINDER SCREW ISO 4762 M10X45 8.8 A3	ZYLINDERSCHRAUBE		
339	46 00 122	12	HEX BOLT ISO 4017 M10X40 8.8 A3C	SECHSKANTSCHRAUBE		
340	46 00 312	6	HEX BOLT ISO 4017 M12X55 8.8 A3C	SECHSKANTSCHRAUBE		
341	46 00 097	20	HEX BOLT ISO 4017 M20X55 8.8 A3C	SECHSKANTSCHRAUBE		
342	40 42 120 08	12	CYLINDER SCREW DIN 912 M12X40 8.8 A3C	ZYLINDERSCHRAUBE		
343	40 97 516 08	8	SCREW AEHNL.ISO 4017 UNC1/2"X13X30 1	SCHRAUBE		
344	40 65 164	4	HEX BOLT ISO 4017 M10X25 8.8 A3C	SECHSKANTSCHRAUBE		
345	40 00 828	2	HEX BOLT ISO 4017 M10X30 8.8 A3C	SECHSKANTSCHRAUBE		
346	40 86 062 08	2	COUNTERSUNK SCREW DIN 7991 M12X20	SENKSCHEIBE		
347	49 00 100	2	HEX BOLT ISO 4017 M12X40 8.8 A3C	SECHSKANTSCHRAUBE		
348	49 00 188	4	HEX BOLT ISO 4017 M8X16 8.8 A2C	SECHSKANTSCHRAUBE		
349	49 00 089	4	HEX BOLT ISO 4017 M8X20 8.8 A2C	SECHSKANTSCHRAUBE		
350	49 00 128	10	HEX BOLT ISO 4017 M8X25 8.8 A2C	SECHSKANTSCHRAUBE		
351	40 02 418	8	CYLINDER SCREW ISO 4762 M6X65 8.8 A2C	ZYLINDERSCHRAUBE		
353	10 41 285 4	8	OVAL HEAD FLAT SCREW AEHNL.ISO7380	LINSENFLACHKOPFSCHRAUBE		
354	46 00 386	4	HEX BOLT ISO 4017 M8X60 8.8 A2C	SECHSKANTSCHRAUBE		
355	49 00 152	2	HEX BOLT ISO 4017 M16X30 8.8 A3C	SECHSKANTSCHRAUBE		
356	10 02 823 7	8	PAN-HEAD SCREW M5X16 A2	FLACHKOPFSCHRAUBE		
361	41 19 007 08	8	HEX NUT DIN 985 M12 8 A3C	SECHSKANTMUTTER		
362	41 19 014 08	4	HEX NUT DIN 985 M16 10 VERZ	SECHSKANTMUTTER		
370	41 15 144 08	4	HEX NUT DIN 934 M10 8 VERZ	SECHSKANTMUTTER		
371	41 15 141 08	10	HEX NUT DIN 934 M8 8 A2C	SECHSKANTMUTTER		
373	41 30 029 08	12	CAGE NUT M6	KAFIGMUTTER		
381	42 15 002 08	12	WASHER DIN 6916 17 C45 VERZ	SCHEIBE		
384	42 16 007 08	10	WASHER DIN 7349 13 ST VERZ	SCHEIBE		
385	42 16 009 08	2	WASHER DIN 7349 17 ST VERZ	SCHEIBE		
386	42 18 011 08	4	WASHER ISO 7093-1 A 13 ST A3C	SCHEIBE		
387	42 18 009 08	22	WASHER DIN 9021 A 8.4 VERZ	SCHEIBE		
388	55 08 998 08	12	WASHER	SCHEIBE		
389	42 15 003 08	4	WASHER DIN 6916 21 C45 VERZ	SCHEIBE		
390	42 18 010 08	12	WASHER DIN 9021 A 10,5 ST VERZ	SCHEIBE		
391	42 15 000 08	2	WASHER DIN 6916 13 C45 VERZ	SCHEIBE		
392	42 16 005 08	6	WASHER DIN 7349 8,4 ST VERZ	SCHEIBE		
395	42 18 006 08	8	WASHER DIN 9021 A 5,3 ST VERZ	SCHEIBE		
403	47 66 076 08	2	FLANGE JOINT XGE18-LM A3P	VERSCHRAUBUNG		
404	50 29 328 08	2	COMPRESSION RING DR/R26X31	DRUCKRING		
405	72 64 223 08	2	O-RING DIN 3770 25X2,5 FPM70	O-RING		

6.2.2009

etk_en_de_074515 LR 1600/2

112 (9/9)

LIEBHERRDIESEL ENGINE, PRE-ASSEMBLED
DIESELMOTOR VORM.⇒ 2 391 001
96 45 719 08

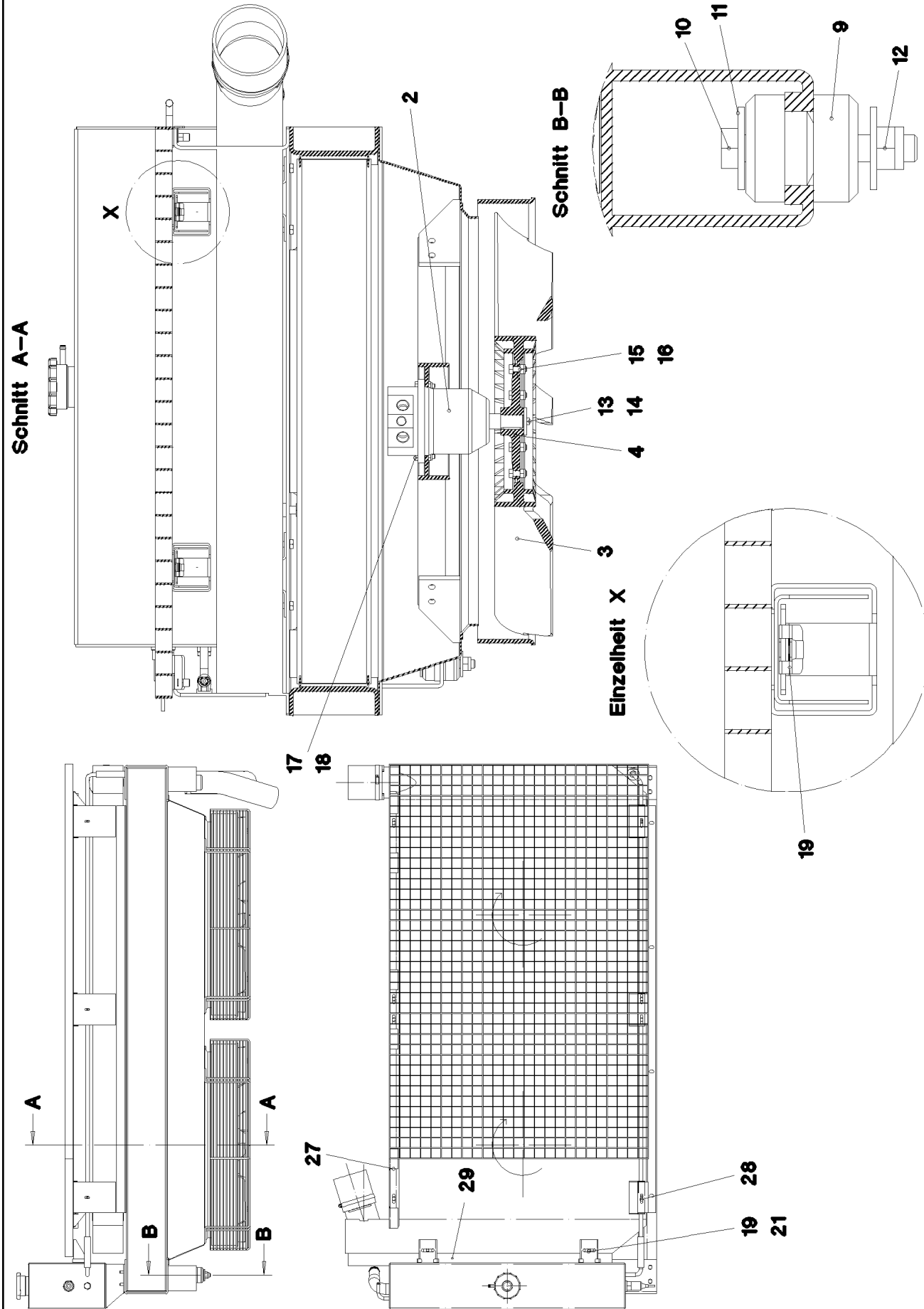

6.2.2009
053053

LIEBHERR

etk_en_de_074515 LR 1600/2

RADIATOR, PRE-ASSEMBLED
KUEHLER VORM.

□ 113 (1/3)

⇒ 2 391 023
96 45 720 08

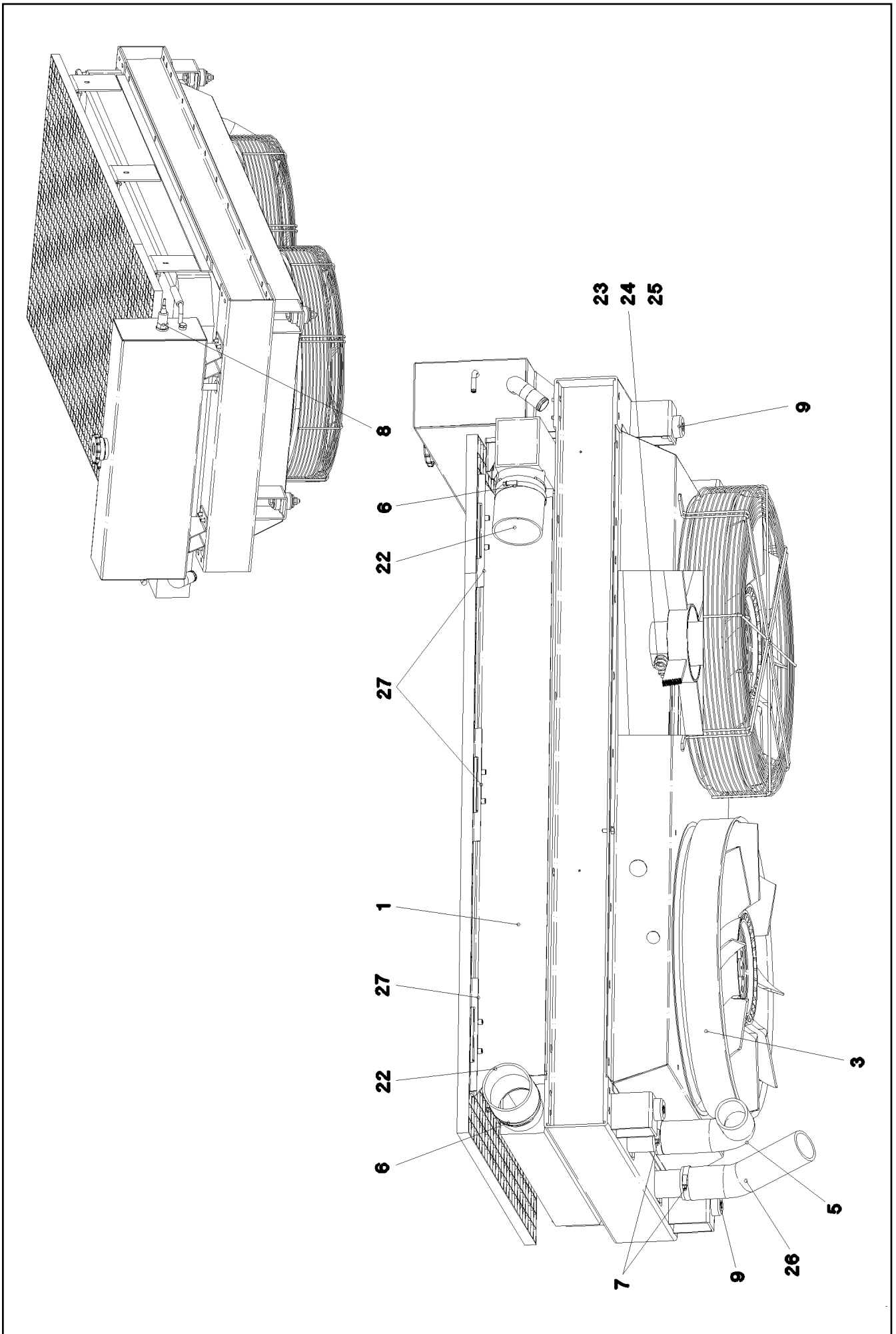

6.2.2009
053054

LIEBHERR

etk_en_de_074515 LR 1600/2

RADIATOR, PRE-ASSEMBLED
KUEHLER VORM.

□ 114 (2/3)

⇒ 2 391 023
96 45 720 08

Pos.	Item	Quantity	Description	Bezeichnung	Serie	K
1	10 41 290 3	1	RADIATOR UNIT AL	KUEHLERANLAGE		
2	51 02 380 08	2	HYDRO MOTOR SPF ⇒ 5 102 380 08 51 02 380 08	HYDROMOTOR		
3	55 06 395 08	2	RING FAN D=654	RINGLUEFTER		
4	95 70 468 08	2	FAN HUB D=168	LUEFTERNABE		
5	97 19 159 08	1	FORM HOSE NW60X90° SPF	FORMSCHLAUCH		
6	55 08 494 08	2	HOSE CLAMP 100-120 W3	SCHLAUCHSCHELLE		
7	77 42 143 08	2	HOSE CLAMP 60-80 W3	SCHLAUCHSCHELLE		
8	10 22 814 3	1	LEVEL PROBE SPF	NIVEAUSONDE		
9	10 09 749 6	4	BEARING 48X50 GUMMI 64CR	LAGER		
10	49 01 057	4	HEX BOLT ISO 4014 M12X80 8.8 A3C	SECHSKANTSCHRAUBE		
11	42 18 011 08	12	WASHER ISO 7093-1 A 13 ST A3C	SCHEIBE		
12	41 19 007 08	4	HEX NUT DIN 985 M12 8 A3C	SECHSKANTMUTTER		
13	40 00 829	2	HEX BOLT ISO 4017 M6X20 8.8 A2C	SECHSKANTSCHRAUBE		
14	95 36 317 08	2	WASHER RD40X4	SCHEIBE		
15	49 00 089	12	HEX BOLT ISO 4017 M8X20 8.8 A2C	SECHSKANTSCHRAUBE		
16	41 19 005 08	12	HEX NUT DIN 985 M8 8 VERZ	SECHSKANTMUTTER		
17	49 00 539	16	HEX BOLT ISO 4017 M6X25 8.8 A3C	SECHSKANTSCHRAUBE		
18	41 19 004 08	16	HEX NUT DIN 985 M6 8 VERZ	SECHSKANTMUTTER		
19	41 30 070 08	2	SHEET METAL NUT M8	BLECHMUTTER		
21	97 80 641 08	2	PLATE 2.5X199X102	BLECH		
22	55 17 166 08	2	HOSE SLEEVE DN100X110	SCHLAUCHMUFFE		
23	47 10 305 08	2	FLANGE JOINT XGE10-LM-ED A3P	VERSCHRAUBUNG		
24	47 10 309 08	2	FLANGE JOINT XGE15-LM-ED A3P	VERSCHRAUBUNG		
25	47 10 370 08	2	FLANGE JOINT XGE18-LM-ED A3P	VERSCHRAUBUNG		
26	97 47 495 08	1	FORM HOSE NW60X30GRAD SPF	FORMSCHLAUCH		
27	96 51 452 08	3	SHEET CPL.	BLECH KPL.		
28	96 51 459 08	3	SHEET CPL.	BLECH KPL.		
29	28 39 057 08	1	INSULATING MATERIAL 40X40X2000	DAEMMSTOFF		

6.2.2009

etk_en_de_074515 LR 1600/2

☐ 115 (3/3)

LIEBHERR

RADIATOR, PRE-ASSEMBLED
KUEHLER VORM.

⇒ 2 391 023
96 45 720 08

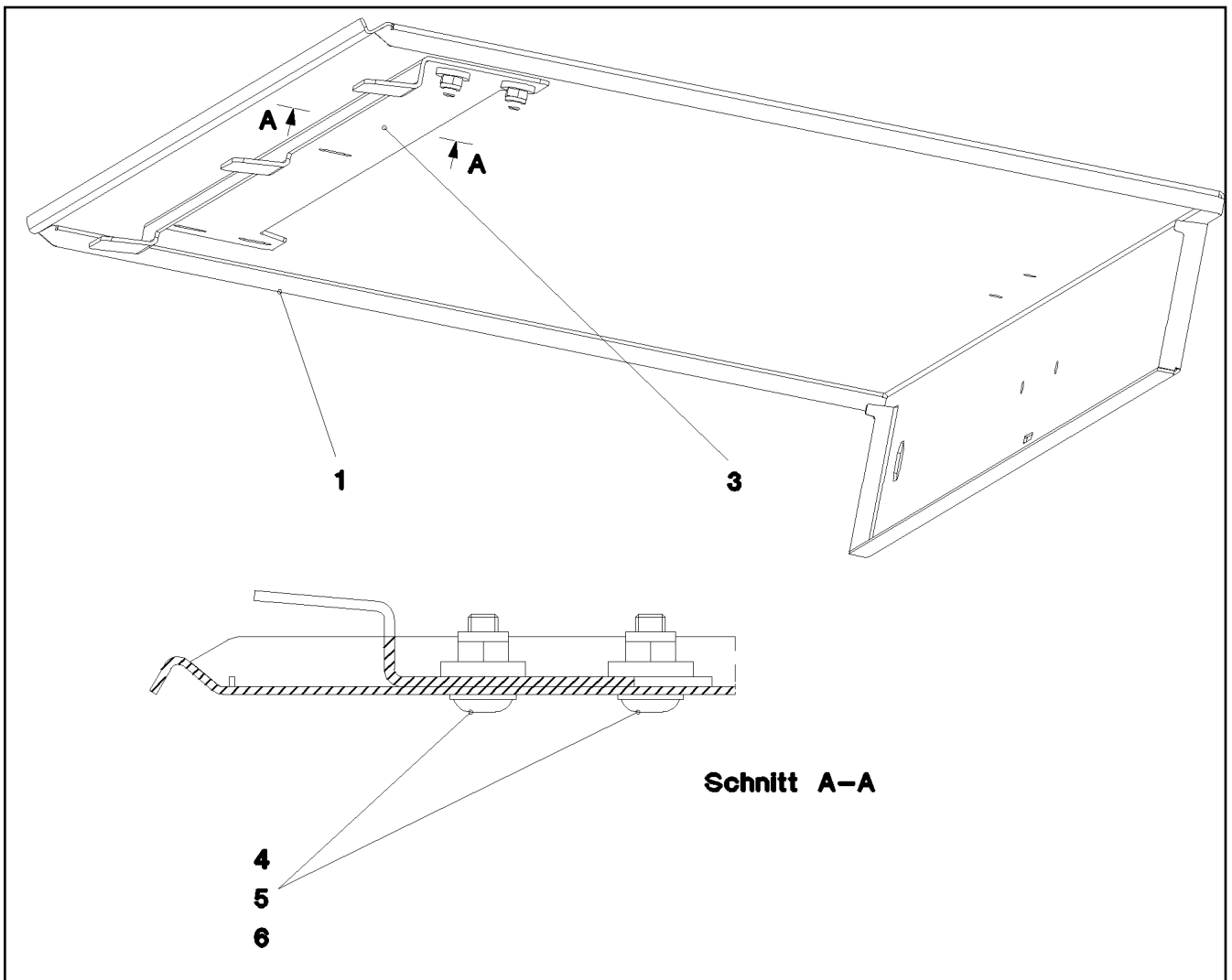

Pos.	Item	Quantity	Description	Bezeichnung	Serie	K
1	97 23 263 08	1	PLATE 1.5X1216X544	BLECH		
3	97 28 766 08	1	PLATE 2X990X104	BLECH		
4	10 41 285 1	5	OVAL HEAD FLAT SCREW AEHNL. ISO 7380	LINSENFLACHKOPFSCHRAUBE		
5	41 19 004 08	5	HEX NUT DIN 985 M6 8 VERZ	SECHSKANTMUTTER		
6	42 16 004 08	5	WASHER DIN 7349 6,4 ST VERZ	SCHEIBE		

6.2.2009
031384

LIEBHERR

etk_en_de_074515 LR 1600/2

COVER/LID/CAP, PRE-ASSEMBLED
DECKEL VORM.

116

⇒ 2 391 036
96 23 055 08

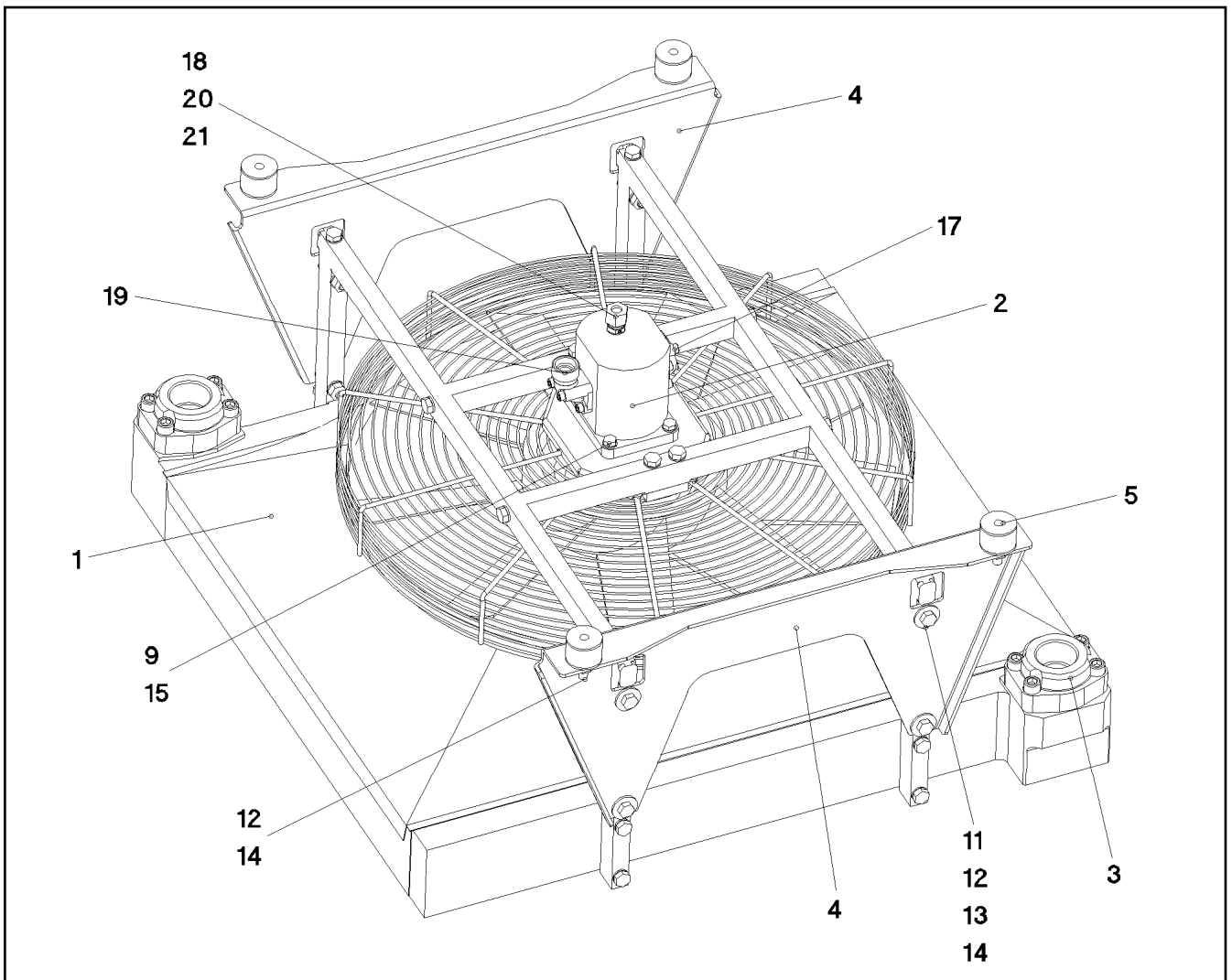

Pos.	Item	Quantity	Description	Bezeichnung	Serie	K
1	10 35 519 6	1	OIL AIR COOLER 75KW ⇒ X10355196 10 35 519 6	OEL-LUFTKUEHLER		
2	51 02 373 08	1	GEAR WHEEL MOTOR	ZAHNRADMOTOR		
(99)	10 49 389 0	1	SEAL KIT GEAR WHEEL MOTOR	DS ZAHNRADMOTOR		
3	51 15 125 08	2	SAE SCREW-IN FLANGE A3P	SAE-EINSCHRAUBFLANSCH		
4	97 73 245 08	2	PLATE 4X611X322	BLECH		
5	72 69 042 08	4	CIRCULAR BEARING B40X30XM10	RUNDLAGER		
9	49 00 111	4	HEX BOLT ISO 4017 M8X30 8.8 A2C	SECHSKANTSCHRAUBE		
11	40 00 472	8	HEX BOLT ISO 4014 M10X50 8.8 A3C	SECHSKANTSCHRAUBE		
12	41 15 144 08	12	HEX NUT DIN 934 M10 8 VERZ	SECHSKANTMUTTER		
13	42 00 507 08	8	WASHER DIN 125 A 10,5 MS	SCHEIBE		
14	42 18 010 08	12	WASHER DIN 9021 A 10,5 ST VERZ	SCHEIBE		
15	42 00 012 08	10	WASHER DIN 125 A8X16 ST VERZ	SCHEIBE		
17	51 01 417 08	1	FLANGE FITTING A3P	FLANSCHVERSCHRAUBUNG		
(1)	72 64 069 08	1	O-RING 18X2,5 NBR70	O-RING		
18	47 10 353 08	1	FLANGE JOINT XGE12-LR-ED1/4" A3P	VERSCHRAUBUNG		
19	51 01 416 08	1	FLANGE FITTING A3P	FLANSCHVERSCHRAUBUNG		
20	47 74 016 08	1	BOX NUT DIN 3870 AL12 A3P	UEBERWURFMUTTER		
21	47 71 004 08	1	PROFILE RING PR12-S/L A3P	PROFILRING		

6.2.2009
053051

LIEBHERR

etk_en_de_074515 LR 1600/2

OIL COOLER, PRE-ASSEMBLED
OELKUEHLER VORM.

117

⇒ 2 391 038
96 47 931 08

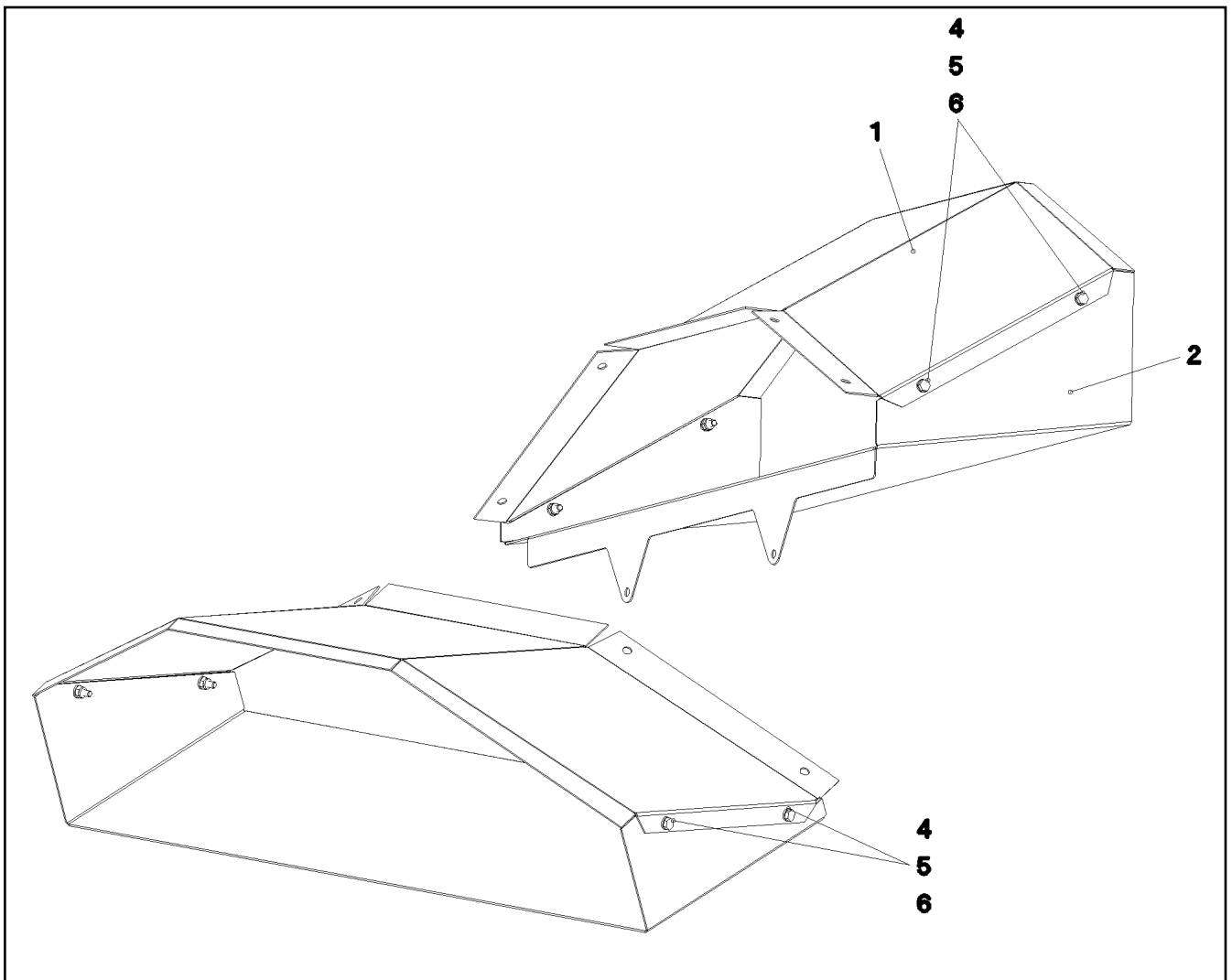

Pos.	Item	Quantity	Description	Bezeichnung	Serie	K
1	97 78 744 08	1	PLATE 1.5X773X420	BLECH		
2	97 78 745 08	1	PLATE 1.5X949X398	BLECH		
4	40 00 829	4	HEX BOLT ISO 4017 M6X20 8.8 A2C	SECHSKANTSCHRAUBE		
5	41 19 004 08	4	HEX NUT DIN 985 M6 8 VERZ	SECHSKANTMUTTER		
6	42 00 009 08	8	WASHER ISO 7089 A 6.4 VERZ	SCHEIBE		

6.2.2009
053052

LIEBHERR

etk_en_de_074515 LR 1600/2

COVER CPL
HUTZE KPL

118

⇒ 2 391 039
96 50 616 08

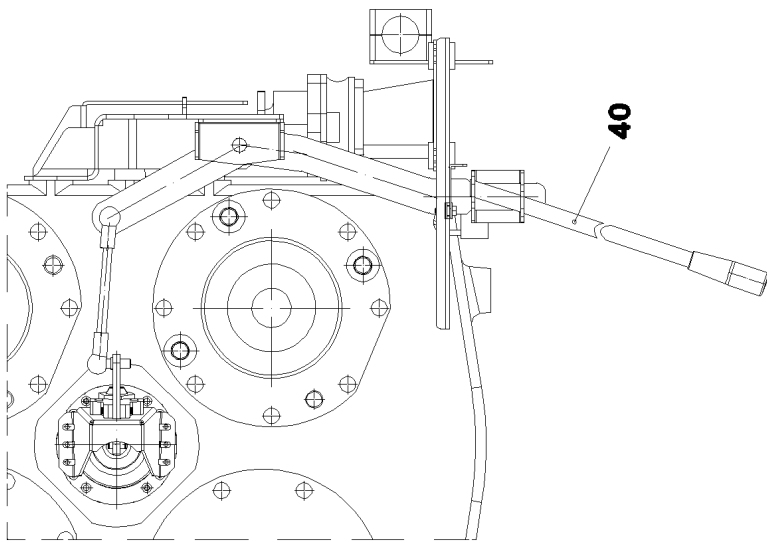

Ansicht Y

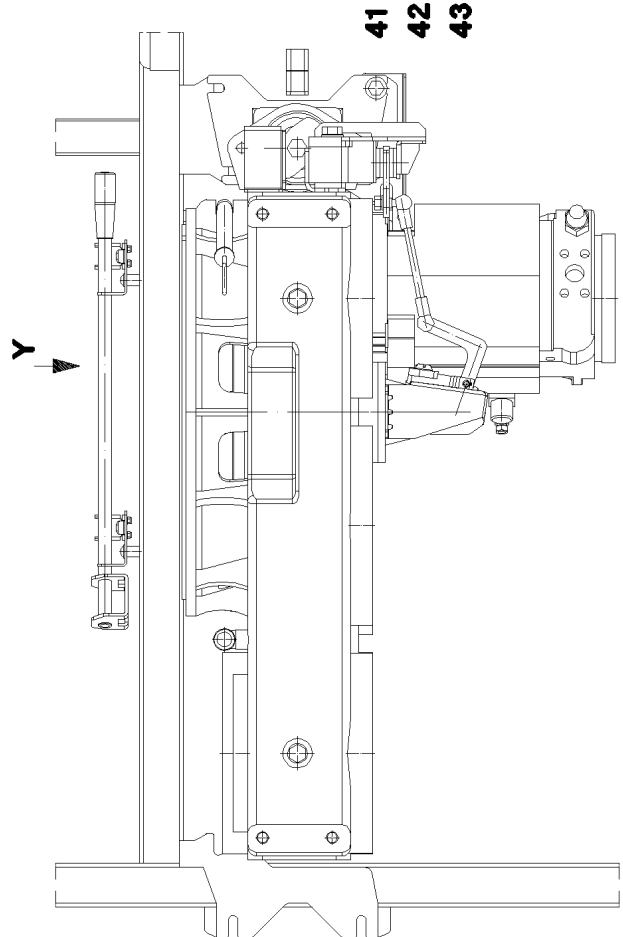
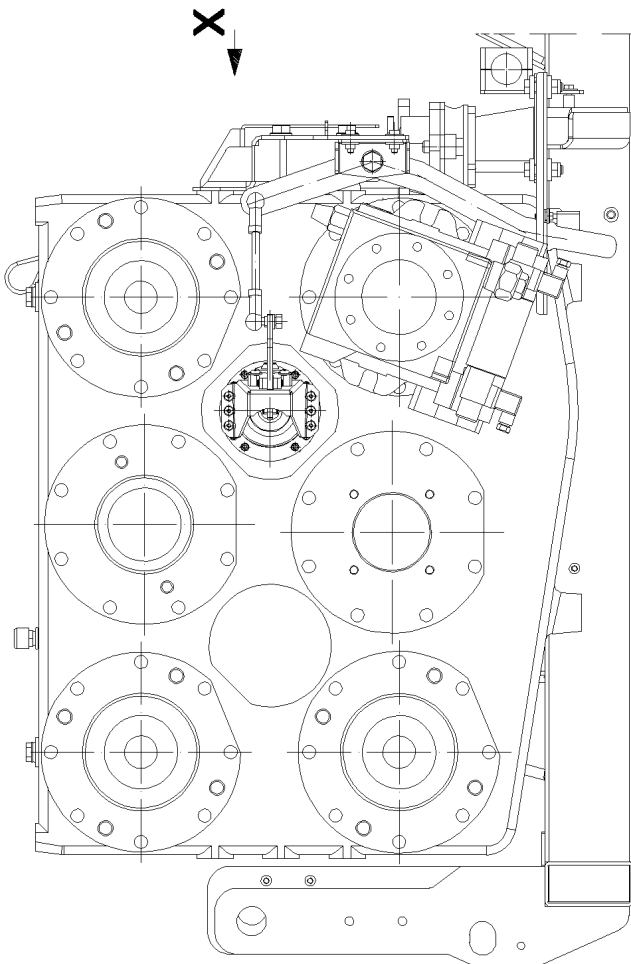
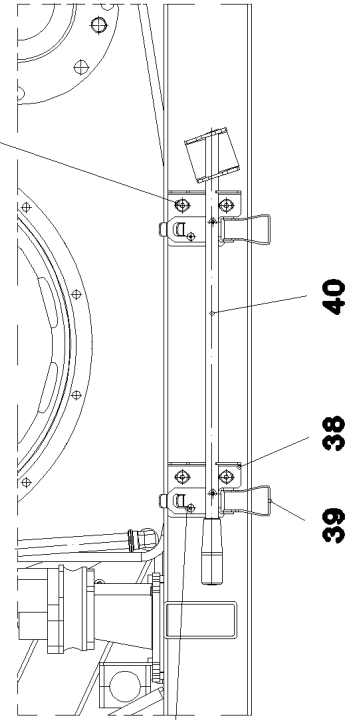

6.2.2009
054193

LIEBHERR

etk_en_de_074515 LR 1600/2

CLUTCH ACTUATOR
KUPPLUNGSSTELLER

□ 119 (1/3)

⇒ 2 391 040
96 53 645 08

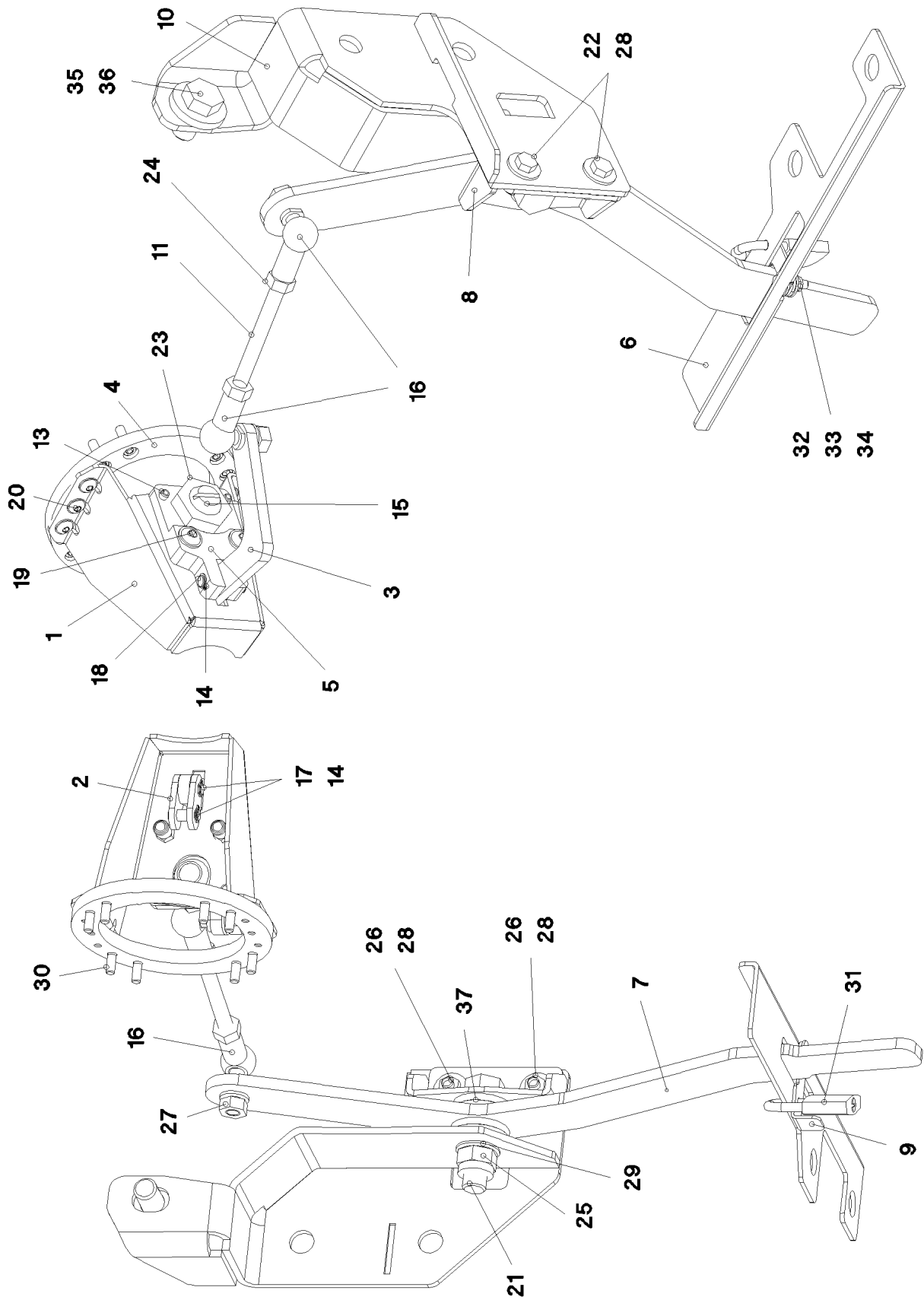

6.2.2009
052376

LIEBHERR

etk_en_de_074515 LR 1600/2

CLUTCH ACTUATOR
KUPPLUNGSSTELLER

120 (2/3)

→ 2 391 040
96 53 645 08

Pos.	Item	Quantity	Description	Bezeichnung	Serie	K
1	96 53 255 08	1	CLAMP WELDED CONST.	HALTER SCHWK.		
2	97 83 610 08	2	BUTT STRAP 4X40X20	LASCHE		
3	97 83 611 08	1	BUTT STRAP 8X113X108	LASCHE		
4	97 83 612 08	1	FLANGE 10X137X137	FLANSCH		
5	97 83 613 08	1	PLATE 15X90X60	BLECH		
6	97 83 924 08	1	PLATE 3X330X95	BLECH		
7	97 83 925 08	1	PLATE 8X125X515	BLECH		
8	97 83 926 08	1	PLATE 4X148X85	BLECH		
9	97 83 927 08	1	PLATE 2X77X20	BLECH		
10	96 53 678 08	1	BRACKET WELDED CONST.	KONSOLE SCHWK.		
11	95 45 915 08	1	THREADED ROD M10X120	GEWINDESTANGE		
13	43 20 057 08	2	DOWEL PIN ISO 8752 6X20	SPANNSTIFT		
14	42 80 002 08	6	LOCKING RING DIN 471 8X0,8	SICHERUNGSRING		
15	24 01 915 02	1	COMPRESSION PAD	DRUCKSTUECK		
16	72 50 069 08	2	ANGLE JOINT DIN 71802 CS 16 VERZ.GELB	WINKELGELENK		
17	97 83 643 08	2	PIN 8.0X21	BOLZEN		
18	97 83 644 08	1	PIN 8.0X34	BOLZEN		
19	40 97 059 08	2	PAN-HEAD SCREW M8X35 A2K	FLACHKOPFSCHRAUBE		
20	10 33 615 7	6	OVAL SCREW M6X12 10.9	LINSENSCHRAUBE		
21	46 00 056	1	HEX BOLT ISO 4014 M16X70 8.8 A3C	SECHSKANTSCHRAUBE		
22	49 00 128	2	HEX BOLT ISO 4017 M8X25 8.8 A2C	SECHSKANTSCHRAUBE		
23	41 17 010 08	1	HEX NUT DIN 936 M24 8 VERZ	SECHSKANTMUTTER		
24	41 15 144 08	2	HEX NUT DIN 934 M10 8 VERZ	SECHSKANTMUTTER		
25	41 19 009 08	1	HEX NUT DIN 985 M16 8 VERZ	SECHSKANTMUTTER		
26	41 15 141 08	2	HEX NUT DIN 934 M8 8 A2C	SECHSKANTMUTTER		
27	42 00 013 08	2	WASHER ISO 7089 A 10.5 A3C	SCHEIBE		
28	42 18 009 08	4	WASHER DIN 9021 A 8.4 VERZ	SCHEIBE		
29	42 00 019 08	2	WASHER DIN 125 A 17 VERZ	SCHEIBE		
30	46 00 048	8	CYLINDER SCREW ISO 4762 M6X16 8.8 A2C	ZYLINDERSCHRAUBE		
31	88 52 515 08	1	PADLOCK ABUS 62/40	VORHAENGESCHLOSS		
32	40 00 829	1	HEX BOLT ISO 4017 M6X20 8.8 A2C	SECHSKANTSCHRAUBE		
33	41 19 004 08	1	HEX NUT DIN 985 M6 8 VERZ	SECHSKANTMUTTER		
34	42 18 007 08	2	WASHER DIN 9021 A 6.4 VERZ	SCHEIBE		
35	49 00 152	1	HEX BOLT ISO 4017 M16X30 8.8 A3C	SECHSKANTSCHRAUBE		
36	42 16 009 08	1	WASHER DIN 7349 17 ST VERZ	SCHEIBE		
37	97 84 522 08	4	WASHER 5X40X40	SCHEIBE		
38	97 87 054 08	2	PLATE 3X100X110	BLECH		
39	70 42 185 08	2	LOCK BEARING	VERSCHLUSSLAGER		
40	96 55 460 08	1	LEVER COMPL.	HEBEL KPL.		
41	40 86 042 08	4	COUNTERSUNK SCREW DIN 7991 M5X12 8	SENKSCHRAUBE		
42	42 00 008 08	4	WASHER DIN 125 A 5.3 VERZ	SCHEIBE		
43	41 19 003 08	4	HEX NUT DIN 985 M5 8 VERZ	SECHSKANTMUTTER		
44	10 41 285 4	4	OVAL HEAD FLAT SCREW AEHNL.ISO7380	LINSENFLACHKOPFSCHRAUBE		

6.2.2009

etk_en_de_074515 LR 1600/2

 121 (3/3)

LIEBHERR
**CLUTCH ACTUATOR
KUPPLUNGSSTELLER**

 ⇒ 2 391 040
96 53 645 08

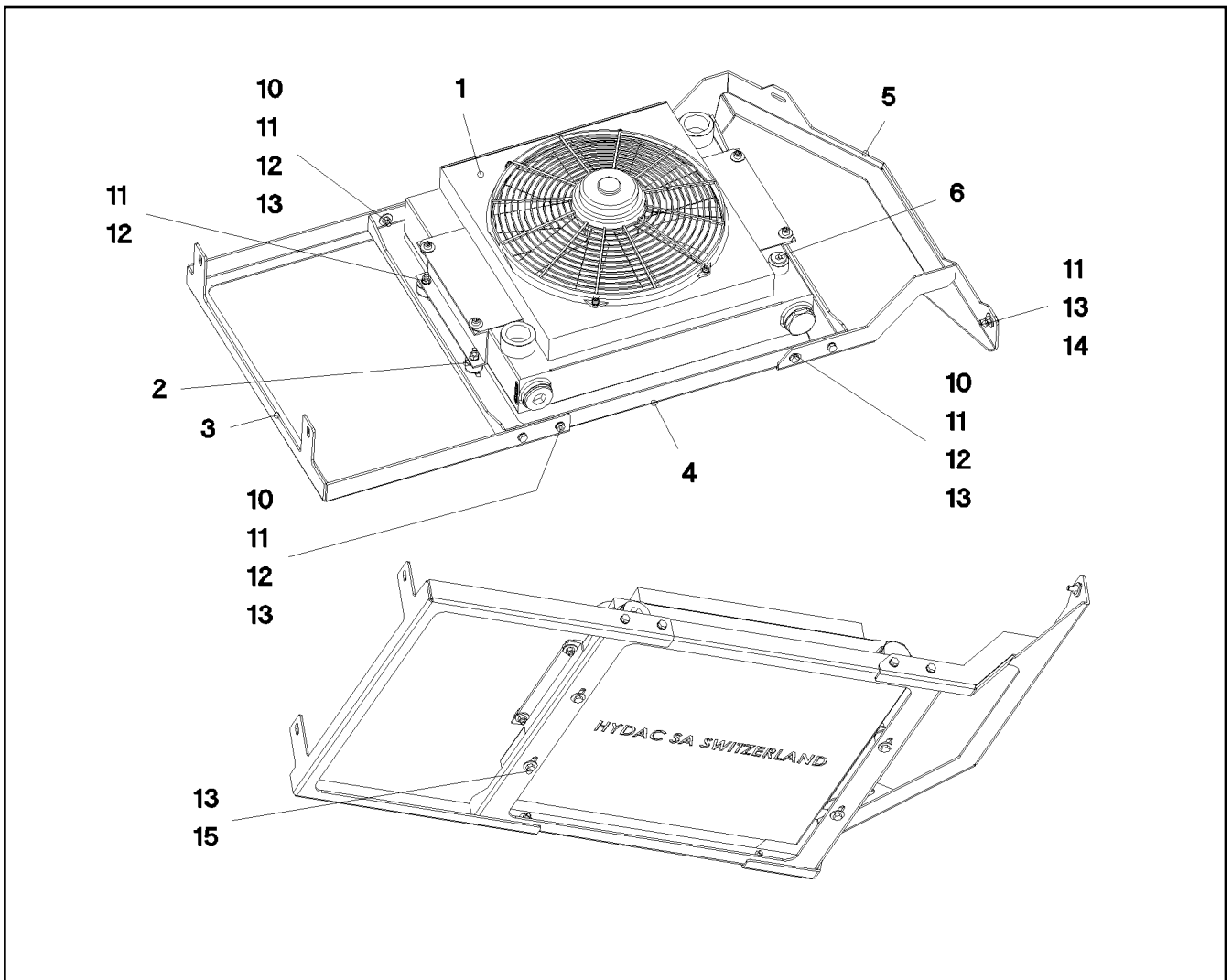

Pos.	Item	Quantity	Description	Bezeichnung	Serie	K
1	10 33 421 5	1	OIL AIR COOLER	OEL-LUFTKUEHLER		
2	72 66 156 08	4	MEGI BUFFER 30X20-M8 NR 60SHORE A	MEGIPUFFER		
3	97 89 189 08	1	PLATE 4X653X578	BLECH		
4	97 89 190 08	1	PLATE 4X711X637	BLECH		
5	97 89 191 08	1	PLATE 4X842X428	BLECH		
6	91 11 097 08	1	ELECTRIC FOR OIL COOLER	ELEKTRIK OELKUEHLER		
(2)	69 11 832 08	1	THERMAL SWITCH 55-50GR.C 5A	THERMOSCHALTER		
(3)	71 01 023 08	1	SEALING RING DIN 7603 A 13X18X1,5 CU	DICHTRING		
10	49 00 128	8	HEX BOLT ISO 4017 M8X25 8.8 A2C	SECHSKANTSCHRAUBE		
11	41 15 141 08	12	HEX NUT DIN 934 M8 8 A2C	SECHSKANTMUTTER		
12	42 00 012 08	12	WASHER DIN 125 A8X16 ST VERZ	SCHEIBE		
13	42 18 009 08	14	WASHER DIN 9021 A 8.4 VERZ	SCHEIBE		
14	40 97 066 08	2	HAMMER HEAD BOLT M8X25 4.6 A2K SPF	HAMMERKOPFSCHRAUBE		
15	40 65 136	4	HEX BOLT ISO 4017 M8X12 8.8 A2C	SECHSKANTSCHRAUBE		

6.2.2009
055314

LIEBHERR

etk_en_de_074515 LR 1600/2

RADIATOR
ZUSATZKUEHLER VORM.

122

⇒ 2 391 102
96 56 360 08

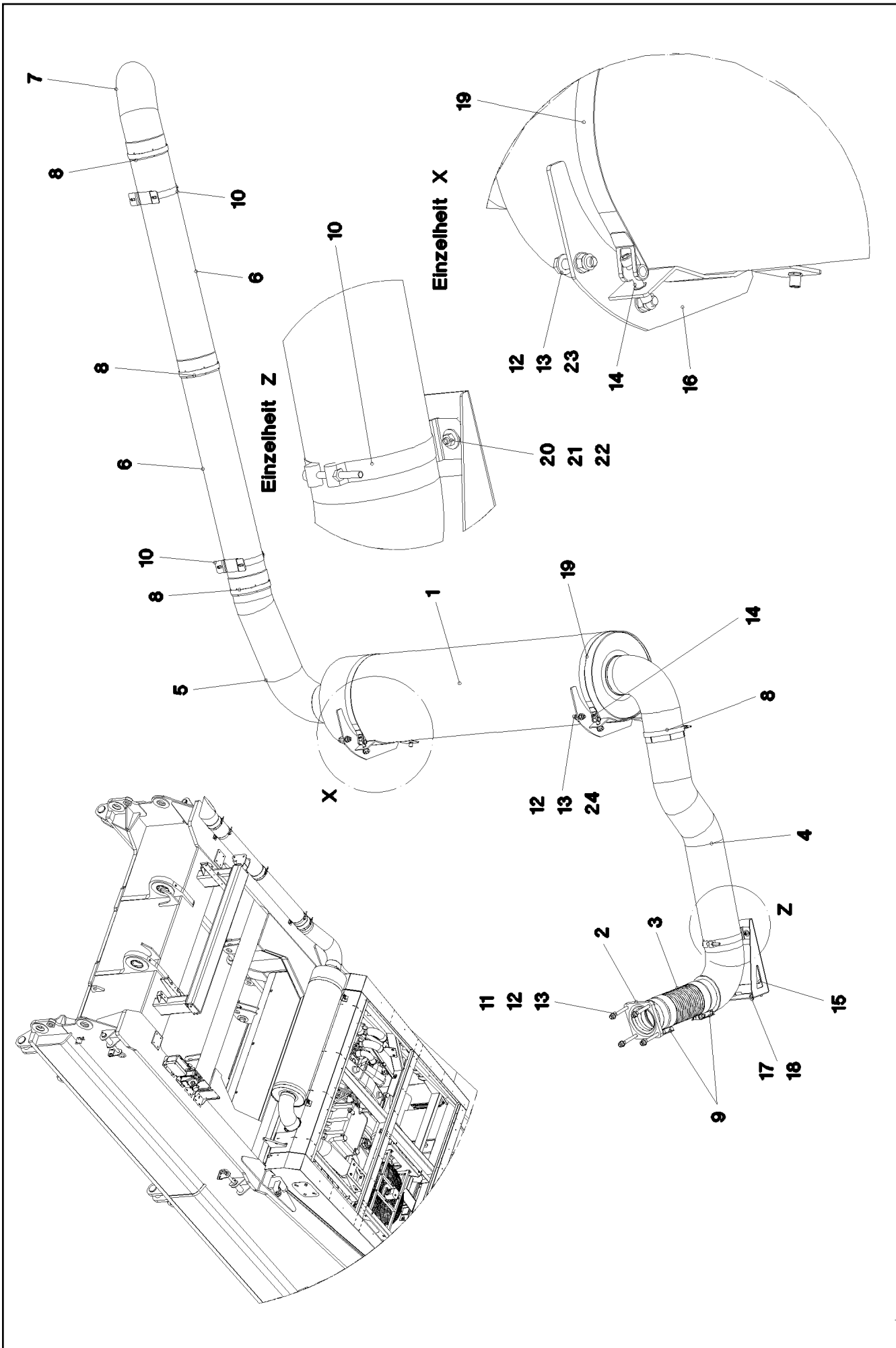

6.2.2009
052283

LIEBHERR

etk_en_de_074515 LR 1600/2

MUFFLER UNIT
SCHALLDAEMPFERANLAGE

□ 123 (1/2)

⇒ 2 392
91 52 785 08

Pos.	Item	Quantity	Description	Bezeichnung	Serie	K
1	10 44 054 3	1	EXHAUST SILENCER 350X1500 EDELSTAHL	SCHALLDAEMPFER		
2	10 44 054 4	1	EXHAUST FLANGE ST	ABGASFLANSCH		
3	10 44 054 2	1	PIPE 127MM EDELSTAHL	POLYFLEXROHR		
4	10 43 037 0	1	EXHAUST PIPE EDELSTAHL	ABGASROHR		
5	10 43 037 2	1	EXHAUST PIPE EDELSTAHL	ABGASROHR		
6	10 43 037 1	2	EXHAUST PIPE EDELSTAHL	ABGASROHR		
7	10 43 036 9	1	EXHAUST TAIL PIPE EDELSTAHL	ABGASENDROHR		
8	55 20 709 08	5	TIGTENING STRAP 155,5//19	SPANNBAND		
9	55 20 669 08	2	TIGTENING STRAP 127	SPANNBAND		
10	77 42 831 08	3	RETAINER CLIP 146-154 ST	SPANNSCHELLE		
11	46 00 247	4	HEX BOLT ISO 4014 M12X120 8.8 A3C	SECHSKANTSCHRAUBE		
12	55 20 022 08	8	NUT M12 CU	MUTTER		
13	42 00 016 08	16	WASHER ISO 7089 A 13 ST A3C	SCHEIBE		
14	46 00 331	4	CYLINDER SCREW ISO 4762 M10X50 8.8 A3	ZYLINDERSCHRAUBE		
15	97 75 707 08	1	PLATE 3X390X380	BLECH		
16	96 49 196 08	2	BRACKET WELDED CONST.	KONSOLE SCHWK.		
17	40 66 005 08	8	HEX BOLT ISO 4017 M8X15 10.9 A2C	SECHSKANTSCHRAUBE		
18	42 16 005 08	8	WASHER DIN 7349 8,4 ST VERZ	SCHEIBE		
19	10 04 160 5	2	TIGTENING STRAP 350X859X30XA1K ST	SPANNBAND		
20	41 15 141 08	2	HEX NUT DIN 934 M8 8 A2C	SECHSKANTMUTTER		
21	49 00 089	2	HEX BOLT ISO 4017 M8X20 8.8 A2C	SECHSKANTSCHRAUBE		
22	42 18 009 08	4	WASHER DIN 9021 A 8.4 VERZ	SCHEIBE		
23	40 00 973	2	HEX BOLT ISO 4014 M12X50 8.8 A3C	SECHSKANTSCHRAUBE		
24	49 00 100	2	HEX BOLT ISO 4017 M12X40 8.8 A3C	SECHSKANTSCHRAUBE		

6.2.2009

etk_en_de_074515 LR 1600/2

124 (2/2)

LIEBHERR

MUFFLER UNIT
SCHALLDAEMPFERANLAGE

⇒ 2 392
91 52 785 08

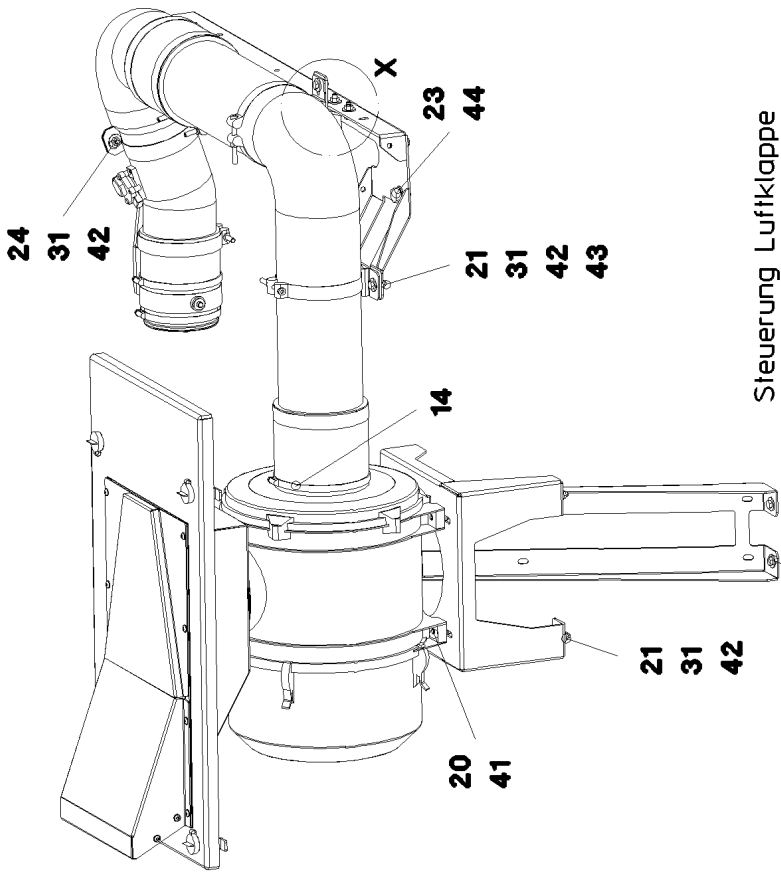

Steuerung Lufiklappe

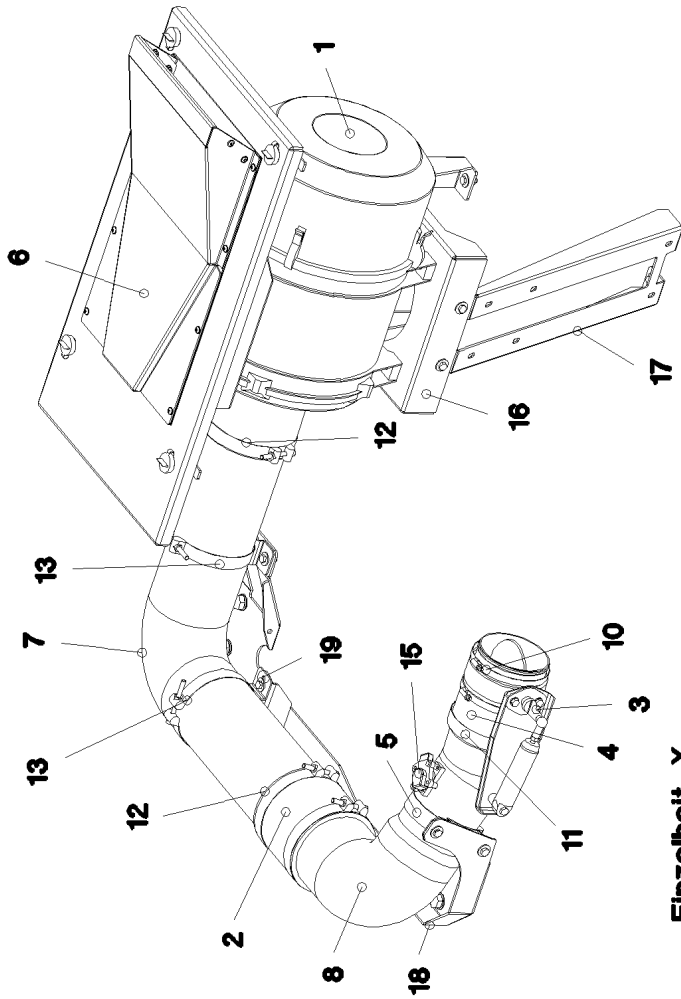
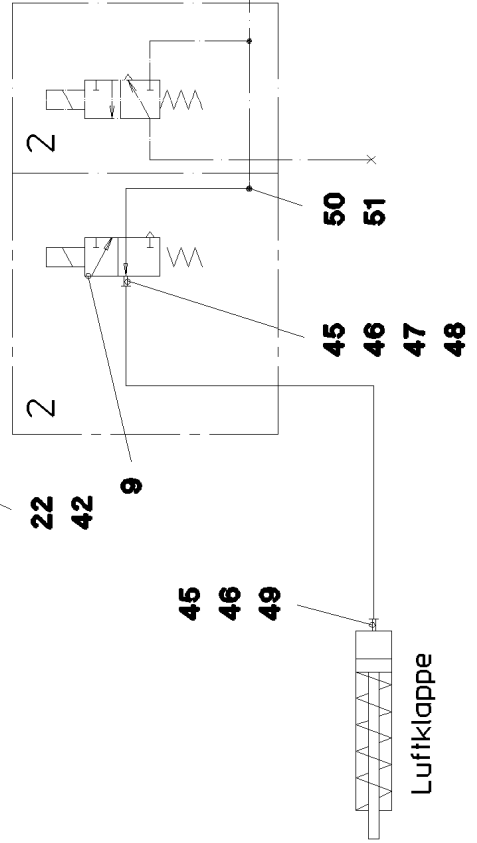

Einzelheit X

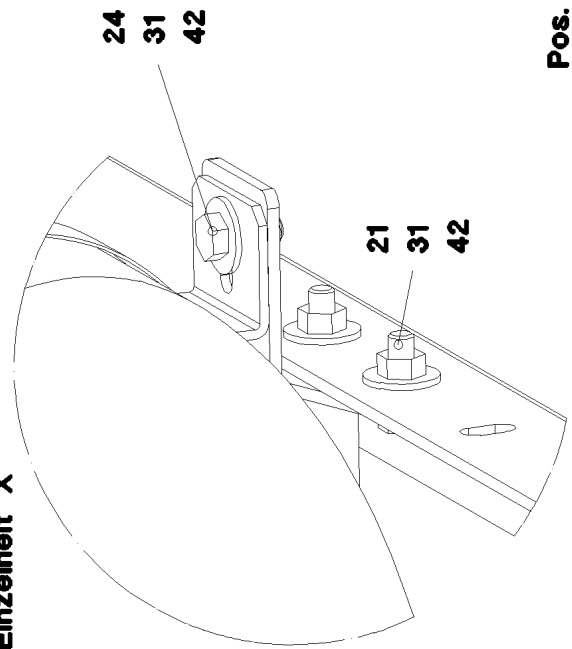

Pos. 500

6.2.2009
054023

LIEBHERR

etk_en_de_074515 LR 1600/2

AIR FILTER UNIT CPL.
LUFTFILTERANLAGE KPL.

□ 125 (1/2)

⇒ 2 393
91 52 787 08

Pos.	Item	Quantity	Description	Bezeichnung	Serie	K
1	55 17 203 08	1	AIR FILTER PICO ⇒ 5 517 203 08 55 17 203 08	LUFTFILTER		
2	55 07 726 08	2	HOSE GUMMI	SCHLAUCH		
3	55 17 068 08	1	RESTRICTOR CAP 130	DROSSELKLAPPE		
4	95 58 181 08	1	HOSE DN130X100	SCHLAUCH		
5	10 02 326 6	1	RETAINER CLIP 128-136 ST	SPANNSCHELLE		
6	96 46 782 08	1	COVER COMPL. ⇒ 2 393 002 96 46 782 08	DECKEL KPL.		
7	96 48 361 08	1	AIR SUCTION PIPE SPF	LUFTANSAUGROHR		
8	96 48 362 08	1	AIR SUCTION PIPE SPF	LUFTANSAUGROHR		
9	50 26 126 08	1	SOLENOID VALVE ⇒ 5 026 126 08 50 26 126 08	MAGNETVENTIL		
10	77 42 099 08	2	HOSE CLAMP 130-150 W3	SCHLAUCHSCHELLE		
11	77 42 118 08	1	HOSE CLAMP 140-148 ST	SCHLAUCHSCHELLE		
12	77 42 830 08	3	HOSE CLAMP HRGB ST	SCHLAUCHSCHELLE		
13	77 42 831 08	2	RETAINER CLIP 146-154 ST	SPANNSCHELLE		
14	10 03 051 7	1	HOSE CLAMP 160-180/12 W3	SCHLAUCHSCHELLE		
15	69 23 083 08	1	PRESSURE SENSOR	DRUCKSENSOR		
16	97 74 253 08	1	PLATE 4X650X479	BLECH		
17	97 74 257 08	1	PLATE 3X718X278	BLECH		
18	97 74 258 08	1	PLATE 4X1177X360	BLECH		
19	97 74 259 08	1	PLATE 4X194X101	BLECH		
20	40 65 164	4	HEX BOLT ISO 4017 M10X25 8.8 A3C	SECHSKANTSCHRAUBE		
21	49 00 128	8	HEX BOLT ISO 4017 M8X25 8.8 A2C	SECHSKANTSCHRAUBE		
22	40 65 136	2	HEX BOLT ISO 4017 M8X12 8.8 A2C	SECHSKANTSCHRAUBE		
23	40 65 156 08	4	HEX BOLT ISO 4017 M16X20 8.8 A3C	SECHSKANTSCHRAUBE		
24	49 00 089	4	HEX BOLT ISO 4017 M8X20 8.8 A2C	SECHSKANTSCHRAUBE		
31	41 15 141 08	12	HEX NUT DIN 934 M8 8 A2C	SECHSKANTMUTTER		
41	42 18 010 08	4	WASHER DIN 9021 A 10,5 ST VERZ	SCHEIBE		
42	42 18 009 08	26	WASHER DIN 9021 A 8.4 VERZ	SCHEIBE		
43	42 06 042 08	2	WASHER DIN 440 V 9 ST VERZ	SCHEIBE		
44	42 00 019 08	4	WASHER DIN 125 A 17 VERZ	SCHEIBE		
45	47 66 077 08	2	FLANGE JOINT GE6-LM12X1,5	VERSCHRAUBUNG		
46	47 25 300 08	2	FLANGE JOINT EWSD6-L A3P	VERSCHRAUBUNG		
47	50 29 332 08	1	O-RING 10X2,2 NBR70	O-RING		
48	50 29 326 08	1	COMPRESSION RING	DRUCKRING		
49	71 01 020 08	1	SEALING RING DIN 7603 A 12X18X1,5 CU	DICHTRING		
50	50 26 088 08	1	SEALING RING	DICHTRING		
51	47 77 043 08	1	PLUG VSTIM12X1,5ED A3P	STOPFEN		
500	96 54 041 08	1	HOSE LINES AIR FLAP	SCHLAUCHLEITUNGEN LUFTK		
(1)	60 27 601 08	1	NAME PLATE 25,4X101,6	BEZEICHNUNGSSCHILD		
(1366)	96 23 354 08	1	HOSE ASS CPL. TFS 1,5M	SCHLAUCH KPL.		

6.2.2009

etk_en_de_074515 LR 1600/2

126 (2/2)

LIEBHERRAIR FILTER UNIT CPL.
LUFTFILTERANLAGE KPL.⇒ 2 393
91 52 787 08

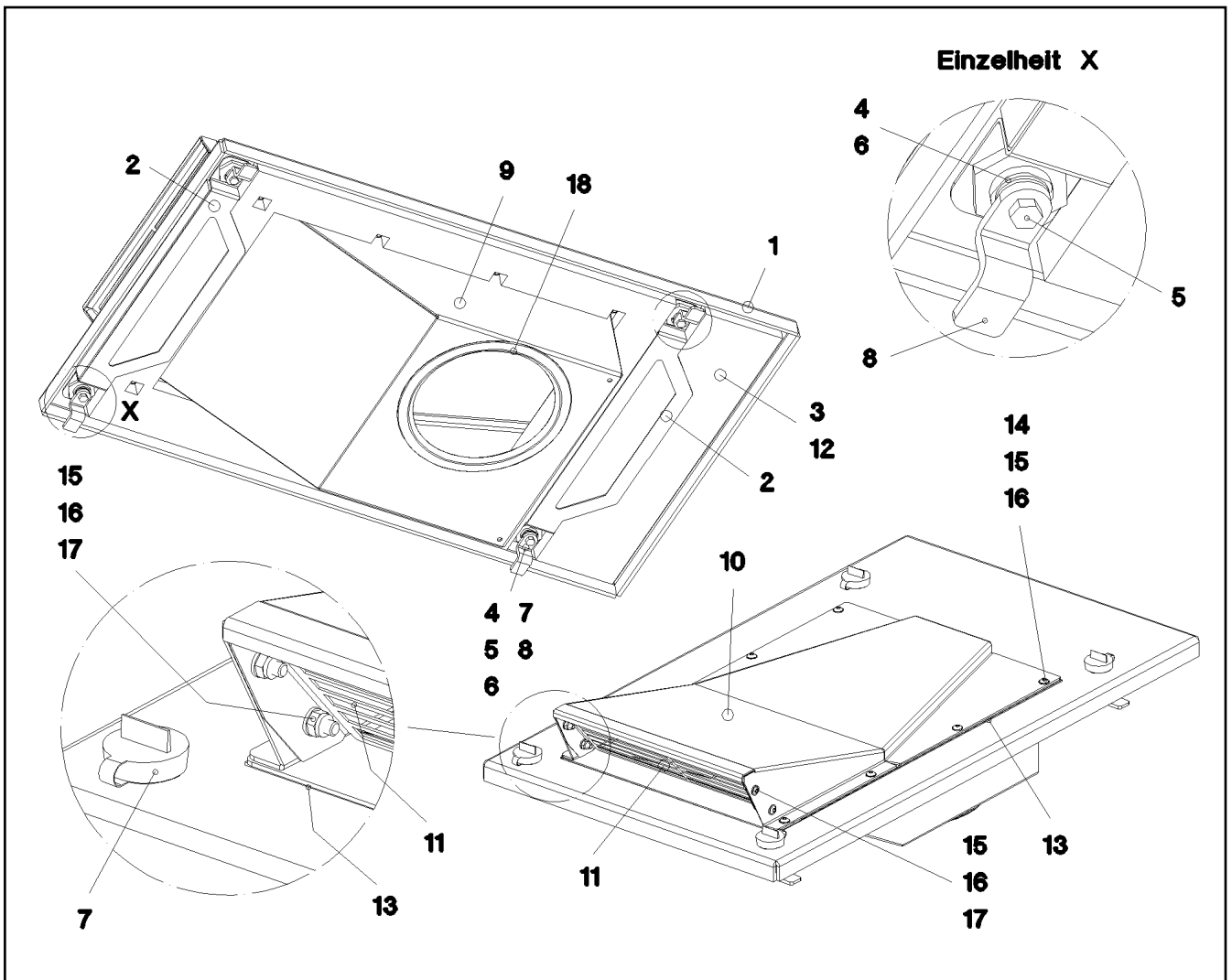

Pos.	Item	Quantity	Description	Bezeichnung	Serie	K
1	97 70 815 08	1	PLATE 5X878X523	BLECH		
2	97 71 634 08	2	PLATE 1.5X471X90	BLECH		
3	97 71 635 08	1	INSULATING MAT 20X798X445	DAEMMMATTE		
4	70 42 566 08	4	HOUSING	GEHAEUSE		
5	70 42 534 08	4	ACTUATION SPIKE	BETAETIGUNGSDORN		
6	70 42 748 08	4	O-RING 12X2 NBR70	O-RING		
7	70 42 548 08	4	DUST CAP	STAUBKAPPE		
8	70 42 551 08	4	TONGUE	ZUNGE		
9	97 71 797 08	1	PLATE 2X719X599	BLECH		
10	97 71 798 08	1	PLATE 2X661X530	BLECH		
11	97 71 799 08	1	PLATE 1X350X136	BLECH		
12	80 21 020 08	2.8	ADHESIVE INSULATING STRIP 25MM PS18	PILZKOPFBAND		
13	26 21 051 08	1.76	FOAM RUBBER BAND 15X5	ZELLGUMMIBAND		
14	10 41 285 2	8	OVAL HEAD FLAT SCREW AEHNL. ISO 7380	LINSENFLACHKOPFSCHRAUBE		
15	42 00 009 08	12	WASHER ISO 7089 A 6.4 VERZ	SCHEIBE		
16	41 19 004 08	12	HEX NUT DIN 985 M6 8 VERZ	SECHSKANTMUTTER		
17	40 97 043 08	4	PAN-HEAD SCREW M6X16 SCHWARZ VERZ	FLACHKOPFSCHRAUBE		
18	26 21 047 08	0.69	SEALING PROFILE	DICHTPROFIL		

6.2.2009
052385

LIEBHERR

etk_en_de_074515 LR 1600/2

COVER COMPL.
DECKEL KPL.

127

⇒ 2 393 002
96 46 782 08

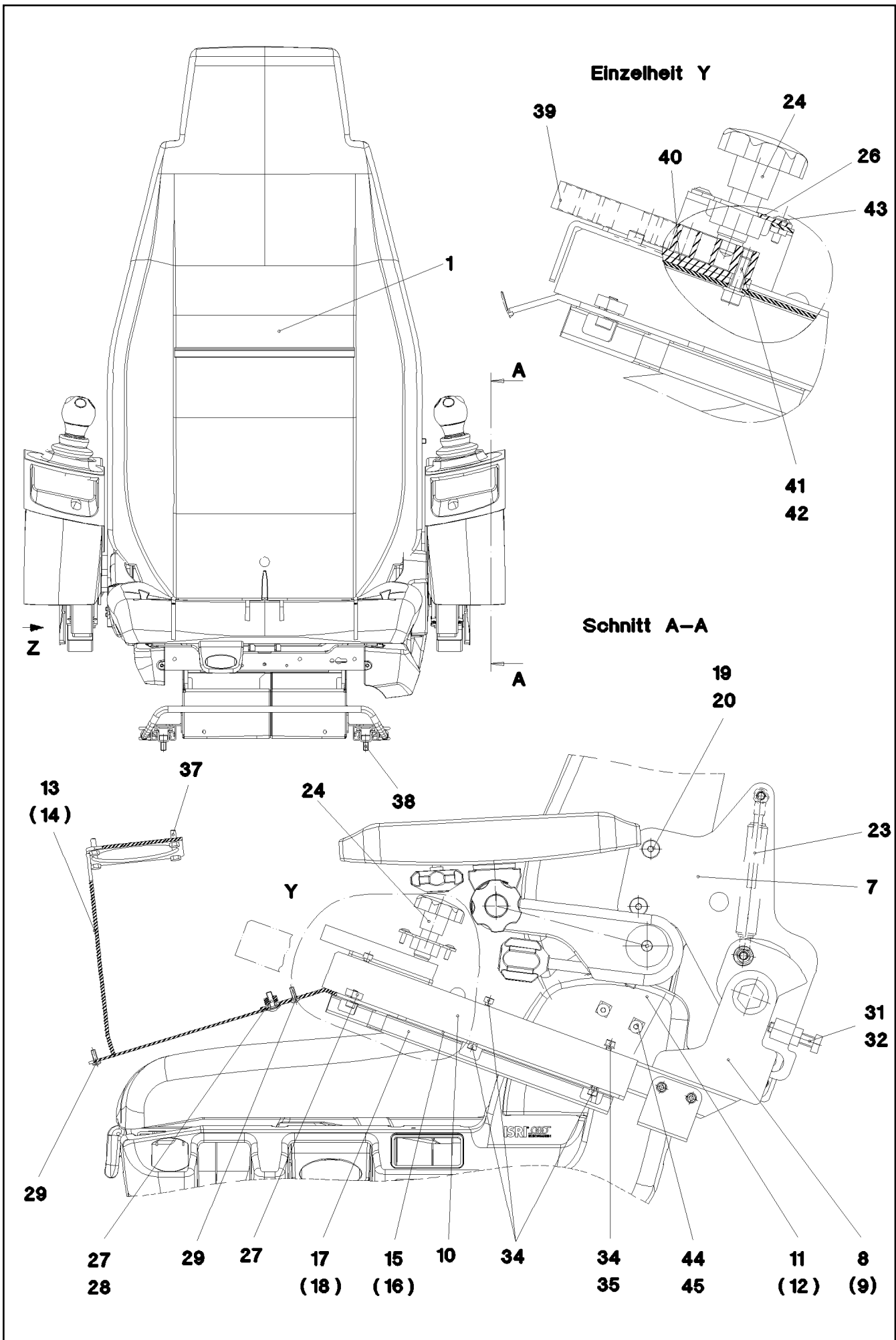

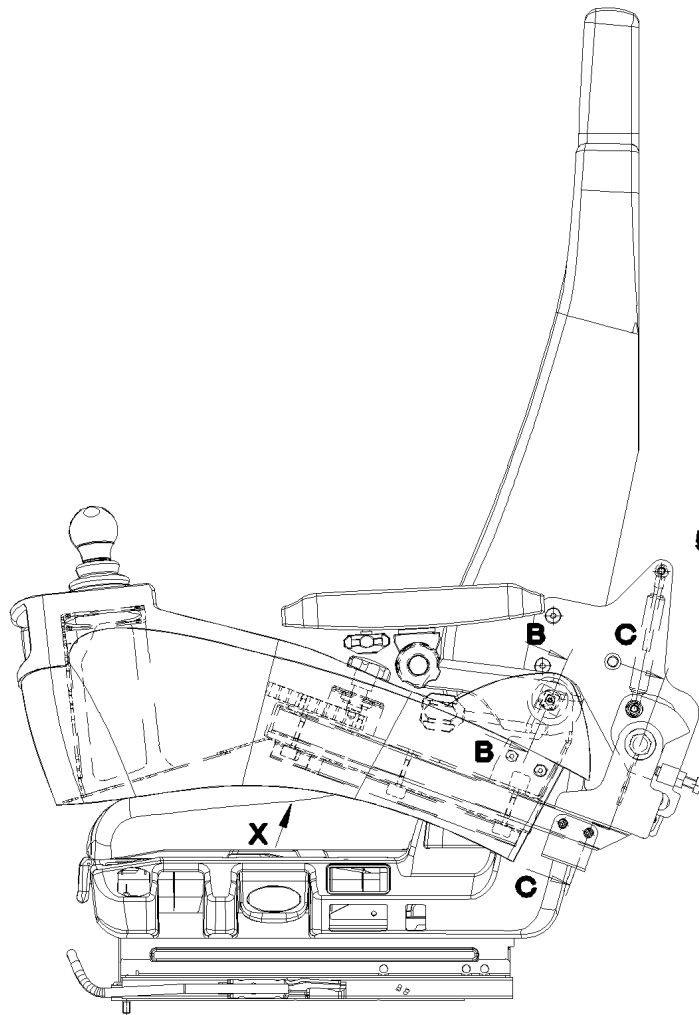

Ansicht Z

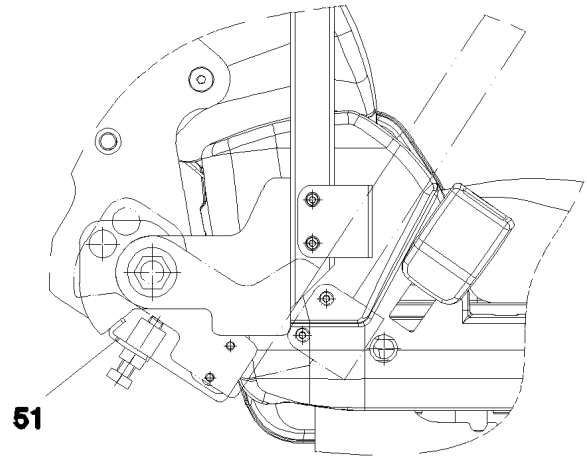

Schnitt C-C

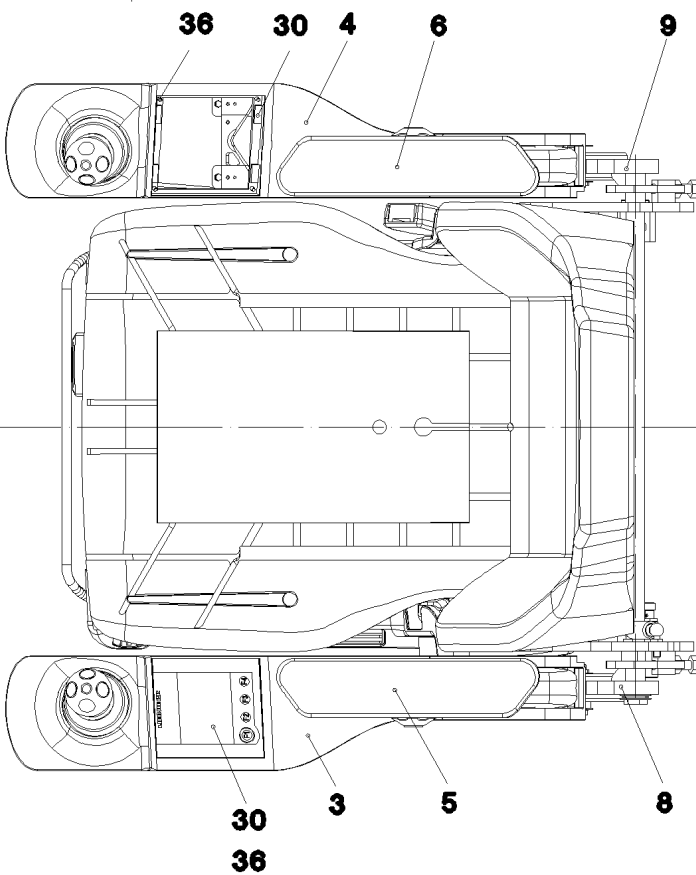
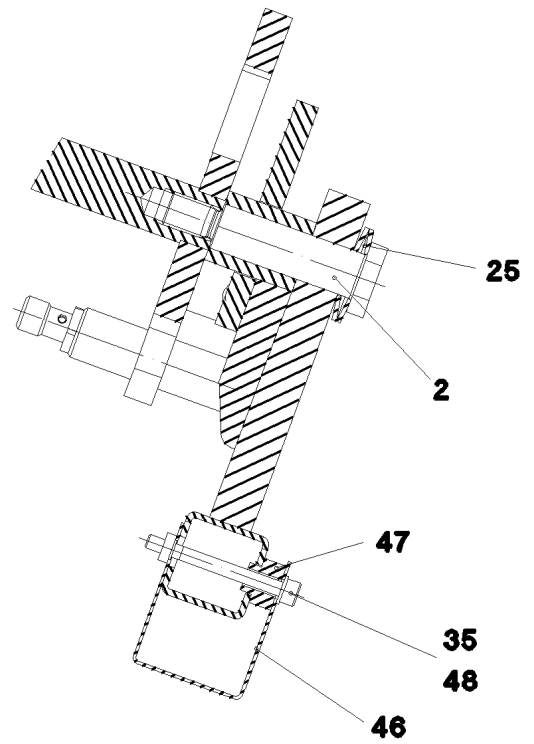

6.2.2009
051847

LIEBHERR

etk_en_de_074515 LR 1600/2

CONTROL STAND
STEUERSTAND

129 (2/4)

→ 2 502
91 55 939 08

Ansicht X

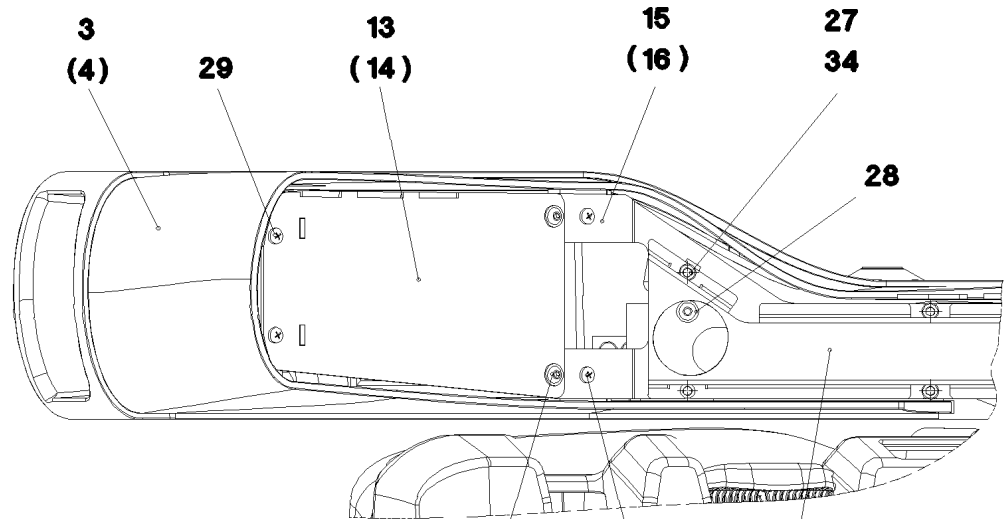

Schnitt B-B

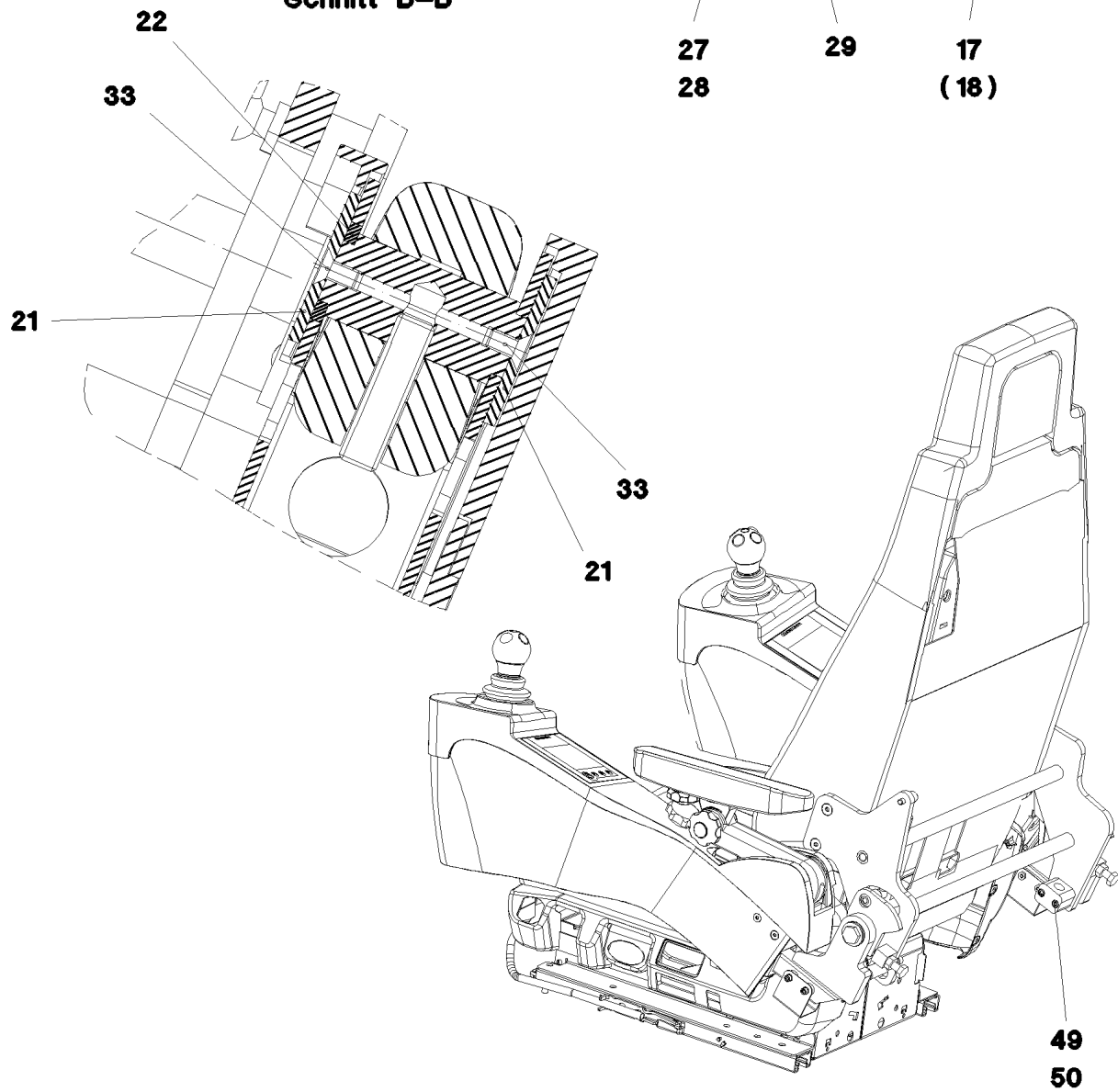

6.2.2009
051848

LIEBHERR

etk_en_de_074515 LR 1600/2

CONTROL STAND
STEUERSTAND

□ 130 (3/4)

⇒ 2 502
91 55 939 08

Pos.	Item	Quantity	Description	Bezeichnung	Serie	K
1	10 29 200 4	1	DRIVERS SEAT ⇒ X10292004 10 29 200 4	FAHRERSITZ		
2	97 74 833 08	2	THREADED BOLT 16F7X52X76 ST37K	GEWINDEBOLZEN		
3	97 23 411 08	1	BRACKET LEFT SPF	KONSOLE LINKS		
4	97 23 412 08	1	BRACKET RIGHT SPF	KONSOLE RECHTS		
5	96 22 822 08	1	ARM REST LEFT ⇒ 2 502 007 96 22 822 08	ARMLEHNE LINKS		
6	96 22 823 08	1	ARM REST RIGHT ⇒ 2 502 008 96 22 823 08	ARMLEHNE RECHTS		
7	96 48 426 08	1	BRACKET WELDED CONST.	KONSOLE SCHWK.		
8	96 48 427 08	1	BRACKET,LEFT WELDED FE//ZN20//F	KONSOLE SCHWK.LI.		
9	96 48 428 08	1	BRACKET,RIGHT WELDED FE//ZN20//F	KONSOLE SCHWK.RE.		
10	97 74 304 08	2	GUIDE 306X48X37 ENAW6060-T66	FUEHRUNG		
12	96 48 437 08	2	BRACKET WELDED CONST.	KONSOLE SCHWK.		
13	96 48 438 08	1	BRACKET,LEFT WELDED	KONSOLE SCHWK.LI.		
14	96 48 439 08	1	BRACKET,RIGHT WELDED	KONSOLE SCHWK.RE.		
15	97 74 440 08	1	PLATE 3X366X104	BLECH		
16	97 74 441 08	1	PLATE 3X366X104	BLECH		
17	97 74 443 08	1	PLATE 1X285X126	BLECH		
18	97 74 444 08	1	PLATE 1X285X126	BLECH		
19	97 18 057 08	4	TUBE 15.0X24 S355J2G3C+C	ROHR		
20	40 86 010 08	4	COUNTERSUNK SCREW DIN 7991 M8X45 8.	SENKSCHRAUBE		
21	97 19 741 08	4	PLATE 3X40X40 ST12.03	BLECH		
22	97 19 742 08	2	PLATE 3X26X26	BLECH		
23	59 10 670 08	1	GAS SPRING	GASFEDER		
24	10 44 362 5	2	STAR HANDLE SCREW	STERNGRIFFSCHRAUBE		
25	72 08 002 08	4	DISC SPRING DIN 2093 34X16,3X1,5	TELLERFEDER		
26	96 49 841 08	2	SHIM FE//ZN20//C	AUSGLEICHSBLECH		
27	10 45 528 1	6	CAGE NUT M5 ST	KAFIGMUTTER		
28	10 03 726 1	6	PAN-HEAD SCREW AEHNL.ISO 7380 M5X16	FLACHKOPFSCHRAUBE		
29	10 01 904 0	8	SCREW 4X12 ST VERZ	SCHRAUBE		
30	26 21 031 08	0.064	SPONGE RUBBER 20X4 MOOSGUMMI	MOOSGUMMI		
31	46 00 355	2	HEX BOLT ISO 4017 M10X45 8.8 A3C	SECHSKANTSCHRAUBE		
32	41 15 144 08	2	HEX NUT DIN 934 M10 8 VERZ	SECHSKANTMUTTER		
33	40 86 035 08	4	COUNTERSUNK SCREW DIN 7991 M5X10 8.	SENKSCHRAUBE		
34	40 01 308	24	CYLINDER SCREW ISO 4762 M5X12 8.8 A2C	ZYLINDERSCHRAUBE		
35	42 00 008 08	8	WASHER DIN 125 A 5.3 VERZ	SCHEIBE		
36	40 00 996	8	CYLINDER SCREW ISO 4762 M4X10 8.8 A2C	ZYLINDERSCHRAUBE		
37	40 00 417	8	HEX BOLT ISO 4017 M5X12 8.8 A2C	SECHSKANTSCHRAUBE		
38	46 00 051	6	CYLINDER SCREW ISO 4762 M8X16 8.8 A2C	ZYLINDERSCHRAUBE		
39	97 77 117 08	2	PLATE 15.0X113	BLECH		
40	97 76 920 08	4	SPACER PLATE 3X84X15 DC01	DISTANZBLECH		
41	40 42 002	4	CYLINDER SCREW ISO 4762 M6X20 8.8 A2C	ZYLINDERSCHRAUBE		
42	42 00 009 08	4	WASHER ISO 7089 A 6.4 VERZ	SCHEIBE		
43	40 97 053 08	4	PAN-HEAD SCREW AEHNL.ISO7380 M4X12	FLACHKOPFSCHRAUBE		
44	41 30 027 08	4	CAGE NUT M6	KAFIGMUTTER		
45	40 86 041 08	4	COUNTERSUNK SCREW DIN 7991 M6X20 8.	SENKSCHRAUBE		
46	96 50 215 08	2	COVER PLATE WELDED	ABDECKBLECH SCHWK.		
47	97 68 666 08	4	BUSH 16.0X12 S355J2G3C+C FE//ZN20//C	BUCHSE		
48	49 00 626	4	CYLINDER SCREW ISO 4762 M5X50 8.8 A2C	ZYLINDERSCHRAUBE		
49	60 20 081 08	2	CLAMP-HALF DIN 3015-1 15 PP SW	KLEMMHAELFTE		
50	46 00 384	2	CYLINDER SCREW ISO 4762 M6X40 8.8 A2C	ZYLINDERSCHRAUBE		
51	97 83 624 08	1	PLATE 3X46X20 FE//ZN20//F	BLECH		

6.2.2009

etk_en_de_074515 LR 1600/2

 131 (4/4)
LIEBHERRCONTROL STAND
STEUERSTAND⇒ 2 502
91 55 939 08

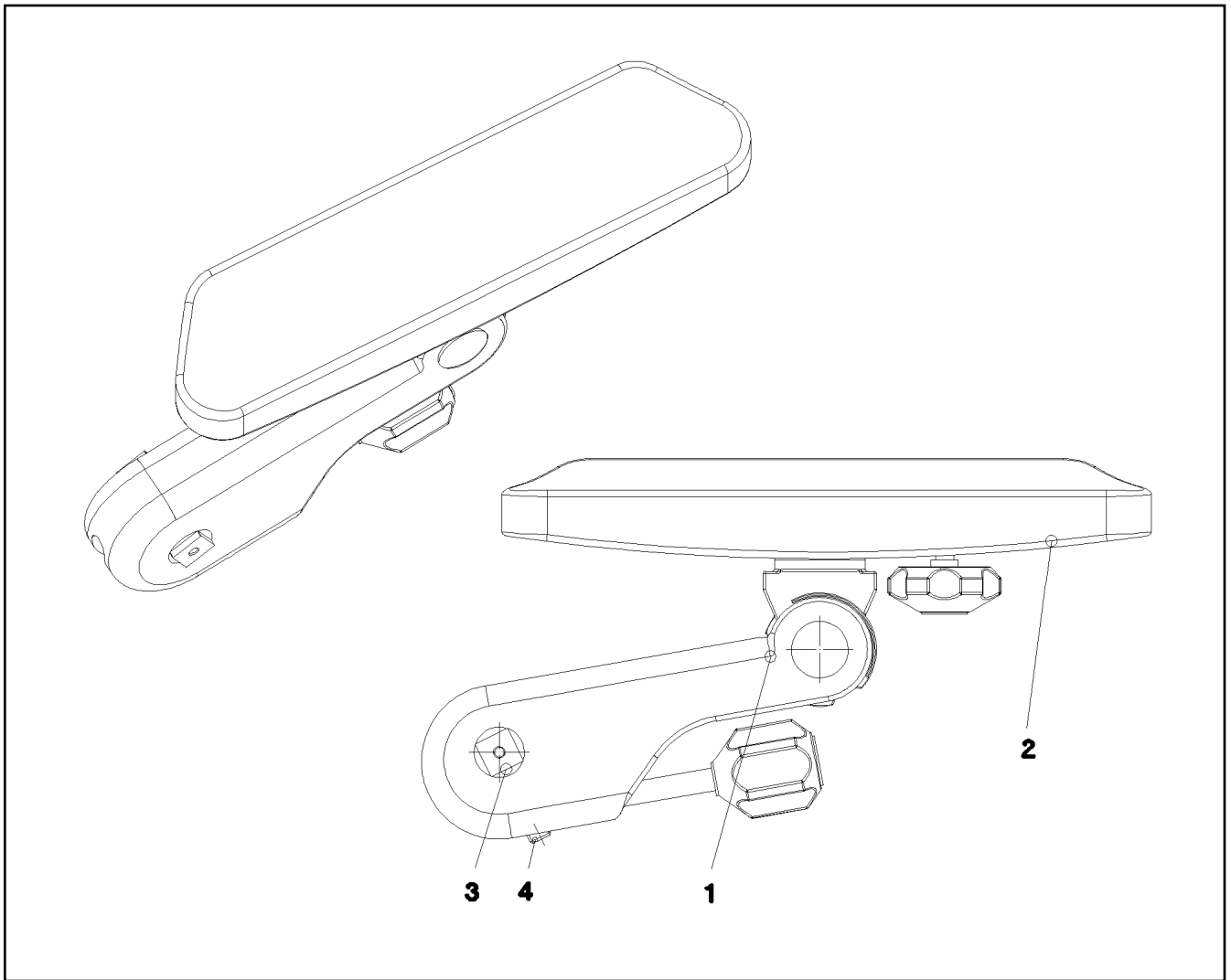

Pos.	Item	Quantity	Description	Bezeichnung	Serie	K
1	77 41 197 08	1	ARM REST 310ERGO	ARMLEHNE		
2	97 16 366 08	1	ARM REST SUPPORT	ARMLEHNENAUFLAGE		
3	97 19 736 08	1	PIN 25.0X52	BOLZEN		
4	40 44 031 08	1	GRUB SCREW DIN 913 M10X40 45 H VERZ	GEWINDESTIFT		

6.2.2009
038069

LIEBHERR

etk_en_de_074515 LR 1600/2

ARM REST LEFT
ARMLEHNE LINKS

132

⇒ 2 502 007
96 22 822 08

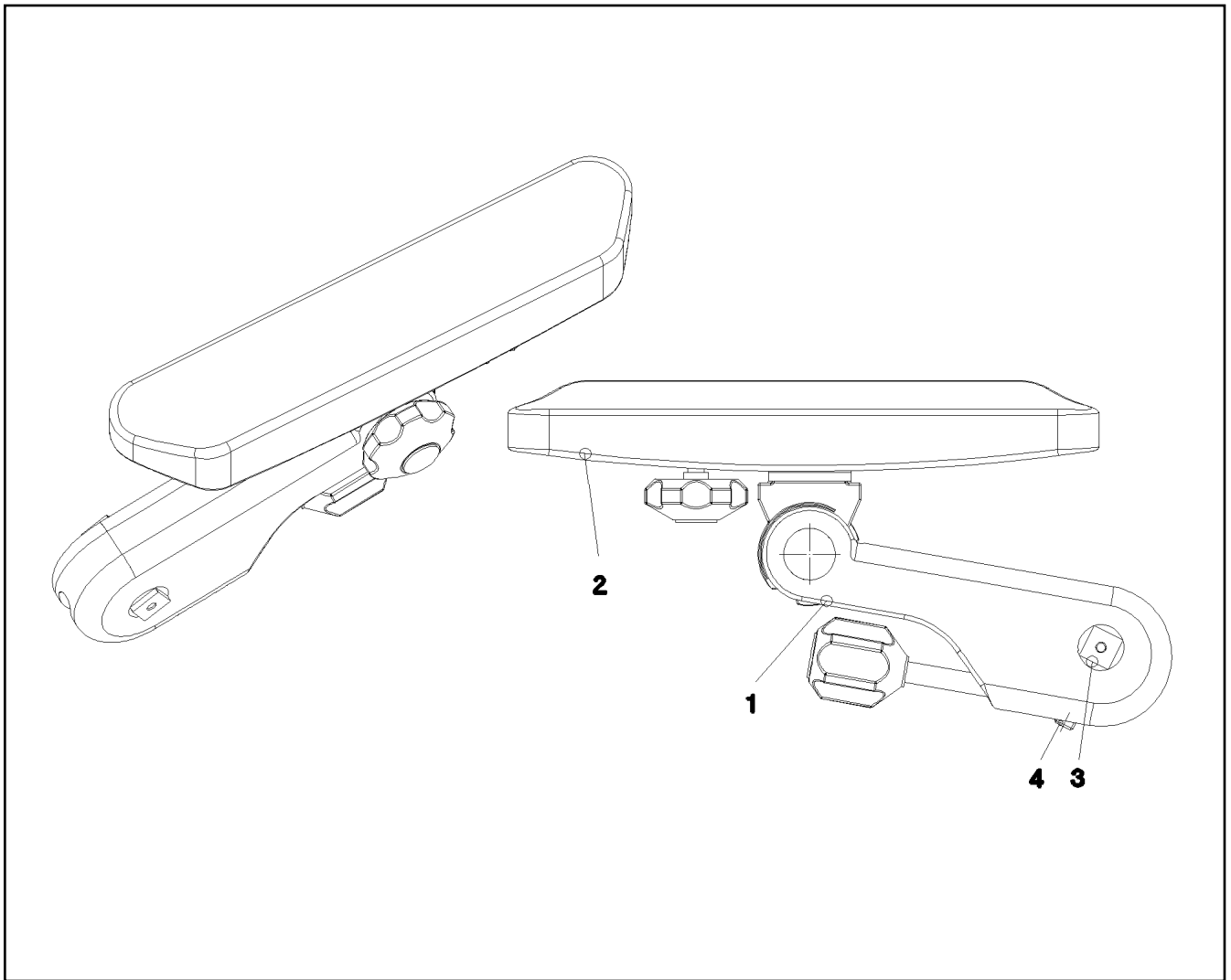

Pos.	Item	Quantity	Description	Bezeichnung	Serie	K
1	77 41 198 08	1	ARM REST 310ERGO	ARMLEHNE		
2	97 16 366 08	1	ARM REST SUPPORT	ARMLEHNENAUFLAGE		
3	97 19 736 08	1	PIN 25.0X52	BOLZEN		
4	40 44 031 08	1	GRUB SCREW DIN 913 M10X40 45 H VERZ	GEWINDESTIFT		

6.2.2009
038070

LIEBHERR

etk_en_de_074515 LR 1600/2

ARM REST RIGHT
ARMLEHNE RECHTS

133

⇒ 2 502 008
96 22 823 08

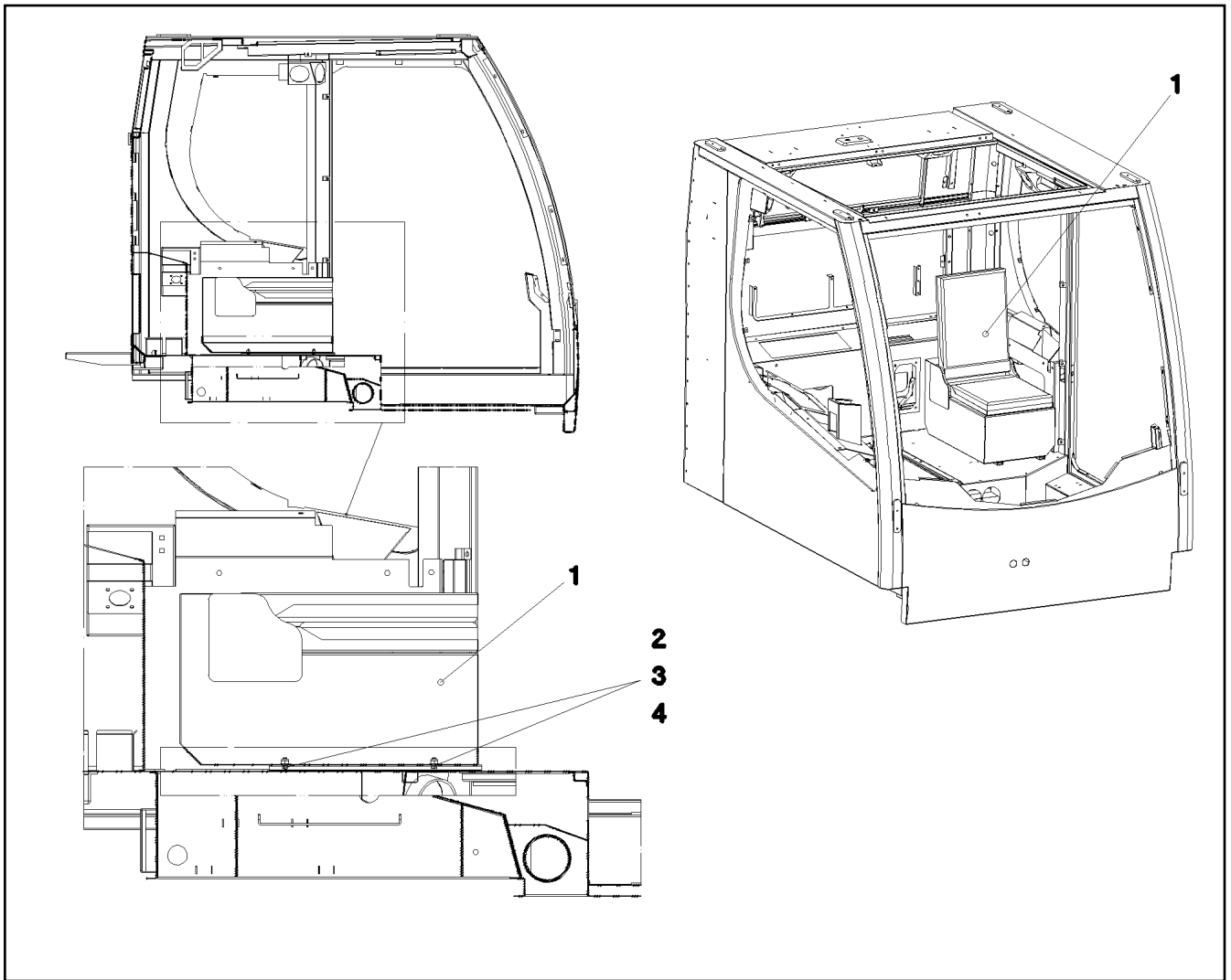

Pos.	Item	Quantity	Description	Bezeichnung	Serie	K
1	96 48 626 08	1	SEAT ⇒ 2 503 101 96 48 626 08	SITZ		
2	40 97 069 08	4	HAMMER HEAD BOLT M8X15 4.6 A2K SPF	HAMMERKOPFSCHRAUBE		
3	41 19 005 08	4	HEX NUT DIN 985 M8 8 VERZ	SECHSKANTMUTTER		
4	42 00 012 08	4	WASHER DIN 125 A8X16 ST VERZ	SCHEIBE		

6.2.2009
052614

LIEBHERR

etk_en_de_074515 LR 1600/2

EMERGENCY SEAT
NOTSITZ

134

⇒ 2 503 100
91 55 873 08

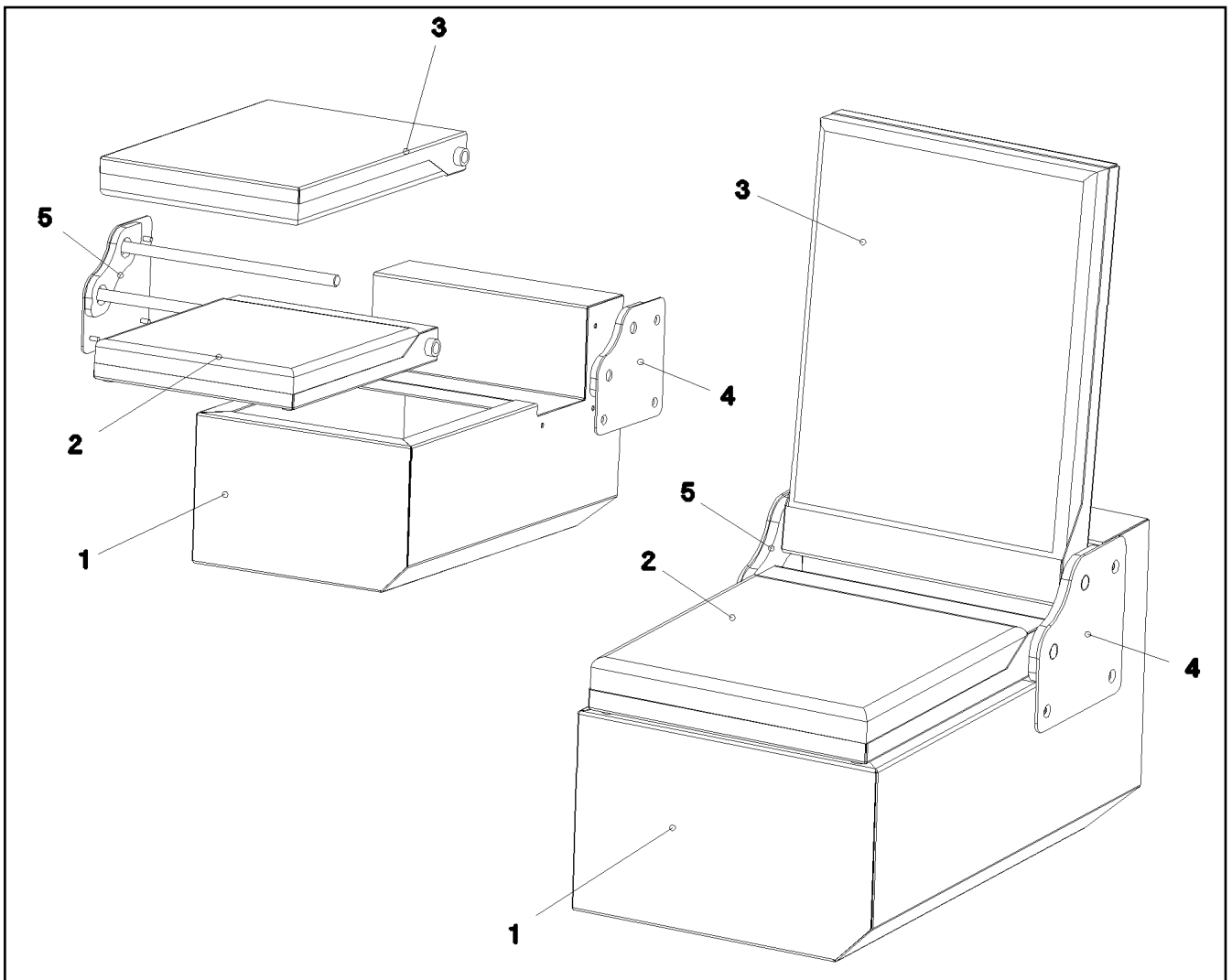

Pos.	Item	Quantity	Description	Bezeichnung	Serie	K
1	97 75 553 08	1	SEAT BRACKET	SITZKONSOLE		
2	97 75 557 08	1	SEAT	SITZ		
3	97 75 558 08	1	CHAIR BACK	LEHNE		
4	97 75 565 08	1	BRACKET LEFT	KONSOLE LINKS		
5	97 75 567 08	1	BRACKET RIGHT	KONSOLE RECHTS		

6.2.2009
052615

LIEBHERR

etk_en_de_074515 LR 1600/2

SEAT
SITZ

135

⇒ 2 503 101
96 48 626 08

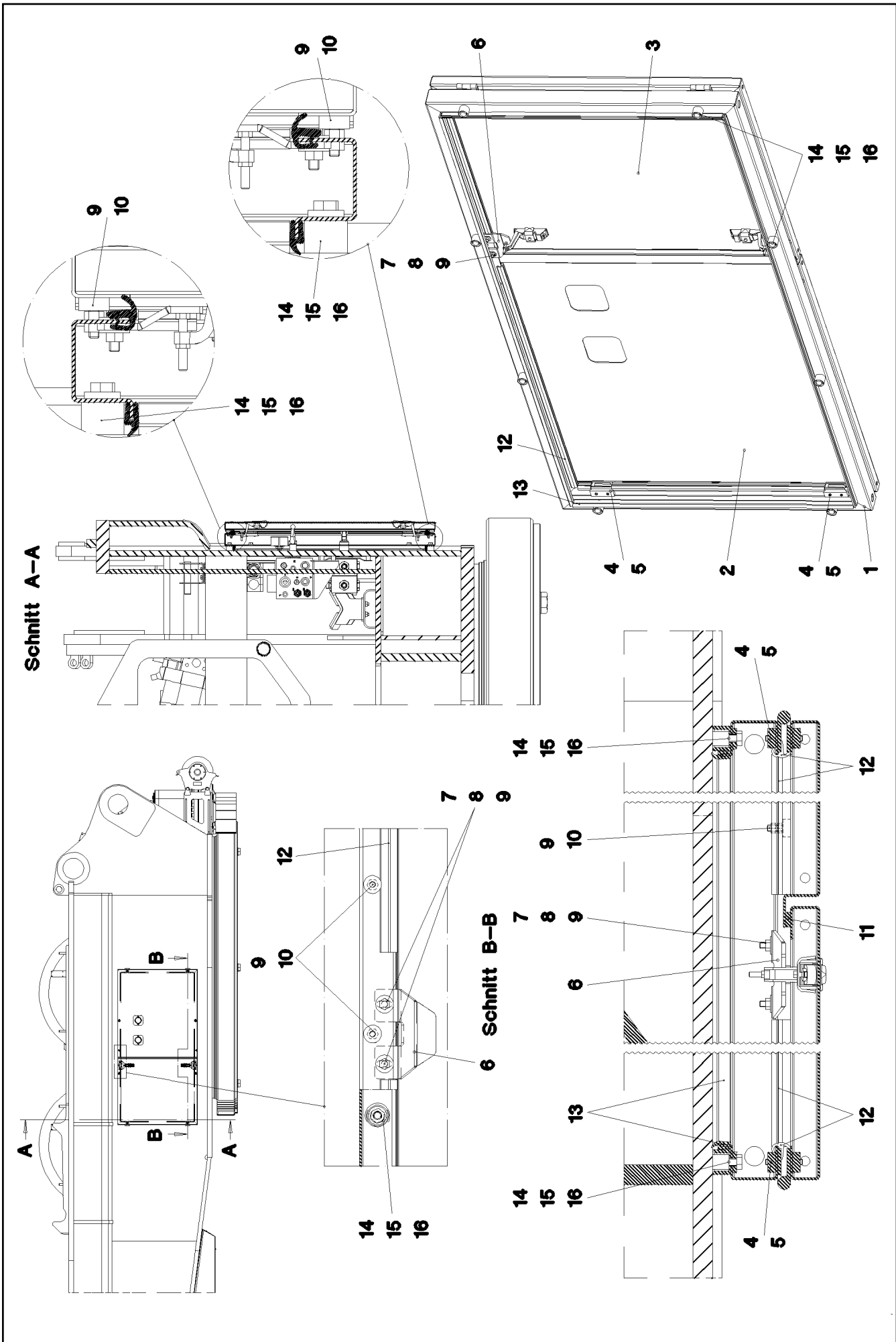

6.2.2009
052284

LIEBHERR

etk_en_de_074515 LR 1600/2

TURNTABLE PANELLING
DREHBUEHNENVERKLEIDUNG

☐ 136 (1/2)

⇒ 2 510
91 52 788 08

Pos.	Item	Quantity	Description	Bezeichnung	Serie	K
1	96 49 182 08	1	FRAME WELDED	RAHMEN SCHWK.		
2	96 49 183 08	1	DOOR COMPL. ⇒ 2 510 040 96 49 183 08	TUER VORM.		
3	96 49 184 08	1	DOOR COMPL. ⇒ 2 510 059 96 49 184 08	TUER VORM.		
4	95 36 953 08	4	THREADED PLATE 8X20X60	GEWINDEPLATTE		
5	40 86 002 08	8	COUNTERSUNK SCREW DIN 7991 M6X16 8.	SENKSCRAUBE		
6	95 41 137 08	2	PLATE 4x63x90 S235JRG2	BLECH		
7	40 00 829	4	HEX BOLT ISO 4017 M6X20 8.8 A2C	SECHSKANTSCHRAUBE		
8	42 18 007 08	8	WASHER DIN 9021 A 6.4 VERZ	SCHEIBE		
9	41 15 140 08	12	HEX NUT DIN 934 M6 8 VERZ	SECHSKANTMUTTER		
10	72 66 167 08	4	MEGI BUFFER 18X7,5	MEGIPUFFER		
11	26 21 051 08	0.78	FOAM RUBBER BAND 15X5	ZELLGUMMIBAND		
12	59 15 078 08	4	SEALING PROFILE	DICHTPROFIL		
13	26 21 047 08	4.46	SEALING PROFILE	DICHTPROFIL		
14	95 38 734 08	8	SLEEVE	HUELSE		
15	42 16 005 08	8	WASHER DIN 7349 8,4 ST VERZ	SCHEIBE		
16	49 00 188	8	HEX BOLT ISO 4017 M8X16 8.8 A2C	SECHSKANTSCHRAUBE		

6.2.2009

etk_en_de_074515 LR 1600/2

137 (2/2)

LIEBHERR

TURNTABLE PANELLING
DREHBUEHNENVERKLEIDUNG

⇒ 2 510
91 52 788 08

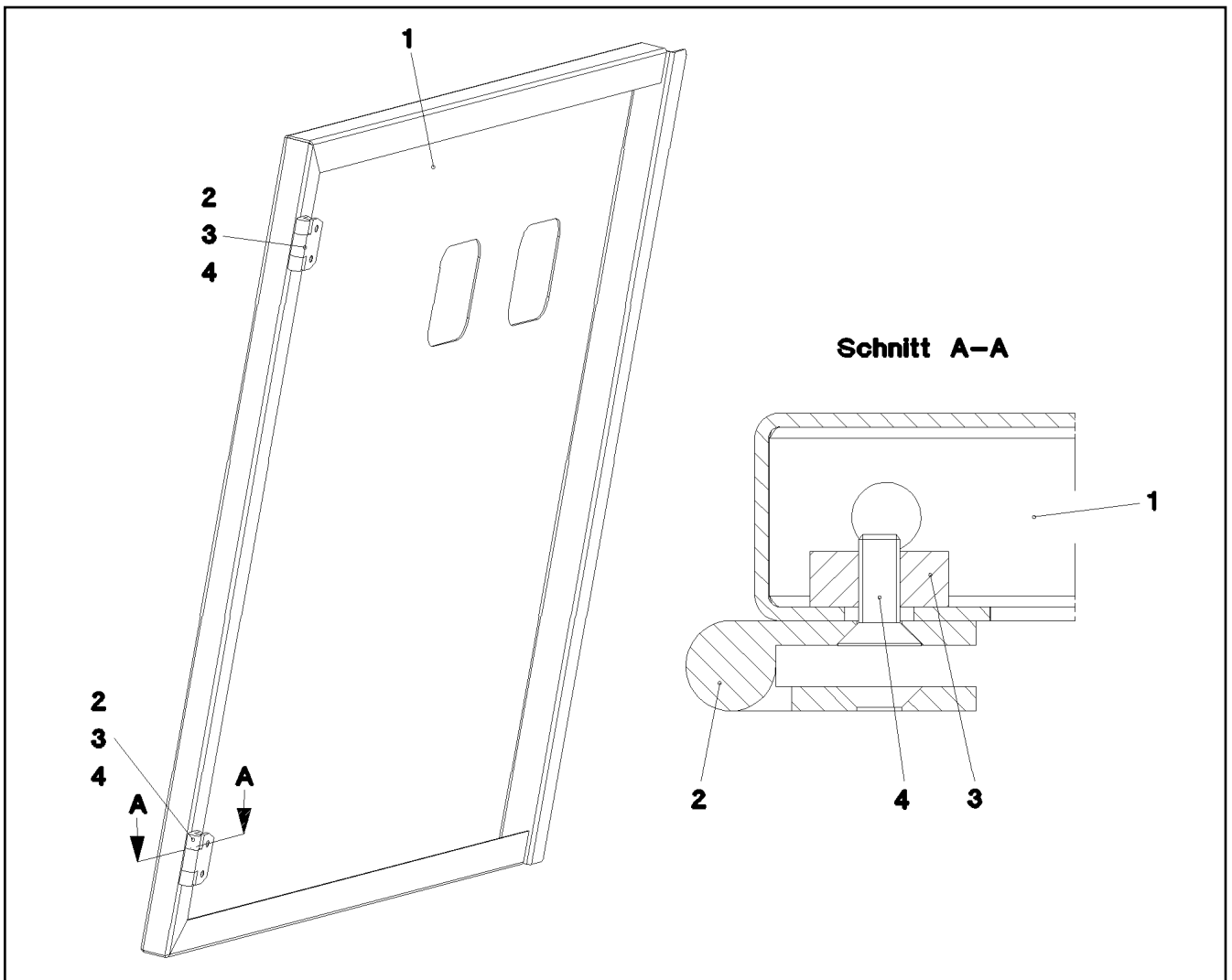

Pos.	Item	Quantity	Description	Bezeichnung	Serie	K
1	97 75 668 08	1	PLATE 2X1010X924	BLECH		
2	70 42 281 08	2	HINGE	SCHARNIER		
3	95 36 953 08	2	THREADED PLATE 8X20X60	GEWINDEPLATTE		
4	40 86 002 08	4	COUNTERSUNK SCREW DIN 7991 M6X16 8.	SENKSCHRAUBE		

6.2.2009
052285

LIEBHERR

etk_en_de_074515 LR 1600/2

DOOR COMPL.
TUER VORM.

138

⇒ 2 510 040
96 49 183 08

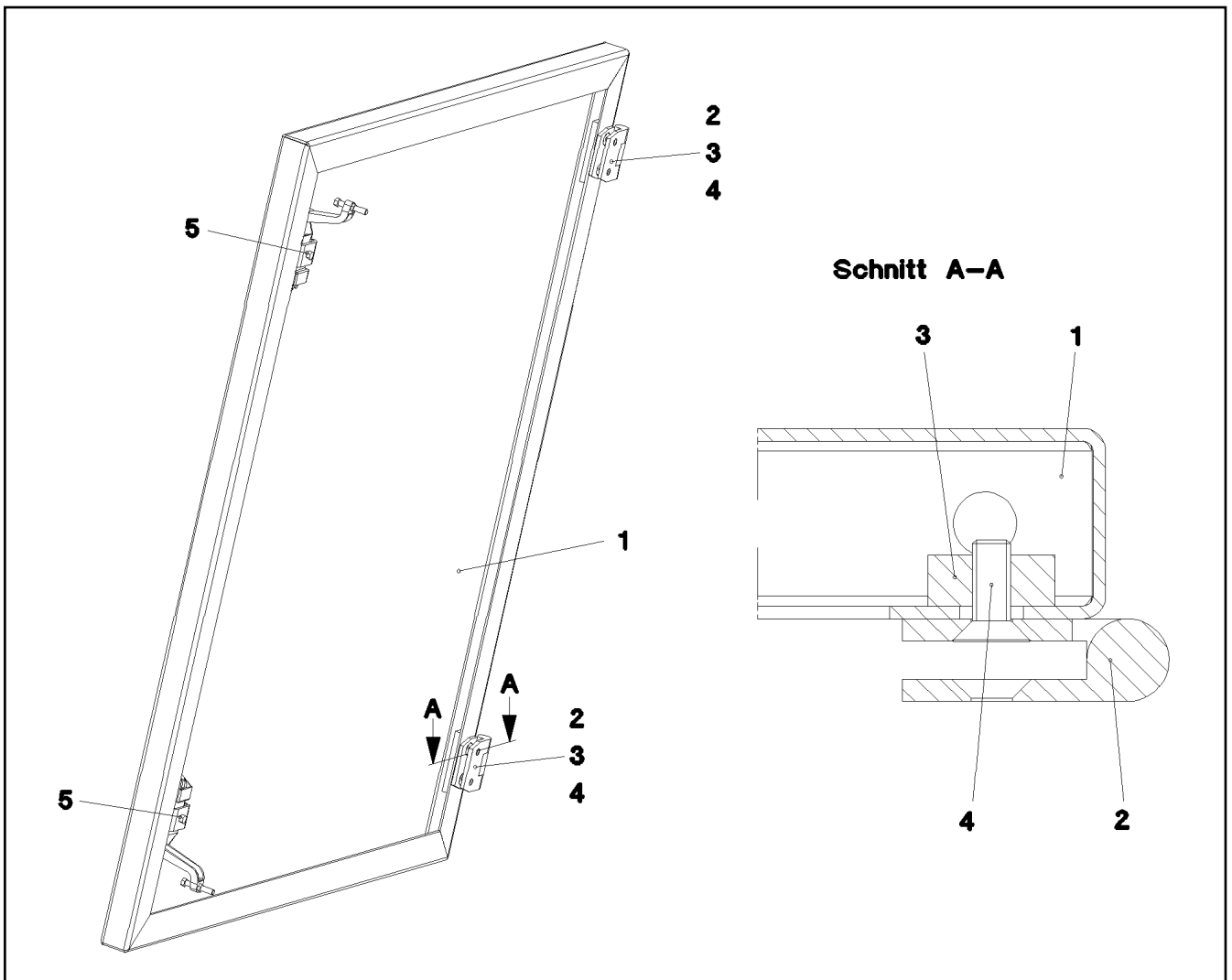

Pos.	Item	Quantity	Description	Bezeichnung	Serie	K
1	97 75 669 08	1	PLATE 2X784X924	BLECH		
2	70 42 281 08	2	HINGE	SCHARNIER		
3	95 36 953 08	2	THREADED PLATE 8X20X60	GEWINDEPLATTE		
4	40 86 002 08	4	COUNTERSUNK SCREW DIN 7991 M6X16 8.	SENKSCHRAUBE		
5	70 42 288 08	2	LEVER FASTENER	HEBELVERSCHLUSS		

6.2.2009
052286

LIEBHERR

etk_en_de_074515 LR 1600/2

DOOR COMPL.
TUER VORM.

139

⇒ 2 510 059
96 49 184 08

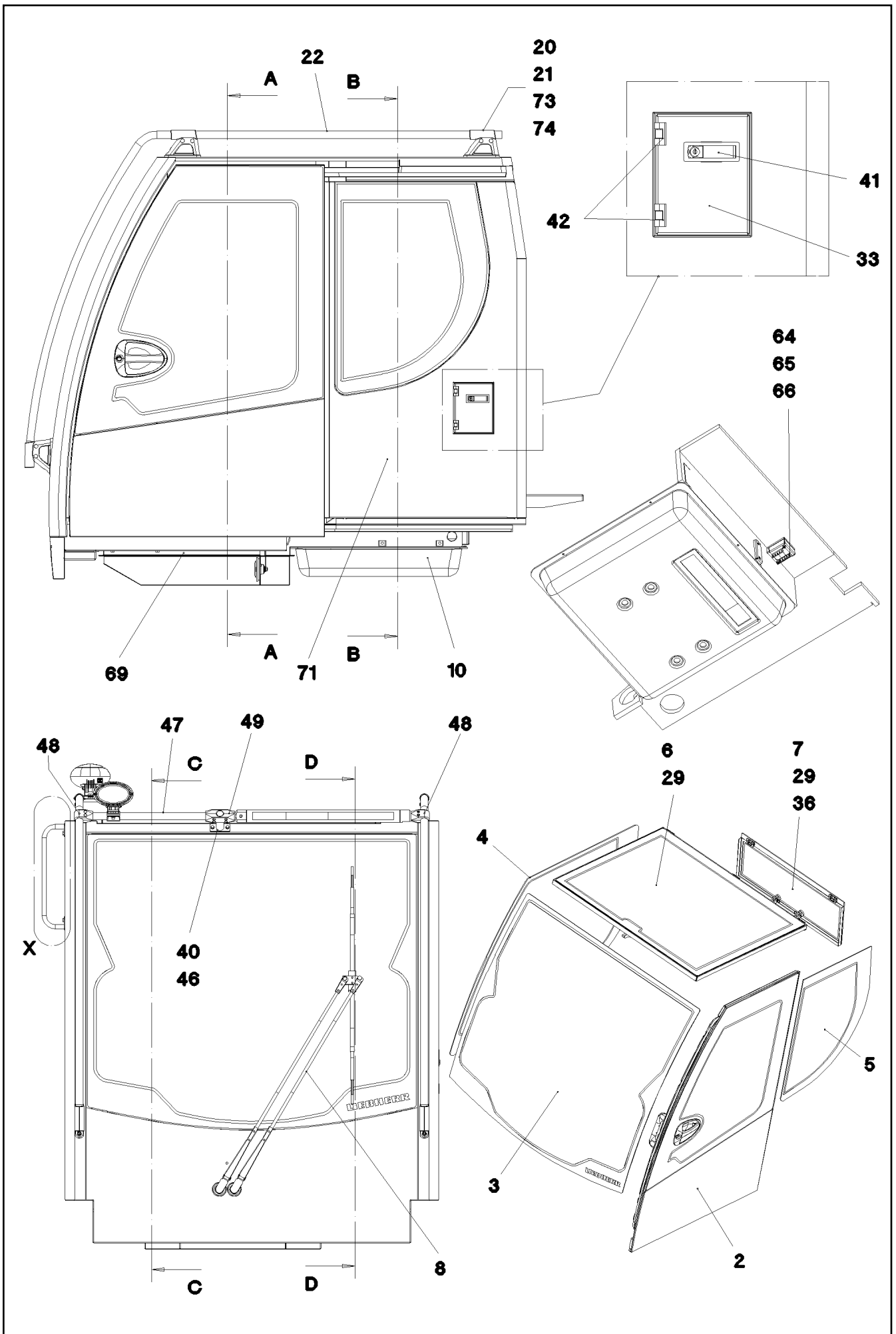

6.2.2009
052591

LIEBHERR

etk_en_de_074515 LR 1600/2

CABIN, GLAZED
KABINE VERGLAST

140 (1/6)

⇒ 2 520
91 53 061 08

Schnitt A-A

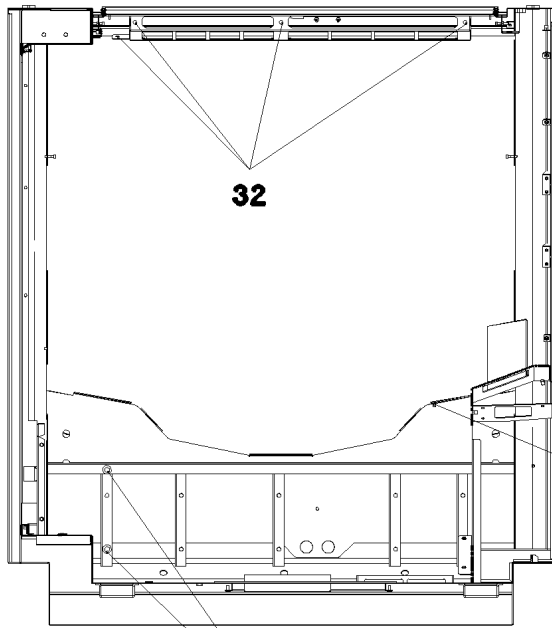

32

44

Schnitt B-B

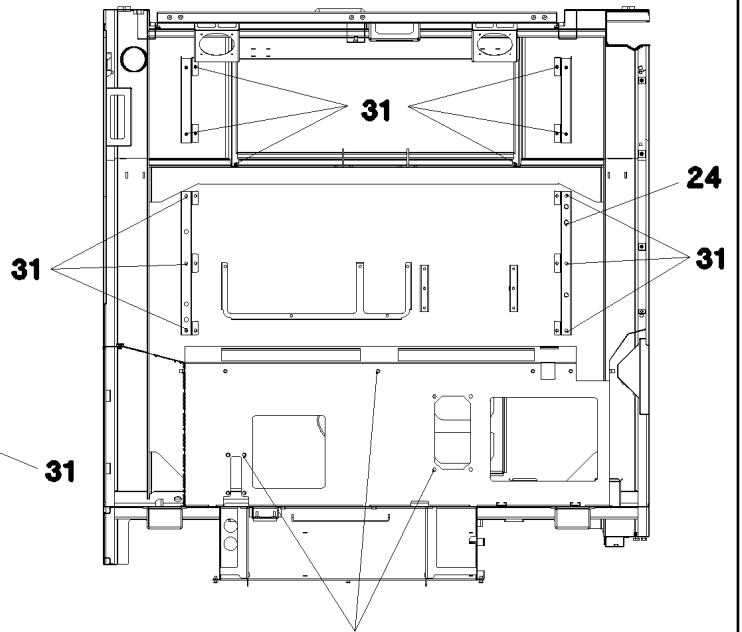

31

24

31

31

31

32

Schnitt C-C

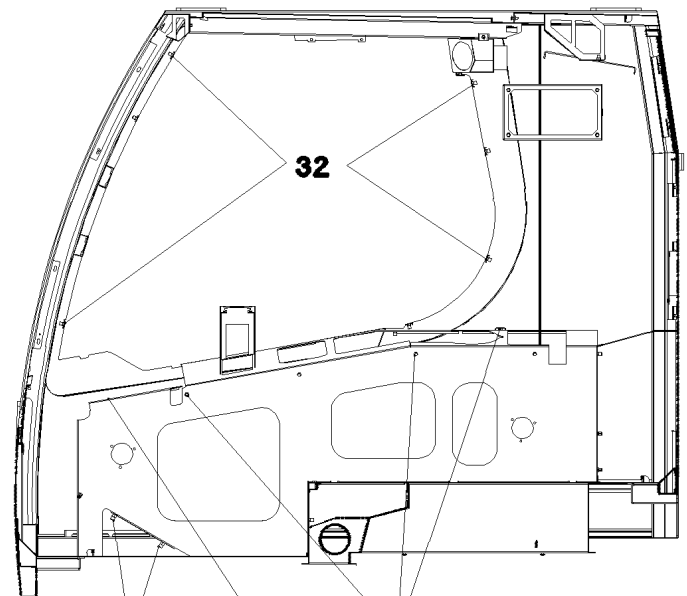

32

24

74

75

32

Schnitt D-D

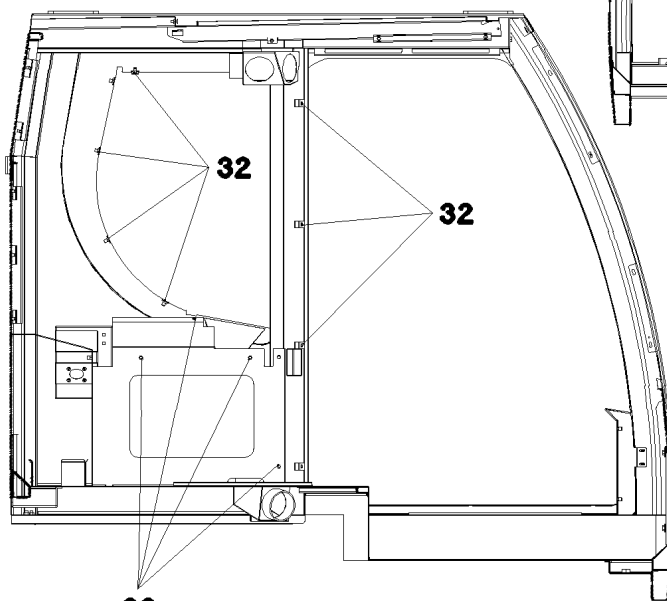

32

32

32

6.2.2009
052592

LIEBHERR

etk_en_de_074515 LR 1600/2

CABIN, GLAZED
KABINE VERGLAST

141 (2/6)

⇒ 2 520
91 53 061 08

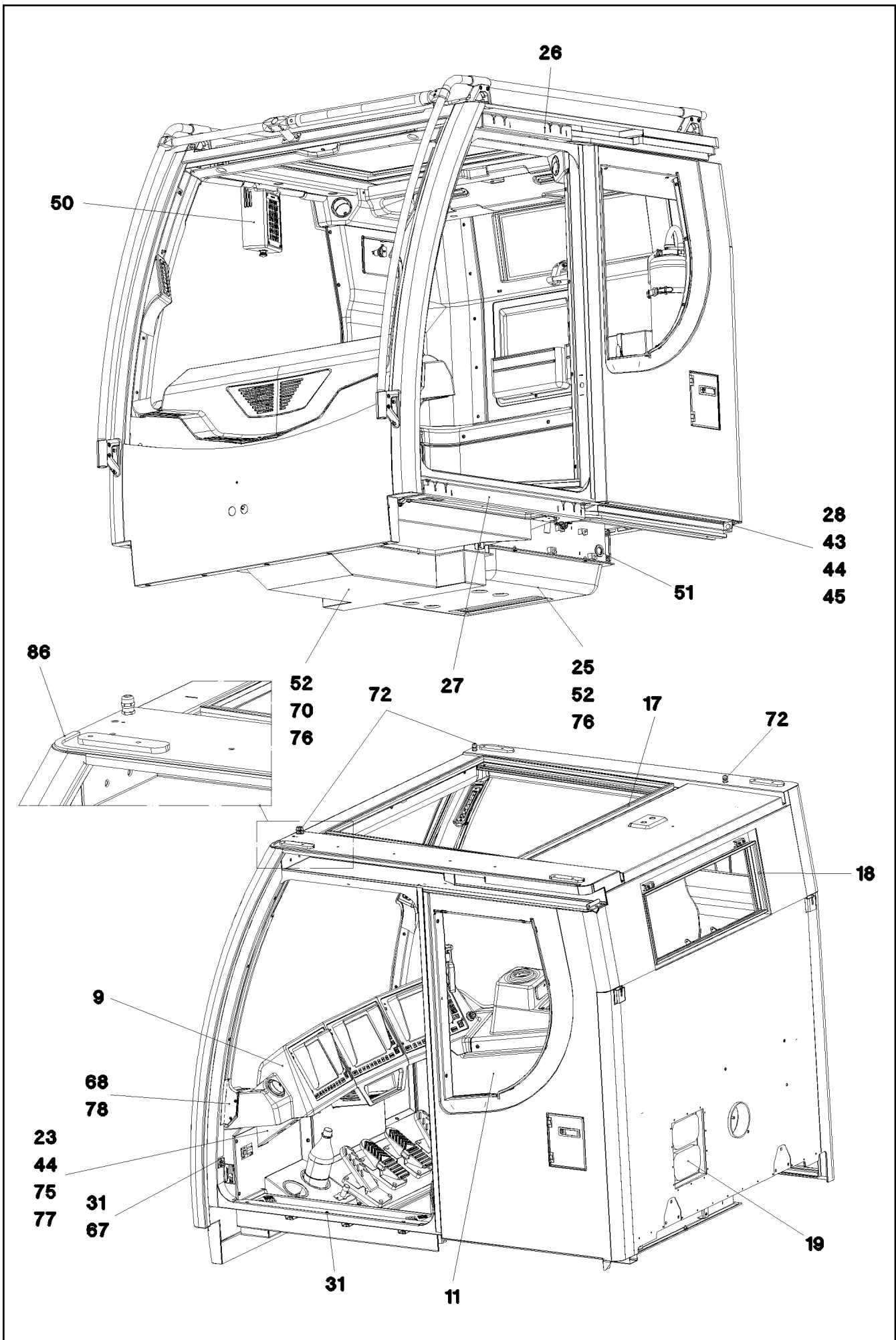

Einzelheit X

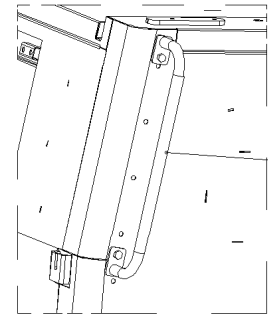
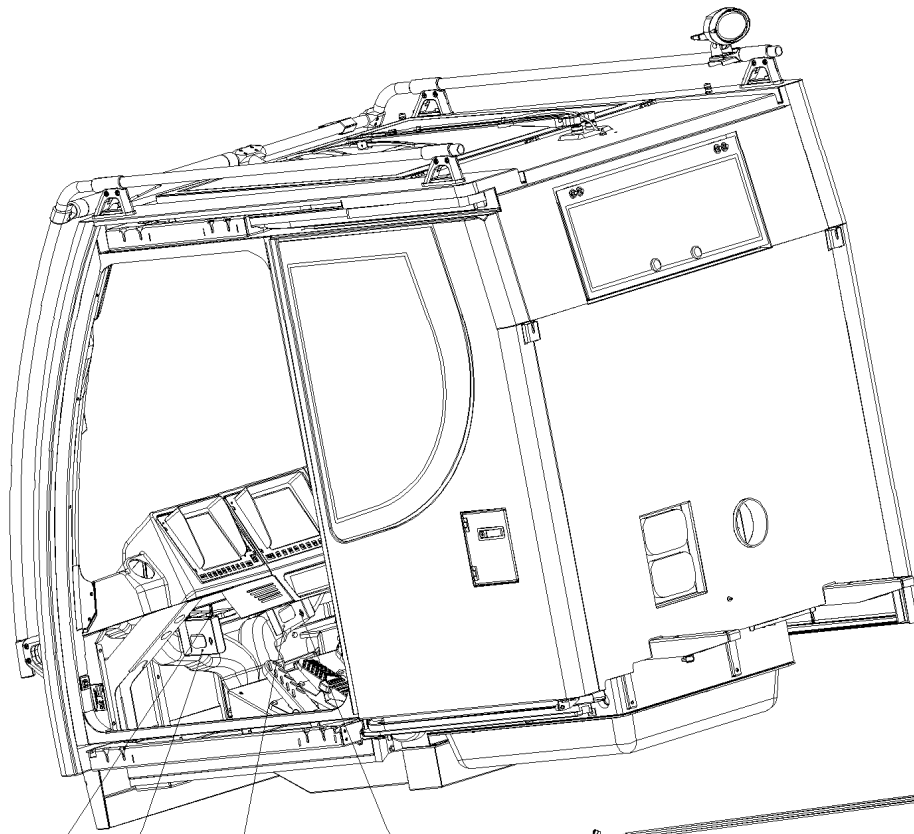

28
44

80 **53** **54** **76**

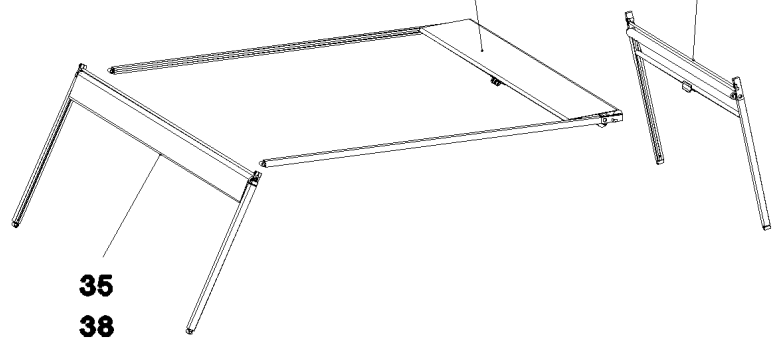

34
37

34
39

35
38

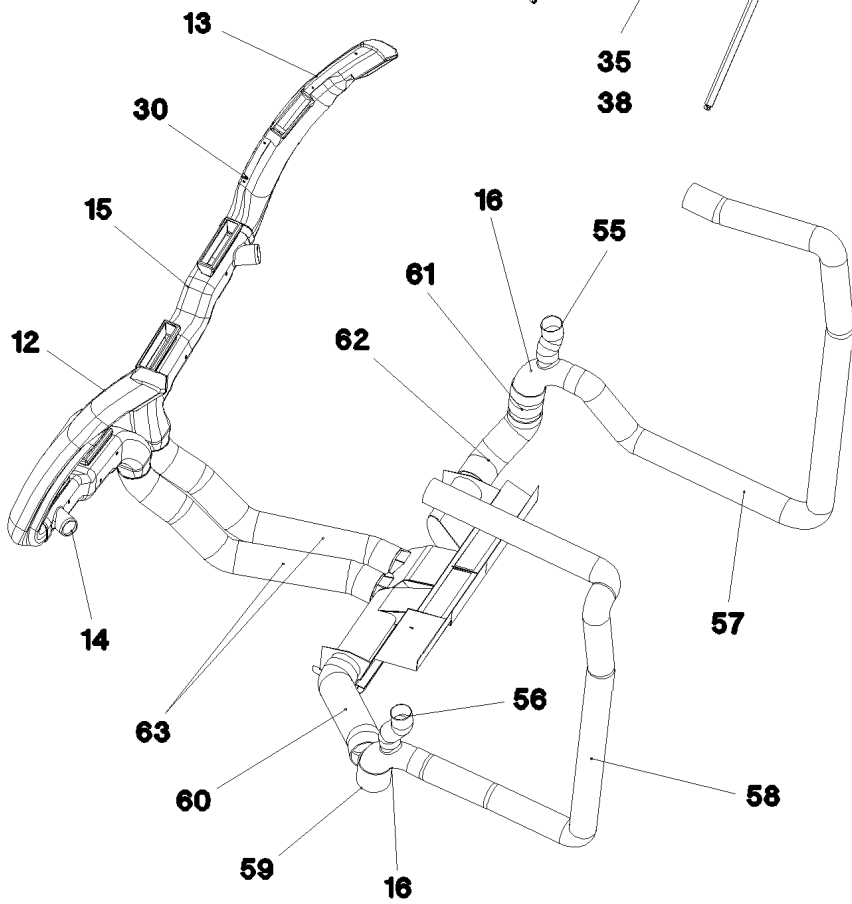

13

30

15

12

14

63

60

59

16

61

62

16

55

57

56

58

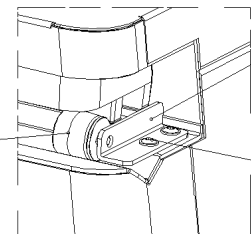

81

76

84

84

82

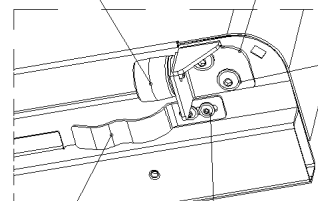

85

80

83

6.2.2009
052594

LIEBHERR

etk_en_de_074515 LR 1600/2

CABIN, GLAZED
KABINE VERGLAST

□ 143 (4/6)

⇒ 2 520
91 53 061 08

Pos.	Item	Quantity	Description	Bezeichnung	Serie	K
2	91 54 115 08	1	SLIDING DOOR CPL. ⇒ 2 522 91 54 115 08	SCHIEBETUER KPL.		
3	97 68 377 08	1	FRONT WINDOW ESG-GLAS SPF	FRONTSCHIEBE		
4	97 68 378 08	1	GRIDIRON CARRIER RIGHT 4X1063X1377 E	SEITENSCHIEBE RE.		
5	97 68 379 08	1	GRIDIRON CARRIER LEFT 4X603.5X844 ESG	SEITENSCHIEBE LI.		
6	96 45 609 08	1	ROOF WINDOW PRE-ASS. ⇒ 2 520 030 96 45 609 08	DACHSCHIEBE VORM.		
7	96 45 610 08	1	REAR WINDOW PRE-ASS. ⇒ 2 520 031 96 45 610 08	HECKSCHIEBE VORM.		
8	96 45 980 08	1	WINDSHIELD WASHER INSTALLATION ⇒ 2 520 032 96 45 980 08	SCHEIBENWISCHANLAGE EIN		
9	96 50 633 08	1	MONITOR CONSOLE ⇒ 2 520 033 96 50 633 08	MONITORKONSOLE		
10	91 53 253 08	1	CLIMA-HEATING INSTALLATION ⇒ 2 540 91 53 253 08	HEIZKLIMAGERAET EINBAU		
11	96 45 984 08	1	INTERNAL LINING ⇒ 2 520 034 96 45 984 08	INNENVERKLEIDUNG		
12	97 69 550 08	1	AIR GUIDE L PP SPF	LUFTFUEHRUNG LI.		
13	97 69 551 08	1	AIR GUIDE R PP SPF	LUFTFUEHRUNG RE.		
14	97 69 672 08	1	AIR GUIDE L PP SPF	LUFTFUEHRUNG LI.		
15	97 69 673 08	1	AIR GUIDE R PP SPF	LUFTFUEHRUNG RE.		
16	97 71 765 08	2	AIR DUCT PP SPF	LUFTFUEHRUNG		
17	10 30 060 5	3.88	CLAMPING PROFILE EPDM	KLEMMPROFIL		
18	10 30 060 5	2.1	CLAMPING PROFILE EPDM	KLEMMPROFIL		
19	10 29 200 0	2	VENTILATION	ENTLUEFTUNG		
20	97 52 186 08	6	HOLDER	HALTER		
21	97 53 845 08	6	HOLDER	HALTER		
22	97 70 466 08	2	TUBE 30.0X2863 X5CRNI18-10	ROHR		
23	97 70 673 08	1	PLATE 2X817X486	BLECH		
24	41 30 065 08	5	BLIND RIVET NUT M 8	BLINDNIETMUTTER		
25	97 73 582 08	1	LID ABS SPF	DECKEL		
26	96 45 884 08	1	GUIDE PRE-ASS. OBEN ⇒ 2 522 012 96 45 884 08	FUEHRUNG VORM.		
27	96 45 883 08	1	GUIDE PRE-ASS. UNTEN ⇒ 2 522 013 96 45 883 08	FUEHRUNG VORM.		
28	96 54 193 08	1	HAND GRIP WELDED	HALTEGRIF SCHWK.		
29	40 86 041 08	10	COUNTERSUNK SCREW DIN 7991 M6X20 8.	SENKSCRAUBE		
30	40 86 035 08	2	COUNTERSUNK SCREW DIN 7991 M5X10 8.	SENKSCRAUBE		
31	10 04 259 2	29	BLIND RIVET NUT M5 ST VERZ	BLINDNIETMUTTER		
32	10 04 259 3	74	BLIND RIVET NUT M6 ST VERZ	BLINDNIETMUTTER		
33	97 72 070 08	1	PLATE 2X196X238	BLECH		
34	40 00 899	6	CYLINDER SCREW ISO 4762 M5X30 8.8 A2C	ZYLINDERSCHRAUBE		
35	40 42 022 01	2	CYLINDER SCREW ISO 4762 M5X25 8.8 A2C	ZYLINDERSCHRAUBE		
36	43 20 034 08	2	DOWEL PIN ISO 8752 5X12	SPANNSTIFT		
37	10 41 336 1	1	BLIND	ROLLO		
38	10 41 336 2	1	BLIND	ROLLO		
39	10 41 336 4	1	BLIND	ROLLO		
40	40 73 502 08	2	HEX BOLT EN 1665 M6X16 8.8 A3C	SECHSKANTSCHRAUBE		
41	70 42 288 08	1	LEVER FASTENER	HEBELVERSCHLUSS		
42	70 42 598 08	2	HINGE	SCHARNIER		
44	49 00 188	6	HEX BOLT ISO 4017 M8X16 8.8 A2C	SECHSKANTSCHRAUBE		
46	96 48 733 08	1	CLAMP WELDED CONST.	HALTER SCHWK.		
47	97 75 036 08	1	TUBE 30.0X495	ROHR		
48	10 28 570 1	2	T-PIECE 30X30X30 G-ALMG	T-STUECK		
49	10 44 099 0	1	CROSS PIECE 30/30/30/30 G-ALMG	KREUZSTUECK		
50	97 58 507 08	1	HOUSING SPF	GEHAEUSE		
51	55 30 278 08	2	DIAPHRAGM SOCKET	MEMBRANTUELLE		
52	26 21 078 14	6	CELL RUBBER 25X4 NEOPRENE	ZELLGUMMI		
53	97 79 157 08	1	PLATE 2X201X127 FE//ZN20//C	BLECH		
54	97 79 158 08	1	PLATE 2X201X128 FE//ZN20//C	BLECH		

6.2.2009

etk_en_de_074515 LR 1600/2

 144 (5/6)
LIEBHERR
CABIN, GLAZED
KABINE VERGLAST

⇒ 2 520
91 53 061 08

Pos.	Item	Quantity	Description	Bezeichnung	Serie	K
55	10 42 558 8	0.12	WARM AIR HOSE DI 55MM PAK	WARMLUFTSCHLAUCH		
56	10 42 558 8	0.18	WARM AIR HOSE DI 55MM PAK	WARMLUFTSCHLAUCH		
57	55 31 812 08	1.7	HEATING HOSE 70	HEIZUNGSSCHLAUCH		
58	55 31 812 08	1.9	HEATING HOSE 70	HEIZUNGSSCHLAUCH		
59	55 30 182 08	0.16	HEATING HOSE 89 Rolle40m	HEIZUNGSSCHLAUCH		
60	55 30 182 08	0.3	HEATING HOSE 89 Rolle40m	HEIZUNGSSCHLAUCH		
61	55 30 182 08	0.13	HEATING HOSE 89 Rolle40m	HEIZUNGSSCHLAUCH		
62	55 30 182 08	0.26	HEATING HOSE 89 Rolle40m	HEIZUNGSSCHLAUCH		
63	55 30 182 08	1.62	HEATING HOSE 89 Rolle40m	HEIZUNGSSCHLAUCH		
64	97 60 772 08	2	PLATE 2X103X117	BLECH		
65	97 61 932 08	1	SEAL 78X64 30	DICHTUNG		
66	40 42 109	2	CYLINDER SCREW ISO 4762 M6X45 8.8 A2C	ZYLINDERSCHRAUBE		
67	97 75 126 08	1	PLATE 1.5X75X75	BLECH		
68	96 49 083 08	1	COVER WELDED	DECKEL SCHWK.		
69	96 49 125 08	1	INSULANT FLOOR PLATE ⇒ 2 520 035 96 49 125 08	DAEMMUNG BODENBLECH		
70	97 75 796 08	1	LID 1.5X954X977	DECKEL		
71	91 55 303 08	1	CABIN SHEET METAL SECTIONS	KABINE BLECHTEILE		
72	60 24 241 08	3	THREADED CABLE GLAND M16X1,5 MS	KABELVERSCHRAUBUNG		
73	46 00 175	24	CYLINDER SCREW ISO 4762 M8X25 8.8 A2C	ZYLINDERSCHRAUBE		
74	41 19 010 08	13	HEX NUT DIN 985 M8 10 VERZ	SECHSKANTMUTTER		
75	42 18 009 08	7	WASHER DIN 9021 A 8.4 VERZ	SCHEIBE		
76	40 97 043 08	13	PAN-HEAD SCREW M6X16 SCHWARZ VERZ	FLACHKOPFSCHRAUBE		
77	59 15 709 08	2	COVER LID 28X30	ABDECKKAPPE		
78	40 97 053 08	2	PAN-HEAD SCREW AEHNL.ISO7380 M4X12	FLACHKOPFSCHRAUBE		
79	10 41 286 1	2	OVAL HEAD FLAT SCREW AEHNL.ISO7380	LINSENFLACHKOPFSCHRAUBE		
80	10 45 069 3	6	OVAL HEAD FLAT SCREW ISO 7380 M5X10 1	LINSENFLACHKOPFSCHRAUBE		
81	96 52 917 08	1	PLATE WELDED	BLECH SCHWK.		
82	96 53 131 08	1	PLATE WELDED	BLECH SCHWK.		
83	97 84 867 08	1	SPRING X5CRNI18-10	FEDER		
84	10 47 289 0	2	RUBBER BUMPER 32X32XM6 ELASTOMER	GUMMIPUFFER		
85	10 41 285 7	2	OVAL HEAD FLAT SCREW AEHNL.ISO7380	LINSENFLACHKOPFSCHRAUBE		
86	97 95 151 08	1	PLATE 3X80X1392	BLECH		

6.2.2009

etk_en_de_074515 LR 1600/2

145 (6/6)

LIEBHERR

CABIN, GLAZED
KABINE VERGLAST

⇒ 2 520
91 53 061 08

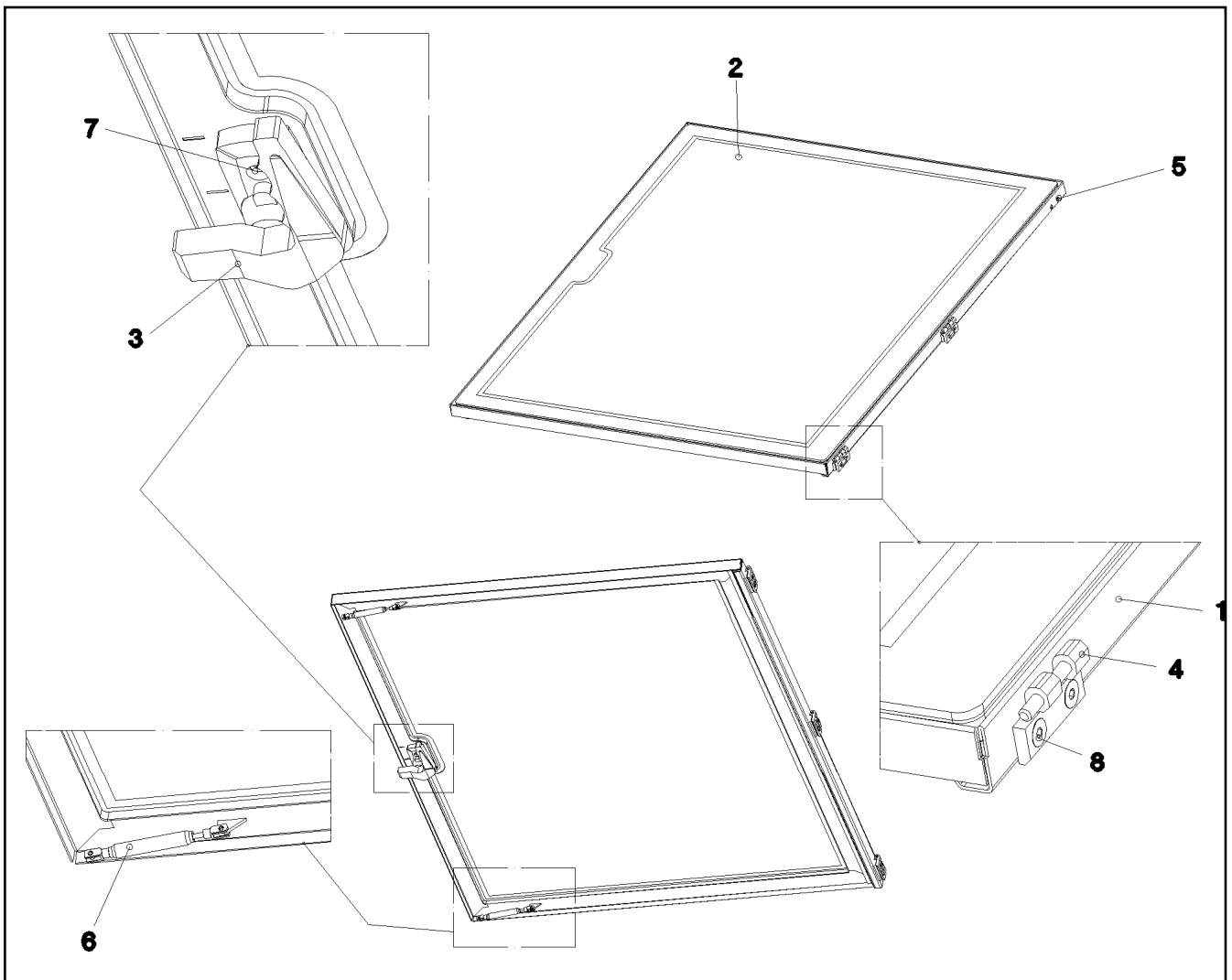

Pos.	Item	Quantity	Description	Bezeichnung	Serie	K
1	96 46 980 08	1	FRAME WELDED	RAHMEN SCHWK.		
2	97 68 380 08	1	ROOF WINDOW SPF	DACHSCHEIBE		
3	59 10 668 08	1	HAND GRIP	HANDGRIFF		
4	70 42 012 08	3	SCREW-ON HINGE	ANSCHRAUBSCHARNIER		
5	10 04 259 3	6	BLIND RIVET NUT M6 ST VERZ	BLINDNIETMUTTER		
6	10 41 287 1	2	GAS SPRING 12X50 130N	GASFEDER		
7	40 93 609 08	2	CYLINDER SCREW DIN 7984 M6X12 8.8 VER	ZYLINDERSCHRAUBE		
8	40 86 041 08	6	COUNTERSUNK SCREW DIN 7991 M6X20 8.	SENKSCHRAUBE		
9	26 21 091 08	3.7	CELL RUBBER 8X10	ZELLGUMMI		

6.2.2009
052576

LIEBHERR

etk_en_de_074515 LR 1600/2

ROOF WINDOW PRE-ASS.
DACHSCHEIBE VORM.

146

⇒ 2 520 030
96 45 609 08

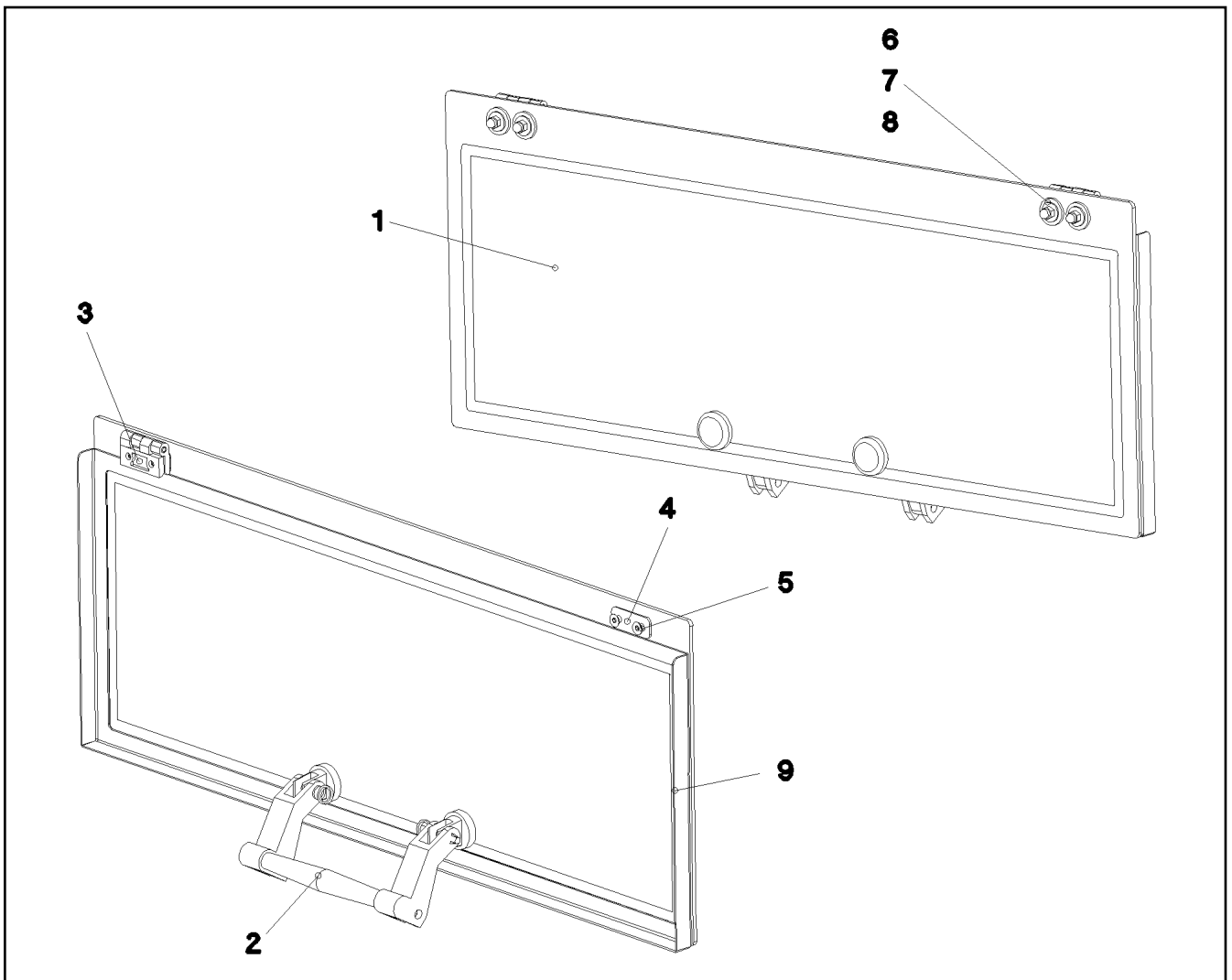

Pos.	Item	Quantity	Description	Bezeichnung	Serie	K
1	97 68 381 08	1	REAR WINDOW ESG-GLAS SPF	HECKSCHEIBE		
2	10 29 202 3	1	HINGED HANDLE KUNSTSTOFF	AUSSTELLGRIFF		
3	70 42 012 08	2	SCREW-ON HINGE	ANSCHRAUBSCHARNIER		
4	97 52 216 08	2	SHEET 50X20X2 PE	PLATTE		
5	40 86 041 08	4	COUNTERSUNK SCREW DIN 7991 M6X20 8.	SENKSCHRAUBE		
6	28 81 831 08	6	WASHER RD25X6 PA6G SCHWARZ	SCHEIBE		
7	42 18 007 08	6	WASHER DIN 9021 A 6.4 VERZ	SCHEIBE		
8	41 21 001 08	6	CAP NUT DIN 1587 M6 6 A2C	HUTMUTTER		
9	97 77 221 08	1	PLATE 1.5X817X297	BLECH		

6.2.2009
052577

LIEBHERR

etk_en_de_074515 LR 1600/2

REAR WINDOW PRE-ASS.
HECKSCHEIBE VORM.

147

⇒ 2 520 031
96 45 610 08

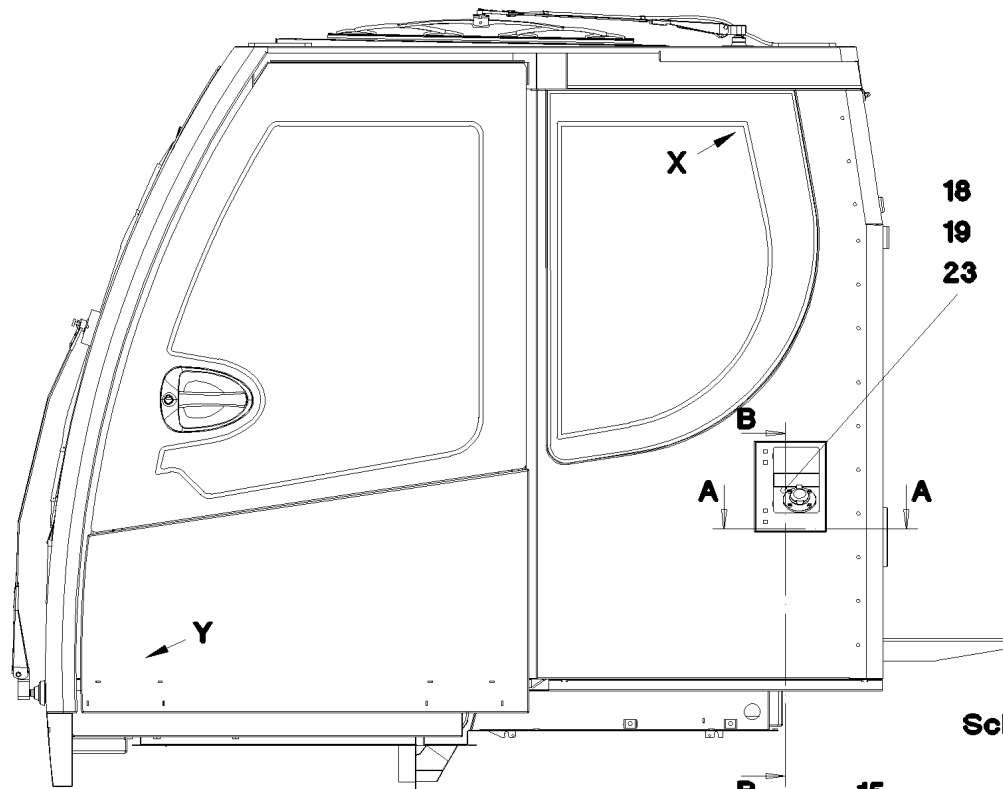

Schnitt B-B

Schnitt A-A

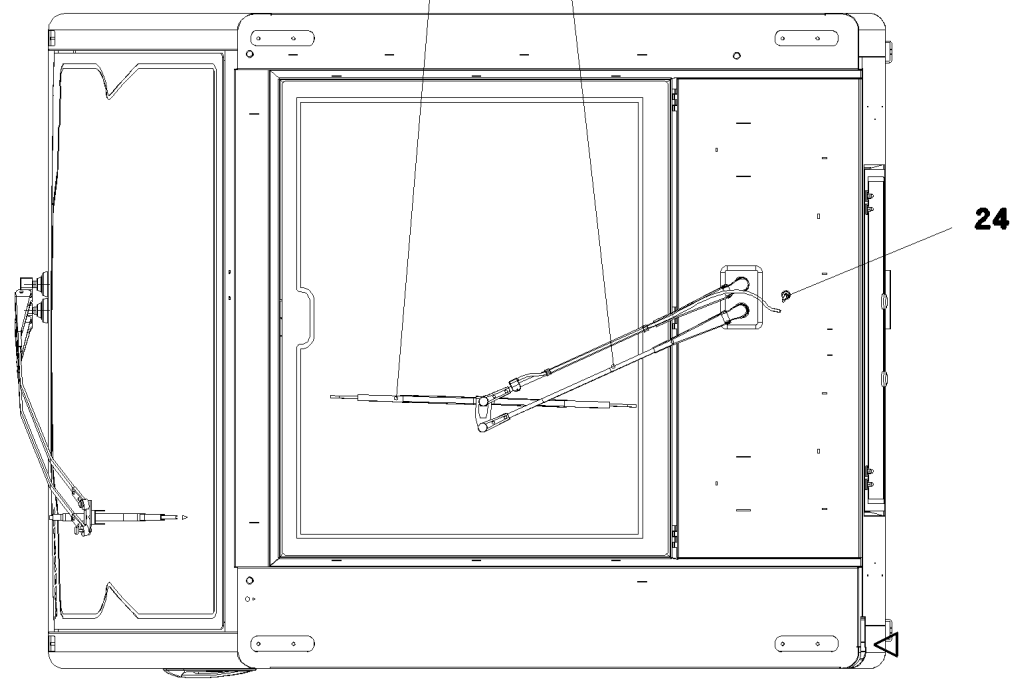
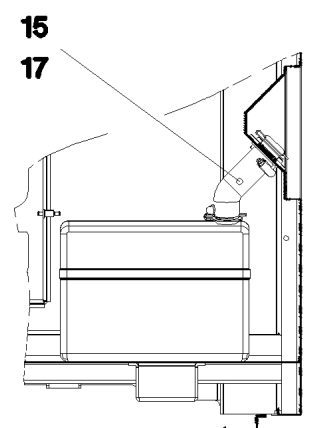
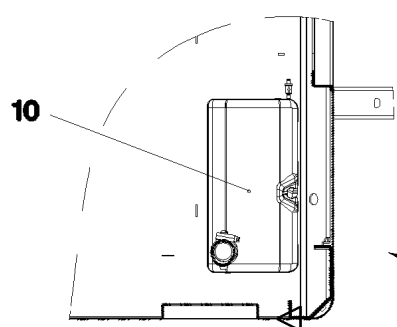

6.2.2009
052578

LIEBHERR

etk_en_de_074515 LR 1600/2

WINDSHIELD WASHER INSTALLATION
SCHEIBENWISCHANLAGE EINBAU

148 (1/3)

⇒ 2 520 032
96 45 980 08

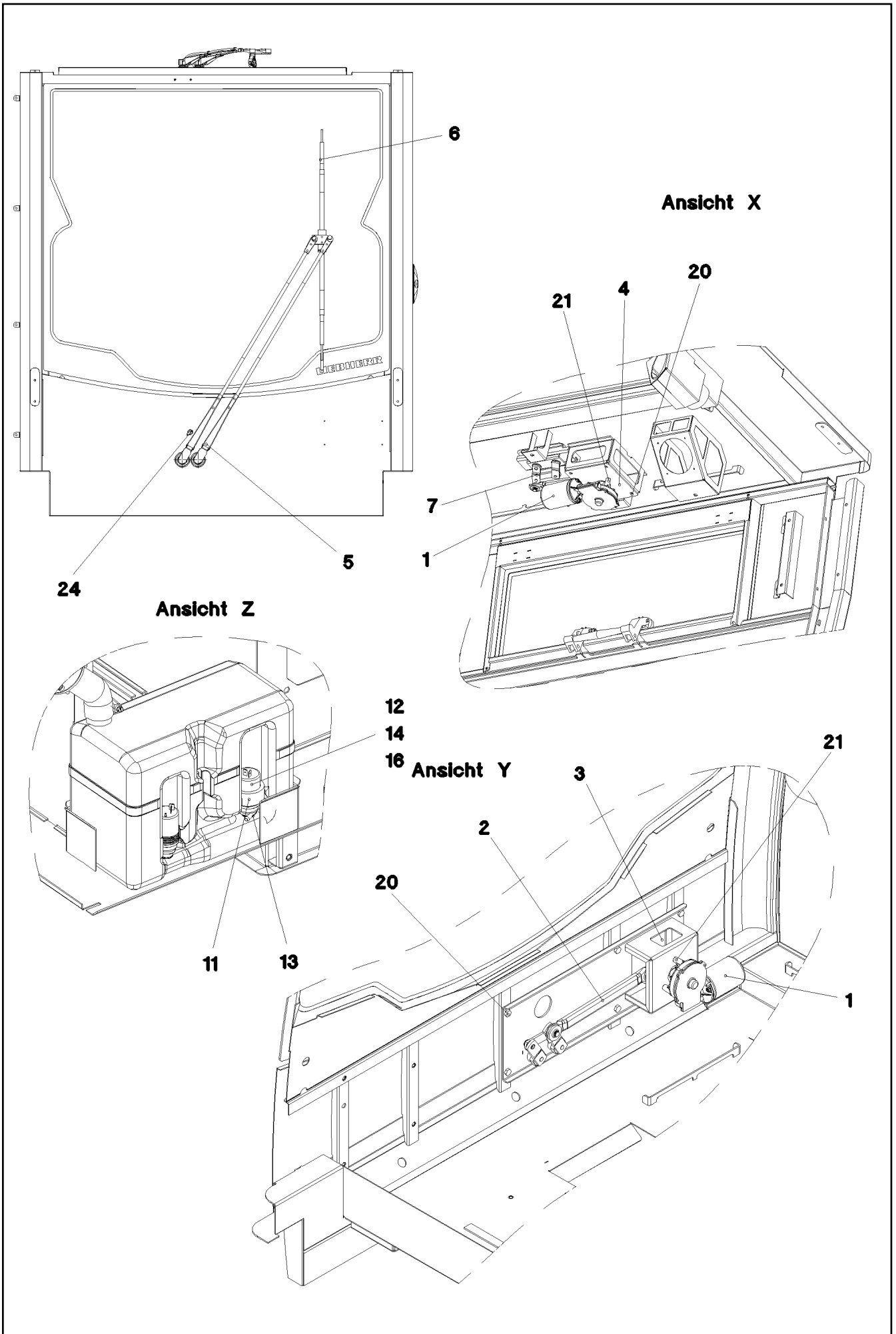

6.2.2009
052579

LIEBHERR

etk_en_de_074515 LR 1600/2

WINDSHIELD WASHER INSTALLATION
SCHEIBENWISCHANLAGE EINBAU

149 (2/3)

⇒ 2 520 032
96 45 980 08

Pos.	Item	Quantity	Description	Bezeichnung	Serie	K
1	10 29 202 1	2	WIPER MOTOR 55NM 24V	WISCHERMOTOR		
2	10 41 288 0	1	WIPER FRAME 12	WISCHERGESTAENGE		
3	96 45 983 08	1	BRACKET WELDED CONST.	KONSOLE SCHWK.		
4	97 69 588 08	1	PLATE 3X151X136	BLECH		
5	10 41 288 1	1	WIPER ARM PARALELL	WISCHERARM		
6	10 29 201 7	1	WIPER BLADE 1000	WISCHERBLATT		
7	10 41 287 9	1	WIPER FRAME 10	WISCHERGESTAENGE		
8	10 29 201 4	1	WIPER ARM	WISCHERARM		
9	10 29 201 6	1	WIPER BLADE 700	WISCHERBLATT		
10	10 03 697 7	1	WATER BASIN 8,0L KUNSTSTOFF	WASSERBEHAELTER		
11	10 03 697 4	1	ADAPTOR KUNSTSTOFF	ADAPTER		
12	59 10 554 08	1	PUMP	PUMPE		
13	59 10 555 08	1	SOCKET GUMMI	TUELLE		
14	59 10 053 08	10	HOSE 4	SCHLAUCH		
15	55 31 684 08	2	HOSE CLAMP DIN 3017 A 32/50 W1	SCHLAUCHSCHELLE		
16	59 10 556 08	2	NON-RETURN VALVE	RUECKSCHLAGVENTIL		
17	97 74 376 08	1	TUBE EPDM	ROHR		
18	97 74 378 08	1	FLANGE POM	FLANSCH		
19	72 64 212 08	1	O-RING 42X3 NBR90	O-RING		
20	40 65 063 08	6	HEX BOLT ISO 4017 M8X16 8.8 BLANK	SECHSKANTSCHRAUBE		
21	40 97 043 08	6	PAN-HEAD SCREW M6X16 SCHWARZ VERZ	FLACHKOPFSCHRAUBE		
23	24 00 465 02	4	CYLINDER SCREW ISO 4762 M5X16 8.8	ZYLINDERSCHRAUBE		
24	59 10 510 08	2	SWIVEL ELBOW	WINKELSTUTZEN		

6.2.2009

etk_en_de_074515 LR 1600/2

150 (3/3)

LIEBHERR

WINDSHIELD WASHER INSTALLATION
SCHEIBENWISCHANLAGE EINBAU

⇒ 2 520 032
96 45 980 08

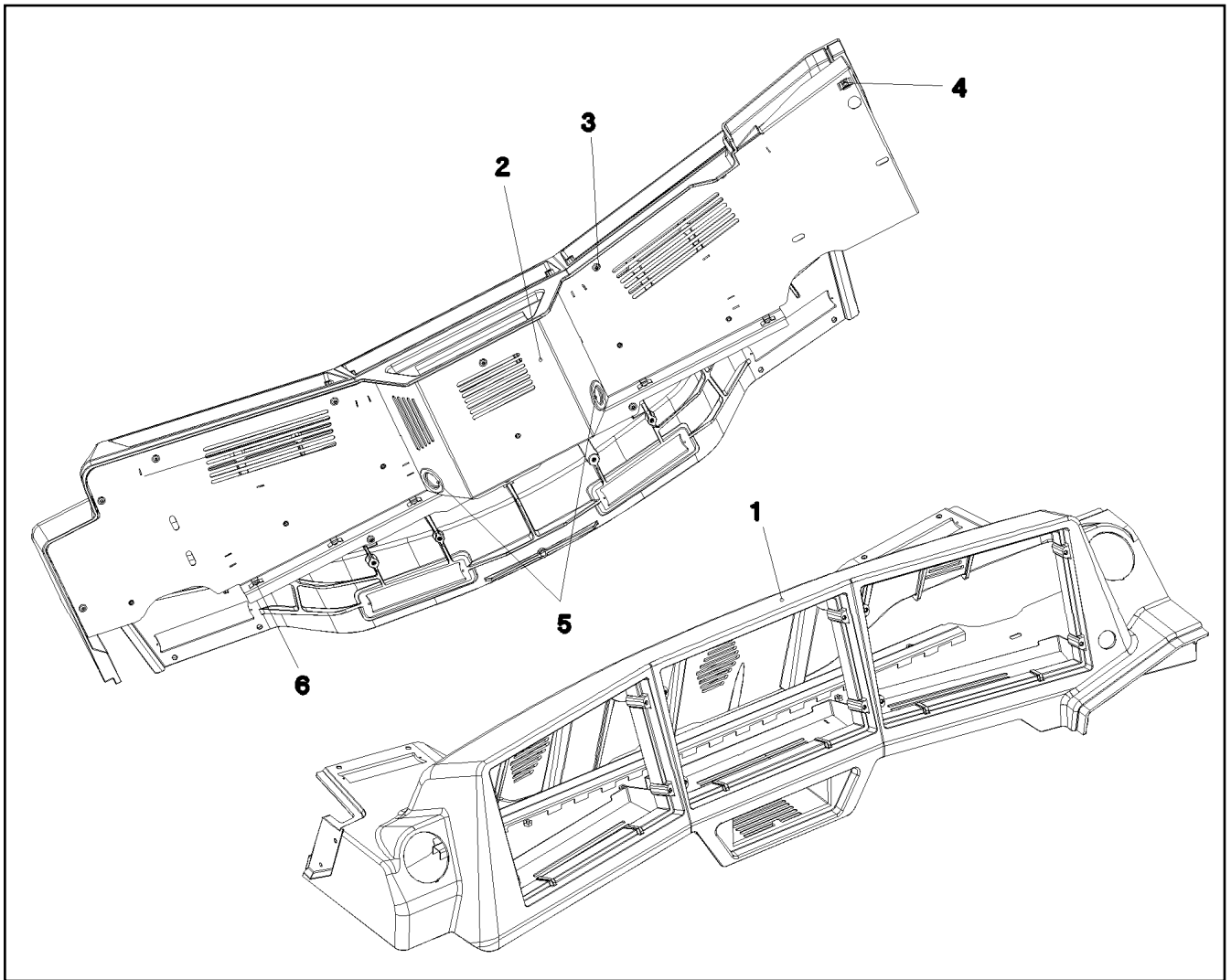

Pos.	Item	Quantity	Description	Bezeichnung	Serie	K
1	97 79 033 08	1	MONITOR CONSOLE PU SPF	MONITORKONSOLE		
2	96 49 873 08	1	COVER ST. CONST.	ABDECKUNG SCHWK.		
3	10 45 069 3	11	OVAL HEAD FLAT SCREW ISO 7380 M5X10 1	LINSENFLACHKOPFSCHRAUBE		
4	41 30 031 08	1	CAGE NUT M8	KAFIGMUTTER		
5	55 30 278 08	2	DIAPHRAGM SOCKET	MEMBRANTUELLE		
6	60 20 611 08	7	CABLE CLIP HOLDER	KABELBINDERHALTER		

6.2.2009
052580

LIEBHERR

etk_en_de_074515 LR 1600/2

MONITOR CONSOLE
MONITORKONSOLE

151

⇒ 2 520 033
96 50 633 08

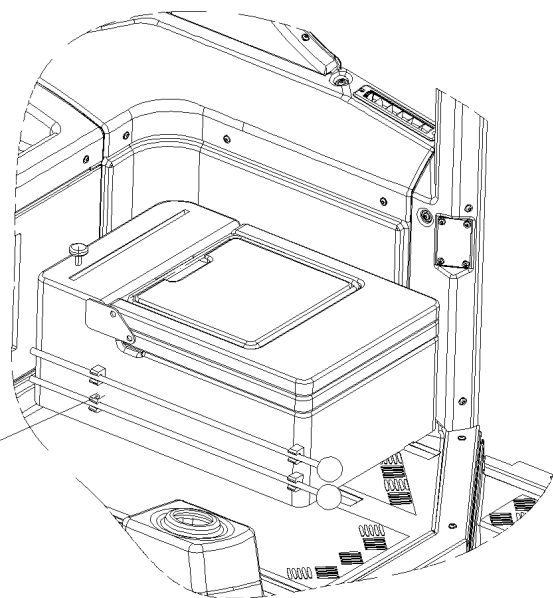
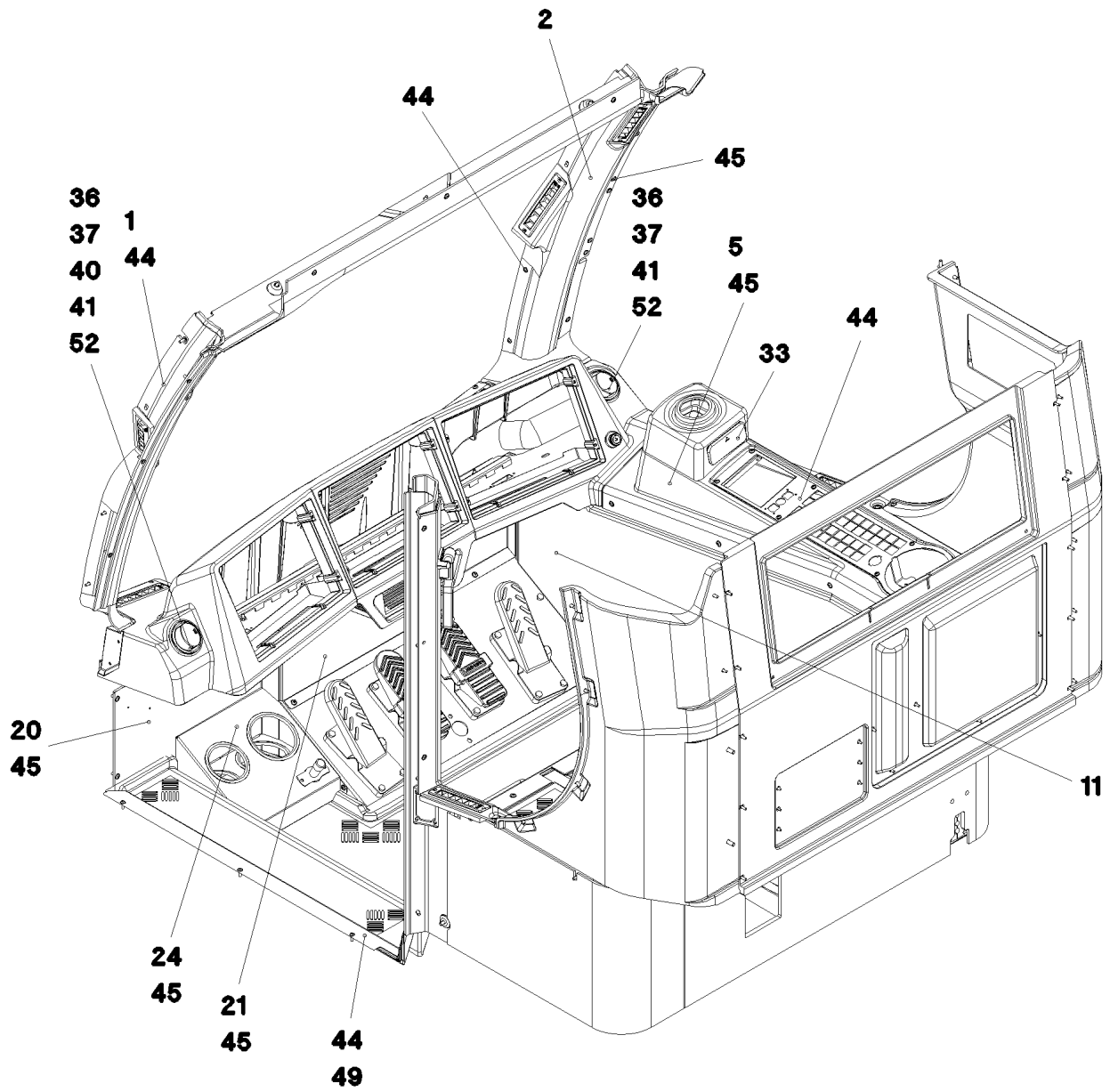

6.2.2009
052588

LIEBHERR

etk_en_de_074515 LR 1600/2

INTERNAL LINING
INNENVERKLEIDUNG

152 (1/4)

⇒ 2 520 034
96 45 984 08

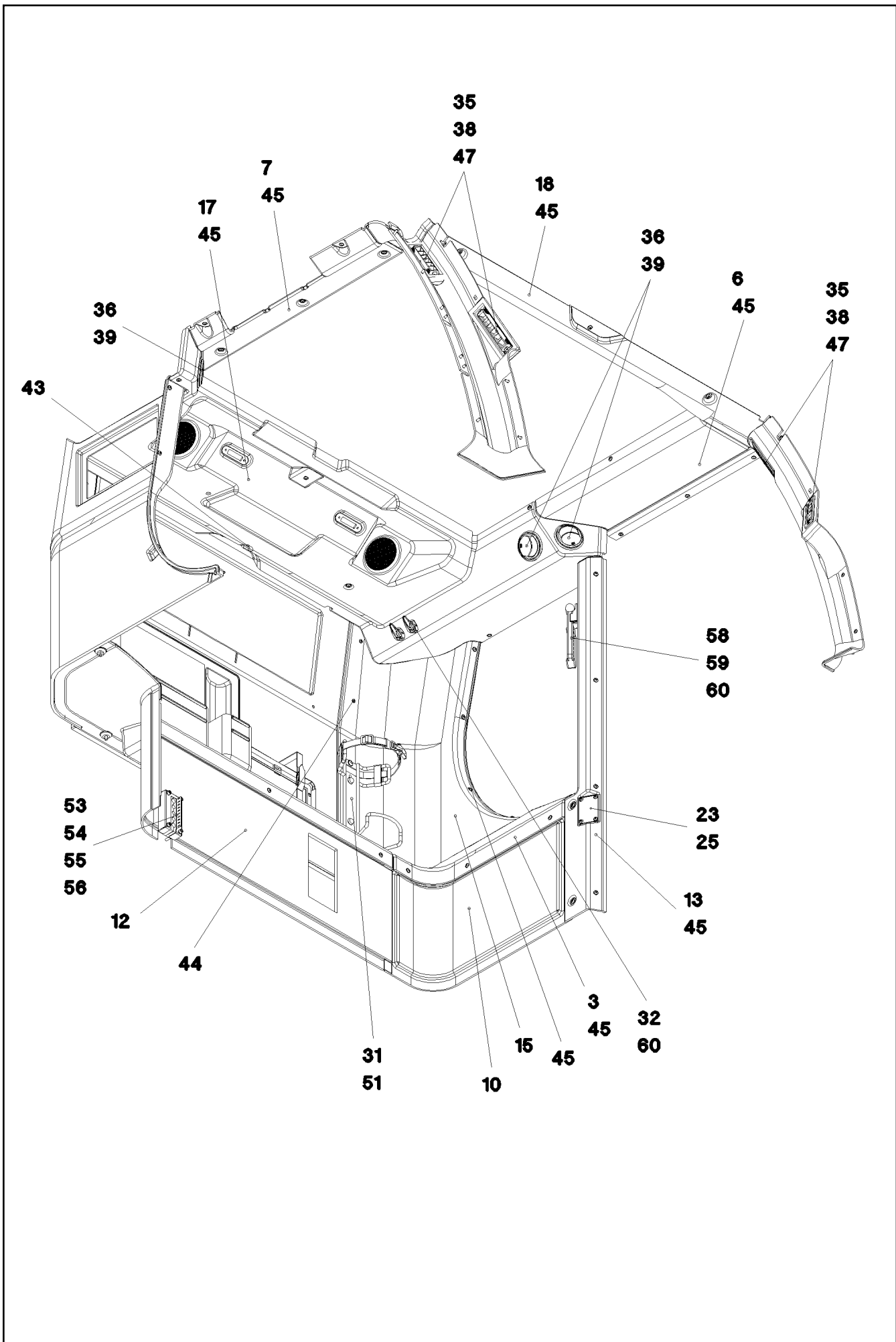

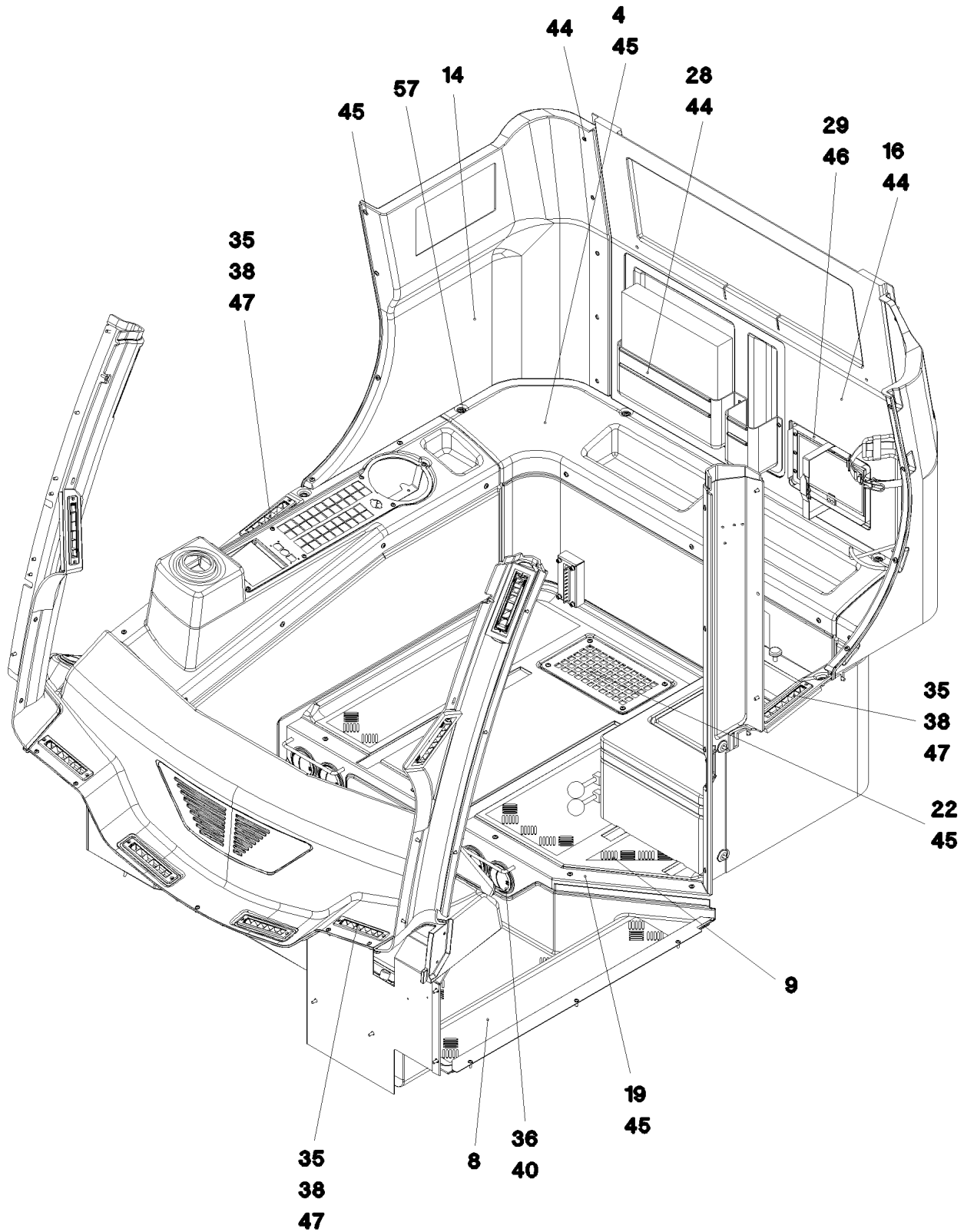

6.2.2009
052590

LIEBHERR

etk_en_de_074515 LR 1600/2

INTERNAL LINING
INNENVERKLEIDUNG

154 (3/4)

⇒ 2 520 034
96 45 984 08

Pos.	Item	Quantity	Description	Bezeichnung	Serie	K
1	97 69 656 08	1	A COLUMN CLADDING LEFT SPF	VERKLEIDUNG A-SAEULE LI.		
2	97 69 657 08	1	A COLUMN CLADDING RIGHT SPF	VERKLEIDUNG A-SAEULE RE.		
3	97 69 890 08	1	PANELLING REST SPF	VERKLEIDUNG ABLAGE		
4	97 69 891 08	1	PANELLING REST SPF	VERKLEIDUNG ABLAGE		
5	97 69 892 08	1	PANELLING SPF	VERKLEIDUNG		
6	97 71 451 08	1	PANELLING,STRUT LEFT SPF	VERKLEIDUNG HOLM LI.		
7	97 71 452 08	1	SMALL HILL COVERING SPF	VERKLEIDUNG HOLM RE.		
8	97 71 453 08	1	FLOOR MAT 1214X894X209 PU-SCHAUM SP	BODENMATTE		
9	97 71 454 08	1	FLOOR MAT 1188X829X28 PU-SCHAUM SP	BODENMATTE		
10	97 69 824 08	1	COVERING LEFT BOTTOM	VERKLEIDUNG UNTEN LINKS		
11	97 69 825 08	1	COVERING RIGHT BOTTOM	VERKLEIDUNG UNTEN RECHTS		
12	97 69 826 08	1	PANELLING	VERKLEIDUNG		
13	97 69 827 08	1	PANELLING,LEFT SPF	VERKLEIDUNG LI.		
14	97 70 804 08	1	PANELLING,RIGHT	VERKLEIDUNG OBEN RECHTS		
15	97 70 806 08	1	PANELLING,LEFT	VERKLEIDUNG LI.		
16	97 70 807 08	1	CLADDING REAR PANEL	VERKLEIDUNG RUECKWAND		
17	97 71 040 08	1	PANELLING ROOF SPF	VERKLEIDUNG DACH		
18	97 71 455 08	1	PANELLING ROLLER BLIND SPF	VERKLEIDUNG ROLLO		
19	96 49 441 08	1	SHUTTER WELDED	BLENDE SCHWK.		
20	97 68 331 08	1	PLATE 2X517X477	BLECH		
21	97 68 329 08	1	PLATE 1.5X813X326	BLECH		
22	97 72 246 08	1	PLATE 3X280X170	BLECH		
23	97 86 675 08	1	PLATE 1.5X85X54	BLECH		
24	97 72 289 08	1	PLATE 1.5X493X622	BLECH		
25	10 45 069 3	4	OVAL HEAD FLAT SCREW ISO 7380 M5X10 1	LINSENFLACHKOPFSCHRAUBE		
28	74 03 000 08	1	POCKET KUNSTSTOFF	TASCHE		
29	70 42 213 08	1	HOLDER ST	HALTER		
31	89 01 014 08	1	HOLDER	HALTER		
32	59 10 501 08	2	COAT HOOK	GARDEROBENHAKEN		
33	10 29 199 7	1	ASH TRAY KUNSTSTOFF	ASCHENBECHER		
35	10 29 201 3	10	ROLLING NOZZLE	WALZENDUESE		
36	55 31 932 08	9	OUTLET JET D=82MM T=5 PA	AUSSTROEMDUESE		
37	10 42 478 5	2	REDUCING PIECE 81,5/53,5 POLYAMID	REDUZIERSTUECK		
38	97 25 613 08	10	SEALING FRAME 10X60X 185 PUR-SCHAUM	DICHTRAHMEN		
39	97 25 615 08	3	SEALING FRAME RD92X20 DI=80 PUR-SCH	DICHTRAHMEN		
40	97 76 153 08	4	PLATE 2.5X86X86	BLECH		
41	10 42 558 8	0.4	WARM AIR HOSE DI 55MM PAK	WARMLUFTSCHLAUCH		
42	26 21 039 08	1.3	EDGE PROTECTION	KANTENSCHUTZ		
43	10 35 526 6	1	STANDOFF M6X50 ST VERZ	ABSTANDSBOLZEN		
44	10 03 726 1	46	PAN-HEAD SCREW AEHNL.ISO 7380 M5X16	FLACHKOPFSCHRAUBE		
45	40 97 043 08	93	PAN-HEAD SCREW M6X16 SCHWARZ VERZ	FLACHKOPFSCHRAUBE		
46	40 97 053 08	6	PAN-HEAD SCREW AEHNL.ISO7380 M4X12	FLACHKOPFSCHRAUBE		
47	59 10 059 08	20	SHEET-METAL SCREW DIN 7982 3,5X16-C-H	BLECHSCHRAUBE		
49	97 76 164 08	1	PLATE 1.5X872X70	BLECH		
50	60 21 160 08	4	LATCH CLAMP	RIEGELKLEMME		
51	10 41 286 1	2	OVAL HEAD FLAT SCREW AEHNL.ISO7380	LINSENFLACHKOPFSCHRAUBE		
52	55 08 380 08	4	HOSE CLAMP 40-60 W3	SCHLAUCHSCHELLE		
53	97 60 941 08	1	PLATE 1.5X175X115	BLECH		
54	97 60 943 08	1	SEAL 120X60X 30	DICHTUNG		
55	40 42 111	4	CYLINDER SCREW ISO 4762 M6X55 8.8 A2C	ZYLINDERSCHRAUBE		
56	42 00 009 08	4	WASHER ISO 7089 A 6.4 VERZ	SCHEIBE		
57	41 30 028 08	1	CAGE NUT M6	KAFIGMUTTER		
58	88 50 422 08	1	EMERGENCY HAMMER	NOTHAMMER		
59	88 50 423 08	1	FASTENER	HALTERUNG		
60	40 83 110 08	8	PAN-HEAD SCREW DIN 7985 M4X14 4.8 SCH	FLACHKOPFSCHRAUBE		

6.2.2009

etk_en_de_074515 LR 1600/2

155 (4/4)

LIEBHERRINTERNAL LINING
INNENVERKLEIDUNG⇒ 2 520 034
96 45 984 08

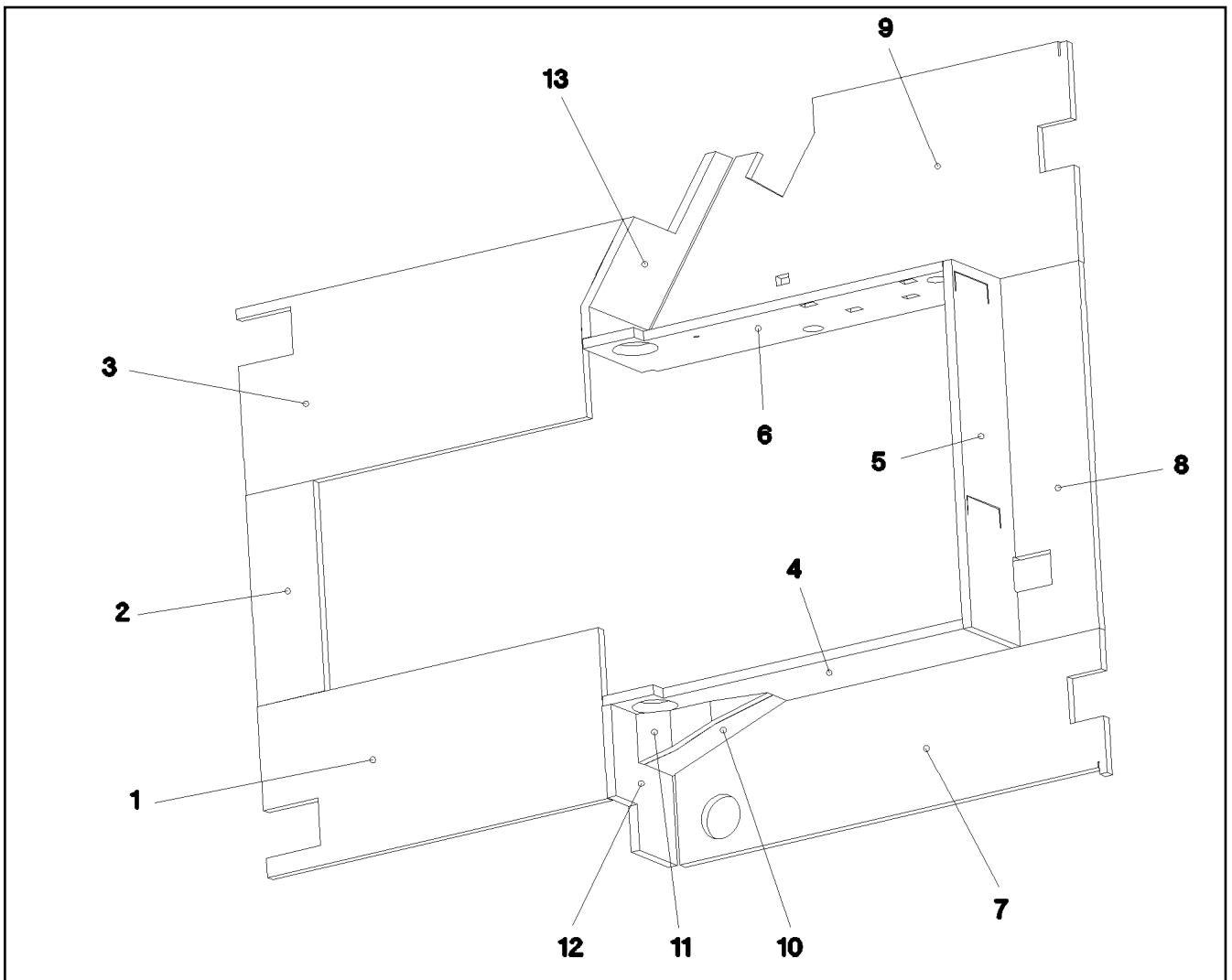

Pos.	Item	Quantity	Description	Bezeichnung	Serie	K
1	97 76 581 08	1	INSULATING MAT 20X348X786 PE-SCHAUM	DAEMMMATTE		
2	97 76 582 08	1	INSULATING MAT 20X155X429 PE-SCHAUM	DAEMMMATTE		
3	97 76 583 08	1	INSULATING MAT 20X380X894 PE-SCHAUM	DAEMMMATTE		
4	97 76 584 08	1	INSULATING MAT 20X229X810 PE-SCHAUM	DAEMMMATTE		
5	97 76 585 08	1	INSULATING MAT 20X195X747 PE-SCHAUM	DAEMMMATTE		
6	97 76 586 08	1	INSULATING MAT 20X229X810 PE-SCHAUM	DAEMMMATTE		
7	97 76 587 08	1	INSULATING MAT 20X294X986 PE-SCHAUM	DAEMMMATTE		
8	97 76 588 08	1	INSULATING MAT 20X182X747 PE-SCHAUM	DAEMMMATTE		
9	97 76 589 08	1	INSULATING MAT 20X451X986 PE-SCHAUM	DAEMMMATTE		
10	97 76 590 08	1	INSULATING MAT 20X123X288 PE-SCHAUM	DAEMMMATTE		
11	97 76 591 08	1	INSULATING MAT 20X100X274 PE-SCHAUM	DAEMMMATTE		
12	97 76 592 08	1	INSULATING MAT 20X213X280 PE-SCHAUM	DAEMMMATTE		
13	97 76 593 08	1	INSULATING MAT 20X215X451 PE-SCHAUM	DAEMMMATTE		

6.2.2009
052595

LIEBHERR

etk_en_de_074515 LR 1600/2

INSULANT FLOOR PLATE
DAEMMUNG BODENBLECH

156

⇒ 2 520 035
96 49 125 08

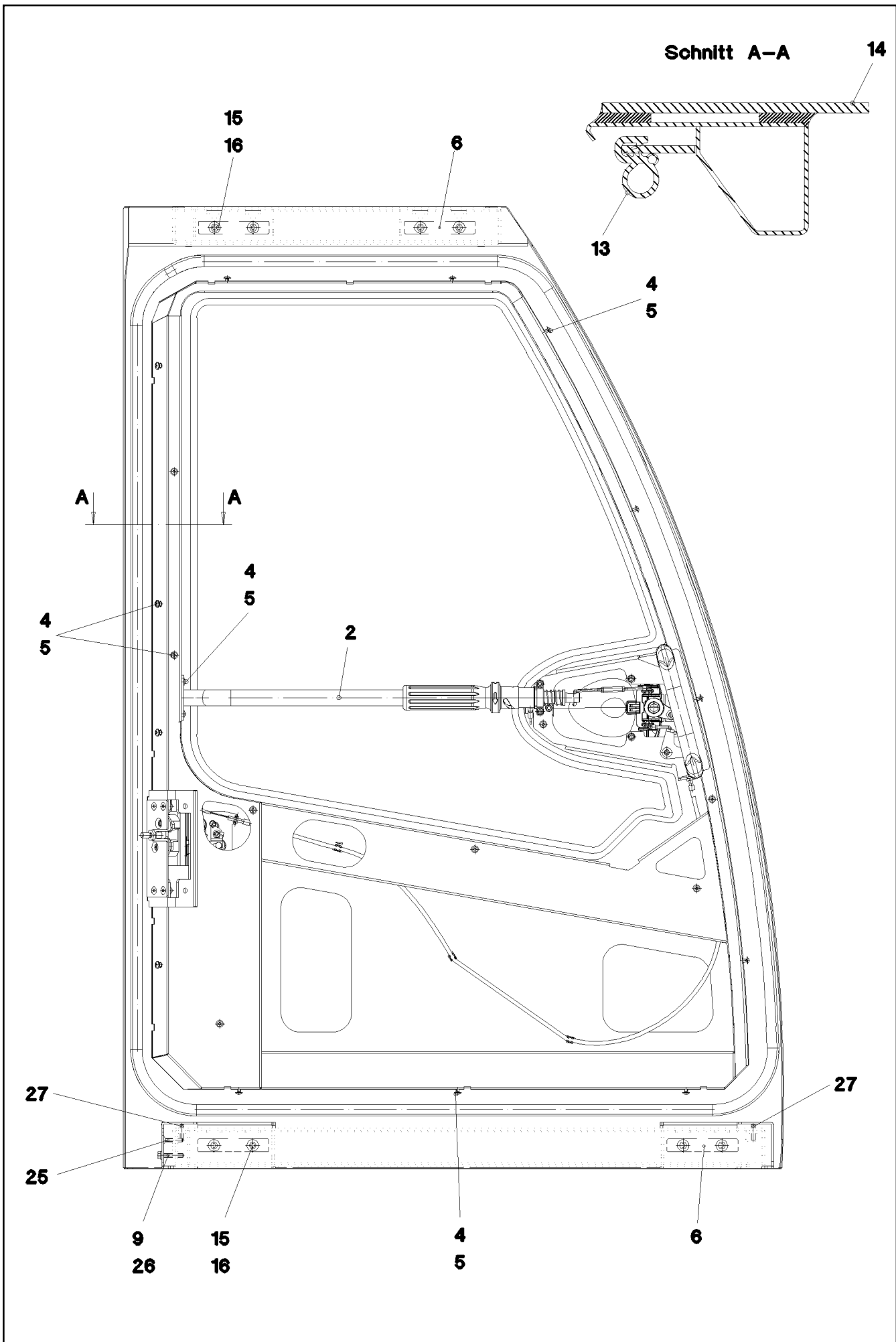

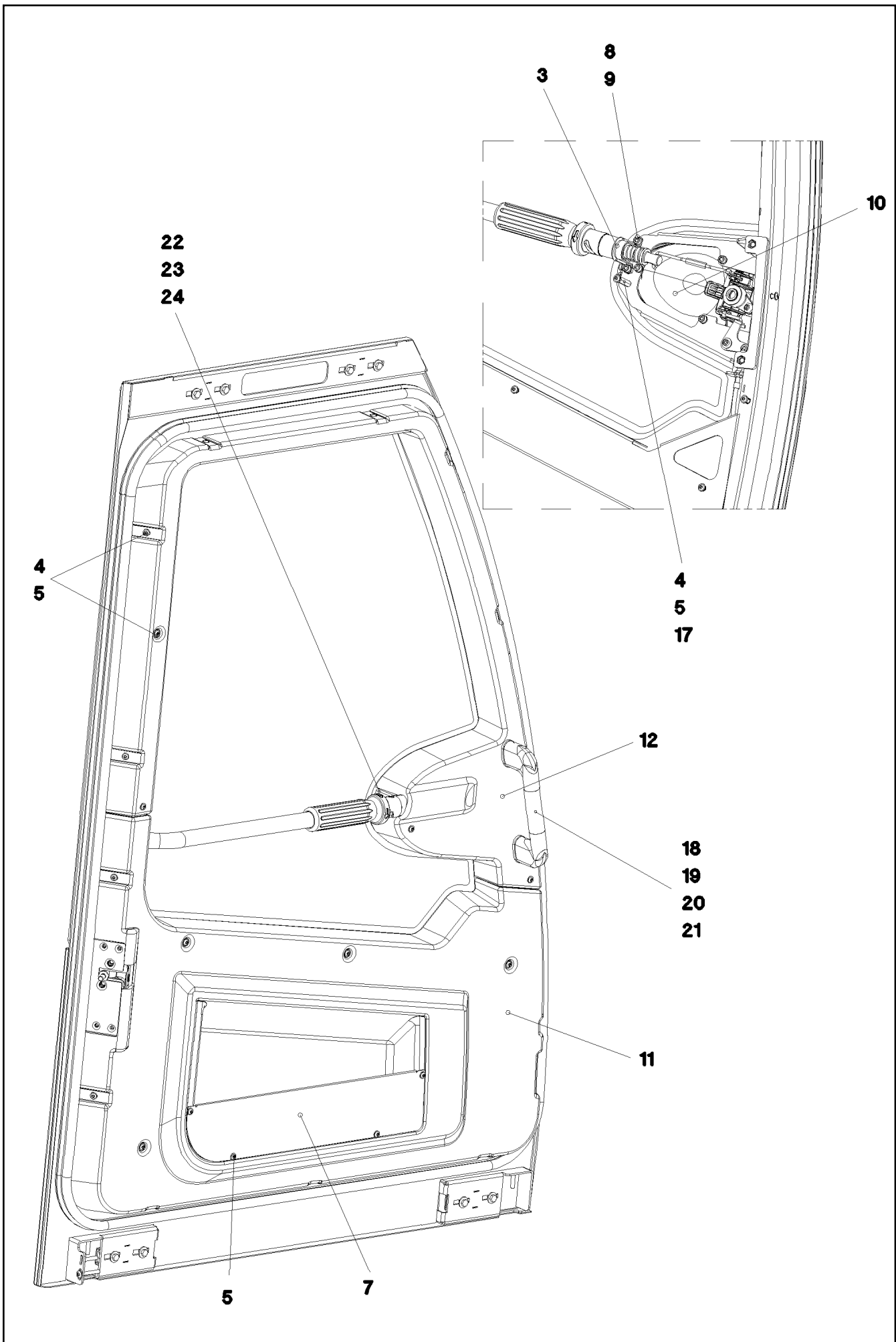

Pos.	Item	Quantity	Description	Bezeichnung	Serie	K
2	96 45 705 08	1	PIPE WELDED	ROHR SCHWK.		
3	97 73 326 08	1	PLATE 1.5X131X10	BLECH		
4	10 04 259 2	23	BLIND RIVET NUT M5 ST VERZ	BLINDNIETMUTTER		
5	10 03 726 1	27	PAN-HEAD SCREW AEHNL.ISO 7380 M5X16	FLACHKOPFSCHRAUBE		
6	97 68 611 08	4	PLATE 5X110X20	BLECH		
7	97 68 612 08	1	PLATE 1.5X500X111	BLECH		
8	46 00 049	2	CYLINDER SCREW ISO 4762 M6X12 8.8 A2C	ZYLINDERSCHRAUBE		
9	42 00 009 08	2	WASHER ISO 7089 A 6.4 VERZ	SCHEIBE		
10	96 45 602 08	1	CLOSING DEVICE SCHIEBETUER ⇒ 2 522 011 96 45 602 08	SCHLIESSANLAGE		
11	97 68 730 08	1	PANELLING ABS-TPU SPF	VERKLEIDUNG		
12	97 68 734 08	1	PANELLING ABS-TPU SPF	VERKLEIDUNG		
13	10 30 060 0	4.5	CLAMPING PROFILE EPDM/MOOS	KLEMMPROFIL		
14	97 68 851 08	1	DOOR PANE ESG-GLAS SPF	TUERSCHEIBE		
15	40 00 829	8	HEX BOLT ISO 4017 M6X20 8.8 A2C	SECHSKANTSCHRAUBE		
16	42 18 007 08	8	WASHER DIN 9021 A 6.4 VERZ	SCHEIBE		
17	66 00 447 08	1	STANDOFF M5X30	ABSTANDSBOLZEN		
18	41 30 065 08	2	BLIND RIVET NUT M 8	BLINDNIETMUTTER		
19	10 44 330 9	1	HANDGRIP 215X25X59,2X169	HALTEGRIFF		
20	42 00 012 08	2	WASHER DIN 125 A8X16 ST VERZ	SCHEIBE		
21	40 42 072 08	2	CYLINDER SCREW DIN 912 M8X55 8.8 A2C	ZYLINDERSCHRAUBE		
22	97 74 350 08	1	PLATE 1.5X60X39	BLECH		
23	40 01 521	1	CYLINDER SCREW ISO 4762 M5X10 8.8 A2C	ZYLINDERSCHRAUBE		
24	42 00 008 08	1	WASHER DIN 125 A 5.3 VERZ	SCHEIBE		
25	40 86 036 08	1	COUNTERSUNK SCREW DIN 7991 M6X30 8	SENKSCHRAUBE		
26	49 00 595	1	HEX BOLT ISO 4017 M6X35 8.8 A2C	SECHSKANTSCHRAUBE		
27	40 44 005 08	2	GRUB SCREW DIN 913 M6X25 45 H VERZ	GEWINDESTIFT		

6.2.2009

etk_en_de_074515 LR 1600/2

☐ 159 (3/3)

LIEBHERR

SLIDING DOOR CPL.
SCHIEBETUER KPL.

⇒ 2 522
91 54 115 08

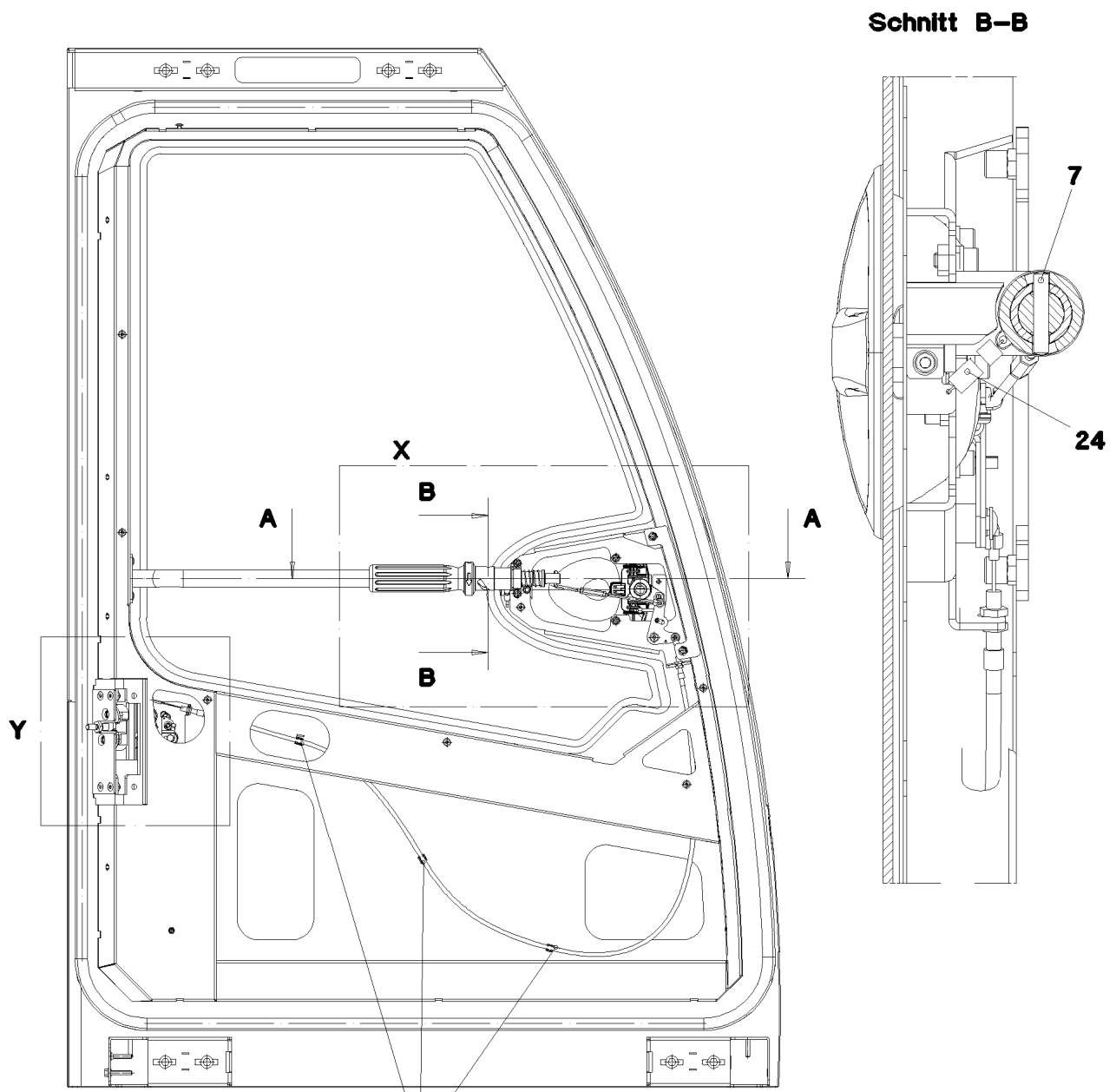

19 Schnitt A-A

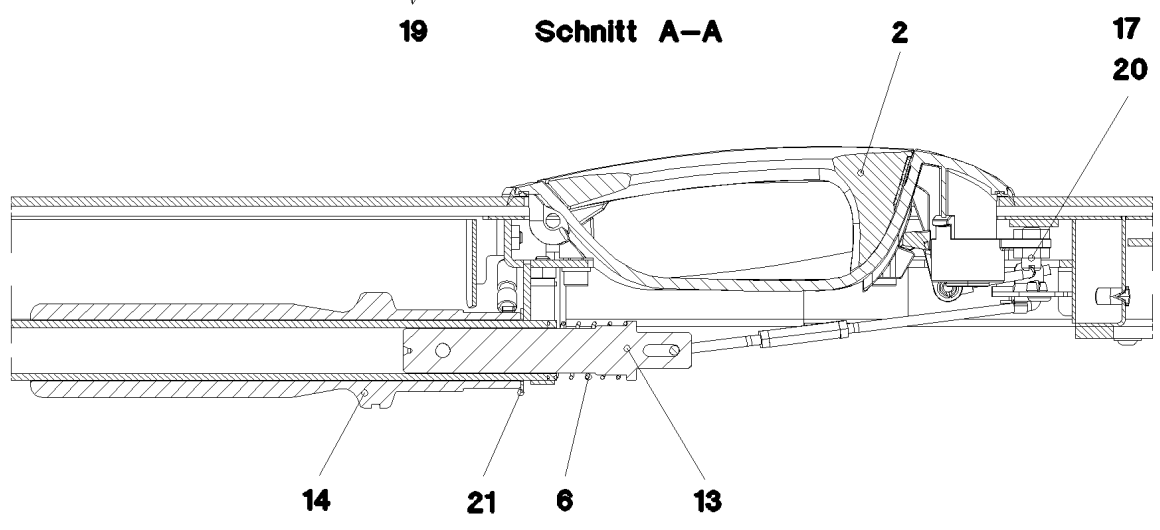

6.2.2009
052584

LIEBHERR

etk_en_de_074515 LR 1600/2

CLOSING DEVICE
SCHLIESSANLAGE

160 (1/3)

⇒ 2 522 011
96 45 602 08

Einzelheit X

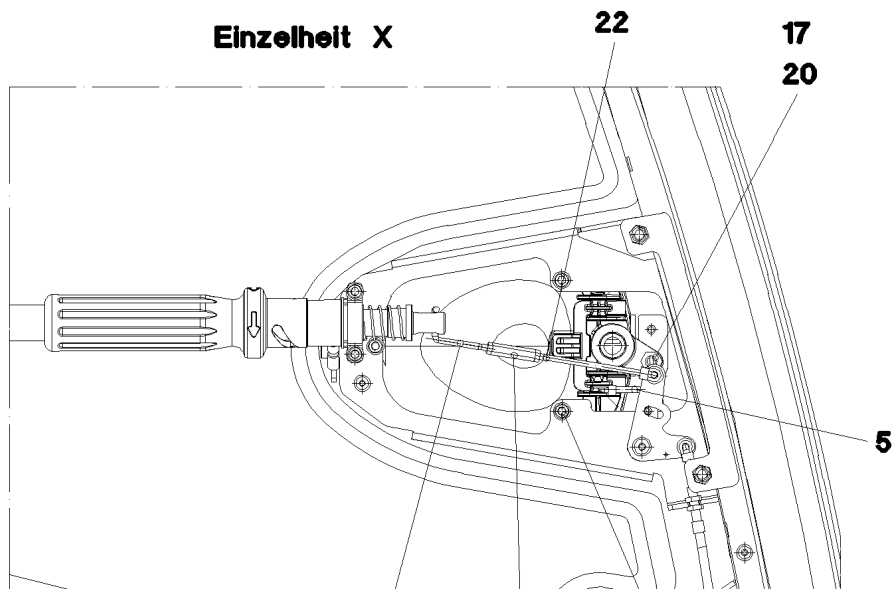

Einzelheit Y

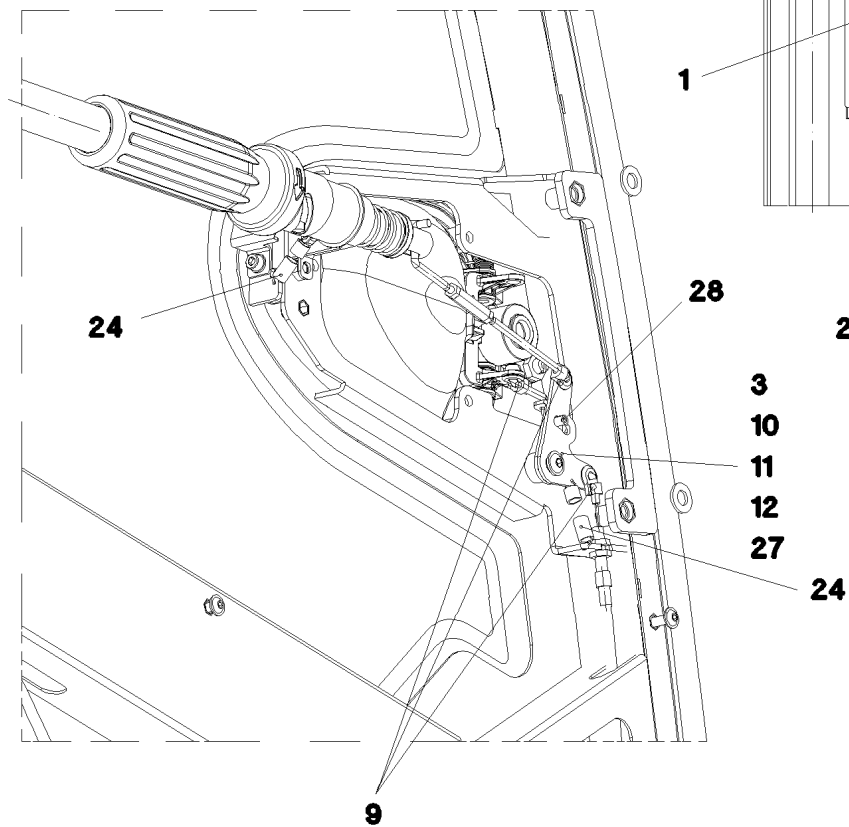
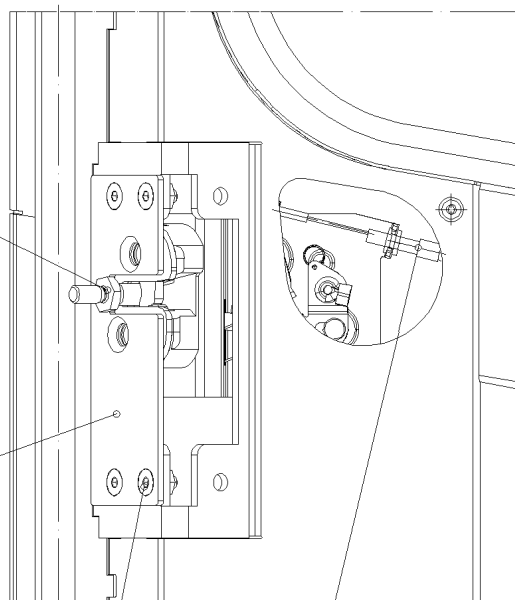

6.2.2009
052585

LIEBHERR

etk_en_de_074515 LR 1600/2

CLOSING DEVICE
SCHLISSANLAGE

161 (2/3)

⇒ 2 522 011
96 45 602 08

Pos.	Item	Quantity	Description	Bezeichnung	Serie	K
1	10 34 246 9	1	LOCK WITH FALLING LATCH	DREHFALLENSCHLOSS		
2	10 42 458 2	1	OUTSIDE HANDLE	AUSSENGRIFF		
3	97 68 660 08	1	PLATE 2X55X21 FE//ZN20//C	BLECH		
4	10 34 246 3	1	CLOSING PIN ST	SCHLIESSBOLZEN		
5	97 68 662 08	1	LINKAGE 4.0X58 ST	GESTAENGE		
6	56 00 192 08	1	PRESSURE SPRING	DRUCKFEDER		
7	43 06 047 08	1	PARALLEL PIN DIN 7 6M6X32 ST	ZYLINDERSTIFT		
8	97 68 665 08	1	LINKAGE 4.0X72 ST	GESTAENGE		
9	70 42 797 08	3	BAR LINKAGE CLIP	GESTAENGECLIP		
10	97 68 666 08	1	BUSH 16.0X12 S355J2G3C+C FE//ZN20//C	BUCHSE		
11	42 18 006 08	1	WASHER DIN 9021 A 5,3 ST VERZ	SCHEIBE		
12	10 41 285 3	1	OVAL HEAD FLAT SCREW AEHNL. ISO 7380	LINSENFLACHKOPFSCHRAUBE		
13	97 68 722 08	1	SLIDE 24.6X120 PA6	SCHIEBER		
14	97 68 724 08	1	SLEEVE 48X204 PA6	HUELSE		
15	46 00 049	3	CYLINDER SCREW ISO 4762 M6X12 8.8 A2C	ZYLINDERSCHRAUBE		
16	42 00 009 08	3	WASHER ISO 7089 A 6.4 VERZ	SCHEIBE		
17	41 01 203 08	2	HEX NUT ISO 4035 M8 04 VERZ	SECHSKANTMUTTER		
18	10 42 458 1	1	BOWDEN PULL SYSTEM L=1300 FWK	BOWDENZUG		
19	70 42 805 08	3	CABLE CLAMP 6,5MM POLYAMID	LEITUNGSHALTER		
20	70 30 031 01	1	COMPRESSION PAD	DRUCKSTUECK		
21	59 10 589 08	1	WASHER	SCHEIBE		
22	97 77 244 08	1	LINKAGE 4.0X106 ST	GESTAENGE		
23	60 20 178 08	1	STANDOFF M4X30 VERZ	ABSTANDBOLZEN		
24	10 44 376 9	2	TENSION SPRING 0,8X8X26,5	ZUGFEDER		
25	40 86 002 08	4	COUNTERSUNK SCREW DIN 7991 M6X16 8.	SENKSCHRAUBE		
26	41 15 142 08	2	HEX NUT DIN 934 M4 8 A3C	SECHSKANTMUTTER		
27	97 78 746 08	1	PLATE 2X67X47	BLECH		
28	43 20 034 08	1	DOWEL PIN ISO 8752 5X12	SPANNSTIFT		

6.2.2009

etk_en_de_074515 LR 1600/2

☐ 162 (3/3)

LIEBHERR

CLOSING DEVICE
SCHLIESSANLAGE

⇒ 2 522 011
96 45 602 08

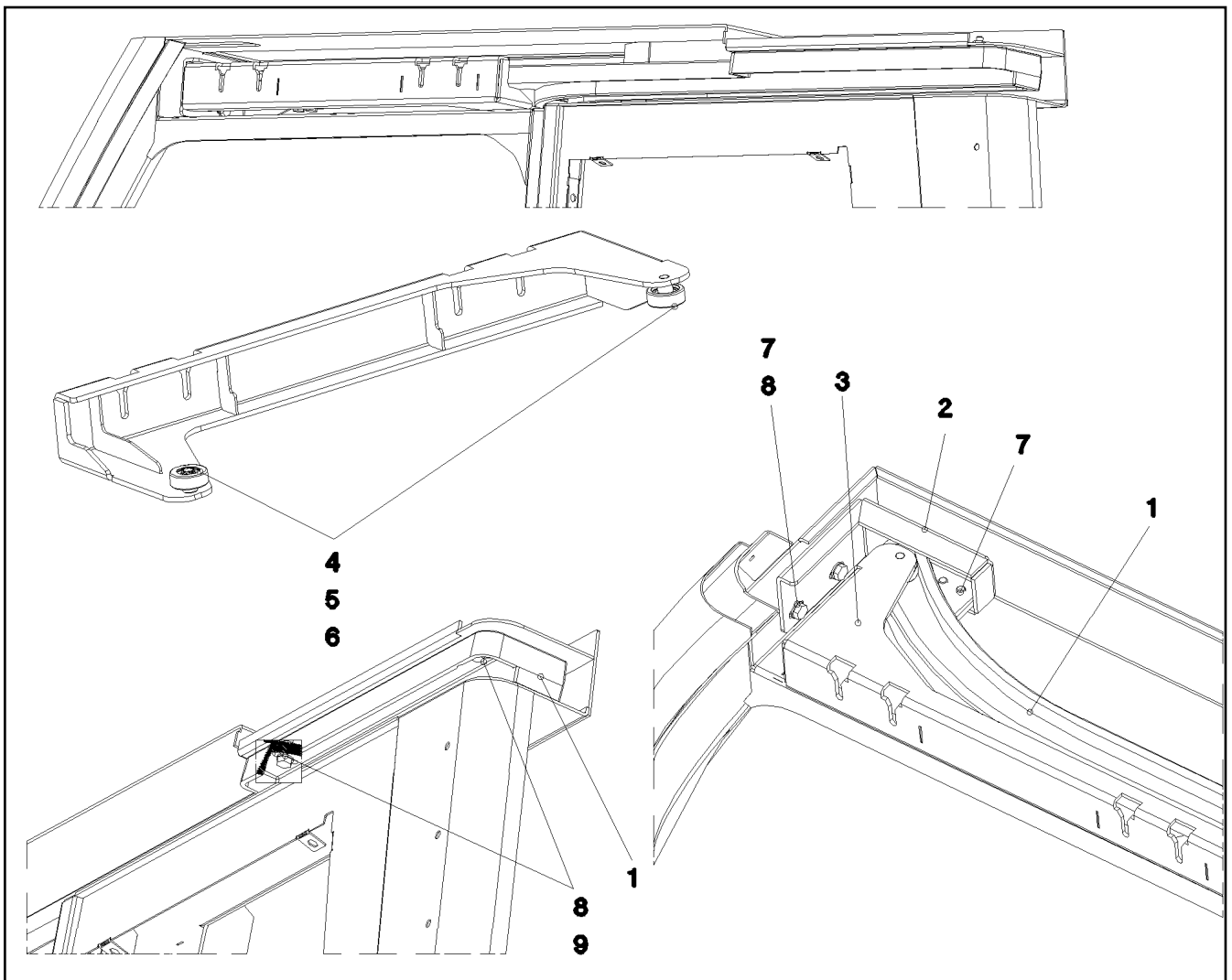

Pos.	Item	Quantity	Description	Bezeichnung	Serie	K
1	97 71 831 08	1	GUIDE G-ALSI10MG	FUEHRUNG		
2	97 73 929 08	1	PLATE 4X293X96	BLECH		
3	96 45 803 08	1	CLAMP WELDED CONST.	HALTER SCHWK.		
4	74 51 295 01	2	DEEP GROOVE BALL BEARING DIN 625 608-	RILLENKUGELLAGER		
5	97 68 888 08	2	ROLLER PA6G	ROLLE		
6	42 80 002 08	2	LOCKING RING DIN 471 8X0,8	SICHERUNGSRING		
7	49 00 188	4	HEX BOLT ISO 4017 M8X16 8.8 A2C	SECHSKANTSCHRAUBE		
8	42 00 012 08	4	WASHER DIN 125 A8X16 ST VERZ	SCHEIBE		
9	50 26 189 08	2	HEX BOLT ISO 4017 M8X22 8.8	SECHSKANTSCHRAUBE		

6.2.2009
052586

LIEBHERR

etk_en_de_074515 LR 1600/2

GUIDE PRE-ASS.
FUEHRUNG VORM.

163

⇒ 2 522 012
96 45 884 08

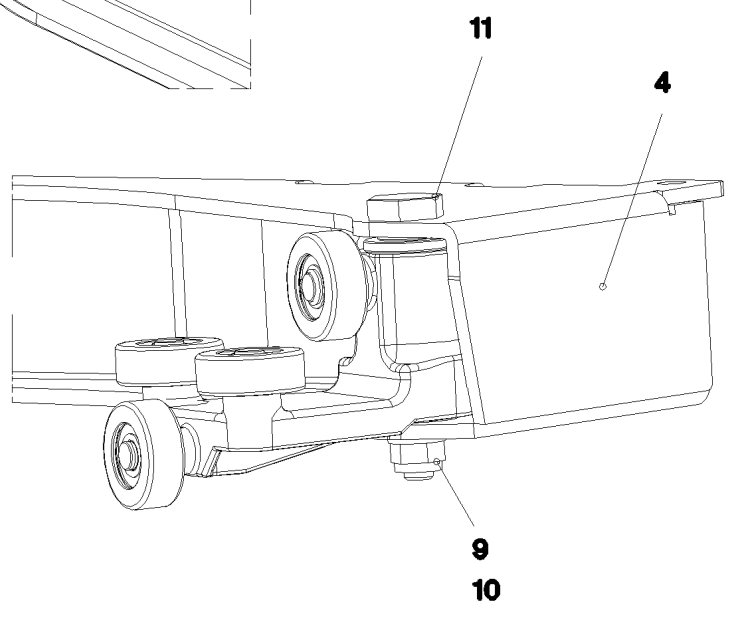
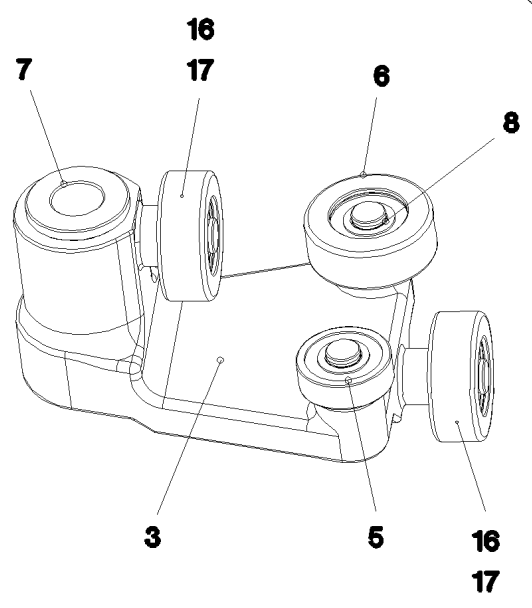
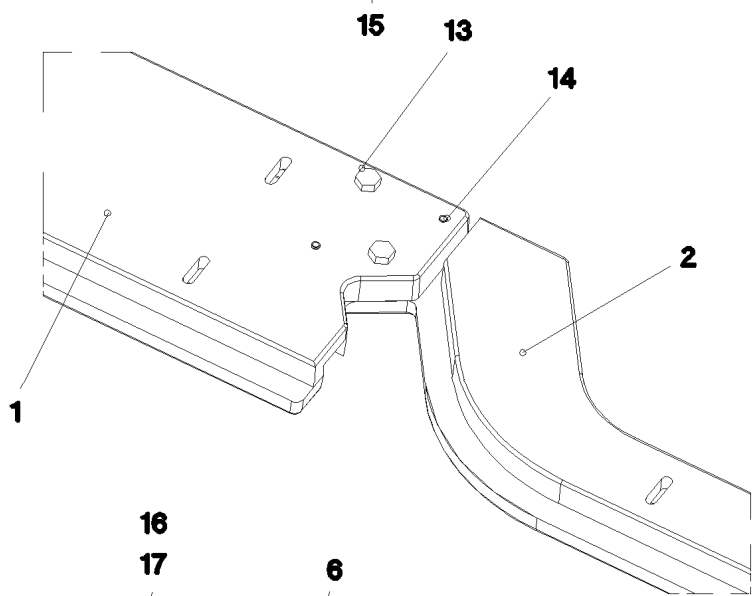
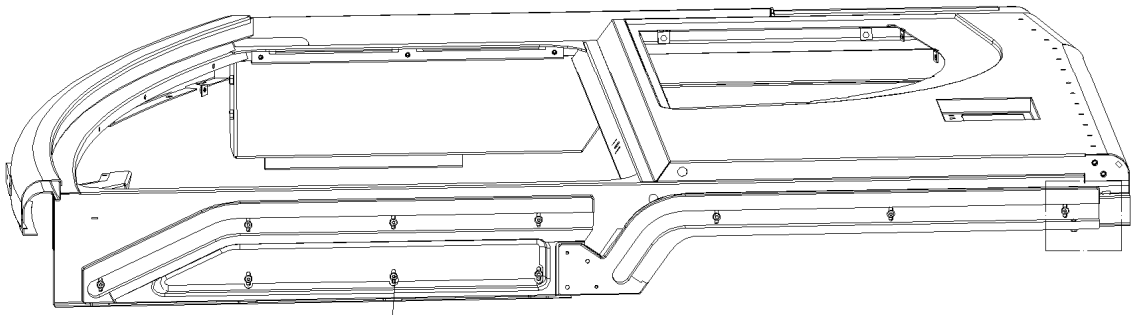
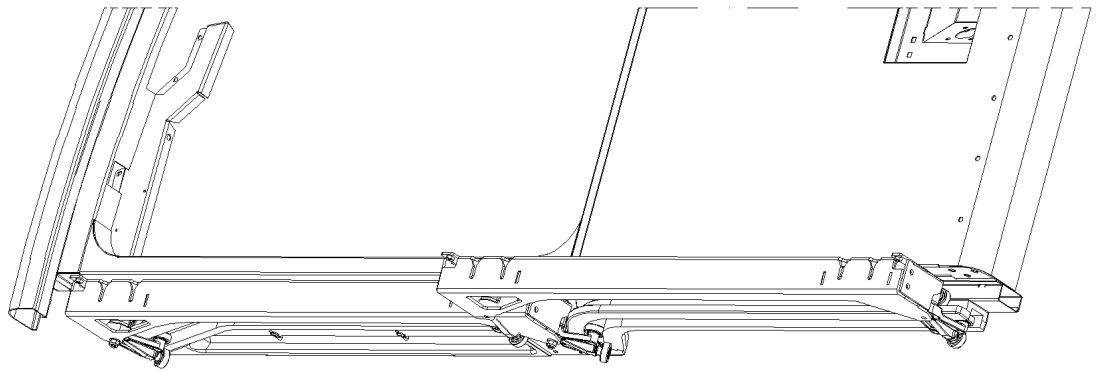

6.2.2009
052587

LIEBHERR

etk_en_de_074515 LR 1600/2

GUIDE PRE-ASS.
FUEHRUNG VORM.

164 (1/2)

⇒ 2 522 013
96 45 883 08

Pos.	Item	Quantity	Description	Bezeichnung	Serie	K
1	97 71 833 08	1	GUIDE	FUEHRUNG		
2	97 72 794 08	1	GUIDE	FUEHRUNG		
3	96 47 880 08	2	SLEIGH CPL.	SCHLITTEN KPL.		
4	96 46 046 08	1	CLAMP WELDED CONST.	HALTER SCHWK.		
5	74 51 295 01	8	DEEP GROOVE BALL BEARING DIN 625 608-	RILLENKUGELLAGER		
6	97 68 888 08	4	ROLLER PA6G	ROLLE		
7	10 42 448 9	4	FLANGE SLEEVE 18X12X12 SINT A50	BUNDLAGER		
8	42 80 002 08	8	LOCKING RING DIN 471 8X0,8	SICHERUNGSRING		
9	42 00 012 08	2	WASHER DIN 125 A8X16 ST VERZ	SCHEIBE		
10	41 19 005 08	2	HEX NUT DIN 985 M8 8 VERZ	SECHSKANTMUTTER		
11	97 68 883 08	2	PIN 19.0X76 FE//ZN20//C	BOLZEN		
13	49 00 111	2	HEX BOLT ISO 4017 M8X30 8.8 A2C	SECHSKANTSCHRAUBE		
14	43 20 045 08	2	DOWEL PIN ISO 8752 5X32	SPANNSTIFT		
15	10 41 285 2	10	OVAL HEAD FLAT SCREW AEHNL. ISO 7380	LINSENFLACHKOPFSCHRAUBE		
16	97 81 003 08	4	ROLLER X20CR13 X20CR13	ROLLE		
17	42 81 006 08	4	LOCKING RING DIN 472 22X1	SICHERUNGSRING		

6.2.2009

etk_en_de_074515 LR 1600/2

165 (2/2)

LIEBHERR

GUIDE PRE-ASS.
FUEHRUNG VORM.

⇒ 2 522 013
96 45 883 08

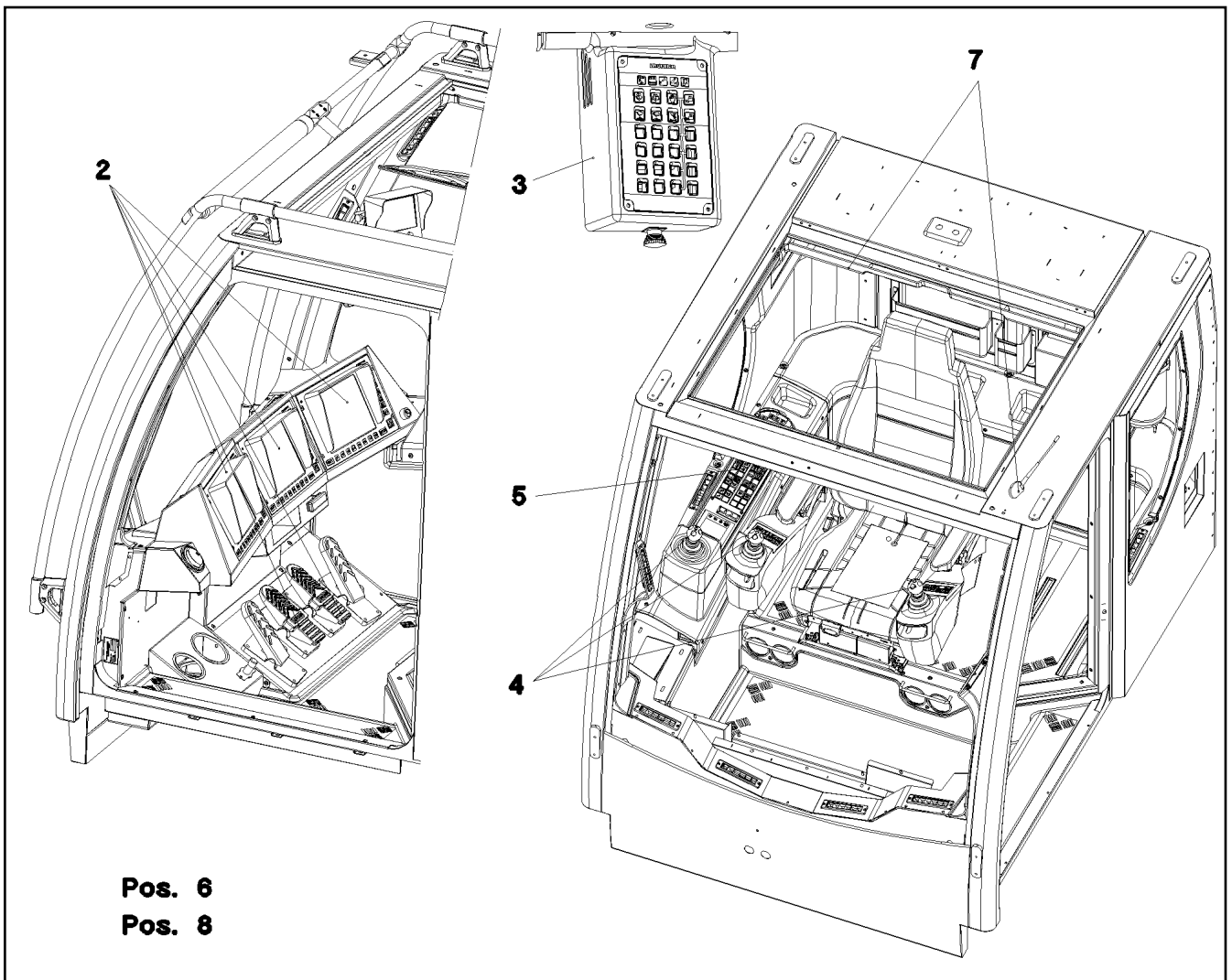

Pos. 6
Pos. 8

Pos.	Item	Quantity	Description	Bezeichnung	Serie	K
2	96 48 359 08	1	EL.EQUIPMENT CABIN FRONT ⇒ 2 533 050 96 48 359 08	ELEKTRIK KABINE		
3	96 48 360 08	1	EL.EQUIPMENT CABIN DACH ⇒ 2 533 051 96 48 360 08	ELEKTRIK KABINE		
4	96 48 366 08	1	ELECTR. FOR CONTROL STAND ⇒ 2 533 054 96 48 366 08	ELEKTRIK STEUERSTAND		
5	96 48 363 08	1	CONTROLS AND FITTINGS RIGHT ⇒ 2 533 070 96 48 363 08	ARMATUREN RE.		
6	96 48 364 08	1	CABLE LIST DRIVER'S CABIN ⇒ 2 533 065 96 48 364 08	KABELLISTE KRANFUEHRERK		
7	96 48 365 08	1	ELECTRIC ADD-ON PARTS CABIN ⇒ 2 533 066 96 48 365 08	ELEKTRIK ANBAUTEILE KABINE		
8	96 52 556 08	1	CONVERTOR TTY-RS232 ⇒ 2 533 071 96 52 556 08	WANDLER		

6.2.2009
052617

LIEBHERR

etk_en_de_074515 LR 1600/2

EL.INSTRUMENTS F.CRANE DRIV.CA
ELEKTRIK KRANFUEHRERKABINE

166

⇒ 2 533
91 52 789 08

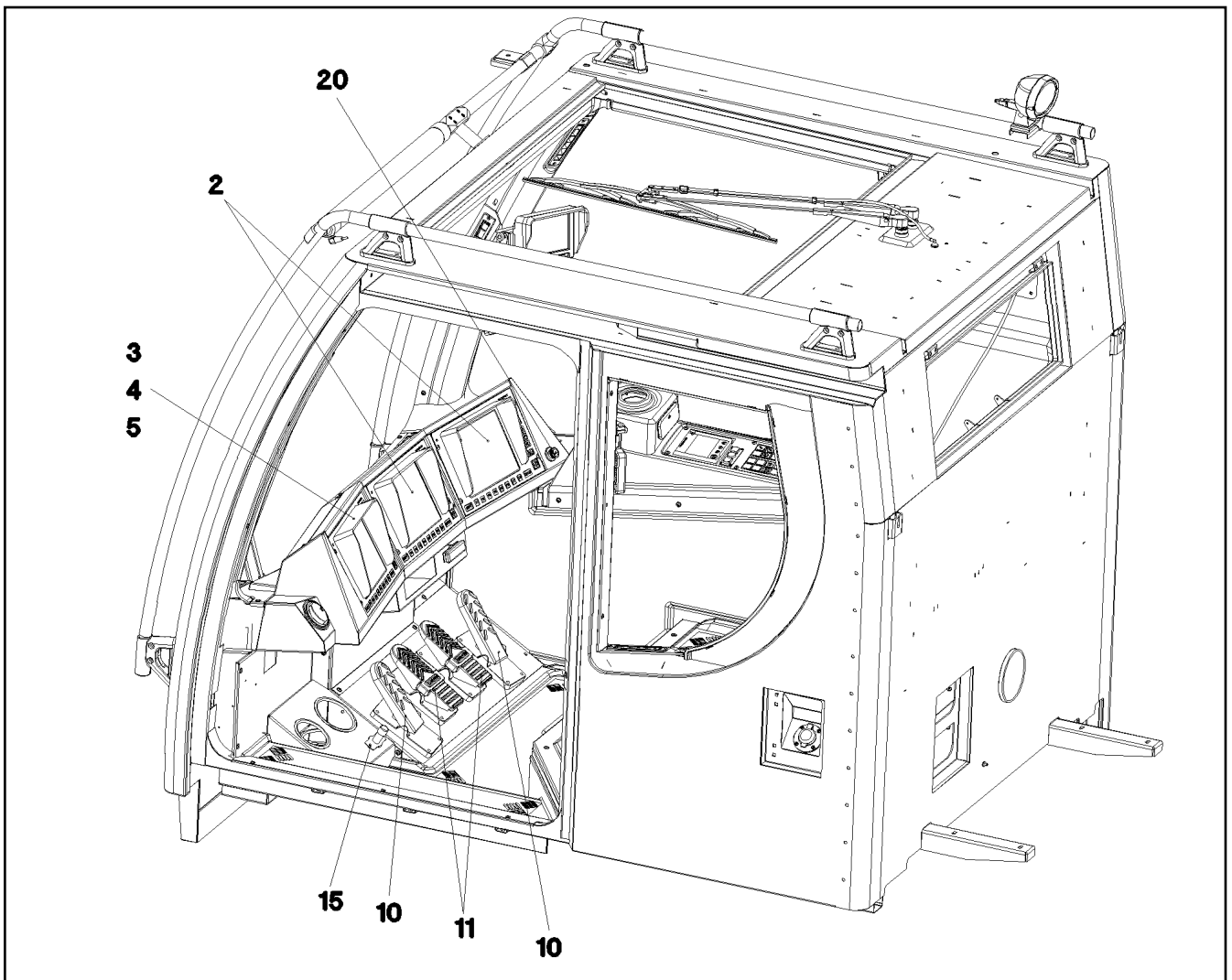

Pos.	Item	Quantity	Description	Bezeichnung	Serie	K
2	91 32 850 08	2	LICCON CONSOLE LCD2 KOMPAT. SPF ⇒ 2 913 91 32 850 08	LICCON KONSOLE LCD2		
3	96 47 216 08	1	LICCON CONSOLE LCD3 KRANEINSATZPL. ⇒ 2 913 200 96 47 216 08	LICCON KONSOLE LCD3		
4	96 50 143 08	1	MEMORY CARD BSE 2GB CF-CARD PROG.	SPEICHERKARTE BSE		
5	10 46 740 3	1	ADAPTER BOARD CF-PCMCIA SPF	ADAPTERKARTE		
10	10 29 730 9	2	PEDAL TRANSDUCER SPF	PEDALGEBER		
11	10 29 731 0	2	FOOT ROCKER SPF	FUSSWIPPE		
15	60 66 035 08	1	FOOT SWITCH	FUSSTASTER		
20	10 42 905 8	1	CIGARETTE LIGHTER	ZIGARETTENANZUENDER		

6.2.2009
052598

LIEBHERR

etk_en_de_074515 LR 1600/2

EL.EQUIPMENT CABIN
ELEKTRIK KABINE

167

⇒ 2 533 050
96 48 359 08

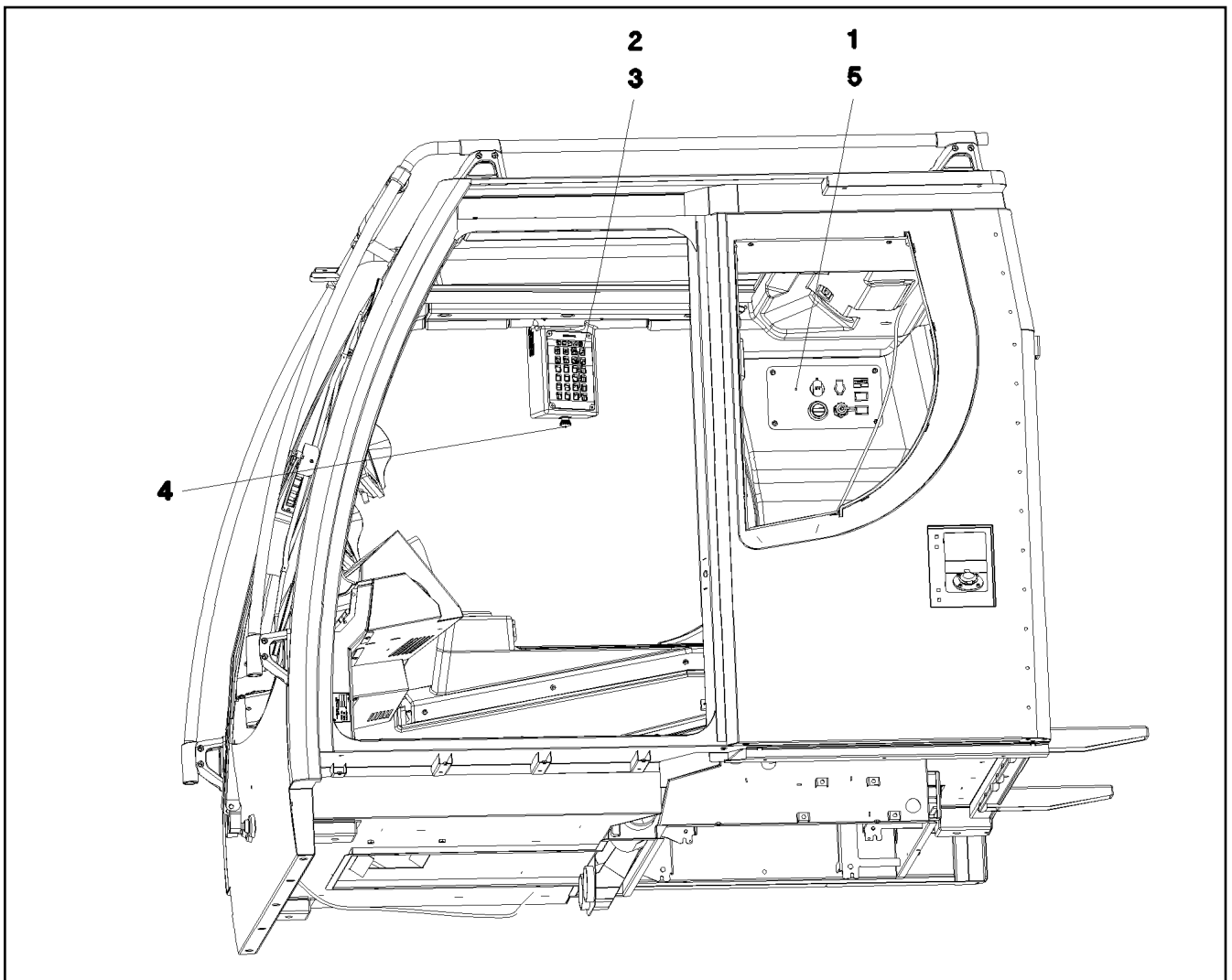

Pos.	Item	Quantity	Description	Bezeichnung	Serie	K
1	96 50 385 08	1	PLATE PRE-ASS. DACH ⇒ 2 533 067 96 50 385 08	BLECH VORM.		
2	10 32 351 7	1	KEYBOARD UNIT LSB-BKE SPF	TASTATUREINHEIT		
3	97 68 423 08	1	MARKING STRIP	EINLEGESTREIFEN		
4	96 41 461 08	1	EMERGENCY CUT-OFF CRANE DRIVER	NOTAUS KRANFUEHRERKABIN		
(2)	60 61 441 08	1	EMERGENCY STOP	NOT-AUS TASTE		
(3)	60 61 438 08	1	TOUCH CONTACT TRANSMITTER 2OE + 2S	TASTKONTAKTGEBER		
5	40 97 043 08	4	PAN-HEAD SCREW M6X16 SCHWARZ VERZ	FLACHKOPFSCHRAUBE		

6.2.2009
052601

LIEBHERR

etk_en_de_074515 LR 1600/2

EL.EQUIPMENT CABIN
ELEKTRIK KABINE

168

⇒ 2 533 051
96 48 360 08

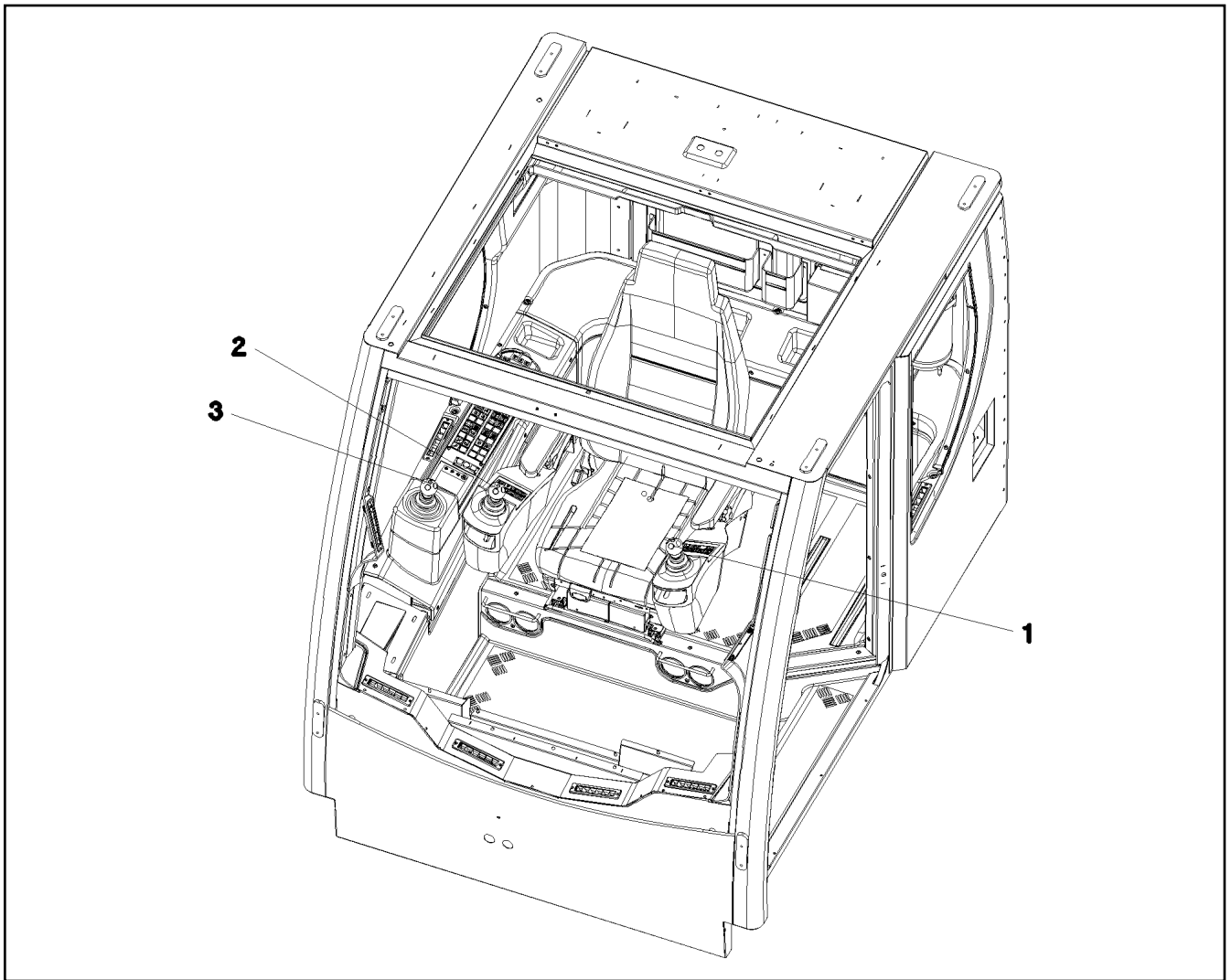

Pos.	Item	Quantity	Description	Bezeichnung	Serie	K
1	96 48 368 08	1	ELECTRIC FOR ARMREST LEFT ⇒ 2 533 060 96 48 368 08	ELEKTRIK ARMLEHNE LI.		
2	96 48 369 08	1	ELECTRIC FOR ARMREST RIGHT ⇒ 2 533 062 96 48 369 08	ELEKTRIK ARMLEHNE RE.		
3	96 48 372 08	1	ELECT.EQUIPMENT THREADED UNION MS ⇒ 2 533 069 96 48 372 08	ELEKTRIK ARMATUR		

6.2.2009
052602

LIEBHERR

etk_en_de_074515 LR 1600/2

ELECTR. FOR CONTROL STAND
ELEKTRIK STEUERSTAND

□ 169

⇒ 2 533 054
96 48 366 08

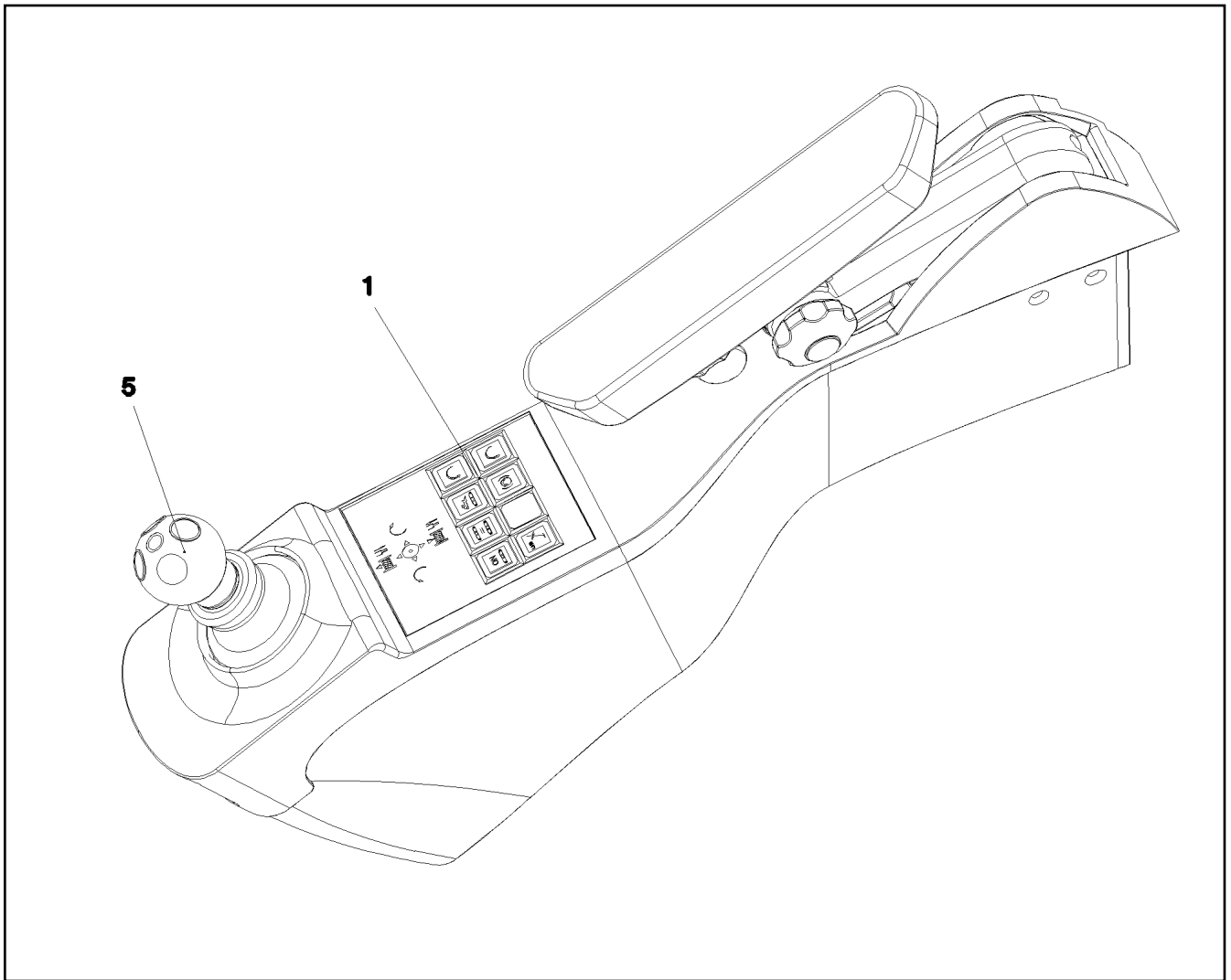

Pos.	Item	Quantity	Description	Bezeichnung	Serie	K
1	96 48 370 08	1	DASH BORD ARM REST LEFT ⇒ 2 533 061 96 48 370 08	ARMATUREN ARMLEHNE LI.		
5	60 60 950 08	1	MASTER SWITCH SPF ⇒ 6 060 950 08 60 60 950 08	MEISTERSCHALTER		

6.2.2009
052603

LIEBHERR

etk_en_de_074515 LR 1600/2

ELECTRIC FOR ARMREST LEFT
ELEKTRIK ARMLEHNE LI.

□ 170

⇒ 2 533 060
96 48 368 08

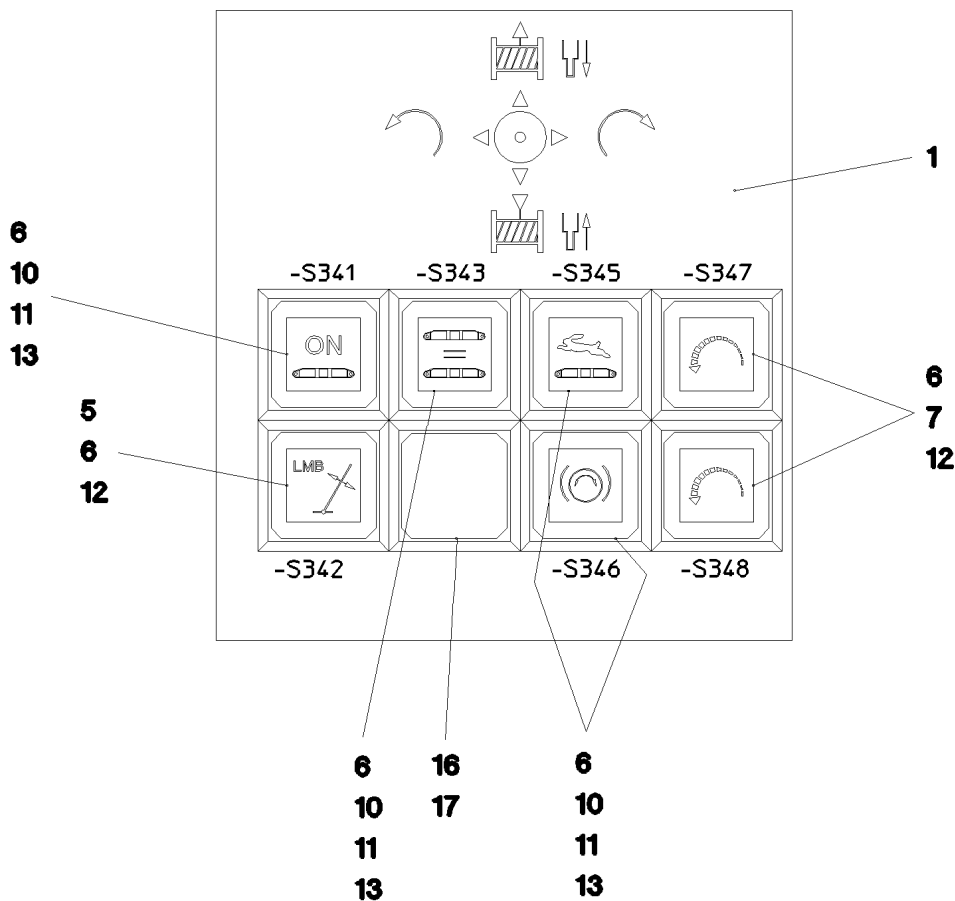

Pos.	Item	Quantity	Description	Bezeichnung	Serie	K
1	97 74 575 08	1	DASHBOARD LINKS	ARMATURENBRETT		
5	60 61 431 08	1	PUSH-BUTTON CAP FLACH ROT	TASTERKAPPE		
6	60 61 430 08	7	PUSHER 25X25	DRUECKER		
7	60 61 444 08	2	PUSH-BUTTON CAP FLACH KLAR	TASTERKAPPE		
10	60 70 087 08	4	LIGHT BULB 1,2W 30V	GLUEHLAMPE		
11	60 61 447 08	4	LUMINOUS SWITCH CONTACT SENDER 2	LEUCHTSCHALTKONTAKTGEBE		
12	60 61 434 08	3	TOUCH CONTACT TRANSMITTER	TASTKONTAKTGEBER		
13	60 61 439 08	4	PUSH-BUTTON CAP FLACH GELB	TASTERKAPPE		
16	60 61 435 08	3	SIGNAL LAMP	LEUCHTMELDER		
17	60 61 440 08	3	SPHERICAL CAP	KALOTTE		

6.2.2009
052604

LIEBHERR

etk_en_de_074515 LR 1600/2

DASH BORD ARM REST LEFT
ARMATUREN ARMLEHNE LI.

171

⇒ 2 533 061
96 48 370 08

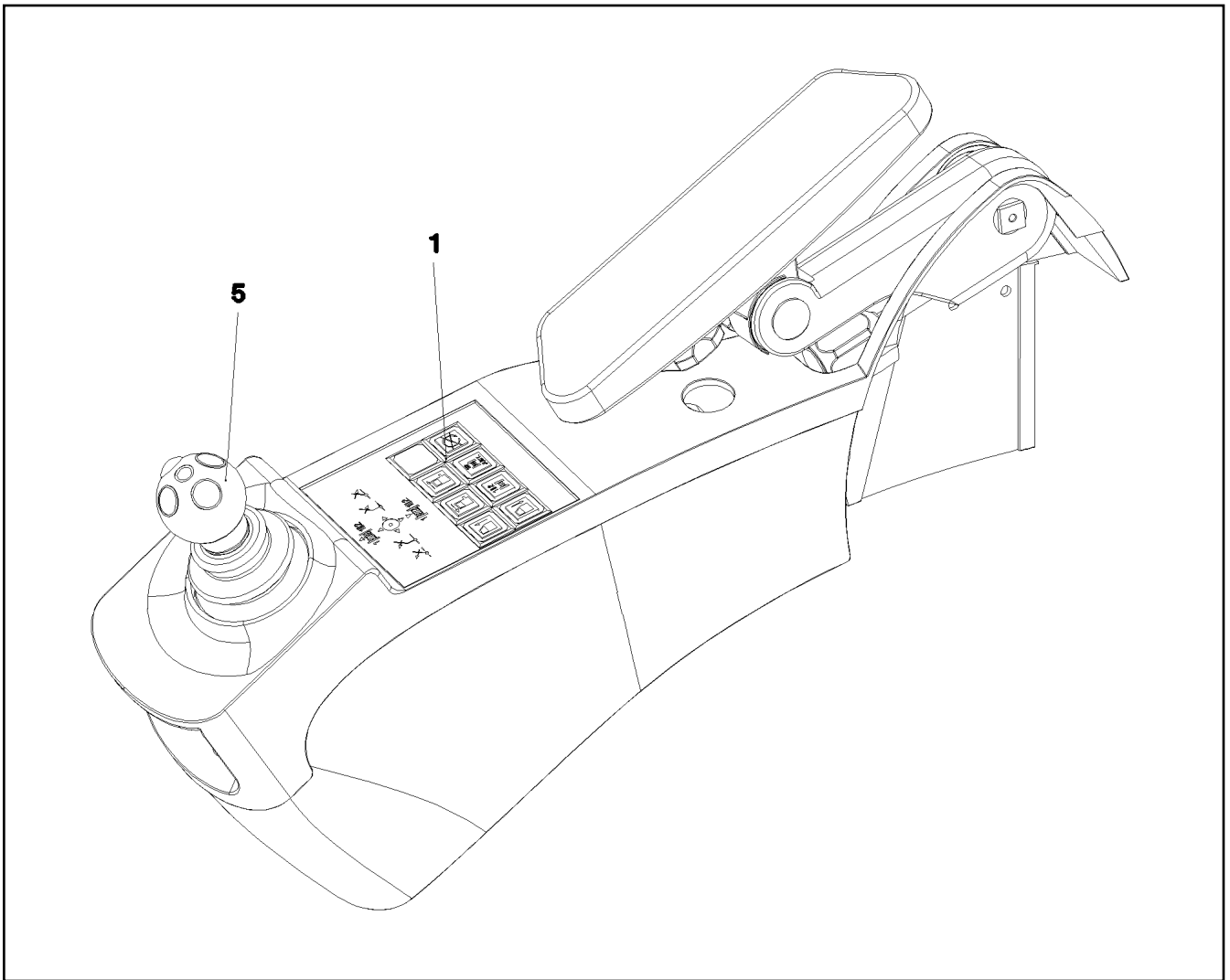

Pos.	Item	Quantity	Description	Bezeichnung	Serie	K
1	96 48 371 08	1	DASH BORD ARM REST RIGHT ⇒ 2 533 063 96 48 371 08	ARMATUREN ARMLEHNE RE.		
5	60 60 950 08	1	MASTER SWITCH SPF ⇒ 6 060 950 08 60 60 950 08	MEISTERSCHALTER		

6.2.2009
052605

LIEBHERR

etk_en_de_074515 LR 1600/2

ELECTRIC FOR ARMREST RIGHT
ELEKTRIK ARMLEHNE RE.

□ 172

⇒ 2 533 062
96 48 369 08

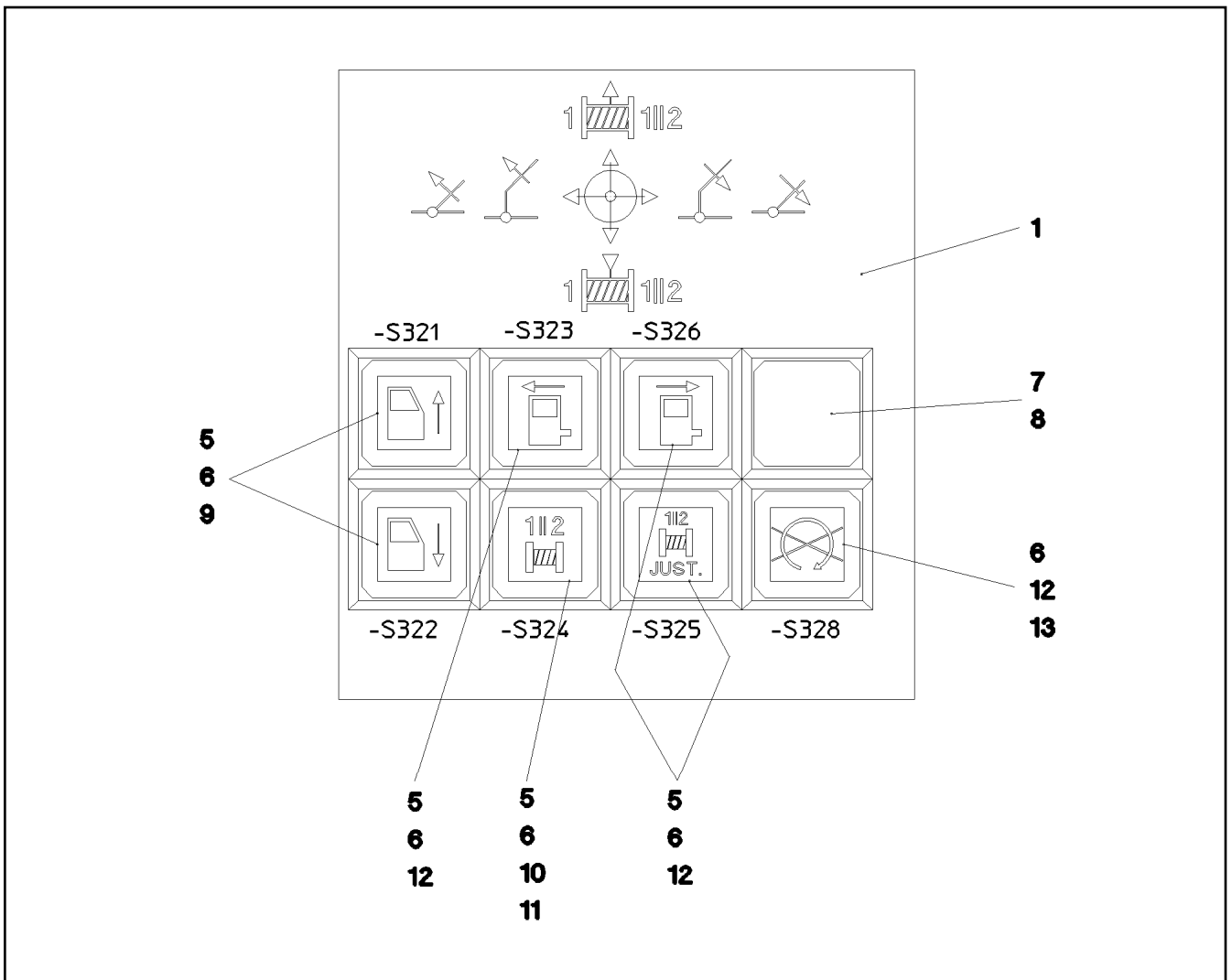

Pos.	Item	Quantity	Description	Bezeichnung	Serie	K
1	97 74 576 08	1	DASHBOARD RECHTS	ARMATURENBRETT		
5	60 61 444 08	6	PUSH-BUTTON CAP FLACH KLAR	TASTERKAPPE		
6	60 61 430 08	7	PUSHER 25X25	DRUECKER		
7	60 61 435 08	1	SIGNAL LAMP	LEUCHTMELDER		
8	60 61 440 08	1	SPHERICAL CAP	KALOTTE		
10	60 70 087 08	1	LIGHT BULB 1,2W 30V	GLUEHLAMPE		
11	60 61 447 08	1	LUMINOUS SWITCH CONTACT SENDER 2	LEUCHTSCHALKONTAKTGEBE		
12	60 61 446 08	6	TOUCH CONTACT TRANSMITTER 2OE + 2S	TASTKONTAKTGEBER		
13	60 61 439 08	1	PUSH-BUTTON CAP FLACH GELB	TASTERKAPPE		

6.2.2009
052606

LIEBHERR

etk_en_de_074515 LR 1600/2

DASH BORD ARM REST RIGHT
ARMATUREN ARMLEHNE RE.

□ 173

⇒ 2 533 063
96 48 371 08

Pos.	Item	Quantity	Description	Bezeichnung	Serie	K
10	96 49 100 08	1	WIRING HARNESS W300	KABELSTRANG		
11	96 49 101 08	1	WIRING HARNESS W301	KABELSTRANG		
12	96 49 102 08	1	WIRING HARNESS W302	KABELSTRANG		
13	96 49 103 08	1	WIRING HARNESS W305	KABELSTRANG		
15	96 49 030 08	1	WIRING HARNESS W309	KABELSTRANG		
16	96 49 105 08	1	WIRING HARNESS W310	KABELSTRANG		
17	96 49 106 08	1	WIRING HARNESS W360	KABELSTRANG		
50	55 31 869 08	1	LOOM 3300MM	KABELBAUM		

6.2.2009

etk_en_de_074515 LR 1600/2

 174

LIEBHERR

CABLE LIST DRIVER'S CABIN
KABELLISTE KRANFUEHRERKABINE

⇒ 2 533 065
96 48 364 08

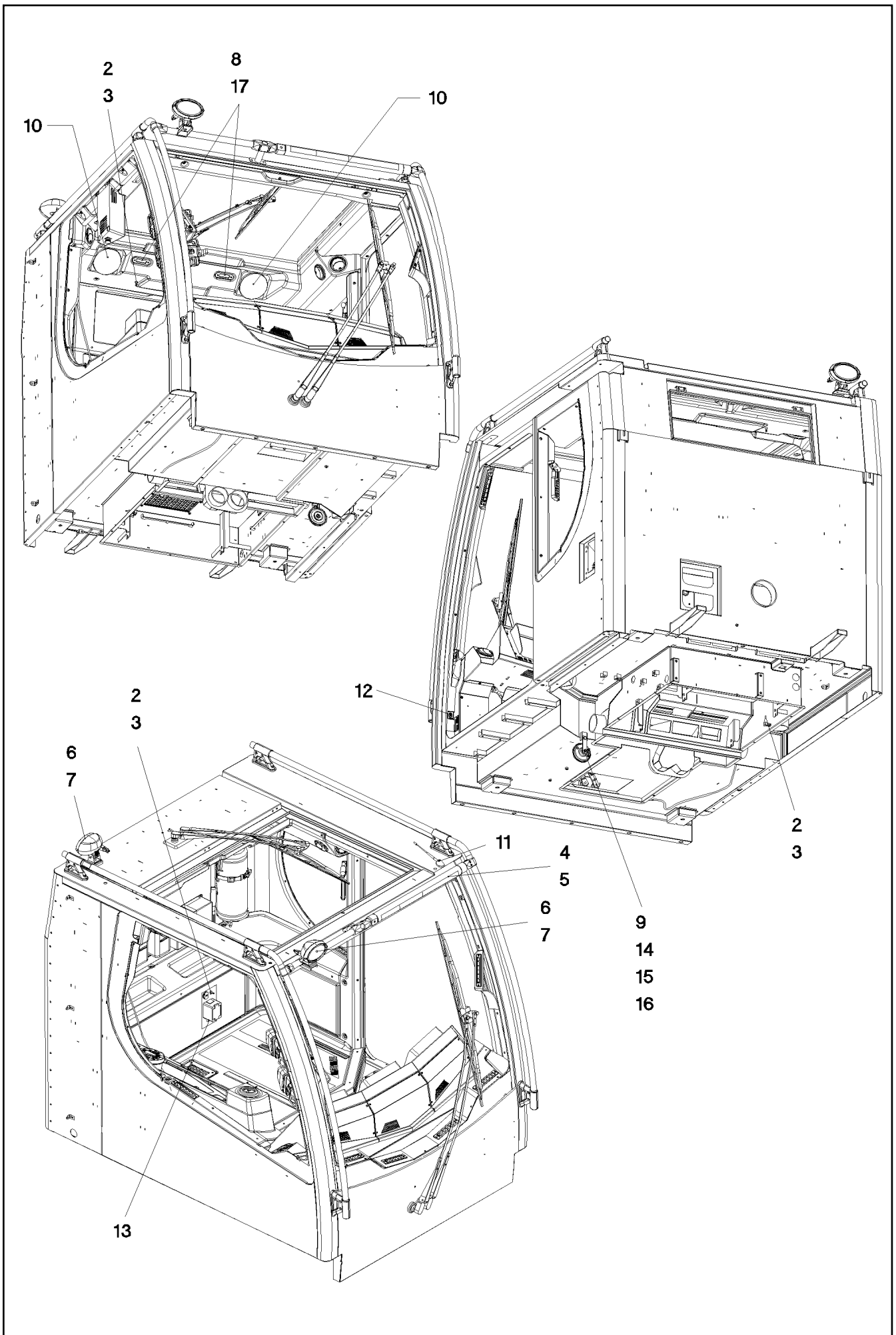

6.2.2009
052596

LIEBHERR

etk_en_de_074515 LR 1600/2

ELECTRIC ADD-ON PARTS CABIN
ELEKTRIK ANBAUTEILE KABINE

□ 175 (1/2)

⇒ 2 533 066
96 48 365 08

Pos.	Item	Quantity	Description	Bezeichnung	Serie	K
2	10 44 951 6	3	PRECISION RESISTOR NTC -40/+125°C	MESSWIDERSTAND		
3	59 15 592 08	3	HEX NUT DIN 439 BM12X1 04 VERZ	SECHSKANTMUTTER		
4	10 28 570 1	2	T-PIECE 30X30X30 G-ALMG	T-STUECK		
5	10 34 010 5	1	WARNING LIGHT 20-36V SPF	WARNLEUCHTE		
6	10 42 527 1	2	WORK FLOODLIGHT 2X70W 24V	ARBEITSSCHEINWERFER		
7	97 76 743 08	2	PLATE 2X227X73 X5CRNI18-10	BLECH		
8	10 34 285 4	2	INTERNAL LIGHT 6W 13-36V	INNENLEUCHTE		
9	61 40 031 08	1	HORN 335HZ 24V	HORN		
10	10 48 901 1	2	LOUDSPEAKER 2,77V 86DBA	LAUTSPRECHER		
11	76 24 428	1	ANTENNA 145MM	ANTENNE		
12	60 60 207 08	1	DOOR CONTACT SWITCH	TUERKONTAKTSCHALTER		
13	96 49 314 08	1	PREMOUNTED PLUG SOCKET ⇒ 2 533 068 96 49 314 08	STECKDOSEN VORM.		
14	10 04 259 3	1	BLIND RIVET NUT M6 ST VERZ	BLINDNIETMUTTER		
15	42 18 007 08	1	WASHER DIN 9021 A 6.4 VERZ	SCHEIBE		
16	40 65 099	1	HEX BOLT ISO 4017 M6X16 8.8 A2C	SECHSKANTSCHRAUBE		
17	10 12 438 50	4	CYLINDER SCREW ISO 4762 M3X16 8.8 A2C	ZYLINDERSCHRAUBE		

6.2.2009

etk_en_de_074515 LR 1600/2

☐ 176 (2/2)

LIEBHERR

ELECTRIC ADD-ON PARTS CABIN
ELEKTRIK ANBAUTEILE KABINE

⇒ 2 533 066
96 48 365 08

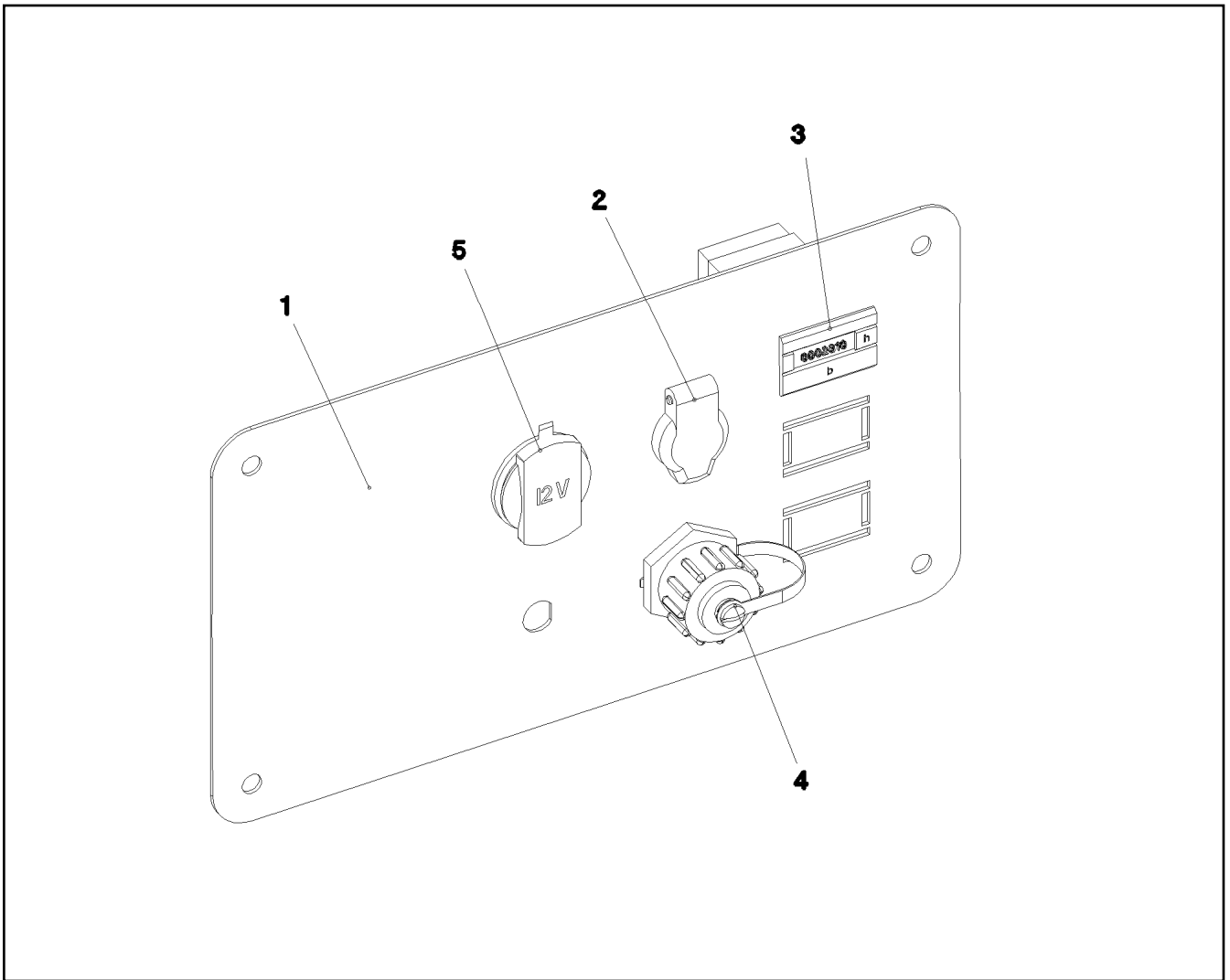

Pos.	Item	Quantity	Description	Bezeichnung	Serie	K
1	97 75 148 08	1	PLATE 1.5X287X160	BLECH		
2	60 52 039 08	1	BUILT-IN SOCKET 2POL 16A	EINBAUSTECKDOSE		
3	69 17 985 08	1	SERVICE HOUR METER 24VDC	BETRIEBSSTUNDENZAehler		
4	10 21 947 7	1	SOCKET	STECKDOSE		
5	10 42 905 7	1	SOCKET 20A	STECKDOSE		

6.2.2009
052600

LIEBHERR

etk_en_de_074515 LR 1600/2

PLATE PRE-ASS.
BLECH VORM.

177

⇒ 2 533 067
96 50 385 08

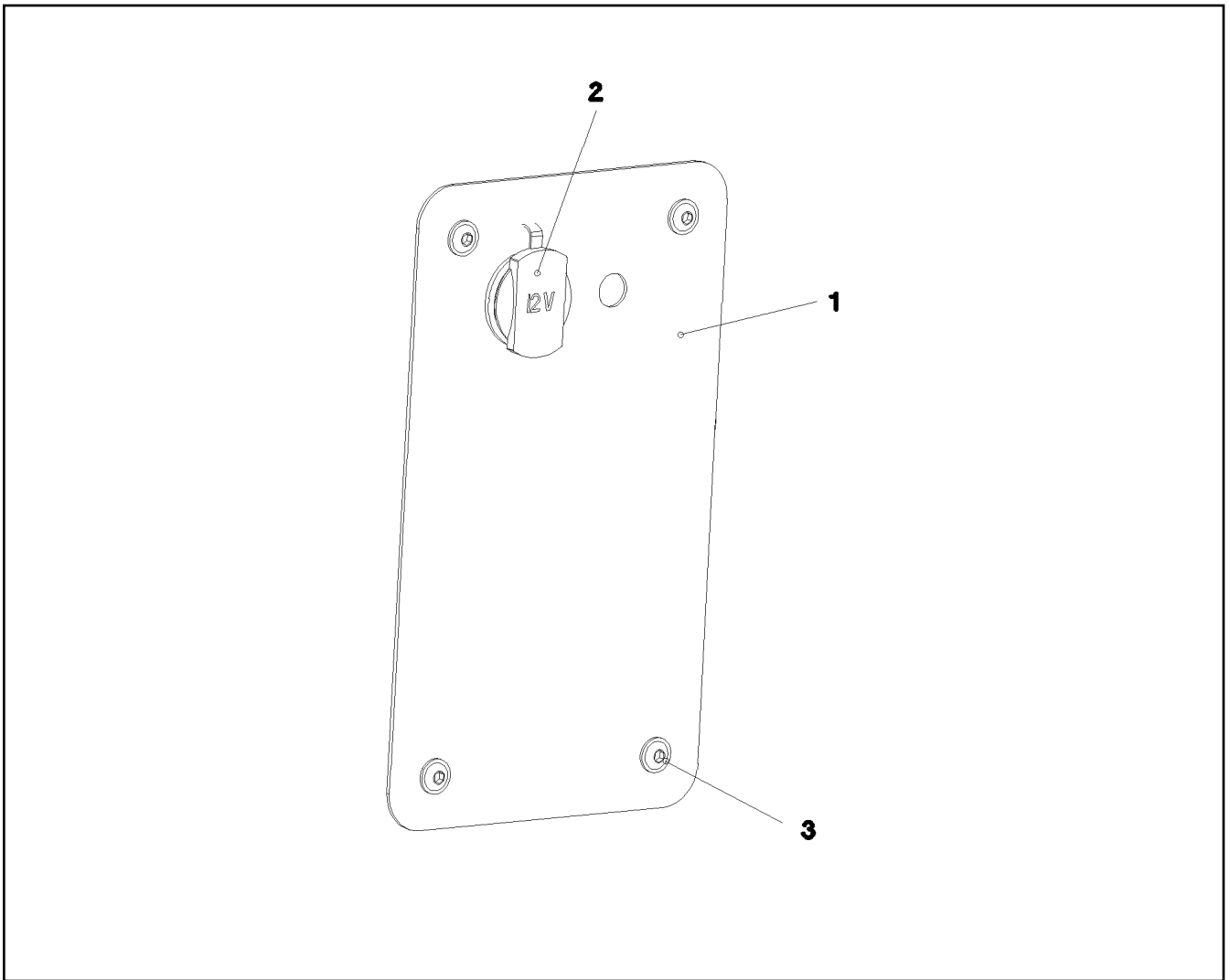

Pos.	Item	Quantity	Description	Bezeichnung	Serie	K
1	97 75 937 08	1	PLATE 1.5X240X140	BLECH		
2	10 42 905 7	1	SOCKET 20A	STECKDOSE		
3	40 97 043 08	4	PAN-HEAD SCREW M6X16 SCHWARZ VERZ	FLACHKOPFSCHRAUBE		

6.2.2009
052597

LIEBHERR

etk_en_de_074515 LR 1600/2

PREMOUNTED PLUG SOCKET
STECKDOSEN VORM.

☐ 178

⇒ 2 533 068
96 49 314 08

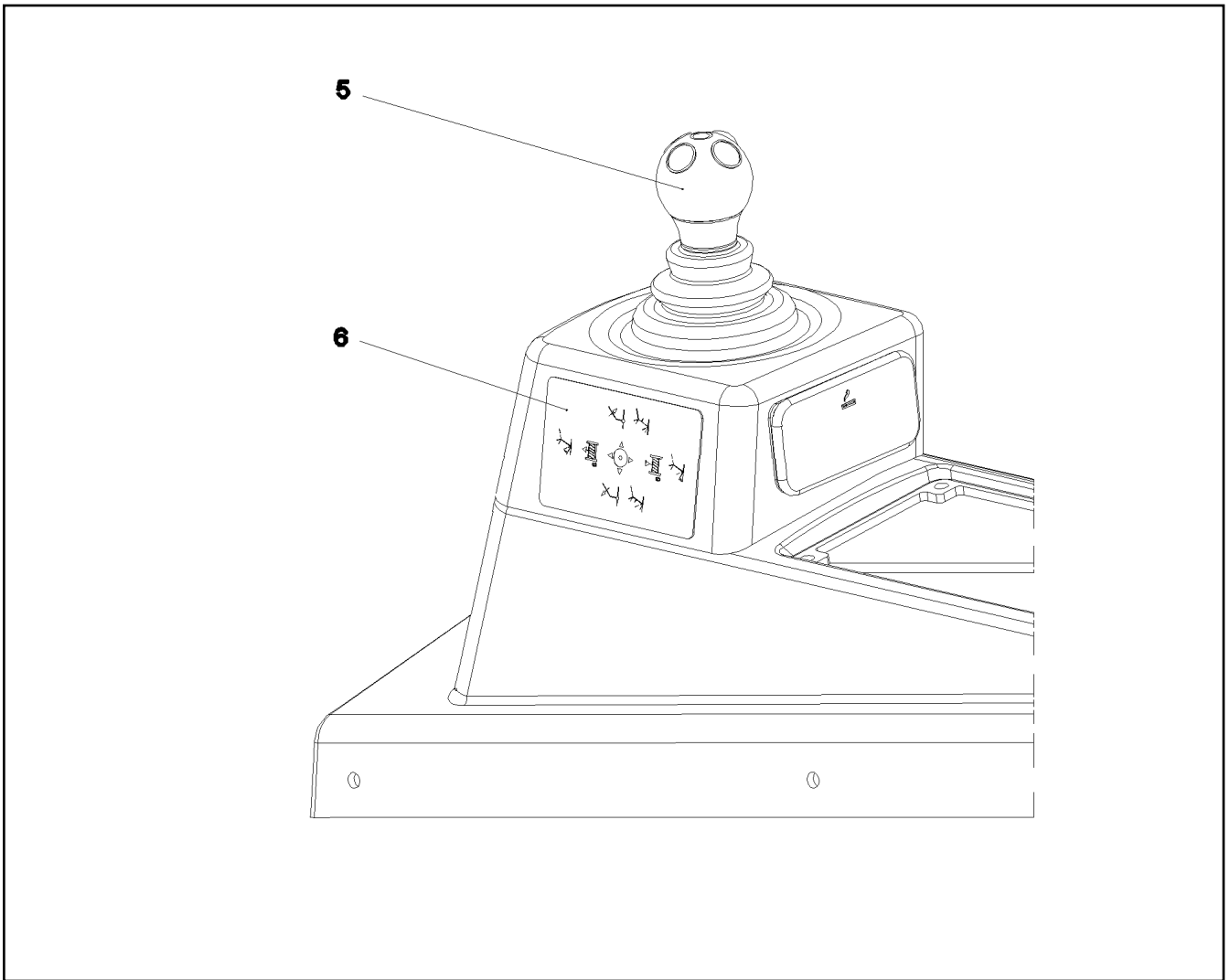

Pos.	Item	Quantity	Description	Bezeichnung	Serie	K
5	60 60 950 08	1	MASTER SWITCH SPF ⇒ 6 060 950 08 60 60 950 08	MEISTERSCHALTER		
6	97 81 106 08	1	LABEL 110X70 LEXEDGE II	SCHILD		

6.2.2009
052607

LIEBHERR

etk_en_de_074515 LR 1600/2

ELECT.EQUIPMENT THREADED UNION
ELEKTRIK ARMATUR

179

⇒ 2 533 069
96 48 372 08

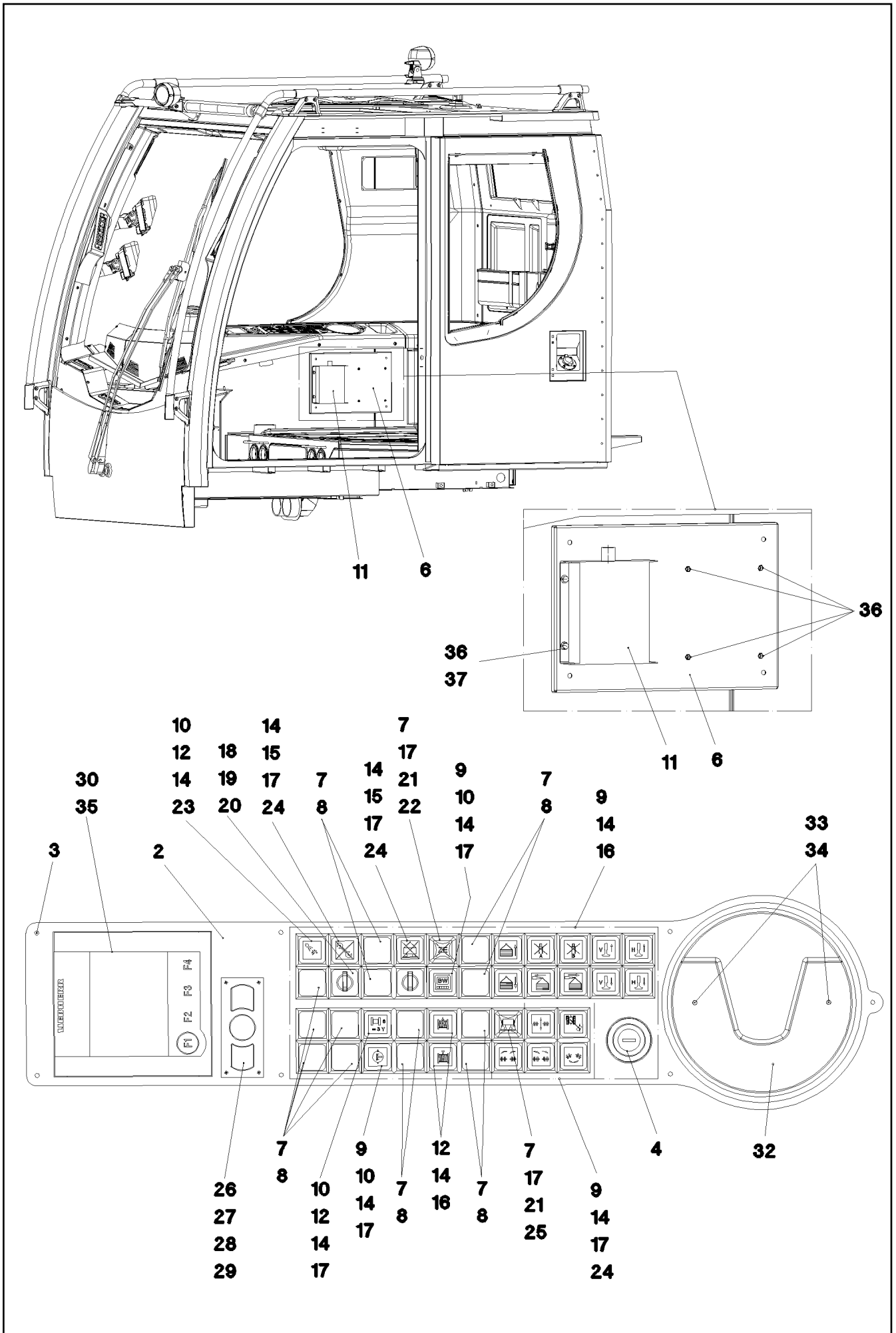

Pos.	Item	Quantity	Description	Bezeichnung	Serie	K
2	96 46 505 08	1	OPERATING PANEL	BEDIENKONSOLE		
3	10 03 726 1	7	PAN-HEAD SCREW AEHNL.ISO 7380 M5X16	FLACHKOPFSCHRAUBE		
4	10 33 555 7	1	IGNITION STARTER SWITCH 3S SPF	ZUENDSTARTSCHALTER		
6	97 76 699 08	1	PLATE 1.5X389X269	BLECH		
7	60 61 435 08	15	SIGNAL LAMP	LEUCHTMELDER		
8	60 61 440 08	13	SPHERICAL CAP	KALOTTE		
9	60 61 439 08	17	PUSH-BUTTON CAP FLACH GELB	TASTERKAPPE		
10	60 61 447 08	4	LUMINOUS SWITCH CONTACT SENDER 2	LEUCHTSCHALTKONTAKTGEBE		
11	61 40 205 08	1	VOLTAGE REGULATOR 24/12DC 24A SPF	SPANNUNGSREGLER		
12	60 61 444 08	4	PUSH-BUTTON CAP FLACH KLAR	TASTERKAPPE		
14	60 61 430 08	23	PUSHER 25X25	DRUECKER		
15	60 61 431 08	2	PUSH-BUTTON CAP FLACH ROT	TASTERKAPPE		
16	60 61 446 08	12	TOUCH CONTACT TRANSMITTER 2OE + 2S	TASTKONTAKTGEBER		
17	60 70 087 08	12	LIGHT BULB 1,2W 30V	GLUEHLAMPE		
18	60 20 422 08	4	RETAINING NUT M16X1	BEFESTIGUNGSMUTTER		
19	60 61 433 08	2	ROTARY LOCK	DREHSCHLOSS		
20	60 61 434 08	2	TOUCH CONTACT TRANSMITTER	TASTKONTAKTGEBER		
21	60 61 445 08	2	LAMP SOCKET	LAMPENFASSUNG		
22	60 61 443 08	1	SPHERICAL CAP	KALOTTE		
23	60 70 117 08	1	LIGHT BULB 1,2W 48V	GLUEHLAMPE		
24	60 61 437 08	7	LUMINOUS PUSH BUTTON CONTACTOR 2	LEUCHTTASTKONTAKTGEBER		
25	60 61 448 08	1	SPHERICAL CAP	KALOTTE		
26	10 44 130 5	4	OVAL HEAD FLAT SCREW AEHNL.ISO 7380	LINSENFLACHKOPFSCHRAUBE		
27	10 32 683 8	1	MOUSE SUBSTITUTE	MAUSERSATZ		
28	10 32 684 4	1	LEAD 8 X	LEITUNG		
29	41 19 001 08	4	HEX NUT DIN 985 M3 8 A3C	SECHSKANTMUTTER		
30	96 48 367 08	1	KEYBOARD UNIT LSB-TE PROG. KLIMA	TASTATUREINHEIT		
(2)	10 29 669 1	1	KEYBOARD UNIT LSB-TE SPF	TASTATUREINHEIT		
(980)	60 27 623 08	2	NAME PLATE 25,4X12,7	BEZEICHNUNGSSCHILD		
32	10 47 141 2	1	LOADING SHELL KUNSTSTOFF	LADESCHALE		
33	41 19 003 08	2	HEX NUT DIN 985 M5 8 VERZ	SECHSKANTMUTTER		
34	40 86 035 08	2	COUNTERSUNK SCREW DIN 7991 M5X10 8.	SENKSCHRAUBE		
35	40 65 002 14	4	HEX BOLT ISO 4017 M4X8 8.8 A2C	SECHSKANTSCHRAUBE		
36	10 04 259 2	8	BLIND RIVET NUT M5 ST VERZ	BLINDNIETMUTTER		
37	40 73 501 08	4	HEX BOLT EN 1665 M5X16 10.9 A2C	SECHSKANTSCHRAUBE		

6.2.2009

etk_en_de_074515 LR 1600/2

☐ 181 (2/2)

LIEBHERRCONTROLS AND FITTINGS RIGHT
ARMATUREN RE.⇒ 2 533 070
96 48 363 08

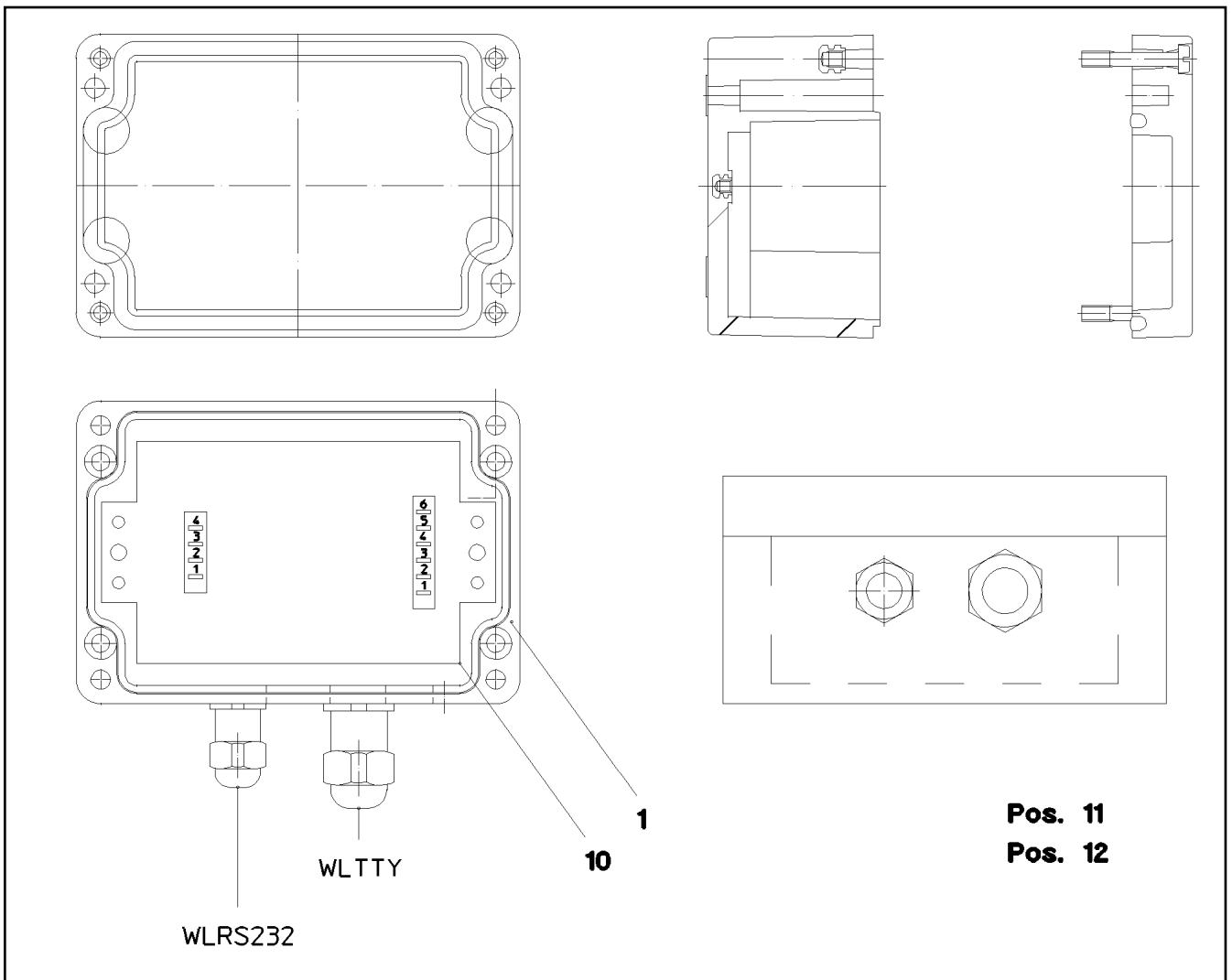

Pos.	Item	Quantity	Description	Bezeichnung	Serie	K
1	97 57 731 08	1	EMPTY CASING 75 110X55X0	LEERGEHAEUSE		
10	91 70 454 14	1	CONVERTOR TTY-RS232	WANDLER		
11	96 52 559 08	1	LEAD W319	LEITUNG		
12	96 52 560 08	1	LEAD W320	LEITUNG		

6.2.2009
052616

LIEBHERR

etk_en_de_074515 LR 1600/2

CONVERTOR
WANDLER

182

⇒ 2 533 071
96 52 556 08

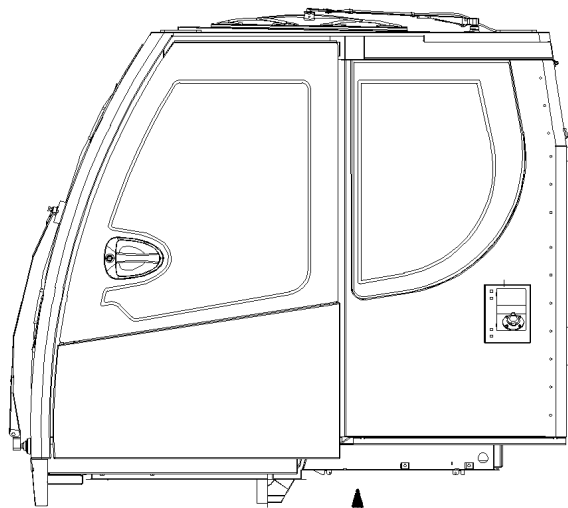

Ansicht A

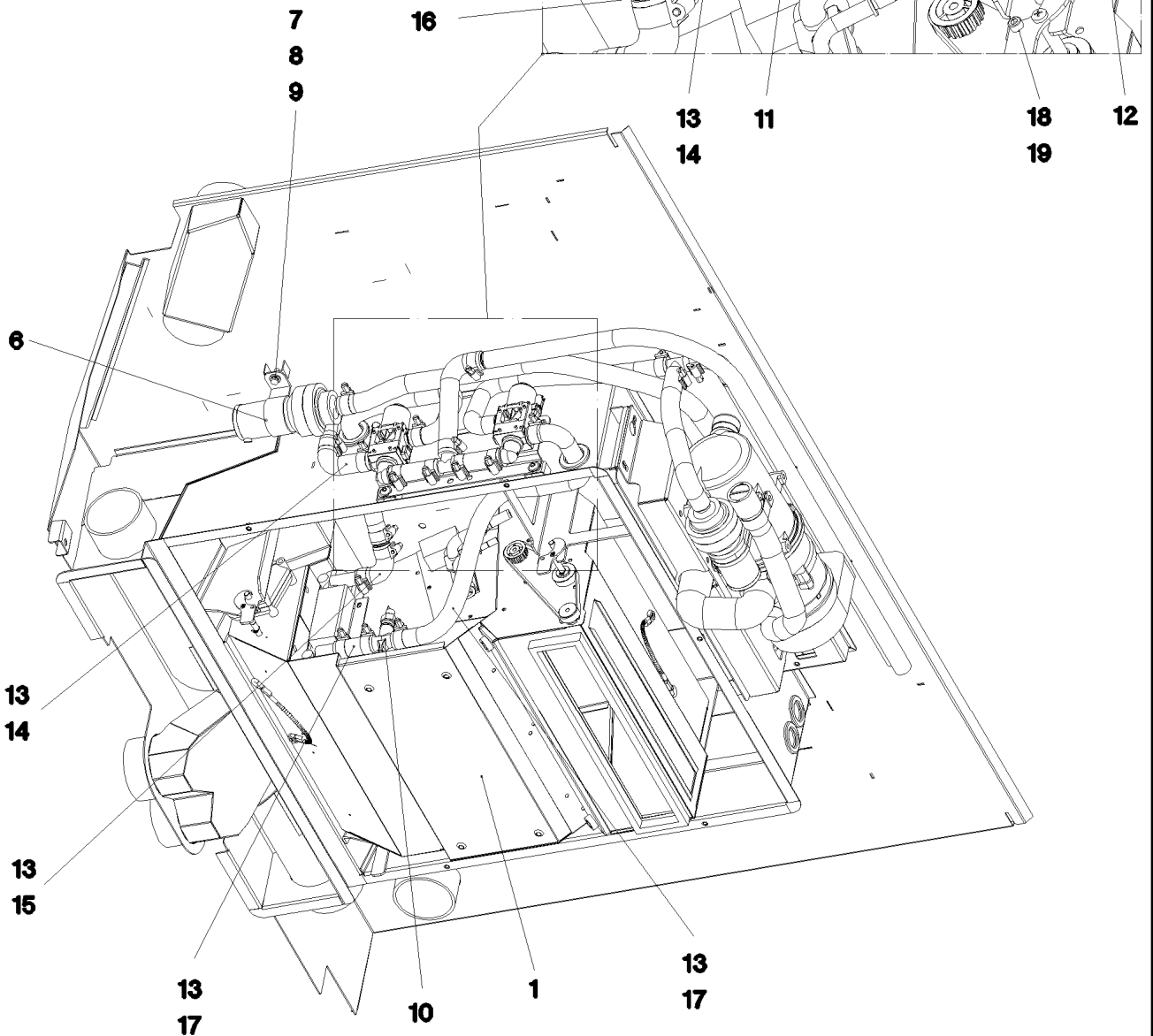
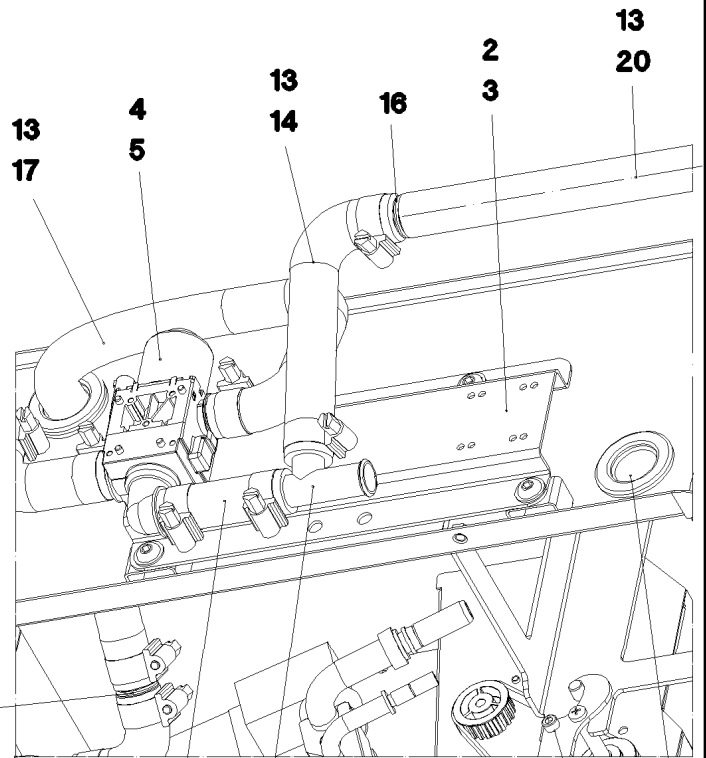

6.2.2009
052581

LIEBHERR

etk_en_de_074515 LR 1600/2

CLIMA-HEATING INSTALLATION
HEIZKLIMAGERAET EINBAU

183 (1/2)

⇒ 2 540
91 53 253 08

Pos.	Item	Quantity	Description	Bezeichnung	Serie	K
1	10 22 811 2	1	AIR CONDITIONING UNIT ⇒ X10228112 10 22 811 2	HEIZKLIMAGERAET		
2	97 65 176 08	1	PLATE 2X251X134	BLECH		
3	10 41 285 4	4	OVAL HEAD FLAT SCREW AEHNL.ISO7380	LINSENFLACHKOPFSCHRAUBE		
4	10 34 300 3	1	SOLENOID VALVE 24V	MAGNETVENTIL		
5	10 01 904 0	4	SCREW 4X12 ST VERZ	SCHRAUBE		
6	55 30 545 08	1	CIRCULATING PUMP U4846 ⇒ 5 530 545 08 55 30 545 08	UMWAEELZPUMPE		
7	40 00 829	2	HEX BOLT ISO 4017 M6X20 8.8 A2C	SECHSKANTSCHRAUBE		
8	42 00 012 08	2	WASHER DIN 125 A8X16 ST VERZ	SCHEIBE		
9	42 00 009 08	2	WASHER ISO 7089 A 6.4 VERZ	SCHEIBE		
10	95 46 242 08	1	PIPE SOCKET GSCK45	ROHRSTUTZEN		
11	55 31 281 08	1	T-PIECE 18/18/18	T-STUECK		
12	55 30 278 08	4	DIAPHRAGM SOCKET	MEMBRANTUELLE		
13	77 42 086 08	17	HOSE CLAMP DIN 3017-1 21,5/16-27/12 W3	SCHLAUCHSCHELLE		
14	55 31 731 08	2	FORM HOSE DN18X90°	FORMSCHLAUCH		
15	55 31 738 08	1	FORM HOSE DN18X90°	FORMSCHLAUCH		
16	55 31 730 08	2	TUBE 18 KUNSTSTOFF	ROHR		
17	55 31 761 08	1	HOSE DN18X2200	SCHLAUCH		
18	40 01 308	2	CYLINDER SCREW ISO 4762 M5X12 8.8 A2C	ZYLINDERSCHRAUBE		
19	51 10 017 08	2	HEX NUT DIN 439 B M5 4	SECHSKANTMUTTER		
20	77 42 329 08	20	COOLING WATER HOSE 18X3,5	KUEHLWASSERSCHLAUCH		

6.2.2009

etk_en_de_074515 LR 1600/2

☐ 184 (2/2)

LIEBHERR

CLIMA-HEATING INSTALLATION
HEIZKLIMAGERAET EINBAU

⇒ 2 540
91 53 253 08

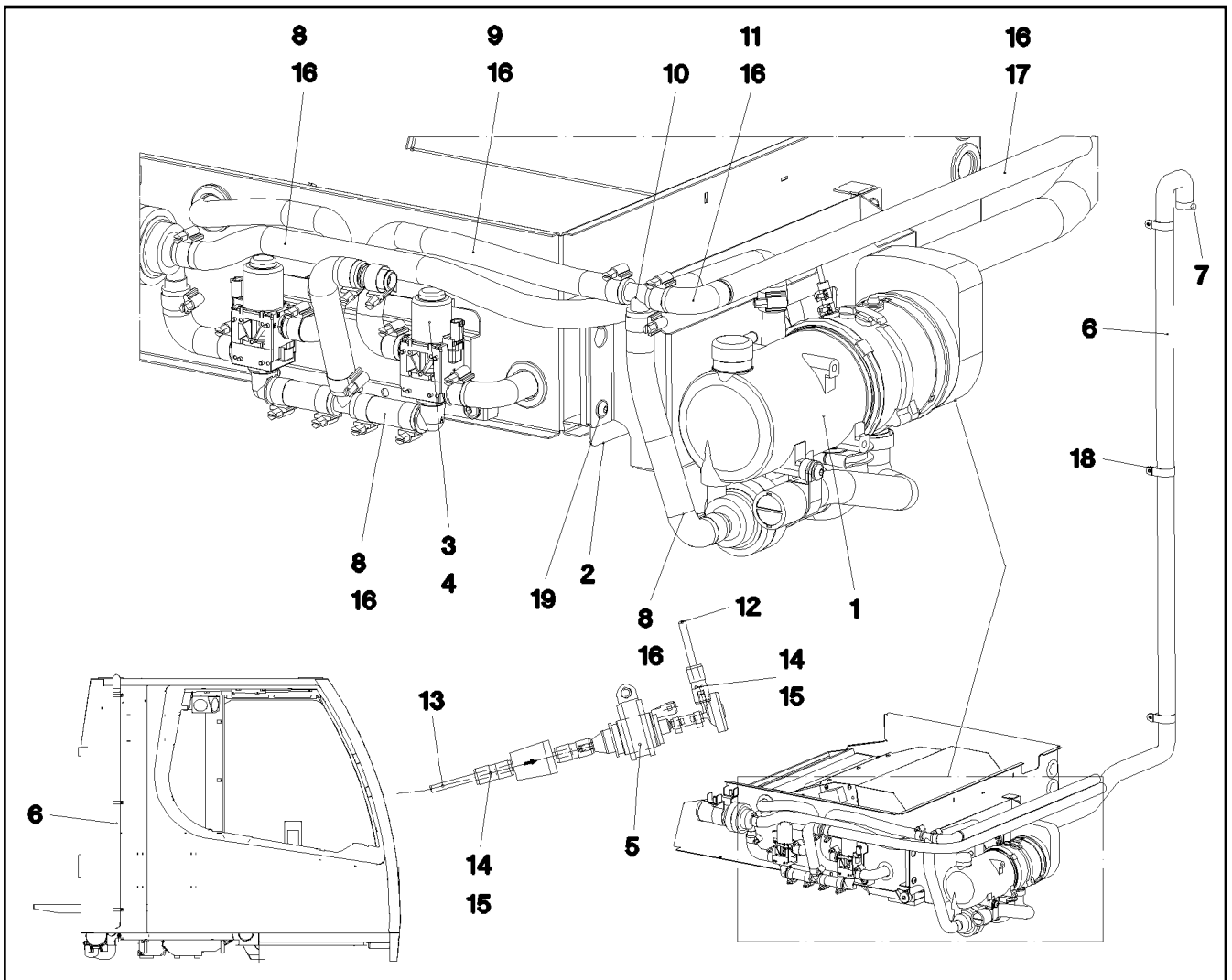

Pos.	Item	Quantity	Description	Bezeichnung	Serie	K
1	96 49 651 08	1	ADDNL.HEATING, PRE-ASSEMBLED ⇒ 2 541 001 96 49 651 08	ZUSATZHEIZUNG VORM.		
2	97 76 595 08	1	PLATE 1.5X486X140	BLECH		
3	10 34 300 3	1	SOLENOID VALVE 24V	MAGNETVENTIL		
4	10 01 904 0	4	SCREW 4X12 ST VERZ	SCHRAUBE		
5	55 31 868 08	1	DOSING PUMP	DOSIERPUMPE		
(1)	55 31 740 08	1	FUEL FILTER	KRAFTSTOFFFILTER		
6	55 30 541 08	2	EXHAUST HOSE 38	ABGASSCHLAUCH		
7	55 31 741 08	1	END CAP 42,3	ENDKAPPE		
8	55 31 731 08	2	FORM HOSE DN18X90°	FORMSCHLAUCH		
9	55 31 761 08	1	HOSE DN18X2200	SCHLAUCH		
10	55 31 281 08	1	T-PIECE 18/18/18	T-STUECK		
11	55 31 738 08	1	FORM HOSE DN18X90°	FORMSCHLAUCH		
12	55 30 187 08	10	HOSE DI=2/DA=5	SCHLAUCH		
13	55 30 187 08	2	HOSE DI=2/DA=5	SCHLAUCH		
14	55 31 911 08	0.15	FUEL HOSE DI=4,5/DA=10,5	KRAFTSTOFFSCHLAUCH		
15	55 31 023 08	6	HOSE CLAMP	SCHLAUCHSCHELLE		
16	77 42 086 08	12	HOSE CLAMP DIN 3017-1 21,5/16-27/12 W3	SCHLAUCHSCHELLE		
17	77 42 329 08	10	COOLING WATER HOSE 18X3,5	KUEHLWASSERSCHLAUCH		
18	77 42 217 08	3	PIPE CLAMP 43/20	ROHRSCHELLE		
19	10 41 285 7	4	OVAL HEAD FLAT SCREW AEHNL.ISO7380	LINSENFLACHKOPFSCHRAUBE		

6.2.2009
052298

LIEBHERR

etk_en_de_074515 LR 1600/2

ADD HEATING SUPERSTRUCTURE
ZUSATZHEIZUNG OW

185

⇒ 2 541
91 52 790 08

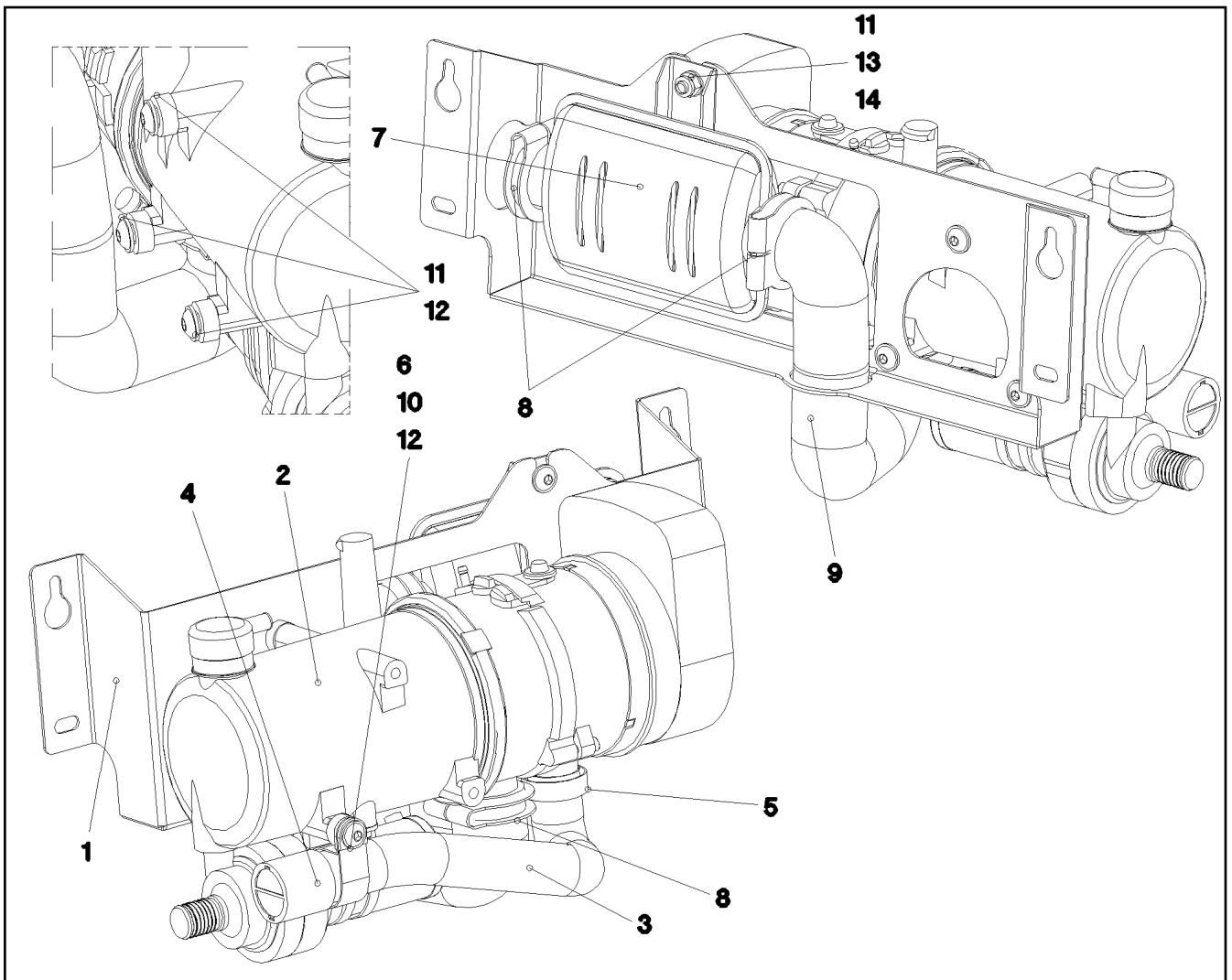

Pos.	Item	Quantity	Description	Bezeichnung	Serie	K
1	97 76 486 08	1	PLATE 2X616X222	BLECH		
2	10 04 204 3	1	WATER HEATING SYSTEM 24V ⇒ X10042043 10 04 204 3	WASSERHEIZGERAET		
3	55 31 594 08	0.33	TUBE 30 Rolle20m PAK	ROHR		
4	55 31 811 08	1	END CAP 34	ENDKAPPE		
5	77 42 040 08	1	HOSE CLAMP 24-38	SCHLAUCHSCHELLE		
6	77 42 250 08	1	PIPE CLAMP 33/20	ROHRSCHELLE		
7	55 31 872 08	1	EXHAUST MUFFLER	ABGASSCHALLDAEMPFER		
8	55 30 542 08	3	TERMINAL CLIP 39-42	KLEMMSCHELLE		
9	55 30 541 08	0.5	EXHAUST HOSE 38	ABGASSCHLAUCH		
10	10 41 286 1	1	OVAL HEAD FLAT SCREW AEHNL.ISO7380	LINSENFLACHKOPFSCHRAUBE		
11	10 41 285 7	4	OVAL HEAD FLAT SCREW AEHNL.ISO7380	LINSENFLACHKOPFSCHRAUBE		
12	42 17 005 08	4	WASHER DIN 7989 B 11 VERZ	SCHEIBE		
13	41 19 005 08	1	HEX NUT DIN 985 M8 8 VERZ	SECHSKANTMUTTER		
14	42 00 012 08	1	WASHER DIN 125 A8X16 ST VERZ	SCHEIBE		

6.2.2009
052299

LIEBHERR

etk_en_de_074515 LR 1600/2

ADDNL.HEATING, PRE-ASSEMBLED
ZUSATZHEIZUNG VORM.

186

⇒ 2 541 001
96 49 651 08

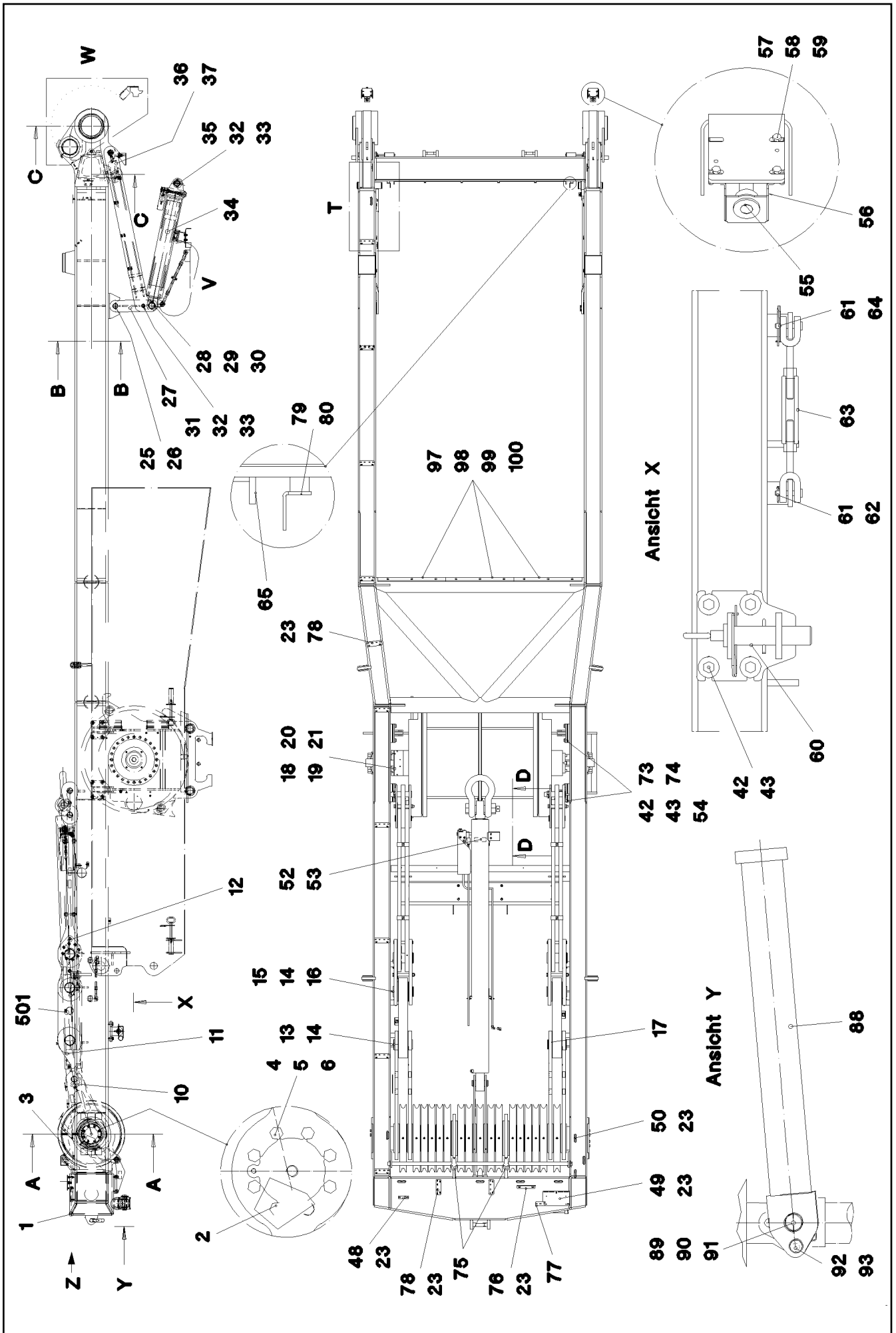

6.2.2009
053688

LIEBHERR

etk_en_de_074515 LR 1600/2

SA FRAME
SA-BOCK

187 (1/6)

→ 2 550
91 57 751 08

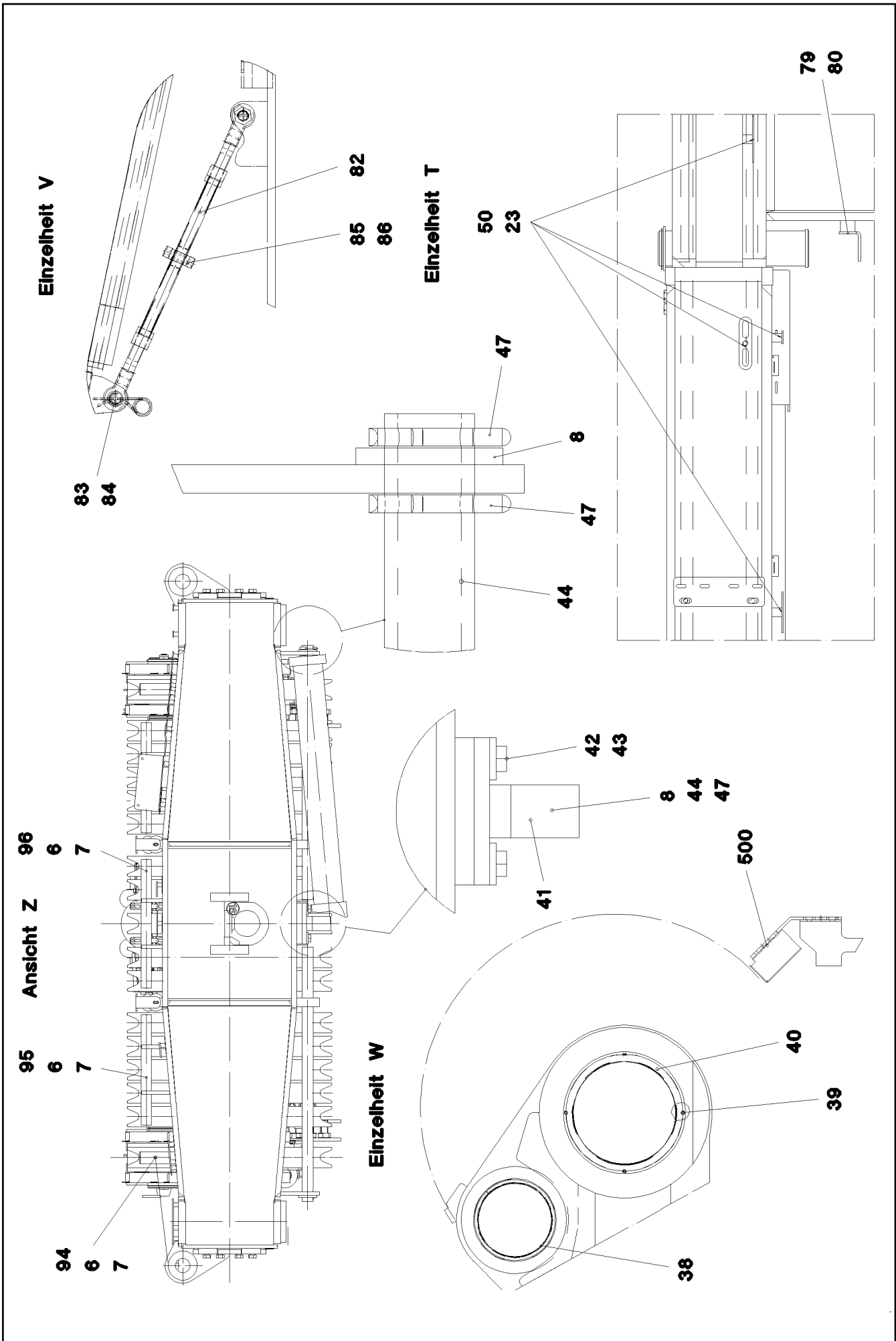

6.2.2009
053689

LIEBHERR

etk_en_de_074515 LR 1600/2

SA FRAME
SA-BOCK

□ 188 (2/6)

⇒ 2 550
91 57 751 08

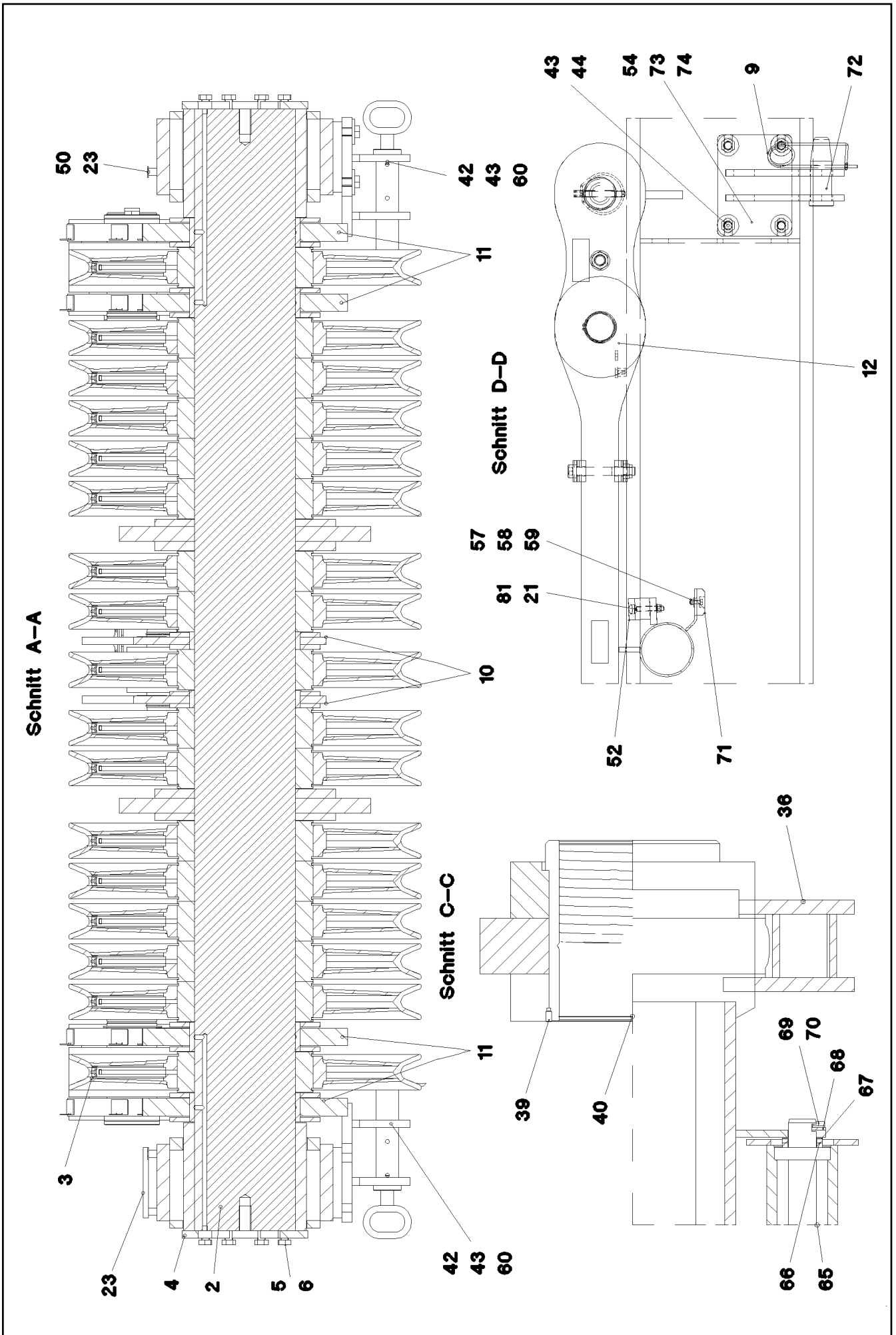

6.2.2009
053690

LIEBHERR

etk_en_de_074515 LR 1600/2

SA FRAME
SA-BOCK

189 (3/6)

→ 2 550
91 57 751 08

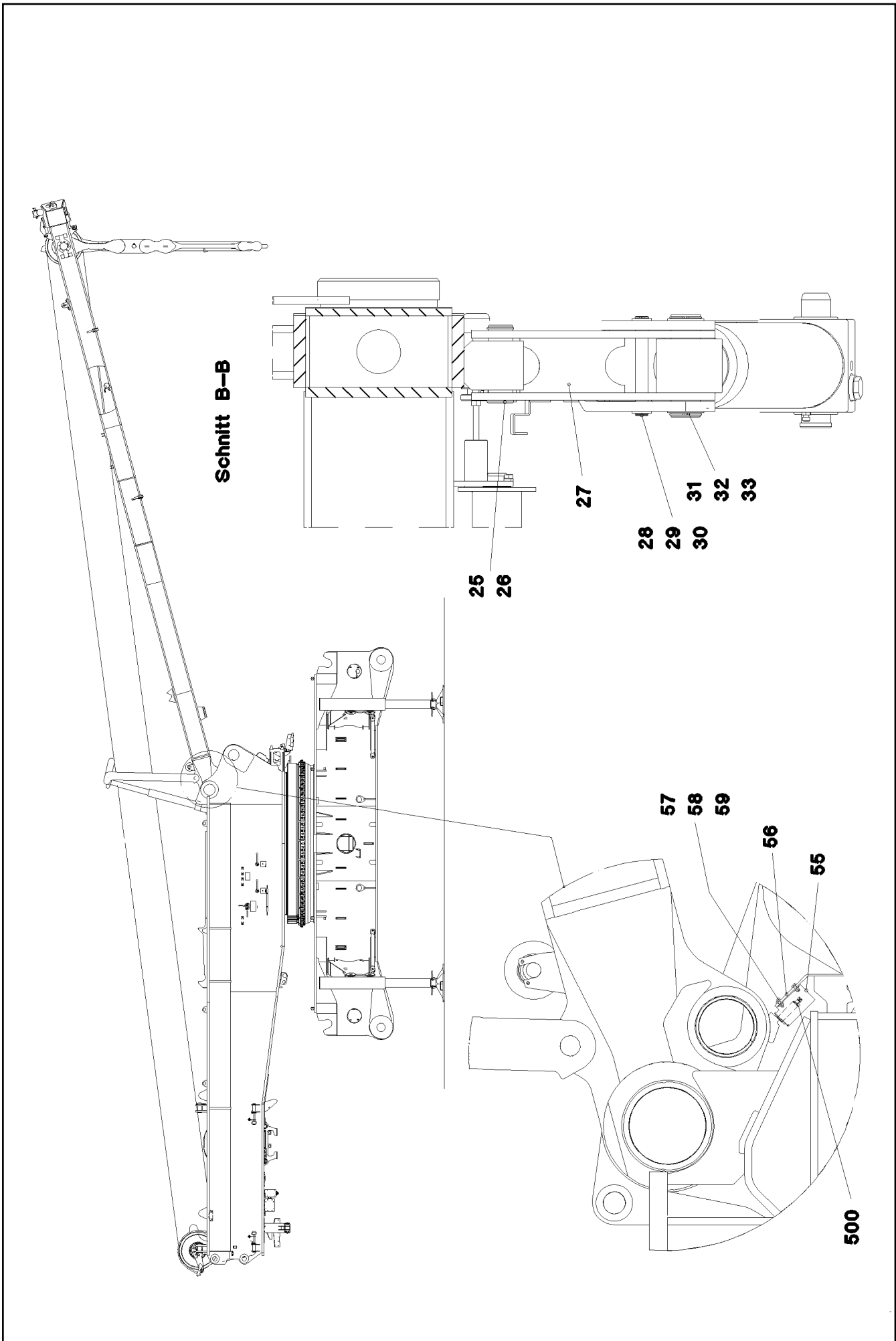

6.2.2009
053691

LIEBHERR

etk_en_de_074515 LR 1600/2

SA FRAME
SA-BOCK

□ 190 (4/6)

⇒ 2 550
91 57 751 08

Pos.	Item	Quantity	Description	Bezeichnung	Serie	K
1	96 45 308 08	1	SA FRAME WELDED CONSTR.	SA-BOCK SCHWK.		
2	97 67 972 08	1	AXLE 220.0X2231 SPF	ACHSE		
3	96 46 246 08	17	ROPE PULLEY CPL. SPF ⇒ 2 550 003 96 46 246 08	SEILROLLE KPL.		
4	97 90 582 08	2	PLATE 15X430X250	BLECH		
5	49 00 153	16	HEX BOLT ISO 4017 M16X40 8.8 A3C	SECHSKANTSCHRAUBE		
6	42 00 019 08	26	WASHER DIN 125 A 17 VERZ	SCHEIBE		
7	49 00 152	10	HEX BOLT ISO 4017 M16X30 8.8 A3C	SECHSKANTSCHRAUBE		
8	42 11 032 08	2	WASHER DIN 1440 45 ST VERZ	SCHEIBE		
9	43 31 009 08	8	RETAINING SPRING 4,5 VERZ	SICHERUNGSFEDER		
10	96 45 603 08	2	BEARING CPL.	LAGERUNG KPL.		
(1)	96 45 611 08	1	BEARING WELDED	LAGERUNG SCHWK.		
(2)	97 73 251 08	1	BEARING BUSH 200X220X35 GZ-CUZN34AL	LAGERBUCHSE		
(3)	97 35 919 08	1	PLATE ASSEMBLY BG-NR. PVC-SILBER SP	SCHILD BAUGRUPPE		
(4)	40 48 003 08	8	GRUB SCREW DIN 915 M8X20 45 H VERZ	GEWINDESTIFT		
(5)	95 36 500 08	5	CABLE HOLDER 2X22X90	KABELHALTER		
(6)	10 41 285 4	5	OVAL HEAD FLAT SCREW AEHNL.ISO7380	LINSENFLACHKOPFSCHRAUBE		
11	96 45 456 08	4	ROD CPL. 1 M	STANGE KPL.		
(1)	96 45 458 08	1	ROD	STANGE SCHWK.		
(2)	97 68 284 08	1	BEARING BUSH 200X220X58 GZ-CUZN25AL	LAGERBUCHSE		
(3)	97 35 919 08	1	PLATE ASSEMBLY BG-NR. PVC-SILBER SP	SCHILD BAUGRUPPE		
(4)	97 07 173 08	4	PLATE 1.5x60x47	BLECH		
(5)	40 48 003 08	6	GRUB SCREW DIN 915 M8X20 45 H VERZ	GEWINDESTIFT		
12	96 45 680 08	2	ROD CPL. 2.05M ⇒ 2 550 005 96 45 680 08	STANGE KPL.		
13	97 68 599 08	2	PIN 110.0X196 SPF	BOLZEN		
14	42 80 067 08	4	LOCKING RING DIN 471 100X3	SICHERUNGSRING		
15	97 68 580 08	2	PIN 110.0X214 SPF	BOLZEN		
16	97 81 710 08	8	WASHER 5X200X200 TZNO	SCHEIBE		
17	94 67 863 08	4	WASHER RD150X1	SCHEIBE		
18	97 29 088 08	1	HOOD 1.5X411X555	HAUBE		
19	49 00 128	2	HEX BOLT ISO 4017 M8X25 8.8 A2C	SECHSKANTSCHRAUBE		
20	42 00 012 08	6	WASHER DIN 125 A8X16 ST VERZ	SCHEIBE		
21	41 19 005 08	4	HEX NUT DIN 985 M8 8 VERZ	SECHSKANTMUTTER		
23	10 41 285 4	40	OVAL HEAD FLAT SCREW AEHNL.ISO7380	LINSENFLACHKOPFSCHRAUBE		
25	97 72 181 08	2	PIN 55.0X160 SPF	BOLZEN		
26	42 80 042 08	2	LOCKING RING DIN 471 50X2	SICHERUNGSRING		
27	96 47 491 08	2	FINGER WELDED	FINGER SCHWK.		
28	94 26 891 08	2	PIN 25.0X204 T ZN O	BOLZEN		
29	42 80 021 08	2	LOCKING RING DIN 471 25X1,2	SICHERUNGSRING		
30	42 12 016 08	2	WASHER DIN 1441 26 ST VERZ	SCHEIBE		
31	94 26 890 08	2	PIN 65.0X210 SPF	BOLZEN		
32	53 00 631 08	8	SUPPORTING RING DIN 988 S 60	STUETZSCHEIBE		
33	42 80 049 08	6	LOCKING RING DIN 471 60X2	SICHERUNGSRING		
34	10 41 101 9	2	HYDRO CYLINDER 150/140-1610 SPF	HYDROZYLINDER		
35	97 74 147 08	2	PIN 65.0X258 SPF	BOLZEN		
36	96 47 645 08	1	RETAINER CPL. ⇒ 2 550 009 96 47 645 08	HALTER KPL.		
37	96 47 628 08	1	RETAINER CPL. ⇒ 2 550 008 96 47 628 08	HALTER KPL.		
38	97 73 314 08	2	BEARING BUSH 150X170X110 37MNB4	LAGERBUCHSE		
39	40 48 003 08	8	GRUB SCREW DIN 915 M8X20 45 H VERZ	GEWINDESTIFT		
40	97 73 315 08	2	BEARING BUSH 210X250X259 GZ-CUZN25	LAGERBUCHSE		
41	96 47 103 08	1	ROPE GUARD WELDED	SEILSCHUTZ SCHWK.		
42	40 65 304 08	28	HEX BOLT ISO 4017 M16X40 8.8 A3C	SECHSKANTSCHRAUBE		
43	42 16 009 08	28	WASHER DIN 7349 17 ST VERZ	SCHEIBE		
44	97 68 872 08	2	TUBE 38.0X870 ST37.0	ROHR		
47	43 30 090 08	4	SPLIT PIN DIN 94 8X63 ST VERZ	SPLINT		
48	95 36 969 08	1	PLATE 4X30X105	BLECH		
49	97 15 521 08	1	PLATE 3X280X154	BLECH		

6.2.2009

etk_en_de_074515 LR 1600/2

 191 (5/6)
LIEBHERRSA FRAME
SA-BOCK⇒ 2 550
91 57 751 08

Pos.	Item	Quantity	Description	Bezeichnung	Serie	K
50	95 36 500 08	19	CABLE HOLDER 2X22X90	KABELHALTER		
52	28 30 209 08	1	BEARING PLATE	LAGERPLATTE		
53	40 86 008 08	2	COUNTERSUNK SCREW DIN 7991 M8X40 8.	SENKSCBRAUBE		
54	96 46 388 08	4	CLAMP WELDED CONST.	HALTER SCHWK.		
55	92 35 694 08	2	HOLDER X12CrNiS188	HALTER		
56	43 20 053 08	4	DOWEL PIN ISO 8752 6X14	SPANNSTIFT		
57	40 00 829	14	HEX BOLT ISO 4017 M6X20 8.8 A2C	SECHSKANTSCHRAUBE		
58	42 18 007 08	28	WASHER DIN 9021 A 6.4 VERZ	SCHEIBE		
59	41 19 004 08	14	HEX NUT DIN 985 M6 8 VERZ	SECHSKANTMUTTER		
60	96 47 007 08	2	CONSOLE COMPL. ⇒ 2 550 011 96 47 007 08	KONSOLE KPL.		
61	45 12 144 08	4	PIN DIN 1435 12H11X60X53 ST.50 FE//ZN20//	BOLZEN		
62	43 30 052 08	2	SPLIT PIN DIN 94 4X32 ST VERZ	SPLINT		
63	77 39 170 08	2	TURNBUCKLE 1,59KN	SPANNSCHLOSS		
64	43 31 028 08	2	RETAINING SPRING 3 VERZ	SICHERUNGSFEDER		
65	92 70 642 08	1	SAFETY ROLLER CPL. SPF ⇒ 3 350 001 92 70 642 08	SCHUTZWALZE KPL.		
66	42 12 024 08	4	WASHER DIN 1441 41 ST A2C	SCHEIBE		
67	97 02 665 08	2	WASHER 1.5x58x58	SCHEIBE		
68	94 66 007 08	2	HOLDER 4X20X80	HALTER		
69	49 00 090	4	HEX BOLT ISO 4017 M10X16 8.8 A3C	SECHSKANTSCHRAUBE		
70	42 40 008 08	4	CIRCLIP DIN 127 A 10 VERZ	FEDERRING		
71	28 81 951 08	2	SUPPORT PLATE 15X50X900 PA6G	AUFLAGE		
72	93 83 160 08	4	PIN RD40X120	BOLZEN		
73	97 80 625 08	4	PLATE 4X190X140	BLECH		
74	97 80 626 08	8	PLATE 2X190X140	BLECH		
75	97 81 069 08	2	PLATE 4X60X224	BLECH		
76	97 81 077 08	1	HOLDING ANGLE 2X190X112	HALTEWINKEL		
77	97 59 503 08	1	PLATE 3X106X42	BLECH		
78	97 81 204 08	12	HOLDING PLATE 4X155X50	HALTEPLATTE		
79	97 03 502 08	2	PLATE 4X110X80	BLECH		
80	95 38 734 08	6	SLEEVE	HUELSE		
81	40 70 317 08	2	COUNTERSUNK SCREW DIN 963 M8X55 5.8	SENKSCBRAUBE		
82	10 47 609 8	2	TURNBUCKLE 7/8"X12 163KN VERZ	SPANNSCHLOSS		
83	45 12 225 08	2	PIN DIN 1435 20H11X75X66 ST.50	BOLZEN		
84	43 32 063 08	2	SPRING PLUG 5 VERZ	FEDERSTECKER		
85	97 88 842 08	2	PLATE 20X68X60	BLECH		
86	43 20 089 01	2	DOWEL PIN ISO 8752 8X60 ST GEOMET321A	SPANNSTIFT		
88	96 53 864 08	1	SUPPORT	STUETZE SCHWK.		
89	94 00 692 08	1	PIN 45X158 SPF	BOLZEN		
90	43 30 101 08	1	SPLIT PIN DIN 94 10X71 ST VERZ	SPLINT		
91	42 12 024 08	3	WASHER DIN 1441 41 ST A2C	SCHEIBE		
92	97 04 625 08	1	PIN 35x178	BOLZEN		
93	43 32 002 08	1	HINGED CONNECTOR DIN 11023 6X42 VER	KLAPPSTECKER		
94	96 56 155 08	2	ROPE GUARD WELDED	SEILSCHUTZ SCHWK.		
95	96 56 165 08	2	ROPE GUARD WELDED	SEILSCHUTZ SCHWK.		
96	96 56 171 08	1	ROPE GUARD WELDED	SEILSCHUTZ SCHWK.		
97	93 72 005 08	3	PLASTIC STRIP 13X45X710 PA6G	LEISTE		
98	40 86 013 08	9	COUNTERSUNK SCREW DIN 7991 M10X35	SENKSCBRAUBE		
99	42 00 013 08	9	WASHER ISO 7089 A 10.5 A3C	SCHEIBE		
100	41 19 006 08	9	HEX NUT DIN 985 M10 8 VERZ	SECHSKANTMUTTER		
500	96 54 379 08	1	ELECTRIC FOR SA - FRAME ⇒ 2 920 578 96 54 379 08	ELEKTRIK SA-BOCK		
501	10 35 469 6	2	TENSION DYNAMOMETER 0-2400KN S960Q	ZUGMESSLASCHE		

6.2.2009

etk_en_de_074515 LR 1600/2

 192 (6/6)
LIEBHERRSA FRAME
SA-BOCK⇒ 2 550
91 57 751 08

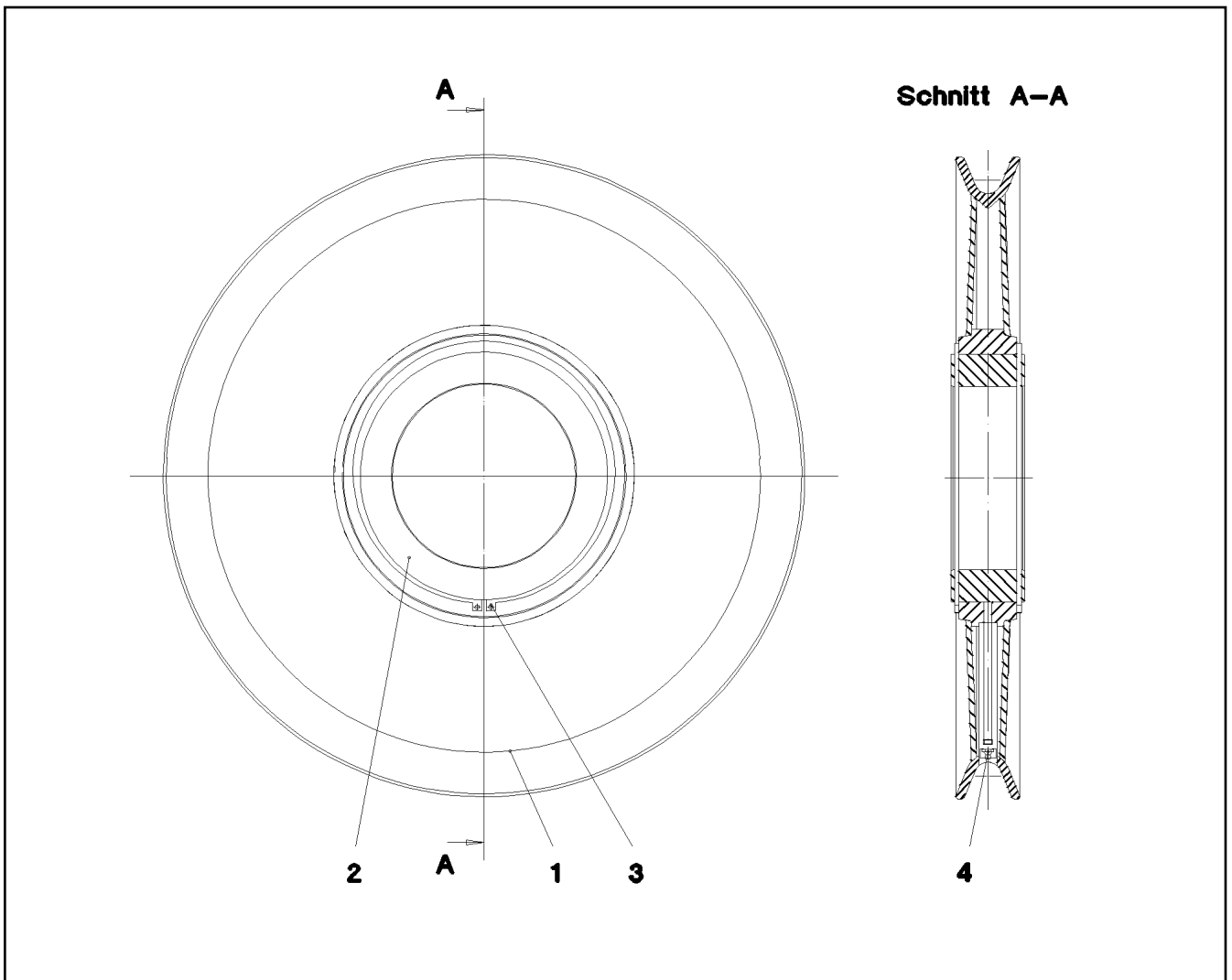

Pos.	Item	Quantity	Description	Bezeichnung	Serie	K
1	97 69 683 08	1	RUNNING ROLLER S355J2G3	LAUFROLLE		
2	74 65 067 08	1	ROLLER BEARING 200X270X80	WAEZLAGER		
3	42 80 103 08	2	LOCKING RING DIN 471 270X5	SICHERUNGSRING		
4	77 43 040 08	1	GREASE NIPPLE DIN 71412 A M10X1	SCHMIERNIPPEL		

6.2.2009
052750

LIEBHERR

etk_en_de_074515 LR 1600/2

ROPE PULLEY CPL.
SEILROLLE KPL.

193

⇒ 2 550 003
96 46 246 08

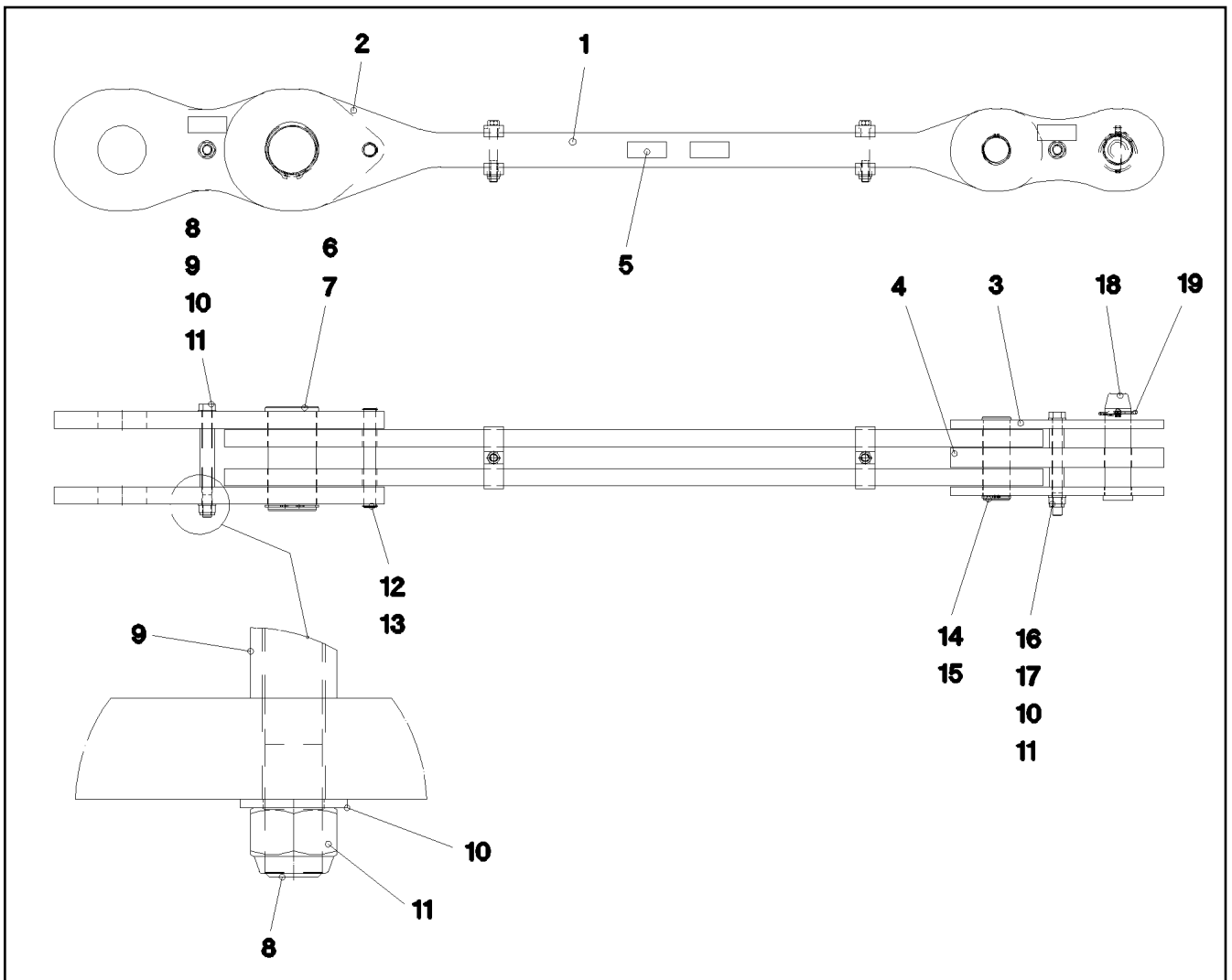

Pos.	Item	Quantity	Description	Bezeichnung	Serie	K
1	96 45 685 08	1	ROD ⇒ 2 550 010 96 45 685 08	STANGE VORM.		
2	96 45 686 08	2	BRACKET WITH BOARD	LASCHE MIT SCHILD		
3	96 45 687 08	2	BRACKET WITH BOARD	LASCHE MIT SCHILD		
4	96 45 688 08	1	BRACKET WITH BOARD	LASCHE MIT SCHILD		
5	97 35 919 08	1	PLATE ASSEMBLY BG-NR. PVC-SILBER SP	SCHILD BAUGRUPPE		
6	97 68 580 08	1	PIN 110.0X214 SPF	BOLZEN		
7	42 80 067 08	1	LOCKING RING DIN 471 100X3	SICHERUNGSRING		
8	40 61 246 01	2	HEX BOLT ISO 4014 M20X220 8.8 A3C	SECHSKANTSCHRAUBE		
9	97 77 023 08	1	TUBE 30.0X120	ROHR		
10	42 00 021 08	4	WASHER ISO 7089 A 21 ST A3C	SCHEIBE		
11	41 19 024 08	2	HEX NUT DIN 985 M20 10 A3C	SECHSKANTMUTTER		
12	94 26 891 08	1	PIN 25.0X204 T ZN O	BOLZEN		
13	42 80 021 08	2	LOCKING RING DIN 471 25X1,2	SICHERUNGSRING		
14	97 68 581 08	1	PIN 65.0X171 SPF	BOLZEN		
15	53 01 333 08	1	LOCKING RING DIN 471 55X3	SICHERUNGSRING		
16	40 61 244 01	1	HEX BOLT ISO 4014 M20X200 8.8 A3C	SECHSKANTSCHRAUBE		
17	94 12 040 08	2	TUBE 30X4X40	ROHR		
18	97 74 800 08	1	PIN 65.0X220 SPF	BOLZEN		
19	43 32 005 08	1	SAFETY PLUG W HINGE-LID 11,5X96 VERZ	SICHERHEITSKLAPPSTECKER		

6.2.2009
052297

LIEBHERR

etk_en_de_074515 LR 1600/2

ROD CPL.
STANGE KPL.

194

⇒ 2 550 005
96 45 680 08

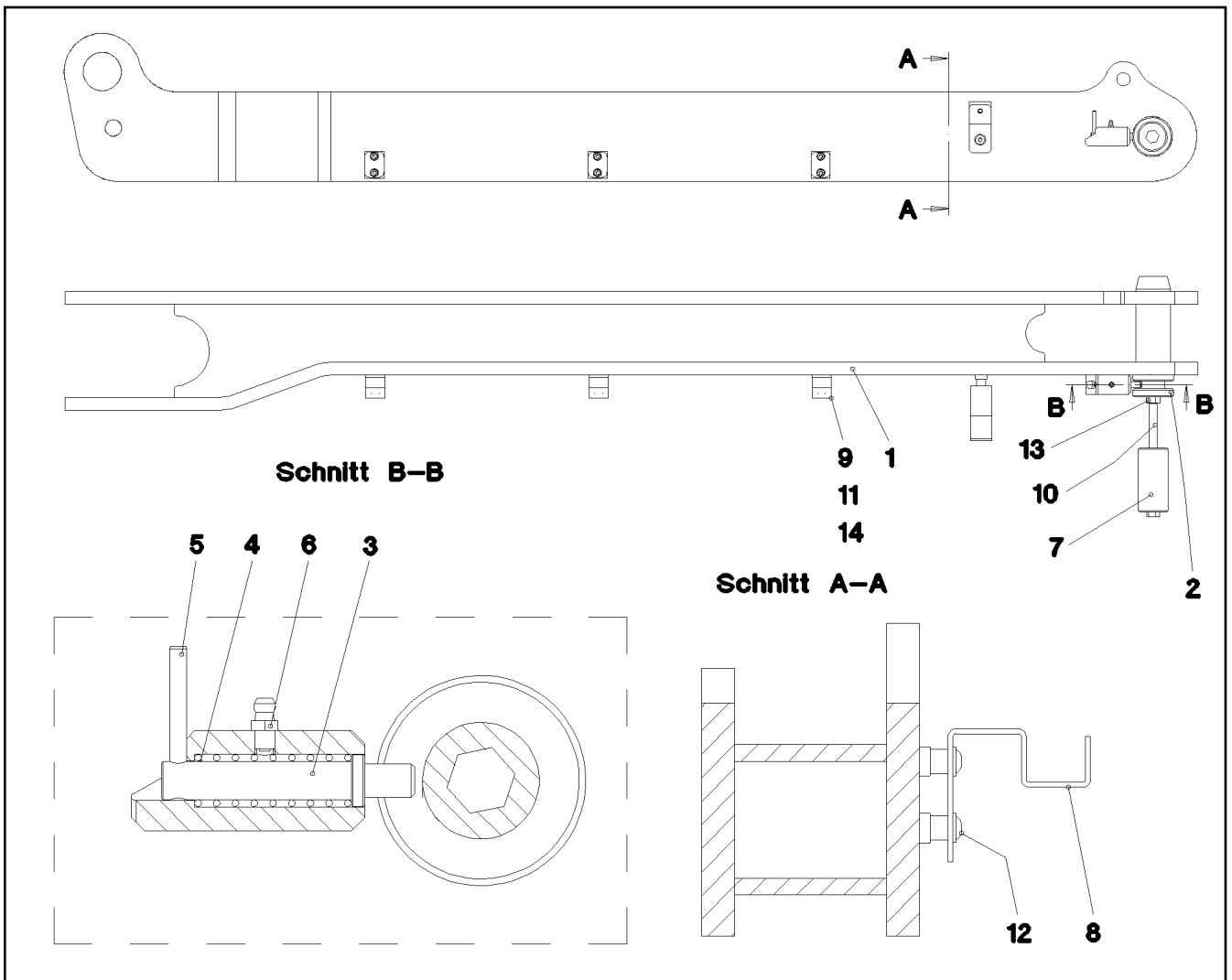

Pos.	Item	Quantity	Description	Bezeichnung	Serie	K
1	96 47 493 08	1	CLAMP WELDED CONST.	HALTER SCHWK.		
2	97 72 405 08	1	PIN 65.0X189 SPF	BOLZEN		
3	97 79 659 08	1	AXLE 16.0X76 FE//ZN20//C	ACHSE		
4	57 06 304 08	1	PRESSURE SPRING	DRUCKFEDER		
5	43 20 048 08	1	DOWEL PIN ISO 8752 5X45	SPANNSTIFT		
6	77 43 009 08	1	GREASE NIPPLE DIN 71412 A M6	SCHMIERNIPPEL		
7	97 80 226 08	1	AXLE 50.0X100 SPF	ACHSE		
8	97 79 305 08	1	PLATE 3X212X34	BLECH		
9	60 20 083 08	6	CLAMP-HALF DIN 3015-1 18 PP SW	KLEMMHAELFTE		
10	46 00 887	1	HEX BOLT ISO 4014 M12X200 8.8 A3C	SECHSKANTSCHRAUBE		
11	40 42 003	6	CYLINDER SCREW ISO 4762 M6X25 8.8 A2C	ZYLINDERSCHRAUBE		
12	10 41 285 4	2	OVAL HEAD FLAT SCREW AEHNL.ISO7380	LINSENFLACHKOPFSCHRAUBE		
13	41 15 143 08	1	HEX NUT DIN 934 M12 8 VERZ	SECHSKANTMUTTER		
14	42 18 017 08	6	WASHER ISO 7093 A 6.4 A2	SCHEIBE		

6.2.2009
052294

LIEBHERR

etk_en_de_074515 LR 1600/2

RETAINER CPL.
HALTER KPL.

195

⇒ 2 550 008
96 47 628 08

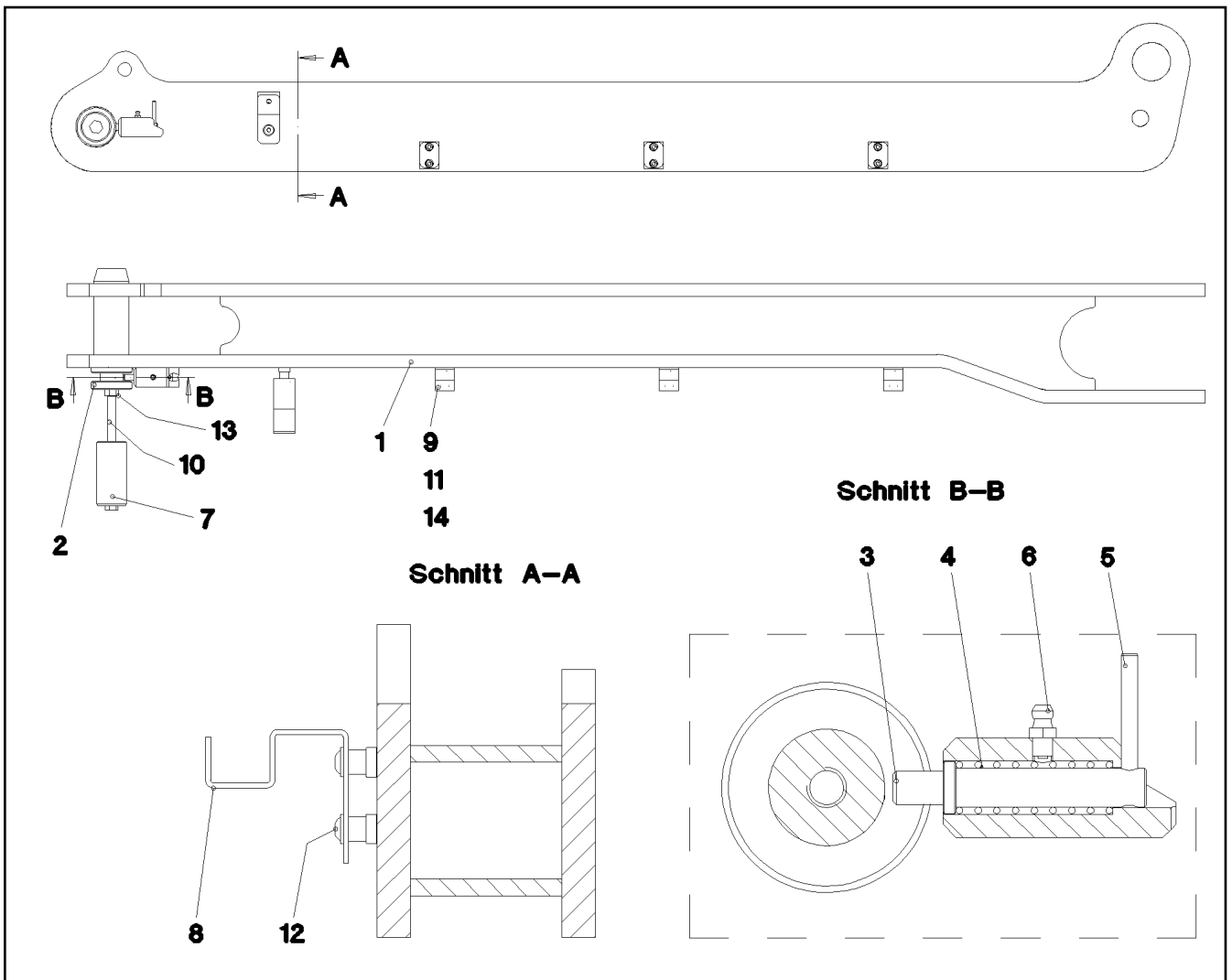

Pos.	Item	Quantity	Description	Bezeichnung	Serie	K
1	96 47 644 08	1	CLAMP WELDED CONST.	HALTER SCHWK.		
2	97 72 405 08	1	PIN 65.0X189 SPF	BOLZEN		
3	97 79 659 08	1	AXLE 16.0X76 FE//ZN20//C	ACHSE		
4	57 06 304 08	1	PRESSURE SPRING	DRUCKFEDER		
5	43 20 048 08	1	DOWEL PIN ISO 8752 5X45	SPANNSTIFT		
6	77 43 009 08	1	GREASE NIPPLE DIN 71412 A M6	SCHMIERNIPPEL		
7	97 80 226 08	1	AXLE 50.0X100 SPF	ACHSE		
8	97 79 305 08	1	PLATE 3X212X34	BLECH		
9	60 20 083 08	6	CLAMP-HALF DIN 3015-1 18 PP SW	KLEMMHAELFTE		
10	46 00 887	1	HEX BOLT ISO 4014 M12X200 8.8 A3C	SECHSKANTSCHRAUBE		
11	40 42 003	6	CYLINDER SCREW ISO 4762 M6X25 8.8 A2C	ZYLINDERSCHRAUBE		
12	10 41 285 4	2	OVAL HEAD FLAT SCREW AEHNL.ISO7380	LINSENFLACHKOPFSCHRAUBE		
13	41 15 143 08	1	HEX NUT DIN 934 M12 8 VERZ	SECHSKANTMUTTER		
14	42 18 017 08	6	WASHER ISO 7093 A 6.4 A2	SCHEIBE		

6.2.2009
052295

LIEBHERR

etk_en_de_074515 LR 1600/2

RETAINER CPL.
HALTER KPL.

196

⇒ 2 550 009
96 47 645 08

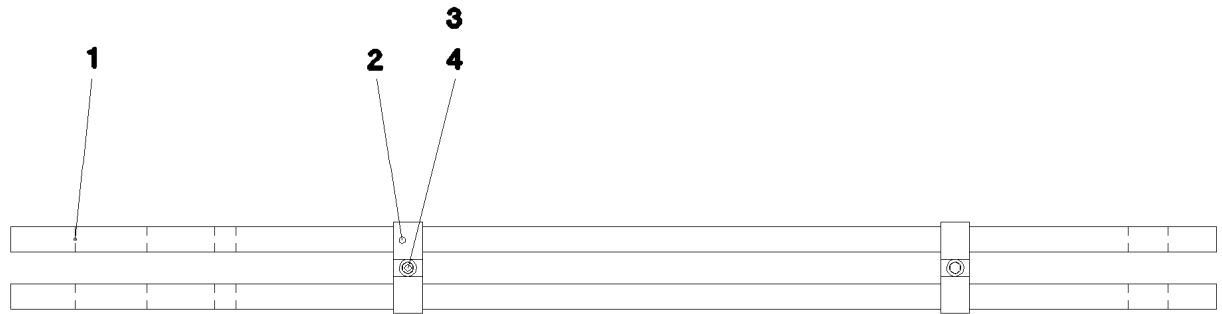
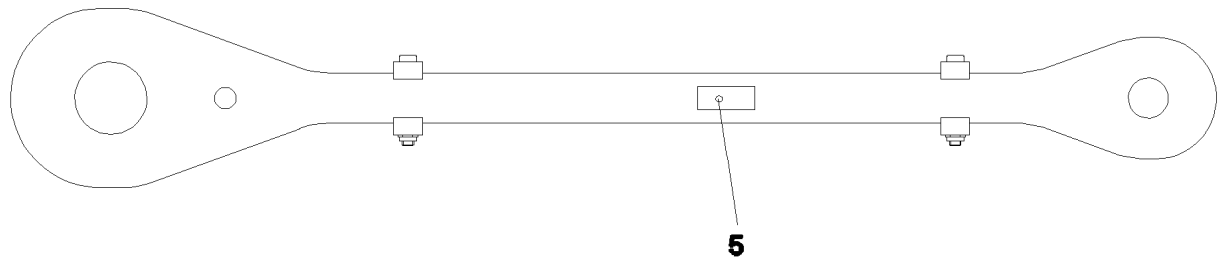

Pos.	Item	Quantity	Description	Bezeichnung	Serie	K
1	97 68 530 08	2	PLATE 35X1689X254	BLECH		
2	95 70 394 08	4	CLAMP 40x127x24	KLAMMER		
3	40 42 181 01	2	CYLINDER SCREW ISO 4762 M16X110 8.8	ZYLINDERSCHRAUBE		
4	41 19 009 08	2	HEX NUT DIN 985 M16 8 VERZ	SECHSKANTMUTTER		
5	97 35 676 08	1	PLATE IDENTIFICATION NUMBER IDENT-N	SCHILD IDENTNR.		

6.2.2009
052296

LIEBHERR

etk_en_de_074515 LR 1600/2

ROD
STANGE VORM.

197

⇒ 2 550 010
96 45 685 08

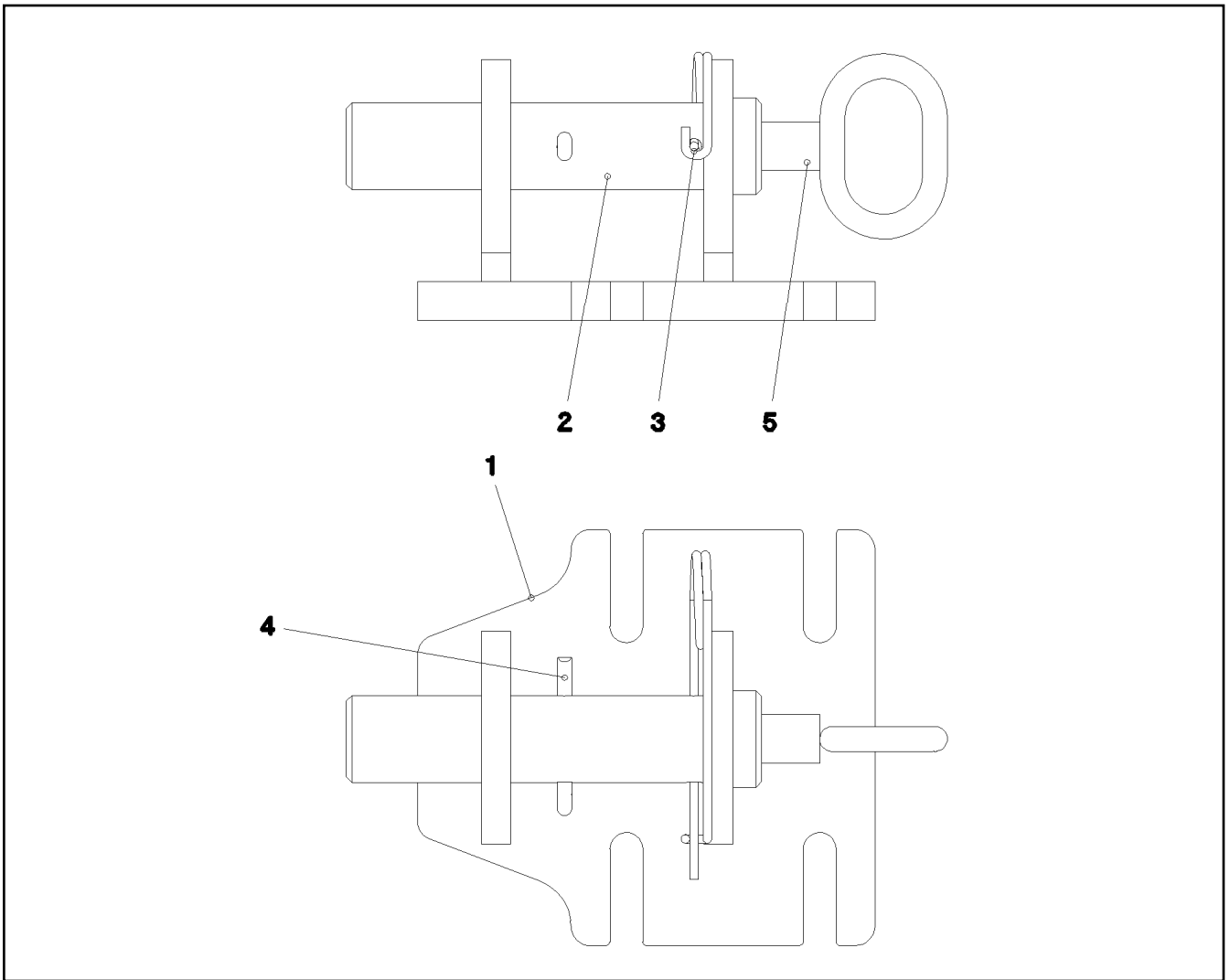

Pos.	Item	Quantity	Description	Bezeichnung	Serie	K
1	96 46 985 08	1	BRACKET WELDED CONST.	KONSOLE SCHWK.		
2	97 71 149 08	1	PIN 50.0X215 SPF	BOLZEN		
3	43 31 009 08	1	RETAINING SPRING 4,5 VERZ	SICHERUNGSFEDER		
4	43 30 090 08	1	SPLIT PIN DIN 94 8X63 ST VERZ	SPLINT		
5	92 10 795 08	1	HANDLE WELD.CONST.	GRIFF SCHWK.		

6.2.2009
052293

LIEBHERR

etk_en_de_074515 LR 1600/2

CONSOLE COMPL.
KONSOLE KPL.

198

⇒ 2 550 011
96 47 007 08

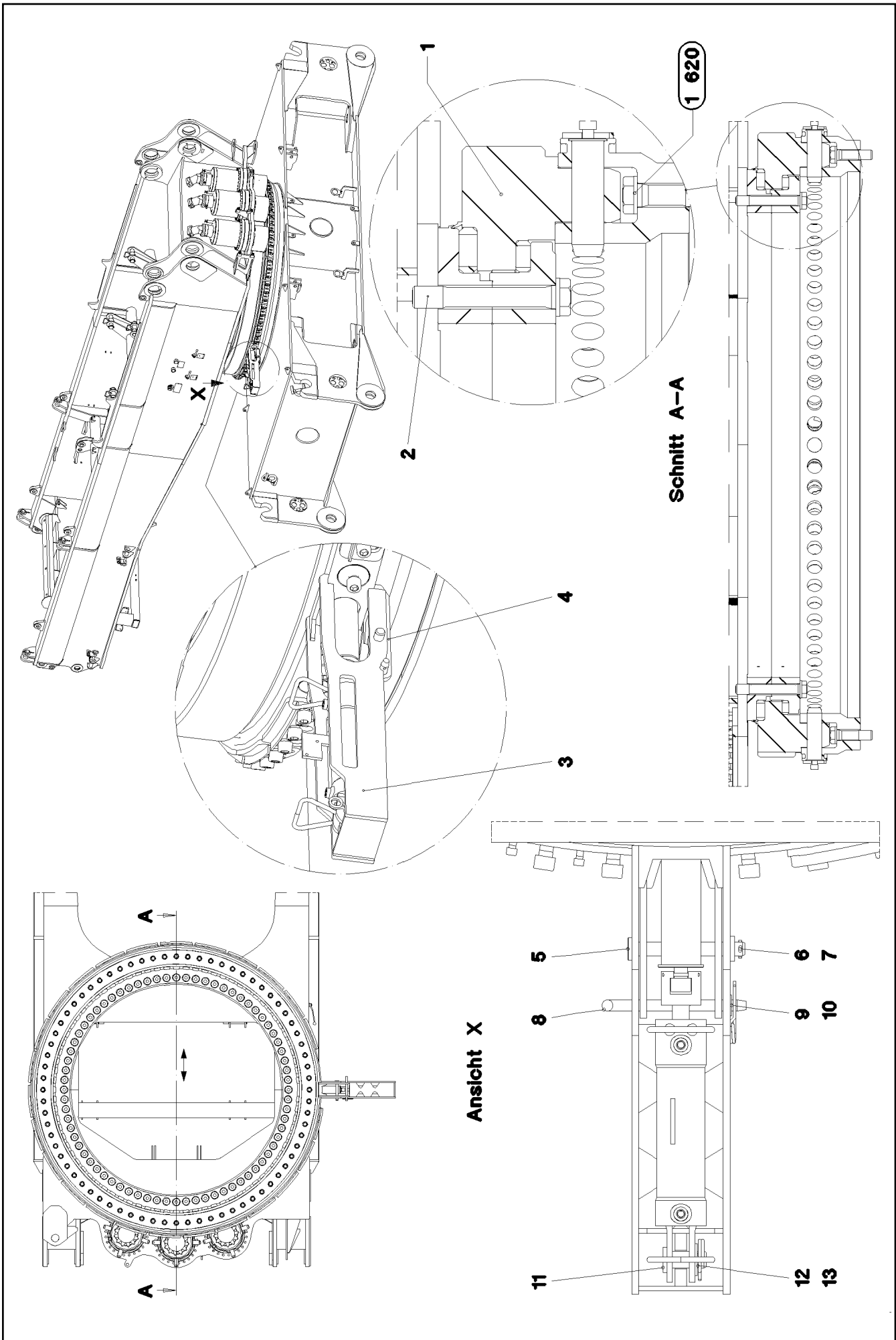

6.2.2009
052287

LIEBHERR

etk_en_de_074515 LR 1600/2

ROLLER SLEWING RING
ROLLENDREHVERBINDUNG

□ 199 (1/2)

→ 2 620
91 52 793 08

Pos.	Item	Quantity	Description	Bezeichnung	Serie	K
1	99 07 151 01	1	ROLLER SLEWING RING ⇒ 9 907 151 01 99 07 151 01	ROLLENDREHVERBINDUNG		
2	97 65 584 08	72	EXPANSION BOLT 10.9 SPF	DEHNSCHRAUBE		
3	92 51 941 08	1	BRACKET WELDED CONST.	KONSOLE SCHWK.		
4	92 51 944 08	1	BRACKET WELDED	BUEGEL SCHWK.		
5	45 14 269 08	1	PIN DIN 1436 25H11X200X192 30CRNIMO8	BOLZEN		
6	42 17 006 08	1	WASHER DIN 7989 A 26 ST VERZ	SCHEIBE		
7	43 30 076 08	1	SPLIT PIN DIN 94 6,3X40 ST VERZ	SPLINT		
8	93 82 940 08	1	PIN 20.0X304	BOLZEN		
9	42 00 021 08	1	WASHER ISO 7089 A 21 ST A3C	SCHEIBE		
10	43 32 063 08	1	SPRING PLUG 5 VERZ	FEDERSTECKER		
11	94 00 689 08	1	PIN DIN 1444 30H11X70X58 30CRNIMO8 GA	BOLZEN		
12	42 00 028 08	1	WASHER ISO 7089 A 31 A3C	SCHEIBE		
13	43 32 064 08	1	SPRING PLUG 6 VERZ	FEDERSTECKER		

6.2.2009

etk_en_de_074515 LR 1600/2

200 (2/2)

LIEBHERR

ROLLER SLEWING RING
ROLLENDREHVERBINDUNG

⇒ 2 620
91 52 793 08

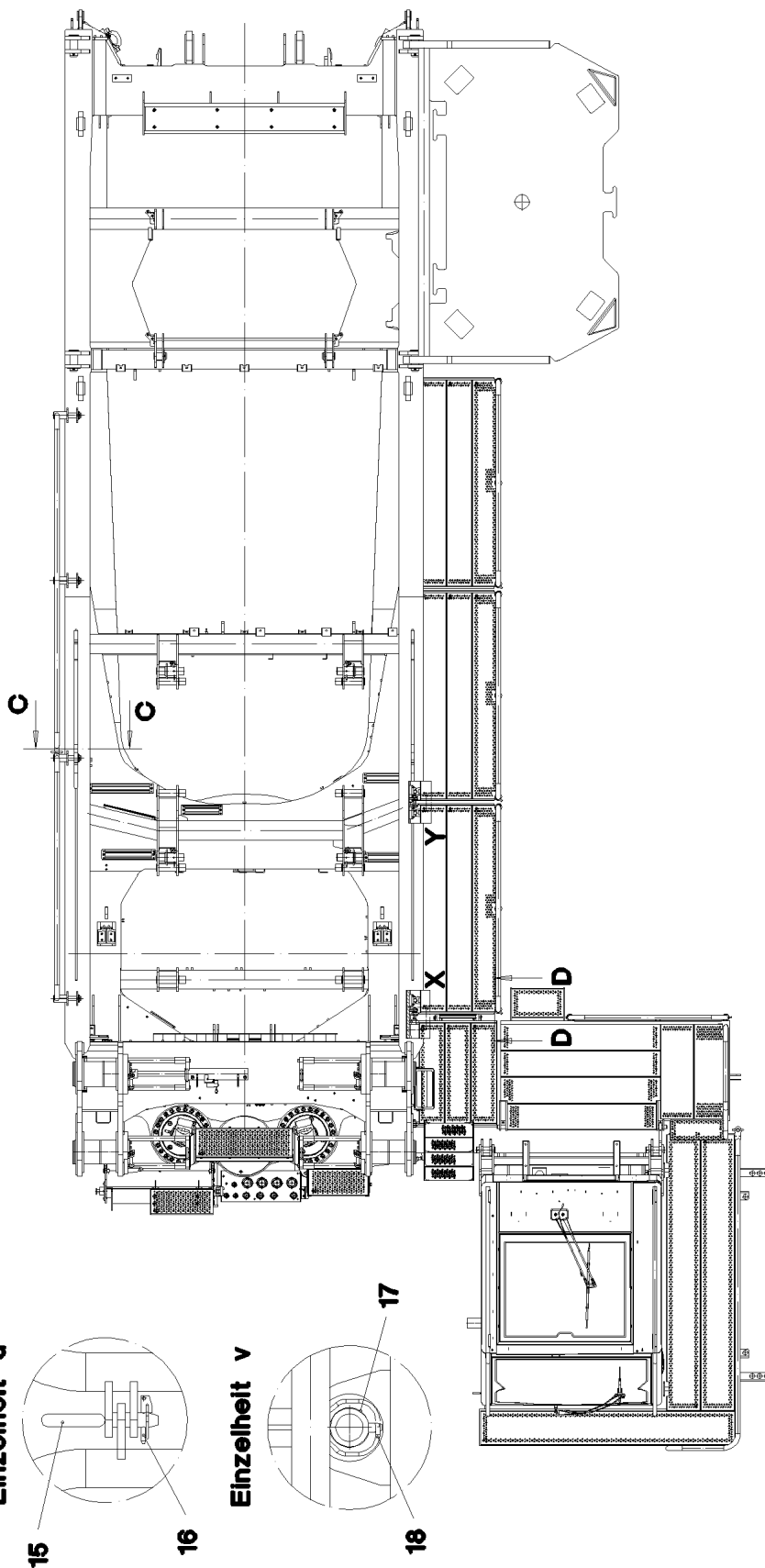
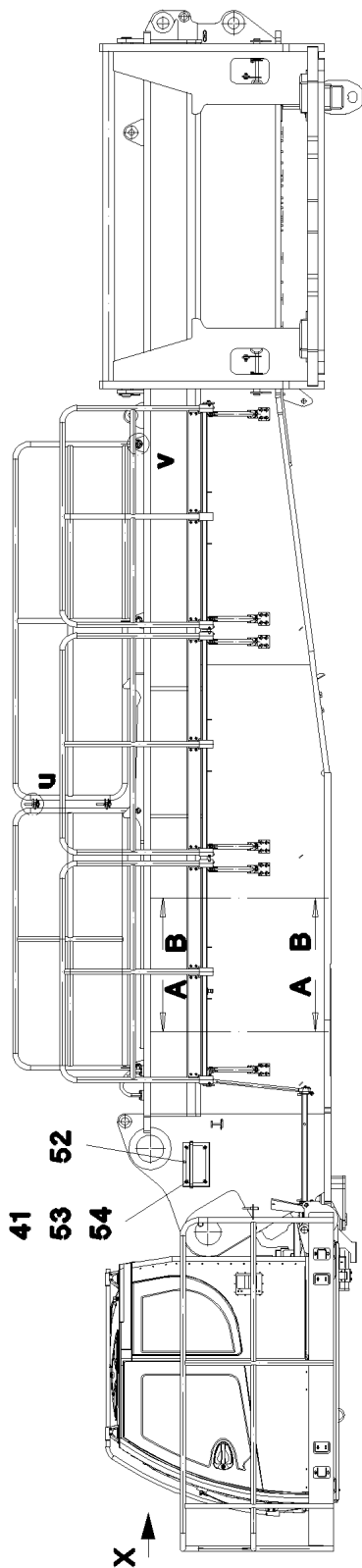

6.2.2009
054197

LIEBHERR

etk_en_de_074515 LR 1600/2

SLEWING PLATFORM CATWALK
LAUFSTEG DREHBUEHNE

□ 201 (1/4)

⇒ 2 631
91 56 817 08

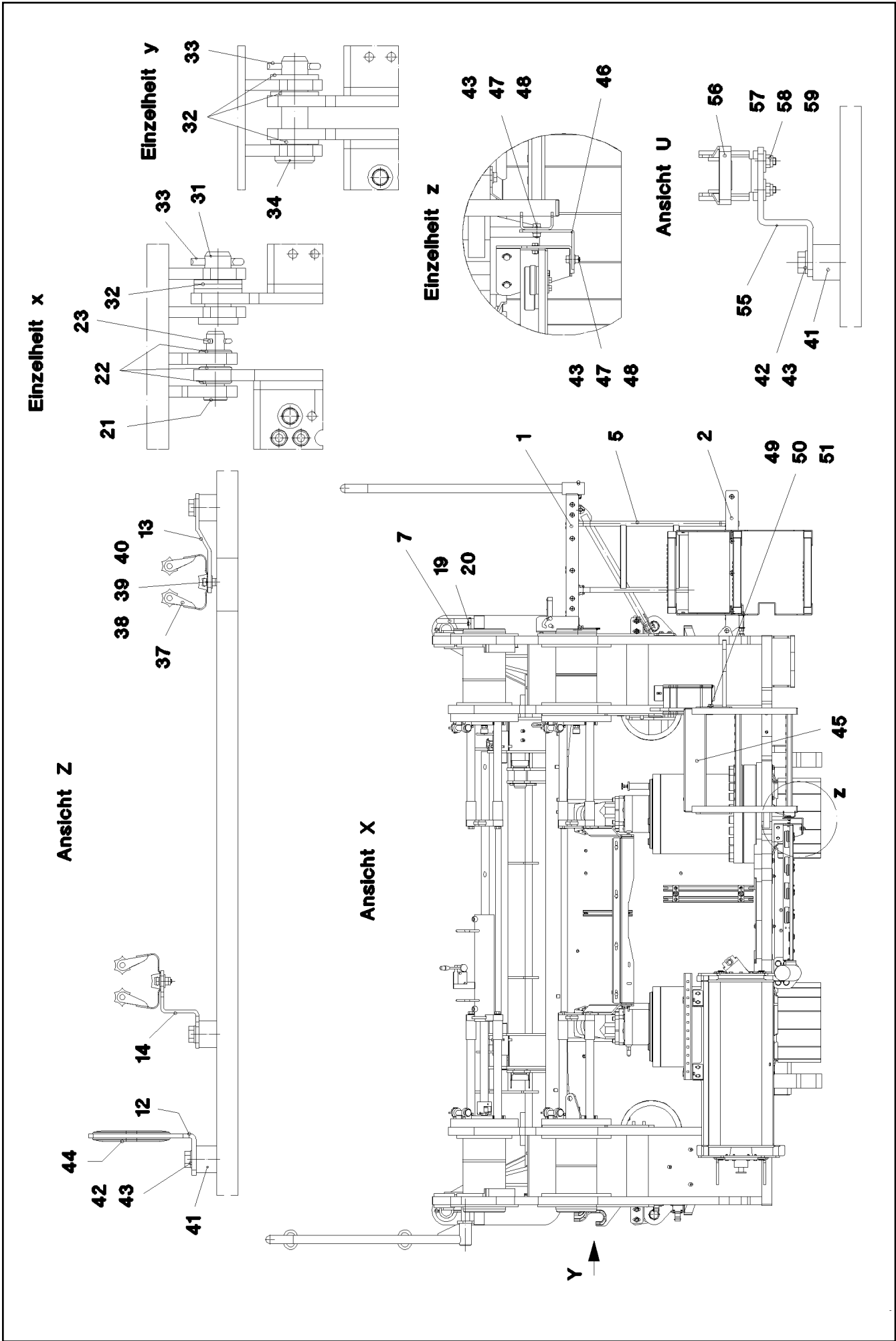

6.2.2009
054198

LIEBHERR

etk_en_de_074515 LR 1600/2

SLEWING PLATFORM CATWALK
LAUFSTEG DREHBUEHNE

□ 202 (2/4)

⇒ 2 631
91 56 817 08

Ansicht Y

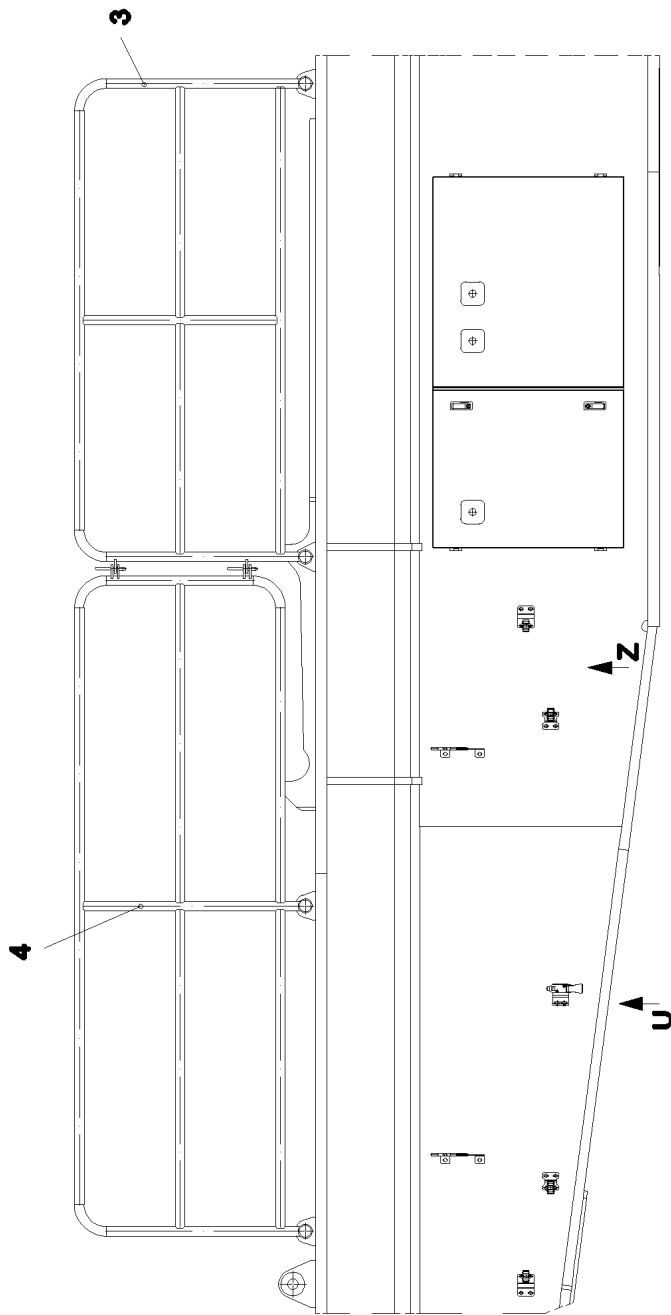

Schnitt A-A

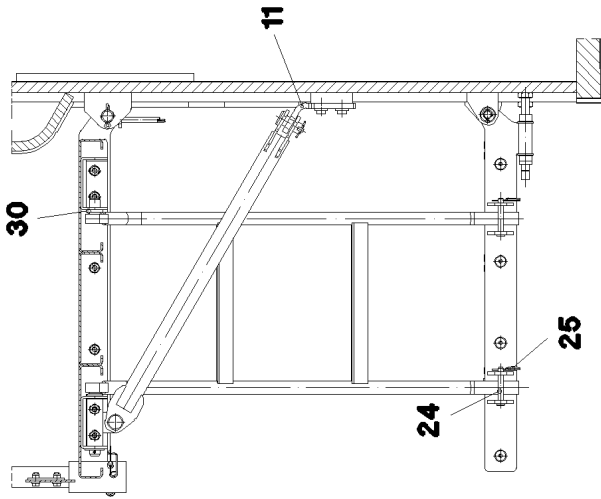

Schnitt B-B

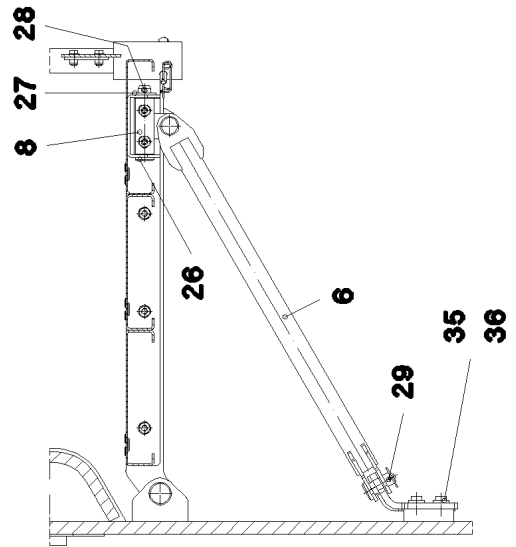

Schnitt D-D

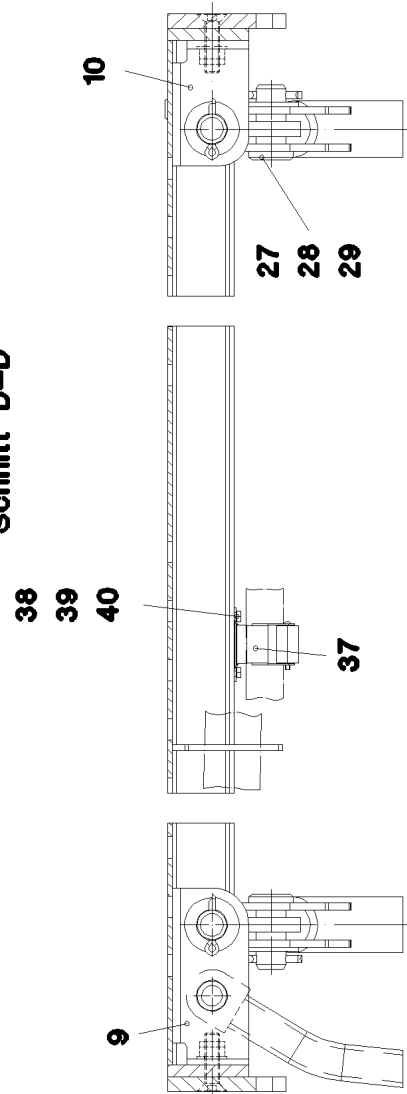

6.2.2009
054199

LIEBHERR

etk_en_de_074515 LR 1600/2

SLEWING PLATFORM CATWALK
LAUFSTEG DREHBUEHNE

□ 203 (3/4)

⇒ 2 631
91 56 817 08

Pos.	Item	Quantity	Description	Bezeichnung	Serie	K
1	96 53 086 08	3	PLATFORM GROSS	PODEST		
2	96 53 087 08	1	PLATFORM KLEIN	PODEST		
3	96 53 088 08	1	RAILING	GELAENDER		
4	96 53 089 08	1	RAILING	GELAENDER		
5	96 53 090 08	1	LADDER WELDED TZNO	LEITER SCHWK.		
6	96 53 091 08	6	SUPPORT TZNO	STUETZE SCHWK.		
7	96 53 092 08	1	HANDLE WELD.CONST. TZNO	GRIFF SCHWK.		
8	96 53 093 08	6	BRACKET WELDED CONST. TZNO	KONSOLE SCHWK.		
9	97 83 084 08	2	PLATE 4X209X189 FE//ZN20//C	BLECH		
10	97 83 085 08	5	PLATE 4X174X191 FE//ZN20//C	BLECH		
11	97 83 086 08	6	PLATE 10X100X163 FE//ZN20//C	BLECH		
12	97 83 114 08	2	PLATE 4X133X225	BLECH		
13	97 83 115 08	2	PLATE 3X95X70	BLECH		
14	97 83 116 08	2	PLATE 3X101X70	BLECH		
15	92 01 005 08	2	PLUG CONTACT CPL.	STECKER KPL.		
16	43 32 001 08	8	HINGED CONNECTOR DIN 11023 5X32 VER	KLAPPSTECKER		
17	94 91 885 08	4	WASHER RD70X2	SCHEIBE		
18	43 32 004 08	4	SAFETY PLUG W HINGE-LID 9,5X77 VERZ	SICHERHEITSKLAPPSTECKER		
19	40 65 164	4	HEX BOLT ISO 4017 M10X25 8.8 A3C	SECHSKANTSCHRAUBE		
20	42 00 013 08	4	WASHER ISO 7089 A 10.5 A3C	SCHEIBE		
21	45 10 011 08	2	PIN DIN 1434 16H11X60X51 30CRNIMO8 SP	BOLZEN		
22	42 00 019 08	6	WASHER DIN 125 A 17 VERZ	SCHEIBE		
23	43 30 050 08	2	SPLIT PIN DIN 94 4X25 ST VERZ	SPLINT		
26	45 30 209 08	6	PIN DIN 1444 20H11X115X107 ST.50-2K VER	BOLZEN		
27	42 00 021 08	12	WASHER ISO 7089 A 21 ST A3C	SCHEIBE		
28	43 30 063 08	12	SPLIT PIN DIN 94 5X28 ST VERZ	SPLINT		
29	45 12 222 08	12	PIN DIN 1435 20H11X45X38 ST.50 VERZ	BOLZEN		
30	42 12 013 08	2	WASHER DIN 1441 21 ST VERZ	SCHEIBE		
31	45 30 220 08	2	PIN DIN 1444 24H11X60X50 42CRMO4 GASN	BOLZEN		
32	42 00 024 08	14	WASHER DIN 125 A 25 ST VERZ	SCHEIBE		
33	43 30 075 08	4	SPLIT PIN DIN 94 6,3X32 ST VERZ	SPLINT		
34	45 30 223 08	2	PIN DIN 1444 24H11X91X82 30CRNIMO8 GA	BOLZEN		
35	40 00 828	24	HEX BOLT ISO 4017 M10X30 8.8 A3C	SECHSKANTSCHRAUBE		
36	42 16 006 08	24	WASHER DIN 7349 10,5 ST VERZ	SCHEIBE		
37	10 32 483 4	5	EQUIPMENT MOUNTING 35MM FEDERSTAH	GERAETEHALTER		
38	40 00 878	10	HEX BOLT ISO 4017 M4X12 8.8 A2C	SECHSKANTSCHRAUBE		
39	42 18 005 08	10	WASHER DIN 9021 A 4.3 ST VERZ	SCHEIBE		
40	41 19 002 08	10	HEX NUT DIN 985 M4 8 VERZ	SECHSKANTMUTTER		
41	95 38 734 08	18	SLEEVE	HUELSE		
42	49 00 188	14	HEX BOLT ISO 4017 M8X16 8.8 A2C	SECHSKANTSCHRAUBE		
43	42 00 012 08	40	WASHER DIN 125 A8X16 ST VERZ	SCHEIBE		
44	26 21 040 08	0.8	EDGE PROTECTION	KANTENSCHUTZ		
45	96 54 367 08	1	STAIR	TREPPE		
46	97 85 767 08	1	PLATE 4X173X102	BLECH		
47	49 00 089	13	HEX BOLT ISO 4017 M8X20 8.8 A2C	SECHSKANTSCHRAUBE		
48	41 15 141 08	13	HEX NUT DIN 934 M8 8 A2C	SECHSKANTMUTTER		
49	40 65 086 05	2	HEX BOLT ISO 4017 M14X40 8.8 A3C	SECHSKANTSCHRAUBE		
50	41 15 083 08	2	HEX NUT DIN 934 M14 8 VERZ	SECHSKANTMUTTER		
51	42 00 018 08	4	WASHER DIN 125 A 15 ST VERZ	SCHEIBE		
52	96 54 406 08	1	ACCESS LADDER PRE-ASS. ⇒ 2 631 003 96 54 406 08	AUFSTIEG VORM.		
53	10 41 285 7	4	OVAL HEAD FLAT SCREW AEHNL.ISO7380	LINSENFLACHKOPFSCHRAUBE		
54	42 18 009 08	4	WASHER DIN 9021 A 8.4 VERZ	SCHEIBE		
55	97 86 827 08	1	PLATE 4X119X70	BLECH		
56	70 42 185 08	1	LOCK BEARING	VERSCHLUSSLAGER		
57	40 86 040 08	2	COUNTERSUNK SCREW DIN 7991 M5X16 8	SENKSCHEIBE		
58	41 19 003 08	2	HEX NUT DIN 985 M5 8 VERZ	SECHSKANTMUTTER		
59	42 18 006 08	2	WASHER DIN 9021 A 5,3 ST VERZ	SCHEIBE		
63	77 39 200 08	18	WIRE ROPE CLAMP DIN 3093 2 AL	PRESSKLEMMME		
64	77 34 003 08	3	ROPE DIN 3055 2MM 2,3KN FE	SEIL		

6.2.2009

etk_en_de_074515 LR 1600/2

□ 204 (4/4)

LIEBHERRSLEWING PLATFORM CATWALK
LAUFSTEG DREHBUEHNE⇒ 2 631
91 56 817 08

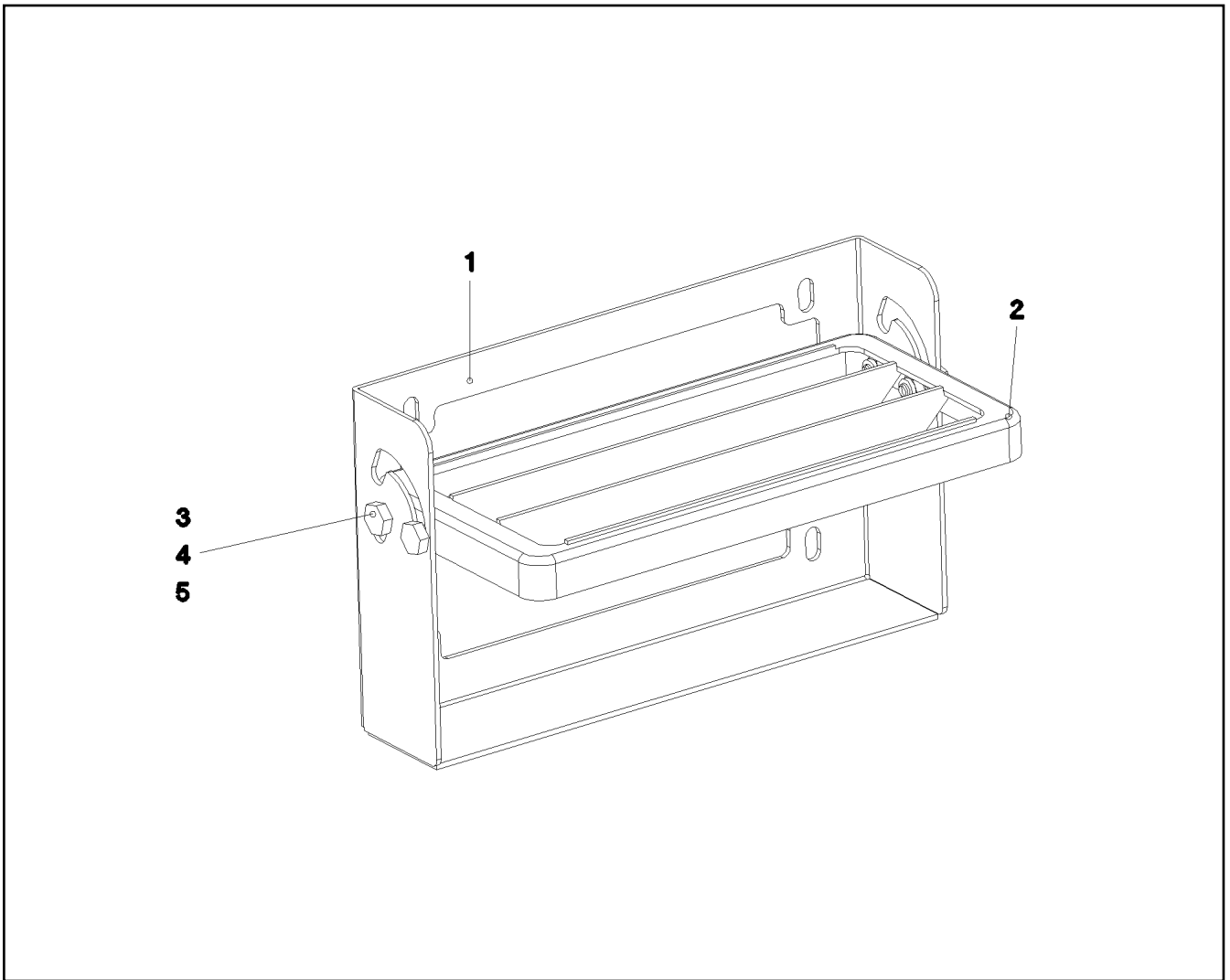

Pos.	Item	Quantity	Description	Bezeichnung	Serie	K
1	97 85 704 08	1	PLATE 3X489X273	BLECH		
2	78 89 058 08	1	UNIVERSAL PERFORMANCE 30X160X340	UNIVERSALAUFTRITT		
3	40 98 312 08	4	SCREW M8X15	SCHRAUBE		
4	41 19 005 08	4	HEX NUT DIN 985 M8 8 VERZ	SECHSKANTMUTTER		
5	42 00 012 08	4	WASHER DIN 125 A8X16 ST VERZ	SCHEIBE		

6.2.2009
053919

LIEBHERR

etk_en_de_074515 LR 1600/2

ACCESS LADDER PRE-ASS.
AUFSTIEG VORM.

205

⇒ 2 631 003
96 54 406 08

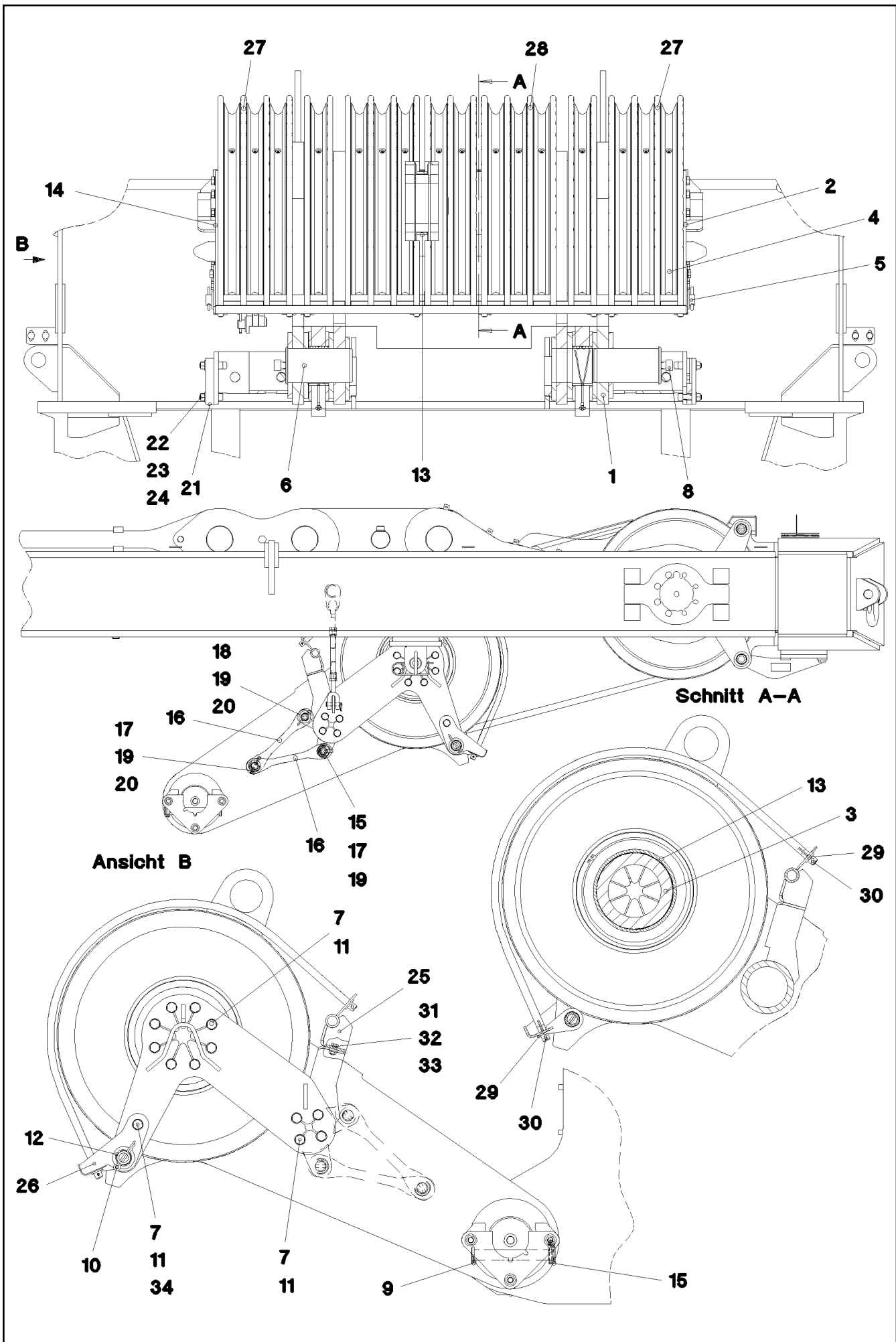

6.2.2009
052567

LIEBHERR

etk_en_de_074515 LR 1600/2

ROLLER BEARING
ROLLENLAGERUNG

□ 206 (1/2)

⇒ 2 652
91 52 794 08

Pos.	Item	Quantity	Description	Bezeichnung	Serie	K
1	96 46 299 08	1	ROLLER BEARING WELDED	ROLLENLAGERUNG SCHWK.		
2	96 46 304 08	1	MOUNTING WELDED	HALTERUNG SCHWK.		
3	97 69 807 08	1	AXLE 219.1X1612	ACHSE		
4	96 46 246 08	16	ROPE PULLEY CPL. SPF ⇒ 2 550 003 96 46 246 08	SEILROLLE KPL.		
5	97 69 808 08	1	TUBE 38.0X1716 T ZN O	ROHR		
6	97 69 809 08	2	PIN 130.0X233 SPF	BOLZEN		
7	40 66 030 08	26	HEX BOLT ISO 4017 M16X40 10.9 FLZN SPF	SECHSKANTSCHRAUBE		
8	40 42 242 08	2	CYLINDER SCREW DIN 912 M24X45 8.8 A3C	ZYLINDERSCHRAUBE		
9	45 30 300 08	2	PIN DIN 1444 30H11X220X210 30CRNIMO8	BOLZEN		
10	43 30 101 08	2	SPLIT PIN DIN 94 10X71 ST VERZ	SPLINT		
11	42 00 019 08	29	WASHER DIN 125 A 17 VERZ	SCHEIBE		
12	42 11 032 08	2	WASHER DIN 1440 45 ST VERZ	SCHEIBE		
13	93 58 827 08	2	SPACER RING RD219,1X36	DISTANZRING		
14	96 46 307 08	1	MOUNTING WELDED	HALTERUNG SCHWK.		
15	43 32 003 08	3	HINGED CONNECTOR DIN 11023 8X42 VER	KLAPPSTECKER		
16	97 72 200 08	3	PLATE 20X61X358	BLECH		
17	45 30 327 08	2	PIN DIN 1444 30H11X95X85 30CRNIMO8+QT	BOLZEN		
18	94 00 689 08	1	PIN DIN 1444 30H11X70X58 30CRNIMO8 GA	BOLZEN		
19	42 11 027 08	3	WASHER DIN 1440 33 ST VERZ	SCHEIBE		
20	43 30 090 08	2	SPLIT PIN DIN 94 8X63 ST VERZ	SPLINT		
21	97 79 903 08	2	PLATE 30X270X160	BLECH		
22	40 42 175 01	6	CYLINDER SCREW ISO 4762 M16X70 8.8 A3	ZYLINDERSCHRAUBE		
23	41 15 145 08	6	HEX NUT DIN 934 M16 8 VERZ	SECHSKANTMUTTER		
24	42 00 020 08	6	WASHER DIN 125 A 19 ST VERZ	SCHEIBE		
25	96 51 810 08	1	BRACKET WELDED IN FRONT	KONSOLE SCHWK.VORN		
26	96 51 811 08	1	BRACKET	KONSOLE SCHWK.HI.		
27	96 51 812 08	2	ROPE GUARD WELDED	SEILSCHUTZ SCHWK.		
28	96 51 813 08	1	ROPE GUARD WELDED	SEILSCHUTZ SCHWK.		
29	42 12 013 08	16	WASHER DIN 1441 21 ST VERZ	SCHEIBE		
30	43 30 075 08	16	SPLIT PIN DIN 94 6,3X32 ST VERZ	SPLINT		
31	40 65 164	6	HEX BOLT ISO 4017 M10X25 8.8 A3C	SECHSKANTSCHRAUBE		
32	42 00 507 08	12	WASHER DIN 125 A 10,5 MS	SCHEIBE		
33	41 17 003 08	6	HEX NUT DIN 936 M10 8 VERZ	SECHSKANTMUTTER		
34	41 15 050 08	2	HEX NUT DIN 934 M16 10 VERZ	SECHSKANTMUTTER		

6.2.2009

etk_en_de_074515 LR 1600/2

□ 207 (2/2)

LIEBHERRROLLER BEARING
ROLLENLAGERUNG⇒ 2 652
91 52 794 08

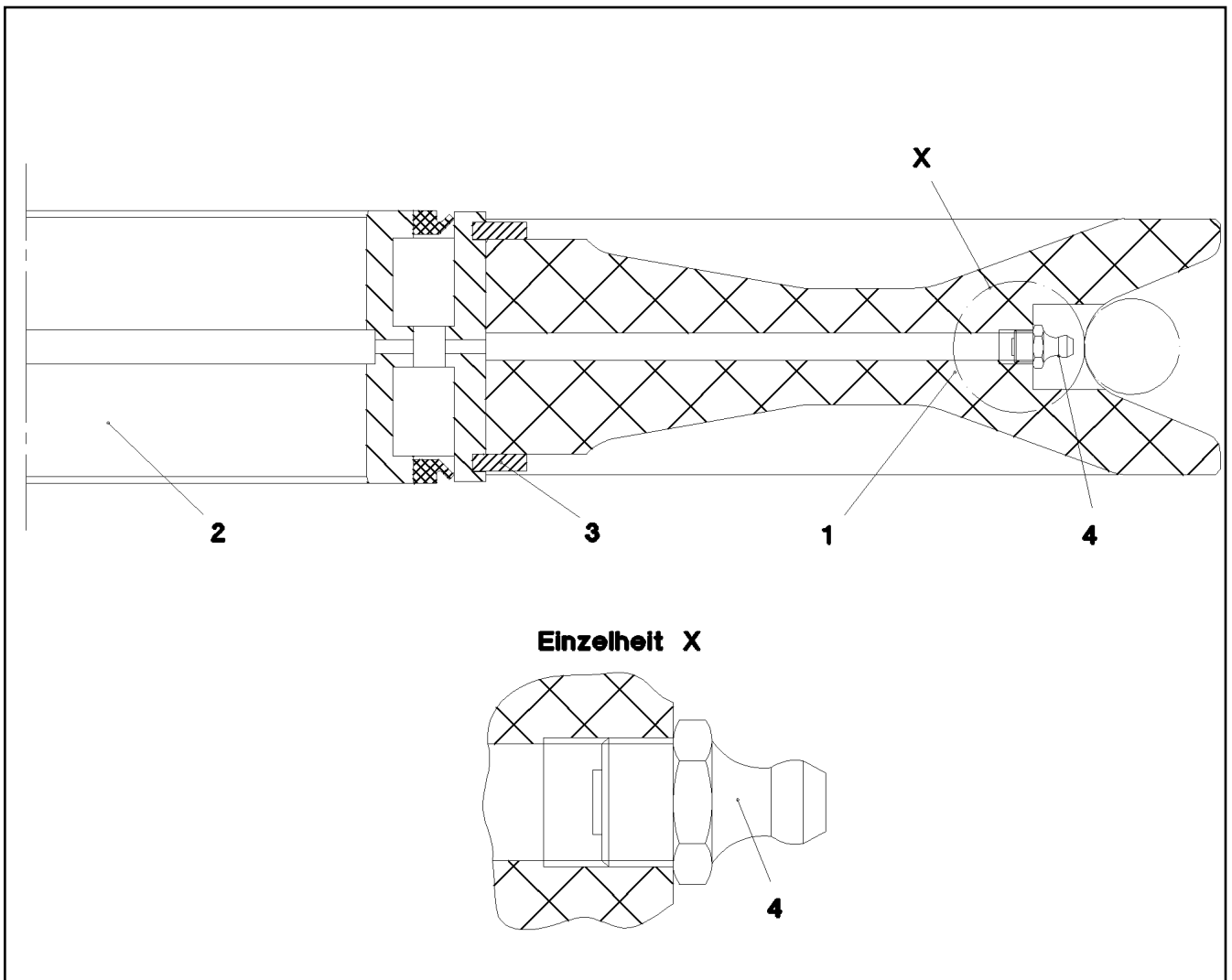

Pos.	Item	Quantity	Description	Bezeichnung	Serie	K
1	28 81 999 08	1	ROPE PULLEY / SHEAVE D=700/620/270X75	SEILROLLE		
2	74 65 067 08	1	ROLLER BEARING 200X270X80	WAEZLAGER		
3	42 80 103 08	2	LOCKING RING DIN 471 270X5	SICHERUNGSRING		
4	77 43 040 08	1	GREASE NIPPLE DIN 71412 A M10X1	SCHMIERNIPPEL		

6.2.2009
022683

LIEBHERR

etk_en_de_074515 LR 1600/2

ROPE PULLEY CPL.
SEILROLLE KPL.

208

⇒ 2 652 007
92 68 928 08

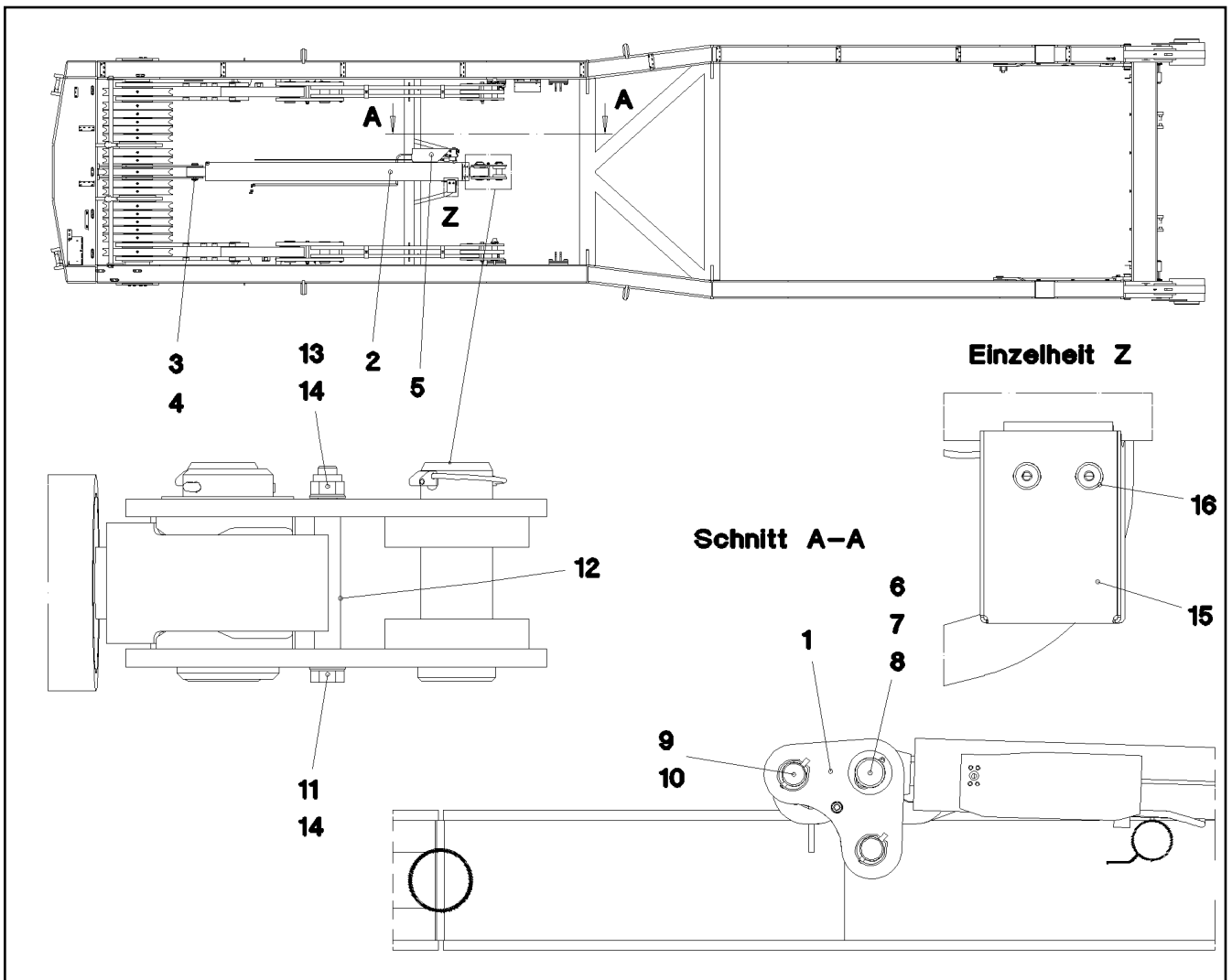

Pos.	Item	Quantity	Description	Bezeichnung	Serie	K
1	96 54 179 08	2	PLATE WELDED	BLECH SCHWK.		
2	10 41 102 1	1	DRAW CYLINDER 150/60-2300 SPF	ZUGZYLINDER		
3	95 36 392 08	1	PIN RD60X170	BOLZEN		
4	42 80 049 08	2	LOCKING RING DIN 471 60X2	SICHERUNGSRING		
5	97 83 458 08	1	PLATE 3X287X452 FE//Zn20//C	BLECH		
6	95 44 447 08	1	PIN RD75X165 35NI	BOLZEN		
7	94 96 354 08	1	WASHER RD110X2	SCHEIBE		
8	43 30 097 08	1	SPLIT PIN DIN 94 8X100 ST VERZ	SPLINT		
9	97 85 235 08	2	PIN 65.0X182 SPF	BOLZEN		
10	43 32 005 08	2	SAFETY PLUG W HINGE-LID 11,5X96 VERZ	SICHERHEITSKLAPPSTECKER		
11	40 61 184 01	1	HEX BOLT ISO 4014 M16X170 8.8 A3C	SECHSKANTSCHRAUBE		
12	94 01 070 08	1	TUBE 22X2,5X110	ROHR		
13	41 19 009 08	1	HEX NUT DIN 985 M16 8 VERZ	SECHSKANTMUTTER		
14	42 00 019 08	2	WASHER DIN 125 A 17 VERZ	SCHEIBE		
15	97 14 477 08	1	HOOD 2X333X329	HAUBE		
16	10 41 285 4	4	OVAL HEAD FLAT SCREW AEHNL.ISO7380	LINSENFLACHKOPFSCHRAUBE		

6.2.2009
053695

LIEBHERR

etk_en_de_074515 LR 1600/2

MOUNTING EQUIPMENT CRAWLER
MONTAGEEINRICHTUNG RAUPE

209

⇒ 2 657
91 57 656 08

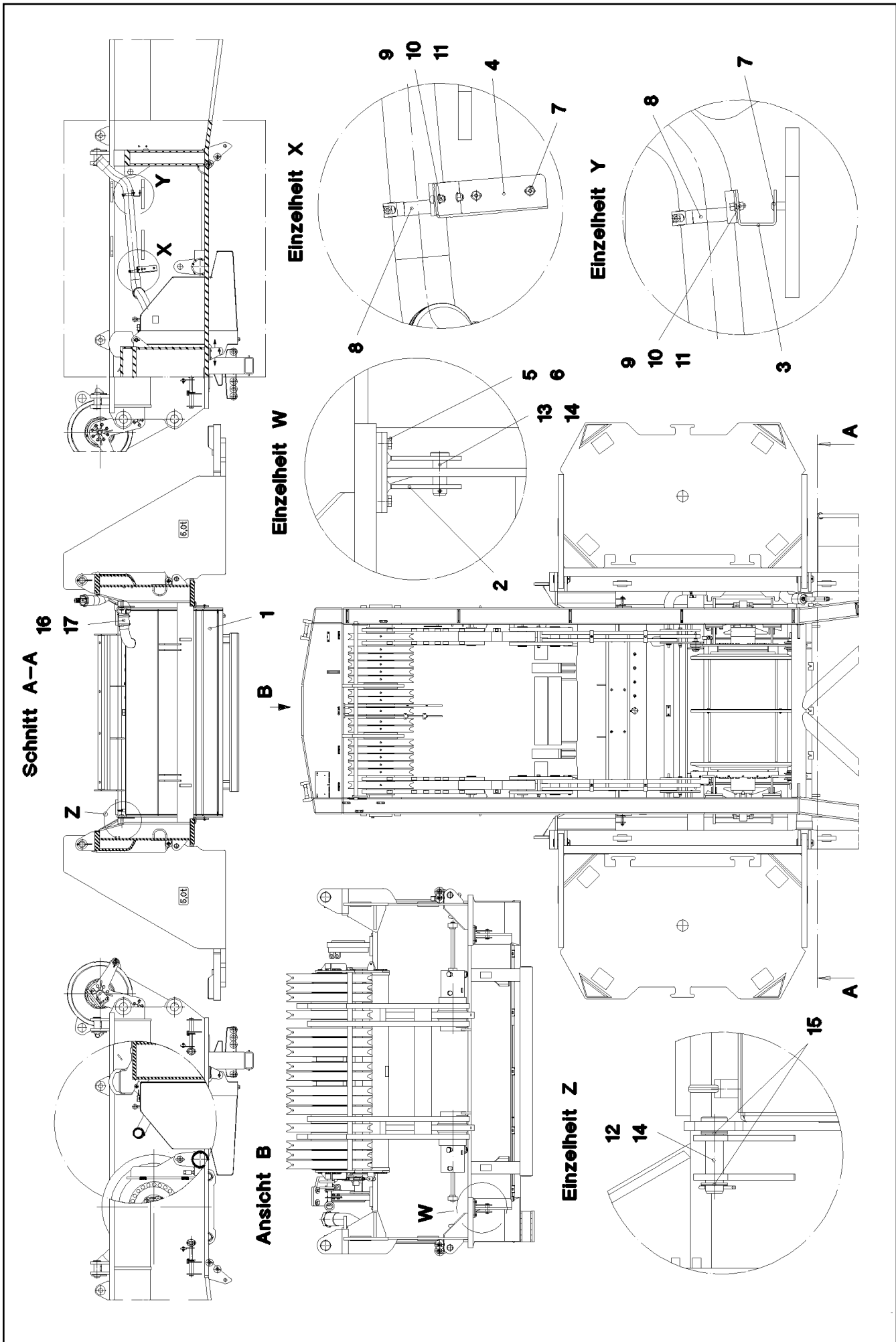

6.2.2009
052451

LIEBHERR

etk_en_de_074515 LR 1600/2

FUEL TANK CPL.
KRAFTSTOFFBEHAELTER KPL.

□ 210 (1/2)

⇒ 2 670
91 52 797 08

Pos.	Item	Quantity	Description	Bezeichnung	Serie	K
1	96 45 352 08	1	FUEL TANK, PRE-ASSEMBLED ⇒ 2 670 002 96 45 352 08	KRAFTSTOFFBEHAELTER VO		
2	96 42 805 08	2	BRACKET WELDED CONST.	KONSOLE SCHWK.		
3	97 69 564 08	1	PLATE 4X120X187	BLECH		
4	97 69 565 08	1	PLATE 4X178X358	BLECH		
5	50 09 175 08	8	WASHER DIN 125 A 10.5 A2	SCHEIBE		
6	40 65 093 08	8	HEX BOLT ISO 4017 M10X20 8.8 BLANK	SECHSKANTSCHRAUBE		
7	10 41 285 4	4	OVAL HEAD FLAT SCREW AEHNL.ISO7380	LINSENFLACHKOPFSCHRAUBE		
8	77 42 237 08	2	HOSE CLAMP 100-104 ST	SCHLAUCHSCHELLE		
9	46 00 079	4	CYLINDER SCREW ISO 4762 M8X20 8.8 A2C	ZYLINDERSCHRAUBE		
10	42 00 012 08	8	WASHER DIN 125 A8X16 ST VERZ	SCHEIBE		
11	41 15 141 08	4	HEX NUT DIN 934 M8 8 A2C	SECHSKANTMUTTER		
12	10 04 126 0	2	PIN ISO 2341 30X120X6,3X110 30CRNIMO8	BOLZEN		
13	45 12 264 08	2	PIN DIN 1435 25H11X75X65 ST.50 VERZ	BOLZEN		
14	43 30 077 08	4	SPLIT PIN DIN 94 6,3X45 ST VERZ	SPLINT		
15	93 94 608 08	10	WASHER RD44X2	SCHEIBE		
16	55 08 494 08	4	HOSE CLAMP 100-120 W3	SCHLAUCHSCHELLE		
17	97 80 893 08	1	FUEL HOSE	KRAFTSTOFFSCHLAUCH		
(1)	10 42 402 5	0.12	FUEL HOSE DN100	KRAFTSTOFFSCHLAUCH		
19	26 21 040 08	0.23	EDGE PROTECTION	KANTENSCHUTZ		
20	26 21 089 08	0.36	CELL RUBBER 3X6X10M	ZELLGUMMI		

6.2.2009

etk_en_de_074515 LR 1600/2

☐ 211 (2/2)

LIEBHERR

FUEL TANK CPL.
KRAFTSTOFFBEHAELTER KPL.

⇒ 2 670
91 52 797 08

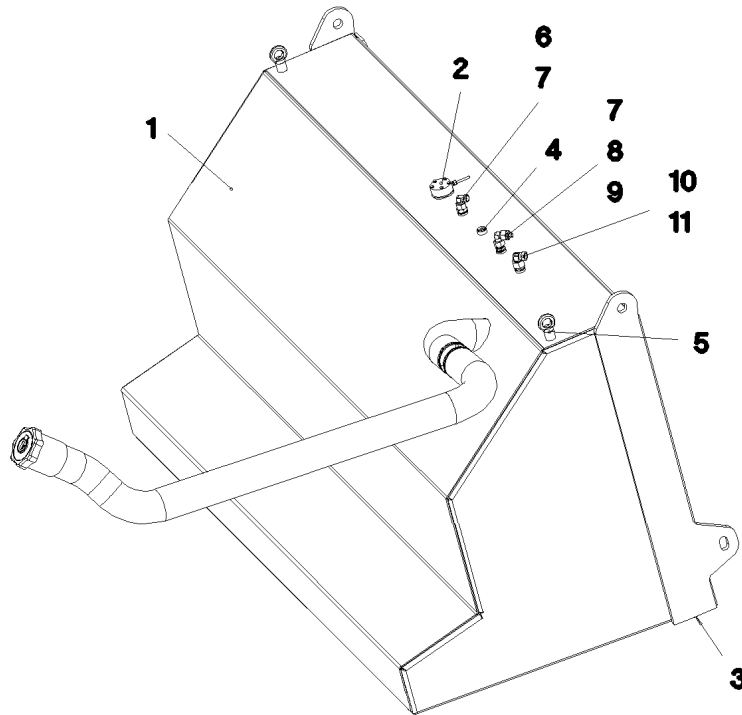

Pos.	Item	Quantity	Description	Bezeichnung	Serie	K
1	96 45 354 08	1	FUEL TANK WELDED CONSTR. 1600L - 1350	KRAFTSTOFFBEHALTER SCH		
2	96 45 717 08	1	ELECTR.F.FUEL TANK ⇒ 2 920 814 96 45 717 08	ELEKTRIK KRAFTSTOFFBEHAEL		
3	78 90 119 08	1	OIL DRAIN PLUG M26X1,5	OELABLASSSCHRAUBE		
4	47 77 051 08	1	PLUG VSTIM18X1,5ED A3P	STOPFEN		
5	40 26 003 08	2	RING BOLT DIN 580 M12 C15E A3C	RINGSCHRAUBE		
6	47 10 309 08	1	FLANGE JOINT XGE15-LM-ED A3P	VERSCHRAUBUNG		
7	47 25 307 08	2	FLANGE JOINT EWSD15-L A3P	VERSCHRAUBUNG		
8	47 19 042 08	1	FLANGE JOINT EGESD15-LM-WD A3P	VERSCHRAUBUNG		
9	47 50 322 08	1	FLANGE JOINT GR 15/8L CR6-FREI	VERSCHRAUBUNG		
10	47 10 370 08	1	FLANGE JOINT XGE18-LM-ED A3P	VERSCHRAUBUNG		
11	47 25 304 08	1	FLANGE JOINT EWSD18-L A3P	VERSCHRAUBUNG		

6.2.2009
052452

LIEBHERR

etk_en_de_074515 LR 1600/2

FUEL TANK, PRE-ASSEMBLED
KRAFTSTOFFBEHAELTER VORM.

212

⇒ 2 670 002
96 45 352 08

Ansicht A

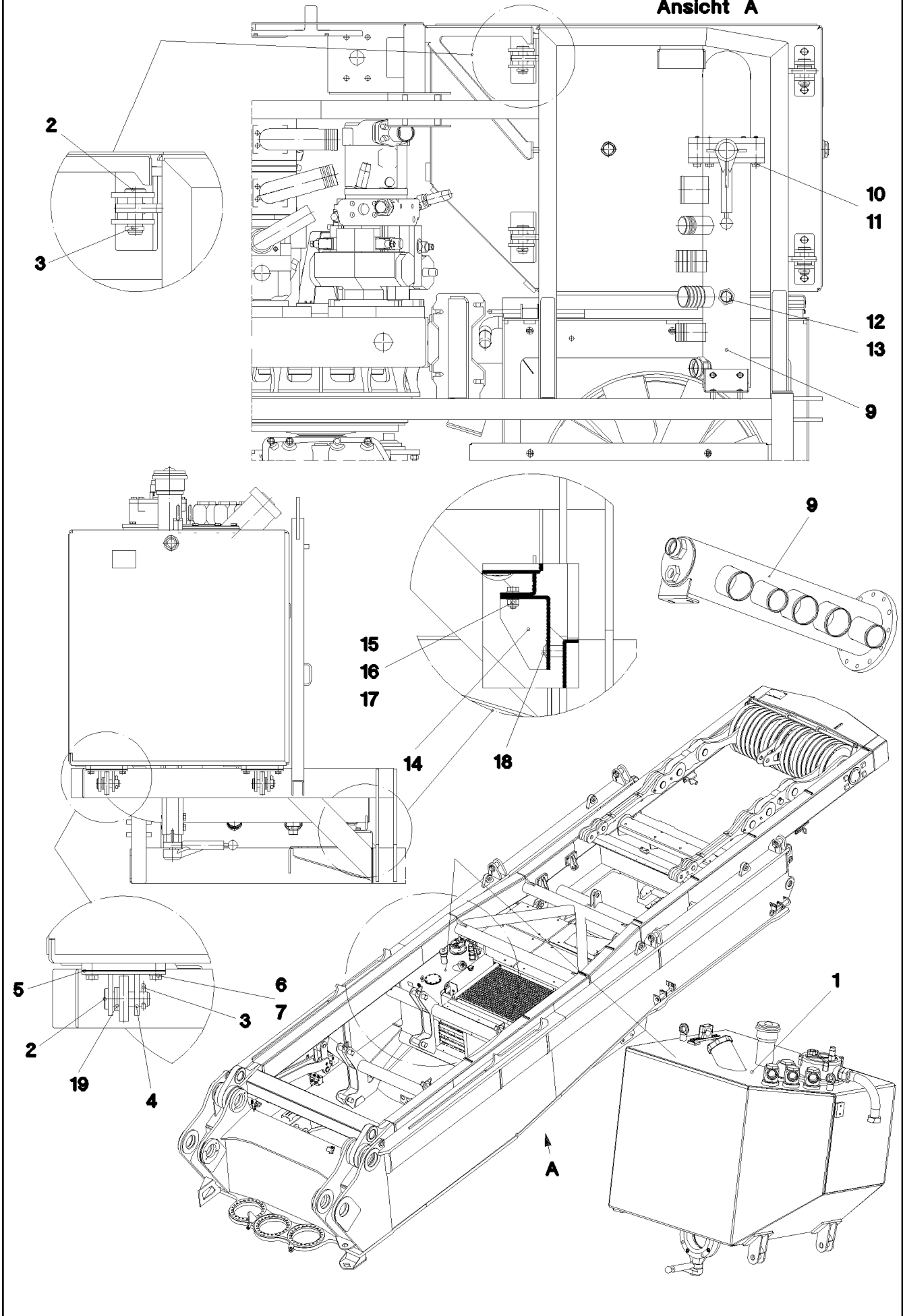

6.2.2009
052564

LIEBHERR

etk_en_de_074515 LR 1600/2

OIL RESERVOIR, COMPLETE
OELBEHAELTER KPL.

□ 213 (1/2)

→ 2 671
91 52 798 08

Pos.	Item	Quantity	Description	Bezeichnung	Serie	K
1	96 46 305 08	1	OIL TANK PRE-ASS. ⇒ 2 671 004 96 46 305 08	OELBEHAELTER VORM.		
2	45 12 269 08	4	PIN DIN 1435 25H11X70X60 ST.50 VERZ	BOLZEN		
3	43 30 076 08	4	SPLIT PIN DIN 94 6,3X40 ST VERZ	SPLINT		
4	96 47 506 08	2	BRACKET WELDED CONST.	KONSOLE SCHWK.		
5	97 72 215 08	6	PLATE 1X142X55	BLECH		
6	50 09 175 08	4	WASHER DIN 125 A 10.5 A2	SCHEIBE		
7	40 65 166	4	HEX BOLT ISO 4017 M10X20 8.8 A3C	SECHSKANTSCHRAUBE		
9	96 47 510 08	1	SUCTION PIPE	ANSAUGROHR		
10	42 00 016 08	4	WASHER ISO 7089 A 13 ST A3C	SCHEIBE		
11	46 00 245	4	HEX BOLT ISO 4014 M12X75 8.8 A3C	SECHSKANTSCHRAUBE		
12	71 01 061 08	1	SEALING RING DIN 7603 A 26X31X2 CU	DICHTRING		
13	78 90 119 08	1	OIL DRAIN PLUG M26X1,5	OELABLASSSCHRAUBE		
14	97 72 220 08	1	PLATE 4X243X155	BLECH		
15	50 26 189 08	2	HEX BOLT ISO 4017 M8X22 8.8	SECHSKANTSCHRAUBE		
16	42 00 607 05	4	WASHER ISO 7089 8 200HV-A2	SCHEIBE		
17	41 19 005 08	2	HEX NUT DIN 985 M8 8 VERZ	SECHSKANTMUTTER		
18	10 41 285 4	2	OVAL HEAD FLAT SCREW AEHNL.ISO7380	LINSENFLACHKOPFSCHRAUBE		
19	42 12 016 08	6	WASHER DIN 1441 26 ST VERZ	SCHEIBE		

6.2.2009

etk_en_de_074515 LR 1600/2

☐ 214 (2/2)

LIEBHERR

OIL RESERVOIR, COMPLETE
OELBEHAELTER KPL.

⇒ 2 671
91 52 798 08

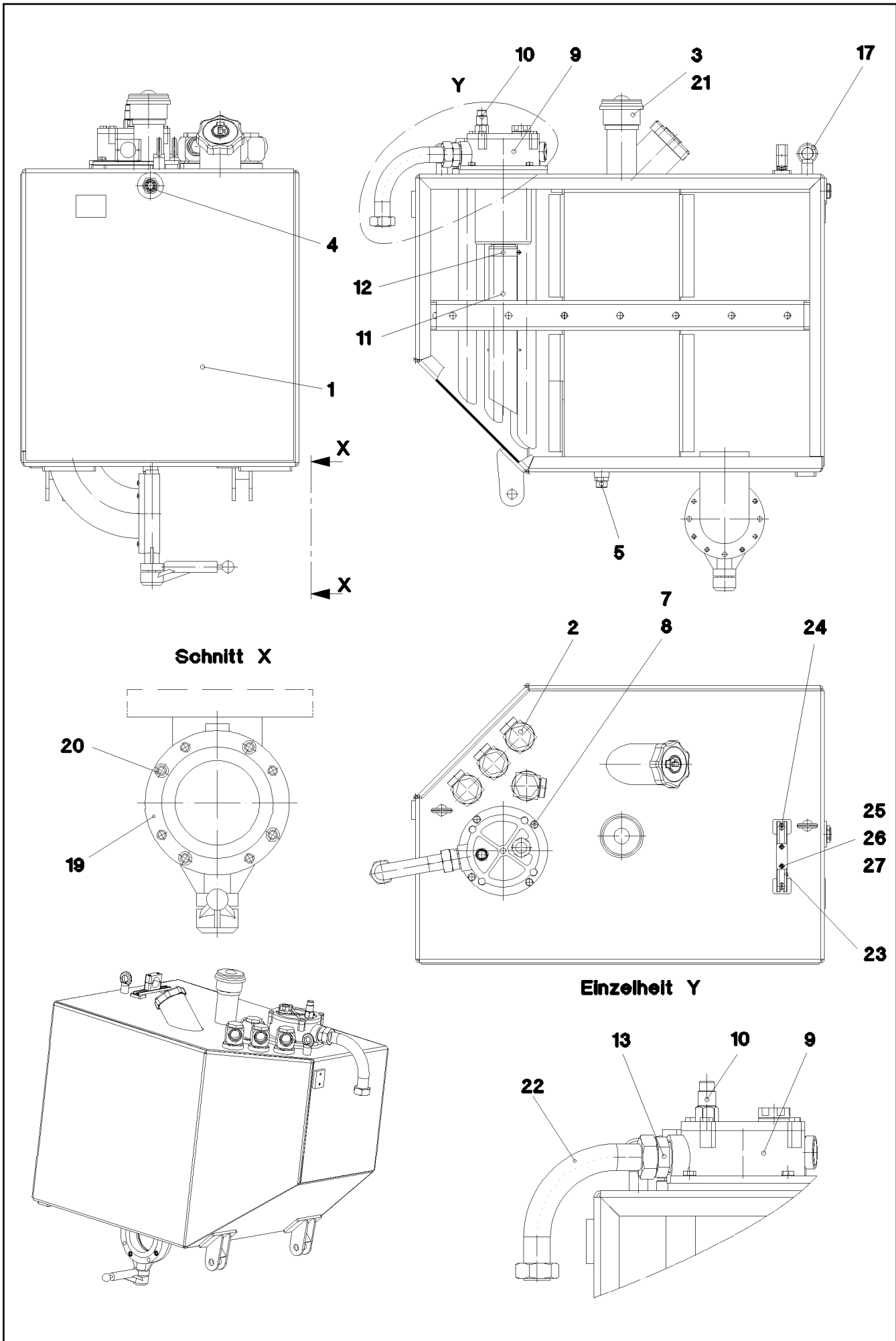

6.2.2009
052565

LIEBHERR

etk_en_de_074515 LR 1600/2

OIL TANK PRE-ASS.
OELBEHAELTER VORM.

□ 215 (1/2)

⇒ 2 671 004
96 46 305 08

Pos.	Item	Quantity	Description	Bezeichnung	Serie	K
1	96 46 306 08	1	OIL TANK WELDED 600L - 564L ALMG3 SPF	OELBEHAELTER SCHWK.		
2	47 32 327 08	4	FLANGE JOINT RSWS42-LR-WD A3P	VERSCHRAUBUNG		
3	51 06 673 08	1	AERATION FILTER	BELUEFTUNGSFILTER		
(1)	51 06 718 08	1	FILTER INSERT	FILTEREINSATZ		
4	77 43 201 08	1	OIL SIGHT GLASS R1"	OELSTANDSAUGE		
5	78 90 119 08	1	OIL DRAIN PLUG M26X1,5	OELABLASSSCHRAUBE		
7	42 00 013 08	4	WASHER ISO 7089 A 10.5 A3C	SCHEIBE		
8	40 65 164	4	HEX BOLT ISO 4017 M10X25 8.8 A3C	SECHSKANTSCHRAUBE		
9	51 06 691 08	1	RETURN FILTER	RUECKLAUFFILTER		
			⇒ 5 106 691 08 51 06 691 08			
10	51 06 693 08	1	CLOGGING INDICATOR	VERSCHMUTZUNGSANZEIGE		
11	97 72 148 08	1	HOSE DN65X5X450	AUSLAUFSCHLAUCH		
12	77 42 139 08	1	HOSE CLAMP 72X20	SCHLAUCHSCHELLE		
13	47 10 319 08	1	FLANGE JOINT XGE42-LM-ED A3P	VERSCHRAUBUNG		
17	40 26 003 08	2	RING BOLT DIN 580 M12 C15E A3C	RINGSCHRAUBE		
19	73 00 043 08	1	SHUT OFF DEVICE DN125	ABSPERRORGAN		
			⇒ 7 300 043 08 73 00 043 08			
20	40 42 035	4	CYLINDER SCREW ISO 4762 M12X45 8.8 A3	ZYLINDERSCHRAUBE		
21	40 06 034 08	6	COUNTERSUNK SCREW DIN 964 M5X16 5.8	SENKSCRAUBE		
22	96 47 854 08	1	PIPE PRE-ASS.	ROHR VORM.		
23	95 41 286 08	1	CARRIER RAIL 190	TRAGSCHIENE		
24	10 41 285 4	2	OVAL HEAD FLAT SCREW AEHNL.ISO7380	LINSENFLACHKOPFSCHRAUBE		
25	60 20 180 08	2	NUT M6 VERZ	MUTTER		
26	60 20 094 08	2	CLAMP-HALF DIN 3015-1 L5R 42 PP SW	KLEMMHAELFTE		
27	46 00 091	2	CYLINDER SCREW ISO 4762 M6X50 8.8 A2C	ZYLINDERSCHRAUBE		

6.2.2009

etk_en_de_074515 LR 1600/2

☐ 216 (2/2)

LIEBHERR

OIL TANK PRE-ASS.
OELBEHAELTER VORM.

⇒ 2 671 004
96 46 305 08

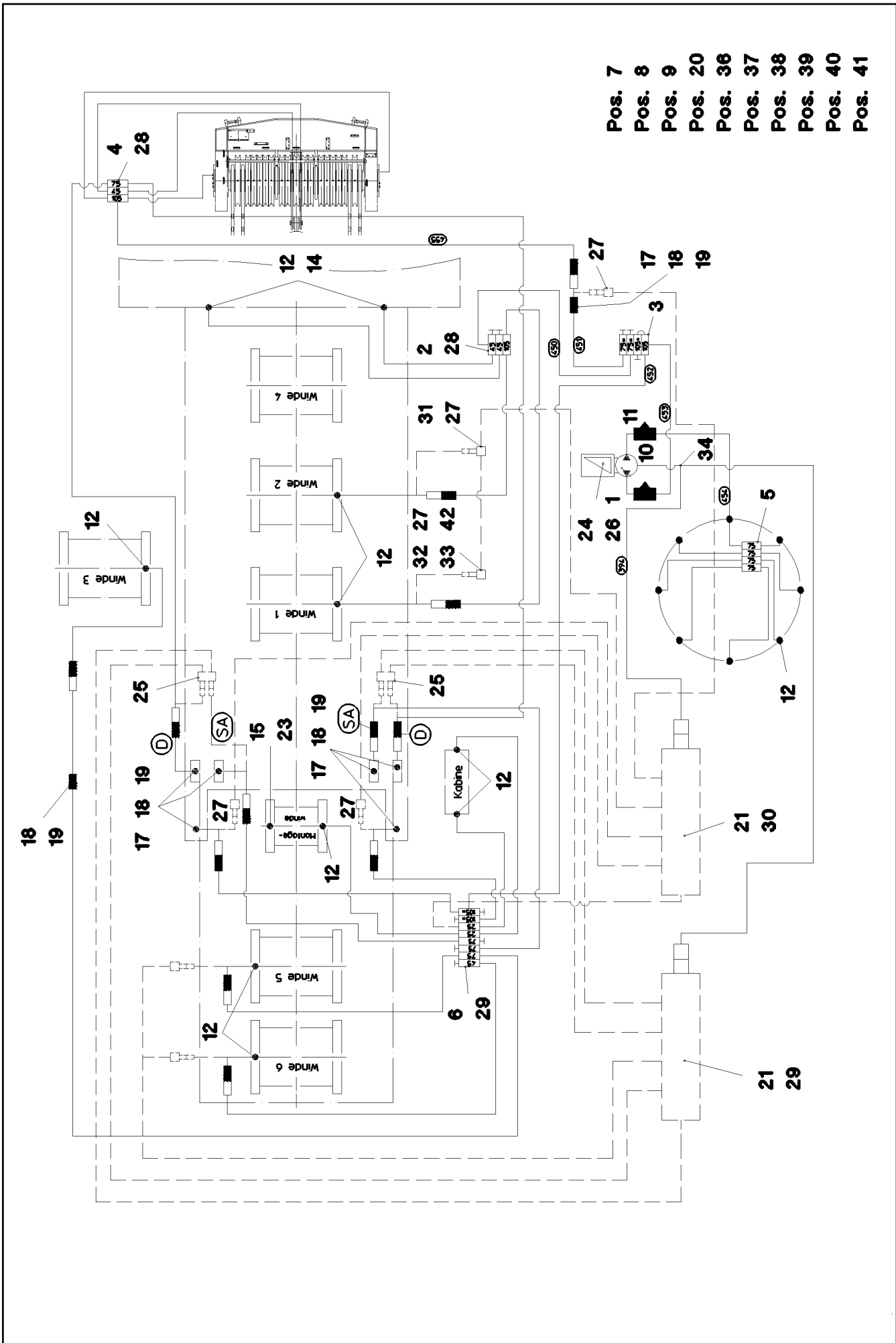

- Pos. 7
- Pos. 8
- Pos. 9
- Pos. 20
- Pos. 36
- Pos. 37
- Pos. 38
- Pos. 39
- Pos. 40
- Pos. 41

6.2.2009
052820

LIEBHERR

etk_en_de_074515 LR 1600/2

CENT. LUBRIC. SYSTEM SUPERST.
ZENTRALSCHMIERANLAGE OW

□ 217 (1/2)

⇒ 2 711
91 52 800 08

Pos.	Item	Quantity	Description	Bezeichnung	Serie	K
1	10 32 716 7	1	ELECTRIC PUMP S-EP4	ELEKTROPUMPE		
2	77 43 859 08	1	DISTRIBUTION BLOCK 3/4	VERTEILERKOMBINATION		
(1)	76 22 803	1	NON-RETURN VALVE	RUECKSCHLAGVENTIL		
3	77 43 860 08	1	DISTRIBUTION BLOCK 4/3	VERTEILERKOMBINATION		
(1)	77 43 781 08	3	NON-RETURN VALVE	RUECKSCHLAGVENTIL		
(2)	77 43 780 08	1	PIPELINE	ROHRLEITUNG		
4	10 47 036 7	1	DISTRIBUTION BLOCK 3/6	VERTEILERKOMBINATION		
(1)	77 43 738 08	1	FLANGE JOINT WE6-M10X1R	VERSCHRAUBUNG		
(2)	76 22 803	6	NON-RETURN VALVE	RUECKSCHLAGVENTIL		
5	77 43 862 08	1	DISTRIBUTION BLOCK 4/8	VERTEILERKOMBINATION		
(1)	77 43 738 08	1	FLANGE JOINT WE6-M10X1R	VERSCHRAUBUNG		
(2)	10 09 761 3	1	PROXIMITY SWITCH M12X1	NAEHERUNGSSCHALTER		
6	10 47 036 6	1	DISTRIBUTION BLOCK 8/11	VERTEILERKOMBINATION		
(1)	77 43 738 08	1	FLANGE JOINT WE6-M10X1R	VERSCHRAUBUNG		
(2)	76 22 803	6	NON-RETURN VALVE	RUECKSCHLAGVENTIL		
7	40 42 025 08	10	CYLINDER SCREW DIN 912 M5X35 8.8 A2C	ZYLINDERSCHRAUBE		
8	41 15 148 08	10	HEX NUT DIN 934 M5 8 VERZ	SECHSKANTMUTTER		
9	42 00 008 08	10	WASHER DIN 125 A 5.3 VERZ	SCHEIBE		
10	77 43 728 08	1	PUMP RETURN FLOW	PUMPENRUECKLAUF		
11	77 43 751 08	2	PASSAGE NIPPLE BLOCK	DURCHGANGSNIPPELBLOCK		
12	77 43 738 08	22	FLANGE JOINT WE6-M10X1R	VERSCHRAUBUNG		
13	77 43 748 08	2	FLANGE JOINT GE6-LM8X1K	VERSCHRAUBUNG		
14	77 43 735 08	8	EXTENSION 35	VERLAENGERUNG		
15	77 43 738 08	1	FLANGE JOINT WE6-M10X1R	VERSCHRAUBUNG		
16	77 43 750 08	4	DOUBLE NIPPLE R1/4"-M10X1	DOPPELNIPPEL		
17	77 43 727 08	24	COUPLING PLUG	KUPPLUNGSSTECKER		
(1)	10 48 800 3	1	DUST CAP	STAUBKAPPE		
18	77 43 726 08	14	COUPLING SLEEVE	KUPPLUNGSMUFFE		
(1)	10 48 800 2	1	DUST PLUG	STAUBSTECKER		
19	47 10 300 08	31	FLANGE JOINT XGE6-LR-ED A3P	VERSCHRAUBUNG		
20	77 43 737 08	100	TUBE 6X1,5 POLYAMID	ROHR		
21	77 43 758 08	2	RETURN STRIP	RUECKLAUFLEISTE		
22	47 32 306 08	2	FLANGE JOINT RSW6-SR-WD A3P	VERSCHRAUBUNG		
23	77 43 748 08	1	FLANGE JOINT GE6-LM8X1K	VERSCHRAUBUNG		
24	95 70 439 08	1	PLATE 4X170X157	BLECH		
25	97 03 502 08	2	PLATE 4X110X80	BLECH		
26	95 38 734 08	2	SLEEVE	HUELSE		
27	97 03 501 08	5	PLATE 4x73x30 S235JRG2	BLECH		
28	95 36 969 08	2	PLATE 4X30X105	BLECH		
29	97 79 216 08	2	PLATE 4X453X40	BLECH		
30	97 73 355 08	1	PLATE 3X70X45	BLECH		
31	47 25 315 08	5	FLANGE JOINT EWSD6-S A3P	VERSCHRAUBUNG		
32	47 42 021 08	1	FLANGE JOINT XWSV6-S A3P	VERSCHRAUBUNG		
33	47 24 312 08	1	FLANGE JOINT ETSD6-S A3P	VERSCHRAUBUNG		
34	47 23 312 08	1	FLANGE JOINT ELSD6-S A3P	VERSCHRAUBUNG		
35	49 00 128	4	HEX BOLT ISO 4017 M8X25 8.8 A2C	SECHSKANTSCHRAUBE		
36	41 15 144 08	2	HEX NUT DIN 934 M10 8 VERZ	SECHSKANTMUTTER		
37	42 00 506 08	4	WASHER DIN 125 A 8.4 MS	SCHEIBE		
38	40 86 506 08	11	PAN-HEAD SCREW ISO 7380 M8X20 A2-70	FLACHKOPFSCHRAUBE		
39	10 41 285 2	4	OVAL HEAD FLAT SCREW AEHNL. ISO 7380	LINSENFLACHKOPFSCHRAUBE		
40	41 15 140 08	4	HEX NUT DIN 934 M6 8 VERZ	SECHSKANTMUTTER		
41	42 00 009 08	4	WASHER ISO 7089 A 6.4 VERZ	SCHEIBE		
42	47 19 003 08	1	FLANGE JOINT EGESD6-SR-WD A3P	VERSCHRAUBUNG		

6.2.2009

etk_en_de_074515 LR 1600/2

218 (2/2)

LIEBHERRCENT. LUBRIC. SYSTEM SUPERST.
ZENTRALSCHMIERANLAGE OW⇒ 2 711
91 52 800 08

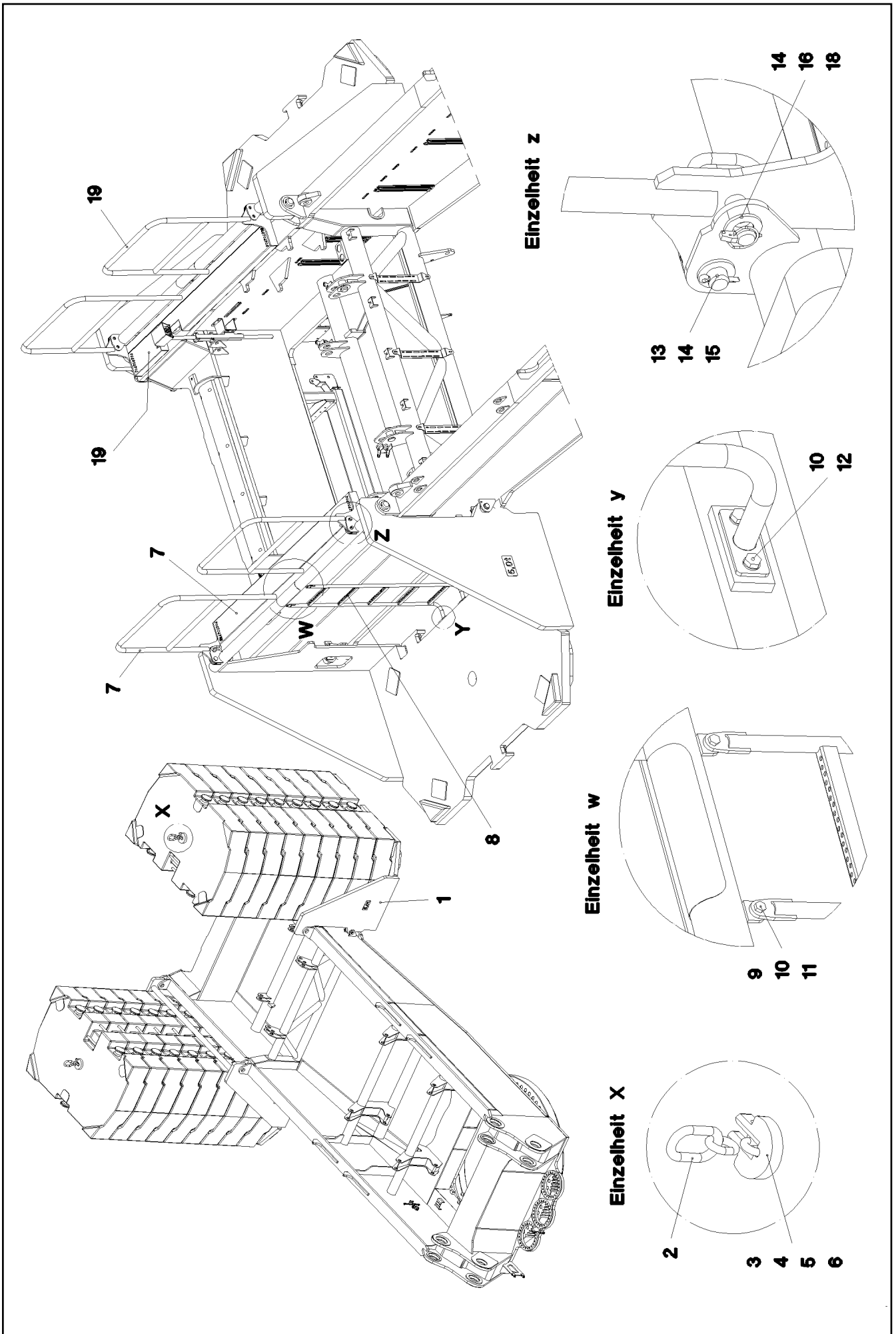

6.2.2009
052765

LIEBHERR

etk_en_de_074515 LR 1600/2

BASE PLATE SLEWING PLATFORM BA
GRUNDPLATTE DREHBUEHNENBALLAST

□ 219 (1/2)

→ 2 730
91 52 802 08

Pos.	Item	Quantity	Description	Bezeichnung	Serie	K
1	96 44 626 08	2	BRACKET WELDED CONST.	KONSOLE SCHWK.		
2	74 00 219 08	2	CHAIN SUSPENSION	KETTENGEHAENGE		
3	95 27 424 08	4	PLATE 40X200X180	BLECH		
4	40 61 179 01	4	HEX BOLT ISO 4014 M16X130 8.8 A3C	SECHSKANTSCHRAUBE		
5	41 15 145 08	4	HEX NUT DIN 934 M16 8 VERZ	SECHSKANTMUTTER		
6	42 00 019 08	4	WASHER DIN 125 A 17 VERZ	SCHEIBE		
7	96 53 121 08	1	PLATFORM T ZN O	PODEST		
8	96 54 670 08	2	LADDER WELDED T ZN O	LEITER SCHWK.		
9	49 00 112	4	HEX BOLT ISO 4017 M10X35 8.8 A3C	SECHSKANTSCHRAUBE		
10	50 09 175 08	12	WASHER DIN 125 A 10.5 A2	SCHEIBE		
11	41 19 006 08	4	HEX NUT DIN 985 M10 8 VERZ	SECHSKANTMUTTER		
12	40 65 166	8	HEX BOLT ISO 4017 M10X20 8.8 A3C	SECHSKANTSCHRAUBE		
13	45 30 220 08	4	PIN DIN 1444 24H11X60X50 42CRMO4 GASN	BOLZEN		
14	42 00 024 08	8	WASHER DIN 125 A 25 ST VERZ	SCHEIBE		
15	43 30 075 08	4	SPLIT PIN DIN 94 6,3X32 ST VERZ	SPLINT		
16	43 32 001 08	4	HINGED CONNECTOR DIN 11023 5X32 VER	KLAPPSTECKER		
17	97 28 594 08	2	ANTI-SLIP SURFACE 150X300	ANTIRUTSCHBELAG		
18	96 54 826 08	4	PIN WELDED FE//ZN20//C	BOLZEN SCHWK.		
19	96 56 268 08	1	PLATFORM	PODEST		

6.2.2009

etk_en_de_074515 LR 1600/2

220 (2/2)

LIEBHERR

BASE PLATE SLEWING PLATFORM BA
GRUNDPLATTE DREHBUEHNENBALLAST

⇒ 2 730
91 52 802 08

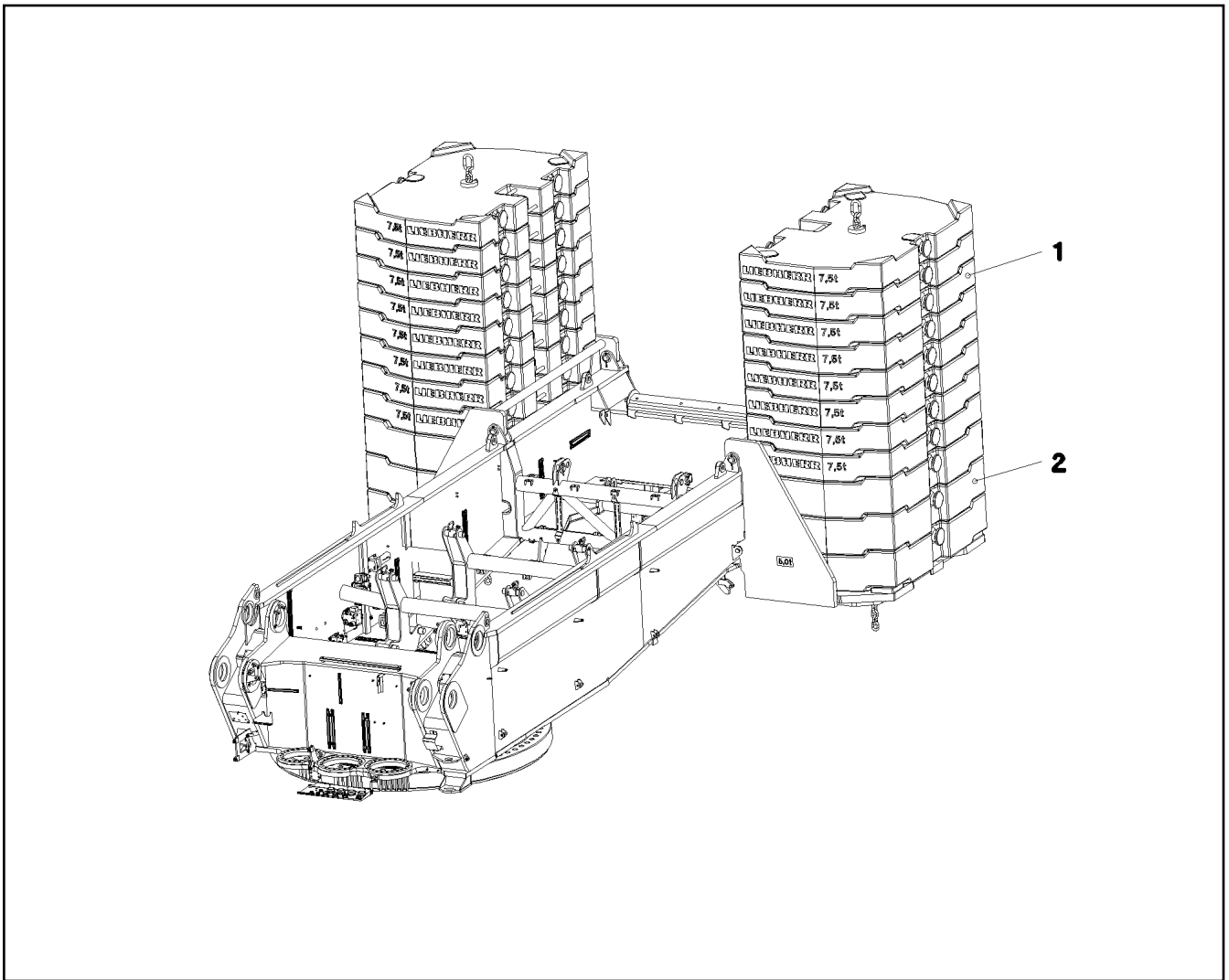

Pos.	Item	Quantity	Description	Bezeichnung	Serie	K
1	97 66 580 08	16	COUNTERWEIGHT SPF	GEGENGEWICHT		
2	38 82 792 08	6	COUNTERWEIGHT SPF	GEGENGEWICHT		

6.2.2009
054184

LIEBHERR

etk_en_de_074515 LR 1600/2

COUNTERWEIGHT
GEGENGEWICHT

□ 221

⇒ 2 740
91 52 770 08

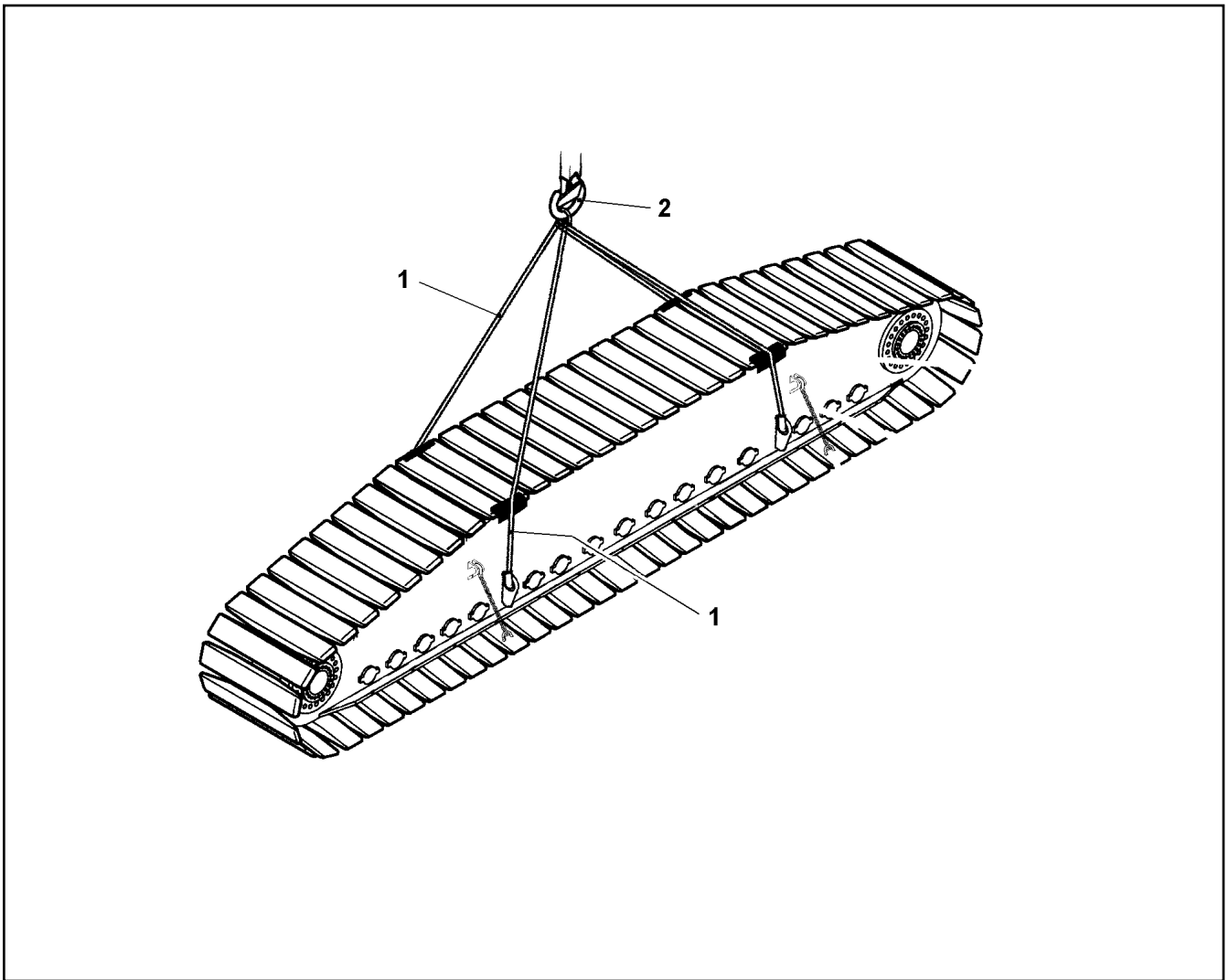

Pos.	Item	Quantity	Description	Bezeichnung	Serie	K
1	10 47 515 7	2	SLING ROPE 22.5T-12.1M VERZ	ANSCHLAGSEIL		
2	77 39 305 08	2	SHACKLE DIN 82101 25T VERZ	SCHAEKEL		

6.2.2009
054185

LIEBHERR

etk_en_de_074515 LR 1600/2

SLING GEAR ERECTION CRAWLER
ANSCHLAGMITTEL MONTAGE RAUPE

222

⇒ 2 750 100
91 57 283 08

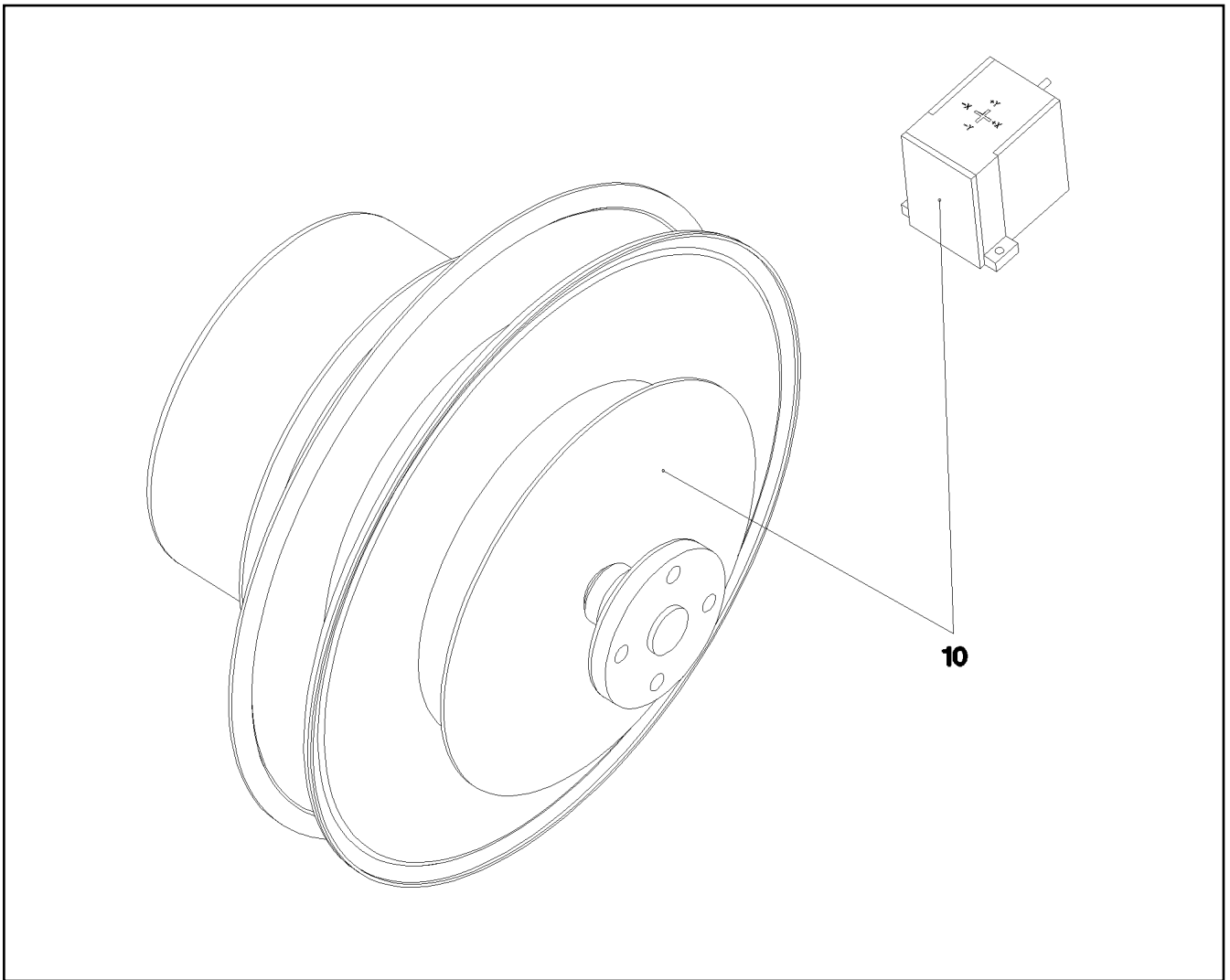

Pos.	Item	Quantity	Description	Bezeichnung	Serie	K
10	96 50 097 08	1	ELECTR.FOR BALLAST PALLET ⇒ 2 780 510 96 50 097 08	ELEKTRIK BALLASTPALETTE		

6.2.2009
055144

LIEBHERR

etk_en_de_074515 LR 1600/2

ELECTRICS F.SUSPENDED BALLAST
ELEKTRIK SCHWEBEBALLAST

223

⇒ 2 780 100
96 50 096 08

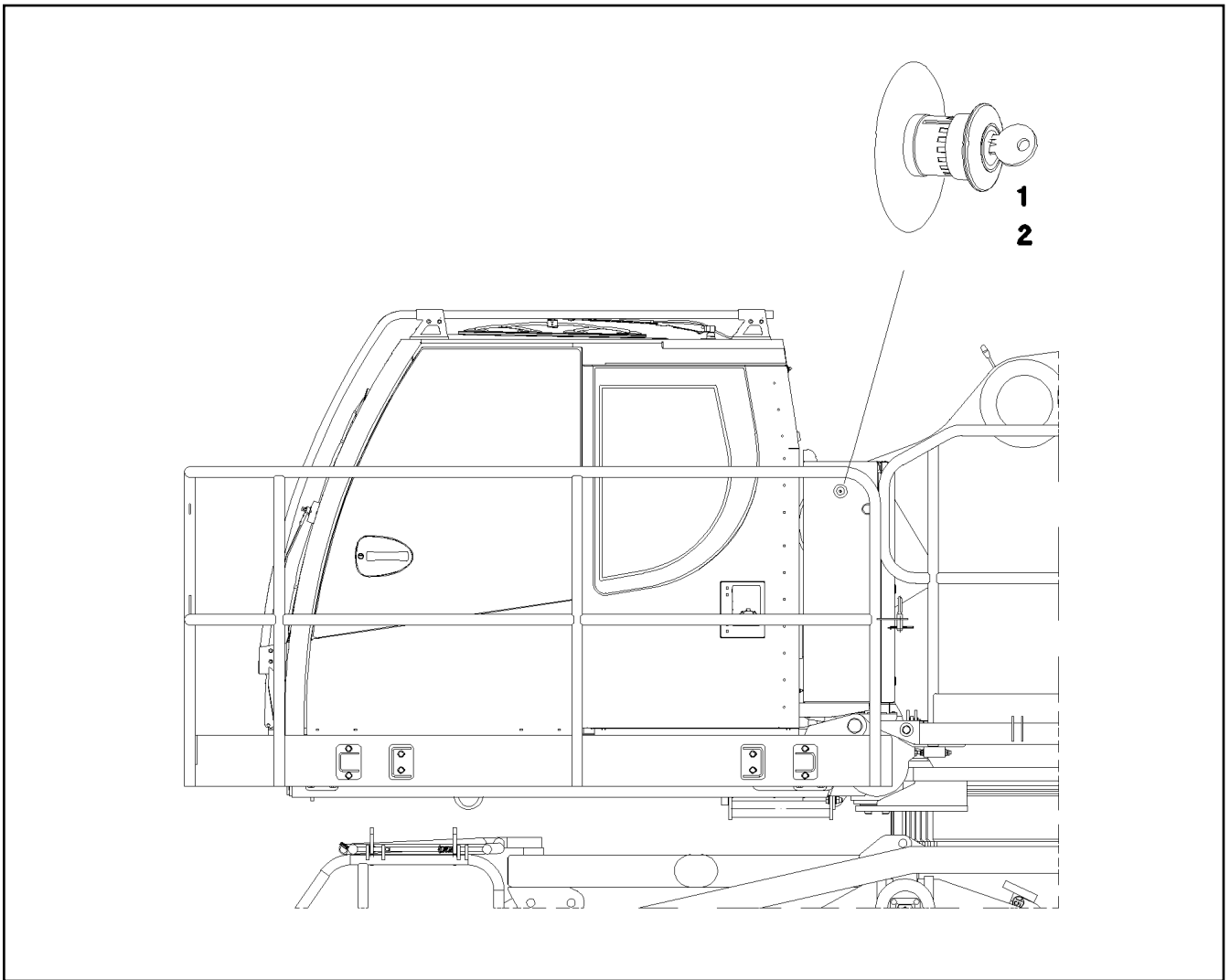

Pos.	Item	Quantity	Description	Bezeichnung	Serie	K
1	60 66 620 08	1	BASE PART	UNTERTEIL		
2	10 47 561 7	1	PUSH BUTTON	DRUCKTASTER		
3	10 47 561 9	1	LABEL	SCHILD		
10	96 48 390 08	1	WIRING HARNESS W811	KABELSTRANG		

6.2.2009
054166

LIEBHERR

etk_en_de_074515 LR 1600/2

EMERGENCY CUT-OFF CRANE DRIVER
NOTAUS KRANFUEHRERKABINE

□ 224

⇒ 2 780 244
91 52 951 08

Pos.	Item	Quantity	Description	Bezeichnung	Serie	K
10	61 40 085 08	1	SOUND TRANSMITTER 12-30VDC	SCHALLGEBER		
11	60 03 420 08	3	LEAD 2 X 1,5	LEITUNG		
12	60 22 034 08	2	FLAG RECEPTACLE	STECKHUELSE		
13	60 23 080 08	2	WIRED END FERRULE DIN 46228 1,5X7 VER	ADERENDHUELSE		
20	60 04 341 08	3	ELECTR.CABLE DIN 72551 1 SPF	KFZ-LEITUNG		

6.2.2009

etk_en_de_074515 LR 1600/2

☐ 225

LIEBHERR

ACOUST.WARN. SLEWING GEAR
AKUSTISCHE WARNUNG DREHWERK

⇒ 2 780 320
91 05 067 08

Pos.	Item	Quantity	Description	Bezeichnung	Serie	K
10	61 40 085 08	1	SOUND TRANSMITTER 12-30VDC	SCHALLGEBER		
11	97 02 854 08	1	PLATE 3X200X150	BLECH		

6.2.2009

etk_en_de_074515 LR 1600/2

226

LIEBHERR

ACOUST. WARN. DISPLACEM. CRAWL
AKUST. WARNUNG VERFAHREN RAUPE

⇒ 2 780 324
91 56 389 08

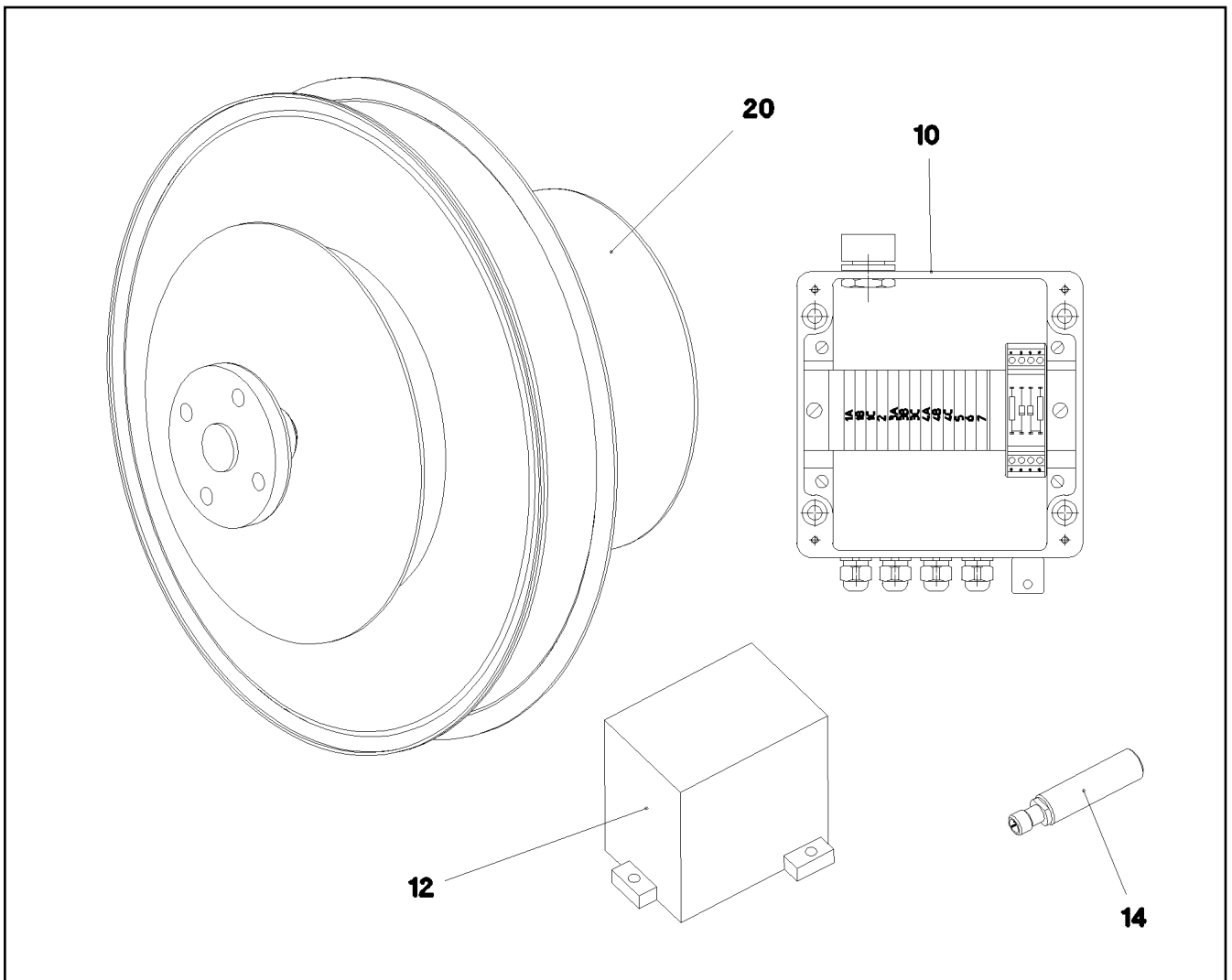

Pos.	Item	Quantity	Description	Bezeichnung	Serie	K
10	96 52 969 08	1	TERMINAL BOX CPL. +S1100 ⇒ 2 780 748 96 52 969 08	KLEMMKASTEN KPL.		
12	69 23 081 08	1	INCLINATION TRANSMITTER SPF	NEIGUNGSGEBER		
14	69 23 087 08	4	INDUCTIVE SENSOR SPF	INDUKTIVSENSOR		
20	96 52 968 08	1	CABLE DRUM COMPL. ⇒ 2 780 524 96 52 968 08	LEITUNGSTROMMEL KPL.		

6.2.2009
055147

LIEBHERR

etk_en_de_074515 LR 1600/2

ELECTR.FOR BALLAST PALLET
ELEKTRIK BALLASTPALETTE

□ 227

⇒ 2 780 510
96 50 097 08

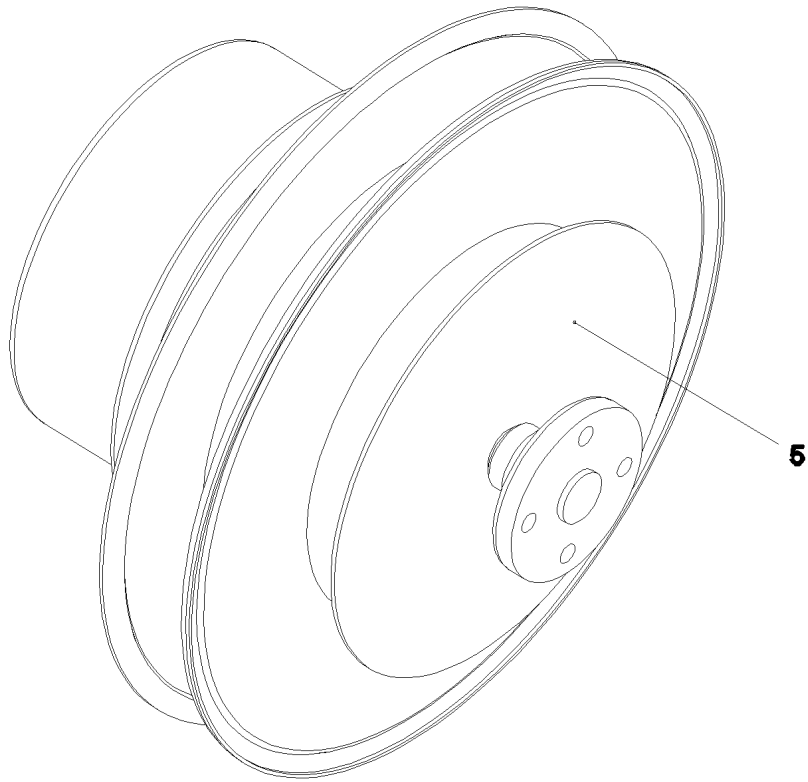

Pos. 9
Pos. 10
Pos. 20

Pos.	Item	Quantity	Description	Bezeichnung	Serie	K
5	10 02 800 2	1	CABLE REEL 30M 6POLIG SPF ⇒ X10028002 10 02 800 2	LEITUNGSTROMMEL		
7	60 26 065 08	1	REDUCTION M32X1,5/M20X1,5 MS	REDUKTION		
8	60 24 242 08	2	THREADED CABLE GLAND M20X1,5 MS	KABELVERSCHRAUBUNG		
9	60 25 013 08	1	VENTILATION SCREW G1/2"X30 POLYAMID	ENTLUEFTUNGSSCHRAUBE		
10	96 52 970 08	1	LEAD W1140	LEITUNG		
20	96 52 971 08	1	LEAD W1140A	LEITUNG		
154	60 32 004 08	5	CABLE TIE 3,6X200	KABELBINDER		

6.2.2009
055145

LIEBHERR

etk_en_de_074515 LR 1600/2

CABLE DRUM COMPL.
LEITUNGSTROMMEL KPL.

228

⇒ 2 780 524
96 52 968 08

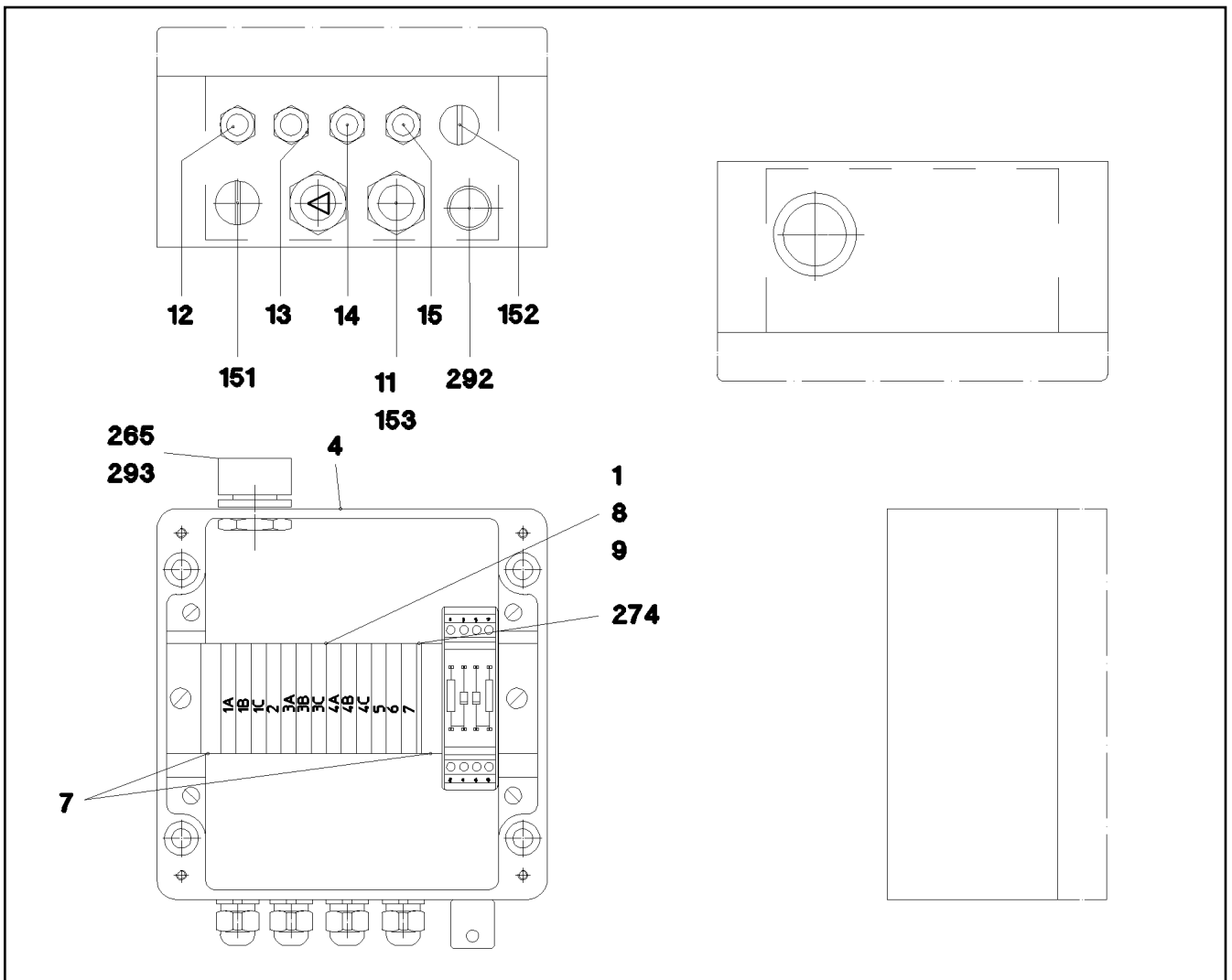

Pos.	Item	Quantity	Description	Bezeichnung	Serie	K
1	96 52 977 08	1	WIRES TERMINAL BOX CPL. S1100	DRAEHTE KLEMMKASTEN KPL.		
(2)	96 53 013 08	1	WIRES PRE-ASS. S1100	DRAEHTE VORM.		
(151)	10 28 635 4	13	TERMINAL/CLAMP	KLEMME		
(152)	96 48 302 08	1	CUSTOM CIRCUIT MODULE 2	BESTUECKUNGSMODUL 2		
4	97 58 522 08	1	EMPTY CASING 160X160X90X0 AL	LEERGEHAEUSE		
5	97 82 953 08	1	LABEL +S1100 LEXAN	SCHILD		
7	60 27 946 08	2	END ANGLE	ENDWINKEL		
11	96 52 978 08	1	LEAD W1142	LEITUNG		
12	96 52 980 08	1	LEAD W1143	LEITUNG		
13	96 52 981 08	1	LEAD W1144	LEITUNG		
14	96 52 982 08	1	LEAD W1145	LEITUNG		
15	96 52 983 08	1	LEAD W1146	LEITUNG		
151	60 24 249 08	1	SCREW PLUG M16X1,5 MS	VERSCHLUSSSCHRAUBE		
152	60 24 255 08	1	SCREW PLUG M12X1,2 MS	VERSCHLUSSSCHRAUBE		
153	60 24 241 08	1	THREADED CABLE GLAND M16X1,5 MS	KABELVERSCHRAUBUNG		
273	60 21 067 08	0.15	TOP HAT RAIL 35X27X7,3X1	HUTSCHIENE		
274	10 28 635 3	1	LID	DECKEL		
292	60 25 012 08	1	WATER DRAIN PLUG PA6G SPF	ENTWAESSERUNGSSTOPFEN		
293	60 25 013 08	1	VENTILATION SCREW G1/2"X30 POLYAMID	ENTLUEFTUNGSSCHRAUBE		

6.2.2009
055146

LIEBHERR

etk_en_de_074515 LR 1600/2

TERMINAL BOX CPL.
KLEMMKASTEN KPL.

229

⇒ 2 780 748
96 52 969 08

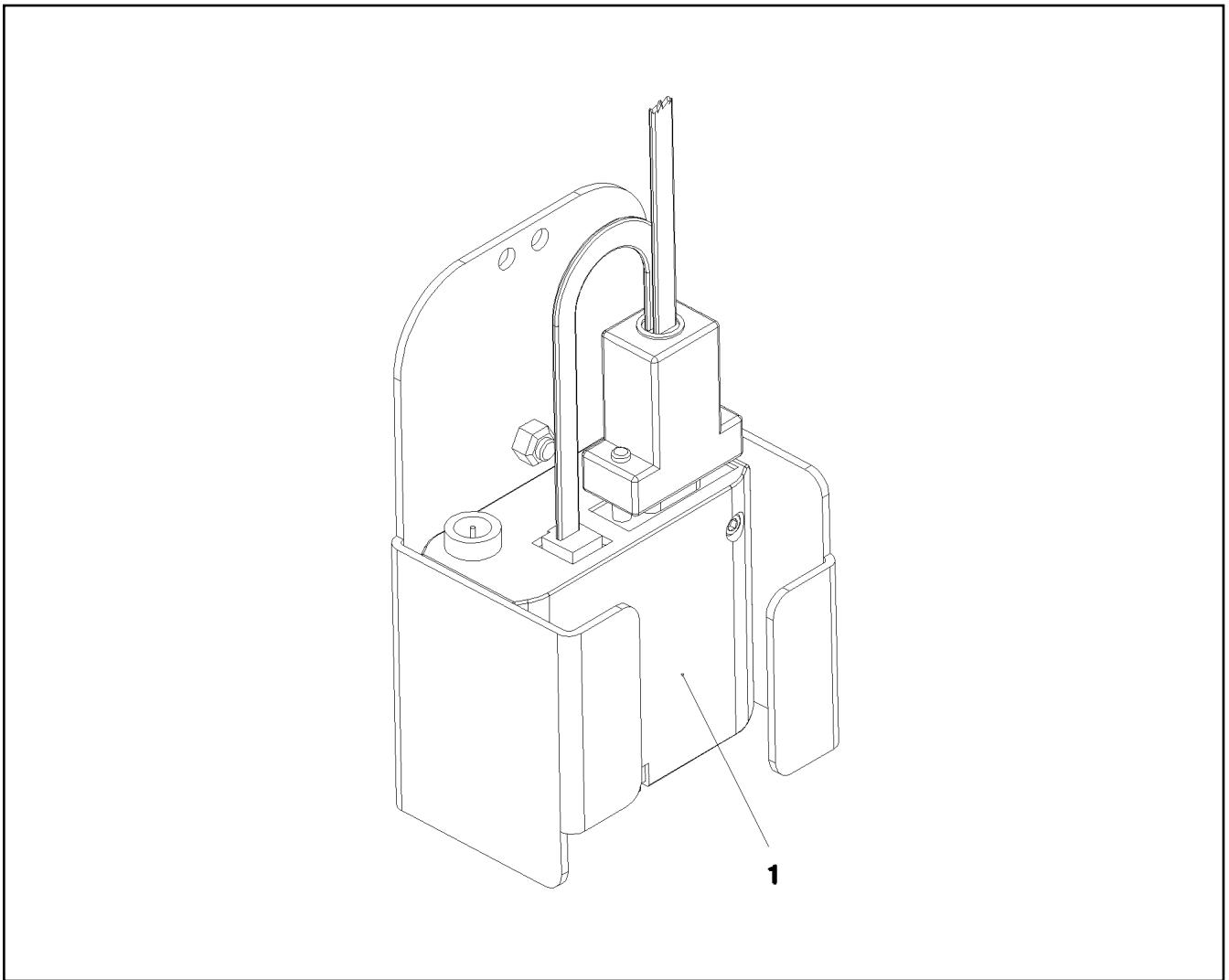

Pos.	Item	Quantity	Description	Bezeichnung	Serie	K
1	96 37 908 08	1	GSM MODULE LICCON 1 ⇒ 2 780 854 96 37 908 08	GSM-MODUL KPL.LICCON 1		

6.2.2009
031224

LIEBHERR

etk_en_de_074515 LR 1600/2

TELEDIAGNOSIS MODULE 1
FERNDIAGNOSE MODUL OW LICCON 1

☐ 230

⇒ 2 780 850
91 24 097 08

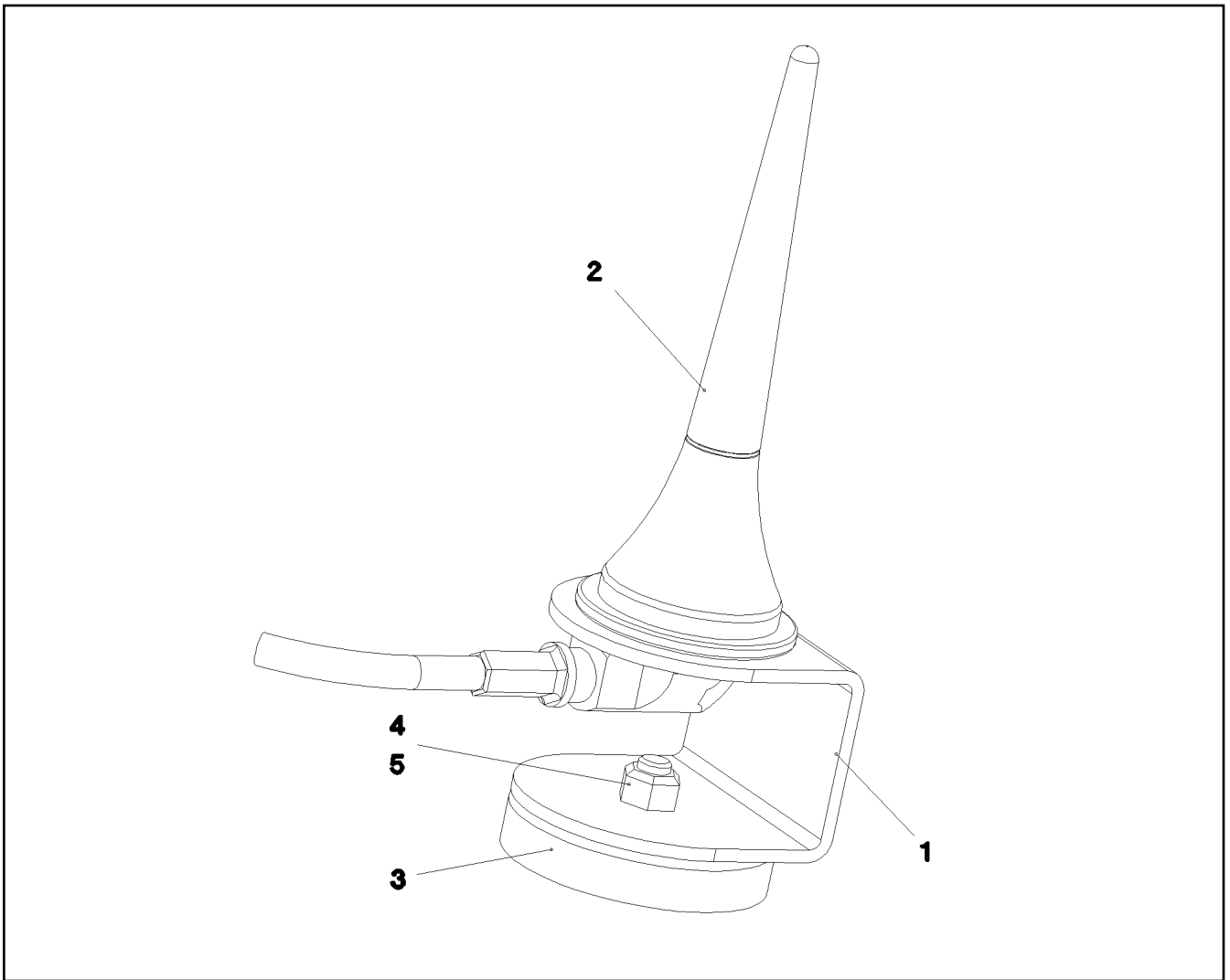

Pos.	Item	Quantity	Description	Bezeichnung	Serie	K
1	97 26 310 08	1	PLATE 2X103X40	BLECH		
2	10 28 963 1	1	ANTENNA	ANTENNE		
3	61 70 001 08	1	PERMANENT MAGNET	DAUERMAGNET		
4	40 86 040 08	1	COUNTERSUNK SCREW DIN 7991 M5X16 8	SENKSCHRAUBE		
5	41 19 003 08	1	HEX NUT DIN 985 M5 8 VERZ	SECHSKANTMUTTER		

6.2.2009
031222

LIEBHERR

etk_en_de_074515 LR 1600/2

RADIO ANTENNA PRE-ASS.
FUNKANTENNE VORM.

231

⇒ 2 780 851
96 24 498 08

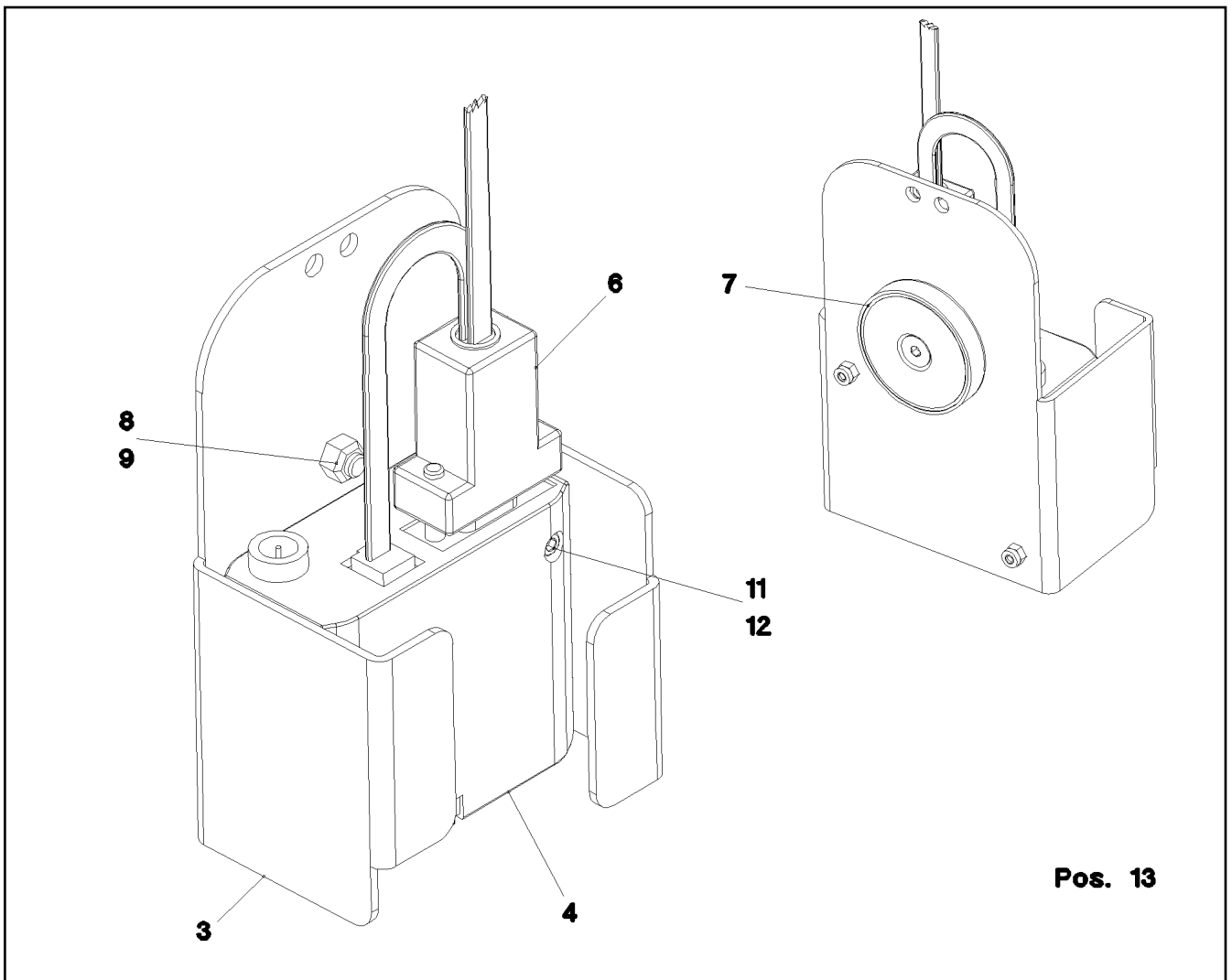

Pos. 13

Pos.	Item	Quantity	Description	Bezeichnung	Serie	K
3	97 47 409 08	1	PLATE 2X214X142 ALMG3 H111	BLECH		
4	96 28 688 08	1	GSM-MODULE PROG. SPF	GSM-MODUL PROG.		
(10)	10 40 975 0	1	GSM MODULE M1 TC63 QUAD-BAND	GSM-MODUL		
6	96 24 499 08	1	LEAD W634	LEITUNG		
7	61 70 001 08	1	PERMANENT MAGNET	DAUERMAGNET		
8	40 86 040 08	1	COUNTERSUNK SCREW DIN 7991 M5X16 8	SENKSCHRAUBE		
9	41 19 003 08	1	HEX NUT DIN 985 M5 8 VERZ	SECHSKANTMUTTER		
11	40 42 002 08	2	CYLINDER SCREW DIN 912 M3X35 8.8 A2C	ZYLINDERSCHRAUBE		
12	41 19 001 08	2	HEX NUT DIN 985 M3 8 A3C	SECHSKANTMUTTER		
13	60 32 022 08	2	CABLE TIE 2,5X102	KABELBINDER		

6.2.2009
031223

LIEBHERR

etk_en_de_074515 LR 1600/2

GSM-MODULE PRE-ASS.LICCON 1
GSM-MODUL VORM.LICCON 1

232

⇒ 2 780 852
96 24 845 08

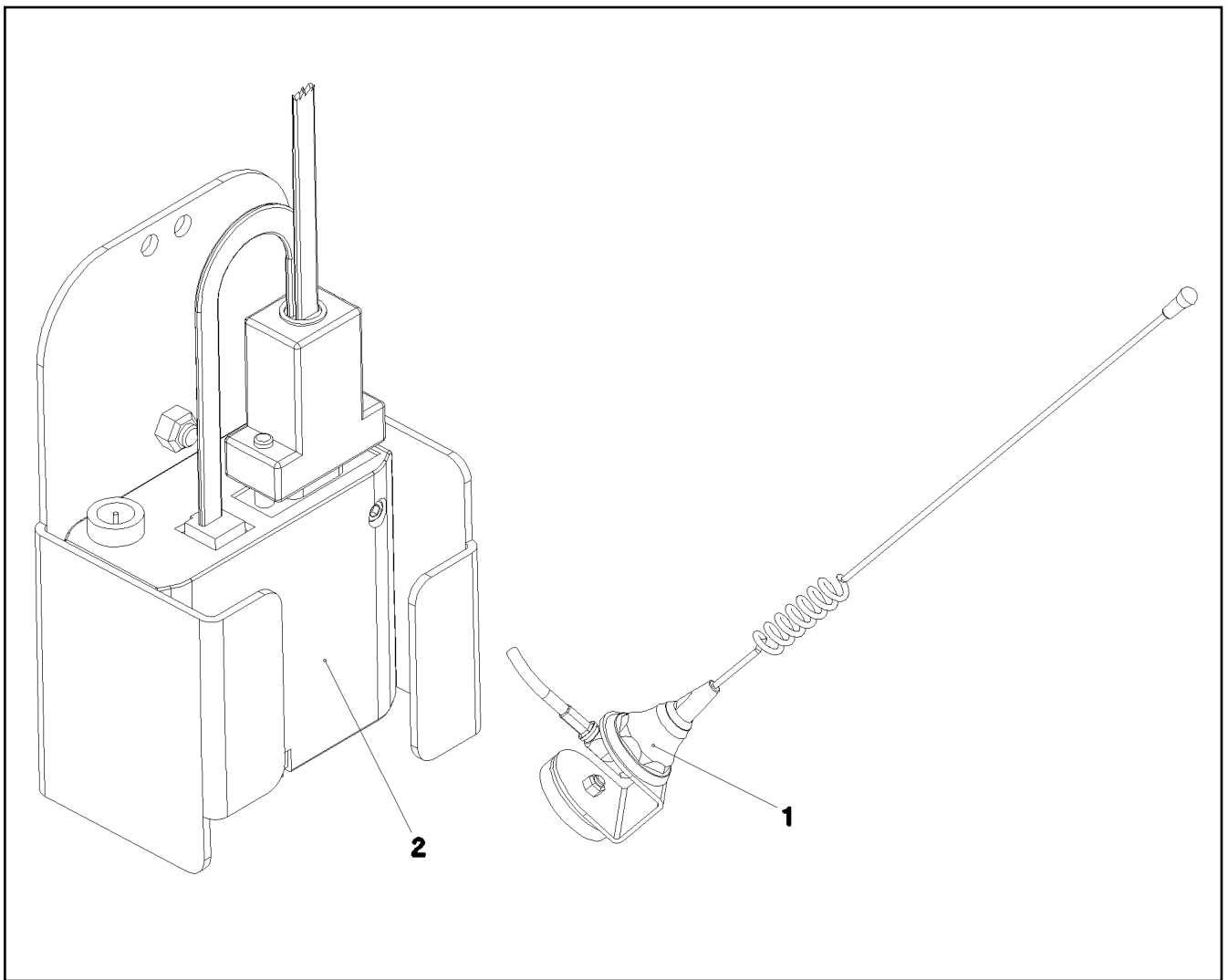

Pos.	Item	Quantity	Description	Bezeichnung	Serie	K
1	96 24 498 08	1	RADIO ANTENNA PRE-ASS. ⇒ 2 780 851 96 24 498 08	FUNKANTENNE VORM.		
2	96 24 845 08	1	GSM-MODULE PRE-ASS.LICCON 1 ⇒ 2 780 852 96 24 845 08	GSM-MODUL VORM.LICCON 1		
3	89 96 346 08	1	TELEDIAGNOSIS MODULE HANDBUCH PAP	LICCON-FERNDIAGNOSE		

6.2.2009
042348

LIEBHERR

etk_en_de_074515 LR 1600/2

GSM MODULE LICCON 1
GSM-MODUL KPL.LICCON 1

233

⇒ 2 780 854
96 37 908 08

Pos. 3

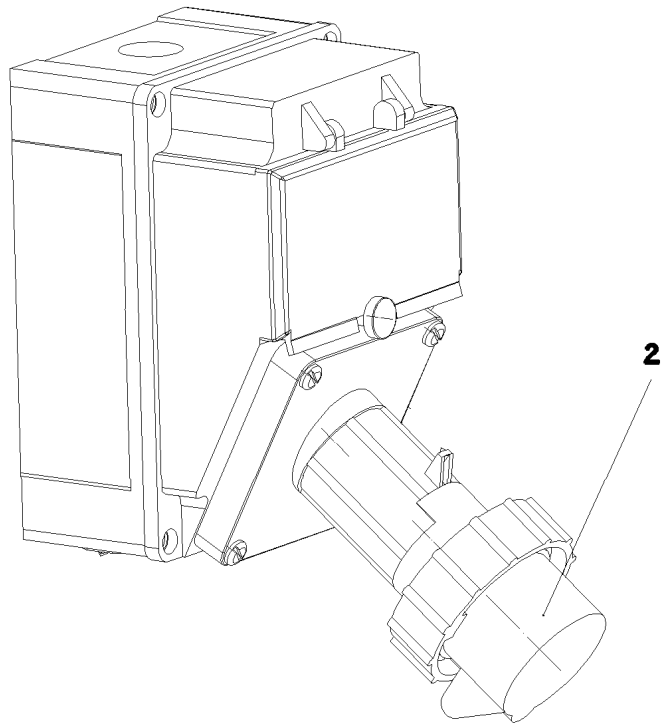

Pos.	Item	Quantity	Description	Bezeichnung	Serie	K
2	96 48 377 08	1	ADD-ON PARTS EXTERNAL FEED ⇒ 2 780 915 96 48 377 08	ANBAUTEILE FREMDEINSPEIS		
3	96 48 376 08	1	CABLE LIST MAINS SUPPLY	KABELLISTE FREMDEINSPEIS		
(1)	96 51 119 08	1	WIRING HARNESS W693	KABELSTRANG		

6.2.2009
052621

LIEBHERR

etk_en_de_074515 LR 1600/2

EXTERNAL FEED
FREMDEINSPEISUNG

□ 234

⇒ 2 780 908
91 52 958 08

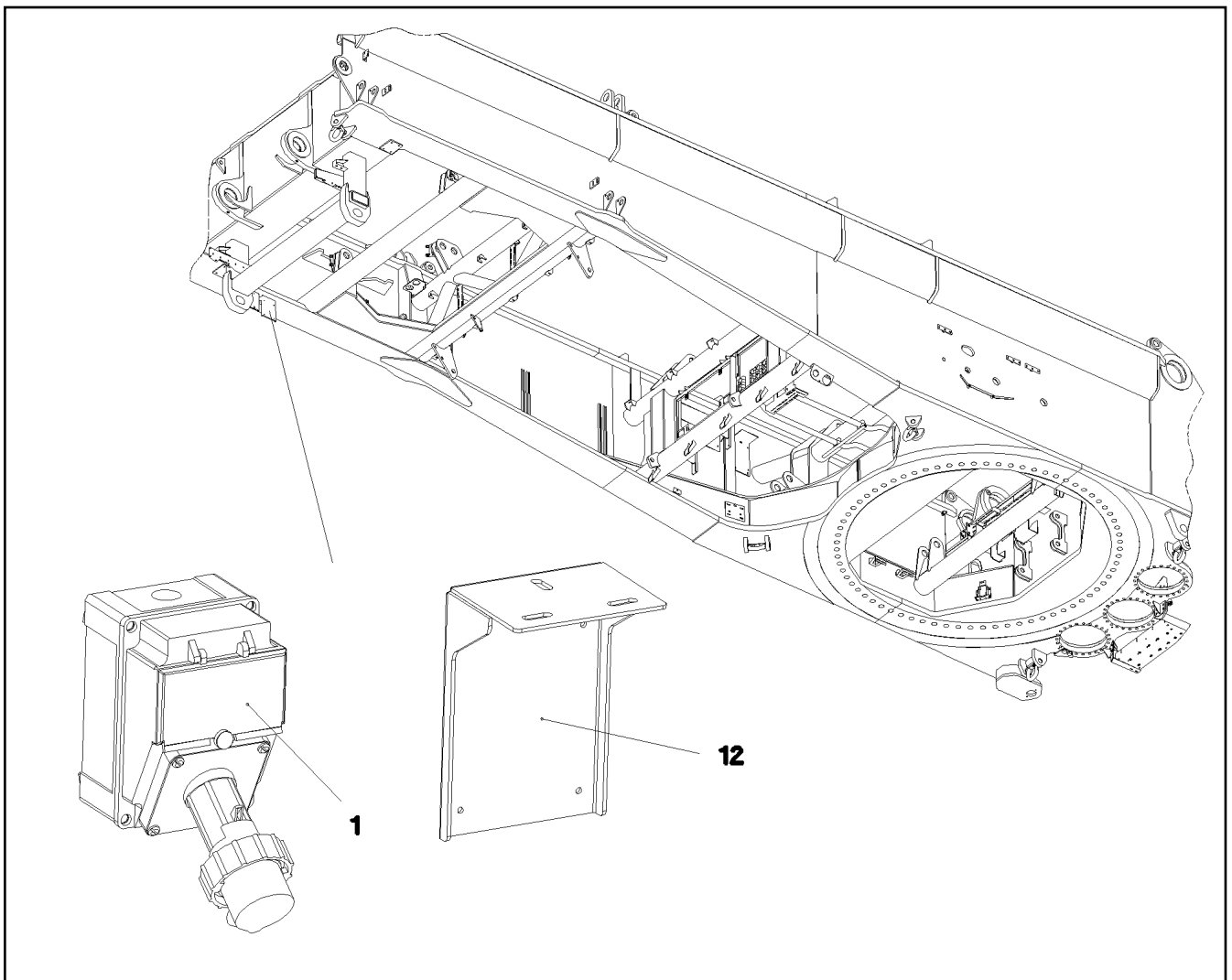

Pos.	Item	Quantity	Description	Bezeichnung	Serie	K
1	60 52 157 08	1	SOCKET COMBINATION 16A MENNEKES	STECKDOSENKOMBINATION		
2	42 00 008 08	4	WASHER DIN 125 A 5.3 VERZ	SCHEIBE		
3	42 52 208 08	4	SERRATED LOCK WASHER DIN 6798 J 5,3	FAECHERSCHEIBE		
4	40 01 034 08	4	CYLINDER SCREW DIN 84 M5X16 4.8 VERZ	ZYLINDERSCHRAUBE		
6	77 25 885 08	1	LABEL	SCHILD		
7	60 50 127 08	1	COUPLING SOCKET	KUPPLUNGSDOSE		
8	41 15 148 08	4	HEX NUT DIN 934 M5 8 VERZ	SECHSKANTMUTTER		
11	60 24 417 01	2	THREADED CABLE GLAND POLYAMID	KABELVERSCHRAUBUNG		
12	97 79 627 08	1	PLATE 3X270X308	BLECH		
15	10 04 464 8	2	REDUCER M25X1,5 M16X1,5 POLYAMID	REDUZIERUNG		
20	10 04 269 6	2	LOCK NUT M25X1,5 POLYAMID	GEGENMUTTER		

6.2.2009
055338

LIEBHERR

etk_en_de_074515 LR 1600/2

ADD-ON PARTS EXTERNAL FEED
ANBAUTEILE FREMDEINSPEISUNG

235

⇒ 2 780 915
96 48 377 08

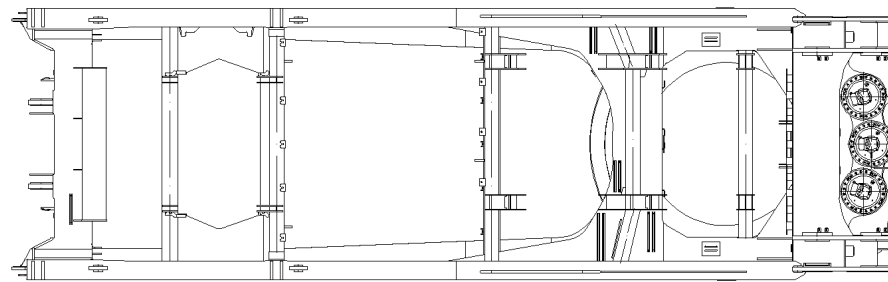
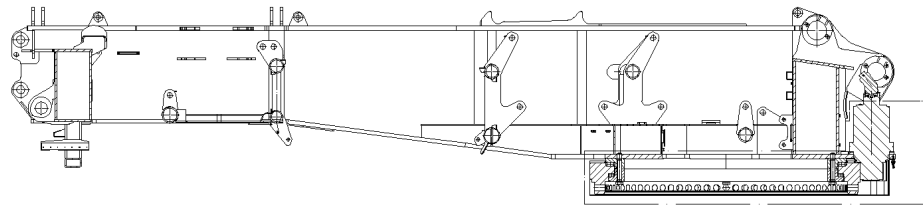

Ansicht W

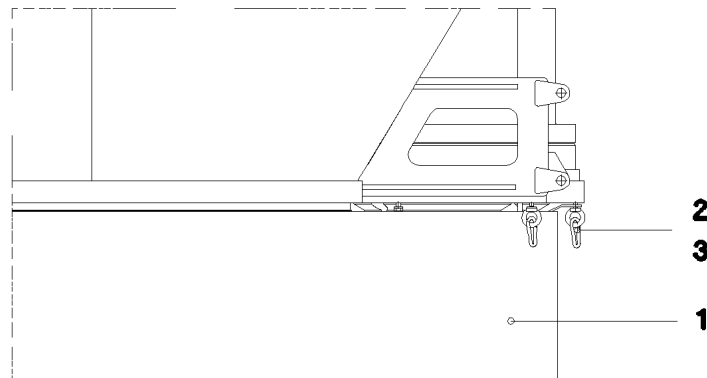

2

3

1

Pos.	Item	Quantity	Description	Bezeichnung	Serie	K
1	97 38 049 08	1	COVER QC UPPER BAND LR 1750	ABDECKUNG QC OBERRING		
2	40 26 002 08	3	RING BOLT DIN 580 M10 C15E A2K	RINGSCHRAUBE		
3	74 40 100 08	3	SNAP HOOK DIN 5299 70X7 ST VERZ	KARABINERHAKEN		

6.2.2009
054022

LIEBHERR

etk_en_de_074515 LR 1600/2

COVER
ABDECKUNG

236

⇒ 2 790 451
91 57 016 08

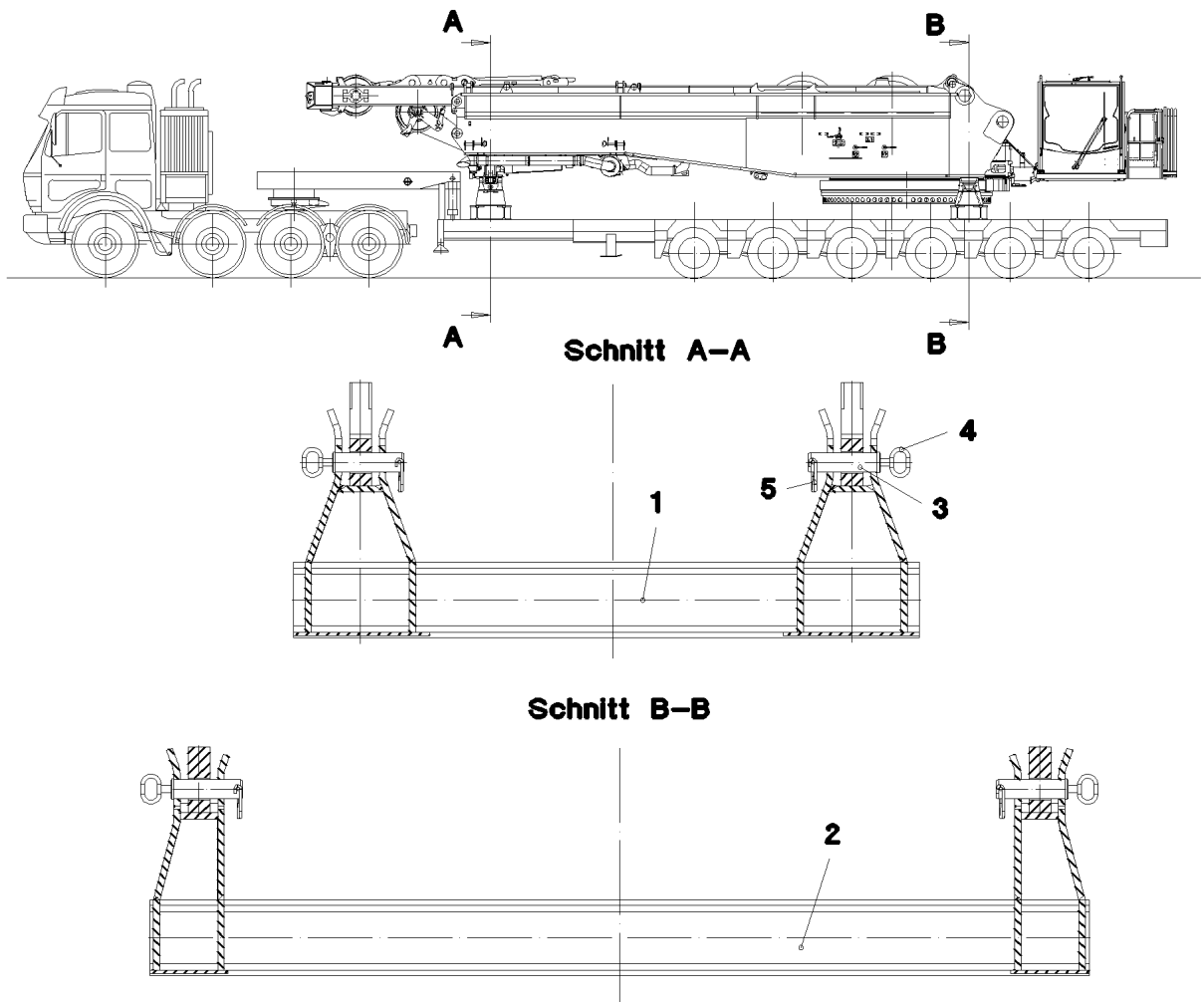

Pos.	Item	Quantity	Description	Bezeichnung	Serie	K
1	96 52 910 08	1	BRACKET WELDED CONST. HINTEN	KONSOLE SCHWK.		
2	96 52 911 08	1	BRACKET WELDED CONST. VORN	KONSOLE SCHWK.		
3	93 73 829 08	4	PIN RD60X220	BOLZEN		
4	92 10 795 08	4	HANDLE WELD.CONST.	GRIFF SCHWK.		
5	43 31 052 08	4	RETAINING SPRING 8 VERZ.	SICHERUNGSFEDER		

6.2.2009
054020

LIEBHERR

etk_en_de_074515 LR 1600/2

TRANSPORT KEEPER
TRANSPORTABLAGE

237

⇒ 2 790 455
91 57 005 08

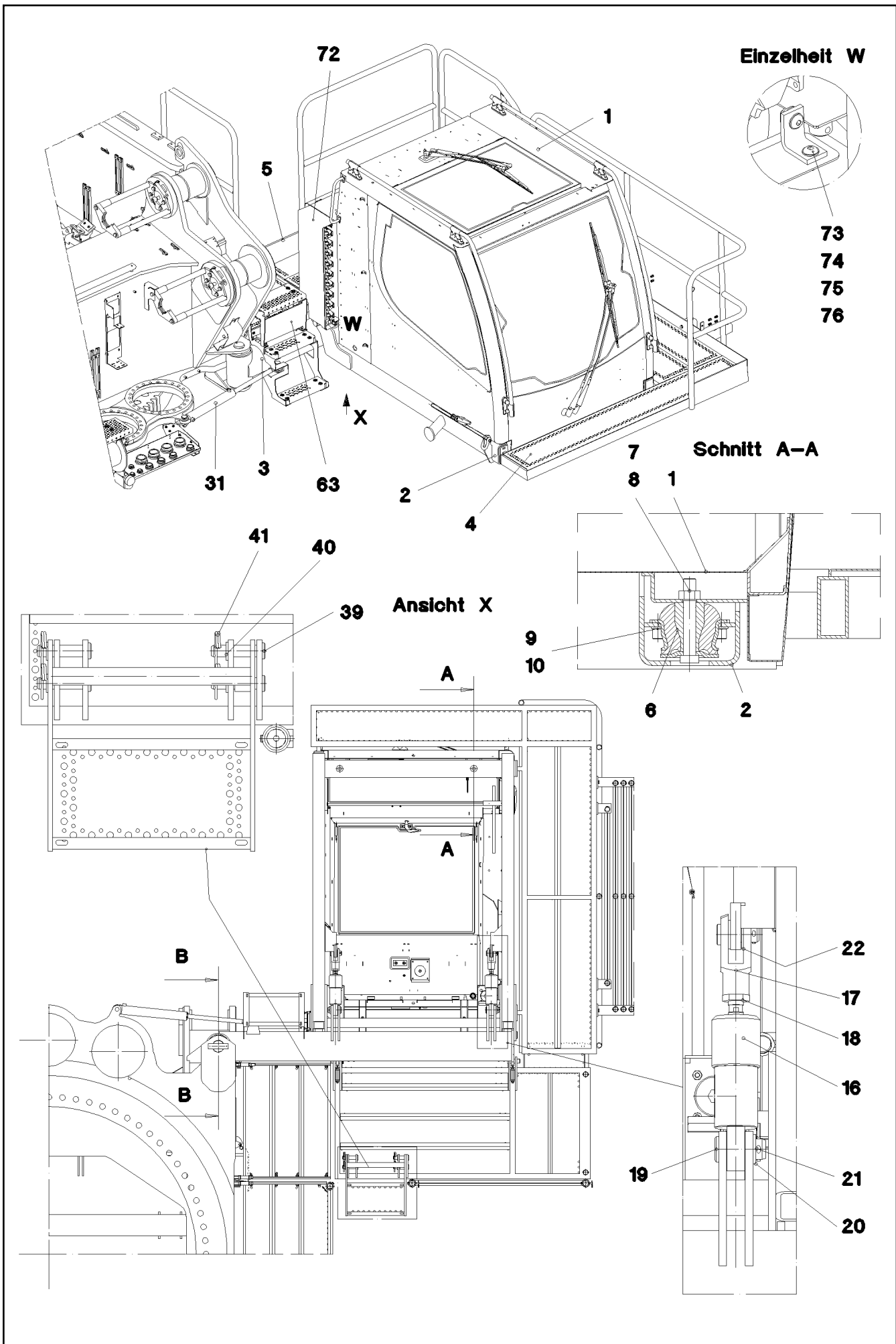

6.2.2009
052569

LIEBHERR

etk_en_de_074515 LR 1600/2

CRANE DRIVER'S CABIN CPL.
KRANFUEHRERKABINE KPL.

□ 238 (1/7)

⇒ 2 810
91 52 806 08

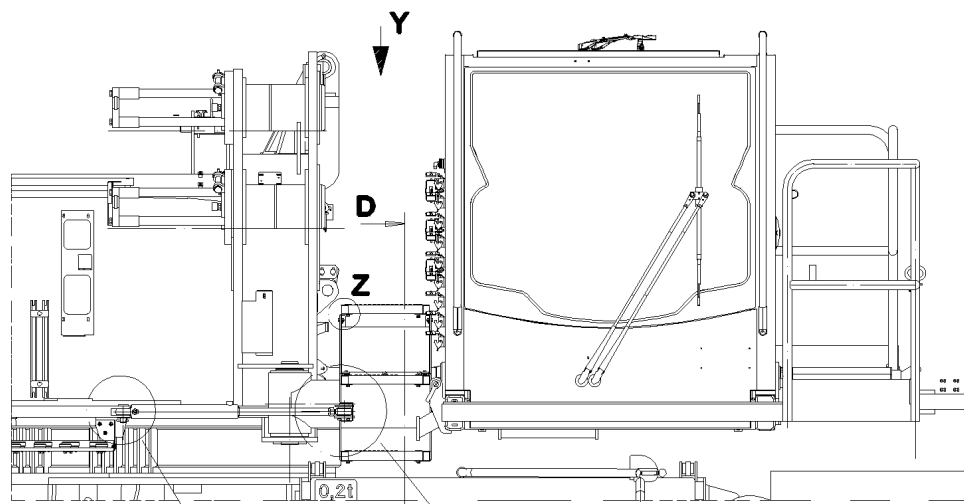

- 65 Einzelheit Z
- 66
- 67
- 70
- 77
- 67
- 68
- 69

Schnitt C-C

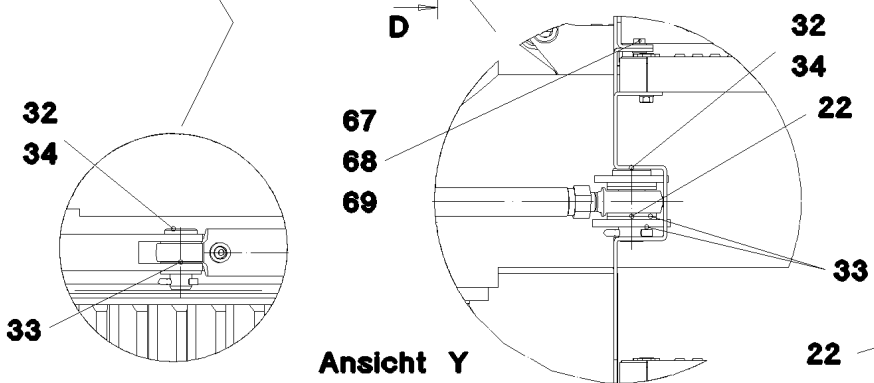
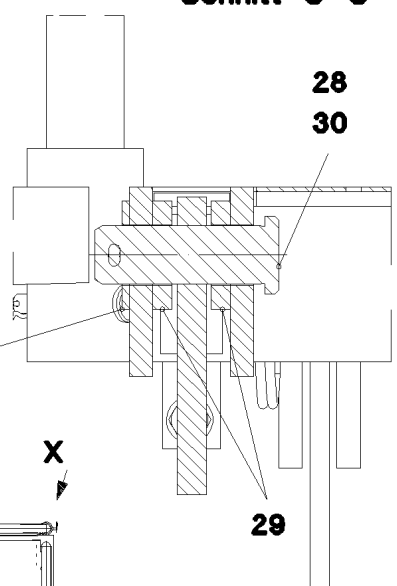

Ansicht Y

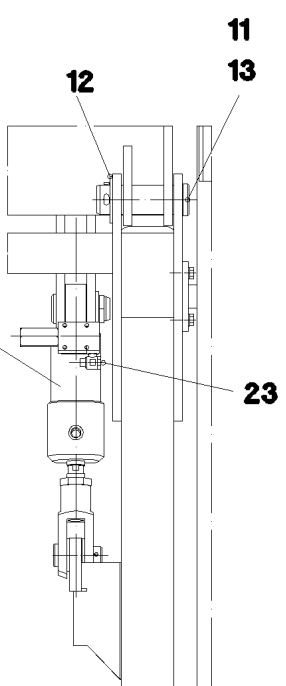
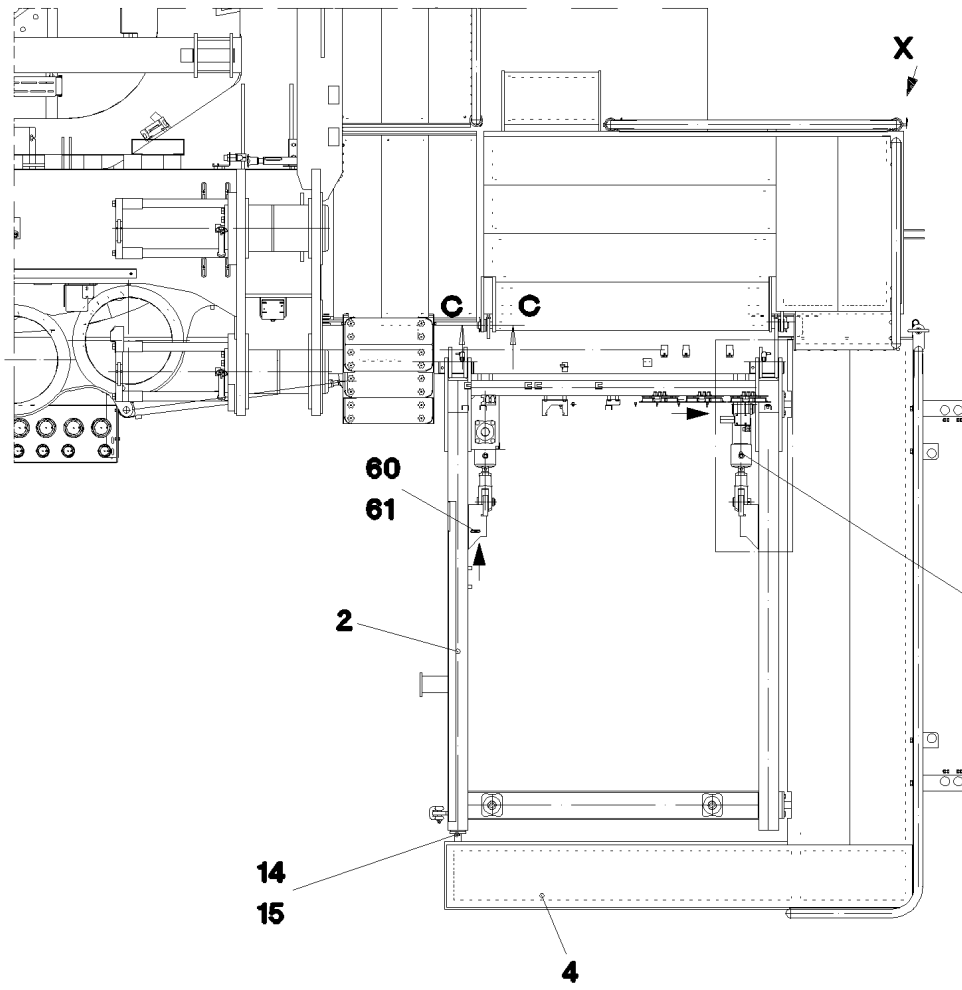

6.2.2009
052570

LIEBHERR

etk_en_de_074515 LR 1600/2

CRANE DRIVER'S CABIN CPL.
KRANFUEHRERKABINE KPL.

□ 239 (2/7)

⇒ 2 810
91 52 806 08

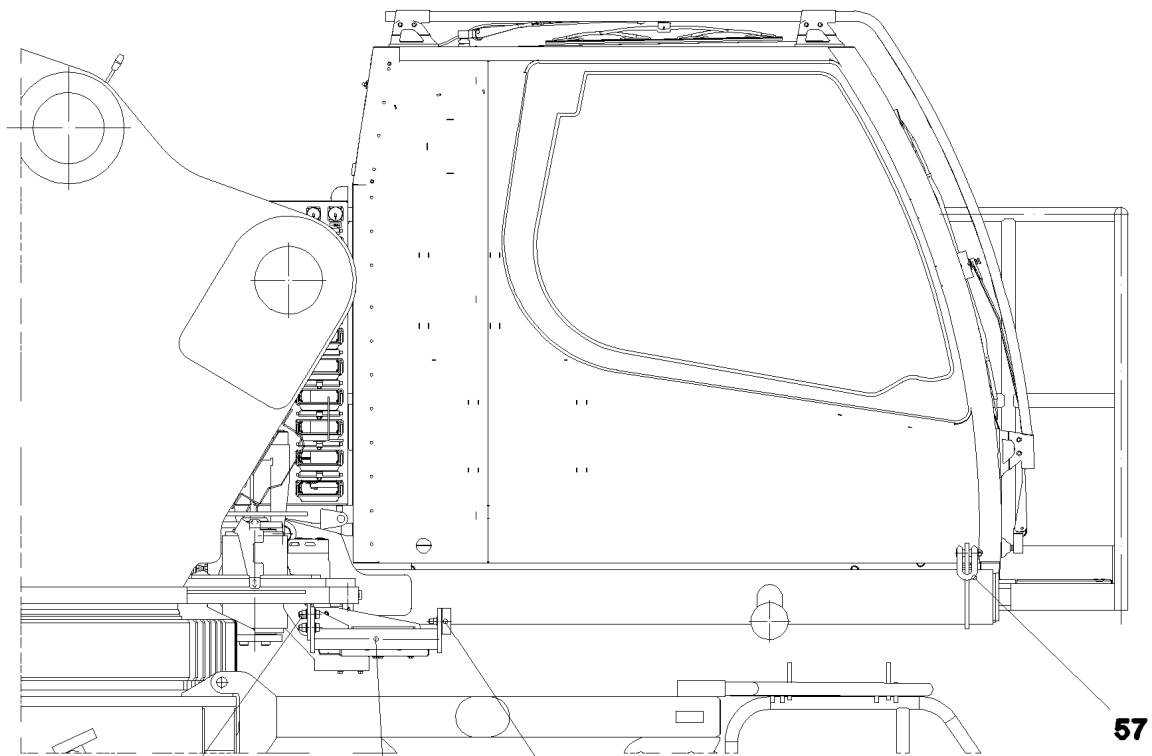

- 50
- 51
- 52
- 49
- 53
- 54
- 55
- 56

Schnitt B-B

- 22
- 28
- 29
- 30

Schnitt D-D

- 11
- 12
- 13

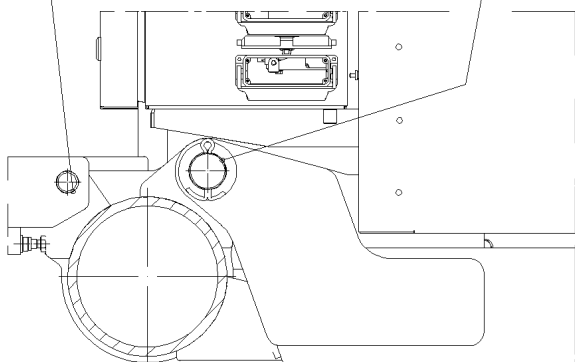

- 27

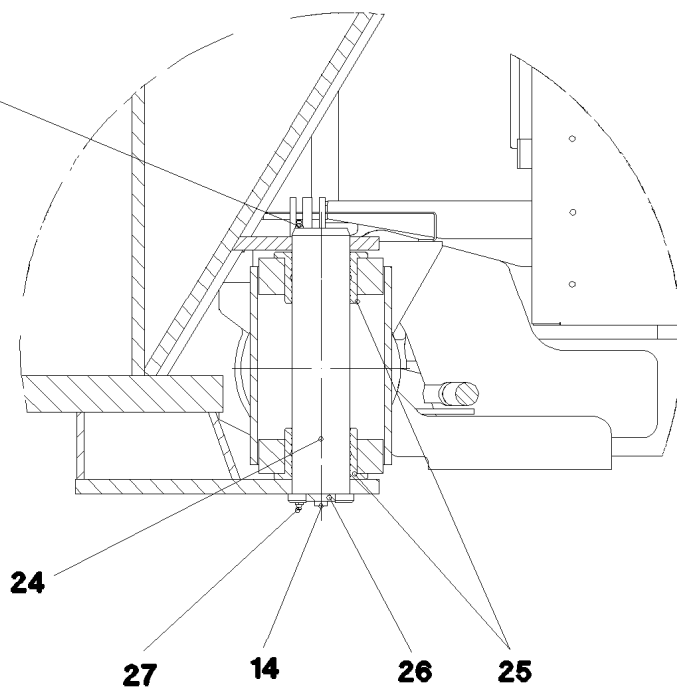

- 24

- 27
- 14
- 26
- 25

6.2.2009
052571

LIEBHERR

etk_en_de_074515 LR 1600/2

CRANE DRIVER'S CABIN CPL.
KRAFUEHRERKABINE KPL.

□ 240 (3/7)

⇒ 2 810
91 52 806 08

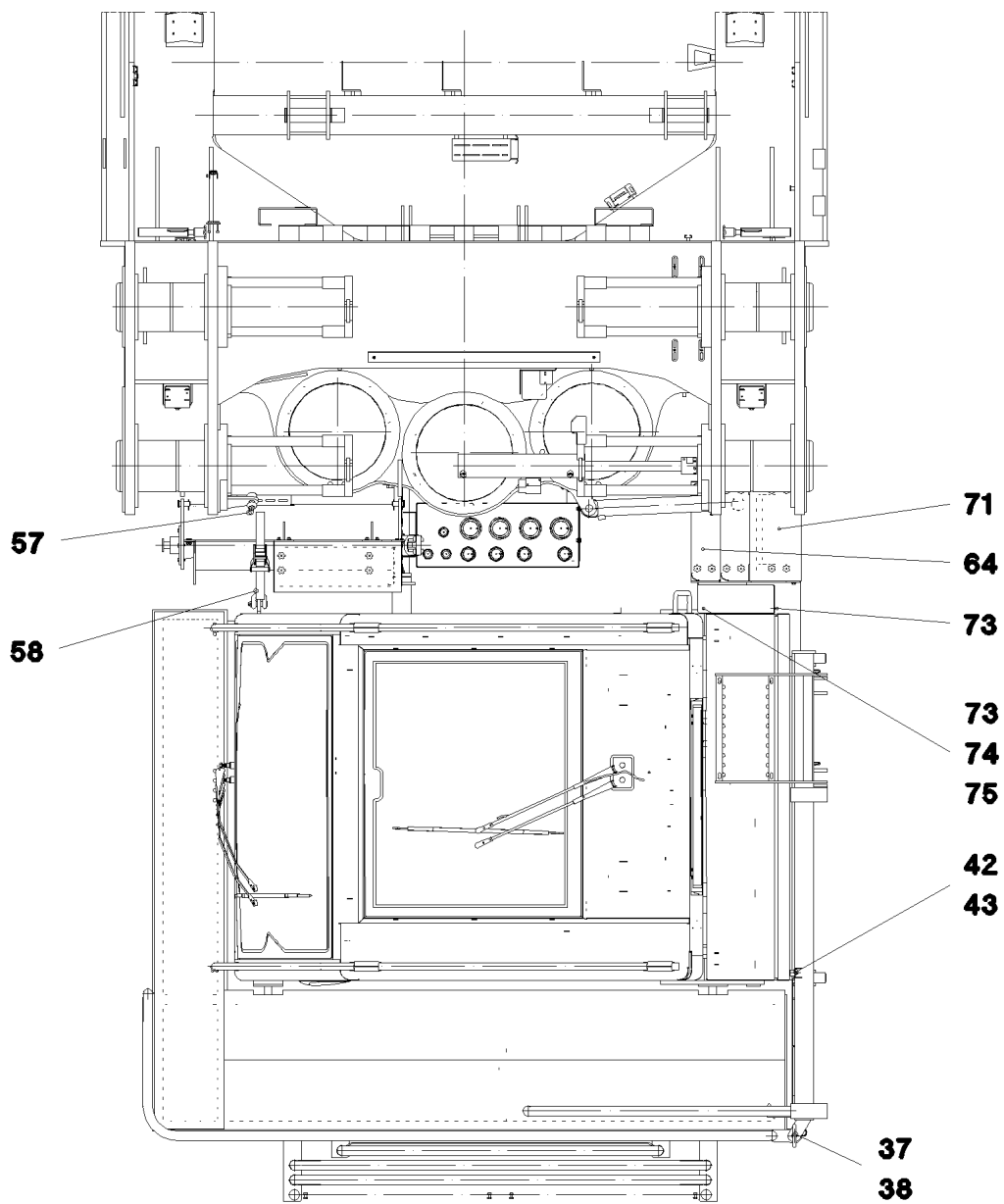
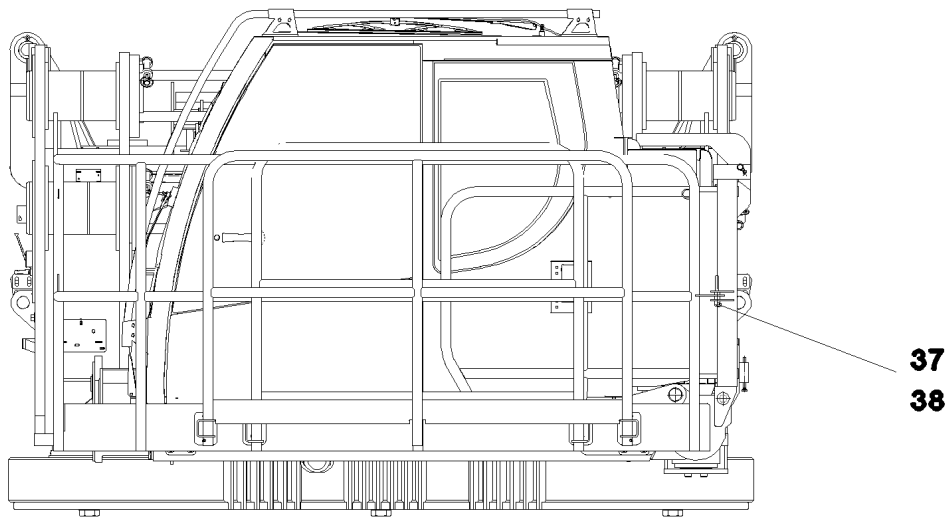

6.2.2009
052572

LIEBHERR

etk_en_de_074515 LR 1600/2

CRANE DRIVER'S CABIN CPL.
KRANFUEHRERKABINE KPL.

□ 241 (4/7)

⇒ 2 810
91 52 806 08

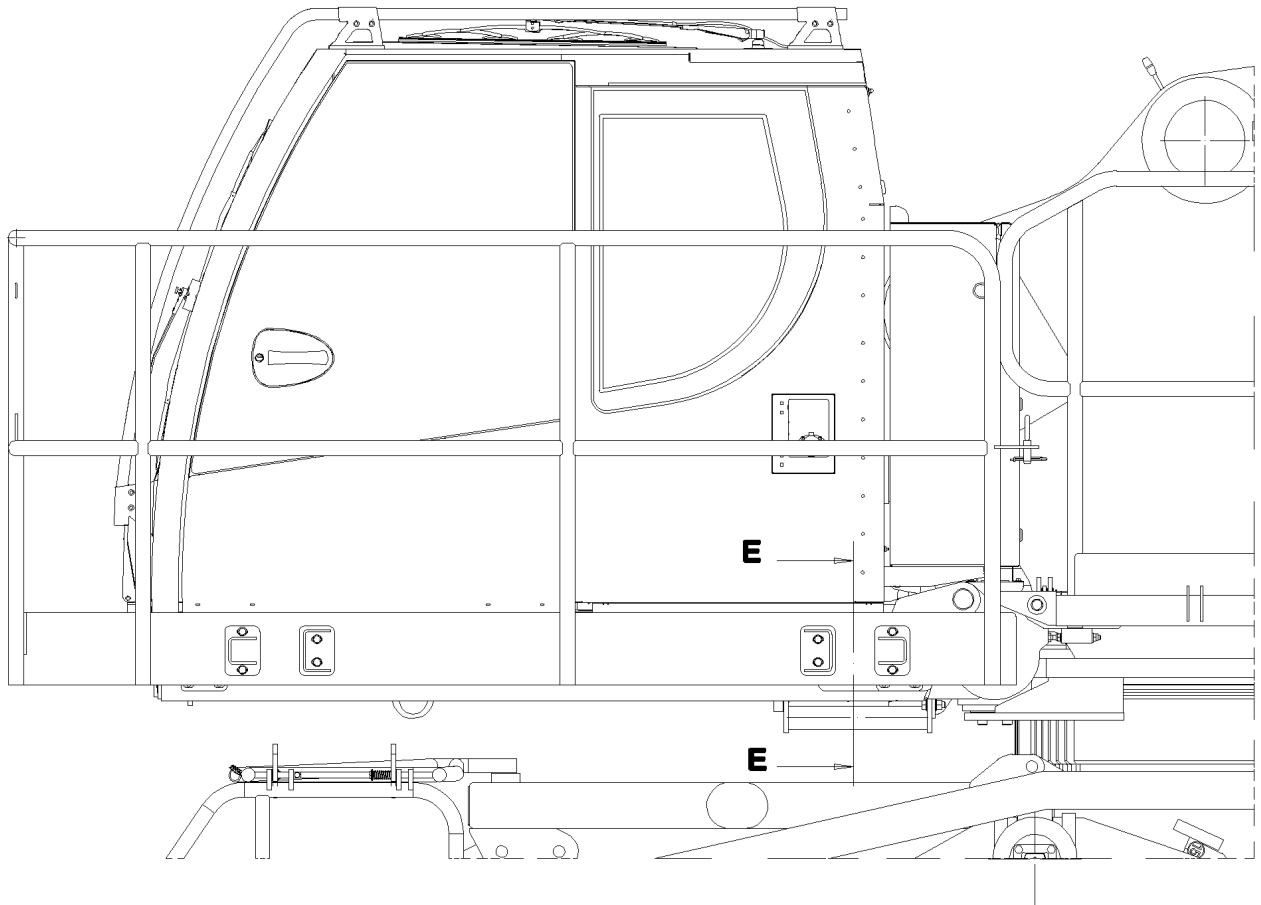

Schnitt E-E

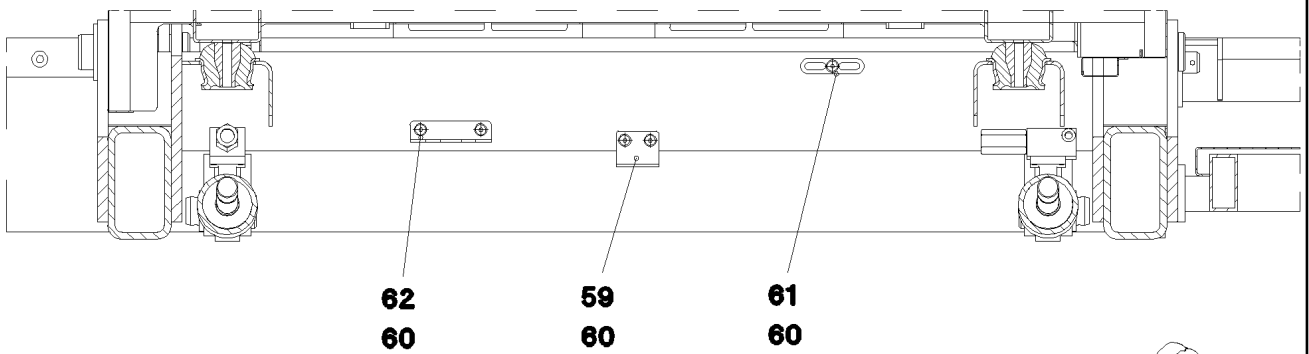

Ansicht X

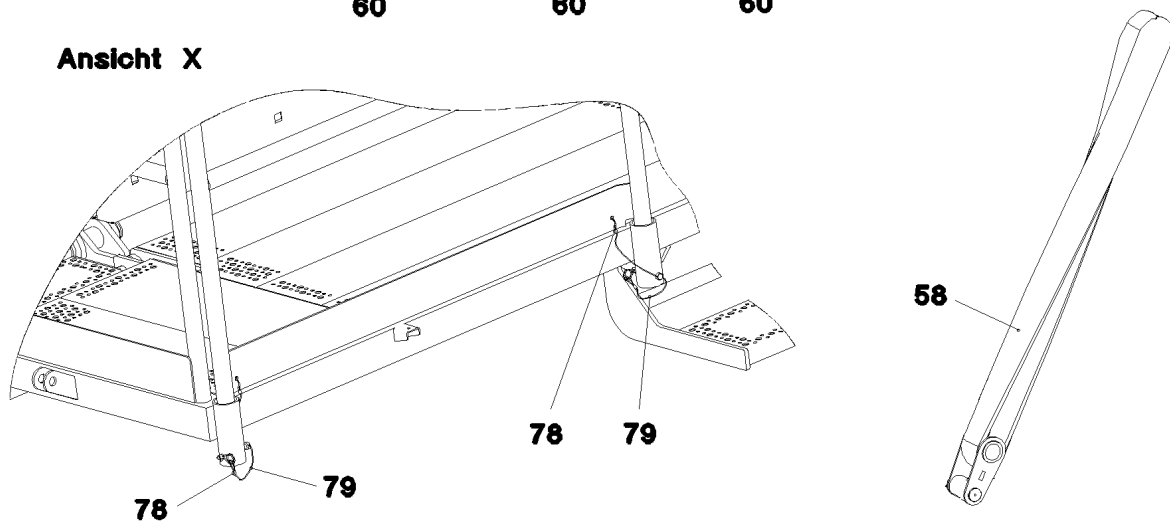

6.2.2009
052573

LIEBHERR

etk_en_de_074515 LR 1600/2

CRANE DRIVER'S CABIN CPL.
KRAFUEHRERKABINE KPL.

▣ 242 (5/7)

⇒ 2 810
91 52 806 08

Pos.	Item	Quantity	Description	Bezeichnung	Serie	K
1	96 43 597 08	1	CRANE DRIVER'S CABIN,PRE-ASSY. ⇒ 2 810 001 96 43 597 08	KRANFUEHRERKABINE VORM.		
2	96 46 382 08	1	FRAME WELDED	RAHMEN SCHWK.		
3	96 46 383 08	1	SWIVEL ARM WELDED	SCHWENKARM SCHWK.		
4	96 46 384 08	1	PLATFORM VORN	PODEST		
5	96 47 414 08	1	PLATFORM HINTEN	PODEST		
6	10 29 198 9	4	CONICAL BEARING 70NR11	KONUSLAGER		
7	46 00 038	4	HEX BOLT ISO 4014 M16X100 8.8 A3C	SECHSKANTSCHRAUBE		
8	10 29 198 8	4	LIMIT STOP RING ST	ANSCHLAGSCHEIBE		
9	40 01 696	16	HEX BOLT ISO 4017 M10X20 10.9 A3C	SECHSKANTSCHRAUBE		
10	41 19 011 08	16	HEX NUT DIN 985 M10 10 VERZ	SECHSKANTMUTTER		
11	93 92 498 08	2	PIN 55.0X158	BOLZEN		
12	94 95 827 08	2	WASHER RD80X5	SCHEIBE		
13	43 30 103 08	2	SPLIT PIN DIN 94 10X80 ST VERZ	SPLINT		
14	40 65 164	12	HEX BOLT ISO 4017 M10X25 8.8 A3C	SECHSKANTSCHRAUBE		
15	50 09 175 08	18	WASHER DIN 125 A 10.5 A2	SCHEIBE		
16	10 32 632 3	2	HYDRO CYLINDER 75/30-100 SPF	HYDROZYLINDER		
17	72 51 010 05	2	FORKED LINK DIN 71752 30X60	GABELGELENK		
18	41 17 011 08	2	HEX NUT DIN 936 M30 8 VERZ	SECHSKANTMUTTER		
19	93 35 587 08	2	PIN RD40X92	BOLZEN		
20	42 12 024 08	2	WASHER DIN 1441 41 ST A2C	SCHEIBE		
21	43 30 090 08	2	SPLIT PIN DIN 94 8X63 ST VERZ	SPLINT		
22	42 00 028 08	10	WASHER ISO 7089 A 31 A3C	SCHEIBE		
23	47 32 306 08	2	FLANGE JOINT RSWS6-SR-WD A3P	VERSCHRAUBUNG		
24	95 56 299 08	1	PIN RD80X365	BOLZEN		
25	70 43 346 08	2	BUSH 80X100X70 GZ-CUZN25AL5	BUCHSE		
26	94 18 461 08	1	PLATE 10X40X150	BLECH		
27	77 43 040 08	2	GREASE NIPPLE DIN 71412 A M10X1	SCHMIERNIPPEL		
28	97 13 432 08	2	PIN 40.0X95 42CRMO4+QT	BOLZEN		
29	42 11 026 08	4	WASHER DIN 1440 32 ST VERZ	SCHEIBE		
30	43 30 078 08	2	SPLIT PIN DIN 94 6,3X50 ST VERZ	SPLINT		
31	51 23 497 08	1	HYDRO CYLINDER 55/32-400 SPF	HYDROZYLINDER		
(4)	40 41 002 08	2	SCREW PLUG DIN 908 M18X1,5 ST A3C	VERSCHLUSSSCHRAUBE		
(6)	42 42 017	2	SPRING RING DIN 70951 47	SPRENGRING		
(9)	57 15 052 08	2	PIVOT BEARING 30	GELENKLAGER		
(999)	10 66 343 9	1	DS HYDRO CYLINDER	DS HYDROZYLINDER		
32	45 30 320 08	2	PIN DIN 1444 30H11X75X65 30CRNIMO8 GA	BOLZEN		
33	42 50 518 08	4	232204 DIN 137 B 30 A3C	FEDERSCHEIBE		
34	43 30 088 08	2	SPLIT PIN DIN 94 8X50 ST VERZ	SPLINT		
37	92 47 131 08	1	PLUG T ZN K	STECKER		
38	43 31 028 08	1	RETAINING SPRING 3 VERZ	SICHERUNGSFEDER		
39	45 12 272 08	4	PIN DIN 1435 25H11X110X100 42CRMO4 GA	BOLZEN		
40	42 12 016 08	4	WASHER DIN 1441 26 ST VERZ	SCHEIBE		
41	43 32 063 08	4	SPRING PLUG 5 VERZ	FEDERSTECKER		
42	72 66 122 08	1	MEGI BUFFER	MEGIPUFFER		
48	26 21 040 08	0.8	EDGE PROTECTION	KANTENSCHUTZ		
49	96 51 181 08	1	SUPPORT BRACKET WELDED	ABSTUETZKONSOLE SCHWK.		
50	46 00 189	4	HEX BOLT ISO 4017 M16X50 8.8 A3C	SECHSKANTSCHRAUBE		
51	42 00 019 08	8	WASHER DIN 125 A 17 VERZ	SCHEIBE		
52	41 15 145 08	4	HEX NUT DIN 934 M16 8 VERZ	SECHSKANTMUTTER		
53	97 80 257 08	2	PLATE 2X75X75 FE//ZN20//C	BLECH		
54	72 66 113 08	1	MEGI BUFFER	MEGIPUFFER		
55	42 00 016 08	1	WASHER ISO 7089 A 13 ST A3C	SCHEIBE		
56	41 15 143 08	1	HEX NUT DIN 934 M12 8 VERZ	SECHSKANTMUTTER		
57	77 39 334 08	2	SHACKLE DIN 82101 1,6T NG 1,6 ST VERZ	SCHAEKEL		
58	77 90 347 08	1	LASHING STRAP EN 12195-2 6M 35MM	ZURRGURT		
59	97 80 640 08	1	PLATE 3X60X70	BLECH		
60	10 41 285 4	7	OVAL HEAD FLAT SCREW AEHNL.ISO7380	LINSENFLACHKOPFSCHRAUBE		
61	95 36 500 08	3	CABLE HOLDER 2X22X90	KABELHALTER		
62	97 12 764 08	1	PLATE 4X115X98	BLECH		

6.2.2009

etk_en_de_074515 LR 1600/2

☐ 243 (6/7)

LIEBHERRCRANE DRIVER'S CABIN CPL.
KRANFUEHRERKABINE KPL.⇒ 2 810
91 52 806 08

Pos.	Item	Quantity	Description	Bezeichnung	Serie	K
63	97 85 691 08	1	PLATE 4X529X368	BLECH		
64	78 89 017 08	2	TREAD 2X40X400X120 AL SPF	AUFSTIEGSTRITT		
65	40 86 049 08	12	COUNTERSUNK SCREW DIN 7991 M8X70 8.	SENKSCRAUBE		
66	41 15 046 08	12	HEX NUT DIN 934 M8 10 VERZ	SECHSKANTMUTTER		
67	42 00 012 08	20	WASHER DIN 125 A8X16 ST VERZ	SCHEIBE		
68	49 00 089	4	HEX BOLT ISO 4017 M8X20 8.8 A2C	SECHSKANTSCHRAUBE		
69	41 15 141 08	4	HEX NUT DIN 934 M8 8 A2C	SECHSKANTMUTTER		
70	78 89 018 08	12	FIXING OR FASTENING PART KUNSTSTOF	BEFESTIGUNGSSTUECK		
71	10 47 603 1	1	TREAD 400X210X40 AL ELOXIERT SPF	AUFSTIEGSTRITT		
72	97 85 999 08	1	PLATE 1.5X1132X447	BLECH		
73	10 41 285 1	6	OVAL HEAD FLAT SCREW AEHNL. ISO 7380	LINSENFLACHKOPFSCHRAUBE		
74	42 18 017 08	3	WASHER ISO 7093 A 6.4 A2	SCHEIBE		
75	41 15 140 08	5	HEX NUT DIN 934 M6 8 VERZ	SECHSKANTMUTTER		
76	95 05 969 08	1	ANGLE 4X20X57	WINKEL		
77	97 88 595 08	12	TUBE 20.0X33	ROHR		
78	77 39 200 08	4	WIRE ROPE CLAMP DIN 3093 2 AL	PRESSKLEMME		
79	77 34 003 08	1	ROPE DIN 3055 2MM 2,3KN FE	SEIL		

6.2.2009

etk_en_de_074515 LR 1600/2

 244 (7/7)

LIEBHERR

CRANE DRIVER'S CABIN CPL.
KRANFUEHRERKABINE KPL.

⇒ 2 810
91 52 806 08

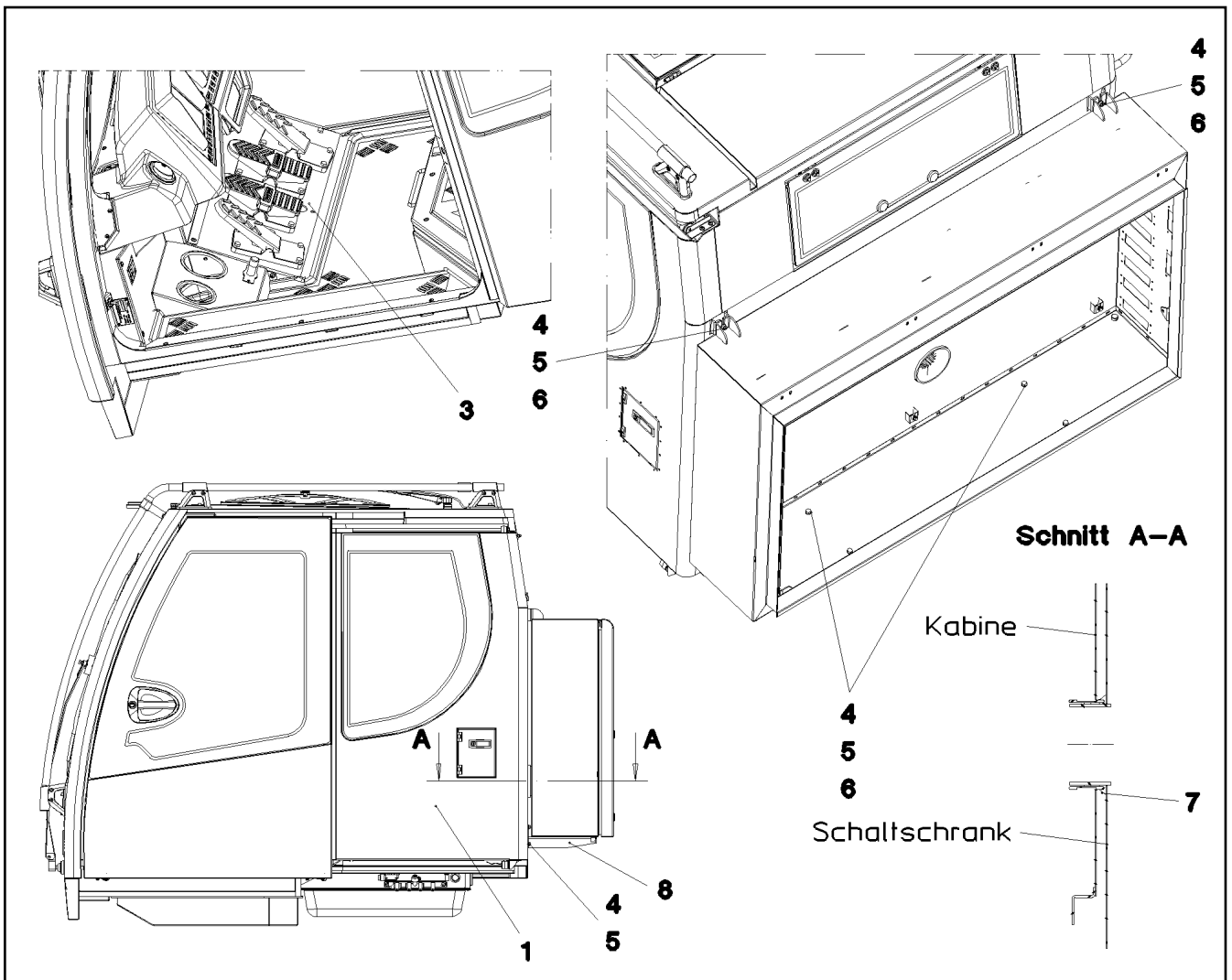

Pos.	Item	Quantity	Description	Bezeichnung	Serie	K
1	91 53 061 08	1	CABIN, GLAZED ⇒ 2 520 91 53 061 08	KABINE VERGLAST		
3	96 47 204 08	1	PEDAL CANTILEVER INSTALLATION ⇒ 2 810 037 96 47 204 08	PEDALTRAEGER EINBAU		
4	50 26 189 08	12	HEX BOLT ISO 4017 M8X22 8.8	SECHSKANTSCHRAUBE		
5	42 00 012 08	18	WASHER DIN 125 A8X16 ST VERZ	SCHEIBE		
6	41 19 005 08	6	HEX NUT DIN 985 M8 8 VERZ	SECHSKANTMUTTER		
7	87 00 018 08	1	SEALING AND FILLING AGENT 100G	DICHT-UND FUELLMASSE		
8	96 54 709 08	2	CARRIER	TRAEGER SCHWK.		

6.2.2009
052574

LIEBHERR

etk_en_de_074515 LR 1600/2

CRANE DRIVER'S CABIN, PRE-ASSY.
KRANFUEHRERKABINE VORM.

□ 245

⇒ 2 810 001
96 43 597 08

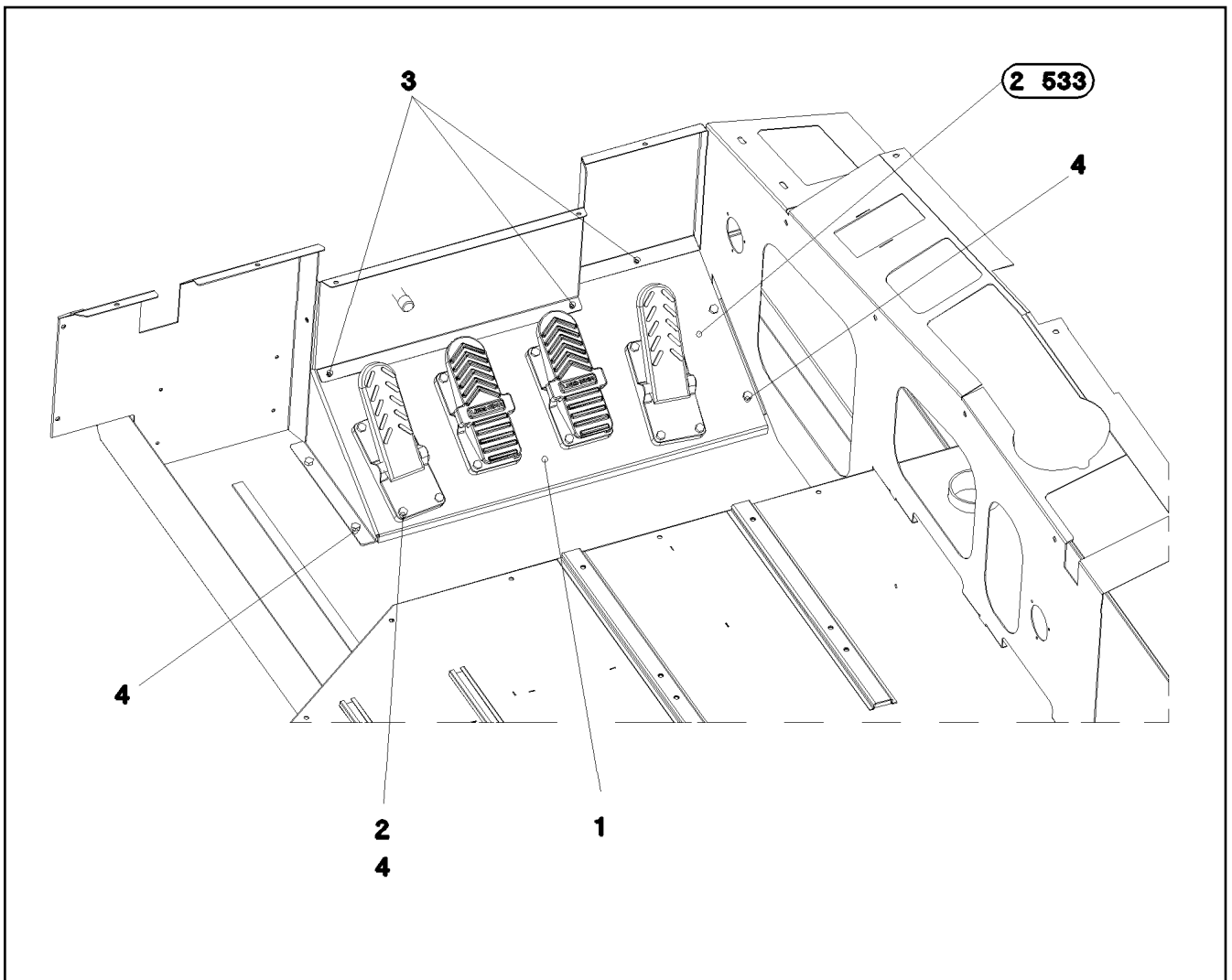

Pos.	Item	Quantity	Description	Bezeichnung	Serie	K
1	97 71 793 08	1	PLATE 3X892X382	BLECH		
2	41 30 065 08	12	BLIND RIVET NUT M 8	BLINDNIETMUTTER		
3	10 04 259 3	5	BLIND RIVET NUT M6 ST VERZ	BLINDNIETMUTTER		
4	49 00 128	20	HEX BOLT ISO 4017 M8X25 8.8 A2C	SECHSKANTSCHRAUBE		
5	60 27 013 08	2	GROMMET 10/12/17,5	DURCHFUEHRUNGSTUELLE		

6.2.2009
052575

LIEBHERR

etk_en_de_074515 LR 1600/2

PEDAL CANTILEVER INSTALLATION
PEDALTRAEGER EINBAU

246

⇒ 2 810 037
96 47 204 08

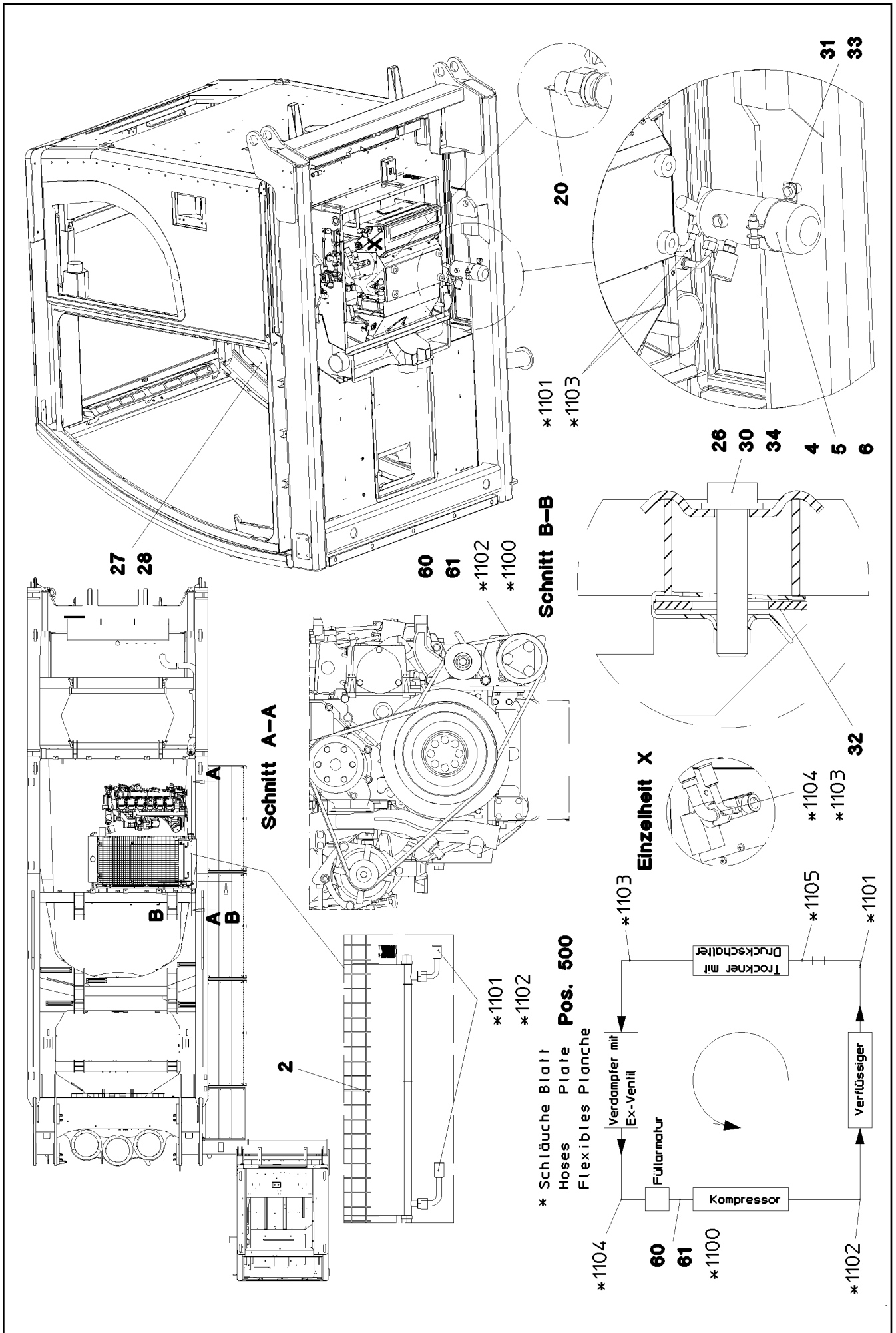

6.2.2009
053698

LIEBHERR

etk_en_de_074515 LR 1600/2

AIR COND. UNIT SUPERSTRUCTURE
KLIMAANLAGE OW

□ 247 (1/2)

⇒ 2 831
91 57 754 08

Pos.	Item	Quantity	Description	Bezeichnung	Serie	K
2	10 11 371 2	1	LIQUEFIER AL	VERFLUESSIGER		
4	57 14 890 08	1	DRYER	TROCKNER		
5	77 42 097 08	1	RETAINER CLIP 75/25	SPANNSCHELLE		
6	57 14 891 08	1	PRESSURE SWITCH	DRUCKSCHALTER		
8	86 16 012 08	2.2	COOLING AGENT R 134 A	KAELTEMITTEL		
20	55 30 310 08	1	LABEL	SCHILD		
26	72 58 100 08	4	UPPER FASTENING 52x26x3	BEFESTIGUNGSOBERTEIL		
27	97 69 555 08	1	LABEL 75X45 ALUMINIUM	SCHILD		
28	70 42 127 08	2	BLIND RIVET 3,2X4,3-5,9	BLINDNIET		
30	49 00 614	4	HEX BOLT ISO 4017 M8X40 8.8 A2C	SECHSKANTSCHRAUBE		
31	42 18 009 08	4	WASHER DIN 9021 A 8.4 VERZ	SCHEIBE		
32	41 30 070 08	4	SHEET METAL NUT M8	BLECHMUTTER		
33	40 65 136	2	HEX BOLT ISO 4017 M8X12 8.8 A2C	SECHSKANTSCHRAUBE		
34	42 00 012 08	4	WASHER DIN 125 A8X16 ST VERZ	SCHEIBE		
60	10 21 652 9	1	BRACKET ST	BUEGEL		
61	10 21 653 4	2	CLIP 23 ST	CLIP		
500	96 54 368 08	1	HOSES AIR CONDITIONING LR1600-2	SCHLAUCHLEITUNGEN KLIMA O		
(1)	60 27 601 08	6	NAME PLATE 25,4X101,6	BEZEICHNUNGSSCHILD		
(1100)	96 54 321 08	1	HOSE ASS CPL. GH134 8,0M	SCHLAUCH KPL.		
(1101)	96 54 322 08	1	HOSE ASS CPL. GH134 8,1M	SCHLAUCH KPL.		
(1102)	96 54 323 08	1	HOSE ASS CPL. GH134 2,8M	SCHLAUCH KPL.		
(1103)	96 51 902 08	1	HOSE ASS CPL. GH134 1,9M	SCHLAUCH KPL.		
(1104)	96 54 324 08	1	HOSE ASS CPL. GH134 2,7M	SCHLAUCH KPL.		
(1105)	96 54 325 08	1	HOSE ASS CPL. GH134 3,6M	SCHLAUCH KPL.		

6.2.2009

etk_en_de_074515 LR 1600/2

☐ 248 (2/2)

LIEBHERR

AIR COND. UNIT SUPERSTRUCTURE
KLIMAANLAGE OW

⇒ 2 831
91 57 754 08

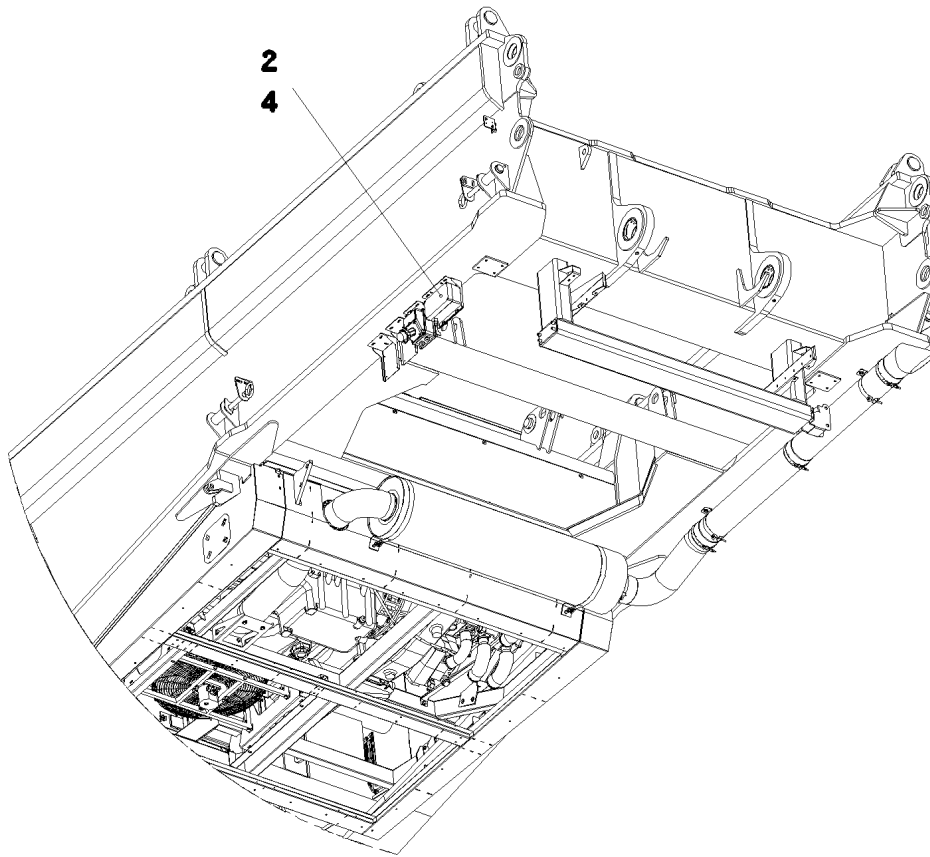

Pos. 3

Pos.	Item	Quantity	Description	Bezeichnung	Serie	K
2	61 33 018 08	1	CHARGER 230V/24V/8A SPF	LADEGERAET		
3	96 48 378 08	1	EL.CHARGER F.BATTERY	ELEKTRIK BATTERIELADEGER		
(10)	96 51 039 08	1	WIRING HARNESS W621	KABELSTRANG		
(20)	96 51 040 08	1	WIRING HARNESS W620	KABELSTRANG		
4	96 48 379 08	1	ADD-ON PARTS LADEGERAET	ANBAUTEILE		
			⇒ 2 835 002 96 48 379 08			

6.2.2009
054191

LIEBHERR

etk_en_de_074515 LR 1600/2

BATTERY CHARGER
BATTERIELADEGERAET

□ 249

⇒ 2 835
91 52 807 08

Pos.	Item	Quantity	Description	Bezeichnung	Serie	K
21	42 52 210 08	4	SERRATED LOCK WASHER DIN 6798 J 6,4	FAECHERSCHEIBE		
22	41 15 140 08	8	HEX NUT DIN 934 M6 8 VERZ	SECHSKANTMUTTER		
23	42 00 009 08	12	WASHER ISO 7089 A 6.4 VERZ	SCHEIBE		
24	49 00 539	4	HEX BOLT ISO 4017 M6X25 8.8 A3C	SECHSKANTSCHRAUBE		
31	40 73 501 08	1	HEX BOLT EN 1665 M5X16 10.9 A2C	SECHSKANTSCHRAUBE		
32	42 52 208 08	1	SERRATED LOCK WASHER DIN 6798 J 5,3	FAECHERSCHEIBE		
33	42 00 008 08	2	WASHER DIN 125 A 5.3 VERZ	SCHEIBE		
34	41 15 148 08	2	HEX NUT DIN 934 M5 8 VERZ	SECHSKANTMUTTER		

6.2.2009

etk_en_de_074515 LR 1600/2

☐ 250

LIEBHERR

ADD-ON PARTS
ANBAUTEILE

⇒ 2 835 002
96 48 379 08

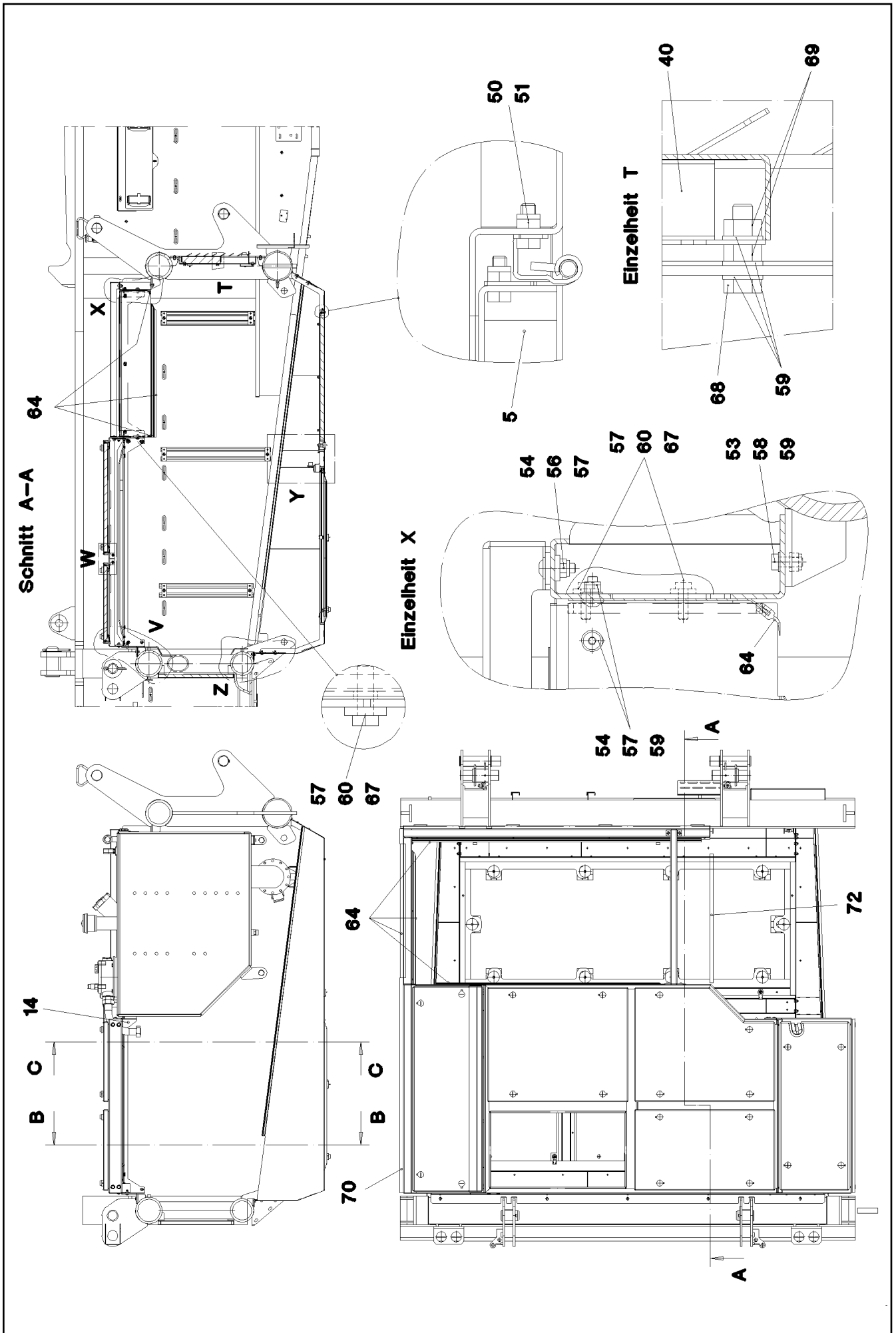

6.2.2009
053014

LIEBHERR

etk_en_de_074515 LR 1600/2

SOUND INSULATION
GERAEUSCHDAEMMUNG

□ 251 (1/6)

⇒ 2 859
91 52 809 08

Schnitt B-B

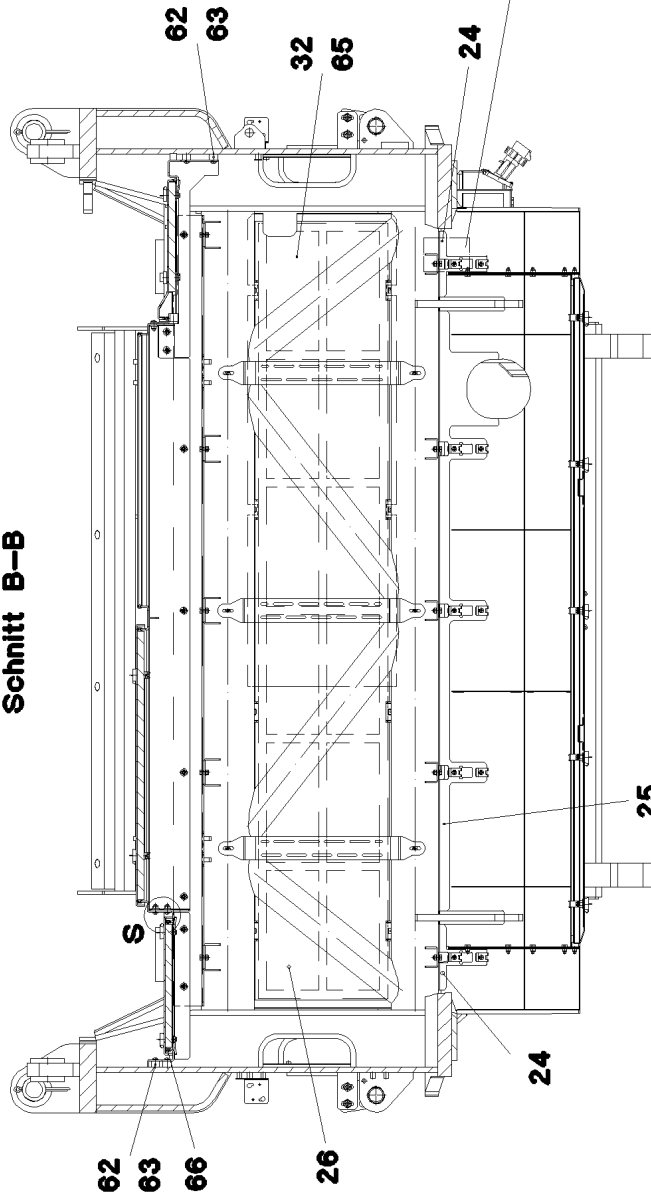

Schnitt C-C

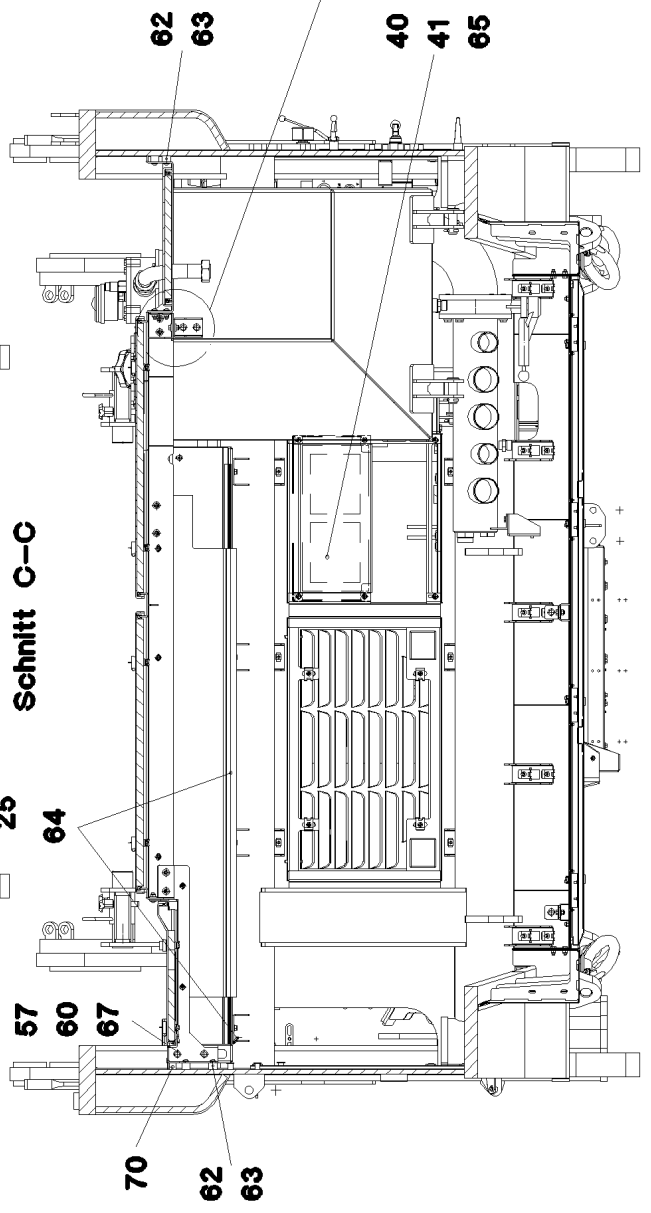

Einzelheit W

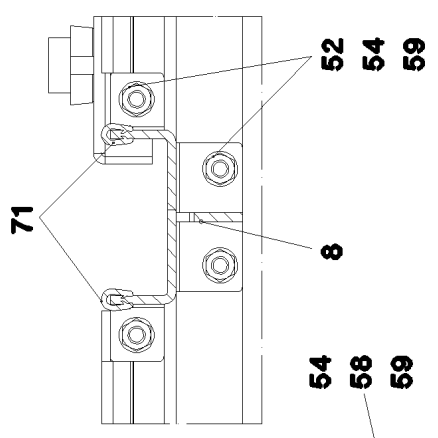

Einzelheit S

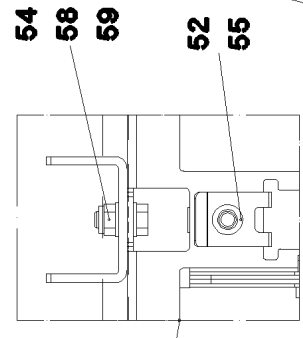
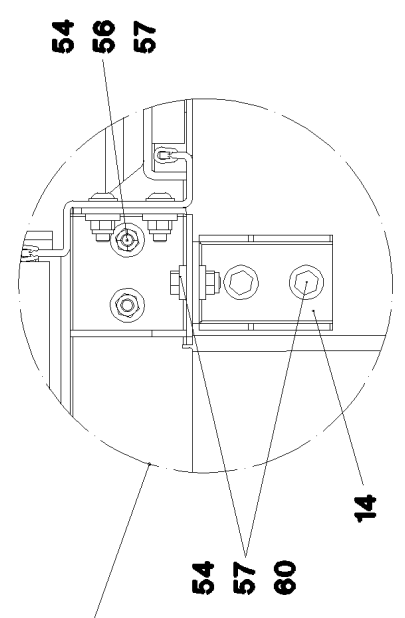
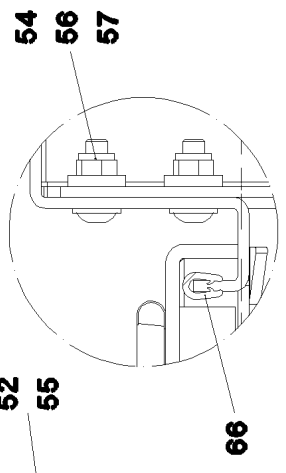

6.2.2009
053015

LIEBHERR

etk_en_de_074515 LR 1600/2

SOUND INSULATION
GERAEUSCHDAEMMUNG

□ 252 (2/6)

→ 2 859
91 52 809 08

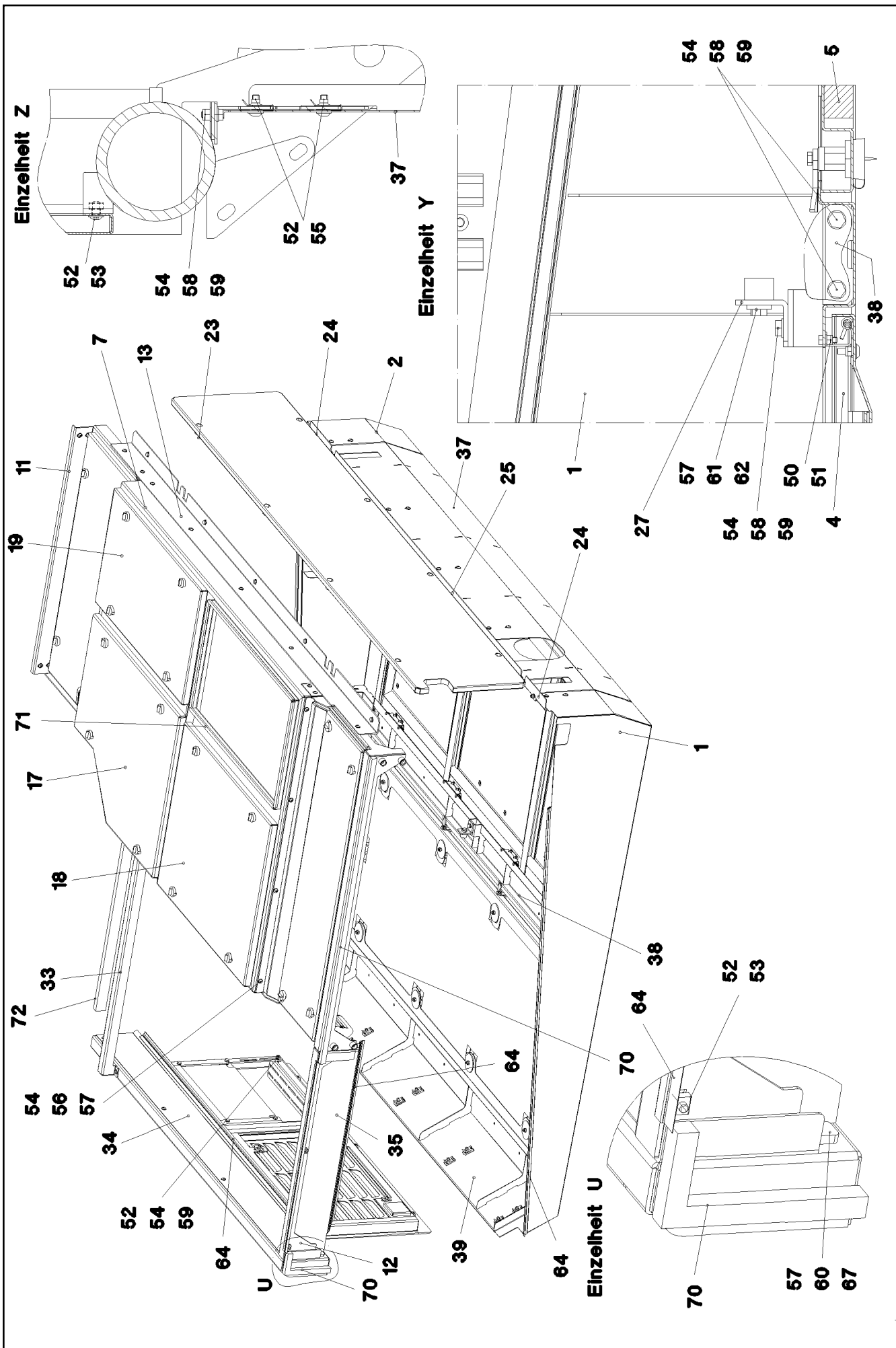

6.2.2009
053016

LIEBHERR

etk_en_de_074515 LR 1600/2

SOUND INSULATION
GERAEUSCHDAEMMUNG

253 (3/6)

→ 2 859
91 52 809 08

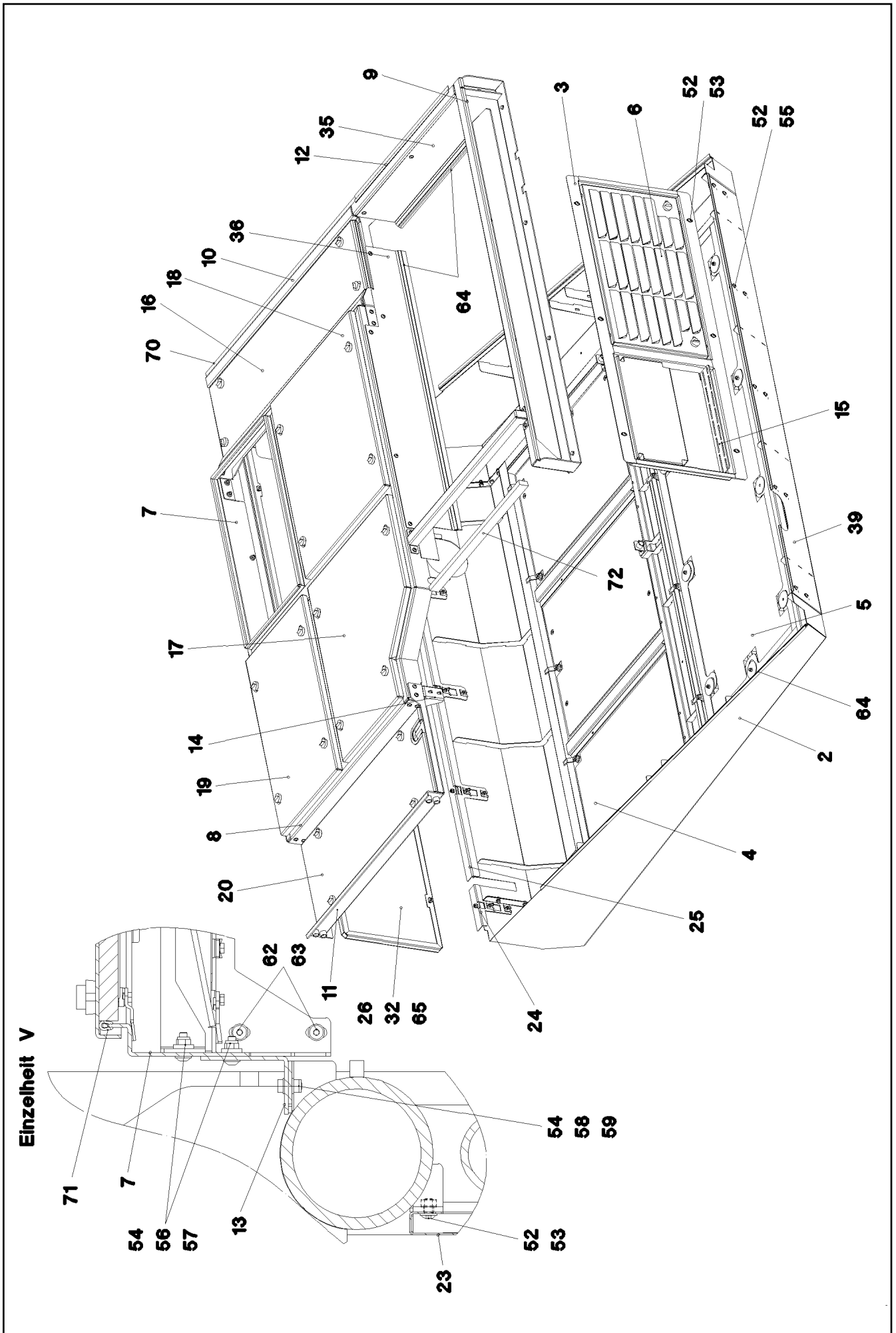

6.2.2009
053017

LIEBHERR

etk_en_de_074515 LR 1600/2

SOUND INSULATION
GERAEUSCHDAEMMUNG

□ 254 (4/6)

→ 2 859
91 52 809 08

Pos.	Item	Quantity	Description	Bezeichnung	Serie	K
1	96 46 753 08	1	PLATE WELDED	BLECH SCHWK.		
2	96 46 754 08	1	PLATE WELDED	BLECH SCHWK.		
3	96 46 755 08	1	FRAME	RAHMEN		
4	96 46 756 08	1	FLAP PRE-ASS. ⇒ 2 859 005 96 46 756 08	KLAPPE VORM.		
5	96 46 757 08	1	GRIDIRON PRE-ASS. ⇒ 2 859 025 96 46 757 08	GITTERROST VORM.		
6	96 46 758 08	1	COVER COMPL. ⇒ 2 859 030 96 46 758 08	DECKEL KPL.		
7	96 46 759 08	1	FRAME	RAHMEN		
8	96 46 760 08	1	FRAME	RAHMEN		
9	96 46 761 08	1	FRAME	RAHMEN		
10	96 48 159 08	1	FRAME	RAHMEN		
11	97 70 775 08	1	FRAME 4X1150X608	RAHMEN		
12	97 70 784 08	1	FRAME 4X1029X189	RAHMEN		
13	97 70 786 08	1	PLATE 4X2346X144	BLECH		
14	97 70 790 08	1	PLATE 4X155X134	BLECH		
15	97 70 792 08	1	PLATE 4X492X101	BLECH		
16	96 46 775 08	1	COVER COMPL. ⇒ 2 859 007 96 46 775 08	DECKEL KPL.		
17	96 46 776 08	1	COVER COMPL. ⇒ 2 859 026 96 46 776 08	DECKEL KPL.		
18	96 46 777 08	1	COVER COMPL. ⇒ 2 859 027 96 46 777 08	DECKEL KPL.		
19	96 46 778 08	1	COVER COMPL. ⇒ 2 859 028 96 46 778 08	DECKEL KPL.		
20	96 46 779 08	1	COVER COMPL. ⇒ 2 859 029 96 46 779 08	DECKEL KPL.		
23	97 70 793 08	1	PLATE 2X2444X554	BLECH		
24	97 70 794 08	2	PLATE 3X196X184	BLECH		
25	97 70 795 08	1	PLATE 3X1779X219	BLECH		
26	97 70 796 08	1	INSULATING MAT 20X953X442	DAEMMMATTE		
27	97 70 797 08	2	PLATE 4X40X78	BLECH		
32	97 70 809 08	1	INSULATING MAT 20X1400X442	DAEMMMATTE		
33	97 70 810 08	1	PLATE 4X1001X183	BLECH		
34	97 70 811 08	1	PLATE 1.5X1770X169	BLECH		
35	97 70 813 08	1	PLATE 1.5X872X194	BLECH		
36	97 70 814 08	1	PLATE 1.5X1489X232	BLECH		
37	96 48 276 08	1	PLATE WELDED	BLECH SCHWK.		
38	96 48 277 08	1	PLATE WELDED	BLECH SCHWK.		
39	96 48 278 08	1	PLATE WELDED	BLECH SCHWK.		
40	97 81 124 08	1	PLATE 2X648X321	BLECH		
41	97 70 907 08	1	INSULATING MAT 40X482X228	DAEMMMATTE		
50	40 00 417	16	HEX BOLT ISO 4017 M5X12 8.8 A2C	SECHSKANTSCHRAUBE		
51	41 19 003 08	16	HEX NUT DIN 985 M5 8 VERZ	SECHSKANTMUTTER		
52	40 97 041 08	48	PAN-HEAD SCREW M8X20	FLACHKOPFSCHRAUBE		
53	41 30 032 08	21	CAGE NUT M8	KAFIGMUTTER		
54	41 19 005 08	77	HEX NUT DIN 985 M8 8 VERZ	SECHSKANTMUTTER		
55	41 30 070 08	24	SHEET METAL NUT M8	BLECHMUTTER		
56	10 41 286 1	25	OVAL HEAD FLAT SCREW AEHNL.ISO7380	LINSENFLACHKOPFSCHRAUBE		
57	42 16 005 08	35	WASHER DIN 7349 8,4 ST VERZ	SCHEIBE		
58	49 00 089	40	HEX BOLT ISO 4017 M8X20 8.8 A2C	SECHSKANTSCHRAUBE		
59	42 00 012 08	104	WASHER DIN 125 A8X16 ST VERZ	SCHEIBE		
60	49 00 128	5	HEX BOLT ISO 4017 M8X25 8.8 A2C	SECHSKANTSCHRAUBE		
61	49 00 188	4	HEX BOLT ISO 4017 M8X16 8.8 A2C	SECHSKANTSCHRAUBE		
62	95 38 734 08	10	SLEEVE	HUELSE		
63	10 41 285 7	16	OVAL HEAD FLAT SCREW AEHNL.ISO7380	LINSENFLACHKOPFSCHRAUBE		
64	26 21 053 08	9.6	EDGE PROTECTION	KANTENSCHUTZ		
65	80 21 020 08	10.8	ADHESIVE INSULATING STRIP 25MM PS18	PILZKOPFBAND		
66	26 21 040 08	1.6	EDGE PROTECTION	KANTENSCHUTZ		

6.2.2009

etk_en_de_074515 LR 1600/2

☐ 255 (5/6)

LIEBHERRSOUND INSULATION
GERAEUSCHDAEMMUNG⇒ 2 859
91 52 809 08

Pos.	Item	Quantity	Description	Bezeichnung	Serie	K
67	95 32 809 08	2	PLATE 8X25X160	BLECH		
68	49 00 111	4	HEX BOLT ISO 4017 M8X30 8.8 A2C	SECHSKANTSCHRAUBE		
69	41 15 141 08	8	HEX NUT DIN 934 M8 8 A2C	SECHSKANTMUTTER		
70	10 42 540 9	1.5	INSULATING MATERIAL 20X20X2000	DAEMMSTOFF		
71	26 21 067 08	10	SEALING PROFILE GUMMI	ABDICHTPROFIL		
72	28 39 057 08	1	INSULATING MATERIAL 40X40X2000	DAEMMSTOFF		

6.2.2009

etk_en_de_074515 LR 1600/2

 256 (6/6)

LIEBHERR

SOUND INSULATION
GERAEUSCHDAEMMUNG

⇒ 2 859
91 52 809 08

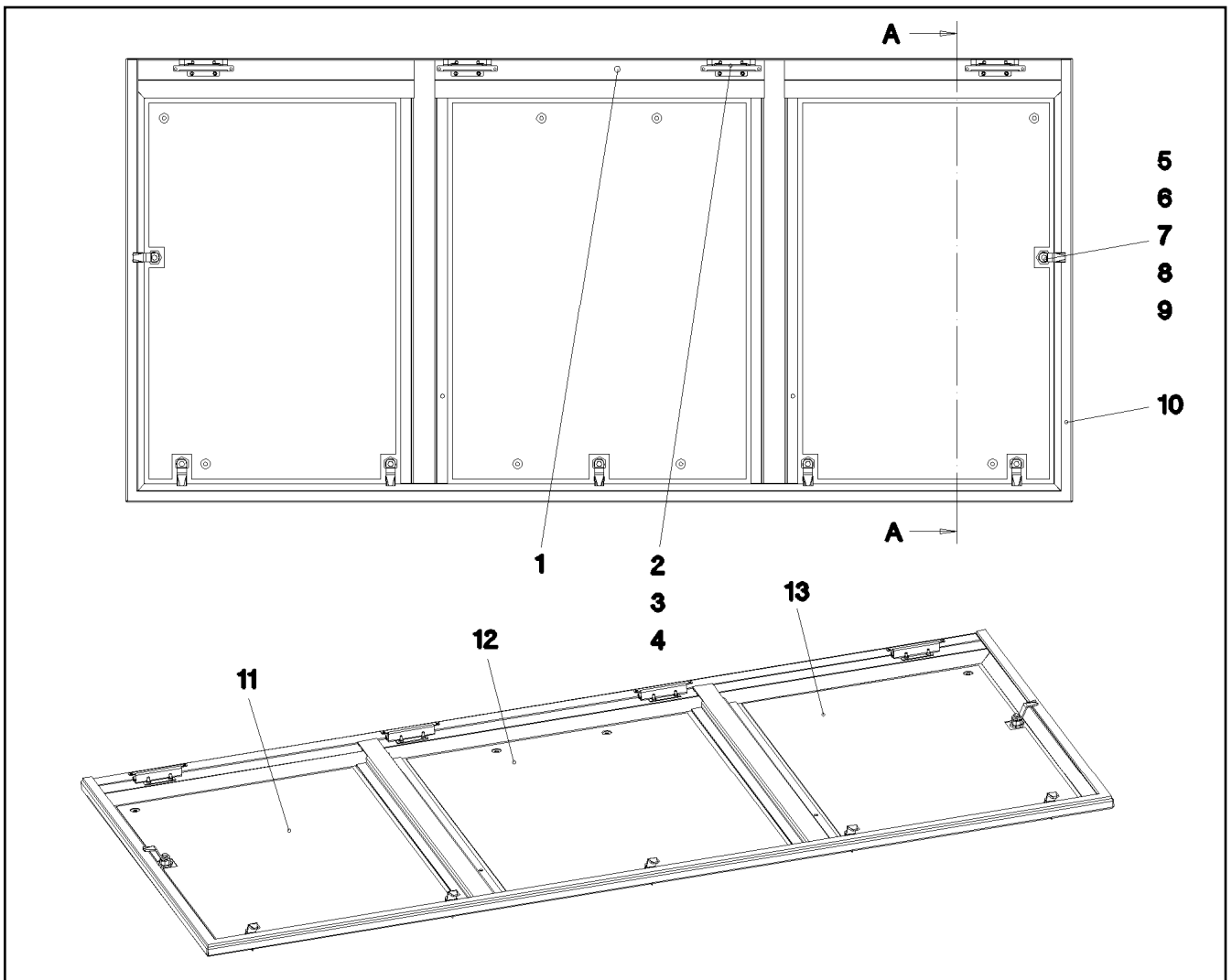

Pos.	Item	Quantity	Description	Bezeichnung	Serie	K
1	96 46 809 08	1	FLAP GLUED SPF	KLAPPE GEKLEBT		
2	70 42 619 08	4	HINGE F6-3 STAHL	SCHARNIER		
3	10 02 823 7	8	PAN-HEAD SCREW M5X16 A2	FLACHKOPFSCHRAUBE		
4	41 19 003 08	8	HEX NUT DIN 985 M5 8 VERZ	SECHSKANTMUTTER		
5	70 42 533 08	7	HOUSING	GEHAEUSE		
6	70 42 534 08	7	ACTUATION SPIKE	BETAETIGUNGSDORN		
7	70 42 548 08	7	DUST CAP	STAUBKAPPE		
8	70 42 553 08	7	TONGUE	ZUNGE		
9	70 42 748 08	7	O-RING 12X2 NBR70	O-RING		
10	26 21 010 08	3.91	CELL RUBBER 20X8	ZELLGUMMI		
11	97 79 354 08	1	HEAVY FOIL MATTING 2X783X515	SCHWERFOLIENMATTE		
12	97 79 355 08	1	HEAVY FOIL MATTING 2X783X613	SCHWERFOLIENMATTE		
13	97 79 356 08	1	HEAVY FOIL MATTING 2X783X515	SCHWERFOLIENMATTE		

6.2.2009
053019

LIEBHERR

etk_en_de_074515 LR 1600/2

FLAP PRE-ASS.
KLAPPE VORM.

257

⇒ 2 859 005
96 46 756 08

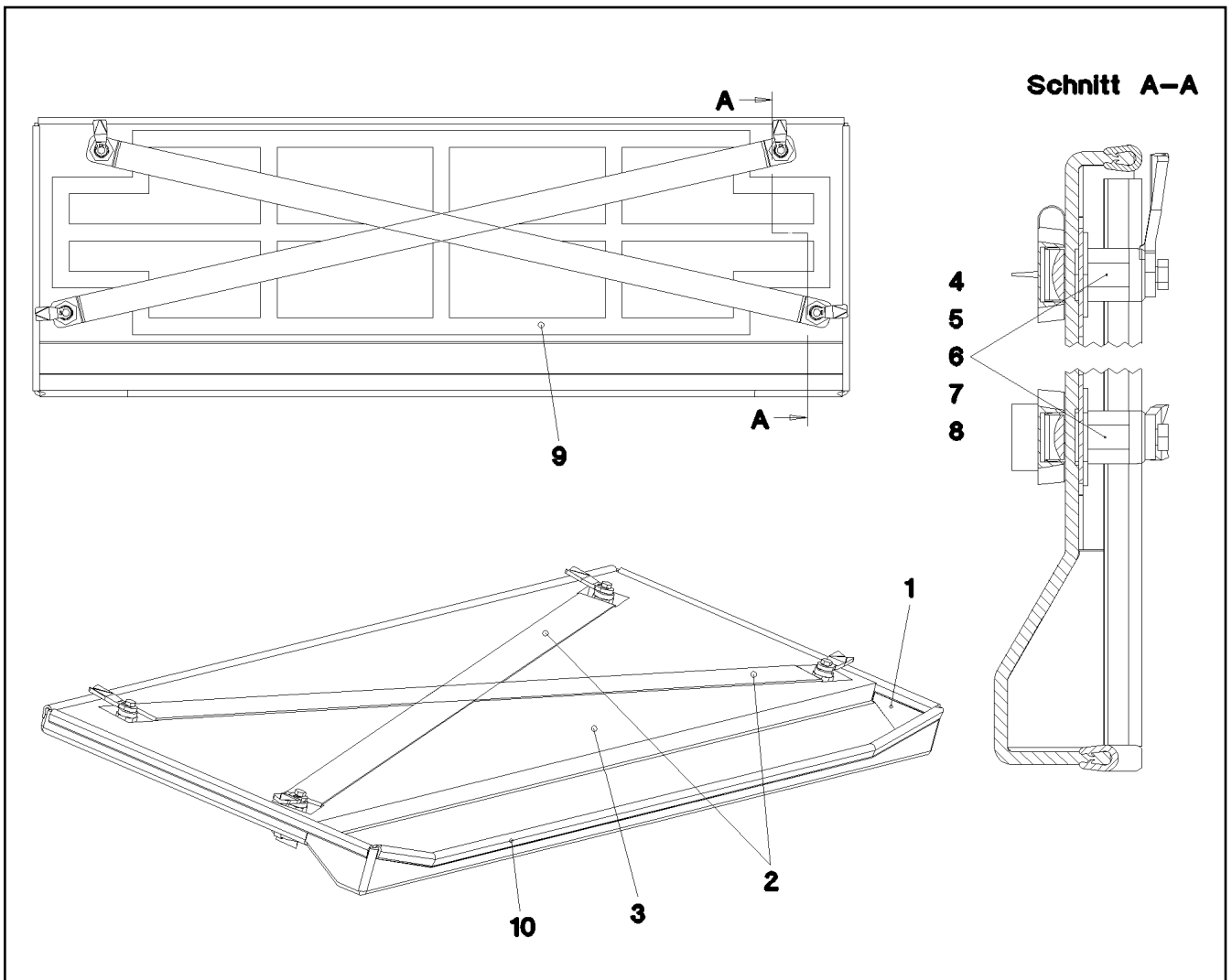

Pos.	Item	Quantity	Description	Bezeichnung	Serie	K
1	97 70 935 08	1	NIPPLE PLATE 5X1372X491	WARZENBLECH		
2	97 70 936 08	2	PLATE 1.5X326X40	BLECH		
3	97 70 937 08	1	INSULATING MAT 20X1206X326	DAEMMMATTE		
4	70 42 566 08	4	HOUSING	GEHAEUSE		
5	70 42 534 08	4	ACTUATION SPIKE	BETAETIGUNGSDORN		
6	70 42 748 08	4	O-RING 12X2 NBR70	O-RING		
7	70 42 548 08	4	DUST CAP	STAUBKAPPE		
8	70 42 540 08	4	TONGUE	ZUNGE		
9	80 21 020 08	3.7	ADHESIVE INSULATING STRIP 25MM PS18	PILZKOPFBAND		
10	26 21 040 08	3.27	EDGE PROTECTION	KANTENSCHUTZ		

6.2.2009
053023

LIEBHERR

etk_en_de_074515 LR 1600/2

COVER COMPL.
DECKEL KPL.

□ 258

⇒ 2 859 007
96 46 775 08

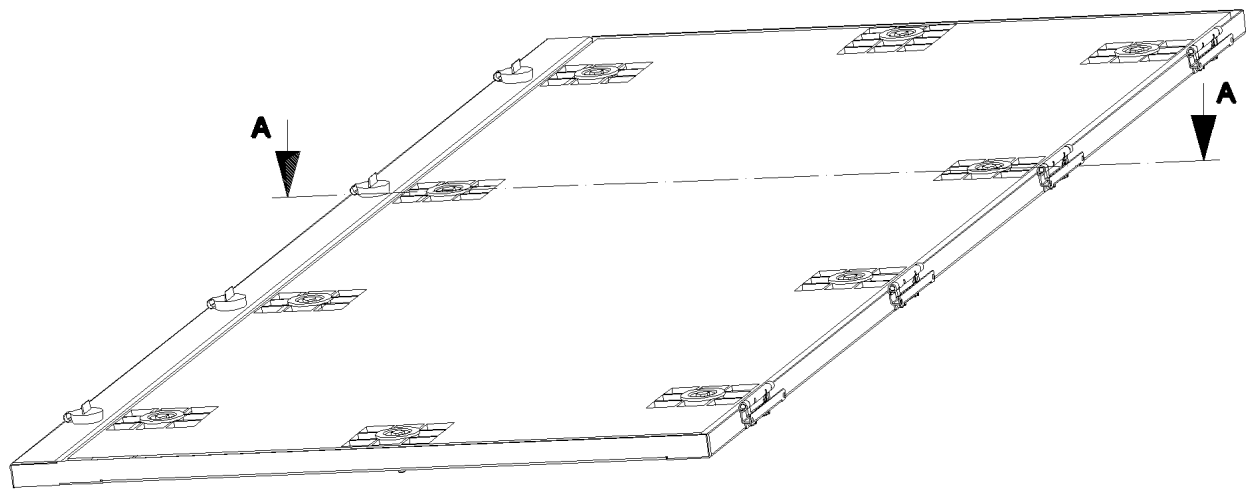

Schnitt A-A

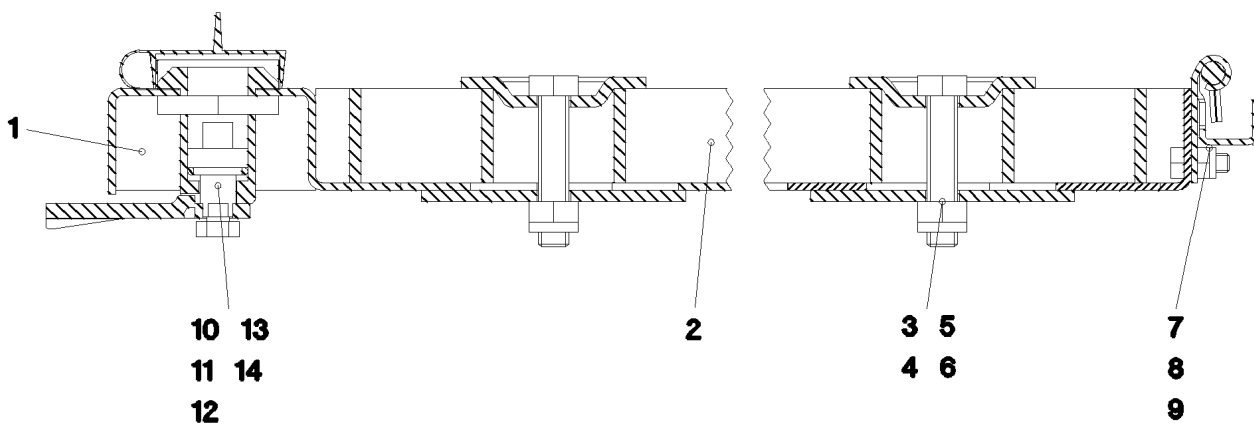

Pos.	Item	Quantity	Description	Bezeichnung	Serie	K
1	96 46 810 08	1	GRATING-FRAME WELDED	GITTERROSTRAHMEN SCHWK.		
2	97 70 899 08	1	GRATING T1950X738X25/3 ALMGSI0.5 SPF	GITTERROST		
3	10 10 062 1	10	DISH MOUNTING	TELLERBEFESTIGUNG		
4	49 00 614	10	HEX BOLT ISO 4017 M8X40 8.8 A2C	SECHSKANTSCHRAUBE		
5	94 11 381 08	10	WASHER 70X3	SCHEIBE		
6	41 19 005 08	10	HEX NUT DIN 985 M8 8 VERZ	SECHSKANTMUTTER		
7	70 42 637 08	4	HINGE F6-1 STAHL	SCHARNIER		
8	40 00 417	8	HEX BOLT ISO 4017 M5X12 8.8 A2C	SECHSKANTSCHRAUBE		
9	41 19 003 08	8	HEX NUT DIN 985 M5 8 VERZ	SECHSKANTMUTTER		
10	70 42 566 08	4	HOUSING	GEHAEUSE		
11	70 42 534 08	4	ACTUATION SPIKE	BETAETIGUNGSDORN		
12	70 42 748 08	4	O-RING 12X2 NBR70	O-RING		
13	70 42 548 08	4	DUST CAP	STAUBKAPPE		
14	70 42 590 08	4	TONGUE	ZUNGE		

6.2.2009
053018

LIEBHERR

etk_en_de_074515 LR 1600/2

GRIDIRON PRE-ASS.
GITTERROST VORM.

259

⇒ 2 859 025
96 46 757 08

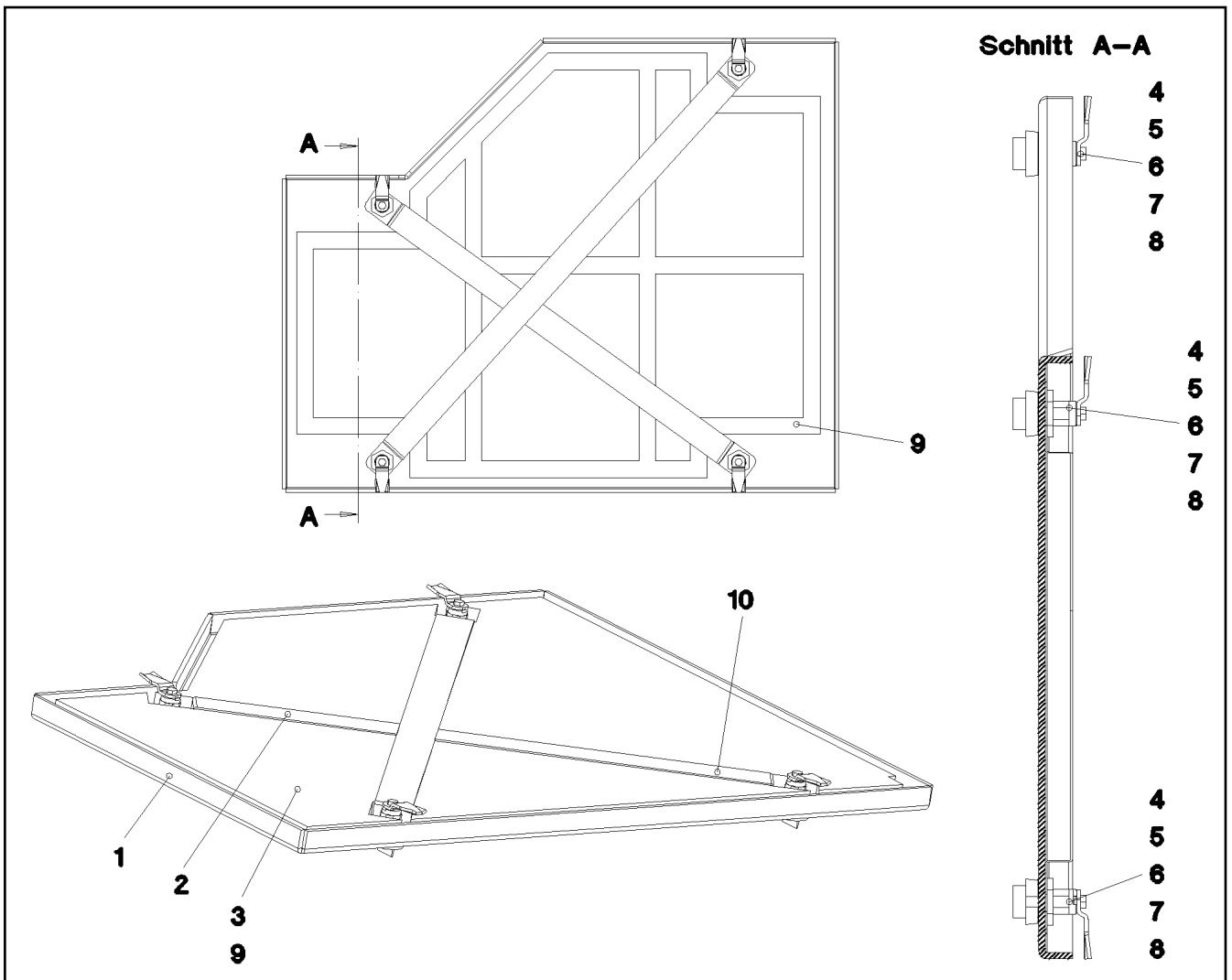

Pos.	Item	Quantity	Description	Bezeichnung	Serie	K
1	97 70 951 08	1	NIPPLE PLATE 5X878X723	WARZENBLECH		
2	97 70 952 08	1	PLATE 1.5X739X40	BLECH		
3	97 70 953 08	1	INSULATING MAT 20X798X643	DAEMMMATTE		
4	70 42 566 08	4	HOUSING	GEHAEUSE		
5	70 42 534 08	4	ACTUATION SPIKE	BETAETIGUNGSDORN		
6	70 42 748 08	4	O-RING 12X2 NBR70	O-RING		
7	70 42 548 08	4	DUST CAP	STAUBKAPPE		
8	70 42 567 08	4	TONGUE	ZUNGE		
9	80 21 020 08	5	ADHESIVE INSULATING STRIP 25MM PS18	PILZKOPFBAND		
10	97 70 983 08	1	PLATE 1.5X872X40 DC01	BLECH		

6.2.2009
053020

LIEBHERR

etk_en_de_074515 LR 1600/2

COVER COMPL.
DECKEL KPL.

260

⇒ 2 859 026
96 46 776 08

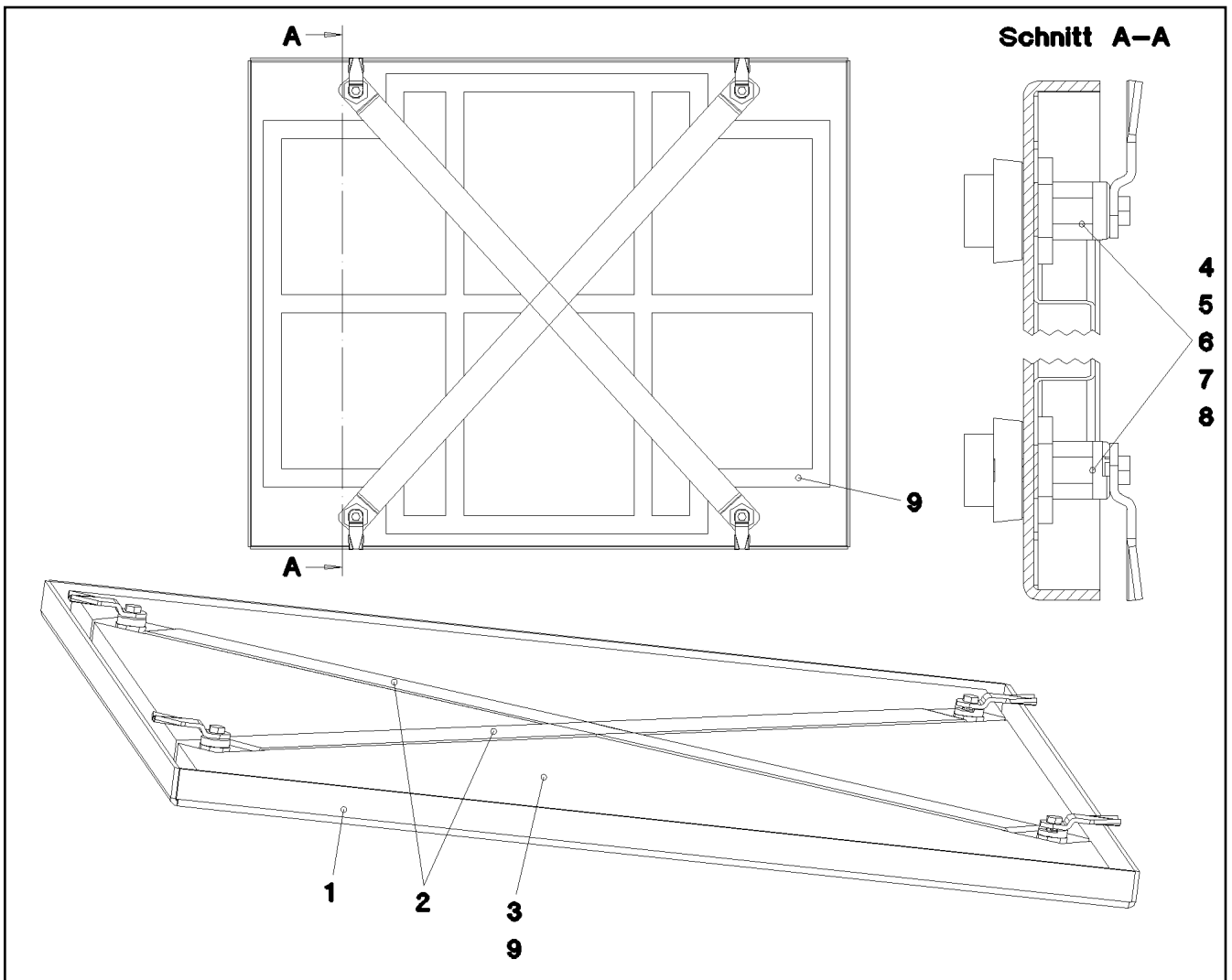

Pos.	Item	Quantity	Description	Bezeichnung	Serie	K
1	97 00 223 08	1	NIPPLE PLATE 3.5x721x876 ALMG3 SPF	WARZENBLECH		
2	97 70 983 08	2	PLATE 1.5X872X40 DC01	BLECH		
3	97 70 984 08	1	INSULATING MAT 20X793X635	DAEMMMATTE		
4	70 42 566 08	4	HOUSING	GEHAEUSE		
5	70 42 534 08	4	ACTUATION SPIKE	BETAETIGUNGSDORN		
6	70 42 748 08	4	O-RING 12X2 NBR70	O-RING		
7	70 42 548 08	4	DUST CAP	STAUBKAPPE		
8	70 42 567 08	4	TONGUE	ZUNGE		
9	80 21 020 08	5.7	ADHESIVE INSULATING STRIP 25MM PS18	PILZKOPFBAND		

6.2.2009
053025

LIEBHERR

etk_en_de_074515 LR 1600/2

COVER COMPL.
DECKEL KPL.

261

⇒ 2 859 027
96 46 777 08

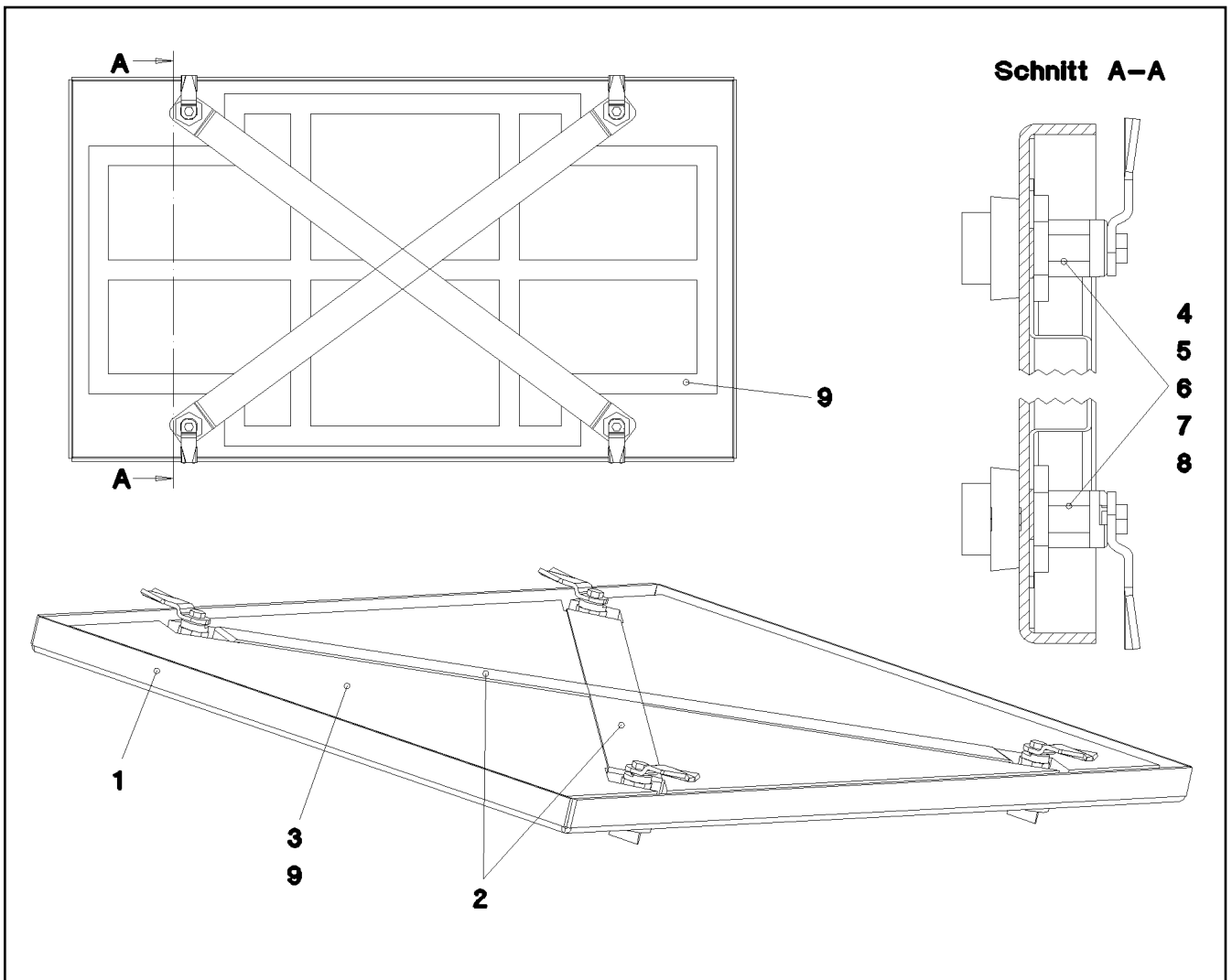

Pos.	Item	Quantity	Description	Bezeichnung	Serie	K
1	97 00 272 08	1	NIPPLE PLATE 3.5x521x876 ALMG3 SPF	WARZENBLECH		
2	97 70 985 08	2	PLATE 1.5X740X40	BLECH		
3	97 70 986 08	1	INSULATING MAT 20X798X443	DAEMMMATTE		
4	70 42 566 08	4	HOUSING	GEHAEUSE		
5	70 42 534 08	4	ACTUATION SPIKE	BETAETIGUNGSDORN		
6	70 42 748 08	4	O-RING 12X2 NBR70	O-RING		
7	70 42 548 08	4	DUST CAP	STAUBKAPPE		
8	70 42 567 08	4	TONGUE	ZUNGE		
9	80 21 020 08	4	ADHESIVE INSULATING STRIP 25MM PS18	PILZKOPFBAND		

6.2.2009
053022

LIEBHERR

etk_en_de_074515 LR 1600/2

COVER COMPL.
DECKEL KPL.

262

⇒ 2 859 028
96 46 778 08

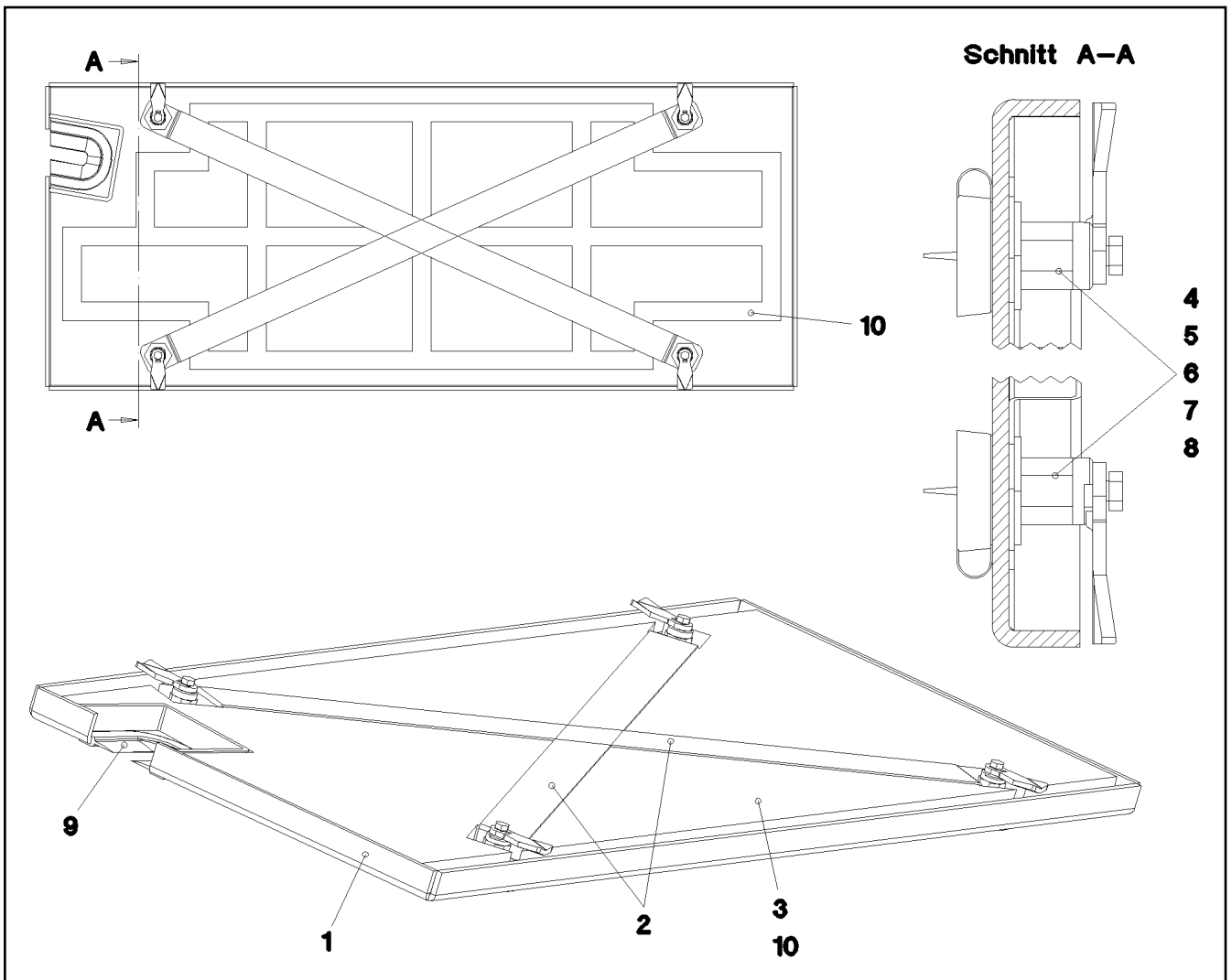

Pos.	Item	Quantity	Description	Bezeichnung	Serie	K
1	96 46 922 08	1	COVER WELDED	DECKEL SCHWK.		
2	97 70 997 08	2	PLATE 1.5X848X40	BLECH		
3	97 70 998 08	1	INSULATING MAT 20X989X365	DAEMMMATTE		
4	70 42 566 08	4	HOUSING	GEHAEUSE		
5	70 42 534 08	4	ACTUATION SPIKE	BETAETIGUNGSDORN		
6	70 42 748 08	4	O-RING 12X2 NBR70	O-RING		
7	70 42 548 08	4	DUST CAP	STAUBKAPPE		
8	70 42 551 08	4	TONGUE	ZUNGE		
9	26 21 053 08	0.16	EDGE PROTECTION	KANTENSCHUTZ		
10	80 21 020 08	4.3	ADHESIVE INSULATING STRIP 25MM PS18	PILZKOPFBAND		

6.2.2009
053021

LIEBHERR

etk_en_de_074515 LR 1600/2

COVER COMPL.
DECKEL KPL.

263

⇒ 2 859 029
96 46 779 08

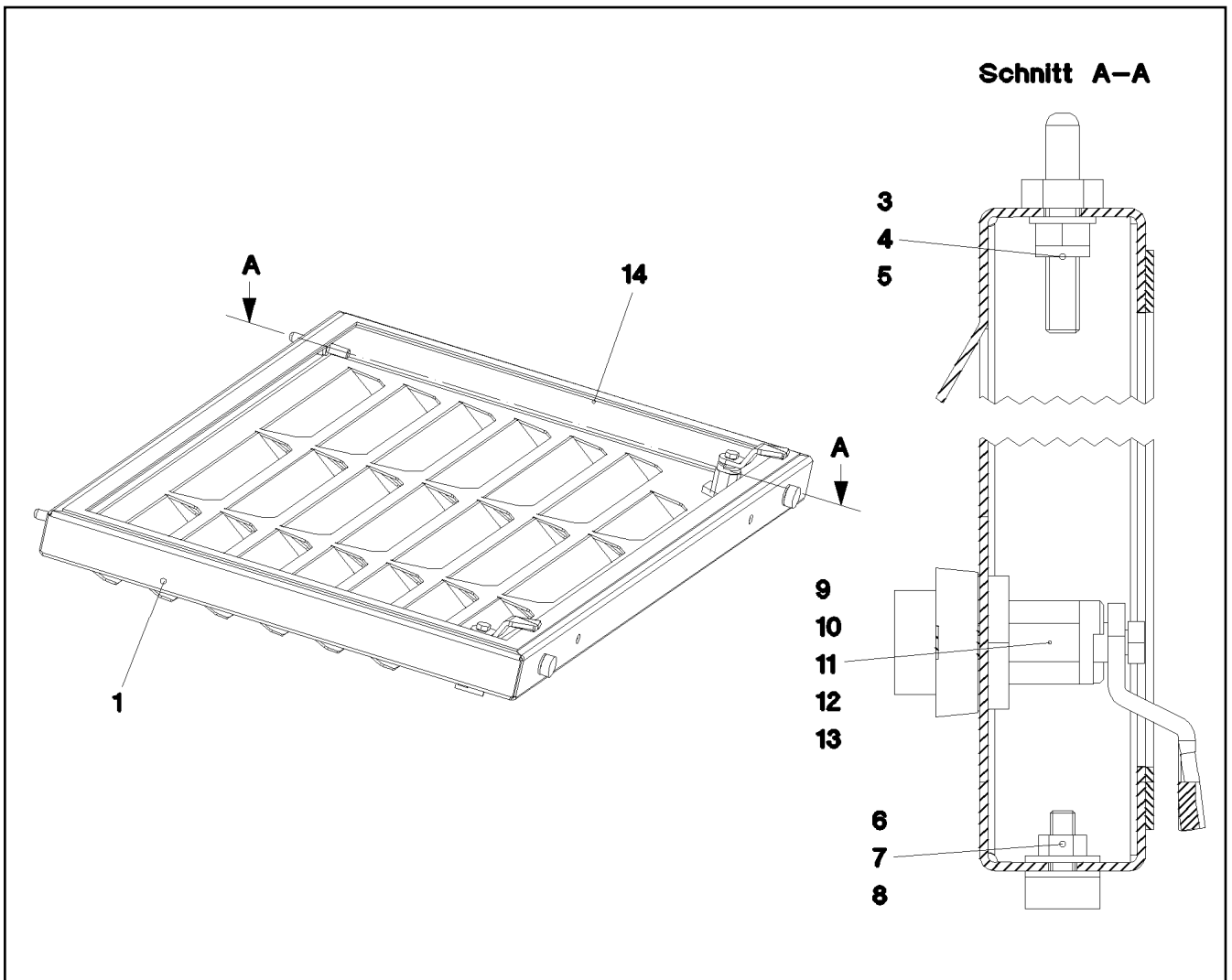

Pos.	Item	Quantity	Description	Bezeichnung	Serie	K
1	97 70 906 08	1	PLATE 2X875X546	BLECH		
3	40 97 109 08	2	CARRYING BOLT M8	STUETZSCHRAUBE		
4	42 00 012 08	2	WASHER DIN 125 A8X16 ST VERZ	SCHEIBE		
5	41 19 005 08	2	HEX NUT DIN 985 M8 8 VERZ	SECHSKANTMUTTER		
6	72 66 167 08	2	MEGI BUFFER 18X7,5	MEGIPUFFER		
7	42 18 007 08	4	WASHER DIN 9021 A 6.4 VERZ	SCHEIBE		
8	41 15 140 08	2	HEX NUT DIN 934 M6 8 VERZ	SECHSKANTMUTTER		
9	70 42 566 08	2	HOUSING	GEHAEUSE		
10	70 42 534 08	2	ACTUATION SPIKE	BETAETIGUNGSDORN		
11	70 42 748 08	2	O-RING 12X2 NBR70	O-RING		
12	70 42 548 08	2	DUST CAP	STAUBKAPPE		
13	70 42 562 08	2	TONGUE	ZUNGE		
14	26 21 051 08	2.24	FOAM RUBBER BAND 15X5	ZELLGUMMIBAND		

6.2.2009
053024

LIEBHERR

etk_en_de_074515 LR 1600/2

COVER COMPL.
DECKEL KPL.

264

⇒ 2 859 030
96 46 758 08

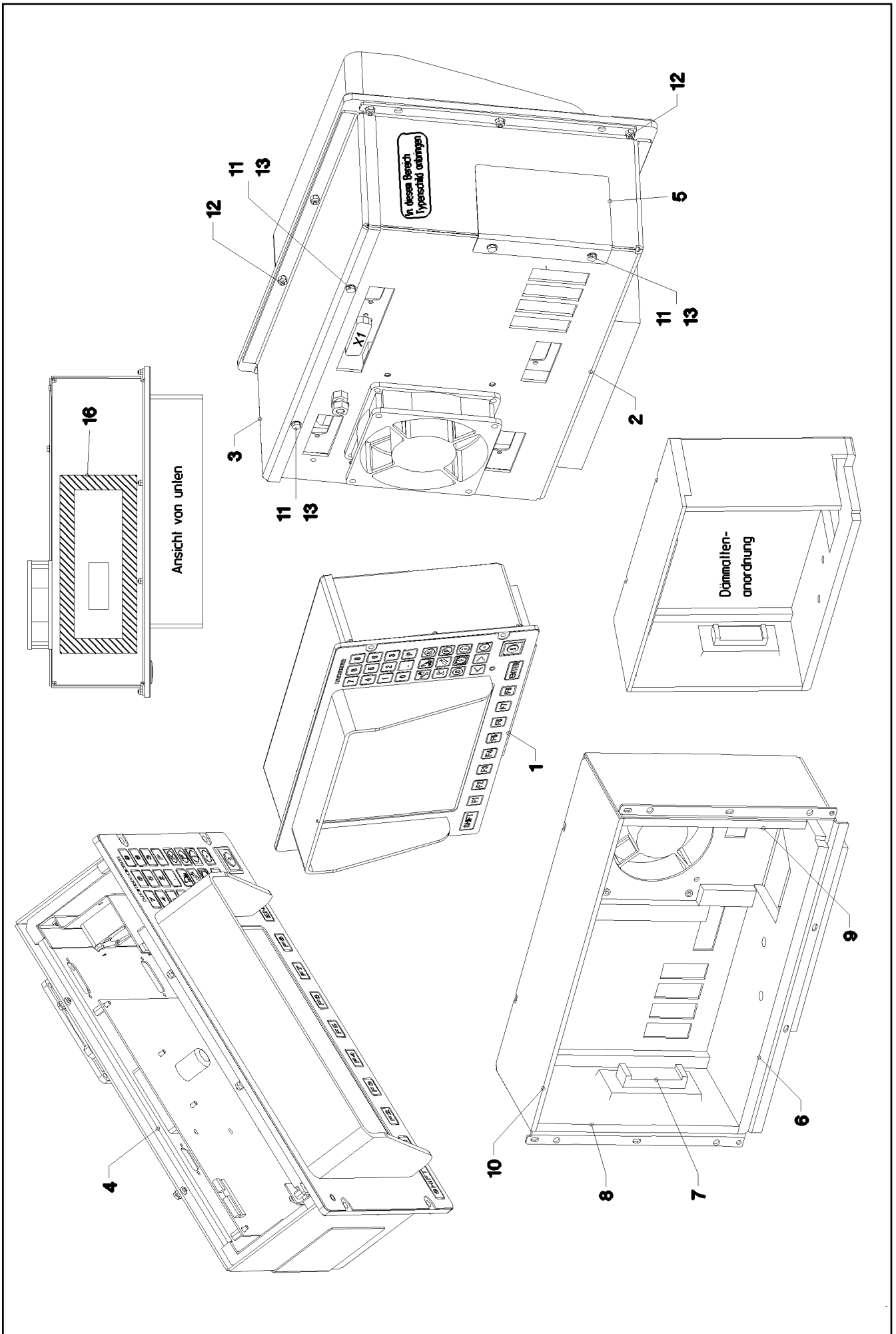

6.2.2009
033730

LIEBHERR

etk_en_de_074515 LR 1600/2

LICCON CONSOLE LCD2
LICCON KONSOLE LCD2

265 (1/2)

⇒ 2 913
91 32 850 08

Pos.	Item	Quantity	Description	Bezeichnung	Serie	K
1	96 20 599 08	1	FOIL KEYPAD PRE-ASS. ⇒ 2 913 003 96 20 599 08	FOLIEN-TASTATUR VORM.		
2	96 20 460 08	1	HOUSING PRE-ASSEMBLED ⇒ 2 913 004 96 20 460 08	GEHÄUSE VORM.		
3	97 17 070 08	1	LID 2X341X116 ALMG3	DECKEL		
4	96 28 696 08	1	INTERIOR HOUSING PRE-ASS. ⇒ 2 913 005 96 28 696 08	INNENGEHÄUSE VORM.		
5	97 09 808 08	1	PLATE 1X95X78 ALMG3 H111	BLECH		
6	97 18 507 08	1	INSULATING MAT BOTTOM 9X97X315	DAEMMMATTE UNTEN		
7	97 18 511 08	1	INSULATING MAT-LOCK 21X36X84	DAEMMMATTE VERSCHLUSS		
8	97 18 512 08	1	LEFT-HAND INSULATING MAT 19X94X183	DAEMMMATTE LINKS		
9	97 18 513 08	1	INSULATION MAT RIGHT 19X94X183	DAEMMMATTE RECHTS		
10	97 18 514 08	1	INSULATING MAT TOP 11.5X94X315	DAEMMMATTE OBEN		
11	40 65 000 08	4	HEX BOLT ISO 4017 M3X8 8.8 A2C	SECHSKANTSCHRAUBE		
12	41 19 001 08	10	HEX NUT DIN 985 M3 8 A3C	SECHSKANTMUTTER		
13	42 52 205 08	4	SERRATED LOCK WASHER DIN 6798 J 3,2	FAECHERSCHEIBE		
16	97 36 626 08	1	SEALING FRAME	DICHTRAHMEN		
19	10 27 921 0	1	ANTIDAZZLE 242X171X55 SCHWARZ RAL9	BLENDENSCHUTZ		

6.2.2009

etk_en_de_074515 LR 1600/2

☐ 266 (2/2)

LIEBHERR

LICCON CONSOLE LCD2
LICCON KONSOLE LCD2

⇒ 2 913
91 32 850 08

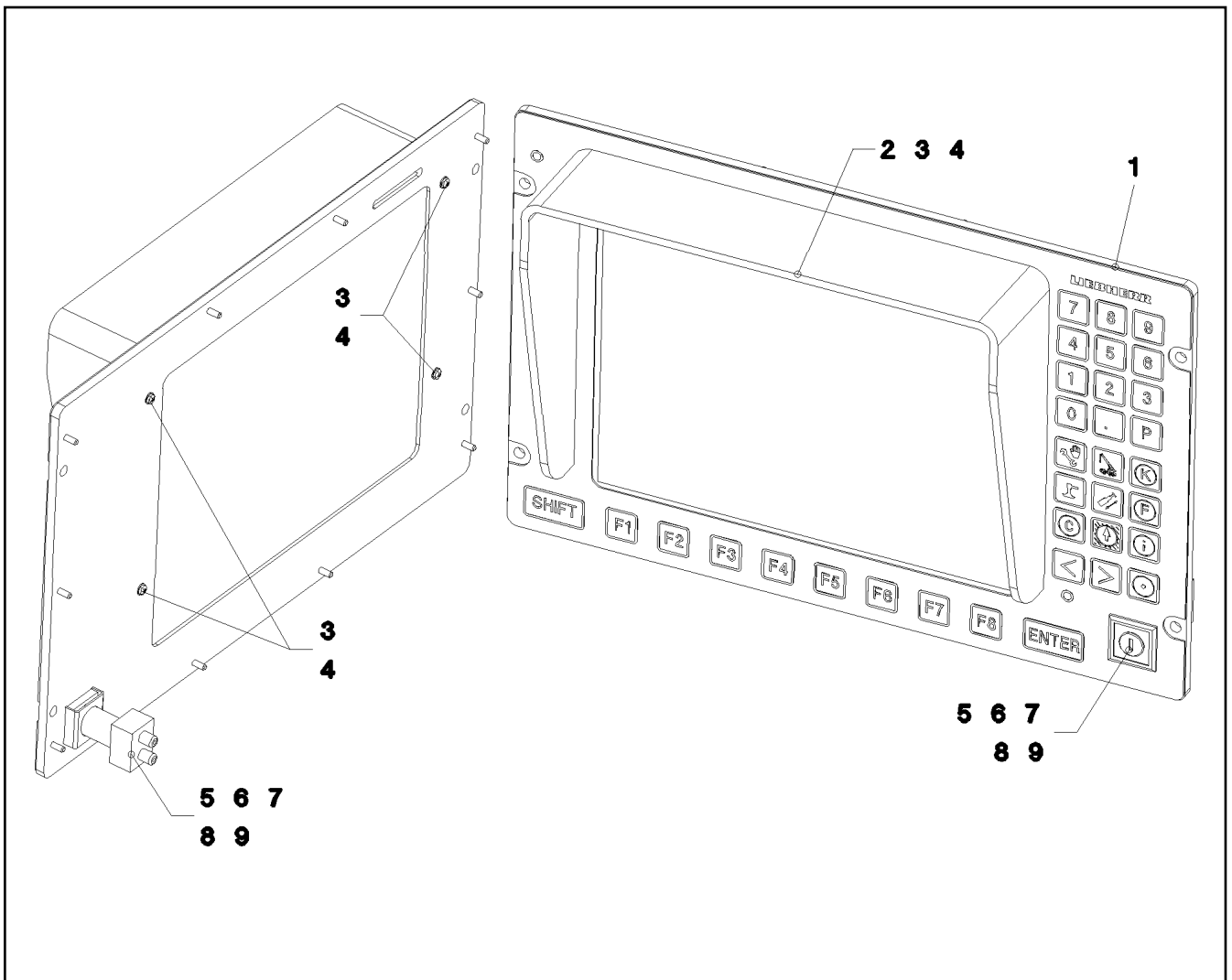

Pos.	Item	Quantity	Description	Bezeichnung	Serie	K
1	69 18 849 08	1	KEY PAD	FOLIEN-TASTATUR		
2	97 09 807 08	1	GLARE SHIELD 4X567X55 ALMG3	BLENDSCHUTZ		
3	42 51 004 08	4	TOOTH LOCK WASHER DIN 6797 A 2,7	ZAHNSCHEIBE		
4	40 83 112 08	4	PAN-HEAD SCREW ISO 7045 M2,5X12 4.8 A2	FLACHKOPFSCHRAUBE		
5	61 10 022 08	1	PLATE 1X35X22 ALMG3	BLECH		
6	69 27 013 08	1	TURNING KNOB	DREHKNOPF		
7	69 27 014 08	1	SWITCHING ELEMENT	SCHALTELEMENT		
8	69 26 004 08	1	FRONT FRAME	FRONTRAHMEN		
9	96 20 750 08	1	WIRING HARNESS W648	KABELSTRANG		

6.2.2009
033731

LIEBHERR

etk_en_de_074515 LR 1600/2

FOIL KEYPAD PRE-ASS.
FOLIEN-TASTATUR VORM.

□ 267

⇒ 2 913 003
96 20 599 08

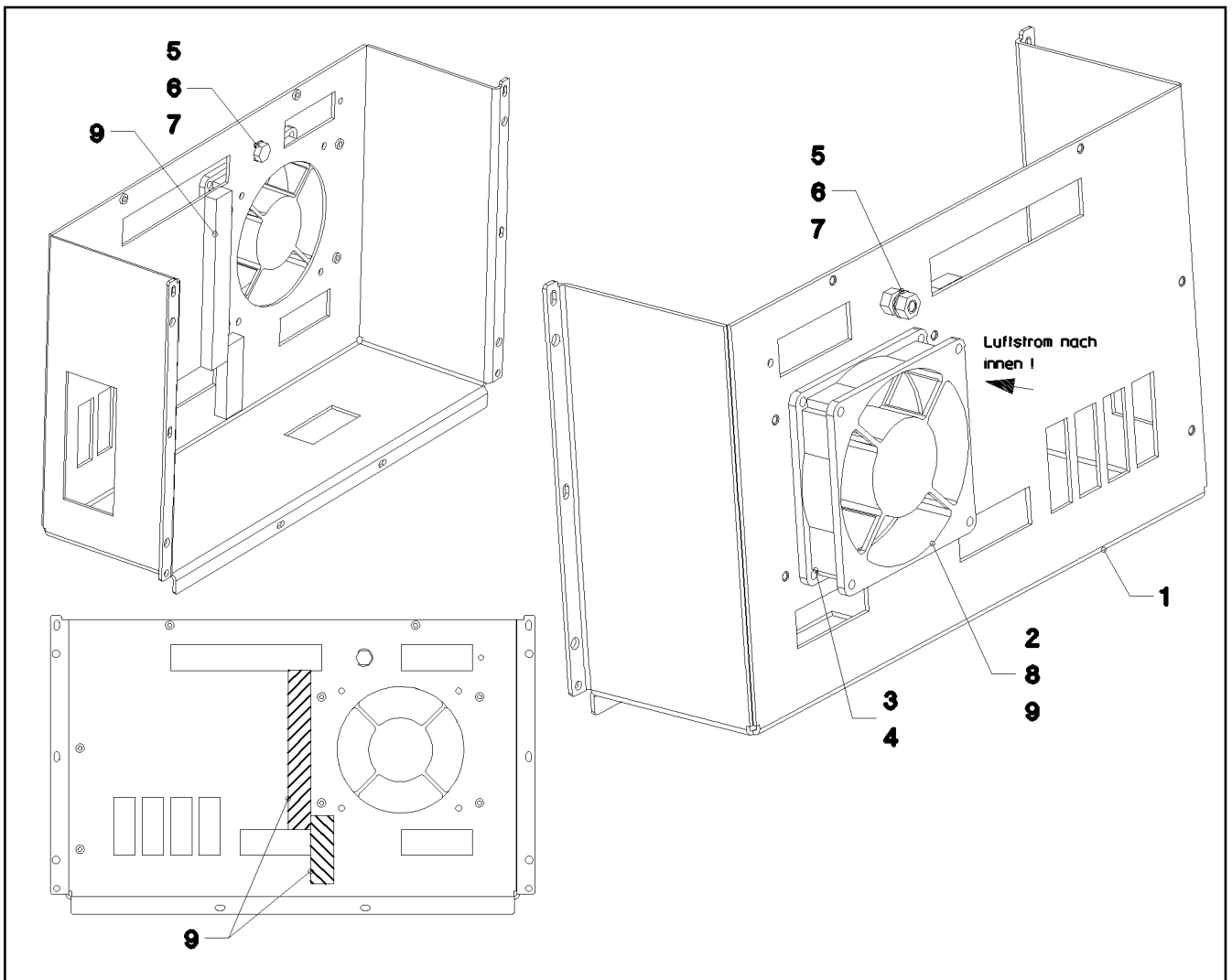

Pos.	Item	Quantity	Description	Bezeichnung	Serie	K
1	92 99 369 08	1	HOUSING	GEHAEUSE		
2	61 07 145 08	1	FAN / BLOWER	LUEFTER		
3	70 42 076 08	4	MANDRIL RIVET 4X10,3	DORNNIET		
4	42 00 007 08	4	WASHER DIN 125 A 4.3 ST VERZ	SCHEIBE		
5	40 65 099	1	HEX BOLT ISO 4017 M6X16 8.8 A2C	SECHSKANTSCHRAUBE		
6	41 15 140 08	2	HEX NUT DIN 934 M6 8 VERZ	SECHSKANTMUTTER		
7	42 52 210 08	2	SERRATED LOCK WASHER DIN 6798 J 6,4	FAECHERSCHEIBE		
8	60 32 022 08	2	CABLE TIE 2,5X102	KABELBINDER		
9	10 02 810 7	0.16	CELL RUBBER 16X8 ZELLKAUTSCHU	ZELLGUMMI		

6.2.2009
033732

LIEBHERR

etk_en_de_074515 LR 1600/2

HOUSING PRE-ASSEMBLED
GEHAEUSE VORM.

268

⇒ 2 913 004
96 20 460 08

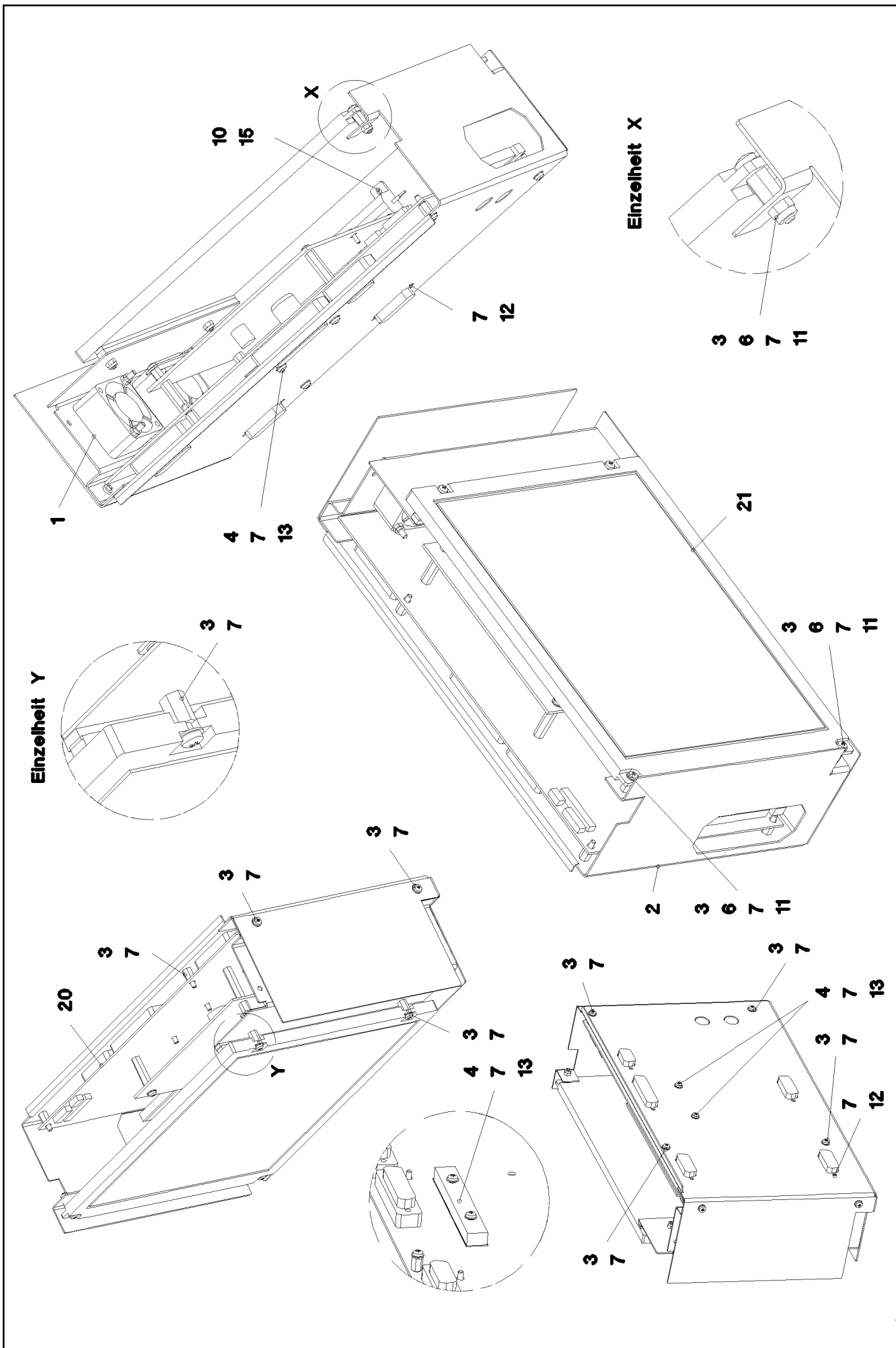

6.2.2009
038073

LIEBHERR

etk_en_de_074515 LR 1600/2

INTERIOR HOUSING PRE-ASS.
INNENGEHÄUSE VORM.

☐ 269 (1/2)

→ 2 913 005
96 20 731 08

Pos.	Item	Quantity	Description	Bezeichnung	Serie	K
1	96 20 732 08	1	FAN PLATE PRE-ASS. ⇒ 2 913 006 96 20 732 08	LUEFTERBLECH VORM.		
2	97 17 132 08	1	PLATE 1X467X259 ALMG3 H111	BLECH		
3	40 83 115 08	8	PAN-HEAD SCREW ISO 7045 M3X6 5.8	FLACHKOPFSCHRAUBE		
4	40 84 007 01	2	SCREW ISO 7045 M3X16 4.8 A2B	SCHRAUBE		
6	41 19 001 08	2	HEX NUT DIN 985 M3 8 A3C	SECHSKANTMUTTER		
7	42 52 205 08	20	SERRATED LOCK WASHER DIN 6798 J 3,2	FAECHERSCHEIBE		
10	70 42 121 08	2	BLIND RIVET 3,0X3,2-5,0	BLINDNIET		
11	10 00 924 4	2	STANDOFF M3X8 STAHL VERZ	ABSTANDSBOLZEN		
12	10 03 021 0	10	STANDOFF M3X4,7 STAHL VERZ SPF	ABSTANDSBOLZEN		
13	10 00 812 5	1	COOLING BODY 84X12X7,7 ALU	KUEHLKOERPER		
15	63 50 576 08	1	RESISTOR 15R 5% 50W	WIDERSTAND		
20	96 20 763 08	1	CONTROLLER UNIT BSE-LSB ⇒ 2 913 007 96 20 763 08	CONTROLLEREREINHEIT		
21	96 20 762 08	1	DISPLAY TFT PRE-ASS. TFT	DISPLAY VORM.		

6.2.2009

etk_en_de_074515 LR 1600/2

☐ 270 (2/2)

LIEBHERR

INTERIOR HOUSING PRE-ASS.
INNENGEHAEUSE VORM.

⇒ 2 913 005
96 20 731 08

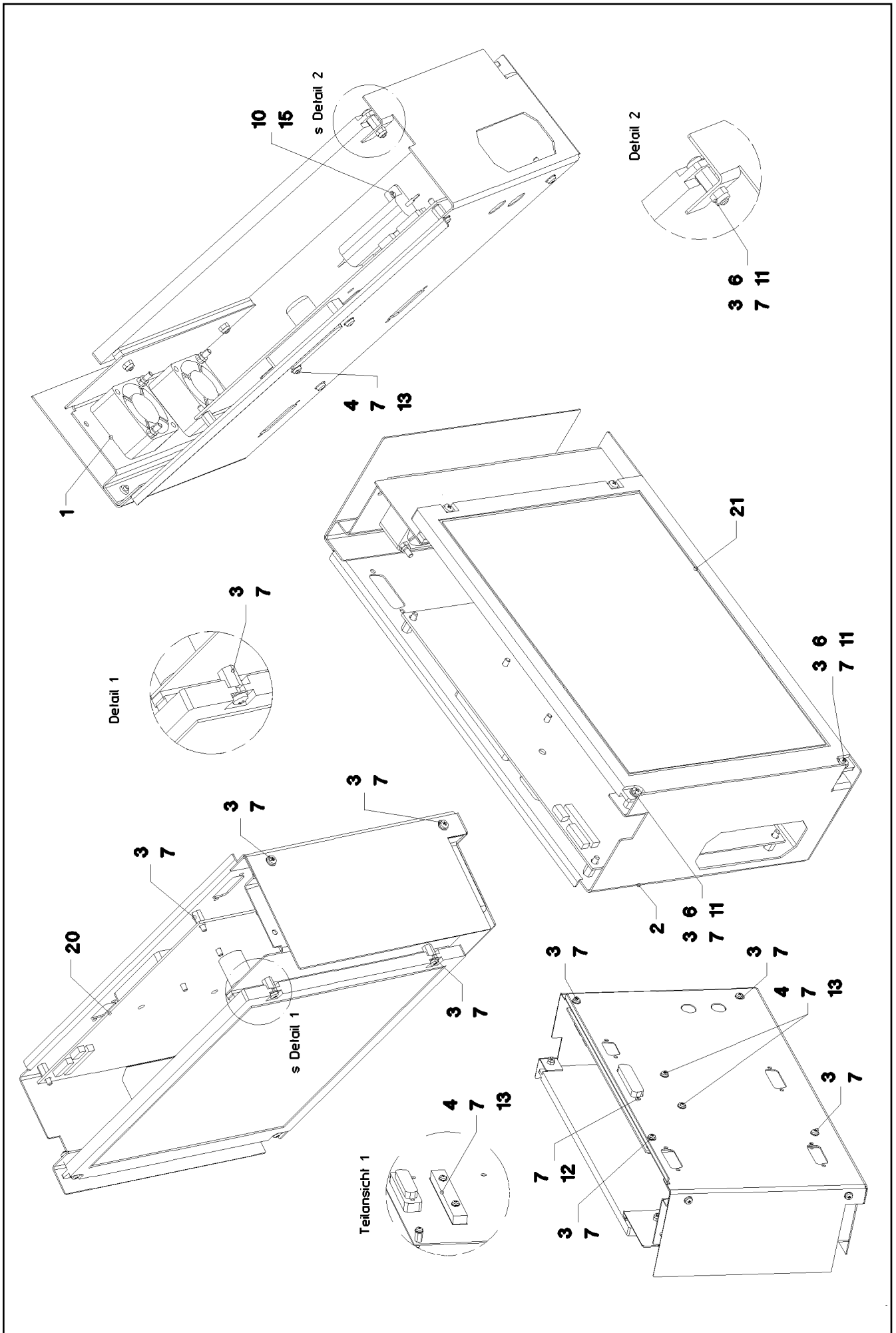

6.2.2009
033733

LIEBHERR

etk_en_de_074515 LR 1600/2

INTERIOR HOUSING PRE-ASS.
INNENGEHÄUSE VORM.

☐ 271 (1/2)

⇒ 2 913 005
96 28 696 08

Pos.	Item	Quantity	Description	Bezeichnung	Serie	K
1	96 20 732 08	1	FAN PLATE PRE-ASS. ⇒ 2 913 006 96 20 732 08	LUEFTERBLECH VORM.		
2	97 17 132 08	1	PLATE 1X467X259 ALMG3 H111	BLECH		
3	40 83 115 08	8	PAN-HEAD SCREW ISO 7045 M3X6 5.8	FLACHKOPFSCHRAUBE		
4	40 84 007 01	2	SCREW ISO 7045 M3X16 4.8 A2B	SCHRAUBE		
6	41 19 001 08	2	HEX NUT DIN 985 M3 8 A3C	SECHSKANTMUTTER		
7	42 52 205 08	12	SERRATED LOCK WASHER DIN 6798 J 3,2	FAECHERSCHEIBE		
10	70 42 121 08	2	BLIND RIVET 3,0X3,2-5,0	BLINDNIET		
11	10 00 924 4	2	STANDOFF M3X8 STAHL VERZ	ABSTANDSBOLZEN		
12	10 03 021 0	2	STANDOFF M3X4,7 STAHL VERZ SPF	ABSTANDSBOLZEN		
13	10 00 812 5	1	COOLING BODY 84X12X7,7 ALU	KUEHLKOERPER		
15	63 50 576 08	1	RESISTOR 15R 5% 50W	WIDERSTAND		
20	10 04 375 9	1	CONTROLLER BOARD KOMP.	CONTROLLERBOARD		
21	96 20 762 08	1	DISPLAY TFT PRE-ASS. TFT	DISPLAY VORM.		

6.2.2009

etk_en_de_074515 LR 1600/2

☐ 272 (2/2)

LIEBHERR

INTERIOR HOUSING PRE-ASS.
INNENGEHAEUSE VORM.

⇒ 2 913 005
96 28 696 08

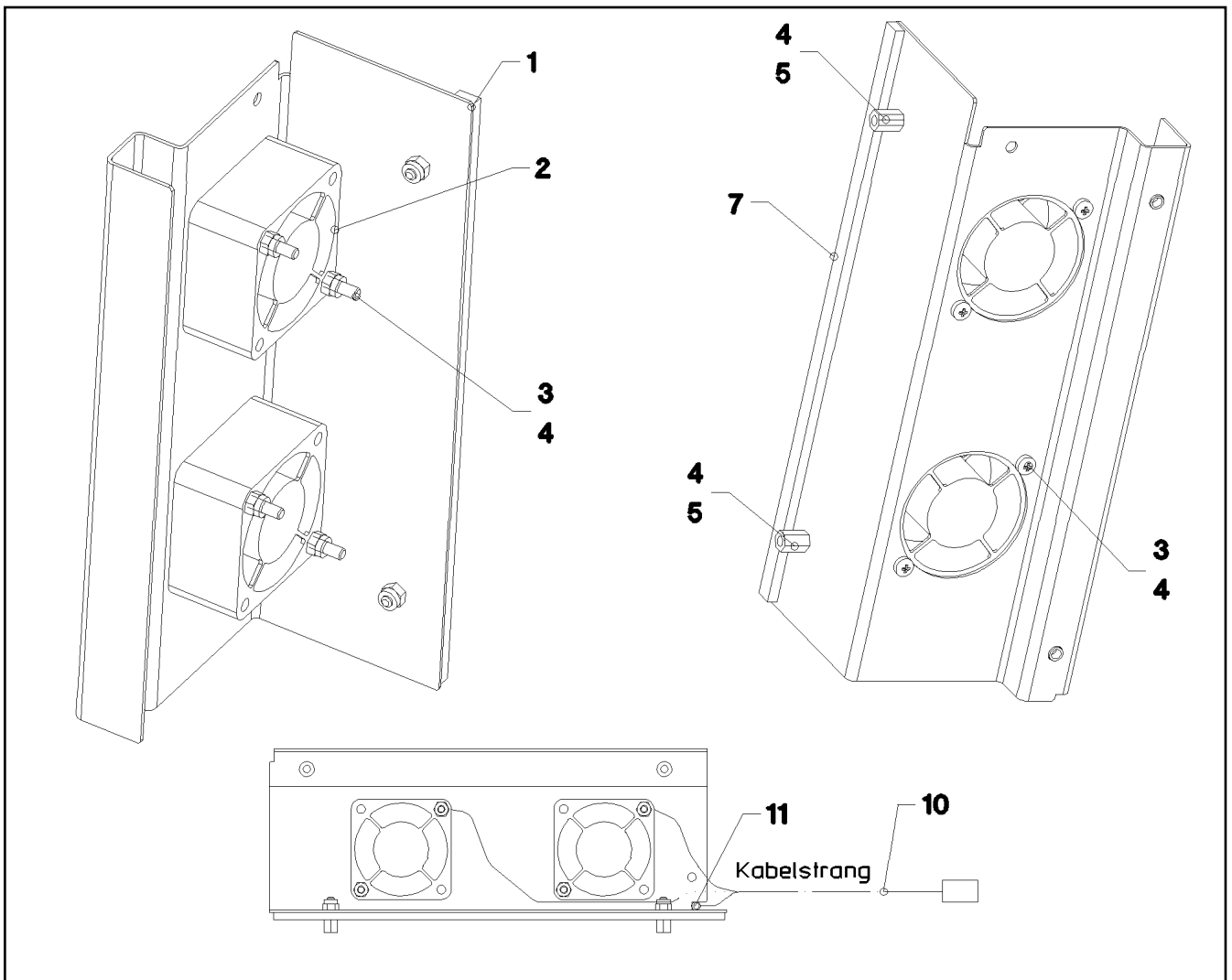

Pos.	Item	Quantity	Description	Bezeichnung	Serie	K
1	92 99 370 08	1	FAN PLATE	LUEFTERBLECH		
2	61 07 146 08	2	FAN / BLOWER	LUEFTER		
3	40 83 114 08	4	PAN-HEAD SCREW ISO 7045 M3X30 4.8 A2	FLACHKOPFSCHRAUBE		
4	41 19 001 08	6	HEX NUT DIN 985 M3 8 A3C	SECHSKANTMUTTER		
5	10 00 924 4	2	STANDOFF M3X8 STAHL VERZ	ABSTANDSBOLZEN		
7	26 21 089 08	0.18	CELL RUBBER 3X6X10M	ZELLGUMMI		
10	96 20 761 08	1	WIRING HARNESS W647	KABELSTRANG		
11	60 32 022 08	1	CABLE TIE 2,5X102	KABELBINDER		

6.2.2009
033734

LIEBHERR

etk_en_de_074515 LR 1600/2

FAN PLATE PRE-ASS.
LUEFTERBLECH VORM.

273

⇒ 2 913 006
96 20 732 08

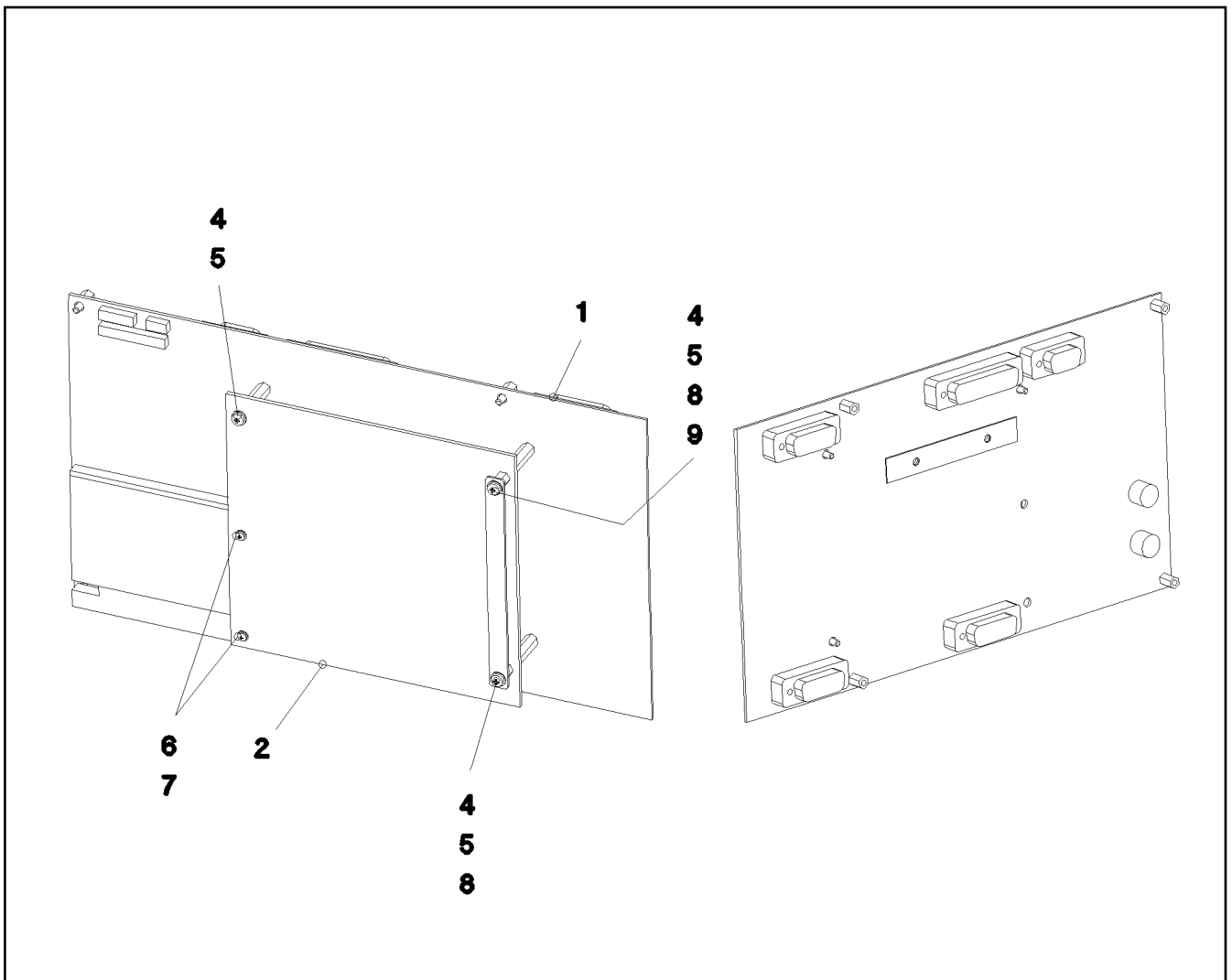

Pos.	Item	Quantity	Description	Bezeichnung	Serie	K
1	10 04 375 7	1	CONTROLLER BOARD LSB-BSE	CONTROLLERBOARD		
2	10 04 376 0	1	CONTROLLER BOARD LSB-CPU	CONTROLLERBOARD		
4	40 83 115 08	3	PAN-HEAD SCREW ISO 7045 M3X6 5.8	FLACHKOPFSCHRAUBE		
5	42 52 205 08	3	SERRATED LOCK WASHER DIN 6798 J 3,2	FAECHERSCHEIBE		
6	10 03 064 2	2	PAN-HEAD SCREW ISO 7045 M2X8 4.8 A2B	FLACHKOPFSCHRAUBE		
7	10 03 064 0	2	CIRCLIP DIN 128 2 FST A2B	FEDERRING		
8	10 00 924 4	2	STANDOFF M3X8 STAHL VERZ	ABSTANDSBOLZEN		
9	97 32 671 08	1	PLATE 1X108X9 ALMG3 H111	BLECH		

6.2.2009
038074

LIEBHERR

etk_en_de_074515 LR 1600/2

CONTROLLER UNIT
CONTROLLEREINHEIT

274

⇒ 2 913 007
96 20 763 08

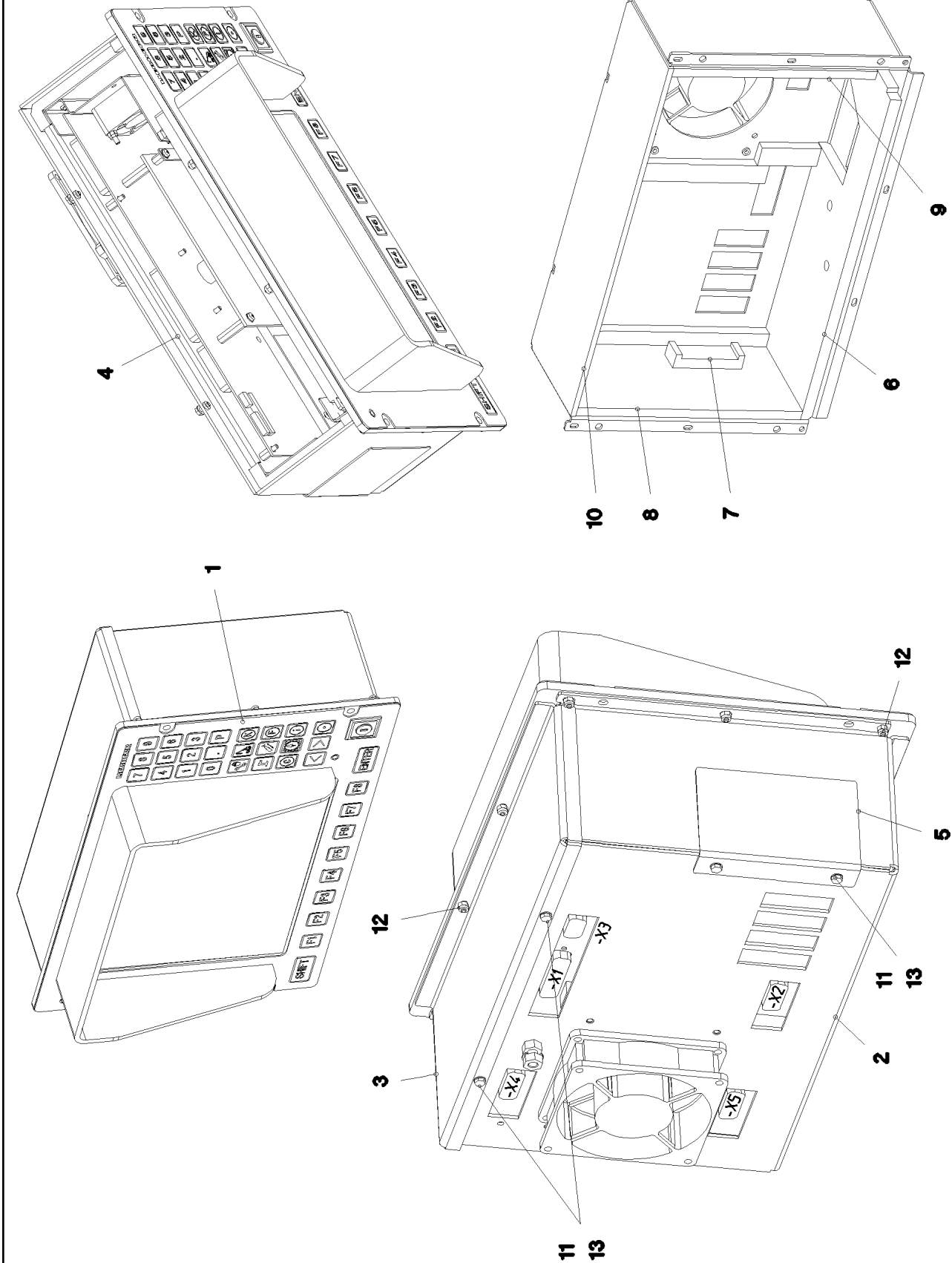

6.2.2009
038072

LIEBHERR

etk_en_de_074515 LR 1600/2

LICCON CONSOLE LCD3
LICCON KONSOLE LCD3

□ 275 (1/2)

→ 2 913 009
91 04 705 08

Pos.	Item	Quantity	Description	Bezeichnung	Serie	K
1	96 20 599 08	1	FOIL KEYPAD PRE-ASS. ⇒ 2 913 003 96 20 599 08	FOLIEN-TASTATUR VORM.		
2	96 20 460 08	1	HOUSING PRE-ASSEMBLED ⇒ 2 913 004 96 20 460 08	GEHÄUSE VORM.		
3	97 17 070 08	1	LID 2X341X116 ALMG3	DECKEL		
4	96 20 731 08	1	INTERIOR HOUSING PRE-ASS. ⇒ 2 913 005 96 20 731 08	INNENGEHÄUSE VORM.		
5	97 09 808 08	1	PLATE 1X95X78 ALMG3 H111	BLECH		
6	97 18 507 08	1	INSULATING MAT BOTTOM 9X97X315	DAEMMMATTE UNTEN		
7	97 18 511 08	1	INSULATING MAT-LOCK 21X36X84	DAEMMMATTE VERSCHLUSS		
8	97 18 512 08	1	LEFT-HAND INSULATING MAT 19X94X183	DAEMMMATTE LINKS		
9	97 18 513 08	1	INSULATION MAT RIGHT 19X94X183	DAEMMMATTE RECHTS		
10	97 18 514 08	1	INSULATING MAT TOP 11.5X94X315	DAEMMMATTE OBEN		
11	40 65 000 08	4	HEX BOLT ISO 4017 M3X8 8.8 A2C	SECHSKANTSCHRAUBE		
12	41 19 001 08	10	HEX NUT DIN 985 M3 8 A3C	SECHSKANTMUTTER		
13	42 52 205 08	4	SERRATED LOCK WASHER DIN 6798 J 3,2	FAECHERSCHEIBE		

6.2.2009	etk_en_de_074515 LR 1600/2	☐ 276 (2/2)
LIEBHERR	LICCON CONSOLE LCD3 LICCON KONSOLE LCD3	⇒ 2 913 009 91 04 705 08

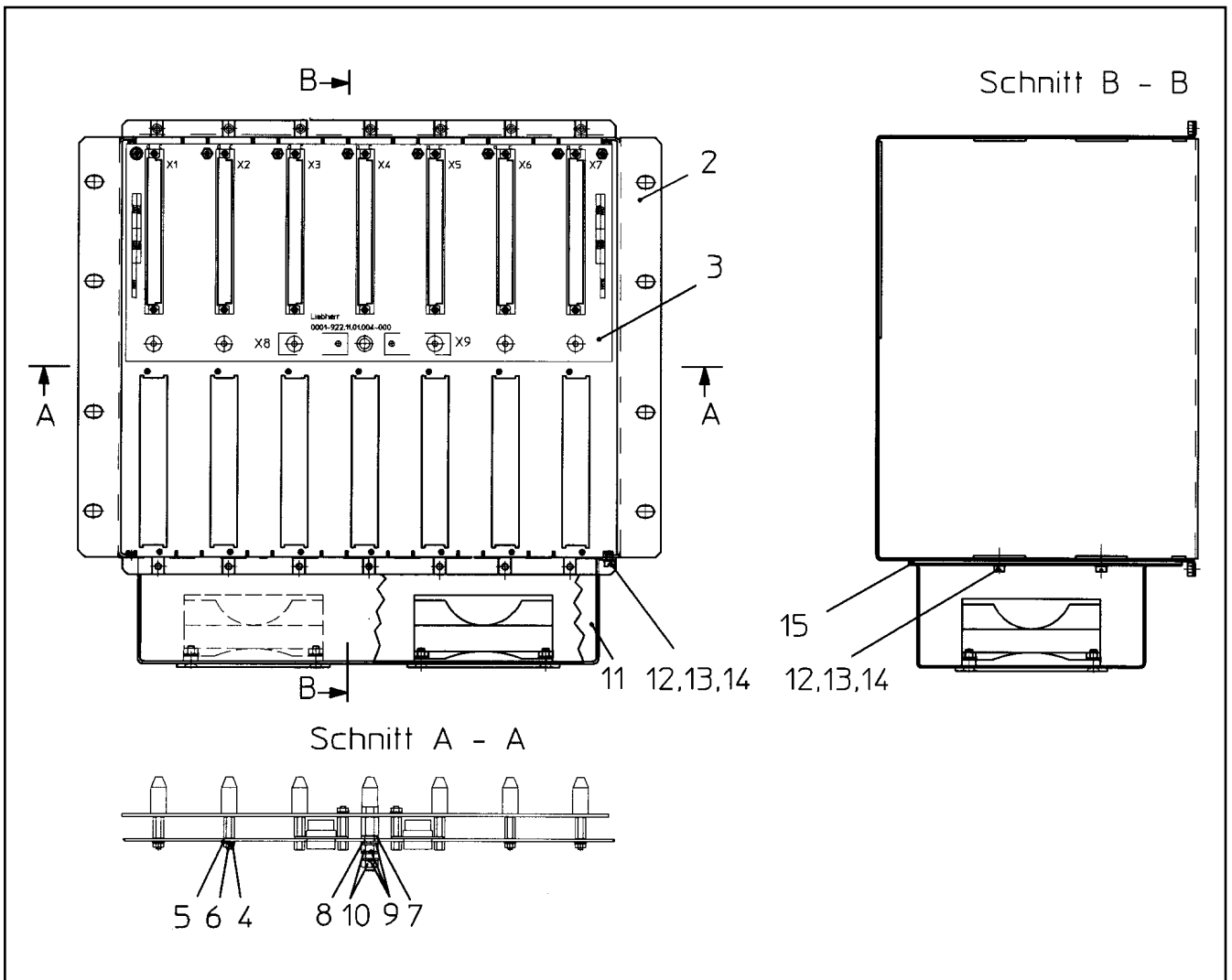

Pos.	Item	Quantity	Description	Bezeichnung	Serie	K
2	61 10 011 08	1	EMPTY CASING 56 TE	LEERGEHAEUSE		
3	92 84 311 08	1	BUS PCB	BUSPLATINE		
			⇒ 2 922 001 92 84 311 08			
4	51 45 994 08	12	PAN-HEAD SCREW DIN 7985 M3X8 8.8 A2C	FLACHKOPFSCHRAUBE		
5	51 45 819 08	12	WASHER DIN 125 A 3.2 ST VERZ	SCHEIBE		
6	42 51 005 08	12	TOOTH LOCK WASHER DIN 6797 A 3,2	ZAHNSCHEIBE		
7	66 00 430 08	1	INSULATING BUSH KUNSTSTOFF SPF	ISOLIERBUCHSE		
8	66 00 414 08	1	WASHER M5 KUNSTSTOFF SPF	SCHEIBE		
9	42 00 008 08	3	WASHER DIN 125 A 5.3 VERZ	SCHEIBE		
10	41 15 148 08	2	HEX NUT DIN 934 M5 8 VERZ	SECHSKANTMUTTER		
11	92 32 870 08	1	FAN UNIT	LUEFTEREINHEIT		
			⇒ 2 913 102 92 32 870 08			
12	55 31 619 08	4	PAN-HEAD SCREW DIN 7985 M4X6 4.8 A2C	FLACHKOPFSCHRAUBE		
13	42 00 007 08	4	WASHER DIN 125 A 4.3 ST VERZ	SCHEIBE		
14	42 51 007 08	4	TOOTH LOCK WASHER DIN 6797 A 4,3	ZAHNSCHEIBE		
15	28 81 799 08	1	FAN SCREEN 1X173X286 PENATUR	LUEFTERMASKE		

6.2.2009
134949

LIEBHERR

etk_en_de_074515 LR 1600/2

ASSEMBLY FRAME
BAUGRUPPENTRAEGER

□ 277

⇒ 2 913 100
91 23 538 08

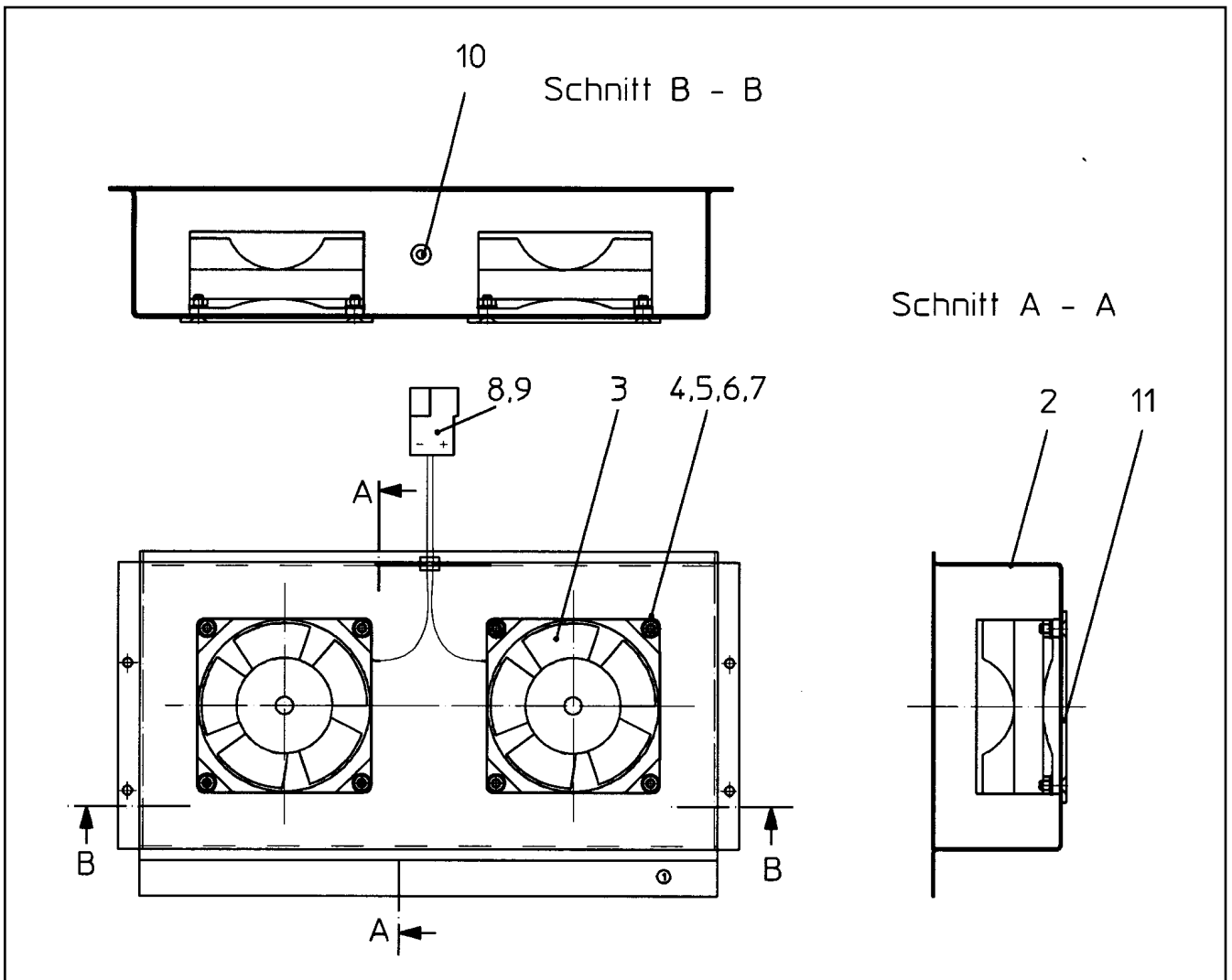

Pos.	Item	Quantity	Description	Bezeichnung	Serie	K
2	61 10 012 08	1	HOUSING 1X400X273 DC01-A-M	GEHAEUSE		
3	61 03 886 14	2	FAN / BLOWER 80X80X25	LUEFTER		
4	40 70 608 08	8	COUNTERSUNK SCREW ISO 7046-1 M4X14	SENKSCHRAUBE		
5	42 00 007 08	8	WASHER DIN 125 A 4.3 ST VERZ	SCHEIBE		
6	42 51 007 08	8	TOOTH LOCK WASHER DIN 6797 A 4,3	ZAHNSCHEIBE		
7	41 15 142 08	8	HEX NUT DIN 934 M4 8 A3C	SECHSKANTMUTTER		
8	60 23 059 08	1	FLAT PLUG HOUSING 2POL	FLACHSTECKERGEHAEUSE		
9	60 23 048 08	2	FLAT PLUG 6,3 - 2,5 MS	FLACHSTECKER		
10	60 27 024 08	1	GROMMET 4/6/9	DURCHFUEHRUNGSTUELLE		
11	61 04 133 08	2	PROTECTIVE GRATING	SCHUTZGITTER		

6.2.2009
134955

LIEBHERR

etk_en_de_074515 LR 1600/2

FAN UNIT
LUEFTEREINHEIT

□ 278

⇒ 2 913 102
92 32 870 08

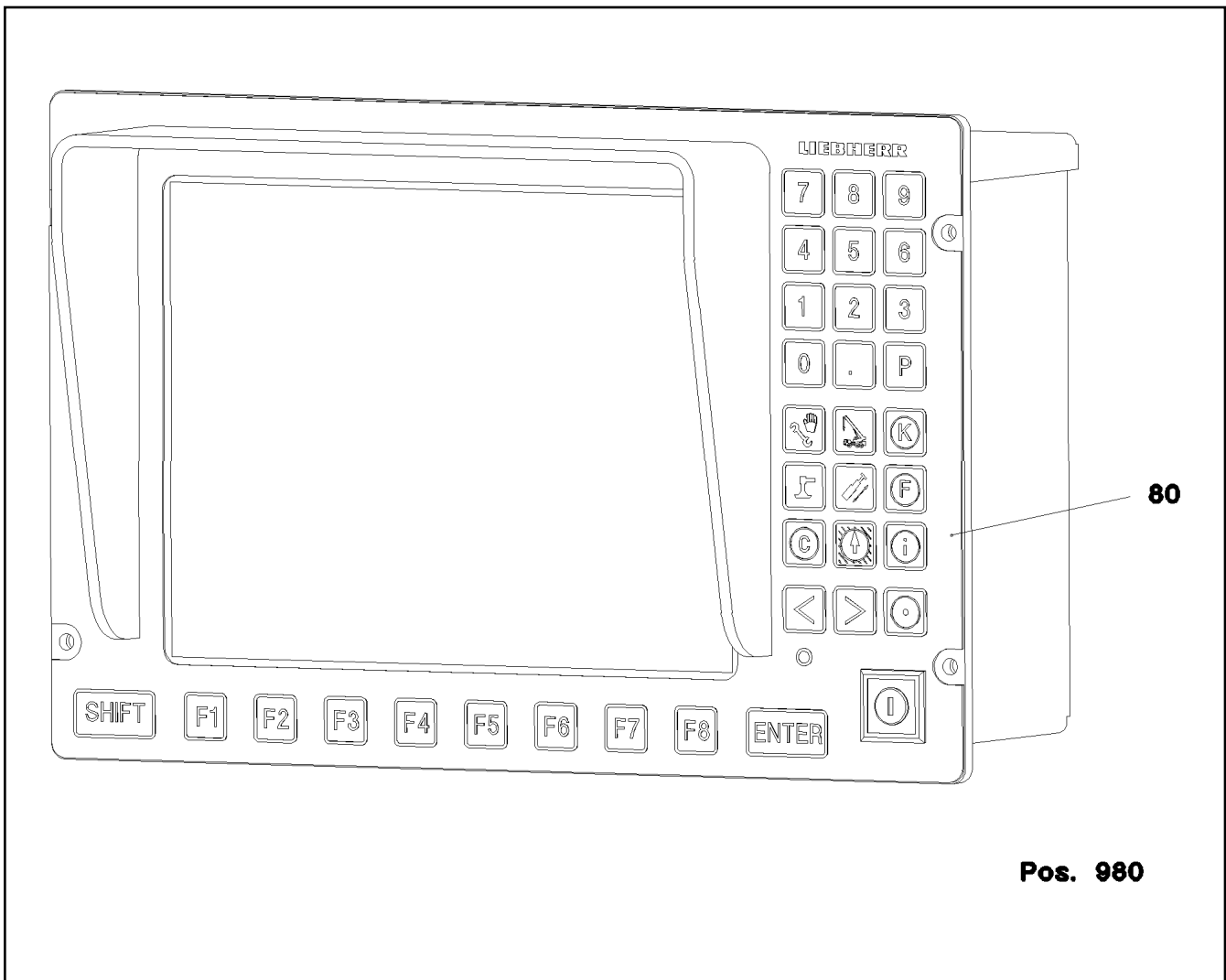

Pos.	Item	Quantity	Description	Bezeichnung	Serie	K
80	91 04 705 08	1	LICCON CONSOLE LCD3 LSB-BSE SPF ⇒ 2 913 009 91 04 705 08	LICCON KONSOLE LCD3		
980	10 28 812 1	1	NAME PLATE 70X40 POLYESTER SPF	BEZEICHNUNGSSCHILD		

6.2.2009
052599

LIEBHERR

etk_en_de_074515 LR 1600/2

LICCON CONSOLE LCD3
LICCON KONSOLE LCD3

□ 279

⇒ 2 913 200
96 47 216 08

Pos.	Item	Quantity	Description	Bezeichnung	Serie	K
8	96 47 914 08	1	LIMIT SWITCH AND SENSOR GENERA ⇒ 2 920 559 96 47 914 08	ENDSCHALTER U.GEBER ALLG		
10	96 48 318 08	1	ELECTRIC F. AGGREGATE ⇒ 2 920 535 96 48 318 08	ELEKTRIK AGGREGAT		
15	96 52 614 08	1	WIRING LIST F.SLEWING PLATFORM ⇒ 2 920 288 96 52 614 08	KABELLISTE DREHBUEHNE		
20	96 54 236 08	1	TERMINAL BOX ELECTRICS SP ⇒ 2 920 443 96 54 236 08	ELEKTRIK KLEMMKASTEN DB		
28	96 51 136 08	1	CONTROL DESK DB ⇒ 2 920 637 96 51 136 08	BEDIENPULT		
35	96 59 398 08	1	WARNING LIGHT LMB ⇒ 2 920 931 96 59 398 08	WARNLEUCHTE		
40	96 48 328 08	1	FIXING PARTS ELECTRIC	BEFESTIGUNGSTEILE ELEKTRI		
(1)	95 56 681 08	4	PLATE X0	BLECH		
(3)	97 02 854 08	1	PLATE 3X200X150	BLECH		
(5)	10 41 285 4	28	OVAL HEAD FLAT SCREW AEHNL.ISO7380	LINSENFLACHKOPFSCHRAUBE		

6.2.2009

etk_en_de_074515 LR 1600/2

☐ 280

LIEBHERR

ELECTR. SYSTEM F.SLEWING PLATF
ELEKTRIK DREHBUEHNE

⇒ 2 920
91 56 833 08

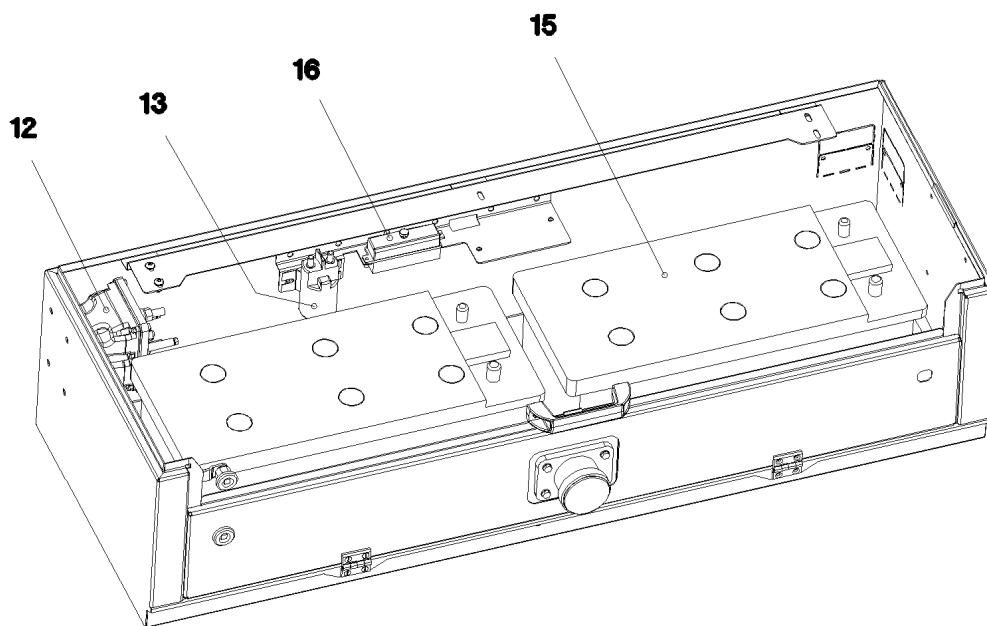

Pos. 10
Pos. 18
Pos. 19

Pos.	Item	Quantity	Description	Bezeichnung	Serie	K
10	96 49 300 08	1	WIRING LIST BATTERY BOX ⇒ 2 920 815 96 49 300 08	KABELLISTE BATTERIEKASTEN		
12	63 01 036 08	1	CUTOFF RELAY 24V	TRENNSCHALTRELAIS		
13	10 01 737 4	1	RELAY	RELAIS		
15	10 11 258 4	2	BATTERY EN 50342 12V 170AH 600/1000A	BATTERIE		
16	60 45 016 08	1	FUSE BOX SMALL 6POL 24V	SICHERUNGSDOSE		
18	61 32 065 08	2	BATTERY TERMINAL CLAMP PLUS VERZINN	BATTERIEKLEMME		
19	61 32 066 08	2	BATTERY TERMINAL CLAMP MINUS VERZI	BATTERIEKLEMME		
30	40 01 034 08	5	CYLINDER SCREW DIN 84 M5X16 4.8 VERZ	ZYLINDERSCHRAUBE		
31	40 01 033 08	2	CYLINDER SCREW DIN 84 M5X12 5.8 VERZ	ZYLINDERSCHRAUBE		
32	41 15 148 08	7	HEX NUT DIN 934 M5 8 VERZ	SECHSKANTMUTTER		
33	42 40 004 08	7	CIRCLIP DIN 128 A 5 VERZ	FEDERRING		
34	42 00 008 08	7	WASHER DIN 125 A 5.3 VERZ	SCHEIBE		

6.2.2009
052449

LIEBHERR

etk_en_de_074515 LR 1600/2

ELECTRIC FOR BATTERY BOX
ELEKTRIK BATTERIEKASTEN

281

⇒ 2 920 083
96 48 319 08

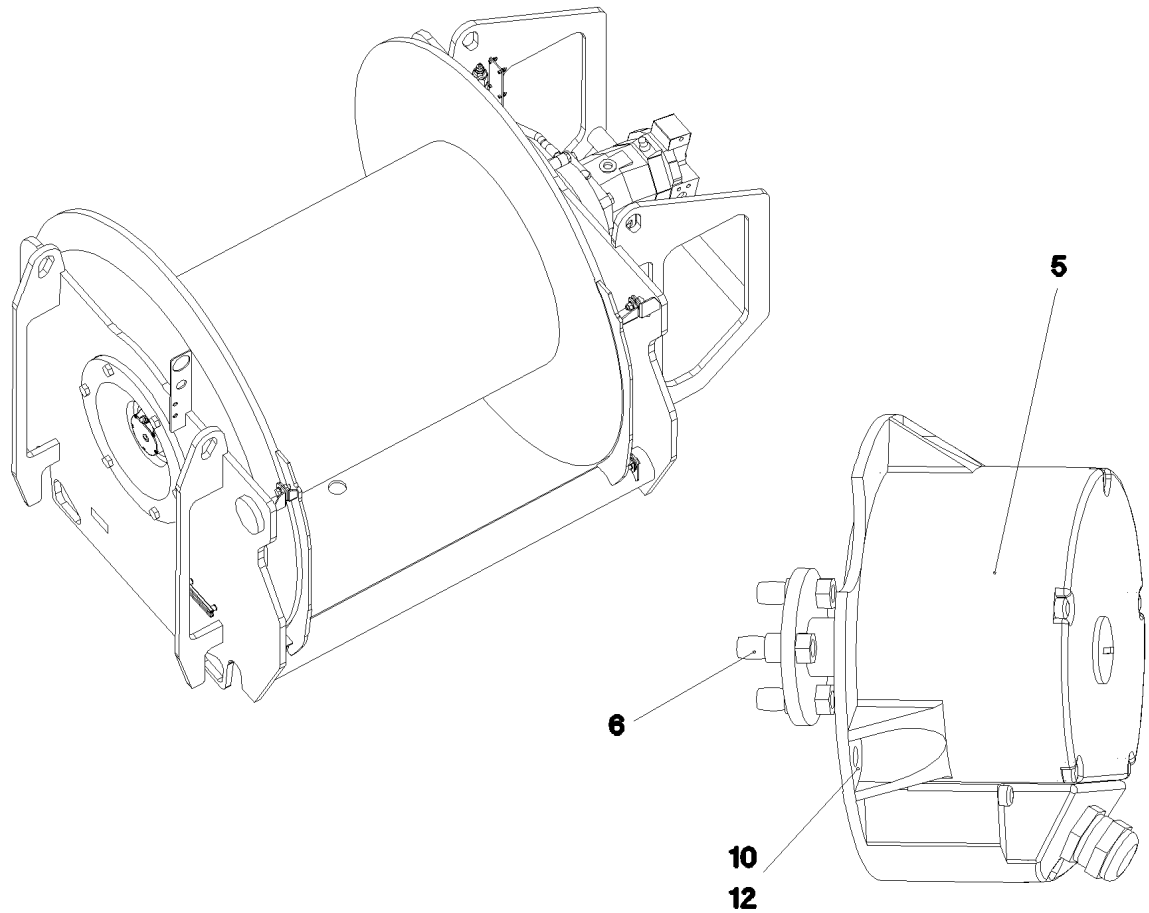

Pos. 20

Pos.	Item	Quantity	Description	Bezeichnung	Serie	K
5	10 04 047 7	1	WINCH REVOLUTION TRANSDUCER SPF ⇒ X10040477 10 04 047 7	WINDENDREHGEBER		
6	60 60 126 08	1	DRIVE FLANGE	ANTRIEBSFLANSCH		
10	40 65 099	3	HEX BOLT ISO 4017 M6X16 8.8 A2C	SECHSKANTSCHRAUBE		
12	42 40 005 08	3	CIRCLIP DIN 127 A 6 VERZ	FEDERRING		
20	96 44 545 08	1	WIRING HARNESS W521	KABELSTRANG		

6.2.2009
052382

LIEBHERR

etk_en_de_074515 LR 1600/2

ELECTRIC FOR WINCH 1
ELEKTRIK WINDE 1

282

⇒ 2 920 200
96 44 536 08

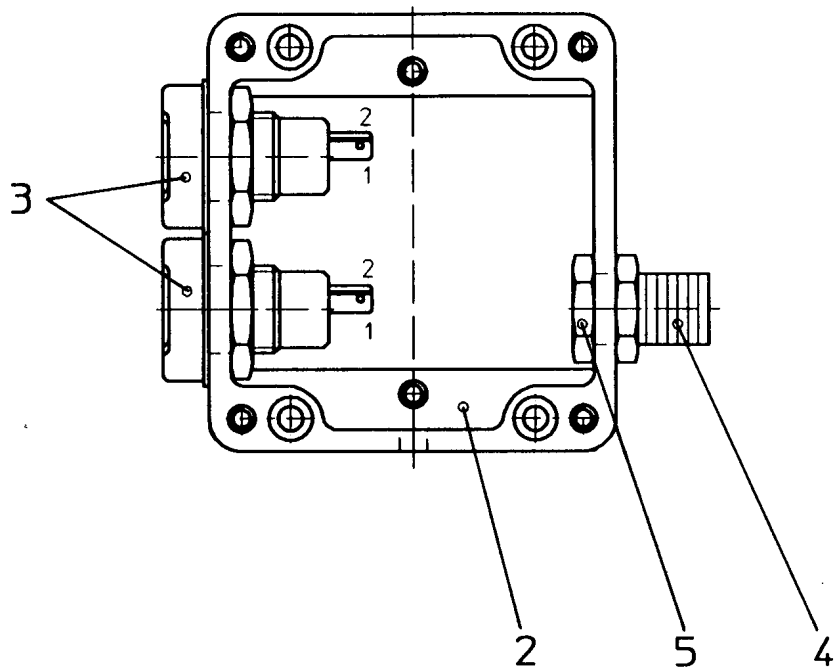

Pos.	Item	Quantity	Description	Bezeichnung	Serie	K
2	94 98 250 08	1	EMPTY CASING	LEERGEHAEUSE		
3	60 52 039 08	2	BUILT-IN SOCKET 2POL 16A	EINBAUSTECKDOSE		
4	60 24 400 08	1	HOSE CLAMP THREADED UNION	SCHLAUCHSCHELLENVERSCH		
5	60 25 019 08	1	LOCK NUT PG9 MS	GEGENMUTTER		

6.2.2009
151028

LIEBHERR

etk_en_de_074515 LR 1600/2

TERMINAL BOX LIGHTING HOIST.GE
KLEMMKASTEN BELEUCHTUNG

283

⇒ 2 920 257
92 78 689 08

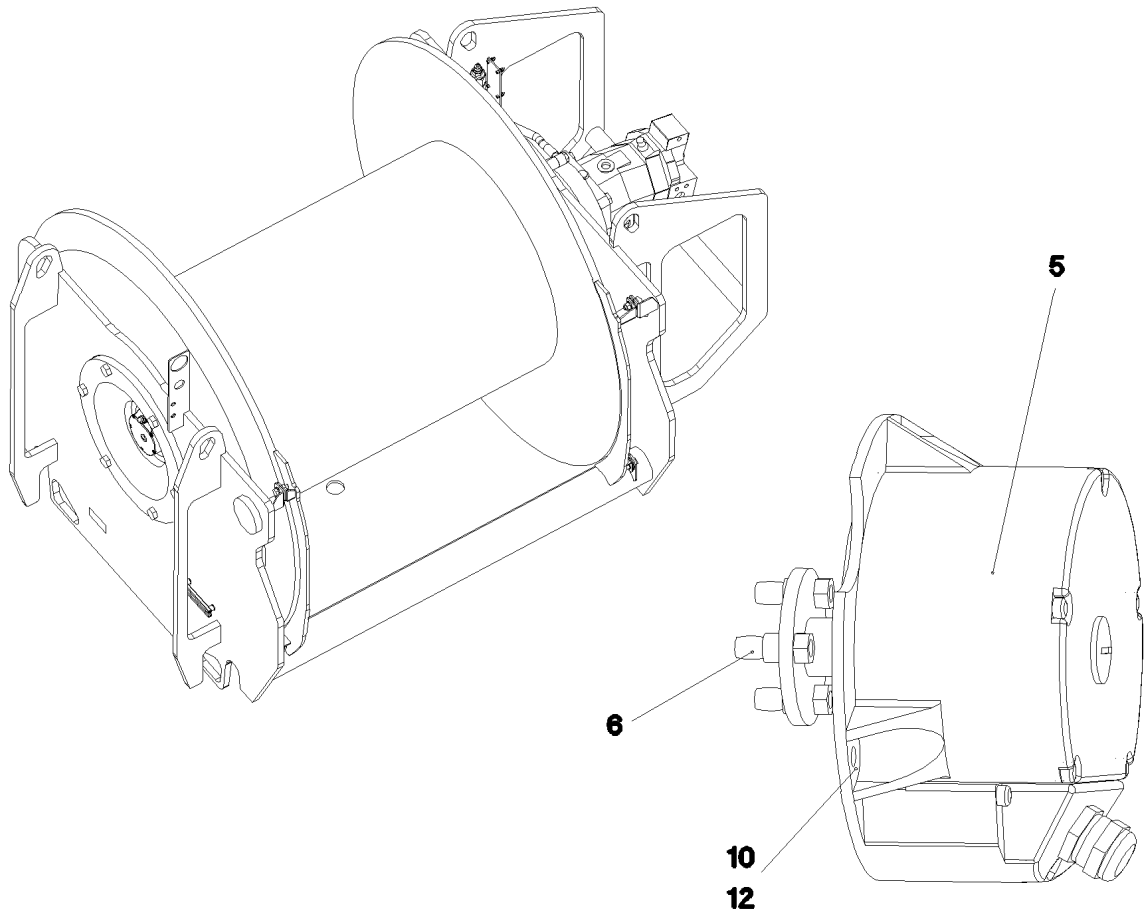

Pos. 20

Pos.	Item	Quantity	Description	Bezeichnung	Serie	K
5	10 04 047 7	1	WINCH REVOLUTION TRANSDUCER SPF ⇒ X10040477 10 04 047 7	WINDENDREHGEBER		
6	60 60 126 08	1	DRIVE FLANGE	ANTRIEBSFLANSCH		
10	40 65 099	3	HEX BOLT ISO 4017 M6X16 8.8 A2C	SECHSKANTSCHRAUBE		
12	42 40 005 08	3	CIRCLIP DIN 127 A 6 VERZ	FEDERRING		
20	96 44 546 08	1	WIRING HARNESS W522	KABELSTRANG		

6.2.2009
052383

LIEBHERR

etk_en_de_074515 LR 1600/2

ELECTRIC FOR WINCH 2
ELEKTRIK WINDE 2

284

⇒ 2 920 260
96 44 537 08

Pos.	Item	Quantity	Description	Bezeichnung	Serie	K
5	96 52 651 08	1	WIRING HARNESS W500 ⇒ 2 920 633 96 52 651 08	KABELSTRANG		
10	96 52 929 08	1	LEAD W330	LEITUNG		
11	96 52 930 08	1	LEAD W331	LEITUNG		
12	96 52 931 08	1	LEAD W332	LEITUNG		
13	96 52 932 08	1	LEAD W333	LEITUNG		
14	96 52 933 08	1	LEAD W334	LEITUNG		
15	96 52 934 08	1	LEAD W540	LEITUNG		
16	96 52 935 08	1	LEAD W560	LEITUNG		
18	96 52 936 08	1	LEAD W571	LEITUNG		
19	96 55 952 08	1	WIRING HARNESS W390	KABELSTRANG		
(57)	60 23 114 08	2	CABLE LUG DIN 46234 8 - 16	KABELSCHUH		
(98)	60 27 101 08	2	CABLE SLEEVE 5,0-7,0/5,0/0,7 SILIKONGU	KABELTUELLE		
(329)	60 04 916 08	2.6	BATTERY CABLE 16	BATTERIEKABEL		
(500)	92 35 122 08	2	CABLE MARKING	KABELMARKIERUNG		
20	96 57 094 08	1	WIRING HARNESS W551	KABELSTRANG		
(5)	68 00 017 08	1	COUPLING SOCKET GERADE PVC SPF	KUPPLUNGSDOSE		
(6)	68 00 000 08	1	COUPLING SOCKET SPF	KUPPLUNGSDOSE		
(500)	92 35 122 08	3	CABLE MARKING	KABELMARKIERUNG		
(501)	60 45 266 08	1	PIN CARRIER	STIFTTRAEGER		
(502)	60 45 085 08	1	SEALING PLUG M 1-K	VERSCHLUSSKAPPE		
(503)	10 47 638 3	1	PLUG	STECKER		
(504)	60 24 260 08	1	THREADED CABLE GLAND M20X1,5 MS	KABELVERSCHRAUBUNG		
(505)	60 24 219 08	1	INSERT M20X1,5 NBR	MEHRFACHDICHTEINSATZ		
(628)	60 45 192 08	3	PIN CONTACT	STIFTKONTAKT		
(812)	60 45 189 08	4	STOPPER PLUG 1,58	BLINDSTOPFEN		

6.2.2009

etk_en_de_074515 LR 1600/2

285

LIEBHERR

WIRING LIST F.SLEWING PLATFORM
KABELLISTE DREHBUEHNE

⇒ 2 920 288
96 52 614 08

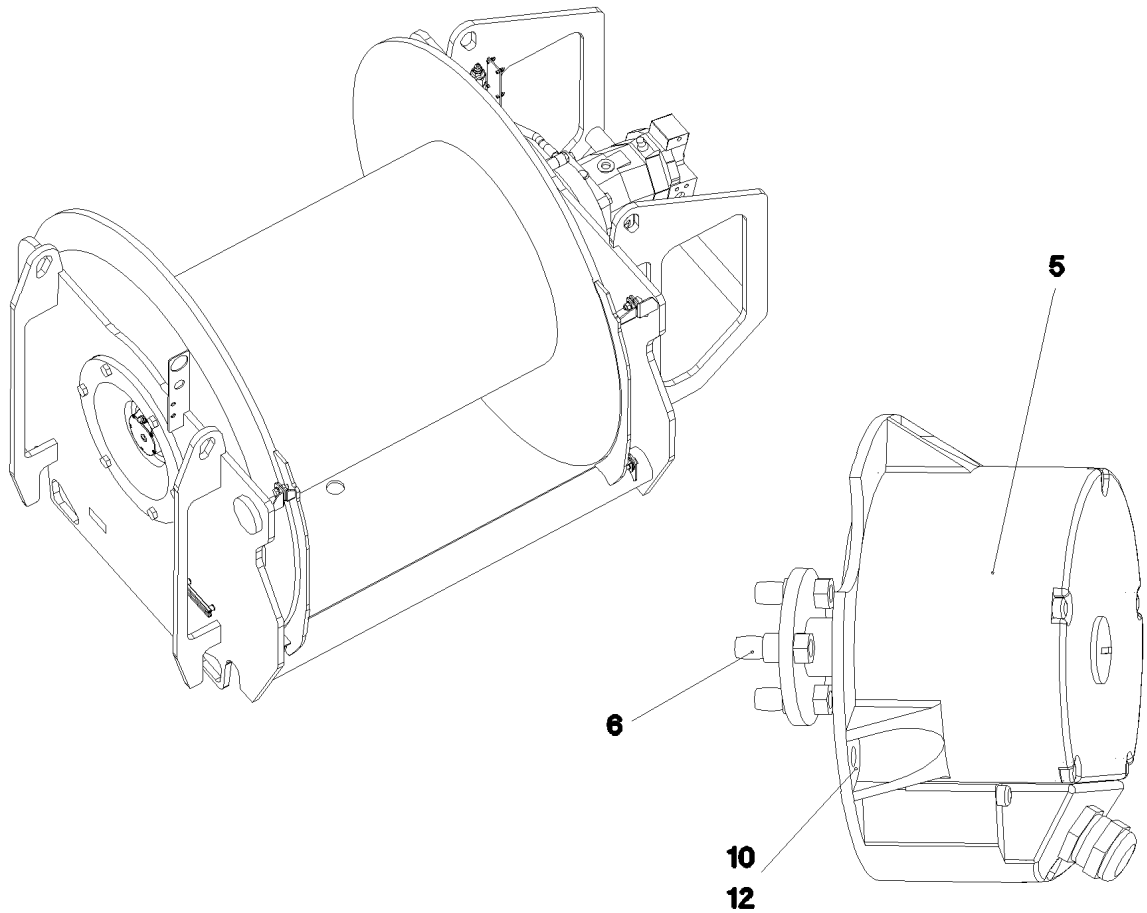

Pos. 20

Pos.	Item	Quantity	Description	Bezeichnung	Serie	K
5	10 04 047 7	1	WINCH REVOLUTION TRANSDUCER SPF ⇒ X10040477 10 04 047 7	WINDENDREHGEBER		
6	60 60 126 08	1	DRIVE FLANGE	ANTRIEBSFLANSCH		
10	40 65 099	3	HEX BOLT ISO 4017 M6X16 8.8 A2C	SECHSKANTSCHRAUBE		
12	42 40 005 08	3	CIRCLIP DIN 127 A 6 VERZ	FEDERRING		
20	96 44 547 08	1	WIRING HARNESS W1063	KABELSTRANG		

6.2.2009
052624

LIEBHERR

etk_en_de_074515 LR 1600/2

ELECTRIC FOR WINCH 3
ELEKTRIK WINDE 3

□ 286

⇒ 2 920 334
96 44 538 08

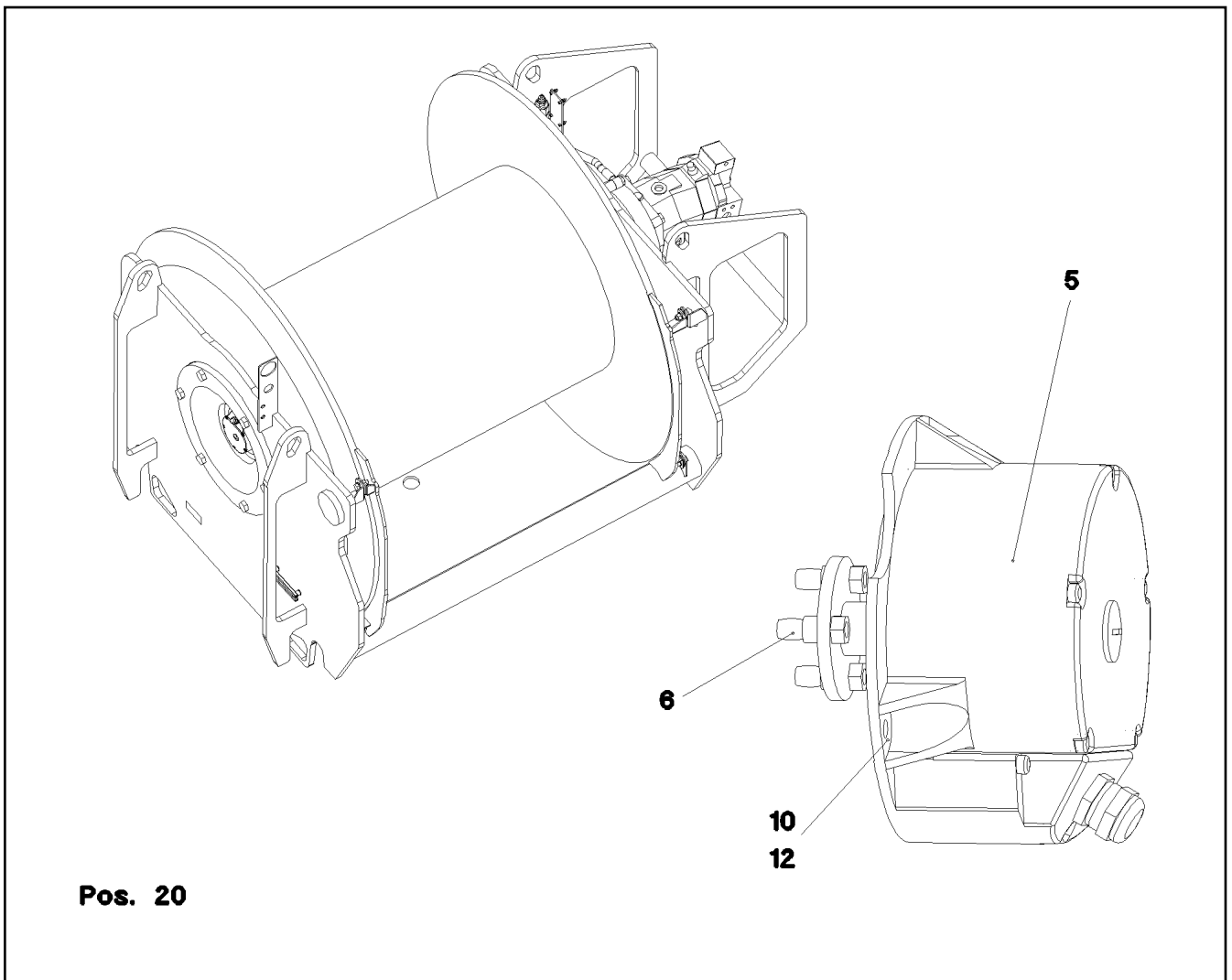

Pos. 20

Pos.	Item	Quantity	Description	Bezeichnung	Serie	K
5	10 04 047 7	1	WINCH REVOLUTION TRANSDUCER SPF ⇒ X10040477 10 04 047 7	WINDENDREHGEBER		
6	60 60 126 08	1	DRIVE FLANGE	ANTRIEBSFLANSCH		
10	40 65 099	3	HEX BOLT ISO 4017 M6X16 8.8 A2C	SECHSKANTSCHRAUBE		
12	42 40 005 08	3	CIRCLIP DIN 127 A 6 VERZ	FEDERRING		
20	96 44 548 08	1	WIRING HARNESS W524	KABELSTRANG		

6.2.2009
052384

LIEBHERR

etk_en_de_074515 LR 1600/2

ELECTRIC FOR WINCH 4
ELEKTRIK WINDE 4

287

⇒ 2 920 350
96 44 539 08

5

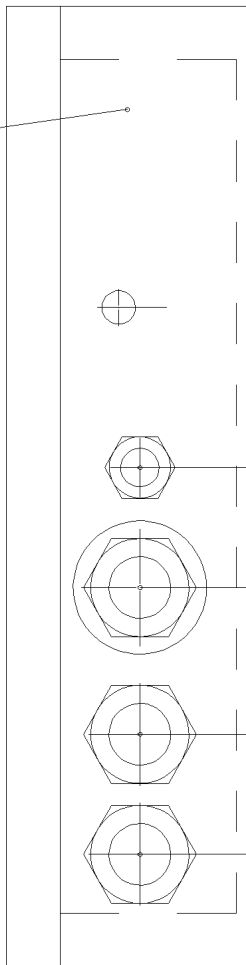

W337 22

W338 23

W339 24

W336 21

293

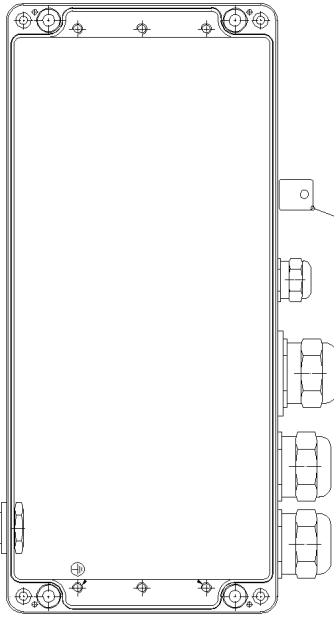

292

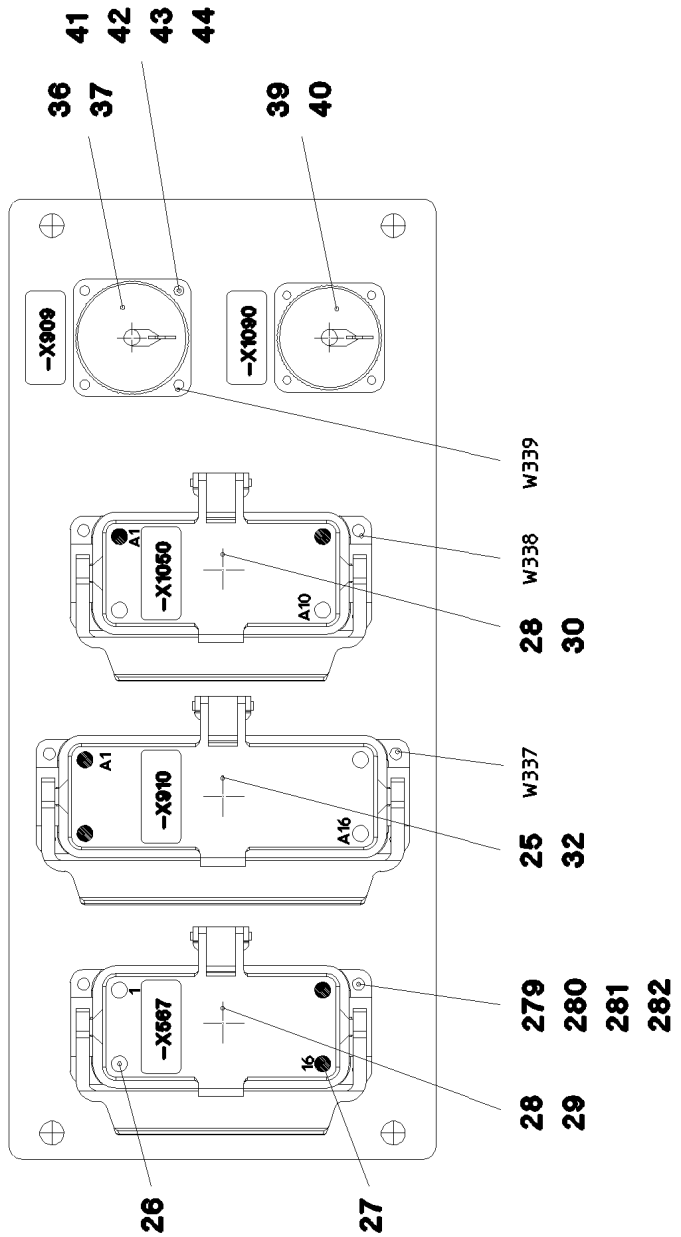

26

27

28 279

29 280

30 281

31 282

32 W337

33

34 W338

35 W339

36

37

41

42

43

44

39

40

Pos. 15

Pos. 16

Pos. 50

6.2.2009
054195

LIEBHERR

etk_en_de_074515 LR 1600/2

TERMINAL BOX CPL.
KLEMMKASTEN KPL.

□ 288 (1/3)

⇒ 2 920 369
96 54 235 08

Pos.	Item	Quantity	Description	Bezeichnung	Serie	K
5	97 85 479 08	1	EMPTY CASING 160X360X90X0	LEERGEHAEUSE		
15	96 56 665 08	1	DUMMY PLUG W909BS	BLINDSTECKER		
(151)	60 56 090 08	1	PIN INSERT 64POL	STIFTEINSATZ		
(152)	40 01 020 08	1	CYLINDER SCREW DIN 84 M4X20 4.8 VERZ	ZYLINDERSCHRAUBE		
(153)	41 15 142 08	2	HEX NUT DIN 934 M4 8 A3C	SECHSKANTMUTTER		
(154)	42 00 007 08	4	WASHER DIN 125 A 4.3 ST VERZ	SCHEIBE		
(155)	42 52 207 08	1	SERRATED LOCK WASHER DIN 6798 J 4,3	FAECHERSCHEIBE		
(156)	60 56 099 08	2	GUIDING BUSH	FUEHRUNGSBUCHSE		
(157)	60 56 100 08	2	GUIDE PIN	FUEHRUNGSSTIFT		
(158)	60 56 176 08	1	SOCKET SHELL 24POL.	TUELLENGEHAEUSE		
(159)	60 24 251 08	1	SCREW PLUG M25X1,5 MS	VERSCHLUSSSCHRAUBE		
(160)	97 85 630 08	1	LABEL	SCHILD		
(266)	74 00 008 08	0.2	KNOTTED-LINK CHAIN DIN 5686 1,8X25	KNOTENKETTE		
(345)	60 04 140 08	0.32	ELECTR.CABLE 0,75Q PVC SPF	KFZ-LEITUNG		
(500)	92 35 122 08	1	CABLE MARKING	KABELMARKIERUNG		
(602)	60 56 023 08	4	CRIMPING CONTACT	CRIMPKONTAKT		
16	96 56 664 08	1	DUMMY PLUG W1050BS	BLINDSTECKER		
(151)	60 56 022 08	1	PLUG INSERT 40POL	STECKEREINSATZ		
(152)	40 01 020 08	1	CYLINDER SCREW DIN 84 M4X20 4.8 VERZ	ZYLINDERSCHRAUBE		
(153)	41 15 142 08	2	HEX NUT DIN 934 M4 8 A3C	SECHSKANTMUTTER		
(154)	42 00 007 08	4	WASHER DIN 125 A 4.3 ST VERZ	SCHEIBE		
(155)	42 52 207 08	1	SERRATED LOCK WASHER DIN 6798 J 4,3	FAECHERSCHEIBE		
(156)	60 56 099 08	2	GUIDING BUSH	FUEHRUNGSBUCHSE		
(157)	60 56 100 08	2	GUIDE PIN	FUEHRUNGSSTIFT		
(158)	97 85 631 08	1	LABEL	SCHILD		
(159)	60 56 174 08	1	SOCKET SHELL 16POL	TUELLENGEHAEUSE		
(160)	60 24 251 08	1	SCREW PLUG M25X1,5 MS	VERSCHLUSSSCHRAUBE		
(266)	74 00 008 08	0.2	KNOTTED-LINK CHAIN DIN 5686 1,8X25	KNOTENKETTE		
(345)	60 04 140 08	0.32	ELECTR.CABLE 0,75Q PVC SPF	KFZ-LEITUNG		
(500)	92 35 122 08	1	CABLE MARKING	KABELMARKIERUNG		
(602)	60 56 023 08	4	CRIMPING CONTACT	CRIMPKONTAKT		
17	96 55 366 08	1	DUMMY PLUG W909BS	BLINDSTECKER		
(151)	10 44 366 0	1	PLUG 24POL 22A	STECKER		
(152)	69 24 000 08	1	DUST CAP METALL	STAUBKAPPE		
(153)	40 01 405 08	1	CYLINDER SCREW DIN 84 M3X6 MS VERNI	ZYLINDERSCHRAUBE		
(154)	60 24 252 08	1	SCREW PLUG M32X1,5 MS	VERSCHLUSSSCHRAUBE		
(266)	74 00 008 08	0.2	KNOTTED-LINK CHAIN DIN 5686 1,8X25	KNOTENKETTE		
(344)	60 04 121 08	0.96	ELECTR.CABLE DIN 72551 0,5 SPF	KFZ-LEITUNG		
(500)	92 35 122 08	1	CABLE MARKING	KABELMARKIERUNG		
(708)	10 47 304 8	7	CABLE SLEEVE 2,4-3,0 SILIKON	KABELTUELLE		
18	96 55 363 08	1	WIRING HARNESS W339A	KABELSTRANG		
(124)	60 23 235 08	10	FLAT PLUG 2,8	FLACHSTECKER		
(125)	60 23 003 08	14	CONTACT 0,5 - 1,0	KONTAKT		
(151)	69 24 016 08	1	BUILD-IN SOCKET 24POL BU	EINBAUDOSE		
(152)	60 23 360 08	1	HOUSING 14POL	GEHAEUSE		
(153)	10 02 156 8	1	PLUG SHELL 14POL	STECKERGEHAEUSE		
(305)	60 04 341 08	3.84	ELECTR.CABLE DIN 72551 1 SPF	KFZ-LEITUNG		
(500)	92 35 122 08	3	CABLE MARKING	KABELMARKIERUNG		
(708)	10 47 304 8	24	CABLE SLEEVE 2,4-3,0 SILIKON	KABELTUELLE		
19	96 55 364 08	1	WIRING HARNESS W339B	KABELSTRANG		
(124)	60 23 235 08	7	FLAT PLUG 2,8	FLACHSTECKER		
(125)	60 23 003 08	9	CONTACT 0,5 - 1,0	KONTAKT		
(151)	69 18 092 08	1	APPLIANCE SOCKET	GERAETESTECKDOSE		
(152)	60 23 328 08	1	HOUSING 10POL	GEHAEUSE		
(153)	10 02 156 7	1	PLUG SHELL 10-POL	STECKERGEHAEUSE		
(305)	60 04 341 08	2.56	ELECTR.CABLE DIN 72551 1 SPF	KFZ-LEITUNG		
(500)	92 35 122 08	3	CABLE MARKING	KABELMARKIERUNG		
(708)	10 47 304 8	16	CABLE SLEEVE 2,4-3,0 SILIKON	KABELTUELLE		
21	96 54 268 08	1	LEAD W336	LEITUNG		
22	96 54 269 08	1	LEAD W337	LEITUNG		

6.2.2009

etk_en_de_074515 LR 1600/2

☐ 289 (2/3)

LIEBHERRTERMINAL BOX CPL.
KLEMMKASTEN KPL.⇒ 2 920 369
96 54 235 08

Pos.	Item	Quantity	Description	Bezeichnung	Serie	K
23	96 54 270 08	1	LEAD W338	LEITUNG		
24	96 54 271 08	1	LEAD W339	LEITUNG		
25	60 56 088 08	1	BUSH INSERT 64POL	BUCHSENEINSATZ		
26	60 56 099 08	6	GUIDING BUSH	FUEHRUNGSBUCHSE		
27	60 56 100 08	6	GUIDE PIN	FUEHRUNGSSTIFT		
28	60 56 171 08	2	ADD-ON HOUSING 16POL.	ANBAUGEHAEUSE		
29	60 56 086 08	1	BUSH INSERT 16POL	BUCHSENEINSATZ		
30	60 56 021 08	1	BUSH INSERT 40POL	BUCHSENEINSATZ		
31	60 23 061 08	2	CABLE LUG 4/2,5mm ² VERZ	KABELSCHUH		
32	60 56 172 08	1	ADD-ON HOUSING 24POL.	ANBAUGEHAEUSE		
34	60 22 179 08	2	CABLE LUG DIN 46237 6 - 2,5	KABELSCHUH		
36	69 21 000 08	1	SEAL	DICHTUNG		
37	69 18 998 08	1	DUST CAP METALL	STAUBKAPPE		
39	69 18 129 08	1	PROTECTING CAP MS	SCHUTZKAPPE		
40	69 18 222 08	1	SEAL	DICHTUNG		
41	40 01 006 08	8	CYLINDER SCREW DIN 84 M3X16 5.8 A3C	ZYLINDERSCHRAUBE		
42	42 51 005 08	8	TOOTH LOCK WASHER DIN 6797 A 3,2	ZAHNSCHEIBE		
43	42 00 006 08	8	WASHER DIN 125 A 3.7 ST VERZ	SCHEIBE		
44	41 19 001 08	8	HEX NUT DIN 985 M3 8 A3C	SECHSKANTMUTTER		
50	55 30 108 08	0.9	PLASTIC SPIRAL HOSE NW50 KUNSTSTOF	SPIRALSCHLAUCH		
279	42 00 007 08	16	WASHER DIN 125 A 4.3 ST VERZ	SCHEIBE		
280	40 01 020 08	12	CYLINDER SCREW DIN 84 M4X20 4.8 VERZ	ZYLINDERSCHRAUBE		
281	41 15 142 08	14	HEX NUT DIN 934 M4 8 A3C	SECHSKANTMUTTER		
282	42 51 007 08	12	TOOTH LOCK WASHER DIN 6797 A 4,3	ZAHNSCHEIBE		
292	60 25 012 08	1	WATER DRAIN PLUG PA6G SPF	ENTWAESSERUNGSSTOPFEN		
293	60 25 013 08	1	VENTILATION SCREW G1/2"X30 POLYAMID	ENTLUEFTUNGSSCHRAUBE		
310	60 04 042 08	0.3	ELECTR.CABLE DIN 72551 2,5	KFZ-LEITUNG		

6.2.2009

etk_en_de_074515 LR 1600/2

290 (3/3)

LIEBHERR

TERMINAL BOX CPL.
KLEMMKASTEN KPL.

⇒ 2 920 369
96 54 235 08

Pos.	Item	Quantity	Description	Bezeichnung	Serie	K
1	96 48 794 08	1	TERMINAL BOX CPL. S10 ⇒ 2 920 448 96 48 794 08	KLEMMKASTEN KPL.		
2	96 54 235 08	1	TERMINAL BOX CPL. S11 ⇒ 2 920 369 96 54 235 08	KLEMMKASTEN KPL.		

6.2.2009	etk_en_de_074515 LR 1600/2	☐ 291
LIEBHERR	TERMINAL BOX ELECTRICS SP ELEKTRIK KLEMMKASTEN DB	⇒ 2 920 443 96 54 236 08

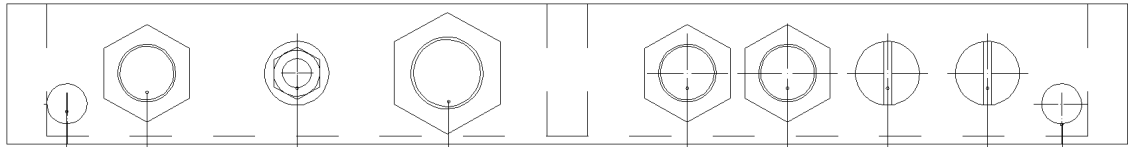

279
280 292 288 **289** **283** **288** **288** **286** **286** **292**
281 **290**
282

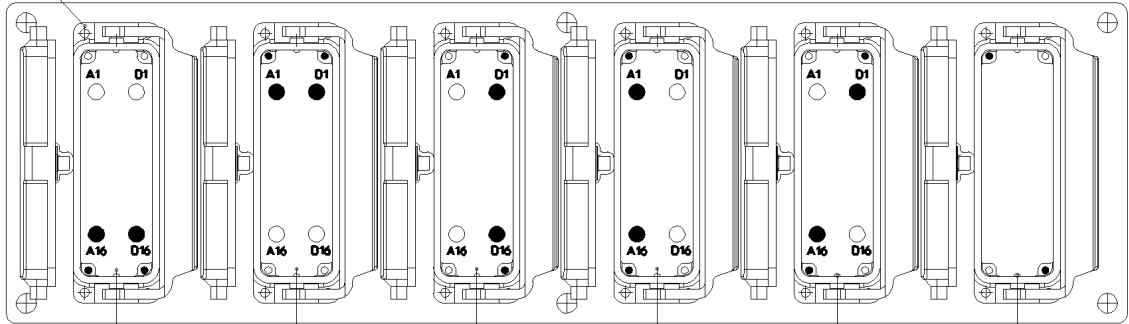

20 **20** **20** **20** **20** **20**
21 **21** **21** **21** **21** **20**
22 **22** **22** **22** **22**
23 **23** **23** **23** **23**

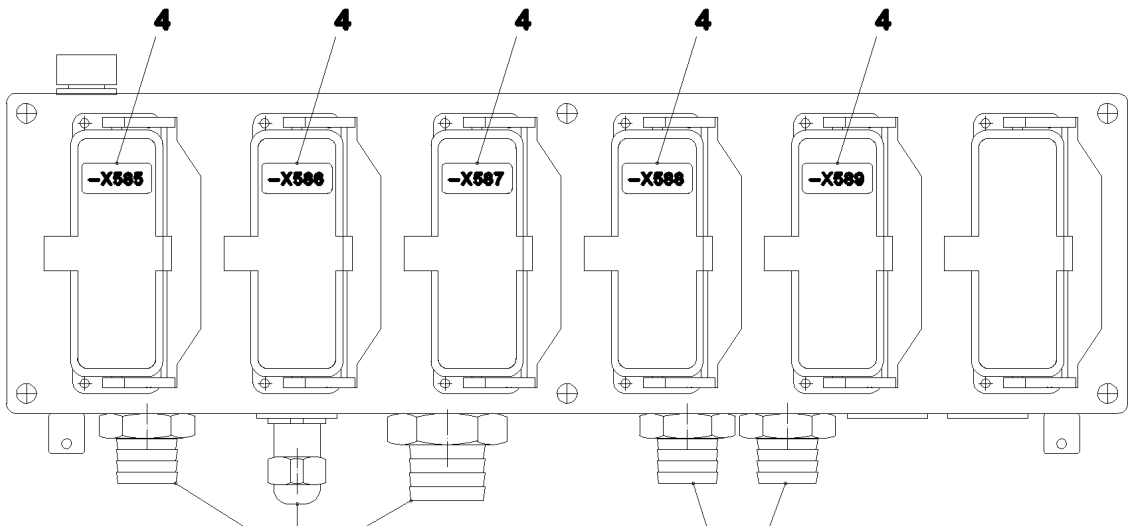

293
W570
W500
W501

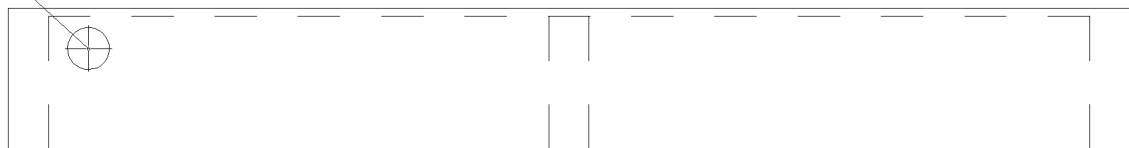

6.2.2009
052634

LIEBHERR

etk_en_de_074515 LR 1600/2

TERMINAL BOX CPL.
KLEMMKASTEN KPL.

▣ 292 (1/2)

⇒ 2 920 448
96 48 794 08

Pos.	Item	Quantity	Description	Bezeichnung	Serie	K
4	96 48 795 08	1	TAGS - TERMINAL BOX S10	SCHILDER KLEMMKASTEN		
(1)	97 75 168 08	1	LABEL	SCHILD		
(2)	97 75 169 08	1	LABEL 35X15 LEXEDGE II	SCHILD		
(3)	97 75 170 08	1	LABEL 35X15 LEXEDGE II	SCHILD		
(4)	97 75 171 08	1	LABEL 35X15 LEXEDGE II	SCHILD		
(5)	97 75 172 08	1	LABEL 35X15 LEXEDGE II	SCHILD		
5	97 51 876 08	1	EMPTY CASING 160X560X90X0	LEERGEHAEUSE		
20	60 56 172 08	6	ADD-ON HOUSING 24POL.	ANBAUGEHAEUSE		
21	60 56 090 08	5	PIN INSERT 64POL	STIFTEINSATZ		
22	60 56 099 08	10	GUIDING BUSH	FUEHRUNGSBUCHSE		
23	60 56 100 08	10	GUIDE PIN	FUEHRUNGSSTIFT		
31	60 23 061 08	2	CABLE LUG 4/2,5mm ² VERZ	KABELSCHUH		
34	60 22 179 08	2	CABLE LUG DIN 46237 6 - 2,5	KABELSCHUH		
279	42 00 007 08	28	WASHER DIN 125 A 4.3 ST VERZ	SCHEIBE		
280	40 01 020 08	24	CYLINDER SCREW DIN 84 M4X20 4.8 VERZ	ZYLINDERSCHRAUBE		
281	41 15 142 08	26	HEX NUT DIN 934 M4 8 A3C	SECHSKANTMUTTER		
282	42 51 007 08	24	TOOTH LOCK WASHER DIN 6797 A 4,3	ZAHNSCHEIBE		
283	60 24 413 08	1	HOSE UNION JOINT M50X1,5 MS	SCHLAUCHVERSCHRAUBUNG		
286	60 24 252 08	2	SCREW PLUG M32X1,5 MS	VERSCHLUSSSCHRAUBE		
288	60 24 412 08	3	HOSE UNION JOINT M40X1,5 MS	SCHLAUCHVERSCHRAUBUNG		
289	60 26 065 08	1	REDUCTION M32X1,5/M20X1,5 MS	REDUKTION		
290	60 24 242 08	1	THREADED CABLE GLAND M20X1,5 MS	KABELVERSCHRAUBUNG		
292	60 25 012 08	2	WATER DRAIN PLUG PA6G SPF	ENTWAESSERUNGSSTOPFEN		
293	60 25 013 08	1	VENTILATION SCREW G1/2"X30 POLYAMID	ENTLUEFTUNGSSCHRAUBE		
310	60 04 042 08	0.3	ELECTR.CABLE DIN 72551 2,5	KFZ-LEITUNG		

6.2.2009

etk_en_de_074515 LR 1600/2

293 (2/2)

LIEBHERR

TERMINAL BOX CPL.
KLEMMKASTEN KPL.

⇒ 2 920 448
96 48 794 08

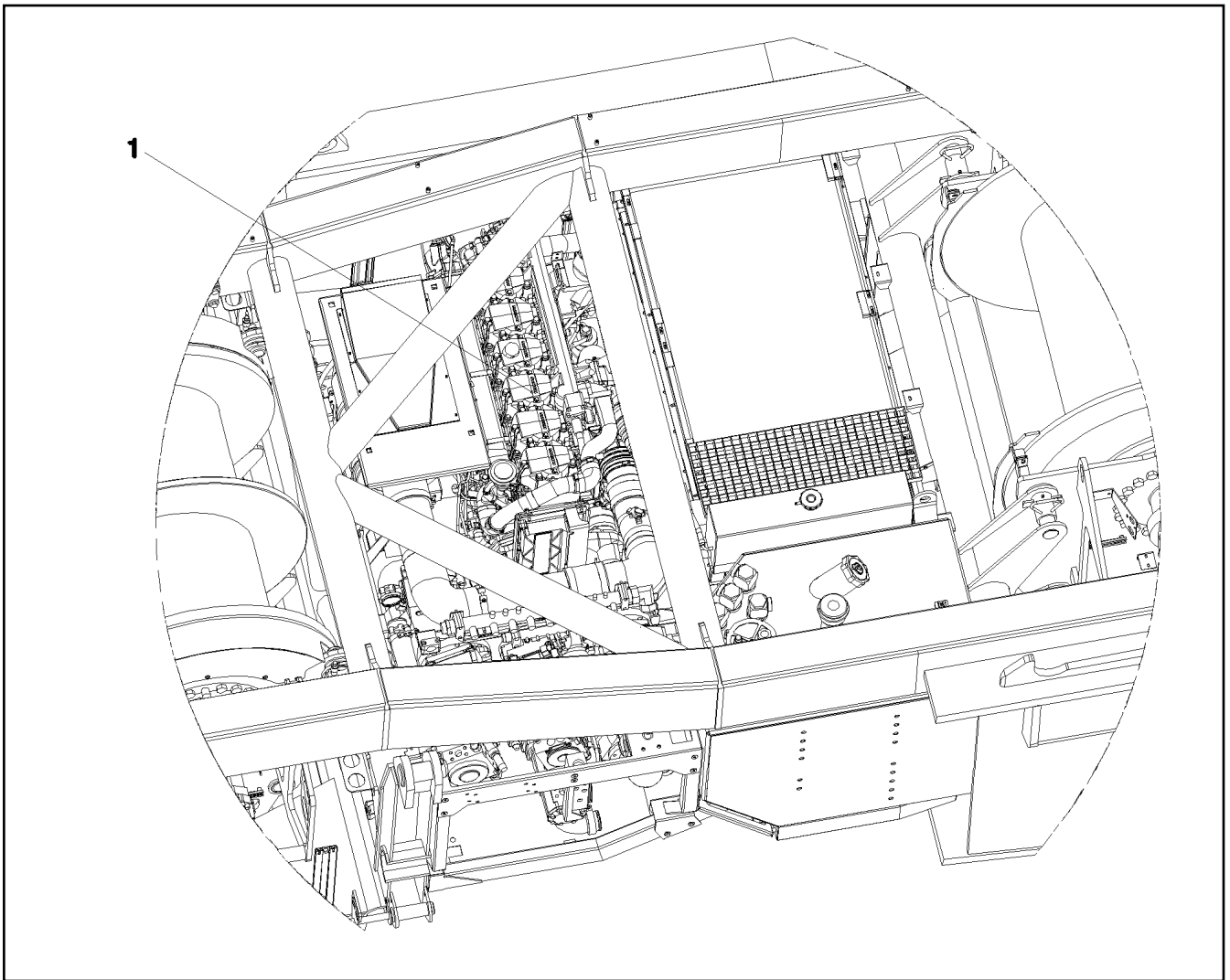

Pos.	Item	Quantity	Description	Bezeichnung	Serie	K
10	96 48 317 08	1	WIRING LIST F.ELECTR.AGGREGATE ⇒ 2 920 536 96 48 317 08	KABELLISTE ELEKTRIK AGGRE		
15	60 20 043 08	1	FASTENING CLAMP 15,9	BEFESTIGUNGSSCHELLE		

6.2.2009
052635

LIEBHERR

etk_en_de_074515 LR 1600/2

ELECTRIC F. AGGREGATE
ELEKTRIK AGGREGAT

□ 294

⇒ 2 920 535
96 48 318 08

Pos.	Item	Quantity	Description	Bezeichnung	Serie	K
15	96 50 161 08	1	WIRING HARNESS W501	KABELSTRANG		
16	96 51 118 08	1	WIRING HARNESS W587	KABELSTRANG		
(80)	60 23 010 08	1	CABLE LUG DIN 46235 10 - 95	KABELSCHUH		
(333)	60 04 918 08	11	BATTERY CABLE DIN 72551 95 SPF	BATTERIEKABEL		
(500)	92 35 122 08	2	CABLE MARKING	KABELMARKIERUNG		
(648)	60 22 221 08	1	ANGLE SOCKET 12-95	WINKELKABELSCHUH		
(712)	10 47 305 2	2	CABLE SLEEVE 15-19 SILIKON	KABELTUELLE		
18	96 51 126 08	1	WIRING HARNESS W589	KABELSTRANG		
19	96 51 127 08	1	WIRING HARNESS W590	KABELSTRANG		
(99)	60 23 011 08	2	CABLE LUG 12 - 95	KABELSCHUH		
(333)	60 04 918 08	1	BATTERY CABLE DIN 72551 95 SPF	BATTERIEKABEL		
(500)	92 35 122 08	2	CABLE MARKING	KABELMARKIERUNG		
(712)	10 47 305 2	2	CABLE SLEEVE 15-19 SILIKON	KABELTUELLE		

6.2.2009

etk_en_de_074515 LR 1600/2

295

LIEBHERR

WIRING LIST F.ELECTR.AGGREGATE
KABELLISTE ELEKTRIK AGGREGAT

⇒ 2 920 536
96 48 317 08

Pos.	Item	Quantity	Description	Bezeichnung	Serie	K
2	96 17 565 08	1	INDUCT. SENSOR BT ASSEMBLED	INDUKTIVSENSOR BW MONTIER		
(1)	69 23 087 08	2	INDUCTIVE SENSOR SPF	INDUKTIVSENSOR		
8	96 21 541 08	1	SIGNAL BELL LMB	SIGNALWECKER LMB		
(5)	61 40 047 08	1	ALARM 24V DC	SIGNALWECKER		
(6)	60 26 062 08	1	REDUCTION M20X1,5/M16X1,5 MS	REDUKTION		
(7)	60 24 408 08	1	HOSE UNION JOINT M16X1,5 MS	SCHLAUCHVERSCHRAUBUNG		

6.2.2009

etk_en_de_074515 LR 1600/2

 296

LIEBHERR

LIMIT SWITCH AND SENSOR GENERA
ENDSCHALTER U.GEBER ALLGEMEIN

⇒ 2 920 559
96 47 914 08

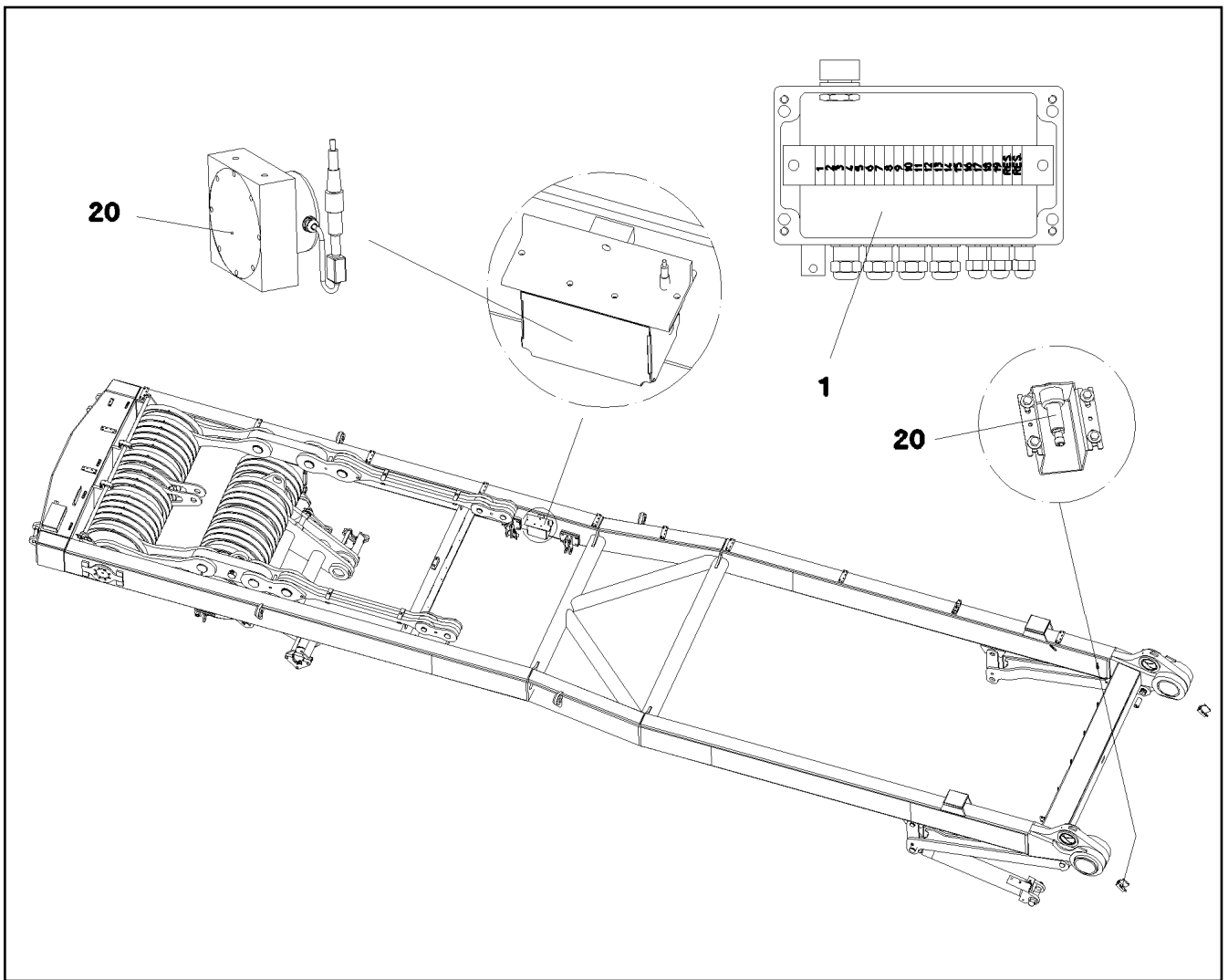

Pos.	Item	Quantity	Description	Bezeichnung	Serie	K
1	96 54 405 08	1	TERMINAL BOX WINCH PRE-ASSY.W. S109 ⇒ 2 920 581 96 54 405 08	KLEMMKASTEN SA-BOCK VORM		
20	96 57 085 08	1	SENSOR ASSEMBLY SA-STAND ⇒ 2 930 96 57 085 08	GEBERANBAU SA-BOCK		

6.2.2009
053693

LIEBHERR

etk_en_de_074515 LR 1600/2

ELECTRIC FOR SA - FRAME
ELEKTRIK SA-BOCK

□ 297

⇒ 2 920 578
96 54 379 08

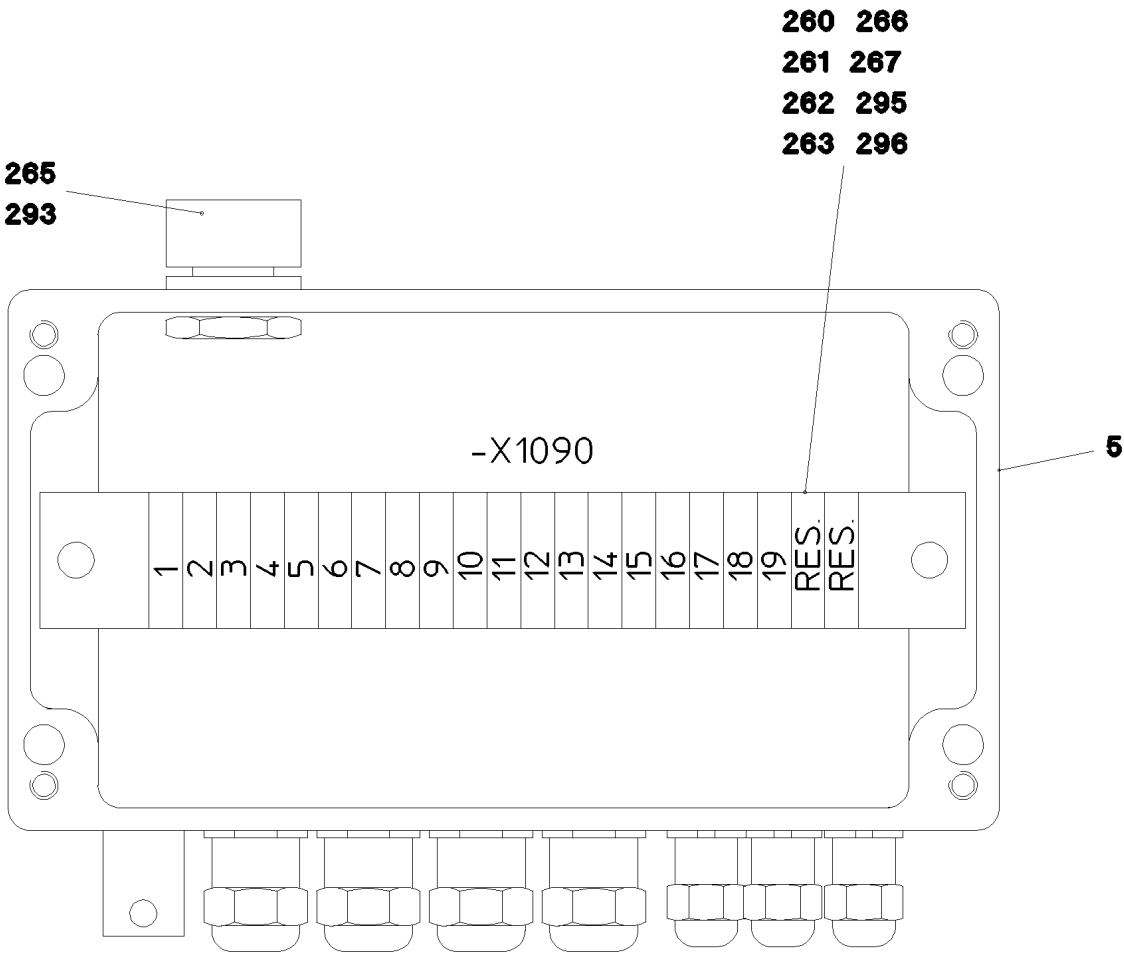
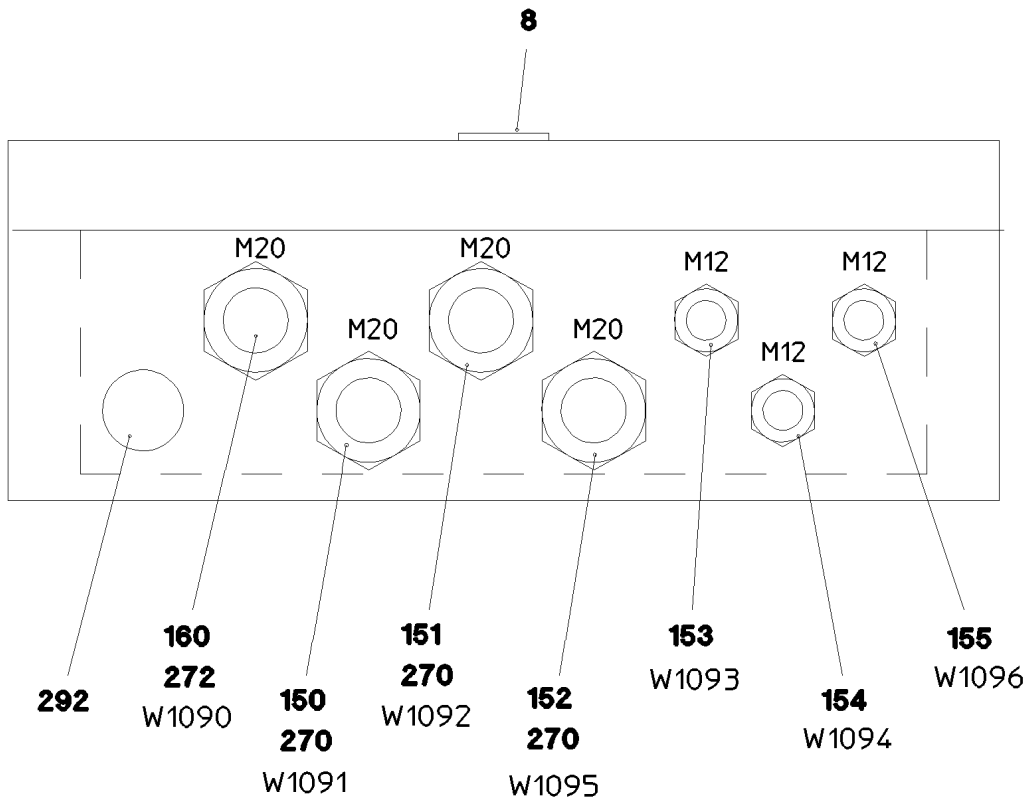

6.2.2009
053692

LIEBHERR

etk_en_de_074515 LR 1600/2

TERMINAL BOX WINCH PRE-ASSY.W.
KLEMMKASTEN SA-BOCK VORM.

☐ 298 (1/2)

⇒ 2 920 581
96 54 405 08

Pos.	Item	Quantity	Description	Bezeichnung	Serie	K
5	97 14 228 08	1	EMPTY CASING	LEERGEHAEUSE		
8	97 80 964 08	1	LABEL +S1090 ALU	SCHILD		
150	96 51 848 08	1	LEAD W1091	LEITUNG		
151	96 51 850 08	1	LEAD W1092	LEITUNG		
152	96 51 854 08	1	LEAD W1095	LEITUNG		
			⇒ 2 920 636 96 51 854 08			
153	96 51 855 08	1	LEAD W1093	LEITUNG		
(5)	68 00 017 08	1	COUPLING SOCKET GERADE PVC SPF	KUPPLUNGSDOSE		
(63)	60 22 037 08	3	RECEPTACLE FOR TABS 6,3 0,3 - 1,5	FLACHSTECKHUELSE		
(151)	60 24 240 08	1	THREADED CABLE GLAND M12X1,5 MS	KABELVERSCHRAUBUNG		
(500)	92 35 122 08	2	CABLE MARKING	KABELMARKIERUNG		
154	96 51 856 08	1	LEAD W1094	LEITUNG		
(5)	68 00 017 08	1	COUPLING SOCKET GERADE PVC SPF	KUPPLUNGSDOSE		
(63)	60 22 037 08	3	RECEPTACLE FOR TABS 6,3 0,3 - 1,5	FLACHSTECKHUELSE		
(151)	60 24 240 08	1	THREADED CABLE GLAND M12X1,5 MS	KABELVERSCHRAUBUNG		
(500)	92 35 122 08	2	CABLE MARKING	KABELMARKIERUNG		
155	96 51 857 08	1	LEAD W1096	LEITUNG		
(5)	68 00 008 08	1	COUPLING SOCKET 90GR SPF	KUPPLUNGSDOSE		
(63)	60 22 037 08	3	RECEPTACLE FOR TABS 6,3 0,3 - 1,5	FLACHSTECKHUELSE		
(151)	60 24 240 08	1	THREADED CABLE GLAND M12X1,5 MS	KABELVERSCHRAUBUNG		
(500)	92 35 122 08	1	CABLE MARKING	KABELMARKIERUNG		
160	96 54 407 08	1	LEAD W1090	LEITUNG		
(5)	60 04 640 08	14.86	CONTROL LEAD 19X0,5 SPF	STEUERLEITUNG		
(63)	60 22 037 08	19	RECEPTACLE FOR TABS 6,3 0,3 - 1,5	FLACHSTECKHUELSE		
(151)	10 44 366 4	1	PLUG 19-POL 22A	STECKER		
(152)	69 18 128 08	1	PROTECTING CAP MS	SCHUTZKAPPE		
(153)	40 01 405 08	1	CYLINDER SCREW DIN 84 M3X6 MS VERNI	ZYLINDERSCHRAUBE		
(154)	60 24 242 08	2	THREADED CABLE GLAND M20X1,5 MS	KABELVERSCHRAUBUNG		
(155)	60 26 065 08	1	REDUCTION M32X1,5/M20X1,5 MS	REDUKTION		
(242)	60 30 167 08	0.03	HEATSHRINK SLEEVING 19-6,0	SCHRUMPFSCHLAUCH		
(500)	92 35 122 08	1	CABLE MARKING	KABELMARKIERUNG		
(707)	10 47 304 7	19	CABLE SLEEVE 1,9-2,5 SILIKON	KABELTUELLE		
260	10 28 635 4	21	TERMINAL/CLAMP	KLEMME		
261	60 27 360 08	2	SUPPORT TRESTLE	AUFLAGEBOCK		
262	60 21 067 08	0.205	TOP HAT RAIL 35X27X7,3X1	HUTSCHIENE		
263	60 27 437 08	1	IDENTIFICATION STRIP 1 - 250	KENNZEICHNUNGSKARTEN		
266	10 28 635 3	1	LID	DECKEL		
267	60 27 946 08	2	END ANGLE	ENDWINKEL		
270	60 24 257 08	3	THREADED CABLE GLAND M20X1,5 MS	KABELVERSCHRAUBUNG		
272	60 24 242 08	1	THREADED CABLE GLAND M20X1,5 MS	KABELVERSCHRAUBUNG		
292	60 25 012 08	1	WATER DRAIN PLUG PA6G SPF	ENTWAESSERUNGSSTOPFEN		
293	60 25 013 08	1	VENTILATION SCREW G1/2"X30 POLYAMID	ENTLUEFTUNGSSCHRAUBE		
295	40 82 010 08	2	SHEET-METAL SCREW DIN 7971 4,8X19-C	BLECHSCHRAUBE		
296	42 18 006 08	2	WASHER DIN 9021 A 5,3 ST VERZ	SCHEIBE		

6.2.2009

etk_en_de_074515 LR 1600/2

□ 299 (2/2)

LIEBHERRTERMINAL BOX WINCH PRE-ASSY.W.
KLEMMKASTEN SA-BOCK VORM.⇒ 2 920 581
96 54 405 08

Pos.	Item	Quantity	Description	Bezeichnung	Serie	K
5	60 04 640 08	3.1	CONTROL LEAD 19X0,5 SPF	STEUERLEITUNG		
6	60 04 640 08	2.7	CONTROL LEAD 19X0,5 SPF	STEUERLEITUNG		
7	60 04 640 08	5.9	CONTROL LEAD 19X0,5 SPF	STEUERLEITUNG		
8	68 00 017 08	1	COUPLING SOCKET GERADE PVC SPF	KUPPLUNGSDOSE		
9	68 00 017 08	1	COUPLING SOCKET GERADE PVC SPF	KUPPLUNGSDOSE		
10	68 00 017 08	1	COUPLING SOCKET GERADE PVC SPF	KUPPLUNGSDOSE		
11	68 00 017 08	1	COUPLING SOCKET GERADE PVC SPF	KUPPLUNGSDOSE		
12	60 03 673 08	9.37	LEAD 2X1,5	LEITUNG		
14	60 04 425 08	6.95	DATA LINE 2X1 SPF	DATENLEITUNG		
15	60 03 673 08	10.57	LEAD 2X1,5	LEITUNG		
16	60 03 673 08	8.77	LEAD 2X1,5	LEITUNG		
19	60 03 673 08	8.47	LEAD 2X1,5	LEITUNG		
72	60 22 034 08	12	FLAG RECEPTACLE	STECKHUELSE		
86	60 23 077 08	42	WIRED END FERRULE 1X6 VERZ	ADERENDHUELSE		
95	60 52 129 08	2	PIN	STIFT		
96	60 52 130 08	2	BUSH	BUCHSE		
97	60 27 100 08	2	CABLE SLEEVE 3,0-7,0/3,0/0,6 SILIKONGU	KABELTUELLE		
104	60 23 085 08	1	WIRED END FERRULE 16X12 VERZ	ADERENDHUELSE		
105	60 23 084 08	3	WIRED END FERRULE 10X12 VERZ	ADERENDHUELSE		
112	60 22 184 08	3	CABLE LUG DIN 46237 0,25 - 1,5	KABELSCHUH		
114	60 23 078 08	3	WIRED END FERRULE 0,5X6 VERZ	ADERENDHUELSE		
126	60 56 045 08	51	CRIMPING CONTACT 0,5	CRIMPKONTAKT		
130	60 56 017 08	6	CONTACT PIN	KONTAKTSTIFT		
134	60 23 033 08	10	RECEPTACLE FOR TABS 6,3 1,0	FLACHSTECKHUELSE		
202	60 30 002 08	28.96	INSULATING TUBE 6	ISOLIERSCHLAUCH		
203	60 30 003 08	22.31	INSULATING TUBE 8	ISOLIERSCHLAUCH		
204	60 30 004 08	0.92	INSULATING TUBE 10	ISOLIERSCHLAUCH		
205	60 30 005 08	0.4	INSULATING TUBE 12	ISOLIERSCHLAUCH		
223	60 30 245 08	3.83	CABLE CONDUIT	KABELSCHLAUCH		
225	60 30 247 08	2.13	CABLE CONDUIT	KABELSCHLAUCH		
226	60 30 252 08	4.66	CABLE CONDUIT	KABELSCHLAUCH		
227	60 30 249 08	2.03	CABLE CONDUIT	KABELSCHLAUCH		
228	60 30 250 08	3.03	CABLE CONDUIT	KABELSCHLAUCH		
229	60 30 253 08	3.3	CABLE CONDUIT	KABELSCHLAUCH		
261	60 32 003 08	1	CABLE TIE 3,6X150	KABELBINDER		
305	60 04 341 08	453.6	ELECTR.CABLE DIN 72551 1 SPF	KFZ-LEITUNG		
345	60 04 140 08	22.2	ELECTR.CABLE 0,75Q PVC SPF	KFZ-LEITUNG		
371	60 03 452 08	2.05	BUS LINE 4X1,0 SPF	BUSLEITUNG		
372	68 00 017 08	1	COUPLING SOCKET GERADE PVC SPF	KUPPLUNGSDOSE		
373	68 00 017 08	1	COUPLING SOCKET GERADE PVC SPF	KUPPLUNGSDOSE		
374	68 00 014 08	1	COUPLING SOCKET SPF	KUPPLUNGSDOSE		
500	92 35 122 08	53	CABLE MARKING	KABELMARKIERUNG		
501	60 52 516 08	1	PLUG SOCKET BODY 4POL SS4R AL	STECKDOSENKOERPER		
502	60 52 128 08	1	MOULDING	FORMTEIL		
503	60 52 155 08	1	CLAMP	KLAMMER		
504	92 79 963 08	2	PLUG	STECKER		
505	60 50 079 08	3	APPLIANCE SOCKET	GERAETESTECKDOSE		
506	60 56 016 08	3	BUSH INSERT	BUCHSENEINSATZ		
507	60 52 106 08	15	APPLIANCE SOCKET DIN 43650 SPF	GERAETESTECKDOSE		
508	60 22 097 08	3	ATTACHABLE SLEEVE HOUSING 2POL	STECKHUELSENGEHAEUSE		
509	60 50 066 08	1	DEVICE PLUG DIN 43650	GERAETESTECKER		
510	69 24 067 08	1	PLUG DIN 72585 7POL POLYBUTOLEN SPF	STECKER		
511	69 24 062 08	1	TERMINAL HOUSING DIN 72585 8,5MM PO	ENDGEHAEUSE		
512	92 03 811 08	1	PLUG	STECKER		
513	60 23 198 08	1	ATTACHABLE SLEEVE HOUSING	STECKHUELSENGEHAEUSE		
514	60 56 015 08	3	INSULATING BODY	ISOLIERKOERPER		
515	10 32 483 0	1	CABLE PLUG 4POL 4A	KABELSTECKER		
516	60 56 099 08	12	GUIDING BUSH	FUEHRUNGSBUCHSE		
517	60 56 100 08	12	GUIDE PIN	FUEHRUNGSSTIFT		
518	60 56 185 08	3	BS HOUSING 24POL.	SOCKELGEHAEUSE		

6.2.2009

etk_en_de_074515 LR 1600/2

 300 (1/2)
LIEBHERR
WIRING HARNESS
KABELSTRANG

⇒ 2 920 633
96 52 651 08

Pos.	Item	Quantity	Description	Bezeichnung	Serie	K
519	60 24 251 08	6	SCREW PLUG M25X1,5 MS	VERSCHLUSSSCHRAUBE		
520	60 24 242 08	3	THREADED CABLE GLAND M20X1,5 MS	KABELVERSCHRAUBUNG		
521	60 26 064 08	3	REDUCTION M25X1,5/M20X1,5 MS	REDUKTION		
522	60 56 176 08	3	SOCKET SHELL 24POL.	TUELLENGEHAEUSE		
523	92 78 689 08	1	TERMINAL BOX LIGHTING HOIST.GE ⇒ 2 920 257 92 78 689 08	KLEMMKASTEN BELEUCHTUNG		
601	60 56 101 08	54	CRIMPING CONTACT 0,5	CRIMPKONTAKT		
602	60 56 023 08	60	CRIMPING CONTACT	CRIMPKONTAKT		
603	60 56 102 08	8	CRIMPING CONTACT 1,5	CRIMPKONTAKT		
647	60 23 395 08	4	SLEEVE CONTACT DIN 72585 0,5-1,5MM ² V	BUCHSENKONTAKT		
702	60 56 114 08	14	CRIMPING CONTACT 0,14 - 0,37	CRIMPKONTAKT		
708	10 47 304 8	2	CABLE SLEEVE 2,4-3,0 SILIKON	KABELTUELLE		
813	60 56 197 08	19	SINGLE STRAND SEALING 2	EINZELADERABDICHTUNG		
820	60 56 200 08	4	SINGLE STRAND SEALING DIN 72585 1,4-2,	EINZELADERABDICHTUNG		
822	69 24 057 08	3	STOPPER PLUG DIN 72585 7POL SPF	BLINDSTOPFEN		

6.2.2009

etk_en_de_074515 LR 1600/2

301 (2/2)

LIEBHERR

WIRING HARNESS
KABELSTRANG

⇒ 2 920 633
96 52 651 08

Pos.	Item	Quantity	Description	Bezeichnung	Serie	K
5	60 04 604 08	6.95	CONTROL LEAD 4X0,5 SPF	STEUERLEITUNG		
63	60 22 037 08	3	RECEPTACLE FOR TABS 6,3 0,3 - 1,5	FLACHSTECKHUELSE		
95	60 52 129 08	1	PIN	STIFT		
96	60 52 130 08	2	BUSH	BUCHSE		
151	60 52 516 08	1	PLUG SOCKET BODY 4POL SS4R AL	STECKDOSENKOERPER		
152	60 52 128 08	1	MOULDING	FORMTEIL		
153	60 52 155 08	1	CLAMP	KLAMMER		
261	60 32 003 08	1	CABLE TIE 3,6X150	KABELBINDER		
500	92 35 122 08	3	CABLE MARKING	KABELMARKIERUNG		
811	69 24 049 08	1	STOPPER PLUG	BLINDSTOPFEN		

6.2.2009

etk_en_de_074515 LR 1600/2

302

LIEBHERR

LEAD
LEITUNG

⇒ 2 920 636
96 51 854 08

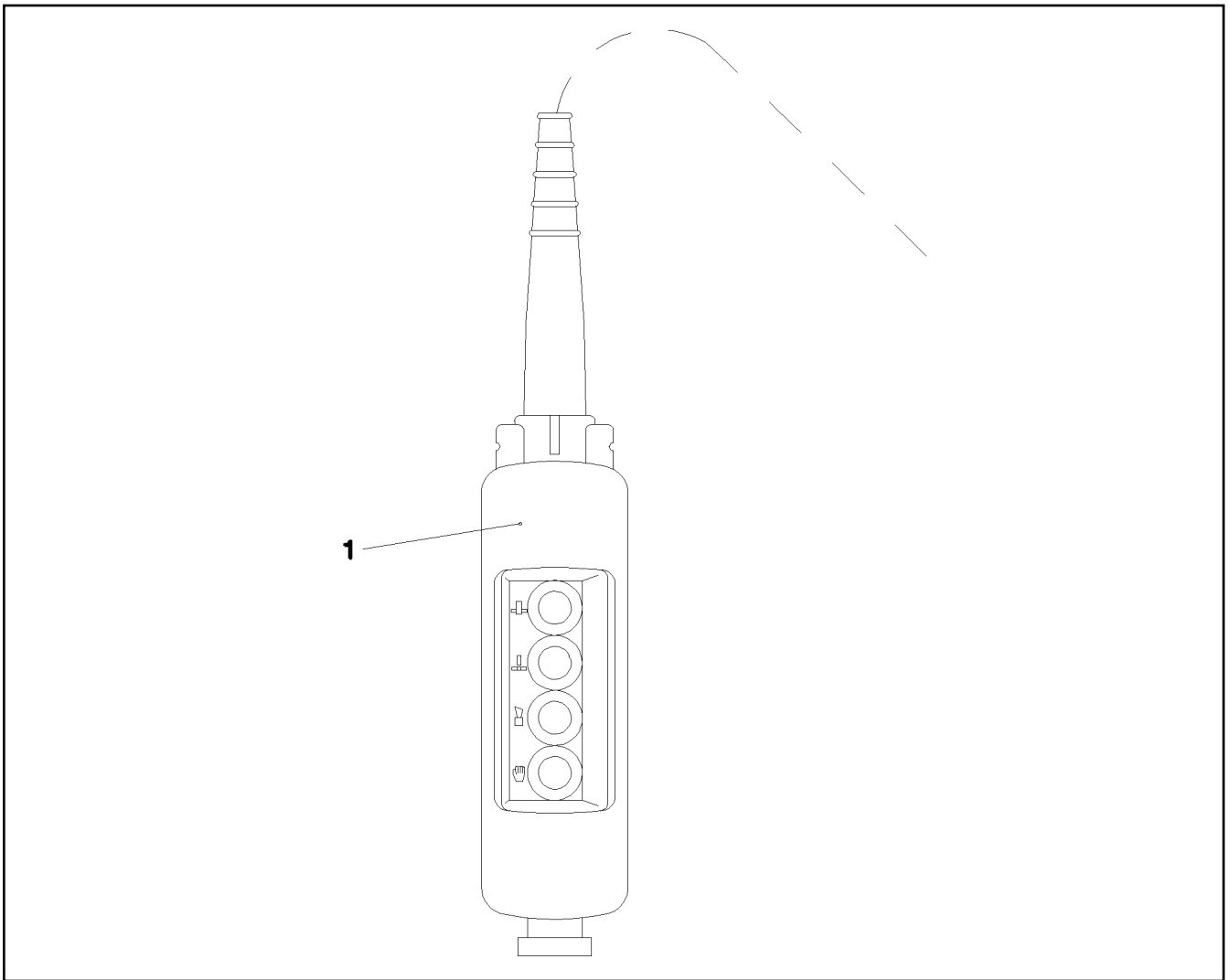

Pos.	Item	Quantity	Description	Bezeichnung	Serie	K
1	96 51 138 08	1	CONTROL DESK A570 ⇒ 2 920 638 96 51 138 08	BEDIENPULT		

6.2.2009
052623

LIEBHERR

etk_en_de_074515 LR 1600/2

CONTROL DESK
BEDIENPULT

☐ 303

⇒ 2 920 637
96 51 136 08

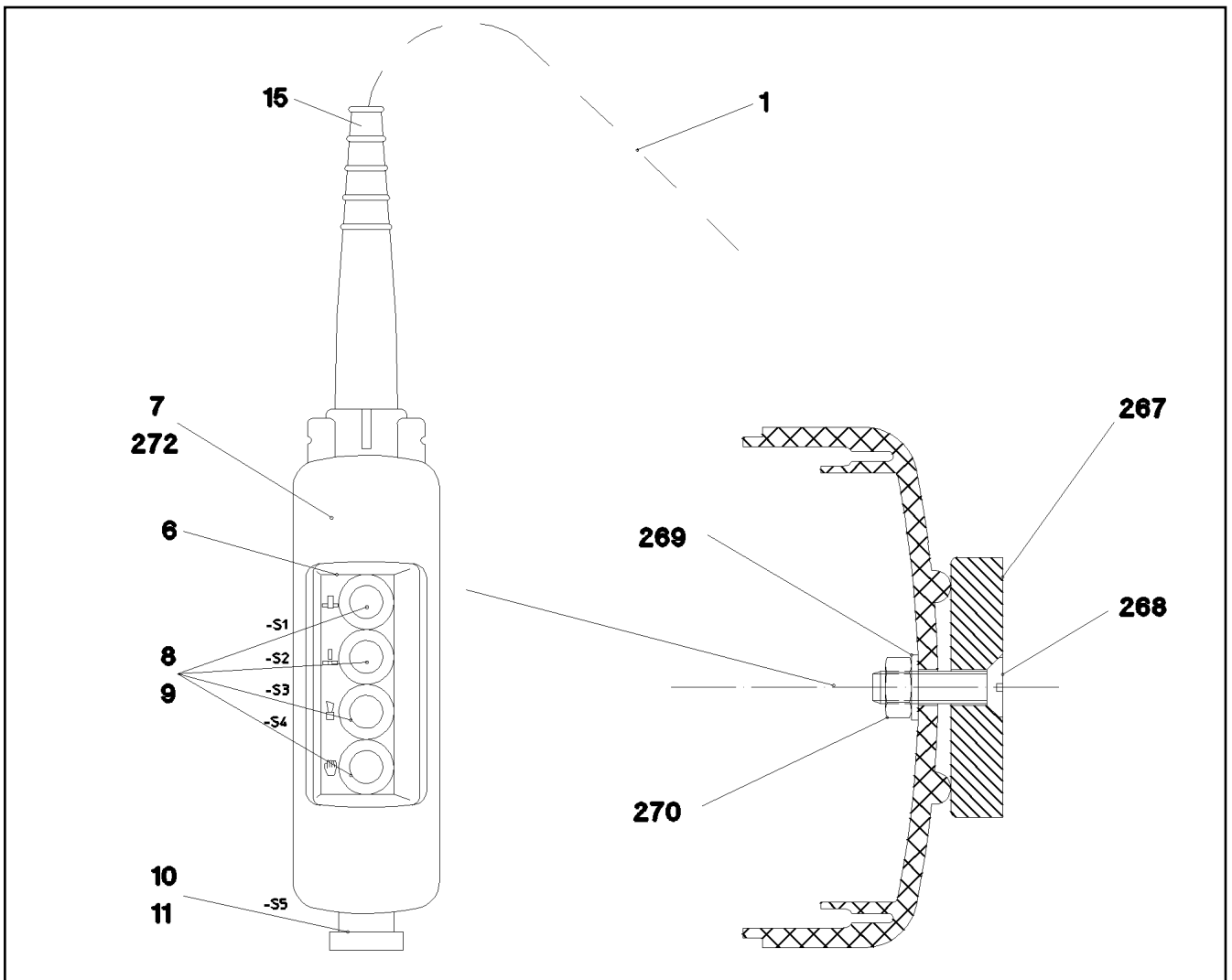

Pos.	Item	Quantity	Description	Bezeichnung	Serie	K
1	96 51 115 08	1	WIRING HARNESS W570	KABELSTRANG		
6	97 79 945 08	1	BOARD CONTROL PANEL 40X120 AL-BL 1M	SCHILD BEDIENPULT		
7	60 66 523 08	1	SUSPENDED PUSH-BUTTON	HAENGETASTER		
8	60 66 525 08	4	FRONT ELEMENT	FRONTELEMENT		
9	60 66 532 08	4	AUXILIARY SWITCH UNIT	HILFSSCHALTERBLOCK		
10	60 66 614 08	1	AUXILIARY SWITCH UNIT	HILFSSCHALTERBLOCK		
11	60 66 526 08	1	MUSHROOM PUSH-BUTTON	PILZTASTE		
15	55 08 496 08	1	HOSE CLAMP 11-20	SCHLAUCHSCHELLE		
267	61 70 001 08	2	PERMANENT MAGNET	DAUERMAGNET		
268	40 06 035 08	2	COUNTERSUNK SCREW DIN 964 M5X18 MS	SENKSCRAUBE		
269	42 40 004 08	2	CIRCLIP DIN 128 A 5 VERZ	FEDERRING		
270	41 15 148 08	2	HEX NUT DIN 934 M5 8 VERZ	SECHSKANTMUTTER		
272	80 10 029 08	1	FOIL 0,2X3000 PE	FOLIE		

6.2.2009
052622

LIEBHERR

etk_en_de_074515 LR 1600/2

CONTROL DESK
BEDIENPULT

304

⇒ 2 920 638
96 51 138 08

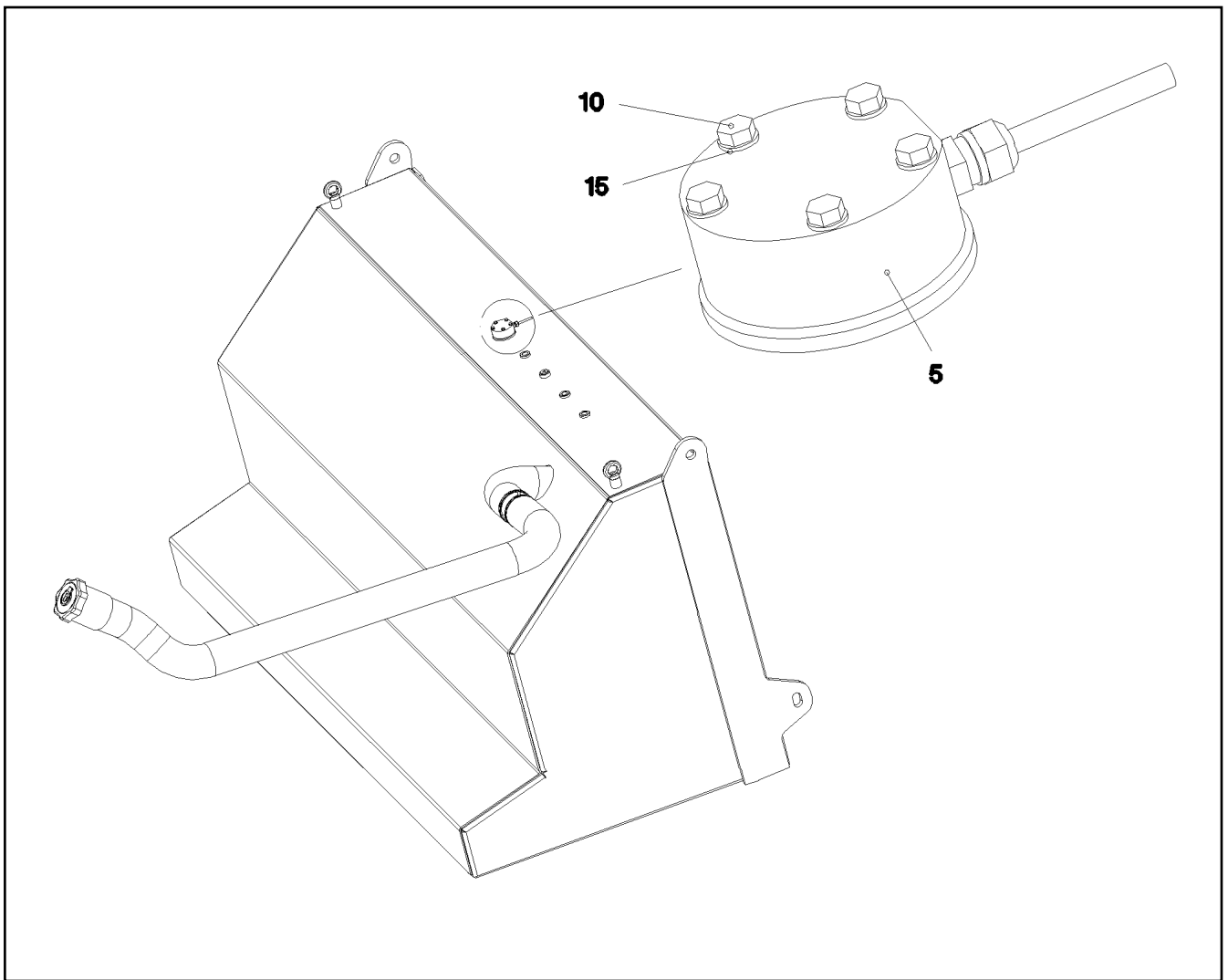

Pos.	Item	Quantity	Description	Bezeichnung	Serie	K
	5 78 90 151 08	1	TANK SENSOR L=1000 SPF	TANKSENSOR		
	(5) 10 34 693 8	1	FLANGE SEALING	FLANSCHDICHTUNG		
	10 46 01 213	5	HEX BOLT ISO 4017 M5X35 8.8 A2C	SECHSKANTSCHRAUBE		
	15 42 00 008 08	5	WASHER DIN 125 A 5.3 VERZ	SCHEIBE		

6.2.2009
052453

LIEBHERR

etk_en_de_074515 LR 1600/2

ELECTR.F.FUEL TANK
ELEKTRIK KRAFTSTOFFBEHAELTER

305

⇒ 2 920 814
96 45 717 08

Pos.	Item	Quantity	Description	Bezeichnung	Serie	K
11	96 48 799 08	1	WIRING HARNESS W591	KABELSTRANG		
(80)	60 23 010 08	2	CABLE LUG DIN 46235 10 - 95	KABELSCHUH		
(333)	60 04 918 08	0.9	BATTERY CABLE DIN 72551 95 SPF	BATTERIEKABEL		
(500)	92 35 122 08	2	CABLE MARKING	KABELMARKIERUNG		
(712)	10 47 305 2	2	CABLE SLEEVE 15-19 SILIKON	KABELTUELLE		
12	96 51 129 08	1	WIRING HARNESS W592	KABELSTRANG		
(80)	60 23 010 08	1	CABLE LUG DIN 46235 10 - 95	KABELSCHUH		
(98)	60 27 101 08	2	CABLE SLEEVE 5,0-7,0/5,0/0,7 SILIKONGU	KABELTUELLE		
(99)	60 23 011 08	1	CABLE LUG 12 - 95	KABELSCHUH		
(333)	60 04 918 08	2	BATTERY CABLE DIN 72551 95 SPF	BATTERIEKABEL		
(500)	92 35 122 08	2	CABLE MARKING	KABELMARKIERUNG		
13	96 51 130 08	1	WIRING HARNESS W593	KABELSTRANG		
(80)	60 23 010 08	2	CABLE LUG DIN 46235 10 - 95	KABELSCHUH		
(98)	60 27 101 08	2	CABLE SLEEVE 5,0-7,0/5,0/0,7 SILIKONGU	KABELTUELLE		
(333)	60 04 918 08	0.16	BATTERY CABLE DIN 72551 95 SPF	BATTERIEKABEL		
(500)	92 35 122 08	2	CABLE MARKING	KABELMARKIERUNG		
14	96 51 131 08	1	WIRING HARNESS W596	KABELSTRANG		
(98)	60 27 101 08	2	CABLE SLEEVE 5,0-7,0/5,0/0,7 SILIKONGU	KABELTUELLE		
(103)	60 22 082 08	2	CABLE LUG DIN 46234 10-50 VERZINNT	KABELSCHUH		
(151)	60 52 082 08	1	SOCKET 2POL	STECKDOSE		
(331)	60 04 912 08	1.4	BATTERY CABLE 50	BATTERIEKABEL		
(500)	92 35 122 08	3	CABLE MARKING	KABELMARKIERUNG		

6.2.2009

etk_en_de_074515 LR 1600/2

306

LIEBHERR

WIRING LIST BATTERY BOX
KABELLISTE BATTERIEKASTEN

⇒ 2 920 815
96 49 300 08

Pos.	Item	Quantity	Description	Bezeichnung	Serie	K
3	60 71 131 08	2	TAIL BRAKE LIGHT ⇒ 6 071 131 08 60 71 131 08	SCHLUSSBREMSLEUCHTE		
4	60 70 217 08	2	LIGHT BULB DIN 72601 21W 24V	GLUEHLAMPE		

6.2.2009

etk_en_de_074515 LR 1600/2

☐ 307

LIEBHERR

WARNING LIGHT
WARNLEUCHTE

⇒ 2 920 931
96 59 398 08

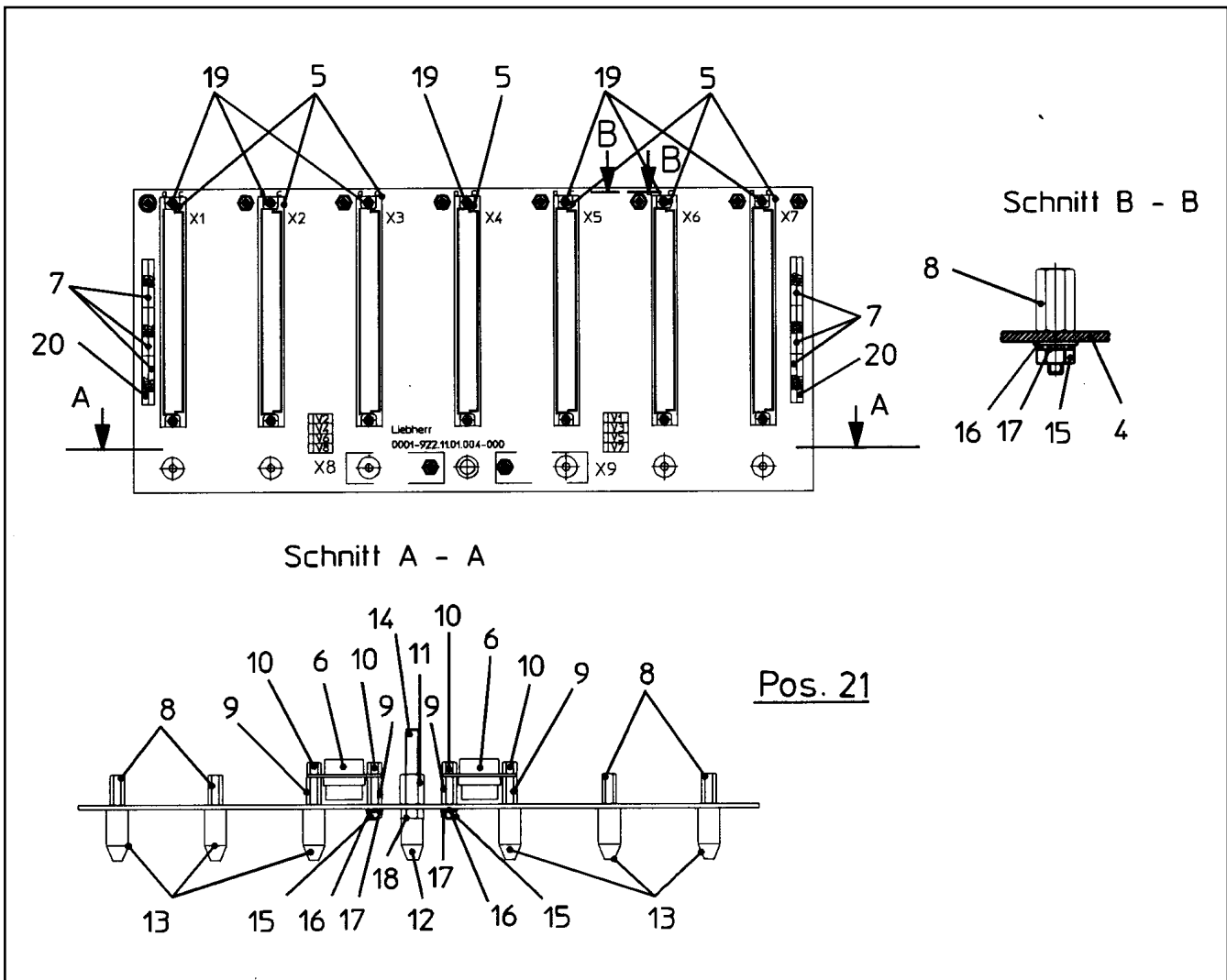

Pos.	Item	Quantity	Description	Bezeichnung	Serie	K
4	66 10 179 08	1	PRINTED CIRCUIT BOARD SPF	LEITERPLATTE		
5	60 23 212 08	7	MULTIPLE PLUG SOCKET B 64POL C SPF	STECKERLEISTE		
6	60 23 219 08	2	SOCKET TERMINAL STRIP 9POL SPF	BUCHSENLEISTE		
7	63 50 842 08	10	MAINS RESISTOR 22K 10% 8X 9SIL	WIDERSTAND NW		
8	66 00 460 08	12	STANDOFF M3X13 ST SPF	ABSTANDSBOLZEN		
9	66 00 428 08	4	STANDOFF M3X6X12 ST SPF	ABSTANDSBOLZEN		
10	66 00 422 08	4	STANDOFF M3X5 ST SPF	ABSTANDSBOLZEN		
11	66 00 429 08	1	STANDOFF M5X12 ST SPF	ABSTANDSBOLZEN		
12	66 00 419 08	1	GUIDING CONE M5 PA6G SPF	FUEHRUNGSKONUS		
13	66 00 420 08	6	GUIDING CONE M3 MS SPF	FUEHRUNGSKONUS		
14	66 00 416 08	1	THREADED BOLT DIN 976 B M5X45 SPF	GEWINDEBOLZEN		
15	41 15 157 08	10	HEX NUT DIN 934 M3 8 A3C	SECHSKANTMUTTER		
16	42 00 006 08	10	WASHER DIN 125 A 3.7 ST VERZ	SCHEIBE		
17	42 51 005 08	10	TOOTH LOCK WASHER DIN 6797 A 3,2	ZAHNSCHEIBE		
18	41 15 148 08	1	HEX NUT DIN 934 M5 8 VERZ	SECHSKANTMUTTER		
19	44 33 003 08	14	TUBULAR RIVET DIN 7340 B2,5X0,3X5 MS	ROHRNIET		
20	63 50 855 08	2	MAINS RESISTOR 1K 5% 8X 9SIL SPF	WIDERSTAND NW		
21	66 03 006 08	8	DIODE S 30V 0A2 DO-35 SPF	DIODE		

6.2.2009
134956

LIEBHERR

etk_en_de_074515 LR 1600/2

BUS PCB
BUSPLATINE

308

⇒ 2 922 001
92 84 311 08

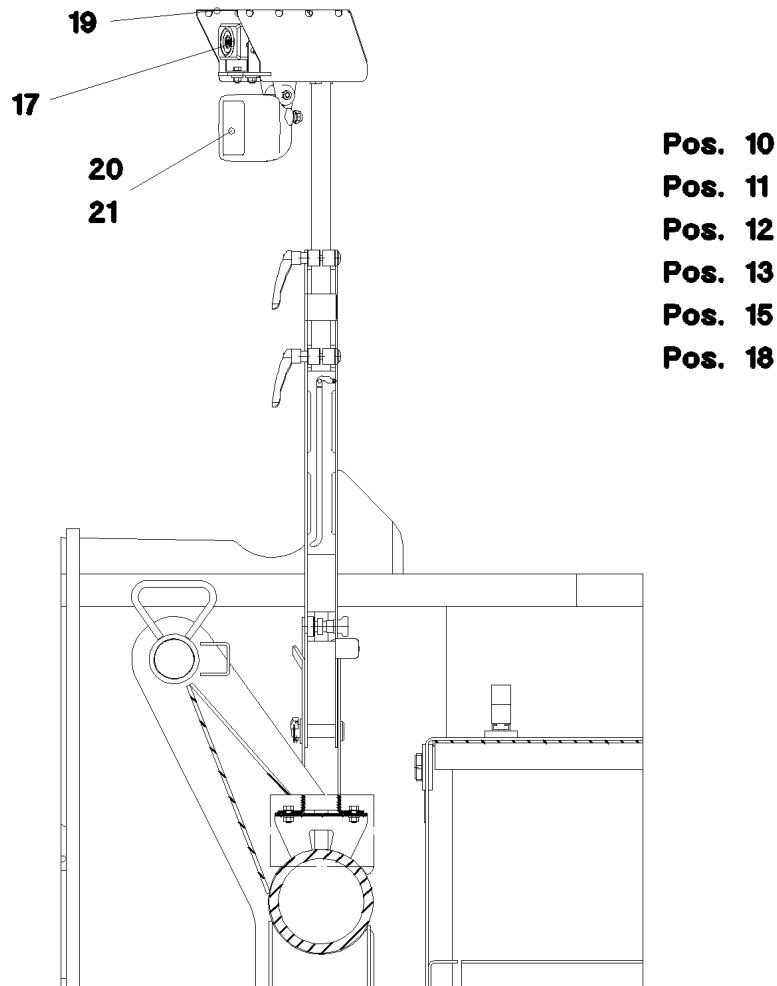

Pos. 10
Pos. 11
Pos. 12
Pos. 13
Pos. 15
Pos. 18

Pos.	Item	Quantity	Description	Bezeichnung	Serie	K
3	96 58 855 08	1	CAMERA EQUIPMENT SLEWING PLATF ⇒ 2 925 402 96 58 855 08	KAMERAANBAU DREHBUEHNE		
10	10 33 264 0	1	CONTROL BOX MB 618	STEUERBOX		
11	61 40 376 08	1	CABLE 12M	KABEL		
12	61 40 418 08	3	CABLE 9M	KABEL		
13	61 40 458 08	2	CABLE 6M	KABEL		
15	10 45 542 1	1	CONNECTING CABLE 8 X 0,37	VERBINDUNGSKABEL		
17	61 40 436 08	3	CAMERA SPF	KAMERA		
(1)	10 02 527 8	1	CABLE PLUG KSB693/7P	KABELSTECKER		
18	10 02 895 4	1	CCD CAMERA 20GRAD	CCD-KAMERA		
19	10 04 105 3	2	PROTECTIVE HOOD V2A	SCHUTZHAUBE		
20	60 71 509 08	3	WORK FLOODLIGHT	ARBEITSSCHEINWERFER		
21	60 70 211 08	3	LIGHT BULB DIN 72601 70W 24V	GLUEHLAMPE		

6.2.2009
056118

LIEBHERR

etk_en_de_074515 LR 1600/2

EQUIPMENT CAMERA SUPERSTRUCTUR
AUSRUESTUNG KAMERA DREHBUEHNE

309

⇒ 2 925 002
96 58 856 08

Pos.	Item	Quantity	Description	Bezeichnung	Serie	K
10	96 58 856 08	1	EQUIPMENT CAMERA SUPERSTRUCTUR ⇒ 2 925 002 96 58 856 08	AUSRUESTUNG KAMERA DRE		
20	96 48 397 08	1	EQUIPMENT CAMERA CAB ⇒ 2 925 405 96 48 397 08	AUSRUESTUNG KAMERA KABIN		

6.2.2009	etk_en_de_074515 LR 1600/2	310
LIEBHERR	CAMERA MONITORING KAMERAUEBERWACHUNG	⇒ 2 925 007 91 60 728 08

Pos.	Item	Quantity	Description	Bezeichnung	Serie	K
10	96 48 421 08	1	SUPPLEMENT CAMERA CAB	ERGAENZUNG KAMERA KABIN		
(5)	97 73 426 08	1	PLATE 2X287X171	BLECH		
(7)	40 97 043 08	2	PAN-HEAD SCREW M6X16 SCHWARZ VERZ	FLACHKOPFSCHRAUBE		
(10)	10 45 478 2	1	DISPLAY MD3072A-QUAD	DISPLAY		
(11)	10 45 478 3	1	CONNECTION CABLE 10 X 0,14	ANSCHLUSSKABEL		
(30)	96 51 859 08	1	ADAPTOR	ADAPTER		
(31)	40 65 002 14	4	HEX BOLT ISO 4017 M4X8 8.8 A2C	SECHSKANTSCHRAUBE		
(32)	42 18 005 08	4	WASHER DIN 9021 A 4.3 ST VERZ	SCHEIBE		
(33)	10 44 966 4	4	KNURLED SCREW M5X10 PA6	RAENDELSCHRAUBE		

6.2.2009

etk_en_de_074515 LR 1600/2

☐ 311

LIEBHERR

ERG. CAMERA CONTROL
ERG.KAMERAUEBERWACHUNG

⇒ 2 925 026
91 55 259 08

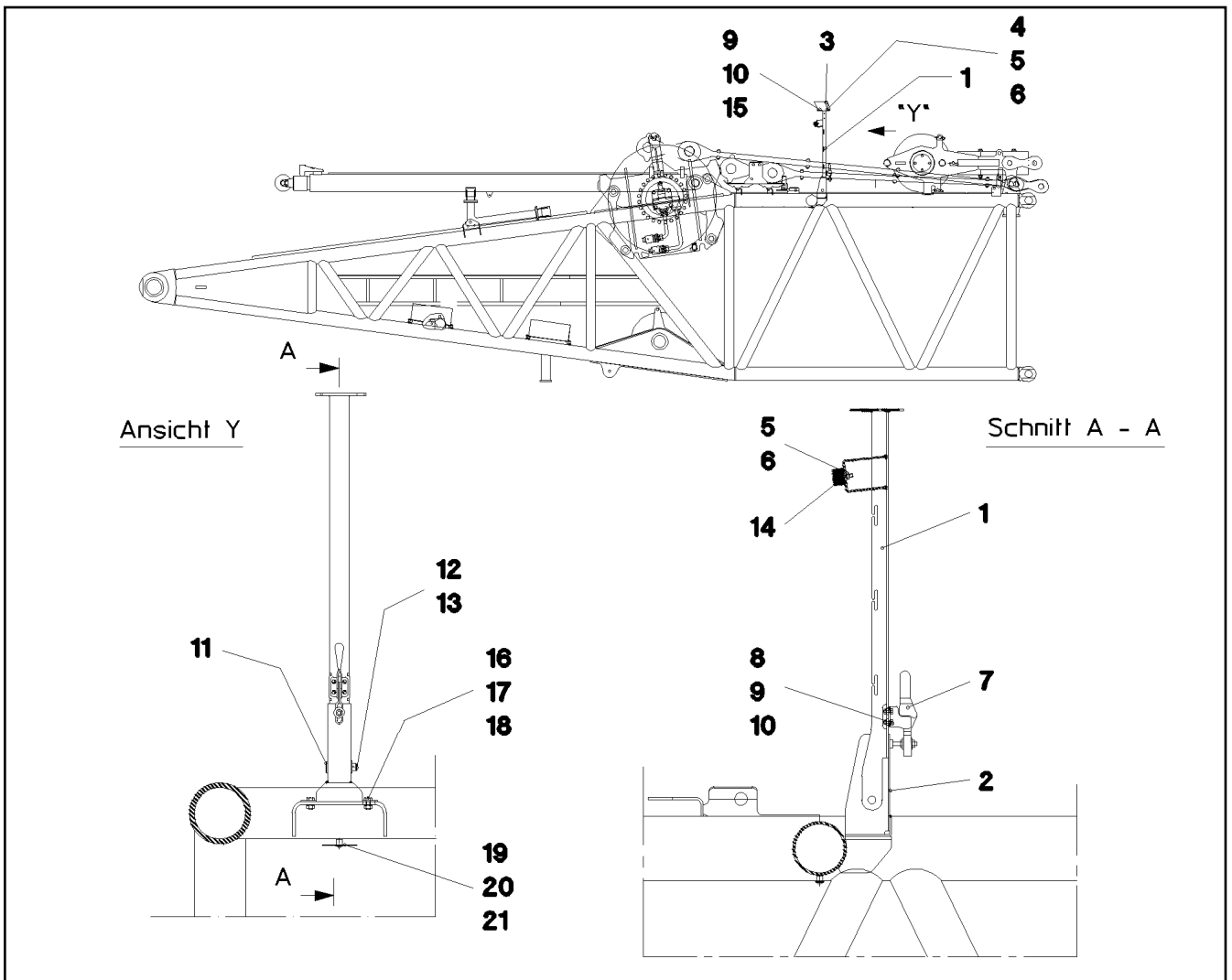

Pos.	Item	Quantity	Description	Bezeichnung	Serie	K
1	92 16 963 08	1	CLAMP	STATIV SCHWK.		
2	92 16 964 08	1	BRACKET WELDED CONST.	KONSOLE SCHWK.		
3	95 63 998 08	1	PLATE 2X248X326	BLECH		
4	49 00 089	1	HEX BOLT ISO 4017 M8X20 8.8 A2C	SECHSKANTSCHRAUBE		
5	41 15 141 08	2	HEX NUT DIN 934 M8 8 A2C	SECHSKANTMUTTER		
6	42 00 012 08	2	WASHER DIN 125 A8X16 ST VERZ	SCHEIBE		
7	77 90 011 08	1	HORIZONTAL TENSIONER	HORIZONTALSPANNER		
8	40 00 829	4	HEX BOLT ISO 4017 M6X20 8.8 A2C	SECHSKANTSCHRAUBE		
9	41 15 140 08	7	HEX NUT DIN 934 M6 8 VERZ	SECHSKANTMUTTER		
10	42 00 009 08	14	WASHER ISO 7089 A 6.4 VERZ	SCHEIBE		
11	45 12 225 08	1	PIN DIN 1435 20H11X75X66 ST.50	BOLZEN		
12	42 12 013 08	1	WASHER DIN 1441 21 ST VERZ	SCHEIBE		
13	43 30 065 08	1	SPLIT PIN DIN 94 5X40 ST VERZ	SPLINT		
14	72 66 127 08	1	MEGI BUFFER	MEGIPUFFER		
15	40 00 829	1	HEX BOLT ISO 4017 M6X20 8.8 A2C	SECHSKANTSCHRAUBE		
16	40 65 164	4	HEX BOLT ISO 4017 M10X25 8.8 A3C	SECHSKANTSCHRAUBE		
17	41 15 144 08	4	HEX NUT DIN 934 M10 8 VERZ	SECHSKANTMUTTER		
18	42 00 013 08	4	WASHER ISO 7089 A 10.5 A3C	SCHEIBE		

6.2.2009
023719

LIEBHERR

etk_en_de_074515 LR 1600/2

CAMERA EQUIPMENT D-PIVOT PIECE
KAMERAANBAU D-ANLENKSTUECK

312

⇒ 2 925 204
92 16 990 08

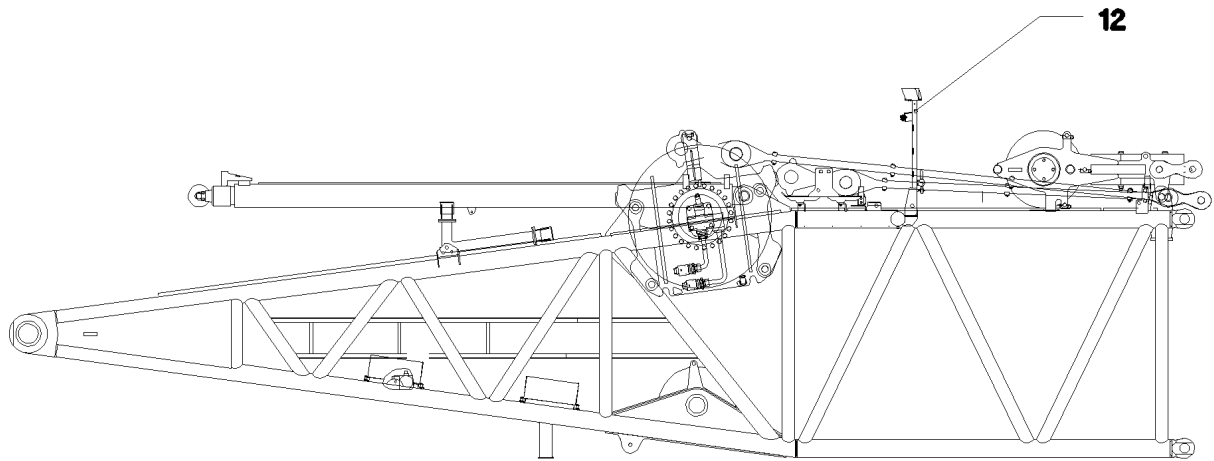

Pos.	Item	Quantity	Description	Bezeichnung	Serie	K
10	96 59 125 08	1	SUPPLEMENT CAMERA WINDE 3	ERGAENZUNG KAMERA		
(11)	61 40 382 08	1	CABLE 12M	KABEL		
(17)	61 40 451 08	1	CAMERA SPF	KAMERA		
(20)	60 71 509 08	1	WORK FLOODLIGHT	ARBEITSSCHEINWERFER		
(21)	60 70 211 08	1	LIGHT BULB DIN 72601 70W 24V	GLUEHLAMPE		
(23)	96 50 276 08	1	LEAD W1056	LEITUNG		
12	92 16 990 08	1	CAMERA EQUIPMENT D-PIVOT PIECE ⇒ 2 925 204 92 16 990 08	KAMERAANBAU D-ANLENKSTU		

6.2.2009
056132

LIEBHERR

etk_en_de_074515 LR 1600/2

CAMERA CONTROL WINCH 3
KAMERAUEBERWACHUNG WINDE 3

313

⇒ 2 925 218
91 60 840 08

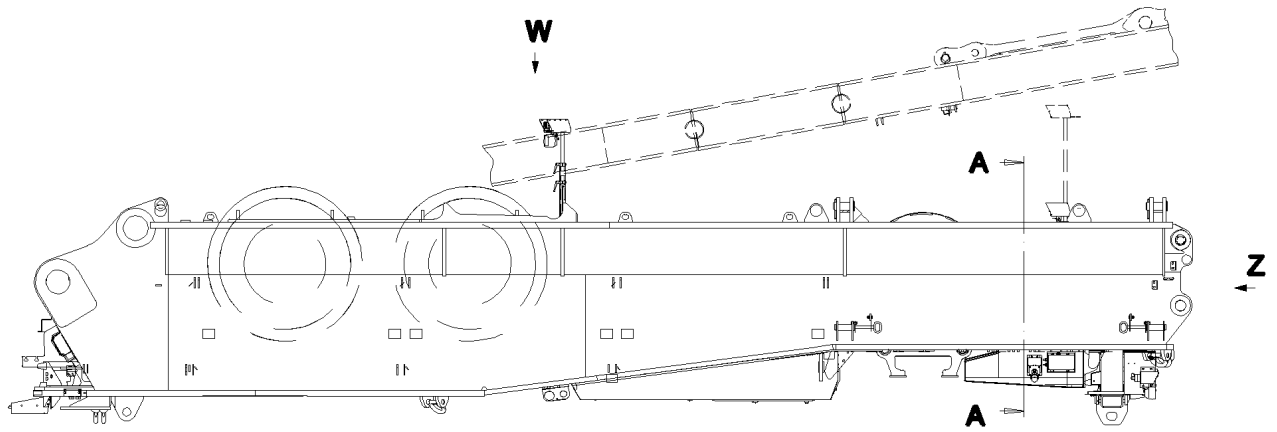

Ansicht Z

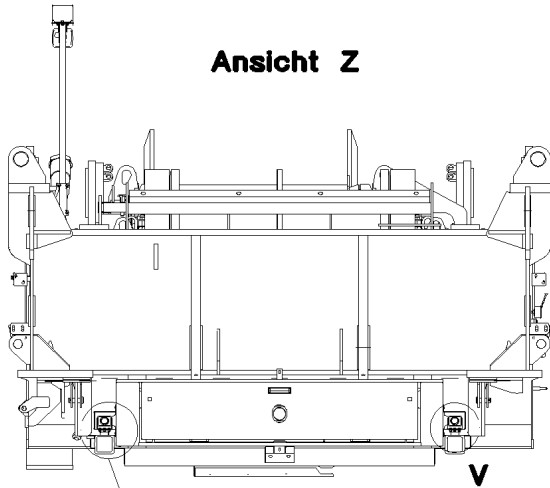

Schnitt A-A

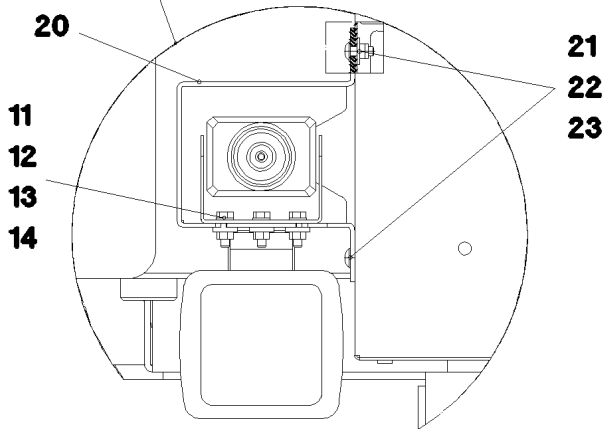
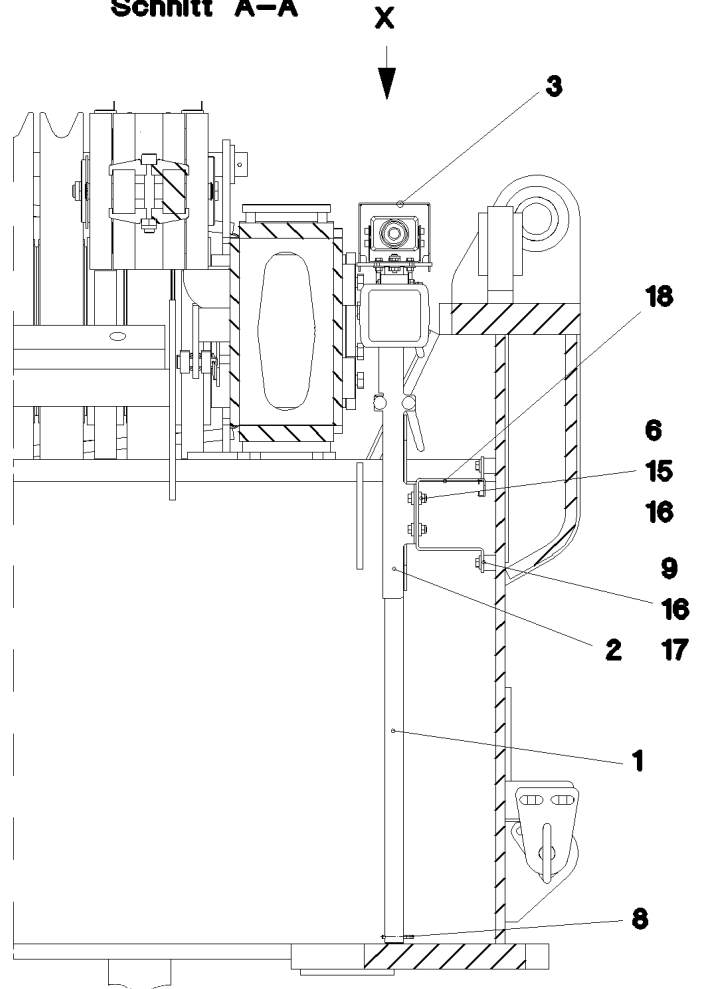

Einzelheit V

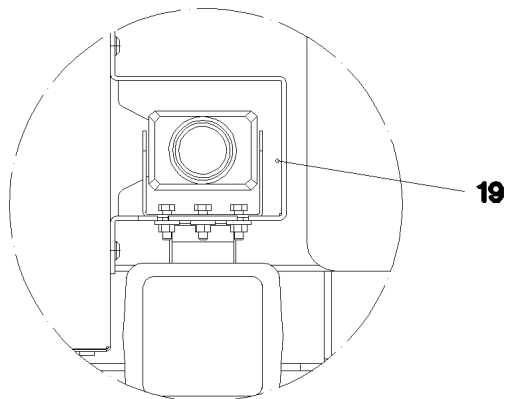

6.2.2009
056115

LIEBHERR

etk_en_de_074515 LR 1600/2

CAMERA EQUIPMENT SLEWING PLATF
KAMERAANBAU DREHBUEHNE

□ 314 (1/4)

⇒ 2 925 402
96 58 855 08

Ansicht W

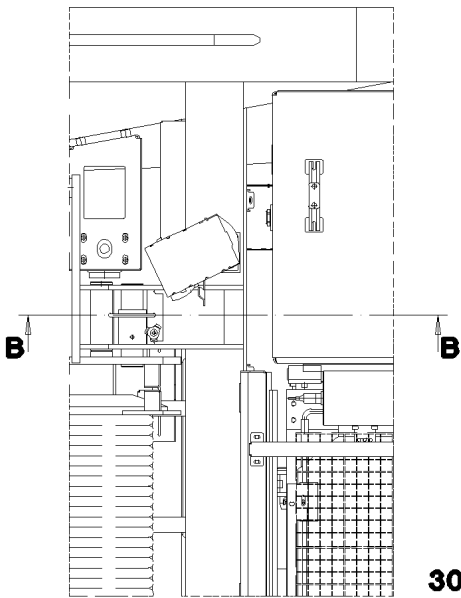

Schnitt B-B

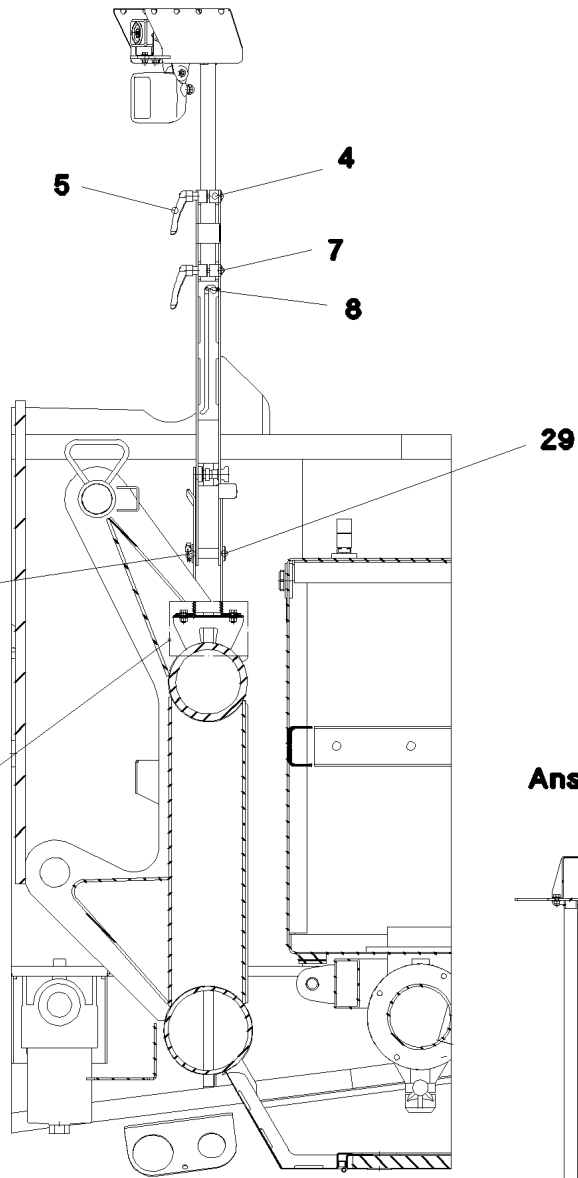

Ansicht Y

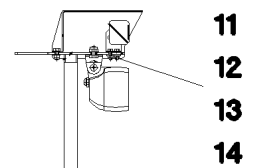

Ansicht X

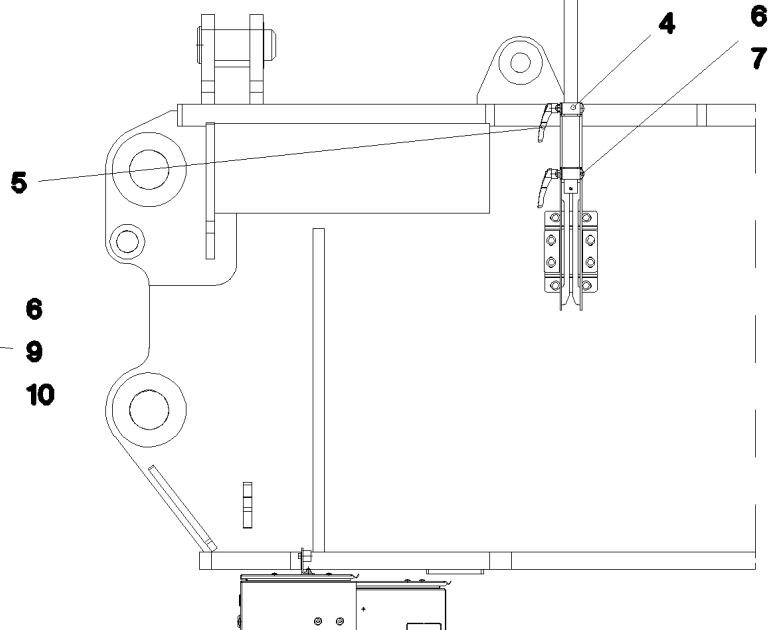
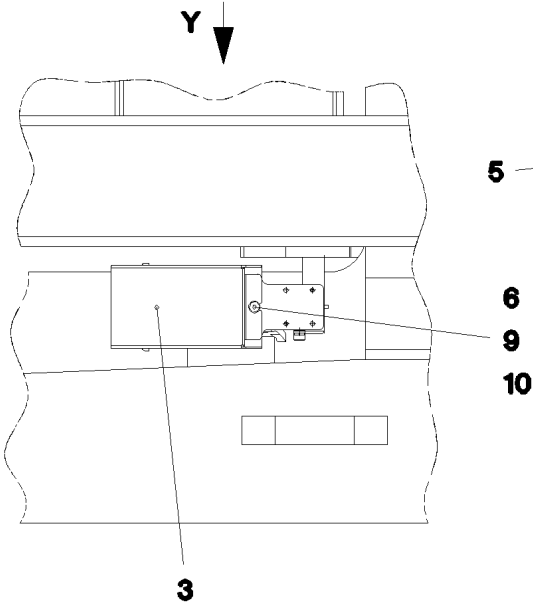

6.2.2009
056116

LIEBHERR

etk_en_de_074515 LR 1600/2

CAMERA EQUIPMENT SLEWING PLATF
KAMERAANBAU DREHBUEHNE

315 (2/4)

⇒ 2 925 402
96 58 855 08

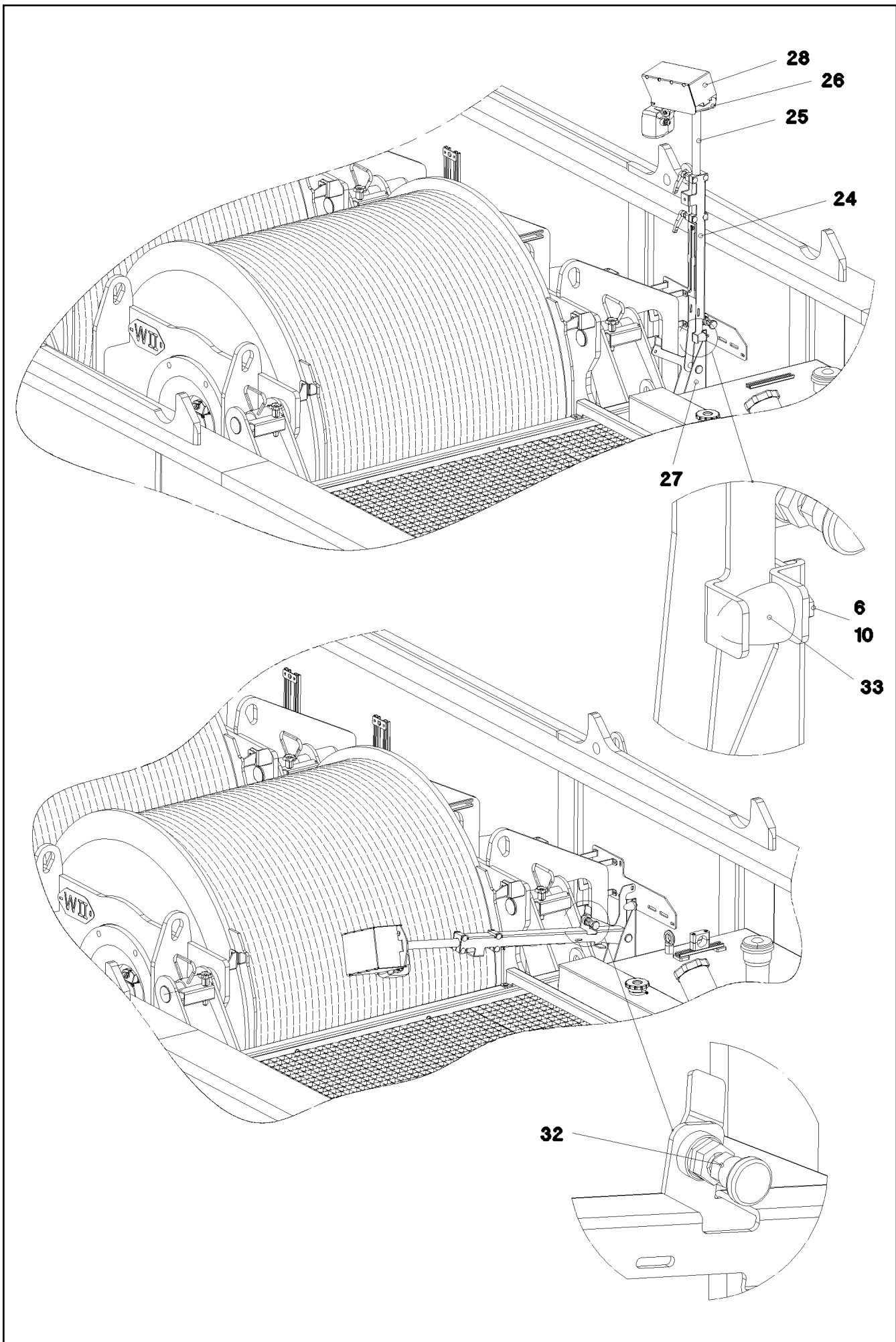

6.2.2009
056117

LIEBHERR

etk_en_de_074515 LR 1600/2

CAMERA EQUIPMENT SLEWING PLATF
KAMERAANBAU DREHBUEHNE

☐ 316 (3/4)

⇒ 2 925 402
96 58 855 08

Pos.	Item	Quantity	Description	Bezeichnung	Serie	K
1	96 51 406 08	1	CLAMP T ZN O	STATIV SCHWK.		
2	96 51 407 08	1	BRIDE DE BLOCAGE	KLEMMKONSOLE		
3	97 80 592 08	1	HOOD 2X298X327 FE//ZN20//C	HAUBE		
4	97 68 737 08	4	CLAMPING PIECE PA6G+OEL	KLEMMSTUECK		
5	10 01 719 2	4	CLAMPING LEVER STAHL 5.8	KLEMMHEBEL		
6	41 15 141 08	12	HEX NUT DIN 934 M8 8 A2C	SECHSKANTMUTTER		
7	40 28 026 14	8	CHEESE HEAD SCREW DIN 603 M8X60 4.6	FLACHRUNDSCHRAUBE		
8	43 20 067 08	2	DOWEL PIN ISO 8752 6X50 A2	SPANNSTIFT		
9	49 00 089	9	HEX BOLT ISO 4017 M8X20 8.8 A2C	SECHSKANTSCHRAUBE		
10	42 00 012 08	9	WASHER DIN 125 A8X16 ST VERZ	SCHEIBE		
11	40 00 829	13	HEX BOLT ISO 4017 M6X20 8.8 A2C	SECHSKANTSCHRAUBE		
12	42 00 009 08	13	WASHER ISO 7089 A 6.4 VERZ	SCHEIBE		
13	42 16 004 08	13	WASHER DIN 7349 6,4 ST VERZ	SCHEIBE		
14	41 15 140 08	13	HEX NUT DIN 934 M6 8 VERZ	SECHSKANTMUTTER		
15	49 00 128	4	HEX BOLT ISO 4017 M8X25 8.8 A2C	SECHSKANTSCHRAUBE		
16	42 16 005 08	12	WASHER DIN 7349 8,4 ST VERZ	SCHEIBE		
17	95 38 734 08	4	SLEEVE	HUELSE		
18	97 80 593 08	1	PLATE 4X382X120	BLECH		
19	97 82 080 08	1	PLATE 3X404X241	BLECH		
20	97 82 081 08	1	PLATE 3X404X241	BLECH		
21	10 41 285 1	8	OVAL HEAD FLAT SCREW AEHNL. ISO 7380	LINSENFLACHKOPFSCHRAUBE		
22	41 19 030 08	8	HEX NUT ISO 10511 M6 A2-70	SECHSKANTMUTTER		
23	42 18 007 08	8	WASHER DIN 9021 A 6.4 VERZ	SCHEIBE		
24	96 23 820 08	1	CLAMP	STATIV SCHWK.		
25	96 45 743 08	1	CLAMP X5CRNI18-10 T ZN O	STATIV SCHWK.		
26	96 23 819 08	1	RECEPTACLE PRE-ASS.	AUFNAHME VORM.		
(1)	97 33 032 08	1	PLATE 5X208X162	BLECH		
(2)	41 30 066 08	2	BLIND RIVET NUT M10 A3C	BLINDNIETMUTTER		
27	97 93 744 08	1	PLATE 4X351X333	BLECH		
28	97 33 034 08	1	PLATE 2X341X363	BLECH		
29	45 12 225 08	1	PIN DIN 1435 20H11X75X66 ST.50	BOLZEN		
30	42 00 021 08	1	WASHER ISO 7089 A 21 ST A3C	SCHEIBE		
31	43 32 001 08	1	HINGED CONNECTOR DIN 11023 5X32 VER	KLAPPSTECKER		
32	70 42 316 08	1	STOP BOLT NIROSTA	RASTBOLZEN		
33	10 04 050 2	1	RUBBER BUFFER 30X36 KAUTSCHUK	PARABEL-GUMMIPUFFER		
34	42 00 013 08	2	WASHER ISO 7089 A 10.5 A3C	SCHEIBE		
35	40 65 164	2	HEX BOLT ISO 4017 M10X25 8.8 A3C	SECHSKANTSCHRAUBE		

6.2.2009

etk_en_de_074515 LR 1600/2

317 (4/4)

LIEBHERRCAMERA EQUIPMENT SLEWING PLATF
KAMERAANBAU DREHBUEHNE⇒ 2 925 402
96 58 855 08

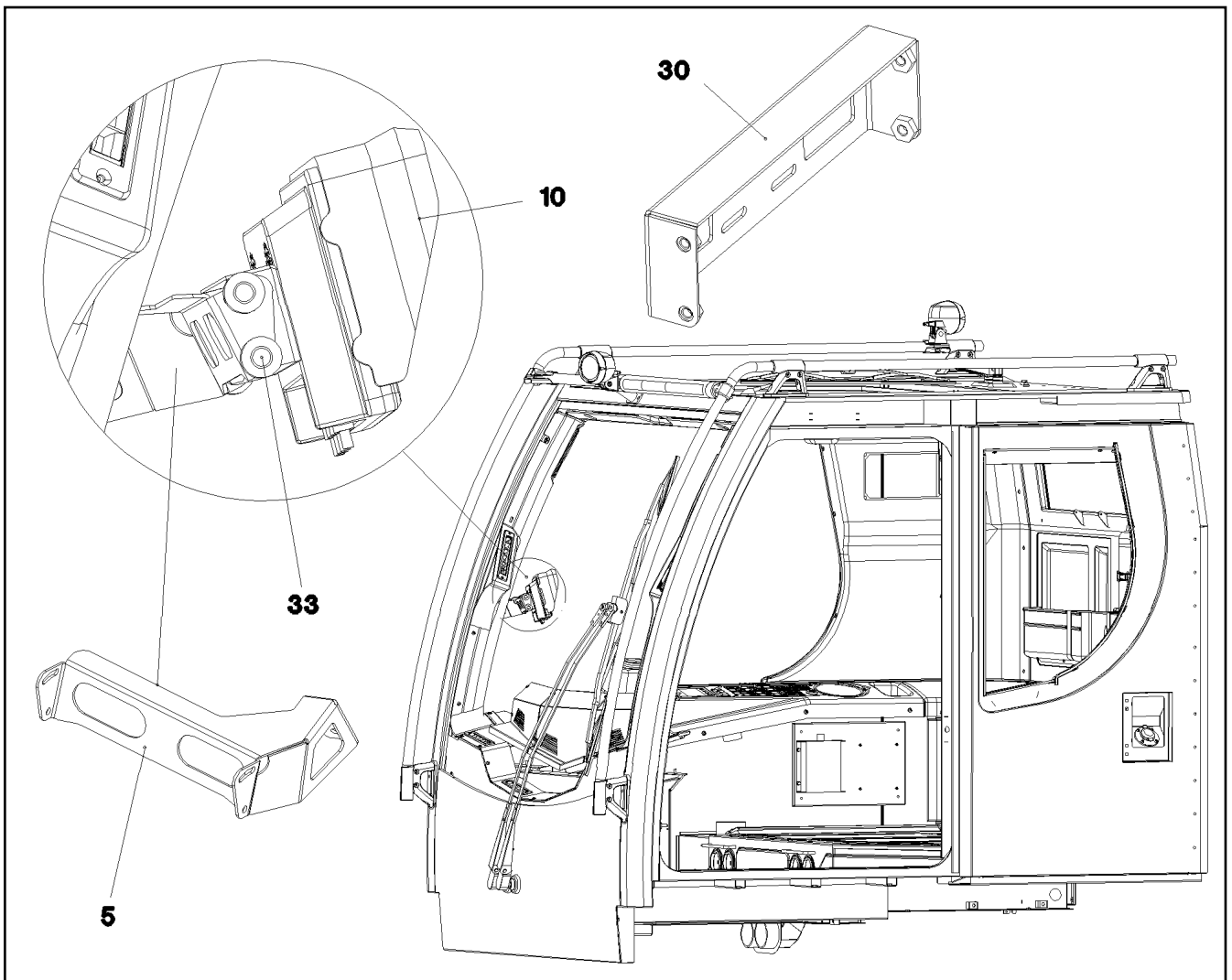

Pos.	Item	Quantity	Description	Bezeichnung	Serie	K
5	97 73 426 08	1	PLATE 2X287X171	BLECH		
7	40 97 043 08	2	PAN-HEAD SCREW M6X16 SCHWARZ VERZ	FLACHKOPFSCHRAUBE		
10	10 45 478 2	1	DISPLAY MD3072A-QUAD	DISPLAY		
11	10 45 478 3	1	CONNECTION CABLE 10 X 0,14	ANSCHLUSSKABEL		
20	10 43 030 5	1	CABLE MK307.4,5	KABEL		
30	96 51 859 08	1	ADAPTOR	ADAPTER		
31	40 65 002 14	4	HEX BOLT ISO 4017 M4X8 8.8 A2C	SECHSKANTSCHRAUBE		
32	42 18 005 08	4	WASHER DIN 9021 A 4.3 ST VERZ	SCHEIBE		
33	10 44 966 4	4	KNURLED SCREW M5X10 PA6	RAENDELSCHRAUBE		

6.2.2009
052627

LIEBHERR

etk_en_de_074515 LR 1600/2

EQUIPMENT CAMERA CAB
AUSRUESTUNG KAMERA KABINE

318

⇒ 2 925 405
96 48 397 08

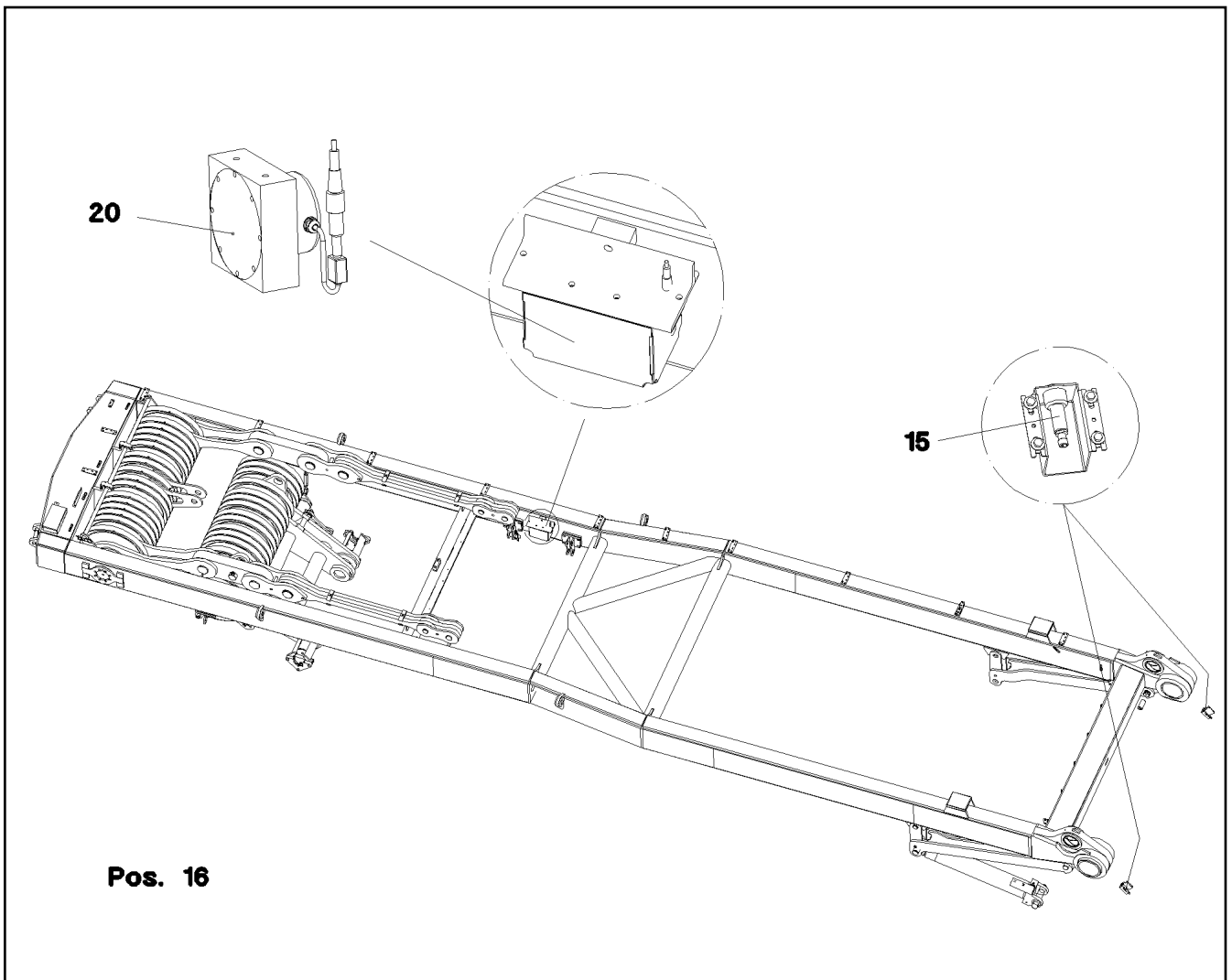

Pos.	Item	Quantity	Description	Bezeichnung	Serie	K
15	69 23 087 08	2	INDUCTIVE SENSOR SPF	INDUKTIVSENSOR		
16	60 60 531 08	1	LIMIT SWITCH SPF	ENDSCHALTER		
20	69 23 100 08	1	ANGLE TRANSMITTER 360° SPF	WINKELGEBER		

6.2.2009
055540

LIEBHERR

etk_en_de_074515 LR 1600/2

SENSOR ASSEMBLY SA-STAND
GEBERANBAU SA-BOCK

□ 319

⇒ 2 930
96 57 085 08

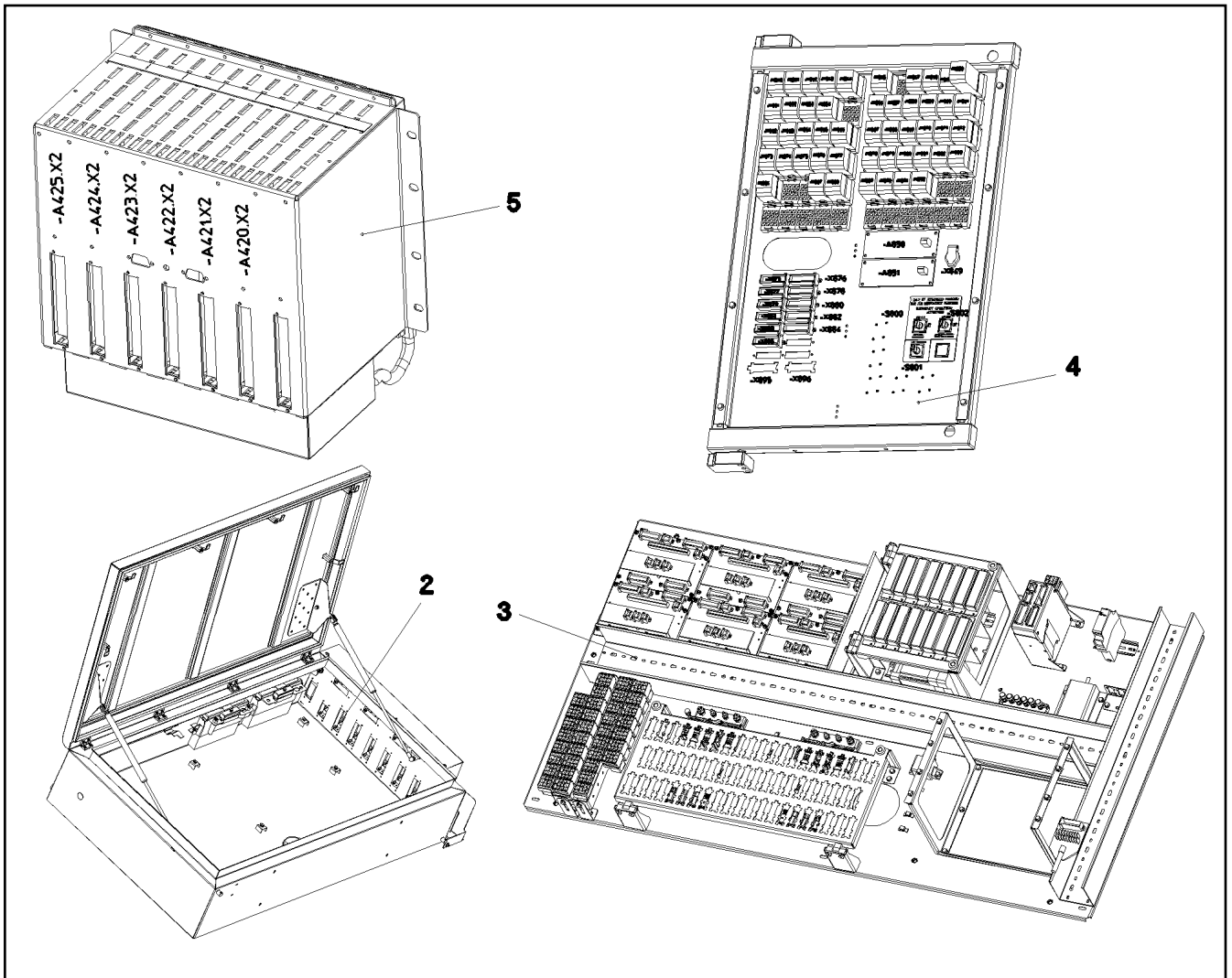

Pos.	Item	Quantity	Description	Bezeichnung	Serie	K
2	96 54 385 08	1	SWITCH CABINET ⇒ 2 932 160 96 54 385 08	SCHALTSCHRANK MECH.		
3	96 54 387 08	1	ASSEMBLY PARTS MOUNTING PANEL ⇒ 2 932 082 96 54 387 08	AUFBAUTEILE MONTAGETAFEL		
4	96 45 393 08	1	RELAY CONTROL SYSTEM ⇒ 2 932 001 96 45 393 08	RELAISSTEUERUNG		
5	96 45 394 08	1	LICCON ASSEMBLY UNIT ⇒ 2 932 122 96 45 394 08	LICCON MONTAGEEINHEIT		

6.2.2009
053699

LIEBHERR

etk_en_de_074515 LR 1600/2

BUILT-IN PARTS SWITCH BOX
EINBAUTEILE SCHALTSCHRANK

□ 320

⇒ 2 932
91 57 750 08

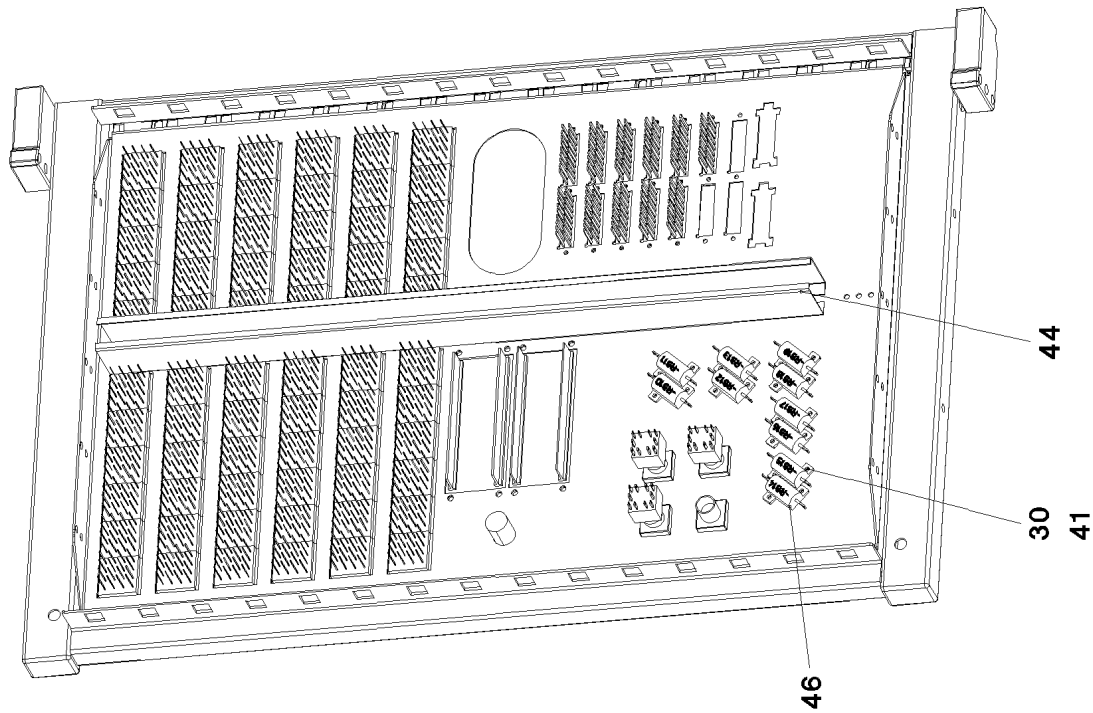

Pos. 3
Pos. 47

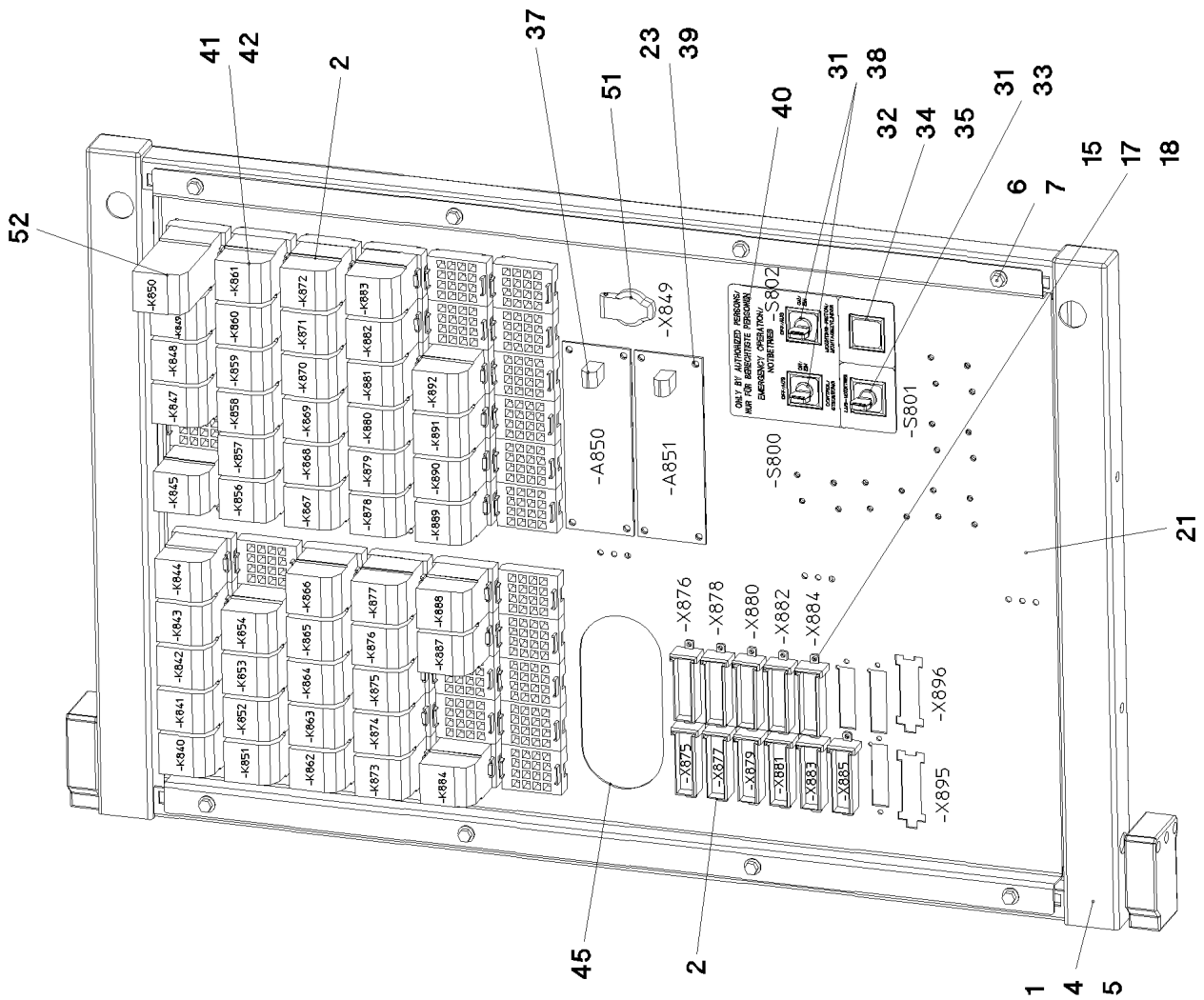

6.2.2009
053006

LIEBHERR

etk_en_de_074515 LR 1600/2

RELAY CONTROL SYSTEM
RELAISSTEUERUNG

□ 321 (1/2)

→ 2 932 001
96 45 393 08

Pos.	Item	Quantity	Description	Bezeichnung	Serie	K
1	61 10 470 08	1	HINGED FRAME 15HE VERZ	SCHWENKRAHMEN		
2	96 49 211 08	1	WIRES CPL. S2	DRAEHTE KPL.		
(2)	96 49 212 08	1	WIRES PRE-ASS. S2	DRAEHTE VORM.		
(151)	63 01 023 08	55	LAMPHOLDER	FASSUNG		
(152)	60 23 250 08	12	PLUG 18POL SPF	STECKER		
3	96 48 313 08	1	WIRES CPL. S3	DRAEHTE KPL.		
(2)	96 49 209 08	1	WIRES PRE-ASS. S3	DRAEHTE VORM.		
(151)	60 23 233 08	2	FLAT PLUG HOUSING 18-POL	FLACHSTECKERGEHAEUSE		
(152)	60 22 097 08	1	ATTACHABLE SLEEVE HOUSING 2POL	STECKHUELSENGEHAEUSE		
(153)	60 23 370 08	3	CONNECTOR PLUG A	ANSCHLUSSSTECKER		
4	10 02 217 1	1	BUILT-IN KIT	EINBAUSATZ		
5	10 02 217 7	1	SEALING INSERT 8MM VIERKANT	VERSCHLUSSEINSATZ		
6	41 30 038 08	8	CAGE NUT M5	KAFIGMUTTER		
7	40 73 500 08	8	HEX BOLT EN 1665 M5X10 10.9 A2C	SECHSKANTSCHRAUBE		
15	40 01 004 08	28	CYLINDER SCREW DIN 84 M3X10 5.8 VERZ	ZYLINDERSCHRAUBE		
17	42 52 205 08	28	SERRATED LOCK WASHER DIN 6798 J 3,2	FAECHERSCHEIBE		
18	41 15 157 08	28	HEX NUT DIN 934 M3 8 A3C	SECHSKANTMUTTER		
21	97 68 157 08	1	RELAY SUPPORT 1.5X725X518	RELAISTRAEGER		
22	61 10 461 08	36	WIRE CLIP	DRAHTHALTER		
23	70 42 076 08	8	MANDRIL RIVET 4X10,3	DORNNIET		
30	42 00 006 08	20	WASHER DIN 125 A 3.7 ST VERZ	SCHEIBE		
31	60 61 446 08	3	TOUCH CONTACT TRANSMITTER 2OE + 2S	TASTKONTAKTGEBER		
32	60 20 422 08	1	RETAINING NUT M16X1	BEFESTIGUNGSMUTTER		
33	60 61 433 08	1	ROTARY LOCK	DREHSCHLOSS		
34	60 61 440 08	1	SPHERICAL CAP	KALOTTE		
35	60 61 435 08	1	SIGNAL LAMP	LEUCHTMELDER		
37	66 01 015 08	2	DIODE VARISTOR MODULE SPF	DIODEN VARISTORENMODUL		
38	60 61 449 08	2	TURNLOCK ACTUATOR	DREHSCHLOSSBETAETIGER		
39	42 00 007 08	8	WASHER DIN 125 A 4.3 ST VERZ	SCHEIBE		
40	97 66 929 08	1	LABEL	SCHILD		
41	70 42 121 08	50	BLIND RIVET 3,0X3,2-5,0	BLINDNIET		
42	63 01 021 08	51	RELAY 18-32V	RELAIS		
44	60 14 058 08	0.63	CABLE CHANNEL	KABELKANAL		
45	26 21 039 08	0.33	EDGE PROTECTION	KANTENSCHUTZ		
46	63 50 170 08	10	RESISTOR 47R 10% 25W	WIDERSTAND		
47	60 21 710 08	90	ADHESIVE LABELS	HAFTETIKETT		
50	60 32 022 08	25	CABLE TIE 2,5X102	KABELBINDER		
51	60 52 039 08	1	BUILT-IN SOCKET 2POL 16A	EINBAUSTECKDOSE		
52	63 01 022 08	1	BEAM RELAY 18 - 32V	KIPPRELAIS		

6.2.2009

etk_en_de_074515 LR 1600/2

322 (2/2)

LIEBHERRRELAY CONTROL SYSTEM
RELAISSTEUERUNG⇒ 2 932 001
96 45 393 08

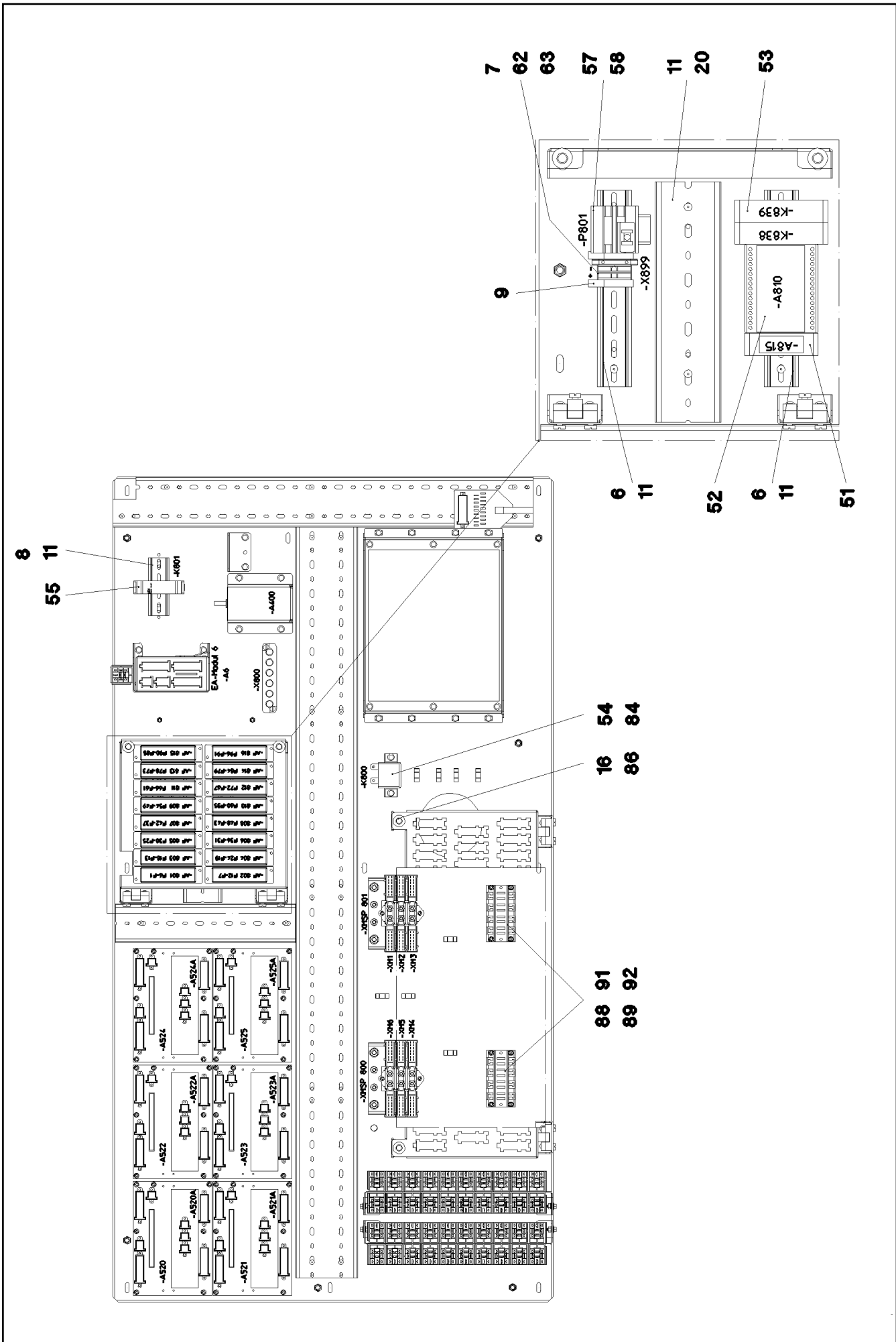

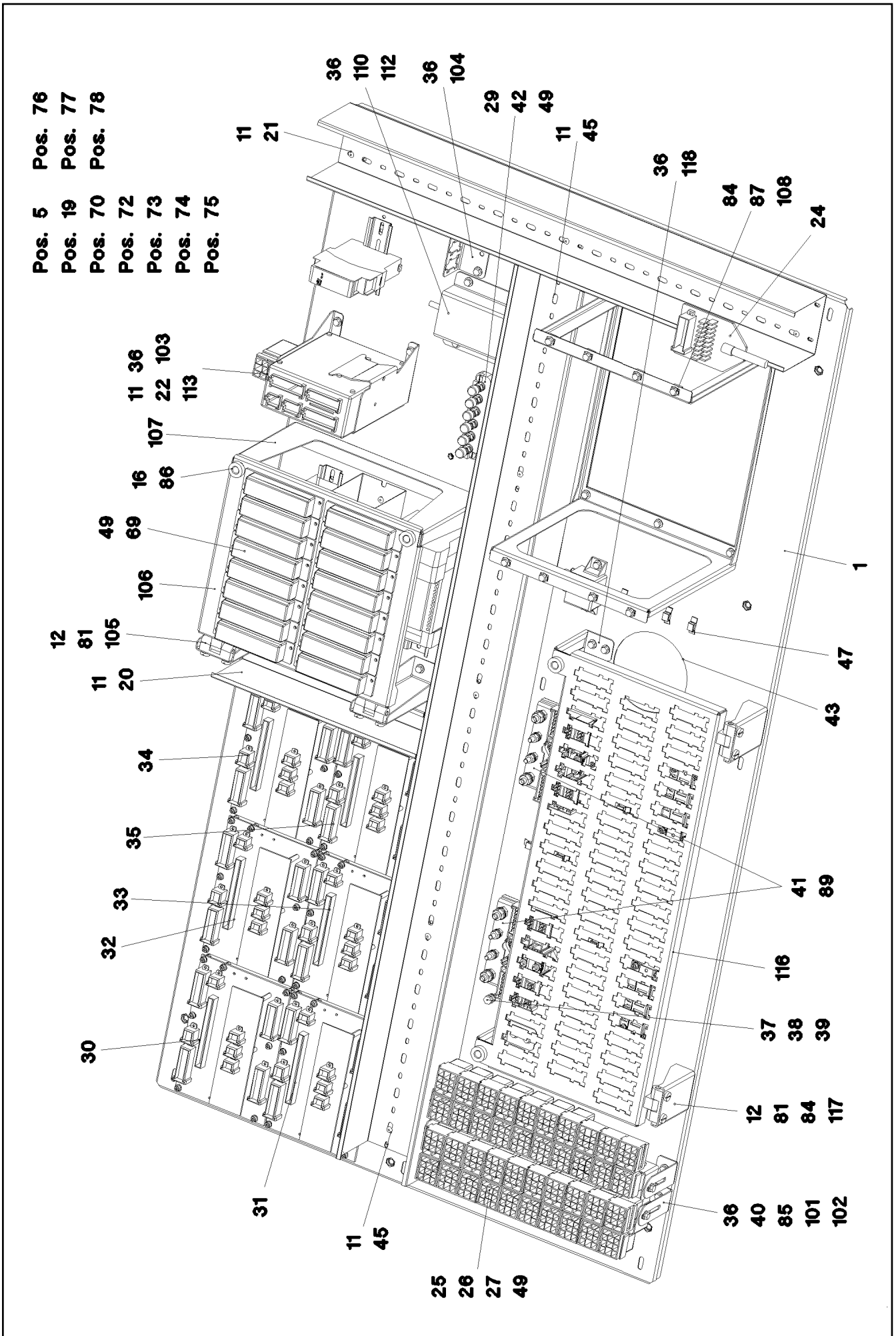

6.2.2009
 053697

LIEBHERR

etk_en_de_074515 LR 1600/2

ASSEMBLY PARTS MOUNTING PANEL
 AUFBAUTEILE MONTAGETAFEL

□ 324 (2/4)

⇒ 2 932 082
 96 54 387 08

Pos.	Item	Quantity	Description	Bezeichnung	Serie	K
1	96 48 552 08	1	PLATE PRE-ASS.	PLATTE VORM.		
5	96 54 388 08	1	CABLING MOUNTING PLATE S1 ⇒ 2 932 116 96 54 388 08	VERKABELUNG MONTAGETAPE		
6	60 21 067 08	0.4	TOP HAT RAIL 35X27X7,3X1	HUTSCHIENE		
7	60 27 616 08	1	TERMINAL MARKER	MESSERTRENNKLEMME		
8	60 21 067 08	0.1	TOP HAT RAIL 35X27X7,3X1	HUTSCHIENE		
9	60 21 101 08	5	END HOLDER	ENDHALTER		
11	70 42 323 08	30	BLIND RIVET 4,0X10,5	BLINDNIET		
12	40 01 054 08	12	CYLINDER SCREW DIN 84 M6X8 5.8 A3C	ZYLINDERSCHRAUBE		
16	10 44 966 4	4	KNURLED SCREW M5X10 PA6	RAENDELSCHRAUBE		
19	60 27 629 08	1	IDENTIFICATION STRIPS	BEZEICHNUNGSSTREIFEN		
20	63 81 092 01	0.62	WIRING DUCT 80X60/83,5X66/20 HART-PVC	VERDRAHTUNGSKANAL		
21	60 14 139 08	0.725	CABLE CHANNEL	KABELKANAL		
22	10 02 485 7	1	RESISTANCE MODULE PBTG-GF20 SPF	WIDERSTANDSMODUL		
24	66 00 245 08	1	ADAPTOR 18POL SPF	ADAPTER		
25	63 01 051 08	4	RELAY 24V S=40A 26X26X24MM SPF	RELAIS		
26	63 01 215 08	24	RELAY 24V S=20A OE=10A 26X26X24MM SP	RELAIS		
27	63 01 054 08	1	RELAY 24V S=40A OE=20A 26X26X24MM SP	RELAIS		
29	40 01 036 08	2	CYLINDER SCREW DIN 84 M5X20 5.8 VERZ	ZYLINDERSCHRAUBE		
30	96 48 329 08	1	INPUT BOARD CPL. EP0	EINGANGSPLATINE KPL.		
31	96 48 330 08	1	INPUT BOARD CPL. EP1	EINGANGSPLATINE KPL.		
32	96 48 331 08	1	INPUT BOARD CPL. EP2	EINGANGSPLATINE KPL.		
33	96 48 332 08	1	INPUT BOARD CPL. EP3	EINGANGSPLATINE KPL.		
34	96 48 333 08	1	INPUT BOARD CPL. EP4	EINGANGSPLATINE KPL.		
35	96 48 334 08	1	INPUT BOARD CPL. EP5	EINGANGSPLATINE KPL.		
36	40 73 500 08	18	HEX BOLT EN 1665 M5X10 10.9 A2C	SECHSKANTSCHRAUBE		
37	40 00 829	1	HEX BOLT ISO 4017 M6X20 8.8 A2C	SECHSKANTSCHRAUBE		
38	41 15 140 08	1	HEX NUT DIN 934 M6 8 VERZ	SECHSKANTMUTTER		
39	42 52 210 08	1	SERRATED LOCK WASHER DIN 6798 J 6,4	FAECHERSCHEIBE		
40	42 52 208 08	4	SERRATED LOCK WASHER DIN 6798 J 5,3	FAECHERSCHEIBE		
41	92 68 911 08	2	GROUND RAIL ⇒ 2 932 166 92 68 911 08	VERTEILER MASSE		
42	92 26 483 08	1	TERMINAL BOARD PRE-ASS. ⇒ 1 830 102 92 26 483 08	KLEMMBRETT VORM.		
43	26 21 039 08	2	EDGE PROTECTION	KANTENSCHUTZ		
45	60 14 142 08	1.295	CABLE CHANNEL	KABELKANAL		
47	60 20 611 08	8	CABLE CLIP HOLDER	KABELBINDERHALTER		
49	70 42 076 08	42	MANDRIL RIVET 4X10,3	DORNNIET		
51	96 45 911 08	1	INSERTION MODULE ⇒ 2 932 515 96 45 911 08	BESTUECKUNGSMODUL		
52	66 03 016 08	1	DIODE MODULE	DIODENMODUL		
53	63 01 013 08	2	TIME RELAY SPF	ZEITRELAIS		
54	63 01 201 08	1	CUTOFF RELAY	TRENNRELAIS		
55	10 47 515 0	1	EMERGENCY SHUT-DOWN DEVICE 24V/DC	NOT-AUS SCHALTGERAET		
57	69 18 022 08	1	SERVICE HOUR METER 12 - 24V	BETRIEBSSTUNDENZAehler		
58	97 12 910 08	1	PLATE OPER. HOUR METER TRAVELL	SCHILD BETRIEBSSTUNDENZ.		
62	60 27 617 08	1	LID	DECKEL		
63	10 28 635 4	2	TERMINAL/CLAMP	KLEMME		
69	60 45 016 08	16	FUSE BOX SMALL 6POL 24V	SICHERUNGSDOSE		
70	60 27 355 08	50	INSERTION BRIDGE	EINLEGEBRUECKE		
72	60 40 077 08	6	FLAT FUSE LINK 3A	FLACHSICHERUNGSEINSATZ		
73	60 40 069 08	6	FLAT FUSE LINK 5A	FLACHSICHERUNGSEINSATZ		
74	60 40 070 08	20	FLAT FUSE LINK 7,5A	FLACHSICHERUNGSEINSATZ		
75	60 40 071 08	22	FLAT FUSE LINK 10A	FLACHSICHERUNGSEINSATZ		
76	60 40 072 08	8	FLAT FUSE LINK 15A	FLACHSICHERUNGSEINSATZ		
77	60 40 073 08	5	FLAT FUSE LINK 20A	FLACHSICHERUNGSEINSATZ		
78	60 40 076 08	1	FLAT FUSE LINK 25A	FLACHSICHERUNGSEINSATZ		
81	70 42 559 08	4	HINGE	SCHARNIER		
84	40 73 501 08	32	HEX BOLT EN 1665 M5X16 10.9 A2C	SECHSKANTSCHRAUBE		
85	41 15 148 08	4	HEX NUT DIN 934 M5 8 VERZ	SECHSKANTMUTTER		

6.2.2009

etk_en_de_074515 LR 1600/2

☐ 325 (3/4)

LIEBHERRASSEMBLY PARTS MOUNTING PANEL
AUFBAUTEILE MONTAGETAPEL⇒ 2 932 082
96 54 387 08

Pos.	Item	Quantity	Description	Bezeichnung	Serie	K
86	10 04 259 2	6	BLIND RIVET NUT M5 ST VERZ	BLINDNIETMUTTER		
87	41 30 026 08	8	CAGE NUT M5	KAFIGMUTTER		
88	42 52 207 08	50	SERRATED LOCK WASHER DIN 6798 J 4,3	FAECHERSCHEIBE		
89	46 00 387	54	CYLINDER SCREW ISO 4762 M4X12 8.8 A2C	ZYLINDERSCHRAUBE		
91	60 20 426 08	2	UMBRELLA RAIL	SCHIRMSCHIENE		
92	42 00 007 08	8	WASHER DIN 125 A 4.3 ST VERZ	SCHEIBE		
101	97 75 662 08	2	PLATE 1.5X399X35	BLECH		
102	97 29 400 08	4	PLATE 1.5X112X30	BLECH		
103	97 29 623 08	1	PLATE 1.5X158X338	BLECH		
104	97 74 908 08	1	PLATE 1.5X79X67 DC01 FE//ZN20//C	BLECH		
105	97 26 606 08	2	PLATE 1.5X191X111	BLECH		
106	97 75 696 08	1	PLATE 1.5X283X325	BLECH		
107	97 73 925 08	1	PLATE 1.5X212X345	BLECH		
108	97 14 053 08	1	PLATE 1.5X272X796	BLECH		
110	97 65 362 08	1	PLATE 2X162X142 ALMG3 H111	BLECH		
112	10 34 043 8	1	DATALOGGER 24V LDL2 SPF	DATENLOGGER		
113	66 01 020 08	1	E/A-MODULE A SPF	E/A-MODUL		
115	26 21 010 08	0.36	CELL RUBBER 20X8	ZELLGUMMI		
116	97 86 281 08	1	PLATE 1.5X635X271 FE//ZN20//C	BLECH		
117	97 75 843 08	2	PLATE 2X110X109	BLECH		
118	97 86 272 08	2	ANGLE 1.5X151X54 FE//ZN20//C	WINKEL		

6.2.2009

etk_en_de_074515 LR 1600/2

326 (4/4)

LIEBHERR

ASSEMBLY PARTS MOUNTING PANEL
AUFBAUTEILE MONTAGETAFEL

⇒ 2 932 082
96 54 387 08

Pos.	Item	Quantity	Description	Bezeichnung	Serie	K
2	96 54 389 08	1	CABLES MOUNTING PANEL CPL. S1 ⇒ 2 932 224 96 54 389 08	DRAEHTE MONTAGETAFEL KPL		
6	92 17 061 08	1	LEAD W635X1800	LEITUNG		
8	92 17 086 08	4	LEAD W635X1600	LEITUNG		
9	92 12 113 08	1	LEAD W635X1250	LEITUNG		
10	91 05 061 08	1	LSB SENSOR TEST ADAPTER	LSB-SENSOR PRUEFADAPTER		
201	60 30 003 08	4	INSULATING TUBE 8	ISOLIERSCHLAUCH		
202	60 30 126 08	3.2	INSULATING TUBE 14 -50°C.- 250° SPF	ISOLIERSCHLAUCH		
261	60 32 003 08	100	CABLE TIE 3,6X150	KABELBINDER		
267	60 32 004 08	100	CABLE TIE 3,6X200	KABELBINDER		
268	60 32 022 08	100	CABLE TIE 2,5X102	KABELBINDER		

6.2.2009

etk_en_de_074515 LR 1600/2

☐ 327

LIEBHERR

CABLING MOUNTING PLATE
VERKABELUNG MONTAGETAFEL

⇒ 2 932 116
96 54 388 08

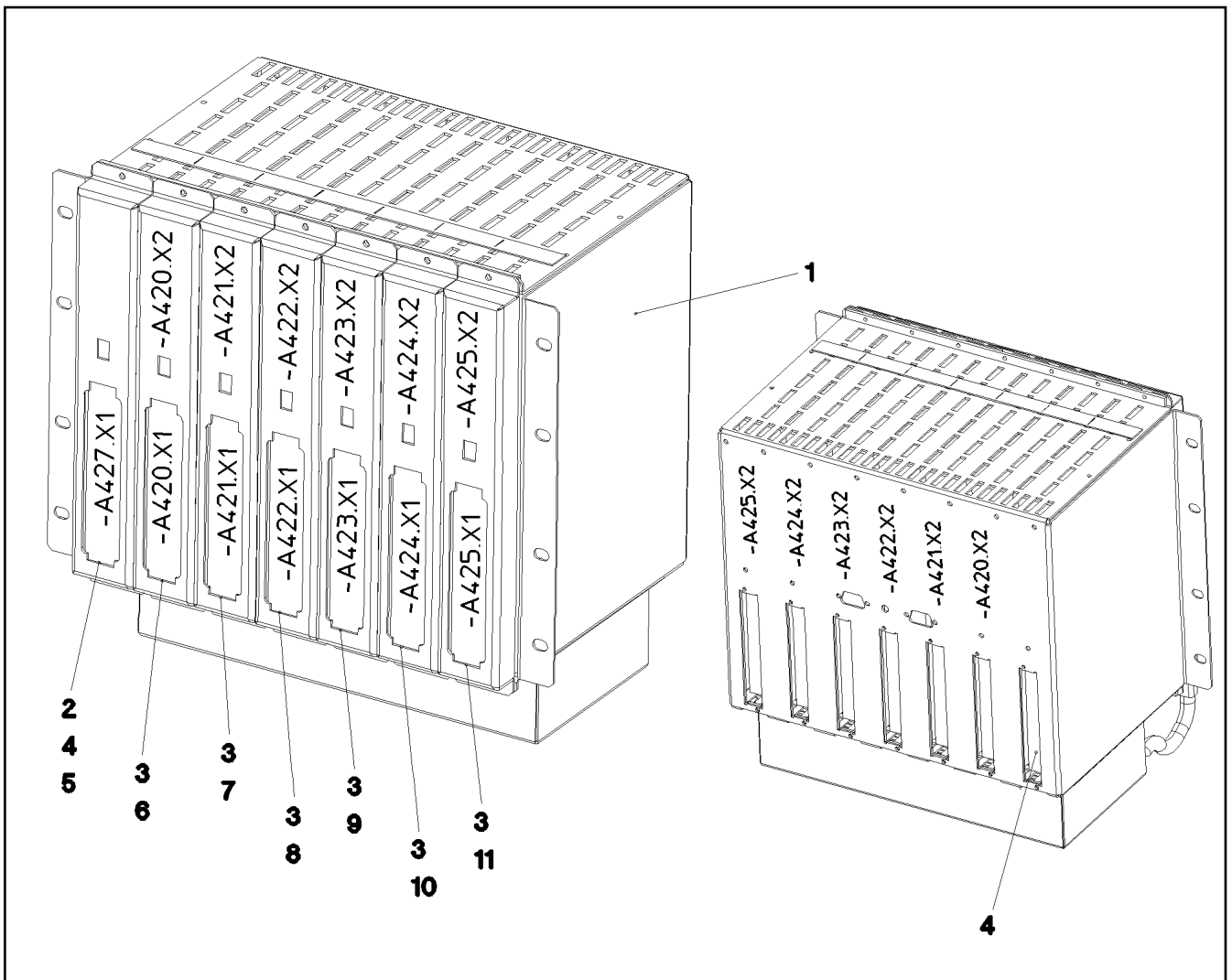

Pos.	Item	Quantity	Description	Bezeichnung	Serie	K
1	91 23 538 08	1	ASSEMBLY FRAME 56TE ⇒ 2 913 100 91 23 538 08	BAUGRUPPENTRAEGER		
2	91 07 635 08	1	POWER UNIT 4 GEPRUEFT	NETZTEIL 4		
3	91 44 006 08	6	CENTRAL UNIT C1 8X2A GEPRUEFT	ZENTRALEINHEIT C1		
4	61 10 017 08	1	SCREEN 1,5X19,5X111	BLLENDE		
5	92 16 203 08	1	PLUG-IN CARD G0 COMM.SP.4 PROG.	EINSCHUBKARTE G0		
6	91 54 570 08	1	PLUG-IN CARD G0Z0 PROG-SP.11 PROG.	EINSCHUBKARTE G0Z0		
7	91 42 856 08	1	PLUG-IN CARD G0Z1 PRPG.SP.6 PROG.	EINSCHUBKARTE G0Z1		
8	91 42 857 08	1	PLUG-IN CARD G0Z2 PROG-SP.6 PROG.	EINSCHUBKARTE G0Z2		
9	91 42 858 08	1	PLUG-IN CARD G0Z3 PROG-SP.6 PROG.	EINSCHUBKARTE G0Z3		
10	91 42 859 08	1	PLUG-IN CARD G0Z4 PROG-SP.6 PROG.	EINSCHUBKARTE G0Z4		
11	91 42 860 08	1	PLUG-IN CARD G0Z5 PROG-SP.6 PROG.	EINSCHUBKARTE G0Z5		

6.2.2009
053005

LIEBHERR

etk_en_de_074515 LR 1600/2

LICCON ASSEMBLY UNIT
LICCON MONTAGEEINHEIT

□ 328

⇒ 2 932 122
96 45 394 08

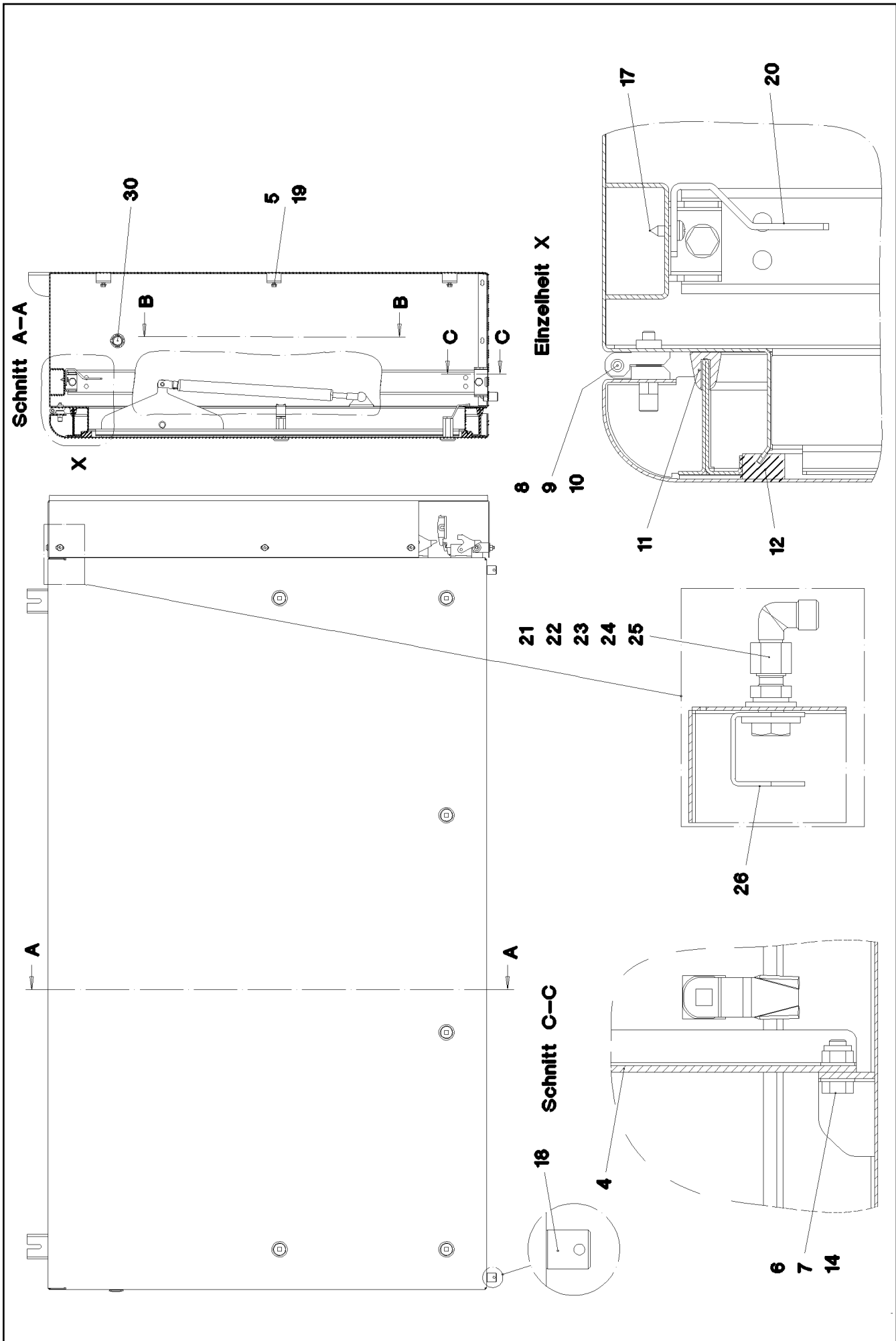

6.2.2009
053700

LIEBHERR

etk_en_de_074515 LR 1600/2

SWITCH CABINET
SCHALTSCHRANK MECH.

☐ 329 (1/4)

⇒ 2 932 160
96 54 385 08

Schnitt B-B

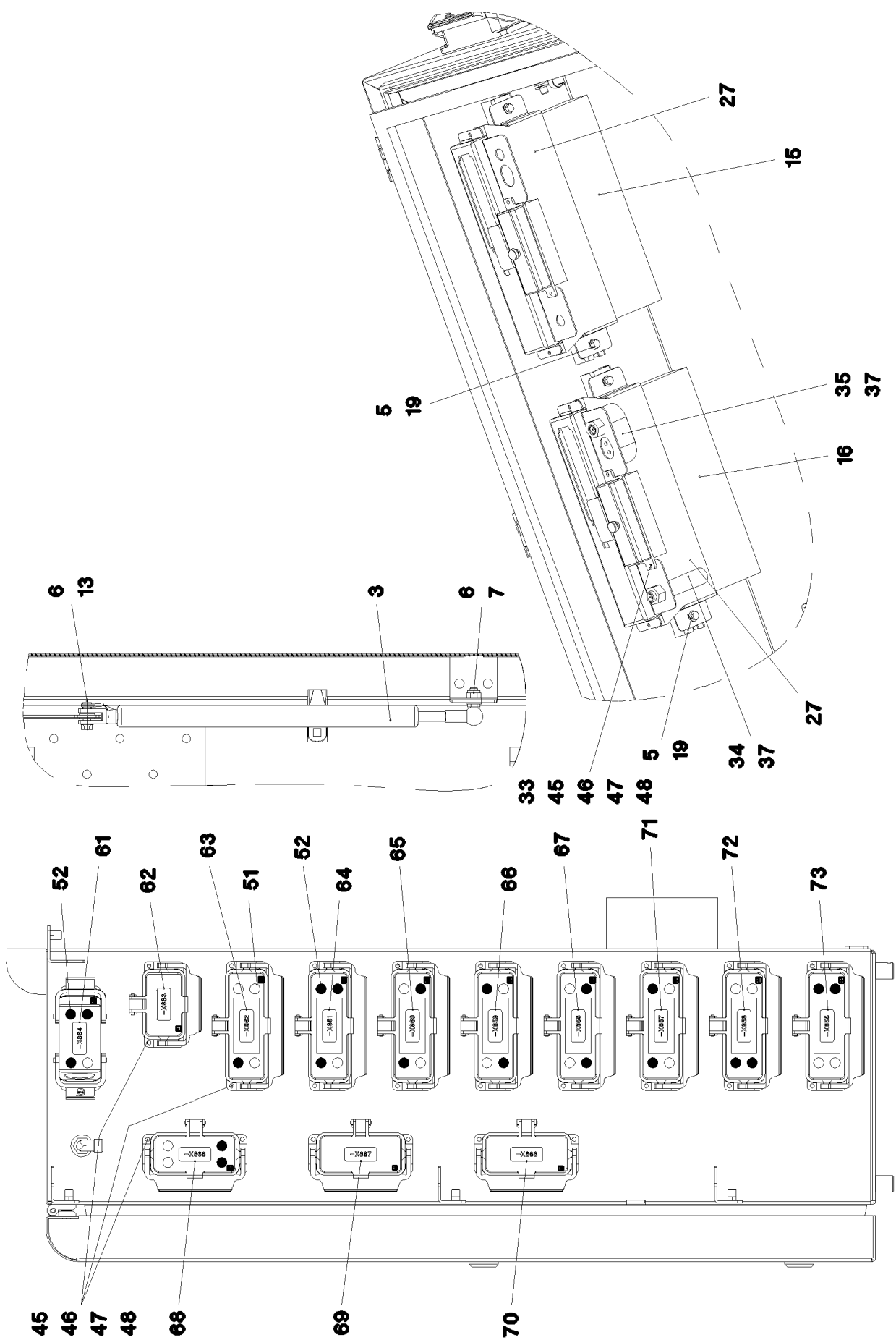

6.2.2009
053701

LIEBHERR

etk_en_de_074515 LR 1600/2

SWITCH CABINET
SCHALTSCHRANK MECH.

□ 330 (2/4)

⇒ 2 932 160
96 54 385 08

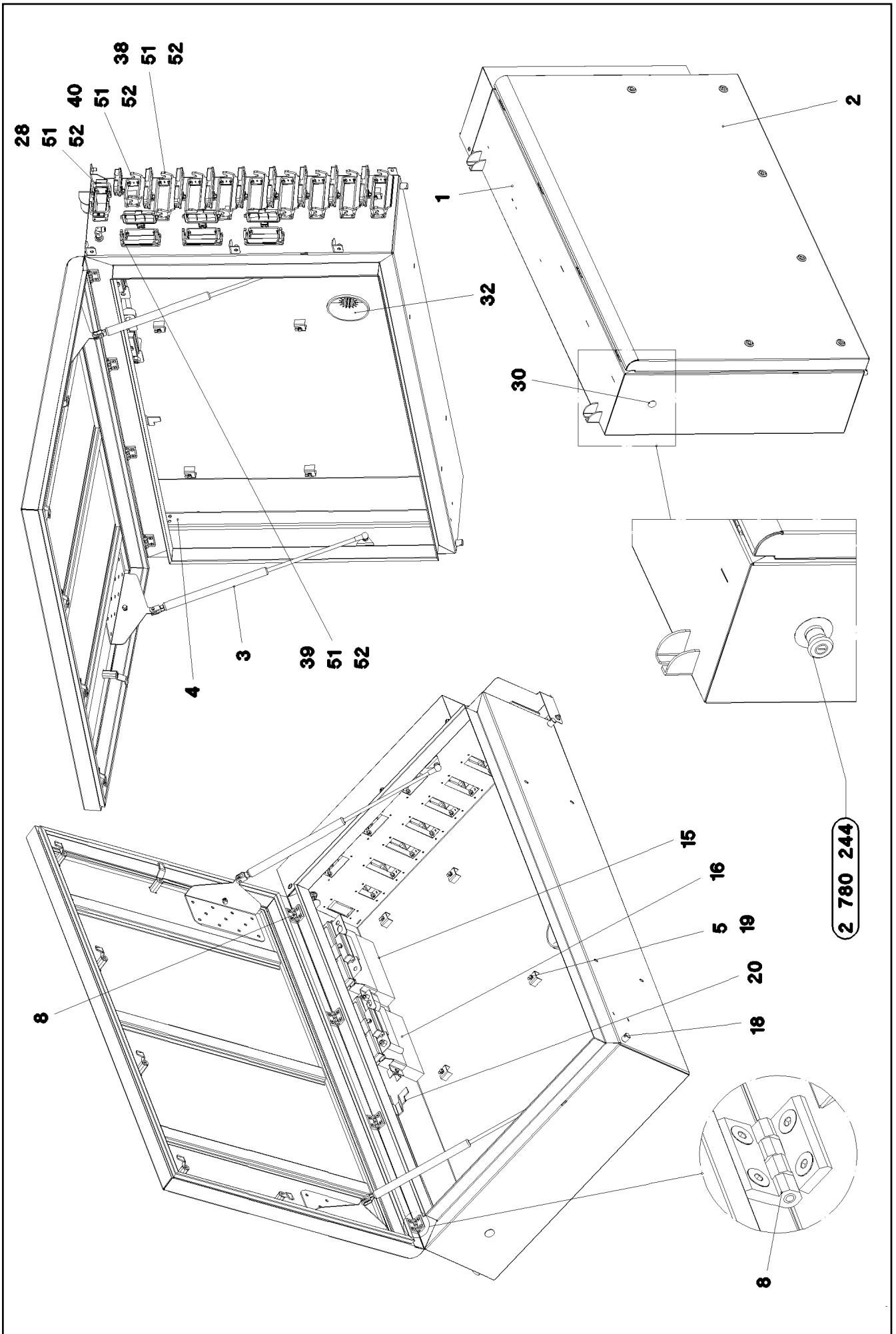

6.2.2009
053702

LIEBHERR

etk_en_de_074515 LR 1600/2

SWITCH CABINET
SCHALTSCHRANK MECH.

□ 331 (3/4)

⇒ 2 932 160
96 54 385 08

Pos.	Item	Quantity	Description	Bezeichnung	Serie	K
1	96 54 384 08	1	SWITCH CABINET WELDED	SCHALTSCHRANK SCHWK.		
2	96 48 167 08	1	COVER COMPL. ⇒ 2 932 168 96 48 167 08	DECKEL KPL.		
3	10 47 202 8	2	GAS SPRING 23X270 350N	GASFEDER		
4	97 73 500 08	1	PLATE 3X853X80	BLECH		
5	40 73 501 08	13	HEX BOLT EN 1665 M5X16 10.9 A2C	SECHSKANTSCHRAUBE		
6	42 00 012 08	12	WASHER DIN 125 A8X16 ST VERZ	SCHEIBE		
7	41 19 005 08	4	HEX NUT DIN 985 M8 8 VERZ	SECHSKANTMUTTER		
8	70 42 012 08	4	SCREW-ON HINGE	ANSCHRAUBSCHARNIER		
9	94 99 977 08	4	PLATE 4X90X12	BLECH		
10	40 86 002 08	16	COUNTERSUNK SCREW DIN 7991 M6X16 8.	SENKSCHRAUBE		
11	97 75 057 08	1	SEALING PROFILE 0 GUMMI 55°	ABDICHTPROFIL		
12	26 21 043 08	4.6	CELL RUBBER 20X12	ZELLGUMMI		
13	72 51 118 08	2	ES PIN 8X16 VERZ	ES BOLZEN		
14	49 00 089	2	HEX BOLT ISO 4017 M8X20 8.8 A2C	SECHSKANTSCHRAUBE		
15	91 07 635 08	1	POWER UNIT 4 GEPRUEFT	NETZTEIL 4		
16	91 44 006 08	1	CENTRAL UNIT C1 8X2A GEPRUEFT	ZENTRALEINHEIT C1		
17	55 31 687 08	2	SHEET-METAL SCREW DIN 7981 4,8X13-F-H	BLECHSCHRAUBE		
18	60 25 012 08	2	WATER DRAIN PLUG PA6G SPF	ENTWAESSERUNGSSTOPFEN		
19	41 30 038 08	13	CAGE NUT M5	KAFIGMUTTER		
20	97 80 496 08	1	ANGLE 3X40X112 FE//ZN20//C	WINKEL		
21	47 10 321 08	1	FLANGE JOINT XGE6-SR-ED A3P	VERSCHRAUBUNG		
22	47 25 315 08	1	FLANGE JOINT EWSD6-S A3P	VERSCHRAUBUNG		
23	41 01 500 08	1	UNION NUT DIN 431 A-G1/4" 14 H VERZ	ROHRMUTTER		
24	42 11 013 08	1	WASHER DIN 1440 14 ST VERZ	SCHEIBE		
25	42 00 016 08	1	WASHER ISO 7089 A 13 ST A3C	SCHEIBE		
26	97 66 066 08	1	PLATE 2X98X32 SPF	BLECH		
27	97 28 092 08	2	PLATE 1.5X336X134	BLECH		
28	10 47 566 6	1	ADD-ON HOUSING ALU/ZINK	ANBAUAEHAEUSE		
30	26 47 366 02	1	STOPPER PLUG	BLINDSTOPFEN		
32	97 75 102 08	2	SEAL 0 PE	DICHTUNG		
33	60 45 016 08	2	FUSE BOX SMALL 6POL 24V	SICHERUNGSDOSE		
34	69 23 087 08	1	INDUCTIVE SENSOR SPF	INDUKTIVSENSOR		
35	69 23 127 08	1	INDUCTIVE SENSOR SPF	INDUKTIVSENSOR		
37	41 15 197 08	2	HEX NUT DIN 934 M12X1 6 BLANK	SECHSKANTMUTTER		
38	60 56 172 08	8	ADD-ON HOUSING 24POL.	ANBAUAEHAEUSE		
39	60 56 171 08	3	ADD-ON HOUSING 16POL.	ANBAUAEHAEUSE		
40	69 31 498 14	1	ADD-ON HOUSING HAN 10 B	ANBAUAEHAEUSE		
45	41 19 002 08	56	HEX NUT DIN 985 M4 8 VERZ	SECHSKANTMUTTER		
46	42 51 007 08	56	TOOTH LOCK WASHER DIN 6797 A 4,3	ZAHNSCHEIBE		
47	42 00 007 08	56	WASHER DIN 125 A 4.3 ST VERZ	SCHEIBE		
48	40 01 018 08	56	CYLINDER SCREW DIN 84 M4X16 4.8 VERZ	ZYLINDERSCHRAUBE		
51	60 56 099 08	19	GUIDING BUSH	FUEHRUNGSBUCHSE		
52	60 56 100 08	21	GUIDE PIN	FUEHRUNGSSTIFT		
61	97 75 395 08	1	LABEL	SCHILD		
62	97 75 396 08	1	LABEL 35X15 LEXEDGE II	SCHILD		
63	97 75 397 08	1	LABEL	SCHILD		
64	97 75 398 08	1	LABEL 35X15 LEXEDGE II	SCHILD		
65	97 75 399 08	1	LABEL 35X15 LEXEDGE II	SCHILD		
66	97 75 400 08	1	LABEL 35X15 LEXEDGE II	SCHILD		
67	97 75 401 08	1	LABEL 35X15 LEXEDGE II	SCHILD		
68	97 75 402 08	1	LABEL	SCHILD		
69	97 75 403 08	1	LABEL	SCHILD		
70	97 75 404 08	1	LABEL 35X15 LEXEDGE II	SCHILD		
71	97 75 405 08	1	LABEL 35X15 LEXEDGE II	SCHILD		
72	97 75 406 08	1	LABEL 35X15 LEXEDGE II	SCHILD		
73	97 75 407 08	1	LABEL	SCHILD		

6.2.2009

etk_en_de_074515 LR 1600/2

332 (4/4)

LIEBHERRSWITCH CABINET
SCHALTSCHRANK MECH.⇒ 2 932 160
96 54 385 08

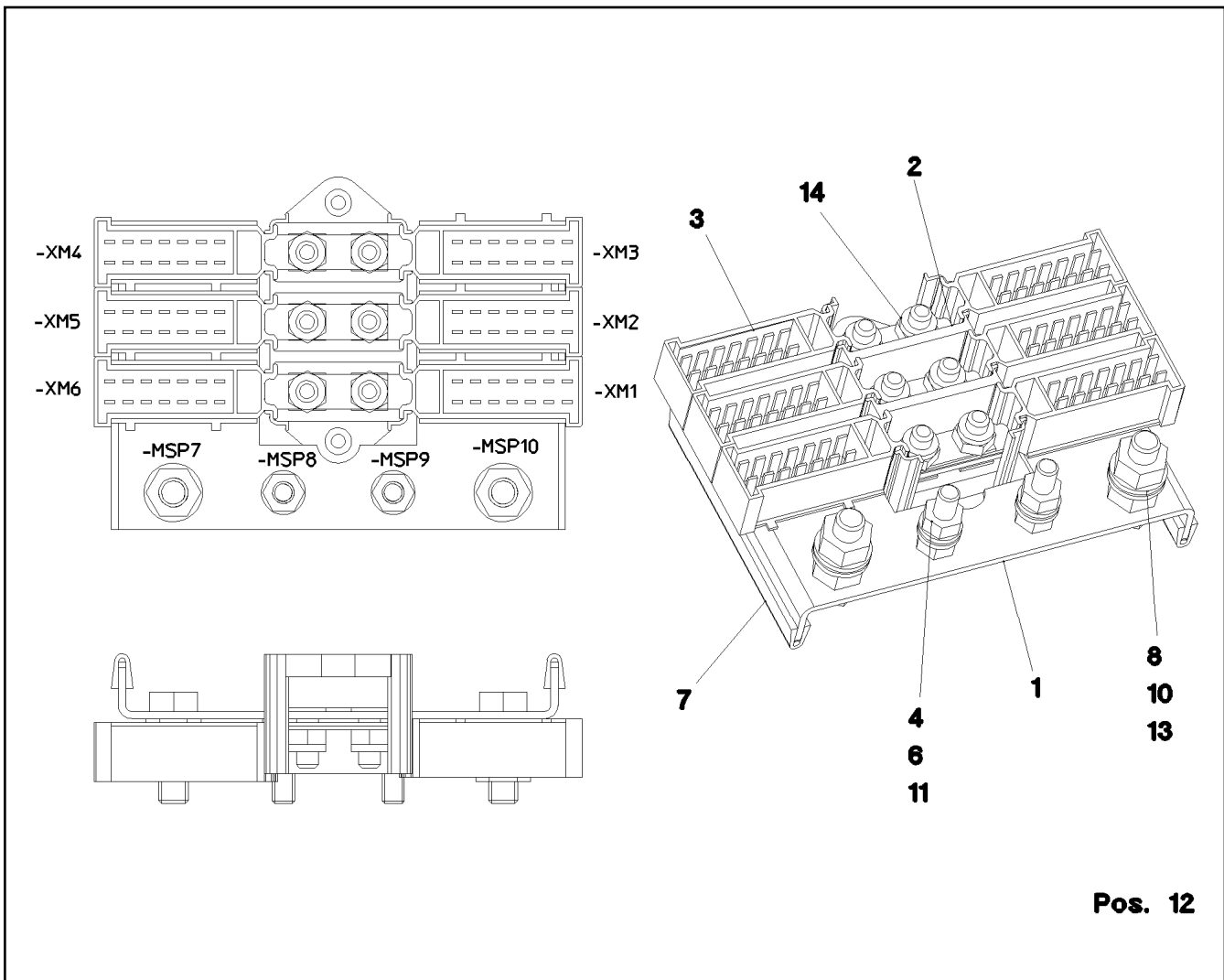

Pos.	Item	Quantity	Description	Bezeichnung	Serie	K
1	95 63 963 08	1	PLATE 2X144X80 ST12.03	BLECH		
2	60 23 364 08	1	CABLE CONNECTOR	KABELVERBINDER		
3	60 23 365 08	6	PLUG SHELL 14POL	STECKERGEHAEUSE		
4	42 00 009 08	4	WASHER ISO 7089 A 6.4 VERZ	SCHEIBE		
6	41 15 140 08	4	HEX NUT DIN 934 M6 8 VERZ	SECHSKANTMUTTER		
7	26 21 039 08	0.16	EDGE PROTECTION	KANTENSCHUTZ		
8	49 00 128	2	HEX BOLT ISO 4017 M8X25 8.8 A2C	SECHSKANTSCHRAUBE		
10	41 15 046 08	4	HEX NUT DIN 934 M8 10 VERZ	SECHSKANTMUTTER		
11	49 00 539	2	HEX BOLT ISO 4017 M6X25 8.8 A3C	SECHSKANTSCHRAUBE		
12	60 27 614 08	10	NAME PLATE 20X8	BEZEICHNUNGSSCHILD		
13	42 00 012 08	4	WASHER DIN 125 A8X16 ST VERZ	SCHEIBE		
14	41 19 004 08	6	HEX NUT DIN 985 M6 8 VERZ	SECHSKANTMUTTER		

6.2.2009
018734

LIEBHERR

etk_en_de_074515 LR 1600/2

GROUND RAIL
VERTEILER MASSE

333

⇒ 2 932 166
92 68 911 08

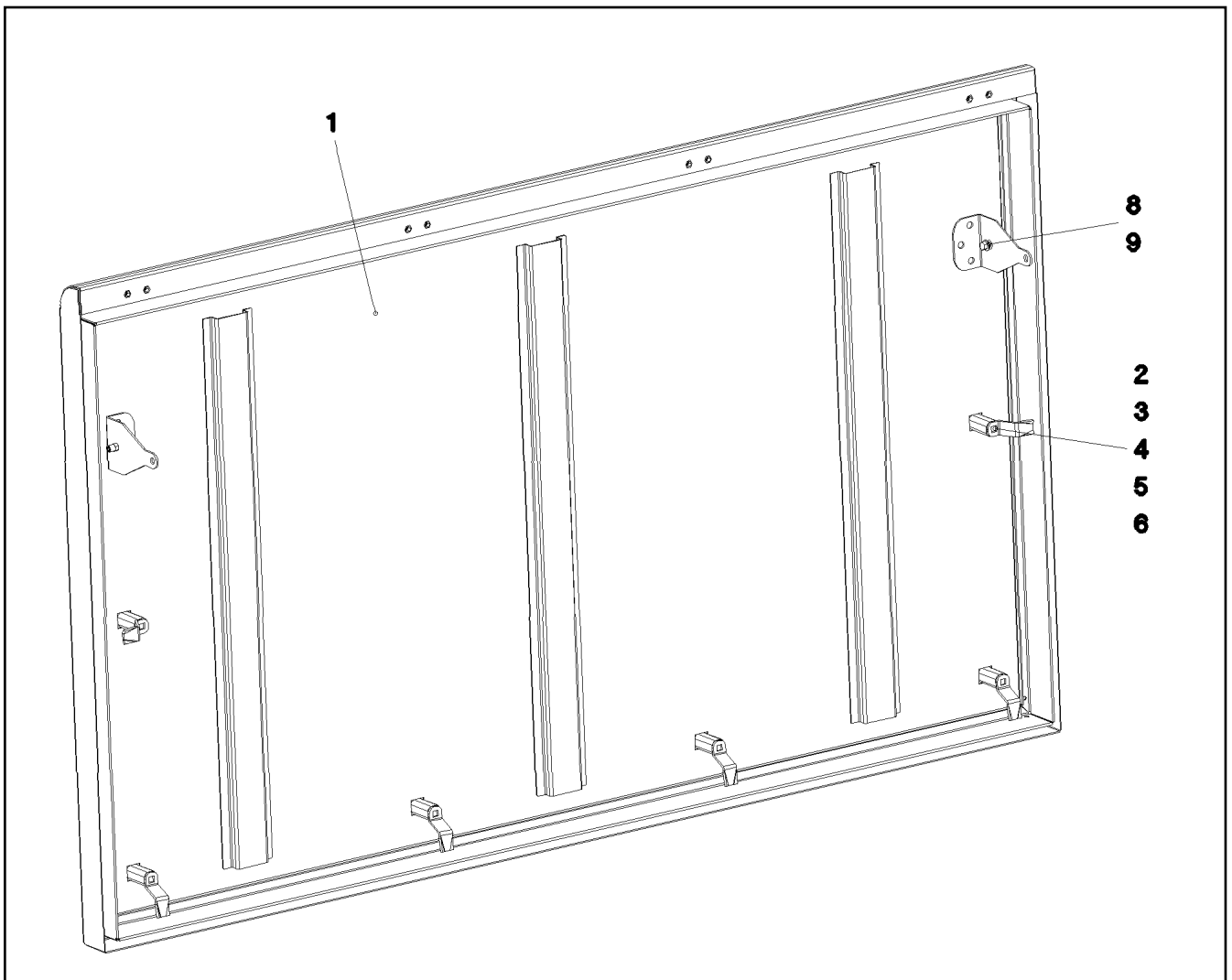

Pos.	Item	Quantity	Description	Bezeichnung	Serie	K
1	96 48 168 08	1	COVER GLUED	DECKEL GEKLEBT		
2	70 42 534 08	6	ACTUATION SPIKE	BETAETIGUNGSDORN		
3	70 42 747 08	6	HOUSING	GEHAEUSE		
4	70 42 553 08	6	TONGUE	ZUNGE		
5	70 42 749 08	6	FLAT GASKET	FLACHDICHTUNG		
6	70 42 748 08	6	O-RING 12X2 NBR70	O-RING		
8	42 00 009 08	4	WASHER ISO 7089 A 6.4 VERZ	SCHEIBE		
9	40 73 502 08	2	HEX BOLT EN 1665 M6X16 8.8 A3C	SECHSKANTSCHRAUBE		

6.2.2009
053004

LIEBHERR

etk_en_de_074515 LR 1600/2

COVER COMPL.
DECKEL KPL.

334

⇒ 2 932 168
96 48 167 08

Pos.	Item	Quantity	Description	Bezeichnung	Serie	K
2	96 54 390 08	1	CABLES MOUNTING PLATES,PRE-ASS S1	DRAEHTE MONTAGETAFEL VO		
501	60 23 002 08	37	PLUG SHELL 18-POL	STECKERGEHAEUSE		
502	60 56 021 08	2	BUSH INSERT 40POL	BUCHSENEINSATZ		
503	60 23 233 08	34	FLAT PLUG HOUSING 18-POL	FLACHSTECKERGEHAEUSE		
504	63 01 229 08	41	PLUG BASE 9-POL	RELAISSTECKSOCKEL		
505	10 04 700 0	12	PLUG 8POL 24V	STECKER		
506	10 04 699 9	15	PLUG 8POL 24V	STECKER		
507	60 23 360 08	12	HOUSING 14POL	GEHAEUSE		
508	60 56 088 08	8	BUSH INSERT 64POL	BUCHSENEINSATZ		
509	10 04 700 1	15	PLUG 8POL 24V	STECKER		
510	60 23 223 08	7	HOUSING 25POL SPF	GEHAEUSE		
511	60 23 014 08	1	HOUSING 8POL	GEHAEUSE		
512	10 09 986 3	1	HOUSING 15POL	GEHAEUSE		
513	10 09 986 7	1	CONTACT RETAINING PIN 15POL	KONTAKTSICHERUNGSSTIFT		
514	60 23 256 08	6	FLAT PLUG HOUSING 6POL	FLACHSTECKERGEHAEUSE		
515	60 23 313 08	13	HOUSING 4POL	GEHAEUSE		
516	60 56 086 08	1	BUSH INSERT 16POL	BUCHSENEINSATZ		
517	60 22 097 08	2	ATTACHABLE SLEEVE HOUSING 2POL	STECKHUELSENGEHAEUSE		
518	10 09 985 6	2	HOUSING 21 POL BRAUN	GEHAEUSE		
519	10 09 986 8	2	CONTACT RETAINING PIN 21 POL BRAUN	KONTAKTSICHERUNGSSTIFT		
520	60 23 255 08	2	HOUSING 6POL	GEHAEUSE		
521	63 61 079 01	2	TERMINAL/CLAMP	KLEMME		
522	10 00 727 2	1	PIN INSERT 4/2POL -40°C	STIFTEINSATZ		
523	60 23 359 08	1	PLUG SHELL 4POL	STECKERGEHAEUSE		

6.2.2009

etk_en_de_074515 LR 1600/2

335

LIEBHERR

CABLES MOUNTING PANEL CPL.
DRAEHTE MONTAGETAFEL KPL.

⇒ 2 932 224
96 54 389 08

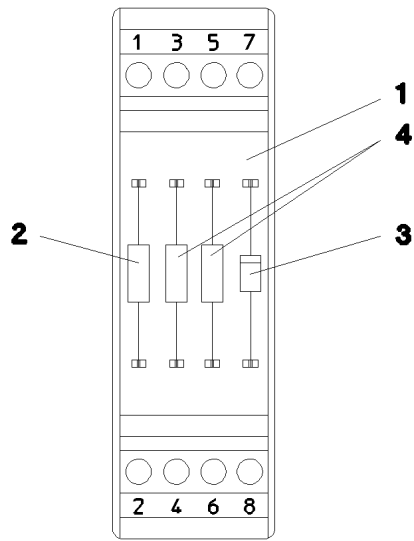

Pos.	Item	Quantity	Description	Bezeichnung	Serie	K
1	60 27 923 08	1	INSERTION MODULE	BESTUECKUNGSMODUL		
2	63 50 585 08	1	RESISTOR 1K 5% 3W 75PPM/K SPF	WIDERSTAND		
3	66 00 331 08	1	DIODE 1000V 1A DO-41 SPF	DIODE		
4	63 50 515 08	2	RESISTOR 500R 0%1 2W5 SPF	WIDERSTAND		

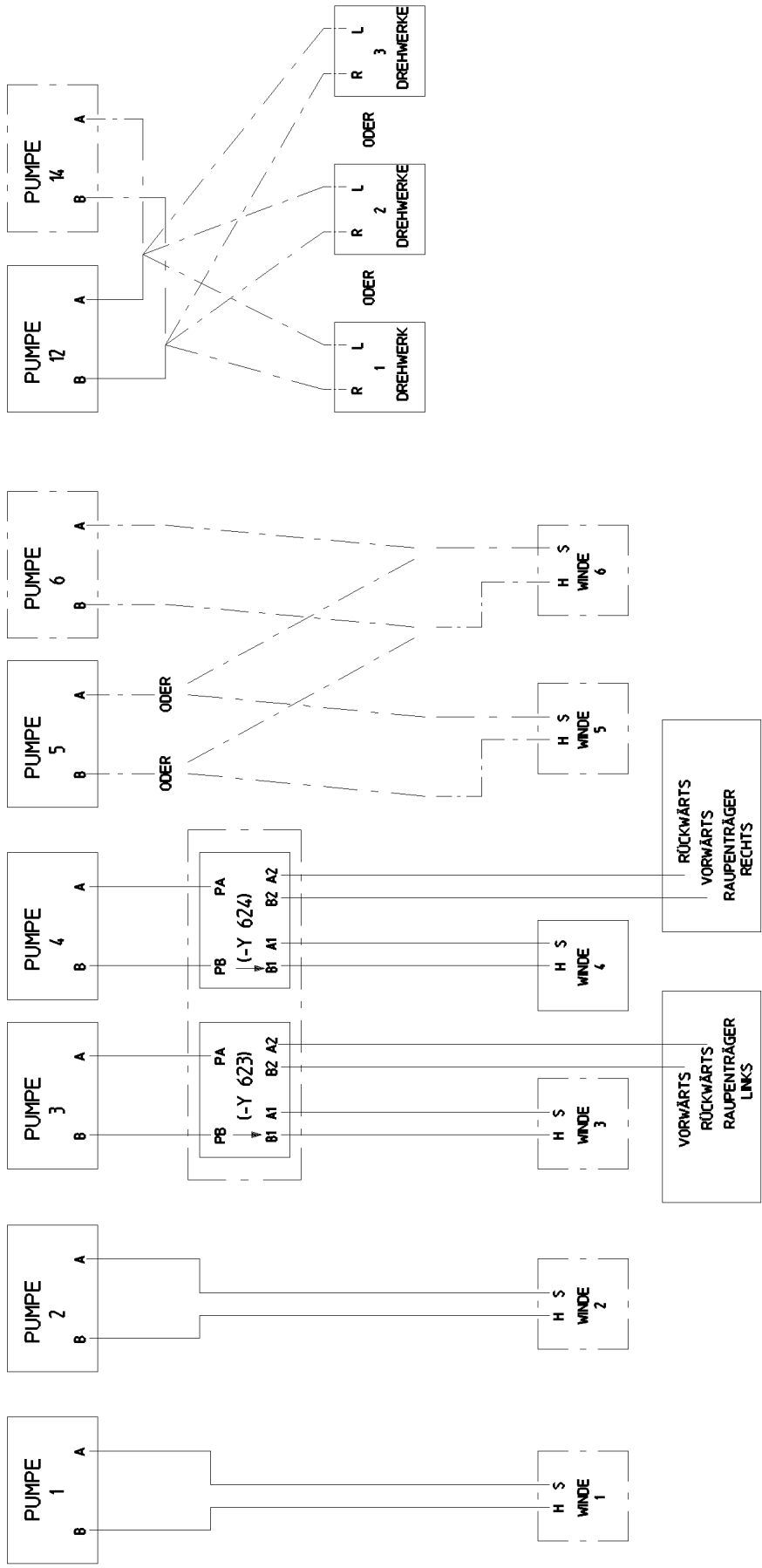

- * Schläuche Blatt 2 997
Hoses Plate
Flexibles Planché
- ** Rohre Blatt 2 998
Pipes Plate
Tuyaux Planché

Pos. 91
Pos. 152
Pos. 156
Pos. 545

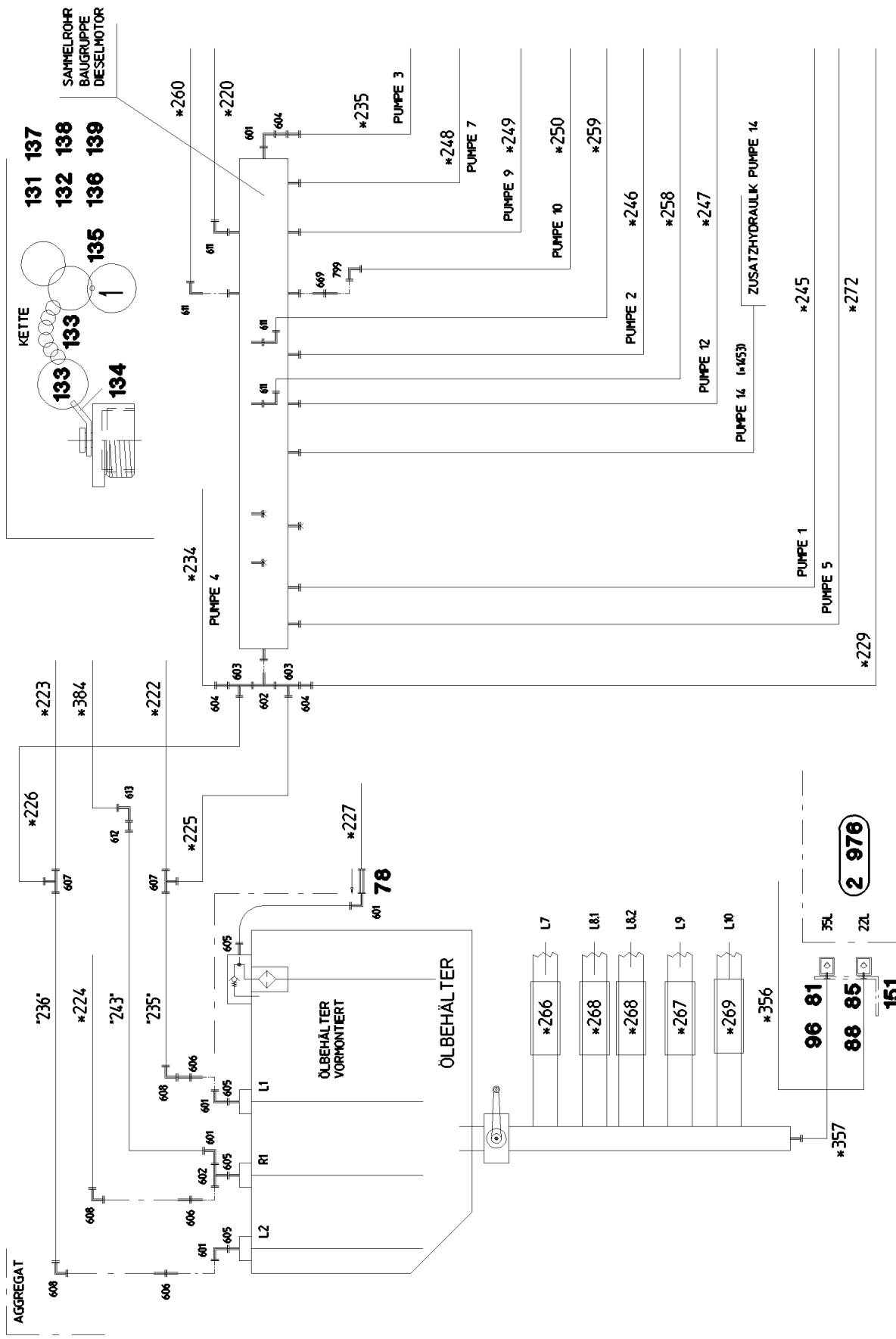

6.2.2009
054201

LIEBHERR

etk_en_de_074515 LR 1600/2

HYDR
HYDRAULIK

□ 338 (2/29)

⇒ 2 970
91 56 537 08

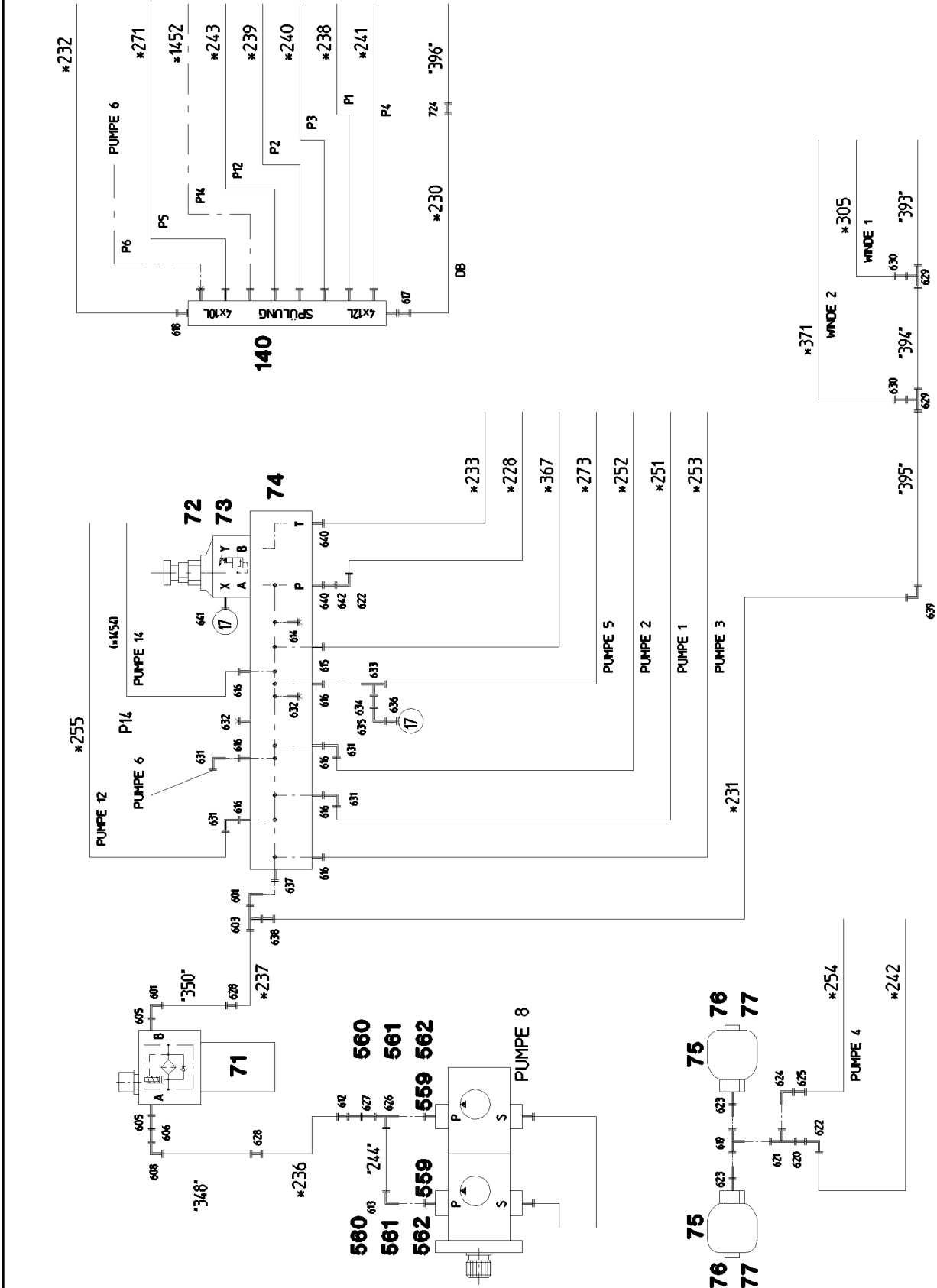

6.2.2009
054202

LIEBHERR

etk_en_de_074515 LR 1600/2

HYDR
HYDRAULIK

339 (3/29)

⇒ 2 970
91 56 537 08

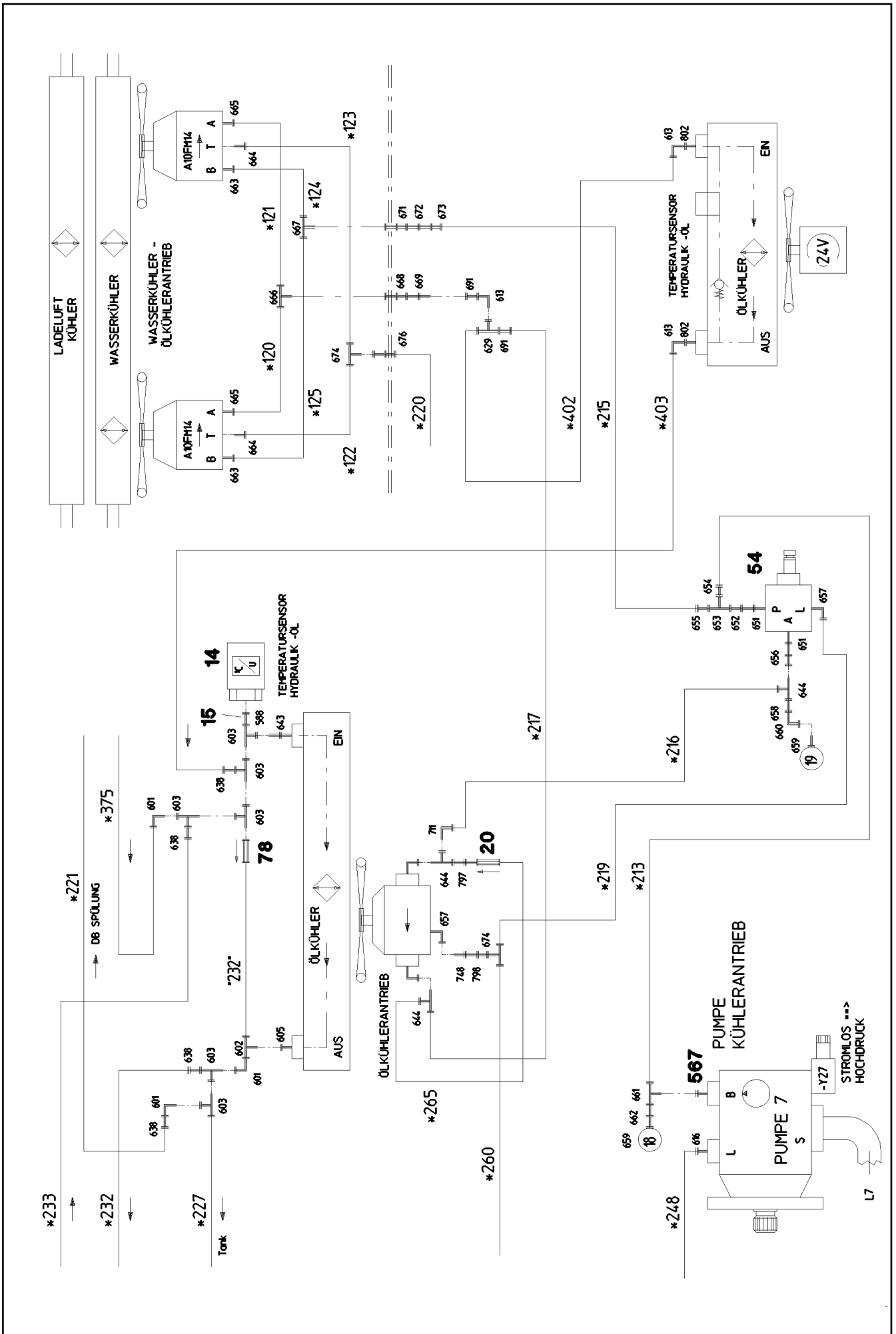

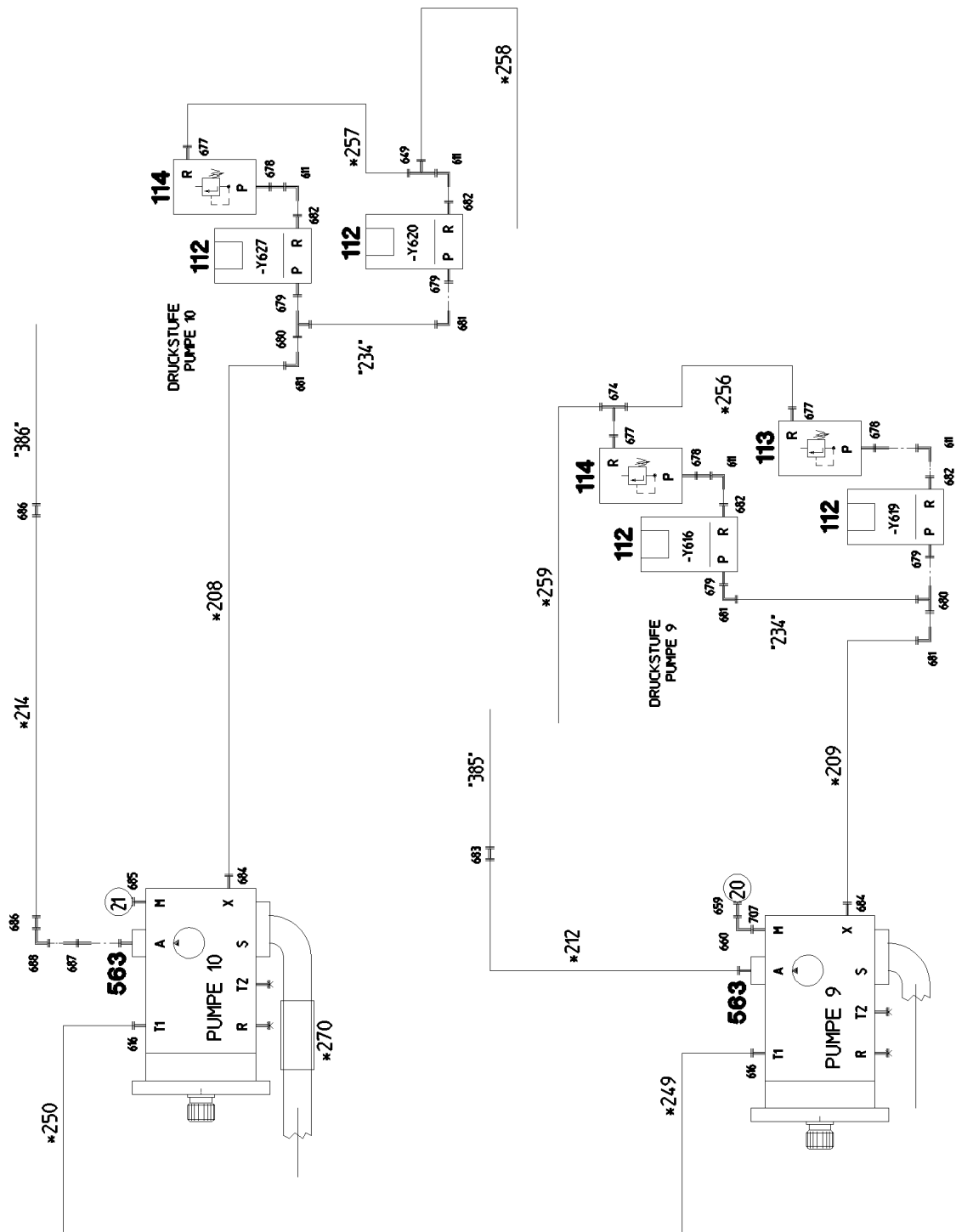

6.2.2009
054204

LIEBHERR

etk_en_de_074515 LR 1600/2

HYDR
HYDRAULIK

341 (5/29)

⇒ 2 970
91 56 537 08

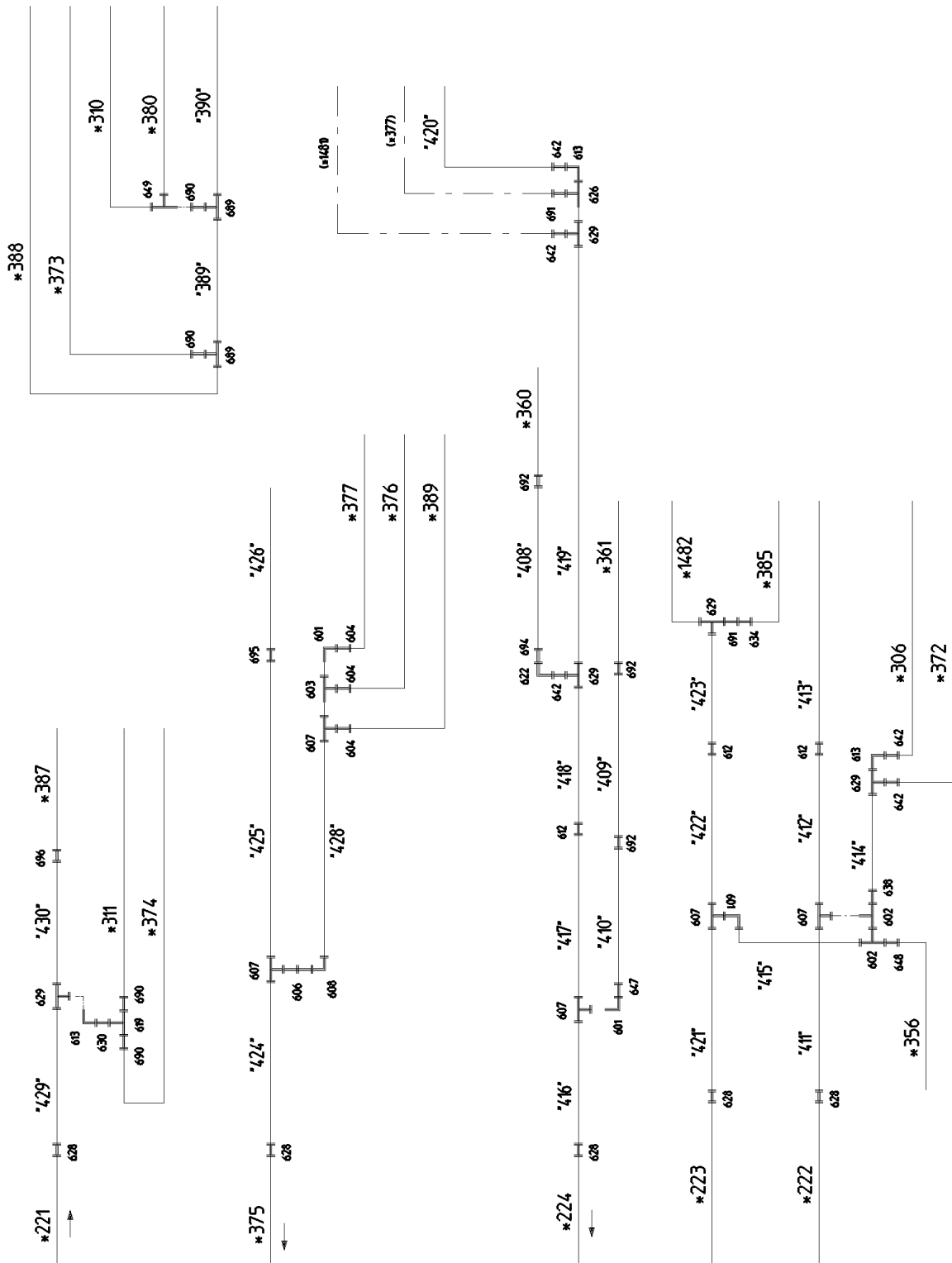

6.2.2009
054205

LIEBHERR

etk_en_de_074515 LR 1600/2

HYDR
HYDRAULIK

342 (6/29)

2 970
91 56 537 08

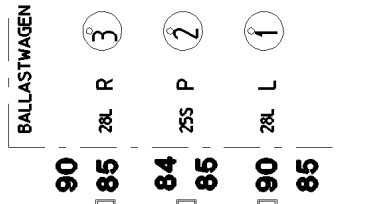
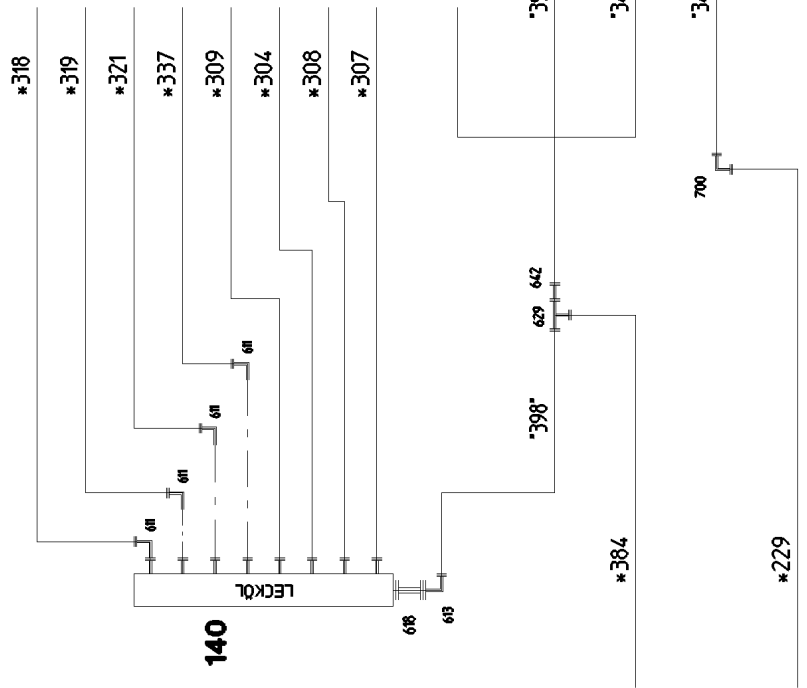
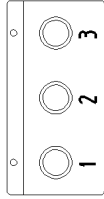

6.2.2009
054206

LIEBHERR

etk_en_de_074515 LR 1600/2

HYDR
HYDRAULIK

☐ 343 (7/29)

⇒ 2 970
91 56 537 08

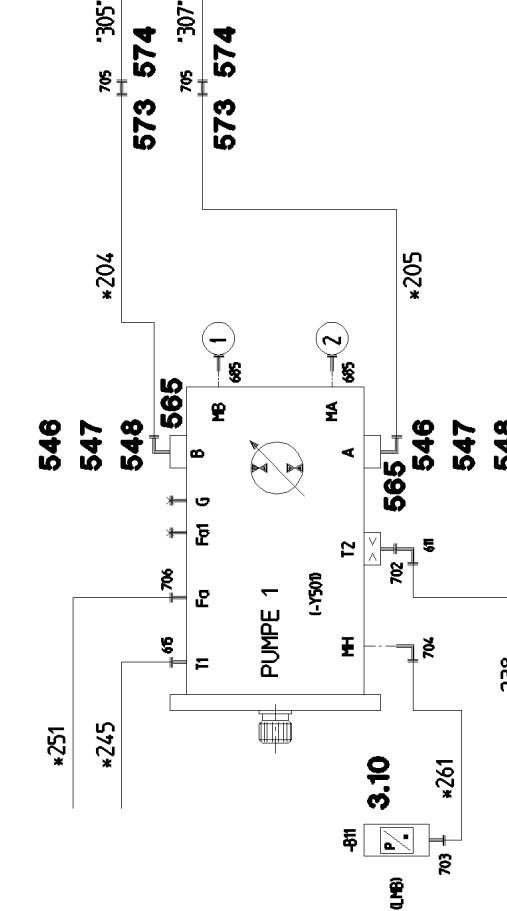
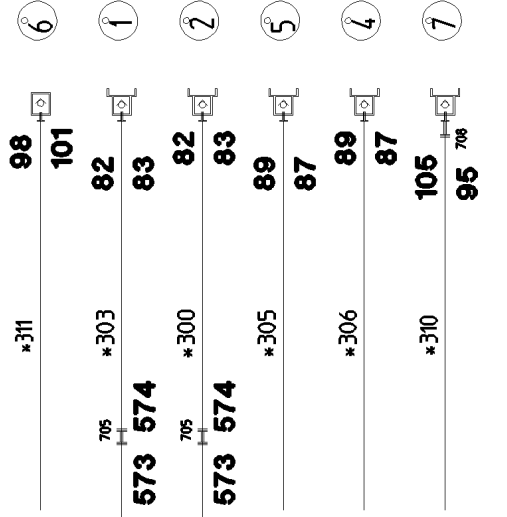
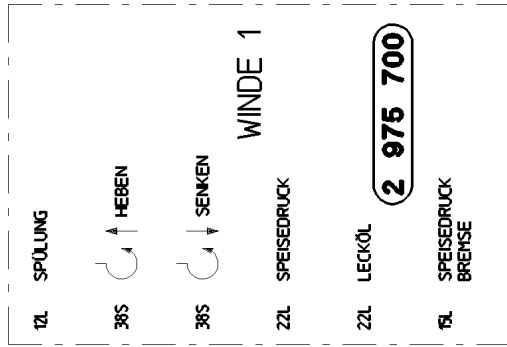

6.2.2009
054207

LIEBHERR

etk_en_de_074515 LR 1600/2

HYDR
HYDRAULIK

□ 344 (8/29)

⇒ 2 970
91 56 537 08

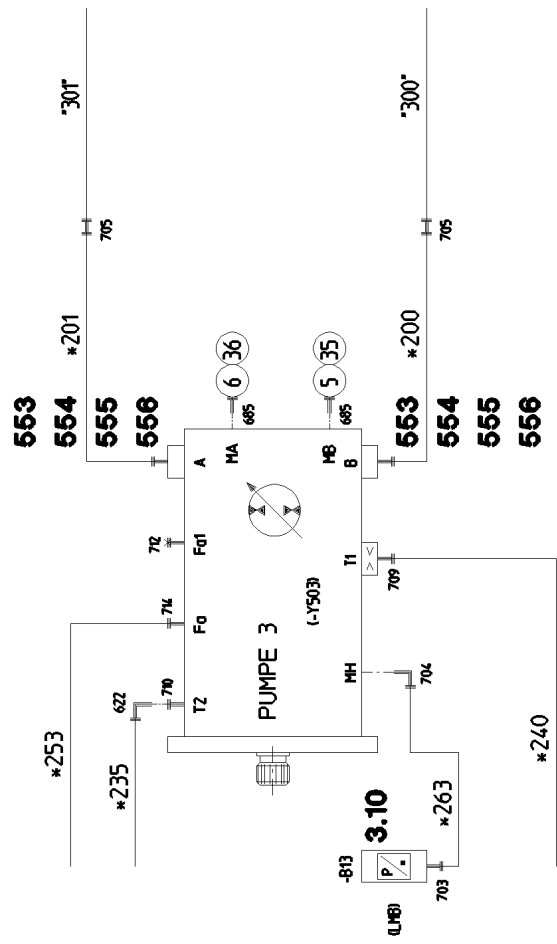
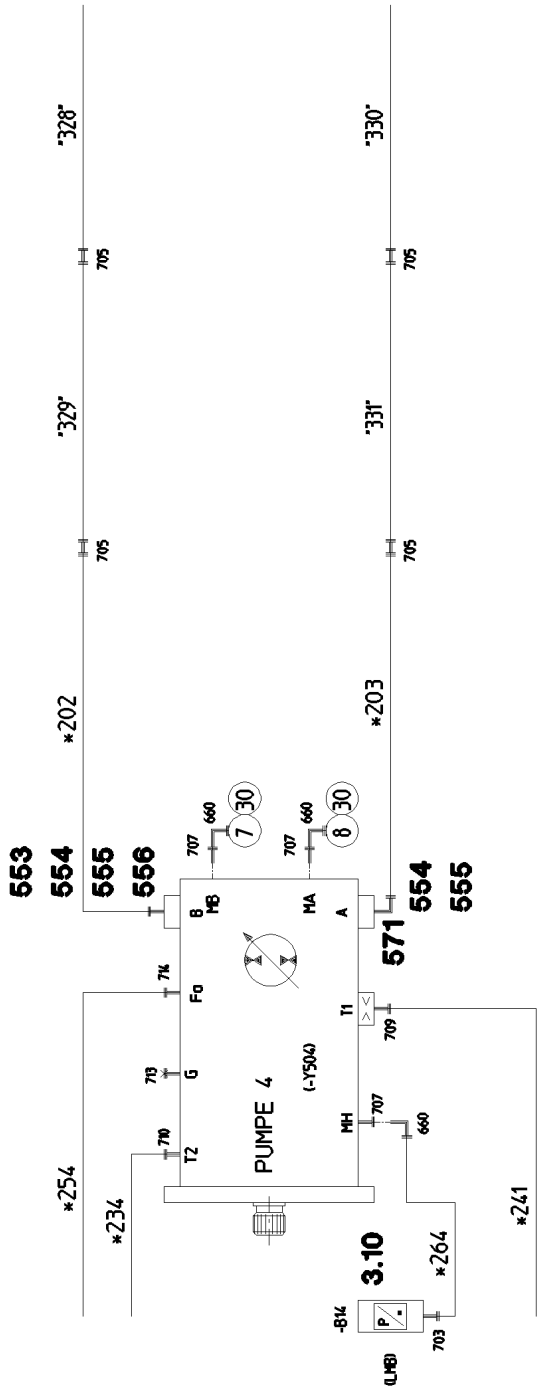

6.2.2009
054208

LIEBHERR

etk_en_de_074515 LR 1600/2

HYDR
HYDRAULIK

□ 345 (9/29)

⇒ 2 970
91 56 537 08

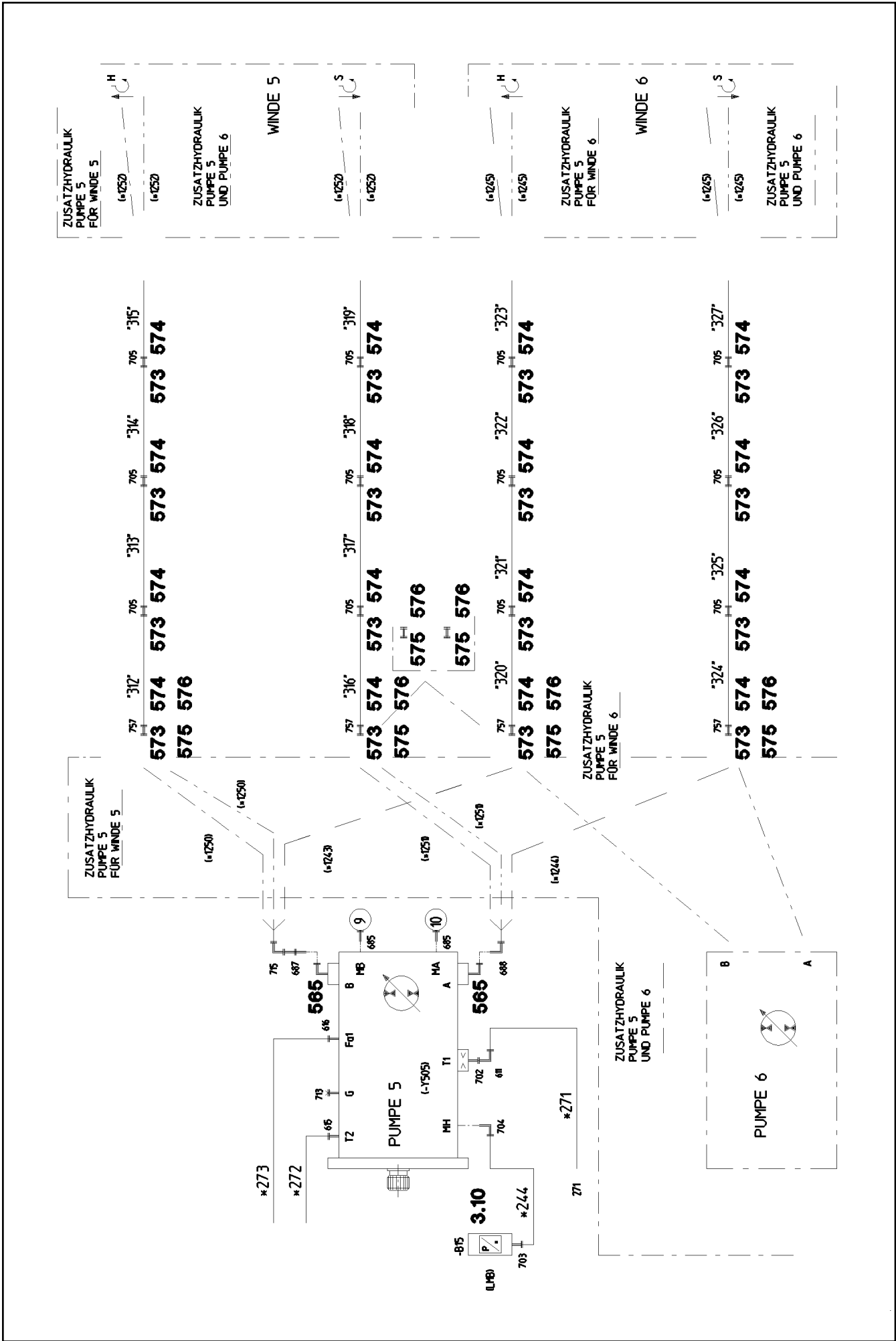

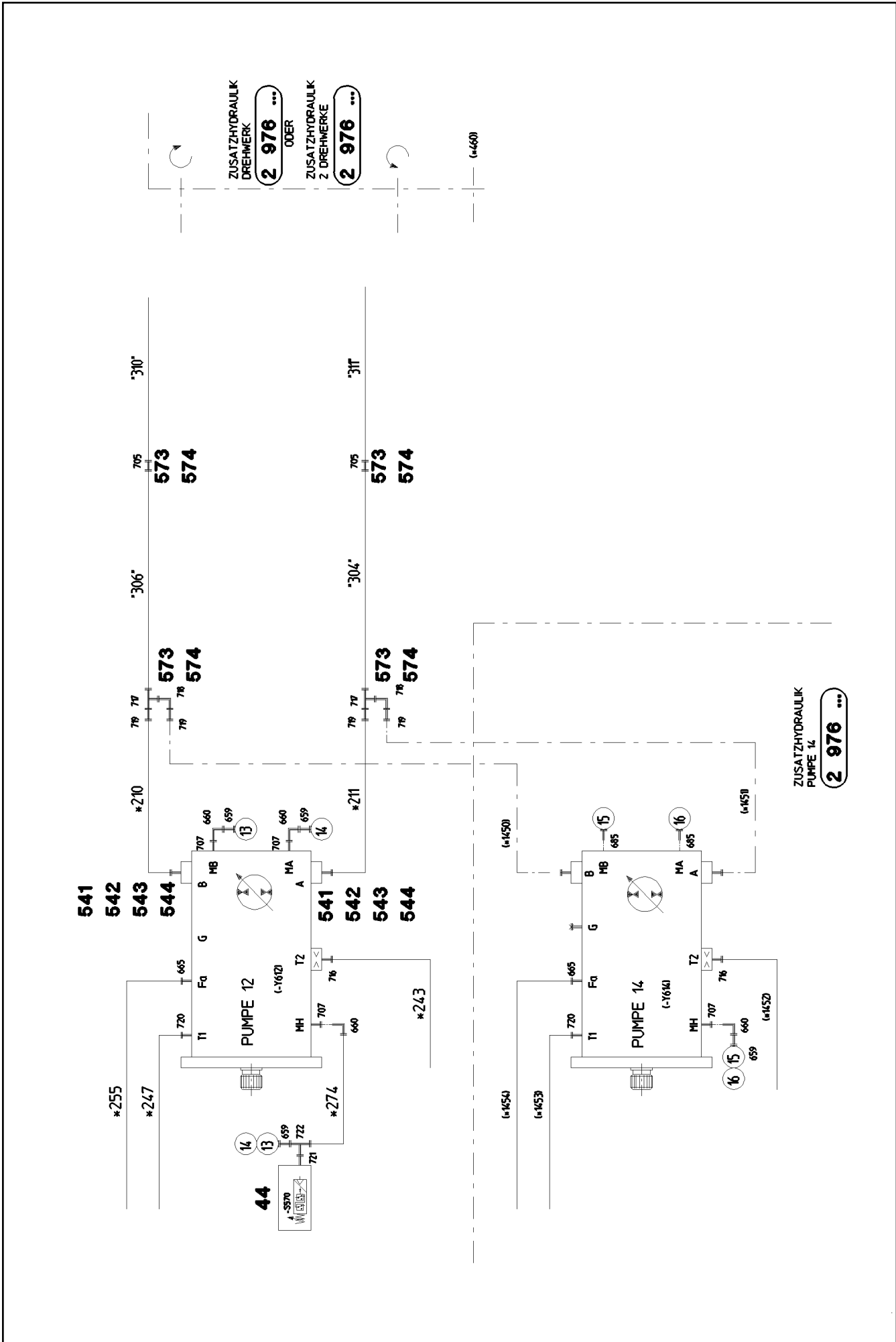

6.2.2009
054210

LIEBHERR

etk_en_de_074515 LR 1600/2

HYDR
HYDRAULIK

☐ 347 (11/29)

⇒ 2 970
91 56 537 08

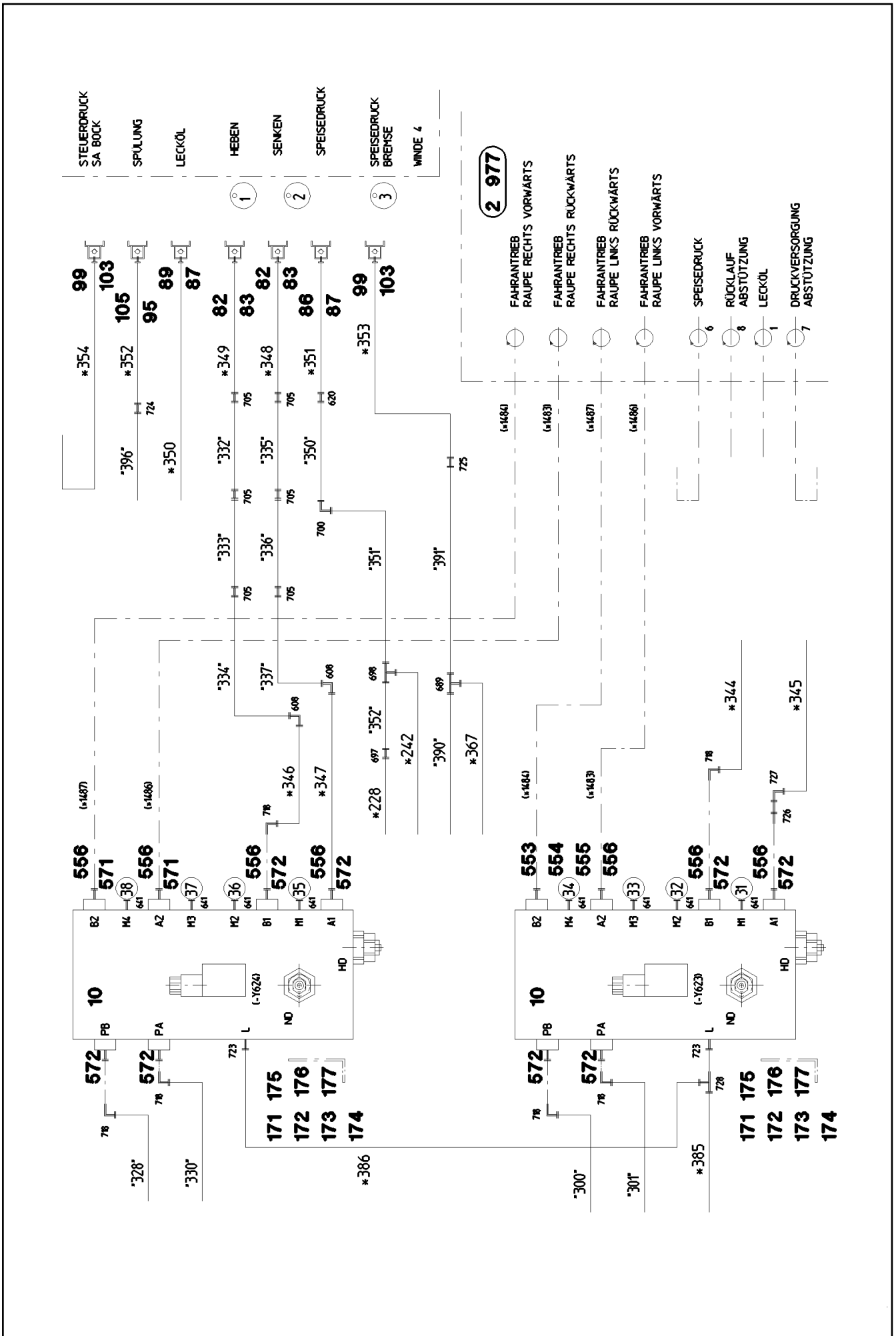

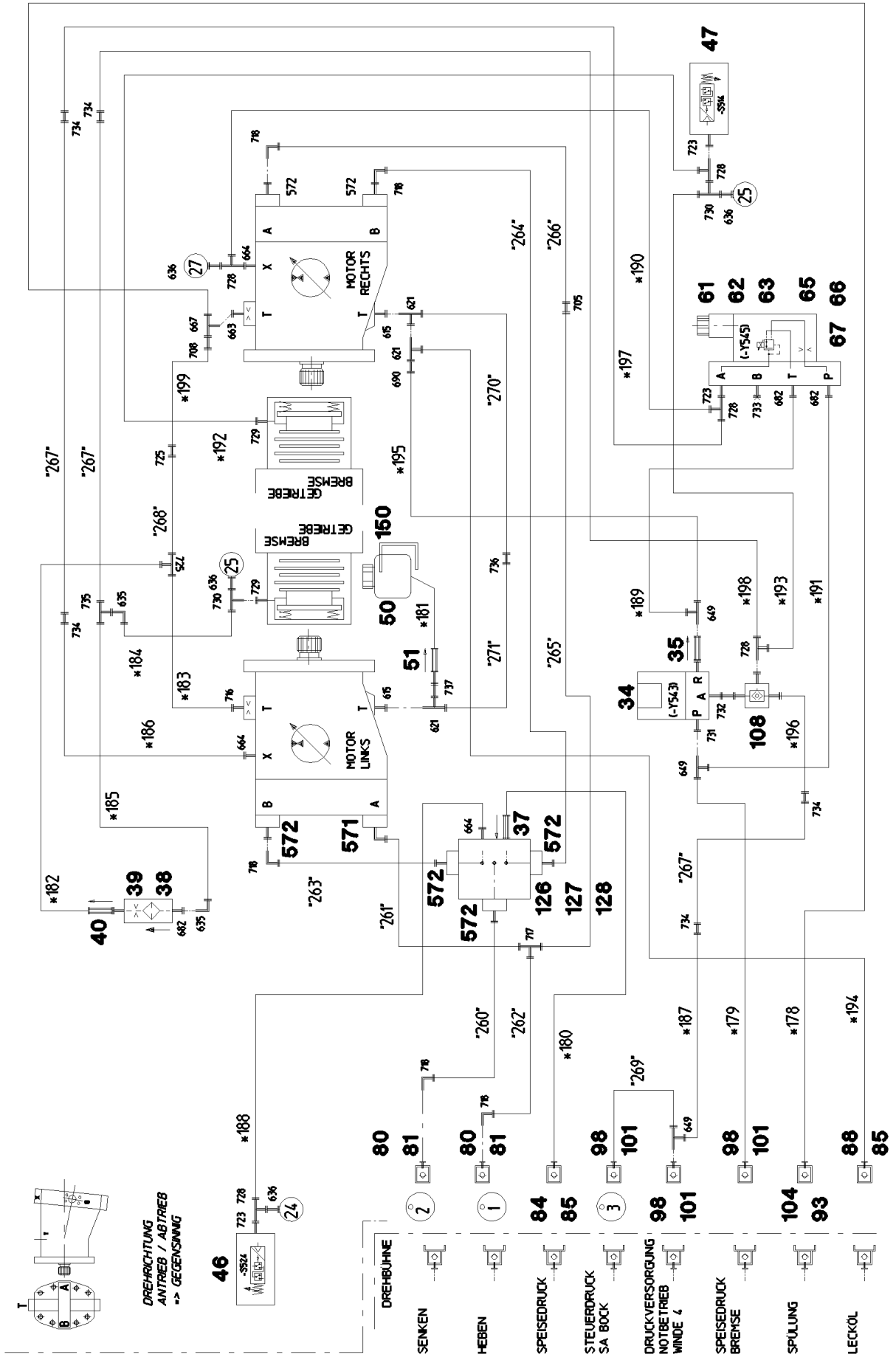

6.2.2009
054212

LIEBHERR

etk_en_de_074515 LR 1600/2

HYDR
HYDRAULIK

349 (13/29)

2 970
91 56 537 08

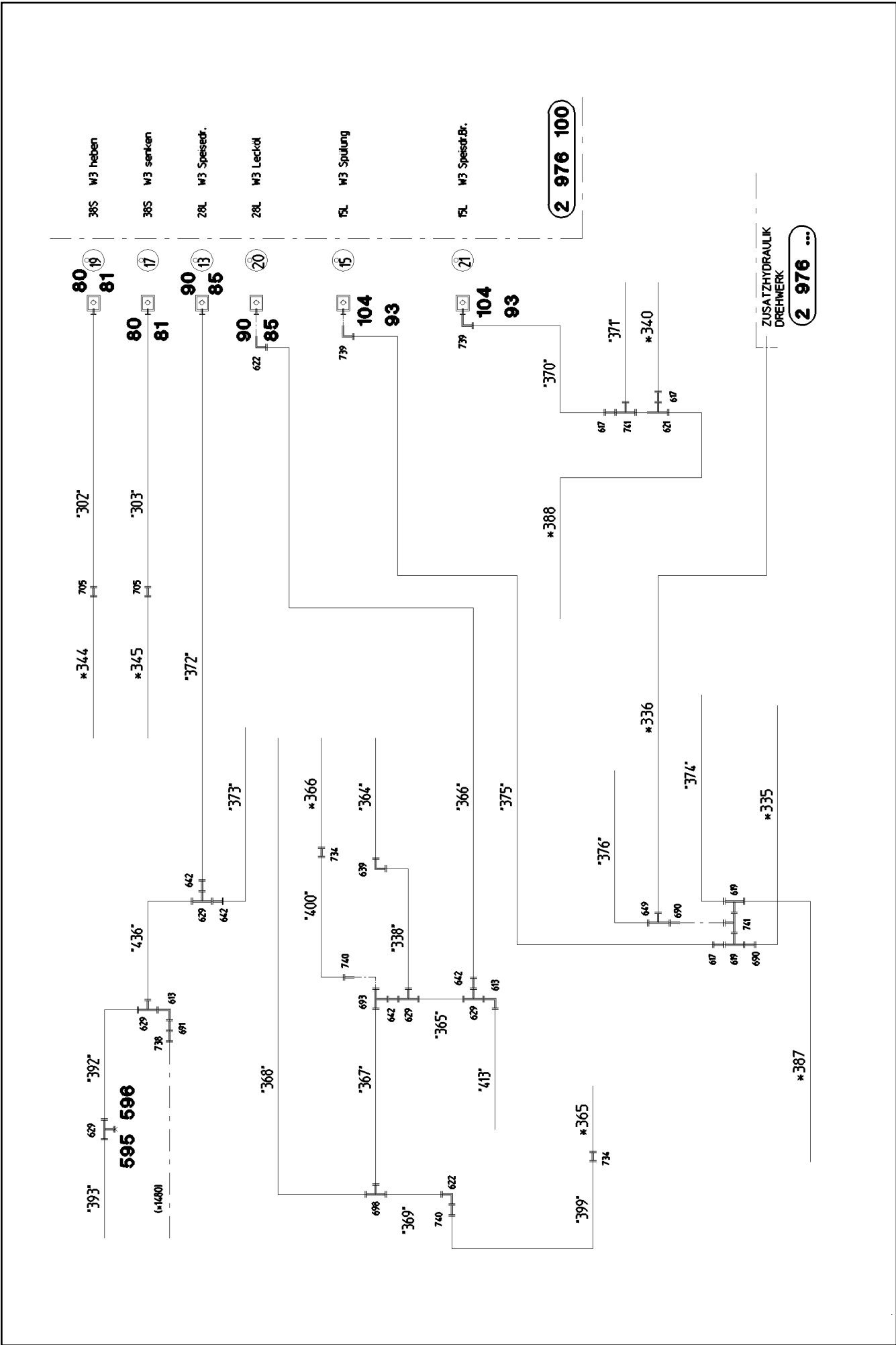

6.2.2009
054213

LIEBHERR

etk_en_de_074515 LR 1600/2

HYDR
HYDRAULIK

350 (14/29)

2 970
91 56 537 08

6.2.2009
054214

LIEBHERR

etk_en_de_074515 LR 1600/2

HYDR
HYDRAULIK

□ 351 (15/29)

⇒ 2 970
91 56 537 08

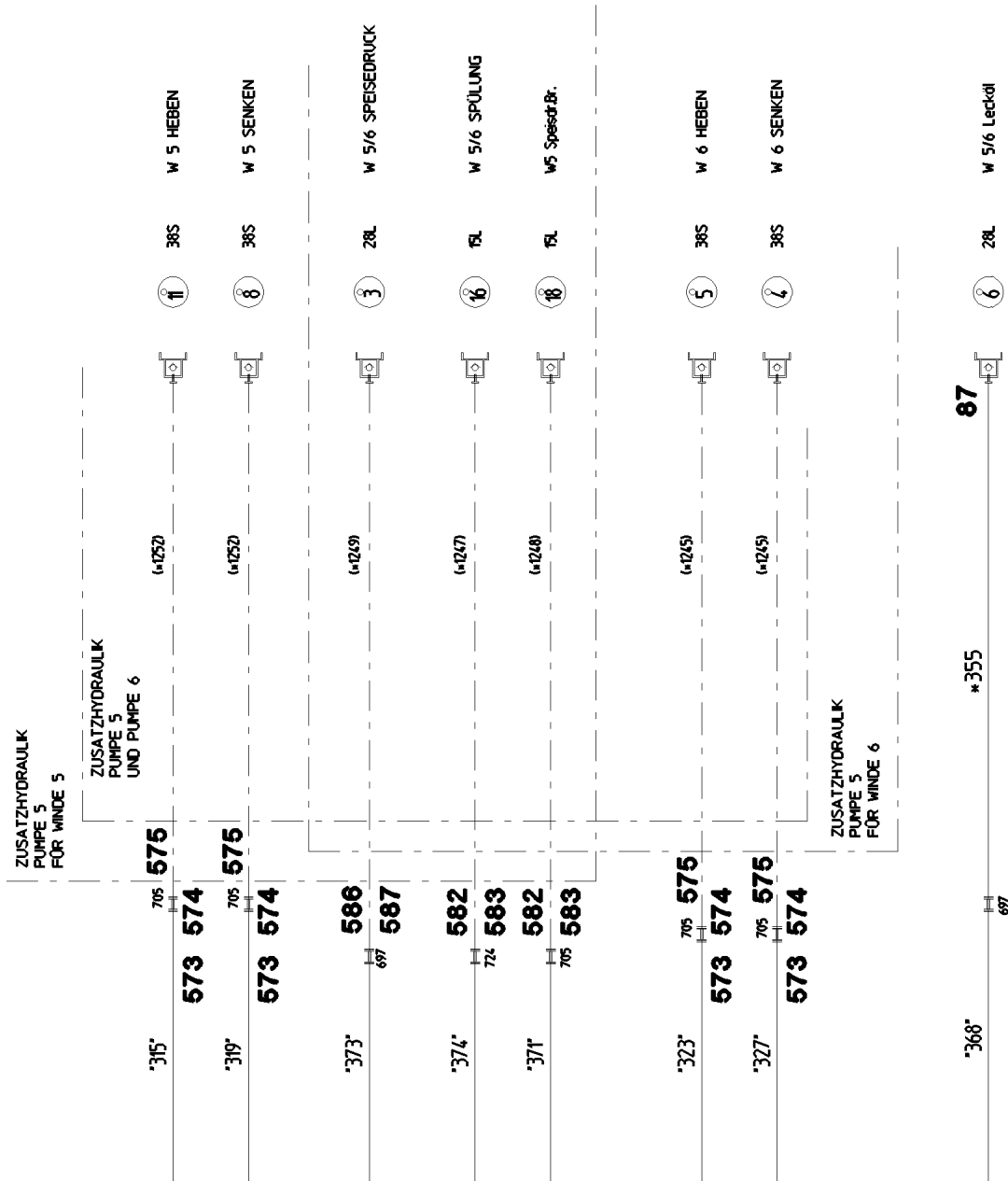

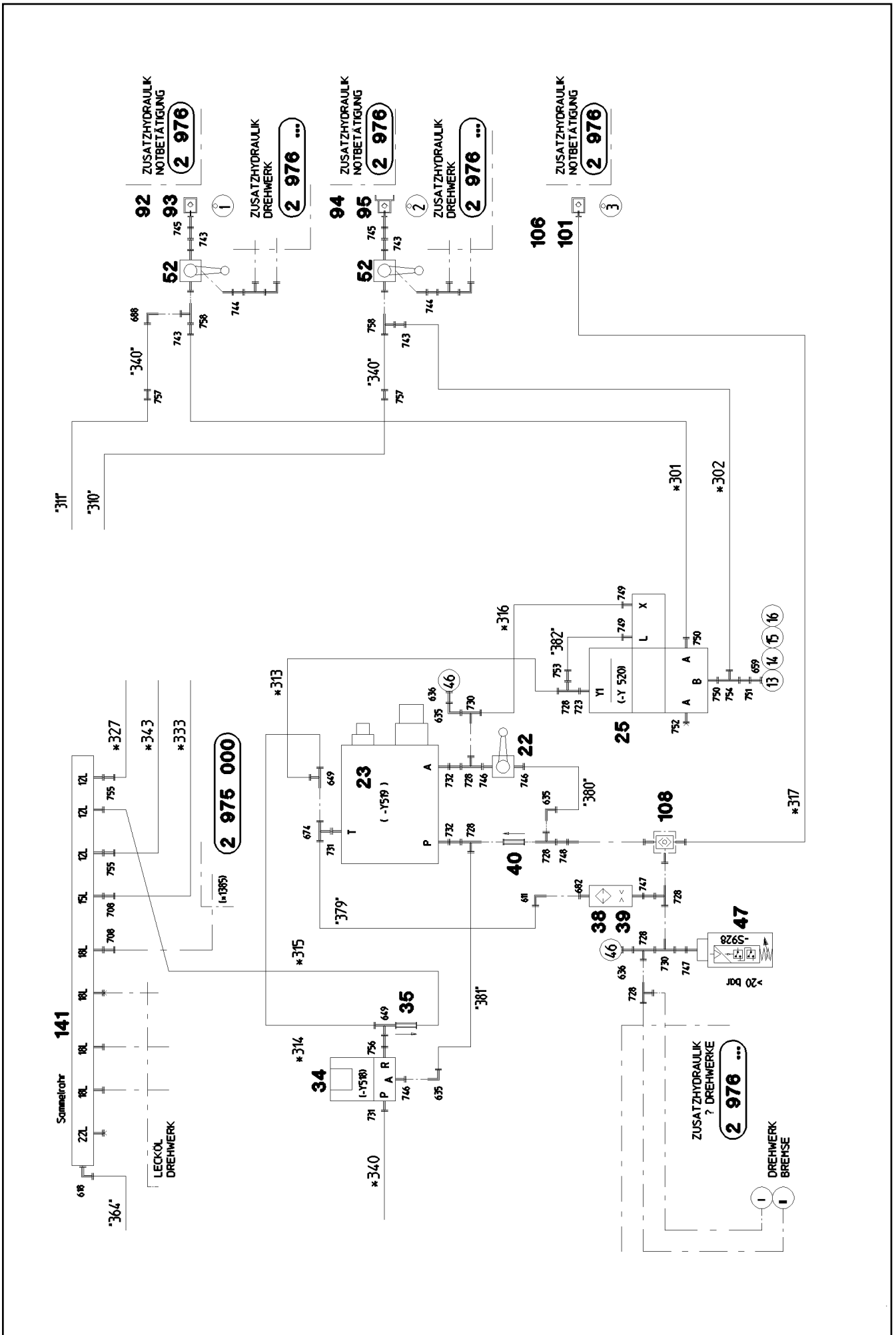

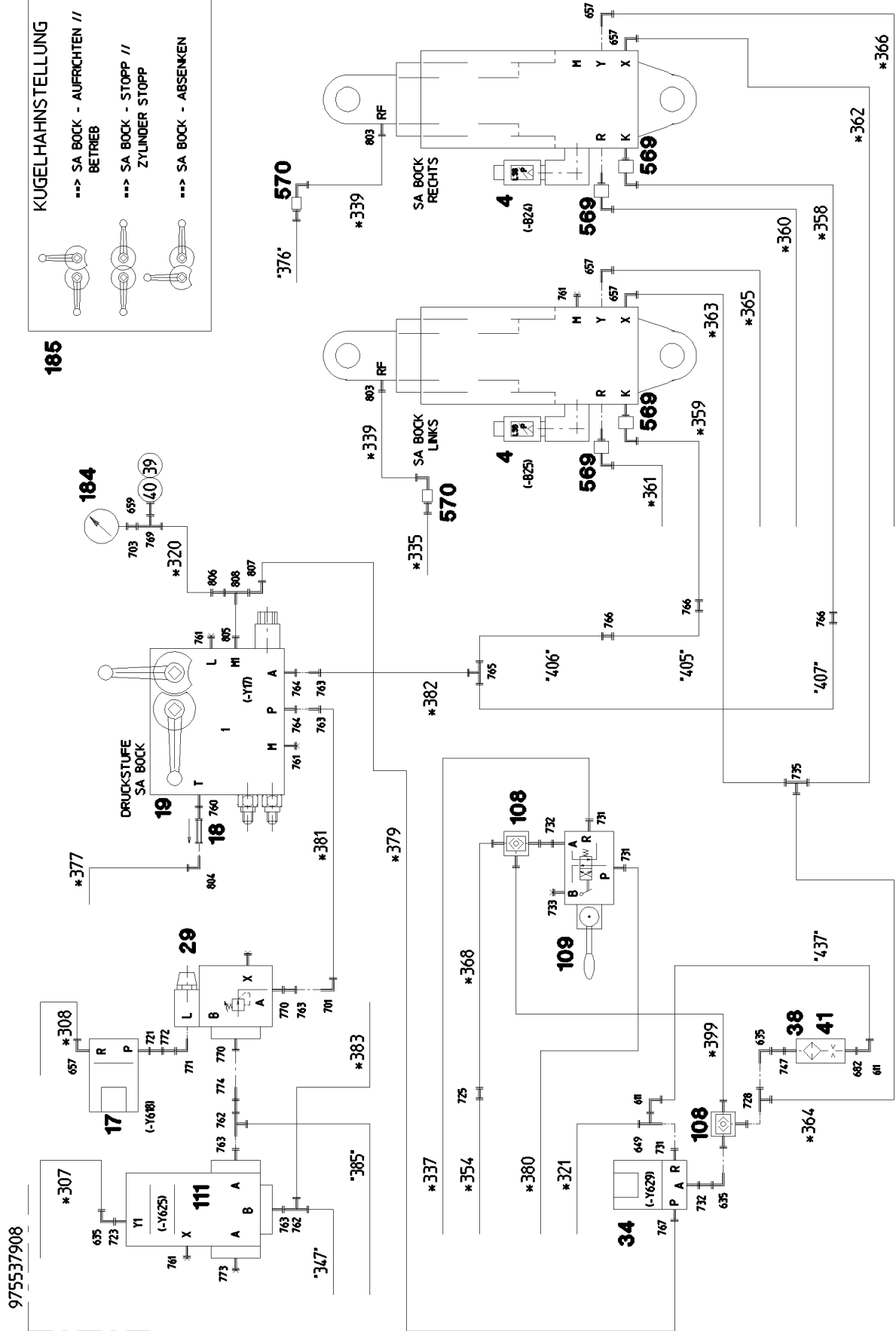
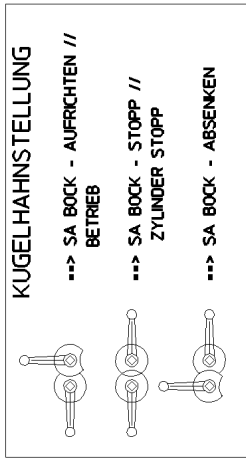

6.2.2009
054216

LIEBHERR

etk_en_de_074515 LR 1600/2

HYDR
HYDRAULIK

□ 353 (17/29)

⇒ 2 970
91 56 537 08

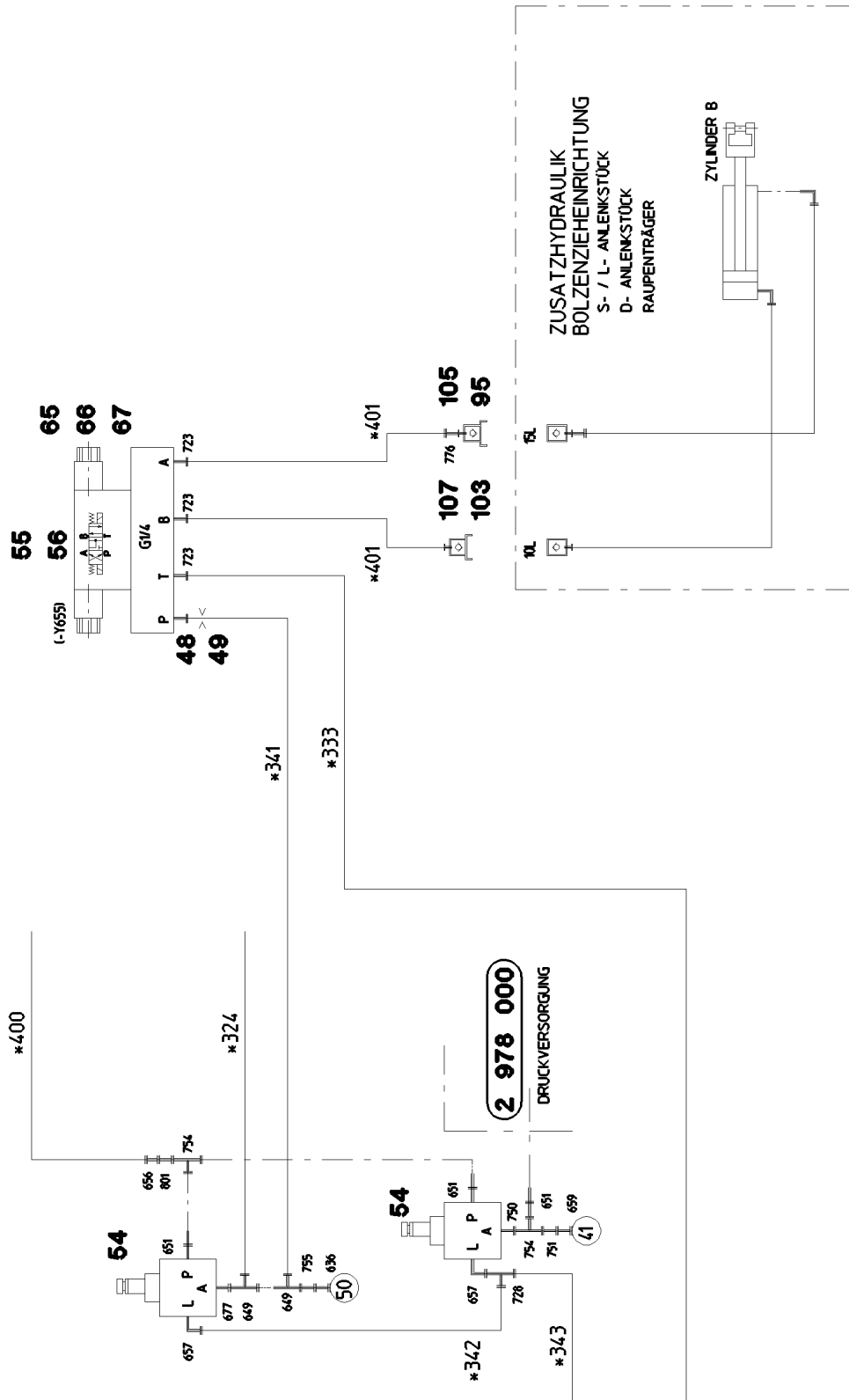

6.2.2009
054217

LIEBHERR

etk_en_de_074515 LR 1600/2

HYDR
HYDRAULIK

354 (18/29)

⇒ 2 970
91 56 537 08

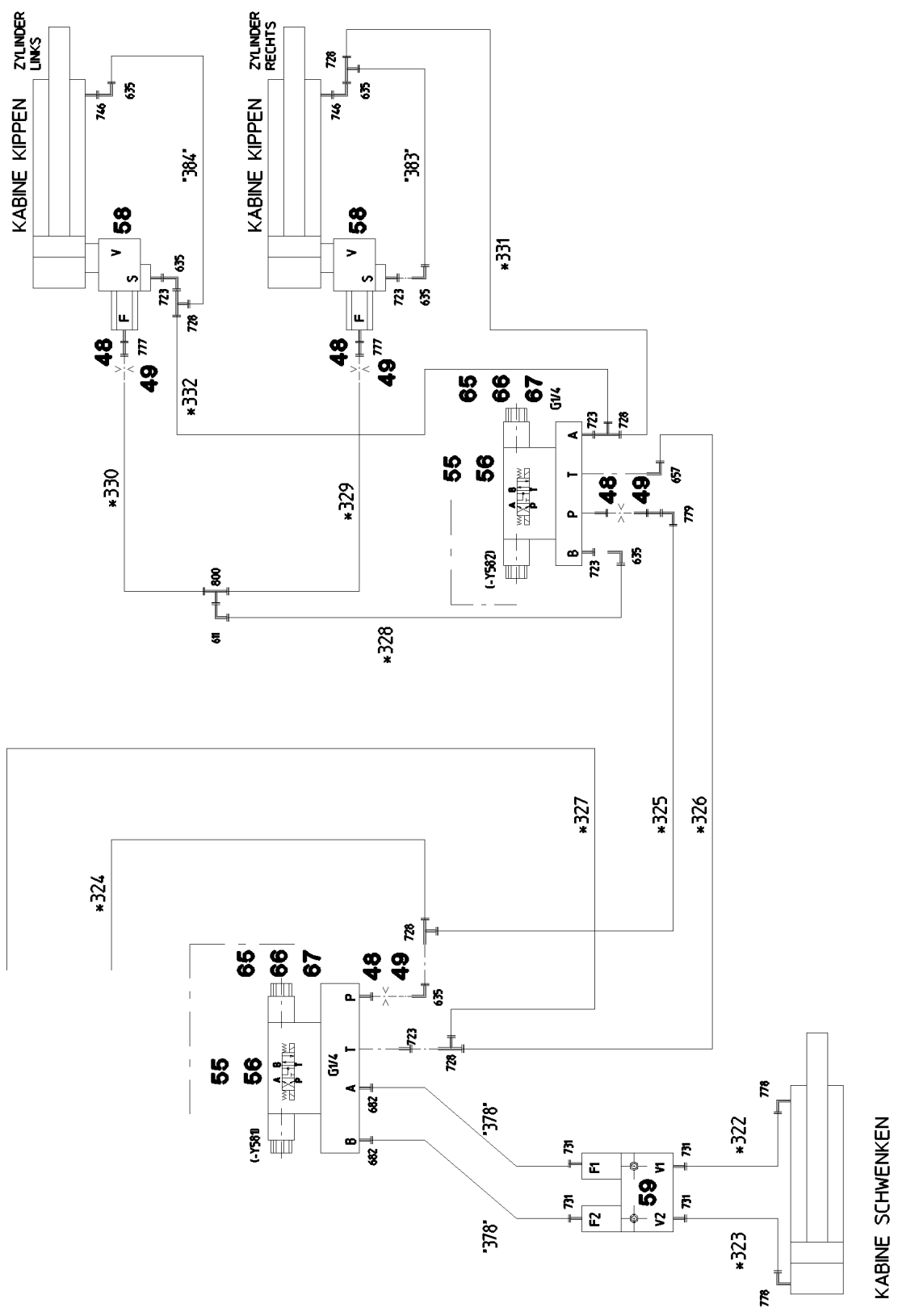

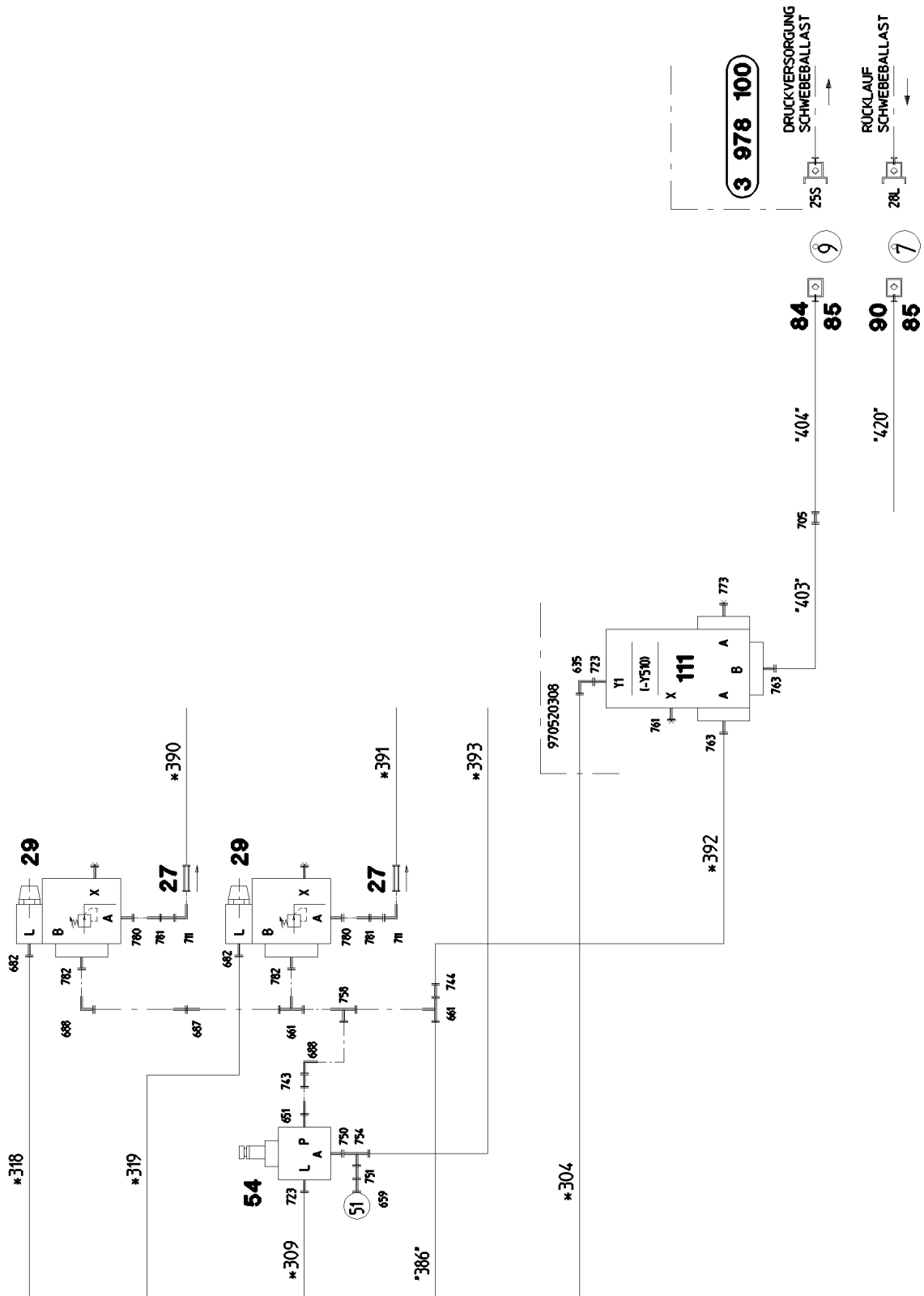

6.2.2009
054219

LIEBHERR

etk_en_de_074515 LR 1600/2

HYDR
HYDRAULIK

356 (20/29)

⇒ 2 970
91 56 537 08

6.2.2009
054220

LIEBHERR

etk_en_de_074515 LR 1600/2

HYDR
HYDRAULIK

357 (21/29)

2 970
91 56 537 08

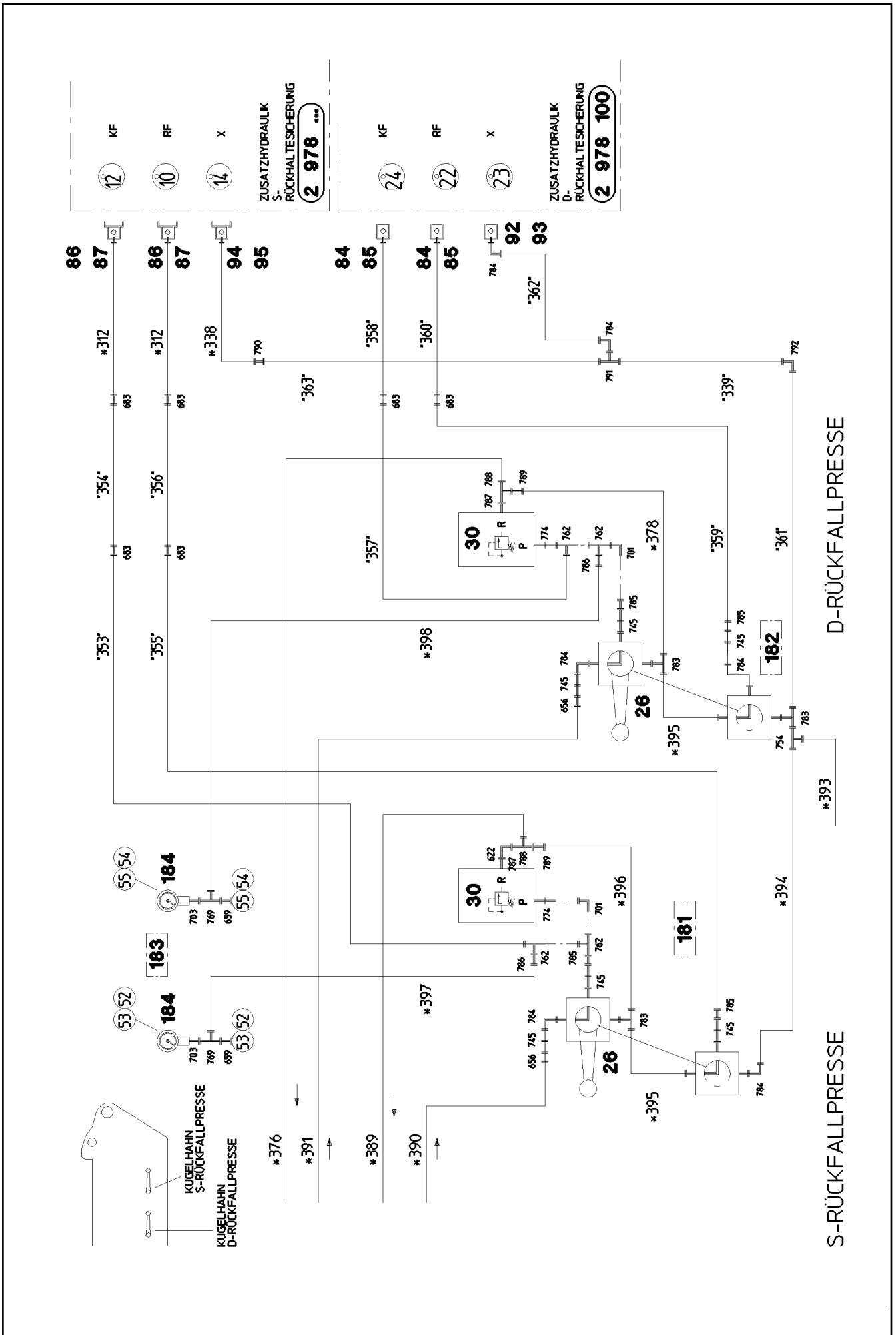

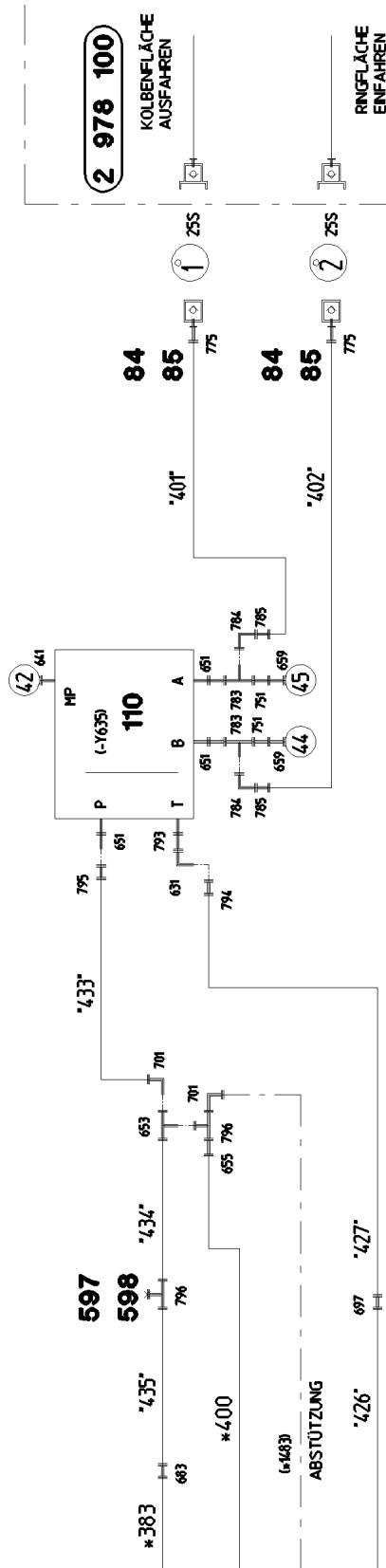

6.2.2009
054221

LIEBHERR

etk_en_de_074515 LR 1600/2

HYDR
HYDRAULIK

□ 358 (22/29)

⇒ 2 970
91 56 537 08

Pos.	Item	Quantity	Description	Bezeichnung	Serie	K
3	96 47 915 08	1	PRESSURE SENSORS PUMPS P1-5	DRUCKGEBER PUMPEN		
(1)	69 23 128 08	5	PRESSURE SENSOR 750/750BAR SPF	DRUCKAUFNEHMER		
4	96 47 918 08	1	PRESSURE SENS.RETAINING RAMS	DRUCKGEBER SA-RUECKFALLP		
(1)	69 23 126 08	2	PRESSURE SENSOR 400/400BAR SPF	DRUCKAUFNEHMER		
10	10 28 786 3	2	CHANGE-OVER BLOCK SPF	UMSCHALTBLOCK		
14	96 47 922 08	1	TEMPER. SENSOR HYDRAULIC OIL	TEMPERATURGEBER HYDRAUL		
(1)	69 11 831 08	1	TEMPERATURE SENSOR 2-9VDC SPF	TEMPERATURGEBER		
15	97 90 338 08	1	ADAPTOR REMACHING 42-LX30	ADAPTER NACHARBEIT		
17	51 14 943 08	1	DIRECTIONAL CONTROL VALVE ⇒ 5 114 943 08 51 14 943 08	WEGEVENTIL		
18	51 14 769 08	1	NON-RETURN VALVE	RUECKSCHLAGVENTIL		
19	10 42 440 2	1	CONTROL BLOCK 350 BAR SPF ⇒ X10424402 10 42 440 2	STUEBERBLOCK		
20	51 04 121 08	1	NON-RETURN VALVE	RUECKSCHLAGVENTIL		
22	51 06 820 08	1	BALL VALVE BKH3/8" A3C	KUGELHAHN		
23	51 13 005 08	1	CONTROL BLOCK ⇒ 5 113 005 08 51 13 005 08	STUEBERBLOCK		
25	51 14 988 08	1	DIRECTIONAL SEAT VALVE	WEGESITZVENTIL		
(1)	10 35 393 0	4	SCREW 3/8"-24NFX7 1/4" 12.9	SCHRAUBE		
(10)	57 16 137 08	1	MAGNET 24V	MAGNET		
(999)	10 42 478 6	1	SEAL KIT DIRECTIONAL VALVE	DS WEGEVENTIL		
26	10 42 471 6	2	BALL VALVE COMBINATION DN13-DK 16S	KUGELHAHNKOMBINATION		
27	51 14 820 08	2	NON-RETURN VALVE	RUECKSCHLAGVENTIL		
29	51 14 853 08	3	PRESSURE CONTROL VALVE	DRUCKREGELVENTIL		
30	51 14 568 08	2	PRESSURE LIMITING VALVE	DRUCKBEGRENZUNGSVENTIL		
34	51 14 444 08	3	DIRECTIONAL CONTROL VALVE ⇒ 5 114 444 08 51 14 444 08	WEGEVENTIL		
35	51 14 535 08	3	NON-RETURN VALVE	RUECKSCHLAGVENTIL		
37	51 04 087 08	1	NON-RETURN VALVE	RUECKSCHLAGVENTIL		
38	51 06 711 08	4	FILTER CARTRIDGE	FILTERPATRONE		
39	51 07 460 08	3	NOZZLE 0,6	DUESE		
40	51 04 124 08	2	NON-RETURN VALVE	RUECKSCHLAGVENTIL		
41	51 10 487 08	1	NOZZLE 0,4 MS	DUESE		
44	51 06 769 08	1	PRESSURE SWITCH	DRUCKSCHALTER		
46	10 22 093 3	1	PRESSURE SWITCH 8BAR SPF	DRUCKSCHALTER		
47	10 28 953 6	2	PRESSURE SWITCH 20BAR SPF	DRUCKSCHALTER		
48	94 79 067 08	5	SCREW-ON CONNECTION	EINSCHRAUBSTUTZEN		
49	57 08 188 08	5	NOZZLE 0,6 10.9	DUESE		
50	50 28 073 08	1	EQUALIZING RESERVOIR	AUSGLEICHSBEHAELTER		
51	51 14 815 08	1	NON-RETURN VALVE	RUECKSCHLAGVENTIL		
52	51 10 634 08	2	BALL VALVE BK3-30S A3C SPF	KUGELHAHN		
54	51 14 975 08	4	PRESSURE RELIEF VALVE	DRUCKMINDERVENTIL		
55	51 13 022 08	3	DIRECTIONAL CONTROL VALVE ⇒ 5 113 022 08 51 13 022 08	WEGEVENTIL		
56	51 06 318 08	3	TERMINAL BOARD	ANSCHLUSSPLATTE		
58	10 21 831 0	2	LOAD HOLDING VALVE 280BAR 10L/MIN SP	LASTHALTEVENTIL		
(1)	51 07 461 08	1	O-RING ARP 568 12,37X2,62 NBR90	O-RING		
59	51 14 716 08	1	LOAD HOLDING VALVE	LASTHALTEVENTIL		
61	10 34 282 3	1	PRESSURE CONTROL VALVE SPF ⇒ X10342823 10 34 282 3	DRUCKREGELVENTIL		
62	40 42 026 01	4	CYLINDER SCREW ISO 4762 M5X40 8.8 A2C	ZYLINDERSCHRAUBE		
63	51 06 295 08	1	TERMINAL BOARD	ANSCHLUSSPLATTE		
65	49 00 605	10	HEX BOLT ISO 4017 M6X12 8.8 A2C	SECHSKANTSCHRAUBE		
66	42 40 005 08	10	CIRCLIP DIN 127 A 6 VERZ	FEDERRING		
67	41 15 140 08	10	HEX NUT DIN 934 M6 8 VERZ	SECHSKANTMUTTER		
71	51 06 715 08	1	PRESSURE FILTER	DRUCKFILTER		
(1)	10 03 762 3	1	FILTER INSERT	FILTEREINSATZ		
(3)	10 10 138 4	1	RS PRESSURE FILTER DF...330FG 1.0	RS DRUCKFILTER		
(4)	57 13 561 08	1	CLOGGING INDICATOR	VERSCHMUTZUNGSANZEIGE		
72	51 14 572 08	1	PRESSURE LIMITING VALVE	DRUCKBEGRENZUNGSVENTIL		

6.2.2009

etk_en_de_074515 LR 1600/2

 359 (23/29)
LIEBHERRHYDR
HYDRAULIK⇒ 2 970
91 56 537 08

Pos.	Item	Quantity	Description	Bezeichnung	Serie	K
73	46 00 017	4	CYLINDER SCREW ISO 4762 M16X45 8.8 A3	ZYLINDERSCHRAUBE		
74	51 10 603 08	1	DISTRIBUTOR BLOCK ALZNMGCU 0,5	VERTEILERBLOCK		
75	51 06 425 08	2	DIAPHRAGM ACCUMULATOR	MEMBRANSPEICHER		
76	77 42 157 08	2	CONSOLE	KONSOLE		
77	77 42 119 08	2	HOSE CLAMP 158-166 ST	SCHLAUCHSCHELLE		
78	51 14 351 08	2	NON-RETURN VALVE	RUECKSCHLAGVENTIL		
80	51 15 122 08	4	COUPLING SLEEVE 38-S	KUPPLUNGSMUFFE		
81	51 05 456 08	5	HEX CAP NUT	VERSCHLUSSMUTTER		
82	51 15 123 08	6	COUPLING PLUG 38-S	KUPPLUNGSSTECKER		
83	51 05 455 08	6	SCREW PLUG	VERSCHLUSSSCHRAUBE		
84	51 05 996 08	6	COUPLING SLEEVE 25-S	KUPPLUNGSMUFFE		
85	51 05 458 08	12	HEX CAP NUT	VERSCHLUSSMUTTER		
86	51 05 997 08	3	COUPLING PLUG 25-S	KUPPLUNGSSTECKER		
87	10 46 691 2	8	SCREW PLUG RD54X4 SPF	VERSCHLUSSSCHRAUBE		
88	51 15 082 08	3	COUPLING SLEEVE 22-L	KUPPLUNGSMUFFE		
89	51 15 081 08	5	COUPLING PLUG 22-L	KUPPLUNGSSTECKER		
90	51 15 010 08	3	COUPLING SLEEVE 28-L	KUPPLUNGSMUFFE		
91	51 15 011 08	1	COUPLING PLUG 28-L	KUPPLUNGSSTECKER		
92	51 15 059 08	2	COUPLING SLEEVE 16-S	KUPPLUNGSMUFFE		
93	51 05 453 08	5	HEX CAP NUT	VERSCHLUSSMUTTER		
94	51 15 086 08	2	COUPLING PLUG 16-S	KUPPLUNGSSTECKER		
95	10 46 691 1	6	SCREW PLUG RD36X3 SPF	VERSCHLUSSSCHRAUBE		
96	51 15 184 08	1	COUPLING SLEEVE	KUPPLUNGSMUFFE		
98	51 15 058 08	5	COUPLING SLEEVE 12-L	KUPPLUNGSMUFFE		
99	51 15 096 08	2	COUPLING PLUG 12-L	KUPPLUNGSSTECKER		
101	51 15 040 08	6	HEX CAP NUT	VERSCHLUSSMUTTER		
103	10 46 691 0	3	SCREW PLUG RD32X3 SPF	VERSCHLUSSSCHRAUBE		
104	51 15 005 08	3	COUPLING SLEEVE 15-L	KUPPLUNGSMUFFE		
105	51 15 004 08	4	COUPLING PLUG 15-L	KUPPLUNGSSTECKER		
106	51 15 084 08	1	COUPLING SLEEVE 10-L	KUPPLUNGSMUFFE		
107	51 15 083 08	1	COUPLING PLUG 10-L	KUPPLUNGSSTECKER		
108	51 14 689 08	4	SHUTTLE VALVE	WECHSELVENTIL		
109	51 13 225 08	1	DIRECTIONAL CTRL. VALVE SPF	WEGESCHIEBER		
(8)	51 10 438 08	1	MANUAL ACTUATION	HANDBETAETIGUNG		
110	51 13 086 08	1	PROPORTIONAL VALVE NG12 ⇒ 5 113 086 08 51 13 086 08	PROPORTIONALVENTIL		
111	51 13 087 08	2	DIRECTIONAL SEAT VALVE	WEGESITZVENTIL		
112	51 14 445 08	4	DIRECTIONAL CONTROL VALVE ⇒ 5 114 445 08 51 14 445 08	WEGEVENTIL		
113	51 14 176 08	1	PRESSURE LIMITING VALVE ⇒ 5 114 176 08 51 14 176 08	DRUCKBEGRENZUNGSVENTIL		
114	51 14 177 08	2	PRESSURE LIMITING VALVE ⇒ 5 114 177 08 51 14 177 08	DRUCKBEGRENZUNGSVENTIL		
115	40 86 002 08	8	COUNTERSUNK SCREW DIN 7991 M6X16 8.	SENKSCHEIBE		
116	41 19 004 08	8	HEX NUT DIN 985 M6 8 VERZ	SECHSKANTMUTTER		
117	43 20 053 08	6	DOWEL PIN ISO 8752 6X14	SPANNSTIFT		
126	51 10 624 08	1	CONNECTION FLANGE 85X85X85	ANSCHLUSSFLANSCH		
127	51 05 867 08	4	O-RING ARP 568 37,69X3,53 NBR90	O-RING		
128	40 42 153 01	12	CYLINDER SCREW ISO 4762 M14X50 8.8 A3	ZYLINDERSCHRAUBE		
129	40 65 166	2	HEX BOLT ISO 4017 M10X20 8.8 A3C	SECHSKANTSCHRAUBE		
130	40 00 828	2	HEX BOLT ISO 4017 M10X30 8.8 A3C	SECHSKANTSCHRAUBE		
131	71 01 077 08	10	SEALING RING DIN 7603 A 52X60X2,5 CU	DICHTRING		
132	71 01 076 08	2	SEALING RING DIN 7603 A 48X55X2 CU	DICHTRING		
133	70 42 141 08	60	KEY RING 25	SCHLUESSELRING		
134	95 05 568 08	30	TRAILERS 25X2	ANHAENGER		
135	97 59 516 08	20	PLATE 1X20X60	BLECH		
136	71 01 075 08	3	SEALING RING DIN 7603 A 42X49X2 CU	DICHTRING		
137	71 01 072 08	20	SEALING RING DIN 7603 A 38X44X2 CU	DICHTRING		
138	71 01 070 08	10	SEALING RING DIN 7603 A 33X39X2 CU	DICHTRING		
139	71 01 059 08	10	SEALING RING DIN 7603 A 27X32X2 CU	DICHTRING		

6.2.2009

etk_en_de_074515 LR 1600/2

 360 (24/29)
LIEBHERRHYDR
HYDRAULIK⇒ 2 970
91 56 537 08

Pos.	Item	Quantity	Description	Bezeichnung	Serie	K
140	92 79 826 08	2	COLLECTING PIPE	SAMMELROHR		
141	92 15 428 08	1	COLLECTING PIPE WELDED	SAMMELROHR SCHWK.		
150	97 67 363 08	1	PLATE 3X85X210 FE//ZN20//C	BLECH		
151	97 12 903 08	1	PLATE 4X156X220	BLECH		
152	40 97 070 08	2	HAMMER HEAD BOLT M8X20 4.6 A2K SPF	HAMMERKOPFSCHRAUBE		
153	42 00 012 08	2	WASHER DIN 125 A8X16 ST VERZ	SCHEIBE		
154	41 19 005 08	2	HEX NUT DIN 985 M8 8 VERZ	SECHSKANTMUTTER		
155	46 00 051	2	CYLINDER SCREW ISO 4762 M8X16 8.8 A2C	ZYLINDERSCHRAUBE		
156	95 41 173 08	1	CARRIER RAIL 140	TRAGSCHIENE		
171	95 51 017 08	2	PLATE 6X128X166	BLECH		
172	95 40 177 08	2	PLATE 6X90X123	BLECH		
173	49 00 161	8	HEX BOLT ISO 4017 M12X30 8.8 A3C	SECHSKANTSCHRAUBE		
174	49 00 153	8	HEX BOLT ISO 4017 M16X40 8.8 A3C	SECHSKANTSCHRAUBE		
175	42 00 019 08	16	WASHER DIN 125 A 17 VERZ	SCHEIBE		
176	42 00 016 08	16	WASHER ISO 7089 A 13 ST A3C	SCHEIBE		
177	41 15 143 08	8	HEX NUT DIN 934 M12 8 VERZ	SECHSKANTMUTTER		
181	97 03 208 08	1	LABEL	SCHILD		
182	97 03 200 08	1	LABEL	SCHILD		
183	97 05 729 08	1	LABEL	SCHILD		
184	75 00 024 08	3	PRESSURE GAUGE 63	MANOMETER		
185	97 57 167 08	1	LABEL 100X200 AL-BL 1MM	SCHILD		
541	51 05 875 08	4	FLANGE HALF A3P	FLANSCHHAELFTE		
542	46 00 132	6	CYLINDER SCREW ISO 4762 M10X35 8.8 A3	ZYLINDERSCHRAUBE		
543	51 05 878 08	2	O-RING ARP 568 24,99X3,53 NBR90	O-RING		
544	49 00 112	2	HEX BOLT ISO 4017 M10X35 8.8 A3C	SECHSKANTSCHRAUBE		
545	51 05 869 08	8	FLANGE HALF 1" A3P	FLANSCHHAELFTE		
546	40 42 120 08	12	CYLINDER SCREW DIN 912 M12X40 8.8 A3C	ZYLINDERSCHRAUBE		
547	51 05 870 08	4	O-RING ARP 568 32,92X3,53 NBR90	O-RING		
548	49 00 100	4	HEX BOLT ISO 4017 M12X40 8.8 A3C	SECHSKANTSCHRAUBE		
553	51 05 866 08	16	FLANGE HALF A3P	FLANSCHHAELFTE		
554	51 05 867 08	20	O-RING ARP 568 37,69X3,53 NBR90	O-RING		
555	40 42 152 08	28	CYLINDER SCREW DIN 912 M14X45 8.8 A3C	ZYLINDERSCHRAUBE		
556	40 65 145 01	4	HEX BOLT ISO 4017 M14X45 8.8 A3C	SECHSKANTSCHRAUBE		
559	47 49 071 08	2	SAE FLANGE CONNECTION	SAE-FLANSCHVERBINDUNG		
560	51 05 867 08	2	O-RING ARP 568 37,69X3,53 NBR90	O-RING		
561	51 15 162 08	4	SAE-FLANGE HALF 11/4" A3P	SAE-FLANSCHHAELFTE		
562	40 97 513 08	8	HEX BOLT 7/16"X30 8.8 A3F	SECHSKANTSCHRAUBE		
563	47 49 075 08	2	SAE FLANGE CONNECTION WFS63/25-S A3	SAE-FLANSCHVERBINDUNG		
564	47 49 019 08	1	SAE FLANGE CONNECTION GFS64/30-S A3	SAE-FLANSCHVERBINDUNG		
(1)	51 05 870 08	1	O-RING ARP 568 32,92X3,53 NBR90	O-RING		
565	47 49 069 08	4	SAE FLANGE CONNECTION WFS64/30-S A3	SAE-FLANSCHVERBINDUNG		
567	47 49 014 08	1	SAE FLANGE CONNECTION GFS34/30-S	SAE-FLANSCHVERBINDUNG		
(1)	51 05 870 08	1	O-RING ARP 568 32,92X3,53 NBR90	O-RING		
(2)	46 00 132	4	CYLINDER SCREW ISO 4762 M10X35 8.8 A3	ZYLINDERSCHRAUBE		
569	10 45 537 2	4	SWIVEL SCREW JOINT 76K 20S ST VERZ SP	DREHVERSCHRAUBUNG		
570	51 05 521 08	2	SWIVEL SCREW JOINT DG10812-PS	DREHVERSCHRAUBUNG		
(1)	51 03 178 08	1	SEAL KIT	DICHTSATZ		
571	51 15 177 08	4	FLANGE STUB PIPE 38-S	FLANSCHSTUTZEN		
572	51 15 178 08	15	FLANGE STUB PIPE 38-S	FLANSCHSTUTZEN		
573	47 74 010 08	10	BOX NUT DIN 3870 AS38	UEBERWURFMUTTER		
574	71 02 004 08	30	SOFT GASKET PERBUNAN	WEICHDICHTUNG		
575	47 77 016 08	4	BUTZEN 30-S A3P	BUTZEN		
576	47 74 009 08	4	BOX NUT DIN 3870 AS30 A3P	UEBERWURFMUTTER		
582	47 74 012 08	2	BOX NUT DIN 3870 AL15 A3P	UEBERWURFMUTTER		
583	47 77 006 08	2	FLANGE JOINT BUZ 15L CR6-FREI	VERSCHRAUBUNG		
584	47 74 026 08	2	BOX NUT DIN 3870 AL22 A3P	UEBERWURFMUTTER		
585	47 77 002 08	2	BUTZEN 22-L A3P	BUTZEN		
586	47 74 017 08	2	BOX NUT DIN 3870 AL28 A3P	UEBERWURFMUTTER		
587	47 77 008 08	2	BUTZEN 28-L A3P	BUTZEN		
588	47 74 019 08	2	BOX NUT DIN 3870 AL42 A3P	UEBERWURFMUTTER		

6.2.2009

etk_en_de_074515 LR 1600/2

 361 (25/29)
LIEBHERR
 HYDR
 HYDRAULIK

 ⇒ 2 970
 91 56 537 08

Pos.	Item	Quantity	Description	Bezeichnung	Serie	K
589	47 77 009 08	2	FLANGE JOINT BUZ 42L CR6-FREI	VERSCHRAUBUNG		
590	73 81 225 23	2	SEALING RING DIN 7603 A 14X20X2,5 CU	DICHRING		
591	47 74 024 08	1	BOX NUT DIN 3870 AL18 A3P	UEBERWURFMUTTER		
592	47 77 001 08	1	BUTZEN 18-L A3P	BUTZEN		
593	47 74 016 08	1	BOX NUT DIN 3870 AL12 A3P	UEBERWURFMUTTER		
594	47 77 005 08	1	FLANGE JOINT BUZ 12L CR6-FREI	VERSCHRAUBUNG		
595	47 74 018 08	1	BOX NUT DIN 3870 AL35 A3P	UEBERWURFMUTTER		
596	47 77 007 08	1	FLANGE JOINT BUZ 35L CR6-FREI	VERSCHRAUBUNG		
597	47 74 008 08	1	BOX NUT DIN 3870 AS25 A3P	UEBERWURFMUTTER		
598	47 77 015 08	1	FLANGE JOINT BUZ 25S CR6-FREI	VERSCHRAUBUNG		
601	47 25 310 08	13	FLANGE JOINT EWSD42-L A3P	VERSCHRAUBUNG		
602	47 24 311 08	5	FLANGE JOINT ETSD42-L A3P	VERSCHRAUBUNG		
603	47 23 311 08	10	FLANGE JOINT ELSD42-L A3P	VERSCHRAUBUNG		
604	47 54 313 08	6	FLANGE JOINT REDSDN42/28-L A3P	VERSCHRAUBUNG		
605	47 10 347 08	7	FLANGE JOINT XGE42-LR-ED A3P	VERSCHRAUBUNG		
606	47 00 114 08	5	FLANGE JOINT SNV42-L A3P	VERSCHRAUBUNG		
607	47 04 314 08	7	FLANGE JOINT XT42-L A3P	VERSCHRAUBUNG		
608	47 02 314 08	7	FLANGE JOINT XW42-L A3P	VERSCHRAUBUNG		
611	47 25 305 08	19	FLANGE JOINT EWSD12-L A3P	VERSCHRAUBUNG		
612	47 50 319 08	5	FLANGE JOINT XGR42/35-L A3P	VERSCHRAUBUNG		
613	47 25 309 08	11	FLANGE JOINT EWSD35-L A3P	VERSCHRAUBUNG		
614	47 77 045 08	1	PLUG VSTIM22X1,5ED A3P	STOPFEN		
615	47 10 313 08	6	FLANGE JOINT XGE22-LM-ED A3P	VERSCHRAUBUNG		
616	47 10 311 08	11	FLANGE JOINT GE 18L M22X1,5 CR6-FREI	VERSCHRAUBUNG		
617	47 54 355 08	4	FLANGE JOINT REDSD22/15-L A3P	VERSCHRAUBUNG		
618	47 00 332 08	3	FLANGE JOINT XG35-L A3P	VERSCHRAUBUNG		
619	47 24 306 08	4	FLANGE JOINT ETSD22-L A3P	VERSCHRAUBUNG		
620	47 50 318 08	2	FLANGE JOINT XGR28/22-L A3P	VERSCHRAUBUNG		
621	47 23 306 08	5	FLANGE JOINT ELSD22-L A3P	VERSCHRAUBUNG		
622	47 25 303 08	10	FLANGE JOINT EWSD28-L A3P	VERSCHRAUBUNG		
623	47 19 014 08	2	FLANGE JOINT EGESD22-LR-WD A3P	VERSCHRAUBUNG		
624	47 25 306 08	1	FLANGE JOINT EWSD22-L A3P	VERSCHRAUBUNG		
625	47 54 360 08	1	FLANGE JOINT REDSD22/18-L A3P	VERSCHRAUBUNG		
626	47 23 308 08	2	FLANGE JOINT EL 35L CR6-FREI	VERSCHRAUBUNG		
627	49 11 008 14	1	FLANGE JOINT GZ 35L CR6-FREI	VERSCHRAUBUNG		
628	47 00 309 08	7	FLANGE JOINT XG42-L A3P	VERSCHRAUBUNG		
629	47 04 315 08	14	FLANGE JOINT XT35-L A3P	VERSCHRAUBUNG		
630	47 54 315 08	3	FLANGE JOINT REDSD35/22-L A3P	VERSCHRAUBUNG		
631	47 25 304 08	5	FLANGE JOINT EWSD18-L A3P	VERSCHRAUBUNG		
632	47 77 056 08	2	PLUG VSTIM27X2ED A3P	STOPFEN		
633	47 23 305 08	1	FLANGE JOINT ELSD18-L A3P	VERSCHRAUBUNG		
634	47 54 303 08	2	FLANGE JOINT REDSD18/10-L A3P	VERSCHRAUBUNG		
635	47 25 302 08	16	FLANGE JOINT EWSD10-L A3P	VERSCHRAUBUNG		
636	51 06 290 08	8	WELD SOCKET DKO 10L	MESSSTUTZEN		
637	47 10 319 08	1	FLANGE JOINT XGE42-LM-ED A3P	VERSCHRAUBUNG		
638	47 54 367 08	6	FLANGE JOINT REDSD42/35-L A3P	VERSCHRAUBUNG		
639	47 02 311 08	2	FLANGE JOINT XW35-L A3P	VERSCHRAUBUNG		
640	47 10 318 08	2	FLANGE JOINT XGE35-LM-ED A3P	VERSCHRAUBUNG		
641	47 56 026 08	10	MEASURING CONNECTION EMA3 1/4 CF	MESSANSCHLUSS		
642	47 54 304 08	11	FLANGE JOINT REDSD35/28-L A3P	VERSCHRAUBUNG		
643	47 19 036 08	1	FLANGE JOINT EGESD42-LR-WD A3P	VERSCHRAUBUNG		
644	47 23 316 08	3	FLANGE JOINT ELSD20-S A3P	VERSCHRAUBUNG		
647	47 54 317 08	1	FLANGE JOINT REDSD42/18-L A3P	VERSCHRAUBUNG		
648	47 54 316 08	1	FLANGE JOINT REDSD42/22-L A3P	VERSCHRAUBUNG		
649	47 23 303 08	11	FLANGE JOINT ELSD12-L A3P	VERSCHRAUBUNG		
651	47 19 006 08	9	FLANGE JOINT EGESD16-SR-WD A3P	VERSCHRAUBUNG		
652	47 54 328 08	1	FLANGE JOINT REDSD25/16-S A3P	VERSCHRAUBUNG		
653	47 24 317 08	2	FLANGE JOINT ETSD25-S A3P	VERSCHRAUBUNG		
654	47 50 329 08	1	FLANGE JOINT XGR30/25-S A3P	VERSCHRAUBUNG		
655	47 54 323 08	2	FLANGE JOINT REDSDN25/20-S A3P	VERSCHRAUBUNG		

6.2.2009

etk_en_de_074515 LR 1600/2

 362 (26/29)
LIEBHERR
 HYDR
 HYDRAULIK

 ⇒ 2 970
 91 56 537 08

Pos.	Item	Quantity	Description	Bezeichnung	Serie	K
656	47 50 336 08	4	FLANGE JOINT XGR20/16-S A3P	VERSCHRAUBUNG		
657	47 32 305 08	10	FLANGE JOINT RSWS10-LR-WD A3P	VERSCHRAUBUNG		
658	47 54 324 08	1	FLANGE JOINT REDSDN20/6-S A3P	VERSCHRAUBUNG		
659	47 56 015 08	15	MEASURING CONNECTION BMA3 6S	MESSANSCHLUSS		
660	47 25 315 08	11	FLANGE JOINT EWSD6-S A3P	VERSCHRAUBUNG		
661	47 24 318 08	3	FLANGE JOINT ETSD30-S A3P	VERSCHRAUBUNG		
662	47 54 341 08	1	FLANGE JOINT REDSDN30/6-S A3P	VERSCHRAUBUNG		
663	47 10 309 08	3	FLANGE JOINT XGE15-LM-ED A3P	VERSCHRAUBUNG		
664	47 10 305 08	5	FLANGE JOINT XGE10-LM-ED A3P	VERSCHRAUBUNG		
665	47 10 370 08	4	FLANGE JOINT XGE18-LM-ED A3P	VERSCHRAUBUNG		
666	47 24 305 08	1	FLANGE JOINT ETSD18-L A3P	VERSCHRAUBUNG		
667	47 24 304 08	2	FLANGE JOINT ETSD15-L A3P	VERSCHRAUBUNG		
668	47 40 307 08	1	FLANGE JOINT XSV18-L A3P	VERSCHRAUBUNG		
669	47 00 104 08	2	FLANGE JOINT GZ 18L CR6-FREI	VERSCHRAUBUNG		
671	47 40 305 08	1	FLANGE JOINT XSV15-L A3P	VERSCHRAUBUNG		
672	47 00 112 08	1	FLANGE JOINT SNV15-L A3P	VERSCHRAUBUNG		
673	47 50 302 08	1	FLANGE JOINT XGR18/15-L A3P	VERSCHRAUBUNG		
674	47 24 302 08	4	FLANGE JOINT ETSD12-L A3P	VERSCHRAUBUNG		
676	47 40 303 08	1	FLANGE JOINT XSV10-L A3P	VERSCHRAUBUNG		
677	47 10 348 08	4	FLANGE JOINT XGE12-LR-ED1/2" A3P	VERSCHRAUBUNG		
678	47 19 038 08	3	FLANGE JOINT EGESD12-LR-WD A3P	VERSCHRAUBUNG		
679	47 10 323 08	4	FLANGE JOINT XGE8-SR-ED A3P	VERSCHRAUBUNG		
680	47 23 300 08	2	FLANGE JOINT ELSD8-S A3P	VERSCHRAUBUNG		
681	47 25 319 08	4	FLANGE JOINT EWSD8-S A3P	VERSCHRAUBUNG		
682	47 10 353 08	13	FLANGE JOINT XGE12-LR-ED1/4" A3P	VERSCHRAUBUNG		
683	47 00 329 08	9	FLANGE JOINT XG25-S A3P	VERSCHRAUBUNG		
684	47 10 322 08	2	FLANGE JOINT XGE8-SM-ED A3P	VERSCHRAUBUNG		
685	47 56 032 08	9	MEASURING CONNECTION M12X1,5ED	MESSANSCHLUSS		
686	47 00 330 08	2	FLANGE JOINT XG30-S A3P	VERSCHRAUBUNG		
687	47 00 111 08	3	FLANGE JOINT SNV30-S A3P	VERSCHRAUBUNG		
688	47 25 316 08	5	FLANGE JOINT EWSD30-S A3P	VERSCHRAUBUNG		
689	47 04 307 08	3	FLANGE JOINT T 22L CR6-FREI	VERSCHRAUBUNG		
690	47 54 361 08	7	FLANGE JOINT REDSD22/12-L A3P	VERSCHRAUBUNG		
691	47 54 312 08	5	FLANGE JOINT REDSD35/18-L A3P	VERSCHRAUBUNG		
692	47 00 306 08	3	FLANGE JOINT XG18-L A3P	VERSCHRAUBUNG		
693	47 24 307 08	1	FLANGE JOINT ETSD28-L A3P	VERSCHRAUBUNG		
694	47 54 309 08	1	FLANGE JOINT REDSD28/18-L A3P	VERSCHRAUBUNG		
695	47 50 310 08	1	FLANGE JOINT XGR42/28-L A3P	VERSCHRAUBUNG		
696	47 50 312 08	1	FLANGE JOINT XGR35/22-L A3C	VERSCHRAUBUNG		
697	47 00 308 08	5	FLANGE JOINT XG28-L A3P	VERSCHRAUBUNG		
698	47 04 308 08	3	FLANGE JOINT XT28-L A3P	VERSCHRAUBUNG		
699	47 54 305 08	1	FLANGE JOINT REDSD28/22-L A3P	VERSCHRAUBUNG		
700	47 02 308 08	2	FLANGE JOINT XW28-L A3P	VERSCHRAUBUNG		
701	47 25 317 08	6	FLANGE JOINT EWSD25-S A3P	VERSCHRAUBUNG		
702	47 10 394 08	3	FLANGE JOINT XGE12-LM-ED A3P	VERSCHRAUBUNG		
703	47 07 002 08	8	FLANGE JOINT XGA16-SR A3P	VERSCHRAUBUNG		
704	47 32 303 08	4	FLANGE JOINT RSWS6-SM-WD A3P	VERSCHRAUBUNG		
705	47 00 331 08	43	FLANGE JOINT XG38-S A3P	VERSCHRAUBUNG		
706	47 66 078 08	2	FLANGE JOINT XGE18-LM-ED A3P	VERSCHRAUBUNG		
707	47 10 302 08	10	FLANGE JOINT XGE6-SM-ED A3P	VERSCHRAUBUNG		
708	47 54 318 08	5	FLANGE JOINT REDSD15/12-L A3P	VERSCHRAUBUNG		
709	47 10 399 08	2	FLANGE JOINT GE 12L M22X1,5 CR6-FREI	VERSCHRAUBUNG		
710	47 10 315 08	2	FLANGE JOINT XGE28-LM-ED A3P	VERSCHRAUBUNG		
711	47 25 314 08	3	FLANGE JOINT EWSD20-S A3P	VERSCHRAUBUNG		
712	47 77 058 08	1	PLUG VSTIM26X1,5ED A3P	STOPFEN		
713	47 77 052 08	2	PLUG VSTIM33X2ED A3P	STOPFEN		
714	47 10 343 08	2	FLANGE JOINT XGE20-SM-ED A3P	VERSCHRAUBUNG		
715	47 02 330 08	1	FLANGE JOINT XW30-S A3P	VERSCHRAUBUNG		
716	47 10 307 08	3	FLANGE JOINT ISO 8434-1 GE 12L M16X1,5	VERSCHRAUBUNG		
717	47 04 330 08	3	FLANGE JOINT XT38-S A3P	VERSCHRAUBUNG		

6.2.2009

etk_en_de_074515 LR 1600/2

 363 (27/29)
LIEBHERRHYDR
HYDRAULIK
 ⇒ 2 970
91 56 537 08

Pos.	Item	Quantity	Description	Bezeichnung	Serie	K
718	47 25 318 08	13	FLANGE JOINT EWSD38-S A3P	VERSCHRAUBUNG		
719	47 54 343 08	4	FLANGE JOINT REDSDN38/25-S A3P	VERSCHRAUBUNG		
720	10 03 689 6	2	FLANGE JOINT XGE22-LM-ED A3P	VERSCHRAUBUNG		
721	47 10 321 08	2	FLANGE JOINT XGE6-SR-ED A3P	VERSCHRAUBUNG		
722	47 24 312 08	1	FLANGE JOINT ETS6-S A3P	VERSCHRAUBUNG		
723	47 10 306 08	17	FLANGE JOINT XGE10-LR-ED A3P	VERSCHRAUBUNG		
724	47 00 305 08	3	FLANGE JOINT XG15-L A3P	VERSCHRAUBUNG		
725	47 00 304 08	4	FLANGE JOINT XG12-L A3P	VERSCHRAUBUNG		
726	47 00 107 08	1	FLANGE JOINT SNV38-S A3P	VERSCHRAUBUNG		
727	47 02 334 08	1	FLANGE JOINT XW38-S A3P	VERSCHRAUBUNG		
728	47 23 302 08	20	FLANGE JOINT ELSD10-L A3P	VERSCHRAUBUNG		
729	47 10 397 08	2	FLANGE JOINT ISO 8434-1 GE 10L M12X1,5	VERSCHRAUBUNG		
730	47 24 303 08	4	FLANGE JOINT ETS10-L A3P	VERSCHRAUBUNG		
731	47 10 308 08	10	FLANGE JOINT XGE12-LR-ED A3P	VERSCHRAUBUNG		
732	47 19 043 08	5	FLANGE JOINT EGE 10L G3/8A CR6-FREI	VERSCHRAUBUNG		
733	47 77 041 08	2	PLUG VSTI3/8"ED A3P	STOPFEN		
734	47 00 303 08	7	FLANGE JOINT XG10-L A3P	VERSCHRAUBUNG		
735	47 04 303 08	2	FLANGE JOINT XT10-L A3P	VERSCHRAUBUNG		
736	47 00 307 08	1	FLANGE JOINT XG22-L A3P	VERSCHRAUBUNG		
737	47 00 113 08	1	FLANGE JOINT SNV12-L A3P	VERSCHRAUBUNG		
738	47 54 356 08	1	FLANGE JOINT REDSD18/15-L A3P	VERSCHRAUBUNG		
739	47 25 307 08	2	FLANGE JOINT EWSD15-L A3P	VERSCHRAUBUNG		
740	47 54 354 08	2	FLANGE JOINT REDSDN28/10-L A3P	VERSCHRAUBUNG		
741	47 51 334 08	2	FLANGE JOINT TR 22/15/22L CR6-FREI	VERSCHRAUBUNG		
743	47 54 325 08	5	FLANGE JOINT REDSDN30/16-S A3P	VERSCHRAUBUNG		
744	47 54 327 08	3	FLANGE JOINT REDSDN30/25-S A3P	VERSCHRAUBUNG		
745	47 00 108 08	8	FLANGE JOINT SNV16-S A3P	VERSCHRAUBUNG		
746	47 10 396 08	5	FLANGE JOINT XGE10-LR-ED3/8" A3P	VERSCHRAUBUNG		
747	47 19 011 08	3	FLANGE JOINT EGESD10-LR-WD A3P	VERSCHRAUBUNG		
748	47 00 101 08	2	FLANGE JOINT SNV10-L A3P	VERSCHRAUBUNG		
749	47 10 300 08	2	FLANGE JOINT XGE6-LR-ED A3P	VERSCHRAUBUNG		
750	47 10 332 08	4	FLANGE JOINT XGE16-SR-ED A3P	VERSCHRAUBUNG		
751	47 54 331 08	5	FLANGE JOINT REDSD16/6-S A3P	VERSCHRAUBUNG		
752	47 77 042 08	1	PLUG VSTI1/2"ED A3P	STOPFEN		
753	47 54 310 08	1	FLANGE JOINT REDSD10/6-L A3P	VERSCHRAUBUNG		
754	47 23 315 08	5	FLANGE JOINT EL 16S CR6-FREI	VERSCHRAUBUNG		
755	47 54 314 08	3	FLANGE JOINT REDSD12/10-L A3P	VERSCHRAUBUNG		
756	47 19 012 08	1	FLANGE JOINT EGESD12-LR-WD A3P	VERSCHRAUBUNG		
757	47 50 339 08	6	FLANGE JOINT XGR38/30-S A3P	VERSCHRAUBUNG		
758	47 23 318 08	3	FLANGE JOINT ELSD30-S A3P	VERSCHRAUBUNG		
760	47 19 015 08	1	FLANGE JOINT EGESD28-LR-WD A3P	VERSCHRAUBUNG		
761	47 77 040 08	5	STOPPER PLUG VSTI1/4"ED A3P	BLINDSTOPFEN		
762	47 23 317 08	6	FLANGE JOINT ELSD25-S A3P	VERSCHRAUBUNG		
763	47 10 336 08	7	FLANGE JOINT XGE25-SR-ED A3P	VERSCHRAUBUNG		
764	47 55 020 08	2	ADAPTOR RI3/4-EDX1 A3P	ADAPTER		
765	47 51 349 08	1	FLANGE JOINT XTR20/25/20-S A3P	VERSCHRAUBUNG		
766	47 00 328 08	3	FLANGE JOINT XG20-S A3P	VERSCHRAUBUNG		
767	47 10 328 08	1	FLANGE JOINT ISO 8434-1 GE 10S G3/8A C	VERSCHRAUBUNG		
769	47 23 312 08	3	FLANGE JOINT ELSD6-S A3P	VERSCHRAUBUNG		
770	47 55 018 08	2	ADAPTOR RI11/4-EDX1 A3P	ADAPTER		
771	47 32 306 08	1	FLANGE JOINT RSWS6-SR-WD A3P	VERSCHRAUBUNG		
772	47 00 115 08	1	FLANGE JOINT SNV6-S A3P	VERSCHRAUBUNG		
773	47 77 046 08	2	PLUG VSTI1"ED A3P	STOPFEN		
774	47 19 008 08	3	FLANGE JOINT EGESD25-SR-WD A3P	VERSCHRAUBUNG		
775	10 42 477 0	2	FLANGE JOINT EV 25S M36X2 CR6-FREI	VERSCHRAUBUNG		
776	47 54 301 08	1	FLANGE JOINT REDSD15/10-L A3P	VERSCHRAUBUNG		
777	47 55 004 08	2	FLANGE JOINT RI G1/2AXG1/4 CR6-FREI	VERSCHRAUBUNG		
778	47 66 303 08	2	FLANGE JOINT RSWS12-SM-WD A3P	VERSCHRAUBUNG		
779	47 02 303 08	1	FLANGE JOINT XW10-L A3P	VERSCHRAUBUNG		
780	47 55 014 08	2	ADAPTOR RI11/4-EDX3/4 A3P	ADAPTER		

6.2.2009

etk_en_de_074515 LR 1600/2

 364 (28/29)
LIEBHERR
**HYDR
HYDRAULIK**

 ⇒ 2 970
91 56 537 08

Pos.	Item	Quantity	Description	Bezeichnung	Serie	K
781	47 19 007 08	2	FLANGE JOINT EGESD20-SR-WD A3P	VERSCHRAUBUNG		
782	47 10 338 08	2	FLANGE JOINT XGEV30-SR-WD A3P	VERSCHRAUBUNG		
783	47 24 315 08	5	FLANGE JOINT ETSD16-S A3P	VERSCHRAUBUNG		
784	47 25 313 08	8	FLANGE JOINT EWSD16-S A3P	VERSCHRAUBUNG		
785	47 50 328 08	6	FLANGE JOINT XGR25/16-S A3P	VERSCHRAUBUNG		
786	47 54 337 08	2	FLANGE JOINT REDSDN25/6-S A3P	VERSCHRAUBUNG		
787	47 10 316 08	2	FLANGE JOINT XGE28-LR-ED A3P	VERSCHRAUBUNG		
788	47 23 307 08	2	FLANGE JOINT EL 28L CR6-FREI	VERSCHRAUBUNG		
789	47 54 345 08	2	FLANGE JOINT REDSDN28/15-L A3P	VERSCHRAUBUNG		
790	47 00 327 08	1	FLANGE JOINT XG16-S A3P	VERSCHRAUBUNG		
791	47 04 325 08	1	FLANGE JOINT T 16S CR6-FREI	VERSCHRAUBUNG		
792	47 02 326 08	1	FLANGE JOINT XW16-S A3P	VERSCHRAUBUNG		
793	47 19 013 08	1	FLANGE JOINT EGESD18-LR-WD A3P	VERSCHRAUBUNG		
794	47 50 311 08	1	FLANGE JOINT XGR28/18-L A3P	VERSCHRAUBUNG		
795	47 50 328 08	1	FLANGE JOINT XGR25/16-S A3P	VERSCHRAUBUNG		
796	47 04 327 08	2	FLANGE JOINT XT25-S A3P	VERSCHRAUBUNG		
797	47 00 105 08	1	FLANGE JOINT SNV20-S A3P	VERSCHRAUBUNG		
798	47 50 315 08	1	FLANGE JOINT XGR12/10-L A3P	VERSCHRAUBUNG		
799	47 02 306 08	1	FLANGE JOINT XW18-L A3P	VERSCHRAUBUNG		
800	47 04 304 08	1	FLANGE JOINT XT12-L A3P	VERSCHRAUBUNG		
801	10 41 077 0	1	FLANGE JOINT EV16S A3C	VERSCHRAUBUNG		
802	47 10 345 08	2	FLANGE JOINT XGE35-LR-ED A3P	VERSCHRAUBUNG		
803	47 10 326 08	2	FLANGE JOINT GE 12S G1/2A CR6-FREI	VERSCHRAUBUNG		
804	10 41 077 2	1	FLANGE JOINT EV 28L M36X2 CR6-FREI	VERSCHRAUBUNG		
805	47 10 045 14	1	FLANGE JOINT XGE10-SR-ED1/4" A3P	VERSCHRAUBUNG		
806	47 54 320 08	1	FLANGE JOINT REDSDN10/6-S A3P	VERSCHRAUBUNG		
807	47 25 311 08	1	FLANGE JOINT EWSD10-S A3P	VERSCHRAUBUNG		
808	47 24 313 08	1	FLANGE JOINT ETSD10-S A3P	VERSCHRAUBUNG		

6.2.2009

etk_en_de_074515 LR 1600/2

365 (29/29)

LIEBHERR

HYDR
HYDRAULIK

⇒ 2 970
91 56 537 08

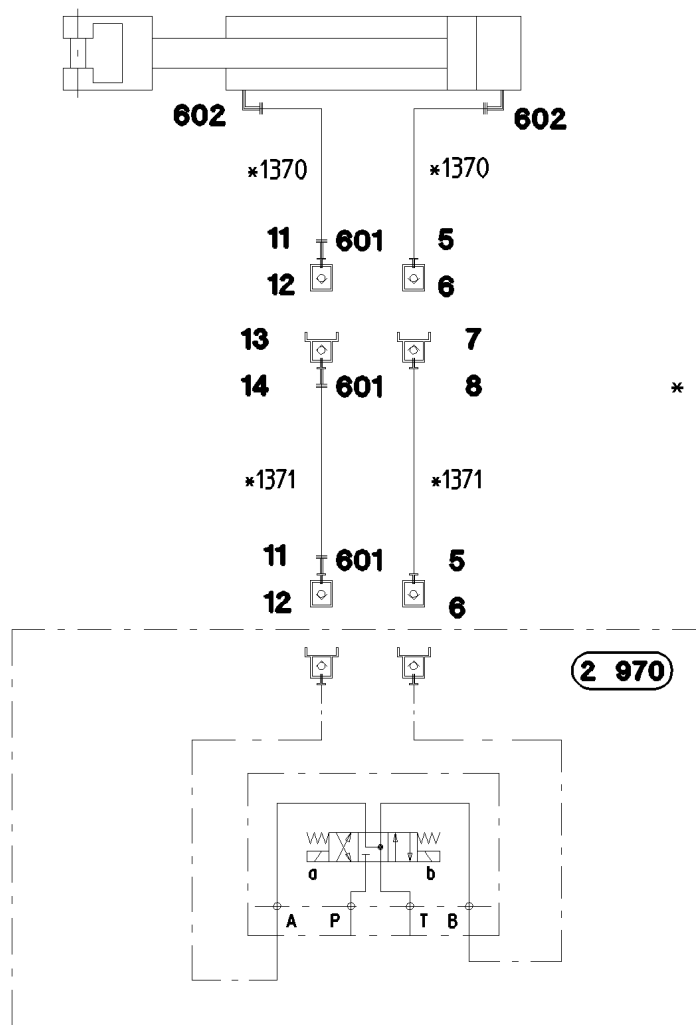

* Schläuche Blatt **Pos. 91**
Hoses Plate
Flexibles Planche

Pos.	Item	Quantity	Description	Bezeichnung	Serie	K
	5 51 15 084 08	2	COUPLING SLEEVE 10-L	KUPPLUNGSMUFFE		
	6 51 15 040 08	2	HEX CAP NUT	VERSCHLUSSMUTTER		
	7 51 15 083 08	1	COUPLING PLUG 10-L	KUPPLUNGSSTECKER		
	8 10 46 691 0	1	SCREW PLUG RD32X3 SPF	VERSCHLUSSSCHRAUBE		
	11 51 15 005 08	2	COUPLING SLEEVE 15-L	KUPPLUNGSMUFFE		
	12 51 05 453 08	2	HEX CAP NUT	VERSCHLUSSMUTTER		
	13 51 15 004 08	1	COUPLING PLUG 15-L	KUPPLUNGSSTECKER		
	14 10 46 691 1	1	SCREW PLUG RD36X3 SPF	VERSCHLUSSSCHRAUBE		
	91 96 52 635 08	1	HOSE LINES BOLT EXTRACTION 9647200	SCHLAUCHLEITUNGEN BOLZEN		
	(1) 60 27 601 08	4	NAME PLATE 25,4X101,6	BEZEICHNUNGSSCHILD		
	(1370) 92 84 646 08	2	HOSE ASS CPL. 2SN 3,0M	SCHLAUCH KPL.		
	(1371) 96 51 586 08	2	HOSE ASS CPL. 2SN 15,0M	SCHLAUCH KPL.		
	601 47 54 301 08	3	FLANGE JOINT REDSD15/10-L A3P	VERSCHRAUBUNG		
	602 47 32 310 08	2	FLANGE JOINT RSWS10-SR-WD A3P	VERSCHRAUBUNG		

6.2.2009
052642

LIEBHERR

etk_en_de_074515 LR 1600/2

ADDL.HYDR.F.PIN PULLING DEVICE
ZUSATZHYDR.BOLZENIEHZYLINDER

366

⇒ 2 970 081
96 50 495 08

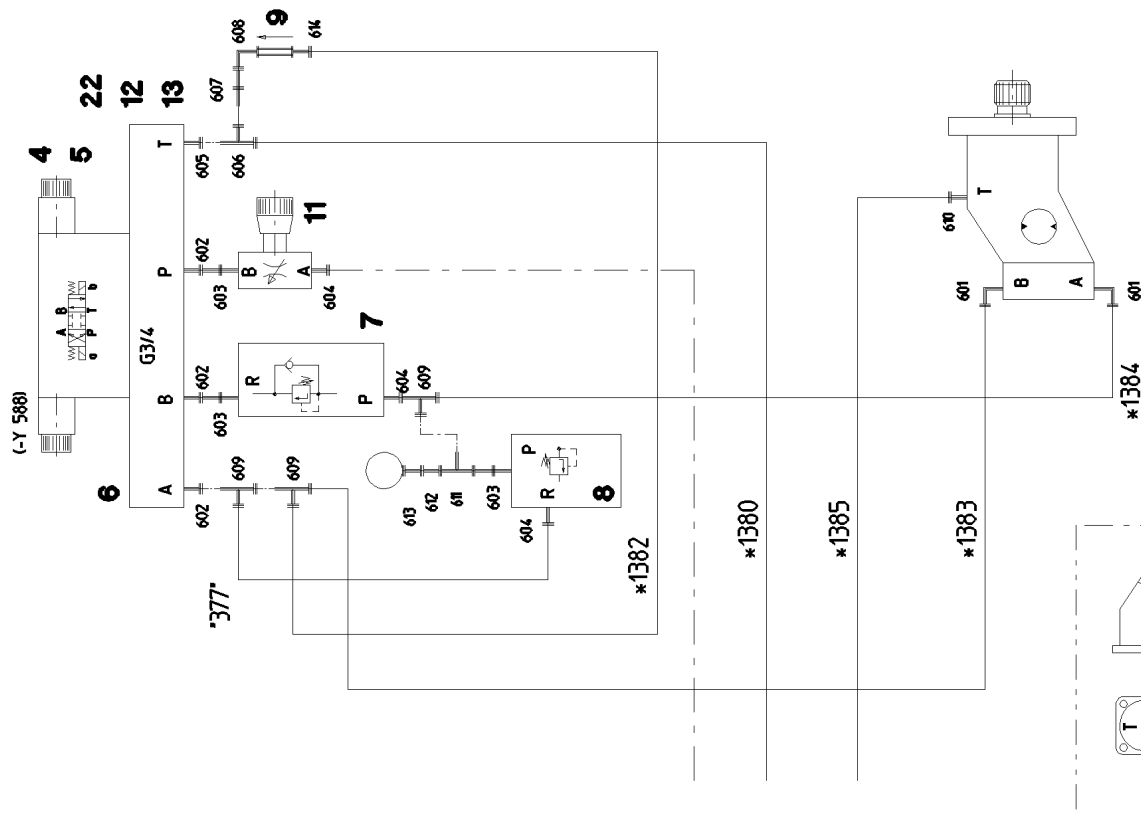

* Pos. 91

▪ Pos. 93

MONTAGEWINDE

6.2.2009
054196

LIEBHERR

etk_en_de_074515 LR 1600/2

ADDNL. HYDR. F. ERECTING WINCH
ZUSATZHYDRAULIK MONTAGEWINDE

367 (1/2)

⇒ 2 975 000
91 57 881 08

Pos.	Item	Quantity	Description	Bezeichnung	Serie	K
4	10 42 393 8	1	DIRECTIONAL CONTROL VALVE SPF	WEGEVENTIL		
5	40 43 601 08	4	CYLINDER SCREW DIN 912 M6X40 12.9	ZYLINDERSCHRAUBE		
6	51 10 583 08	1	TERMINAL BOARD	ANSCHLUSSPLATTE		
7	51 14 320 08	1	PRETENSIONING VALVE ⇒ 5 114 320 08 51 14 320 08	VORSPANNVENTIL		
8	51 14 333 08	1	PRESSURE LIMITING VALVE	DRUCKBEGRENZUNGSVENTIL		
9	51 14 469 08	1	NON-RETURN VALVE FE/ZN12 CR6-FREI	RUECKSCHLAGVENTIL		
11	51 14 277 08	1	RESTRICTOR VALVE	DROSSELVENTIL		
12	40 61 056	2	HEX BOLT ISO 4014 M10X40 8.8 A3C	SECHSKANTSCHRAUBE		
13	41 15 144 08	2	HEX NUT DIN 934 M10 8 VERZ	SECHSKANTMUTTER		
22	95 60 933 08	1	PLATE 5X98X140	BLECH		
91	96 48 196 08	1	HOSE LINES MOUNTING JACK ⇒ 2 975 191 96 48 196 08	SCHLAUCHLEITUNGEN MONT		
93	96 47 540 08	1	PIPELINES ERECTION WINCH	ROHRLEITUNGEN MONTAGEWI		
(377)	96 51 670 08	1	PIPE COMPL. 16X2X294	ROHR KPL.		
601	47 66 114 08	2	FLANGE JOINT RSWS16-SM-WD A3P	VERSCHRAUBUNG		
602	47 10 331 08	3	FLANGE JOINT XGE16-SR-ED3/4" A3P	VERSCHRAUBUNG		
603	47 19 006 08	3	FLANGE JOINT EGESD16-SR-WD A3P	VERSCHRAUBUNG		
604	47 10 332 08	3	FLANGE JOINT XGE16-SR-ED A3P	VERSCHRAUBUNG		
605	47 10 375 08	1	FLANGE JOINT XGE18-LR-ED3/4" A3P	VERSCHRAUBUNG		
606	47 23 305 08	1	FLANGE JOINT ELSD18-L A3P	VERSCHRAUBUNG		
607	47 00 104 08	1	FLANGE JOINT GZ 18L CR6-FREI	VERSCHRAUBUNG		
608	47 25 304 08	1	FLANGE JOINT EWSD18-L A3P	VERSCHRAUBUNG		
609	47 23 315 08	3	FLANGE JOINT EL 16S CR6-FREI	VERSCHRAUBUNG		
610	47 10 397 08	1	FLANGE JOINT ISO 8434-1 GE 10L M12X1,5	VERSCHRAUBUNG		
611	47 24 315 08	1	FLANGE JOINT ETS16-S A3P	VERSCHRAUBUNG		
612	47 54 331 08	1	FLANGE JOINT REDSD16/6-S A3P	VERSCHRAUBUNG		
613	47 56 015 08	1	MEASURING CONNECTION BMA3 6S	MESSANSCHLUSS		
614	47 54 356 08	1	FLANGE JOINT REDSD18/15-L A3P	VERSCHRAUBUNG		

6.2.2009	etk_en_de_074515 LR 1600/2	<input type="checkbox"/> 368 (2/2)
LIEBHERR	ADDNL. HYDR. F. ERECTING WINCH ZUSATZHYDRAULIK MONTAGEWINDE	⇒ 2 975 000 91 57 881 08



Schlauchnummer
Hose number
Número de flexible
Número de flexible
Номера шланга

Die Schlauchnummern auf den Schläuchen entsprechen den Positionen in der Schlauchliste.

The hose numbers from the hoses are in accordance with the items in the hose list.

Les numéros indiqués sur les flexibles correspondent aux repères de la nomenclature des flexibles.

Los números indicados en los flexibles corresponden a las posiciones de la lista de flexibles.

Нанесенные на шлангах номера соответствуют позициям в перечне.

Pos.	Item	Quantity	Description	Bezeichnung	Serie	K
1	60 27 601 08	9	NAME PLATE 25,4X101,6	BEZEICHNUNGSSCHILD		
1401	92 27 451 08	1	HOSE ASS CPL. 2SN 0,8M	SCHLAUCH KPL.		
1402	96 51 589 08	1	HOSE ASS CPL. 2SN 0,41M	SCHLAUCH KPL.		
1403	96 51 590 08	1	HOSE ASS CPL. 2SN 0,64M	SCHLAUCH KPL.		
1404	92 76 161 08	1	HOSE ASS CPL. 2SN 0,35M	SCHLAUCH KPL.		
1405	92 76 973 08	1	HOSE ASS CPL. 2SN 0,25M	SCHLAUCH KPL.		
1406	92 76 379 08	1	HOSE ASS CPL. 1SC 0,3M	SCHLAUCH KPL.		
1407	92 76 407 08	1	HOSE ASS CPL. 2TE 0,32M	SCHLAUCH KPL.		
1408	96 33 352 08	1	HOSE ASS CPL. 2TE 0,43M	SCHLAUCH KPL.		
1409	92 76 109 08	1	HOSE ASS CPL. 2TE 0,45M	SCHLAUCH KPL.		

6.2.2009
133089

LIEBHERR

etk_en_de_074515 LR 1600/2

HOSES WINCH 2
SCHLAUCHLEITUNGEN WINDE 2

369

⇒ 2 975 061
96 47 201 08

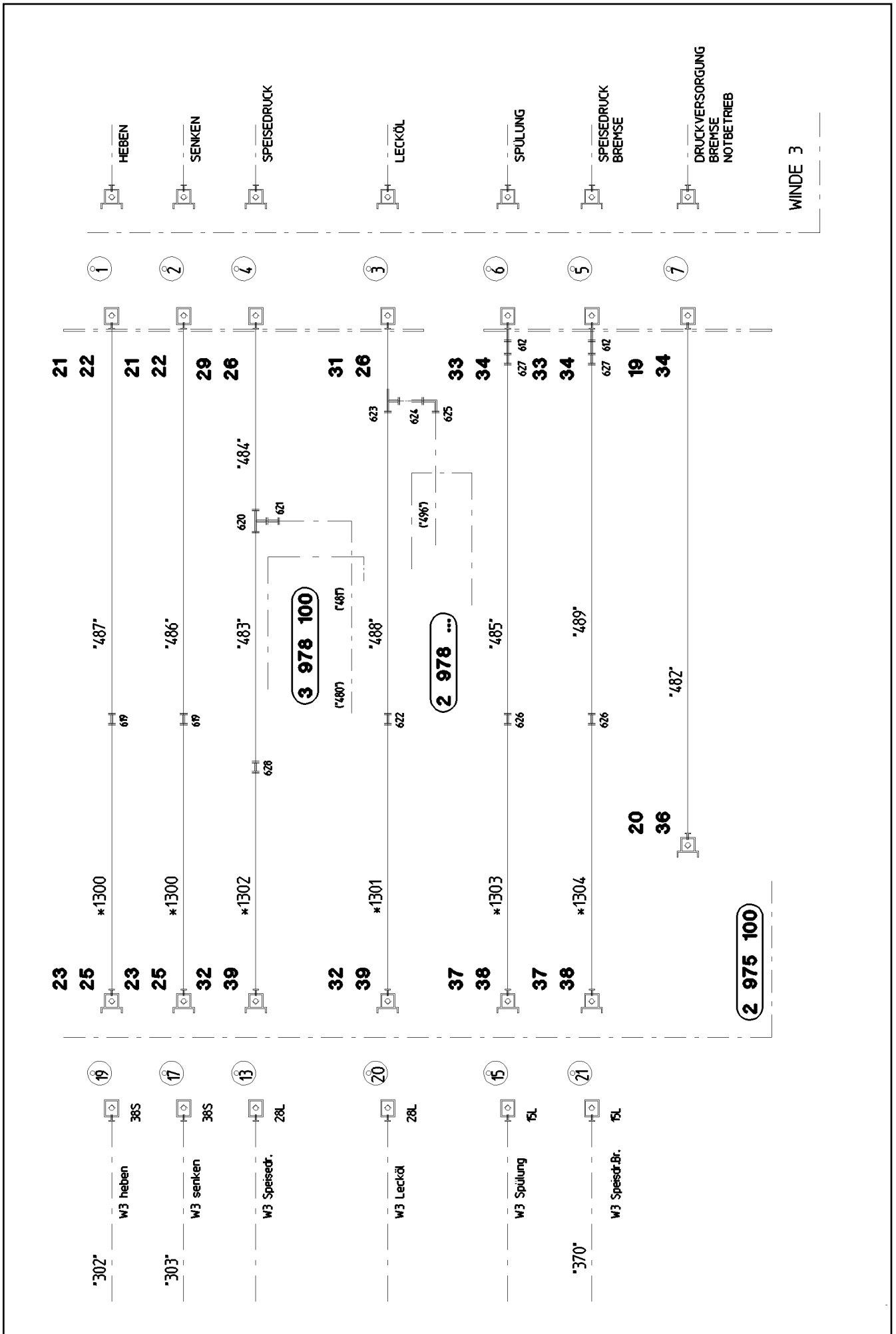

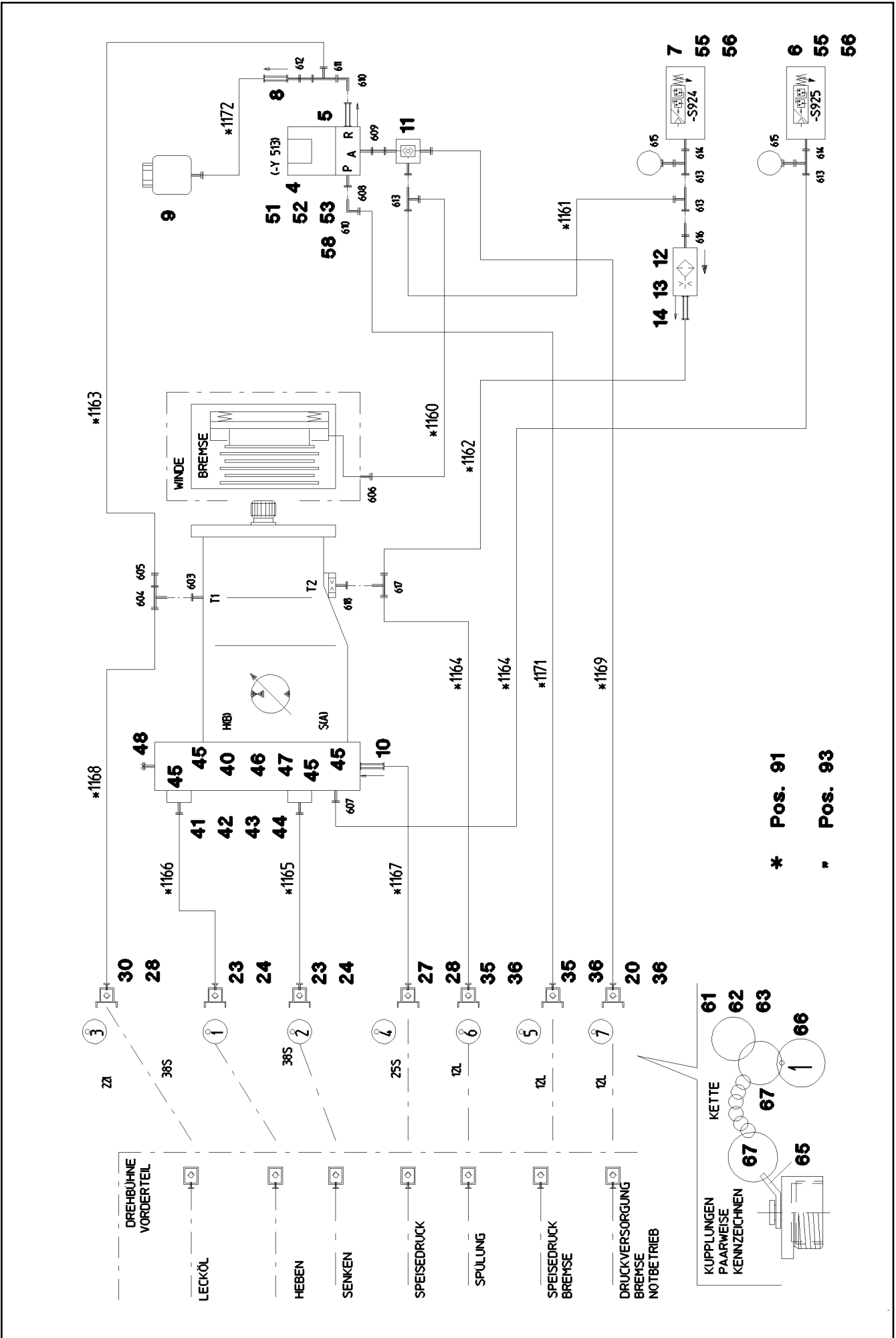

6.2.2009
 055157

LIEBHERR

etk_en_de_074515 LR 1600/2

ADDITIONAL HYDRAULICS WINCH 3
 ZUSATZHYDRAULIK WINDE 3

371 (2/4)

⇒ 2 975 100
 91 52 860 08

* Pos. 91

" Pos. 93

Pos.	Item	Quantity	Description	Bezeichnung	Serie	K
4	51 14 444 08	1	DIRECTIONAL CONTROL VALVE ⇒ 5 114 444 08 51 14 444 08	WEGEVENTIL		
5	51 14 606 08	1	NON-RETURN VALVE	RUECKSCHLAGVENTIL		
6	10 22 093 3	1	PRESSURE SWITCH 8BAR SPF	DRUCKSCHALTER		
7	10 28 953 6	1	PRESSURE SWITCH 20BAR SPF	DRUCKSCHALTER		
8	51 14 815 08	1	NON-RETURN VALVE	RUECKSCHLAGVENTIL		
9	50 28 073 08	1	EQUALIZING RESERVOIR	AUSGLEICHSBEHAELTER		
10	51 04 087 08	1	NON-RETURN VALVE	RUECKSCHLAGVENTIL		
11	51 14 689 08	1	SHUTTLE VALVE	WECHSELVENTIL		
12	51 06 711 08	1	FILTER CARTRIDGE	FILTERPATRONE		
13	51 07 460 08	1	NOZZLE 0,6	DUESE		
14	51 14 937 08	1	NON-RETURN VALVE	RUECKSCHLAGVENTIL		
19	51 15 084 08	1	COUPLING SLEEVE 10-L	KUPPLUNGSMUFFE		
20	51 15 083 08	2	COUPLING PLUG 10-L	KUPPLUNGSSTECKER		
21	51 15 122 08	2	COUPLING SLEEVE 38-S	KUPPLUNGSMUFFE		
22	51 05 456 08	2	HEX CAP NUT	VERSCHLUSSMUTTER		
23	51 15 123 08	4	COUPLING PLUG 38-S	KUPPLUNGSSTECKER		
24	10 46 691 3	2	SCREW PLUG RD79X4 SPF	VERSCHLUSSSCHRAUBE		
25	10 46 690 9	2	SCREW PLUG RD79X4 SPF	VERSCHLUSSSCHRAUBE		
26	51 05 458 08	2	HEX CAP NUT	VERSCHLUSSMUTTER		
27	51 05 997 08	1	COUPLING PLUG 25-S	KUPPLUNGSSTECKER		
28	10 46 691 2	2	SCREW PLUG RD54X4 SPF	VERSCHLUSSSCHRAUBE		
29	51 15 082 08	1	COUPLING SLEEVE 22-L	KUPPLUNGSMUFFE		
30	51 15 081 08	1	COUPLING PLUG 22-L	KUPPLUNGSSTECKER		
31	51 15 010 08	1	COUPLING SLEEVE 28-L	KUPPLUNGSMUFFE		
32	51 15 011 08	2	COUPLING PLUG 28-L	KUPPLUNGSSTECKER		
33	51 15 058 08	2	COUPLING SLEEVE 12-L	KUPPLUNGSMUFFE		
34	51 15 040 08	3	HEX CAP NUT	VERSCHLUSSMUTTER		
35	51 15 096 08	2	COUPLING PLUG 12-L	KUPPLUNGSSTECKER		
36	10 46 691 0	4	SCREW PLUG RD32X3 SPF	VERSCHLUSSSCHRAUBE		
37	51 15 004 08	2	COUPLING PLUG 15-L	KUPPLUNGSSTECKER		
38	10 46 690 7	2	SCREW PLUG RD36X3 SPF	VERSCHLUSSSCHRAUBE		
39	10 46 690 8	2	SCREW PLUG RD54X4 SPF	VERSCHLUSSSCHRAUBE		
40	51 10 623 08	1	CONNECTION FLANGE ALZNMGCU 1,5	ANSCHLUSSFLANSCH		
41	51 05 866 08	4	FLANGE HALF A3P	FLANSCHHAELFTE		
43	40 65 145 01	4	HEX BOLT ISO 4017 M14X45 8.8 A3C	SECHSKANTSCHRAUBE		
44	40 65 145 01	4	HEX BOLT ISO 4017 M14X45 8.8 A3C	SECHSKANTSCHRAUBE		
45	51 05 867 08	4	O-RING ARP 568 37,69X3,53 NBR90	O-RING		
46	40 42 159 08	4	CYLINDER SCREW DIN 912 M14X80 8.8 A3C	ZYLINDERSCHRAUBE		
47	40 42 156 08	4	CYLINDER SCREW DIN 912 M14X65 8.8 A3C	ZYLINDERSCHRAUBE		
48	47 77 052 08	1	PLUG VSTIM33X2ED A3P	STOPFEN		
51	49 00 605	2	HEX BOLT ISO 4017 M6X12 8.8 A2C	SECHSKANTSCHRAUBE		
52	42 40 005 08	2	CIRCLIP DIN 127 A 6 VERZ	FEDERRING		
53	41 15 140 08	2	HEX NUT DIN 934 M6 8 VERZ	SECHSKANTMUTTER		
55	40 65 060	2	HEX BOLT ISO 4017 M5X10 8.8 A2C	SECHSKANTSCHRAUBE		
56	42 00 008 08	2	WASHER DIN 125 A 5.3 VERZ	SCHEIBE		
58	97 01 621 08	1	PLATE 4x103x60	BLECH		
61	71 01 077 08	6	SEALING RING DIN 7603 A 52X60X2,5 CU	DICHTRING		
62	71 01 072 08	6	SEALING RING DIN 7603 A 38X44X2 CU	DICHTRING		
63	71 01 059 08	6	SEALING RING DIN 7603 A 27X32X2 CU	DICHTRING		
65	97 59 516 08	4	PLATE 1X20X60	BLECH		
66	95 05 568 08	5	TRAILERS 25X2	ANHAENGER		
67	70 42 141 08	10	KEY RING 25	SCHLUESSELRING		
91	96 50 585 08	1	HOSES WINCH 3 ⇒ 2 975 154 96 50 585 08	SCHLAUCHLEITUNGEN WINDE		
93	96 50 586 08	1	PIPELINE WINCH III ⇒ 2 975 155 96 50 586 08	ROHRLEITUNGEN WINDE		
603	47 10 313 08	1	FLANGE JOINT XGE22-LM-ED A3P	VERSCHRAUBUNG		
604	47 24 306 08	1	FLANGE JOINT ETS22-L A3P	VERSCHRAUBUNG		
605	47 54 361 08	1	FLANGE JOINT REDSD22/12-L A3P	VERSCHRAUBUNG		

6.2.2009

etk_en_de_074515 LR 1600/2

☐ 372 (3/4)

LIEBHERR
ADDITIONAL HYDRAULICS WINCH 3
ZUSATZHYDRAULIK WINDE 3

 ⇒ 2 975 100
 91 52 860 08

Pos.	Item	Quantity	Description	Bezeichnung	Serie	K
606	47 10 397 08	1	FLANGE JOINT ISO 8434-1 GE 10L M12X1,5	VERSCHRAUBUNG		
607	47 10 305 08	1	FLANGE JOINT XGE10-LM-ED A3P	VERSCHRAUBUNG		
608	47 10 308 08	1	FLANGE JOINT XGE12-LR-ED A3P	VERSCHRAUBUNG		
609	47 19 043 08	1	FLANGE JOINT EGE 10L G3/8A CR6-FREI	VERSCHRAUBUNG		
610	47 25 305 08	2	FLANGE JOINT EWSD12-L A3P	VERSCHRAUBUNG		
611	47 23 303 08	1	FLANGE JOINT ELSD12-L A3P	VERSCHRAUBUNG		
612	47 00 113 08	3	FLANGE JOINT SNV12-L A3P	VERSCHRAUBUNG		
613	47 23 302 08	4	FLANGE JOINT ELSD10-L A3P	VERSCHRAUBUNG		
614	47 10 306 08	2	FLANGE JOINT XGE10-LR-ED A3P	VERSCHRAUBUNG		
615	51 06 290 08	2	WELD SOCKET DKO 10L	MESSSTUTZEN		
616	47 19 011 08	1	FLANGE JOINT EGESD10-LR-WD A3P	VERSCHRAUBUNG		
617	47 24 302 08	1	FLANGE JOINT ETS12-L A3P	VERSCHRAUBUNG		
618	47 10 394 08	1	FLANGE JOINT XGE12-LM-ED A3P	VERSCHRAUBUNG		
619	47 00 331 08	2	FLANGE JOINT XG38-S A3P	VERSCHRAUBUNG		
620	47 04 307 08	1	FLANGE JOINT T 22L CR6-FREI	VERSCHRAUBUNG		
621	47 54 308 08	1	FLANGE JOINT REDSD22/10-L A3P	VERSCHRAUBUNG		
622	47 00 308 08	1	FLANGE JOINT XG28-L A3P	VERSCHRAUBUNG		
623	47 23 307 08	1	FLANGE JOINT EL 28L CR6-FREI	VERSCHRAUBUNG		
624	47 54 305 08	1	FLANGE JOINT REDSD28/22-L A3P	VERSCHRAUBUNG		
625	47 25 306 08	1	FLANGE JOINT EWSD22-L A3P	VERSCHRAUBUNG		
626	47 00 305 08	2	FLANGE JOINT XG15-L A3P	VERSCHRAUBUNG		
627	47 50 317 08	2	FLANGE JOINT XGR15/12-L A3P	VERSCHRAUBUNG		
628	47 50 318 08	1	FLANGE JOINT XGR28/22-L A3P	VERSCHRAUBUNG		

6.2.2009

etk_en_de_074515 LR 1600/2

373 (4/4)

LIEBHERR

ADDITIONAL HYDRAULICS WINCH 3
ZUSATZHYDRAULIK WINDE 3

⇒ 2 975 100
91 52 860 08

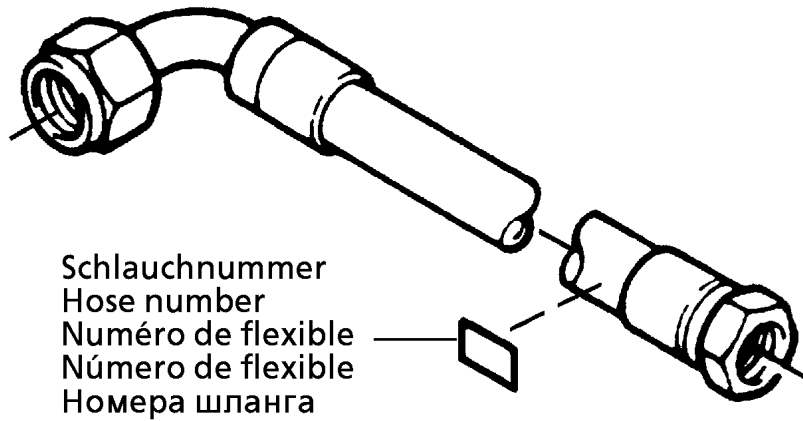

Schlauchnummer
Hose number
Número de flexible
Número de flexible
Номера шланга

Die Schlauchnummern auf den Schläuchen entsprechen den Positionen in der Schlauchliste.

The hose numbers from the hoses are in accordance with the items in the hose list.

Les numéros indiqués sur les flexibles correspondent aux repères de la nomenclature des flexibles.

Los números indicados en los flexibles corresponden a las posiciones de la lista de flexibles.

Нанесенные на шлангах номера соответствуют позициям в перечне.

Pos.	Item	Quantity	Description	Bezeichnung	Serie	K
1	60 27 601 08	9	NAME PLATE 25,4X101,6	BEZEICHNUNGSSCHILD		
1401	92 27 451 08	1	HOSE ASS CPL. 2SN 0,8M	SCHLAUCH KPL.		
1402	96 51 589 08	1	HOSE ASS CPL. 2SN 0,41M	SCHLAUCH KPL.		
1403	96 51 590 08	1	HOSE ASS CPL. 2SN 0,64M	SCHLAUCH KPL.		
1404	92 76 161 08	1	HOSE ASS CPL. 2SN 0,35M	SCHLAUCH KPL.		
1405	92 76 973 08	1	HOSE ASS CPL. 2SN 0,25M	SCHLAUCH KPL.		
1406	92 76 379 08	1	HOSE ASS CPL. 1SC 0,3M	SCHLAUCH KPL.		
1407	92 76 407 08	1	HOSE ASS CPL. 2TE 0,32M	SCHLAUCH KPL.		
1408	96 33 352 08	1	HOSE ASS CPL. 2TE 0,43M	SCHLAUCH KPL.		
1409	92 76 109 08	1	HOSE ASS CPL. 2TE 0,45M	SCHLAUCH KPL.		

6.2.2009
133089

LIEBHERR

etk_en_de_074515 LR 1600/2

HOSES WINCH 1
SCHLAUCHLEITUNGEN WINDE 1

374

⇒ 2 975 118
96 47 200 08

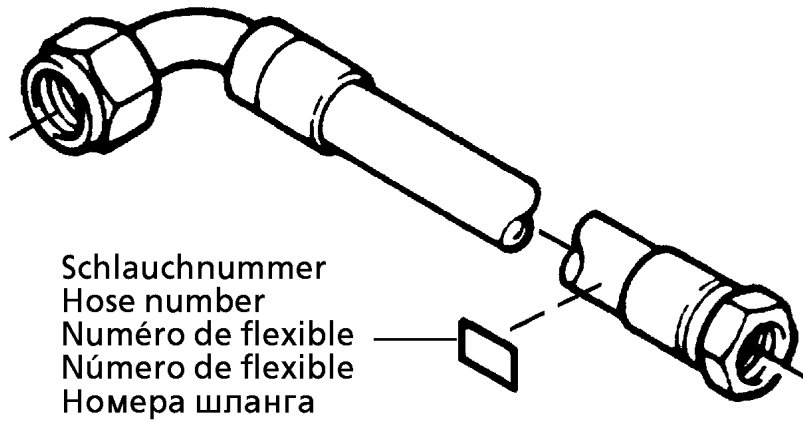

Die Schlauchnummern auf den Schläuchen entsprechen den Positionen in der Schlauchliste.

The hose numbers from the hoses are in accordance with the items in the hose list.

Les numéros indiqués sur les flexibles correspondent aux repères de la nomenclature des flexibles.

Los números indicados en los flexibles corresponden a las posiciones de la lista de flexibles.

Нанесенные на шлангах номера соответствуют позициям в перечне.

Pos.	Item	Quantity	Description	Bezeichnung	Serie	K
1	60 27 601 08	11	NAME PLATE 25,4X101,6	BEZEICHNUNGSSCHILD		
2	60 27 603 08	8	NAME PLATE 25,4X165,1	BEZEICHNUNGSSCHILD		
1160	92 30 161 08	1	HOSE ASS CPL. 2SN 0,62M	SCHLAUCH KPL.		
1161	92 17 502 08	1	HOSE ASS CPL. 2SN 0,28M	SCHLAUCH KPL.		
1162	96 33 357 08	1	HOSE ASS CPL. 2SN 0,7M	SCHLAUCH KPL.		
1163	92 84 526 08	1	HOSE ASS CPL. 2TE 0,46M	SCHLAUCH KPL.		
1164	92 93 107 08	1	HOSE ASS CPL. 2SN 1,0M	SCHLAUCH KPL.		
1165	96 49 549 08	1	HOSE ASS CPL. GH466 1,5M	SCHLAUCH KPL.		
1166	96 54 723 08	1	HOSE ASS CPL. GH466 1,34M	SCHLAUCH KPL.		
1167	96 54 724 08	1	HOSE ASS CPL. 2TE 2,05M	SCHLAUCH KPL.		
1168	92 80 485 08	1	HOSE ASS CPL. 2TE 1,9M	SCHLAUCH KPL.		
1169	92 97 484 08	1	HOSE ASS CPL. 2SN 1,9M	SCHLAUCH KPL.		
1170	92 43 724 08	1	HOSE ASS CPL. 2TE 1,3M	SCHLAUCH KPL.		
1171	92 87 630 08	1	HOSE ASS CPL. 2TE 1,95M	SCHLAUCH KPL.		
1172	92 96 478 08	1	HOSE ASS CPL. 2TE 0,6M	SCHLAUCH KPL.		
1300	96 31 973 08	2	HOSE ASS CPL. GH466 2,35M	SCHLAUCH KPL.		
1301	92 60 668 08	1	HOSE ASS CPL. 1SN 2,5M	SCHLAUCH KPL.		
1302	92 96 157 08	1	HOSE ASS CPL. 1SN 2,3M	SCHLAUCH KPL.		
1303	92 76 848 08	1	HOSE ASS CPL. 2SN 2,5M	SCHLAUCH KPL.		
1304	92 76 848 08	1	HOSE ASS CPL. 2SN 2,5M	SCHLAUCH KPL.		

6.2.2009
133089

LIEBHERR

etk_en_de_074515 LR 1600/2

HOSES WINCH 3
SCHLAUCHLEITUNGEN WINDE 3

375

⇒ 2 975 154
96 50 585 08

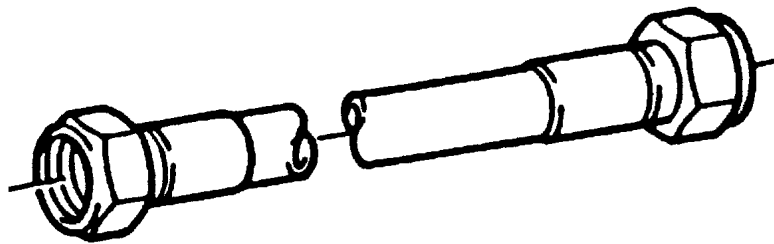

Die Positionsnummern der Rohre auf den Bildtafeln entsprechen den Positionen in der Rohrliste.

The pipe numbers from the illustrations are in accordance with the items in the pipe list.

Les numéros des tuyaux sur les illustrations correspondent aux repères de la nomenclature des tuyaux.

Los números de tubos en las ilustraciones corresponden a las posiciones de la lista de tubos.

Номера позиций труб на изображениях соответствуют позициям в перечне труб.

Pos.	Item	Quantity	Description	Bezeichnung	Serie	K
482	96 55 058 08	1	PIPE COMPL. 10X1,5X3082	ROHR KPL.		
483	96 55 059 08	1	PIPE COMPL. 22X2,5X1300	ROHR KPL.		
484	96 55 060 08	1	PIPE COMPL. 22X2,5X1342	ROHR KPL.		
485	96 55 061 08	1	PIPE COMPL. 15X1,5X2371	ROHR KPL.		
486	96 55 062 08	1	PIPE COMPL. 38X4X2700	ROHR KPL.		
487	96 55 063 08	1	PIPE COMPL. 38X4X2674	ROHR KPL.		
488	96 55 064 08	1	PIPE COMPL. 28X2X2356	ROHR KPL.		
489	96 55 065 08	1	PIPE COMPL. 15X1,5X2231	ROHR KPL.		

6.2.2009
133088

LIEBHERR

etk_en_de_074515 LR 1600/2

PIPELINE WINCH
ROHRLEITUNGEN WINDE

376

⇒ 2 975 155
96 50 586 08

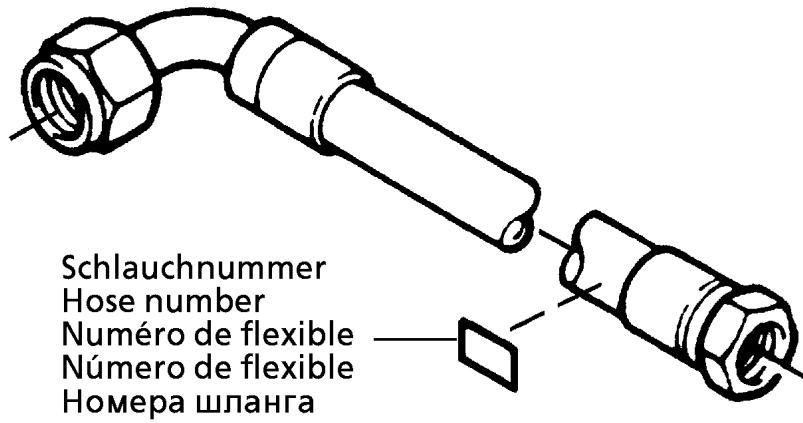

Schlauchnummer
Hose number
Numéro de flexible
Número de flexible
Номера шланга

Die Schlauchnummern auf den Schläuchen entsprechen den Positionen in der Schlauchliste.

The hose numbers from the hoses are in accordance with the items in the hose list.

Les numéros indiqués sur les flexibles correspondent aux repères de la nomenclature des flexibles.

Los números indicados en los flexibles corresponden a las posiciones de la lista de flexibles.

Нанесенные на шлангах номера соответствуют позициям в перечне.

Pos.	Item	Quantity	Description	Bezeichnung	Serie	K
1	60 27 601 08	4	NAME PLATE 25,4X101,6	BEZEICHNUNGSSCHILD		
2	60 27 603 08	1	NAME PLATE 25,4X165,1	BEZEICHNUNGSSCHILD		
1380	92 61 388 08	1	HOSE ASS CPL. 2TE 2,4M	SCHLAUCH KPL.		
1382	92 76 147 08	1	HOSE ASS CPL. 2SN 0,4M	SCHLAUCH KPL.		
1383	92 80 300 08	1	HOSE ASS CPL. 2SN 1,0M	SCHLAUCH KPL.		
1384	92 76 838 08	1	HOSE ASS CPL. 2SN 0,78M	SCHLAUCH KPL.		
1385	96 17 986 08	1	HOSE ASS CPL. 1SC 2,3M	SCHLAUCH KPL.		

6.2.2009
133089

LIEBHERR

etk_en_de_074515 LR 1600/2

HOSE LINES MOUNTING JACK
SCHLAUCHLEITUNGEN MONTAGEWINDE

377

⇒ 2 975 191
96 48 196 08

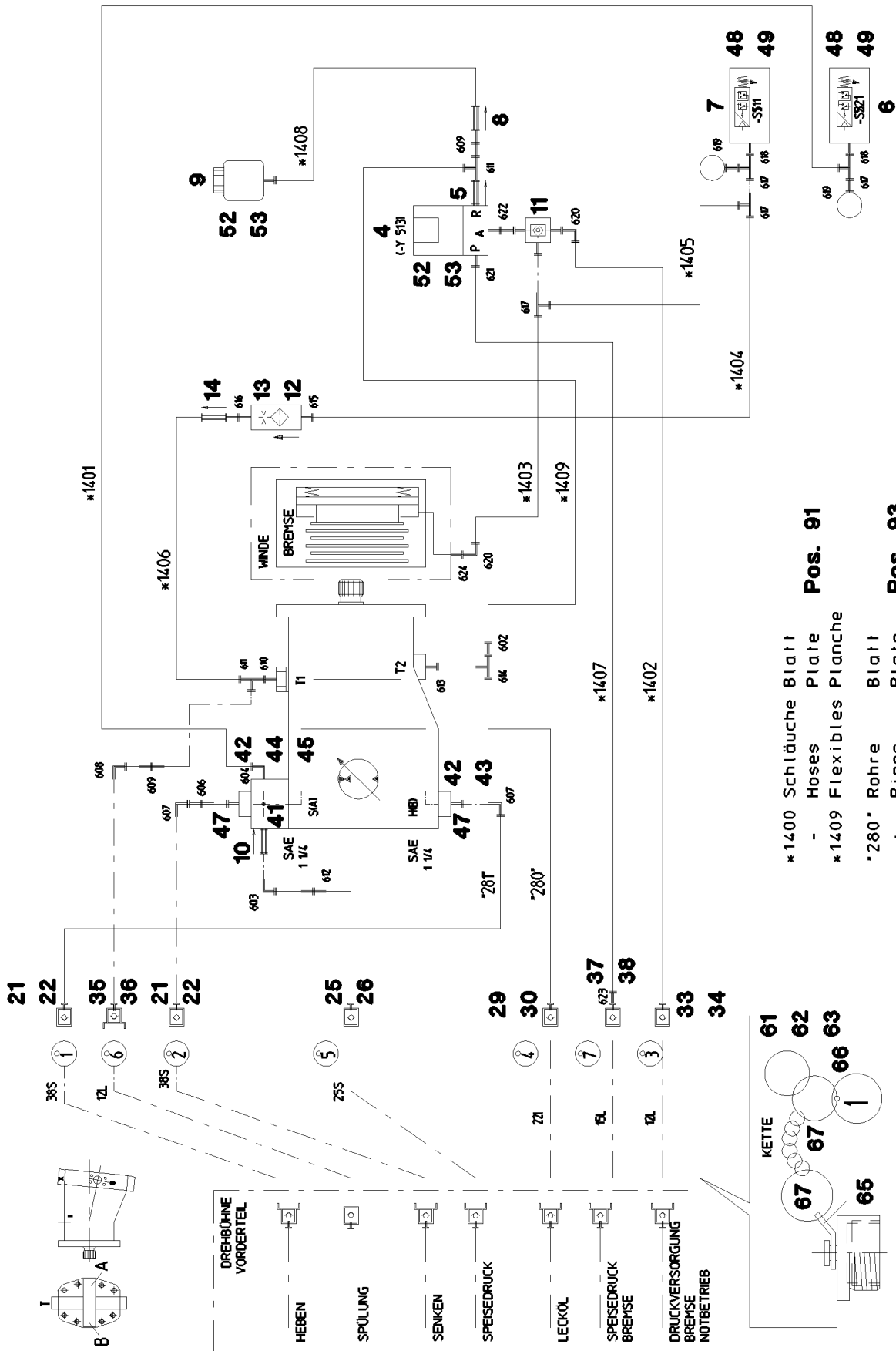

- Pos. 91**
- *1400 Schläuche Blatt
 - Hoses
 - *1409 Flexibles Planche
- Pos. 93**
- *280* Rohre Blatt
 - + Pipes Plate
 - *281* Tuyaux Planche

6.2.2009
053062

LIEBHERR

etk_en_de_074515 LR 1600/2

ADDITIONAL HYDRAULICS WINCH
ZUSATZHYDRAULIK WINDE 2

□ 378 (1/3)

⇒ 2 975 200
91 52 775 08

Pos.	Item	Quantity	Description	Bezeichnung	Serie	K
4	51 14 444 08	1	DIRECTIONAL CONTROL VALVE ⇒ 5 114 444 08 51 14 444 08	WEGEVENTIL		
5	51 14 606 08	1	NON-RETURN VALVE	RUECKSCHLAGVENTIL		
6	10 22 093 3	1	PRESSURE SWITCH 8BAR SPF	DRUCKSCHALTER		
7	10 28 953 6	1	PRESSURE SWITCH 20BAR SPF	DRUCKSCHALTER		
8	51 14 815 08	1	NON-RETURN VALVE	RUECKSCHLAGVENTIL		
9	50 28 073 08	1	EQUALIZING RESERVOIR	AUSGLEICHSBEHAELTER		
10	51 04 087 08	1	NON-RETURN VALVE	RUECKSCHLAGVENTIL		
11	51 14 689 08	1	SHUTTLE VALVE	WECHSELVENTIL		
12	51 06 711 08	1	FILTER CARTRIDGE	FILTERPATRONE		
13	51 07 460 08	1	NOZZLE 0,6	DUESE		
14	51 04 124 08	1	NON-RETURN VALVE	RUECKSCHLAGVENTIL		
21	51 15 122 08	2	COUPLING SLEEVE 38-S	KUPPLUNGSMUFFE		
22	10 46 691 7	2	HEX CAP NUT RD79X4 SPF	VERSCHLUSSMUTTER		
25	51 05 996 08	1	COUPLING SLEEVE 25-S	KUPPLUNGSMUFFE		
26	10 46 691 6	1	HEX CAP NUT RD54X4 SPF	VERSCHLUSSMUTTER		
29	51 15 082 08	1	COUPLING SLEEVE 22-L	KUPPLUNGSMUFFE		
30	10 46 691 6	1	HEX CAP NUT RD54X4 SPF	VERSCHLUSSMUTTER		
33	51 15 058 08	1	COUPLING SLEEVE 12-L	KUPPLUNGSMUFFE		
34	51 15 040 08	1	HEX CAP NUT	VERSCHLUSSMUTTER		
35	51 15 096 08	1	COUPLING PLUG 12-L	KUPPLUNGSSTECKER		
36	10 46 691 0	1	SCREW PLUG RD32X3 SPF	VERSCHLUSSSCHRAUBE		
37	51 15 005 08	1	COUPLING SLEEVE 15-L	KUPPLUNGSMUFFE		
38	51 05 453 08	1	HEX CAP NUT	VERSCHLUSSMUTTER		
41	51 10 561 08	1	CONNECTION FLANGE	ANSCHLUSSFLANSCH		
42	51 05 867 08	3	O-RING ARP 568 37,69X3,53 NBR90	O-RING		
43	40 42 153 01	4	CYLINDER SCREW ISO 4762 M14X50 8.8 A3	ZYLINDERSCHRAUBE		
44	40 43 161 01	4	CYLINDER SCREW ISO 4762 M14X100 10.9	ZYLINDERSCHRAUBE		
45	47 77 052 08	1	PLUG VSTIM33X2ED A3P	STOPFEN		
47	51 15 178 08	2	FLANGE STUB PIPE 38-S	FLANSCHSTUTZEN		
48	40 01 521	4	CYLINDER SCREW ISO 4762 M5X10 8.8 A2C	ZYLINDERSCHRAUBE		
49	42 18 006 08	4	WASHER DIN 9021 A 5,3 ST VERZ	SCHEIBE		
52	49 00 605	4	HEX BOLT ISO 4017 M6X12 8.8 A2C	SECHSKANTSCHRAUBE		
53	42 40 005 08	4	CIRCLIP DIN 127 A 6 VERZ	FEDERRING		
61	71 01 072 08	1	SEALING RING DIN 7603 A 38X44X2 CU	DICHTRING		
62	71 01 070 08	1	SEALING RING DIN 7603 A 33X39X2 CU	DICHTRING		
63	71 01 077 08	2	SEALING RING DIN 7603 A 52X60X2,5 CU	DICHTRING		
65	97 59 516 08	7	PLATE 1X20X60	BLECH		
66	95 05 568 08	7	TRAILERS 25X2	ANHAENGER		
67	70 42 141 08	14	KEY RING 25	SCHLUESSELRING		
91	96 47 201 08	1	HOSES WINCH 2 ⇒ 2 975 061 96 47 201 08	SCHLAUCHLEITUNGEN WINDE		
93	96 51 219 08	1	PIPELINE WINCH I+II	ROHRLEITUNGEN WINDE		
602	47 54 361 08	1	FLANGE JOINT REDSD22/12-L A3P	VERSCHRAUBUNG		
603	47 25 317 08	1	FLANGE JOINT EWSD25-S A3P	VERSCHRAUBUNG		
604	47 66 102 08	1	FLANGE JOINT RSWS10-LM-WD A3P	VERSCHRAUBUNG		
605	47 10 307 08	1	FLANGE JOINT ISO 8434-1 GE 12L M16X1,5	VERSCHRAUBUNG		
606	47 00 107 08	1	FLANGE JOINT SNV38-S A3P	VERSCHRAUBUNG		
607	47 25 318 08	2	FLANGE JOINT EWSD38-S A3P	VERSCHRAUBUNG		
608	47 25 305 08	1	FLANGE JOINT EWSD12-L A3P	VERSCHRAUBUNG		
609	47 00 113 08	2	FLANGE JOINT SNV12-L A3P	VERSCHRAUBUNG		
610	47 10 394 08	1	FLANGE JOINT XGE12-LM-ED A3P	VERSCHRAUBUNG		
611	47 23 303 08	2	FLANGE JOINT ELSD12-L A3P	VERSCHRAUBUNG		
612	47 00 110 08	1	FLANGE JOINT SNV25-S A3P	VERSCHRAUBUNG		
613	47 10 313 08	1	FLANGE JOINT XGE22-LM-ED A3P	VERSCHRAUBUNG		
614	47 24 306 08	1	FLANGE JOINT ETS22-L A3P	VERSCHRAUBUNG		
615	47 10 353 08	1	FLANGE JOINT XGE12-LR-ED1/4" A3P	VERSCHRAUBUNG		
616	47 19 011 08	1	FLANGE JOINT EGESD10-LR-WD A3P	VERSCHRAUBUNG		
617	47 23 302 08	4	FLANGE JOINT ELSD10-L A3P	VERSCHRAUBUNG		
618	47 10 306 08	2	FLANGE JOINT XGE10-LR-ED A3P	VERSCHRAUBUNG		

6.2.2009

etk_en_de_074515 LR 1600/2

☐ 379 (2/3)

LIEBHERR
ADDITIONAL HYDRAULICS WINCH
ZUSATZHYDRAULIK WINDE 2

⇒ 2 975 200
91 52 775 08

Pos.	Item	Quantity	Description	Bezeichnung	Serie	K
619	51 06 290 08	2	WELD SOCKET DKO 10L	MESSSTUTZEN		
620	47 25 302 08	1	FLANGE JOINT EWSD10-L A3P	VERSCHRAUBUNG		
621	47 10 308 08	1	FLANGE JOINT XGE12-LR-ED A3P	VERSCHRAUBUNG		
622	47 19 043 08	1	FLANGE JOINT EGE 10L G3/8A CR6-FREI	VERSCHRAUBUNG		
623	47 54 318 08	1	FLANGE JOINT REDSD15/12-L A3P	VERSCHRAUBUNG		
624	47 10 397 08	1	FLANGE JOINT ISO 8434-1 GE 10L M12X1,5	VERSCHRAUBUNG		

6.2.2009

etk_en_de_074515 LR 1600/2

380 (3/3)

LIEBHERR

ADDITIONAL HYDRAULICS WINCH
ZUSATZHYDRAULIK WINDE 2

⇒ 2 975 200
91 52 775 08

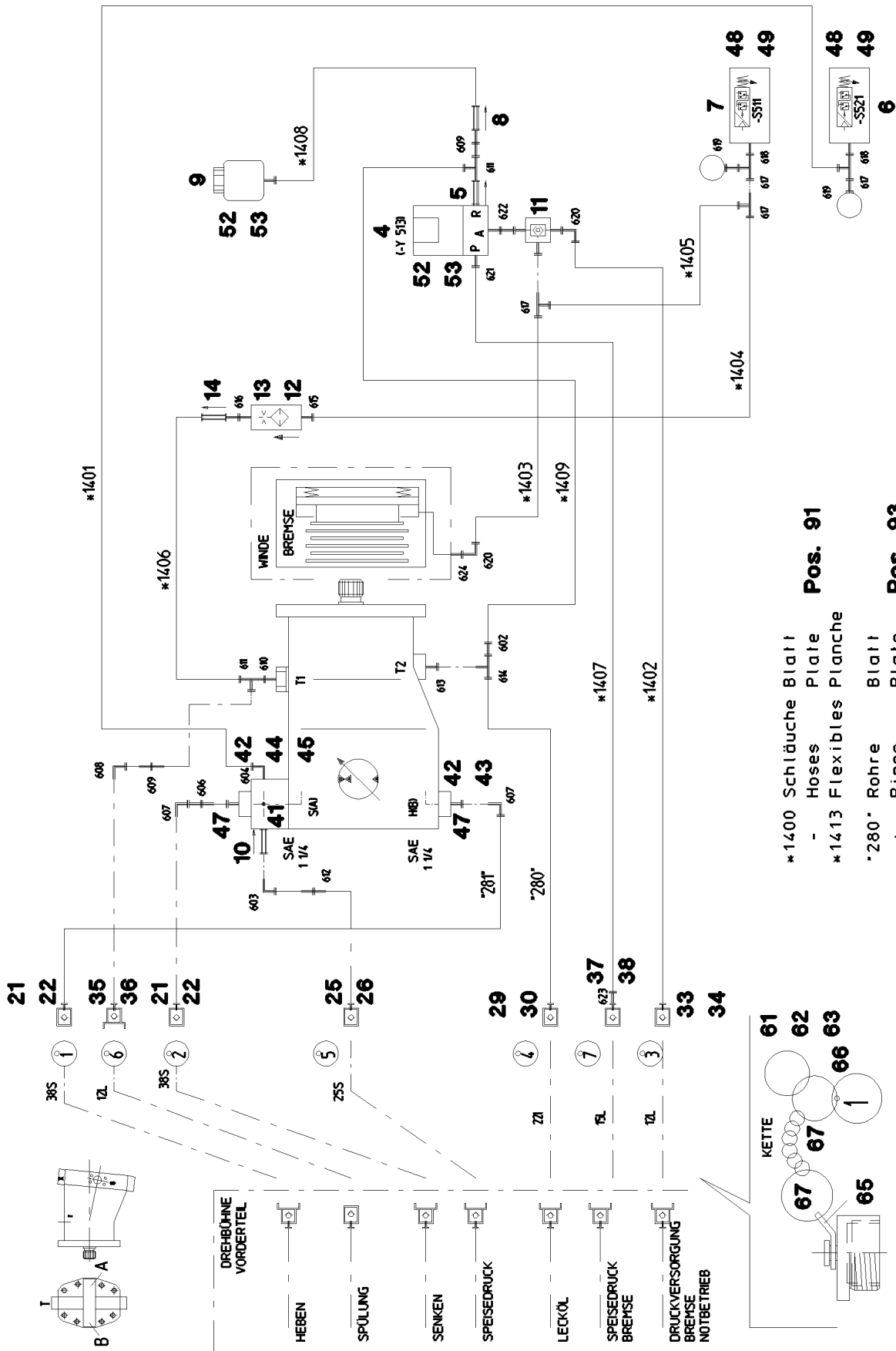

- Pos. 91**
 *1400 Schläuche Blatt
 - Hoses
 Plate
 *1413 Flexibles Planche
 -280° Rohre
 + Pipes
 Planche
 *281° Tuyaux
 Planche
- Pos. 93**
 *1400 Schläuche Blatt
 - Hoses
 Plate
 *1413 Flexibles Planche
 -280° Rohre
 + Pipes
 Planche
 *281° Tuyaux
 Planche

Pos.	Item	Quantity	Description	Bezeichnung	Serie	K
4	51 14 444 08	1	DIRECTIONAL CONTROL VALVE ⇒ 5 114 444 08 51 14 444 08	WEGEVENTIL		
5	51 14 606 08	1	NON-RETURN VALVE	RUECKSCHLAGVENTIL		
6	10 22 093 3	1	PRESSURE SWITCH 8BAR SPF	DRUCKSCHALTER		
7	10 28 953 6	1	PRESSURE SWITCH 20BAR SPF	DRUCKSCHALTER		
8	51 14 815 08	1	NON-RETURN VALVE	RUECKSCHLAGVENTIL		
9	50 28 073 08	1	EQUALIZING RESERVOIR	AUSGLEICHSBEHAELTER		
10	51 04 087 08	1	NON-RETURN VALVE	RUECKSCHLAGVENTIL		
11	51 14 689 08	1	SHUTTLE VALVE	WECHSELVENTIL		
12	51 06 711 08	1	FILTER CARTRIDGE	FILTERPATRONE		
13	51 07 460 08	1	NOZZLE 0,6	DUESE		
14	51 04 124 08	1	NON-RETURN VALVE	RUECKSCHLAGVENTIL		
21	51 15 122 08	2	COUPLING SLEEVE 38-S	KUPPLUNGSMUFFE		
22	10 46 691 7	2	HEX CAP NUT RD79X4 SPF	VERSCHLUSSMUTTER		
25	51 05 996 08	1	COUPLING SLEEVE 25-S	KUPPLUNGSMUFFE		
(1)	57 10 768 08	1	VALVE	VENTIL		
(2)	57 10 769 08	1	O-RING 32X3 FPM70	O-RING		
(3)	57 10 770 08	1	SUPPORTING RING	STUETZRING		
(4)	57 10 771 08	1	O-RING 40X3 FPM70	O-RING		
(5)	57 10 772 08	1	NUT	MUTTER		
26	10 46 691 6	1	HEX CAP NUT RD54X4 SPF	VERSCHLUSSMUTTER		
29	51 15 082 08	1	COUPLING SLEEVE 22-L	KUPPLUNGSMUFFE		
30	10 46 691 6	1	HEX CAP NUT RD54X4 SPF	VERSCHLUSSMUTTER		
33	51 15 058 08	1	COUPLING SLEEVE 12-L	KUPPLUNGSMUFFE		
34	51 15 040 08	1	HEX CAP NUT	VERSCHLUSSMUTTER		
35	51 15 096 08	1	COUPLING PLUG 12-L	KUPPLUNGSSTECKER		
36	10 46 691 0	1	SCREW PLUG RD32X3 SPF	VERSCHLUSSSCHRAUBE		
37	51 15 005 08	1	COUPLING SLEEVE 15-L	KUPPLUNGSMUFFE		
38	51 05 453 08	1	HEX CAP NUT	VERSCHLUSSMUTTER		
41	51 10 561 08	1	CONNECTION FLANGE	ANSCHLUSSFLANSCH		
42	51 05 867 08	3	O-RING ARP 568 37,69X3,53 NBR90	O-RING		
43	40 42 153 01	4	CYLINDER SCREW ISO 4762 M14X50 8.8 A3	ZYLINDERSCHRAUBE		
44	40 43 161 01	4	CYLINDER SCREW ISO 4762 M14X100 10.9	ZYLINDERSCHRAUBE		
45	47 77 052 08	1	PLUG VSTIM33X2ED A3P	STOPFEN		
47	51 15 178 08	2	FLANGE STUB PIPE 38-S	FLANSCHSTUTZEN		
48	40 01 521	4	CYLINDER SCREW ISO 4762 M5X10 8.8 A2C	ZYLINDERSCHRAUBE		
49	42 18 006 08	4	WASHER DIN 9021 A 5,3 ST VERZ	SCHEIBE		
52	49 00 605	4	HEX BOLT ISO 4017 M6X12 8.8 A2C	SECHSKANTSCHRAUBE		
53	42 40 005 08	4	CIRCLIP DIN 127 A 6 VERZ	FEDERRING		
61	71 01 072 08	1	SEALING RING DIN 7603 A 38X44X2 CU	DICHTRING		
62	71 01 070 08	1	SEALING RING DIN 7603 A 33X39X2 CU	DICHTRING		
63	71 01 077 08	2	SEALING RING DIN 7603 A 52X60X2,5 CU	DICHTRING		
65	97 59 516 08	7	PLATE 1X20X60	BLECH		
66	95 05 568 08	7	TRAILERS 25X2	ANHAENGER		
67	70 42 141 08	14	KEY RING 25	SCHLUESSELRING		
91	96 47 200 08	1	HOSES WINCH 1 ⇒ 2 975 118 96 47 200 08	SCHLAUCHLEITUNGEN WINDE		
93	96 51 219 08	1	PIPELINE WINCH I+II	ROHRLEITUNGEN WINDE		
(280)	96 51 350 08	1	PIPE COMPL. 38X4X1013	ROHR KPL.		
(281)	96 51 490 08	1	PIPE COMPL. 22X2,5X269	ROHR KPL.		
602	47 54 361 08	1	FLANGE JOINT REDSD22/12-L A3P	VERSCHRAUBUNG		
603	47 25 317 08	1	FLANGE JOINT EWSD25-S A3P	VERSCHRAUBUNG		
604	47 66 102 08	1	FLANGE JOINT RSWS10-LM-WD A3P	VERSCHRAUBUNG		
605	47 10 307 08	1	FLANGE JOINT ISO 8434-1 GE 12L M16X1,5	VERSCHRAUBUNG		
606	47 00 107 08	1	FLANGE JOINT SNV38-S A3P	VERSCHRAUBUNG		
607	47 25 318 08	2	FLANGE JOINT EWSD38-S A3P	VERSCHRAUBUNG		
608	47 25 305 08	1	FLANGE JOINT EWSD12-L A3P	VERSCHRAUBUNG		
609	47 00 113 08	2	FLANGE JOINT SNV12-L A3P	VERSCHRAUBUNG		
610	47 10 394 08	1	FLANGE JOINT XGE12-LM-ED A3P	VERSCHRAUBUNG		
611	47 23 303 08	2	FLANGE JOINT ELSD12-L A3P	VERSCHRAUBUNG		

6.2.2009

etk_en_de_074515 LR 1600/2

☐ 382 (2/3)

LIEBHERR
ADDITIONAL HYDRAULICS WINCH 1
ZUSATZHYDRAULIK WINDE 1

 ⇒ 2 975 700
 91 52 774 08

Pos.	Item	Quantity	Description	Bezeichnung	Serie	K
612	47 00 110 08	1	FLANGE JOINT SNV25-S A3P	VERSCHRAUBUNG		
613	47 10 313 08	1	FLANGE JOINT XGE22-LM-ED A3P	VERSCHRAUBUNG		
614	47 24 306 08	1	FLANGE JOINT ETSD22-L A3P	VERSCHRAUBUNG		
615	47 10 353 08	1	FLANGE JOINT XGE12-LR-ED1/4" A3P	VERSCHRAUBUNG		
616	47 19 011 08	1	FLANGE JOINT EGESD10-LR-WD A3P	VERSCHRAUBUNG		
617	47 23 302 08	4	FLANGE JOINT ELSD10-L A3P	VERSCHRAUBUNG		
618	47 10 306 08	2	FLANGE JOINT XGE10-LR-ED A3P	VERSCHRAUBUNG		
619	51 06 290 08	2	WELD SOCKET DKO 10L	MESSSTUTZEN		
620	47 25 302 08	1	FLANGE JOINT EWSD10-L A3P	VERSCHRAUBUNG		
621	47 10 308 08	1	FLANGE JOINT XGE12-LR-ED A3P	VERSCHRAUBUNG		
622	47 19 043 08	1	FLANGE JOINT EGE 10L G3/8A CR6-FREI	VERSCHRAUBUNG		
623	47 54 318 08	1	FLANGE JOINT REDSD15/12-L A3P	VERSCHRAUBUNG		
624	47 10 397 08	1	FLANGE JOINT ISO 8434-1 GE 10L M12X1,5	VERSCHRAUBUNG		

6.2.2009

etk_en_de_074515 LR 1600/2

383 (3/3)

LIEBHERR

ADDITIONAL HYDRAULICS WINCH 1
ZUSATZHYDRAULIK WINDE 1

⇒ 2 975 700
91 52 774 08

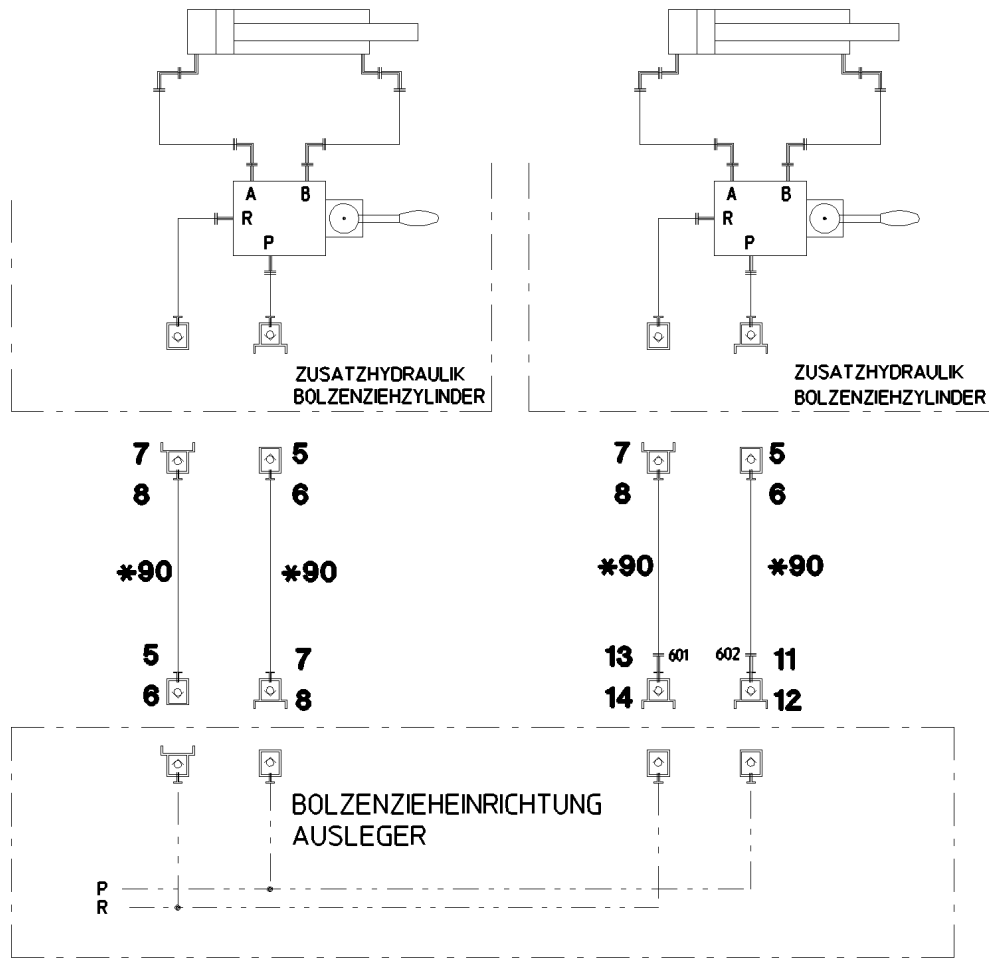

Pos.	Item	Quantity	Description	Bezeichnung	Serie	K
5	51 15 058 08	3	COUPLING SLEEVE 12-L	KUPPLUNGSMUFFE		
6	51 15 040 08	3	HEX CAP NUT	VERSCHLUSSMUTTER		
7	51 15 096 08	3	COUPLING PLUG 12-L	KUPPLUNGSSTECKER		
8	10 46 691 0	3	SCREW PLUG RD32X3 SPF	VERSCHLUSSSCHRAUBE		
11	51 15 004 08	1	COUPLING PLUG 15-L	KUPPLUNGSSTECKER		
12	10 46 691 1	1	SCREW PLUG RD36X3 SPF	VERSCHLUSSSCHRAUBE		
13	57 05 048 08	1	COUPLING PLUG 18-L	KUPPLUNGSSTECKER		
14	10 46 691 2	1	SCREW PLUG RD54X4 SPF	VERSCHLUSSSCHRAUBE		
90	92 87 559 08	4	HOSE ASS CPL. 2SN 15,0M	SCHLAUCH KPL.		
601	47 54 363 08	1	FLANGE JOINT REDSD18/12-L A3P	VERSCHRAUBUNG		
602	47 54 318 08	1	FLANGE JOINT REDSD15/12-L A3P	VERSCHRAUBUNG		

6.2.2009
017086

LIEBHERR

etk_en_de_074515 LR 1600/2

AUX.HYDR.PIN EXTRACTION DEVICE
ZUS.HYDR.BOLZENZIEHEINRICHTUNG

384

⇒ 2 976 200
91 44 034 08

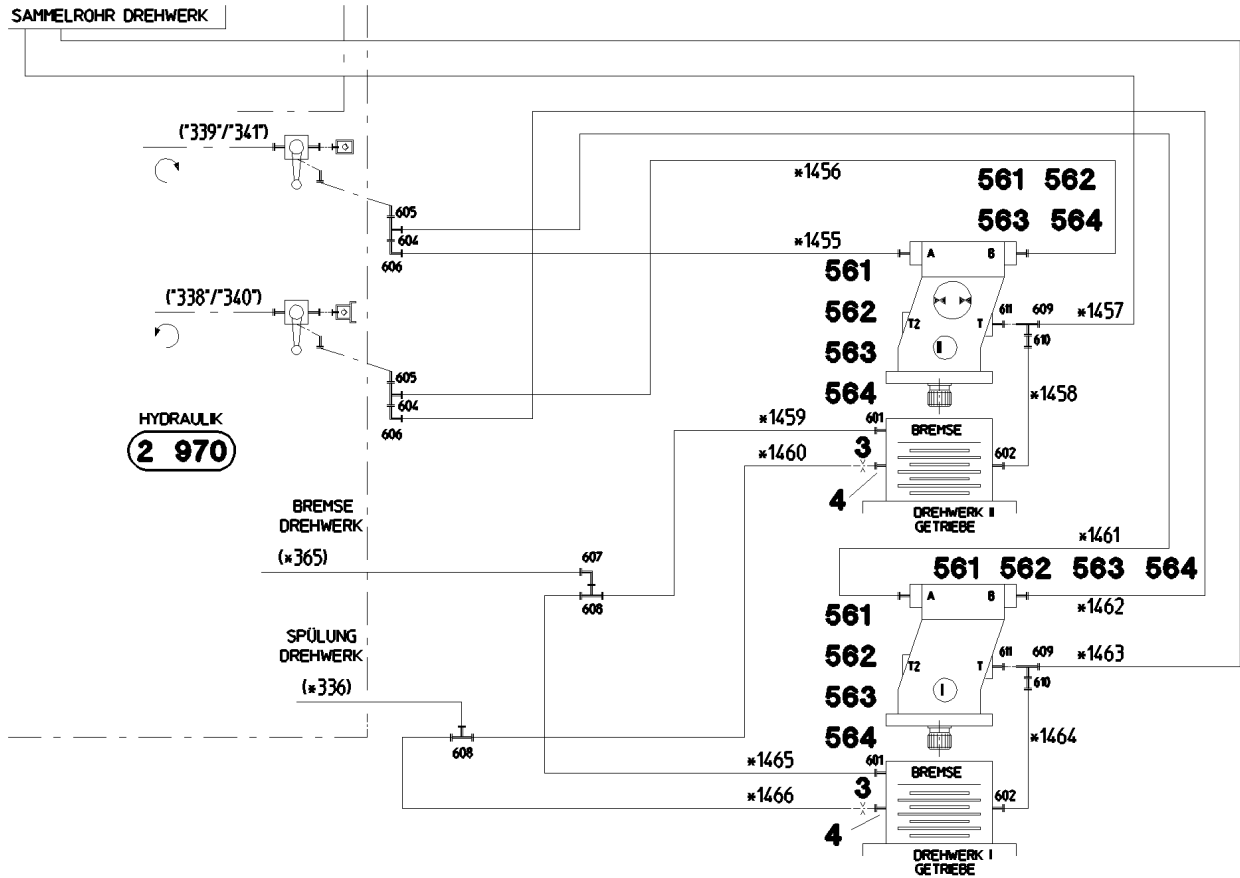

*1455 Schläuche Blatt
 - Hoses Plate **Pos. 91**
 *1466 Flexibles Planche

Pos.	Item	Quantity	Description	Bezeichnung	Serie	K
3	51 10 575 08	2	NOZZLE D 1,5 M8X8 MS	DUESE		
4	93 75 014 08	2	SCREW FITTING ELEMENT XGE10-SM-EDX3	VERSCHRAUBUNGSKOERPER		
91	96 47 202 08	1	HOSE LINES 2 SLEWING GEAR ⇒ 2 976 204 96 47 202 08	SCHLAUCHLEITUNGEN 2 DREH		
561	51 05 875 08	12	FLANGE HALF A3P	FLANSCHHAELFTE		
562	51 05 878 08	6	O-RING ARP 568 24,99X3,53 NBR90	O-RING		
563	46 00 132	20	CYLINDER SCREW ISO 4762 M10X35 8.8 A3	ZYLINDERSCHRAUBE		
564	49 00 112	4	HEX BOLT ISO 4017 M10X35 8.8 A3C	SECHSKANTSCHRAUBE		
601	47 10 397 08	2	FLANGE JOINT ISO 8434-1 GE 10L M12X1,5	VERSCHRAUBUNG		
602	47 10 307 08	2	FLANGE JOINT ISO 8434-1 GE 12L M16X1,5	VERSCHRAUBUNG		
604	47 23 317 08	2	FLANGE JOINT ELSD25-S A3P	VERSCHRAUBUNG		
605	47 54 327 08	2	FLANGE JOINT REDSDN30/25-S A3P	VERSCHRAUBUNG		
606	47 25 317 08	2	FLANGE JOINT EWSD25-S A3P	VERSCHRAUBUNG		
607	47 25 305 08	1	FLANGE JOINT EWSD12-L A3P	VERSCHRAUBUNG		
608	47 04 304 08	2	FLANGE JOINT XT12-L A3P	VERSCHRAUBUNG		
609	47 23 305 08	2	FLANGE JOINT ELSD18-L A3P	VERSCHRAUBUNG		
610	47 54 363 08	2	FLANGE JOINT REDSD18/12-L A3P	VERSCHRAUBUNG		
611	47 10 370 08	2	FLANGE JOINT XGE18-LM-ED A3P	VERSCHRAUBUNG		

6.2.2009
052817

LIEBHERR

etk_en_de_074515 LR 1600/2

ADDITIONAL HYDRAULICS
ZUSATZHYDRAULIK DREHWERKE

□ 385

⇒ 2 976 200
91 52 780 08

ZUSATZHYDRAULIK
BOLZENZIEHZYLINDER

*95 Schläuche Blatt
Hoses Plate **Pos. 91**
Flexibles Planche

372 Rohre Blatt
+ Pipes Plate **Pos. 95**
373 Tuyaux Planche

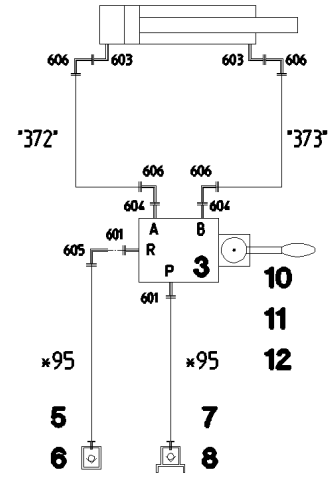
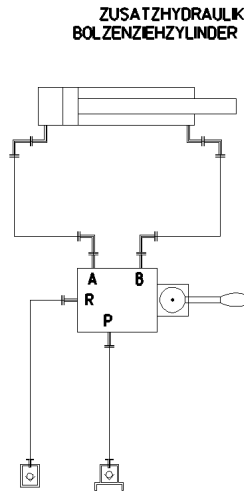

ZUSATZHYDRAULIK
BOLZENZIEHEINRICHTUNG

2 976 ...

BOLZENZIEHEINRICHTUNG
AUSLEGER

P
R

Pos.	Item	Quantity	Description	Bezeichnung	Serie	K
3	51 13 045 08	1	DIRECTIONAL CTRL. VALVE	WEGESCHIEBER		
5	51 15 058 08	1	COUPLING SLEEVE 12-L	KUPPLUNGSMUFFE		
6	51 15 040 08	1	HEX CAP NUT	VERSCHLUSSMUTTER		
7	51 15 096 08	1	COUPLING PLUG 12-L	KUPPLUNGSSTECKER		
8	10 46 691 0	1	SCREW PLUG RD32X3 SPF	VERSCHLUSSSCHRAUBE		
10	46 00 023	2	HEX BOLT ISO 4014 M6X50 8.8 A2C	SECHSKANTSCHRAUBE		
11	41 15 140 08	2	HEX NUT DIN 934 M6 8 VERZ	SECHSKANTMUTTER		
12	42 00 009 08	2	WASHER ISO 7089 A 6.4 VERZ	SCHEIBE		
90	96 46 081 08	1	PIPELINE PIN PULLING CYLINDER	ROHRLEITUNGEN BOLZENZIE		
(372)	92 09 706 08	1	PIPE COMPL. 10X1,5X190	ROHR KPL.		
(373)	96 18 464 08	1	PIPE COMPL. 10X1,5X175	ROHR KPL.		
91	96 46 080 08	1	HOSE LINES BOLT EXTRACTION	SCHLAUCHLEITUNGEN BOLZEN		
(1)	60 27 601 08	2	NAME PLATE 25,4X101,6	BEZEICHNUNGSSCHILD		
(95)	92 65 600 08	2	HOSE ASS CPL. 2SN 0,7M	SCHLAUCH KPL.		
601	47 10 308 08	2	FLANGE JOINT XGE12-LR-ED A3P	VERSCHRAUBUNG		
603	47 32 310 08	2	FLANGE JOINT RSWS10-SR-WD A3P	VERSCHRAUBUNG		
604	47 10 328 08	2	FLANGE JOINT ISO 8434-1 GE 10S G3/8A C	VERSCHRAUBUNG		
605	47 25 305 08	1	FLANGE JOINT EWSD12-L A3P	VERSCHRAUBUNG		
606	47 25 311 08	4	FLANGE JOINT EWSD10-S A3P	VERSCHRAUBUNG		

6.2.2009
142542

LIEBHERR

etk_en_de_074515 LR 1600/2

ADDL.HYDR.F.PIN PULLING DEVICE
ZUSATZHYDR.BOLZENZIEHZYLINDER

386

⇒ 2 976 203
92 27 489 08



Die Schlauchnummern auf den Schläuchen entsprechen den Positionen in der Schlauchliste.

The hose numbers from the hoses are in accordance with the items in the hose list.

Les numéros indiqués sur les flexibles correspondent aux repères de la nomenclature des flexibles.

Los números indicados en los flexibles corresponden a las posiciones de la lista de flexibles.

Нанесенные на шлангах номера соответствуют позициям в перечне.

Pos.	Item	Quantity	Description	Bezeichnung	Serie	K
1	60 27 601 08	6	NAME PLATE 25,4X101,6	BEZEICHNUNGSSCHILD		
2	60 27 603 08	6	NAME PLATE 25,4X165,1	BEZEICHNUNGSSCHILD		
1455	92 61 208 08	1	HOSE ASS CPL. 2755 2,05M	SCHLAUCH KPL.		
1456	92 19 240 08	1	HOSE ASS CPL. 2755 2,35M	SCHLAUCH KPL.		
1457	92 61 473 08	1	HOSE ASS CPL. 2TE 2,1M	SCHLAUCH KPL.		
1458	92 87 646 08	1	HOSE ASS CPL. 2TE 0,34M	SCHLAUCH KPL.		
1459	92 60 981 08	1	HOSE ASS CPL. 1SC 0,5M	SCHLAUCH KPL.		
1460	92 32 713 08	1	HOSE ASS CPL. 1SC 1,2M	SCHLAUCH KPL.		
1461	96 51 591 08	1	HOSE ASS CPL. 2755 0,74M	SCHLAUCH KPL.		
1462	92 96 166 08	1	HOSE ASS CPL. 2755 1,02M	SCHLAUCH KPL.		
1463	96 40 959 08	1	HOSE ASS CPL. 2TE 0,68M	SCHLAUCH KPL.		
1464	92 87 646 08	1	HOSE ASS CPL. 2TE 0,34M	SCHLAUCH KPL.		
1465	92 87 596 08	1	HOSE ASS CPL. 2SN 1,4M	SCHLAUCH KPL.		
1466	96 42 753 08	1	HOSE ASS CPL. 1SC 0,72M	SCHLAUCH KPL.		

6.2.2009
133089

LIEBHERR

etk_en_de_074515 LR 1600/2

HOSE LINES 2 SLEWING GEAR
SCHLAUCHLEITUNGEN 2 DREHWERKE

387

⇒ 2 976 204
96 47 202 08

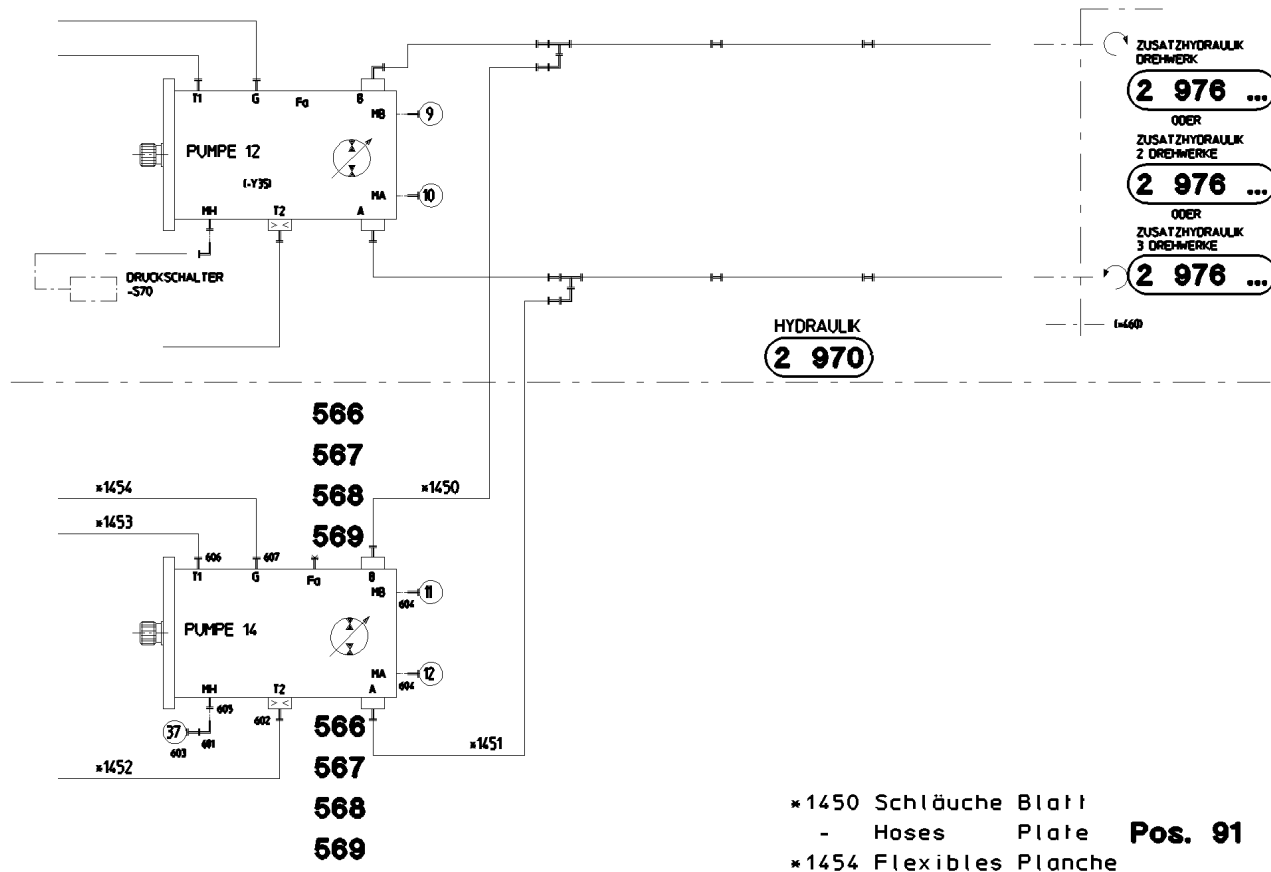

Pos.	Item	Quantity	Description	Bezeichnung	Serie	K
91	96 47 196 08	1	HOSE LINES PUMPE 12 ⇒ 2 976 701 96 47 196 08	SCHLAUCHLEITUNGEN PUMPE		
566	51 05 875 08	4	FLANGE HALF A3P	FLANSCHHAELFTE		
567	51 05 878 08	4	O-RING ARP 568 24,99X3,53 NBR90	O-RING		
568	46 00 132	8	CYLINDER SCREW ISO 4762 M10X35 8.8 A3	ZYLINDERSCHRAUBE		
569	49 00 112	4	HEX BOLT ISO 4017 M10X35 8.8 A3C	SECHSKANTSCHRAUBE		
601	47 25 315 08	1	FLANGE JOINT EWSD6-S A3P	VERSCHRAUBUNG		
602	47 10 307 08	1	FLANGE JOINT ISO 8434-1 GE 12L M16X1,5	VERSCHRAUBUNG		
603	47 56 015 08	1	MEASURING CONNECTION BMA3 6S	MESSANSCHLUSS		
604	47 56 032 08	2	MEASURING CONNECTION M12X1,5ED	MESSANSCHLUSS		
605	47 10 302 08	1	FLANGE JOINT XGE6-SM-ED A3P	VERSCHRAUBUNG		
606	47 10 313 08	1	FLANGE JOINT XGE22-LM-ED A3P	VERSCHRAUBUNG		
607	47 10 370 08	1	FLANGE JOINT XGE18-LM-ED A3P	VERSCHRAUBUNG		

6.2.2009
052823

LIEBHERR

etk_en_de_074515 LR 1600/2

ADDITIONAL HYDRAULICS PUMP
ZUSATZHYDRAULIK PUMPE

388

⇒ 2 976 700
91 54 795 08

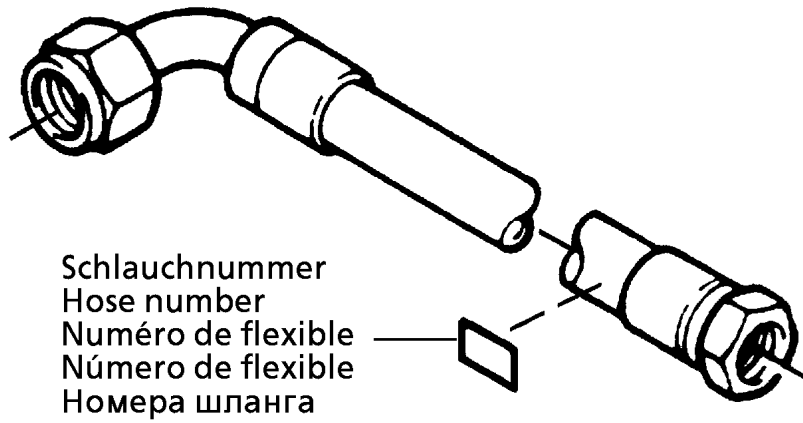

Schlauchnummer
Hose number
Número de flexible
Número de flexible
Номера шланга

Die Schlauchnummern auf den Schläuchen entsprechen den Positionen in der Schlauchliste.

The hose numbers from the hoses are in accordance with the items in the hose list.

Les numéros indiqués sur les flexibles correspondent aux repères de la nomenclature des flexibles.

Los números indicados en los flexibles corresponden a las posiciones de la lista de flexibles.

Нанесенные на шлангах номера соответствуют позициям в перечне.

Pos.	Item	Quantity	Description	Bezeichnung	Serie	K
1	60 27 601 08	1	NAME PLATE 25,4X101,6	BEZEICHNUNGSSCHILD		
2	60 27 603 08	4	NAME PLATE 25,4X165,1	BEZEICHNUNGSSCHILD		
1450	96 51 572 08	1	HOSE ASS CPL. 2755 0,8M	SCHLAUCH KPL.		
1451	96 51 573 08	1	HOSE ASS CPL. 2755 0,84M	SCHLAUCH KPL.		
1452	92 97 592 08	1	HOSE ASS CPL. 1SC 0,66M	SCHLAUCH KPL.		
1453	92 87 641 08	1	HOSE ASS CPL. 2TE 0,56M	SCHLAUCH KPL.		
1454	92 80 172 08	1	HOSE ASS CPL. 2TE 0,47M	SCHLAUCH KPL.		

6.2.2009
133089

LIEBHERR

etk_en_de_074515 LR 1600/2

HOSE LINES PUMP 12
SCHLAUCHLEITUNGEN PUMPE 12

389

⇒ 2 976 701
96 47 196 08

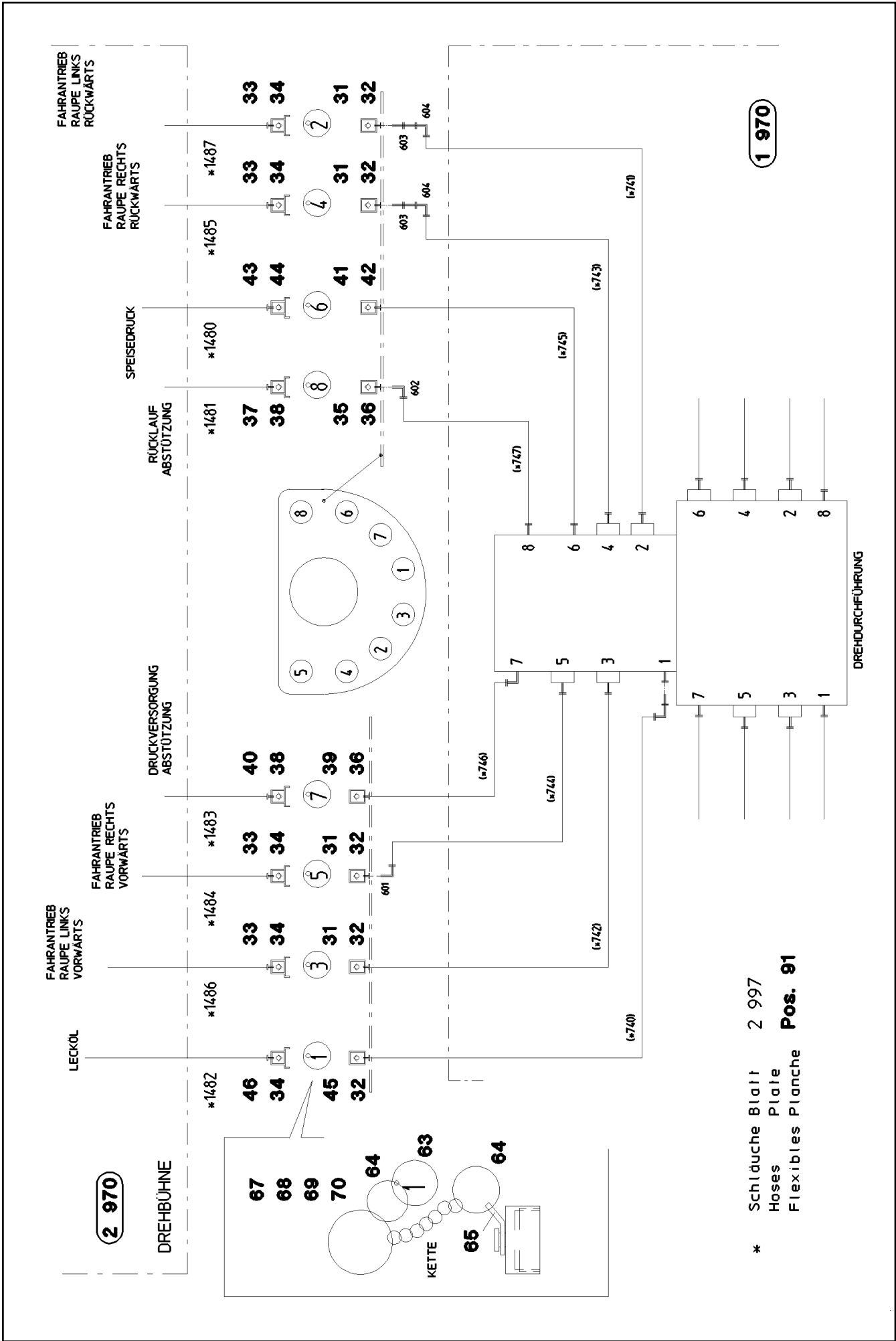

* Schläuche Blatt 2 997
Hoses Plate
Flexibles Planche Pos. 91

Pos.	Item	Quantity	Description	Bezeichnung	Serie	K
31	51 15 122 08	4	COUPLING SLEEVE 38-S	KUPPLUNGSMUFFE		
32	51 05 456 08	5	HEX CAP NUT	VERSCHLUSSMUTTER		
33	51 15 123 08	4	COUPLING PLUG 38-S	KUPPLUNGSSTECKER		
34	51 05 455 08	5	SCREW PLUG	VERSCHLUSSSCHRAUBE		
35	51 15 010 08	1	COUPLING SLEEVE 28-L	KUPPLUNGSMUFFE		
36	51 05 458 08	2	HEX CAP NUT	VERSCHLUSSMUTTER		
37	51 15 011 08	1	COUPLING PLUG 28-L	KUPPLUNGSSTECKER		
38	10 46 691 2	2	SCREW PLUG RD54X4 SPF	VERSCHLUSSSCHRAUBE		
39	51 15 007 08	1	COUPLING SLEEVE 20-S	KUPPLUNGSMUFFE		
40	51 05 997 08	1	COUPLING PLUG 25-S	KUPPLUNGSSTECKER		
41	51 15 086 08	1	COUPLING PLUG 16-S	KUPPLUNGSSTECKER		
42	51 05 453 08	1	HEX CAP NUT	VERSCHLUSSMUTTER		
43	51 15 086 08	1	COUPLING PLUG 16-S	KUPPLUNGSSTECKER		
44	10 46 691 1	1	SCREW PLUG RD36X3 SPF	VERSCHLUSSSCHRAUBE		
45	51 15 184 08	1	COUPLING SLEEVE	KUPPLUNGSMUFFE		
46	51 15 185 08	1	COUPLING PLUG BGR.8 35-L	KUPPLUNGSSTECKER		
63	95 05 568 08	16	TRAILERS 25X2	ANHAENGER		
64	70 42 141 08	16	KEY RING 25	SCHLUESSELRING		
65	97 59 516 08	8	PLATE 1X20X60	BLECH		
67	71 01 077 08	4	SEALING RING DIN 7603 A 52X60X2,5 CU	DICHTRING		
68	71 01 076 08	1	SEALING RING DIN 7603 A 48X55X2 CU	DICHTRING		
69	71 01 072 08	2	SEALING RING DIN 7603 A 38X44X2 CU	DICHTRING		
70	71 01 059 08	1	SEALING RING DIN 7603 A 27X32X2 CU	DICHTRING		
91	96 48 195 08	1	HOSE LINES ADD HYDR ⇒ 2 977 005 96 48 195 08	SCHLAUCHLEITUNGEN ZUSATZ		
601	47 25 318 08	1	FLANGE JOINT EWSD38-S A3P	VERSCHRAUBUNG		
602	47 25 303 08	1	FLANGE JOINT EWSD28-L A3P	VERSCHRAUBUNG		
603	47 00 107 08	2	FLANGE JOINT SNV38-S A3P	VERSCHRAUBUNG		
604	47 02 334 08	2	FLANGE JOINT XW38-S A3P	VERSCHRAUBUNG		

6.2.2009

etk_en_de_074515 LR 1600/2

☐ 391 (2/2)

LIEBHERR

ADDITIONAL HYDR.SLEWING PLATFO
ZUSATZHYDRAULIK DREHBUEHNE

⇒ 2 977
91 57 756 08

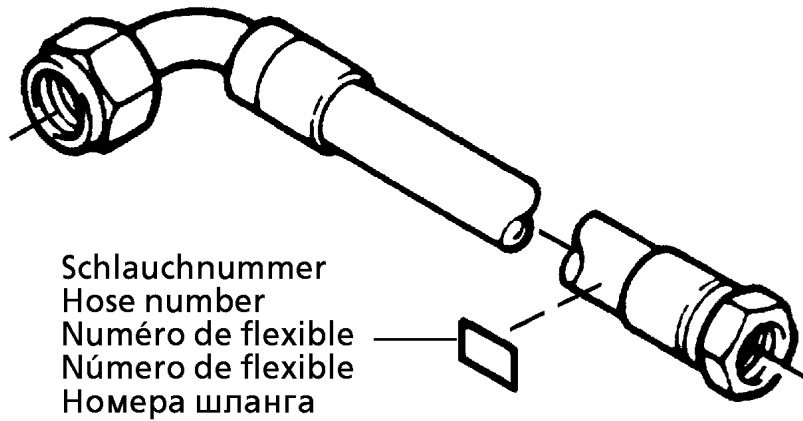

Schlauchnummer
Hose number
Número de flexible
Número de flexible
Номера шланга

Die Schlauchnummern auf den Schläuchen entsprechen den Positionen in der Schlauchliste.

The hose numbers from the hoses are in accordance with the items in the hose list.

Les numéros indiqués sur les flexibles correspondent aux repères de la nomenclature des flexibles.

Los números indicados en los flexibles corresponden a las posiciones de la lista de flexibles.

Нанесенные на шлангах номера соответствуют позициям в перечне.

Pos.	Item	Quantity	Description	Bezeichnung	Serie	K
1	60 27 601 08	1	NAME PLATE 25,4X101,6	BEZEICHNUNGSSCHILD		
2	60 27 603 08	7	NAME PLATE 25,4X165,1	BEZEICHNUNGSSCHILD		
1480	92 35 237 08	1	HOSE ASS CPL. 2TE 1,1M	SCHLAUCH KPL.		
1481	96 54 781 08	1	HOSE ASS CPL. 1SN 0,84M	SCHLAUCH KPL.		
1482	96 54 337 08	1	HOSE ASS CPL. 1SN 1,5M	SCHLAUCH KPL.		
1483	92 27 352 08	1	HOSE ASS CPL. 2755 1,04M	SCHLAUCH KPL.		
1484	96 51 905 08	1	HOSE ASS CPL. GH466 1,02M	SCHLAUCH KPL.		
1485	96 23 356 08	1	HOSE ASS CPL. GH466 1,1M	SCHLAUCH KPL.		
1486	96 51 906 08	1	HOSE ASS CPL. GH466 0,92M	SCHLAUCH KPL.		
1487	96 49 548 08	1	HOSE ASS CPL. GH466 1,12M	SCHLAUCH KPL.		

6.2.2009
133089

LIEBHERR

etk_en_de_074515 LR 1600/2

HOSE LINES ADD HYDR
SCHLAUCHLEITUNGEN ZUSATZHYDR.

392

⇒ 2 977 005
96 48 195 08

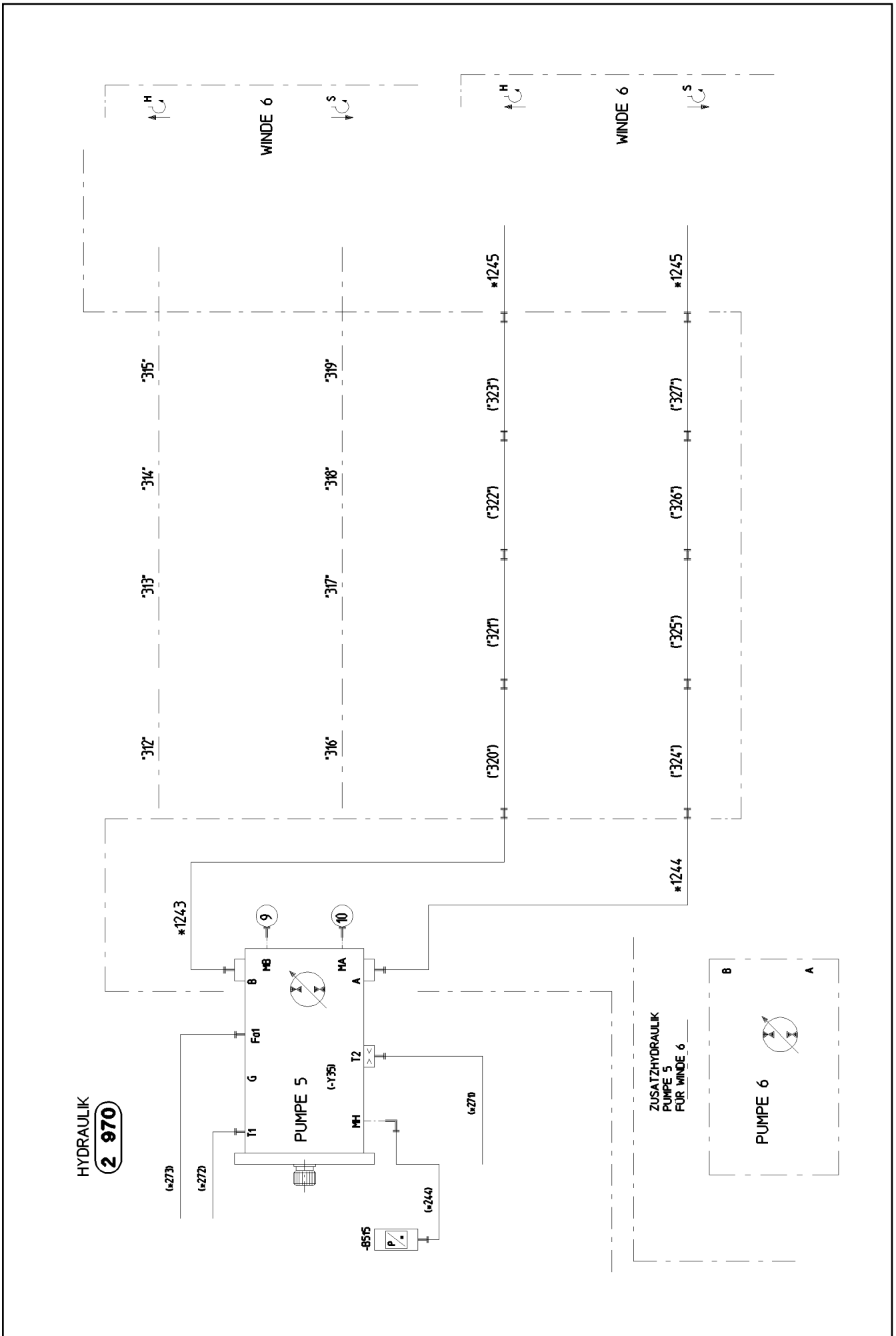

6.2.2009
052821

LIEBHERR

etk_en_de_074515 LR 1600/2

ADDITIONAL HYDR.PUMP/WINCH
ZUSATZHYDR.PUMPE 5/WINDE 6

393 (1/3)

⇒ 2 977 200
91 55 149 08

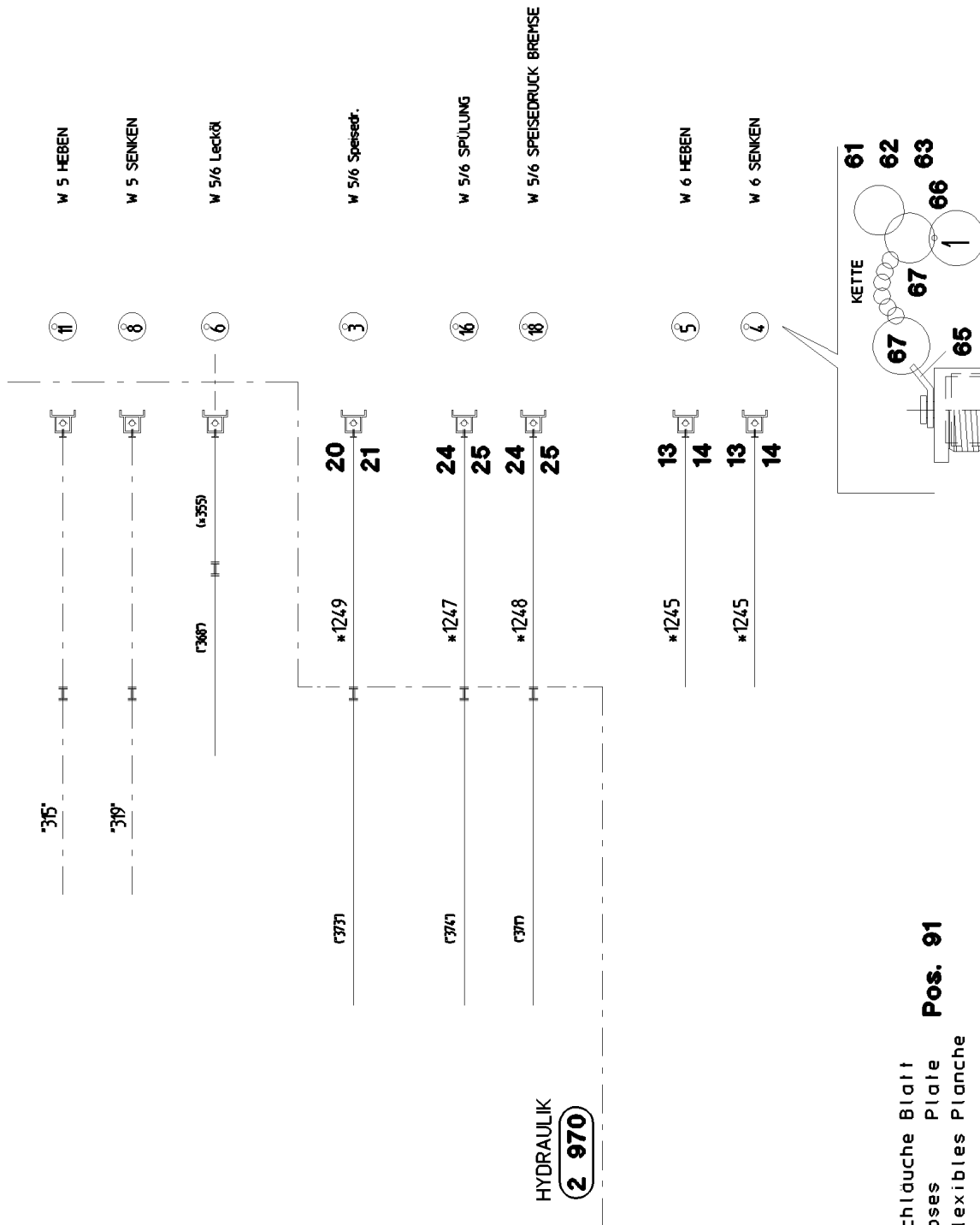

- Pos. 91**
- *1243 Schlauche Blatt
 - Hoses Plate
 - *1249 Flexibles Plancher

6.2.2009
052822

LIEBHERR

etk_en_de_074515 LR 1600/2

ADDITIONAL HYDR.PUMP/WINCH
ZUSATZHYDR.PUMPE 5/WINDE 6

□ 394 (2/3)

⇒ 2 977 200
91 55 149 08

Pos.	Item	Quantity	Description	Bezeichnung	Serie	K
13	51 15 123 08	2	COUPLING PLUG 38-S	KUPPLUNGSSTECKER		
14	51 05 455 08	2	SCREW PLUG	VERSCHLUSSSCHRAUBE		
20	51 15 011 08	1	COUPLING PLUG 28-L	KUPPLUNGSSTECKER		
21	10 46 691 2	1	SCREW PLUG RD54X4 SPF	VERSCHLUSSSCHRAUBE		
24	51 15 004 08	2	COUPLING PLUG 15-L	KUPPLUNGSSTECKER		
25	10 46 691 1	2	SCREW PLUG RD36X3 SPF	VERSCHLUSSSCHRAUBE		
61	71 01 072 08	1	SEALING RING DIN 7603 A 38X44X2 CU	DICHTRING		
62	71 01 070 08	1	SEALING RING DIN 7603 A 33X39X2 CU	DICHTRING		
63	71 01 077 08	2	SEALING RING DIN 7603 A 52X60X2,5 CU	DICHTRING		
65	97 59 516 08	7	PLATE 1X20X60	BLECH		
66	95 05 568 08	5	TRAILERS 25X2	ANHAENGER		
67	70 42 141 08	10	KEY RING 25	SCHLUESSELRING		
91	96 48 618 08	1	HOSES PUMP 6	SCHLAUCHLEITUNGEN PUMPE		
			⇒ 2 977 201	96 48 618 08		

6.2.2009

etk_en_de_074515 LR 1600/2

395 (3/3)

LIEBHERR

ADDITIONAL HYDR.PUMP/WINCH
ZUSATZHYDR.PUMPE 5/WINDE 6

⇒ 2 977 200
91 55 149 08

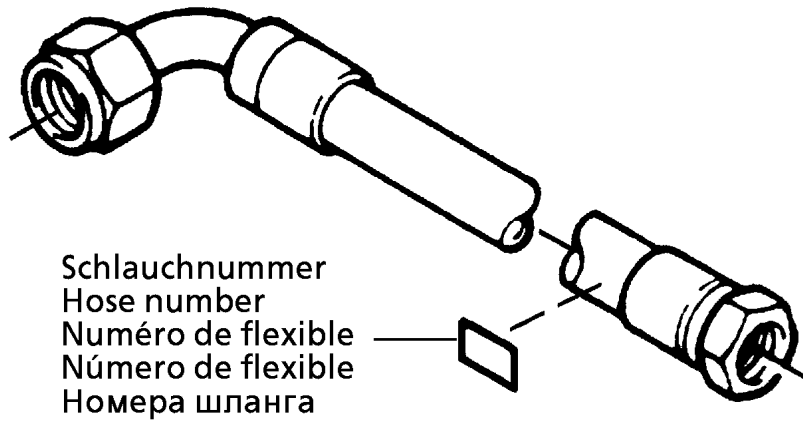

Die Schlauchnummern auf den Schläuchen entsprechen den Positionen in der Schlauchliste.

The hose numbers from the hoses are in accordance with the items in the hose list.

Les numéros indiqués sur les flexibles correspondent aux repères de la nomenclature des flexibles.

Los números indicados en los flexibles corresponden a las posiciones de la lista de flexibles.

Нанесенные на шлангах номера соответствуют позициям в перечне.

Pos.	Item	Quantity	Description	Bezeichnung	Serie	K
1	60 27 601 08	2	NAME PLATE 25,4X101,6	BEZEICHNUNGSSCHILD		
2	60 27 603 08	5	NAME PLATE 25,4X165,1	BEZEICHNUNGSSCHILD		
1243	96 51 908 08	1	HOSE ASS CPL. GH506 0,74M	SCHLAUCH KPL.		
1244	96 51 909 08	1	HOSE ASS CPL. GH506 0,62M	SCHLAUCH KPL.		
1245	96 51 907 08	2	HOSE ASS CPL. GH466 1,6M	SCHLAUCH KPL.		
1247	92 76 030 08	1	HOSE ASS CPL. 2SN 1,85M	SCHLAUCH KPL.		
1248	92 76 030 08	1	HOSE ASS CPL. 2SN 1,85M	SCHLAUCH KPL.		
1249	92 75 706 08	1	HOSE ASS CPL. 1SN 1,7M	SCHLAUCH KPL.		

6.2.2009
133089

LIEBHERR

etk_en_de_074515 LR 1600/2

HOSES PUMP 6
SCHLAUCHLEITUNGEN PUMPE 6

396

⇒ 2 977 201
96 48 618 08

- *1220 Schläuche Blatt
- Hoses
*1224 Flexibles Planche
- Pos. 91**
- *180" Rohre Blatt
- Pipes
*190" Tuyaux
- Pos. 93**

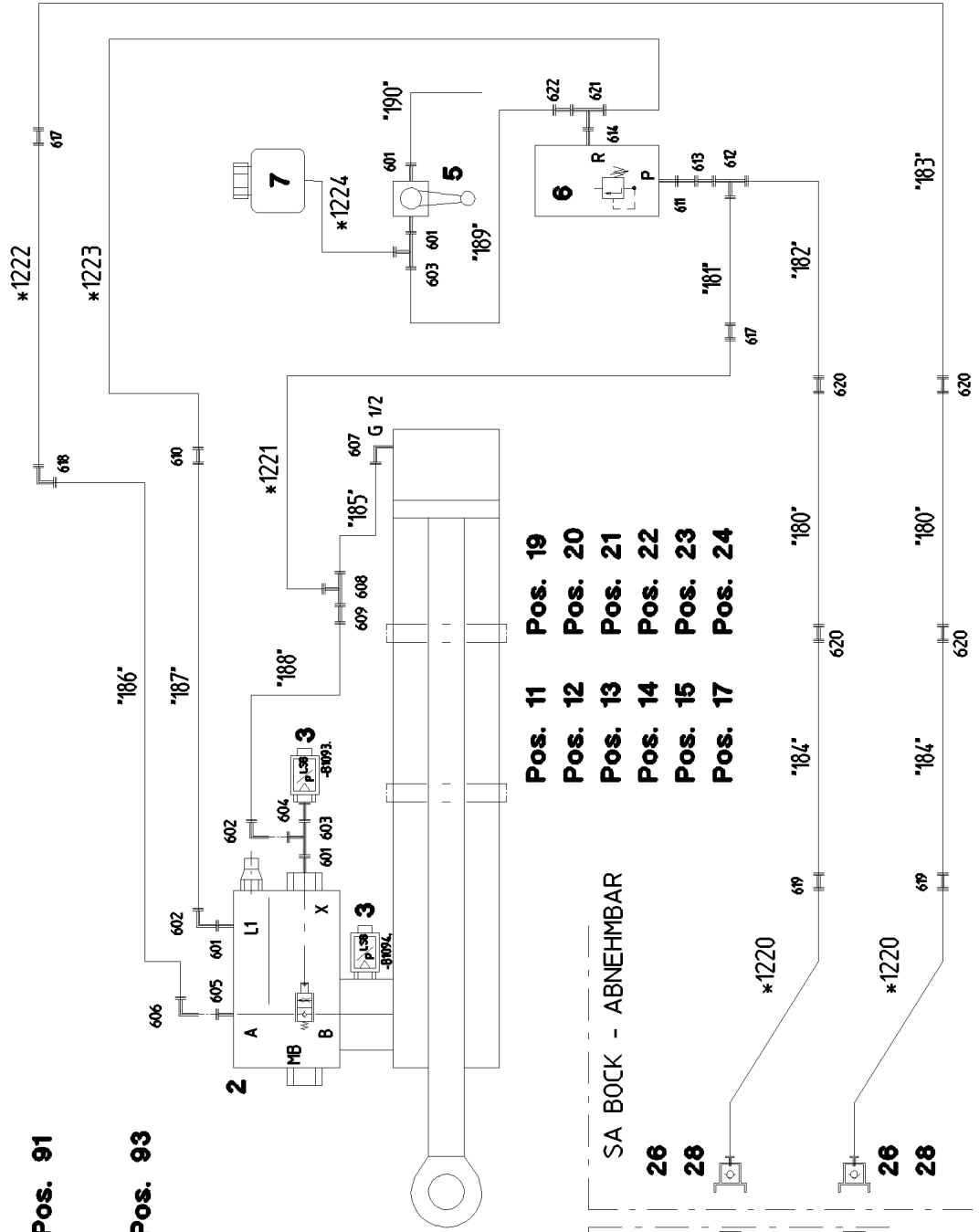

- Pos. 11 Pos. 19
- Pos. 12 Pos. 20
- Pos. 13 Pos. 21
- Pos. 14 Pos. 22
- Pos. 15 Pos. 23
- Pos. 17 Pos. 24

SA BOCK - ABNEHMBAR

26
28

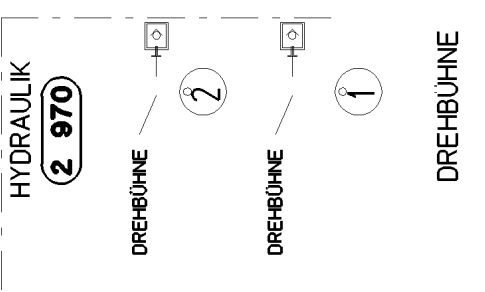

DREHBÜHNE

SA BOCK

6.2.2009
052819

LIEBHERR

etk_en_de_074515 LR 1600/2

ADDNL.HYDR.ERECTION DEVICE
ZUSATZHYDR.MONTAGEEINRICHTUNG

397 (1/2)

⇒ 2 978 100
91 52 796 08

Pos.	Item	Quantity	Description	Bezeichnung	Serie	K
2	10 21 769 5	1	LOWERING BRAKE VALVE 420BAR 60L/MIN ⇒ X10217695 10 21 769 5	SENKBREMSVENTIL		
3	96 47 919 08	1	PRESSURE SENSOR ERECT. DEVICE	DRUCKGEBER MONTAGEEINR		
(1)	69 23 125 08	2	PRESSURE SENSOR SPF	DRUCKAUFNEHMER		
5	51 06 960 08	1	BALL VALVE DN8-1/4" MS	KUGELHAHN		
6	51 14 177 08	1	PRESSURE LIMITING VALVE ⇒ 5 114 177 08 51 14 177 08	DRUCKBEGRENZUNGSVENTIL		
7	50 28 065 08	1	EQUALIZING RESERVOIR ⇒ 5 028 065 08 50 28 065 08	AUSGLEICHSBEHAELTER		
11	77 42 283 08	2	HOSE CLAMP 176-184 ST	SCHLAUCHSCHELLE		
12	77 42 157 08	4	CONSOLE	KONSOLE		
13	95 41 173 08	4	CARRIER RAIL 140	TRAGSCHIENE		
14	10 41 285 4	8	OVAL HEAD FLAT SCREW AEHNL.ISO7380	LINSENFLACHKOPFSCHRAUBE		
15	41 15 141 08	8	HEX NUT DIN 934 M8 8 A2C	SECHSKANTMUTTER		
17	60 20 180 08	8	NUT M6 VERZ	MUTTER		
19	73 62 946	6	CLAMP-HALF DIN 3015-1 L 2 R 16 PP SW	KLEMMHAELFTE		
20	40 42 003	6	CYLINDER SCREW ISO 4762 M6X25 8.8 A2C	ZYLINDERSCHRAUBE		
21	73 65 090	2	CLAMP-HALF DIN 3015-1 L 0 R 12 PP SW	KLEMMHAELFTE		
22	40 42 002	2	CYLINDER SCREW ISO 4762 M6X20 8.8 A2C	ZYLINDERSCHRAUBE		
23	60 20 089 08	40	CLAMP-HALF DIN 3015-1 L 4 R 30 PP SW	KLEMMHAELFTE		
24	40 42 107	40	CYLINDER SCREW ISO 4762 M6X35 8.8 A2C	ZYLINDERSCHRAUBE		
26	51 05 997 08	2	COUPLING PLUG 25-S	KUPPLUNGSSTECKER		
28	10 46 691 2	2	SCREW PLUG RD54X4 SPF	VERSCHLUSSSCHRAUBE		
91	96 47 912 08	1	HOSE LINES MOUNTING INSTAL. ⇒ 2 978 101 96 47 912 08	SCHLAUCHLEITUNGEN MONT		
93	96 47 913 08	1	PIPELINES MOUNTING DEVICE ⇒ 2 978 102 96 47 913 08	ROHRLEITUNGEN MONTAGEEIN		
601	47 10 306 08	4	FLANGE JOINT XGE10-LR-ED A3P	VERSCHRAUBUNG		
602	47 25 302 08	2	FLANGE JOINT EWSD10-L A3P	VERSCHRAUBUNG		
603	47 23 302 08	2	FLANGE JOINT ELSD10-L A3P	VERSCHRAUBUNG		
604	47 09 005 08	1	PRESSURE GAUGE CONNECTION A3P	MANOMETERANSCHLUSS		
605	47 10 332 08	1	FLANGE JOINT XGE16-SR-ED A3P	VERSCHRAUBUNG		
606	47 25 313 08	1	FLANGE JOINT EWSD16-S A3P	VERSCHRAUBUNG		
607	47 32 312 08	1	FLANGE JOINT RSWS16-SR-WD A3P	VERSCHRAUBUNG		
608	47 04 325 08	1	FLANGE JOINT T 16S CR6-FREI	VERSCHRAUBUNG		
609	47 54 335 08	1	FLANGE JOINT REDSD16/10-S A3P	VERSCHRAUBUNG		
610	47 00 303 08	1	FLANGE JOINT XG10-L A3P	VERSCHRAUBUNG		
611	47 19 018 08	1	FLANGE JOINT EGE 12S G1/2A CR6-FREI	VERSCHRAUBUNG		
612	47 04 329 08	1	FLANGE JOINT XT30-S A3P	VERSCHRAUBUNG		
613	47 54 340 08	1	FLANGE JOINT REDSDN30/12-S A3P	VERSCHRAUBUNG		
614	47 10 348 08	1	FLANGE JOINT XGE12-LR-ED1/2" A3P	VERSCHRAUBUNG		
617	47 50 337 08	2	FLANGE JOINT XGR30/16-S A3P	VERSCHRAUBUNG		
618	47 02 326 08	1	FLANGE JOINT XW16-S A3P	VERSCHRAUBUNG		
619	47 50 329 08	2	FLANGE JOINT XGR30/25-S A3P	VERSCHRAUBUNG		
620	47 00 330 08	4	FLANGE JOINT XG30-S A3P	VERSCHRAUBUNG		
621	47 24 302 08	1	FLANGE JOINT ETSD12-L A3P	VERSCHRAUBUNG		
622	47 54 314 08	1	FLANGE JOINT REDSD12/10-L A3P	VERSCHRAUBUNG		

6.2.2009

etk_en_de_074515 LR 1600/2

☐ 398 (2/2)

LIEBHERRADDNL.HYDR.ERECTION DEVICE
ZUSATZHYDR.MONTAGEEINRICHTUNG⇒ 2 978 100
91 52 796 08

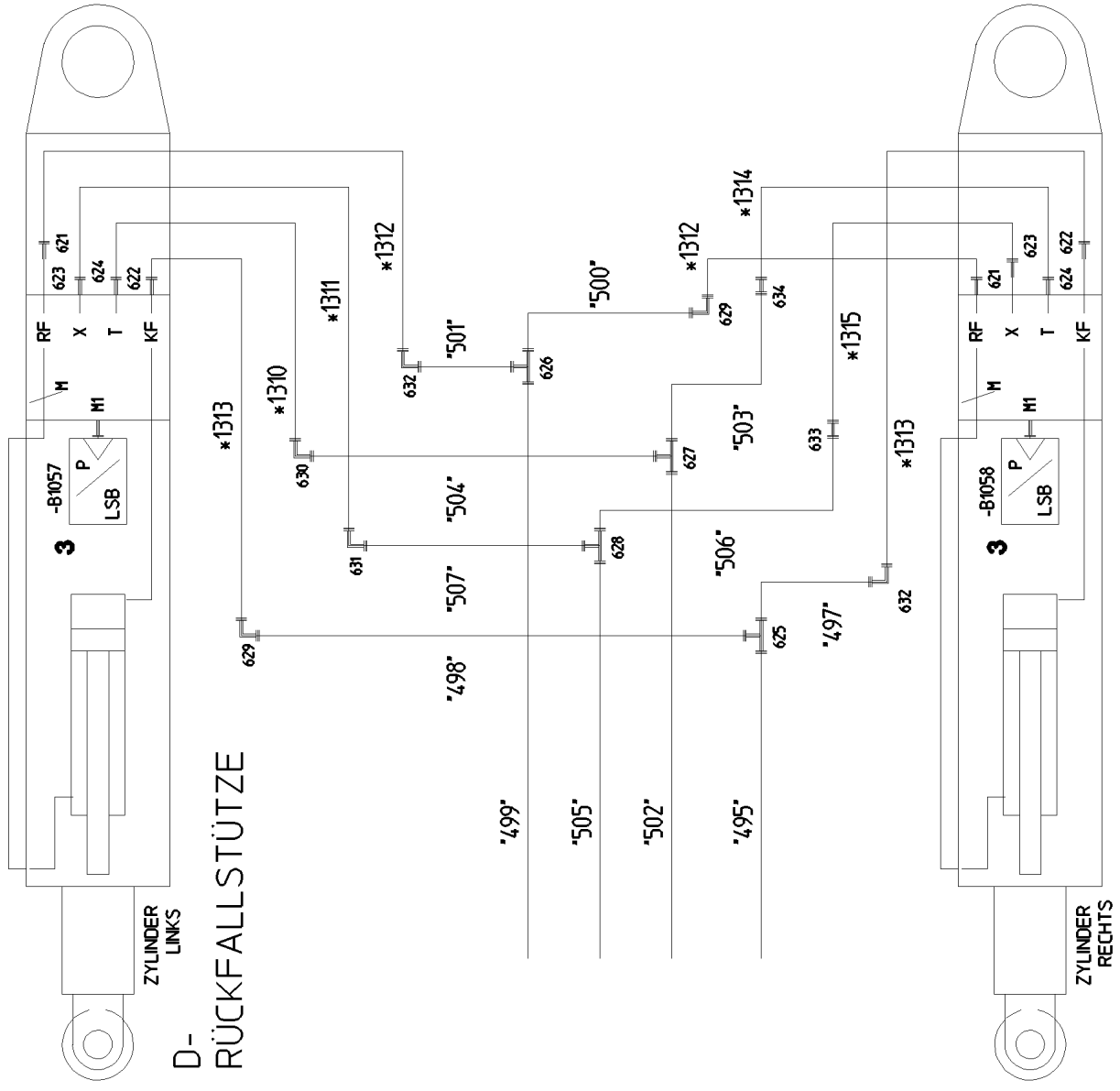

6.2.2009
055223

LIEBHERR

etk_en_de_074515 LR 1600/2

ADDNL.HYDR.RETAINING DEVICE
ZUSATZHYDR.D-RUECKHALTESICHER.

☐ 400 (2/4)

⇒ 2 978 100
91 52 827 08

Pos.	Item	Quantity	Description	Bezeichnung	Serie	K
3	96 47 916 08	1	PRESSURE SENS.RETAINING RAMS	DRUCKGEBER D-RUECKFALLPR		
(1)	69 23 126 08	2	PRESSURE SENSOR 400/400BAR SPF	DRUCKAUFNEHMER		
4	51 14 444 08	1	DIRECTIONAL CONTROL VALVE	WEGEVENTIL		
			⇒ 5 114 444 08 51 14 444 08			
5	51 14 689 08	1	SHUTTLE VALVE	WECHSELVENTIL		
7	51 06 711 08	1	FILTER CARTRIDGE	FILTERPATRONE		
8	51 10 487 08	1	NOZZLE 0,4 MS	DUESE		
10	51 14 177 08	1	PRESSURE LIMITING VALVE	DRUCKBEGRENZUNGSVENTIL		
			⇒ 5 114 177 08 51 14 177 08			
11	51 13 082 08	1	PRETENSIONING VALVE 30BAR	VORSPANNVENTIL		
12	50 28 065 08	1	EQUALIZING RESERVOIR	AUSGLEICHSBEHAELTER		
			⇒ 5 028 065 08 50 28 065 08			
21	51 05 997 08	1	COUPLING PLUG 25-S	KUPPLUNGSSTECKER		
22	10 46 690 8	2	SCREW PLUG RD54X4 SPF	VERSCHLUSSSCHRAUBE		
23	51 15 081 08	1	COUPLING PLUG 22-L	KUPPLUNGSSTECKER		
25	51 15 086 08	1	COUPLING PLUG 16-S	KUPPLUNGSSTECKER		
26	10 46 690 7	1	SCREW PLUG RD36X3 SPF	VERSCHLUSSSCHRAUBE		
61	77 34 003 08	2	ROPE DIN 3055 2MM 2,3KN FE	SEIL		
62	77 39 200 08	3	WIRE ROPE CLAMP DIN 3093 2 AL	PRESSKLEMME		
63	70 42 141 08	3	KEY RING 25	SCHLUESSELRING		
64	95 05 568 08	3	TRAILERS 25X2	ANHAENGER		
65	97 59 516 08	2	PLATE 1X20X60	BLECH		
68	71 01 072 08	1	SEALING RING DIN 7603 A 38X44X2 CU	DICHTRING		
69	71 01 070 08	1	SEALING RING DIN 7603 A 33X39X2 CU	DICHTRING		
70	71 01 059 08	1	SEALING RING DIN 7603 A 27X32X2 CU	DICHTRING		
91	96 50 433 08	1	HOSE LINES GUY MOUNTING	SCHLAUCHLEITUNGEN D-RUEC		
			⇒ 2 978 107 96 50 433 08			
93	96 44 195 08	1	PIPELINES DERR.	ROHRLEITUNGEN DERRICK		
			⇒ 2 978 108 96 44 195 08			
601	47 19 012 08	2	FLANGE JOINT EGESD12-LR-WD A3P	VERSCHRAUBUNG		
602	47 19 043 08	1	FLANGE JOINT EGE 10L G3/8A CR6-FREI	VERSCHRAUBUNG		
603	47 24 314 08	1	FLANGE JOINT ETSD12-S A3P	VERSCHRAUBUNG		
604	47 25 305 08	1	FLANGE JOINT EWSD12-L A3P	VERSCHRAUBUNG		
605	47 50 325 08	1	FLANGE JOINT XGR16/12-S A3P	VERSCHRAUBUNG		
606	51 06 290 08	2	WELD SOCKET DKO 10L	MESSSTUTZEN		
607	47 54 329 08	1	FLANGE JOINT REDSD12/6-S A3P	VERSCHRAUBUNG		
608	47 25 302 08	3	FLANGE JOINT EWSD10-L A3P	VERSCHRAUBUNG		
609	47 54 318 08	2	FLANGE JOINT REDSD15/12-L A3P	VERSCHRAUBUNG		
610	47 24 304 08	1	FLANGE JOINT ETSD15-L A3P	VERSCHRAUBUNG		
611	47 04 305 08	1	FLANGE JOINT XT15-L A3P	VERSCHRAUBUNG		
612	47 19 035 08	1	FLANGE JOINT EGESD15-LR-WD A3P	VERSCHRAUBUNG		
613	47 10 310 08	1	FLANGE JOINT XGE15-LR-ED A3P	VERSCHRAUBUNG		
614	47 23 304 08	1	FLANGE JOINT ELSD15-L A3P	VERSCHRAUBUNG		
615	47 54 301 08	1	FLANGE JOINT REDSD15/10-L A3P	VERSCHRAUBUNG		
616	47 25 312 08	1	FLANGE JOINT EWSD12-S A3P	VERSCHRAUBUNG		
617	47 23 303 08	2	FLANGE JOINT ELSD12-L A3P	VERSCHRAUBUNG		
618	47 23 302 08	2	FLANGE JOINT ELSD10-L A3P	VERSCHRAUBUNG		
619	47 19 011 08	1	FLANGE JOINT EGESD10-LR-WD A3P	VERSCHRAUBUNG		
620	47 10 353 08	1	FLANGE JOINT XGE12-LR-ED1/4" A3P	VERSCHRAUBUNG		
621	47 10 314 08	2	FLANGE JOINT XGE22-LR-ED A3P	VERSCHRAUBUNG		
622	47 10 336 08	2	FLANGE JOINT XGE25-SR-ED A3P	VERSCHRAUBUNG		
623	47 10 306 08	2	FLANGE JOINT XGE10-LR-ED A3P	VERSCHRAUBUNG		
624	47 10 308 08	2	FLANGE JOINT XGE12-LR-ED A3P	VERSCHRAUBUNG		
625	47 04 327 08	1	FLANGE JOINT XT25-S A3P	VERSCHRAUBUNG		
626	47 04 307 08	3	FLANGE JOINT T 22L CR6-FREI	VERSCHRAUBUNG		
627	47 04 304 08	1	FLANGE JOINT XT12-L A3P	VERSCHRAUBUNG		
628	47 04 303 08	1	FLANGE JOINT XT10-L A3P	VERSCHRAUBUNG		
629	47 02 328 08	3	FLANGE JOINT XW25-S A3P	VERSCHRAUBUNG		
630	47 02 304 08	1	FLANGE JOINT XW12-L A3P	VERSCHRAUBUNG		
631	47 02 303 08	1	FLANGE JOINT XW10-L A3P	VERSCHRAUBUNG		

6.2.2009

etk_en_de_074515 LR 1600/2

 401 (3/4)
LIEBHERR
 ADDNL.HYDR.RETAINING DEVICE
 ZUSATZHYDR.D-RUECKHALTESICHER.

 ⇒ 2 978 100
 91 52 827 08

Pos.	Item	Quantity	Description	Bezeichnung	Serie	K
632	47 02 307 08	3	FLANGE JOINT XW22-L A3P	VERSCHRAUBUNG		
633	47 00 303 08	1	FLANGE JOINT XG10-L A3P	VERSCHRAUBUNG		
634	47 00 304 08	1	FLANGE JOINT XG12-L A3P	VERSCHRAUBUNG		
635	47 10 353 08	1	FLANGE JOINT XGE12-LR-ED1/4" A3P	VERSCHRAUBUNG		
636	47 00 327 08	1	FLANGE JOINT XG16-S A3P	VERSCHRAUBUNG		
637	47 00 307 08	1	FLANGE JOINT XG22-L A3P	VERSCHRAUBUNG		
638	47 00 329 08	1	FLANGE JOINT XG25-S A3P	VERSCHRAUBUNG		
639	47 54 355 08	2	FLANGE JOINT REDSD22/15-L A3P	VERSCHRAUBUNG		
640	47 54 361 08	1	FLANGE JOINT REDSD22/12-L A3P	VERSCHRAUBUNG		
641	47 24 303 08	1	FLANGE JOINT ETS10-L A3P	VERSCHRAUBUNG		
642	47 02 326 08	1	FLANGE JOINT XW16-S A3P	VERSCHRAUBUNG		
643	47 19 005 08	1	FLANGE JOINT EGESD12-SR-WD A3P	VERSCHRAUBUNG		
644	47 56 015 08	1	MEASURING CONNECTION BMA3 6S	MESSANSCHLUSS		

6.2.2009

etk_en_de_074515 LR 1600/2

402 (4/4)

LIEBHERR

ADDNL.HYDR.RETAINING DEVICE
ZUSATZHYDR.D-RUECKHALTESICHER.

⇒ 2 978 100
91 52 827 08



Schlauchnummer
Hose number
Número de flexible
Número de flexible
Номера шланга

Die Schlauchnummern auf den Schläuchen entsprechen den Positionen in der Schlauchliste.

The hose numbers from the hoses are in accordance with the items in the hose list.

Les numéros indiqués sur les flexibles correspondent aux repères de la nomenclature des flexibles.

Los números indicados en los flexibles corresponden a las posiciones de la lista de flexibles.

Нанесенные на шлангах номера соответствуют позициям в перечне.

Pos.	Item	Quantity	Description	Bezeichnung	Serie	K
1	60 27 601 08	2	NAME PLATE 25,4X101,6	BEZEICHNUNGSSCHILD		
2	60 27 603 08	4	NAME PLATE 25,4X165,1	BEZEICHNUNGSSCHILD		
1220	92 80 222 08	2	HOSE ASS CPL. 2755 1,42M	SCHLAUCH KPL.		
1221	92 56 341 08	1	HOSE ASS CPL. 2755 1,12M	SCHLAUCH KPL.		
1222	92 45 280 08	1	HOSE ASS CPL. 2755 0,96M	SCHLAUCH KPL.		
1223	96 24 770 08	1	HOSE ASS CPL. 1SC 2,0M	SCHLAUCH KPL.		
1224	96 49 567 08	1	HOSE ASS CPL. 2TE 0,22M	SCHLAUCH KPL.		

6.2.2009
133089

LIEBHERR

etk_en_de_074515 LR 1600/2

HOSE LINES MOUNTING INSTAL.
SCHLAUCHLEITUNGEN MONTAGEEINR.

403

⇒ 2 978 101
96 47 912 08

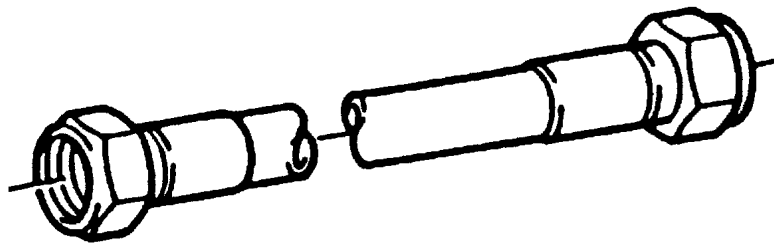

Die Positionsnummern der Rohre auf den Bildtafeln entsprechen den Positionen in der Rohrliste.

The pipe numbers from the illustrations are in accordance with the items in the pipe list.

Les numéros des tuyaux sur les illustrations correspondent aux repères de la nomenclature des tuyaux.

Los números de tubos en las ilustraciones corresponden a las posiciones de la lista de tubos.

Номера позиций труб на изображениях соответствуют позициям в перечне труб.

Pos.	Item	Quantity	Description	Bezeichnung	Serie	K
180	96 51 731 08	2	PIPE COMPL. 30X4X3500	ROHR KPL.		
181	96 51 732 08	1	PIPE COMPL. 30X4X654	ROHR KPL.		
182	96 51 733 08	1	PIPE COMPL. 30X4X1733	ROHR KPL.		
183	96 51 734 08	1	PIPE COMPL. 30X4X3221	ROHR KPL.		
184	96 51 735 08	2	PIPE COMPL. 30X4X5473	ROHR KPL.		
185	96 51 736 08	1	PIPE COMPL. 16X2X495	ROHR KPL.		
186	96 51 737 08	1	PIPE COMPL. 16X2X2228	ROHR KPL.		
187	96 51 738 08	1	PIPE COMPL. 10X1,5X2021	ROHR KPL.		
188	96 51 739 08	1	PIPE COMPL. 10X1,5X1681	ROHR KPL.		
189	96 51 740 08	1	PIPE COMPL. 10X1,5X768	ROHR KPL.		
190	96 51 741 08	1	PIPE COMPL. 10X1,5X166	ROHR KPL.		

6.2.2009
133088

LIEBHERR

etk_en_de_074515 LR 1600/2

PIPELINES MOUNTING DEVICE
ROHRLEITUNGEN MONTAGEEINRICHT.

404

⇒ 2 978 102
96 47 913 08



Schlauchnummer
Hose number
Número de flexible
Número de flexible
Номера шланга

Die Schlauchnummern auf den Schläuchen entsprechen den Positionen in der Schlauchliste.

The hose numbers from the hoses are in accordance with the items in the hose list.

Les numéros indiqués sur les flexibles correspondent aux repères de la nomenclature des flexibles.

Los números indicados en los flexibles corresponden a las posiciones de la lista de flexibles.

Нанесенные на шлангах номера соответствуют позициям в перечне.

Pos.	Item	Quantity	Description	Bezeichnung	Serie	K
1	60 27 601 08	6	NAME PLATE 25,4X101,6	BEZEICHNUNGSSCHILD		
2	60 27 603 08	6	NAME PLATE 25,4X165,1	BEZEICHNUNGSSCHILD		
1307	96 31 991 08	1	HOSE ASS CPL. 2SN 2,5M	SCHLAUCH KPL.		
1308	96 54 735 08	1	HOSE ASS CPL. 2755 2,45M	SCHLAUCH KPL.		
1309	92 76 036 08	1	HOSE ASS CPL. 2SN 2,45M	SCHLAUCH KPL.		
1310	96 25 946 08	1	HOSE ASS CPL. 2SN 1,06M	SCHLAUCH KPL.		
1311	92 99 672 08	1	HOSE ASS CPL. 2SN 1,04M	SCHLAUCH KPL.		
1312	92 93 328 08	2	HOSE ASS CPL. 2SN 1,0M	SCHLAUCH KPL.		
1313	92 22 505 08	2	HOSE ASS CPL. 2755 1,0M	SCHLAUCH KPL.		
1314	92 68 547 08	1	HOSE ASS CPL. 2SN 0,88M	SCHLAUCH KPL.		
1315	96 41 973 08	1	HOSE ASS CPL. 2SN 0,86M	SCHLAUCH KPL.		
1316	96 54 736 08	1	HOSE ASS CPL. 2TE 0,98M	SCHLAUCH KPL.		

6.2.2009
133089

LIEBHERR

etk_en_de_074515 LR 1600/2

HOSE LINES GUY MOUNTING
SCHLAUCHLEITUNGEN D-RUECKHALTE

405

⇒ 2 978 107
96 50 433 08

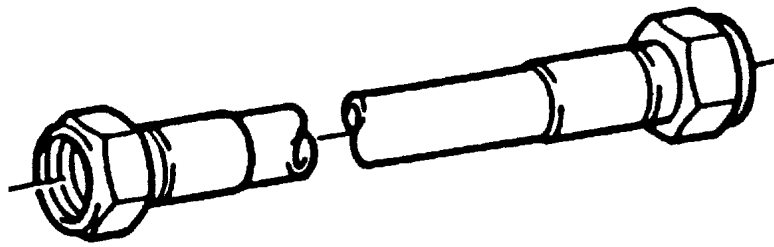

Die Positionsnummern der Rohre auf den Bildtafeln entsprechen den Positionen in der Rohrliste.

The pipe numbers from the illustrations are in accordance with the items in the pipe list.

Les numéros des tuyaux sur les illustrations correspondent aux repères de la nomenclature des tuyaux.

Los números de tubos en las ilustraciones corresponden a las posiciones de la lista de tubos.

Номера позиций труб на изображениях соответствуют позициям в перечне труб.

Pos.	Item	Quantity	Description	Bezeichnung	Serie	K
490	96 55 066 08	1	PIPE COMPL. 25X3X1938	ROHR KPL.		
491	96 55 067 08	1	PIPE COMPL. 16X2X1882	ROHR KPL.		
492	96 55 068 08	1	PIPE COMPL. 22X2,5X1776	ROHR KPL.		
493	96 55 069 08	1	PIPE COMPL. 22X2,5X1130	ROHR KPL.		
494	96 55 070 08	1	PIPE COMPL. 16X2X1714	ROHR KPL.		
495	96 55 071 08	1	PIPE COMPL. 25X3X1416	ROHR KPL.		
496	96 55 072 08	1	PIPE COMPL. 22X2,5X1530	ROHR KPL.		
497	96 55 073 08	1	PIPE COMPL. 25X3X325	ROHR KPL.		
498	96 55 074 08	1	PIPE COMPL. 25X3X2376	ROHR KPL.		
499	96 55 075 08	1	PIPE COMPL. 22X2,5X527	ROHR KPL.		
500	96 55 076 08	1	PIPE COMPL. 22X2,5X360	ROHR KPL.		
501	96 55 077 08	1	PIPE COMPL. 22X2,5X2407	ROHR KPL.		
502	96 55 078 08	1	PIPE COMPL. 12X1,5X366	ROHR KPL.		
503	96 55 079 08	1	PIPE COMPL. 12X1,5X329	ROHR KPL.		
504	96 55 080 08	1	PIPE COMPL. 12X1,5X2370	ROHR KPL.		
505	96 55 081 08	1	PIPE COMPL. 10X1,5X945	ROHR KPL.		
506	96 55 082 08	1	PIPE COMPL. 10X1,5X340	ROHR KPL.		
507	96 55 083 08	1	PIPE COMPL. 10X1,5X2374	ROHR KPL.		
508	96 55 084 08	1	PIPE COMPL. 15X1,5X666	ROHR KPL.		
509	96 55 085 08	1	PIPE COMPL. 15X1,5X621	ROHR KPL.		
510	96 55 086 08	1	PIPE COMPL. 12X1,5X280	ROHR KPL.		
511	96 55 087 08	1	PIPE COMPL. 10X1,5X86	ROHR KPL.		

6.2.2009
133088

LIEBHERR

etk_en_de_074515 LR 1600/2

PIPELINES DERR.
ROHRLEITUNGEN DERRICK

406

⇒ 2 978 108
96 44 195 08

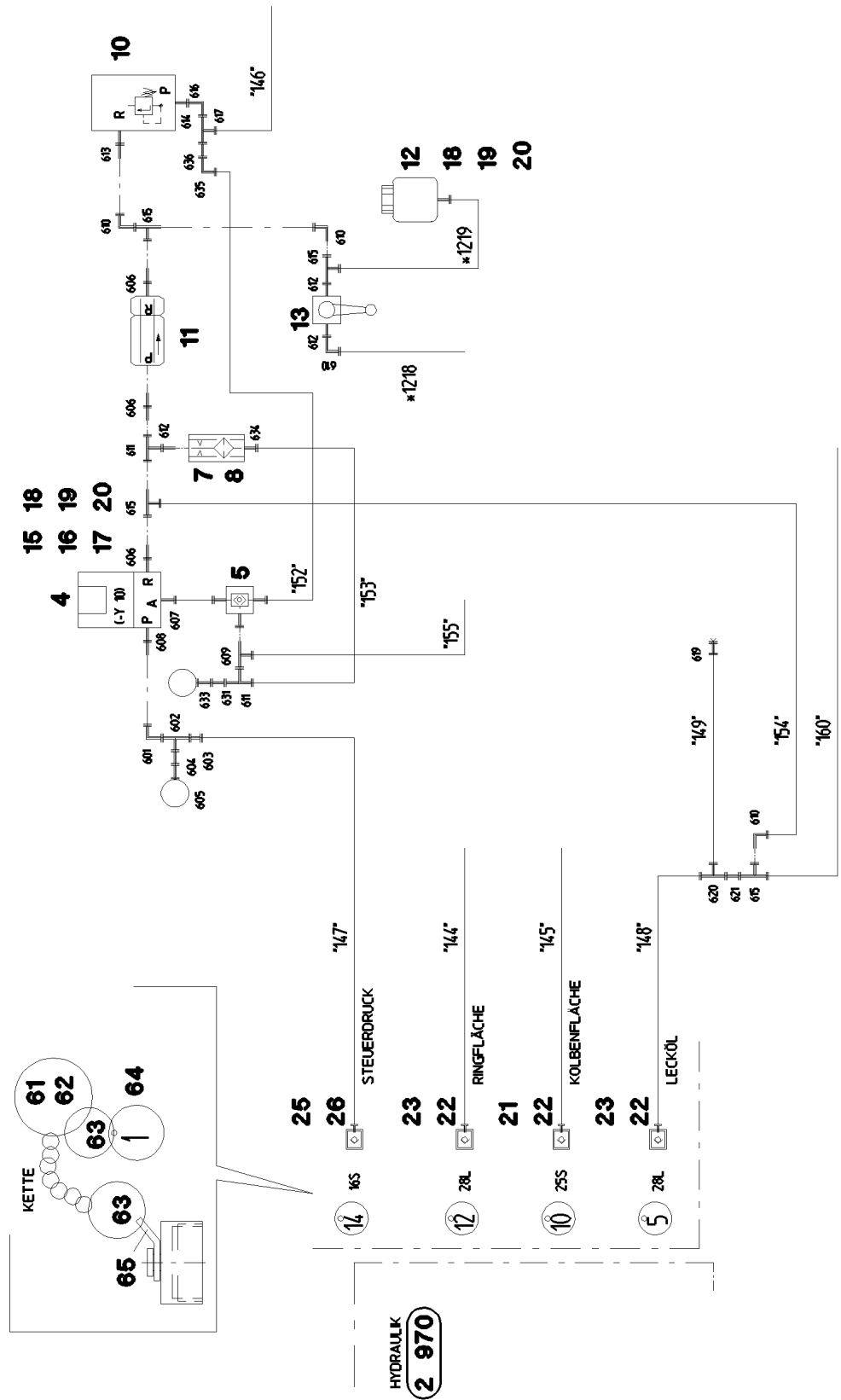

6.2.2009
052767

LIEBHERR

etk_en_de_074515 LR 1600/2

ADD.HYDR.S_RETAINING RAM
ZUSATZHYDR.S-RUECKHALTESICH.

□ 407 (1/4)

⇒ 2 978 200
91 54 843 08

* Pos. 91

• Pos. 93

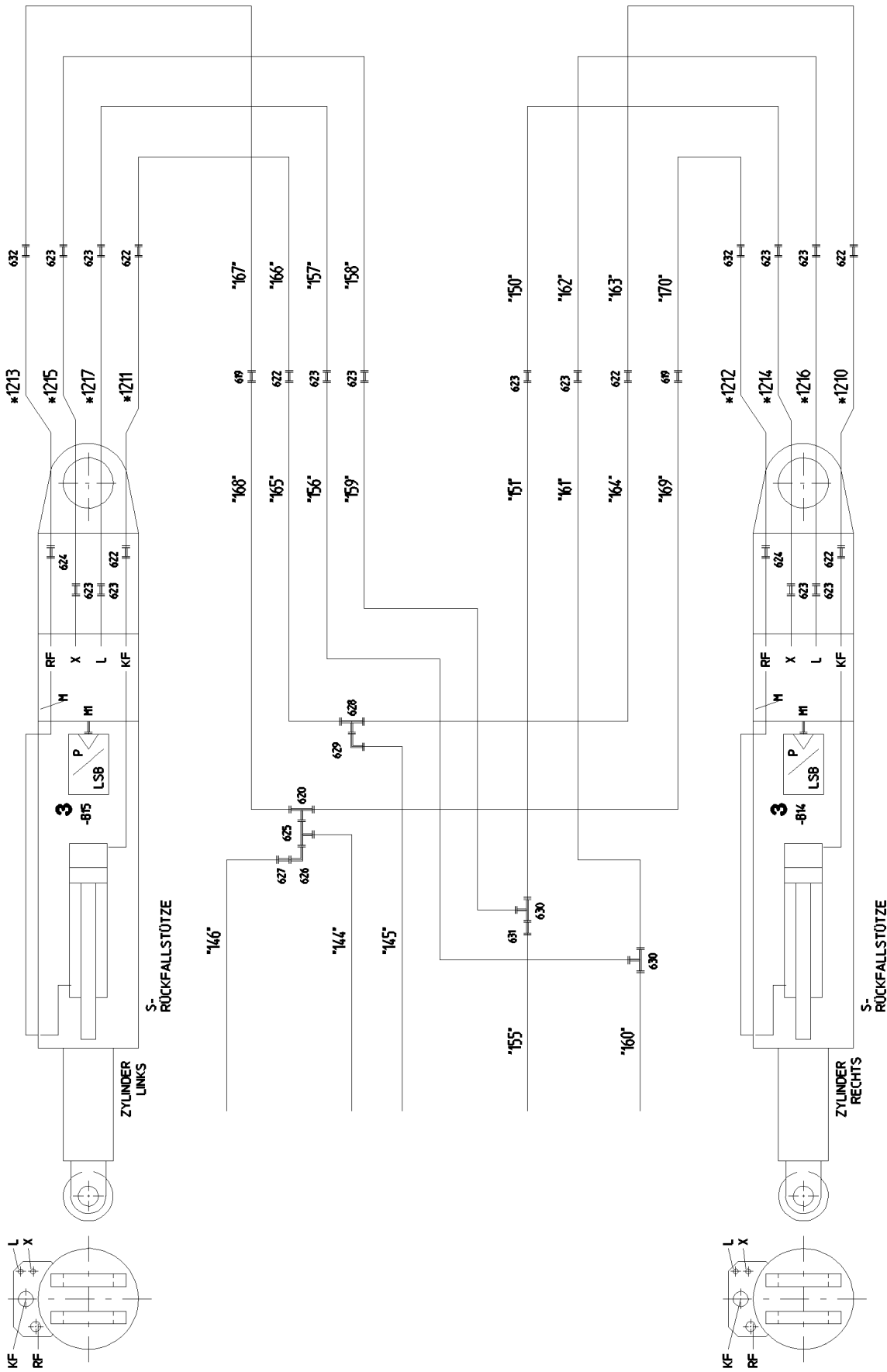

6.2.2009
052768

LIEBHERR

etk_en_de_074515 LR 1600/2

ADD.HYDR.S_RETAINING RAM
ZUSATZHYDR.S-RUECKHALTESICH.

408 (2/4)

→ 2 978 200
91 54 843 08

Pos.	Item	Quantity	Description	Bezeichnung	Serie	K
3	96 47 917 08	1	PRESSURE SENS.RETAINING RAMS	DRUCKGEBER S-RUECKFALLPR		
(1)	69 23 126 08	2	PRESSURE SENSOR 400/400BAR SPF	DRUCKAUFNEHMER		
4	51 14 444 08	1	DIRECTIONAL CONTROL VALVE	WEGEVENTIL		
			⇒ 5 114 444 08 51 14 444 08			
5	51 14 689 08	1	SHUTTLE VALVE	WECHSELVENTIL		
7	51 06 711 08	1	FILTER CARTRIDGE	FILTERPATRONE		
8	51 10 487 08	1	NOZZLE 0,4 MS	DUESE		
10	51 14 177 08	1	PRESSURE LIMITING VALVE	DRUCKBEGRENZUNGSVENTIL		
			⇒ 5 114 177 08 51 14 177 08			
11	51 13 082 08	1	PRETENSIONING VALVE 30BAR	VORSPANNVENTIL		
12	50 28 065 08	1	EQUALIZING RESERVOIR	AUSGLEICHSBEHAELTER		
			⇒ 5 028 065 08 50 28 065 08			
13	51 06 960 08	1	BALL VALVE DN8-1/4" MS	KUGELHAHN		
15	95 51 525 08	1	PLATE 4X60X103	BLECH		
16	10 41 285 7	2	OVAL HEAD FLAT SCREW AEHNL.ISO7380	LINSENFLACHKOPFSCHRAUBE		
17	41 15 141 08	2	HEX NUT DIN 934 M8 8 A2C	SECHSKANTMUTTER		
18	40 65 103	4	HEX BOLT ISO 4017 M6X10 8.8 A2C	SECHSKANTSCHRAUBE		
19	42 18 017 08	4	WASHER ISO 7093 A 6.4 A2	SCHEIBE		
20	41 15 140 08	2	HEX NUT DIN 934 M6 8 VERZ	SECHSKANTMUTTER		
21	51 05 996 08	1	COUPLING SLEEVE 25-S	KUPPLUNGSMUFFE		
22	51 05 458 08	3	HEX CAP NUT	VERSCHLUSSMUTTER		
23	51 15 010 08	2	COUPLING SLEEVE 28-L	KUPPLUNGSMUFFE		
25	51 15 086 08	1	COUPLING PLUG 16-S	KUPPLUNGSSTECKER		
26	51 05 453 08	1	HEX CAP NUT	VERSCHLUSSMUTTER		
61	71 01 075 08	3	SEALING RING DIN 7603 A 42X49X2 CU	DICHTRING		
62	71 01 059 08	1	SEALING RING DIN 7603 A 27X32X2 CU	DICHTRING		
63	70 42 141 08	8	KEY RING 25	SCHLUESSELRING		
64	95 05 568 08	4	TRAILERS 25X2	ANHAENGER		
65	97 59 516 08	4	PLATE 1X20X60	BLECH		
91	96 47 114 08	1	HOSE LINES	SCHLAUCHLEITUNGEN S-RUEC		
			⇒ 2 978 204 96 47 114 08			
93	96 47 115 08	1	PIPELINE S OVERRUN PROTECTION	ROHRLEITUNGEN S-RUECKHAL		
			⇒ 2 978 205 96 47 115 08			
598	47 74 017 08	1	BOX NUT DIN 3870 AL28 A3P	UEBERWURFMUTTER		
599	47 77 008 08	1	BUTZEN 28-L A3P	BUTZEN		
601	47 25 312 08	1	FLANGE JOINT EWSD12-S A3P	VERSCHRAUBUNG		
602	47 23 314 08	1	FLANGE JOINT ELSD12-S A3P	VERSCHRAUBUNG		
603	47 50 325 08	1	FLANGE JOINT XGR16/12-S A3P	VERSCHRAUBUNG		
604	47 54 329 08	1	FLANGE JOINT REDSD12/6-S A3P	VERSCHRAUBUNG		
605	47 56 015 08	1	MEASURING CONNECTION BMA3 6S	MESSANSCHLUSS		
606	47 19 012 08	3	FLANGE JOINT EGESD12-LR-WD A3P	VERSCHRAUBUNG		
607	47 19 043 08	1	FLANGE JOINT EGE 10L G3/8A CR6-FREI	VERSCHRAUBUNG		
608	47 19 005 08	1	FLANGE JOINT EGESD12-SR-WD A3P	VERSCHRAUBUNG		
609	47 23 302 08	1	FLANGE JOINT ELSD10-L A3P	VERSCHRAUBUNG		
610	47 25 305 08	4	FLANGE JOINT EWSD12-L A3P	VERSCHRAUBUNG		
611	47 24 302 08	2	FLANGE JOINT ETSD12-L A3P	VERSCHRAUBUNG		
612	47 10 353 08	3	FLANGE JOINT XGE12-LR-ED1/4" A3P	VERSCHRAUBUNG		
613	47 19 038 08	1	FLANGE JOINT EGESD12-LR-WD A3P	VERSCHRAUBUNG		
614	47 10 312 08	1	FLANGE JOINT XGE18-LR-ED A3P	VERSCHRAUBUNG		
615	47 23 303 08	4	FLANGE JOINT ELSD12-L A3P	VERSCHRAUBUNG		
616	47 25 304 08	1	FLANGE JOINT EWSD18-L A3P	VERSCHRAUBUNG		
617	47 23 305 08	1	FLANGE JOINT ELSD18-L A3P	VERSCHRAUBUNG		
619	47 00 308 08	3	FLANGE JOINT XG28-L A3P	VERSCHRAUBUNG		
620	47 04 308 08	2	FLANGE JOINT XT28-L A3P	VERSCHRAUBUNG		
621	47 54 357 08	1	FLANGE JOINT REDSDN28/12-L A3P	VERSCHRAUBUNG		
622	47 00 329 08	6	FLANGE JOINT XG25-S A3P	VERSCHRAUBUNG		
623	47 00 304 08	12	FLANGE JOINT XG12-L A3P	VERSCHRAUBUNG		
624	47 00 307 08	2	FLANGE JOINT XG22-L A3P	VERSCHRAUBUNG		
625	47 23 307 08	1	FLANGE JOINT EL 28L CR6-FREI	VERSCHRAUBUNG		
626	47 25 303 08	1	FLANGE JOINT EWSD28-L A3P	VERSCHRAUBUNG		

6.2.2009

etk_en_de_074515 LR 1600/2

☐ 409 (3/4)

LIEBHERRADD.HYDR.S_RETAINING RAM
ZUSATZHYDR.S-RUECKHALTESICH.⇒ 2 978 200
91 54 843 08

Pos.	Item	Quantity	Description	Bezeichnung	Serie	K
627	47 54 309 08	1	FLANGE JOINT REDSD28/18-L A3P	VERSCHRAUBUNG		
628	47 04 327 08	1	FLANGE JOINT XT25-S A3P	VERSCHRAUBUNG		
629	47 25 317 08	1	FLANGE JOINT EWSD25-S A3P	VERSCHRAUBUNG		
630	47 04 304 08	2	FLANGE JOINT XT12-L A3P	VERSCHRAUBUNG		
631	47 54 314 08	2	FLANGE JOINT REDSD12/10-L A3P	VERSCHRAUBUNG		
632	47 50 318 08	2	FLANGE JOINT XGR28/22-L A3P	VERSCHRAUBUNG		
633	51 06 290 08	1	WELD SOCKET DKO 10L	MESSSTUTZEN		
634	47 10 306 08	1	FLANGE JOINT XGE10-LR-ED A3P	VERSCHRAUBUNG		
635	47 25 302 08	1	FLANGE JOINT EWSD10-L A3P	VERSCHRAUBUNG		
636	47 54 303 08	1	FLANGE JOINT REDSD18/10-L A3P	VERSCHRAUBUNG		

6.2.2009

etk_en_de_074515 LR 1600/2

410 (4/4)

LIEBHERR

ADD.HYDR.S_RETAINING RAM
ZUSATZHYDR.S-RUECKHALTESICH.

⇒ 2 978 200
91 54 843 08



Schlauchnummer
Hose number
Número de flexible
Número de flexible
Номера шланга

Die Schlauchnummern auf den Schläuchen entsprechen den Positionen in der Schlauchliste.

The hose numbers from the hoses are in accordance with the items in the hose list.

Les numéros indiqués sur les flexibles correspondent aux repères de la nomenclature des flexibles.

Los números indicados en los flexibles corresponden a las posiciones de la lista de flexibles.

Нанесенные на шлангах номера соответствуют позициям в перечне.

Pos.	Item	Quantity	Description	Bezeichnung	Serie	K
1	60 27 601 08	6	NAME PLATE 25,4X101,6	BEZEICHNUNGSSCHILD		
2	60 27 603 08	4	NAME PLATE 25,4X165,1	BEZEICHNUNGSSCHILD		
1210	96 49 579 08	1	HOSE ASS CPL. 2755 0,46M	SCHLAUCH KPL.		
1211	92 87 114 08	1	HOSE ASS CPL. 2755 0,54M	SCHLAUCH KPL.		
1212	96 54 722 08	1	HOSE ASS CPL. 2SN 0,58M	SCHLAUCH KPL.		
1213	92 99 231 08	1	HOSE ASS CPL. 2SN 0,48M	SCHLAUCH KPL.		
1214	92 93 119 08	1	HOSE ASS CPL. 2SN 0,51M	SCHLAUCH KPL.		
1215	96 51 914 08	1	HOSE ASS CPL. 2SN 0,62M	SCHLAUCH KPL.		
1216	96 22 558 08	1	HOSE ASS CPL. 2SN 0,48M	SCHLAUCH KPL.		
1217	96 51 914 08	1	HOSE ASS CPL. 2SN 0,62M	SCHLAUCH KPL.		
1218	96 27 578 08	1	HOSE ASS CPL. 2TE 0,15M	SCHLAUCH KPL.		
1219	92 26 702 08	1	HOSE ASS CPL. 2TE 0,3M	SCHLAUCH KPL.		

6.2.2009
133089

LIEBHERR

etk_en_de_074515 LR 1600/2

HOSE LINES
SCHLAUCHLEITUNGEN S-RUECKFALL.

411

⇒ 2 978 204
96 47 114 08

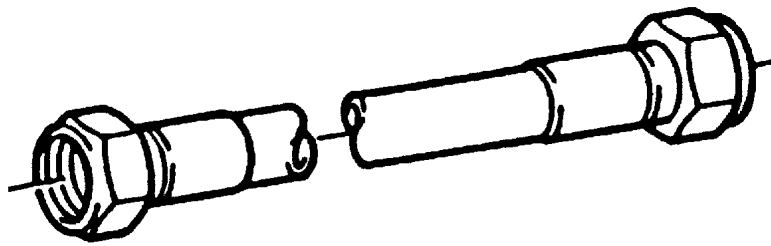

Die Positionsnummern der Rohre auf den Bildtafeln entsprechen den Positionen in der Rohrliste.

The pipe numbers from the illustrations are in accordance with the items in the pipe list.

Les numéros des tuyaux sur les illustrations correspondent aux repères de la nomenclature des tuyaux.

Los números de tubos en las ilustraciones corresponden a las posiciones de la lista de tubos.

Номера позиций труб на изображениях соответствуют позициям в перечне труб.

Pos.	Item	Quantity	Description	Bezeichnung	Serie	K
144	96 51 750 08	1	PIPE COMPL. 28X2X137	ROHR KPL.		
145	96 51 751 08	1	PIPE COMPL. 25X3X200	ROHR KPL.		
146	96 51 752 08	1	PIPE COMPL. 18X1,5X1383	ROHR KPL.		
147	96 51 753 08	1	PIPE COMPL. 16X2X1919	ROHR KPL.		
148	96 51 754 08	1	PIPE COMPL. 28X2X1570	ROHR KPL.		
149	96 51 755 08	1	PIPE COMPL. 28X2X1315	ROHR KPL.		
150	96 51 756 08	1	PIPE COMPL. 12X1,5X447	ROHR KPL.		
151	96 51 757 08	1	PIPE COMPL. 12X1,5X2259	ROHR KPL.		
152	96 51 758 08	1	PIPE COMPL. 10X1,5X289	ROHR KPL.		
153	96 51 759 08	1	PIPE COMPL. 10X1,5X376	ROHR KPL.		
154	96 51 760 08	1	PIPE COMPL. 12X1,5X829	ROHR KPL.		
155	96 52 296 08	1	PIPE COMPL. 10X1,5X860	ROHR KPL.		
156	96 52 297 08	1	PIPE COMPL. 12X1,5X3663	ROHR KPL.		
157	96 52 298 08	1	PIPE COMPL. 12X1,5X4100	ROHR KPL.		
158	96 52 299 08	1	PIPE COMPL. 12X1,5X4111	ROHR KPL.		
159	96 52 300 08	1	PIPE COMPL. 12X1,5X3363	ROHR KPL.		
160	96 52 301 08	1	PIPE COMPL. 12X1,5X2169	ROHR KPL.		
161	96 52 302 08	1	PIPE COMPL. 12X1,5X2329	ROHR KPL.		
162	96 52 303 08	1	PIPE COMPL. 12X1,5X2215	ROHR KPL.		
163	96 52 304 08	1	PIPE COMPL. 25X3X2160	ROHR KPL.		
164	96 52 305 08	1	PIPE COMPL. 25X3X3544	ROHR KPL.		
165	96 52 306 08	1	PIPE COMPL. 25X3X3014	ROHR KPL.		
166	96 52 307 08	1	PIPE COMPL. 25X3X2664	ROHR KPL.		
167	96 52 308 08	1	PIPE COMPL. 28X2X2917	ROHR KPL.		
168	96 52 309 08	1	PIPE COMPL. 28X2X2896	ROHR KPL.		
169	96 52 310 08	1	PIPE COMPL. 28X2X3255	ROHR KPL.		
170	96 52 311 08	1	PIPE COMPL. 28X2X2498	ROHR KPL.		

6.2.2009

etk_en_de_074515 LR 1600/2

413 (2/2)

LIEBHERR

PIPELINE S OVERRUN PROTECTION
ROHRLEITUNGEN S-RUECKHALTESICH

⇒ 2 978 205
96 47 115 08

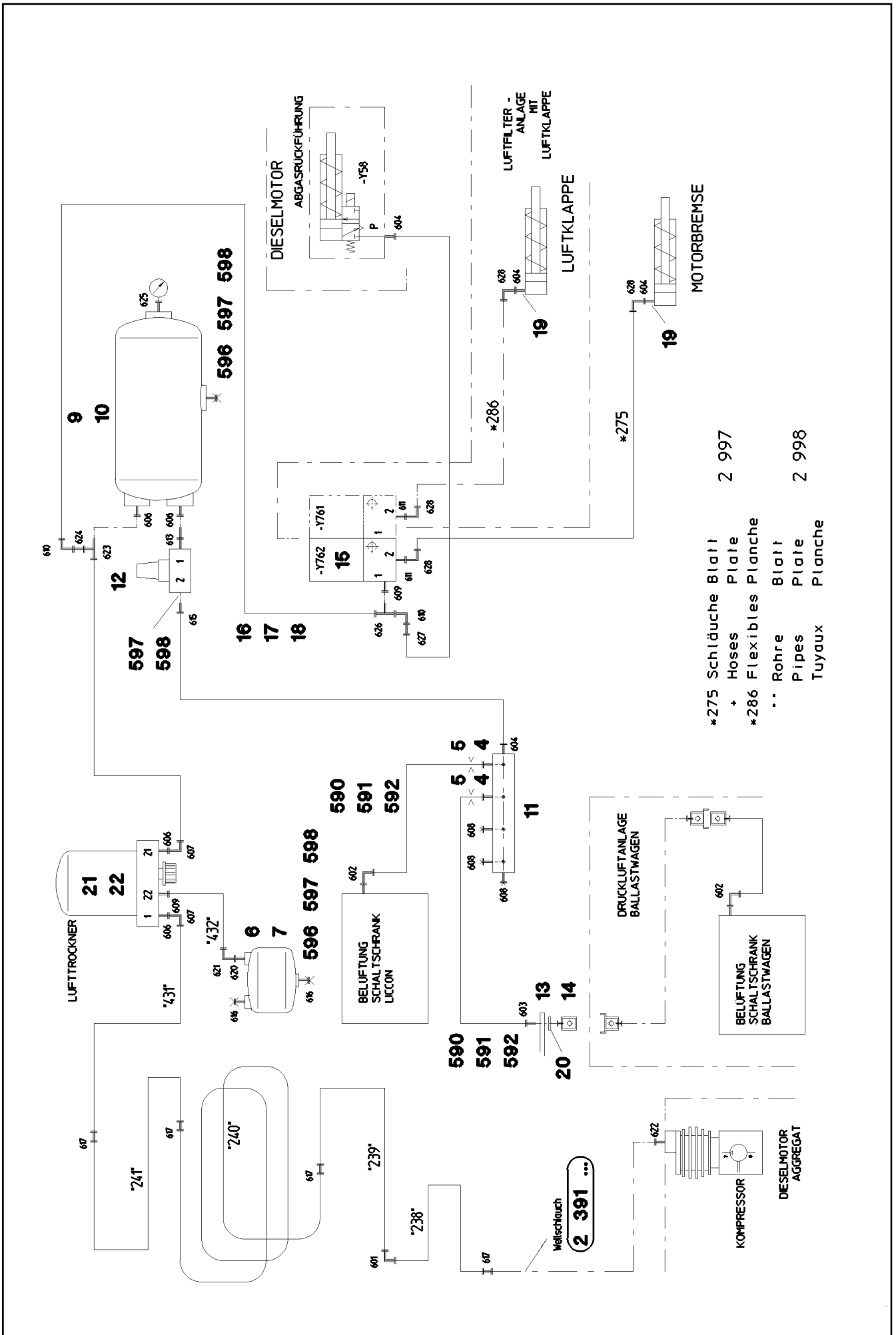

6.2.2009
055227

LIEBHERR

etk_en_de_074515 LR 1600/2

COMPRESSED AIR PLANT
DRUCKLUFTANLAGE

414 (1/2)

⇒ 2 990
91 59 244 08

Pos.	Item	Quantity	Description	Bezeichnung	Serie	K
4	95 62 043 08	2	FLANGE JOINT X0	VERSCHRAUBUNG		
5	51 07 543 08	2	NOZZLE 0,4	DUESE		
6	50 29 871 08	1	AIR BOTTLE DIN 74281 4.5L 15.5BAR ST	LUFTBEHAELTER		
7	77 42 113 08	1	TIGHTENING STRAP ST	SPANNBAND		
9	50 26 558 08	1	AIR BOTTLE 39,8L 10BAR ST	LUFTBEHAELTER		
10	77 42 105 08	2	TIGHTENING STRAP ST	SPANNBAND		
11	77 43 837 08	1	DISTRIBUTION STRIP	VERTEILERLEISTE		
12	50 26 628 08	1	OVERFLOW VALVE	UEBERSTROEMVENTIL		
13	51 15 062 08	1	CLOSING NIPPLE	VERSCHLUSSNIPPEL		
14	51 15 066 08	1	DUST CAP	STAUBKAPPE		
15	50 26 596 08	1	SOLENOID VALVE	MAGNETVENTIL		
16	40 00 970	2	HEX BOLT ISO 4014 M6X90 8.8 A2C	SECHSKANTSCHRAUBE		
17	41 15 141 08	2	HEX NUT DIN 934 M8 8 A2C	SECHSKANTMUTTER		
18	42 18 007 08	6	WASHER DIN 9021 A 6.4 VERZ	SCHEIBE		
19	71 01 018 08	4	SEALING RING DIN 7603 A 12X17X1,5 CU	DICHTRING		
20	71 01 060 08	1	SEALING RING DIN 7603 A 26X32X2 CU	DICHTRING		
21	50 26 573 08	1	AIR DRYER	LUFTTROCKNER		
			⇒ 5 026 573 08 50 26 573 08			
22	50 26 616 08	1	SILENCER	GERAEUSCHDAEMPFER		
590	47 74 001 08	2	BOX NUT DIN 3870 AS6 A3P	UEBERWURFMUTTER		
591	47 71 014 08	2	PROFILE RING PR6-S/L A3P	PROFILRING		
592	77 20 022 08	2	PLUG-IN SLEEVE E6-4	EINSTECKHUELSE		
593	47 74 015 08	1	BOX NUT DIN 3870 AL10 A3P	UEBERWURFMUTTER		
594	47 71 003 08	1	PROFILE RING PR10-S/L A3P	PROFILRING		
595	77 20 023 08	1	PLUG-IN SLEEVE E10-8	EINSTECKHUELSE		
596	50 29 401 08	2	SCREW PLUG M22X1,5 A3P	VERSCHLUSSSCHRAUBE		
597	50 29 329 08	4	O-RING 20,3X2,4 NBR70	O-RING		
598	50 29 325 08	4	COMPRESSION RING DR/R22X27	DRUCKRING		
601	47 02 306 08	1	FLANGE JOINT XW18-L A3P	VERSCHRAUBUNG		
602	47 25 315 08	2	FLANGE JOINT EWSD6-S A3P	VERSCHRAUBUNG		
603	47 10 321 08	1	FLANGE JOINT XGE6-SR-ED A3P	VERSCHRAUBUNG		
604	47 10 301 08	4	FLANGE JOINT XGE6-LM-ED A3P	VERSCHRAUBUNG		
605	95 62 043 08	1	FLANGE JOINT X0	VERSCHRAUBUNG		
606	47 10 311 08	4	FLANGE JOINT GE 18L M22X1,5 CR6-FREI	VERSCHRAUBUNG		
607	47 25 304 08	2	FLANGE JOINT EWSD18-L A3P	VERSCHRAUBUNG		
608	47 77 055 08	3	STOPPER PLUG VSTIM10X1ED A3P	BLINDSTOPFEN		
609	47 10 397 08	2	FLANGE JOINT ISO 8434-1 GE 10L M12X1,5	VERSCHRAUBUNG		
610	47 25 302 08	4	FLANGE JOINT EWSD10-L A3P	VERSCHRAUBUNG		
611	47 10 302 08	2	FLANGE JOINT XGE6-SM-ED A3P	VERSCHRAUBUNG		
613	47 19 023 08	1	FLANGE JOINT EGESD18-LM-WD A3P	VERSCHRAUBUNG		
615	50 29 461 08	1	FLANGE JOINT GA6-LM22X1,5 A3P	VERSCHRAUBUNG		
616	47 77 045 08	2	PLUG VSTIM22X1,5ED A3P	STOPFEN		
617	47 00 306 08	4	FLANGE JOINT XG18-L A3P	VERSCHRAUBUNG		
620	47 10 398 08	1	FLANGE JOINT XGE10-LM-ED A3P	VERSCHRAUBUNG		
622	47 66 076 08	1	FLANGE JOINT XGE18-LM A3P	VERSCHRAUBUNG		
623	47 23 305 08	1	FLANGE JOINT ELSD18-L A3P	VERSCHRAUBUNG		
624	47 54 303 08	1	FLANGE JOINT REDSD18/10-L A3P	VERSCHRAUBUNG		
625	50 29 214 08	1	TEST CONNECTION A3P	PRUEFANSCHLUSS		
626	47 24 303 08	1	FLANGE JOINT ETSD10-L A3P	VERSCHRAUBUNG		
627	47 54 310 08	1	FLANGE JOINT REDSD10/6-L A3P	VERSCHRAUBUNG		
628	47 25 300 08	4	FLANGE JOINT EWSD6-L A3P	VERSCHRAUBUNG		

6.2.2009

etk_en_de_074515 LR 1600/2

☐ 415 (2/2)

LIEBHERRCOMPRESSED AIR PLANT
DRUCKLUFTANLAGE⇒ 2 990
91 59 244 08

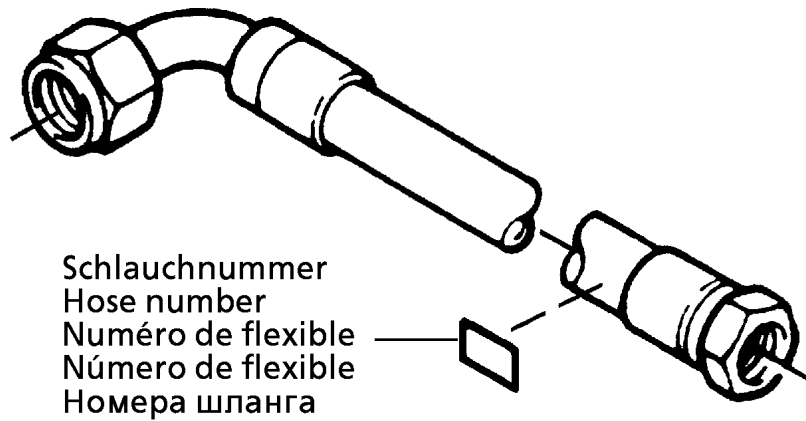

Die Schlauchnummern auf den Schläuchen entsprechen den Positionen in der Schlauchliste.

The hose numbers from the hoses are in accordance with the items in the hose list.

Les numéros indiqués sur les flexibles correspondent aux repères de la nomenclature des flexibles.

Los números indicados en los flexibles corresponden a las posiciones de la lista de flexibles.

Нанесенные на шлангах номера соответствуют позициям в перечне.

Pos.	Item	Quantity	Description	Bezeichnung	Serie	K
1	60 27 601 08	119	NAME PLATE 25,4X101,6	BEZEICHNUNGSSCHILD		
2	60 27 603 08	117	NAME PLATE 25,4X165,1	BEZEICHNUNGSSCHILD		
120	92 87 508 08	1	HOSE ASS CPL. 2TE 0,38M	SCHLAUCH KPL.		
121	92 76 825 08	1	HOSE ASS CPL. 2TE 0,64M	SCHLAUCH KPL.		
122	96 52 045 08	1	HOSE ASS CPL. 2SN 0,24M	SCHLAUCH KPL.		
123	96 52 046 08	1	HOSE ASS CPL. 2SN 0,92M	SCHLAUCH KPL.		
124	92 84 715 08	1	HOSE ASS CPL. 2SN 0,4M	SCHLAUCH KPL.		
125	92 76 164 08	1	HOSE ASS CPL. 2SN 0,62M	SCHLAUCH KPL.		
178	92 80 398 08	1	HOSE ASS CPL. 2TE 0,34M	SCHLAUCH KPL.		
179	92 88 722 08	1	HOSE ASS CPL. 2TE 0,62M	SCHLAUCH KPL.		
180	92 64 932 08	1	HOSE ASS CPL. 2TE 0,86M	SCHLAUCH KPL.		
181	96 31 691 08	1	HOSE ASS CPL. 2TE 0,47M	SCHLAUCH KPL.		
182	92 96 492 08	1	HOSE ASS CPL. 1SC 0,6M	SCHLAUCH KPL.		
183	92 66 066 08	1	HOSE ASS CPL. 2TE 0,8M	SCHLAUCH KPL.		
184	92 76 428 08	1	HOSE ASS CPL. 2SN 0,78M	SCHLAUCH KPL.		
185	92 80 057 08	1	HOSE ASS CPL. 2SN 0,2M	SCHLAUCH KPL.		
186	92 60 582 08	1	HOSE ASS CPL. 1SC 1,0M	SCHLAUCH KPL.		
187	96 51 587 08	1	HOSE ASS CPL. 2SN 0,66M	SCHLAUCH KPL.		
188	92 66 576 08	1	HOSE ASS CPL. 2SN 0,35M	SCHLAUCH KPL.		
189	96 37 039 08	1	HOSE ASS CPL. 2TE 0,26M	SCHLAUCH KPL.		
190	92 84 682 08	1	HOSE ASS CPL. 1SC 0,58M	SCHLAUCH KPL.		
191	92 87 642 08	1	HOSE ASS CPL. 2TE 0,43M	SCHLAUCH KPL.		
192	92 66 576 08	1	HOSE ASS CPL. 2SN 0,35M	SCHLAUCH KPL.		
193	92 32 286 08	1	HOSE ASS CPL. 2SN 0,33M	SCHLAUCH KPL.		
194	92 96 377 08	1	HOSE ASS CPL. 2TE 0,3M	SCHLAUCH KPL.		
195	92 87 646 08	1	HOSE ASS CPL. 2TE 0,34M	SCHLAUCH KPL.		
196	96 51 588 08	1	HOSE ASS CPL. 2SN 0,48M	SCHLAUCH KPL.		
197	92 67 113 08	1	HOSE ASS CPL. 1SC 0,34M	SCHLAUCH KPL.		
198	92 80 056 08	1	HOSE ASS CPL. 2SN 0,42M	SCHLAUCH KPL.		
199	96 38 237 08	1	HOSE ASS CPL. 2TE 0,74M	SCHLAUCH KPL.		
200	96 49 600 08	1	HOSE ASS CPL. GH466 1,32M	SCHLAUCH KPL.		
201	96 33 350 08	1	HOSE ASS CPL. GH466 1,15M	SCHLAUCH KPL.		
202	96 51 553 08	1	HOSE ASS CPL. GH466 1,5M	SCHLAUCH KPL.		
203	96 51 554 08	1	HOSE ASS CPL. GH466 1,75M	SCHLAUCH KPL.		
204	96 36 987 08	1	HOSE ASS CPL. GH506 0,62M	SCHLAUCH KPL.		
205	96 51 557 08	1	HOSE ASS CPL. GH506 0,7M	SCHLAUCH KPL.		
206	96 51 556 08	1	HOSE ASS CPL. GH506 1,44M	SCHLAUCH KPL.		
207	96 52 047 08	1	HOSE ASS CPL. GH506 1,44M	SCHLAUCH KPL.		
208	96 51 559 08	1	HOSE ASS CPL. 2SN 1,5M	SCHLAUCH KPL.		
209	96 51 560 08	1	HOSE ASS CPL. 2SN 1,1M	SCHLAUCH KPL.		
210	96 52 066 08	1	HOSE ASS CPL. 2755 0,9M	SCHLAUCH KPL.		
211	96 52 067 08	1	HOSE ASS CPL. 2755 0,88M	SCHLAUCH KPL.		
212	96 51 561 08	1	HOSE ASS CPL. 2755 1,2M	SCHLAUCH KPL.		
213	96 51 562 08	1	HOSE ASS CPL. 2755 1,55M	SCHLAUCH KPL.		
214	96 28 576 08	1	HOSE ASS CPL. GH506 1,65M	SCHLAUCH KPL.		
215	96 29 580 08	1	HOSE ASS CPL. 2SN 0,54M	SCHLAUCH KPL.		
216	92 84 567 08	1	HOSE ASS CPL. 2SN 0,56M	SCHLAUCH KPL.		
217	96 55 636 08	1	HOSE ASS CPL. 2SN 1,65M	SCHLAUCH KPL.		
219	96 25 348 08	1	HOSE ASS CPL. 1SC 0,8M	SCHLAUCH KPL.		
220	92 60 246 08	1	HOSE ASS CPL. 2TE 2,05M	SCHLAUCH KPL.		
221	92 26 313 08	1	HOSE ASS CPL. 1SN 0,86M	SCHLAUCH KPL.		
222	96 49 594 08	1	HOSE ASS CPL. 1SN 1,44M	SCHLAUCH KPL.		
223	96 49 595 08	1	HOSE ASS CPL. 1SN 1,34M	SCHLAUCH KPL.		
224	92 74 292 08	1	HOSE ASS CPL. 1SN 1,6M	SCHLAUCH KPL.		
225	96 49 596 08	1	HOSE ASS CPL. 1SN 0,8M	SCHLAUCH KPL.		
226	92 97 527 08	1	HOSE ASS CPL. 1SN 0,96M	SCHLAUCH KPL.		
227	96 26 895 08	1	HOSE ASS CPL. 1SN 0,98M	SCHLAUCH KPL.		
228	96 52 068 08	1	HOSE ASS CPL. 1SN 0,82M	SCHLAUCH KPL.		
229	92 61 308 08	1	HOSE ASS CPL. 1SN 0,7M	SCHLAUCH KPL.		
230	96 49 597 08	1	HOSE ASS CPL. 2TE 1,04M	SCHLAUCH KPL.		

6.2.2009

etk_en_de_074515 LR 1600/2

☐ 417 (2/5)

LIEBHERRHOSE LINES SUPERSTRUCTURE
SCHLAUCHLEITUNGEN OBERWAGEN⇒ 2 997
91 56 539 08

Pos.	Item	Quantity	Description	Bezeichnung	Serie	K
231	92 15 391 08	1	HOSE ASS CPL. 1SN 0,5M	SCHLAUCH KPL.		
232	96 49 598 08	1	HOSE ASS CPL. 1SN 0,94M	SCHLAUCH KPL.		
233	92 68 364 08	1	HOSE ASS CPL. 1SN 3,0M	SCHLAUCH KPL.		
234	92 97 467 08	1	HOSE ASS CPL. 1SN 1,0M	SCHLAUCH KPL.		
235	96 49 599 08	1	HOSE ASS CPL. 1SN 0,8M	SCHLAUCH KPL.		
236	96 46 874 08	1	HOSE ASS CPL. 1SN 1,55M	SCHLAUCH KPL.		
237	92 96 216 08	1	HOSE ASS CPL. 1SN 2,05M	SCHLAUCH KPL.		
238	96 47 719 08	1	HOSE ASS CPL. 2TE 0,88M	SCHLAUCH KPL.		
239	92 65 663 08	1	HOSE ASS CPL. 2TE 0,46M	SCHLAUCH KPL.		
240	96 47 719 08	1	HOSE ASS CPL. 2TE 0,88M	SCHLAUCH KPL.		
241	92 99 224 08	1	HOSE ASS CPL. 2TE 2,0M	SCHLAUCH KPL.		
242	92 06 036 08	1	HOSE ASS CPL. 1SN 1,36M	SCHLAUCH KPL.		
243	92 68 546 08	1	HOSE ASS CPL. 1SC 0,64M	SCHLAUCH KPL.		
244	92 09 958 08	1	HOSE ASS CPL. 2SN 1,85M	SCHLAUCH KPL.		
245	92 96 106 08	1	HOSE ASS CPL. 2TE 0,52M	SCHLAUCH KPL.		
246	92 97 535 08	1	HOSE ASS CPL. 2TE 0,96M	SCHLAUCH KPL.		
247	92 26 284 08	1	HOSE ASS CPL. 2TE 0,76M	SCHLAUCH KPL.		
248	92 30 874 08	1	HOSE ASS CPL. 2TE 0,5M	SCHLAUCH KPL.		
249	92 87 176 08	1	HOSE ASS CPL. 2TE 0,92M	SCHLAUCH KPL.		
250	92 60 962 08	1	HOSE ASS CPL. 2TE 1,85M	SCHLAUCH KPL.		
251	96 40 959 08	1	HOSE ASS CPL. 2TE 0,68M	SCHLAUCH KPL.		
252	92 76 825 08	1	HOSE ASS CPL. 2TE 0,64M	SCHLAUCH KPL.		
253	96 51 567 08	1	HOSE ASS CPL. 2TE 1,55M	SCHLAUCH KPL.		
254	96 49 593 08	1	HOSE ASS CPL. 2TE 0,5M	SCHLAUCH KPL.		
255	92 72 931 08	1	HOSE ASS CPL. 2TE 0,58M	SCHLAUCH KPL.		
256	92 60 417 08	1	HOSE ASS CPL. 2TE 0,5M	SCHLAUCH KPL.		
257	92 60 954 08	1	HOSE ASS CPL. 2TE 0,4M	SCHLAUCH KPL.		
258	92 64 954 08	1	HOSE ASS CPL. 2TE 1,36M	SCHLAUCH KPL.		
259	96 42 737 08	1	HOSE ASS CPL. 2TE 0,74M	SCHLAUCH KPL.		
260	92 61 392 08	1	HOSE ASS CPL. 2TE 1,7M	SCHLAUCH KPL.		
261	92 09 806 08	1	HOSE ASS CPL. 2SN 1,75M	SCHLAUCH KPL.		
262	92 74 187 08	1	HOSE ASS CPL. 2SN 1,7M	SCHLAUCH KPL.		
263	96 22 426 08	1	HOSE ASS CPL. 2SN 1,55M	SCHLAUCH KPL.		
264	92 24 554 08	1	HOSE ASS CPL. 2SN 0,4M	SCHLAUCH KPL.		
265	92 68 659 08	1	HOSE ASS CPL. 2SN 0,5M	SCHLAUCH KPL.		
266	10 04 167 5	1.1	SIPHON PIPE NW60X6,5 NBR SPF	SAUGSCHLAUCH		
267	10 04 167 5	1.2	SIPHON PIPE NW60X6,5 NBR SPF	SAUGSCHLAUCH		
268	10 34 353 0	2.4	SIPHON PIPE 76X6 NBR SPF	SAUGSCHLAUCH		
269	10 34 353 0	1.6	SIPHON PIPE 76X6 NBR SPF	SAUGSCHLAUCH		
270	10 34 353 0	0.22	SIPHON PIPE 76X6 NBR SPF	SAUGSCHLAUCH		
271	92 76 122 08	1	HOSE ASS CPL. 1SC 1,46M	SCHLAUCH KPL.		
272	96 24 526 08	1	HOSE ASS CPL. 2TE 0,82M	SCHLAUCH KPL.		
273	92 65 763 08	1	HOSE ASS CPL. 2TE 1,46M	SCHLAUCH KPL.		
274	92 68 678 08	1	HOSE ASS CPL. 2SN 0,7M	SCHLAUCH KPL.		
275	92 12 619 08	1	HOSE ASS CPL. TFS 1,0M	SCHLAUCH KPL.		
300	96 51 609 08	1	HOSE ASS CPL. GH466 1,34M	SCHLAUCH KPL.		
301	92 29 002 08	1	HOSE ASS CPL. 2755 1,75M	SCHLAUCH KPL.		
302	92 40 284 08	1	HOSE ASS CPL. 2755 1,7M	SCHLAUCH KPL.		
303	96 51 607 08	1	HOSE ASS CPL. GH466 1,46M	SCHLAUCH KPL.		
304	92 80 465 08	1	HOSE ASS CPL. 1SC 1,26M	SCHLAUCH KPL.		
305	92 64 194 08	1	HOSE ASS CPL. 2TE 1,34M	SCHLAUCH KPL.		
306	96 28 615 08	1	HOSE ASS CPL. 2TE 3,2M	SCHLAUCH KPL.		
307	92 61 198 08	1	HOSE ASS CPL. 1SC 0,66M	SCHLAUCH KPL.		
308	92 75 502 08	1	HOSE ASS CPL. 1SC 0,88M	SCHLAUCH KPL.		
309	92 88 791 08	1	HOSE ASS CPL. 1SC 0,48M	SCHLAUCH KPL.		
310	92 70 110 08	1	HOSE ASS CPL. 2TE 1,26M	SCHLAUCH KPL.		
311	92 61 496 08	1	HOSE ASS CPL. 2TE 3,3M	SCHLAUCH KPL.		
312	92 20 800 08	2	HOSE ASS CPL. 2755 1,65M	SCHLAUCH KPL.		
313	96 51 592 08	1	HOSE ASS CPL. 1SC 0,22M	SCHLAUCH KPL.		
314	92 66 122 08	1	HOSE ASS CPL. 2TE 0,32M	SCHLAUCH KPL.		

6.2.2009

etk_en_de_074515 LR 1600/2

 418 (3/5)
LIEBHERR
HOSE LINES SUPERSTRUCTURE
SCHLAUCHLEITUNGEN OBERWAGEN

⇒ 2 997
91 56 539 08

Pos.	Item	Quantity	Description	Bezeichnung	Serie	K
315	92 65 761 08	1	HOSE ASS CPL. 2TE 1,1M	SCHLAUCH KPL.		
316	96 51 593 08	1	HOSE ASS CPL. 2SN 0,46M	SCHLAUCH KPL.		
317	92 09 849 08	1	HOSE ASS CPL. 2SN 2,0M	SCHLAUCH KPL.		
318	92 93 122 08	1	HOSE ASS CPL. 2TE 1,55M	SCHLAUCH KPL.		
319	96 25 943 08	1	HOSE ASS CPL. 2TE 1,46M	SCHLAUCH KPL.		
320	96 51 917 08	1	HOSE ASS CPL. 2SN 0,86M	SCHLAUCH KPL.		
321	92 66 066 08	1	HOSE ASS CPL. 2TE 0,8M	SCHLAUCH KPL.		
322	96 52 071 08	1	HOSE ASS CPL. 2SN 0,8M	SCHLAUCH KPL.		
323	96 52 072 08	1	HOSE ASS CPL. 2SN 0,9M	SCHLAUCH KPL.		
324	96 51 595 08	1	HOSE ASS CPL. 2SN 2,55M	SCHLAUCH KPL.		
325	96 52 073 08	1	HOSE ASS CPL. 2SN 2,7M	SCHLAUCH KPL.		
326	92 76 383 08	1	HOSE ASS CPL. 1SC 2,7M	SCHLAUCH KPL.		
327	92 61 225 08	1	HOSE ASS CPL. 1SC 1,46M	SCHLAUCH KPL.		
328	92 74 496 08	1	HOSE ASS CPL. 2SN 0,23M	SCHLAUCH KPL.		
329	96 51 596 08	1	HOSE ASS CPL. 2SN 0,43M	SCHLAUCH KPL.		
330	96 51 596 08	1	HOSE ASS CPL. 2SN 0,43M	SCHLAUCH KPL.		
331	92 80 060 08	1	HOSE ASS CPL. 2SN 0,4M	SCHLAUCH KPL.		
332	92 80 363 08	1	HOSE ASS CPL. 2SN 0,94M	SCHLAUCH KPL.		
333	92 63 790 08	1	HOSE ASS CPL. 1SC 0,82M	SCHLAUCH KPL.		
334	92 80 170 08	1	HOSE ASS CPL. 2TE 1,0M	SCHLAUCH KPL.		
335	96 18 625 08	1	HOSE ASS CPL. 2TE 1,6M	SCHLAUCH KPL.		
336	92 88 607 08	1	HOSE ASS CPL. 2TE 2,3M	SCHLAUCH KPL.		
337	92 76 814 08	1	HOSE ASS CPL. 2TE 0,9M	SCHLAUCH KPL.		
338	92 87 626 08	1	HOSE ASS CPL. 2SN 1,85M	SCHLAUCH KPL.		
339	92 97 568 08	2	HOSE ASS CPL. 2SN 2,5M	SCHLAUCH KPL.		
340	96 52 074 08	1	HOSE ASS CPL. 2TE 2,7M	SCHLAUCH KPL.		
341	96 33 357 08	1	HOSE ASS CPL. 2SN 0,7M	SCHLAUCH KPL.		
342	92 60 254 08	1	HOSE ASS CPL. 1SC 0,4M	SCHLAUCH KPL.		
343	96 52 075 08	1	HOSE ASS CPL. 1SC 1,3M	SCHLAUCH KPL.		
344	96 51 598 08	1	HOSE ASS CPL. GH466 0,62M	SCHLAUCH KPL.		
345	96 51 599 08	1	HOSE ASS CPL. GH466 0,74M	SCHLAUCH KPL.		
346	96 51 600 08	1	HOSE ASS CPL. GH466 0,48M	SCHLAUCH KPL.		
347	96 51 601 08	1	HOSE ASS CPL. GH466 0,62M	SCHLAUCH KPL.		
348	96 51 602 08	1	HOSE ASS CPL. GH466 1,0M	SCHLAUCH KPL.		
349	96 51 603 08	1	HOSE ASS CPL. GH466 1,08M	SCHLAUCH KPL.		
350	92 69 710 08	1	HOSE ASS CPL. 2TE 0,5M	SCHLAUCH KPL.		
351	96 51 604 08	1	HOSE ASS CPL. 2TE 0,52M	SCHLAUCH KPL.		
352	96 28 573 08	1	HOSE ASS CPL. 2TE 0,54M	SCHLAUCH KPL.		
353	92 69 908 08	1	HOSE ASS CPL. 2TE 0,58M	SCHLAUCH KPL.		
354	92 88 897 08	1	HOSE ASS CPL. 2SN 0,6M	SCHLAUCH KPL.		
355	92 75 706 08	1	HOSE ASS CPL. 1SN 1,7M	SCHLAUCH KPL.		
356	92 97 535 08	1	HOSE ASS CPL. 2TE 0,96M	SCHLAUCH KPL.		
357	92 87 633 08	1	HOSE ASS CPL. 1SN 1,7M	SCHLAUCH KPL.		
358	92 60 732 08	1	HOSE ASS CPL. 2755 0,78M	SCHLAUCH KPL.		
359	92 22 817 08	1	HOSE ASS CPL. 2755 0,6M	SCHLAUCH KPL.		
360	96 49 576 08	1	HOSE ASS CPL. 2SN 0,86M	SCHLAUCH KPL.		
361	96 41 931 08	1	HOSE ASS CPL. 2SN 0,72M	SCHLAUCH KPL.		
362	92 27 451 08	1	HOSE ASS CPL. 2SN 0,8M	SCHLAUCH KPL.		
363	92 10 438 08	1	HOSE ASS CPL. 2SN 2,7M	SCHLAUCH KPL.		
364	92 12 548 08	1	HOSE ASS CPL. 2SN 3,6M	SCHLAUCH KPL.		
365	96 24 385 08	1	HOSE ASS CPL. 2SN 0,54M	SCHLAUCH KPL.		
366	92 80 058 08	1	HOSE ASS CPL. 2SN 0,6M	SCHLAUCH KPL.		
367	92 84 719 08	1	HOSE ASS CPL. 2TE 0,9M	SCHLAUCH KPL.		
368	96 51 606 08	1	HOSE ASS CPL. 2SN 7,9M	SCHLAUCH KPL.		
369	96 51 607 08	1	HOSE ASS CPL. GH466 1,46M	SCHLAUCH KPL.		
370	96 51 608 08	1	HOSE ASS CPL. GH466 1,4M	SCHLAUCH KPL.		
371	96 49 589 08	1	HOSE ASS CPL. 2TE 1,18M	SCHLAUCH KPL.		
372	92 72 524 08	1	HOSE ASS CPL. 2TE 1,4M	SCHLAUCH KPL.		
373	92 76 775 08	1	HOSE ASS CPL. 2TE 1,15M	SCHLAUCH KPL.		
374	92 76 918 08	1	HOSE ASS CPL. 2TE 2,55M	SCHLAUCH KPL.		

6.2.2009

etk_en_de_074515 LR 1600/2

 419 (4/5)
LIEBHERR
**HOSE LINES SUPERSTRUCTURE
SCHLAUCHLEITUNGEN OBERWAGEN**

 ⇒ 2 997
91 56 539 08

Pos.	Item	Quantity	Description	Bezeichnung	Serie	K
375	92 87 111 08	1	HOSE ASS CPL. 1SN 0,56M	SCHLAUCH KPL.		
376	92 97 579 08	1	HOSE ASS CPL. 1SN 1,2M	SCHLAUCH KPL.		
377	92 76 051 08	1	HOSE ASS CPL. 1SN 1,0M	SCHLAUCH KPL.		
378	96 51 610 08	1	HOSE ASS CPL. 2TE 1,0M	SCHLAUCH KPL.		
379	92 96 122 08	1	HOSE ASS CPL. 2SN 0,54M	SCHLAUCH KPL.		
380	96 39 296 08	1	HOSE ASS CPL. 2TE 0,64M	SCHLAUCH KPL.		
381	96 51 896 08	1	HOSE ASS CPL. 2755 0,86M	SCHLAUCH KPL.		
382	92 28 969 08	1	HOSE ASS CPL. 2755 0,7M	SCHLAUCH KPL.		
383	92 44 585 08	1	HOSE ASS CPL. 2755 1,06M	SCHLAUCH KPL.		
384	92 13 504 08	1	HOSE ASS CPL. 1SN 0,56M	SCHLAUCH KPL.		
385	92 93 776 08	1	HOSE ASS CPL. 1SC 1,04M	SCHLAUCH KPL.		
386	92 76 816 08	1	HOSE ASS CPL. 1SC 0,72M	SCHLAUCH KPL.		
387	96 54 282 08	1	HOSE ASS CPL. 2TE 3,3M	SCHLAUCH KPL.		
388	92 88 763 08	1	HOSE ASS CPL. 2TE 2,3M	SCHLAUCH KPL.		
389	96 27 618 08	1	HOSE ASS CPL. 1SN 1,55M	SCHLAUCH KPL.		
390	92 48 756 08	1	HOSE ASS CPL. 2755 1,9M	SCHLAUCH KPL.		
391	92 18 495 08	1	HOSE ASS CPL. 2755 0,62M	SCHLAUCH KPL.		
392	96 43 235 08	1	HOSE ASS CPL. 2755 0,76M	SCHLAUCH KPL.		
393	92 76 776 08	1	HOSE ASS CPL. 2SN 0,92M	SCHLAUCH KPL.		
394	92 87 660 08	1	HOSE ASS CPL. 2SN 0,35M	SCHLAUCH KPL.		
395	92 87 505 08	2	HOSE ASS CPL. 2TE 0,48M	SCHLAUCH KPL.		
396	96 54 283 08	1	HOSE ASS CPL. 2TE 0,28M	SCHLAUCH KPL.		
397	92 24 554 08	1	HOSE ASS CPL. 2SN 0,4M	SCHLAUCH KPL.		
398	92 09 765 08	1	HOSE ASS CPL. 2SN 0,33M	SCHLAUCH KPL.		
399	92 80 058 08	1	HOSE ASS CPL. 2SN 0,6M	SCHLAUCH KPL.		
400	92 64 556 08	1	HOSE ASS CPL. 2755 1,8M	SCHLAUCH KPL.		
401	92 93 259 08	2	HOSE ASS CPL. 2SN 0,32M	SCHLAUCH KPL.		
402	96 55 637 08	1	HOSE ASS CPL. 1SN 2,85M	SCHLAUCH KPL.		
403	96 55 638 08	1	HOSE ASS CPL. 1SN 1,95M	SCHLAUCH KPL.		
430	92 61 458 08	1	HOSE ASS CPL. 2TE 5,0M	SCHLAUCH KPL.		
431	92 97 516 08	1	HOSE ASS CPL. 2TE 4,7M	SCHLAUCH KPL.		
432	92 99 240 08	1	HOSE ASS CPL. 2TE 0,66M	SCHLAUCH KPL.		
450	96 38 619 08	1	HOSE ASS CPL. HPC 2,9M	SCHLAUCH KPL.		
451	92 14 563 08	1	HOSE ASS CPL. HPC 0,6M	SCHLAUCH KPL.		
452	96 51 948 08	1	HOSE ASS CPL. HPC 1,06M	SCHLAUCH KPL.		
453	96 52 070 08	1	HOSE ASS CPL. HPC 2,7M	SCHLAUCH KPL.		
454	96 38 619 08	1	HOSE ASS CPL. HPC 2,9M	SCHLAUCH KPL.		
455	96 54 779 08	1	HOSE ASS CPL. HPC 12,3M	SCHLAUCH KPL.		

6.2.2009

etk_en_de_074515 LR 1600/2

420 (5/5)

LIEBHERR

HOSE LINES SUPERSTRUCTURE
SCHLAUCHLEITUNGEN OBERWAGEN

⇒ 2 997
91 56 539 08

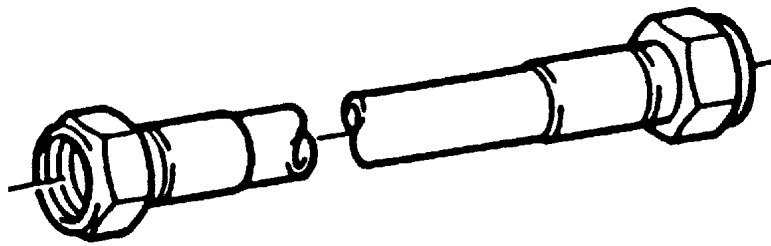

Die Positionsnummern der Rohre auf den Bildtafeln entsprechen den Positionen in der Rohrliste.

The pipe numbers from the illustrations are in accordance with the items in the pipe list.

Les numéros des tuyaux sur les illustrations correspondent aux repères de la nomenclature des tuyaux.

Los números de tubos en las ilustraciones corresponden a las posiciones de la lista de tubos.

Номера позиций труб на изображениях соответствуют позициям в перечне труб.

Pos.	Item	Quantity	Description	Bezeichnung	Serie	K
232	96 51 341 08	1	PIPE COMPL. 42X3X1020	ROHR KPL.		
233	97 84 036 08	1	TUBE 10X1,5X1558	ROHR		
234	96 51 342 08	2	PIPE COMPL. 8X1X318	ROHR KPL.		
235	96 51 343 08	1	PIPE COMPL. 42X3X200	ROHR KPL.		
236	96 51 344 08	1	PIPE COMPL. 42X3X150	ROHR KPL.		
237	96 51 345 08	1	PIPE COMPL. 18X1,5X384	ROHR KPL.		
238	96 51 346 08	1	PIPE COMPL. 18X1,5X1095	ROHR KPL.		
239	96 51 347 08	1	PIPE COMPL. 18X1,5X865	ROHR KPL.		
240	96 47 355 08	1	PIPE COMPL. 18X1,5X3196	ROHR KPL.		
241	96 51 348 08	1	PIPE COMPL. 18X1,5X859	ROHR KPL.		
243	96 54 087 08	1	PIPE COMPL. 42X3X796	ROHR KPL.		
244	96 54 086 08	1	PIPE COMPL. 35X2X85	ROHR KPL.		
260	96 51 329 08	1	PIPE COMPL. 38X4X779	ROHR KPL.		
261	96 51 330 08	1	PIPE COMPL. 38X4X564	ROHR KPL.		
262	96 51 331 08	1	PIPE COMPL. 38X4X572	ROHR KPL.		
263	96 51 332 08	1	PIPE COMPL. 38X4X495	ROHR KPL.		
264	96 51 333 08	1	PIPE COMPL. 38X4X2411	ROHR KPL.		
265	96 51 334 08	1	PIPE COMPL. 38X4X1369	ROHR KPL.		
266	96 51 336 08	1	PIPE COMPL. 38X4X1133	ROHR KPL.		
267	96 51 335 08	3	PIPE COMPL. 10X1,5X1885	ROHR KPL.		
268	96 51 337 08	1	PIPE COMPL. 12X1,5X1875	ROHR KPL.		
269	96 51 338 08	1	PIPE COMPL. 12X1,5X261	ROHR KPL.		
270	96 51 339 08	1	PIPE COMPL. 22X2,5X1009	ROHR KPL.		
271	96 51 340 08	1	PIPE COMPL. 22X2,5X1599	ROHR KPL.		
300	96 51 491 08	1	PIPE COMPL. 38X4X2025	ROHR KPL.		
301	96 51 492 08	1	PIPE COMPL. 38X4X2062	ROHR KPL.		
302	96 55 147 08	1	PIPE COMPL. 38X4X2409	ROHR KPL.		
303	96 55 148 08	1	PIPE COMPL. 38X4X2609	ROHR KPL.		
304	96 51 495 08	1	PIPE COMPL. 38X4X3974	ROHR KPL.		
305	96 51 496 08	1	PIPE COMPL. 38X4X3240	ROHR KPL.		
306	96 51 497 08	1	PIPE COMPL. 38X4X3645	ROHR KPL.		
307	96 58 312 08	1	PIPE COMPL. 38X4X3213	ROHR KPL.		
308	96 51 499 08	1	PIPE COMPL. 38X4X914	ROHR KPL.		
309	96 51 500 08	1	PIPE COMPL. 38X4X681	ROHR KPL.		
310	96 53 041 08	1	PIPE COMPL. 38X4X2030	ROHR KPL.		
311	96 53 042 08	1	PIPE COMPL. 38X4X1752	ROHR KPL.		
312	96 53 043 08	1	PIPE COMPL. 38X4X3302	ROHR KPL.		
313	96 53 044 08	1	PIPE COMPL. 38X4X1726	ROHR KPL.		
314	96 51 506 08	1	PIPE COMPL. 38X4X1213	ROHR KPL.		
315	96 51 507 08	1	PIPE COMPL. 38X4X2010	ROHR KPL.		
316	96 53 045 08	1	PIPE COMPL. 38X4X3272	ROHR KPL.		
317	96 53 046 08	1	PIPE COMPL. 38X4X1745	ROHR KPL.		
318	96 51 510 08	1	PIPE COMPL. 38X4X1632	ROHR KPL.		
319	96 51 511 08	1	PIPE COMPL. 38X4X1670	ROHR KPL.		
320	96 53 047 08	1	PIPE COMPL. 38X4X4004	ROHR KPL.		
321	96 53 048 08	1	PIPE COMPL. 38X4X1608	ROHR KPL.		
322	96 51 514 08	1	PIPE COMPL. 38X4X2184	ROHR KPL.		
323	96 51 515 08	1	PIPE COMPL. 38X4X1232	ROHR KPL.		
324	96 53 049 08	1	PIPE COMPL. 38X4X4000	ROHR KPL.		
325	96 53 050 08	1	PIPE COMPL. 38X4X1595	ROHR KPL.		
326	96 51 518 08	1	PIPE COMPL. 38X4X2326	ROHR KPL.		
327	96 51 519 08	1	PIPE COMPL. 38X4X1141	ROHR KPL.		
328	96 51 520 08	1	PIPE COMPL. 38X4X1264	ROHR KPL.		
329	96 51 521 08	1	PIPE COMPL. 38X4X2737	ROHR KPL.		
330	96 51 522 08	1	PIPE COMPL. 38X4X1243	ROHR KPL.		
331	96 51 523 08	1	PIPE COMPL. 38X4X2571	ROHR KPL.		
332	96 51 524 08	1	PIPE COMPL. 38X4X1761	ROHR KPL.		
333	96 51 525 08	1	PIPE COMPL. 38X4X2763	ROHR KPL.		
334	96 51 526 08	1	PIPE COMPL. 38X4X1648	ROHR KPL.		
335	96 51 527 08	1	PIPE COMPL. 38X4X1602	ROHR KPL.		

6.2.2009

etk_en_de_074515 LR 1600/2

 422 (2/4)
LIEBHERR
**PIPELINES SUPERSTRUCTURE
ROHRLEITUNGEN OBERWAGEN**

⇒ 2 998

91 56 540 08

Pos.	Item	Quantity	Description	Bezeichnung	Serie	K
336	96 51 528 08	1	PIPE COMPL. 38X4X2843	ROHR KPL.		
337	96 51 529 08	1	PIPE COMPL. 38X4X2308	ROHR KPL.		
338	96 54 088 08	1	PIPE COMPL. 35X2X914	ROHR KPL.		
339	96 53 053 08	1	PIPE COMPL. 16X2X421	ROHR KPL.		
340	96 53 054 08	2	PIPE COMPL. 30X4X115	ROHR KPL.		
343	96 54 089 08	1	PIPE COMPL. 28X2X1888	ROHR KPL.		
344	96 54 094 08	1	PIPE COMPL. 28X2X1115	ROHR KPL.		
346	96 54 090 08	1	PIPE COMPL. 25X3X2240	ROHR KPL.		
347	96 54 091 08	1	PIPE COMPL. 25X3X3800	ROHR KPL.		
348	96 54 092 08	1	PIPE COMPL. 42X3X345	ROHR KPL.		
349	96 54 093 08	1	PIPE COMPL. 28X2X2191	ROHR KPL.		
350	96 54 095 08	1	PIPE COMPL. 42X3X1279	ROHR KPL.		
351	96 54 096 08	1	PIPE COMPL. 28X2X1920	ROHR KPL.		
352	96 51 544 08	1	PIPE COMPL. 28X2X1216	ROHR KPL.		
353	96 53 064 08	1	PIPE COMPL. 25X3X2133	ROHR KPL.		
354	96 53 055 08	1	PIPE COMPL. 25X3X1681	ROHR KPL.		
355	96 53 058 08	1	PIPE COMPL. 25X3X2790	ROHR KPL.		
356	96 53 056 08	1	PIPE COMPL. 25X3X1471	ROHR KPL.		
357	96 53 063 08	1	PIPE COMPL. 25X3X2435	ROHR KPL.		
358	96 53 065 08	1	PIPE COMPL. 25X3X636	ROHR KPL.		
359	96 53 060 08	1	PIPE COMPL. 25X3X2489	ROHR KPL.		
360	96 53 062 08	1	PIPE COMPL. 25X3X551	ROHR KPL.		
361	96 53 059 08	1	PIPE COMPL. 16X2X3017	ROHR KPL.		
362	96 51 655 08	1	PIPE COMPL. 16X2X535	ROHR KPL.		
363	96 51 656 08	1	PIPE COMPL. 16X2X1122	ROHR KPL.		
364	96 53 051 08	1	PIPE COMPL. 35X2X483	ROHR KPL.		
365	96 53 052 08	1	PIPE COMPL. 35X2X95	ROHR KPL.		
366	96 54 097 08	1	PIPE COMPL. 28X2X829	ROHR KPL.		
367	96 53 066 08	1	PIPE COMPL. 28X2X945	ROHR KPL.		
368	96 51 661 08	1	PIPE COMPL. 28X2X513	ROHR KPL.		
369	96 51 662 08	1	PIPE COMPL. 28X2X160	ROHR KPL.		
370	96 51 663 08	1	PIPE COMPL. 15X1,5X520	ROHR KPL.		
371	96 51 664 08	1	PIPE COMPL. 15X1,5X835	ROHR KPL.		
372	96 51 665 08	1	PIPE COMPL. 28X2X1186	ROHR KPL.		
373	96 54 098 08	1	PIPE COMPL. 28X2X1725	ROHR KPL.		
374	96 54 099 08	1	PIPE COMPL. 15X1,5X682	ROHR KPL.		
375	96 51 668 08	1	PIPE COMPL. 15X1,5X540	ROHR KPL.		
378	96 51 671 08	2	PIPE COMPL. 12X1,5X168	ROHR KPL.		
379	96 51 672 08	1	PIPE COMPL. 12X1,5X309	ROHR KPL.		
380	96 51 673 08	1	PIPE COMPL. 10X1,5X187	ROHR KPL.		
381	96 51 674 08	1	PIPE COMPL. 10X1,5X156	ROHR KPL.		
382	96 51 675 08	1	PIPE COMPL. 6X1X316	ROHR KPL.		
383	96 51 676 08	1	PIPE COMPL. 10X1,5X300	ROHR KPL.		
384	96 51 677 08	1	PIPE COMPL. 10X1,5X259	ROHR KPL.		
385	96 51 678 08	1	PIPE COMPL. 25X3X2414	ROHR KPL.		
386	96 54 121 08	1	PIPE COMPL. 30X4X3030	ROHR KPL.		
389	96 51 680 08	1	PIPE COMPL. 22X2,5X1509	ROHR KPL.		
390	96 51 681 08	1	PIPE COMPL. 22X2,5X1685	ROHR KPL.		
391	96 54 100 08	1	PIPE COMPL. 12X1,5X1548	ROHR KPL.		
392	96 54 101 08	1	PIPE COMPL. 35X2X828	ROHR KPL.		
393	96 51 684 08	1	PIPE COMPL. 35X2X1149	ROHR KPL.		
394	96 51 685 08	1	PIPE COMPL. 35X2X1409	ROHR KPL.		
395	96 51 686 08	1	PIPE COMPL. 35X2X1518	ROHR KPL.		
396	96 54 102 08	1	PIPE COMPL. 15X1,5X1120	ROHR KPL.		
397	96 54 103 08	1	PIPE COMPL. 28X2X3108	ROHR KPL.		
398	96 51 689 08	1	PIPE COMPL. 35X2X720	ROHR KPL.		
399	96 54 104 08	1	PIPE COMPL. 10X1,5X621	ROHR KPL.		
400	96 53 057 08	1	PIPE COMPL. 10X1,5X966	ROHR KPL.		
401	96 51 692 08	1	PIPE COMPL. 25X3X778	ROHR KPL.		
402	96 51 693 08	1	PIPE COMPL. 25X3X748	ROHR KPL.		

6.2.2009

etk_en_de_074515 LR 1600/2

 423 (3/4)
LIEBHERR
**PIPELINES SUPERSTRUCTURE
ROHRLEITUNGEN OBERWAGEN**

⇒ 2 998

91 56 540 08

Pos.	Item	Quantity	Description	Bezeichnung	Serie	K
403	96 51 694 08	1	PIPE COMPL. 25X3X2068	ROHR KPL.		
404	96 51 695 08	1	PIPE COMPL. 25X3X1218	ROHR KPL.		
405	96 51 696 08	1	PIPE COMPL. 20X2,5X2296	ROHR KPL.		
406	96 51 697 08	1	PIPE COMPL. 20X2,5X1553	ROHR KPL.		
407	96 51 698 08	1	PIPE COMPL. 20X2,5X1039	ROHR KPL.		
408	96 54 105 08	1	PIPE COMPL. 18X1,5X482	ROHR KPL.		
409	96 51 700 08	1	PIPE COMPL. 18X1,5X2036	ROHR KPL.		
410	96 51 701 08	1	PIPE COMPL. 18X1,5X1195	ROHR KPL.		
411	96 51 702 08	1	PIPE COMPL. 42X3X625	ROHR KPL.		
412	96 51 703 08	1	PIPE COMPL. 42X3X1109	ROHR KPL.		
413	96 53 067 08	1	PIPE COMPL. 35X2X1900	ROHR KPL.		
414	96 51 705 08	1	PIPE COMPL. 35X2X939	ROHR KPL.		
415	96 54 106 08	1	PIPE COMPL. 42X3X115	ROHR KPL.		
416	96 51 707 08	1	PIPE COMPL. 42X3X1033	ROHR KPL.		
417	96 51 708 08	1	PIPE COMPL. 42X3X508	ROHR KPL.		
418	96 51 709 08	1	PIPE COMPL. 35X2X1749	ROHR KPL.		
419	96 53 061 08	1	PIPE COMPL. 35X2X652	ROHR KPL.		
420	96 51 711 08	1	PIPE COMPL. 28X2X1805	ROHR KPL.		
421	96 51 712 08	1	PIPE COMPL. 42X3X791	ROHR KPL.		
422	96 51 713 08	1	PIPE COMPL. 42X3X911	ROHR KPL.		
423	96 51 714 08	1	PIPE COMPL. 35X2X699	ROHR KPL.		
424	96 51 715 08	1	PIPE COMPL. 42X3X935	ROHR KPL.		
425	96 51 716 08	1	PIPE COMPL. 42X3X732	ROHR KPL.		
426	96 51 717 08	1	PIPE COMPL. 28X2X1466	ROHR KPL.		
427	96 51 718 08	1	PIPE COMPL. 28X2X880	ROHR KPL.		
428	96 51 719 08	1	PIPE COMPL. 42X3X1555	ROHR KPL.		
429	96 51 720 08	1	PIPE COMPL. 35X2X765	ROHR KPL.		
430	96 51 721 08	1	PIPE COMPL. 35X2X990	ROHR KPL.		
431	96 51 722 08	1	PIPE COMPL. 18X1,5X1518	ROHR KPL.		
432	96 51 723 08	1	PIPE COMPL. 10X1,5X604	ROHR KPL.		
433	96 54 107 08	1	PIPE COMPL. 25X3X1585	ROHR KPL.		
434	96 51 725 08	1	PIPE COMPL. 25X3X495	ROHR KPL.		
435	96 54 108 08	1	PIPE COMPL. 25X3X1162	ROHR KPL.		
436	96 51 727 08	1	PIPE COMPL. 35X2X549	ROHR KPL.		
437	96 52 313 08	1	PIPE COMPL. 12X1,5X291	ROHR KPL.		

6.2.2009

etk_en_de_074515 LR 1600/2

424 (4/4)

LIEBHERR

PIPELINES SUPERSTRUCTURE
ROHRLEITUNGEN OBERWAGEN

⇒ 2 998

91 56 540 08

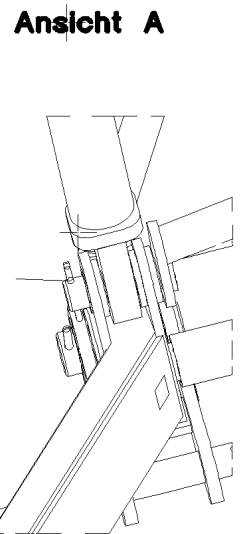
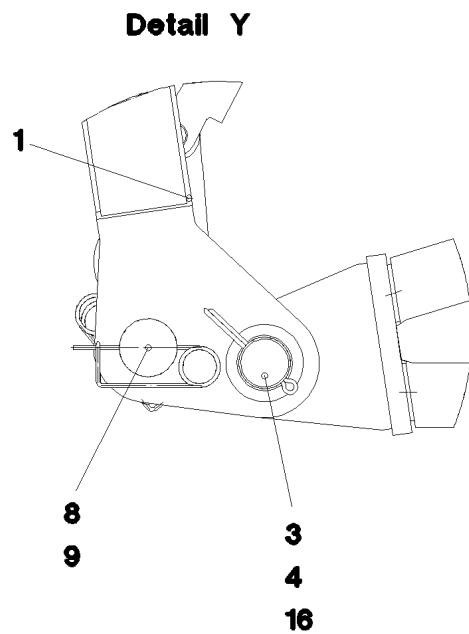
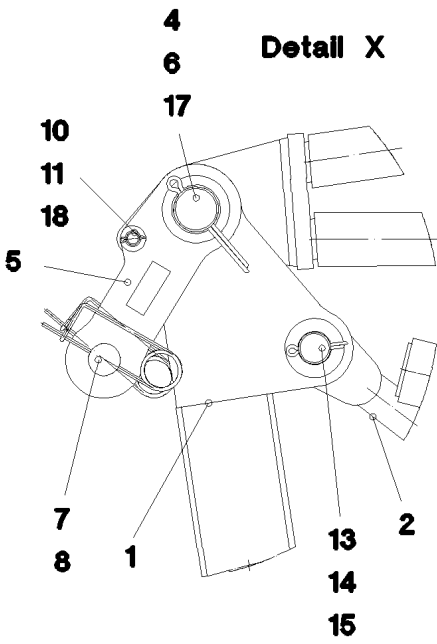
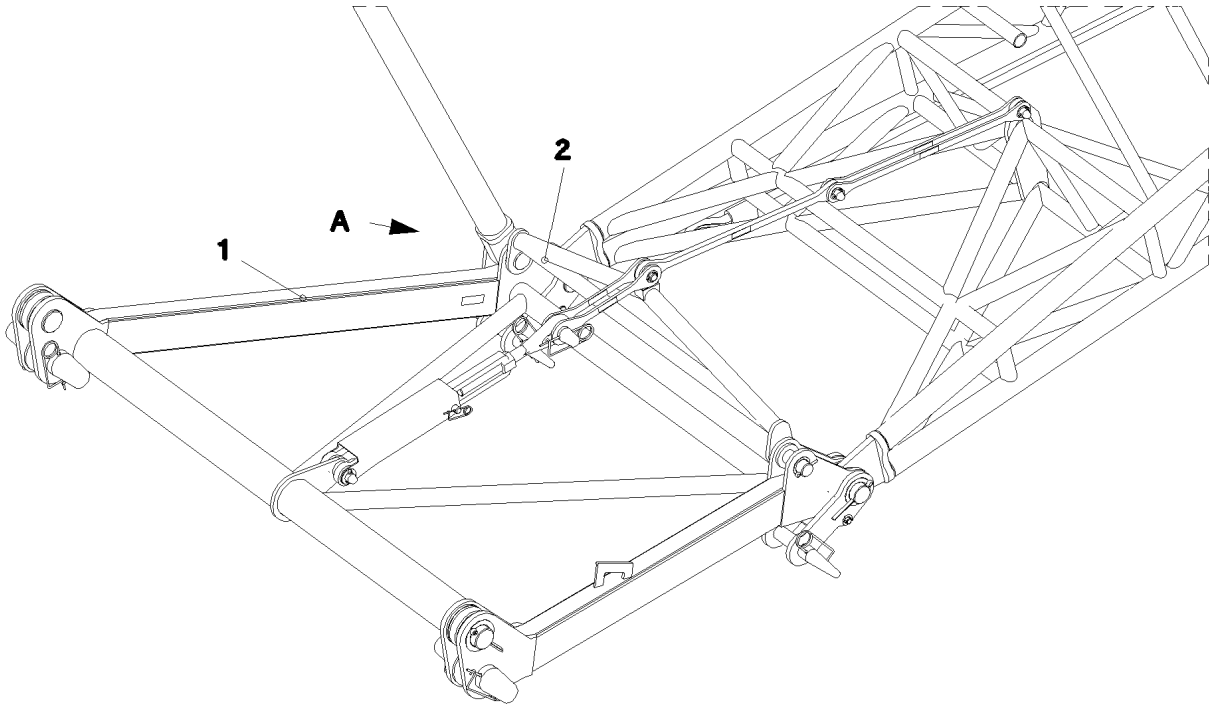
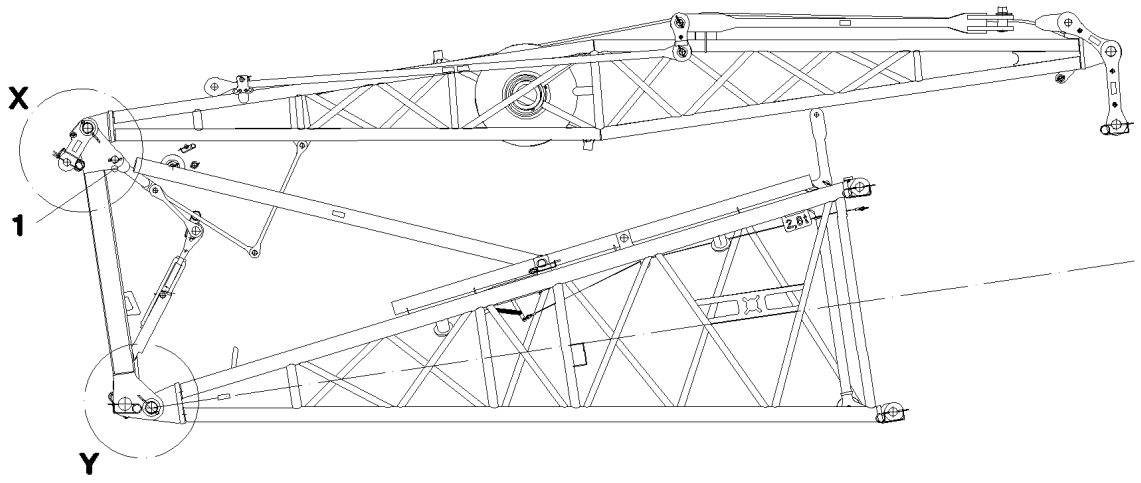

6.2.2009
052917

LIEBHERR

etk_en_de_074515 LR 1600/2

F-ASSEMBLY UNIT
F-MONTAGEEINHEIT

□ 425 (1/2)

⇒ 3 205
91 52 880 08

Pos.	Item	Quantity	Description	Bezeichnung	Serie	K
1	96 47 500 08	1	FRAME WELDED	RAHMEN SCHWK.		
2	96 47 596 08	1	DISTANCE PIECE	ABSTANDSHALTER		
3	97 73 608 08	2	PIN 85.0X150 SPF	BOLZEN		
4	43 30 115 08	4	SPLIT PIN DIN 94 13X160 ST VERZ	SPLINT		
5	96 47 562 08	2	BUTT STRAP	LASCHE		
6	97 72 368 08	2	PIN 75.0X195 SPF	BOLZEN		
7	97 72 887 08	2	PIN 55.0X542 SPF	BOLZEN		
8	43 31 050 08	8	RETAINING SPRING 6 A3C	SICHERUNGSFEDER		
9	97 72 369 08	2	PIN 100.0X390 SPF	BOLZEN		
10	45 30 221 08	2	PIN DIN 1444 20H11X170X162 30CRNIMO8	BOLZEN		
11	43 30 063 08	2	SPLIT PIN DIN 94 5X28 ST VERZ	SPLINT		
13	42 00 040 08	2	WASHER DIN 125 B 52 ST VERZ	SCHEIBE		
14	43 30 101 08	2	SPLIT PIN DIN 94 10X71 ST VERZ	SPLINT		
15	45 30 448 08	2	PIN DIN 1444 50H11X162X150 30CRNIMO8	BOLZEN		
16	95 36 382 08	2	PLATE RD120X2	BLECH		
17	97 04 902 08	2	PLATE 2X105X105 DC01-A-M	BLECH		
18	95 57 168 08	2	PLATE RD40X1	BLECH		

6.2.2009

etk_en_de_074515 LR 1600/2

426 (2/2)

LIEBHERR

F-ASSEMBLY UNIT
F-MONTAGEEINHEIT

⇒ 3 205
91 52 880 08

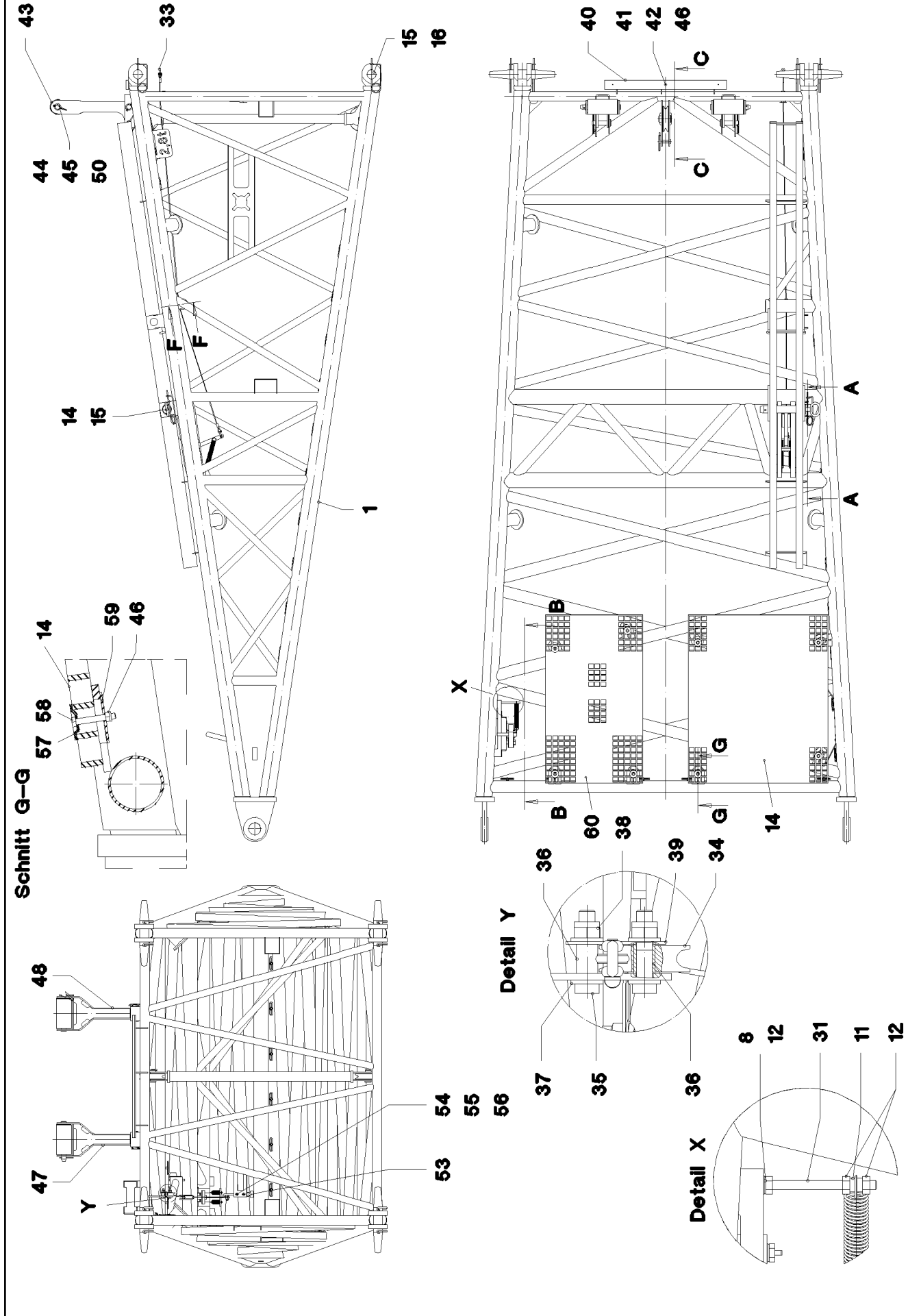

6.2.2009
052918

LIEBHERR

etk_en_de_074515 LR 1600/2

PIVOT SECTION
F-ANLENKSTUECK

427 (1/4)

→ 3 206
91 52 881 08

Schnitt A-A

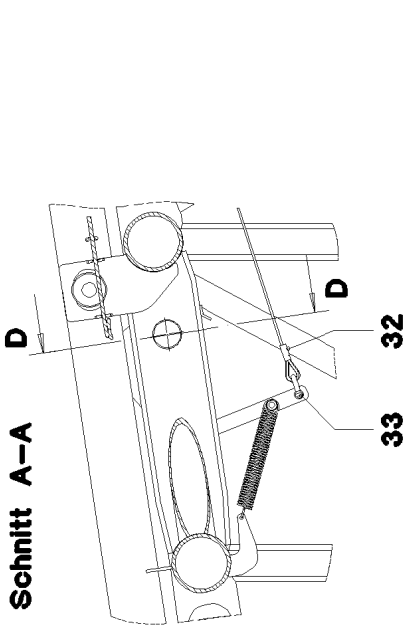

Schnitt D-D

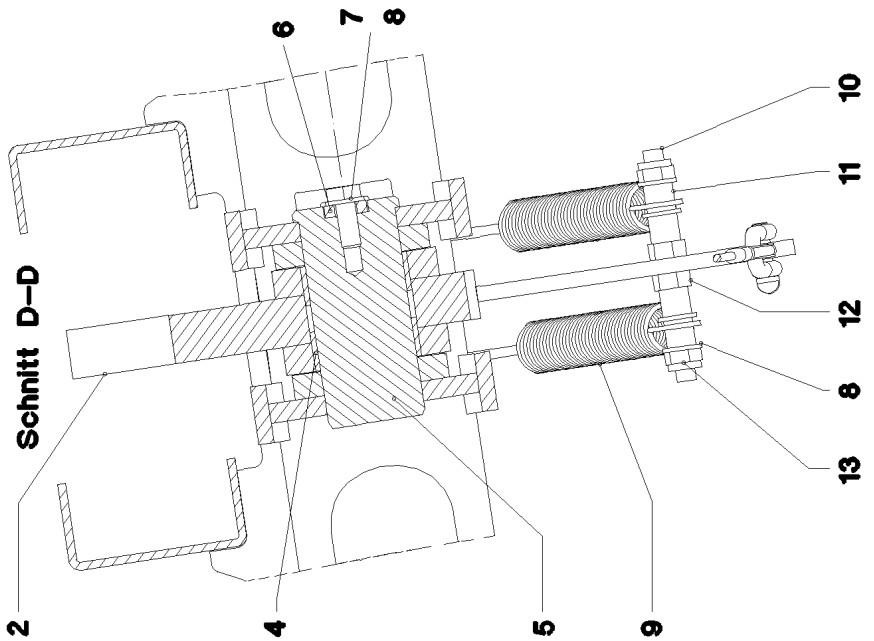

Schnitt B-B

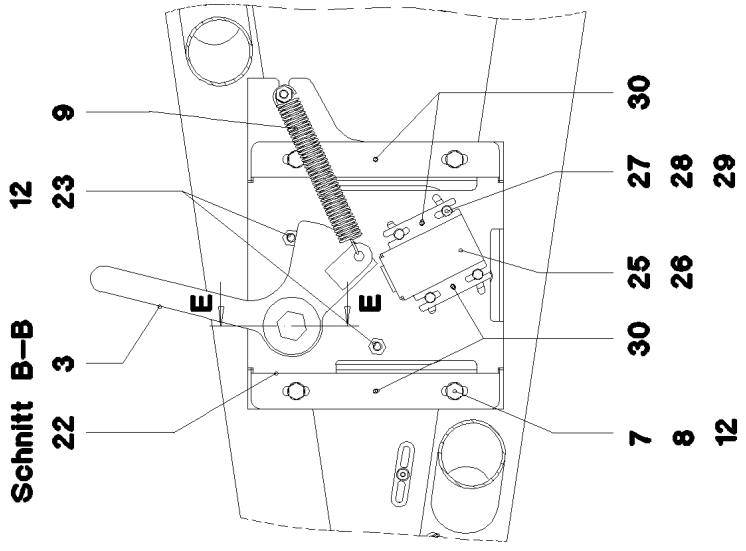

Schnitt E-E

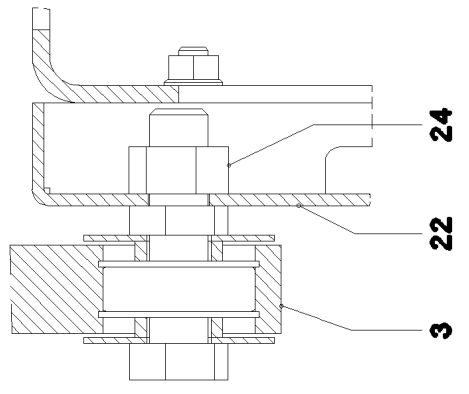

Schnitt F-F

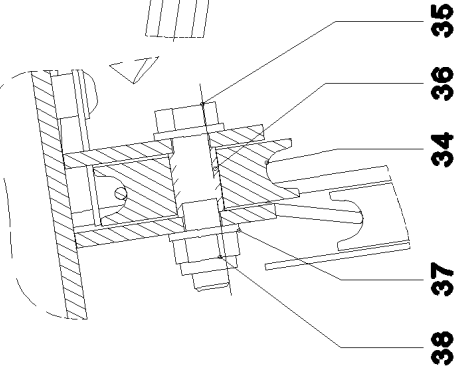

Schnitt C-C

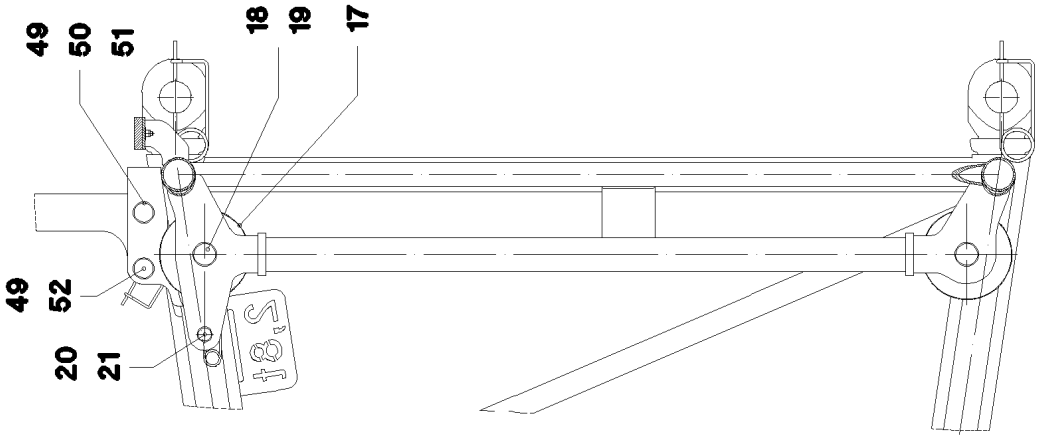

6.2.2009
052919

LIEBHERR

etk_en_de_074515 LR 1600/2

PIVOT SECTION
F-ANLENKSTUECK

□ 428 (2/4)

→ 3 206
91 52 881 08

Pos.	Item	Quantity	Description	Bezeichnung	Serie	K
1	96 46 767 08	1	F BASE SECTION WELDMENT	F-ANLENKSTUECK SCHWK.		
2	96 47 951 08	1	FLAP ST.CONST.	KLAPPE SCHWK.		
3	96 47 960 08	1	LEVER COMPL. ⇒ 3 206 002 96 47 960 08	HEBEL KPL.		
4	70 80 101 08	2	DU BUSH	DU-BUCHSE		
5	97 73 189 08	1	PIN 55.0X113 SPF	BOLZEN		
6	97 18 723 08	1	PLATE 6X90X22	BLECH		
7	40 65 164	5	HEX BOLT ISO 4017 M10X25 8.8 A3C	SECHSKANTSCHRAUBE		
8	42 00 013 08	14	WASHER ISO 7089 A 10.5 A3C	SCHEIBE		
9	72 01 091 08	3	TENSION SPRING	ZUGFEDER		
10	95 45 915 08	1	THREADED ROD M10X120	GEWINDESTANGE		
11	95 30 759 08	5	TUBE 15X1,5X14	ROHR		
12	41 15 144 08	11	HEX NUT DIN 934 M10 8 VERZ	SECHSKANTMUTTER		
13	41 19 006 08	2	HEX NUT DIN 985 M10 8 VERZ	SECHSKANTMUTTER		
14	97 86 922 08	1	GRATING 1127X927X30 GFK	GITTERROST		
15	43 31 050 08	9	RETAINING SPRING 6 A3C	SICHERUNGSFEDER		
16	97 62 324 08	4	PIN 65.0X435 35NICRMOV125 SPF	BOLZEN		
17	96 20 920 08	2	ROPE PULLEY CPL. ⇒ 3 206 001 96 20 920 08	SEILROLLE KPL.		
18	95 60 974 08	2	PIN RD40X75 30CRNIMO8+QT	BOLZEN		
19	43 30 090 08	2	SPLIT PIN DIN 94 8X63 ST VERZ	SPLINT		
20	10 42 572 5	1	PIN ISO 2341 B18H11X75X68 30CRNIMO8	BOLZEN		
21	43 31 012 08	1	RETAINING SPRING 4X68 VERZ	SICHERUNGSFEDER		
22	97 25 209 08	1	PLATE 4X352X345	BLECH		
23	46 00 122	2	HEX BOLT ISO 4017 M10X40 8.8 A3C	SECHSKANTSCHRAUBE		
24	41 15 147 08	1	HEX NUT DIN 934 M20 8 VERZ	SECHSKANTMUTTER		
25	92 35 704 08	1	HOLDER X12CrNiS188	HALTER		
26	97 25 222 08	1	PLATE 2X90X110	BLECH		
27	40 00 829	4	HEX BOLT ISO 4017 M6X20 8.8 A2C	SECHSKANTSCHRAUBE		
28	42 00 009 08	4	WASHER ISO 7089 A 6.4 VERZ	SCHEIBE		
29	41 19 004 08	4	HEX NUT DIN 985 M6 8 VERZ	SECHSKANTMUTTER		
30	43 20 039 08	4	DOWEL PIN ISO 8752 5X20	SPANNSTIFT		
31	24 02 184 02	1	HEX BOLT ISO 4017 M10X130 8.8 A3C	SECHSKANTSCHRAUBE		
32	97 73 190 08	1	ROPE 4X2416	SEIL		
33	77 39 335 08	2	SHACKLE DIN 82101 A 0,25 0,25T ST VERZ	SCHAEKEL		
34	28 30 961 08	2	ROLLER RD68X20 PA6G	ROLLE		
35	46 00 047	3	HEX BOLT ISO 4014 M12X55 8.8 A3C	SECHSKANTSCHRAUBE		
36	97 18 575 08	3	TUBE 16.0X22	ROHR		
37	42 00 016 08	6	WASHER ISO 7089 A 13 ST A3C	SCHEIBE		
38	41 19 007 08	11	HEX NUT DIN 985 M12 8 A3C	SECHSKANTMUTTER		
39	97 18 510 08	1	PLATE 2X50X75	BLECH		
40	97 64 327 08	1	BEARING PLATE 15 X 60 X 810 PA6G	LAGERPLATTE		
41	40 86 007 08	3	COUNTERSUNK SCREW DIN 7991 M8X30 8.	SENKSCHRAUBE		
42	42 18 009 08	3	WASHER DIN 9021 A 8.4 VERZ	SCHEIBE		
43	93 24 583 08	2	ROLLER RD100X200 PA6G	ROLLE		
44	94 04 740 08	2	PIN RD30X255	BOLZEN		
45	43 30 085 08	2	SPLIT PIN DIN 94 6,3X90 ST VERZ	SPLINT		
46	41 19 005 08	11	HEX NUT DIN 985 M8 8 VERZ	SECHSKANTMUTTER		
47	96 48 347 08	2	SUPPORT FRAME WELDED STRUCTURE	ABSTUETZBOCK SCHWK.		
48	96 48 349 08	1	PIN W. HANDLE	BOLZEN MIT GRIFF		
49	10 47 124 9	4	PIN ISO 2341 B 30X115X105 30CRNIMO8+Q	BOLZEN		
50	93 94 608 08	4	WASHER RD44X2	SCHEIBE		
51	43 30 079 08	2	SPLIT PIN DIN 94 6,3X56 ST VERZ	SPLINT		
52	43 31 009 08	2	RETAINING SPRING 4,5 VERZ	SICHERUNGSFEDER		
53	70 42 624 08	1	CLOSURE	HAKENVERSCHLUSS		
54	40 65 099	2	HEX BOLT ISO 4017 M6X16 8.8 A2C	SECHSKANTSCHRAUBE		
55	42 18 007 08	2	WASHER DIN 9021 A 6.4 VERZ	SCHEIBE		
56	41 15 140 08	2	HEX NUT DIN 934 M6 8 VERZ	SECHSKANTMUTTER		
57	10 10 062 1	8	DISH MOUNTING	TELLERBEFESTIGUNG		
58	40 61 024	8	HEX BOLT ISO 4014 M8X55 8.8 A2C	SECHSKANTSCHRAUBE		

6.2.2009

etk_en_de_074515 LR 1600/2

□ 429 (3/4)

LIEBHERRPIVOT SECTION
F-ANLENKSTUECK⇒ 3 206
91 52 881 08

Pos.	Item	Quantity	Description	Bezeichnung	Serie	K
59	94 11 381 08	8	WASHER 70X3	SCHEIBE		
60	97 79 207 08	1	GRATING 1127X647X30 GFK SPF	GITTERROST		
500	96 48 374 08	1	ELECTRICS F BASE SECTION	ELEKTRIK F-ANLENKSTUECK		
			⇒ 3 930 731 96 48 374 08			

<p>6.2.2009</p> <p>LIEBHERR</p>	<p>etk_en_de_074515 LR 1600/2</p> <p>PIVOT SECTION F-ANLENKSTUECK</p>	<p>430 (4/4)</p> <p>⇒ 3 206 91 52 881 08</p>
--	---	--

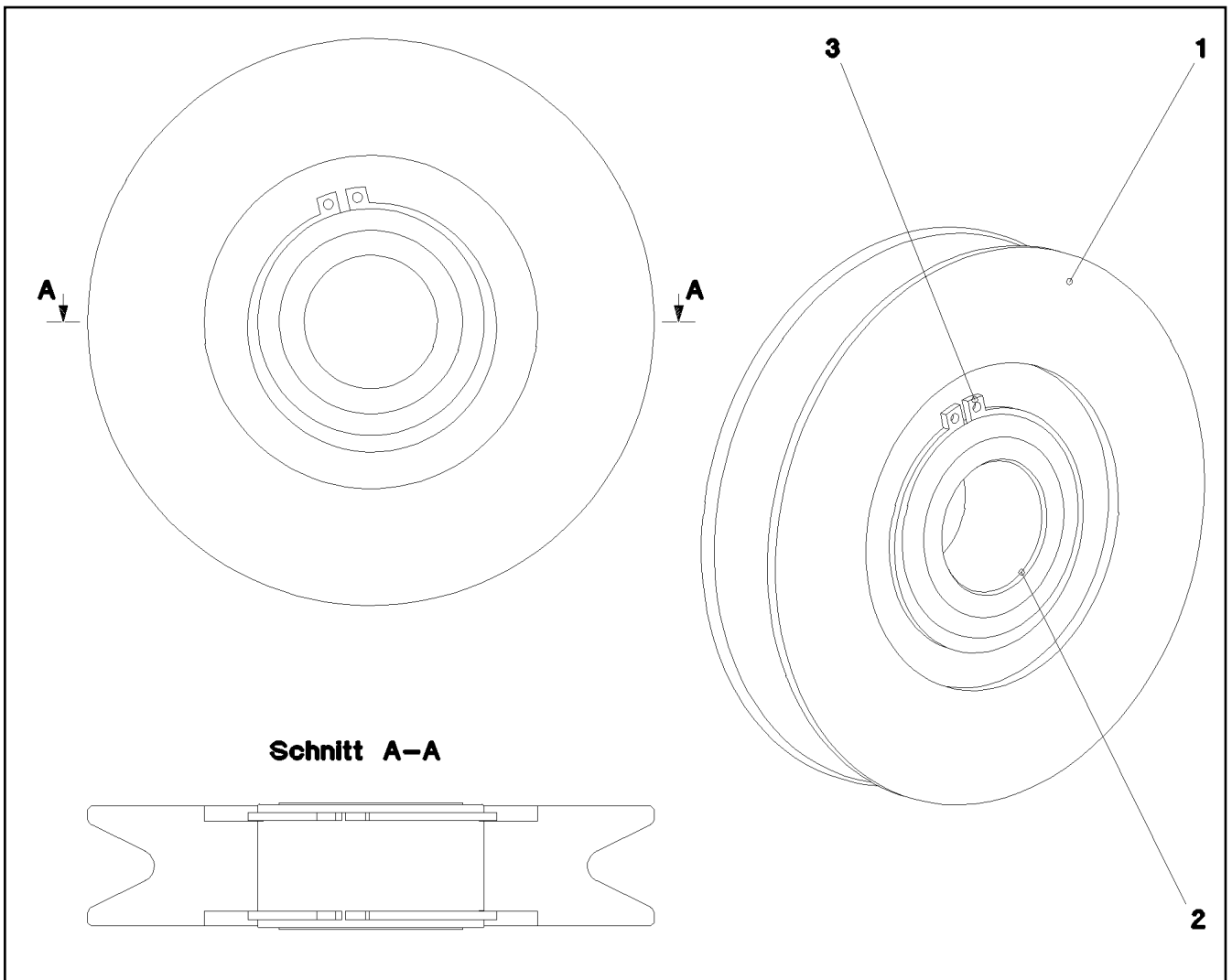

Pos.	Item	Quantity	Description	Bezeichnung	Serie	K
1	97 18 725 08	1	ROPE PULLEY / SHEAVE SPF	SEILROLLE		
2	74 59 008 08	1	ROLLER BEARING 68X40X38	WAEZLAGER		
3	42 80 055 08	2	LOCKING RING DIN 471 68X2,5	SICHERUNGSRING		

6.2.2009
029642

LIEBHERR

etk_en_de_074515 LR 1600/2

ROPE PULLEY CPL.
SEILROLLE KPL.

431

⇒ 3 206 001
96 20 920 08

Schnitt A-A

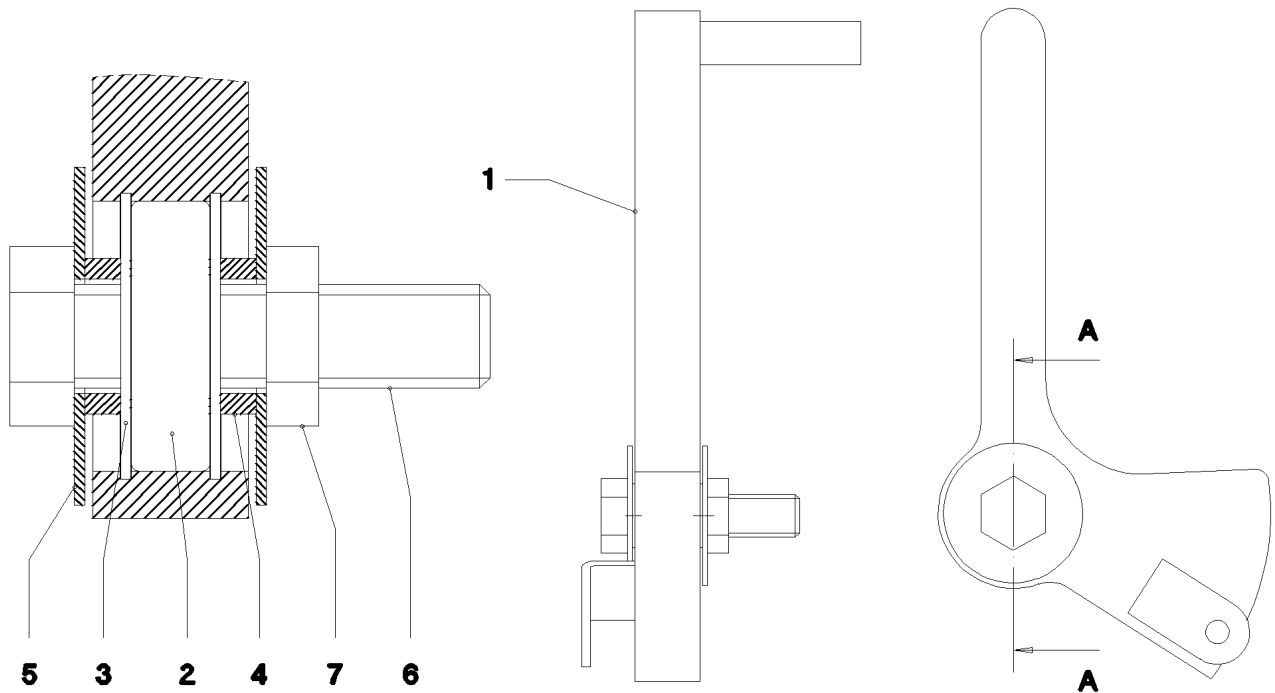

Pos.	Item	Quantity	Description	Bezeichnung	Serie	K
1	96 47 983 08	1	LEVER WELDED	HEBEL SCHWK.		
2	74 51 684 08	1	DEEP GROOVE BALL BEARING DIN 625 630	RILLENKUGELLAGER		
3	42 81 013 08	2	LOCKING RING DIN 472 52X2	SICHERUNGSRING		
4	94 70 655 08	2	TUBE 30X4X9	ROHR		
5	95 41 978 08	2	PLATE RD2X65	BLECH		
6	40 65 215 01	1	HEX BOLT ISO 4017 M20X80 8.8 A3C	SECHSKANTSCHRAUBE		
7	41 01 012 08	1	HEX NUT DIN 439 B M20 4 VERZ	SECHSKANTMUTTER		

6.2.2009
052923

LIEBHERR

etk_en_de_074515 LR 1600/2

LEVER COMPL.
HEBEL KPL.

432

⇒ 3 206 002
96 47 960 08

Feste Spitze 15°

Feste Spitze 30°

Detail X

Detail Y

Detail X

Detail Y

Ansicht A

1

6

4

1

5

4

2

3

6.2.2009
052920

LIEBHERR

etk_en_de_074515 LR 1600/2

F-GUYING
F-ABSPANNUNG

433 (1/2)

3 207
91 53 433 08

Pos.	Item	Quantity	Description	Bezeichnung	Serie	K
1	97 69 999 08	2	TENSIONING ROPE 13M	ABSPANNSEIL		
2	96 48 259 08	4	ROD CPL. 5.15M ⇒ 3 207 003 96 48 259 08	STANGE KPL.		
3	96 48 261 08	2	BRACKET COMPL. ⇒ 3 207 100 96 48 261 08	LASCHE KPL.		
4	96 48 292 08	2	BRACKET COMPL. ⇒ 3 207 101 96 48 292 08	LASCHE KPL.		
5	96 48 310 08	2	ROD WITH BOARD 0.43M	STANGE MIT SCHILD		
6	96 48 354 08	2	ROD WITH BOARD 2.13M	STANGE MIT SCHILD		

6.2.2009

etk_en_de_074515 LR 1600/2

434 (2/2)

LIEBHERR

F-GUYING
F-ABSPANNUNG

⇒ 3 207
91 53 433 08

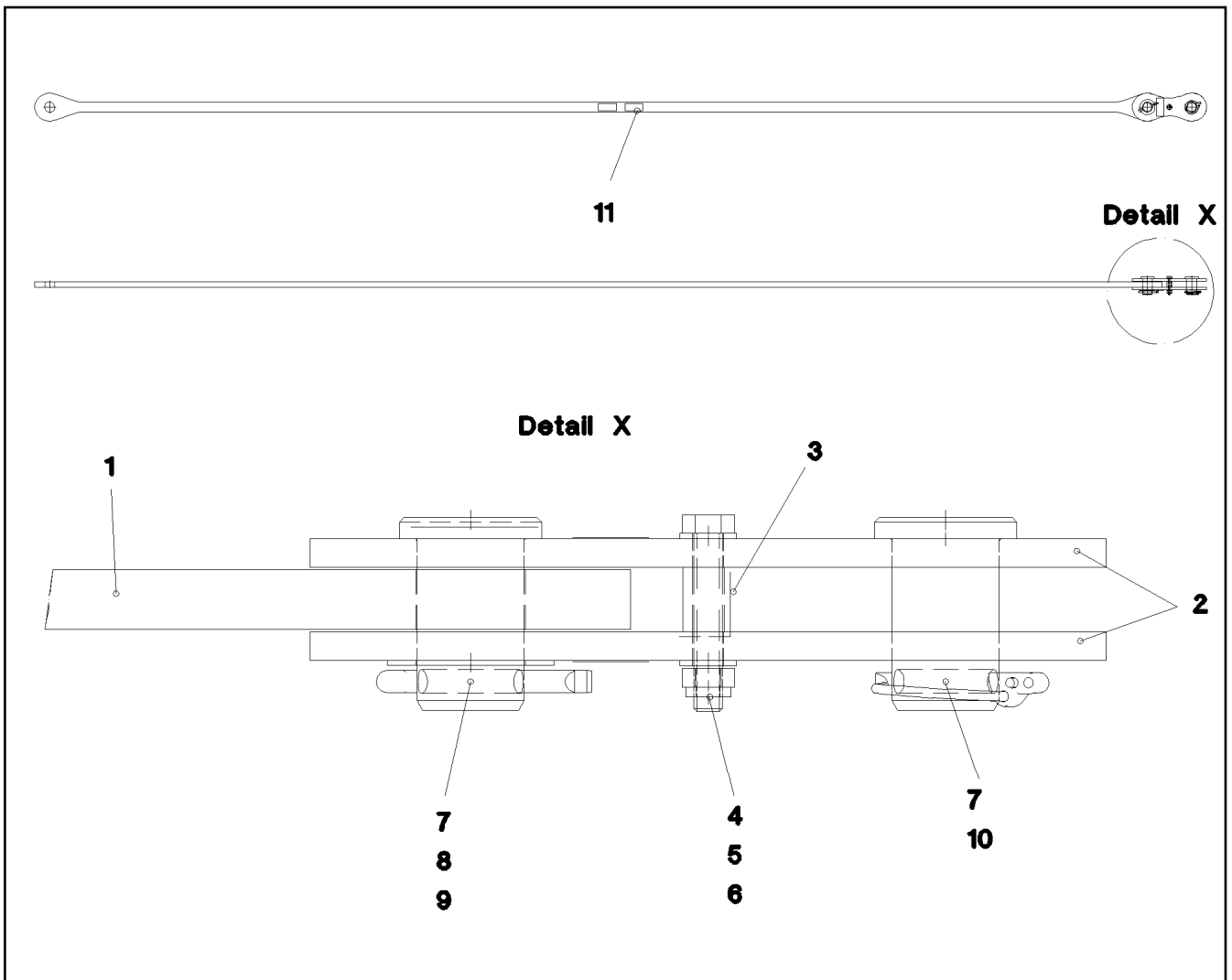

Pos.	Item	Quantity	Description	Bezeichnung	Serie	K
1	96 48 260 08	1	ROD WITH BOARD 4950	STANGE MIT SCHILD		
2	96 45 290 08	2	BRACKET WITH BOARD 200	LASCHE MIT SCHILD		
3	97 71 899 08	1	SPACER SLEEVE 21.3X27	DISTANZHUELSE		
4	46 00 245	1	HEX BOLT ISO 4014 M12X75 8.8 A3C	SECHSKANTSCHRAUBE		
5	42 00 016 08	2	WASHER ISO 7089 A 13 ST A3C	SCHEIBE		
6	41 19 007 08	1	HEX NUT DIN 985 M12 8 A3C	SECHSKANTMUTTER		
7	45 30 328 08	2	PIN DIN 1444 45H11X72X60 35NICRMOV125	BOLZEN		
8	43 30 101 08	1	SPLIT PIN DIN 94 10X71 ST VERZ	SPLINT		
9	94 90 229 08	1	PLATE RD70X2	BLECH		
10	43 32 004 08	1	SAFETY PLUG W HINGE-LID 9,5X77 VERZ	SICHERHEITSKLAPPSTECKER		
11	97 35 919 08	1	PLATE ASSEMBLY BG-NR. PVC-SILBER SP	SCHILD BAUGRUPPE		

6.2.2009
052928

LIEBHERR

etk_en_de_074515 LR 1600/2

ROD CPL.
STANGE KPL.

435

⇒ 3 207 003
96 48 259 08

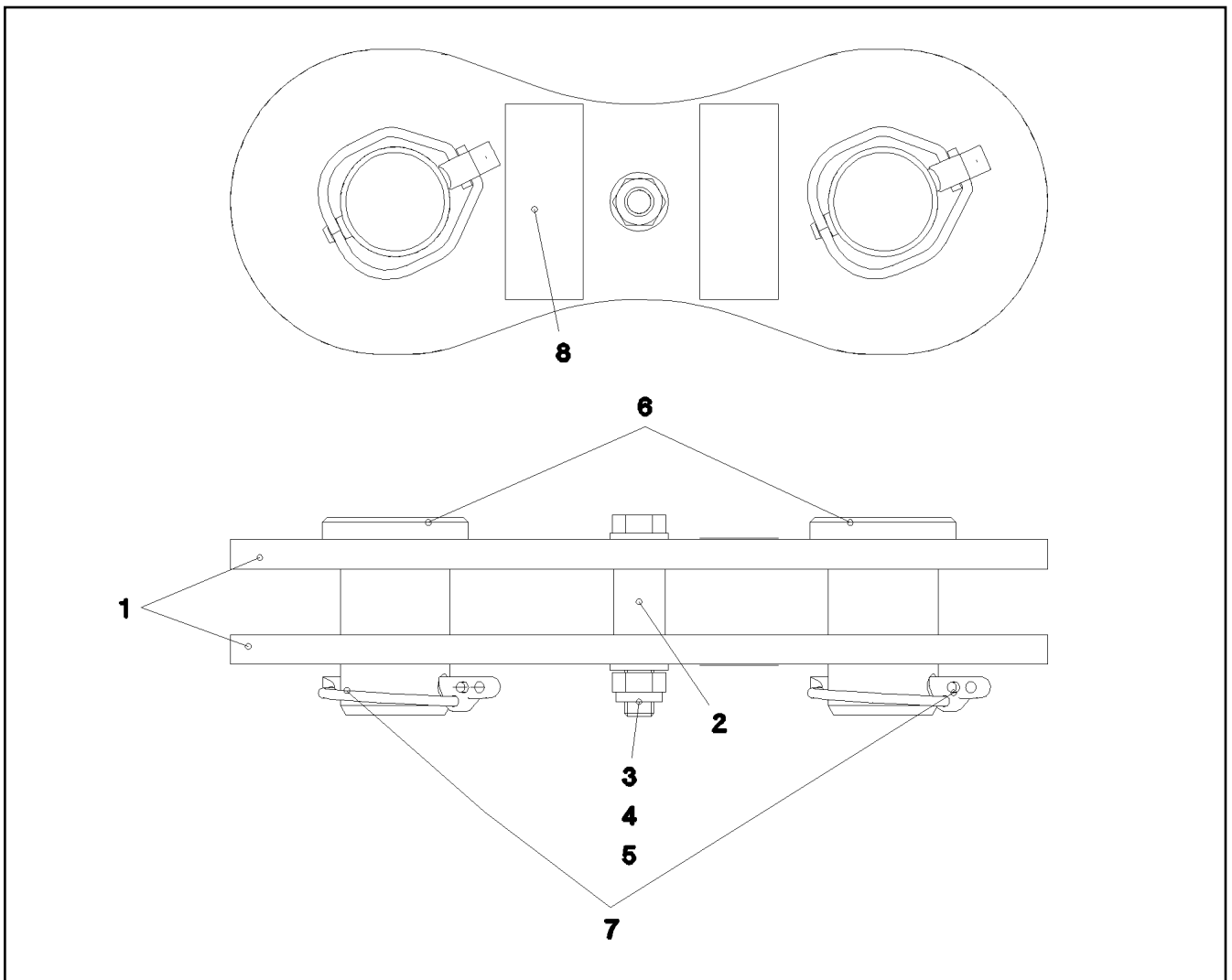

Pos.	Item	Quantity	Description	Bezeichnung	Serie	K
1	96 45 290 08	2	BRACKET WITH BOARD 200	LASCHE MIT SCHILD		
2	97 71 899 08	1	SPACER SLEEVE 21.3X27	DISTANZHUELSE		
3	46 00 245	1	HEX BOLT ISO 4014 M12X75 8.8 A3C	SECHSKANTSCHRAUBE		
4	42 00 016 08	2	WASHER ISO 7089 A 13 ST A3C	SCHEIBE		
5	41 19 007 08	1	HEX NUT DIN 985 M12 8 A3C	SECHSKANTMUTTER		
6	45 30 328 08	2	PIN DIN 1444 45H11X72X60 35NICRMOV125	BOLZEN		
7	43 32 004 08	2	SAFETY PLUG W HINGE-LID 9,5X77 VERZ	SICHERHEITSKLAPPSTECKER		
8	97 35 919 08	1	PLATE ASSEMBLY BG-NR. PVC-SILBER SP	SCHILD BAUGRUPPE		

6.2.2009
052927

LIEBHERR

etk_en_de_074515 LR 1600/2

BRACKET COMPL.
LASCHE KPL.

436

⇒ 3 207 100
96 48 261 08

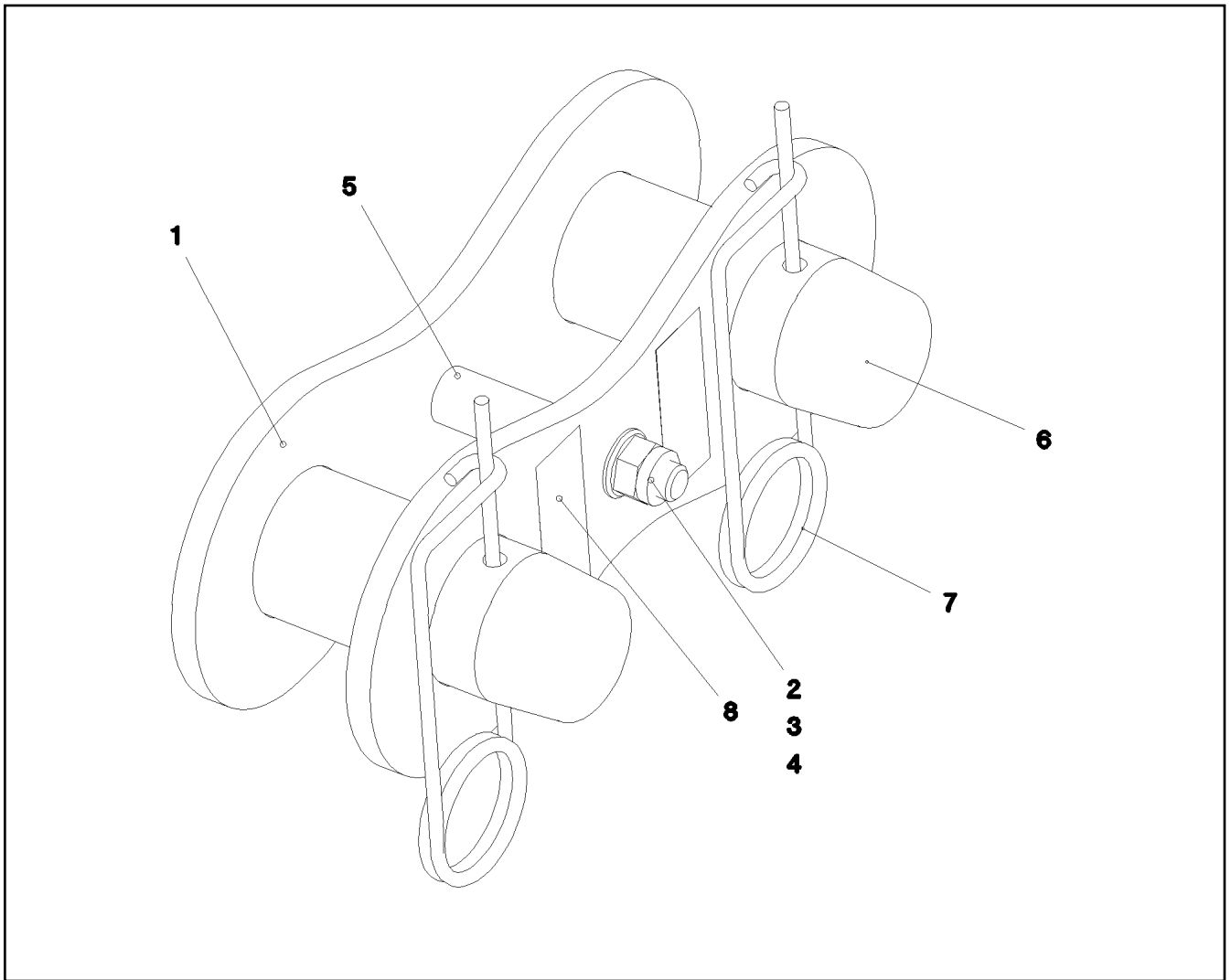

Pos.	Item	Quantity	Description	Bezeichnung	Serie	K
1	96 48 337 08	2	BRACKET WITH BOARD	LASCHE MIT SCHILD		
2	40 61 179 01	1	HEX BOLT ISO 4014 M16X130 8.8 A3C	SECHSKANTSCHRAUBE		
3	41 19 009 08	1	HEX NUT DIN 985 M16 8 VERZ	SECHSKANTMUTTER		
4	42 00 019 08	2	WASHER DIN 125 A 17 VERZ	SCHEIBE		
5	97 71 883 08	1	SPACER SLEEVE 25.0X75	DISTANZHUELSE		
6	97 20 177 08	2	PIN 70.0X170	BOLZEN		
7	43 31 050 08	2	RETAINING SPRING 6 A3C	SICHERUNGSFEDER		
8	97 35 919 08	1	PLATE ASSEMBLY BG-NR. PVC-SILBER SP	SCHILD BAUGRUPPE		

6.2.2009
052926

LIEBHERR

etk_en_de_074515 LR 1600/2

BRACKET COMPL.
LASCHE KPL.

437

⇒ 3 207 101
96 48 292 08

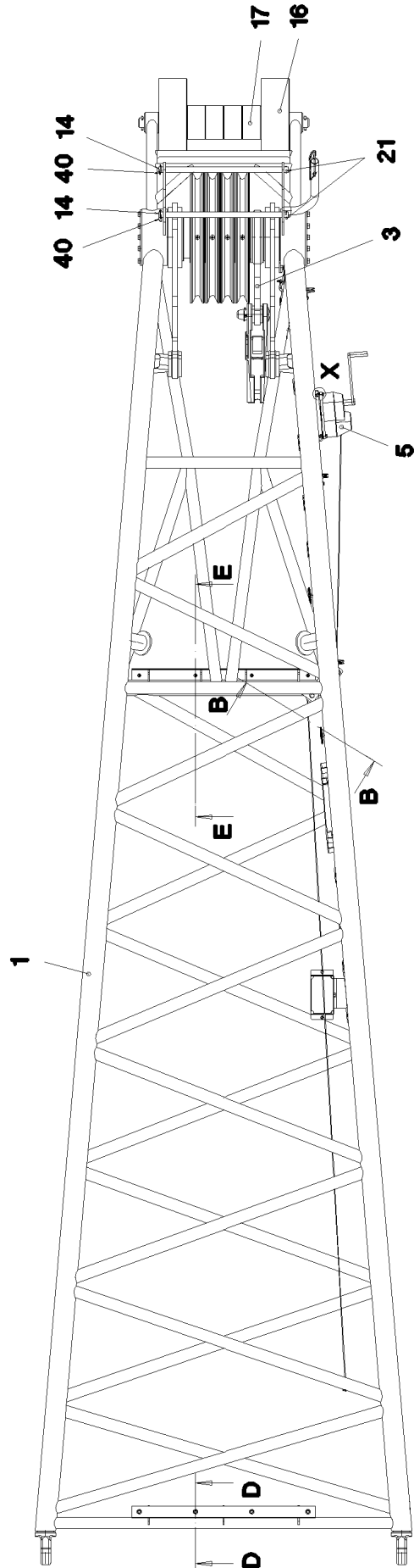
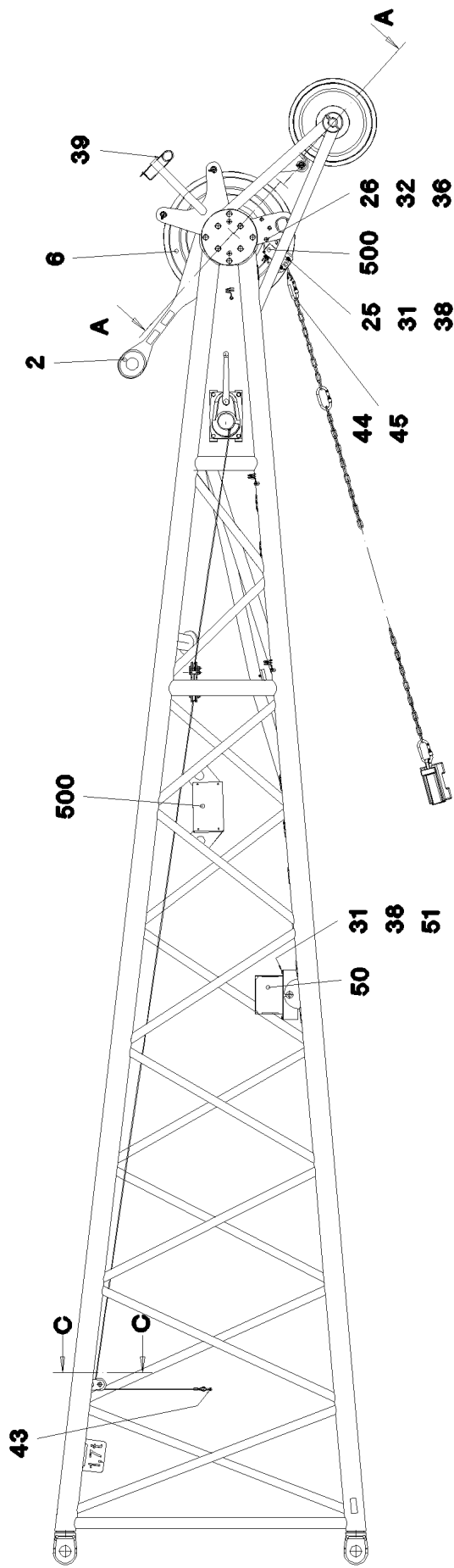

6.2.2009
052934

LIEBHERR

etk_en_de_074515 LR 1600/2

F-HEAD SECTION
F-KOPFSTUECK

438 (1/3)

→ 3 208 001
91 52 883 08

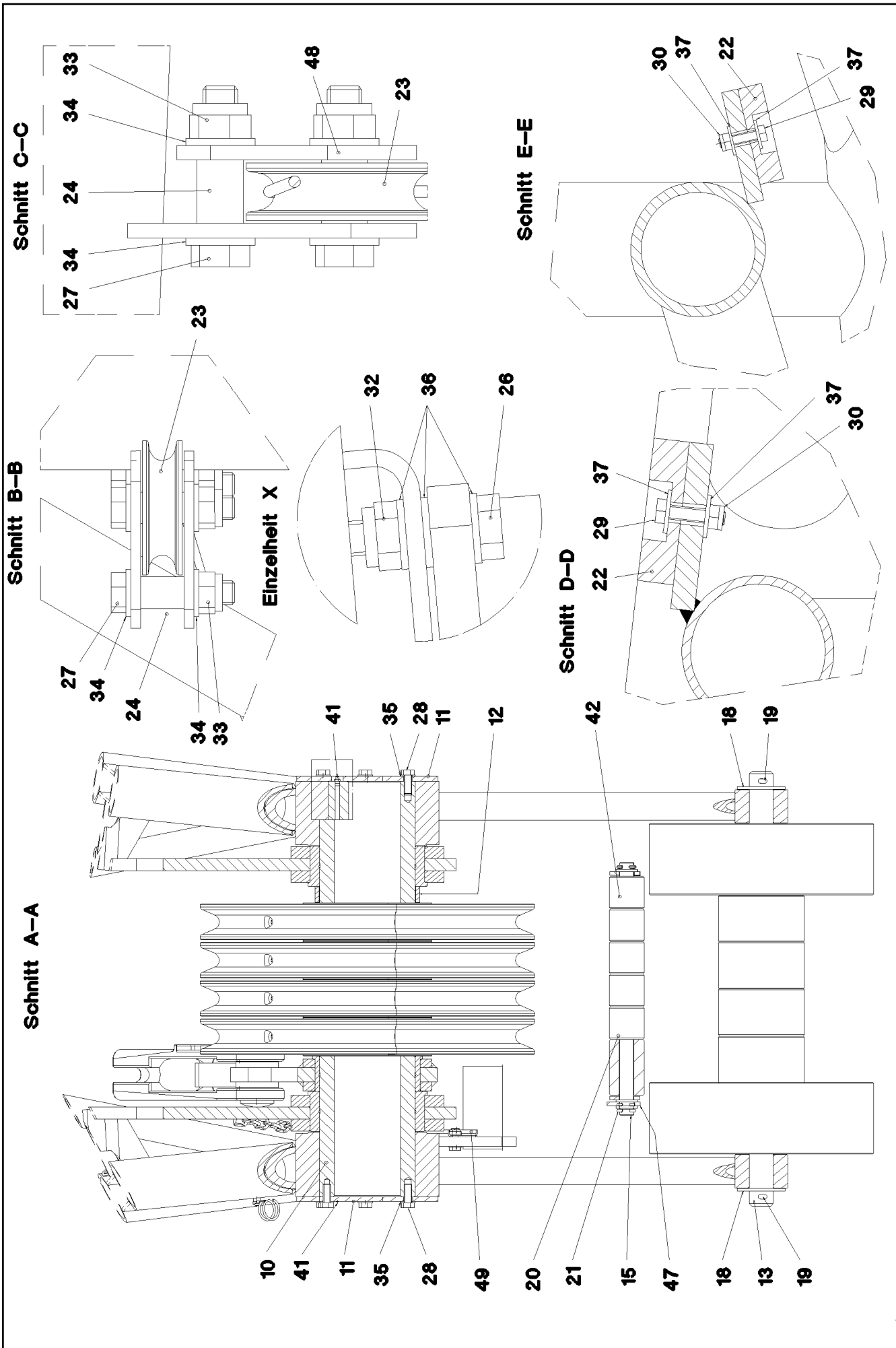

6.2.2009
052935

LIEBHERR

etk_en_de_074515 LR 1600/2

F-HEAD SECTION
F-KOPFSTUECK

□ 439 (2/3)

→ 3 208 001
91 52 883 08

Pos.	Item	Quantity	Description	Bezeichnung	Serie	K
1	96 47 129 08	1	F-HEAD SECTION WELDM.	F-KOPFSTUECK SCHWK.		
2	96 47 187 08	2	BRACKET COMPL. 0	LASCHE KPL.		
3	96 47 218 08	1	BRACKET COMPL.	LASCHE KPL.		
5	54 00 569 08	1	ROPE WINCH	SEILWINDE		
6	92 68 928 08	4	ROPE PULLEY CPL. SPF ⇒ 2 652 007 92 68 928 08	SEILROLLE KPL.		
10	97 71 893 08	1	AXLE 219.1X870 SPF	ACHSE		
11	97 71 943 08	2	PLATE 10X296X296	BLECH		
12	97 71 946 08	1	WASHER 219.1X34	SCHEIBE		
13	97 71 953 08	1	AXLE 50.0X910	ACHSE		
14	97 71 958 08	2	TUBE 30.0X690 ST37.0	ROHR		
15	97 71 968 08	1	AXLE 30.0X530 ST37.0	ACHSE		
16	97 71 970 08	2	ROLLER 470X140 PA6GZAEHHART	ROLLE		
17	93 99 680 08	4	ROLLER RD180X98 PA6G	ROLLE		
18	93 97 916 08	2	WASHER RD100X6	SCHEIBE		
19	43 30 101 08	2	SPLIT PIN DIN 94 10X71 ST VERZ	SPLINT		
20	93 89 752 08	1	ROLLER RD75X120 PA6G	ROLLE		
21	43 30 077 08	4	SPLIT PIN DIN 94 6,3X45 ST VERZ	SPLINT		
22	28 81 926 08	2	SUPPORT PLATE 15X60X980 PA6G	AUFLAGE		
23	28 30 961 08	3	ROLLER RD68X20 PA6G	ROLLE		
24	97 18 575 08	6	TUBE 16.0X22	ROHR		
25	40 01 461	2	HEX BOLT ISO 4014 M8X50 8.8 A2C	SECHSKANTSCHRAUBE		
26	40 62 011 08	7	HEX BOLT ISO 4014 M10X40 10.9 FLZN SPF	SECHSKANTSCHRAUBE		
27	46 00 047	6	HEX BOLT ISO 4014 M12X55 8.8 A3C	SECHSKANTSCHRAUBE		
28	40 66 030 08	16	HEX BOLT ISO 4017 M16X40 10.9 FLZN SPF	SECHSKANTSCHRAUBE		
29	49 00 539	8	HEX BOLT ISO 4017 M6X25 8.8 A3C	SECHSKANTSCHRAUBE		
30	41 19 004 08	8	HEX NUT DIN 985 M6 8 VERZ	SECHSKANTMUTTER		
31	41 19 005 08	4	HEX NUT DIN 985 M8 8 VERZ	SECHSKANTMUTTER		
32	41 19 006 08	7	HEX NUT DIN 985 M10 8 VERZ	SECHSKANTMUTTER		
33	41 19 007 08	6	HEX NUT DIN 985 M12 8 A3C	SECHSKANTMUTTER		
34	42 00 016 08	12	WASHER ISO 7089 A 13 ST A3C	SCHEIBE		
35	42 00 019 08	16	WASHER DIN 125 A 17 VERZ	SCHEIBE		
36	42 00 507 08	18	WASHER DIN 125 A 10,5 MS	SCHEIBE		
37	42 18 007 08	16	WASHER DIN 9021 A 6.4 VERZ	SCHEIBE		
38	42 00 012 08	8	WASHER DIN 125 A8X16 ST VERZ	SCHEIBE		
39	43 31 025 08	1	RETAINING SPRING 5 VERZ	SICHERUNGSFEDER		
40	43 32 002 08	2	HINGED CONNECTOR DIN 11023 6X42 VER	KLAPPSTECKER		
41	77 43 040 08	3	GREASE NIPPLE DIN 71412 A M10X1	SCHMIERNIPPEL		
42	93 26 439 08	5	ROLLER RD75X70 PA6G	ROLLE		
43	77 39 335 08	1	SHACKLE DIN 82101 A 0,25 0,25T ST VERZ	SCHAEKEL		
44	10 47 304 0	1	SCREW CARABINER OVAL 130X70X12 S35	SCHRAUBKARABINER		
45	74 00 002 08	0.5	CHAIN DIN 763 6X42 0.2t UST 35-2 GALV. V	KETTE		
47	42 12 019 08	2	WASHER DIN 1441 31 ST VERZ	SCHEIBE		
48	97 71 697 08	1	PLATE 5X82X50	BLECH		
49	97 71 705 08	1	PLATE 3X283X216	BLECH		
50	97 29 088 08	1	HOOD 1.5X411X555	HAUBE		
51	49 00 128	2	HEX BOLT ISO 4017 M8X25 8.8 A2C	SECHSKANTSCHRAUBE		
500	96 48 375 08	1	ELECTR. F-HEAD SECTION ⇒ 3 930 546 96 48 375 08	ELEKTRIK F-KOPFSTUECK		

6.2.2009

etk_en_de_074515 LR 1600/2

440 (3/3)

LIEBHERRF-HEAD SECTION
F-KOPFSTUECK⇒ 3 208 001
91 52 883 08

Pos. 500

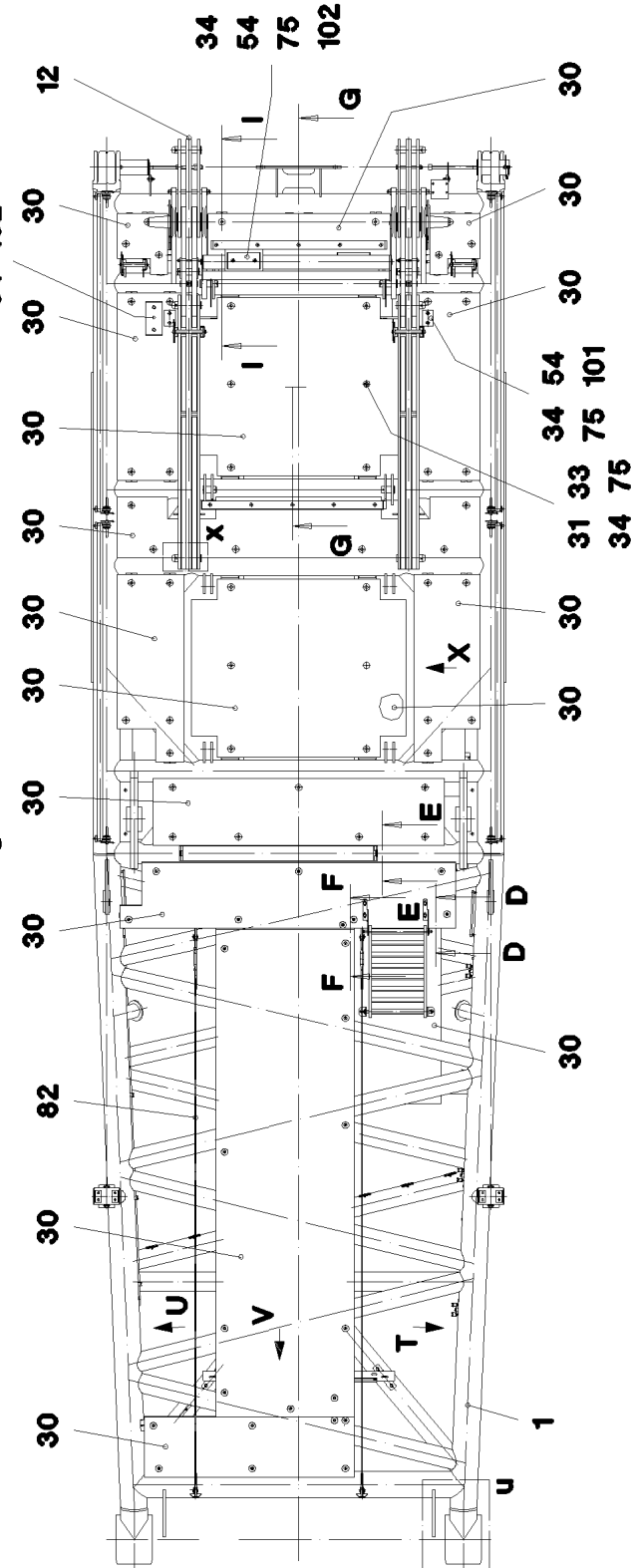
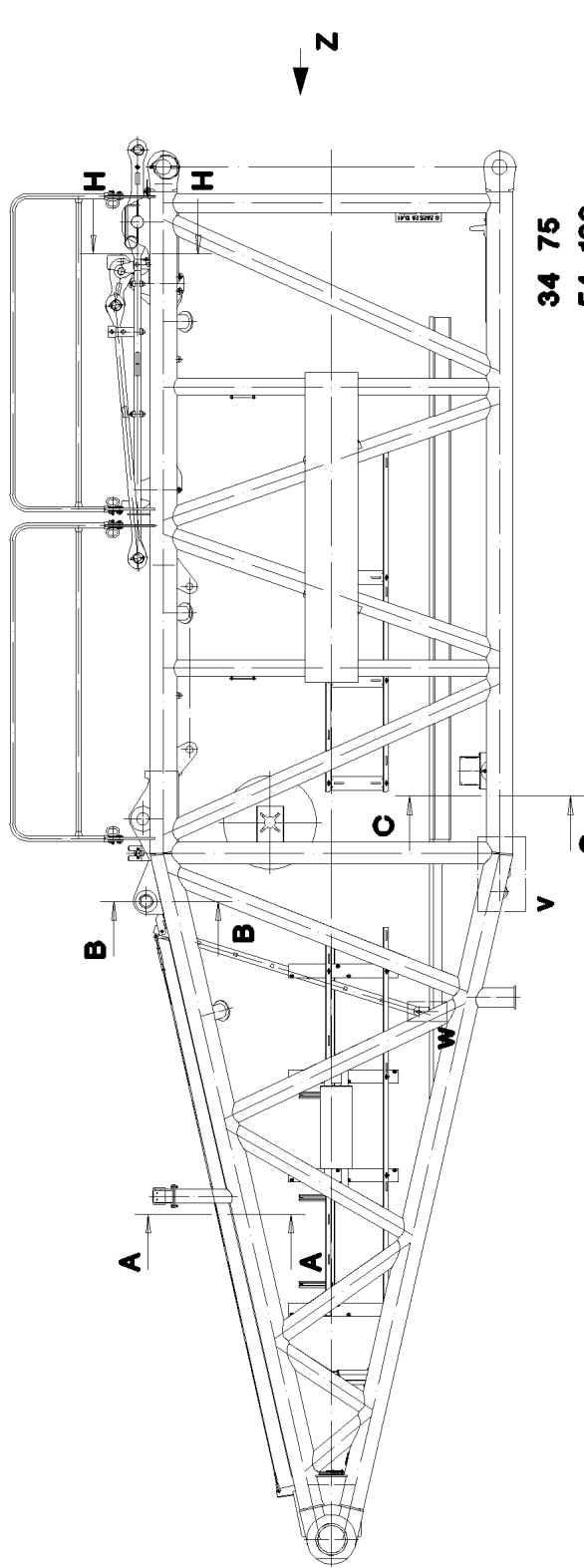

6.2.2009
054186

LIEBHERR

etk_en_de_074515 LR 1600/2

S PIVOT SECTION
S-ANLENKSTUECK

□ 441 (1/7)

⇒ 3 211
91 57 748 08

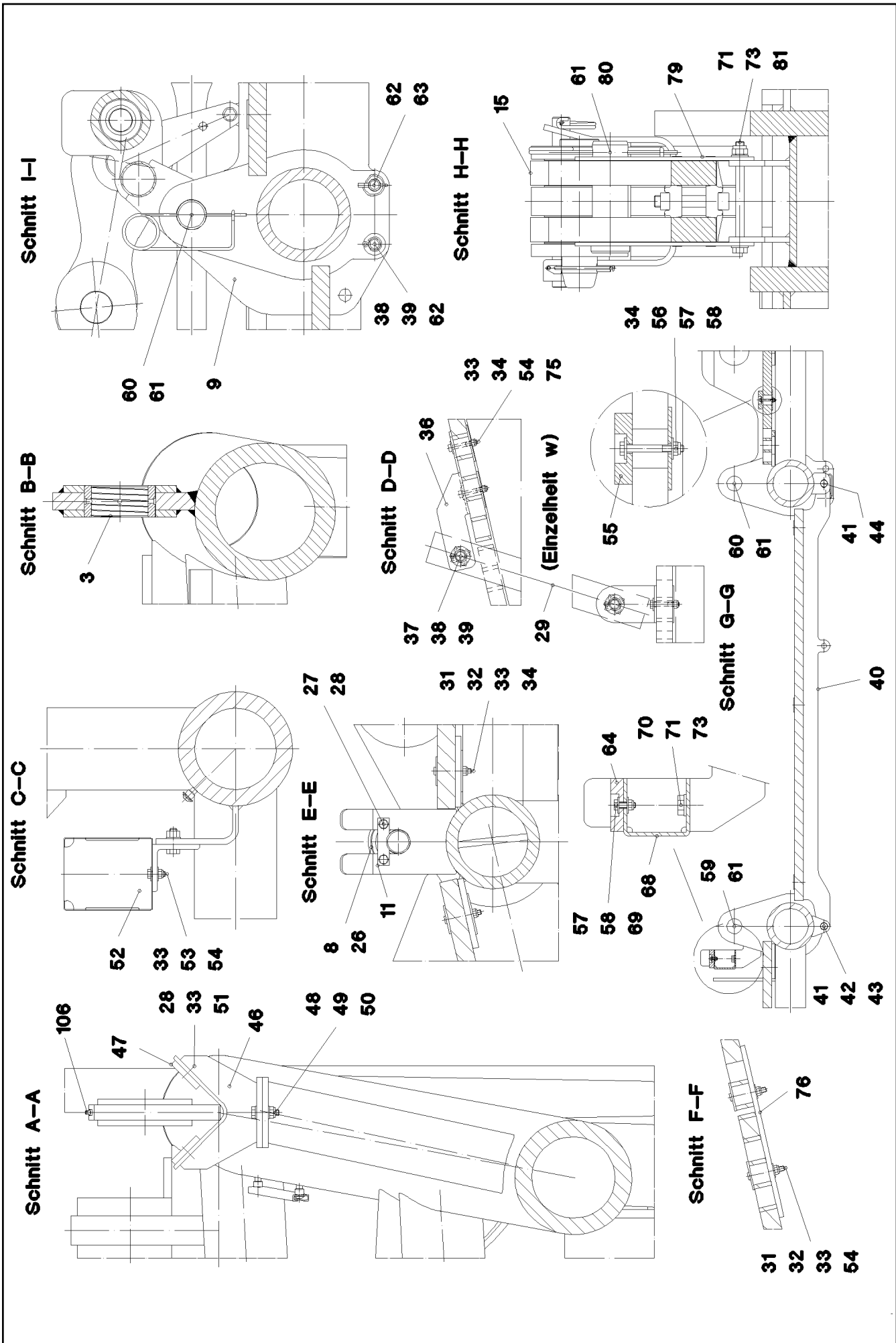

6.2.2009
054187

LIEBHERR

etk_en_de_074515 LR 1600/2

S PIVOT SECTION
S-ANLENKSTUECK

□ 442 (2/7)

⇒ 3 211
91 57 748 08

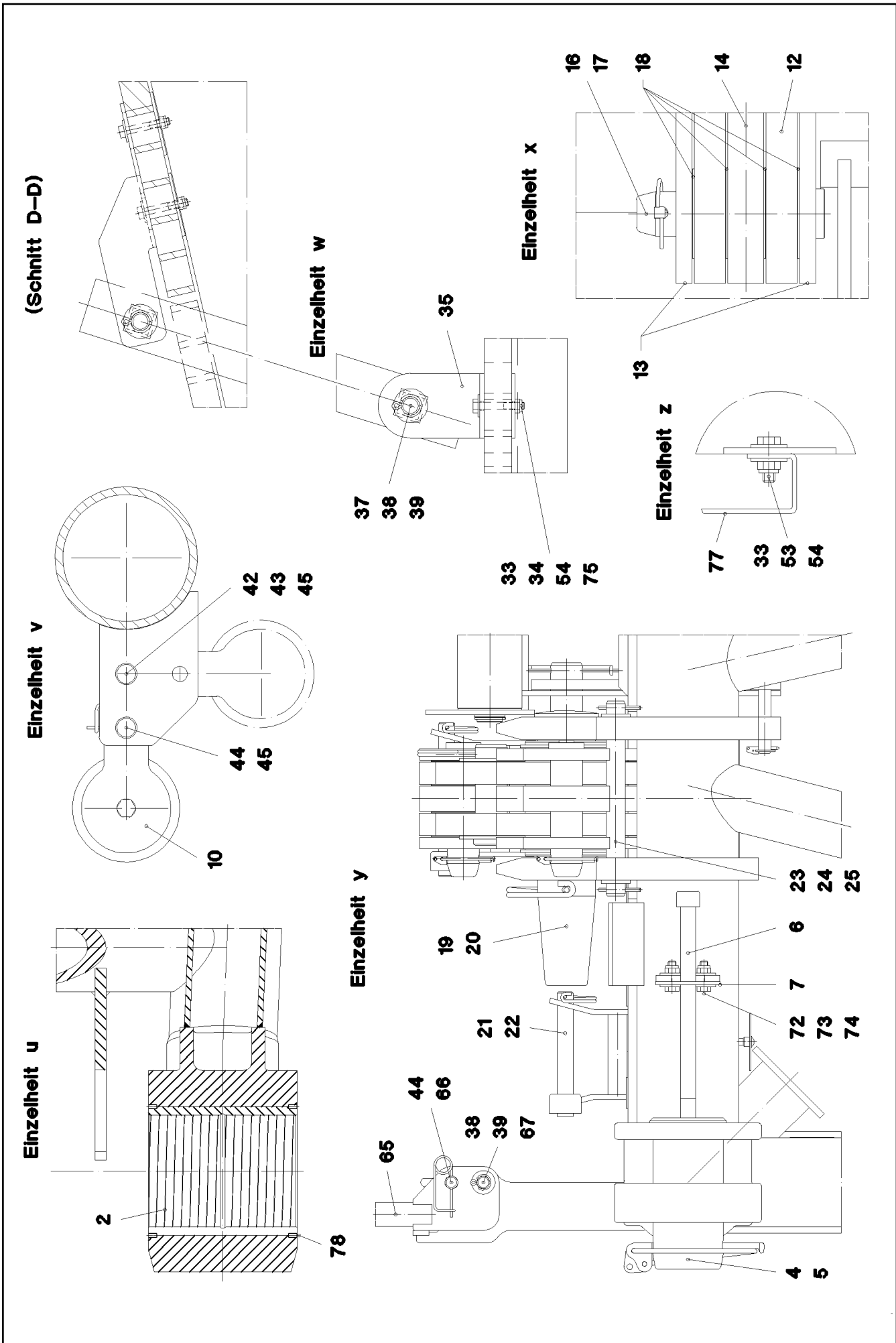

6.2.2009
054188

LIEBHERR

etk_en_de_074515 LR 1600/2

S PIVOT SECTION
S-ANLENKSTUECK

□ 443 (3/7)

⇒ 3 211
91 57 748 08

Ansicht X

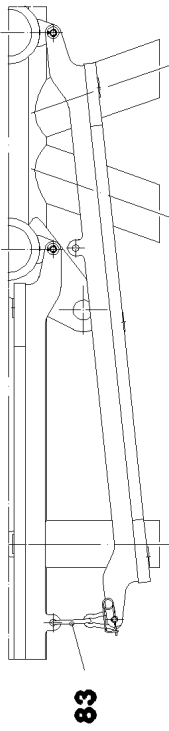

83

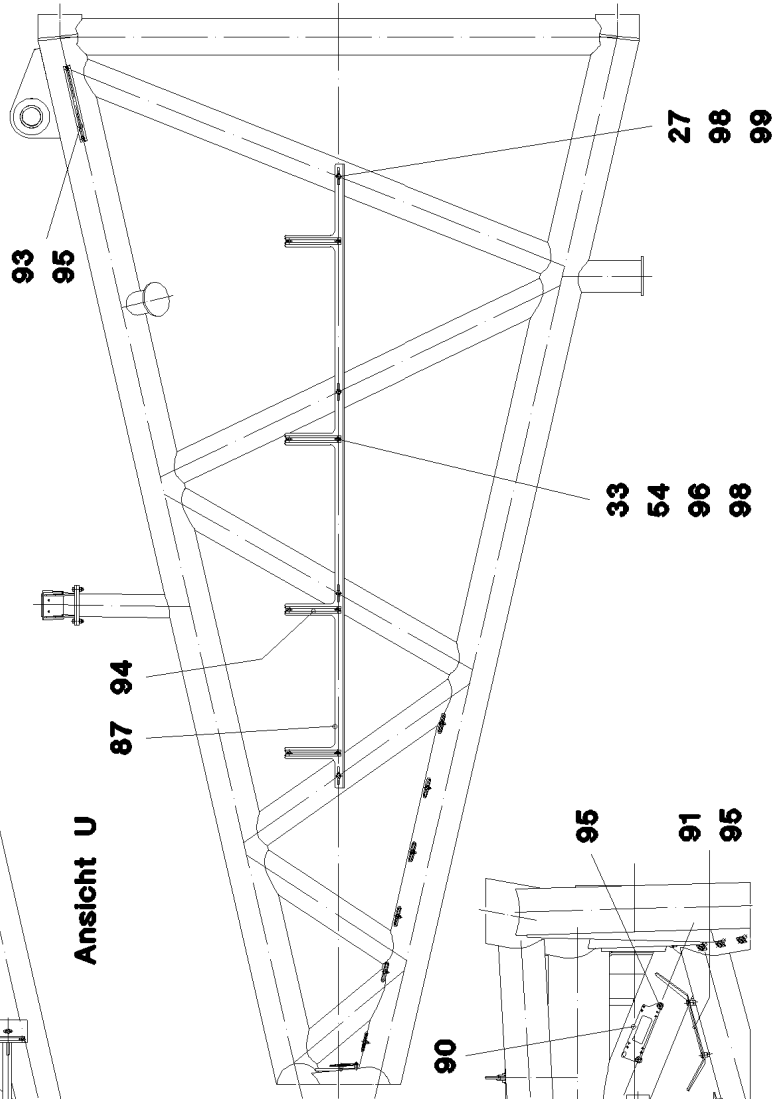

93

95

87 94

Ansicht U

27

98

99

33

54

96

98

Ansicht T

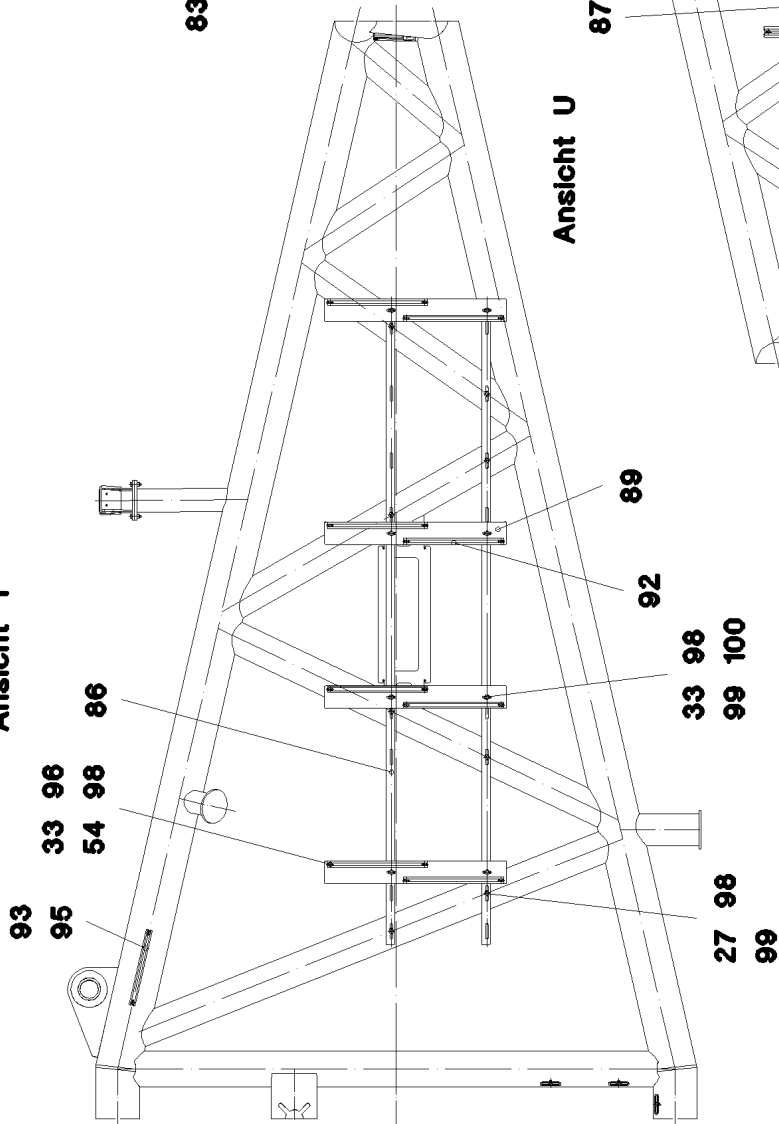

93

95

33

96

54

98

86

86

89

92

33

98

99

100

27

98

99

Ansicht V

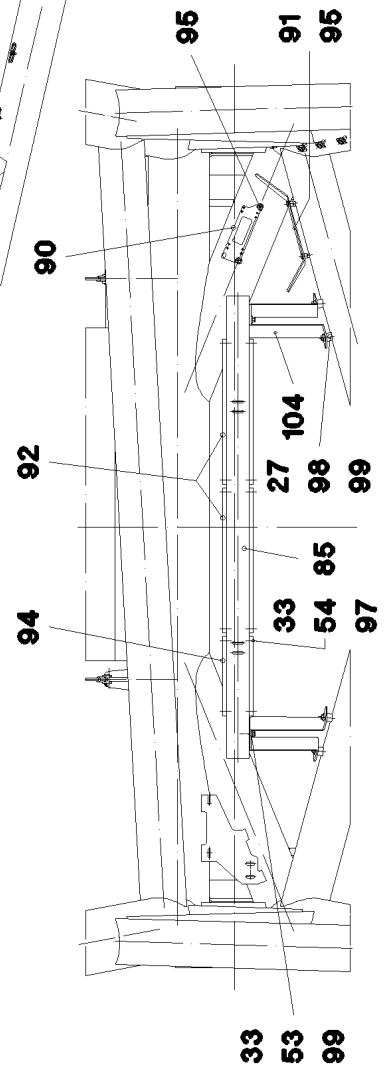

94

92

90

95

91

95

33

53

99

27

104

98

99

33

54

85

97

6.2.2009
054189

LIEBHERR

etk_en_de_074515 LR 1600/2

S PIVOT SECTION
S-ANLENKSTUECK

□ 444 (4/7)

⇒ 3 211

91 57 748 08

Ansicht R

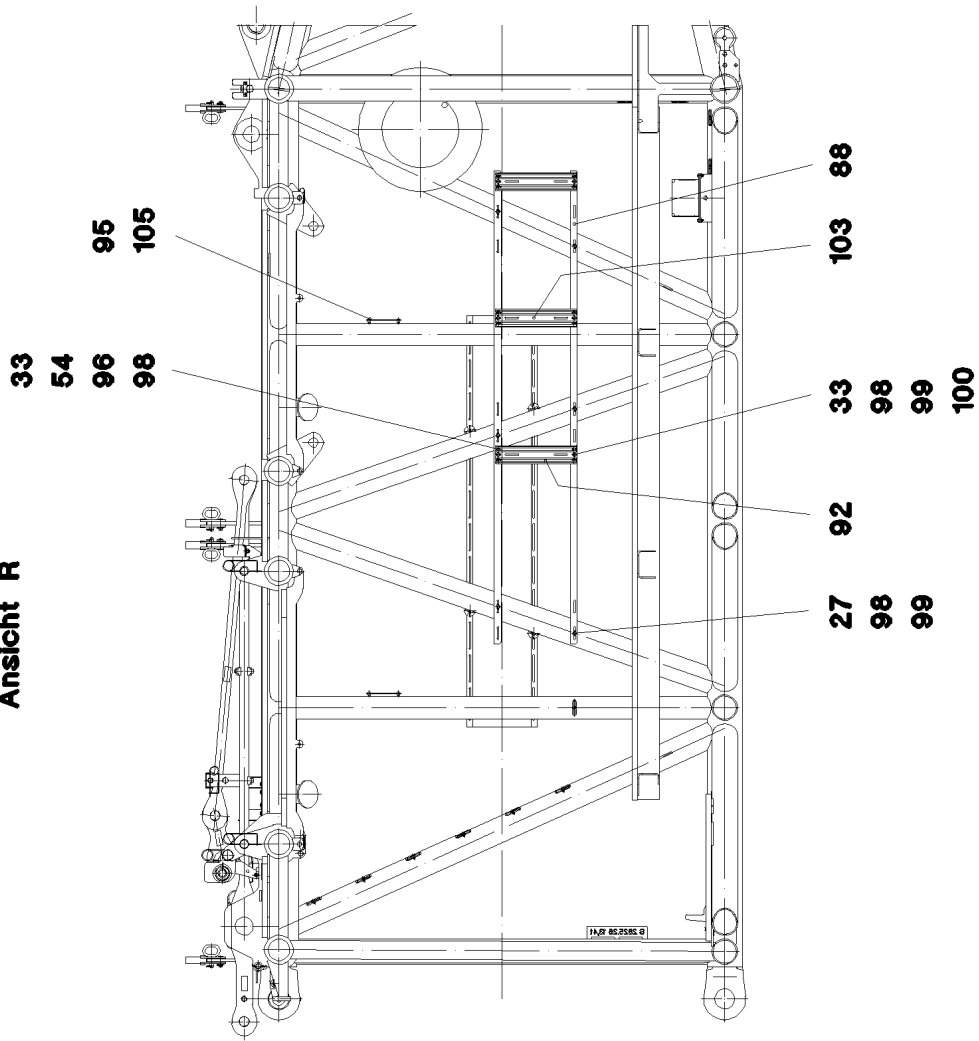

Ansicht Z

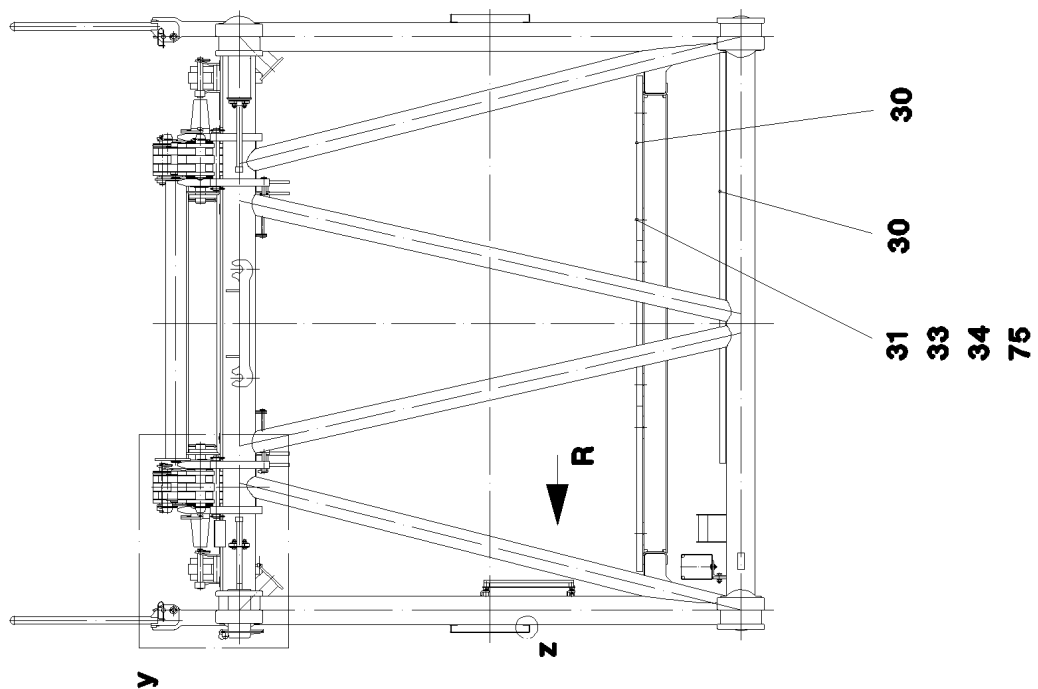

6.2.2009
055316

LIEBHERR

etk_en_de_074515 LR 1600/2

S PIVOT SECTION
S-ANLENKSTUECK

□ 445 (5/7)

⇒ 3 211
91 57 748 08

Pos.	Item	Quantity	Description	Bezeichnung	Serie	K
1	96 45 098 08	1	S PIVOT SECTION, WELD.CONSTR. 10M	S-ANLENKSTUECK SCHWK.		
2	97 69 084 08	2	BUSH 230X200X266 GZ-CUZN25AL5	BUCHSE		
3	97 88 106 08	2	BUSH RD100X45 GZ-CUZN25AL5	BUCHSE		
4	97 64 994 08	2	PIN 120.0X237 SPF	BOLZEN		
5	10 41 062 2	2	SAFETY PLUG W HINGE-LID 20X175 A3C	SICHERHEITSKLAPPSTECKER		
6	40 43 263 08	2	CYLINDER SCREW DIN 912 M24X360 10.9	ZYLINDERSCHRAUBE		
7	95 50 518 08	2	PLATE 5X104X140	BLECH		
8	96 46 978 08	1	SAFETY ROLLER CPL. ⇒ 3 211 008 96 46 978 08	SCHUTZWALZE KPL.		
9	96 46 979 08	1	SAFETY ROLLER CPL. ⇒ 3 211 009 96 46 979 08	SCHUTZWALZE KPL.		
10	92 88 302 08	1	SAFETY ROLLER CPL. ⇒ 3 211 002 92 88 302 08	SCHUTZWALZE KPL.		
11	94 13 244 08	2	AXLE HOLDER 6X20X80	ACHSHALTER		
12	96 46 986 08	2	ROD CPL. 2.975M ⇒ 3 211 003 96 46 986 08	STANGE KPL.		
13	96 46 998 08	4	ROD WITH BOARD 1.85M	STANGE MIT SCHILD		
14	96 46 999 08	2	ROD WITH BOARD 1.85M	STANGE MIT SCHILD		
15	96 47 000 08	4	BRACKET WITH BOARD 0.25M	LASCHE MIT SCHILD		
16	95 28 920 08	4	PIN 55.0X210 30CRNIMO8+QT SPF	BOLZEN		
17	43 32 005 08	4	SAFETY PLUG W HINGE-LID 11,5X96 VERZ	SICHERHEITSKLAPPSTECKER		
18	97 18 386 08	16	WASHER 2X100X100	SCHEIBE		
19	97 71 117 08	2	PIN 100.0X430 SPF	BOLZEN		
20	43 31 052 08	2	RETAINING SPRING 8 VERZ.	SICHERUNGSFEDER		
21	96 43 771 08	2	CONNECTING PIN WELDED	ABSTECKBOLZEN SCHWK.		
22	43 31 009 08	2	RETAINING SPRING 4,5 VERZ	SICHERUNGSFEDER		
23	45 00 333 08	2	PIN AEHN. ISO 2340 30X305X 285 S235JRC	BOLZEN		
24	42 12 019 08	4	WASHER DIN 1441 31 ST VERZ	SCHEIBE		
25	43 30 078 08	4	SPLIT PIN DIN 94 6,3X50 ST VERZ	SPLINT		
26	95 00 775 08	2	SPACER RING RD48X2	DISTANZRING		
27	49 00 188	28	HEX BOLT ISO 4017 M8X16 8.8 A2C	SECHSKANTSCHRAUBE		
28	42 00 012 08	12	WASHER DIN 125 A8X16 ST VERZ	SCHEIBE		
29	78 89 054 08	1	LADDER 8/2110X370 AL	LEITER		
30	96 47 004 08	1	GRATINGS ⇒ 3 211 006 96 47 004 08	GITTERROSTE		
31	10 10 062 1	112	DISH MOUNTING	TELLERBEFESTIGUNG		
32	40 42 072 08	78	CYLINDER SCREW DIN 912 M8X55 8.8 A2C	ZYLINDERSCHRAUBE		
33	41 19 005 08	174	HEX NUT DIN 985 M8 8 VERZ	SECHSKANTMUTTER		
34	94 11 381 08	62	WASHER 70X3	SCHEIBE		
35	97 05 395 08	2	ANGLE 5x154x70	WINKEL		
36	97 46 733 08	2	PLATE 4X260X93	BLECH		
37	45 00 232 08	2	PIN ISO 2340 20X500X485 ST.50K FE//ZN20//	BOLZEN		
38	42 00 021 08	14	WASHER ISO 7089 A 21 ST A3C	SCHEIBE		
39	43 30 065 08	14	SPLIT PIN DIN 94 5X40 ST VERZ	SPLINT		
40	97 71 157 08	4	PLATE 4X1540X297	BLECH		
41	45 30 093 08	8	PIN DIN 1444 16H11X152X146 ST.50-2K VER	BOLZEN		
42	42 00 019 08	6	WASHER DIN 125 A 17 VERZ	SCHEIBE		
43	43 30 050 08	6	SPLIT PIN DIN 94 4X25 ST VERZ	SPLINT		
44	43 31 028 08	14	RETAINING SPRING 3 VERZ	SICHERUNGSFEDER		
45	45 12 412 08	4	PIN DIN 1435 16H11X40X35 ST.50K VERZ	BOLZEN		
46	92 85 715 08	2	SUPPORT WELDED	AUFLAGE SCHWK.		
47	93 22 470 08	4	BEARING PLATE 10X60X90 PA6G	LAGERPLATTE		
48	46 00 122	4	HEX BOLT ISO 4017 M10X40 8.8 A3C	SECHSKANTSCHRAUBE		
49	41 19 006 08	4	HEX NUT DIN 985 M10 8 VERZ	SECHSKANTMUTTER		
50	42 00 013 08	8	WASHER ISO 7089 A 10.5 A3C	SCHEIBE		
51	40 86 005 08	8	COUNTERSUNK SCREW DIN 7991 M8X25 8.	SENKSCHEIBE		
52	97 29 088 08	1	HOOD 1.5X411X555	HAUBE		
53	49 00 128	8	HEX BOLT ISO 4017 M8X25 8.8 A2C	SECHSKANTSCHRAUBE		
54	42 18 009 08	46	WASHER DIN 9021 A 8.4 VERZ	SCHEIBE		
55	28 81 537 08	1	SUPPORT PLATE 15X60X1280 PA6G	AUFLAGE		

6.2.2009

etk_en_de_074515 LR 1600/2

□ 446 (6/7)

LIEBHERR**S PIVOT SECTION
S-ANLENKSTUECK**⇒ 3 211
91 57 748 08

Pos.	Item	Quantity	Description	Bezeichnung	Serie	K
56	46 00 023	5	HEX BOLT ISO 4014 M6X50 8.8 A2C	SECHSKANTSCHRAUBE		
57	41 19 004 08	10	HEX NUT DIN 985 M6 8 VERZ	SECHSKANTMUTTER		
58	42 18 007 08	20	WASHER DIN 9021 A 6.4 VERZ	SCHEIBE		
59	95 54 699 08	2	PIN RD50X90 30CR	BOLZEN		
60	94 57 205 08	2	PIN RD50X120	BOLZEN		
61	43 31 025 08	6	RETAINING SPRING 5 VERZ	SICHERUNGSFEDER		
62	45 30 209 08	4	PIN DIN 1444 20H11X115X107 ST.50-2K VER	BOLZEN		
63	43 32 001 08	2	HINGED CONNECTOR DIN 11023 5X32 VER	KLAPPSTECKER		
64	28 81 766 08	1	SUPPORT PLATE 15X60X1318 PA6G	AUFLAGE		
65	96 47 099 08	4	HAND RAIL WELDED STRUCTURE	GELAENDER SCHWK.		
66	92 47 131 08	8	PLUG T ZN K	STECKER		
67	45 10 012 08	8	PIN DIN 1434 20H11X55X46 30CRNIMO8 GA	BOLZEN		
68	97 71 636 08	1	PLATE 4X1445X192	BLECH		
69	40 00 829	5	HEX BOLT ISO 4017 M6X20 8.8 A2C	SECHSKANTSCHRAUBE		
70	49 00 161	2	HEX BOLT ISO 4017 M12X30 8.8 A3C	SECHSKANTSCHRAUBE		
71	42 00 016 08	8	WASHER ISO 7089 A 13 ST A3C	SCHEIBE		
72	49 00 100	4	HEX BOLT ISO 4017 M12X40 8.8 A3C	SECHSKANTSCHRAUBE		
73	41 19 007 08	8	HEX NUT DIN 985 M12 8 A3C	SECHSKANTMUTTER		
74	42 18 011 08	8	WASHER ISO 7093-1 A 13 ST A3C	SCHEIBE		
75	40 01 461	44	HEX BOLT ISO 4014 M8X50 8.8 A2C	SECHSKANTSCHRAUBE		
76	95 54 048 08	2	PLATE 8X300X50	BLECH		
77	97 32 004 08	2	PLATE 3X2260X511	BLECH		
78	40 44 011 08	16	GRUB SCREW DIN 913 M8X16 45 H A3C	GEWINDESTIFT		
79	95 66 430 08	4	PLATE 5X100X270	BLECH		
80	93 92 498 08	2	PIN 55.0X158	BOLZEN		
81	40 61 076	2	HEX BOLT ISO 4014 M12X150 8.8 A3C	SECHSKANTSCHRAUBE		
82	10 65 280 6	2	ROUND STRAND ROPE 10MM 4,13M EDEL	RUNDLITZENSEIL		
83	74 40 104 08	4	SNAP HOOK DIN 5299 100X10 ST VERZ	KARABINERHAKEN		
84	97 80 936 08	1	PLATE 4X581X113	BLECH		
85	97 80 937 08	1	PLATE 4X1400X207	BLECH		
86	97 81 550 08	2	PLATE 4X2834X53	BLECH		
87	97 81 551 08	1	PLATE 4X2744X273	BLECH		
88	97 86 531 08	2	PLATE 4X2600X53	BLECH		
89	97 55 895 08	4	PLATE 4X800X100	BLECH		
90	95 56 681 08	1	PLATE X0	BLECH		
91	95 37 411 08	1	PLATE 4X20X500	BLECH		
92	97 03 448 08	18	CARRIER RAIL	TRAGSCHIENE		
93	95 41 175 08	2	CARRIER RAIL 340	TRAGSCHIENE		
94	95 41 174 08	6	CARRIER RAIL 240	TRAGSCHIENE		
95	10 41 285 4	12	OVAL HEAD FLAT SCREW AEHNL.ISO7380	LINSENFLACHKOPFSCHRAUBE		
96	40 97 059 08	36	PAN-HEAD SCREW M8X35 A2K	FLACHKOPFSCHRAUBE		
97	40 97 041 08	12	PAN-HEAD SCREW M8X20	FLACHKOPFSCHRAUBE		
98	95 38 734 08	72	SLEEVE	HUELSE		
99	42 16 005 08	55	WASHER DIN 7349 8,4 ST VERZ	SCHEIBE		
100	40 01 466	14	HEX BOLT ISO 4014 M8X45 8.8 A2C	SECHSKANTSCHRAUBE		
101	97 81 823 08	2	PLATE 3X280X80	BLECH		
102	97 81 896 08	2	PLATE 4X487X120	BLECH		
103	97 57 447 08	3	PLATE 4X450X100	BLECH		
104	97 86 533 08	1	PLATE 4X581X113	BLECH		
105	97 15 627 08	2	PLATE 3X190X60	BLECH		
106	77 43 040 08	2	GREASE NIPPLE DIN 71412 A M10X1	SCHMIERNIPPEL		
500	96 54 377 08	1	ELECTRIC FOR S-PIVOT SECTION	ELEKTRIK S-ANLENKSTUECK		
			⇒ 3 930 138 96 54 377 08			

6.2.2009

etk_en_de_074515 LR 1600/2

□ 447 (7/7)

LIEBHERRS PIVOT SECTION
S-ANLENKSTUECK⇒ 3 211
91 57 748 08

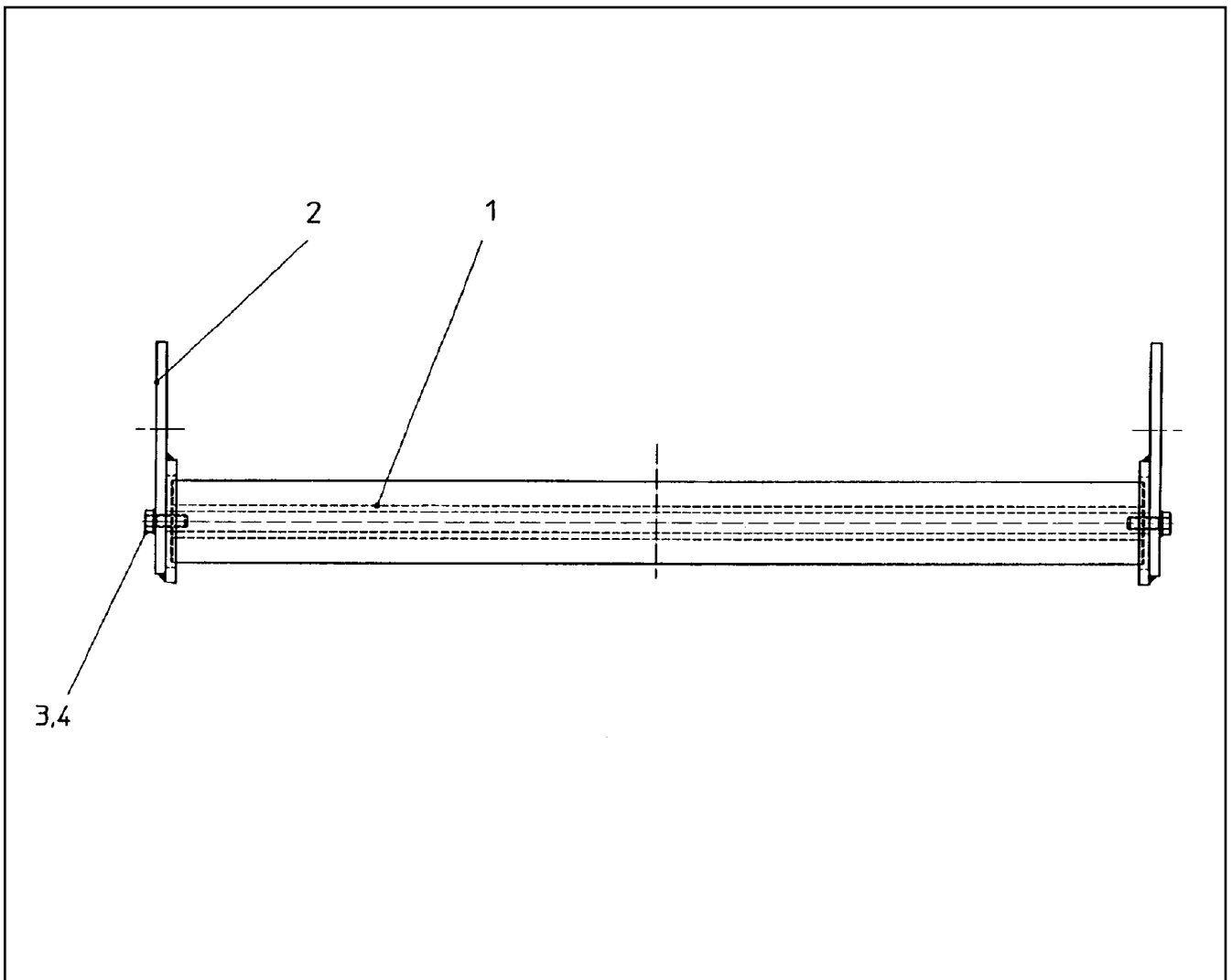

Pos.	Item	Quantity	Description	Bezeichnung	Serie	K
1	74 90 102 08	1	CARRYING ROLLER 80/5/20X950 ST.52 GA	TRAGROLLE		
2	92 88 304 08	2	BRACKET COMPL.	LASCHE KPL.		
3	49 00 204	2	HEX BOLT ISO 4017 M12X35 8.8 A3C	SECHSKANTSCHRAUBE		
4	42 40 009 08	2	CIRCLIP DIN 127 A 12 VERZ	FEDERRING		

6.2.2009
134568

LIEBHERR

etk_en_de_074515 LR 1600/2

SAFETY ROLLER CPL.
SCHUTZWALZE KPL.

448

⇒ 3 211 002
92 88 302 08

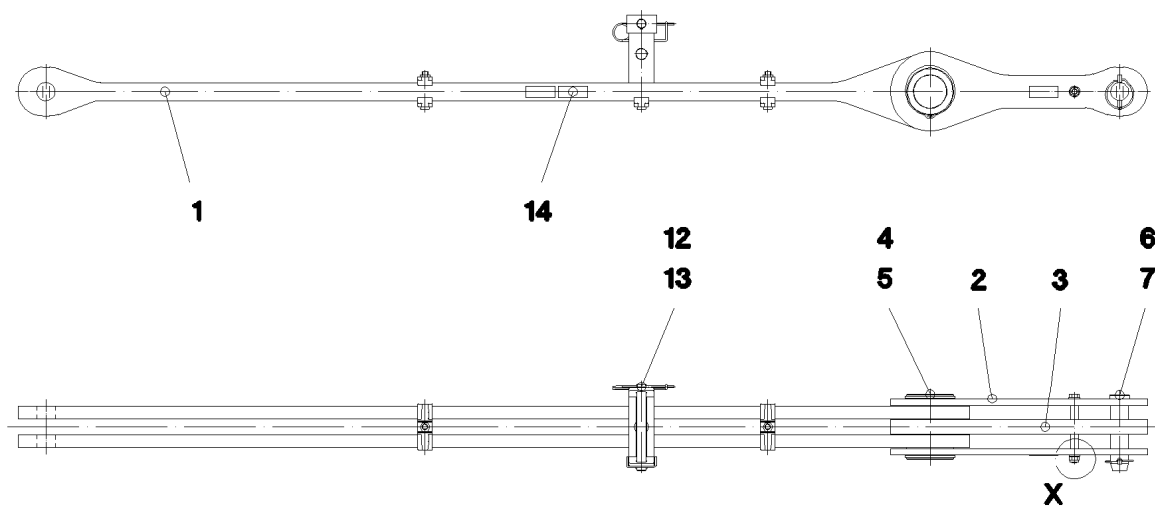

Einzelheit X

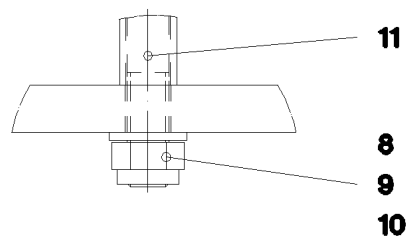

Pos.	Item	Quantity	Description	Bezeichnung	Serie	K
1	96 47 008 08	1	ROD 2.45M	STANGE VORM.		
2	96 47 009 08	2	ROD WITH BOARD 0.525M	STANGE MIT SCHILD		
3	96 47 010 08	1	ROD WITH BOARD 0.525M	STANGE MIT SCHILD		
4	97 71 198 08	1	AXLE 140.0X180 SPF	ACHSE		
5	42 80 076 08	2	LOCKING RING DIN 4 130X4	SICHERUNGSRING		
6	95 28 920 08	1	PIN 55.0X210 30CRNIMO8+QT SPF	BOLZEN		
7	43 32 005 08	1	SAFETY PLUG W HINGE-LID 11,5X96 VERZ	SICHERHEITSKLAPPSTECKER		
8	40 61 186 01	1	HEX BOLT ISO 4014 M16X180 8.8 A3C	SECHSKANTSCHRAUBE		
9	41 19 009 08	1	HEX NUT DIN 985 M16 8 VERZ	SECHSKANTMUTTER		
10	42 00 019 08	2	WASHER DIN 125 A 17 VERZ	SCHEIBE		
11	93 92 551 08	2	TUBE 22X2,5X40	ROHR		
12	96 47 595 08	1	CONNECTING PIN WELDED FE//ZN20//C	ABSTECKBOLZEN SCHWK.		
13	43 31 009 08	1	RETAINING SPRING 4,5 VERZ	SICHERUNGSFEDER		
14	97 35 919 08	1	PLATE ASSEMBLY BG-NR. PVC-SILBER SP	SCHILD BAUGRUPPE		

6.2.2009
052359

LIEBHERR

etk_en_de_074515 LR 1600/2

ROD CPL.
STANGE KPL.

449

⇒ 3 211 003
96 46 986 08

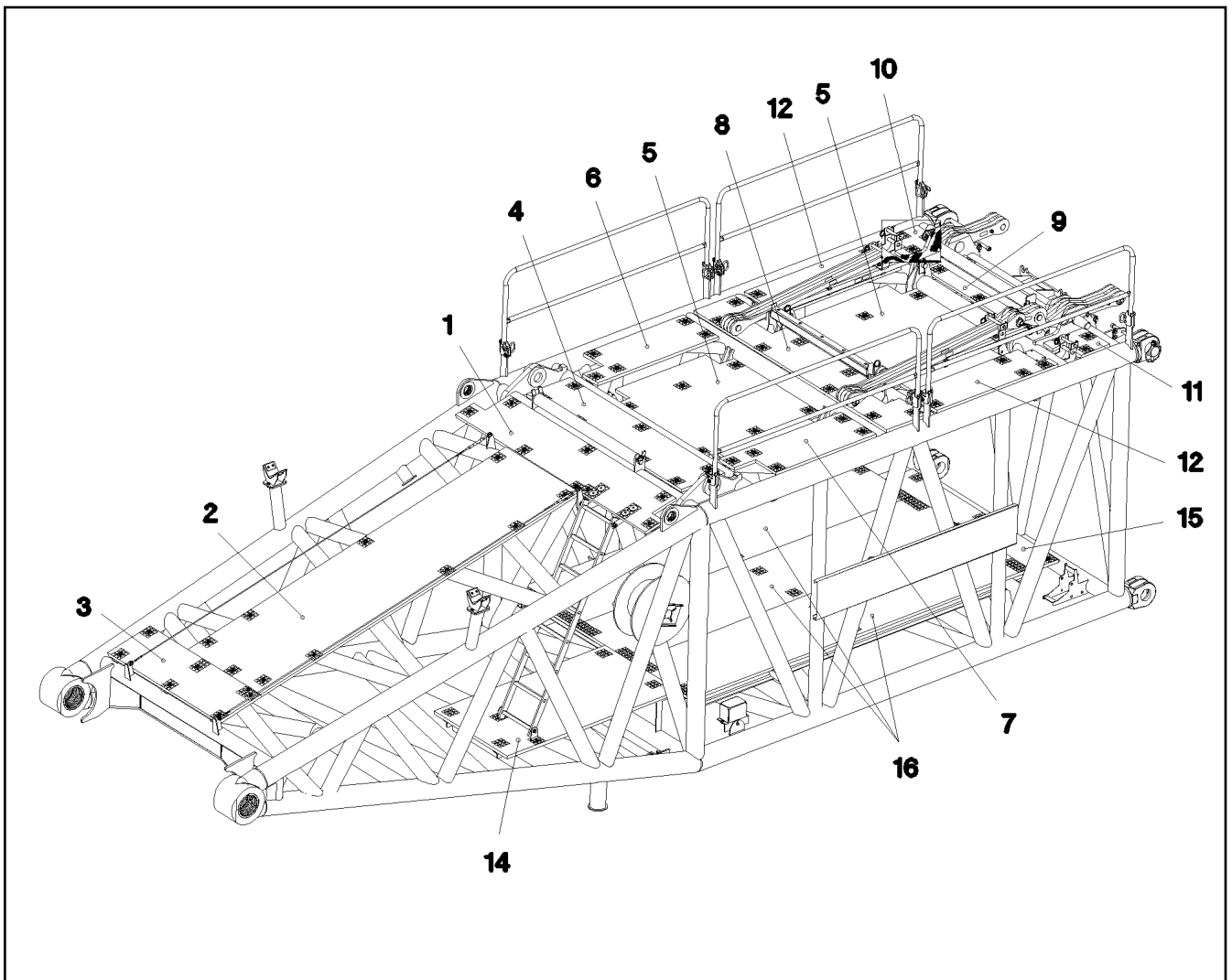

Pos.	Item	Quantity	Description	Bezeichnung	Serie	K
1	97 72 097 08	1	GRATING 2447X487X30 GFK SPF	GITTERROST		
2	97 72 098 08	1	GRATING 3647X1007X30 GFK SPF	GITTERROST		
3	97 72 730 08	1	GRATING 1527X447X30 GFK SPF	GITTERROST		
4	97 72 733 08	1	GRATING 2127X487X30 GFK SPF	GITTERROST		
5	97 72 734 08	2	GRATING 1607X1294X30 GFK SPF	GITTERROST		
6	97 72 735 08	1	GRATING 1367X487X30 GFK SPF	GITTERROST		
7	97 72 736 08	1	GRATING 1367X487X30 GFK SPF	GITTERROST		
8	97 72 737 08	1	GRATING 2647X447X30 GFK SPF	GITTERROST		
9	97 72 738 08	1	GRATING 1327X447X30 GFK SPF	GITTERROST		
10	97 72 739 08	1	GRATING 447X367X30 GFK SPF	GITTERROST		
11	97 72 740 08	1	GRATING 447X367X30 GFK SPF	GITTERROST		
12	97 72 741 08	2	GRATING 1367X487X30 GFK SPF	GITTERROST		
14	97 72 743 08	1	GRATING 1927X1007X30 GFK SPF	GITTERROST		
15	97 72 744 08	1	GRATING 2007X807X30 GFK SPF	GITTERROST		
16	97 72 745 08	3	GRATING 3807X807X30 GFK SPF	GITTERROST		

6.2.2009
052360

LIEBHERR

etk_en_de_074515 LR 1600/2

GRATINGS
GITTERROSTE

▣ 450

⇒ 3 211 006
96 47 004 08

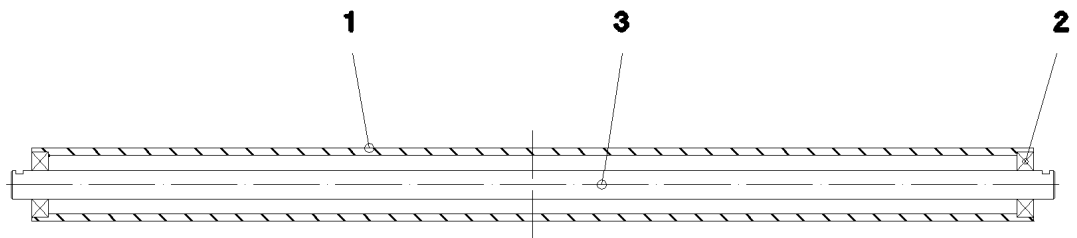

Pos.	Item	Quantity	Description	Bezeichnung	Serie	K
1	95 66 948 08	1	TUBE RD101,6X10X1388	ROHR		
2	74 51 688 08	2	DEEP GROOVE BALL BEARING DIN 625 630	RILLENKUGELLAGER		
3	97 71 244 08	1	AXLE 40.0X1446	ACHSE		

6.2.2009
052357

LIEBHERR

etk_en_de_074515 LR 1600/2

SAFETY ROLLER CPL.
SCHUTZWALZE KPL.

451

⇒ 3 211 008
96 46 978 08

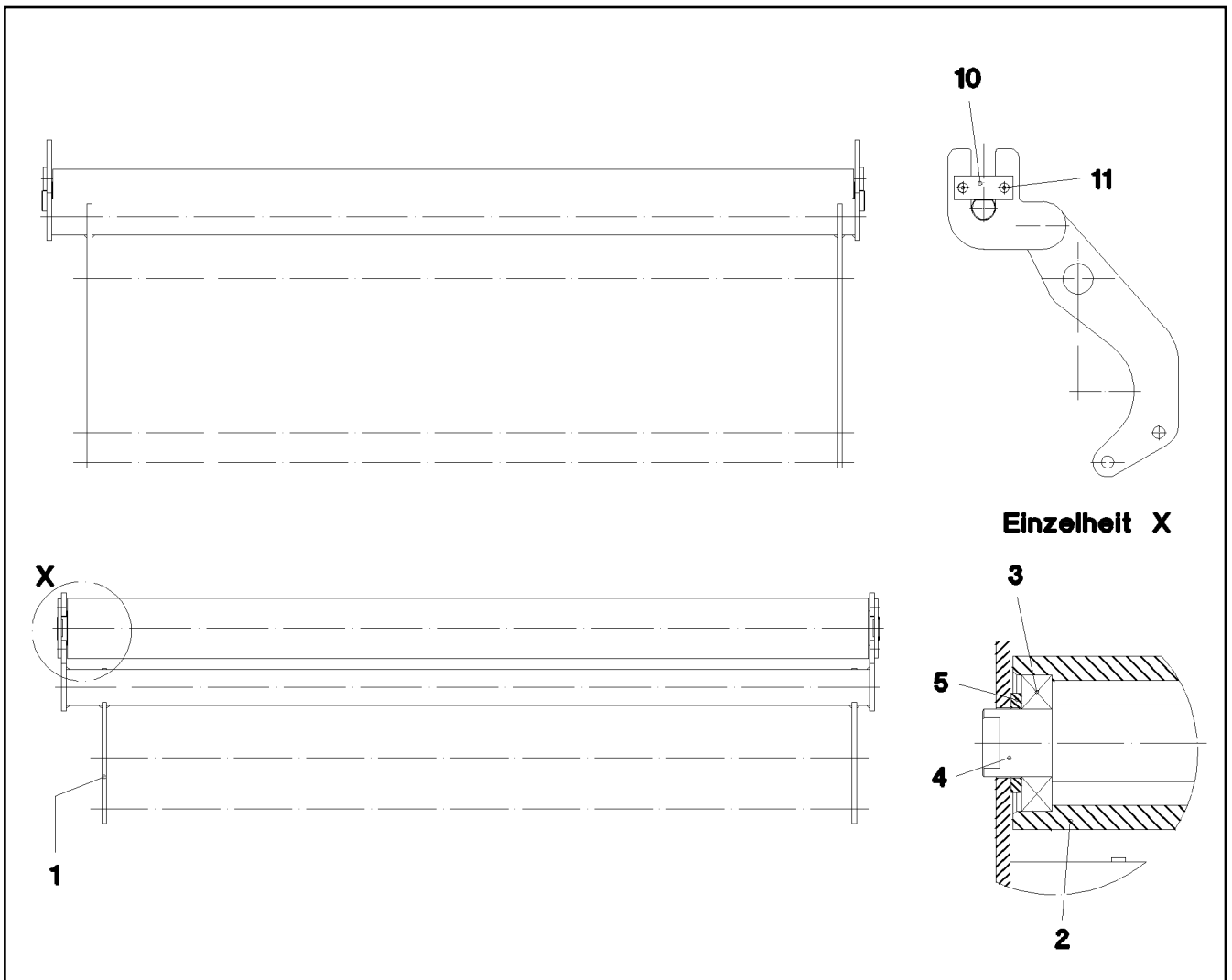

Einzelheit X

Pos.	Item	Quantity	Description	Bezeichnung	Serie	K
1	96 47 021 08	1	MOUNTING WELDED	HALTERUNG SCHWK.		
2	97 71 247 08	1	TUBE 101.6X1356	ROHR		
3	74 51 488 08	2	DEEP GROOVE BALL BEARING DIN 625 620	RILLENKUGELLAGER		
4	97 71 246 08	1	AXLE 45.0X1392 S355J2G3 FE//ZN20//C	ACHSE		
5	42 12 024 08	2	WASHER DIN 1441 41 ST A2C	SCHEIBE		
10	99 70 411 01	2	AXLE HOLDER LN 4/11 6X40X100 S235JR+	ACHSHALTER		
11	40 86 043 08	4	COUNTERSUNK SCREW DIN 7991 M8X12 8.	SENKSCRAUBE		

6.2.2009
052358

LIEBHERR

etk_en_de_074515 LR 1600/2

SAFETY ROLLER CPL.
SCHUTZWALZE KPL.

452

⇒ 3 211 009
96 46 979 08

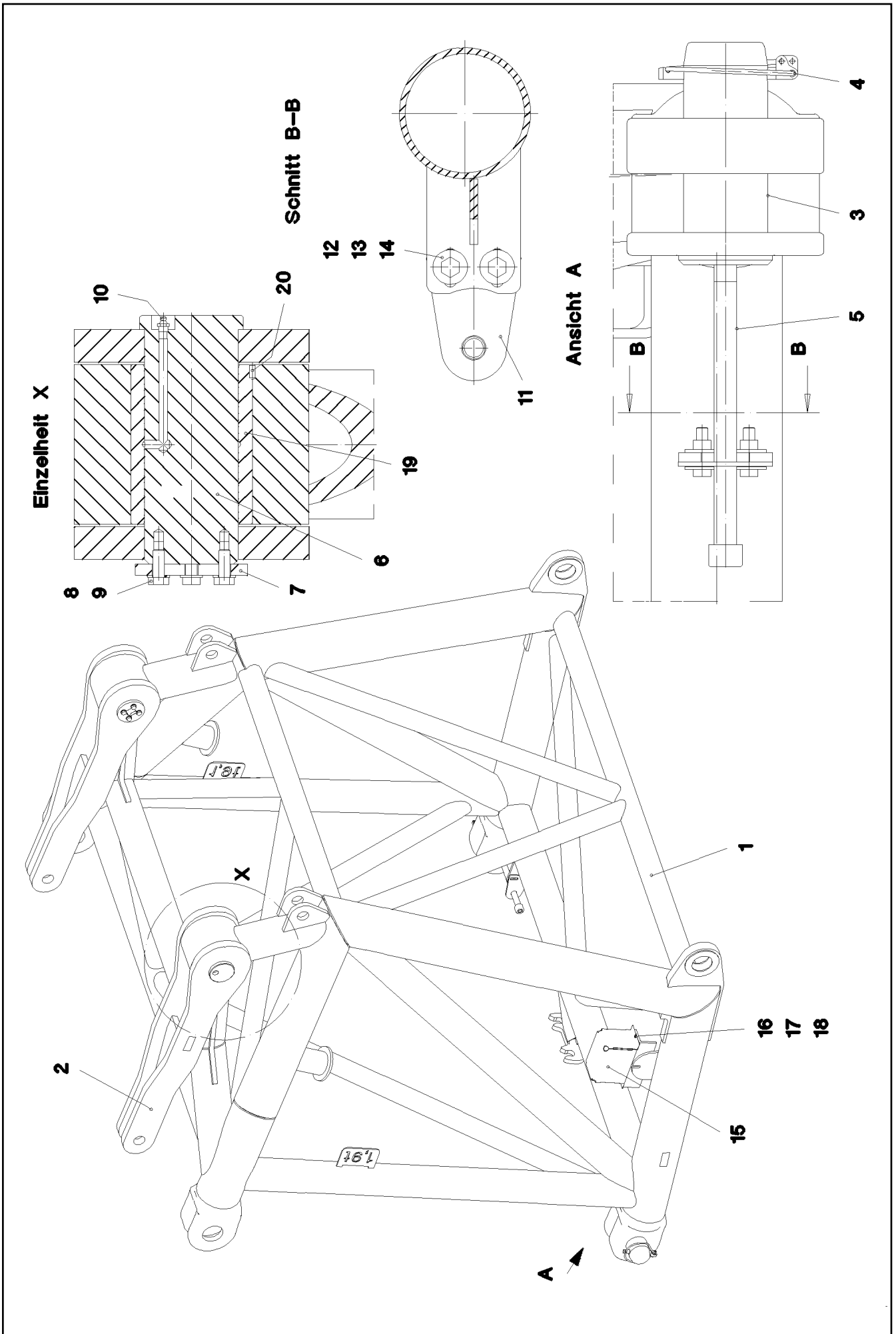

Pos.	Item	Quantity	Description	Bezeichnung	Serie	K
1	96 46 750 08	1	F-CONNECTING HEAD WELDED	F-ANSCHLUSSKOPF SCHWK.		
2	96 46 787 08	2	ROD	STANGE SCHWK.		
3	97 68 649 08	2	PIN 100.0X237 35NICRMOV125 SPF	BOLZEN		
4	43 32 015 08	2	SAFETY PLUG W HINGE-LID 17X125 VERZ	SICHERHEITSKLAPPSTECKER		
5	46 30 212	2	CYLINDER SCREW ISO 4762 M24X340 10.9	ZYLINDERSCHRAUBE		
6	97 70 828 08	2	PIN 110.0X265 SPF	BOLZEN		
7	97 70 829 08	2	PLATE 12X120X120 SPF	BLECH		
8	49 00 161	8	HEX BOLT ISO 4017 M12X30 8.8 A3C	SECHSKANTSCHRAUBE		
9	42 00 508 08	8	WASHER DIN 125 A 13 MS	SCHEIBE		
10	77 43 040 08	2	GREASE NIPPLE DIN 71412 A M10X1	SCHMIERNIPPEL		
11	95 50 518 08	2	PLATE 5X104X140	BLECH		
12	46 00 158	4	HEX BOLT ISO 4017 M12X45 8.8 A3C	SECHSKANTSCHRAUBE		
13	41 15 143 08	4	HEX NUT DIN 934 M12 8 VERZ	SECHSKANTMUTTER		
14	42 18 011 08	8	WASHER ISO 7093-1 A 13 ST A3C	SCHEIBE		
15	97 29 088 08	1	HOOD 1.5X411X555	HAUBE		
16	49 00 128	2	HEX BOLT ISO 4017 M8X25 8.8 A2C	SECHSKANTSCHRAUBE		
17	41 19 005 08	2	HEX NUT DIN 985 M8 8 VERZ	SECHSKANTMUTTER		
18	42 00 012 08	4	WASHER DIN 125 A8X16 ST VERZ	SCHEIBE		
19	97 70 818 08	2	BUSH 100X130X170 GZ-CUZN25AL5	BUCHSE		
20	40 46 005 08	2	GRUB SCREW DIN 914 M6X16 45 H VERZ	GEWINDESTIFT		
500	96 48 380 08	1	EL.F-CONNECTING HEAD	EL.F-ANSCHLUSS KOPFSTUEC		
			⇒ 3 930 575 96 48 380 08			

6.2.2009	etk_en_de_074515 LR 1600/2	<input type="checkbox"/> 454 (2/2)
LIEBHERR	F-CONNECTING HEAD F-ANSCHLUSSKOPF	⇒ 3 213 91 52 842 08

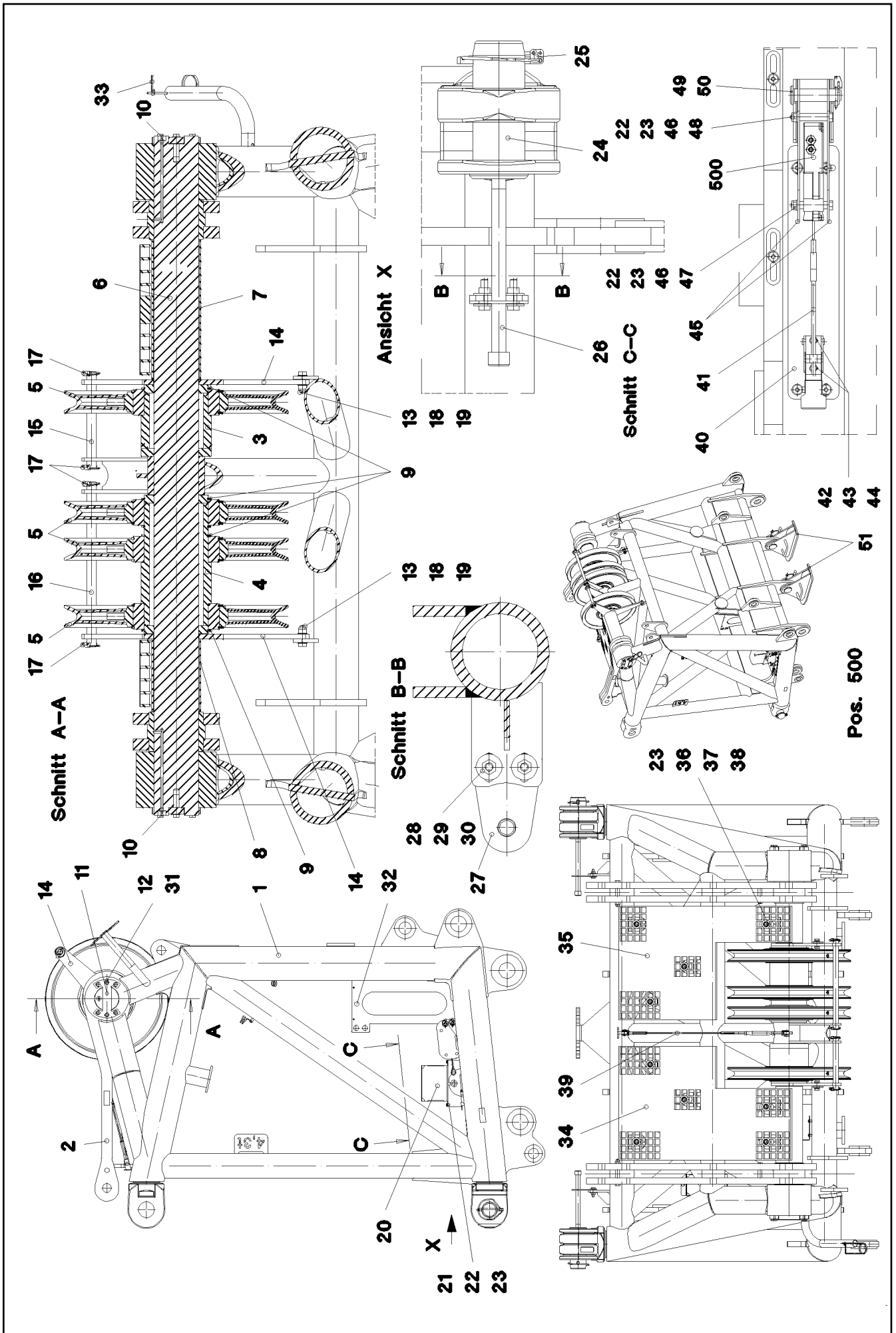

6.2.2009
052748

LIEBHERR

etk_en_de_074515 LR 1600/2

SW HEAD SECTION
SW-KOPFSTUECK

455 (1/2)

⇒ 3 214
91 52 843 08

Pos.	Item	Quantity	Description	Bezeichnung	Serie	K
1	96 46 991 08	1	SW HEAD SECTION WELDMENT	SW-KOPFSTUECK SCHWK.		
2	96 49 042 08	2	ROD CPL. 1.075M	STANGE KPL.		
3	96 49 043 08	1	BEARING LEFT	LAGERUNG LI.		
4	96 49 044 08	1	BEARING RIGHT	LAGERUNG RE.		
5	96 46 246 08	4	ROPE PULLEY CPL. SPF ⇒ 2 550 003 96 46 246 08	SEILROLLE KPL.		
6	97 75 240 08	1	AXLE 150.0X2123 SPF	ACHSE		
7	96 51 173 08	1	TUBE CPL.LEFT	ROHR KPL.LI.		
8	96 51 174 08	1	TUBE CPL. RIGHT	ROHR KPL.RE.		
9	42 80 093 08	5	LOCKING RING DIN 471 200X4	SICHERUNGSRING		
10	77 43 040 08	2	GREASE NIPPLE DIN 71412 A M10X1	SCHMIERNIPPEL		
11	97 76 161 08	2	AXLE HOLDER 20X220X150 S960QL	ACHSHALTER		
12	46 00 366	12	HEX BOLT ISO 4017 M12X40 10.9 A3C	SECHSKANTSCHRAUBE		
13	42 00 019 08	4	WASHER DIN 125 A 17 VERZ	SCHEIBE		
14	97 75 244 08	2	PLATE 15X578X490	BLECH		
15	97 75 245 08	1	PIN 30.0X305 FE//ZN20//C	BOLZEN		
16	97 75 246 08	1	PIN 30.0X515 FE//ZN20//C	BOLZEN		
17	43 32 014 08	4	SAFETY PLUG W HINGE-LID 8X42 VERZ	SICHERHEITSKLAPPSTECKER		
18	46 00 044	2	HEX BOLT ISO 4017 M16X55 8.8 A3C	SECHSKANTSCHRAUBE		
19	41 19 009 08	2	HEX NUT DIN 985 M16 8 VERZ	SECHSKANTMUTTER		
20	97 29 088 08	1	HOOD 1.5X411X555	HAUBE		
21	49 00 128	2	HEX BOLT ISO 4017 M8X25 8.8 A2C	SECHSKANTSCHRAUBE		
22	42 00 012 08	10	WASHER DIN 125 A8X16 ST VERZ	SCHEIBE		
23	41 19 005 08	17	HEX NUT DIN 985 M8 8 VERZ	SECHSKANTMUTTER		
24	97 68 649 08	2	PIN 100.0X237 35NICRMOV125 SPF	BOLZEN		
25	43 32 015 08	2	SAFETY PLUG W HINGE-LID 17X125 VERZ	SICHERHEITSKLAPPSTECKER		
26	46 30 212	2	CYLINDER SCREW ISO 4762 M24X340 10.9	ZYLINDERSCHRAUBE		
27	95 50 518 08	2	PLATE 5X104X140	BLECH		
28	46 00 158	4	HEX BOLT ISO 4017 M12X45 8.8 A3C	SECHSKANTSCHRAUBE		
29	42 18 011 08	8	WASHER ISO 7093-1 A 13 ST A3C	SCHEIBE		
30	41 15 143 08	4	HEX NUT DIN 934 M12 8 VERZ	SECHSKANTMUTTER		
31	42 00 016 08	12	WASHER ISO 7089 A 13 ST A3C	SCHEIBE		
32	97 15 345 08	1	PLATE 4X650X443	BLECH		
33	43 31 025 08	1	RETAINING SPRING 5 VERZ	SICHERUNGSFEDER		
34	97 80 165 08	1	GRATING 1007X647X30 GFK SPF	GITTERROST		
35	97 80 166 08	1	GRATING 1007X647X30 GFK SPF	GITTERROST		
36	40 61 024	9	HEX BOLT ISO 4014 M8X55 8.8 A2C	SECHSKANTSCHRAUBE		
37	10 10 062 1	9	DISH MOUNTING	TELLERBEFESTIGUNG		
38	94 11 381 08	9	WASHER 70X3	SCHEIBE		
39	10 65 281 3	1	ROUND STRAND ROPE 10MM 0,95M EDEL	RUNDLITZENSEIL		
40	97 49 296 08	2	PLATE 4X505X168	BLECH		
41	70 42 624 08	2	CLOSURE	HAKENVERSCHLUSS		
42	40 65 099	4	HEX BOLT ISO 4017 M6X16 8.8 A2C	SECHSKANTSCHRAUBE		
43	42 00 009 08	8	WASHER ISO 7089 A 6.4 VERZ	SCHEIBE		
44	41 19 004 08	4	HEX NUT DIN 985 M6 8 VERZ	SECHSKANTMUTTER		
45	97 81 184 08	4	PLATE 3X224X121 FE//ZN20//C	BLECH		
46	46 00 386	6	HEX BOLT ISO 4017 M8X60 8.8 A2C	SECHSKANTSCHRAUBE		
47	95 12 474 08	8	TUBE 12X1,5X6	ROHR		
48	97 49 575 08	2	TUBE 12.0X44	ROHR		
49	45 12 225 08	4	PIN DIN 1435 20H11X75X66 ST.50	BOLZEN		
50	43 32 001 08	4	HINGED CONNECTOR DIN 11023 5X32 VER	KLAPPSTECKER		
51	96 50 697 08	2	FOOT COMPLETE ⇒ 3 216 005 96 50 697 08	FUSS KPL.		
500	96 48 381 08	1	EL.EQUIPMENT SW HEAD SECTION ⇒ 3 930 576 96 48 381 08	ELEKTRIK SW-KOPFSTUECK		

6.2.2009

etk_en_de_074515 LR 1600/2

 456 (2/2)
LIEBHERR
SW HEAD SECTION
SW-KOPFSTUECK

⇒ 3 214
91 52 843 08

Schnitt B-B

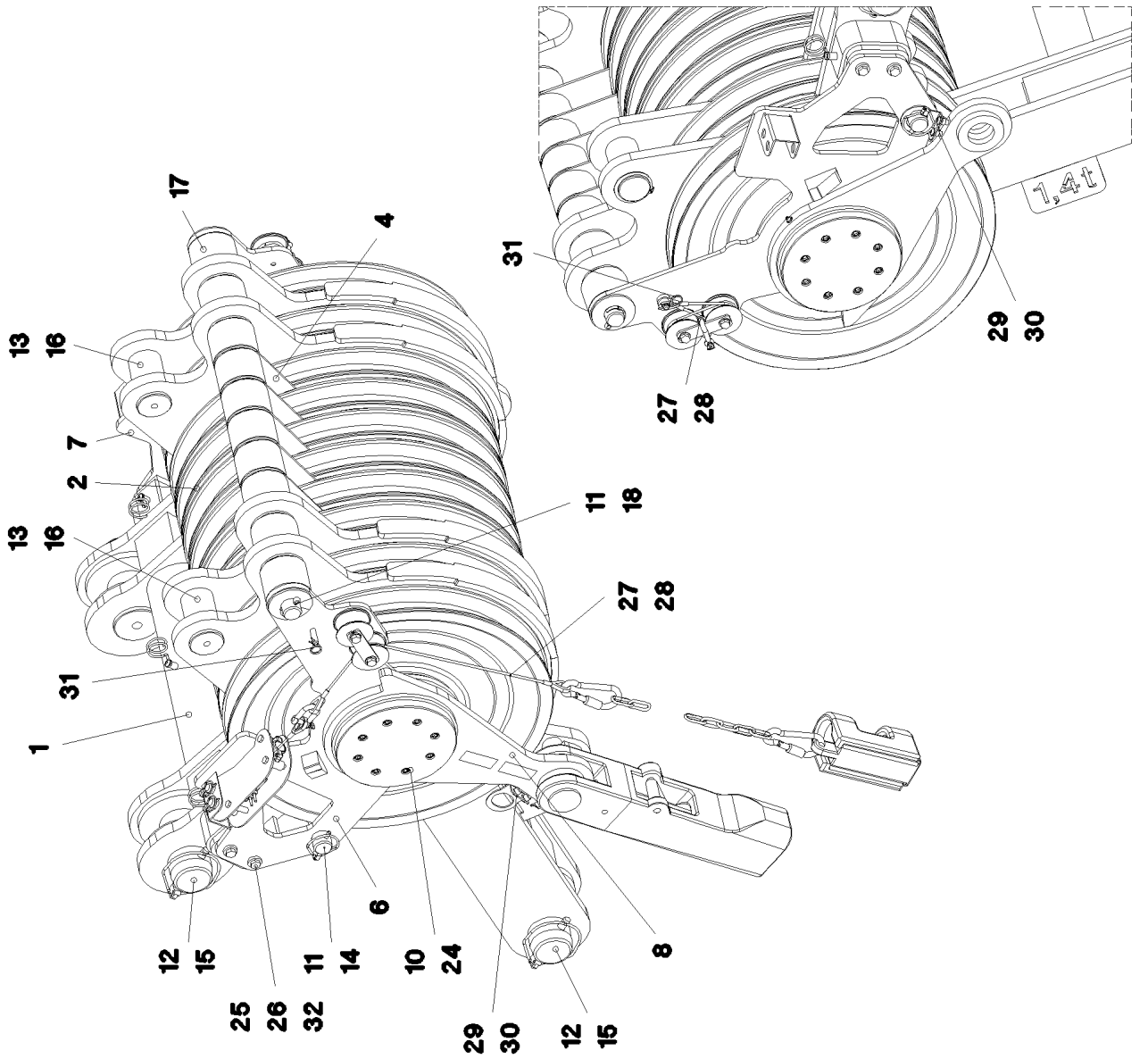
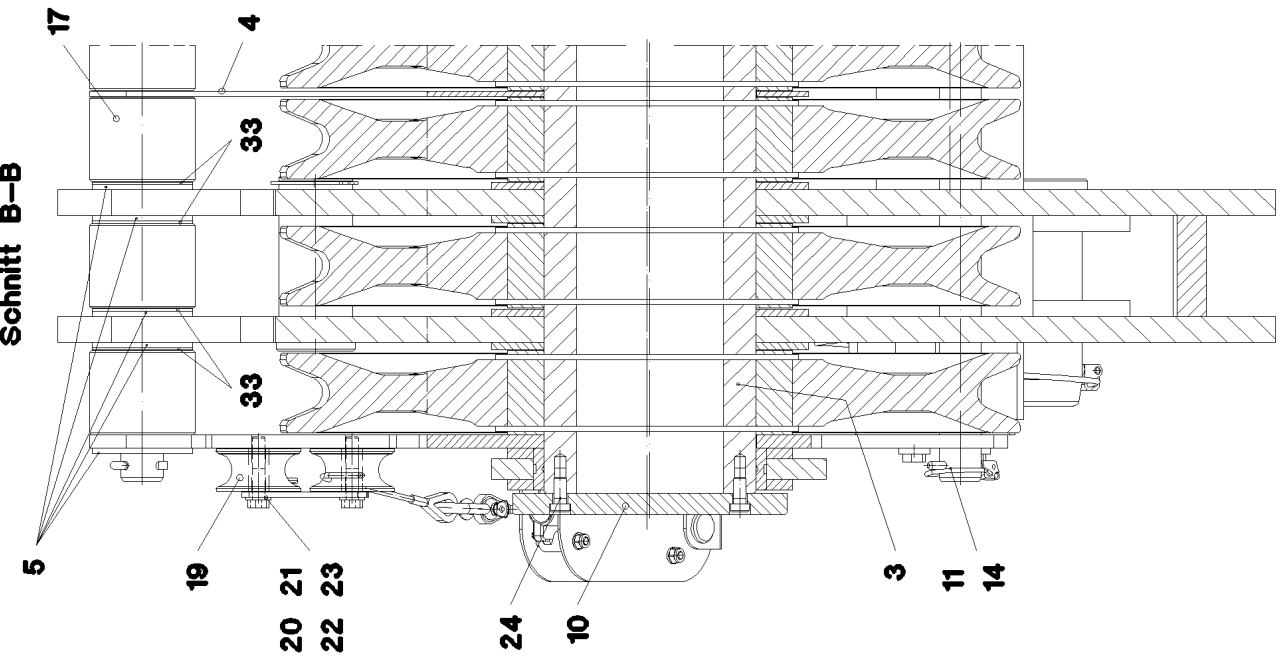

6.2.2009
052751

LIEBHERR

etk_en_de_074515 LR 1600/2

ROLLER SET
ROLLENSATZ

457 (1/3)

→ 3 215 005
91 52 846 08

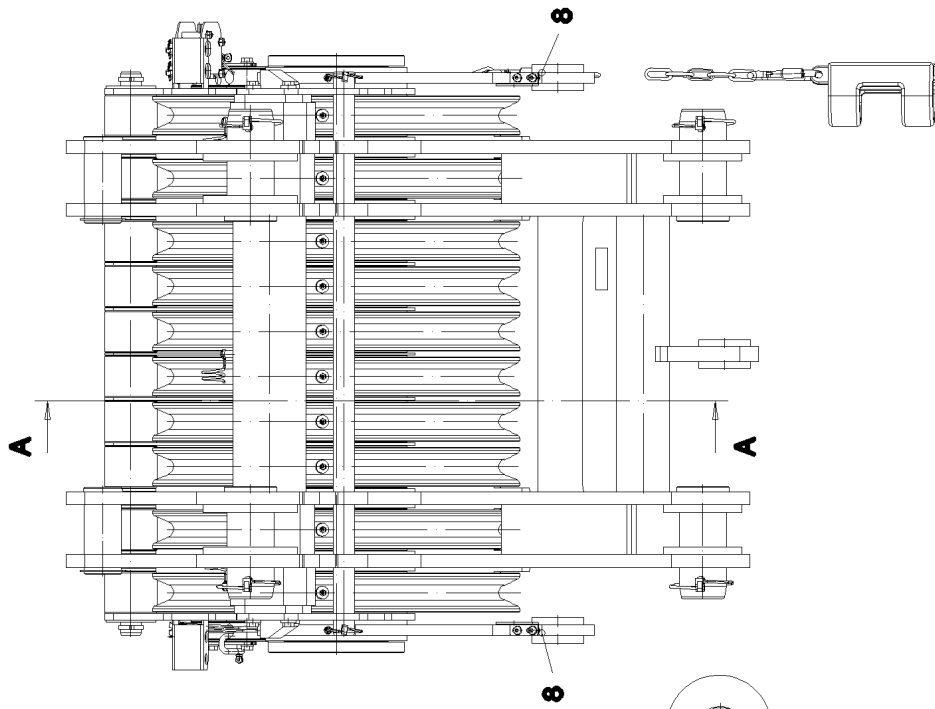

Schnitt A-A

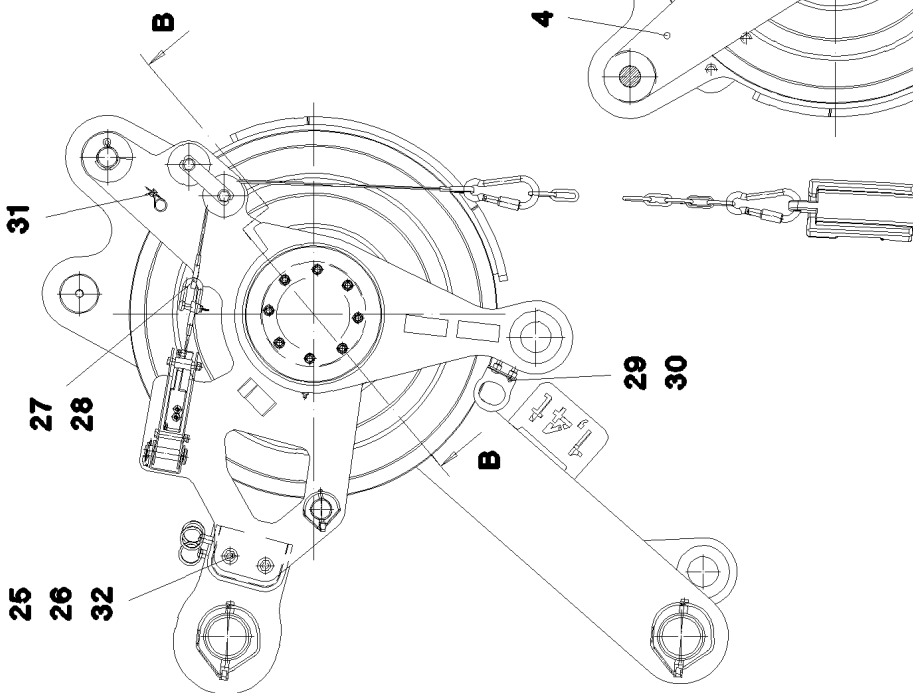
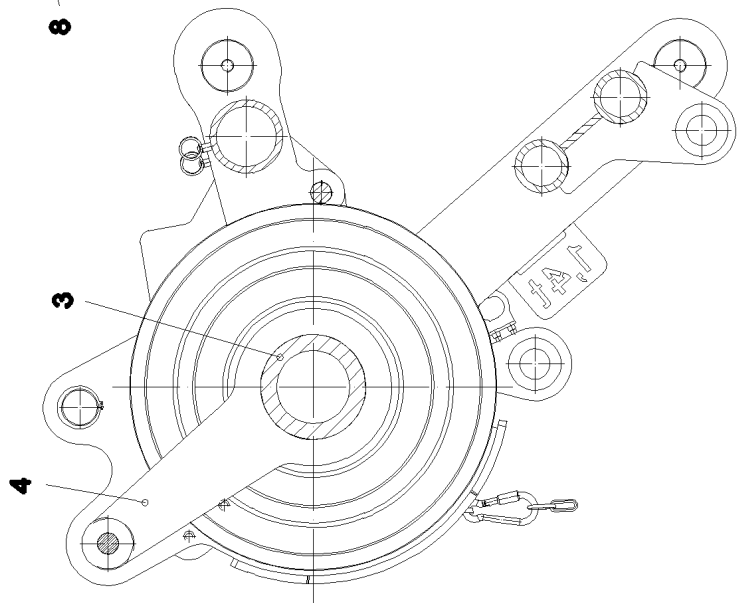

6.2.2009
052752

LIEBHERR

etk_en_de_074515 LR 1600/2

ROLLER SET
ROLLENSATZ

□ 458 (2/3)

⇒ 3 215 005
91 52 846 08

Pos.	Item	Quantity	Description	Bezeichnung	Serie	K
1	96 48 667 08	1	ROLLER SET WELDED 300T	ROLLENSATZ SCHWK.		
2	92 68 928 08	10	ROPE PULLEY CPL. SPF ⇒ 2 652 007 92 68 928 08	SEILROLLE KPL.		
3	97 74 962 08	1	AXLE 219.1X1100 SPF	ACHSE		
4	97 74 820 08	5	PLATE 5X691X300	BLECH		
5	97 74 824 08	10	PLATE 5X95X95	BLECH		
6	96 48 607 08	1	PLATE WELDED	BLECH SCHWK.		
7	96 48 608 08	1	PLATE WELDED	BLECH SCHWK.		
8	96 48 609 08	2	FIXATION POINT	FESTPUNKT		
10	97 74 857 08	2	PLATE 20X260X260	BLECH		
11	45 25 485 08	2	PIN ISO 2340 B40X1075X1045 ST	BOLZEN		
12	97 74 861 08	4	PIN 100.0X215 SPF	BOLZEN		
13	97 74 862 08	2	PIN 75.0X166 SPF	BOLZEN		
14	43 32 008 08	2	HINGED CONNECTOR DIN 11023 8X60 VER	KLAPPSTECKER		
15	43 32 015 08	4	SAFETY PLUG W HINGE-LID 17X125 VERZ	SICHERHEITSKLAPPSTECKER		
16	42 80 056 08	2	LOCKING RING DIN 471 70X2,5	SICHERUNGSRING		
17	94 37 683 08	10	ROLLER 40.5X100X80 PA6G	ROLLE		
18	43 30 090 08	2	SPLIT PIN DIN 94 8X63 ST VERZ	SPLINT		
19	93 01 339 08	4	ROLLER RD80X40 PA6G	ROLLE		
20	97 06 963 08	4	TUBE 20x3,6x42	ROHR		
21	97 62 431 08	2	PLATE 5X120X30	BLECH		
22	40 61 065	4	HEX BOLT ISO 4014 M12X60 8.8 A3C	SECHSKANTSCHRAUBE		
23	42 00 016 08	4	WASHER ISO 7089 A 13 ST A3C	SCHEIBE		
24	40 72 046 08	16	CYLINDER SCREW DIN 6912 M12X25 10.9 V	ZYLINDERSCHRAUBE		
25	42 16 007 08	8	WASHER DIN 7349 13 ST VERZ	SCHEIBE		
26	46 00 047	4	HEX BOLT ISO 4014 M12X55 8.8 A3C	SECHSKANTSCHRAUBE		
27	97 06 965 08	2	ROPE 5x750	SEIL		
28	77 39 300 08	2	SHACKLE DIN 82101 A 10 0,4T EDELSTAHL	SCHAEKEL		
29	97 82 921 08	2	PLATE 3X70X101	BLECH		
30	10 41 285 4	4	OVAL HEAD FLAT SCREW AEHNL.ISO7380	LINSENFLACHKOPFSCHRAUBE		
31	43 32 060 08	2	SPRING PLUG DIN 11024 B 2,5 VERZ	FEDERSTECKER		
32	41 19 007 08	4	HEX NUT DIN 985 M12 8 A3C	SECHSKANTMUTTER		
33	97 88 785 08	10	PLATE 2X95X95	BLECH		

6.2.2009

etk_en_de_074515 LR 1600/2

459 (3/3)

LIEBHERRROLLER SET
ROLLENSATZ⇒ 3 215 005
91 52 846 08

Schnitt B-B

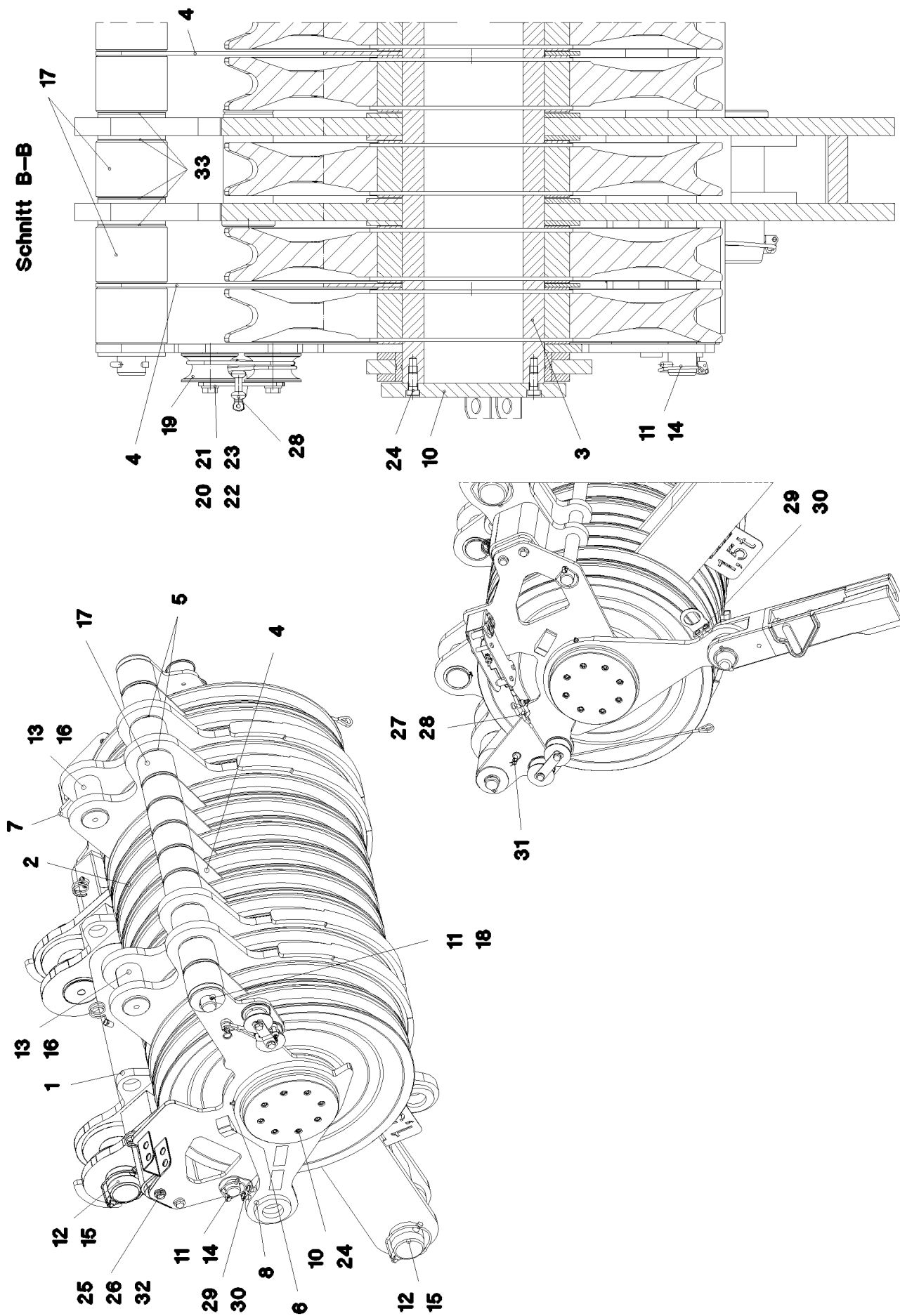

6.2.2009
052753

LIEBHERR

etk_en_de_074515 LR 1600/2

ROLLER SET
ROLLENSATZ

□ 460 (1/3)

→ 3 215 006
91 52 847 08

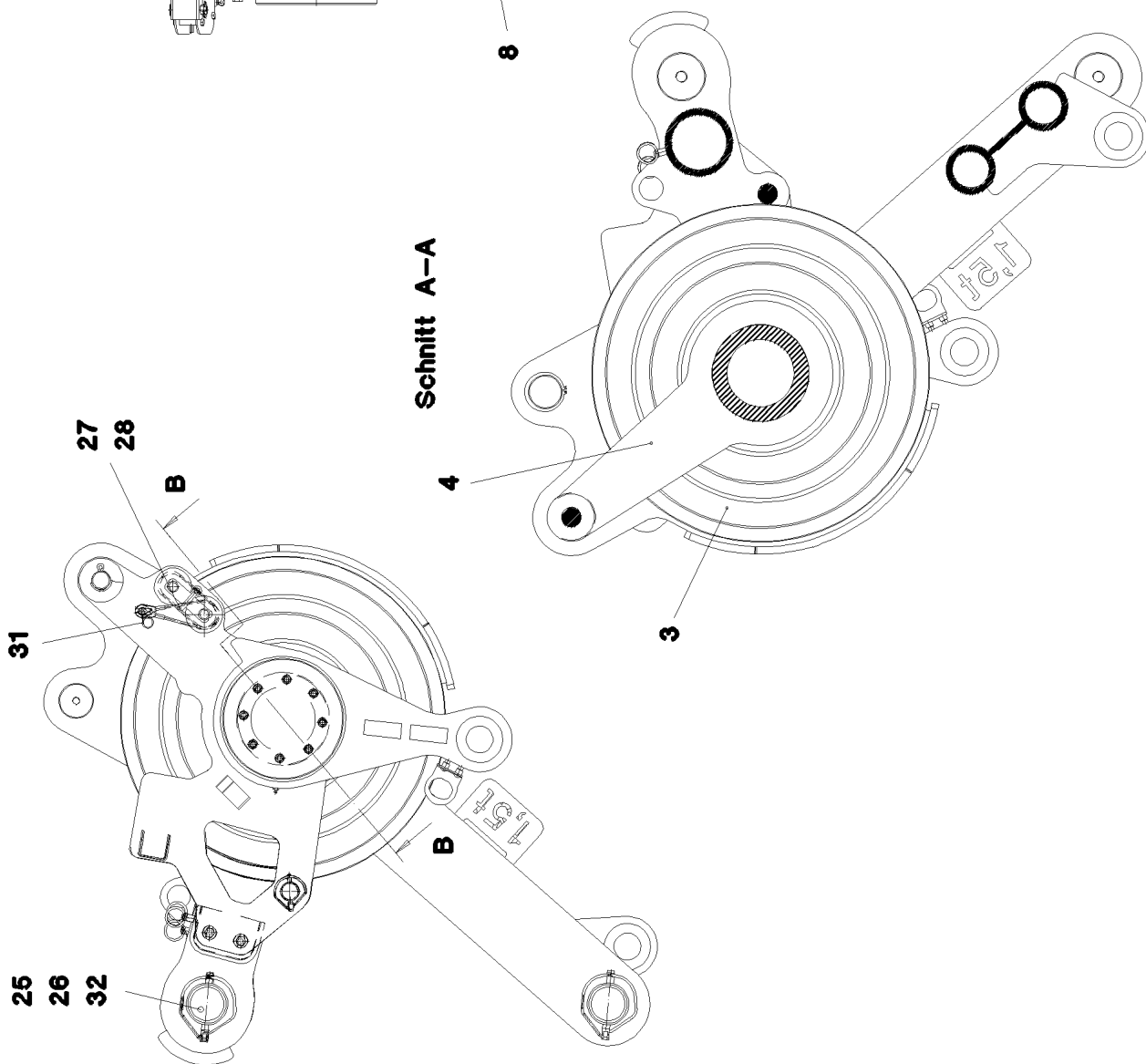
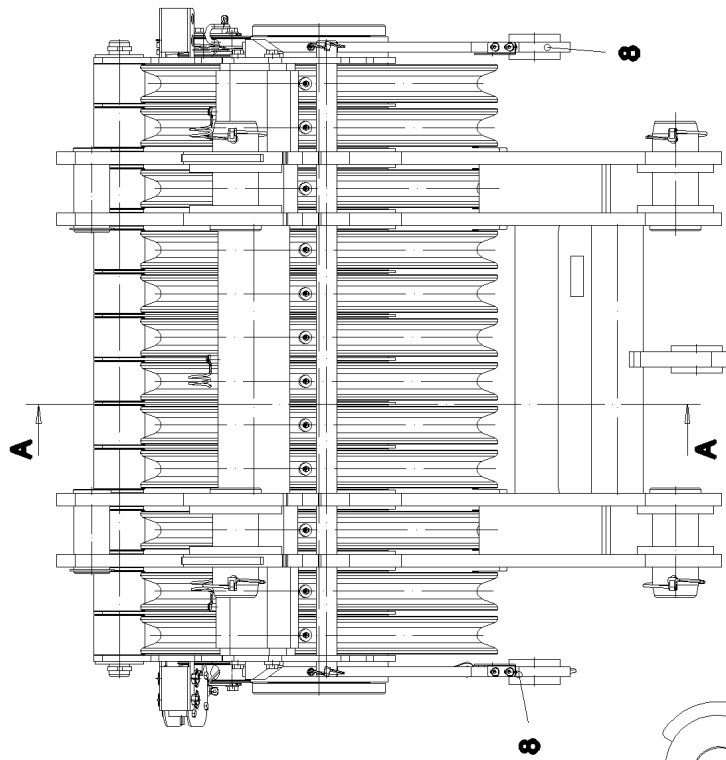

6.2.2009
052754

LIEBHERR

etk_en_de_074515 LR 1600/2

ROLLER SET
ROLLENSATZ

461 (2/3)

⇒ 3 215 006
91 52 847 08

Pos.	Item	Quantity	Description	Bezeichnung	Serie	K
1	96 48 526 08	1	ROLLER SET WELDED 320T	ROLLENSATZ SCHWK.		
2	92 68 928 08	12	ROPE PULLEY CPL. SPF ⇒ 2 652 007 92 68 928 08	SEILROLLE KPL.		
3	97 74 817 08	1	AXLE 219.1X1272 SPF	ACHSE		
4	97 74 820 08	7	PLATE 5X691X300	BLECH		
5	97 74 824 08	10	PLATE 5X95X95	BLECH		
6	96 48 607 08	1	PLATE WELDED	BLECH SCHWK.		
7	96 48 608 08	1	PLATE WELDED	BLECH SCHWK.		
8	96 48 609 08	2	FIXATION POINT	FESTPUNKT		
10	97 74 857 08	2	PLATE 20X260X260	BLECH		
11	97 74 860 08	2	AXLE 40.0X1247	ACHSE		
12	97 74 861 08	4	PIN 100.0X215 SPF	BOLZEN		
13	97 74 862 08	2	PIN 75.0X166 SPF	BOLZEN		
14	43 32 008 08	2	HINGED CONNECTOR DIN 11023 8X60 VER	KLAPPSTECKER		
15	43 32 015 08	4	SAFETY PLUG W HINGE-LID 17X125 VERZ	SICHERHEITSKLAPPSTECKER		
16	42 80 056 08	2	LOCKING RING DIN 471 70X2,5	SICHERUNGSRING		
17	94 37 683 08	12	ROLLER 40.5X100X80 PA6G	ROLLE		
18	43 30 090 08	2	SPLIT PIN DIN 94 8X63 ST VERZ	SPLINT		
19	93 01 339 08	4	ROLLER RD80X40 PA6G	ROLLE		
20	97 06 963 08	4	TUBE 20x3,6x42	ROHR		
21	97 62 431 08	2	PLATE 5X120X30	BLECH		
22	40 61 065	4	HEX BOLT ISO 4014 M12X60 8.8 A3C	SECHSKANTSCHRAUBE		
23	42 00 016 08	4	WASHER ISO 7089 A 13 ST A3C	SCHEIBE		
24	40 72 046 08	16	CYLINDER SCREW DIN 6912 M12X25 10.9 V	ZYLINDERSCHRAUBE		
25	42 16 007 08	8	WASHER DIN 7349 13 ST VERZ	SCHEIBE		
26	46 00 047	4	HEX BOLT ISO 4014 M12X55 8.8 A3C	SECHSKANTSCHRAUBE		
27	97 06 965 08	2	ROPE 5x750	SEIL		
28	77 39 300 08	2	SHACKLE DIN 82101 A 10 0,4T EDELSTAHL	SCHAEKEL		
29	97 82 921 08	2	PLATE 3X70X101	BLECH		
30	10 41 285 4	4	OVAL HEAD FLAT SCREW AEHNL.ISO7380	LINSENFLACHKOPFSCHRAUBE		
31	43 32 060 08	2	SPRING PLUG DIN 11024 B 2,5 VERZ	FEDERSTECKER		
32	41 19 007 08	4	HEX NUT DIN 985 M12 8 A3C	SECHSKANTMUTTER		
33	97 88 785 08	10	PLATE 2X95X95	BLECH		

6.2.2009

etk_en_de_074515 LR 1600/2

462 (3/3)

LIEBHERRROLLER SET
ROLLENSATZ⇒ 3 215 006
91 52 847 08

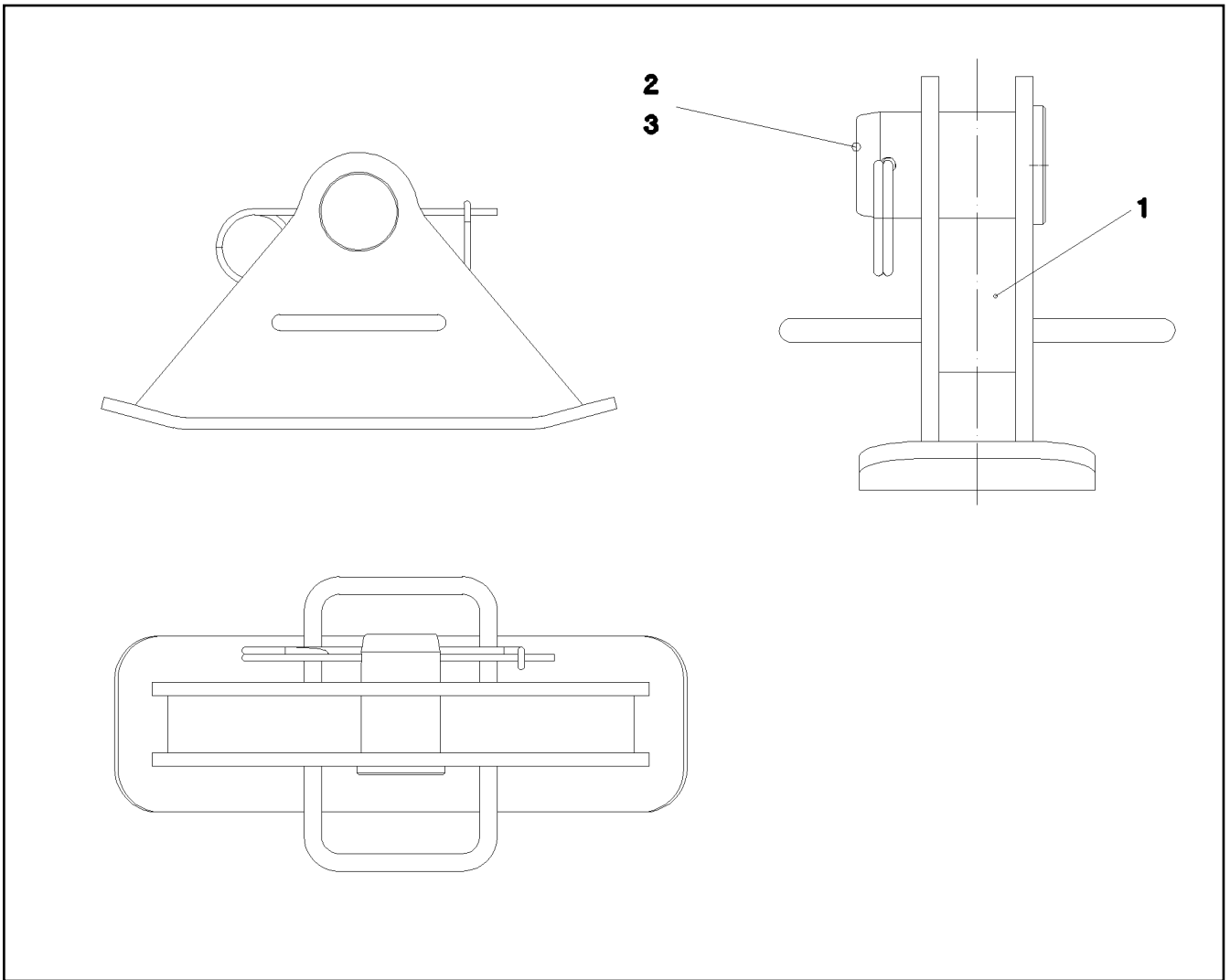

Pos.	Item	Quantity	Description	Bezeichnung	Serie	K
1	96 50 698 08	1	SUPPORT WELDED	FUSS SCHWK.		
2	95 26 739 08	1	PIN 100.0X160 SPF	BOLZEN		
3	43 31 052 08	1	RETAINING SPRING 8 VERZ.	SICHERUNGSFEDER		

6.2.2009
055217

LIEBHERR

etk_en_de_074515 LR 1600/2

FOOT COMPLETE
FUSS KPL.

463

⇒ 3 216 005
96 50 697 08

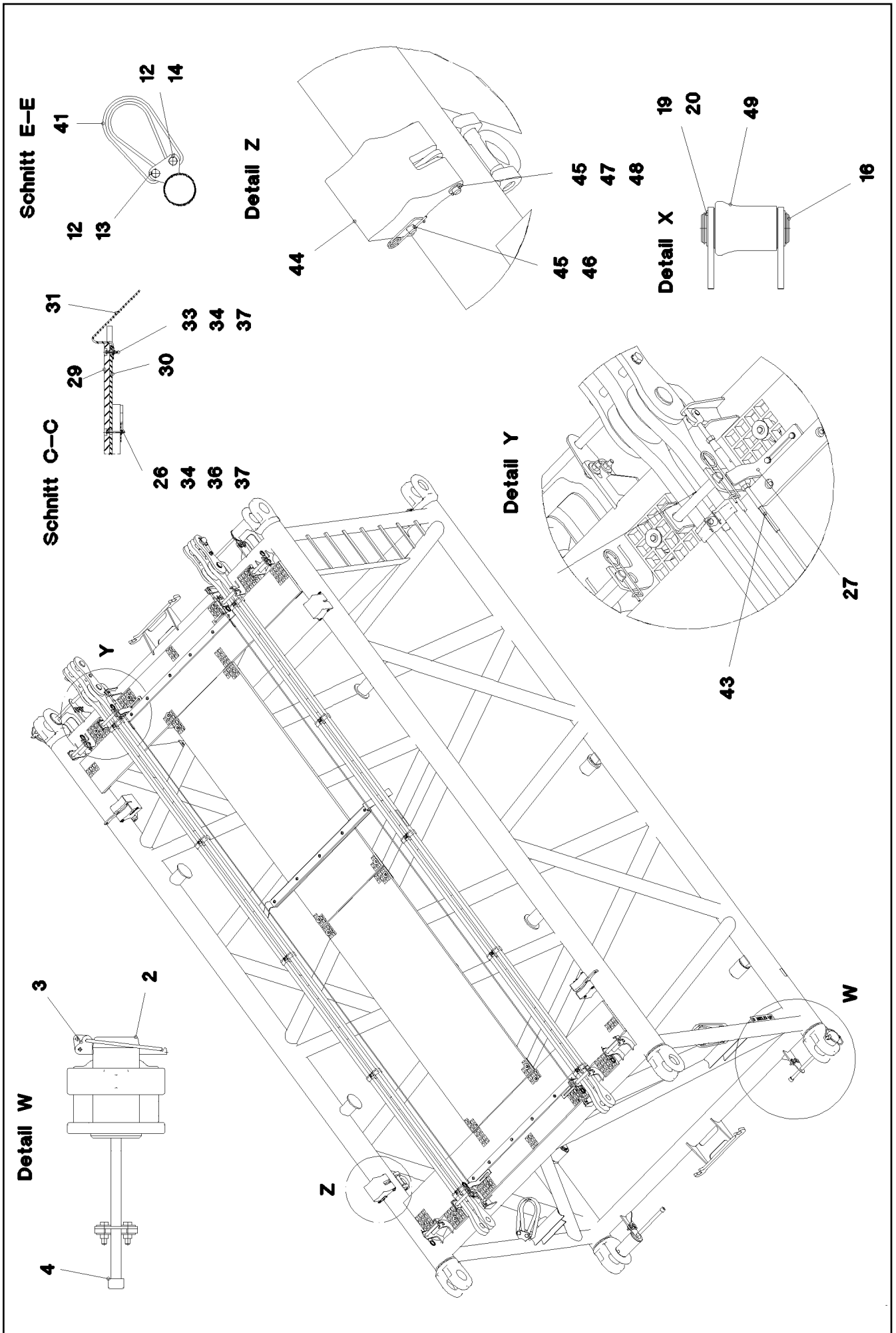

6.2.2009
052900

LIEBHERR

etk_en_de_074515 LR 1600/2

S INTERMEDIATE SECTION
S-ZWISCHENSTUECK

□ 464 (1/3)

⇒ 3 220 500
91 52 849 08

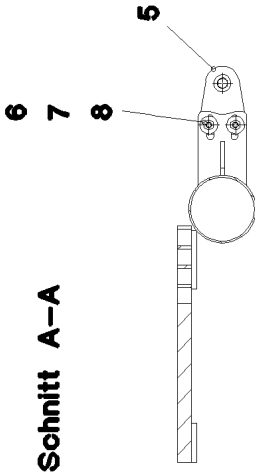

Schnitt A-A

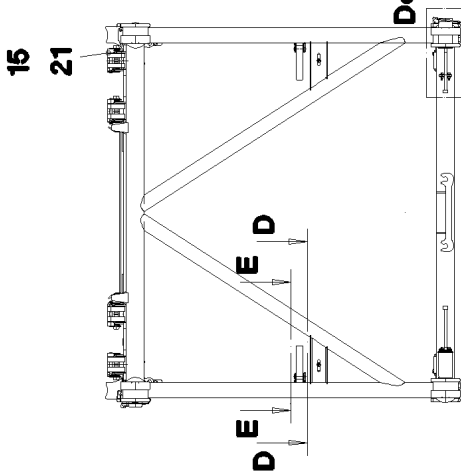

Detail W

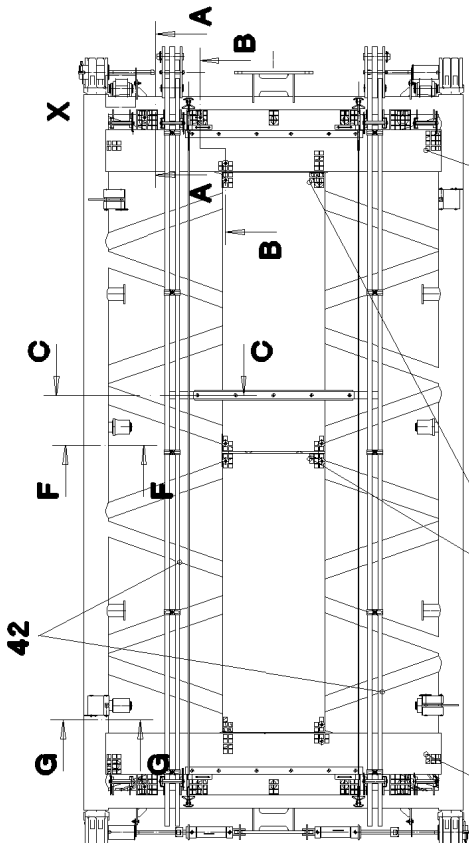
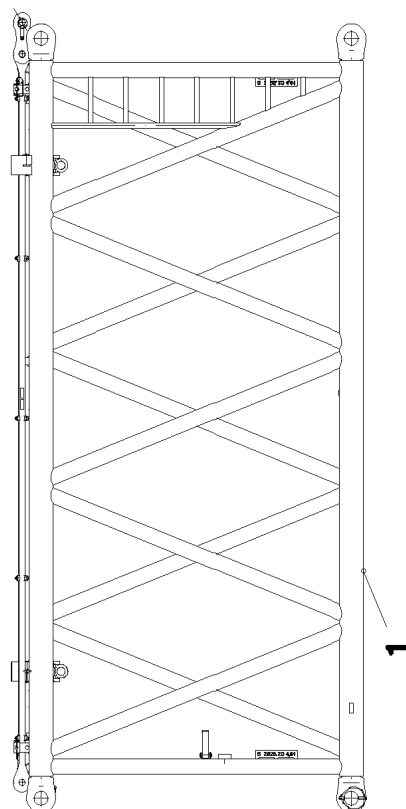

Schnitt B-B



Schnitt C-C

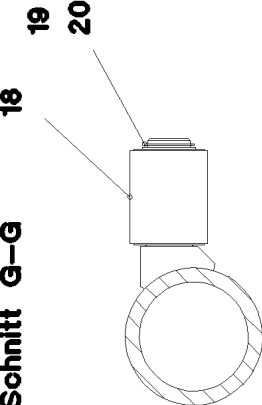

Schnitt G-G

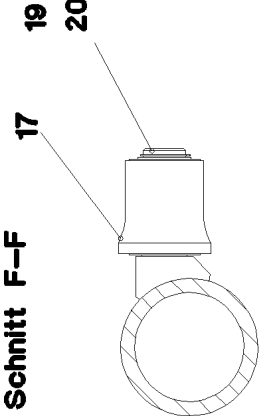

Schnitt F-F

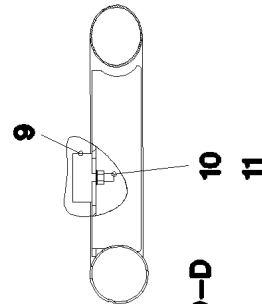

Schnitt D-D

6.2.2009
052901

LIEBHERR

etk_en_de_074515 LR 1600/2

S INTERMEDIATE SECTION
S-ZWISCHENSTUECK

□ 465 (2/3)

→ 3 220 500
91 52 849 08

Pos.	Item	Quantity	Description	Bezeichnung	Serie	K
1	96 43 376 08	1	S INTERMED.SECTION WELD.CONSTR 282	S-ZWISCHENSTUECK SCHWK.		
2	97 64 994 08	4	PIN 120.0X237 SPF	BOLZEN		
3	10 41 062 2	4	SAFETY PLUG W HINGE-LID 20X175 A3C	SICHERHEITSKLAPPSTECKER		
4	40 43 263 08	4	CYLINDER SCREW DIN 912 M24X360 10.9	ZYLINDERSCHRAUBE		
5	95 50 518 08	4	PLATE 5X104X140	BLECH		
6	46 00 158	8	HEX BOLT ISO 4017 M12X45 8.8 A3C	SECHSKANTSCHRAUBE		
7	42 18 011 08	16	WASHER ISO 7093-1 A 13 ST A3C	SCHEIBE		
8	41 15 143 08	8	HEX NUT DIN 934 M12 8 VERZ	SECHSKANTMUTTER		
9	72 66 160 08	2	MEGI BUFFER 100X40-M16 NR 60SHORE A	MEGIPUFFER		
10	42 00 019 08	2	WASHER DIN 125 A 17 VERZ	SCHEIBE		
11	41 15 050 08	2	HEX NUT DIN 934 M16 10 VERZ	SECHSKANTMUTTER		
12	45 14 223 08	4	PIN DIN 1436 20H11X85X78 30CRNIMO8 SP	BOLZEN		
13	43 32 001 08	2	HINGED CONNECTOR DIN 11023 5X32 VER	KLAPPSTECKER		
14	43 30 078 08	2	SPLIT PIN DIN 94 6,3X50 ST VERZ	SPLINT		
15	96 43 771 08	8	CONNECTING PIN WELDED	ABSTECKBOLZEN SCHWK.		
16	97 66 499 08	2	PIN 65.0X187 SPF	BOLZEN		
17	97 66 500 08	2	ROLLER PA6G	ROLLE		
18	97 66 501 08	2	ROLLER	ROLLE		
19	51 45 410 08	8	SUPPORTING RING DIN 988 S 63X80X3	STUETZSCHEIBE		
20	42 80 049 08	8	LOCKING RING DIN 471 60X2	SICHERUNGSRING		
21	43 31 009 08	8	RETAINING SPRING 4,5 VERZ	SICHERUNGSFEDER		
22	97 71 971 08	2	GRATING 2207X807X30 GFK SPF	GITTERROST		
23	97 66 514 08	2	GRATING 2647X487X30 GFK SPF	GITTERROST		
24	10 10 062 1	37	DISH MOUNTING	TELLERBEFESTIGUNG		
25	40 61 024	45	HEX BOLT ISO 4014 M8X55 8.8 A2C	SECHSKANTSCHRAUBE		
26	94 11 381 08	55	WASHER 70X3	SCHEIBE		
27	97 08 336 08	4	PLATE 8x40x276	BLECH		
28	97 66 612 08	2	SUPPORT PLATE 1400X60 PA6G	AUFLAGE		
29	97 41 439 08	1	SUPPORT PLATE 60X1270 PA6G	AUFLAGE		
30	97 41 440 08	1	PLATE 10X1250X80	BLECH		
31	95 64 428 08	2	PLATE 5X393X60 S380MC	BLECH		
32	95 54 048 08	4	PLATE 8X300X50	BLECH		
33	40 01 928	2	HEX BOLT ISO 4014 M6X40 8.8 A2C	SECHSKANTSCHRAUBE		
34	41 19 004 08	17	HEX NUT DIN 985 M6 8 VERZ	SECHSKANTMUTTER		
35	41 19 005 08	41	HEX NUT DIN 985 M8 8 VERZ	SECHSKANTMUTTER		
36	46 00 356	15	HEX BOLT ISO 4014 M6X65 8.8 A2C	SECHSKANTSCHRAUBE		
37	42 18 007 08	17	WASHER DIN 9021 A 6.4 VERZ	SCHEIBE		
38	42 18 009 08	8	WASHER DIN 9021 A 8.4 VERZ	SCHEIBE		
39	42 00 012 08	8	WASHER DIN 125 A8X16 ST VERZ	SCHEIBE		
41	10 28 562 6	2	ROUND SLING DIN EN 1492-2 3T-0,75M PO	RUNDSCHLINGE		
42	96 43 440 08	2	ROD CPL. 6 M	STANGE KPL.		
			⇒ 3 220 501 96 43 440 08			
43	10 65 243 9	2	ROUND STRAND ROPE 10MM 5,54M EDEL	RUNDLITZENSEIL		
44	97 76 196 08	4	BEARING BLOCK PA6G	LAGERKLOTZ		
45	45 30 083 08	8	PIN DIN 1444 16H11X162X157 30CRNIMO8	BOLZEN		
46	43 31 028 08	4	RETAINING SPRING 3 VERZ	SICHERUNGSFEDER		
47	43 30 036 08	4	SPLIT PIN DIN 94 3,2X25 ST VERZ	SPLINT		
48	55 31 248 08	4	WASHER DIN 433 17 ST	SCHEIBE		
49	97 80 631 08	2	ROLLER PA6G	ROLLE		

6.2.2009

etk_en_de_074515 LR 1600/2

□ 466 (3/3)

LIEBHERR**S INTERMEDIATE SECTION
S-ZWISCHENSTUECK**⇒ 3 220 500
91 52 849 08

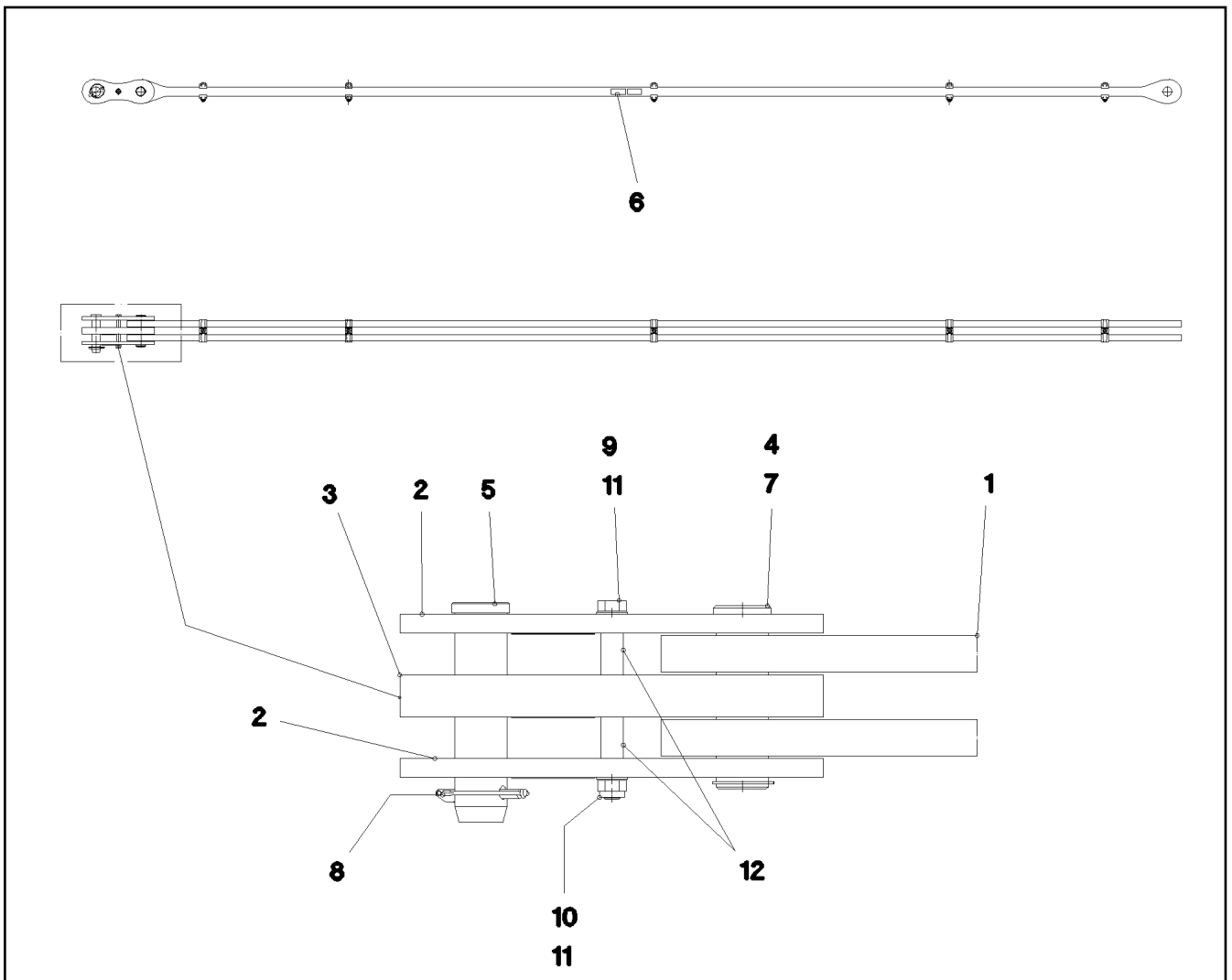

Pos.	Item	Quantity	Description	Bezeichnung	Serie	K
1	96 45 249 08	1	ROD 5.75 M	STANGE VORM.		
2	96 45 231 08	2	BRACKET WITH BOARD 0.25 M	LASCHE MIT SCHILD		
3	96 45 232 08	1	BRACKET WITH BOARD 0.25 M	LASCHE MIT SCHILD		
4	97 67 727 08	1	PIN 55.0X175 30CRNIMO8+QT	BOLZEN		
5	95 28 920 08	1	PIN 55.0X210 30CRNIMO8+QT SPF	BOLZEN		
6	97 35 919 08	1	PLATE ASSEMBLY BG-NR. PVC-SILBER SP	SCHILD BAUGRUPPE		
7	42 80 042 08	1	LOCKING RING DIN 471 50X2	SICHERUNGSRING		
8	43 32 005 08	1	SAFETY PLUG W HINGE-LID 11,5X96 VERZ	SICHERHEITSKLAPPSTECKER		
9	40 61 186 01	1	HEX BOLT ISO 4014 M16X180 8.8 A3C	SECHSKANTSCHRAUBE		
10	41 19 009 08	1	HEX NUT DIN 985 M16 8 VERZ	SECHSKANTMUTTER		
11	42 00 019 08	2	WASHER DIN 125 A 17 VERZ	SCHEIBE		
12	93 92 551 08	2	TUBE 22X2,5X40	ROHR		

6.2.2009
052921

LIEBHERR

etk_en_de_074515 LR 1600/2

ROD CPL.
STANGE KPL.

467

⇒ 3 220 501
96 43 440 08

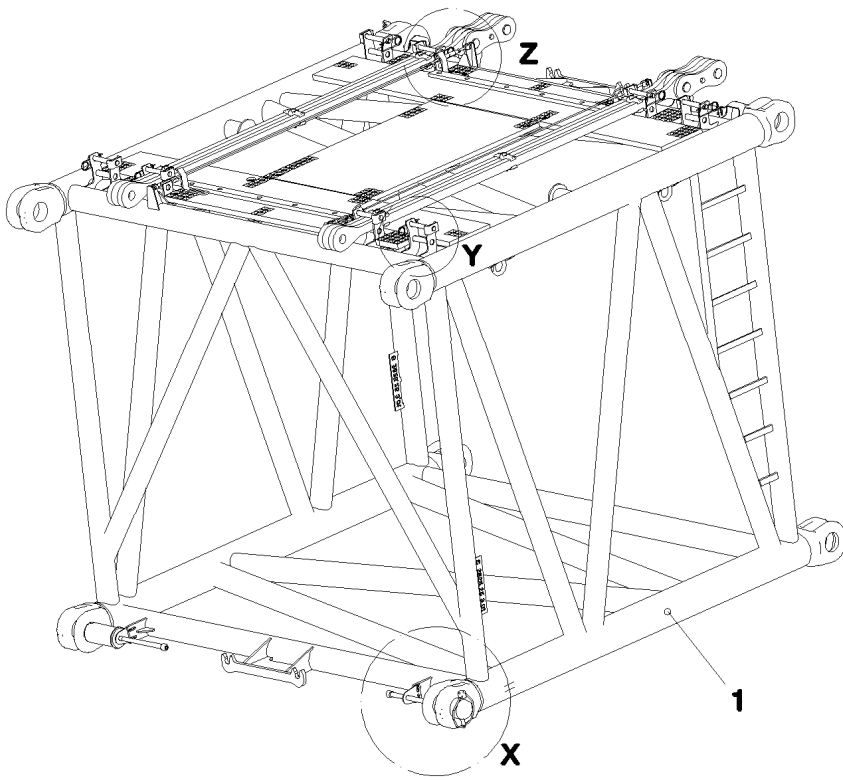

Detail X

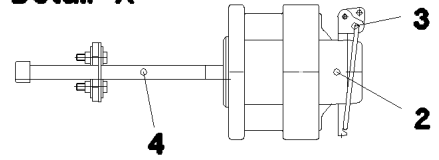

Detail Y

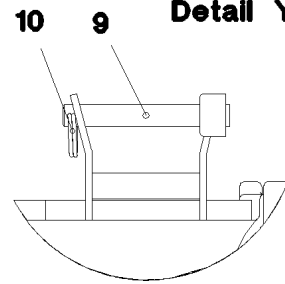

Detail Z

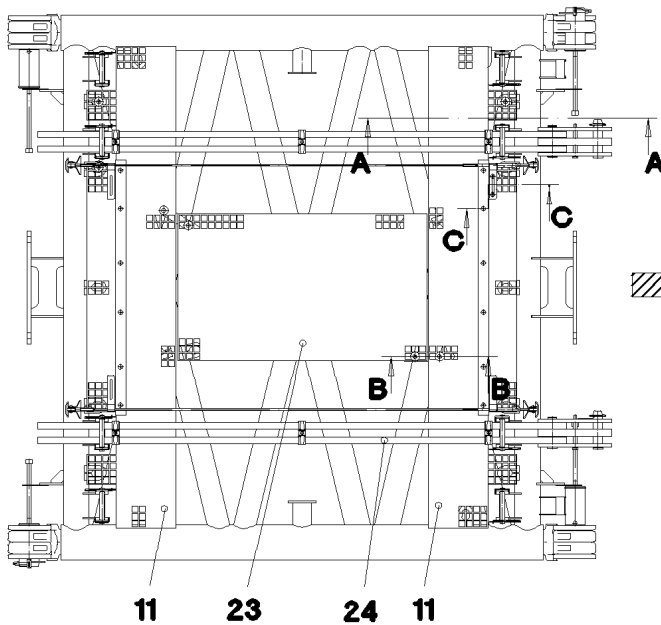
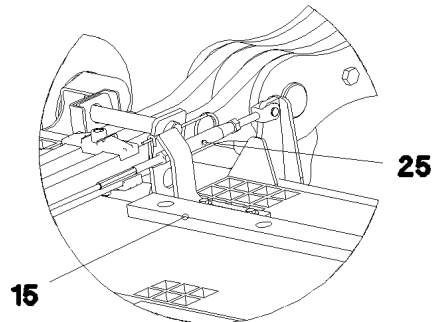

Schnitt A-A

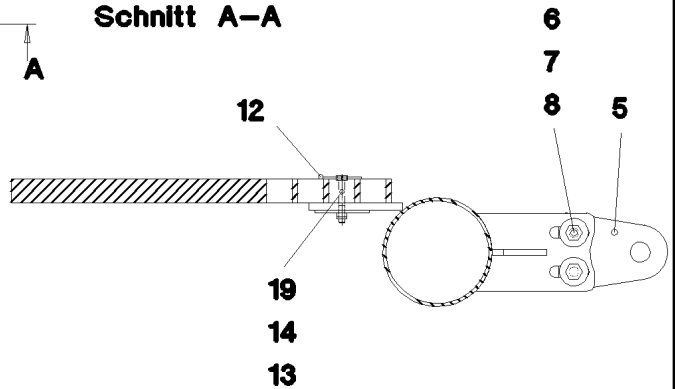

Schnitt B-B

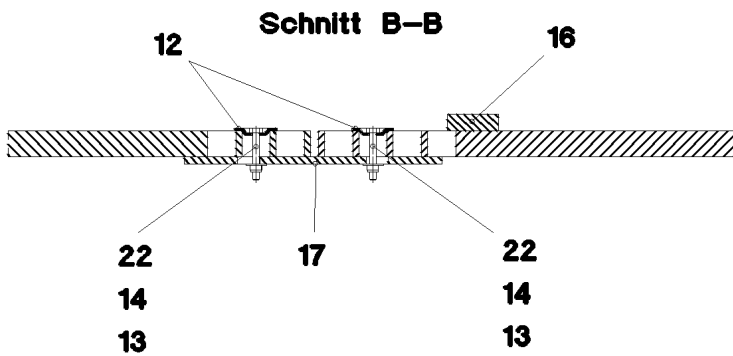

Schnitt C-C

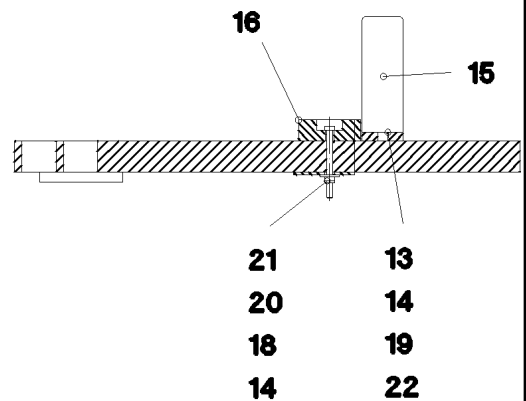

6.2.2009
052908

LIEBHERR

etk_en_de_074515 LR 1600/2

S INTERMEDIATE SECTION
S-ZWISCHENSTUECK

468 (1/2)

⇒ 3 221
91 54 668 08

Pos.	Item	Quantity	Description	Bezeichnung	Serie	K
1	96 47 979 08	1	S INTERMED.SECTION WELD.CONSTR 3 M	S-ZWISCHENSTUECK SCHWK.		
2	97 64 994 08	4	PIN 120.0X237 SPF	BOLZEN		
3	10 41 062 2	4	SAFETY PLUG W HINGE-LID 20X175 A3C	SICHERHEITSKLAPPSTECKER		
4	40 43 263 08	4	CYLINDER SCREW DIN 912 M24X360 10.9	ZYLINDERSCHRAUBE		
5	95 50 518 08	4	PLATE 5X104X140	BLECH		
6	46 00 158	8	HEX BOLT ISO 4017 M12X45 8.8 A3C	SECHSKANTSCHRAUBE		
7	42 18 011 08	16	WASHER ISO 7093-1 A 13 ST A3C	SCHEIBE		
8	41 15 143 08	8	HEX NUT DIN 934 M12 8 VERZ	SECHSKANTMUTTER		
9	96 43 771 08	8	CONNECTING PIN WELDED	ABSTECKBOLZEN SCHWK.		
10	43 31 009 08	8	RETAINING SPRING 4,5 VERZ	SICHERUNGSFEDER		
11	97 66 514 08	2	GRATING 2647X487X30 GFK SPF	GITTERROST		
12	10 10 062 1	24	DISH MOUNTING	TELLERBEFESTIGUNG		
13	40 61 024	36	HEX BOLT ISO 4014 M8X55 8.8 A2C	SECHSKANTSCHRAUBE		
14	94 11 381 08	44	WASHER 70X3	SCHEIBE		
15	97 08 336 08	4	PLATE 8x40x276	BLECH		
16	97 66 612 08	2	SUPPORT PLATE 1400X60 PA6G	AUFLAGE		
17	95 54 048 08	2	PLATE 8X300X50	BLECH		
18	41 19 004 08	12	HEX NUT DIN 985 M6 8 VERZ	SECHSKANTMUTTER		
19	41 19 005 08	36	HEX NUT DIN 985 M8 8 VERZ	SECHSKANTMUTTER		
20	46 00 356	12	HEX BOLT ISO 4014 M6X65 8.8 A2C	SECHSKANTSCHRAUBE		
21	42 18 007 08	12	WASHER DIN 9021 A 6.4 VERZ	SCHEIBE		
22	42 18 009 08	12	WASHER DIN 9021 A 8.4 VERZ	SCHEIBE		
23	97 73 275 08	1	GRATING 1367X807X30 GFK SPF	GITTERROST		
24	96 47 984 08	2	ROD CPL. 3 M ⇒ 3 221 200 96 47 984 08	STANGE KPL.		
25	10 65 243 8	2	ROUND STRAND ROPE 10MM 2,54M EDEL	RUNDLITZENSEIL		

6.2.2009

etk_en_de_074515 LR 1600/2

☐ 469 (2/2)

LIEBHERRS INTERMEDIATE SECTION
S-ZWISCHENSTUECK

⇒ 3 221

91 54 668 08

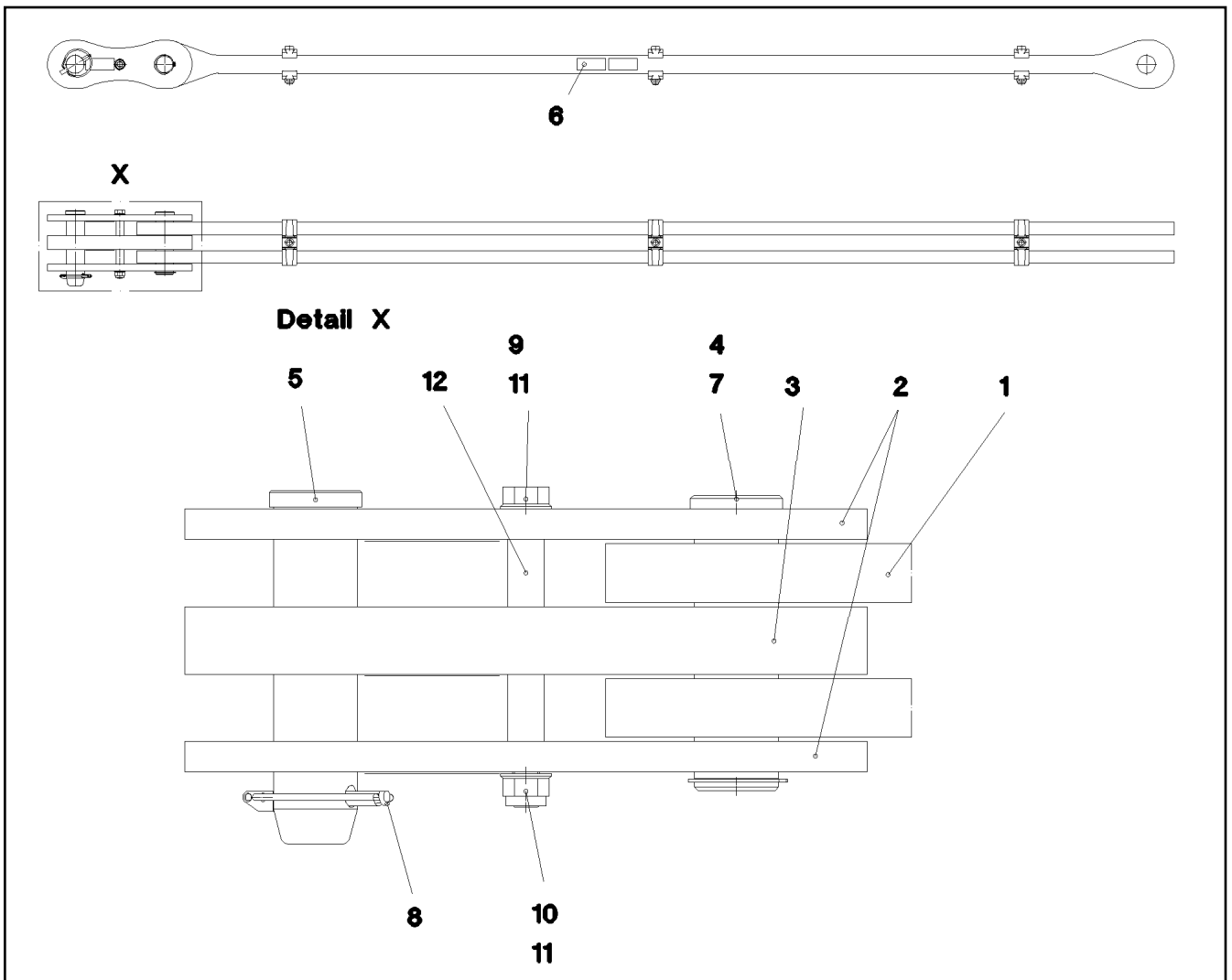

Pos.	Item	Quantity	Description	Bezeichnung	Serie	K
1	96 47 985 08	1	ROD 2.75 M	STANGE VORM.		
2	96 45 231 08	2	BRACKET WITH BOARD 0.25 M	LASCHE MIT SCHILD		
3	96 45 232 08	1	BRACKET WITH BOARD 0.25 M	LASCHE MIT SCHILD		
4	97 67 727 08	1	PIN 55.0X175 30CRNIMO8+QT	BOLZEN		
5	95 28 920 08	1	PIN 55.0X210 30CRNIMO8+QT SPF	BOLZEN		
6	97 35 919 08	1	PLATE ASSEMBLY BG-NR. PVC-SILBER SP	SCHILD BAUGRUPPE		
7	42 80 042 08	1	LOCKING RING DIN 471 50X2	SICHERUNGSRING		
8	43 32 005 08	1	SAFETY PLUG W HINGE-LID 11,5X96 VERZ	SICHERHEITSKLAPPSTECKER		
9	40 61 186 01	1	HEX BOLT ISO 4014 M16X180 8.8 A3C	SECHSKANTSCHRAUBE		
10	41 19 009 08	1	HEX NUT DIN 985 M16 8 VERZ	SECHSKANTMUTTER		
11	42 00 019 08	2	WASHER DIN 125 A 17 VERZ	SCHEIBE		
12	93 92 551 08	2	TUBE 22X2,5X40	ROHR		

6.2.2009
052929

LIEBHERR

etk_en_de_074515 LR 1600/2

ROD CPL.
STANGE KPL.

470

⇒ 3 221 200
96 47 984 08

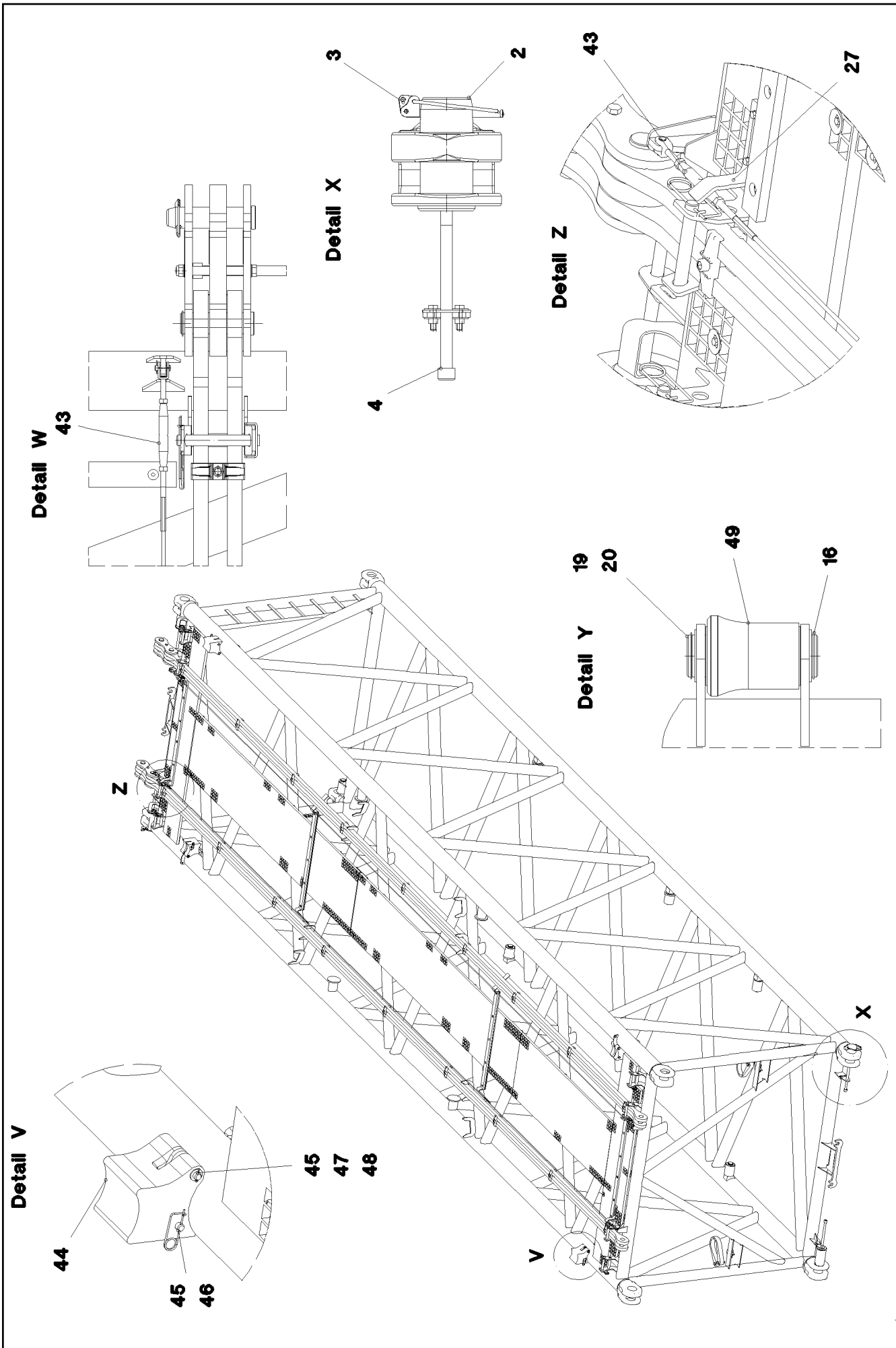

6.2.2009
052902

LIEBHERR

etk_en_de_074515 LR 1600/2

S INTERMEDIATE SECTION
S-ZWISCHENSTUECK

□ 471 (1/4)

⇒ 3 223
91 52 852 08

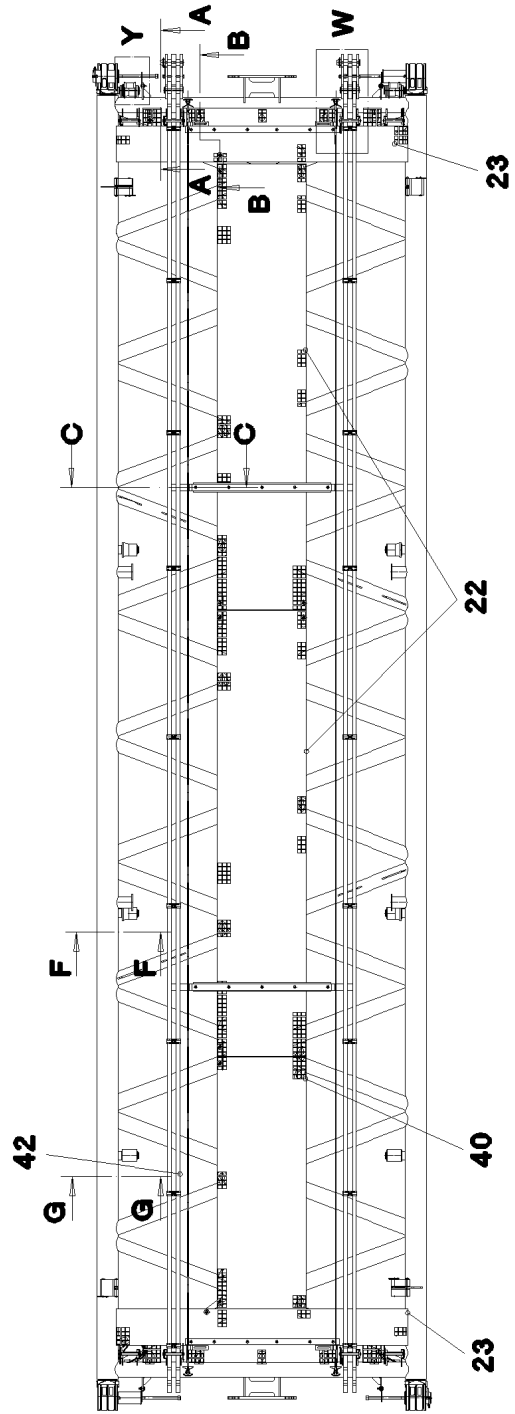
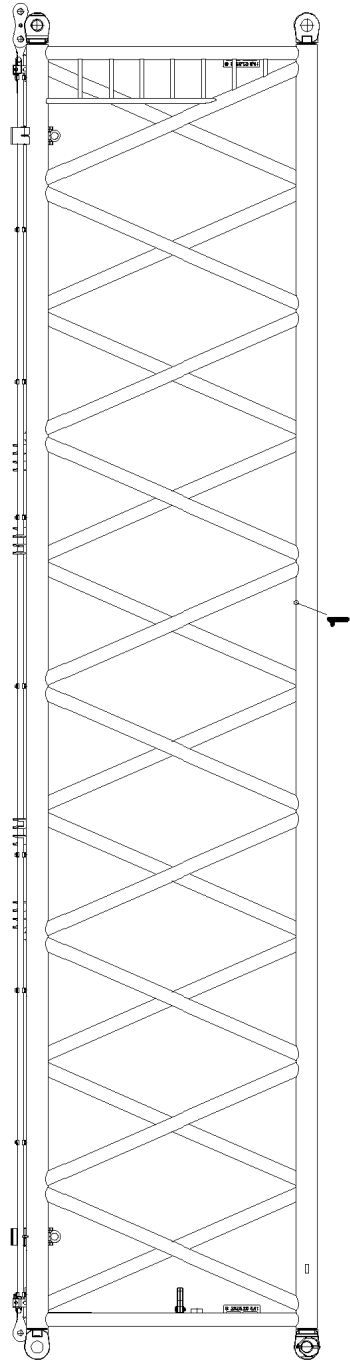
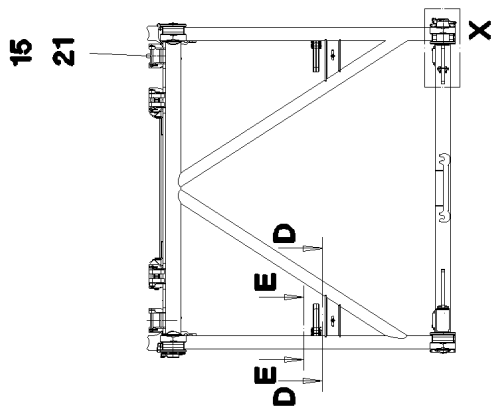

6.2.2009
052903

LIEBHERR

etk_en_de_074515 LR 1600/2

S INTERMEDIATE SECTION
S-ZWISCHENSTUECK

☐ 472 (2/4)

→ 3 223
91 52 852 08

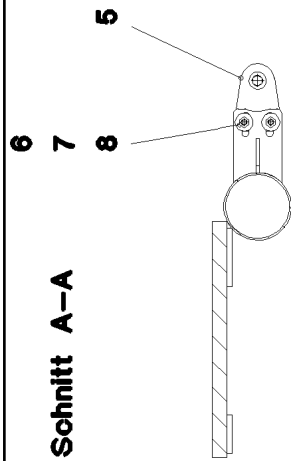

Schnitt C-C

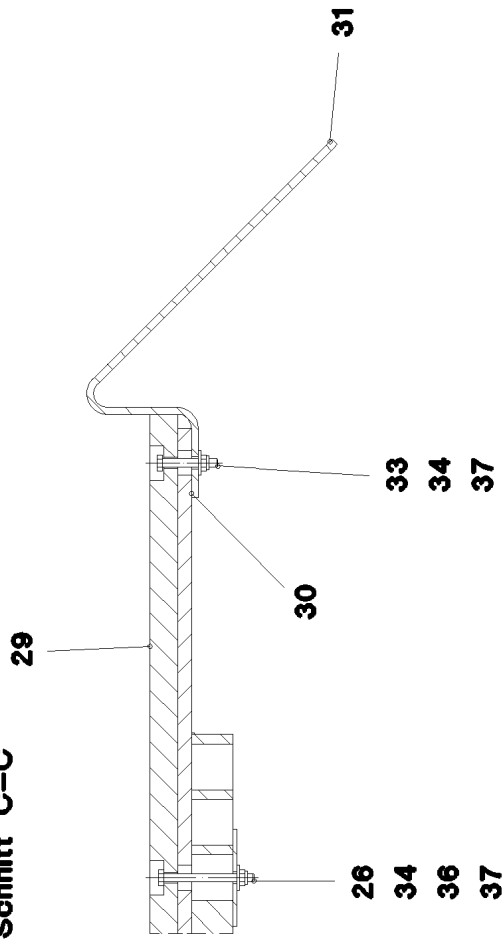

Schnitt B-B

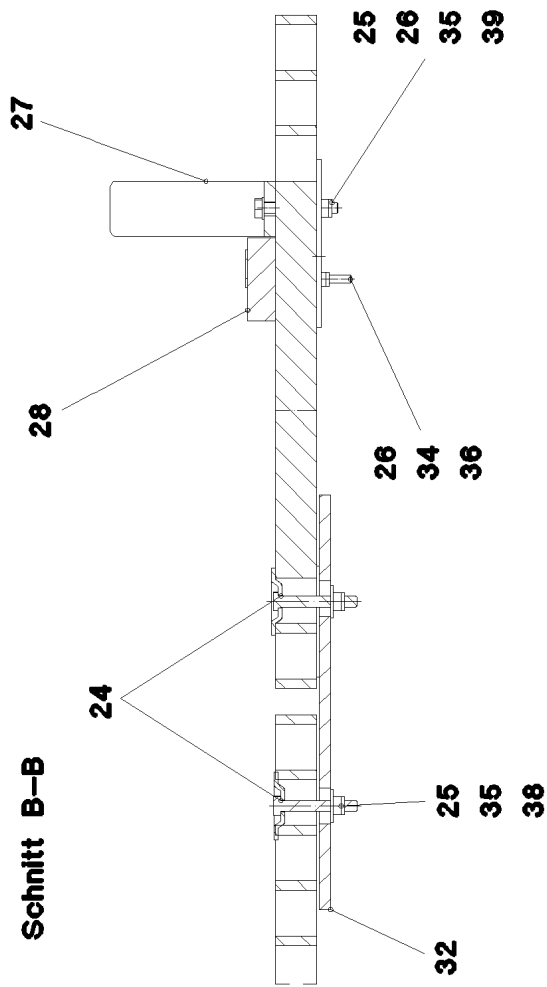

Schnitt D-D

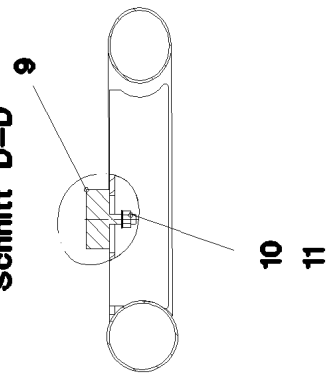

Schnitt E-E

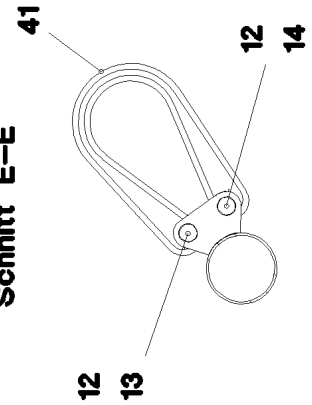

Schnitt F-F

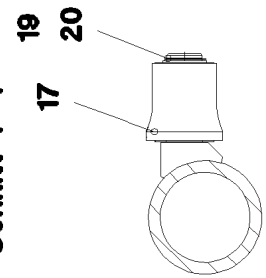

Schnitt G-G

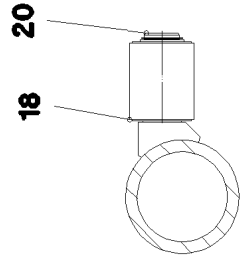

6.2.2009
052904

LIEBHERR

etk_en_de_074515 LR 1600/2

S INTERMEDIATE SECTION
S-ZWISCHENSTUECK

□ 473 (3/4)

⇒ 3 223
91 52 852 08

Pos.	Item	Quantity	Description	Bezeichnung	Serie	K
1	96 44 096 08	1	S INTERMED.SECTION WELD.CONSTR 2825	S-ZWISCHENSTUECK SCHWK.		
2	97 64 994 08	4	PIN 120.0X237 SPF	BOLZEN		
3	10 41 062 2	4	SAFETY PLUG W HINGE-LID 20X175 A3C	SICHERHEITSKLAPPSTECKER		
4	40 43 263 08	4	CYLINDER SCREW DIN 912 M24X360 10.9	ZYLINDERSCHRAUBE		
5	95 50 518 08	4	PLATE 5X104X140	BLECH		
6	46 00 158	8	HEX BOLT ISO 4017 M12X45 8.8 A3C	SECHSKANTSCHRAUBE		
7	42 18 011 08	16	WASHER ISO 7093-1 A 13 ST A3C	SCHEIBE		
8	41 15 143 08	8	HEX NUT DIN 934 M12 8 VERZ	SECHSKANTMUTTER		
9	72 66 160 08	2	MEGI BUFFER 100X40-M16 NR 60SHORE A	MEGIPUFFER		
10	42 00 019 08	2	WASHER DIN 125 A 17 VERZ	SCHEIBE		
11	41 15 050 08	2	HEX NUT DIN 934 M16 10 VERZ	SECHSKANTMUTTER		
12	45 14 223 08	4	PIN DIN 1436 20H11X85X78 30CRNIMO8 SP	BOLZEN		
13	43 32 001 08	2	HINGED CONNECTOR DIN 11023 5X32 VER	KLAPPSTECKER		
14	43 30 078 08	2	SPLIT PIN DIN 94 6,3X50 ST VERZ	SPLINT		
15	96 43 771 08	8	CONNECTING PIN WELDED	ABSTECKBOLZEN SCHWK.		
16	97 66 499 08	2	PIN 65.0X187 SPF	BOLZEN		
17	97 66 500 08	4	ROLLER PA6G	ROLLE		
18	97 66 501 08	2	ROLLER	ROLLE		
19	51 45 410 08	10	SUPPORTING RING DIN 988 S 63X80X3	STUETZSCHEIBE		
20	42 80 049 08	10	LOCKING RING DIN 471 60X2	SICHERUNGSRING		
21	43 31 009 08	8	RETAINING SPRING 4,5 VERZ	SICHERUNGSFEDER		
22	97 71 763 08	2	GRATING 4047X807X30 GFK SPF	GITTERROST		
23	97 66 514 08	2	GRATING 2647X487X30 GFK SPF	GITTERROST		
24	10 10 062 1	49	DISH MOUNTING	TELLERBEFESTIGUNG		
25	40 61 024	49	HEX BOLT ISO 4014 M8X55 8.8 A2C	SECHSKANTSCHRAUBE		
26	94 11 381 08	56	WASHER 70X3	SCHEIBE		
27	97 08 336 08	4	PLATE 8x40x276	BLECH		
28	97 66 612 08	2	SUPPORT PLATE 1400X60 PA6G	AUFLAGE		
29	97 41 439 08	2	SUPPORT PLATE 60X1270 PA6G	AUFLAGE		
30	97 41 440 08	2	PLATE 10X1250X80	BLECH		
31	95 64 428 08	4	PLATE 5X393X60 S380MC	BLECH		
32	95 54 048 08	5	PLATE 8X300X50	BLECH		
33	40 01 928	4	HEX BOLT ISO 4014 M6X40 8.8 A2C	SECHSKANTSCHRAUBE		
34	41 19 004 08	22	HEX NUT DIN 985 M6 8 VERZ	SECHSKANTMUTTER		
35	41 19 005 08	51	HEX NUT DIN 985 M8 8 VERZ	SECHSKANTMUTTER		
36	46 00 356	18	HEX BOLT ISO 4014 M6X65 8.8 A2C	SECHSKANTSCHRAUBE		
37	42 18 007 08	22	WASHER DIN 9021 A 6.4 VERZ	SCHEIBE		
38	42 18 009 08	40	WASHER DIN 9021 A 8.4 VERZ	SCHEIBE		
39	42 00 012 08	8	WASHER DIN 125 A8X16 ST VERZ	SCHEIBE		
40	97 71 942 08	1	GRATING 2287X807X30 GFK SPF	GITTERROST		
41	10 28 562 6	2	ROUND SLING DIN EN 1492-2 3T-0,75M PO	RUNDSCHLINGE		
42	96 45 222 08	2	ROD CPL. 12 M ⇒ 3 561 003 96 45 222 08	STANGE KPL.		
43	10 65 244 0	2	ROUND STRAND ROPE 10MM 11,54M EDEL	RUNDLITZENSEIL		
44	97 76 196 08	4	BEARING BLOCK PA6G	LAGERKLOTZ		
45	45 30 083 08	8	PIN DIN 1444 16H11X162X157 30CRNIMO8	BOLZEN		
46	43 31 028 08	4	RETAINING SPRING 3 VERZ	SICHERUNGSFEDER		
47	43 30 036 08	4	SPLIT PIN DIN 94 3,2X25 ST VERZ	SPLINT		
48	55 31 248 08	4	WASHER DIN 433 17 ST	SCHEIBE		
49	97 80 631 08	2	ROLLER PA6G	ROLLE		

6.2.2009

etk_en_de_074515 LR 1600/2

 474 (4/4)
LIEBHERR
S INTERMEDIATE SECTION
S-ZWISCHENSTUECK

⇒ 3 223

91 52 852 08

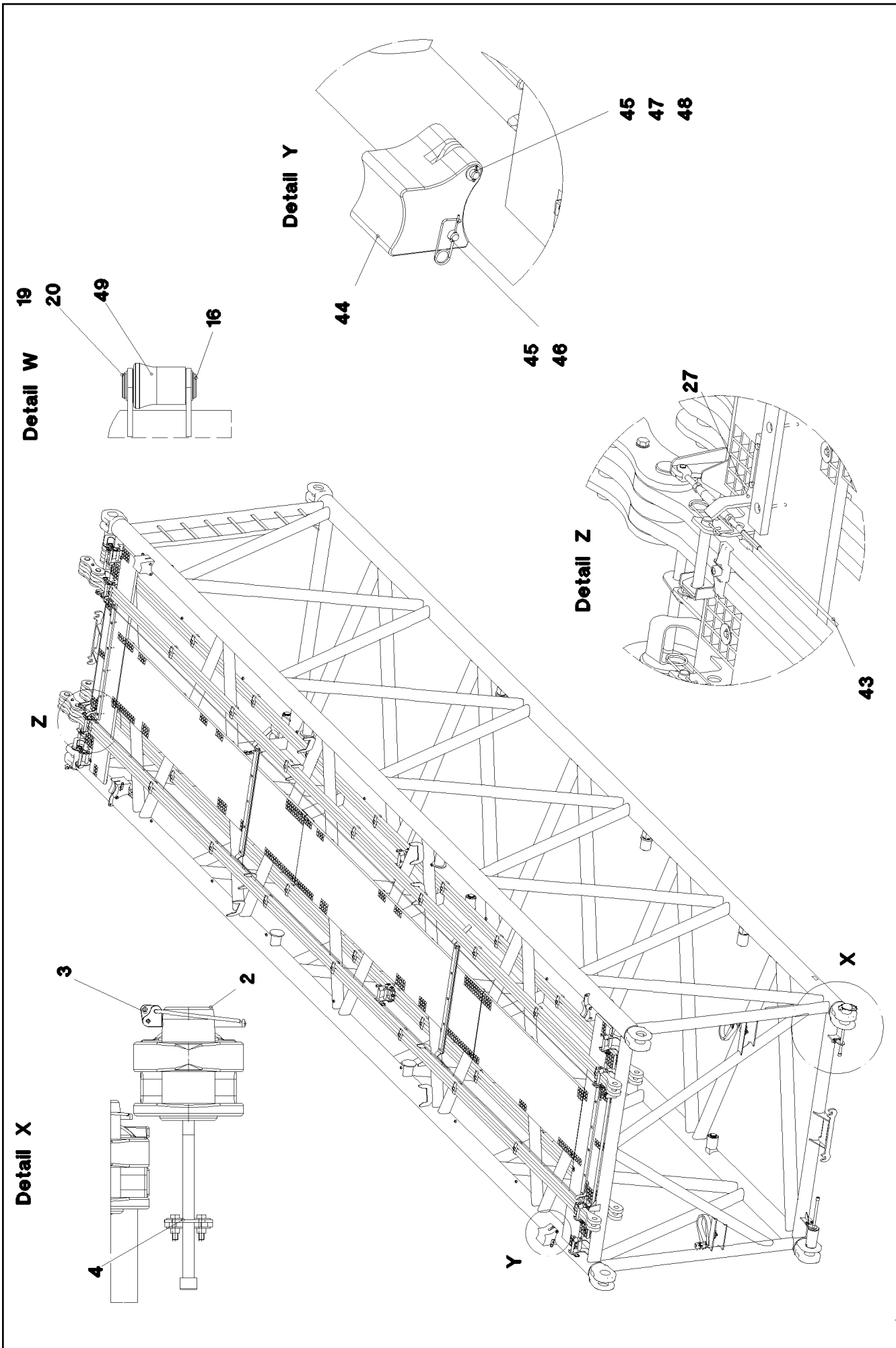

6.2.2009
052905
LIEBHERR

etk_en_de_074515 LR 1600/2
S INTERMEDIATE SECTION
S-ZWISCHENSTUECK

□ 475 (1/4)
⇒ 3 223 010
91 52 853 08

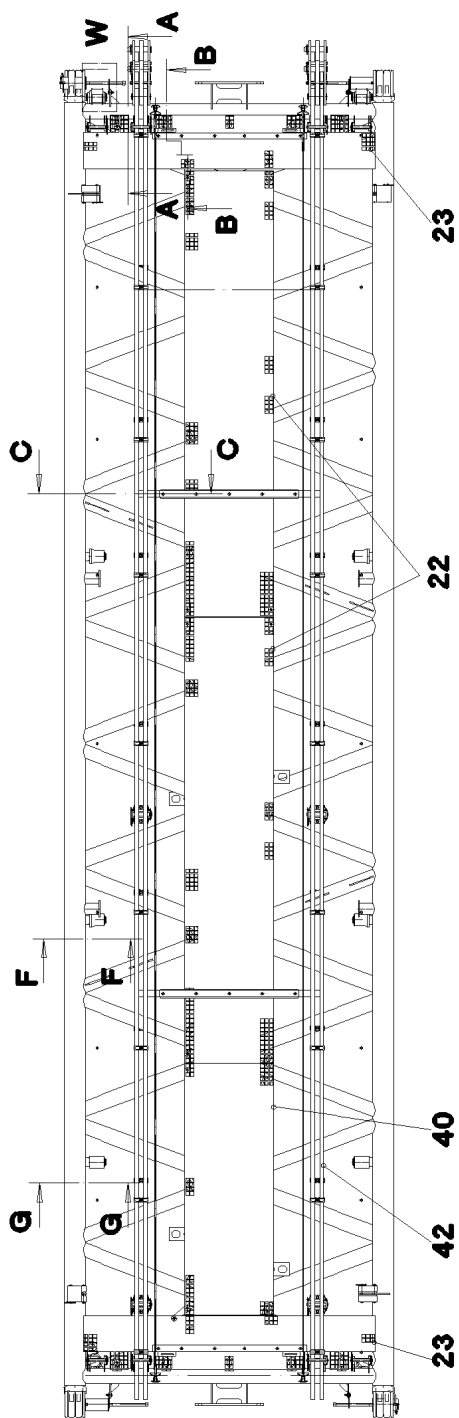
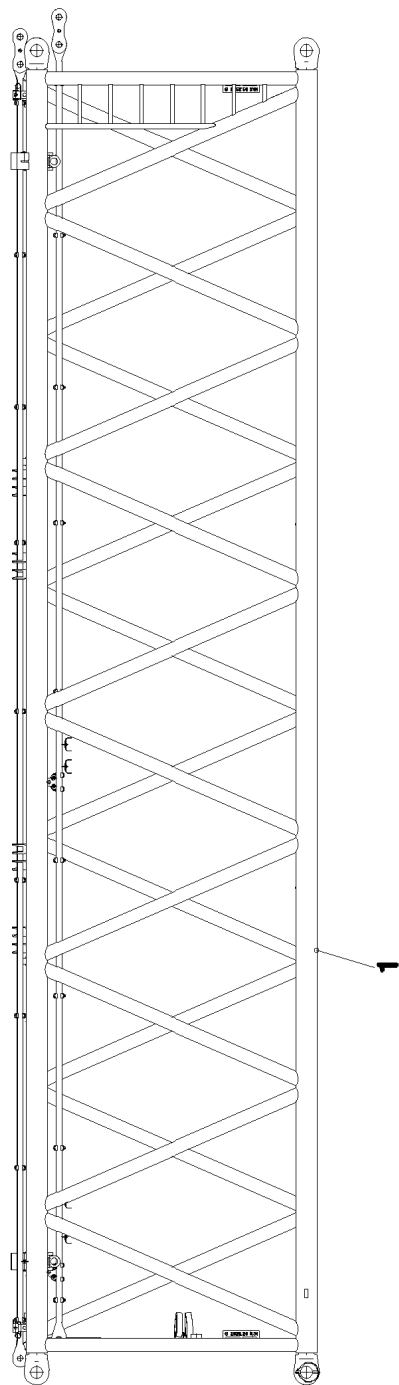
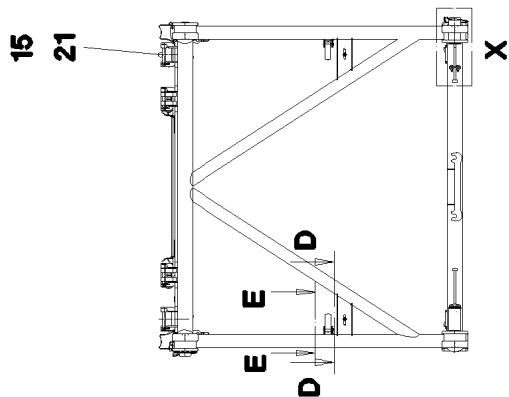

6.2.2009
052906

LIEBHERR

etk_en_de_074515 LR 1600/2

S INTERMEDIATE SECTION
S-ZWISCHENSTUECK

476 (2/4)

⇒ 3 223 010
91 52 853 08

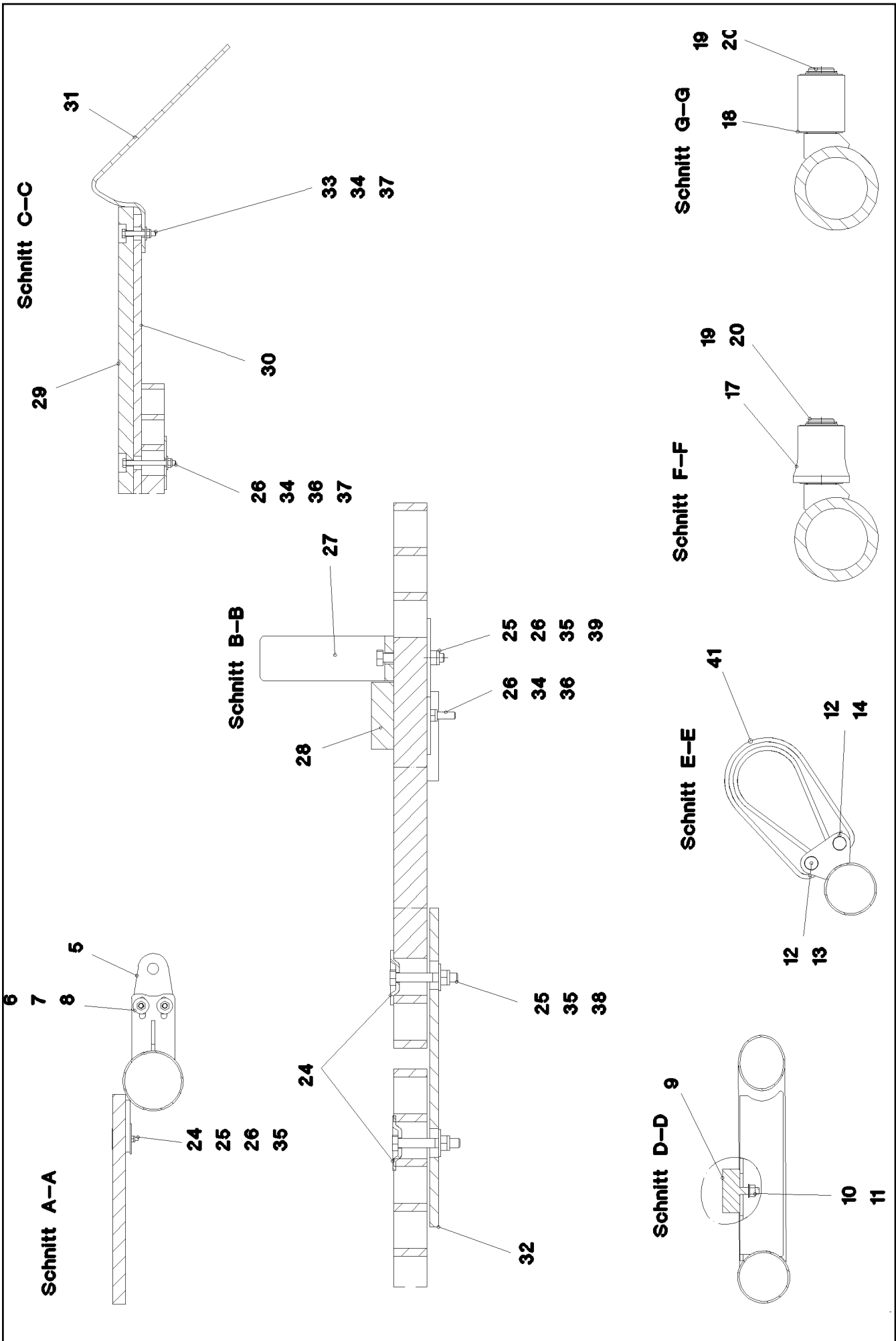

6.2.2009
052907

LIEBHERR

etk_en_de_074515 LR 1600/2

S INTERMEDIATE SECTION
S-ZWISCHENSTUECK

□ 477 (3/4)

→ 3 223 010
91 52 853 08

Pos.	Item	Quantity	Description	Bezeichnung	Serie	K
1	96 45 126 08	1	S INTERMED.SECTION WELD.CONSTR 2825	S-ZWISCHENSTUECK SCHWK.		
2	97 64 994 08	4	PIN 120.0X237 SPF	BOLZEN		
3	10 41 062 2	4	SAFETY PLUG W HINGE-LID 20X175 A3C	SICHERHEITSKLAPPSTECKER		
4	40 43 263 08	4	CYLINDER SCREW DIN 912 M24X360 10.9	ZYLINDERSCHRAUBE		
5	95 50 518 08	4	PLATE 5X104X140	BLECH		
6	46 00 158	8	HEX BOLT ISO 4017 M12X45 8.8 A3C	SECHSKANTSCHRAUBE		
7	42 18 011 08	16	WASHER ISO 7093-1 A 13 ST A3C	SCHEIBE		
8	41 15 143 08	8	HEX NUT DIN 934 M12 8 VERZ	SECHSKANTMUTTER		
9	72 66 160 08	2	MEGI BUFFER 100X40-M16 NR 60SHORE A	MEGIPUFFER		
10	42 00 019 08	2	WASHER DIN 125 A 17 VERZ	SCHEIBE		
11	41 15 050 08	2	HEX NUT DIN 934 M16 10 VERZ	SECHSKANTMUTTER		
12	45 14 223 08	4	PIN DIN 1436 20H11X85X78 30CRNIMO8 SP	BOLZEN		
13	43 32 001 08	2	HINGED CONNECTOR DIN 11023 5X32 VER	KLAPPSTECKER		
14	43 30 078 08	2	SPLIT PIN DIN 94 6,3X50 ST VERZ	SPLINT		
15	96 43 771 08	8	CONNECTING PIN WELDED	ABSTECKBOLZEN SCHWK.		
16	97 66 499 08	2	PIN 65.0X187 SPF	BOLZEN		
17	97 66 500 08	4	ROLLER PA6G	ROLLE		
18	97 66 501 08	2	ROLLER	ROLLE		
19	51 45 410 08	10	SUPPORTING RING DIN 988 S 63X80X3	STUETZSCHEIBE		
20	42 80 049 08	10	LOCKING RING DIN 471 60X2	SICHERUNGSRING		
21	43 31 009 08	8	RETAINING SPRING 4,5 VERZ	SICHERUNGSFEDER		
22	97 71 763 08	2	GRATING 4047X807X30 GFK SPF	GITTERROST		
23	97 66 514 08	2	GRATING 2647X487X30 GFK SPF	GITTERROST		
24	10 10 062 1	49	DISH MOUNTING	TELLERBEFESTIGUNG		
25	40 61 024	49	HEX BOLT ISO 4014 M8X55 8.8 A2C	SECHSKANTSCHRAUBE		
26	94 11 381 08	56	WASHER 70X3	SCHEIBE		
27	97 08 336 08	4	PLATE 8x40x276	BLECH		
28	97 66 612 08	2	SUPPORT PLATE 1400X60 PA6G	AUFLAGE		
29	97 41 439 08	2	SUPPORT PLATE 60X1270 PA6G	AUFLAGE		
30	97 41 440 08	2	PLATE 10X1250X80	BLECH		
31	97 75 617 08	4	PLATE 5X60X388 FE//ZN20//C	BLECH		
32	95 54 048 08	5	PLATE 8X300X50	BLECH		
33	40 01 928	4	HEX BOLT ISO 4014 M6X40 8.8 A2C	SECHSKANTSCHRAUBE		
34	41 19 004 08	22	HEX NUT DIN 985 M6 8 VERZ	SECHSKANTMUTTER		
35	41 19 005 08	51	HEX NUT DIN 985 M8 8 VERZ	SECHSKANTMUTTER		
36	46 00 356	18	HEX BOLT ISO 4014 M6X65 8.8 A2C	SECHSKANTSCHRAUBE		
37	42 18 007 08	22	WASHER DIN 9021 A 6.4 VERZ	SCHEIBE		
38	42 18 009 08	40	WASHER DIN 9021 A 8.4 VERZ	SCHEIBE		
39	42 00 012 08	8	WASHER DIN 125 A8X16 ST VERZ	SCHEIBE		
40	97 71 942 08	1	GRATING 2287X807X30 GFK SPF	GITTERROST		
41	10 28 562 6	2	ROUND SLING DIN EN 1492-2 3T-0,75M PO	RUNDSCHLINGE		
42	96 45 222 08	2	ROD CPL. 12 M ⇒ 3 561 003 96 45 222 08	STANGE KPL.		
43	10 65 244 0	2	ROUND STRAND ROPE 10MM 11,54M EDEL	RUNDLITZENSEIL		
44	97 76 196 08	4	BEARING BLOCK PA6G	LAGERKLOTZ		
45	45 30 083 08	8	PIN DIN 1444 16H11X162X157 30CRNIMO8	BOLZEN		
46	43 31 028 08	4	RETAINING SPRING 3 VERZ	SICHERUNGSFEDER		
47	43 30 036 08	4	SPLIT PIN DIN 94 3,2X25 ST VERZ	SPLINT		
48	55 31 248 08	4	WASHER DIN 433 17 ST	SCHEIBE		
49	97 80 631 08	2	ROLLER PA6G	ROLLE		

6.2.2009

etk_en_de_074515 LR 1600/2

 478 (4/4)
LIEBHERR
S INTERMEDIATE SECTION
S-ZWISCHENSTUECK

⇒ 3 223 010
91 52 853 08

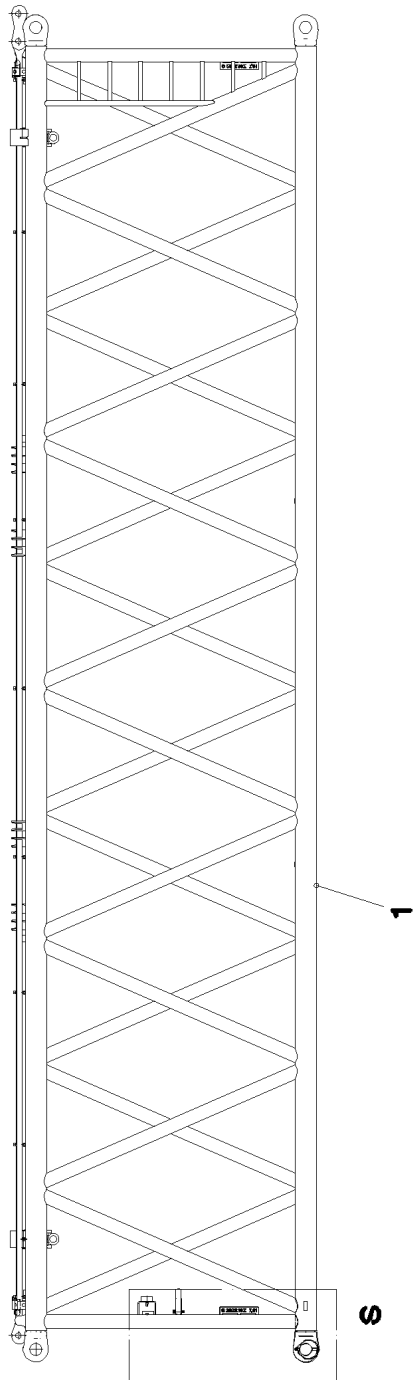
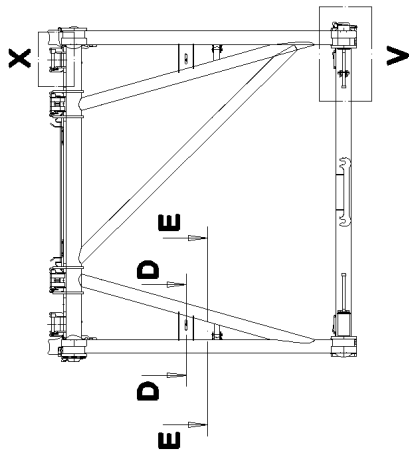

Einzelheit S

11
50
51
52 9
10
11

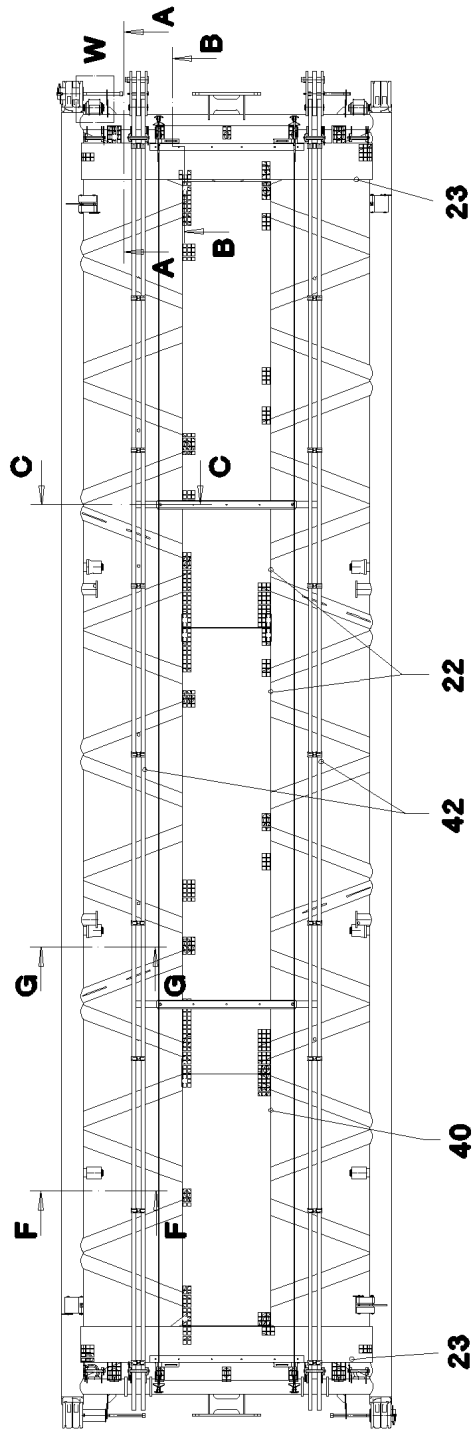
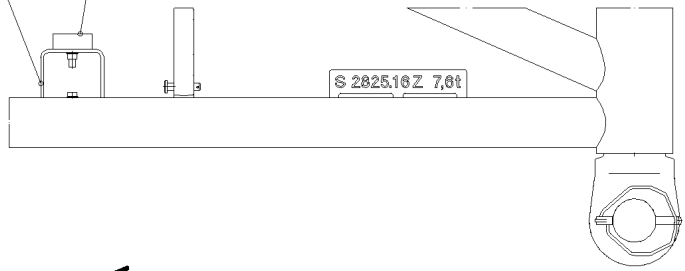

6.2.2009
052909

LIEBHERR

etk_en_de_074515 LR 1600/2

S INTERMEDIATE SECTION
S-ZWISCHENSTUECK

479 (1/4)

→ 3 223 100
91 55 327 08

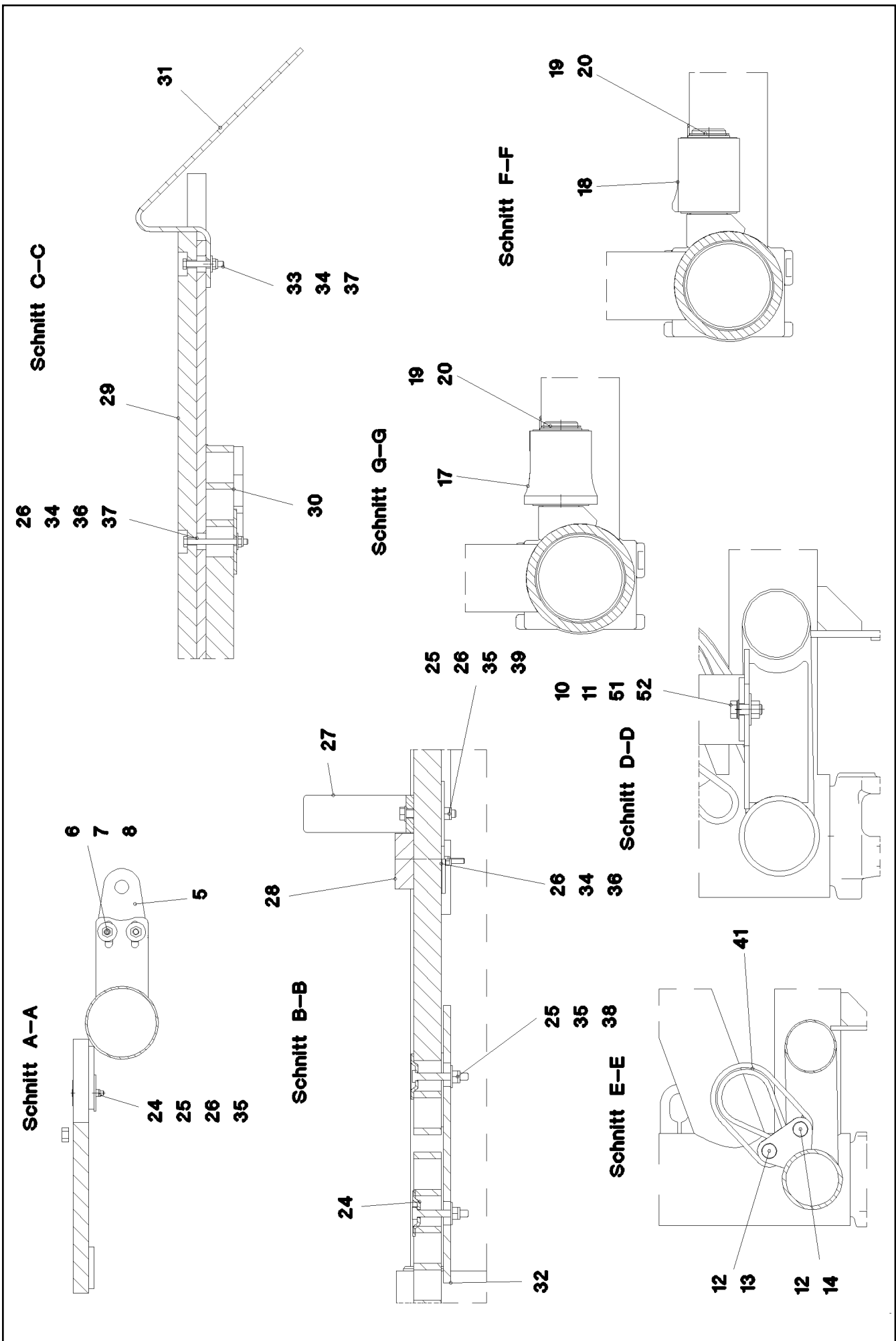

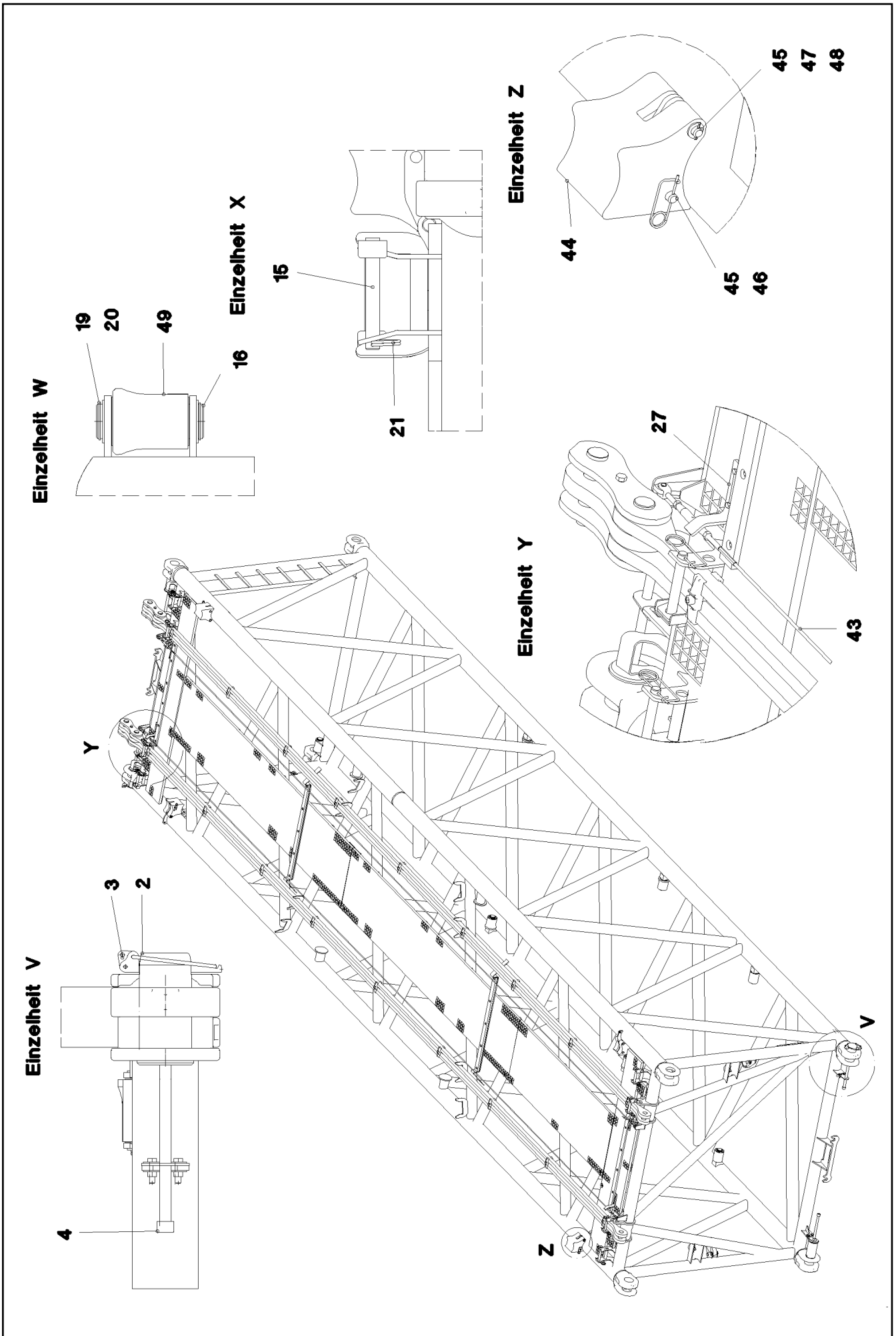

6.2.2009
052911

LIEBHERR

etk_en_de_074515 LR 1600/2

S INTERMEDIATE SECTION
S-ZWISCHENSTUECK

☐ 481 (3/4)

⇒ 3 223 100
91 55 327 08

Pos.	Item	Quantity	Description	Bezeichnung	Serie	K
1	96 48 482 08	1	S INTERMED.SECTION WELD.CONSTR 12 M	S-ZWISCHENSTUECK SCHWK.		
2	97 64 994 08	4	PIN 120.0X237 SPF	BOLZEN		
3	10 41 062 2	4	SAFETY PLUG W HINGE-LID 20X175 A3C	SICHERHEITSKLAPPSTECKER		
4	40 43 263 08	4	CYLINDER SCREW DIN 912 M24X360 10.9	ZYLINDERSCHRAUBE		
5	95 50 518 08	4	PLATE 5X104X140	BLECH		
6	46 00 158	8	HEX BOLT ISO 4017 M12X45 8.8 A3C	SECHSKANTSCHRAUBE		
7	42 18 011 08	16	WASHER ISO 7093-1 A 13 ST A3C	SCHEIBE		
8	41 15 143 08	8	HEX NUT DIN 934 M12 8 VERZ	SECHSKANTMUTTER		
9	72 66 160 08	2	MEGI BUFFER 100X40-M16 NR 60SHORE A	MEGIPUFFER		
10	42 00 019 08	4	WASHER DIN 125 A 17 VERZ	SCHEIBE		
11	41 15 050 08	4	HEX NUT DIN 934 M16 10 VERZ	SECHSKANTMUTTER		
12	45 14 223 08	4	PIN DIN 1436 20H11X85X78 30CRNIMO8 SP	BOLZEN		
13	43 32 001 08	2	HINGED CONNECTOR DIN 11023 5X32 VER	KLAPPSTECKER		
14	43 30 078 08	2	SPLIT PIN DIN 94 6,3X50 ST VERZ	SPLINT		
15	96 43 771 08	8	CONNECTING PIN WELDED	ABSTECKBOLZEN SCHWK.		
16	97 66 499 08	2	PIN 65.0X187 SPF	BOLZEN		
17	97 66 500 08	4	ROLLER PA6G	ROLLE		
18	97 66 501 08	2	ROLLER	ROLLE		
19	51 45 410 08	10	SUPPORTING RING DIN 988 S 63X80X3	STUETZSCHEIBE		
20	42 80 049 08	10	LOCKING RING DIN 471 60X2	SICHERUNGSRING		
21	43 31 009 08	8	RETAINING SPRING 4,5 VERZ	SICHERUNGSFEDER		
22	97 71 763 08	2	GRATING 4047X807X30 GFK SPF	GITTERROST		
23	97 74 648 08	2	GRATING 2647X487X30 GFK SPF	GITTERROST		
24	10 10 062 1	49	DISH MOUNTING	TELLERBEFESTIGUNG		
25	40 61 024	49	HEX BOLT ISO 4014 M8X55 8.8 A2C	SECHSKANTSCHRAUBE		
26	94 11 381 08	56	WASHER 70X3	SCHEIBE		
27	97 08 336 08	4	PLATE 8x40x276	BLECH		
28	97 66 612 08	2	SUPPORT PLATE 1400X60 PA6G	AUFLAGE		
29	97 41 439 08	2	SUPPORT PLATE 60X1270 PA6G	AUFLAGE		
30	97 41 440 08	2	PLATE 10X1250X80	BLECH		
31	95 64 428 08	4	PLATE 5X393X60 S380MC	BLECH		
32	95 54 048 08	5	PLATE 8X300X50	BLECH		
33	40 01 928	4	HEX BOLT ISO 4014 M6X40 8.8 A2C	SECHSKANTSCHRAUBE		
34	41 19 004 08	22	HEX NUT DIN 985 M6 8 VERZ	SECHSKANTMUTTER		
35	41 19 005 08	51	HEX NUT DIN 985 M8 8 VERZ	SECHSKANTMUTTER		
36	46 00 356	18	HEX BOLT ISO 4014 M6X65 8.8 A2C	SECHSKANTSCHRAUBE		
37	42 18 007 08	22	WASHER DIN 9021 A 6.4 VERZ	SCHEIBE		
38	42 18 009 08	40	WASHER DIN 9021 A 8.4 VERZ	SCHEIBE		
39	42 00 012 08	8	WASHER DIN 125 A8X16 ST VERZ	SCHEIBE		
40	97 71 942 08	1	GRATING 2287X807X30 GFK SPF	GITTERROST		
41	10 28 562 6	2	ROUND SLING DIN EN 1492-2 3T-0,75M PO	RUNDSCHLINGE		
42	96 45 222 08	2	ROD CPL. 12 M ⇒ 3 561 003 96 45 222 08	STANGE KPL.		
43	10 65 244 0	2	ROUND STRAND ROPE 10MM 11,54M EDEL	RUNDLITZENSEIL		
44	97 76 196 08	4	BEARING BLOCK PA6G	LAGERKLOTZ		
45	45 30 083 08	8	PIN DIN 1444 16H11X162X157 30CRNIMO8	BOLZEN		
46	43 31 028 08	4	RETAINING SPRING 3 VERZ	SICHERUNGSFEDER		
47	43 30 036 08	4	SPLIT PIN DIN 94 3,2X25 ST VERZ	SPLINT		
48	55 31 248 08	4	WASHER DIN 433 17 ST	SCHEIBE		
49	97 80 631 08	2	ROLLER PA6G	ROLLE		
50	96 56 719 08	2	CONSOLE	KONSOLE		
51	49 00 153	2	HEX BOLT ISO 4017 M16X40 8.8 A3C	SECHSKANTSCHRAUBE		
52	42 18 013 08	2	WASHER DIN 9021 A 17 ST VERZ	SCHEIBE		

6.2.2009

etk_en_de_074515 LR 1600/2

 482 (4/4)
LIEBHERR
S INTERMEDIATE SECTION
S-ZWISCHENSTUECK

⇒ 3 223 100
91 55 327 08

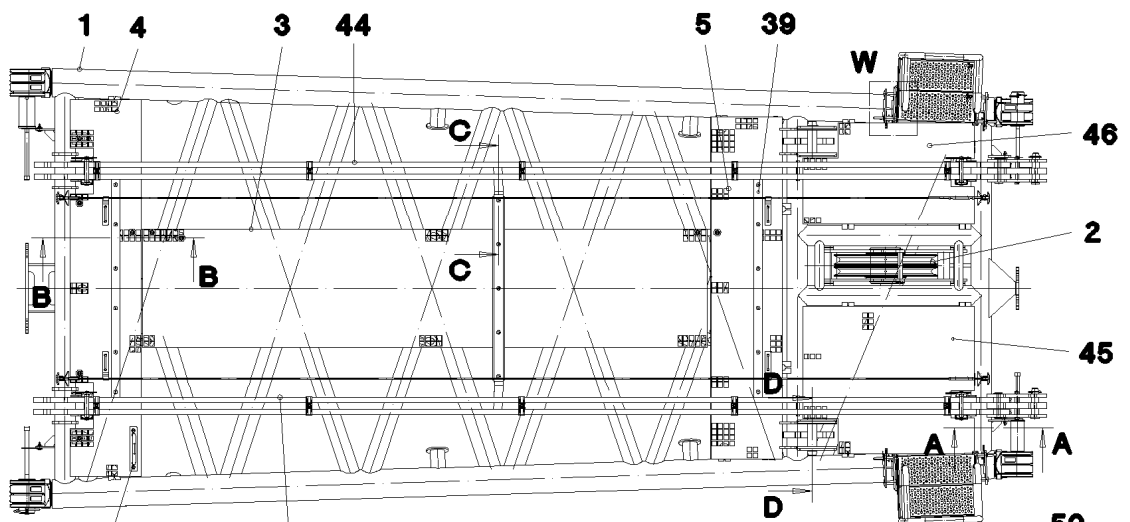
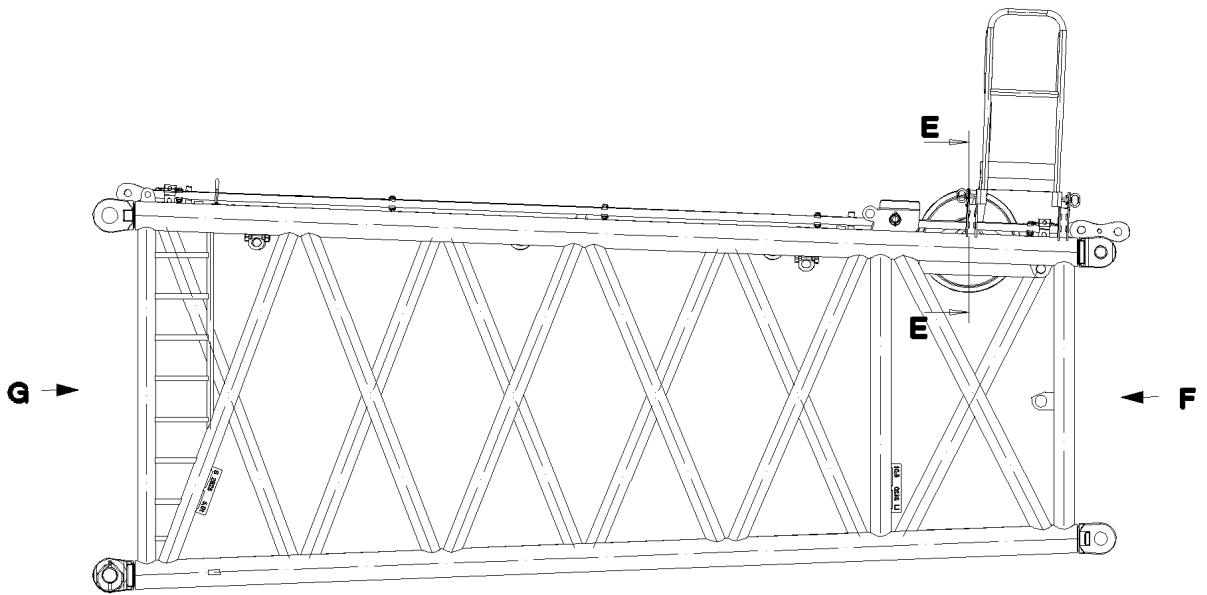

35 42 44
37 57
38 **Ansicht F**

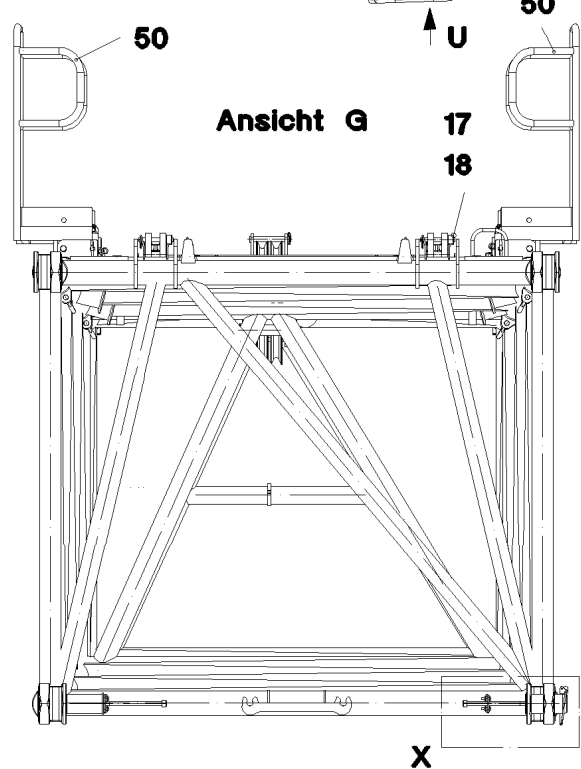

Ansicht G

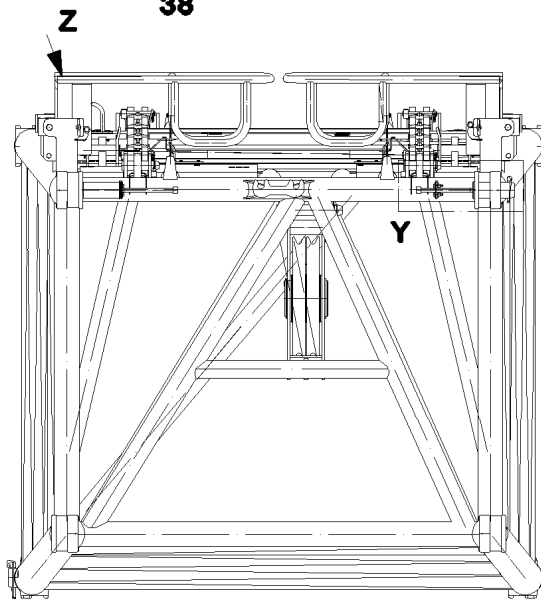

6.2.2009
052912

LIEBHERR

etk_en_de_074515 LR 1600/2

SL REDUCING SECTION
SL-REDUZIERSTUECK

483 (1/3)

→ 3 225
91 52 854 08

Einzelheit X

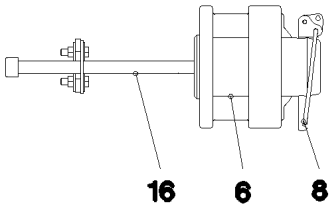

Ansicht Z

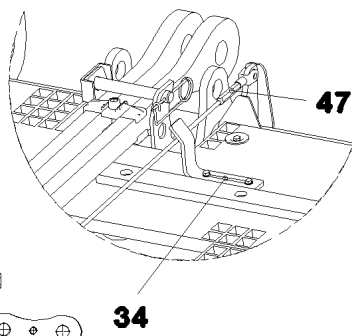

Einzelheit W

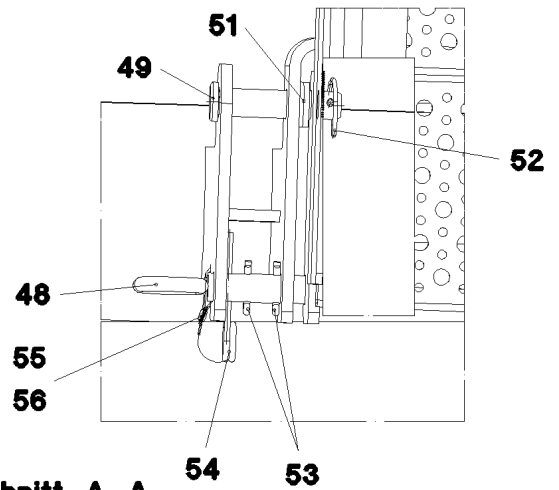

Ansicht U

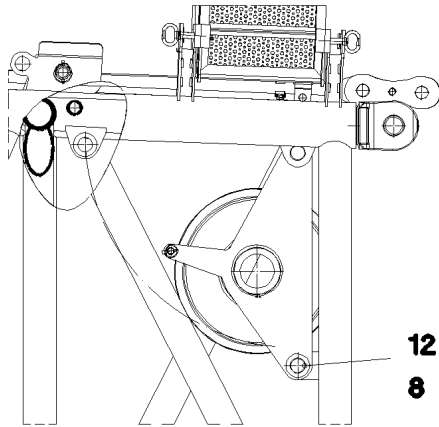

Schnitt A-A

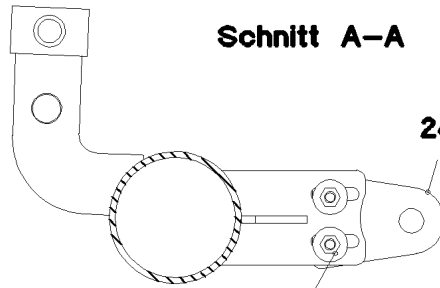

Detail Y

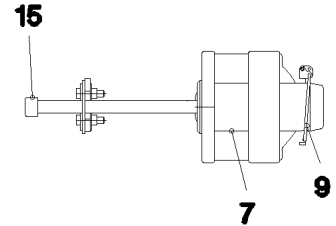

Schnitt E-E

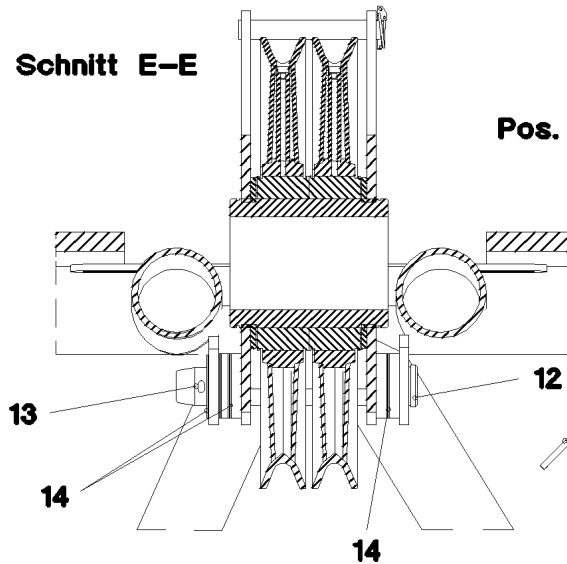

Pos. 20

- 25 31
- 26 32
- 27 33

Schnitt C-C

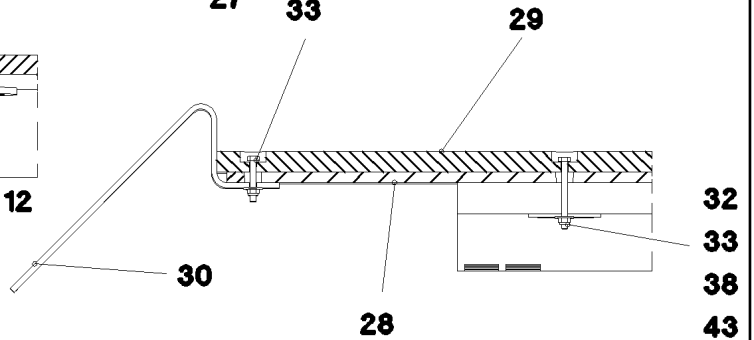

Schnitt B-B

Schnitt D-D

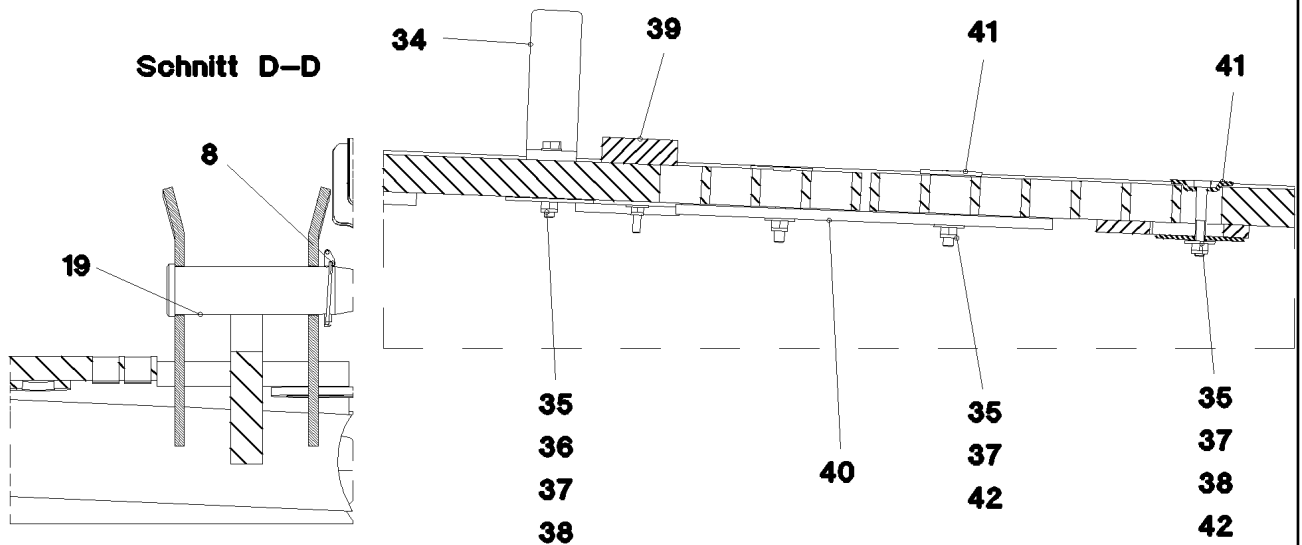

6.2.2009
052913

LIEBHERR

etk_en_de_074515 LR 1600/2

SL REDUCING SECTION
SL-REDUZIERSTUECK

484 (2/3)

3 225
91 52 854 08

Pos.	Item	Quantity	Description	Bezeichnung	Serie	K
1	96 46 385 08	1	LI INTERMEDIATE SECTION 6.75 M	SL-REDUZIERSTUECK SCHWK.		
2	96 48 582 08	1	BEARING CPL ⇒ 3 225 100 96 48 582 08	LAGERUNG KPL.		
3	97 74 743 08	1	GRATING 3847X807X30 GFK SPF	GITTERROST		
4	97 74 744 08	1	GRATING 2567X487X30 GFK SPF	GITTERROST		
5	97 74 745 08	1	GRATING 2327X487X30 GFK SPF	GITTERROST		
6	97 64 994 08	2	PIN 120.0X237 SPF	BOLZEN		
7	97 68 649 08	2	PIN 100.0X237 35NICRMOV125 SPF	BOLZEN		
8	10 41 062 2	2	SAFETY PLUG W HINGE-LID 20X175 A3C	SICHERHEITSKLAPPSTECKER		
9	43 32 015 08	2	SAFETY PLUG W HINGE-LID 17X125 VERZ	SICHERHEITSKLAPPSTECKER		
12	97 74 903 08	2	PIN 65.0X375 SPF	BOLZEN		
13	43 30 103 08	1	SPLIT PIN DIN 94 10X80 ST VERZ	SPLINT		
14	93 97 306 08	7	PLATE 1.5X100X100	BLECH		
15	46 30 212	2	CYLINDER SCREW ISO 4762 M24X340 10.9	ZYLINDERSCHRAUBE		
16	40 43 263 08	2	CYLINDER SCREW DIN 912 M24X360 10.9	ZYLINDERSCHRAUBE		
17	96 43 771 08	4	CONNECTING PIN WELDED	ABSTECKBOLZEN SCHWK.		
18	43 31 009 08	4	RETAINING SPRING 4,5 VERZ	SICHERUNGSFEDER		
19	97 09 155 08	2	PIN 65.0X240 SPF	BOLZEN		
20	43 32 005 08	3	SAFETY PLUG W HINGE-LID 11,5X96 VERZ	SICHERHEITSKLAPPSTECKER		
24	95 50 518 08	4	PLATE 5X104X140	BLECH		
25	46 00 158	8	HEX BOLT ISO 4017 M12X45 8.8 A3C	SECHSKANTSCHRAUBE		
26	41 15 143 08	8	HEX NUT DIN 934 M12 8 VERZ	SECHSKANTMUTTER		
27	42 18 011 08	16	WASHER ISO 7093-1 A 13 ST A3C	SCHEIBE		
28	97 41 440 08	1	PLATE 10X1250X80	BLECH		
29	97 41 439 08	1	SUPPORT PLATE 60X1270 PA6G	AUFLAGE		
30	95 64 428 08	2	PLATE 5X393X60 S380MC	BLECH		
31	40 01 928	2	HEX BOLT ISO 4014 M6X40 8.8 A2C	SECHSKANTSCHRAUBE		
32	41 19 004 08	17	HEX NUT DIN 985 M6 8 VERZ	SECHSKANTMUTTER		
33	42 18 007 08	17	WASHER DIN 9021 A 6.4 VERZ	SCHEIBE		
34	97 08 336 08	4	PLATE 8x40x276	BLECH		
35	40 61 024	47	HEX BOLT ISO 4014 M8X55 8.8 A2C	SECHSKANTSCHRAUBE		
36	42 00 012 08	31	WASHER DIN 125 A8X16 ST VERZ	SCHEIBE		
37	41 19 005 08	47	HEX NUT DIN 985 M8 8 VERZ	SECHSKANTMUTTER		
38	94 11 381 08	53	WASHER 70X3	SCHEIBE		
39	97 41 438 08	2	SUPPORT PLATE 60X1520 PA6G	AUFLAGE		
40	95 54 048 08	2	PLATE 8X300X50	BLECH		
41	10 10 062 1	37	DISH MOUNTING	TELLERBEFESTIGUNG		
42	42 18 009 08	43	WASHER DIN 9021 A 8.4 VERZ	SCHEIBE		
43	46 00 356	15	HEX BOLT ISO 4014 M6X65 8.8 A2C	SECHSKANTSCHRAUBE		
44	96 48 679 08	2	ROD CPL. 6.75M ⇒ 3 225 200 96 48 679 08	STANGE KPL.		
45	97 75 015 08	1	GRATING 1167X1007X30 GFK SPF	GITTERROST		
46	97 75 016 08	1	GRATING 1167X687X30 GFK SPF	GITTERROST		
47	10 65 281 6	2	ROUND STRAND ROPE 10MM 6,3M EDELST	RUNDLITZENSEIL		
48	96 54 983 08	4	GRIP BOLT	GRIFFBOLZEN		
49	45 12 272 08	4	PIN DIN 1435 25H11X110X100 42CRMO4 GA	BOLZEN		
50	96 54 984 08	2	PLATFORM	PODEST		
51	42 11 022 08	8	WASHER DIN 1440 26 ST VERZ	SCHEIBE		
52	43 32 002 08	4	HINGED CONNECTOR DIN 11023 6X42 VER	KLAPPSTECKER		
53	43 30 075 08	8	SPLIT PIN DIN 94 6,3X32 ST VERZ	SPLINT		
54	43 32 064 08	4	SPRING PLUG 6 VERZ	FEDERSTECKER		
55	77 34 003 08	1	ROPE DIN 3055 2MM 2,3KN FE	SEIL		
56	77 39 200 08	8	WIRE ROPE CLAMP DIN 3093 2 AL	PRESSKLEMME		
57	96 27 295 08	1	HANDLE WELD.CONST.	GRIFF SCHWK.		

6.2.2009

etk_en_de_074515 LR 1600/2

 485 (3/3)
LIEBHERR
SL REDUCING SECTION
SL-REDUZIERSTUECK

 ⇒ 3 225
 91 52 854 08

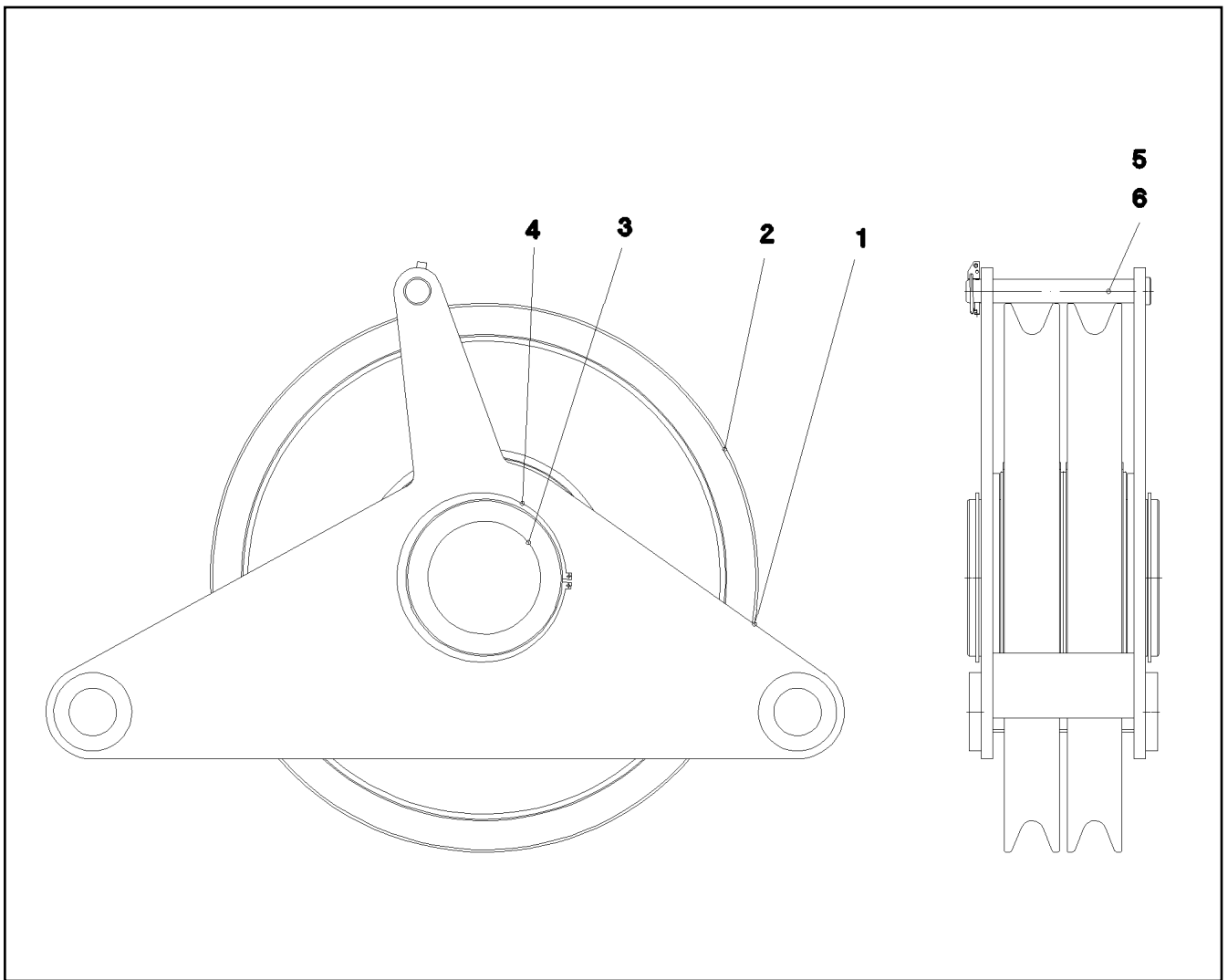

Pos.	Item	Quantity	Description	Bezeichnung	Serie	K
1	96 48 584 08	1	BEARING WELDED	LAGERUNG SCHWK.		
2	96 46 246 08	2	ROPE PULLEY CPL. SPF ⇒ 2 550 003 96 46 246 08	SEILROLLE KPL.		
3	95 66 984 08	1	AXLE 219,1X40X245 SPF	ACHSE		
4	42 80 093 08	2	LOCKING RING DIN 471 200X4	SICHERUNGSRING		
5	97 83 727 08	1	PIN 35.0X236 SPF	BOLZEN		
6	43 32 014 08	1	SAFETY PLUG W HINGE-LID 8X42 VERZ	SICHERHEITSKLAPPSTECKER		

6.2.2009
052931

LIEBHERR

etk_en_de_074515 LR 1600/2

BEARING CPL
LAGERUNG KPL.

486

⇒ 3 225 100
96 48 582 08

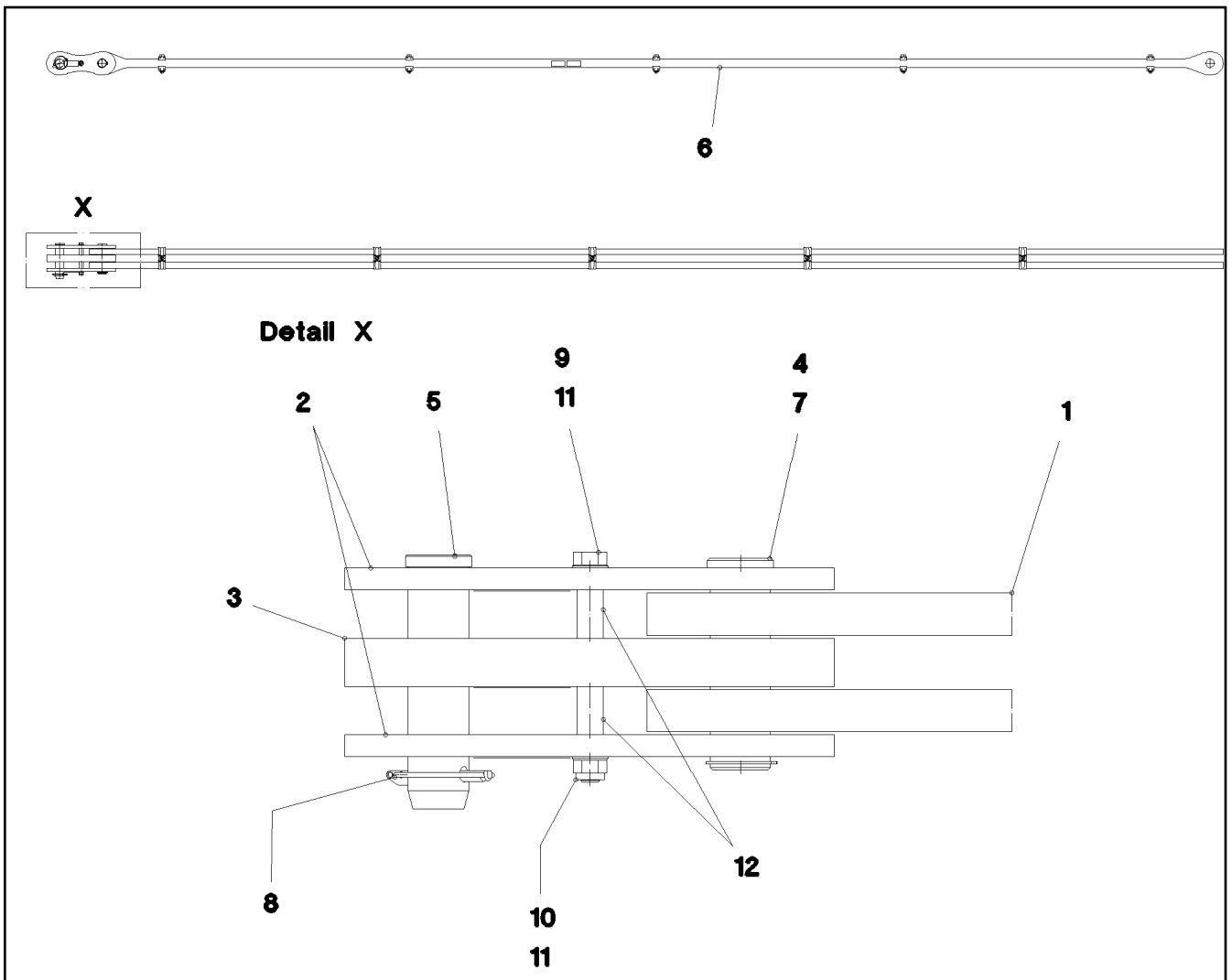

Pos.	Item	Quantity	Description	Bezeichnung	Serie	K
1	96 48 680 08	1	ROD	STANGE VORM.		
2	96 45 231 08	2	BRACKET WITH BOARD 0.25 M	LASCHE MIT SCHILD		
3	96 45 232 08	1	BRACKET WITH BOARD 0.25 M	LASCHE MIT SCHILD		
4	97 67 727 08	1	PIN 55.0X175 30CRNIMO8+QT	BOLZEN		
5	95 28 920 08	1	PIN 55.0X210 30CRNIMO8+QT SPF	BOLZEN		
6	97 35 919 08	1	PLATE ASSEMBLY BG-NR. PVC-SILBER SP	SCHILD BAUGRUPPE		
7	42 80 042 08	1	LOCKING RING DIN 471 50X2	SICHERUNGSRING		
8	43 32 005 08	1	SAFETY PLUG W HINGE-LID 11,5X96 VERZ	SICHERHEITSKLAPPSTECKER		
9	40 61 186 01	1	HEX BOLT ISO 4014 M16X180 8.8 A3C	SECHSKANTSCHRAUBE		
10	41 19 009 08	1	HEX NUT DIN 985 M16 8 VERZ	SECHSKANTMUTTER		
11	42 00 019 08	2	WASHER DIN 125 A 17 VERZ	SCHEIBE		
12	93 92 551 08	2	TUBE 22X2,5X40	ROHR		

6.2.2009
052930

LIEBHERR

etk_en_de_074515 LR 1600/2

ROD CPL.
STANGE KPL.

487

⇒ 3 225 200
96 48 679 08

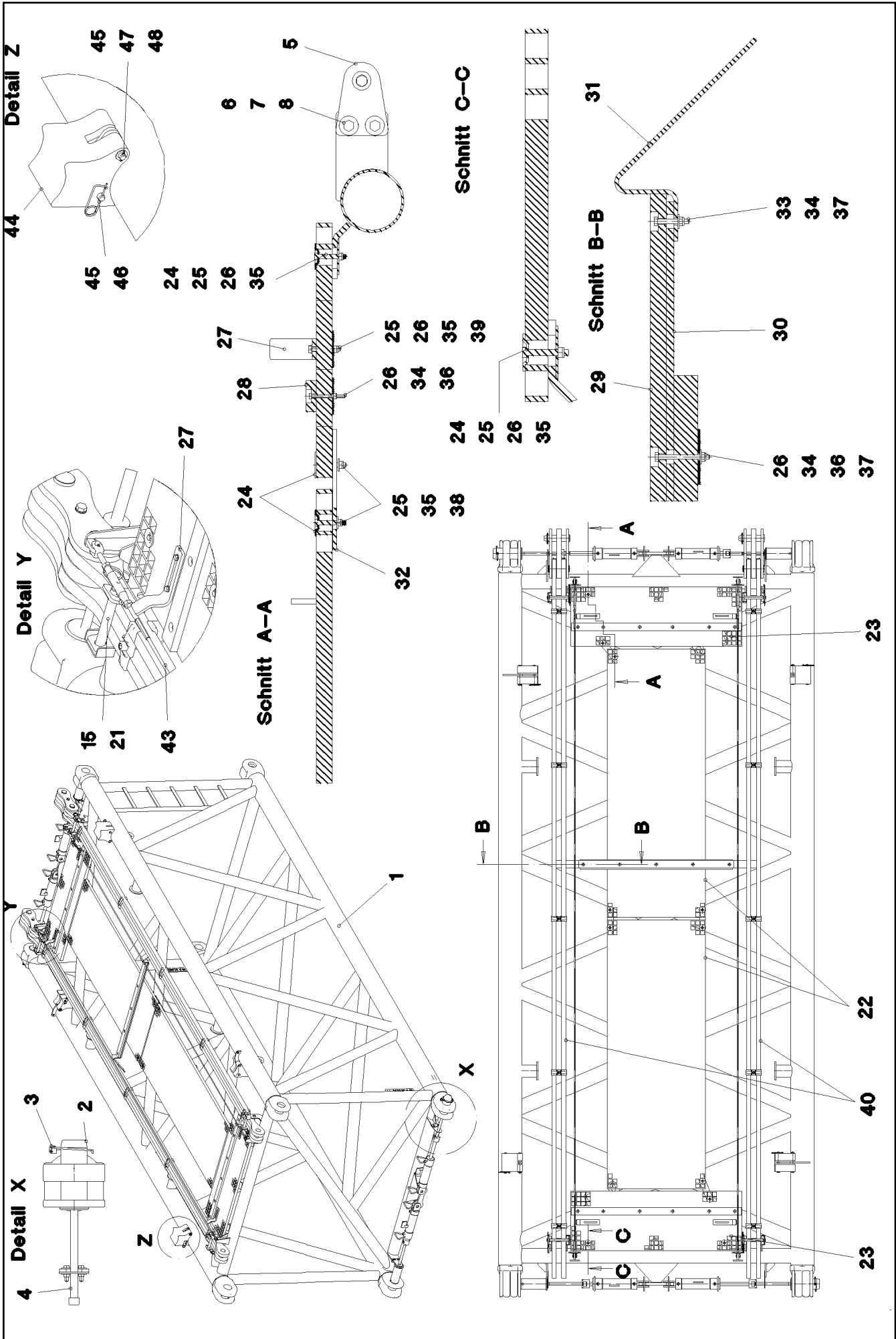

6.2.2009
052914

LIEBHERR

etk_en_de_074515 LR 1600/2

L INTERMEDIATE SECTION
LI-ZWISCHENSTUECK

488 (1/2)

→ 3 226
91 52 870 08

Pos.	Item	Quantity	Description	Bezeichnung	Serie	K
1	96 43 434 08	1	LI INTERMEDIATE SECT.WELD.CONS 2420.	LI-ZWISCHENSTUECK SCHWK.		
2	97 68 649 08	4	PIN 100.0X237 35NICRMOV125 SPF	BOLZEN		
3	43 32 015 08	4	SAFETY PLUG W HINGE-LID 17X125 VERZ	SICHERHEITSKLAPPSTECKER		
4	46 30 212	4	CYLINDER SCREW ISO 4762 M24X340 10.9	ZYLINDERSCHRAUBE		
5	95 50 518 08	4	PLATE 5X104X140	BLECH		
6	46 00 158	8	HEX BOLT ISO 4017 M12X45 8.8 A3C	SECHSKANTSCHRAUBE		
7	42 18 011 08	16	WASHER ISO 7093-1 A 13 ST A3C	SCHEIBE		
8	41 15 143 08	8	HEX NUT DIN 934 M12 8 VERZ	SECHSKANTMUTTER		
15	96 43 771 08	4	CONNECTING PIN WELDED	ABSTECKBOLZEN SCHWK.		
21	43 31 009 08	4	RETAINING SPRING 4,5 VERZ	SICHERUNGSFEDER		
22	97 71 971 08	2	GRATING 2207X807X30 GFK SPF	GITTERROST		
23	97 66 610 08	2	GRATING 1407X487X30 GFK SPF	GITTERROST		
24	10 10 062 1	25	DISH MOUNTING	TELLERBEFESTIGUNG		
25	40 61 024	34	HEX BOLT ISO 4014 M8X55 8.8 A2C	SECHSKANTSCHRAUBE		
26	94 11 381 08	40	WASHER 70X3	SCHEIBE		
27	97 73 817 08	4	PLATE 8X40X246	BLECH		
28	97 66 612 08	2	SUPPORT PLATE 1400X60 PA6G	AUFLAGE		
29	97 41 439 08	1	SUPPORT PLATE 60X1270 PA6G	AUFLAGE		
30	97 41 440 08	1	PLATE 10X1250X80	BLECH		
31	95 64 428 08	2	PLATE 5X393X60 S380MC	BLECH		
32	95 54 048 08	4	PLATE 8X300X50	BLECH		
33	40 01 928	2	HEX BOLT ISO 4014 M6X40 8.8 A2C	SECHSKANTSCHRAUBE		
34	41 19 004 08	17	HEX NUT DIN 985 M6 8 VERZ	SECHSKANTMUTTER		
35	41 19 005 08	34	HEX NUT DIN 985 M8 8 VERZ	SECHSKANTMUTTER		
36	46 00 356	15	HEX BOLT ISO 4014 M6X65 8.8 A2C	SECHSKANTSCHRAUBE		
37	42 18 007 08	17	WASHER DIN 9021 A 6.4 VERZ	SCHEIBE		
38	42 18 009 08	8	WASHER DIN 9021 A 8.4 VERZ	SCHEIBE		
39	42 00 012 08	8	WASHER DIN 125 A8X16 ST VERZ	SCHEIBE		
40	96 43 440 08	2	ROD CPL. 6 M ⇒ 3 220 501 96 43 440 08	STANGE KPL.		
43	10 65 243 9	2	ROUND STRAND ROPE 10MM 5,54M EDEL	RUNDLITZENSEIL		
44	97 76 196 08	4	BEARING BLOCK PA6G	LAGERKLOTZ		
45	45 30 083 08	8	PIN DIN 1444 16H11X162X157 30CRNIMO8	BOLZEN		
46	43 31 028 08	4	RETAINING SPRING 3 VERZ	SICHERUNGSFEDER		
47	43 30 036 08	4	SPLIT PIN DIN 94 3,2X25 ST VERZ	SPLINT		
48	55 31 248 08	4	WASHER DIN 433 17 ST	SCHEIBE		

6.2.2009

etk_en_de_074515 LR 1600/2

489 (2/2)

LIEBHERRL INTERMEDIATE SECTION
LI-ZWISCHENSTUECK⇒ 3 226
91 52 870 08

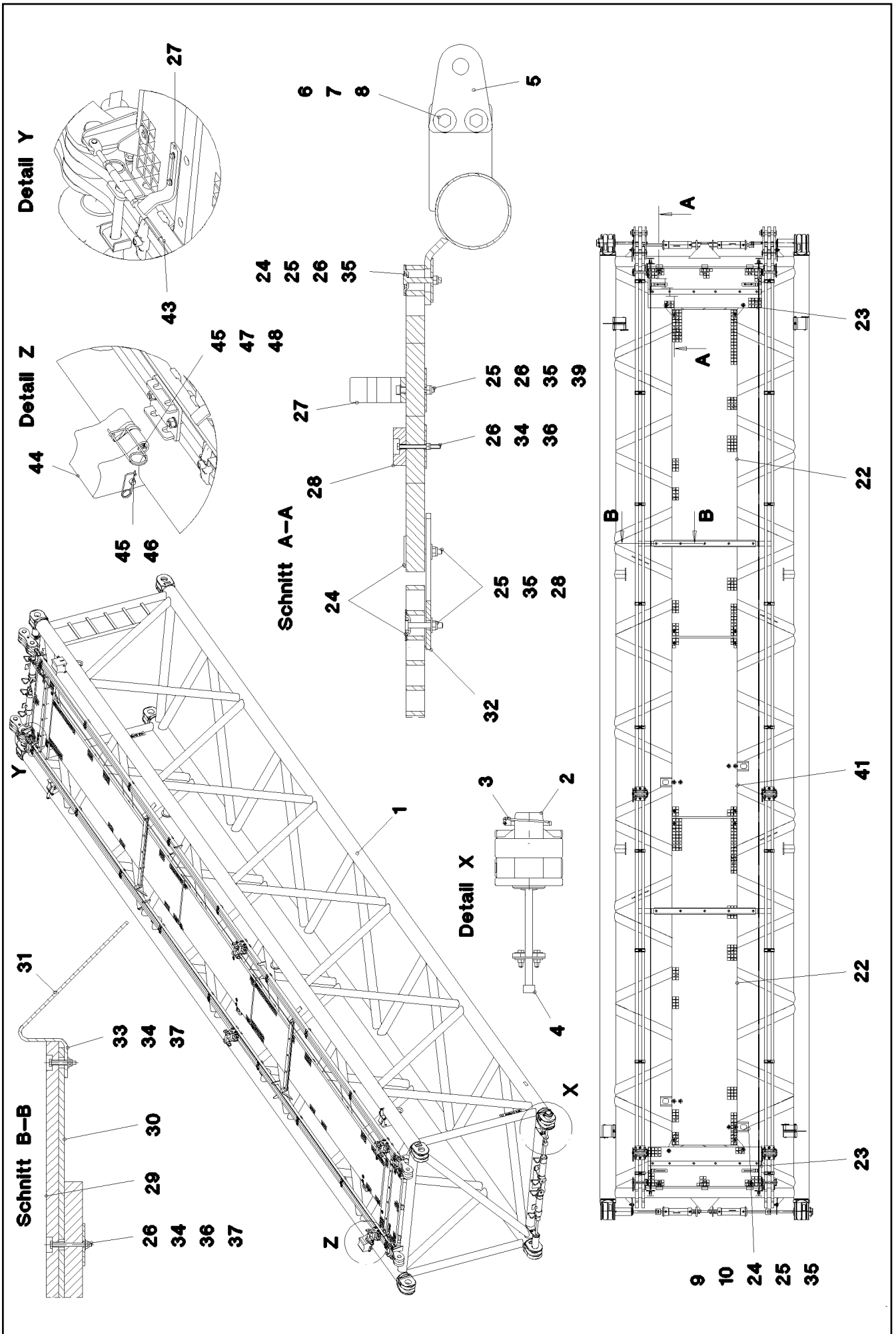

6.2.2009
052916

LIEBHERR

etk_en_de_074515 LR 1600/2

L INTERMEDIATE SECTION
LI-ZWISCHENSTUECK

□ 490 (1/2)

⇒ 3 227

91 52 873 08

Pos.	Item	Quantity	Description	Bezeichnung	Serie	K
1	96 46 294 08	1	LI INTERMEDIATE SECT.WELD.CONS 2420.1	LI-ZWISCHENSTUECK SCHWK.		
2	97 68 649 08	4	PIN 100.0X237 35NICRMOV125 SPF	BOLZEN		
3	43 32 015 08	4	SAFETY PLUG W HINGE-LID 17X125 VERZ	SICHERHEITSKLAPPSTECKER		
4	46 30 212	4	CYLINDER SCREW ISO 4762 M24X340 10.9	ZYLINDERSCHRAUBE		
5	95 50 518 08	4	PLATE 5X104X140	BLECH		
6	46 00 158	8	HEX BOLT ISO 4017 M12X45 8.8 A3C	SECHSKANTSCHRAUBE		
7	42 18 011 08	16	WASHER ISO 7093-1 A 13 ST A3C	SCHEIBE		
8	41 15 143 08	8	HEX NUT DIN 934 M12 8 VERZ	SECHSKANTMUTTER		
9	97 78 526 08	4	PLATE 4X209X275 FE//ZN20//C	BLECH		
10	94 10 097 08	8	WASHER RD60X5	SCHEIBE		
15	96 43 771 08	8	CONNECTING PIN WELDED	ABSTECKBOLZEN SCHWK.		
21	43 31 009 08	4	RETAINING SPRING 4,5 VERZ	SICHERUNGSFEDER		
22	97 71 763 08	2	GRATING 4047X807X30 GFK SPF	GITTERROST		
23	97 66 610 08	2	GRATING 1407X487X30 GFK SPF	GITTERROST		
24	10 10 062 1	40	DISH MOUNTING	TELLERBEFESTIGUNG		
25	40 61 024	48	HEX BOLT ISO 4014 M8X55 8.8 A2C	SECHSKANTSCHRAUBE		
26	94 11 381 08	49	WASHER 70X3	SCHEIBE		
27	97 73 817 08	4	PLATE 8X40X246	BLECH		
28	97 66 612 08	2	SUPPORT PLATE 1400X60 PA6G	AUFLAGE		
29	97 41 439 08	2	SUPPORT PLATE 60X1270 PA6G	AUFLAGE		
30	97 41 440 08	2	PLATE 10X1250X80	BLECH		
31	95 64 428 08	4	PLATE 5X393X60 S380MC	BLECH		
32	95 54 048 08	5	PLATE 8X300X50	BLECH		
33	40 01 928	4	HEX BOLT ISO 4014 M6X40 8.8 A2C	SECHSKANTSCHRAUBE		
34	41 19 004 08	22	HEX NUT DIN 985 M6 8 VERZ	SECHSKANTMUTTER		
35	41 19 005 08	39	HEX NUT DIN 985 M8 8 VERZ	SECHSKANTMUTTER		
36	46 00 356	18	HEX BOLT ISO 4014 M6X65 8.8 A2C	SECHSKANTSCHRAUBE		
37	42 18 007 08	22	WASHER DIN 9021 A 6.4 VERZ	SCHEIBE		
38	42 18 009 08	24	WASHER DIN 9021 A 8.4 VERZ	SCHEIBE		
39	42 00 012 08	8	WASHER DIN 125 A8X16 ST VERZ	SCHEIBE		
40	96 50 498 08	2	ROD CPL. 12 M	STANGE KPL.		
			⇒ 3 227 002 96 50 498 08			
41	97 71 971 08	1	GRATING 2207X807X30 GFK SPF	GITTERROST		
43	10 65 244 0	2	ROUND STRAND ROPE 10MM 11,54M EDEL	RUNDLITZENSEIL		
44	97 76 196 08	4	BEARING BLOCK PA6G	LAGERKLOTZ		
45	45 30 083 08	8	PIN DIN 1444 16H11X162X157 30CRNIMO8	BOLZEN		
46	43 31 028 08	4	RETAINING SPRING 3 VERZ	SICHERUNGSFEDER		
47	43 30 036 08	4	SPLIT PIN DIN 94 3,2X25 ST VERZ	SPLINT		
48	55 31 248 08	4	WASHER DIN 433 17 ST	SCHEIBE		

6.2.2009

etk_en_de_074515 LR 1600/2

☐ 491 (2/2)

LIEBHERRL INTERMEDIATE SECTION
LI-ZWISCHENSTUECK

⇒ 3 227

91 52 873 08

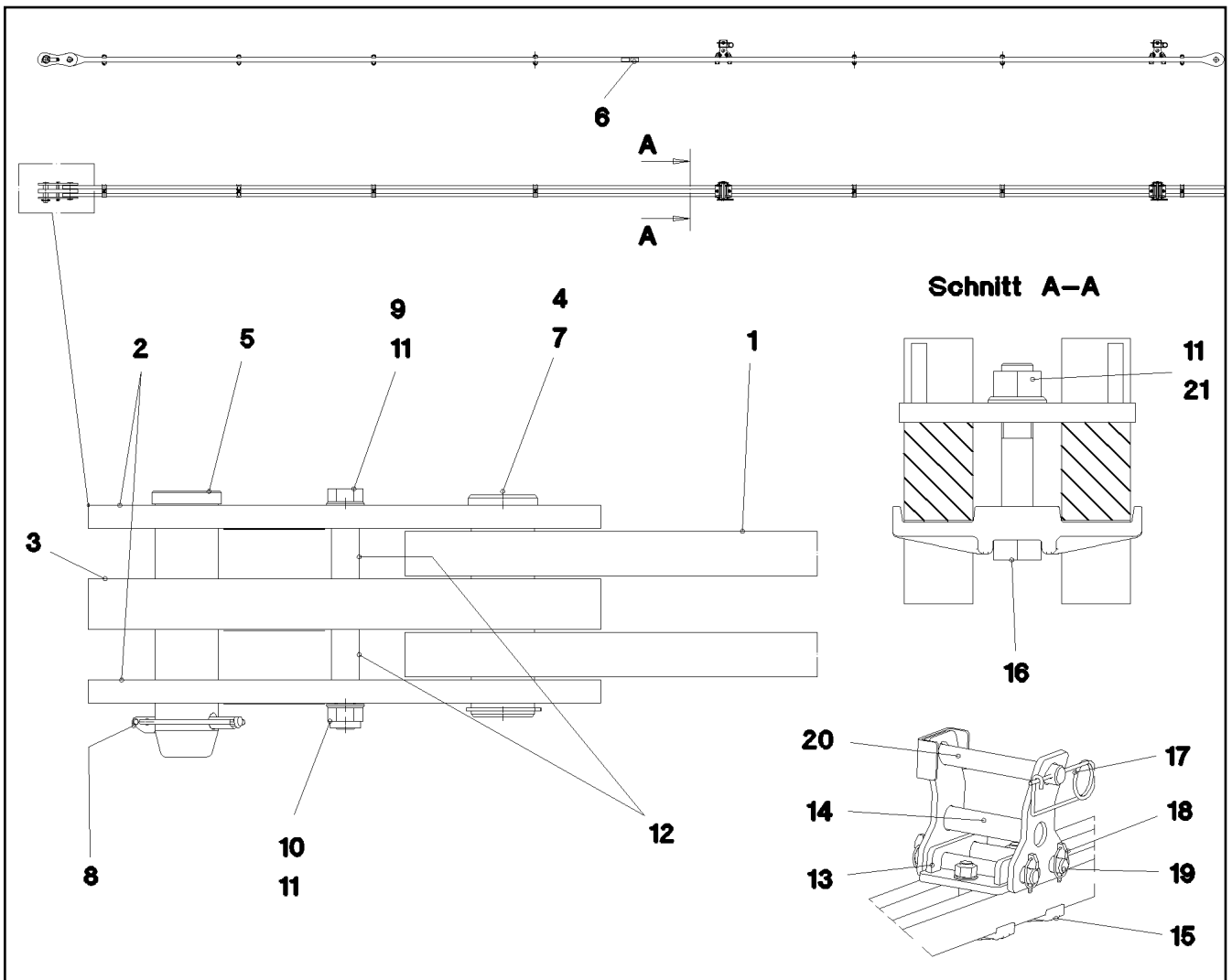

Pos.	Item	Quantity	Description	Bezeichnung	Serie	K
1	96 45 230 08	1	ROD 11.75M	STANGE VORM.		
2	96 45 231 08	2	BRACKET WITH BOARD 0.25 M	LASCHE MIT SCHILD		
3	96 45 232 08	1	BRACKET WITH BOARD 0.25 M	LASCHE MIT SCHILD		
4	97 67 727 08	1	PIN 55.0X175 30CRNIMO8+QT	BOLZEN		
5	95 28 920 08	1	PIN 55.0X210 30CRNIMO8+QT SPF	BOLZEN		
6	97 35 919 08	1	PLATE ASSEMBLY BG-NR. PVC-SILBER SP	SCHILD BAUGRUPPE		
7	42 80 042 08	1	LOCKING RING DIN 471 50X2	SICHERUNGSRING		
8	43 32 005 08	1	SAFETY PLUG W HINGE-LID 11,5X96 VERZ	SICHERHEITSKLAPPSTECKER		
9	40 61 186 01	1	HEX BOLT ISO 4014 M16X180 8.8 A3C	SECHSKANTSCHRAUBE		
10	41 19 009 08	1	HEX NUT DIN 985 M16 8 VERZ	SECHSKANTMUTTER		
11	42 00 019 08	4	WASHER DIN 125 A 17 VERZ	SCHEIBE		
12	93 92 551 08	2	TUBE 22X2,5X40	ROHR		
13	96 50 492 08	2	BRACKET WELDED CONST. FE//ZN20//C	KONSOLE SCHWK.		
14	96 50 494 08	2	REST WELDED FE//ZN20//C	ABLAGE SCHWK.		
15	38 00 707 08	2	CLAMP G21MN5V SPF	KLAMMER		
16	40 62 044 08	4	HEX BOLT ISO 4014 M16X90 10.9 FLZN SPF	SECHSKANTSCHRAUBE		
17	43 31 009 08	2	RETAINING SPRING 4,5 VERZ	SICHERUNGSFEDER		
18	43 32 013 08	8	SAFETY PLUG W HINGE-LID 5X32 VERZ	SICHERHEITSKLAPPSTECKER		
19	45 00 239 08	4	PIN DIN 1433 20X175X160 ST.50K FE//ZN20//	BOLZEN		
20	96 43 771 08	2	CONNECTING PIN WELDED	ABSTECKBOLZEN SCHWK.		
21	41 15 050 08	4	HEX NUT DIN 934 M16 10 VERZ	SECHSKANTMUTTER		

6.2.2009
052933

LIEBHERR

etk_en_de_074515 LR 1600/2

ROD CPL.
STANGE KPL.

492

⇒ 3 227 002
96 50 498 08

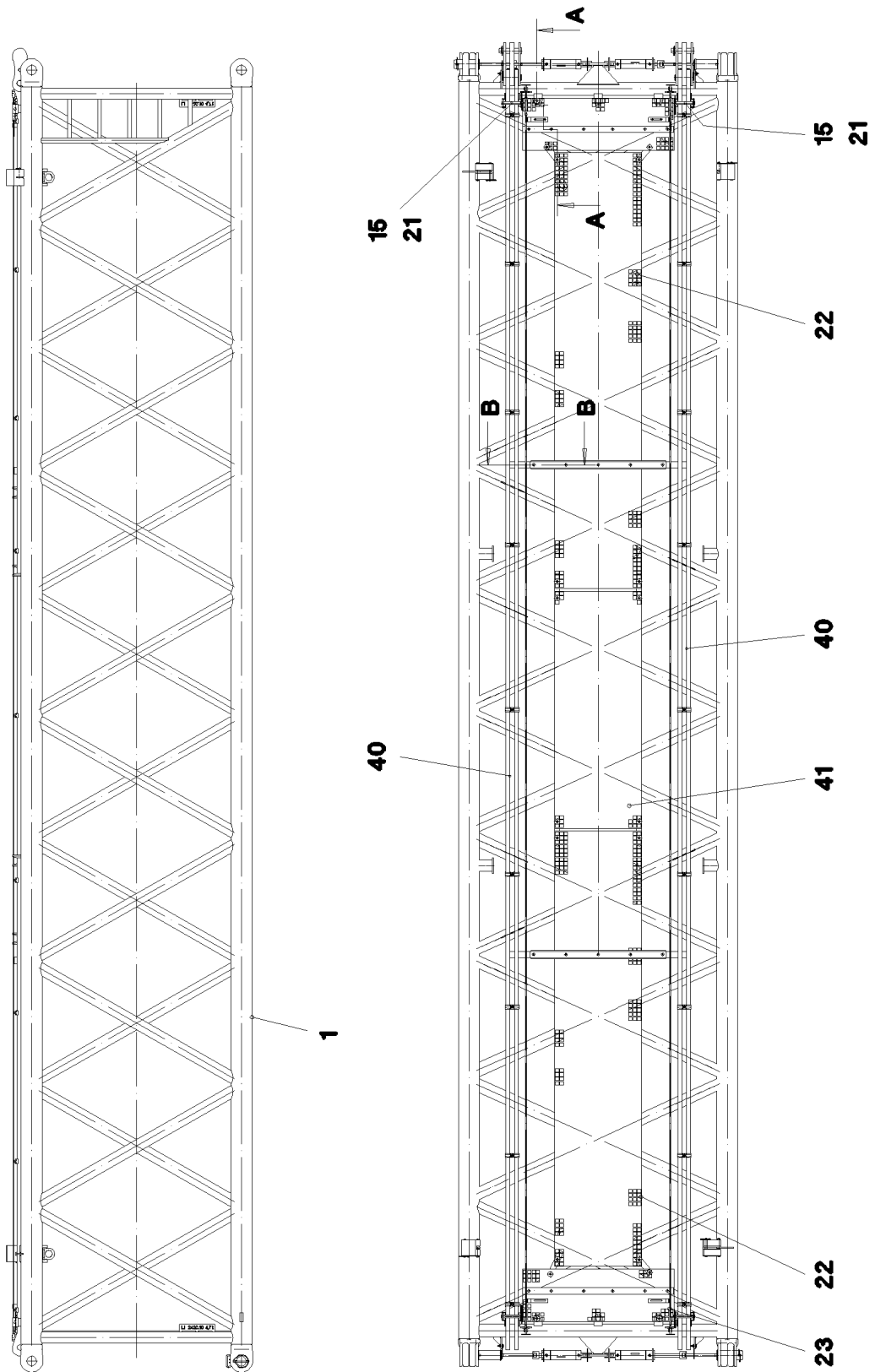

6.2.2009
055303

LIEBHERR

etk_en_de_074515 LR 1600/2

L INTERMEDIATE SECTION
LI-ZWISCHENSTUECK

493 (1/3)

→ 3 227 008
91 52 872 08

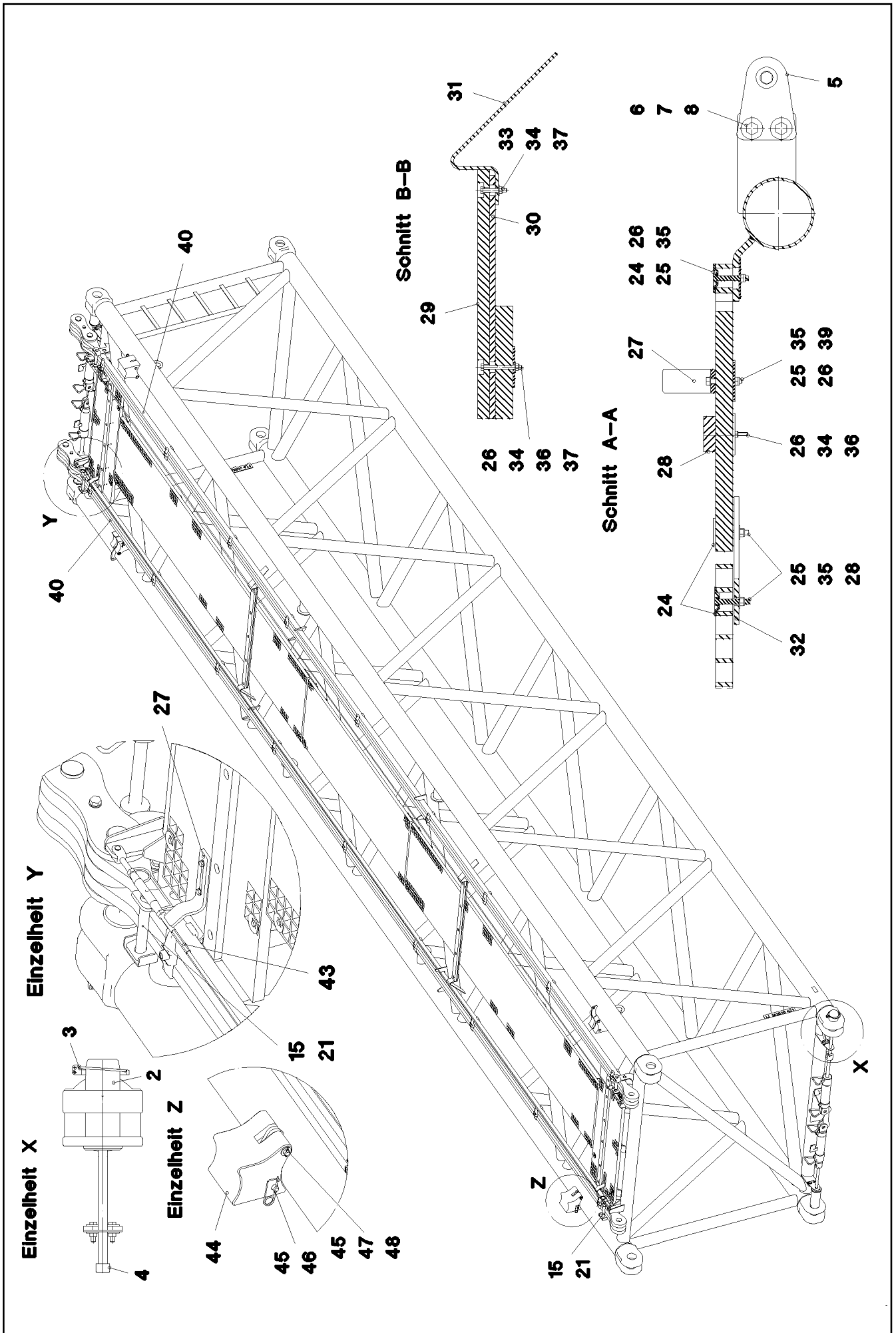

6.2.2009
055304

LIEBHERR

etk_en_de_074515 LR 1600/2

L INTERMEDIATE SECTION
LI-ZWISCHENSTUECK

□ 494 (2/3)

⇒ 3 227 008
91 52 872 08

Pos.	Item	Quantity	Description	Bezeichnung	Serie	K
1	96 44 853 08	1	LI INTERMEDIATE SECT.WELD.CONS 2420.1	LI-ZWISCHENSTUECK SCHWK.		
2	97 68 649 08	4	PIN 100.0X237 35NICRMOV125 SPF	BOLZEN		
3	43 32 015 08	4	SAFETY PLUG W HINGE-LID 17X125 VERZ	SICHERHEITSKLAPPSTECKER		
4	46 30 212	4	CYLINDER SCREW ISO 4762 M24X340 10.9	ZYLINDERSCHRAUBE		
5	95 50 518 08	4	PLATE 5X104X140	BLECH		
6	46 00 158	8	HEX BOLT ISO 4017 M12X45 8.8 A3C	SECHSKANTSCHRAUBE		
7	42 18 011 08	16	WASHER ISO 7093-1 A 13 ST A3C	SCHEIBE		
8	41 15 143 08	8	HEX NUT DIN 934 M12 8 VERZ	SECHSKANTMUTTER		
15	96 43 771 08	8	CONNECTING PIN WELDED	ABSTECKBOLZEN SCHWK.		
21	43 31 009 08	4	RETAINING SPRING 4,5 VERZ	SICHERUNGSFEDER		
22	97 71 763 08	2	GRATING 4047X807X30 GFK SPF	GITTERROST		
23	97 66 610 08	2	GRATING 1407X487X30 GFK SPF	GITTERROST		
24	10 10 062 1	32	DISH MOUNTING	TELLERBEFESTIGUNG		
25	40 61 024	40	HEX BOLT ISO 4014 M8X55 8.8 A2C	SECHSKANTSCHRAUBE		
26	94 11 381 08	49	WASHER 70X3	SCHEIBE		
27	97 73 817 08	4	PLATE 8X40X246	BLECH		
28	97 66 612 08	2	SUPPORT PLATE 1400X60 PA6G	AUFLAGE		
29	97 41 439 08	2	SUPPORT PLATE 60X1270 PA6G	AUFLAGE		
30	97 41 440 08	2	PLATE 10X1250X80	BLECH		
31	95 64 428 08	4	PLATE 5X393X60 S380MC	BLECH		
32	95 54 048 08	5	PLATE 8X300X50	BLECH		
33	40 01 928	4	HEX BOLT ISO 4014 M6X40 8.8 A2C	SECHSKANTSCHRAUBE		
34	41 19 004 08	22	HEX NUT DIN 985 M6 8 VERZ	SECHSKANTMUTTER		
35	41 19 005 08	31	HEX NUT DIN 985 M8 8 VERZ	SECHSKANTMUTTER		
36	46 00 356	18	HEX BOLT ISO 4014 M6X65 8.8 A2C	SECHSKANTSCHRAUBE		
37	42 18 007 08	22	WASHER DIN 9021 A 6.4 VERZ	SCHEIBE		
38	42 18 009 08	16	WASHER DIN 9021 A 8.4 VERZ	SCHEIBE		
39	42 00 012 08	8	WASHER DIN 125 A8X16 ST VERZ	SCHEIBE		
40	96 45 222 08	2	ROD CPL. 12 M	STANGE KPL.		
			⇒ 3 561 003 96 45 222 08			
41	97 71 971 08	1	GRATING 2207X807X30 GFK SPF	GITTERROST		
43	10 65 244 0	2	ROUND STRAND ROPE 10MM 11,54M EDEL	RUNDLITZENSEIL		
44	97 76 196 08	4	BEARING BLOCK PA6G	LAGERKLOTZ		
45	45 30 083 08	8	PIN DIN 1444 16H11X162X157 30CRNIMO8	BOLZEN		
46	43 31 028 08	4	RETAINING SPRING 3 VERZ	SICHERUNGSFEDER		
47	43 30 036 08	4	SPLIT PIN DIN 94 3,2X25 ST VERZ	SPLINT		
48	55 31 248 08	4	WASHER DIN 433 17 ST	SCHEIBE		

6.2.2009

etk_en_de_074515 LR 1600/2

 495 (3/3)
LIEBHERR
 L INTERMEDIATE SECTION
 LI-ZWISCHENSTUECK

 ⇒ 3 227 008
 91 52 872 08

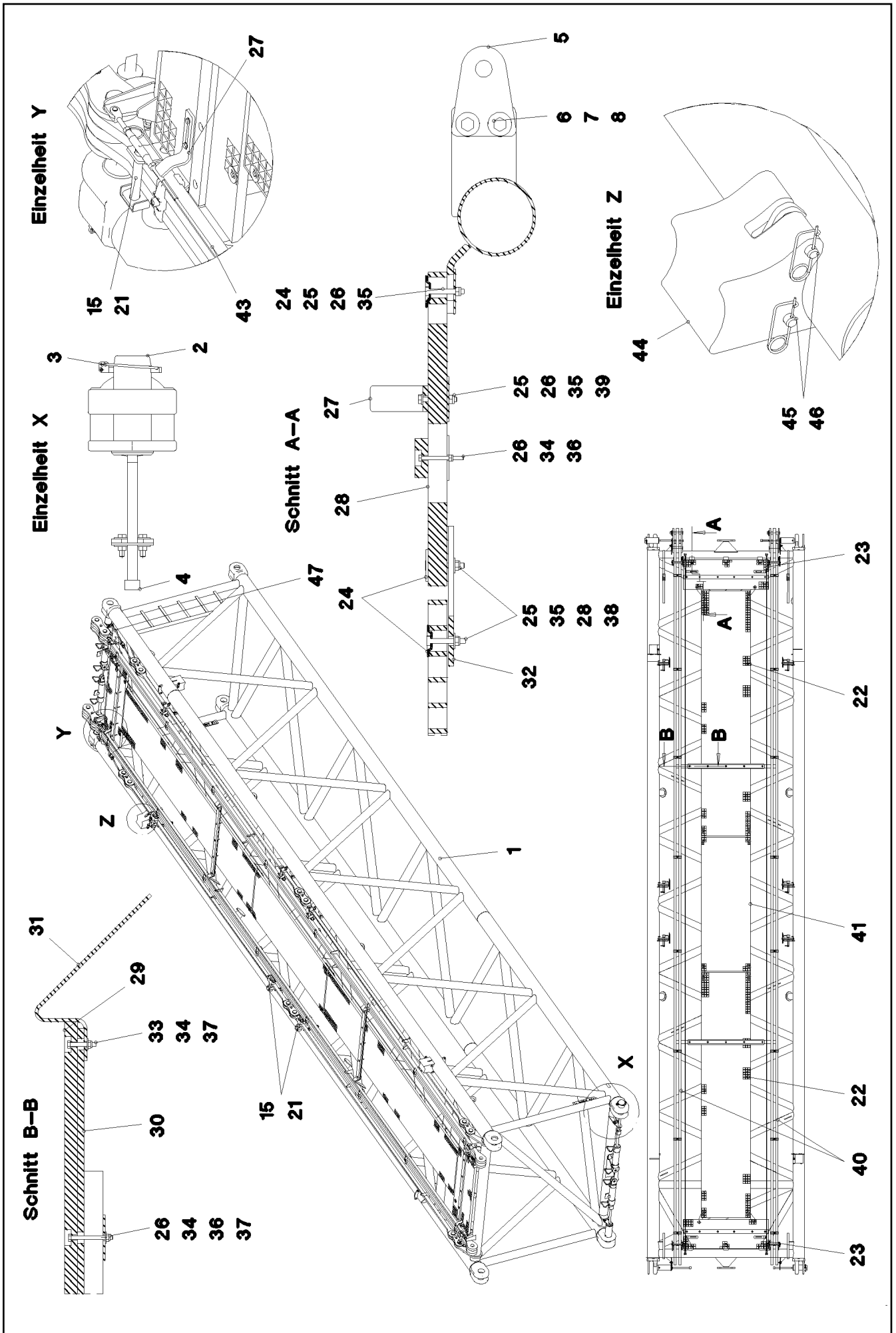

6.2.2009
052915

LIEBHERR

etk_en_de_074515 LR 1600/2

LI INTERMEDIATE SECT. F-GUYING
LI-ZWISCHENSTUECK F-ABSPANNUNG

496 (1/2)

→ 3 227 200
91 53 519 08

Pos.	Item	Quantity	Description	Bezeichnung	Serie	K
1	96 46 324 08	1	LI INTERMEDIATE SECT.WELD.CONS 12 M 2	LI-ZWISCHENSTUECK SCHWK.		
2	97 68 649 08	4	PIN 100.0X237 35NICRMOV125 SPF	BOLZEN		
3	43 32 015 08	4	SAFETY PLUG W HINGE-LID 17X125 VERZ	SICHERHEITSKLAPPSTECKER		
4	46 30 212	4	CYLINDER SCREW ISO 4762 M24X340 10.9	ZYLINDERSCHRAUBE		
5	95 50 518 08	4	PLATE 5X104X140	BLECH		
6	46 00 158	8	HEX BOLT ISO 4017 M12X45 8.8 A3C	SECHSKANTSCHRAUBE		
7	42 18 011 08	16	WASHER ISO 7093-1 A 13 ST A3C	SCHEIBE		
8	41 15 143 08	8	HEX NUT DIN 934 M12 8 VERZ	SECHSKANTMUTTER		
15	96 43 771 08	10	CONNECTING PIN WELDED	ABSTECKBOLZEN SCHWK.		
21	43 31 009 08	10	RETAINING SPRING 4,5 VERZ	SICHERUNGSFEDER		
22	97 71 763 08	2	GRATING 4047X807X30 GFK SPF	GITTERROST		
23	97 66 610 08	2	GRATING 1407X487X30 GFK SPF	GITTERROST		
24	10 10 062 1	41	DISH MOUNTING	TELLERBEFESTIGUNG		
25	40 61 024	49	HEX BOLT ISO 4014 M8X55 8.8 A2C	SECHSKANTSCHRAUBE		
26	94 11 381 08	49	WASHER 70X3	SCHEIBE		
27	97 73 817 08	4	PLATE 8X40X246	BLECH		
28	97 66 612 08	2	SUPPORT PLATE 1400X60 PA6G	AUFLAGE		
29	97 41 439 08	2	SUPPORT PLATE 60X1270 PA6G	AUFLAGE		
30	97 41 440 08	2	PLATE 10X1250X80	BLECH		
31	95 64 428 08	4	PLATE 5X393X60 S380MC	BLECH		
32	95 54 048 08	8	PLATE 8X300X50	BLECH		
33	40 01 928	4	HEX BOLT ISO 4014 M6X40 8.8 A2C	SECHSKANTSCHRAUBE		
34	41 19 004 08	22	HEX NUT DIN 985 M6 8 VERZ	SECHSKANTMUTTER		
35	41 19 005 08	49	HEX NUT DIN 985 M8 8 VERZ	SECHSKANTMUTTER		
36	46 00 356	18	HEX BOLT ISO 4014 M6X65 8.8 A2C	SECHSKANTSCHRAUBE		
37	42 18 007 08	22	WASHER DIN 9021 A 6.4 VERZ	SCHEIBE		
38	42 18 009 08	10	WASHER DIN 9021 A 8.4 VERZ	SCHEIBE		
39	42 00 012 08	8	WASHER DIN 125 A8X16 ST VERZ	SCHEIBE		
40	96 45 222 08	2	ROD CPL. 12 M	STANGE KPL.		
			⇒ 3 561 003 96 45 222 08			
41	97 71 971 08	1	GRATING 2207X807X30 GFK SPF	GITTERROST		
43	10 65 244 0	2	ROUND STRAND ROPE 10MM 11,54M EDEL	RUNDLITZENSEIL		
44	97 76 196 08	4	BEARING BLOCK PA6G	LAGERKLOTZ		
45	45 30 083 08	8	PIN DIN 1444 16H11X162X157 30CRNIMO8	BOLZEN		
46	43 31 028 08	8	RETAINING SPRING 3 VERZ	SICHERUNGSFEDER		
47	77 90 362 08	2	LASHING STRAP L=5M POLYTEX	ZURRGURT		

6.2.2009

etk_en_de_074515 LR 1600/2

 497 (2/2)
LIEBHERR
 LI INTERMEDIATE SECT. F-GUYING
 LI-ZWISCHENSTUECK F-ABSPANNUNG

 ⇒ 3 227 200
 91 53 519 08

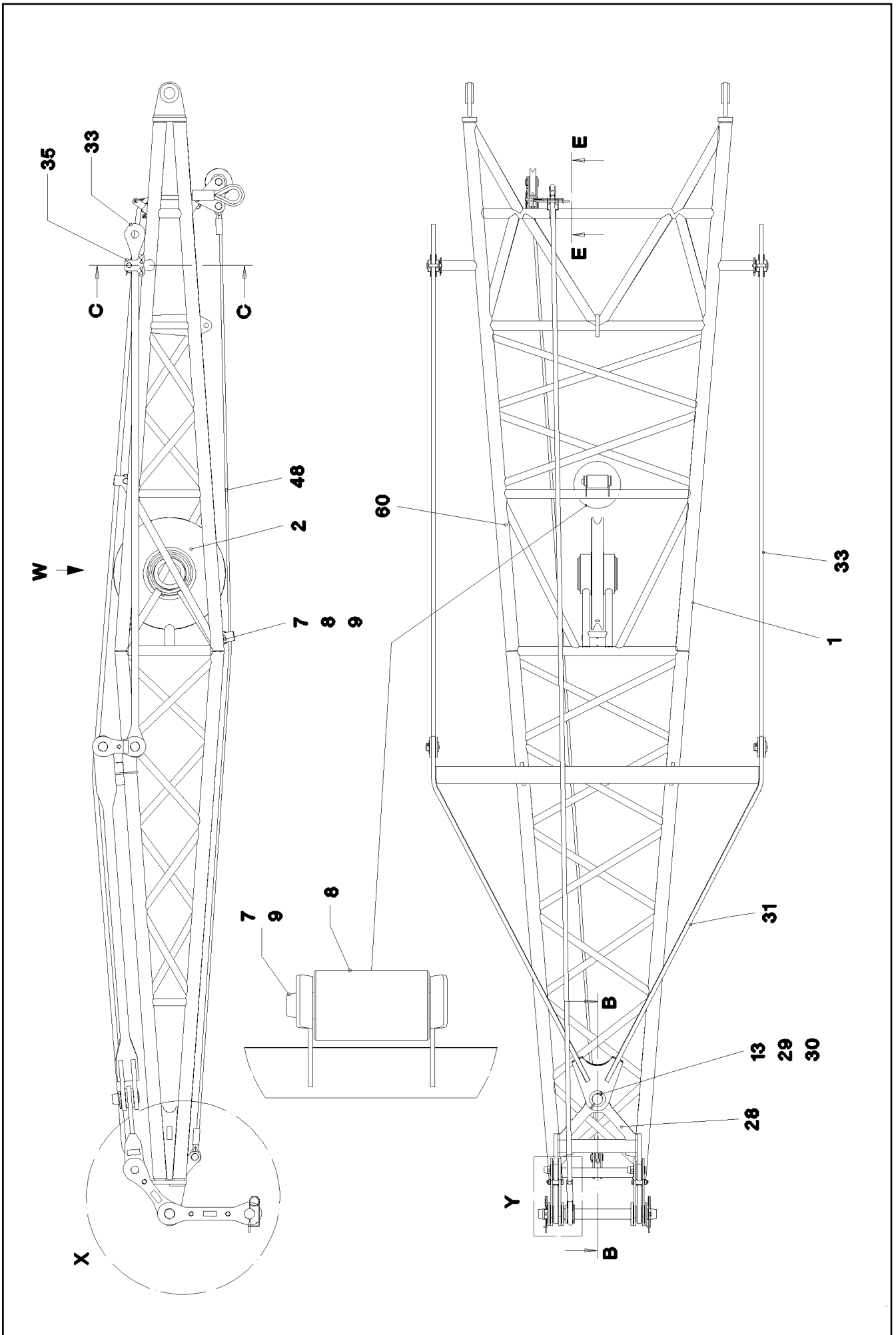

6.2.2009
052773

LIEBHERR

etk_en_de_074515 LR 1600/2

ERECTION FRAME
FA-BOCK

□ 498 (1/5)

⇒ 3 281
91 52 896 08

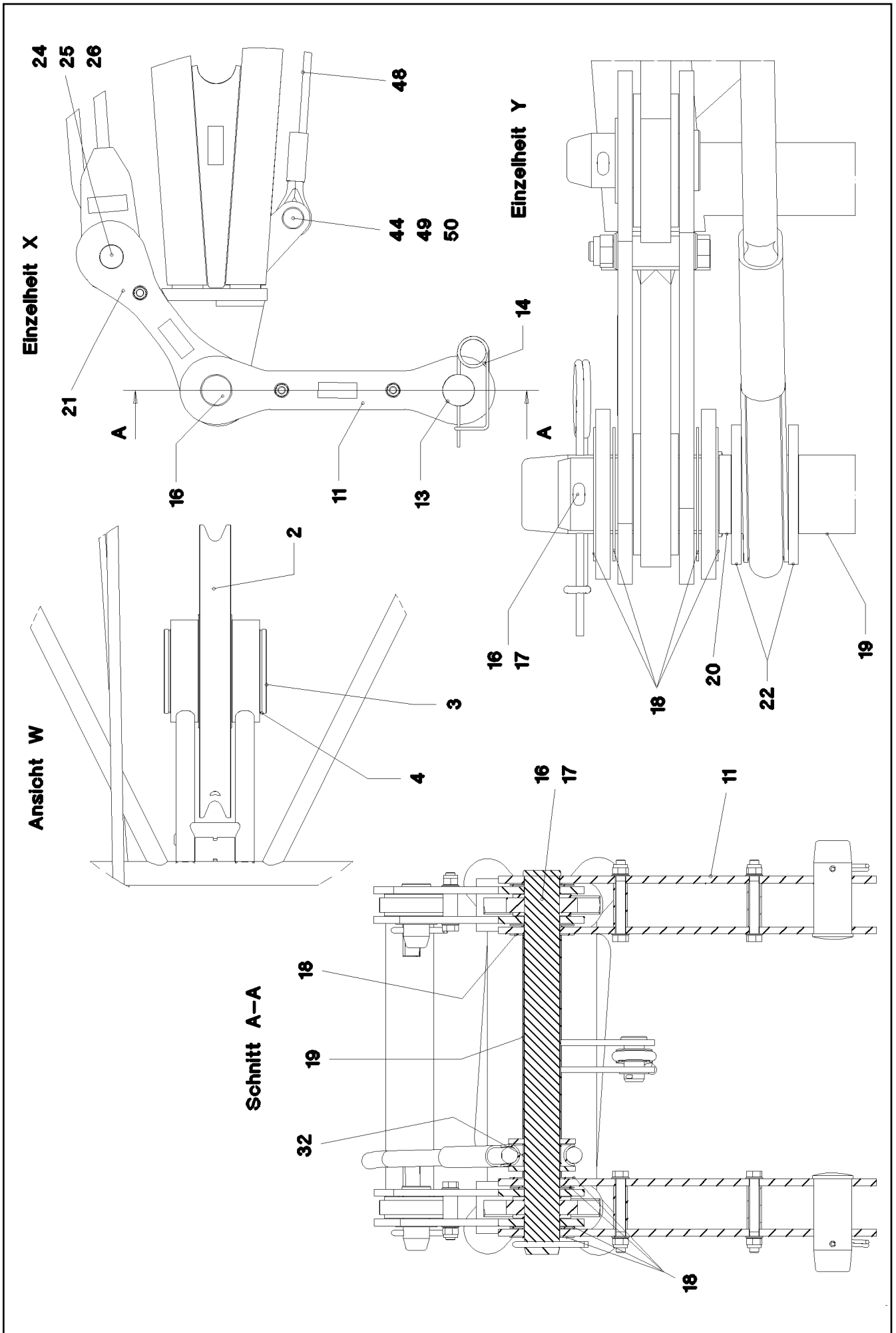

6.2.2009
052774

LIEBHERR

etk_en_de_074515 LR 1600/2

ERECTION FRAME
FA-BOCK

□ 499 (2/5)

→ 3 281
91 52 896 08

Schnitt D-D

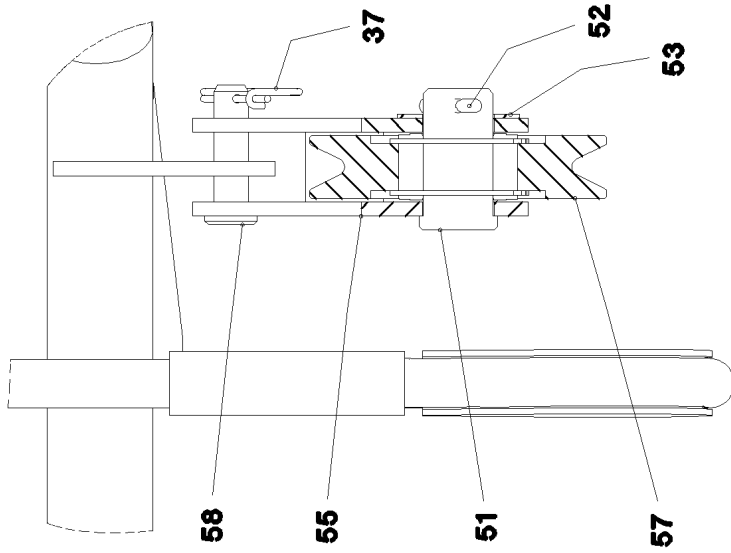

Schnitt E-E

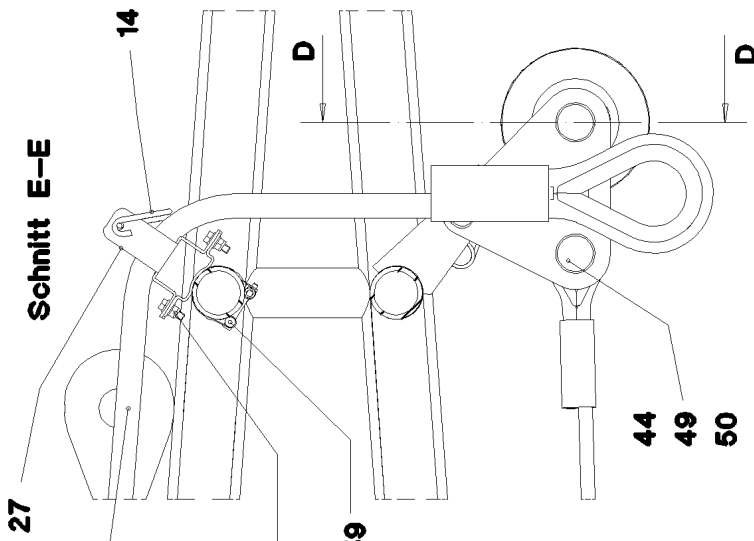

Schnitt C-C

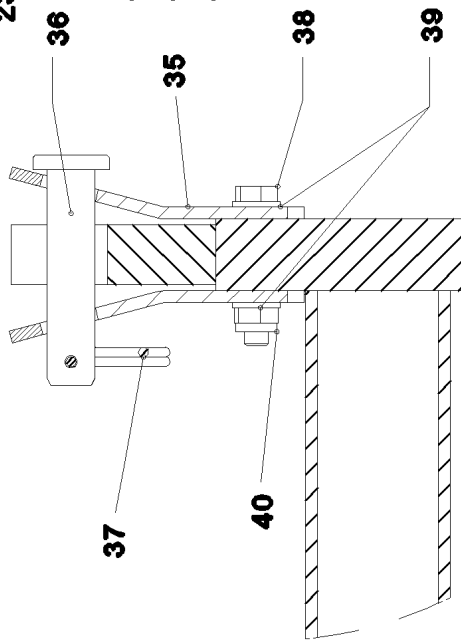

Schnitt B-B

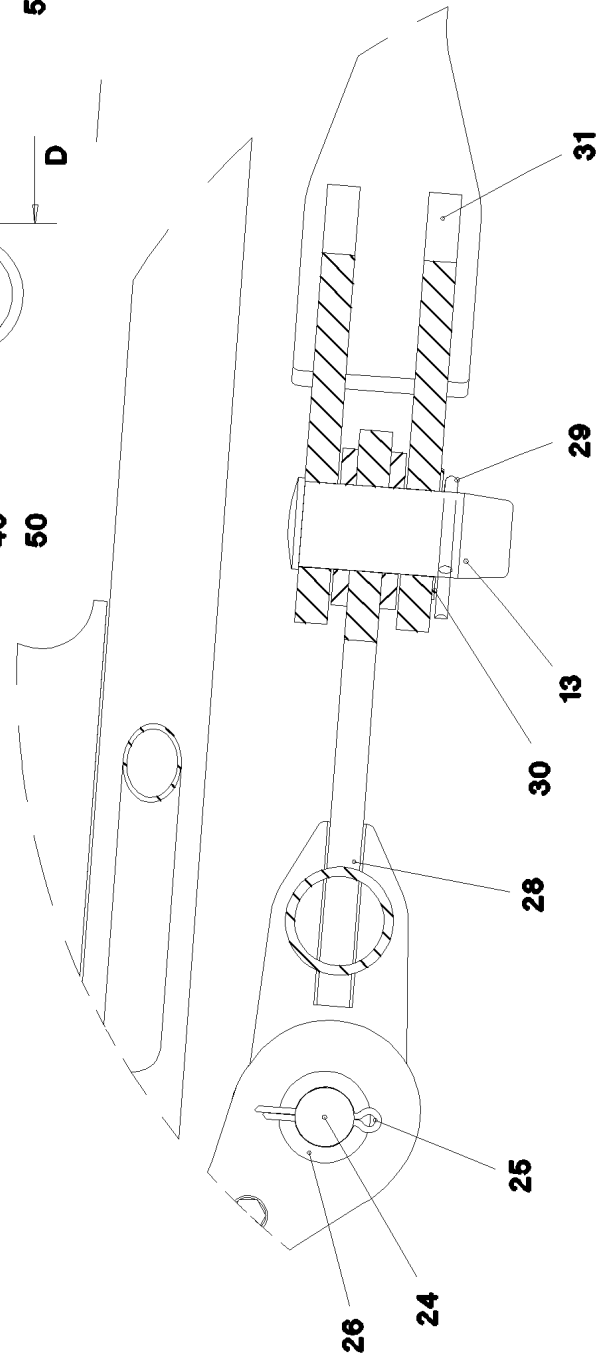

6.2.2009
056119

LIEBHERR

etk_en_de_074515 LR 1600/2

ERECTION FRAME
FA-BOCK

□ 500 (3/5)

→ 3 281
91 52 896 08

Pos.	Item	Quantity	Description	Bezeichnung	Serie	K
1	96 46 996 08	1	FA FRAME WELDMENT	FA-BOCK SCHWK.		
2	92 68 928 08	1	ROPE PULLEY CPL. SPF ⇒ 2 652 007 92 68 928 08	SEILROLLE KPL.		
3	95 66 984 08	1	AXLE 219,1X40X245 SPF	ACHSE		
4	42 80 093 08	2	LOCKING RING DIN 471 200X4	SICHERUNGSRING		
7	97 04 625 08	2	PIN 35x178	BOLZEN		
8	97 71 335 08	2	RUNNING ROLLER PA6G	LAUFROLLE		
9	43 30 077 08	2	SPLIT PIN DIN 94 6,3X45 ST VERZ	SPLINT		
11	96 48 024 08	2	BRACKET COMPL.	LASCHE KPL.		
(1)	96 47 237 08	2	BRACKET WITH BOARD 350	LASCHE MIT SCHILD		
(2)	97 71 883 08	2	SPACER SLEEVE 25.0X75	DISTANZHUELSE		
(3)	40 61 179 01	2	HEX BOLT ISO 4014 M16X130 8.8 A3C	SECHSKANTSCHRAUBE		
(4)	42 00 019 08	4	WASHER DIN 125 A 17 VERZ	SCHEIBE		
(5)	41 19 009 08	2	HEX NUT DIN 985 M16 8 VERZ	SECHSKANTMUTTER		
(6)	97 35 919 08	1	PLATE ASSEMBLY BG-NR. PVC-SILBER SP	SCHILD BAUGRUPPE		
13	97 20 177 08	3	PIN 70.0X170	BOLZEN		
14	43 31 050 08	3	RETAINING SPRING 6 A3C	SICHERUNGSFEDER		
16	97 93 900 08	1	PIN 65.0X660 SPF	BOLZEN		
17	43 30 106 08	1	SPLIT PIN DIN 94 10X100 ST VERZ	SPLINT		
18	94 59 385 08	7	WASHER 2X110X110 DC01-A-M	SCHEIBE		
19	97 93 901 08	1	TUBE 65.0X350	ROHR		
20	97 93 902 08	1	TUBE 65.0X10	ROHR		
21	96 48 027 08	2	BRACKET COMPL.	LASCHE KPL.		
(1)	96 47 239 08	2	BRACKET WITH BOARD 350	LASCHE MIT SCHILD		
(2)	97 71 884 08	1	SPACER SLEEVE 25.0X39	DISTANZHUELSE		
(3)	46 00 332	1	HEX BOLT ISO 4014 M16X90 8.8 A3C	SECHSKANTSCHRAUBE		
(4)	42 00 019 08	2	WASHER DIN 125 A 17 VERZ	SCHEIBE		
(5)	41 19 009 08	1	HEX NUT DIN 985 M16 8 VERZ	SECHSKANTMUTTER		
(6)	97 35 919 08	1	PLATE ASSEMBLY BG-NR. PVC-SILBER SP	SCHILD BAUGRUPPE		
22	97 93 903 08	2	PLATE 8X115X115 FE//Zn20//C	BLECH		
23	97 93 904 08	1	ROPE 28X7000	SEIL		
24	97 72 671 08	2	PIN 50.0X110 SPF	BOLZEN		
25	43 30 101 08	2	SPLIT PIN DIN 94 10X71 ST VERZ	SPLINT		
26	94 90 229 08	2	PLATE RD70X2	BLECH		
27	97 93 905 08	1	PLATE 3X220X176	BLECH		
28	96 47 240 08	1	ROCKER WELDED	SCHWINGE SCHWK.		
29	43 30 105 08	1	SPLIT PIN DIN 94 10X90 ST VERZ	SPLINT		
30	94 33 992 08	1	WASHER 100X2	SCHEIBE		
31	96 47 241 08	1	ROCKER WELDED	SCHWINGE SCHWK.		
32	97 94 005 08	1	TUBE 65.0X39	ROHR		
33	96 45 288 08	2	ROD CPL. 3.2M	STANGE KPL.		
(1)	96 45 289 08	1	ROD WITH BOARD 3200	STANGE MIT SCHILD		
(2)	96 45 290 08	2	BRACKET WITH BOARD 200	LASCHE MIT SCHILD		
(3)	97 71 899 08	1	SPACER SLEEVE 21.3X27	DISTANZHUELSE		
(4)	46 00 245	1	HEX BOLT ISO 4014 M12X75 8.8 A3C	SECHSKANTSCHRAUBE		
(5)	42 00 016 08	2	WASHER ISO 7089 A 13 ST A3C	SCHEIBE		
(6)	41 19 007 08	1	HEX NUT DIN 985 M12 8 A3C	SECHSKANTMUTTER		
(7)	45 30 328 08	2	PIN DIN 1444 45H11X72X60 35NICRMOV125	BOLZEN		
(8)	43 30 101 08	2	SPLIT PIN DIN 94 10X71 ST VERZ	SPLINT		
(9)	94 90 229 08	2	PLATE RD70X2	BLECH		
(11)	97 35 919 08	1	PLATE ASSEMBLY BG-NR. PVC-SILBER SP	SCHILD BAUGRUPPE		
35	97 17 862 08	4	PLATE 5X140X180	BLECH		
36	45 14 220 08	2	PIN DIN 1436 20H11X90X80 ST.50-2K VERZ	BOLZEN		
37	43 31 012 08	3	RETAINING SPRING 4X68 VERZ	SICHERUNGSFEDER		
38	49 01 053	4	HEX BOLT ISO 4014 M10X60 8.8 A3C	SECHSKANTSCHRAUBE		
39	42 00 013 08	8	WASHER ISO 7089 A 10.5 A3C	SCHEIBE		
40	41 19 006 08	4	HEX NUT DIN 985 M10 8 VERZ	SECHSKANTMUTTER		
44	95 51 616 08	2	WASHER RD50X2	SCHEIBE		
48	10 43 004 8	1	SLING ROPE EN 13414 2,7T-6M VERZINKT	ANSCHLAGSEIL		
49	93 59 891 08	2	PIN RD35X72	BOLZEN		

6.2.2009

etk_en_de_074515 LR 1600/2

□ 501 (4/5)

LIEBHERRERECTION FRAME
FA-BOCK⇒ 3 281
91 52 896 08

Pos.	Item	Quantity	Description	Bezeichnung	Serie	K
50	43 30 078 08	2	SPLIT PIN DIN 94 6,3X50 ST VERZ	SPLINT		
51	95 60 974 08	1	PIN RD40X75 30CRNIMO8+QT	BOLZEN		
52	43 30 090 08	1	SPLIT PIN DIN 94 8X63 ST VERZ	SPLINT		
53	94 91 885 08	1	WASHER RD70X2	SCHEIBE		
55	96 52 291 08	1	ROPE PULLEY ATTACHM. WELDM.	SEILROLLENHALTERUNG SCH		
57	96 20 920 08	1	ROPE PULLEY CPL. ⇒ 3 206 001 96 20 920 08	SEILROLLE KPL.		
58	45 12 225 08	1	PIN DIN 1435 20H11X75X66 ST.50	BOLZEN		
59	77 42 844 08	1	RETAINER CLIP 59-62 ST	SPANNSCHELLE		
60	49 00 128	2	HEX BOLT ISO 4017 M8X25 8.8 A2C	SECHSKANTSCHRAUBE		
61	42 00 012 08	4	WASHER DIN 125 A8X16 ST VERZ	SCHEIBE		
62	41 19 005 08	2	HEX NUT DIN 985 M8 8 VERZ	SECHSKANTMUTTER		

6.2.2009

etk_en_de_074515 LR 1600/2

502 (5/5)

LIEBHERR

ERECTION FRAME
FA-BOCK

⇒ 3 281
91 52 896 08

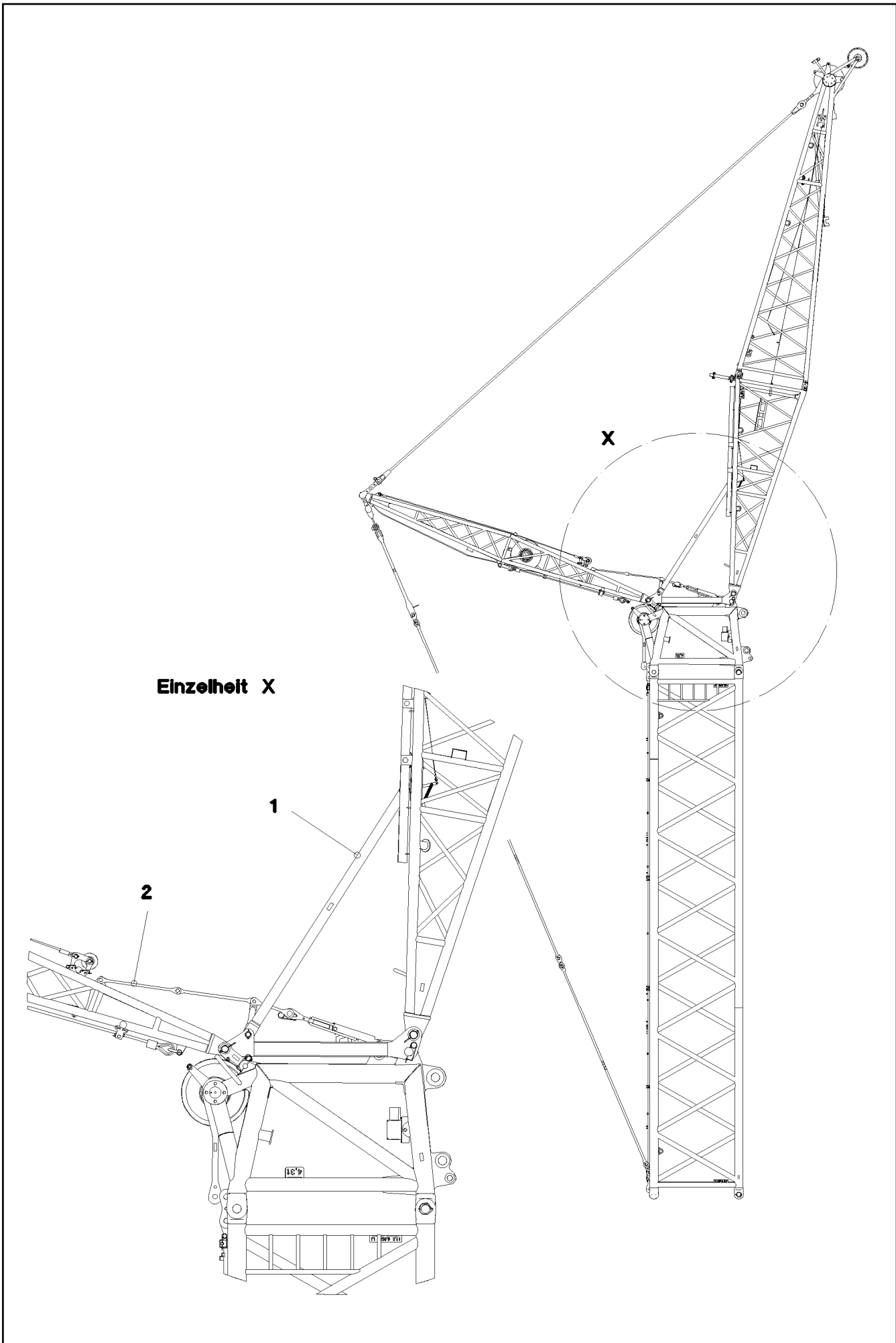

Einzelheit X

6.2.2009
052775

LIEBHERR

etk_en_de_074515 LR 1600/2

**OVERRUN PROTECTION
F-RUECKHALTESICHERUNG**

503 (1/2)

⇒ 3 282
91 52 897 08

Pos.	Item	Quantity	Description	Bezeichnung	Serie	K
1	96 47 888 08	1	F-STAY COMPL. ⇒ 3 282 001 96 47 888 08	F-STUETZE KPL.		
2	96 47 890 08	1	FAB-STAY ⇒ 3 282 002 96 47 890 08	FAB-STUETZE		

6.2.2009	etk_en_de_074515 LR 1600/2	504 (2/2)
LIEBHERR	OVERRUN PROTECTION F-RUECKHALTESICHERUNG	⇒ 3 282 91 52 897 08

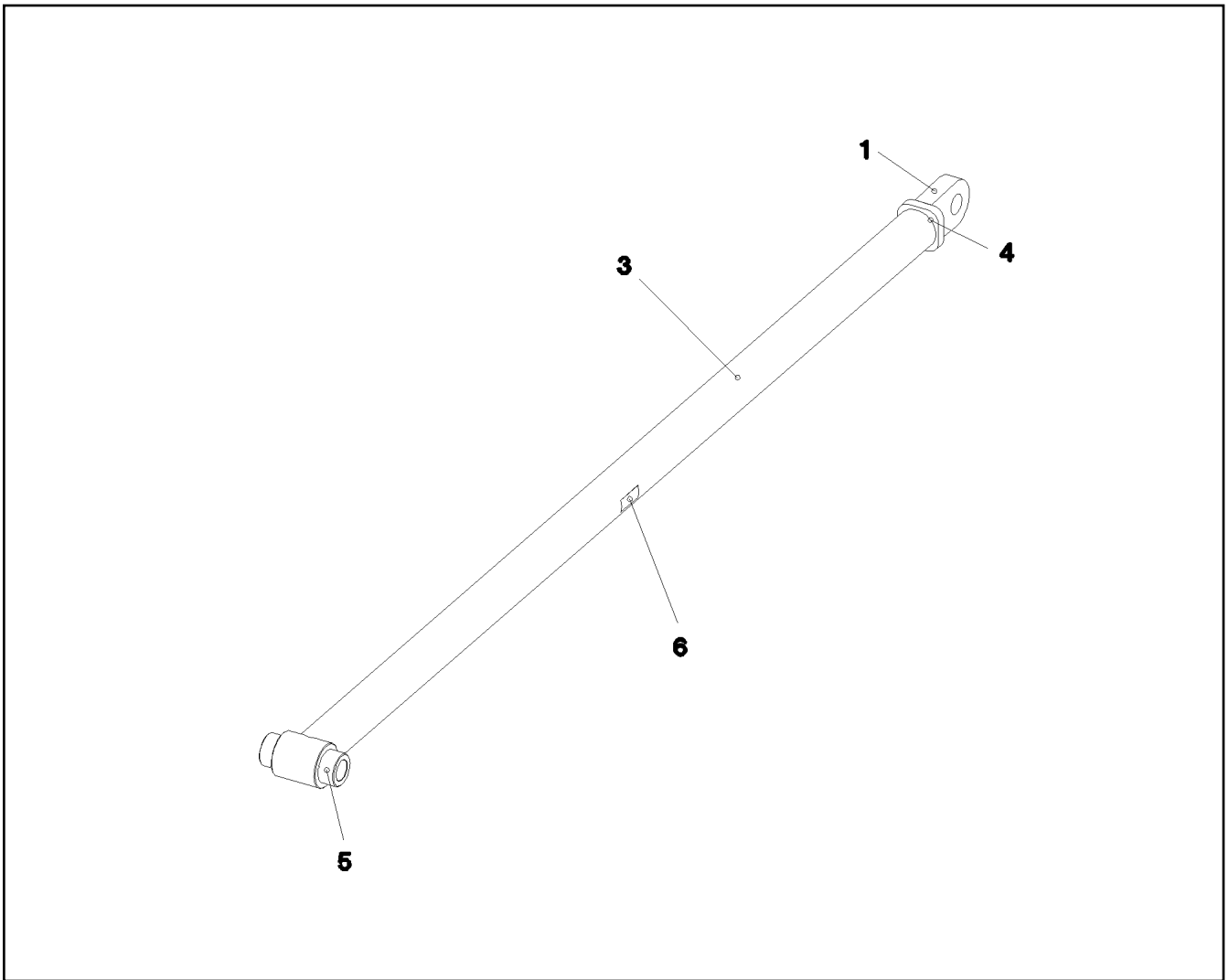

Pos.	Item	Quantity	Description	Bezeichnung	Serie	K
1	96 49 669 08	1	BEARING WELDED	LAGER SCHWK.		
3	97 73 249 08	1	TUBE 101.6X2799	ROHR		
4	93 87 145 08	1	RING RD84X23	RING		
5	97 73 250 08	1	BEARING STUB SHAFT 110.0X200	LAGERZAPFEN		
6	97 35 676 08	1	PLATE IDENTIFICATION NUMBER IDENT-N	SCHILD IDENTNR.		

6.2.2009
052776

LIEBHERR

etk_en_de_074515 LR 1600/2

F-STAY COMPL.
F-STUETZE KPL.

505

⇒ 3 282 001
96 47 888 08

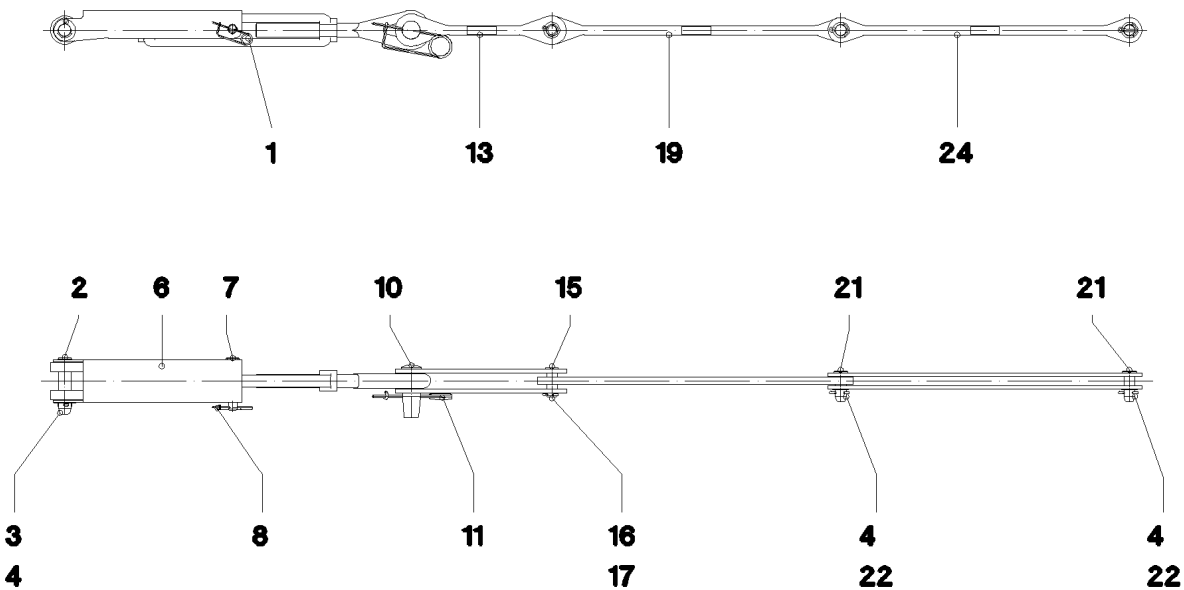

Pos.	Item	Quantity	Description	Bezeichnung	Serie	K
1	10 42 540 8	1	TURNBUCKLE VERZ	SPANNSCHLOSS		
2	97 73 264 08	1	PIN 45.0X155 SPF	BOLZEN		
3	94 87 177 08	1	WASHER RD60X2	SCHEIBE		
4	43 30 088 08	3	SPLIT PIN DIN 94 8X50 ST VERZ	SPLINT		
6	97 73 267 08	1	LOCKING PLATE 5X522X269	SICHERUNGSBLECH		
7	10 02 966 6	1	PIN ISO 2341 B24H11X140X131 30CRNIMO8	BOLZEN		
8	43 31 012 08	1	RETAINING SPRING 4X68 VERZ	SICHERUNGSFEDER		
10	95 36 201 08	1	PIN RD50X135 30CRNIMO8+QT	BOLZEN		
11	43 31 050 08	1	RETAINING SPRING 6 A3C	SICHERUNGSFEDER		
13	96 47 889 08	2	BRACKET WITH BOARD 390	LASCHE MIT SCHILD		
15	94 28 899 08	1	PIN 35.0X82	BOLZEN		
16	43 30 077 08	1	SPLIT PIN DIN 94 6,3X45 ST VERZ	SPLINT		
17	42 20 015 08	1	SHIM RING DIN 988 32X45X1	PASSSCHEIBE		
19	96 47 989 08	1	ROD WITH BOARD 800	STANGE MIT SCHILD		
21	97 73 270 08	2	PIN 35.0X85 SPF	BOLZEN		
22	42 00 028 08	2	WASHER ISO 7089 A 31 A3C	SCHEIBE		
24	96 47 990 08	2	ROD WITH BOARD 800	STANGE MIT SCHILD		

6.2.2009
052777

LIEBHERR

etk_en_de_074515 LR 1600/2

FAB-STAY
FAB-STUETZE

506

⇒ 3 282 002
96 47 890 08

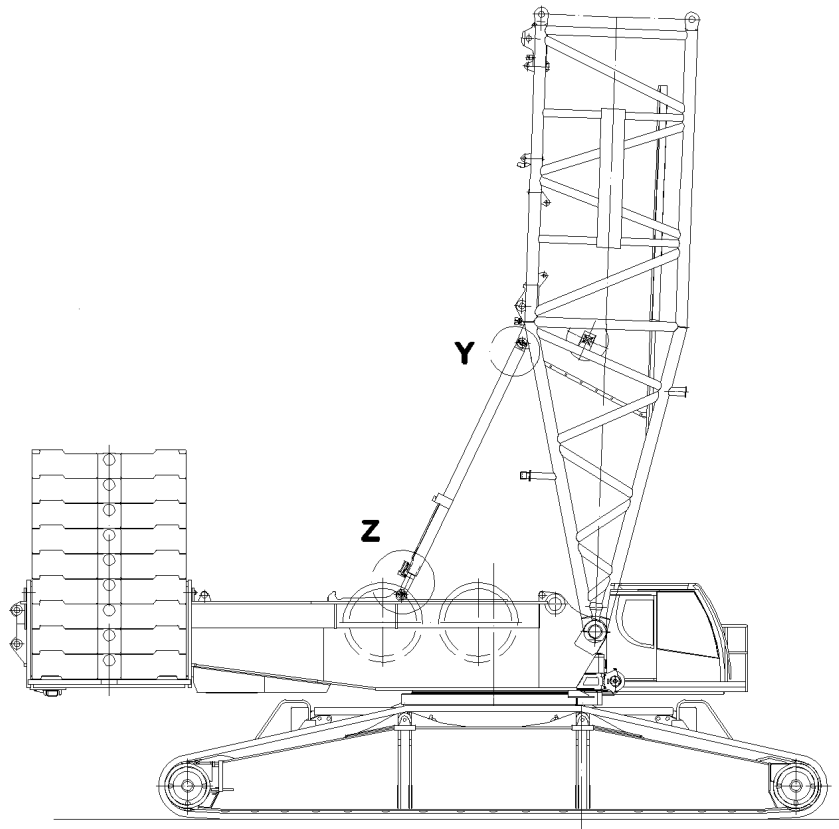

Einzelheit Y

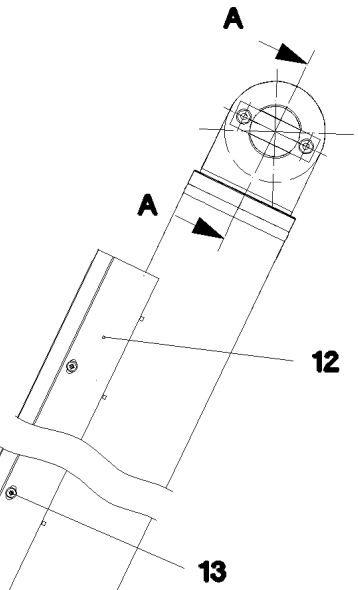

Schnitt A-A

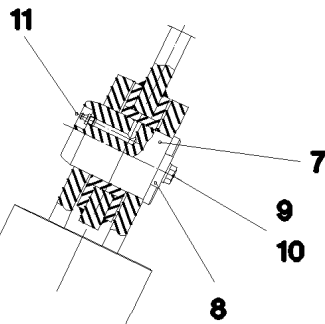

Einzelheit Z

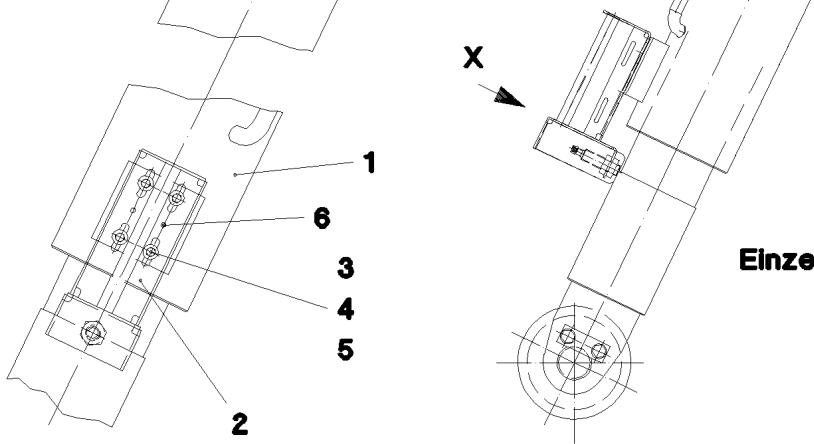

Ansicht X

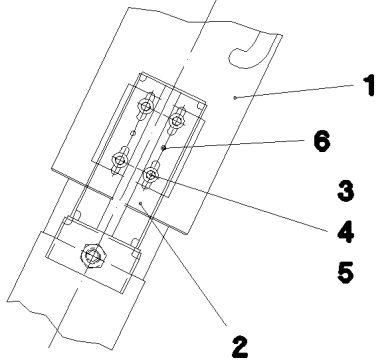

6.2.2009
052566

LIEBHERR

etk_en_de_074515 LR 1600/2

S OVERRUN PROTECTION
S-RUECKHALTESICHERUNG

□ 507 (1/2)

⇒ 3 291
91 52 831 08

Pos.	Item	Quantity	Description	Bezeichnung	Serie	K
1	10 41 101 5	2	TILTING-BACK SUPPORT 150/130-1000 SPF ⇒ X10411015 10 41 101 5	RUECKFALLSTUETZE		
2	96 17 503 08	2	BRACKET WELDED CONST.	KONSOLE SCHWK.		
3	49 00 128	8	HEX BOLT ISO 4017 M8X25 8.8 A2C	SECHSKANTSCHRAUBE		
4	41 19 005 08	8	HEX NUT DIN 985 M8 8 VERZ	SECHSKANTMUTTER		
5	42 18 007 08	16	WASHER DIN 9021 A 6.4 VERZ	SCHEIBE		
6	43 11 037 08	4	CLOSE TOLERANCE GROOVED PIN ISO 874	PASSKERBSTIFT		
7	10 49 005 7	2	FORCE MEASURING AXLE DRUCK 0-700KN	KRAFTMESSACHSE		
9	49 00 161	4	HEX BOLT ISO 4017 M12X30 8.8 A3C	SECHSKANTSCHRAUBE		
10	42 00 016 08	4	WASHER ISO 7089 A 13 ST A3C	SCHEIBE		
12	97 86 100 08	2	PLATE 2X2400X356	BLECH		
13	10 41 285 7	12	OVAL HEAD FLAT SCREW AEHNL.ISO7380	LINSENFLACHKOPFSCHRAUBE		
500	92 95 070 08	1	EL.EQUIPMENT SAFETY RETAINER ⇒ 3 930 713 92 95 070 08	ELEKTRIK S-RUECKHALTESIC		

6.2.2009

etk_en_de_074515 LR 1600/2

508 (2/2)

LIEBHERR

S OVERRUN PROTECTION
S-RUECKHALTESICHERUNG

⇒ 3 291
91 52 831 08

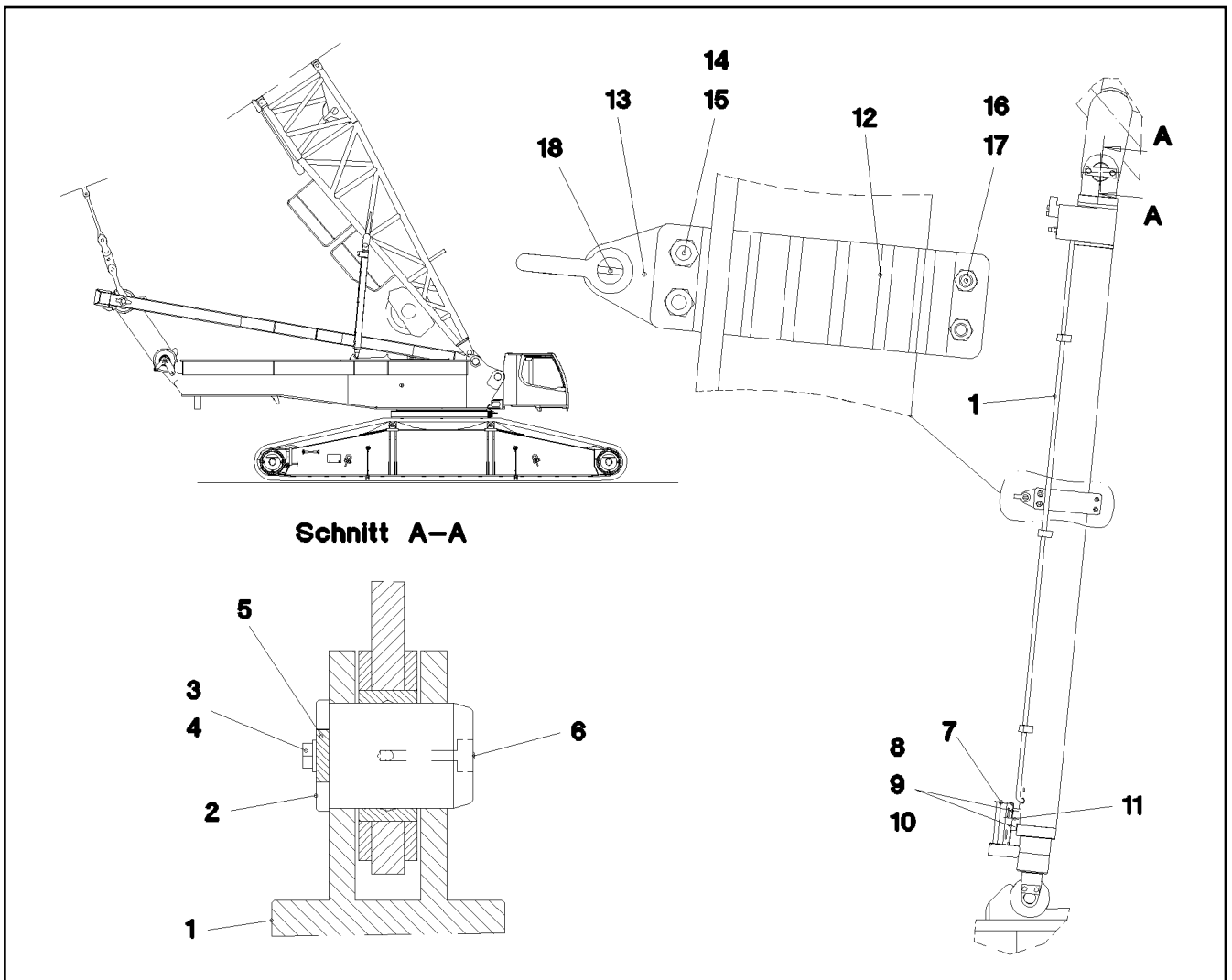

Schnitt A-A

Pos.	Item	Quantity	Description	Bezeichnung	Serie	K
1	10 41 101 8	2	TILTING-BACK SUPPORT 150/140-2500 SPF ⇒ X10411018 10 41 101 8	RUECKFALLSTUETZE		
2	95 67 585 08	2	PIN 85.0X120 SPF	BOLZEN		
3	49 00 161	4	HEX BOLT ISO 4017 M12X30 8.8 A3C	SECHSKANTSCHRAUBE		
4	42 00 016 08	4	WASHER ISO 7089 A 13 ST A3C	SCHEIBE		
5	94 21 646 08	2	AXLE HOLDER 10X140X40 S380MC	ACHSHALTER		
6	77 43 040 08	2	GREASE NIPPLE DIN 71412 A M10X1	SCHMIERNIPPEL		
7	96 17 503 08	2	BRACKET WELDED CONST.	KONSOLE SCHWK.		
8	49 00 128	8	HEX BOLT ISO 4017 M8X25 8.8 A2C	SECHSKANTSCHRAUBE		
9	41 19 005 08	8	HEX NUT DIN 985 M8 8 VERZ	SECHSKANTMUTTER		
10	42 18 007 08	8	WASHER DIN 9021 A 6.4 VERZ	SCHEIBE		
11	43 11 037 08	4	CLOSE TOLERANCE GROOVED PIN ISO 874	PASSKERBSTIFT		
12	97 91 624 08	4	PLATE 8X95X374	BLECH		
13	97 91 625 08	2	PLATE 25X95X115	BLECH		
14	40 61 167 01	4	HEX BOLT ISO 4014 M16X60 8.8 A3C	SECHSKANTSCHRAUBE		
15	41 19 009 08	4	HEX NUT DIN 985 M16 8 VERZ	SECHSKANTMUTTER		
16	49 00 204	4	HEX BOLT ISO 4017 M12X35 8.8 A3C	SECHSKANTSCHRAUBE		
17	41 19 007 08	4	HEX NUT DIN 985 M12 8 A3C	SECHSKANTMUTTER		
18	10 28 319 6	2	SHACKLE 3,25T	SCHAEKEL		
500	96 51 078 08	1	EL.BACKING PROTECTION D ⇒ 3 930 501 96 51 078 08	ELEKTRIK D-RUECKHALTESIC		

6.2.2009
055216

LIEBHERR

etk_en_de_074515 LR 1600/2

D OVERRUN PROTECTION
D-RUECKHALTESICHERUNG

509

⇒ 3 292
91 52 865 08

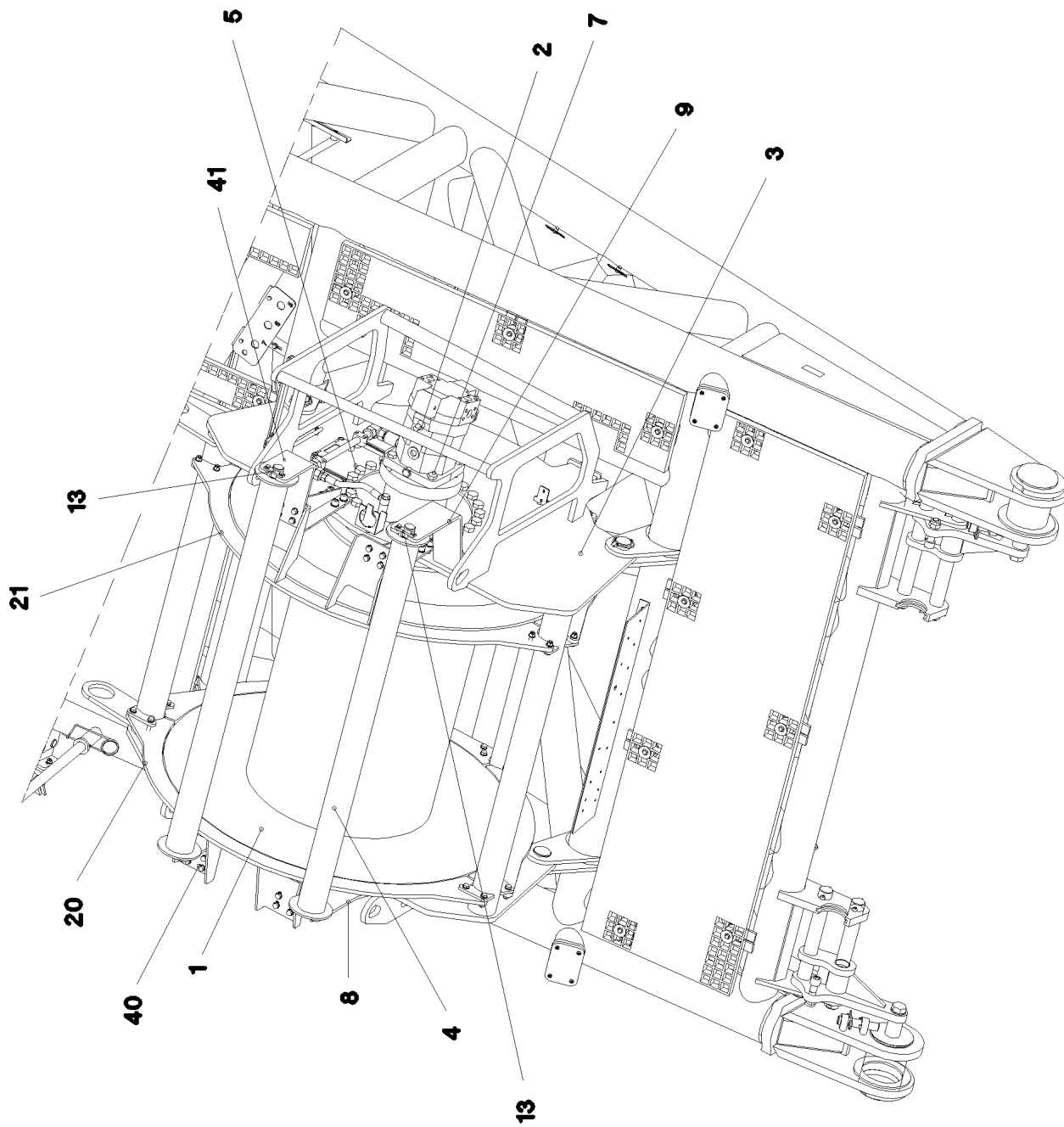

6.2.2009
054256

LIEBHERR

etk_en_de_074515 LR 1600/2

WINCH 3
WINDE 3

510 (1/3)

⇒ 3 350
91 52 859 08

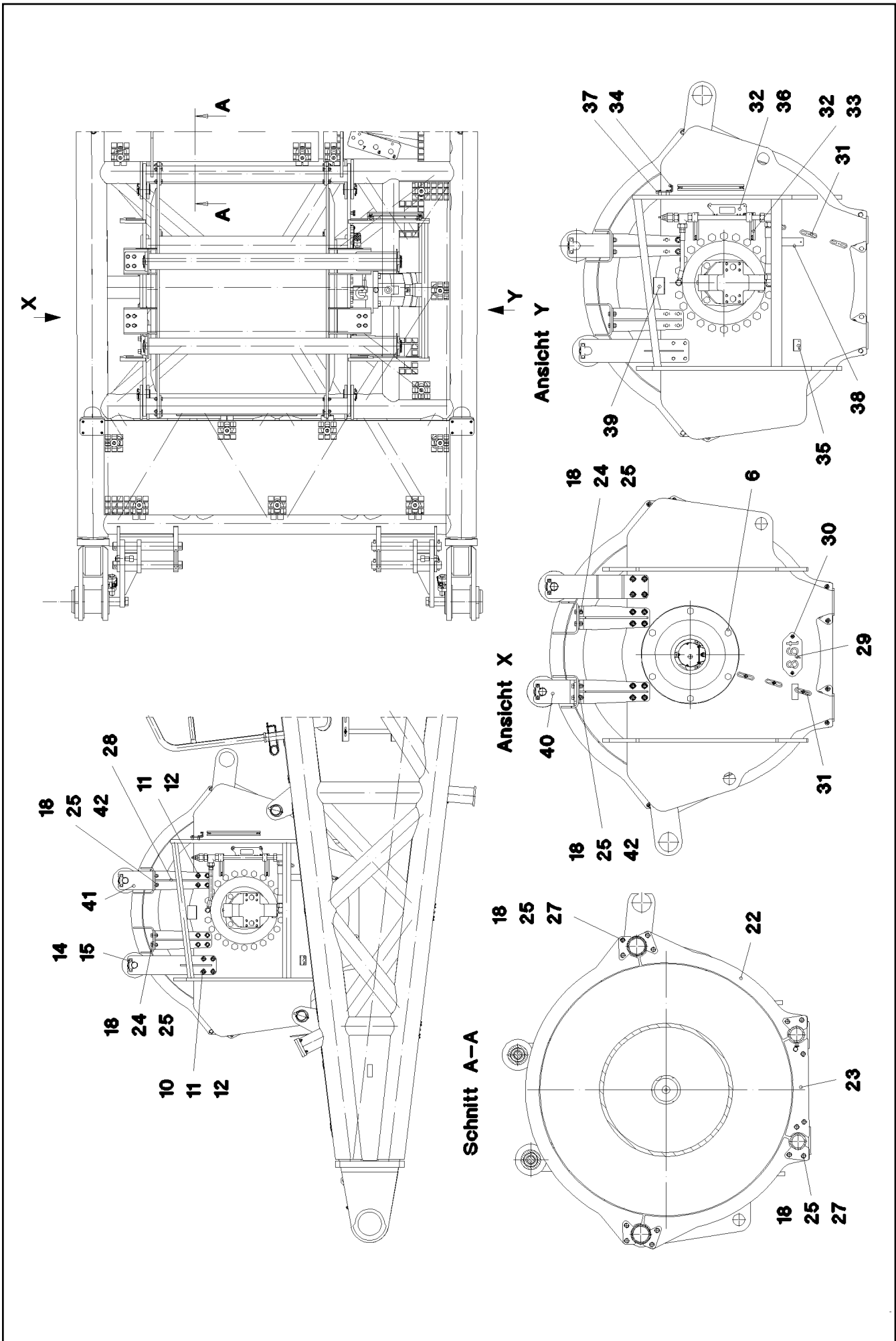

6.2.2009
054257

LIEBHERR

etk_en_de_074515 LR 1600/2

WINCH 3
WINDE 3

□ 511 (2/3)

⇒ 3 350
91 52 859 08

Pos.	Item	Quantity	Description	Bezeichnung	Serie	K
1	10 35 411 4	1	HOISTING WINCH ZHP 4.29 SPF ⇒ X10354114 10 35 411 4	HUBWINDE		
2	10 42 876 7	1	VARIABLE DISPLACEMENT MOTOR A6VM 2	VERSTELLMOTOR		
3	96 49 298 08	1	WINCH BEARING	WINDENLAGERUNG SCHWK.		
4	96 18 667 08	2	SAFETY ROLLER CPL. SPF	SCHUTZWALZE KPL.		
(1)	92 38 783 08	1	SAFETY ROLLER WELDED	SCHUTZWALZE SCHWK.		
(2)	95 63 347 08	1	AXLE RD40X1650	ACHSE		
(3)	74 51 488 08	2	DEEP GROOVE BALL BEARING DIN 625 620	RILLENKUGELLAGER		
5	40 66 057 08	22	HEX BOLT ISO 4017 M24X50 10.9 A3C	SECHSKANTSCHRAUBE		
6	46 00 020	6	HEX BOLT ISO 4017 M20X45 8.8 A3C	SECHSKANTSCHRAUBE		
7	40 65 211 01	4	HEX BOLT ISO 4017 M20X60 8.8 A3C	SECHSKANTSCHRAUBE		
8	97 75 895 08	1	PLATE 12X120X532	BLECH		
9	96 49 299 08	1	CLAMP WELDED CONST.	HALTER SCHWK.		
10	97 03 987 08	2	PLATE 1x120x100	BLECH		
11	46 00 329	24	CYLINDER SCREW ISO 4762 M16X35 8.8 A3	ZYLINDERSCHRAUBE		
12	42 00 019 08	24	WASHER DIN 125 A 17 VERZ	SCHEIBE		
13	94 13 244 08	4	AXLE HOLDER 6X20X80	ACHSHALTER		
14	49 00 188	8	HEX BOLT ISO 4017 M8X16 8.8 A2C	SECHSKANTSCHRAUBE		
15	42 00 012 08	8	WASHER DIN 125 A8X16 ST VERZ	SCHEIBE		
18	41 15 143 08	48	HEX NUT DIN 934 M12 8 VERZ	SECHSKANTMUTTER		
20	96 54 012 08	1	PLATE	SICHELBLECH SCHWK.		
21	96 54 011 08	1	PLATE	SICHELBLECH SCHWK.		
22	97 85 057 08	4	PLATE 15X964X235	BLECH		
23	97 84 978 08	2	PLATE 15X507X124	BLECH		
24	49 00 204	8	HEX BOLT ISO 4017 M12X35 8.8 A3C	SECHSKANTSCHRAUBE		
25	42 00 508 08	96	WASHER DIN 125 A 13 MS	SCHEIBE		
27	46 00 158	32	HEX BOLT ISO 4017 M12X45 8.8 A3C	SECHSKANTSCHRAUBE		
28	96 53 928 08	4	CLAMP WELDED CONST.	HALTER SCHWK.		
29	97 44 570 08	1	PLATE 2X228X100	BLECH		
30	10 41 285 4	32	OVAL HEAD FLAT SCREW AEHNL.ISO7380	LINSENFLACHKOPFSCHRAUBE		
31	95 36 500 08	13	CABLE HOLDER 2X22X90	KABELHALTER		
32	95 38 734 08	7	SLEEVE	HUELSE		
33	95 41 173 08	2	CARRIER RAIL 140	TRAGSCHIENE		
34	95 41 175 08	2	CARRIER RAIL 340	TRAGSCHIENE		
35	95 51 525 08	1	PLATE 4X60X103	BLECH		
36	95 56 681 08	1	PLATE X0	BLECH		
37	95 58 096 08	2	PLATE 4X40X105	BLECH		
38	97 55 008 08	1	PLATE 3X150X40	BLECH		
39	97 67 363 08	1	PLATE 3X85X210 FE//ZN20//C	BLECH		
40	97 88 636 08	1	PLATE 12X337X120	BLECH		
41	97 88 637 08	1	PLATE 12X471X120	BLECH		
42	46 00 156	8	HEX BOLT ISO 4017 M12X50 8.8 A3C	SECHSKANTSCHRAUBE		
500	96 44 538 08	1	ELECTRIC FOR WINCH 3 ⇒ 2 920 334 96 44 538 08	ELEKTRIK WINDE 3		

6.2.2009

etk_en_de_074515 LR 1600/2

512 (3/3)

LIEBHERRWINCH 3
WINDE 3⇒ 3 350
91 52 859 08

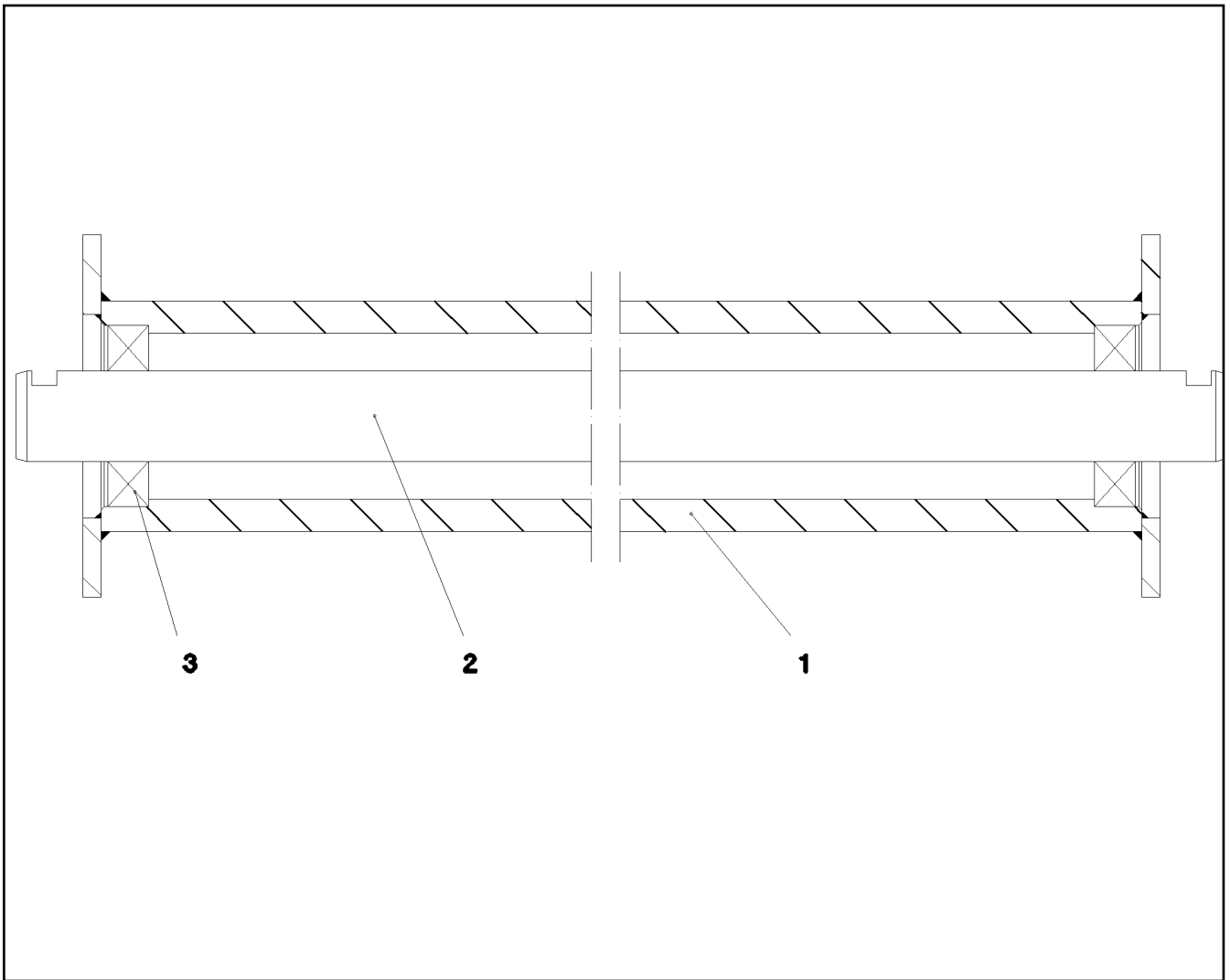

Pos.	Item	Quantity	Description	Bezeichnung	Serie	K
1	92 70 643 08	1	ROLLER WELDED CONSTR.	ROLLE SCHWK.		
2	93 72 521 08	1	SHAFT 40.0x1854	WELLE		
3	74 51 488 08	2	DEEP GROOVE BALL BEARING DIN 625 620	RILLENKUGELLAGER		

6.2.2009
023802

LIEBHERR

etk_en_de_074515 LR 1600/2

SAFETY ROLLER CPL.
SCHUTZWALZE KPL.

513

⇒ 3 350 001
92 70 642 08

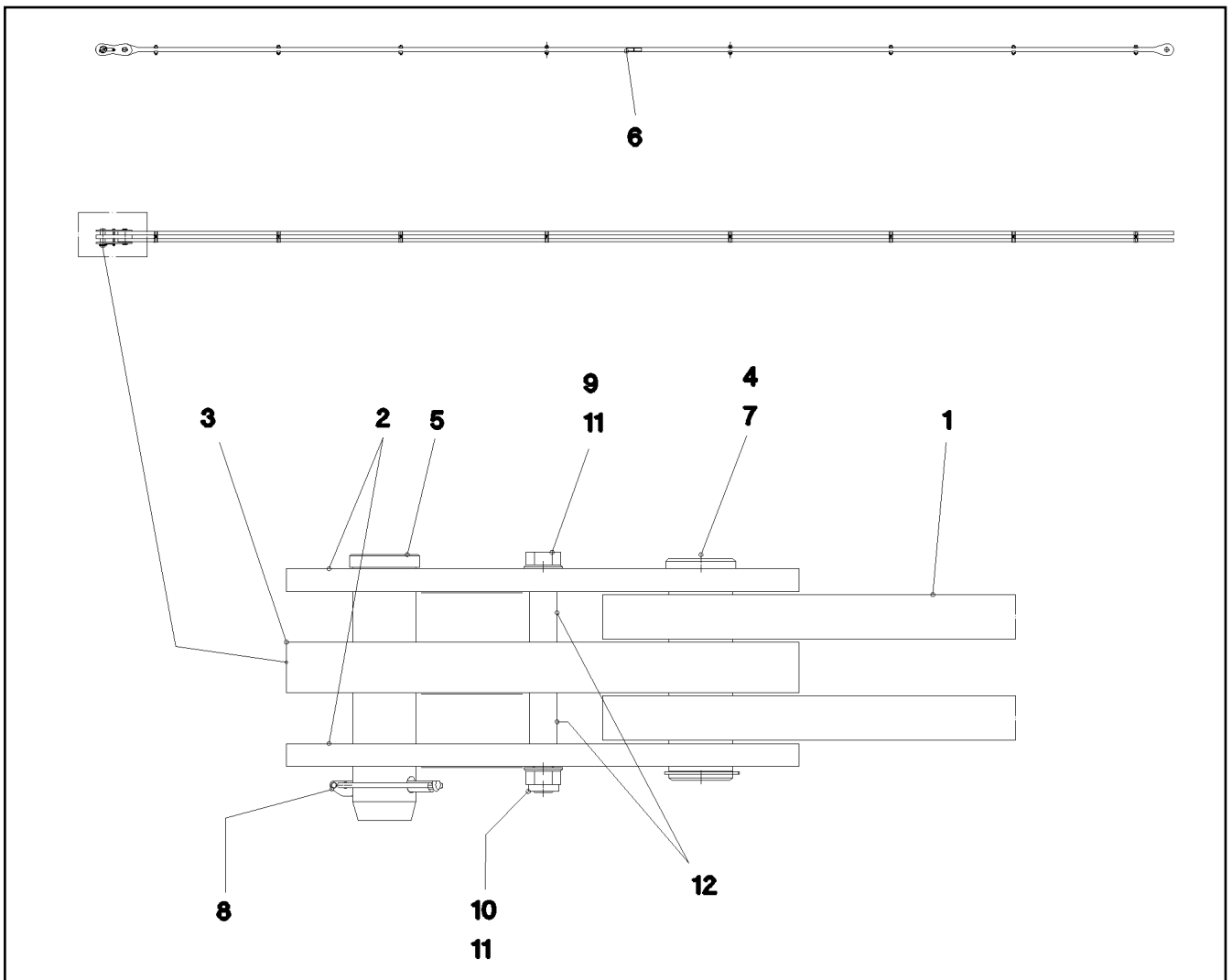

Pos.	Item	Quantity	Description	Bezeichnung	Serie	K
1	96 45 230 08	1	ROD 11.75M	STANGE VORM.		
2	96 45 231 08	2	BRACKET WITH BOARD 0.25 M	LASCHE MIT SCHILD		
3	96 45 232 08	1	BRACKET WITH BOARD 0.25 M	LASCHE MIT SCHILD		
4	97 67 727 08	1	PIN 55.0X175 30CRNIMO8+QT	BOLZEN		
5	95 28 920 08	1	PIN 55.0X210 30CRNIMO8+QT SPF	BOLZEN		
6	97 35 919 08	1	PLATE ASSEMBLY BG-NR. PVC-SILBER SP	SCHILD BAUGRUPPE		
7	42 80 042 08	1	LOCKING RING DIN 471 50X2	SICHERUNGSRING		
8	43 32 005 08	1	SAFETY PLUG W HINGE-LID 11,5X96 VERZ	SICHERHEITSKLAPPSTECKER		
9	40 61 186 01	1	HEX BOLT ISO 4014 M16X180 8.8 A3C	SECHSKANTSCHRAUBE		
10	41 19 009 08	1	HEX NUT DIN 985 M16 8 VERZ	SECHSKANTMUTTER		
11	42 00 019 08	2	WASHER DIN 125 A 17 VERZ	SCHEIBE		
12	93 92 551 08	2	TUBE 22X2,5X40	ROHR		

6.2.2009
052922

LIEBHERR

etk_en_de_074515 LR 1600/2

ROD CPL.
STANGE KPL.

514

⇒ 3 561 003
96 45 222 08

Pos. 400
Pos. 500

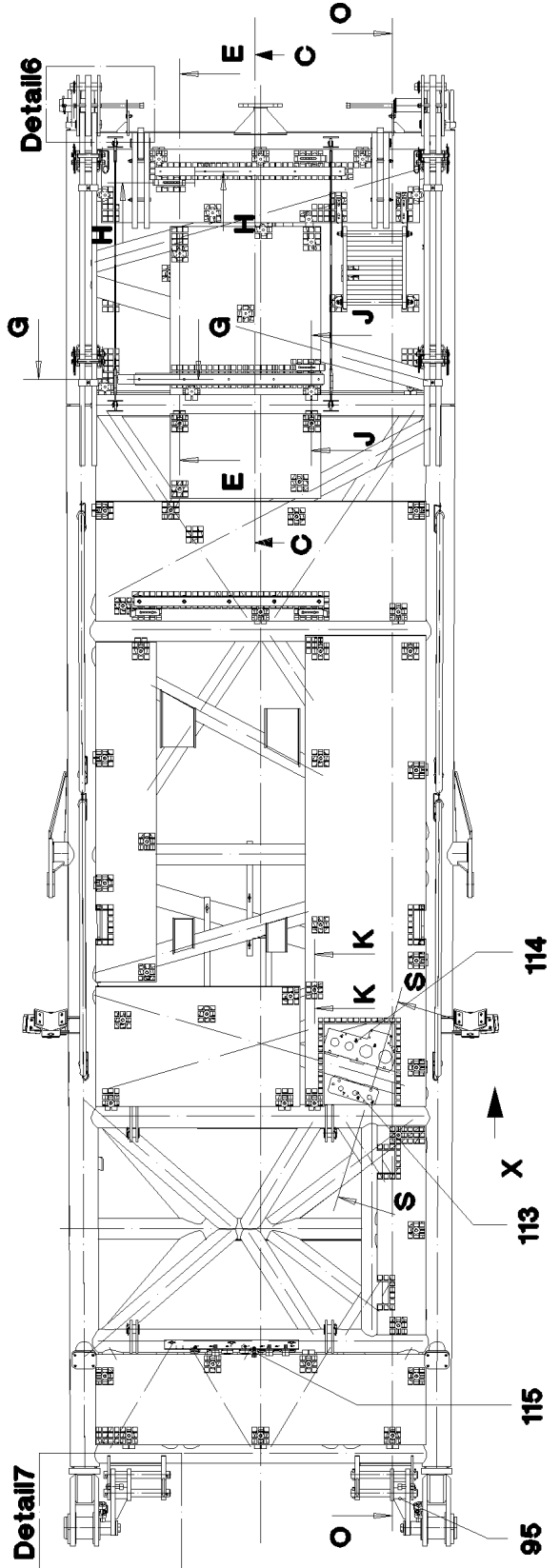
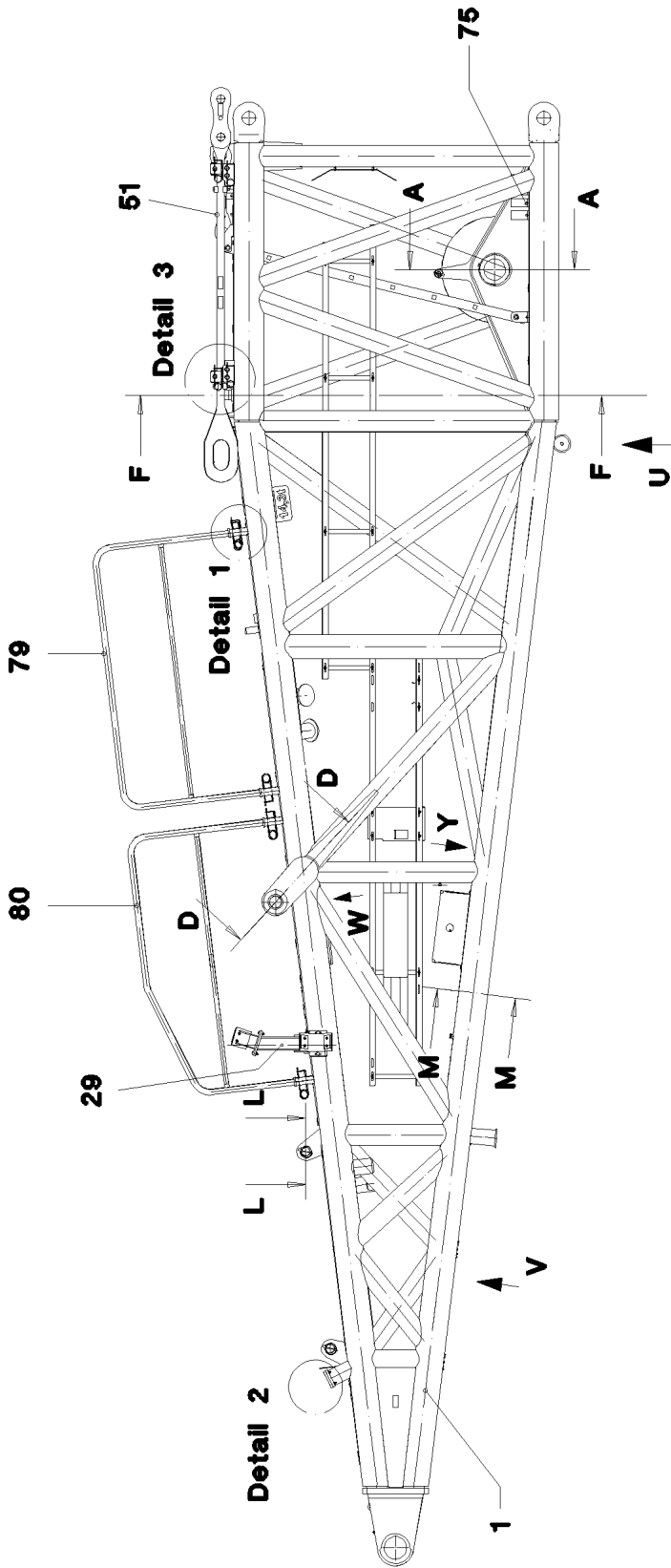

6.2.2009
054260

LIEBHERR

etk_en_de_074515 LR 1600/2

D PIVOT SECTION
D-ANLENKSTUECK

□ 515 (1/9)

⇒ 3 713
91 57 749 08

Ansicht X

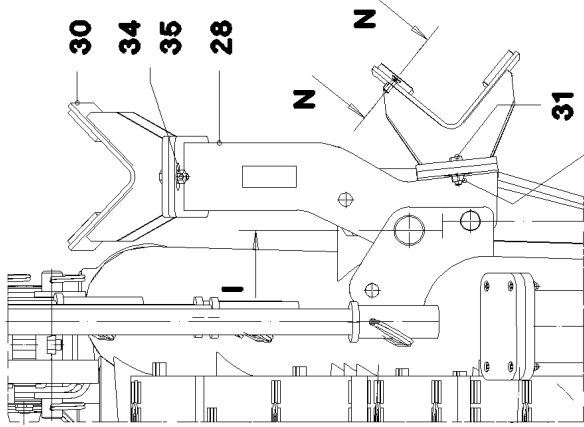

Ansicht V

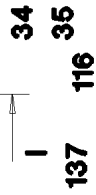

Ansicht W

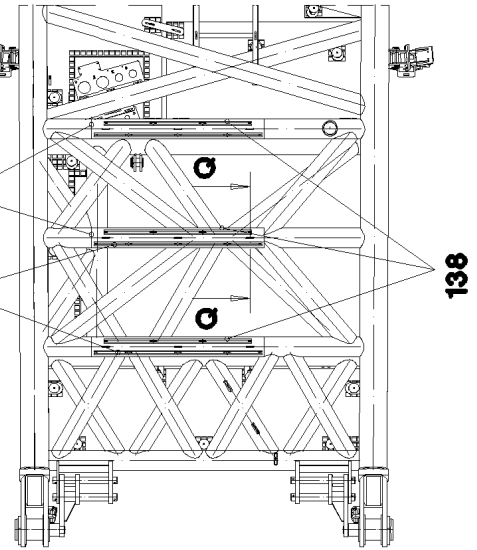

Ansicht Y

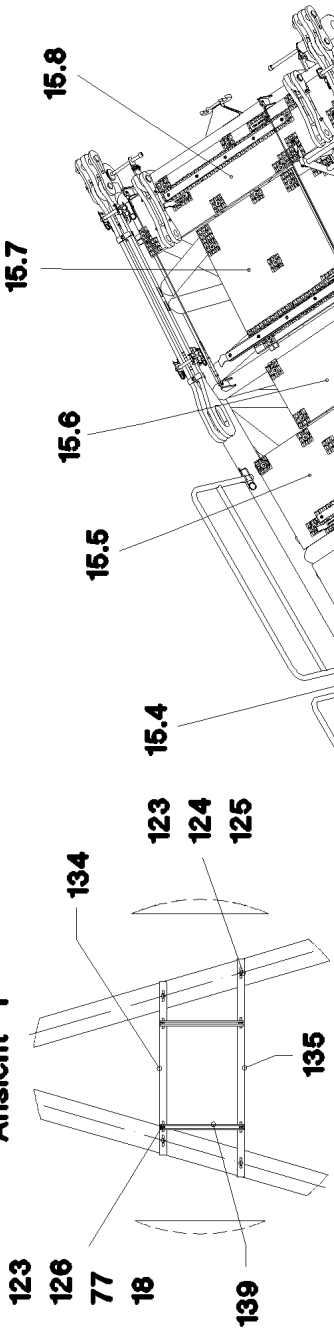

Ansicht Z

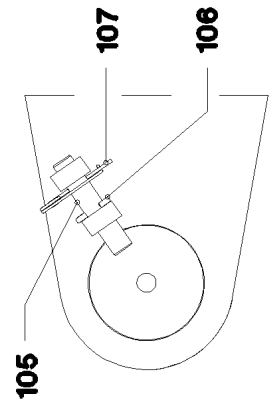

6.2.2009
054261

LIEBHERR

etk_en_de_074515 LR 1600/2

D PIVOT SECTION
D-ANLENKSTUECK

□ 516 (2/9)

→ 3 713
91 57 749 08

Schnitt A-A

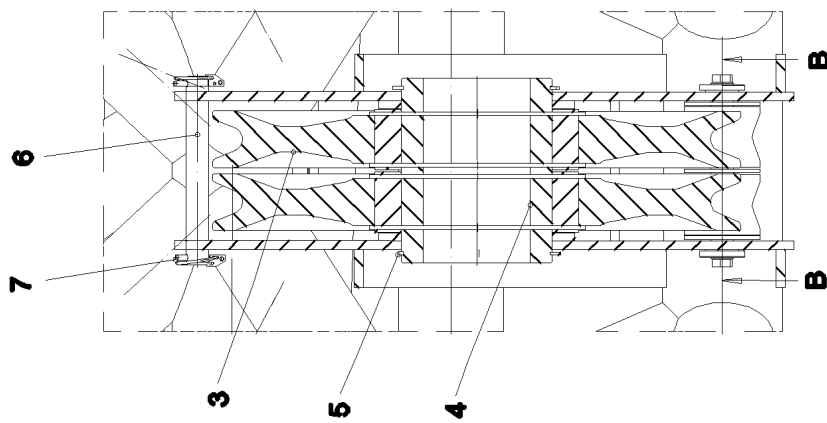

Schnitt B-B

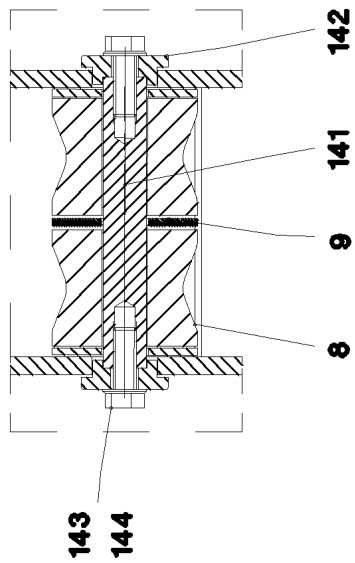

Schnitt D-D

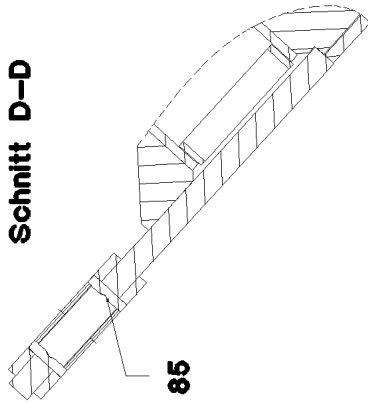

Schnitt C-C

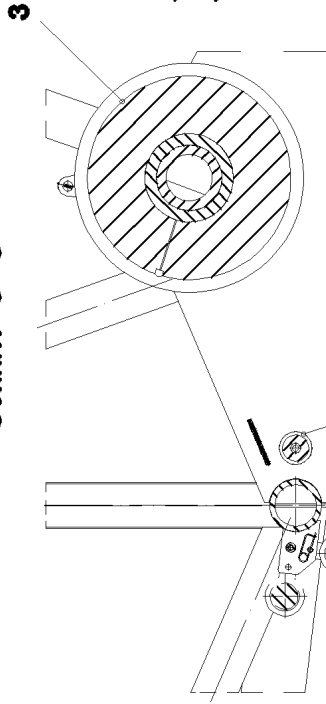

Ansicht U

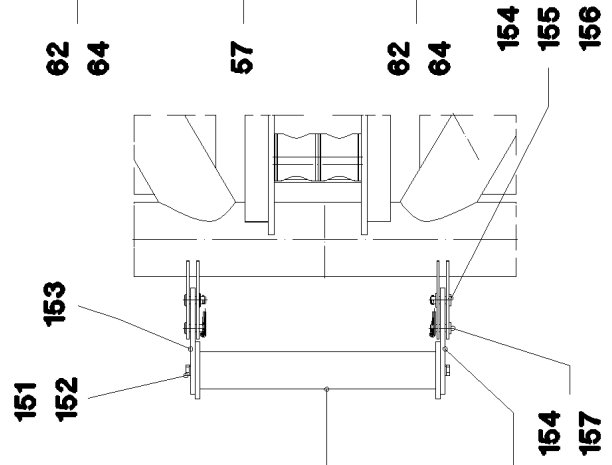

Schnitt G-G

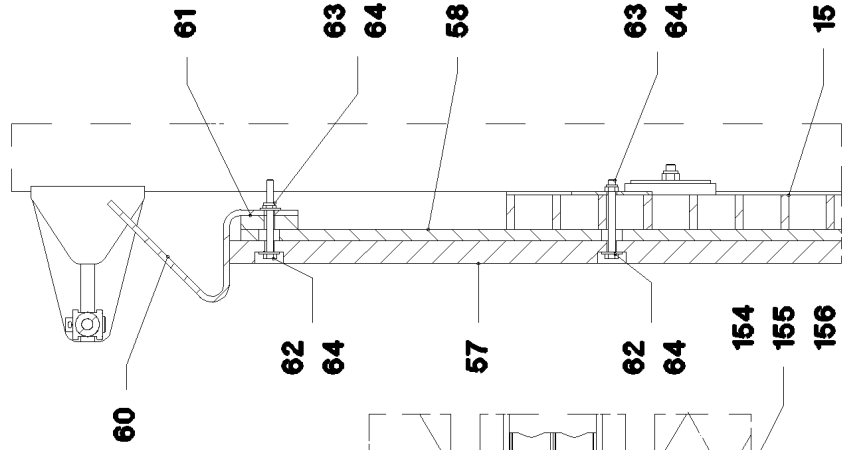

Schnitt E-E

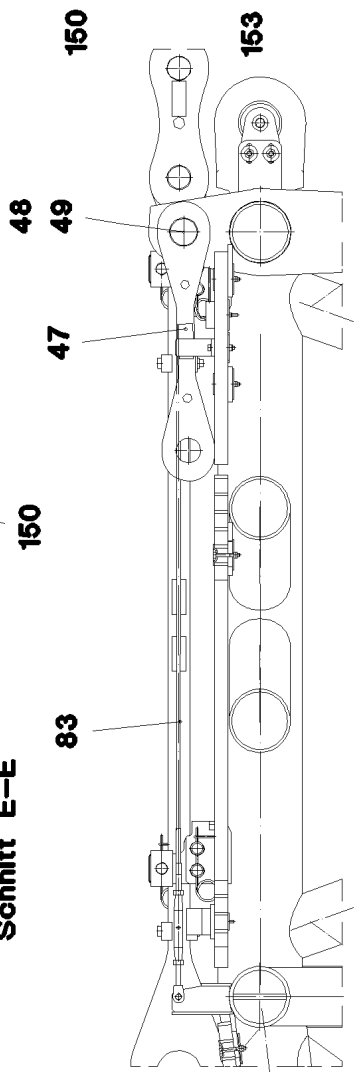

6.2.2009
054262

LIEBHERR

etk_en_de_074515 LR 1600/2

D PIVOT SECTION
D-ANLENKSTUECK

□ 517 (3/9)

→ 3 713
91 57 749 08

Schnitt F-F

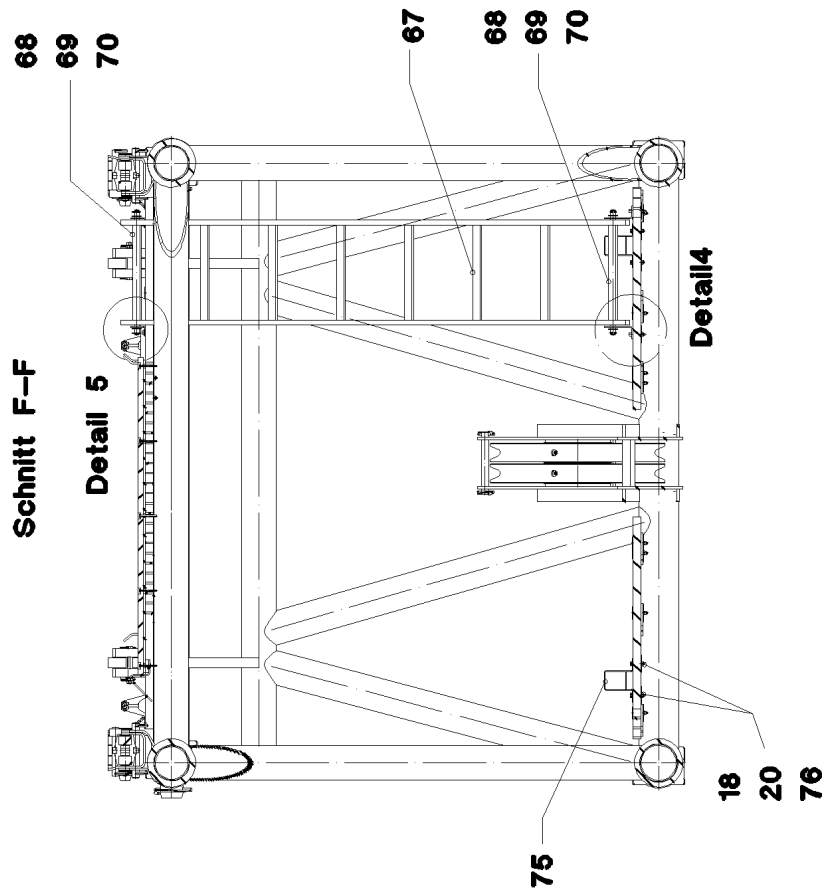

Schnitt H-H

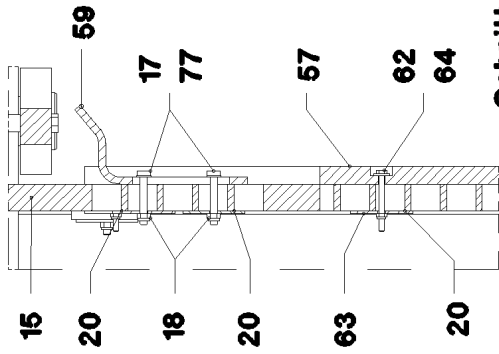

Schnitt M-M

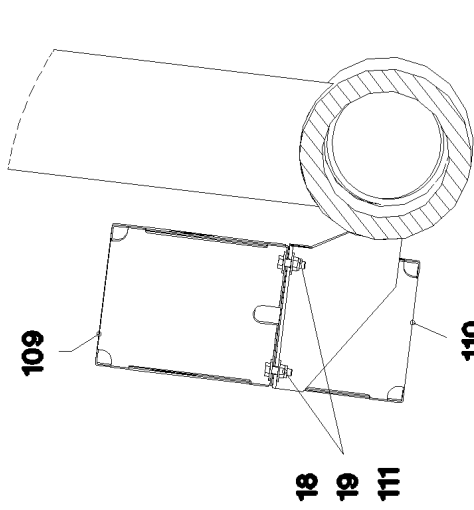

Schnitt K-K

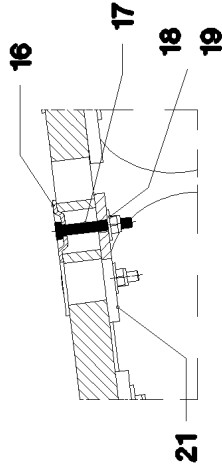

Schnitt I-I

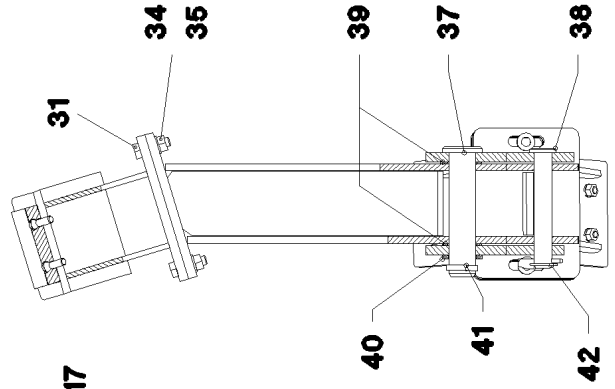

Schnitt N-N

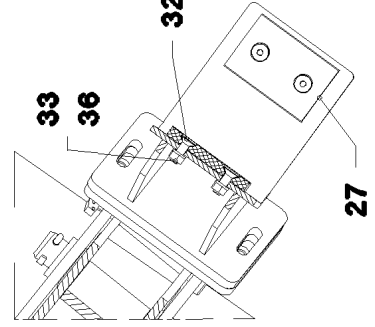

Schnitt J-J

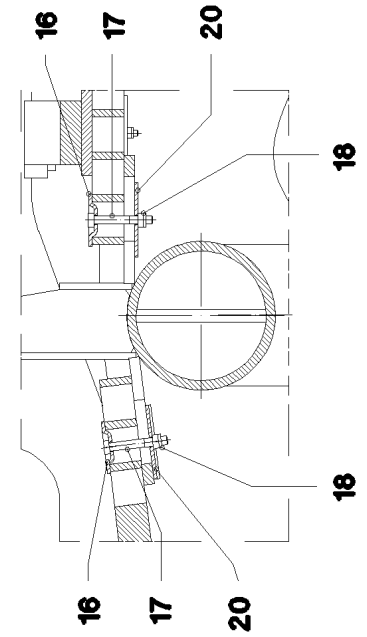

Schnitt L-L

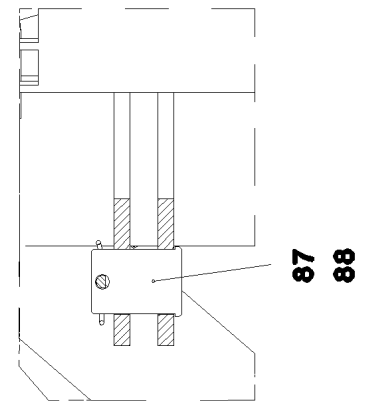

6.2.2009
054263

LIEBHERR

etk_en_de_074515 LR 1600/2

D PIVOT SECTION
D-ANLENKSTUECK

□ 518 (4/9)

⇒ 3 713
91 57 749 08

Schnitt O-O

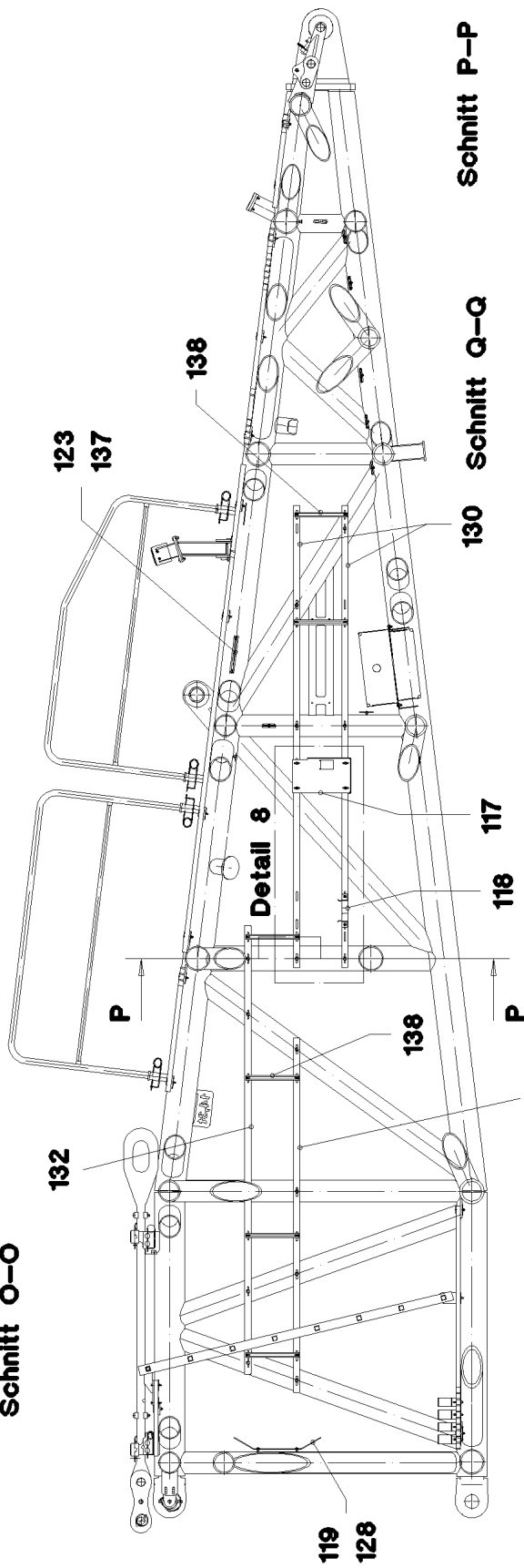

Schnitt P-P

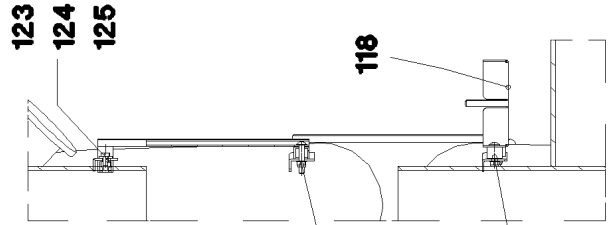

Schnitt Q-Q

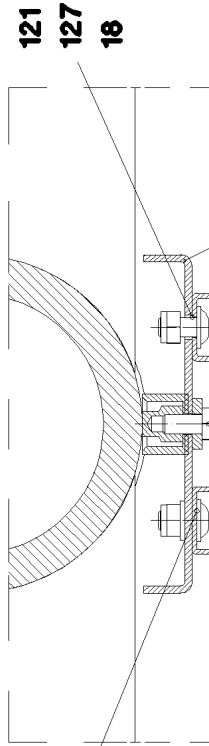

Schnitt S-S

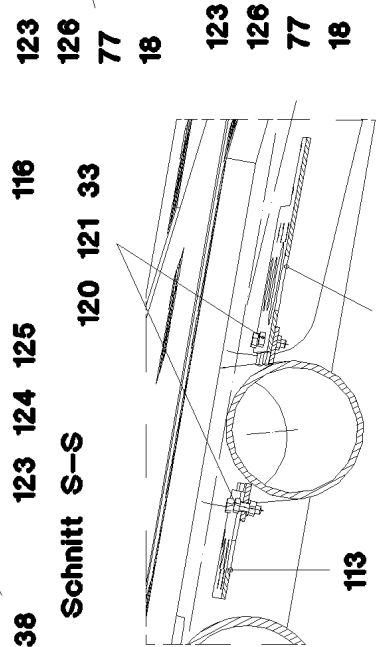

Schnitt R-R

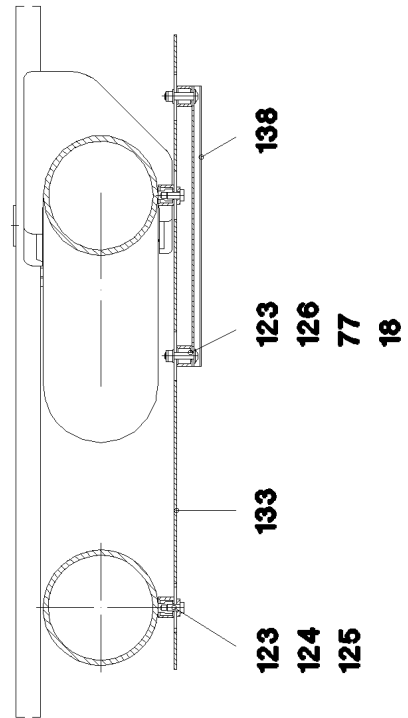

6.2.2009
054264

LIEBHERR

etk_en_de_074515 LR 1600/2

D PIVOT SECTION
D-ANLENKSTUECK

519 (5/9)

3 713
91 57 749 08

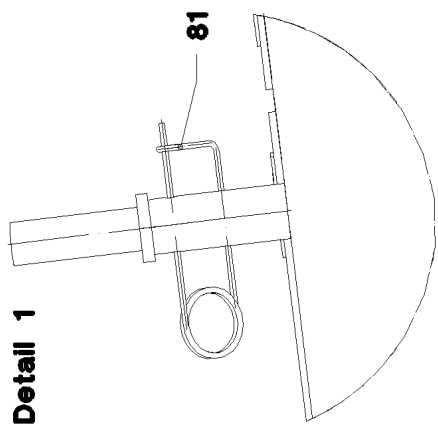

Detail 1

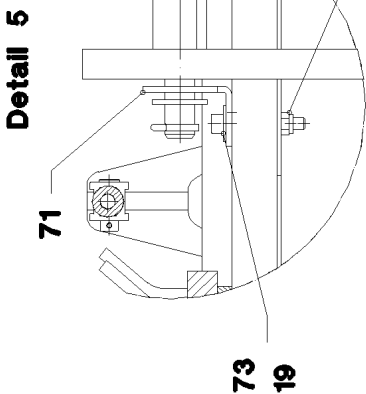

Detail 5

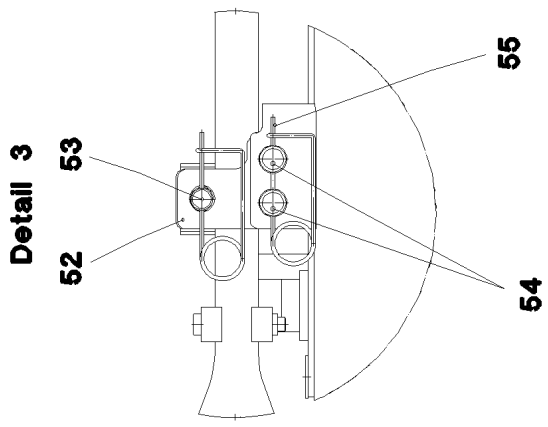

Detail 3

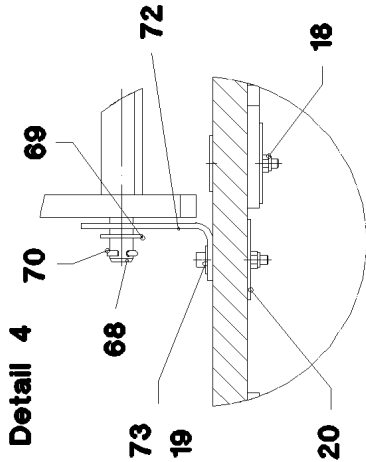

Detail 4

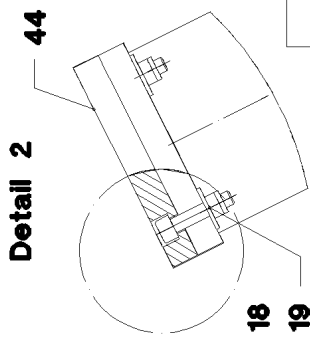

Detail 2

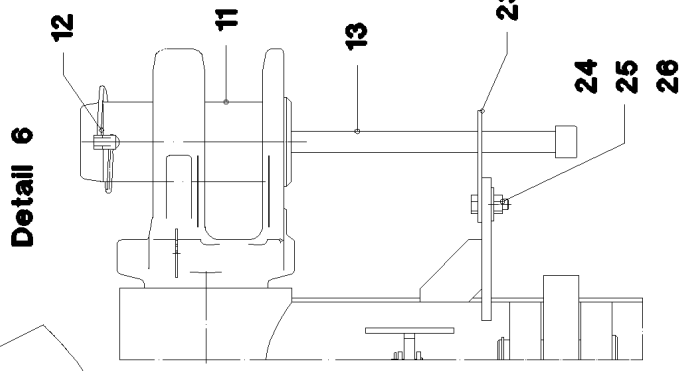

Detail 6

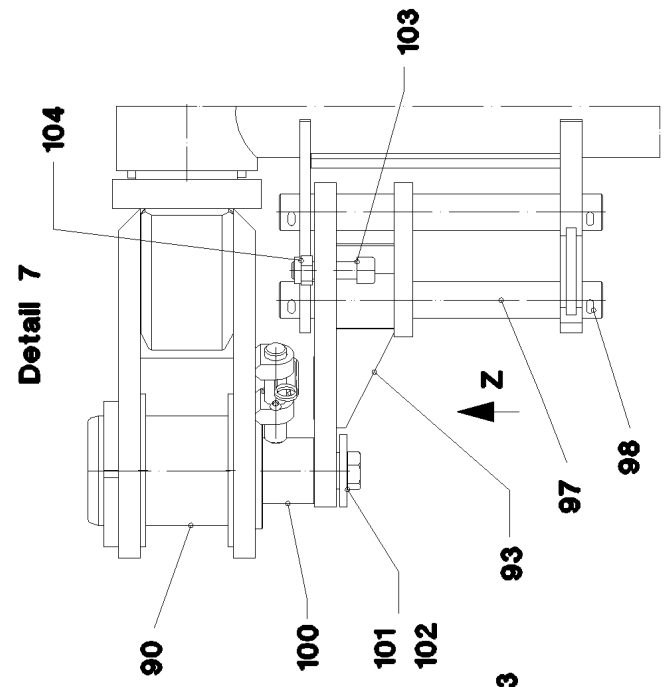

Detail 7

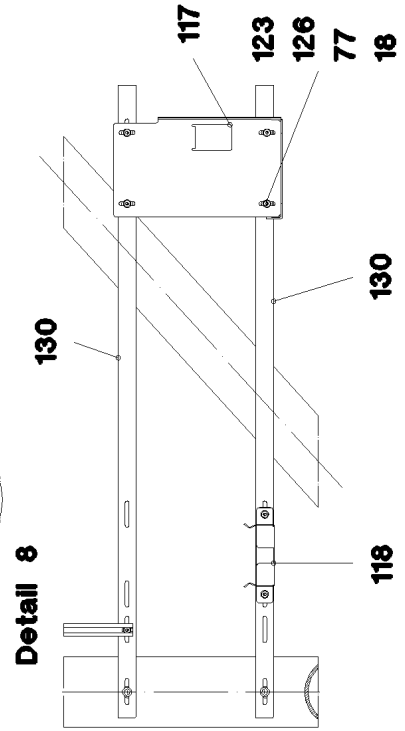

Detail 8

6.2.2009
054265

LIEBHERR

etk_en_de_074515 LR 1600/2

D PIVOT SECTION
D-ANLENKSTUECK

□ 520 (6/9)

→ 3 713
91 57 749 08

Pos.	Item	Quantity	Description	Bezeichnung	Serie	K
1	96 49 113 08	1	D PIVOT SECTION WELDED CONSTR.	D-ANLENKSTUECK SCHWK.		
3	92 68 928 08	2	ROPE PULLEY CPL. SPF ⇒ 2 652 007 92 68 928 08	SEILROLLE KPL.		
4	97 19 034 08	1	AXLE 219.1X245	ACHSE		
5	42 80 093 08	2	LOCKING RING DIN 471 200X4	SICHERUNGSRING		
6	45 25 413 08	1	PIN ISO 2340 B30X250X234 ST FE//ZN20//C	BOLZEN		
7	43 32 003 08	2	HINGED CONNECTOR DIN 11023 8X42 VER	KLAPPSTECKER		
8	28 81 883 08	2	ROLLER RD100X80 PA6G	ROLLE		
9	93 30 481 08	4	WASHER RD100X5	SCHEIBE		
11	97 68 649 08	2	PIN 100.0X237 35NICRMOV125 SPF	BOLZEN		
12	46 30 212	2	CYLINDER SCREW ISO 4762 M24X340 10.9	ZYLINDERSCHRAUBE		
13	43 32 015 08	2	SAFETY PLUG W HINGE-LID 17X125 VERZ	SICHERHEITSKLAPPSTECKER		
15	96 50 099 08	1	GRATINGS ⇒ 3 713 006 96 50 099 08	GITTERROSTE		
16	10 10 062 1	63	DISH MOUNTING	TELLERBEFESTIGUNG		
17	40 61 024	73	HEX BOLT ISO 4014 M8X55 8.8 A2C	SECHSKANTSCHRAUBE		
18	41 19 005 08	173	HEX NUT DIN 985 M8 8 VERZ	SECHSKANTMUTTER		
19	42 18 009 08	28	WASHER DIN 9021 A 8.4 VERZ	SCHEIBE		
20	94 11 381 08	103	WASHER 70X3	SCHEIBE		
21	95 54 048 08	3	PLATE 8X300X50	BLECH		
23	95 47 547 08	2	PLATE 5X100X125	BLECH		
24	49 00 204	4	HEX BOLT ISO 4017 M12X35 8.8 A3C	SECHSKANTSCHRAUBE		
25	42 18 011 08	4	WASHER ISO 7093-1 A 13 ST A3C	SCHEIBE		
26	41 15 143 08	4	HEX NUT DIN 934 M12 8 VERZ	SECHSKANTMUTTER		
27	93 22 470 08	8	BEARING PLATE 10X60X90 PA6G	LAGERPLATTE		
28	96 50 130 08	1	FOLDING BRACKET WELDED	KLAPPKONSOLE SCHWK.		
29	96 50 131 08	1	FOLDING BRACKET WELDED	KLAPPKONSOLE SCHWK.		
30	92 69 017 08	4	SUPPORT WELDED	AUFLAGE SCHWK.		
31	49 00 112	8	HEX BOLT ISO 4017 M10X35 8.8 A3C	SECHSKANTSCHRAUBE		
32	40 86 005 08	16	COUNTERSUNK SCREW DIN 7991 M8X25 8.	SENKSCHEIBE		
33	41 15 141 08	21	HEX NUT DIN 934 M8 8 A2C	SECHSKANTMUTTER		
34	41 15 144 08	8	HEX NUT DIN 934 M10 8 VERZ	SECHSKANTMUTTER		
35	42 00 013 08	8	WASHER ISO 7089 A 10.5 A3C	SCHEIBE		
36	42 40 007 08	16	CIRCLIP DIN 127 A 8 VERZ	FEDERRING		
37	45 14 304 08	2	PIN DIN 1436 30H11X140X130 ST.50-2K	BOLZEN		
38	45 30 210 08	2	PIN DIN 1444 20H11X130X122 ST.50-2K SPF	BOLZEN		
39	93 94 608 08	4	WASHER RD44X2	SCHEIBE		
40	42 12 019 08	2	WASHER DIN 1441 31 ST VERZ	SCHEIBE		
41	43 30 077 08	2	SPLIT PIN DIN 94 6,3X45 ST VERZ	SPLINT		
42	43 32 001 08	2	HINGED CONNECTOR DIN 11023 5X32 VER	KLAPPSTECKER		
44	97 77 650 08	2	LIMIT STOP 15X160X120 PA6 G	ANSCHLAG		
45	40 01 620	8	CYLINDER SCREW ISO 4762 M8X35 8.8 A2C	ZYLINDERSCHRAUBE		
47	96 50 162 08	2	BRACKET COMPL. 0.50M	LASCHE KPL.		
48	97 09 178 08	2	PIN 65x135	BOLZEN		
49	42 80 045 08	2	LOCKING RING DIN 471 55X2	SICHERUNGSRING		
51	96 50 197 08	2	ROD CPL. 2.3M ⇒ 3 713 012 96 50 197 08	STANGE KPL.		
52	97 74 758 08	4	PLATE 8X407X110 T ZN O	BLECH		
53	96 43 771 08	4	CONNECTING PIN WELDED	ABSTECKBOLZEN SCHWK.		
54	97 74 759 08	8	PIN 30.0X220 S355J2G3 T ZN O	BOLZEN		
55	43 31 009 08	12	RETAINING SPRING 4,5 VERZ	SICHERUNGSFEDER		
57	97 41 439 08	3	SUPPORT PLATE 60X1270 PA6G	AUFLAGE		
58	97 41 440 08	1	PLATE 10X1250X80	BLECH		
59	97 73 817 08	5	PLATE 8X40X246	BLECH		
60	97 79 283 08	1	PLATE 5X263X60	BLECH		
61	97 74 760 08	1	WASHER 12X50X50 T ZN O	SCHEIBE		
62	46 00 356	15	HEX BOLT ISO 4014 M6X65 8.8 A2C	SECHSKANTSCHRAUBE		
63	41 19 004 08	15	HEX NUT DIN 985 M6 8 VERZ	SECHSKANTMUTTER		
64	42 18 007 08	16	WASHER DIN 9021 A 6.4 VERZ	SCHEIBE		
67	78 89 054 08	1	LADDER 8/2110X370 AL	LEITER		

6.2.2009

etk_en_de_074515 LR 1600/2

☐ 521 (7/9)

LIEBHERRD PIVOT SECTION
D-ANLENKSTUECK⇒ 3 713
91 57 749 08

Pos.	Item	Quantity	Description	Bezeichnung	Serie	K
68	45 00 232 08	2	PIN ISO 2340 20X500X485 ST.50K FE//ZN20//	BOLZEN		
69	42 00 021 08	4	WASHER ISO 7089 A 21 ST A3C	SCHEIBE		
70	43 30 065 08	4	SPLIT PIN DIN 94 5X40 ST VERZ	SPLINT		
71	97 46 733 08	2	PLATE 4X260X93	BLECH		
72	97 05 395 08	2	ANGLE 5x154x70	WINKEL		
73	40 42 072 08	6	CYLINDER SCREW DIN 912 M8X55 8.8 A2C	ZYLINDERSCHRAUBE		
75	92 83 955 08	8	FASTENER	HALTERUNG		
76	40 01 461	16	HEX BOLT ISO 4014 M8X50 8.8 A2C	SECHSKANTSCHRAUBE		
77	42 00 012 08	26	WASHER DIN 125 A8X16 ST VERZ	SCHEIBE		
79	96 56 362 08	2	RAILING ALMG3	GELAENDER		
80	96 56 363 08	2	RAILING ALMG3	GELAENDER		
81	43 31 025 08	8	RETAINING SPRING 5 VERZ	SICHERUNGSFEDER		
83	10 65 281 4	2	ROUND STRAND ROPE 10MM 1,75M EDEL	RUNDLITZENSEIL		
85	70 43 378 08	2	BUSH RD100X45 GZ-CUZN25AL5	BUCHSE		
87	95 71 127 08	4	PIN 65.0X84 35NICRMOV125	BOLZEN		
88	43 32 005 08	4	SAFETY PLUG W HINGE-LID 11,5X96 VERZ	SICHERHEITSKLAPPSTECKER		
90	97 79 763 08	2	PIN 160.0X240 SPF	BOLZEN		
93	96 50 735 08	1	CONSOLE	KONSOLE		
95	96 50 968 08	1	CONSOLE	KONSOLE		
97	97 79 764 08	4	PIN 55.0X445 SPF	BOLZEN		
98	43 30 101 08	8	SPLIT PIN DIN 94 10X71 ST VERZ	SPLINT		
100	97 79 781 08	2	TUBE 90.0X106 SPF	ROHR		
101	40 65 269 14	2	HEX BOLT ISO 4017 M30X150 8.8 A3C	SECHSKANTSCHRAUBE		
102	97 91 266 08	2	WASHER 10X100X100	SCHEIBE		
103	40 43 246 08	2	CYLINDER SCREW DIN 912 M24X90 10.9 A3	ZYLINDERSCHRAUBE		
104	41 19 026 08	2	HEX NUT DIN 985 M24 10 A3C	SECHSKANTMUTTER		
105	97 80 472 08	2	PIN 35.0X150 SPF	BOLZEN		
106	43 30 088 08	2	SPLIT PIN DIN 94 8X50 ST VERZ	SPLINT		
107	43 31 012 08	2	RETAINING SPRING 4X68 VERZ	SICHERUNGSFEDER		
109	95 32 110 08	1	HOOD 1.5X931X548	HAUBE		
110	95 47 461 08	1	HOOD 1.5X831X448	HAUBE		
111	49 00 128	4	HEX BOLT ISO 4017 M8X25 8.8 A2C	SECHSKANTSCHRAUBE		
113	97 87 754 08	1	PLATE 4X330X110	BLECH		
114	97 87 755 08	1	PLATE 4X480X230	BLECH		
115	96 57 159 08	1	SHEET CPL. ⇒ 3 713 013 96 57 159 08	BLECH KPL.		
116	97 87 757 08	3	PLATE 3X1200X170	BLECH		
117	97 90 053 08	1	PLATE 4X405X527	BLECH		
118	97 86 372 08	1	PLATE 2X274X212 FE//ZN20//C	BLECH		
119	95 37 411 08	1	PLATE 4X20X500	BLECH		
120	50 26 189 08	5	HEX BOLT ISO 4017 M8X22 8.8	SECHSKANTSCHRAUBE		
121	42 11 006 08	5	WASHER DIN 1440 8 ST VERZ	SCHEIBE		
123	95 38 734 08	61	SLEEVE	HUELSE		
124	49 00 188	33	HEX BOLT ISO 4017 M8X16 8.8 A2C	SECHSKANTSCHRAUBE		
125	42 16 005 08	33	WASHER DIN 7349 8,4 ST VERZ	SCHEIBE		
126	40 97 059 08	20	PAN-HEAD SCREW M8X35 A2K	FLACHKOPFSCHRAUBE		
127	10 41 285 7	42	OVAL HEAD FLAT SCREW AEHNL.ISO7380	LINSENFLACHKOPFSCHRAUBE		
128	10 41 285 4	6	OVAL HEAD FLAT SCREW AEHNL.ISO7380	LINSENFLACHKOPFSCHRAUBE		
130	97 87 760 08	2	PLATE 3X3000X55 DC01	BLECH		
131	97 87 762 08	1	PLATE 3X2285X55 DC01	BLECH		
132	97 87 763 08	1	PLATE 3X2895X55 DC01	BLECH		
133	97 87 764 08	1	PLATE 3X770X55	BLECH		
134	97 87 765 08	1	PLATE 3X915X55	BLECH		
135	97 87 766 08	1	PLATE 3X1155X55	BLECH		
137	95 41 174 08	2	CARRIER RAIL 240	TRAGSCHIENE		
138	95 41 175 08	28	CARRIER RAIL 340	TRAGSCHIENE		
139	97 03 448 08	2	CARRIER RAIL	TRAGSCHIENE		
141	97 93 096 08	1	AXLE 30.0X200 S355J2G3C+C FE//ZN20//C	ACHSE		
142	97 93 097 08	2	SLEEVE 60.0X20 S355J2G3 FE//ZN20//C	HUELSE		
143	46 00 016	2	HEX BOLT ISO 4017 M16X45 8.8 A3C	SECHSKANTSCHRAUBE		

6.2.2009

etk_en_de_074515 LR 1600/2

☐ 522 (8/9)

LIEBHERRD PIVOT SECTION
D-ANLENKSTUECK⇒ 3 713
91 57 749 08

Pos.	Item	Quantity	Description	Bezeichnung	Serie	K
144	42 00 019 08	2	WASHER DIN 125 A 17 VERZ	SCHEIBE		
150	74 90 120 08	1	CARRYING ROLLER 80/5/20X510 ST.52 GA	TRAGROLLE		
151	49 00 204	2	HEX BOLT ISO 4017 M12X35 8.8 A3C	SECHSKANTSCHRAUBE		
152	42 40 009 08	2	CIRCLIP DIN 127 A 12 VERZ	FEDERRING		
153	92 88 304 08	2	BRACKET COMPL.	LASCHE KPL.		
154	45 12 412 08	4	PIN DIN 1435 16H11X40X35 ST.50K VERZ	BOLZEN		
155	42 00 019 08	2	WASHER DIN 125 A 17 VERZ	SCHEIBE		
156	43 30 050 08	2	SPLIT PIN DIN 94 4X25 ST VERZ	SPLINT		
157	43 31 028 08	2	RETAINING SPRING 3 VERZ	SICHERUNGSFEDER		
400	91 56 428 08	1	HYDR. SUSPENDED BALLAST ⇒ 3 978 100 91 56 428 08	HYDR.SCHWEBEBALLAST-ANLE		
500	96 54 378 08	1	D PIVOT SECTION ELEC. EQUIPT. ⇒ 3 930 330 96 54 378 08	ELEKTRIK D-ANLENKSTUECK		

6.2.2009

etk_en_de_074515 LR 1600/2

523 (9/9)

LIEBHERR

D PIVOT SECTION
D-ANLENKSTUECK

⇒ 3 713
91 57 749 08

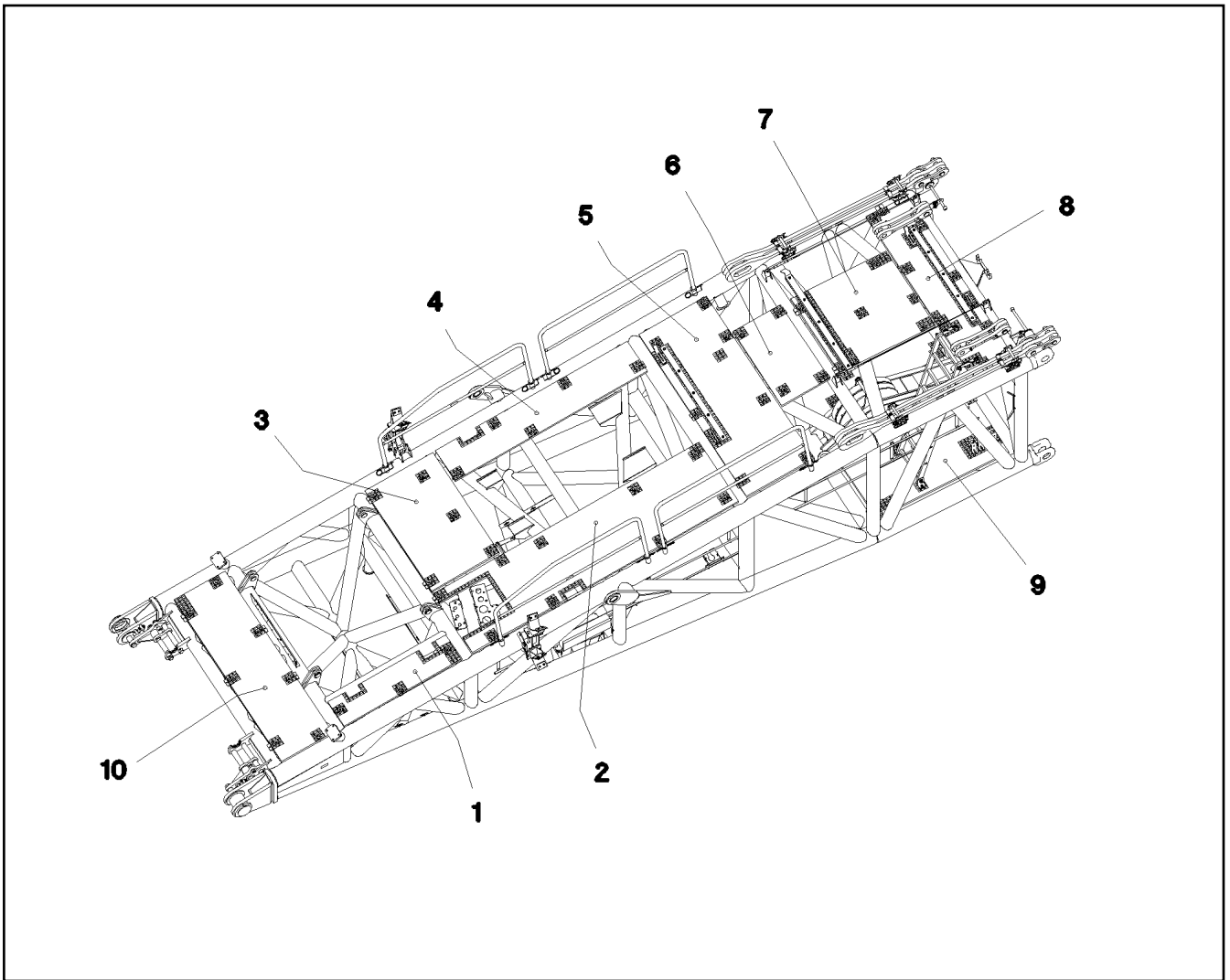

Pos.	Item	Quantity	Description	Bezeichnung	Serie	K
1	97 77 561 08	1	GRATING 1407X327X30 GFK SPF	GITTERROST		
2	97 77 560 08	1	GRATING 3167X807X30 GFK SPF	GITTERROST		
3	97 73 275 08	1	GRATING 1367X807X30 GFK SPF	GITTERROST		
4	97 77 562 08	1	GRATING 2287X407X30 GFK SPF	GITTERROST		
5	97 71 971 08	1	GRATING 2207X807X30 GFK SPF	GITTERROST		
6	97 77 563 08	1	GRATING 1007X567X30 GFK SPF	GITTERROST		
7	97 77 558 08	1	GRATING 1127X1007X30 GFK SPF	GITTERROST		
8	97 77 559 08	1	GRATING 2127X487X30 GFK SPF	GITTERROST		
9	97 77 564 08	2	GRATING 1567X887X30 GFK SPF	GITTERROST		
10	97 77 787 08	1	GRATING 2207X607X30 GFK SPF	GITTERROST		

6.2.2009
054267

LIEBHERR

etk_en_de_074515 LR 1600/2

GRATINGS
GITTERROSTE

524

⇒ 3 713 006
96 50 099 08

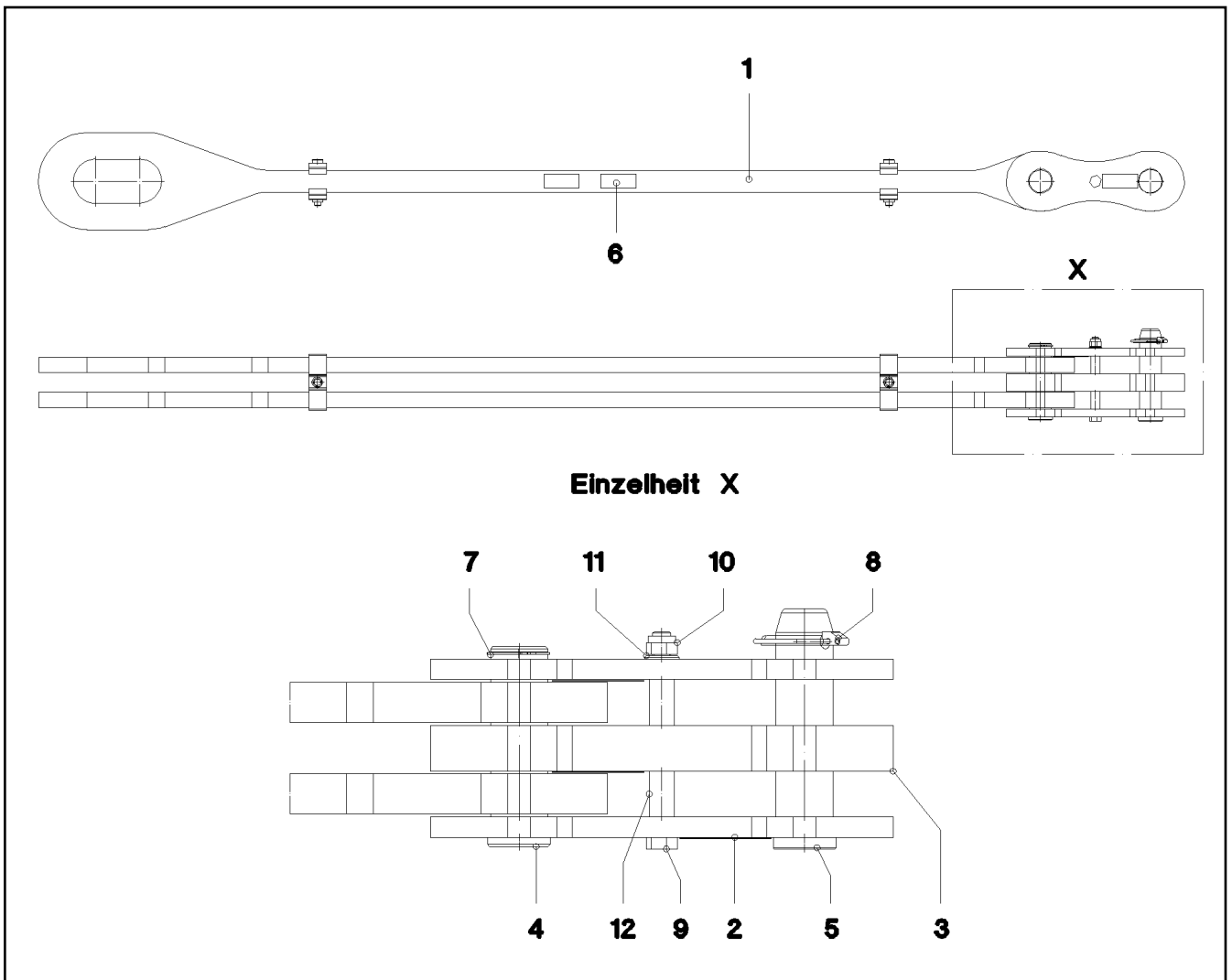

Pos.	Item	Quantity	Description	Bezeichnung	Serie	K
1	96 50 198 08	1	ROD 2.15M	STANGE VORM.		
2	96 45 231 08	2	BRACKET WITH BOARD 0.25 M	LASCHE MIT SCHILD		
3	96 45 232 08	1	BRACKET WITH BOARD 0.25 M	LASCHE MIT SCHILD		
4	97 67 727 08	1	PIN 55.0X175 30CRNIMO8+QT	BOLZEN		
5	95 28 920 08	1	PIN 55.0X210 30CRNIMO8+QT SPF	BOLZEN		
6	97 35 919 08	1	PLATE ASSEMBLY BG-NR. PVC-SILBER SP	SCHILD BAUGRUPPE		
7	42 80 042 08	1	LOCKING RING DIN 471 50X2	SICHERUNGSRING		
8	43 32 005 08	1	SAFETY PLUG W HINGE-LID 11,5X96 VERZ	SICHERHEITSKLAPPSTECKER		
9	40 61 186 01	1	HEX BOLT ISO 4014 M16X180 8.8 A3C	SECHSKANTSCHRAUBE		
10	41 19 009 08	1	HEX NUT DIN 985 M16 8 VERZ	SECHSKANTMUTTER		
11	42 00 019 08	1	WASHER DIN 125 A 17 VERZ	SCHEIBE		
12	93 92 551 08	1	TUBE 22X2,5X40	ROHR		

6.2.2009
054266

LIEBHERR

etk_en_de_074515 LR 1600/2

ROD CPL.
STANGE KPL.

525

⇒ 3 713 012
96 50 197 08

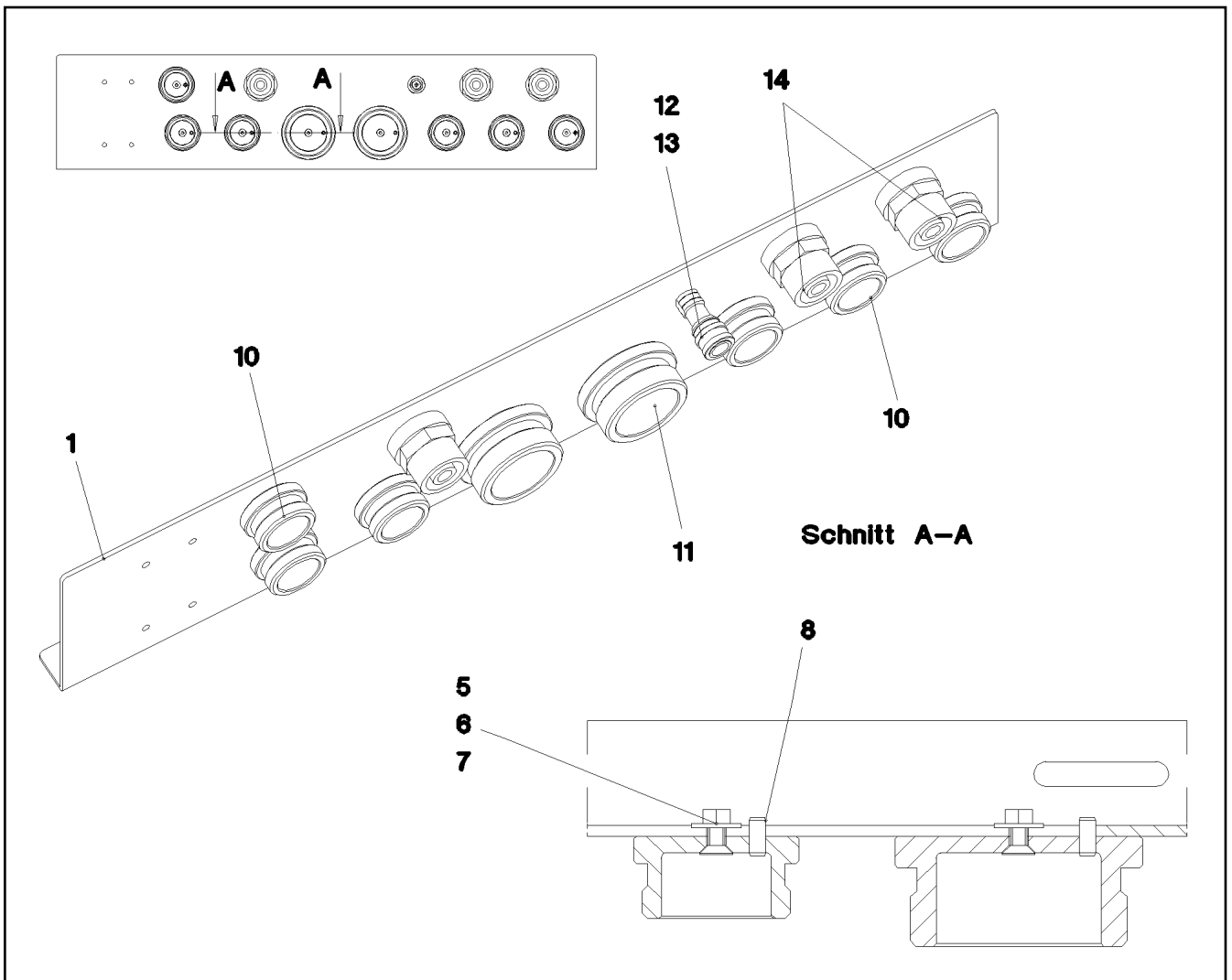

Pos.	Item	Quantity	Description	Bezeichnung	Serie	K
1	97 87 756 08	1	PLATE 4X900X225	BLECH		
5	40 86 002 08	11	COUNTERSUNK SCREW DIN 7991 M6X16 8.	SENKSCHRAUBE		
6	41 15 140 08	11	HEX NUT DIN 934 M6 8 VERZ	SECHSKANTMUTTER		
7	42 18 017 08	11	WASHER ISO 7093 A 6.4 A2	SCHEIBE		
8	43 20 053 08	8	DOWEL PIN ISO 8752 6X14	SPANNSTIFT		
10	10 46 690 8	6	SCREW PLUG RD54X4 SPF	VERSCHLUSSSCHRAUBE		
11	10 46 690 9	2	SCREW PLUG RD79X4 SPF	VERSCHLUSSSCHRAUBE		
12	47 77 040 08	1	STOPPER PLUG VST11/4"ED A3P	BLINDSTOPFEN		
13	77 43 726 08	1	COUPLING SLEEVE	KUPPLUNGSMUFFE		
14	51 15 004 08	3	COUPLING PLUG 15-L	KUPPLUNGSSTECKER		

6.2.2009
055586

LIEBHERR

etk_en_de_074515 LR 1600/2

SHEET CPL.
BLECH KPL.

526

⇒ 3 713 013
96 57 159 08

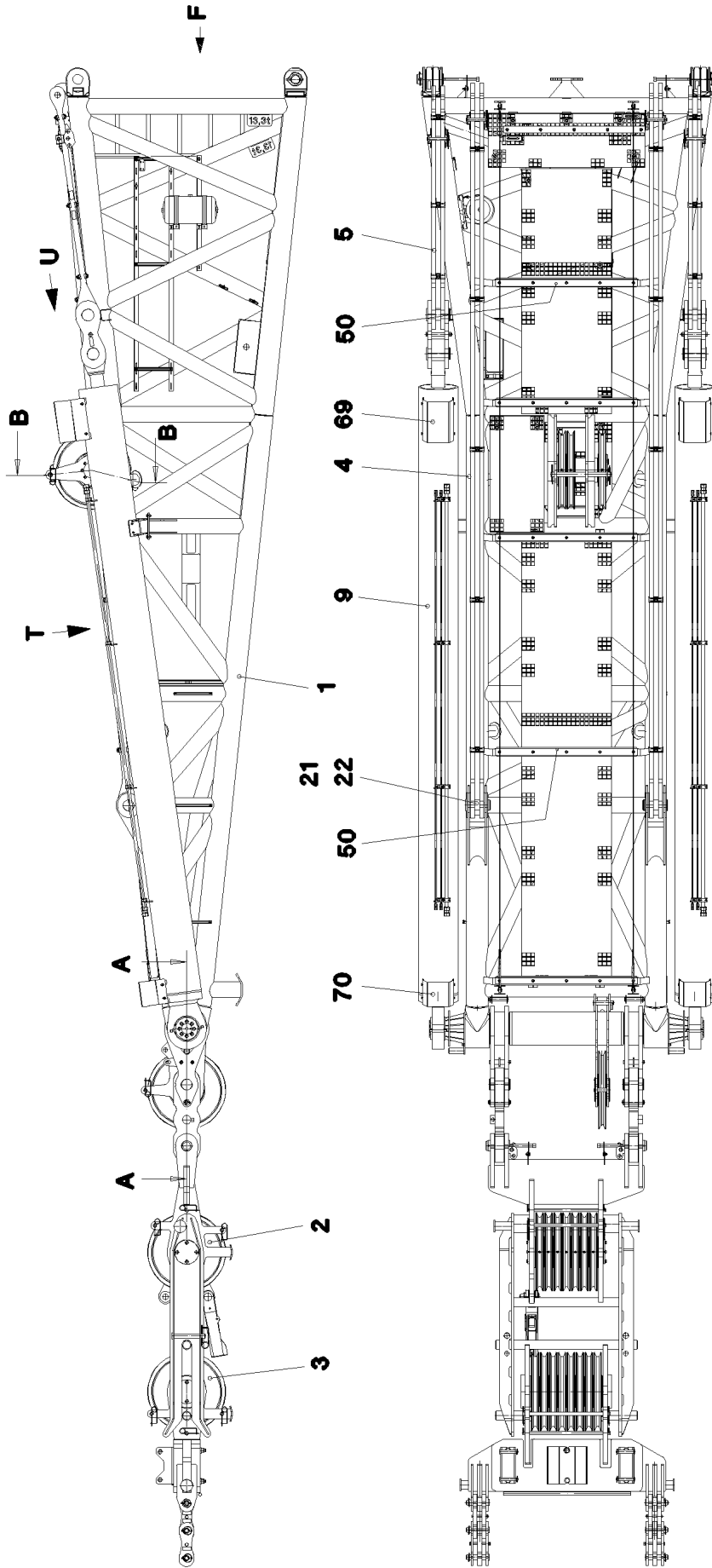

Einzelheit Z

Einzelheit Y

Einzelheit X

83
87
88

48
49
83
89

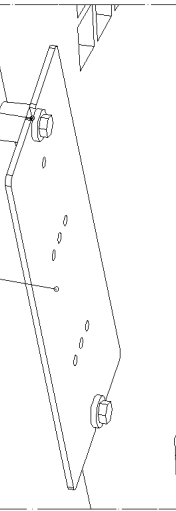

92

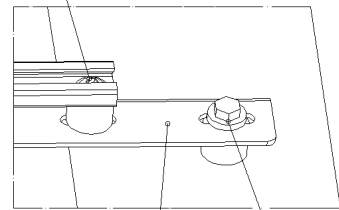

80
83
87
88

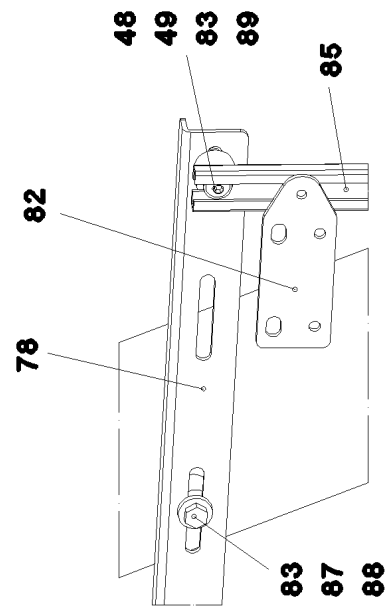

48
49
83
89

82

78

83
87
88

85

6.2.2009
054271

LIEBHERR

etk_en_de_074515 LR 1600/2

D HEAD SECTION
D-KOPFSTUECK

□ 527 (1/6)

⇒ 3 714
91 52 862 08

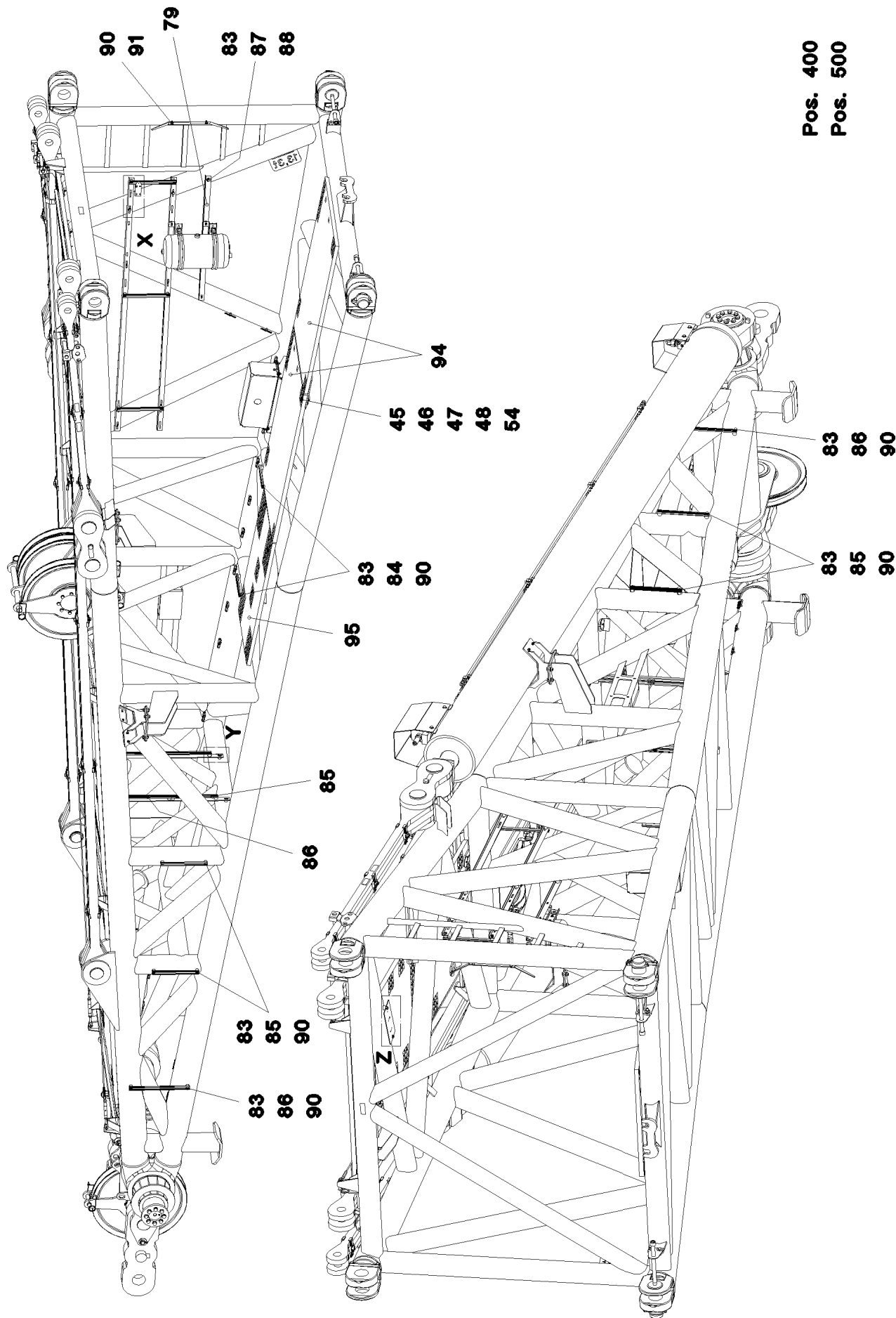

Pos. 400
Pos. 500

6.2.2009
054272

LIEBHERR

etk_en_de_074515 LR 1600/2

D HEAD SECTION
D-KOPFSTUECK

528 (2/6)

→ 3 714
91 52 862 08

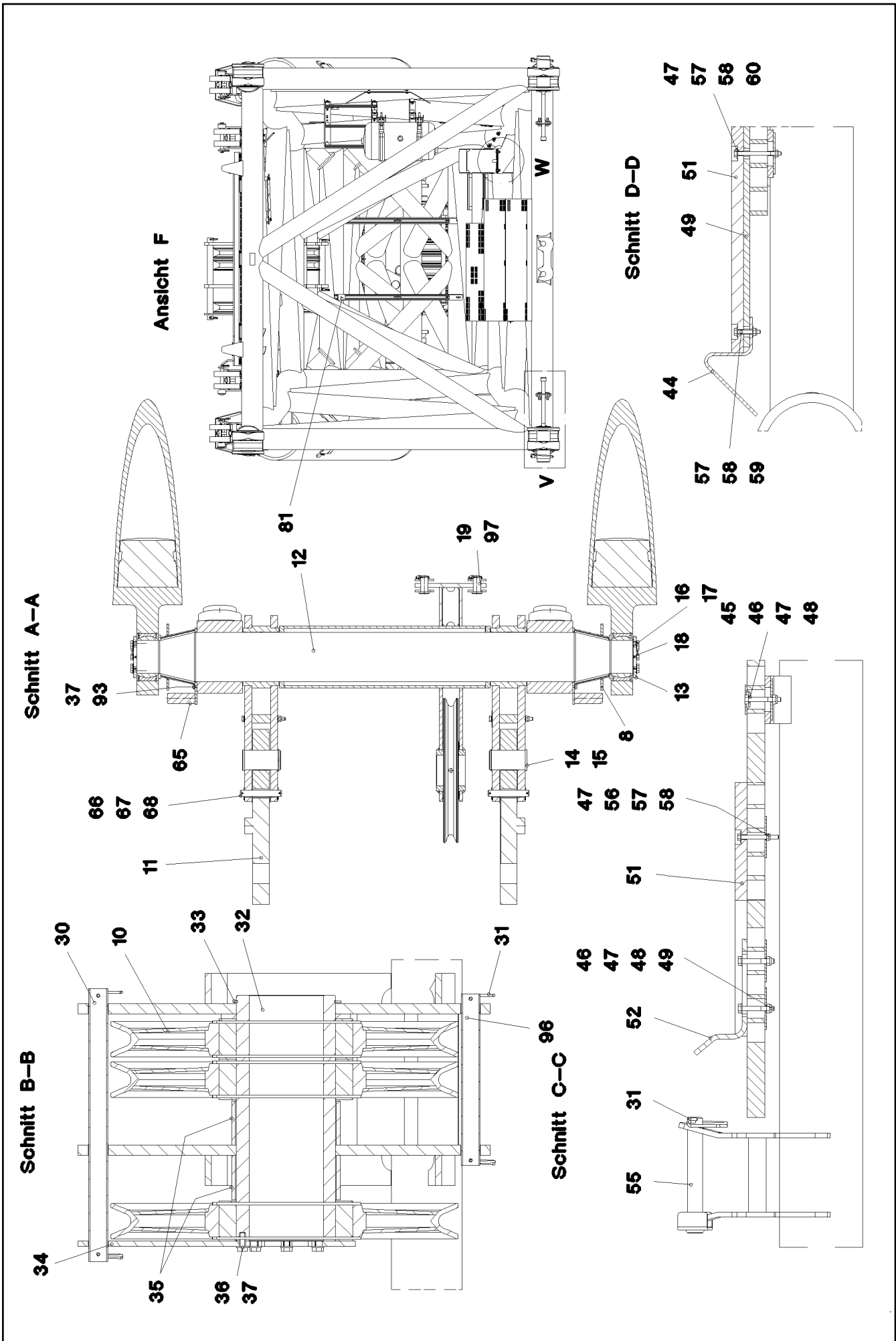

6.2.2009
054273

LIEBHERR

etk_en_de_074515 LR 1600/2

D HEAD SECTION
D-KOPFSTUECK

□ 529 (3/6)

→ 3 714
91 52 862 08

Ansicht U

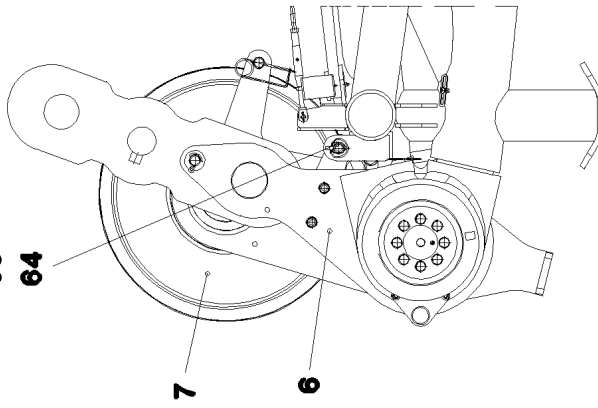

Einzelheit W

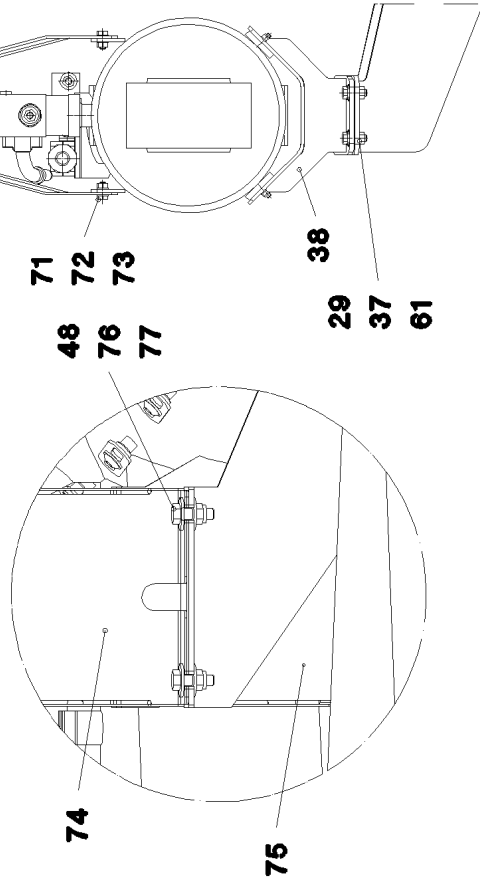

Einzelheit V

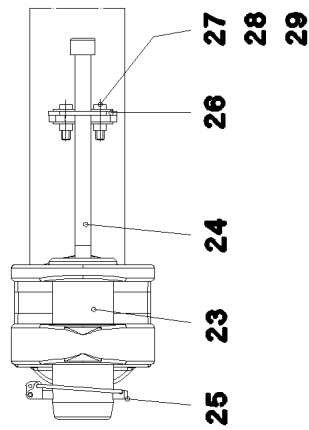

Ansicht T

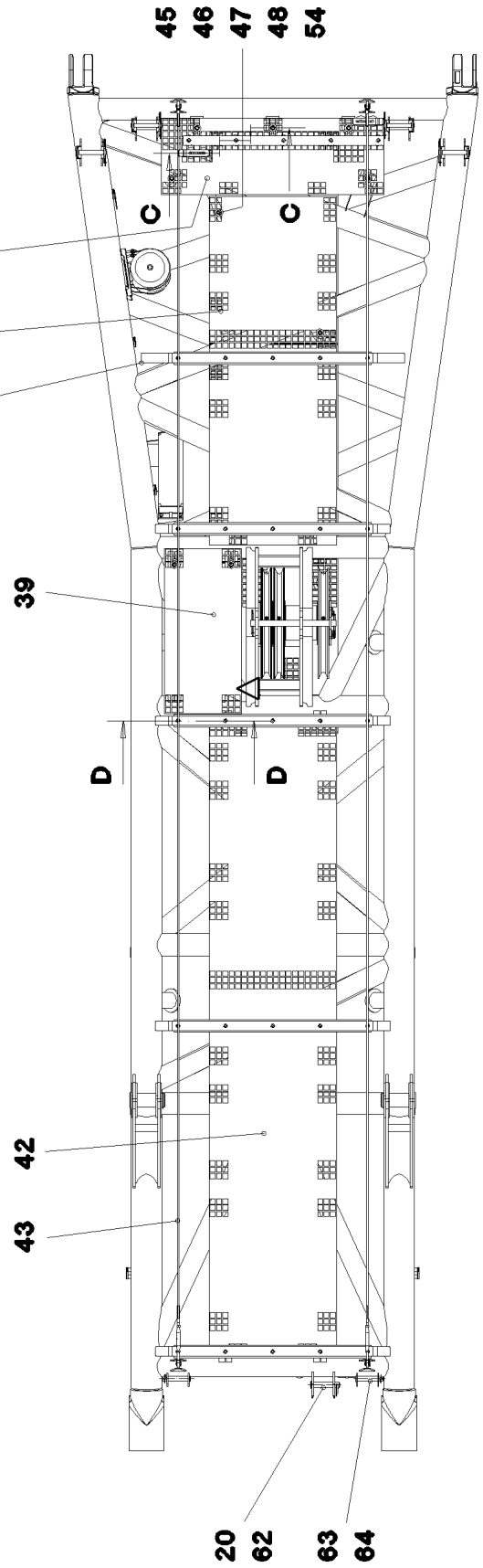

6.2.2009
054274

LIEBHERR

etk_en_de_074515 LR 1600/2

D HEAD SECTION
D-KOPFSTUECK

□ 530 (4/6)

⇒ 3 714
91 52 862 08

Pos.	Item	Quantity	Description	Bezeichnung	Serie	K
1	96 49 265 08	1	D HEAD SECTION WELDED CONSTR.	D-KOPFSTUECK SCHWK.		
2	96 49 266 08	1	LUFFING PULLEY BLOCK COMPLETE ⇒ 3 714 008 96 49 266 08	VERSTELLFLASCHE KPL.		
3	96 49 267 08	1	LUFFING PULLEY BLOCK COMPLETE TZNO ⇒ 3 714 009 96 49 267 08	VERSTELLFLASCHE KPL.		
4	96 49 268 08	2	ROD CPL.	STANGE KPL.		
5	96 49 269 08	2	ROD CPL. 2.34M ⇒ 3 714 025 96 49 269 08	STANGE KPL.		
6	96 49 270 08	2	BRACKET COMPL. ⇒ 3 714 013 96 49 270 08	LASCHE KPL.		
7	96 49 271 08	1	ROLLER SEATING COMPL. ⇒ 3 714 021 96 49 271 08	ROLLENLAGERUNG KPL.		
8	96 49 272 08	2	DISTANCE PIECE WELDED	DISTANZSTUECK SCHWK.		
9	96 49 797 08	2	TRACTION RAM PRE-ASS. ⇒ 3 714 016 96 49 797 08	ZUGZYLINDER VORM.		
10	96 46 246 08	3	ROPE PULLEY CPL. SPF ⇒ 2 550 003 96 46 246 08	SEILROLLE KPL.		
11	10 28 861 0	2	TENSION DYNAMOMETER ZUG 0-1650KN -4	ZUGMESSLASCHE		
12	97 76 838 08	1	AXLE 260.0X2407 SPF	ACHSE		
13	97 76 839 08	2	PLATE 15X200X200	BLECH		
14	97 76 840 08	2	PIN 100.0X185 SPF	BOLZEN		
15	42 80 065 08	2	LOCKING RING DIN 471 95X3	SICHERUNGSRING		
16	40 66 030 08	16	HEX BOLT ISO 4017 M16X40 10.9 FLZN SPF	SECHSKANTSCHRAUBE		
17	42 00 019 08	16	WASHER DIN 125 A 17 VERZ	SCHEIBE		
18	77 43 040 08	2	GREASE NIPPLE DIN 71412 A M10X1	SCHMIERNIPPEL		
19	45 30 324 08	2	PIN DIN 1444 36H11X80X70 30CRNIMO8V	BOLZEN		
20	43 31 025 08	1	RETAINING SPRING 5 VERZ	SICHERUNGSFEDER		
21	95 66 686 08	2	PIN 100.0X225 35NICRMOV125 SPF	BOLZEN		
22	42 80 064 08	2	LOCKING RING DIN 471 90X3	SICHERUNGSRING		
23	97 68 649 08	2	PIN 100.0X237 35NICRMOV125 SPF	BOLZEN		
24	46 30 212	2	CYLINDER SCREW ISO 4762 M24X340 10.9	ZYLINDERSCHRAUBE		
25	43 32 015 08	2	SAFETY PLUG W HINGE-LID 17X125 VERZ	SICHERHEITSKLAPPSTECKER		
26	95 50 518 08	2	PLATE 5X104X140	BLECH		
27	46 00 158	4	HEX BOLT ISO 4017 M12X45 8.8 A3C	SECHSKANTSCHRAUBE		
28	42 18 011 08	8	WASHER ISO 7093-1 A 13 ST A3C	SCHEIBE		
29	41 15 143 08	4	HEX NUT DIN 934 M12 8 VERZ	SECHSKANTMUTTER		
30	97 15 586 08	1	TUBE 38.0X540	ROHR		
31	43 31 009 08	8	RETAINING SPRING 4,5 VERZ	SICHERUNGSFEDER		
32	97 76 908 08	1	AXLE 219.1X487 SPF	ACHSE		
33	42 80 093 08	1	LOCKING RING DIN 471 200X4	SICHERUNGSRING		
34	97 76 909 08	1	PLATE 10X549X280	BLECH		
35	97 76 910 08	2	TUBE 219.1X88	ROHR		
36	49 00 161	8	HEX BOLT ISO 4017 M12X30 8.8 A3C	SECHSKANTSCHRAUBE		
37	42 00 016 08	28	WASHER ISO 7089 A 13 ST A3C	SCHEIBE		
38	96 50 752 08	2	SUPPORT CPL. ⇒ 3 714 017 96 50 752 08	AUFLAGE KPL.		
39	97 79 282 08	1	GRATING 1047X487X30 GFK SPF	GITTERROST		
40	97 66 610 08	1	GRATING 1407X487X30 GFK SPF	GITTERROST		
41	97 71 971 08	1	GRATING 2207X807X30 GFK SPF	GITTERROST		
42	97 71 763 08	1	GRATING 4047X807X30 GFK SPF	GITTERROST		
43	10 65 281 8	2	ROUND STRAND ROPE 10MM 7,97M EDEL	RUNDLITZENSEIL		
44	97 79 283 08	8	PLATE 5X263X60	BLECH		
45	10 10 062 1	51	DISH MOUNTING	TELLERBEFESTIGUNG		
46	40 61 024	55	HEX BOLT ISO 4014 M8X55 8.8 A2C	SECHSKANTSCHRAUBE		
47	94 11 381 08	65	WASHER 70X3	SCHEIBE		
48	41 19 005 08	71	HEX NUT DIN 985 M8 8 VERZ	SECHSKANTMUTTER		
49	42 00 012 08	16	WASHER DIN 125 A8X16 ST VERZ	SCHEIBE		
50	97 41 440 08	5	PLATE 10X1250X80	BLECH		
51	97 41 439 08	6	SUPPORT PLATE 60X1270 PA6G	AUFLAGE		
52	97 73 817 08	2	PLATE 8X40X246	BLECH		

6.2.2009

etk_en_de_074515 LR 1600/2

☐ 531 (5/6)

LIEBHERRD HEAD SECTION
D-KOPFSTUECK⇒ 3 714
91 52 862 08

Pos.	Item	Quantity	Description	Bezeichnung	Serie	K
53	95 64 428 08	2	PLATE 5X393X60 S380MC	BLECH		
54	95 54 048 08	2	PLATE 8X300X50	BLECH		
55	96 43 771 08	4	CONNECTING PIN WELDED	ABSTECKBOLZEN SCHWK.		
56	46 00 356	9	HEX BOLT ISO 4014 M6X65 8.8 A2C	SECHSKANTSCHRAUBE		
57	42 18 007 08	40	WASHER DIN 9021 A 6.4 VERZ	SCHEIBE		
58	41 19 004 08	30	HEX NUT DIN 985 M6 8 VERZ	SECHSKANTMUTTER		
59	40 01 928	10	HEX BOLT ISO 4014 M6X40 8.8 A2C	SECHSKANTSCHRAUBE		
60	49 81 024	11	HEX BOLT ISO 4014 M6X75 8.8 A2C	SECHSKANTSCHRAUBE		
61	49 00 204	8	HEX BOLT ISO 4017 M12X35 8.8 A3C	SECHSKANTSCHRAUBE		
62	95 59 982 08	1	PIN 45X183 30CRNIMO8+QT	BOLZEN		
63	97 04 625 08	2	PIN 35x178	BOLZEN		
64	43 32 002 08	2	HINGED CONNECTOR DIN 11023 6X42 VER	KLAPPSTECKER		
65	96 50 831 08	2	CLAMP WELDED CONST.	HALTER SCHWK.		
66	45 25 412 08	2	PIN ISO 2340 B30X200X180 30CRNIMO8 GA	BOLZEN		
67	42 00 028 08	4	WASHER ISO 7089 A 31 A3C	SCHEIBE		
68	43 30 088 08	4	SPLIT PIN DIN 94 8X50 ST VERZ	SPLINT		
69	97 79 663 08	2	PLATE 4X747X370	BLECH		
70	97 79 664 08	2	PLATE 4X667X220	BLECH		
71	40 65 164	16	HEX BOLT ISO 4017 M10X25 8.8 A3C	SECHSKANTSCHRAUBE		
72	42 00 013 08	32	WASHER ISO 7089 A 10.5 A3C	SCHEIBE		
73	41 15 144 08	16	HEX NUT DIN 934 M10 8 VERZ	SECHSKANTMUTTER		
74	95 32 110 08	1	HOOD 1.5X931X548	HAUBE		
75	95 47 461 08	1	HOOD 1.5X831X448	HAUBE		
76	49 00 128	4	HEX BOLT ISO 4017 M8X25 8.8 A2C	SECHSKANTSCHRAUBE		
77	42 18 009 08	8	WASHER DIN 9021 A 8.4 VERZ	SCHEIBE		
78	97 86 361 08	2	PLATE 3X2120X55	BLECH		
79	97 86 362 08	1	PLATE 3X1040X55	BLECH		
80	97 86 363 08	2	PLATE 3X880X55	BLECH		
81	97 86 364 08	2	PLATE 3X40X95	BLECH		
82	95 37 609 08	1	PLATE 3X45X120	BLECH		
83	95 38 734 08	48	SLEEVE	HUELSE		
84	95 41 174 08	2	CARRIER RAIL 240	TRAGSCHIENE		
85	95 41 175 08	9	CARRIER RAIL 340	TRAGSCHIENE		
86	97 03 448 08	4	CARRIER RAIL	TRAGSCHIENE		
87	49 00 188	12	HEX BOLT ISO 4017 M8X16 8.8 A2C	SECHSKANTSCHRAUBE		
88	42 16 005 08	12	WASHER DIN 7349 8,4 ST VERZ	SCHEIBE		
89	40 97 059 08	14	PAN-HEAD SCREW M8X35 A2K	FLACHKOPFSCHRAUBE		
90	10 41 285 4	18	OVAL HEAD FLAT SCREW AEHNL.ISO7380	LINSENFLACHKOPFSCHRAUBE		
91	95 37 411 08	1	PLATE 4X20X500	BLECH		
92	97 57 099 08	1	PLATE 4X310X120	BLECH		
93	40 42 032	4	CYLINDER SCREW ISO 4762 M12X30 8.8 A3	ZYLINDERSCHRAUBE		
94	97 73 275 08	2	GRATING 1367X807X30 GFK SPF	GITTERROST		
95	97 79 207 08	1	GRATING 1127X647X30 GFK SPF	GITTERROST		
96	97 91 001 08	1	TUBE 38.0X340 ST.37.0 TZNO	ROHR		
97	43 32 014 08	2	SAFETY PLUG W HINGE-LID 8X42 VERZ	SICHERHEITSKLAPPSTECKER		
400	91 56 430 08	1	ADDL.HYDRAULIC SB-HEAD PIECE ⇒ 3 978 005 91 56 430 08	ZUSATZHYDRAULIK SB-KOPFS		
500	96 47 149 08	1	ELECTR. FOR HEAD SECTION ⇒ 3 930 421 96 47 149 08	ELEKTRIK D-KOPFSTUECK		

6.2.2009

etk_en_de_074515 LR 1600/2

532 (6/6)

LIEBHERRD HEAD SECTION
D-KOPFSTUECK⇒ 3 714
91 52 862 08

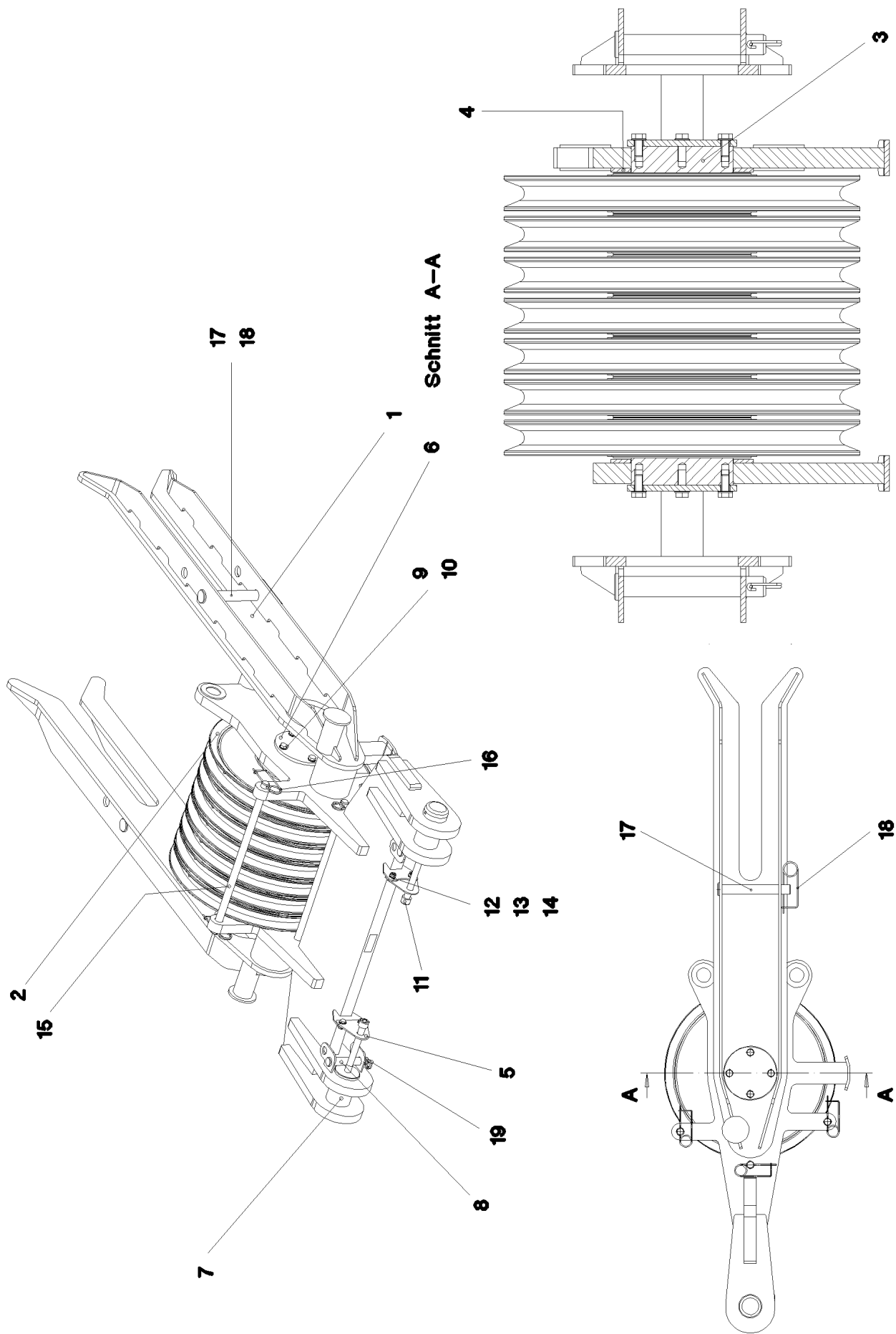

6.2.2009
055212

LIEBHERR

etk_en_de_074515 LR 1600/2

LUFFING PULLEY BLOCK COMPLETE
VERSTELLFLASCHE KPL.

533 (1/2)

→ 3 714 008
96 49 266 08

Pos.	Item	Quantity	Description	Bezeichnung	Serie	K
1	96 49 290 08	1	LUFFING PULLEY BLOCK WELDED C.	VERSTELLFLASCHE SCHWK.		
2	96 46 246 08	7	ROPE PULLEY CPL. SPF ⇒ 2 550 003 96 46 246 08	SEILROLLE KPL.		
3	97 75 885 08	1	AXLE 220.0X665 SPF	ACHSE		
4	97 75 886 08	2	PLATE 8X280X280 FE//ZN20//C	BLECH		
5	97 75 887 08	2	PLATE 5X130X125 FE//ZN20//C	BLECH		
6	94 23 101 08	2	WASHER 12X215X215 FE//ZN20//C	SCHEIBE		
7	97 03 556 08	2	PIN 100x210	BOLZEN		
8	97 04 625 08	2	PIN 35x178	BOLZEN		
9	49 00 123	8	HEX BOLT ISO 4017 M16X35 8.8 A3C	SECHSKANTSCHRAUBE		
10	42 00 019 08	8	WASHER DIN 125 A 17 VERZ	SCHEIBE		
11	54 01 790 08	2	CYLINDER SCREW DIN EN ISO 4762 M24X24	ZYLINDERSCHRAUBE		
12	49 00 161	4	HEX BOLT ISO 4017 M12X30 8.8 A3C	SECHSKANTSCHRAUBE		
13	42 00 508 08	8	WASHER DIN 125 A 13 MS	SCHEIBE		
14	41 19 007 08	4	HEX NUT DIN 985 M12 8 A3C	SECHSKANTMUTTER		
15	45 00 312 08	3	PIN DIN 1433 30X700X680 ST.37K	BOLZEN		
16	43 31 009 08	3	RETAINING SPRING 4,5 VERZ	SICHERUNGSFEDER		
17	45 12 370 08	2	PIN DIN 1435 40H11X290X260 ST.52 VERZ	BOLZEN		
18	43 31 025 08	2	RETAINING SPRING 5 VERZ	SICHERUNGSFEDER		
19	43 32 064 08	2	SPRING PLUG 6 VERZ	FEDERSTECKER		

6.2.2009

etk_en_de_074515 LR 1600/2

☐ 534 (2/2)

LIEBHERR

LUFFING PULLEY BLOCK COMPLETE
VERSTELLFLASCHE KPL.

⇒ 3 714 008
96 49 266 08

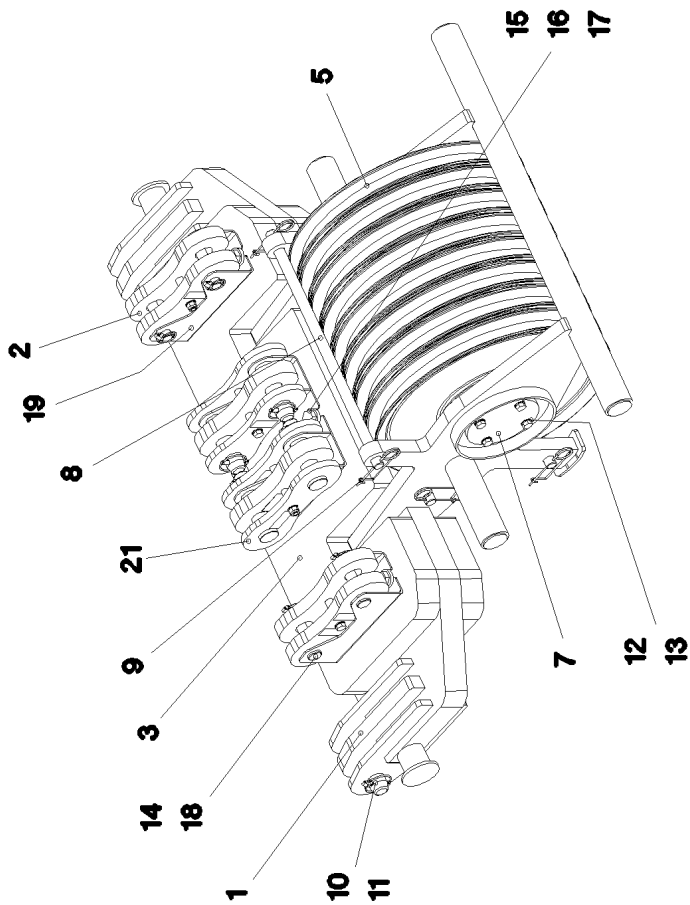
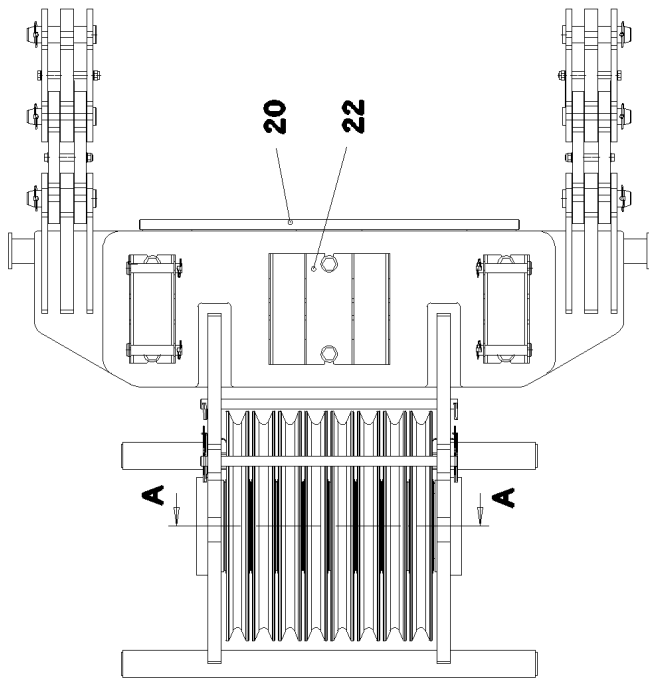

Schnitt A-A

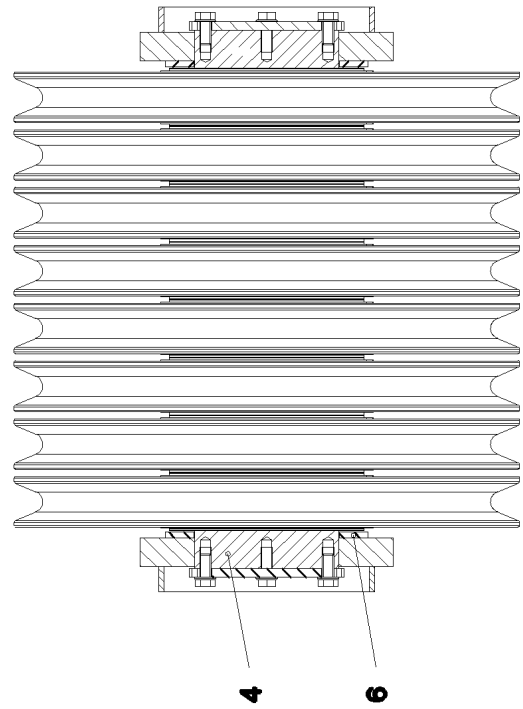

6.2.2009
055213

LIEBHERR

etk_en_de_074515 LR 1600/2

LUFFING PULLEY BLOCK COMPLETE
VERSTELLFLASCHE KPL.

▣ 535 (1/2)

⇒ 3 714 009
96 49 267 08

Pos.	Item	Quantity	Description	Bezeichnung	Serie	K
1	96 49 455 08	1	LUFFING PULLEY BLOCK WELDED C.	VERSTELLFLASCHE SCHWK.		
2	96 49 456 08	2	BRACKET COMPL. ⇒ 3 714 014 96 49 456 08	LASCHE KPL.		
3	97 76 224 08	2	PLATE 80X1380X475	BLECH		
4	97 76 225 08	1	AXLE 220.0X745 SPF	ACHSE		
5	96 46 246 08	8	ROPE PULLEY CPL. SPF ⇒ 2 550 003 96 46 246 08	SEILROLLE KPL.		
6	97 75 886 08	2	PLATE 8X280X280 FE//ZN20//C	BLECH		
7	94 23 101 08	2	WASHER 12X215X215 FE//ZN20//C	SCHEIBE		
8	93 88 891 08	3	AXLE RD30X786	ACHSE		
9	43 31 009 08	6	RETAINING SPRING 4,5 VERZ	SICHERUNGSFEDER		
10	95 28 920 08	2	PIN 55.0X210 30CRNIMO8+QT SPF	BOLZEN		
11	43 32 005 08	2	SAFETY PLUG W HINGE-LID 11,5X96 VERZ	SICHERHEITSKLAPPSTECKER		
12	49 00 123	8	HEX BOLT ISO 4017 M16X35 8.8 A3C	SECHSKANTSCHRAUBE		
13	42 00 019 08	8	WASHER DIN 125 A 17 VERZ	SCHEIBE		
14	43 32 014 08	4	SAFETY PLUG W HINGE-LID 8X42 VERZ	SICHERHEITSKLAPPSTECKER		
15	40 61 291 08	6	HEX BOLT ISO 4014 M24X300 8.8 A3C	SECHSKANTSCHRAUBE		
16	42 16 013 08	12	WASHER DIN 7349 25 ST VERZ	SCHEIBE		
17	41 19 025 08	6	HEX NUT DIN 985 M24 8 VERZ	SECHSKANTMUTTER		
18	97 03 523 08	4	PIN 40x166	BOLZEN		
19	97 89 198 08	2	PLATE 5X330X429	BLECH		
20	96 58 269 08	1	ROPE GUARD WELDED	SEILSCHUTZ SCHWK.		
21	96 59 083 08	2	BRACKET COMPL. ⇒ 3 714 013 96 59 083 08	LASCHE KPL.		
22	96 59 096 08	1	REST WELDED	ABLAGE SCHWK.		

6.2.2009

etk_en_de_074515 LR 1600/2

☐ 536 (2/2)

LIEBHERR

LUFFING PULLEY BLOCK COMPLETE
VERSTELLFLASCHE KPL.

⇒ 3 714 009
96 49 267 08

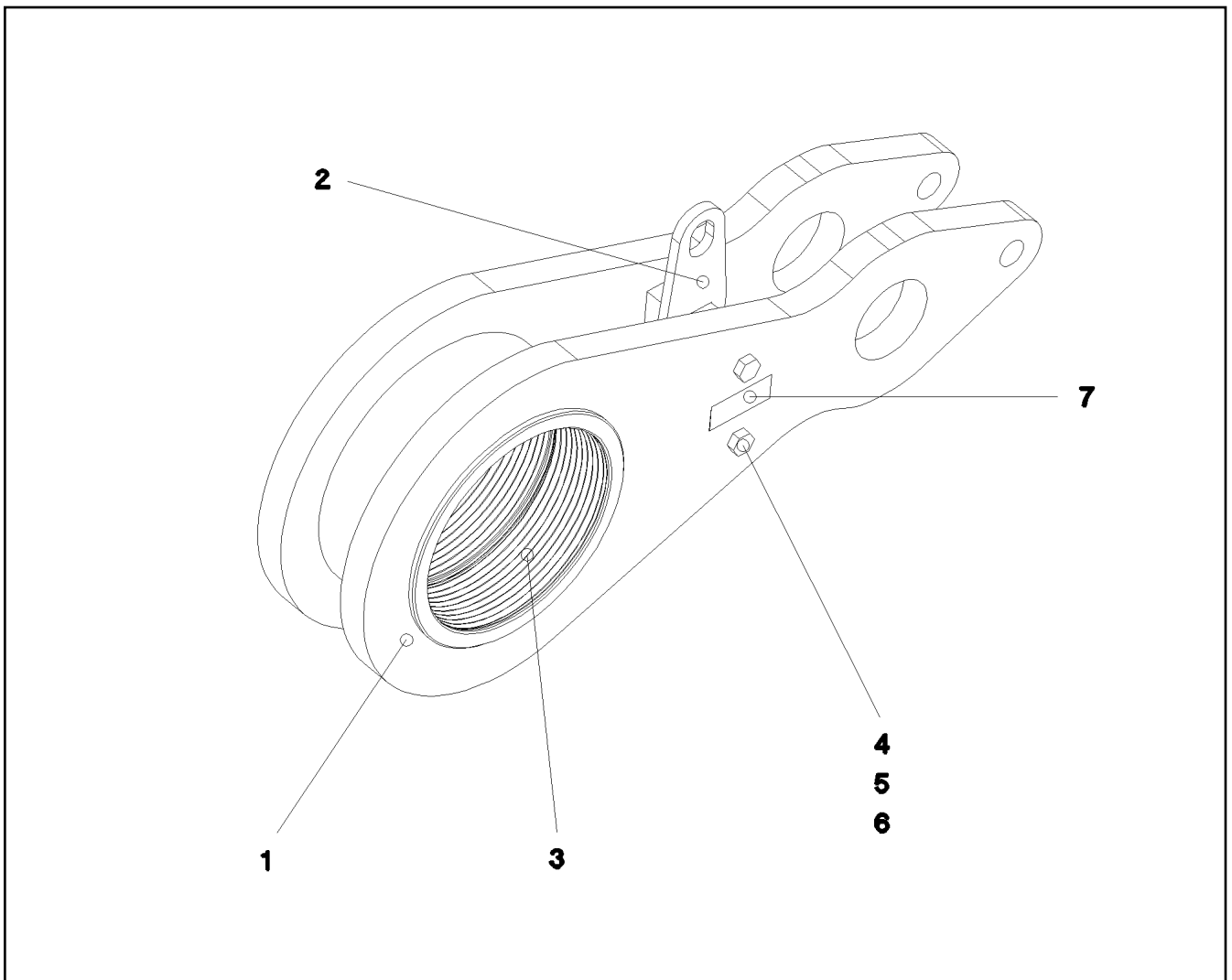

Pos.	Item	Quantity	Description	Bezeichnung	Serie	K
1	97 76 390 08	2	PLATE 35X904X404	BLECH		
2	96 50 800 08	1	DISTANCE PIECE WELDED	DISTANZSTUECK SCHWK.		
3	97 76 392 08	1	BUSH 240X280X175 GZ-ZUZN25AL5	BUCHSE		
4	40 61 186 01	2	HEX BOLT ISO 4014 M16X180 8.8 A3C	SECHSKANTSCHRAUBE		
5	42 00 019 08	2	WASHER DIN 125 A 17 VERZ	SCHEIBE		
6	41 19 009 08	2	HEX NUT DIN 985 M16 8 VERZ	SECHSKANTMUTTER		
7	97 35 676 08	1	PLATE IDENTIFICATION NUMBER IDENT-N	SCHILD IDENTNR.		

6.2.2009
055210

LIEBHERR

etk_en_de_074515 LR 1600/2

BRACKET COMPL.
LASCHE KPL.

537

⇒ 3 714 013
96 49 270 08

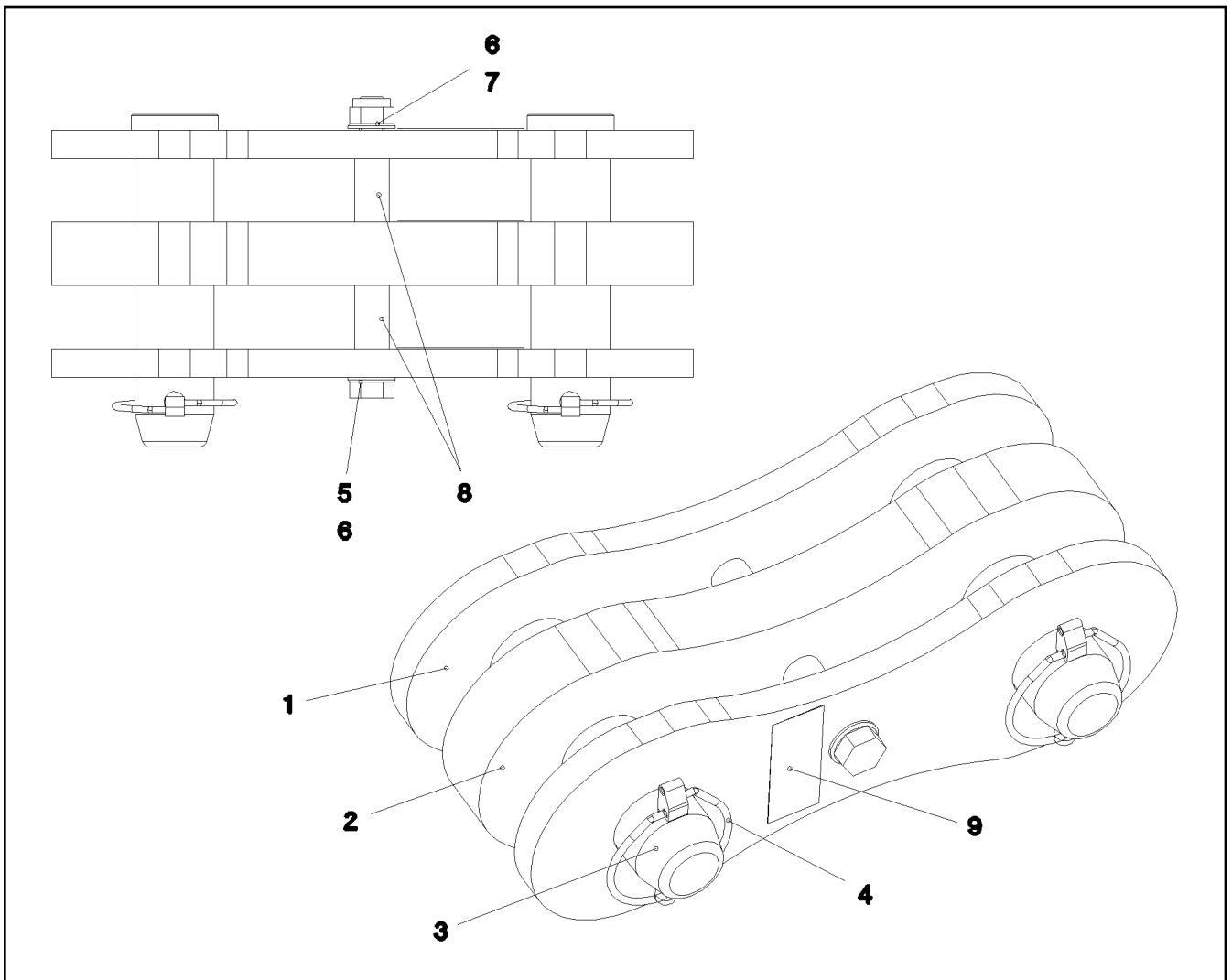

Pos.	Item	Quantity	Description	Bezeichnung	Serie	K
1	96 45 231 08	2	BRACKET WITH BOARD 0.25 M	LASCHE MIT SCHILD		
2	96 45 232 08	1	BRACKET WITH BOARD 0.25 M	LASCHE MIT SCHILD		
3	95 28 920 08	2	PIN 55.0X210 30CRNIMO8+QT SPF	BOLZEN		
4	43 32 005 08	2	SAFETY PLUG W HINGE-LID 11,5X96 VERZ	SICHERHEITSKLAPPSTECKER		
5	40 61 186 01	1	HEX BOLT ISO 4014 M16X180 8.8 A3C	SECHSKANTSCHRAUBE		
6	42 00 019 08	2	WASHER DIN 125 A 17 VERZ	SCHEIBE		
7	41 19 009 08	1	HEX NUT DIN 985 M16 8 VERZ	SECHSKANTMUTTER		
8	93 92 551 08	2	TUBE 22X2,5X40	ROHR		
9	97 35 919 08	1	PLATE ASSEMBLY BG-NR. PVC-SILBER SP	SCHILD BAUGRUPPE		

6.2.2009
056133

LIEBHERR

etk_en_de_074515 LR 1600/2

BRACKET COMPL.
LASCHE KPL.

538

⇒ 3 714 013
96 59 083 08

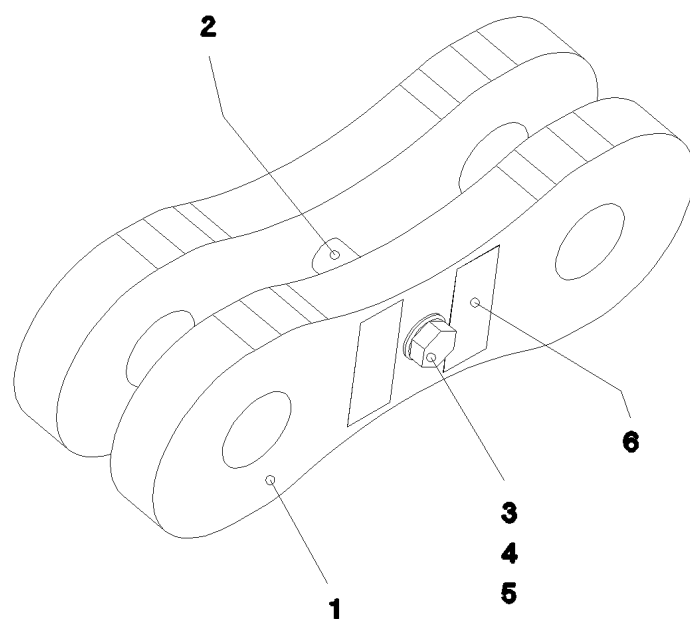

Pos.	Item	Quantity	Description	Bezeichnung	Serie	K
1	96 49 464 08	2	BRACKET WITH BOARD	LASCHE MIT SCHILD		
2	94 36 973 08	1	TUBE 22X2,5X45	ROHR		
3	40 61 180 01	1	HEX BOLT ISO 4014 M16X140 8.8 A3C	SECHSKANTSCHRAUBE		
4	42 00 019 08	2	WASHER DIN 125 A 17 VERZ	SCHEIBE		
5	41 19 009 08	1	HEX NUT DIN 985 M16 8 VERZ	SECHSKANTMUTTER		
6	97 35 919 08	1	PLATE ASSEMBLY BG-NR. PVC-SILBER SP	SCHILD BAUGRUPPE		

6.2.2009
054276

LIEBHERR

etk_en_de_074515 LR 1600/2

BRACKET COMPL.
LASCHE KPL.

539

⇒ 3 714 014
96 49 456 08

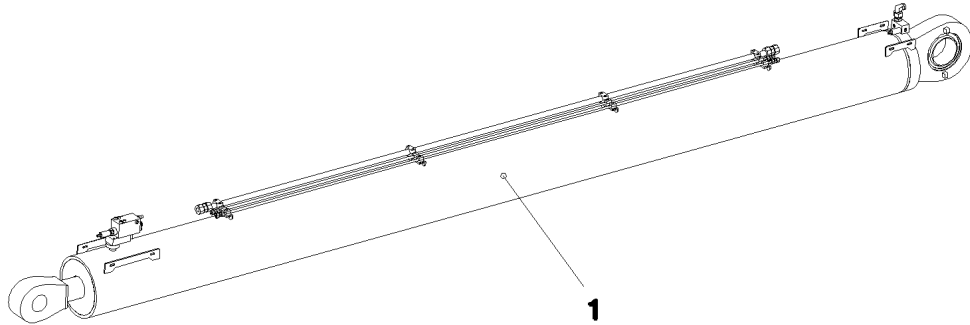

Pos. 400

Pos.	Item	Quantity	Description	Bezeichnung	Serie	K
1	10 42 959 8	1	DRAW CYLINDER 310/120-5000 SPF	ZUGZYLINDER		
400	91 56 431 08	1	AUX.HYDR.CYLINDER SB-BW ⇒ 3 978 019 91 56 431 08	ZUSATZHYDRAULIK ZYLINDER		

6.2.2009
054275

LIEBHERR

etk_en_de_074515 LR 1600/2

TRACTION RAM PRE-ASS.
ZUGZYLINDER VORM.

540

⇒ 3 714 016
96 49 797 08

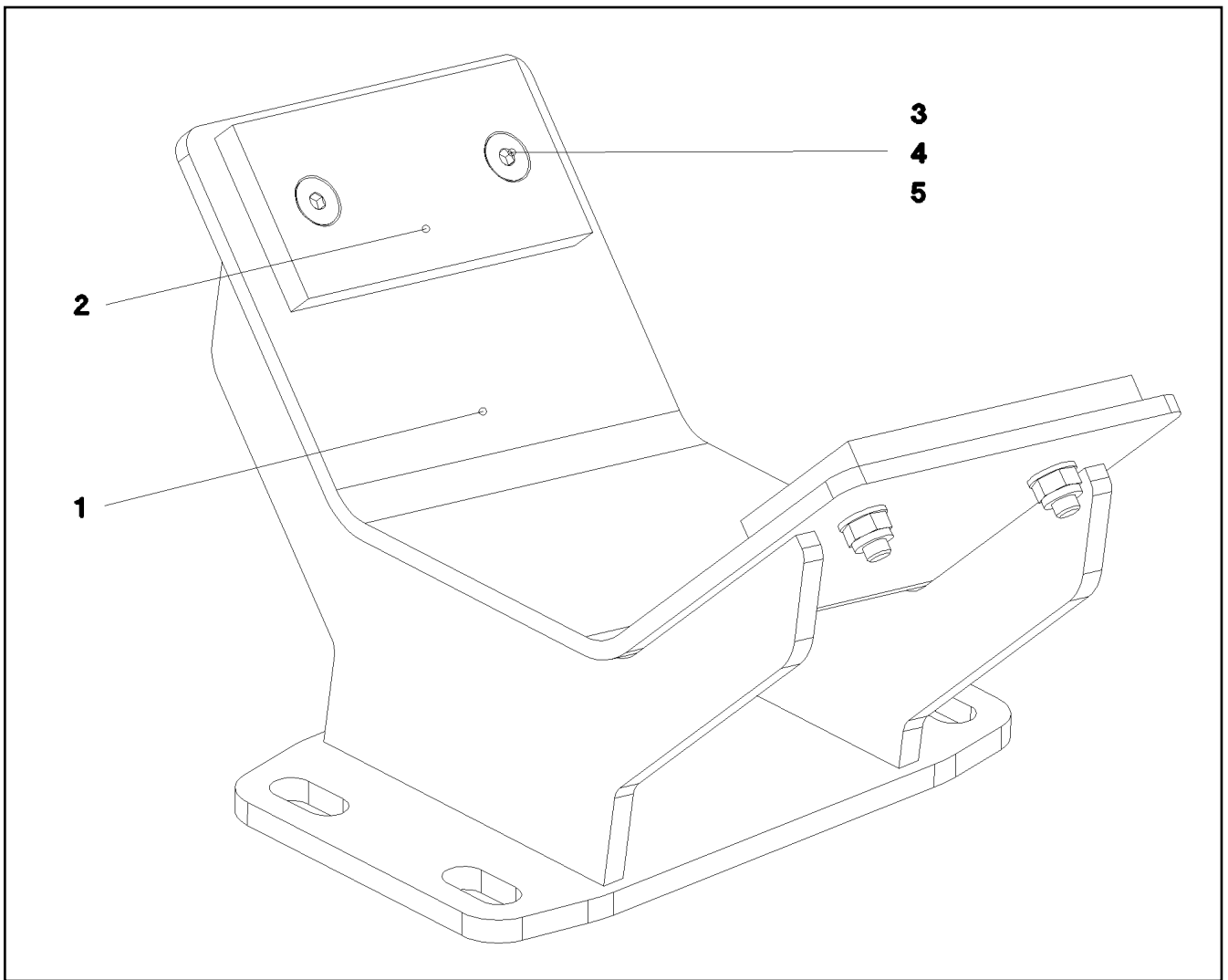

Pos.	Item	Quantity	Description	Bezeichnung	Serie	K
1	96 50 763 08	1	SUPPORT WELDED	AUFLAGE SCHWK.		
2	93 54 692 08	2	BEARING PLATE 10X60X120 PA6G	LAGERPLATTE		
3	40 86 007 08	4	COUNTERSUNK SCREW DIN 7991 M8X30 8.	SENKSCRAUBE		
4	41 19 005 08	4	HEX NUT DIN 985 M8 8 VERZ	SECHSKANTMUTTER		
5	42 00 012 08	4	WASHER DIN 125 A8X16 ST VERZ	SCHEIBE		

6.2.2009
055208

LIEBHERR

etk_en_de_074515 LR 1600/2

SUPPORT CPL.
AUFLAGE KPL.

541

⇒ 3 714 017
96 50 752 08

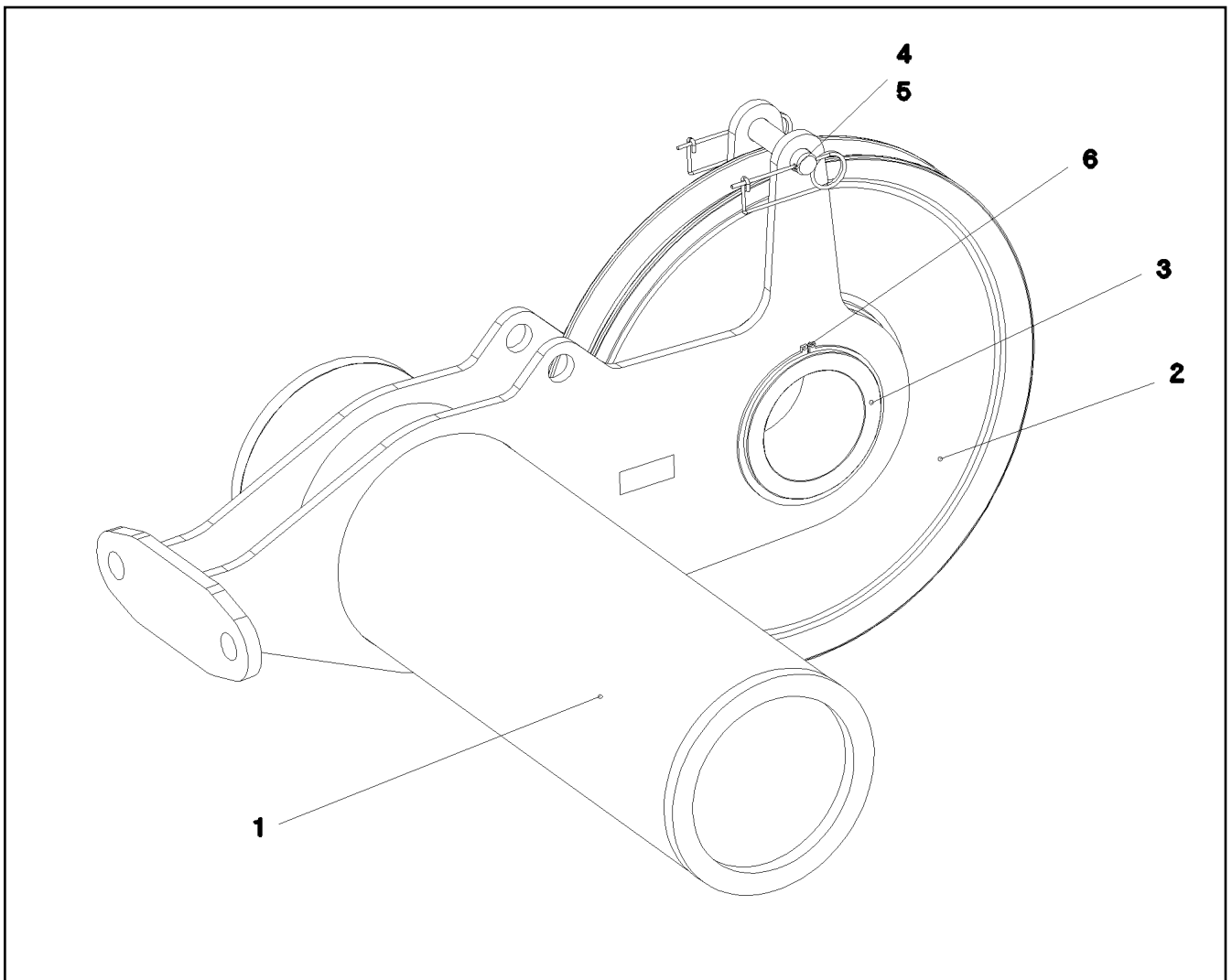

Pos.	Item	Quantity	Description	Bezeichnung	Serie	K
1	96 49 761 08	1	ROLLER BEARING WELDED	ROLLENLAGERUNG SCHWK.		
2	96 46 246 08	1	ROPE PULLEY CPL. SPF ⇒ 2 550 003 96 46 246 08	SEILROLLE KPL.		
3	97 76 746 08	1	AXLE 219.1X140 SPF	ACHSE		
4	45 00 330 08	1	PIN DIN 1433 30X140X125 ST.50K FE//ZN20//	BOLZEN		
5	43 31 009 08	2	RETAINING SPRING 4,5 VERZ	SICHERUNGSFEDER		
6	42 80 093 08	2	LOCKING RING DIN 471 200X4	SICHERUNGSRING		

6.2.2009
055211

LIEBHERR

etk_en_de_074515 LR 1600/2

ROLLER SEATING COMPL.
ROLLENLAGERUNG KPL.

542

⇒ 3 714 021
96 49 271 08

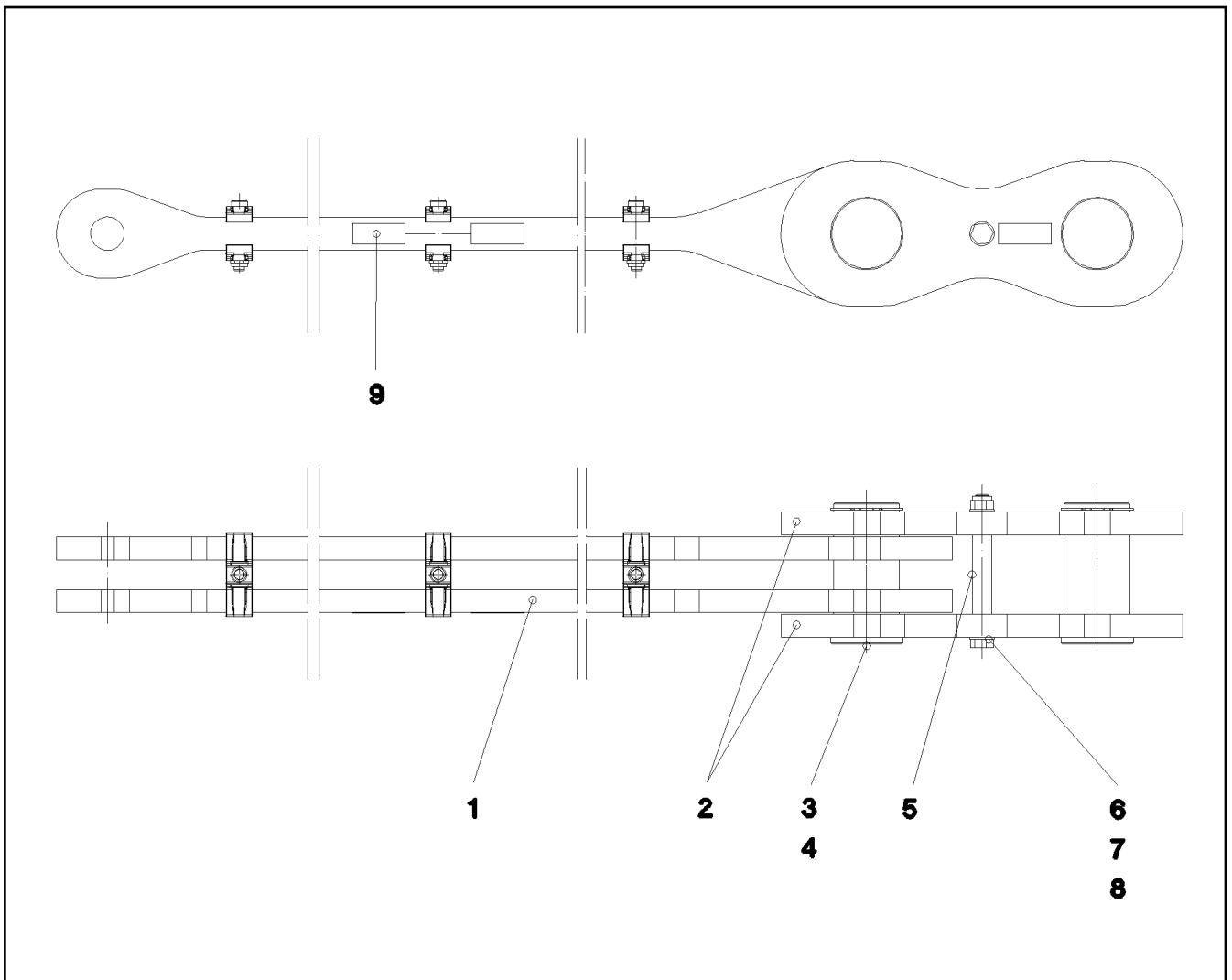

Pos.	Item	Quantity	Description	Bezeichnung	Serie	K
1	96 49 610 08	1	ROD 1.99M	STANGE VORM.		
2	96 49 611 08	2	BRACKET WITH BOARD 0.35M	LASCHE MIT SCHILD		
3	97 68 580 08	2	PIN 110.0X214 SPF	BOLZEN		
4	42 80 067 08	2	LOCKING RING DIN 471 100X3	SICHERUNGSRING		
5	97 77 023 08	1	TUBE 30.0X120	ROHR		
6	40 61 246 01	1	HEX BOLT ISO 4014 M20X220 8.8 A3C	SECHSKANTSCHRAUBE		
7	42 00 021 08	2	WASHER ISO 7089 A 21 ST A3C	SCHEIBE		
8	41 18 806 08	1	HEX NUT DIN 980 V M20 10 VERZ	SECHSKANTMUTTER		
9	97 35 919 08	1	PLATE ASSEMBLY BG-NR. PVC-SILBER SP	SCHILD BAUGRUPPE		

6.2.2009
055209

LIEBHERR

etk_en_de_074515 LR 1600/2

ROD CPL.
STANGE KPL.

543

⇒ 3 714 025
96 49 269 08

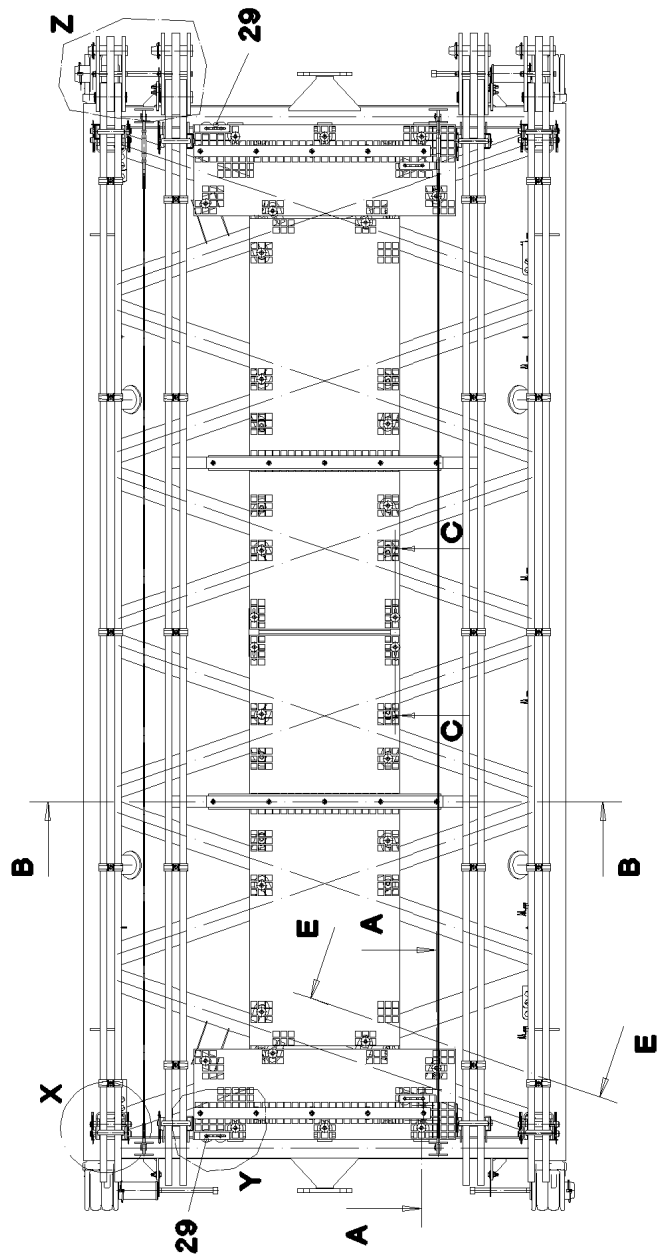
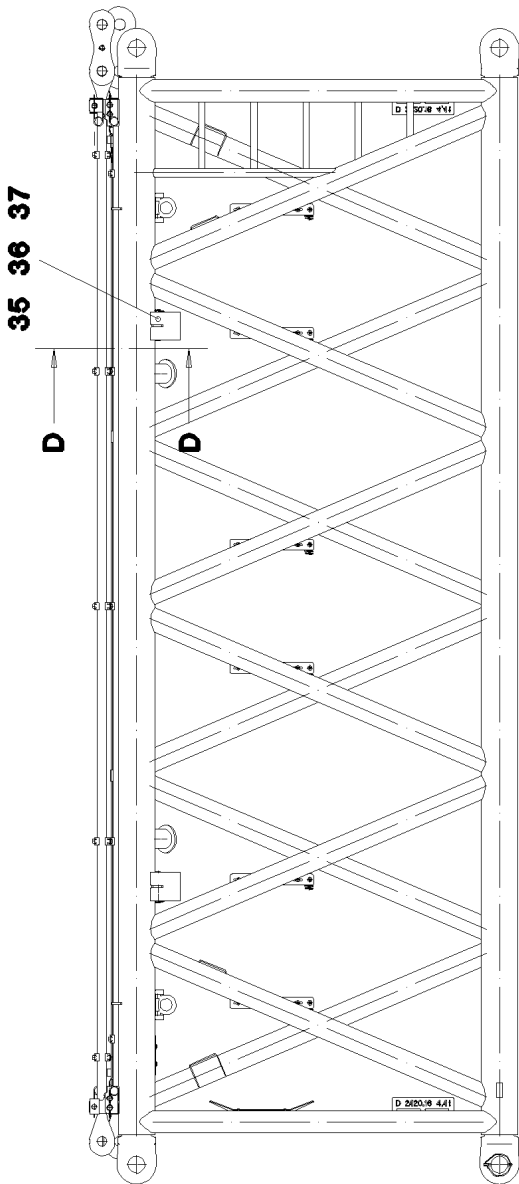
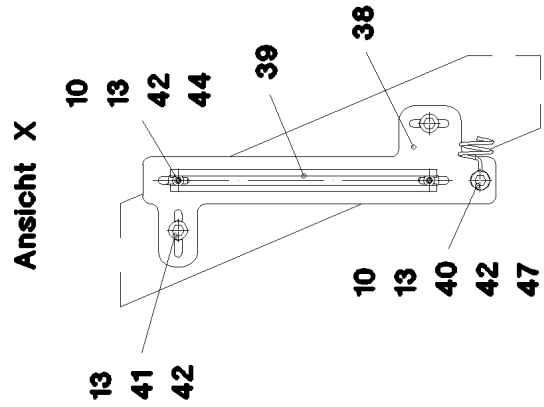
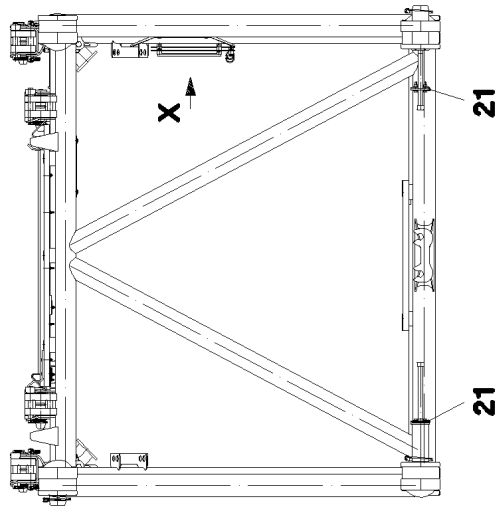

6.2.2009
055300

LIEBHERR

etk_en_de_074515 LR 1600/2

D INTERMEDIATE SECTION
D-ZWISCHENSTUECK

□ 544 (1/3)

→ 3 715 008
91 52 863 08

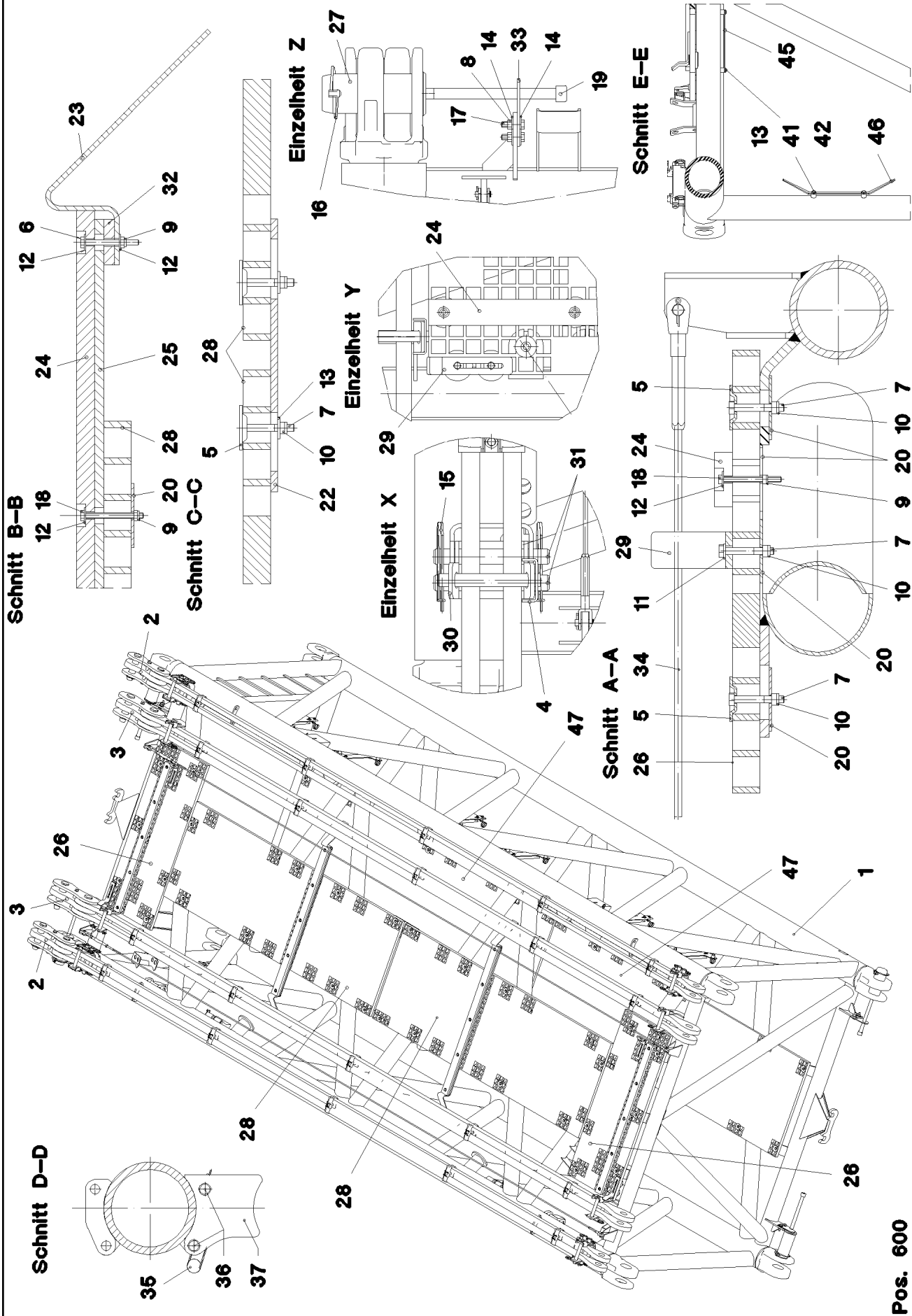

Pos. 600

6.2.2009
 055301

LIEBHERR

etk_en_de_074515 LR 1600/2

D INTERMEDIATE SECTION
 D-ZWISCHENSTUECK

545 (2/3)

→ 3 715 008
 91 52 863 08

Pos.	Item	Quantity	Description	Bezeichnung	Serie	K
1	96 48 588 08	1	D INTERMED. SECTION WELD. CON.	D-ZWISCHENSTUECK SCHWK.		
2	96 43 440 08	2	ROD CPL. 6 M ⇒ 3 220 501 96 43 440 08	STANGE KPL.		
3	96 48 593 08	2	ROD CPL. 6 M	STANGE KPL.		
4	96 43 771 08	8	CONNECTING PIN WELDED	ABSTECKBOLZEN SCHWK.		
5	10 10 062 1	48	DISH MOUNTING	TELLERBEFESTIGUNG		
6	40 01 929	4	HEX BOLT ISO 4014 M6X60 8.8 A2C	SECHSKANTSCHRAUBE		
7	40 61 024	56	HEX BOLT ISO 4014 M8X55 8.8 A2C	SECHSKANTSCHRAUBE		
8	41 15 143 08	8	HEX NUT DIN 934 M12 8 VERZ	SECHSKANTMUTTER		
9	41 19 004 08	20	HEX NUT DIN 985 M6 8 VERZ	SECHSKANTMUTTER		
10	41 19 005 08	74	HEX NUT DIN 985 M8 8 VERZ	SECHSKANTMUTTER		
11	42 00 012 08	8	WASHER DIN 125 A8X16 ST VERZ	SCHEIBE		
12	42 18 007 08	24	WASHER DIN 9021 A 6.4 VERZ	SCHEIBE		
13	42 18 009 08	48	WASHER DIN 9021 A 8.4 VERZ	SCHEIBE		
14	42 18 011 08	16	WASHER ISO 7093-1 A 13 ST A3C	SCHEIBE		
15	43 31 009 08	16	RETAINING SPRING 4,5 VERZ	SICHERUNGSFEDER		
16	43 32 015 08	4	SAFETY PLUG W HINGE-LID 17X125 VERZ	SICHERHEITSKLAPPSTECKER		
17	46 00 158	8	HEX BOLT ISO 4017 M12X45 8.8 A3C	SECHSKANTSCHRAUBE		
18	46 00 356	16	HEX BOLT ISO 4014 M6X65 8.8 A2C	SECHSKANTSCHRAUBE		
19	46 30 212	4	CYLINDER SCREW ISO 4762 M24X340 10.9	ZYLINDERSCHRAUBE		
20	94 11 381 08	64	WASHER 70X3	SCHEIBE		
21	95 50 518 08	2	PLATE 5X104X140	BLECH		
22	95 54 048 08	4	PLATE 8X300X50	BLECH		
23	95 64 428 08	4	PLATE 5X393X60 S380MC	BLECH		
24	97 41 439 08	4	SUPPORT PLATE 60X1270 PA6G	AUFLAGE		
25	97 41 440 08	2	PLATE 10X1250X80	BLECH		
26	97 66 610 08	2	GRATING 1407X487X30 GFK SPF	GITTERROST		
27	97 68 649 08	4	PIN 100.0X237 35NICRMOV125 SPF	BOLZEN		
28	97 71 971 08	2	GRATING 2207X807X30 GFK SPF	GITTERROST		
29	97 73 817 08	4	PLATE 8X40X246	BLECH		
30	97 74 758 08	4	PLATE 8X407X110 T ZN O	BLECH		
31	97 74 759 08	8	PIN 30.0X220 S355J2G3 T ZN O	BOLZEN		
32	97 74 760 08	4	WASHER 12X50X50 T ZN O	SCHEIBE		
33	97 74 928 08	2	PLATE 5X150X101	BLECH		
34	10 65 243 9	2	ROUND STRAND ROPE 10MM 5,54M EDEL	RUNDLITZENSEIL		
35	43 31 028 08	8	RETAINING SPRING 3 VERZ	SICHERUNGSFEDER		
36	45 30 083 08	8	PIN DIN 1444 16H11X162X157 30CRNIMO8	BOLZEN		
37	97 76 196 08	4	BEARING BLOCK PA6G	LAGERKLOTZ		
38	97 88 000 08	6	PLATE 4X205X450 FE//ZN20//C	BLECH		
39	95 41 175 08	6	CARRIER RAIL 340	TRAGSCHIENE		
40	72 00 144 08	6	CABLE HOLDER	KABELHALTER		
41	49 00 188	16	HEX BOLT ISO 4017 M8X16 8.8 A2C	SECHSKANTSCHRAUBE		
42	95 38 734 08	34	SLEEVE	HUELSE		
43	40 61 062	6	HEX BOLT ISO 4014 M8X40 8.8 A2C	SECHSKANTSCHRAUBE		
44	10 45 022 6	12	PAN-HEAD SCREW ISO 7380 M8X35 A2-70	FLACHKOPFSCHRAUBE		
45	97 57 099 08	1	PLATE 4X310X120	BLECH		
46	95 37 411 08	1	PLATE 4X20X500	BLECH		
47	97 88 638 08	2	GRATING 2687X807X30 GFK	GITTERROST		
600	91 56 432 08	1	ADDITIONAL HYDRAULICS INTERMED 6 M ⇒ 3 978 015 91 56 432 08	ZUSATZHYDRAULIK ZWISCHEN		

6.2.2009

etk_en_de_074515 LR 1600/2

546 (3/3)

LIEBHERRD INTERMEDIATE SECTION
D-ZWISCHENSTUECK⇒ 3 715 008
91 52 863 08

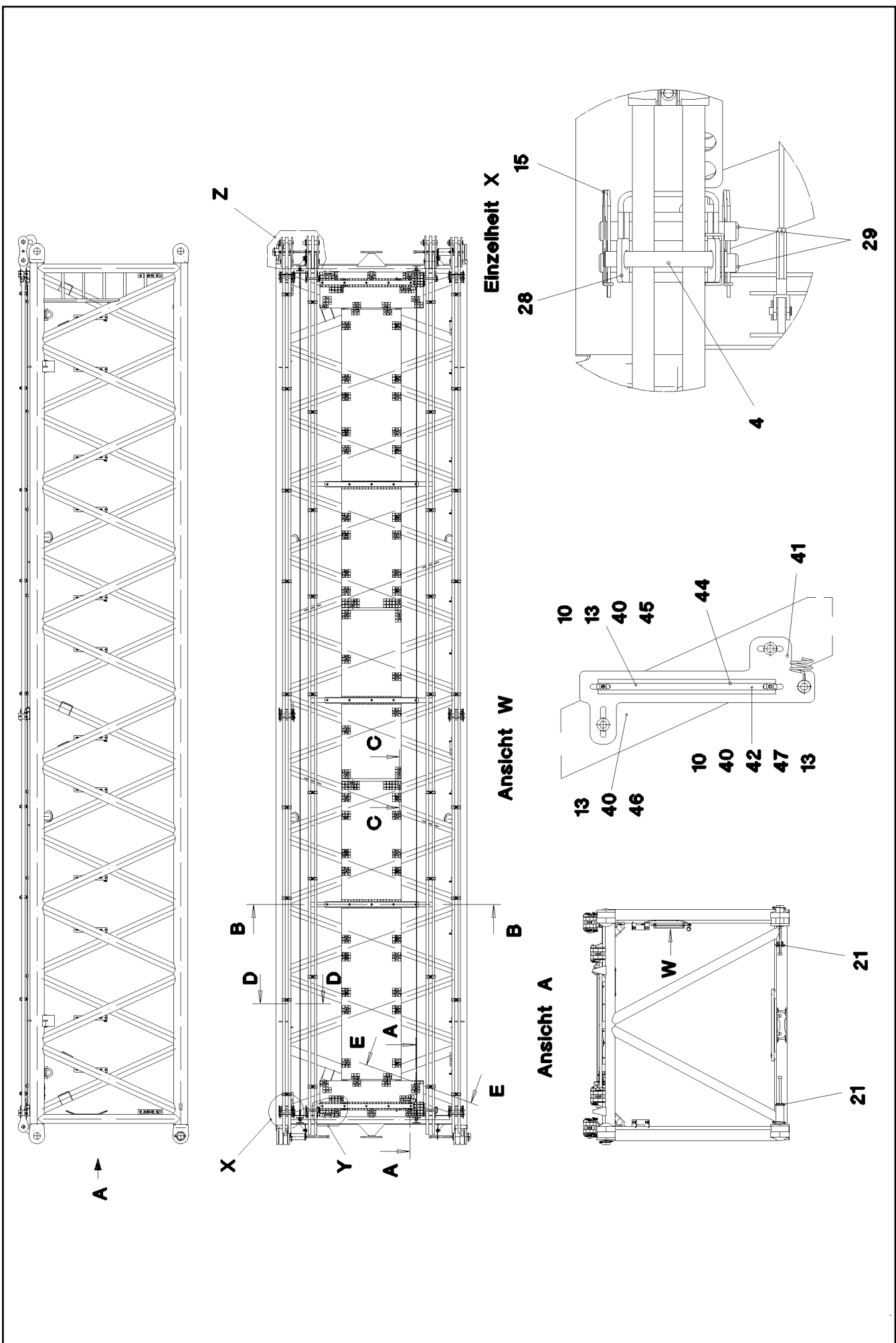

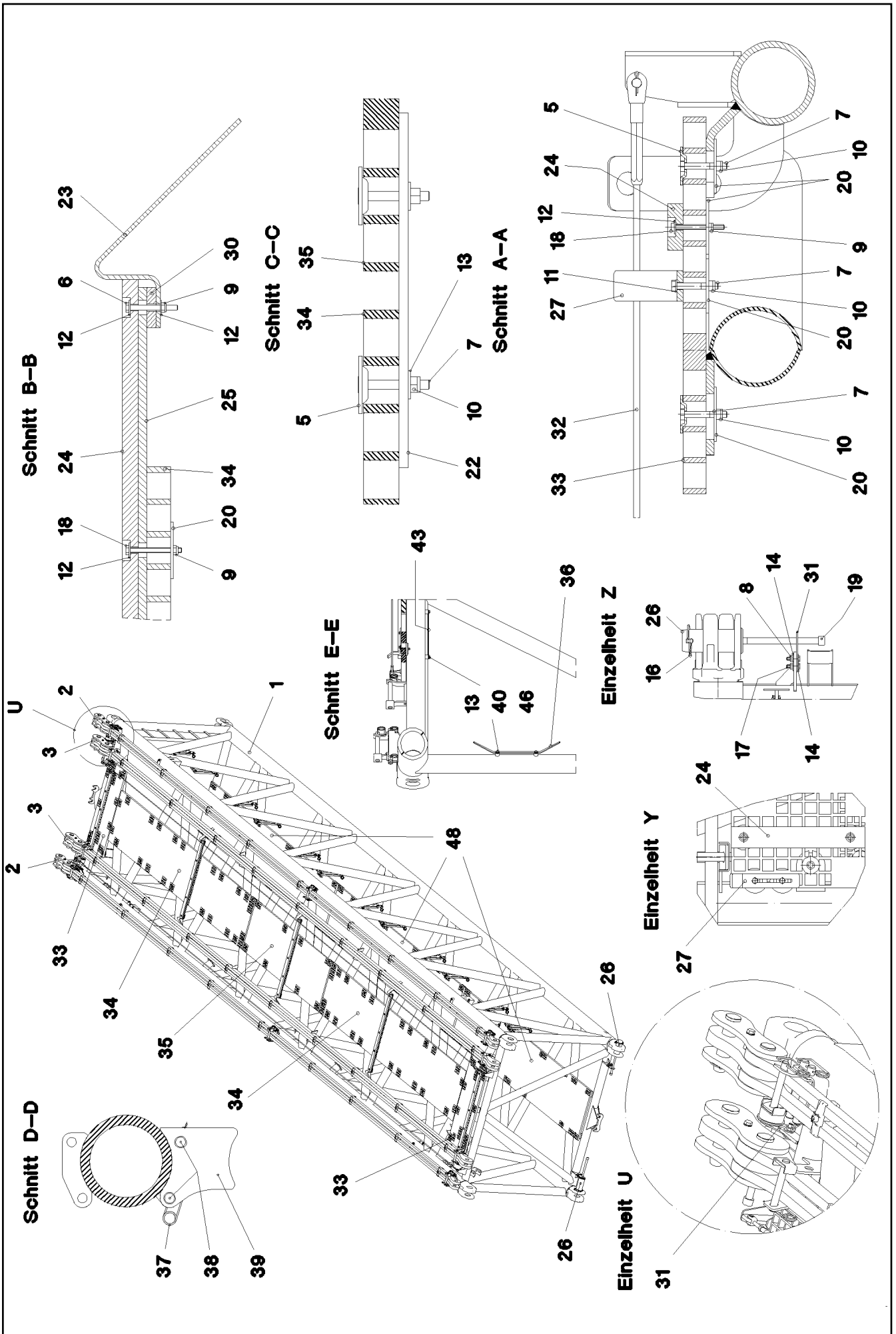

6.2.2009
 055229

LIEBHERR

etk_en_de_074515 LR 1600/2

D INTERMEDIATE SECTION
 D-ZWISCHENSTUECK

548 (2/3)

3 716
 91 52 864 08

Pos.	Item	Quantity	Description	Bezeichnung	Serie	K
1	96 49 123 08	1	D INTERMED. SECTION WELD. CON.	D-ZWISCHENSTUECK SCHWK.		
2	96 45 222 08	2	ROD CPL. 12 M ⇒ 3 561 003 96 45 222 08	STANGE KPL.		
3	96 49 159 08	2	ROD CPL. 12 M ⇒ 3 716 001 96 49 159 08	STANGE KPL.		
4	96 43 771 08	10	CONNECTING PIN WELDED	ABSTECKBOLZEN SCHWK.		
5	10 10 062 1	80	DISH MOUNTING	TELLERBEFESTIGUNG		
6	40 01 929	6	HEX BOLT ISO 4014 M6X60 8.8 A2C	SECHSKANTSCHRAUBE		
7	40 61 024	88	HEX BOLT ISO 4014 M8X55 8.8 A2C	SECHSKANTSCHRAUBE		
8	41 15 143 08	8	HEX NUT DIN 934 M12 8 VERZ	SECHSKANTMUTTER		
9	41 19 004 08	25	HEX NUT DIN 985 M6 8 VERZ	SECHSKANTMUTTER		
10	41 19 005 08	124	HEX NUT DIN 985 M8 8 VERZ	SECHSKANTMUTTER		
11	42 00 012 08	8	WASHER DIN 125 A8X16 ST VERZ	SCHEIBE		
12	42 18 007 08	31	WASHER DIN 9021 A 6.4 VERZ	SCHEIBE		
13	42 18 009 08	92	WASHER DIN 9021 A 8.4 VERZ	SCHEIBE		
14	42 18 011 08	16	WASHER ISO 7093-1 A 13 ST A3C	SCHEIBE		
15	43 31 009 08	22	RETAINING SPRING 4,5 VERZ	SICHERUNGSFEDER		
16	43 32 015 08	4	SAFETY PLUG W HINGE-LID 17X125 VERZ	SICHERHEITSKLAPPSTECKER		
17	46 00 158	8	HEX BOLT ISO 4017 M12X45 8.8 A3C	SECHSKANTSCHRAUBE		
18	46 00 356	19	HEX BOLT ISO 4014 M6X65 8.8 A2C	SECHSKANTSCHRAUBE		
19	46 30 212	4	CYLINDER SCREW ISO 4762 M24X340 10.9	ZYLINDERSCHRAUBE		
20	94 11 381 08	91	WASHER 70X3	SCHEIBE		
21	95 50 518 08	2	PLATE 5X104X140	BLECH		
22	95 54 048 08	8	PLATE 8X300X50	BLECH		
23	95 64 428 08	6	PLATE 5X393X60 S380MC	BLECH		
24	97 41 439 08	5	SUPPORT PLATE 60X1270 PA6G	AUFLAGE		
25	97 41 440 08	3	PLATE 10X1250X80	BLECH		
26	97 68 649 08	4	PIN 100.0X237 35NICRMOV125 SPF	BOLZEN		
27	97 73 817 08	4	PLATE 8X40X246	BLECH		
28	97 74 758 08	6	PLATE 8X407X110 T ZN O	BLECH		
29	97 74 759 08	12	PIN 30.0X220 S355J2G3 T ZN O	BOLZEN		
30	97 74 760 08	6	WASHER 12X50X50 T ZN O	SCHEIBE		
31	97 74 928 08	2	PLATE 5X150X101	BLECH		
32	10 65 244 0	2	ROUND STRAND ROPE 10MM 11,54M EDEL	RUNDLITZENSEIL		
33	97 66 610 08	2	GRATING 1407X487X30 GFK SPF	GITTERROST		
34	97 71 763 08	2	GRATING 4047X807X30 GFK SPF	GITTERROST		
35	97 71 942 08	1	GRATING 2287X807X30 GFK SPF	GITTERROST		
36	95 37 411 08	1	PLATE 4X20X500	BLECH		
37	43 31 028 08	8	RETAINING SPRING 3 VERZ	SICHERUNGSFEDER		
38	45 30 083 08	8	PIN DIN 1444 16H11X162X157 30CRNIMO8	BOLZEN		
39	97 76 196 08	4	BEARING BLOCK PA6G	LAGERKLOTZ		
40	95 38 734 08	65	SLEEVE	HUELSE		
41	97 88 000 08	12	PLATE 4X205X450 FE//ZN20//C	BLECH		
42	72 00 144 08	12	CABLE HOLDER	KABELHALTER		
43	97 57 099 08	1	PLATE 4X310X120	BLECH		
44	95 41 175 08	12	CARRIER RAIL 340	TRAGSCHIENE		
45	10 45 022 6	24	PAN-HEAD SCREW ISO 7380 M8X35 A2-70	FLACHKOPFSCHRAUBE		
46	49 00 188	28	HEX BOLT ISO 4017 M8X16 8.8 A2C	SECHSKANTSCHRAUBE		
47	40 61 062	12	HEX BOLT ISO 4014 M8X40 8.8 A2C	SECHSKANTSCHRAUBE		
48	97 72 745 08	3	GRATING 3807X807X30 GFK SPF	GITTERROST		
600	91 56 429 08	1	ADDITIONAL HYDRAULICS INTERMED 12 M ⇒ 3 978 015 91 56 429 08	ZUSATZHYDRAULIK ZWISCHEN		

6.2.2009

etk_en_de_074515 LR 1600/2

☐ 549 (3/3)

LIEBHERRD INTERMEDIATE SECTION
D-ZWISCHENSTUECK⇒ 3 716
91 52 864 08

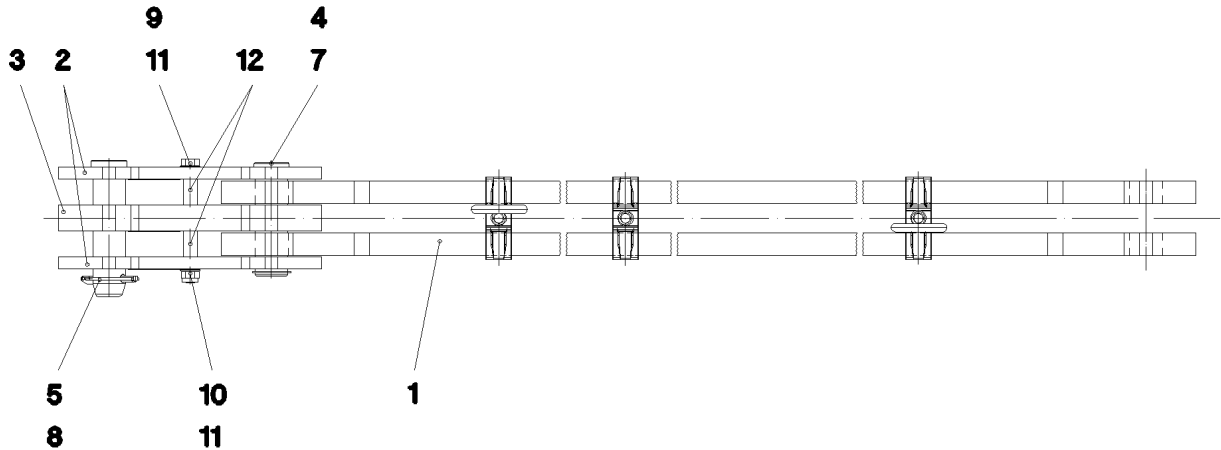
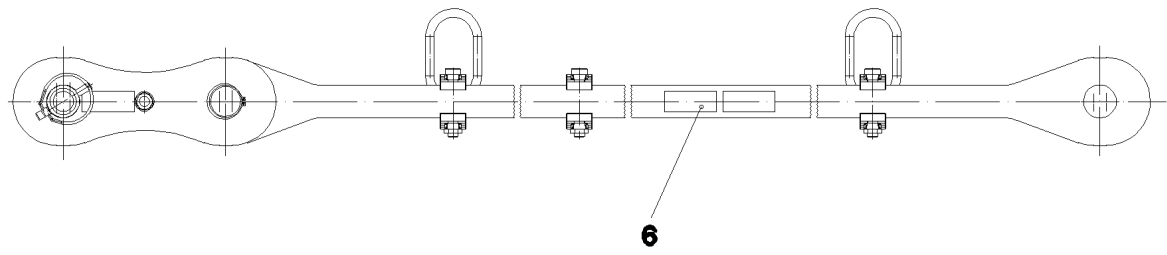

Pos.	Item	Quantity	Description	Bezeichnung	Serie	K
1	96 49 158 08	1	ROD 11.75 M	STANGE VORM.		
2	96 48 595 08	2	BRACKET WITH BOARD 0.25 M	LASCHE MIT SCHILD		
3	96 48 596 08	1	BRACKET WITH BOARD 0.25 M	LASCHE MIT SCHILD		
4	97 74 799 08	1	PIN 65.0X177 SPF	BOLZEN		
5	97 74 800 08	1	PIN 65.0X220 SPF	BOLZEN		
6	97 35 919 08	1	PLATE ASSEMBLY BG-NR. PVC-SILBER SP	SCHILD BAUGRUPPE		
7	42 80 045 08	1	LOCKING RING DIN 471 55X2	SICHERUNGSRING		
8	43 32 005 08	1	SAFETY PLUG W HINGE-LID 11,5X96 VERZ	SICHERHEITSKLAPPSTECKER		
9	40 61 186 01	1	HEX BOLT ISO 4014 M16X180 8.8 A3C	SECHSKANTSCHRAUBE		
10	41 19 009 08	1	HEX NUT DIN 985 M16 8 VERZ	SECHSKANTMUTTER		
11	42 00 019 08	2	WASHER DIN 125 A 17 VERZ	SCHEIBE		
12	93 92 551 08	2	TUBE 22X2,5X40	ROHR		

6.2.2009
055239

LIEBHERR

etk_en_de_074515 LR 1600/2

ROD CPL.
STANGE KPL.

550

⇒ 3 716 001
96 49 159 08

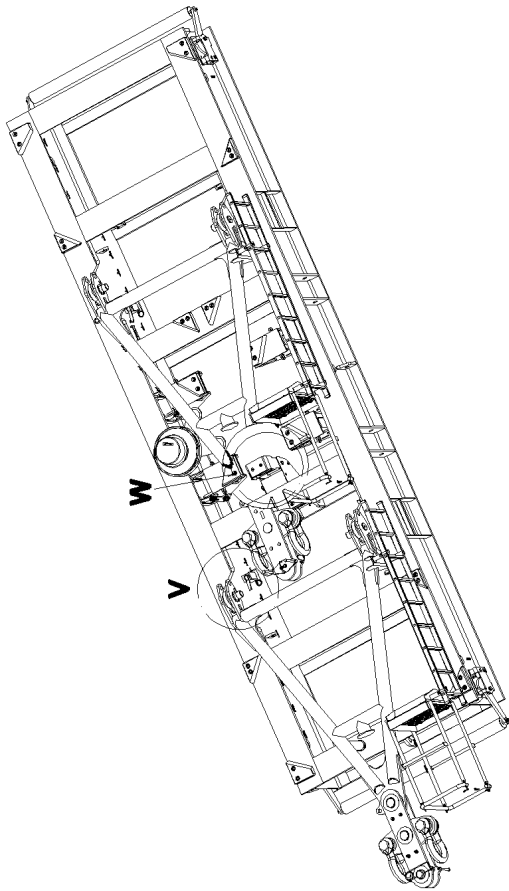

Einzelheit V

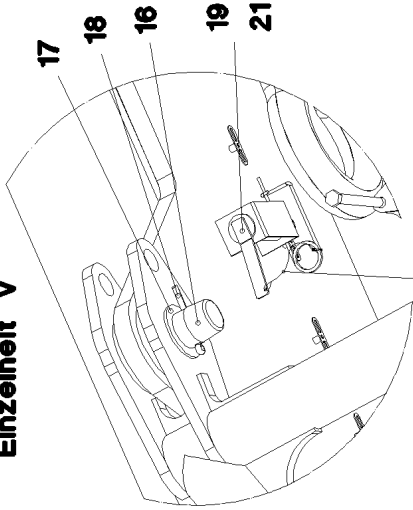

61
62

Einzelheit W

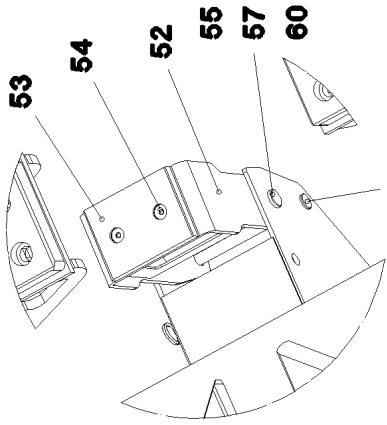

Einzelheit Y

35
36
37

30
42
43

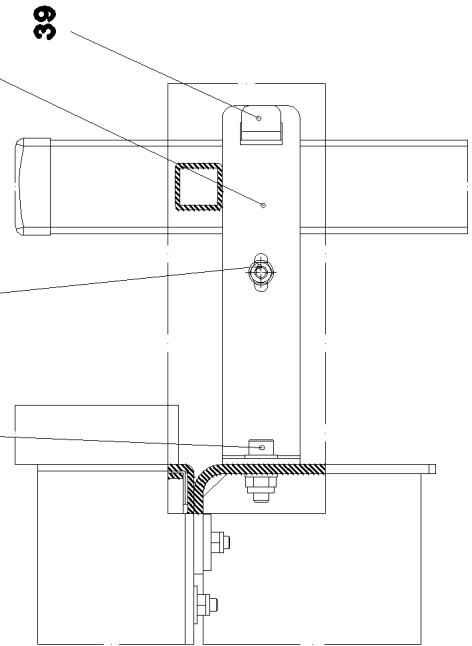

Einzelheit Z

35
36
37

30
42
43

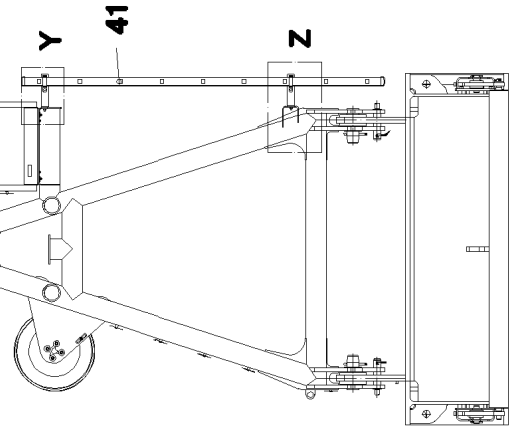
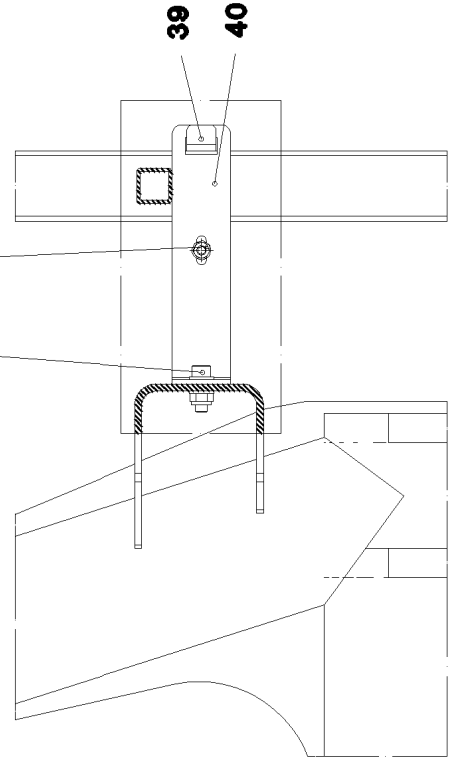

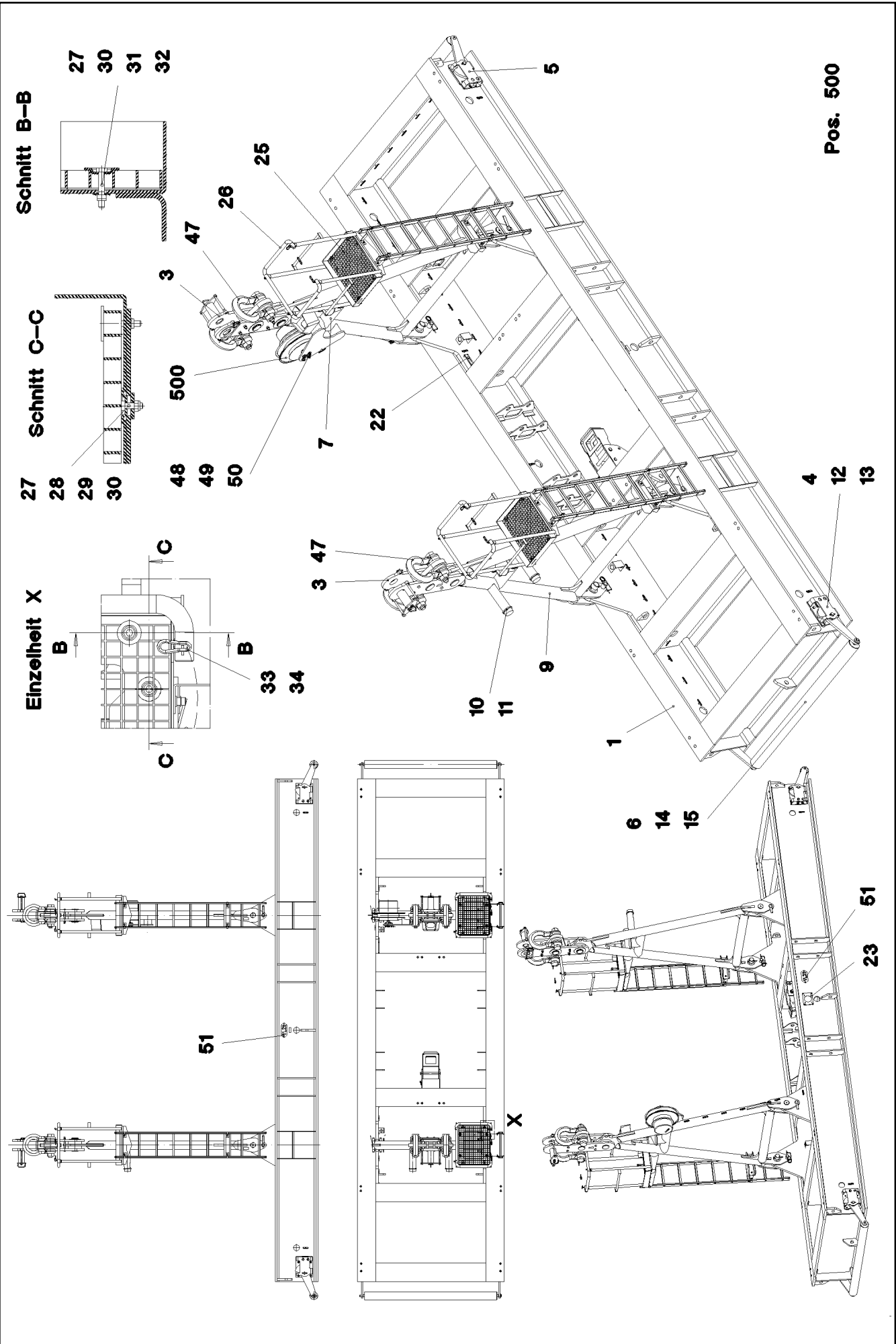

Pos. 500

6.2.2009
055149
LIEBHERR

etk_en_de_074515 LR 1600/2
SUSPENDED BALLAST
SCHWEBEBALLAST

552 (2/3)
→ 3 745
91 52 948 08

Pos.	Item	Quantity	Description	Bezeichnung	Serie	K
1	96 49 614 08	1	BALLAST PALLET WELDED	BALLASTPALETTE SCHWK.		
3	96 49 677 08	2	BRACKET COMPL. ⇒ 3 745 011 96 49 677 08	LASCHE KPL.		
4	92 17 236 08	2	SWITCH UNIT ⇒ 3 745 002 92 17 236 08	SCHALTEINHEIT		
5	92 17 237 08	2	SWITCH UNIT ⇒ 3 745 003 92 17 237 08	SCHALTEINHEIT		
6	92 17 259 08	2	ROLLER	WALZE		
7	96 49 676 08	1	STAND WELDED	BOCK SCHWK.		
9	96 49 679 08	1	STAND WELDED	BOCK SCHWK.		
10	72 66 160 08	2	MEGI BUFFER 100X40-M16 NR 60SHORE A	MEGIPUFFER		
11	41 15 145 08	2	HEX NUT DIN 934 M16 8 VERZ	SECHSKANTMUTTER		
12	49 00 123	16	HEX BOLT ISO 4017 M16X35 8.8 A3C	SECHSKANTSCHRAUBE		
13	42 00 019 08	16	WASHER DIN 125 A 17 VERZ	SCHEIBE		
14	93 24 016 08	4	WASHER RD65X8	SCHEIBE		
15	43 30 077 08	4	SPLIT PIN DIN 94 6,3X45 ST VERZ	SPLINT		
16	95 20 313 08	4	PIN 85x235	BOLZEN		
17	93 96 841 08	4	RING RD120X6	RING		
18	43 30 112 08	4	SPLIT PIN DIN 94 13X125 ST VERZ	SPLINT		
19	96 36 836 08	4	PIN COMPL.	BOLZEN KPL.		
21	43 31 050 08	4	RETAINING SPRING 6 A3C	SICHERUNGSFEDER		
22	95 56 681 08	1	PLATE X0	BLECH		
23	95 57 495 08	1	PLATE 4X165X225	BLECH		
25	72 58 469 08	2	GRIDIRON T626X500X25/2 S235JR TZN K SP	GITTERROST-P		
26	92 36 315 08	2	PLATFORM WELDED	PODEST SCHWK.		
27	10 10 062 1	16	DISH MOUNTING	TELLERBEFESTIGUNG		
28	49 00 128	8	HEX BOLT ISO 4017 M8X25 8.8 A2C	SECHSKANTSCHRAUBE		
29	94 10 542 08	8	WASHER 5X36X36	SCHEIBE		
30	41 19 005 08	24	HEX NUT DIN 985 M8 8 VERZ	SECHSKANTMUTTER		
31	40 01 461	8	HEX BOLT ISO 4014 M8X50 8.8 A2C	SECHSKANTSCHRAUBE		
32	42 18 614 05	8	WASHER DIN EN ISO 7093-1 8 A2	SCHEIBE		
33	74 00 002 08	1.2	CHAIN DIN 763 6X42 0.2t UST 35-2 GALV. V	KETTE		
34	74 40 100 08	2	SNAP HOOK DIN 5299 70X7 ST VERZ	KARABINERHAKEN		
35	41 19 006 08	8	HEX NUT DIN 985 M10 8 VERZ	SECHSKANTMUTTER		
36	42 00 013 08	16	WASHER ISO 7089 A 10.5 A3C	SCHEIBE		
37	49 00 537	8	CYLINDER SCREW ISO 4762 M10X30 8.8 A3	ZYLINDERSCHRAUBE		
38	97 78 520 08	4	PLATE 4X283X50	BLECH		
39	97 78 521 08	8	PLATE 4X167X25	BLECH		
40	97 78 522 08	4	PLATE 4X274X50	BLECH		
41	78 89 047 08	2	LADDER 2,4M AL	LEITER		
42	49 00 111	8	HEX BOLT ISO 4017 M8X30 8.8 A2C	SECHSKANTSCHRAUBE		
43	42 00 012 08	8	WASHER DIN 125 A8X16 ST VERZ	SCHEIBE		
47	10 02 211 1	4	SHACKLE 85t	SCHAEKEL		
48	40 62 036 08	4	HEX BOLT ISO 4014 M14X60 10.9 A3C	SECHSKANTSCHRAUBE		
49	42 18 024 08	4	WASHER DIN 9021 A 15 ST VERZ	SCHEIBE		
50	41 19 013 08	4	HEX NUT DIN 985 M14 10 A3C	SECHSKANTMUTTER		
51	97 86 732 08	2	LABEL 2X240X100	SCHILD		
52	96 50 486 08	1	FOLDING BRACKET	KLAPPKONSOLE		
53	28 30 405 08	1	BEARING PLATE 20X160X210	LAGERPLATTE		
54	40 86 027 08	2	COUNTERSUNK SCREW DIN 7991 M16X30	SENKSCHEIBE		
55	95 09 414 08	1	PIN RD35X320	BOLZEN		
56	97 06 477 08	1	PIN 35.0x330	BOLZEN		
57	42 00 033 08	1	WASHER DIN 125 B 37 VERZ	SCHEIBE		
59	43 31 009 08	1	RETAINING SPRING 4,5 VERZ	SICHERUNGSFEDER		
60	43 30 088 08	1	SPLIT PIN DIN 94 8X50 ST VERZ	SPLINT		
61	77 39 200 08	8	WIRE ROPE CLAMP DIN 3093 2 AL	PRESSKLEMMEN		
62	77 34 003 08	1.5	ROPE DIN 3055 2MM 2,3KN FE	SEIL		
500	96 50 096 08	1	ELECTRICS F.SUSPENDED BALLAST ⇒ 2 780 100 96 50 096 08	ELEKTRIK SCHWEBEBALLAST		

6.2.2009

etk_en_de_074515 LR 1600/2

553 (3/3)

LIEBHERRSUSPENDED BALLAST
SCHWEBEBALLAST⇒ 3 745
91 52 948 08

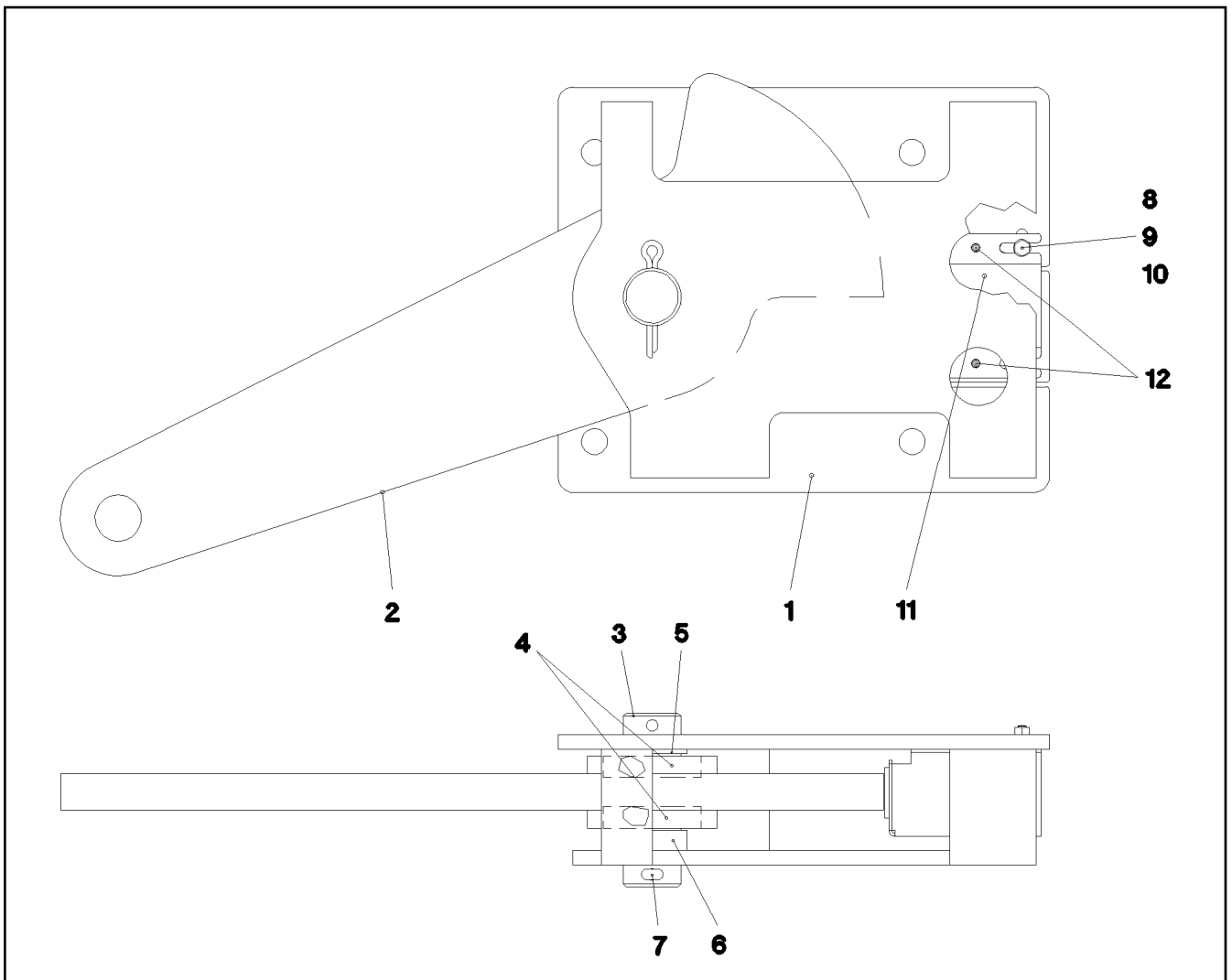

Pos.	Item	Quantity	Description	Bezeichnung	Serie	K
1	92 17 245 08	1	CONSOLE	KONSOLE		
2	92 17 246 08	1	LEVER	HEBEL		
3	94 45 545 08	1	PIN RD40X120	BOLZEN		
4	74 51 288 08	2	DEEP GROOVE BALL BEARING DIN 625 600	RILLENKUGELLAGER		
5	94 15 400 08	1	SPACER RING RD48X3	DISTANZRING		
6	95 61 143 08	1	TUBE 48,3X3,2X14	ROHR		
7	43 30 090 08	2	SPLIT PIN DIN 94 8X63 ST VERZ	SPLINT		
8	40 00 829	4	HEX BOLT ISO 4017 M6X20 8.8 A2C	SECHSKANTSCHRAUBE		
9	41 15 140 08	4	HEX NUT DIN 934 M6 8 VERZ	SECHSKANTMUTTER		
10	42 00 009 08	8	WASHER ISO 7089 A 6.4 VERZ	SCHEIBE		
11	92 35 694 08	1	HOLDER X12CrNiS188	HALTER		
12	43 20 053 08	2	DOWEL PIN ISO 8752 6X14	SPANNSTIFT		

6.2.2009
023370

LIEBHERR

etk_en_de_074515 LR 1600/2

SWITCH UNIT
SCHALTEINHEIT

554

⇒ 3 745 002
92 17 236 08

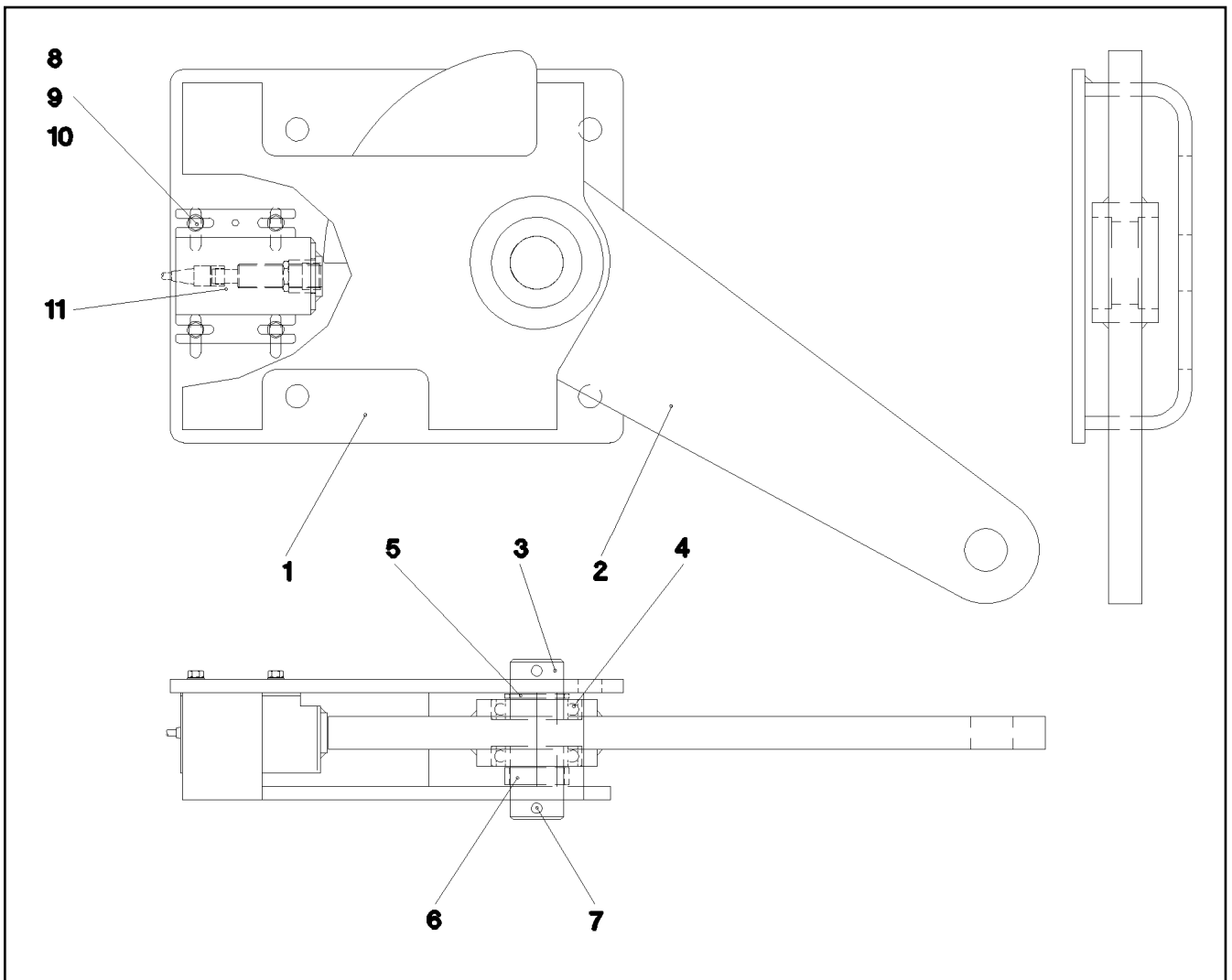

Pos.	Item	Quantity	Description	Bezeichnung	Serie	K
1	92 17 251 08	1	CONSOLE	KONSOLE		
2	92 17 246 08	1	LEVER	HEBEL		
3	94 45 545 08	1	PIN RD40X120	BOLZEN		
4	74 51 288 08	2	DEEP GROOVE BALL BEARING DIN 625 600	RILLENKUGELLAGER		
5	94 15 400 08	1	SPACER RING RD48X3	DISTANZRING		
6	95 61 143 08	1	TUBE 48,3X3,2X14	ROHR		
7	43 30 090 08	2	SPLIT PIN DIN 94 8X63 ST VERZ	SPLINT		
8	40 00 829	4	HEX BOLT ISO 4017 M6X20 8.8 A2C	SECHSKANTSCHRAUBE		
9	41 15 140 08	4	HEX NUT DIN 934 M6 8 VERZ	SECHSKANTMUTTER		
10	42 00 009 08	8	WASHER ISO 7089 A 6.4 VERZ	SCHEIBE		
11	92 35 694 08	1	HOLDER X12CrNiS188	HALTER		

6.2.2009
023371

LIEBHERR

etk_en_de_074515 LR 1600/2

SWITCH UNIT
SCHALTEINHEIT

555

⇒ 3 745 003
92 17 237 08

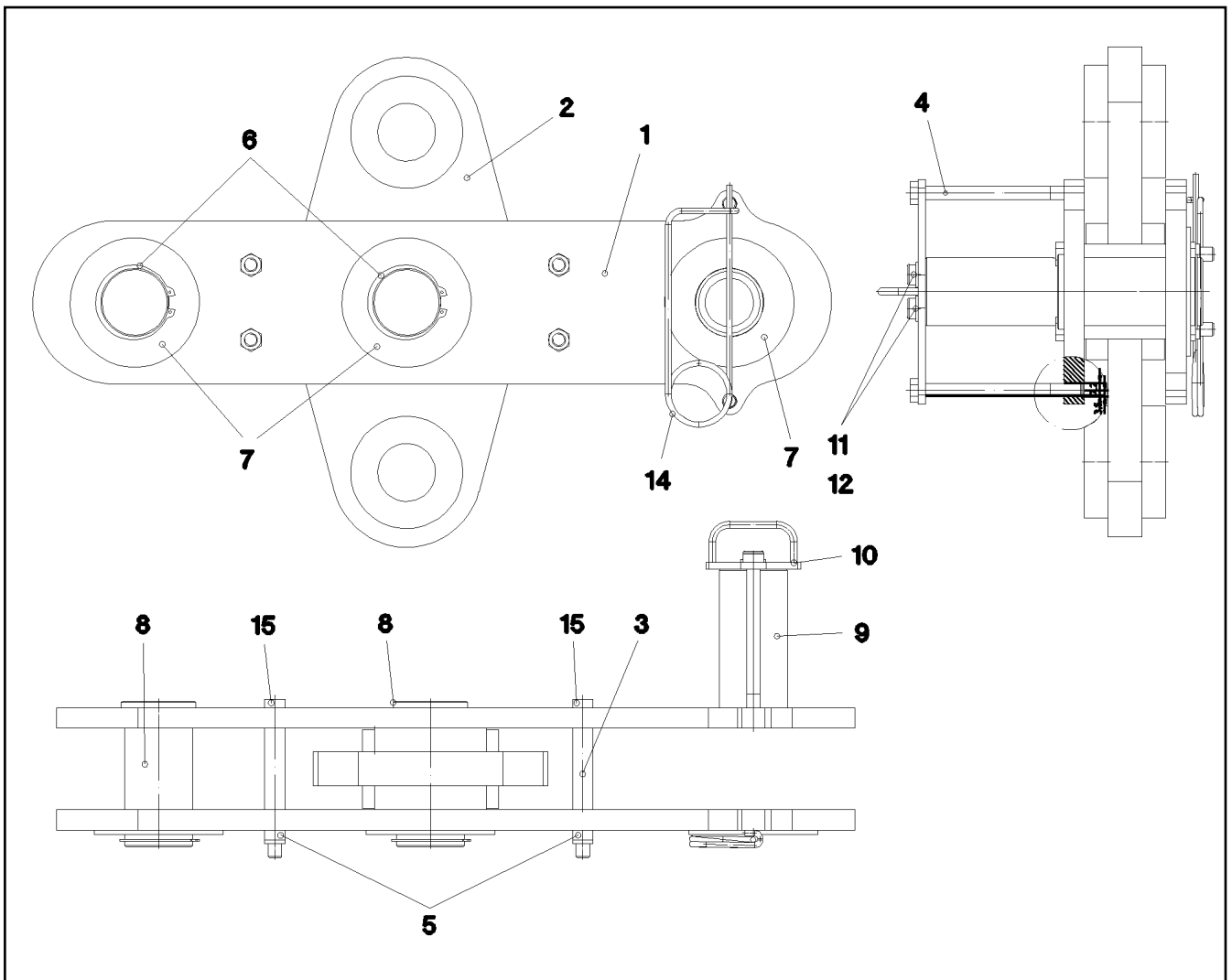

Pos.	Item	Quantity	Description	Bezeichnung	Serie	K
1	96 49 847 08	2	CONNECTING LINK PRE-ASS.	LASCHE VORM.		
2	96 49 851 08	1	PLATE WELDED	BLECH SCHWK.		
3	97 77 023 08	4	TUBE 30.0X120	ROHR		
4	40 61 248 14	2	HEX BOLT ISO 4014 M20X240 8.8 A3C	SECHSKANTSCHRAUBE		
5	41 19 024 08	4	HEX NUT DIN 985 M20 10 A3C	SECHSKANTMUTTER		
6	42 80 067 08	2	LOCKING RING DIN 471 100X3	SICHERUNGSRING		
7	93 55 088 08	3	LID RD190X6	DECKEL		
8	97 68 580 08	2	PIN 110.0X214 SPF	BOLZEN		
9	97 78 406 08	1	PIN 105.0X230 SPF	BOLZEN		
10	96 36 694 08	1	COVER WELDED	DECKEL SCHWK.		
11	40 72 086 08	2	CYLINDER SCREW DIN 6912 M20X35 10.9	ZYLINDERSCHRAUBE		
12	42 15 003 08	2	WASHER DIN 6916 21 C45 VERZ	SCHEIBE		
14	43 31 052 08	1	RETAINING SPRING 8 VERZ.	SICHERUNGSFEDER		
15	46 35 436	4	HEX BOLT ISO 4014 M20X220 10.9 A3C	SECHSKANTSCHRAUBE		

6.2.2009
055143

LIEBHERR

etk_en_de_074515 LR 1600/2

BRACKET COMPL.
LASCHE KPL.

556

⇒ 3 745 011
96 49 677 08

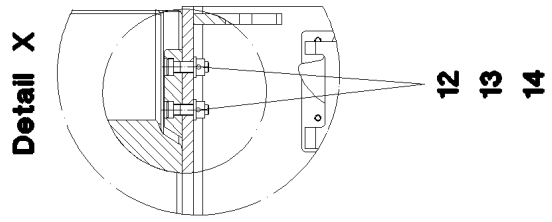
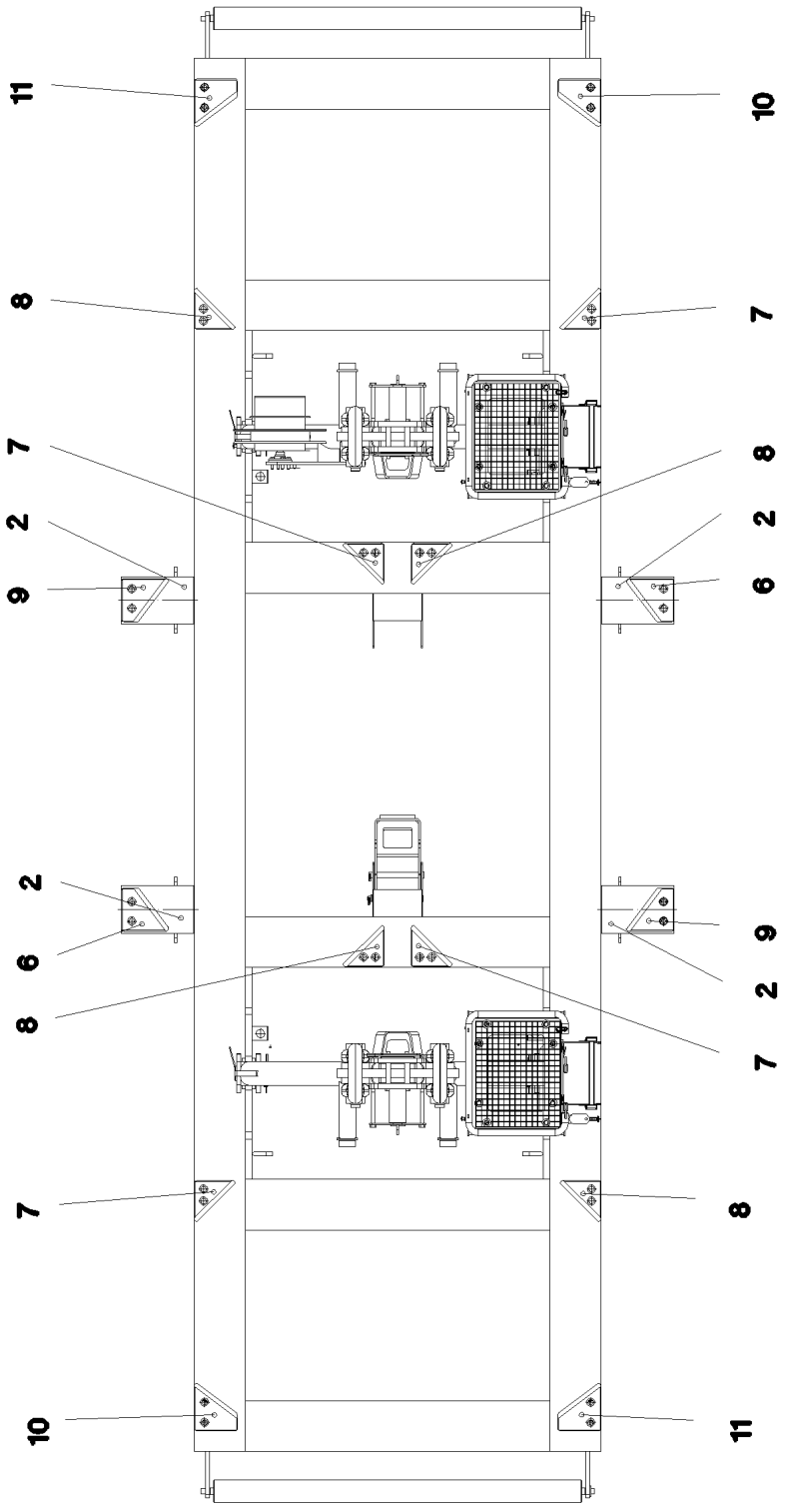
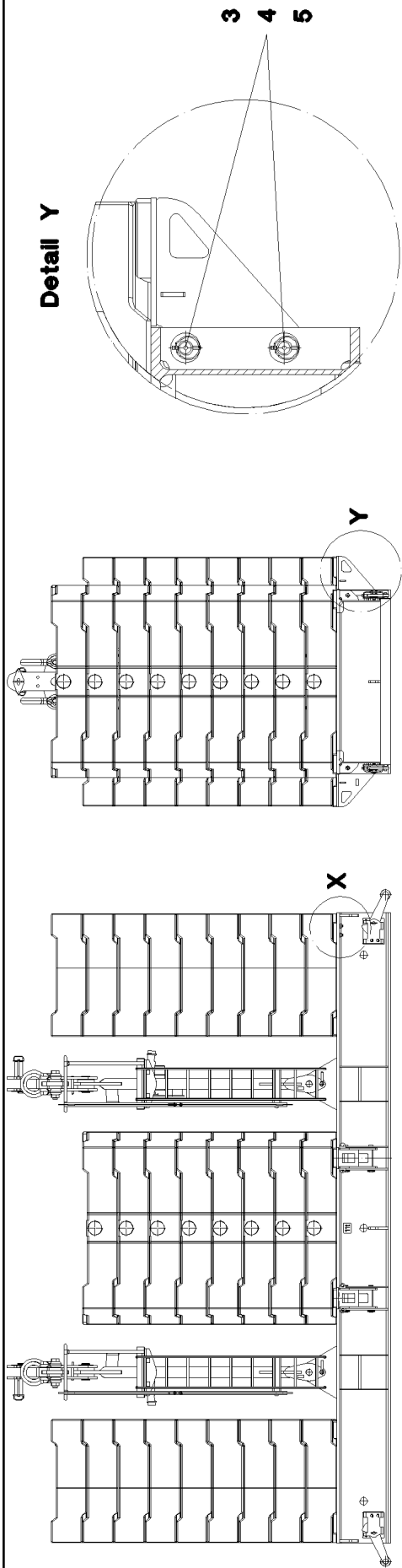

Pos.	Item	Quantity	Description	Bezeichnung	Serie	K
2	96 49 689 08	4	BRACKET WELDED CONST.	KONSOLE SCHWK.		
3	97 78 361 08	8	PIN 65.0X355 SPF	BOLZEN		
4	42 11 033 08	8	WASHER DIN 1440 50 ST VERZ	SCHEIBE		
5	43 32 005 08	8	SAFETY PLUG W HINGE-LID 11,5X96 VERZ	SICHERHEITSKLAPPSTECKER		
6	97 43 187 08	2	BRICK 50X279X255	KLOTZ		
7	97 43 188 08	4	BRICK 50X242X242	KLOTZ		
8	97 43 189 08	4	BRICK 50X242X242	KLOTZ		
9	97 43 190 08	2	BRICK 50X280X255	KLOTZ		
10	97 76 956 08	2	BRICK 50X280X255	KLOTZ		
11	97 76 964 08	2	BRICK 50X255X280	KLOTZ		
12	40 72 101 14	32	CYLINDER SCREW DIN 6912 M30X100 10.9	ZYLINDERSCHRAUBE		
13	42 17 009 08	32	WASHER DIN 7989 A 33 ST VERZ	SCHEIBE		
14	41 15 152 08	32	HEX NUT DIN 934 M30 8 VERZ	SECHSKANTMUTTER		

6.2.2009

etk_en_de_074515 LR 1600/2

558 (2/2)

LIEBHERR

CENTERING STANDARD
ZENTRIERUNG STANDARD

⇒ 3 747

91 52 950 08

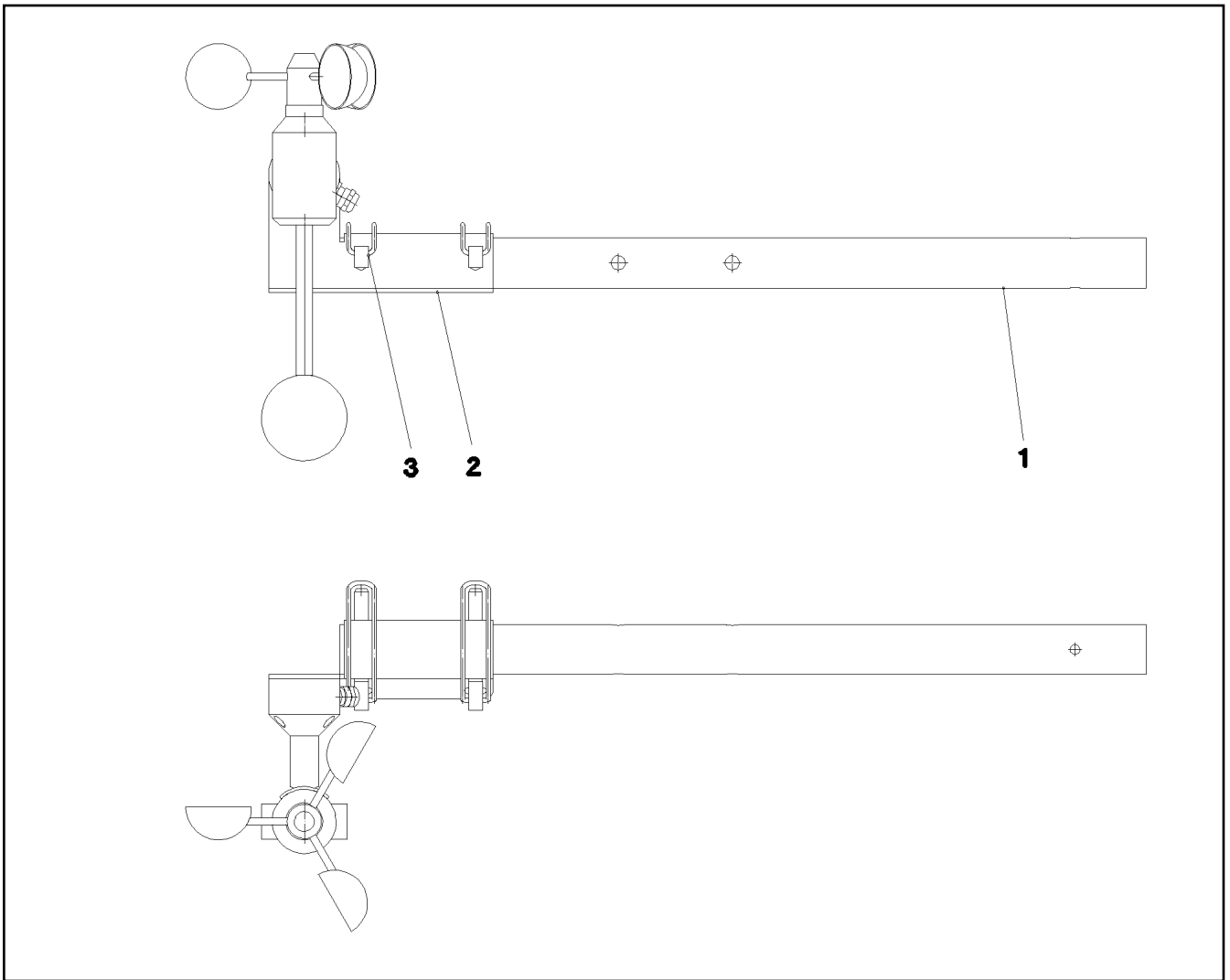

Pos.	Item	Quantity	Description	Bezeichnung	Serie	K
1	95 70 053 08	1	TUBE 35X2X665 X5CRNI1810	ROHR		
2	95 70 054 08	1	PLATE 3X157X156	BLECH		
3	43 32 010 08	2	FORMCLIP AEHNL.DIN 11023 10X65 ST VER	FORMCLIP		
11	40 00 996	3	CYLINDER SCREW ISO 4762 M4X10 8.8 A2C	ZYLINDERSCHRAUBE		
12	41 19 002 08	3	HEX NUT DIN 985 M4 8 VERZ	SECHSKANTMUTTER		

6.2.2009
054362

LIEBHERR

etk_en_de_074515 LR 1600/2

ELECTRIC WIND WARNING TELE
ELEKTRIK WINDWARNUNG TELE

559

⇒ 3 780 200
96 54 370 08

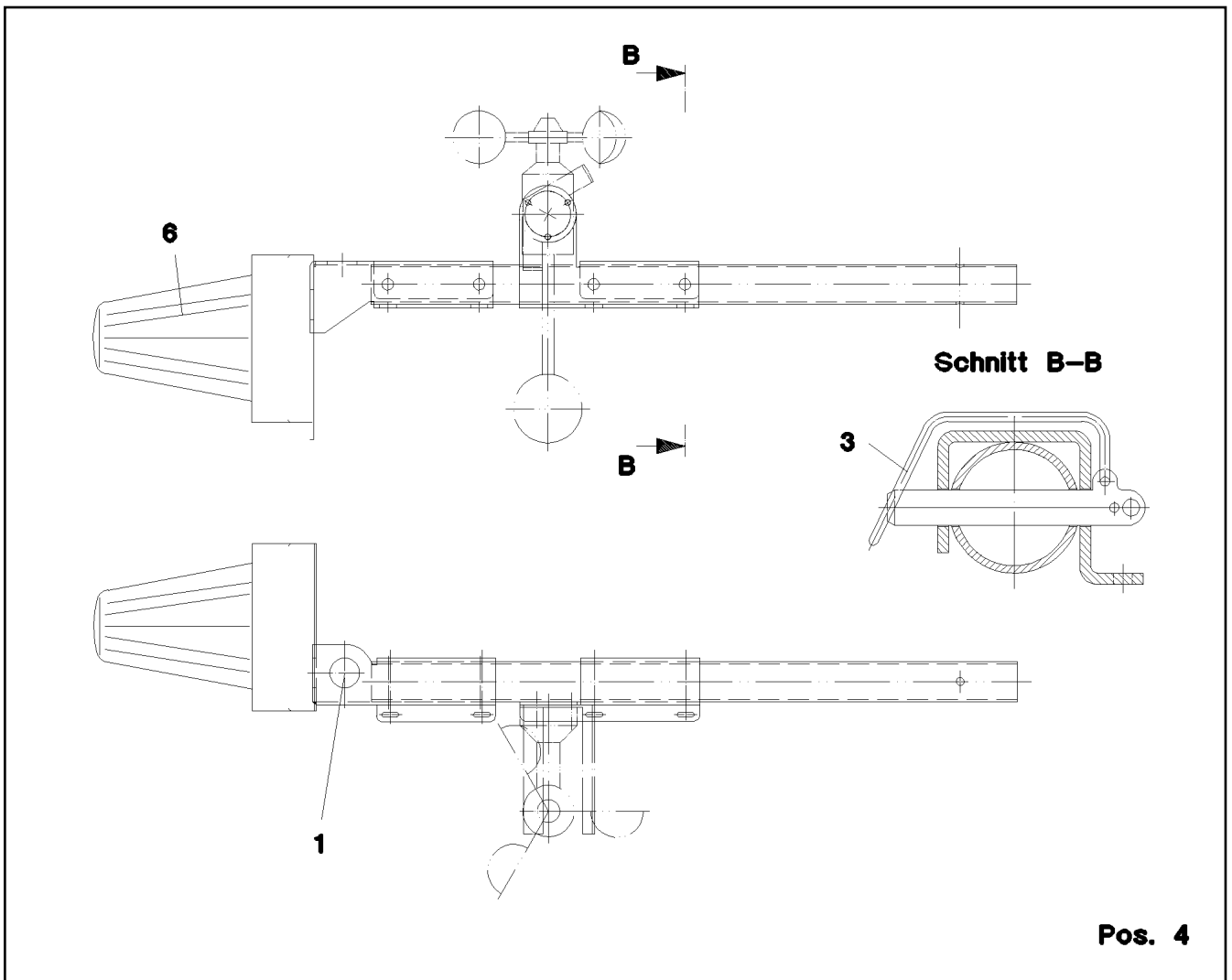

Pos.	Item	Quantity	Description	Bezeichnung	Serie	K
1	96 56 483 08	1	MOUNTING PARTS	BEFESTIGUNGSMATERIAL		
(1)	97 44 917 08	1	PLATE 3X353X300	BLECH		
(2)	40 01 034 08	3	CYLINDER SCREW DIN 84 M5X16 4.8 VERZ	ZYLINDERSCHRAUBE		
(3)	41 19 003 08	3	HEX NUT DIN 985 M5 8 VERZ	SECHSKANTMUTTER		
(4)	42 18 006 08	3	WASHER DIN 9021 A 5,3 ST VERZ	SCHEIBE		
(5)	42 00 008 08	3	WASHER DIN 125 A 5.3 VERZ	SCHEIBE		
(6)	40 42 002	3	CYLINDER SCREW ISO 4762 M6X20 8.8 A2C	ZYLINDERSCHRAUBE		
(7)	41 19 004 08	3	HEX NUT DIN 985 M6 8 VERZ	SECHSKANTMUTTER		
3	43 32 010 08	2	FORMCLIP AEHNL.DIN 11023 10X65 ST VER	FORMCLIP		
4	96 51 045 08	1	LEAD WL934	LEITUNG		
6	10 01 646 5	1	SIGNAL LAMP 24V DC ROT	SIGNALLEUCHE		

6.2.2009
055315

LIEBHERR

etk_en_de_074515 LR 1600/2

ELECTRIC AIRCRAFT PROTECTION
ELEKTRIK FLUGWARNSICHERUNG

560

⇒ 3 780 258
96 56 482 08

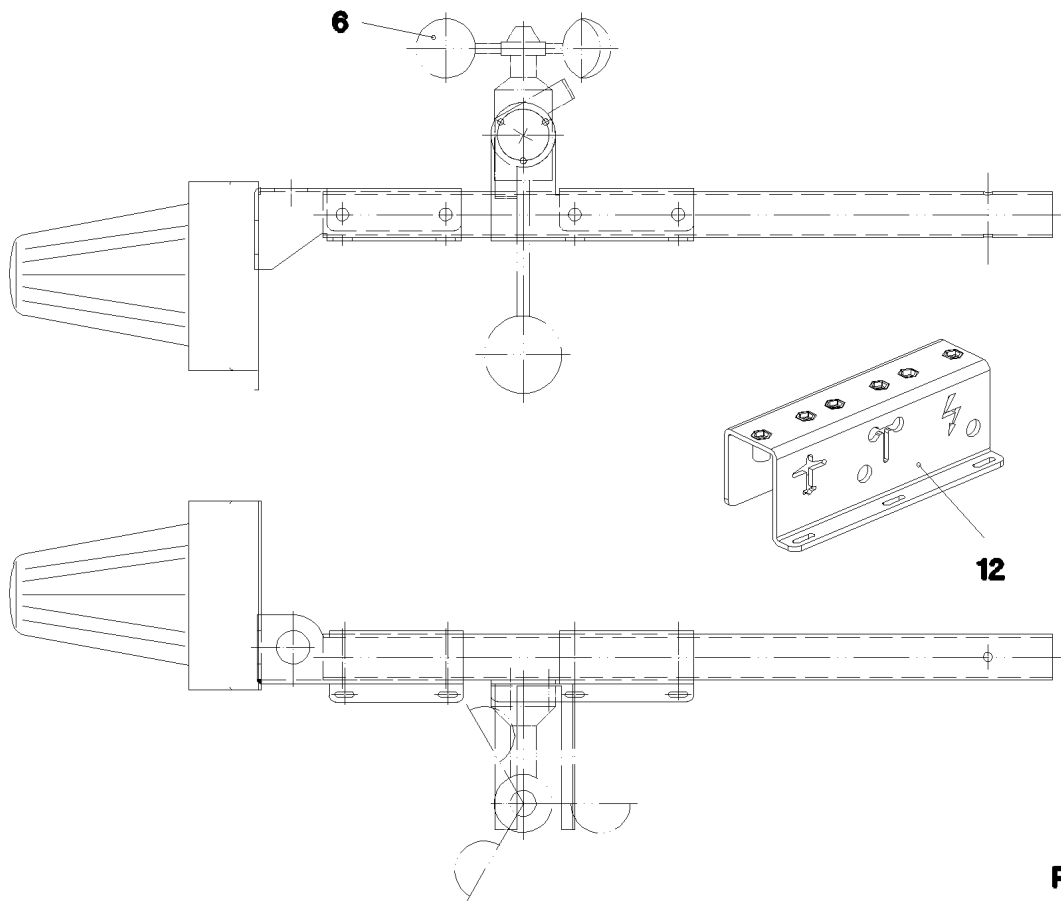

Pos. 5
Pos. 11

Pos.	Item	Quantity	Description	Bezeichnung	Serie	K
5	96 54 370 08	1	ELECTRIC WIND WARNING TELE ⇒ 3 780 200 96 54 370 08	ELEKTRIK WINDWARNUNG TEL		
6	10 42 954 9	1	WIND VELOCITY TRANSMITTER MAGN. 0-50 ⇒ X10429549 10 42 954 9	WINDGESCHWINDIGKEITSGEBE		
8	96 52 546 08	1	LEAD W985Y	LEITUNG		
11	96 56 482 08	1	ELECTRIC AIRCRAFT PROTECTION ⇒ 3 780 258 96 56 482 08	ELEKTRIK FLUGWARNSICHER		
12	96 48 533 08	1	PLATE PRE-ASS.	BLECH VORM.		
15	46 00 532	2	HEX BOLT ISO 4017 M6X50 8.8 A2C	SECHSKANTSCHRAUBE		
16	41 19 004 08	2	HEX NUT DIN 985 M6 8 VERZ	SECHSKANTMUTTER		
17	42 00 009 08	6	WASHER ISO 7089 A 6.4 VERZ	SCHEIBE		
18	70 05 052	12	CLAMP-HALF DIN 3015-1 L 3 R 25 PP SW	KLEMMHAELFTE		
20	46 00 384	6	CYLINDER SCREW ISO 4762 M6X40 8.8 A2C	ZYLINDERSCHRAUBE		

6.2.2009
052804

LIEBHERR

etk_en_de_074515 LR 1600/2

AIR-CRAFT & WIND WARNING
FLUG-U.WINDWARNUNG

561

⇒ 3 780 751
91 52 952 08

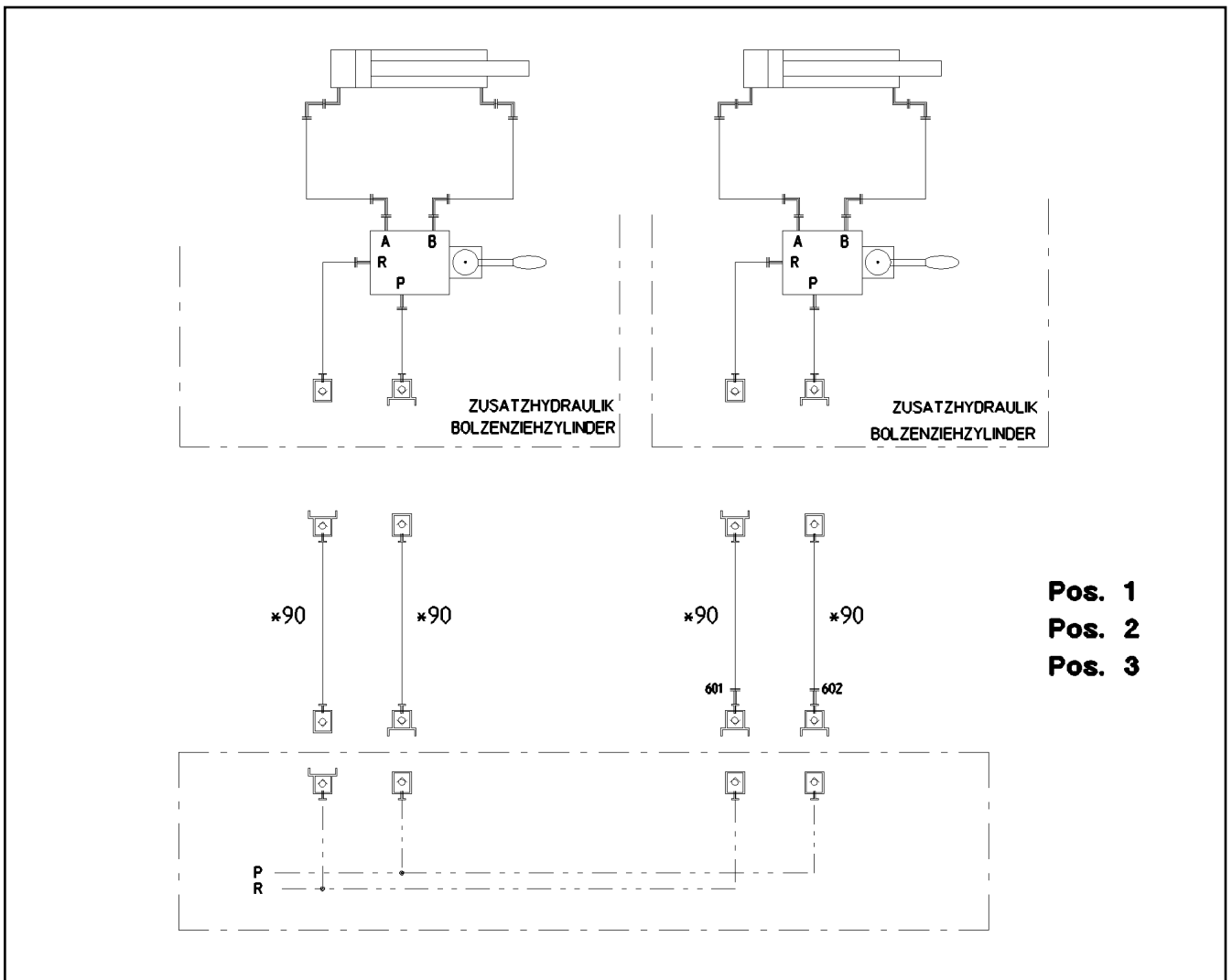

Pos.	Item	Quantity	Description	Bezeichnung	Serie	K
1	96 19 989 08	1	PIN PULLING CYLINDER CPL. ⇒ 3 790 006 96 19 989 08	BOLZENZIEHZYLLINDER KPL.		
2	91 44 034 08	1	AUX.HYDR.PIN EXTRACTION DEVICE ⇒ 2 976 200 91 44 034 08	ZUS.HYDR.BOLZENZIEHEINRI		
3	96 19 990 08	1	PIN PULLING CYLINDER CPL. ⇒ 3 790 007 96 19 990 08	BOLZENZIEHZYLLINDER KPL.		

6.2.2009
032006

LIEBHERR

etk_en_de_074515 LR 1600/2

BOLT EXTRACTION ATTACHMENT
BOLZENZIEHEINRICHTUNG

562

⇒ 3 790
91 08 481 08

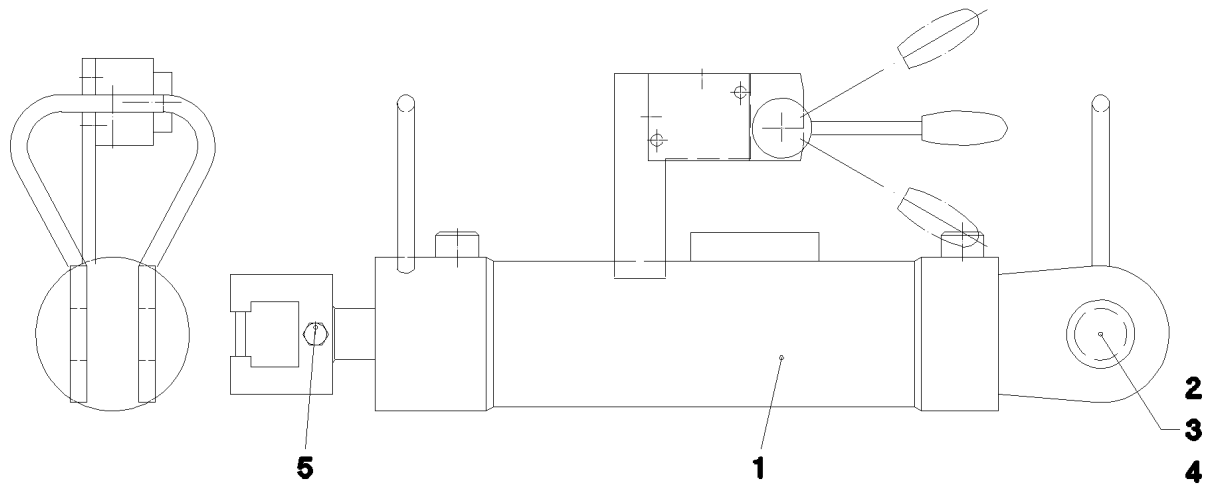

Pos. 6

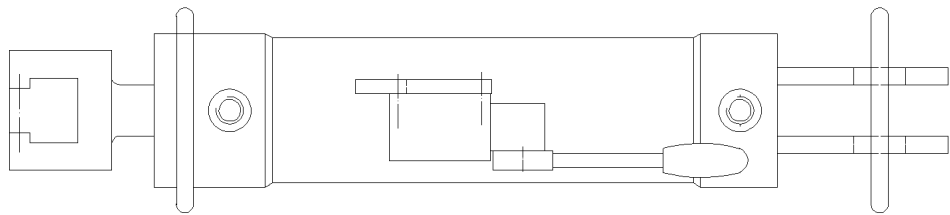

Pos.	Item	Quantity	Description	Bezeichnung	Serie	K
1	51 23 943 08	1	HYDRO CYLINDER 75/30-260 -40°C SPF	HYDROZYLINDER		
(999)	10 10 103 9	1	DS HYDRO CYLINDER	DS HYDROZYLINDER		
2	45 12 305 08	1	PIN DIN EN 22341 30H11X85X70 30CRNIMO8	BOLZEN		
3	42 12 019 08	1	WASHER DIN 1441 31 ST VERZ	SCHEIBE		
4	43 30 088 08	1	SPLIT PIN DIN 94 8X50 ST VERZ	SPLINT		
5	46 00 578	1	CYLINDER SCREW ISO 4762 M8X70 8.8 A2C	ZYLINDERSCHRAUBE		
6	92 27 489 08	1	ADDL.HYDR.F.PIN PULLING DEVICE	ZUSATZHYDR.BOLZENZIEHZYL		
			⇒ 2 976 203 92 27 489 08			

6.2.2009
028128

LIEBHERR

etk_en_de_074515 LR 1600/2

PIN PULLING CYLINDER CPL.
BOLZENZIEHZYLINDER KPL.

563

⇒ 3 790 006
96 19 989 08

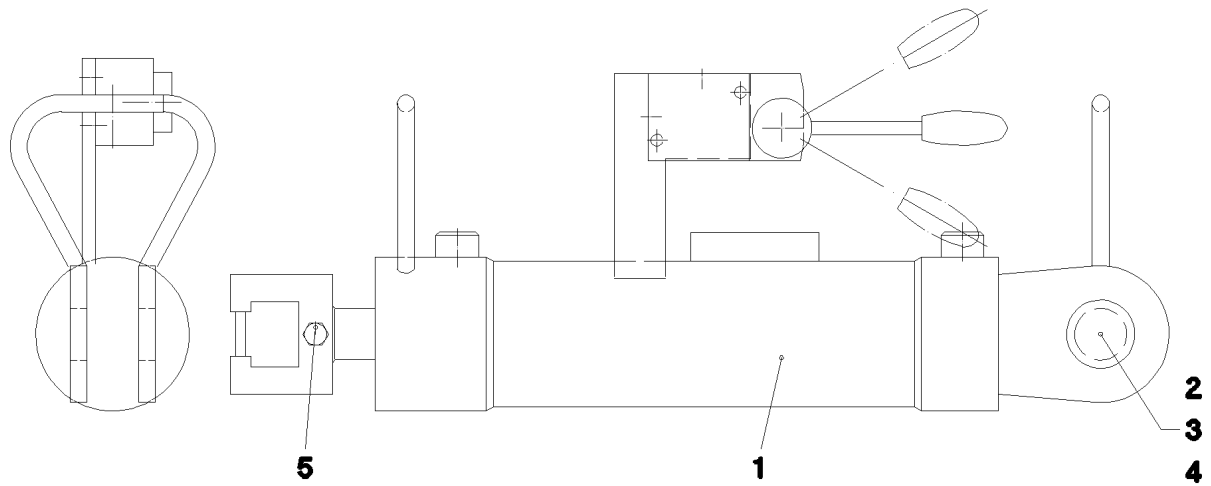

Pos. 6

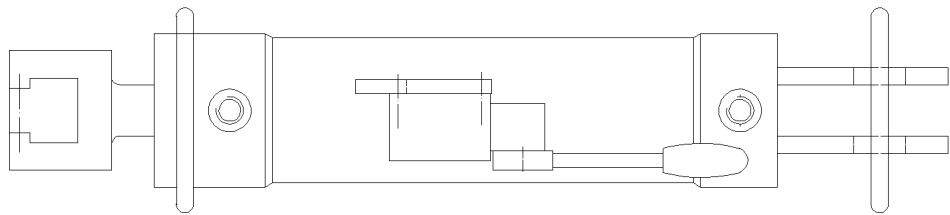

Pos.	Item	Quantity	Description	Bezeichnung	Serie	K
1	51 23 944 08	1	HYDRO CYLINDER 75/30-260 -40°C SPF	HYDROZYLINDER		
(999)	10 10 103 8	1	DS HYDRO CYLINDER	DS HYDROZYLINDER		
2	45 12 305 08	1	PIN DIN EN 22341 30H11X85X70 30CRNIMO8	BOLZEN		
3	42 12 019 08	1	WASHER DIN 1441 31 ST VERZ	SCHEIBE		
4	43 30 088 08	1	SPLIT PIN DIN 94 8X50 ST VERZ	SPLINT		
5	46 00 578	1	CYLINDER SCREW ISO 4762 M8X70 8.8 A2C	ZYLINDERSCHRAUBE		
6	92 27 489 08	1	ADDL.HYDR.F.PIN PULLING DEVICE	ZUSATZHYDR.BOLZENZIEHZYL		
			⇒ 2 976 203 92 27 489 08			

6.2.2009
028129

LIEBHERR

etk_en_de_074515 LR 1600/2

PIN PULLING CYLINDER CPL.
BOLZENZIEHZYLINDER KPL.

564

⇒ 3 790 007
96 19 990 08

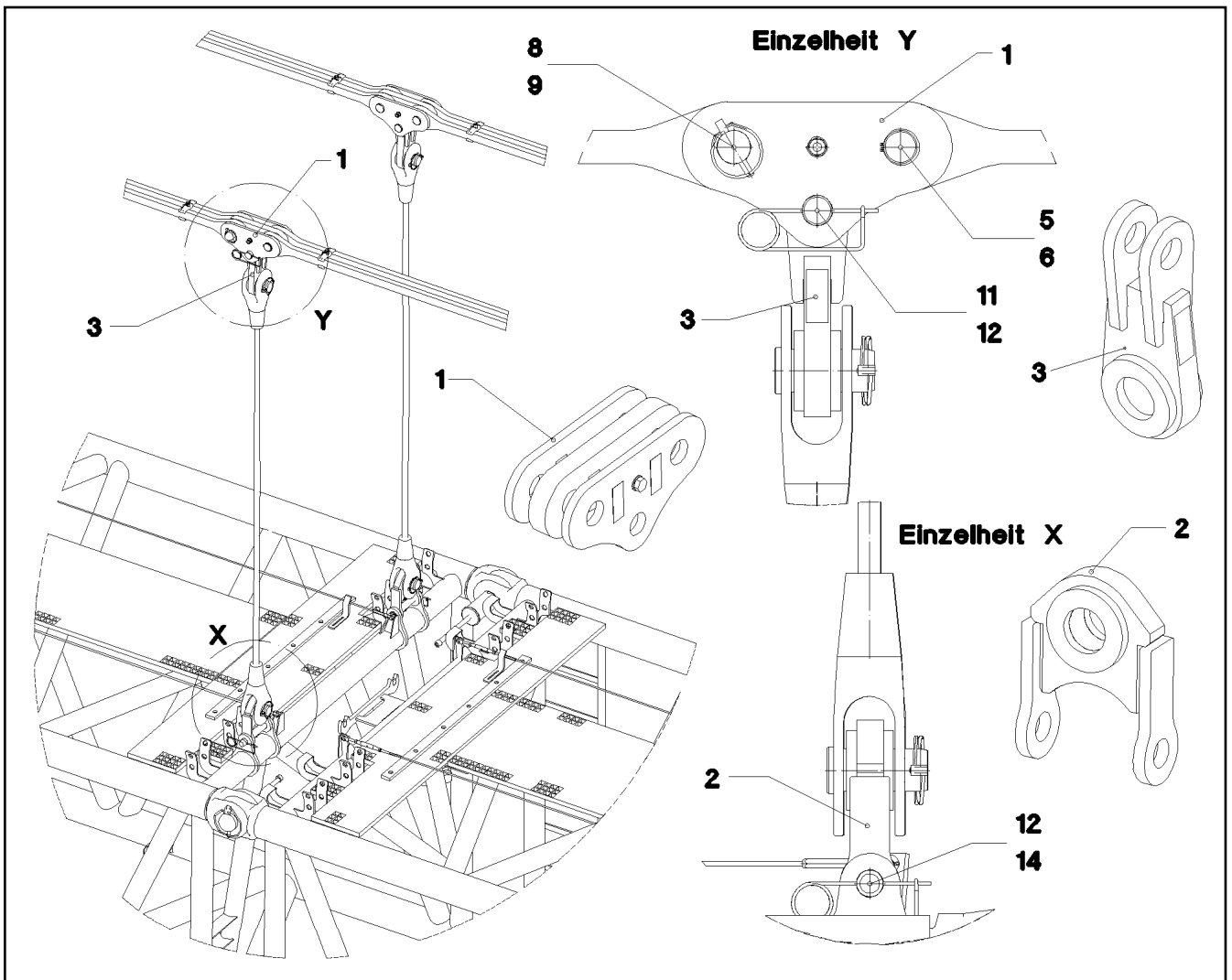

Pos.	Item	Quantity	Description	Bezeichnung	Serie	K
1	96 48 638 08	2	CONNECTING LINK PRE-ASS. 0.25M	LASCHE VORM.		
2	96 48 640 08	2	CROSS CONNECTING LINK WELDED	KREUZLASCHE SCHWK.		
3	96 48 639 08	2	CROSS CONNECTING LINK WELDED	KREUZLASCHE SCHWK.		
5	97 67 727 08	2	PIN 55.0X175 30CRNIMO8+QT	BOLZEN		
6	42 80 042 08	2	LOCKING RING DIN 471 50X2	SICHERUNGSRING		
8	95 28 920 08	2	PIN 55.0X210 30CRNIMO8+QT SPF	BOLZEN		
9	43 32 005 08	2	SAFETY PLUG W HINGE-LID 11,5X96 VERZ	SICHERHEITSKLAPPSTECKER		
11	94 99 163 08	2	PIN RD45X177	BOLZEN		
12	43 31 025 08	4	RETAINING SPRING 5 VERZ	SICHERUNGSFEDER		
14	97 19 655 08	2	PIN 45.0X290	BOLZEN		

6.2.2009
052639

LIEBHERR

etk_en_de_074515 LR 1600/2

SUPPLEMENTARY GUYING DEVICE
ZUSATZABSPANNUNG

565

⇒ 3 830
91 55 535 08

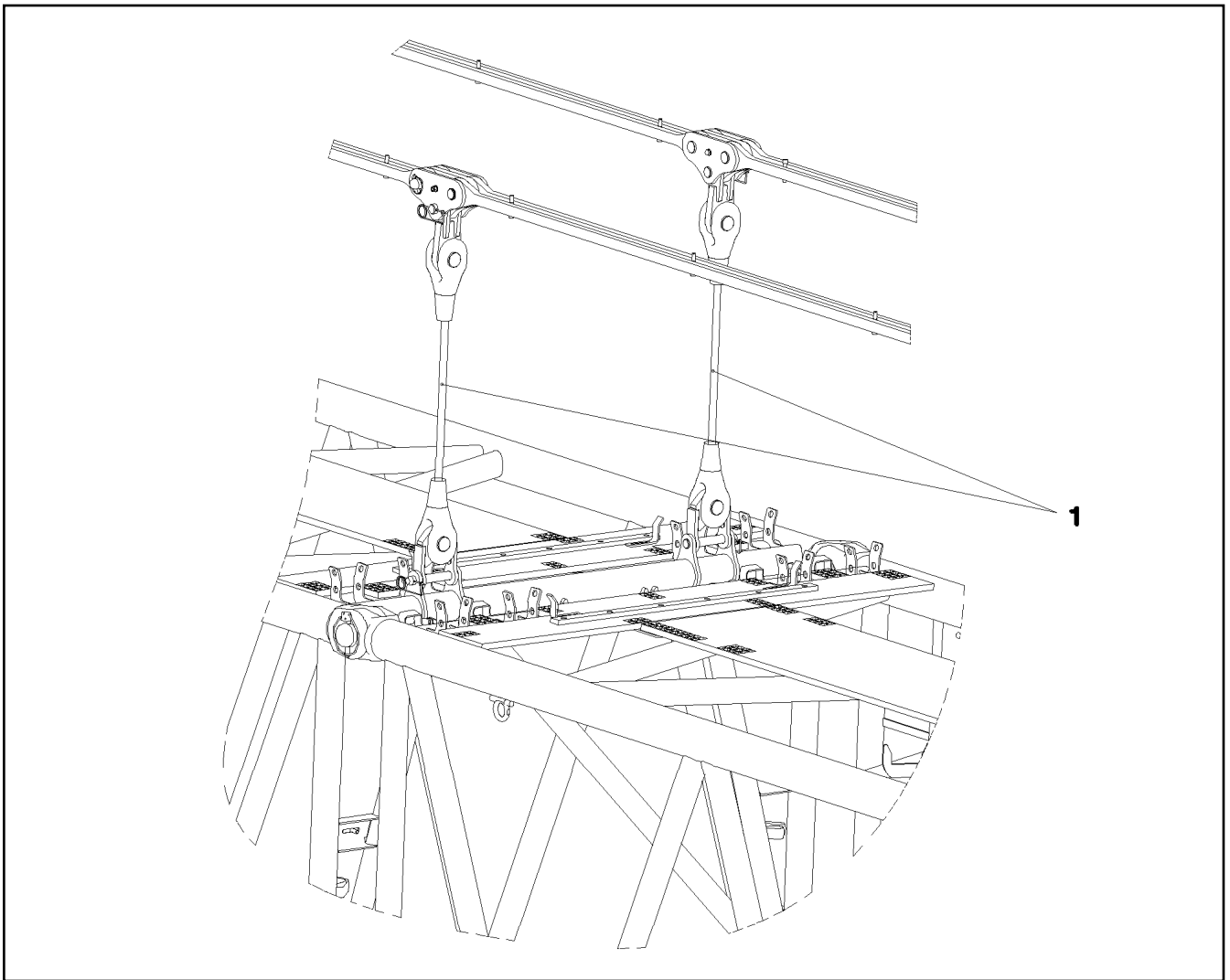

Pos.	Item	Quantity	Description	Bezeichnung	Serie	K
1	97 75 537 08	2	ROPE 34MM 1.525M	SEIL		

6.2.2009
052637

LIEBHERR

etk_en_de_074515 LR 1600/2

SUPPLEMENTARY GUYING DEVICE
ZUSATZABSPANNUNG

566

⇒ 3 832
91 55 536 08

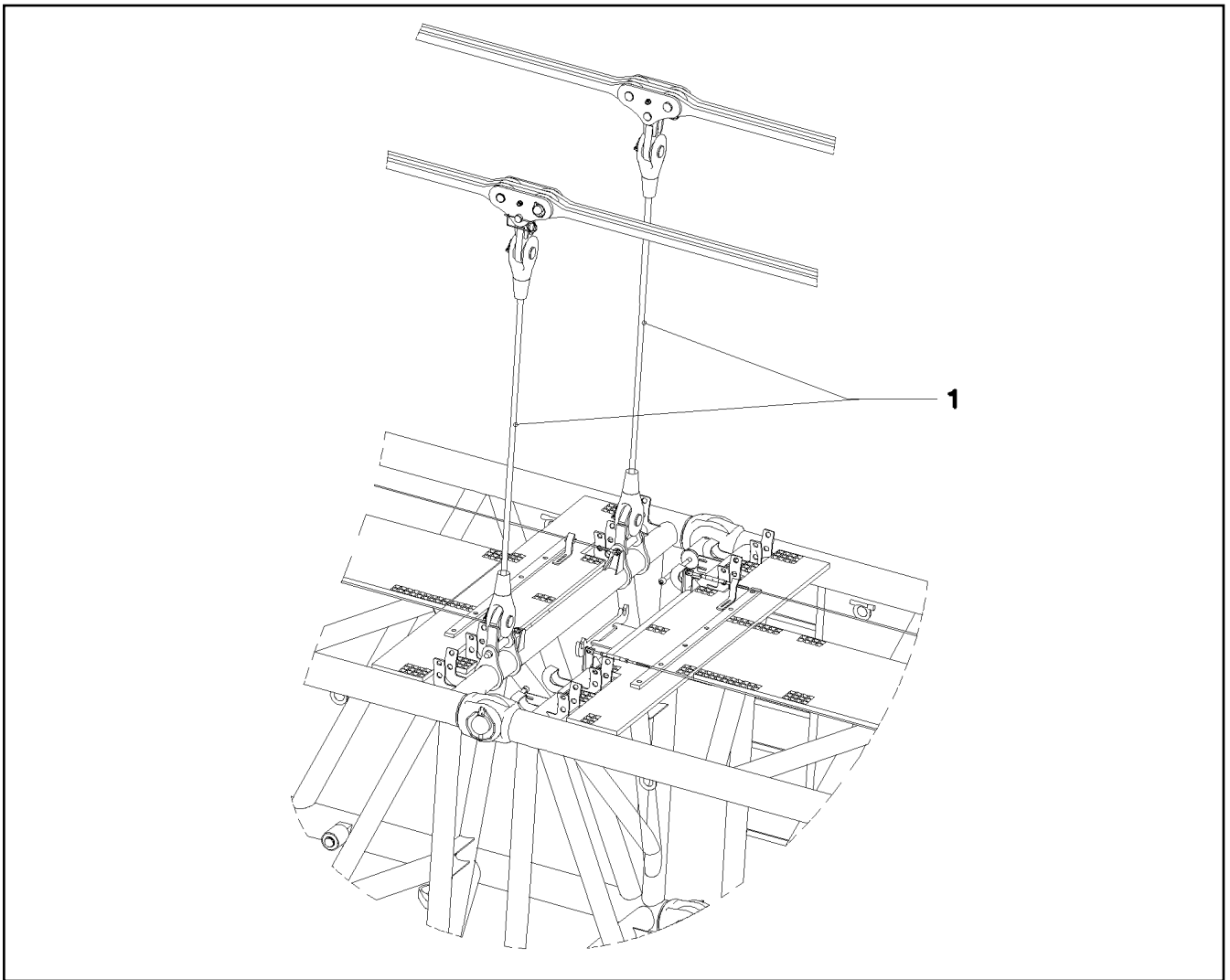

Pos.	Item	Quantity	Description	Bezeichnung	Serie	K
1	97 75 541 08	2	ROPE 34MM 2.525M	SEIL		

6.2.2009
052638

LIEBHERR

etk_en_de_074515 LR 1600/2

SUPPLEMENTARY GUYING DEVICE
ZUSATZABSPANNUNG

567

⇒ 3 832 001
91 55 537 08

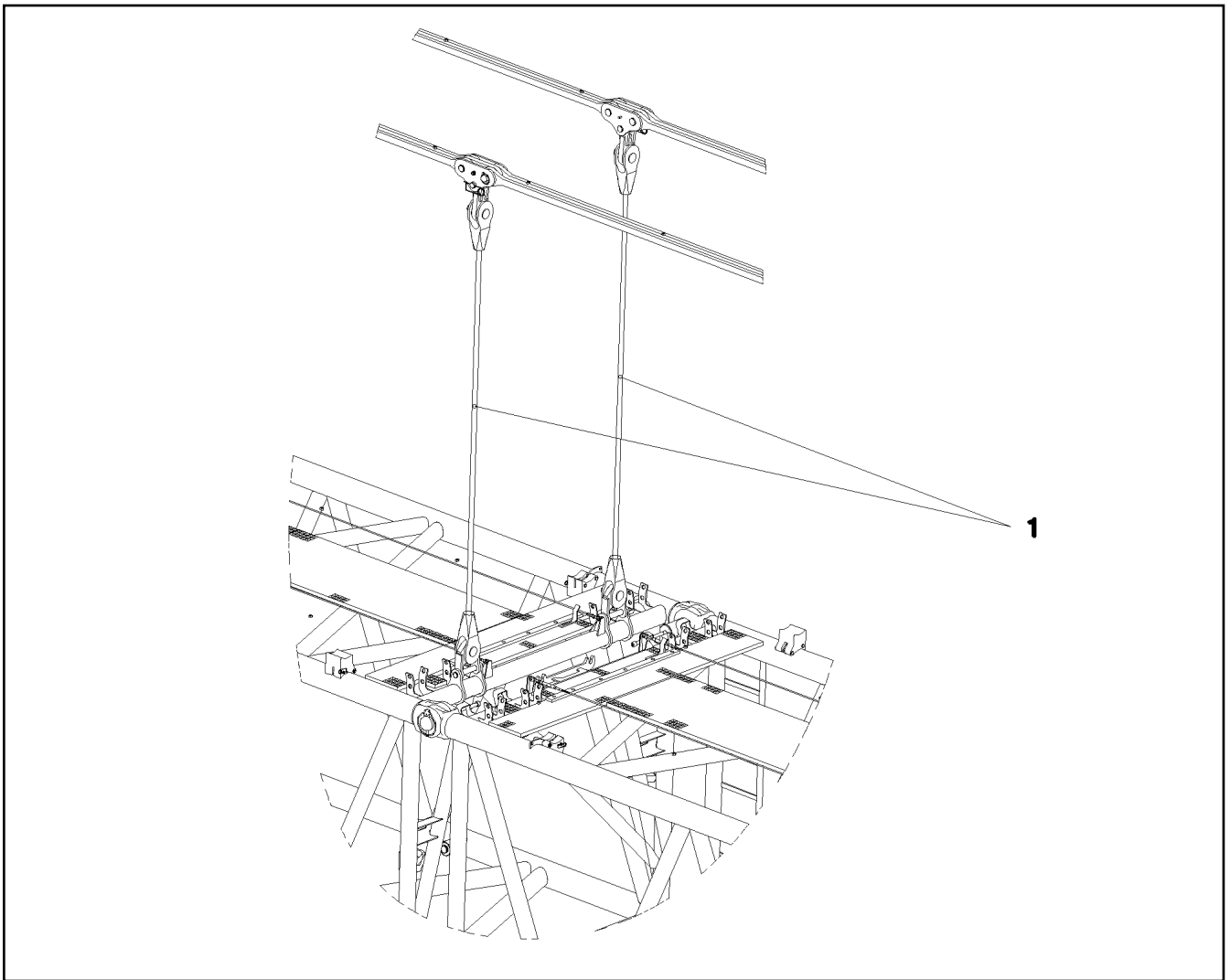

Pos.	Item	Quantity	Description	Bezeichnung	Serie	K
1	97 75 548 08	2	ROPE 34MM 3.525M	SEIL		

6.2.2009
055201

LIEBHERR

etk_en_de_074515 LR 1600/2

SUPPLEMENTARY GUYING DEVICE
ZUSATZABSPANNUNG

568

⇒ 3 834
91 55 538 08

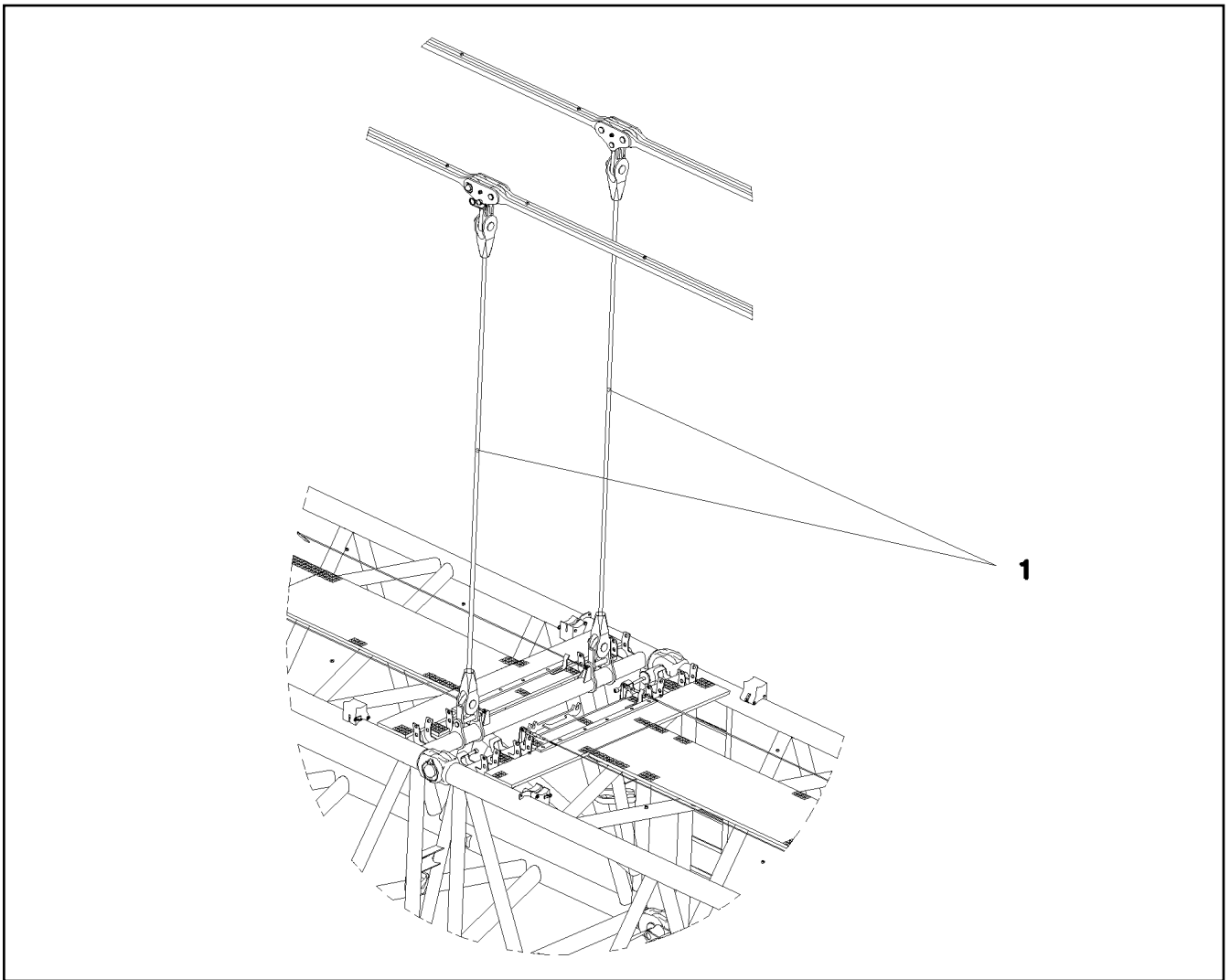

Pos.	Item	Quantity	Description	Bezeichnung	Serie	K
1	97 74 938 08	2	ROPE 34MM 4.525M	SEIL		

6.2.2009
055202

LIEBHERR

etk_en_de_074515 LR 1600/2

SUPPLEMENTARY GUYING DEVICE
ZUSATZABSPANNUNG

569

⇒ 3 835 000
91 55 539 08

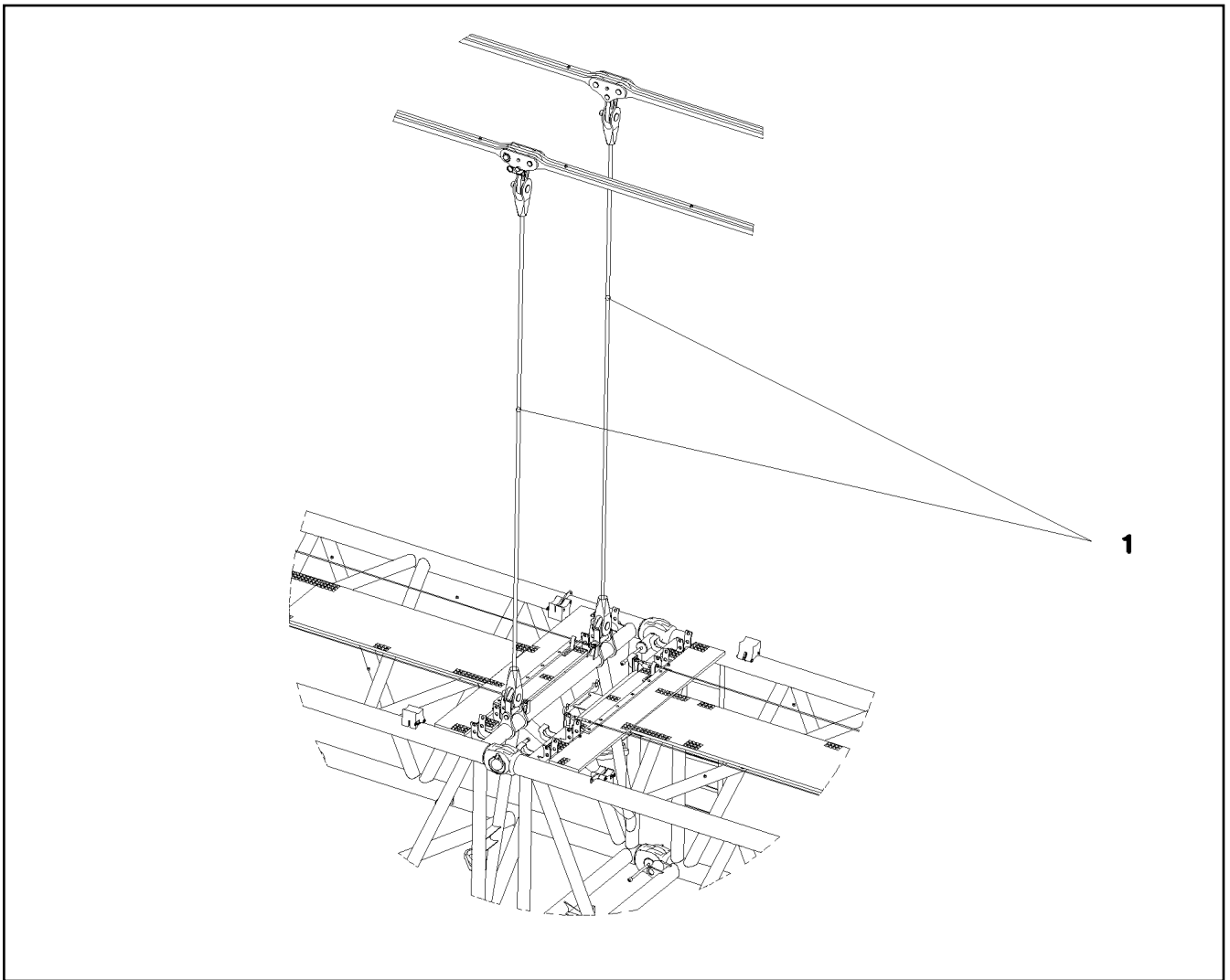

Pos.	Item	Quantity	Description	Bezeichnung	Serie	K
1	97 74 939 08	2	ROPE 34MM 5.525M	SEIL		

6.2.2009
055203

LIEBHERR

etk_en_de_074515 LR 1600/2

SUPPLEMENTARY GUYING DEVICE
ZUSATZABSPANNUNG

570

⇒ 3 836 000
91 55 540 08

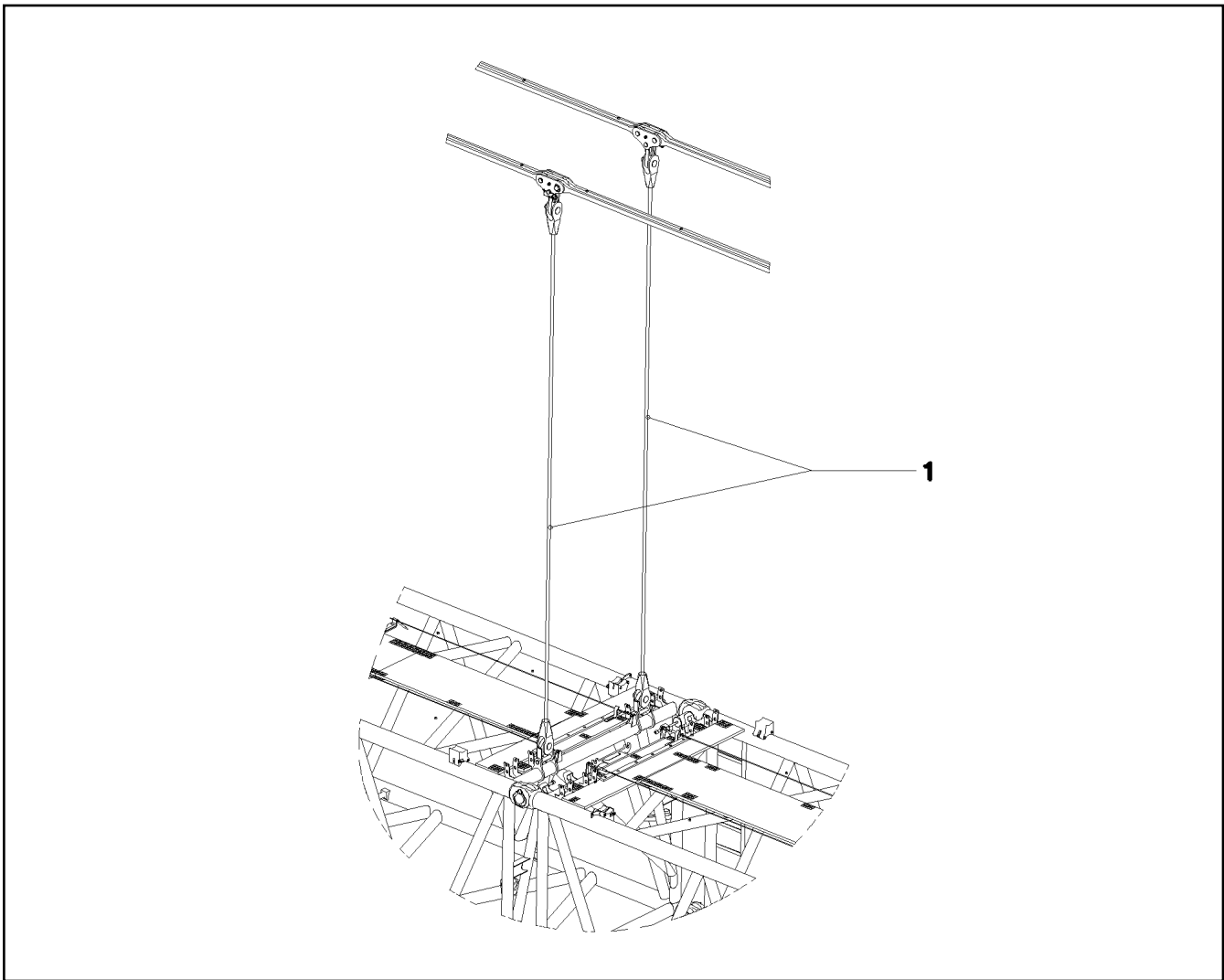

Pos.	Item	Quantity	Description	Bezeichnung	Serie	K
1	97 74 940 08	2	ROPE 34MM 6.525M	SEIL		

6.2.2009
055462

LIEBHERR

etk_en_de_074515 LR 1600/2

SUPPLEMENTARY GUYING DEVICE
ZUSATZABSPANNUNG

571

⇒ 3 837
91 55 541 08

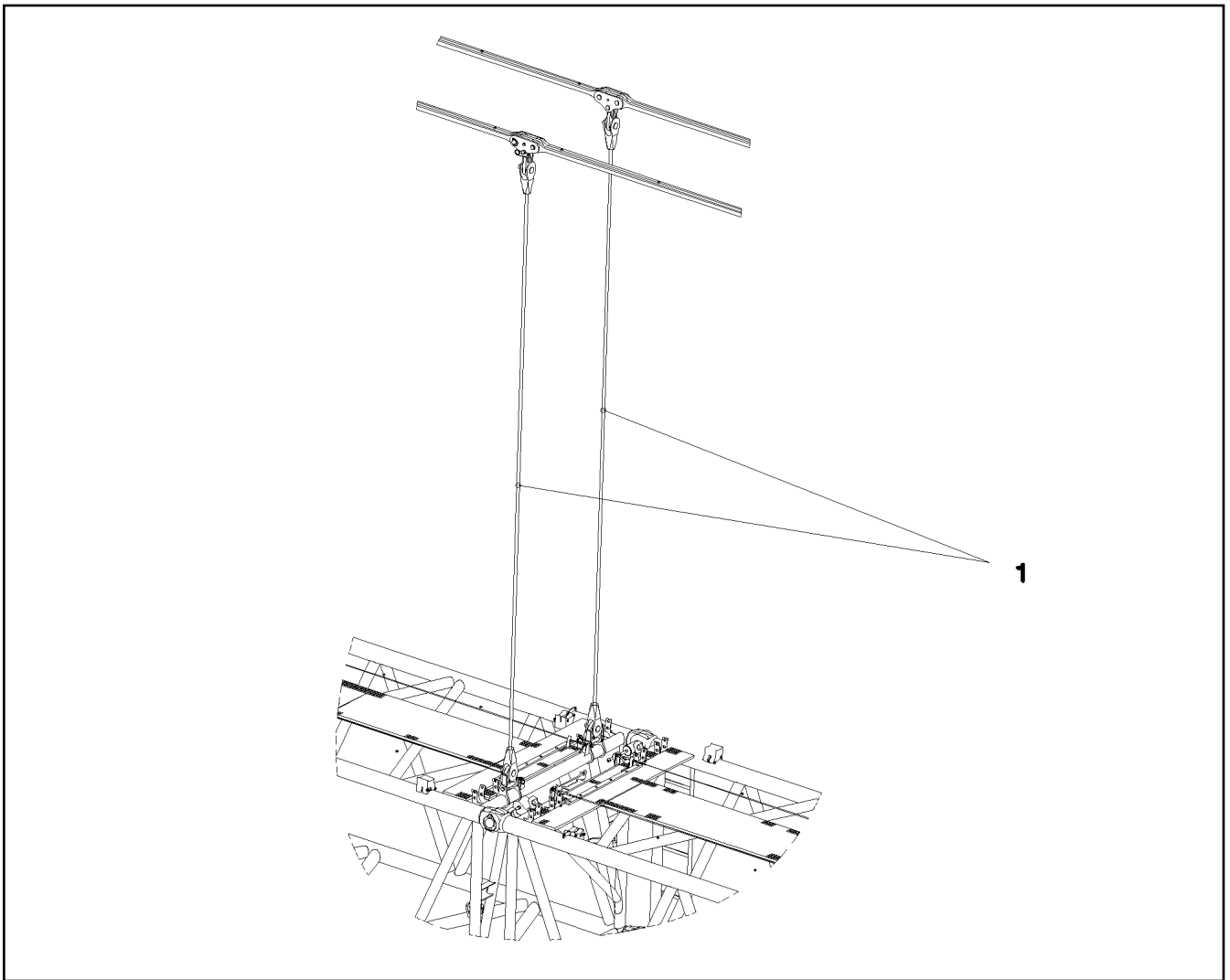

Pos.	Item	Quantity	Description	Bezeichnung	Serie	K
1	97 74 941 08	2	ROPE 34MM 7.525M	SEIL		

6.2.2009
055205

LIEBHERR

etk_en_de_074515 LR 1600/2

SUPPLEMENTARY GUYING DEVICE
ZUSATZABSPANNUNG

572

⇒ 3 838 000
91 55 542 08

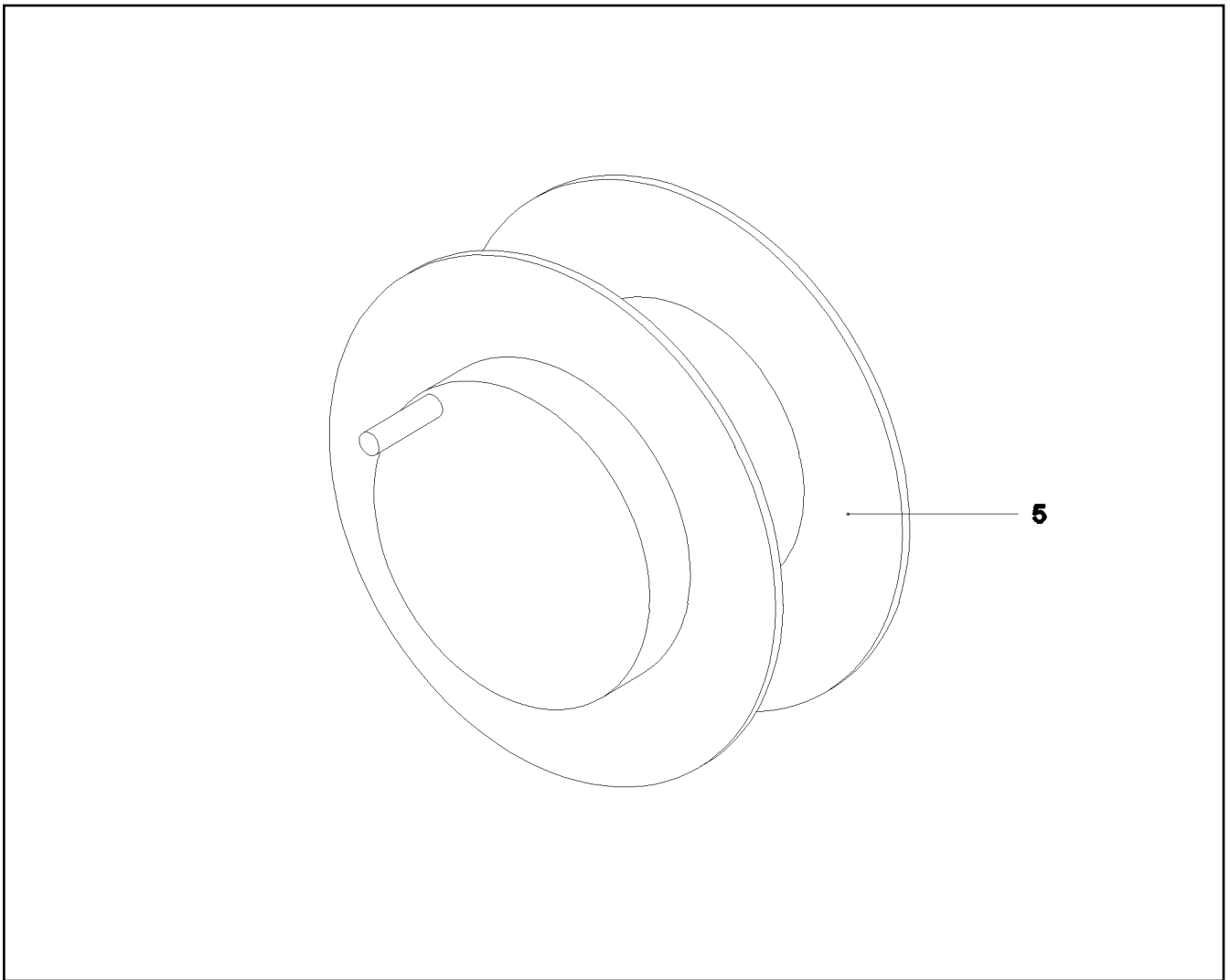

Pos.	Item	Quantity	Description	Bezeichnung	Serie	K
5	97 22 660 08	1	CABLE DRUM	KABELTROMMEL		
6	96 50 575 08	1	LEAD W1001A	LEITUNG		
			⇒ 3 930 732 96 50 575 08			
32	60 22 060 08	1	CABLE LUG DIN 46237 3,5/2,5mm ² VERZ	KABELSCHUH		
34	60 22 061 08	1	CABLE LUG DIN 46237 6 - 2,5	KABELSCHUH		
152	69 18 998 08	1	DUST CAP METALL	STAUBKAPPE		
155	69 21 000 08	1	SEAL	DICHTUNG		
164	60 27 040 08	1	CABLE SLEEVE 10-13	KABELTUELLE		
266	40 01 701 08	4	CYLINDER SCREW DIN 84 M3X15 MS	ZYLINDERSCHRAUBE		
267	41 15 157 08	4	HEX NUT DIN 934 M3 8 A3C	SECHSKANTMUTTER		
268	42 00 501 08	4	WASHER DIN 125 A 3.2 MS	SCHEIBE		
269	42 52 205 08	4	SERRATED LOCK WASHER DIN 6798 J 3,2	FAECHERSCHEIBE		
342	60 01 313 08	1	WIRE BRAID 0,5	LITZE		

6.2.2009
052925

LIEBHERR

etk_en_de_074515 LR 1600/2

CABLE DRUM COMPL.
LEITUNGSTROMMEL KPL.

□ 573

⇒ 3 930 009
96 50 573 08

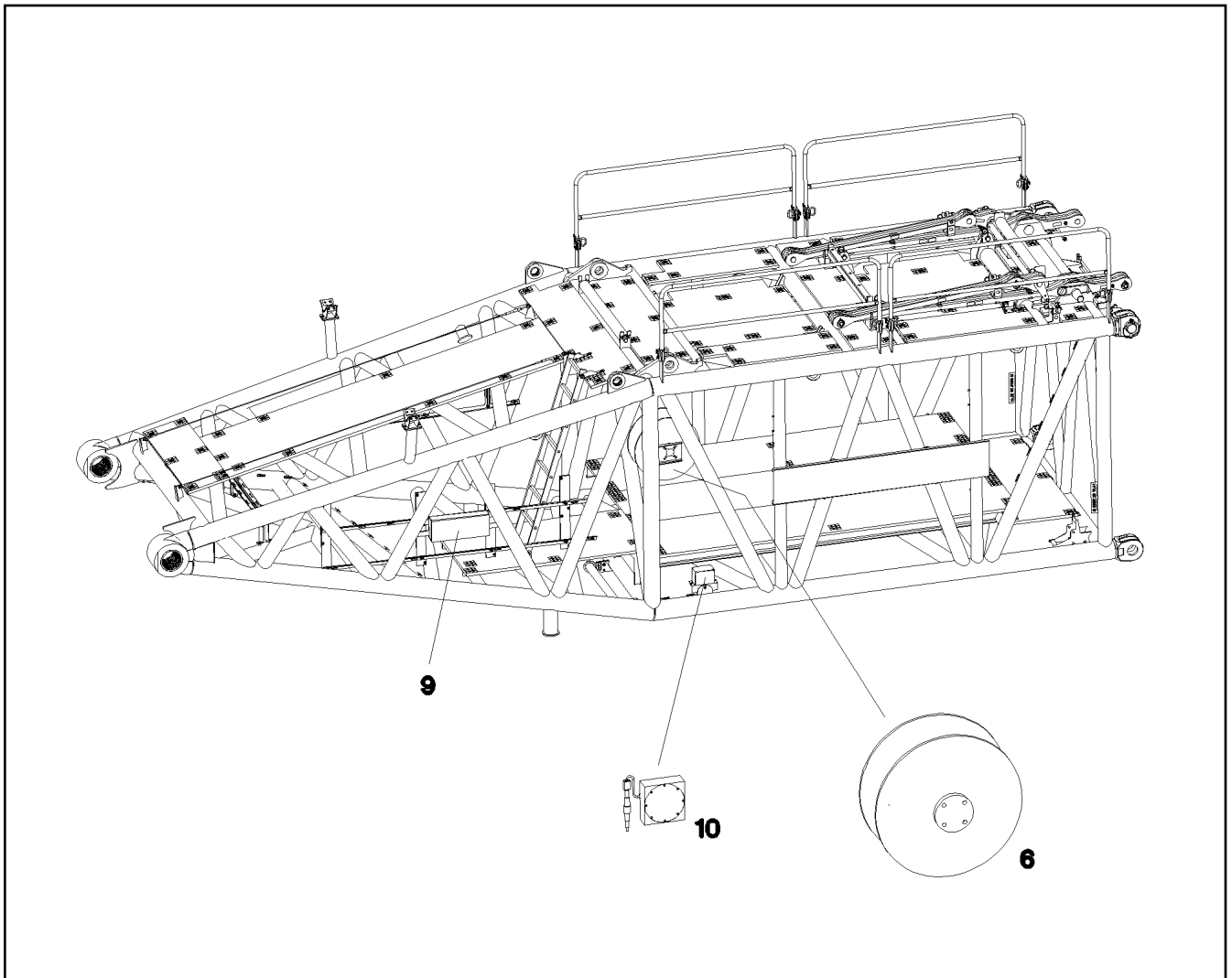

Pos.	Item	Quantity	Description	Bezeichnung	Serie	K
6	96 48 489 08	1	CABLE DRUM COMPL.	LEITUNGSTROMMEL KPL.		
(6)	96 49 011 08	1	LINE WITH PLUG W911A	LEITUNG M.STECKER		
(97)	60 27 100 08	25	CABLE SLEEVE 3,0-7,0/3,0/0,6 SILIKONGU	KABELTUELLE		
(151)	61 60 249 08	1	CABLE DRUM M25X1,5 SPF	KABELTROMMEL		
(154)	42 00 501 08	1	WASHER DIN 125 A 3.2 MS	SCHEIBE		
(155)	42 52 207 08	1	SERRATED LOCK WASHER DIN 6798 J 4,3	FAECHERSCHEIBE		
(170)	10 44 365 9	1	WALL OUTLET 24-POL 22A SPF	WANDSTECKDOSE		
(171)	69 21 000 08	1	SEAL	DICHTUNG		
(172)	69 18 998 08	1	DUST CAP METALL	STAUBKAPPE		
(265)	87 00 028 08	0.01	SEALANT A80MR HYLOMAR	DICHTMITTEL		
(266)	41 15 157 08	4	HEX NUT DIN 934 M3 8 A3C	SECHSKANTMUTTER		
(267)	42 51 005 08	4	TOOTH LOCK WASHER DIN 6797 A 3,2	ZAHNSCHEIBE		
(268)	40 01 701 08	4	CYLINDER SCREW DIN 84 M3X15 MS	ZYLINDERSCHRAUBE		
(269)	60 24 243 08	1	THREADED CABLE GLAND M25X1,5 MS	KABELVERSCHRAUBUNG		
9	96 54 398 08	1	TERMINAL BOX CPL. S910 ⇒ 3 930 730 96 54 398 08	KLEMMKASTEN KPL.		
10	96 19 877 08	1	SENSOR FITTING ANGLE SENSOR	GEBERANBAU WINKELGEBER		
(152)	69 23 100 08	1	ANGLE TRANSMITTER 360° SPF	WINKELGEBER		

6.2.2009
054190

LIEBHERR

etk_en_de_074515 LR 1600/2

ELECTRIC FOR S-PIVOT SECTION
ELEKTRIK S-ANLENKSTUECK

574

⇒ 3 930 138
96 54 377 08

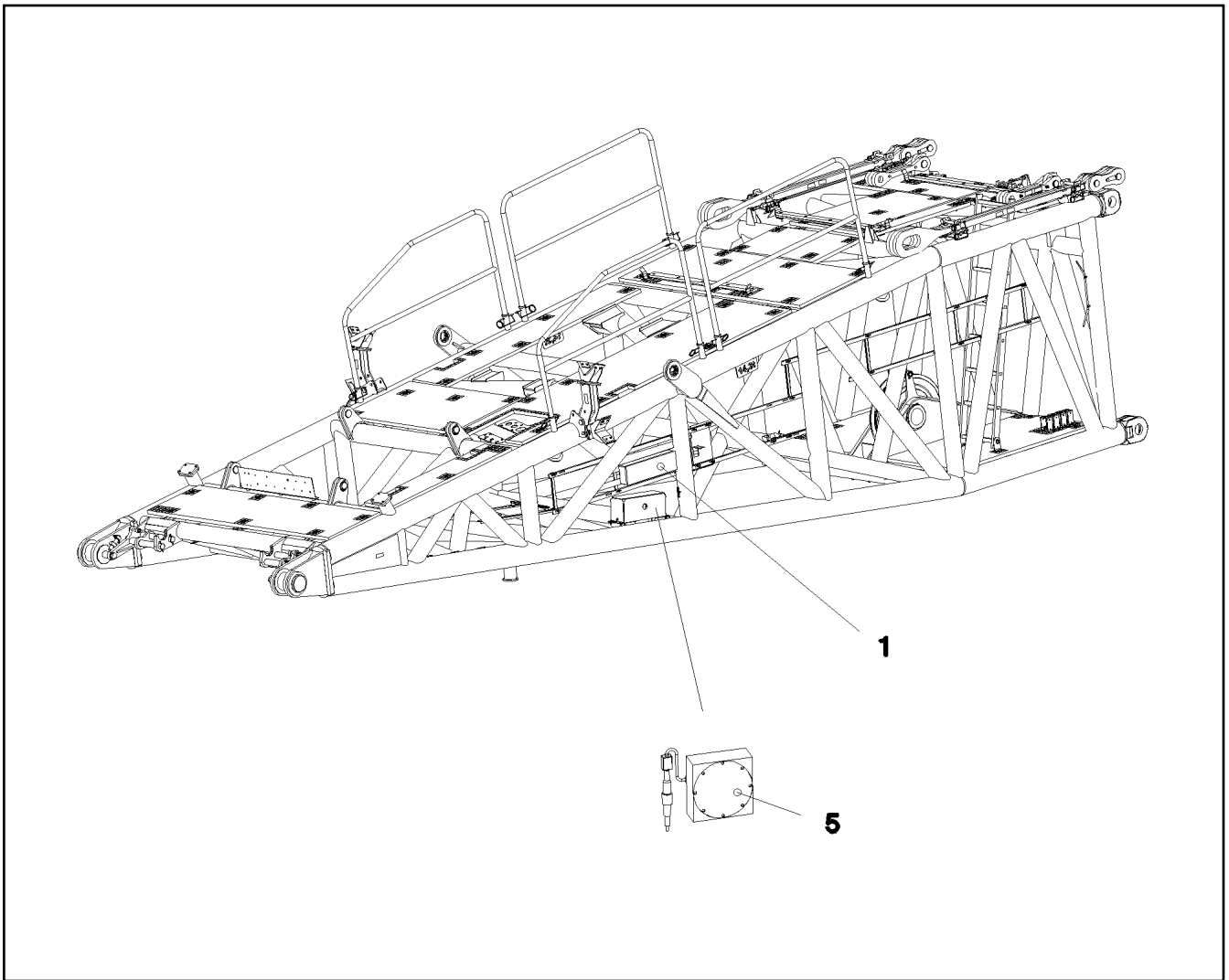

Pos.	Item	Quantity	Description	Bezeichnung	Serie	K
1	96 54 401 08	1	TERMINAL BOX S1050 ⇒ 3 930 734 96 54 401 08	KLEMMKASTEN		
5	96 19 877 08	1	SENSOR FITTING ANGLE SENSOR	GEBERANBAU WINKELGEBER		

6.2.2009
054270

LIEBHERR

etk_en_de_074515 LR 1600/2

D PIVOT SECTION ELEC. EQUIPT.
ELEKTRIK D-ANLENKSTUECK

□ 575

⇒ 3 930 330
96 54 378 08

4
5

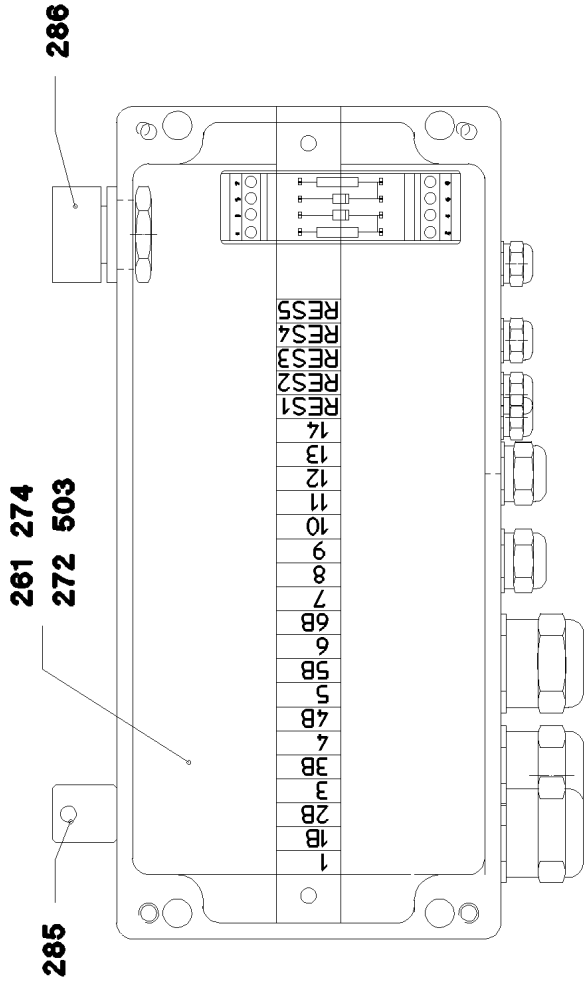
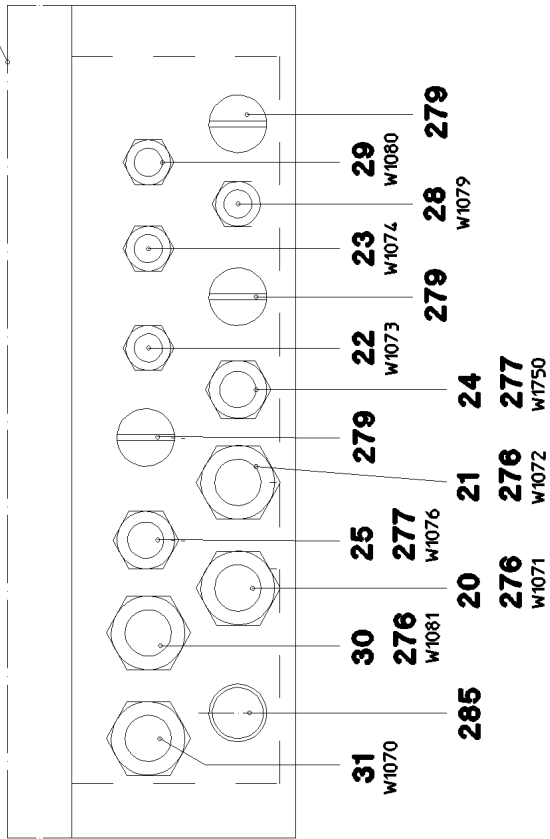

6.2.2009
054283

LIEBHERR

etk_en_de_074515 LR 1600/2

TERMINAL BOX CPL.
KLEMMKASTEN KPL.

576 (1/2)

⇒ 3 930 363
96 52 979 08

Pos.	Item	Quantity	Description	Bezeichnung	Serie	K
4	97 83 741 08	1	LABEL +S1070 LEXAN	SCHILD		
5	97 54 075 08	1	EMPTY CASING 160X260X90X0 AL	LEERGEHAEUSE		
20	96 52 996 08	1	LEAD W1071	LEITUNG		
21	96 52 997 08	1	LEAD W1072	LEITUNG		
22	96 52 998 08	1	LEAD W1073	LEITUNG		
23	96 52 999 08	1	LEAD W1074	LEITUNG		
24	96 53 000 08	1	LEAD W1075	LEITUNG		
25	96 53 001 08	1	LEAD W1076	LEITUNG		
28	96 53 004 08	1	LEAD W1079	LEITUNG		
29	96 53 008 08	1	LEAD W1080	LEITUNG		
30	96 53 009 08	1	LEAD W1081	LEITUNG		
31	96 53 010 08	1	LEAD W1052	LEITUNG		
32	96 53 011 08	1	WIRES TERMINAL BOX CPL. +S1070	DRAEHTE KLEMMKASTEN KPL.		
(2)	96 53 012 08	1	WIRES PRE-ASS. +S1070	DRAEHTE VORM.		
(151)	10 28 635 4	20	TERMINAL/CLAMP	KLEMME		
(152)	96 48 302 08	1	CUSTOM CIRCUIT MODULE 2	BESTUECKUNGSMODUL 2		
261	60 32 022 08	5	CABLE TIE 2,5X102	KABELBINDER		
272	60 21 067 08	0.245	TOP HAT RAIL 35X27X7,3X1	HUTSCHIENE		
274	60 27 417 08	10	CRAMP	KRAMPE		
276	60 24 257 08	3	THREADED CABLE GLAND M20X1,5 MS	KABELVERSCHRAUBUNG		
277	60 24 241 08	2	THREADED CABLE GLAND M16X1,5 MS	KABELVERSCHRAUBUNG		
279	60 24 249 08	3	SCREW PLUG M16X1,5 MS	VERSCHLUSSSCHRAUBE		
285	60 25 012 08	2	WATER DRAIN PLUG PA6G SPF	ENTWAESSERUNGSSTOPFEN		
286	60 25 013 08	1	VENTILATION SCREW G1/2"X30 POLYAMID	ENTLUEFTUNGSSCHRAUBE		
503	60 27 426 08	0.25	IDENTIFICATION STRIP	KENNZEICHNUNGSKARTEN		

6.2.2009

etk_en_de_074515 LR 1600/2

577 (2/2)

LIEBHERR

TERMINAL BOX CPL.
KLEMMKASTEN KPL.

⇒ 3 930 363
96 52 979 08

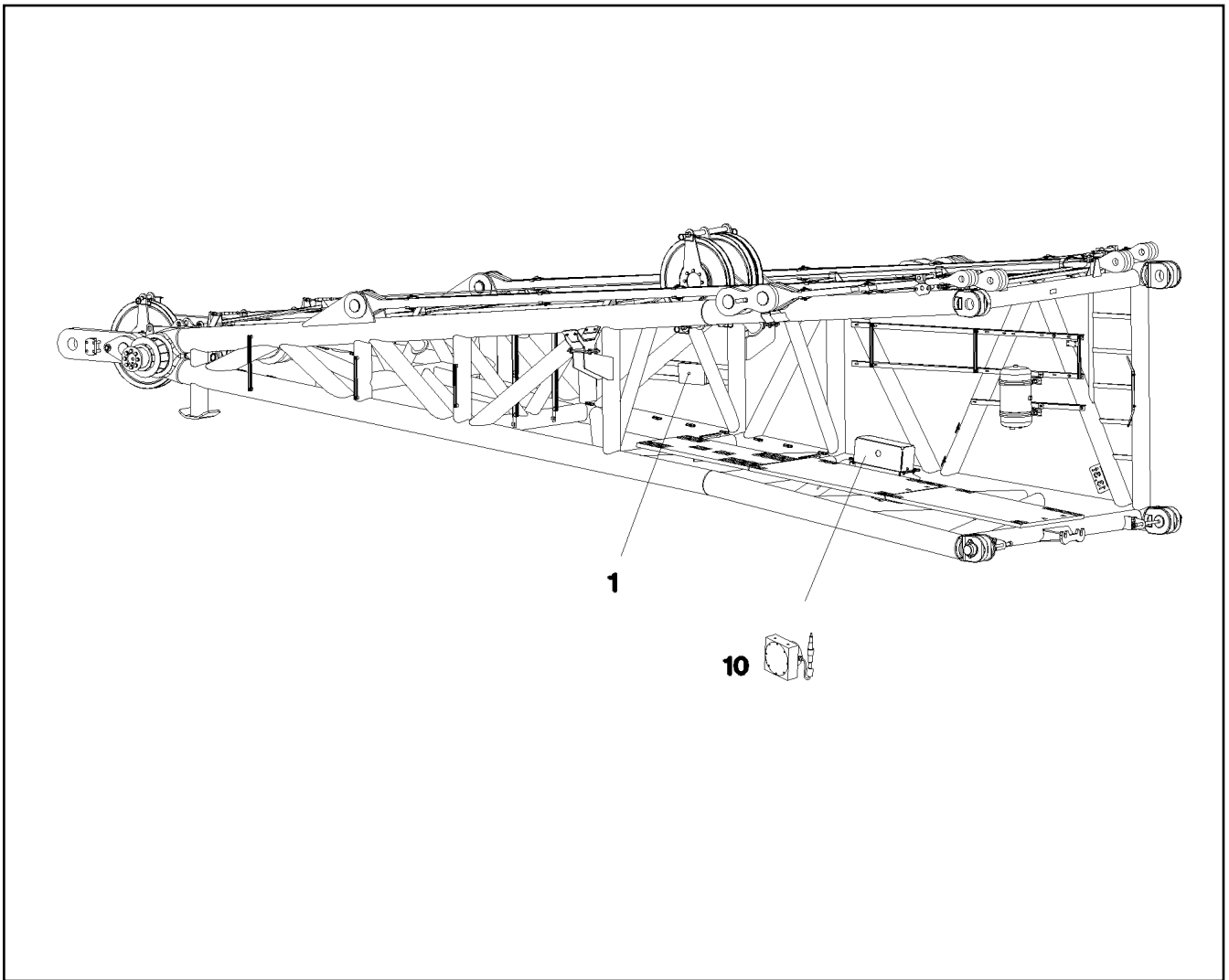

Pos.	Item	Quantity	Description	Bezeichnung	Serie	K
1	96 52 979 08	1	TERMINAL BOX CPL. S1070 ⇒ 3 930 363 96 52 979 08	KLEMMKASTEN KPL.		
10	96 19 877 08	1	SENSOR FITTING ANGLE SENSOR	GEBERANBAU WINKELGEBER		

6.2.2009
054281

LIEBHERR

etk_en_de_074515 LR 1600/2

ELECTR. FOR HEAD SECTION
ELEKTRIK D-KOPFSTUECK

□ 578

⇒ 3 930 421
96 47 149 08

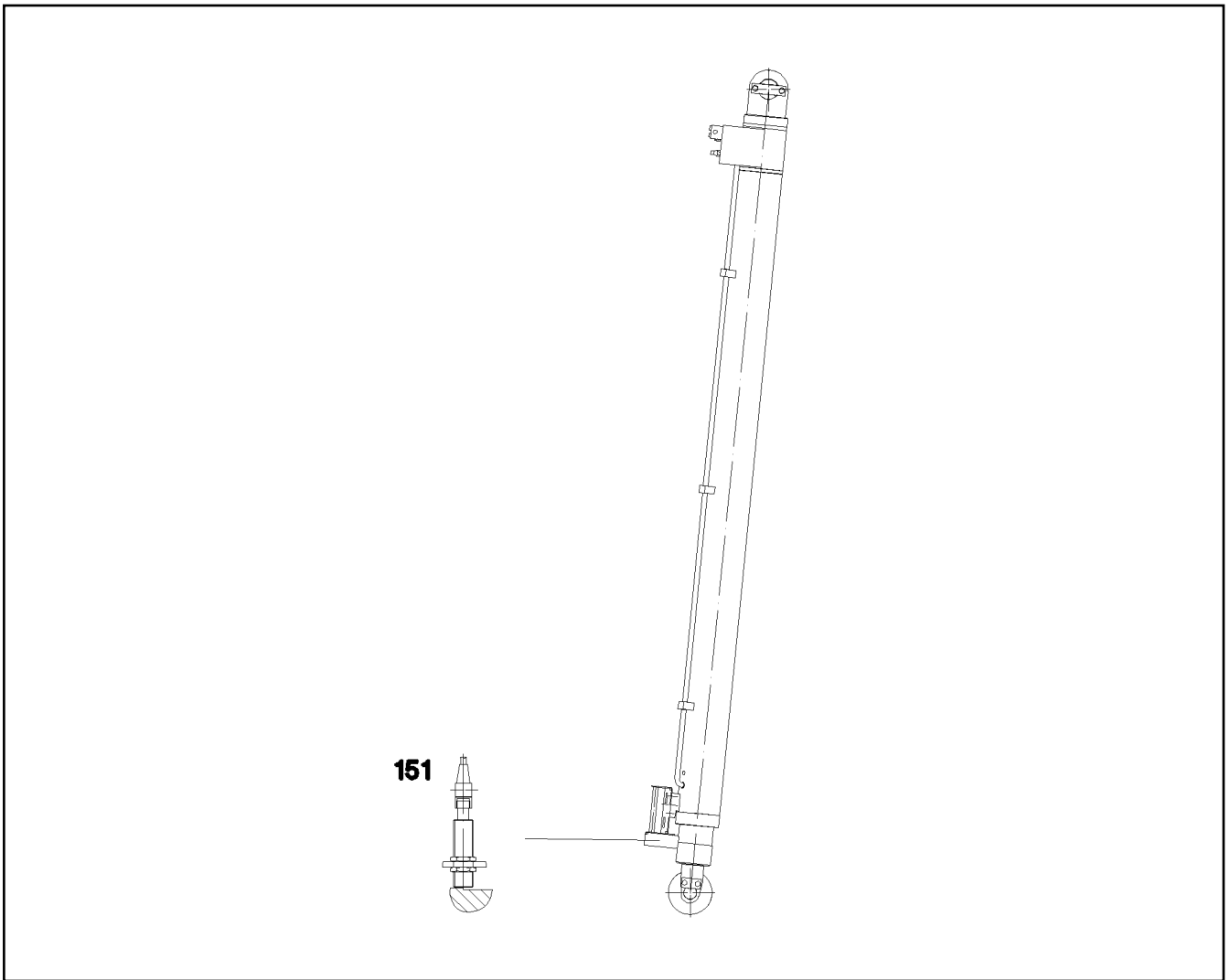

Pos.	Item	Quantity	Description	Bezeichnung	Serie	K
151	69 23 087 08	2	INDUCTIVE SENSOR SPF	INDUKTIVSENSOR		

6.2.2009
054282

LIEBHERR

etk_en_de_074515 LR 1600/2

EL.BACKING PROTECTION D
ELEKTRIK D-RUECKHALTESICHERUNG

579

⇒ 3 930 501
96 51 078 08

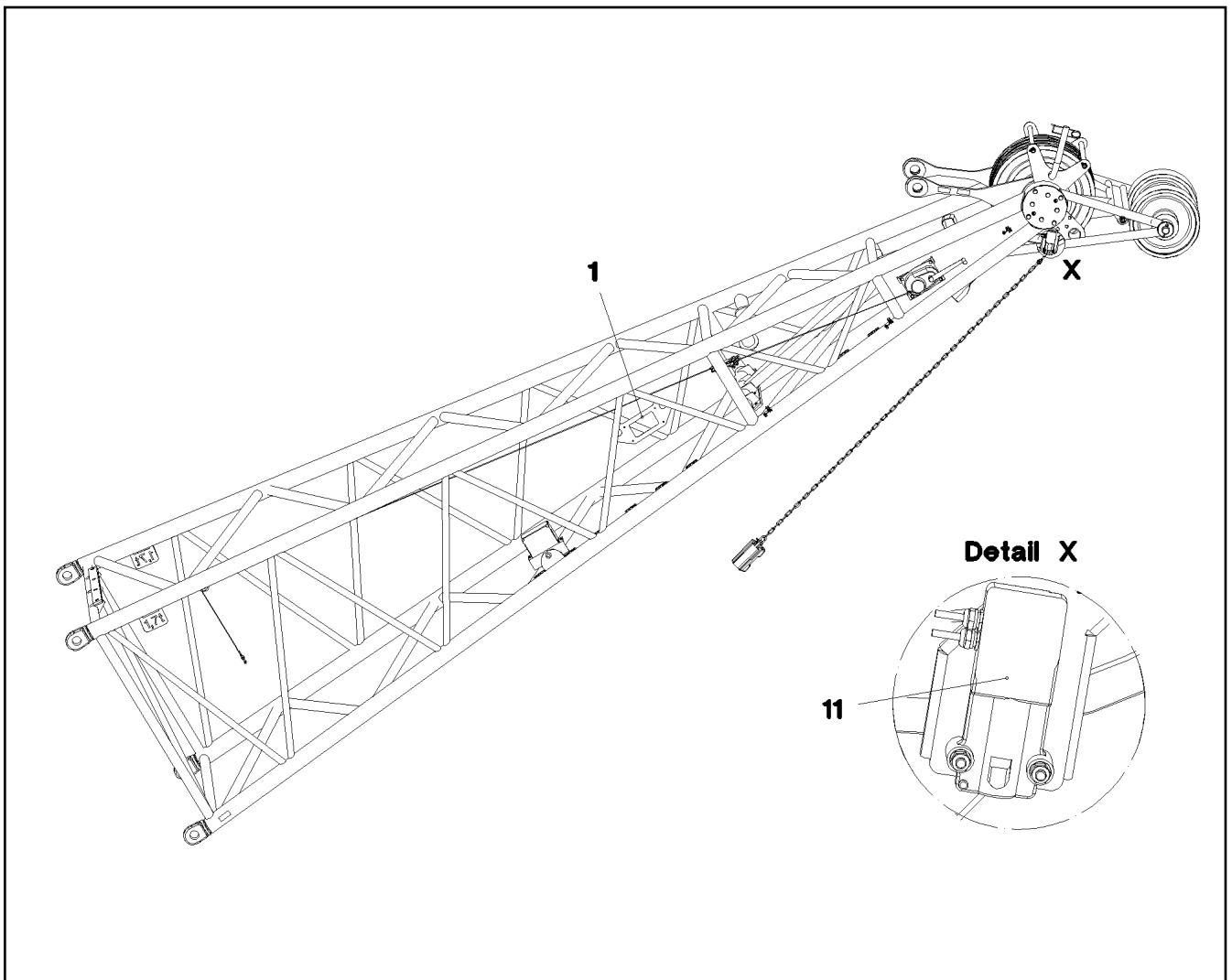

Pos.	Item	Quantity	Description	Bezeichnung	Serie	K
1	96 50 599 08	1	TERMINAL BOX CPL. S1020 ⇒ 3 930 730 96 50 599 08	KLEMMKASTEN KPL.		
11	96 20 219 08	1	SENSOR LIFT TOP LIMIT SWITCH MIT M12	GEBER HUB OBEN ENDSCHAL		
(7)	60 60 533 08	1	LIMIT SWITCH HUB-OBEN SPF	ENDSCHALTER		

6.2.2009
052932

LIEBHERR

etk_en_de_074515 LR 1600/2

ELECTR. F-HEAD SECTION
ELEKTRIK F-KOPFSTUECK

580

⇒ 3 930 546
96 48 375 08

Pos.	Item	Quantity	Description	Bezeichnung	Serie	K
1	96 50 481 08	1	TERMINAL BOX CPL. S1000 ⇒ 3 930 640 96 50 481 08	KLEMMKASTEN KPL.		
10	96 19 877 08	1	SENSOR FITTING ANGLE SENSOR	GEBERANBAU WINKELGEBER		

6.2.2009	etk_en_de_074515 LR 1600/2	581
LIEBHERR	EL.F-CONNECTING HEAD EL.F-ANSCHLUSS KOPFSTUECK	⇒ 3 930 575 96 48 380 08

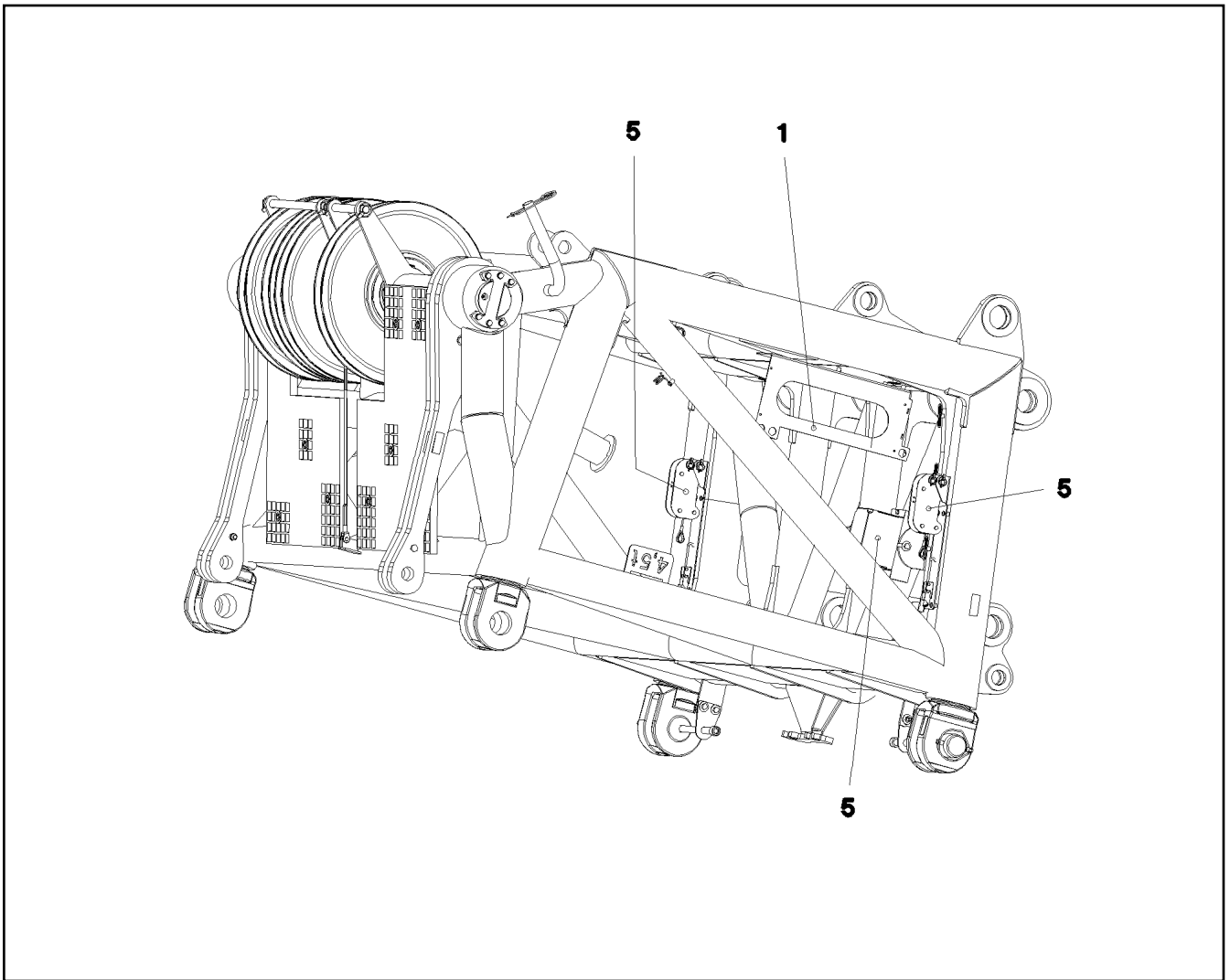

Pos.	Item	Quantity	Description	Bezeichnung	Serie	K
1	96 51 624 08	1	TERMINAL BOX S980 ⇒ 3 930 638 96 51 624 08	KLEMMKASTEN		
5	96 37 685 08	1	SENSOR ASSEMBLY S-HEAD	GEBERANBAU S-KOPF		
(5)	69 23 100 08	1	ANGLE TRANSMITTER 360° SPF	WINKELGEBER		
(7)	60 60 533 08	2	LIMIT SWITCH HUB-OBEN SPF	ENDSCHALTER		

6.2.2009
041606

LIEBHERR

etk_en_de_074515 LR 1600/2

EL.EQUIPMENT SW HEAD SECTION
ELEKTRIK SW-KOPFSTUECK

582

⇒ 3 930 576
96 48 381 08

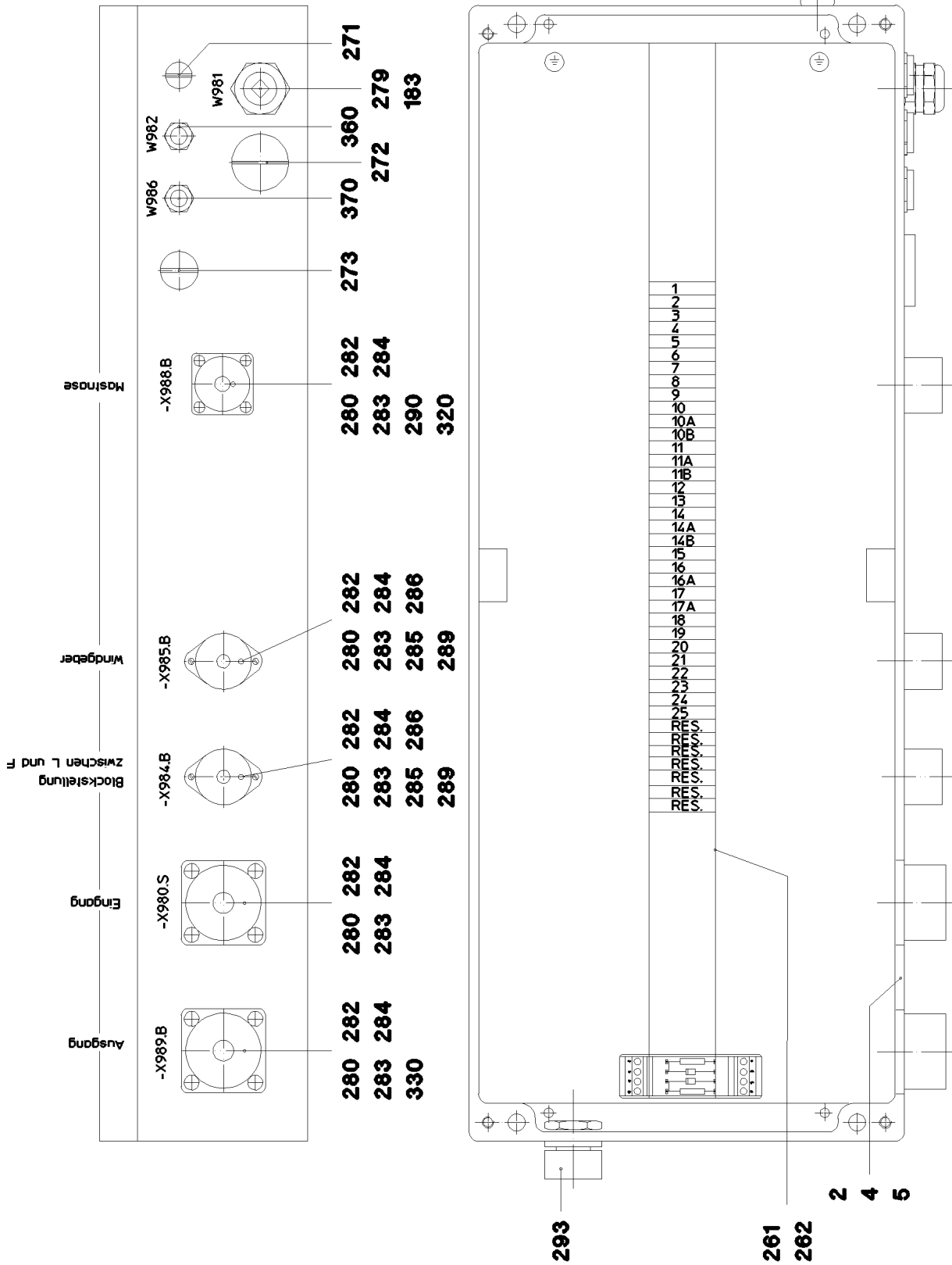

6.2.2009
052749

LIEBHERR

etk_en_de_074515 LR 1600/2

TERMINAL BOX
KLEMMKASTEN

583 (1/2)

⇒ 3 930 638
96 51 624 08

Pos.	Item	Quantity	Description	Bezeichnung	Serie	K
2	96 50 132 08	1	WIRES TERMINAL BOX CPL. S980 ⇒ 3 930 639 96 50 132 08	DRAEHTE KLEMMKASTEN KPL.		
4	97 80 749 08	1	EMPTY CASING 230X600X110X0	LEERGEHAEUSE		
5	97 80 757 08	1	LABEL +S980 ALU	SCHILD		
183	60 26 064 08	1	REDUCTION M25X1,5/M20X1,5 MS	REDUKTION		
261	60 21 067 08	0.58	TOP HAT RAIL 35X27X7,3X1	HUTSCHIENE		
262	10 28 635 3	1	LID	DECKEL		
271	60 24 255 08	1	SCREW PLUG M12X1,2 MS	VERSCHLUSSSCHRAUBE		
272	60 24 251 08	1	SCREW PLUG M25X1,5 MS	VERSCHLUSSSCHRAUBE		
273	60 24 249 08	1	SCREW PLUG M16X1,5 MS	VERSCHLUSSSCHRAUBE		
279	60 24 257 08	1	THREADED CABLE GLAND M20X1,5 MS	KABELVERSCHRAUBUNG		
280	40 01 701 08	16	CYLINDER SCREW DIN 84 M3X15 MS	ZYLINDERSCHRAUBE		
282	42 00 006 08	16	WASHER DIN 125 A 3.7 ST VERZ	SCHEIBE		
283	42 51 005 08	16	TOOTH LOCK WASHER DIN 6797 A 3,2	ZAHNSCHEIBE		
284	41 15 157 08	16	HEX NUT DIN 934 M3 8 A3C	SECHSKANTMUTTER		
285	60 45 081 08	2	TIN M13	DOSE		
286	60 45 121 08	2	SEALING PLUG M1-D	VERSCHLUSSKAPPE		
289	69 18 998 08	2	DUST CAP METALL	STAUBKAPPE		
290	69 18 129 08	1	PROTECTING CAP MS	SCHUTZKAPPE		
292	60 25 012 08	1	WATER DRAIN PLUG PA6G SPF	ENTWAESSERUNGSSTOPFEN		
293	10 48 866 2	1	VENTILATION SCREW M20X1,5 POLYAMID	ENTLUEFTUNGSSCHRAUBE		
320	96 52 267 08	1	DUMMY PLUG W988BS	BLINDSTECKER		
330	96 52 272 08	1	DUMMY PLUG W989BS	BLINDSTECKER		
350	96 50 233 08	1	LEAD W981	LEITUNG		
360	96 50 235 08	1	LEAD W982	LEITUNG		
370	96 50 237 08	1	LEAD W983	LEITUNG		

6.2.2009

etk_en_de_074515 LR 1600/2

584 (2/2)

LIEBHERRTERMINAL BOX
KLEMMKASTEN⇒ 3 930 638
96 51 624 08

Pos.	Item	Quantity	Description	Bezeichnung	Serie	K
2	96 50 045 08	1	WIRES PRE-ASS. -S980	DRAEHTE VORM.		
151	69 24 016 08	1	BUILD-IN SOCKET 24POL BU	EINBAUDOSE		
152	10 28 635 4	36	TERMINAL/CLAMP	KLEMME		
153	69 18 092 08	1	APPLIANCE SOCKET	GERAETESTECKDOSE		
154	69 18 996 08	1	BUILD-IN SOCKET 24POL STI	EINBAUDOSE		
155	60 45 265 08	2	BUSH SUPPORT M1 E-6S	BUCHSENTRAEGER		
156	96 48 302 08	1	CUSTOM CIRCUIT MODULE 2	BESTUECKUNGSMODUL 2		

6.2.2009

etk_en_de_074515 LR 1600/2

585

LIEBHERR

WIRES TERMINAL BOX CPL.
DRAEHTE KLEMMKASTEN KPL.

⇒ 3 930 639
96 50 132 08

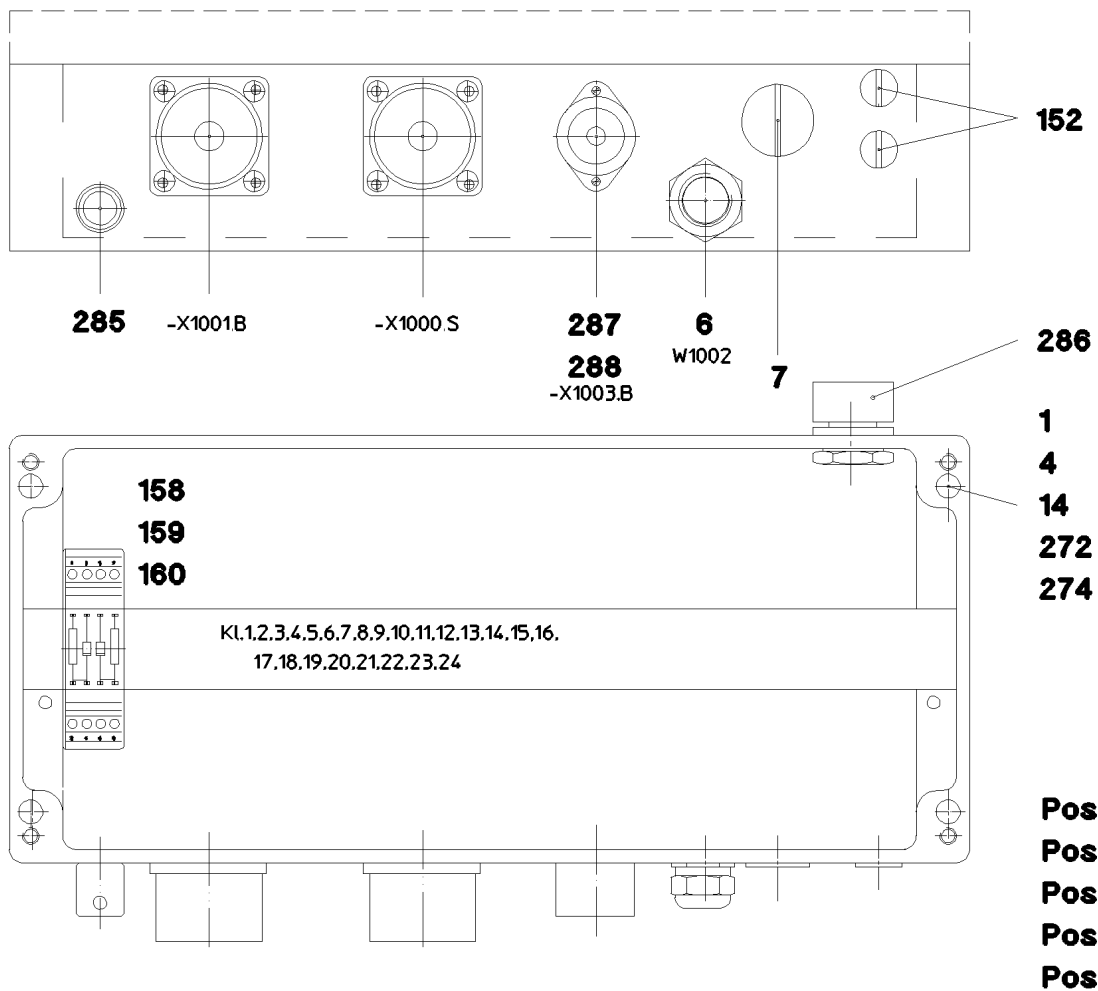

Pos.	Item	Quantity	Description	Bezeichnung	Serie	K
1	97 79 690 08	1	LABEL S1000	SCHILD		
4	97 79 684 08	1	EMPTY CASING 160X360X90X0	LEERGEHAEUSE		
6	96 50 478 08	1	LEAD W1002	LEITUNG		
7	60 24 250 08	1	SCREW PLUG M20X1,5 MS	VERSCHLUSSSCHRAUBE		
8	96 50 482 08	1	WIRES TERMINAL BOX CPL. S1000	DRAEHTE KLEMMKASTEN KPL.		
(2)	96 50 483 08	1	WIRES PRE-ASS. -S1000	DRAEHTE VORM.		
(151)	69 24 016 08	1	BUILD-IN SOCKET 24POL BU	EINBAUDOSE		
(152)	10 28 635 4	24	TERMINAL/CLAMP	KLEMME		
(153)	69 18 996 08	1	BUILD-IN SOCKET 24POL STI	EINBAUDOSE		
(154)	60 45 265 08	1	BUSH SUPPORT M1 E-6S	BUCHSENTRAEGER		
(155)	60 45 121 08	1	SEALING PLUG M1-D	VERSCHLUSSKAPPE		
(156)	96 48 302 08	1	CUSTOM CIRCUIT MODULE 2	BESTUECKUNGSMODUL 2		
14	60 27 426 08	0.1	IDENTIFICATION STRIP	KENNZEICHNUNGSKARTEN		
152	60 24 255 08	2	SCREW PLUG M12X1,2 MS	VERSCHLUSSSCHRAUBE		
154	40 01 701 08	10	CYLINDER SCREW DIN 84 M3X15 MS	ZYLINDERSCHRAUBE		
155	41 15 157 08	10	HEX NUT DIN 934 M3 8 A3C	SECHSKANTMUTTER		
156	42 00 501 08	10	WASHER DIN 125 A 3.2 MS	SCHEIBE		
157	42 52 205 08	10	SERRATED LOCK WASHER DIN 6798 J 3,2	FAECHERSCHEIBE		
158	60 27 360 08	2	SUPPORT TRESTLE	AUFLAGEBOCK		
159	55 31 687 08	2	SHEET-METAL SCREW DIN 7981 4,8X13-F-H	BLECHSCHRAUBE		
160	42 18 006 08	2	WASHER DIN 9021 A 5,3 ST VERZ	SCHEIBE		
272	60 21 067 08	0.35	TOP HAT RAIL 35X27X7,3X1	HUTSCHIENE		
274	60 27 417 08	12	CRAMP	KRAMPE		
285	60 25 012 08	1	WATER DRAIN PLUG PA6G SPF	ENTWAESSERUNGSSTOPFEN		
286	60 25 013 08	1	VENTILATION SCREW G1/2"X30 POLYAMID	ENTLUEFTUNGSSCHRAUBE		
287	60 45 081 08	1	TIN M13	DOSE		

6.2.2009
052747

etk_en_de_074515 LR 1600/2

586 (1/2)

LIEBHERR

TERMINAL BOX CPL.
KLEMMKASTEN KPL.

⇒ 3 930 640
96 50 481 08

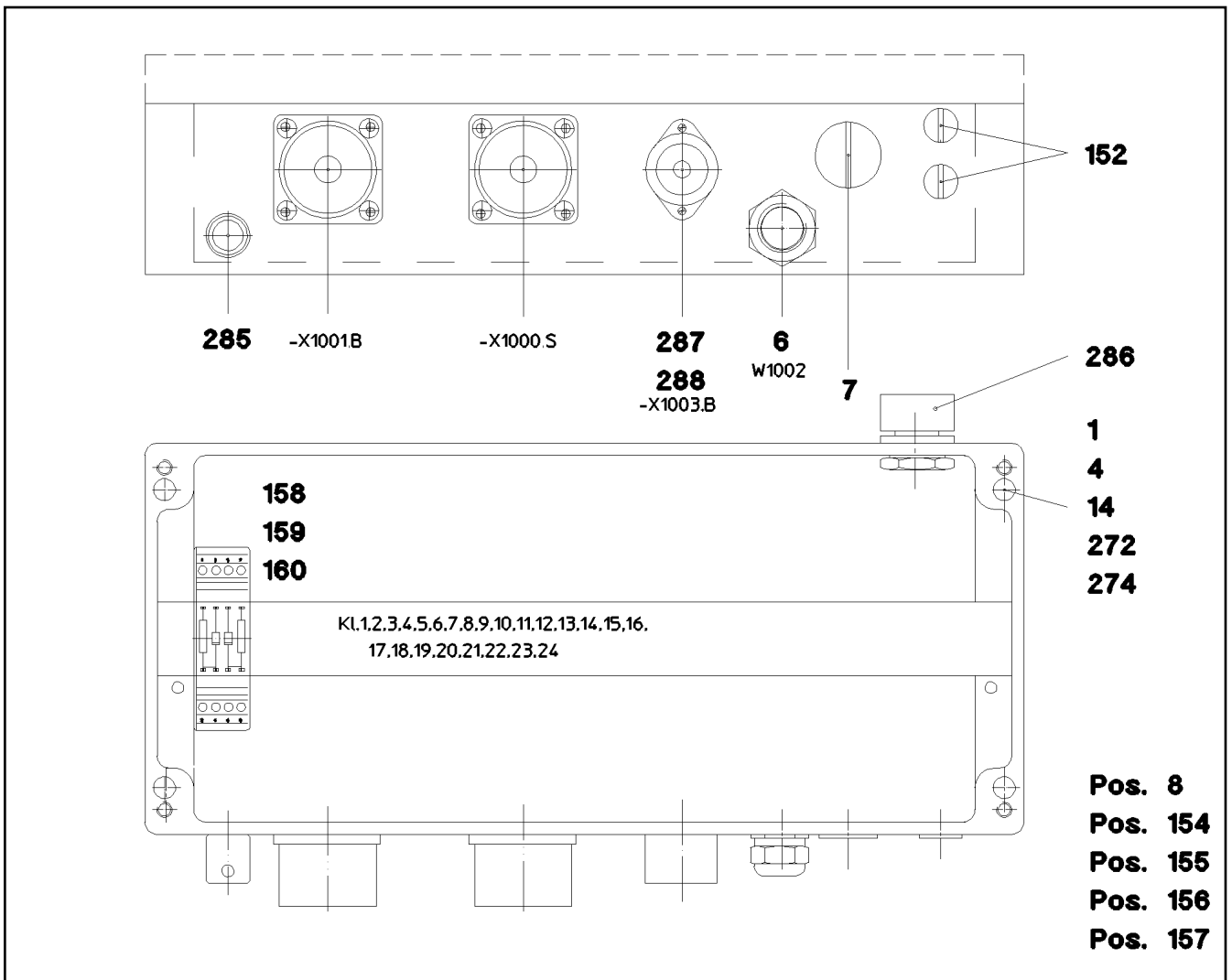

Pos.	Item	Quantity	Description	Bezeichnung	Serie	K
288	60 45 121 08	1	SEALING PLUG M1-D	VERSCHLUSSKAPPE		

6.2.2009
052747

LIEBHERR

etk_en_de_074515 LR 1600/2

TERMINAL BOX CPL.
KLEMMKASTEN KPL.

587 (2/2)

⇒ 3 930 640
96 50 481 08

Pos. 151

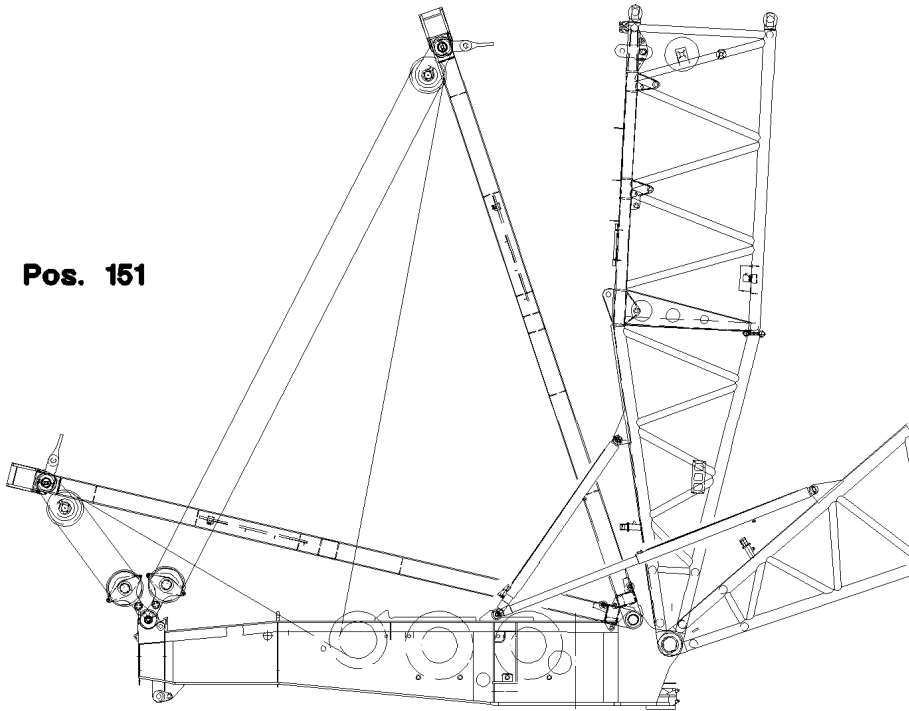

Pos.	Item	Quantity	Description	Bezeichnung	Serie	K
151	69 23 087 08	2	INDUCTIVE SENSOR SPF	INDUKTIVSENSOR		

6.2.2009
023706

LIEBHERR

etk_en_de_074515 LR 1600/2

EL.EQUIPMENT SAFETY RETAINER
ELEKTRIK S-RUECKHALTESICHERUNG

588

⇒ 3 930 713
92 95 070 08

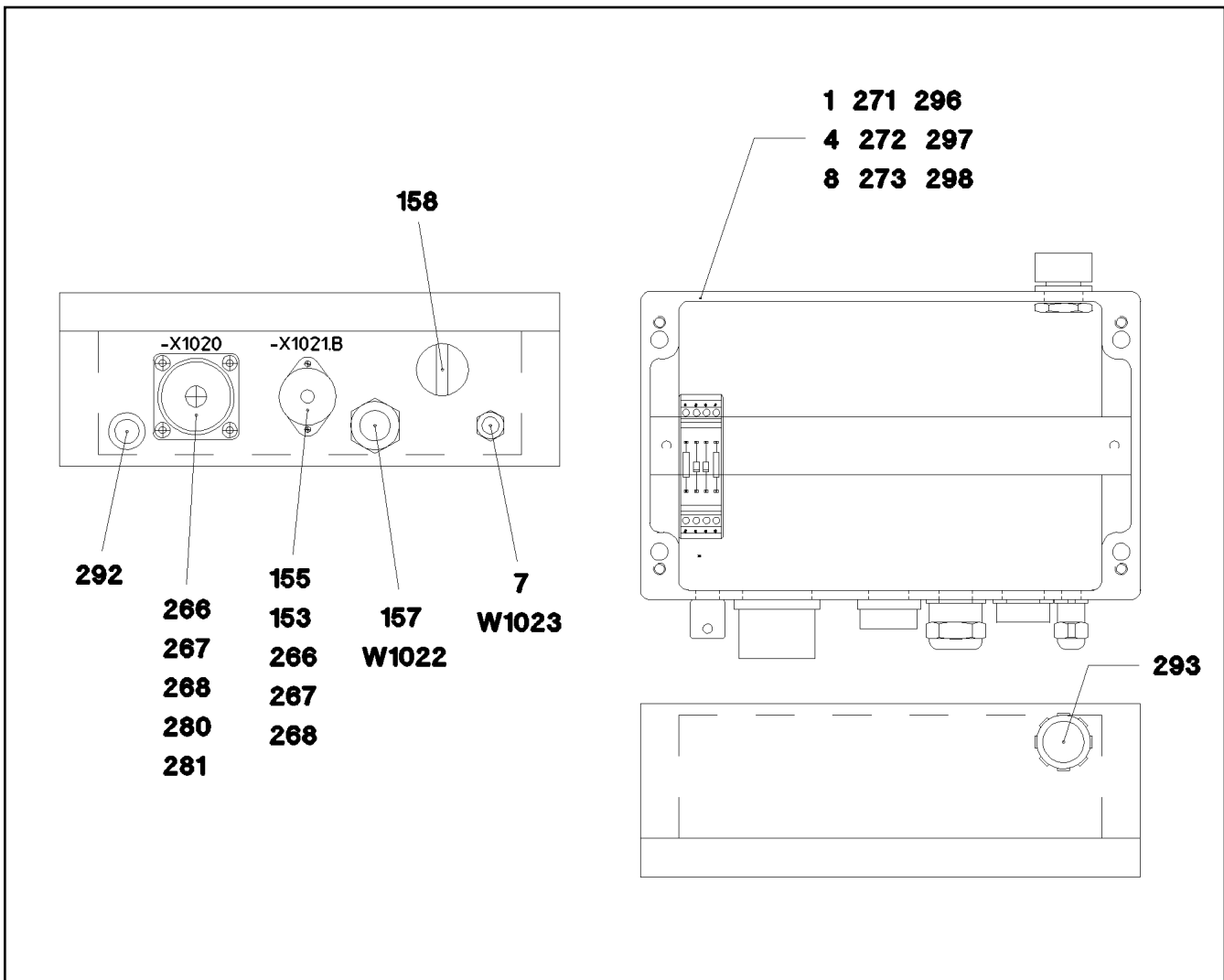

Pos.	Item	Quantity	Description	Bezeichnung	Serie	K
1	97 79 111 08	1	EMPTY CASING 160X260X90X0	LEERGEHAUSE		
4	97 78 943 08	1	LABEL +S1020 ALU	SCHILD		
7	96 50 641 08	1	LEAD W1023	LEITUNG		
8	96 50 642 08	1	WIRES TERMINAL BOX CPL. S1020	DRAEHTE KLEMMKASTEN KPL.		
(2)	96 50 643 08	1	WIRES PRE-ASS. -S1020	DRAEHTE VORM.		
(501)	69 18 996 08	2	BUILD-IN SOCKET 24POL STI	EINBAUDOSE		
(502)	10 28 635 4	28	TERMINAL/CLAMP	KLEMME		
(503)	60 45 265 08	1	BUSH SUPPORT M1 E-6S	BUCHSENTRAEGER		
(504)	96 48 302 08	1	CUSTOM CIRCUIT MODULE 2	BESTUECKUNGSMODUL 2		
153	60 45 121 08	1	SEALING PLUG M1-D	VERSCHLUSSKAPPE		
155	60 45 081 08	1	TIN M13	DOSE		
157	60 24 251 08	1	SCREW PLUG M25X1,5 MS	VERSCHLUSSSCHRAUBE		
158	60 24 251 08	1	SCREW PLUG M25X1,5 MS	VERSCHLUSSSCHRAUBE		
266	40 01 701 08	10	CYLINDER SCREW DIN 84 M3X15 MS	ZYLINDERSCHRAUBE		
267	41 15 157 08	10	HEX NUT DIN 934 M3 8 A3C	SECHSKANTMUTTER		
268	42 00 501 08	10	WASHER DIN 125 A 3.2 MS	SCHEIBE		
271	60 27 360 08	2	SUPPORT TRESTLE	AUFLAGEBOCK		
272	55 31 687 08	2	SHEET-METAL SCREW DIN 7981 4,8X13-F-H	BLECHSCHRAUBE		
273	42 18 006 08	2	WASHER DIN 9021 A 5,3 ST VERZ	SCHEIBE		
280	69 18 998 08	2	DUST CAP METALL	STAUBKAPPE		
281	69 21 000 08	2	SEAL	DICHTUNG		
289	87 00 028 08	0.1	SEALANT A80MR HYLOMAR	DICHTMITTEL		
292	60 25 012 08	1	WATER DRAIN PLUG PA6G SPF	ENTWAESSERUNGSSTOPFEN		
293	10 48 866 2	1	VENTILATION SCREW M20X1,5 POLYAMID	ENTLUEFTUNGSSCHRAUBE		
296	10 28 635 3	1	LID	DECKEL		
297	60 27 946 08	2	END ANGLE	ENDWINKEL		

6.2.2009
052936

LIEBHERR

etk_en_de_074515 LR 1600/2

TERMINAL BOX CPL.
KLEMMKASTEN KPL.

☐ 589 (1/2)

⇒ 3 930 730
96 50 599 08

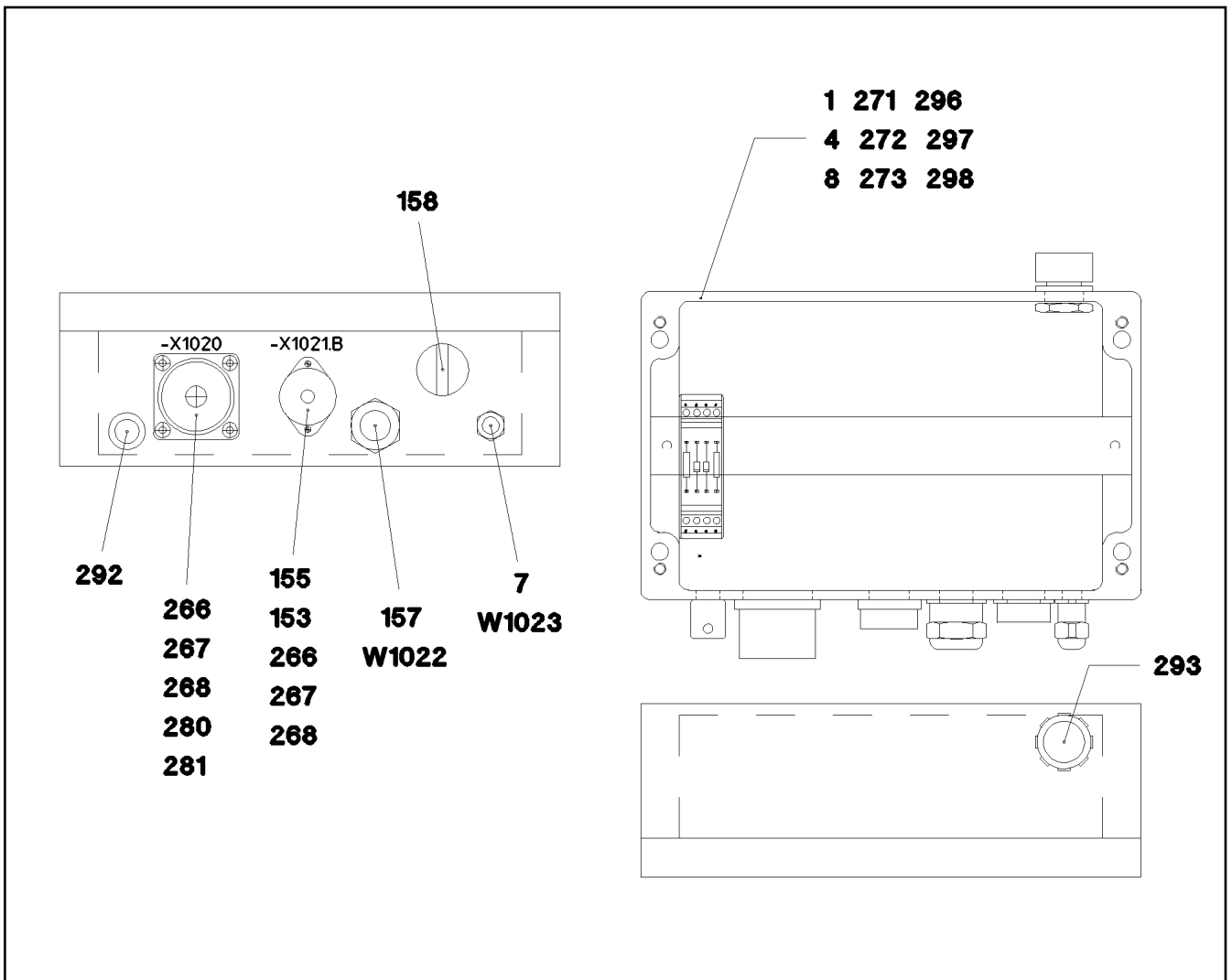

Pos.	Item	Quantity	Description	Bezeichnung	Serie	K
298	60 21 067 08	0.245	TOP HAT RAIL 35X27X7,3X1	HUTSCHIENE		

6.2.2009
052936

LIEBHERR

etk_en_de_074515 LR 1600/2

TERMINAL BOX CPL.
KLEMMKASTEN KPL.

590 (2/2)

⇒ 3 930 730
96 50 599 08

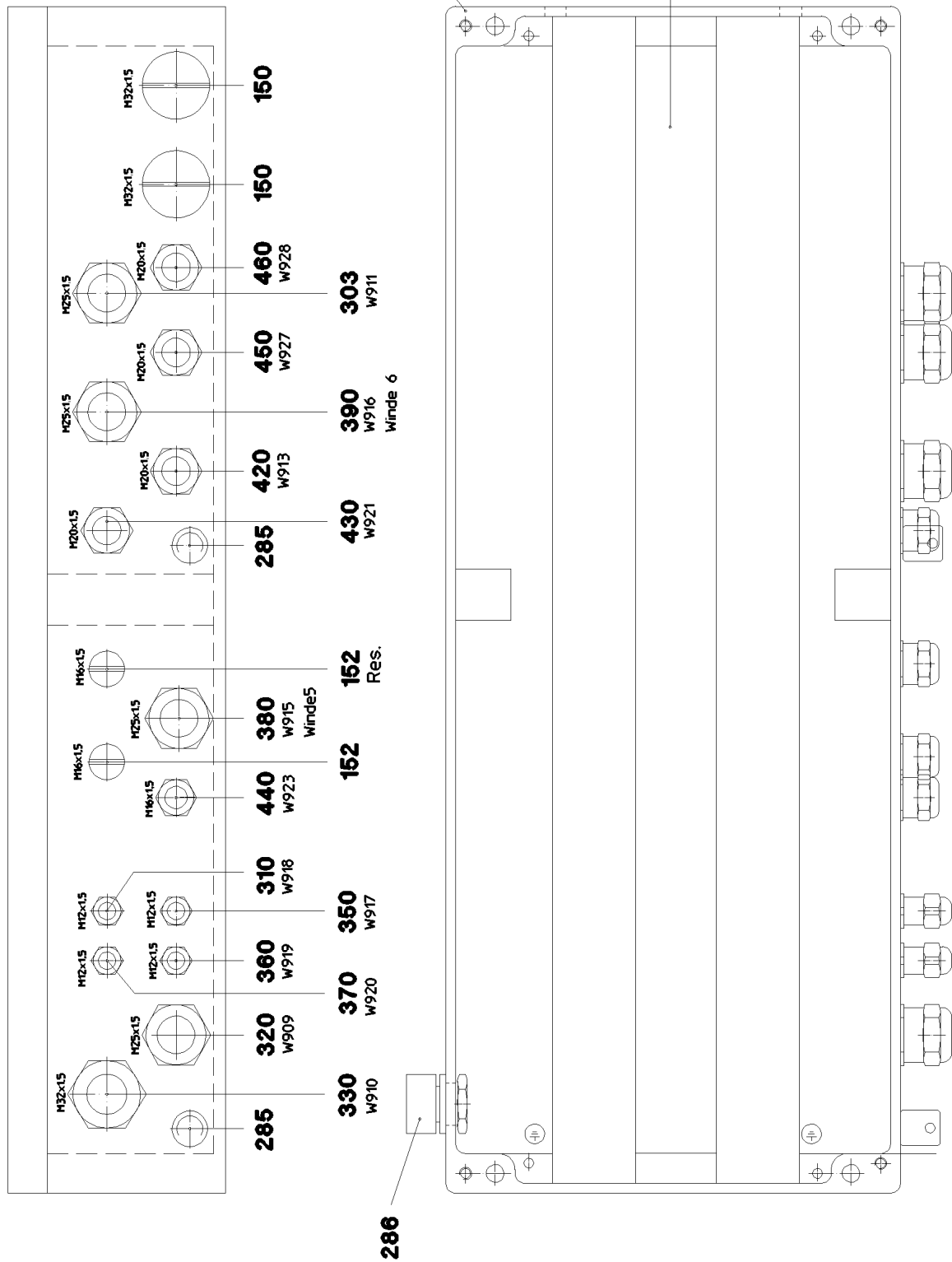

6.2.2009
054269

LIEBHERR

etk_en_de_074515 LR 1600/2

TERMINAL BOX CPL.
KLEMMKASTEN KPL.

591 (1/2)

⇒ 3 930 730
96 54 398 08

Pos.	Item	Quantity	Description	Bezeichnung	Serie	K
4	97 73 509 08	1	LABEL S910 LEXAN-SCHILD	SCHILD		
5	97 52 217 08	1	EMPTY CASING 230X600X110X0	LEERGEHAEUSE		
150	60 24 252 08	2	SCREW PLUG M32X1,5 MS	VERSCHLUSSSCHRAUBE		
152	60 24 249 08	2	SCREW PLUG M16X1,5 MS	VERSCHLUSSSCHRAUBE		
272	42 00 008 08	2	WASHER DIN 125 A 5.3 VERZ	SCHEIBE		
273	40 82 010 08	2	SHEET-METAL SCREW DIN 7971 4,8X19-C	BLECHSCHRAUBE		
274	60 27 360 08	2	SUPPORT TRESTLE	AUFLAGEBOCK		
278	60 21 067 08	1.16	TOP HAT RAIL 35X27X7,3X1	HUTSCHIENE		
279	10 28 635 4	88	TERMINAL/CLAMP	KLEMME		
280	10 28 635 3	2	LID	DECKEL		
281	60 27 946 08	4	END ANGLE	ENDWINKEL		
285	60 25 012 08	2	WATER DRAIN PLUG PA6G SPF	ENTWAESSERUNGSSTOPFEN		
286	10 48 866 2	1	VENTILATION SCREW M20X1,5 POLYAMID	ENTLUEFTUNGSSCHRAUBE		
303	96 49 064 08	1	LEAD W911	LEITUNG		
310	96 49 052 08	1	LEAD W918	LEITUNG		
320	96 54 399 08	1	LEAD W909	LEITUNG		
330	96 54 400 08	1	LEAD W910	LEITUNG		
350	96 49 053 08	1	LEAD W917	LEITUNG		
360	96 49 041 08	1	LEAD W919	LEITUNG		
370	96 49 047 08	1	LEAD W920	LEITUNG		
380	96 49 026 08	1	LEAD W915	LEITUNG		
390	96 49 027 08	1	LEAD W916	LEITUNG		
420	96 49 055 08	1	LEAD W913	LEITUNG		
430	96 49 056 08	1	LEAD W921	LEITUNG		
440	96 50 211 08	1	LEAD W923	LEITUNG		
450	96 57 437 08	1	LEAD W927	LEITUNG		
460	96 57 438 08	1	LEAD W928	LEITUNG		
503	60 27 426 08	0.56	IDENTIFICATION STRIP	KENNZEICHNUNGSKARTEN		

6.2.2009

etk_en_de_074515 LR 1600/2

☐ 592 (2/2)

LIEBHERR

TERMINAL BOX CPL.
KLEMMKASTEN KPL.

⇒ 3 930 730
96 54 398 08

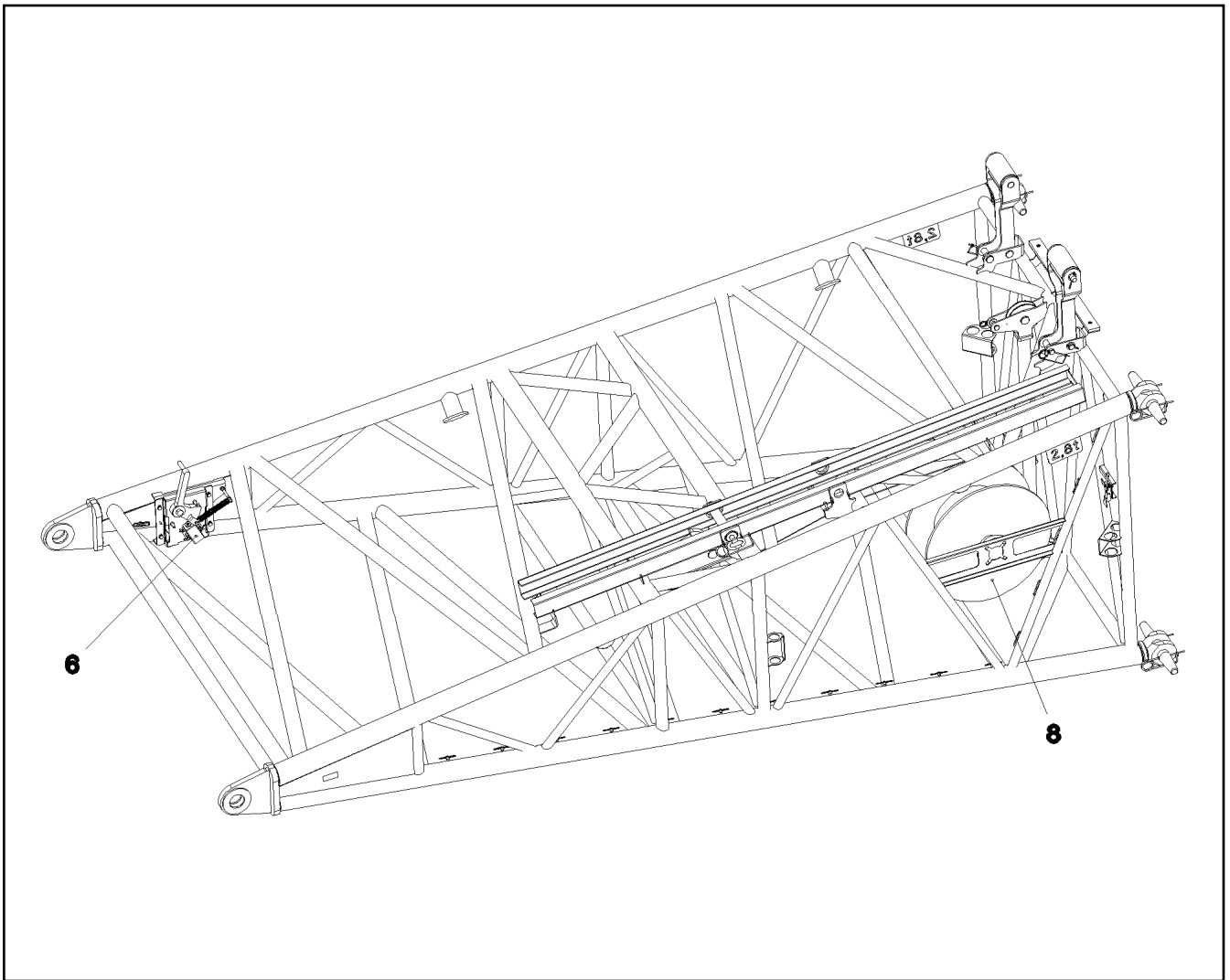

Pos.	Item	Quantity	Description	Bezeichnung	Serie	K
6	96 24 232 08	1	SENSOR ASSEMBLY	GEBERANBAU ANLENKSTUECK		
(151)	69 23 087 08	1	INDUCTIVE SENSOR SPF	INDUKTIVSENSOR		
7	96 50 572 08	1	LEAD W1003	LEITUNG		
8	96 50 573 08	1	CABLE DRUM COMPL. ⇒ 3 930 009 96 50 573 08	LEITUNGSTROMMEL KPL.		
9	96 50 574 08	1	LEAD W1001	LEITUNG		

6.2.2009
052924

LIEBHERR

etk_en_de_074515 LR 1600/2

ELECTRICS F BASE SECTION
ELEKTRIK F-ANLENKSTUECK

■ 593

⇒ 3 930 731
96 48 374 08

Pos.	Item	Quantity	Description	Bezeichnung	Serie	K
5	60 04 407 08	39.12	CONTROL LEAD 8X0,5C+16X0,75 SPF	STEUERLEITUNG		
97	60 27 100 08	4	CABLE SLEEVE 3,0-7,0/3,0/0,6 SILIKONGU	KABELTUELLE		
151	10 44 365 9	1	WALL OUTLET 24-POL 22A SPF	WANDSTECKDOSE		
152	10 44 365 8	1	PLUG 24POL 22A	STECKER		
153	60 27 073 08	1	CABLE SOCK 8 - 15 700	KABELSTRUMPF		
154	74 40 101 08	1	SNAP HOOK DIN 5299 80X8 ST VERZ	KARABINERHAKEN		
155	74 00 006 08	1	KNOTTED-LINK CHAIN 2,8 GALV.VERZ.	KNOTENKETTE		
156	60 24 258 08	1	THREADED CABLE GLAND M25X1,5 MS	KABELVERSCHRAUBUNG		
157	60 26 066 08	1	REDUCTION M32X1,5/M25X1,5 MS	REDUKTION		
341	60 01 312 08	0.32	WIRE BRAID 0,5	LITZE		
500	92 35 122 08	9	CABLE MARKING	KABELMARKIERUNG		
707	10 47 304 7	18	CABLE SLEEVE 1,9-2,5 SILIKON	KABELTUELLE		
708	10 47 304 8	28	CABLE SLEEVE 2,4-3,0 SILIKON	KABELTUELLE		

6.2.2009

etk_en_de_074515 LR 1600/2

594

LIEBHERR

LEAD
LEITUNG

⇒ 3 930 732
96 50 575 08

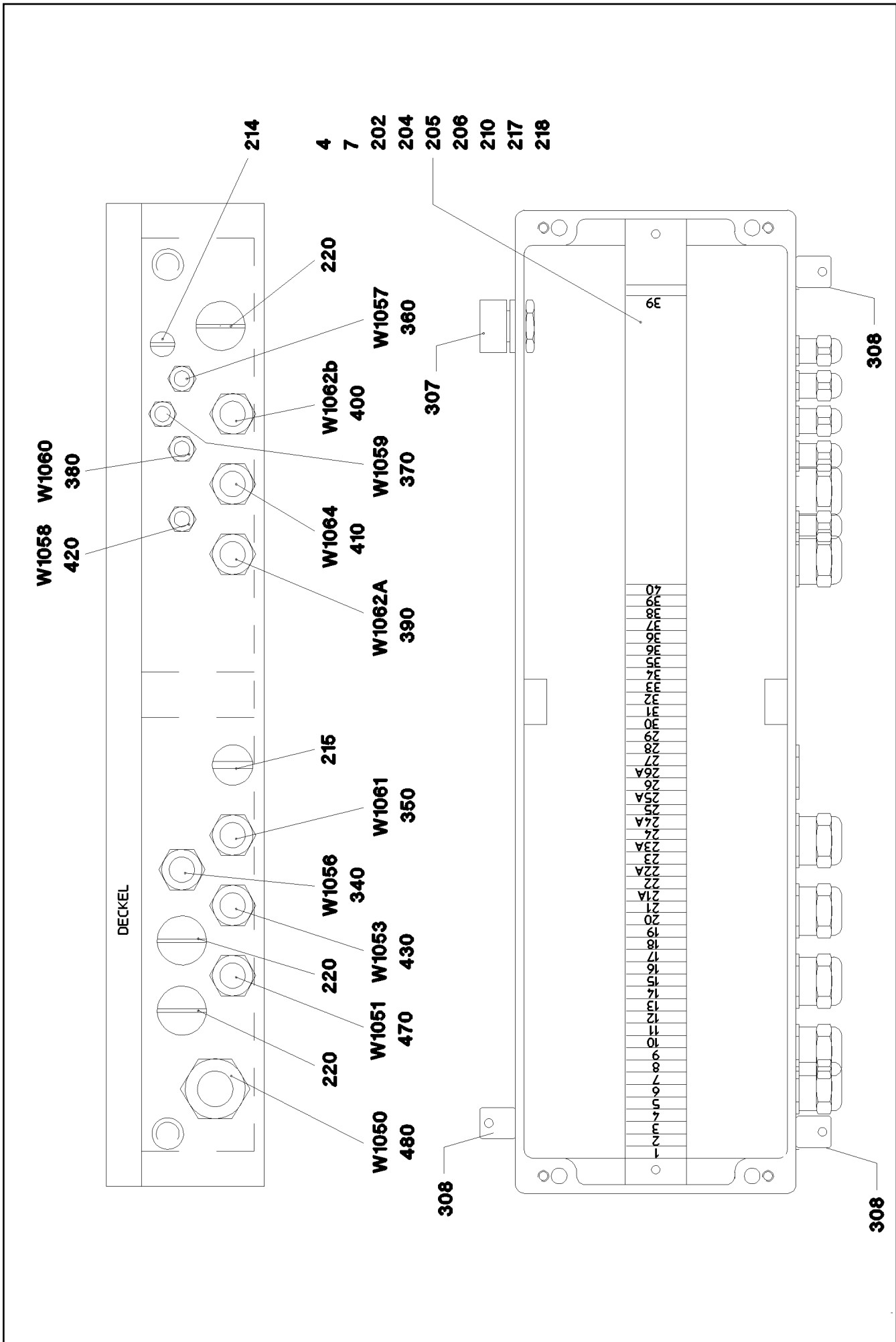

6.2.2009
056071

LIEBHERR

etk_en_de_074515 LR 1600/2

TERMINAL BOX
KLEMMKASTEN

595 (1/2)

⇒ 3 930 734
96 54 401 08

Pos.	Item	Quantity	Description	Bezeichnung	Serie	K
2	96 54 484 08	1	WIRES TERMINAL BOX CPL. S1050	DRAEHTE KLEMMKASTEN KPL.		
(2)	96 54 485 08	1	WIRES PRE-ASS. S1050	DRAEHTE VORM.		
(501)	10 28 635 4	47	TERMINAL/CLAMP	KLEMME		
4	97 82 166 08	1	LABEL S1050 LEXAN	SCHILD		
7	97 54 042 08	1	EMPTY CASING 160X560X90X0 AL	LEERGEHAEUSE		
202	60 21 067 08	0.55	TOP HAT RAIL 35X27X7,3X1	HUTSCHIENE		
204	60 27 946 08	2	END ANGLE	ENDWINKEL		
205	60 27 360 08	2	SUPPORT TRESTLE	AUFLAGEBOCK		
206	10 28 635 3	1	LID	DECKEL		
210	40 82 010 08	2	SHEET-METAL SCREW DIN 7971 4,8X19-C	BLECHSCHRAUBE		
214	60 24 255 08	1	SCREW PLUG M12X1,2 MS	VERSCHLUSSSCHRAUBE		
215	60 24 250 08	1	SCREW PLUG M20X1,5 MS	VERSCHLUSSSCHRAUBE		
217	60 32 022 08	10	CABLE TIE 2,5X102	KABELBINDER		
218	42 18 006 08	2	WASHER DIN 9021 A 5,3 ST VERZ	SCHEIBE		
220	60 24 251 08	3	SCREW PLUG M25X1,5 MS	VERSCHLUSSSCHRAUBE		
307	10 48 866 2	1	VENTILATION SCREW M20X1,5 POLYAMID	ENTLUEFTUNGSSCHRAUBE		
308	60 25 012 08	3	WATER DRAIN PLUG PA6G SPF	ENTWAESSERUNGSSTOPFEN		
340	96 50 276 08	1	LEAD W1056	LEITUNG		
350	96 52 783 08	1	LEAD W1061	LEITUNG		
360	96 52 787 08	1	LEAD W1057	LEITUNG		
370	96 52 795 08	1	LEAD W1059	LEITUNG		
380	96 52 797 08	1	LEAD W1060	LEITUNG		
390	96 52 798 08	1	LEAD W1062A	LEITUNG		
400	96 52 800 08	1	LEAD W1062B	LEITUNG		
410	96 52 801 08	1	LEAD W1064	LEITUNG		
420	96 52 835 08	1	LEAD W1058	LEITUNG		
430	96 54 483 08	1	LEAD W1053	LEITUNG		
470	96 52 804 08	1	LEAD W1051	LEITUNG		
(5)	60 04 640 08	15.43	CONTROL LEAD 19X0,5 SPF	STEUERLEITUNG		
(63)	60 22 037 08	14	RECEPTACLE FOR TABS 6,3 0,3 - 1,5	FLACHSTECKHUELSE		
(151)	10 44 366 5	1	WALL OUTLET 19-POL SPF	WANDSTECKDOSE		
(152)	69 18 129 08	1	PROTECTING CAP MS	SCHUTZKAPPE		
(153)	60 24 242 08	2	THREADED CABLE GLAND M20X1,5 MS	KABELVERSCHRAUBUNG		
(154)	60 26 065 08	1	REDUCTION M32X1,5/M20X1,5 MS	REDUKTION		
(500)	92 35 122 08	1	CABLE MARKING	KABELMARKIERUNG		
(708)	10 47 304 8	14	CABLE SLEEVE 2,4-3,0 SILIKON	KABELTUELLE		
480	96 54 402 08	1	LEAD W1050	LEITUNG		

6.2.2009

etk_en_de_074515 LR 1600/2

☐ 596 (2/2)

LIEBHERRTERMINAL BOX
KLEMMKASTEN⇒ 3 930 734
96 54 401 08

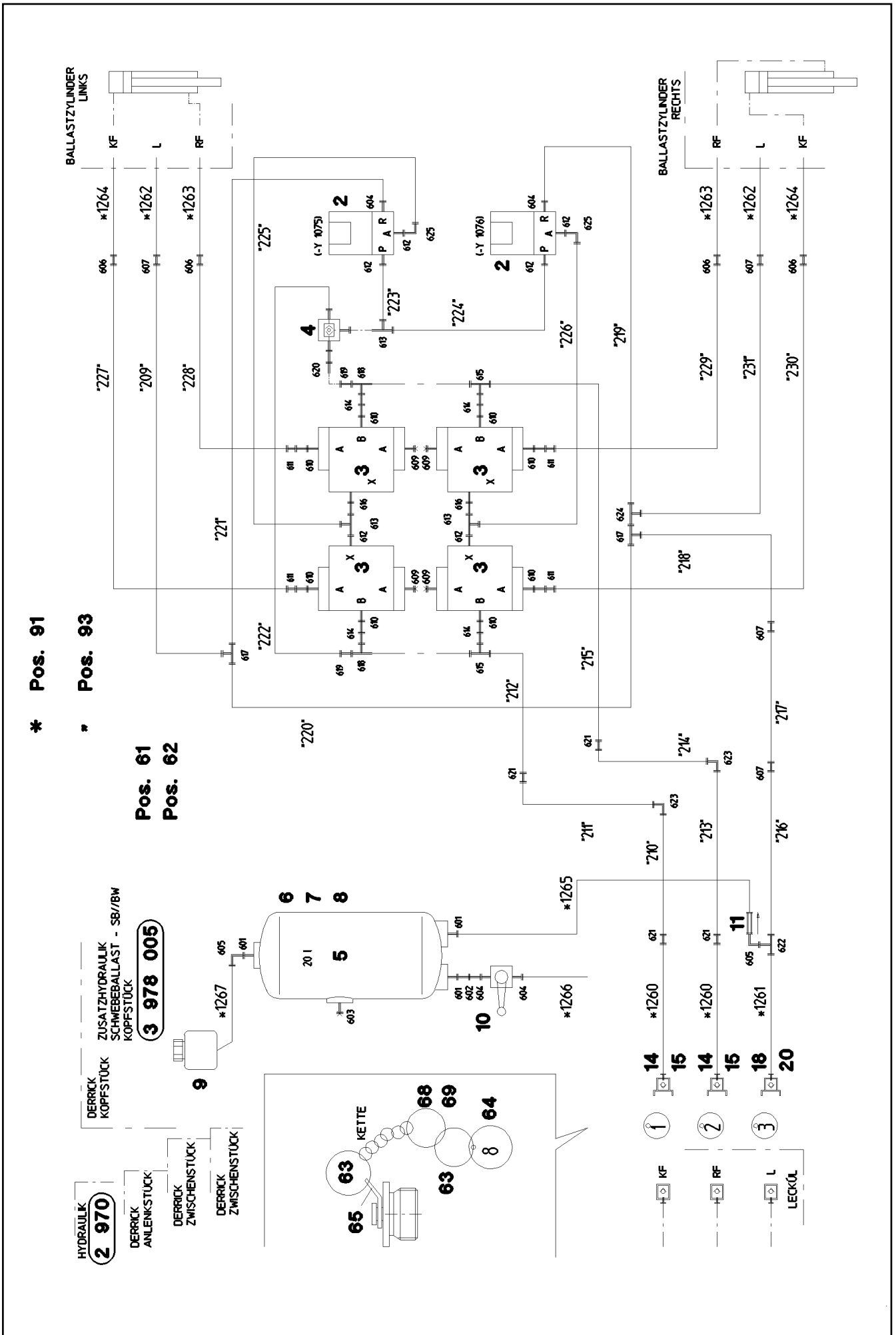

6.2.2009
054277

LIEBHERR

etk_en_de_074515 LR 1600/2

ADDL.HYDRAULIC SB-HEAD PIECE
ZUSATZHYDRAULIK SB-KOPFSTUECK

597 (1/2)

→ 3 978 005
91 56 430 08

Pos.	Item	Quantity	Description	Bezeichnung	Serie	K
2	51 14 498 08	2	DIRECTIONAL CONTROL VALVE ⇒ 5 114 498 08 51 14 498 08	WEGEVENTIL		
3	51 14 829 08	4	DIRECTIONAL SEAT VALVE	WEGESITZVENTIL		
4	51 14 493 08	1	SHUTTLE VALVE	WECHSELVENTIL		
5	50 26 577 08	1	AIR BOTTLE DIN 74281 20L 15,5BAR ALMG2.	LUFTBEHAELTER		
6	77 42 105 08	2	TIGHTENING STRAP ST	SPANNBAND		
7	49 00 188	4	HEX BOLT ISO 4017 M8X16 8.8 A2C	SECHSKANTSCHRAUBE		
8	42 18 009 08	4	WASHER DIN 9021 A 8.4 VERZ	SCHEIBE		
9	50 28 073 08	1	EQUALIZING RESERVOIR	AUSGLEICHSBEHAELTER		
10	51 06 960 08	1	BALL VALVE DN8-1/4" MS	KUGELHAHN		
11	51 14 815 08	1	NON-RETURN VALVE	RUECKSCHLAGVENTIL		
14	51 15 123 08	1	COUPLING PLUG 38-S	KUPPLUNGSSTECKER		
15	51 05 455 08	1	SCREW PLUG	VERSCHLUSSSCHRAUBE		
18	51 15 096 08	1	COUPLING PLUG 12-L	KUPPLUNGSSTECKER		
20	10 46 691 0	1	SCREW PLUG RD32X3 SPF	VERSCHLUSSSCHRAUBE		
51	60 20 092 08	20	CLAMP-HALF DIN 3015-1 L 5 R 38 PP SW	KLEMMHAELFTE		
54	46 00 091	20	CYLINDER SCREW ISO 4762 M6X50 8.8 A2C	ZYLINDERSCHRAUBE		
55	60 20 180 08	20	NUT M6 VERZ	MUTTER		
61	77 34 003 08	2	ROPE DIN 3055 2MM 2,3KN FE	SEIL		
62	77 39 200 08	3	WIRE ROPE CLAMP DIN 3093 2 AL	PRESSKLEMME		
63	70 42 141 08	5	KEY RING 25	SCHLUESSELRING		
64	95 05 568 08	3	TRAILERS 25X2	ANHAENGER		
65	97 59 516 08	2	PLATE 1X20X60	BLECH		
68	71 01 077 08	2	SEALING RING DIN 7603 A 52X60X2,5 CU	DICHTRING		
69	71 01 053 08	1	SEALING RING DIN 7603 A 24X30X2 CU	DICHTRING		
91	96 50 881 08	1	HOSE LINES D-HEAD SECTION ⇒ 3 978 009 96 50 881 08	SCHLAUCHLEITUNGEN D-KOPF		
93	96 50 882 08	1	PIPELINES DERR. HEAD SECT. ⇒ 3 978 010 96 50 882 08	ROHRLEITUNGEN DERR.KOPFS		
601	47 10 399 08	3	FLANGE JOINT GE 12L M22X1,5 CR6-FREI	VERSCHRAUBUNG		
602	47 00 113 08	1	FLANGE JOINT SNV12-L A3P	VERSCHRAUBUNG		
603	47 77 045 08	1	PLUG VSTIM22X1,5ED A3P	STOPFEN		
604	47 10 353 08	4	FLANGE JOINT XGE12-LR-ED1/4" A3P	VERSCHRAUBUNG		
605	47 25 305 08	2	FLANGE JOINT EWSD12-L A3P	VERSCHRAUBUNG		
606	47 50 340 08	4	FLANGE JOINT XGR30/20-S A3P	VERSCHRAUBUNG		
607	47 00 304 08	4	FLANGE JOINT XG12-L A3P	VERSCHRAUBUNG		
609	47 77 042 08	4	PLUG VSTI1/2"ED A3P	STOPFEN		
610	47 19 006 08	8	FLANGE JOINT EGESD16-SR-WD A3P	VERSCHRAUBUNG		
611	47 50 337 08	4	FLANGE JOINT XGR30/16-S A3P	VERSCHRAUBUNG		
612	47 10 321 08	6	FLANGE JOINT XGE6-SR-ED A3P	VERSCHRAUBUNG		
613	47 23 312 08	3	FLANGE JOINT ELSD6-S A3P	VERSCHRAUBUNG		
614	47 54 342 08	4	FLANGE JOINT REDSD38/16-S A3P	VERSCHRAUBUNG		
615	47 04 330 08	2	FLANGE JOINT XT38-S A3P	VERSCHRAUBUNG		
616	47 19 003 08	2	FLANGE JOINT EGESD6-SR-WD A3P	VERSCHRAUBUNG		
617	47 04 304 08	2	FLANGE JOINT XT12-L A3P	VERSCHRAUBUNG		
618	47 23 319 08	2	FLANGE JOINT ELSD38-S A3P	VERSCHRAUBUNG		
619	47 54 081 08	2	FLANGE JOINT REDSD38/6-S A3P	VERSCHRAUBUNG		
620	47 00 115 08	1	FLANGE JOINT SNV6-S A3P	VERSCHRAUBUNG		
621	47 00 331 08	4	FLANGE JOINT XG38-S A3P	VERSCHRAUBUNG		
622	47 24 302 08	1	FLANGE JOINT ETS12-L A3P	VERSCHRAUBUNG		
623	47 02 334 08	2	FLANGE JOINT XW38-S A3P	VERSCHRAUBUNG		
624	47 23 303 08	1	FLANGE JOINT ELSD12-L A3P	VERSCHRAUBUNG		
625	47 25 315 08	2	FLANGE JOINT EWSD6-S A3P	VERSCHRAUBUNG		

6.2.2009

etk_en_de_074515 LR 1600/2

☐ 598 (2/2)

LIEBHERRADDL.HYDRAULIC SB-HEAD PIECE
ZUSATZHYDRAULIK SB-KOPFSTUECK⇒ 3 978 005
91 56 430 08

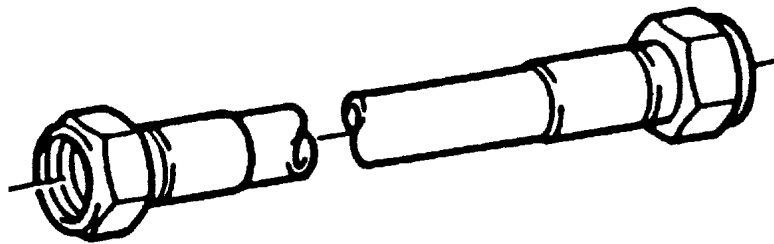

Die Positionsnummern der Rohre auf den Bildtafeln entsprechen den Positionen in der Rohrliste.

The pipe numbers from the illustrations are in accordance with the items in the pipe list.

Les numéros des tuyaux sur les illustrations correspondent aux repères de la nomenclature des tuyaux.

Los números de tubos en las ilustraciones corresponden a las posiciones de la lista de tubos.

Номера позиций труб на изображениях соответствуют позициям в перечне труб.

Pos.	Item	Quantity	Description	Bezeichnung	Serie	K
460	96 54 143 08	1	PIPE COMPL. 12X1,5X4400	ROHR KPL.		
461	96 54 144 08	1	PIPE COMPL. 38X4X4400	ROHR KPL.		
462	96 54 145 08	1	PIPE COMPL. 38X4X4400	ROHR KPL.		

6.2.2009
133088

LIEBHERR

etk_en_de_074515 LR 1600/2

PIPELINES DERR. INT. SECT.
ROHRLEITUNGEN DERR.ZWISCHENST.

599

⇒ 3 978 007
96 50 879 08

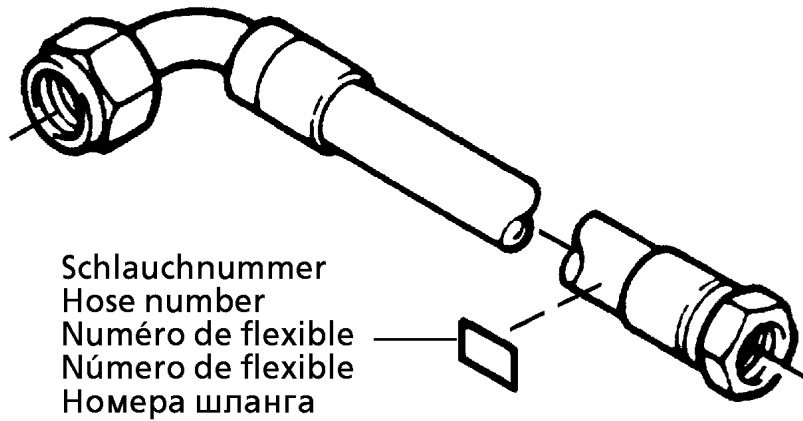

Schlauchnummer
Hose number
Número de flexible
Número de flexible
Номера шланга

Die Schlauchnummern auf den Schläuchen entsprechen den Positionen in der Schlauchliste.

The hose numbers from the hoses are in accordance with the items in the hose list.

Les numéros indiqués sur les flexibles correspondent aux repères de la nomenclature des flexibles.

Los números indicados en los flexibles corresponden a las posiciones de la lista de flexibles.

Нанесенные на шлангах номера соответствуют позициям в перечне.

Pos.	Item	Quantity	Description	Bezeichnung	Serie	K
1	60 27 601 08	6	NAME PLATE 25,4X101,6	BEZEICHNUNGSSCHILD		
2	60 27 603 08	6	NAME PLATE 25,4X165,1	BEZEICHNUNGSSCHILD		
1260	96 39 267 08	2	HOSE ASS CPL. GH506 1,3M	SCHLAUCH KPL.		
1261	96 31 722 08	1	HOSE ASS CPL. 2SN 1,5M	SCHLAUCH KPL.		
1262	96 47 681 08	2	HOSE ASS CPL. 2SN 3,7M	SCHLAUCH KPL.		
1263	92 44 929 08	2	HOSE ASS CPL. 2755 3,3M	SCHLAUCH KPL.		
1264	92 60 420 08	2	HOSE ASS CPL. 2755 2,6M	SCHLAUCH KPL.		
1265	92 76 814 08	1	HOSE ASS CPL. 2TE 0,9M	SCHLAUCH KPL.		
1266	96 54 309 08	1	HOSE ASS CPL. 2TE 0,16M	SCHLAUCH KPL.		
1267	92 65 511 08	1	HOSE ASS CPL. 2TE 0,6M	SCHLAUCH KPL.		

6.2.2009
133089

LIEBHERR

etk_en_de_074515 LR 1600/2

HOSE LINES D-HEAD SECTION
SCHLAUCHLEITUNGEN D-KOPFSTUECK

600

⇒ 3 978 009
96 50 881 08

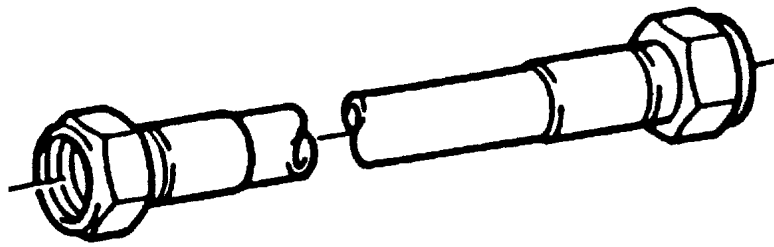

Die Positionsnummern der Rohre auf den Bildtafeln entsprechen den Positionen in der Rohrliste.

The pipe numbers from the illustrations are in accordance with the items in the pipe list.

Les numéros des tuyaux sur les illustrations correspondent aux repères de la nomenclature des tuyaux.

Los números de tubos en las ilustraciones corresponden a las posiciones de la lista de tubos.

Номера позиций труб на изображениях соответствуют позициям в перечне труб.

Pos.	Item	Quantity	Description	Bezeichnung	Serie	K
209	96 54 146 08	1	PIPE COMPL. 12X1,5X2027	ROHR KPL.		
210	96 54 147 08	1	PIPE COMPL. 38X4X2226	ROHR KPL.		
211	96 54 148 08	1	PIPE COMPL. 38X4X1698	ROHR KPL.		
212	96 54 149 08	1	PIPE COMPL. 38X4X2066	ROHR KPL.		
213	96 54 150 08	1	PIPE COMPL. 38X4X2133	ROHR KPL.		
214	96 55 028 08	1	PIPE COMPL. 38X4X1767	ROHR KPL.		
215	96 55 029 08	1	PIPE COMPL. 38X4X2195	ROHR KPL.		
216	96 55 030 08	1	PIPE COMPL. 12X1,5X2092	ROHR KPL.		
217	96 55 031 08	1	PIPE COMPL. 12X1,5X1979	ROHR KPL.		
218	96 55 032 08	1	PIPE COMPL. 12X1,5X1786	ROHR KPL.		
219	96 55 033 08	1	PIPE COMPL. 12X1,5X547	ROHR KPL.		
220	96 55 034 08	1	PIPE COMPL. 12X1,5X518	ROHR KPL.		
221	96 55 035 08	1	PIPE COMPL. 12X1,5X506	ROHR KPL.		
222	96 55 036 08	1	PIPE COMPL. 6X1X824	ROHR KPL.		
223	96 55 037 08	1	PIPE COMPL. 6X1X387	ROHR KPL.		
224	96 55 038 08	1	PIPE COMPL. 6X1X525	ROHR KPL.		
225	96 55 039 08	1	PIPE COMPL. 6X1X555	ROHR KPL.		
226	96 55 040 08	1	PIPE COMPL. 6X1X563	ROHR KPL.		
227	96 55 041 08	1	PIPE COMPL. 30X4X2154	ROHR KPL.		
228	96 55 042 08	1	PIPE COMPL. 30X4X2042	ROHR KPL.		
229	96 55 043 08	1	PIPE COMPL. 30X4X2172	ROHR KPL.		
230	96 55 044 08	1	PIPE COMPL. 30X4X2055	ROHR KPL.		
231	96 55 045 08	1	PIPE COMPL. 12X1,5X2045	ROHR KPL.		

6.2.2009
133088

LIEBHERR

etk_en_de_074515 LR 1600/2

PIPELINES DERR. HEAD SECT.
ROHRLEITUNGEN DERR.KOPFSTUECK

601

⇒ 3 978 010
96 50 882 08

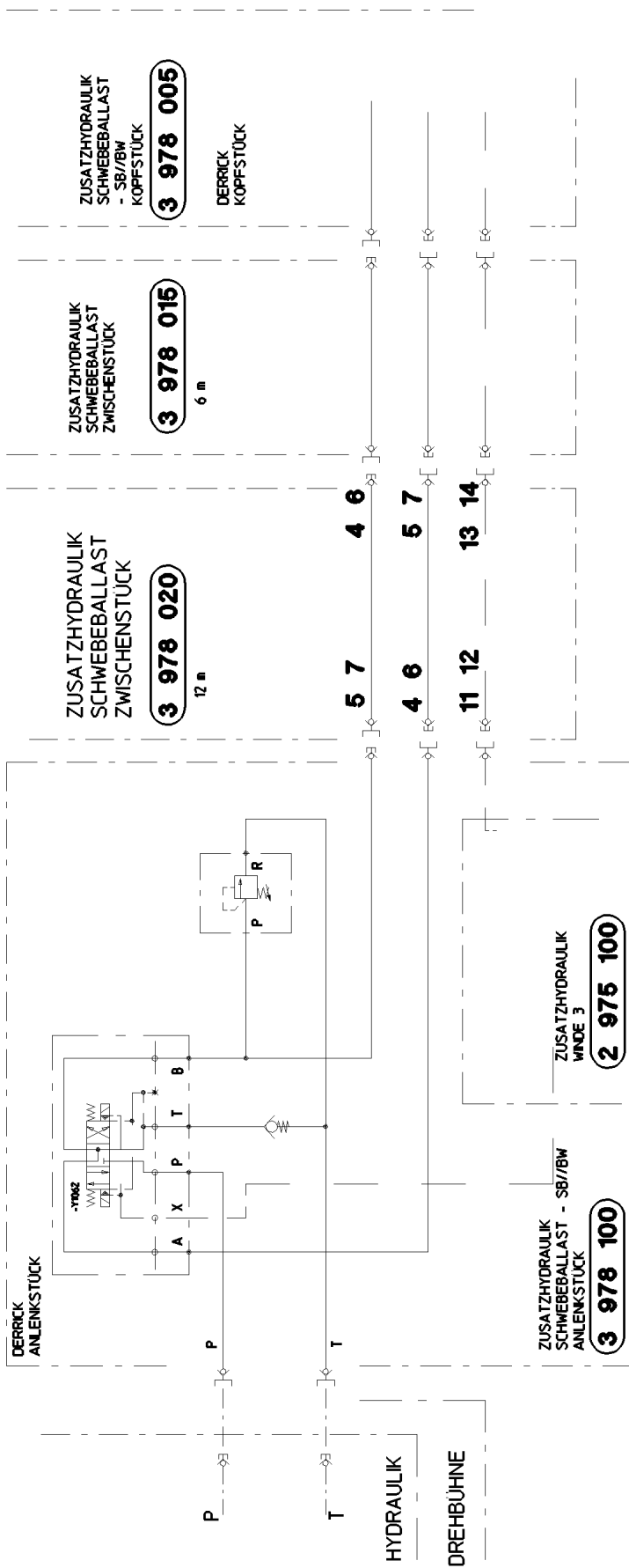

* Pos. 91 Pos. 51
 * Pos. 93 Pos. 54
 Pos. 55

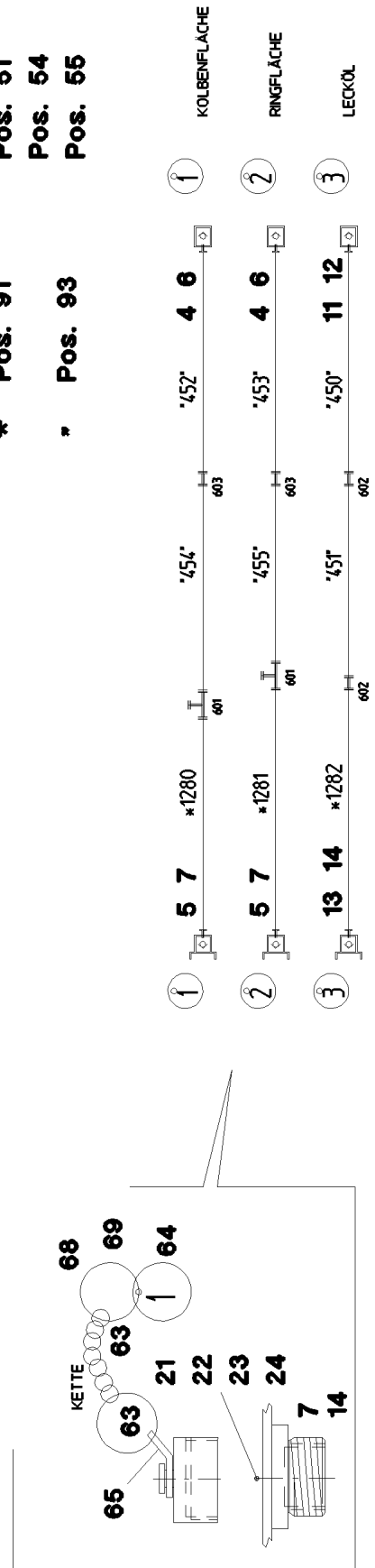

6.2.2009
055230

LIEBHERR

etk_en_de_074515 LR 1600/2

ADDITIONAL HYDRAULICS INTERMED
ZUSATZHYDRAULIK ZWISCHENSTUECK

□ 602 (1/2)

⇒ 3 978 015
91 56 429 08

Pos.	Item	Quantity	Description	Bezeichnung	Serie	K
4	51 15 122 08	2	COUPLING SLEEVE 38-S	KUPPLUNGSMUFFE		
5	51 15 123 08	2	COUPLING PLUG 38-S	KUPPLUNGSSTECKER		
6	51 05 456 08	2	HEX CAP NUT	VERSCHLUSSMUTTER		
7	10 46 690 9	2	SCREW PLUG RD79X4 SPF	VERSCHLUSSSCHRAUBE		
11	51 15 058 08	1	COUPLING SLEEVE 12-L	KUPPLUNGSMUFFE		
12	51 15 040 08	1	HEX CAP NUT	VERSCHLUSSMUTTER		
13	51 15 096 08	1	COUPLING PLUG 12-L	KUPPLUNGSSTECKER		
14	10 46 690 6	1	SCREW PLUG RD32X3 SPF	VERSCHLUSSSCHRAUBE		
21	40 86 002 08	3	COUNTERSUNK SCREW DIN 7991 M6X16 8.	SENKSCRAUBE		
22	41 19 004 08	3	HEX NUT DIN 985 M6 8 VERZ	SECHSKANTMUTTER		
23	42 00 009 08	3	WASHER ISO 7089 A 6.4 VERZ	SCHEIBE		
24	43 20 053 08	2	DOWEL PIN ISO 8752 6X14	SPANNSTIFT		
51	60 20 092 08	40	CLAMP-HALF DIN 3015-1 L 5 R 38 PP SW	KLEMMHAELFTE		
54	46 00 091	40	CYLINDER SCREW ISO 4762 M6X50 8.8 A2C	ZYLINDERSCHRAUBE		
55	60 20 180 08	40	NUT M6 VERZ	MUTTER		
63	70 42 141 08	6	KEY RING 25	SCHLUESSELRING		
64	95 05 568 08	6	TRAILERS 25X2	ANHAENGER		
65	97 59 516 08	6	PLATE 1X20X60	BLECH		
68	71 01 077 08	4	SEALING RING DIN 7603 A 52X60X2,5 CU	DICHTRING		
69	71 01 053 08	2	SEALING RING DIN 7603 A 24X30X2 CU	DICHTRING		
91	96 50 883 08	1	HOSE LINES INTERM. SECTION 12METER	SCHLAUCHLEITUNGEN ZWISCH		
(1)	60 27 601 08	1	NAME PLATE 25,4X101,6	BEZEICHNUNGSSCHILD		
(2)	60 27 603 08	2	NAME PLATE 25,4X165,1	BEZEICHNUNGSSCHILD		
(1280)	96 54 719 08	1	HOSE ASS CPL. GH506 1,5M	SCHLAUCH KPL.		
(1281)	96 54 719 08	1	HOSE ASS CPL. GH506 1,5M	SCHLAUCH KPL.		
(1282)	96 31 723 08	1	HOSE ASS CPL. 2SN 1,7M	SCHLAUCH KPL.		
93	96 50 884 08	1	PIPELINES DERR. INT. SECT.	ROHRLEITUNGEN DERR.ZWISC		
(450)	96 55 088 08	1	PIPE COMPL. 12X1,5X5190	ROHR KPL.		
(451)	96 55 089 08	1	PIPE COMPL. 12X1,5X5190	ROHR KPL.		
(452)	96 55 090 08	1	PIPE COMPL. 38X4X5190	ROHR KPL.		
(453)	96 55 091 08	1	PIPE COMPL. 38X4X5190	ROHR KPL.		
(454)	96 55 092 08	1	PIPE COMPL. 38X4X5190	ROHR KPL.		
(455)	96 55 093 08	1	PIPE COMPL. 38X4X5190	ROHR KPL.		
601	47 56 034 08	2	MEASURING CONNECTION GMA3 38S CR6	MESSANSCHLUSS		
602	47 00 304 08	2	FLANGE JOINT XG12-L A3P	VERSCHRAUBUNG		
603	47 00 331 08	2	FLANGE JOINT XG38-S A3P	VERSCHRAUBUNG		

6.2.2009

etk_en_de_074515 LR 1600/2

603 (2/2)

LIEBHERR
 ADDITIONAL HYDRAULICS INTERMED
 ZUSATZHYDRAULIK ZWISCHENSTUECK

 ⇒ 3 978 015
 91 56 429 08

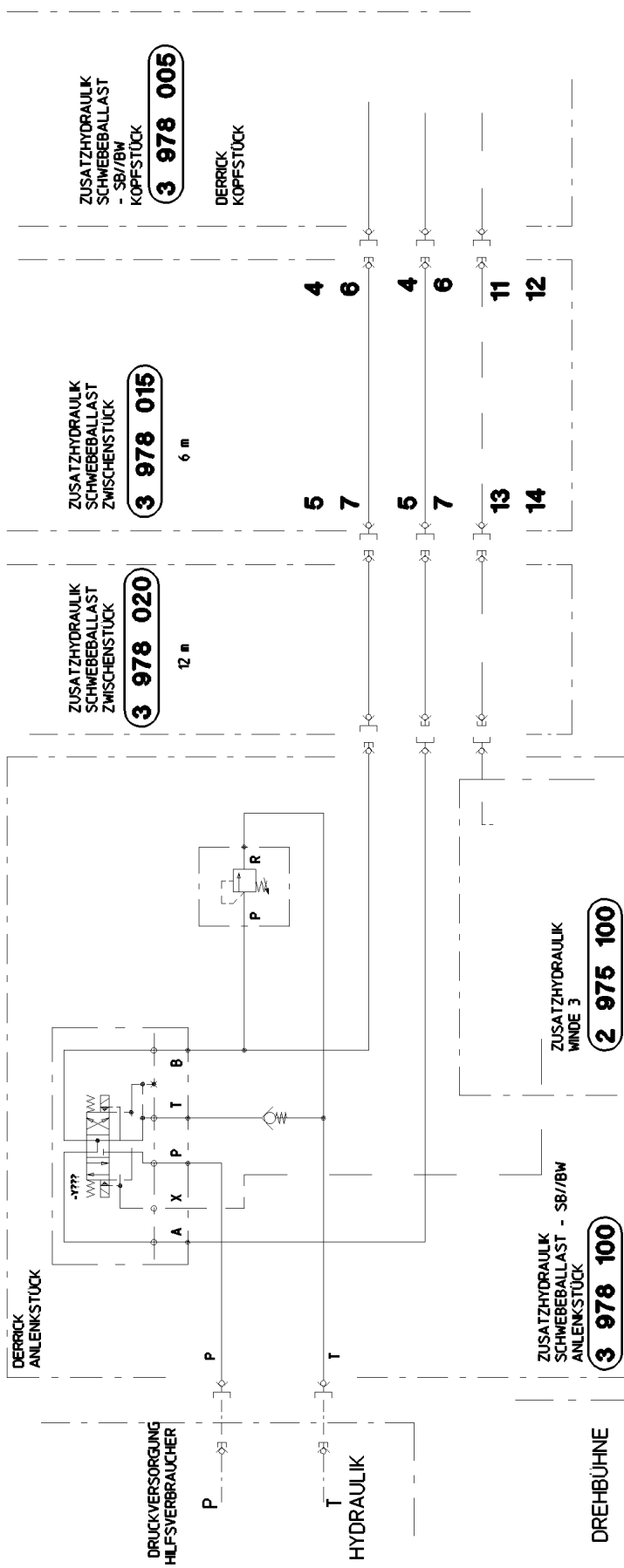

* Pos. 91
 * Pos. 93

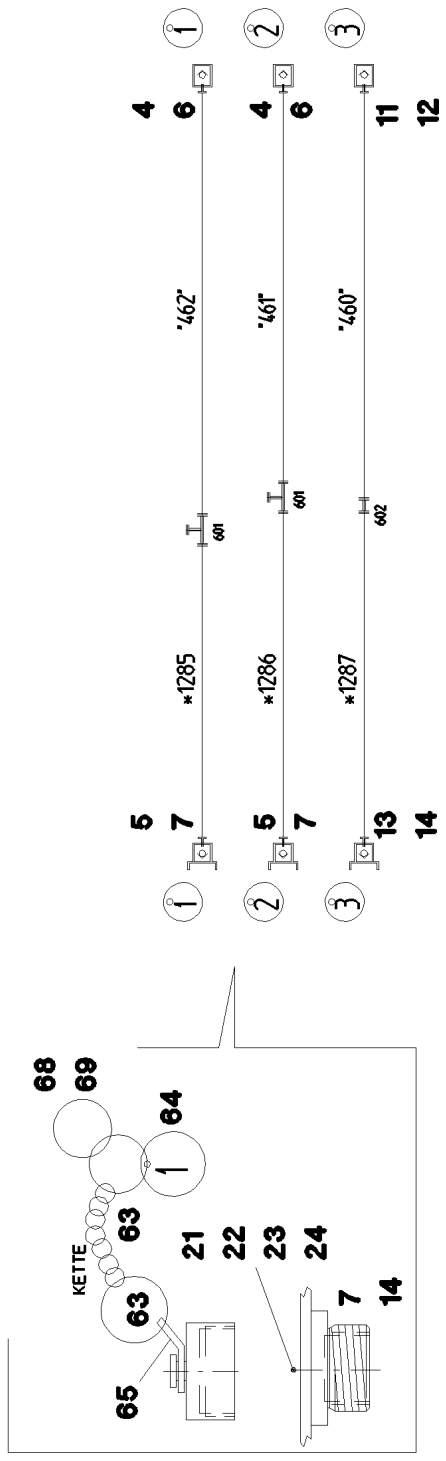

6.2.2009
 055302

LIEBHERR

etk_en_de_074515 LR 1600/2

ADDITIONAL HYDRAULICS INTERMED
 ZUSATZHYDRAULIK ZWISCHENSTUECK

604 (1/2)

→ 3 978 015
 91 56 432 08

Pos.	Item	Quantity	Description	Bezeichnung	Serie	K
4	51 15 122 08	2	COUPLING SLEEVE 38-S	KUPPLUNGSMUFFE		
5	51 15 123 08	2	COUPLING PLUG 38-S	KUPPLUNGSSTECKER		
6	51 05 456 08	2	HEX CAP NUT	VERSCHLUSSMUTTER		
7	10 46 690 9	2	SCREW PLUG RD79X4 SPF	VERSCHLUSSSCHRAUBE		
11	51 15 058 08	1	COUPLING SLEEVE 12-L	KUPPLUNGSMUFFE		
12	51 15 040 08	1	HEX CAP NUT	VERSCHLUSSMUTTER		
13	51 15 096 08	1	COUPLING PLUG 12-L	KUPPLUNGSSTECKER		
14	10 46 690 6	1	SCREW PLUG RD32X3 SPF	VERSCHLUSSSCHRAUBE		
21	40 86 002 08	3	COUNTERSUNK SCREW DIN 7991 M6X16 8.	SENKSCHRAUBE		
22	41 19 004 08	3	HEX NUT DIN 985 M6 8 VERZ	SECHSKANTMUTTER		
23	42 00 009 08	3	WASHER ISO 7089 A 6.4 VERZ	SCHEIBE		
24	43 20 053 08	2	DOWEL PIN ISO 8752 6X14	SPANNSTIFT		
51	60 20 092 08	40	CLAMP-HALF DIN 3015-1 L 5 R 38 PP SW	KLEMMHAELFTE		
54	46 00 091	40	CYLINDER SCREW ISO 4762 M6X50 8.8 A2C	ZYLINDERSCHRAUBE		
55	60 20 180 08	40	NUT M6 VERZ	MUTTER		
63	70 42 141 08	6	KEY RING 25	SCHLUESSELRING		
64	95 05 568 08	6	TRAILERS 25X2	ANHAENGER		
65	97 59 516 08	6	PLATE 1X20X60	BLECH		
68	71 01 077 08	4	SEALING RING DIN 7603 A 52X60X2,5 CU	DICHTRING		
69	71 01 053 08	2	SEALING RING DIN 7603 A 24X30X2 CU	DICHTRING		
91	96 50 878 08	1	HOSE LINES INTERM. SECTION 6METER ⇒ 3 978 016 96 50 878 08	SCHLAUCHLEITUNGEN ZWISCH		
93	96 50 879 08	1	PIPELINES DERR. INT. SECT. 6METER ⇒ 3 978 007 96 50 879 08	ROHRLEITUNGEN DERR.ZWISC		
601	47 56 034 08	2	MEASURING CONNECTION GMA3 38S CR6	MESSANSCHLUSS		
602	47 00 304 08	1	FLANGE JOINT XG12-L A3P	VERSCHRAUBUNG		

6.2.2009

etk_en_de_074515 LR 1600/2

☐ 605 (2/2)

LIEBHERR

ADDITIONAL HYDRAULICS INTERMED
ZUSATZHYDRAULIK ZWISCHENSTUECK

⇒ 3 978 015
91 56 432 08

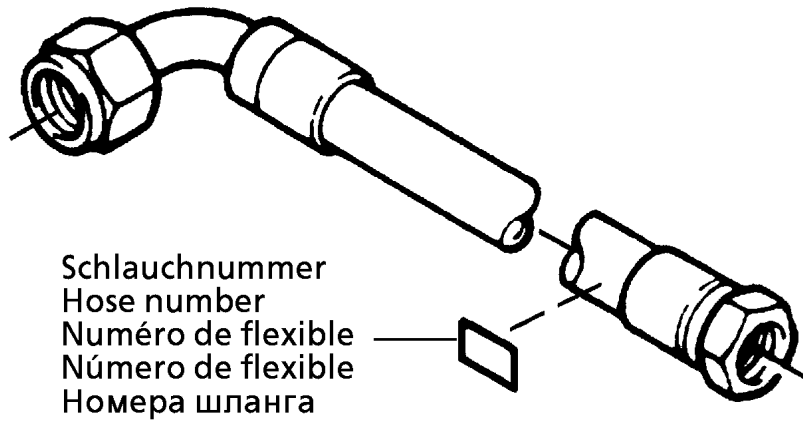

Schlauchnummer
Hose number
Numéro de flexible
Número de flexible
Номера шланга

Die Schlauchnummern auf den Schläuchen entsprechen den Positionen in der Schlauchliste.

The hose numbers from the hoses are in accordance with the items in the hose list.

Les numéros indiqués sur les flexibles correspondent aux repères de la nomenclature des flexibles.

Los números indicados en los flexibles corresponden a las posiciones de la lista de flexibles.

Нанесенные на шлангах номера соответствуют позициям в перечне.

Pos.	Item	Quantity	Description	Bezeichnung	Serie	K
1	60 27 601 08	1	NAME PLATE 25,4X101,6	BEZEICHNUNGSSCHILD		
2	60 27 603 08	2	NAME PLATE 25,4X165,1	BEZEICHNUNGSSCHILD		
1285	96 54 719 08	1	HOSE ASS CPL. GH506 1,5M	SCHLAUCH KPL.		
1286	96 54 719 08	1	HOSE ASS CPL. GH506 1,5M	SCHLAUCH KPL.		
1287	96 29 984 08	1	HOSE ASS CPL. 2SN 1,75M	SCHLAUCH KPL.		

6.2.2009
133089

LIEBHERR

etk_en_de_074515 LR 1600/2

HOSE LINES INTERM. SECTION
SCHLAUCHLEITUNGEN ZWISCHENST.

606

⇒ 3 978 016
96 50 878 08

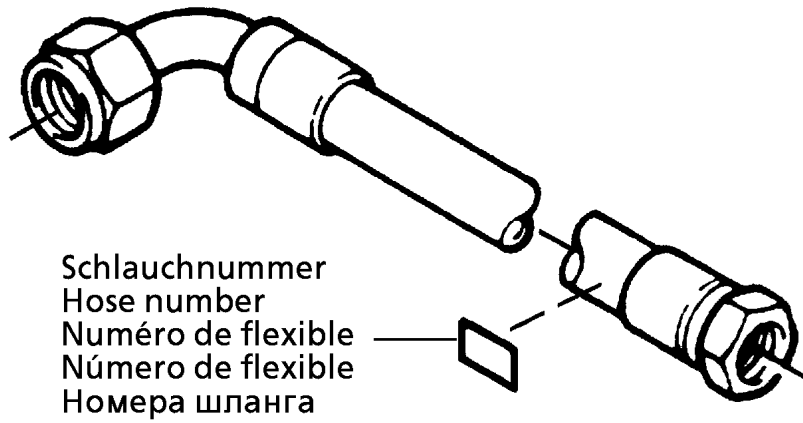

Schlauchnummer
Hose number
Numéro de flexible
Número de flexible
Номера шланга

Die Schlauchnummern auf den Schläuchen entsprechen den Positionen in der Schlauchliste.

The hose numbers from the hoses are in accordance with the items in the hose list.

Les numéros indiqués sur les flexibles correspondent aux repères de la nomenclature des flexibles.

Los números indicados en los flexibles corresponden a las posiciones de la lista de flexibles.

Нанесенные на шлангах номера соответствуют позициям в перечне.

Pos.	Item	Quantity	Description	Bezeichnung	Serie	K
1	60 27 601 08	3	NAME PLATE 25,4X101,6	BEZEICHNUNGSSCHILD		
2	60 27 603 08	1	NAME PLATE 25,4X165,1	BEZEICHNUNGSSCHILD		
1270	92 25 870 08	1	HOSE ASS CPL. 2755 0,54M	SCHLAUCH KPL.		
1271	92 93 262 08	1	HOSE ASS CPL. 2SN 0,58M	SCHLAUCH KPL.		
1272	96 54 718 08	1	HOSE ASS CPL. 2SN 0,48M	SCHLAUCH KPL.		
1273	92 88 711 08	1	HOSE ASS CPL. 2SN 0,76M	SCHLAUCH KPL.		

6.2.2009
133089

LIEBHERR

etk_en_de_074515 LR 1600/2

HOSE LINES PULL CYL
SCHLAUCHLEITUNGEN ZUGZYL.SWB

607

⇒ 3 978 018
96 50 880 08

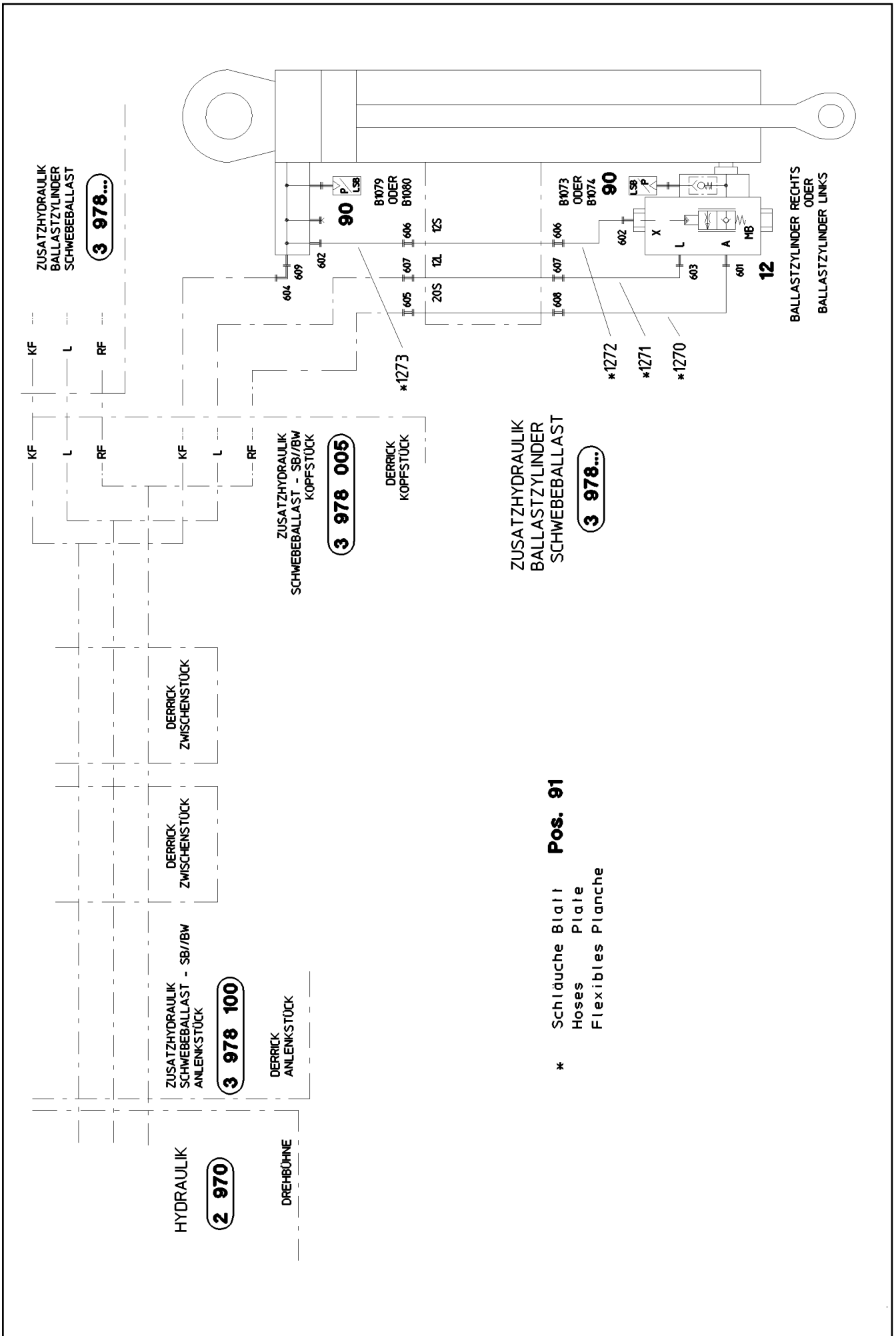

6.2.2009
055457

LIEBHERR

etk_en_de_074515 LR 1600/2

AUX.HYDR.CYLINDER SB-BW
ZUSATZHYDRAULIK ZYLINDER SB-BW

□ 608 (1/2)

⇒ 3 978 019
91 56 431 08

Pos.	Item	Quantity	Description	Bezeichnung	Serie	K
12	10 46 565 9	1	LOWERING BRAKE VALVE 420BAR 100L/MI	SENKBREMSVENTIL		
90	96 36 406 08	1	PRESSURE TRANSMITTER BW-B	DRUCKGEBER		
91	96 50 880 08	1	HOSE LINES PULL CYL ⇒ 3 978 018 96 50 880 08	SCHLAUCHLEITUNGEN ZUGZYL.		
601	47 10 332 08	1	FLANGE JOINT XGE16-SR-ED A3P	VERSCHRAUBUNG		
602	47 10 045 14	2	FLANGE JOINT XGE10-SR-ED1/4" A3P	VERSCHRAUBUNG		
603	47 10 353 08	1	FLANGE JOINT XGE12-LR-ED1/4" A3P	VERSCHRAUBUNG		
604	47 25 314 08	1	FLANGE JOINT EWSD20-S A3P	VERSCHRAUBUNG		
605	47 00 328 08	1	FLANGE JOINT XG20-S A3P	VERSCHRAUBUNG		
606	47 00 325 08	2	FLANGE JOINT XG12-S A3P	VERSCHRAUBUNG		
607	47 00 304 08	2	FLANGE JOINT XG12-L A3P	VERSCHRAUBUNG		
608	47 50 336 08	1	FLANGE JOINT XGR20/16-S A3P	VERSCHRAUBUNG		
609	47 10 334 08	1	FLANGE JOINT XGE20-SR-ED A3P	VERSCHRAUBUNG		

6.2.2009

etk_en_de_074515 LR 1600/2

☐ 609 (2/2)

LIEBHERR

AUX.HYDR.CYLINDER SB-BW
ZUSATZHYDRAULIK ZYLINDER SB-BW

⇒ 3 978 019
91 56 431 08

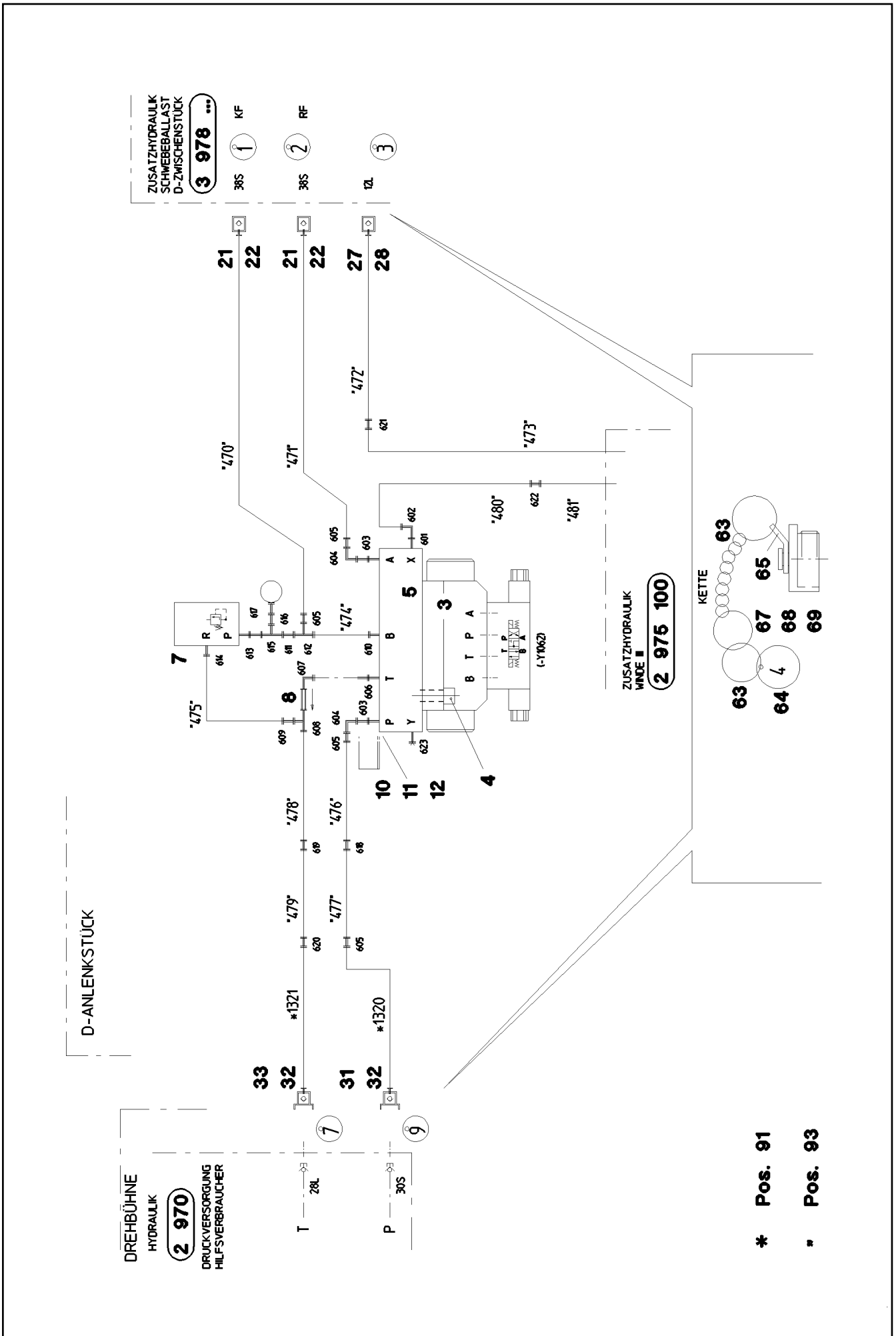

6.2.2009
 054268

LIEBHERR

etk_en_de_074515 LR 1600/2

HYDR. SUSPENDED BALLAST
 HYDR.SCHWEBEBALLAST-ANLENKST.

□ 610 (1/2)

⇒ 3 978 100
 91 56 428 08

Pos.	Item	Quantity	Description	Bezeichnung	Serie	K
3	57 10 349 08	1	DIRECTIONAL CONTROL VALVE ⇒ 5 710 349 08 57 10 349 08	WEGEVENTIL		
4	40 00 784	6	CYLINDER SCREW ISO 4762 M12X50 10.9	ZYLINDERSCHRAUBE		
5	51 06 340 08	1	SUBPLATE	MONTAGEPLATTE		
7	51 14 562 08	1	PRESSURE LIMITING VALVE	DRUCKBEGRENZUNGSVENTIL		
8	51 14 982 08	1	NON-RETURN VALVE	RUECKSCHLAGVENTIL		
10	24 00 551 02	4	CYLINDER SCREW ISO 4762 M12X90 8.8	ZYLINDERSCHRAUBE		
11	41 15 143 08	4	HEX NUT DIN 934 M12 8 VERZ	SECHSKANTMUTTER		
12	42 00 016 08	4	WASHER ISO 7089 A 13 ST A3C	SCHEIBE		
21	51 15 122 08	2	COUPLING SLEEVE 38-S	KUPPLUNGSMUFFE		
22	10 46 691 7	2	HEX CAP NUT RD79X4 SPF	VERSCHLUSSMUTTER		
27	51 15 058 08	1	COUPLING SLEEVE 12-L	KUPPLUNGSMUFFE		
28	10 46 691 4	1	HEX CAP NUT RD32X3 SPF	VERSCHLUSSMUTTER		
31	51 15 108 08	1	COUPLING PLUG 30-S	KUPPLUNGSSTECKER		
(1)	57 10 773 08	1	SHEET GASKET	DICHTSCHEIBE		
(2)	57 10 769 08	1	O-RING 32X3 FPM70	O-RING		
(3)	57 10 770 08	1	SUPPORTING RING	STUETZRING		
(4)	57 10 774 08	1	O-RING 24X3 FPM70	O-RING		
32	10 46 690 8	2	SCREW PLUG RD54X4 SPF	VERSCHLUSSSCHRAUBE		
33	51 15 011 08	1	COUPLING PLUG 28-L	KUPPLUNGSSTECKER		
63	70 42 141 08	10	KEY RING 25	SCHLUESSELRING		
64	95 05 568 08	5	TRAILERS 25X2	ANHAENGER		
65	97 59 516 08	5	PLATE 1X20X60	BLECH		
67	71 01 072 08	2	SEALING RING DIN 7603 A 38X44X2 CU	DICHTRING		
68	71 01 077 08	2	SEALING RING DIN 7603 A 52X60X2,5 CU	DICHTRING		
69	71 01 053 08	1	SEALING RING DIN 7603 A 24X30X2 CU	DICHTRING		
91	96 56 946 08	1	HOSE LINES SUSPENDED BALLAST	SCHLAUCHLEITUNGEN SCHW		
(1)	60 27 603 08	2	NAME PLATE 25,4X165,1	BEZEICHNUNGSSCHILD		
(1320)	92 80 473 08	1	HOSE ASS CPL. 2755 2,3M	SCHLAUCH KPL.		
(1321)	92 96 157 08	1	HOSE ASS CPL. 1SN 2,3M	SCHLAUCH KPL.		
93	96 50 885 08	1	PIPELINES SUSP. BALL. BASE SE ⇒ 3 978 106 96 50 885 08	ROHRLEITUNGEN SCHWEBEB.A		
601	47 10 306 08	1	FLANGE JOINT XGE10-LR-ED A3P	VERSCHRAUBUNG		
602	47 25 302 08	1	FLANGE JOINT EWSD10-L A3P	VERSCHRAUBUNG		
603	47 19 009 08	2	FLANGE JOINT EGESD30-SR-WD A3P	VERSCHRAUBUNG		
604	47 25 316 08	2	FLANGE JOINT EWSD30-S A3P	VERSCHRAUBUNG		
605	47 50 339 08	4	FLANGE JOINT XGR38/30-S A3P	VERSCHRAUBUNG		
606	47 19 016 08	1	FLANGE JOINT EGESD35-LR-WD A3P	VERSCHRAUBUNG		
607	47 25 309 08	1	FLANGE JOINT EWSD35-L A3P	VERSCHRAUBUNG		
608	47 23 308 08	1	FLANGE JOINT EL 35L CR6-FREI	VERSCHRAUBUNG		
609	47 54 304 08	1	FLANGE JOINT REDSD35/28-L A3P	VERSCHRAUBUNG		
610	47 10 338 08	1	FLANGE JOINT XGEV30-SR-WD A3P	VERSCHRAUBUNG		
611	47 54 327 08	1	FLANGE JOINT REDSDN30/25-S A3P	VERSCHRAUBUNG		
612	47 24 318 08	1	FLANGE JOINT ETSD30-S A3P	VERSCHRAUBUNG		
613	47 19 008 08	1	FLANGE JOINT EGESD25-SR-WD A3P	VERSCHRAUBUNG		
614	47 10 316 08	1	FLANGE JOINT XGE28-LR-ED A3P	VERSCHRAUBUNG		
615	47 23 317 08	1	FLANGE JOINT ELSD25-S A3P	VERSCHRAUBUNG		
616	47 54 337 08	1	FLANGE JOINT REDSDN25/6-S A3P	VERSCHRAUBUNG		
617	47 56 015 08	1	MEASURING CONNECTION BMA3 6S	MESSANSCHLUSS		
618	47 00 331 08	1	FLANGE JOINT XG38-S A3P	VERSCHRAUBUNG		
619	47 00 332 08	1	FLANGE JOINT XG35-L A3P	VERSCHRAUBUNG		
620	47 50 313 08	1	FLANGE JOINT XGR35/28-L A3P	VERSCHRAUBUNG		
621	47 00 304 08	1	FLANGE JOINT XG12-L A3P	VERSCHRAUBUNG		
622	47 00 303 08	1	FLANGE JOINT XG10-L A3P	VERSCHRAUBUNG		
623	47 77 040 08	1	STOPPER PLUG VST11/4"ED A3P	BLINDSTOPFEN		

6.2.2009

etk_en_de_074515 LR 1600/2

☐ 611 (2/2)

LIEBHERRHYDR. SUSPENDED BALLAST
HYDR.SCHWEBEBALLAST-ANLENKST.⇒ 3 978 100
91 56 428 08

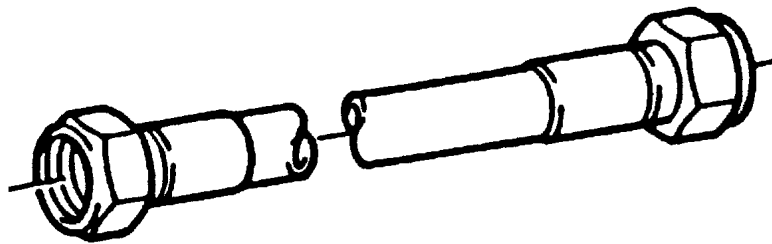

Die Positionsnummern der Rohre auf den Bildtafeln entsprechen den Positionen in der Rohrliste.

The pipe numbers from the illustrations are in accordance with the items in the pipe list.

Les numéros des tuyaux sur les illustrations correspondent aux repères de la nomenclature des tuyaux.

Los números de tubos en las ilustraciones corresponden a las posiciones de la lista de tubos.

Номера позиций труб на изображениях соответствуют позициям в перечне труб.

Pos.	Item	Quantity	Description	Bezeichnung	Serie	K
470	96 55 046 08	1	PIPE COMPL. 38X4X4015	ROHR KPL.		
471	96 55 047 08	1	PIPE COMPL. 38X4X3935	ROHR KPL.		
472	96 55 048 08	1	PIPE COMPL. 12X1,5X2600	ROHR KPL.		
473	96 55 049 08	1	PIPE COMPL. 12X1,5X1181	ROHR KPL.		
474	96 55 050 08	1	PIPE COMPL. 30X4X125	ROHR KPL.		
475	96 55 051 08	1	PIPE COMPL. 28X2X973	ROHR KPL.		
476	96 55 052 08	1	PIPE COMPL. 38X4X2041	ROHR KPL.		
477	96 55 053 08	1	PIPE COMPL. 38X4X2200	ROHR KPL.		
478	96 55 054 08	1	PIPE COMPL. 35X2X2265	ROHR KPL.		
479	96 55 055 08	1	PIPE COMPL. 35X2X2055	ROHR KPL.		
480	96 55 056 08	1	PIPE COMPL. 10X1,5X2394	ROHR KPL.		
481	96 55 057 08	1	PIPE COMPL. 10X1,5X746	ROHR KPL.		

6.2.2009
133088

LIEBHERR

etk_en_de_074515 LR 1600/2

PIPELINES SUSP. BALL. BASE SE
ROHRLEITUNGEN SCHWEBEB.ANLENK.

612

⇒ 3 978 106
96 50 885 08

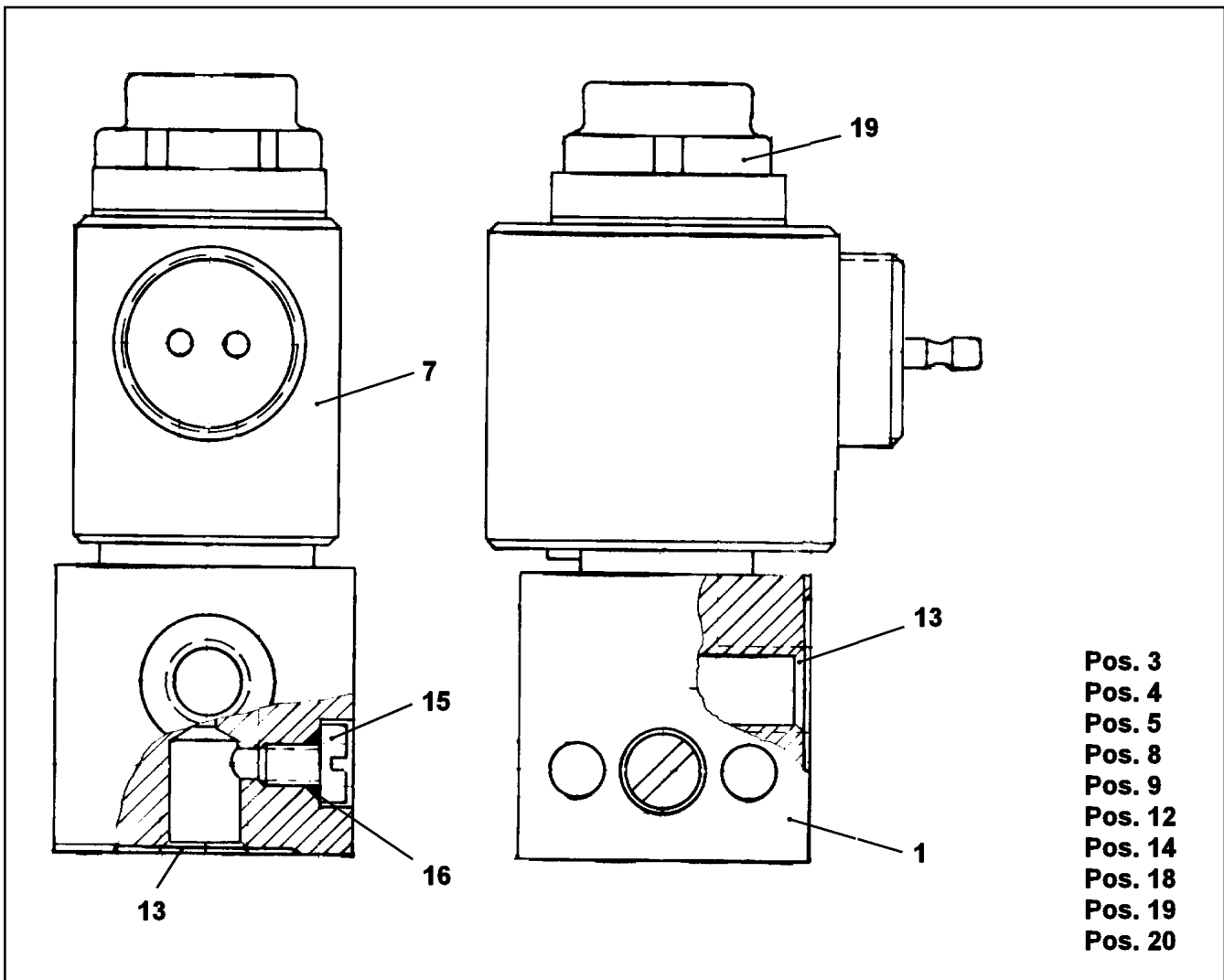

Pos. 3
 Pos. 4
 Pos. 5
 Pos. 8
 Pos. 9
 Pos. 12
 Pos. 14
 Pos. 18
 Pos. 19
 Pos. 20

Pos.	Item	Quantity	Description	Bezeichnung	Serie	K
1	57 00 092 08	1	HOUSING	GEHAEUSE		
3	51 10 492 08	1	O-RING ARP 568 2,9X1,78 NBR90	O-RING		
4	57 00 101 08	1	O-RING 14X1,1 NBR70	O-RING		
5	57 00 093 08	1	MAGNETIC LOCKING SLEEVE	MAGNETSCHLUSSHUELSE		
7	57 00 094 08	1	MAGNET 24V	MAGNET		
8	57 00 095 08	1	PRESSURE SPRING	DRUCKFEDER		
9	57 00 096 08	1	SOLENOID ARMATURE	MAGNETANKER		
12	57 00 097 08	1	SHEET	PLATTE		
13	51 07 461 08	2	O-RING ARP 568 12,37X2,62 NBR90	O-RING		
14	57 00 098 08	1	VALVE SEAT	VENTILSITZ		
15	40 01 054 08	2	CYLINDER SCREW DIN 84 M6X8 5.8 A3C	ZYLINDERSCHRAUBE		
16	57 00 102 08	2	SEALING RING DIN 7603 A 6,5X11X1 AL	DICHTRING		
18	57 00 103 08	4	THREAD FORM SCREW DIN 7500 M4X10	GEWINDEFORMSCHRAUBE		
19	57 00 099 08	1	NUT	MUTTER		
20	57 00 100 08	1	LOCKING PLATE	SICHERUNGSBLECH		

6.2.2009
 140157

LIEBHERR

etk_en_de_074515 LR 1600/2

SOLENOID VALVE
 MAGNETVENTIL

613

⇒ 5 026 126 08
 50 26 126 08

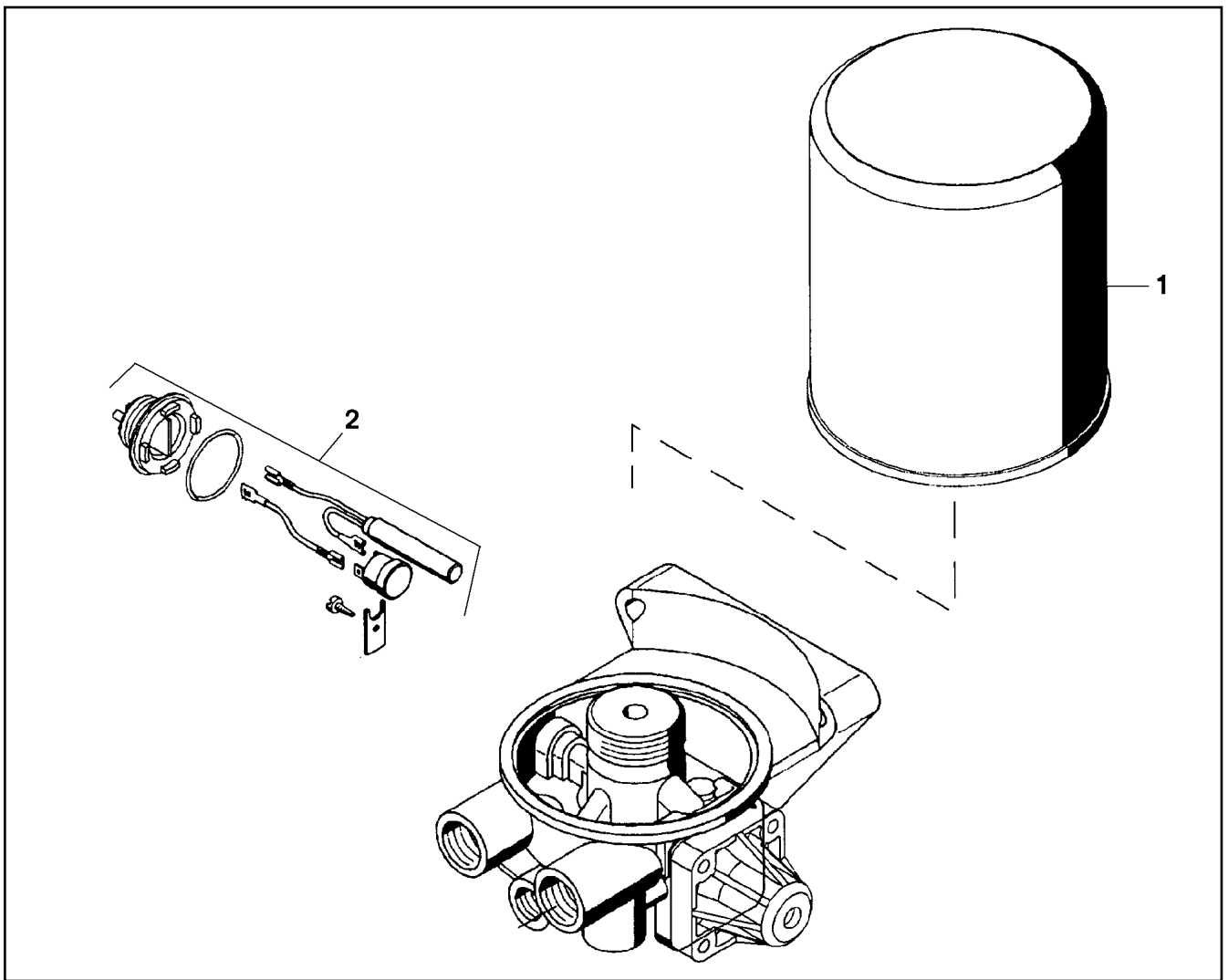

Pos.	Item	Quantity	Description	Bezeichnung	Serie	K
1	57 13 523 08	1	CARTOUCHE	KARTUSCHE		
2	50 26 514 08	1	HEATING SYSTEM	HEIZUNG		

6.2.2009
019832

LIEBHERR

etk_en_de_074515 LR 1600/2

AIR DRYER
LUFTTROCKNER

614

⇒ 5 026 573 08
50 26 573 08

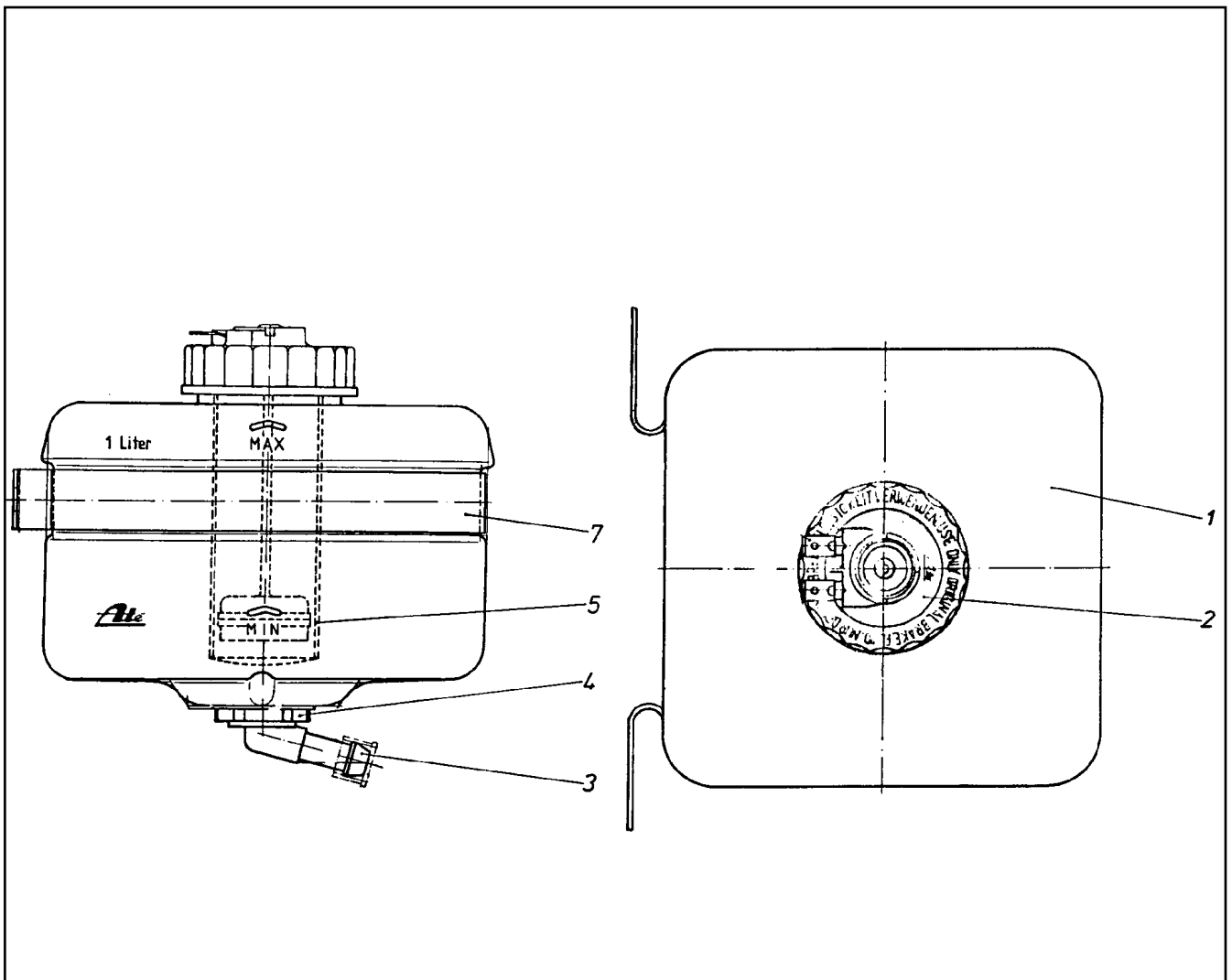

Pos.	Item	Quantity	Description	Bezeichnung	Serie	K
1	57 00 659 08	1	EQUALIZING RESERVOIR	AUSGLEICHSBEHAELTER		
2	57 00 660 08	1	FLANGE JOINT	VERSCHRAUBUNG		
3	57 00 661 08	1	PIPE ELBOW	KNIESTUECK		
4	57 00 662 08	1	CONTAINER PLUG	BEHAELTERSTOPFEN		
5	57 00 663 08	1	SIEVE SLEEVE	SIEBHUELSE		
7	57 00 664 08	1	FASTENING CLAMP	BEFESTIGUNGSSCHELLE		

6.2.2009
010632

LIEBHERR

etk_en_de_074515 LR 1600/2

EQUALIZING RESERVOIR
AUSGLEICHSBEHAELTER

615

⇒ 5 028 065 08
50 28 065 08

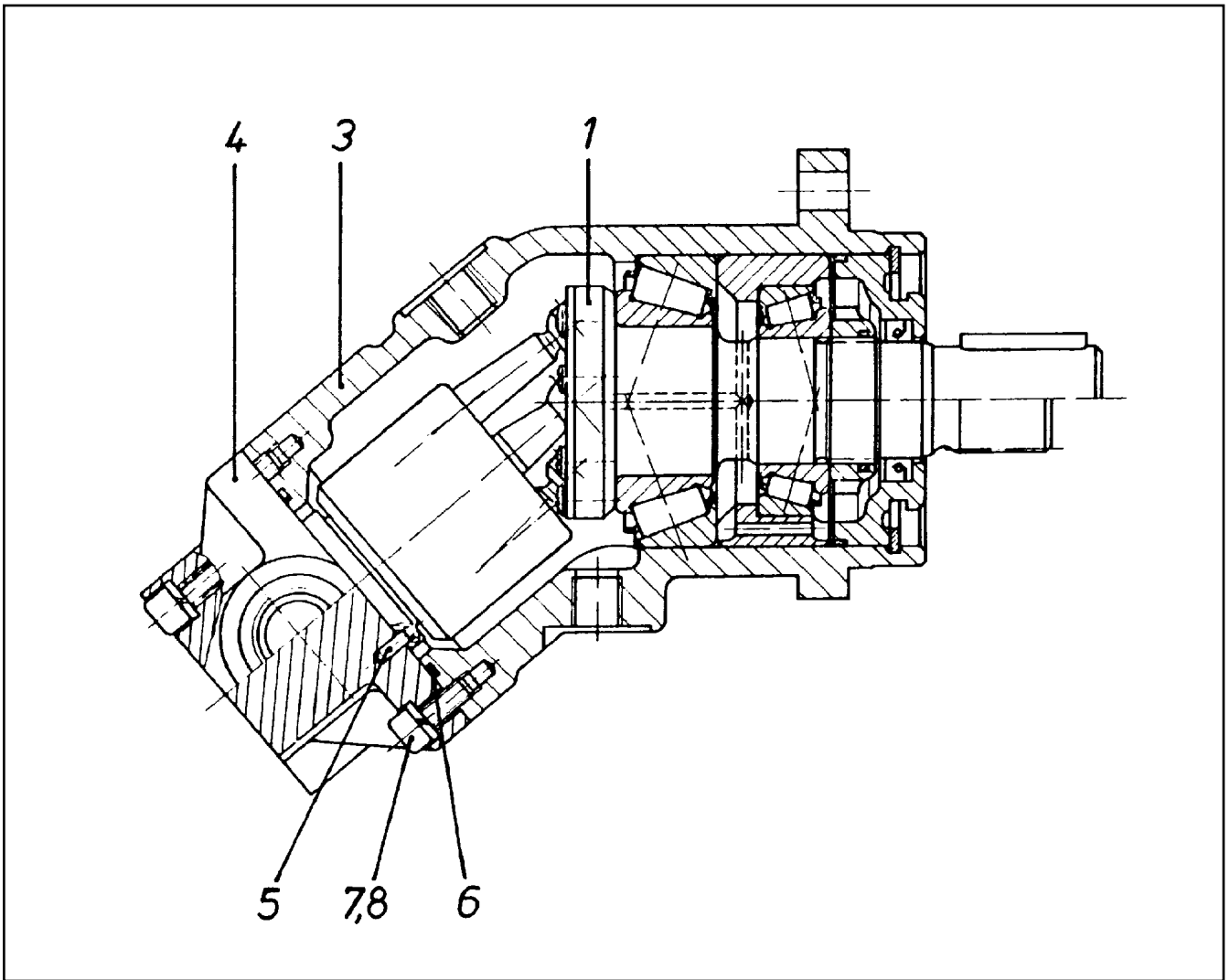

Pos.	Item	Quantity	Description	Bezeichnung	Serie	K
1	57 01 129 08	1	DRIVING GEAR ⇒ 5 701 129 08 57 01 129 08	TRIEBWERK		
3	57 01 130 08	1	HOUSING	GEHAEUSE		
4	57 07 719 08	1	TERMINAL BOARD	ANSCHLUSSPLATTE		
5	57 01 132 08	1	PARALLEL PIN DIN 7 3M6X10 ST	ZYLINDERSTIFT		
6	72 64 265 08	1	O-RING ARP 568 52,07X2,62 NBR90	O-RING		
7	46 00 048	6	CYLINDER SCREW ISO 4762 M6X16 8.8 A2C	ZYLINDERSCHRAUBE		
8	42 41 006 08	6	CIRCLIP DIN 7980 6 VERZ	FEDERRING		

6.2.2009
131598

LIEBHERR

etk_en_de_074515 LR 1600/2

HYDRO MOTOR
HYDROMOTOR

□ 616

⇒ 5 102 306 08
51 02 306 08

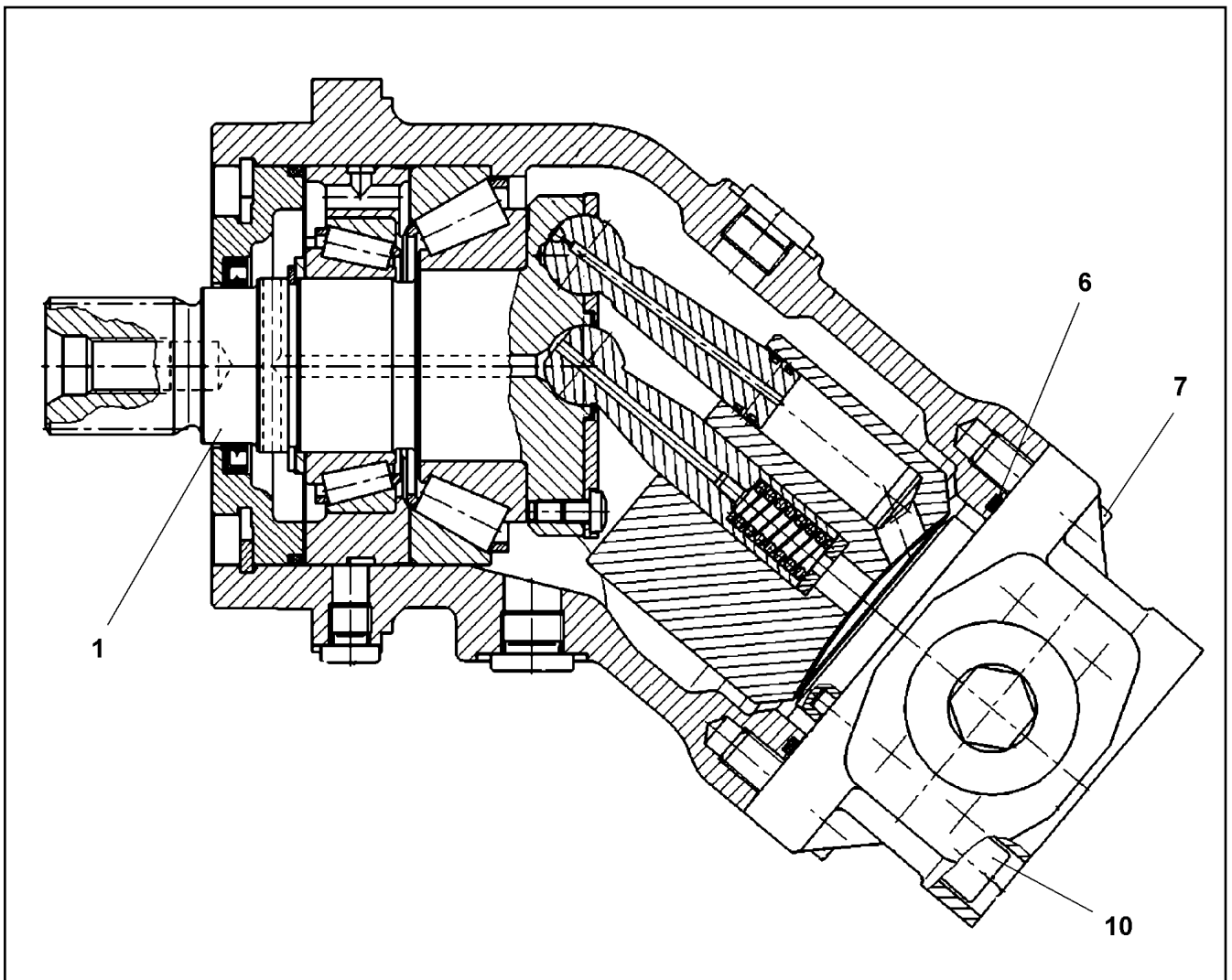

Pos.	Item	Quantity	Description	Bezeichnung	Serie	K
1	10 65 006 5	1	DRIVING GEAR	TRIEBWERK		
(14)	57 07 018 08	1	ROTARY SHAFT LIP SEAL DIN 3760 AS 40X5	RADIALWELLENDICHTRING		
(15)	73 72 303	1	O-RING 98,02X3,53 S-FPM 75	O-RING		
6	10 22 070 7	1	O-RING 78,97X3,53 FKM 70	O-RING		
7	40 42 014	2	CYLINDER SCREW ISO 4762 M10X25 8.8 A3	ZYLINDERSCHRAUBE		
10	46 00 143	4	CYLINDER SCREW ISO 4762 M10X60 8.8 A3	ZYLINDERSCHRAUBE		

6.2.2009
059320

LIEBHERR

etk_en_de_074515 LR 1600/2

HYDRO MOTOR
HYDROMOTOR

617

⇒ 5 102 354 08
51 02 354 08

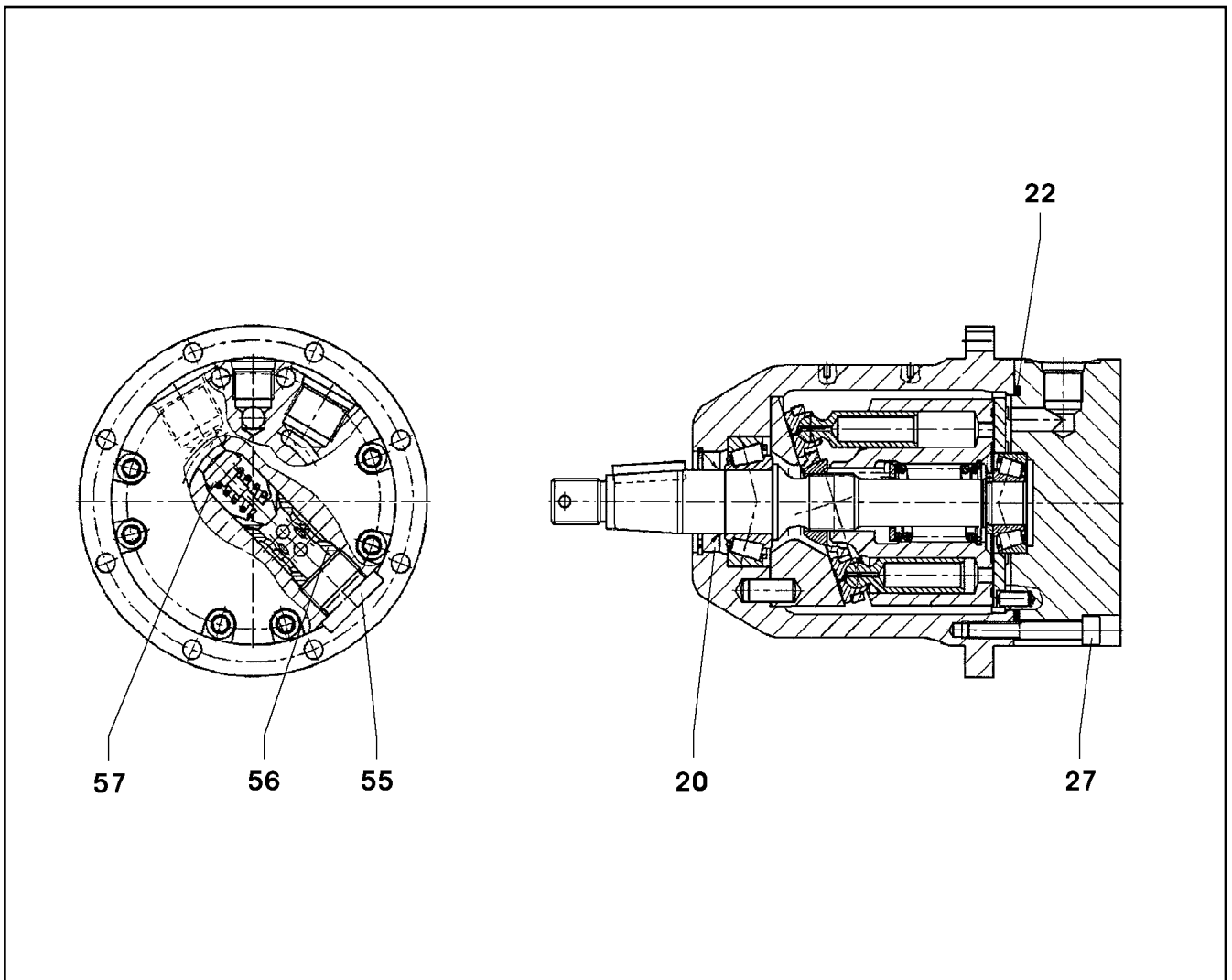

Pos.	Item	Quantity	Description	Bezeichnung	Serie	K
20	57 15 168 08	1	SHAFT SEAL 22X35X6	WELLENDICHTRING		
22	52 12 028 08	1	O-RING 75X2,5 NBR70	O-RING		
27	46 00 340	8	CYLINDER SCREW ISO 4762 M6X40 10.9 A2	ZYLINDERSCHRAUBE		
55	57 17 778 08	1	SCREW PLUG	VERSCHLUSSSCHRAUBE		
56	57 17 779 08	1	VALVE SEAT SLEEVE	VENTILSITZHUELSE		
57	57 17 780 08	1	VALVE INSERT	VENTILEINSATZ		

6.2.2009
021773

LIEBHERR

etk_en_de_074515 LR 1600/2

HYDRO MOTOR
HYDROMOTOR

618

⇒ 5 102 380 08
51 02 380 08

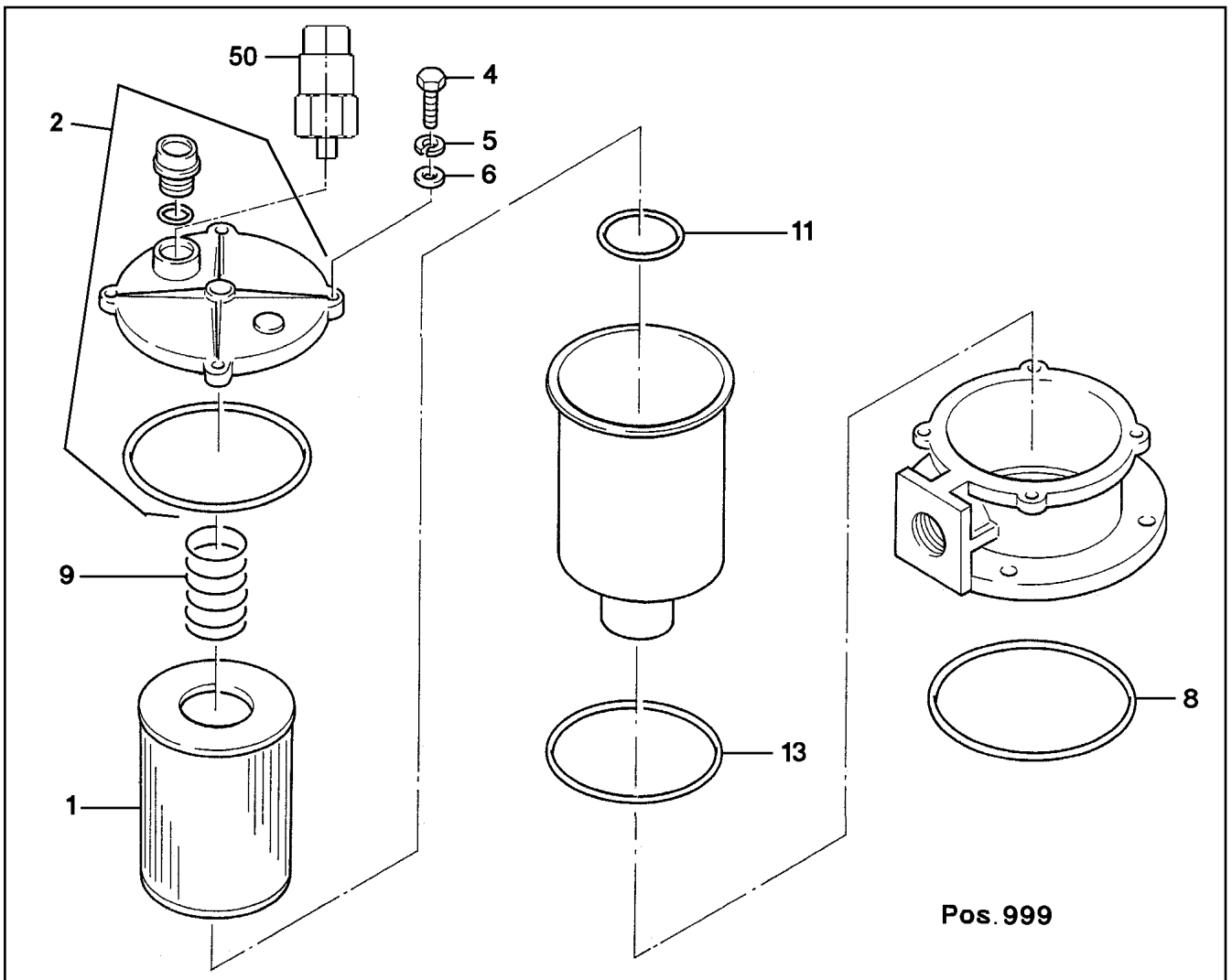

Pos.	Item	Quantity	Description	Bezeichnung	Serie	K
1	51 06 692 08	1	FILTER INSERT	FILTEREINSATZ		
2	57 08 320 08	1	FILTER COVER ⇒ 5 708 320 08 57 08 320 08	FILTERDECKEL		
4	49 00 111	4	HEX BOLT ISO 4017 M8X30 8.8 A2C	SECHSKANTSCHRAUBE		
5	42 40 007 08	4	CIRCLIP DIN 127 A 8 VERZ	FEDERRING		
6	42 00 012 08	4	WASHER DIN 125 A8X16 ST VERZ	SCHEIBE		
8	57 05 883 08	1	O-RING ARP 568 170,82X7 NBR70	O-RING		
9	57 08 310 08	1	SPRING	FEDER		
11	57 05 888 08	1	O-RING ARP 568 63,09X3,53 NBR70	O-RING		
13	51 45 275 08	1	O-RING ARP 568 148,49X5,33 NBR70	O-RING		
50	51 06 693 08	1	CLOGGING INDICATOR	VERSCHMUTZUNGSANZEIGE		
999	57 05 881 08	1	SEAL KIT	DICHTSATZ		

6.2.2009
033231

LIEBHERR

etk_en_de_074515 LR 1600/2

RETURN FILTER
RUECKLAUFFILTER

619

⇒ 5 106 691 08
51 06 691 08

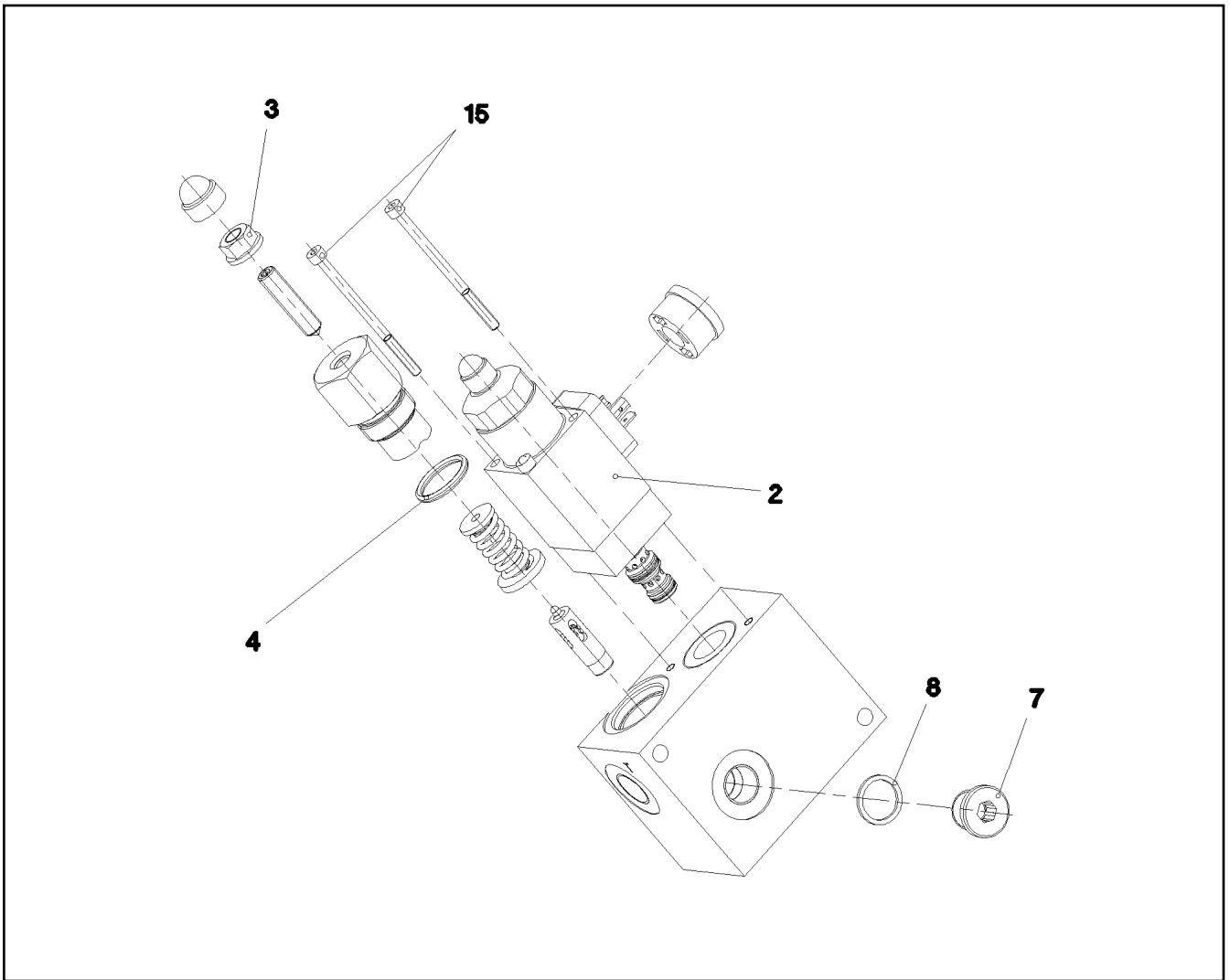

Pos.	Item	Quantity	Description	Bezeichnung	Serie	K
2	10 48 973 4	1	PRESSURE LIMITING VALVE ⇒ X10489734 10 48 973 4	DRUCKBEGRENZUNGSVENTIL		
4	72 64 202 08	1	O-RING ARP 568 20,29X2,62 NBR70	O-RING		
7	40 41 001 08	1	SCREW PLUG DIN 908 M16X1,5 ST A2C	VERSCHLUSSSCHRAUBE		
8	71 01 034 08	1	SEALING RING DIN 7603 A 16X20X1,5 CU	DICHTRING		
15	46 00 338	2	CYLINDER SCREW ISO 4762 M4X65 8.8 A2C	ZYLINDERSCHRAUBE		
25	57 06 523 08	1	O-RING ARP 568 23,52X1,78 N903890SHOR	O-RING		
26	51 07 190 08	1	O-RING ARP 568 9,25X1,78 NBR75	O-RING		
27	51 07 181 08	1	O-RING ARP 568 10,82X1,78 NBR75	O-RING		

6.2.2009
059004

LIEBHERR

etk_en_de_074515 LR 1600/2

CONTROL BLOCK
STUEBERBLOCK

620

⇒ 5 113 005 08
51 13 005 08

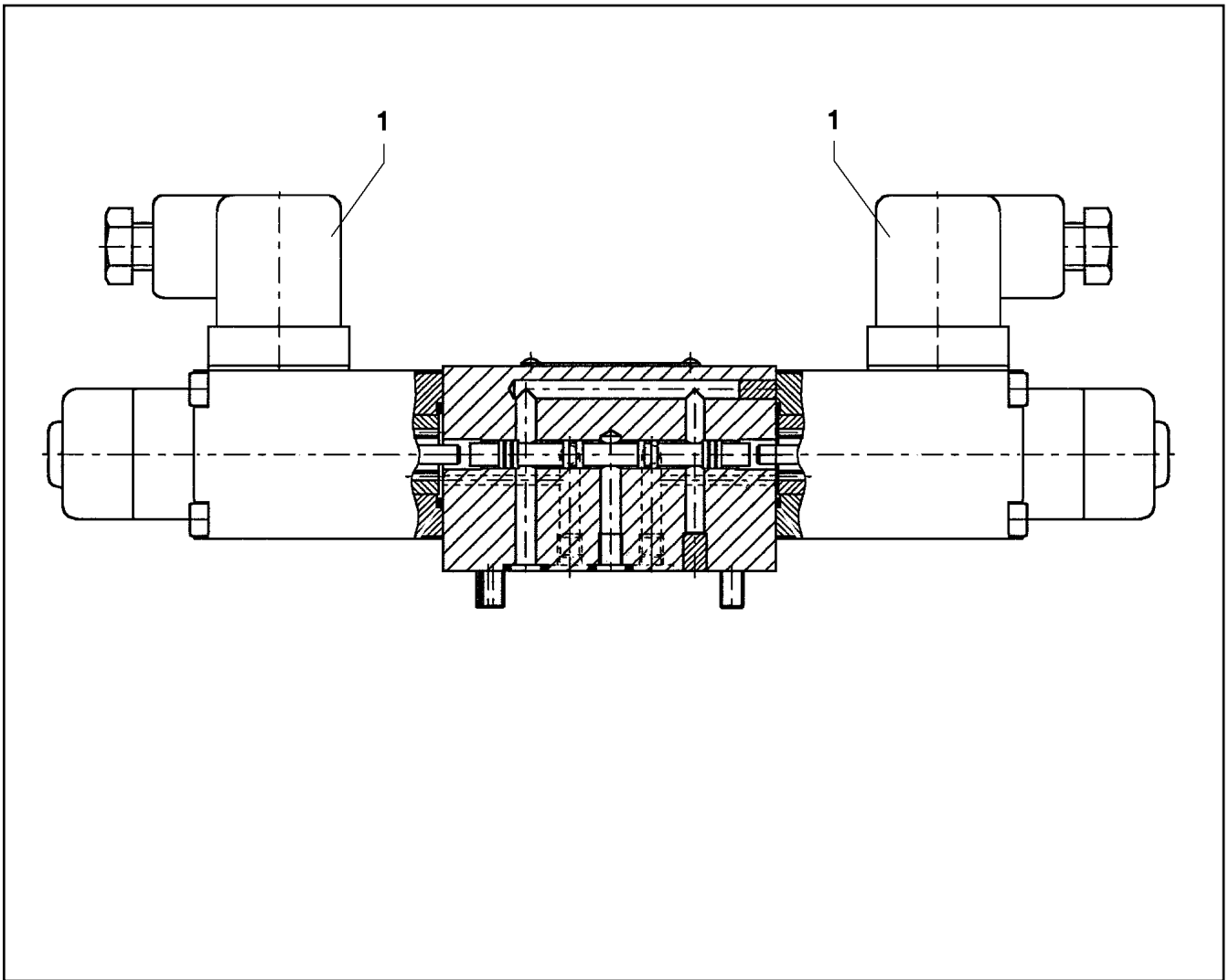

Pos.	Item	Quantity	Description	Bezeichnung	Serie	K
1	57 17 127 08	2	MAGNET COIL 24VDC 1,25A	MAGNETSPULE		
2	70 27 459	2	NUT GZ45-01	MUTTER		
999	74 11 445	1	SEAL KIT	DICHTSATZ		

6.2.2009
023659

LIEBHERR

etk_en_de_074515 LR 1600/2

DIRECTIONAL CONTROL VALVE
WEGEVENTIL

621

⇒ 5 113 022 08
51 13 022 08

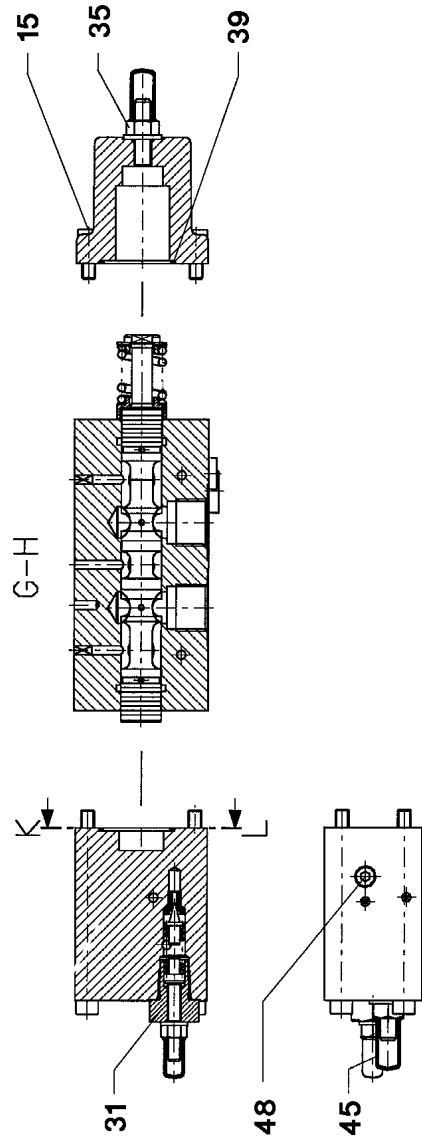
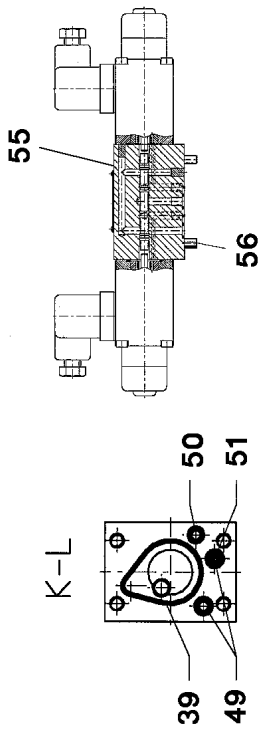
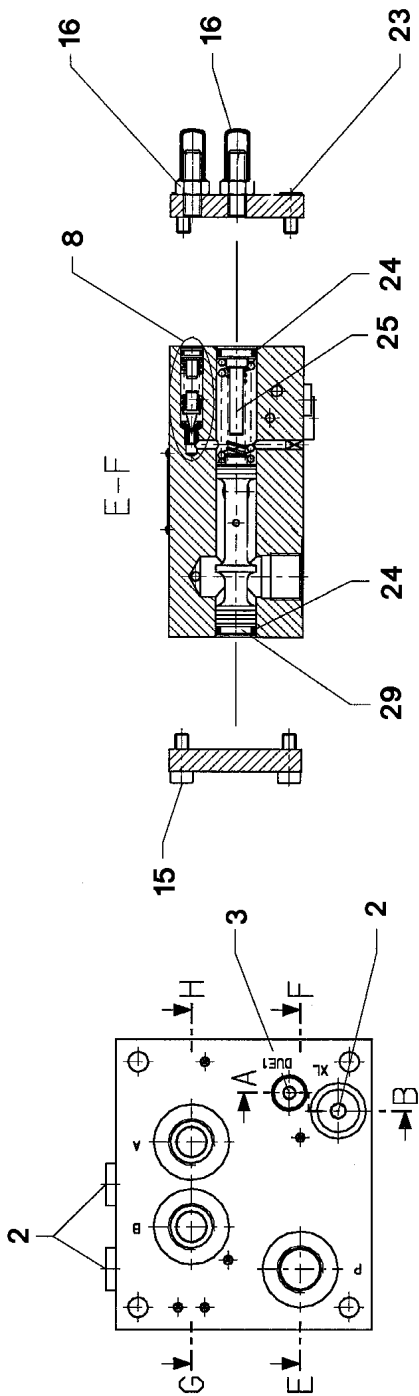

6.2.2009
026100

LIEBHERR

etk_en_de_074515 LR 1600/2

PROPORTIONAL VALVE
PROPORTIONALVENTIL

□ 622 (1/2)

→ 5 113 086 08
51 13 086 08

Pos.	Item	Quantity	Description	Bezeichnung	Serie	K
2	47 77 040 08	3	STOPPER PLUG VST11/4"ED A3P	BLINDSTOPFEN		
3	51 07 415 08	1	PLUG VST11/8"ED ST A3C	STOPFEN		
8	57 15 296 08	1	PRESSURE VALVE ⇒ 5 715 296 08 57 15 296 08	DRUCKVENTIL		
15	51 07 466 08	8	CYLINDER SCREW DIN 912 M6X16 12.9	ZYLINDERSCHRAUBE		
16	57 15 610 08	2	CHECK SCREW	STELLSCHRAUBE		
23	40 02 601	4	CYLINDER SCREW ISO 4762 M6X12 12.9	ZYLINDERSCHRAUBE		
24	51 07 461 08	2	O-RING ARP 568 12,37X2,62 NBR90	O-RING		
25	57 06 903 08	1	SPACER PIECE	DISTANZSTUECK		
29	51 07 457 08	1	LIMIT STOP	ANSCHLAG		
31	57 11 301 08	1	PRESSURE LIMITING VALVE ⇒ 5 711 301 08 57 11 301 08	DRUCKBEGRENZUNGSVENTIL		
35	57 18 141 08	1	CHECK SCREW	STELLSCHRAUBE		
39	51 07 478 08	2	O-RING ARP 568 29,87X1,78 NBR90	O-RING		
45	57 19 037 08	1	CHECK SCREW	STELLSCHRAUBE		
48	57 19 038 08	1	NON-RETURN VALVE	RUECKSCHLAGVENTIL		
49	72 64 266 08	2	O-RING ARP 568 5,28X1,78 NBR90	O-RING		
50	51 31 192 08	1	O-RING ARP 568 4,47X1,78 NBR90	O-RING		
51	57 19 039 08	1	NOZZLE D=1,2	DUESE		
55	57 13 626 08	1	PILOT VALVE ⇒ 5 713 626 08 57 13 626 08	VORSTEUERVENTIL		
56	40 43 612 08	4	CYLINDER SCREW DIN 912 M5X45 12.9	ZYLINDERSCHRAUBE		

6.2.2009

etk_en_de_074515 LR 1600/2

☐ 623 (2/2)

LIEBHERR

PROPORTIONAL VALVE
PROPORTIONALVENTIL

⇒ 5 113 086 08
51 13 086 08

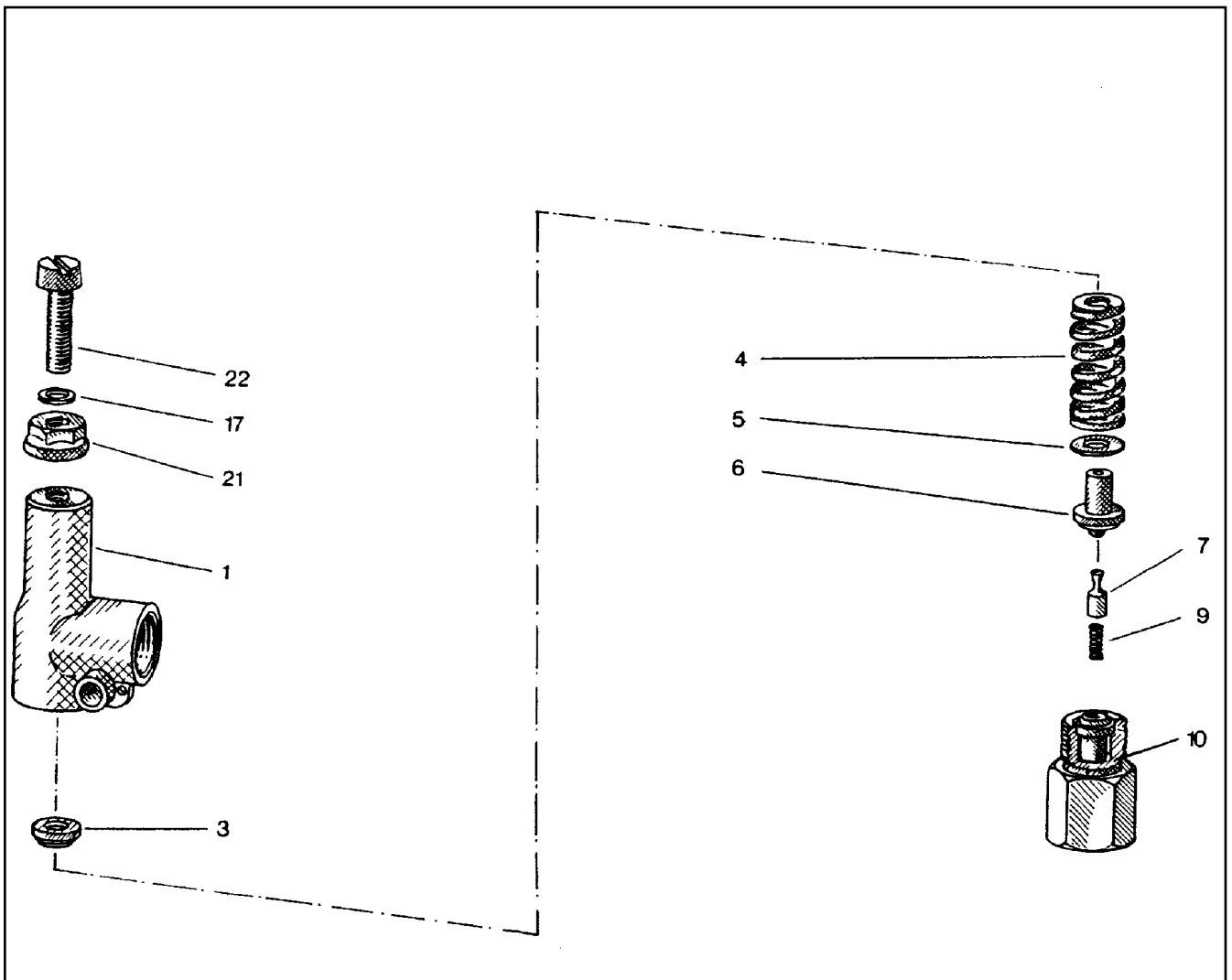

Pos.	Item	Quantity	Description	Bezeichnung	Serie	K
1	51 07 969 08	1	HOUSING	GEHAEUSE		
3	51 07 970 08	1	SPRING CUP	FEDERTELLER		
4	51 07 971 08	1	PRESSURE SPRING	DRUCKFEDER		
5	51 07 972 08	1	WASHER	SCHEIBE		
6	51 07 973 08	1	SPRING PIN	FEDERBOLZEN		
7	51 07 974 08	1	DAMPING PISTON	DAEMPUNGSKOLBEN		
9	51 07 975 08	1	PRESSURE SPRING	DRUCKFEDER		
10	51 07 976 08	1	VALVE SEAT	VENTILSITZ		
17	51 07 832 08	1	SHIM	AUSGLEICHSCHEIBE		
21	51 07 417 08	1	SEALING NUT M8	DICHTMUTTER		
22	51 07 977 08	1	CYLINDER SCREW DIN 84 M8X35 5.8	ZYLINDERSCHRAUBE		

6.2.2009
010374

LIEBHERR

etk_en_de_074515 LR 1600/2

PRESSURE LIMITING VALVE
DRUCKBEGRENZUNGSVENTIL

624

⇒ 5 114 176 08
51 14 176 08

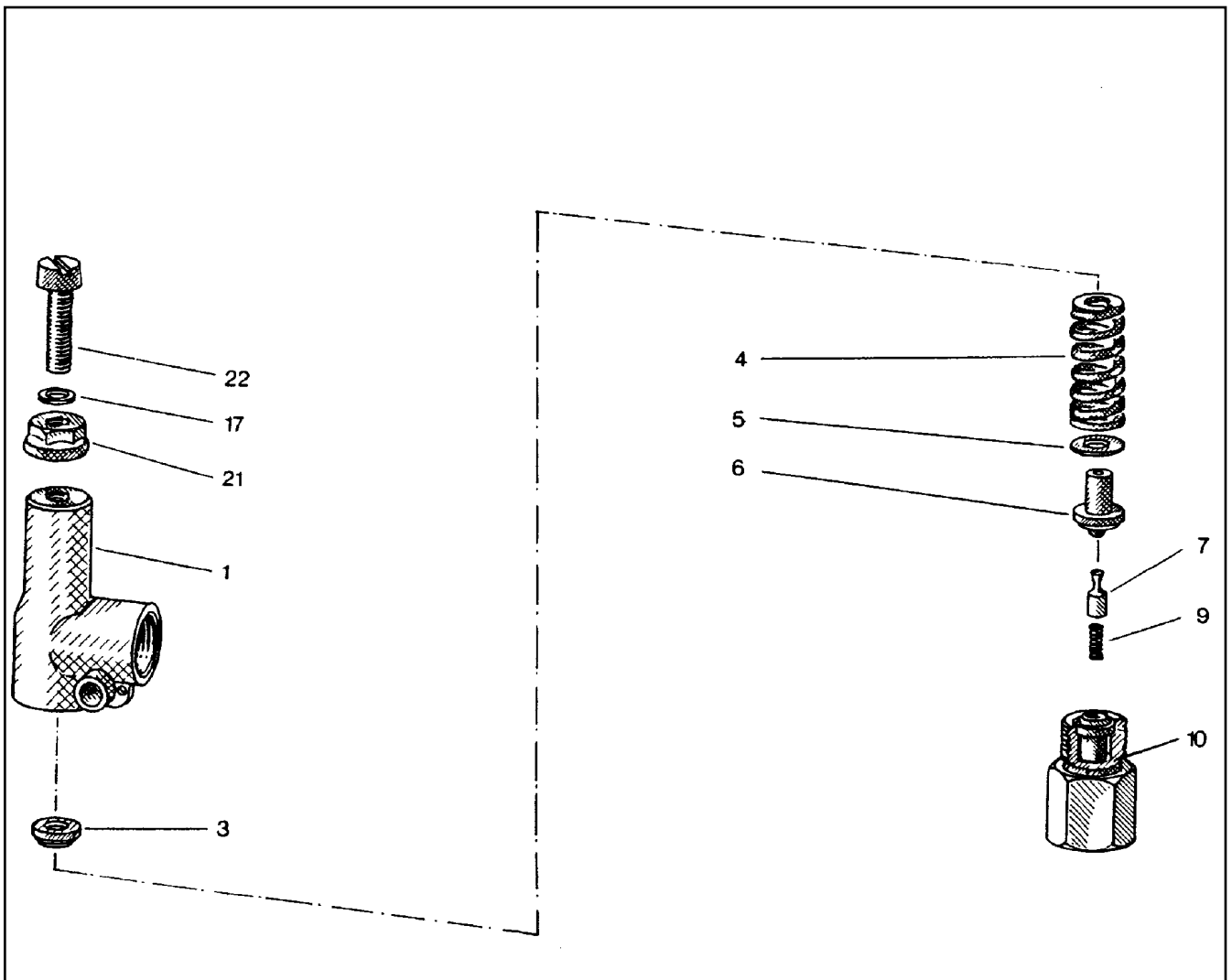

Pos.	Item	Quantity	Description	Bezeichnung	Serie	K
1	51 07 969 08	1	HOUSING	GEHAEUSE		
3	51 07 970 08	1	SPRING CUP	FEDERTELLER		
4	51 10 151 08	1	PRESSURE SPRING	DRUCKFEDER		
5	51 07 972 08	1	WASHER	SCHEIBE		
6	51 07 973 08	1	SPRING PIN	FEDERBOLZEN		
7	51 07 974 08	1	DAMPING PISTON	DAEMPUNGSKOLBEN		
9	51 07 975 08	1	PRESSURE SPRING	DRUCKFEDER		
10	51 07 976 08	1	VALVE SEAT	VENTILSITZ		
17	51 07 832 08	1	SHIM	AUSGLEICHSCHEIBE		
21	51 07 417 08	1	SEALING NUT M8	DICHTMUTTER		
22	51 07 977 08	1	CYLINDER SCREW DIN 84 M8X35 5.8	ZYLINDERSCHRAUBE		

6.2.2009
010374

LIEBHERR

etk_en_de_074515 LR 1600/2

PRESSURE LIMITING VALVE
DRUCKBEGRENZUNGSVENTIL

□ 625

⇒ 5 114 177 08
51 14 177 08

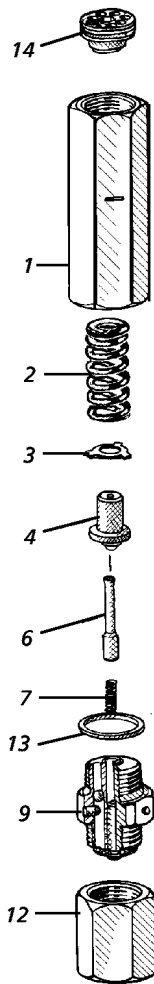

Pos.	Item	Quantity	Description	Bezeichnung	Serie	K
1	57 00 728 08	1	HOUSING	GEHAEUSE		
2	51 07 971 08	1	PRESSURE SPRING	DRUCKFEDER		
3	57 00 729 08	1	WASHER	SCHEIBE		
4	51 07 973 08	1	SPRING PIN	FEDERBOLZEN		
6	51 07 974 08	1	DAMPING PISTON	DAEMPUNGSKOLBEN		
7	51 07 975 08	1	PRESSURE SPRING	DRUCKFEDER		
9	57 00 731 08	1	VALVE SCREW	VENTILSCHRAUBE		
12	57 00 734 08	1	CONNECTION PIECE	ANSCHLUSSSTUECK		
13	71 01 044 08	1	SEALING RING DIN 7603 A 21X26X1,5 CU	DICHTRING		
14	51 10 072 08	1	THREADED DISK	GEWINDESCHIEBE		

6.2.2009
132170

LIEBHERR

etk_en_de_074515 LR 1600/2

PRETENSIONING VALVE
VORSPANNVENTIL

626

⇒ 5 114 320 08
51 14 320 08

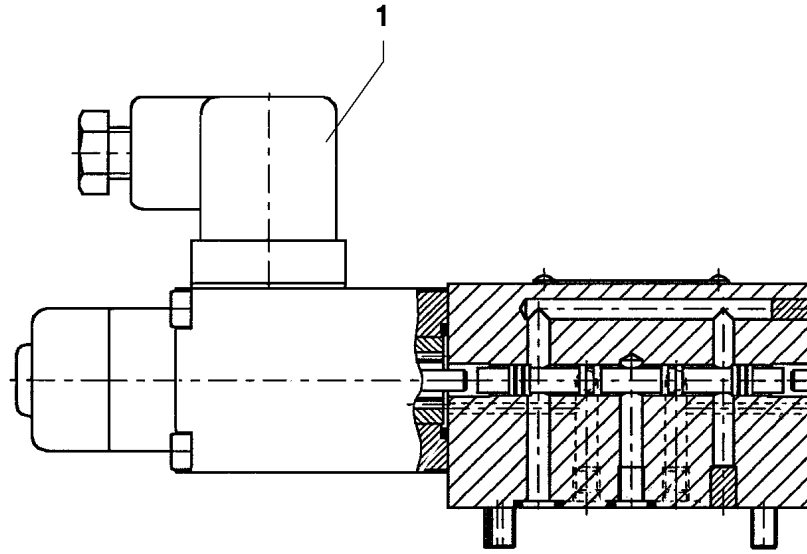

Pos.	Item	Quantity	Description	Bezeichnung	Serie	K
1	57 08 278 08	1	MAGNET 24V DC	MAGNET		

6.2.2009
023658

LIEBHERR

etk_en_de_074515 LR 1600/2

DIRECTIONAL CONTROL VALVE
WEGEVENTIL

627

⇒ 5 114 444 08
51 14 444 08

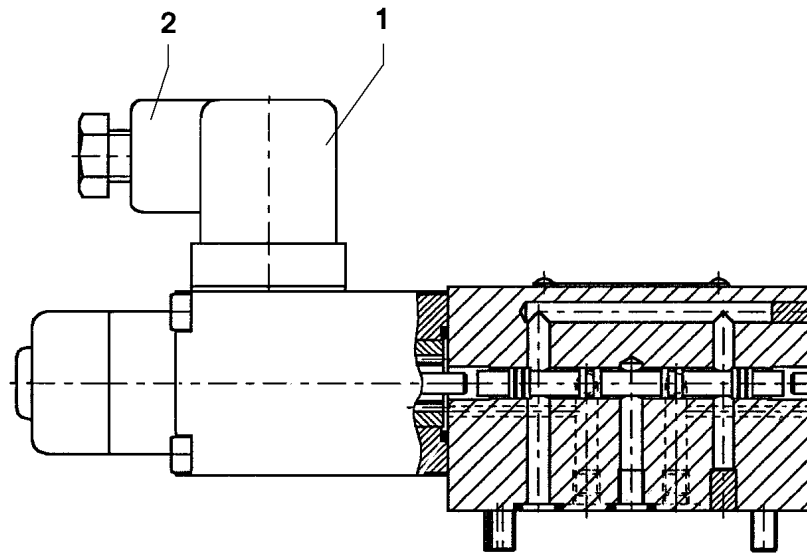

Pos.	Item	Quantity	Description	Bezeichnung	Serie	K
1	57 06 338 08	1	MAGNET 24V	MAGNET		
2	60 50 066 08	1	DEVICE PLUG DIN 43650	GERAETESTECKER		

6.2.2009
023657

LIEBHERR

etk_en_de_074515 LR 1600/2

DIRECTIONAL CONTROL VALVE
WEGEVENTIL

628

⇒ 5 114 445 08
51 14 445 08

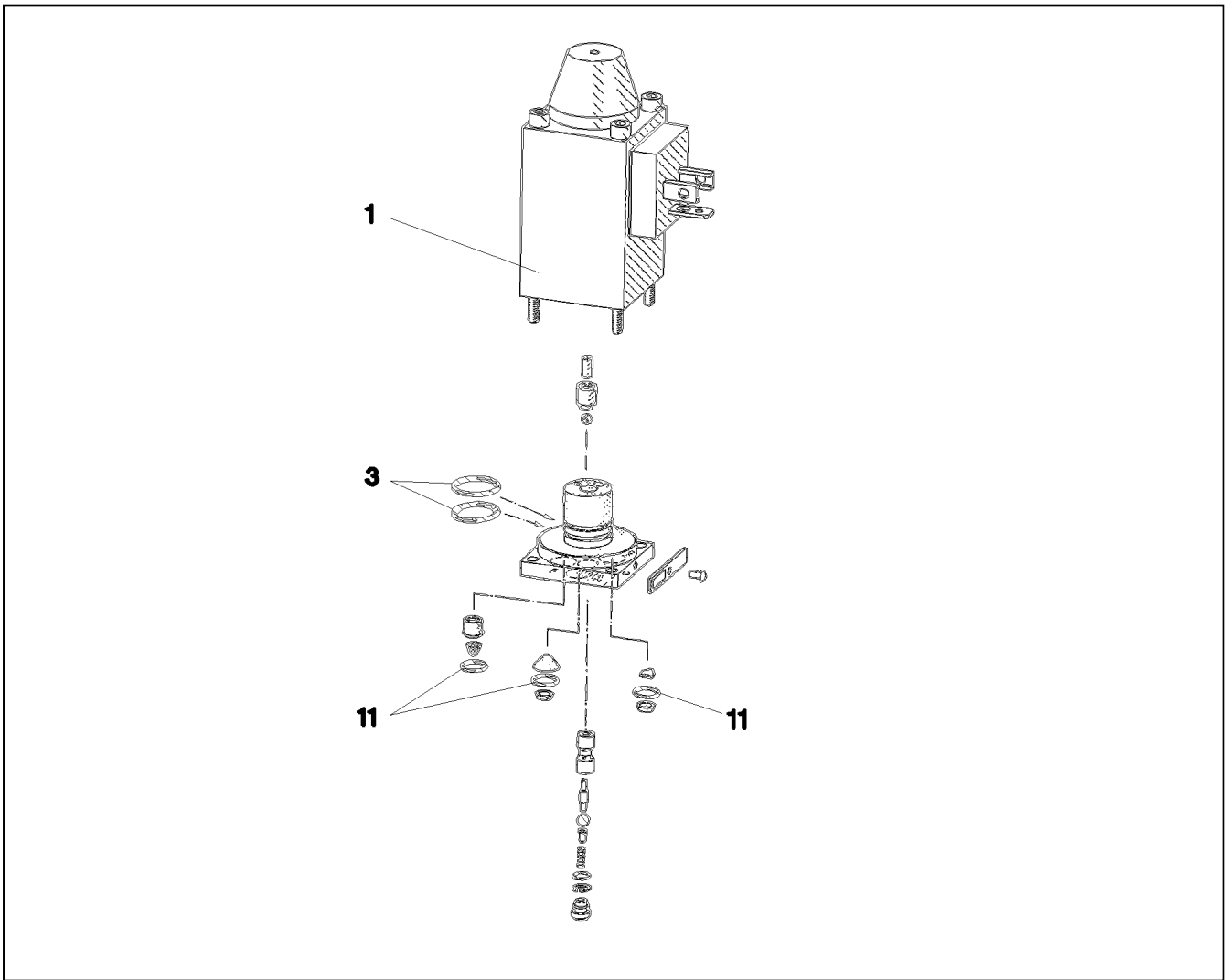

Pos.	Item	Quantity	Description	Bezeichnung	Serie	K
1	57 06 338 08	1	MAGNET 24V	MAGNET		
3	57 00 101 08	2	O-RING 14X1,1 NBR70	O-RING		
11	51 07 129 08	3	O-RING 6X1,5 NBR90	O-RING		

6.2.2009
059099

LIEBHERR

etk_en_de_074515 LR 1600/2

DIRECTIONAL CONTROL VALVE
WEGEVENTIL

629

⇒ 5 114 498 08
51 14 498 08

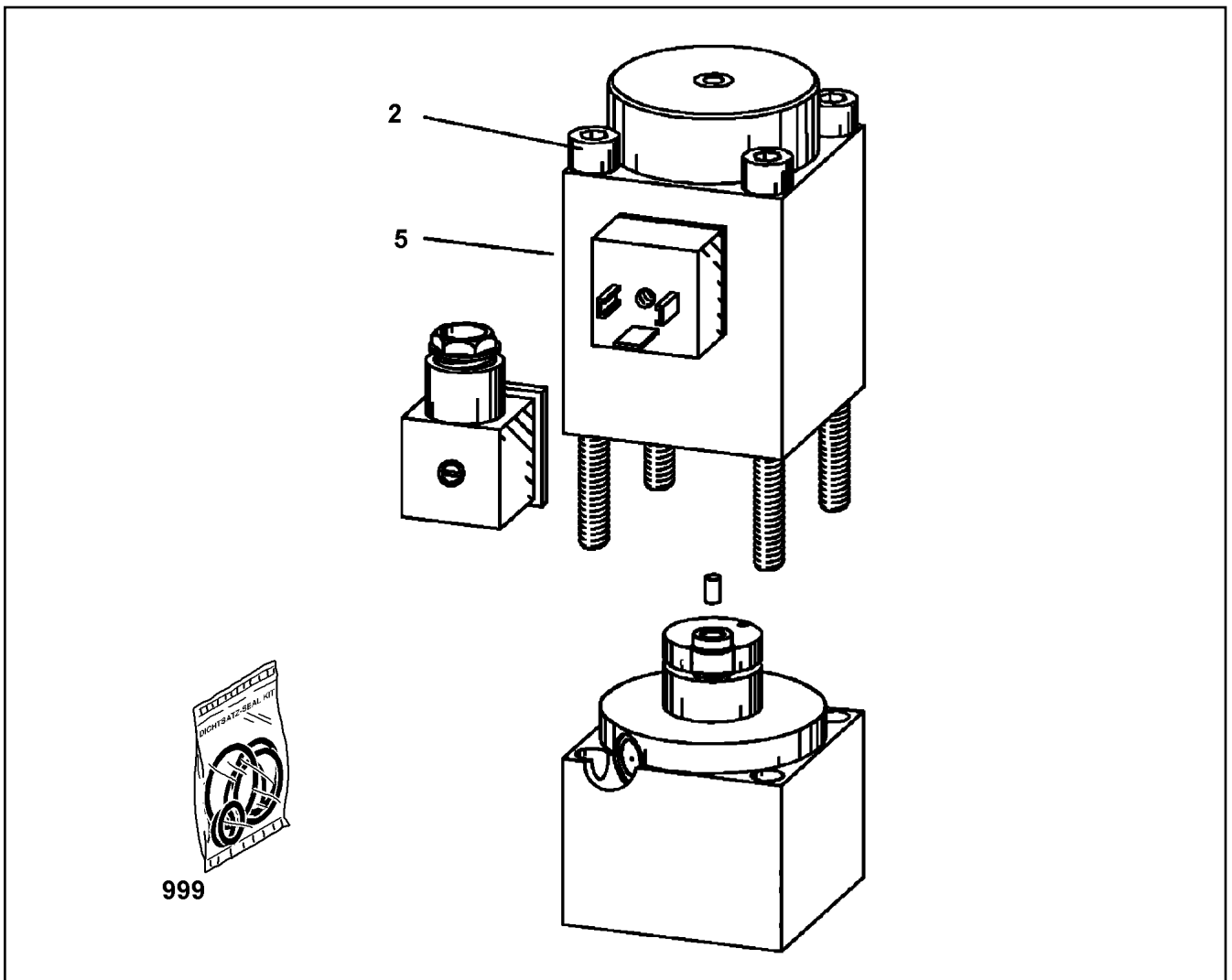

Pos.	Item	Quantity	Description	Bezeichnung	Serie	K
	2 10 66 372 5	4	CYLINDER SCREW ISO 4762 M5X95 12.9	ZYLINDERSCHRAUBE		
	5 10 42 953 2	1	MAGNET 24V DC	MAGNET		
	999 10 66 373 0	1	SEALING SET VALVE	DS VENTIL		

6.2.2009
059607

LIEBHERR

etk_en_de_074515 LR 1600/2

DIRECTIONAL CONTROL VALVE
WEGEVENTIL

630

⇒ 5 114 651 08
51 14 651 08

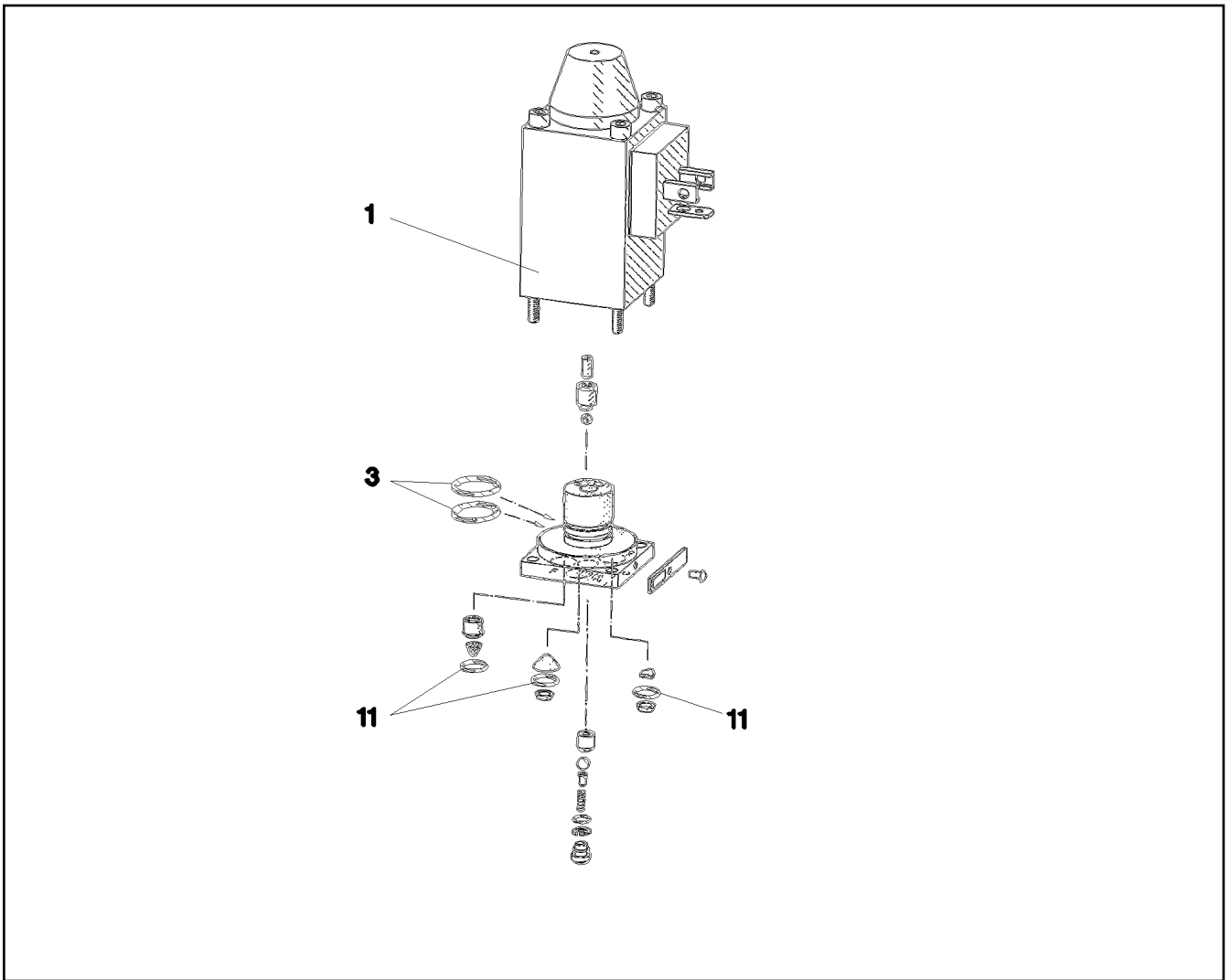

Pos.	Item	Quantity	Description	Bezeichnung	Serie	K
1	57 06 338 08	1	MAGNET 24V	MAGNET		
(1)	57 06 810 08	1	O-RING 27,5X2,5 FPM70	O-RING		
3	57 00 101 08	2	O-RING 14X1,1 NBR70	O-RING		
11	51 07 129 08	3	O-RING 6X1,5 NBR90	O-RING		

6.2.2009
059301

LIEBHERR

etk_en_de_074515 LR 1600/2

DIRECTIONAL CONTROL VALVE
WEGEVENTIL

631

⇒ 5 114 943 08
51 14 943 08

Pos.	Item	Quantity	Description	Bezeichnung	Serie	K
1	57 17 080 08	1	HANDPUMP ZPH1A/5PN500	HANDPUMPE		
2	57 17 120 08	1	HOSE DN6,3	SCHLAUCH		
3	57 17 230 08	1	CONNECTING NIPPLE G 1/4" M14X1,5	ANSCHLUSSNIPPEL		
4	57 17 231 08	1	QUICK COUPLING FEMALE	STECKKUPPLUNGSMUFFE		
5	57 19 135 08	1	CYLINDER 50/25-165	ZYLINDER		
(10)	57 19 136 08	1	DS ASSEMBLY CYLINDER	DS MONTAGEZYLINDER		

6.2.2009

etk_en_de_074515 LR 1600/2

632

LIEBHERR

MOUNTING - PISTON W. PUMP
MONTAGEZYLINDER

⇒ 5 123 682 08
51 23 682 08

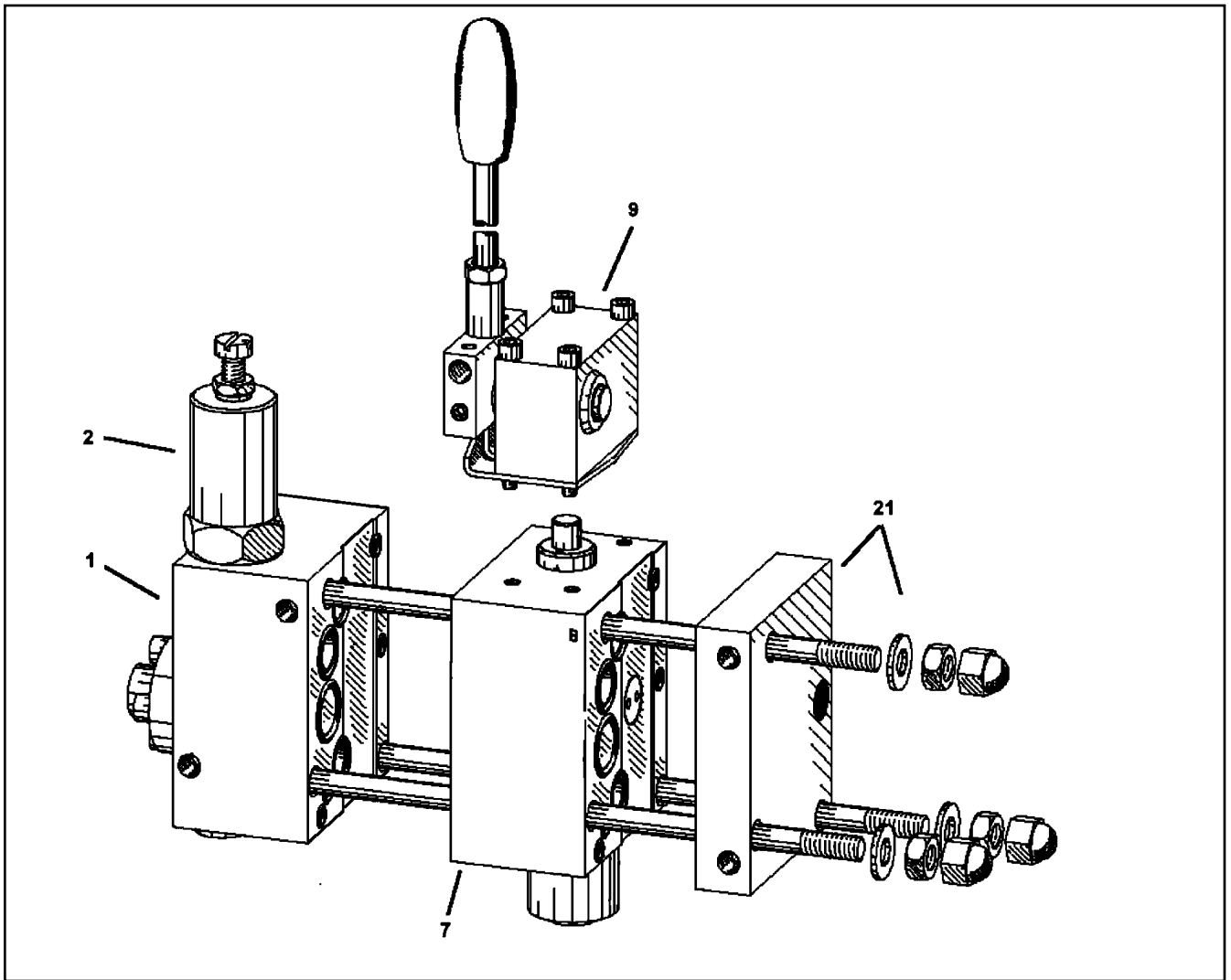

Pos.	Item	Quantity	Description	Bezeichnung	Serie	K
1	96 40 276 08	1	CONNECTION BLOCK PSV4 ⇒ 9 640 276 08 96 40 276 08	ANSCHLUSSBLOCK		
2	10 41 267 5	1	PRESSURE LIMITING VALVE ⇒ X10412675 10 41 267 5	DRUCKBEGRENZUNGSVENTIL		
7	96 40 277 08	1	DIRECTIONAL CTRL. VALVE SL3-41 ⇒ 9 640 277 08 96 40 277 08	WEGESCHIEBER		
9	10 41 267 7	1	MANUAL ACTUATION ⇒ X10412677 10 41 267 7	HANDBETAETIGUNG		
21	10 41 267 8	1	END PLATE ⇒ X10412678 10 41 267 8	ENDPLATTE		

6.2.2009
049045

LIEBHERR

etk_en_de_074515 LR 1600/2

SLIDE VALVE BLOCK
WEGESCHIEBERBLOCK

▣ 633

⇒ 5 133 090 08
51 13 090 08

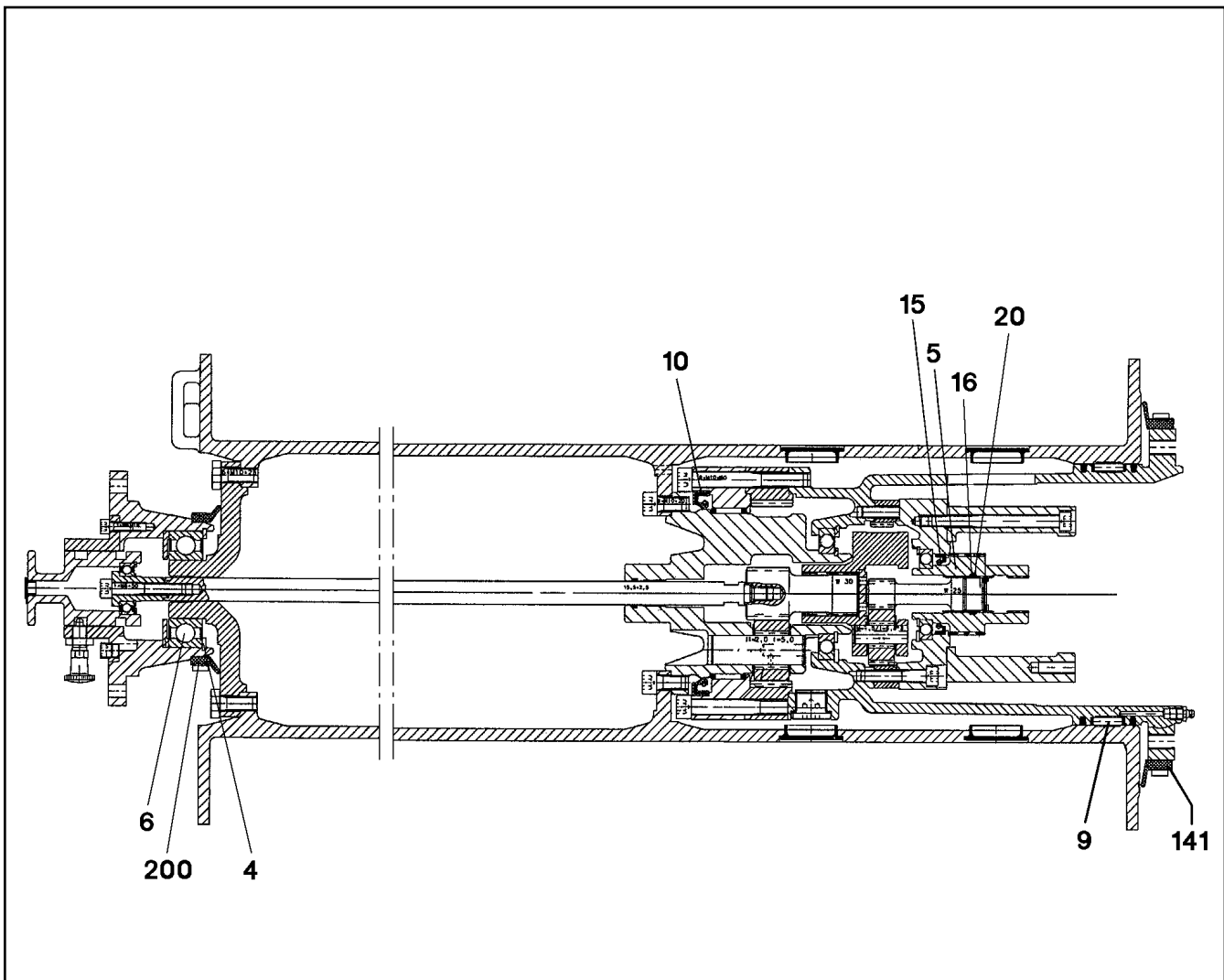

Pos.	Item	Quantity	Description	Bezeichnung	Serie	K
4	42 81 025 08	1	LOCKING RING DIN 472 80X2,5	SICHERUNGSRING		
5	57 17 272 08	1	DRIVE SLEEVE	ANTRIEBSHUELSE		
6	57 17 273 08	1	DEEP GROOVE BALL BEARING	RILLENKUGELLAGER		
9	50 15 271 08	1	FLAT CAGE BEARING	FLACHKAEFIG		
10	71 00 312 08	1	ROTARY SHAFT LIP SEAL DIN 3760 A 115X1	RADIALWELLENDICHTRING		
15	57 01 519 08	1	ROTARY SHAFT LIP SEAL DIN 3760 A 40X5	RADIALWELLENDICHTRING		
16	54 01 843 08	1	O-RING 22,2X3 NBR70	O-RING		
20	54 01 844 08	1	SPIRAL BACK-UP RING	SPIRALBACKRING		
141	54 01 323 08	1	SEALING RUBBER	ABDICHTGUMMI		
200	54 01 323 08	1	SEALING RUBBER	ABDICHTGUMMI		

6.2.2009
025688

LIEBHERR

etk_en_de_074515 LR 1600/2

ROPE WINCH
SEILWINDE

634

⇒ 5 400 565 08
54 00 565 08

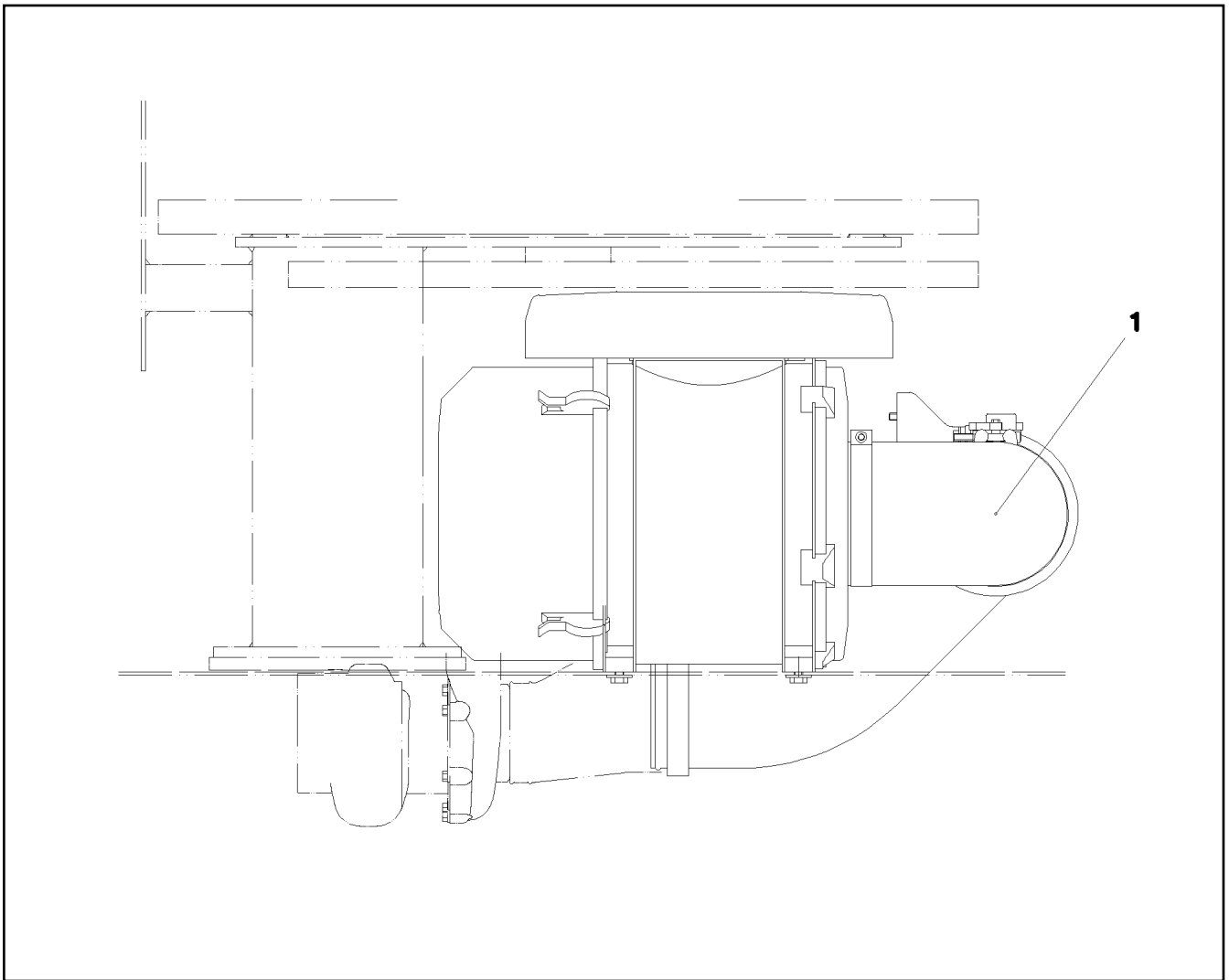

Pos.	Item	Quantity	Description	Bezeichnung	Serie	K
1	57 17 556 08	1	FILTER INSERT	FILTEREINSATZ		
2	10 27 991 9	1	POT	TOPF		

6.2.2009
024676

LIEBHERR

etk_en_de_074515 LR 1600/2

AIR FILTER
LUFTFILTER

635

⇒ 5 517 203 08
55 17 203 08

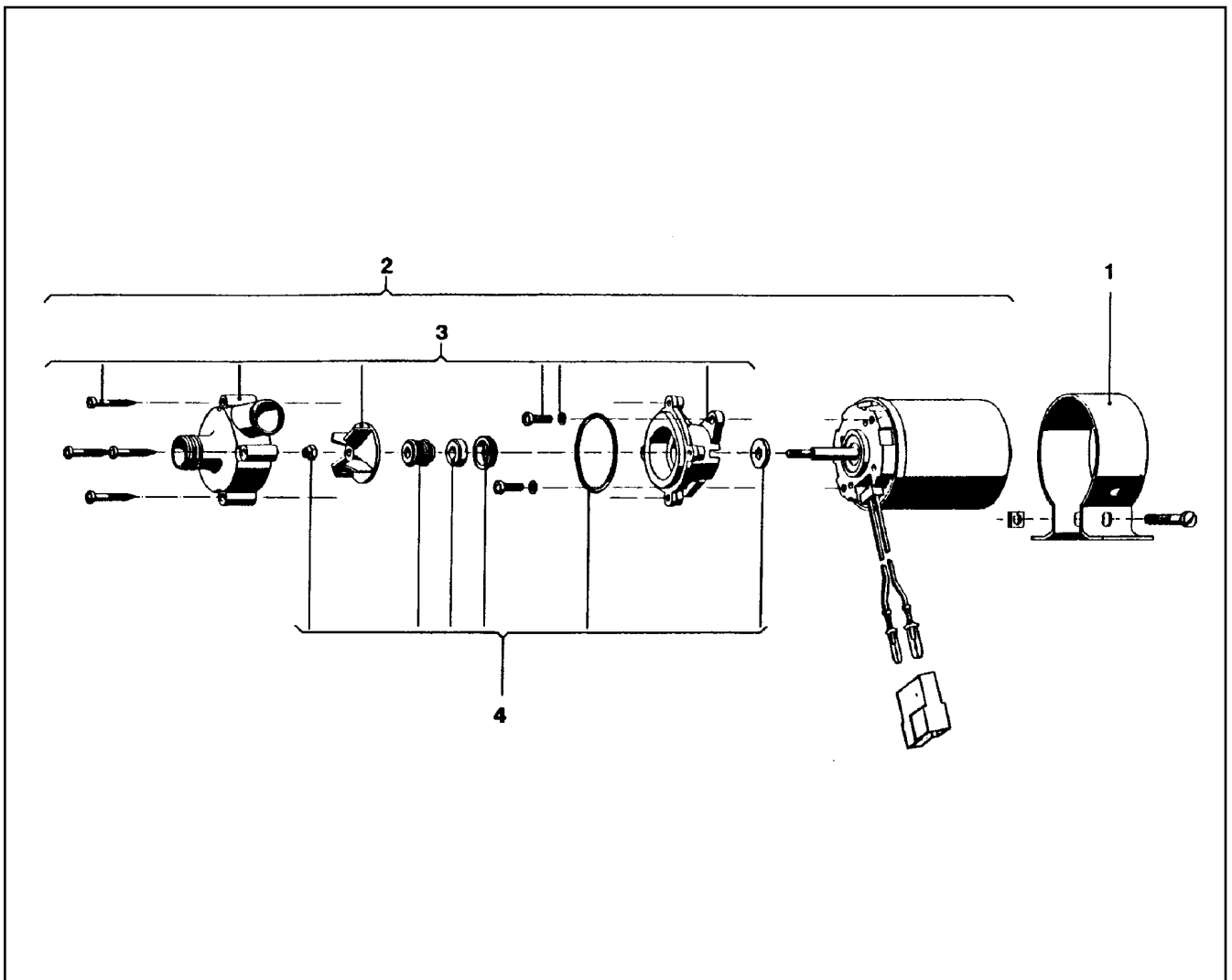

Pos.	Item	Quantity	Description	Bezeichnung	Serie	K
1	55 31 352 08	1	FASTENING CLAMP	BEFESTIGUNGSSHELLE		
2	55 31 353 08	1	CIRCULATING PUMP	UMWÄELZPUMPE		
3	55 31 354 08	1	SET OF BRUSHES	TEILESATZ		
4	55 31 355 08	1	SEAL KIT	DICHTSATZ		

6.2.2009
040668

LIEBHERR

etk_en_de_074515 LR 1600/2

CIRCULATING PUMP
UMWÄELZPUMPE

636

⇒ 5 530 545 08
55 30 545 08

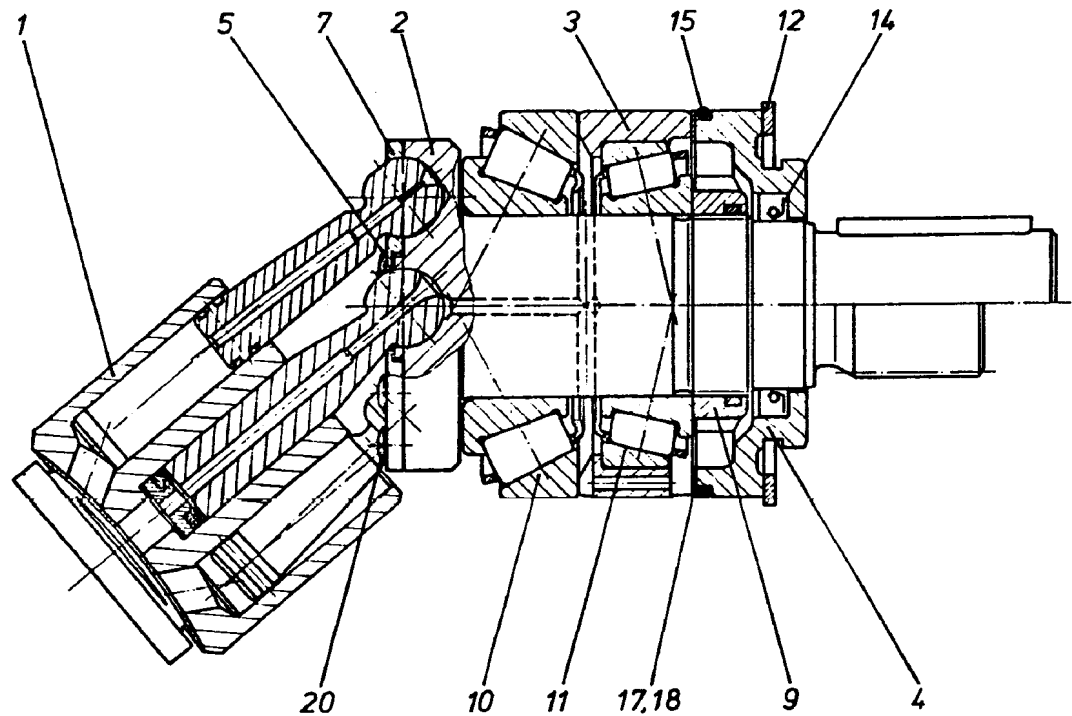

Pos.	Item	Quantity	Description	Bezeichnung	Serie	K
1	57 01 133 08	1	DRIVING GEAR ⇒ 5 701 133 08 57 01 133 08	TRIEBWERK		
2	57 01 134 08	1	DRIVING SHAFT	TRIEBWELLE		
3	57 01 135 08	1	BEARING RING	LAGERRING		
4	57 01 136 08	1	CLOSING RING	VERSCHLUSSRING		
5	57 01 137 08	1	WASHER	SCHEIBE		
7	57 01 138 08	1	PULL-BACK PLATE	RUECKZUGPLATTE		
9	57 01 139 08	1	SLOTTED NUT M30X1,5	NUTMUTTER		
10	57 01 140 08	1	TAPERED ROLLER BEARING	KEGELROLLENLAGER		
11	74 62 216 08	1	TAPERED ROLLER BEARING DIN 720 32006	KEGELROLLENLAGER		
12	42 81 022 08	1	LOCKING RING DIN 472 70X2,5	SICHERUNGSRING		
14	57 01 141 08	1	SHAFT SEAL 28X40X6 NBR	WELLENDICHTRING		
15	51 57 051 08	1	O-RING ARP 568 64,77X2,62 NBR70	O-RING		
17	57 01 142 08	2	SHIM RING 58X70X0,1	PASSSCHEIBE		
18	57 01 143 08	1	SHIM RING 58X70X0,3	PASSSCHEIBE		
20	51 45 994 08	7	PAN-HEAD SCREW DIN 7985 M3X8 8.8 A2C	FLACHKOPFSCHRAUBE		

6.2.2009
100571

LIEBHERR

etk_en_de_074515 LR 1600/2

DRIVING GEAR
TRIEBWERK

637

⇒ 5 701 129 08
57 01 129 08

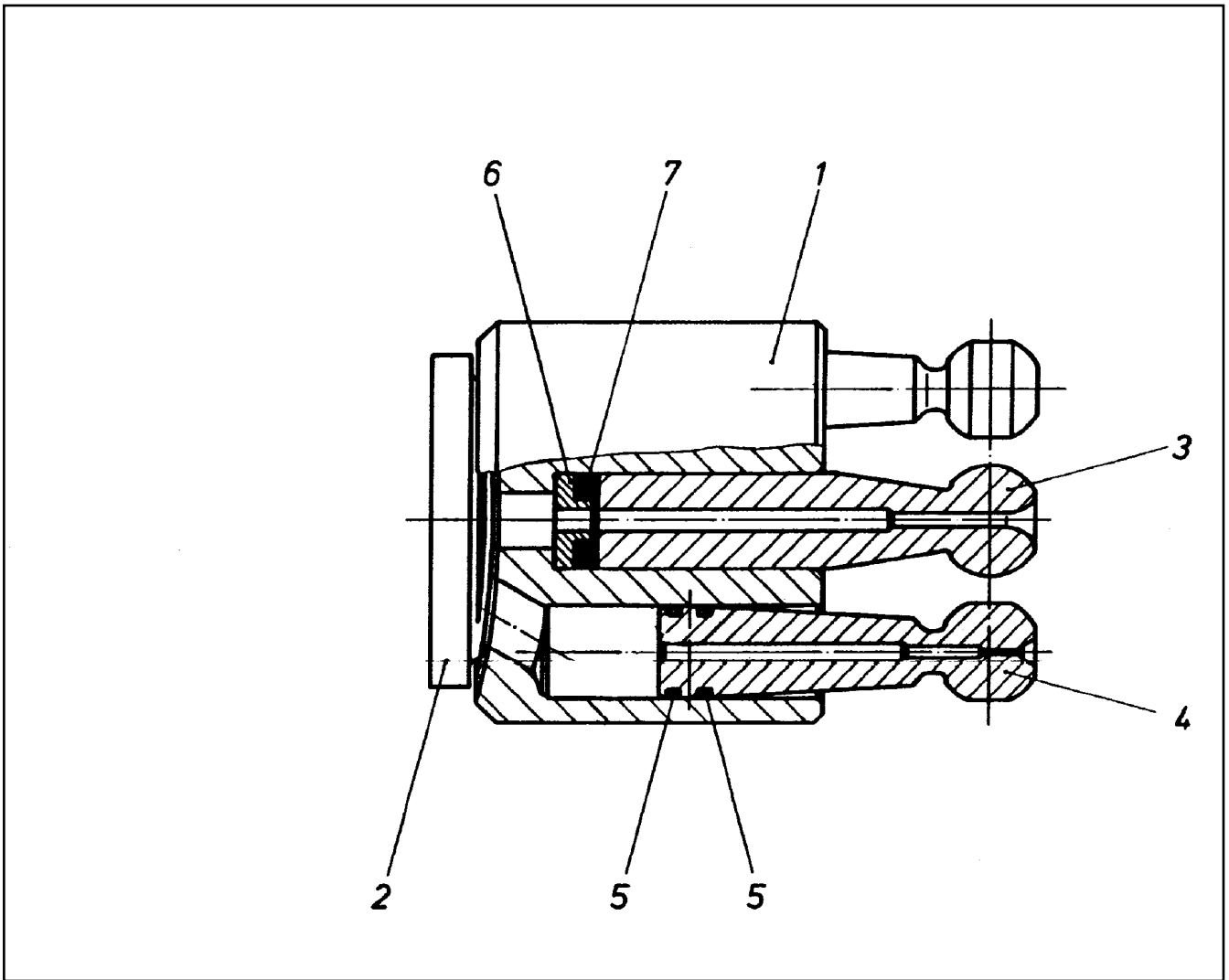

Pos.	Item	Quantity	Description	Bezeichnung	Serie	K
1	57 01 144 08	1	CYLINDER	ZYLINDER		
2	57 01 145 08	1	GUIDE PLATE	STEUERPLATTE		
3	57 01 146 08	1	CENTER STUD	MITTELZAPFEN		
4	57 01 147 08	7	PISTON	KOLBEN		
5	57 01 148 08	14	RING	RING		
6	57 01 149 08	1	SPRING CUP	FEDERTELLER		
7	57 01 150 08	4	DISC SPRING	TELLERFEDER		

6.2.2009
100572

LIEBHERR

etk_en_de_074515 LR 1600/2

DRIVING GEAR
TRIEBWERK

638

⇒ 5 701 133 08
57 01 133 08

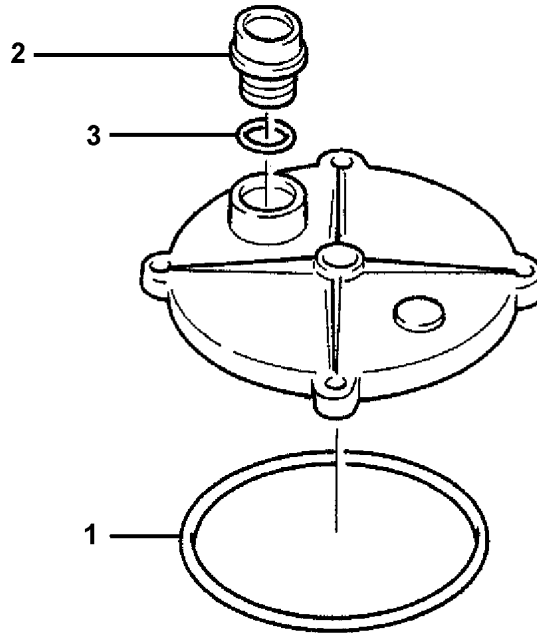

Pos.	Item	Quantity	Description	Bezeichnung	Serie	K
1	57 05 883 08	1	O-RING ARP 568 170,82X7 NBR70	O-RING		
2	51 06 623 08	1	SCREW CAP	SCHRAUBKAPPE		
3	57 05 889 08	1	O-RING 39,7X3,5 NBR70	O-RING		

6.2.2009
044633

LIEBHERR

etk_en_de_074515 LR 1600/2

FILTER COVER
FILTERDECKEL

639

⇒ 5 708 320 08
57 08 320 08

Pos.	Item	Quantity	Description	Bezeichnung	Serie	K
1	57 08 179 08	2	MAGNET COIL 28V DC	MAGNETSPULE		
(1)	57 14 553 08	1	NUT	RAENDELMUTTER		
999	57 10 356 08	1	SEAL KIT	DICHTSATZ		

6.2.2009

etk_en_de_074515 LR 1600/2

640

LIEBHERR

DIRECTIONAL CONTROL VALVE
WEGEVENTIL

⇒ 5 710 349 08
57 10 349 08

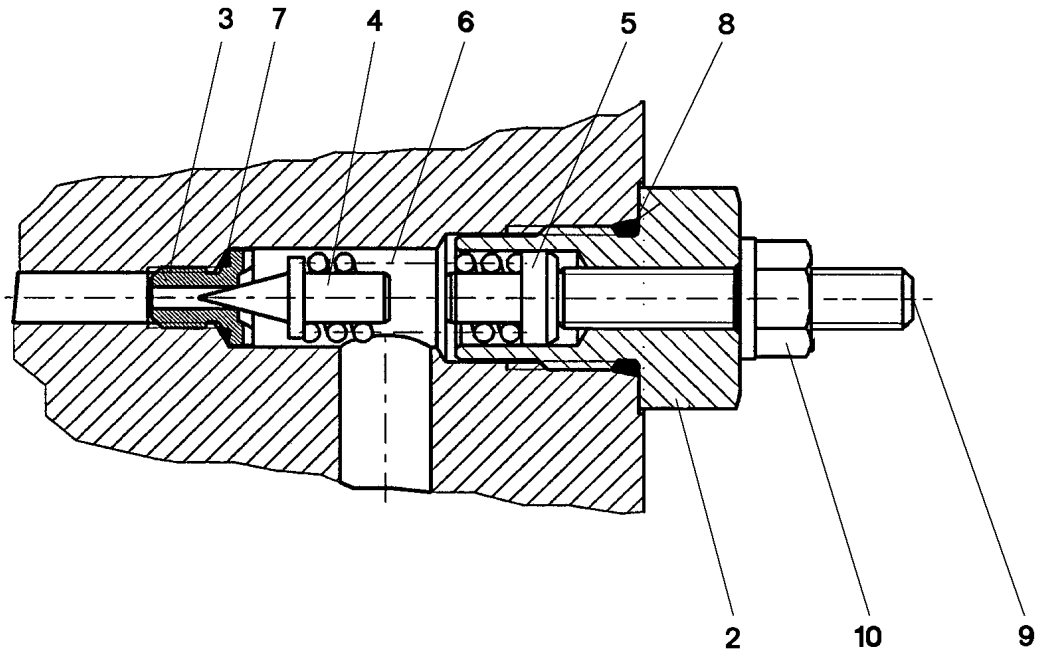

Pos.	Item	Quantity	Description	Bezeichnung	Serie	K
2	57 11 303 08	1	SLEEVE	HUELSE		
3	57 06 475 08	1	VALVE SEAT	VENTILSITZ		
4	51 07 921 08	1	TAPER	KEGEL		
5	57 11 304 08	1	SPACER PIECE	DISTANZSTUECK		
6	51 07 359 08	1	PRESSURE SPRING 1,9X6,9X21,5	DRUCKFEDER		
7	57 06 906 08	1	O-RING 6X1 NBR90	O-RING		
8	57 11 305 08	1	O-RING ARP 568 11,89X1,98 N903890SHOR	O-RING		
9	51 07 533 08	1	GRUB SCREW DIN 913 M6X35 45 H	GEWINDESTIFT		
10	51 07 534 08	1	SEALING NUT M6	DICHTMUTTER		

6.2.2009
137725

LIEBHERR

etk_en_de_074515 LR 1600/2

PRESSURE LIMITING VALVE
DRUCKBEGRENZUNGSVENTIL

641

⇒ 5 711 301 08
57 11 301 08

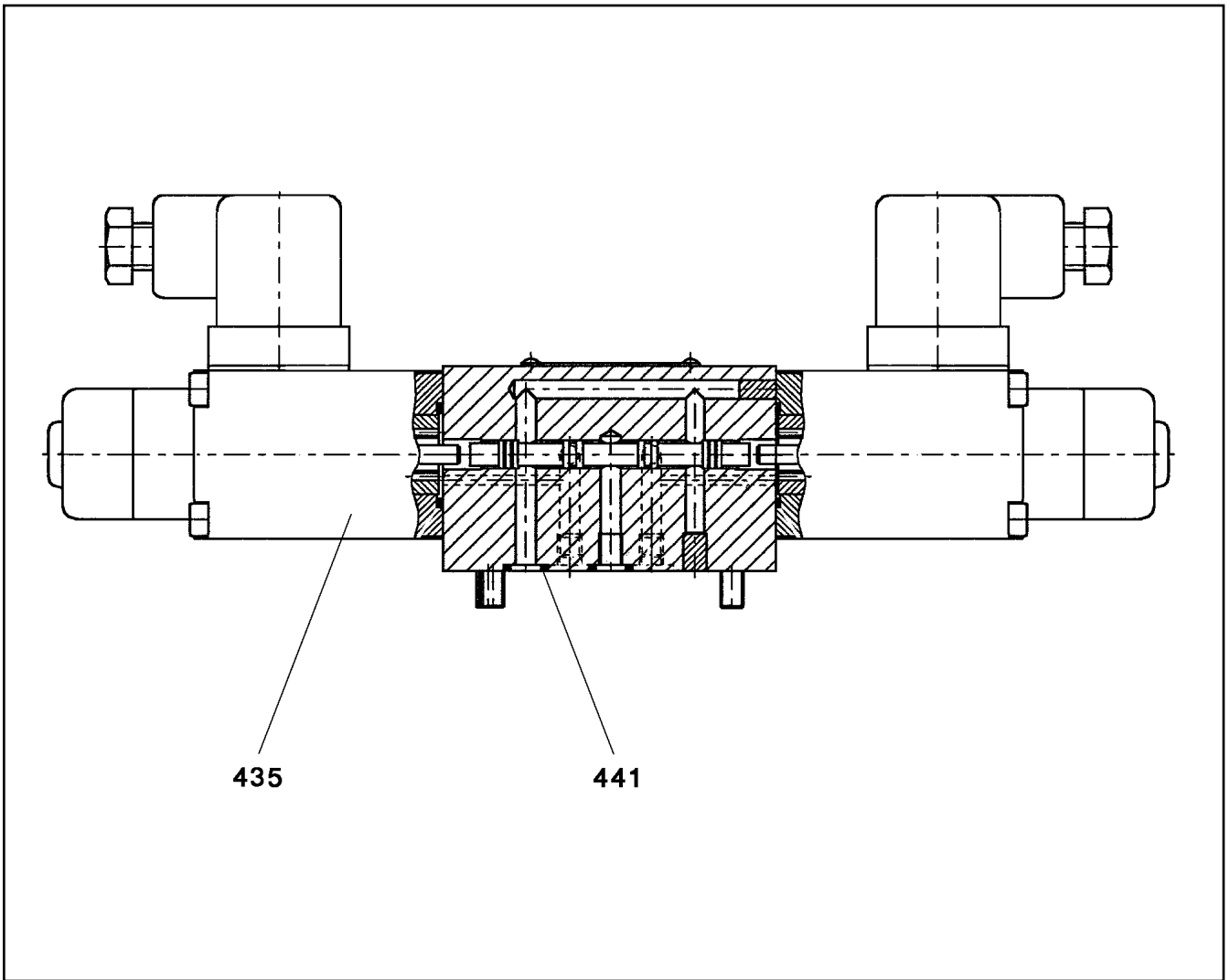

Pos.	Item	Quantity	Description	Bezeichnung	Serie	K
435	57 19 101 08	2	MAGNET COIL	MAGNETSPULE		
441	51 07 384 08	4	O-RING ARP 568 6,07X1,78 NBR90	O-RING		

6.2.2009
137486

LIEBHERR

etk_en_de_074515 LR 1600/2

PILOT VALVE
VORSTEUERVENTIL

□ 642

⇒ 5 713 626 08
57 13 626 08

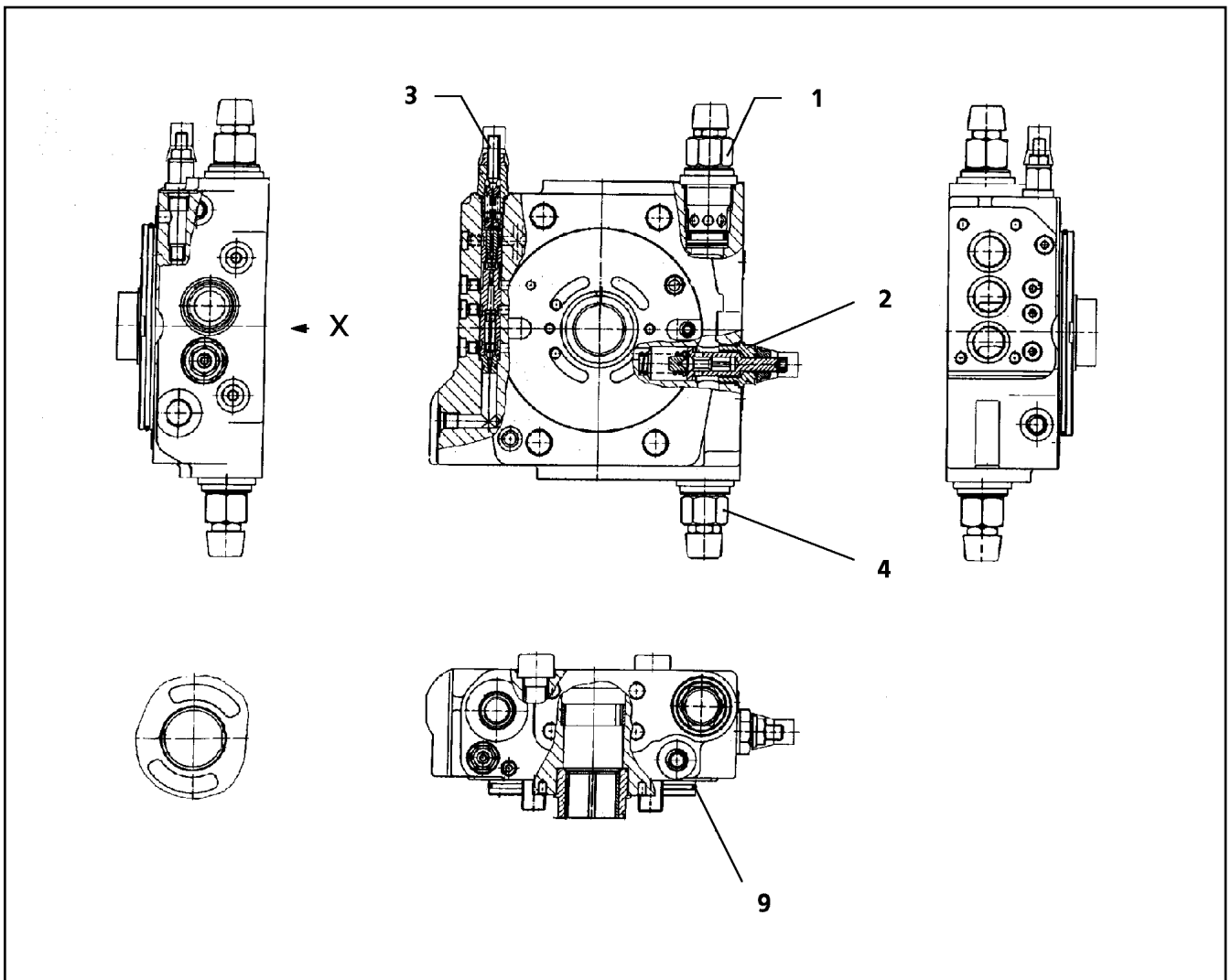

Pos.	Item	Quantity	Description	Bezeichnung	Serie	K
1	57 15 145 08	1	PRESSURE LIMITING VALVE	DRUCKBEGRENZUNGSVENTIL		
2	57 12 395 08	1	PRESSURE LIMITING VALVE	DRUCKBEGRENZUNGSVENTIL		
3	57 15 146 08	1	SHUTDOWN VALVE	ABSCHALTVENTIL		
4	57 15 147 08	1	PRESSURE LIMITING VALVE	DRUCKBEGRENZUNGSVENTIL		
9	57 07 108 08	1	O-RING ARP 568 133,02X2,62 NBR90	O-RING		
26	51 45 915 08	2	O-RING ARP 568 12,42X1,78 NBR90	O-RING		

6.2.2009
137447

LIEBHERR

etk_en_de_074515 LR 1600/2

TERMINAL BOARD
ANSCHLUSSPLATTE

643

⇒ 5 715 142 08
57 15 142 08

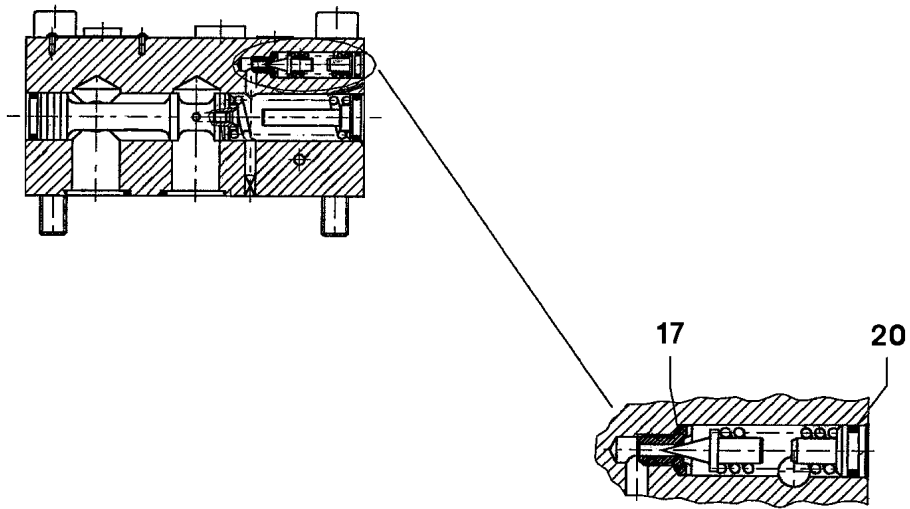

Pos.	Item	Quantity	Description	Bezeichnung	Serie	K
17	57 06 906 08	1	O-RING 6X1 NBR90	O-RING		
20	72 64 196 08	1	O-RING ARP 568 6,07X1,78 NBR70	O-RING		

6.2.2009
021996

LIEBHERR

etk_en_de_074515 LR 1600/2

PRESSURE VALVE
DRUCKVENTIL

644

⇒ 5 715 296 08
57 15 296 08

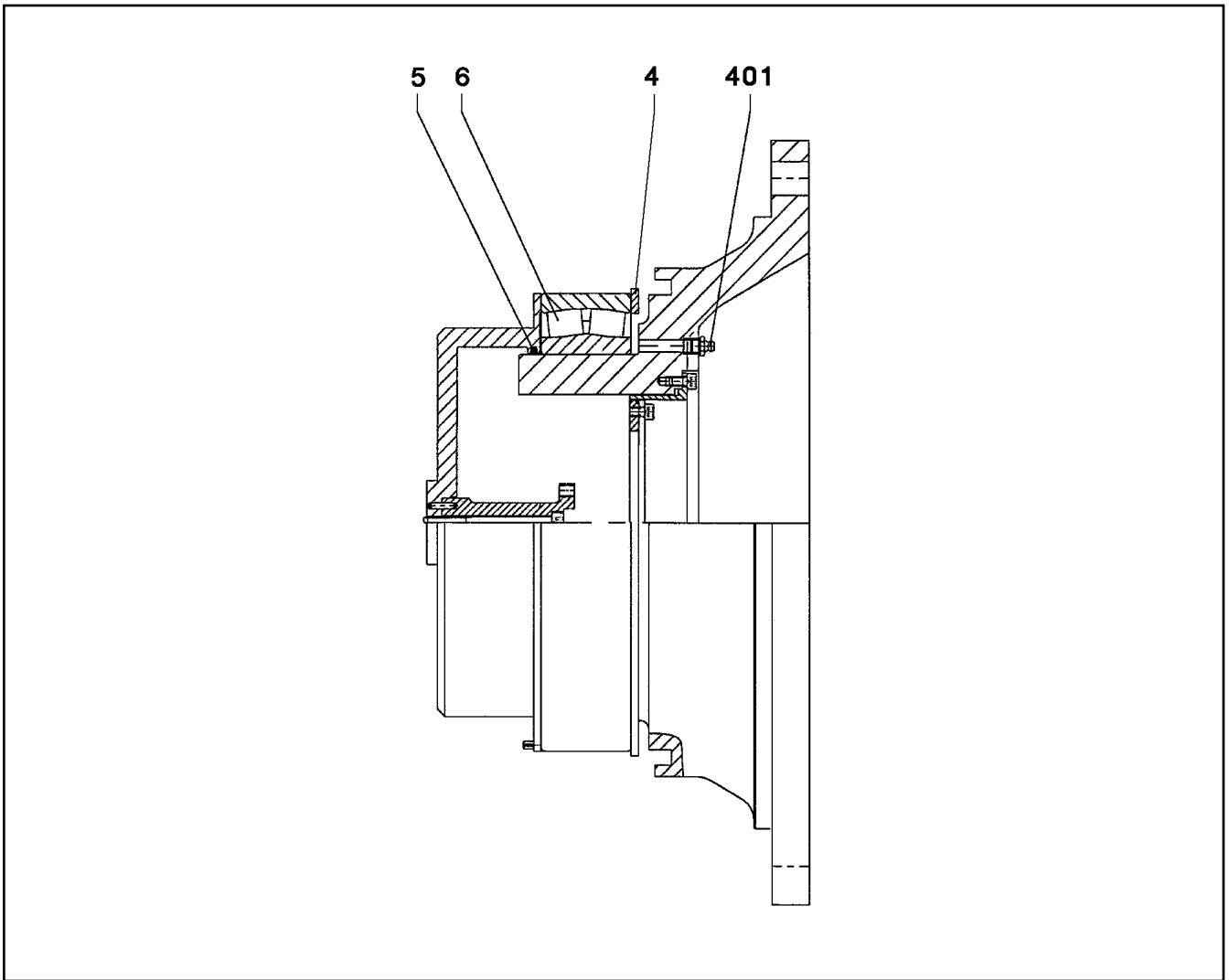

Pos.	Item	Quantity	Description	Bezeichnung	Serie	K
4	50 15 497 08	1	LOCKING RING DIN 472 300X5	SICHERUNGSRING		
5	26 11 007 08	1	FELT STRIP DIN 5419 5X4	FILZSTREIFEN		
6	74 61 600 08	1	PENDULUM ROLLER BEARING DIN 635 2394	PENDELROLLENLAGER		
401	77 43 040 08	1	GREASE NIPPLE DIN 71412 A M10X1	SCHMIERNIPPEL		

6.2.2009
022996

LIEBHERR

etk_en_de_074515 LR 1600/2

FLANGE
FLANSCH

645

⇒ 5 718 420 08
57 18 420 08

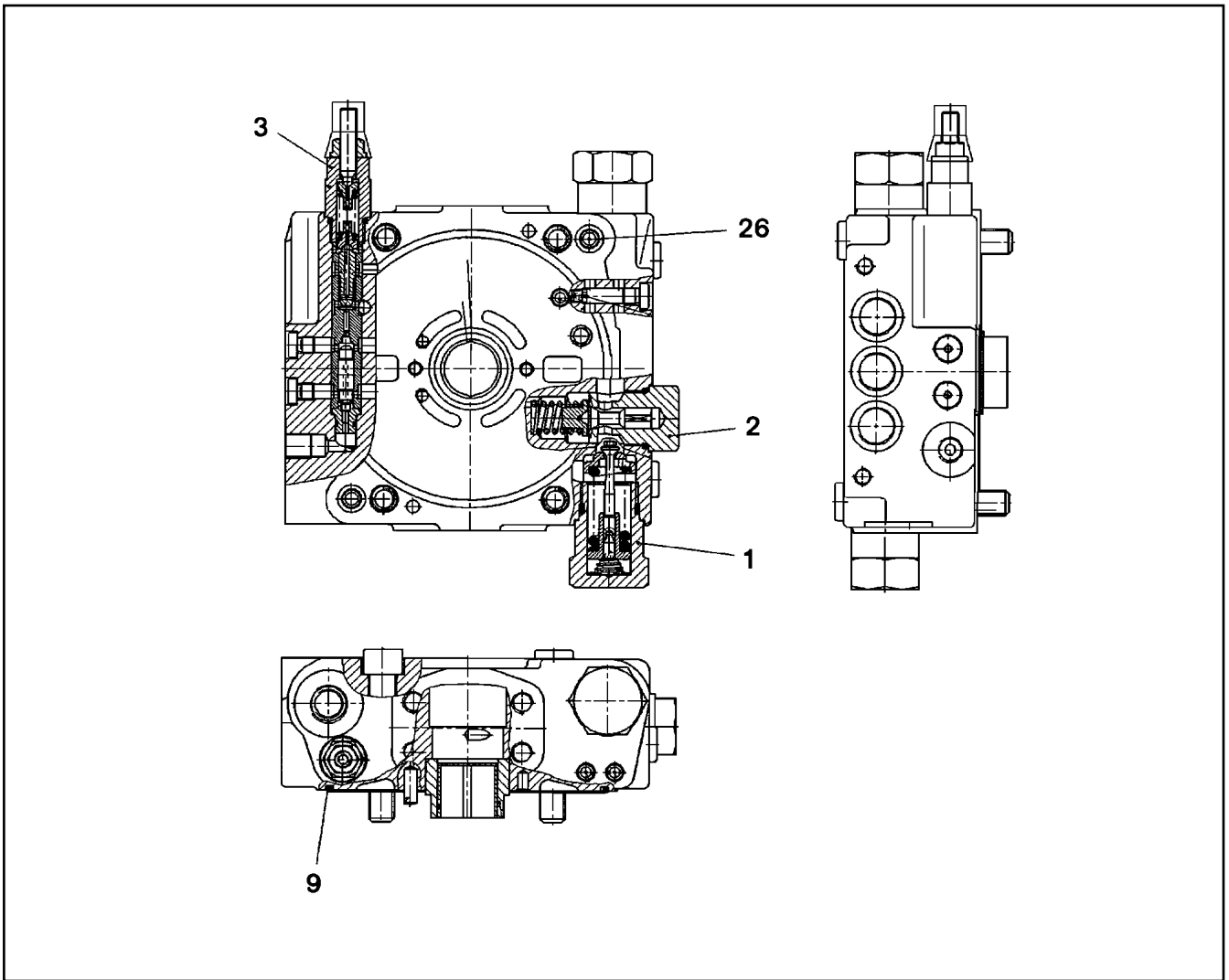

Pos.	Item	Quantity	Description	Bezeichnung	Serie	K
1	57 18 994 08	2	PRESSURE LIMITING VALVE	DRUCKBEGRENZUNGSVENTIL		
2	57 12 325 08	1	PRESSURE LIMITING VALVE	DRUCKBEGRENZUNGSVENTIL		
3	57 18 995 08	1	SHUTDOWN VALVE	ABSCHALTVENTIL		
9	57 06 662 08	1	O-RING ARP 568 139,37X2,62 NBR70	O-RING		
26	51 07 386 08	2	O-RING ARP 568 9,25X1,78 NBR90	O-RING		

6.2.2009
027113

LIEBHERR

etk_en_de_074515 LR 1600/2

TERMINAL BOARD
ANSCHLUSSPLATTE

646

⇒ 5 718 989 08
57 18 989 08

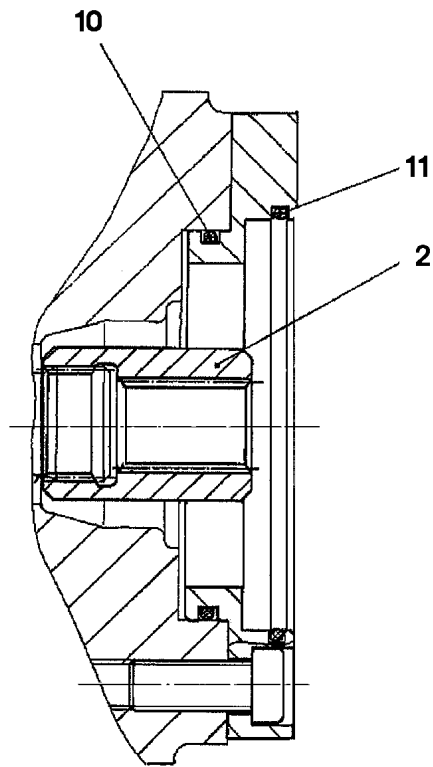

Pos.	Item	Quantity	Description	Bezeichnung	Serie	K
2	57 19 010 08	1	HUB	NABE		
10	51 45 304 08	1	O-RING ARP 568 75,87X2,62 NBR90	O-RING		
11	51 31 150 08	1	O-RING ARP 568 101,19X3,53 NBR90	O-RING		

6.2.2009
026196

LIEBHERR

etk_en_de_074515 LR 1600/2

PUMP SUPPORT
PUMPENTRAEGER

647

⇒ 5 719 006 08
57 19 006 08

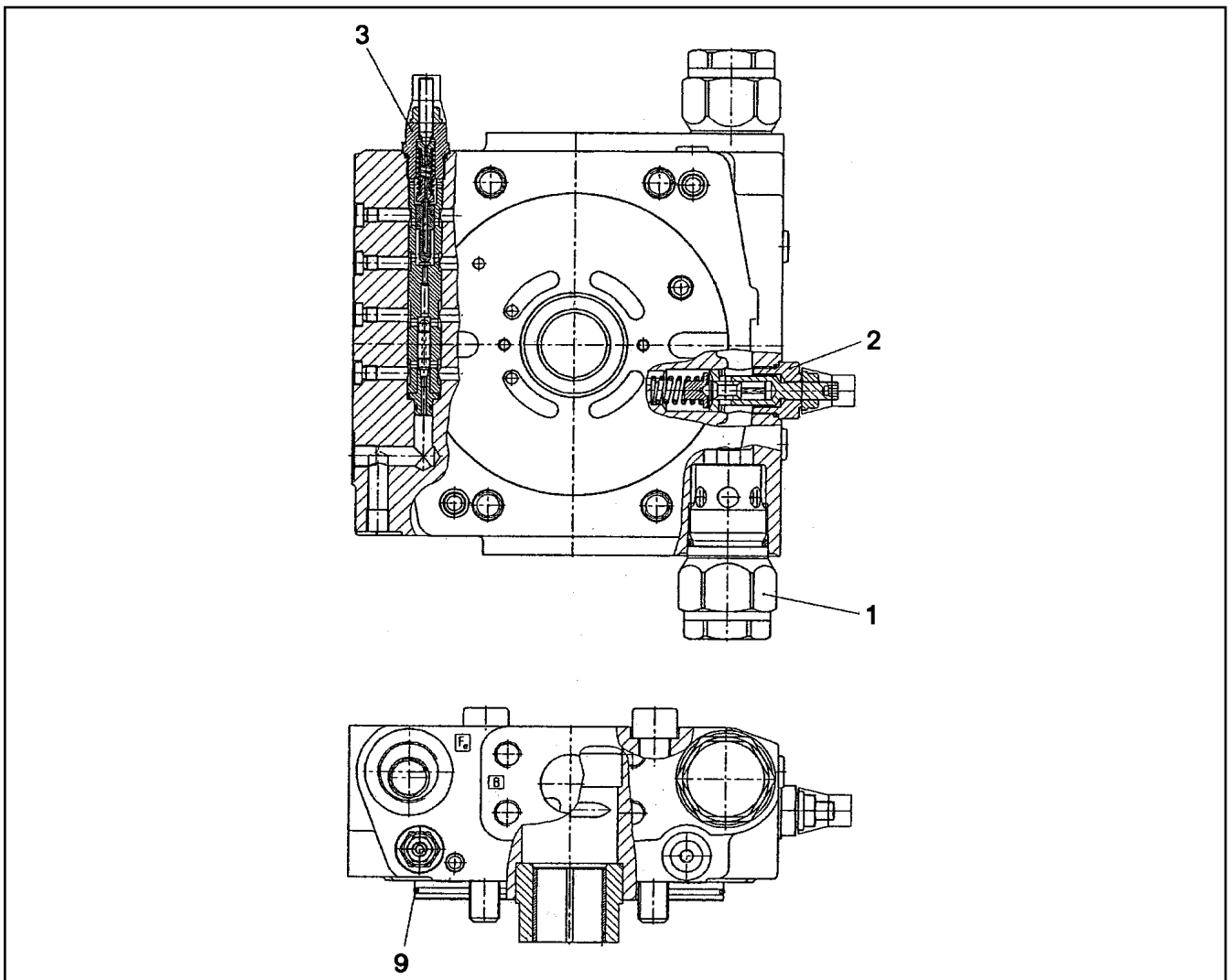

Pos.	Item	Quantity	Description	Bezeichnung	Serie	K
1	57 19 033 08	2	PRESSURE LIMITING VALVE	DRUCKBEGRENZUNGSVENTIL		
2	57 12 395 08	1	PRESSURE LIMITING VALVE	DRUCKBEGRENZUNGSVENTIL		
9	57 12 398 08	1	O-RING ARP 568 158,42X2,62 NBR90	O-RING		

6.2.2009
029700

LIEBHERR

etk_en_de_074515 LR 1600/2

TERMINAL BOARD
ANSCHLUSSPLATTE

648

⇒ 5 719 030 08
57 19 030 08

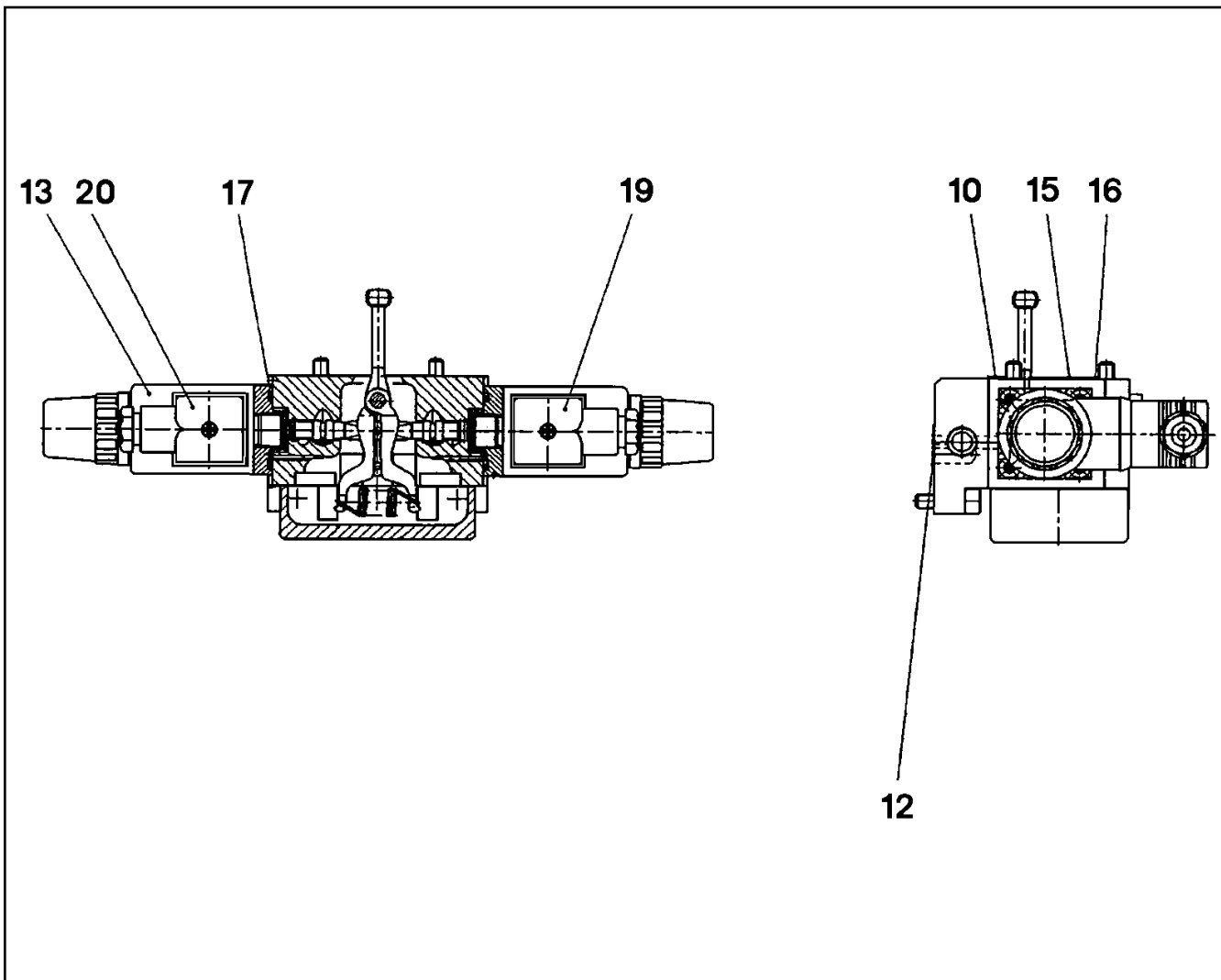

Pos.	Item	Quantity	Description	Bezeichnung	Serie	K
10	51 07 478 08	1	O-RING ARP 568 29,87X1,78 NBR90	O-RING		
12	51 07 181 08	3	O-RING ARP 568 10,82X1,78 NBR75	O-RING		
13	57 19 117 08	2	PROPORTIONAL MAGNET 24V	PROPORTIONALMAGNET		
15	51 45 915 08	2	O-RING ARP 568 12,42X1,78 NBR90	O-RING		
16	51 07 384 08	1	O-RING ARP 568 6,07X1,78 NBR90	O-RING		
17	57 00 488 08	2	O-RING ARP 568 26,64X2,62 NBR90	O-RING		
19	51 45 948 08	1	SOCKET	STECKDOSE		
20	51 45 947 08	1	SOCKET	STECKDOSE		

6.2.2009
028121

LIEBHERR

etk_en_de_074515 LR 1600/2

CONTROL UNIT
ANSTEUERGERAET

649

⇒ 5 719 113 08
57 19 113 08

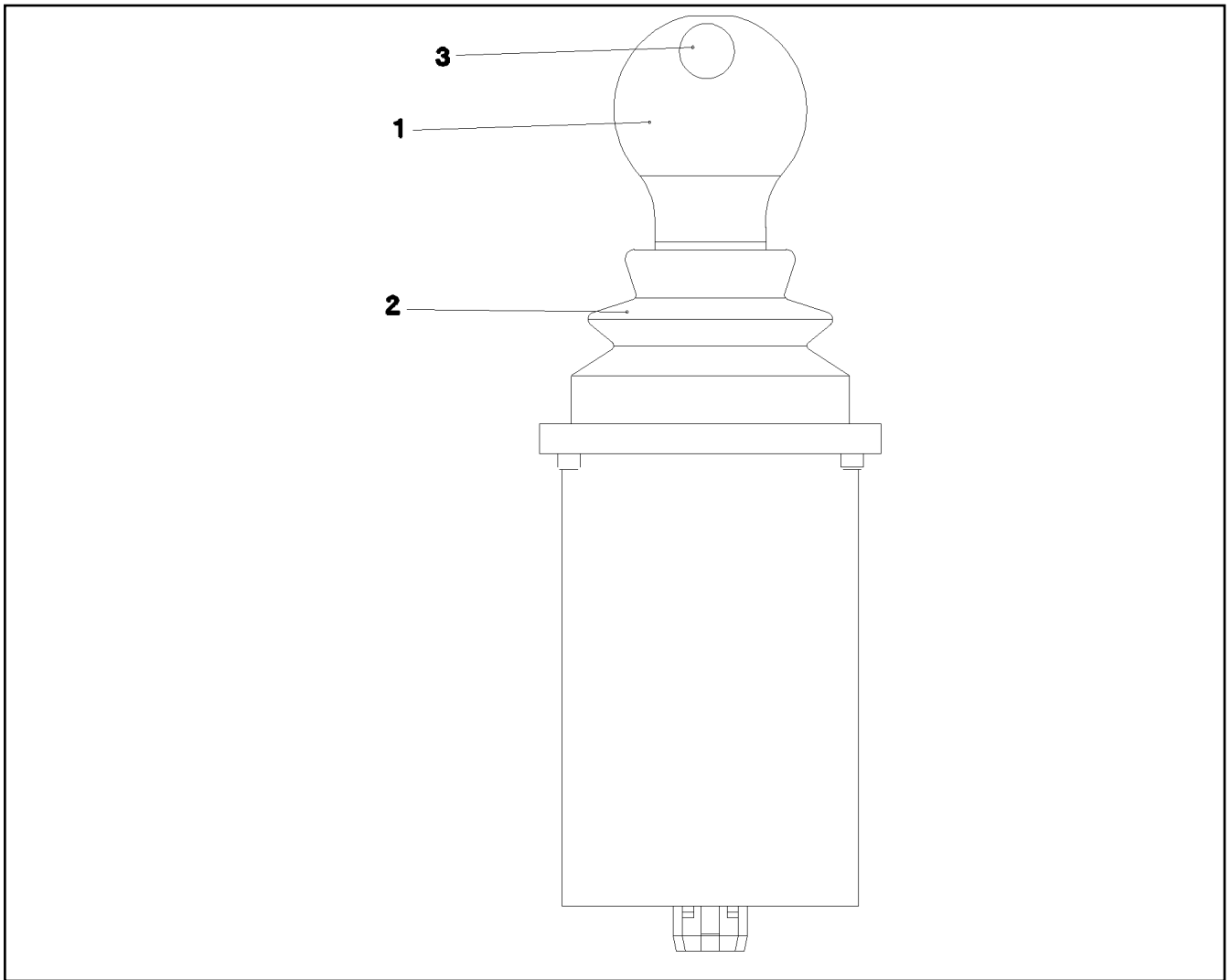

Pos.	Item	Quantity	Description	Bezeichnung	Serie	K
1	57 18 247 08	1	HANDLE CAP	GRIFFKAPPE		
2	57 19 123 08	1	RUBBER BELLOWS	FALTENBALG		
3	10 33 559 6	4	MICRO SWITCH	MIKROSCHALTER		

6.2.2009
023044

LIEBHERR

etk_en_de_074515 LR 1600/2

MASTER SWITCH
MEISTERSCHALTER

650

⇒ 6 060 950 08
60 60 950 08

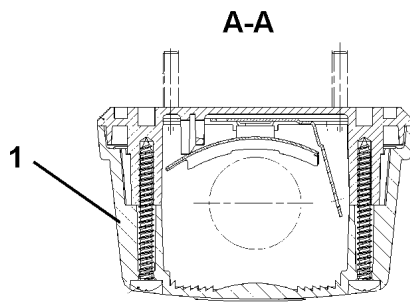
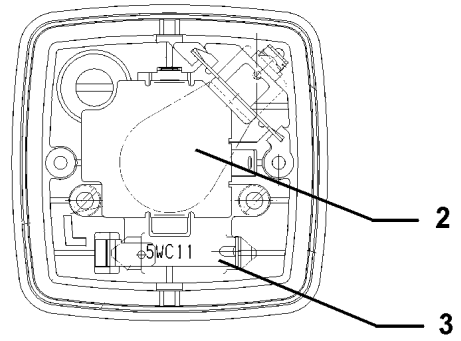
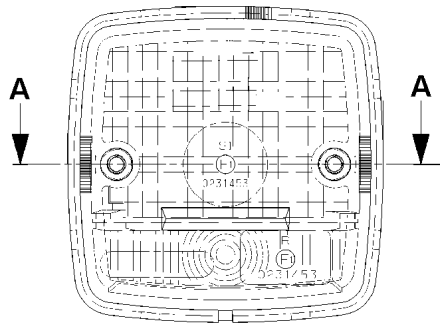

Pos.	Item	Quantity	Description	Bezeichnung	Serie	K
1	60 72 126 08	1	LENS	LICHTSCHEIBE		
2	60 70 217 08	1	LIGHT BULB DIN 72601 21W 24V	GLUEHLAMPE		
3	60 70 201 08	1	LIGHT BULB DIN 72601 5W 24V	GLUEHLAMPE		

6.2.2009
051899

LIEBHERR

etk_en_de_074515 LR 1600/2

TAIL BRAKE LIGHT
SCHLUSSBREMSLEUCHTE

651

⇒ 6 071 131 08
60 71 131 08

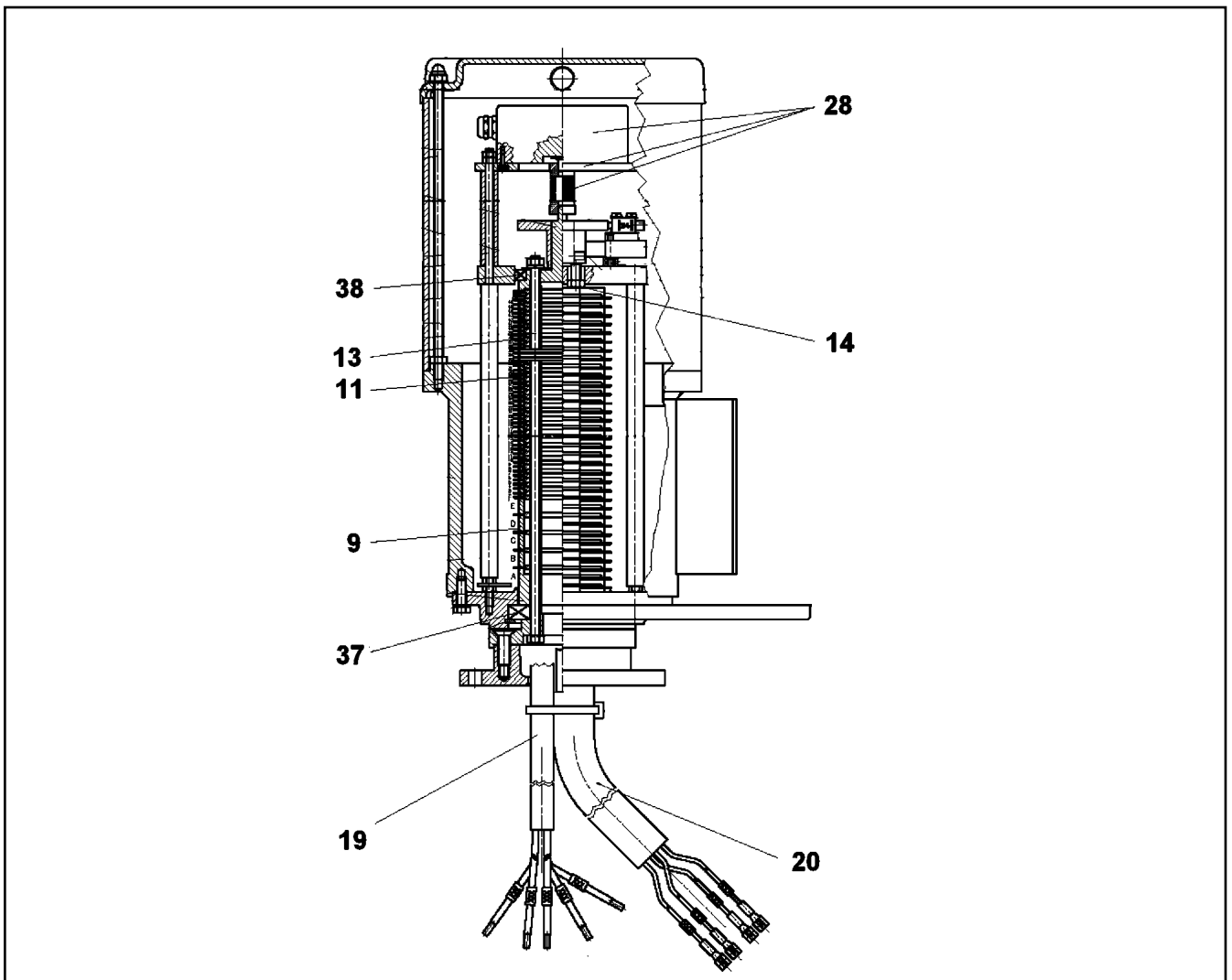

Pos.	Item	Quantity	Description	Bezeichnung	Serie	K
9	57 14 224 08	4	SLIP RING	SCHLEIFRING		
11	10 11 484 3	46	SLIP RING 60X2 2,5MM ²	SCHLEIFRING		
13	69 10 417 08	52	INSULATING RING	ISOLIERRING		
14	69 10 431 08	68	HOLDER	HALTER		
19	10 46 727 4	1	LEAD W75	LEITUNG		
20	10 46 727 5	1	LEAD W50	LEITUNG		
28	69 23 091 08	1	ROTARY ENCODER OPTISCH 360° SPF	DREHGEBER		
(60)	57 18 705 08	1	BELLOWS COUPLING	FALTENBALGKUPPLUNG		
37	54 05 073 08	1	DEEP GROOVE BALL BEARING DIN 625 16	RILLENKUGELLAGER		
38	10 11 483 8	1	DEEP GROOVE BALL BEARING 50X65X7	RILLENKUGELLAGER		

6.2.2009
049613

LIEBHERR

etk_en_de_074515 LR 1600/2

COLLECTING RING
SCHLEIFRINGUEBERTRAEGER

652

⇒ 6 909 010 08
69 09 010 08

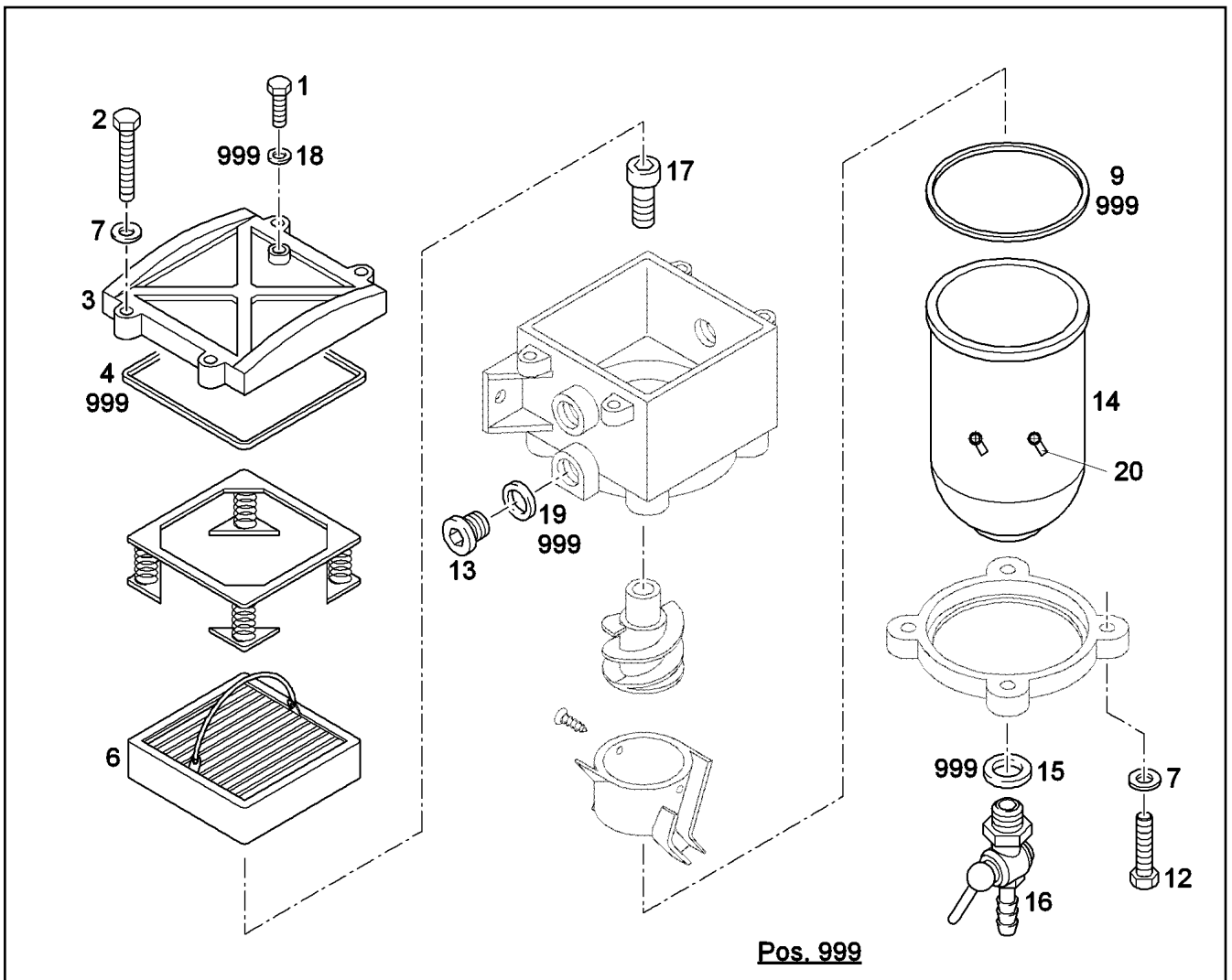

Pos.	Item	Quantity	Description	Bezeichnung	Serie	K
1	74 12 942	1	VENTILATION SCREW	ENTLUEFTUNGSSCHRAUBE		
2	46 00 102	4	HEX BOLT ISO 4017 M6X30 8.8 A2C	SECHSKANTSCHRAUBE		
3	70 27 755	1	LID GK-ALSI12CU	DECKEL		
4	10 29 417 1	1	LID SEAL HNBR	DECKELDICHUNG		
6	70 27 479	1	FILTER INSERT KRAFTSTOFF	FILTEREINSATZ		
7	42 00 009 08	8	WASHER ISO 7089 A 6.4 VERZ	SCHEIBE		
9	10 29 417 0	1	BOWLEN SEALING HNBR	BOWLENDICHUNG		
12	49 00 539	4	HEX BOLT ISO 4017 M6X25 8.8 A3C	SECHSKANTSCHRAUBE		
13	10 34 023 6	2	SCREW PLUG M22X1,5	VERSCHLUSSSCHRAUBE		
14	70 30 235	1	BOWL	BOWLE		
15	74 12 937	1	O-RING 12X2,5 HNBR	O-RING		
16	74 12 936	1	DRAIN TAP	ABLASSHAHN		
17	40 83 023 08	1	CYLINDER SCREW DIN 7984 M10X16 8.8 V	ZYLINDERSCHRAUBE		
18	51 45 080 08	1	USIT RING U 6,7X10X1	USIT-RING		
19	10 34 022 6	2	O-RING 19,4X2,5 HNBR	O-RING		
20	10 34 675 2	2	WATER SOUND WASSER	WASSERSONDE		
999	70 27 982	1	SEAL KIT HNBR70	DICHTSATZ		

6.2.2009
049197

LIEBHERR

etk_en_de_074515 LR 1600/2

WATER SEPARATOR
WASSERABSCHIEDER

653

⇒ 7 027 481 03
70 27 481 03

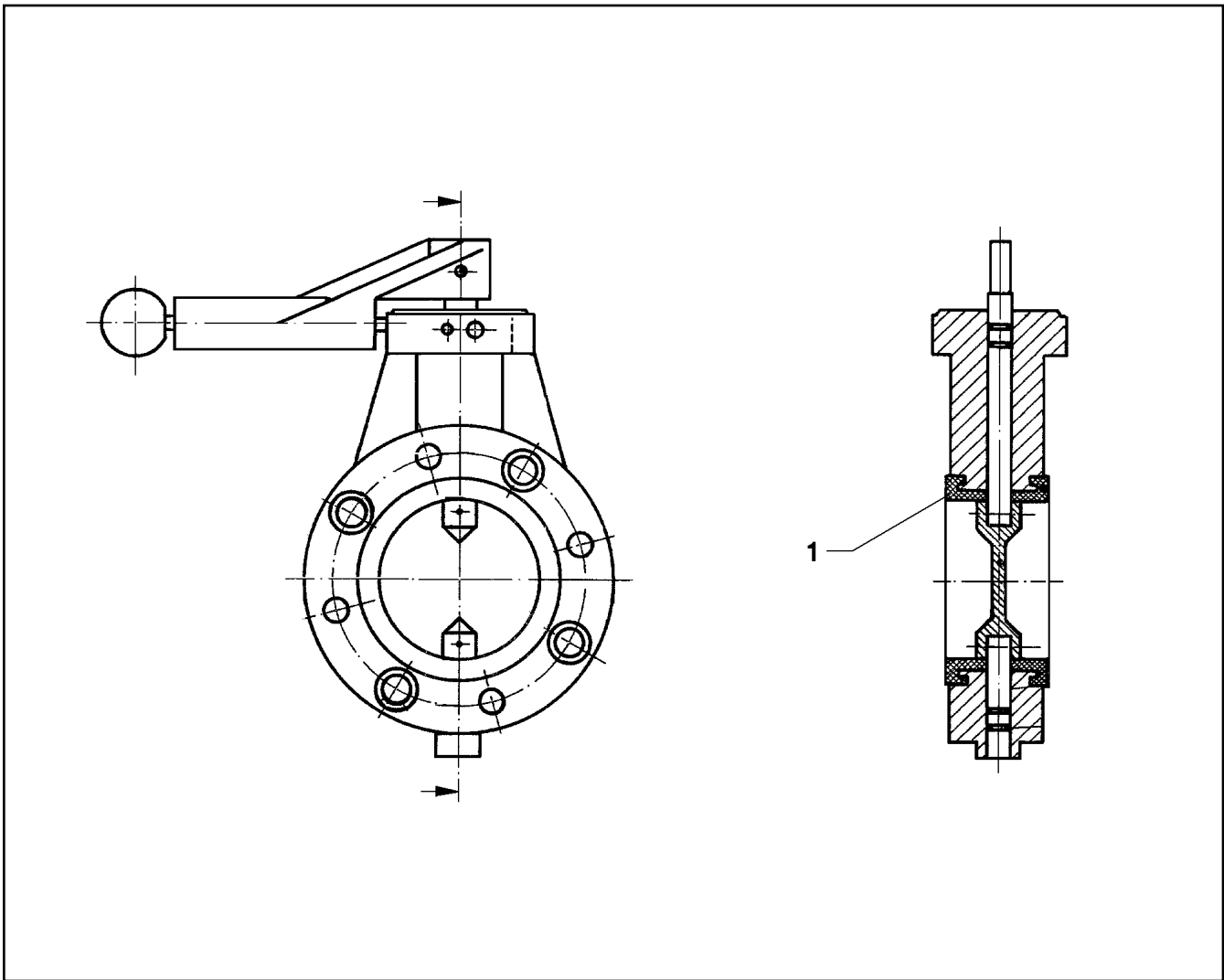

Pos.	Item	Quantity	Description	Bezeichnung	Serie	K
1	57 13 378 08	1	REPAIR KIT	REPARATURSATZ		

6.2.2009
023058

LIEBHERR

etk_en_de_074515 LR 1600/2

SHUT OFF DEVICE
ABSPERRORGAN

654

⇒ 7 300 043 08
73 00 043 08

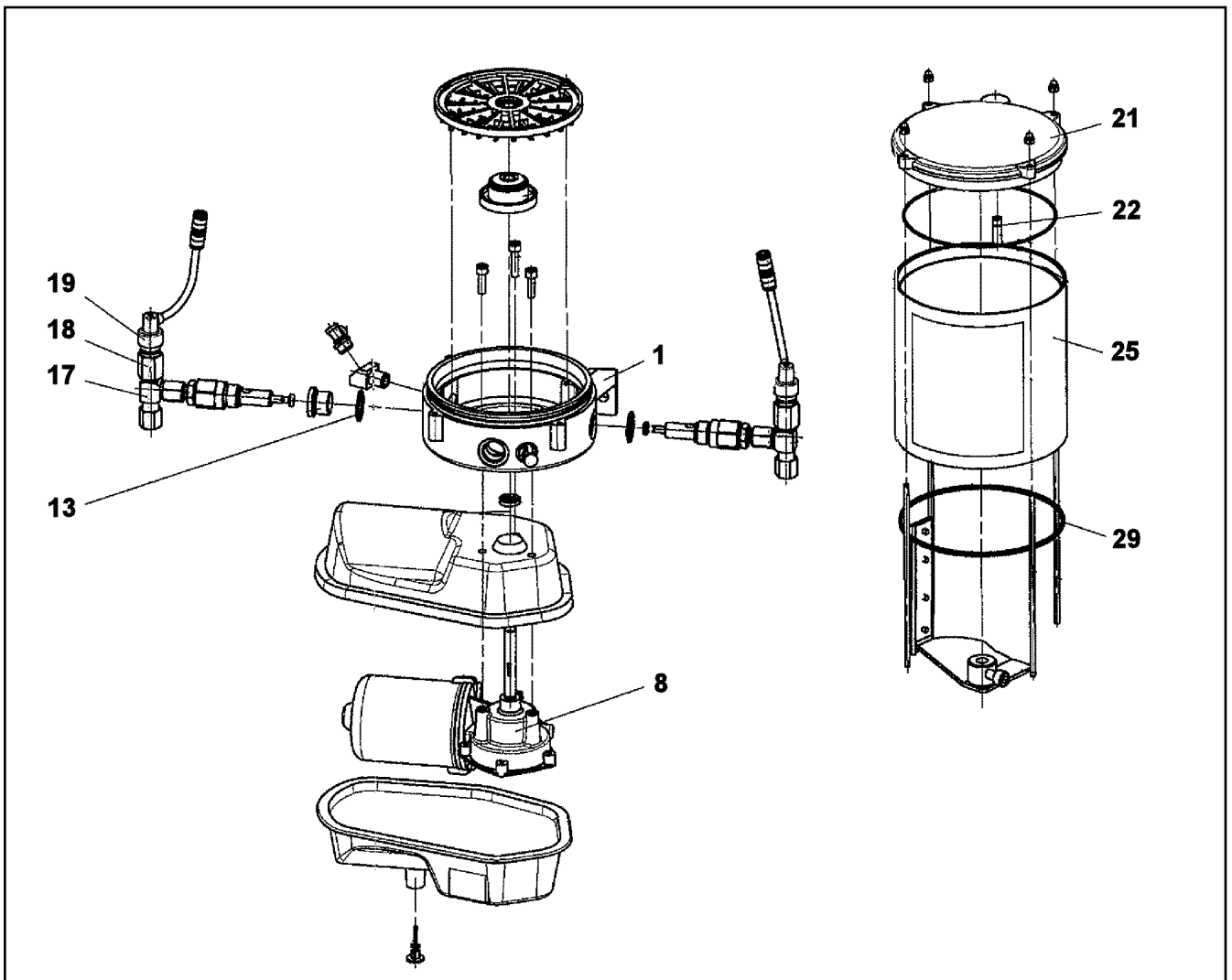

Pos.	Item	Quantity	Description	Bezeichnung	Serie	K
1	10 01 469 3	1	PUMP HOUSING	PUMPENGEHAEUSE		
8	10 01 469 1	1	DIRECT-CURRENT MOTOR 24V	GLEICHSTROMMOTOR		
13	71 01 044 08	3	SEALING RING DIN 7603 A 21X26X1,5 CU	DICHTRING		
17	10 03 827 2	2	PUMP ELEMENT	PUMPENELEMENT		
18	10 03 827 4	2	OVERPRESSURE VALVE 280BAR	UEBERDRUCKVENTIL		
19	10 42 995 2	2	FAULT INDICATOR	STOERANZEIGE		
21	10 40 981 7	1	CONTAINER COVER	BEHAELTERABDECKKAPPE		
22	57 06 906 08	1	O-RING 6X1 NBR90	O-RING		
25	10 03 827 1	1	CONTAINER 2,5 KG	BEHAELTER		
29	72 64 528 01	1	O-RING 135X3 NBR70	O-RING		

6.2.2009
049248

LIEBHERR

etk_en_de_074515 LR 1600/2

ELECTRIC PUMP
ELEKTROPUMPE

655

⇒ 7 743 566 08
77 43 566 08

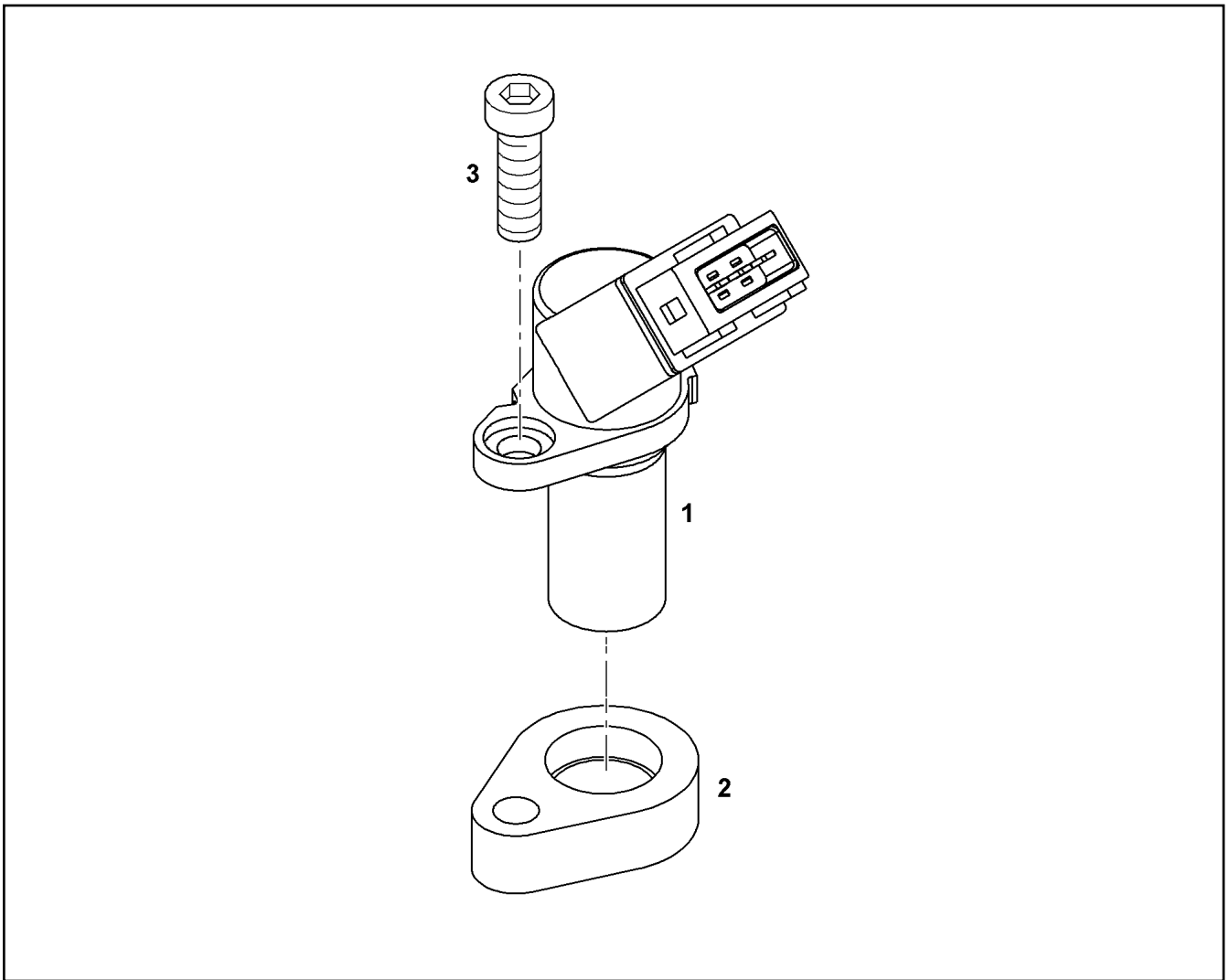

Pos.	Item	Quantity	Description	Bezeichnung	Serie	K
1	10 11 789 8	1	TACHOMETER HALL 0,3-16000HZ	DREHZAHLGEBER		
2	90 80 533	1	SPACER RING	DISTANZRING		
3	40 42 003	1	CYLINDER SCREW ISO 4762 M6X25 8.8 A2C	ZYLINDERSCHRAUBE		

6.2.2009
038650

LIEBHERR

etk_en_de_074515 LR 1600/2

TACHOMETER
DREHZAHLGEBER

656

⇒ 9 079 185
90 79 185

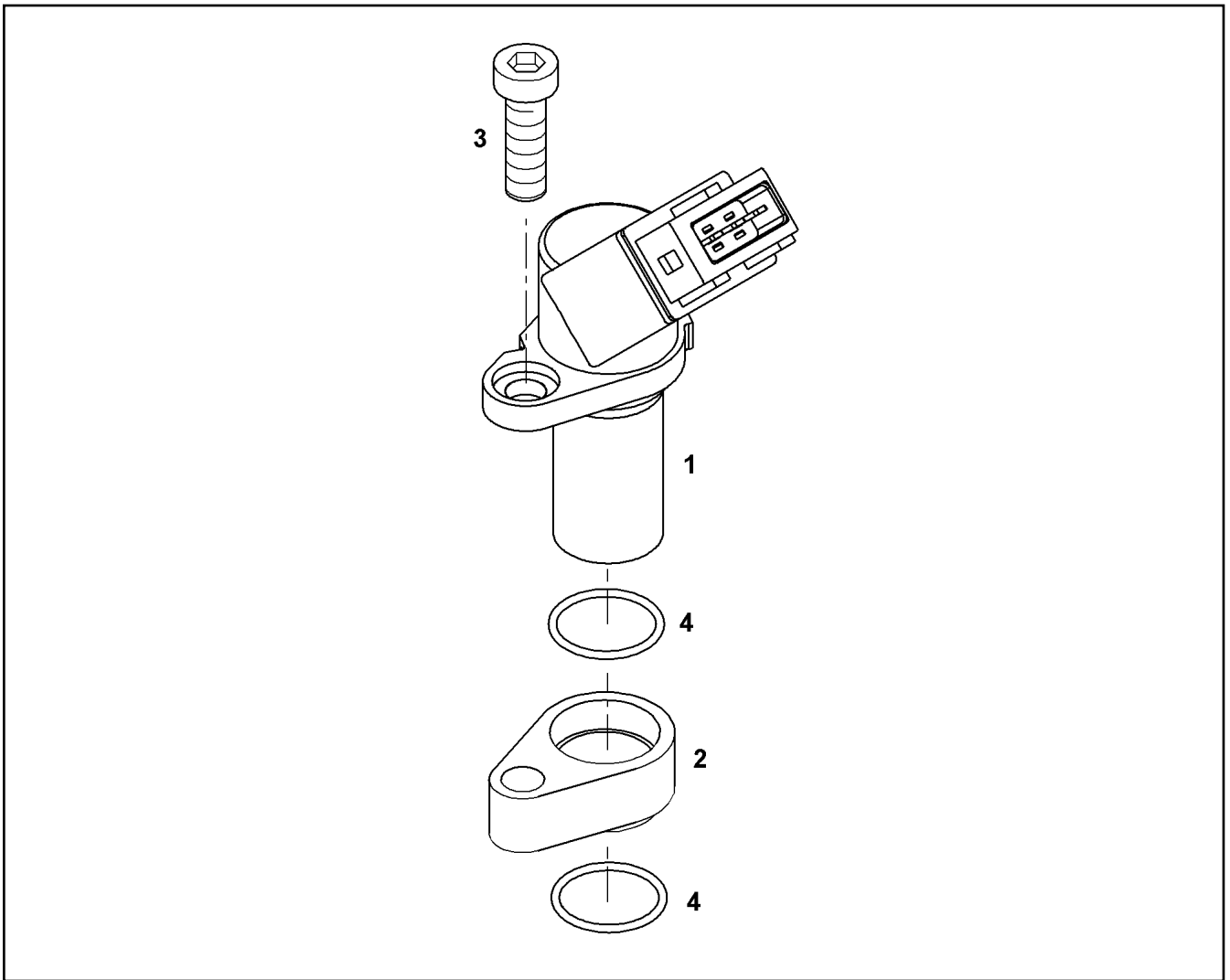

Pos.	Item	Quantity	Description	Bezeichnung	Serie	K
1	10 11 789 8	1	TACHOMETER HALL 0,3-16000HZ	DREHZAHLGEBER		
2	90 80 288	1	SPACER RING	DISTANZRING		
3	40 42 003	1	CYLINDER SCREW ISO 4762 M6X25 8.8 A2C	ZYLINDERSCHRAUBE		
4	73 81 103	2	O-RING DIN 3771 17,17X1,78 FPM70 SHORE	O-RING		

6.2.2009
038651

LIEBHERR

etk_en_de_074515 LR 1600/2

TACHOMETER
DREHZAHLGEBER

657

⇒ 9 079 186
90 79 186

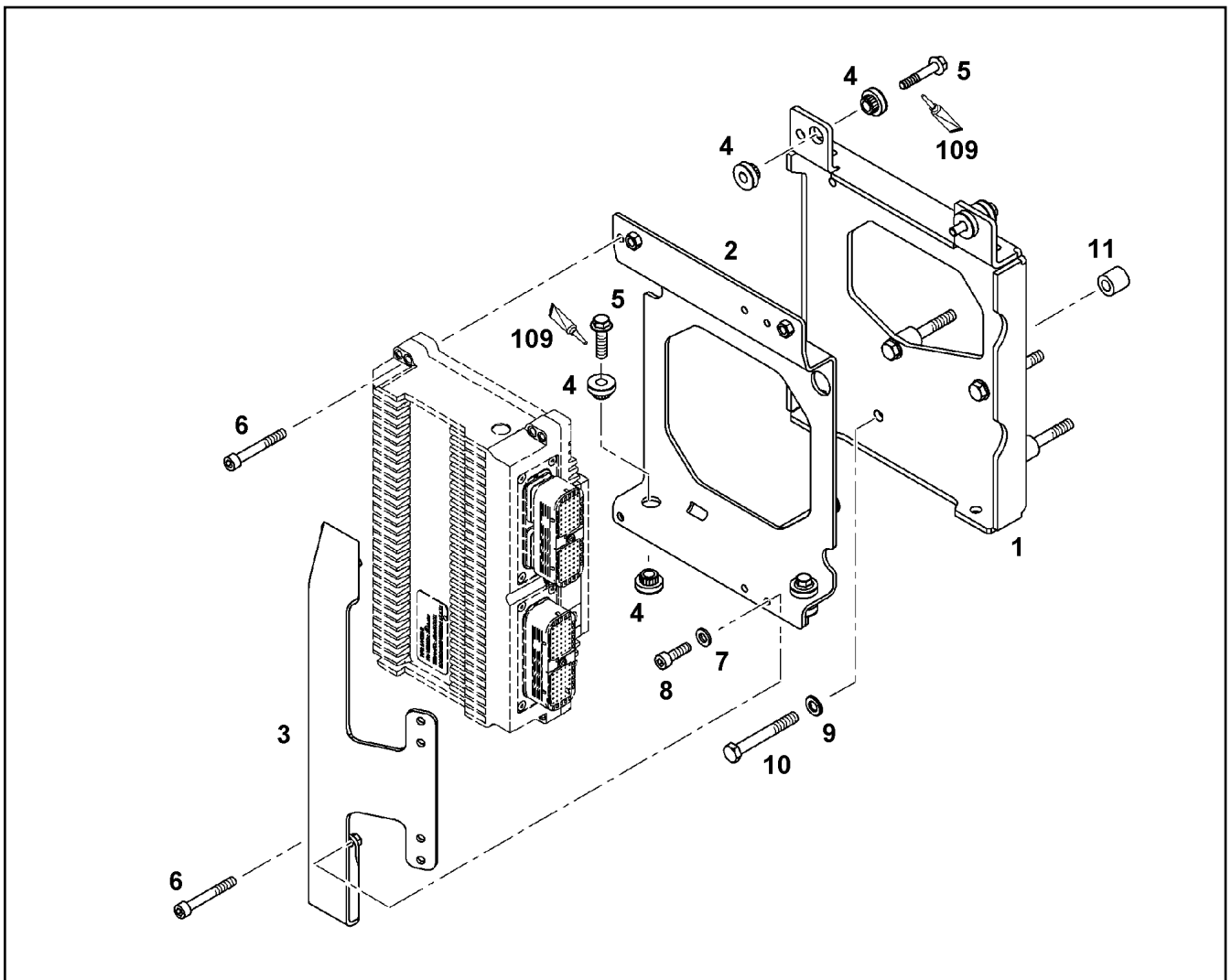

Pos.	Item	Quantity	Description	Bezeichnung	Serie	K
1	90 80 704	1	HOLDER	HALTER		
2	90 80 706	1	HOLDER	HALTER		
3	10 11 880 5	1	RETAINER CPL. S235JR	HALTER KPL.		
4	10 11 627 4	8	SOCKET HD.SCREW 3X26X8,3X17,8 30VM	ZYLINDERFEDER		
5	10 01 690 7	4	HEX BOLT EN 1665 M8X45 8.8 A3C	SECHSKANTSCHRAUBE		
6	40 42 109	4	CYLINDER SCREW ISO 4762 M6X45 8.8 A2C	ZYLINDERSCHRAUBE		
7	42 00 009 08	2	WASHER ISO 7089 A 6.4 VERZ	SCHEIBE		
8	46 00 048	2	CYLINDER SCREW ISO 4762 M6X16 8.8 A2C	ZYLINDERSCHRAUBE		
9	42 00 013 08	4	WASHER ISO 7089 A 10.5 A3C	SCHEIBE		
10	10 00 613 0	4	HEX BOLT ISO 4014 M10X80 12.9	SECHSKANTSCHRAUBE		
11	98 82 075	4	SPACER SLEEVE 11X21X20	DISTANZHUELSE		
109	86 55 016	1	FUS 10ML	SCHRAUBENSICHERUNG		

6.2.2009
039282

LIEBHERR

etk_en_de_074515 LR 1600/2

CONTROL GEAR
STEUERGERAET

658

⇒ 9 080 702
90 80 702

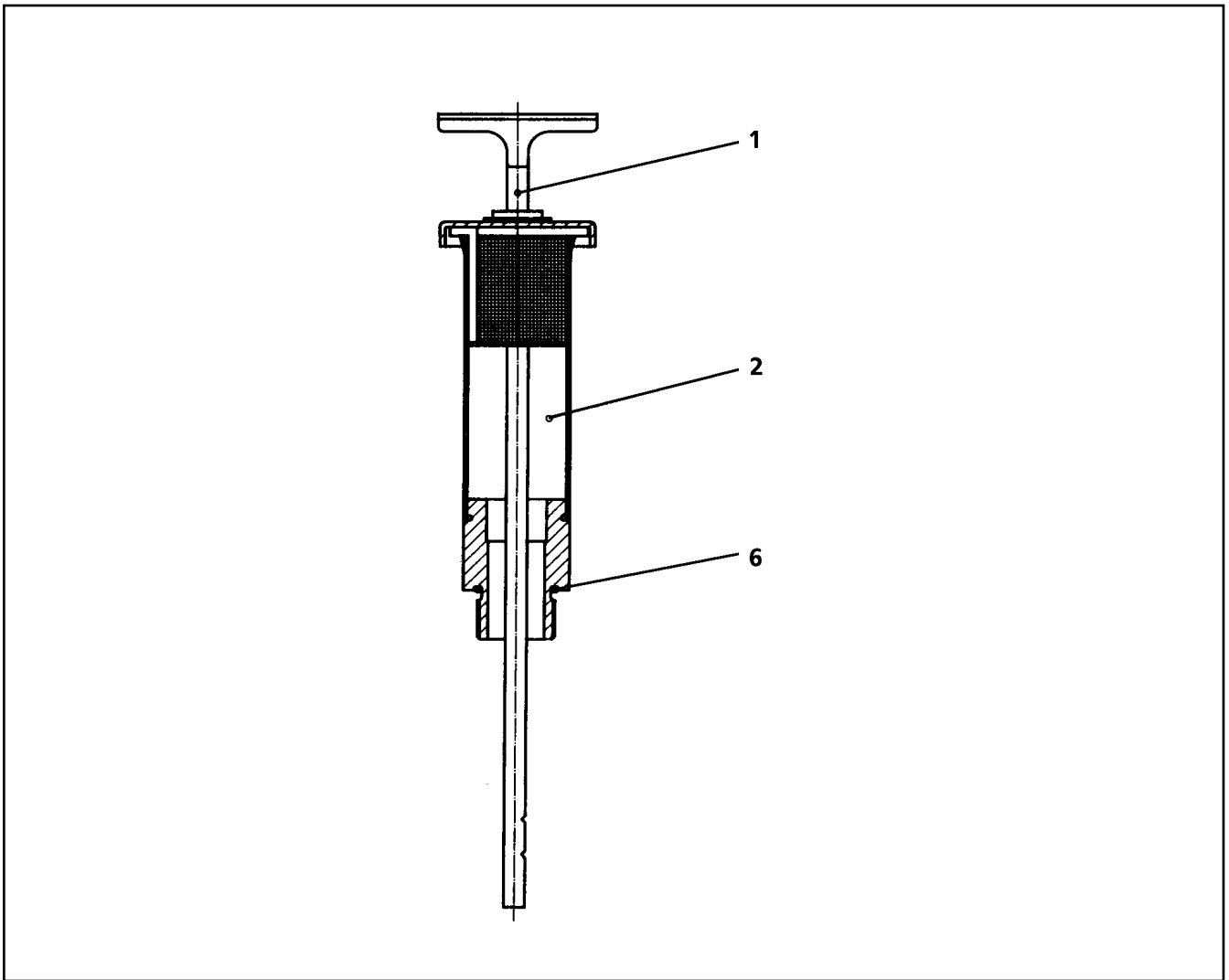

Pos.	Item	Quantity	Description	Bezeichnung	Serie	K
1	92 75 544 01	1	OIL-LEVEL GAUGE 11/8"	OELMESSSTAB		
2	92 75 019 01	1	VENTILATION CONNECTING PIECE	ENTLUEFTUNGSSTUTZEN		
6	76 10 225 03	1	SEALING RING 19,6X24,3X1,5 NBR 85	DICHTRING		

6.2.2009
047371

LIEBHERR

etk_en_de_074515 LR 1600/2

VENTILATION CONNECTING PIECE
ENTLUEFTUNGSSTUTZEN

659

⇒ 9 275 543 01
92 75 543 01

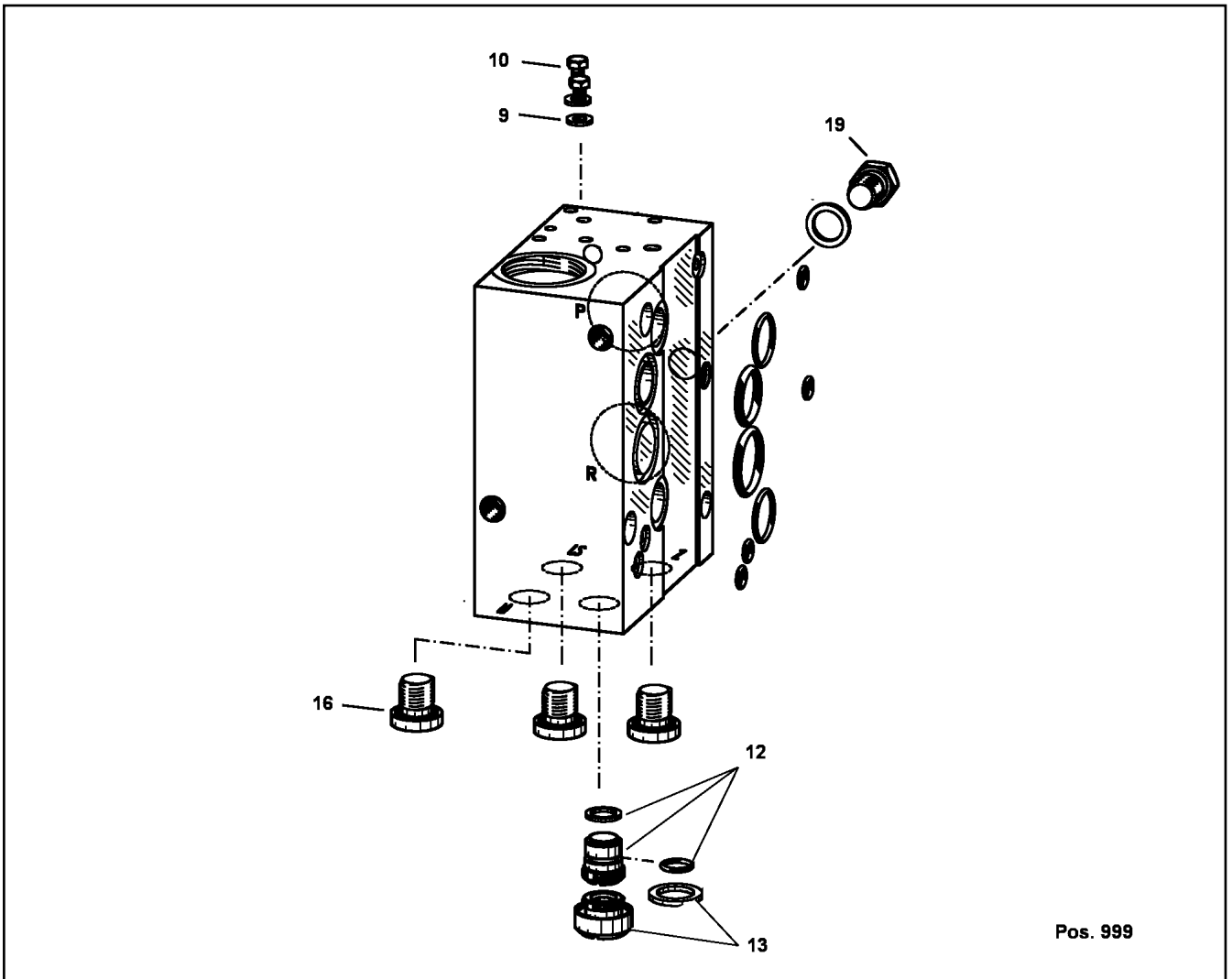

Pos. 999

Pos.	Item	Quantity	Description	Bezeichnung	Serie	K
9	51 10 089 08	2	SEALING RING DIN 7603 A 4X8X1 CU	DICHTRING		
10	40 65 002 01	2	HEX BOLT ISO 4017 M4X6 8.8 A2C	SECHSKANTSCHRAUBE		
12	10 41 274 0	1	SLEEVE CPL.	HUELSE KPL.		
13	10 41 274 6	1	SCREW	SCHRAUBE		
16	47 77 054 08	3	PLUG VST11/4"ED A3P	STOPFEN		
19	10 41 274 8	1	SCREW PLUG	VERSCHLUSSSCHRAUBE		
999	10 41 275 1	1	SEAL KIT CONNECTING BLOCK	DS ANSCHLUSSBLOCK		

6.2.2009
049046

LIEBHERR

etk_en_de_074515 LR 1600/2

CONNECTION BLOCK
ANSCHLUSSBLOCK

660

⇒ 9 640 276 08
96 40 276 08

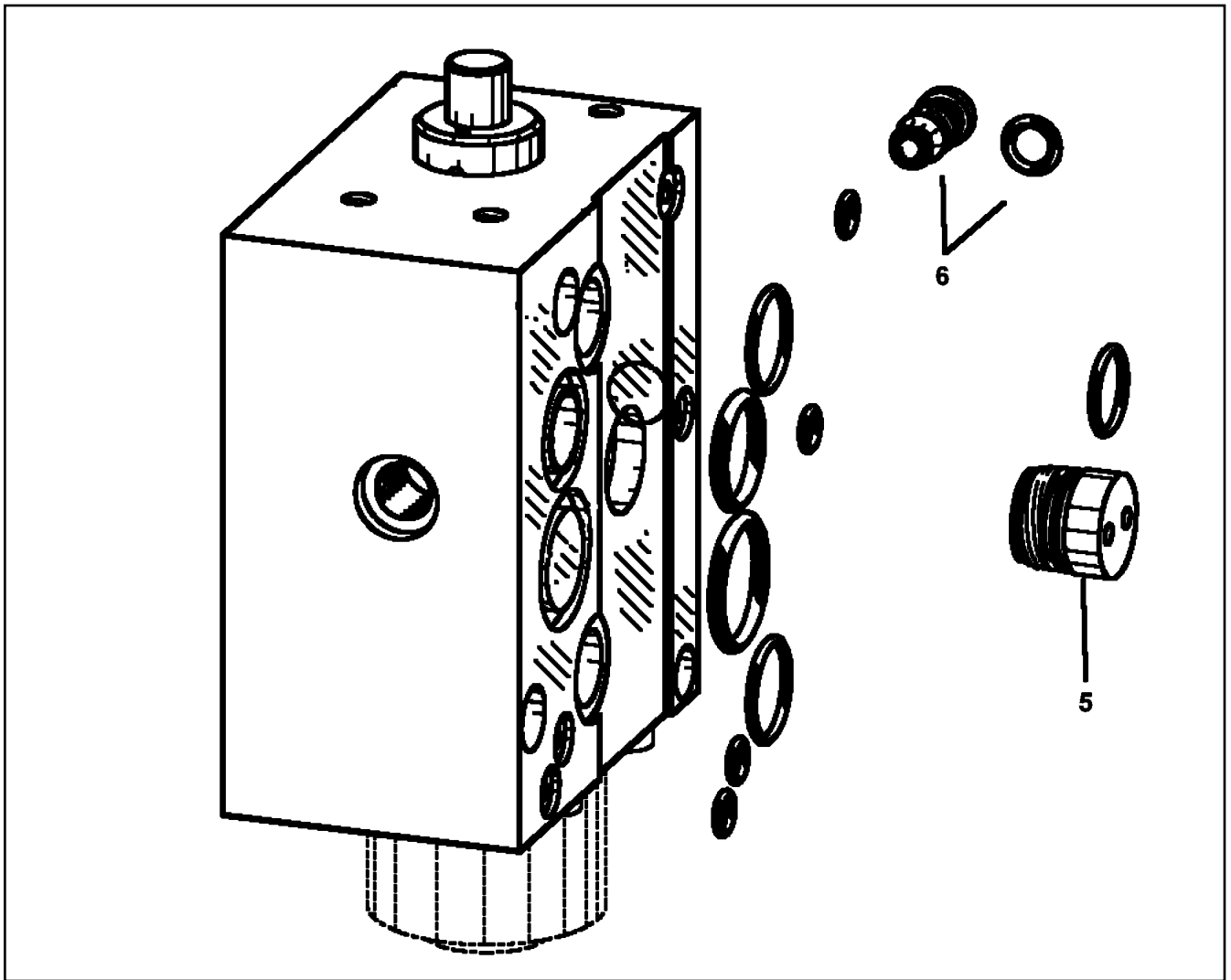

Pos.	Item	Quantity	Description	Bezeichnung	Serie	K
5	10 41 275 3	1	SCREW PLUG	SCHRAUBSTOPFEN		
6	10 41 276 3	1	SHUTTLE VALVE	WECHSELVENTIL		
999	10 41 278 1	1	SEAL KIT WEGESCHIEBER	DICHTSATZ		

6.2.2009
049048

LIEBHERR

etk_en_de_074515 LR 1600/2

DIRECTIONAL CTRL. VALVE
WEGESCHIEBER

661

⇒ 9 640 277 08
96 40 277 08

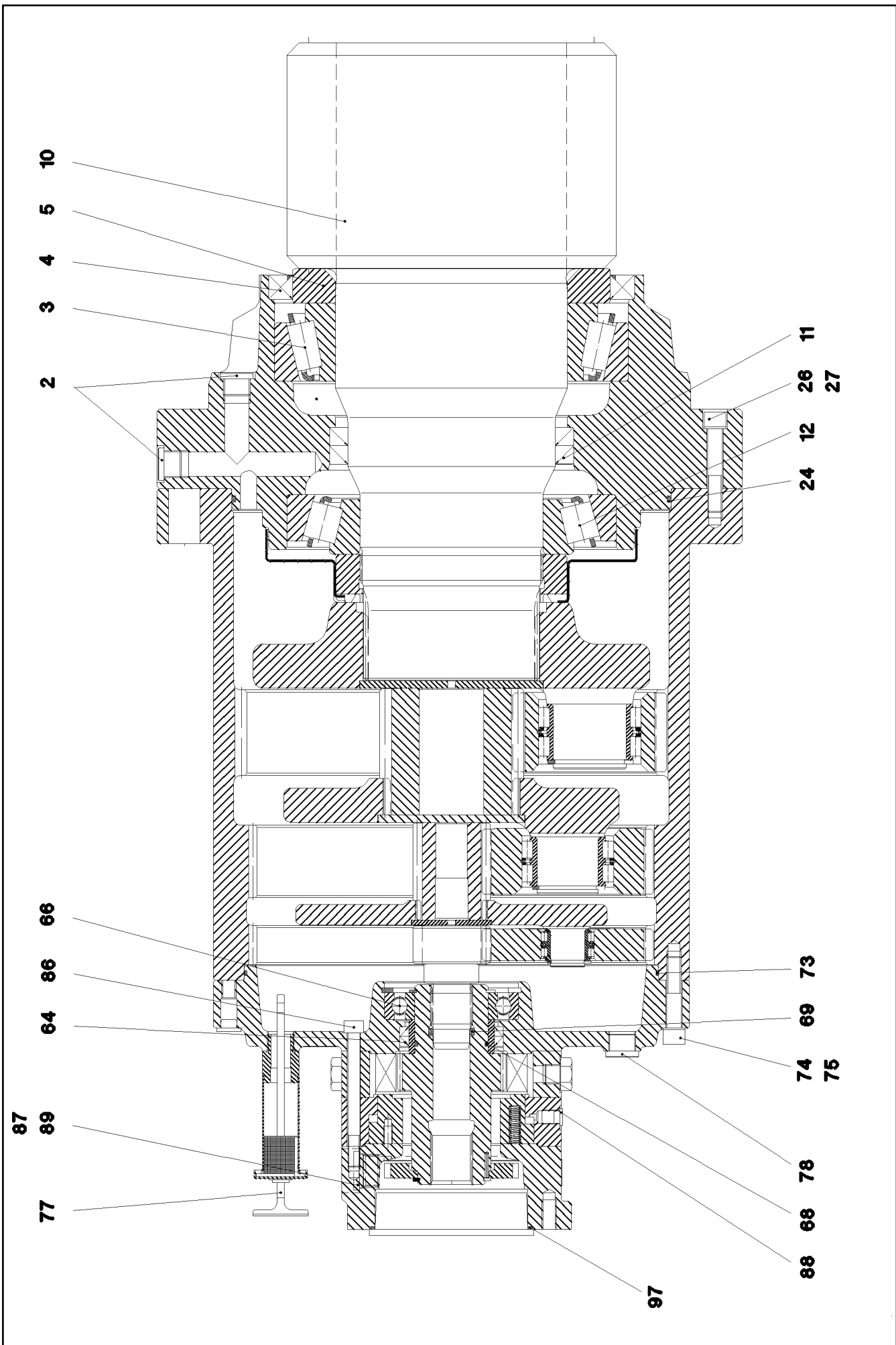

6.2.2009
049295

LIEBHERR

etk_en_de_074515 LR 1600/2

SLEWING GEAR
DREHWERK

□ 662 (1/2)

⇒ 9 697 916 01
96 97 916 01

Pos.	Item	Quantity	Description	Bezeichnung	Serie	K
2	47 75 104 01	7	SCREW PLUG VSTI M22X1,5 CF	VERSCHLUSSSCHRAUBE		
3	74 62 237 01	1	TAPERED ROLLER BEARING DIN 720 320 3	KEGELROLLENLAGER		
4	71 00 630 01	1	ROTARY SHAFT LIP SEAL DIN 3760 AS 260X	RADIALWELLENDICHTRING		
5	92 76 333 01	1	WASHER	SCHEIBE		
10	92 76 334 01	1	OUTPUT SHAFT	ABTRIEBSWELLE		
11	71 00 341 08	2	ROTARY SHAFT LIP SEAL DIN 3761 C 170X2	RADIALWELLENDICHTRING		
12	74 62 026 01	1	TAPERED ROLLER BEARING DIN 720 302 3	KEGELROLLENLAGER		
24	76 10 341 03	1	O-RING 340X4 72 NBR 872	O-RING		
26	40 43 126 08	8	CYLINDER SCREW DIN 912 M12X70 10.9 SP	ZYLINDERSCHRAUBE		
27	42 39 112 01	8	LOCK WASHER VS 12 VERZ	SICHERUNGSSCHEIBE		
64	71 00 241 08	2	ROTARY SHAFT LIP SEAL DIN 3761 A 70X8	RADIALWELLENDICHTRING		
66	50 15 339 08	1	DEEP GROOVE BALL BEARING DIN 625 621	RILLENKUGELLAGER		
68	72 64 055 08	1	O-RING 54X3 NBR70	O-RING		
69	72 64 538 01	1	O-RING 29X4,5 NBR70	O-RING		
73	76 10 203 03	1	O-RING 320X3 NBR70	O-RING		
74	40 42 124 01	12	CYLINDER SCREW ISO 4762 M12X60 8.8 A3	ZYLINDERSCHRAUBE		
75	42 39 112 01	12	LOCK WASHER VS 12 VERZ	SICHERUNGSSCHEIBE		
77	92 75 543 01	1	VENTILATION CONNECTING PIECE ⇒ 9 275 543 01 92 75 543 01	ENTLUEFTUNGSSTUTZEN		
78	47 75 104 01	3	SCREW PLUG VSTI M22X1,5 CF	VERSCHLUSSSCHRAUBE		
86	40 42 104 01	12	CYLINDER SCREW ISO 4762 M10X110 8.8	ZYLINDERSCHRAUBE		
88	77 90 162 01	1	BLANKING PLUG	VERSCHLUSSSTOPFEN		
89	47 77 056 08	1	PLUG VSTIM27X2ED A3P	STOPFEN		
97	72 62 030 08	1	O-RING 120X3 NBR70	O-RING		

6.2.2009

etk_en_de_074515 LR 1600/2

663 (2/2)

LIEBHERR

SLEWING GEAR
DREHWERK

⇒ 9 697 916 01
96 97 916 01

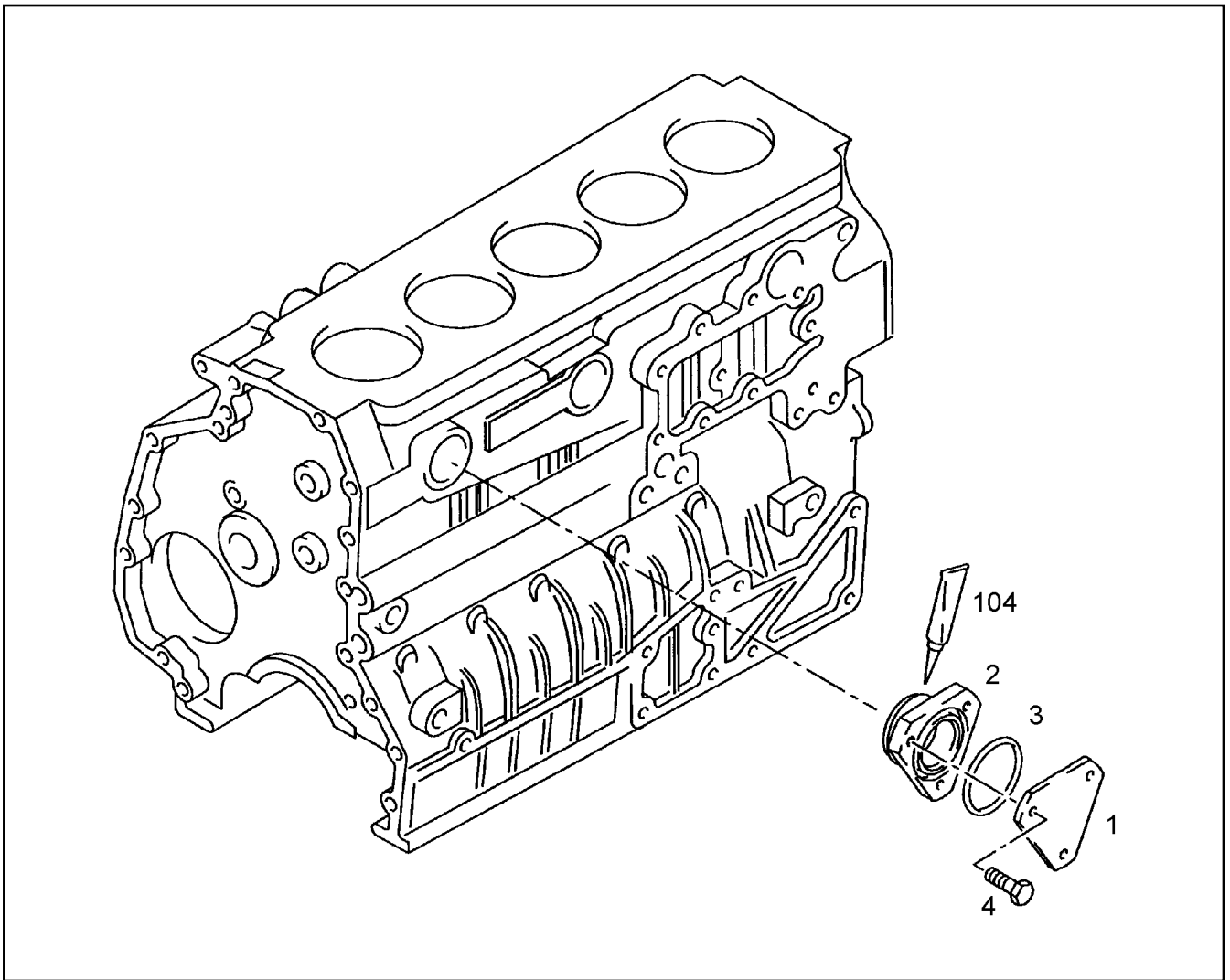

Pos.	Item	Quantity	Description	Bezeichnung	Serie	K
1	97 39 036	1	SCREW CAP SJ 355	VERSCHLUSSDECKEL		
2	10 01 271 5	1	FLANGE	FLANSCH		
3	10 01 185 5	1	O RING 59X3 B-FPM1-70	RUNDDICHTRING		
4	10 01 136 0	3	SCREW M8X16 8.8	SCHRAUBE		
104	86 55 023 23	1	GLUE 250ML	KLEBSTOFF		

6.2.2009
031547

LIEBHERR

etk_en_de_074515 LR 1600/2

LOCKING PIECES
VERSCHLUSSTEIL

664

⇒ 9 739 035
97 39 035

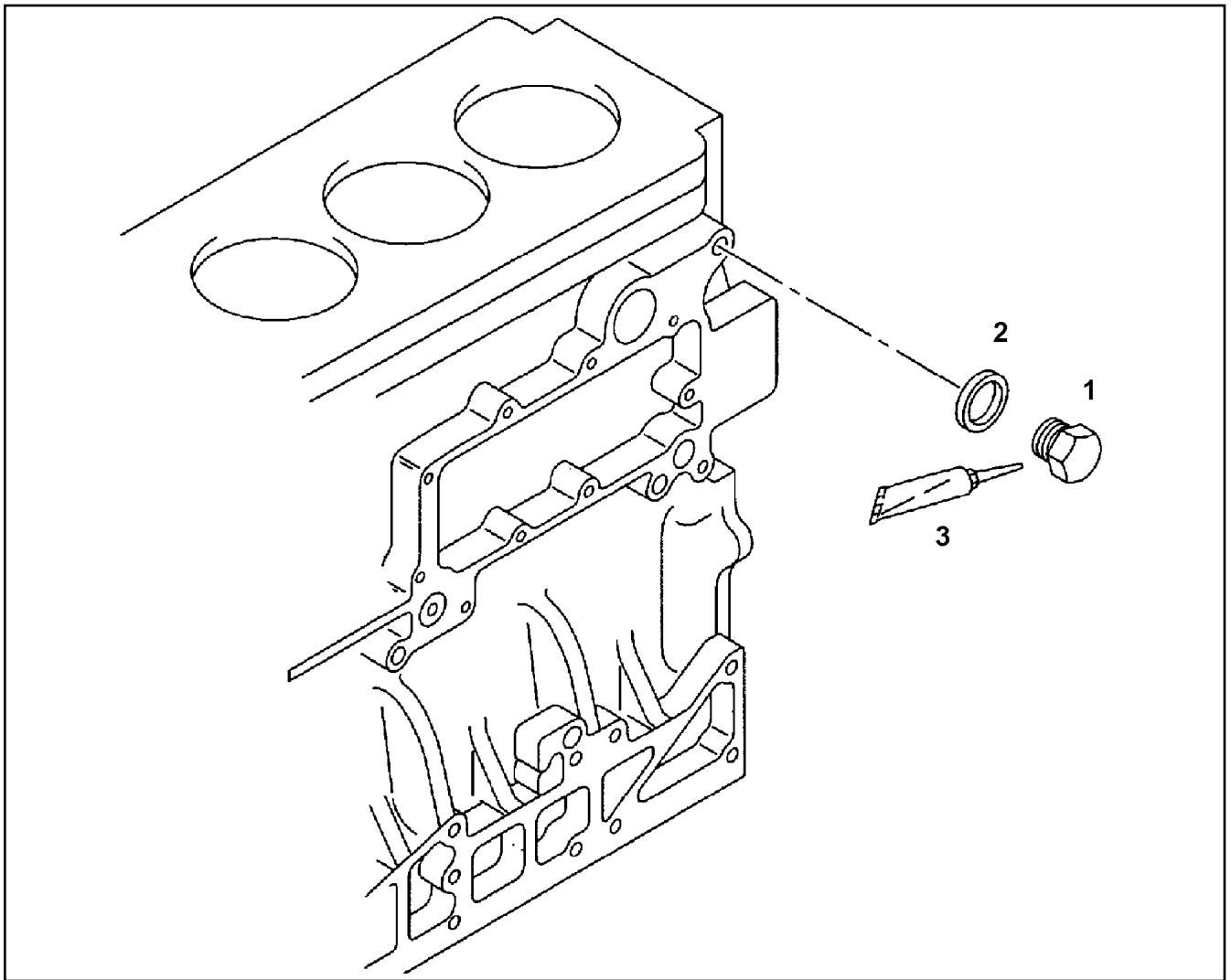

Pos.	Item	Quantity	Description	Bezeichnung	Serie	K
1	10 01 252 2	1	SCREW PLUG M16X15 9SMNPB28K	VERSCHLUSSSCHRAUBE		
2	10 01 186 7	1	SEALING RING 16,7X24X1,5 ST/FPM1-80	DICHTRING		
3	81 12 059 08	1	GLUE 50ML	KLEBSTOFF		

6.2.2009
030888

LIEBHERR

etk_en_de_074515 LR 1600/2

SCREW PLUG
VERSCHLUSSSCHRAUBE

665

⇒ 9 739 096
97 39 096

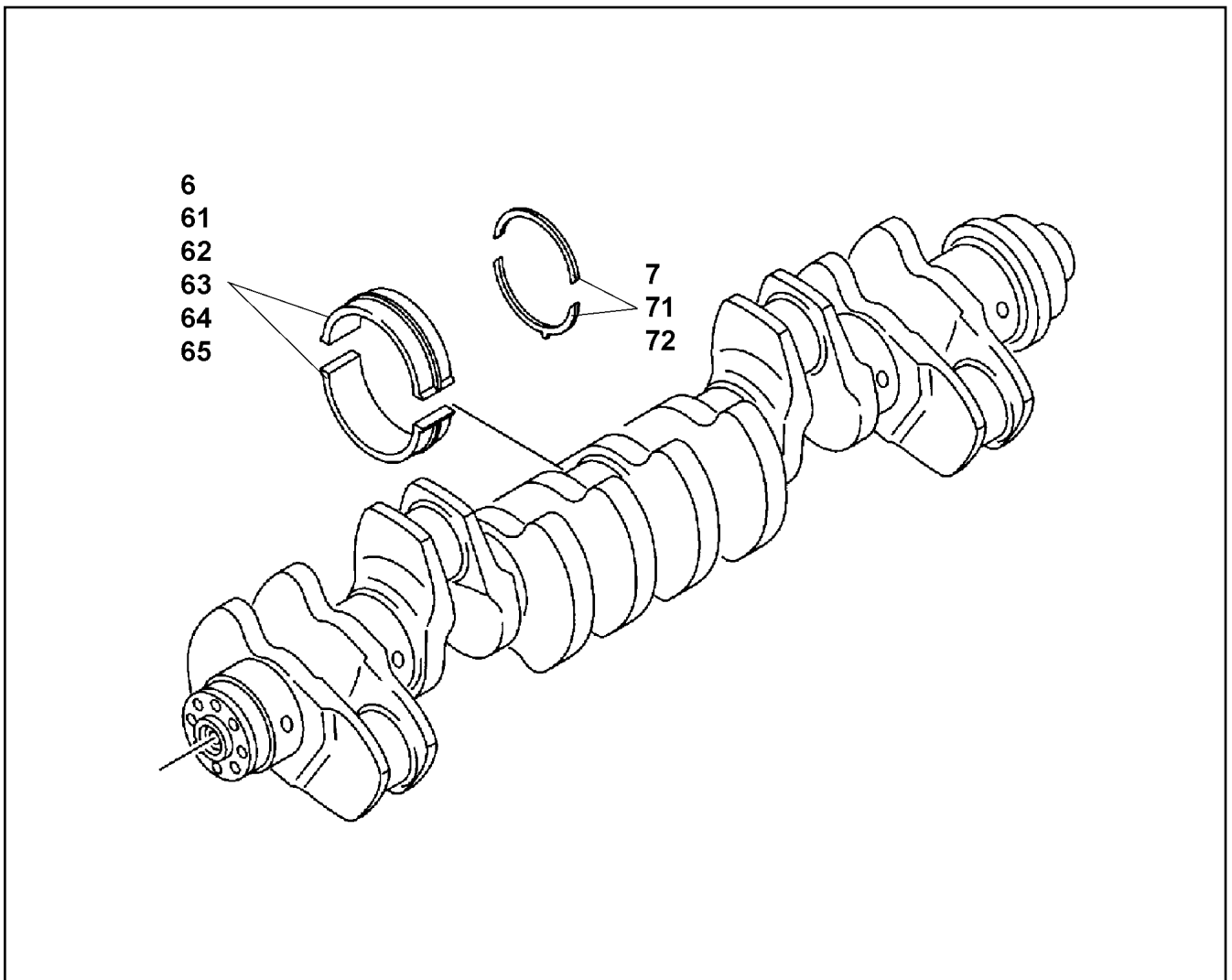

Pos.	Item	Quantity	Description	Bezeichnung	Serie	K
6	10 01 208 3	7	MAIN BEARING	HAUPTLAGER		
7	10 01 211 7	2	THRUST WASHER	ANLAUFSCHIEBE		
61	10 01 210 7	7	MAIN BEARING D= -0,10MM	HAUPTLAGER		
62	10 01 208 8	7	MAIN BEARING R-MOTORXD2876	HAUPTLAGER		
63	10 01 210 9	7	MAIN BEARING D= -0,50MM	HAUPTLAGER		
64	10 01 211 0	7	MAIN BEARING D= -0,75MM	HAUPTLAGER		
65	10 01 211 2	7	MAIN BEARING D= -1,00MM	HAUPTLAGER		
71	10 01 211 8	2	THRUST WASHER	ANLAUFSCHIEBE		
72	10 01 212 0	2	THRUST WASHER	ANLAUFSCHIEBE		

6.2.2009
030890

LIEBHERR

etk_en_de_074515 LR 1600/2

CRANKSHAFT BEARINGS
KURBELWELLENLAGERUNG

666

⇒ 9 739 102
97 39 102

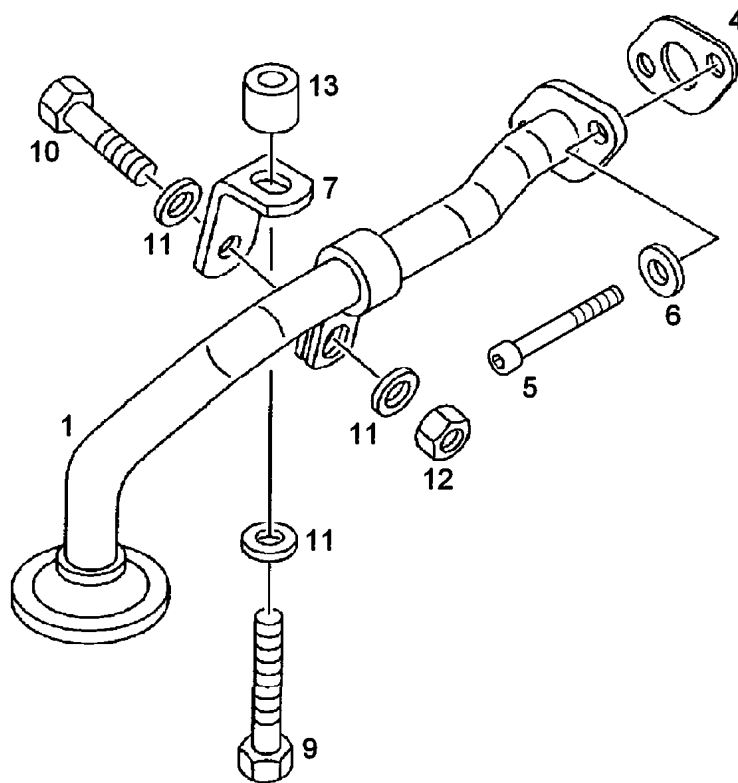

Pos.	Item	Quantity	Description	Bezeichnung	Serie	K
1	10 01 229 0	1	SUCTION LINE JOINING	SAUGLEITUNG		
4	10 01 184 7	1	SEAL	DICHTUNG		
5	10 22 235 9	2	CYLINDER SCREW	ZYLINDERSCHRAUBE		
6	10 01 165 4	2	WASHER A 8,4X16X1,6 200HV	SCHEIBE		
7	10 01 229 5	1	HOLDER	HALTER		
9	10 01 125 3	1	SCREW M8X40 8.8	SCHRAUBE		
10	10 01 121 4	1	SCREW M8X28 8.8 A2C	SCHRAUBE		
11	10 03 288 2	3	WASHER 9X19X3	SCHEIBE		
12	10 01 163 7	1	LOCK NUT BM8-8	SICHERUNGSMUTTER		
13	10 03 239 2	1	BUSH	BUCHSE		

6.2.2009
031116

LIEBHERR

etk_en_de_074515 LR 1600/2

OIL LINE
OELLEITUNG

667

⇒ 9 739 118
97 39 118

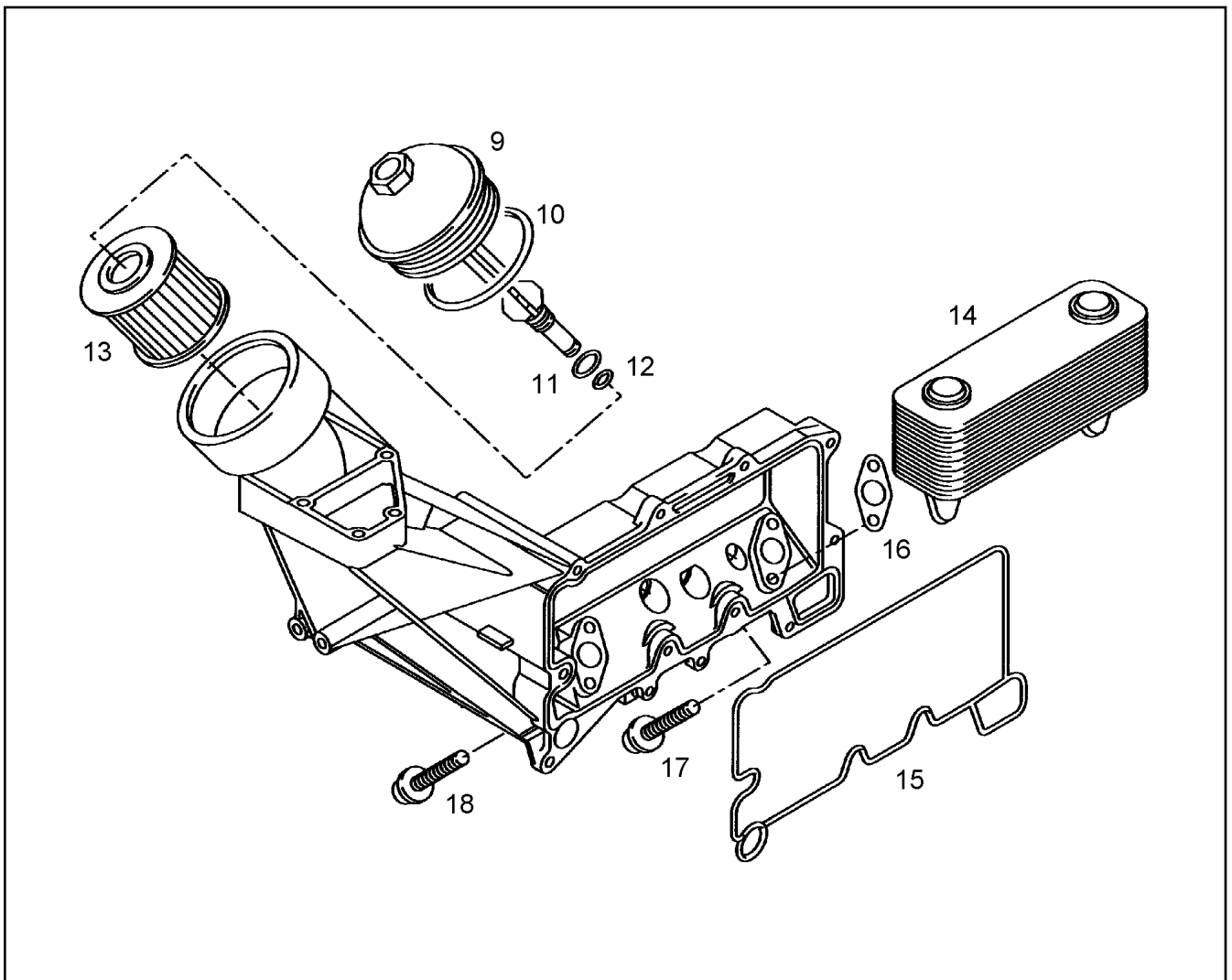

Pos.	Item	Quantity	Description	Bezeichnung	Serie	K
9	10 01 228 8	1	LID	DECKEL		
10	10 01 263 8	1	O RING 130X4 ACM1-60	RUNDDICHTRING		
11	10 01 263 7	1	O RING 12X2 ACM1-60	RUNDDICHTRING		
12	10 01 263 6	1	O RING 8X2 ACM1-60	RUNDDICHTRING		
13	10 01 228 7	1	MOTOR OIL FILTER	MOTOROELFILTER		
14	10 01 228 9	1	OIL COOLER	OELKUEHLER		
15	10 01 229 8	1	SEAL	DICHTUNG		
16	10 01 184 5	2	SEAL	DICHTUNG		
17	10 01 254 7	2	FLANGED BOLT M8X40,5 AK 8.8 FE//ZN12//C	BUNDSCHRAUBE		
18	10 01 254 9	2	FLANGED BOLT M8X65,5 AK 8.8 FE//ZN12//C	BUNDSCHRAUBE		

6.2.2009
031115

LIEBHERR

etk_en_de_074515 LR 1600/2

OIL COOLER
OELKUEHLER

668

⇒ 9 739 122
97 39 122

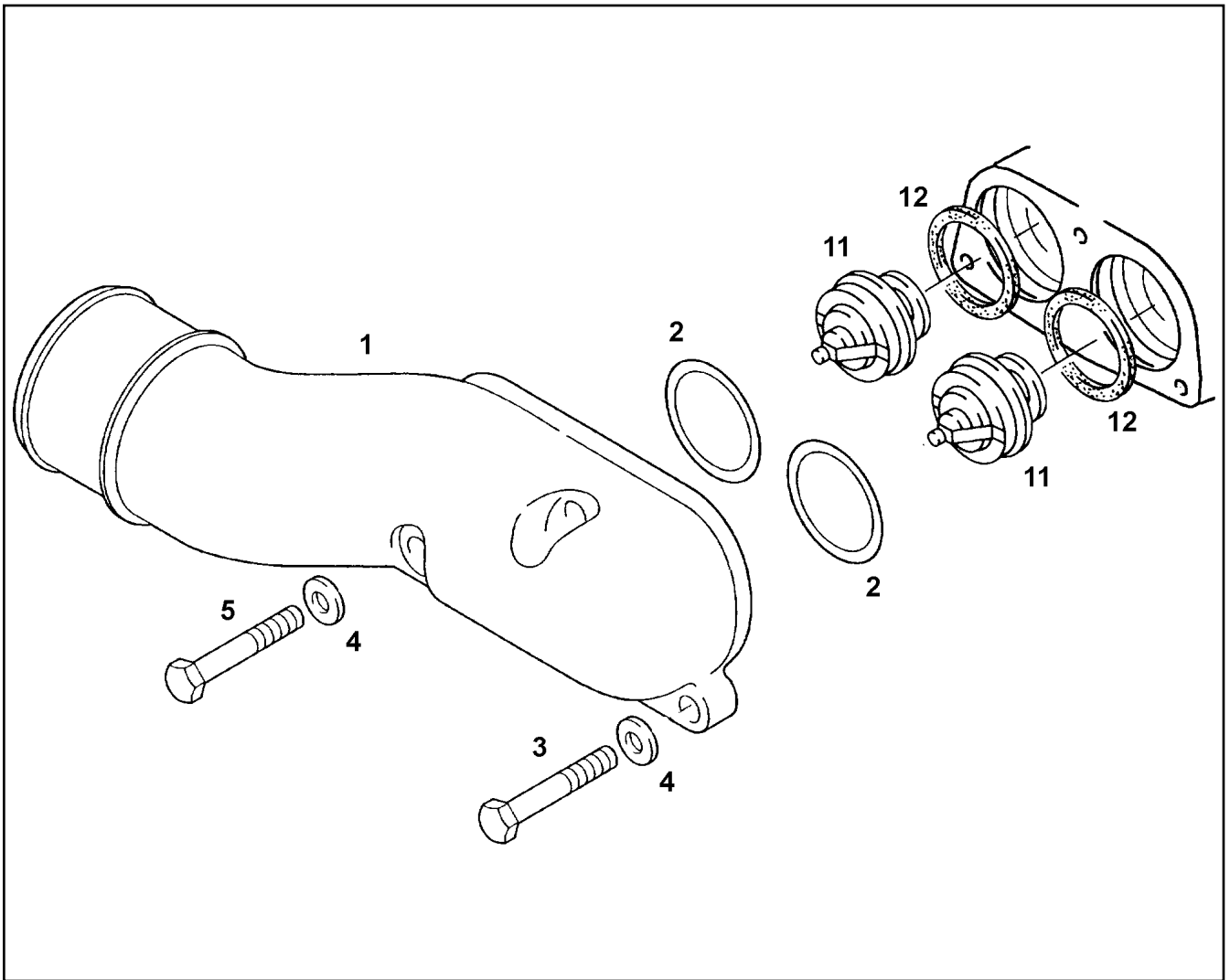

Pos.	Item	Quantity	Description	Bezeichnung	Serie	K
1	10 01 230 1	1	ELBOW	KRUEMMER		
2	10 01 185 3	2	O RING 60X4 B-NBR3-60	RUNDDICHTRING		
3	10 01 132 8	2	SCREW M8X55 8.8	SCHRAUBE		
4	10 01 165 4	3	WASHER A 8,4X16X1,6 200HV	SCHEIBE		
5	10 01 122 5	1	SCREW M8X65 8.8 A2C	SCHRAUBE		
11	10 01 232 0	2	THERMOSTAT	THERMOSTAT		
12	10 01 234 5	2	SEAL	DICHTUNG		

6.2.2009
031146

LIEBHERR

etk_en_de_074515 LR 1600/2

THERMOSTAT HOUSING
THERMOSTATGEHAEUSE

669

⇒ 9 739 126
97 39 126

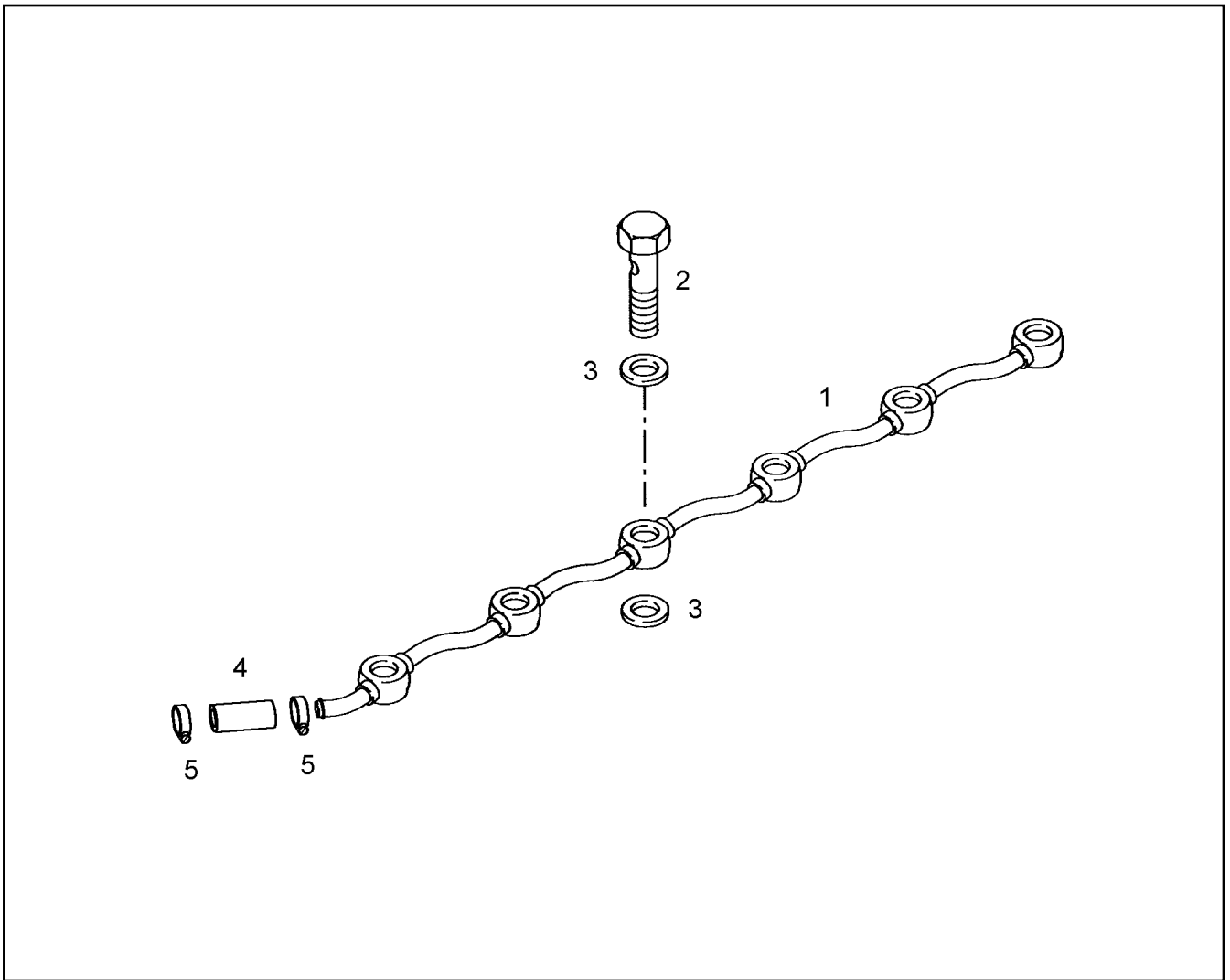

Pos.	Item	Quantity	Description	Bezeichnung	Serie	K
1	10 01 231 4	1	COOLING WATER LINE	KUEHLWASSERLEITUNG		
2	10 01 272 8	6	HOLLOW SCREW	HOHLSCHRAUBE		
3	10 01 186 6	12	SEALING RING 14,7X22X1,5 ST/FPM1-80	DICHTRING		
4	10 01 872 9	1	HOSE	SCHLAUCH		
5	10 02 307 6	2	STRIP CLIP 19X12	BANDSCHELLE		

6.2.2009
031145

LIEBHERR

etk_en_de_074515 LR 1600/2

WATER BLEEDER PIPELINE
WASSERENTLUEFTUNGSLEITUNG

670

⇒ 9 739 127
97 39 127

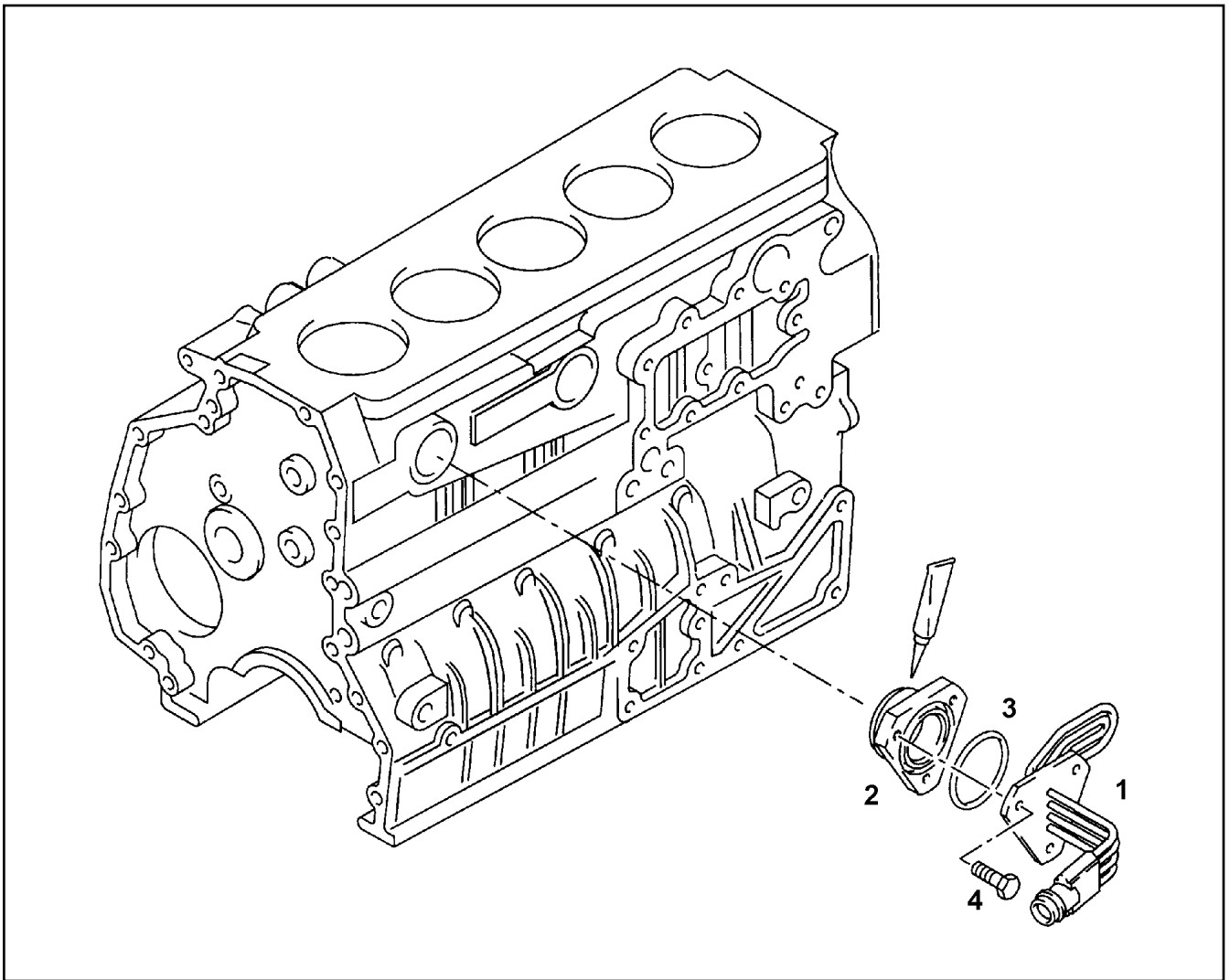

Pos.	Item	Quantity	Description	Bezeichnung	Serie	K
1	10 01 234 3	1	COOLING WATER PREHEATING	KUEHLWASSERVORWAERMUN		
2	10 01 271 5	1	FLANGE	FLANSCH		
3	10 01 185 5	1	O RING 59X3 B-FPM1-70	RUNDDICHTRING		
4	10 01 136 0	3	SCREW M8X16 8.8	SCHRAUBE		
6	81 12 017 08	1	ADHESIVE 50ML	KLEBER		

6.2.2009
031169

LIEBHERR

etk_en_de_074515 LR 1600/2

COOLANT PREHEATING
KUEHLMITTELVORWAERMUNG

□ 671

⇒ 9 739 129
97 39 129

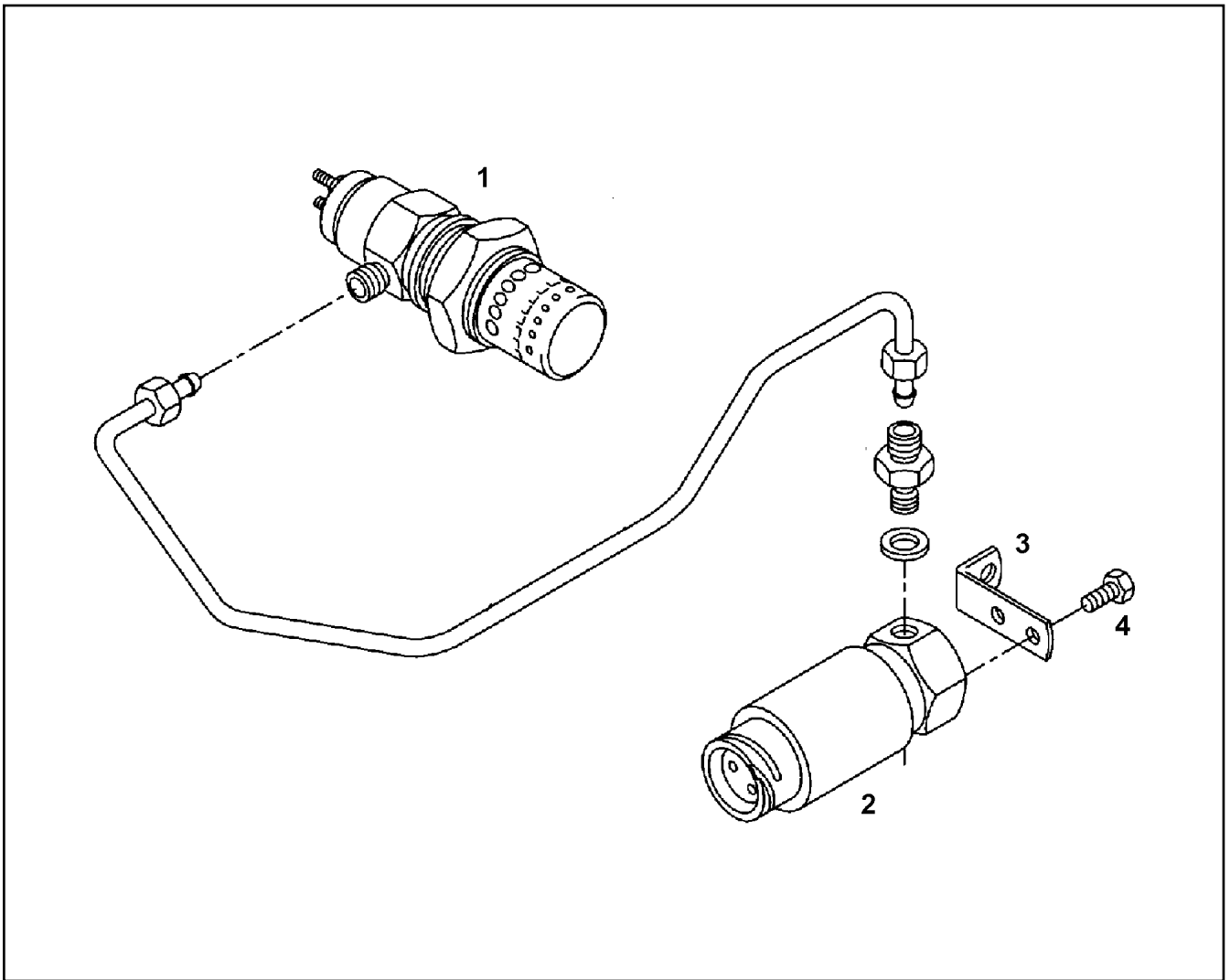

Pos.	Item	Quantity	Description	Bezeichnung	Serie	K
1	10 01 246 3	1	FLAME GLOW PLUG	FLAMMGLUEHKERZE		
2	10 01 245 8	1	SOLENOID VALVE	MAGNETVENTIL		
3	10 01 268 5	1	HOLDER	HALTER		
4	10 01 135 8	2	HEX BOLT M6X12 8.8 MAN183-A2C	SECHSKANTSCHRAUBE		

6.2.2009
031134

LIEBHERR

etk_en_de_074515 LR 1600/2

FLAME STARTING SYSTEM
FLAMMSTARTANLAGE

672

⇒ 9 739 140
97 39 140

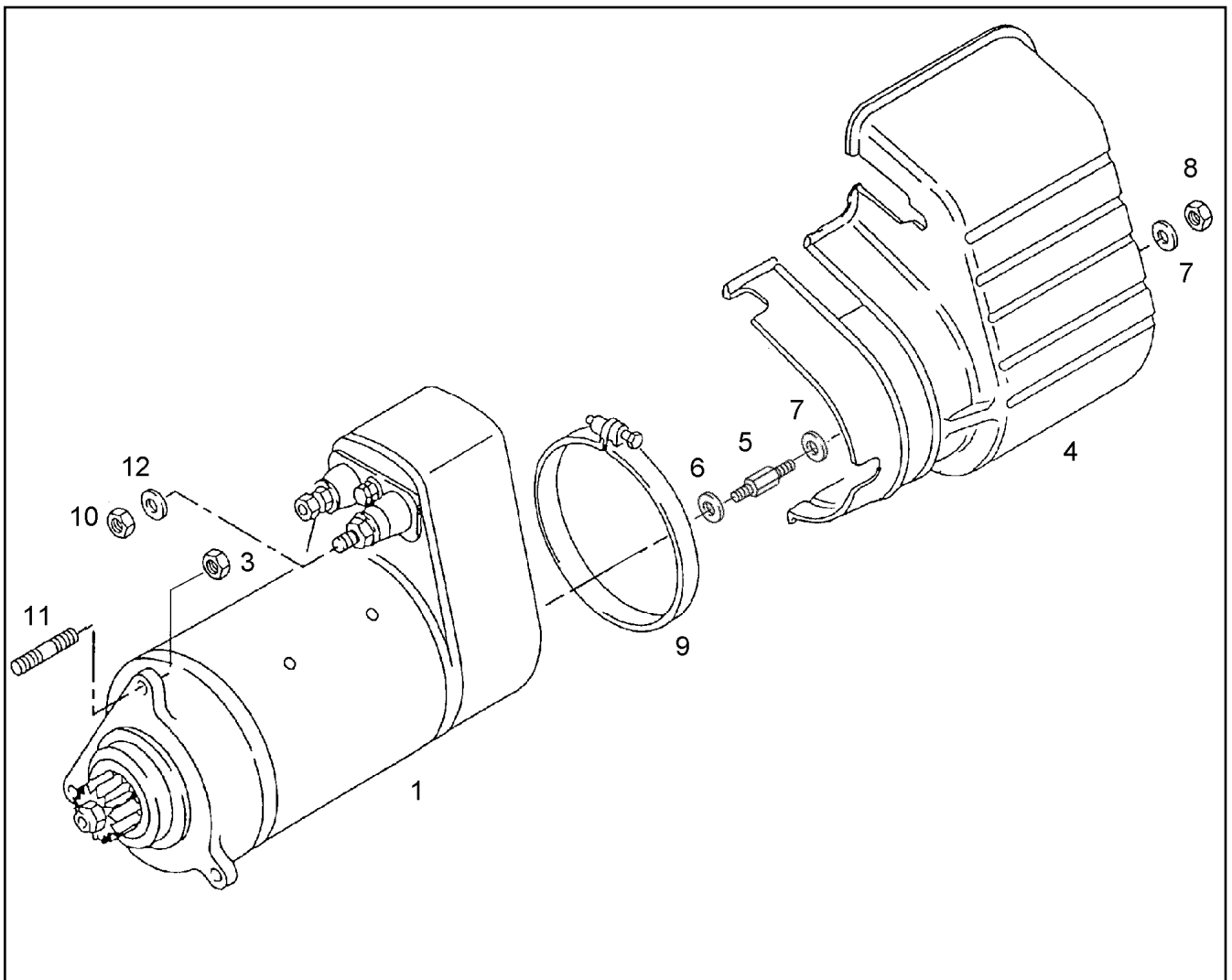

Pos.	Item	Quantity	Description	Bezeichnung	Serie	K
1	10 01 246 1	1	STARTER KB24V 6,6KW	STARTER		
3	10 01 163 2	3	NUT M12X1,5 8	MUTTER		
4	10 01 246 2	1	PROTECTION PLATE	SCHUTZBLECH		
5	10 01 253 1	1	SPACER BOLT B M6XM6X10 9SMNPB28K	DISTANZBOLZEN		
6	10 01 256 5	1	WASHER CU	SCHEIBE		
7	10 01 165 3	2	WASHER A 6,4X12X1,6 200HV	SCHEIBE		
8	10 01 162 9	1	NUT M6 8	MUTTER		
9	10 01 268 1	1	FASTENING CLAMP 125X15 W1-2	HALTERUNGSSCHELLE		
10	10 01 427 8	1	NUT M10 -8 A3C	MUTTER		
11	10 01 159 6	3	DOUBLE-ENDED STUD M12X1,5X30 8.8	STIFTSCHRAUBE		
12	10 01 165 8	2	WASHER A 10,5X20X2,0 200HV	SCHEIBE		

6.2.2009
031565

LIEBHERR

etk_en_de_074515 LR 1600/2

STARTER
STARTER

673

⇒ 9 739 159
97 39 159

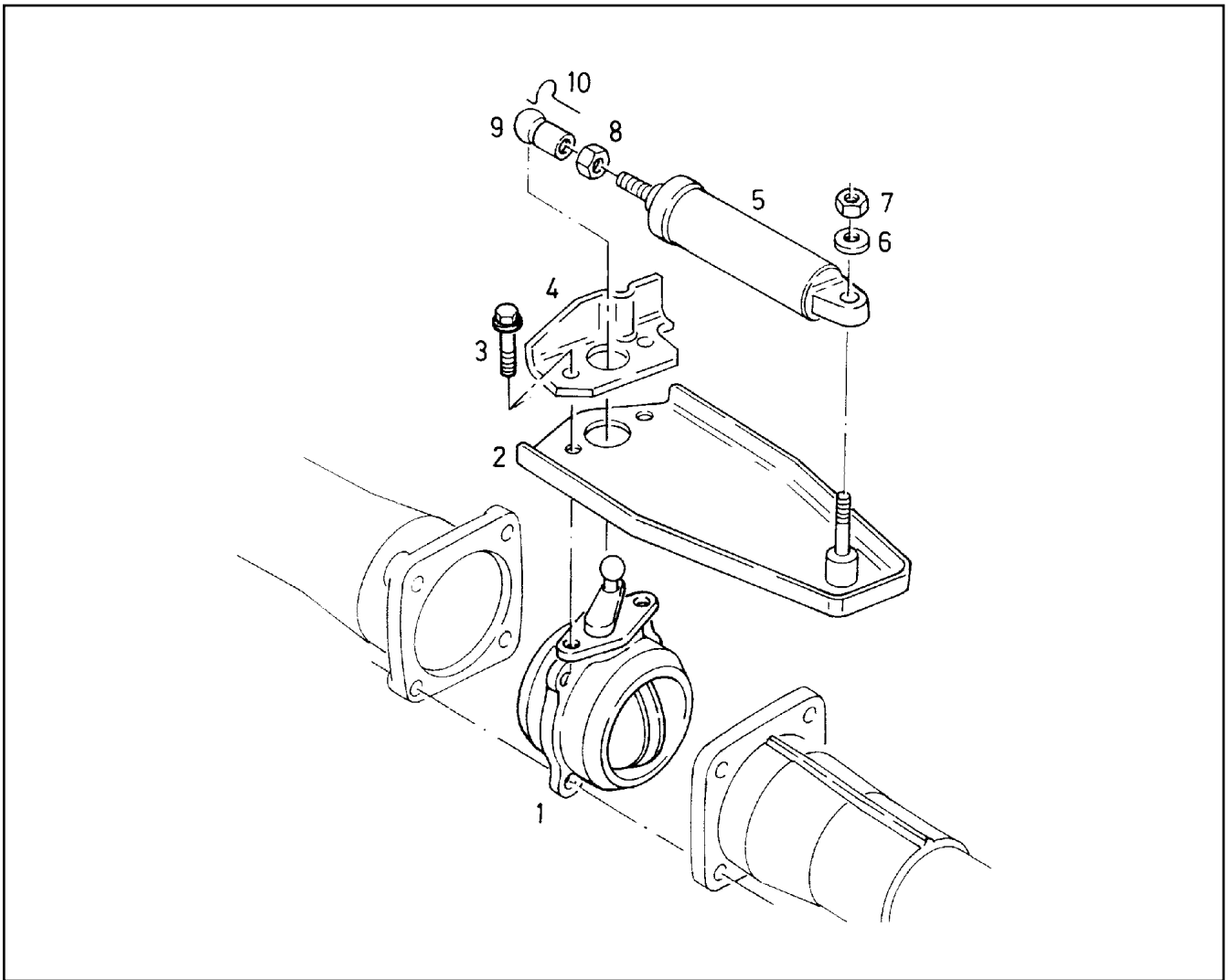

Pos.	Item	Quantity	Description	Bezeichnung	Serie	K
1	10 01 754 4	1	RESTRICTOR CAP	DROSSELKLAPPE		
2	10 01 749 3	1	CONSOLE	KONSOLE		
3	10 01 752 6	2	LOCKING SCREW M8X20 10.9 SP	SICHERUNGSSCHRAUBE		
4	10 01 752 9	1	LIMIT STOP ANGLE	ANSCHLAGWINKEL		
5	10 01 752 1	1	COMPRESSED-AIR CYLINDER	DRUCKLUFTZYLINDER		
6	10 01 165 4	1	WASHER A 8,4X16X1,6 200HV	SCHEIBE		
7	10 01 751 7	1	LOCK NUT AM8-10	SICHERUNGSMUTTER		
8	10 01 427 8	1	NUT M10 -8 A3C	MUTTER		
9	10 01 186 3	1	BALL SOCKET	KUGELPFANNE		
10	10 01 751 3	1	SAFETY STIRRUP S16 A3C	SICHERUNGSBUEGEL		

6.2.2009
031166

LIEBHERR

etk_en_de_074515 LR 1600/2

MOTOR BRAKE
MOTORBREMSE

□ 674

⇒ 9 739 186
97 39 186

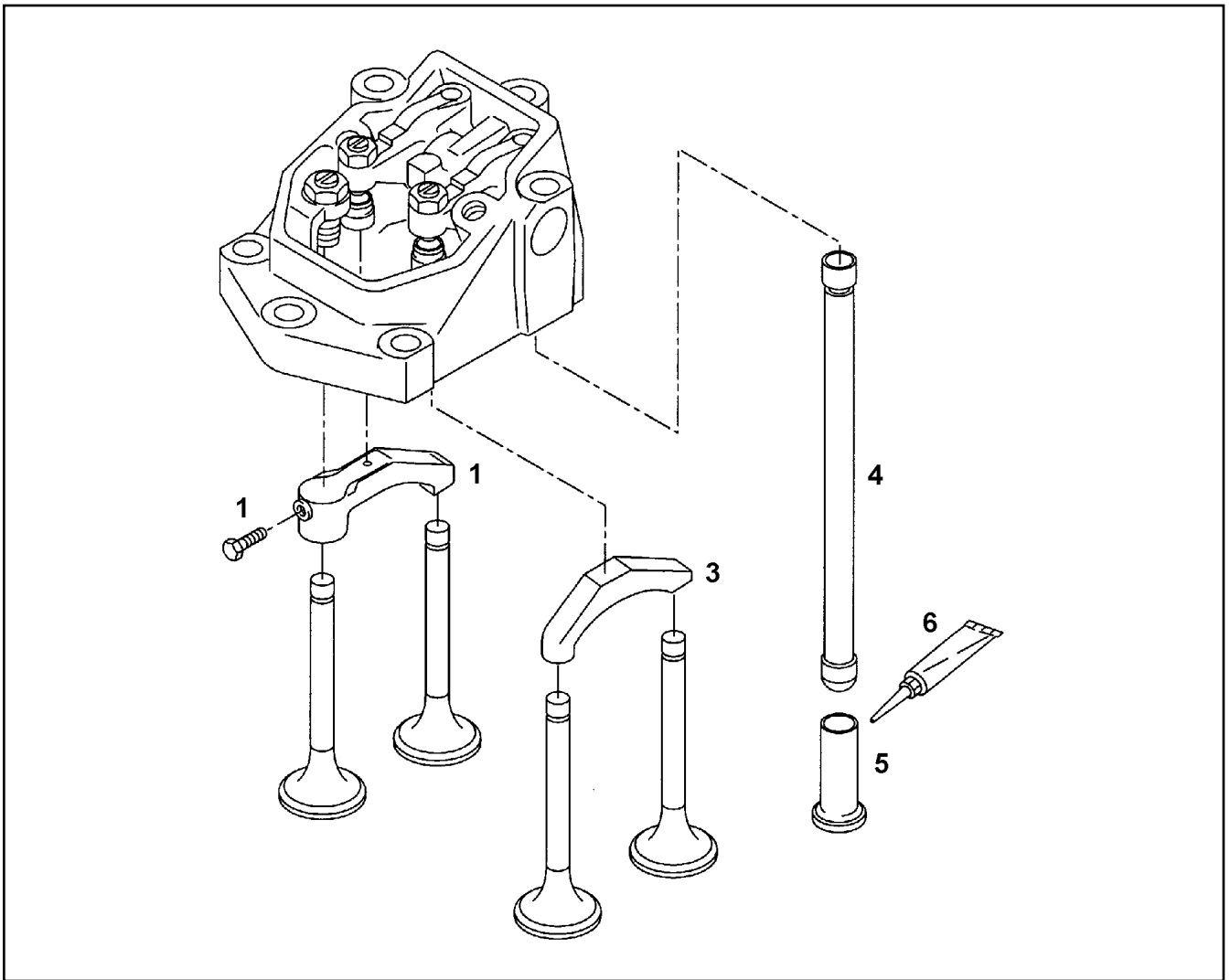

Pos.	Item	Quantity	Description	Bezeichnung	Serie	K
1	10 01 706 2	1	VALVE BRIDGE	VENTILBRUECKE		
3	10 01 706 4	1	VALVE BRIDGE	VENTILBRUECKE		
4	10 01 707 9	2	TAPPET PUSH ROD	STOESSELSTANGE		
5	10 01 711 0	2	VALVE LIFTER	VENTILSTOESSEL		
6	10 01 732 5	1	LUBRICATION	SCHMIERSTOFF		

6.2.2009
031112

LIEBHERR

etk_en_de_074515 LR 1600/2

CONTROL PARTS
STEUERUNGSTEILE

▣ 675

⇒ 9 739 187
97 39 187

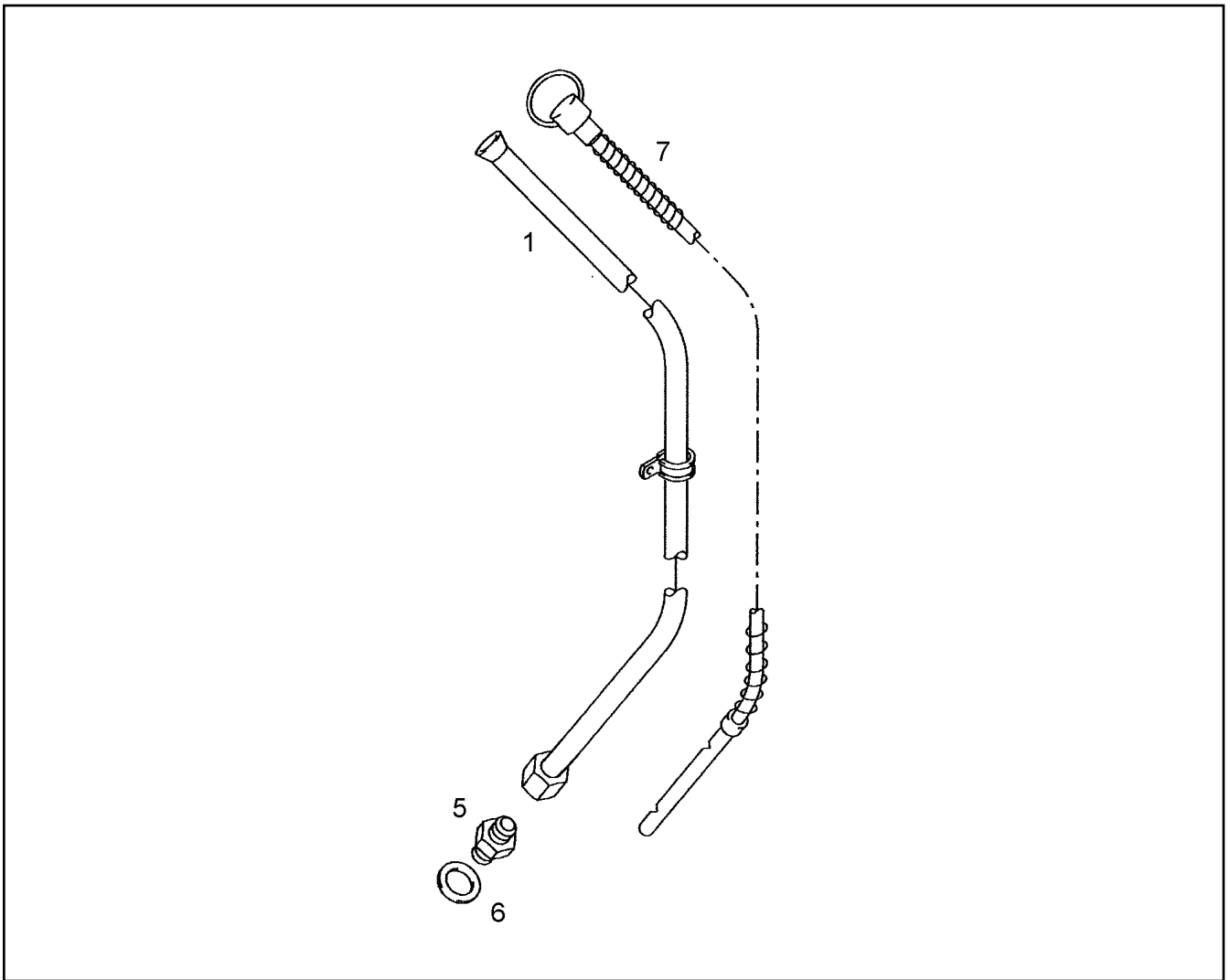

Pos.	Item	Quantity	Description	Bezeichnung	Serie	K
1	10 02 919 1	1	GUIDING PIPE	FUEHRUNGSRÖHR		
5	10 01 199 8	1	SCREW-ON CONNECTION L10 A-M ST	EINSCHRAUBSTUTZEN		
6	10 01 186 6	1	SEALING RING 14,7X22X1,5 ST/FPM1-80	DICHTRING		
7	10 01 745 0	1	OIL-LEVEL GAUGE	OELMESSSTAB		

6.2.2009
030886

LIEBHERR

etk_en_de_074515 LR 1600/2

OIL-LEVEL GAUGE
OELMESSSTAB

676

⇒ 9 739 188
97 39 188

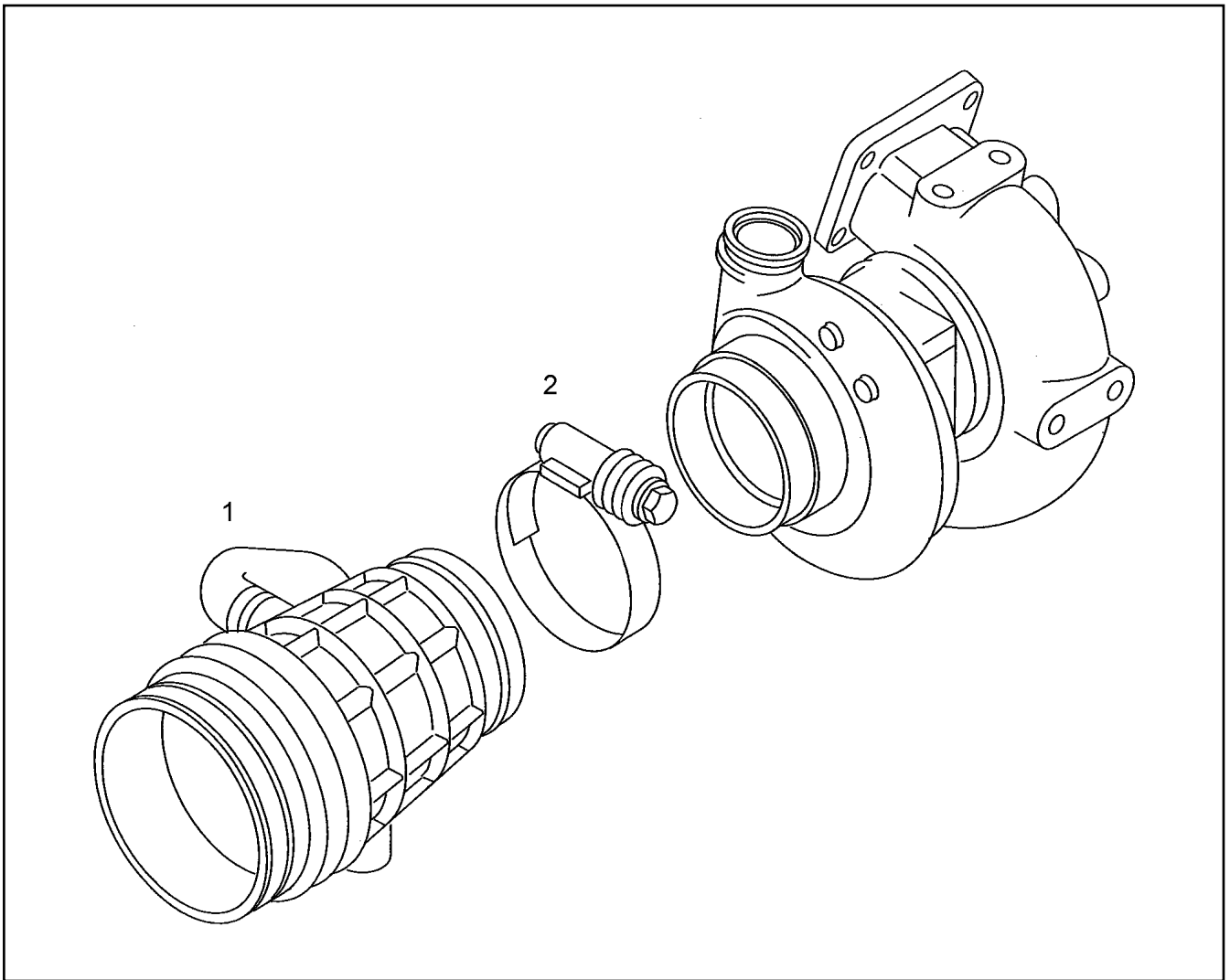

Pos.	Item	Quantity	Description	Bezeichnung	Serie	K
1	10 03 716 3	1	SUCTION NOZZLE D 2876	ANSAUGSTUTZEN		
2	10 03 717 1	1	HOSE CLAMP 100X120 12-W2	SCHLAUCHSCHELLE		

6.2.2009
034385

LIEBHERR

etk_en_de_074515 LR 1600/2

SUCTION NOZZLE
ANSAUGSTUTZEN

677

⇒ 9 739 209
97 39 209

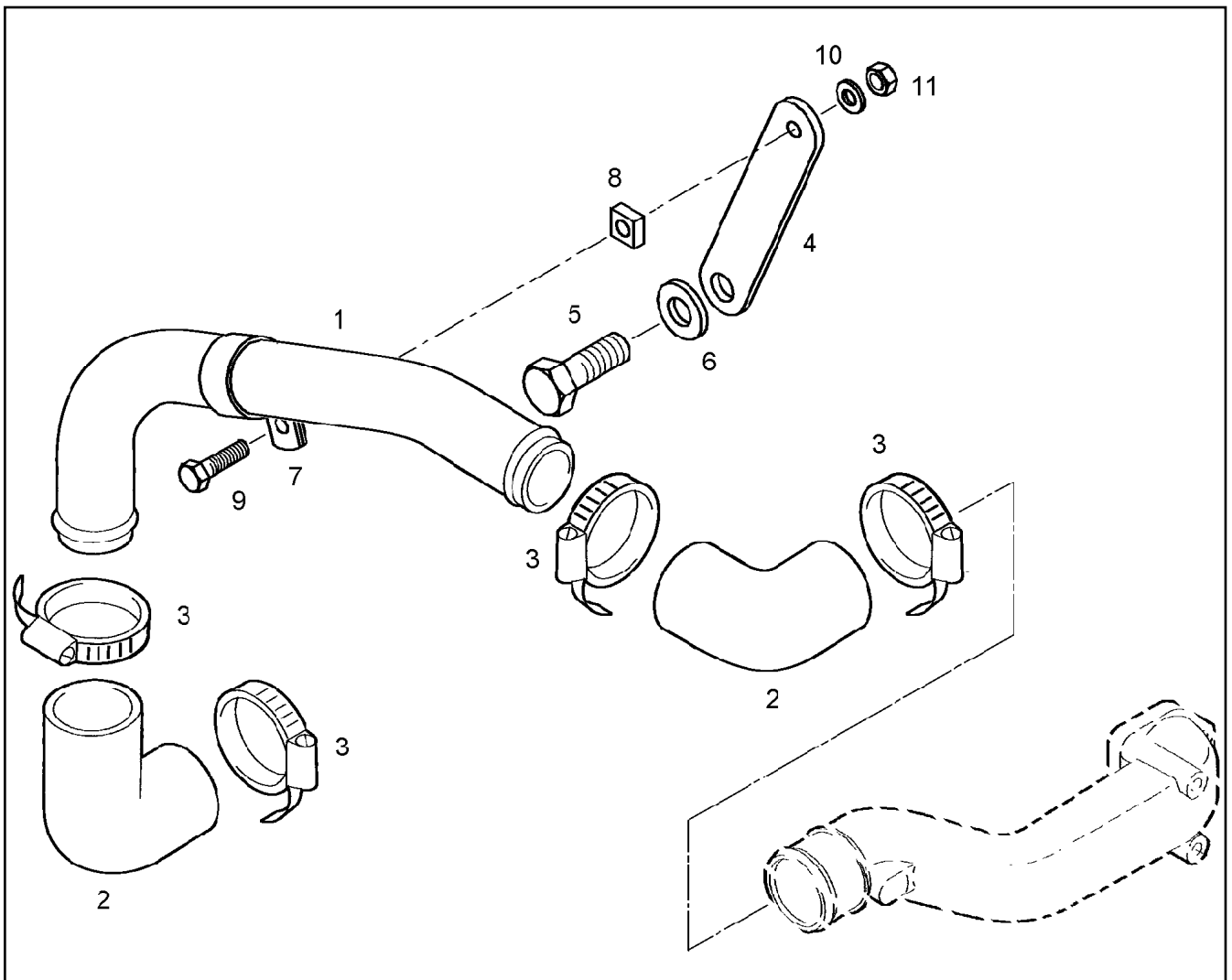

Pos.	Item	Quantity	Description	Bezeichnung	Serie	K
1	10 03 716 9	1	LIQUID COOLING PIPELINE	KUEHLMITTELLEITUNG		
2	10 03 717 3	2	HOSE BEND 90°	SCHLAUCHBOGEN		
3	10 03 717 6	4	HOSE CLAMP 60X80 12-W2	SCHLAUCHSCHELLE		
4	10 03 718 2	1	HOLDER	HALTER		
5	10 03 719 1	1	HEX BOLT M16X30 8.8	SECHSKANTSCHRAUBE		
6	10 03 722 6	1	WASHER A 17,0 200HV A3C	SCHEIBE		
7	10 03 723 0	1	PIPE CLAMP DIN 71555 60,5	ROHRSCHELLE		
8	10 03 723 6	1	SQUARE WASHER	VIERKANTSCHNEIBE		
9	10 01 136 2	1	SCREW M8X25 8.8	SCHRAUBE		
10	10 01 165 4	1	WASHER A 8,4X16X1,6 200HV	SCHEIBE		
11	10 01 163 1	1	NUT M8 8	MUTTER		

6.2.2009
034395

LIEBHERR

etk_en_de_074515 LR 1600/2

LIQUID COOLING PIPELINE
KUEHLMITTELLEITUNG

▣ 678

⇒ 9 739 210
97 39 210

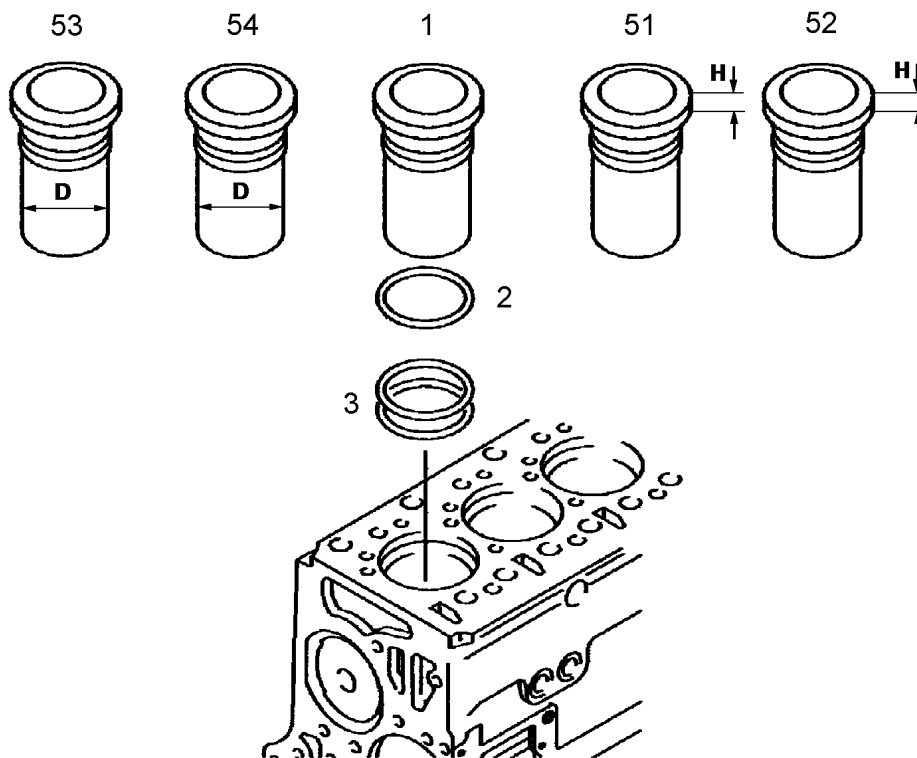

Pos.	Item	Quantity	Description	Bezeichnung	Serie	K
1	10 22 231 7	1	CYLINDER BUSH	ZYLINDERLAUFBUCHSE		
2	10 03 234 8	1	PROFILE PACKING	PROFILDICHTRING		
3	10 01 264 1	2	O RING 144X4 FPM2-70	RUNDDICHTRING		
51	10 22 231 9	6	CYLINDER BUSH	ZYLINDERLAUFBUCHSE		
52	10 22 232 1	6	CYLINDER BUSH	ZYLINDERLAUFBUCHSE		
53	10 22 232 0	6	CYLINDER BUSH	ZYLINDERLAUFBUCHSE		
54	10 22 231 8	6	CYLINDER BUSH	ZYLINDERLAUFBUCHSE		

6.2.2009
041494

LIEBHERR

etk_en_de_074515 LR 1600/2

CYLINDER BUSH
ZYLINDERLAUFBUCHSE

679

⇒ 9 739 242
97 39 242

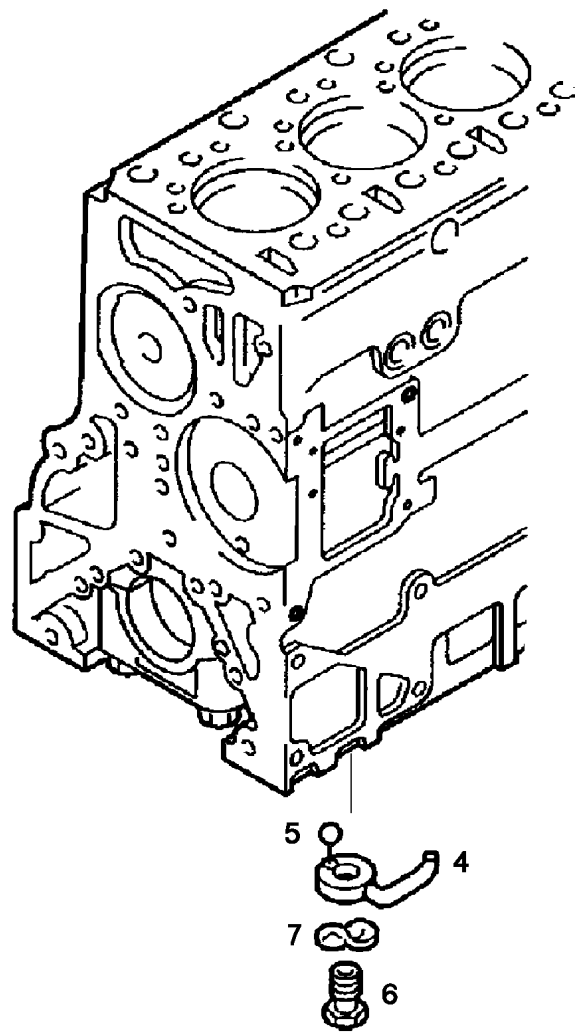

Pos.	Item	Quantity	Description	Bezeichnung	Serie	K
4	10 22 232 2	1	NOZZLE	OELSPRITZDUESE		
5	10 01 183 1	2	BALL 3	KUGEL		
6	10 22 232 3	1	HOLLOW SCREW	HOHLSCHRAUBE		
7	10 01 171 0	1	232204 B 14 FST A3C	FEDERSCHEIBE		

6.2.2009
041495

LIEBHERR

etk_en_de_074515 LR 1600/2

PISTON COOLING
KOLBENKUEHLUNG

680

⇒ 9 739 243
97 39 243

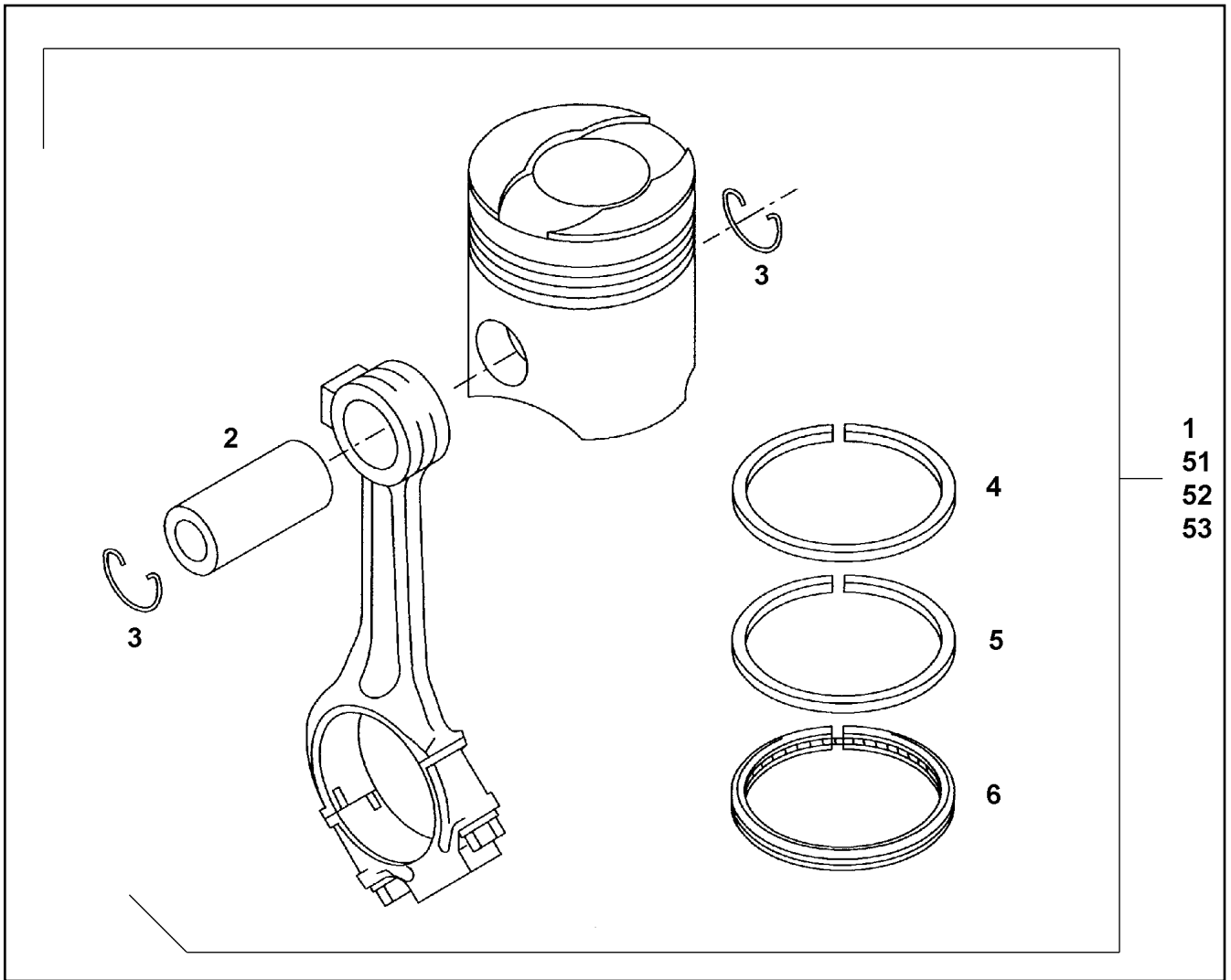

Pos.	Item	Quantity	Description	Bezeichnung	Serie	K
1	10 22 233 3	1	PISTON	KOLBEN		
2	10 22 233 5	1	PISTON BOLT	KOLBENBOLZEN		
3	10 22 233 6	2	SPRING RING	SPRENGRING		
4	10 01 216 0	1	TRAPEZOIDAL RING	TRAPEZRING		
5	10 01 215 7	1	MINUTE RING	MINUTENRING		
6	10 01 215 9	1	CHAMFERED RING	DACHFASENRING		
51	10 22 233 2	1	PISTON	KOLBEN		
52	10 22 233 4	1	PISTON	KOLBEN		
53	10 22 233 1	1	PISTON	KOLBEN		

6.2.2009
041266

LIEBHERR

etk_en_de_074515 LR 1600/2

PISTON
KOLBEN

681

⇒ 9 739 246
97 39 246

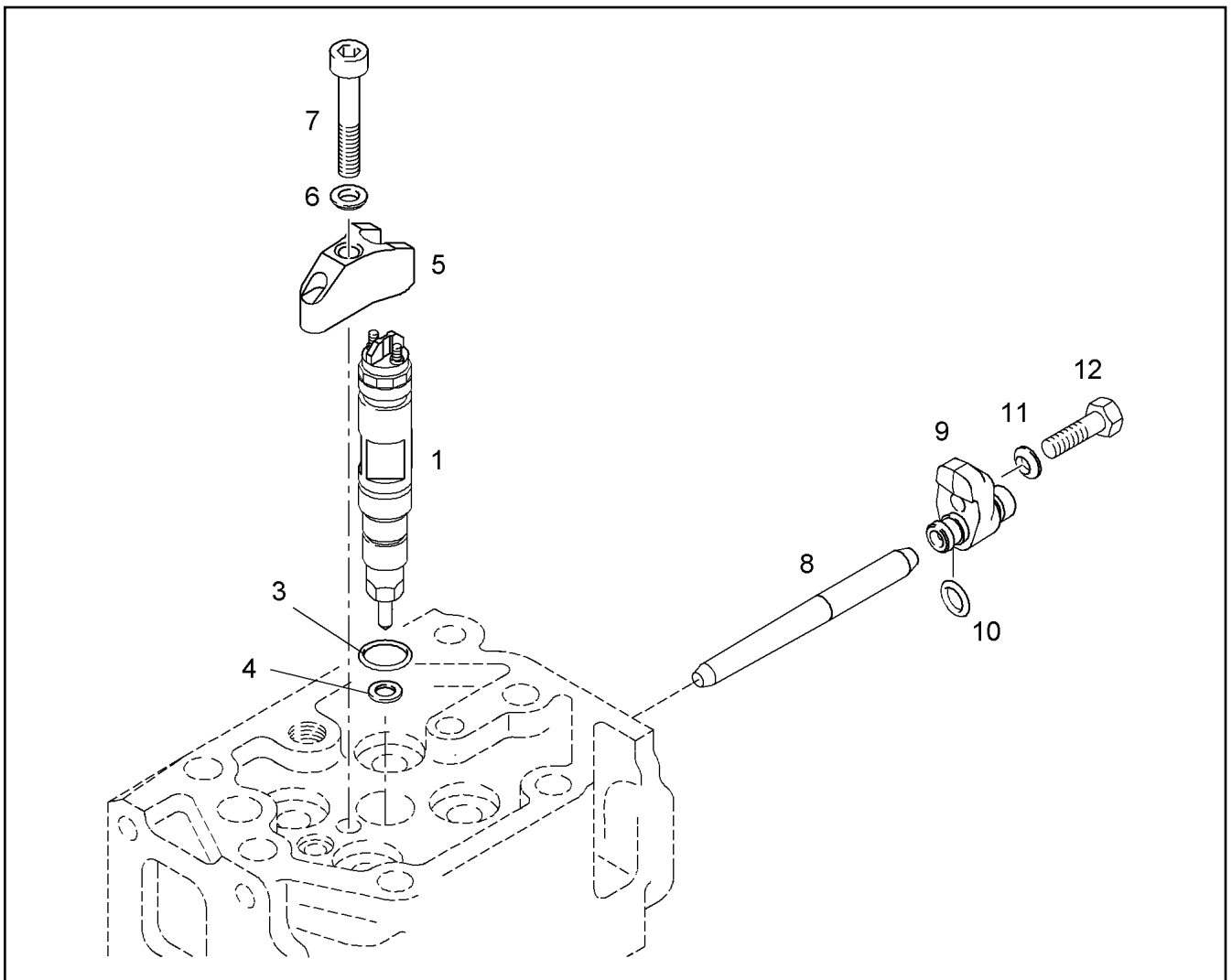

Pos.	Item	Quantity	Description	Bezeichnung	Serie	K
1	10 22 019 8	1	INJECTOR ASSY	INJEKTOR		
3	10 22 273 5	1	O RING	RUNDDICHTRING		
4	10 22 273 6	1	SEALING RING	DICHTRING		
5	90 78 321	1	CLAW SINT-D39	PRATZE		
6	10 01 173 8	1	SPHERICAL WASHER DIN 6319 C 8.4 ST A2	KUGELSCHIEBE		
7	10 22 273 7	1	FLANGED BOLT	BUNDSCHRAUBE		
8	10 01 242 4	1	PIPE SOCKET	ROHRSTUTZEN		
9	10 22 273 8	1	FASTENING	BEFESTIGUNG		
10	10 01 191 9	1	O RING 9X3 N-FPM1-70-GN	RUNDDICHTRING		
11	10 01 173 6	1	SPHERICAL WASHER C 10,5	KUGELSCHIEBE		
12	10 01 133 1	1	SCREW M10X35 8.8	SCHRAUBE		

6.2.2009
041277

LIEBHERR

etk_en_de_074515 LR 1600/2

INJECTOR
EINSPRITZDUENSE

682

⇒ 9 739 248
97 39 248

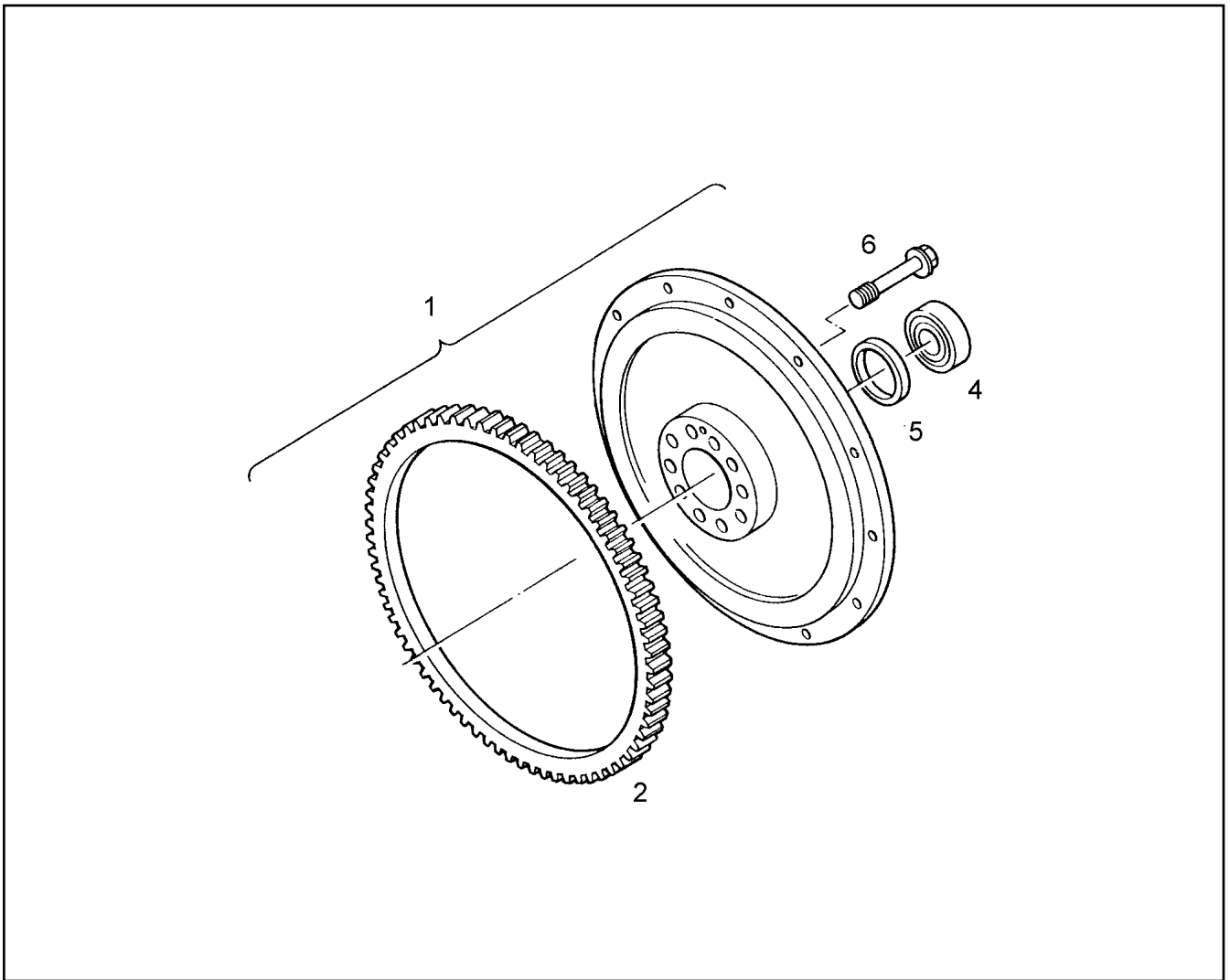

Pos.	Item	Quantity	Description	Bezeichnung	Serie	K
1	10 22 233 9	1	FLYWHEEL	SCHWUNGRAD		
2	10 01 219 1	1	CROWN GEAR	ZAHNKRANZ		
4	10 34 330 8	1	DEEP GROOVE BALL BEARING 6305-2RS2C	RILLENKUGELLAGER		
5	10 01 261 7	1	SPACER RING	DISTANZRING		
6	10 01 250 5	10	SCREW M16X1,5X75 12.9	SCHRAUBE		

6.2.2009
042176

LIEBHERR

etk_en_de_074515 LR 1600/2

FLYWHEEL
SCHWUNGRAD

683

⇒ 9 739 250
97 39 250

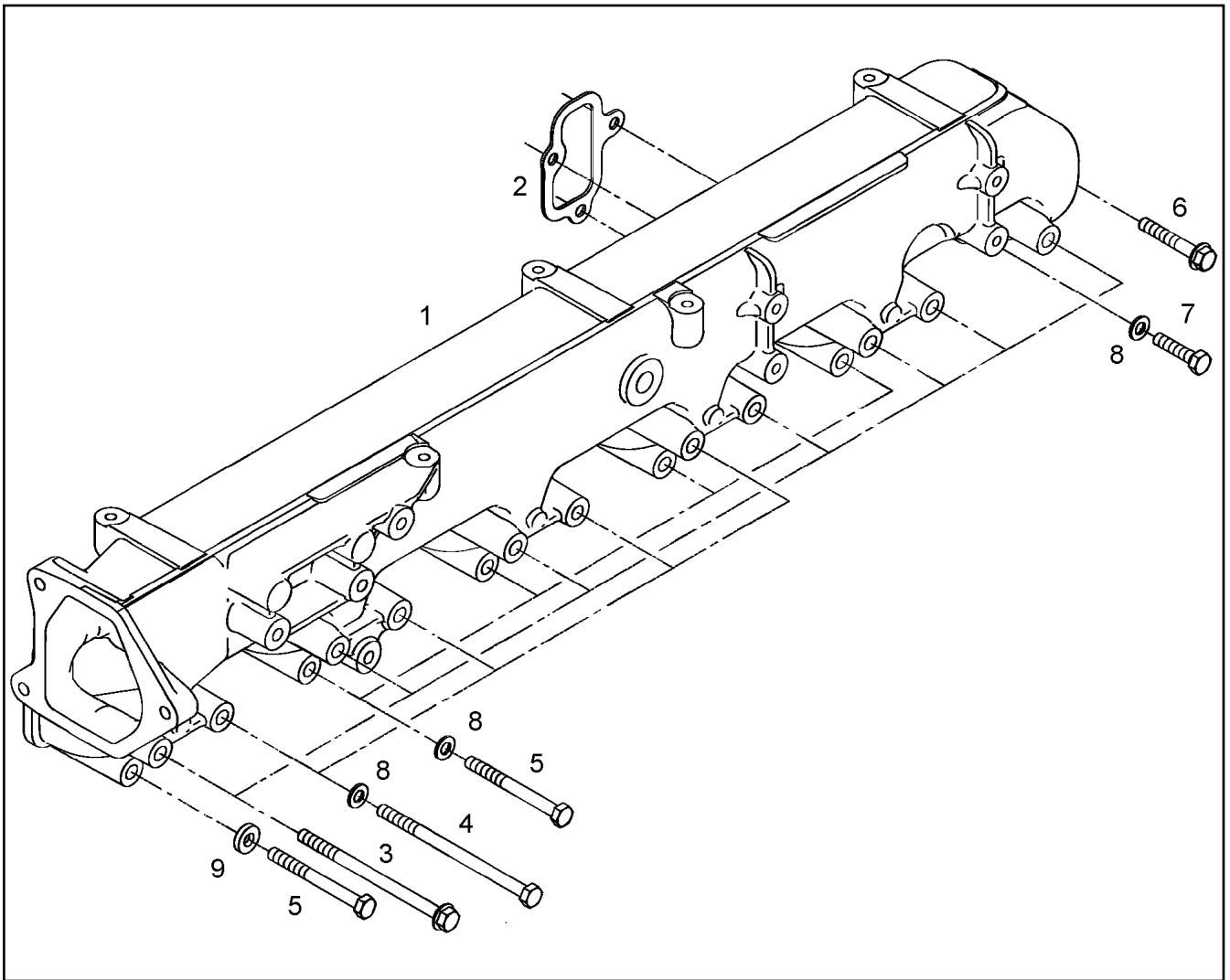

Pos.	Item	Quantity	Description	Bezeichnung	Serie	K
1	10 22 272 6	1	AIR DISTRIBUTOR	LUFTVERTEILER		
2	10 22 272 7	6	SEAL	DICHTUNG		
3	10 22 272 8	7	FLANGED BOLT	BUNDSCHRAUBE		
4	10 01 126 7	4	SCREW M8X130 10.9	SCHRAUBE		
5	10 22 272 9	4	HEX BOLT M8X80 10.9 MAN183-PHR	SECHSKANTSCHRAUBE		
6	10 22 236 1	1	FLANGED BOLT	BUNDSCHRAUBE		
7	10 01 133 9	1	SCREW M8X35 10.9	SCHRAUBE		
8	10 01 165 4	9	WASHER A 8,4X16X1,6 200HV	SCHEIBE		
9	10 01 256 8	1	WASHER 8,4X19X4 C45K	SCHEIBE		

6.2.2009
041284

LIEBHERR

etk_en_de_074515 LR 1600/2

AIR SUCTION PIPE
LUFTANSAUGROHR

684

⇒ 9 739 256
97 39 256

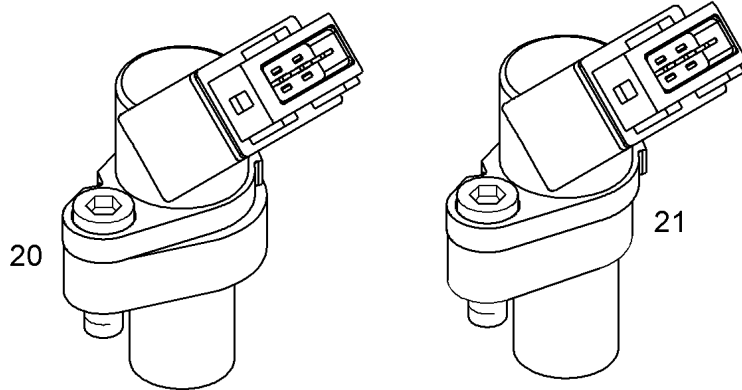

Pos.	Item	Quantity	Description	Bezeichnung	Serie	K
20	90 79 185	1	TACHOMETER ⇒ 9 079 185 90 79 185	DREHZAHLGEBER		
21	90 79 186	1	TACHOMETER ⇒ 9 079 186 90 79 186	DREHZAHLGEBER		

6.2.2009
038649

LIEBHERR

etk_en_de_074515 LR 1600/2

ENGINE CONTROL SENSORS
MOTORREGELUNGSENSORIK

685

⇒ 9 739 257
97 39 257

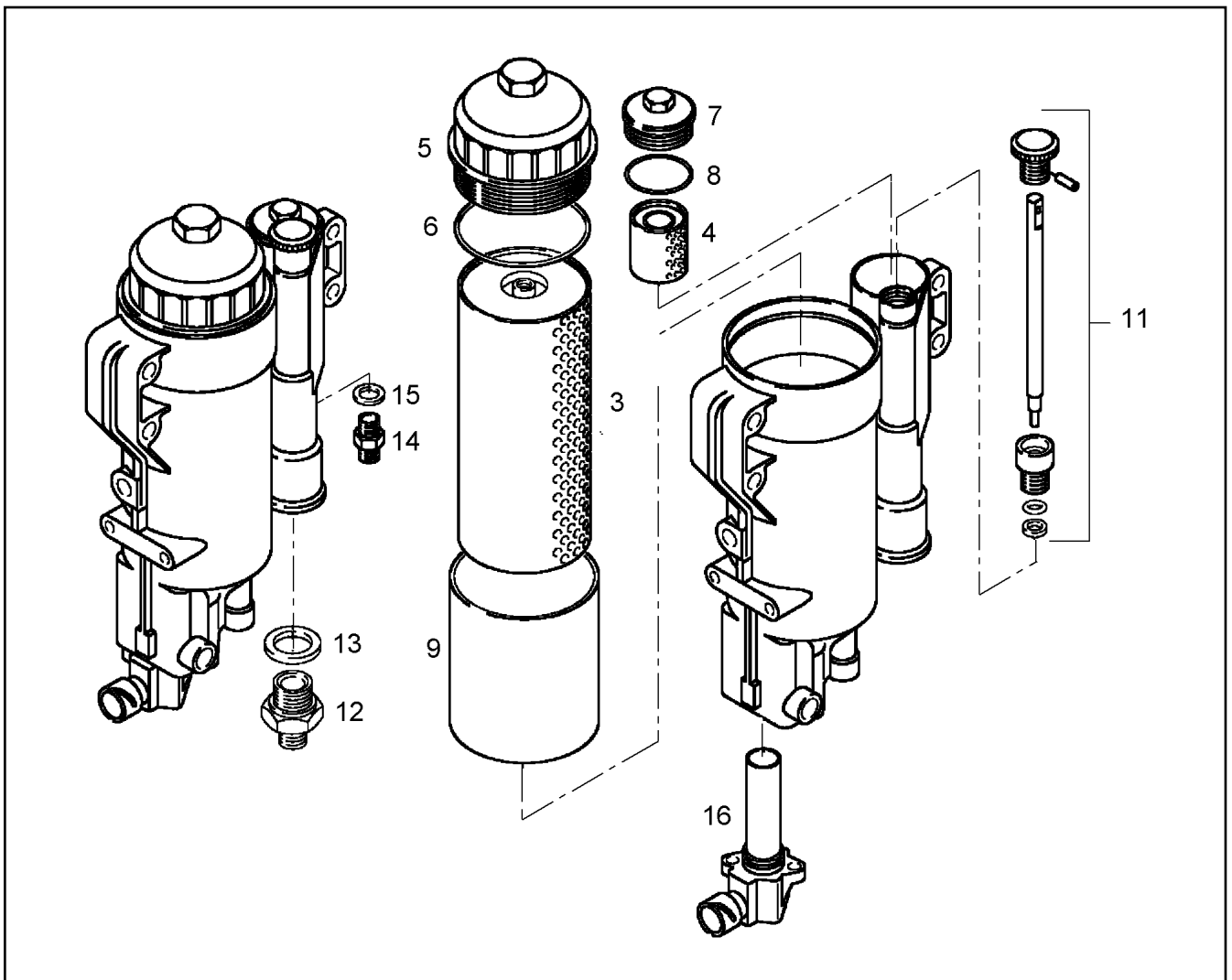

Pos.	Item	Quantity	Description	Bezeichnung	Serie	K
3	10 22 275 7	1	FUEL FILTER ELEMENT	KRAFTSTOFFFILTEREINSATZ		
4	10 01 245 0	1	STRAINER FILTER	SIEBFILTER		
5	10 01 245 1	1	LID	DECKEL		
6	10 01 191 6	1	O RING 91X4 N-NBR3-70	RUNDDICHTRING		
7	10 01 245 2	1	LID	DECKEL		
8	10 01 185 2	1	O RING 48X3 B-NBR3-70	RUNDDICHTRING		
9	10 22 275 8	1	HOUSING	GEHAEUSE		
11	10 01 243 7	1	SET OF BRUSHES	TEILESATZ		
12	10 01 271 8	1	SCREW-ON CONNECTION	EINSCHRAUBSTUTZEN		
13	10 01 186 9	1	SEALING RING 22,7X30X2 ST/FPM1-80	DICHTRING		
14	10 01 200 4	1	SCREW-ON CONNECTION L12 A M14X1,5 S	EINSCHRAUBSTUTZEN		
15	10 01 186 6	1	SEALING RING 14,7X22X1,5 ST/FPM1-80	DICHTRING		
16	10 01 245 3	1	FUEL HEATING	KRAFTSTOFFHEIZUNG		

6.2.2009
041279

LIEBHERR

etk_en_de_074515 LR 1600/2

FUEL FILTER
KRAFTSTOFFFILTER

686

⇒ 9 739 258
97 39 258

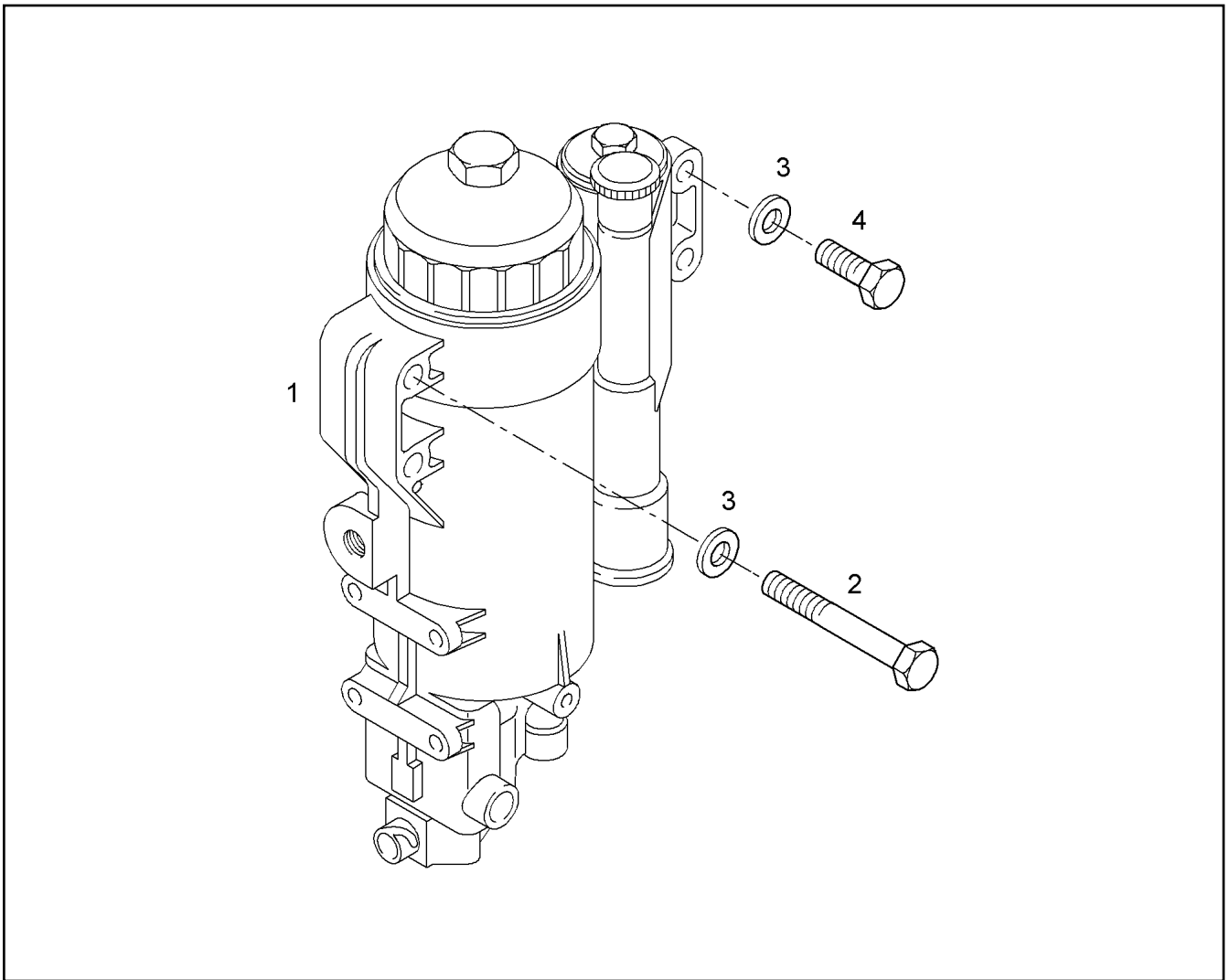

Pos.	Item	Quantity	Description	Bezeichnung	Serie	K
1	97 39 258	1	FUEL FILTER ⇒ 9 739 258 97 39 258	KRAFTSTOFFFILTER		
2	10 01 126 2	2	SCREW M8X90 8.8	SCHRAUBE		
3	10 01 165 4	2	WASHER A 8,4X16X1,6 200HV	SCHEIBE		
4	10 01 132 6	2	SCREW M8X45 8.8	SCHRAUBE		

6.2.2009
041278

LIEBHERR

etk_en_de_074515 LR 1600/2

FUEL FILTER
KRAFTSTOFFFILTER

687

⇒ 9 739 259
97 39 259

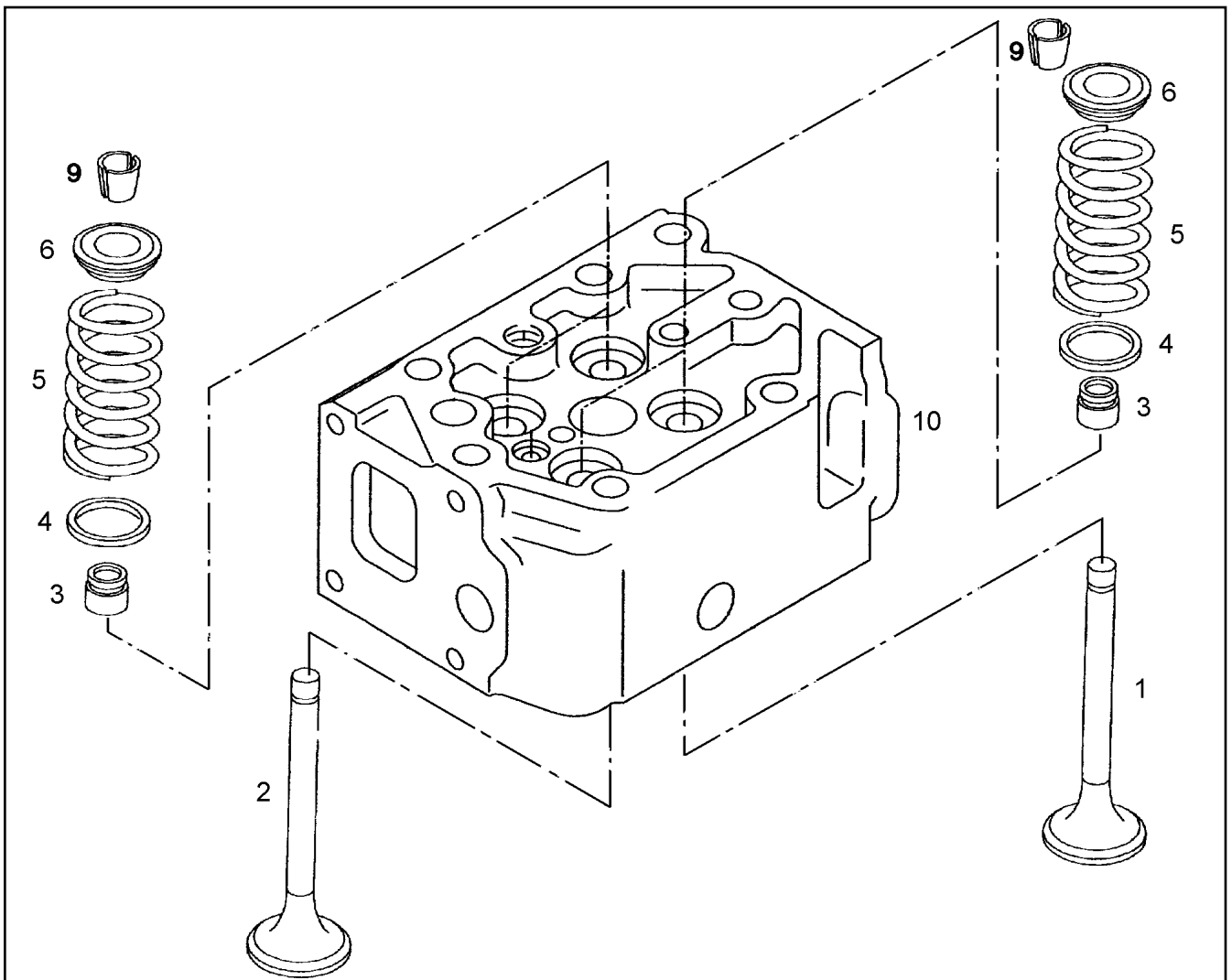

Pos.	Item	Quantity	Description	Bezeichnung	Serie	K
1	10 22 234 7	2	ADMISSION VALVE	EINLASSVENTIL		
2	10 22 234 8	2	OUTLET VALVE	AUSLASSVENTIL		
3	10 01 224 7	4	VALVE STEM SEAL	VENTILSCHAFTDICHTUNG		
4	10 01 256 3	4	WASHER 15,5X34X0,5 CK67V	SCHEIBE		
5	10 01 221 0	4	VALVE SPRING 4,25X28,35X63,32 SICR	VENTILFEDER		
6	90 78 515	4	SPRING CUP 16MNCR5	FEDERTELLER		
9	10 10 164 9	8	VALVE COLLET	VENTILKEGELSTUECK		
10	97 39 260	1	CYLINDER HEAD R-MOTOR	ZYLINDERKOPF		

6.2.2009
041269

LIEBHERR

etk_en_de_074515 LR 1600/2

CYLINDER HEAD
ZYLINDERKOPF

688

⇒ 9 739 261
97 39 261

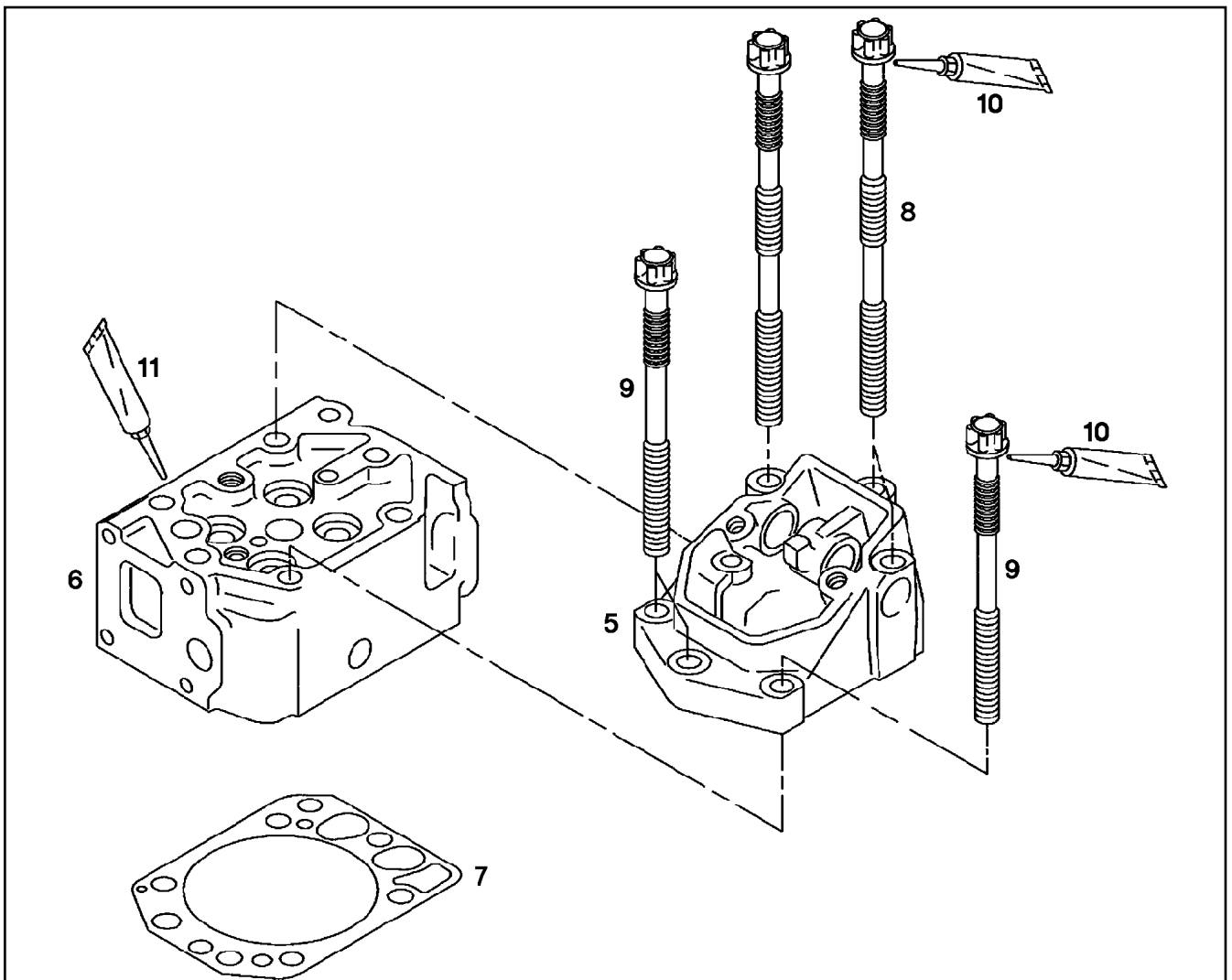

Pos.	Item	Quantity	Description	Bezeichnung	Serie	K
5	97 39 263	1	ROCKER ARM BEARING HOUSING ⇒ 9 739 263 97 39 263	KIPPHEBELLAGERGEHAEUSE		
6	97 39 261	1	CYLINDER HEAD ⇒ 9 739 261 97 39 261	ZYLINDERKOPF		
7	10 03 231 8	1	CYLINDER HEAD GASKET	ZYLINDERKOPFDICHTUNG		
8	10 22 234 3	3	FILLISTER SOCKET HEAD SCREW M16X2X	ZYLINDERKOPFSCHRAUBE		
9	10 22 234 4	3	FILLISTER SOCKET HEAD SCREW M16X2X	ZYLINDERKOPFSCHRAUBE		
10	86 13 009 08	1	SPECIAL GREASE 100G TUBE	SPEZIALFETT		
11	10 01 117 2	1	SEALANT	DICHTMITTEL		

6.2.2009
041267

LIEBHERR

etk_en_de_074515 LR 1600/2

CYLINDER HEAD
ZYLINDERKOPF

689

⇒ 9 739 262
97 39 262

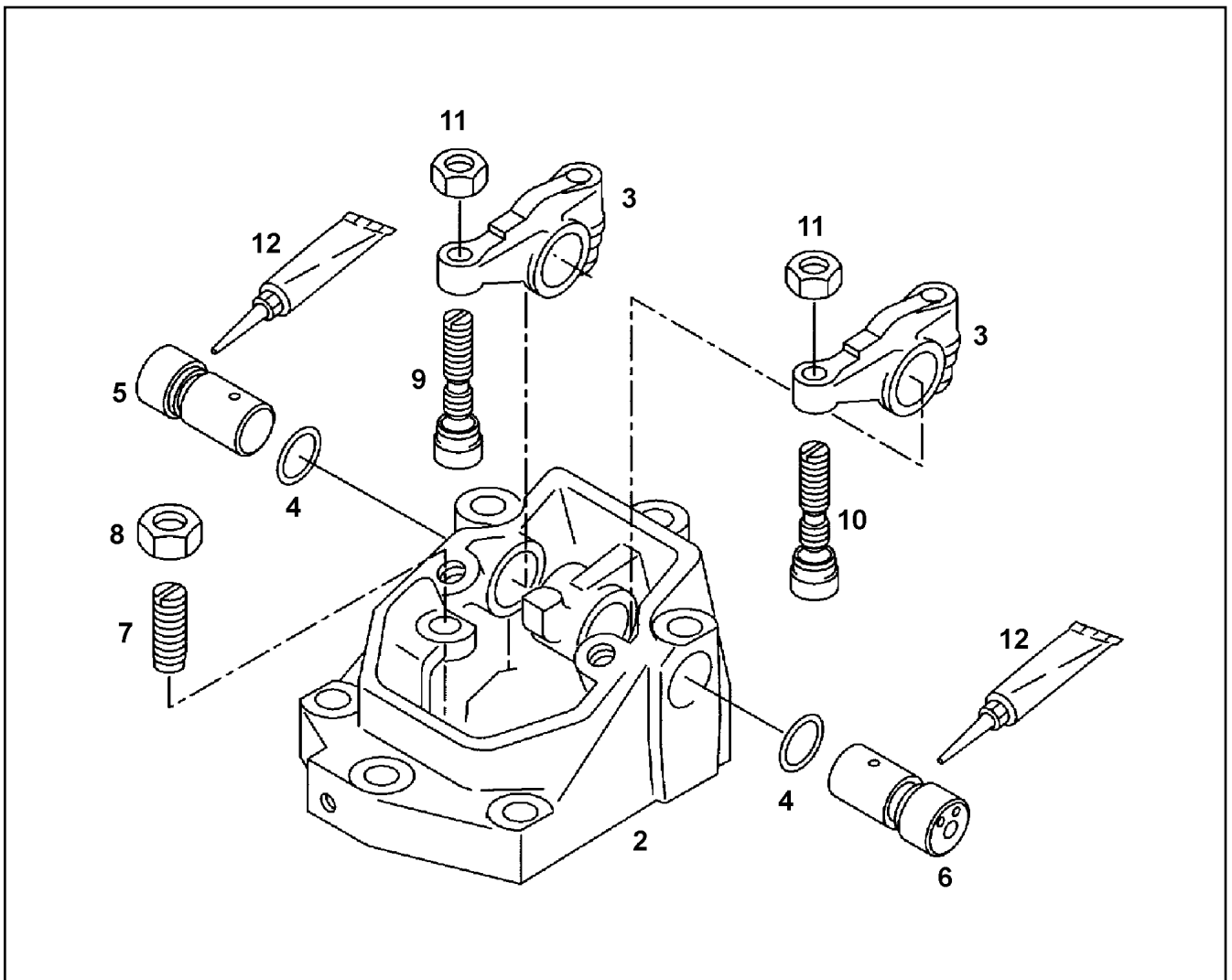

Pos.	Item	Quantity	Description	Bezeichnung	Serie	K
2	10 22 235 1	1	ROCKER ARM BEARING HOUSING	KIPPHEBELLAGERGEHAEUSE		
3	10 01 221 3	2	ROCKER LEVER	KIPPHEBEL		
4	10 01 192 0	2	O RING 23X2,5 FPM1-70-GN	RUNDDICHTRING		
5	10 22 234 9	1	ROCKER AXLE	KIPPHEBELACHSE		
6	10 22 235 0	1	ROCKER AXLE	KIPPHEBELACHSE		
7	10 01 222 0	1	ADJUSTING SCREW M14X1X35	EINSTELLSCHRAUBE		
8	10 01 256 0	1	HEX NUT M14X1	SECHSKANTMUTTER		
9	10 01 222 1	1	ADJUSTING SCREW M10X1X41,1	EINSTELLSCHRAUBE		
10	10 01 222 5	1	ADJUSTING SCREW M10X1X41,1	EINSTELLSCHRAUBE		
11	10 01 255 7	2	HEX NUT M10X1 -8	SECHSKANTMUTTER		
12	86 13 009 08	1	SPECIAL GREASE 100G TUBE	SPEZIALFETT		

6.2.2009
041268

LIEBHERR

etk_en_de_074515 LR 1600/2

ROCKER ARM BEARING HOUSING
KIPPHEBELLAGERGEHAEUSE

▣ 690

⇒ 9 739 263
97 39 263

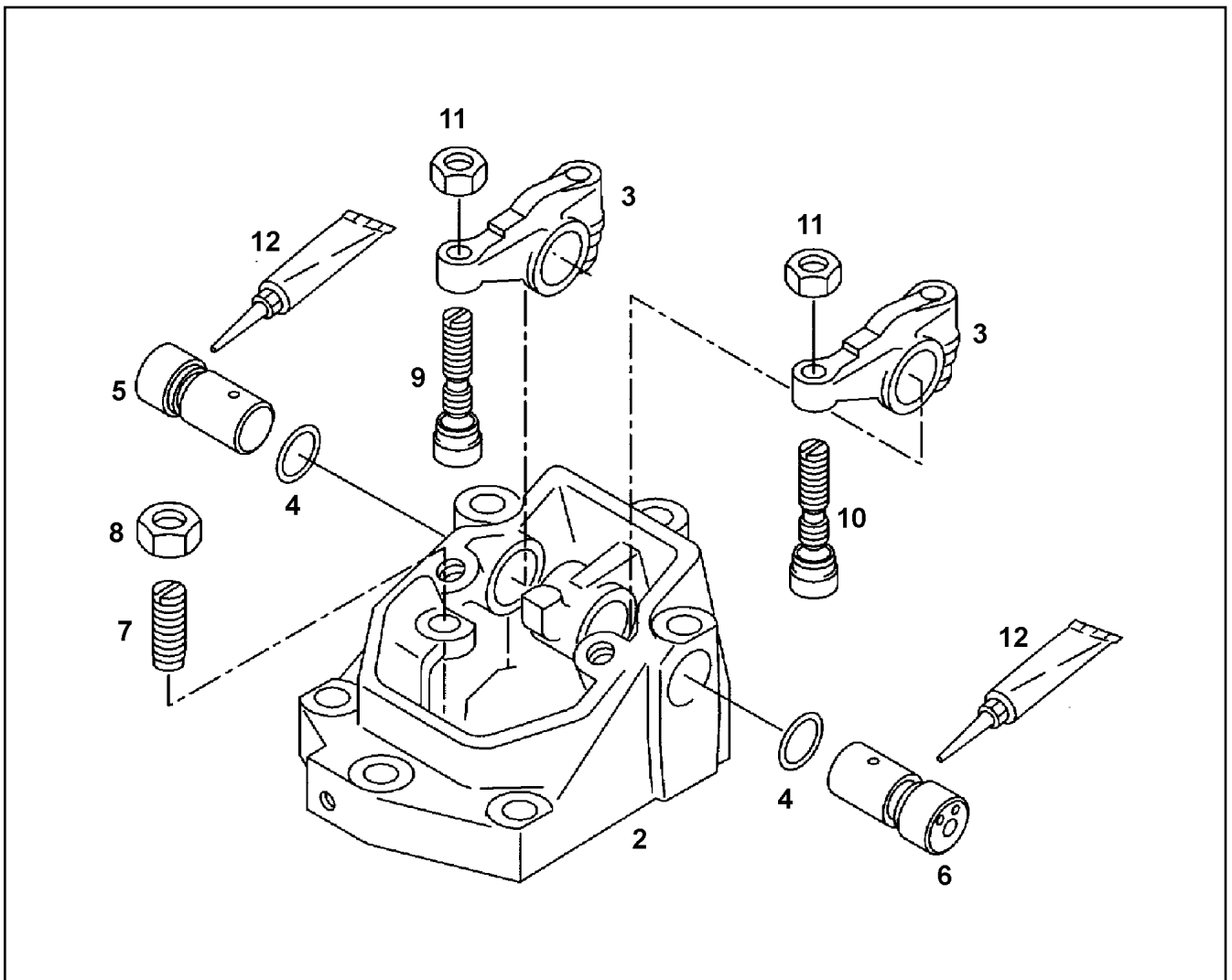

Pos.	Item	Quantity	Description	Bezeichnung	Serie	K
2	10 22 235 2	1	ROCKER ARM BEARING HOUSING	KIPPHEBELLAGERGEHAEUSE		
3	10 01 221 3	2	ROCKER LEVER	KIPPHEBEL		
4	10 01 192 0	2	O RING 23X2,5 FPM1-70-GN	RUNDDICHTRING		
5	10 22 234 9	1	ROCKER AXLE	KIPPHEBELACHSE		
6	10 22 235 0	1	ROCKER AXLE	KIPPHEBELACHSE		
7	10 01 222 0	1	ADJUSTING SCREW M14X1X35	EINSTELLSCHRAUBE		
8	10 01 256 0	1	HEX NUT M14X1	SECHSKANTMUTTER		
9	10 01 222 1	1	ADJUSTING SCREW M10X1X41,1	EINSTELLSCHRAUBE		
10	10 01 222 5	1	ADJUSTING SCREW M10X1X41,1	EINSTELLSCHRAUBE		
11	10 01 255 7	2	HEX NUT M10X1 -8	SECHSKANTMUTTER		
12	86 13 009 08	1	SPECIAL GREASE 100G TUBE	SPEZIALFETT		

6.2.2009
041271

LIEBHERR

etk_en_de_074515 LR 1600/2

ROCKER ARM BEARING HOUSING
KIPPHEBELLAGERGEHAEUSE

▣ 691

⇒ 9 739 264
97 39 264

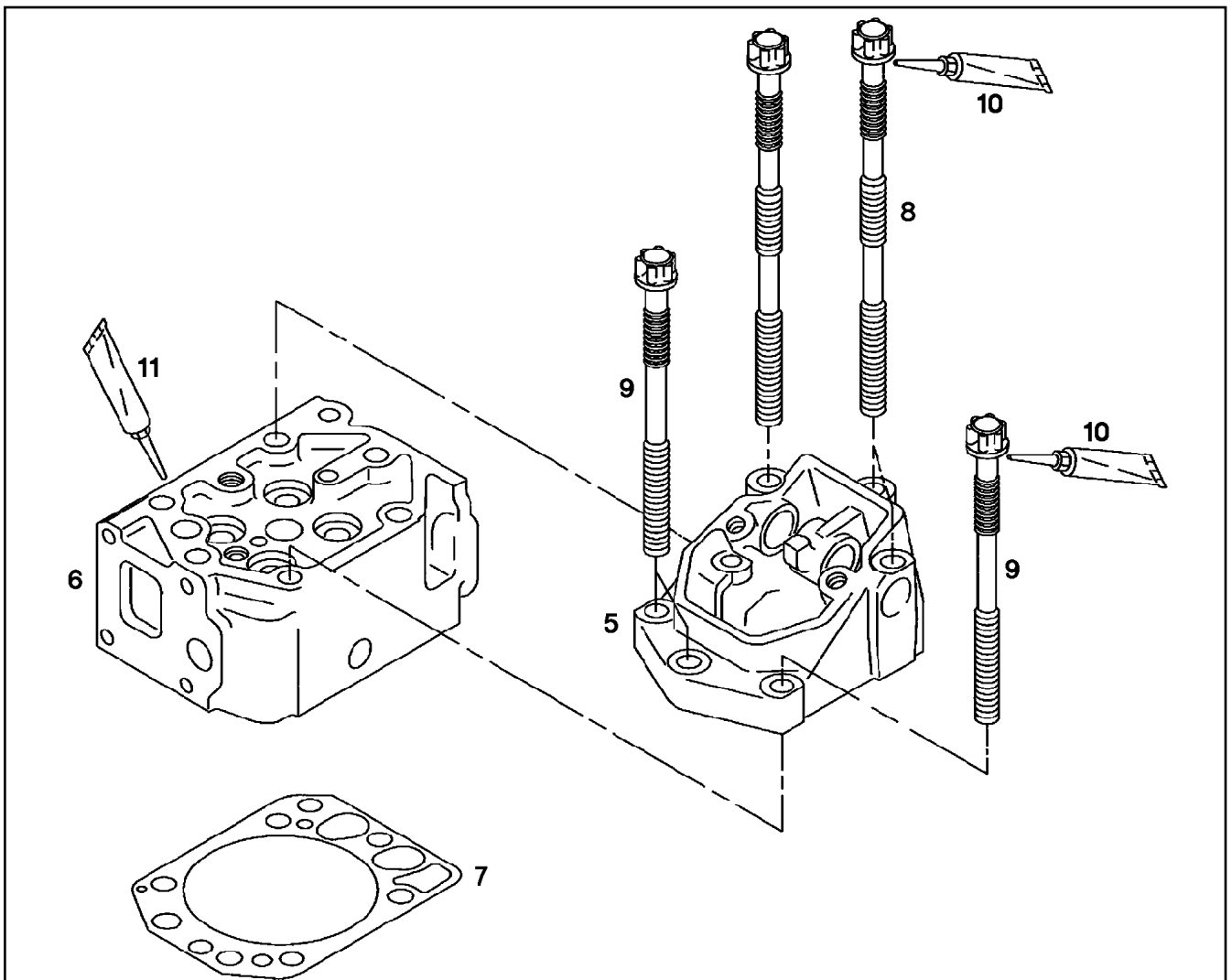

Pos.	Item	Quantity	Description	Bezeichnung	Serie	K
5	97 39 264	1	ROCKER ARM BEARING HOUSING ⇒ 9 739 264 97 39 264	KIPPHEBELLAGERGEHAEUSE		
6	97 39 261	1	CYLINDER HEAD ⇒ 9 739 261 97 39 261	ZYLINDERKOPF		
7	10 03 231 8	1	CYLINDER HEAD GASKET	ZYLINDERKOPFDICHTUNG		
8	10 22 234 3	3	FILLISTER SOCKET HEAD SCREW M16X2X	ZYLINDERKOPFSCHRAUBE		
9	10 22 234 4	3	FILLISTER SOCKET HEAD SCREW M16X2X	ZYLINDERKOPFSCHRAUBE		
10	86 13 009 08	1	SPECIAL GREASE 100G TUBE	SPEZIALFETT		
11	10 01 117 2	1	SEALANT	DICHTMITTEL		

6.2.2009
041270

LIEBHERR

etk_en_de_074515 LR 1600/2

CYLINDER HEAD
ZYLINDERKOPF

▣ 692

⇒ 9 739 266
97 39 266

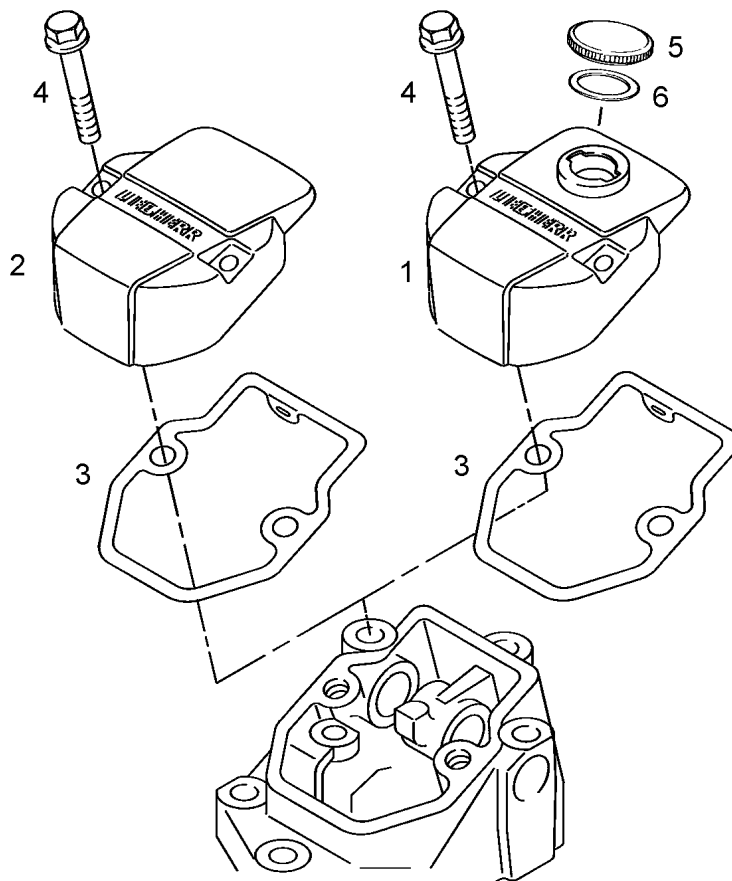

Pos.	Item	Quantity	Description	Bezeichnung	Serie	K
1	10 01 333 5	1	CYLINDER HEAD COVER	ZYLINDERKOPFDECKEL		
2	10 01 219 8	5	CYLINDER HEAD COVER	ZYLINDERKOPFDECKEL		
3	10 22 234 5	6	SEAL	DICHTUNG		
4	10 01 250 7	12	HEX BOLT M8X43,5 8.8 A2C	SECHSKANTSCHRAUBE		
5	10 01 333 6	1	SCREW CAP	VERSCHLUSSDECKEL		
6	10 01 333 7	1	SEAL	DICHTUNG		

6.2.2009
041272

LIEBHERR

etk_en_de_074515 LR 1600/2

CYLINDER FAIRING
ZYLINDERKOPFHAUBE

693

⇒ 9 739 267
97 39 267

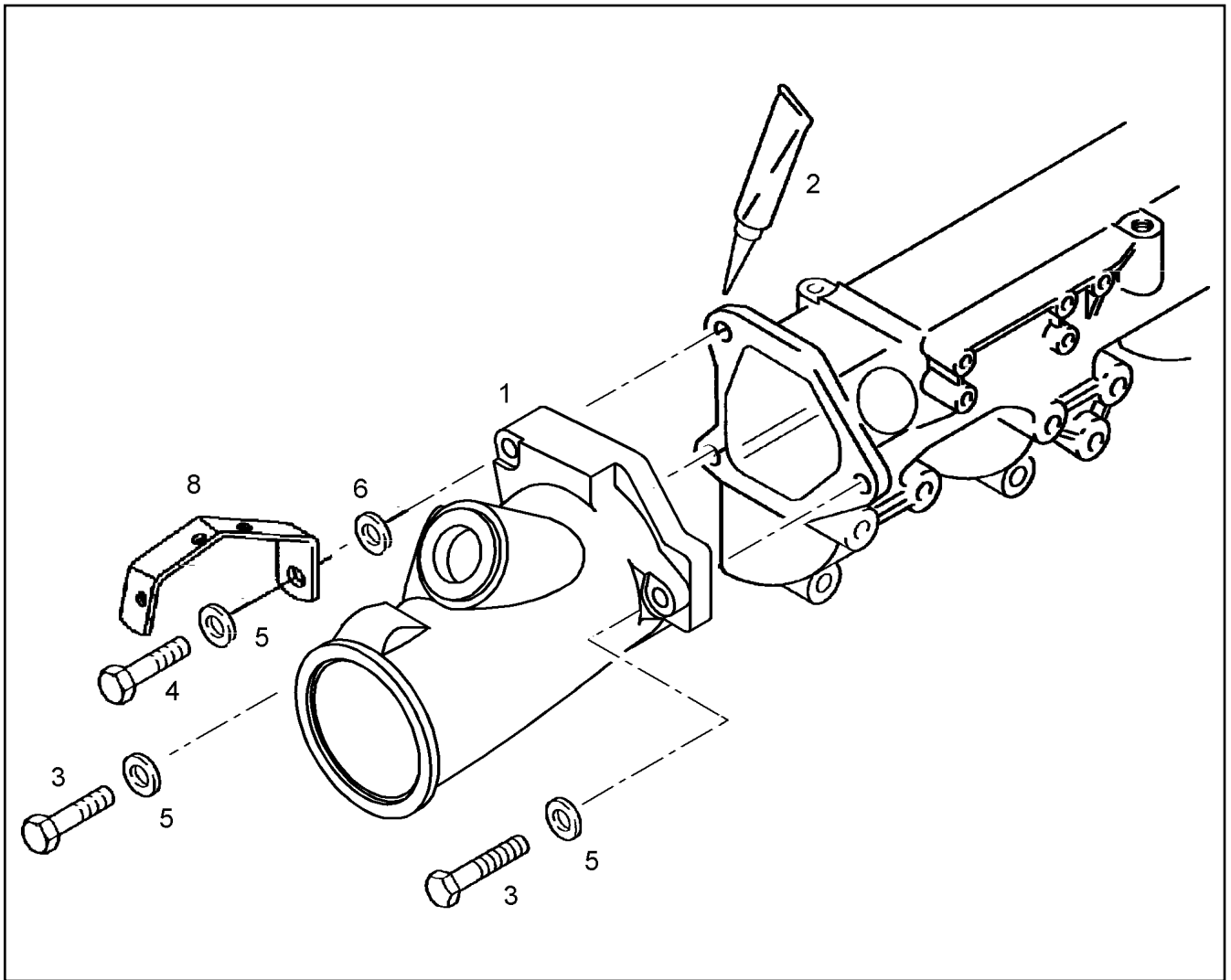

Pos.	Item	Quantity	Description	Bezeichnung	Serie	K
1	10 22 273 0	1	AIR ELBOW	LADELUFTKRUEMMER		
2	10 01 117 2	1	SEALANT	DICHTMITTEL		
3	10 01 133 4	2	SCREW M8X55 8.8	SCHRAUBE		
4	10 01 133 7	1	SCREW M10X65 10.9 A3C	SCHRAUBE		
5	10 01 165 8	3	WASHER A 10,5X20X2,0 200HV	SCHEIBE		
6	10 01 256 6	1	WASHER 11X22X5 9SMNPB28	SCHEIBE		
8	10 02 091 7	1	HOLDER	HALTER		

6.2.2009
041286

LIEBHERR

etk_en_de_074515 LR 1600/2

CONNECTING LINE
VERBINDUNGSLEITUNG

694

⇒ 9 739 271
97 39 271

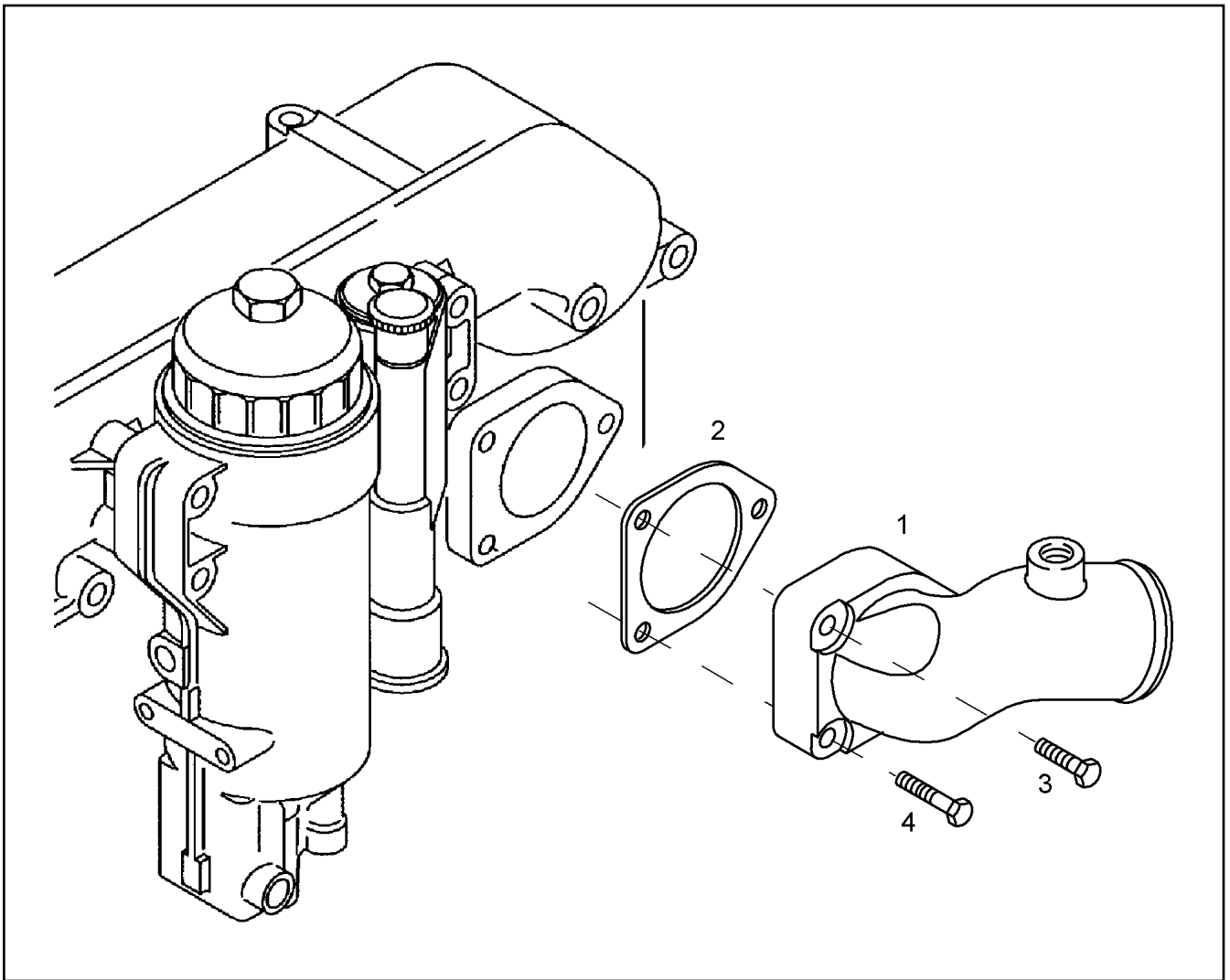

Pos.	Item	Quantity	Description	Bezeichnung	Serie	K
1	10 22 237 4	1	ELBOW	KRUEMMER		
2	10 01 234 6	1	SEAL	DICHTUNG		
3	10 01 132 6	2	SCREW M8X45 8.8	SCHRAUBE		
4	10 01 132 8	1	SCREW M8X55 8.8	SCHRAUBE		

6.2.2009
041296

LIEBHERR

etk_en_de_074515 LR 1600/2

WATER CONNECTION
WASSERANSCHLUSS

695

⇒ 9 739 276
97 39 276

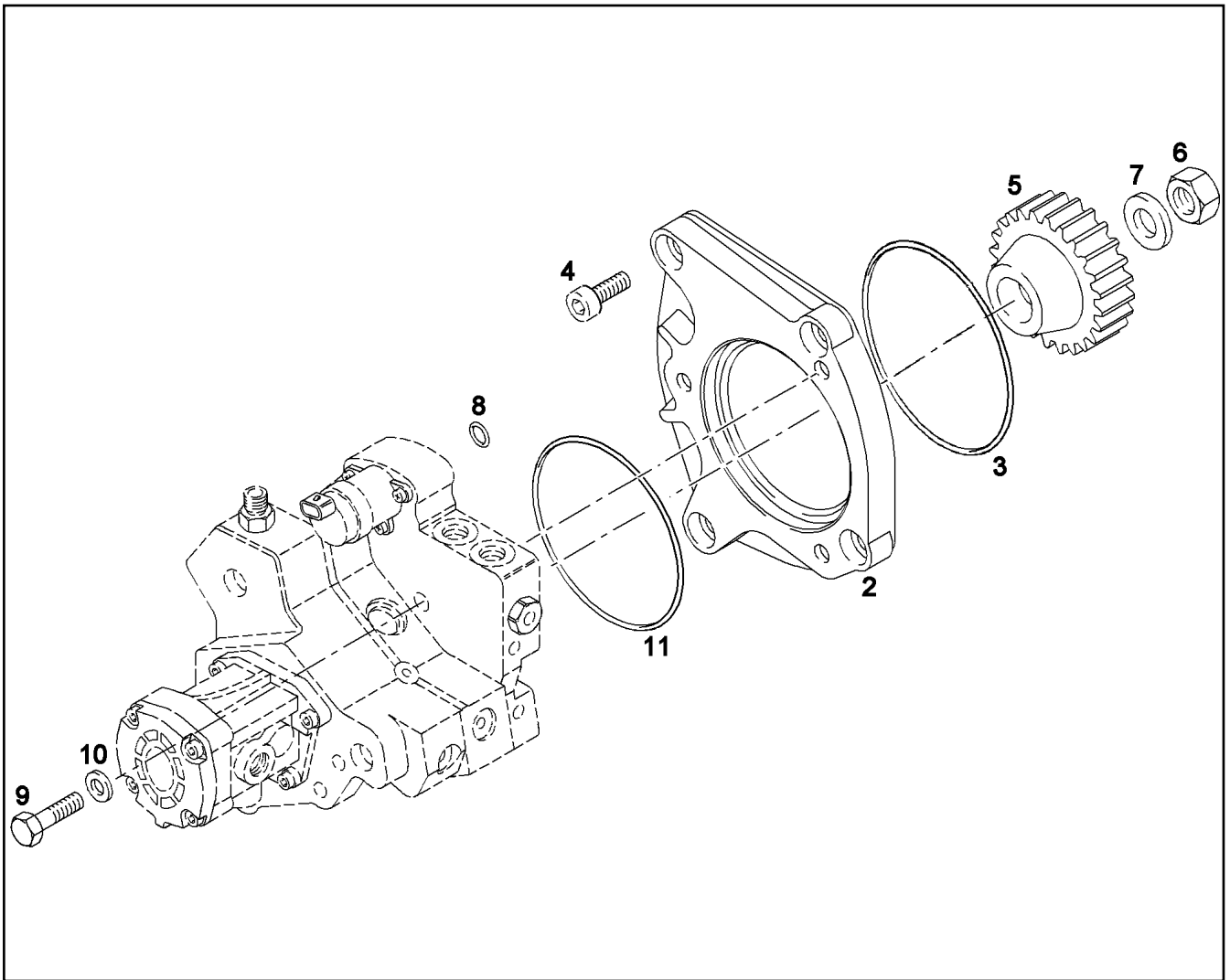

Pos.	Item	Quantity	Description	Bezeichnung	Serie	K
	2 10 22 275 1	1	FLANGE	FLANSCH		
	3 10 01 263 5	1	O RING 138X3,5 FPM1-70-GN	RUNDDICHTRING		
	4 10 01 122 8	4	CYLINDER SCREW M10X25 8.8 A3C	ZYLINDERSCHRAUBE		
	5 10 22 275 2	1	DRIVE WHEEL	ANTRIEBSRAD		
	6 10 22 275 3	1	HEX NUT BM18X1,5 ZNPHR3F	SECHSKANTMUTTER		
	7 10 22 275 4	1	WASHER	SCHEIBE		
	8 10 01 192 5	1	O RING 10X3 FPM1-80-GN	RUNDDICHTRING		
	9 10 29 431 8	3	CYLINDER SCREW M10X40 8.8 A3C	ZYLINDERSCHRAUBE		
	10 10 01 165 8	3	WASHER A 10,5X20X2,0 200HV	SCHEIBE		
	11 10 33 210 8	1	O RING 100X3 N-FPM1-70	RUNDDICHTRING		

6.2.2009
041276

LIEBHERR

etk_en_de_074515 LR 1600/2

ADD-ON PARTS
ANBAUTEILE

696

⇒ 9 739 278
97 39 278

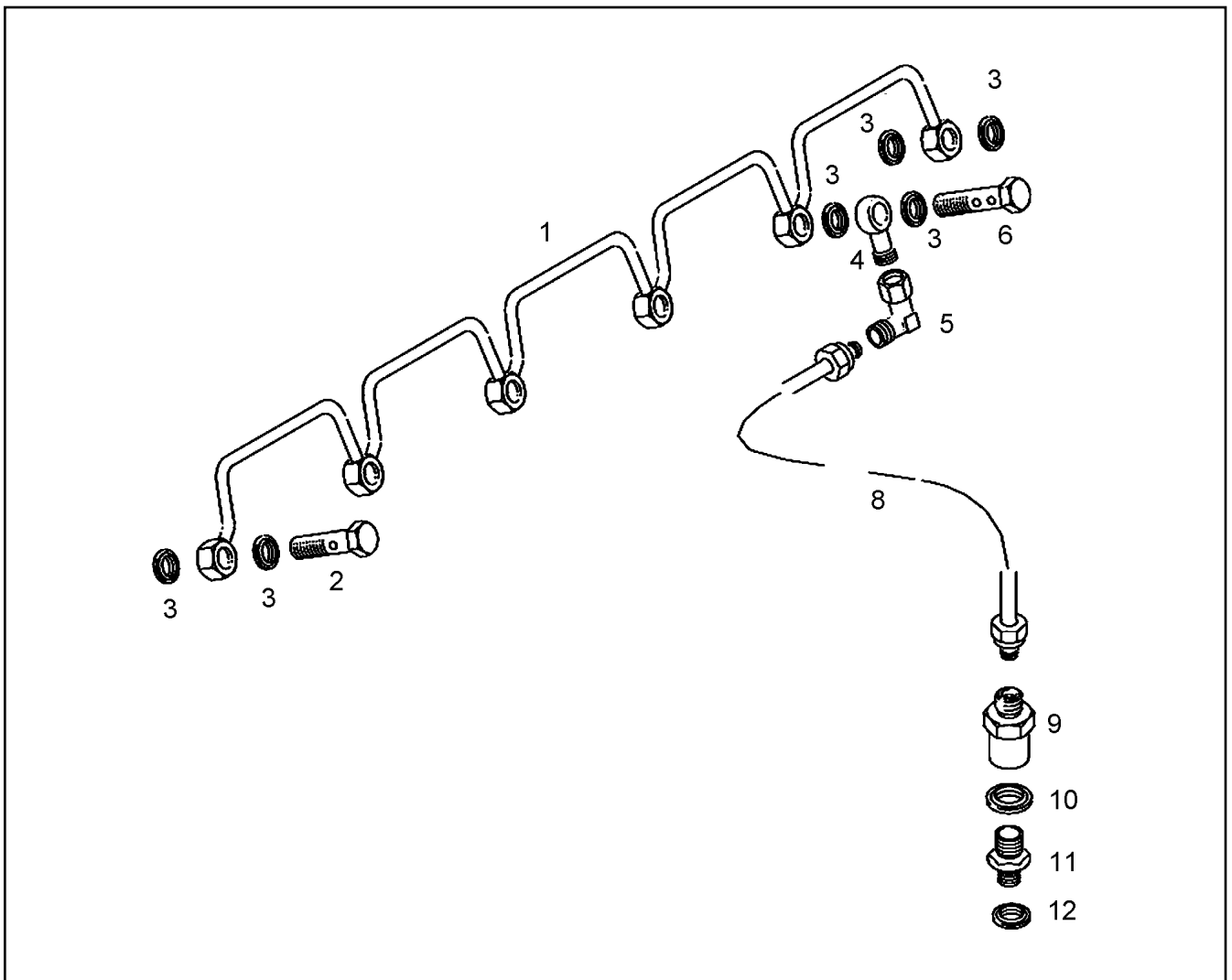

Pos.	Item	Quantity	Description	Bezeichnung	Serie	K
1	10 22 275 9	1	OVERFLOW-OIL LINE	LECKOELLEITUNG		
2	10 22 276 0	5	HOLLOW SCREW	HOHLSCHRAUBE		
3	10 01 187 1	12	SEALING RING 8,7X14X1 ST/FPM1-80	DICHTRING		
4	10 22 276 1	1	RING	RING		
5	10 22 276 2	1	LUG L-8 WVE	STUTZEN		
6	10 22 276 3	1	HOLLOW SCREW	HOHLSCHRAUBE		
8	10 22 276 4	1	OVERFLOW-OIL LINE	LECKOELLEITUNG		
9	10 27 976 0	1	OVERFLOW VALVE	UEBERSTROEMVENTIL		
10	10 01 186 7	1	SEALING RING 16,7X24X1,5 ST/FPM1-80	DICHTRING		
11	10 22 276 5	1	THREADED CONNECTION	GEWINDESTUTZEN		
12	10 01 186 6	1	SEALING RING 14,7X22X1,5 ST/FPM1-80	DICHTRING		

6.2.2009
041282

LIEBHERR

etk_en_de_074515 LR 1600/2

OVERFLOW-OIL LINE
LECKOELLEITUNG

697

⇒ 9 739 281
97 39 281

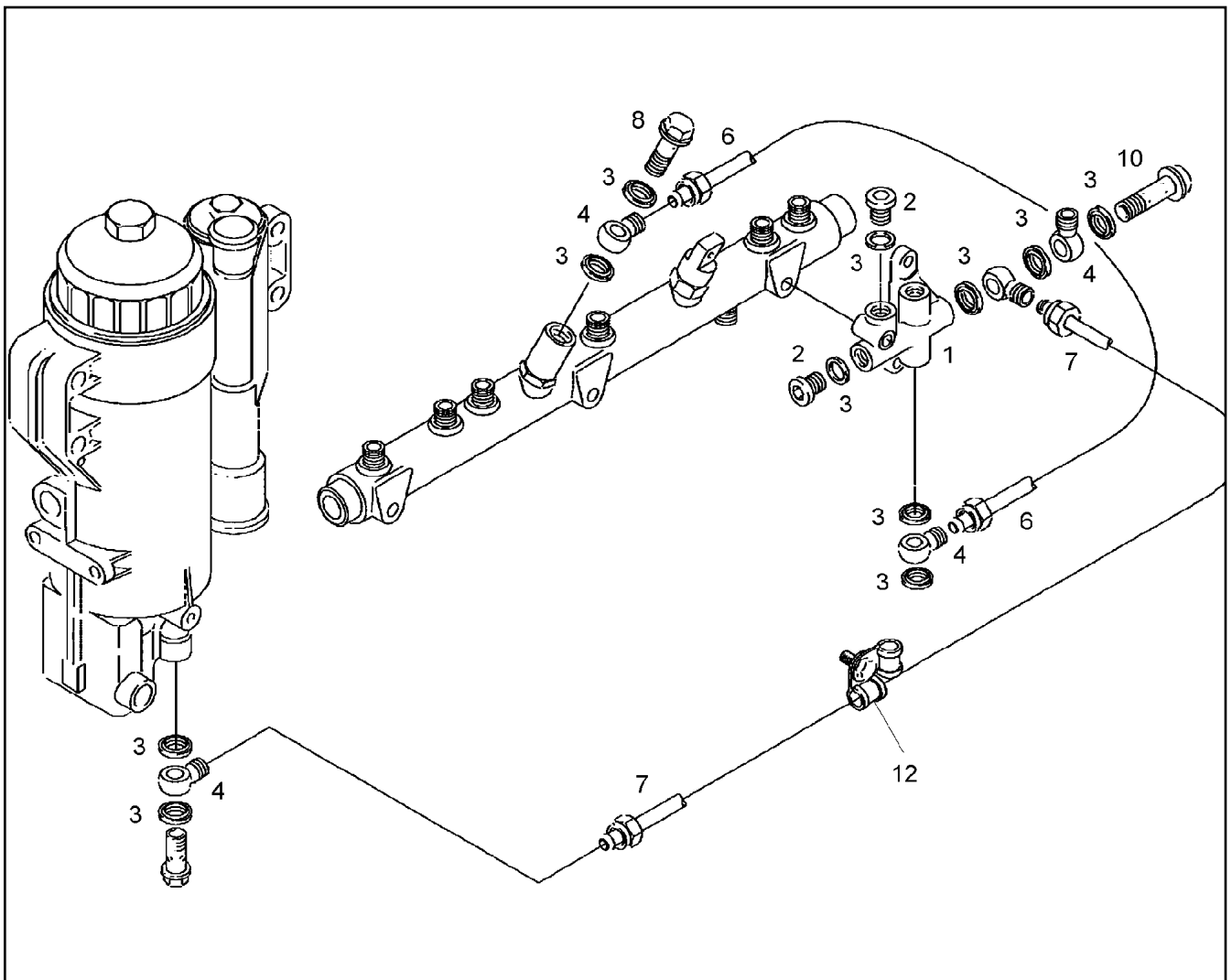

Pos.	Item	Quantity	Description	Bezeichnung	Serie	K
1	10 22 277 2	1	CONNECTION PIECE	ANSCHLUSSSTUECK		
2	10 01 161 2	2	SCREW PLUG M14X1,5 ST A3C	VERSCHLUSSSCHRAUBE		
3	10 01 186 6	11	SEALING RING 14,7X22X1,5 ST/FPM1-80	DICHTRING		
4	10 01 271 0	5	RING ADAPTER	RINGSTUTZEN		
6	10 22 277 3	1	FUEL LINE	KRAFTSTOFFLEITUNG		
7	10 22 277 4	1	FUEL LINE	KRAFTSTOFFLEITUNG		
8	10 01 273 0	2	HOLLOW SCREW	HOHLSCHRAUBE		
10	10 22 277 0	1	HOLLOW SCREW M14X1,5X41,5	HOHLSCHRAUBE		
12	10 01 198 9	1	FASTENING CLAMP D1-10X15 W1-EPDM-2	HALTERUNGSSCHELLE		

6.2.2009
041283

LIEBHERR

etk_en_de_074515 LR 1600/2

OVERFLOW-OIL LINE
LECKOELLEITUNG

698

⇒ 9 739 282
97 39 282

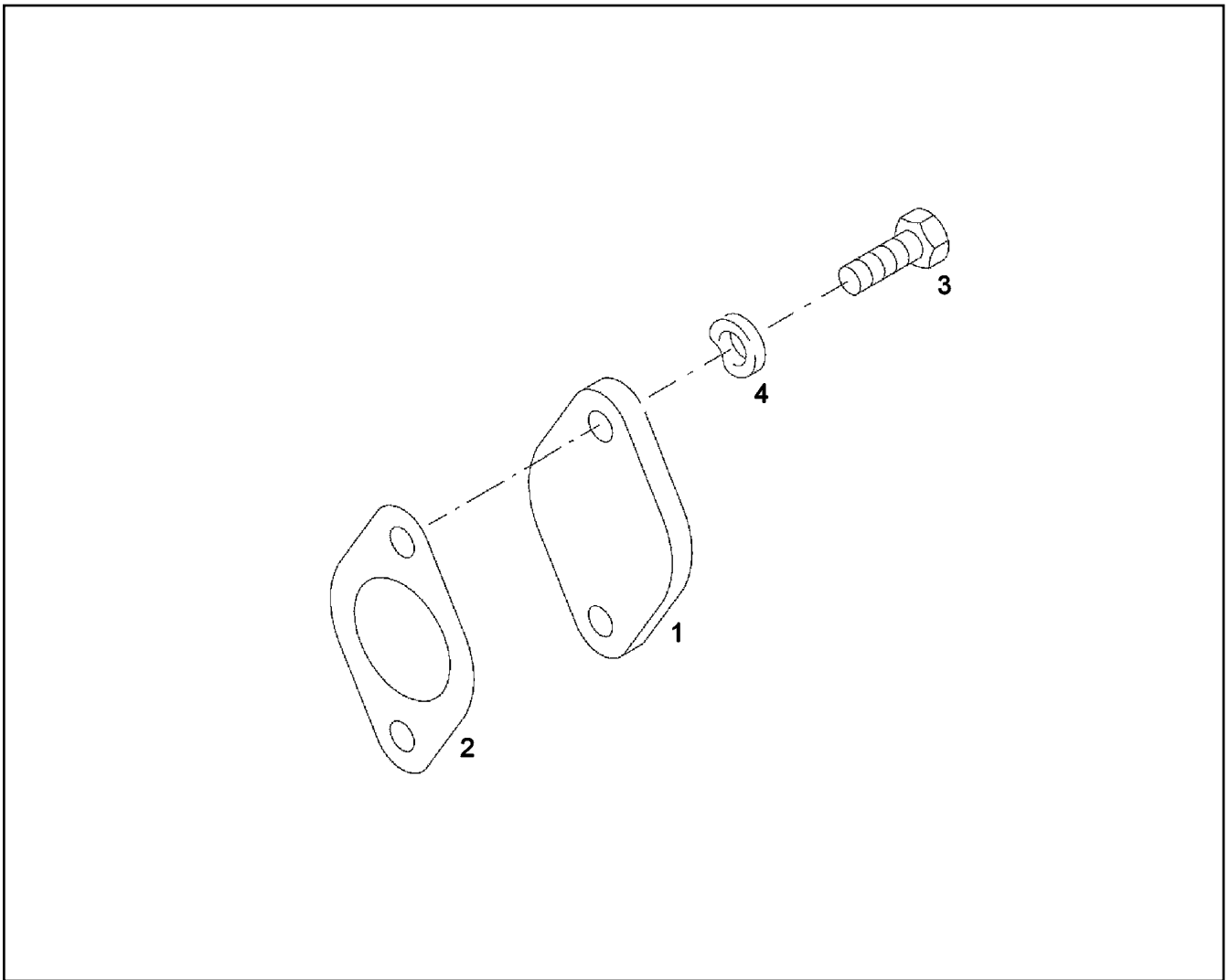

Pos.	Item	Quantity	Description	Bezeichnung	Serie	K
1	10 28 030 8	1	FLANGE	FLANSCH		
2	10 28 030 9	1	SEAL	DICHTUNG		
3	10 01 133 0	2	SCREW M10X30 8.8	SCHRAUBE		
4	10 01 165 8	2	WASHER A 10,5X20X2,0 200HV	SCHEIBE		

6.2.2009
049535

LIEBHERR

etk_en_de_074515 LR 1600/2

SCREW CAP
VERSCHLUSSDECKEL

699

⇒ 9 739 286
97 39 286

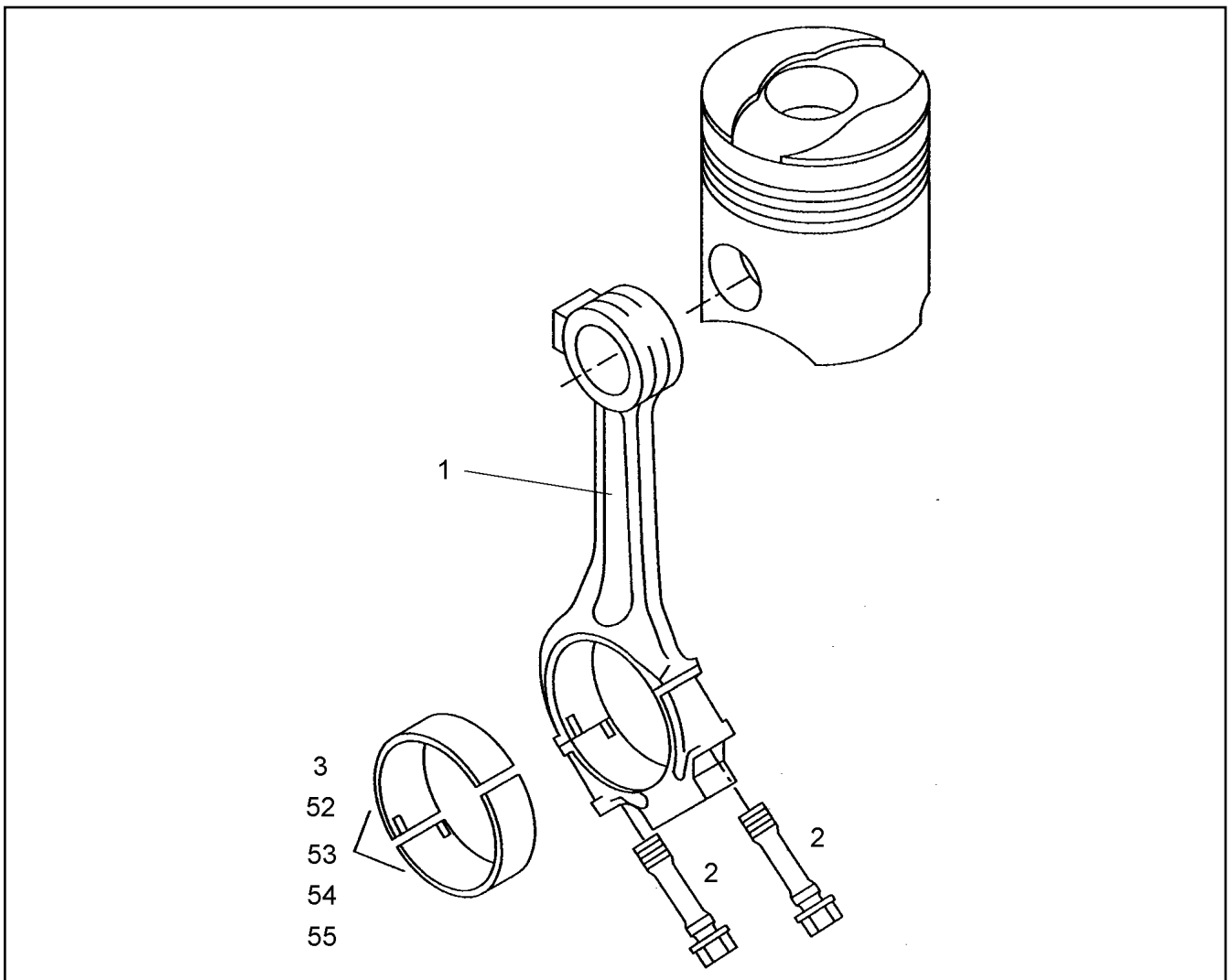

Pos.	Item	Quantity	Description	Bezeichnung	Serie	K
1	10 22 233 7	1	MAIN ROD	PLEUELSTANGE		
2	90 77 199	2	BEARING CAP BOLT M14X1,5 10.9	PLEUELSCHRAUBE		
3	10 01 215 0	1	CONNECTING ROD BEARING	PLEUELLAGER		
52	10 01 215 2	1	CONNECTING ROD BEARING	PLEUELLAGER		
53	10 01 215 3	1	CONNECTING ROD BEARING	PLEUELLAGER		
54	10 01 215 4	1	CONNECTING ROD BEARING	PLEUELLAGER		
55	10 01 215 5	1	CONNECTING ROD BEARING	PLEUELLAGER		

6.2.2009
041265

LIEBHERR

etk_en_de_074515 LR 1600/2

MAIN ROD
PLEUELSTANGE

700

⇒ 9 739 287
97 39 287

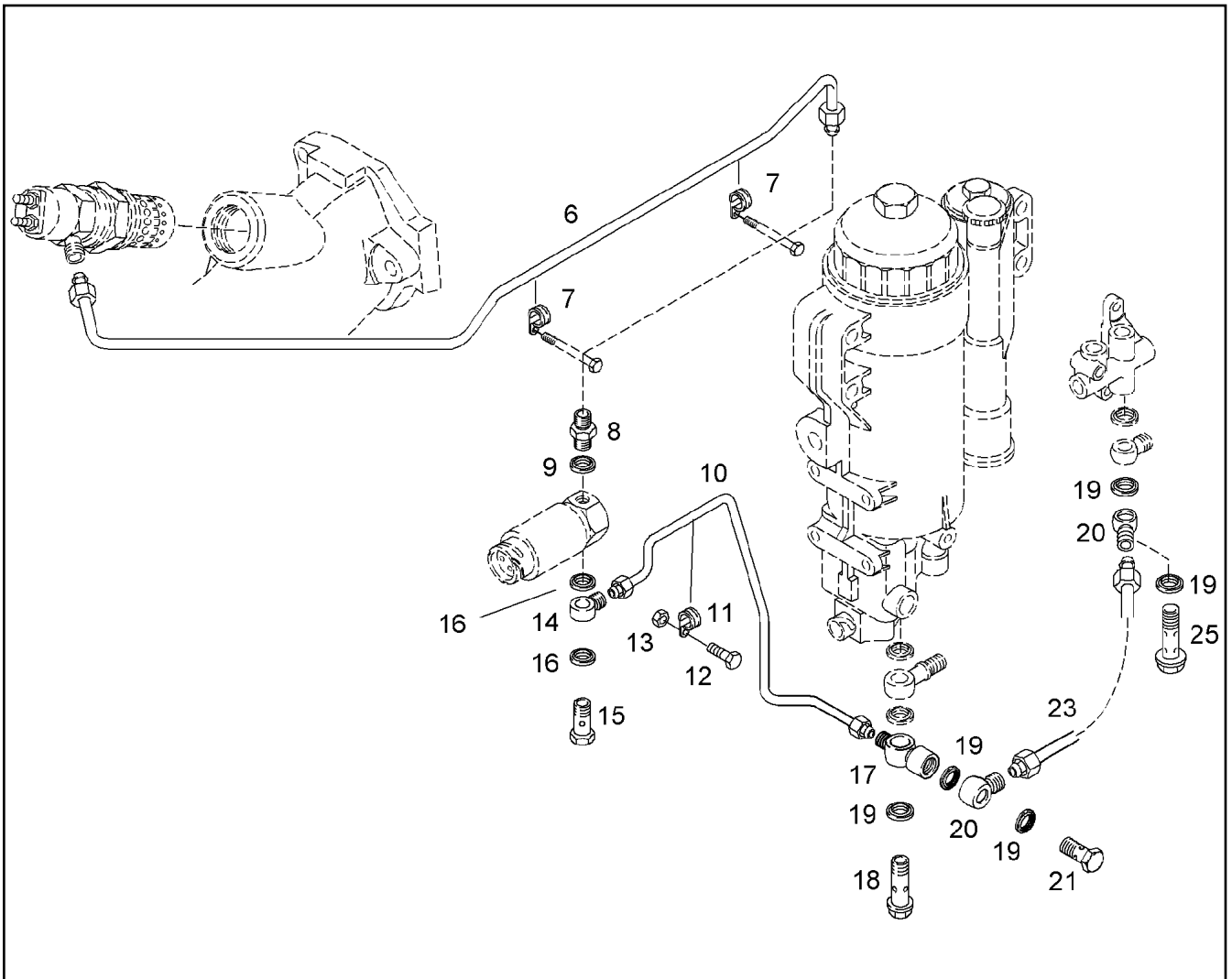

Pos.	Item	Quantity	Description	Bezeichnung	Serie	K
6	10 03 574 7	1	FUEL LINE	KRAFTSTOFFLEITUNG		
7	10 01 256 6	2	WASHER 11X22X5 9SMNPB28	SCHEIBE		
8	10 02 919 5	1	TRANSITION CONNECTION PIECE	UEBERGANGSSTUTZEN		
9	10 01 187 2	1	SEALING RING 32,7X40X2 ST/FPM1-80	DICHTRING		
10	10 28 515 3	1	FUEL LINE	KRAFTSTOFFLEITUNG		
11	10 01 265 5	1	PIPE CLAMP	ROHRSCHELLE		
12	10 22 274 4	1	HEX BOLT	SECHSKANTSCHRAUBE		
13	10 01 162 9	1	NUT M6 8	MUTTER		
14	10 01 271 1	1	RING ADAPTER	RINGSTUTZEN		
15	10 01 272 6	1	HOLLOW SCREW M10X1X19E 9SMNPB28K	HOHLSCHRAUBE		
16	10 01 186 4	2	SEALING RING 10,7X16X1,5 ST/FPM1-80	DICHTRING		
17	10 28 515 5	1	RING ADAPTER	RINGSTUTZEN		
18	10 28 515 6	1	HOLLOW SCREW	HOHLSCHRAUBE		
19	10 01 186 6	5	SEALING RING 14,7X22X1,5 ST/FPM1-80	DICHTRING		
20	10 01 271 3	2	RING ADAPTER 14MM	RINGSTUTZEN		
21	10 28 517 0	1	OVERFLOW VALVE	UEBERSTROEMVENTIL		
23	10 28 515 7	1	OVERFLOW-OIL LINE	LECKOELLEITUNG		
25	10 01 273 0	1	HOLLOW SCREW	HOHLSCHRAUBE		

6.2.2009
041288

LIEBHERR

etk_en_de_074515 LR 1600/2

FUEL LINE
KRAFTSTOFFLEITUNG

701

⇒ 9 739 288
97 39 288

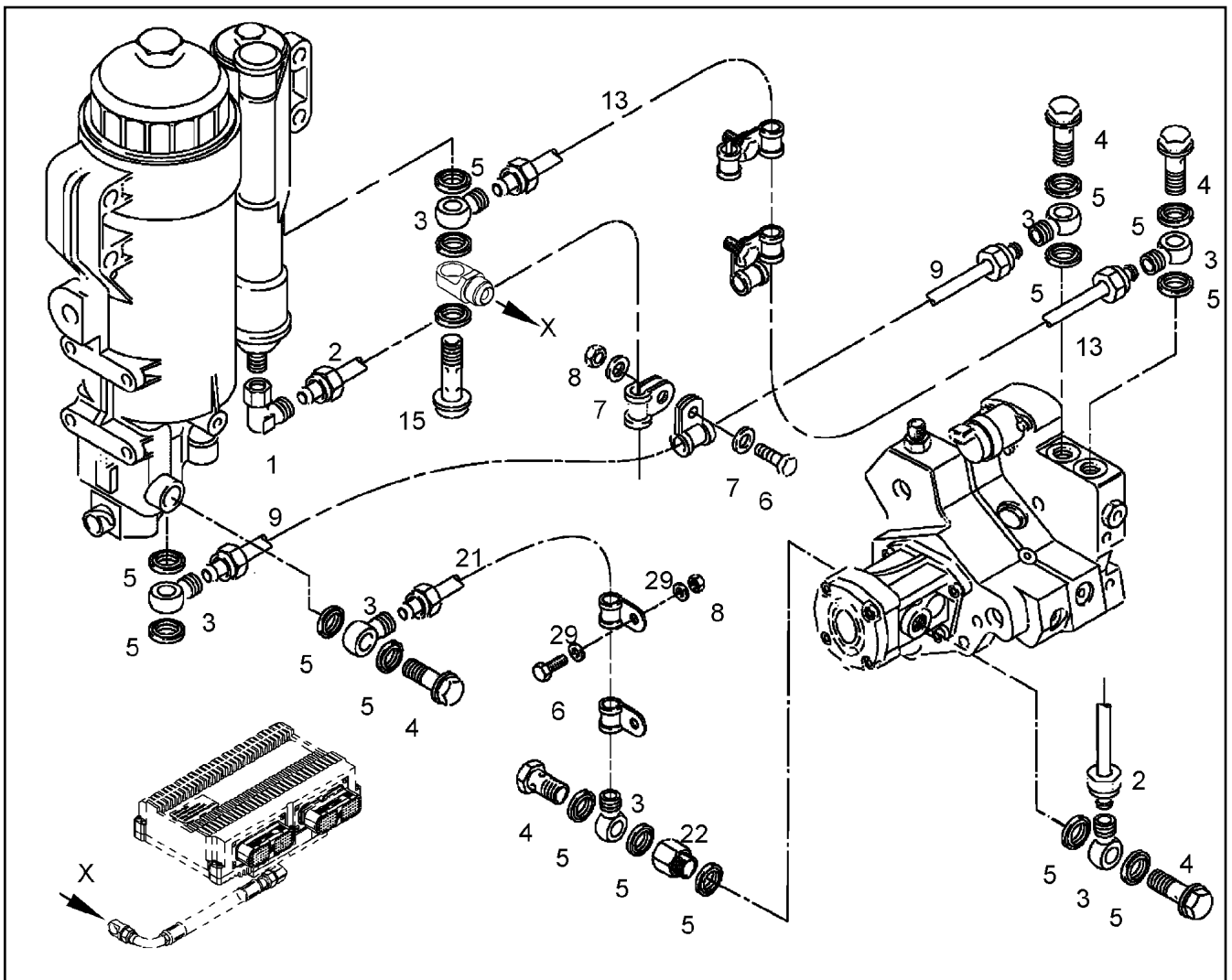

Pos.	Item	Quantity	Description	Bezeichnung	Serie	K
1	10 22 276 6	1	LUG L-10 WVE	STUTZEN		
2	10 22 276 7	1	FUEL LINE	KRAFTSTOFFLEITUNG		
3	10 01 271 0	7	RING ADAPTER	RINGSTUTZEN		
4	10 01 273 0	6	HOLLOW SCREW	HOHLSCHRAUBE		
5	10 01 186 6	14	SEALING RING 14,7X22X1,5 ST/FPM1-80	DICHTRING		
6	10 01 124 8	4	SCREW M6X22 8.8	SCHRAUBE		
7	10 01 165 3	2	WASHER A 6,4X12X1,6 200HV	SCHEIBE		
8	10 01 162 9	4	NUT M6 8	MUTTER		
9	10 22 276 8	1	FUEL LINE	KRAFTSTOFFLEITUNG		
13	10 22 276 9	1	FUEL LINE	KRAFTSTOFFLEITUNG		
15	10 22 277 0	1	HOLLOW SCREW M14X1,5X41,5	HOHLSCHRAUBE		
21	10 22 277 5	1	FUEL LINE	KRAFTSTOFFLEITUNG		
22	10 22 277 6	1	SPACER PIECE	DISTANZSTUECK		
29	10 01 165 3	6	WASHER A 6,4X12X1,6 200HV	SCHEIBE		

6.2.2009
041280

LIEBHERR

etk_en_de_074515 LR 1600/2

FUEL LINE
KRAFTSTOFFLEITUNG

702

⇒ 9 739 292
97 39 292

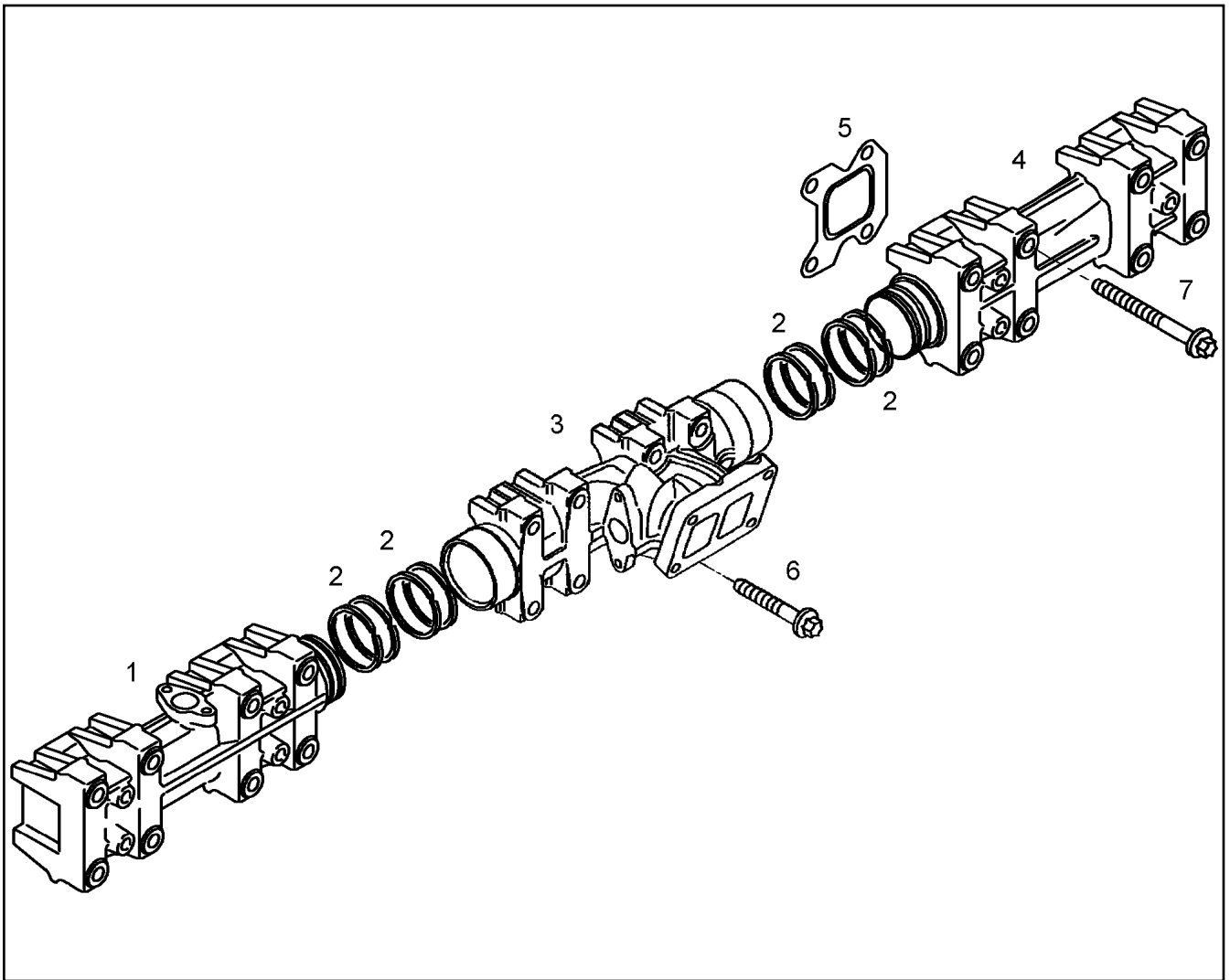

Pos.	Item	Quantity	Description	Bezeichnung	Serie	K
1	10 22 237 7	1	EXHAUST PIPE	ABGASROHR		
2	10 01 273 4	8	LEAF RING	LAMELLENRING		
3	10 28 710 2	1	EXHAUST PIPE	ABGASROHR		
4	10 22 271 7	1	EXHAUST PIPE	ABGASROHR		
5	10 22 271 8	6	SEAL	DICHTUNG		
6	10 03 034 6	2	FLANGED BOLT M10X55 X5NICRT126-1	BUNDSCHRAUBE		
7	10 01 255 0	22	FLANGED BOLT M10X95	BUNDSCHRAUBE		

6.2.2009
042194

LIEBHERR

etk_en_de_074515 LR 1600/2

EXHAUST PIPE
ABGASROHR

703

⇒ 9 739 295
97 39 295

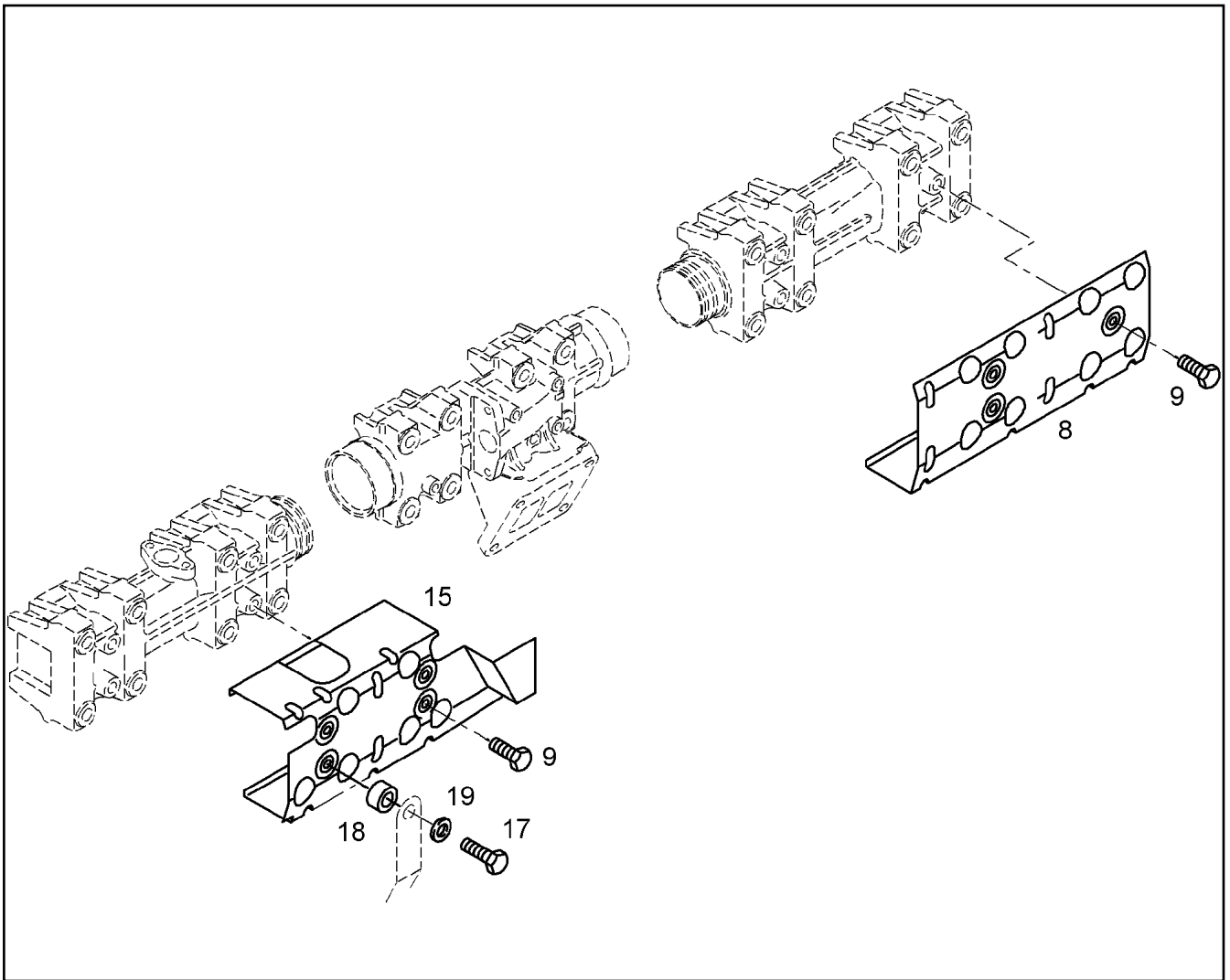

Pos.	Item	Quantity	Description	Bezeichnung	Serie	K
8	10 22 271 9	1	HEAT INSULATION PLATE	WAERMESCHUTZBLECH		
9	10 01 135 1	6	SCREW M8X12 8.8	SCHRAUBE		
15	10 22 272 3	1	HEAT INSULATION PLATE	WAERMESCHUTZBLECH		
17	10 01 134 9	1	SCREW M8X20 8.8	SCHRAUBE		
18	10 01 256 8	1	WASHER 8,4X19X4 C45K	SCHEIBE		
19	10 01 165 4	1	WASHER A 8,4X16X1,6 200HV	SCHEIBE		

6.2.2009
042195

LIEBHERR

etk_en_de_074515 LR 1600/2

HEAT PROTECTION
HITZESCHUTZ

704

⇒ 9 739 296
97 39 296

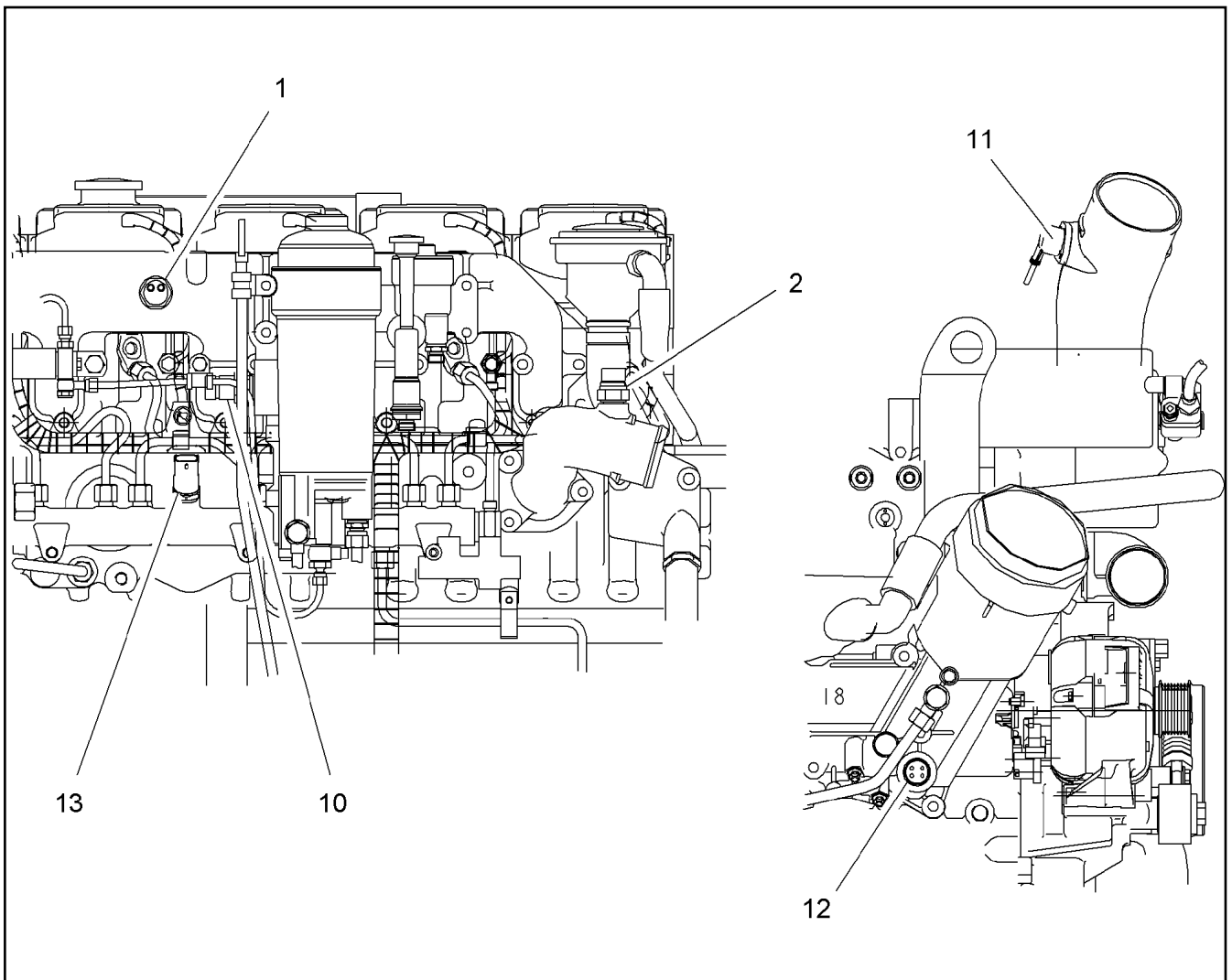

Pos.	Item	Quantity	Description	Bezeichnung	Serie	K
1	10 11 740 5	1	TEMPERATURE TEST	TEMPERATURSENSOR		
(1)	10 01 246 7	1	TEMPERATURE SENSOR	TEMPERATURGEBER		
(2)	10 01 186 7	1	SEALING RING 16,7X24X1,5 ST/FPM1-80	DICHTRING		
2	10 11 740 6	1	TEMPERATURE TEST	TEMPERATURSENSOR		
(1)	10 01 246 6	1	TEMPERATURE SENSOR	TEMPERATURFUEHLER		
(2)	10 01 186 7	1	SEALING RING 16,7X24X1,5 ST/FPM1-80	DICHTRING		
10	10 11 740 4	1	PRESSURE TRANSMITTER CPL. M18X1,5 0-	DRUCKGEBER KPL.		
(1)	10 22 021 8	1	SENSOR	SENSOR		
(2)	10 01 186 8	1	SEALING RING 18,7X26X1,5 ST/FPM1-80	DICHTRING		
11	10 11 740 7	1	PRESSURE TRANSMITTER CPL.	DRUCKGEBER KPL.		
(1)	10 01 247 0	1	PRESSURE SENSOR	DRUCKFUEHLER		
(2)	10 01 159 4	2	DOUBLE-ENDED STUD M6X16 8.8 A2C	STIFTSCHRAUBE		
(3)	10 01 699 2	2	WASHER 6,3X10,8X6 9SMNPB28K	SCHEIBE		
(4)	10 01 165 3	2	WASHER A 6,4X12X1,6 200HV	SCHEIBE		
(5)	10 01 162 9	2	NUT M6 8	MUTTER		
12	10 11 740 9	1	PRESSURE TRANSMITTER CPL.	DRUCKGEBER KPL.		
(1)	10 01 274 0	1	PRESSURE TRANSMITTER 0-5BAR	DRUCKGEBER		
(2)	10 01 186 8	1	SEALING RING 18,7X26X1,5 ST/FPM1-80	DICHTRING		
13	10 22 274 1	1	PRESSURE TRANSMITTER	DRUCKGEBER		

6.2.2009
042839

LIEBHERR

etk_en_de_074515 LR 1600/2

SENSOR ELEMENT
SENSORIK

705

⇒ 9 739 318
97 39 318

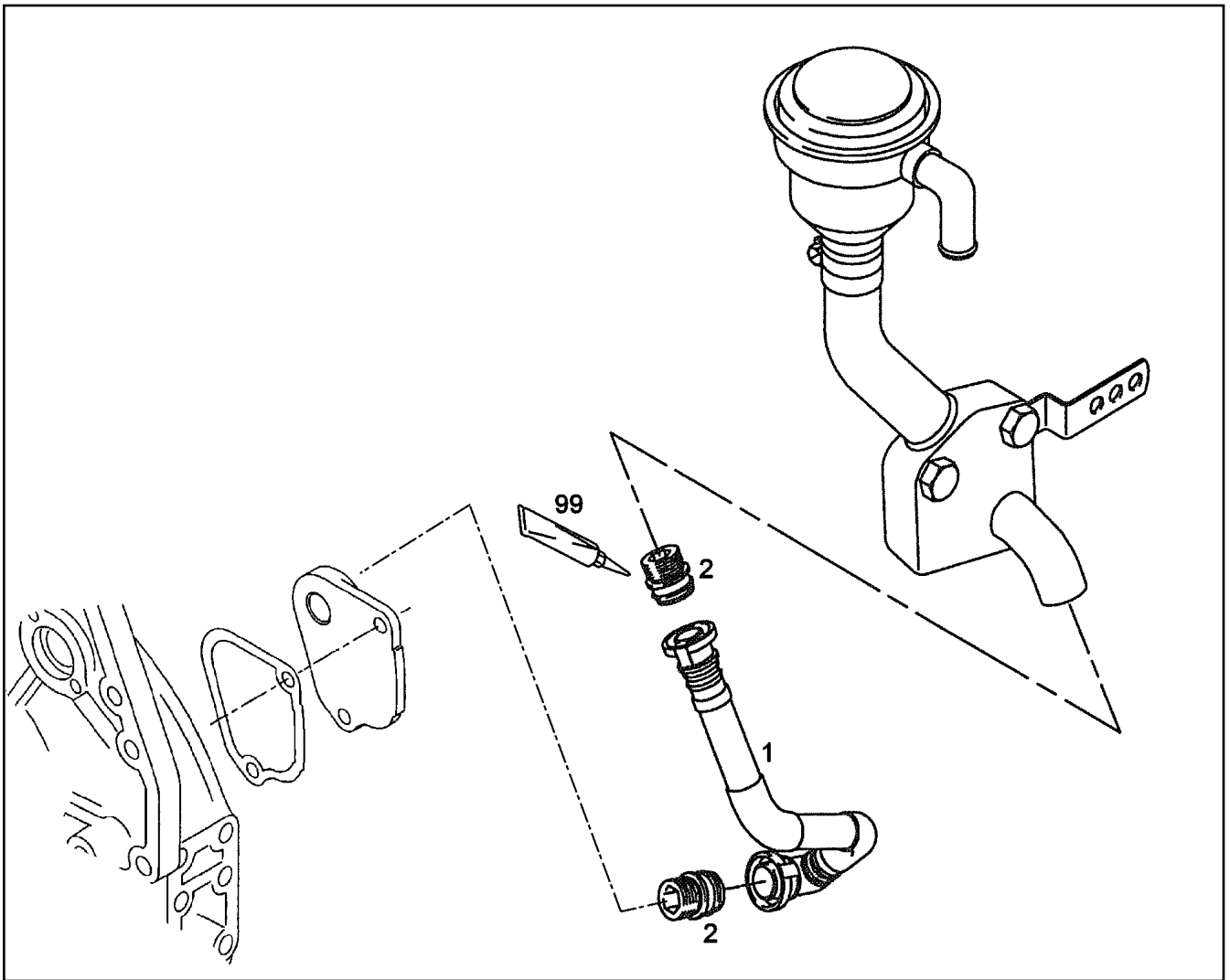

Pos.	Item	Quantity	Description	Bezeichnung	Serie	K
1	10 29 720 3	1	VENTILATION LINE	ENTLUEFTUNGSLEITUNG		
2	10 29 720 4	2	SCREW-ON CONNECTION	EINSCHRAUBSTUTZEN		
99	81 12 073 01	1	GLUE 10ML	KLEBSTOFF		

6.2.2009
049163

LIEBHERR

etk_en_de_074515 LR 1600/2

REPAIR KIT PIPE LINE
RS ROHRLEITUNG

706

⇒ 9 739 322
97 39 322

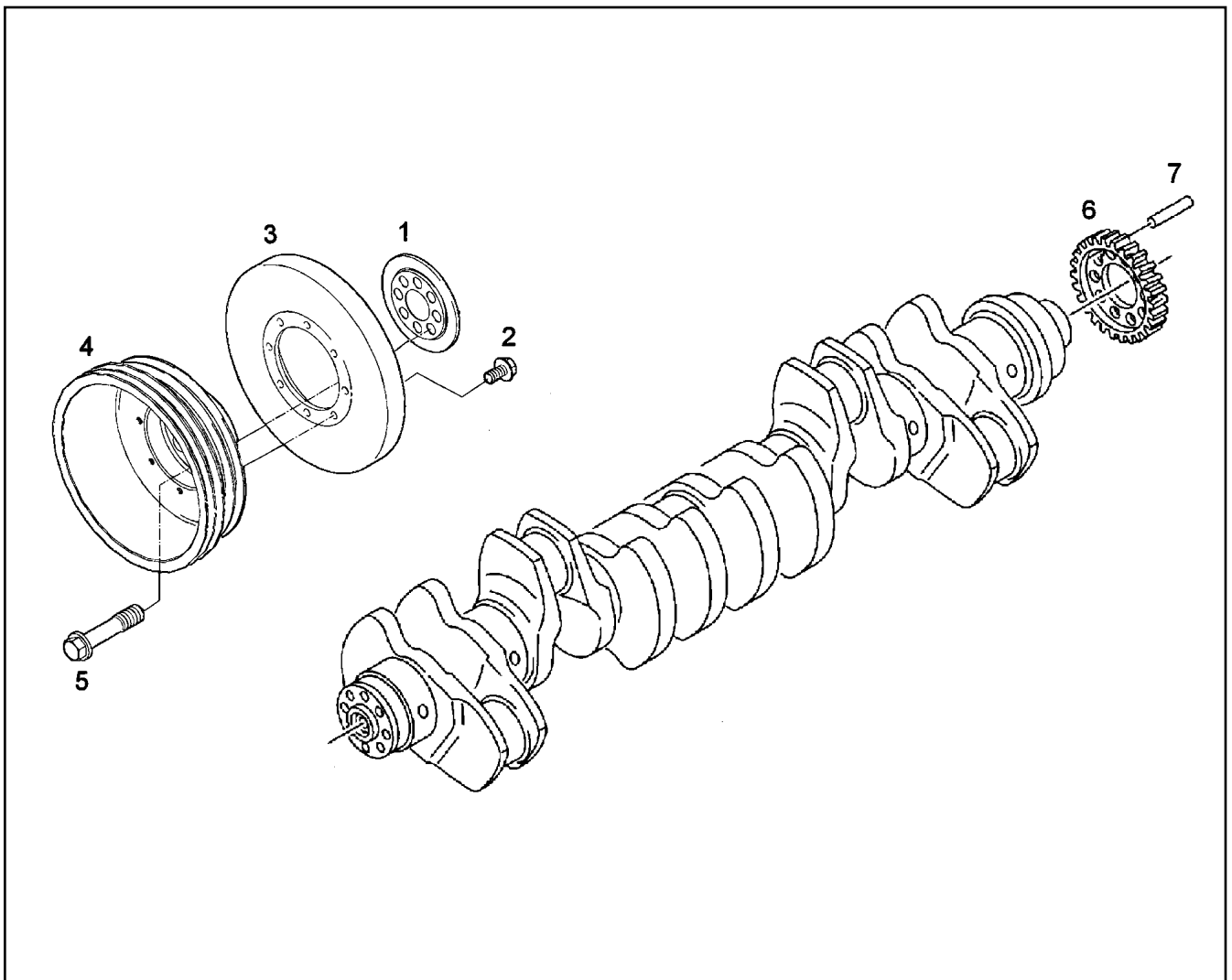

Pos.	Item	Quantity	Description	Bezeichnung	Serie	K
1	10 34 283 6	1	OIL SPLASH RING	SPRITZRING		
2	10 04 535 6	8	HEX BOLT EN 1665 M10X20 10.9 A3C	SECHSKANTSCHRAUBE		
3	10 34 283 9	1	VIBRATION DAMPER	SCHWINGUNGSDAEMPFER		
4	10 34 284 0	1	V-BELT PULLEY	KEILRIEMENSCHIEBE		
5	10 34 318 6	8	HEX BOLT M16X45 10.9 ZNPHR3F	SECHSKANTSCHRAUBE		
6	10 01 214 2	1	CRANKSHAFT WHEEL	KURBELWELLENRAD		
7	10 47 688 3	1	DOWEL PIN 8X40 ST	SPANNSTIFT		

6.2.2009
049723

LIEBHERR

etk_en_de_074515 LR 1600/2

DRIVING PARTS
ANTRIEBSTEILE M.SCHWINGUNGSD.

707

⇒ 9 739 341
97 39 341

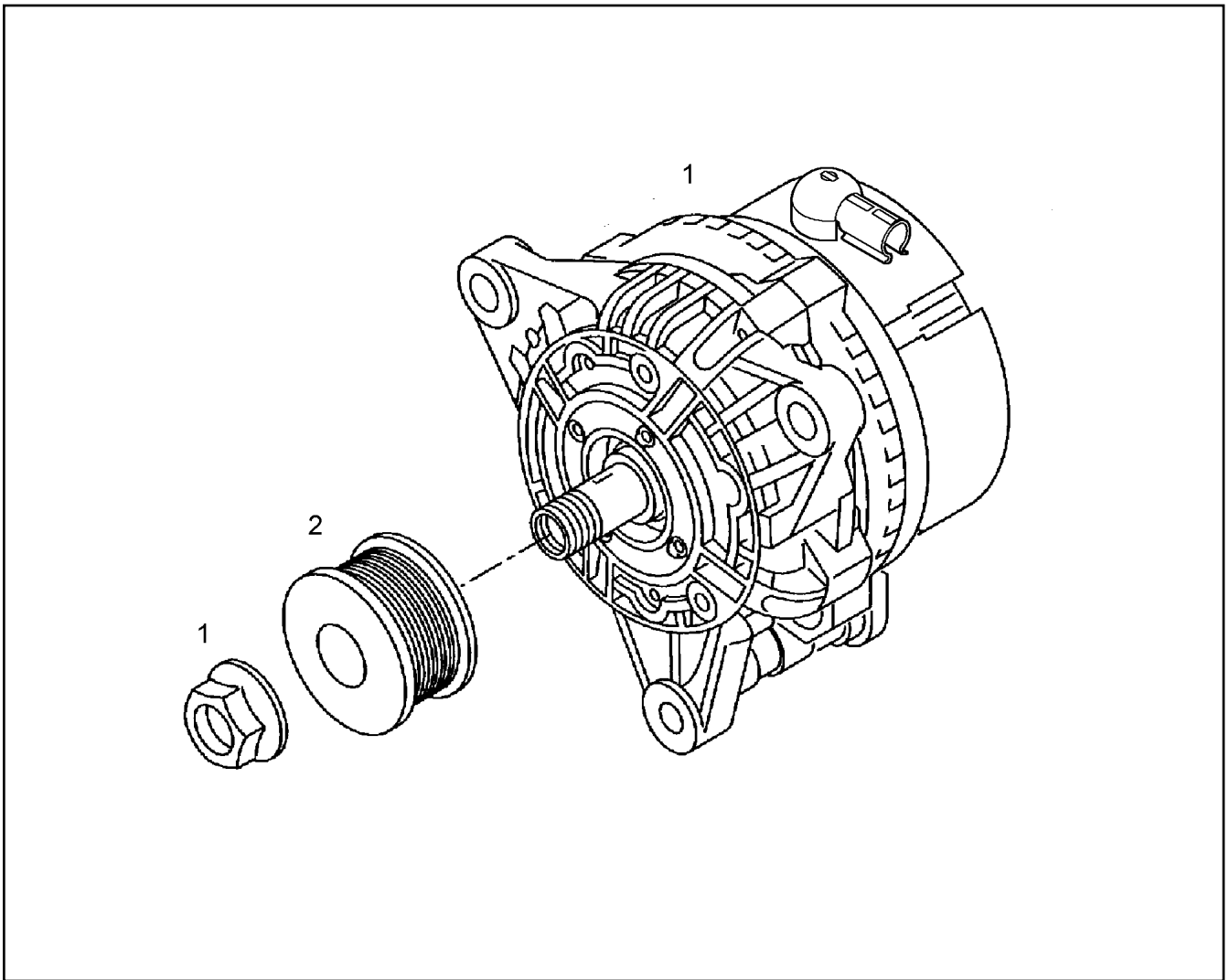

Pos.	Item	Quantity	Description	Bezeichnung	Serie	K
1	10 03 240 2	1	THREE PHASE CURRENT GENERATOR 28V	DREHSTROMGENERATOR		
(1)	10 47 599 4	1	REGULATOR	REGLER		
2	10 34 313 1	1	V-BELT PULLEY	KEILRIEMENSCHLEIBE		

6.2.2009
049739

LIEBHERR

etk_en_de_074515 LR 1600/2

GENERATOR, PRE-ASSEMBLED
GENERATOR VORM.

708

⇒ 9 739 343
97 39 343

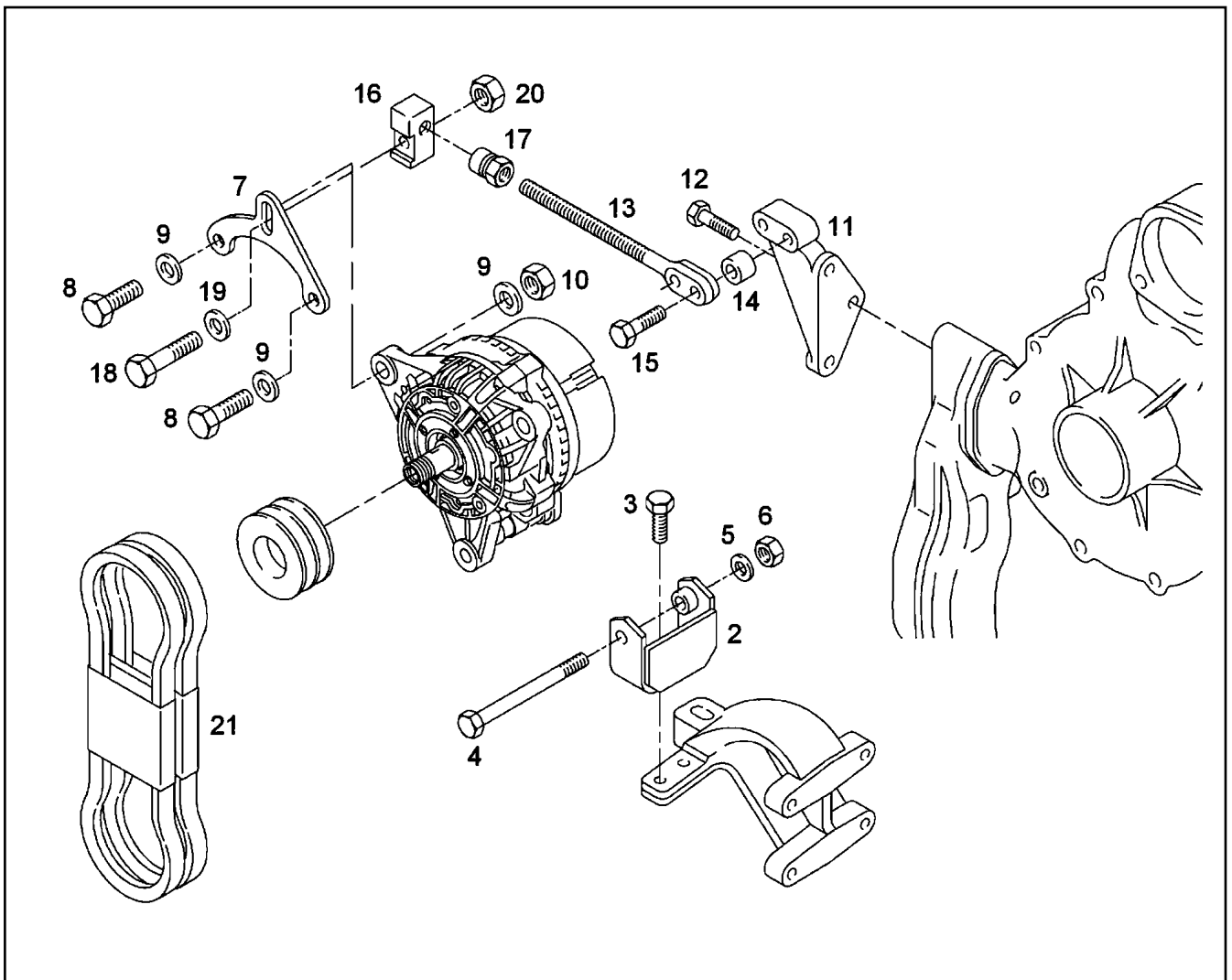

Pos.	Item	Quantity	Description	Bezeichnung	Serie	K
2	10 34 310 4	1	HOLDER	HALTER		
3	10 04 535 6	2	HEX BOLT EN 1665 M10X20 10.9 A3C	SECHSKANTSCHRAUBE		
4	10 01 127 2	1	SCREW M10X130 8.8 A3C	SCHRAUBE		
5	10 01 165 8	1	WASHER A 10,5X20X2,0 200HV	SCHEIBE		
6	10 01 427 8	1	NUT M10 -8 A3C	MUTTER		
7	10 34 310 7	1	RETAINING PLATE	HALTEBLECH		
8	10 01 134 5	2	SCREW M12X40 8.8 A3C	SCHRAUBE		
9	10 01 165 9	2	WASHER A 13X24X2,5 200HV	SCHEIBE		
10	10 02 092 2	2	NUT M12 8	MUTTER		
11	10 34 310 6	1	HOLDER	HALTER		
12	10 01 133 0	1	SCREW M10X30 8.8	SCHRAUBE		
13	10 34 328 8	1	EYE BOLT DIN 444 M12X188 6.8 A3C	AUGENSCHRAUBE		
14	10 34 329 9	2	BUSH DIN 444 11X20X11,5 ST35NBK	BUCHSE		
15	10 01 134 3	2	SCREW M10X40 8.8 A3C	SCHRAUBE		
16	10 34 311 0	1	GUIDING PIECE	FUEHRUNGSSTUECK		
17	10 34 329 6	1	CHECKING NUT DIN 444 B M12 9SMNPB28K	STELLMUTTER		
18	10 34 318 3	1	HEX BOLT M12X50 8.8 A3C	SECHSKANTSCHRAUBE		
19	10 01 256 7	1	WASHER 12,5X24X4 C45K	SCHEIBE		
20	10 02 092 2	1	NUT M12 8	MUTTER		
21	10 34 342 2	1	V-BELT 10 2AVX 1500 LA	KEILRIEMEN		

6.2.2009
049740

LIEBHERR

etk_en_de_074515 LR 1600/2

GENERATOR, PRE-ASSEMBLED
GENERATOR VORM.

709

⇒ 9 739 344
97 39 344

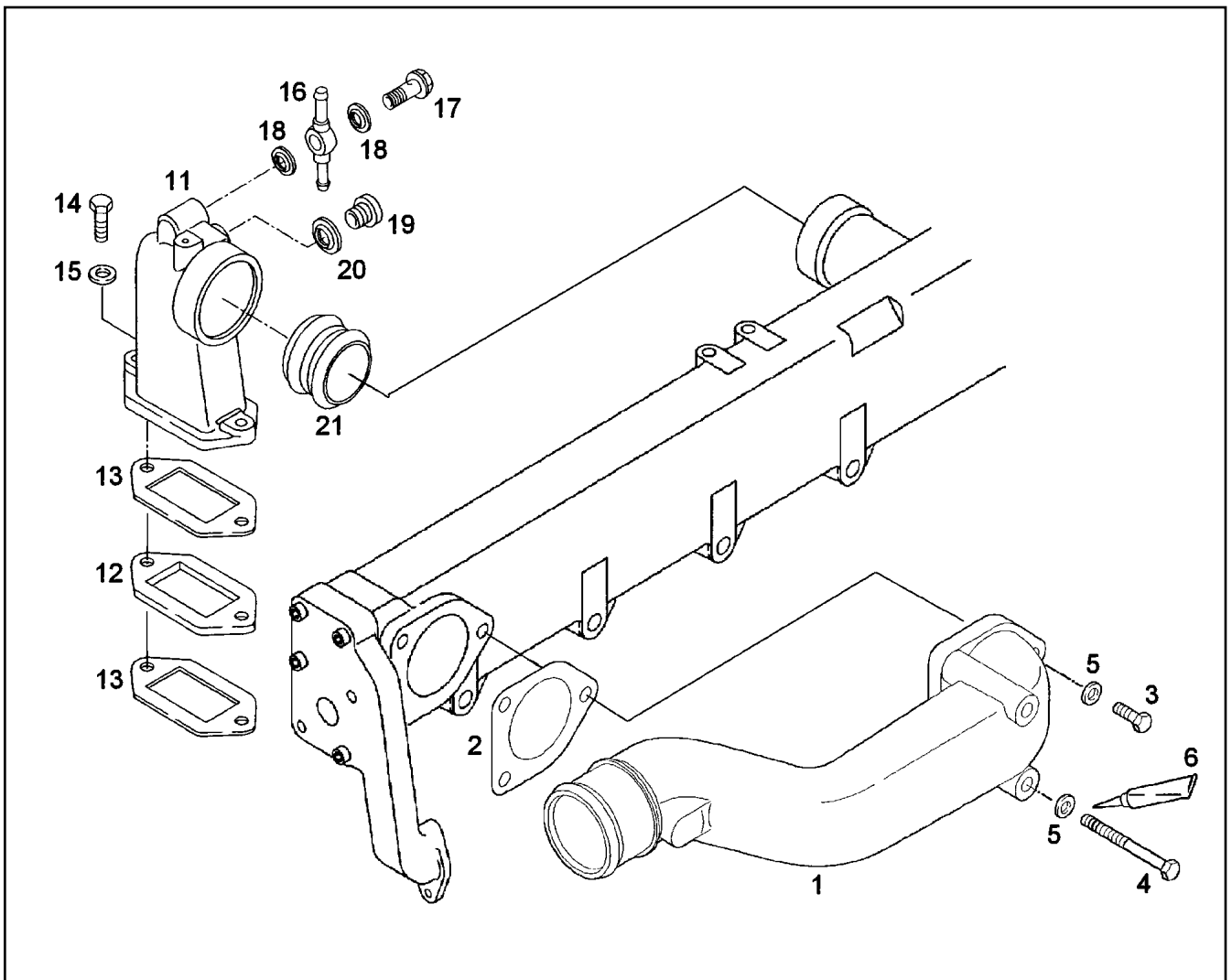

Pos.	Item	Quantity	Description	Bezeichnung	Serie	K
1	10 01 230 2	1	ELBOW	KRUEMMER		
2	10 01 234 6	1	SEAL	DICHTUNG		
3	10 01 125 2	1	SCREW M8X35 8.8	SCHRAUBE		
4	10 01 126 1	2	SCREW M8X105 8.8 A2C	SCHRAUBE		
5	10 01 165 4	5	WASHER A 8,4X16X1,6 200HV	SCHEIBE		
6	81 12 017 08	1	ADHESIVE 50ML	KLEBER		
11	10 34 286 8	1	COOLANT PIPE BEND	KUEHLMITTELKRUEMMER		
12	10 34 334 0	1	FLANGE	FLANSCH		
13	10 34 287 9	2	SEAL	DICHTUNG		
14	10 01 125 2	1	SCREW M8X35 8.8	SCHRAUBE		
15	10 01 165 4	1	WASHER A 8,4X16X1,6 200HV	SCHEIBE		
16	10 01 696 0	1	RING ADAPTER	RINGSTUTZEN		
17	10 01 272 4	1	HOLLOW SCREW 10S	HOHLSCHRAUBE		
18	10 01 186 6	2	SEALING RING 14,7X22X1,5 ST/FPM1-80	DICHTRING		
19	10 01 696 8	1	SCREW PLUG AM16X1,5 ST A3C	VERSCHLUSSSCHRAUBE		
20	10 01 186 7	1	SEALING RING 16,7X24X1,5 ST/FPM1-80	DICHTRING		
21	10 01 273 3	1	PLUG-IN PIPE	STECKROHR		

6.2.2009
049736

LIEBHERR

etk_en_de_074515 LR 1600/2

CONNECTION F.WATER PIPE
WASSERLEITUNGSANSCHLUESSE

710

⇒ 9 739 349
97 39 349

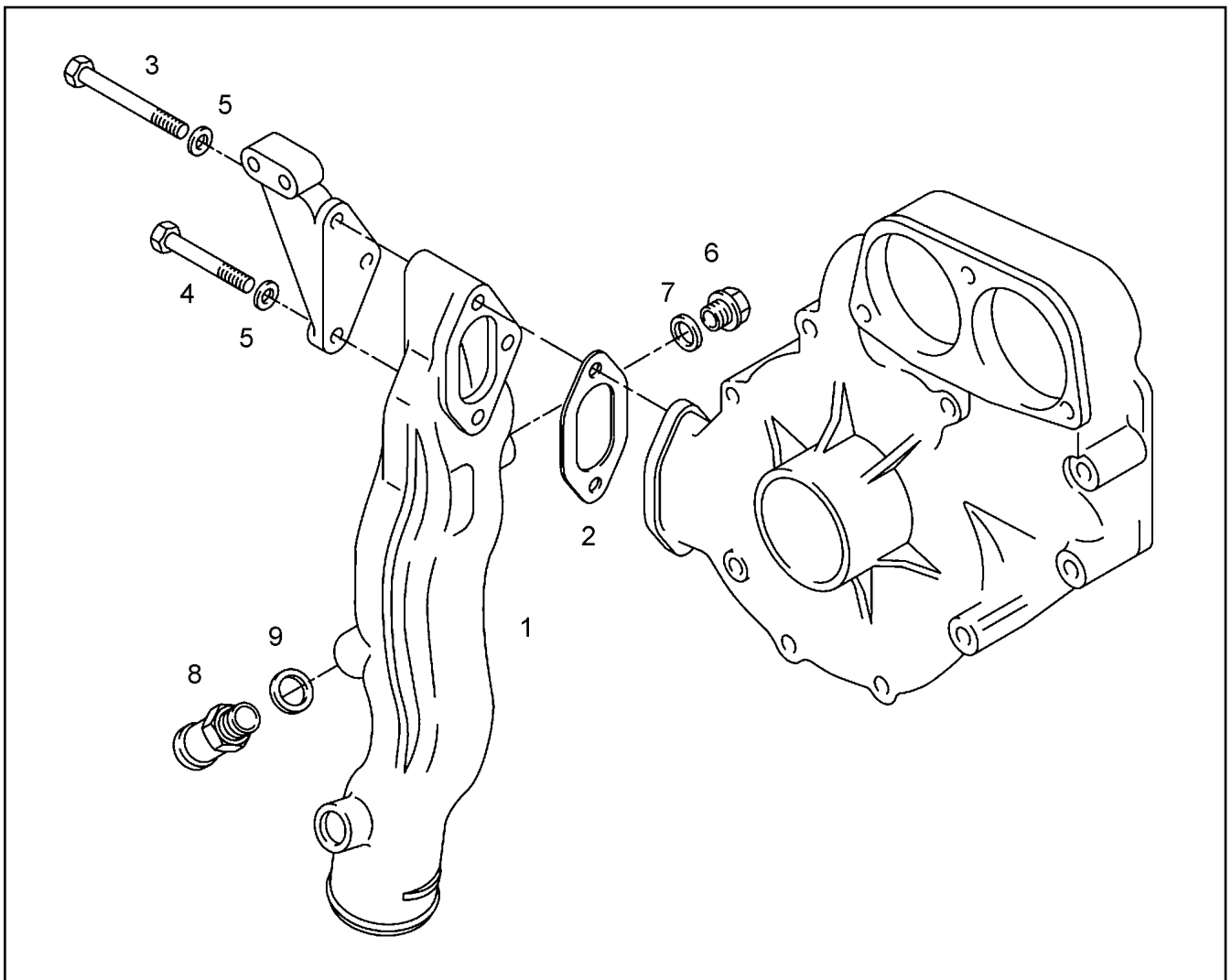

Pos.	Item	Quantity	Description	Bezeichnung	Serie	K
1	97 39 383	1	LIQUID COOLING PIPELINE	KUEHLMITTELLEITUNG		
2	10 34 287 8	1	SEAL	DICHTUNG		
3	10 34 225 4	1	HEX BOLT M10X100 8.8 A3C	SECHSKANTSCHRAUBE		
4	10 34 225 9	1	HEX BOLT M10X75 8.8 MAN183-A3C	SECHSKANTSCHRAUBE		
5	10 01 165 8	2	WASHER A 10,5X20X2,0 200HV	SCHEIBE		
6	10 34 227 2	1	SCREW PLUG M22 5.8 ZNPHR3F	VERSCHLUSSSCHRAUBE		
7	10 01 186 9	1	SEALING RING 22,7X30X2 ST/FPM1-80	DICHTRING		
8	10 34 334 3	1	HOSE UNION 18 M24X 1,5 ST	SCHLAUCHSTUTZEN		
9	10 01 184 2	1	SEALING RING 24,7X32X2 ST/FPM1-80	DICHTRING		

6.2.2009
049735

LIEBHERR

etk_en_de_074515 LR 1600/2

COOLING MEDIUM PIPELINE
KUEHLMITTELLEITUNG ANBAU

711

⇒ 9 739 351
97 39 351

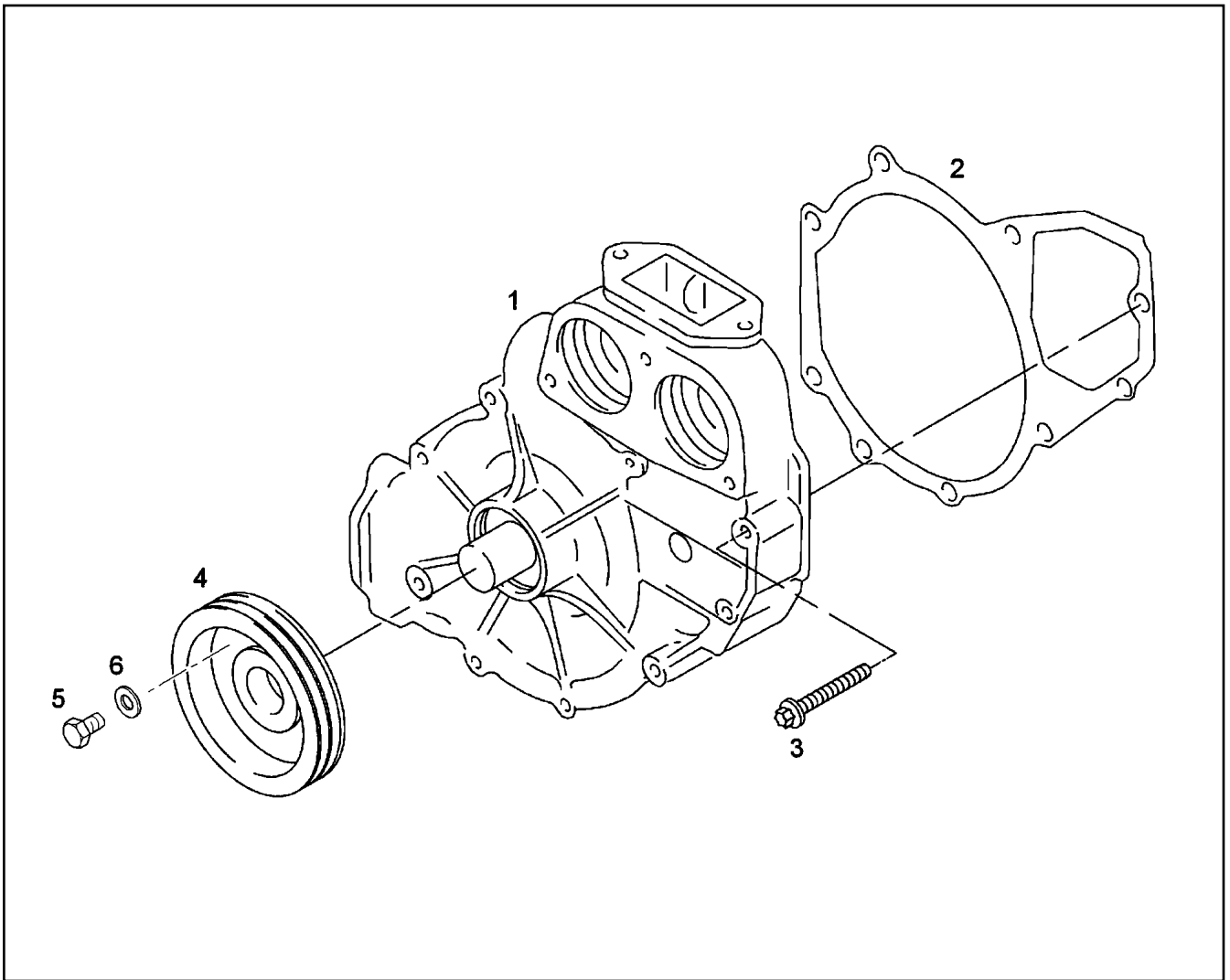

Pos.	Item	Quantity	Description	Bezeichnung	Serie	K
1	10 34 287 1	1	COOLANT PUMP	KUEHLMITTELPUMPE		
2	10 34 288 0	1	SEAL	DICHTUNG		
3	10 34 226 9	9	HEXALOBULAR HEAD SCREW M8X55 8.8 M	SECHSRUNDSCHRAUBE		
4	10 41 013 0	1	V-BELT PULLEY	KEILRIEMENSCHIEBE		
5	10 01 124 9	6	SCREW M8X18 8.8	SCHRAUBE		
6	10 01 165 4	6	WASHER A 8,4X16X1,6 200HV	SCHEIBE		

6.2.2009
049734

LIEBHERR

etk_en_de_074515 LR 1600/2

AT-WATER PUMP WITH FASTENING
WASSERPUMPE MIT BEFEST.

712

⇒ 9 739 352
97 39 352

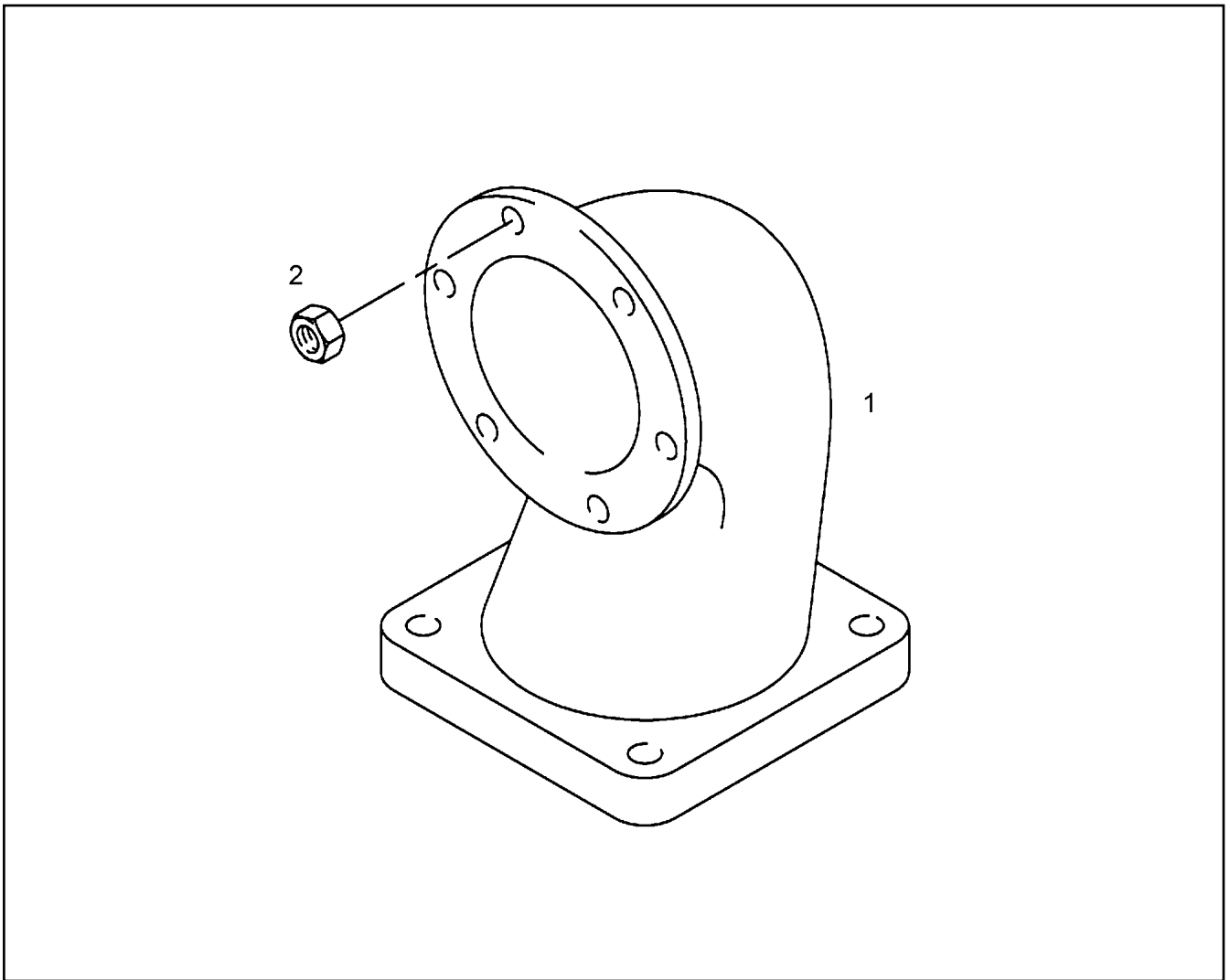

Pos.	Item	Quantity	Description	Bezeichnung	Serie	K
1	10 34 334 8	1	OUTLET MANIFOLD	ABGASKRUEMMER		
2	10 04 443 0	6	RIBBED HEX NUT M10 KL.10 ZN	SECHSKANTRIPPENMUTTER		

6.2.2009
049738

LIEBHERR

etk_en_de_074515 LR 1600/2

EXHAUST NOZZLE
ABGASSTUTZEN

713

⇒ 9 739 353
97 39 353

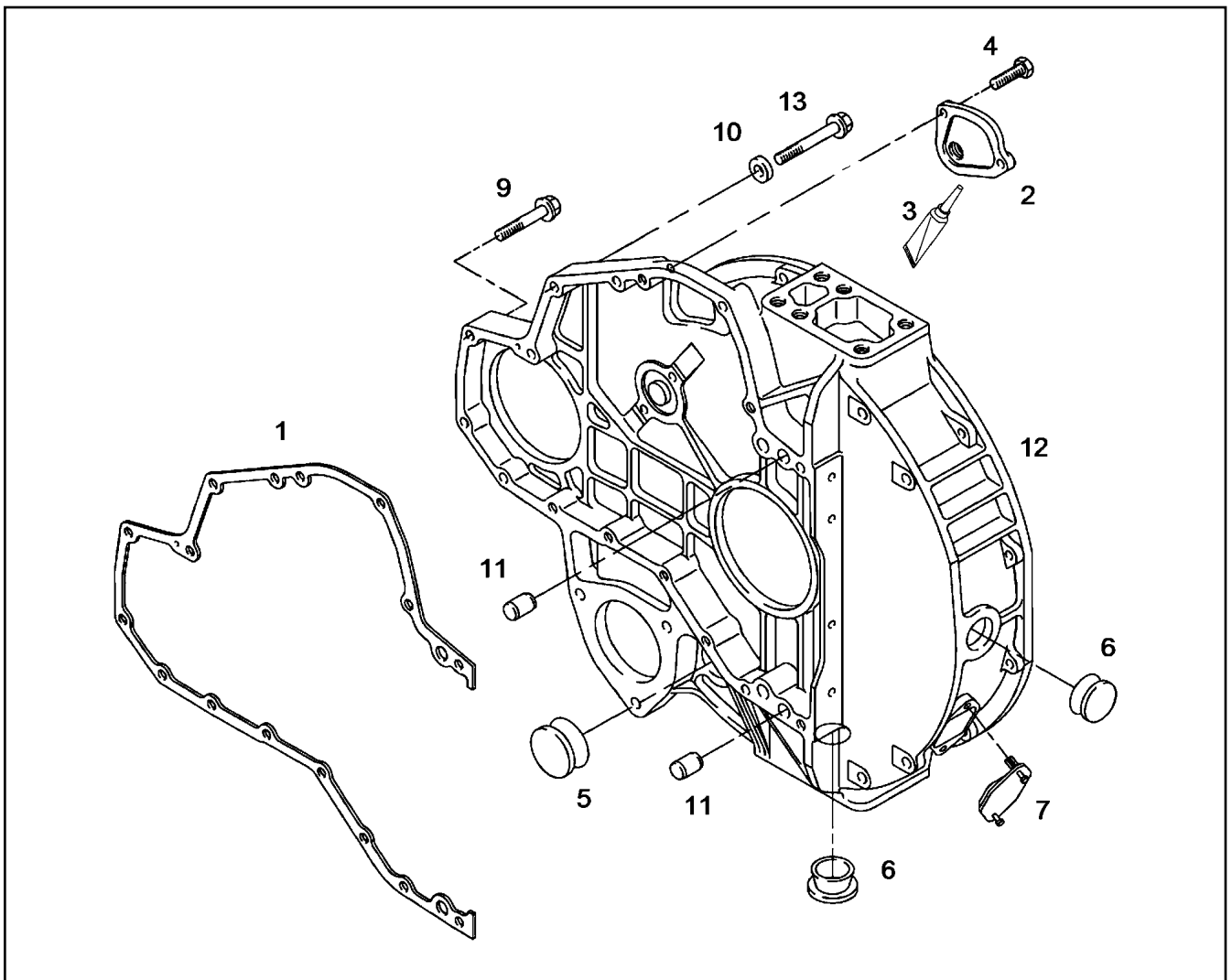

Pos.	Item	Quantity	Description	Bezeichnung	Serie	K
1	10 01 213 9	1	SEAL	DICHTUNG		
2	10 01 212 9	1	SCREW CAP	VERSCHLUSSDECKEL		
3	10 01 213 8	1	SEALING MATERIAL 50ML TUBE	DICHTUNGSMITTEL		
4	10 01 125 0	2	SCREW M8X22 8.8	SCHRAUBE		
5	10 01 263 0	1	PLUG 46/38X19-59/51 CR2-70	STOPFEN		
6	10 01 262 8	2	BLANKING PLUG	VERSCHLUSSSTOPFEN		
7	10 01 260 2	1	SCREW CAP	VERSCHLUSSDECKEL		
9	10 01 250 3	13	SCREW M10X54 12.9	SCHRAUBE		
10	10 01 694 9	3	WASHER 11X23X6 9SMNPB28K	SCHEIBE		
11	10 01 177 8	2	PARALLEL PIN 16H8X24 ST.50-2K	ZYLINDERSTIFT		
12	10 34 283 2	1	FLYWHEEL HOUSING	SCHWUNGRADGEHAEUSE		
13	10 01 250 0	3	SCREW M10X70 10.9	SCHRAUBE		

6.2.2009
049743

LIEBHERR

etk_en_de_074515 LR 1600/2

FLYWHEEL HOUSING MOUNTING
SCHWUNGRADGEHAEUSE ANBAU

714

⇒ 9 739 354
97 39 354

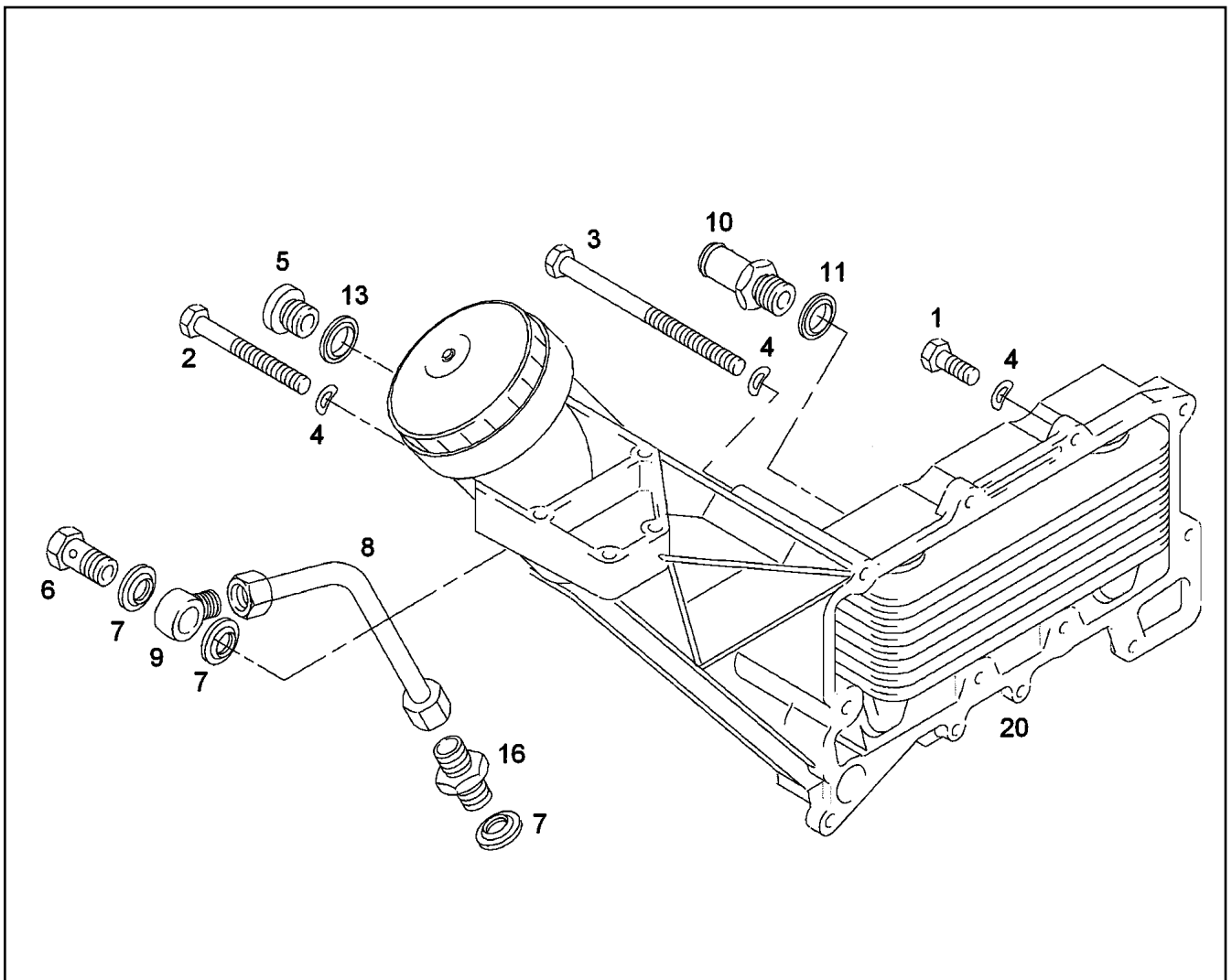

Pos.	Item	Quantity	Description	Bezeichnung	Serie	K
1	10 01 133 1	8	SCREW M10X35 8.8	SCHRAUBE		
2	10 01 127 1	1	SCREW M10X145 8.8 A3C	SCHRAUBE		
3	10 01 127 4	1	SCREW M10X170 8.8 A3C	SCHRAUBE		
4	10 01 170 9	10	232204 B 10 FST A3C	FEDERSCHEIBE		
5	10 01 161 5	1	SCREW PLUG M18 ST A3C	VERSCHLUSSSCHRAUBE		
6	10 01 200 7	1	HOLLOW SCREW 12 A4D	HOHLSCHRAUBE		
7	10 01 186 7	3	SEALING RING 16,7X24X1,5 ST/FPM1-80	DICHTRING		
8	10 22 236 5	1	HYDT.TUBE	OELRUECKLAUFLEITUNG		
9	10 22 236 6	1	RING ADAPTER	RINGSTUTZEN		
10	10 01 272 5	1	HOSE UNION 22-M26X1,5 ST	SCHLAUCHSTUTZEN		
11	10 01 187 0	1	SEALING RING 26,7X34,93X2 ST/FPM1-80	DICHTRING		
13	10 01 186 8	1	SEALING RING 18,7X26X1,5 ST/FPM1-80	DICHTRING		
16	10 01 199 9	1	SCREW-ON CONNECTION L12A-M ST	EINSCHRAUBSTUTZEN		
20	97 39 122	1	OIL COOLER	OELKUEHLER		
			⇒ 9 739 122		97 39 122	

6.2.2009
049724

LIEBHERR

etk_en_de_074515 LR 1600/2

OIL COOLER ADD-ON
OELKUEHLER ANBAU

715

⇒ 9 739 355
97 39 355

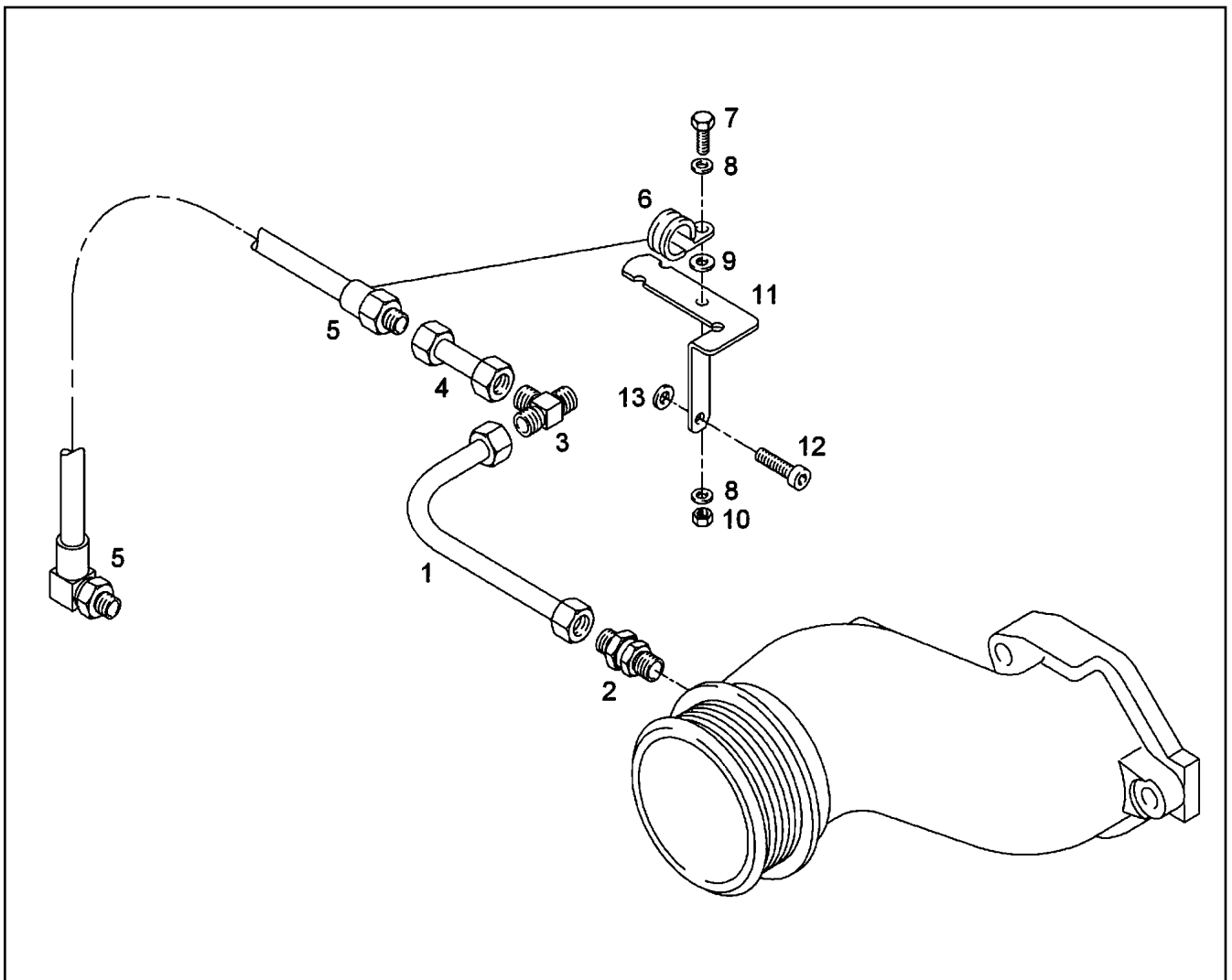

Pos.	Item	Quantity	Description	Bezeichnung	Serie	K
1	10 34 309 2	1	PRESSURE LINE	DRUCKLEITUNG		
2	10 34 334 2	1	NON-RETURN VALVE	RUECKSCHLAGVENTIL		
3	10 34 230 2	1	REDUCING STUD ST MAN272	REDUZIERSTUTZEN		
4	10 34 309 3	1	PRESSURE LINE	DRUCKLEITUNG		
5	10 34 342 0	1	HOSE LINE	SCHLAUCHLEITUNG		
6	10 34 229 7	1	FASTENING CLAMP DIN 3016-1 6 W1-EPDM-	SHELLE		
7	10 34 225 7	1	HEX BOLT M6X16 10.9 MAN183-PHR	SECHSKANTSCHRAUBE		
8	10 22 279 4	2	WASHER A 5.3 ST MAN183-B1	SCHEIBE		
9	10 34 375 2	1	WASHER 6,4X17X3 ST MAN183-B1	SCHEIBE		
10	10 01 162 9	1	NUT M6 8	MUTTER		
11	10 28 507 0	1	HOLDER	HALTER		
12	10 34 226 5	1	CYLINDER SCREW M8X30 8.8 A2C	ZYLINDERSCHRAUBE		
13	10 01 165 4	1	WASHER A 8,4X16X1,6 200HV	SCHEIBE		

6.2.2009
049730

LIEBHERR

etk_en_de_074515 LR 1600/2

PIPELINE INSTALLATION
ROHRLEITUNG ANBAU

716

⇒ 9 739 356
97 39 356

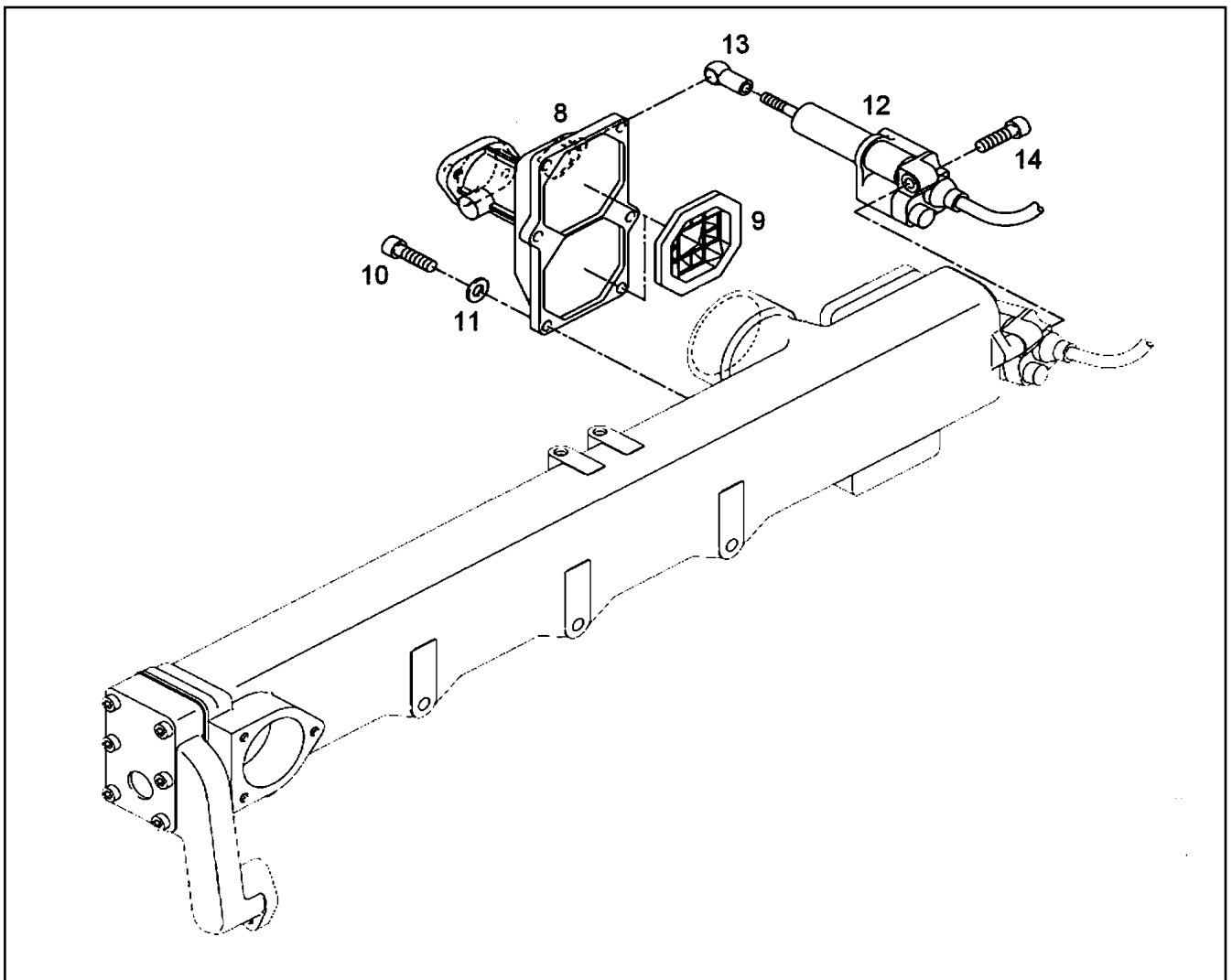

Pos.	Item	Quantity	Description	Bezeichnung	Serie	K
8	10 01 239 4	1	FLAP	KLAPPE		
9	10 01 239 5	2	NON-RETURN VALVE	RUECKSCHLAGVENTIL		
10	10 22 272 5	6	CYLINDER SCREW M8X25 10.9 MAN183-A2	ZYLINDERSCHRAUBE		
11	10 01 165 4	6	WASHER A 8,4X16X1,6 200HV	SCHEIBE		
12	10 33 276 5	1	COMPRESSED-AIR CYLINDER	DRUCKLUFTZYLINDER		
13	72 50 066 08	1	ANGLE JOINT DIN 71802 CS 13-M8 GELB V	WINKELGELENK		
14	10 01 148 8	1	SCREW M8X40 8.8 A2C	SCHRAUBE		

6.2.2009
049729

LIEBHERR

etk_en_de_074515 LR 1600/2

EXHAUST GAS RECIRCUL.PRE-ASS.
ABGASRUECKFUEHRUNG VORM.

717

⇒ 9 739 357
97 39 357

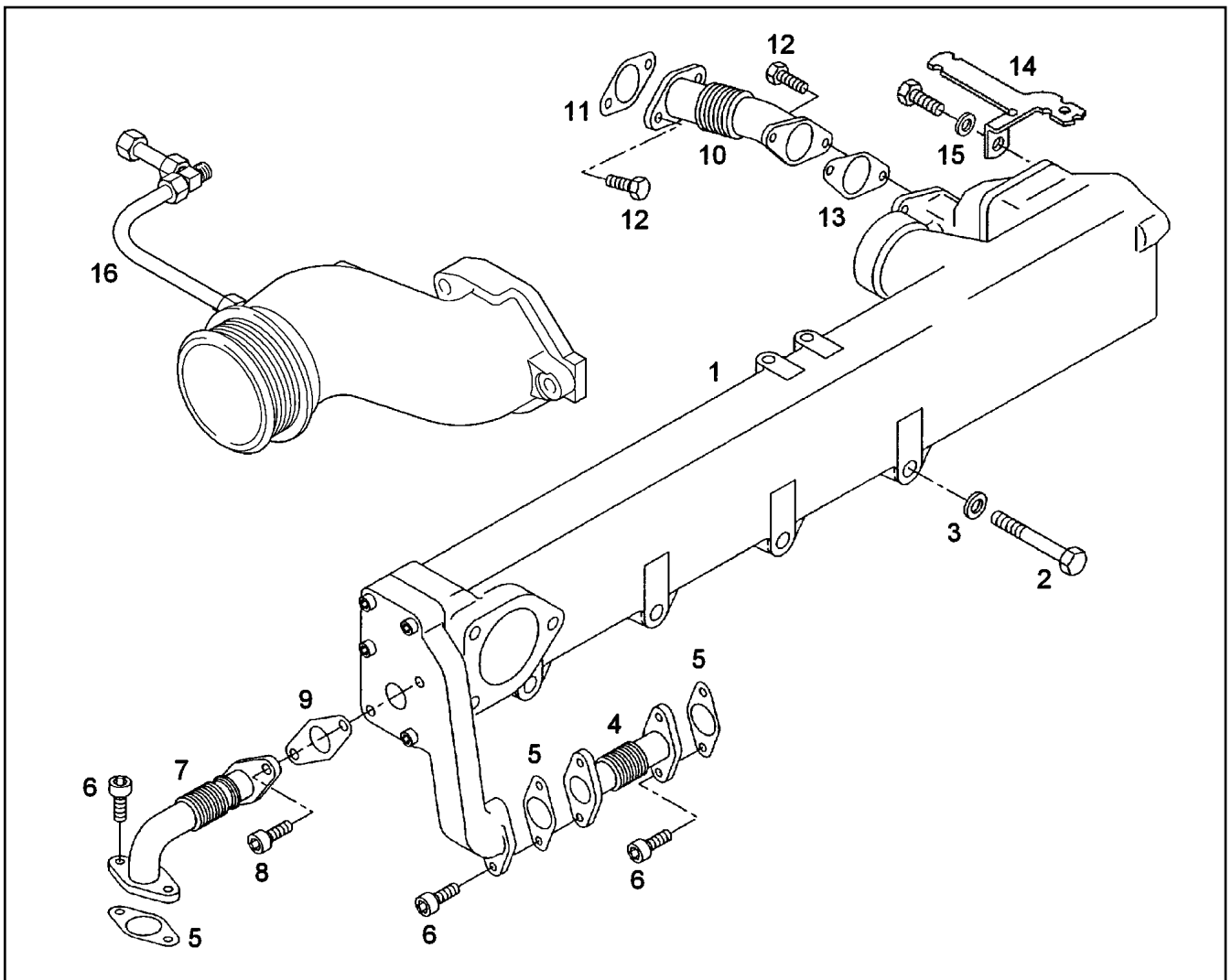

Pos.	Item	Quantity	Description	Bezeichnung	Serie	K
1	97 39 357	1	EXHAUST GAS RECIRCUL.PRE-ASS. ⇒ 9 739 357 97 39 357	ABGASRUECKFUEHRUNG VO		
2	10 01 134 7	4	SCREW M10X85 8.8 A3C	SCHRAUBE		
3	10 01 165 8	4	WASHER A 10,5X20X2,0 200HV	SCHEIBE		
4	10 22 237 3	1	EXHAUST DUCT	ABGASLEITUNG		
5	10 01 241 1	3	SEAL	DICHTUNG		
6	10 01 251 3	6	CYLINDER SCREW M8X20 GA C3J	ZYLINDERSCHRAUBE		
7	10 01 240 0	1	EXHAUST DUCT	ABGASLEITUNG		
8	10 01 251 4	2	CYLINDER SCREW M8X58 GA	ZYLINDERSCHRAUBE		
9	10 01 240 8	1	SEAL	DICHTUNG		
10	10 22 237 6	1	EXHAUST DUCT	ABGASLEITUNG		
11	10 01 240 9	1	SEAL	DICHTUNG		
12	10 01 125 0	4	SCREW M8X22 8.8	SCHRAUBE		
13	10 01 241 3	1	SEAL	DICHTUNG		
14	10 02 091 8	1	HOLDER	HALTER		
15	10 01 256 8	1	WASHER 8,4X19X4 C45K	SCHEIBE		
16	97 39 356	1	PIPELINE INSTALLATION ⇒ 9 739 356 97 39 356	ROHRLEITUNG ANBAU		

6.2.2009
049728

LIEBHERR

etk_en_de_074515 LR 1600/2

EXHAUST GAS RECIRCUL.ATTACHM.
ABGASRUECKFUEHRUNG ANBAU

718

⇒ 9 739 358
97 39 358

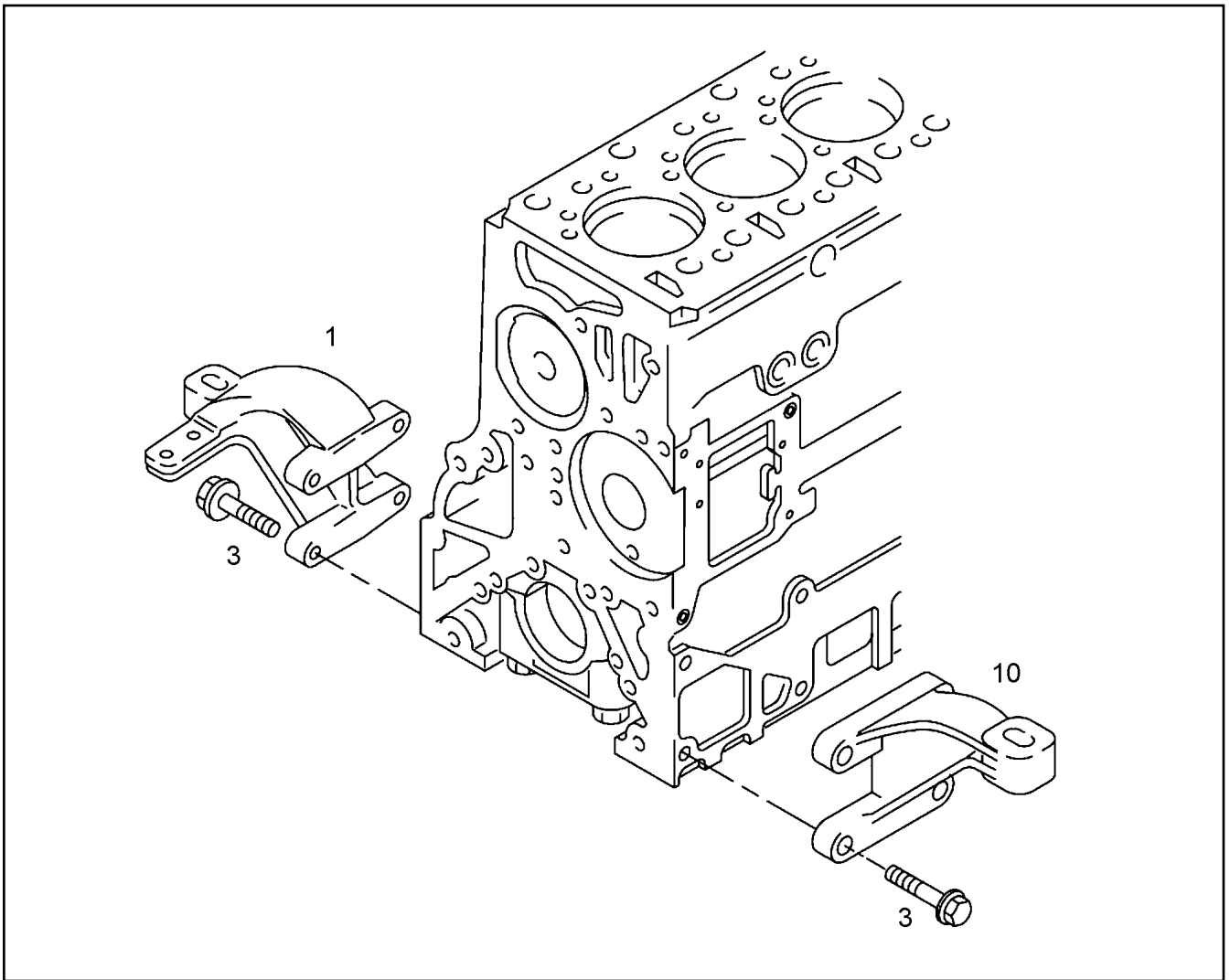

Pos.	Item	Quantity	Description	Bezeichnung	Serie	K
1	10 34 317 4	1	CONSOLE	KONSOLE		
3	10 34 226 6	8	LOCKING SCREW M14X45 12.9 MAN183-PH	SICHERUNGSSCHRAUBE		
10	10 34 317 6	1	CONSOLE	KONSOLE		

6.2.2009
049741

LIEBHERR

etk_en_de_074515 LR 1600/2

MOTOR SUPPORT
MOTORLAGERUNG

719

⇒ 9 739 360
97 39 360

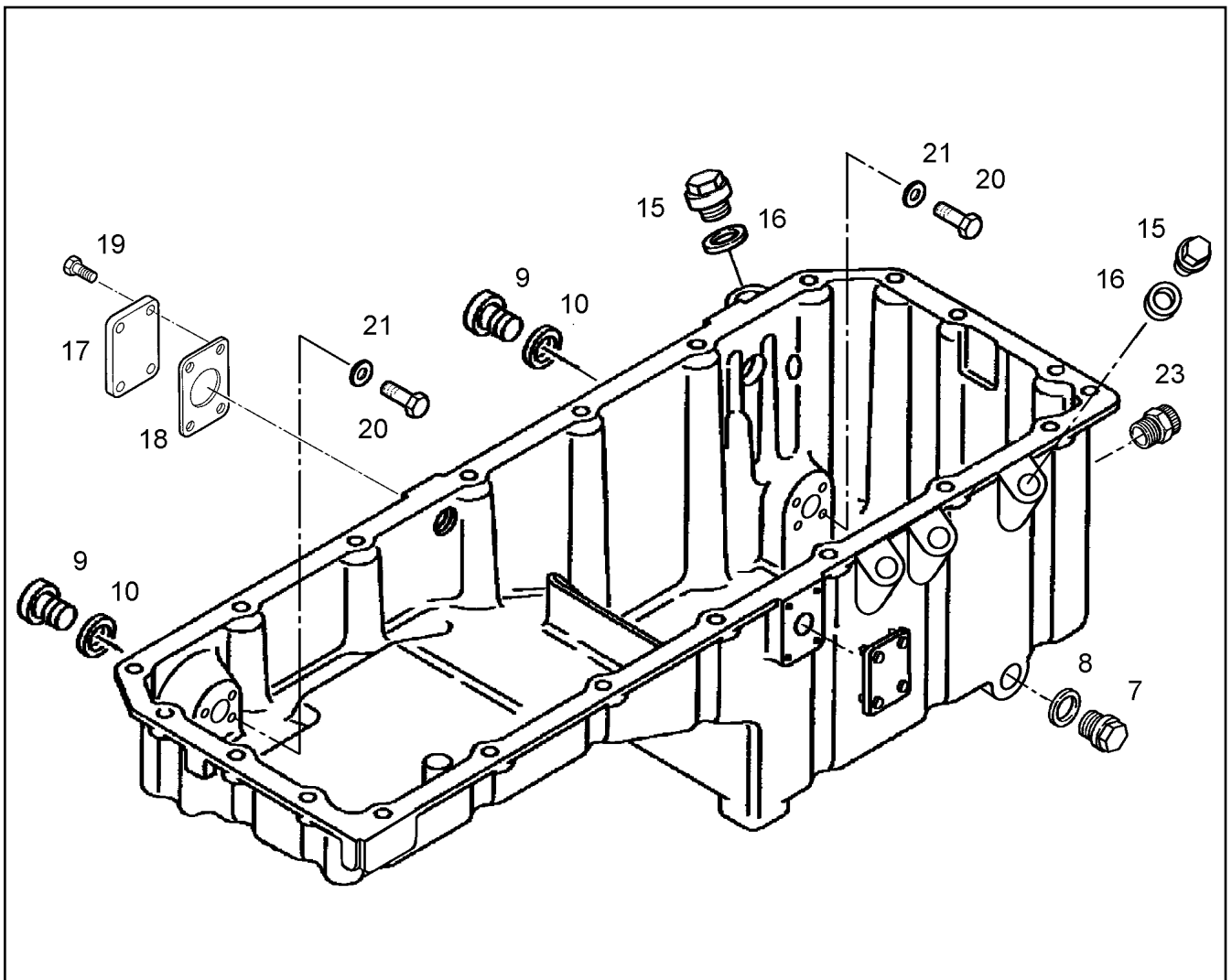

Pos.	Item	Quantity	Description	Bezeichnung	Serie	K
7	10 01 252 6	1	SCREW PLUG M25X1,5X20 9SMNPB28K	VERSCHLUSSSCHRAUBE		
8	10 01 264 3	1	SEAL	DICHTUNG		
9	10 01 161 9	2	SCREW PLUG M26X1,5 ST A3C	VERSCHLUSSSCHRAUBE		
10	10 01 187 0	2	SEALING RING 26,7X34,93X2 ST/FPM1-80	DICHTRING		
15	10 01 161 2	2	SCREW PLUG M14X1,5 ST A3C	VERSCHLUSSSCHRAUBE		
16	10 01 186 6	2	SEALING RING 14,7X22X1,5 ST/FPM1-80	DICHTRING		
17	10 01 271 4	2	FLANGE	FLANSCH		
18	10 01 214 0	2	SEAL	DICHTUNG		
19	10 03 730 4	8	HEX BOLT M8X20 8.8	SECHSKANTSCHRAUBE		
20	10 03 291 2	8	HEX BOLT ISO 4017 M8X12 8.8	SECHSKANTSCHRAUBE		
21	10 01 165 4	8	WASHER A 8,4X16X1,6 200HV	SCHEIBE		
23	10 03 290 6	1	DRAIN VALVE	ABLASSVENTIL		

6.2.2009
053957

LIEBHERR

etk_en_de_074515 LR 1600/2

OIL SUMP
OELWANNE

720

⇒ 9 739 361
97 39 361

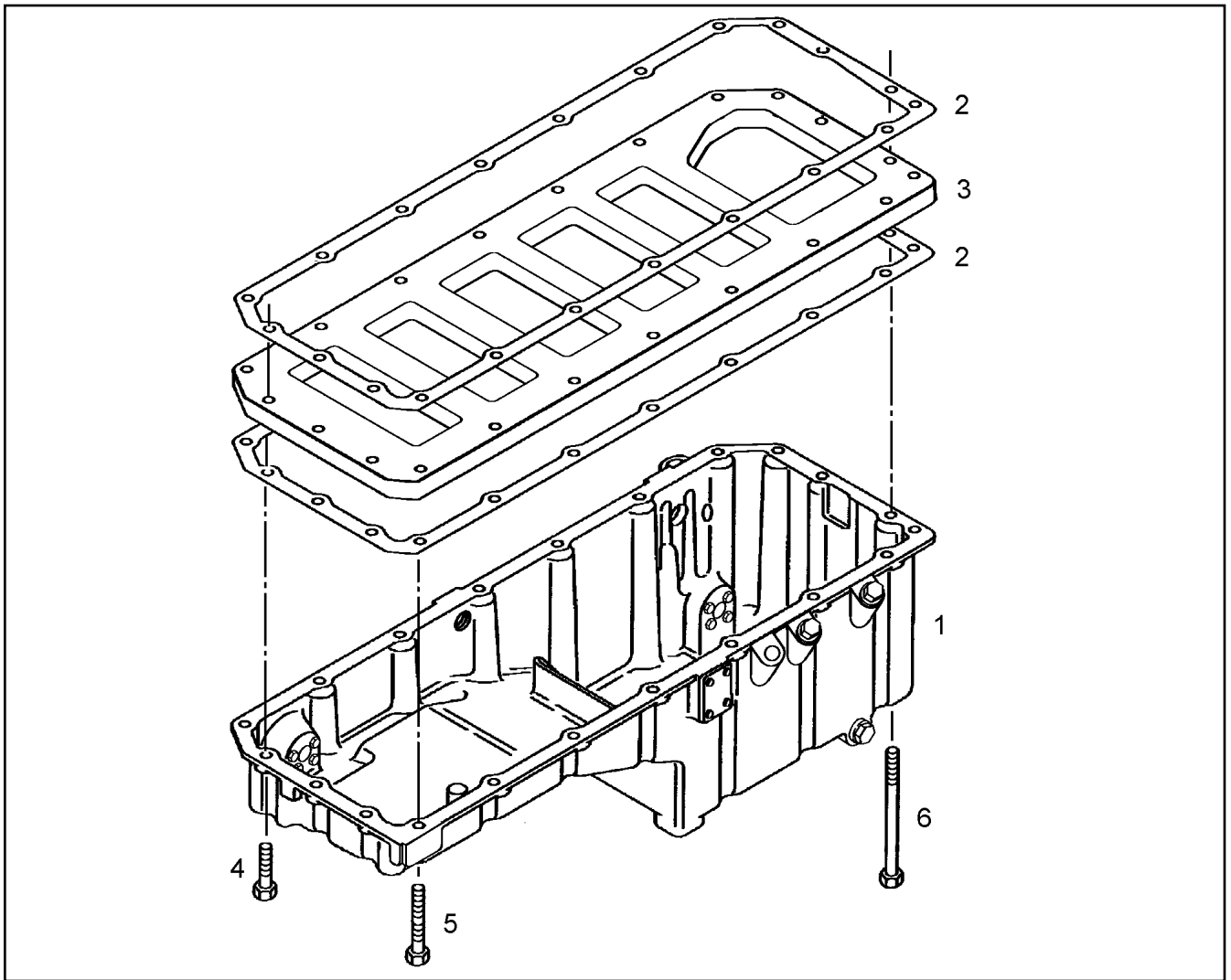

Pos.	Item	Quantity	Description	Bezeichnung	Serie	K
1	97 39 361	1	OIL SUMP R-MOTORXD846 A7 ⇒ 9 739 361 97 39 361	OELWANNE		
2	10 01 229 9	2	SEAL	DICHTUNG		
3	10 02 918 8	1	STIFFENING PLATE	VERSTEIFUNGSBLECH		
4	10 34 226 7	19	HEX HEAD SCREW WITH FLANGE M8X45 1	SECHSKANTSCHRAUBE MIT FL		
5	10 34 226 8	1	HEX HEAD SCREW WITH FLANGE M8X90 1	SECHSKANTSCHRAUBE MIT FL		
6	10 03 731 0	1	HEX BOLT EN 1665 M8X140 10.9 A3C	SECHSKANTSCHRAUBE		

6.2.2009
053956

LIEBHERR

etk_en_de_074515 LR 1600/2

OIL SUMP
OELWANNE

721

⇒ 9 739 362
97 39 362

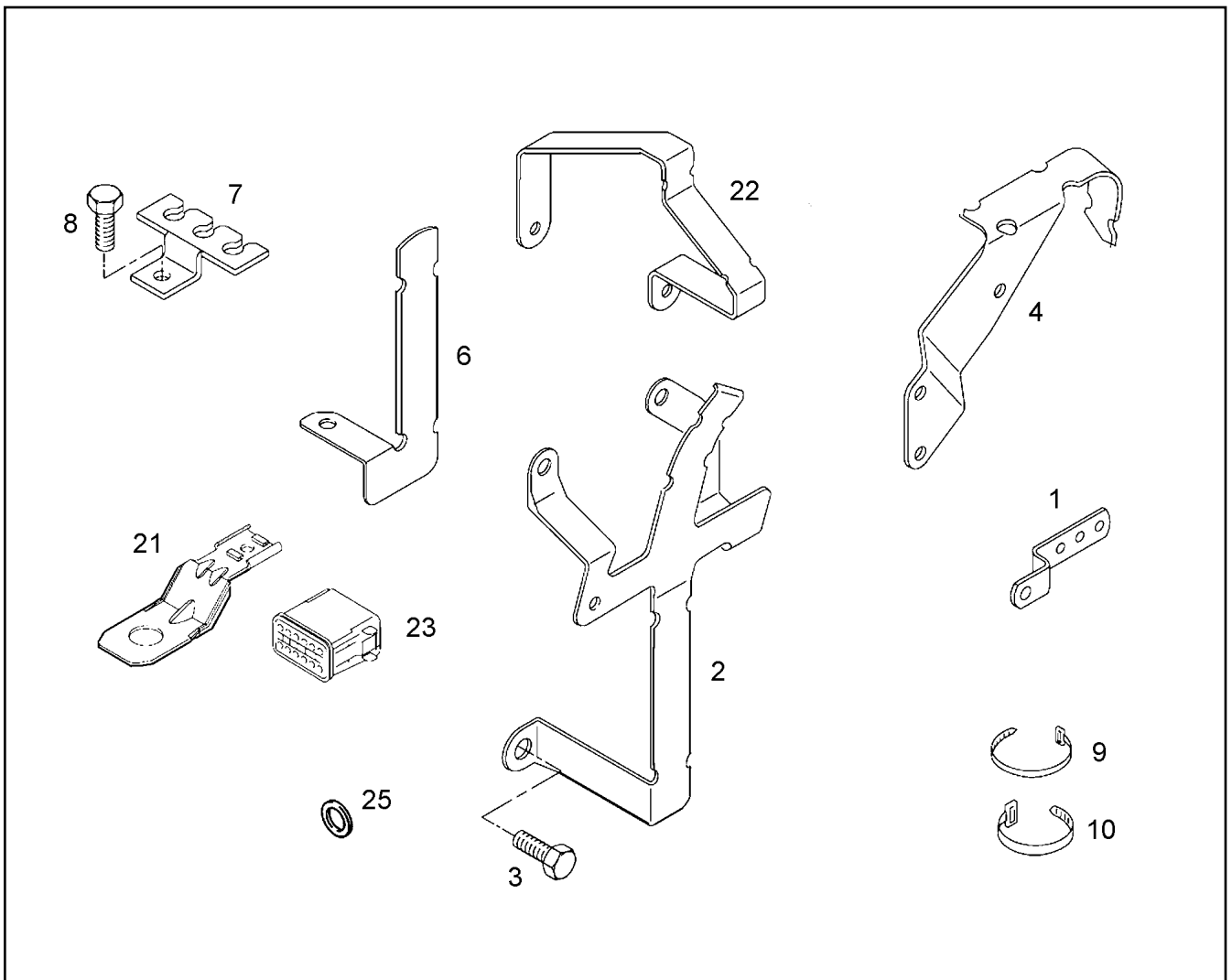

Pos.	Item	Quantity	Description	Bezeichnung	Serie	K
1	10 02 092 1	1	HOLDER	HALTER		
2	10 28 506 8	1	HOLDER	HALTER		
3	10 01 134 4	1	SCREW M12X16 8.8 A3C	SCHRAUBE		
4	10 28 506 9	1	HOLDER	HALTER		
6	10 28 507 0	1	HOLDER	HALTER		
7	10 02 095 5	4	HOLDER	HALTER		
8	10 01 136 0	5	SCREW M8X16 8.8	SCHRAUBE		
9	10 34 342 4	5	CABLE TIE 3,5X150XSCHWARZ PA6.6 SW	KABELBINDER		
10	10 02 093 1	3	CABLE TIE 4,6X385 PA6.6-SW	KABELBINDER		
21	10 34 312 6	1	HOLDER	HALTER		
22	10 34 312 8	1	HOLDER	HALTER		
23	10 34 312 1	1	PLUG 12-POL	STECKER		
25	10 01 165 4	3	WASHER A 8,4X16X1,6 200HV	SCHEIBE		

6.2.2009
049742

LIEBHERR

etk_en_de_074515 LR 1600/2

FASTENING PIECES ASSEMBLY
BEFESTIGUNGSTEILE ANBAU

722

⇒ 9 739 366
97 39 366

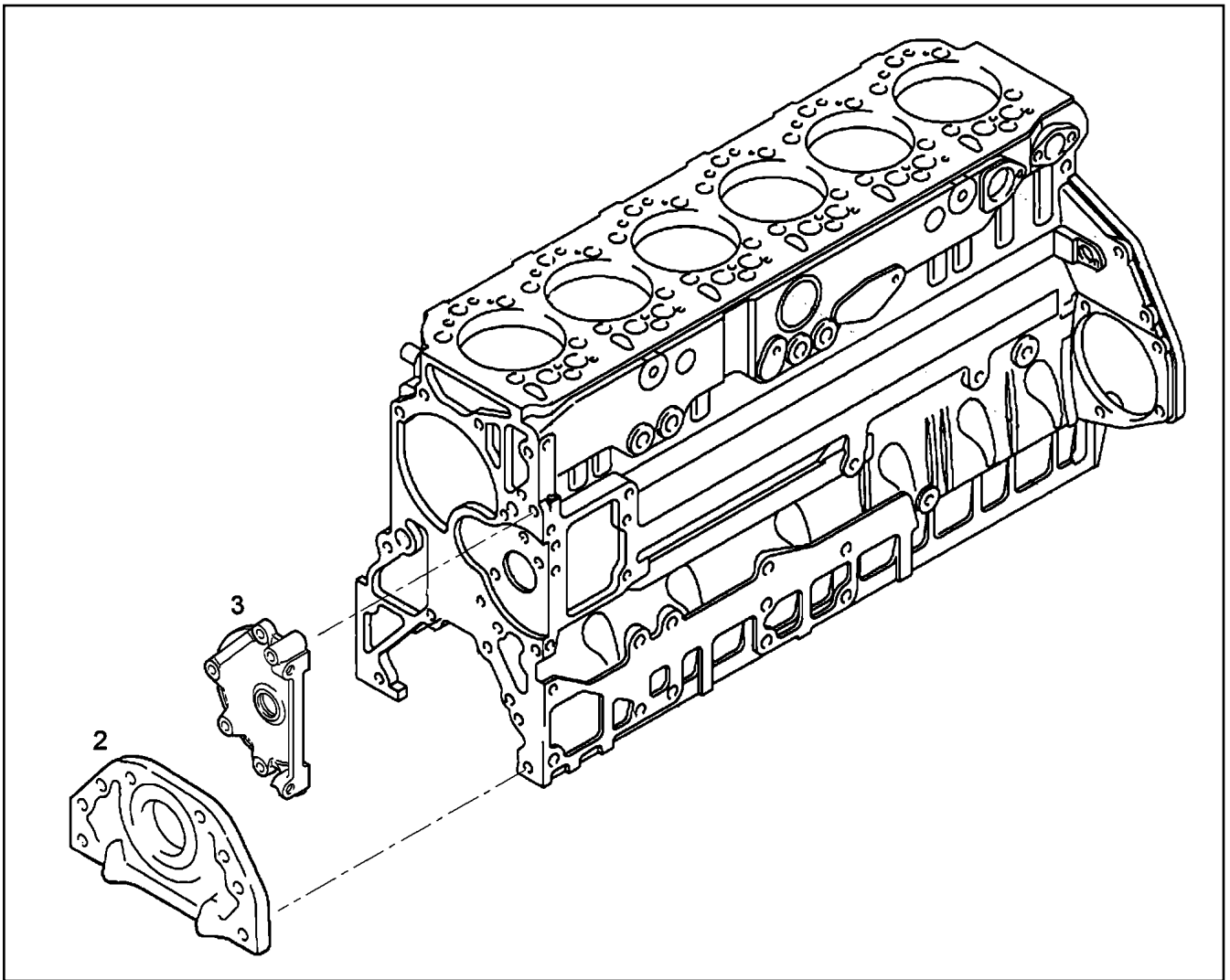

Pos.	Item	Quantity	Description	Bezeichnung	Serie	K
2	97 39 367	1	SCREW CAP	VERSCHLUSSDECKEL		
3	97 39 365	1	SCREW CAP	VERSCHLUSSDECKEL		

6.2.2009
049722

LIEBHERR

etk_en_de_074515 LR 1600/2

CRANKCASE CPL.
KURBELGEHAEUSE KPL.

723

⇒ 9 739 368
97 39 368

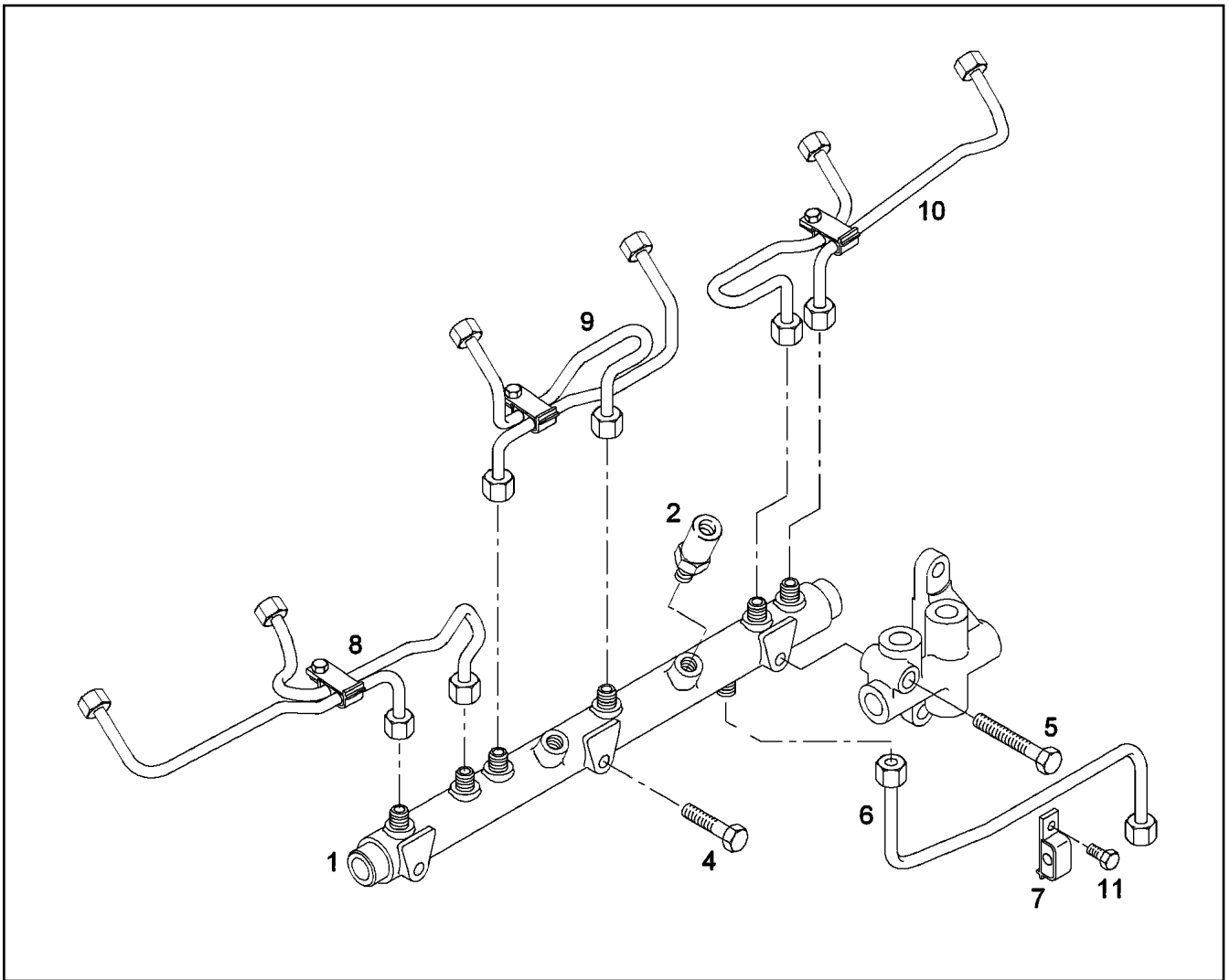

Pos.	Item	Quantity	Description	Bezeichnung	Serie	K
1	10 22 273 9	1	PRESSURE PIPE	DRUCKROHR		
2	10 22 274 0	1	PRESSURE LIMITING VALVE	DRUCKBEGRENZUNGSVENTIL		
4	10 01 122 5	2	SCREW M8X65 8.8 A2C	SCHRAUBE		
5	10 02 919 3	1	SCREW M8X95 8.8	SCHRAUBE		
6	10 34 309 5	1	PRESSURE LINE	DRUCKLEITUNG		
7	10 22 274 3	1	PIPE CLAMP	ROHRSCHELLE		
8	10 22 274 5	1	INJECTION LINE	EINSPRITZLEITUNG		
9	10 22 274 6	1	INJECTION LINE	EINSPRITZLEITUNG		
10	10 22 274 7	1	INJECTION LINE	EINSPRITZLEITUNG		
11	10 22 274 4	1	HEX BOLT	SECHSKANTSCHRAUBE		

6.2.2009
049727

LIEBHERR

etk_en_de_074515 LR 1600/2

PRESSURE PIPE
DRUCKROHR

724

⇒ 9 739 369
97 39 369

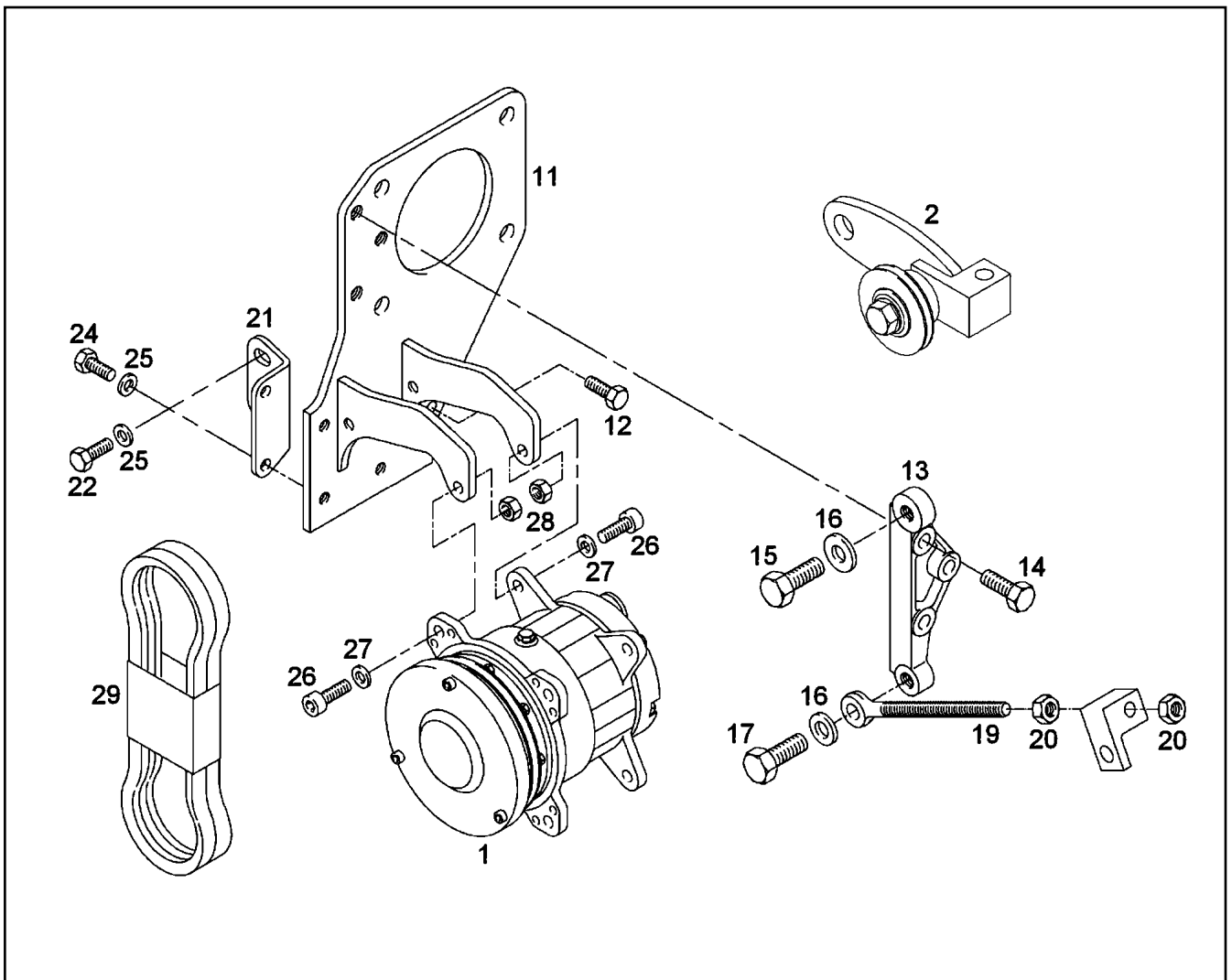

Pos.	Item	Quantity	Description	Bezeichnung	Serie	K
1	10 29 994 8	1	AIR CONDITIONING COMPRESSOR	KLIMAKOMPRESSOR		
2	10 34 330 9	1	TIGHTENING ROLLER	SPANNROLLE		
11	10 34 310 5	1	BEAM	TRAEGER		
12	10 01 136 2	1	SCREW M8X25 8.8	SCHRAUBE		
13	10 34 331 8	1	CONSOLE	KONSOLE		
14	10 01 133 1	1	SCREW M10X35 8.8	SCHRAUBE		
15	10 34 226 2	1	FITTED SCREW M12X32 8.8	PASSSCHRAUBE		
16	10 01 165 9	2	WASHER A 13X24X2,5 200HV	SCHEIBE		
17	10 01 134 5	1	SCREW M12X40 8.8 A3C	SCHRAUBE		
19	10 34 328 5	1	EYE BOLT DIN 444 M12X150 6.8	AUGENSCHRAUBE		
20	10 34 227 9	2	HEX NUT M12 04 A3C	SECHSKANTMUTTER		
21	10 34 310 3	1	HOLDER	HALTER		
22	10 01 125 0	2	SCREW M8X22 8.8	SCHRAUBE		
23	10 01 165 4	4	WASHER A 8,4X16X1,6 200HV	SCHEIBE		
24	10 03 730 4	2	HEX BOLT M8X20 8.8	SECHSKANTSCHRAUBE		
26	10 01 148 8	4	SCREW M8X40 8.8 A2C	SCHRAUBE		
27	10 01 256 8	4	WASHER 8,4X19X4 C45K	SCHEIBE		
28	10 01 163 7	4	LOCK NUT BM8-8	SICHERUNGSMUTTER		
29	10 34 229 2	1	V-BELT SET 2C 1325	KEILRIEMENSATZ		

6.2.2009
049733

LIEBHERR

etk_en_de_074515 LR 1600/2

AIR COND. COMPRESSOR ADD-ON
KLIMAKOMPRESSOR ANBAU

725

⇒ 9 739 371
97 39 371

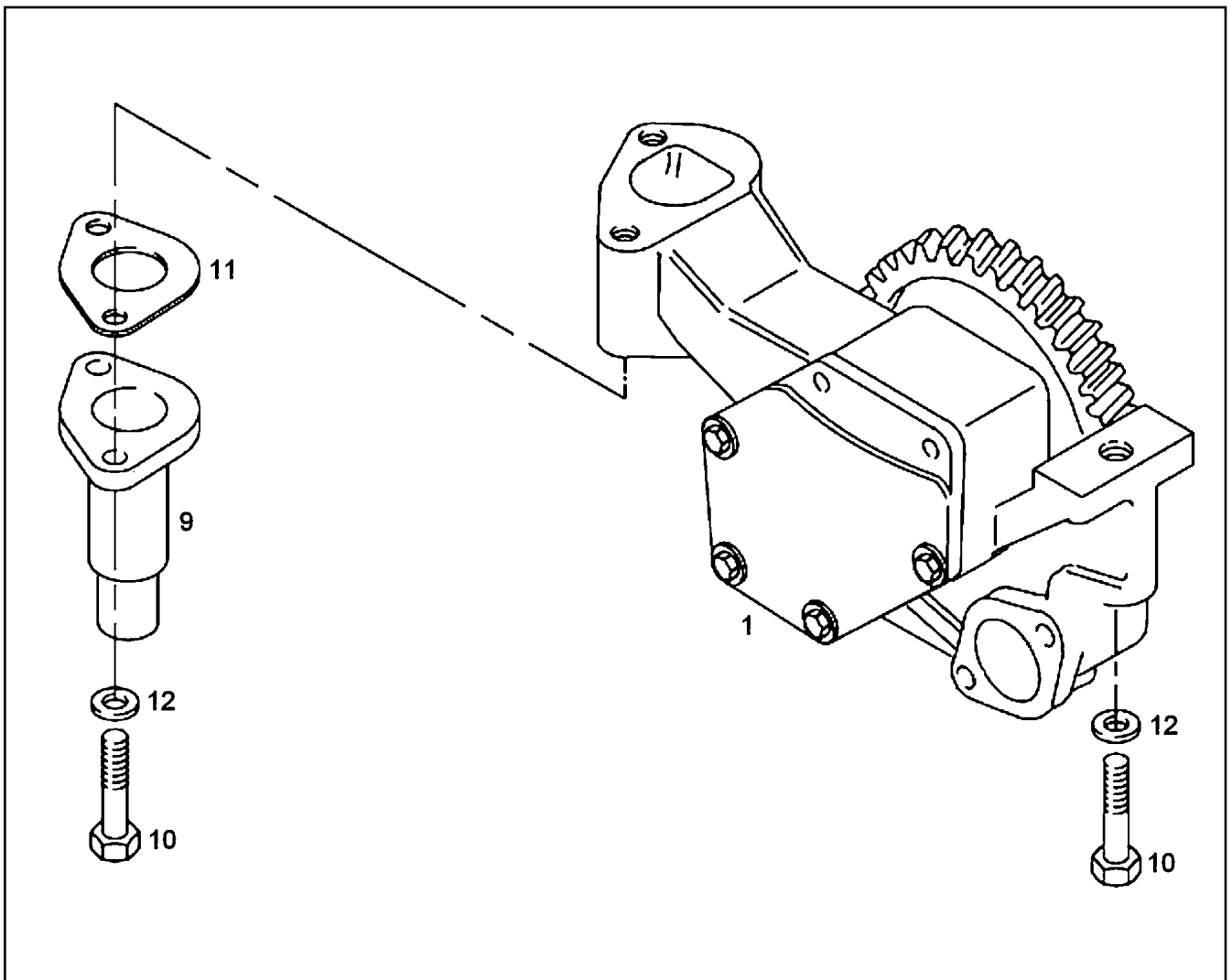

Pos.	Item	Quantity	Description	Bezeichnung	Serie	K
1	10 02 919 2	1	LUBRICATING OIL PUMP	SCHMIEROELPUMPE		
9	10 01 228 3	1	OVERPRESSURE VALVE	UEBERDRUCKVENTIL		
10	10 01 132 8	3	SCREW M8X55 8.8	SCHRAUBE		
11	10 34 286 4	1	FLANGE	FLANSCH		
12	10 01 165 4	3	WASHER A 8,4X16X1,6 200HV	SCHEIBE		

6.2.2009
049725

LIEBHERR

etk_en_de_074515 LR 1600/2

LUBRICATING OIL PUMP
SCHMIEROELPUMPE

726

⇒ 9 739 372
97 39 372

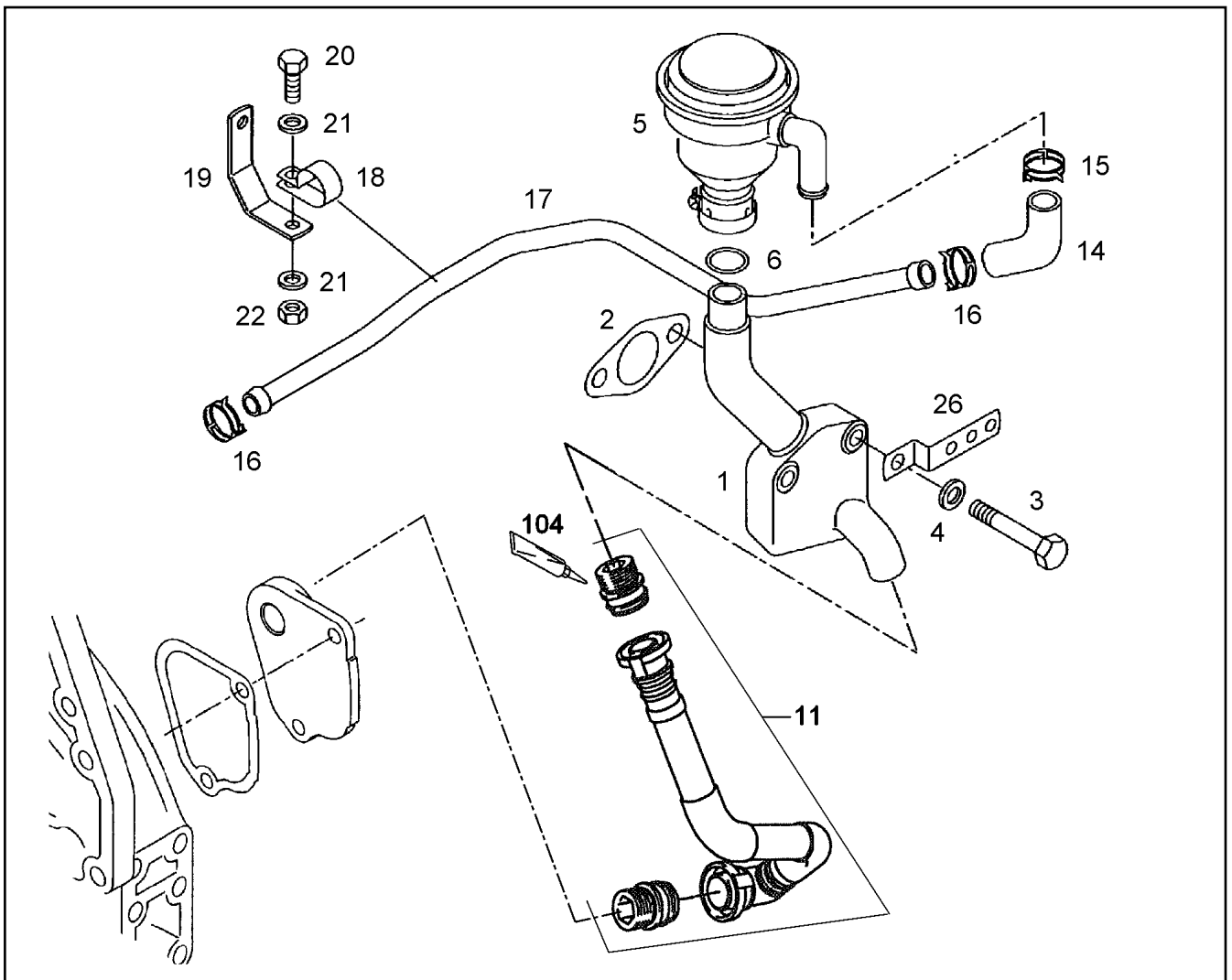

Pos.	Item	Quantity	Description	Bezeichnung	Serie	K
1	10 01 219 0	1	ELBOW	KRUEMMER		
2	10 01 184 6	1	SEAL	DICHTUNG		
3	10 01 126 4	2	SCREW M10X70 8.8	SCHRAUBE		
4	10 01 165 8	2	WASHER A 10,5X20X2,0 200HV	SCHEIBE		
5	10 01 213 6	1	OIL SEPARATOR	OELABSCHIEDER		
6	10 01 263 4	1	O RING 30X3,5 N-NBR3-70	RUNDDICHTRING		
11	97 39 322	1	REPAIR KIT PIPE LINE ⇒ 9 739 322 97 39 322	RS ROHRLEITUNG		
14	10 01 263 1	1	FORM HOSE	FORMSCHLAUCH		
15	10 01 266 8	1	HOSE CLAMP 29 CK75	SCHLAUCHSCHELLE		
16	10 01 267 1	2	HOSE CLAMP 26 CK75	SCHLAUCHSCHELLE		
17	10 03 733 9	1	VENTILATION LINE	ENTLUEFTUNGSLEITUNG		
18	10 47 687 9	1	PIPE CLAMP 18 A4C	ROHRSCHELLE		
19	10 01 268 4	1	HOLDER	HALTER		
20	10 01 124 9	1	SCREW M8X18 8.8	SCHRAUBE		
21	10 01 165 4	2	WASHER A 8,4X16X1,6 200HV	SCHEIBE		
22	10 01 163 1	1	NUT M8 8	MUTTER		
26	10 02 092 1	1	HOLDER	HALTER		
104	81 12 073 01	1	GLUE 10ML	KLEBSTOFF		

6.2.2009
049164

LIEBHERR

etk_en_de_074515 LR 1600/2

CRANKCASE BREATHER
KURBELGEHAEUSEENTLUEFTUNG

727

⇒ 9 739 386
97 39 386

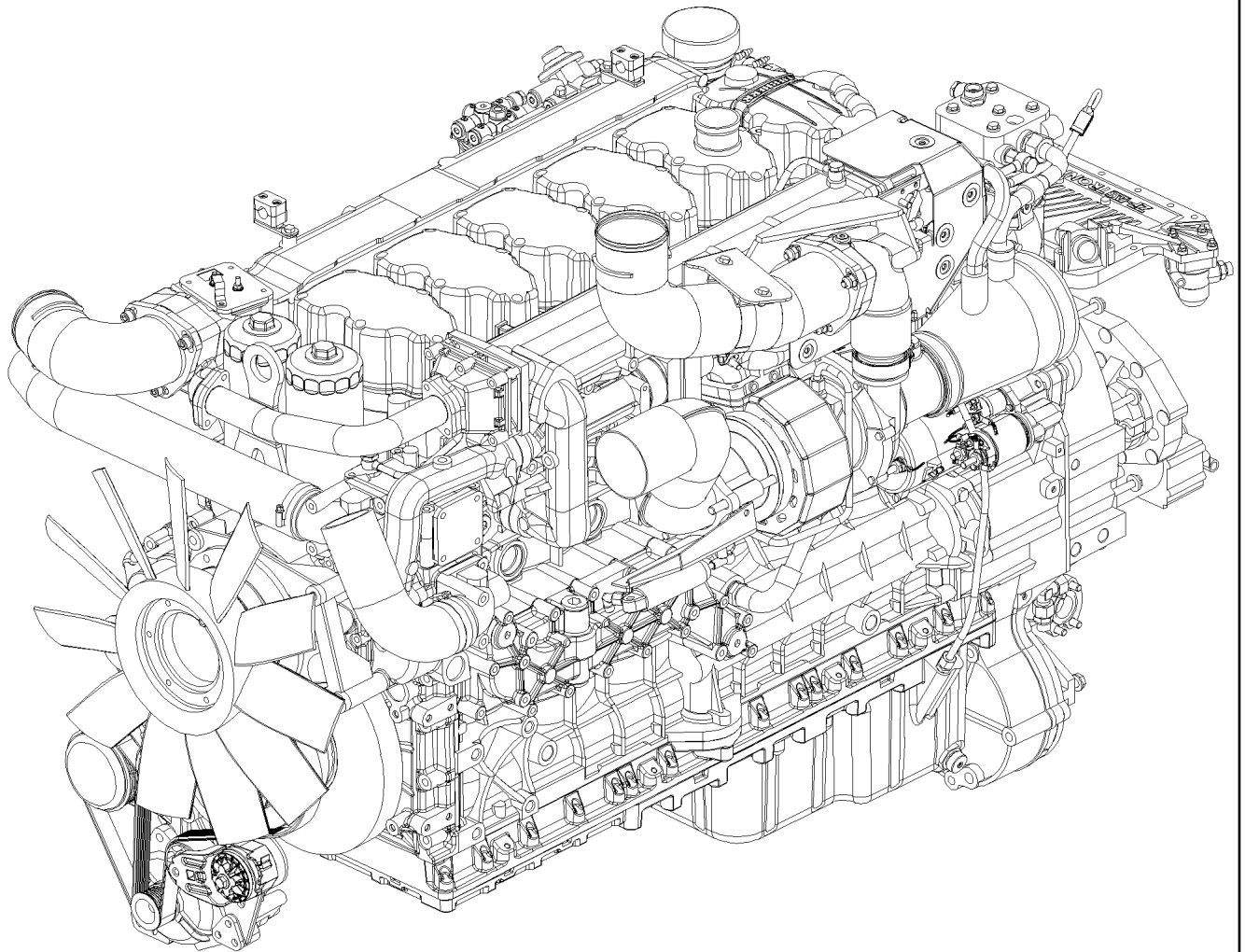

6.2.2009
048699

LIEBHERR

etk_en_de_074515 LR 1600/2

DIESEL ENGINE
DIESELMOTOR

728 (1/2)

→ 9 739 400
97 39 400

Pos.	Item	Quantity	Description	Bezeichnung	Serie	K
1	10 12 059 0	1	DIESEL ENGINE D2876 LE131 ⇒ X10120590 10 12 059 0	DIESELMOTOR		
49	97 39 082	1	INFORMATION LABEL PVC 2	HINWEISSCHILD		
71	97 39 403	1	MOTOR CONTROL DEVICE LH-ECU-UP/CR	MOTORSTEUERGERAET		
72	90 80 702	1	CONTROL GEAR ⇒ 9 080 702 90 80 702	STEUERGERAET		
97	10 11 614 1	1	FUEL HOSE ⇒ X10116141 10 11 614 1	KRAFTSTOFFSCHLAUCH		
230	97 39 326	1	CABLE BOOM MOUNTING	KABELBAUM ANBAU		
(1)	10 11 922 6	1	LOOM	KABELBAUM		
231	97 39 257	1	ENGINE CONTROL SENSORS ⇒ 9 739 257 97 39 257	MOTORREGELUNGSENSORIK		
277	90 77 248	1	BEAM	TRAEGER		
282	97 39 035	1	LOCKING PIECES ⇒ 9 739 035 97 39 035	VERSCHLUSSTEIL		
330	97 39 186	1	MOTOR BRAKE ⇒ 9 739 186 97 39 186	MOTORBREMSE		
492	10 22 281 7	6	SEAL KIT CYLINDER HEAD ⇒ X10222817 10 22 281 7	DS ZYLINDERKOPF		

6.2.2009

etk_en_de_074515 LR 1600/2

729 (2/2)

LIEBHERR

DIESEL ENGINE
DIESELMOTOR

⇒ 9 739 400
97 39 400

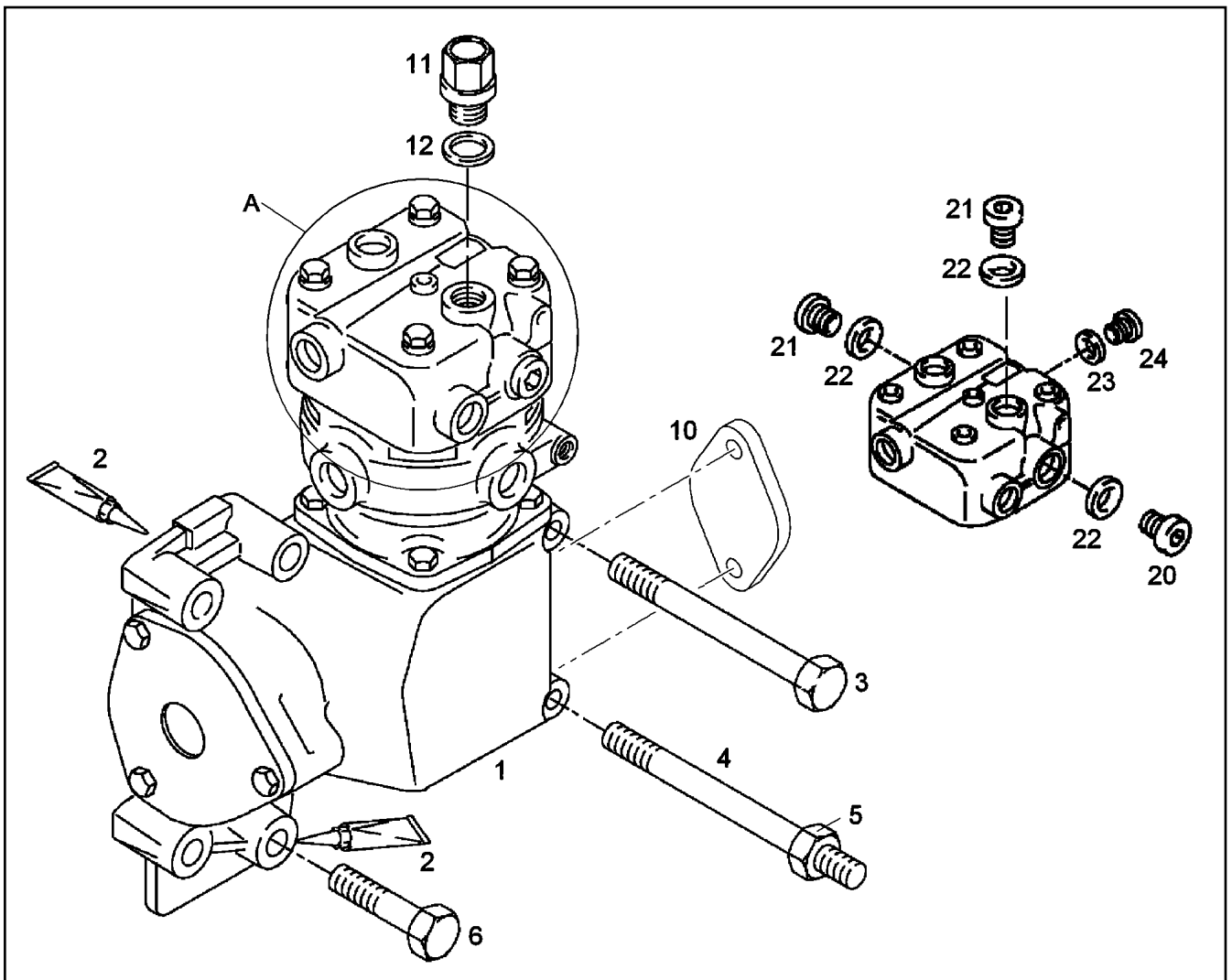

Pos.	Item	Quantity	Description	Bezeichnung	Serie	K
1	10 47 688 5	1	AIR COMPRESSOR	LUFTPRESSER		
2	10 01 117 2	1	SEALANT	DICHTMITTEL		
3	10 47 688 8	1	HEX HEAD SCREW WITH FLANGE M8X140 1	SECHSKANTSCHRAUBE MIT FL		
4	10 47 689 0	1	DOUBLE-ENDED STUD M8X150 10.9 MAN18	STIFTSCHRAUBE		
5	10 47 690 5	1	HEX NUT M8X10 MAN183-B1	SECHSKANTMUTTER		
6	10 22 273 7	4	FLANGED BOLT	BUNDSCHRAUBE		
10	97 39 286	1	SCREW CAP ⇒ 9 739 286 97 39 286	VERSCHLUSSDECKEL		
11	10 01 248 1	1	SAFETY VALVE 17BAR	SICHERHEITSVENTIL		
12	10 01 187 0	1	SEALING RING 26,7X34,93X2 ST/FPM1-80	DICHTRING		
20	10 22 280 4	1	LUG GE LL 16M26X1,5 ST A4C	STUTZEN		
21	10 01 161 9	2	SCREW PLUG M26X1,5 ST A3C	VERSCHLUSSSCHRAUBE		
22	10 03 730 5	3	SEALING RING A26X34 CU	DICHTRING		
23	10 01 184 1	1	SEALING RING A22X27 CU	DICHTRING		
24	40 41 016 08	1	SCREW PLUG DIN 908 M22X1,5 ST A2C	VERSCHLUSSSCHRAUBE		

6.2.2009
049731

LIEBHERR

etk_en_de_074515 LR 1600/2

INSTALLATION BRAKE COMPRESSOR
LUFTPRESSER ANBAU

730

⇒ 9 739 491
97 39 491

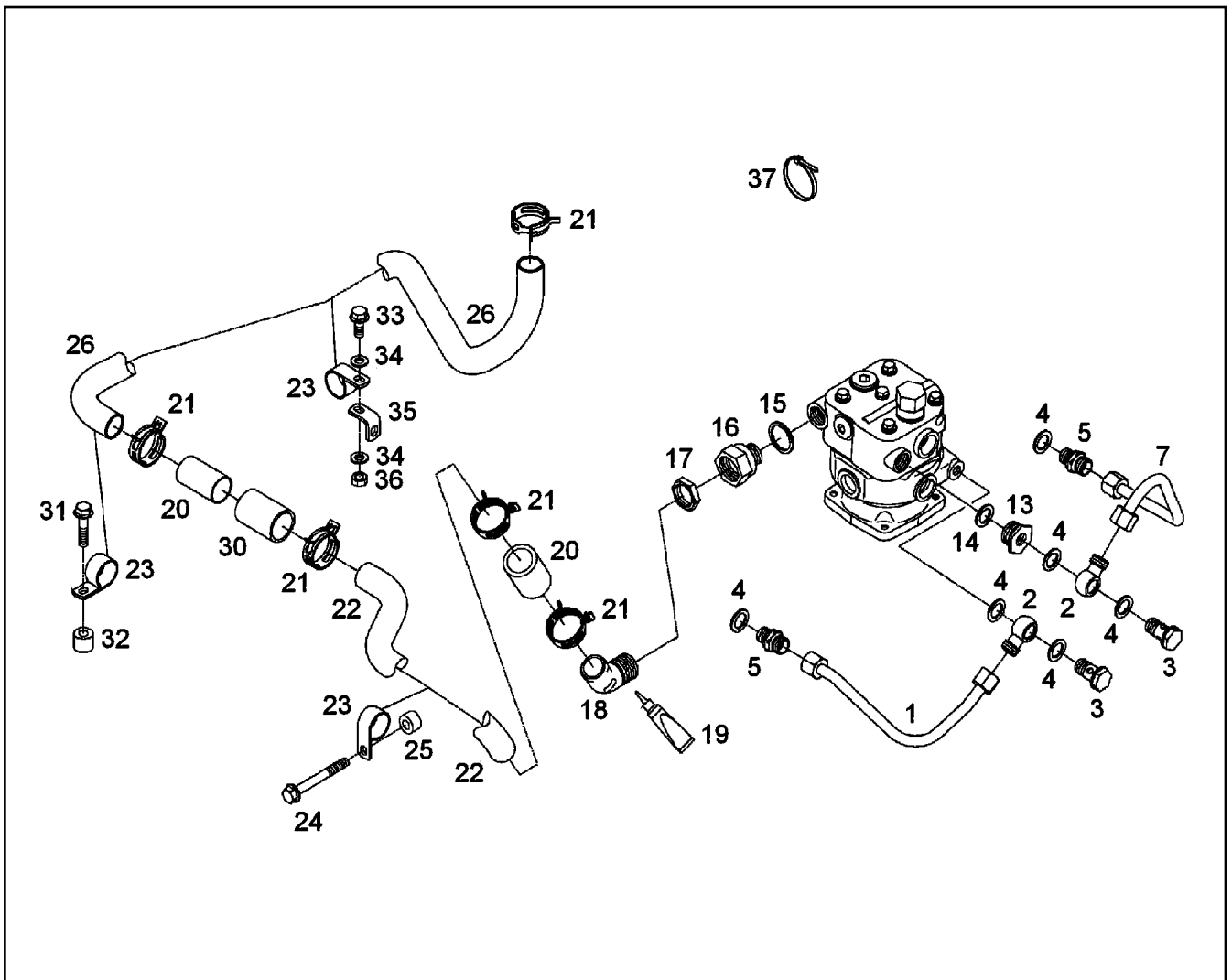

Pos.	Item	Quantity	Description	Bezeichnung	Serie	K
1	10 47 689 5	1	LIQUID COOLING PIPELINE	KUEHLMITTELEITUNG		
2	10 01 271 0	2	RING ADAPTER	RINGSTUTZEN		
3	10 01 273 0	2	HOLLOW SCREW	HOHLSCHRAUBE		
4	10 01 186 6	6	SEALING RING 14,7X22X1,5 ST/FPM1-80	DICHTRING		
5	10 01 199 8	2	SCREW-ON CONNECTION L10 A-M ST	EINSCHRAUBSTUTZEN		
7	10 47 690 7	1	LIQUID COOLING PIPELINE	KUEHLMITTELEITUNG		
13	10 02 919 5	1	TRANSITION CONNECTION PIECE	UEBERGANGSSTUTZEN		
14	10 01 186 9	1	SEALING RING 22,7X30X2 ST/FPM1-80	DICHTRING		
15	10 01 187 2	2	SEALING RING 32,7X40X2 ST/FPM1-80	DICHTRING		
16	10 01 272 1	1	SCREW-ON CONNECTION M26X1,5/M32X1 9	EINSCHRAUBSTUTZEN		
17	10 01 255 9	1	HEX NUT M32X1,5 8	SECHSKANTMUTTER		
18	10 01 247 7	1	SUCTION BEND	SAUGKRUEMMER		
19	10 01 117 6	1	SEALANT	DICHTMITTEL		
20	10 01 120 0	2	HOSE N1-32	SCHLAUCH		
21	10 01 267 4	5	HOSE CLAMP 44 CK75	SCHLAUCHSCHELLE		
22	10 47 691 2	1	SUCTION LINE JOINING	SAUGLEITUNG		
23	10 01 265 3	3	PIPE CLAMP 32.2 UST37-2	ROHRSCHELLE		
24	10 44 335 6	1	HEX BOLT M8X70 10.9 MAN183-B1	SECHSKANTSCHRAUBE		
25	10 48 693 4	1	BUSH 9X18X11	BUCHSE		
26	10 48 691 6	1	SUCTION LINE JOINING	SAUGLEITUNG		
30	10 48 691 7	1	INSULATING TUBE DN25 0,8 GF/AL	ISOLIERSCHAUCH		
31	10 44 336 5	1	HEX BOLT M8X35 10.9 MAN183-B1	SECHSKANTSCHRAUBE		
32	10 48 694 0	1	BUSH 9X18X15 ST35NBK	BUCHSE		
33	10 44 335 2	1	HEX BOLT M8X20 10.9 MAN183-B1	SECHSKANTSCHRAUBE		
34	10 01 165 4	2	WASHER A 8,4X16X1,6 200HV	SCHEIBE		
35	10 48 693 3	1	HOLDER	HALTER		

6.2.2009
049732

LIEBHERR

etk_en_de_074515 LR 1600/2

PIPELINE INSTALLATION
ROHRLEITUNG ANBAU

731 (1/2)

⇒ 9 739 492
97 39 492

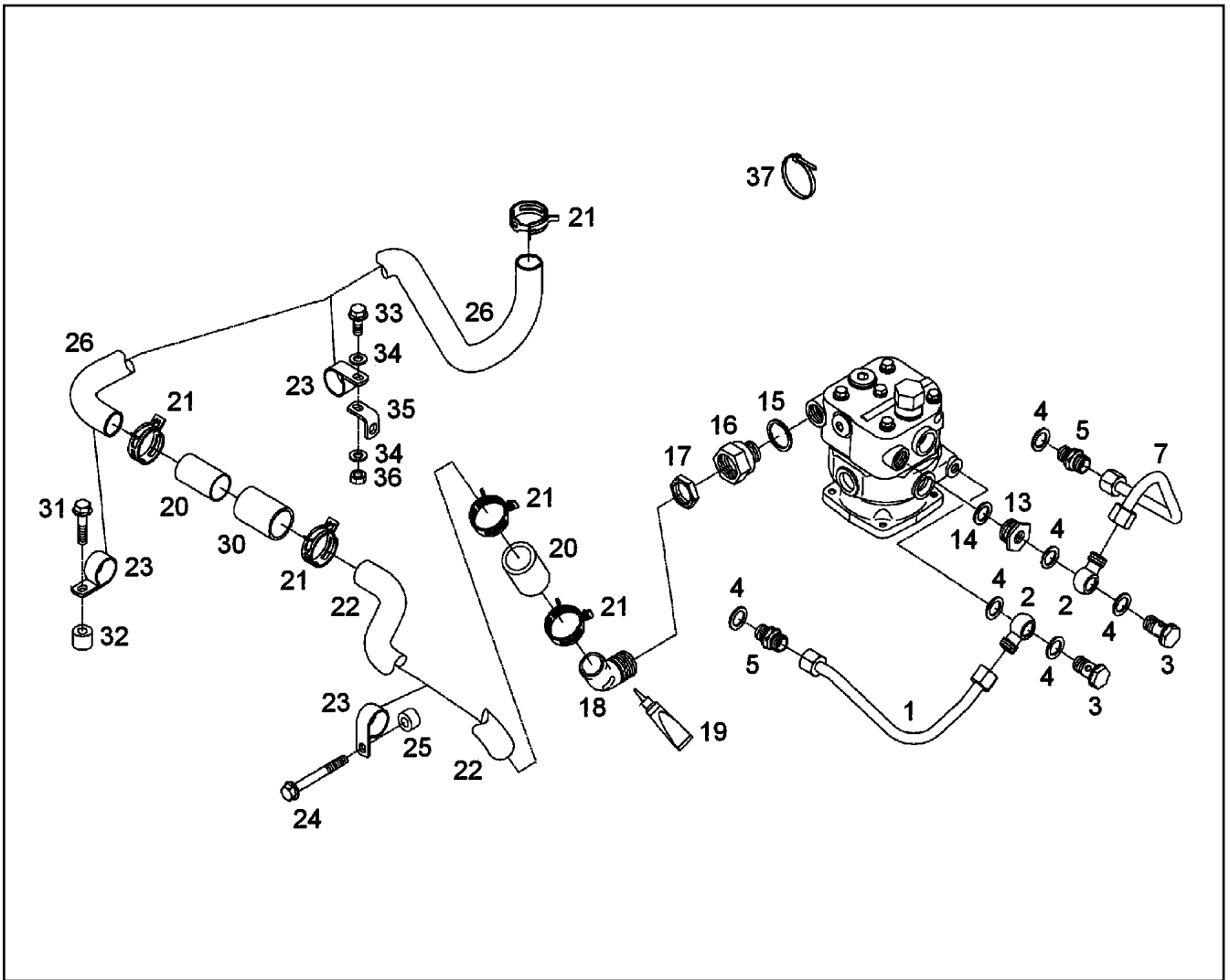

Pos.	Item	Quantity	Description	Bezeichnung	Serie	K
36	10 01 163 1	1	NUT M8 8	MUTTER		
37	10 02 093 1	2	CABLE TIE 4,6X385 PA6.6-SW	KABELBINDER		

6.2.2009
049732

LIEBHERR

etk_en_de_074515 LR 1600/2

PIPELINE INSTALLATION
ROHRLEITUNG ANBAU

732 (2/2)

⇒ 9 739 492
97 39 492

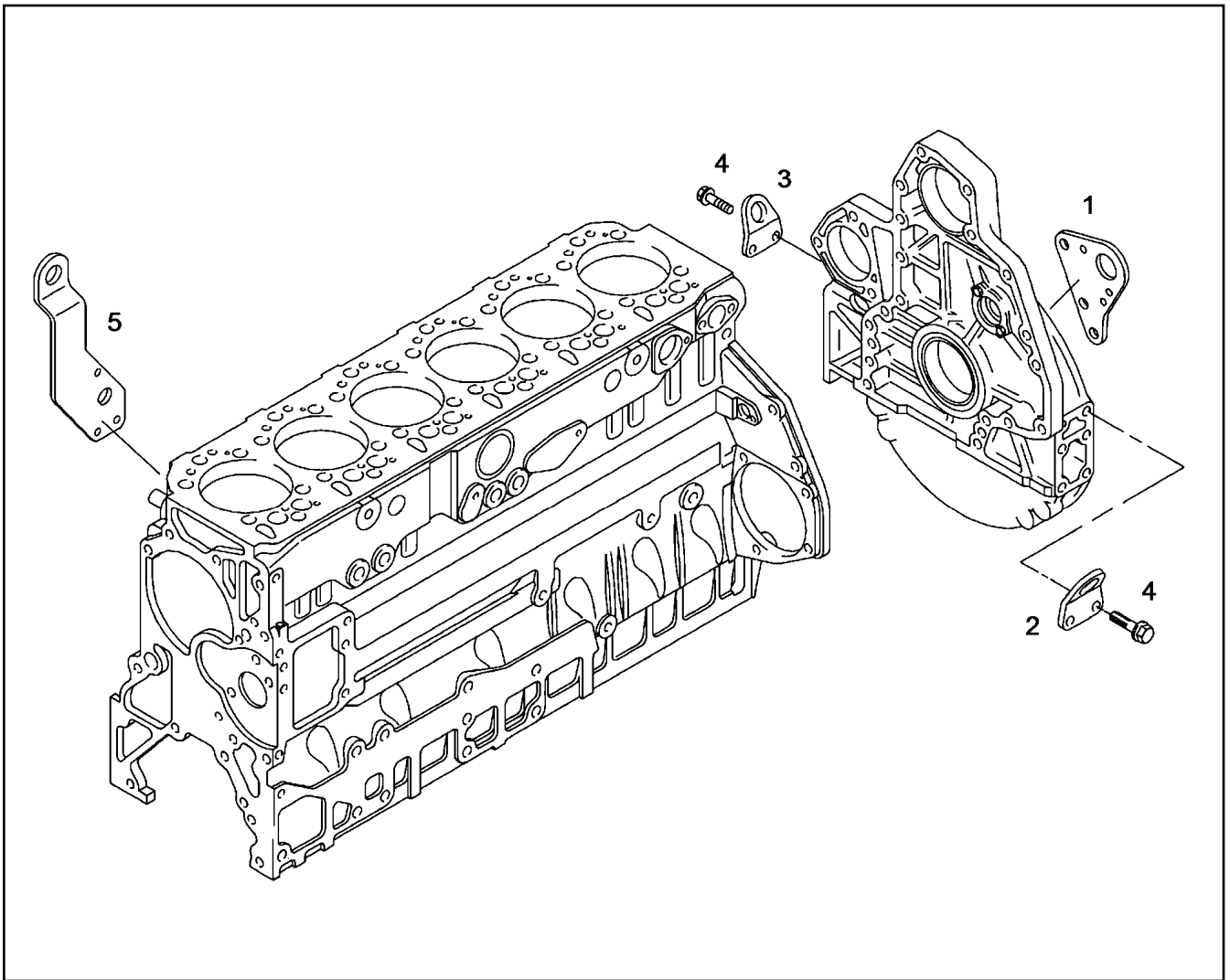

Pos.	Item	Quantity	Description	Bezeichnung	Serie	K
1	10 01 245 6	1	SUSPENSION RING	AUFHAENGOESE		
2	10 29 431 6	1	SUSPENSION EYE	AUFHAENGOESE		
3	10 01 734 7	1	SUSPENSION RING	AUFHAENGOESE		
4	10 01 133 5	4	SCREW M16X35 8.8	SCHRAUBE		
5	10 22 277 7	1	SUSPENSION EYE	AUFHAENGOESE		

6.2.2009
049972

LIEBHERR

etk_en_de_074515 LR 1600/2

TRANSPORT DEVICE
TRANSPORTVORRICHTUNG

733

⇒ 9 739 493
97 39 493

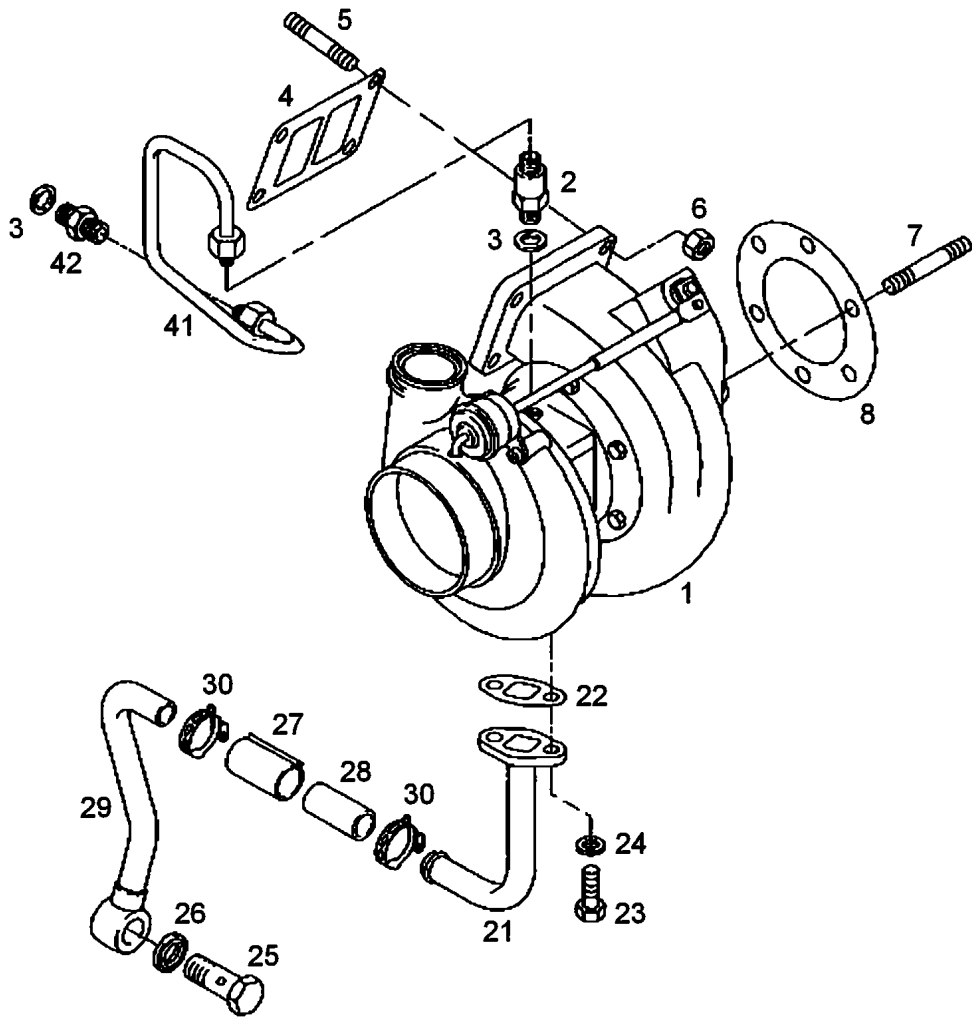

Pos.	Item	Quantity	Description	Bezeichnung	Serie	K
1	10 47 688 6	1	EXHAUST GAS TURBOCHARGER	ABGASTURBOLADER		
2	10 01 272 2	1	SCREW-ON CONNECTION	EINSCHRAUBSTUTZEN		
3	10 01 186 7	2	SEALING RING 16,7X24X1,5 ST/FPM1-80	DICHTRING		
4	10 22 081 3	1	SEAL	DICHTUNG		
5	10 28 710 4	4	DOUBLE-ENDED STUD M10X35	STIFTSCHRAUBE		
6	10 22 273 2	4	HEX COLLAR NUT	SECHSKANTBUNDMUTTER		
7	10 03 729 8	6	DOUBLE-ENDED STUD M10X25	STIFTSCHRAUBE		
8	10 01 245 4	1	SEAL	DICHTUNG		
21	10 28 710 5	1	HYDT.TUBE	OELRUECKLAUFLEITUNG		
22	10 01 265 1	1	SEAL	DICHTUNG		
23	10 03 730 4	2	HEX BOLT M8X20 8.8	SECHSKANTSCHRAUBE		
24	10 01 165 4	2	WASHER A 8,4X16X1,6 200HV	SCHEIBE		
25	10 28 710 8	1	HOLLOW SCREW	HOHLSCHRAUBE		
26	10 01 187 0	2	SEALING RING 26,7X34,93X2 ST/FPM1-80	DICHTRING		
27	10 28 710 6	1	INSULATING TUBE	ISOLIERSCHLAUCH		
28	10 01 263 2	1	HOSE 22X65 -1	SCHLAUCH		
29	10 28 710 7	1	HYDT.TUBE	OELRUECKLAUFLEITUNG		
30	10 28 505 2	2	HOSE CLAMP 29	SCHLAUCHSCHELLE		
41	10 03 730 0	1	PRESSURE LINE	DRUCKLEITUNG		
42	10 01 199 9	1	SCREW-ON CONNECTION L12A-M ST	EINSCHRAUBSTUTZEN		

6.2.2009
049737

LIEBHERR

etk_en_de_074515 LR 1600/2

ATL ATTACHMENT
ATL-ANBAU

734

⇒ 9 739 494
97 39 494

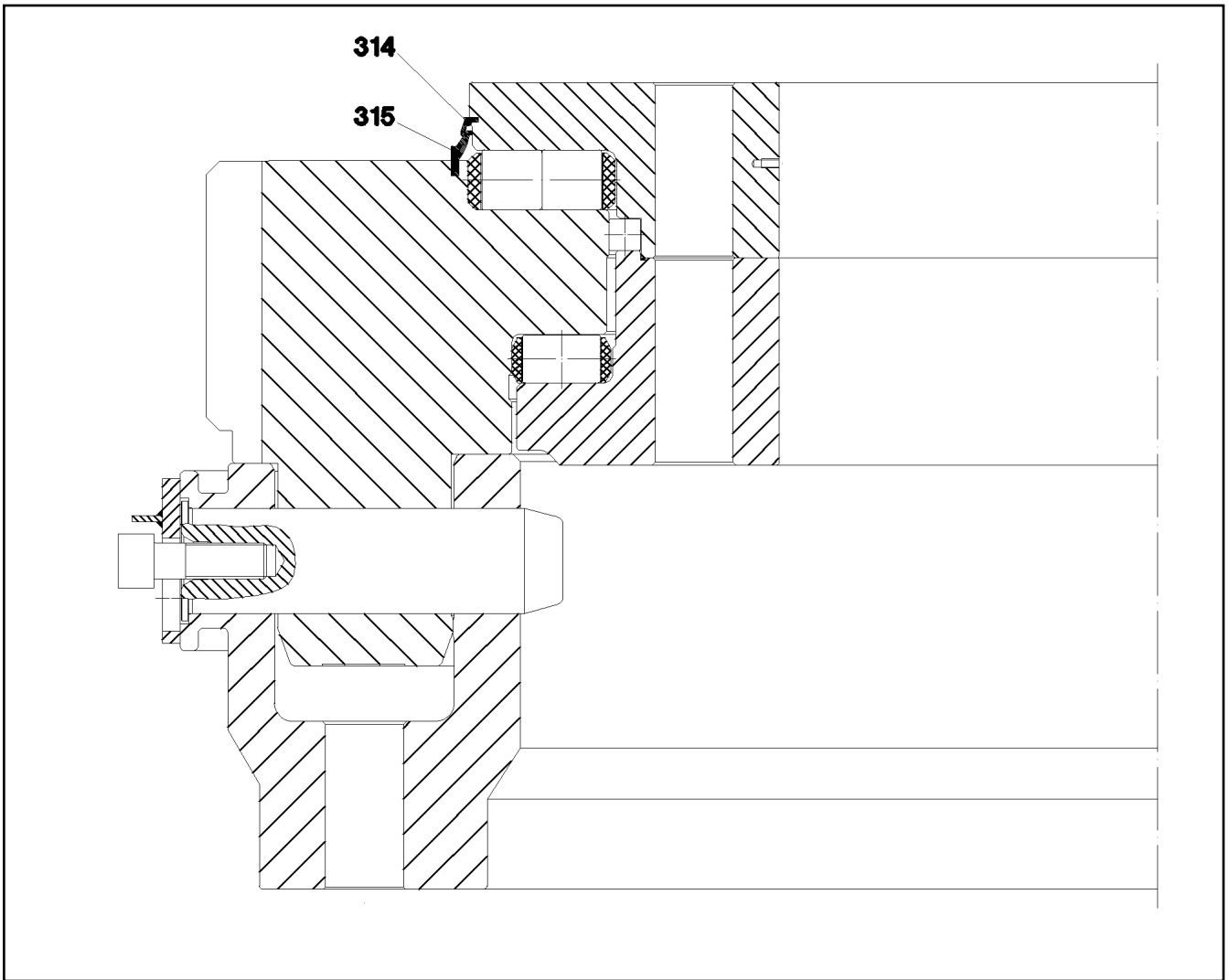

Pos.	Item	Quantity	Description	Bezeichnung	Serie	K
314	26 21 835 01	8.31	SEALING PROFILE	DICHTPROFIL		
315	26 21 821 01	8.36	SEALING PROFILE	DICHTPROFIL		

6.2.2009
059038

LIEBHERR

etk_en_de_074515 LR 1600/2

ROLLER SLEWING RING
ROLLENDREHVERBINDUNG

735

⇒ 9 907 151 01
99 07 151 01

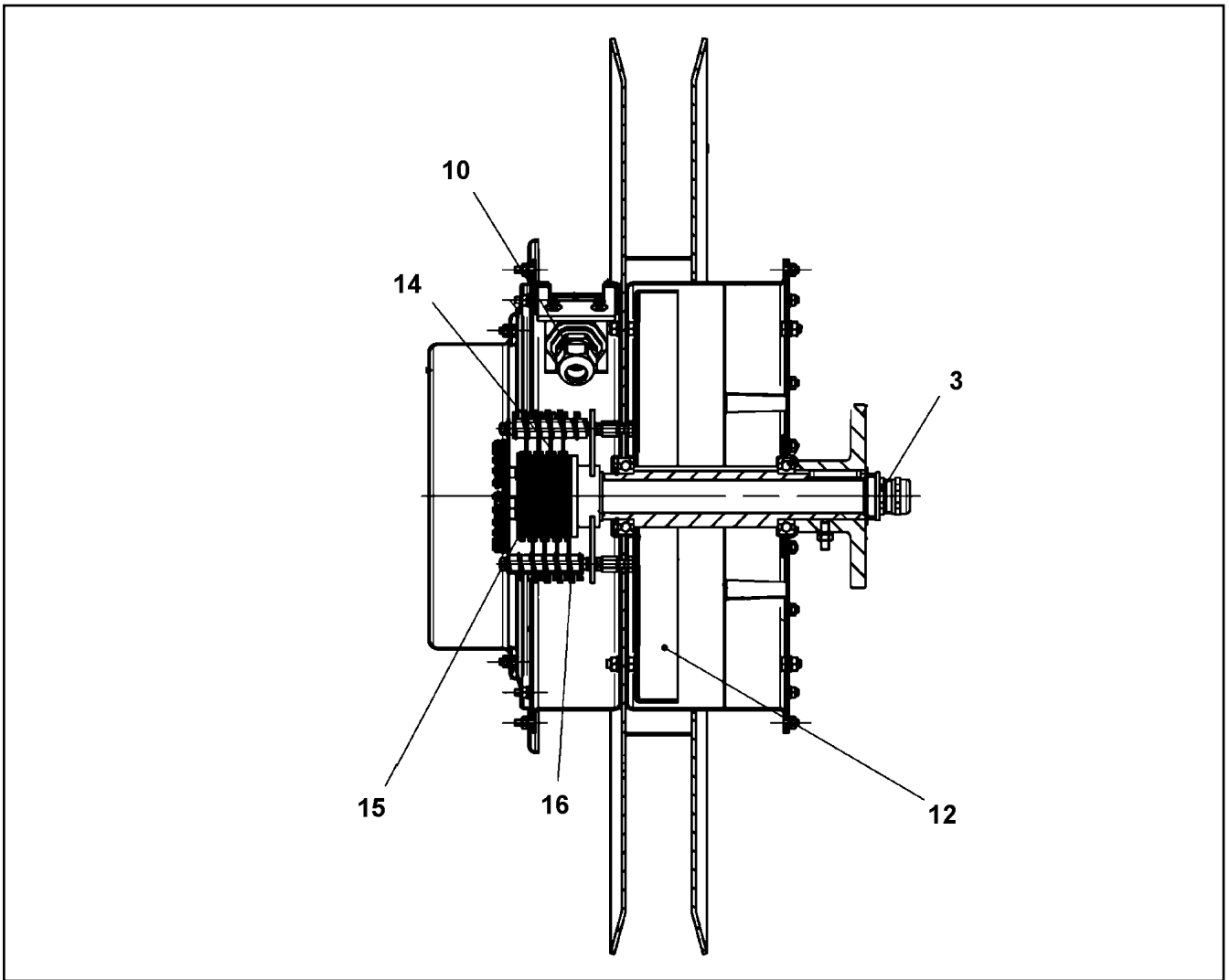

Pos.	Item	Quantity	Description	Bezeichnung	Serie	K
3	60 24 242 08	1	THREADED CABLE GLAND M20X1,5 MS	KABELVERSCHRAUBUNG		
10	60 24 241 08	1	THREADED CABLE GLAND M16X1,5 MS	KABELVERSCHRAUBUNG		
12	57 01 989 08	2	SPIRAL SPRING	SPIRALFEDER		
14	10 41 178 0	1	SLIP RING	SCHLEIFRING		
15	10 41 178 1	7	SLIP RING	SCHLEIFRING		
16	10 41 178 6	8	BRUSH SUPPORT	BUERSTENHALTER		
18	10 65 300 5	1	COVER HOOD	ABDECKHAUBE		

6.2.2009
059365

LIEBHERR

etk_en_de_074515 LR 1600/2

CABLE REEL
LEITUNGSTROMMEL

736

⇒ X10028002
10 02 800 2

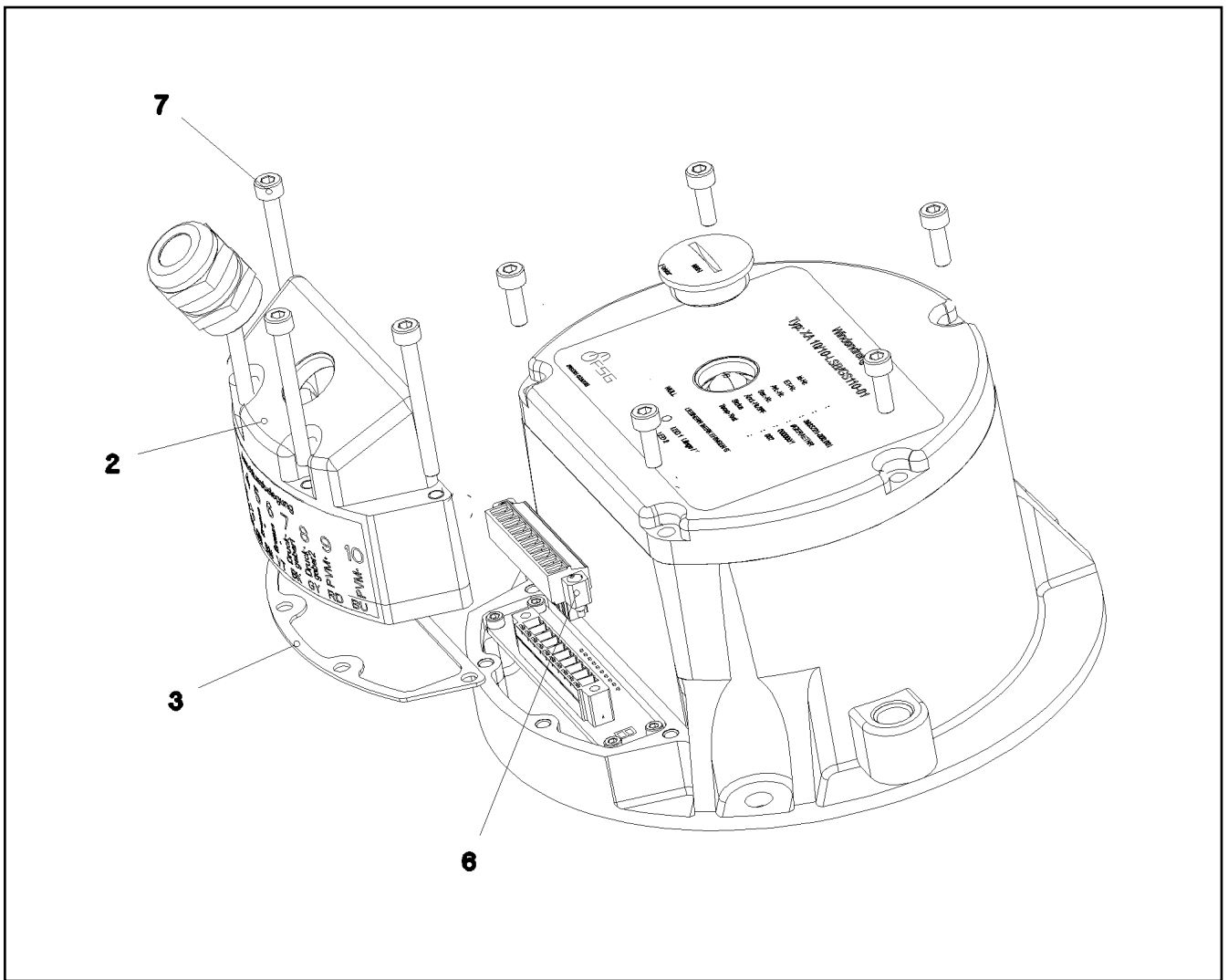

Pos.	Item	Quantity	Description	Bezeichnung	Serie	K
2	10 66 332 8	1	CAP	KAPPE		
3	10 66 332 9	1	SEAL	DICHTUNG		
6	10 49 058 6	1	PLUG-IN CONNECTOR	STECKVERBINDER		
7	40 43 012 08	4	CYLINDER SCREW DIN 912 M4X40 10.9 A2C	ZYLINDERSCHRAUBE		

6.2.2009
059375

LIEBHERR

etk_en_de_074515 LR 1600/2

WINCH REVOLUTION TRANSDUCER
WINDENDREHGEBER

737

⇒ X1004077
10 04 047 7

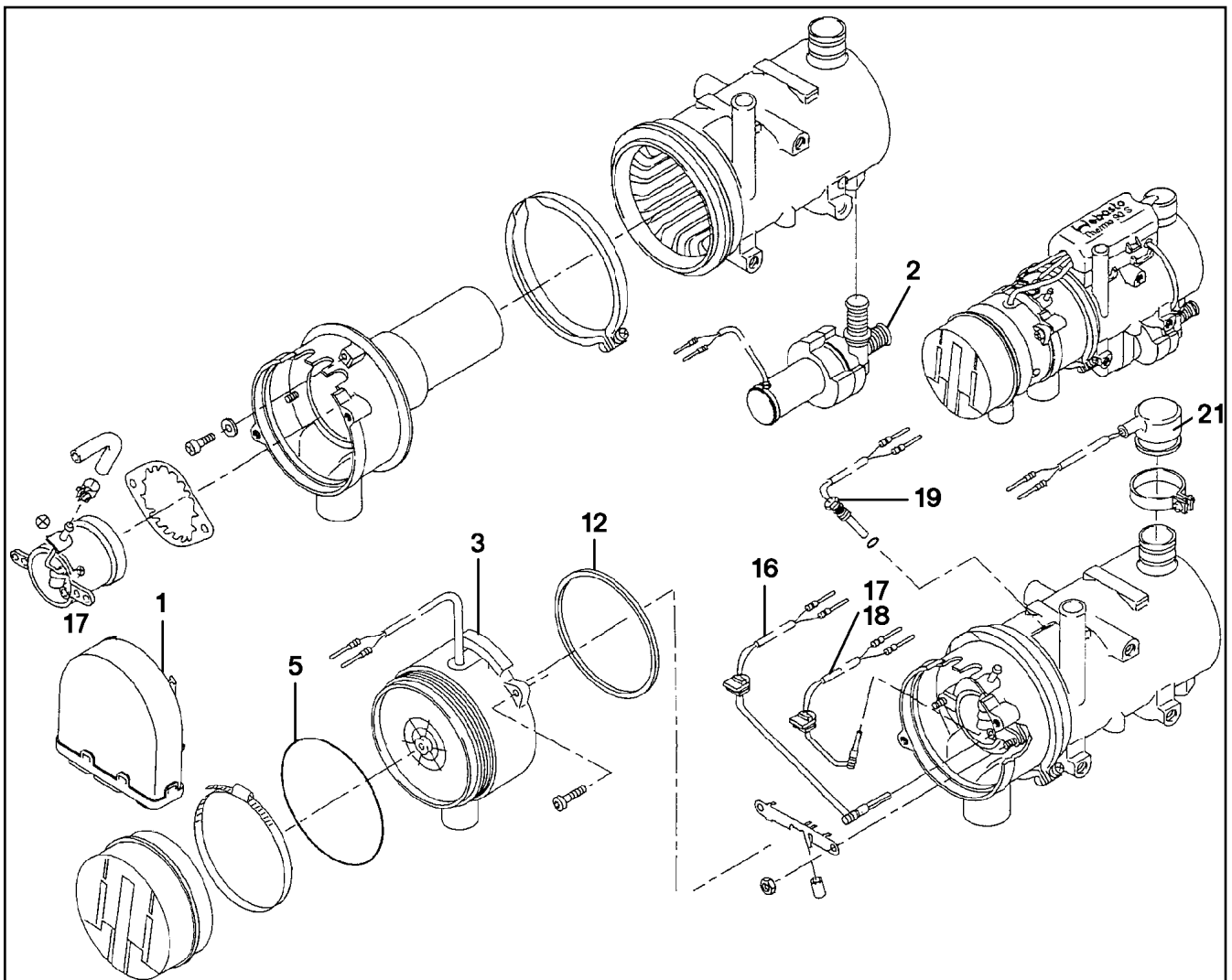

Pos.	Item	Quantity	Description	Bezeichnung	Serie	K
	1	10 27 869 8	1	CONTROL GEAR 24V	STEUERGERAET	
	2	10 29 012 1	1	CIRCULATING PUMP	UMWAEELZPUMPE	
	3	10 29 012 2	1	FAN 24V	GEBLAESE	
	5	72 64 234 01	1	O-RING 110X2 NBR70	O-RING	
	12	10 02 119 1	1	SEALING RING 109X113X3	DICHTRING	
	16	10 29 012 3	1	FLAME DETECTOR	FLAMMWAECHTER	
	17	10 29 012 4	1	BURNER	BRENNER	
	18	10 29 012 5	1	PENCIL-TYPE GLOW PLUG	GLUEHSTIFT	
	19	10 29 012 6	1	TEMPERATURE SENSOR	TEMPERATURFUEHLER	
	21	10 29 012 7	1	OVERHEAT PROTECTION	UEBERHITZUNGSSCHUTZ	

6.2.2009
037335

LIEBHERR

etk_en_de_074515 LR 1600/2

WATER HEATING SYSTEM
WASSERHEIZGERAET

738

⇒ X10042043
10 04 204 3

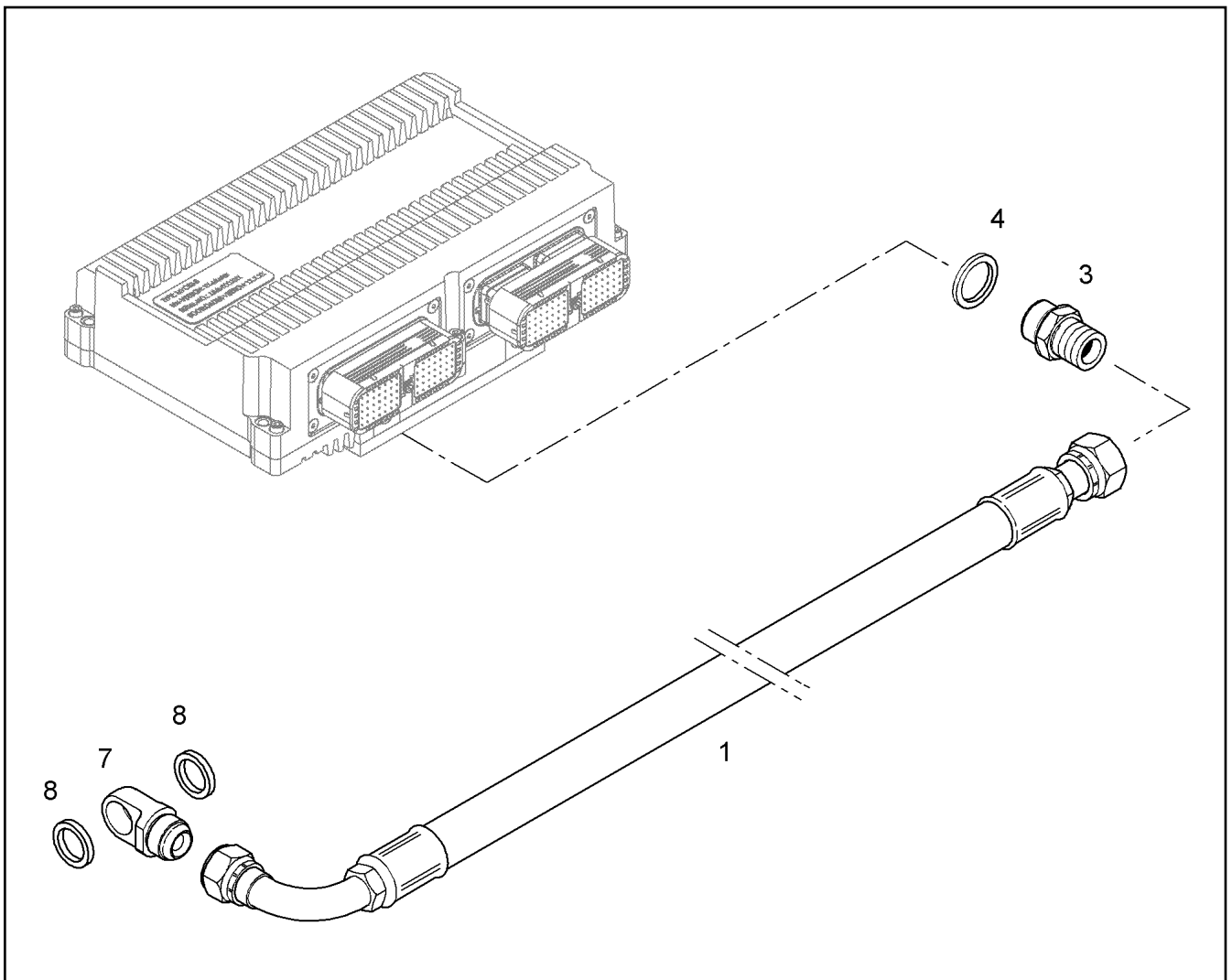

Pos.	Item	Quantity	Description	Bezeichnung	Serie	K
1	10 11 573 5	1	HOSE LINE DN10 1200	SCHLAUCHLEITUNG		
3	24 72 399 02	1	REDUCING SCREW GR 12/10L CF	REDUZIERVERSCHRAUBUNG		
4	71 01 037 08	1	SEALING RING DIN 7603 A 16X22X1,5 CU	DICHTRING		
7	10 11 610 9	1	RING ADAPTER	RINGSTUTZEN		
8	71 01 030 08	2	SEALING RING DIN 7603 A 14X20X1,5 CU	DICHTRING		

6.2.2009
041289

LIEBHERR

etk_en_de_074515 LR 1600/2

FUEL HOSE
KRAFTSTOFFSCHLAUCH

739

⇒ X10116141
10 11 614 1

Pos.	Item	Quantity	Description	Bezeichnung	Serie	K
1	97 39 368	1	CRANKCASE CPL. R-MOTORXD846 A7 ⇒ 9 739 368 97 39 368	KURBELGEHAEUSE KPL.		
2	97 39 096	1	SCREW PLUG ⇒ 9 739 096 97 39 096	VERSCHLUSSSCHRAUBE		
9	97 39 243	6	PISTON COOLING ⇒ 9 739 243 97 39 243	KOLBENKUEHLUNG		
11	97 39 386	1	CRANKCASE BREATHER ⇒ 9 739 386 97 39 386	KURBELGEHAEUSEENTLUEFT		
16	97 39 362	1	OIL SUMP R-MOTORXD846 A7 ⇒ 9 739 362 97 39 362	OELWANNE		
18	97 39 188	1	OIL-LEVEL GAUGE ⇒ 9 739 188 97 39 188	OELMESSSTAB		
26	97 39 242	6	CYLINDER BUSH ⇒ 9 739 242 97 39 242	ZYLINDERLAUFBUCHSE		
28	97 39 101	1	CRANKSHAFT	KURBELWELLE		
29	97 39 102	1	CRANKSHAFT BEARINGS ⇒ 9 739 102 97 39 102	KURBELWELLENLAGERUNG		
31	97 39 341	1	DRIVING PARTS ⇒ 9 739 341 97 39 341	ANTRIEBSTEILE M.SCHWINGU		
38	97 39 287	6	MAIN ROD ⇒ 9 739 287 97 39 287	PLEUELSTANGE		
40	97 39 246	6	PISTON ⇒ 9 739 246 97 39 246	KOLBEN		
41	97 39 262	4	CYLINDER HEAD R-MOTOR ⇒ 9 739 262 97 39 262	ZYLINDERKOPF		
42	97 39 266	2	CYLINDER HEAD R-MOTOR ⇒ 9 739 266 97 39 266	ZYLINDERKOPF		
43	97 39 267	1	CYLINDER FAIRING ⇒ 9 739 267 97 39 267	ZYLINDERKOPFHAUBE		
44	10 34 284 2	1	CAMS SHAFT R-MOTORXD 2876	NOCKENWELLE		
46	97 39 187	6	CONTROL PARTS ⇒ 9 739 187 97 39 187	STEUERUNGSTEILE		
50	97 39 355	1	OIL COOLER ADD-ON ⇒ 9 739 355 97 39 355	OELKUEHLER ANBAU		
56	97 39 372	1	LUBRICATING OIL PUMP ⇒ 9 739 372 97 39 372	SCHMIEROELPUMPE		
65	97 39 118	1	OIL LINE ⇒ 9 739 118 97 39 118	OELLEITUNG		
70	10 34 309 6	1	HIGH PRESSURE PUMP ⇒ X10343096 10 34 309 6	HOCHDRUCKPUMPE		
73	97 39 278	1	ADD-ON PARTS ⇒ 9 739 278 97 39 278	ANBAUTEILE		
90	97 39 248	6	INJECTOR ⇒ 9 739 248 97 39 248	EINSPRITZDUESE		
93	97 39 259	1	FUEL FILTER ⇒ 9 739 259 97 39 259	KRAFTSTOFFFILTER		
97	97 39 292	1	FUEL LINE ⇒ 9 739 292 97 39 292	KRAFTSTOFFLEITUNG		
101	97 39 369	1	PRESSURE PIPE ⇒ 9 739 369 97 39 369	DRUCKROHR		
105	97 39 281	1	OVERFLOW-OIL LINE ⇒ 9 739 281 97 39 281	LECKOELLEITUNG		
107	97 39 282	1	OVERFLOW-OIL LINE ⇒ 9 739 282 97 39 282	LECKOELLEITUNG		
110	97 39 256	1	AIR SUCTION PIPE ⇒ 9 739 256 97 39 256	LUFTANSAUGROHR		
112	97 39 209	1	SUCTION NOZZLE D 2876 ⇒ 9 739 209 97 39 209	ANSAUGSTUTZEN		
115	97 39 358	1	EXHAUST GAS RECIRCUL.ATTACHM. ⇒ 9 739 358 97 39 358	ABGASRUECKFUEHRUNG ANBA		

6.2.2009

etk_en_de_074515 LR 1600/2

740 (1/2)

LIEBHERRDIESEL ENGINE
DIESELMOTOR⇒ X10120590
10 12 059 0

Pos.	Item	Quantity	Description	Bezeichnung	Serie	K
126	97 39 271	1	CONNECTING LINE ⇒ 9 739 271 97 39 271	VERBINDUNGSLEITUNG		
130	97 39 140	1	FLAME STARTING SYSTEM ⇒ 9 739 140 97 39 140	FLAMMSTARTANLAGE		
131	97 39 288	1	FUEL LINE ⇒ 9 739 288 97 39 288	KRAFTSTOFFLEITUNG		
140	97 39 491	1	INSTALLATION BRAKE COMPRESSOR ⇒ 9 739 491 97 39 491	LUFTPRESSER ANBAU		
143	97 39 492	1	PIPELINE INSTALLATION ⇒ 9 739 492 97 39 492	ROHRLEITUNG ANBAU		
150	97 39 371	1	AIR COND. COMPRESSOR ADD-ON ⇒ 9 739 371 97 39 371	KLIMAKOMPRESSOR ANBAU		
165	97 39 352	1	AT-WATER PUMP WITH FASTENING R-MO ⇒ 9 739 352 97 39 352	WASSERPUMPE MIT BEFEST.		
166	97 39 351	1	COOLING MEDIUM PIPELINE ⇒ 9 739 351 97 39 351	KUEHLMITTELLEITUNG ANBAU		
169	97 39 349	1	CONNECTION F.WATER PIPE ⇒ 9 739 349 97 39 349	WASSERLEITUNGSANSCHLUE		
170	97 39 127	1	WATER BLEEDER PIPELINE ⇒ 9 739 127 97 39 127	WASSERENTLUEFTUNGSLEIT		
171	97 39 210	1	LIQUID COOLING PIPELINE ⇒ 9 739 210 97 39 210	KUEHLMITTELLEITUNG		
172	97 39 126	1	THERMOSTAT HOUSING ⇒ 9 739 126 97 39 126	THERMOSTATGEHAEUSE		
173	97 39 276	1	WATER CONNECTION ⇒ 9 739 276 97 39 276	WASSERANSCHLUSS		
180	97 39 295	1	EXHAUST PIPE ⇒ 9 739 295 97 39 295	ABGASROHR		
181	97 39 296	1	HEAT PROTECTION ⇒ 9 739 296 97 39 296	HITZESCHUTZ		
190	97 39 494	1	ATL ATTACHMENT ⇒ 9 739 494 97 39 494	ATL-ANBAU		
192	97 39 353	1	EXHAUST NOZZLE ⇒ 9 739 353 97 39 353	ABGASSTUTZEN		
195	97 39 343	1	GENERATOR, PRE-ASSEMBLED ⇒ 9 739 343 97 39 343	GENERATOR VORM.		
200	97 39 344	1	GENERATOR, PRE-ASSEMBLED ⇒ 9 739 344 97 39 344	GENERATOR VORM.		
205	97 39 159	1	STARTER 6,6KW ⇒ 9 739 159 97 39 159	STARTER		
208	97 39 360	1	MOTOR SUPPORT ⇒ 9 739 360 97 39 360	MOTORLAGERUNG		
210	97 39 493	1	TRANSPORT DEVICE ⇒ 9 739 493 97 39 493	TRANSPORTVORRICHTUNG		
229	97 39 366	1	FASTENING PIECES ASSEMBLY ⇒ 9 739 366 97 39 366	BEFESTIGUNGSTEILE ANBAU		
230	10 22 067 0	1	WIRING HARNESS FOR INJECTOR	INJEKTORKABELBAUM		
231	97 39 318	1	SENSOR ELEMENT ⇒ 9 739 318 97 39 318	SENSORIK		
240	97 39 354	1	FLYWHEEL HOUSING MOUNTING ⇒ 9 739 354 97 39 354	SCHWUNGRADGEHAEUSE AN		
250	97 39 250	1	FLYWHEEL ⇒ 9 739 250 97 39 250	SCHWUNGRAD		
282	97 39 129	1	COOLANT PREHEATING ⇒ 9 739 129 97 39 129	KUEHLMITTELVORWAERMUNG		

6.2.2009	etk_en_de_074515 LR 1600/2	 741 (2/2)
LIEBHERR	DIESEL ENGINE DIESELMOTOR	⇒ X10120590 10 12 059 0

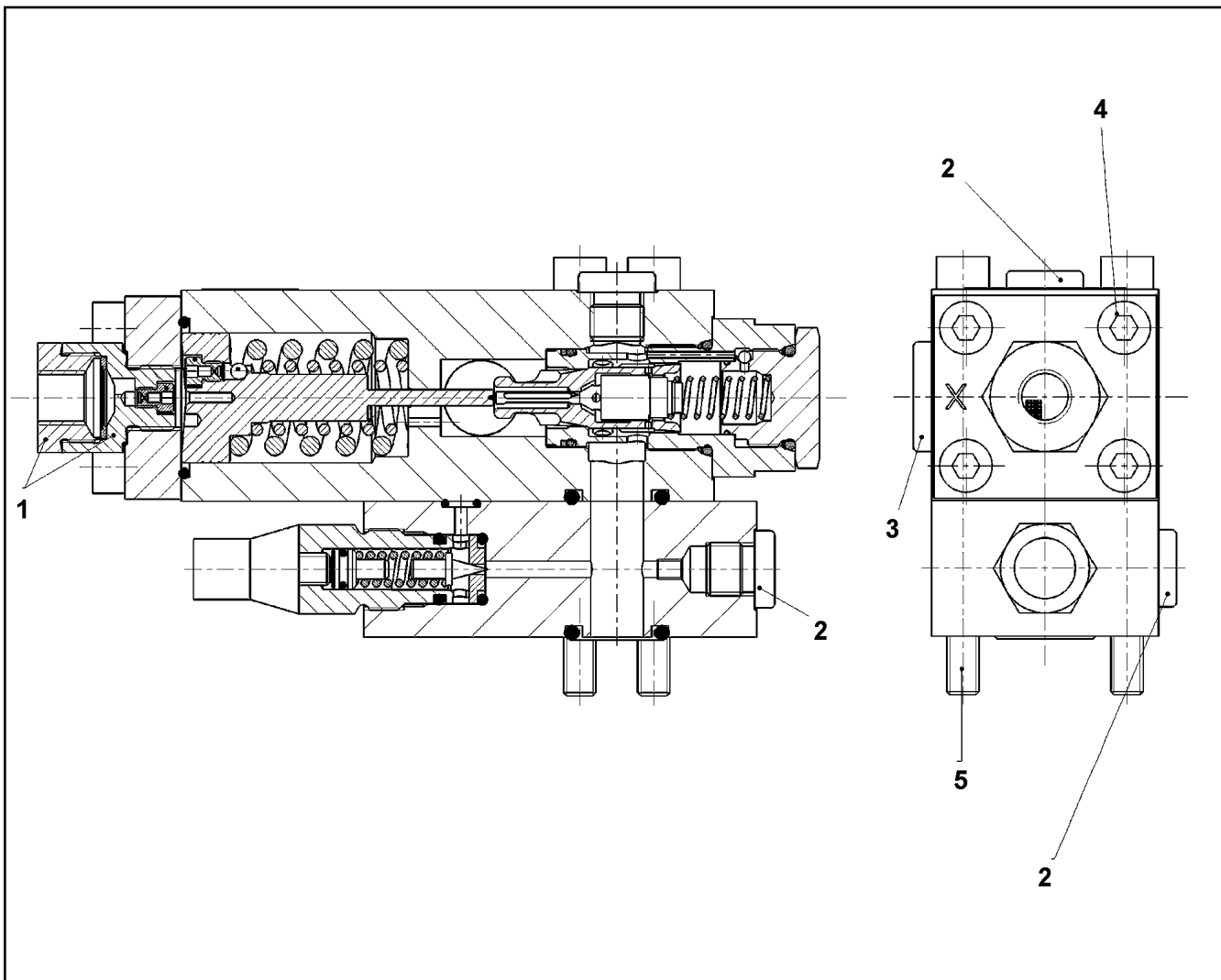

Pos.	Item	Quantity	Description	Bezeichnung	Serie	K
1	10 34 659 9	1	STRAINER FILTER	SIEBFILTER		
2	47 77 040 08	2	STOPPER PLUG VST11/4"ED A3P	BLINDSTOPFEN		
3	47 77 042 08	1	PLUG VST11/2"ED A3P	STOPFEN		
4	49 01 217	4	CYLINDER SCREW ISO 4762 M8X25 10.9 A2	ZYLINDERSCHRAUBE		
5	49 00 953	4	CYLINDER SCREW ISO 4762 M8X100 8.8 A2	ZYLINDERSCHRAUBE		
99	10 65 006 8	1	DS LOWERING BRAKE VALVE	DS SENKBREMSVENTIL		

6.2.2009
059319

LIEBHERR

etk_en_de_074515 LR 1600/2

LOWERING BRAKE VALVE
SENKBREMSVENTIL

742

⇒ X10217695
10 21 769 5

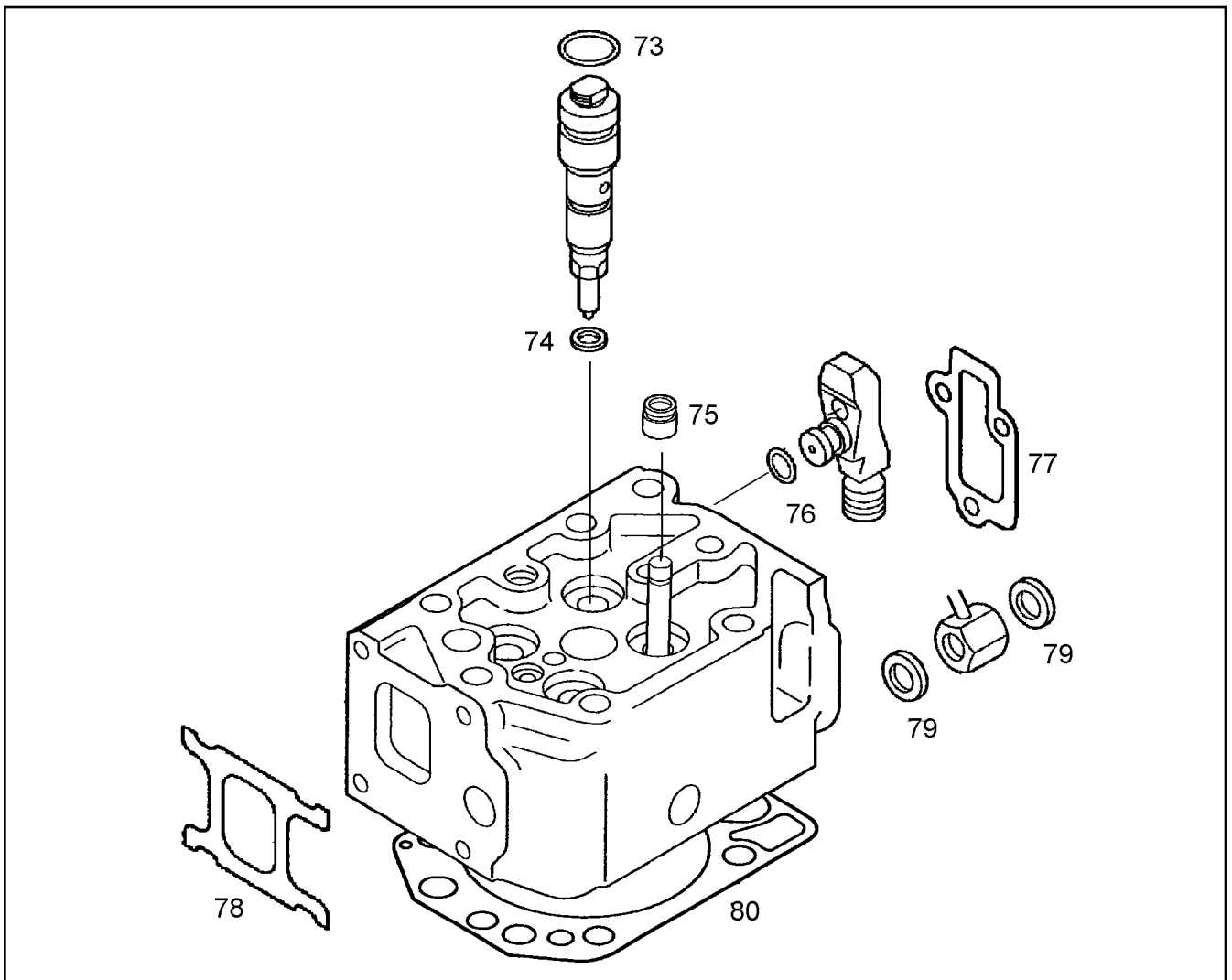

Pos.	Item	Quantity	Description	Bezeichnung	Serie	K
73	10 22 273 5	1	O RING	RUNDDICHTRING		
74	10 22 273 6	1	SEALING RING	DICHTRING		
75	10 01 224 7	4	VALVE STEM SEAL	VENTILSCHAFTDICHTUNG		
76	10 01 191 9	1	O RING 9X3 N-FPM1-70-GN	RUNDDICHTRING		
77	10 22 272 7	1	SEAL	DICHTUNG		
78	10 22 271 8	1	SEAL	DICHTUNG		
79	10 01 187 1	2	SEALING RING 8,7X14X1 ST/FPM1-80	DICHTRING		
80	10 03 231 8	1	CYLINDER HEAD GASKET	ZYLINDERKOPFDICHTUNG		

6.2.2009
046909

LIEBHERR

etk_en_de_074515 LR 1600/2

SEAL KIT CYLINDER HEAD
DS ZYLINDERKOPF

743

⇒ X10222817
10 22 281 7

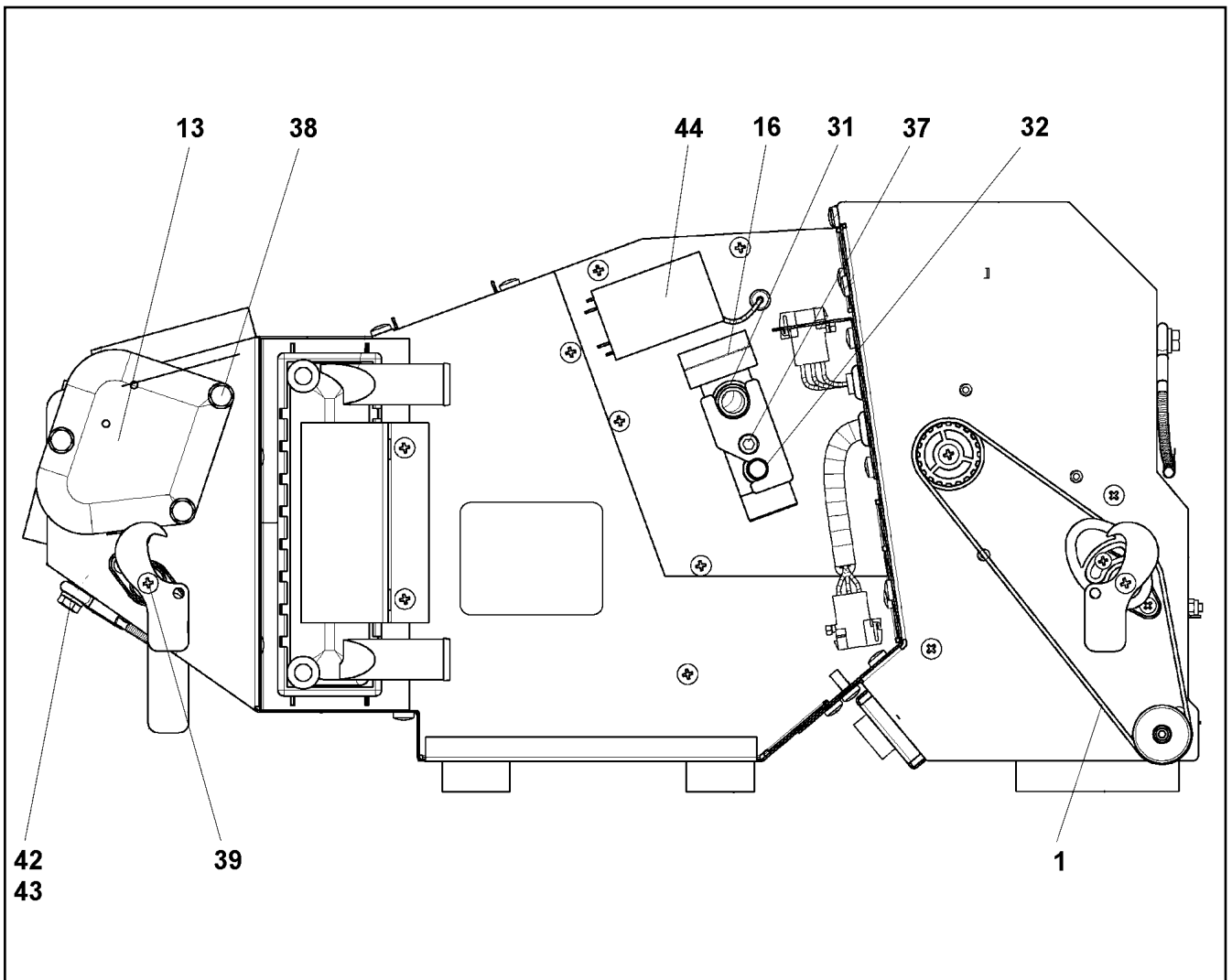

Pos.	Item	Quantity	Description	Bezeichnung	Serie	K
1	10 48 983 6	1	TOOTHED BELT 12T5 445	ZAHNRIEMEN		
13	10 28 730 1	1	SERVOMOTOR	STELLMOTOR		
16	76 22 478	1	VALVE	VENTIL		
31	51 57 106 08	1	O-RING ARP 568 14X1,78 NBR90	O-RING		
32	51 07 604 08	1	O-RING ARP 568 10,82X1,78 NBR90	O-RING		
37	40 42 026 01	2	CYLINDER SCREW ISO 4762 M5X40 8.8 A2C	ZYLINDERSCHRAUBE		
38	46 00 091	3	CYLINDER SCREW ISO 4762 M6X50 8.8 A2C	ZYLINDERSCHRAUBE		
39	55 31 699 08	4	PAN-HEAD SCREW DIN 7985 M4X10 4.8 SCH	FLACHKOPFSCHRAUBE		
42	40 00 829	1	HEX BOLT ISO 4017 M6X20 8.8 A2C	SECHSKANTSCHRAUBE		
43	42 00 009 08	2	WASHER ISO 7089 A 6.4 VERZ	SCHEIBE		
44	57 18 677 08	1	THERMOSTAT	THERMOSTAT		

6.2.2009
059010

LIEBHERR

etk_en_de_074515 LR 1600/2

AIR CONDITIONING UNIT
HEIZKLIMAGERAET

744

⇒ X10228112
10 22 811 2

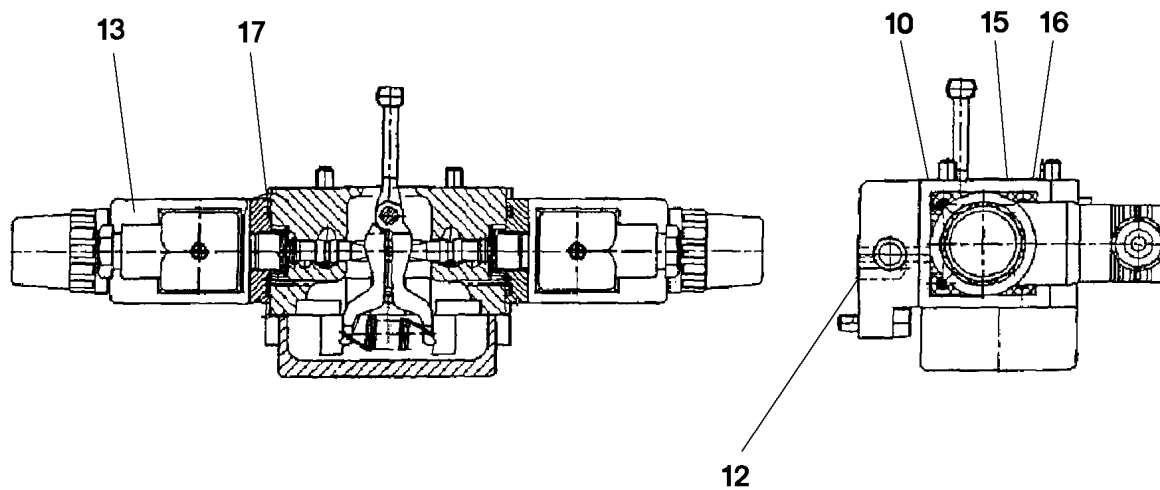

Pos.	Item	Quantity	Description	Bezeichnung	Serie	K
10	51 07 478 08	1	O-RING ARP 568 29,87X1,78 NBR90	O-RING		
12	51 07 181 08	3	O-RING ARP 568 10,82X1,78 NBR75	O-RING		
13	57 19 117 08	2	PROPORTIONAL MAGNET 24V	PROPORTIONALMAGNET		
15	51 45 915 08	2	O-RING ARP 568 12,42X1,78 NBR90	O-RING		
16	51 07 384 08	1	O-RING ARP 568 6,07X1,78 NBR90	O-RING		
17	57 00 488 08	2	O-RING ARP 568 26,64X2,62 NBR90	O-RING		

6.2.2009
039466

LIEBHERR

etk_en_de_074515 LR 1600/2

CONTROL UNIT
ANSTEUERGERAET

745

⇒ X10291840
10 29 184 0

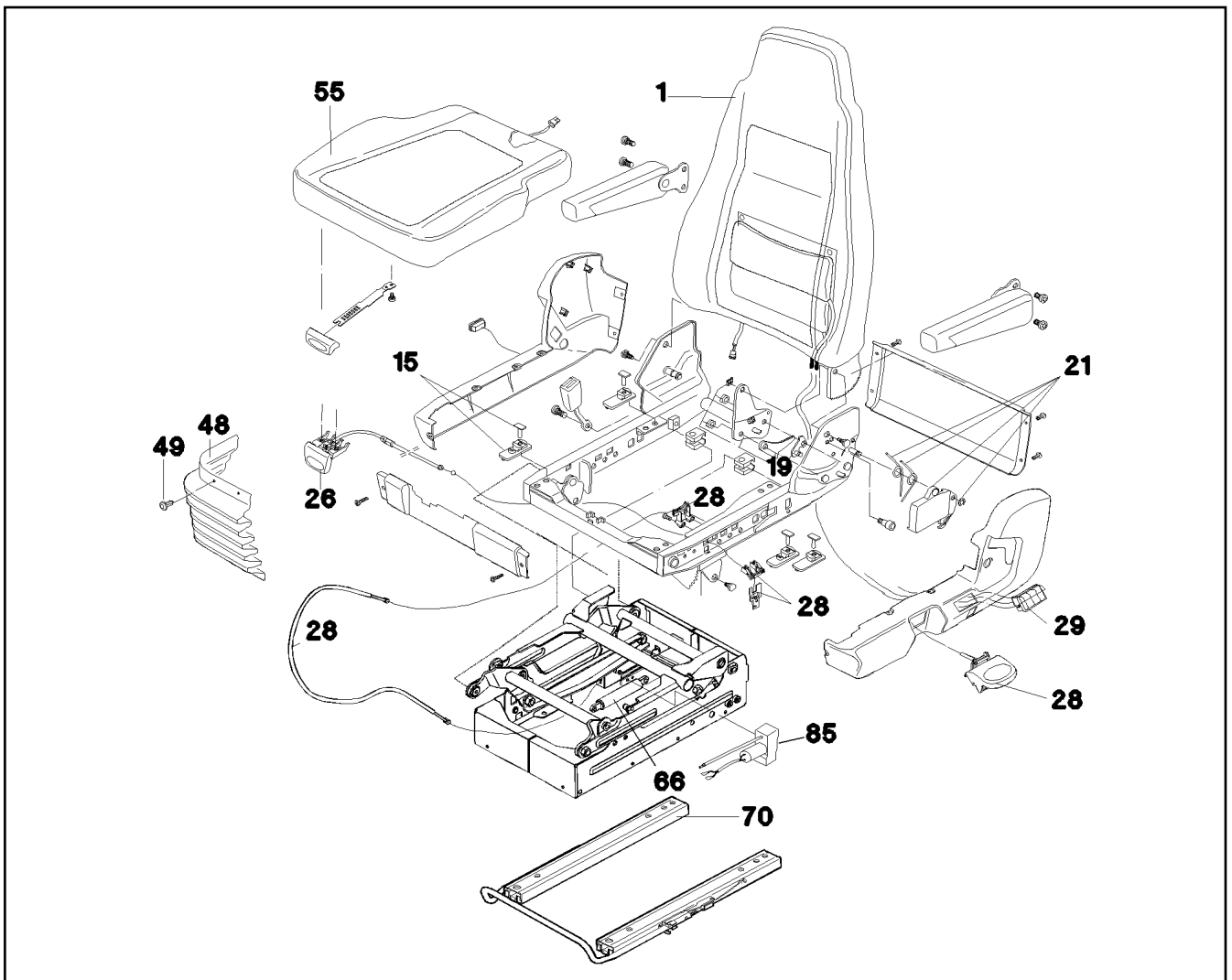

Pos.	Item	Quantity	Description	Bezeichnung	Serie	K
1	10 49 234 5	1	BACK PART	RUECKENTEIL		
15	10 45 514 4	1	SLIDE BLOCK CPL.	GLEITKLOTZ KPL.		
19	10 49 234 7	1	LOCKING PIECE	RASTE		
21	10 49 234 8	1	REAR REST HANDLE	RUECKENLEHNENGRIF		
26	10 65 039 3	1	ADJUSTMENT	VERSTELLUNG		
28	10 65 048 3	1	FIXED BOOM RAISING DEVICE	HOEHENVERSTELLUNG		
29	10 65 048 4	1	OPERATION	BETAETIGUNG		
48	10 65 048 5	1	RUBBER BELLOWS	FALTENBALG		
49	10 65 040 3	1	MOUNTING PARTS	BEFESTIGUNGSMATERIAL		
55	10 65 048 7	1	SEAT CUSHION	SITZKISSEN		
66	10 65 048 8	1	ABSORBER	DAEMPFER		
70	10 65 048 9	1	RAIL PAIR	SCHIENENPAAR		
85	10 65 049 0	1	AIR COMPRESSOR	LUFTPRESSER		

6.2.2009
059324

LIEBHERR

etk_en_de_074515 LR 1600/2

DRIVERS SEAT
FAHRERSITZ

746

⇒ X10292004
10 29 200 4

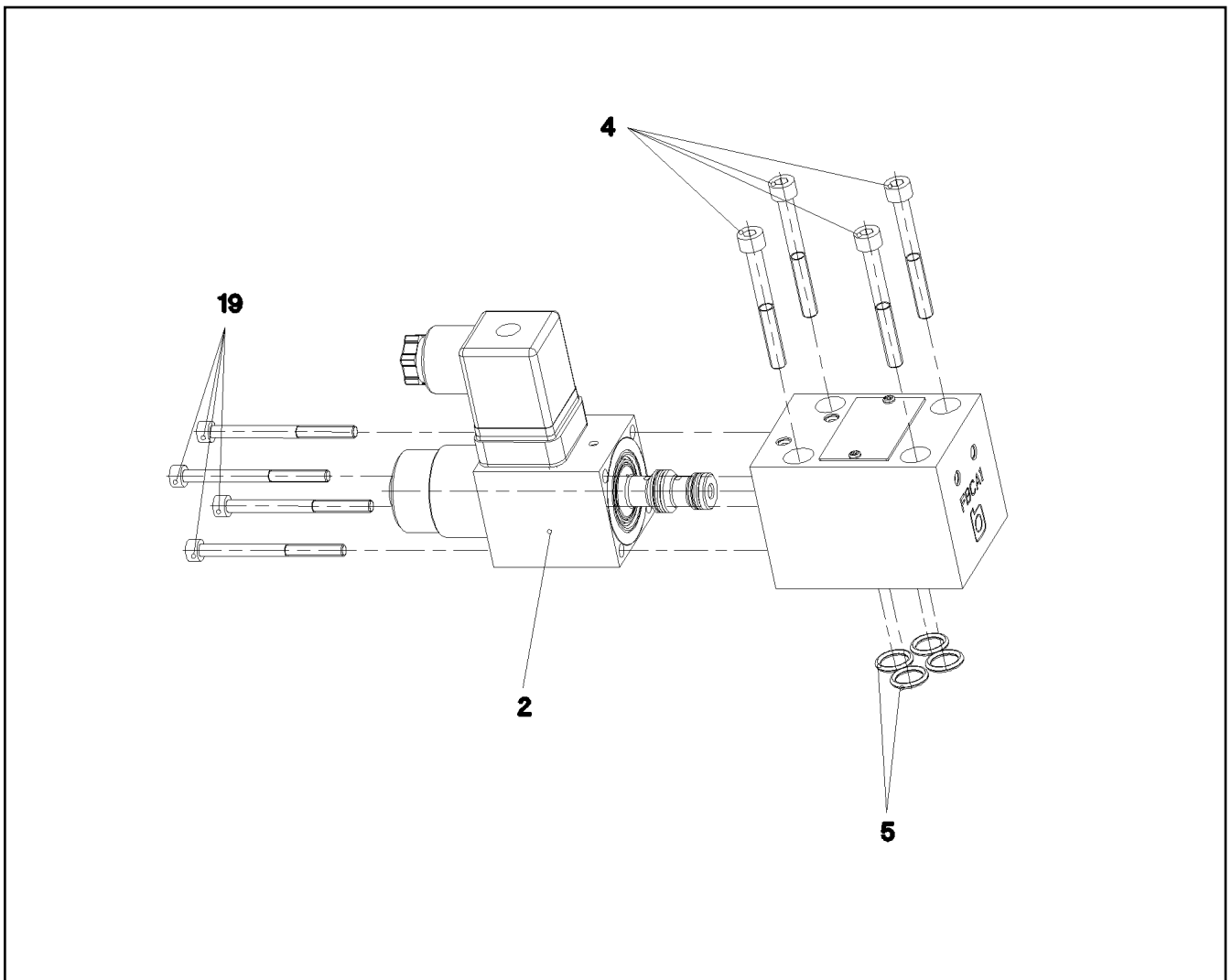

Pos.	Item	Quantity	Description	Bezeichnung	Serie	K
2	10 65 009 2	1	MAGNET 24V	MAGNET		
4	40 43 612 08	4	CYLINDER SCREW DIN 912 M5X45 12.9	ZYLINDERSCHRAUBE		
5	73 80 574	4	O-RING DIN 3771 9,25X1,78 FPM90 SHORE	O-RING		
19	49 01 531	4	CYLINDER SCREW ISO 4762 M4X50 8.8 A2C	ZYLINDERSCHRAUBE		

6.2.2009
059318

LIEBHERR

etk_en_de_074515 LR 1600/2

PRESSURE CONTROL VALVE
DRUCKREGELVENTIL

747

⇒ X10342823
10 34 282 3

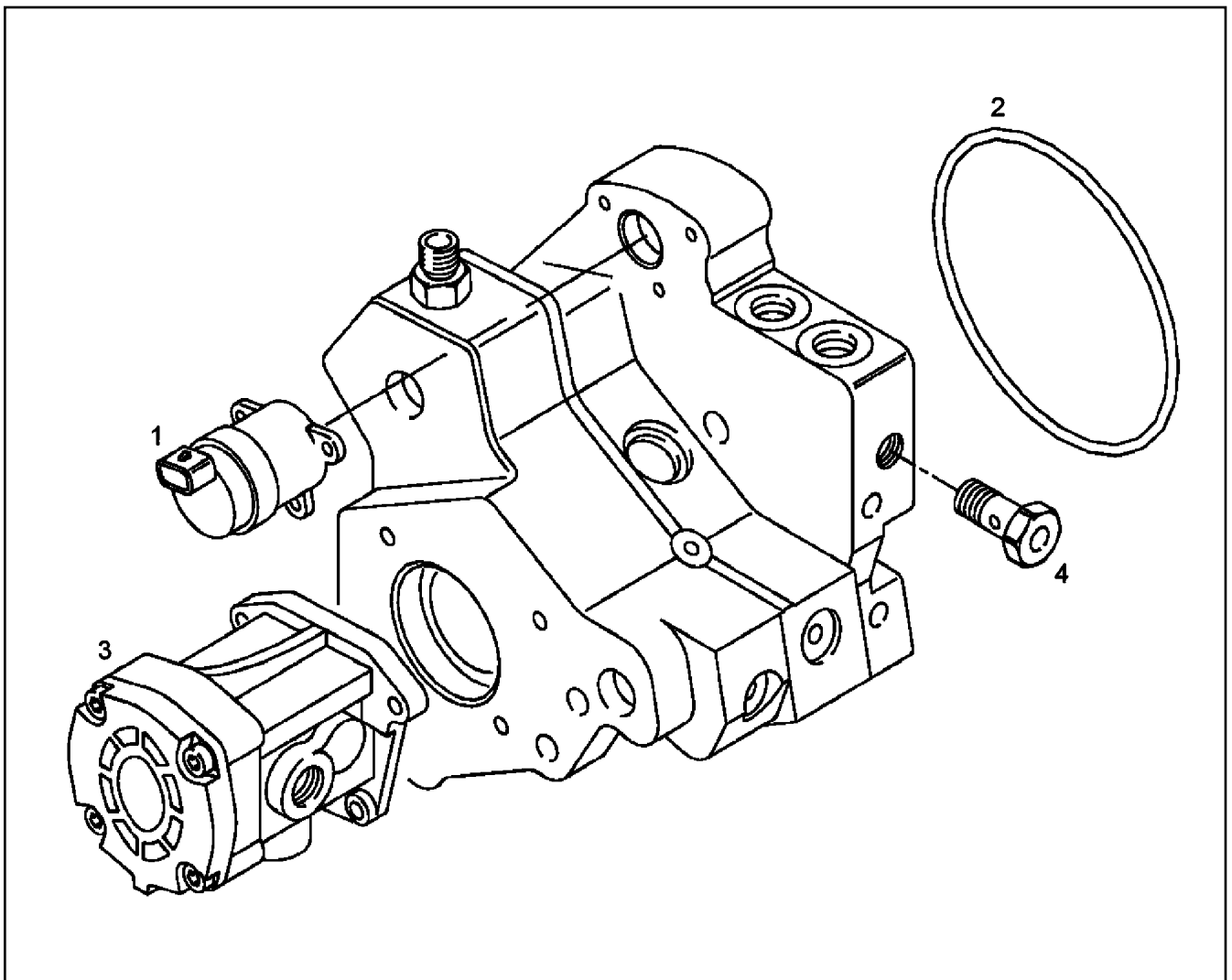

Pos.	Item	Quantity	Description	Bezeichnung	Serie	K
1	10 30 300 5	1	DOSING VALVE	ZUMESSVENTIL		
2	10 33 210 8	1	O RING 100X3 N-FPM1-70	RUNDDICHTRING		
3	10 22 274 8	1	FUEL FEED PUMP	KRAFTSTOFFOERDERPUMPE		
4	10 34 310 0	1	OVERFLOW VALVE	UEBERSTROEMVENTIL		

6.2.2009
049726

LIEBHERR

etk_en_de_074515 LR 1600/2

HIGH PRESSURE PUMP
HOCHDRUCKPUMPE

748

⇒ X10343096
10 34 309 6

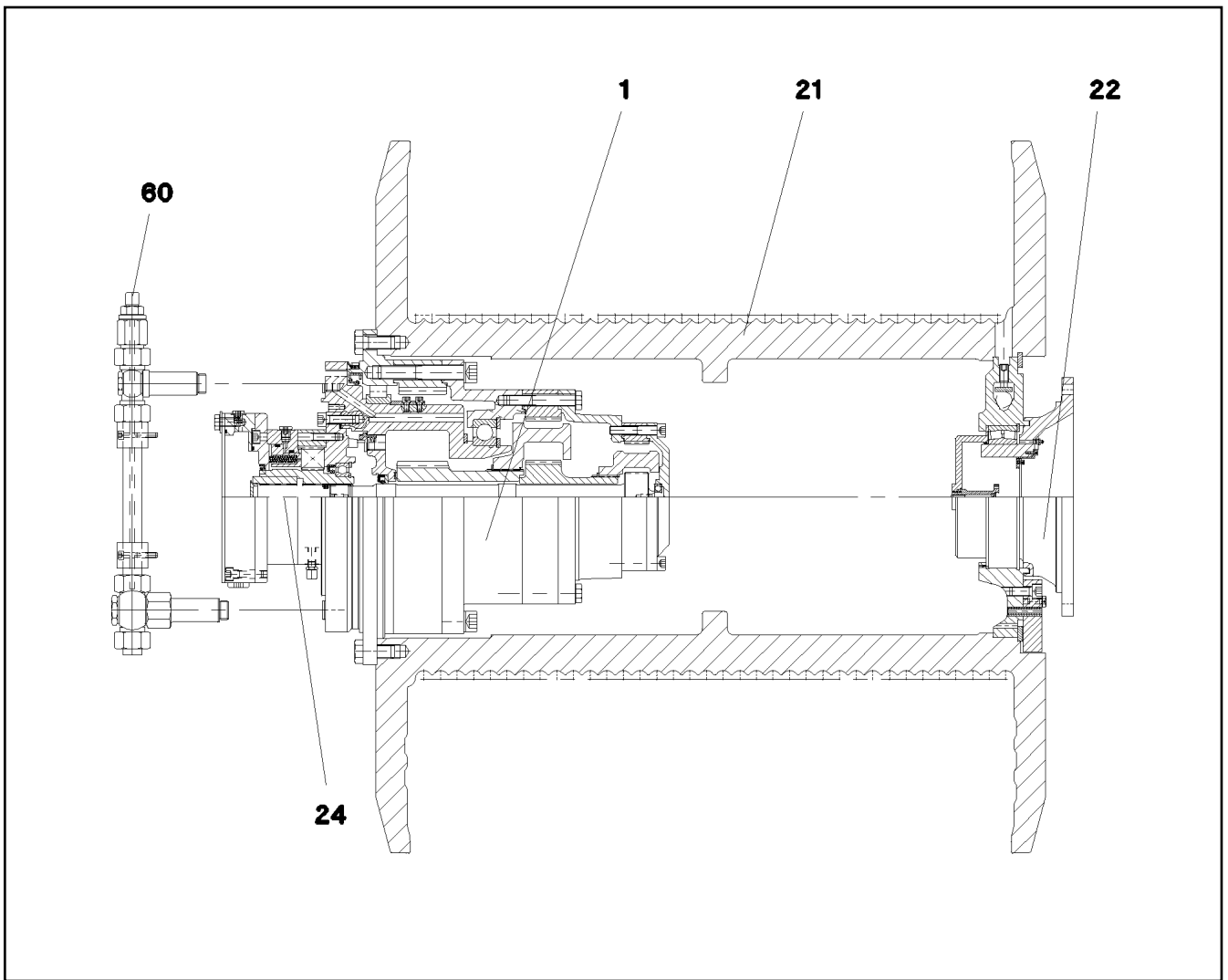

Pos.	Item	Quantity	Description	Bezeichnung	Serie	K
1	10 65 015 5	1	GEARBOX ⇒ X10650155 10 65 015 5	GETRIEBE		
21	10 65 015 6	1	ROPE DRUM ⇒ X10650156 10 65 015 6	SEILTROMMEL		
22	57 18 420 08	1	FLANGE ⇒ 5 718 420 08 57 18 420 08	FLANSCH		
24	10 65 015 8	1	DRIVE UNIT ⇒ X10650158 10 65 015 8	ANTRIEB		
60	10 65 015 9	1	OIL LINE	OELLEITUNG		

6.2.2009
059313

LIEBHERR

etk_en_de_074515 LR 1600/2

HOISTING WINCH
HUBWINDE

749

⇒ X10354114
10 35 411 4

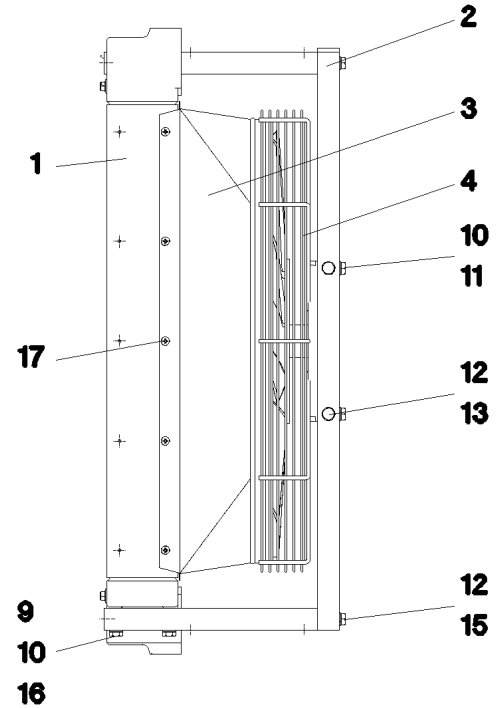
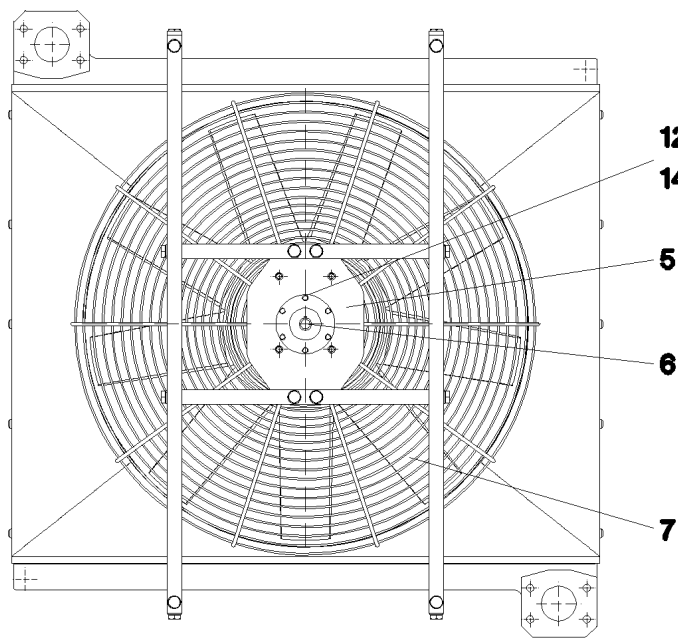

Pos.	Item	Quantity	Description	Bezeichnung	Serie	K
1	10 65 066 9	1	OIL COOLER	OELKUEHLER		
2	10 65 067 0	1	BRACKET	BUEGEL		
3	10 65 067 1	1	FAN HOOD	VENTILATORHAUBE		
4	10 65 067 2	1	PROTECTIVE GRATING	SCHUTZGITTER		
5	10 65 067 4	1	MOTOR FLANGE	MOTORFLANSCH		
6	10 65 067 5	1	HUB	NABE		
7	10 65 067 6	1	FAN BLADE	LUEFTERFLUEGEL		
9	46 00 355	10	HEX BOLT ISO 4017 M10X45 8.8 A3C	SECHSKANTSCHRAUBE		
10	42 40 008 08	14	CIRCLIP DIN 127 A 10 VERZ	FEDERRING		
11	49 00 112	4	HEX BOLT ISO 4017 M10X35 8.8 A3C	SECHSKANTSCHRAUBE		
12	42 40 607 08	14	CIRCLIP DIN 128 A 8	FEDERRING		
13	49 00 128	4	HEX BOLT ISO 4017 M8X25 8.8 A2C	SECHSKANTSCHRAUBE		
14	49 00 089	6	HEX BOLT ISO 4017 M8X20 8.8 A2C	SECHSKANTSCHRAUBE		
15	40 01 667	4	HEX BOLT ISO 4017 M8X45 8.8 A2C	SECHSKANTSCHRAUBE		
16	41 15 047 08	2	HEX NUT DIN 934 M10 10 VERZ	SECHSKANTMUTTER		
17	55 31 687 08	6	SHEET-METAL SCREW DIN 7981 4,8X13-F-H	BLECHSCHRAUBE		

6.2.2009
059325

LIEBHERR

etk_en_de_074515 LR 1600/2

OIL AIR COOLER
OEL-LUFTKUEHLER

750

⇒ X10355196
10 35 519 6

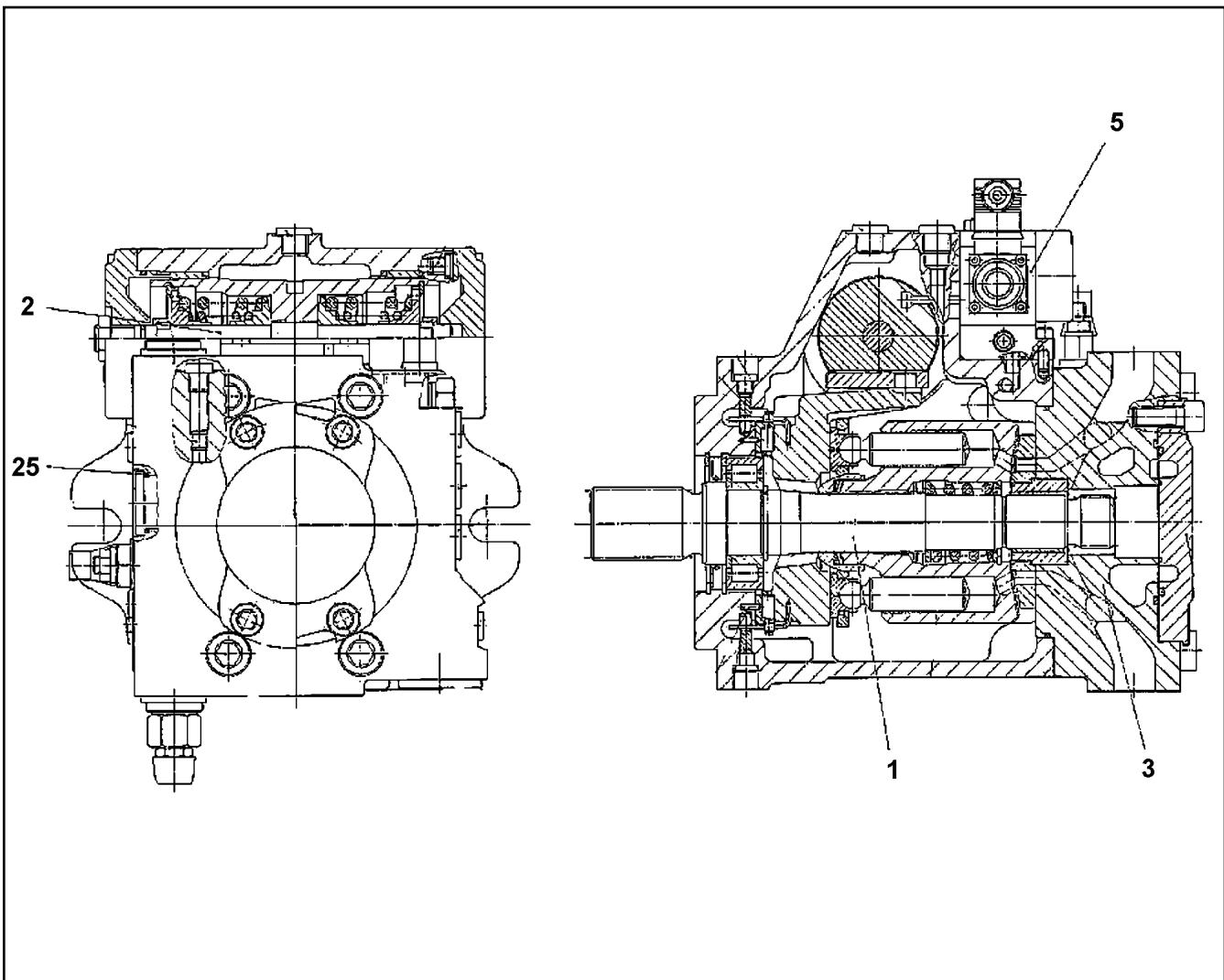

Pos.	Item	Quantity	Description	Bezeichnung	Serie	K
1	10 33 104 7	1	DRIVING GEAR	TRIEBWERK		
(98)	10 33 111 6	1	RADIAL PACKING SET DRIVE SHAFT	DS TRIEBWELLE		
2	10 33 104 8	1	ADJUSTMENT	VERSTELLUNG		
(98)	10 33 111 7	1	SEAL KIT ADJUSTMENT	DS VERSTELLUNG		
3	57 15 142 08	1	TERMINAL BOARD	ANSCHLUSSPLATTE		
			⇒ 5 715 142 08 57 15 142 08			
5	57 19 113 08	1	CONTROL UNIT	ANSTEUERGERAET		
			⇒ 5 719 113 08 57 19 113 08			
25	51 86 135 08	1	O-RING ARP 568 29,82X2,62 NBR90	O-RING		

6.2.2009
049690

LIEBHERR

etk_en_de_074515 LR 1600/2

VARIABLE PUMP
VERSTELLPUMPE

751

⇒ X10359241
10 35 924 1

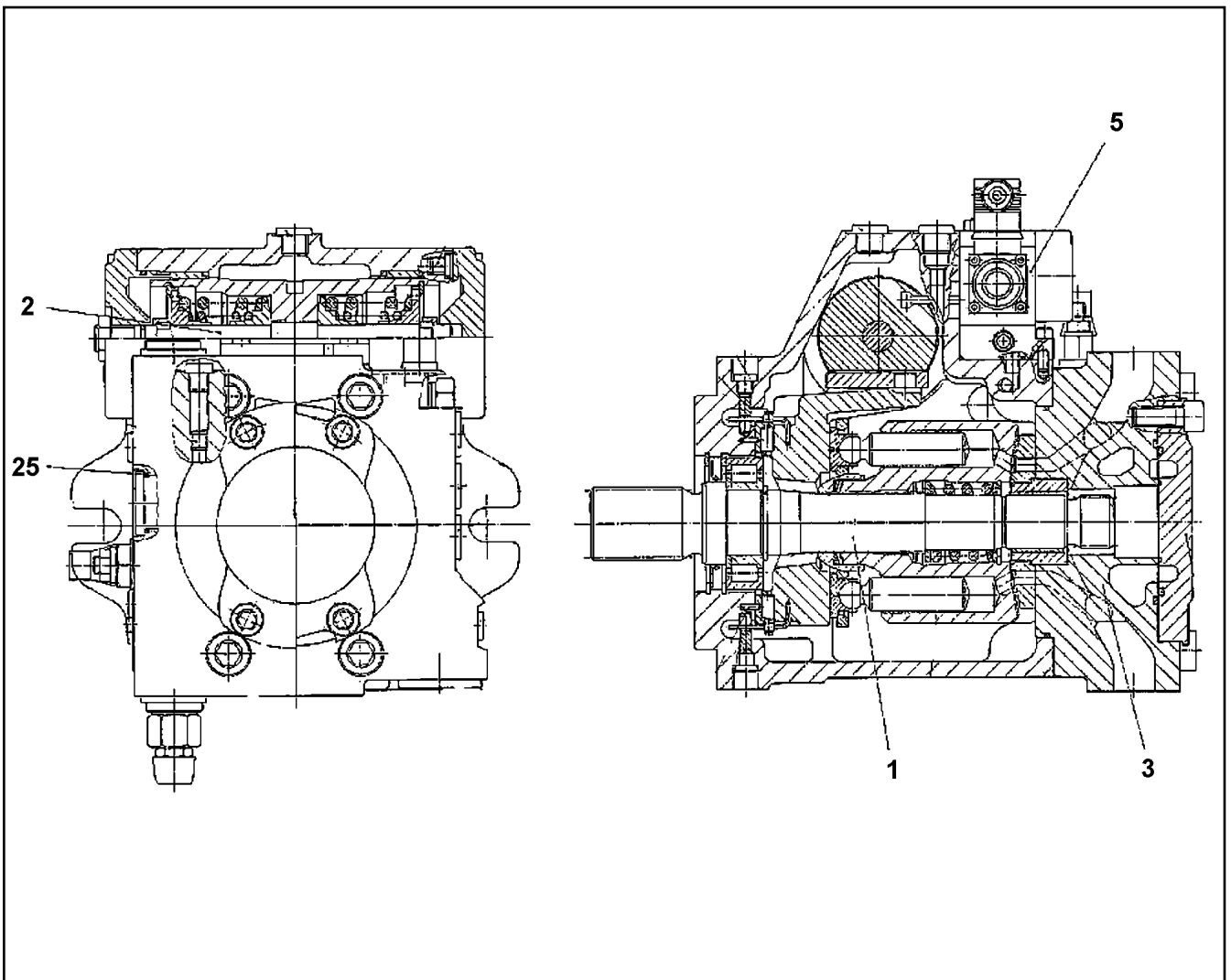

Pos.	Item	Quantity	Description	Bezeichnung	Serie	K
1	10 33 104 7	1	DRIVING GEAR	TRIEBWERK		
2	10 33 104 8	1	ADJUSTMENT	VERSTELLUNG		
3	57 15 142 08	1	TERMINAL BOARD	ANSCHLUSSPLATTE		
			⇒ 5 715 142 08 57 15 142 08			
5	57 19 113 08	1	CONTROL UNIT	ANSTEUERGERAET		
			⇒ 5 719 113 08 57 19 113 08			
25	51 86 135 08	1	O-RING ARP 568 29,82X2,62 NBR90	O-RING		

6.2.2009
049691

LIEBHERR

etk_en_de_074515 LR 1600/2

VARIABLE PUMP
VERSTELLPUMPE

752

⇒ X10359242
10 35 924 2

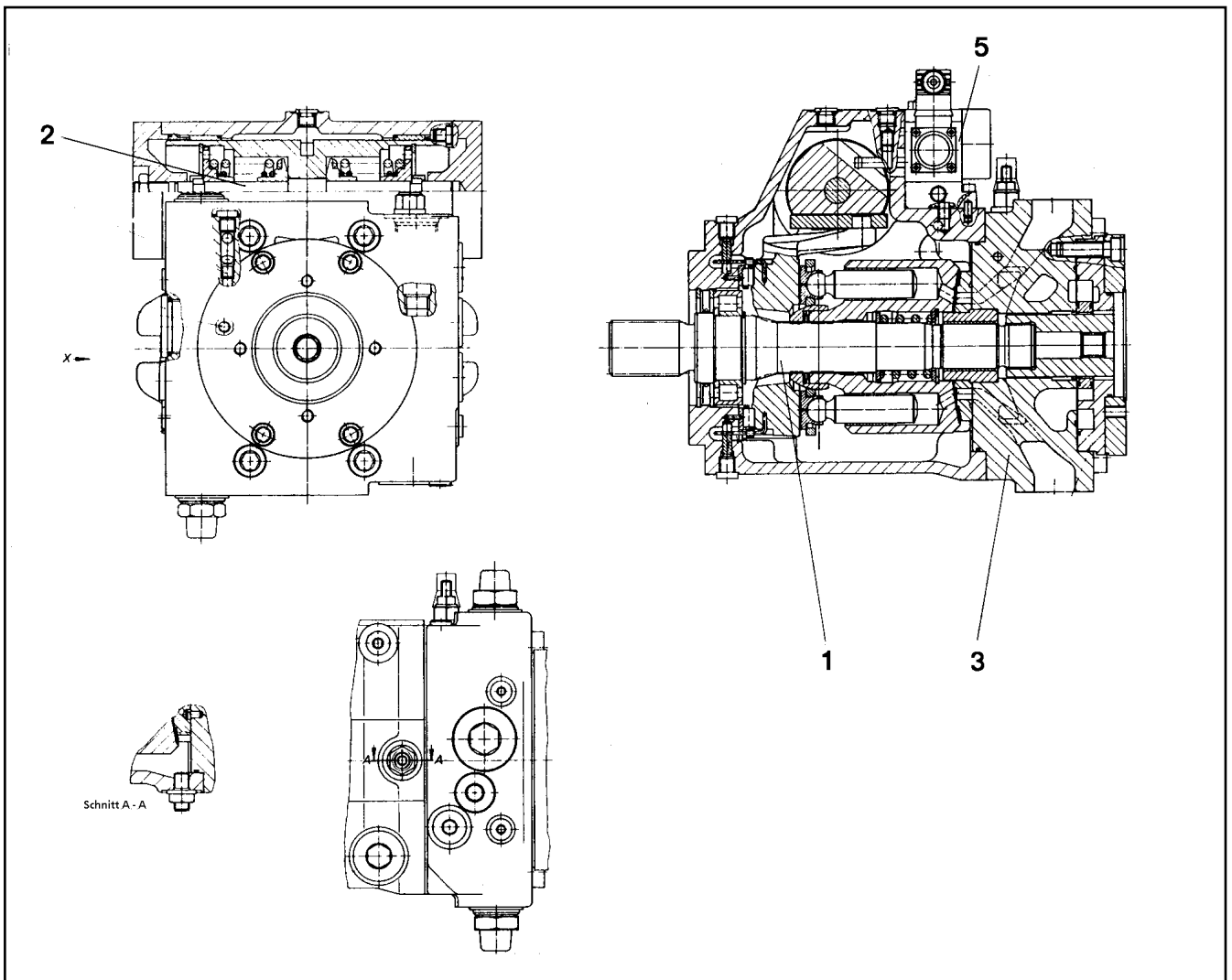

Pos.	Item	Quantity	Description	Bezeichnung	Serie	K
	1 10 47 137 0	1	DRIVING GEAR	TRIEBWERK		
	2 10 47 137 1	1	ADJUSTMENT	VERSTELLUNG		
	(999) 10 30 092 5	1	SEAL KIT	DICHTSATZ		
	3 57 19 030 08	1	TERMINAL BOARD	ANSCHLUSSPLATTE		
			⇒ 5 719 030 08 57 19 030 08			
	5 10 29 184 0	1	CONTROL UNIT	ANSTEUERGERAET		
			⇒ X10291840 10 29 184 0			
	25 72 64 191 08	1	O-RING ARP 568 39,34X2,62 NBR90	O-RING		

6.2.2009
049692

LIEBHERR

etk_en_de_074515 LR 1600/2

VARIABLE PUMP
VERSTELLPUMPE

753

⇒ X10359243
10 35 924 3

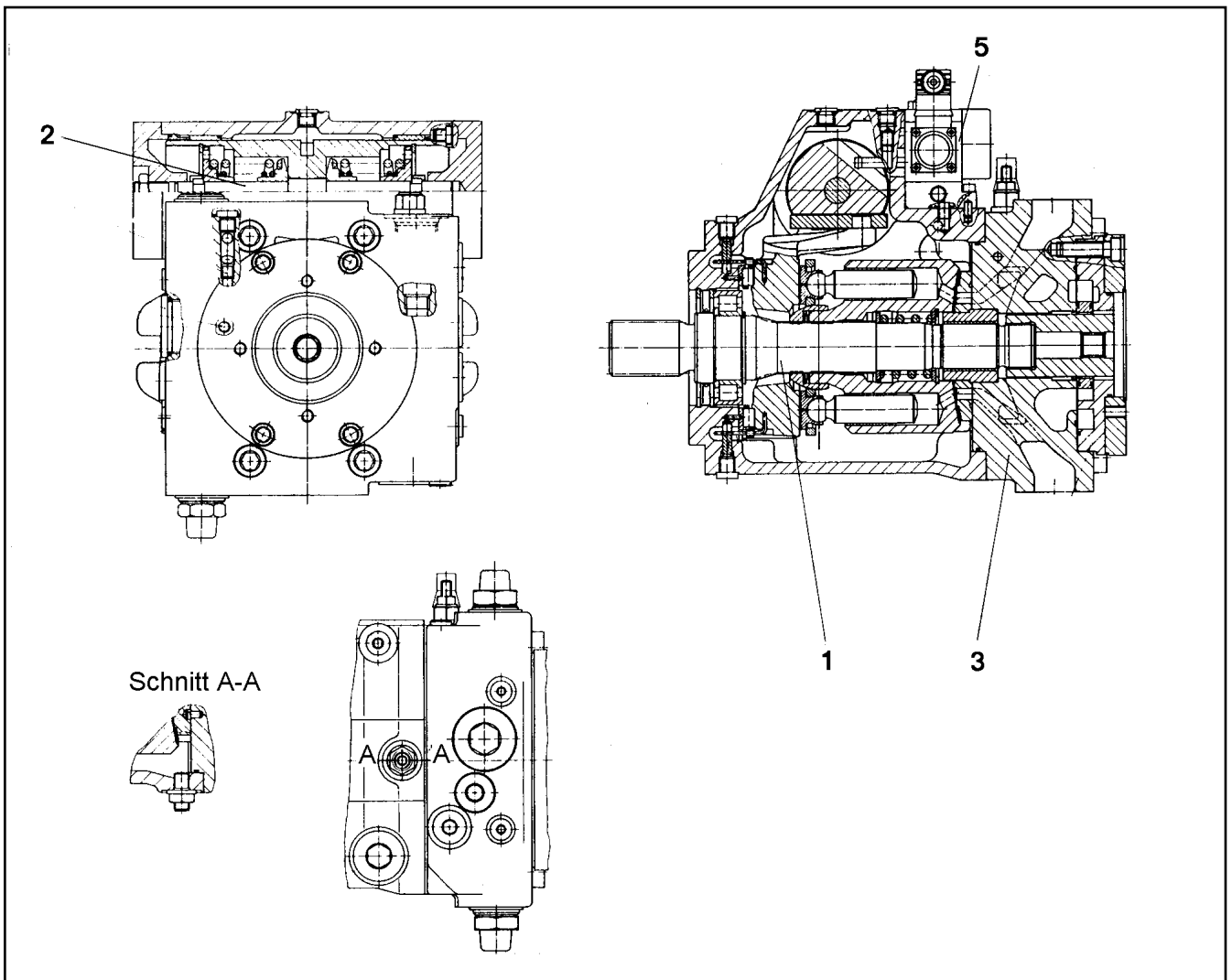

Pos.	Item	Quantity	Description	Bezeichnung	Serie	K
1	10 47 138 0	1	DRIVING GEAR	TRIEBWERK		
2	10 47 137 1	1	ADJUSTMENT	VERSTELLUNG		
3	57 19 030 08	1	TERMINAL BOARD	ANSCHLUSSPLATTE		
			⇒ 5 719 030 08 57 19 030 08			
5	10 29 184 0	1	CONTROL UNIT	ANSTEUERGERAET		
			⇒ X10291840 10 29 184 0			
25	72 64 191 08	1	O-RING ARP 568 39,34X2,62 NBR90	O-RING		

6.2.2009
049693

LIEBHERR

etk_en_de_074515 LR 1600/2

VARIABLE PUMP
VERSTELLPUMPE

754

⇒ X10359244
10 35 924 4

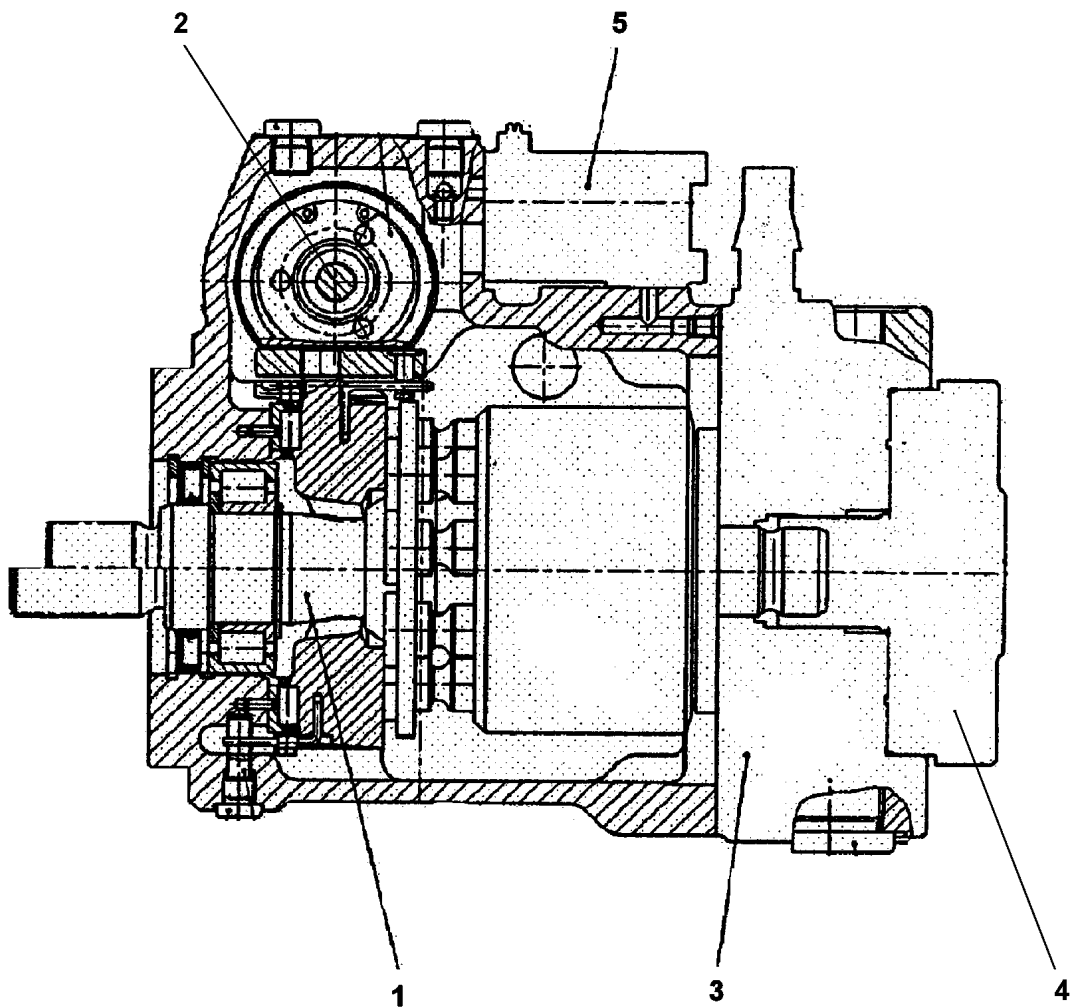

Pos. 25

Pos.	Item	Quantity	Description	Bezeichnung	Serie	K
1	10 32 692 4	1	DRIVING GEAR	TRIEBWERK		
2	10 32 692 5	1	ADJUSTMENT	VERSTELLUNG		
3	57 18 989 08	1	TERMINAL BOARD	ANSCHLUSSPLATTE		
			⇒ 5 718 989 08 57 18 989 08			
4	10 32 692 6	1	PUMP SUPPORT	PUMPENTRAEGER		
5	10 47 138 4	1	CONTROL UNIT	ANSTEUERGERAET		
(2)	10 47 143 7	1	PROPORTIONAL MAGNET 24V	PROPORTIONALMAGNET		
(98)	10 47 143 9	1	SEALING SET CONTROL UNITS	DS ANSTEUERGERAET		
25	51 86 135 08	1	O-RING ARP 568 29,82X2,62 NBR90	O-RING		

6.2.2009
049695

LIEBHERR

etk_en_de_074515 LR 1600/2

VARIABLE PUMP
VERSTELLPUMPE

□ 755

⇒ X10359246
10 35 924 6

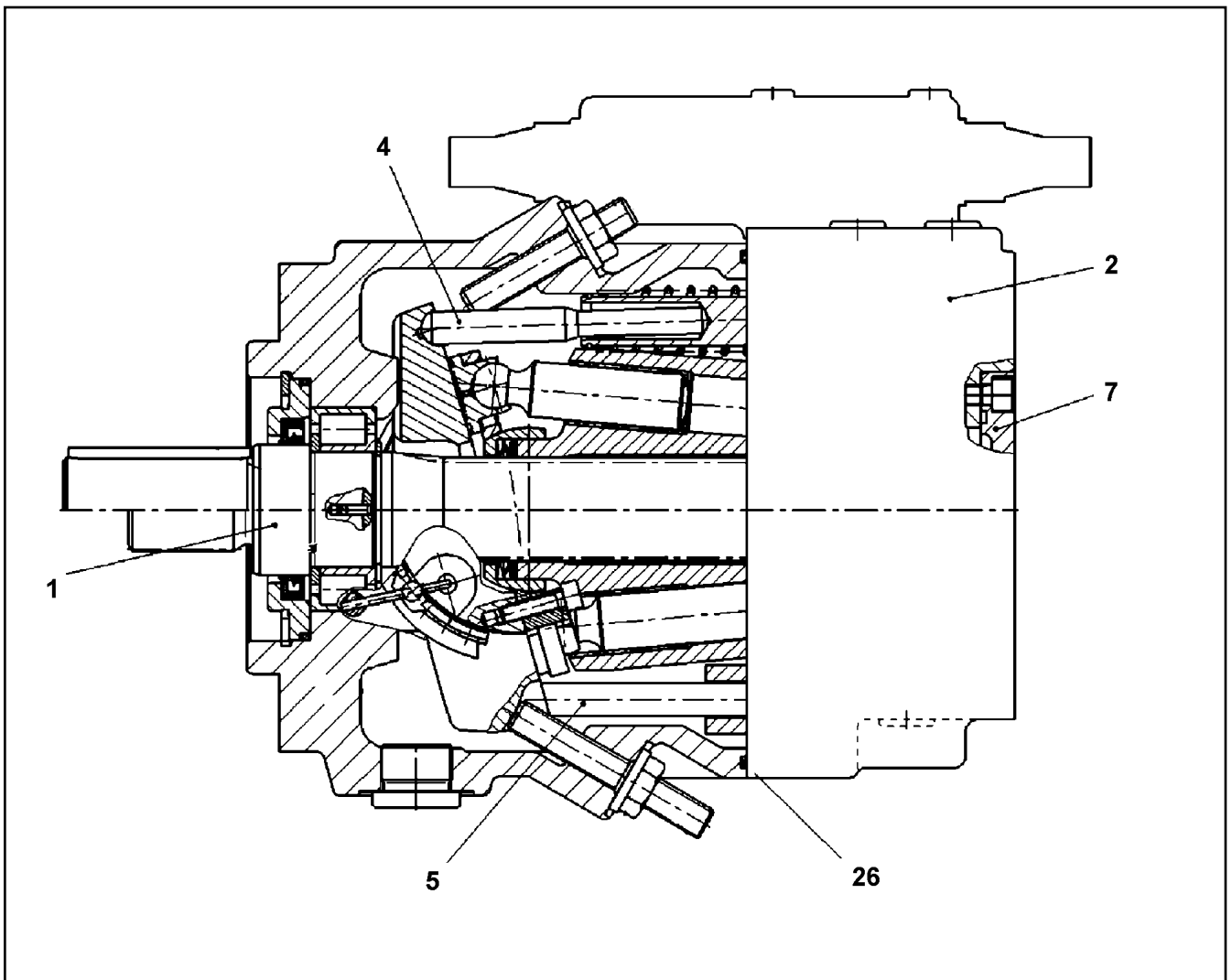

Pos.	Item	Quantity	Description	Bezeichnung	Serie	K
1	10 47 218 5	1	DRIVING GEAR	TRIEBWERK		
2	57 19 004 08	1	TERMINAL BOARD	ANSCHLUSSPLATTE		
3	10 47 219 6	1	REGULATOR	REGLER		
			⇒ X10472196 10 47 219 6			
4	10 33 323 8	1	HYDRAULIC ADJUSTMENT	HYDRAULIKVERSTELLUNG		
5	10 47 220 0	1	ADJUSTMENT	VERSTELLUNG		
7	57 19 006 08	1	PUMP SUPPORT	PUMPENTRAEGER		
			⇒ 5 719 006 08 57 19 006 08			
26	51 85 009 08	1	O-RING ARP 568 145,72X2,62 NBR70	O-RING		

6.2.2009
049697

LIEBHERR

etk_en_de_074515 LR 1600/2

VARIABLE PUMP
VERSTELLPUMPE

756

⇒ X10359247
10 35 924 7

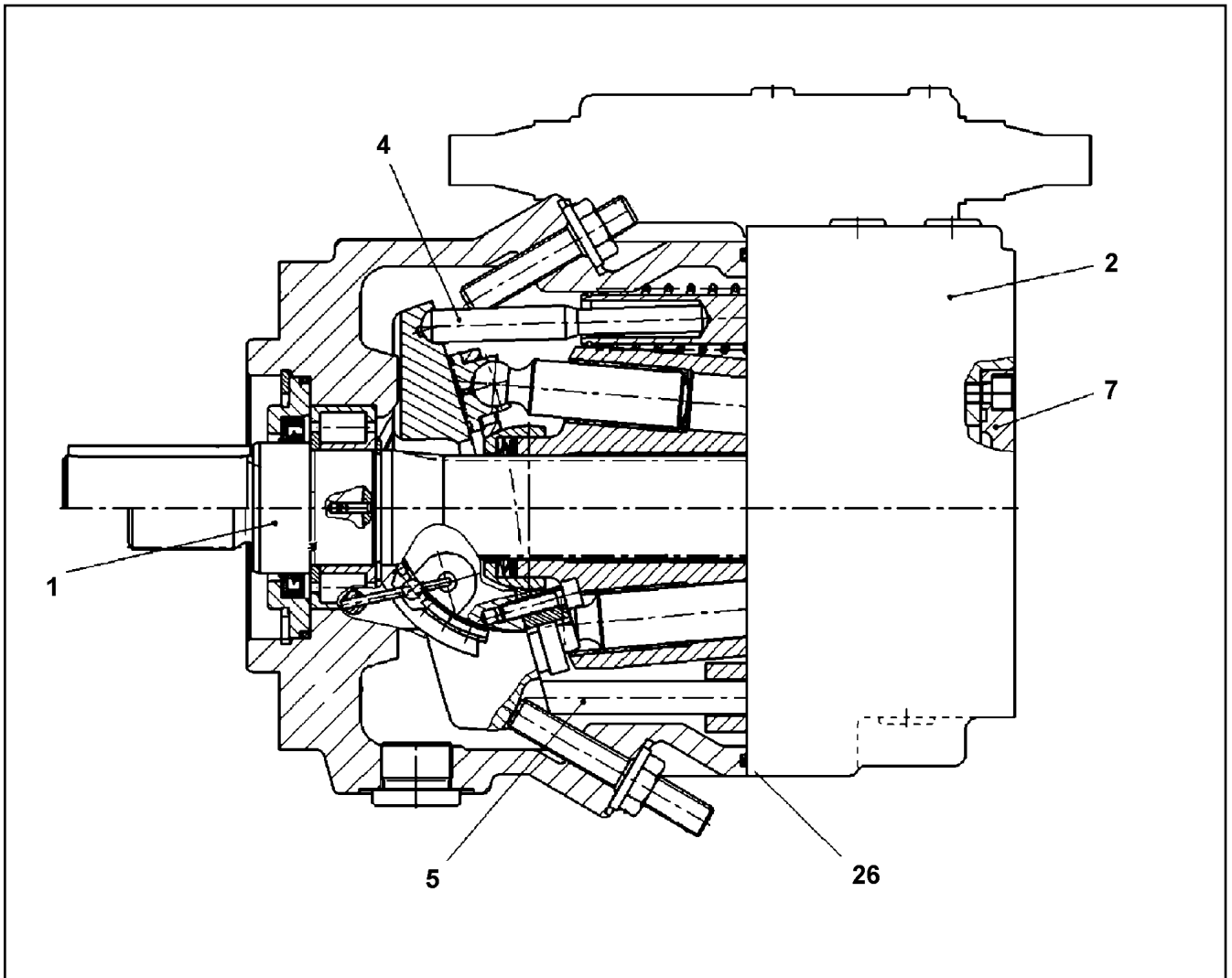

Pos.	Item	Quantity	Description	Bezeichnung	Serie	K
1	10 47 220 4	1	DRIVING GEAR	TRIEBWERK		
2	70 23 640	1	TERMINAL BOARD	ANSCHLUSSPLATTE		
(98)	10 47 221 9	1	GASKET KIT INT.FLANGE LPVD	DS ANSCHLUSSPLATTE		
3	10 47 219 6	1	REGULATOR	REGLER		
			⇒ X10472196 10 47 219 6			
4	10 47 220 8	1	ADJUSTMENT	VERSTELLUNG		
5	70 23 643	1	ADJUSTMENT	VERSTELLUNG		
7	70 23 645	1	LID	DECKEL		
(5)	51 45 042 08	1	O-RING ARP 568 66,34X2,62 NBR70	O-RING		
26	57 12 398 08	1	O-RING ARP 568 158,42X2,62 NBR90	O-RING		

6.2.2009
049699

LIEBHERR

etk_en_de_074515 LR 1600/2

VARIABLE PUMP
VERSTELLPUMPE

757

⇒ X10359248
10 35 924 8

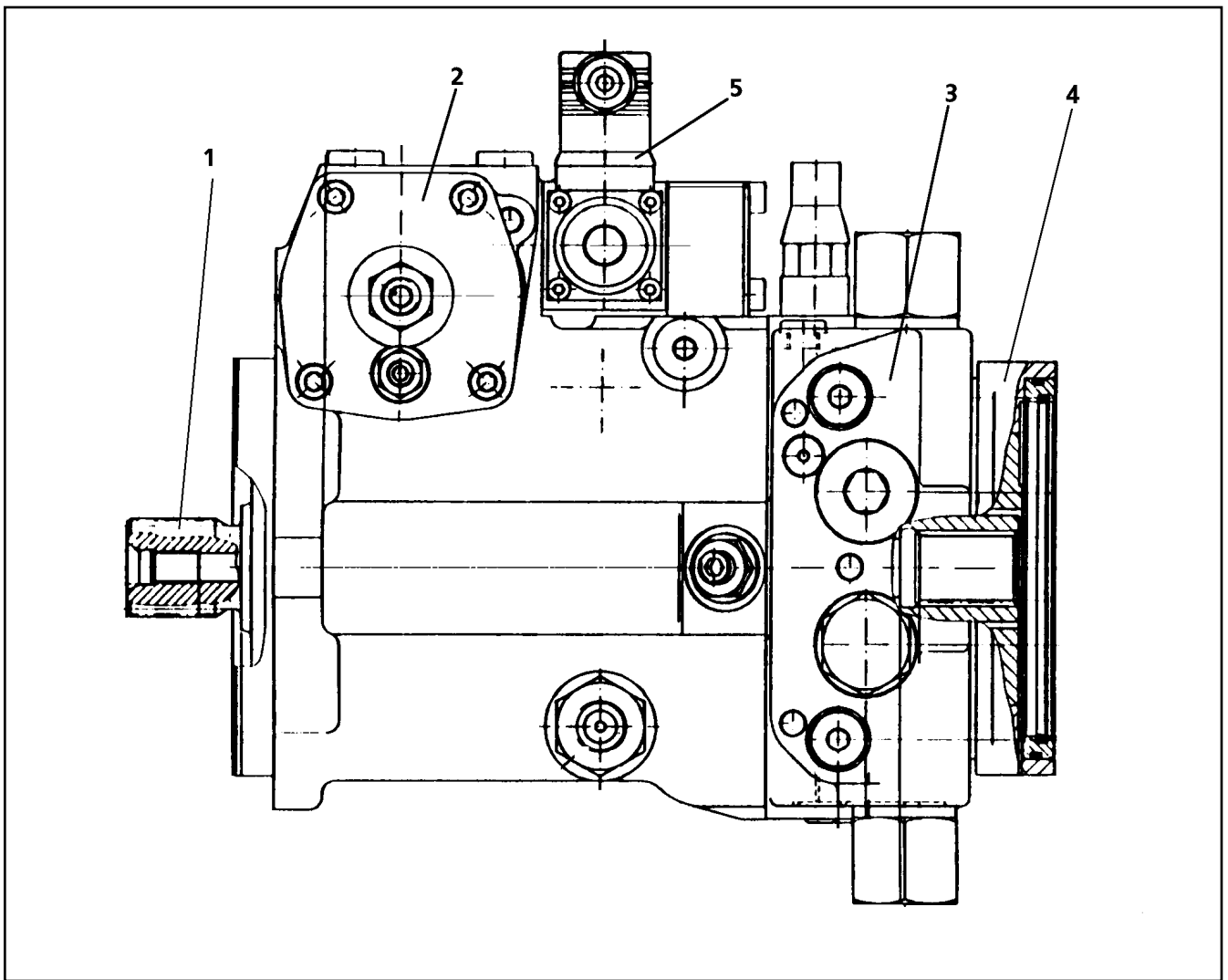

Pos.	Item	Quantity	Description	Bezeichnung	Serie	K
	1 10 65 068 5	1	DRIVING GEAR	TRIEBWERK		
	(37) 10 00 942 4	2	LOCKING RING DIN 984 54X2	SICHERUNGSRING		
	(38) 10 65 070 1	1	SHAFT SEAL BA 35X54X6	WELLENDICHRING		
	2 10 65 068 6	1	ADJUSTMENT	VERSTELLUNG		
	(98) 10 65 070 7	1	SEAL KIT ADJUSTMENT	DS VERSTELLUNG		
	3 10 65 068 8	1	TERMINAL BOARD	ANSCHLUSSPLATTE		
			⇒ X10650688 10 65 068 8			
	4 10 65 068 9	1	PUMP COVER	PUMPENDECKEL		
	(98) 10 65 071 7	1	SEAL KIT F.PUMP	DS PUMPE		
	5 10 65 069 2	1	CONTROL ELEMENT	STEUERTEIL		
	(1) 10 47 143 7	2	PROPORTIONAL MAGNET 24V	PROPORTIONALMAGNET		
	(98) 10 47 143 9	1	SEALING SET CONTROL UNITS	DS ANSTEUERGERAET		

6.2.2009
059327

LIEBHERR

etk_en_de_074515 LR 1600/2

VARIABLE PUMP
VERSTELLPUMPE

758

⇒ X10359249
10 35 924 9

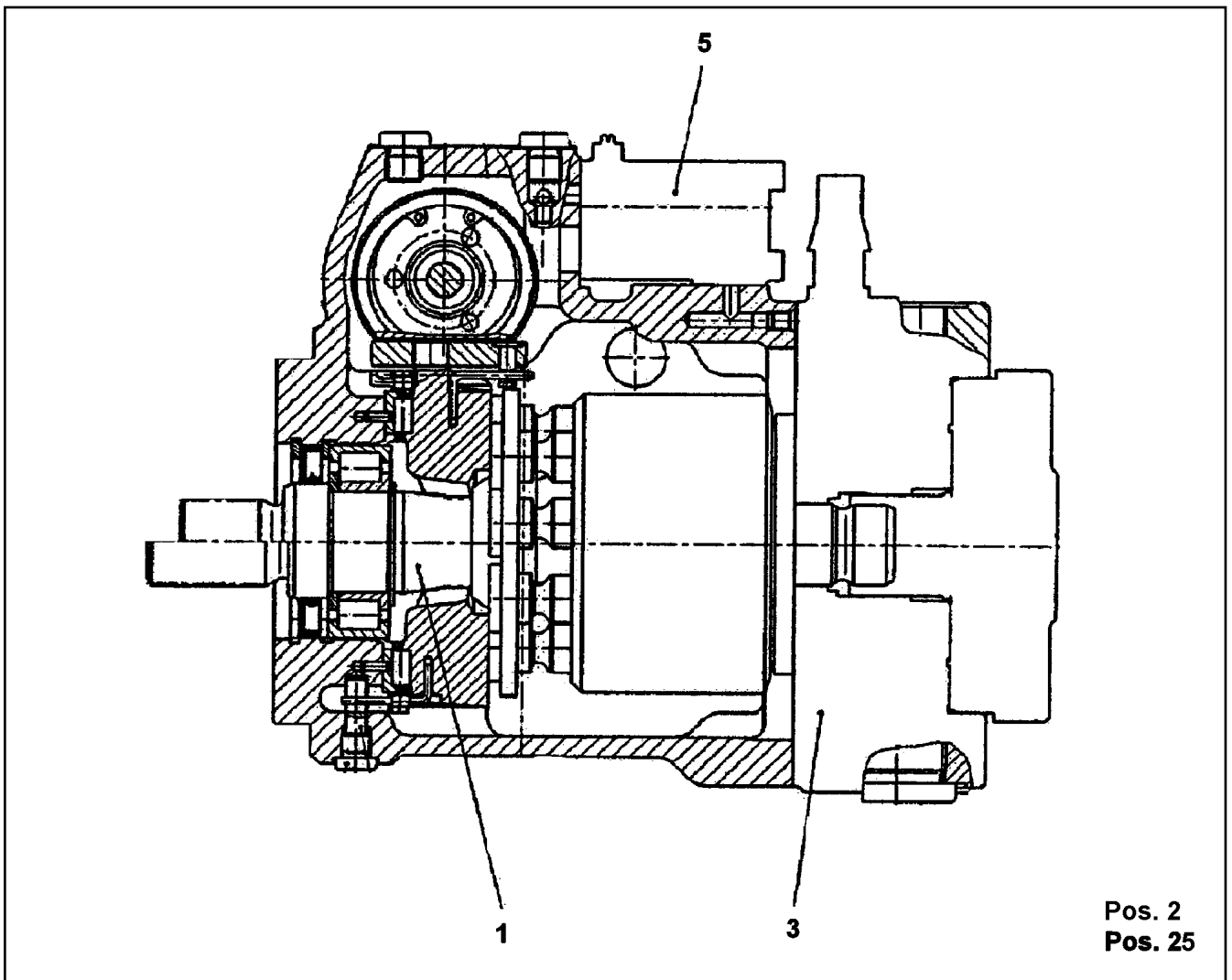

Pos.	Item	Quantity	Description	Bezeichnung	Serie	K
1	10 33 104 7	1	DRIVING GEAR	TRIEBWERK		
2	10 33 104 8	1	ADJUSTMENT	VERSTELLUNG		
3	57 15 142 08	1	TERMINAL BOARD	ANSCHLUSSPLATTE		
			⇒ 5 715 142 08 57 15 142 08			
5	57 19 133 08	1	NRS CHECK VALVE	NRS RUECKSCHLAGVENTIL		
25	51 86 135 08	1	O-RING ARP 568 29,82X2,62 NBR90	O-RING		

6.2.2009
049800

LIEBHERR

etk_en_de_074515 LR 1600/2

VARIABLE PUMP
VERSTELLPUMPE

759

⇒ X10359250
10 35 925 0

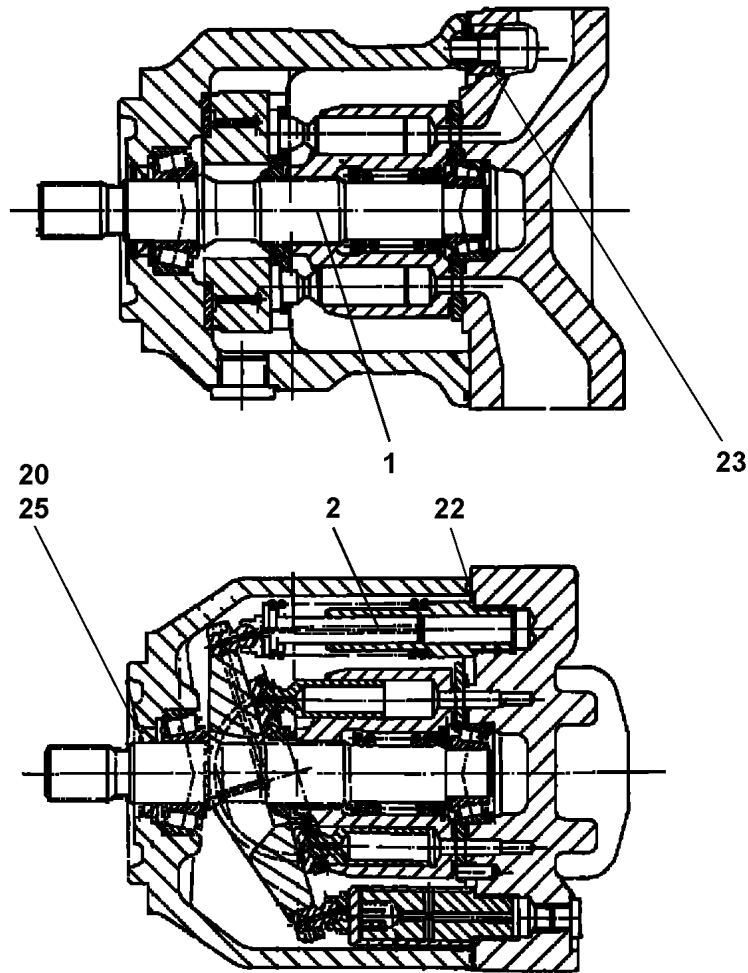

Pos. 40

Pos.	Item	Quantity	Description	Bezeichnung	Serie	K
1	10 21 996 8	1	DRIVING GEAR	TRIEBWERK		
2	10 41 120 7	1	SEAT ADJUSTMENT	VERSTELLEINRICHTUNG		
20	10 22 035 9	1	SHAFT SEAL 28X40X6.5/5.5 75V	WELLENDICHTRING		
22	57 15 165 08	1	O-RING 167X2,5 NBR80	O-RING		
23	57 12 342 08	4	O-RING 15X2 FPM80	O-RING		
25	10 22 093 7	1	LOCKING RING AEHNL.DIN 984 40X1,75	SICHERUNGSRING		
40	10 11 497 5	1	CONTROL VALVE	STEUERVENTIL		
(1)	10 29 624 5	1	PROPORTIONAL MAGNET	PROPORTIONALMAGNET		
(2)	10 29 787 6	1	SEAL	DICHTUNG		
(3)	49 01 159	4	CYLINDER SCREW ISO 4762 M6X30 10.9 A2	ZYLINDERSCHRAUBE		

6.2.2009
059321

LIEBHERR

etk_en_de_074515 LR 1600/2

VARIABLE PUMP
VERSTELLPUMPE

760

⇒ X10359251
10 35 925 1

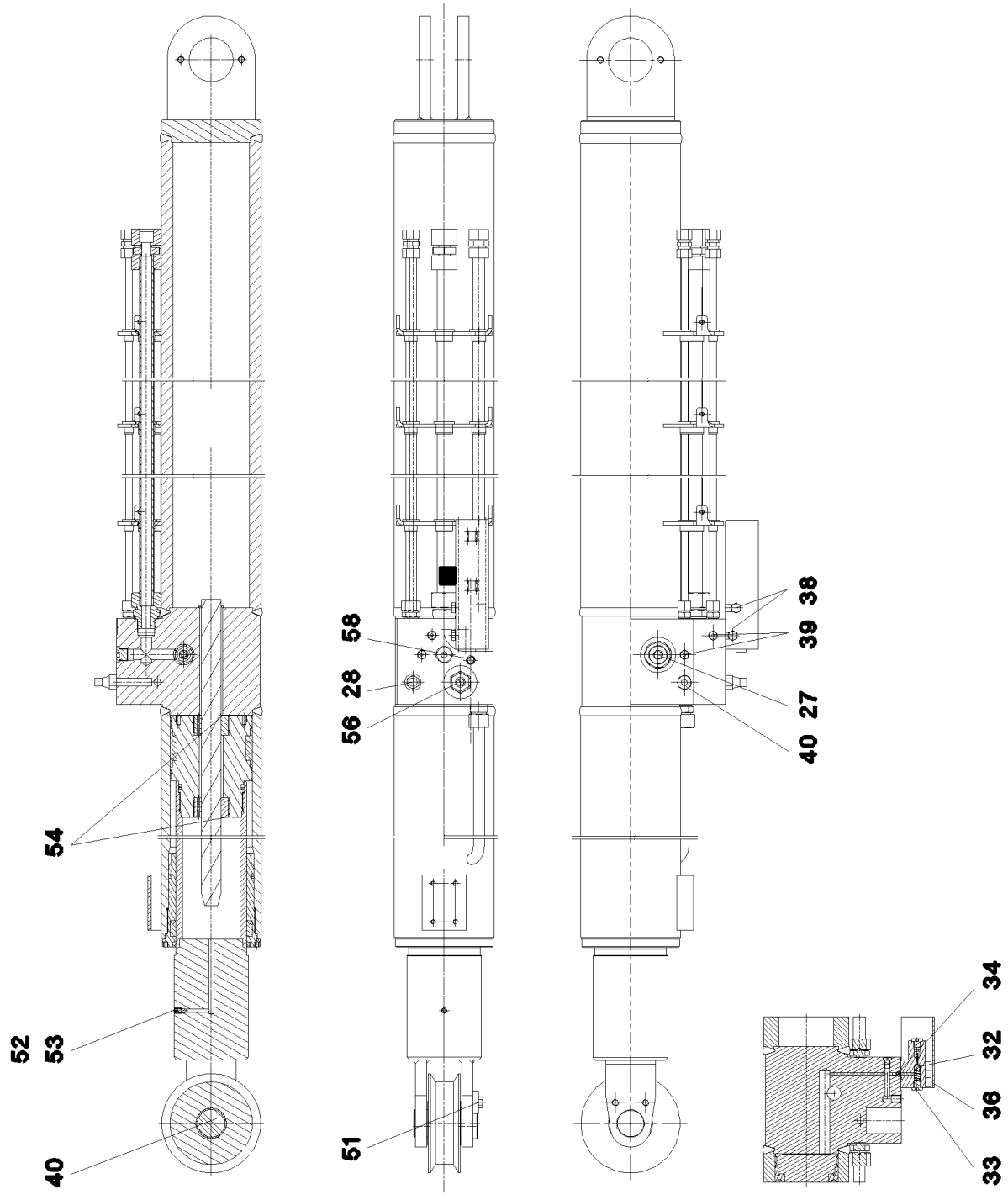

6.2.2009
059631

LIEBHERR

etk_en_de_074515 LR 1600/2

TILTING-BACK SUPPORT
RUECKFALLSTUETZE

761 (1/2)

⇒ X10411015
10 41 101 5

Pos.	Item	Quantity	Description	Bezeichnung	Serie	K
270	10 66 432 1	1	NON-RETURN VALVE 350BAR 300L/MIN	RUECKSCHLAGVENTIL		
280	57 17 286 08	1	OVERPRESSURE VALVE	UEBERDRUCKVENTIL		
320	74 70 006 08	1	BALL DIN 5401 10	KUGEL		
330	47 77 040 77	2	PLUG VSTI1/4"ED A3P	STOPFEN		
400	47 77 051 08	1	PLUG VSTIM18X1,5ED A3P	STOPFEN		
410	10 04 243 0	1	PIN	BOLZEN		
430	10 66 425 0	1	ROLLER	ROLLE		
520	74 70 004 08	1	BALL DIN 5401 8	KUGEL		
530	40 44 022 08	1	GRUB SCREW DIN 913 M10X12 45 H VERZ	GEWINDESTIFT		
540	40 46 013 08	4	GRUB SCREW DIN 914 M8X10 45 H VERZ	GEWINDESTIFT		
560	10 66 433 3	1	PRESSURE LIMITING VALVE 290BAR	DRUCKBEGRENZUNGSVENTIL		
580	47 77 045 08	1	PLUG VSTIM22X1,5ED A3P	STOPFEN		
999	10 66 433 4	1	DS RELAPSE SUPPORT	DS RUECKFALLSTUETZE		

6.2.2009

etk_en_de_074515 LR 1600/2

 762 (2/2)

LIEBHERR

TILTING-BACK SUPPORT
RUECKFALLSTUETZE

⇒ X10411015
10 41 101 5



Pos. 999

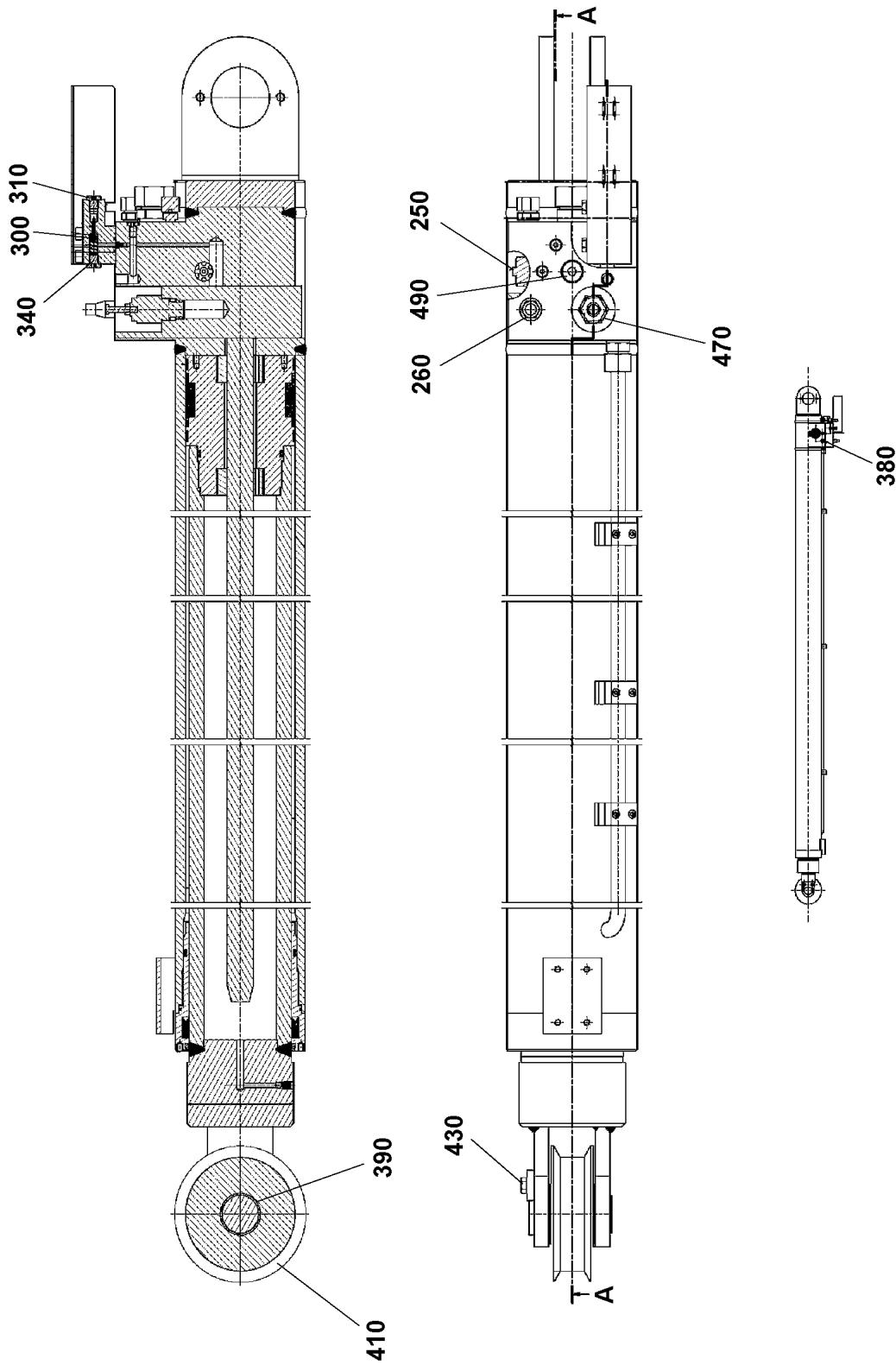

6.2.2009
059801

LIEBHERR

etk_en_de_074515 LR 1600/2

TILTING-BACK SUPPORT
RUECKFALLSTUETZE

763 (1/2)

⇒ X10411018
10 41 101 8

Pos.	Item	Quantity	Description	Bezeichnung	Serie	K
250	10 66 432 1	1	NON-RETURN VALVE 350BAR 300L/MIN	RUECKSCHLAGVENTIL		
260	57 17 286 08	1	OVERPRESSURE VALVE	UEBERDRUCKVENTIL		
300	74 70 006 08	1	BALL DIN 5401 10	KUGEL		
310	47 77 040 77	2	PLUG VSTI1/4"ED A3P	STOPFEN		
340	40 43 097 08	4	CYLINDER SCREW DIN 912 M10X60 10.9 A3	ZYLINDERSCHRAUBE		
380	47 77 051 08	1	PLUG VSTIM18X1,5ED A3P	STOPFEN		
390	10 04 243 0	1	PIN	BOLZEN		
410	10 66 425 0	1	ROLLER	ROLLE		
430	40 66 087 08	2	HEX BOLT ISO 4017 M12X25 10.9 FLZN SPF	SECHSKANTSCHRAUBE		
440	74 70 004 08	1	BALL DIN 5401 8	KUGEL		
450	40 44 022 08	1	GRUB SCREW DIN 913 M10X12 45 H VERZ	GEWINDESTIFT		
460	40 46 013 08	4	GRUB SCREW DIN 914 M8X10 45 H VERZ	GEWINDESTIFT		
470	10 66 433 3	1	PRESSURE LIMITING VALVE 290BAR	DRUCKBEGRENZUNGSVENTIL		
490	47 77 045 08	1	PLUG VSTIM22X1,5ED A3P	STOPFEN		
999	10 66 444 9	1	DS RELAPSE SUPPORT	DS RUECKFALLSTUETZE		

6.2.2009

etk_en_de_074515 LR 1600/2

764 (2/2)

LIEBHERR

TILTING-BACK SUPPORT
RUECKFALLSTUETZE

⇒ X10411018
10 41 101 8

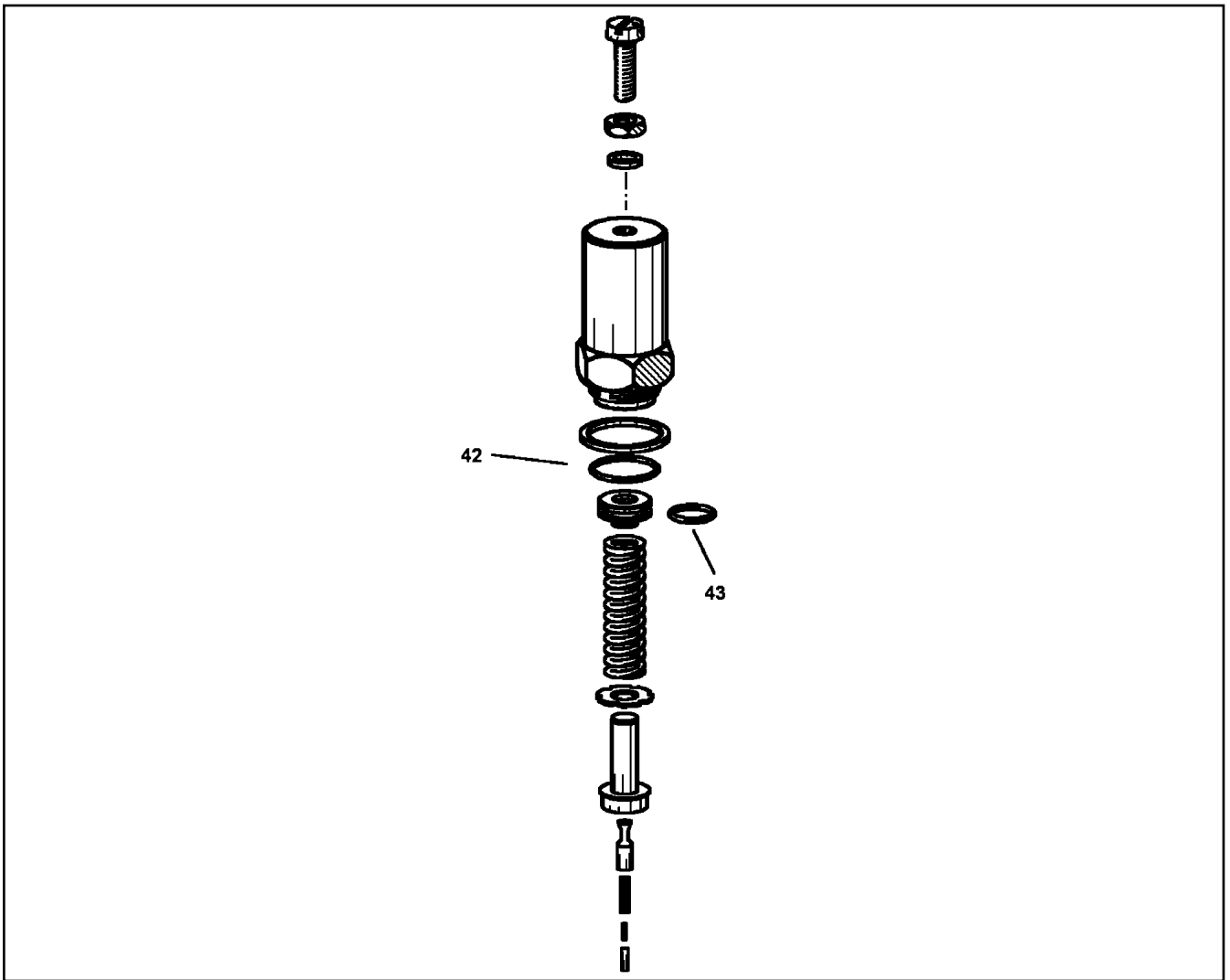

Pos.	Item	Quantity	Description	Bezeichnung	Serie	K
42	51 45 495 08	1	O-RING ARP 568 23,4X3,53 NBR90	O-RING		
43	51 45 424 08	1	O-RING 15X2 NBR90	O-RING		

6.2.2009
049047

LIEBHERR

etk_en_de_074515 LR 1600/2

PRESSURE LIMITING VALVE
DRUCKBEGRENZUNGSVENTIL

765

⇒ X10412675
10 41 267 5

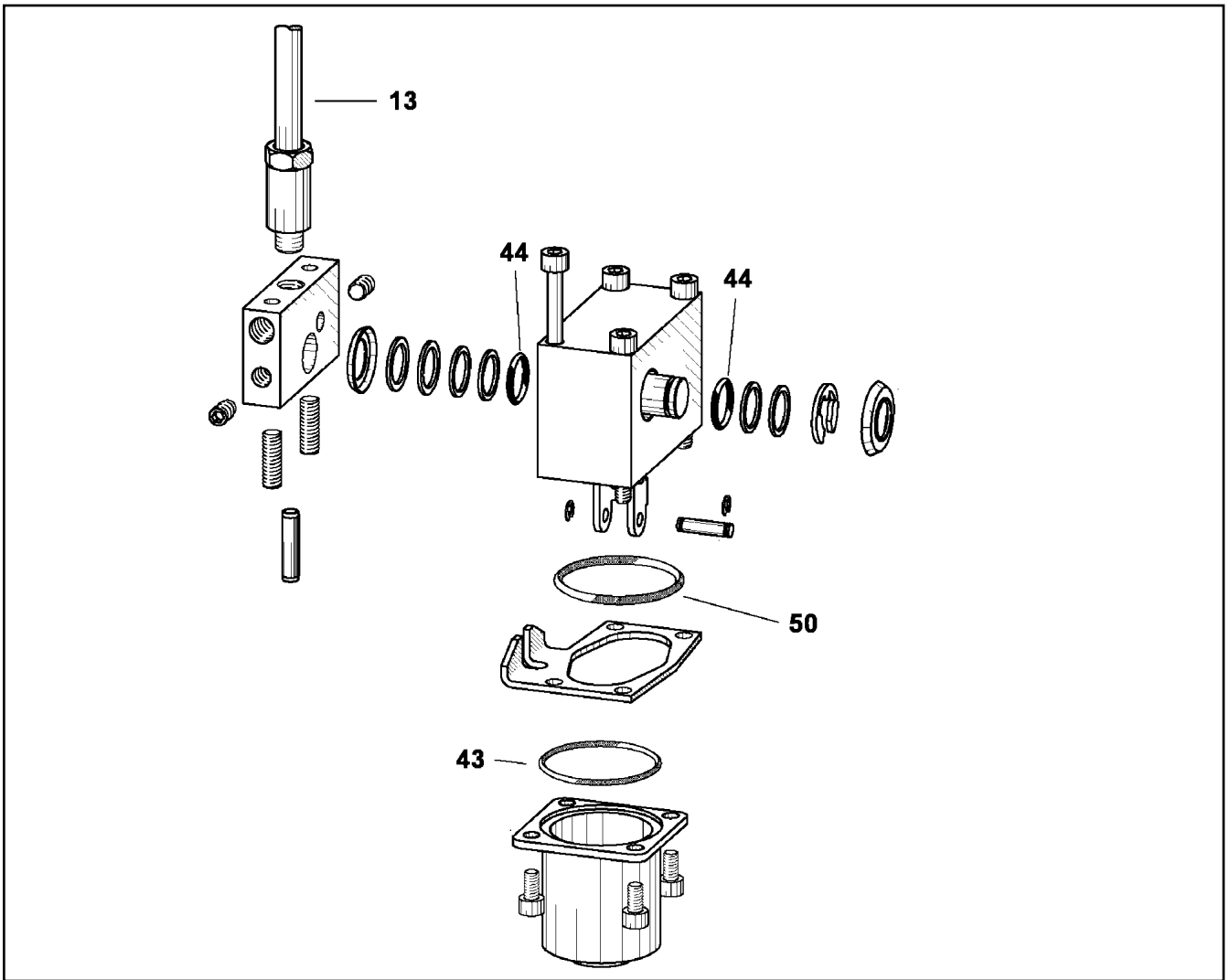

Pos.	Item	Quantity	Description	Bezeichnung	Serie	K
13	10 41 278 8	1	LEVER ARM	HEBELSTANGE		
43	51 07 399 08	1	O-RING ARP 568 34,65X1,78 NBR90	O-RING		
44	51 45 915 08	1	O-RING ARP 568 12,42X1,78 NBR90	O-RING		
50	72 64 252 08	1	O-RING ARP 568 36,17X2,62 NBR90	O-RING		

6.2.2009
049049

LIEBHERR

etk_en_de_074515 LR 1600/2

MANUAL ACTUATION
HANDBETAETIGUNG

766

⇒ X10412677
10 41 267 7

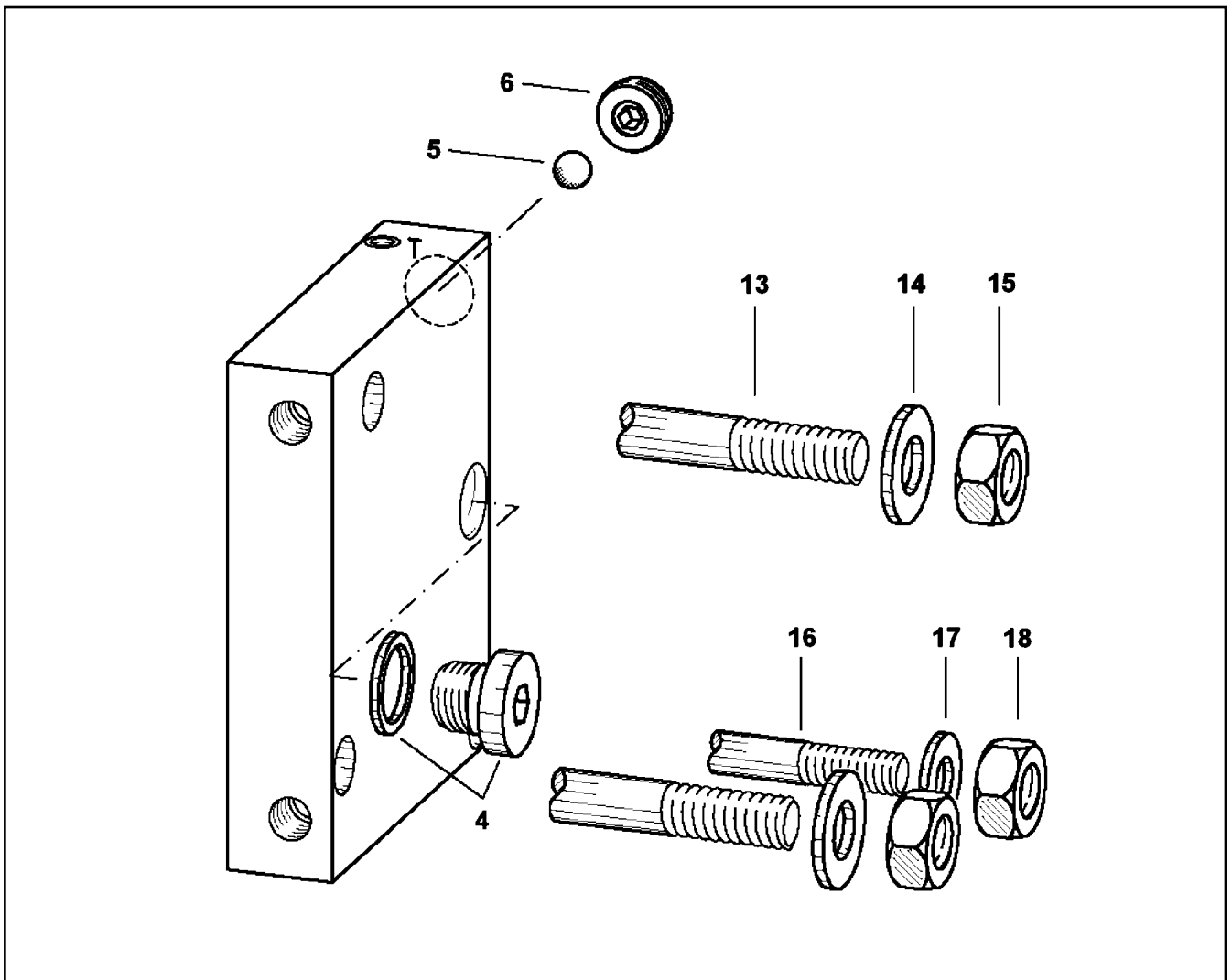

Pos.	Item	Quantity	Description	Bezeichnung	Serie	K
4	47 77 054 08	1	PLUG VSTI11/4"ED A3P	STOPFEN		
5	57 08 621 08	1	BALL DIN 5401 7	KUGEL		
6	10 41 278 9	1	THREADED DISK	GEWINDESCHEIBE		
13	10 35 370 5	2	CYLINDER SCREW ISO 4762 M10X80 A2-70	ZYLINDERSCHRAUBE		
14	42 00 013 08	2	WASHER ISO 7089 A 10.5 A3C	SCHEIBE		
15	41 15 031 03	2	HEX NUT ISO 4032 M10 8 A2E	SECHSKANTMUTTER		
16	46 00 179	1	CYLINDER SCREW ISO 4762 M8X80 8.8 A2C	ZYLINDERSCHRAUBE		
17	46 00 373 03	1	WASHER ISO 7089 A8.4X16 ST A3C	SCHEIBE		
18	51 07 374 08	1	HEX NUT ISO 4032 M8 A2-70	SECHSKANTMUTTER		

6.2.2009
049050

LIEBHERR

etk_en_de_074515 LR 1600/2

END PLATE
ENDPLATTE

767

⇒ X10412678
10 41 267 8

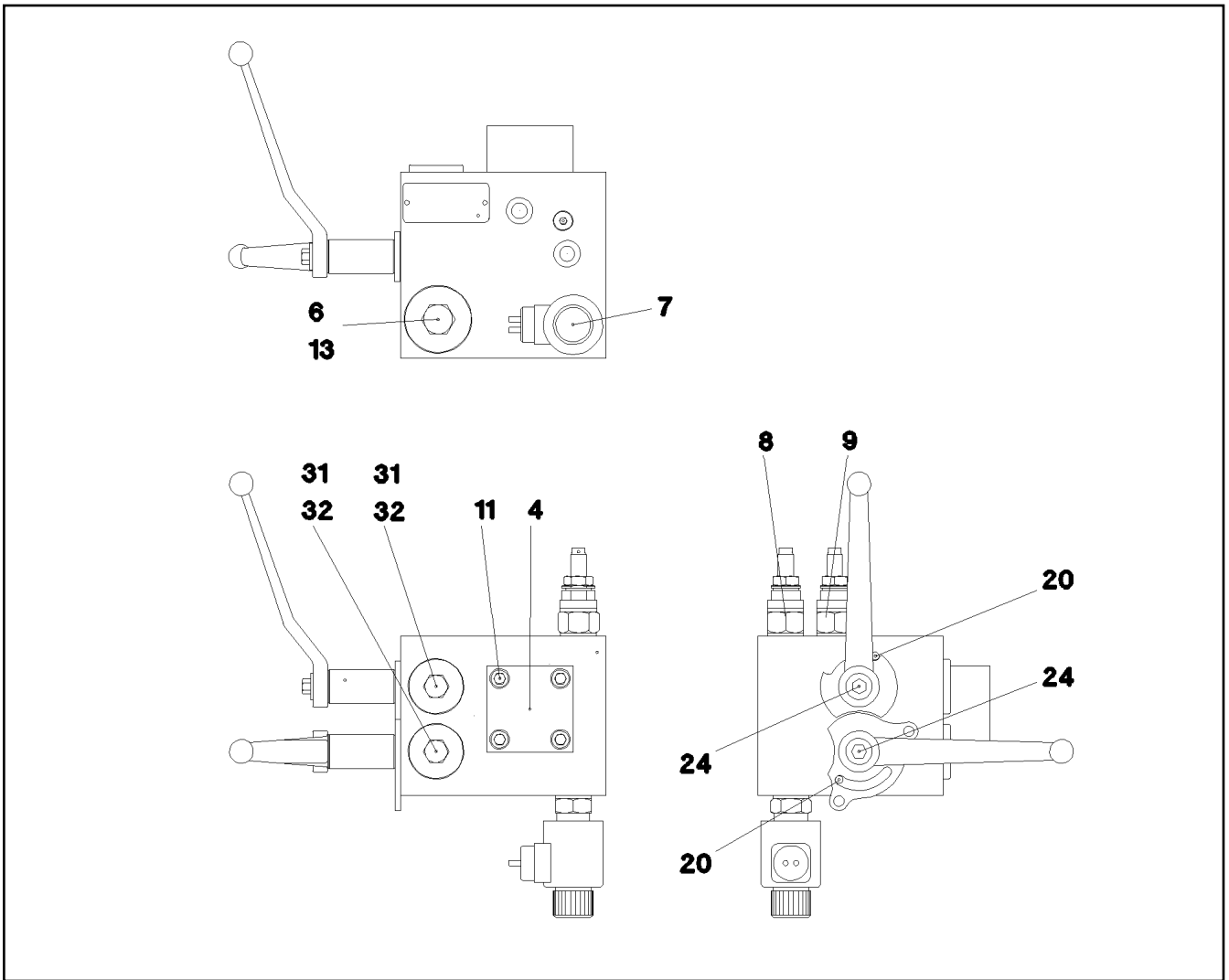

Pos.	Item	Quantity	Description	Bezeichnung	Serie	K
4	10 47 082 9	1	DIRECTIONAL CONTROL VALVE	WEGEVENTIL		
6	10 45 104 8	1	NON-RETURN VALVE	RUECKSCHLAGVENTIL		
7	10 45 104 9	1	DIRECTIONAL CONTROL VALVE	WEGEVENTIL		
8	57 16 910 08	1	PRESSURE LIMITING VALVE	DRUCKBEGRENZUNGSVENTIL		
(21)	72 64 241 08	2	O-RING 19X2,5 NBR70	O-RING		
(22)	72 64 065 08	1	O-RING 10X2 NBR70	O-RING		
9	10 45 106 0	1	PRESSURE LIMITING VALVE 100BAR	DRUCKBEGRENZUNGSVENTIL		
11	24 01 920 02	4	CYLINDER SCREW ISO 4762 M8X35 12.9	ZYLINDERSCHRAUBE		
13	47 77 048 08	1	PLUG VSTIM42X2ED A3P	STOPFEN		
15	47 77 049 08	1	PLUG VSTIM14X1,5ED A3P	STOPFEN		
20	51 45 349 08	2	PARALLEL PIN DIN 7 6M6X16 ST	ZYLINDERSTIFT		
24	40 65 055 08	2	HEX BOLT ISO 4017 M6X60 8.8 A2C	SECHSKANTSCHRAUBE		
31	53 00 732 08	2	O-RING 29X3 NBR70	O-RING		
32	72 64 306 08	2	O-RING 24X2 NBR70	O-RING		

6.2.2009
049688

LIEBHERR

etk_en_de_074515 LR 1600/2

CONTROL BLOCK
STUEBERBLOCK

768

⇒ X10424402
10 42 440 2

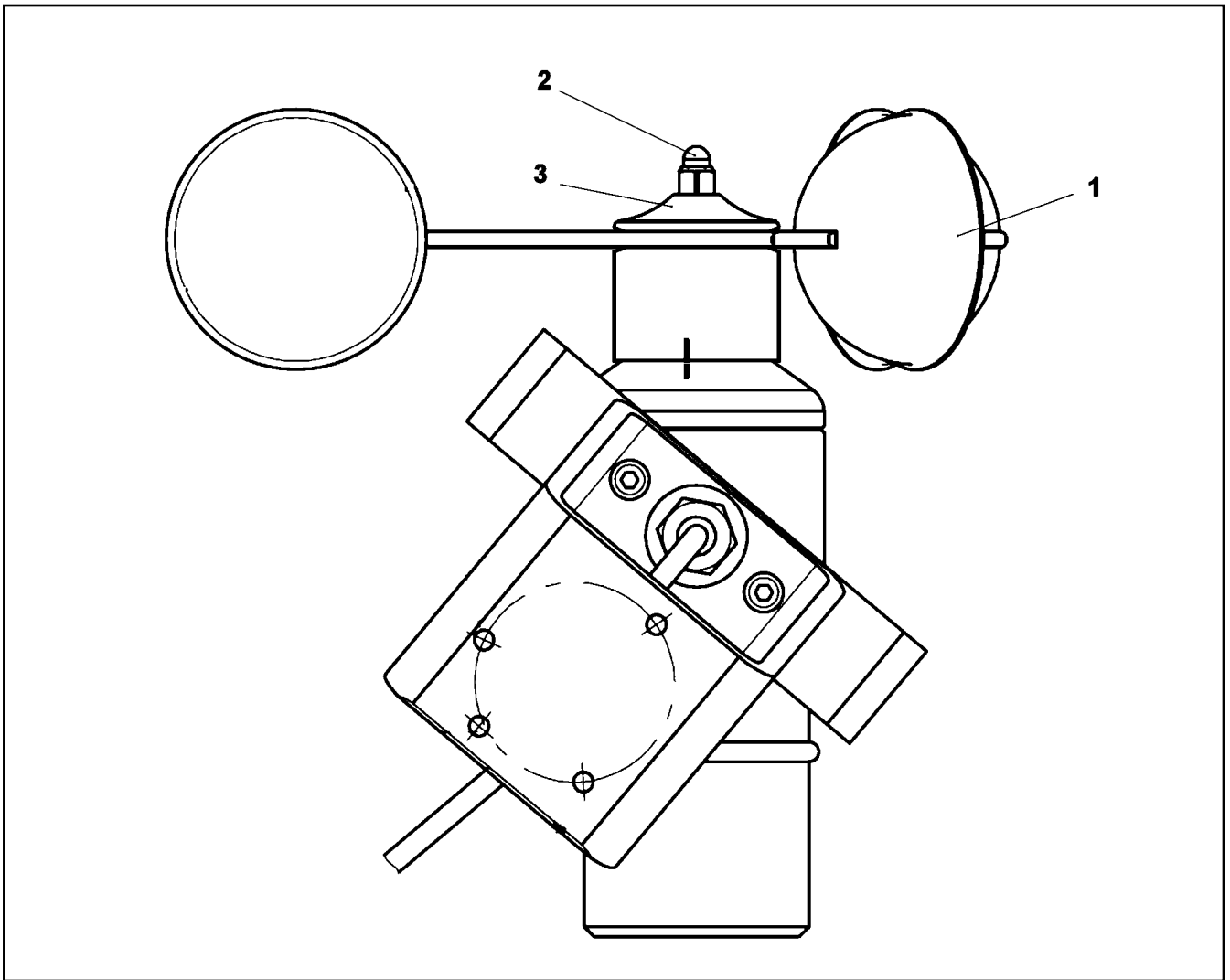

Pos.	Item	Quantity	Description	Bezeichnung	Serie	K
1	10 47 043 3	1	ANEMOMETER	WINDSTERN		
2	40 02 886	1	ECROU HEXAGONAL AUTOFREINE DIN 986	SECHSKANTHUTMUTTER M.KLE		
3	10 47 043 4	1	CLAMPING DISK	KLEMMSCHEIBE		

6.2.2009
049658

LIEBHERR

etk_en_de_074515 LR 1600/2

WIND VELOCITY TRANSMITTER
WINDGESCHWINDIGKEITSGEBER

769

⇒ X10429549
10 42 954 9

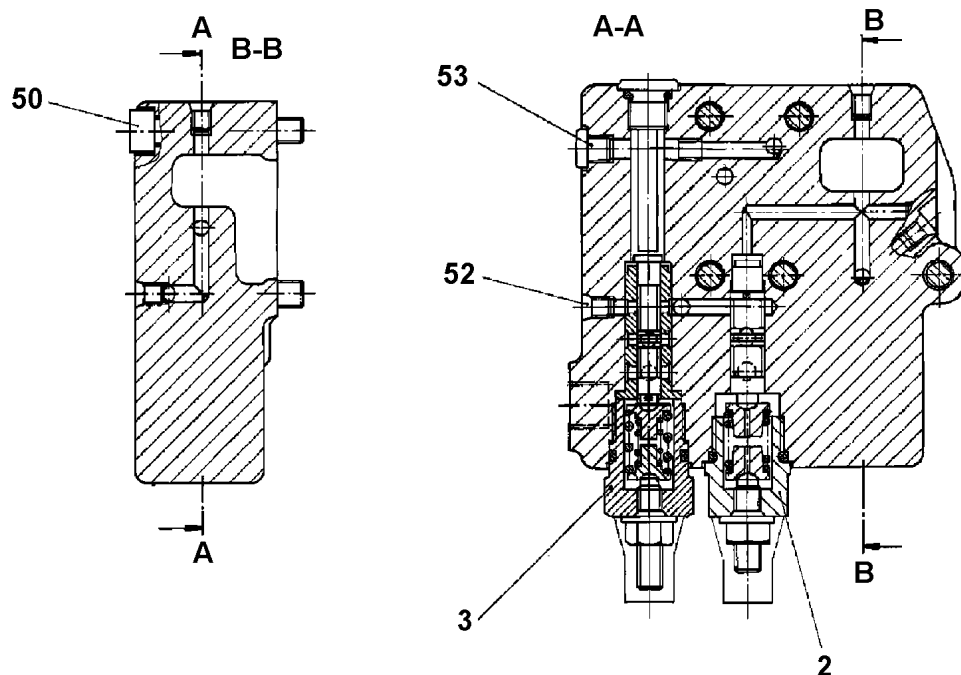

Pos. 999

Pos.	Item	Quantity	Description	Bezeichnung	Serie	K
	2	57 19 008 08	1 REGULATOR ELEMENT	REGLERELEMENT		
	3	10 47 220 2	1 REGULATOR ELEMENT	REGLERELEMENT		
	50	40 42 044 05	5 CYLINDER SCREW ISO 4762 M8X45 8.8 A2C	ZYLINDERSCHRAUBE		
	52	51 45 851 08	7 PLUG M6	ABREISSSTOPFEN		
	53	51 45 195 08	1 PLUG VSTIM8X1ED	STOPFEN		
	999	10 44 097 6	1 SEAL KIT F.REGULATOR	DS REGLER		

6.2.2009
049698

LIEBHERR

etk_en_de_074515 LR 1600/2

REGULATOR
REGLER

770

⇒ X10472196
10 47 219 6

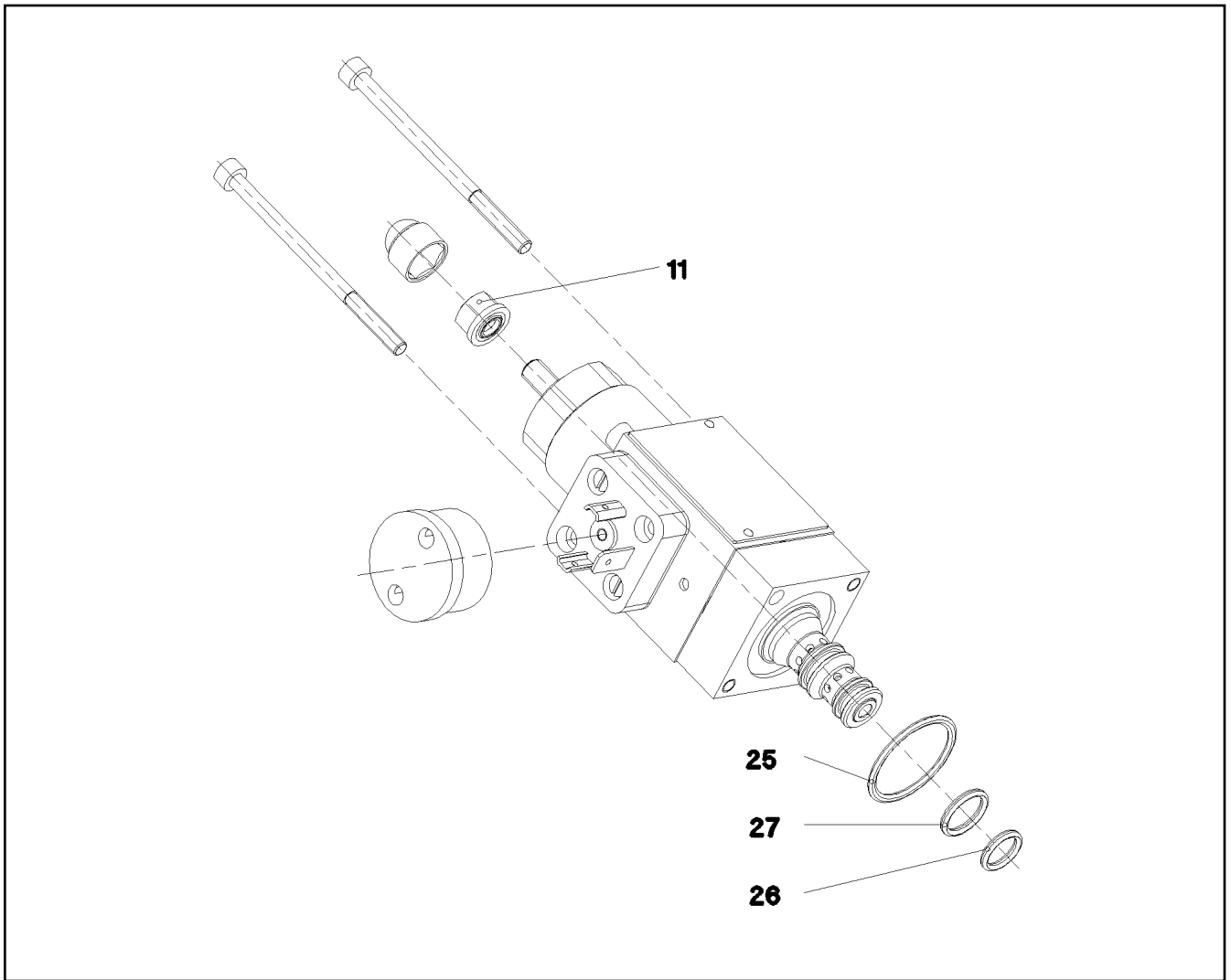

Pos.	Item	Quantity	Description	Bezeichnung	Serie	K
11	51 07 534 08	1	SEALING NUT M6	DICHTMUTTER		
25	57 06 523 08	1	O-RING ARP 568 23,52X1,78 N903890SHOR	O-RING		
26	51 07 190 08	1	O-RING ARP 568 9,25X1,78 NBR75	O-RING		
27	51 07 181 08	1	O-RING ARP 568 10,82X1,78 NBR75	O-RING		

6.2.2009
059005

LIEBHERR

etk_en_de_074515 LR 1600/2

PRESSURE LIMITING VALVE
DRUCKBEGRENZUNGSVENTIL

771

⇒ X10489734
10 48 973 4

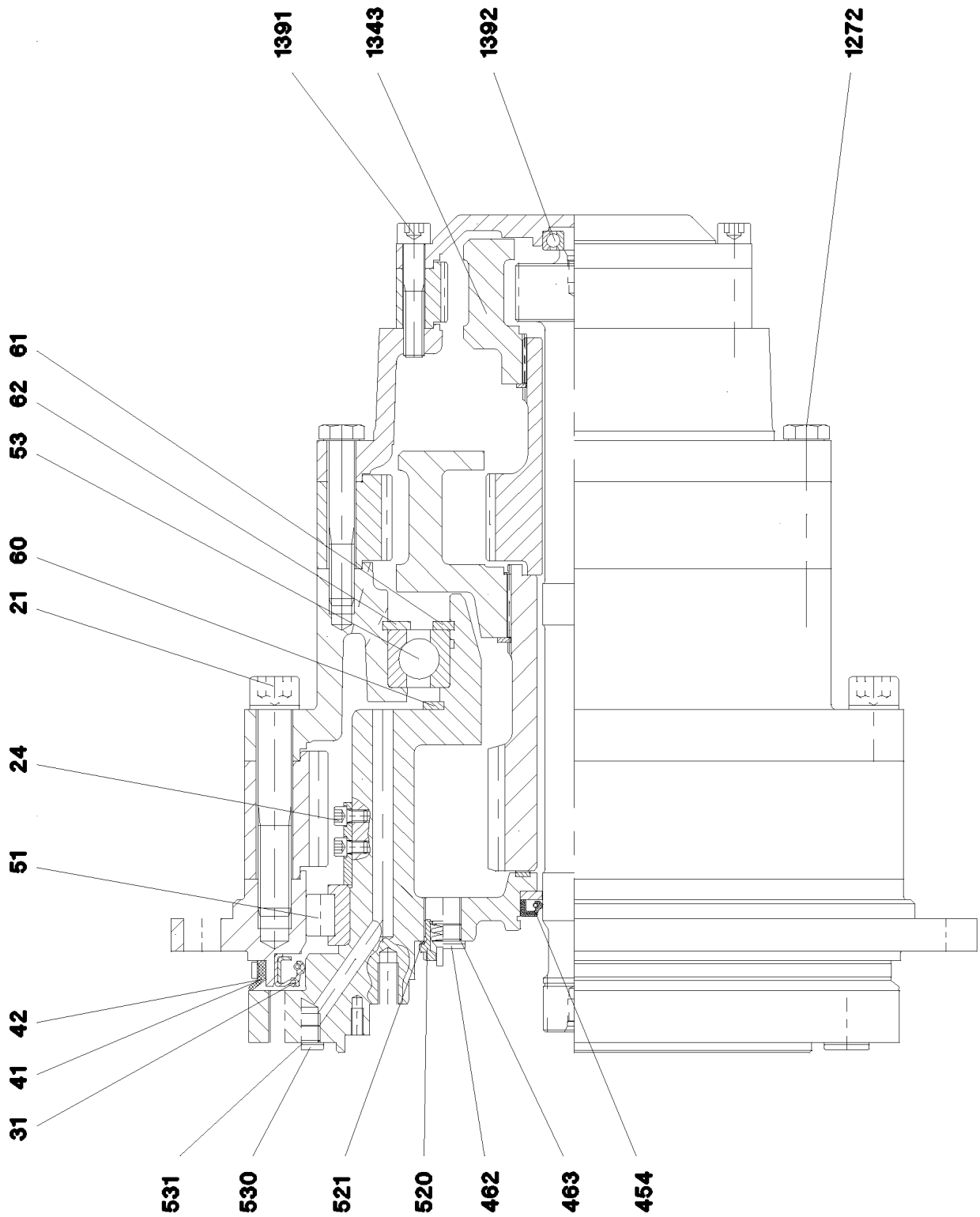

6.2.2009
059314

LIEBHERR

etk_en_de_074515 LR 1600/2

GEARBOX
GETRIEBE

772 (1/2)

⇒ X10650155
10 65 015 5

Pos.	Item	Quantity	Description	Bezeichnung	Serie	K
21	40 42 566 14	18	CYLINDER SCREW ISO 4762 M24X150 10.9	ZYLINDERSCHRAUBE		
24	40 42 030	8	CYLINDER SCREW ISO 4762 M12X20 8.8 A3	ZYLINDERSCHRAUBE		
31	57 15 521 08	1	ROTARY SHAFT LIP SEAL DIN 3760 440X470	RADIALWELLENDICHTRING		
41	50 15 070 14	1.6	PROFILE CORD	PROFILSCHNUR		
42	54 01 368 08	1.7	FIXING TAPE	BEFESTIGUNGSBAND		
51	57 18 448 08	1	CYLINDRICAL ROLLER BEARING 375X444,	ZYLINDERROLLENLAGER		
53	74 51 960 08	1	DEEP GROOVE BALL BEARING DIN 625 604	RILLENKUGELLAGER		
60	42 80 101 08	1	LOCKING RING DIN 471 260X5	SICHERUNGSRING		
61	42 80 105 08	1	LOCKING RING DIN 471 220X5	SICHERUNGSRING		
62	42 80 113 08	1	LOCKING RING DIN 471 340X6	SICHERUNGSRING		
454	79 04 950 14	1	SHAFT SEAL DIN 3760 BA 50X75X10 NBR	WELLENDICHTRING		
462	40 41 007 08	4	SCREW PLUG DIN 908 M30X1,5 ST A3C	VERSCHLUSSSCHRAUBE		
463	50 15 366 08	4	SEALING RING DIN 7603 A 30X36X2 ST	DICHTRING		
520	54 02 537 14	1	OIL VALVE	OELVENTIL		
521	51 45 171 08	2	SEALING RING DIN 7603 A 18X22X1,5 ST	DICHTRING		
530	40 41 017 08	2	SCREW PLUG DIN 908 M22X1,5 ST	VERSCHLUSSSCHRAUBE		
531	54 01 452 08	2	SEALING RING DIN 7603 A 22X27X1,5 ST	DICHTRING		
1272	40 61 234 14	18	HEX BOLT ISO 4014 M20X140 8.8 A3C	SECHSKANTSCHRAUBE		
1343	42 80 061 08	1	LOCKING RING DIN 471 80X2,5	SICHERUNGSRING		
1362	74 51 604 08	1	DEEP GROOVE BALL BEARING DIN 625 630	RILLENKUGELLAGER		
1391	40 42 183 01	18	CYLINDER SCREW ISO 4762 M16X130 8.8	ZYLINDERSCHRAUBE		

6.2.2009

etk_en_de_074515 LR 1600/2

773 (2/2)

LIEBHERR

GEARBOX
GETRIEBE

⇒ X10650155
10 65 015 5

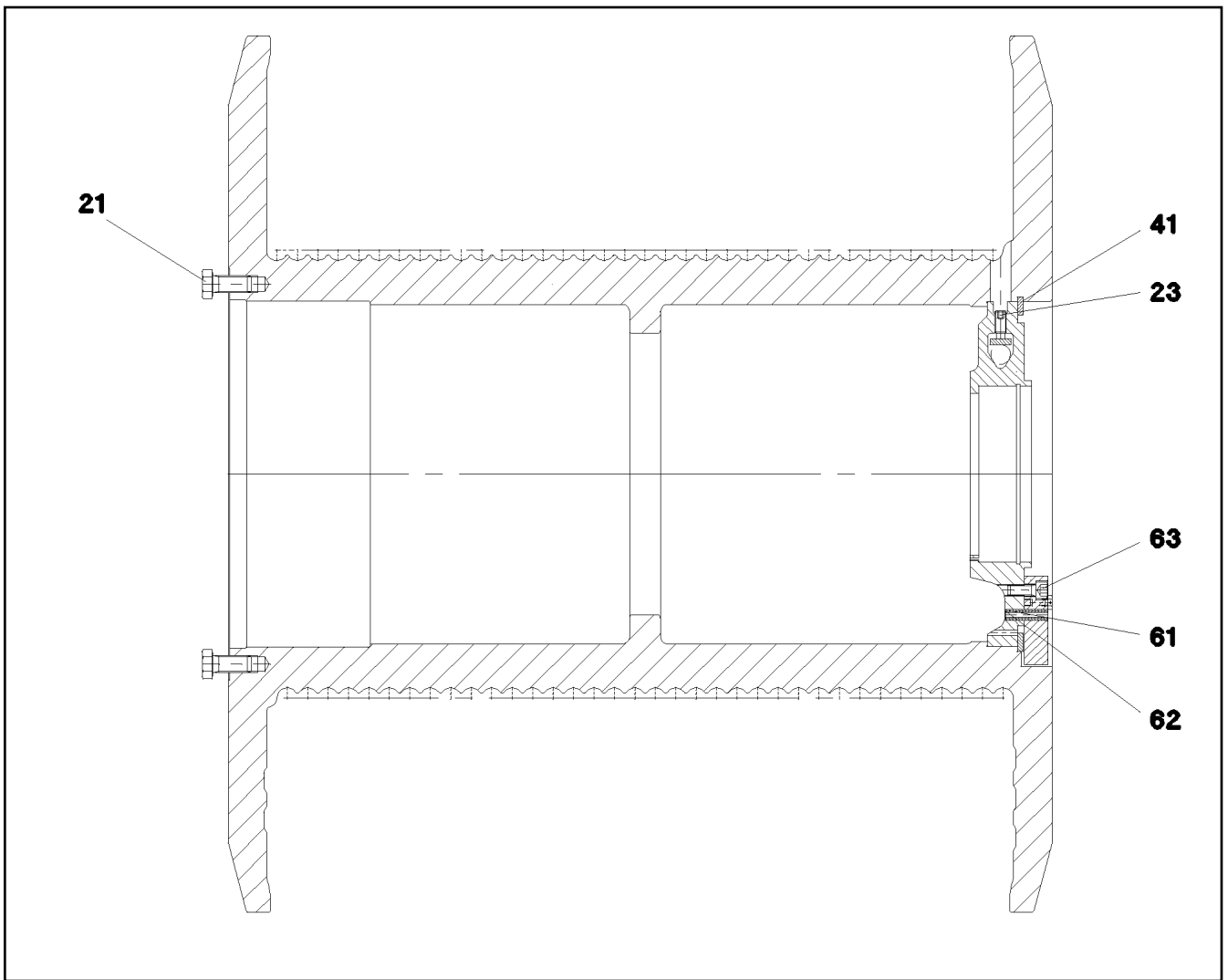

Pos.	Item	Quantity	Description	Bezeichnung	Serie	K
21	40 65 232 01	24	HEX BOLT ISO 4017 M24X55 8.8 A3C	SECHSKANTSCHRAUBE		
23	40 48 046 08	5	GRUB SCREW DIN 915 M16X40 45 H VERZ	GEWINDESTIFT		
41	10 65 017 7	1	LOCKING RING DIN 472 540X8	SICHERUNGSRING		
61	53 06 131 08	2	DOWEL PIN ISO 8752 16X60	SPANNSTIFT		
62	43 20 111 08	2	DOWEL PIN ISO 8752 10X60	SPANNSTIFT		
63	40 43 169 01	10	CYLINDER SCREW ISO 4762 M16X40 10.9	ZYLINDERSCHRAUBE		

6.2.2009
059315

LIEBHERR

etk_en_de_074515 LR 1600/2

ROPE DRUM
SEILTROMMEL

774

⇒ X10650156
10 65 015 6

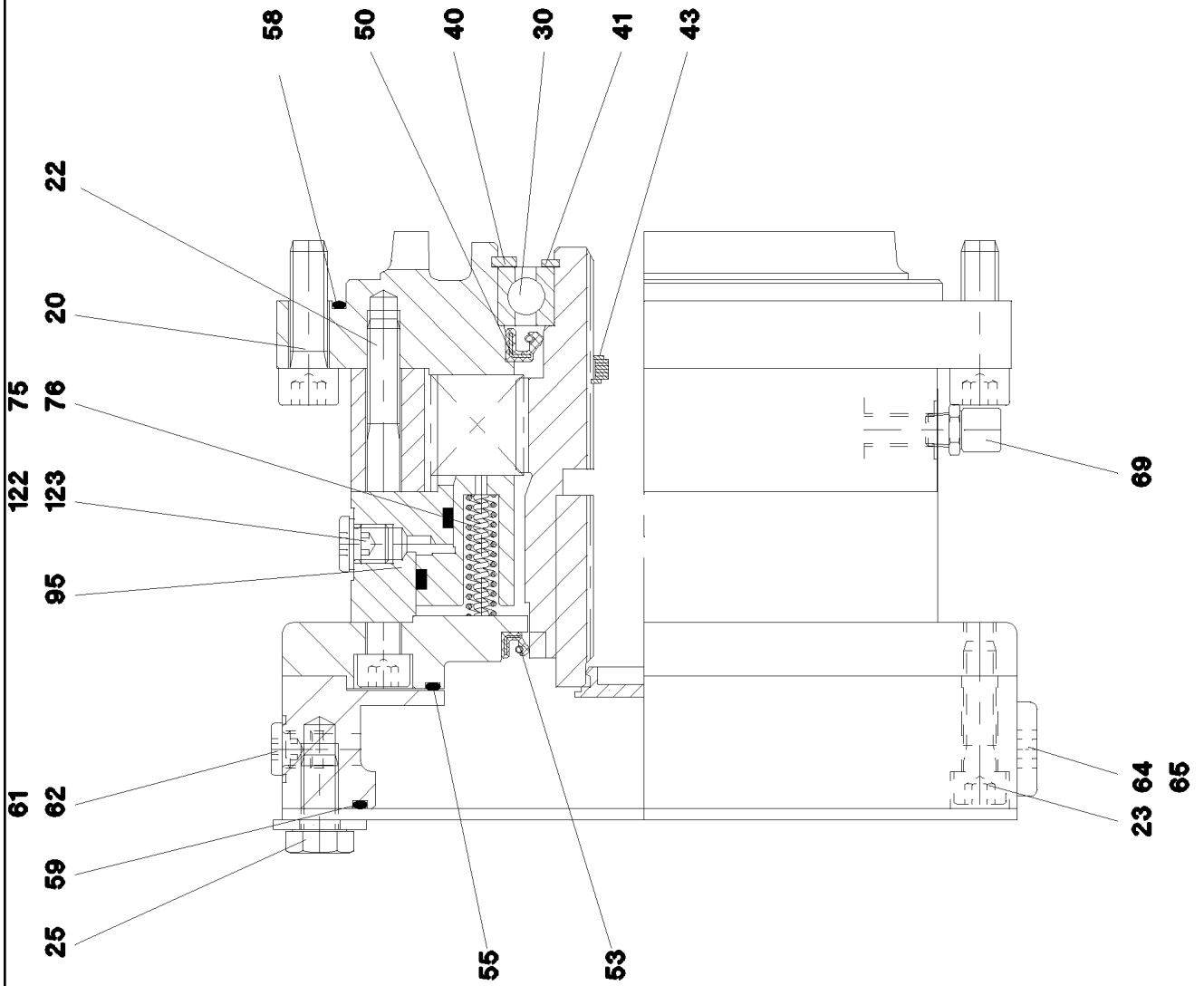

6.2.2009
059316

LIEBHERR

etk_en_de_074515 LR 1600/2

DRIVE UNIT
ANTRIEB

775 (1/2)

⇒ X10650158
10 65 015 8

Pos.	Item	Quantity	Description	Bezeichnung	Serie	K
20	46 00 017	8	CYLINDER SCREW ISO 4762 M16X45 8.8 A3	ZYLINDERSCHRAUBE		
22	40 42 132 01	12	CYLINDER SCREW ISO 4762 M12X120 8.8	ZYLINDERSCHRAUBE		
23	40 42 036	8	CYLINDER SCREW ISO 4762 M12X50 8.8 A3	ZYLINDERSCHRAUBE		
25	46 00 380	4	HEX BOLT ISO 4017 M20X30 8.8 A3C	SECHSKANTSCHRAUBE		
30	74 51 215 08	1	DEEP GROOVE BALL BEARING DIN 625 601	RILLENKUGELLAGER		
40	42 81 041 08	1	LOCKING RING DIN 472 140X4	SICHERUNGSRING		
41	42 80 064 08	1	LOCKING RING DIN 471 90X3	SICHERUNGSRING		
43	50 40 077 08	2	LOCKING RING DIN 472 46X1,75	SICHERUNGSRING		
50	54 01 943 08	1	ROTARY SHAFT LIP SEAL DIN 3760 A 100X1	RADIALWELLENDICHTRING		
53	57 15 512 08	1	ROTARY SHAFT LIP SEAL DIN 3760 110X13	RADIALWELLENDICHTRING		
55	57 18 445 08	1	O-RING 174X4 NBR70	O-RING		
58	57 15 514 08	1	O-RING 285X3 NBR70	O-RING		
59	72 64 215 01	1	O-RING 200X3 NBR70	O-RING		
60	46 00 319	4	SCREW PLUG DIN 908 M10X1 ST A3C	VERSCHLUSSSCHRAUBE		
61	71 01 013 08	4	SEALING RING DIN 7603 A 10X13,5X1 CU	DICHTRING		
64	40 41 002 08	1	SCREW PLUG DIN 908 M18X1,5 ST A3C	VERSCHLUSSSCHRAUBE		
65	51 45 171 08	1	SEALING RING DIN 7603 A 18X22X1,5 ST	DICHTRING		
69	57 18 446 08	1	VENTILATION VALVE M10X1	ENTLUEFTUNGSVENTIL		
75	50 15 241 08	22	PRESSURE SPRING	DRUCKFEDER		
76	50 15 240 08	22	PRESSURE SPRING	DRUCKFEDER		
95	57 13 664 08	1	ACTUATING UNIT	BETAETIGUNGSEINHEIT		
122	51 07 192 08	1	SCREW PLUG DIN 908 M12X1,5 ST	VERSCHLUSSSCHRAUBE		
123	71 01 017 08	1	SEALING RING DIN 7603 A 12X16X1,5 CU	DICHTRING		

6.2.2009

etk_en_de_074515 LR 1600/2

776 (2/2)

LIEBHERR

DRIVE UNIT
ANTRIEB

⇒ X10650158
10 65 015 8

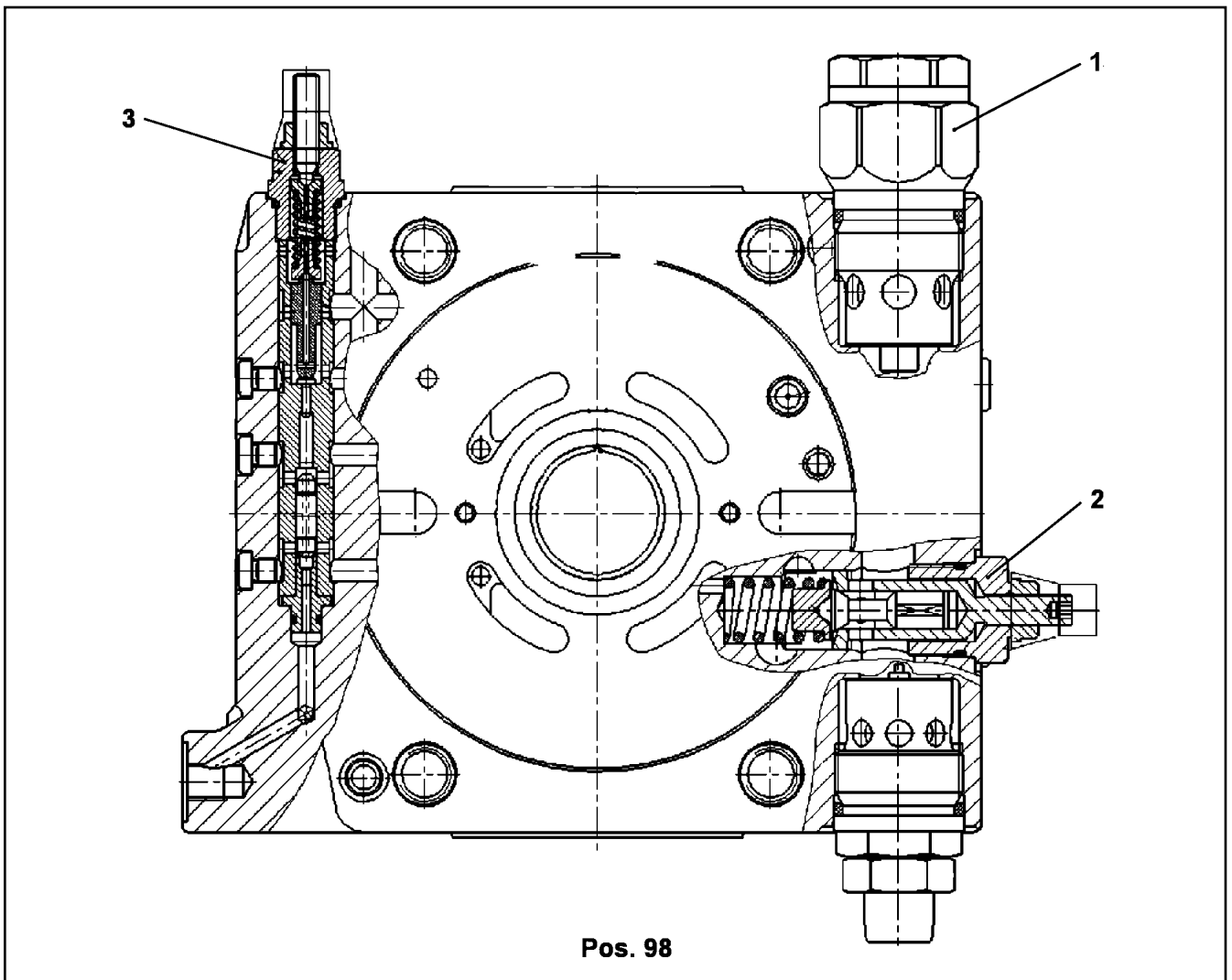

Pos.	Item	Quantity	Description	Bezeichnung	Serie	K
1	57 15 139 08	2	PRESSURE LIMITING VALVE	DRUCKBEGRENZUNGSVENTIL		
2	70 28 133	1	PRESSURE LIMITING VALVE	DRUCKBEGRENZUNGSVENTIL		
3	57 15 140 08	1	SHUTDOWN VALVE	ABSCHALTVENTIL		
98	10 65 071 0	1	SEAL KIT	DS ANSCHLUSSPLATTE M.VEN		

6.2.2009
059328

LIEBHERR

etk_en_de_074515 LR 1600/2

TERMINAL BOARD
ANSCHLUSSPLATTE

777

⇒ X10650688
10 65 068 8

Item	Page	Assembly	Pos.	Quantity	Item	Page	Assembly	Pos.	Quantity
10 00 613 0	9 080 702	90 80 702	10	4	10 01 136 2	9 739 210	97 39 210	9	1
10 00 727 2	2 932 224	96 54 389 08	522	1	10 01 136 2	9 739 371	97 39 371	12	1
10 00 812 5	2 913 005	96 20 731 08	13	1	10 01 148 8	9 739 357	97 39 357	14	1
10 00 812 5	2 913 005	96 28 696 08	13	1	10 01 148 8	9 739 371	97 39 371	26	4
10 00 924 4	2 913 005	96 20 731 08	11	2	10 01 159 4	9 739 318	97 39 318	(2)	2
10 00 924 4	2 913 005	96 28 696 08	11	2	10 01 159 6	9 739 159	97 39 159	11	3
10 00 924 4	2 913 006	96 20 732 08	5	2	10 01 161 2	9 739 282	97 39 282	2	2
10 00 924 4	2 913 007	96 20 763 08	8	2	10 01 161 2	9 739 361	97 39 361	15	2
10 00 942 4	X1035924	10 35 924 9	(37)	2	10 01 161 5	9 739 355	97 39 355	5	1
10 01 117 2	9 739 262	97 39 262	11	1	10 01 161 9	9 739 361	97 39 361	9	2
10 01 117 2	9 739 266	97 39 266	11	1	10 01 161 9	9 739 491	97 39 491	21	2
10 01 117 2	9 739 271	97 39 271	2	1	10 01 162 9	9 739 159	97 39 159	8	1
10 01 117 2	9 739 491	97 39 491	2	1	10 01 162 9	9 739 288	97 39 288	13	1
10 01 117 6	9 739 492	97 39 492	19	1	10 01 162 9	9 739 292	97 39 292	8	4
10 01 120 0	9 739 492	97 39 492	20	2	10 01 162 9	9 739 318	97 39 318	(5)	2
10 01 121 4	9 739 118	97 39 118	10	1	10 01 162 9	9 739 356	97 39 356	10	1
10 01 122 5	9 739 126	97 39 126	5	1	10 01 163 1	9 739 210	97 39 210	11	1
10 01 122 5	9 739 369	97 39 369	4	2	10 01 163 1	9 739 386	97 39 386	22	1
10 01 122 8	9 739 278	97 39 278	4	4	10 01 163 1	9 739 492	97 39 492	36	1
10 01 124 8	9 739 292	97 39 292	6	4	10 01 163 2	9 739 159	97 39 159	3	3
10 01 124 9	9 739 352	97 39 352	5	6	10 01 163 7	9 739 118	97 39 118	12	1
10 01 124 9	9 739 386	97 39 386	20	1	10 01 163 7	9 739 371	97 39 371	28	4
10 01 125 0	9 739 354	97 39 354	4	2	10 01 165 3	9 739 159	97 39 159	7	2
10 01 125 0	9 739 358	97 39 358	12	4	10 01 165 3	9 739 292	97 39 292	7	2
10 01 125 0	9 739 371	97 39 371	22	2	10 01 165 3	9 739 292	97 39 292	29	6
10 01 125 2	9 739 349	97 39 349	3	1	10 01 165 3	9 739 318	97 39 318	(4)	2
10 01 125 2	9 739 349	97 39 349	14	1	10 01 165 4	9 739 118	97 39 118	6	2
10 01 125 3	9 739 118	97 39 118	9	1	10 01 165 4	9 739 126	97 39 126	4	3
10 01 126 1	9 739 349	97 39 349	4	2	10 01 165 4	9 739 186	97 39 186	6	1
10 01 126 2	9 739 259	97 39 259	2	2	10 01 165 4	9 739 210	97 39 210	10	1
10 01 126 4	9 739 386	97 39 386	3	2	10 01 165 4	9 739 256	97 39 256	8	9
10 01 126 7	9 739 256	97 39 256	4	4	10 01 165 4	9 739 259	97 39 259	3	2
10 01 127 1	9 739 355	97 39 355	2	1	10 01 165 4	9 739 296	97 39 296	19	1
10 01 127 2	9 739 344	97 39 344	4	1	10 01 165 4	9 739 349	97 39 349	5	5
10 01 127 4	9 739 355	97 39 355	3	1	10 01 165 4	9 739 349	97 39 349	15	1
10 01 132 6	9 739 259	97 39 259	4	2	10 01 165 4	9 739 352	97 39 352	6	6
10 01 132 6	9 739 276	97 39 276	3	2	10 01 165 4	9 739 356	97 39 356	13	1
10 01 132 8	9 739 126	97 39 126	3	2	10 01 165 4	9 739 357	97 39 357	11	6
10 01 132 8	9 739 276	97 39 276	4	1	10 01 165 4	9 739 361	97 39 361	21	8
10 01 132 8	9 739 372	97 39 372	10	3	10 01 165 4	9 739 366	97 39 366	25	3
10 01 133 0	9 739 286	97 39 286	3	2	10 01 165 4	9 739 371	97 39 371	23	4
10 01 133 0	9 739 344	97 39 344	12	1	10 01 165 4	9 739 372	97 39 372	12	3
10 01 133 1	9 739 248	97 39 248	12	1	10 01 165 4	9 739 386	97 39 386	21	2
10 01 133 1	9 739 355	97 39 355	1	8	10 01 165 4	9 739 492	97 39 492	34	2
10 01 133 1	9 739 371	97 39 371	14	1	10 01 165 4	9 739 494	97 39 494	24	2
10 01 133 4	9 739 271	97 39 271	3	2	10 01 165 8	9 739 159	97 39 159	12	2
10 01 133 5	9 739 493	97 39 493	4	4	10 01 165 8	9 739 271	97 39 271	5	3
10 01 133 7	9 739 271	97 39 271	4	1	10 01 165 8	9 739 278	97 39 278	10	3
10 01 133 9	9 739 256	97 39 256	7	1	10 01 165 8	9 739 286	97 39 286	4	2
10 01 134 3	9 739 344	97 39 344	15	2	10 01 165 8	9 739 344	97 39 344	5	1
10 01 134 4	9 739 366	97 39 366	3	1	10 01 165 8	9 739 351	97 39 351	5	2
10 01 134 5	9 739 344	97 39 344	8	2	10 01 165 8	9 739 358	97 39 358	3	4
10 01 134 5	9 739 371	97 39 371	17	1	10 01 165 8	9 739 386	97 39 386	4	2
10 01 134 7	9 739 358	97 39 358	2	4	10 01 165 9	9 739 344	97 39 344	9	2
10 01 134 9	9 739 296	97 39 296	17	1	10 01 165 9	9 739 371	97 39 371	16	2
10 01 135 1	9 739 296	97 39 296	9	6	10 01 170 9	9 739 355	97 39 355	4	10
10 01 135 8	9 739 140	97 39 140	4	2	10 01 171 0	9 739 243	97 39 243	7	1
10 01 136 0	9 739 035	97 39 035	4	3	10 01 173 6	9 739 248	97 39 248	11	1
10 01 136 0	9 739 129	97 39 129	4	3	10 01 173 8	9 739 248	97 39 248	6	1
10 01 136 0	9 739 366	97 39 366	8	5	10 01 177 8	9 739 354	97 39 354	11	2

6.2.2009

etk_en_de_074515 LR 1600/2

779

LIEBHERRNumerical index
Numerischer Index

Item	Page	Assembly	Pos.	Quantity	Item	Page	Assembly	Pos.	Quantity
10 01 183 1	9 739 243	97 39 243	5	2	10 01 210 9	9 739 102	97 39 102	63	7
10 01 184 1	9 739 491	97 39 491	23	1	10 01 211 0	9 739 102	97 39 102	64	7
10 01 184 2	9 739 351	97 39 351	9	1	10 01 211 2	9 739 102	97 39 102	65	7
10 01 184 5	9 739 122	97 39 122	16	2	10 01 211 7	9 739 102	97 39 102	7	2
10 01 184 6	9 739 386	97 39 386	2	1	10 01 211 8	9 739 102	97 39 102	71	2
10 01 184 7	9 739 118	97 39 118	4	1	10 01 212 0	9 739 102	97 39 102	72	2
10 01 185 2	9 739 258	97 39 258	8	1	10 01 212 9	9 739 354	97 39 354	2	1
10 01 185 3	9 739 126	97 39 126	2	2	10 01 213 6	9 739 386	97 39 386	5	1
10 01 185 5	9 739 035	97 39 035	3	1	10 01 213 8	9 739 354	97 39 354	3	1
10 01 185 5	9 739 129	97 39 129	3	1	10 01 213 9	9 739 354	97 39 354	1	1
10 01 186 3	9 739 186	97 39 186	9	1	10 01 214 0	9 739 361	97 39 361	18	2
10 01 186 4	9 739 288	97 39 288	16	2	10 01 214 2	9 739 341	97 39 341	6	1
10 01 186 6	9 739 127	97 39 127	3	12	10 01 215 0	9 739 287	97 39 287	3	1
10 01 186 6	9 739 188	97 39 188	6	1	10 01 215 2	9 739 287	97 39 287	52	1
10 01 186 6	9 739 258	97 39 258	15	1	10 01 215 3	9 739 287	97 39 287	53	1
10 01 186 6	9 739 281	97 39 281	12	1	10 01 215 4	9 739 287	97 39 287	54	1
10 01 186 6	9 739 282	97 39 282	3	11	10 01 215 5	9 739 287	97 39 287	55	1
10 01 186 6	9 739 288	97 39 288	19	5	10 01 215 7	9 739 246	97 39 246	5	1
10 01 186 6	9 739 292	97 39 292	5	14	10 01 215 9	9 739 246	97 39 246	6	1
10 01 186 6	9 739 349	97 39 349	18	2	10 01 216 0	9 739 246	97 39 246	4	1
10 01 186 6	9 739 361	97 39 361	16	2	10 01 219 0	9 739 386	97 39 386	1	1
10 01 186 6	9 739 492	97 39 492	4	6	10 01 219 1	9 739 250	97 39 250	2	1
10 01 186 7	9 739 096	97 39 096	2	1	10 01 219 8	9 739 267	97 39 267	2	5
10 01 186 7	9 739 281	97 39 281	10	1	10 01 221 0	9 739 261	97 39 261	5	4
10 01 186 7	9 739 318	97 39 318	(2)	1	10 01 221 3	9 739 263	97 39 263	3	2
10 01 186 7	9 739 318	97 39 318	(2)	1	10 01 221 3	9 739 264	97 39 264	3	2
10 01 186 7	9 739 349	97 39 349	20	1	10 01 222 0	9 739 263	97 39 263	7	1
10 01 186 7	9 739 355	97 39 355	7	3	10 01 222 0	9 739 264	97 39 264	7	1
10 01 186 7	9 739 494	97 39 494	3	2	10 01 222 1	9 739 263	97 39 263	9	1
10 01 186 8	9 739 318	97 39 318	(2)	1	10 01 222 1	9 739 264	97 39 264	9	1
10 01 186 8	9 739 318	97 39 318	(2)	1	10 01 222 5	9 739 263	97 39 263	10	1
10 01 186 8	9 739 355	97 39 355	13	1	10 01 222 5	9 739 264	97 39 264	10	1
10 01 186 9	9 739 258	97 39 258	13	1	10 01 224 7	9 739 261	97 39 261	3	4
10 01 186 9	9 739 351	97 39 351	7	1	10 01 224 7	X1022281	10 22 281 7	75	4
10 01 186 9	9 739 492	97 39 492	14	1	10 01 228 3	9 739 372	97 39 372	9	1
10 01 187 0	9 739 355	97 39 355	11	1	10 01 228 7	9 739 122	97 39 122	13	1
10 01 187 0	9 739 361	97 39 361	10	2	10 01 228 8	9 739 122	97 39 122	9	1
10 01 187 0	9 739 491	97 39 491	12	1	10 01 228 9	9 739 122	97 39 122	14	1
10 01 187 0	9 739 494	97 39 494	26	2	10 01 229 0	9 739 118	97 39 118	1	1
10 01 187 1	9 739 281	97 39 281	3	12	10 01 229 5	9 739 118	97 39 118	7	1
10 01 187 1	X1022281	10 22 281 7	79	2	10 01 229 8	9 739 122	97 39 122	15	1
10 01 187 2	9 739 288	97 39 288	9	1	10 01 229 9	9 739 362	97 39 362	2	2
10 01 187 2	9 739 492	97 39 492	15	2	10 01 230 1	9 739 126	97 39 126	1	1
10 01 191 6	9 739 258	97 39 258	6	1	10 01 230 2	9 739 349	97 39 349	1	1
10 01 191 9	9 739 248	97 39 248	10	1	10 01 231 4	9 739 127	97 39 127	1	1
10 01 191 9	X1022281	10 22 281 7	76	1	10 01 232 0	9 739 126	97 39 126	11	2
10 01 192 0	9 739 263	97 39 263	4	2	10 01 234 3	9 739 129	97 39 129	1	1
10 01 192 0	9 739 264	97 39 264	4	2	10 01 234 5	9 739 126	97 39 126	12	2
10 01 192 1	2 391 001	96 45 719 08	125	1	10 01 234 6	9 739 276	97 39 276	2	1
10 01 192 5	9 739 278	97 39 278	8	1	10 01 234 6	9 739 349	97 39 349	2	1
10 01 198 9	9 739 282	97 39 282	12	1	10 01 239 4	9 739 357	97 39 357	8	1
10 01 199 8	9 739 188	97 39 188	5	1	10 01 239 5	9 739 357	97 39 357	9	2
10 01 199 8	9 739 492	97 39 492	5	2	10 01 240 0	9 739 358	97 39 358	7	1
10 01 199 9	9 739 355	97 39 355	16	1	10 01 240 8	9 739 358	97 39 358	9	1
10 01 199 9	9 739 494	97 39 494	42	1	10 01 240 9	9 739 358	97 39 358	11	1
10 01 200 4	9 739 258	97 39 258	14	1	10 01 241 1	9 739 358	97 39 358	5	3
10 01 200 7	9 739 355	97 39 355	6	1	10 01 241 3	9 739 358	97 39 358	13	1
10 01 208 3	9 739 102	97 39 102	6	7	10 01 242 0	2 391 001	96 45 719 08	202	1
10 01 208 8	9 739 102	97 39 102	62	7	10 01 242 4	9 739 248	97 39 248	8	1
10 01 210 7	9 739 102	97 39 102	61	7	10 01 243 7	9 739 258	97 39 258	11	1

6.2.2009

etk_en_de_074515 LR 1600/2

780

LIEBHERRNumerical index
Numerischer Index

Item	Page	Assembly	Pos.	Quantity	Item	Page	Assembly	Pos.	Quantity
10 01 245 0	9 739 258	97 39 258	4	1	10 01 268 1	9 739 159	97 39 159	9	1
10 01 245 1	9 739 258	97 39 258	5	1	10 01 268 4	9 739 386	97 39 386	19	1
10 01 245 2	9 739 258	97 39 258	7	1	10 01 268 5	9 739 140	97 39 140	3	1
10 01 245 3	9 739 258	97 39 258	16	1	10 01 271 0	9 739 282	97 39 282	4	5
10 01 245 4	9 739 494	97 39 494	8	1	10 01 271 0	9 739 292	97 39 292	3	7
10 01 245 6	9 739 493	97 39 493	1	1	10 01 271 0	9 739 492	97 39 492	2	2
10 01 245 8	9 739 140	97 39 140	2	1	10 01 271 1	9 739 288	97 39 288	14	1
10 01 246 1	9 739 159	97 39 159	1	1	10 01 271 3	9 739 288	97 39 288	20	2
10 01 246 2	9 739 159	97 39 159	4	1	10 01 271 4	9 739 361	97 39 361	17	2
10 01 246 3	9 739 140	97 39 140	1	1	10 01 271 5	9 739 035	97 39 035	2	1
10 01 246 6	9 739 318	97 39 318	(1)	1	10 01 271 5	9 739 129	97 39 129	2	1
10 01 246 7	9 739 318	97 39 318	(1)	1	10 01 271 8	9 739 258	97 39 258	12	1
10 01 247 0	9 739 318	97 39 318	(1)	1	10 01 272 1	9 739 492	97 39 492	16	1
10 01 247 7	9 739 492	97 39 492	18	1	10 01 272 2	9 739 494	97 39 494	2	1
10 01 248 1	9 739 491	97 39 491	11	1	10 01 272 4	9 739 349	97 39 349	17	1
10 01 250 0	9 739 354	97 39 354	13	3	10 01 272 5	9 739 355	97 39 355	10	1
10 01 250 3	9 739 354	97 39 354	9	13	10 01 272 6	9 739 288	97 39 288	15	1
10 01 250 5	9 739 250	97 39 250	6	10	10 01 272 8	9 739 127	97 39 127	2	6
10 01 250 7	9 739 267	97 39 267	4	12	10 01 273 0	9 739 282	97 39 282	8	2
10 01 251 3	9 739 358	97 39 358	6	6	10 01 273 0	9 739 288	97 39 288	25	1
10 01 251 4	9 739 358	97 39 358	8	2	10 01 273 0	9 739 292	97 39 292	4	6
10 01 252 2	9 739 096	97 39 096	1	1	10 01 273 0	9 739 492	97 39 492	3	2
10 01 252 6	9 739 361	97 39 361	7	1	10 01 273 3	9 739 349	97 39 349	21	1
10 01 253 1	9 739 159	97 39 159	5	1	10 01 273 4	9 739 295	97 39 295	2	8
10 01 254 7	9 739 122	97 39 122	17	2	10 01 274 0	9 739 318	97 39 318	(1)	1
10 01 254 9	9 739 122	97 39 122	18	2	10 01 333 5	9 739 267	97 39 267	1	1
10 01 255 0	9 739 295	97 39 295	7	22	10 01 333 6	9 739 267	97 39 267	5	1
10 01 255 7	9 739 263	97 39 263	11	2	10 01 333 7	9 739 267	97 39 267	6	1
10 01 255 7	9 739 264	97 39 264	11	2	10 01 427 8	9 739 159	97 39 159	10	1
10 01 255 9	9 739 492	97 39 492	17	1	10 01 427 8	9 739 186	97 39 186	8	1
10 01 256 0	9 739 263	97 39 263	8	1	10 01 427 8	9 739 344	97 39 344	6	1
10 01 256 0	9 739 264	97 39 264	8	1	10 01 469 1	7 743 566	77 43 566 08	8	1
10 01 256 3	9 739 261	97 39 261	4	4	10 01 469 3	7 743 566	77 43 566 08	1	1
10 01 256 5	9 739 159	97 39 159	6	1	10 01 646 5	3 780 258	96 56 482 08	6	1
10 01 256 6	9 739 271	97 39 271	6	1	10 01 690 7	9 080 702	90 80 702	5	4
10 01 256 6	9 739 288	97 39 288	7	2	10 01 694 9	9 739 354	97 39 354	10	3
10 01 256 7	9 739 344	97 39 344	19	1	10 01 696 0	9 739 349	97 39 349	16	1
10 01 256 8	9 739 256	97 39 256	9	1	10 01 696 8	9 739 349	97 39 349	19	1
10 01 256 8	9 739 296	97 39 296	18	1	10 01 699 2	9 739 318	97 39 318	(3)	2
10 01 256 8	9 739 358	97 39 358	15	1	10 01 706 2	9 739 187	97 39 187	1	1
10 01 256 8	9 739 371	97 39 371	27	4	10 01 706 4	9 739 187	97 39 187	3	1
10 01 260 2	9 739 354	97 39 354	7	1	10 01 707 9	9 739 187	97 39 187	4	2
10 01 261 7	9 739 250	97 39 250	5	1	10 01 711 0	9 739 187	97 39 187	5	2
10 01 262 8	9 739 354	97 39 354	6	2	10 01 719 2	2 925 402	96 58 855 08	5	4
10 01 263 0	9 739 354	97 39 354	5	1	10 01 732 5	9 739 187	97 39 187	6	1
10 01 263 1	9 739 386	97 39 386	14	1	10 01 734 7	9 739 493	97 39 493	3	1
10 01 263 2	9 739 494	97 39 494	28	1	10 01 737 4	2 920 083	96 48 319 08	13	1
10 01 263 4	9 739 386	97 39 386	6	1	10 01 745 0	9 739 188	97 39 188	7	1
10 01 263 5	9 739 278	97 39 278	3	1	10 01 749 3	9 739 186	97 39 186	2	1
10 01 263 6	9 739 122	97 39 122	12	1	10 01 751 3	9 739 186	97 39 186	10	1
10 01 263 7	9 739 122	97 39 122	11	1	10 01 751 7	9 739 186	97 39 186	7	1
10 01 263 8	9 739 122	97 39 122	10	1	10 01 752 1	9 739 186	97 39 186	5	1
10 01 264 1	9 739 242	97 39 242	3	2	10 01 752 6	9 739 186	97 39 186	3	2
10 01 264 3	9 739 361	97 39 361	8	1	10 01 752 9	9 739 186	97 39 186	4	1
10 01 265 1	9 739 494	97 39 494	22	1	10 01 754 4	9 739 186	97 39 186	1	1
10 01 265 3	9 739 492	97 39 492	23	3	10 01 872 9	9 739 127	97 39 127	4	1
10 01 265 5	9 739 288	97 39 288	11	1	10 01 904 0	2 502	91 55 939 08	29	8
10 01 266 8	9 739 386	97 39 386	15	1	10 01 904 0	2 540	91 53 253 08	5	4
10 01 267 1	9 739 386	97 39 386	16	2	10 01 904 0	2 541	91 52 790 08	4	4
10 01 267 4	9 739 492	97 39 492	21	5	10 02 091 7	9 739 271	97 39 271	8	1

6.2.2009

etk_en_de_074515 LR 1600/2

781

LIEBHERRNumerical index
Numerischer Index

Item	Page	Assembly	Pos.	Quantity	Item	Page	Assembly	Pos.	Quantity
10 02 091 8	9 739 358	97 39 358	14	1	10 03 726 1	2 502	91 55 939 08	28	6
10 02 092 1	9 739 366	97 39 366	1	1	10 03 726 1	2 520 034	96 45 984 08	44	46
10 02 092 1	9 739 386	97 39 386	26	1	10 03 726 1	2 522	91 54 115 08	5	27
10 02 092 2	9 739 344	97 39 344	10	2	10 03 726 1	2 533 070	96 48 363 08	3	7
10 02 092 2	9 739 344	97 39 344	20	1	10 03 729 8	9 739 494	97 39 494	7	6
10 02 093 1	9 739 366	97 39 366	10	3	10 03 730 0	9 739 494	97 39 494	41	1
10 02 093 1	9 739 492	97 39 492	37	2	10 03 730 4	9 739 361	97 39 361	19	8
10 02 095 5	9 739 366	97 39 366	7	4	10 03 730 4	9 739 371	97 39 371	24	2
10 02 119 1	X1004204	10 04 204 3	12	1	10 03 730 4	9 739 494	97 39 494	23	2
10 02 156 7	2 920 369	96 54 235 08	(153)	1	10 03 730 5	9 739 491	97 39 491	22	3
10 02 156 8	2 920 369	96 54 235 08	(153)	1	10 03 731 0	9 739 362	97 39 362	6	1
10 02 211 1	3 745	91 52 948 08	47	4	10 03 733 9	9 739 386	97 39 386	17	1
10 02 217 1	2 932 001	96 45 393 08	4	1	10 03 762 3	2 970	91 56 537 08	(1)	1
10 02 217 7	2 932 001	96 45 393 08	5	1	10 03 825 9	2 372	91 33 648 08	1	1
10 02 307 6	9 739 127	97 39 127	5	2	10 03 827 1	7 743 566	77 43 566 08	25	1
10 02 326 6	2 393	91 52 787 08	5	1	10 03 827 2	7 743 566	77 43 566 08	17	2
10 02 485 7	2 932 082	96 54 387 08	22	1	10 03 827 4	7 743 566	77 43 566 08	18	2
10 02 527 8	2 925 002	96 58 856 08	(1)	1	10 04 047 7	2 920 200	96 44 536 08	5	1
10 02 800 2	2 780 524	96 52 968 08	5	1	10 04 047 7	2 920 260	96 44 537 08	5	1
10 02 810 7	2 913 004	96 20 460 08	9	0.16	10 04 047 7	2 920 334	96 44 538 08	5	1
10 02 823 7	2 391 001	96 45 719 08	356	8	10 04 047 7	2 920 350	96 44 539 08	5	1
10 02 823 7	2 859 005	96 46 756 08	3	8	10 04 050 2	2 925 402	96 58 855 08	33	1
10 02 895 4	2 925 002	96 58 856 08	18	1	10 04 097 9	1 400	91 56 853 08	55	35
10 02 918 8	9 739 362	97 39 362	3	1	10 04 097 9	1 410 300	91 56 855 08	55	35
10 02 919 1	9 739 188	97 39 188	1	1	10 04 105 3	2 925 002	96 58 856 08	19	2
10 02 919 2	9 739 372	97 39 372	1	1	10 04 126 0	2 670	91 52 797 08	12	2
10 02 919 3	9 739 369	97 39 369	5	1	10 04 160 5	2 392	91 52 785 08	19	2
10 02 919 5	9 739 288	97 39 288	8	1	10 04 167 5	2 997	91 56 539 08	266	1.1
10 02 919 5	9 739 492	97 39 492	13	1	10 04 167 5	2 997	91 56 539 08	267	1.2
10 02 966 6	3 282 002	96 47 890 08	7	1	10 04 204 3	2 541 001	96 49 651 08	2	1
10 03 021 0	2 913 005	96 20 731 08	12	10	10 04 243 0	X1041101	10 41 101 5	410	1
10 03 021 0	2 913 005	96 28 696 08	12	2	10 04 243 0	X1041101	10 41 101 8	390	1
10 03 034 6	9 739 295	97 39 295	6	2	10 04 259 2	2 520	91 53 061 08	31	29
10 03 051 7	2 393	91 52 787 08	14	1	10 04 259 2	2 522	91 54 115 08	4	23
10 03 064 0	2 913 007	96 20 763 08	7	2	10 04 259 2	2 533 070	96 48 363 08	36	8
10 03 064 2	2 913 007	96 20 763 08	6	2	10 04 259 2	2 932 082	96 54 387 08	86	6
10 03 229 7	1 750	91 52 394 08	41	1	10 04 259 3	2 520	91 53 061 08	32	74
10 03 231 8	9 739 262	97 39 262	7	1	10 04 259 3	2 520 030	96 45 609 08	5	6
10 03 231 8	9 739 266	97 39 266	7	1	10 04 259 3	2 533 066	96 48 365 08	14	1
10 03 231 8	X1022281	10 22 281 7	80	1	10 04 259 3	2 810 037	96 47 204 08	3	5
10 03 234 8	9 739 242	97 39 242	2	1	10 04 262 0	1 991	91 52 510 08	1	1
10 03 239 2	9 739 118	97 39 118	13	1	10 04 269 6	2 780 915	96 48 377 08	20	2
10 03 240 2	9 739 343	97 39 343	1	1	10 04 375 7	2 913 007	96 20 763 08	1	1
10 03 288 2	9 739 118	97 39 118	11	3	10 04 375 9	2 913 005	96 28 696 08	20	1
10 03 290 6	9 739 361	97 39 361	23	1	10 04 376 0	2 913 007	96 20 763 08	2	1
10 03 291 2	9 739 361	97 39 361	20	8	10 04 443 0	9 739 353	97 39 353	2	6
10 03 574 7	9 739 288	97 39 288	6	1	10 04 464 8	2 780 915	96 48 377 08	15	2
10 03 689 6	2 970	91 56 537 08	720	2	10 04 535 6	9 739 341	97 39 341	2	8
10 03 697 4	2 520 032	96 45 980 08	11	1	10 04 535 6	9 739 344	97 39 344	3	2
10 03 697 7	2 520 032	96 45 980 08	10	1	10 04 699 9	2 932 224	96 54 389 08	506	15
10 03 716 3	9 739 209	97 39 209	1	1	10 04 700 0	2 932 224	96 54 389 08	505	12
10 03 716 9	9 739 210	97 39 210	1	1	10 04 700 1	2 932 224	96 54 389 08	509	15
10 03 717 1	9 739 209	97 39 209	2	1	10 09 749 6	2 391 023	96 45 720 08	9	4
10 03 717 3	9 739 210	97 39 210	2	2	10 09 761 3	2 711	91 52 800 08	(2)	1
10 03 717 6	9 739 210	97 39 210	3	4	10 09 985 6	2 932 224	96 54 389 08	518	2
10 03 718 2	9 739 210	97 39 210	4	1	10 09 986 3	2 932 224	96 54 389 08	512	1
10 03 719 1	9 739 210	97 39 210	5	1	10 09 986 7	2 932 224	96 54 389 08	513	1
10 03 722 6	9 739 210	97 39 210	6	1	10 09 986 8	2 932 224	96 54 389 08	519	2
10 03 723 0	9 739 210	97 39 210	7	1	10 10 062 1	1 620	91 52 386 08	6	4
10 03 723 6	9 739 210	97 39 210	8	1	10 10 062 1	1 631 100	91 52 388 08	9	48

6.2.2009

etk_en_de_074515 LR 1600/2

782

LIEBHERRNumerical index
Numerischer Index

Item	Page	Assembly	Pos.	Quantity	Item	Page	Assembly	Pos.	Quantity
10 10 062 1	2 859 025	96 46 757 08	3	10	10 22 093 7	X1035925	10 35 925 1	25	1
10 10 062 1	3 206	91 52 881 08	57	8	10 22 231 7	9 739 242	97 39 242	1	1
10 10 062 1	3 211	91 57 748 08	31	112	10 22 231 8	9 739 242	97 39 242	54	6
10 10 062 1	3 214	91 52 843 08	37	9	10 22 231 9	9 739 242	97 39 242	51	6
10 10 062 1	3 220 500	91 52 849 08	24	37	10 22 232 0	9 739 242	97 39 242	53	6
10 10 062 1	3 221	91 54 668 08	12	24	10 22 232 1	9 739 242	97 39 242	52	6
10 10 062 1	3 223	91 52 852 08	24	49	10 22 232 2	9 739 243	97 39 243	4	1
10 10 062 1	3 223 010	91 52 853 08	24	49	10 22 232 3	9 739 243	97 39 243	6	1
10 10 062 1	3 223 100	91 55 327 08	24	49	10 22 233 1	9 739 246	97 39 246	53	1
10 10 062 1	3 225	91 52 854 08	41	37	10 22 233 2	9 739 246	97 39 246	51	1
10 10 062 1	3 226	91 52 870 08	24	25	10 22 233 3	9 739 246	97 39 246	1	1
10 10 062 1	3 227	91 52 873 08	24	40	10 22 233 4	9 739 246	97 39 246	52	1
10 10 062 1	3 227 008	91 52 872 08	24	32	10 22 233 5	9 739 246	97 39 246	2	1
10 10 062 1	3 227 200	91 53 519 08	24	41	10 22 233 6	9 739 246	97 39 246	3	2
10 10 062 1	3 713	91 57 749 08	16	63	10 22 233 7	9 739 287	97 39 287	1	1
10 10 062 1	3 714	91 52 862 08	45	51	10 22 233 9	9 739 250	97 39 250	1	1
10 10 062 1	3 715 008	91 52 863 08	5	48	10 22 234 3	9 739 262	97 39 262	8	3
10 10 062 1	3 716	91 52 864 08	5	80	10 22 234 3	9 739 266	97 39 266	8	3
10 10 062 1	3 745	91 52 948 08	27	16	10 22 234 4	9 739 262	97 39 262	9	3
10 10 075 2	2 391 001	96 45 719 08	157	2.2	10 22 234 4	9 739 266	97 39 266	9	3
10 10 103 8	3 790 007	96 19 990 08	(999)	1	10 22 234 5	9 739 267	97 39 267	3	6
10 10 103 9	3 790 006	96 19 989 08	(999)	1	10 22 234 7	9 739 261	97 39 261	1	2
10 10 138 4	2 970	91 56 537 08	(3)	1	10 22 234 8	9 739 261	97 39 261	2	2
10 10 164 9	9 739 261	97 39 261	9	8	10 22 234 9	9 739 263	97 39 263	5	1
10 11 258 4	2 920 083	96 48 319 08	15	2	10 22 234 9	9 739 264	97 39 264	5	1
10 11 371 2	2 831	91 57 754 08	2	1	10 22 235 0	9 739 263	97 39 263	6	1
10 11 483 8	6 909 010	69 09 010 08	38	1	10 22 235 0	9 739 264	97 39 264	6	1
10 11 484 3	6 909 010	69 09 010 08	11	46	10 22 235 1	9 739 263	97 39 263	2	1
10 11 497 5	X1035925	10 35 925 1	40	1	10 22 235 2	9 739 264	97 39 264	2	1
10 11 573 5	X1011614	10 11 614 1	1	1	10 22 235 9	9 739 118	97 39 118	5	2
10 11 610 9	X1011614	10 11 614 1	7	1	10 22 236 1	9 739 256	97 39 256	6	1
10 11 614 1	9 739 400	97 39 400	97	1	10 22 236 5	9 739 355	97 39 355	8	1
10 11 627 4	9 080 702	90 80 702	4	8	10 22 236 6	9 739 355	97 39 355	9	1
10 11 740 4	9 739 318	97 39 318	10	1	10 22 237 3	9 739 358	97 39 358	4	1
10 11 740 5	9 739 318	97 39 318	1	1	10 22 237 4	9 739 276	97 39 276	1	1
10 11 740 6	9 739 318	97 39 318	2	1	10 22 237 6	9 739 358	97 39 358	10	1
10 11 740 7	9 739 318	97 39 318	11	1	10 22 237 7	9 739 295	97 39 295	1	1
10 11 740 9	9 739 318	97 39 318	12	1	10 22 271 7	9 739 295	97 39 295	4	1
10 11 789 8	9 079 185	90 79 185	1	1	10 22 271 8	9 739 295	97 39 295	5	6
10 11 789 8	9 079 186	90 79 186	1	1	10 22 271 8	X1022281	10 22 281 7	78	1
10 11 880 5	9 080 702	90 80 702	3	1	10 22 271 9	9 739 296	97 39 296	8	1
10 11 922 6	9 739 400	97 39 400	(1)	1	10 22 272 3	9 739 296	97 39 296	15	1
10 12 059 0	9 739 400	97 39 400	1	1	10 22 272 5	9 739 357	97 39 357	10	6
10 12 438 50	2 533 066	96 48 365 08	17	4	10 22 272 6	9 739 256	97 39 256	1	1
10 21 652 9	2 831	91 57 754 08	60	1	10 22 272 7	9 739 256	97 39 256	2	6
10 21 653 4	2 831	91 57 754 08	61	2	10 22 272 7	X1022281	10 22 281 7	77	1
10 21 769 5	2 978 100	91 52 796 08	2	1	10 22 272 8	9 739 256	97 39 256	3	7
10 21 831 0	2 970	91 56 537 08	58	2	10 22 272 9	9 739 256	97 39 256	5	4
10 21 947 7	2 533 067	96 50 385 08	4	1	10 22 273 0	9 739 271	97 39 271	1	1
10 21 996 8	X1035925	10 35 925 1	1	1	10 22 273 2	9 739 494	97 39 494	6	4
10 22 019 8	9 739 248	97 39 248	1	1	10 22 273 5	9 739 248	97 39 248	3	1
10 22 021 8	9 739 318	97 39 318	(1)	1	10 22 273 5	X1022281	10 22 281 7	73	1
10 22 035 9	X1035925	10 35 925 1	20	1	10 22 273 6	9 739 248	97 39 248	4	1
10 22 067 0	X1012059	10 12 059 0	230	1	10 22 273 6	X1022281	10 22 281 7	74	1
10 22 070 7	5 102 354	51 02 354 08	6	1	10 22 273 7	9 739 248	97 39 248	7	1
10 22 081 3	9 739 494	97 39 494	4	1	10 22 273 7	9 739 491	97 39 491	6	4
10 22 093 3	2 970	91 56 537 08	46	1	10 22 273 8	9 739 248	97 39 248	9	1
10 22 093 3	2 975 100	91 52 860 08	6	1	10 22 273 9	9 739 369	97 39 369	1	1
10 22 093 3	2 975 200	91 52 775 08	6	1	10 22 274 0	9 739 369	97 39 369	2	1
10 22 093 3	2 975 700	91 52 774 08	6	1	10 22 274 1	9 739 318	97 39 318	13	1

6.2.2009

etk_en_de_074515 LR 1600/2

783

LIEBHERRNumerical index
Numerischer Index

Item	Page	Assembly	Pos.	Quantity	Item	Page	Assembly	Pos.	Quantity
10 22 274 3	9 739 369	97 39 369	7	1	10 28 570 1	2 533 066	96 48 365 08	4	2
10 22 274 4	9 739 288	97 39 288	12	1	10 28 635 3	1 920 418	96 48 687 08	11	1
10 22 274 4	9 739 369	97 39 369	11	1	10 28 635 3	2 780 748	96 52 969 08	274	1
10 22 274 5	9 739 369	97 39 369	8	1	10 28 635 3	2 920 581	96 54 405 08	266	1
10 22 274 6	9 739 369	97 39 369	9	1	10 28 635 3	3 930 638	96 51 624 08	262	1
10 22 274 7	9 739 369	97 39 369	10	1	10 28 635 3	3 930 730	96 50 599 08	296	1
10 22 274 8	X1034309	10 34 309 6	3	1	10 28 635 3	3 930 730	96 54 398 08	280	2
10 22 275 1	9 739 278	97 39 278	2	1	10 28 635 3	3 930 734	96 54 401 08	206	1
10 22 275 2	9 739 278	97 39 278	5	1	10 28 635 4	1 920 403	96 48 707 08	274	12
10 22 275 3	9 739 278	97 39 278	6	1	10 28 635 4	1 920 417	96 48 703 08	274	12
10 22 275 4	9 739 278	97 39 278	7	1	10 28 635 4	1 920 418	96 48 687 08	(151)	47
10 22 275 7	9 739 258	97 39 258	3	1	10 28 635 4	2 780 748	96 52 969 08	(151)	13
10 22 275 8	9 739 258	97 39 258	9	1	10 28 635 4	2 920 581	96 54 405 08	260	21
10 22 275 9	9 739 281	97 39 281	1	1	10 28 635 4	2 932 082	96 54 387 08	63	2
10 22 276 0	9 739 281	97 39 281	2	5	10 28 635 4	3 930 363	96 52 979 08	(151)	20
10 22 276 1	9 739 281	97 39 281	4	1	10 28 635 4	3 930 639	96 50 132 08	152	36
10 22 276 2	9 739 281	97 39 281	5	1	10 28 635 4	3 930 640	96 50 481 08	(152)	24
10 22 276 3	9 739 281	97 39 281	6	1	10 28 635 4	3 930 730	96 50 599 08	(502)	28
10 22 276 4	9 739 281	97 39 281	8	1	10 28 635 4	3 930 730	96 54 398 08	279	88
10 22 276 5	9 739 281	97 39 281	11	1	10 28 635 4	3 930 734	96 54 401 08	(501)	47
10 22 276 6	9 739 292	97 39 292	1	1	10 28 710 2	9 739 295	97 39 295	3	1
10 22 276 7	9 739 292	97 39 292	2	1	10 28 710 4	9 739 494	97 39 494	5	4
10 22 276 8	9 739 292	97 39 292	9	1	10 28 710 5	9 739 494	97 39 494	21	1
10 22 276 9	9 739 292	97 39 292	13	1	10 28 710 6	9 739 494	97 39 494	27	1
10 22 277 0	9 739 282	97 39 282	10	1	10 28 710 7	9 739 494	97 39 494	29	1
10 22 277 0	9 739 292	97 39 292	15	1	10 28 710 8	9 739 494	97 39 494	25	1
10 22 277 2	9 739 282	97 39 282	1	1	10 28 730 1	X1022811	10 22 811 2	13	1
10 22 277 3	9 739 282	97 39 282	6	1	10 28 786 3	2 970	91 56 537 08	10	2
10 22 277 4	9 739 282	97 39 282	7	1	10 28 812 1	2 913 200	96 47 216 08	980	1
10 22 277 5	9 739 292	97 39 292	21	1	10 28 861 0	3 714	91 52 862 08	11	2
10 22 277 6	9 739 292	97 39 292	22	1	10 28 953 6	2 970	91 56 537 08	47	2
10 22 277 7	9 739 493	97 39 493	5	1	10 28 953 6	2 975 100	91 52 860 08	7	1
10 22 279 4	9 739 356	97 39 356	8	2	10 28 953 6	2 975 200	91 52 775 08	7	1
10 22 280 4	9 739 491	97 39 491	20	1	10 28 953 6	2 975 700	91 52 774 08	7	1
10 22 281 7	9 739 400	97 39 400	492	6	10 28 963 1	2 780 851	96 24 498 08	2	1
10 22 566 6	2 391 001	96 45 719 08	127	1	10 29 012 1	X1004204	10 04 204 3	2	1
10 22 811 2	2 540	91 53 253 08	1	1	10 29 012 2	X1004204	10 04 204 3	3	1
10 22 814 3	2 391 023	96 45 720 08	8	1	10 29 012 3	X1004204	10 04 204 3	16	1
10 27 869 8	X1004204	10 04 204 3	1	1	10 29 012 4	X1004204	10 04 204 3	17	1
10 27 921 0	2 913	91 32 850 08	19	1	10 29 012 5	X1004204	10 04 204 3	18	1
10 27 976 0	9 739 281	97 39 281	9	1	10 29 012 6	X1004204	10 04 204 3	19	1
10 27 991 9	5 517 203	55 17 203 08	2	1	10 29 012 7	X1004204	10 04 204 3	21	1
10 28 030 8	9 739 286	97 39 286	1	1	10 29 184 0	X1035924	10 35 924 3	5	1
10 28 030 9	9 739 286	97 39 286	2	1	10 29 184 0	X1035924	10 35 924 4	5	1
10 28 319 6	3 292	91 52 865 08	18	2	10 29 198 8	2 810	91 52 806 08	8	4
10 28 505 2	9 739 494	97 39 494	30	2	10 29 198 9	2 810	91 52 806 08	6	4
10 28 506 8	9 739 366	97 39 366	2	1	10 29 199 7	2 520 034	96 45 984 08	33	1
10 28 506 9	9 739 366	97 39 366	4	1	10 29 200 0	2 520	91 53 061 08	19	2
10 28 507 0	9 739 356	97 39 356	11	1	10 29 200 4	2 502	91 55 939 08	1	1
10 28 507 0	9 739 366	97 39 366	6	1	10 29 201 3	2 520 034	96 45 984 08	35	10
10 28 515 3	9 739 288	97 39 288	10	1	10 29 201 4	2 520 032	96 45 980 08	8	1
10 28 515 5	9 739 288	97 39 288	17	1	10 29 201 6	2 520 032	96 45 980 08	9	1
10 28 515 6	9 739 288	97 39 288	18	1	10 29 201 7	2 520 032	96 45 980 08	6	1
10 28 515 7	9 739 288	97 39 288	23	1	10 29 202 1	2 520 032	96 45 980 08	1	2
10 28 517 0	9 739 288	97 39 288	21	1	10 29 202 3	2 520 031	96 45 610 08	2	1
10 28 562 6	3 220 500	91 52 849 08	41	2	10 29 417 0	7 027 481	70 27 481 03	9	1
10 28 562 6	3 223	91 52 852 08	41	2	10 29 417 1	7 027 481	70 27 481 03	4	1
10 28 562 6	3 223 010	91 52 853 08	41	2	10 29 431 6	9 739 493	97 39 493	2	1
10 28 562 6	3 223 100	91 55 327 08	41	2	10 29 431 8	9 739 278	97 39 278	9	3
10 28 570 1	2 520	91 53 061 08	48	2	10 29 624 5	X1035925	10 35 925 1	(1)	1

6.2.2009

etk_en_de_074515 LR 1600/2

784

LIEBHERRNumerical index
Numerischer Index

Item	Page	Assembly	Pos.	Quantity	Item	Page	Assembly	Pos.	Quantity
10 29 669 1	2 533 070	96 48 363 08	(2)	1	10 34 282 3	2 970	91 56 537 08	61	1
10 29 720 3	9 739 322	97 39 322	1	1	10 34 283 2	9 739 354	97 39 354	12	1
10 29 720 4	9 739 322	97 39 322	2	2	10 34 283 6	9 739 341	97 39 341	1	1
10 29 730 9	2 533 050	96 48 359 08	10	2	10 34 283 9	9 739 341	97 39 341	3	1
10 29 731 0	2 533 050	96 48 359 08	11	2	10 34 284 0	9 739 341	97 39 341	4	1
10 29 787 6	X1035925	10 35 925 1	(2)	1	10 34 284 2	X1012059	10 12 059 0	44	1
10 29 994 8	9 739 371	97 39 371	1	1	10 34 285 4	2 533 066	96 48 365 08	8	2
10 30 060 0	2 522	91 54 115 08	13	4.5	10 34 286 4	9 739 372	97 39 372	11	1
10 30 060 5	2 520	91 53 061 08	17	3.88	10 34 286 8	9 739 349	97 39 349	11	1
10 30 060 5	2 520	91 53 061 08	18	2.1	10 34 287 1	9 739 352	97 39 352	1	1
10 30 092 5	X1035924	10 35 924 3	(999)	1	10 34 287 8	9 739 351	97 39 351	2	1
10 30 300 5	X1034309	10 34 309 6	1	1	10 34 287 9	9 739 349	97 39 349	13	2
10 32 351 7	2 533 051	96 48 360 08	2	1	10 34 288 0	9 739 352	97 39 352	2	1
10 32 483 0	2 920 633	96 52 651 08	515	1	10 34 300 3	2 540	91 53 253 08	4	1
10 32 483 4	2 631	91 56 817 08	37	5	10 34 300 3	2 541	91 52 790 08	3	1
10 32 632 3	2 810	91 52 806 08	16	2	10 34 309 2	9 739 356	97 39 356	1	1
10 32 683 8	2 533 070	96 48 363 08	27	1	10 34 309 3	9 739 356	97 39 356	4	1
10 32 684 4	2 533 070	96 48 363 08	28	1	10 34 309 5	9 739 369	97 39 369	6	1
10 32 692 4	X1035924	10 35 924 6	1	1	10 34 309 6	X1012059	10 12 059 0	70	1
10 32 692 5	X1035924	10 35 924 6	2	1	10 34 310 0	X1034309	10 34 309 6	4	1
10 32 692 6	X1035924	10 35 924 6	4	1	10 34 310 3	9 739 371	97 39 371	21	1
10 32 716 7	2 711	91 52 800 08	1	1	10 34 310 4	9 739 344	97 39 344	2	1
10 33 104 7	X1035924	10 35 924 1	1	1	10 34 310 5	9 739 371	97 39 371	11	1
10 33 104 7	X1035924	10 35 924 2	1	1	10 34 310 6	9 739 344	97 39 344	11	1
10 33 104 7	X1035925	10 35 925 0	1	1	10 34 310 7	9 739 344	97 39 344	7	1
10 33 104 8	X1035924	10 35 924 1	2	1	10 34 311 0	9 739 344	97 39 344	16	1
10 33 104 8	X1035924	10 35 924 2	2	1	10 34 312 1	9 739 366	97 39 366	23	1
10 33 104 8	X1035925	10 35 925 0	2	1	10 34 312 6	9 739 366	97 39 366	21	1
10 33 111 6	X1035924	10 35 924 1	(98)	1	10 34 312 8	9 739 366	97 39 366	22	1
10 33 111 7	X1035924	10 35 924 1	(98)	1	10 34 313 1	9 739 343	97 39 343	2	1
10 33 210 8	9 739 278	97 39 278	11	1	10 34 317 4	9 739 360	97 39 360	1	1
10 33 210 8	X1034309	10 34 309 6	2	1	10 34 317 6	9 739 360	97 39 360	10	1
10 33 216 1	2 372	91 33 648 08	2	2	10 34 318 3	9 739 344	97 39 344	18	1
10 33 264 0	2 925 002	96 58 856 08	10	1	10 34 318 6	9 739 341	97 39 341	5	8
10 33 276 5	9 739 357	97 39 357	12	1	10 34 328 5	9 739 371	97 39 371	19	1
10 33 323 8	X1035924	10 35 924 7	4	1	10 34 328 8	9 739 344	97 39 344	13	1
10 33 421 5	2 391 102	96 56 360 08	1	1	10 34 329 6	9 739 344	97 39 344	17	1
10 33 555 7	2 533 070	96 48 363 08	4	1	10 34 329 9	9 739 344	97 39 344	14	2
10 33 559 6	6 060 950	60 60 950 08	3	4	10 34 330 8	9 739 250	97 39 250	4	1
10 33 615 7	2 391 040	96 53 645 08	20	6	10 34 330 9	9 739 371	97 39 371	2	1
10 34 010 5	2 533 066	96 48 365 08	5	1	10 34 331 8	9 739 371	97 39 371	13	1
10 34 022 6	7 027 481	70 27 481 03	19	2	10 34 334 0	9 739 349	97 39 349	12	1
10 34 023 6	7 027 481	70 27 481 03	13	2	10 34 334 2	9 739 356	97 39 356	2	1
10 34 043 8	2 932 082	96 54 387 08	112	1	10 34 334 3	9 739 351	97 39 351	8	1
10 34 225 4	9 739 351	97 39 351	3	1	10 34 334 8	9 739 353	97 39 353	1	1
10 34 225 7	9 739 356	97 39 356	7	1	10 34 342 0	9 739 356	97 39 356	5	1
10 34 225 9	9 739 351	97 39 351	4	1	10 34 342 2	9 739 344	97 39 344	21	1
10 34 226 2	9 739 371	97 39 371	15	1	10 34 342 4	9 739 366	97 39 366	9	5
10 34 226 5	9 739 356	97 39 356	12	1	10 34 353 0	2 391 001	96 45 719 08	155	4
10 34 226 6	9 739 360	97 39 360	3	8	10 34 353 0	2 997	91 56 539 08	268	2.4
10 34 226 7	9 739 362	97 39 362	4	19	10 34 353 0	2 997	91 56 539 08	269	1.6
10 34 226 8	9 739 362	97 39 362	5	1	10 34 353 0	2 997	91 56 539 08	270	0.22
10 34 226 9	9 739 352	97 39 352	3	9	10 34 375 2	9 739 356	97 39 356	9	1
10 34 227 2	9 739 351	97 39 351	6	1	10 34 659 9	X1021769	10 21 769 5	1	1
10 34 227 9	9 739 371	97 39 371	20	2	10 34 675 2	7 027 481	70 27 481 03	20	2
10 34 229 2	9 739 371	97 39 371	29	1	10 34 693 8	2 920 814	96 45 717 08	(5)	1
10 34 229 7	9 739 356	97 39 356	6	1	10 35 370 5	X1041267	10 41 267 8	13	2
10 34 230 2	9 739 356	97 39 356	3	1	10 35 393 0	2 970	91 56 537 08	(1)	4
10 34 246 3	2 522 011	96 45 602 08	4	1	10 35 411 4	2 310	91 52 503 08	2	1
10 34 246 9	2 522 011	96 45 602 08	1	1	10 35 411 4	2 320	91 52 504 08	2	1

6.2.2009

etk_en_de_074515 LR 1600/2

785

LIEBHERRNumerical index
Numerischer Index

Item	Page	Assembly	Pos.	Quantity	Item	Page	Assembly	Pos.	Quantity
10 35 411 4	3 350	91 52 859 08	1	1	10 41 285 1	2 810	91 52 806 08	73	6
10 35 433 2	2 340	91 52 776 08	1	1	10 41 285 1	2 925 402	96 58 855 08	21	8
10 35 469 6	2 550	91 57 751 08	501	2	10 41 285 2	2 393 002	96 46 782 08	14	8
10 35 482 8	2 310	91 52 503 08	3	1	10 41 285 2	2 522 013	96 45 883 08	15	10
10 35 482 8	2 320	91 52 504 08	3	1	10 41 285 2	2 711	91 52 800 08	39	4
10 35 519 6	2 391 038	96 47 931 08	1	1	10 41 285 3	2 522 011	96 45 602 08	12	1
10 35 526 6	2 520 034	96 45 984 08	43	1	10 41 285 4	1 620	91 52 386 08	11	4
10 35 659 9	2 391 001	96 45 719 08	102	1	10 41 285 4	1 970	91 56 958 08	62	8
10 35 924 1	2 391 001	96 45 719 08	103	1	10 41 285 4	1 970	91 56 958 08	76	40
10 35 924 2	2 391 001	96 45 719 08	104	1	10 41 285 4	2 310	91 52 503 08	13	30
10 35 924 3	2 391 001	96 45 719 08	105	1	10 41 285 4	2 320	91 52 504 08	13	30
10 35 924 4	2 391 001	96 45 719 08	106	1	10 41 285 4	2 340	91 52 776 08	20	47
10 35 924 6	2 391 001	96 45 719 08	108	1	10 41 285 4	2 391 001	96 45 719 08	353	8
10 35 924 7	2 391 001	96 45 719 08	110	1	10 41 285 4	2 391 040	96 53 645 08	44	4
10 35 924 8	2 391 001	96 45 719 08	111	1	10 41 285 4	2 540	91 53 253 08	3	4
10 35 924 9	2 212	91 54 561 08	1	1	10 41 285 4	2 550	91 57 751 08	(6)	5
10 35 925 0	2 391 001	96 45 719 08	107	1	10 41 285 4	2 550	91 57 751 08	23	40
10 35 925 1	2 391 001	96 45 719 08	109	1	10 41 285 4	2 550 008	96 47 628 08	12	2
10 40 975 0	2 780 852	96 24 845 08	(10)	1	10 41 285 4	2 550 009	96 47 645 08	12	2
10 40 981 7	7 743 566	77 43 566 08	21	1	10 41 285 4	2 657	91 57 656 08	16	4
10 41 013 0	9 739 352	97 39 352	4	1	10 41 285 4	2 670	91 52 797 08	7	4
10 41 062 2	3 211	91 57 748 08	5	2	10 41 285 4	2 671	91 52 798 08	18	2
10 41 062 2	3 220 500	91 52 849 08	3	4	10 41 285 4	2 671 004	96 46 305 08	24	2
10 41 062 2	3 221	91 54 668 08	3	4	10 41 285 4	2 810	91 52 806 08	60	7
10 41 062 2	3 223	91 52 852 08	3	4	10 41 285 4	2 920	91 56 833 08	(5)	28
10 41 062 2	3 223 010	91 52 853 08	3	4	10 41 285 4	2 978 100	91 52 796 08	14	8
10 41 062 2	3 223 100	91 55 327 08	3	4	10 41 285 4	3 211	91 57 748 08	95	12
10 41 062 2	3 225	91 52 854 08	8	2	10 41 285 4	3 215 005	91 52 846 08	30	4
10 41 077 0	2 970	91 56 537 08	801	1	10 41 285 4	3 215 006	91 52 847 08	30	4
10 41 077 2	2 970	91 56 537 08	804	1	10 41 285 4	3 350	91 52 859 08	30	32
10 41 080 3	1 630	91 52 387 08	4	4	10 41 285 4	3 713	91 57 749 08	128	6
10 41 082 0	2 311	91 52 834 08	1	1	10 41 285 4	3 714	91 52 862 08	90	18
10 41 082 0	2 312	91 52 835 08	1	1	10 41 285 7	2 520	91 53 061 08	85	2
10 41 082 4	2 313	91 52 836 08	1	1	10 41 285 7	2 541	91 52 790 08	19	4
10 41 082 9	2 314	91 52 837 08	1	1	10 41 285 7	2 541 001	96 49 651 08	11	4
10 41 101 5	3 291	91 52 831 08	1	2	10 41 285 7	2 631	91 56 817 08	53	4
10 41 101 8	3 292	91 52 865 08	1	2	10 41 285 7	2 859	91 52 809 08	63	16
10 41 101 9	2 550	91 57 751 08	34	2	10 41 285 7	2 978 200	91 54 843 08	16	2
10 41 102 1	2 657	91 57 656 08	2	1	10 41 285 7	3 291	91 52 831 08	13	12
10 41 102 2	2 125	91 52 773 08	1	1	10 41 285 7	3 713	91 57 749 08	127	42
10 41 120 7	X1035925	10 35 925 1	2	1	10 41 286 1	2 391 001	96 45 719 08	331	4
10 41 178 0	X1002800	10 02 800 2	14	1	10 41 286 1	2 520	91 53 061 08	79	2
10 41 178 1	X1002800	10 02 800 2	15	7	10 41 286 1	2 520 034	96 45 984 08	51	2
10 41 178 6	X1002800	10 02 800 2	16	8	10 41 286 1	2 541 001	96 49 651 08	10	1
10 41 235 8	2 260	91 53 057 08	7	2	10 41 286 1	2 859	91 52 809 08	56	25
10 41 267 5	5 133 090	51 13 090 08	2	1	10 41 287 1	2 520 030	96 45 609 08	6	2
10 41 267 7	5 133 090	51 13 090 08	9	1	10 41 287 9	2 520 032	96 45 980 08	7	1
10 41 267 8	5 133 090	51 13 090 08	21	1	10 41 288 0	2 520 032	96 45 980 08	2	1
10 41 274 0	9 640 276	96 40 276 08	12	1	10 41 288 1	2 520 032	96 45 980 08	5	1
10 41 274 6	9 640 276	96 40 276 08	13	1	10 41 289 2	1 400	91 56 853 08	56	35
10 41 274 8	9 640 276	96 40 276 08	19	1	10 41 289 2	1 410 300	91 56 855 08	56	35
10 41 275 1	9 640 276	96 40 276 08	999	1	10 41 290 3	2 391 023	96 45 720 08	1	1
10 41 275 3	9 640 277	96 40 277 08	5	1	10 41 336 1	2 520	91 53 061 08	37	1
10 41 276 3	9 640 277	96 40 277 08	6	1	10 41 336 2	2 520	91 53 061 08	38	1
10 41 278 1	9 640 277	96 40 277 08	999	1	10 41 336 4	2 520	91 53 061 08	39	1
10 41 278 8	X1041267	10 41 267 7	13	1	10 42 393 8	2 975 000	91 57 881 08	4	1
10 41 278 9	X1041267	10 41 267 8	6	1	10 42 402 5	2 670	91 52 797 08	(1)	0.12
10 41 285 1	2 260	91 53 057 08	27	5	10 42 440 2	2 970	91 56 537 08	19	1
10 41 285 1	2 260 006	96 46 501 08	23	2	10 42 448 9	2 522 013	96 45 883 08	7	4
10 41 285 1	2 391 036	96 23 055 08	4	5	10 42 458 1	2 522 011	96 45 602 08	18	1

6.2.2009

etk_en_de_074515 LR 1600/2

786

LIEBHERRNumerical index
Numerischer Index

Item	Page	Assembly	Pos.	Quantity	Item	Page	Assembly	Pos.	Quantity
10 42 458 2	2 522 011	96 45 602 08	2	1	10 45 106 0	X1042440	10 42 440 2	9	1
10 42 471 6	2 970	91 56 537 08	26	2	10 45 120 6	2 391 001	96 45 719 08	115	1
10 42 477 0	2 970	91 56 537 08	775	2	10 45 165 0	2 340	91 52 776 08	38	4
10 42 478 5	2 520 034	96 45 984 08	37	2	10 45 478 2	2 925 026	91 55 259 08	(10)	1
10 42 478 6	2 970	91 56 537 08	(999)	1	10 45 478 2	2 925 405	96 48 397 08	10	1
10 42 527 1	2 533 066	96 48 365 08	6	2	10 45 478 3	2 925 026	91 55 259 08	(11)	1
10 42 540 8	3 282 002	96 47 890 08	1	1	10 45 478 3	2 925 405	96 48 397 08	11	1
10 42 540 9	2 859	91 52 809 08	70	1.5	10 45 514 4	X1029200	10 29 200 4	15	1
10 42 558 8	2 520	91 53 061 08	55	0.12	10 45 528 1	2 502	91 55 939 08	27	6
10 42 558 8	2 520	91 53 061 08	56	0.18	10 45 537 2	2 970	91 56 537 08	569	4
10 42 558 8	2 520 034	96 45 984 08	41	0.4	10 45 542 1	2 925 002	96 58 856 08	15	1
10 42 572 5	3 206	91 52 881 08	20	1	10 46 565 9	3 978 019	91 56 431 08	12	1
10 42 823 9	2 391 001	96 45 719 08	128	1	10 46 690 6	3 978 015	91 56 429 08	14	1
10 42 876 6	2 340	91 52 776 08	2	2	10 46 690 6	3 978 015	91 56 432 08	14	1
10 42 876 7	3 350	91 52 859 08	2	1	10 46 690 7	2 975 100	91 52 860 08	38	2
10 42 876 8	1 400	91 56 853 08	8	2	10 46 690 7	2 978 100	91 52 827 08	26	1
10 42 876 8	1 410 300	91 56 855 08	8	2	10 46 690 8	2 975 100	91 52 860 08	39	2
10 42 905 7	2 533 067	96 50 385 08	5	1	10 46 690 8	2 978 100	91 52 827 08	22	2
10 42 905 7	2 533 068	96 49 314 08	2	1	10 46 690 8	3 713 013	96 57 159 08	10	6
10 42 905 8	2 533 050	96 48 359 08	20	1	10 46 690 8	3 978 100	91 56 428 08	32	2
10 42 953 2	5 114 651	51 14 651 08	5	1	10 46 690 9	2 975 100	91 52 860 08	25	2
10 42 954 9	3 780 751	91 52 952 08	6	1	10 46 690 9	3 713 013	96 57 159 08	11	2
10 42 959 8	3 714 016	96 49 797 08	1	1	10 46 690 9	3 978 015	91 56 429 08	7	2
10 42 995 2	7 743 566	77 43 566 08	19	2	10 46 690 9	3 978 015	91 56 432 08	7	2
10 43 004 8	3 281	91 52 896 08	48	1	10 46 691 0	1 970	91 56 958 08	24	1
10 43 030 5	2 925 405	96 48 397 08	20	1	10 46 691 0	2 970	91 56 537 08	103	3
10 43 036 9	2 392	91 52 785 08	7	1	10 46 691 0	2 970 081	96 50 495 08	8	1
10 43 037 0	2 392	91 52 785 08	4	1	10 46 691 0	2 975 100	91 52 860 08	36	4
10 43 037 1	2 392	91 52 785 08	6	2	10 46 691 0	2 975 200	91 52 775 08	36	1
10 43 037 2	2 392	91 52 785 08	5	1	10 46 691 0	2 975 700	91 52 774 08	36	1
10 44 054 2	2 392	91 52 785 08	3	1	10 46 691 0	2 976 200	91 44 034 08	8	3
10 44 054 3	2 392	91 52 785 08	1	1	10 46 691 0	2 976 203	92 27 489 08	8	1
10 44 054 4	2 392	91 52 785 08	2	1	10 46 691 0	3 978 005	91 56 430 08	20	1
10 44 097 6	X1047219	10 47 219 6	999	1	10 46 691 1	1 970	91 56 958 08	42	2
10 44 099 0	2 520	91 53 061 08	49	1	10 46 691 1	2 970	91 56 537 08	95	6
10 44 130 5	2 533 070	96 48 363 08	26	4	10 46 691 1	2 970 081	96 50 495 08	14	1
10 44 330 9	2 522	91 54 115 08	19	1	10 46 691 1	2 976 200	91 44 034 08	12	1
10 44 335 2	9 739 492	97 39 492	33	1	10 46 691 1	2 977	91 57 756 08	44	1
10 44 335 6	9 739 492	97 39 492	24	1	10 46 691 1	2 977 200	91 55 149 08	25	2
10 44 336 5	9 739 492	97 39 492	31	1	10 46 691 2	1 970	91 56 958 08	38	2
10 44 362 5	2 502	91 55 939 08	24	2	10 46 691 2	2 970	91 56 537 08	87	8
10 44 365 8	3 930 732	96 50 575 08	152	1	10 46 691 2	2 975 100	91 52 860 08	28	2
10 44 365 9	3 930 138	96 54 377 08	(170)	1	10 46 691 2	2 976 200	91 44 034 08	14	1
10 44 365 9	3 930 732	96 50 575 08	151	1	10 46 691 2	2 977	91 57 756 08	38	2
10 44 366 0	2 920 369	96 54 235 08	(151)	1	10 46 691 2	2 977 200	91 55 149 08	21	1
10 44 366 4	2 920 581	96 54 405 08	(151)	1	10 46 691 2	2 978 100	91 52 796 08	28	2
10 44 366 5	3 930 734	96 54 401 08	(151)	1	10 46 691 3	2 975 100	91 52 860 08	24	2
10 44 376 9	2 522 011	96 45 602 08	24	2	10 46 691 4	3 978 100	91 56 428 08	28	1
10 44 951 6	2 533 066	96 48 365 08	2	3	10 46 691 6	2 975 200	91 52 775 08	26	1
10 44 966 4	2 925 026	91 55 259 08	(33)	4	10 46 691 6	2 975 200	91 52 775 08	30	1
10 44 966 4	2 925 405	96 48 397 08	33	4	10 46 691 6	2 975 700	91 52 774 08	26	1
10 44 966 4	2 932 082	96 54 387 08	16	4	10 46 691 6	2 975 700	91 52 774 08	30	1
10 45 022 6	3 715 008	91 52 863 08	44	12	10 46 691 7	2 975 200	91 52 775 08	22	2
10 45 022 6	3 716	91 52 864 08	45	24	10 46 691 7	2 975 700	91 52 774 08	22	2
10 45 067 1	1 630	91 52 387 08	23	4	10 46 691 7	3 978 100	91 56 428 08	22	2
10 45 069 3	2 520	91 53 061 08	80	6	10 46 727 4	6 909 010	69 09 010 08	19	1
10 45 069 3	2 520 033	96 50 633 08	3	11	10 46 727 5	6 909 010	69 09 010 08	20	1
10 45 069 3	2 520 034	96 45 984 08	25	4	10 46 740 3	2 533 050	96 48 359 08	5	1
10 45 104 8	X1042440	10 42 440 2	6	1	10 46 788 6	1 975 006	91 52 509 08	19	4
10 45 104 9	X1042440	10 42 440 2	7	1	10 47 036 6	2 711	91 52 800 08	6	1

6.2.2009

etk_en_de_074515 LR 1600/2

787

LIEBHERRNumerical index
Numerischer Index

Item	Page	Assembly	Pos.	Quantity	Item	Page	Assembly	Pos.	Quantity
10 47 036 7	2 711	91 52 800 08	4	1	10 48 691 7	9 739 492	97 39 492	30	1
10 47 036 8	1 711	91 52 392 08	3	2	10 48 693 3	9 739 492	97 39 492	35	1
10 47 037 0	1 711	91 52 392 08	2	2	10 48 693 4	9 739 492	97 39 492	25	1
10 47 043 3	X1042954	10 42 954 9	1	1	10 48 694 0	9 739 492	97 39 492	32	1
10 47 043 4	X1042954	10 42 954 9	3	1	10 48 800 2	2 711	91 52 800 08	(1)	1
10 47 082 9	X1042440	10 42 440 2	4	1	10 48 800 3	2 711	91 52 800 08	(1)	1
10 47 124 9	3 206	91 52 881 08	49	4	10 48 866 2	3 930 638	96 51 624 08	293	1
10 47 137 0	X1035924	10 35 924 3	1	1	10 48 866 2	3 930 730	96 50 599 08	293	1
10 47 137 1	X1035924	10 35 924 3	2	1	10 48 866 2	3 930 730	96 54 398 08	286	1
10 47 137 1	X1035924	10 35 924 4	2	1	10 48 866 2	3 930 734	96 54 401 08	307	1
10 47 138 0	X1035924	10 35 924 4	1	1	10 48 901 1	2 533 066	96 48 365 08	10	2
10 47 138 4	X1035924	10 35 924 6	5	1	10 48 973 4	5 113 005	51 13 005 08	2	1
10 47 141 2	2 533 070	96 48 363 08	32	1	10 48 983 6	X1022811	10 22 811 2	1	1
10 47 143 7	X1035924	10 35 924 6	(2)	1	10 49 005 7	3 291	91 52 831 08	7	2
10 47 143 7	X1035924	10 35 924 9	(1)	2	10 49 058 6	X1004047	10 04 047 7	6	1
10 47 143 9	X1035924	10 35 924 6	(98)	1	10 49 234 5	X1029200	10 29 200 4	1	1
10 47 143 9	X1035924	10 35 924 9	(98)	1	10 49 234 7	X1029200	10 29 200 4	19	1
10 47 202 8	2 932 160	96 54 385 08	3	2	10 49 234 8	X1029200	10 29 200 4	21	1
10 47 218 5	X1035924	10 35 924 7	1	1	10 49 389 0	2 391 038	96 47 931 08	(99)	1
10 47 219 6	X1035924	10 35 924 7	3	1	10 65 006 5	5 102 354	51 02 354 08	1	1
10 47 219 6	X1035924	10 35 924 8	3	1	10 65 006 8	X1021769	10 21 769 5	99	1
10 47 220 0	X1035924	10 35 924 7	5	1	10 65 009 2	X1034282	10 34 282 3	2	1
10 47 220 2	X1047219	10 47 219 6	3	1	10 65 015 5	X1035411	10 35 411 4	1	1
10 47 220 4	X1035924	10 35 924 8	1	1	10 65 015 6	X1035411	10 35 411 4	21	1
10 47 220 8	X1035924	10 35 924 8	4	1	10 65 015 8	X1035411	10 35 411 4	24	1
10 47 221 9	X1035924	10 35 924 8	(98)	1	10 65 015 9	X1035411	10 35 411 4	60	1
10 47 289 0	2 520	91 53 061 08	84	2	10 65 017 7	X1065015	10 65 015 6	41	1
10 47 304 0	2 311 001	96 25 639 08	3	2	10 65 039 3	X1029200	10 29 200 4	26	1
10 47 304 0	3 208 001	91 52 883 08	44	1	10 65 040 3	X1029200	10 29 200 4	49	1
10 47 304 7	2 920 581	96 54 405 08	(707)	19	10 65 048 3	X1029200	10 29 200 4	28	1
10 47 304 7	3 930 732	96 50 575 08	707	18	10 65 048 4	X1029200	10 29 200 4	29	1
10 47 304 8	2 920 369	96 54 235 08	(708)	7	10 65 048 5	X1029200	10 29 200 4	48	1
10 47 304 8	2 920 369	96 54 235 08	(708)	24	10 65 048 7	X1029200	10 29 200 4	55	1
10 47 304 8	2 920 369	96 54 235 08	(708)	16	10 65 048 8	X1029200	10 29 200 4	66	1
10 47 304 8	2 920 633	96 52 651 08	708	2	10 65 048 9	X1029200	10 29 200 4	70	1
10 47 304 8	3 930 732	96 50 575 08	708	28	10 65 049 0	X1029200	10 29 200 4	85	1
10 47 304 8	3 930 734	96 54 401 08	(708)	14	10 65 066 9	X1035519	10 35 519 6	1	1
10 47 305 2	2 920 536	96 48 317 08	(712)	2	10 65 067 0	X1035519	10 35 519 6	2	1
10 47 305 2	2 920 536	96 48 317 08	(712)	2	10 65 067 1	X1035519	10 35 519 6	3	1
10 47 305 2	2 920 815	96 49 300 08	(712)	2	10 65 067 2	X1035519	10 35 519 6	4	1
10 47 515 0	2 932 082	96 54 387 08	55	1	10 65 067 4	X1035519	10 35 519 6	5	1
10 47 515 7	2 750 100	91 57 283 08	1	2	10 65 067 5	X1035519	10 35 519 6	6	1
10 47 561 7	2 780 244	91 52 951 08	2	1	10 65 067 6	X1035519	10 35 519 6	7	1
10 47 561 9	2 780 244	91 52 951 08	3	1	10 65 068 5	X1035924	10 35 924 9	1	1
10 47 566 6	2 932 160	96 54 385 08	28	1	10 65 068 6	X1035924	10 35 924 9	2	1
10 47 599 4	9 739 343	97 39 343	(1)	1	10 65 068 8	X1035924	10 35 924 9	3	1
10 47 603 1	2 810	91 52 806 08	71	1	10 65 068 9	X1035924	10 35 924 9	4	1
10 47 609 8	2 550	91 57 751 08	82	2	10 65 069 2	X1035924	10 35 924 9	5	1
10 47 638 3	2 920 288	96 52 614 08	(503)	1	10 65 070 1	X1035924	10 35 924 9	(38)	1
10 47 687 9	9 739 386	97 39 386	18	1	10 65 070 7	X1035924	10 35 924 9	(98)	1
10 47 688 3	9 739 341	97 39 341	7	1	10 65 071 0	X1065068	10 65 068 8	98	1
10 47 688 5	9 739 491	97 39 491	1	1	10 65 071 7	X1035924	10 35 924 9	(98)	1
10 47 688 6	9 739 494	97 39 494	1	1	10 65 243 8	3 221	91 54 668 08	25	2
10 47 688 8	9 739 491	97 39 491	3	1	10 65 243 9	3 220 500	91 52 849 08	43	2
10 47 689 0	9 739 491	97 39 491	4	1	10 65 243 9	3 226	91 52 870 08	43	2
10 47 689 5	9 739 492	97 39 492	1	1	10 65 243 9	3 715 008	91 52 863 08	34	2
10 47 690 5	9 739 491	97 39 491	5	1	10 65 244 0	3 223	91 52 852 08	43	2
10 47 690 7	9 739 492	97 39 492	7	1	10 65 244 0	3 223 010	91 52 853 08	43	2
10 47 691 2	9 739 492	97 39 492	22	1	10 65 244 0	3 223 100	91 55 327 08	43	2
10 48 691 6	9 739 492	97 39 492	26	1	10 65 244 0	3 227	91 52 873 08	43	2

6.2.2009

etk_en_de_074515 LR 1600/2

788

LIEBHERRNumerical index
Numerischer Index

Item	Page	Assembly	Pos.	Quantity	Item	Page	Assembly	Pos.	Quantity
10 65 244 0	3 227 008	91 52 872 08	43	2	26 47 366 02	2 932 160	96 54 385 08	30	1
10 65 244 0	3 227 200	91 53 519 08	43	2	28 30 209 08	2 550	91 57 751 08	52	1
10 65 244 0	3 716	91 52 864 08	32	2	28 30 405 08	3 745	91 52 948 08	53	1
10 65 265 7	2 391 001	96 45 719 08	135	6	28 30 961 08	3 206	91 52 881 08	34	2
10 65 280 6	3 211	91 57 748 08	82	2	28 30 961 08	3 208 001	91 52 883 08	23	3
10 65 281 3	3 214	91 52 843 08	39	1	28 39 057 08	2 391 023	96 45 720 08	29	1
10 65 281 4	3 713	91 57 749 08	83	2	28 39 057 08	2 859	91 52 809 08	72	1
10 65 281 6	3 225	91 52 854 08	47	2	28 81 537 08	3 211	91 57 748 08	55	1
10 65 281 8	3 714	91 52 862 08	43	2	28 81 762 08	1 920 305	92 15 300 08	12	1
10 65 300 5	X1002800	10 02 800 2	18	1	28 81 766 08	3 211	91 57 748 08	64	1
10 66 332 8	X1004047	10 04 047 7	2	1	28 81 799 08	2 913 100	91 23 538 08	15	1
10 66 332 9	X1004047	10 04 047 7	3	1	28 81 831 08	2 520 031	96 45 610 08	6	6
10 66 343 9	2 810	91 52 806 08	(999)	1	28 81 883 08	3 713	91 57 749 08	8	2
10 66 372 5	5 114 651	51 14 651 08	2	4	28 81 926 08	3 208 001	91 52 883 08	22	2
10 66 373 0	5 114 651	51 14 651 08	999	1	28 81 951 08	2 550	91 57 751 08	71	2
10 66 425 0	X1041101	10 41 101 5	430	1	28 81 999 08	2 652 007	92 68 928 08	1	1
10 66 425 0	X1041101	10 41 101 8	410	1	38 00 707 08	3 227 002	96 50 498 08	15	2
10 66 432 1	X1041101	10 41 101 5	270	1	38 82 792 08	2 740	91 52 770 08	2	6
10 66 432 1	X1041101	10 41 101 8	250	1	38 82 831 08	2 311 001	96 25 639 08	2	1
10 66 433 3	X1041101	10 41 101 5	560	1	38 82 832 08	2 311 001	96 25 639 08	1	1
10 66 433 3	X1041101	10 41 101 8	470	1	40 00 417	2 502	91 55 939 08	37	8
10 66 433 4	X1041101	10 41 101 5	999	1	40 00 417	2 859	91 52 809 08	50	16
10 66 444 9	X1041101	10 41 101 8	999	1	40 00 417	2 859 025	96 46 757 08	8	8
24 00 465 02	2 520 032	96 45 980 08	23	4	40 00 472	2 391 038	96 47 931 08	11	8
24 00 551 02	3 978 100	91 56 428 08	10	4	40 00 784	3 978 100	91 56 428 08	4	6
24 01 915 02	2 391 040	96 53 645 08	15	1	40 00 828	1 400	91 56 853 08	67	12
24 01 920 02	X1042440	10 42 440 2	11	4	40 00 828	1 410 300	91 56 855 08	67	12
24 02 184 02	3 206	91 52 881 08	31	1	40 00 828	2 391 001	96 45 719 08	345	2
24 72 399 02	X1011614	10 11 614 1	3	1	40 00 828	2 631	91 56 817 08	35	24
26 11 007 08	5 718 420	57 18 420 08	5	1	40 00 828	2 970	91 56 537 08	130	2
26 21 010 08	2 859 005	96 46 756 08	10	3.91	40 00 829	1 970	91 56 958 08	66	8
26 21 010 08	2 932 082	96 54 387 08	115	0.36	40 00 829	2 260	91 53 057 08	20	8
26 21 031 08	2 502	91 55 939 08	30	0.064	40 00 829	2 260 006	96 46 501 08	22	4
26 21 039 08	2 260 006	96 46 501 08	11	3.6	40 00 829	2 370	91 52 782 08	22	8
26 21 039 08	2 391	91 52 784 08	9	1.75	40 00 829	2 391 023	96 45 720 08	13	2
26 21 039 08	2 520 034	96 45 984 08	42	1.3	40 00 829	2 391 039	96 50 616 08	4	4
26 21 039 08	2 932 001	96 45 393 08	45	0.33	40 00 829	2 391 040	96 53 645 08	32	1
26 21 039 08	2 932 082	96 54 387 08	43	2	40 00 829	2 510	91 52 788 08	7	4
26 21 039 08	2 932 166	92 68 911 08	7	0.16	40 00 829	2 522	91 54 115 08	15	8
26 21 040 08	2 631	91 56 817 08	44	0.8	40 00 829	2 540	91 53 253 08	7	2
26 21 040 08	2 670	91 52 797 08	19	0.23	40 00 829	2 550	91 57 751 08	57	14
26 21 040 08	2 810	91 52 806 08	48	0.8	40 00 829	2 925 204	92 16 990 08	8	4
26 21 040 08	2 859	91 52 809 08	66	1.6	40 00 829	2 925 204	92 16 990 08	15	1
26 21 040 08	2 859 007	96 46 775 08	10	3.27	40 00 829	2 925 402	96 58 855 08	11	13
26 21 043 08	2 932 160	96 54 385 08	12	4.6	40 00 829	2 932 082	96 54 387 08	37	1
26 21 047 08	2 391 001	96 45 719 08	154	0.85	40 00 829	3 206	91 52 881 08	27	4
26 21 047 08	2 393 002	96 46 782 08	18	0.69	40 00 829	3 211	91 57 748 08	69	5
26 21 047 08	2 510	91 52 788 08	13	4.46	40 00 829	3 745 002	92 17 236 08	8	4
26 21 051 08	2 393 002	96 46 782 08	13	1.76	40 00 829	3 745 003	92 17 237 08	8	4
26 21 051 08	2 510	91 52 788 08	11	0.78	40 00 829	X1022811	10 22 811 2	42	1
26 21 051 08	2 859 030	96 46 758 08	14	2.24	40 00 878	2 631	91 56 817 08	38	10
26 21 053 08	2 859	91 52 809 08	64	9.6	40 00 899	2 520	91 53 061 08	34	6
26 21 053 08	2 859 029	96 46 779 08	9	0.16	40 00 970	2 990	91 59 244 08	16	2
26 21 067 08	2 859	91 52 809 08	71	10	40 00 973	2 392	91 52 785 08	23	2
26 21 078 14	2 520	91 53 061 08	52	6	40 00 996	2 502	91 55 939 08	36	8
26 21 089 08	2 670	91 52 797 08	20	0.36	40 00 996	3 780 200	96 54 370 08	11	3
26 21 089 08	2 913 006	96 20 732 08	7	0.18	40 01 004 08	2 932 001	96 45 393 08	15	28
26 21 091 08	2 520 030	96 45 609 08	9	3.7	40 01 006 08	2 920 369	96 54 235 08	41	8
26 21 821 01	9 907 151	99 07 151 01	315	8.36	40 01 018 08	2 932 160	96 54 385 08	48	56
26 21 835 01	9 907 151	99 07 151 01	314	8.31	40 01 020 08	2 920 369	96 54 235 08	(152)	1

6.2.2009

etk_en_de_074515 LR 1600/2

789

LIEBHERRNumerical index
Numerischer Index

Item	Page	Assembly	Pos.	Quantity	Item	Page	Assembly	Pos.	Quantity
40 01 020 08	2 920 369	96 54 235 08	(152)	1	40 41 002 08	2 810	91 52 806 08	(4)	2
40 01 020 08	2 920 369	96 54 235 08	280	12	40 41 002 08	X1065015	10 65 015 8	64	1
40 01 020 08	2 920 448	96 48 794 08	280	24	40 41 007 08	X1065015	10 65 015 5	462	4
40 01 033 08	2 260	91 53 057 08	28	4	40 41 016 08	9 739 491	97 39 491	24	1
40 01 033 08	2 260 009	96 46 972 08	4	4	40 41 017 08	X1065015	10 65 015 5	530	2
40 01 033 08	2 920 083	96 48 319 08	31	2	40 42 002	2 502	91 55 939 08	41	4
40 01 034 08	2 780 915	96 48 377 08	4	4	40 42 002	2 978 100	91 52 796 08	22	2
40 01 034 08	2 920 083	96 48 319 08	30	5	40 42 002	3 780 258	96 56 482 08	(6)	3
40 01 034 08	3 780 258	96 56 482 08	(2)	3	40 42 002 08	2 780 852	96 24 845 08	11	2
40 01 036 08	2 932 082	96 54 387 08	29	2	40 42 003	2 550 008	96 47 628 08	11	6
40 01 041 08	1 100	91 52 375 08	6	3	40 42 003	2 550 009	96 47 645 08	11	6
40 01 054 08	2 932 082	96 54 387 08	12	12	40 42 003	2 978 100	91 52 796 08	20	6
40 01 054 08	5 026 126	50 26 126 08	15	2	40 42 003	9 079 185	90 79 185	3	1
40 01 308	2 502	91 55 939 08	34	24	40 42 003	9 079 186	90 79 186	3	1
40 01 308	2 540	91 53 253 08	18	2	40 42 014	5 102 354	51 02 354 08	7	2
40 01 405 08	2 920 369	96 54 235 08	(153)	1	40 42 022 01	2 520	91 53 061 08	35	2
40 01 405 08	2 920 581	96 54 405 08	(153)	1	40 42 025 08	1 711	91 52 392 08	5	8
40 01 447	1 400	91 56 853 08	(32)	3	40 42 025 08	2 711	91 52 800 08	7	10
40 01 461	1 620	91 52 386 08	7	4	40 42 026 01	2 970	91 56 537 08	62	4
40 01 461	3 208 001	91 52 883 08	25	2	40 42 026 01	X1022811	10 22 811 2	37	2
40 01 461	3 211	91 57 748 08	75	44	40 42 030	X1065015	10 65 015 5	24	8
40 01 461	3 713	91 57 749 08	76	16	40 42 032	3 714	91 52 862 08	93	4
40 01 461	3 745	91 52 948 08	31	8	40 42 035	2 671 004	96 46 305 08	20	4
40 01 466	3 211	91 57 748 08	100	14	40 42 036	X1065015	10 65 015 8	23	8
40 01 521	2 522	91 54 115 08	23	1	40 42 044 05	X1047219	10 47 219 6	50	5
40 01 521	2 975 200	91 52 775 08	48	4	40 42 072 08	2 522	91 54 115 08	21	2
40 01 521	2 975 700	91 52 774 08	48	4	40 42 072 08	3 211	91 57 748 08	32	78
40 01 620	3 713	91 57 749 08	45	8	40 42 072 08	3 713	91 57 749 08	73	6
40 01 667	X1035519	10 35 519 6	15	4	40 42 104 01	9 697 916	96 97 916 01	86	12
40 01 696	1 400	91 56 853 08	(56)	8	40 42 107	2 978 100	91 52 796 08	24	40
40 01 696	2 810	91 52 806 08	9	16	40 42 109	2 520	91 53 061 08	66	2
40 01 701 08	3 930 009	96 50 573 08	266	4	40 42 109	9 080 702	90 80 702	6	4
40 01 701 08	3 930 138	96 54 377 08	(268)	4	40 42 111	2 520 034	96 45 984 08	55	4
40 01 701 08	3 930 638	96 51 624 08	280	16	40 42 120 08	2 350	91 52 778 08	7	8
40 01 701 08	3 930 640	96 50 481 08	154	10	40 42 120 08	2 391 001	96 45 719 08	342	12
40 01 701 08	3 930 730	96 50 599 08	266	10	40 42 120 08	2 970	91 56 537 08	546	12
40 01 928	3 220 500	91 52 849 08	33	2	40 42 124 01	9 697 916	96 97 916 01	74	12
40 01 928	3 223	91 52 852 08	33	4	40 42 132 01	X1065015	10 65 015 8	22	12
40 01 928	3 223 010	91 52 853 08	33	4	40 42 143 05	2 125	91 52 773 08	7	4
40 01 928	3 223 100	91 55 327 08	33	4	40 42 152 08	1 970	91 56 958 08	56	32
40 01 928	3 225	91 52 854 08	31	2	40 42 152 08	1 970 161	96 50 706 08	56	8
40 01 928	3 226	91 52 870 08	33	2	40 42 152 08	2 970	91 56 537 08	555	28
40 01 928	3 227	91 52 873 08	33	4	40 42 153 01	2 970	91 56 537 08	128	12
40 01 928	3 227 008	91 52 872 08	33	4	40 42 153 01	2 975 200	91 52 775 08	43	4
40 01 928	3 227 200	91 53 519 08	33	4	40 42 153 01	2 975 700	91 52 774 08	43	4
40 01 928	3 714	91 52 862 08	59	10	40 42 156 08	2 975 100	91 52 860 08	47	4
40 01 929	3 715 008	91 52 863 08	6	4	40 42 159 08	2 975 100	91 52 860 08	46	4
40 01 929	3 716	91 52 864 08	6	6	40 42 175 01	2 652	91 52 794 08	22	6
40 02 418	2 391 001	96 45 719 08	351	8	40 42 181 01	2 550 010	96 45 685 08	3	2
40 02 601	5 113 086	51 13 086 08	23	4	40 42 183 01	X1065015	10 65 015 5	1391	18
40 02 886	X1042954	10 42 954 9	2	1	40 42 242 08	1 400	91 56 853 08	46	2
40 04 016 08	2 260 006	96 46 501 08	17	8	40 42 242 08	1 410 300	91 56 855 08	46	2
40 06 034 08	2 671 004	96 46 305 08	21	6	40 42 242 08	2 652	91 52 794 08	8	2
40 06 035 08	2 920 638	96 51 138 08	268	2	40 42 566 14	X1065015	10 65 015 5	21	18
40 26 002 08	2 790 451	91 57 016 08	2	3	40 43 012 08	X1004047	10 04 047 7	7	4
40 26 003 08	2 670 002	96 45 352 08	5	2	40 43 028 08	1 970	91 56 958 08	65	16
40 26 003 08	2 671 004	96 46 305 08	17	2	40 43 097 08	X1041101	10 41 101 8	340	4
40 26 007 08	1 632	91 52 389 08	6	4	40 43 126 08	9 697 916	96 97 916 01	26	8
40 28 026 14	2 925 402	96 58 855 08	7	8	40 43 161 01	2 975 200	91 52 775 08	44	4
40 41 001 08	5 113 005	51 13 005 08	7	1	40 43 161 01	2 975 700	91 52 774 08	44	4

6.2.2009

etk_en_de_074515 LR 1600/2

790

LIEBHERRNumerical index
Numerischer Index

Item	Page	Assembly	Pos.	Quantity	Item	Page	Assembly	Pos.	Quantity
40 43 169 01	X1065015	10 65 015 6	63	10	40 61 186 01	3 561 003	96 45 222 08	9	1
40 43 246 08	3 713	91 57 749 08	103	2	40 61 186 01	3 713 012	96 50 197 08	9	1
40 43 263 08	3 211	91 57 748 08	6	2	40 61 186 01	3 714 013	96 49 270 08	4	2
40 43 263 08	3 220 500	91 52 849 08	4	4	40 61 186 01	3 714 013	96 59 083 08	5	1
40 43 263 08	3 221	91 54 668 08	4	4	40 61 186 01	3 716 001	96 49 159 08	9	1
40 43 263 08	3 223	91 52 852 08	4	4	40 61 234 14	X1065015	10 65 015 5	1272	18
40 43 263 08	3 223 010	91 52 853 08	4	4	40 61 244 01	2 550 005	96 45 680 08	16	1
40 43 263 08	3 223 100	91 55 327 08	4	4	40 61 246 01	1 632 032	96 20 093 08	2	1
40 43 263 08	3 225	91 52 854 08	16	2	40 61 246 01	2 550 005	96 45 680 08	8	2
40 43 601 08	2 975 000	91 57 881 08	5	4	40 61 246 01	3 714 025	96 49 269 08	6	1
40 43 612 08	5 113 086	51 13 086 08	56	4	40 61 248 14	3 745 011	96 49 677 08	4	2
40 43 612 08	X1034282	10 34 282 3	4	4	40 61 291 08	3 714 009	96 49 267 08	15	6
40 44 005 08	2 522	91 54 115 08	27	2	40 62 011 08	3 208 001	91 52 883 08	26	7
40 44 011 08	3 211	91 57 748 08	78	16	40 62 036 08	3 745	91 52 948 08	48	4
40 44 022 08	X1041101	10 41 101 5	530	1	40 62 044 08	3 227 002	96 50 498 08	16	4
40 44 022 08	X1041101	10 41 101 8	450	1	40 62 049 08	2 391 001	96 45 719 08	333	4
40 44 031 08	2 502 007	96 22 822 08	4	1	40 62 051 08	1 400	91 56 853 08	49	13
40 44 031 08	2 502 008	96 22 823 08	4	1	40 62 051 08	1 410 300	91 56 855 08	49	13
40 46 005 08	3 213	91 52 842 08	20	2	40 62 181 08	1 400	91 56 853 08	45	13
40 46 013 08	X1041101	10 41 101 5	540	4	40 62 181 08	1 410 300	91 56 855 08	45	13
40 46 013 08	X1041101	10 41 101 8	460	4	40 65 000 08	2 913	91 32 850 08	11	4
40 46 047 08	1 632	91 52 389 08	12	2	40 65 000 08	2 913 009	91 04 705 08	11	4
40 48 003 08	2 550	91 57 751 08	(4)	8	40 65 002 01	9 640 276	96 40 276 08	10	2
40 48 003 08	2 550	91 57 751 08	(5)	6	40 65 002 14	2 533 070	96 48 363 08	35	4
40 48 003 08	2 550	91 57 751 08	39	8	40 65 002 14	2 925 026	91 55 259 08	(31)	4
40 48 046 08	X1065015	10 65 015 6	23	5	40 65 002 14	2 925 405	96 48 397 08	31	4
40 61 024	1 631 100	91 52 388 08	10	48	40 65 055 08	X1042440	10 42 440 2	24	2
40 61 024	3 206	91 52 881 08	58	8	40 65 060	2 260	91 53 057 08	23	28
40 61 024	3 214	91 52 843 08	36	9	40 65 060	2 975 100	91 52 860 08	55	2
40 61 024	3 220 500	91 52 849 08	25	45	40 65 063 08	2 520 032	96 45 980 08	20	6
40 61 024	3 221	91 54 668 08	13	36	40 65 086 05	2 631	91 56 817 08	49	2
40 61 024	3 223	91 52 852 08	25	49	40 65 093 08	2 670	91 52 797 08	6	8
40 61 024	3 223 010	91 52 853 08	25	49	40 65 099	2 260 006	96 46 501 08	19	2
40 61 024	3 223 100	91 55 327 08	25	49	40 65 099	2 533 066	96 48 365 08	16	1
40 61 024	3 225	91 52 854 08	35	47	40 65 099	2 913 004	96 20 460 08	5	1
40 61 024	3 226	91 52 870 08	25	34	40 65 099	2 920 200	96 44 536 08	10	3
40 61 024	3 227	91 52 873 08	25	48	40 65 099	2 920 260	96 44 537 08	10	3
40 61 024	3 227 008	91 52 872 08	25	40	40 65 099	2 920 334	96 44 538 08	10	3
40 61 024	3 227 200	91 53 519 08	25	49	40 65 099	2 920 350	96 44 539 08	10	3
40 61 024	3 713	91 57 749 08	17	73	40 65 099	3 206	91 52 881 08	54	2
40 61 024	3 714	91 52 862 08	46	55	40 65 099	3 214	91 52 843 08	42	4
40 61 024	3 715 008	91 52 863 08	7	56	40 65 103	2 978 200	91 54 843 08	18	4
40 61 024	3 716	91 52 864 08	7	88	40 65 136	1 970	91 56 958 08	8	2
40 61 056	2 975 000	91 57 881 08	12	2	40 65 136	1 970	91 56 958 08	63	8
40 61 062	3 715 008	91 52 863 08	43	6	40 65 136	1 970	91 56 958 08	81	4
40 61 062	3 716	91 52 864 08	47	12	40 65 136	2 391 102	96 56 360 08	15	4
40 61 065	3 215 005	91 52 846 08	22	4	40 65 136	2 393	91 52 787 08	22	2
40 61 065	3 215 006	91 52 847 08	22	4	40 65 136	2 831	91 57 754 08	33	2
40 61 076	3 211	91 57 748 08	81	2	40 65 140 05	2 340	91 52 776 08	15	2
40 61 167 01	3 292	91 52 865 08	14	4	40 65 145 01	1 970	91 56 958 08	57	8
40 61 179 01	2 730	91 52 802 08	4	4	40 65 145 01	1 970 161	96 50 706 08	57	8
40 61 179 01	3 207 101	96 48 292 08	2	1	40 65 145 01	2 970	91 56 537 08	556	4
40 61 179 01	3 281	91 52 896 08	(3)	2	40 65 145 01	2 975 100	91 52 860 08	43	4
40 61 180 01	3 714 014	96 49 456 08	3	1	40 65 145 01	2 975 100	91 52 860 08	44	4
40 61 184 01	2 657	91 57 656 08	11	1	40 65 156 08	2 393	91 52 787 08	23	4
40 61 186 01	3 211 003	96 46 986 08	8	1	40 65 164	2 350	91 52 778 08	5	6
40 61 186 01	3 220 501	96 43 440 08	9	1	40 65 164	2 370	91 52 782 08	7	12
40 61 186 01	3 221 200	96 47 984 08	9	1	40 65 164	2 391 001	96 45 719 08	344	4
40 61 186 01	3 225 200	96 48 679 08	9	1	40 65 164	2 393	91 52 787 08	20	4
40 61 186 01	3 227 002	96 50 498 08	9	1	40 65 164	2 631	91 56 817 08	19	4

6.2.2009

etk_en_de_074515 LR 1600/2

791

LIEBHERRNumerical index
Numerischer Index

Item	Page	Assembly	Pos.	Quantity	Item	Page	Assembly	Pos.	Quantity
40 65 164	2 652	91 52 794 08	31	6	40 86 002 08	2 510 040	96 49 183 08	4	4
40 65 164	2 671 004	96 46 305 08	8	4	40 86 002 08	2 510 059	96 49 184 08	4	4
40 65 164	2 810	91 52 806 08	14	12	40 86 002 08	2 522 011	96 45 602 08	25	4
40 65 164	2 925 204	92 16 990 08	16	4	40 86 002 08	2 932 160	96 54 385 08	10	16
40 65 164	2 925 402	96 58 855 08	35	2	40 86 002 08	2 970	91 56 537 08	115	8
40 65 164	3 206	91 52 881 08	7	5	40 86 002 08	3 713 013	96 57 159 08	5	11
40 65 164	3 714	91 52 862 08	71	16	40 86 002 08	3 978 015	91 56 429 08	21	3
40 65 166	2 671	91 52 798 08	7	4	40 86 002 08	3 978 015	91 56 432 08	21	3
40 65 166	2 730	91 52 802 08	12	8	40 86 005 08	3 211	91 57 748 08	51	8
40 65 166	2 970	91 56 537 08	129	2	40 86 005 08	3 713	91 57 749 08	32	16
40 65 211 01	2 310	91 52 503 08	11	4	40 86 007 08	3 206	91 52 881 08	41	3
40 65 211 01	2 320	91 52 504 08	11	4	40 86 007 08	3 714 017	96 50 752 08	3	4
40 65 211 01	3 350	91 52 859 08	7	4	40 86 008 08	2 550	91 57 751 08	53	2
40 65 215 01	3 206 002	96 47 960 08	6	1	40 86 010 08	2 502	91 55 939 08	20	4
40 65 232 01	1 400	91 56 853 08	51	34	40 86 013 08	2 550	91 57 751 08	98	9
40 65 232 01	1 410 300	91 56 855 08	51	34	40 86 027 08	3 745	91 52 948 08	54	2
40 65 232 01	X1065015	10 65 015 6	21	24	40 86 035 08	2 502	91 55 939 08	33	4
40 65 269 14	3 713	91 57 749 08	101	2	40 86 035 08	2 520	91 53 061 08	30	2
40 65 304 08	2 550	91 57 751 08	42	28	40 86 035 08	2 533 070	96 48 363 08	34	2
40 66 005 08	2 392	91 52 785 08	17	8	40 86 036 08	2 522	91 54 115 08	25	1
40 66 030 08	1 400	91 56 853 08	47	8	40 86 040 08	2 631	91 56 817 08	57	2
40 66 030 08	1 410 300	91 56 855 08	47	8	40 86 040 08	2 780 851	96 24 498 08	4	1
40 66 030 08	2 652	91 52 794 08	7	26	40 86 040 08	2 780 852	96 24 845 08	8	1
40 66 030 08	3 208 001	91 52 883 08	28	16	40 86 041 08	2 502	91 55 939 08	45	4
40 66 030 08	3 714	91 52 862 08	16	16	40 86 041 08	2 520	91 53 061 08	29	10
40 66 042	2 350	91 52 778 08	17	4	40 86 041 08	2 520 030	96 45 609 08	8	6
40 66 043 08	1 400	91 56 853 08	48	8	40 86 041 08	2 520 031	96 45 610 08	5	4
40 66 043 08	1 410 300	91 56 855 08	48	8	40 86 042 08	2 391 040	96 53 645 08	41	4
40 66 056 08	2 340	91 52 776 08	9	44	40 86 043 08	3 211 009	96 46 979 08	11	4
40 66 057 08	2 310	91 52 503 08	9	22	40 86 049 08	2 370	91 52 782 08	20	4
40 66 057 08	2 320	91 52 504 08	9	22	40 86 049 08	2 810	91 52 806 08	65	12
40 66 057 08	3 350	91 52 859 08	5	22	40 86 062 08	2 391 001	96 45 719 08	346	2
40 66 087 08	X1041101	10 41 101 8	430	2	40 86 506 08	2 711	91 52 800 08	38	11
40 70 317 08	2 550	91 57 751 08	81	2	40 93 609 08	2 520 030	96 45 609 08	7	2
40 70 608 08	2 913 102	92 32 870 08	4	8	40 97 041 08	2 260	91 53 057 08	26	8
40 72 046 08	3 215 005	91 52 846 08	24	16	40 97 041 08	2 859	91 52 809 08	52	48
40 72 046 08	3 215 006	91 52 847 08	24	16	40 97 041 08	3 211	91 57 748 08	97	12
40 72 086 08	3 745 011	96 49 677 08	11	2	40 97 043 08	2 393 002	96 46 782 08	17	4
40 72 101 14	3 747	91 52 950 08	12	32	40 97 043 08	2 520	91 53 061 08	76	13
40 73 500 08	2 932 001	96 45 393 08	7	8	40 97 043 08	2 520 032	96 45 980 08	21	6
40 73 500 08	2 932 082	96 54 387 08	36	18	40 97 043 08	2 520 034	96 45 984 08	45	93
40 73 501 08	2 533 070	96 48 363 08	37	4	40 97 043 08	2 533 051	96 48 360 08	5	4
40 73 501 08	2 835 002	96 48 379 08	31	1	40 97 043 08	2 533 068	96 49 314 08	3	4
40 73 501 08	2 932 082	96 54 387 08	84	32	40 97 043 08	2 925 026	91 55 259 08	(7)	2
40 73 501 08	2 932 160	96 54 385 08	5	13	40 97 043 08	2 925 405	96 48 397 08	7	2
40 73 502 08	2 520	91 53 061 08	40	2	40 97 053 08	2 502	91 55 939 08	43	4
40 73 502 08	2 932 168	96 48 167 08	9	2	40 97 053 08	2 520	91 53 061 08	78	2
40 82 010 08	2 920 581	96 54 405 08	295	2	40 97 053 08	2 520 034	96 45 984 08	46	6
40 82 010 08	3 930 730	96 54 398 08	273	2	40 97 059 08	2 391 040	96 53 645 08	19	2
40 82 010 08	3 930 734	96 54 401 08	210	2	40 97 059 08	3 211	91 57 748 08	96	36
40 83 023 08	7 027 481	70 27 481 03	17	1	40 97 059 08	3 713	91 57 749 08	126	20
40 83 110 08	2 520 034	96 45 984 08	60	8	40 97 059 08	3 714	91 52 862 08	89	14
40 83 112 08	2 913 003	96 20 599 08	4	4	40 97 066 08	2 391 102	96 56 360 08	14	2
40 83 114 08	2 913 006	96 20 732 08	3	4	40 97 069 08	2 503 100	91 55 873 08	2	4
40 83 115 08	2 913 005	96 20 731 08	3	8	40 97 070 08	2 310	91 52 503 08	32	2
40 83 115 08	2 913 005	96 28 696 08	3	8	40 97 070 08	2 320	91 52 504 08	32	2
40 83 115 08	2 913 007	96 20 763 08	4	3	40 97 070 08	2 970	91 56 537 08	152	2
40 84 007 01	2 913 005	96 20 731 08	4	2	40 97 109 08	2 859 030	96 46 758 08	3	2
40 84 007 01	2 913 005	96 28 696 08	4	2	40 97 513 08	2 970	91 56 537 08	562	8
40 86 002 08	2 510	91 52 788 08	5	8	40 97 516 08	2 391 001	96 45 719 08	343	8

6.2.2009

etk_en_de_074515 LR 1600/2

792

LIEBHERRNumerical index
Numerischer Index

Item	Page	Assembly	Pos.	Quantity	Item	Page	Assembly	Pos.	Quantity
40 98 296 08	1 620	91 52 386 08	1	72	41 15 141 08	2 978 200	91 54 843 08	17	2
40 98 312 08	2 631 003	96 54 406 08	3	4	41 15 141 08	2 990	91 59 244 08	17	2
41 01 012 08	3 206 002	96 47 960 08	7	1	41 15 141 08	3 713	91 57 749 08	33	21
41 01 203 08	2 522 011	96 45 602 08	17	2	41 15 142 08	2 522 011	96 45 602 08	26	2
41 01 500 08	2 932 160	96 54 385 08	23	1	41 15 142 08	2 913 102	92 32 870 08	7	8
41 15 031 03	X1041267	10 41 267 8	15	2	41 15 142 08	2 920 369	96 54 235 08	(153)	2
41 15 046 08	2 370	91 52 782 08	21	4	41 15 142 08	2 920 369	96 54 235 08	(153)	2
41 15 046 08	2 810	91 52 806 08	66	12	41 15 142 08	2 920 369	96 54 235 08	281	14
41 15 046 08	2 932 166	92 68 911 08	10	4	41 15 142 08	2 920 448	96 48 794 08	281	26
41 15 047 08	X1035519	10 35 519 6	16	2	41 15 143 08	1 991	91 52 510 08	16	1
41 15 050 08	2 652	91 52 794 08	34	2	41 15 143 08	2 310	91 52 503 08	22	4
41 15 050 08	3 220 500	91 52 849 08	11	2	41 15 143 08	2 320	91 52 504 08	22	4
41 15 050 08	3 223	91 52 852 08	11	2	41 15 143 08	2 391	91 52 784 08	5	8
41 15 050 08	3 223 010	91 52 853 08	11	2	41 15 143 08	2 550 008	96 47 628 08	13	1
41 15 050 08	3 223 100	91 55 327 08	11	4	41 15 143 08	2 550 009	96 47 645 08	13	1
41 15 050 08	3 227 002	96 50 498 08	21	4	41 15 143 08	2 810	91 52 806 08	56	1
41 15 083 08	1 630	91 52 387 08	29	16	41 15 143 08	2 970	91 56 537 08	177	8
41 15 083 08	2 631	91 56 817 08	50	2	41 15 143 08	3 213	91 52 842 08	13	4
41 15 140 08	1 830 102	92 26 483 08	5	12	41 15 143 08	3 214	91 52 843 08	30	4
41 15 140 08	1 970	91 56 958 08	67	8	41 15 143 08	3 220 500	91 52 849 08	8	8
41 15 140 08	1 970	91 56 958 08	75	8	41 15 143 08	3 221	91 54 668 08	8	8
41 15 140 08	1 991	91 52 510 08	18	2	41 15 143 08	3 223	91 52 852 08	8	8
41 15 140 08	2 370	91 52 782 08	24	8	41 15 143 08	3 223 010	91 52 853 08	8	8
41 15 140 08	2 510	91 52 788 08	9	12	41 15 143 08	3 223 100	91 55 327 08	8	8
41 15 140 08	2 711	91 52 800 08	40	4	41 15 143 08	3 225	91 52 854 08	26	8
41 15 140 08	2 810	91 52 806 08	75	5	41 15 143 08	3 226	91 52 870 08	8	8
41 15 140 08	2 835 002	96 48 379 08	22	8	41 15 143 08	3 227	91 52 873 08	8	8
41 15 140 08	2 859 030	96 46 758 08	8	2	41 15 143 08	3 227 008	91 52 872 08	8	8
41 15 140 08	2 913 004	96 20 460 08	6	2	41 15 143 08	3 227 200	91 53 519 08	8	8
41 15 140 08	2 925 204	92 16 990 08	9	7	41 15 143 08	3 350	91 52 859 08	18	48
41 15 140 08	2 925 402	96 58 855 08	14	13	41 15 143 08	3 713	91 57 749 08	26	4
41 15 140 08	2 932 082	96 54 387 08	38	1	41 15 143 08	3 714	91 52 862 08	29	4
41 15 140 08	2 932 166	92 68 911 08	6	4	41 15 143 08	3 715 008	91 52 863 08	8	8
41 15 140 08	2 970	91 56 537 08	67	10	41 15 143 08	3 716	91 52 864 08	8	8
41 15 140 08	2 975 100	91 52 860 08	53	2	41 15 143 08	3 978 100	91 56 428 08	11	4
41 15 140 08	2 976 203	92 27 489 08	11	2	41 15 144 08	2 391 001	96 45 719 08	370	4
41 15 140 08	2 978 200	91 54 843 08	20	2	41 15 144 08	2 391 038	96 47 931 08	12	12
41 15 140 08	3 206	91 52 881 08	56	2	41 15 144 08	2 391 040	96 53 645 08	24	2
41 15 140 08	3 713 013	96 57 159 08	6	11	41 15 144 08	2 502	91 55 939 08	32	2
41 15 140 08	3 745 002	92 17 236 08	9	4	41 15 144 08	2 711	91 52 800 08	36	2
41 15 140 08	3 745 003	92 17 237 08	9	4	41 15 144 08	2 925 204	92 16 990 08	17	4
41 15 141 08	1 630	91 52 387 08	26	12	41 15 144 08	2 975 000	91 57 881 08	13	2
41 15 141 08	2 260	91 53 057 08	19	33	41 15 144 08	3 206	91 52 881 08	12	11
41 15 141 08	2 260 006	96 46 501 08	25	8	41 15 144 08	3 713	91 57 749 08	34	8
41 15 141 08	2 310	91 52 503 08	34	2	41 15 144 08	3 714	91 52 862 08	73	16
41 15 141 08	2 320	91 52 504 08	34	2	41 15 145 08	1 631 100	91 52 388 08	7	12
41 15 141 08	2 350	91 52 778 08	19	12	41 15 145 08	1 991	91 52 510 08	11	6
41 15 141 08	2 370	91 52 782 08	18	4	41 15 145 08	2 652	91 52 794 08	23	6
41 15 141 08	2 391 001	96 45 719 08	371	10	41 15 145 08	2 730	91 52 802 08	5	4
41 15 141 08	2 391 040	96 53 645 08	26	2	41 15 145 08	2 810	91 52 806 08	52	4
41 15 141 08	2 391 102	96 56 360 08	11	12	41 15 145 08	3 745	91 52 948 08	11	2
41 15 141 08	2 392	91 52 785 08	20	2	41 15 147 08	1 632 032	96 20 093 08	4	1
41 15 141 08	2 393	91 52 787 08	31	12	41 15 147 08	3 206	91 52 881 08	24	1
41 15 141 08	2 631	91 56 817 08	48	13	41 15 148 08	1 100	91 52 375 08	7	9
41 15 141 08	2 670	91 52 797 08	11	4	41 15 148 08	1 711	91 52 392 08	15	8
41 15 141 08	2 810	91 52 806 08	69	4	41 15 148 08	2 260 006	96 46 501 08	18	8
41 15 141 08	2 859	91 52 809 08	69	8	41 15 148 08	2 711	91 52 800 08	8	10
41 15 141 08	2 925 204	92 16 990 08	5	2	41 15 148 08	2 780 915	96 48 377 08	8	4
41 15 141 08	2 925 402	96 58 855 08	6	12	41 15 148 08	2 835 002	96 48 379 08	34	2
41 15 141 08	2 978 100	91 52 796 08	15	8	41 15 148 08	2 913 100	91 23 538 08	10	2

6.2.2009

etk_en_de_074515 LR 1600/2

793

LIEBHERRNumerical index
Numerischer Index

Item	Page	Assembly	Pos.	Quantity	Item	Page	Assembly	Pos.	Quantity
41 15 148 08	2 920 083	96 48 319 08	32	7	41 19 004 08	3 225	91 52 854 08	32	17
41 15 148 08	2 920 638	96 51 138 08	270	2	41 19 004 08	3 226	91 52 870 08	34	17
41 15 148 08	2 922 001	92 84 311 08	18	1	41 19 004 08	3 227	91 52 873 08	34	22
41 15 148 08	2 932 082	96 54 387 08	85	4	41 19 004 08	3 227 008	91 52 872 08	34	22
41 15 149 08	2 340	91 52 776 08	16	2	41 19 004 08	3 227 200	91 53 519 08	34	22
41 15 152 08	3 747	91 52 950 08	14	32	41 19 004 08	3 713	91 57 749 08	63	15
41 15 157 08	2 922 001	92 84 311 08	15	10	41 19 004 08	3 714	91 52 862 08	58	30
41 15 157 08	2 932 001	96 45 393 08	18	28	41 19 004 08	3 715 008	91 52 863 08	9	20
41 15 157 08	3 930 009	96 50 573 08	267	4	41 19 004 08	3 716	91 52 864 08	9	25
41 15 157 08	3 930 138	96 54 377 08	(266)	4	41 19 004 08	3 780 258	96 56 482 08	(7)	3
41 15 157 08	3 930 638	96 51 624 08	284	16	41 19 004 08	3 780 751	91 52 952 08	16	2
41 15 157 08	3 930 640	96 50 481 08	155	10	41 19 004 08	3 978 015	91 56 429 08	22	3
41 15 157 08	3 930 730	96 50 599 08	267	10	41 19 004 08	3 978 015	91 56 432 08	22	3
41 15 197 08	2 932 160	96 54 385 08	37	2	41 19 005 08	1 400	91 56 853 08	62	2
41 17 003 08	2 652	91 52 794 08	33	6	41 19 005 08	1 410 300	91 56 855 08	62	2
41 17 010 08	2 391 040	96 53 645 08	23	1	41 19 005 08	1 620	91 52 386 08	8	4
41 17 011 08	2 810	91 52 806 08	18	2	41 19 005 08	1 631 100	91 52 388 08	12	48
41 17 209 08	1 630	91 52 387 08	33	4	41 19 005 08	2 350	91 52 778 08	12	3
41 18 806 08	3 714 025	96 49 269 08	8	1	41 19 005 08	2 391 023	96 45 720 08	16	12
41 19 001 08	2 533 070	96 48 363 08	29	4	41 19 005 08	2 503 100	91 55 873 08	3	4
41 19 001 08	2 780 852	96 24 845 08	12	2	41 19 005 08	2 522 013	96 45 883 08	10	2
41 19 001 08	2 913	91 32 850 08	12	10	41 19 005 08	2 541 001	96 49 651 08	13	1
41 19 001 08	2 913 005	96 20 731 08	6	2	41 19 005 08	2 550	91 57 751 08	21	4
41 19 001 08	2 913 005	96 28 696 08	6	2	41 19 005 08	2 631 003	96 54 406 08	4	4
41 19 001 08	2 913 006	96 20 732 08	4	6	41 19 005 08	2 671	91 52 798 08	17	2
41 19 001 08	2 913 009	91 04 705 08	12	10	41 19 005 08	2 810 001	96 43 597 08	6	6
41 19 001 08	2 920 369	96 54 235 08	44	8	41 19 005 08	2 859	91 52 809 08	54	77
41 19 002 08	2 631	91 56 817 08	40	10	41 19 005 08	2 859 025	96 46 757 08	6	10
41 19 002 08	2 932 160	96 54 385 08	45	56	41 19 005 08	2 859 030	96 46 758 08	5	2
41 19 002 08	3 780 200	96 54 370 08	12	3	41 19 005 08	2 932 160	96 54 385 08	7	4
41 19 003 08	2 260	91 53 057 08	29	4	41 19 005 08	2 970	91 56 537 08	154	2
41 19 003 08	2 260 009	96 46 972 08	5	4	41 19 005 08	3 206	91 52 881 08	46	11
41 19 003 08	2 391 040	96 53 645 08	43	4	41 19 005 08	3 208 001	91 52 883 08	31	4
41 19 003 08	2 533 070	96 48 363 08	33	2	41 19 005 08	3 211	91 57 748 08	33	174
41 19 003 08	2 631	91 56 817 08	58	2	41 19 005 08	3 213	91 52 842 08	17	2
41 19 003 08	2 780 851	96 24 498 08	5	1	41 19 005 08	3 214	91 52 843 08	23	17
41 19 003 08	2 780 852	96 24 845 08	9	1	41 19 005 08	3 220 500	91 52 849 08	35	41
41 19 003 08	2 859	91 52 809 08	51	16	41 19 005 08	3 221	91 54 668 08	19	36
41 19 003 08	2 859 005	96 46 756 08	4	8	41 19 005 08	3 223	91 52 852 08	35	51
41 19 003 08	2 859 025	96 46 757 08	9	8	41 19 005 08	3 223 010	91 52 853 08	35	51
41 19 003 08	3 780 258	96 56 482 08	(3)	3	41 19 005 08	3 223 100	91 55 327 08	35	51
41 19 004 08	2 260	91 53 057 08	22	13	41 19 005 08	3 225	91 52 854 08	37	47
41 19 004 08	2 260 006	96 46 501 08	21	4	41 19 005 08	3 226	91 52 870 08	35	34
41 19 004 08	2 391 023	96 45 720 08	18	16	41 19 005 08	3 227	91 52 873 08	35	39
41 19 004 08	2 391 036	96 23 055 08	5	5	41 19 005 08	3 227 008	91 52 872 08	35	31
41 19 004 08	2 391 039	96 50 616 08	5	4	41 19 005 08	3 227 200	91 53 519 08	35	49
41 19 004 08	2 391 040	96 53 645 08	33	1	41 19 005 08	3 281	91 52 896 08	62	2
41 19 004 08	2 393 002	96 46 782 08	16	12	41 19 005 08	3 291	91 52 831 08	4	8
41 19 004 08	2 550	91 57 751 08	59	14	41 19 005 08	3 292	91 52 865 08	9	8
41 19 004 08	2 932 166	92 68 911 08	14	6	41 19 005 08	3 713	91 57 749 08	18	173
41 19 004 08	2 970	91 56 537 08	116	8	41 19 005 08	3 714	91 52 862 08	48	71
41 19 004 08	3 206	91 52 881 08	29	4	41 19 005 08	3 714 017	96 50 752 08	4	4
41 19 004 08	3 208 001	91 52 883 08	30	8	41 19 005 08	3 715 008	91 52 863 08	10	74
41 19 004 08	3 211	91 57 748 08	57	10	41 19 005 08	3 716	91 52 864 08	10	124
41 19 004 08	3 214	91 52 843 08	44	4	41 19 005 08	3 745	91 52 948 08	30	24
41 19 004 08	3 220 500	91 52 849 08	34	17	41 19 006 08	1 400	91 56 853 08	69	12
41 19 004 08	3 221	91 54 668 08	18	12	41 19 006 08	1 410 300	91 56 855 08	69	12
41 19 004 08	3 223	91 52 852 08	34	22	41 19 006 08	2 550	91 57 751 08	100	9
41 19 004 08	3 223 010	91 52 853 08	34	22	41 19 006 08	2 730	91 52 802 08	11	4
41 19 004 08	3 223 100	91 55 327 08	34	22	41 19 006 08	3 206	91 52 881 08	13	2

6.2.2009

etk_en_de_074515 LR 1600/2

794

LIEBHERRNumerical index
Numerischer Index

Item	Page	Assembly	Pos.	Quantity	Item	Page	Assembly	Pos.	Quantity
41 19 006 08	3 208 001	91 52 883 08	32	7	41 30 065 08	2 810 037	96 47 204 08	2	12
41 19 006 08	3 211	91 57 748 08	49	4	41 30 066 08	2 925 402	96 58 855 08	(2)	2
41 19 006 08	3 281	91 52 896 08	40	4	41 30 070 08	2 391 023	96 45 720 08	19	2
41 19 006 08	3 745	91 52 948 08	35	8	41 30 070 08	2 831	91 57 754 08	32	4
41 19 007 08	2 340	91 52 776 08	14	2	41 30 070 08	2 859	91 52 809 08	55	24
41 19 007 08	2 391 001	96 45 719 08	361	8	42 00 006 08	2 920 369	96 54 235 08	43	8
41 19 007 08	2 391 023	96 45 720 08	12	4	42 00 006 08	2 922 001	92 84 311 08	16	10
41 19 007 08	3 206	91 52 881 08	38	11	42 00 006 08	2 932 001	96 45 393 08	30	20
41 19 007 08	3 207 003	96 48 259 08	6	1	42 00 006 08	3 930 638	96 51 624 08	282	16
41 19 007 08	3 207 100	96 48 261 08	5	1	42 00 007 08	2 913 004	96 20 460 08	4	4
41 19 007 08	3 208 001	91 52 883 08	33	6	42 00 007 08	2 913 100	91 23 538 08	13	4
41 19 007 08	3 211	91 57 748 08	73	8	42 00 007 08	2 913 102	92 32 870 08	5	8
41 19 007 08	3 215 005	91 52 846 08	32	4	42 00 007 08	2 920 369	96 54 235 08	(154)	4
41 19 007 08	3 215 006	91 52 847 08	32	4	42 00 007 08	2 920 369	96 54 235 08	(154)	4
41 19 007 08	3 281	91 52 896 08	(6)	1	42 00 007 08	2 920 369	96 54 235 08	279	16
41 19 007 08	3 292	91 52 865 08	17	4	42 00 007 08	2 920 448	96 48 794 08	279	28
41 19 007 08	3 714 008	96 49 266 08	14	4	42 00 007 08	2 932 001	96 45 393 08	39	8
41 19 009 08	1 300 011	96 52 493 08	4	162	42 00 007 08	2 932 082	96 54 387 08	92	8
41 19 009 08	2 391 040	96 53 645 08	25	1	42 00 007 08	2 932 160	96 54 385 08	47	56
41 19 009 08	2 550 010	96 45 685 08	4	2	42 00 008 08	1 711	91 52 392 08	16	8
41 19 009 08	2 657	91 57 656 08	13	1	42 00 008 08	2 260 006	96 46 501 08	16	8
41 19 009 08	3 207 101	96 48 292 08	3	1	42 00 008 08	2 391 040	96 53 645 08	42	4
41 19 009 08	3 211 003	96 46 986 08	9	1	42 00 008 08	2 502	91 55 939 08	35	8
41 19 009 08	3 214	91 52 843 08	19	2	42 00 008 08	2 522	91 54 115 08	24	1
41 19 009 08	3 220 501	96 43 440 08	10	1	42 00 008 08	2 711	91 52 800 08	9	10
41 19 009 08	3 221 200	96 47 984 08	10	1	42 00 008 08	2 780 915	96 48 377 08	2	4
41 19 009 08	3 225 200	96 48 679 08	10	1	42 00 008 08	2 835 002	96 48 379 08	33	2
41 19 009 08	3 227 002	96 50 498 08	10	1	42 00 008 08	2 913 100	91 23 538 08	9	3
41 19 009 08	3 281	91 52 896 08	(5)	2	42 00 008 08	2 920 083	96 48 319 08	34	7
41 19 009 08	3 281	91 52 896 08	(5)	1	42 00 008 08	2 920 814	96 45 717 08	15	5
41 19 009 08	3 292	91 52 865 08	15	4	42 00 008 08	2 975 100	91 52 860 08	56	2
41 19 009 08	3 561 003	96 45 222 08	10	1	42 00 008 08	3 780 258	96 56 482 08	(5)	3
41 19 009 08	3 713 012	96 50 197 08	10	1	42 00 008 08	3 930 730	96 54 398 08	272	2
41 19 009 08	3 714 013	96 49 270 08	6	2	42 00 009 08	1 830 102	92 26 483 08	3	6
41 19 009 08	3 714 013	96 59 083 08	7	1	42 00 009 08	1 970	91 56 958 08	74	8
41 19 009 08	3 714 014	96 49 456 08	5	1	42 00 009 08	1 991	91 52 510 08	19	2
41 19 009 08	3 716 001	96 49 159 08	10	1	42 00 009 08	2 260	91 53 057 08	21	24
41 19 010 08	2 260	91 53 057 08	30	8	42 00 009 08	2 260 006	96 46 501 08	20	6
41 19 010 08	2 520	91 53 061 08	74	13	42 00 009 08	2 260 009	96 46 972 08	6	8
41 19 011 08	2 810	91 52 806 08	10	16	42 00 009 08	2 370	91 52 782 08	23	16
41 19 013 08	3 745	91 52 948 08	50	4	42 00 009 08	2 391 039	96 50 616 08	6	8
41 19 014 08	2 391 001	96 45 719 08	362	4	42 00 009 08	2 393 002	96 46 782 08	15	12
41 19 024 08	2 550 005	96 45 680 08	11	2	42 00 009 08	2 502	91 55 939 08	42	4
41 19 024 08	3 745 011	96 49 677 08	5	4	42 00 009 08	2 520 034	96 45 984 08	56	4
41 19 025 08	3 714 009	96 49 267 08	17	6	42 00 009 08	2 522	91 54 115 08	9	2
41 19 026 08	3 713	91 57 749 08	104	2	42 00 009 08	2 522 011	96 45 602 08	16	3
41 19 030 08	2 925 402	96 58 855 08	22	8	42 00 009 08	2 540	91 53 253 08	9	2
41 21 001 08	2 520 031	96 45 610 08	8	6	42 00 009 08	2 711	91 52 800 08	41	4
41 30 026 08	2 932 082	96 54 387 08	87	8	42 00 009 08	2 835 002	96 48 379 08	23	12
41 30 027 08	2 502	91 55 939 08	44	4	42 00 009 08	2 925 204	92 16 990 08	10	14
41 30 028 08	2 520 034	96 45 984 08	57	1	42 00 009 08	2 925 402	96 58 855 08	12	13
41 30 029 08	2 391 001	96 45 719 08	373	12	42 00 009 08	2 932 166	92 68 911 08	4	4
41 30 031 08	2 520 033	96 50 633 08	4	1	42 00 009 08	2 932 168	96 48 167 08	8	4
41 30 032 08	1 400	91 56 853 08	61	12	42 00 009 08	2 976 203	92 27 489 08	12	2
41 30 032 08	1 410 300	91 56 855 08	61	12	42 00 009 08	3 206	91 52 881 08	28	4
41 30 032 08	2 859	91 52 809 08	53	21	42 00 009 08	3 214	91 52 843 08	43	8
41 30 038 08	2 932 001	96 45 393 08	6	8	42 00 009 08	3 745 002	92 17 236 08	10	8
41 30 038 08	2 932 160	96 54 385 08	19	13	42 00 009 08	3 745 003	92 17 237 08	10	8
41 30 065 08	2 520	91 53 061 08	24	5	42 00 009 08	3 780 751	91 52 952 08	17	6
41 30 065 08	2 522	91 54 115 08	18	2	42 00 009 08	3 978 015	91 56 429 08	23	3

6.2.2009

etk_en_de_074515 LR 1600/2

795

LIEBHERRNumerical index
Numerischer Index

Item	Page	Assembly	Pos.	Quantity	Item	Page	Assembly	Pos.	Quantity
42 00 009 08	3 978 015	91 56 432 08	23	3	42 00 013 08	1 620	91 52 386 08	4	16
42 00 009 08	7 027 481	70 27 481 03	7	8	42 00 013 08	2 391 040	96 53 645 08	27	2
42 00 009 08	9 080 702	90 80 702	7	2	42 00 013 08	2 550	91 57 751 08	99	9
42 00 009 08	X1022811	10 22 811 2	43	2	42 00 013 08	2 631	91 56 817 08	20	4
42 00 012 08	1 400	91 56 853 08	39	18	42 00 013 08	2 671 004	96 46 305 08	7	4
42 00 012 08	1 410 300	91 56 855 08	39	18	42 00 013 08	2 925 204	92 16 990 08	18	4
42 00 012 08	1 630	91 52 387 08	25	24	42 00 013 08	2 925 402	96 58 855 08	34	2
42 00 012 08	1 970	91 56 958 08	64	8	42 00 013 08	3 206	91 52 881 08	8	14
42 00 012 08	1 970	91 56 958 08	82	4	42 00 013 08	3 211	91 57 748 08	50	8
42 00 012 08	1 991	91 52 510 08	22	4	42 00 013 08	3 281	91 52 896 08	39	8
42 00 012 08	2 260	91 53 057 08	18	57	42 00 013 08	3 713	91 57 749 08	35	8
42 00 012 08	2 260 006	96 46 501 08	24	2	42 00 013 08	3 714	91 52 862 08	72	32
42 00 012 08	2 310	91 52 503 08	33	2	42 00 013 08	3 745	91 52 948 08	36	16
42 00 012 08	2 320	91 52 504 08	33	2	42 00 013 08	9 080 702	90 80 702	9	4
42 00 012 08	2 350	91 52 778 08	20	24	42 00 013 08	X1041267	10 41 267 8	14	2
42 00 012 08	2 370	91 52 782 08	17	12	42 00 016 08	1 630	91 52 387 08	34	8
42 00 012 08	2 391 038	96 47 931 08	15	10	42 00 016 08	2 310	91 52 503 08	21	8
42 00 012 08	2 391 102	96 56 360 08	12	12	42 00 016 08	2 320	91 52 504 08	21	8
42 00 012 08	2 503 100	91 55 873 08	4	4	42 00 016 08	2 340	91 52 776 08	13	2
42 00 012 08	2 522	91 54 115 08	20	2	42 00 016 08	2 392	91 52 785 08	13	16
42 00 012 08	2 522 012	96 45 884 08	8	4	42 00 016 08	2 671	91 52 798 08	10	4
42 00 012 08	2 522 013	96 45 883 08	9	2	42 00 016 08	2 810	91 52 806 08	55	1
42 00 012 08	2 540	91 53 253 08	8	2	42 00 016 08	2 932 160	96 54 385 08	25	1
42 00 012 08	2 541 001	96 49 651 08	14	1	42 00 016 08	2 970	91 56 537 08	176	16
42 00 012 08	2 550	91 57 751 08	20	6	42 00 016 08	3 206	91 52 881 08	37	6
42 00 012 08	2 631	91 56 817 08	43	40	42 00 016 08	3 207 003	96 48 259 08	5	2
42 00 012 08	2 631 003	96 54 406 08	5	4	42 00 016 08	3 207 100	96 48 261 08	4	2
42 00 012 08	2 670	91 52 797 08	10	8	42 00 016 08	3 208 001	91 52 883 08	34	12
42 00 012 08	2 810	91 52 806 08	67	20	42 00 016 08	3 211	91 57 748 08	71	8
42 00 012 08	2 810 001	96 43 597 08	5	18	42 00 016 08	3 214	91 52 843 08	31	12
42 00 012 08	2 831	91 57 754 08	34	4	42 00 016 08	3 215 005	91 52 846 08	23	4
42 00 012 08	2 859	91 52 809 08	59	104	42 00 016 08	3 215 006	91 52 847 08	23	4
42 00 012 08	2 859 030	96 46 758 08	4	2	42 00 016 08	3 281	91 52 896 08	(5)	2
42 00 012 08	2 925 204	92 16 990 08	6	2	42 00 016 08	3 291	91 52 831 08	10	4
42 00 012 08	2 925 402	96 58 855 08	10	9	42 00 016 08	3 292	91 52 865 08	4	4
42 00 012 08	2 932 160	96 54 385 08	6	12	42 00 016 08	3 714	91 52 862 08	37	28
42 00 012 08	2 932 166	92 68 911 08	13	4	42 00 016 08	3 978 100	91 56 428 08	12	4
42 00 012 08	2 970	91 56 537 08	153	2	42 00 018 08	2 631	91 56 817 08	51	4
42 00 012 08	3 208 001	91 52 883 08	38	8	42 00 019 08	1 641 014	92 53 053 08	5	4
42 00 012 08	3 211	91 57 748 08	28	12	42 00 019 08	1 991	91 52 510 08	12	6
42 00 012 08	3 213	91 52 842 08	18	4	42 00 019 08	2 125	91 52 773 08	9	24
42 00 012 08	3 214	91 52 843 08	22	10	42 00 019 08	2 391 040	96 53 645 08	29	2
42 00 012 08	3 220 500	91 52 849 08	39	8	42 00 019 08	2 393	91 52 787 08	44	4
42 00 012 08	3 223	91 52 852 08	39	8	42 00 019 08	2 550	91 57 751 08	6	26
42 00 012 08	3 223 010	91 52 853 08	39	8	42 00 019 08	2 631	91 56 817 08	22	6
42 00 012 08	3 223 100	91 55 327 08	39	8	42 00 019 08	2 652	91 52 794 08	11	29
42 00 012 08	3 225	91 52 854 08	36	31	42 00 019 08	2 657	91 57 656 08	14	2
42 00 012 08	3 226	91 52 870 08	39	8	42 00 019 08	2 730	91 52 802 08	6	4
42 00 012 08	3 227	91 52 873 08	39	8	42 00 019 08	2 810	91 52 806 08	51	8
42 00 012 08	3 227 008	91 52 872 08	39	8	42 00 019 08	2 970	91 56 537 08	175	16
42 00 012 08	3 227 200	91 53 519 08	39	8	42 00 019 08	3 207 101	96 48 292 08	4	2
42 00 012 08	3 281	91 52 896 08	61	4	42 00 019 08	3 208 001	91 52 883 08	35	16
42 00 012 08	3 350	91 52 859 08	15	8	42 00 019 08	3 211	91 57 748 08	42	6
42 00 012 08	3 713	91 57 749 08	77	26	42 00 019 08	3 211 003	96 46 986 08	10	2
42 00 012 08	3 714	91 52 862 08	49	16	42 00 019 08	3 214	91 52 843 08	13	4
42 00 012 08	3 714 017	96 50 752 08	5	4	42 00 019 08	3 220 500	91 52 849 08	10	2
42 00 012 08	3 715 008	91 52 863 08	11	8	42 00 019 08	3 220 501	96 43 440 08	11	2
42 00 012 08	3 716	91 52 864 08	11	8	42 00 019 08	3 221 200	96 47 984 08	11	2
42 00 012 08	3 745	91 52 948 08	43	8	42 00 019 08	3 223	91 52 852 08	10	2
42 00 012 08	5 106 691	51 06 691 08	6	4	42 00 019 08	3 223 010	91 52 853 08	10	2

6.2.2009

etk_en_de_074515 LR 1600/2

796

LIEBHERRNumerical index
Numerischer Index

Item	Page	Assembly	Pos.	Quantity	Item	Page	Assembly	Pos.	Quantity
42 00 019 08	3 223 100	91 55 327 08	10	4	42 11 027 08	2 652	91 52 794 08	19	3
42 00 019 08	3 225 200	96 48 679 08	11	2	42 11 032 08	2 550	91 57 751 08	8	2
42 00 019 08	3 227 002	96 50 498 08	11	4	42 11 032 08	2 652	91 52 794 08	12	2
42 00 019 08	3 281	91 52 896 08	(4)	4	42 11 033 08	3 747	91 52 950 08	4	8
42 00 019 08	3 281	91 52 896 08	(4)	2	42 12 013 08	2 631	91 56 817 08	30	2
42 00 019 08	3 350	91 52 859 08	12	24	42 12 013 08	2 652	91 52 794 08	29	16
42 00 019 08	3 561 003	96 45 222 08	11	2	42 12 013 08	2 925 204	92 16 990 08	12	1
42 00 019 08	3 713	91 57 749 08	144	2	42 12 016 08	2 550	91 57 751 08	30	2
42 00 019 08	3 713	91 57 749 08	155	2	42 12 016 08	2 671	91 52 798 08	19	6
42 00 019 08	3 713 012	96 50 197 08	11	1	42 12 016 08	2 810	91 52 806 08	40	4
42 00 019 08	3 714	91 52 862 08	17	16	42 12 019 08	3 208 001	91 52 883 08	47	2
42 00 019 08	3 714 008	96 49 266 08	10	8	42 12 019 08	3 211	91 57 748 08	24	4
42 00 019 08	3 714 009	96 49 267 08	13	8	42 12 019 08	3 713	91 57 749 08	40	2
42 00 019 08	3 714 013	96 49 270 08	5	2	42 12 019 08	3 790 006	96 19 989 08	3	1
42 00 019 08	3 714 013	96 59 083 08	6	2	42 12 019 08	3 790 007	96 19 990 08	3	1
42 00 019 08	3 714 014	96 49 456 08	4	2	42 12 024 08	2 550	91 57 751 08	66	4
42 00 019 08	3 716 001	96 49 159 08	11	2	42 12 024 08	2 550	91 57 751 08	91	3
42 00 019 08	3 745	91 52 948 08	13	16	42 12 024 08	2 810	91 52 806 08	20	2
42 00 020 08	1 631 100	91 52 388 08	8	60	42 12 024 08	3 211 009	96 46 979 08	5	2
42 00 020 08	2 652	91 52 794 08	24	6	42 15 000 08	2 391 001	96 45 719 08	391	2
42 00 021 01	1 400	91 56 853 08	(69)	1	42 15 002 08	1 400	91 56 853 08	42	26
42 00 021 08	1 400	91 56 853 08	41	4	42 15 002 08	1 410 300	91 56 855 08	42	26
42 00 021 08	1 410 300	91 56 855 08	41	4	42 15 002 08	2 391 001	96 45 719 08	381	12
42 00 021 08	1 632 032	96 20 093 08	3	2	42 15 003 08	2 391 001	96 45 719 08	389	4
42 00 021 08	1 991	91 52 510 08	14	8	42 15 003 08	3 745 011	96 49 677 08	12	2
42 00 021 08	2 550 005	96 45 680 08	10	4	42 15 004 08	1 400	91 56 853 08	43	70
42 00 021 08	2 620	91 52 793 08	9	1	42 15 004 08	1 410 300	91 56 855 08	43	70
42 00 021 08	2 631	91 56 817 08	27	12	42 16 004 08	2 260	91 53 057 08	32	5
42 00 021 08	2 925 402	96 58 855 08	30	1	42 16 004 08	2 391 036	96 23 055 08	6	5
42 00 021 08	3 211	91 57 748 08	38	14	42 16 004 08	2 925 402	96 58 855 08	13	13
42 00 021 08	3 713	91 57 749 08	69	4	42 16 005 08	2 260	91 53 057 08	33	12
42 00 021 08	3 714 025	96 49 269 08	7	2	42 16 005 08	2 260 006	96 46 501 08	10	3
42 00 024 08	1 400	91 56 853 08	40	34	42 16 005 08	2 391 001	96 45 719 08	392	6
42 00 024 08	1 410 300	91 56 855 08	40	34	42 16 005 08	2 392	91 52 785 08	18	8
42 00 024 08	2 631	91 56 817 08	32	14	42 16 005 08	2 510	91 52 788 08	15	8
42 00 024 08	2 730	91 52 802 08	14	8	42 16 005 08	2 859	91 52 809 08	57	35
42 00 028 08	2 620	91 52 793 08	12	1	42 16 005 08	2 925 402	96 58 855 08	16	12
42 00 028 08	2 810	91 52 806 08	22	10	42 16 005 08	3 211	91 57 748 08	99	55
42 00 028 08	3 282 002	96 47 890 08	22	2	42 16 005 08	3 713	91 57 749 08	125	33
42 00 028 08	3 714	91 52 862 08	67	4	42 16 005 08	3 714	91 52 862 08	88	12
42 00 033 08	3 745	91 52 948 08	57	1	42 16 006 08	2 631	91 56 817 08	36	24
42 00 040 08	3 205	91 52 880 08	13	2	42 16 007 08	2 212	91 54 561 08	3	2
42 00 501 08	3 930 009	96 50 573 08	268	4	42 16 007 08	2 391 001	96 45 719 08	384	10
42 00 501 08	3 930 138	96 54 377 08	(154)	1	42 16 007 08	3 215 005	91 52 846 08	25	8
42 00 501 08	3 930 640	96 50 481 08	156	10	42 16 007 08	3 215 006	91 52 847 08	25	8
42 00 501 08	3 930 730	96 50 599 08	268	10	42 16 009 08	2 391 001	96 45 719 08	385	2
42 00 506 08	2 711	91 52 800 08	37	4	42 16 009 08	2 391 040	96 53 645 08	36	1
42 00 507 08	2 391 038	96 47 931 08	13	8	42 16 009 08	2 550	91 57 751 08	43	28
42 00 507 08	2 652	91 52 794 08	32	12	42 16 013 08	3 714 009	96 49 267 08	16	12
42 00 507 08	3 208 001	91 52 883 08	36	18	42 17 005 08	2 541 001	96 49 651 08	12	4
42 00 508 08	3 213	91 52 842 08	9	8	42 17 006 08	2 620	91 52 793 08	6	1
42 00 508 08	3 350	91 52 859 08	25	96	42 17 009 08	3 747	91 52 950 08	13	32
42 00 508 08	3 714 008	96 49 266 08	13	8	42 18 005 08	2 631	91 56 817 08	39	10
42 00 607 05	2 671	91 52 798 08	16	4	42 18 005 08	2 925 026	91 55 259 08	(32)	4
42 06 042 08	2 260	91 53 057 08	31	8	42 18 005 08	2 925 405	96 48 397 08	32	4
42 06 042 08	2 393	91 52 787 08	43	2	42 18 006 08	2 260	91 53 057 08	24	28
42 11 006 08	3 713	91 57 749 08	121	5	42 18 006 08	2 391 001	96 45 719 08	395	8
42 11 013 08	2 932 160	96 54 385 08	24	1	42 18 006 08	2 522 011	96 45 602 08	11	1
42 11 022 08	3 225	91 52 854 08	51	8	42 18 006 08	2 631	91 56 817 08	59	2
42 11 026 08	2 810	91 52 806 08	29	4	42 18 006 08	2 920 581	96 54 405 08	296	2

6.2.2009

etk_en_de_074515 LR 1600/2

797

LIEBHERRNumerical index
Numerischer Index

Item	Page	Assembly	Pos.	Quantity	Item	Page	Assembly	Pos.	Quantity
42 18 006 08	2 975 200	91 52 775 08	49	4	42 18 009 08	3 715 008	91 52 863 08	13	48
42 18 006 08	2 975 700	91 52 774 08	49	4	42 18 009 08	3 716	91 52 864 08	13	92
42 18 006 08	3 780 258	96 56 482 08	(4)	3	42 18 009 08	3 978 005	91 56 430 08	8	4
42 18 006 08	3 930 640	96 50 481 08	160	2	42 18 010 08	2 391 001	96 45 719 08	390	12
42 18 006 08	3 930 730	96 50 599 08	273	2	42 18 010 08	2 391 038	96 47 931 08	14	12
42 18 006 08	3 930 734	96 54 401 08	218	2	42 18 010 08	2 393	91 52 787 08	41	4
42 18 007 08	2 391 040	96 53 645 08	34	2	42 18 011 08	2 310	91 52 503 08	23	8
42 18 007 08	2 510	91 52 788 08	8	8	42 18 011 08	2 320	91 52 504 08	23	8
42 18 007 08	2 520 031	96 45 610 08	7	6	42 18 011 08	2 391	91 52 784 08	386	4
42 18 007 08	2 522	91 54 115 08	16	8	42 18 011 08	2 391 001	96 45 719 08	386	4
42 18 007 08	2 533 066	96 48 365 08	15	1	42 18 011 08	2 391 023	96 45 720 08	11	12
42 18 007 08	2 550	91 57 751 08	58	28	42 18 011 08	3 211	91 57 748 08	74	8
42 18 007 08	2 859 030	96 46 758 08	7	4	42 18 011 08	3 213	91 52 842 08	14	8
42 18 007 08	2 925 402	96 58 855 08	23	8	42 18 011 08	3 214	91 52 843 08	29	8
42 18 007 08	2 990	91 59 244 08	18	6	42 18 011 08	3 220 500	91 52 849 08	7	16
42 18 007 08	3 206	91 52 881 08	55	2	42 18 011 08	3 221	91 54 668 08	7	16
42 18 007 08	3 208 001	91 52 883 08	37	16	42 18 011 08	3 223	91 52 852 08	7	16
42 18 007 08	3 211	91 57 748 08	58	20	42 18 011 08	3 223 010	91 52 853 08	7	16
42 18 007 08	3 220 500	91 52 849 08	37	17	42 18 011 08	3 223 100	91 55 327 08	7	16
42 18 007 08	3 221	91 54 668 08	21	12	42 18 011 08	3 225	91 52 854 08	27	16
42 18 007 08	3 223	91 52 852 08	37	22	42 18 011 08	3 226	91 52 870 08	7	16
42 18 007 08	3 223 010	91 52 853 08	37	22	42 18 011 08	3 227	91 52 873 08	7	16
42 18 007 08	3 223 100	91 55 327 08	37	22	42 18 011 08	3 227 008	91 52 872 08	7	16
42 18 007 08	3 225	91 52 854 08	33	17	42 18 011 08	3 227 200	91 53 519 08	7	16
42 18 007 08	3 226	91 52 870 08	37	17	42 18 011 08	3 713	91 57 749 08	25	4
42 18 007 08	3 227	91 52 873 08	37	22	42 18 011 08	3 714	91 52 862 08	28	8
42 18 007 08	3 227 008	91 52 872 08	37	22	42 18 011 08	3 715 008	91 52 863 08	14	16
42 18 007 08	3 227 200	91 53 519 08	37	22	42 18 011 08	3 716	91 52 864 08	14	16
42 18 007 08	3 291	91 52 831 08	5	16	42 18 013 08	1 400	91 56 853 08	64	4
42 18 007 08	3 292	91 52 865 08	10	8	42 18 013 08	1 410 300	91 56 855 08	64	4
42 18 007 08	3 713	91 57 749 08	64	16	42 18 013 08	3 223 100	91 55 327 08	52	2
42 18 007 08	3 714	91 52 862 08	57	40	42 18 017 08	2 550 008	96 47 628 08	14	6
42 18 007 08	3 715 008	91 52 863 08	12	24	42 18 017 08	2 550 009	96 47 645 08	14	6
42 18 007 08	3 716	91 52 864 08	12	31	42 18 017 08	2 810	91 52 806 08	74	3
42 18 009 08	1 400	91 56 853 08	63	2	42 18 017 08	2 978 200	91 54 843 08	19	4
42 18 009 08	1 410 300	91 56 855 08	63	2	42 18 017 08	3 713 013	96 57 159 08	7	11
42 18 009 08	2 350	91 52 778 08	10	3	42 18 024 08	3 745	91 52 948 08	49	4
42 18 009 08	2 350	91 52 778 08	21	4	42 18 614 05	3 745	91 52 948 08	32	8
42 18 009 08	2 391 001	96 45 719 08	387	22	42 20 015 08	3 282 002	96 47 890 08	17	1
42 18 009 08	2 391 040	96 53 645 08	28	4	42 20 075 08	1 400	91 56 853 08	(28)	3
42 18 009 08	2 391 102	96 56 360 08	13	14	42 39 110 01	1 400	91 56 853 08	(57)	8
42 18 009 08	2 392	91 52 785 08	22	4	42 39 112 01	9 697 916	96 97 916 01	27	8
42 18 009 08	2 393	91 52 787 08	42	26	42 39 112 01	9 697 916	96 97 916 01	75	12
42 18 009 08	2 520	91 53 061 08	75	7	42 40 004 08	2 920 083	96 48 319 08	33	7
42 18 009 08	2 631	91 56 817 08	54	4	42 40 004 08	2 920 638	96 51 138 08	269	2
42 18 009 08	2 831	91 57 754 08	31	4	42 40 005 08	2 920 200	96 44 536 08	12	3
42 18 009 08	3 206	91 52 881 08	42	3	42 40 005 08	2 920 260	96 44 537 08	12	3
42 18 009 08	3 211	91 57 748 08	54	46	42 40 005 08	2 920 334	96 44 538 08	12	3
42 18 009 08	3 220 500	91 52 849 08	38	8	42 40 005 08	2 920 350	96 44 539 08	12	3
42 18 009 08	3 221	91 54 668 08	22	12	42 40 005 08	2 970	91 56 537 08	66	10
42 18 009 08	3 223	91 52 852 08	38	40	42 40 005 08	2 975 100	91 52 860 08	52	2
42 18 009 08	3 223 010	91 52 853 08	38	40	42 40 005 08	2 975 200	91 52 775 08	53	4
42 18 009 08	3 223 100	91 55 327 08	38	40	42 40 005 08	2 975 700	91 52 774 08	53	4
42 18 009 08	3 225	91 52 854 08	42	43	42 40 007 08	1 970	91 56 958 08	9	2
42 18 009 08	3 226	91 52 870 08	38	8	42 40 007 08	3 713	91 57 749 08	36	16
42 18 009 08	3 227	91 52 873 08	38	24	42 40 007 08	5 106 691	51 06 691 08	5	4
42 18 009 08	3 227 008	91 52 872 08	38	16	42 40 008 08	2 550	91 57 751 08	70	4
42 18 009 08	3 227 200	91 53 519 08	38	10	42 40 008 08	X1035519	10 35 519 6	10	14
42 18 009 08	3 713	91 57 749 08	19	28	42 40 009 08	3 211 002	92 88 302 08	4	2
42 18 009 08	3 714	91 52 862 08	77	8	42 40 009 08	3 713	91 57 749 08	152	2

6.2.2009

etk_en_de_074515 LR 1600/2

798

LIEBHERRNumerical index
Numerischer Index

Item	Page	Assembly	Pos.	Quantity	Item	Page	Assembly	Pos.	Quantity
42 40 607 08	X1035519	10 35 519 6	12	14	42 80 064 08	X1065015	10 65 015 8	41	1
42 41 006 08	5 102 306	51 02 306 08	8	6	42 80 065 08	3 714	91 52 862 08	15	2
42 42 017	2 810	91 52 806 08	(6)	2	42 80 067 08	2 550	91 57 751 08	14	4
42 50 518 08	2 810	91 52 806 08	33	4	42 80 067 08	2 550 005	96 45 680 08	7	1
42 51 004 08	2 913 003	96 20 599 08	3	4	42 80 067 08	3 714 025	96 49 269 08	4	2
42 51 005 08	2 913 100	91 23 538 08	6	12	42 80 067 08	3 745 011	96 49 677 08	6	2
42 51 005 08	2 920 369	96 54 235 08	42	8	42 80 076 08	3 211 003	96 46 986 08	5	2
42 51 005 08	2 922 001	92 84 311 08	17	10	42 80 085 08	1 400	91 56 853 08	59	2
42 51 005 08	3 930 138	96 54 377 08	(267)	4	42 80 085 08	1 410 300	91 56 855 08	59	2
42 51 005 08	3 930 638	96 51 624 08	283	16	42 80 093 08	3 214	91 52 843 08	9	5
42 51 007 08	2 913 100	91 23 538 08	14	4	42 80 093 08	3 225 100	96 48 582 08	4	2
42 51 007 08	2 913 102	92 32 870 08	6	8	42 80 093 08	3 281	91 52 896 08	4	2
42 51 007 08	2 920 369	96 54 235 08	282	12	42 80 093 08	3 713	91 57 749 08	5	2
42 51 007 08	2 920 448	96 48 794 08	282	24	42 80 093 08	3 714	91 52 862 08	33	1
42 51 007 08	2 932 160	96 54 385 08	46	56	42 80 093 08	3 714 021	96 49 271 08	6	2
42 52 205 08	2 913	91 32 850 08	13	4	42 80 101 08	X1065015	10 65 015 5	60	1
42 52 205 08	2 913 005	96 20 731 08	7	20	42 80 103 08	2 550 003	96 46 246 08	3	2
42 52 205 08	2 913 005	96 28 696 08	7	12	42 80 103 08	2 652 007	92 68 928 08	3	2
42 52 205 08	2 913 007	96 20 763 08	5	3	42 80 105 08	X1065015	10 65 015 5	61	1
42 52 205 08	2 913 009	91 04 705 08	13	4	42 80 113 08	X1065015	10 65 015 5	62	1
42 52 205 08	2 932 001	96 45 393 08	17	28	42 80 119 01	1 400	91 56 853 08	(18)	5
42 52 205 08	3 930 009	96 50 573 08	269	4	42 81 006 08	2 522 013	96 45 883 08	17	4
42 52 205 08	3 930 640	96 50 481 08	157	10	42 81 013 08	3 206 002	96 47 960 08	3	2
42 52 207 08	2 920 369	96 54 235 08	(155)	1	42 81 022 08	5 701 129	57 01 129 08	12	1
42 52 207 08	2 920 369	96 54 235 08	(155)	1	42 81 025 08	5 400 565	54 00 565 08	4	1
42 52 207 08	2 932 082	96 54 387 08	88	50	42 81 041 08	X1065015	10 65 015 8	40	1
42 52 207 08	3 930 138	96 54 377 08	(155)	1	43 06 047 08	2 522 011	96 45 602 08	7	1
42 52 208 08	2 780 915	96 48 377 08	3	4	43 11 037 08	3 291	91 52 831 08	6	4
42 52 208 08	2 835 002	96 48 379 08	32	1	43 11 037 08	3 292	91 52 865 08	11	4
42 52 208 08	2 932 082	96 54 387 08	40	4	43 20 025 08	1 641 014	92 53 053 08	4	4
42 52 210 08	1 830 102	92 26 483 08	4	12	43 20 034 08	2 520	91 53 061 08	36	2
42 52 210 08	2 835 002	96 48 379 08	21	4	43 20 034 08	2 522 011	96 45 602 08	28	1
42 52 210 08	2 913 004	96 20 460 08	7	2	43 20 039 08	3 206	91 52 881 08	30	4
42 52 210 08	2 932 082	96 54 387 08	39	1	43 20 045 08	2 522 013	96 45 883 08	14	2
42 80 002 08	2 391 040	96 53 645 08	14	6	43 20 048 08	2 550 008	96 47 628 08	5	1
42 80 002 08	2 522 012	96 45 884 08	6	2	43 20 048 08	2 550 009	96 47 645 08	5	1
42 80 002 08	2 522 013	96 45 883 08	8	8	43 20 053 08	2 550	91 57 751 08	56	4
42 80 021 08	2 550	91 57 751 08	29	2	43 20 053 08	2 970	91 56 537 08	117	6
42 80 021 08	2 550 005	96 45 680 08	13	2	43 20 053 08	3 713 013	96 57 159 08	8	8
42 80 042 08	2 550	91 57 751 08	26	2	43 20 053 08	3 745 002	92 17 236 08	12	2
42 80 042 08	3 220 501	96 43 440 08	7	1	43 20 053 08	3 978 015	91 56 429 08	24	2
42 80 042 08	3 221 200	96 47 984 08	7	1	43 20 053 08	3 978 015	91 56 432 08	24	2
42 80 042 08	3 225 200	96 48 679 08	7	1	43 20 057 08	2 391 040	96 53 645 08	13	2
42 80 042 08	3 227 002	96 50 498 08	7	1	43 20 067 08	2 925 402	96 58 855 08	8	2
42 80 042 08	3 561 003	96 45 222 08	7	1	43 20 089 01	2 550	91 57 751 08	86	2
42 80 042 08	3 713 012	96 50 197 08	7	1	43 20 111 08	X1065015	10 65 015 6	62	2
42 80 042 08	3 830	91 55 535 08	6	2	43 30 036 08	3 220 500	91 52 849 08	47	4
42 80 045 08	3 713	91 57 749 08	49	2	43 30 036 08	3 223	91 52 852 08	47	4
42 80 045 08	3 716 001	96 49 159 08	7	1	43 30 036 08	3 223 010	91 52 853 08	47	4
42 80 049 08	2 550	91 57 751 08	33	6	43 30 036 08	3 223 100	91 55 327 08	47	4
42 80 049 08	2 657	91 57 656 08	4	2	43 30 036 08	3 226	91 52 870 08	47	4
42 80 049 08	3 220 500	91 52 849 08	20	8	43 30 036 08	3 227	91 52 873 08	47	4
42 80 049 08	3 223	91 52 852 08	20	10	43 30 036 08	3 227 008	91 52 872 08	47	4
42 80 049 08	3 223 010	91 52 853 08	20	10	43 30 050 08	1 630	91 52 387 08	27	8
42 80 049 08	3 223 100	91 55 327 08	20	10	43 30 050 08	2 631	91 56 817 08	23	2
42 80 055 08	3 206 001	96 20 920 08	3	2	43 30 050 08	3 211	91 57 748 08	43	6
42 80 056 08	3 215 005	91 52 846 08	16	2	43 30 050 08	3 713	91 57 749 08	156	2
42 80 056 08	3 215 006	91 52 847 08	16	2	43 30 052 08	2 370	91 52 782 08	5	4
42 80 061 08	X1065015	10 65 015 5	1343	1	43 30 052 08	2 550	91 57 751 08	62	2
42 80 064 08	3 714	91 52 862 08	22	2	43 30 063 08	2 631	91 56 817 08	28	12

6.2.2009

etk_en_de_074515 LR 1600/2

799

LIEBHERRNumerical index
Numerischer Index

Item	Page	Assembly	Pos.	Quantity	Item	Page	Assembly	Pos.	Quantity
43 30 063 08	3 205	91 52 880 08	11	2	43 30 112 08	3 745	91 52 948 08	18	4
43 30 065 08	2 925 204	92 16 990 08	13	1	43 30 115 08	3 205	91 52 880 08	4	4
43 30 065 08	3 211	91 57 748 08	39	14	43 31 009 08	1 630	91 52 387 08	13	4
43 30 065 08	3 713	91 57 749 08	70	4	43 31 009 08	2 550	91 57 751 08	9	8
43 30 075 08	2 631	91 56 817 08	33	4	43 31 009 08	2 550 011	96 47 007 08	3	1
43 30 075 08	2 652	91 52 794 08	30	16	43 31 009 08	3 206	91 52 881 08	52	2
43 30 075 08	2 730	91 52 802 08	15	4	43 31 009 08	3 211	91 57 748 08	22	2
43 30 075 08	3 225	91 52 854 08	53	8	43 31 009 08	3 211 003	96 46 986 08	13	1
43 30 076 08	2 620	91 52 793 08	7	1	43 31 009 08	3 220 500	91 52 849 08	21	8
43 30 076 08	2 671	91 52 798 08	3	4	43 31 009 08	3 221	91 54 668 08	10	8
43 30 077 08	2 670	91 52 797 08	14	4	43 31 009 08	3 223	91 52 852 08	21	8
43 30 077 08	3 208 001	91 52 883 08	21	4	43 31 009 08	3 223 010	91 52 853 08	21	8
43 30 077 08	3 281	91 52 896 08	9	2	43 31 009 08	3 223 100	91 55 327 08	21	8
43 30 077 08	3 282 002	96 47 890 08	16	1	43 31 009 08	3 225	91 52 854 08	18	4
43 30 077 08	3 713	91 57 749 08	41	2	43 31 009 08	3 226	91 52 870 08	21	4
43 30 077 08	3 745	91 52 948 08	15	4	43 31 009 08	3 227	91 52 873 08	21	4
43 30 078 08	2 810	91 52 806 08	30	2	43 31 009 08	3 227 002	96 50 498 08	17	2
43 30 078 08	3 211	91 57 748 08	25	4	43 31 009 08	3 227 008	91 52 872 08	21	4
43 30 078 08	3 220 500	91 52 849 08	14	2	43 31 009 08	3 227 200	91 53 519 08	21	10
43 30 078 08	3 223	91 52 852 08	14	2	43 31 009 08	3 713	91 57 749 08	55	12
43 30 078 08	3 223 010	91 52 853 08	14	2	43 31 009 08	3 714	91 52 862 08	31	8
43 30 078 08	3 223 100	91 55 327 08	14	2	43 31 009 08	3 714 008	96 49 266 08	16	3
43 30 078 08	3 281	91 52 896 08	50	2	43 31 009 08	3 714 009	96 49 267 08	9	6
43 30 079 08	3 206	91 52 881 08	51	2	43 31 009 08	3 714 021	96 49 271 08	5	2
43 30 085 08	3 206	91 52 881 08	45	2	43 31 009 08	3 715 008	91 52 863 08	15	16
43 30 088 08	1 630	91 52 387 08	17	8	43 31 009 08	3 716	91 52 864 08	15	22
43 30 088 08	2 810	91 52 806 08	34	2	43 31 009 08	3 745	91 52 948 08	59	1
43 30 088 08	3 282 002	96 47 890 08	4	3	43 31 012 08	1 400	91 56 853 08	60	12
43 30 088 08	3 713	91 57 749 08	106	2	43 31 012 08	1 410 300	91 56 855 08	60	12
43 30 088 08	3 714	91 52 862 08	68	4	43 31 012 08	1 632	91 52 389 08	10	4
43 30 088 08	3 745	91 52 948 08	60	1	43 31 012 08	1 991	91 52 510 08	9	1
43 30 088 08	3 790 006	96 19 989 08	4	1	43 31 012 08	3 206	91 52 881 08	21	1
43 30 088 08	3 790 007	96 19 990 08	4	1	43 31 012 08	3 281	91 52 896 08	37	3
43 30 090 08	1 991	91 52 510 08	8	4	43 31 012 08	3 282 002	96 47 890 08	8	1
43 30 090 08	2 550	91 57 751 08	47	4	43 31 012 08	3 713	91 57 749 08	107	2
43 30 090 08	2 550 011	96 47 007 08	4	1	43 31 025 08	2 391	91 52 784 08	3	4
43 30 090 08	2 652	91 52 794 08	20	2	43 31 025 08	3 208 001	91 52 883 08	39	1
43 30 090 08	2 810	91 52 806 08	21	2	43 31 025 08	3 211	91 57 748 08	61	6
43 30 090 08	3 206	91 52 881 08	19	2	43 31 025 08	3 214	91 52 843 08	33	1
43 30 090 08	3 215 005	91 52 846 08	18	2	43 31 025 08	3 713	91 57 749 08	81	8
43 30 090 08	3 215 006	91 52 847 08	18	2	43 31 025 08	3 714	91 52 862 08	20	1
43 30 090 08	3 281	91 52 896 08	52	1	43 31 025 08	3 714 008	96 49 266 08	18	2
43 30 090 08	3 745 002	92 17 236 08	7	2	43 31 025 08	3 830	91 55 535 08	12	4
43 30 090 08	3 745 003	92 17 237 08	7	2	43 31 028 08	1 630	91 52 387 08	19	8
43 30 097 08	1 630	91 52 387 08	16	4	43 31 028 08	2 550	91 57 751 08	64	2
43 30 097 08	2 657	91 57 656 08	8	1	43 31 028 08	2 810	91 52 806 08	38	1
43 30 101 08	2 550	91 57 751 08	90	1	43 31 028 08	3 211	91 57 748 08	44	14
43 30 101 08	2 652	91 52 794 08	10	2	43 31 028 08	3 220 500	91 52 849 08	46	4
43 30 101 08	3 205	91 52 880 08	14	2	43 31 028 08	3 223	91 52 852 08	46	4
43 30 101 08	3 207 003	96 48 259 08	8	1	43 31 028 08	3 223 010	91 52 853 08	46	4
43 30 101 08	3 208 001	91 52 883 08	19	2	43 31 028 08	3 223 100	91 55 327 08	46	4
43 30 101 08	3 281	91 52 896 08	25	2	43 31 028 08	3 226	91 52 870 08	46	4
43 30 101 08	3 281	91 52 896 08	(8)	2	43 31 028 08	3 227	91 52 873 08	46	4
43 30 101 08	3 713	91 57 749 08	98	8	43 31 028 08	3 227 008	91 52 872 08	46	4
43 30 103 08	2 810	91 52 806 08	13	2	43 31 028 08	3 227 200	91 53 519 08	46	8
43 30 103 08	3 225	91 52 854 08	13	1	43 31 028 08	3 713	91 57 749 08	157	2
43 30 105 08	3 281	91 52 896 08	29	1	43 31 028 08	3 715 008	91 52 863 08	35	8
43 30 106 08	1 400	91 56 853 08	78	2	43 31 028 08	3 716	91 52 864 08	37	8
43 30 106 08	1 410 300	91 56 855 08	78	2	43 31 050 08	1 632	91 52 389 08	11	4
43 30 106 08	3 281	91 52 896 08	17	1	43 31 050 08	3 205	91 52 880 08	8	8

6.2.2009

etk_en_de_074515 LR 1600/2

800

LIEBHERRNumerical index
Numerischer Index

Item	Page	Assembly	Pos.	Quantity	Item	Page	Assembly	Pos.	Quantity
43 31 050 08	3 206	91 52 881 08	15	9	43 32 014 08	3 714	91 52 862 08	97	2
43 31 050 08	3 207 101	96 48 292 08	7	2	43 32 014 08	3 714 009	96 49 267 08	14	4
43 31 050 08	3 281	91 52 896 08	14	3	43 32 015 08	3 213	91 52 842 08	4	2
43 31 050 08	3 282 002	96 47 890 08	11	1	43 32 015 08	3 214	91 52 843 08	25	2
43 31 050 08	3 745	91 52 948 08	21	4	43 32 015 08	3 215 005	91 52 846 08	15	4
43 31 052 08	2 790 455	91 57 005 08	5	4	43 32 015 08	3 215 006	91 52 847 08	15	4
43 31 052 08	3 211	91 57 748 08	20	2	43 32 015 08	3 225	91 52 854 08	9	2
43 31 052 08	3 216 005	96 50 697 08	3	1	43 32 015 08	3 226	91 52 870 08	3	4
43 31 052 08	3 745 011	96 49 677 08	14	1	43 32 015 08	3 227	91 52 873 08	3	4
43 32 001 08	2 631	91 56 817 08	16	8	43 32 015 08	3 227 008	91 52 872 08	3	4
43 32 001 08	2 730	91 52 802 08	16	4	43 32 015 08	3 227 200	91 53 519 08	3	4
43 32 001 08	2 925 402	96 58 855 08	31	1	43 32 015 08	3 713	91 57 749 08	13	2
43 32 001 08	3 211	91 57 748 08	63	2	43 32 015 08	3 714	91 52 862 08	25	2
43 32 001 08	3 214	91 52 843 08	50	4	43 32 015 08	3 715 008	91 52 863 08	16	4
43 32 001 08	3 220 500	91 52 849 08	13	2	43 32 015 08	3 716	91 52 864 08	16	4
43 32 001 08	3 223	91 52 852 08	13	2	43 32 060 08	3 215 005	91 52 846 08	31	2
43 32 001 08	3 223 010	91 52 853 08	13	2	43 32 060 08	3 215 006	91 52 847 08	31	2
43 32 001 08	3 223 100	91 55 327 08	13	2	43 32 062 08	1 632 032	96 20 093 08	8	1
43 32 001 08	3 713	91 57 749 08	42	2	43 32 063 08	2 550	91 57 751 08	84	2
43 32 002 08	1 631 100	91 52 388 08	5	20	43 32 063 08	2 620	91 52 793 08	10	1
43 32 002 08	2 125	91 52 773 08	12	4	43 32 063 08	2 810	91 52 806 08	41	4
43 32 002 08	2 550	91 57 751 08	93	1	43 32 064 08	2 620	91 52 793 08	13	1
43 32 002 08	3 208 001	91 52 883 08	40	2	43 32 064 08	3 225	91 52 854 08	54	4
43 32 002 08	3 225	91 52 854 08	52	4	43 32 064 08	3 714 008	96 49 266 08	19	2
43 32 002 08	3 714	91 52 862 08	64	2	44 33 003 08	2 922 001	92 84 311 08	19	14
43 32 003 08	1 400	91 56 853 08	79	2	45 00 191 08	1 641 014	92 53 053 08	3	2
43 32 003 08	1 410 300	91 56 855 08	79	2	45 00 232 08	3 211	91 57 748 08	37	2
43 32 003 08	2 652	91 52 794 08	15	3	45 00 232 08	3 713	91 57 749 08	68	2
43 32 003 08	3 713	91 57 749 08	7	2	45 00 239 08	3 227 002	96 50 498 08	19	4
43 32 004 08	1 742	91 53 021 08	3	4	45 00 312 08	3 714 008	96 49 266 08	15	3
43 32 004 08	2 631	91 56 817 08	18	4	45 00 330 08	3 714 021	96 49 271 08	4	1
43 32 004 08	3 207 003	96 48 259 08	10	1	45 00 333 08	3 211	91 57 748 08	23	2
43 32 004 08	3 207 100	96 48 261 08	7	2	45 10 011 08	2 631	91 56 817 08	21	2
43 32 005 08	2 550 005	96 45 680 08	19	1	45 10 012 08	3 211	91 57 748 08	67	8
43 32 005 08	2 657	91 57 656 08	10	2	45 12 144 08	2 550	91 57 751 08	61	4
43 32 005 08	3 211	91 57 748 08	17	4	45 12 222 08	2 370	91 52 782 08	4	4
43 32 005 08	3 211 003	96 46 986 08	7	1	45 12 222 08	2 631	91 56 817 08	29	12
43 32 005 08	3 220 501	96 43 440 08	8	1	45 12 225 08	2 550	91 57 751 08	83	2
43 32 005 08	3 221 200	96 47 984 08	8	1	45 12 225 08	2 925 204	92 16 990 08	11	1
43 32 005 08	3 225	91 52 854 08	20	3	45 12 225 08	2 925 402	96 58 855 08	29	1
43 32 005 08	3 225 200	96 48 679 08	8	1	45 12 225 08	3 214	91 52 843 08	49	4
43 32 005 08	3 227 002	96 50 498 08	8	1	45 12 225 08	3 281	91 52 896 08	58	1
43 32 005 08	3 561 003	96 45 222 08	8	1	45 12 264 08	2 670	91 52 797 08	13	2
43 32 005 08	3 713	91 57 749 08	88	4	45 12 269 08	2 671	91 52 798 08	2	4
43 32 005 08	3 713 012	96 50 197 08	8	1	45 12 272 08	2 810	91 52 806 08	39	4
43 32 005 08	3 714 009	96 49 267 08	11	2	45 12 272 08	3 225	91 52 854 08	49	4
43 32 005 08	3 714 013	96 59 083 08	4	2	45 12 305 08	3 790 006	96 19 989 08	2	1
43 32 005 08	3 716 001	96 49 159 08	8	1	45 12 305 08	3 790 007	96 19 990 08	2	1
43 32 005 08	3 747	91 52 950 08	5	8	45 12 370 08	3 714 008	96 49 266 08	17	2
43 32 005 08	3 830	91 55 535 08	9	2	45 12 372 08	1 991	91 52 510 08	6	4
43 32 008 08	3 215 005	91 52 846 08	14	2	45 12 375 08	1 991	91 52 510 08	7	1
43 32 008 08	3 215 006	91 52 847 08	14	2	45 12 412 08	3 211	91 57 748 08	45	4
43 32 010 08	3 780 200	96 54 370 08	3	2	45 12 412 08	3 713	91 57 749 08	154	4
43 32 010 08	3 780 258	96 56 482 08	3	2	45 14 220 08	3 281	91 52 896 08	36	2
43 32 011 08	1 400	91 56 853 08	58	6	45 14 223 08	3 220 500	91 52 849 08	12	4
43 32 011 08	1 410 300	91 56 855 08	58	6	45 14 223 08	3 223	91 52 852 08	12	4
43 32 011 08	1 630	91 52 387 08	30	4	45 14 223 08	3 223 010	91 52 853 08	12	4
43 32 013 08	3 227 002	96 50 498 08	18	8	45 14 223 08	3 223 100	91 55 327 08	12	4
43 32 014 08	3 214	91 52 843 08	17	4	45 14 269 08	2 620	91 52 793 08	5	1
43 32 014 08	3 225 100	96 48 582 08	6	1	45 14 304 08	3 713	91 57 749 08	37	2

6.2.2009

etk_en_de_074515 LR 1600/2

801

LIEBHERRNumerical index
Numerischer Index

Item	Page	Assembly	Pos.	Quantity	Item	Page	Assembly	Pos.	Quantity
45 14 308 08	1 631 100	91 52 388 08	4	20	46 00 056	2 391 040	96 53 645 08	21	1
45 25 412 08	3 714	91 52 862 08	66	2	46 00 079	2 670	91 52 797 08	9	4
45 25 413 08	3 713	91 57 749 08	6	1	46 00 091	2 671 004	96 46 305 08	27	2
45 25 485 08	3 215 005	91 52 846 08	11	2	46 00 091	3 978 005	91 56 430 08	54	20
45 30 083 08	3 220 500	91 52 849 08	45	8	46 00 091	3 978 015	91 56 429 08	54	40
45 30 083 08	3 223	91 52 852 08	45	8	46 00 091	3 978 015	91 56 432 08	54	40
45 30 083 08	3 223 010	91 52 853 08	45	8	46 00 091	X1022811	10 22 811 2	38	3
45 30 083 08	3 223 100	91 55 327 08	45	8	46 00 097	1 400	91 56 853 08	50	6
45 30 083 08	3 226	91 52 870 08	45	8	46 00 097	1 410 300	91 56 855 08	50	6
45 30 083 08	3 227	91 52 873 08	45	8	46 00 097	2 391 001	96 45 719 08	341	20
45 30 083 08	3 227 008	91 52 872 08	45	8	46 00 102	7 027 481	70 27 481 03	2	4
45 30 083 08	3 227 200	91 53 519 08	45	8	46 00 122	2 391 001	96 45 719 08	339	12
45 30 083 08	3 715 008	91 52 863 08	36	8	46 00 122	3 206	91 52 881 08	23	2
45 30 083 08	3 716	91 52 864 08	38	8	46 00 122	3 211	91 57 748 08	48	4
45 30 093 08	3 211	91 57 748 08	41	8	46 00 132	2 970	91 56 537 08	542	6
45 30 209 08	2 631	91 56 817 08	26	6	46 00 132	2 970	91 56 537 08	(2)	4
45 30 209 08	3 211	91 57 748 08	62	4	46 00 132	2 976 200	91 52 780 08	563	20
45 30 210 08	3 713	91 57 749 08	38	2	46 00 132	2 976 700	91 54 795 08	568	8
45 30 213 08	1 632	91 52 389 08	9	4	46 00 143	5 102 354	51 02 354 08	10	4
45 30 220 08	2 631	91 56 817 08	31	2	46 00 156	2 391	91 52 784 08	4	8
45 30 220 08	2 730	91 52 802 08	13	4	46 00 156	3 350	91 52 859 08	42	8
45 30 221 08	3 205	91 52 880 08	10	2	46 00 158	1 991	91 52 510 08	15	1
45 30 223 08	2 631	91 56 817 08	34	2	46 00 158	2 340	91 52 776 08	12	2
45 30 300 08	1 400	91 56 853 08	76	2	46 00 158	2 391 001	96 45 719 08	337	8
45 30 300 08	1 410 300	91 56 855 08	76	2	46 00 158	3 213	91 52 842 08	12	4
45 30 300 08	2 652	91 52 794 08	9	2	46 00 158	3 214	91 52 843 08	28	4
45 30 318 08	1 630	91 52 387 08	9	8	46 00 158	3 220 500	91 52 849 08	6	8
45 30 320 08	2 810	91 52 806 08	32	2	46 00 158	3 221	91 54 668 08	6	8
45 30 324 08	3 714	91 52 862 08	19	2	46 00 158	3 223	91 52 852 08	6	8
45 30 327 08	2 652	91 52 794 08	17	2	46 00 158	3 223 010	91 52 853 08	6	8
45 30 328 08	3 207 003	96 48 259 08	7	2	46 00 158	3 223 100	91 55 327 08	6	8
45 30 328 08	3 207 100	96 48 261 08	6	2	46 00 158	3 225	91 52 854 08	25	8
45 30 328 08	3 281	91 52 896 08	(7)	2	46 00 158	3 226	91 52 870 08	6	8
45 30 448 08	3 205	91 52 880 08	15	2	46 00 158	3 227	91 52 873 08	6	8
46 00 016	1 991	91 52 510 08	10	6	46 00 158	3 227 008	91 52 872 08	6	8
46 00 016	2 391 001	96 45 719 08	332	4	46 00 158	3 227 200	91 53 519 08	6	8
46 00 016	3 713	91 57 749 08	143	2	46 00 158	3 350	91 52 859 08	27	32
46 00 017	1 400	91 56 853 08	(37)	4	46 00 158	3 714	91 52 862 08	27	4
46 00 017	2 970	91 56 537 08	73	4	46 00 158	3 715 008	91 52 863 08	17	8
46 00 017	X1065015	10 65 015 8	20	8	46 00 158	3 716	91 52 864 08	17	8
46 00 020	1 991	91 52 510 08	13	8	46 00 175	2 520	91 53 061 08	73	24
46 00 020	2 310	91 52 503 08	10	6	46 00 179	X1041267	10 41 267 8	16	1
46 00 020	2 320	91 52 504 08	10	6	46 00 189	1 631 100	91 52 388 08	6	12
46 00 020	3 350	91 52 859 08	6	6	46 00 189	2 391 001	96 45 719 08	334	4
46 00 023	2 976 203	92 27 489 08	10	2	46 00 189	2 810	91 52 806 08	50	4
46 00 023	3 211	91 57 748 08	56	5	46 00 206	2 125	91 52 773 08	10	8
46 00 038	2 391 001	96 45 719 08	336	8	46 00 237	2 340	91 52 776 08	10	8
46 00 038	2 810	91 52 806 08	7	4	46 00 245	2 671	91 52 798 08	11	4
46 00 044	3 214	91 52 843 08	18	2	46 00 245	3 207 003	96 48 259 08	4	1
46 00 047	3 206	91 52 881 08	35	3	46 00 245	3 207 100	96 48 261 08	3	1
46 00 047	3 208 001	91 52 883 08	27	6	46 00 245	3 281	91 52 896 08	(4)	1
46 00 047	3 215 005	91 52 846 08	26	4	46 00 247	2 392	91 52 785 08	11	4
46 00 047	3 215 006	91 52 847 08	26	4	46 00 310	2 350	91 52 778 08	9	3
46 00 048	2 391 040	96 53 645 08	30	8	46 00 312	2 391 001	96 45 719 08	340	6
46 00 048	5 102 306	51 02 306 08	7	6	46 00 319	X1065015	10 65 015 8	60	4
46 00 048	9 080 702	90 80 702	8	2	46 00 329	3 350	91 52 859 08	11	24
46 00 049	2 522	91 54 115 08	8	2	46 00 331	2 392	91 52 785 08	14	4
46 00 049	2 522 011	96 45 602 08	15	3	46 00 332	3 281	91 52 896 08	(3)	1
46 00 051	2 502	91 55 939 08	38	6	46 00 334	2 260	91 53 057 08	17	24
46 00 051	2 970	91 56 537 08	155	2	46 00 338	5 113 005	51 13 005 08	15	2

6.2.2009

etk_en_de_074515 LR 1600/2

802

LIEBHERRNumerical index
Numerischer Index

Item	Page	Assembly	Pos.	Quantity	Item	Page	Assembly	Pos.	Quantity
46 00 340	5 102 380	51 02 380 08	27	8	47 00 112 08	2 970	91 56 537 08	672	1
46 00 355	2 502	91 55 939 08	31	2	47 00 113 08	1 970	91 56 958 08	633	2
46 00 355	X1035519	10 35 519 6	9	10	47 00 113 08	2 970	91 56 537 08	737	1
46 00 356	3 220 500	91 52 849 08	36	15	47 00 113 08	2 975 100	91 52 860 08	612	3
46 00 356	3 221	91 54 668 08	20	12	47 00 113 08	2 975 200	91 52 775 08	609	2
46 00 356	3 223	91 52 852 08	36	18	47 00 113 08	2 975 700	91 52 774 08	609	2
46 00 356	3 223 010	91 52 853 08	36	18	47 00 113 08	3 978 005	91 56 430 08	602	1
46 00 356	3 223 100	91 55 327 08	36	18	47 00 114 08	2 970	91 56 537 08	606	5
46 00 356	3 225	91 52 854 08	43	15	47 00 115 08	2 970	91 56 537 08	772	1
46 00 356	3 226	91 52 870 08	36	15	47 00 115 08	3 978 005	91 56 430 08	620	1
46 00 356	3 227	91 52 873 08	36	18	47 00 303 08	2 970	91 56 537 08	734	7
46 00 356	3 227 008	91 52 872 08	36	18	47 00 303 08	2 978 100	91 52 796 08	610	1
46 00 356	3 227 200	91 53 519 08	36	18	47 00 303 08	2 978 100	91 52 827 08	633	1
46 00 356	3 713	91 57 749 08	62	15	47 00 303 08	3 978 100	91 56 428 08	622	1
46 00 356	3 714	91 52 862 08	56	9	47 00 304 08	2 970	91 56 537 08	725	4
46 00 356	3 715 008	91 52 863 08	18	16	47 00 304 08	2 978 100	91 52 827 08	634	1
46 00 356	3 716	91 52 864 08	18	19	47 00 304 08	2 978 200	91 54 843 08	623	12
46 00 366	3 214	91 52 843 08	12	12	47 00 304 08	3 978 005	91 56 430 08	607	4
46 00 373 03	X1041267	10 41 267 8	17	1	47 00 304 08	3 978 015	91 56 429 08	602	2
46 00 380	X1065015	10 65 015 8	25	4	47 00 304 08	3 978 015	91 56 432 08	602	1
46 00 384	2 502	91 55 939 08	50	2	47 00 304 08	3 978 019	91 56 431 08	607	2
46 00 384	3 780 751	91 52 952 08	20	6	47 00 304 08	3 978 100	91 56 428 08	621	1
46 00 386	2 391 001	96 45 719 08	354	4	47 00 305 08	2 970	91 56 537 08	724	3
46 00 386	3 214	91 52 843 08	46	6	47 00 305 08	2 975 100	91 52 860 08	626	2
46 00 387	2 932 082	96 54 387 08	89	54	47 00 306 08	2 970	91 56 537 08	692	3
46 00 532	1 991	91 52 510 08	17	2	47 00 306 08	2 990	91 59 244 08	617	4
46 00 532	3 780 751	91 52 952 08	15	2	47 00 307 08	2 970	91 56 537 08	736	1
46 00 578	3 790 006	96 19 989 08	5	1	47 00 307 08	2 978 100	91 52 827 08	637	1
46 00 578	3 790 007	96 19 990 08	5	1	47 00 307 08	2 978 200	91 54 843 08	624	2
46 00 887	2 550 008	96 47 628 08	10	1	47 00 308 08	1 970	91 56 958 08	626	6
46 00 887	2 550 009	96 47 645 08	10	1	47 00 308 08	2 970	91 56 537 08	697	5
46 01 213	2 920 814	96 45 717 08	10	5	47 00 308 08	2 975 100	91 52 860 08	622	1
46 01 292	1 400	91 56 853 08	(68)	1	47 00 308 08	2 978 200	91 54 843 08	619	3
46 01 349	1 630	91 52 387 08	28	8	47 00 309 08	2 970	91 56 537 08	628	7
46 30 212	3 213	91 52 842 08	5	2	47 00 310 08	1 970	91 56 958 08	661	1
46 30 212	3 214	91 52 843 08	26	2	47 00 325 08	3 978 019	91 56 431 08	606	2
46 30 212	3 225	91 52 854 08	15	2	47 00 327 08	1 970	91 56 958 08	620	10
46 30 212	3 226	91 52 870 08	4	4	47 00 327 08	2 970	91 56 537 08	790	1
46 30 212	3 227	91 52 873 08	4	4	47 00 327 08	2 978 100	91 52 827 08	636	1
46 30 212	3 227 008	91 52 872 08	4	4	47 00 328 08	1 970	91 56 958 08	628	1
46 30 212	3 227 200	91 53 519 08	4	4	47 00 328 08	2 970	91 56 537 08	766	3
46 30 212	3 713	91 57 749 08	12	2	47 00 328 08	3 978 019	91 56 431 08	605	1
46 30 212	3 714	91 52 862 08	24	2	47 00 329 08	2 970	91 56 537 08	683	9
46 30 212	3 715 008	91 52 863 08	19	4	47 00 329 08	2 978 100	91 52 827 08	638	1
46 30 212	3 716	91 52 864 08	19	4	47 00 329 08	2 978 200	91 54 843 08	622	6
46 35 436	3 745 011	96 49 677 08	15	4	47 00 330 08	2 970	91 56 537 08	686	2
47 00 101 08	2 970	91 56 537 08	748	2	47 00 330 08	2 978 100	91 52 796 08	620	4
47 00 103 08	1 970	91 56 958 08	629	1	47 00 331 08	1 970	91 56 958 08	601	12
47 00 104 08	2 970	91 56 537 08	669	2	47 00 331 08	2 970	91 56 537 08	705	43
47 00 104 08	2 975 000	91 57 881 08	607	1	47 00 331 08	2 975 100	91 52 860 08	619	2
47 00 105 08	2 970	91 56 537 08	797	1	47 00 331 08	3 978 005	91 56 430 08	621	4
47 00 107 08	2 970	91 56 537 08	726	1	47 00 331 08	3 978 015	91 56 429 08	603	2
47 00 107 08	2 975 200	91 52 775 08	606	1	47 00 331 08	3 978 100	91 56 428 08	618	1
47 00 107 08	2 975 700	91 52 774 08	606	1	47 00 332 08	2 970	91 56 537 08	618	3
47 00 107 08	2 977	91 57 756 08	603	2	47 00 332 08	3 978 100	91 56 428 08	619	1
47 00 108 08	1 970	91 56 958 08	675	2	47 02 303 08	2 970	91 56 537 08	779	1
47 00 108 08	2 970	91 56 537 08	745	8	47 02 303 08	2 978 100	91 52 827 08	631	1
47 00 110 08	2 975 200	91 52 775 08	612	1	47 02 304 08	2 978 100	91 52 827 08	630	1
47 00 110 08	2 975 700	91 52 774 08	612	1	47 02 306 08	2 970	91 56 537 08	799	1
47 00 111 08	2 970	91 56 537 08	687	3	47 02 306 08	2 990	91 59 244 08	601	1

6.2.2009

etk_en_de_074515 LR 1600/2

803

LIEBHERRNumerical index
Numerischer Index

Item	Page	Assembly	Pos.	Quantity	Item	Page	Assembly	Pos.	Quantity
47 02 307 08	1 970	91 56 958 08	678	1	47 10 306 08	2 978 100	91 52 796 08	601	4
47 02 307 08	2 978 100	91 52 827 08	632	3	47 10 306 08	2 978 100	91 52 827 08	623	2
47 02 308 08	2 970	91 56 537 08	700	2	47 10 306 08	2 978 200	91 54 843 08	634	1
47 02 311 08	2 970	91 56 537 08	639	2	47 10 306 08	3 978 100	91 56 428 08	601	1
47 02 314 08	2 970	91 56 537 08	608	7	47 10 307 08	2 970	91 56 537 08	716	3
47 02 326 08	1 970	91 56 958 08	676	2	47 10 307 08	2 975 200	91 52 775 08	605	1
47 02 326 08	2 970	91 56 537 08	792	1	47 10 307 08	2 975 700	91 52 774 08	605	1
47 02 326 08	2 978 100	91 52 796 08	618	1	47 10 307 08	2 976 200	91 52 780 08	602	2
47 02 326 08	2 978 100	91 52 827 08	642	1	47 10 307 08	2 976 700	91 54 795 08	602	1
47 02 328 08	2 978 100	91 52 827 08	629	3	47 10 308 08	2 970	91 56 537 08	731	10
47 02 330 08	2 970	91 56 537 08	715	1	47 10 308 08	2 975 100	91 52 860 08	608	1
47 02 334 08	2 970	91 56 537 08	727	1	47 10 308 08	2 975 200	91 52 775 08	621	1
47 02 334 08	2 977	91 57 756 08	604	2	47 10 308 08	2 975 700	91 52 774 08	621	1
47 02 334 08	3 978 005	91 56 430 08	623	2	47 10 308 08	2 976 203	92 27 489 08	601	2
47 04 303 08	2 970	91 56 537 08	735	2	47 10 308 08	2 978 100	91 52 827 08	624	2
47 04 303 08	2 978 100	91 52 827 08	628	1	47 10 309 08	2 391 023	96 45 720 08	24	2
47 04 304 08	2 970	91 56 537 08	800	1	47 10 309 08	2 670 002	96 45 352 08	6	1
47 04 304 08	2 976 200	91 52 780 08	608	2	47 10 309 08	2 970	91 56 537 08	663	3
47 04 304 08	2 978 100	91 52 827 08	627	1	47 10 310 08	1 750	91 52 394 08	27	1
47 04 304 08	2 978 200	91 54 843 08	630	2	47 10 310 08	2 978 100	91 52 827 08	613	1
47 04 304 08	3 978 005	91 56 430 08	617	2	47 10 311 08	2 970	91 56 537 08	616	11
47 04 305 08	2 978 100	91 52 827 08	611	1	47 10 311 08	2 990	91 59 244 08	606	4
47 04 307 08	2 970	91 56 537 08	689	3	47 10 312 08	1 970	91 56 958 08	614	1
47 04 307 08	2 975 100	91 52 860 08	620	1	47 10 312 08	2 978 200	91 54 843 08	614	1
47 04 307 08	2 978 100	91 52 827 08	626	3	47 10 313 08	1 970	91 56 958 08	643	2
47 04 308 08	1 970	91 56 958 08	651	2	47 10 313 08	1 970 161	96 50 706 08	601	2
47 04 308 08	2 970	91 56 537 08	698	3	47 10 313 08	2 970	91 56 537 08	615	6
47 04 308 08	2 978 200	91 54 843 08	620	2	47 10 313 08	2 975 100	91 52 860 08	603	1
47 04 314 08	2 970	91 56 537 08	607	7	47 10 313 08	2 975 200	91 52 775 08	613	1
47 04 315 08	2 970	91 56 537 08	629	14	47 10 313 08	2 975 700	91 52 774 08	613	1
47 04 325 08	1 970	91 56 958 08	652	2	47 10 313 08	2 976 700	91 54 795 08	606	1
47 04 325 08	2 970	91 56 537 08	791	1	47 10 314 08	2 978 100	91 52 827 08	621	2
47 04 325 08	2 978 100	91 52 796 08	608	1	47 10 315 08	2 970	91 56 537 08	710	2
47 04 327 08	2 970	91 56 537 08	796	2	47 10 316 08	1 970	91 56 958 08	606	2
47 04 327 08	2 978 100	91 52 827 08	625	1	47 10 316 08	2 970	91 56 537 08	787	2
47 04 327 08	2 978 200	91 54 843 08	628	1	47 10 316 08	3 978 100	91 56 428 08	614	1
47 04 329 08	2 978 100	91 52 796 08	612	1	47 10 318 08	2 970	91 56 537 08	640	2
47 04 330 08	1 970	91 56 958 08	650	4	47 10 319 08	2 671 004	96 46 305 08	13	1
47 04 330 08	2 970	91 56 537 08	717	3	47 10 319 08	2 970	91 56 537 08	637	1
47 04 330 08	3 978 005	91 56 430 08	615	2	47 10 321 08	1 970	91 56 958 08	663	1
47 07 002 08	2 970	91 56 537 08	703	8	47 10 321 08	2 932 160	96 54 385 08	21	1
47 09 005 08	2 978 100	91 52 796 08	604	1	47 10 321 08	2 970	91 56 537 08	721	2
47 09 008 08	1 750	91 52 394 08	32	3	47 10 321 08	2 990	91 59 244 08	603	1
47 09 018 08	1 750	91 52 394 08	33	3	47 10 321 08	3 978 005	91 56 430 08	612	6
47 09 019 08	1 750	91 52 394 08	34	2	47 10 322 08	2 970	91 56 537 08	684	2
47 10 045 14	2 970	91 56 537 08	805	1	47 10 323 08	2 970	91 56 537 08	679	4
47 10 045 14	3 978 019	91 56 431 08	602	2	47 10 326 08	1 975 006	91 52 509 08	603	4
47 10 300 08	2 711	91 52 800 08	19	31	47 10 326 08	2 970	91 56 537 08	803	2
47 10 300 08	2 970	91 56 537 08	749	2	47 10 328 08	2 970	91 56 537 08	767	1
47 10 301 08	2 990	91 59 244 08	604	4	47 10 328 08	2 976 203	92 27 489 08	604	2
47 10 302 08	2 970	91 56 537 08	707	10	47 10 331 08	1 970	91 56 958 08	657	6
47 10 302 08	2 976 700	91 54 795 08	605	1	47 10 331 08	2 975 000	91 57 881 08	602	3
47 10 302 08	2 990	91 59 244 08	611	2	47 10 332 08	1 970	91 56 958 08	604	4
47 10 305 08	2 391 023	96 45 720 08	23	2	47 10 332 08	2 970	91 56 537 08	750	4
47 10 305 08	2 970	91 56 537 08	664	5	47 10 332 08	2 975 000	91 57 881 08	604	3
47 10 305 08	2 975 100	91 52 860 08	607	1	47 10 332 08	2 978 100	91 52 796 08	605	1
47 10 306 08	2 970	91 56 537 08	723	17	47 10 332 08	3 978 019	91 56 431 08	601	1
47 10 306 08	2 975 100	91 52 860 08	614	2	47 10 334 08	1 970	91 56 958 08	656	3
47 10 306 08	2 975 200	91 52 775 08	618	2	47 10 334 08	3 978 019	91 56 431 08	609	1
47 10 306 08	2 975 700	91 52 774 08	618	2	47 10 336 08	2 970	91 56 537 08	763	7

6.2.2009

etk_en_de_074515 LR 1600/2

804

LIEBHERRNumerical index
Numerischer Index

Item	Page	Assembly	Pos.	Quantity	Item	Page	Assembly	Pos.	Quantity
47 10 336 08	2 978 100	91 52 827 08	622	2	47 19 013 08	2 970	91 56 537 08	793	1
47 10 338 08	2 970	91 56 537 08	782	2	47 19 014 08	2 970	91 56 537 08	623	2
47 10 338 08	3 978 100	91 56 428 08	610	1	47 19 015 08	2 970	91 56 537 08	760	1
47 10 343 08	2 970	91 56 537 08	714	2	47 19 016 08	3 978 100	91 56 428 08	606	1
47 10 345 08	2 970	91 56 537 08	802	2	47 19 018 08	1 975 006	91 52 509 08	601	4
47 10 347 08	1 970	91 56 958 08	602	2	47 19 018 08	2 978 100	91 52 796 08	611	1
47 10 347 08	2 970	91 56 537 08	605	7	47 19 019 08	1 970	91 56 958 08	658	2
47 10 348 08	2 970	91 56 537 08	677	4	47 19 020 08	1 970	91 56 958 08	645	2
47 10 348 08	2 978 100	91 52 796 08	614	1	47 19 020 08	1 970 161	96 50 706 08	603	2
47 10 353 08	2 391 038	96 47 931 08	18	1	47 19 023 08	2 990	91 59 244 08	613	1
47 10 353 08	2 970	91 56 537 08	682	13	47 19 035 08	2 978 100	91 52 827 08	612	1
47 10 353 08	2 975 200	91 52 775 08	615	1	47 19 036 08	2 970	91 56 537 08	643	1
47 10 353 08	2 975 700	91 52 774 08	615	1	47 19 038 08	2 970	91 56 537 08	678	3
47 10 353 08	2 978 100	91 52 827 08	620	1	47 19 038 08	2 978 200	91 54 843 08	613	1
47 10 353 08	2 978 100	91 52 827 08	635	1	47 19 042 08	2 670 002	96 45 352 08	8	1
47 10 353 08	2 978 200	91 54 843 08	612	3	47 19 043 08	2 970	91 56 537 08	732	5
47 10 353 08	3 978 005	91 56 430 08	604	4	47 19 043 08	2 975 100	91 52 860 08	609	1
47 10 353 08	3 978 019	91 56 431 08	603	1	47 19 043 08	2 975 200	91 52 775 08	622	1
47 10 370 08	2 391 023	96 45 720 08	25	2	47 19 043 08	2 975 700	91 52 774 08	622	1
47 10 370 08	2 670 002	96 45 352 08	10	1	47 19 043 08	2 978 100	91 52 827 08	602	1
47 10 370 08	2 970	91 56 537 08	665	4	47 19 043 08	2 978 200	91 54 843 08	607	1
47 10 370 08	2 976 200	91 52 780 08	611	2	47 20 323 08	1 970	91 56 958 08	647	3
47 10 370 08	2 976 700	91 54 795 08	607	1	47 23 300 08	2 970	91 56 537 08	680	2
47 10 375 08	2 975 000	91 57 881 08	605	1	47 23 302 08	2 970	91 56 537 08	728	20
47 10 394 08	2 970	91 56 537 08	702	3	47 23 302 08	2 975 100	91 52 860 08	613	4
47 10 394 08	2 975 100	91 52 860 08	618	1	47 23 302 08	2 975 200	91 52 775 08	617	4
47 10 394 08	2 975 200	91 52 775 08	610	1	47 23 302 08	2 975 700	91 52 774 08	617	4
47 10 394 08	2 975 700	91 52 774 08	610	1	47 23 302 08	2 978 100	91 52 796 08	603	2
47 10 396 08	2 970	91 56 537 08	746	5	47 23 302 08	2 978 100	91 52 827 08	618	2
47 10 397 08	2 970	91 56 537 08	729	2	47 23 302 08	2 978 200	91 54 843 08	609	1
47 10 397 08	2 975 000	91 57 881 08	610	1	47 23 303 08	2 970	91 56 537 08	649	11
47 10 397 08	2 975 100	91 52 860 08	606	1	47 23 303 08	2 975 100	91 52 860 08	611	1
47 10 397 08	2 975 200	91 52 775 08	624	1	47 23 303 08	2 975 200	91 52 775 08	611	2
47 10 397 08	2 975 700	91 52 774 08	624	1	47 23 303 08	2 975 700	91 52 774 08	611	2
47 10 397 08	2 976 200	91 52 780 08	601	2	47 23 303 08	2 978 100	91 52 827 08	617	2
47 10 397 08	2 990	91 59 244 08	609	2	47 23 303 08	2 978 200	91 54 843 08	615	4
47 10 398 08	2 990	91 59 244 08	620	1	47 23 303 08	3 978 005	91 56 430 08	624	1
47 10 399 08	2 970	91 56 537 08	709	2	47 23 304 08	2 978 100	91 52 827 08	614	1
47 10 399 08	3 978 005	91 56 430 08	601	3	47 23 305 08	1 970	91 56 958 08	610	1
47 10 503 08	2 391	91 52 784 08	401	2	47 23 305 08	2 970	91 56 537 08	633	1
47 19 003 08	2 711	91 52 800 08	42	1	47 23 305 08	2 975 000	91 57 881 08	606	1
47 19 003 08	3 978 005	91 56 430 08	616	2	47 23 305 08	2 976 200	91 52 780 08	609	2
47 19 005 08	2 978 100	91 52 827 08	643	1	47 23 305 08	2 978 200	91 54 843 08	617	1
47 19 005 08	2 978 200	91 54 843 08	608	1	47 23 305 08	2 990	91 59 244 08	623	1
47 19 006 08	2 970	91 56 537 08	651	9	47 23 306 08	1 970	91 56 958 08	665	1
47 19 006 08	2 975 000	91 57 881 08	603	3	47 23 306 08	2 970	91 56 537 08	621	5
47 19 006 08	3 978 005	91 56 430 08	610	8	47 23 307 08	2 970	91 56 537 08	788	2
47 19 007 08	1 970	91 56 958 08	621	1	47 23 307 08	2 975 100	91 52 860 08	623	1
47 19 007 08	2 970	91 56 537 08	781	2	47 23 307 08	2 978 200	91 54 843 08	625	1
47 19 008 08	2 970	91 56 537 08	774	3	47 23 308 08	2 970	91 56 537 08	626	2
47 19 008 08	3 978 100	91 56 428 08	613	1	47 23 308 08	3 978 100	91 56 428 08	608	1
47 19 009 08	3 978 100	91 56 428 08	603	2	47 23 311 08	1 970	91 56 958 08	608	1
47 19 011 08	2 970	91 56 537 08	747	3	47 23 311 08	2 970	91 56 537 08	603	10
47 19 011 08	2 975 100	91 52 860 08	616	1	47 23 312 08	2 711	91 52 800 08	34	1
47 19 011 08	2 975 200	91 52 775 08	616	1	47 23 312 08	2 970	91 56 537 08	769	3
47 19 011 08	2 975 700	91 52 774 08	616	1	47 23 312 08	3 978 005	91 56 430 08	613	3
47 19 011 08	2 978 100	91 52 827 08	619	1	47 23 314 08	1 975 006	91 52 509 08	606	4
47 19 012 08	2 970	91 56 537 08	756	1	47 23 314 08	2 978 200	91 54 843 08	602	1
47 19 012 08	2 978 100	91 52 827 08	601	2	47 23 315 08	2 970	91 56 537 08	754	5
47 19 012 08	2 978 200	91 54 843 08	606	3	47 23 315 08	2 975 000	91 57 881 08	609	3

6.2.2009

etk_en_de_074515 LR 1600/2

805

LIEBHERRNumerical index
Numerischer Index

Item	Page	Assembly	Pos.	Quantity	Item	Page	Assembly	Pos.	Quantity
47 23 316 08	1 970	91 56 958 08	640	1	47 25 305 08	2 975 700	91 52 774 08	608	1
47 23 316 08	2 970	91 56 537 08	644	3	47 25 305 08	2 976 200	91 52 780 08	607	1
47 23 317 08	2 970	91 56 537 08	762	6	47 25 305 08	2 976 203	92 27 489 08	605	1
47 23 317 08	2 976 200	91 52 780 08	604	2	47 25 305 08	2 978 100	91 52 827 08	604	1
47 23 317 08	3 978 100	91 56 428 08	615	1	47 25 305 08	2 978 200	91 54 843 08	610	4
47 23 318 08	2 970	91 56 537 08	758	3	47 25 305 08	3 978 005	91 56 430 08	605	2
47 23 319 08	3 978 005	91 56 430 08	618	2	47 25 306 08	2 970	91 56 537 08	624	1
47 24 302 08	2 970	91 56 537 08	674	4	47 25 306 08	2 975 100	91 52 860 08	625	1
47 24 302 08	2 975 100	91 52 860 08	617	1	47 25 307 08	2 670 002	96 45 352 08	7	2
47 24 302 08	2 978 100	91 52 796 08	621	1	47 25 307 08	2 970	91 56 537 08	739	2
47 24 302 08	2 978 200	91 54 843 08	611	2	47 25 309 08	1 970	91 56 958 08	679	1
47 24 302 08	3 978 005	91 56 430 08	622	1	47 25 309 08	2 970	91 56 537 08	613	11
47 24 303 08	2 970	91 56 537 08	730	4	47 25 309 08	3 978 100	91 56 428 08	607	1
47 24 303 08	2 978 100	91 52 827 08	641	1	47 25 310 08	2 970	91 56 537 08	601	13
47 24 303 08	2 990	91 59 244 08	626	1	47 25 311 08	2 970	91 56 537 08	807	1
47 24 304 08	2 970	91 56 537 08	667	2	47 25 311 08	2 976 203	92 27 489 08	606	4
47 24 304 08	2 978 100	91 52 827 08	610	1	47 25 312 08	1 975 006	91 52 509 08	604	12
47 24 305 08	2 970	91 56 537 08	666	1	47 25 312 08	2 978 100	91 52 827 08	616	1
47 24 306 08	2 970	91 56 537 08	619	4	47 25 312 08	2 978 200	91 54 843 08	601	1
47 24 306 08	2 975 100	91 52 860 08	604	1	47 25 313 08	1 970	91 56 958 08	616	3
47 24 306 08	2 975 200	91 52 775 08	614	1	47 25 313 08	2 970	91 56 537 08	784	8
47 24 306 08	2 975 700	91 52 774 08	614	1	47 25 313 08	2 978 100	91 52 796 08	606	1
47 24 307 08	1 970	91 56 958 08	649	2	47 25 314 08	1 970	91 56 958 08	639	2
47 24 307 08	2 970	91 56 537 08	693	1	47 25 314 08	2 970	91 56 537 08	711	3
47 24 311 08	1 970	91 56 958 08	624	1	47 25 314 08	3 978 019	91 56 431 08	604	1
47 24 311 08	2 970	91 56 537 08	602	5	47 25 315 08	2 711	91 52 800 08	31	5
47 24 312 08	2 711	91 52 800 08	33	1	47 25 315 08	2 932 160	96 54 385 08	22	1
47 24 312 08	2 970	91 56 537 08	722	1	47 25 315 08	2 970	91 56 537 08	660	11
47 24 313 08	2 970	91 56 537 08	808	1	47 25 315 08	2 976 700	91 54 795 08	601	1
47 24 314 08	2 978 100	91 52 827 08	603	1	47 25 315 08	2 990	91 59 244 08	602	2
47 24 315 08	1 970	91 56 958 08	615	2	47 25 315 08	3 978 005	91 56 430 08	625	2
47 24 315 08	2 970	91 56 537 08	783	5	47 25 316 08	2 970	91 56 537 08	688	5
47 24 315 08	2 975 000	91 57 881 08	611	1	47 25 316 08	3 978 100	91 56 428 08	604	2
47 24 317 08	2 970	91 56 537 08	653	2	47 25 317 08	2 970	91 56 537 08	701	6
47 24 318 08	2 970	91 56 537 08	661	3	47 25 317 08	2 975 200	91 52 775 08	603	1
47 24 318 08	3 978 100	91 56 428 08	612	1	47 25 317 08	2 975 700	91 52 774 08	603	1
47 25 300 08	1 970 161	96 50 706 08	605	2	47 25 317 08	2 976 200	91 52 780 08	606	2
47 25 300 08	2 393	91 52 787 08	46	2	47 25 317 08	2 978 200	91 54 843 08	629	1
47 25 300 08	2 990	91 59 244 08	628	4	47 25 318 08	1 970	91 56 958 08	607	8
47 25 302 08	2 970	91 56 537 08	635	16	47 25 318 08	2 970	91 56 537 08	718	13
47 25 302 08	2 975 200	91 52 775 08	620	1	47 25 318 08	2 975 200	91 52 775 08	607	2
47 25 302 08	2 975 700	91 52 774 08	620	1	47 25 318 08	2 975 700	91 52 774 08	607	2
47 25 302 08	2 978 100	91 52 796 08	602	2	47 25 318 08	2 977	91 57 756 08	601	1
47 25 302 08	2 978 100	91 52 827 08	608	3	47 25 319 08	2 970	91 56 537 08	681	4
47 25 302 08	2 978 200	91 54 843 08	635	1	47 32 303 08	2 970	91 56 537 08	704	4
47 25 302 08	2 990	91 59 244 08	610	4	47 32 305 08	1 970	91 56 958 08	655	1
47 25 302 08	3 978 100	91 56 428 08	602	1	47 32 305 08	2 970	91 56 537 08	657	10
47 25 303 08	2 970	91 56 537 08	622	10	47 32 306 08	1 975 006	91 52 509 08	608	4
47 25 303 08	2 977	91 57 756 08	602	1	47 32 306 08	2 711	91 52 800 08	22	2
47 25 303 08	2 978 200	91 54 843 08	626	1	47 32 306 08	2 810	91 52 806 08	23	2
47 25 304 08	1 970	91 56 958 08	612	1	47 32 306 08	2 970	91 56 537 08	771	1
47 25 304 08	2 391	91 52 784 08	402	2	47 32 310 08	2 970 081	96 50 495 08	602	2
47 25 304 08	2 670 002	96 45 352 08	11	1	47 32 310 08	2 976 203	92 27 489 08	603	2
47 25 304 08	2 970	91 56 537 08	631	5	47 32 312 08	2 978 100	91 52 796 08	607	1
47 25 304 08	2 975 000	91 57 881 08	608	1	47 32 314 08	1 970	91 56 958 08	605	1
47 25 304 08	2 978 200	91 54 843 08	616	1	47 32 327 08	2 671 004	96 46 305 08	2	4
47 25 304 08	2 990	91 59 244 08	607	2	47 33 002 08	1 970	91 56 958 08	666	1
47 25 305 08	2 970	91 56 537 08	611	19	47 40 303 08	2 970	91 56 537 08	676	1
47 25 305 08	2 975 100	91 52 860 08	610	2	47 40 305 08	2 970	91 56 537 08	671	1
47 25 305 08	2 975 200	91 52 775 08	608	1	47 40 307 08	2 970	91 56 537 08	668	1

6.2.2009

etk_en_de_074515 LR 1600/2

806

LIEBHERRNumerical index
Numerischer Index

Item	Page	Assembly	Pos.	Quantity	Item	Page	Assembly	Pos.	Quantity
47 40 326 08	1 970	91 56 958 08	677	4	47 54 314 08	2 970	91 56 537 08	755	3
47 40 326 08	1 975 006	91 52 509 08	616	4	47 54 314 08	2 978 100	91 52 796 08	622	1
47 42 021 08	2 711	91 52 800 08	32	1	47 54 314 08	2 978 200	91 54 843 08	631	2
47 49 014 08	2 970	91 56 537 08	567	1	47 54 315 08	2 970	91 56 537 08	630	3
47 49 019 08	2 970	91 56 537 08	564	1	47 54 316 08	2 970	91 56 537 08	648	1
47 49 069 08	2 970	91 56 537 08	565	4	47 54 317 08	1 970	91 56 958 08	609	1
47 49 071 08	2 970	91 56 537 08	559	2	47 54 317 08	2 970	91 56 537 08	647	1
47 49 075 08	2 970	91 56 537 08	563	2	47 54 318 08	2 970	91 56 537 08	708	5
47 50 302 08	2 970	91 56 537 08	673	1	47 54 318 08	2 975 200	91 52 775 08	623	1
47 50 303 08	1 970	91 56 958 08	646	2	47 54 318 08	2 975 700	91 52 774 08	623	1
47 50 303 08	1 970 161	96 50 706 08	604	3	47 54 318 08	2 976 200	91 44 034 08	602	1
47 50 310 08	2 970	91 56 537 08	695	1	47 54 318 08	2 978 100	91 52 827 08	609	2
47 50 311 08	2 970	91 56 537 08	794	1	47 54 320 08	2 970	91 56 537 08	806	1
47 50 312 08	2 970	91 56 537 08	696	1	47 54 323 08	2 970	91 56 537 08	655	2
47 50 313 08	3 978 100	91 56 428 08	620	1	47 54 324 08	2 970	91 56 537 08	658	1
47 50 315 08	2 970	91 56 537 08	798	1	47 54 325 08	2 970	91 56 537 08	743	5
47 50 317 08	2 975 100	91 52 860 08	627	2	47 54 327 08	2 970	91 56 537 08	744	3
47 50 318 08	1 970	91 56 958 08	653	3	47 54 327 08	2 976 200	91 52 780 08	605	2
47 50 318 08	2 970	91 56 537 08	620	2	47 54 327 08	3 978 100	91 56 428 08	611	1
47 50 318 08	2 975 100	91 52 860 08	628	1	47 54 328 08	2 970	91 56 537 08	652	1
47 50 318 08	2 978 200	91 54 843 08	632	2	47 54 329 08	1 975 006	91 52 509 08	607	4
47 50 319 08	2 970	91 56 537 08	612	5	47 54 329 08	2 978 100	91 52 827 08	607	1
47 50 322 08	2 670 002	96 45 352 08	9	1	47 54 329 08	2 978 200	91 54 843 08	604	1
47 50 325 08	1 975 006	91 52 509 08	605	8	47 54 331 08	1 970	91 56 958 08	618	1
47 50 325 08	2 978 100	91 52 827 08	605	1	47 54 331 08	2 970	91 56 537 08	751	5
47 50 325 08	2 978 200	91 54 843 08	603	1	47 54 331 08	2 975 000	91 57 881 08	612	1
47 50 328 08	2 970	91 56 537 08	785	6	47 54 335 08	2 978 100	91 52 796 08	609	1
47 50 328 08	2 970	91 56 537 08	795	1	47 54 337 08	2 970	91 56 537 08	786	2
47 50 329 08	2 970	91 56 537 08	654	1	47 54 337 08	3 978 100	91 56 428 08	616	1
47 50 329 08	2 978 100	91 52 796 08	619	2	47 54 340 08	2 978 100	91 52 796 08	613	1
47 50 336 08	2 970	91 56 537 08	656	4	47 54 341 08	2 970	91 56 537 08	662	1
47 50 336 08	3 978 019	91 56 431 08	608	1	47 54 342 08	3 978 005	91 56 430 08	614	4
47 50 337 08	2 978 100	91 52 796 08	617	2	47 54 343 08	2 970	91 56 537 08	719	4
47 50 337 08	3 978 005	91 56 430 08	611	4	47 54 345 08	2 970	91 56 537 08	789	2
47 50 339 08	2 970	91 56 537 08	757	6	47 54 348 08	1 970	91 56 958 08	641	1
47 50 339 08	3 978 100	91 56 428 08	605	4	47 54 354 08	2 970	91 56 537 08	740	2
47 50 340 08	3 978 005	91 56 430 08	606	4	47 54 355 08	2 970	91 56 537 08	617	4
47 51 334 08	2 970	91 56 537 08	741	2	47 54 355 08	2 978 100	91 52 827 08	639	2
47 51 349 08	2 970	91 56 537 08	765	1	47 54 356 08	2 391	91 52 784 08	403	1
47 54 081 08	3 978 005	91 56 430 08	619	2	47 54 356 08	2 970	91 56 537 08	738	1
47 54 301 08	2 970	91 56 537 08	776	1	47 54 356 08	2 975 000	91 57 881 08	614	1
47 54 301 08	2 970 081	96 50 495 08	601	3	47 54 357 08	1 970	91 56 958 08	623	2
47 54 301 08	2 978 100	91 52 827 08	615	1	47 54 357 08	2 978 200	91 54 843 08	621	1
47 54 303 08	1 970	91 56 958 08	611	1	47 54 360 08	2 970	91 56 537 08	625	1
47 54 303 08	2 970	91 56 537 08	634	2	47 54 361 08	1 970	91 56 958 08	659	1
47 54 303 08	2 978 200	91 54 843 08	636	1	47 54 361 08	2 970	91 56 537 08	690	7
47 54 303 08	2 990	91 59 244 08	624	1	47 54 361 08	2 975 100	91 52 860 08	605	1
47 54 304 08	2 970	91 56 537 08	642	11	47 54 361 08	2 975 200	91 52 775 08	602	1
47 54 304 08	3 978 100	91 56 428 08	609	1	47 54 361 08	2 975 700	91 52 774 08	602	1
47 54 305 08	1 970	91 56 958 08	674	2	47 54 361 08	2 978 100	91 52 827 08	640	1
47 54 305 08	2 970	91 56 537 08	699	1	47 54 363 08	2 976 200	91 44 034 08	601	1
47 54 305 08	2 975 100	91 52 860 08	624	1	47 54 363 08	2 976 200	91 52 780 08	610	2
47 54 308 08	2 975 100	91 52 860 08	621	1	47 54 367 08	1 970	91 56 958 08	603	1
47 54 309 08	2 970	91 56 537 08	694	1	47 54 367 08	2 970	91 56 537 08	638	6
47 54 309 08	2 978 200	91 54 843 08	627	1	47 55 004 08	2 970	91 56 537 08	777	2
47 54 310 08	2 970	91 56 537 08	753	1	47 55 014 08	2 970	91 56 537 08	780	2
47 54 310 08	2 990	91 59 244 08	627	1	47 55 018 08	2 970	91 56 537 08	770	2
47 54 312 08	2 970	91 56 537 08	691	5	47 55 020 08	2 970	91 56 537 08	764	2
47 54 313 08	1 970	91 56 958 08	625	2	47 56 014 08	1 970	91 56 958 08	648	2
47 54 313 08	2 970	91 56 537 08	604	6	47 56 015 08	1 970	91 56 958 08	619	2

6.2.2009

etk_en_de_074515 LR 1600/2

807

LIEBHERRNumerical index
Numerischer Index

Item	Page	Assembly	Pos.	Quantity	Item	Page	Assembly	Pos.	Quantity
47 56 015 08	2 970	91 56 537 08	659	15	47 77 042 08	2 970	91 56 537 08	752	1
47 56 015 08	2 975 000	91 57 881 08	613	1	47 77 042 08	3 978 005	91 56 430 08	609	4
47 56 015 08	2 976 700	91 54 795 08	603	1	47 77 042 08	X1021769	10 21 769 5	3	1
47 56 015 08	2 978 100	91 52 827 08	644	1	47 77 043 08	2 393	91 52 787 08	51	1
47 56 015 08	2 978 200	91 54 843 08	605	1	47 77 045 08	2 970	91 56 537 08	614	1
47 56 015 08	3 978 100	91 56 428 08	617	1	47 77 045 08	2 990	91 59 244 08	616	2
47 56 026 08	2 970	91 56 537 08	641	10	47 77 045 08	3 978 005	91 56 430 08	603	1
47 56 032 08	2 970	91 56 537 08	685	9	47 77 045 08	X1041101	10 41 101 5	580	1
47 56 032 08	2 976 700	91 54 795 08	604	2	47 77 045 08	X1041101	10 41 101 8	490	1
47 56 034 08	1 970	91 56 958 08	627	4	47 77 046 08	2 970	91 56 537 08	773	2
47 56 034 08	3 978 015	91 56 429 08	601	2	47 77 048 08	1 400	91 56 853 08	(62)	3
47 56 034 08	3 978 015	91 56 432 08	601	2	47 77 048 08	X1042440	10 42 440 2	13	1
47 66 076 08	2 391 001	96 45 719 08	403	2	47 77 049 08	X1042440	10 42 440 2	15	1
47 66 076 08	2 990	91 59 244 08	622	1	47 77 051 08	1 970	91 56 958 08	644	2
47 66 077 08	2 393	91 52 787 08	45	2	47 77 051 08	1 970 161	96 50 706 08	602	2
47 66 078 08	2 970	91 56 537 08	706	2	47 77 051 08	2 670 002	96 45 352 08	4	1
47 66 102 08	2 975 200	91 52 775 08	604	1	47 77 051 08	X1041101	10 41 101 5	400	1
47 66 102 08	2 975 700	91 52 774 08	604	1	47 77 051 08	X1041101	10 41 101 8	380	1
47 66 114 08	2 975 000	91 57 881 08	601	2	47 77 052 08	2 970	91 56 537 08	713	2
47 66 115 08	1 975 006	91 52 509 08	602	8	47 77 052 08	2 975 100	91 52 860 08	48	1
47 66 303 08	2 970	91 56 537 08	778	2	47 77 052 08	2 975 200	91 52 775 08	45	1
47 71 003 08	2 990	91 59 244 08	594	1	47 77 052 08	2 975 700	91 52 774 08	45	1
47 71 004 08	2 391 038	96 47 931 08	21	1	47 77 054 08	9 640 276	96 40 276 08	16	3
47 71 014 08	2 990	91 59 244 08	591	2	47 77 054 08	X1041267	10 41 267 8	4	1
47 74 001 08	2 990	91 59 244 08	590	2	47 77 055 08	2 990	91 59 244 08	608	3
47 74 008 08	2 970	91 56 537 08	597	1	47 77 056 08	2 970	91 56 537 08	632	2
47 74 009 08	2 970	91 56 537 08	576	4	47 77 056 08	9 697 916	96 97 916 01	89	1
47 74 010 08	1 970	91 56 958 08	60	4	47 77 058 08	2 970	91 56 537 08	712	1
47 74 010 08	2 970	91 56 537 08	573	10	49 00 089	2 350	91 52 778 08	18	8
47 74 012 08	2 970	91 56 537 08	582	2	49 00 089	2 370	91 52 782 08	16	4
47 74 015 08	2 990	91 59 244 08	593	1	49 00 089	2 391 001	96 45 719 08	349	4
47 74 016 08	2 391 038	96 47 931 08	20	1	49 00 089	2 391 023	96 45 720 08	15	12
47 74 016 08	2 970	91 56 537 08	593	1	49 00 089	2 392	91 52 785 08	21	2
47 74 017 08	2 970	91 56 537 08	586	2	49 00 089	2 393	91 52 787 08	24	4
47 74 017 08	2 978 200	91 54 843 08	598	1	49 00 089	2 631	91 56 817 08	47	13
47 74 018 08	2 970	91 56 537 08	595	1	49 00 089	2 810	91 52 806 08	68	4
47 74 019 08	2 970	91 56 537 08	588	2	49 00 089	2 859	91 52 809 08	58	40
47 74 024 08	2 970	91 56 537 08	591	1	49 00 089	2 925 204	92 16 990 08	4	1
47 74 026 08	2 970	91 56 537 08	584	2	49 00 089	2 925 402	96 58 855 08	9	9
47 75 104 01	9 697 916	96 97 916 01	2	7	49 00 089	2 932 160	96 54 385 08	14	2
47 75 104 01	9 697 916	96 97 916 01	78	3	49 00 089	X1035519	10 35 519 6	14	6
47 77 001 08	2 970	91 56 537 08	592	1	49 00 090	1 620	91 52 386 08	3	16
47 77 002 08	2 970	91 56 537 08	585	2	49 00 090	2 550	91 57 751 08	69	4
47 77 005 08	2 970	91 56 537 08	594	1	49 00 100	2 391 001	96 45 719 08	347	2
47 77 006 08	2 970	91 56 537 08	583	2	49 00 100	2 392	91 52 785 08	24	2
47 77 007 08	2 970	91 56 537 08	596	1	49 00 100	2 970	91 56 537 08	548	4
47 77 008 08	2 970	91 56 537 08	587	2	49 00 100	3 211	91 57 748 08	72	4
47 77 008 08	2 978 200	91 54 843 08	599	1	49 00 111	2 391 038	96 47 931 08	9	4
47 77 009 08	2 970	91 56 537 08	589	2	49 00 111	2 522 013	96 45 883 08	13	2
47 77 015 08	2 970	91 56 537 08	598	1	49 00 111	2 859	91 52 809 08	68	4
47 77 016 08	2 970	91 56 537 08	575	4	49 00 111	3 745	91 52 948 08	42	8
47 77 040 08	1 970	91 56 958 08	664	1	49 00 111	5 106 691	51 06 691 08	4	4
47 77 040 08	2 970	91 56 537 08	761	5	49 00 112	2 730	91 52 802 08	9	4
47 77 040 08	3 713 013	96 57 159 08	12	1	49 00 112	2 970	91 56 537 08	544	2
47 77 040 08	3 978 100	91 56 428 08	623	1	49 00 112	2 976 200	91 52 780 08	564	4
47 77 040 08	5 113 086	51 13 086 08	2	3	49 00 112	2 976 700	91 54 795 08	569	4
47 77 040 08	X1021769	10 21 769 5	2	2	49 00 112	3 713	91 57 749 08	31	8
47 77 040 77	X1041101	10 41 101 5	330	2	49 00 112	X1035519	10 35 519 6	11	4
47 77 040 77	X1041101	10 41 101 8	310	2	49 00 120	1 630	91 52 387 08	10	8
47 77 041 08	2 970	91 56 537 08	733	2	49 00 120	2 391	91 52 784 08	357	4

6.2.2009

etk_en_de_074515 LR 1600/2

808

LIEBHERRNumerical index
Numerischer Index

Item	Page	Assembly	Pos.	Quantity	Item	Page	Assembly	Pos.	Quantity
49 00 123	1 400	91 56 853 08	54	4	49 00 188	3 713	91 57 749 08	124	33
49 00 123	1 410 300	91 56 855 08	54	4	49 00 188	3 714	91 52 862 08	87	12
49 00 123	3 714 008	96 49 266 08	9	8	49 00 188	3 715 008	91 52 863 08	41	16
49 00 123	3 714 009	96 49 267 08	12	8	49 00 188	3 716	91 52 864 08	46	28
49 00 123	3 745	91 52 948 08	12	16	49 00 188	3 978 005	91 56 430 08	7	4
49 00 128	1 400	91 56 853 08	57	2	49 00 195	2 391 001	96 45 719 08	338	12
49 00 128	1 410 300	91 56 855 08	57	2	49 00 204	2 212	91 54 561 08	2	2
49 00 128	1 630	91 52 387 08	24	12	49 00 204	2 310	91 52 503 08	20	4
49 00 128	1 991	91 52 510 08	21	4	49 00 204	2 320	91 52 504 08	20	4
49 00 128	2 260	91 53 057 08	25	10	49 00 204	2 391 001	96 45 719 08	335	10
49 00 128	2 260 006	96 46 501 08	9	3	49 00 204	3 211 002	92 88 302 08	3	2
49 00 128	2 370	91 52 782 08	6	10	49 00 204	3 292	91 52 865 08	16	4
49 00 128	2 391 001	96 45 719 08	350	10	49 00 204	3 350	91 52 859 08	24	8
49 00 128	2 391 040	96 53 645 08	22	2	49 00 204	3 713	91 57 749 08	24	4
49 00 128	2 391 102	96 56 360 08	10	8	49 00 204	3 713	91 57 749 08	151	2
49 00 128	2 393	91 52 787 08	21	8	49 00 204	3 714	91 52 862 08	61	8
49 00 128	2 550	91 57 751 08	19	2	49 00 537	3 745	91 52 948 08	37	8
49 00 128	2 711	91 52 800 08	35	4	49 00 539	2 391 023	96 45 720 08	17	16
49 00 128	2 810 037	96 47 204 08	4	20	49 00 539	2 835 002	96 48 379 08	24	4
49 00 128	2 859	91 52 809 08	60	5	49 00 539	2 932 166	92 68 911 08	11	2
49 00 128	2 925 402	96 58 855 08	15	4	49 00 539	3 208 001	91 52 883 08	29	8
49 00 128	2 932 166	92 68 911 08	8	2	49 00 539	7 027 481	70 27 481 03	12	4
49 00 128	3 208 001	91 52 883 08	51	2	49 00 595	2 522	91 54 115 08	26	1
49 00 128	3 211	91 57 748 08	53	8	49 00 605	1 970	91 56 958 08	73	8
49 00 128	3 213	91 52 842 08	16	2	49 00 605	2 970	91 56 537 08	65	10
49 00 128	3 214	91 52 843 08	21	2	49 00 605	2 975 100	91 52 860 08	51	2
49 00 128	3 281	91 52 896 08	60	2	49 00 605	2 975 200	91 52 775 08	52	4
49 00 128	3 291	91 52 831 08	3	8	49 00 605	2 975 700	91 52 774 08	52	4
49 00 128	3 292	91 52 865 08	8	8	49 00 614	2 831	91 57 754 08	30	4
49 00 128	3 713	91 57 749 08	111	4	49 00 614	2 859 025	96 46 757 08	4	10
49 00 128	3 714	91 52 862 08	76	4	49 00 626	2 502	91 55 939 08	48	4
49 00 128	3 745	91 52 948 08	28	8	49 00 953	X1021769	10 21 769 5	5	4
49 00 128	X1035519	10 35 519 6	13	4	49 01 053	3 281	91 52 896 08	38	4
49 00 152	1 300 011	96 52 493 08	3	162	49 01 057	2 391 023	96 45 720 08	10	4
49 00 152	2 391 001	96 45 719 08	355	2	49 01 159	X1035925	10 35 925 1	(3)	4
49 00 152	2 391 040	96 53 645 08	35	1	49 01 217	X1021769	10 21 769 5	4	4
49 00 152	2 550	91 57 751 08	7	10	49 01 531	X1034282	10 34 282 3	19	4
49 00 153	2 125	91 52 773 08	8	16	49 01 989	2 350	91 52 778 08	3	48
49 00 153	2 550	91 57 751 08	5	16	49 11 008 14	2 970	91 56 537 08	627	1
49 00 153	2 970	91 56 537 08	174	8	49 81 024	3 714	91 52 862 08	60	11
49 00 153	3 223 100	91 55 327 08	51	2	50 09 175 08	1 400	91 56 853 08	68	24
49 00 161	1 400	91 56 853 08	52	8	50 09 175 08	1 410 300	91 56 855 08	68	24
49 00 161	1 410 300	91 56 855 08	52	8	50 09 175 08	2 350	91 52 778 08	6	6
49 00 161	2 970	91 56 537 08	173	8	50 09 175 08	2 670	91 52 797 08	5	8
49 00 161	3 211	91 57 748 08	70	2	50 09 175 08	2 671	91 52 798 08	6	4
49 00 161	3 213	91 52 842 08	8	8	50 09 175 08	2 730	91 52 802 08	10	12
49 00 161	3 291	91 52 831 08	9	4	50 09 175 08	2 810	91 52 806 08	15	18
49 00 161	3 292	91 52 865 08	3	4	50 15 070 14	X1065015	10 65 015 5	41	1.6
49 00 161	3 714	91 52 862 08	36	8	50 15 240 08	X1065015	10 65 015 8	76	22
49 00 161	3 714 008	96 49 266 08	12	4	50 15 241 08	X1065015	10 65 015 8	75	22
49 00 188	1 400	91 56 853 08	53	18	50 15 271 08	5 400 565	54 00 565 08	9	1
49 00 188	1 410 300	91 56 855 08	53	18	50 15 339 08	9 697 916	96 97 916 01	66	1
49 00 188	2 391 001	96 45 719 08	348	4	50 15 366 08	X1065015	10 65 015 5	463	4
49 00 188	2 510	91 52 788 08	16	8	50 15 497 08	5 718 420	57 18 420 08	4	1
49 00 188	2 520	91 53 061 08	44	6	50 26 088 08	2 393	91 52 787 08	50	1
49 00 188	2 522 012	96 45 884 08	7	4	50 26 126 08	2 393	91 52 787 08	9	1
49 00 188	2 631	91 56 817 08	42	14	50 26 189 08	2 522 012	96 45 884 08	9	2
49 00 188	2 859	91 52 809 08	61	4	50 26 189 08	2 671	91 52 798 08	15	2
49 00 188	3 211	91 57 748 08	27	28	50 26 189 08	2 810 001	96 43 597 08	4	12
49 00 188	3 350	91 52 859 08	14	8	50 26 189 08	3 713	91 57 749 08	120	5

6.2.2009

etk_en_de_074515 LR 1600/2

809

LIEBHERRNumerical index
Numerischer Index

Item	Page	Assembly	Pos.	Quantity	Item	Page	Assembly	Pos.	Quantity
50 26 514 08	5 026 573	50 26 573 08	2	1	51 05 456 08	3 978 015	91 56 429 08	6	2
50 26 558 08	2 990	91 59 244 08	9	1	51 05 456 08	3 978 015	91 56 432 08	6	2
50 26 573 08	2 990	91 59 244 08	21	1	51 05 458 08	1 970	91 56 958 08	36	2
50 26 577 08	3 978 005	91 56 430 08	5	1	51 05 458 08	2 970	91 56 537 08	85	12
50 26 596 08	2 990	91 59 244 08	15	1	51 05 458 08	2 975 100	91 52 860 08	26	2
50 26 616 08	2 990	91 59 244 08	22	1	51 05 458 08	2 977	91 57 756 08	36	2
50 26 628 08	2 990	91 59 244 08	12	1	51 05 458 08	2 978 200	91 54 843 08	22	3
50 28 065 08	2 978 100	91 52 796 08	7	1	51 05 521 08	2 970	91 56 537 08	570	2
50 28 065 08	2 978 100	91 52 827 08	12	1	51 05 696 08	1 750	91 52 394 08	26	1
50 28 065 08	2 978 200	91 54 843 08	12	1	51 05 866 08	1 970	91 56 958 08	58	16
50 28 073 08	1 970	91 56 958 08	12	2	51 05 866 08	1 970 161	96 50 706 08	58	8
50 28 073 08	2 970	91 56 537 08	50	1	51 05 866 08	2 970	91 56 537 08	553	16
50 28 073 08	2 975 100	91 52 860 08	9	1	51 05 866 08	2 975 100	91 52 860 08	41	4
50 28 073 08	2 975 200	91 52 775 08	9	1	51 05 867 08	1 970	91 56 958 08	53	12
50 28 073 08	2 975 700	91 52 774 08	9	1	51 05 867 08	1 970 161	96 50 706 08	53	4
50 28 073 08	3 978 005	91 56 430 08	9	1	51 05 867 08	2 970	91 56 537 08	127	4
50 29 214 08	2 990	91 59 244 08	625	1	51 05 867 08	2 970	91 56 537 08	554	20
50 29 325 08	2 990	91 59 244 08	598	4	51 05 867 08	2 970	91 56 537 08	560	2
50 29 326 08	2 393	91 52 787 08	48	1	51 05 867 08	2 975 100	91 52 860 08	45	4
50 29 328 08	2 391 001	96 45 719 08	404	2	51 05 867 08	2 975 200	91 52 775 08	42	3
50 29 329 08	2 990	91 59 244 08	597	4	51 05 867 08	2 975 700	91 52 774 08	42	3
50 29 332 08	2 393	91 52 787 08	47	1	51 05 869 08	2 970	91 56 537 08	545	8
50 29 401 08	2 990	91 59 244 08	596	2	51 05 870 08	2 970	91 56 537 08	547	4
50 29 461 08	2 990	91 59 244 08	615	1	51 05 870 08	2 970	91 56 537 08	(1)	1
50 29 871 08	2 990	91 59 244 08	6	1	51 05 870 08	2 970	91 56 537 08	(1)	1
50 40 077 08	X1065015	10 65 015 8	43	2	51 05 875 08	2 970	91 56 537 08	541	4
51 01 416 08	2 391 038	96 47 931 08	19	1	51 05 875 08	2 976 200	91 52 780 08	561	12
51 01 417 08	2 391 038	96 47 931 08	17	1	51 05 875 08	2 976 700	91 54 795 08	566	4
51 02 306 08	2 370	91 52 782 08	2	1	51 05 878 08	2 970	91 56 537 08	543	2
51 02 354 08	2 350	91 52 778 08	2	2	51 05 878 08	2 976 200	91 52 780 08	562	6
51 02 373 08	2 391 038	96 47 931 08	2	1	51 05 878 08	2 976 700	91 54 795 08	567	4
51 02 380 08	2 391 023	96 45 720 08	2	2	51 05 879 08	2 391 001	96 45 719 08	43	3
51 03 178 08	2 970	91 56 537 08	(1)	1	51 05 993 08	2 391 001	96 45 719 08	60	1
51 04 087 08	2 970	91 56 537 08	37	1	51 05 996 08	2 970	91 56 537 08	84	6
51 04 087 08	2 975 100	91 52 860 08	10	1	51 05 996 08	2 975 200	91 52 775 08	25	1
51 04 087 08	2 975 200	91 52 775 08	10	1	51 05 996 08	2 975 700	91 52 774 08	25	1
51 04 087 08	2 975 700	91 52 774 08	10	1	51 05 996 08	2 978 200	91 54 843 08	21	1
51 04 121 08	1 970	91 56 958 08	18	1	51 05 997 08	2 970	91 56 537 08	86	3
51 04 121 08	2 970	91 56 537 08	20	1	51 05 997 08	2 975 100	91 52 860 08	27	1
51 04 124 08	2 970	91 56 537 08	40	2	51 05 997 08	2 977	91 57 756 08	40	1
51 04 124 08	2 975 200	91 52 775 08	14	1	51 05 997 08	2 978 100	91 52 796 08	26	2
51 04 124 08	2 975 700	91 52 774 08	14	1	51 05 997 08	2 978 100	91 52 827 08	21	1
51 04 129 08	1 970	91 56 958 08	19	1	51 06 290 08	2 970	91 56 537 08	636	8
51 05 010 08	2 391 001	96 45 719 08	121	1	51 06 290 08	2 975 100	91 52 860 08	615	2
51 05 453 08	1 970	91 56 958 08	40	2	51 06 290 08	2 975 200	91 52 775 08	619	2
51 05 453 08	2 970	91 56 537 08	93	5	51 06 290 08	2 975 700	91 52 774 08	619	2
51 05 453 08	2 970 081	96 50 495 08	12	2	51 06 290 08	2 978 100	91 52 827 08	606	2
51 05 453 08	2 975 200	91 52 775 08	38	1	51 06 290 08	2 978 200	91 54 843 08	633	1
51 05 453 08	2 975 700	91 52 774 08	38	1	51 06 295 08	2 970	91 56 537 08	63	1
51 05 453 08	2 977	91 57 756 08	42	1	51 06 318 08	2 970	91 56 537 08	56	3
51 05 453 08	2 978 200	91 54 843 08	26	1	51 06 340 08	3 978 100	91 56 428 08	5	1
51 05 455 08	1 970	91 56 958 08	34	4	51 06 425 08	2 970	91 56 537 08	75	2
51 05 455 08	2 970	91 56 537 08	83	6	51 06 623 08	5 708 320	57 08 320 08	2	1
51 05 455 08	2 977	91 57 756 08	34	5	51 06 673 08	2 671 004	96 46 305 08	3	1
51 05 455 08	2 977 200	91 55 149 08	14	2	51 06 691 08	2 671 004	96 46 305 08	9	1
51 05 455 08	3 978 005	91 56 430 08	15	1	51 06 692 08	5 106 691	51 06 691 08	1	1
51 05 456 08	1 970	91 56 958 08	32	4	51 06 693 08	2 671 004	96 46 305 08	10	1
51 05 456 08	2 970	91 56 537 08	81	5	51 06 693 08	5 106 691	51 06 691 08	50	1
51 05 456 08	2 975 100	91 52 860 08	22	2	51 06 711 08	2 970	91 56 537 08	38	4
51 05 456 08	2 977	91 57 756 08	32	5	51 06 711 08	2 975 100	91 52 860 08	12	1

6.2.2009

etk_en_de_074515 LR 1600/2

810

LIEBHERRNumerical index
Numerischer Index

Item	Page	Assembly	Pos.	Quantity	Item	Page	Assembly	Pos.	Quantity
51 06 711 08	2 975 200	91 52 775 08	12	1	51 07 973 08	5 114 177	51 14 177 08	6	1
51 06 711 08	2 975 700	91 52 774 08	12	1	51 07 973 08	5 114 320	51 14 320 08	4	1
51 06 711 08	2 978 100	91 52 827 08	7	1	51 07 974 08	5 114 176	51 14 176 08	7	1
51 06 711 08	2 978 200	91 54 843 08	7	1	51 07 974 08	5 114 177	51 14 177 08	7	1
51 06 715 08	2 970	91 56 537 08	71	1	51 07 974 08	5 114 320	51 14 320 08	6	1
51 06 718 08	2 671 004	96 46 305 08	(1)	1	51 07 975 08	5 114 176	51 14 176 08	9	1
51 06 769 08	2 970	91 56 537 08	44	1	51 07 975 08	5 114 177	51 14 177 08	9	1
51 06 820 08	2 970	91 56 537 08	22	1	51 07 975 08	5 114 320	51 14 320 08	7	1
51 06 923 08	1 970	91 56 958 08	20	1	51 07 976 08	5 114 176	51 14 176 08	10	1
51 06 960 08	2 978 100	91 52 796 08	5	1	51 07 976 08	5 114 177	51 14 177 08	10	1
51 06 960 08	2 978 200	91 54 843 08	13	1	51 07 977 08	5 114 176	51 14 176 08	22	1
51 06 960 08	3 978 005	91 56 430 08	10	1	51 07 977 08	5 114 177	51 14 177 08	22	1
51 07 129 08	5 114 498	51 14 498 08	11	3	51 10 017 08	2 540	91 53 253 08	19	2
51 07 129 08	5 114 943	51 14 943 08	11	3	51 10 072 08	5 114 320	51 14 320 08	14	1
51 07 181 08	5 113 005	51 13 005 08	27	1	51 10 089 08	9 640 276	96 40 276 08	9	2
51 07 181 08	5 719 113	57 19 113 08	12	3	51 10 151 08	5 114 177	51 14 177 08	4	1
51 07 181 08	X1029184	10 29 184 0	12	3	51 10 438 08	2 970	91 56 537 08	(8)	1
51 07 181 08	X1048973	10 48 973 4	27	1	51 10 487 08	2 970	91 56 537 08	41	1
51 07 190 08	5 113 005	51 13 005 08	26	1	51 10 487 08	2 978 100	91 52 827 08	8	1
51 07 190 08	X1048973	10 48 973 4	26	1	51 10 487 08	2 978 200	91 54 843 08	8	1
51 07 192 08	X1065015	10 65 015 8	122	1	51 10 492 08	5 026 126	50 26 126 08	3	1
51 07 359 08	5 711 301	57 11 301 08	6	1	51 10 561 08	2 975 200	91 52 775 08	41	1
51 07 374 08	X1041267	10 41 267 8	18	1	51 10 561 08	2 975 700	91 52 774 08	41	1
51 07 384 08	5 713 626	57 13 626 08	441	4	51 10 575 08	2 976 200	91 52 780 08	3	2
51 07 384 08	5 719 113	57 19 113 08	16	1	51 10 583 08	2 975 000	91 57 881 08	6	1
51 07 384 08	X1029184	10 29 184 0	16	1	51 10 603 08	2 970	91 56 537 08	74	1
51 07 386 08	5 718 989	57 18 989 08	26	2	51 10 623 08	2 975 100	91 52 860 08	40	1
51 07 399 08	X1041267	10 41 267 7	43	1	51 10 624 08	2 970	91 56 537 08	126	1
51 07 415 08	5 113 086	51 13 086 08	3	1	51 10 634 08	2 970	91 56 537 08	52	2
51 07 417 08	5 114 176	51 14 176 08	21	1	51 13 005 08	2 970	91 56 537 08	23	1
51 07 417 08	5 114 177	51 14 177 08	21	1	51 13 022 08	2 970	91 56 537 08	55	3
51 07 457 08	5 113 086	51 13 086 08	29	1	51 13 045 08	2 976 203	92 27 489 08	3	1
51 07 460 08	2 970	91 56 537 08	39	3	51 13 082 08	2 978 100	91 52 827 08	11	1
51 07 460 08	2 975 100	91 52 860 08	13	1	51 13 082 08	2 978 200	91 54 843 08	11	1
51 07 460 08	2 975 200	91 52 775 08	13	1	51 13 086 08	2 970	91 56 537 08	110	1
51 07 460 08	2 975 700	91 52 774 08	13	1	51 13 087 08	2 970	91 56 537 08	111	2
51 07 461 08	2 970	91 56 537 08	(1)	1	51 13 087 08	2 970	91 56 537 08	111	2
51 07 461 08	5 026 126	50 26 126 08	13	2	51 13 090 08	1 970	91 56 958 08	16	1
51 07 461 08	5 113 086	51 13 086 08	24	2	51 13 225 08	2 970	91 56 537 08	109	1
51 07 466 08	5 113 086	51 13 086 08	15	8	51 14 176 08	2 970	91 56 537 08	113	1
51 07 478 08	5 113 086	51 13 086 08	39	2	51 14 177 08	2 970	91 56 537 08	114	2
51 07 478 08	5 719 113	57 19 113 08	10	1	51 14 177 08	2 978 100	91 52 796 08	6	1
51 07 478 08	X1029184	10 29 184 0	10	1	51 14 177 08	2 978 100	91 52 827 08	10	1
51 07 533 08	5 711 301	57 11 301 08	9	1	51 14 177 08	2 978 200	91 54 843 08	10	1
51 07 534 08	5 711 301	57 11 301 08	10	1	51 14 277 08	2 975 000	91 57 881 08	11	1
51 07 534 08	X1048973	10 48 973 4	11	1	51 14 320 08	2 975 000	91 57 881 08	7	1
51 07 543 08	2 990	91 59 244 08	5	2	51 14 333 08	2 975 000	91 57 881 08	8	1
51 07 604 08	X1022811	10 22 811 2	32	1	51 14 351 08	2 970	91 56 537 08	78	2
51 07 832 08	5 114 176	51 14 176 08	17	1	51 14 444 08	2 970	91 56 537 08	34	3
51 07 832 08	5 114 177	51 14 177 08	17	1	51 14 444 08	2 975 100	91 52 860 08	4	1
51 07 921 08	5 711 301	57 11 301 08	4	1	51 14 444 08	2 975 200	91 52 775 08	4	1
51 07 969 08	5 114 176	51 14 176 08	1	1	51 14 444 08	2 975 700	91 52 774 08	4	1
51 07 969 08	5 114 177	51 14 177 08	1	1	51 14 444 08	2 978 100	91 52 827 08	4	1
51 07 970 08	5 114 176	51 14 176 08	3	1	51 14 444 08	2 978 200	91 54 843 08	4	1
51 07 970 08	5 114 177	51 14 177 08	3	1	51 14 445 08	2 970	91 56 537 08	112	4
51 07 971 08	5 114 176	51 14 176 08	4	1	51 14 469 08	2 975 000	91 57 881 08	9	1
51 07 971 08	5 114 320	51 14 320 08	2	1	51 14 493 08	3 978 005	91 56 430 08	4	1
51 07 972 08	5 114 176	51 14 176 08	5	1	51 14 498 08	3 978 005	91 56 430 08	2	2
51 07 972 08	5 114 177	51 14 177 08	5	1	51 14 535 08	2 970	91 56 537 08	35	3
51 07 973 08	5 114 176	51 14 176 08	6	1	51 14 562 08	3 978 100	91 56 428 08	7	1
					51 14 568 08	2 970	91 56 537 08	30	2

6.2.2009

etk_en_de_074515 LR 1600/2

811

LIEBHERRNumerical index
Numerischer Index

Item	Page	Assembly	Pos.	Quantity	Item	Page	Assembly	Pos.	Quantity
51 14 572 08	2 970	91 56 537 08	72	1	51 15 040 08	3 978 015	91 56 432 08	12	1
51 14 606 08	2 975 100	91 52 860 08	5	1	51 15 058 08	1 970	91 56 958 08	27	1
51 14 606 08	2 975 200	91 52 775 08	5	1	51 15 058 08	2 970	91 56 537 08	98	5
51 14 606 08	2 975 700	91 52 774 08	5	1	51 15 058 08	2 975 100	91 52 860 08	33	2
51 14 651 08	1 970	91 56 958 08	10	1	51 15 058 08	2 975 200	91 52 775 08	33	1
51 14 689 08	2 970	91 56 537 08	108	4	51 15 058 08	2 975 700	91 52 774 08	33	1
51 14 689 08	2 975 100	91 52 860 08	11	1	51 15 058 08	2 976 200	91 44 034 08	5	3
51 14 689 08	2 975 200	91 52 775 08	11	1	51 15 058 08	2 976 203	92 27 489 08	5	1
51 14 689 08	2 975 700	91 52 774 08	11	1	51 15 058 08	3 978 015	91 56 429 08	11	1
51 14 689 08	2 978 100	91 52 827 08	5	1	51 15 058 08	3 978 015	91 56 432 08	11	1
51 14 689 08	2 978 200	91 54 843 08	5	1	51 15 058 08	3 978 100	91 56 428 08	27	1
51 14 716 08	2 970	91 56 537 08	59	1	51 15 059 08	1 970	91 56 958 08	39	2
51 14 769 08	2 970	91 56 537 08	18	1	51 15 059 08	2 970	91 56 537 08	92	2
51 14 815 08	1 970	91 56 958 08	11	2	51 15 062 08	2 990	91 59 244 08	13	1
51 14 815 08	2 970	91 56 537 08	51	1	51 15 066 08	2 990	91 59 244 08	14	1
51 14 815 08	2 975 100	91 52 860 08	8	1	51 15 081 08	2 970	91 56 537 08	89	5
51 14 815 08	2 975 200	91 52 775 08	8	1	51 15 081 08	2 975 100	91 52 860 08	30	1
51 14 815 08	2 975 700	91 52 774 08	8	1	51 15 081 08	2 978 100	91 52 827 08	23	1
51 14 815 08	3 978 005	91 56 430 08	11	1	51 15 082 08	2 970	91 56 537 08	88	3
51 14 820 08	2 970	91 56 537 08	27	2	51 15 082 08	2 975 100	91 52 860 08	29	1
51 14 829 08	3 978 005	91 56 430 08	3	4	51 15 082 08	2 975 200	91 52 775 08	29	1
51 14 853 08	2 970	91 56 537 08	29	3	51 15 082 08	2 975 700	91 52 774 08	29	1
51 14 937 08	2 975 100	91 52 860 08	14	1	51 15 083 08	2 970	91 56 537 08	107	1
51 14 943 08	2 970	91 56 537 08	17	1	51 15 083 08	2 970 081	96 50 495 08	7	1
51 14 975 08	2 970	91 56 537 08	54	4	51 15 083 08	2 975 100	91 52 860 08	20	2
51 14 982 08	3 978 100	91 56 428 08	8	1	51 15 084 08	2 970	91 56 537 08	106	1
51 14 988 08	2 970	91 56 537 08	25	1	51 15 084 08	2 970 081	96 50 495 08	5	2
51 15 004 08	2 970	91 56 537 08	105	4	51 15 084 08	2 975 100	91 52 860 08	19	1
51 15 004 08	2 970 081	96 50 495 08	13	1	51 15 086 08	1 970	91 56 958 08	41	2
51 15 004 08	2 975 100	91 52 860 08	37	2	51 15 086 08	2 970	91 56 537 08	94	2
51 15 004 08	2 976 200	91 44 034 08	11	1	51 15 086 08	2 977	91 57 756 08	41	1
51 15 004 08	2 977 200	91 55 149 08	24	2	51 15 086 08	2 977	91 57 756 08	43	1
51 15 004 08	3 713 013	96 57 159 08	14	3	51 15 086 08	2 978 100	91 52 827 08	25	1
51 15 005 08	2 970	91 56 537 08	104	3	51 15 086 08	2 978 200	91 54 843 08	25	1
51 15 005 08	2 970 081	96 50 495 08	11	2	51 15 096 08	2 970	91 56 537 08	99	2
51 15 005 08	2 975 200	91 52 775 08	37	1	51 15 096 08	2 975 100	91 52 860 08	35	2
51 15 005 08	2 975 700	91 52 774 08	37	1	51 15 096 08	2 975 200	91 52 775 08	35	1
51 15 007 08	2 977	91 57 756 08	39	1	51 15 096 08	2 975 700	91 52 774 08	35	1
51 15 010 08	1 970	91 56 958 08	35	2	51 15 096 08	2 976 200	91 44 034 08	7	3
51 15 010 08	2 970	91 56 537 08	90	3	51 15 096 08	2 976 203	92 27 489 08	7	1
51 15 010 08	2 975 100	91 52 860 08	31	1	51 15 096 08	3 978 005	91 56 430 08	18	1
51 15 010 08	2 977	91 57 756 08	35	1	51 15 096 08	3 978 015	91 56 429 08	13	1
51 15 010 08	2 978 200	91 54 843 08	23	2	51 15 096 08	3 978 015	91 56 432 08	13	1
51 15 011 08	1 970	91 56 958 08	37	2	51 15 108 08	3 978 100	91 56 428 08	31	1
51 15 011 08	2 970	91 56 537 08	91	1	51 15 122 08	1 970	91 56 958 08	31	4
51 15 011 08	2 975 100	91 52 860 08	32	2	51 15 122 08	2 970	91 56 537 08	80	4
51 15 011 08	2 977	91 57 756 08	37	1	51 15 122 08	2 975 100	91 52 860 08	21	2
51 15 011 08	2 977 200	91 55 149 08	20	1	51 15 122 08	2 975 200	91 52 775 08	21	2
51 15 011 08	3 978 100	91 56 428 08	33	1	51 15 122 08	2 975 700	91 52 774 08	21	2
51 15 013 08	1 970	91 56 958 08	23	1	51 15 122 08	2 977	91 57 756 08	31	4
51 15 026 08	2 391 001	96 45 719 08	42	6	51 15 122 08	3 978 015	91 56 429 08	4	2
51 15 040 08	1 970	91 56 958 08	22	1	51 15 122 08	3 978 015	91 56 432 08	4	2
51 15 040 08	2 970	91 56 537 08	101	6	51 15 122 08	3 978 100	91 56 428 08	21	2
51 15 040 08	2 970 081	96 50 495 08	6	2	51 15 123 08	1 970	91 56 958 08	33	4
51 15 040 08	2 975 100	91 52 860 08	34	3	51 15 123 08	2 970	91 56 537 08	82	6
51 15 040 08	2 975 200	91 52 775 08	34	1	51 15 123 08	2 975 100	91 52 860 08	23	4
51 15 040 08	2 975 700	91 52 774 08	34	1	51 15 123 08	2 977	91 57 756 08	33	4
51 15 040 08	2 976 200	91 44 034 08	6	3	51 15 123 08	2 977 200	91 55 149 08	13	2
51 15 040 08	2 976 203	92 27 489 08	6	1	51 15 123 08	3 978 005	91 56 430 08	14	1
51 15 040 08	3 978 015	91 56 429 08	12	1	51 15 123 08	3 978 015	91 56 429 08	5	2

6.2.2009

etk_en_de_074515 LR 1600/2

812

LIEBHERRNumerical index
Numerischer Index

Item	Page	Assembly	Pos.	Quantity	Item	Page	Assembly	Pos.	Quantity
51 15 123 08	3 978 015	91 56 432 08	5	2	54 01 323 08	5 400 565	54 00 565 08	200	1
51 15 125 08	2 391 038	96 47 931 08	3	2	54 01 368 08	X1065015	10 65 015 5	42	1.7
51 15 162 08	2 970	91 56 537 08	561	4	54 01 452 08	X1065015	10 65 015 5	531	2
51 15 167 08	2 391 001	96 45 719 08	41	4	54 01 790 08	3 714 008	96 49 266 08	11	2
51 15 177 08	2 970	91 56 537 08	571	4	54 01 843 08	5 400 565	54 00 565 08	16	1
51 15 178 08	1 970	91 56 958 08	52	4	54 01 844 08	5 400 565	54 00 565 08	20	1
51 15 178 08	2 970	91 56 537 08	572	15	54 01 943 08	X1065015	10 65 015 8	50	1
51 15 178 08	2 975 200	91 52 775 08	47	2	54 02 537 14	X1065015	10 65 015 5	520	1
51 15 178 08	2 975 700	91 52 774 08	47	2	54 05 073 08	6 909 010	69 09 010 08	37	1
51 15 184 08	2 970	91 56 537 08	96	1	55 04 515 08	2 391 001	96 45 719 08	122	2
51 15 184 08	2 977	91 57 756 08	45	1	55 04 516 08	2 391 001	96 45 719 08	123	2
51 15 185 08	2 977	91 57 756 08	46	1	55 06 395 08	2 391 023	96 45 720 08	3	2
51 21 370 08	2 391 001	96 45 719 08	114	1	55 07 726 08	2 393	91 52 787 08	2	2
51 23 497 08	2 810	91 52 806 08	31	1	55 08 380 08	2 520 034	96 45 984 08	52	4
51 23 682 08	1 410 300	91 56 855 08	11	1	55 08 494 08	2 391 001	96 45 719 08	132	8
51 23 943 08	3 790 006	96 19 989 08	1	1	55 08 494 08	2 391 023	96 45 720 08	6	2
51 23 944 08	3 790 007	96 19 990 08	1	1	55 08 494 08	2 670	91 52 797 08	16	4
51 31 150 08	5 719 006	57 19 006 08	11	1	55 08 495 08	2 391 001	96 45 719 08	134	2
51 31 192 08	5 113 086	51 13 086 08	50	1	55 08 496 08	2 920 638	96 51 138 08	15	1
51 45 042 08	X1035924	10 35 924 8	(5)	1	55 08 984 08	2 391 001	96 45 719 08	200	1
51 45 080 08	7 027 481	70 27 481 03	18	1	55 08 998 08	2 391 001	96 45 719 08	388	12
51 45 171 08	X1065015	10 65 015 5	521	2	55 17 025 08	2 391 001	96 45 719 08	124	2
51 45 171 08	X1065015	10 65 015 8	65	1	55 17 068 08	2 393	91 52 787 08	3	1
51 45 195 08	X1047219	10 47 219 6	53	1	55 17 166 08	2 391 023	96 45 720 08	22	2
51 45 275 08	5 106 691	51 06 691 08	13	1	55 17 203 08	2 393	91 52 787 08	1	1
51 45 304 08	5 719 006	57 19 006 08	10	1	55 20 022 08	2 392	91 52 785 08	12	8
51 45 349 08	X1042440	10 42 440 2	20	2	55 20 506 08	2 391 001	96 45 719 08	126	4
51 45 410 08	3 220 500	91 52 849 08	19	8	55 20 669 08	2 392	91 52 785 08	9	2
51 45 410 08	3 223	91 52 852 08	19	10	55 20 709 08	2 392	91 52 785 08	8	5
51 45 410 08	3 223 010	91 52 853 08	19	10	55 30 108 08	2 920 369	96 54 235 08	50	0.9
51 45 410 08	3 223 100	91 55 327 08	19	10	55 30 182 08	2 520	91 53 061 08	59	0.16
51 45 424 08	X1041267	10 41 267 5	43	1	55 30 182 08	2 520	91 53 061 08	60	0.3
51 45 495 08	X1041267	10 41 267 5	42	1	55 30 182 08	2 520	91 53 061 08	61	0.13
51 45 819 08	2 913 100	91 23 538 08	5	12	55 30 182 08	2 520	91 53 061 08	62	0.26
51 45 851 08	X1047219	10 47 219 6	52	7	55 30 182 08	2 520	91 53 061 08	63	1.62
51 45 915 08	5 715 142	57 15 142 08	26	2	55 30 187 08	2 541	91 52 790 08	12	10
51 45 915 08	5 719 113	57 19 113 08	15	2	55 30 187 08	2 541	91 52 790 08	13	2
51 45 915 08	X1029184	10 29 184 0	15	2	55 30 278 08	2 520	91 53 061 08	51	2
51 45 915 08	X1041267	10 41 267 7	44	1	55 30 278 08	2 520 033	96 50 633 08	5	2
51 45 947 08	5 719 113	57 19 113 08	20	1	55 30 278 08	2 540	91 53 253 08	12	4
51 45 948 08	5 719 113	57 19 113 08	19	1	55 30 310 08	2 831	91 57 754 08	20	1
51 45 994 08	2 913 100	91 23 538 08	4	12	55 30 541 08	2 541	91 52 790 08	6	2
51 45 994 08	5 701 129	57 01 129 08	20	7	55 30 541 08	2 541 001	96 49 651 08	9	0.5
51 57 051 08	5 701 129	57 01 129 08	15	1	55 30 542 08	2 541 001	96 49 651 08	8	3
51 57 106 08	X1022811	10 22 811 2	31	1	55 30 545 08	2 540	91 53 253 08	6	1
51 85 009 08	X1035924	10 35 924 7	26	1	55 31 023 08	2 541	91 52 790 08	15	6
51 85 781 08	2 391 001	96 45 719 08	142	5	55 31 248 08	3 220 500	91 52 849 08	48	4
51 86 135 08	X1035924	10 35 924 1	25	1	55 31 248 08	3 223	91 52 852 08	48	4
51 86 135 08	X1035924	10 35 924 2	25	1	55 31 248 08	3 223 010	91 52 853 08	48	4
51 86 135 08	X1035924	10 35 924 6	25	1	55 31 248 08	3 223 100	91 55 327 08	48	4
51 86 135 08	X1035925	10 35 925 0	25	1	55 31 248 08	3 226	91 52 870 08	48	4
52 12 028 08	5 102 380	51 02 380 08	22	1	55 31 248 08	3 227	91 52 873 08	48	4
53 00 631 08	2 550	91 57 751 08	32	8	55 31 248 08	3 227 008	91 52 872 08	48	4
53 00 732 08	X1042440	10 42 440 2	31	2	55 31 281 08	2 540	91 53 253 08	11	1
53 01 333 08	2 550 005	96 45 680 08	15	1	55 31 281 08	2 541	91 52 790 08	10	1
53 06 131 08	X1065015	10 65 015 6	61	2	55 31 352 08	5 530 545	55 30 545 08	1	1
54 00 018 08	1 630	91 52 387 08	7	4	55 31 353 08	5 530 545	55 30 545 08	2	1
54 00 565 08	2 370	91 52 782 08	1	1	55 31 354 08	5 530 545	55 30 545 08	3	1
54 00 569 08	3 208 001	91 52 883 08	5	1	55 31 355 08	5 530 545	55 30 545 08	4	1
54 01 323 08	5 400 565	54 00 565 08	141	1	55 31 594 08	2 541 001	96 49 651 08	3	0.33

6.2.2009

etk_en_de_074515 LR 1600/2

813

LIEBHERRNumerical index
Numerischer Index

Item	Page	Assembly	Pos.	Quantity	Item	Page	Assembly	Pos.	Quantity
55 31 619 08	2 913 100	91 23 538 08	12	4	57 01 139 08	5 701 129	57 01 129 08	9	1
55 31 684 08	2 520 032	96 45 980 08	15	2	57 01 140 08	5 701 129	57 01 129 08	10	1
55 31 687 08	2 932 160	96 54 385 08	17	2	57 01 141 08	5 701 129	57 01 129 08	14	1
55 31 687 08	3 930 640	96 50 481 08	159	2	57 01 142 08	5 701 129	57 01 129 08	17	2
55 31 687 08	3 930 730	96 50 599 08	272	2	57 01 143 08	5 701 129	57 01 129 08	18	1
55 31 687 08	X1035519	10 35 519 6	17	6	57 01 144 08	5 701 133	57 01 133 08	1	1
55 31 699 08	X1022811	10 22 811 2	39	4	57 01 145 08	5 701 133	57 01 133 08	2	1
55 31 730 08	2 540	91 53 253 08	16	2	57 01 146 08	5 701 133	57 01 133 08	3	1
55 31 731 08	2 540	91 53 253 08	14	2	57 01 147 08	5 701 133	57 01 133 08	4	7
55 31 731 08	2 541	91 52 790 08	8	2	57 01 148 08	5 701 133	57 01 133 08	5	14
55 31 738 08	2 540	91 53 253 08	15	1	57 01 149 08	5 701 133	57 01 133 08	6	1
55 31 738 08	2 541	91 52 790 08	11	1	57 01 150 08	5 701 133	57 01 133 08	7	4
55 31 740 08	2 541	91 52 790 08	(1)	1	57 01 519 08	5 400 565	54 00 565 08	15	1
55 31 741 08	2 541	91 52 790 08	7	1	57 01 989 08	X1002800	10 02 800 2	12	2
55 31 761 08	2 540	91 53 253 08	17	1	57 04 059 08	1 750	91 52 394 08	(1)	1
55 31 761 08	2 541	91 52 790 08	9	1	57 05 048 08	2 976 200	91 44 034 08	13	1
55 31 811 08	2 541 001	96 49 651 08	4	1	57 05 881 08	5 106 691	51 06 691 08	999	1
55 31 812 08	2 520	91 53 061 08	57	1.7	57 05 883 08	5 106 691	51 06 691 08	8	1
55 31 812 08	2 520	91 53 061 08	58	1.9	57 05 883 08	5 708 320	57 08 320 08	1	1
55 31 868 08	2 541	91 52 790 08	5	1	57 05 888 08	5 106 691	51 06 691 08	11	1
55 31 869 08	2 533 065	96 48 364 08	50	1	57 05 889 08	5 708 320	57 08 320 08	3	1
55 31 872 08	2 541 001	96 49 651 08	7	1	57 06 304 08	2 550 008	96 47 628 08	4	1
55 31 911 08	2 541	91 52 790 08	14	0.15	57 06 304 08	2 550 009	96 47 645 08	4	1
55 31 932 08	2 520 034	96 45 984 08	36	9	57 06 338 08	5 114 445	51 14 445 08	1	1
56 00 192 08	2 522 011	96 45 602 08	6	1	57 06 338 08	5 114 498	51 14 498 08	1	1
57 00 092 08	5 026 126	50 26 126 08	1	1	57 06 338 08	5 114 943	51 14 943 08	1	1
57 00 093 08	5 026 126	50 26 126 08	5	1	57 06 475 08	5 711 301	57 11 301 08	3	1
57 00 094 08	5 026 126	50 26 126 08	7	1	57 06 523 08	5 113 005	51 13 005 08	25	1
57 00 095 08	5 026 126	50 26 126 08	8	1	57 06 523 08	X1048973	10 48 973 4	25	1
57 00 096 08	5 026 126	50 26 126 08	9	1	57 06 662 08	5 718 989	57 18 989 08	9	1
57 00 097 08	5 026 126	50 26 126 08	12	1	57 06 810 08	5 114 943	51 14 943 08	(1)	1
57 00 098 08	5 026 126	50 26 126 08	14	1	57 06 903 08	5 113 086	51 13 086 08	25	1
57 00 099 08	5 026 126	50 26 126 08	19	1	57 06 906 08	5 711 301	57 11 301 08	7	1
57 00 100 08	5 026 126	50 26 126 08	20	1	57 06 906 08	5 715 296	57 15 296 08	17	1
57 00 101 08	5 026 126	50 26 126 08	4	1	57 06 906 08	7 743 566	77 43 566 08	22	1
57 00 101 08	5 114 498	51 14 498 08	3	2	57 07 018 08	5 102 354	51 02 354 08	(14)	1
57 00 101 08	5 114 943	51 14 943 08	3	2	57 07 108 08	5 715 142	57 15 142 08	9	1
57 00 102 08	5 026 126	50 26 126 08	16	2	57 07 719 08	5 102 306	51 02 306 08	4	1
57 00 103 08	5 026 126	50 26 126 08	18	4	57 08 179 08	5 710 349	57 10 349 08	1	2
57 00 488 08	5 719 113	57 19 113 08	17	2	57 08 188 08	2 970	91 56 537 08	49	5
57 00 488 08	X1029184	10 29 184 0	17	2	57 08 278 08	5 114 444	51 14 444 08	1	1
57 00 659 08	5 028 065	50 28 065 08	1	1	57 08 310 08	5 106 691	51 06 691 08	9	1
57 00 660 08	5 028 065	50 28 065 08	2	1	57 08 320 08	5 106 691	51 06 691 08	2	1
57 00 661 08	5 028 065	50 28 065 08	3	1	57 08 621 08	X1041267	10 41 267 8	5	1
57 00 662 08	5 028 065	50 28 065 08	4	1	57 10 349 08	3 978 100	91 56 428 08	3	1
57 00 663 08	5 028 065	50 28 065 08	5	1	57 10 356 08	5 710 349	57 10 349 08	999	1
57 00 664 08	5 028 065	50 28 065 08	7	1	57 10 768 08	2 975 700	91 52 774 08	(1)	1
57 00 728 08	5 114 320	51 14 320 08	1	1	57 10 769 08	2 975 700	91 52 774 08	(2)	1
57 00 729 08	5 114 320	51 14 320 08	3	1	57 10 769 08	3 978 100	91 56 428 08	(2)	1
57 00 731 08	5 114 320	51 14 320 08	9	1	57 10 770 08	2 975 700	91 52 774 08	(3)	1
57 00 734 08	5 114 320	51 14 320 08	12	1	57 10 770 08	3 978 100	91 56 428 08	(3)	1
57 01 129 08	5 102 306	51 02 306 08	1	1	57 10 771 08	2 975 700	91 52 774 08	(4)	1
57 01 130 08	5 102 306	51 02 306 08	3	1	57 10 772 08	2 975 700	91 52 774 08	(5)	1
57 01 132 08	5 102 306	51 02 306 08	5	1	57 10 773 08	3 978 100	91 56 428 08	(1)	1
57 01 133 08	5 701 129	57 01 129 08	1	1	57 10 774 08	3 978 100	91 56 428 08	(4)	1
57 01 134 08	5 701 129	57 01 129 08	2	1	57 10 819 08	1 970	91 56 958 08	(1)	1
57 01 135 08	5 701 129	57 01 129 08	3	1	57 10 820 08	1 970	91 56 958 08	(2)	1
57 01 136 08	5 701 129	57 01 129 08	4	1	57 10 820 08	1 970	91 56 958 08	(2)	1
57 01 137 08	5 701 129	57 01 129 08	5	1	57 10 821 08	1 970	91 56 958 08	(3)	1
57 01 138 08	5 701 129	57 01 129 08	7	1	57 10 822 08	1 970	91 56 958 08	(4)	1

6.2.2009

etk_en_de_074515 LR 1600/2

814

LIEBHERRNumerical index
Numerischer Index

Item	Page	Assembly	Pos.	Quantity	Item	Page	Assembly	Pos.	Quantity
57 10 822 08	1 970	91 56 958 08	(3)	1	57 18 420 08	X1035411	10 35 411 4	22	1
57 10 823 08	1 970	91 56 958 08	(5)	1	57 18 445 08	X1065015	10 65 015 8	55	1
57 10 824 08	1 970	91 56 958 08	(1)	1	57 18 446 08	X1065015	10 65 015 8	69	1
57 10 826 08	1 970	91 56 958 08	(2)	1	57 18 448 08	X1065015	10 65 015 5	51	1
57 10 828 08	1 970	91 56 958 08	(3)	1	57 18 677 08	X1022811	10 22 811 2	44	1
57 10 830 08	1 970	91 56 958 08	(1)	1	57 18 705 08	6 909 010	69 09 010 08	(60)	1
57 11 301 08	5 113 086	51 13 086 08	31	1	57 18 989 08	X1035924	10 35 924 6	3	1
57 11 303 08	5 711 301	57 11 301 08	2	1	57 18 994 08	5 718 989	57 18 989 08	1	2
57 11 304 08	5 711 301	57 11 301 08	5	1	57 18 995 08	5 718 989	57 18 989 08	3	1
57 11 305 08	5 711 301	57 11 301 08	8	1	57 19 004 08	X1035924	10 35 924 7	2	1
57 12 325 08	5 718 989	57 18 989 08	2	1	57 19 006 08	X1035924	10 35 924 7	7	1
57 12 342 08	X1035925	10 35 925 1	23	4	57 19 008 08	X1047219	10 47 219 6	2	1
57 12 395 08	5 715 142	57 15 142 08	2	1	57 19 010 08	5 719 006	57 19 006 08	2	1
57 12 395 08	5 719 030	57 19 030 08	2	1	57 19 030 08	X1035924	10 35 924 3	3	1
57 12 398 08	5 719 030	57 19 030 08	9	1	57 19 030 08	X1035924	10 35 924 4	3	1
57 12 398 08	X1035924	10 35 924 8	26	1	57 19 033 08	5 719 030	57 19 030 08	1	2
57 13 378 08	7 300 043	73 00 043 08	1	1	57 19 037 08	5 113 086	51 13 086 08	45	1
57 13 523 08	5 026 573	50 26 573 08	1	1	57 19 038 08	5 113 086	51 13 086 08	48	1
57 13 561 08	2 970	91 56 537 08	(4)	1	57 19 039 08	5 113 086	51 13 086 08	51	1
57 13 626 08	5 113 086	51 13 086 08	55	1	57 19 055 08	2 212	91 54 561 08	4	1
57 13 664 08	X1065015	10 65 015 8	95	1	57 19 101 08	5 713 626	57 13 626 08	435	2
57 14 224 08	6 909 010	69 09 010 08	9	4	57 19 113 08	X1035924	10 35 924 1	5	1
57 14 553 08	5 710 349	57 10 349 08	(1)	1	57 19 113 08	X1035924	10 35 924 2	5	1
57 14 890 08	2 831	91 57 754 08	4	1	57 19 117 08	5 719 113	57 19 113 08	13	2
57 14 891 08	2 831	91 57 754 08	6	1	57 19 117 08	X1029184	10 29 184 0	13	2
57 15 052 08	2 810	91 52 806 08	(9)	2	57 19 123 08	6 060 950	60 60 950 08	2	1
57 15 139 08	X1065068	10 65 068 8	1	2	57 19 133 08	X1035925	10 35 925 0	5	1
57 15 140 08	X1065068	10 65 068 8	3	1	57 19 135 08	5 123 682	51 23 682 08	5	1
57 15 142 08	X1035924	10 35 924 1	3	1	57 19 136 08	5 123 682	51 23 682 08	(10)	1
57 15 142 08	X1035924	10 35 924 2	3	1	59 10 053 08	2 520 032	96 45 980 08	14	10
57 15 142 08	X1035925	10 35 925 0	3	1	59 10 059 08	2 520 034	96 45 984 08	47	20
57 15 145 08	5 715 142	57 15 142 08	1	1	59 10 501 08	2 520 034	96 45 984 08	32	2
57 15 146 08	5 715 142	57 15 142 08	3	1	59 10 510 08	2 520 032	96 45 980 08	24	2
57 15 147 08	5 715 142	57 15 142 08	4	1	59 10 554 08	2 520 032	96 45 980 08	12	1
57 15 165 08	X1035925	10 35 925 1	22	1	59 10 555 08	2 520 032	96 45 980 08	13	1
57 15 168 08	5 102 380	51 02 380 08	20	1	59 10 556 08	2 520 032	96 45 980 08	16	2
57 15 296 08	5 113 086	51 13 086 08	8	1	59 10 589 08	2 522 011	96 45 602 08	21	1
57 15 512 08	X1065015	10 65 015 8	53	1	59 10 668 08	2 520 030	96 45 609 08	3	1
57 15 514 08	X1065015	10 65 015 8	58	1	59 10 670 08	2 502	91 55 939 08	23	1
57 15 521 08	X1065015	10 65 015 5	31	1	59 15 078 08	2 510	91 52 788 08	12	4
57 15 610 08	5 113 086	51 13 086 08	16	2	59 15 592 08	2 533 066	96 48 365 08	3	3
57 15 786 08	1 711	91 52 392 08	(1)	1	59 15 709 08	2 520	91 53 061 08	77	2
57 16 137 08	2 970	91 56 537 08	(10)	1	60 01 312 08	3 930 732	96 50 575 08	341	0.32
57 16 648 08	1 400	91 56 853 08	(52)	1	60 01 313 08	3 930 009	96 50 573 08	342	1
57 16 910 08	X1042440	10 42 440 2	8	1	60 03 420 08	2 780 320	91 05 067 08	11	3
57 17 080 08	5 123 682	51 23 682 08	1	1	60 03 452 08	2 920 633	96 52 651 08	371	2.05
57 17 120 08	5 123 682	51 23 682 08	2	1	60 03 673 08	2 920 633	96 52 651 08	12	9.37
57 17 127 08	5 113 022	51 13 022 08	1	2	60 03 673 08	2 920 633	96 52 651 08	15	10.57
57 17 230 08	5 123 682	51 23 682 08	3	1	60 03 673 08	2 920 633	96 52 651 08	16	8.77
57 17 231 08	5 123 682	51 23 682 08	4	1	60 03 673 08	2 920 633	96 52 651 08	19	8.47
57 17 272 08	5 400 565	54 00 565 08	5	1	60 04 042 08	2 920 369	96 54 235 08	310	0.3
57 17 273 08	5 400 565	54 00 565 08	6	1	60 04 042 08	2 920 448	96 48 794 08	310	0.3
57 17 286 08	X1041101	10 41 101 5	280	1	60 04 121 08	2 920 369	96 54 235 08	(344)	0.96
57 17 286 08	X1041101	10 41 101 8	260	1	60 04 140 08	2 920 369	96 54 235 08	(345)	0.32
57 17 556 08	5 517 203	55 17 203 08	1	1	60 04 140 08	2 920 369	96 54 235 08	(345)	0.32
57 17 778 08	5 102 380	51 02 380 08	55	1	60 04 140 08	2 920 633	96 52 651 08	345	22.2
57 17 779 08	5 102 380	51 02 380 08	56	1	60 04 341 08	2 780 320	91 05 067 08	20	3
57 17 780 08	5 102 380	51 02 380 08	57	1	60 04 341 08	2 920 369	96 54 235 08	(305)	3.84
57 18 141 08	5 113 086	51 13 086 08	35	1	60 04 341 08	2 920 369	96 54 235 08	(305)	2.56
57 18 247 08	6 060 950	60 60 950 08	1	1	60 04 341 08	2 920 633	96 52 651 08	305	453.6

6.2.2009

etk_en_de_074515 LR 1600/2

815

LIEBHERRNumerical index
Numerischer Index

Item	Page	Assembly	Pos.	Quantity	Item	Page	Assembly	Pos.	Quantity
60 04 407 08	3 930 732	96 50 575 08	5	39.12	60 22 034 08	2 780 320	91 05 067 08	12	2
60 04 425 08	2 920 633	96 52 651 08	14	6.95	60 22 034 08	2 920 633	96 52 651 08	72	12
60 04 604 08	2 920 636	96 51 854 08	5	6.95	60 22 037 08	2 920 581	96 54 405 08	(63)	3
60 04 640 08	2 920 581	96 54 405 08	(5)	14.86	60 22 037 08	2 920 581	96 54 405 08	(63)	3
60 04 640 08	2 920 633	96 52 651 08	5	3.1	60 22 037 08	2 920 581	96 54 405 08	(63)	3
60 04 640 08	2 920 633	96 52 651 08	6	2.7	60 22 037 08	2 920 581	96 54 405 08	(63)	19
60 04 640 08	2 920 633	96 52 651 08	7	5.9	60 22 037 08	2 920 636	96 51 854 08	63	3
60 04 640 08	3 930 734	96 54 401 08	(5)	15.43	60 22 037 08	3 930 734	96 54 401 08	(63)	14
60 04 912 08	2 920 815	96 49 300 08	(331)	1.4	60 22 060 08	3 930 009	96 50 573 08	32	1
60 04 916 08	2 920 288	96 52 614 08	(329)	2.6	60 22 061 08	3 930 009	96 50 573 08	34	1
60 04 918 08	2 920 536	96 48 317 08	(333)	11	60 22 082 08	2 920 815	96 49 300 08	(103)	2
60 04 918 08	2 920 536	96 48 317 08	(333)	1	60 22 097 08	2 920 633	96 52 651 08	508	3
60 04 918 08	2 920 815	96 49 300 08	(333)	0.9	60 22 097 08	2 932 001	96 45 393 08	(152)	1
60 04 918 08	2 920 815	96 49 300 08	(333)	2	60 22 097 08	2 932 224	96 54 389 08	517	2
60 04 918 08	2 920 815	96 49 300 08	(333)	0.16	60 22 179 08	2 920 369	96 54 235 08	34	2
60 14 058 08	2 932 001	96 45 393 08	44	0.63	60 22 179 08	2 920 448	96 48 794 08	34	2
60 14 139 08	2 932 082	96 54 387 08	21	0.725	60 22 184 08	2 920 633	96 52 651 08	112	3
60 14 142 08	2 932 082	96 54 387 08	45	1.295	60 22 221 08	2 920 536	96 48 317 08	(648)	1
60 20 014 08	2 391 001	96 45 719 08	146	4	60 23 002 08	2 932 224	96 54 389 08	501	37
60 20 015 08	2 391 001	96 45 719 08	147	2	60 23 003 08	2 920 369	96 54 235 08	(125)	14
60 20 022 08	2 391 001	96 45 719 08	139	4	60 23 003 08	2 920 369	96 54 235 08	(125)	9
60 20 043 08	2 920 535	96 48 318 08	15	1	60 23 010 08	2 920 536	96 48 317 08	(80)	1
60 20 078 08	2 391 001	96 45 719 08	156	2	60 23 010 08	2 920 815	96 49 300 08	(80)	2
60 20 081 08	2 502	91 55 939 08	49	2	60 23 010 08	2 920 815	96 49 300 08	(80)	1
60 20 083 08	2 550 008	96 47 628 08	9	6	60 23 010 08	2 920 815	96 49 300 08	(80)	2
60 20 083 08	2 550 009	96 47 645 08	9	6	60 23 011 08	2 920 536	96 48 317 08	(99)	2
60 20 089 08	2 978 100	91 52 796 08	23	40	60 23 011 08	2 920 815	96 49 300 08	(99)	1
60 20 091 08	2 391 001	96 45 719 08	116	4	60 23 014 08	2 932 224	96 54 389 08	511	1
60 20 092 08	3 978 005	91 56 430 08	51	20	60 23 033 08	2 920 633	96 52 651 08	134	10
60 20 092 08	3 978 015	91 56 429 08	51	40	60 23 048 08	2 913 102	92 32 870 08	9	2
60 20 092 08	3 978 015	91 56 432 08	51	40	60 23 059 08	2 913 102	92 32 870 08	8	1
60 20 094 08	2 391 001	96 45 719 08	145	1	60 23 061 08	2 920 369	96 54 235 08	31	2
60 20 094 08	2 671 004	96 46 305 08	26	2	60 23 061 08	2 920 448	96 48 794 08	31	2
60 20 178 08	2 522 011	96 45 602 08	23	1	60 23 077 08	2 920 633	96 52 651 08	86	42
60 20 180 08	2 671 004	96 46 305 08	25	2	60 23 078 08	2 920 633	96 52 651 08	114	3
60 20 180 08	2 978 100	91 52 796 08	17	8	60 23 080 08	2 780 320	91 05 067 08	13	2
60 20 180 08	3 978 005	91 56 430 08	55	20	60 23 084 08	2 920 633	96 52 651 08	105	3
60 20 180 08	3 978 015	91 56 429 08	55	40	60 23 085 08	2 920 633	96 52 651 08	104	1
60 20 180 08	3 978 015	91 56 432 08	55	40	60 23 114 08	2 920 288	96 52 614 08	(57)	2
60 20 422 08	2 533 070	96 48 363 08	18	4	60 23 198 08	2 920 633	96 52 651 08	513	1
60 20 422 08	2 932 001	96 45 393 08	32	1	60 23 212 08	2 922 001	92 84 311 08	5	7
60 20 426 08	2 932 082	96 54 387 08	91	2	60 23 219 08	2 922 001	92 84 311 08	6	2
60 20 611 08	2 520 033	96 50 633 08	6	7	60 23 223 08	2 932 224	96 54 389 08	510	7
60 20 611 08	2 932 082	96 54 387 08	47	8	60 23 233 08	2 932 001	96 45 393 08	(151)	2
60 21 067 08	1 920 403	96 48 707 08	273	0.15	60 23 233 08	2 932 224	96 54 389 08	503	34
60 21 067 08	1 920 417	96 48 703 08	273	0.15	60 23 235 08	2 920 369	96 54 235 08	(124)	10
60 21 067 08	1 920 418	96 48 687 08	10	0.585	60 23 235 08	2 920 369	96 54 235 08	(124)	7
60 21 067 08	2 780 748	96 52 969 08	273	0.15	60 23 250 08	2 932 001	96 45 393 08	(152)	12
60 21 067 08	2 920 581	96 54 405 08	262	0.205	60 23 255 08	2 932 224	96 54 389 08	520	2
60 21 067 08	2 932 082	96 54 387 08	6	0.4	60 23 256 08	2 932 224	96 54 389 08	514	6
60 21 067 08	2 932 082	96 54 387 08	8	0.1	60 23 313 08	2 932 224	96 54 389 08	515	13
60 21 067 08	3 930 363	96 52 979 08	272	0.245	60 23 328 08	2 920 369	96 54 235 08	(152)	1
60 21 067 08	3 930 638	96 51 624 08	261	0.58	60 23 359 08	2 932 224	96 54 389 08	523	1
60 21 067 08	3 930 640	96 50 481 08	272	0.35	60 23 360 08	2 920 369	96 54 235 08	(152)	1
60 21 067 08	3 930 730	96 50 599 08	298	0.245	60 23 360 08	2 932 224	96 54 389 08	507	12
60 21 067 08	3 930 730	96 54 398 08	278	1.16	60 23 364 08	2 932 166	92 68 911 08	2	1
60 21 067 08	3 930 734	96 54 401 08	202	0.55	60 23 365 08	2 932 166	92 68 911 08	3	6
60 21 101 08	2 932 082	96 54 387 08	9	5	60 23 370 08	2 932 001	96 45 393 08	(153)	3
60 21 160 08	2 520 034	96 45 984 08	50	4	60 23 395 08	2 920 633	96 52 651 08	647	4
60 21 710 08	2 932 001	96 45 393 08	47	90	60 24 219 08	2 920 288	96 52 614 08	(505)	1

6.2.2009

etk_en_de_074515 LR 1600/2

816

LIEBHERRNumerical index
Numerischer Index

Item	Page	Assembly	Pos.	Quantity	Item	Page	Assembly	Pos.	Quantity
60 24 240 08	2 920 581	96 54 405 08	(151)	1	60 25 012 08	1 920 418	96 48 687 08	292	2
60 24 240 08	2 920 581	96 54 405 08	(151)	1	60 25 012 08	2 780 748	96 52 969 08	292	1
60 24 240 08	2 920 581	96 54 405 08	(151)	1	60 25 012 08	2 920 369	96 54 235 08	292	1
60 24 241 08	1 920 403	96 48 707 08	267	2	60 25 012 08	2 920 448	96 48 794 08	292	2
60 24 241 08	1 920 417	96 48 703 08	267	2	60 25 012 08	2 920 581	96 54 405 08	292	1
60 24 241 08	2 520	91 53 061 08	72	3	60 25 012 08	2 932 160	96 54 385 08	18	2
60 24 241 08	2 780 748	96 52 969 08	153	1	60 25 012 08	3 930 363	96 52 979 08	285	2
60 24 241 08	3 930 363	96 52 979 08	277	2	60 25 012 08	3 930 638	96 51 624 08	292	1
60 24 241 08	X1002800	10 02 800 2	10	1	60 25 012 08	3 930 640	96 50 481 08	285	1
60 24 242 08	2 780 524	96 52 968 08	8	2	60 25 012 08	3 930 730	96 50 599 08	292	1
60 24 242 08	2 920 448	96 48 794 08	290	1	60 25 012 08	3 930 730	96 54 398 08	285	2
60 24 242 08	2 920 581	96 54 405 08	(154)	2	60 25 012 08	3 930 734	96 54 401 08	308	3
60 24 242 08	2 920 581	96 54 405 08	272	1	60 25 013 08	1 920 403	96 48 707 08	293	1
60 24 242 08	2 920 633	96 52 651 08	520	3	60 25 013 08	1 920 417	96 48 703 08	293	1
60 24 242 08	3 930 734	96 54 401 08	(153)	2	60 25 013 08	1 920 418	96 48 687 08	293	1
60 24 242 08	X1002800	10 02 800 2	3	1	60 25 013 08	2 780 524	96 52 968 08	9	1
60 24 243 08	1 920 403	96 48 707 08	270	1	60 25 013 08	2 780 748	96 52 969 08	293	1
60 24 243 08	1 920 417	96 48 703 08	270	1	60 25 013 08	2 920 369	96 54 235 08	293	1
60 24 243 08	3 930 138	96 54 377 08	(269)	1	60 25 013 08	2 920 448	96 48 794 08	293	1
60 24 246 08	1 920 418	96 48 687 08	18	1	60 25 013 08	2 920 581	96 54 405 08	293	1
60 24 249 08	1 920 403	96 48 707 08	269	1	60 25 013 08	3 930 363	96 52 979 08	286	1
60 24 249 08	1 920 417	96 48 703 08	269	1	60 25 013 08	3 930 640	96 50 481 08	286	1
60 24 249 08	2 780 748	96 52 969 08	151	1	60 25 019 08	2 920 257	92 78 689 08	5	1
60 24 249 08	3 930 363	96 52 979 08	279	3	60 26 062 08	2 920 559	96 47 914 08	(6)	1
60 24 249 08	3 930 638	96 51 624 08	273	1	60 26 064 08	2 920 633	96 52 651 08	521	3
60 24 249 08	3 930 730	96 54 398 08	152	2	60 26 064 08	3 930 638	96 51 624 08	183	1
60 24 250 08	1 920 403	96 48 707 08	268	1	60 26 065 08	2 780 524	96 52 968 08	7	1
60 24 250 08	1 920 417	96 48 703 08	268	1	60 26 065 08	2 920 448	96 48 794 08	289	1
60 24 250 08	3 930 640	96 50 481 08	7	1	60 26 065 08	2 920 581	96 54 405 08	(155)	1
60 24 250 08	3 930 734	96 54 401 08	215	1	60 26 065 08	3 930 734	96 54 401 08	(154)	1
60 24 251 08	1 920 418	96 48 687 08	19	3	60 26 066 08	3 930 732	96 50 575 08	157	1
60 24 251 08	2 920 369	96 54 235 08	(159)	1	60 27 011 08	1 750	91 52 394 08	28	1
60 24 251 08	2 920 369	96 54 235 08	(160)	1	60 27 013 08	2 810 037	96 47 204 08	5	2
60 24 251 08	2 920 633	96 52 651 08	519	6	60 27 024 08	2 913 102	92 32 870 08	10	1
60 24 251 08	3 930 638	96 51 624 08	272	1	60 27 040 08	3 930 009	96 50 573 08	164	1
60 24 251 08	3 930 730	96 50 599 08	157	1	60 27 073 08	3 930 732	96 50 575 08	153	1
60 24 251 08	3 930 730	96 50 599 08	158	1	60 27 099 08	1 750	91 52 394 08	29	1
60 24 251 08	3 930 734	96 54 401 08	220	3	60 27 100 08	2 920 633	96 52 651 08	97	2
60 24 252 08	2 920 369	96 54 235 08	(154)	1	60 27 100 08	3 930 138	96 54 377 08	(97)	25
60 24 252 08	2 920 448	96 48 794 08	286	2	60 27 100 08	3 930 732	96 50 575 08	97	4
60 24 252 08	3 930 730	96 54 398 08	150	2	60 27 101 08	2 920 288	96 52 614 08	(98)	2
60 24 255 08	2 780 748	96 52 969 08	152	1	60 27 101 08	2 920 815	96 49 300 08	(98)	2
60 24 255 08	3 930 638	96 51 624 08	271	1	60 27 101 08	2 920 815	96 49 300 08	(98)	2
60 24 255 08	3 930 640	96 50 481 08	152	2	60 27 101 08	2 920 815	96 49 300 08	(98)	2
60 24 255 08	3 930 734	96 54 401 08	214	1	60 27 355 08	2 932 082	96 54 387 08	70	50
60 24 257 08	2 920 581	96 54 405 08	270	3	60 27 360 08	2 920 581	96 54 405 08	261	2
60 24 257 08	3 930 363	96 52 979 08	276	3	60 27 360 08	3 930 640	96 50 481 08	158	2
60 24 257 08	3 930 638	96 51 624 08	279	1	60 27 360 08	3 930 730	96 50 599 08	271	2
60 24 258 08	3 930 732	96 50 575 08	156	1	60 27 360 08	3 930 730	96 54 398 08	274	2
60 24 260 08	2 920 288	96 52 614 08	(504)	1	60 27 360 08	3 930 734	96 54 401 08	205	2
60 24 400 08	2 920 257	92 78 689 08	4	1	60 27 417 08	1 920 403	96 48 707 08	275	6
60 24 408 08	2 920 559	96 47 914 08	(7)	1	60 27 417 08	1 920 417	96 48 703 08	275	6
60 24 412 08	2 920 448	96 48 794 08	288	3	60 27 417 08	3 930 363	96 52 979 08	274	10
60 24 413 08	1 920 418	96 48 687 08	17	1	60 27 417 08	3 930 640	96 50 481 08	274	12
60 24 413 08	2 920 448	96 48 794 08	283	1	60 27 426 08	3 930 363	96 52 979 08	503	0.25
60 24 414 08	1 920 403	96 48 707 08	271	1	60 27 426 08	3 930 640	96 50 481 08	14	0.1
60 24 414 08	1 920 417	96 48 703 08	271	1	60 27 426 08	3 930 730	96 54 398 08	503	0.56
60 24 417 01	2 780 915	96 48 377 08	11	2	60 27 437 08	2 920 581	96 54 405 08	263	1
60 25 012 08	1 920 403	96 48 707 08	292	1	60 27 601 08	1 976 050	96 50 707 08	1	2
60 25 012 08	1 920 417	96 48 703 08	292	1	60 27 601 08	1 997	91 52 512 08	1	15

6.2.2009

etk_en_de_074515 LR 1600/2

817

LIEBHERRNumerical index
Numerischer Index

Item	Page	Assembly	Pos.	Quantity	Item	Page	Assembly	Pos.	Quantity
60 27 601 08	2 393	91 52 787 08	(1)	1	60 30 250 08	2 920 633	96 52 651 08	228	3.03
60 27 601 08	2 831	91 57 754 08	(1)	6	60 30 252 08	2 920 633	96 52 651 08	226	4.66
60 27 601 08	2 970 081	96 50 495 08	(1)	4	60 30 253 08	2 920 633	96 52 651 08	229	3.3
60 27 601 08	2 975 061	96 47 201 08	1	9	60 32 003 08	1 920 418	96 48 687 08	261	10
60 27 601 08	2 975 118	96 47 200 08	1	9	60 32 003 08	2 920 633	96 52 651 08	261	1
60 27 601 08	2 975 154	96 50 585 08	1	11	60 32 003 08	2 920 636	96 51 854 08	261	1
60 27 601 08	2 975 191	96 48 196 08	1	4	60 32 003 08	2 932 116	96 54 388 08	261	100
60 27 601 08	2 976 203	92 27 489 08	(1)	2	60 32 004 08	2 780 524	96 52 968 08	154	5
60 27 601 08	2 976 204	96 47 202 08	1	6	60 32 004 08	2 932 116	96 54 388 08	267	100
60 27 601 08	2 976 701	96 47 196 08	1	1	60 32 022 08	2 780 852	96 24 845 08	13	2
60 27 601 08	2 977 005	96 48 195 08	1	1	60 32 022 08	2 913 004	96 20 460 08	8	2
60 27 601 08	2 977 201	96 48 618 08	1	2	60 32 022 08	2 913 006	96 20 732 08	11	1
60 27 601 08	2 978 101	96 47 912 08	1	2	60 32 022 08	2 932 001	96 45 393 08	50	25
60 27 601 08	2 978 107	96 50 433 08	1	6	60 32 022 08	2 932 116	96 54 388 08	268	100
60 27 601 08	2 978 204	96 47 114 08	1	6	60 32 022 08	3 930 363	96 52 979 08	261	5
60 27 601 08	2 997	91 56 539 08	1	119	60 32 022 08	3 930 734	96 54 401 08	217	10
60 27 601 08	3 978 009	96 50 881 08	1	6	60 40 069 08	2 932 082	96 54 387 08	73	6
60 27 601 08	3 978 015	91 56 429 08	(1)	1	60 40 070 08	2 932 082	96 54 387 08	74	20
60 27 601 08	3 978 016	96 50 878 08	1	1	60 40 071 08	2 932 082	96 54 387 08	75	22
60 27 601 08	3 978 018	96 50 880 08	1	3	60 40 072 08	2 932 082	96 54 387 08	76	8
60 27 603 08	1 975 006	91 52 509 08	(1)	8	60 40 073 08	2 932 082	96 54 387 08	77	5
60 27 603 08	1 976 050	96 50 707 08	2	6	60 40 076 08	2 932 082	96 54 387 08	78	1
60 27 603 08	1 997	91 52 512 08	2	33	60 40 077 08	2 932 082	96 54 387 08	72	6
60 27 603 08	2 975 154	96 50 585 08	2	8	60 44 124 08	1 830 102	92 26 483 08	1	1
60 27 603 08	2 975 191	96 48 196 08	2	1	60 45 016 08	2 920 083	96 48 319 08	16	1
60 27 603 08	2 976 204	96 47 202 08	2	6	60 45 016 08	2 932 082	96 54 387 08	69	16
60 27 603 08	2 976 701	96 47 196 08	2	4	60 45 016 08	2 932 160	96 54 385 08	33	2
60 27 603 08	2 977 005	96 48 195 08	2	7	60 45 081 08	3 930 638	96 51 624 08	285	2
60 27 603 08	2 977 201	96 48 618 08	2	5	60 45 081 08	3 930 640	96 50 481 08	287	1
60 27 603 08	2 978 101	96 47 912 08	2	4	60 45 081 08	3 930 730	96 50 599 08	155	1
60 27 603 08	2 978 107	96 50 433 08	2	6	60 45 085 08	2 920 288	96 52 614 08	(502)	1
60 27 603 08	2 978 204	96 47 114 08	2	4	60 45 121 08	3 930 638	96 51 624 08	286	2
60 27 603 08	2 997	91 56 539 08	2	117	60 45 121 08	3 930 640	96 50 481 08	(155)	1
60 27 603 08	3 978 009	96 50 881 08	2	6	60 45 121 08	3 930 640	96 50 481 08	288	1
60 27 603 08	3 978 015	91 56 429 08	(2)	2	60 45 121 08	3 930 730	96 50 599 08	153	1
60 27 603 08	3 978 016	96 50 878 08	2	2	60 45 189 08	2 920 288	96 52 614 08	(812)	4
60 27 603 08	3 978 018	96 50 880 08	2	1	60 45 192 08	2 920 288	96 52 614 08	(628)	3
60 27 603 08	3 978 100	91 56 428 08	(1)	2	60 45 265 08	3 930 639	96 50 132 08	155	2
60 27 614 08	2 932 166	92 68 911 08	12	10	60 45 265 08	3 930 640	96 50 481 08	(154)	1
60 27 616 08	2 932 082	96 54 387 08	7	1	60 45 265 08	3 930 730	96 50 599 08	(503)	1
60 27 617 08	2 932 082	96 54 387 08	62	1	60 45 266 08	2 920 288	96 52 614 08	(501)	1
60 27 623 08	2 533 070	96 48 363 08	(980)	2	60 50 066 08	2 920 633	96 52 651 08	509	1
60 27 629 08	2 932 082	96 54 387 08	19	1	60 50 066 08	5 114 445	51 14 445 08	2	1
60 27 923 08	2 932 515	96 45 911 08	1	1	60 50 079 08	2 920 633	96 52 651 08	505	3
60 27 946 08	1 920 418	96 48 687 08	12	2	60 50 127 08	2 780 915	96 48 377 08	7	1
60 27 946 08	2 780 748	96 52 969 08	7	2	60 52 039 08	2 533 067	96 50 385 08	2	1
60 27 946 08	2 920 581	96 54 405 08	267	2	60 52 039 08	2 920 257	92 78 689 08	3	2
60 27 946 08	3 930 730	96 50 599 08	297	2	60 52 039 08	2 932 001	96 45 393 08	51	1
60 27 946 08	3 930 730	96 54 398 08	281	4	60 52 082 08	2 920 815	96 49 300 08	(151)	1
60 27 946 08	3 930 734	96 54 401 08	204	2	60 52 106 08	2 920 633	96 52 651 08	507	15
60 30 002 08	2 920 633	96 52 651 08	202	28.96	60 52 128 08	2 920 633	96 52 651 08	502	1
60 30 003 08	2 920 633	96 52 651 08	203	22.31	60 52 128 08	2 920 636	96 51 854 08	152	1
60 30 003 08	2 932 116	96 54 388 08	201	4	60 52 129 08	2 920 633	96 52 651 08	95	2
60 30 004 08	2 920 633	96 52 651 08	204	0.92	60 52 129 08	2 920 636	96 51 854 08	95	1
60 30 005 08	2 920 633	96 52 651 08	205	0.4	60 52 130 08	2 920 633	96 52 651 08	96	2
60 30 126 08	2 932 116	96 54 388 08	202	3.2	60 52 130 08	2 920 636	96 51 854 08	96	2
60 30 167 08	2 920 581	96 54 405 08	(242)	0.03	60 52 155 08	2 920 633	96 52 651 08	503	1
60 30 245 08	2 920 633	96 52 651 08	223	3.83	60 52 155 08	2 920 636	96 51 854 08	153	1
60 30 247 08	2 920 633	96 52 651 08	225	2.13	60 52 157 08	2 780 915	96 48 377 08	1	1
60 30 249 08	2 920 633	96 52 651 08	227	2.03	60 52 516 08	2 920 633	96 52 651 08	501	1

6.2.2009

etk_en_de_074515 LR 1600/2

818

LIEBHERRNumerical index
Numerischer Index

Item	Page	Assembly	Pos.	Quantity	Item	Page	Assembly	Pos.	Quantity
60 52 516 08	2 920 636	96 51 854 08	151	1	60 61 433 08	2 932 001	96 45 393 08	33	1
60 56 015 08	2 920 633	96 52 651 08	514	3	60 61 434 08	2 533 061	96 48 370 08	12	3
60 56 016 08	2 920 633	96 52 651 08	506	3	60 61 434 08	2 533 070	96 48 363 08	20	2
60 56 017 08	2 920 633	96 52 651 08	130	6	60 61 435 08	2 533 061	96 48 370 08	16	3
60 56 021 08	2 920 369	96 54 235 08	30	1	60 61 435 08	2 533 063	96 48 371 08	7	1
60 56 021 08	2 932 224	96 54 389 08	502	2	60 61 435 08	2 533 070	96 48 363 08	7	15
60 56 022 08	2 920 369	96 54 235 08	(151)	1	60 61 435 08	2 932 001	96 45 393 08	35	1
60 56 023 08	2 920 369	96 54 235 08	(602)	4	60 61 437 08	2 533 070	96 48 363 08	24	7
60 56 023 08	2 920 369	96 54 235 08	(602)	4	60 61 438 08	2 533 051	96 48 360 08	(3)	1
60 56 023 08	2 920 633	96 52 651 08	602	60	60 61 439 08	2 533 061	96 48 370 08	13	4
60 56 045 08	2 920 633	96 52 651 08	126	51	60 61 439 08	2 533 063	96 48 371 08	13	1
60 56 086 08	2 920 369	96 54 235 08	29	1	60 61 439 08	2 533 070	96 48 363 08	9	17
60 56 086 08	2 932 224	96 54 389 08	516	1	60 61 440 08	2 533 061	96 48 370 08	17	3
60 56 088 08	2 920 369	96 54 235 08	25	1	60 61 440 08	2 533 063	96 48 371 08	8	1
60 56 088 08	2 932 224	96 54 389 08	508	8	60 61 440 08	2 533 070	96 48 363 08	8	13
60 56 090 08	2 920 369	96 54 235 08	(151)	1	60 61 440 08	2 932 001	96 45 393 08	34	1
60 56 090 08	2 920 448	96 48 794 08	21	5	60 61 441 08	2 533 051	96 48 360 08	(2)	1
60 56 099 08	2 920 369	96 54 235 08	(156)	2	60 61 443 08	2 533 070	96 48 363 08	22	1
60 56 099 08	2 920 369	96 54 235 08	(156)	2	60 61 444 08	2 533 061	96 48 370 08	7	2
60 56 099 08	2 920 369	96 54 235 08	26	6	60 61 444 08	2 533 063	96 48 371 08	5	6
60 56 099 08	2 920 448	96 48 794 08	22	10	60 61 444 08	2 533 070	96 48 363 08	12	4
60 56 099 08	2 920 633	96 52 651 08	516	12	60 61 445 08	2 533 070	96 48 363 08	21	2
60 56 099 08	2 932 160	96 54 385 08	51	19	60 61 446 08	2 533 063	96 48 371 08	12	6
60 56 100 08	2 920 369	96 54 235 08	(157)	2	60 61 446 08	2 533 070	96 48 363 08	16	12
60 56 100 08	2 920 369	96 54 235 08	(157)	2	60 61 446 08	2 932 001	96 45 393 08	31	3
60 56 100 08	2 920 369	96 54 235 08	27	6	60 61 447 08	2 533 061	96 48 370 08	11	4
60 56 100 08	2 920 448	96 48 794 08	23	10	60 61 447 08	2 533 063	96 48 371 08	11	1
60 56 100 08	2 920 633	96 52 651 08	517	12	60 61 447 08	2 533 070	96 48 363 08	10	4
60 56 100 08	2 932 160	96 54 385 08	52	21	60 61 448 08	2 533 070	96 48 363 08	25	1
60 56 101 08	2 920 633	96 52 651 08	601	54	60 61 449 08	2 932 001	96 45 393 08	38	2
60 56 102 08	2 920 633	96 52 651 08	603	8	60 66 035 08	2 533 050	96 48 359 08	15	1
60 56 114 08	2 920 633	96 52 651 08	702	14	60 66 523 08	2 920 638	96 51 138 08	7	1
60 56 171 08	2 920 369	96 54 235 08	28	2	60 66 525 08	2 920 638	96 51 138 08	8	4
60 56 171 08	2 932 160	96 54 385 08	39	3	60 66 526 08	2 920 638	96 51 138 08	11	1
60 56 172 08	2 920 369	96 54 235 08	32	1	60 66 532 08	2 920 638	96 51 138 08	9	4
60 56 172 08	2 920 448	96 48 794 08	20	6	60 66 614 08	2 920 638	96 51 138 08	10	1
60 56 172 08	2 932 160	96 54 385 08	38	8	60 66 620 08	2 780 244	91 52 951 08	1	1
60 56 174 08	2 920 369	96 54 235 08	(159)	1	60 70 087 08	2 533 061	96 48 370 08	10	4
60 56 176 08	2 920 369	96 54 235 08	(158)	1	60 70 087 08	2 533 063	96 48 371 08	10	1
60 56 176 08	2 920 633	96 52 651 08	522	3	60 70 087 08	2 533 070	96 48 363 08	17	12
60 56 185 08	2 920 633	96 52 651 08	518	3	60 70 091 08	1 933 100	91 25 249 08	11	1
60 56 197 08	2 920 633	96 52 651 08	813	19	60 70 117 08	2 533 070	96 48 363 08	23	1
60 56 200 08	2 920 633	96 52 651 08	820	4	60 70 201 08	6 071 131	60 71 131 08	3	1
60 60 126 08	2 920 200	96 44 536 08	6	1	60 70 211 08	2 925 002	96 58 856 08	21	3
60 60 126 08	2 920 260	96 44 537 08	6	1	60 70 211 08	2 925 218	91 60 840 08	(21)	1
60 60 126 08	2 920 334	96 44 538 08	6	1	60 70 217 08	2 920 931	96 59 398 08	4	2
60 60 126 08	2 920 350	96 44 539 08	6	1	60 70 217 08	6 071 131	60 71 131 08	2	1
60 60 207 08	2 533 066	96 48 365 08	12	1	60 71 040 08	1 750	91 52 394 08	24	1
60 60 531 08	2 930	96 57 085 08	16	1	60 71 131 08	2 920 931	96 59 398 08	3	2
60 60 533 08	3 930 546	96 48 375 08	(7)	1	60 71 318 08	1 933 100	91 25 249 08	10	1
60 60 533 08	3 930 576	96 48 381 08	(7)	2	60 71 509 08	2 925 002	96 58 856 08	20	3
60 60 950 08	2 533 060	96 48 368 08	5	1	60 71 509 08	2 925 218	91 60 840 08	(20)	1
60 60 950 08	2 533 062	96 48 369 08	5	1	60 72 126 08	6 071 131	60 71 131 08	1	1
60 60 950 08	2 533 069	96 48 372 08	5	1	61 03 886 14	2 913 102	92 32 870 08	3	2
60 61 430 08	2 533 061	96 48 370 08	6	7	61 04 133 08	2 913 102	92 32 870 08	11	2
60 61 430 08	2 533 063	96 48 371 08	6	7	61 07 145 08	2 913 004	96 20 460 08	2	1
60 61 430 08	2 533 070	96 48 363 08	14	23	61 07 146 08	2 913 006	96 20 732 08	2	2
60 61 431 08	2 533 061	96 48 370 08	5	1	61 10 011 08	2 913 100	91 23 538 08	2	1
60 61 431 08	2 533 070	96 48 363 08	15	2	61 10 012 08	2 913 102	92 32 870 08	2	1
60 61 433 08	2 533 070	96 48 363 08	19	2	61 10 017 08	2 932 122	96 45 394 08	4	1

6.2.2009

etk_en_de_074515 LR 1600/2

819

LIEBHERRNumerical index
Numerischer Index

Item	Page	Assembly	Pos.	Quantity	Item	Page	Assembly	Pos.	Quantity
61 10 022 08	2 913 003	96 20 599 08	5	1	68 00 014 08	2 920 633	96 52 651 08	374	1
61 10 461 08	2 932 001	96 45 393 08	22	36	68 00 017 08	2 920 288	96 52 614 08	(5)	1
61 10 470 08	2 932 001	96 45 393 08	1	1	68 00 017 08	2 920 581	96 54 405 08	(5)	1
61 32 065 08	2 920 083	96 48 319 08	18	2	68 00 017 08	2 920 581	96 54 405 08	(5)	1
61 32 066 08	2 920 083	96 48 319 08	19	2	68 00 017 08	2 920 633	96 52 651 08	8	1
61 33 018 08	2 835	91 52 807 08	2	1	68 00 017 08	2 920 633	96 52 651 08	9	1
61 40 031 08	2 533 066	96 48 365 08	9	1	68 00 017 08	2 920 633	96 52 651 08	10	1
61 40 047 08	2 920 559	96 47 914 08	(5)	1	68 00 017 08	2 920 633	96 52 651 08	11	1
61 40 085 08	2 780 320	91 05 067 08	10	1	68 00 017 08	2 920 633	96 52 651 08	372	1
61 40 085 08	2 780 324	91 56 389 08	10	1	68 00 017 08	2 920 633	96 52 651 08	373	1
61 40 205 08	2 533 070	96 48 363 08	11	1	69 09 010 08	1 920 305	92 15 300 08	10	1
61 40 376 08	2 925 002	96 58 856 08	11	1	69 10 417 08	6 909 010	69 09 010 08	13	52
61 40 382 08	2 925 218	91 60 840 08	(11)	1	69 10 431 08	6 909 010	69 09 010 08	14	68
61 40 418 08	2 925 002	96 58 856 08	12	3	69 11 831 08	2 970	91 56 537 08	(1)	1
61 40 436 08	2 925 002	96 58 856 08	17	3	69 11 832 08	2 391 102	96 56 360 08	(2)	1
61 40 451 08	2 925 218	91 60 840 08	(17)	1	69 17 985 08	2 533 067	96 50 385 08	3	1
61 40 458 08	2 925 002	96 58 856 08	13	2	69 18 022 08	2 932 082	96 54 387 08	57	1
61 60 249 08	3 930 138	96 54 377 08	(151)	1	69 18 092 08	2 920 369	96 54 235 08	(151)	1
61 70 000 08	1 933 100	91 25 249 08	12	1	69 18 092 08	3 930 639	96 50 132 08	153	1
61 70 001 08	2 780 851	96 24 498 08	3	1	69 18 128 08	2 920 581	96 54 405 08	(152)	1
61 70 001 08	2 780 852	96 24 845 08	7	1	69 18 129 08	2 920 369	96 54 235 08	39	1
61 70 001 08	2 920 638	96 51 138 08	267	2	69 18 129 08	3 930 638	96 51 624 08	290	1
63 01 013 08	2 932 082	96 54 387 08	53	2	69 18 129 08	3 930 734	96 54 401 08	(152)	1
63 01 021 08	2 932 001	96 45 393 08	42	51	69 18 222 08	2 920 369	96 54 235 08	40	1
63 01 022 08	2 932 001	96 45 393 08	52	1	69 18 849 08	2 913 003	96 20 599 08	1	1
63 01 023 08	2 932 001	96 45 393 08	(151)	55	69 18 996 08	3 930 639	96 50 132 08	154	1
63 01 036 08	2 920 083	96 48 319 08	12	1	69 18 996 08	3 930 640	96 50 481 08	(153)	1
63 01 051 08	2 932 082	96 54 387 08	25	4	69 18 996 08	3 930 730	96 50 599 08	(501)	2
63 01 054 08	2 932 082	96 54 387 08	27	1	69 18 998 08	2 920 369	96 54 235 08	37	1
63 01 201 08	2 932 082	96 54 387 08	54	1	69 18 998 08	3 930 009	96 50 573 08	152	1
63 01 215 08	2 932 082	96 54 387 08	26	24	69 18 998 08	3 930 138	96 54 377 08	(172)	1
63 01 229 08	2 932 224	96 54 389 08	504	41	69 18 998 08	3 930 638	96 51 624 08	289	2
63 50 170 08	2 932 001	96 45 393 08	46	10	69 18 998 08	3 930 730	96 50 599 08	280	2
63 50 515 08	2 932 515	96 45 911 08	4	2	69 21 000 08	2 920 369	96 54 235 08	36	1
63 50 576 08	2 913 005	96 20 731 08	15	1	69 21 000 08	3 930 009	96 50 573 08	155	1
63 50 576 08	2 913 005	96 28 696 08	15	1	69 21 000 08	3 930 138	96 54 377 08	(171)	1
63 50 585 08	2 932 515	96 45 911 08	2	1	69 21 000 08	3 930 730	96 50 599 08	281	2
63 50 842 08	2 922 001	92 84 311 08	7	10	69 23 081 08	1 920 307	96 48 383 08	10	1
63 50 855 08	2 922 001	92 84 311 08	20	2	69 23 081 08	2 780 510	96 50 097 08	12	1
63 61 079 01	2 932 224	96 54 389 08	521	2	69 23 083 08	2 393	91 52 787 08	15	1
63 81 092 01	2 932 082	96 54 387 08	20	0.62	69 23 087 08	2 780 510	96 50 097 08	14	4
66 00 245 08	2 932 082	96 54 387 08	24	1	69 23 087 08	2 920 559	96 47 914 08	(1)	2
66 00 331 08	2 932 515	96 45 911 08	3	1	69 23 087 08	2 930	96 57 085 08	15	2
66 00 414 08	2 913 100	91 23 538 08	8	1	69 23 087 08	2 932 160	96 54 385 08	34	1
66 00 416 08	2 922 001	92 84 311 08	14	1	69 23 087 08	3 930 501	96 51 078 08	151	2
66 00 419 08	2 922 001	92 84 311 08	12	1	69 23 087 08	3 930 713	92 95 070 08	151	2
66 00 420 08	2 922 001	92 84 311 08	13	6	69 23 087 08	3 930 731	96 48 374 08	(151)	1
66 00 422 08	2 922 001	92 84 311 08	10	4	69 23 091 08	1 920 305	92 15 300 08	11	1
66 00 428 08	2 922 001	92 84 311 08	9	4	69 23 091 08	6 909 010	69 09 010 08	28	1
66 00 429 08	2 922 001	92 84 311 08	11	1	69 23 100 08	2 930	96 57 085 08	20	1
66 00 430 08	2 913 100	91 23 538 08	7	1	69 23 100 08	3 930 138	96 54 377 08	(152)	1
66 00 447 08	2 522	91 54 115 08	17	1	69 23 100 08	3 930 576	96 48 381 08	(5)	1
66 00 460 08	2 922 001	92 84 311 08	8	12	69 23 125 08	2 978 100	91 52 796 08	(1)	2
66 01 015 08	2 932 001	96 45 393 08	37	2	69 23 126 08	2 970	91 56 537 08	(1)	2
66 01 020 08	2 932 082	96 54 387 08	113	1	69 23 126 08	2 978 100	91 52 827 08	(1)	2
66 03 006 08	2 922 001	92 84 311 08	21	8	69 23 126 08	2 978 200	91 54 843 08	(1)	2
66 03 016 08	2 932 082	96 54 387 08	52	1	69 23 127 08	2 932 160	96 54 385 08	35	1
66 10 179 08	2 922 001	92 84 311 08	4	1	69 23 128 08	2 970	91 56 537 08	(1)	5
68 00 000 08	2 920 288	96 52 614 08	(6)	1	69 24 000 08	2 920 369	96 54 235 08	(152)	1
68 00 008 08	2 920 581	96 54 405 08	(5)	1	69 24 016 08	2 920 369	96 54 235 08	(151)	1

6.2.2009

etk_en_de_074515 LR 1600/2

820

LIEBHERRNumerical index
Numerischer Index

Item	Page	Assembly	Pos.	Quantity	Item	Page	Assembly	Pos.	Quantity
69 24 016 08	3 930 639	96 50 132 08	151	1	70 42 533 08	2 859 005	96 46 756 08	5	7
69 24 016 08	3 930 640	96 50 481 08	(151)	1	70 42 534 08	2 260 006	96 46 501 08	15	4
69 24 049 08	2 920 636	96 51 854 08	811	1	70 42 534 08	2 393 002	96 46 782 08	5	4
69 24 057 08	2 920 633	96 52 651 08	822	3	70 42 534 08	2 859 005	96 46 756 08	6	7
69 24 062 08	2 920 633	96 52 651 08	511	1	70 42 534 08	2 859 007	96 46 775 08	5	4
69 24 067 08	2 920 633	96 52 651 08	510	1	70 42 534 08	2 859 025	96 46 757 08	11	4
69 26 004 08	2 913 003	96 20 599 08	8	1	70 42 534 08	2 859 026	96 46 776 08	5	4
69 27 013 08	2 913 003	96 20 599 08	6	1	70 42 534 08	2 859 027	96 46 777 08	5	4
69 27 014 08	2 913 003	96 20 599 08	7	1	70 42 534 08	2 859 028	96 46 778 08	5	4
69 27 015 08	1 920 308	96 48 384 08	5	2	70 42 534 08	2 859 029	96 46 779 08	5	4
69 27 015 08	1 920 309	96 48 385 08	5	2	70 42 534 08	2 859 030	96 46 758 08	10	2
69 27 015 08	2 350	91 52 778 08	(1)	2	70 42 534 08	2 932 168	96 48 167 08	2	6
69 31 498 14	2 932 160	96 54 385 08	40	1	70 42 535 08	2 260 006	96 46 501 08	13	4
70 05 052	2 391 001	96 45 719 08	138	10	70 42 540 08	2 859 007	96 46 775 08	8	4
70 05 052	3 780 751	91 52 952 08	18	12	70 42 545 08	2 260 006	96 46 501 08	8	1
70 23 640	X1035924	10 35 924 8	2	1	70 42 548 08	2 393 002	96 46 782 08	7	4
70 23 643	X1035924	10 35 924 8	5	1	70 42 548 08	2 859 005	96 46 756 08	7	7
70 23 645	X1035924	10 35 924 8	7	1	70 42 548 08	2 859 007	96 46 775 08	7	4
70 27 459	5 113 022	51 13 022 08	2	2	70 42 548 08	2 859 025	96 46 757 08	13	4
70 27 479	7 027 481	70 27 481 03	6	1	70 42 548 08	2 859 026	96 46 776 08	7	4
70 27 481 03	2 391	91 52 784 08	7	1	70 42 548 08	2 859 027	96 46 777 08	7	4
70 27 755	7 027 481	70 27 481 03	3	1	70 42 548 08	2 859 028	96 46 778 08	7	4
70 27 982	7 027 481	70 27 481 03	999	1	70 42 548 08	2 859 029	96 46 779 08	7	4
70 28 133	X1065068	10 65 068 8	2	1	70 42 548 08	2 859 030	96 46 758 08	12	2
70 30 031 01	2 522 011	96 45 602 08	20	1	70 42 551 08	2 393 002	96 46 782 08	8	4
70 30 235	7 027 481	70 27 481 03	14	1	70 42 551 08	2 859 029	96 46 779 08	8	4
70 42 012 08	2 520 030	96 45 609 08	4	3	70 42 553 08	2 859 005	96 46 756 08	8	7
70 42 012 08	2 520 031	96 45 610 08	3	2	70 42 553 08	2 932 168	96 48 167 08	4	6
70 42 012 08	2 932 160	96 54 385 08	8	4	70 42 559 08	2 932 082	96 54 387 08	81	4
70 42 076 08	2 913 004	96 20 460 08	3	4	70 42 562 08	2 859 030	96 46 758 08	13	2
70 42 076 08	2 932 001	96 45 393 08	23	8	70 42 566 08	2 393 002	96 46 782 08	4	4
70 42 076 08	2 932 082	96 54 387 08	49	42	70 42 566 08	2 859 007	96 46 775 08	4	4
70 42 089 08	2 260	91 53 057 08	9	2	70 42 566 08	2 859 025	96 46 757 08	10	4
70 42 121 08	2 913 005	96 20 731 08	10	2	70 42 566 08	2 859 026	96 46 776 08	4	4
70 42 121 08	2 913 005	96 28 696 08	10	2	70 42 566 08	2 859 027	96 46 777 08	4	4
70 42 121 08	2 932 001	96 45 393 08	41	50	70 42 566 08	2 859 028	96 46 778 08	4	4
70 42 127 08	2 831	91 57 754 08	28	2	70 42 566 08	2 859 029	96 46 779 08	4	4
70 42 141 08	2 970	91 56 537 08	133	60	70 42 566 08	2 859 030	96 46 758 08	9	2
70 42 141 08	2 975 100	91 52 860 08	67	10	70 42 567 08	2 859 026	96 46 776 08	8	4
70 42 141 08	2 975 200	91 52 775 08	67	14	70 42 567 08	2 859 027	96 46 777 08	8	4
70 42 141 08	2 975 700	91 52 774 08	67	14	70 42 567 08	2 859 028	96 46 778 08	8	4
70 42 141 08	2 977	91 57 756 08	64	16	70 42 582 08	2 260 006	96 46 501 08	12	2
70 42 141 08	2 977 200	91 55 149 08	67	10	70 42 590 08	2 859 025	96 46 757 08	14	4
70 42 141 08	2 978 100	91 52 827 08	63	3	70 42 598 08	2 520	91 53 061 08	42	2
70 42 141 08	2 978 200	91 54 843 08	63	8	70 42 619 08	2 859 005	96 46 756 08	2	4
70 42 141 08	3 978 005	91 56 430 08	63	5	70 42 624 08	3 206	91 52 881 08	53	1
70 42 141 08	3 978 015	91 56 429 08	63	6	70 42 624 08	3 214	91 52 843 08	41	2
70 42 141 08	3 978 015	91 56 432 08	63	6	70 42 637 08	2 260 009	96 46 972 08	3	2
70 42 141 08	3 978 100	91 56 428 08	63	10	70 42 637 08	2 859 025	96 46 757 08	7	4
70 42 185 08	2 391 040	96 53 645 08	39	2	70 42 710 08	2 260 009	96 46 972 08	2	2
70 42 185 08	2 631	91 56 817 08	56	1	70 42 747 08	2 932 168	96 48 167 08	3	6
70 42 213 08	2 520 034	96 45 984 08	29	1	70 42 748 08	2 393 002	96 46 782 08	6	4
70 42 281 08	2 510 040	96 49 183 08	2	2	70 42 748 08	2 859 005	96 46 756 08	9	7
70 42 281 08	2 510 059	96 49 184 08	2	2	70 42 748 08	2 859 007	96 46 775 08	6	4
70 42 288 08	2 510 059	96 49 184 08	5	2	70 42 748 08	2 859 025	96 46 757 08	12	4
70 42 288 08	2 520	91 53 061 08	41	1	70 42 748 08	2 859 026	96 46 776 08	6	4
70 42 316 08	2 925 402	96 58 855 08	32	1	70 42 748 08	2 859 027	96 46 777 08	6	4
70 42 323 08	2 932 082	96 54 387 08	11	30	70 42 748 08	2 859 028	96 46 778 08	6	4
70 42 326 08	1 630	91 52 387 08	32	4	70 42 748 08	2 859 029	96 46 779 08	6	4
70 42 533 08	2 260 006	96 46 501 08	14	4	70 42 748 08	2 859 030	96 46 758 08	11	2

6.2.2009

etk_en_de_074515 LR 1600/2

821

LIEBHERRNumerical index
Numerischer Index

Item	Page	Assembly	Pos.	Quantity	Item	Page	Assembly	Pos.	Quantity
70 42 748 08	2 932 168	96 48 167 08	6	6	71 01 077 08	3 978 015	91 56 432 08	68	4
70 42 749 08	2 260 006	96 46 501 08	26	4	71 01 077 08	3 978 100	91 56 428 08	68	2
70 42 749 08	2 260 006	96 46 501 08	27	4	71 02 004 08	1 970	91 56 958 08	59	4
70 42 749 08	2 932 168	96 48 167 08	5	6	71 02 004 08	2 970	91 56 537 08	574	30
70 42 797 08	2 522 011	96 45 602 08	9	3	71 40 008 08	1 100	91 52 375 08	5	1
70 42 805 08	2 522 011	96 45 602 08	19	3	72 00 144 08	3 715 008	91 52 863 08	40	6
70 43 316 08	1 400 017	92 51 976 08	2	1	72 00 144 08	3 716	91 52 864 08	42	12
70 43 346 08	2 810	91 52 806 08	25	2	72 01 091 08	3 206	91 52 881 08	9	3
70 43 378 08	3 713	91 57 749 08	85	2	72 08 002 08	2 502	91 55 939 08	25	4
70 80 101 08	3 206	91 52 881 08	4	2	72 50 066 08	9 739 357	97 39 357	13	1
71 00 241 08	9 697 916	96 97 916 01	64	2	72 50 069 08	2 391 040	96 53 645 08	16	2
71 00 312 08	5 400 565	54 00 565 08	10	1	72 51 010 05	2 810	91 52 806 08	17	2
71 00 341 08	9 697 916	96 97 916 01	11	2	72 51 118 08	2 932 160	96 54 385 08	13	2
71 00 630 01	9 697 916	96 97 916 01	4	1	72 58 067 08	1 620	91 52 386 08	5	2
71 01 013 08	X1065015	10 65 015 8	61	4	72 58 100 08	2 831	91 57 754 08	26	4
71 01 017 08	X1065015	10 65 015 8	123	1	72 58 469 08	3 745	91 52 948 08	25	2
71 01 018 08	2 990	91 59 244 08	19	4	72 58 549 08	1 631 100	91 52 388 08	2	4
71 01 020 08	2 393	91 52 787 08	49	1	72 62 030 08	9 697 916	96 97 916 01	97	1
71 01 023 08	2 391 102	96 56 360 08	(3)	1	72 64 055 08	9 697 916	96 97 916 01	68	1
71 01 030 08	X1011614	10 11 614 1	8	2	72 64 065 08	X1042440	10 42 440 2	(22)	1
71 01 034 08	5 113 005	51 13 005 08	8	1	72 64 069 08	2 391 038	96 47 931 08	(1)	1
71 01 037 08	X1011614	10 11 614 1	4	1	72 64 191 08	X1035924	10 35 924 3	25	1
71 01 044 08	5 114 320	51 14 320 08	13	1	72 64 191 08	X1035924	10 35 924 4	25	1
71 01 044 08	7 743 566	77 43 566 08	13	3	72 64 196 08	5 715 296	57 15 296 08	20	1
71 01 053 08	3 978 005	91 56 430 08	69	1	72 64 202 08	5 113 005	51 13 005 08	4	1
71 01 053 08	3 978 015	91 56 429 08	69	2	72 64 212 08	2 520 032	96 45 980 08	19	1
71 01 053 08	3 978 015	91 56 432 08	69	2	72 64 215 01	X1065015	10 65 015 8	59	1
71 01 053 08	3 978 100	91 56 428 08	69	1	72 64 216 08	2 391 001	96 45 719 08	40	2
71 01 059 08	2 970	91 56 537 08	139	10	72 64 223 08	2 391 001	96 45 719 08	405	2
71 01 059 08	2 975 100	91 52 860 08	63	6	72 64 234 01	X1004204	10 04 204 3	5	1
71 01 059 08	2 977	91 57 756 08	70	1	72 64 241 08	X1042440	10 42 440 2	(21)	2
71 01 059 08	2 978 100	91 52 827 08	70	1	72 64 252 08	X1041267	10 41 267 7	50	1
71 01 059 08	2 978 200	91 54 843 08	62	1	72 64 260 08	2 391 001	96 45 719 08	143	2
71 01 060 08	2 990	91 59 244 08	20	1	72 64 265 08	5 102 306	51 02 306 08	6	1
71 01 061 08	2 671	91 52 798 08	12	1	72 64 266 08	5 113 086	51 13 086 08	49	2
71 01 070 08	2 970	91 56 537 08	138	10	72 64 306 08	X1042440	10 42 440 2	32	2
71 01 070 08	2 975 200	91 52 775 08	62	1	72 64 351 08	2 391 001	96 45 719 08	144	1
71 01 070 08	2 975 700	91 52 774 08	62	1	72 64 528 01	7 743 566	77 43 566 08	29	1
71 01 070 08	2 977 200	91 55 149 08	62	1	72 64 538 01	9 697 916	96 97 916 01	69	1
71 01 070 08	2 978 100	91 52 827 08	69	1	72 66 113 08	2 810	91 52 806 08	54	1
71 01 072 08	2 970	91 56 537 08	137	20	72 66 122 08	2 810	91 52 806 08	42	1
71 01 072 08	2 975 100	91 52 860 08	62	6	72 66 127 08	2 925 204	92 16 990 08	14	1
71 01 072 08	2 975 200	91 52 775 08	61	1	72 66 156 08	2 391 102	96 56 360 08	2	4
71 01 072 08	2 975 700	91 52 774 08	61	1	72 66 158 08	2 260	91 53 057 08	8	2
71 01 072 08	2 977	91 57 756 08	69	2	72 66 160 08	3 220 500	91 52 849 08	9	2
71 01 072 08	2 977 200	91 55 149 08	61	1	72 66 160 08	3 223	91 52 852 08	9	2
71 01 072 08	2 978 100	91 52 827 08	68	1	72 66 160 08	3 223 010	91 52 853 08	9	2
71 01 072 08	3 978 100	91 56 428 08	67	2	72 66 160 08	3 223 100	91 55 327 08	9	2
71 01 075 08	2 970	91 56 537 08	136	3	72 66 160 08	3 745	91 52 948 08	10	2
71 01 075 08	2 978 200	91 54 843 08	61	3	72 66 167 08	2 510	91 52 788 08	10	4
71 01 076 08	2 970	91 56 537 08	132	2	72 66 167 08	2 859 030	96 46 758 08	6	2
71 01 076 08	2 977	91 57 756 08	68	1	72 69 042 08	2 391 038	96 47 931 08	5	4
71 01 077 08	2 970	91 56 537 08	131	10	73 00 009 08	2 391 001	96 45 719 08	74	1
71 01 077 08	2 975 100	91 52 860 08	61	6	73 00 043 08	2 671 004	96 46 305 08	19	1
71 01 077 08	2 975 200	91 52 775 08	63	2	73 62 946	2 978 100	91 52 796 08	19	6
71 01 077 08	2 975 700	91 52 774 08	63	2	73 65 090	2 978 100	91 52 796 08	21	2
71 01 077 08	2 977	91 57 756 08	67	4	73 72 303	5 102 354	51 02 354 08	(15)	1
71 01 077 08	2 977 200	91 55 149 08	63	2	73 80 574	X1034282	10 34 282 3	5	4
71 01 077 08	3 978 005	91 56 430 08	68	2	73 81 103	9 079 186	90 79 186	4	2
71 01 077 08	3 978 015	91 56 429 08	68	4	73 81 225 23	2 970	91 56 537 08	590	2

6.2.2009

etk_en_de_074515 LR 1600/2

822

LIEBHERRNumerical index
Numerischer Index

Item	Page	Assembly	Pos.	Quantity	Item	Page	Assembly	Pos.	Quantity
74 00 002 08	2 311 001	96 25 639 08	4	2	77 20 023 08	2 990	91 59 244 08	595	1
74 00 002 08	3 208 001	91 52 883 08	45	0.5	77 25 885 08	2 780 915	96 48 377 08	6	1
74 00 002 08	3 745	91 52 948 08	33	1.2	77 33 137 08	1 750	91 52 394 08	39	4
74 00 006 08	3 930 732	96 50 575 08	155	1	77 34 003 08	2 631	91 56 817 08	64	3
74 00 008 08	1 632 032	96 20 093 08	7	0.25	77 34 003 08	2 810	91 52 806 08	79	1
74 00 008 08	2 920 369	96 54 235 08	(266)	0.2	77 34 003 08	2 978 100	91 52 827 08	61	2
74 00 008 08	2 920 369	96 54 235 08	(266)	0.2	77 34 003 08	3 225	91 52 854 08	55	1
74 00 008 08	2 920 369	96 54 235 08	(266)	0.2	77 34 003 08	3 745	91 52 948 08	62	1.5
74 00 026 08	2 372	91 33 648 08	4	2	77 34 003 08	3 978 005	91 56 430 08	61	2
74 00 219 08	2 730	91 52 802 08	2	2	77 39 091 08	1 750	91 52 394 08	37	1
74 00 244 08	1 400	91 56 853 08	12	4	77 39 118 08	1 750	91 52 394 08	38	1
74 00 244 08	1 410 300	91 56 855 08	12	4	77 39 132 08	1 750	91 52 394 08	45	1
74 03 000 08	2 520 034	96 45 984 08	28	1	77 39 170 08	2 550	91 57 751 08	63	2
74 11 445	5 113 022	51 13 022 08	999	1	77 39 200 08	2 631	91 56 817 08	63	18
74 12 936	7 027 481	70 27 481 03	16	1	77 39 200 08	2 810	91 52 806 08	78	4
74 12 937	7 027 481	70 27 481 03	15	1	77 39 200 08	2 978 100	91 52 827 08	62	3
74 12 942	7 027 481	70 27 481 03	1	1	77 39 200 08	3 225	91 52 854 08	56	8
74 13 103	2 391 001	96 45 719 08	117	4	77 39 200 08	3 745	91 52 948 08	61	8
74 40 100 08	2 790 451	91 57 016 08	3	3	77 39 200 08	3 978 005	91 56 430 08	62	3
74 40 100 08	3 745	91 52 948 08	34	2	77 39 284 08	1 750	91 52 394 08	35	4
74 40 101 08	3 930 732	96 50 575 08	154	1	77 39 300 08	3 215 005	91 52 846 08	28	2
74 40 104 08	3 211	91 57 748 08	83	4	77 39 300 08	3 215 006	91 52 847 08	28	2
74 51 215 08	X1065015	10 65 015 8	30	1	77 39 305 08	2 750 100	91 57 283 08	2	2
74 51 288 08	3 745 002	92 17 236 08	4	2	77 39 334 08	2 810	91 52 806 08	57	2
74 51 288 08	3 745 003	92 17 237 08	4	2	77 39 335 08	1 630	91 52 387 08	14	4
74 51 295 01	2 522 012	96 45 884 08	4	2	77 39 335 08	3 206	91 52 881 08	33	2
74 51 295 01	2 522 013	96 45 883 08	5	8	77 39 335 08	3 208 001	91 52 883 08	43	1
74 51 488 08	3 211 009	96 46 979 08	3	2	77 39 399 08	2 311	91 52 834 08	2	1
74 51 488 08	3 350	91 52 859 08	(3)	2	77 39 399 08	2 312	91 52 835 08	2	1
74 51 488 08	3 350 001	92 70 642 08	3	2	77 39 399 08	2 313	91 52 836 08	2	1
74 51 604 08	X1065015	10 65 015 5	1362	1	77 39 401 08	1 750	91 52 394 08	44	1
74 51 684 08	3 206 002	96 47 960 08	2	1	77 39 466 08	2 372	91 33 648 08	3	1
74 51 688 08	3 211 008	96 46 978 08	2	2	77 41 197 08	2 502 007	96 22 822 08	1	1
74 51 960 08	X1065015	10 65 015 5	53	1	77 41 198 08	2 502 008	96 22 823 08	1	1
74 59 008 08	3 206 001	96 20 920 08	2	1	77 42 040 08	2 541 001	96 49 651 08	5	1
74 61 600 08	5 718 420	57 18 420 08	6	1	77 42 086 08	2 391 001	96 45 719 08	153	2
74 62 026 01	9 697 916	96 97 916 01	12	1	77 42 086 08	2 540	91 53 253 08	13	17
74 62 216 08	5 701 129	57 01 129 08	11	1	77 42 086 08	2 541	91 52 790 08	16	12
74 62 237 01	9 697 916	96 97 916 01	3	1	77 42 097 08	2 831	91 57 754 08	5	1
74 65 067 08	2 550 003	96 46 246 08	2	1	77 42 099 08	2 393	91 52 787 08	10	2
74 65 067 08	2 652 007	92 68 928 08	2	1	77 42 105 08	2 990	91 59 244 08	10	2
74 70 004 08	X1041101	10 41 101 5	520	1	77 42 105 08	3 978 005	91 56 430 08	6	2
74 70 004 08	X1041101	10 41 101 8	440	1	77 42 113 08	2 990	91 59 244 08	7	1
74 70 006 08	X1041101	10 41 101 5	320	1	77 42 118 08	2 393	91 52 787 08	11	1
74 70 006 08	X1041101	10 41 101 8	300	1	77 42 119 08	2 970	91 56 537 08	77	2
74 90 102 08	3 211 002	92 88 302 08	1	1	77 42 139 08	2 671 004	96 46 305 08	12	1
74 90 120 08	3 713	91 57 749 08	150	1	77 42 143 08	2 391 001	96 45 719 08	136	8
75 00 011 08	1 750	91 52 394 08	30	1	77 42 143 08	2 391 023	96 45 720 08	7	2
75 00 018 08	1 750	91 52 394 08	31	2	77 42 157 08	2 970	91 56 537 08	76	2
75 00 024 08	2 970	91 56 537 08	184	3	77 42 157 08	2 978 100	91 52 796 08	12	4
76 10 203 03	9 697 916	96 97 916 01	73	1	77 42 217 08	2 541	91 52 790 08	18	3
76 10 208 03	1 400	91 56 853 08	(2)	1	77 42 229 08	2 391 001	96 45 719 08	137	1
76 10 225 03	9 275 543	92 75 543 01	6	1	77 42 237 08	2 670	91 52 797 08	8	2
76 10 341 03	9 697 916	96 97 916 01	24	1	77 42 250 08	2 541 001	96 49 651 08	6	1
76 22 478	X1022811	10 22 811 2	16	1	77 42 279 08	2 391 001	96 45 719 08	148	8
76 22 803	2 711	91 52 800 08	(1)	1	77 42 283 08	2 978 100	91 52 796 08	11	2
76 22 803	2 711	91 52 800 08	(2)	6	77 42 306 08	2 391 001	96 45 719 08	250	2
76 22 803	2 711	91 52 800 08	(2)	6	77 42 307 08	2 391 001	96 45 719 08	133	2
76 24 428	2 533 066	96 48 365 08	11	1	77 42 329 08	2 540	91 53 253 08	20	20
77 20 022 08	2 990	91 59 244 08	592	2	77 42 329 08	2 541	91 52 790 08	17	10

6.2.2009

etk_en_de_074515 LR 1600/2

823

LIEBHERRNumerical index
Numerischer Index

Item	Page	Assembly	Pos.	Quantity	Item	Page	Assembly	Pos.	Quantity
77 42 830 08	2 393	91 52 787 08	12	3	78 89 054 08	3 211	91 57 748 08	29	1
77 42 831 08	2 392	91 52 785 08	10	3	78 89 054 08	3 713	91 57 749 08	67	1
77 42 831 08	2 393	91 52 787 08	13	2	78 89 058 08	2 631 003	96 54 406 08	2	1
77 42 844 08	3 281	91 52 896 08	59	1	78 90 119 08	2 670 002	96 45 352 08	3	1
77 42 856 08	2 391 001	96 45 719 08	119	1	78 90 119 08	2 671	91 52 798 08	13	1
77 43 009 08	2 550 008	96 47 628 08	6	1	78 90 119 08	2 671 004	96 46 305 08	5	1
77 43 009 08	2 550 009	96 47 645 08	6	1	78 90 151 08	2 920 814	96 45 717 08	5	1
77 43 040 08	2 125	91 52 773 08	13	4	79 00 039 08	1 750	91 52 394 08	4	1
77 43 040 08	2 550 003	96 46 246 08	4	1	79 00 046 08	1 750	91 52 394 08	6	1
77 43 040 08	2 652 007	92 68 928 08	4	1	79 00 079 08	1 750	91 52 394 08	3	1
77 43 040 08	2 810	91 52 806 08	27	2	79 00 126 08	1 750	91 52 394 08	7	1
77 43 040 08	3 208 001	91 52 883 08	41	3	79 00 236 08	1 750	91 52 394 08	8	1
77 43 040 08	3 211	91 57 748 08	106	2	79 00 249 08	1 750	91 52 394 08	17	1
77 43 040 08	3 213	91 52 842 08	10	2	79 00 301 08	1 750	91 52 394 08	10	1
77 43 040 08	3 214	91 52 843 08	10	2	79 00 303 08	1 750	91 52 394 08	9	1
77 43 040 08	3 292	91 52 865 08	6	2	79 00 315 08	1 750	91 52 394 08	12	1
77 43 040 08	3 714	91 52 862 08	18	2	79 00 320 08	1 750	91 52 394 08	13	1
77 43 040 08	5 718 420	57 18 420 08	401	1	79 00 323 08	1 750	91 52 394 08	15	1
77 43 201 08	2 671 004	96 46 305 08	4	1	79 00 420 08	1 750	91 52 394 08	18	1
77 43 566 08	1 711	91 52 392 08	4	2	79 00 429 08	1 750	91 52 394 08	19	1
77 43 726 08	2 711	91 52 800 08	18	14	79 00 444 08	1 750	91 52 394 08	16	1
77 43 726 08	3 713 013	96 57 159 08	13	1	79 04 950 14	X1065015	10 65 015 5	454	1
77 43 727 08	2 711	91 52 800 08	17	24	80 10 029 08	2 920 638	96 51 138 08	272	1
77 43 728 08	1 711	91 52 392 08	1	2	80 21 020 08	2 393 002	96 46 782 08	12	2.8
77 43 728 08	2 711	91 52 800 08	10	1	80 21 020 08	2 859	91 52 809 08	65	10.8
77 43 734 08	1 711	91 52 392 08	7	46	80 21 020 08	2 859 007	96 46 775 08	9	3.7
77 43 735 08	2 711	91 52 800 08	14	8	80 21 020 08	2 859 026	96 46 776 08	9	5
77 43 737 08	1 711	91 52 392 08	9	120	80 21 020 08	2 859 027	96 46 777 08	9	5.7
77 43 737 08	2 711	91 52 800 08	20	100	80 21 020 08	2 859 028	96 46 778 08	9	4
77 43 738 08	1 711	91 52 392 08	8	50	80 21 020 08	2 859 029	96 46 779 08	10	4.3
77 43 738 08	2 711	91 52 800 08	(1)	1	81 00 354 08	1 750	91 52 394 08	46	1
77 43 738 08	2 711	91 52 800 08	(1)	1	81 12 017 08	9 739 129	97 39 129	6	1
77 43 738 08	2 711	91 52 800 08	(1)	1	81 12 017 08	9 739 349	97 39 349	6	1
77 43 738 08	2 711	91 52 800 08	12	22	81 12 059 08	9 739 096	97 39 096	3	1
77 43 738 08	2 711	91 52 800 08	15	1	81 12 073 01	9 739 322	97 39 322	99	1
77 43 748 08	2 711	91 52 800 08	13	2	81 12 073 01	9 739 386	97 39 386	104	1
77 43 748 08	2 711	91 52 800 08	23	1	86 13 009 08	9 739 262	97 39 262	10	1
77 43 750 08	2 711	91 52 800 08	16	4	86 13 009 08	9 739 263	97 39 263	12	1
77 43 751 08	1 711	91 52 392 08	6	4	86 13 009 08	9 739 264	97 39 264	12	1
77 43 751 08	2 711	91 52 800 08	11	2	86 13 009 08	9 739 266	97 39 266	10	1
77 43 752 08	1 711	91 52 392 08	14	4	86 16 012 08	2 831	91 57 754 08	8	2.2
77 43 758 08	2 711	91 52 800 08	21	2	86 55 016	9 080 702	90 80 702	109	1
77 43 765 08	1 711	91 52 392 08	11	8	86 55 023 23	9 739 035	97 39 035	104	1
77 43 780 08	2 711	91 52 800 08	(2)	1	87 00 018 08	2 810 001	96 43 597 08	7	1
77 43 781 08	2 711	91 52 800 08	(1)	3	87 00 028 08	3 930 138	96 54 377 08	(265)	0.01
77 43 832 08	1 711	91 52 392 08	17	8	87 00 028 08	3 930 730	96 50 599 08	289	0.1
77 43 835 08	1 711	91 52 392 08	10	14	88 50 341 08	1 750	91 52 394 08	11	1
77 43 837 08	2 990	91 59 244 08	11	1	88 50 422 08	2 520 034	96 45 984 08	58	1
77 43 859 08	2 711	91 52 800 08	2	1	88 50 423 08	2 520 034	96 45 984 08	59	1
77 43 860 08	2 711	91 52 800 08	3	1	88 51 322 08	1 750	91 52 394 08	5	1
77 43 862 08	2 711	91 52 800 08	5	1	88 51 828 08	1 750	91 52 394 08	40	1
77 90 011 08	2 925 204	92 16 990 08	7	1	88 52 004 08	1 750	91 52 394 08	14	1
77 90 162 01	9 697 916	96 97 916 01	88	1	88 52 515 08	2 391 040	96 53 645 08	31	1
77 90 201 08	1 830 102	92 26 483 08	2	6	89 01 014 08	2 520 034	96 45 984 08	31	1
77 90 347 08	2 810	91 52 806 08	58	1	89 96 346 08	2 780 854	96 37 908 08	3	1
77 90 362 08	3 227 200	91 53 519 08	47	2	90 00 510 6	1 400	91 56 853 08	4	1
78 89 017 08	2 810	91 52 806 08	64	2	90 00 510 6	1 410 300	91 56 855 08	80	1
78 89 018 08	2 370	91 52 782 08	19	4	90 00 521 4	1 400	91 56 853 08	80	1
78 89 018 08	2 810	91 52 806 08	70	12	90 00 521 4	1 410 300	91 56 855 08	4	1
78 89 047 08	3 745	91 52 948 08	41	2	90 77 199	9 739 287	97 39 287	2	2

6.2.2009

etk_en_de_074515 LR 1600/2

824

LIEBHERRNumerical index
Numerischer Index

Item	Page	Assembly	Pos.	Quantity	Item	Page	Assembly	Pos.	Quantity
90 77 248	9 739 400	97 39 400	277	1	91 52 793 08		LR 1600-2-0	137	1
90 78 321	9 739 248	97 39 248	5	1	91 52 794 08		LR 1600-2-0	138	1
90 78 515	9 739 261	97 39 261	6	4	91 52 796 08		LR 1600-2-0	142	1
90 79 185	9 739 257	97 39 257	20	1	91 52 797 08		LR 1600-2-0	143	1
90 79 186	9 739 257	97 39 257	21	1	91 52 798 08		LR 1600-2-0	144	1
90 80 288	9 079 186	90 79 186	2	1	91 52 800 08		LR 1600-2-0	147	1
90 80 533	9 079 185	90 79 185	2	1	91 52 802 08		LR 1600-2-0	150	1
90 80 702	9 739 400	97 39 400	72	1	91 52 806 08		LR 1600-2-0	153	1
90 80 704	9 080 702	90 80 702	1	1	91 52 807 08		LR 1600-2-0	156	1
90 80 706	9 080 702	90 80 702	2	1	91 52 809 08		LR 1600-2-0	159	1
91 04 705 08	2 913 200	96 47 216 08	80	1	91 52 827 08		LR 1600-2-0	175	1
91 05 061 08	2 932 116	96 54 388 08	10	1	91 52 831 08		LR 1600-2-0	183	1
91 05 067 08		LR 1600-2-0	358	1	91 52 834 08		LR 1600-2-0	190	1
91 07 635 08	2 932 122	96 45 394 08	2	1	91 52 835 08		LR 1600-2-0	191	1
91 07 635 08	2 932 160	96 54 385 08	15	1	91 52 836 08		LR 1600-2-0	192	1
91 08 481 08		LR 1600-2-0	344	1	91 52 837 08		LR 1600-2-0	193	1
91 11 097 08	2 391 102	96 56 360 08	6	1	91 52 842 08		LR 1600-2-0	202	1
91 23 538 08	2 932 122	96 45 394 08	1	1	91 52 843 08		LR 1600-2-0	203	1
91 24 097 08		LR 1600-2-0	354	1	91 52 846 08		LR 1600-2-0	204	1
91 25 249 08	1 750	91 52 394 08	42	1	91 52 847 08		LR 1600-2-0	205	1
91 32 850 08	2 533 050	96 48 359 08	2	2	91 52 849 08		LR 1600-2-0	207	1
91 33 648 08		LR 1600-2-0	198	1	91 52 852 08		LR 1600-2-0	210	2
91 42 856 08	2 932 122	96 45 394 08	7	1	91 52 853 08		LR 1600-2-0	211	3
91 42 857 08	2 932 122	96 45 394 08	8	1	91 52 854 08		LR 1600-2-0	214	1
91 42 858 08	2 932 122	96 45 394 08	9	1	91 52 859 08		LR 1600-2-0	223	1
91 42 859 08	2 932 122	96 45 394 08	10	1	91 52 860 08		LR 1600-2-0	225	1
91 42 860 08	2 932 122	96 45 394 08	11	1	91 52 862 08		LR 1600-2-0	252	1
91 44 006 08	2 932 122	96 45 394 08	3	6	91 52 863 08		LR 1600-2-0	254	1
91 44 006 08	2 932 160	96 54 385 08	16	1	91 52 864 08		LR 1600-2-0	256	1
91 44 034 08	3 790	91 08 481 08	2	1	91 52 865 08		LR 1600-2-0	258	1
91 52 375 08		LR 1600-2-0	2	1	91 52 870 08		LR 1600-2-0	268	1
91 52 377 08		LR 1600-2-0	4	1	91 52 872 08		LR 1600-2-0	272	1
91 52 386 08		LR 1600-2-0	13	1	91 52 873 08		LR 1600-2-0	273	1
91 52 387 08		LR 1600-2-0	15	1	91 52 880 08		LR 1600-2-0	282	1
91 52 388 08		LR 1600-2-0	16	1	91 52 881 08		LR 1600-2-0	284	1
91 52 389 08		LR 1600-2-0	17	1	91 52 883 08		LR 1600-2-0	288	1
91 52 392 08		LR 1600-2-0	20	1	91 52 896 08		LR 1600-2-0	294	1
91 52 394 08		LR 1600-2-0	25	1	91 52 897 08		LR 1600-2-0	296	1
91 52 503 08		LR 1600-2-0	103	1	91 52 948 08		LR 1600-2-0	346	1
91 52 504 08		LR 1600-2-0	104	1	91 52 950 08		LR 1600-2-0	350	1
91 52 505 08		LR 1600-2-0	28	1	91 52 951 08		LR 1600-2-0	352	1
91 52 509 08		LR 1600-2-0	32	1	91 52 952 08		LR 1600-2-0	362	1
91 52 510 08		LR 1600-2-0	33	1	91 52 958 08		LR 1600-2-0	414	1
91 52 512 08		LR 1600-2-0	35	1	91 53 020 08		LR 1600-2-0	22	1
91 52 513 08		LR 1600-2-0	37	1	91 53 021 08		LR 1600-2-0	23	1
91 52 768 08		LR 1600-2-0	6	2	91 53 057 08		LR 1600-2-0	126	1
91 52 770 08		LR 1600-2-0	152	1	91 53 061 08	2 810 001	96 43 597 08	1	1
91 52 773 08		LR 1600-2-0	102	1	91 53 253 08	2 520	91 53 061 08	10	1
91 52 774 08		LR 1600-2-0	106	1	91 53 433 08		LR 1600-2-0	286	1
91 52 775 08		LR 1600-2-0	108	1	91 53 519 08		LR 1600-2-0	271	1
91 52 776 08		LR 1600-2-0	111	1	91 54 115 08	2 520	91 53 061 08	2	1
91 52 778 08		LR 1600-2-0	117	1	91 54 561 08		LR 1600-2-0	123	1
91 52 780 08		LR 1600-2-0	118	1	91 54 570 08	2 932 122	96 45 394 08	6	1
91 52 782 08		LR 1600-2-0	119	1	91 54 668 08		LR 1600-2-0	212	1
91 52 784 08		LR 1600-2-0	121	1	91 54 795 08		LR 1600-2-0	176	1
91 52 785 08		LR 1600-2-0	124	1	91 54 843 08		LR 1600-2-0	184	1
91 52 787 08		LR 1600-2-0	125	1	91 55 149 08		LR 1600-2-0	174	1
91 52 788 08		LR 1600-2-0	131	1	91 55 259 08		LR 1600-2-0	323	1
91 52 789 08		LR 1600-2-0	133	1	91 55 303 08	2 520	91 53 061 08	71	1
91 52 790 08		LR 1600-2-0	134	1	91 55 327 08		LR 1600-2-0	213	1

6.2.2009

etk_en_de_074515 LR 1600/2

825

LIEBHERRNumerical index
Numerischer Index

Item	Page	Assembly	Pos.	Quantity	Item	Page	Assembly	Pos.	Quantity
91 55 527 08		LR 1600-2-0	317	4	92 15 391 08	2 997	91 56 539 08	231	1
91 55 528 08		LR 1600-2-0	314	1	92 15 428 08	2 970	91 56 537 08	141	1
91 55 535 08		LR 1600-2-0	450	1	92 15 736 08	1 997	91 52 512 08	747	1
91 55 536 08		LR 1600-2-0	451	1	92 16 203 08	2 932 122	96 45 394 08	5	1
91 55 537 08		LR 1600-2-0	452	1	92 16 963 08	2 925 204	92 16 990 08	1	1
91 55 538 08		LR 1600-2-0	453	1	92 16 964 08	2 925 204	92 16 990 08	2	1
91 55 539 08		LR 1600-2-0	454	1	92 16 990 08	2 925 218	91 60 840 08	12	1
91 55 540 08		LR 1600-2-0	455	1	92 17 061 08	2 932 116	96 54 388 08	6	1
91 55 541 08		LR 1600-2-0	456	1	92 17 086 08	2 932 116	96 54 388 08	8	4
91 55 542 08		LR 1600-2-0	457	1	92 17 236 08	3 745	91 52 948 08	4	2
91 55 873 08		LR 1600-2-0	130	1	92 17 237 08	3 745	91 52 948 08	5	2
91 55 939 08		LR 1600-2-0	129	1	92 17 245 08	3 745 002	92 17 236 08	1	1
91 56 389 08		LR 1600-2-0	341	1	92 17 246 08	3 745 002	92 17 236 08	2	1
91 56 428 08	3 713	91 57 749 08	400	1	92 17 246 08	3 745 003	92 17 237 08	2	1
91 56 429 08	3 716	91 52 864 08	600	1	92 17 251 08	3 745 003	92 17 237 08	1	1
91 56 430 08	3 714	91 52 862 08	400	1	92 17 259 08	3 745	91 52 948 08	6	2
91 56 431 08	3 714 016	96 49 797 08	400	1	92 17 502 08	2 975 154	96 50 585 08	1161	1
91 56 432 08	3 715 008	91 52 863 08	600	1	92 18 495 08	2 997	91 56 539 08	391	1
91 56 537 08		LR 1600-2-0	169	1	92 18 746 08	1 997	91 52 512 08	812	1
91 56 539 08		LR 1600-2-0	179	1	92 19 240 08	2 976 204	96 47 202 08	1456	1
91 56 540 08		LR 1600-2-0	181	1	92 20 800 08	2 997	91 56 539 08	312	2
91 56 817 08		LR 1600-2-0	132	1	92 22 505 08	2 978 107	96 50 433 08	1313	2
91 56 833 08		LR 1600-2-0	163	1	92 22 817 08	2 997	91 56 539 08	359	1
91 56 853 08		LR 1600-2-0	10	1	92 24 554 08	2 997	91 56 539 08	264	1
91 56 855 08		LR 1600-2-0	11	1	92 24 554 08	2 997	91 56 539 08	397	1
91 56 958 08		LR 1600-2-0	31	1	92 25 870 08	3 978 018	96 50 880 08	1270	1
91 57 005 08		LR 1600-2-0	427	1	92 26 284 08	2 997	91 56 539 08	247	1
91 57 016 08		LR 1600-2-0	429	1	92 26 313 08	2 997	91 56 539 08	221	1
91 57 017 08		LR 1600-2-0	430	1	92 26 483 08	2 932 082	96 54 387 08	42	1
91 57 283 08		LR 1600-2-0	148	1	92 26 702 08	2 978 204	96 47 114 08	1219	1
91 57 656 08		LR 1600-2-0	139	1	92 27 352 08	2 977 005	96 48 195 08	1483	1
91 57 748 08		LR 1600-2-0	201	1	92 27 451 08	2 975 061	96 47 201 08	1401	1
91 57 749 08		LR 1600-2-0	250	1	92 27 451 08	2 975 118	96 47 200 08	1401	1
91 57 750 08		LR 1600-2-0	165	1	92 27 451 08	2 997	91 56 539 08	362	1
91 57 751 08		LR 1600-2-0	135	1	92 27 489 08	3 790 006	96 19 989 08	6	1
91 57 754 08		LR 1600-2-0	320	1	92 27 489 08	3 790 007	96 19 990 08	6	1
91 57 756 08		LR 1600-2-0	173	1	92 28 969 08	2 997	91 56 539 08	382	1
91 57 881 08		LR 1600-2-0	120	1	92 29 002 08	2 997	91 56 539 08	301	1
91 59 244 08		LR 1600-2-0	177	1	92 30 161 08	2 975 154	96 50 585 08	1160	1
91 60 728 08		LR 1600-2-0	322	1	92 30 874 08	2 997	91 56 539 08	248	1
91 60 840 08		LR 1600-2-0	324	1	92 32 286 08	2 997	91 56 539 08	193	1
91 70 454 14	2 533 071	96 52 556 08	10	1	92 32 713 08	2 976 204	96 47 202 08	1460	1
92 01 005 08	2 631	91 56 817 08	15	2	92 32 870 08	2 913 100	91 23 538 08	11	1
92 03 811 08	2 920 633	96 52 651 08	512	1	92 35 122 08	2 920 288	96 52 614 08	(500)	2
92 06 036 08	2 997	91 56 539 08	242	1	92 35 122 08	2 920 288	96 52 614 08	(500)	3
92 09 034 08	1 997	91 52 512 08	870	2	92 35 122 08	2 920 369	96 54 235 08	(500)	1
92 09 706 08	2 976 203	92 27 489 08	(372)	1	92 35 122 08	2 920 369	96 54 235 08	(500)	1
92 09 765 08	2 997	91 56 539 08	398	1	92 35 122 08	2 920 369	96 54 235 08	(500)	1
92 09 806 08	2 997	91 56 539 08	261	1	92 35 122 08	2 920 369	96 54 235 08	(500)	3
92 09 849 08	2 997	91 56 539 08	317	1	92 35 122 08	2 920 369	96 54 235 08	(500)	3
92 09 958 08	2 997	91 56 539 08	244	1	92 35 122 08	2 920 536	96 48 317 08	(500)	2
92 10 438 08	2 997	91 56 539 08	363	1	92 35 122 08	2 920 536	96 48 317 08	(500)	2
92 10 795 08	2 550 011	96 47 007 08	5	1	92 35 122 08	2 920 581	96 54 405 08	(500)	2
92 10 795 08	2 790 455	91 57 005 08	4	4	92 35 122 08	2 920 581	96 54 405 08	(500)	2
92 12 113 08	2 932 116	96 54 388 08	9	1	92 35 122 08	2 920 581	96 54 405 08	(500)	1
92 12 548 08	2 997	91 56 539 08	364	1	92 35 122 08	2 920 581	96 54 405 08	(500)	1
92 12 619 08	2 997	91 56 539 08	275	1	92 35 122 08	2 920 633	96 52 651 08	500	53
92 13 504 08	2 997	91 56 539 08	384	1	92 35 122 08	2 920 636	96 51 854 08	500	3
92 14 563 08	2 997	91 56 539 08	451	1	92 35 122 08	2 920 815	96 49 300 08	(500)	2
92 15 300 08	1 991	91 52 510 08	2	1	92 35 122 08	2 920 815	96 49 300 08	(500)	2

6.2.2009

etk_en_de_074515 LR 1600/2

826

LIEBHERRNumerical index
Numerischer Index

Item	Page	Assembly	Pos.	Quantity	Item	Page	Assembly	Pos.	Quantity
92 35 122 08	2 920 815	96 49 300 08	(500)	2	92 65 763 08	2 997	91 56 539 08	273	1
92 35 122 08	2 920 815	96 49 300 08	(500)	3	92 66 066 08	2 997	91 56 539 08	183	1
92 35 122 08	3 930 732	96 50 575 08	500	9	92 66 066 08	2 997	91 56 539 08	321	1
92 35 122 08	3 930 734	96 54 401 08	(500)	1	92 66 115 08	1 997	91 52 512 08	809	1
92 35 237 08	2 977 005	96 48 195 08	1480	1	92 66 122 08	2 997	91 56 539 08	314	1
92 35 694 08	2 550	91 57 751 08	55	2	92 66 576 08	2 997	91 56 539 08	188	1
92 35 694 08	3 745 002	92 17 236 08	11	1	92 66 576 08	2 997	91 56 539 08	192	1
92 35 694 08	3 745 003	92 17 237 08	11	1	92 67 113 08	2 997	91 56 539 08	197	1
92 35 704 08	3 206	91 52 881 08	25	1	92 68 364 08	2 997	91 56 539 08	233	1
92 36 315 08	3 745	91 52 948 08	26	2	92 68 546 08	2 997	91 56 539 08	243	1
92 38 783 08	3 350	91 52 859 08	(1)	1	92 68 547 08	2 978 107	96 50 433 08	1314	1
92 40 284 08	2 997	91 56 539 08	302	1	92 68 659 08	2 997	91 56 539 08	265	1
92 40 956 08	1 997	91 52 512 08	746	1	92 68 678 08	2 997	91 56 539 08	274	1
92 43 724 08	2 975 154	96 50 585 08	1170	1	92 68 911 08	2 932 082	96 54 387 08	41	2
92 44 585 08	2 997	91 56 539 08	383	1	92 68 928 08	3 208 001	91 52 883 08	6	4
92 44 929 08	3 978 009	96 50 881 08	1263	2	92 68 928 08	3 215 005	91 52 846 08	2	10
92 45 280 08	2 978 101	96 47 912 08	1222	1	92 68 928 08	3 215 006	91 52 847 08	2	12
92 47 131 08	2 810	91 52 806 08	37	1	92 68 928 08	3 281	91 52 896 08	2	1
92 47 131 08	3 211	91 57 748 08	66	8	92 68 928 08	3 713	91 57 749 08	3	2
92 48 756 08	2 997	91 56 539 08	390	1	92 69 017 08	3 713	91 57 749 08	30	4
92 51 224 08	1 991	91 52 510 08	5	1	92 69 710 08	2 997	91 56 539 08	350	1
92 51 941 08	2 620	91 52 793 08	3	1	92 69 908 08	2 997	91 56 539 08	353	1
92 51 944 08	2 620	91 52 793 08	4	1	92 69 930 08	1 933 100	91 25 249 08	1	1
92 51 976 08	1 400	91 56 853 08	10	4	92 70 110 08	2 997	91 56 539 08	310	1
92 51 976 08	1 410 300	91 56 855 08	10	4	92 70 642 08	2 550	91 57 751 08	65	1
92 53 053 08	1 630	91 52 387 08	5	4	92 70 643 08	3 350 001	92 70 642 08	1	1
92 53 054 08	1 641 014	92 53 053 08	1	1	92 71 131 08	1 976 050	96 50 707 08	1843	2
92 56 341 08	2 978 101	96 47 912 08	1221	1	92 72 524 08	2 997	91 56 539 08	372	1
92 57 933 08	2 391 001	96 45 719 08	62	1	92 72 931 08	2 997	91 56 539 08	255	1
92 60 246 08	2 997	91 56 539 08	220	1	92 74 187 08	2 997	91 56 539 08	262	1
92 60 254 08	2 997	91 56 539 08	342	1	92 74 292 08	2 997	91 56 539 08	224	1
92 60 417 08	2 997	91 56 539 08	256	1	92 74 496 08	2 997	91 56 539 08	328	1
92 60 420 08	3 978 009	96 50 881 08	1264	2	92 75 019 01	9 275 543	92 75 543 01	2	1
92 60 465 08	1 997	91 52 512 08	804	1	92 75 502 08	2 997	91 56 539 08	308	1
92 60 582 08	2 997	91 56 539 08	186	1	92 75 543 01	9 697 916	96 97 916 01	77	1
92 60 668 08	2 975 154	96 50 585 08	1301	1	92 75 544 01	9 275 543	92 75 543 01	1	1
92 60 732 08	2 997	91 56 539 08	358	1	92 75 706 08	2 977 201	96 48 618 08	1249	1
92 60 954 08	2 997	91 56 539 08	257	1	92 75 706 08	2 997	91 56 539 08	355	1
92 60 962 08	2 997	91 56 539 08	250	1	92 75 709 08	1 997	91 52 512 08	837	2
92 60 981 08	2 976 204	96 47 202 08	1459	1	92 76 030 08	2 977 201	96 48 618 08	1247	1
92 61 198 08	2 997	91 56 539 08	307	1	92 76 030 08	2 977 201	96 48 618 08	1248	1
92 61 208 08	2 976 204	96 47 202 08	1455	1	92 76 036 08	2 978 107	96 50 433 08	1309	1
92 61 222 08	1 997	91 52 512 08	832	2	92 76 051 08	2 997	91 56 539 08	377	1
92 61 225 08	2 997	91 56 539 08	327	1	92 76 109 08	2 975 061	96 47 201 08	1409	1
92 61 308 08	2 997	91 56 539 08	229	1	92 76 109 08	2 975 118	96 47 200 08	1409	1
92 61 388 08	2 975 191	96 48 196 08	1380	1	92 76 122 08	2 997	91 56 539 08	271	1
92 61 392 08	2 997	91 56 539 08	260	1	92 76 147 08	2 975 191	96 48 196 08	1382	1
92 61 458 08	2 997	91 56 539 08	430	1	92 76 161 08	2 975 061	96 47 201 08	1404	1
92 61 473 08	2 976 204	96 47 202 08	1457	1	92 76 161 08	2 975 118	96 47 200 08	1404	1
92 61 496 08	2 997	91 56 539 08	311	1	92 76 164 08	2 997	91 56 539 08	125	1
92 63 790 08	2 997	91 56 539 08	333	1	92 76 333 01	9 697 916	96 97 916 01	5	1
92 63 791 08	1 997	91 52 512 08	807	1	92 76 334 01	9 697 916	96 97 916 01	10	1
92 64 194 08	2 997	91 56 539 08	305	1	92 76 379 08	2 975 061	96 47 201 08	1406	1
92 64 556 08	2 997	91 56 539 08	400	1	92 76 379 08	2 975 118	96 47 200 08	1406	1
92 64 932 08	2 997	91 56 539 08	180	1	92 76 383 08	2 997	91 56 539 08	326	1
92 64 954 08	2 997	91 56 539 08	258	1	92 76 407 08	2 975 061	96 47 201 08	1407	1
92 65 511 08	3 978 009	96 50 881 08	1267	1	92 76 407 08	2 975 118	96 47 200 08	1407	1
92 65 600 08	2 976 203	92 27 489 08	(95)	2	92 76 428 08	2 997	91 56 539 08	184	1
92 65 663 08	2 997	91 56 539 08	239	1	92 76 750 08	1 997	91 52 512 08	806	1
92 65 761 08	2 997	91 56 539 08	315	1	92 76 775 08	2 997	91 56 539 08	373	1

6.2.2009

etk_en_de_074515 LR 1600/2

827

LIEBHERRNumerical index
Numerischer Index

Item	Page	Assembly	Pos.	Quantity	Item	Page	Assembly	Pos.	Quantity
92 76 776 08	2 997	91 56 539 08	393	1	92 88 304 08	3 713	91 57 749 08	153	2
92 76 814 08	2 997	91 56 539 08	337	1	92 88 607 08	2 997	91 56 539 08	336	1
92 76 814 08	3 978 009	96 50 881 08	1265	1	92 88 711 08	3 978 018	96 50 880 08	1273	1
92 76 816 08	2 997	91 56 539 08	386	1	92 88 722 08	2 997	91 56 539 08	179	1
92 76 825 08	2 997	91 56 539 08	121	1	92 88 763 08	2 997	91 56 539 08	388	1
92 76 825 08	2 997	91 56 539 08	252	1	92 88 791 08	2 997	91 56 539 08	309	1
92 76 838 08	2 975 191	96 48 196 08	1384	1	92 88 897 08	2 997	91 56 539 08	354	1
92 76 848 08	2 975 154	96 50 585 08	1303	1	92 90 527 08	1 991	91 52 510 08	3	1
92 76 848 08	2 975 154	96 50 585 08	1304	1	92 93 107 08	2 975 154	96 50 585 08	1164	1
92 76 918 08	2 997	91 56 539 08	374	1	92 93 119 08	2 978 204	96 47 114 08	1214	1
92 76 973 08	2 975 061	96 47 201 08	1405	1	92 93 122 08	2 997	91 56 539 08	318	1
92 76 973 08	2 975 118	96 47 200 08	1405	1	92 93 167 08	1 976 050	96 50 707 08	1842	2
92 76 977 08	1 997	91 52 512 08	803	1	92 93 211 08	1 997	91 52 512 08	871	2
92 78 689 08	2 920 633	96 52 651 08	523	1	92 93 259 08	2 997	91 56 539 08	401	2
92 79 826 08	2 391 001	96 45 719 08	61	1	92 93 262 08	3 978 018	96 50 880 08	1271	1
92 79 826 08	2 970	91 56 537 08	140	2	92 93 328 08	2 978 107	96 50 433 08	1312	2
92 79 963 08	2 920 633	96 52 651 08	504	2	92 93 381 08	1 997	91 52 512 08	740	1
92 80 056 08	2 997	91 56 539 08	198	1	92 93 776 08	2 997	91 56 539 08	385	1
92 80 057 08	2 997	91 56 539 08	185	1	92 95 070 08	3 291	91 52 831 08	500	1
92 80 058 08	2 997	91 56 539 08	366	1	92 96 106 08	1 997	91 52 512 08	808	1
92 80 058 08	2 997	91 56 539 08	399	1	92 96 106 08	2 997	91 56 539 08	245	1
92 80 060 08	2 997	91 56 539 08	331	1	92 96 122 08	2 997	91 56 539 08	379	1
92 80 170 08	2 997	91 56 539 08	334	1	92 96 157 08	2 975 154	96 50 585 08	1302	1
92 80 172 08	2 976 701	96 47 196 08	1454	1	92 96 157 08	3 978 100	91 56 428 08	(1321)	1
92 80 222 08	2 978 101	96 47 912 08	1220	2	92 96 166 08	2 976 204	96 47 202 08	1462	1
92 80 300 08	2 975 191	96 48 196 08	1383	1	92 96 216 08	2 997	91 56 539 08	237	1
92 80 363 08	2 997	91 56 539 08	332	1	92 96 377 08	2 997	91 56 539 08	194	1
92 80 398 08	2 997	91 56 539 08	178	1	92 96 478 08	2 975 154	96 50 585 08	1172	1
92 80 465 08	2 997	91 56 539 08	304	1	92 96 492 08	2 997	91 56 539 08	182	1
92 80 473 08	3 978 100	91 56 428 08	(1320)	1	92 97 467 08	1 997	91 52 512 08	813	2
92 80 485 08	2 975 154	96 50 585 08	1168	1	92 97 467 08	2 997	91 56 539 08	234	1
92 83 955 08	3 713	91 57 749 08	75	8	92 97 484 08	2 975 154	96 50 585 08	1169	1
92 84 311 08	2 913 100	91 23 538 08	3	1	92 97 516 08	2 997	91 56 539 08	431	1
92 84 526 08	2 975 154	96 50 585 08	1163	1	92 97 527 08	2 997	91 56 539 08	226	1
92 84 567 08	2 997	91 56 539 08	216	1	92 97 535 08	2 997	91 56 539 08	246	1
92 84 646 08	2 970 081	96 50 495 08	(1370)	2	92 97 535 08	2 997	91 56 539 08	356	1
92 84 682 08	2 997	91 56 539 08	190	1	92 97 568 08	2 997	91 56 539 08	339	2
92 84 715 08	2 997	91 56 539 08	124	1	92 97 579 08	2 997	91 56 539 08	376	1
92 84 719 08	2 997	91 56 539 08	367	1	92 97 592 08	2 976 701	96 47 196 08	1452	1
92 85 715 08	3 211	91 57 748 08	46	2	92 99 224 08	2 997	91 56 539 08	241	1
92 87 111 08	2 997	91 56 539 08	375	1	92 99 231 08	2 978 204	96 47 114 08	1213	1
92 87 114 08	2 978 204	96 47 114 08	1211	1	92 99 240 08	2 997	91 56 539 08	432	1
92 87 176 08	2 997	91 56 539 08	249	1	92 99 369 08	2 913 004	96 20 460 08	1	1
92 87 505 08	1 997	91 52 512 08	745	1	92 99 370 08	2 913 006	96 20 732 08	1	1
92 87 505 08	2 997	91 56 539 08	395	2	92 99 672 08	2 978 107	96 50 433 08	1311	1
92 87 508 08	2 997	91 56 539 08	120	1	93 01 339 08	3 215 005	91 52 846 08	19	4
92 87 559 08	2 976 200	91 44 034 08	90	4	93 01 339 08	3 215 006	91 52 847 08	19	4
92 87 562 08	1 975 006	91 52 509 08	(1880)	8	93 03 581 08	1 632 032	96 20 093 08	5	1
92 87 596 08	2 976 204	96 47 202 08	1465	1	93 06 259 08	1 632 032	96 20 093 08	6	2
92 87 626 08	2 997	91 56 539 08	338	1	93 14 640 08	1 630	91 52 387 08	15	4
92 87 630 08	2 975 154	96 50 585 08	1171	1	93 22 268 08	1 400	91 56 853 08	13	4
92 87 633 08	2 997	91 56 539 08	357	1	93 22 268 08	1 410 300	91 56 855 08	13	4
92 87 641 08	2 976 701	96 47 196 08	1453	1	93 22 470 08	3 211	91 57 748 08	47	4
92 87 642 08	2 997	91 56 539 08	191	1	93 22 470 08	3 713	91 57 749 08	27	8
92 87 646 08	2 976 204	96 47 202 08	1458	1	93 24 016 08	3 745	91 52 948 08	14	4
92 87 646 08	2 976 204	96 47 202 08	1464	1	93 24 583 08	3 206	91 52 881 08	43	2
92 87 646 08	2 997	91 56 539 08	195	1	93 26 439 08	3 208 001	91 52 883 08	42	5
92 87 660 08	2 997	91 56 539 08	394	1	93 27 102 01	1 400	91 56 853 08	3	2
92 88 302 08	3 211	91 57 748 08	10	1	93 27 102 01	1 410 300	91 56 855 08	3	2
92 88 304 08	3 211 002	92 88 302 08	2	2	93 30 481 08	3 713	91 57 749 08	9	4

6.2.2009

etk_en_de_074515 LR 1600/2

828

LIEBHERRNumerical index
Numerischer Index

Item	Page	Assembly	Pos.	Quantity	Item	Page	Assembly	Pos.	Quantity
93 33 460 08	1 630	91 52 387 08	11	8	94 11 381 08	3 227 008	91 52 872 08	26	49
93 35 587 08	2 810	91 52 806 08	19	2	94 11 381 08	3 227 200	91 53 519 08	26	49
93 54 692 08	3 714 017	96 50 752 08	2	2	94 11 381 08	3 713	91 57 749 08	20	103
93 55 088 08	3 745 011	96 49 677 08	7	3	94 11 381 08	3 714	91 52 862 08	47	65
93 58 827 08	2 652	91 52 794 08	13	2	94 11 381 08	3 715 008	91 52 863 08	20	64
93 59 891 08	3 281	91 52 896 08	49	2	94 11 381 08	3 716	91 52 864 08	20	91
93 72 005 08	2 550	91 57 751 08	97	3	94 12 040 08	2 550 005	96 45 680 08	17	2
93 72 521 08	3 350 001	92 70 642 08	2	1	94 13 244 08	3 211	91 57 748 08	11	2
93 73 829 08	2 790 455	91 57 005 08	3	4	94 13 244 08	3 350	91 52 859 08	13	4
93 75 014 08	2 976 200	91 52 780 08	4	2	94 15 400 08	3 745 002	92 17 236 08	5	1
93 81 367 08	1 632	91 52 389 08	2	2	94 15 400 08	3 745 003	92 17 237 08	5	1
93 82 940 08	2 620	91 52 793 08	8	1	94 18 461 08	2 810	91 52 806 08	26	1
93 83 160 08	2 550	91 57 751 08	72	4	94 21 646 08	3 292	91 52 865 08	5	2
93 87 145 08	3 282 001	96 47 888 08	4	1	94 23 101 08	3 714 008	96 49 266 08	6	2
93 88 891 08	3 714 009	96 49 267 08	8	3	94 23 101 08	3 714 009	96 49 267 08	7	2
93 89 752 08	3 208 001	91 52 883 08	20	1	94 26 890 08	2 550	91 57 751 08	31	2
93 92 498 08	2 810	91 52 806 08	11	2	94 26 891 08	2 550	91 57 751 08	28	2
93 92 498 08	3 211	91 57 748 08	80	2	94 26 891 08	2 550 005	96 45 680 08	12	1
93 92 551 08	3 211 003	96 46 986 08	11	2	94 28 899 08	3 282 002	96 47 890 08	15	1
93 92 551 08	3 220 501	96 43 440 08	12	2	94 33 992 08	1 400	91 56 853 08	77	2
93 92 551 08	3 221 200	96 47 984 08	12	2	94 33 992 08	1 410 300	91 56 855 08	77	2
93 92 551 08	3 225 200	96 48 679 08	12	2	94 33 992 08	3 281	91 52 896 08	30	1
93 92 551 08	3 227 002	96 50 498 08	12	2	94 36 973 08	3 714 014	96 49 456 08	2	1
93 92 551 08	3 561 003	96 45 222 08	12	2	94 37 683 08	3 215 005	91 52 846 08	17	10
93 92 551 08	3 713 012	96 50 197 08	12	1	94 37 683 08	3 215 006	91 52 847 08	17	12
93 92 551 08	3 714 013	96 59 083 08	8	2	94 45 545 08	3 745 002	92 17 236 08	3	1
93 92 551 08	3 716 001	96 49 159 08	12	2	94 45 545 08	3 745 003	92 17 237 08	3	1
93 94 608 08	2 670	91 52 797 08	15	10	94 51 057 08	2 391	91 52 784 08	2	4
93 94 608 08	3 206	91 52 881 08	50	4	94 54 958 08	1 641 014	92 53 053 08	2	2
93 94 608 08	3 713	91 57 749 08	39	4	94 56 112 08	1 630	91 52 387 08	12	8
93 95 668 01	1 400	91 56 853 08	5	1	94 57 205 08	3 211	91 57 748 08	60	2
93 95 668 01	1 410 300	91 56 855 08	5	1	94 59 385 08	3 281	91 52 896 08	18	7
93 95 675 01	1 400	91 56 853 08	6	1	94 66 007 08	2 550	91 57 751 08	68	2
93 95 675 01	1 410 300	91 56 855 08	6	1	94 67 863 08	2 550	91 57 751 08	17	4
93 96 841 08	3 745	91 52 948 08	17	4	94 70 655 08	3 206 002	96 47 960 08	4	2
93 97 306 08	3 225	91 52 854 08	14	7	94 73 392 08	2 391 001	96 45 719 08	55	1
93 97 916 08	3 208 001	91 52 883 08	18	2	94 78 115 08	2 391 001	96 45 719 08	45	2
93 99 680 08	3 208 001	91 52 883 08	17	4	94 79 067 08	2 970	91 56 537 08	48	5
94 00 689 08	2 620	91 52 793 08	11	1	94 83 965 08	1 400	91 56 853 08	23	17
94 00 689 08	2 652	91 52 794 08	18	1	94 83 965 08	1 410 300	91 56 855 08	23	17
94 00 692 08	2 550	91 57 751 08	89	1	94 87 177 08	3 282 002	96 47 890 08	3	1
94 01 070 08	2 657	91 57 656 08	12	1	94 90 229 08	3 207 003	96 48 259 08	9	1
94 04 740 08	3 206	91 52 881 08	44	2	94 90 229 08	3 281	91 52 896 08	26	2
94 10 097 08	3 227	91 52 873 08	10	8	94 90 229 08	3 281	91 52 896 08	(9)	2
94 10 542 08	3 745	91 52 948 08	29	8	94 91 885 08	2 631	91 56 817 08	17	4
94 11 381 08	1 620	91 52 386 08	9	4	94 91 885 08	3 281	91 52 896 08	53	1
94 11 381 08	1 631 100	91 52 388 08	11	48	94 95 827 08	2 810	91 52 806 08	12	2
94 11 381 08	2 350	91 52 778 08	11	3	94 96 354 08	2 657	91 57 656 08	7	1
94 11 381 08	2 859 025	96 46 757 08	5	10	94 98 250 08	2 920 257	92 78 689 08	2	1
94 11 381 08	3 206	91 52 881 08	59	8	94 99 163 08	1 742	91 53 021 08	2	4
94 11 381 08	3 211	91 57 748 08	34	62	94 99 163 08	3 830	91 55 535 08	11	2
94 11 381 08	3 214	91 52 843 08	38	9	94 99 872 08	2 391 001	96 45 719 08	36	4
94 11 381 08	3 220 500	91 52 849 08	26	55	94 99 977 08	2 932 160	96 54 385 08	9	4
94 11 381 08	3 221	91 54 668 08	14	44	95 00 775 08	3 211	91 57 748 08	26	2
94 11 381 08	3 223	91 52 852 08	26	56	95 05 282 08	1 970	91 56 958 08	7	1
94 11 381 08	3 223 010	91 52 853 08	26	56	95 05 568 08	2 970	91 56 537 08	134	30
94 11 381 08	3 223 100	91 55 327 08	26	56	95 05 568 08	2 975 100	91 52 860 08	66	5
94 11 381 08	3 225	91 52 854 08	38	53	95 05 568 08	2 975 200	91 52 775 08	66	7
94 11 381 08	3 226	91 52 870 08	26	40	95 05 568 08	2 975 700	91 52 774 08	66	7
94 11 381 08	3 227	91 52 873 08	26	49	95 05 568 08	2 977	91 57 756 08	63	16

6.2.2009

etk_en_de_074515 LR 1600/2

829

LIEBHERRNumerical index
Numerischer Index

Item	Page	Assembly	Pos.	Quantity	Item	Page	Assembly	Pos.	Quantity
95 05 568 08	2 977 200	91 55 149 08	66	5	95 38 734 08	2 260	91 53 057 08	12	5
95 05 568 08	2 978 100	91 52 827 08	64	3	95 38 734 08	2 340	91 52 776 08	28	10
95 05 568 08	2 978 200	91 54 843 08	64	4	95 38 734 08	2 391	91 52 784 08	10	4
95 05 568 08	3 978 005	91 56 430 08	64	3	95 38 734 08	2 391 001	96 45 719 08	30	11
95 05 568 08	3 978 015	91 56 429 08	64	6	95 38 734 08	2 510	91 52 788 08	14	8
95 05 568 08	3 978 015	91 56 432 08	64	6	95 38 734 08	2 550	91 57 751 08	80	6
95 05 568 08	3 978 100	91 56 428 08	64	5	95 38 734 08	2 631	91 56 817 08	41	18
95 05 969 08	2 810	91 52 806 08	76	1	95 38 734 08	2 711	91 52 800 08	26	2
95 09 414 08	3 745	91 52 948 08	55	1	95 38 734 08	2 859	91 52 809 08	62	10
95 12 474 08	3 214	91 52 843 08	47	8	95 38 734 08	2 925 402	96 58 855 08	17	4
95 14 733 08	2 391 001	96 45 719 08	58	7	95 38 734 08	3 211	91 57 748 08	98	72
95 19 655 08	1 400	91 56 853 08	14	2	95 38 734 08	3 350	91 52 859 08	32	7
95 19 655 08	1 410 300	91 56 855 08	14	2	95 38 734 08	3 713	91 57 749 08	123	61
95 20 313 08	3 745	91 52 948 08	16	4	95 38 734 08	3 714	91 52 862 08	83	48
95 26 739 08	3 216 005	96 50 697 08	2	1	95 38 734 08	3 715 008	91 52 863 08	42	34
95 27 424 08	2 730	91 52 802 08	3	4	95 38 734 08	3 716	91 52 864 08	40	65
95 27 658 08	1 400	91 56 853 08	22	4	95 40 177 08	2 970	91 56 537 08	172	2
95 27 658 08	1 410 300	91 56 855 08	22	4	95 41 137 08	2 510	91 52 788 08	6	2
95 28 598 08	2 391 001	96 45 719 08	66	3	95 41 173 08	2 310	91 52 503 08	7	1
95 28 920 08	3 211	91 57 748 08	16	4	95 41 173 08	2 320	91 52 504 08	7	1
95 28 920 08	3 211 003	96 46 986 08	6	1	95 41 173 08	2 970	91 56 537 08	156	1
95 28 920 08	3 220 501	96 43 440 08	5	1	95 41 173 08	2 978 100	91 52 796 08	13	4
95 28 920 08	3 221 200	96 47 984 08	5	1	95 41 173 08	3 350	91 52 859 08	33	2
95 28 920 08	3 225 200	96 48 679 08	5	1	95 41 174 08	2 310	91 52 503 08	30	2
95 28 920 08	3 227 002	96 50 498 08	5	1	95 41 174 08	2 320	91 52 504 08	30	2
95 28 920 08	3 561 003	96 45 222 08	5	1	95 41 174 08	2 391 001	96 45 719 08	151	1
95 28 920 08	3 713 012	96 50 197 08	5	1	95 41 174 08	3 211	91 57 748 08	94	6
95 28 920 08	3 714 009	96 49 267 08	10	2	95 41 174 08	3 713	91 57 749 08	137	2
95 28 920 08	3 714 013	96 59 083 08	3	2	95 41 174 08	3 714	91 52 862 08	84	2
95 28 920 08	3 830	91 55 535 08	8	2	95 41 175 08	2 310	91 52 503 08	29	1
95 28 924 08	1 632	91 52 389 08	8	2	95 41 175 08	2 320	91 52 504 08	29	1
95 30 759 08	3 206	91 52 881 08	11	5	95 41 175 08	2 340	91 52 776 08	33	2
95 32 110 08	3 713	91 57 749 08	109	1	95 41 175 08	3 211	91 57 748 08	93	2
95 32 110 08	3 714	91 52 862 08	74	1	95 41 175 08	3 350	91 52 859 08	34	2
95 32 809 08	2 859	91 52 809 08	67	2	95 41 175 08	3 713	91 57 749 08	138	28
95 35 616 08	1 630	91 52 387 08	22	40	95 41 175 08	3 714	91 52 862 08	85	9
95 36 201 08	3 282 002	96 47 890 08	10	1	95 41 175 08	3 715 008	91 52 863 08	39	6
95 36 317 08	2 391 023	96 45 720 08	14	2	95 41 175 08	3 716	91 52 864 08	44	12
95 36 382 08	3 205	91 52 880 08	16	2	95 41 286 08	2 671 004	96 46 305 08	23	1
95 36 392 08	2 657	91 57 656 08	3	1	95 41 978 08	3 206 002	96 47 960 08	5	2
95 36 500 08	2 310	91 52 503 08	31	8	95 44 254 08	1 400	91 56 853 08	21	2
95 36 500 08	2 320	91 52 504 08	31	8	95 44 254 08	1 410 300	91 56 855 08	21	2
95 36 500 08	2 391 001	96 45 719 08	152	2	95 44 255 08	1 400 017	92 51 976 08	1	1
95 36 500 08	2 550	91 57 751 08	(5)	5	95 44 447 08	2 657	91 57 656 08	6	1
95 36 500 08	2 550	91 57 751 08	50	19	95 44 783 08	1 400	91 56 853 08	24	2
95 36 500 08	2 810	91 52 806 08	61	3	95 44 783 08	1 410 300	91 56 855 08	24	2
95 36 500 08	3 350	91 52 859 08	31	13	95 44 784 08	1 400	91 56 853 08	20	6
95 36 953 08	2 510	91 52 788 08	4	4	95 44 784 08	1 410 300	91 56 855 08	20	6
95 36 953 08	2 510 040	96 49 183 08	3	2	95 44 785 08	1 400	91 56 853 08	35	2
95 36 953 08	2 510 059	96 49 184 08	3	2	95 44 785 08	1 410 300	91 56 855 08	35	2
95 36 969 08	2 550	91 57 751 08	48	1	95 45 849 08	1 300 011	96 52 493 08	2	162
95 36 969 08	2 711	91 52 800 08	28	2	95 45 915 08	2 391 040	96 53 645 08	11	1
95 37 411 08	3 211	91 57 748 08	91	1	95 45 915 08	3 206	91 52 881 08	10	1
95 37 411 08	3 713	91 57 749 08	119	1	95 46 242 08	2 540	91 53 253 08	10	1
95 37 411 08	3 714	91 52 862 08	91	1	95 47 461 08	3 713	91 57 749 08	110	1
95 37 411 08	3 715 008	91 52 863 08	46	1	95 47 461 08	3 714	91 52 862 08	75	1
95 37 411 08	3 716	91 52 864 08	36	1	95 47 547 08	3 713	91 57 749 08	23	2
95 37 609 08	2 310	91 52 503 08	4	1	95 50 518 08	3 211	91 57 748 08	7	2
95 37 609 08	2 320	91 52 504 08	4	1	95 50 518 08	3 213	91 52 842 08	11	2
95 37 609 08	3 714	91 52 862 08	82	1	95 50 518 08	3 214	91 52 843 08	27	2

6.2.2009

etk_en_de_074515 LR 1600/2

830

LIEBHERRNumerical index
Numerischer Index

Item	Page	Assembly	Pos.	Quantity	Item	Page	Assembly	Pos.	Quantity
95 50 518 08	3 220 500	91 52 849 08	5	4	95 62 981 08	1 100	91 52 375 08	3	2
95 50 518 08	3 221	91 54 668 08	5	4	95 62 982 08	1 100	91 52 375 08	4	2
95 50 518 08	3 223	91 52 852 08	5	4	95 63 347 08	3 350	91 52 859 08	(2)	1
95 50 518 08	3 223 010	91 52 853 08	5	4	95 63 963 08	2 932 166	92 68 911 08	1	1
95 50 518 08	3 223 100	91 55 327 08	5	4	95 63 998 08	2 925 204	92 16 990 08	3	1
95 50 518 08	3 225	91 52 854 08	24	4	95 64 428 08	3 220 500	91 52 849 08	31	2
95 50 518 08	3 226	91 52 870 08	5	4	95 64 428 08	3 223	91 52 852 08	31	4
95 50 518 08	3 227	91 52 873 08	5	4	95 64 428 08	3 223 100	91 55 327 08	31	4
95 50 518 08	3 227 008	91 52 872 08	5	4	95 64 428 08	3 225	91 52 854 08	30	2
95 50 518 08	3 227 200	91 53 519 08	5	4	95 64 428 08	3 226	91 52 870 08	31	2
95 50 518 08	3 714	91 52 862 08	26	2	95 64 428 08	3 227	91 52 873 08	31	4
95 50 518 08	3 715 008	91 52 863 08	21	2	95 64 428 08	3 227 008	91 52 872 08	31	4
95 50 518 08	3 716	91 52 864 08	21	2	95 64 428 08	3 227 200	91 53 519 08	31	4
95 50 681 08	1 400	91 56 853 08	75	2	95 64 428 08	3 714	91 52 862 08	53	2
95 50 681 08	1 410 300	91 56 855 08	75	2	95 64 428 08	3 715 008	91 52 863 08	23	4
95 51 017 08	2 970	91 56 537 08	171	2	95 64 428 08	3 716	91 52 864 08	23	6
95 51 525 08	2 340	91 52 776 08	35	1	95 66 430 08	3 211	91 57 748 08	79	4
95 51 525 08	2 978 200	91 54 843 08	15	1	95 66 686 08	3 714	91 52 862 08	21	2
95 51 525 08	3 350	91 52 859 08	35	1	95 66 948 08	3 211 008	96 46 978 08	1	1
95 51 616 08	3 281	91 52 896 08	44	2	95 66 984 08	3 225 100	96 48 582 08	3	1
95 54 048 08	3 211	91 57 748 08	76	2	95 66 984 08	3 281	91 52 896 08	3	1
95 54 048 08	3 220 500	91 52 849 08	32	4	95 67 585 08	3 292	91 52 865 08	2	2
95 54 048 08	3 221	91 54 668 08	17	2	95 70 053 08	3 780 200	96 54 370 08	1	1
95 54 048 08	3 223	91 52 852 08	32	5	95 70 054 08	3 780 200	96 54 370 08	2	1
95 54 048 08	3 223 010	91 52 853 08	32	5	95 70 394 08	2 550 010	96 45 685 08	2	4
95 54 048 08	3 223 100	91 55 327 08	32	5	95 70 439 08	2 711	91 52 800 08	24	1
95 54 048 08	3 225	91 52 854 08	40	2	95 70 468 08	2 391 023	96 45 720 08	4	2
95 54 048 08	3 226	91 52 870 08	32	4	95 71 127 08	3 713	91 57 749 08	87	4
95 54 048 08	3 227	91 52 873 08	32	5	96 17 203 08	1 997	91 52 512 08	834	2
95 54 048 08	3 227 008	91 52 872 08	32	5	96 17 270 08	1 991	91 52 510 08	4	1
95 54 048 08	3 227 200	91 53 519 08	32	8	96 17 503 08	3 291	91 52 831 08	2	2
95 54 048 08	3 713	91 57 749 08	21	3	96 17 503 08	3 292	91 52 865 08	7	2
95 54 048 08	3 714	91 52 862 08	54	2	96 17 565 08	2 920 559	96 47 914 08	2	1
95 54 048 08	3 715 008	91 52 863 08	22	4	96 17 591 08	2 391 001	96 45 719 08	39	2
95 54 048 08	3 716	91 52 864 08	22	8	96 17 986 08	2 975 191	96 48 196 08	1385	1
95 54 699 08	3 211	91 57 748 08	59	2	96 18 464 08	2 976 203	92 27 489 08	(373)	1
95 56 299 08	2 810	91 52 806 08	24	1	96 18 625 08	2 997	91 56 539 08	335	1
95 56 681 08	2 310	91 52 503 08	26	1	96 18 667 08	3 350	91 52 859 08	4	2
95 56 681 08	2 320	91 52 504 08	26	1	96 19 877 08	3 930 138	96 54 377 08	10	1
95 56 681 08	2 340	91 52 776 08	36	1	96 19 877 08	3 930 330	96 54 378 08	5	1
95 56 681 08	2 920	91 56 833 08	(1)	4	96 19 877 08	3 930 421	96 47 149 08	10	1
95 56 681 08	3 211	91 57 748 08	90	1	96 19 877 08	3 930 575	96 48 380 08	10	1
95 56 681 08	3 350	91 52 859 08	36	1	96 19 989 08	3 790	91 08 481 08	1	1
95 56 681 08	3 745	91 52 948 08	22	1	96 19 990 08	3 790	91 08 481 08	3	1
95 57 168 08	3 205	91 52 880 08	18	2	96 20 093 08	1 632	91 52 389 08	5	2
95 57 495 08	1 920 308	96 48 384 08	20	1	96 20 102 08	1 632 032	96 20 093 08	1	1
95 57 495 08	1 920 309	96 48 385 08	20	1	96 20 219 08	3 930 546	96 48 375 08	11	1
95 57 495 08	3 745	91 52 948 08	23	1	96 20 460 08	2 913	91 32 850 08	2	1
95 58 096 08	3 350	91 52 859 08	37	2	96 20 460 08	2 913 009	91 04 705 08	2	1
95 58 181 08	2 393	91 52 787 08	4	1	96 20 599 08	2 913	91 32 850 08	1	1
95 59 982 08	3 714	91 52 862 08	62	1	96 20 599 08	2 913 009	91 04 705 08	1	1
95 60 933 08	2 975 000	91 57 881 08	22	1	96 20 654 08	1 997	91 52 512 08	802	4
95 60 974 08	3 206	91 52 881 08	18	2	96 20 731 08	2 913 009	91 04 705 08	4	1
95 60 974 08	3 281	91 52 896 08	51	1	96 20 732 08	2 913 005	96 20 731 08	1	1
95 61 143 08	3 745 002	92 17 236 08	6	1	96 20 732 08	2 913 005	96 28 696 08	1	1
95 61 143 08	3 745 003	92 17 237 08	6	1	96 20 750 08	2 913 003	96 20 599 08	9	1
95 62 043 08	2 990	91 59 244 08	4	2	96 20 761 08	2 913 006	96 20 732 08	10	1
95 62 043 08	2 990	91 59 244 08	605	1	96 20 762 08	2 913 005	96 20 731 08	21	1
95 62 979 08	1 100	91 52 375 08	1	2	96 20 762 08	2 913 005	96 28 696 08	21	1
95 62 980 08	1 100	91 52 375 08	2	2	96 20 763 08	2 913 005	96 20 731 08	20	1

6.2.2009

etk_en_de_074515 LR 1600/2

831

LIEBHERRNumerical index
Numerischer Index

Item	Page	Assembly	Pos.	Quantity	Item	Page	Assembly	Pos.	Quantity
96 20 920 08	3 206	91 52 881 08	17	2	96 39 267 08	3 978 009	96 50 881 08	1260	2
96 20 920 08	3 281	91 52 896 08	57	1	96 39 296 08	2 997	91 56 539 08	380	1
96 21 541 08	2 920 559	96 47 914 08	8	1	96 40 276 08	5 133 090	51 13 090 08	1	1
96 22 426 08	2 997	91 56 539 08	263	1	96 40 277 08	5 133 090	51 13 090 08	7	1
96 22 558 08	2 978 204	96 47 114 08	1216	1	96 40 959 08	2 976 204	96 47 202 08	1463	1
96 22 822 08	2 502	91 55 939 08	5	1	96 40 959 08	2 997	91 56 539 08	251	1
96 22 823 08	2 502	91 55 939 08	6	1	96 41 461 08	2 533 051	96 48 360 08	4	1
96 23 055 08	2 260 006	96 46 501 08	2	1	96 41 931 08	2 997	91 56 539 08	361	1
96 23 354 08	2 393	91 52 787 08	(1366)	1	96 41 973 08	2 978 107	96 50 433 08	1315	1
96 23 356 08	2 977 005	96 48 195 08	1485	1	96 42 737 08	2 997	91 56 539 08	259	1
96 23 819 08	2 925 402	96 58 855 08	26	1	96 42 753 08	2 976 204	96 47 202 08	1466	1
96 23 820 08	2 925 402	96 58 855 08	24	1	96 42 805 08	2 670	91 52 797 08	2	2
96 24 232 08	3 930 731	96 48 374 08	6	1	96 43 235 08	2 997	91 56 539 08	392	1
96 24 385 08	2 997	91 56 539 08	365	1	96 43 376 08	3 220 500	91 52 849 08	1	1
96 24 498 08	2 780 854	96 37 908 08	1	1	96 43 434 08	3 226	91 52 870 08	1	1
96 24 499 08	2 780 852	96 24 845 08	6	1	96 43 440 08	3 220 500	91 52 849 08	42	2
96 24 526 08	2 997	91 56 539 08	272	1	96 43 440 08	3 226	91 52 870 08	40	2
96 24 770 08	2 978 101	96 47 912 08	1223	1	96 43 440 08	3 715 008	91 52 863 08	2	2
96 24 845 08	2 780 854	96 37 908 08	2	1	96 43 477 08	2 391 001	96 45 719 08	8	2
96 25 348 08	2 997	91 56 539 08	219	1	96 43 597 08	2 810	91 52 806 08	1	1
96 25 639 08	2 311	91 52 834 08	3	1	96 43 771 08	3 211	91 57 748 08	21	2
96 25 639 08	2 312	91 52 835 08	3	1	96 43 771 08	3 220 500	91 52 849 08	15	8
96 25 943 08	2 997	91 56 539 08	319	1	96 43 771 08	3 221	91 54 668 08	9	8
96 25 946 08	2 978 107	96 50 433 08	1310	1	96 43 771 08	3 223	91 52 852 08	15	8
96 26 895 08	2 997	91 56 539 08	227	1	96 43 771 08	3 223 010	91 52 853 08	15	8
96 27 295 08	3 225	91 52 854 08	57	1	96 43 771 08	3 223 100	91 55 327 08	15	8
96 27 578 08	2 978 204	96 47 114 08	1218	1	96 43 771 08	3 225	91 52 854 08	17	4
96 27 618 08	2 997	91 56 539 08	389	1	96 43 771 08	3 226	91 52 870 08	15	4
96 28 573 08	2 997	91 56 539 08	352	1	96 43 771 08	3 227	91 52 873 08	15	8
96 28 576 08	2 997	91 56 539 08	214	1	96 43 771 08	3 227 002	96 50 498 08	20	2
96 28 615 08	2 997	91 56 539 08	306	1	96 43 771 08	3 227 008	91 52 872 08	15	8
96 28 688 08	2 780 852	96 24 845 08	4	1	96 43 771 08	3 227 200	91 53 519 08	15	10
96 28 696 08	2 913	91 32 850 08	4	1	96 43 771 08	3 713	91 57 749 08	53	4
96 29 580 08	2 997	91 56 539 08	215	1	96 43 771 08	3 714	91 52 862 08	55	4
96 29 984 08	3 978 016	96 50 878 08	1287	1	96 43 771 08	3 715 008	91 52 863 08	4	8
96 31 691 08	2 997	91 56 539 08	181	1	96 43 771 08	3 716	91 52 864 08	4	10
96 31 722 08	3 978 009	96 50 881 08	1261	1	96 43 852 08	2 310	91 52 503 08	1	1
96 31 723 08	3 978 015	91 56 429 08	(1282)	1	96 43 852 08	2 320	91 52 504 08	1	1
96 31 973 08	1 997	91 52 512 08	836	2	96 44 096 08	3 223	91 52 852 08	1	1
96 31 973 08	2 975 154	96 50 585 08	1300	2	96 44 195 08	2 978 100	91 52 827 08	93	1
96 31 991 08	2 978 107	96 50 433 08	1307	1	96 44 241 08	2 310	91 52 503 08	18	1
96 32 001 08	1 997	91 52 512 08	838	2	96 44 241 08	2 320	91 52 504 08	18	1
96 33 350 08	2 997	91 56 539 08	201	1	96 44 242 08	2 310	91 52 503 08	19	1
96 33 352 08	2 975 061	96 47 201 08	1408	1	96 44 242 08	2 320	91 52 504 08	19	1
96 33 352 08	2 975 118	96 47 200 08	1408	1	96 44 536 08	2 310	91 52 503 08	500	1
96 33 357 08	2 975 154	96 50 585 08	1162	1	96 44 537 08	2 320	91 52 504 08	500	1
96 33 357 08	2 997	91 56 539 08	341	1	96 44 538 08	3 350	91 52 859 08	500	1
96 34 249 08	2 260 006	96 46 501 08	1	1	96 44 539 08	2 340	91 52 776 08	500	1
96 36 000 08	1 997	91 52 512 08	742	1	96 44 545 08	2 920 200	96 44 536 08	20	1
96 36 406 08	3 978 019	91 56 431 08	90	1	96 44 546 08	2 920 260	96 44 537 08	20	1
96 36 694 08	3 745 011	96 49 677 08	10	1	96 44 547 08	2 920 334	96 44 538 08	20	1
96 36 836 08	3 745	91 52 948 08	19	4	96 44 548 08	2 920 350	96 44 539 08	20	1
96 36 987 08	2 997	91 56 539 08	204	1	96 44 562 08	2 340	91 52 776 08	3	1
96 37 039 08	2 997	91 56 539 08	189	1	96 44 563 08	2 340	91 52 776 08	4	1
96 37 685 08	3 930 576	96 48 381 08	5	1	96 44 583 08	2 340	91 52 776 08	5	2
96 37 908 08	2 780 850	91 24 097 08	1	1	96 44 626 08	2 730	91 52 802 08	1	2
96 38 237 08	2 997	91 56 539 08	199	1	96 44 763 08	1 997	91 52 512 08	816	1
96 38 619 08	2 997	91 56 539 08	450	1	96 44 853 08	3 227 008	91 52 872 08	1	1
96 38 619 08	2 997	91 56 539 08	454	1	96 44 950 08	1 632	91 52 389 08	1	2
96 39 243 08	1 997	91 52 512 08	835	2	96 45 098 08	3 211	91 57 748 08	1	1

6.2.2009

etk_en_de_074515 LR 1600/2

832

LIEBHERRNumerical index
Numerischer Index

Item	Page	Assembly	Pos.	Quantity	Item	Page	Assembly	Pos.	Quantity
96 45 126 08	3 223 010	91 52 853 08	1	1	96 45 819 08	1 630	91 52 387 08	3	4
96 45 222 08	3 223	91 52 852 08	42	2	96 45 883 08	2 520	91 53 061 08	27	1
96 45 222 08	3 223 010	91 52 853 08	42	2	96 45 884 08	2 520	91 53 061 08	26	1
96 45 222 08	3 223 100	91 55 327 08	42	2	96 45 911 08	2 932 082	96 54 387 08	51	1
96 45 222 08	3 227 008	91 52 872 08	40	2	96 45 980 08	2 520	91 53 061 08	8	1
96 45 222 08	3 227 200	91 53 519 08	40	2	96 45 983 08	2 520 032	96 45 980 08	3	1
96 45 222 08	3 716	91 52 864 08	2	2	96 45 984 08	2 520	91 53 061 08	11	1
96 45 230 08	3 227 002	96 50 498 08	1	1	96 46 046 08	2 522 013	96 45 883 08	4	1
96 45 230 08	3 561 003	96 45 222 08	1	1	96 46 080 08	2 976 203	92 27 489 08	91	1
96 45 231 08	3 220 501	96 43 440 08	2	2	96 46 081 08	2 976 203	92 27 489 08	90	1
96 45 231 08	3 221 200	96 47 984 08	2	2	96 46 246 08	2 550	91 57 751 08	3	17
96 45 231 08	3 225 200	96 48 679 08	2	2	96 46 246 08	2 652	91 52 794 08	4	16
96 45 231 08	3 227 002	96 50 498 08	2	2	96 46 246 08	3 214	91 52 843 08	5	4
96 45 231 08	3 561 003	96 45 222 08	2	2	96 46 246 08	3 225 100	96 48 582 08	2	2
96 45 231 08	3 713 012	96 50 197 08	2	2	96 46 246 08	3 714	91 52 862 08	10	3
96 45 231 08	3 714 013	96 59 083 08	1	2	96 46 246 08	3 714 008	96 49 266 08	2	7
96 45 232 08	3 220 501	96 43 440 08	3	1	96 46 246 08	3 714 009	96 49 267 08	5	8
96 45 232 08	3 221 200	96 47 984 08	3	1	96 46 246 08	3 714 021	96 49 271 08	2	1
96 45 232 08	3 225 200	96 48 679 08	3	1	96 46 294 08	3 227	91 52 873 08	1	1
96 45 232 08	3 227 002	96 50 498 08	3	1	96 46 299 08	2 652	91 52 794 08	1	1
96 45 232 08	3 561 003	96 45 222 08	3	1	96 46 304 08	2 652	91 52 794 08	2	1
96 45 232 08	3 713 012	96 50 197 08	3	1	96 46 305 08	2 671	91 52 798 08	1	1
96 45 232 08	3 714 013	96 59 083 08	2	1	96 46 306 08	2 671 004	96 46 305 08	1	1
96 45 249 08	3 220 501	96 43 440 08	1	1	96 46 307 08	2 652	91 52 794 08	14	1
96 45 287 08	1 400	91 56 853 08	9	34	96 46 324 08	3 227 200	91 53 519 08	1	1
96 45 287 08	1 410 300	91 56 855 08	9	34	96 46 382 08	2 810	91 52 806 08	2	1
96 45 288 08	3 281	91 52 896 08	33	2	96 46 383 08	2 810	91 52 806 08	3	1
96 45 289 08	3 281	91 52 896 08	(1)	1	96 46 384 08	2 810	91 52 806 08	4	1
96 45 290 08	3 207 003	96 48 259 08	2	2	96 46 385 08	3 225	91 52 854 08	1	1
96 45 290 08	3 207 100	96 48 261 08	1	2	96 46 388 08	2 550	91 57 751 08	54	4
96 45 290 08	3 281	91 52 896 08	(2)	2	96 46 501 08	2 260	91 53 057 08	1	1
96 45 308 08	2 550	91 57 751 08	1	1	96 46 505 08	2 533 070	96 48 363 08	2	1
96 45 352 08	2 670	91 52 797 08	1	1	96 46 540 08	1 631 100	91 52 388 08	1	4
96 45 354 08	2 670 002	96 45 352 08	1	1	96 46 563 08	2 391 001	96 45 719 08	50	1
96 45 385 08	1 130	91 52 377 08	1	1	96 46 750 08	3 213	91 52 842 08	1	1
96 45 393 08	2 932	91 57 750 08	4	1	96 46 753 08	2 859	91 52 809 08	1	1
96 45 394 08	2 932	91 57 750 08	5	1	96 46 754 08	2 859	91 52 809 08	2	1
96 45 400 08	1 400	91 56 853 08	2	1	96 46 755 08	2 859	91 52 809 08	3	1
96 45 401 08	1 410 300	91 56 855 08	2	1	96 46 756 08	2 859	91 52 809 08	4	1
96 45 456 08	2 550	91 57 751 08	11	4	96 46 757 08	2 859	91 52 809 08	5	1
96 45 458 08	2 550	91 57 751 08	(1)	1	96 46 758 08	2 859	91 52 809 08	6	1
96 45 602 08	2 522	91 54 115 08	10	1	96 46 759 08	2 859	91 52 809 08	7	1
96 45 603 08	2 550	91 57 751 08	10	2	96 46 760 08	2 859	91 52 809 08	8	1
96 45 609 08	2 520	91 53 061 08	6	1	96 46 761 08	2 859	91 52 809 08	9	1
96 45 610 08	2 520	91 53 061 08	7	1	96 46 767 08	3 206	91 52 881 08	1	1
96 45 611 08	2 550	91 57 751 08	(1)	1	96 46 775 08	2 859	91 52 809 08	16	1
96 45 680 08	2 550	91 57 751 08	12	2	96 46 776 08	2 859	91 52 809 08	17	1
96 45 685 08	2 550 005	96 45 680 08	1	1	96 46 777 08	2 859	91 52 809 08	18	1
96 45 686 08	2 550 005	96 45 680 08	2	2	96 46 778 08	2 859	91 52 809 08	19	1
96 45 687 08	2 550 005	96 45 680 08	3	2	96 46 779 08	2 859	91 52 809 08	20	1
96 45 688 08	2 550 005	96 45 680 08	4	1	96 46 782 08	2 393	91 52 787 08	6	1
96 45 705 08	2 522	91 54 115 08	2	1	96 46 787 08	3 213	91 52 842 08	2	2
96 45 717 08	2 670 002	96 45 352 08	2	1	96 46 809 08	2 859 005	96 46 756 08	1	1
96 45 719 08	2 391	91 52 784 08	1	1	96 46 810 08	2 859 025	96 46 757 08	1	1
96 45 720 08	2 391 001	96 45 719 08	120	1	96 46 874 08	2 997	91 56 539 08	236	1
96 45 743 08	2 925 402	96 58 855 08	25	1	96 46 922 08	2 859 029	96 46 779 08	1	1
96 45 748 08	1 742	91 53 021 08	1	2	96 46 971 08	2 260	91 53 057 08	2	1
96 45 803 08	2 522 012	96 45 884 08	3	1	96 46 972 08	2 260	91 53 057 08	3	1
96 45 817 08	1 630	91 52 387 08	1	2	96 46 978 08	3 211	91 57 748 08	8	1
96 45 818 08	1 630	91 52 387 08	2	2	96 46 979 08	3 211	91 57 748 08	9	1

6.2.2009

etk_en_de_074515 LR 1600/2

833

LIEBHERRNumerical index
Numerischer Index

Item	Page	Assembly	Pos.	Quantity	Item	Page	Assembly	Pos.	Quantity
96 46 980 08	2 520 030	96 45 609 08	1	1	96 47 915 08	2 970	91 56 537 08	3	1
96 46 985 08	2 550 011	96 47 007 08	1	1	96 47 916 08	2 978 100	91 52 827 08	3	1
96 46 986 08	3 211	91 57 748 08	12	2	96 47 917 08	2 978 200	91 54 843 08	3	1
96 46 991 08	3 214	91 52 843 08	1	1	96 47 918 08	2 970	91 56 537 08	4	1
96 46 996 08	3 281	91 52 896 08	1	1	96 47 919 08	2 978 100	91 52 796 08	3	1
96 46 998 08	3 211	91 57 748 08	13	4	96 47 922 08	2 970	91 56 537 08	14	1
96 46 999 08	3 211	91 57 748 08	14	2	96 47 931 08	2 391 001	96 45 719 08	130	1
96 47 000 08	3 211	91 57 748 08	15	4	96 47 951 08	3 206	91 52 881 08	2	1
96 47 004 08	3 211	91 57 748 08	30	1	96 47 960 08	3 206	91 52 881 08	3	1
96 47 007 08	2 550	91 57 751 08	60	2	96 47 979 08	3 221	91 54 668 08	1	1
96 47 008 08	3 211 003	96 46 986 08	1	1	96 47 983 08	3 206 002	96 47 960 08	1	1
96 47 009 08	3 211 003	96 46 986 08	2	2	96 47 984 08	3 221	91 54 668 08	24	2
96 47 010 08	3 211 003	96 46 986 08	3	1	96 47 985 08	3 221 200	96 47 984 08	1	1
96 47 021 08	3 211 009	96 46 979 08	1	1	96 47 989 08	3 282 002	96 47 890 08	19	1
96 47 099 08	3 211	91 57 748 08	65	4	96 47 990 08	3 282 002	96 47 890 08	24	2
96 47 103 08	2 550	91 57 751 08	41	1	96 48 024 08	3 281	91 52 896 08	11	2
96 47 114 08	2 978 200	91 54 843 08	91	1	96 48 027 08	3 281	91 52 896 08	21	2
96 47 115 08	2 978 200	91 54 843 08	93	1	96 48 159 08	2 859	91 52 809 08	10	1
96 47 129 08	3 208 001	91 52 883 08	1	1	96 48 167 08	2 932 160	96 54 385 08	2	1
96 47 149 08	3 714	91 52 862 08	500	1	96 48 168 08	2 932 168	96 48 167 08	1	1
96 47 187 08	3 208 001	91 52 883 08	2	2	96 48 170 08	2 391 001	96 45 719 08	6	1
96 47 196 08	2 976 700	91 54 795 08	91	1	96 48 195 08	2 977	91 57 756 08	91	1
96 47 200 08	2 975 700	91 52 774 08	91	1	96 48 196 08	2 975 000	91 57 881 08	91	1
96 47 201 08	2 975 200	91 52 775 08	91	1	96 48 259 08	3 207	91 53 433 08	2	4
96 47 202 08	2 976 200	91 52 780 08	91	1	96 48 260 08	3 207 003	96 48 259 08	1	1
96 47 204 08	2 810 001	96 43 597 08	3	1	96 48 261 08	3 207	91 53 433 08	3	2
96 47 216 08	2 533 050	96 48 359 08	3	1	96 48 276 08	2 859	91 52 809 08	37	1
96 47 218 08	3 208 001	91 52 883 08	3	1	96 48 277 08	2 859	91 52 809 08	38	1
96 47 237 08	3 281	91 52 896 08	(1)	2	96 48 278 08	2 859	91 52 809 08	39	1
96 47 239 08	3 281	91 52 896 08	(1)	2	96 48 292 08	3 207	91 53 433 08	4	2
96 47 240 08	3 281	91 52 896 08	28	1	96 48 302 08	1 920 418	96 48 687 08	(152)	1
96 47 241 08	3 281	91 52 896 08	31	1	96 48 302 08	2 780 748	96 52 969 08	(152)	1
96 47 355 08	2 998	91 56 540 08	240	1	96 48 302 08	3 930 363	96 52 979 08	(152)	1
96 47 414 08	2 810	91 52 806 08	5	1	96 48 302 08	3 930 639	96 50 132 08	156	1
96 47 474 08	2 350	91 52 778 08	500	1	96 48 302 08	3 930 640	96 50 481 08	(156)	1
96 47 491 08	2 550	91 57 751 08	27	2	96 48 302 08	3 930 730	96 50 599 08	(504)	1
96 47 493 08	2 550 008	96 47 628 08	1	1	96 48 310 08	3 207	91 53 433 08	5	2
96 47 500 08	3 205	91 52 880 08	1	1	96 48 313 08	2 932 001	96 45 393 08	3	1
96 47 504 08	1 975 006	91 52 509 08	91	1	96 48 317 08	2 920 535	96 48 318 08	10	1
96 47 505 08	1 975 006	91 52 509 08	93	1	96 48 318 08	2 920	91 56 833 08	10	1
96 47 506 08	2 671	91 52 798 08	4	2	96 48 319 08	2 260 006	96 46 501 08	5	1
96 47 510 08	2 671	91 52 798 08	9	1	96 48 328 08	2 920	91 56 833 08	40	1
96 47 540 08	2 975 000	91 57 881 08	93	1	96 48 329 08	2 932 082	96 54 387 08	30	1
96 47 562 08	3 205	91 52 880 08	5	2	96 48 330 08	2 932 082	96 54 387 08	31	1
96 47 595 08	3 211 003	96 46 986 08	12	1	96 48 331 08	2 932 082	96 54 387 08	32	1
96 47 596 08	3 205	91 52 880 08	2	1	96 48 332 08	2 932 082	96 54 387 08	33	1
96 47 628 08	2 550	91 57 751 08	37	1	96 48 333 08	2 932 082	96 54 387 08	34	1
96 47 644 08	2 550 009	96 47 645 08	1	1	96 48 334 08	2 932 082	96 54 387 08	35	1
96 47 645 08	2 550	91 57 751 08	36	1	96 48 337 08	3 207 101	96 48 292 08	1	2
96 47 681 08	3 978 009	96 50 881 08	1262	2	96 48 347 08	3 206	91 52 881 08	47	2
96 47 719 08	2 997	91 56 539 08	238	1	96 48 349 08	3 206	91 52 881 08	48	1
96 47 719 08	2 997	91 56 539 08	240	1	96 48 354 08	3 207	91 53 433 08	6	2
96 47 854 08	2 671 004	96 46 305 08	22	1	96 48 359 08	2 533	91 52 789 08	2	1
96 47 880 08	2 522 013	96 45 883 08	3	2	96 48 360 08	2 533	91 52 789 08	3	1
96 47 888 08	3 282	91 52 897 08	1	1	96 48 361 08	2 393	91 52 787 08	7	1
96 47 889 08	3 282 002	96 47 890 08	13	2	96 48 362 08	2 393	91 52 787 08	8	1
96 47 890 08	3 282	91 52 897 08	2	1	96 48 363 08	2 533	91 52 789 08	5	1
96 47 912 08	2 978 100	91 52 796 08	91	1	96 48 364 08	2 533	91 52 789 08	6	1
96 47 913 08	2 978 100	91 52 796 08	93	1	96 48 365 08	2 533	91 52 789 08	7	1
96 47 914 08	2 920	91 56 833 08	8	1	96 48 366 08	2 533	91 52 789 08	4	1

6.2.2009

etk_en_de_074515 LR 1600/2

834

LIEBHERRNumerical index
Numerischer Index

Item	Page	Assembly	Pos.	Quantity	Item	Page	Assembly	Pos.	Quantity
96 48 367 08	2 533 070	96 48 363 08	30	1	96 48 688 08	1 920 418	96 48 687 08	2	1
96 48 368 08	2 533 054	96 48 366 08	1	1	96 48 693 08	1 920 418	96 48 687 08	1	1
96 48 369 08	2 533 054	96 48 366 08	2	1	96 48 703 08	1 920 308	96 48 384 08	10	1
96 48 370 08	2 533 060	96 48 368 08	1	1	96 48 707 08	1 920 309	96 48 385 08	10	1
96 48 371 08	2 533 062	96 48 369 08	1	1	96 48 718 08	1 920 417	96 48 703 08	10	1
96 48 372 08	2 533 054	96 48 366 08	3	1	96 48 719 08	1 920 403	96 48 707 08	10	1
96 48 374 08	3 206	91 52 881 08	500	1	96 48 733 08	2 520	91 53 061 08	46	1
96 48 375 08	3 208 001	91 52 883 08	500	1	96 48 747 08	1 920 417	96 48 703 08	2	1
96 48 376 08	2 780 908	91 52 958 08	3	1	96 48 748 08	1 920 417	96 48 703 08	3	1
96 48 377 08	2 780 908	91 52 958 08	2	1	96 48 749 08	1 920 403	96 48 707 08	2	1
96 48 378 08	2 835	91 52 807 08	3	1	96 48 750 08	1 920 403	96 48 707 08	3	1
96 48 379 08	2 835	91 52 807 08	4	1	96 48 794 08	2 920 443	96 54 236 08	1	1
96 48 380 08	3 213	91 52 842 08	500	1	96 48 795 08	2 920 448	96 48 794 08	4	1
96 48 381 08	3 214	91 52 843 08	500	1	96 48 799 08	2 920 815	96 49 300 08	11	1
96 48 383 08	1 920 300	91 52 505 08	2	1	96 48 896 08	1 975 006	91 52 509 08	(760)	4
96 48 384 08	1 920 300	91 52 505 08	3	1	96 48 897 08	1 975 006	91 52 509 08	(761)	4
96 48 385 08	1 920 300	91 52 505 08	4	1	96 48 898 08	1 975 006	91 52 509 08	(762)	4
96 48 390 08	2 780 244	91 52 951 08	10	1	96 48 907 08	1 998	91 52 513 08	730	2
96 48 397 08	2 925 007	91 60 728 08	20	1	96 48 908 08	1 998	91 52 513 08	731	2
96 48 421 08	2 925 026	91 55 259 08	10	1	96 48 909 08	1 998	91 52 513 08	732	2
96 48 426 08	2 502	91 55 939 08	7	1	96 48 910 08	1 998	91 52 513 08	733	2
96 48 427 08	2 502	91 55 939 08	8	1	96 48 911 08	1 998	91 52 513 08	734	2
96 48 428 08	2 502	91 55 939 08	9	1	96 48 912 08	1 998	91 52 513 08	735	2
96 48 437 08	2 502	91 55 939 08	12	2	96 48 913 08	1 998	91 52 513 08	736	2
96 48 438 08	2 502	91 55 939 08	13	1	96 48 914 08	1 998	91 52 513 08	737	2
96 48 439 08	2 502	91 55 939 08	14	1	96 48 922 08	1 998	91 52 513 08	700	2
96 48 449 08	2 391 001	96 45 719 08	4	1	96 48 923 08	1 998	91 52 513 08	701	2
96 48 457 08	2 391 001	96 45 719 08	3	1	96 48 924 08	1 998	91 52 513 08	702	2
96 48 468 08	2 391 001	96 45 719 08	2	1	96 48 925 08	1 998	91 52 513 08	703	2
96 48 482 08	3 223 100	91 55 327 08	1	1	96 48 926 08	1 998	91 52 513 08	704	2
96 48 489 08	3 930 138	96 54 377 08	6	1	96 48 927 08	1 998	91 52 513 08	705	2
96 48 491 08	2 391 001	96 45 719 08	1	1	96 48 931 08	1 998	91 52 513 08	706	2
96 48 500 08	2 391 001	96 45 719 08	25	1	96 48 932 08	1 998	91 52 513 08	707	2
96 48 501 08	2 391 001	96 45 719 08	26	1	96 48 933 08	1 998	91 52 513 08	708	1
96 48 526 08	3 215 006	91 52 847 08	1	1	96 48 934 08	1 998	91 52 513 08	709	1
96 48 528 08	2 391 001	96 45 719 08	29	1	96 48 935 08	1 998	91 52 513 08	710	1
96 48 533 08	3 780 751	91 52 952 08	12	1	96 48 936 08	1 998	91 52 513 08	711	1
96 48 552 08	2 932 082	96 54 387 08	1	1	96 48 938 08	1 998	91 52 513 08	713	1
96 48 582 08	3 225	91 52 854 08	2	1	96 48 939 08	1 998	91 52 513 08	714	1
96 48 584 08	3 225 100	96 48 582 08	1	1	96 49 011 08	3 930 138	96 54 377 08	(6)	1
96 48 588 08	3 715 008	91 52 863 08	1	1	96 49 026 08	3 930 730	96 54 398 08	380	1
96 48 593 08	3 715 008	91 52 863 08	3	2	96 49 027 08	3 930 730	96 54 398 08	390	1
96 48 595 08	3 716 001	96 49 159 08	2	2	96 49 030 08	2 533 065	96 48 364 08	15	1
96 48 596 08	3 716 001	96 49 159 08	3	1	96 49 041 08	3 930 730	96 54 398 08	360	1
96 48 606 08	2 391 001	96 45 719 08	31	1	96 49 042 08	3 214	91 52 843 08	2	2
96 48 607 08	3 215 005	91 52 846 08	6	1	96 49 043 08	3 214	91 52 843 08	3	1
96 48 607 08	3 215 006	91 52 847 08	6	1	96 49 044 08	3 214	91 52 843 08	4	1
96 48 608 08	3 215 005	91 52 846 08	7	1	96 49 047 08	3 930 730	96 54 398 08	370	1
96 48 608 08	3 215 006	91 52 847 08	7	1	96 49 052 08	3 930 730	96 54 398 08	310	1
96 48 609 08	3 215 005	91 52 846 08	8	2	96 49 053 08	3 930 730	96 54 398 08	350	1
96 48 609 08	3 215 006	91 52 847 08	8	2	96 49 055 08	3 930 730	96 54 398 08	420	1
96 48 618 08	2 977 200	91 55 149 08	91	1	96 49 056 08	3 930 730	96 54 398 08	430	1
96 48 626 08	2 503 100	91 55 873 08	1	1	96 49 064 08	3 930 730	96 54 398 08	303	1
96 48 638 08	3 830	91 55 535 08	1	2	96 49 083 08	2 520	91 53 061 08	68	1
96 48 639 08	3 830	91 55 535 08	3	2	96 49 100 08	2 533 065	96 48 364 08	10	1
96 48 640 08	3 830	91 55 535 08	2	2	96 49 101 08	2 533 065	96 48 364 08	11	1
96 48 667 08	3 215 005	91 52 846 08	1	1	96 49 102 08	2 533 065	96 48 364 08	12	1
96 48 679 08	3 225	91 52 854 08	44	2	96 49 103 08	2 533 065	96 48 364 08	13	1
96 48 680 08	3 225 200	96 48 679 08	1	1	96 49 105 08	2 533 065	96 48 364 08	16	1
96 48 687 08	1 920 307	96 48 383 08	2	1	96 49 106 08	2 533 065	96 48 364 08	17	1

6.2.2009

etk_en_de_074515 LR 1600/2

835

LIEBHERRNumerical index
Numerischer Index

Item	Page	Assembly	Pos.	Quantity	Item	Page	Assembly	Pos.	Quantity
96 49 113 08	3 713	91 57 749 08	1	1	96 49 669 08	3 282 001	96 47 888 08	1	1
96 49 120 08	1 920 417	96 48 703 08	1	1	96 49 676 08	3 745	91 52 948 08	7	1
96 49 121 08	1 920 403	96 48 707 08	1	1	96 49 677 08	3 745	91 52 948 08	3	2
96 49 123 08	3 716	91 52 864 08	1	1	96 49 679 08	3 745	91 52 948 08	9	1
96 49 125 08	2 520	91 53 061 08	69	1	96 49 689 08	3 747	91 52 950 08	2	4
96 49 134 08	2 391 001	96 45 719 08	38	1	96 49 761 08	3 714 021	96 49 271 08	1	1
96 49 158 08	3 716 001	96 49 159 08	1	1	96 49 797 08	3 714	91 52 862 08	9	2
96 49 159 08	3 716	91 52 864 08	3	2	96 49 841 08	2 502	91 55 939 08	26	2
96 49 182 08	2 510	91 52 788 08	1	1	96 49 847 08	3 745 011	96 49 677 08	1	2
96 49 183 08	2 510	91 52 788 08	2	1	96 49 851 08	3 745 011	96 49 677 08	2	1
96 49 184 08	2 510	91 52 788 08	3	1	96 49 873 08	2 520 033	96 50 633 08	2	1
96 49 196 08	2 392	91 52 785 08	16	2	96 49 935 08	2 391 001	96 45 719 08	44	1
96 49 209 08	2 932 001	96 45 393 08	(2)	1	96 50 045 08	3 930 639	96 50 132 08	2	1
96 49 211 08	2 932 001	96 45 393 08	2	1	96 50 096 08	3 745	91 52 948 08	500	1
96 49 212 08	2 932 001	96 45 393 08	(2)	1	96 50 097 08	2 780 100	96 50 096 08	10	1
96 49 265 08	3 714	91 52 862 08	1	1	96 50 099 08	3 713	91 57 749 08	15	1
96 49 266 08	3 714	91 52 862 08	2	1	96 50 130 08	3 713	91 57 749 08	28	1
96 49 267 08	3 714	91 52 862 08	3	1	96 50 131 08	3 713	91 57 749 08	29	1
96 49 268 08	3 714	91 52 862 08	4	2	96 50 132 08	3 930 638	96 51 624 08	2	1
96 49 269 08	3 714	91 52 862 08	5	2	96 50 143 08	2 533 050	96 48 359 08	4	1
96 49 270 08	3 714	91 52 862 08	6	2	96 50 161 08	2 920 536	96 48 317 08	15	1
96 49 271 08	3 714	91 52 862 08	7	1	96 50 162 08	3 713	91 57 749 08	47	2
96 49 272 08	3 714	91 52 862 08	8	2	96 50 197 08	3 713	91 57 749 08	51	2
96 49 290 08	3 714 008	96 49 266 08	1	1	96 50 198 08	3 713 012	96 50 197 08	1	1
96 49 298 08	3 350	91 52 859 08	3	1	96 50 211 08	3 930 730	96 54 398 08	440	1
96 49 299 08	3 350	91 52 859 08	9	1	96 50 215 08	2 502	91 55 939 08	46	2
96 49 300 08	2 920 083	96 48 319 08	10	1	96 50 233 08	3 930 638	96 51 624 08	350	1
96 49 314 08	2 533 066	96 48 365 08	13	1	96 50 235 08	3 930 638	96 51 624 08	360	1
96 49 441 08	2 520 034	96 45 984 08	19	1	96 50 237 08	3 930 638	96 51 624 08	370	1
96 49 455 08	3 714 009	96 49 267 08	1	1	96 50 276 08	2 925 218	91 60 840 08	(23)	1
96 49 456 08	3 714 009	96 49 267 08	2	2	96 50 276 08	3 930 734	96 54 401 08	340	1
96 49 464 08	3 714 014	96 49 456 08	1	2	96 50 385 08	2 533 051	96 48 360 08	1	1
96 49 535 08	1 997	91 52 512 08	805	1	96 50 433 08	2 978 100	91 52 827 08	91	1
96 49 541 08	1 997	91 52 512 08	833	2	96 50 478 08	3 930 640	96 50 481 08	6	1
96 49 545 08	1 997	91 52 512 08	744	1	96 50 481 08	3 930 575	96 48 380 08	1	1
96 49 546 08	1 997	91 52 512 08	814	1	96 50 482 08	3 930 640	96 50 481 08	8	1
96 49 547 08	1 997	91 52 512 08	815	1	96 50 483 08	3 930 640	96 50 481 08	(2)	1
96 49 548 08	1 997	91 52 512 08	817	1	96 50 486 08	3 745	91 52 948 08	52	1
96 49 548 08	2 977 005	96 48 195 08	1487	1	96 50 492 08	3 227 002	96 50 498 08	13	2
96 49 549 08	1 997	91 52 512 08	830	2	96 50 494 08	3 227 002	96 50 498 08	14	2
96 49 549 08	2 975 154	96 50 585 08	1165	1	96 50 495 08	2 125	91 52 773 08	14	1
96 49 550 08	1 997	91 52 512 08	831	2	96 50 498 08	3 227	91 52 873 08	40	2
96 49 551 08	1 976 050	96 50 707 08	1840	2	96 50 514 08	2 391 001	96 45 719 08	47	1
96 49 553 08	1 976 050	96 50 707 08	1841	2	96 50 520 08	2 391 001	96 45 719 08	48	1
96 49 567 08	2 978 101	96 47 912 08	1224	1	96 50 546 08	2 391 001	96 45 719 08	51	1
96 49 576 08	2 997	91 56 539 08	360	1	96 50 572 08	3 930 731	96 48 374 08	7	1
96 49 579 08	2 978 204	96 47 114 08	1210	1	96 50 573 08	3 930 731	96 48 374 08	8	1
96 49 589 08	2 997	91 56 539 08	371	1	96 50 574 08	3 930 731	96 48 374 08	9	1
96 49 593 08	2 997	91 56 539 08	254	1	96 50 575 08	3 930 009	96 50 573 08	6	1
96 49 594 08	2 997	91 56 539 08	222	1	96 50 585 08	2 975 100	91 52 860 08	91	1
96 49 595 08	2 997	91 56 539 08	223	1	96 50 586 08	2 975 100	91 52 860 08	93	1
96 49 596 08	2 997	91 56 539 08	225	1	96 50 599 08	3 930 546	96 48 375 08	1	1
96 49 597 08	2 997	91 56 539 08	230	1	96 50 603 08	2 340	91 52 776 08	22	4
96 49 598 08	2 997	91 56 539 08	232	1	96 50 616 08	2 391	91 52 784 08	6	1
96 49 599 08	2 997	91 56 539 08	235	1	96 50 633 08	2 520	91 53 061 08	9	1
96 49 600 08	2 997	91 56 539 08	200	1	96 50 641 08	3 930 730	96 50 599 08	7	1
96 49 610 08	3 714 025	96 49 269 08	1	1	96 50 642 08	3 930 730	96 50 599 08	8	1
96 49 611 08	3 714 025	96 49 269 08	2	2	96 50 643 08	3 930 730	96 50 599 08	(2)	1
96 49 614 08	3 745	91 52 948 08	1	1	96 50 697 08	3 214	91 52 843 08	51	2
96 49 651 08	2 541	91 52 790 08	1	1	96 50 698 08	3 216 005	96 50 697 08	1	1

6.2.2009

etk_en_de_074515 LR 1600/2

836

LIEBHERRNumerical index
Numerischer Index

Item	Page	Assembly	Pos.	Quantity	Item	Page	Assembly	Pos.	Quantity
96 50 706 08	1 970	91 56 958 08	2	1	96 51 406 08	2 925 402	96 58 855 08	1	1
96 50 707 08	1 970 161	96 50 706 08	91	1	96 51 407 08	2 925 402	96 58 855 08	2	1
96 50 735 08	3 713	91 57 749 08	93	1	96 51 452 08	2 391 023	96 45 720 08	27	3
96 50 752 08	3 714	91 52 862 08	38	2	96 51 459 08	2 391 023	96 45 720 08	28	3
96 50 763 08	3 714 017	96 50 752 08	1	1	96 51 490 08	2 975 700	91 52 774 08	(281)	1
96 50 778 08	2 340	91 52 776 08	31	1	96 51 491 08	2 998	91 56 540 08	300	1
96 50 779 08	2 340	91 52 776 08	32	1	96 51 492 08	2 998	91 56 540 08	301	1
96 50 800 08	3 714 013	96 49 270 08	2	1	96 51 495 08	2 998	91 56 540 08	304	1
96 50 831 08	3 714	91 52 862 08	65	2	96 51 496 08	2 998	91 56 540 08	305	1
96 50 878 08	3 978 015	91 56 432 08	91	1	96 51 497 08	2 998	91 56 540 08	306	1
96 50 879 08	3 978 015	91 56 432 08	93	1	96 51 499 08	2 998	91 56 540 08	308	1
96 50 880 08	3 978 019	91 56 431 08	91	1	96 51 500 08	2 998	91 56 540 08	309	1
96 50 881 08	3 978 005	91 56 430 08	91	1	96 51 506 08	2 998	91 56 540 08	314	1
96 50 882 08	3 978 005	91 56 430 08	93	1	96 51 507 08	2 998	91 56 540 08	315	1
96 50 883 08	3 978 015	91 56 429 08	91	1	96 51 510 08	2 998	91 56 540 08	318	1
96 50 884 08	3 978 015	91 56 429 08	93	1	96 51 511 08	2 998	91 56 540 08	319	1
96 50 885 08	3 978 100	91 56 428 08	93	1	96 51 514 08	2 998	91 56 540 08	322	1
96 50 968 08	3 713	91 57 749 08	95	1	96 51 515 08	2 998	91 56 540 08	323	1
96 51 039 08	2 835	91 52 807 08	(10)	1	96 51 518 08	2 998	91 56 540 08	326	1
96 51 040 08	2 835	91 52 807 08	(20)	1	96 51 519 08	2 998	91 56 540 08	327	1
96 51 045 08	3 780 258	96 56 482 08	4	1	96 51 520 08	2 998	91 56 540 08	328	1
96 51 071 08	2 391 001	96 45 719 08	56	1	96 51 521 08	2 998	91 56 540 08	329	1
96 51 072 08	1 920 418	96 48 687 08	(2)	1	96 51 522 08	2 998	91 56 540 08	330	1
96 51 078 08	3 292	91 52 865 08	500	1	96 51 523 08	2 998	91 56 540 08	331	1
96 51 115 08	2 920 638	96 51 138 08	1	1	96 51 524 08	2 998	91 56 540 08	332	1
96 51 118 08	2 920 536	96 48 317 08	16	1	96 51 525 08	2 998	91 56 540 08	333	1
96 51 119 08	2 780 908	91 52 958 08	(1)	1	96 51 526 08	2 998	91 56 540 08	334	1
96 51 126 08	2 920 536	96 48 317 08	18	1	96 51 527 08	2 998	91 56 540 08	335	1
96 51 127 08	2 920 536	96 48 317 08	19	1	96 51 528 08	2 998	91 56 540 08	336	1
96 51 129 08	2 920 815	96 49 300 08	12	1	96 51 529 08	2 998	91 56 540 08	337	1
96 51 130 08	2 920 815	96 49 300 08	13	1	96 51 544 08	2 998	91 56 540 08	352	1
96 51 131 08	2 920 815	96 49 300 08	14	1	96 51 553 08	2 997	91 56 539 08	202	1
96 51 136 08	2 920	91 56 833 08	28	1	96 51 554 08	2 997	91 56 539 08	203	1
96 51 138 08	2 920 637	96 51 136 08	1	1	96 51 556 08	2 997	91 56 539 08	206	1
96 51 173 08	3 214	91 52 843 08	7	1	96 51 557 08	2 997	91 56 539 08	205	1
96 51 174 08	3 214	91 52 843 08	8	1	96 51 559 08	2 997	91 56 539 08	208	1
96 51 181 08	2 810	91 52 806 08	49	1	96 51 560 08	2 997	91 56 539 08	209	1
96 51 219 08	2 975 200	91 52 775 08	93	1	96 51 561 08	2 997	91 56 539 08	212	1
96 51 219 08	2 975 700	91 52 774 08	93	1	96 51 562 08	2 997	91 56 539 08	213	1
96 51 329 08	2 998	91 56 540 08	260	1	96 51 567 08	2 997	91 56 539 08	253	1
96 51 330 08	2 998	91 56 540 08	261	1	96 51 572 08	2 976 701	96 47 196 08	1450	1
96 51 331 08	2 998	91 56 540 08	262	1	96 51 573 08	2 976 701	96 47 196 08	1451	1
96 51 332 08	2 998	91 56 540 08	263	1	96 51 586 08	2 970 081	96 50 495 08	(1371)	2
96 51 333 08	2 998	91 56 540 08	264	1	96 51 587 08	2 997	91 56 539 08	187	1
96 51 334 08	2 998	91 56 540 08	265	1	96 51 588 08	2 997	91 56 539 08	196	1
96 51 335 08	2 998	91 56 540 08	267	3	96 51 589 08	2 975 061	96 47 201 08	1402	1
96 51 336 08	2 998	91 56 540 08	266	1	96 51 589 08	2 975 118	96 47 200 08	1402	1
96 51 337 08	2 998	91 56 540 08	268	1	96 51 590 08	2 975 061	96 47 201 08	1403	1
96 51 338 08	2 998	91 56 540 08	269	1	96 51 590 08	2 975 118	96 47 200 08	1403	1
96 51 339 08	2 998	91 56 540 08	270	1	96 51 591 08	2 976 204	96 47 202 08	1461	1
96 51 340 08	2 998	91 56 540 08	271	1	96 51 592 08	2 997	91 56 539 08	313	1
96 51 341 08	2 998	91 56 540 08	232	1	96 51 593 08	2 997	91 56 539 08	316	1
96 51 342 08	2 998	91 56 540 08	234	2	96 51 595 08	2 997	91 56 539 08	324	1
96 51 343 08	2 998	91 56 540 08	235	1	96 51 596 08	2 997	91 56 539 08	329	1
96 51 344 08	2 998	91 56 540 08	236	1	96 51 596 08	2 997	91 56 539 08	330	1
96 51 345 08	2 998	91 56 540 08	237	1	96 51 598 08	2 997	91 56 539 08	344	1
96 51 346 08	2 998	91 56 540 08	238	1	96 51 599 08	2 997	91 56 539 08	345	1
96 51 347 08	2 998	91 56 540 08	239	1	96 51 600 08	2 997	91 56 539 08	346	1
96 51 348 08	2 998	91 56 540 08	241	1	96 51 601 08	2 997	91 56 539 08	347	1
96 51 350 08	2 975 700	91 52 774 08	(280)	1	96 51 602 08	2 997	91 56 539 08	348	1

6.2.2009

etk_en_de_074515 LR 1600/2

837

LIEBHERRNumerical index
Numerischer Index

Item	Page	Assembly	Pos.	Quantity	Item	Page	Assembly	Pos.	Quantity
96 51 603 08	2 997	91 56 539 08	349	1	96 51 725 08	2 998	91 56 540 08	434	1
96 51 604 08	2 997	91 56 539 08	351	1	96 51 727 08	2 998	91 56 540 08	436	1
96 51 606 08	2 997	91 56 539 08	368	1	96 51 731 08	2 978 102	96 47 913 08	180	2
96 51 607 08	2 997	91 56 539 08	303	1	96 51 732 08	2 978 102	96 47 913 08	181	1
96 51 607 08	2 997	91 56 539 08	369	1	96 51 733 08	2 978 102	96 47 913 08	182	1
96 51 608 08	2 997	91 56 539 08	370	1	96 51 734 08	2 978 102	96 47 913 08	183	1
96 51 609 08	2 997	91 56 539 08	300	1	96 51 735 08	2 978 102	96 47 913 08	184	2
96 51 610 08	2 997	91 56 539 08	378	1	96 51 736 08	2 978 102	96 47 913 08	185	1
96 51 624 08	3 930 576	96 48 381 08	1	1	96 51 737 08	2 978 102	96 47 913 08	186	1
96 51 655 08	2 998	91 56 540 08	362	1	96 51 738 08	2 978 102	96 47 913 08	187	1
96 51 656 08	2 998	91 56 540 08	363	1	96 51 739 08	2 978 102	96 47 913 08	188	1
96 51 661 08	2 998	91 56 540 08	368	1	96 51 740 08	2 978 102	96 47 913 08	189	1
96 51 662 08	2 998	91 56 540 08	369	1	96 51 741 08	2 978 102	96 47 913 08	190	1
96 51 663 08	2 998	91 56 540 08	370	1	96 51 750 08	2 978 205	96 47 115 08	144	1
96 51 664 08	2 998	91 56 540 08	371	1	96 51 751 08	2 978 205	96 47 115 08	145	1
96 51 665 08	2 998	91 56 540 08	372	1	96 51 752 08	2 978 205	96 47 115 08	146	1
96 51 668 08	2 998	91 56 540 08	375	1	96 51 753 08	2 978 205	96 47 115 08	147	1
96 51 670 08	2 975 000	91 57 881 08	(377)	1	96 51 754 08	2 978 205	96 47 115 08	148	1
96 51 671 08	2 998	91 56 540 08	378	2	96 51 755 08	2 978 205	96 47 115 08	149	1
96 51 672 08	2 998	91 56 540 08	379	1	96 51 756 08	2 978 205	96 47 115 08	150	1
96 51 673 08	2 998	91 56 540 08	380	1	96 51 757 08	2 978 205	96 47 115 08	151	1
96 51 674 08	2 998	91 56 540 08	381	1	96 51 758 08	2 978 205	96 47 115 08	152	1
96 51 675 08	2 998	91 56 540 08	382	1	96 51 759 08	2 978 205	96 47 115 08	153	1
96 51 676 08	2 998	91 56 540 08	383	1	96 51 760 08	2 978 205	96 47 115 08	154	1
96 51 677 08	2 998	91 56 540 08	384	1	96 51 810 08	2 652	91 52 794 08	25	1
96 51 678 08	2 998	91 56 540 08	385	1	96 51 811 08	2 652	91 52 794 08	26	1
96 51 680 08	2 998	91 56 540 08	389	1	96 51 812 08	2 652	91 52 794 08	27	2
96 51 681 08	2 998	91 56 540 08	390	1	96 51 813 08	2 652	91 52 794 08	28	1
96 51 684 08	2 998	91 56 540 08	393	1	96 51 848 08	2 920 581	96 54 405 08	150	1
96 51 685 08	2 998	91 56 540 08	394	1	96 51 850 08	2 920 581	96 54 405 08	151	1
96 51 686 08	2 998	91 56 540 08	395	1	96 51 854 08	2 920 581	96 54 405 08	152	1
96 51 689 08	2 998	91 56 540 08	398	1	96 51 855 08	2 920 581	96 54 405 08	153	1
96 51 692 08	2 998	91 56 540 08	401	1	96 51 856 08	2 920 581	96 54 405 08	154	1
96 51 693 08	2 998	91 56 540 08	402	1	96 51 857 08	2 920 581	96 54 405 08	155	1
96 51 694 08	2 998	91 56 540 08	403	1	96 51 859 08	2 925 026	91 55 259 08	(30)	1
96 51 695 08	2 998	91 56 540 08	404	1	96 51 859 08	2 925 405	96 48 397 08	30	1
96 51 696 08	2 998	91 56 540 08	405	1	96 51 896 08	2 997	91 56 539 08	381	1
96 51 697 08	2 998	91 56 540 08	406	1	96 51 902 08	2 831	91 57 754 08	(1103)	1
96 51 698 08	2 998	91 56 540 08	407	1	96 51 905 08	2 977 005	96 48 195 08	1484	1
96 51 700 08	2 998	91 56 540 08	409	1	96 51 906 08	2 977 005	96 48 195 08	1486	1
96 51 701 08	2 998	91 56 540 08	410	1	96 51 907 08	2 977 201	96 48 618 08	1245	2
96 51 702 08	2 998	91 56 540 08	411	1	96 51 908 08	2 977 201	96 48 618 08	1243	1
96 51 703 08	2 998	91 56 540 08	412	1	96 51 909 08	2 977 201	96 48 618 08	1244	1
96 51 705 08	2 998	91 56 540 08	414	1	96 51 914 08	2 978 204	96 47 114 08	1215	1
96 51 707 08	2 998	91 56 540 08	416	1	96 51 914 08	2 978 204	96 47 114 08	1217	1
96 51 708 08	2 998	91 56 540 08	417	1	96 51 917 08	2 997	91 56 539 08	320	1
96 51 709 08	2 998	91 56 540 08	418	1	96 51 948 08	2 997	91 56 539 08	452	1
96 51 711 08	2 998	91 56 540 08	420	1	96 52 045 08	2 997	91 56 539 08	122	1
96 51 712 08	2 998	91 56 540 08	421	1	96 52 046 08	2 997	91 56 539 08	123	1
96 51 713 08	2 998	91 56 540 08	422	1	96 52 047 08	2 997	91 56 539 08	207	1
96 51 714 08	2 998	91 56 540 08	423	1	96 52 049 08	1 997	91 52 512 08	741	1
96 51 715 08	2 998	91 56 540 08	424	1	96 52 049 08	1 997	91 52 512 08	743	1
96 51 716 08	2 998	91 56 540 08	425	1	96 52 066 08	2 997	91 56 539 08	210	1
96 51 717 08	2 998	91 56 540 08	426	1	96 52 067 08	2 997	91 56 539 08	211	1
96 51 718 08	2 998	91 56 540 08	427	1	96 52 068 08	2 997	91 56 539 08	228	1
96 51 719 08	2 998	91 56 540 08	428	1	96 52 070 08	2 997	91 56 539 08	453	1
96 51 720 08	2 998	91 56 540 08	429	1	96 52 071 08	2 997	91 56 539 08	322	1
96 51 721 08	2 998	91 56 540 08	430	1	96 52 072 08	2 997	91 56 539 08	323	1
96 51 722 08	2 998	91 56 540 08	431	1	96 52 073 08	2 997	91 56 539 08	325	1
96 51 723 08	2 998	91 56 540 08	432	1	96 52 074 08	2 997	91 56 539 08	340	1

6.2.2009

etk_en_de_074515 LR 1600/2

838

LIEBHERRNumerical index
Numerischer Index

Item	Page	Assembly	Pos.	Quantity	Item	Page	Assembly	Pos.	Quantity
96 52 075 08	2 997	91 56 539 08	343	1	96 52 983 08	2 780 748	96 52 969 08	15	1
96 52 267 08	3 930 638	96 51 624 08	320	1	96 52 996 08	3 930 363	96 52 979 08	20	1
96 52 272 08	3 930 638	96 51 624 08	330	1	96 52 997 08	3 930 363	96 52 979 08	21	1
96 52 291 08	3 281	91 52 896 08	55	1	96 52 998 08	3 930 363	96 52 979 08	22	1
96 52 296 08	2 978 205	96 47 115 08	155	1	96 52 999 08	3 930 363	96 52 979 08	23	1
96 52 297 08	2 978 205	96 47 115 08	156	1	96 53 000 08	3 930 363	96 52 979 08	24	1
96 52 298 08	2 978 205	96 47 115 08	157	1	96 53 001 08	3 930 363	96 52 979 08	25	1
96 52 299 08	2 978 205	96 47 115 08	158	1	96 53 004 08	3 930 363	96 52 979 08	28	1
96 52 300 08	2 978 205	96 47 115 08	159	1	96 53 008 08	3 930 363	96 52 979 08	29	1
96 52 301 08	2 978 205	96 47 115 08	160	1	96 53 009 08	3 930 363	96 52 979 08	30	1
96 52 302 08	2 978 205	96 47 115 08	161	1	96 53 010 08	3 930 363	96 52 979 08	31	1
96 52 303 08	2 978 205	96 47 115 08	162	1	96 53 011 08	3 930 363	96 52 979 08	32	1
96 52 304 08	2 978 205	96 47 115 08	163	1	96 53 012 08	3 930 363	96 52 979 08	(2)	1
96 52 305 08	2 978 205	96 47 115 08	164	1	96 53 013 08	2 780 748	96 52 969 08	(2)	1
96 52 306 08	2 978 205	96 47 115 08	165	1	96 53 041 08	2 998	91 56 540 08	310	1
96 52 307 08	2 978 205	96 47 115 08	166	1	96 53 042 08	2 998	91 56 540 08	311	1
96 52 308 08	2 978 205	96 47 115 08	167	1	96 53 043 08	2 998	91 56 540 08	312	1
96 52 309 08	2 978 205	96 47 115 08	168	1	96 53 044 08	2 998	91 56 540 08	313	1
96 52 310 08	2 978 205	96 47 115 08	169	1	96 53 045 08	2 998	91 56 540 08	316	1
96 52 311 08	2 978 205	96 47 115 08	170	1	96 53 046 08	2 998	91 56 540 08	317	1
96 52 313 08	2 998	91 56 540 08	437	1	96 53 047 08	2 998	91 56 540 08	320	1
96 52 448 08	2 391 001	96 45 719 08	73	1	96 53 048 08	2 998	91 56 540 08	321	1
96 52 493 08	1 300	91 52 768 08	1	1	96 53 049 08	2 998	91 56 540 08	324	1
96 52 546 08	3 780 751	91 52 952 08	8	1	96 53 050 08	2 998	91 56 540 08	325	1
96 52 556 08	2 533	91 52 789 08	8	1	96 53 051 08	2 998	91 56 540 08	364	1
96 52 559 08	2 533 071	96 52 556 08	11	1	96 53 052 08	2 998	91 56 540 08	365	1
96 52 560 08	2 533 071	96 52 556 08	12	1	96 53 053 08	2 998	91 56 540 08	339	1
96 52 614 08	2 920	91 56 833 08	15	1	96 53 054 08	2 998	91 56 540 08	340	2
96 52 635 08	2 970 081	96 50 495 08	91	1	96 53 055 08	2 998	91 56 540 08	354	1
96 52 651 08	2 920 288	96 52 614 08	5	1	96 53 056 08	2 998	91 56 540 08	356	1
96 52 783 08	3 930 734	96 54 401 08	350	1	96 53 057 08	2 998	91 56 540 08	400	1
96 52 787 08	3 930 734	96 54 401 08	360	1	96 53 058 08	2 998	91 56 540 08	355	1
96 52 795 08	3 930 734	96 54 401 08	370	1	96 53 059 08	2 998	91 56 540 08	361	1
96 52 797 08	3 930 734	96 54 401 08	380	1	96 53 060 08	2 998	91 56 540 08	359	1
96 52 798 08	3 930 734	96 54 401 08	390	1	96 53 061 08	2 998	91 56 540 08	419	1
96 52 800 08	3 930 734	96 54 401 08	400	1	96 53 062 08	2 998	91 56 540 08	360	1
96 52 801 08	3 930 734	96 54 401 08	410	1	96 53 063 08	2 998	91 56 540 08	357	1
96 52 804 08	3 930 734	96 54 401 08	470	1	96 53 064 08	2 998	91 56 540 08	353	1
96 52 835 08	3 930 734	96 54 401 08	420	1	96 53 065 08	2 998	91 56 540 08	358	1
96 52 910 08	2 790 455	91 57 005 08	1	1	96 53 066 08	2 998	91 56 540 08	367	1
96 52 911 08	2 790 455	91 57 005 08	2	1	96 53 067 08	2 998	91 56 540 08	413	1
96 52 917 08	2 520	91 53 061 08	81	1	96 53 086 08	2 631	91 56 817 08	1	3
96 52 929 08	2 920 288	96 52 614 08	10	1	96 53 087 08	2 631	91 56 817 08	2	1
96 52 930 08	2 920 288	96 52 614 08	11	1	96 53 088 08	2 631	91 56 817 08	3	1
96 52 931 08	2 920 288	96 52 614 08	12	1	96 53 089 08	2 631	91 56 817 08	4	1
96 52 932 08	2 920 288	96 52 614 08	13	1	96 53 090 08	2 631	91 56 817 08	5	1
96 52 933 08	2 920 288	96 52 614 08	14	1	96 53 091 08	2 631	91 56 817 08	6	6
96 52 934 08	2 920 288	96 52 614 08	15	1	96 53 092 08	2 631	91 56 817 08	7	1
96 52 935 08	2 920 288	96 52 614 08	16	1	96 53 093 08	2 631	91 56 817 08	8	6
96 52 936 08	2 920 288	96 52 614 08	18	1	96 53 121 08	2 730	91 52 802 08	7	1
96 52 968 08	2 780 510	96 50 097 08	20	1	96 53 131 08	2 520	91 53 061 08	82	1
96 52 969 08	2 780 510	96 50 097 08	10	1	96 53 234 08	1 400	91 56 853 08	1	1
96 52 970 08	2 780 524	96 52 968 08	10	1	96 53 235 08	1 400	91 56 853 08	(1)	1
96 52 971 08	2 780 524	96 52 968 08	20	1	96 53 255 08	2 391 040	96 53 645 08	1	1
96 52 977 08	2 780 748	96 52 969 08	1	1	96 53 258 08	1 410 300	91 56 855 08	1	1
96 52 978 08	2 780 748	96 52 969 08	11	1	96 53 259 08	1 410 300	91 56 855 08	(1)	1
96 52 979 08	3 930 421	96 47 149 08	1	1	96 53 262 08	1 400	91 56 853 08	70	1
96 52 980 08	2 780 748	96 52 969 08	12	1	96 53 262 08	1 410 300	91 56 855 08	70	1
96 52 981 08	2 780 748	96 52 969 08	13	1	96 53 263 08	1 400	91 56 853 08	71	1
96 52 982 08	2 780 748	96 52 969 08	14	1	96 53 263 08	1 410 300	91 56 855 08	71	1

6.2.2009

etk_en_de_074515 LR 1600/2

839

LIEBHERRNumerical index
Numerischer Index

Item	Page	Assembly	Pos.	Quantity	Item	Page	Assembly	Pos.	Quantity
96 53 645 08	2 391 001	96 45 719 08	13	1	96 54 378 08	3 713	91 57 749 08	500	1
96 53 678 08	2 391 040	96 53 645 08	10	1	96 54 379 08	2 550	91 57 751 08	500	1
96 53 864 08	2 550	91 57 751 08	88	1	96 54 384 08	2 932 160	96 54 385 08	1	1
96 53 928 08	3 350	91 52 859 08	28	4	96 54 385 08	2 932	91 57 750 08	2	1
96 54 011 08	3 350	91 52 859 08	21	1	96 54 387 08	2 932	91 57 750 08	3	1
96 54 012 08	3 350	91 52 859 08	20	1	96 54 388 08	2 932 082	96 54 387 08	5	1
96 54 041 08	2 393	91 52 787 08	500	1	96 54 389 08	2 932 116	96 54 388 08	2	1
96 54 086 08	2 998	91 56 540 08	244	1	96 54 390 08	2 932 224	96 54 389 08	2	1
96 54 087 08	2 998	91 56 540 08	243	1	96 54 398 08	3 930 138	96 54 377 08	9	1
96 54 088 08	2 998	91 56 540 08	338	1	96 54 399 08	3 930 730	96 54 398 08	320	1
96 54 089 08	2 998	91 56 540 08	343	1	96 54 400 08	3 930 730	96 54 398 08	330	1
96 54 090 08	2 998	91 56 540 08	346	1	96 54 401 08	3 930 330	96 54 378 08	1	1
96 54 091 08	2 998	91 56 540 08	347	1	96 54 402 08	3 930 734	96 54 401 08	480	1
96 54 092 08	2 998	91 56 540 08	348	1	96 54 405 08	2 920 578	96 54 379 08	1	1
96 54 093 08	2 998	91 56 540 08	349	1	96 54 406 08	2 631	91 56 817 08	52	1
96 54 094 08	2 998	91 56 540 08	344	1	96 54 407 08	2 920 581	96 54 405 08	160	1
96 54 095 08	2 998	91 56 540 08	350	1	96 54 448 08	2 370	91 52 782 08	3	1
96 54 096 08	2 998	91 56 540 08	351	1	96 54 483 08	3 930 734	96 54 401 08	430	1
96 54 097 08	2 998	91 56 540 08	366	1	96 54 484 08	3 930 734	96 54 401 08	2	1
96 54 098 08	2 998	91 56 540 08	373	1	96 54 485 08	3 930 734	96 54 401 08	(2)	1
96 54 099 08	2 998	91 56 540 08	374	1	96 54 670 08	2 730	91 52 802 08	8	2
96 54 100 08	2 998	91 56 540 08	391	1	96 54 709 08	2 810 001	96 43 597 08	8	2
96 54 101 08	2 998	91 56 540 08	392	1	96 54 718 08	3 978 018	96 50 880 08	1272	1
96 54 102 08	2 998	91 56 540 08	396	1	96 54 719 08	3 978 015	91 56 429 08	(1280)	1
96 54 103 08	2 998	91 56 540 08	397	1	96 54 719 08	3 978 015	91 56 429 08	(1281)	1
96 54 104 08	2 998	91 56 540 08	399	1	96 54 719 08	3 978 016	96 50 878 08	1285	1
96 54 105 08	2 998	91 56 540 08	408	1	96 54 719 08	3 978 016	96 50 878 08	1286	1
96 54 106 08	2 998	91 56 540 08	415	1	96 54 722 08	2 978 204	96 47 114 08	1212	1
96 54 107 08	2 998	91 56 540 08	433	1	96 54 723 08	2 975 154	96 50 585 08	1166	1
96 54 108 08	2 998	91 56 540 08	435	1	96 54 724 08	2 975 154	96 50 585 08	1167	1
96 54 121 08	2 998	91 56 540 08	386	1	96 54 735 08	2 978 107	96 50 433 08	1308	1
96 54 143 08	3 978 007	96 50 879 08	460	1	96 54 736 08	2 978 107	96 50 433 08	1316	1
96 54 144 08	3 978 007	96 50 879 08	461	1	96 54 779 08	2 997	91 56 539 08	455	1
96 54 145 08	3 978 007	96 50 879 08	462	1	96 54 781 08	2 977 005	96 48 195 08	1481	1
96 54 146 08	3 978 010	96 50 882 08	209	1	96 54 826 08	2 730	91 52 802 08	18	4
96 54 147 08	3 978 010	96 50 882 08	210	1	96 54 983 08	3 225	91 52 854 08	48	4
96 54 148 08	3 978 010	96 50 882 08	211	1	96 54 984 08	3 225	91 52 854 08	50	2
96 54 149 08	3 978 010	96 50 882 08	212	1	96 55 027 08	1 631 100	91 52 388 08	14	2
96 54 150 08	3 978 010	96 50 882 08	213	1	96 55 028 08	3 978 010	96 50 882 08	214	1
96 54 179 08	2 657	91 57 656 08	1	2	96 55 029 08	3 978 010	96 50 882 08	215	1
96 54 193 08	2 520	91 53 061 08	28	1	96 55 030 08	3 978 010	96 50 882 08	216	1
96 54 235 08	2 920 443	96 54 236 08	2	1	96 55 031 08	3 978 010	96 50 882 08	217	1
96 54 236 08	2 920	91 56 833 08	20	1	96 55 032 08	3 978 010	96 50 882 08	218	1
96 54 268 08	2 920 369	96 54 235 08	21	1	96 55 033 08	3 978 010	96 50 882 08	219	1
96 54 269 08	2 920 369	96 54 235 08	22	1	96 55 034 08	3 978 010	96 50 882 08	220	1
96 54 270 08	2 920 369	96 54 235 08	23	1	96 55 035 08	3 978 010	96 50 882 08	221	1
96 54 271 08	2 920 369	96 54 235 08	24	1	96 55 036 08	3 978 010	96 50 882 08	222	1
96 54 282 08	2 997	91 56 539 08	387	1	96 55 037 08	3 978 010	96 50 882 08	223	1
96 54 283 08	2 997	91 56 539 08	396	1	96 55 038 08	3 978 010	96 50 882 08	224	1
96 54 309 08	3 978 009	96 50 881 08	1266	1	96 55 039 08	3 978 010	96 50 882 08	225	1
96 54 321 08	2 831	91 57 754 08	(1100)	1	96 55 040 08	3 978 010	96 50 882 08	226	1
96 54 322 08	2 831	91 57 754 08	(1101)	1	96 55 041 08	3 978 010	96 50 882 08	227	1
96 54 323 08	2 831	91 57 754 08	(1102)	1	96 55 042 08	3 978 010	96 50 882 08	228	1
96 54 324 08	2 831	91 57 754 08	(1104)	1	96 55 043 08	3 978 010	96 50 882 08	229	1
96 54 325 08	2 831	91 57 754 08	(1105)	1	96 55 044 08	3 978 010	96 50 882 08	230	1
96 54 337 08	2 977 005	96 48 195 08	1482	1	96 55 045 08	3 978 010	96 50 882 08	231	1
96 54 367 08	2 631	91 56 817 08	45	1	96 55 046 08	3 978 106	96 50 885 08	470	1
96 54 368 08	2 831	91 57 754 08	500	1	96 55 047 08	3 978 106	96 50 885 08	471	1
96 54 370 08	3 780 751	91 52 952 08	5	1	96 55 048 08	3 978 106	96 50 885 08	472	1
96 54 377 08	3 211	91 57 748 08	500	1	96 55 049 08	3 978 106	96 50 885 08	473	1

6.2.2009

etk_en_de_074515 LR 1600/2

840

LIEBHERRNumerical index
Numerischer Index

Item	Page	Assembly	Pos.	Quantity	Item	Page	Assembly	Pos.	Quantity
96 55 050 08	3 978 106	96 50 885 08	474	1	96 56 363 08	3 713	91 57 749 08	80	2
96 55 051 08	3 978 106	96 50 885 08	475	1	96 56 482 08	3 780 751	91 52 952 08	11	1
96 55 052 08	3 978 106	96 50 885 08	476	1	96 56 483 08	3 780 258	96 56 482 08	1	1
96 55 053 08	3 978 106	96 50 885 08	477	1	96 56 664 08	2 920 369	96 54 235 08	16	1
96 55 054 08	3 978 106	96 50 885 08	478	1	96 56 665 08	2 920 369	96 54 235 08	15	1
96 55 055 08	3 978 106	96 50 885 08	479	1	96 56 719 08	3 223 100	91 55 327 08	50	2
96 55 056 08	3 978 106	96 50 885 08	480	1	96 56 946 08	3 978 100	91 56 428 08	91	1
96 55 057 08	3 978 106	96 50 885 08	481	1	96 57 085 08	2 920 578	96 54 379 08	20	1
96 55 058 08	2 975 155	96 50 586 08	482	1	96 57 094 08	2 920 288	96 52 614 08	20	1
96 55 059 08	2 975 155	96 50 586 08	483	1	96 57 159 08	3 713	91 57 749 08	115	1
96 55 060 08	2 975 155	96 50 586 08	484	1	96 57 437 08	3 930 730	96 54 398 08	450	1
96 55 061 08	2 975 155	96 50 586 08	485	1	96 57 438 08	3 930 730	96 54 398 08	460	1
96 55 062 08	2 975 155	96 50 586 08	486	1	96 58 269 08	3 714 009	96 49 267 08	20	1
96 55 063 08	2 975 155	96 50 586 08	487	1	96 58 312 08	2 998	91 56 540 08	307	1
96 55 064 08	2 975 155	96 50 586 08	488	1	96 58 855 08	2 925 002	96 58 856 08	3	1
96 55 065 08	2 975 155	96 50 586 08	489	1	96 58 856 08	2 925 007	91 60 728 08	10	1
96 55 066 08	2 978 108	96 44 195 08	490	1	96 59 083 08	3 714 009	96 49 267 08	21	2
96 55 067 08	2 978 108	96 44 195 08	491	1	96 59 096 08	3 714 009	96 49 267 08	22	1
96 55 068 08	2 978 108	96 44 195 08	492	1	96 59 125 08	2 925 218	91 60 840 08	10	1
96 55 069 08	2 978 108	96 44 195 08	493	1	96 59 398 08	2 920	91 56 833 08	35	1
96 55 070 08	2 978 108	96 44 195 08	494	1	96 89 130 01	2 340	91 52 776 08	17	1
96 55 071 08	2 978 108	96 44 195 08	495	1	96 97 916 01	2 350	91 52 778 08	1	2
96 55 072 08	2 978 108	96 44 195 08	496	1	97 00 223 08	2 859 027	96 46 777 08	1	1
96 55 073 08	2 978 108	96 44 195 08	497	1	97 00 272 08	2 859 028	96 46 778 08	1	1
96 55 074 08	2 978 108	96 44 195 08	498	1	97 01 621 08	2 975 100	91 52 860 08	58	1
96 55 075 08	2 978 108	96 44 195 08	499	1	97 02 119 08	2 260 006	96 46 501 08	3	2
96 55 076 08	2 978 108	96 44 195 08	500	1	97 02 120 08	2 260 006	96 46 501 08	4	1
96 55 077 08	2 978 108	96 44 195 08	501	1	97 02 204 08	2 340	91 52 776 08	40	1
96 55 078 08	2 978 108	96 44 195 08	502	1	97 02 665 08	2 550	91 57 751 08	67	2
96 55 079 08	2 978 108	96 44 195 08	503	1	97 02 854 08	2 780 324	91 56 389 08	11	1
96 55 080 08	2 978 108	96 44 195 08	504	1	97 02 854 08	2 920	91 56 833 08	(3)	1
96 55 081 08	2 978 108	96 44 195 08	505	1	97 03 200 08	2 970	91 56 537 08	182	1
96 55 082 08	2 978 108	96 44 195 08	506	1	97 03 208 08	2 970	91 56 537 08	181	1
96 55 083 08	2 978 108	96 44 195 08	507	1	97 03 448 08	2 391 001	96 45 719 08	149	1
96 55 084 08	2 978 108	96 44 195 08	508	1	97 03 448 08	3 211	91 57 748 08	92	18
96 55 085 08	2 978 108	96 44 195 08	509	1	97 03 448 08	3 713	91 57 749 08	139	2
96 55 086 08	2 978 108	96 44 195 08	510	1	97 03 448 08	3 714	91 52 862 08	86	4
96 55 087 08	2 978 108	96 44 195 08	511	1	97 03 501 08	2 310	91 52 503 08	28	1
96 55 088 08	3 978 015	91 56 429 08	(450)	1	97 03 501 08	2 320	91 52 504 08	28	1
96 55 089 08	3 978 015	91 56 429 08	(451)	1	97 03 501 08	2 711	91 52 800 08	27	5
96 55 090 08	3 978 015	91 56 429 08	(452)	1	97 03 502 08	2 550	91 57 751 08	79	2
96 55 091 08	3 978 015	91 56 429 08	(453)	1	97 03 502 08	2 711	91 52 800 08	25	2
96 55 092 08	3 978 015	91 56 429 08	(454)	1	97 03 523 08	3 714 009	96 49 267 08	18	4
96 55 093 08	3 978 015	91 56 429 08	(455)	1	97 03 556 08	3 714 008	96 49 266 08	7	2
96 55 147 08	2 998	91 56 540 08	302	1	97 03 987 08	3 350	91 52 859 08	10	2
96 55 148 08	2 998	91 56 540 08	303	1	97 04 309 08	1 920 307	96 48 383 08	8	2
96 55 363 08	2 920 369	96 54 235 08	18	1	97 04 625 08	2 550	91 57 751 08	92	1
96 55 364 08	2 920 369	96 54 235 08	19	1	97 04 625 08	3 281	91 52 896 08	7	2
96 55 366 08	2 920 369	96 54 235 08	17	1	97 04 625 08	3 714	91 52 862 08	63	2
96 55 460 08	2 391 040	96 53 645 08	40	1	97 04 625 08	3 714 008	96 49 266 08	8	2
96 55 636 08	2 997	91 56 539 08	217	1	97 04 902 08	3 205	91 52 880 08	17	2
96 55 637 08	2 997	91 56 539 08	402	1	97 05 395 08	3 211	91 57 748 08	35	2
96 55 638 08	2 997	91 56 539 08	403	1	97 05 395 08	3 713	91 57 749 08	72	2
96 55 952 08	2 920 288	96 52 614 08	19	1	97 05 729 08	2 970	91 56 537 08	183	1
96 56 155 08	2 550	91 57 751 08	94	2	97 06 477 08	3 745	91 52 948 08	56	1
96 56 165 08	2 550	91 57 751 08	95	2	97 06 963 08	3 215 005	91 52 846 08	20	4
96 56 171 08	2 550	91 57 751 08	96	1	97 06 963 08	3 215 006	91 52 847 08	20	4
96 56 268 08	2 730	91 52 802 08	19	1	97 06 965 08	3 215 005	91 52 846 08	27	2
96 56 360 08	2 391	91 52 784 08	11	1	97 06 965 08	3 215 006	91 52 847 08	27	2
96 56 362 08	3 713	91 57 749 08	79	2	97 07 173 08	2 550	91 57 751 08	(4)	4

6.2.2009

etk_en_de_074515 LR 1600/2

841

LIEBHERRNumerical index
Numerischer Index

Item	Page	Assembly	Pos.	Quantity	Item	Page	Assembly	Pos.	Quantity
97 07 719 08	2 391 001	96 45 719 08	72	1	97 18 514 08	2 913	91 32 850 08	10	1
97 08 336 08	3 220 500	91 52 849 08	27	4	97 18 514 08	2 913 009	91 04 705 08	10	1
97 08 336 08	3 221	91 54 668 08	15	4	97 18 575 08	3 206	91 52 881 08	36	3
97 08 336 08	3 223	91 52 852 08	27	4	97 18 575 08	3 208 001	91 52 883 08	24	6
97 08 336 08	3 223 010	91 52 853 08	27	4	97 18 723 08	3 206	91 52 881 08	6	1
97 08 336 08	3 223 100	91 55 327 08	27	4	97 18 725 08	3 206 001	96 20 920 08	1	1
97 08 336 08	3 225	91 52 854 08	34	4	97 19 034 08	3 713	91 57 749 08	4	1
97 08 391 08	1 970	91 56 958 08	14	1	97 19 159 08	2 391 023	96 45 720 08	5	1
97 09 048 08	1 991	91 52 510 08	20	10	97 19 655 08	3 830	91 55 535 08	14	2
97 09 155 08	3 225	91 52 854 08	19	2	97 19 736 08	2 502 007	96 22 822 08	3	1
97 09 178 08	3 713	91 57 749 08	48	2	97 19 736 08	2 502 008	96 22 823 08	3	1
97 09 807 08	2 913 003	96 20 599 08	2	1	97 19 741 08	2 502	91 55 939 08	21	4
97 09 808 08	2 913	91 32 850 08	5	1	97 19 742 08	2 502	91 55 939 08	22	2
97 09 808 08	2 913 009	91 04 705 08	5	1	97 20 177 08	3 207 101	96 48 292 08	6	2
97 10 255 08	1 620	91 52 386 08	2	4	97 20 177 08	3 281	91 52 896 08	13	3
97 10 780 08	2 125	91 52 773 08	11	4	97 22 660 08	3 930 009	96 50 573 08	5	1
97 11 958 08	1 400	91 56 853 08	7	2	97 23 263 08	2 391 036	96 23 055 08	1	1
97 11 958 08	1 410 300	91 56 855 08	7	2	97 23 317 08	2 260 006	96 46 501 08	6	1
97 12 071 08	1 400	91 56 853 08	25	8	97 23 319 08	2 260 006	96 46 501 08	7	1
97 12 071 08	1 410 300	91 56 855 08	25	8	97 23 411 08	2 502	91 55 939 08	3	1
97 12 764 08	2 810	91 52 806 08	62	1	97 23 412 08	2 502	91 55 939 08	4	1
97 12 903 08	2 970	91 56 537 08	151	1	97 25 170 08	2 391 001	96 45 719 08	27	1
97 12 910 08	2 932 082	96 54 387 08	58	1	97 25 209 08	3 206	91 52 881 08	22	1
97 13 432 08	2 810	91 52 806 08	28	2	97 25 222 08	3 206	91 52 881 08	26	1
97 13 661 08	1 920 418	96 48 687 08	3	1	97 25 613 08	2 520 034	96 45 984 08	38	10
97 14 053 08	2 932 082	96 54 387 08	108	1	97 25 615 08	2 520 034	96 45 984 08	39	3
97 14 073 08	1 920 403	96 48 707 08	4	1	97 26 310 08	2 780 851	96 24 498 08	1	1
97 14 073 08	1 920 417	96 48 703 08	4	1	97 26 606 08	2 932 082	96 54 387 08	105	2
97 14 228 08	2 920 581	96 54 405 08	5	1	97 28 092 08	2 932 160	96 54 385 08	27	2
97 14 450 08	1 400	91 56 853 08	26	1	97 28 594 08	2 730	91 52 802 08	17	2
97 14 477 08	2 657	91 57 656 08	15	1	97 28 766 08	2 391 036	96 23 055 08	3	1
97 14 596 08	1 410 300	91 56 855 08	26	1	97 29 088 08	2 550	91 57 751 08	18	1
97 15 061 08	2 310	91 52 503 08	6	1	97 29 088 08	3 208 001	91 52 883 08	50	1
97 15 061 08	2 320	91 52 504 08	6	1	97 29 088 08	3 211	91 57 748 08	52	1
97 15 345 08	3 214	91 52 843 08	32	1	97 29 088 08	3 213	91 52 842 08	15	1
97 15 435 08	1 920 307	96 48 383 08	9	1	97 29 088 08	3 214	91 52 843 08	20	1
97 15 521 08	2 550	91 57 751 08	49	1	97 29 400 08	2 932 082	96 54 387 08	102	4
97 15 586 08	3 714	91 52 862 08	30	1	97 29 623 08	2 932 082	96 54 387 08	103	1
97 15 627 08	3 211	91 57 748 08	105	2	97 32 004 08	3 211	91 57 748 08	77	2
97 16 366 08	2 502 007	96 22 822 08	2	1	97 32 671 08	2 913 007	96 20 763 08	9	1
97 16 366 08	2 502 008	96 22 823 08	2	1	97 33 032 08	2 925 402	96 58 855 08	(1)	1
97 17 070 08	2 913	91 32 850 08	3	1	97 33 034 08	2 925 402	96 58 855 08	28	1
97 17 070 08	2 913 009	91 04 705 08	3	1	97 35 676 08	2 550 010	96 45 685 08	5	1
97 17 087 08	1 632	91 52 389 08	3	2	97 35 676 08	3 282 001	96 47 888 08	6	1
97 17 132 08	2 913 005	96 20 731 08	2	1	97 35 676 08	3 714 013	96 49 270 08	7	1
97 17 132 08	2 913 005	96 28 696 08	2	1	97 35 919 08	2 550	91 57 751 08	(3)	1
97 17 777 08	1 400	91 56 853 08	27	1	97 35 919 08	2 550	91 57 751 08	(3)	1
97 17 862 08	3 281	91 52 896 08	35	4	97 35 919 08	2 550 005	96 45 680 08	5	1
97 17 950 08	1 410 300	91 56 855 08	27	1	97 35 919 08	3 207 003	96 48 259 08	11	1
97 18 057 08	2 502	91 55 939 08	19	4	97 35 919 08	3 207 100	96 48 261 08	8	1
97 18 386 08	3 211	91 57 748 08	18	16	97 35 919 08	3 207 101	96 48 292 08	8	1
97 18 507 08	2 913	91 32 850 08	6	1	97 35 919 08	3 211 003	96 46 986 08	14	1
97 18 507 08	2 913 009	91 04 705 08	6	1	97 35 919 08	3 220 501	96 43 440 08	6	1
97 18 510 08	3 206	91 52 881 08	39	1	97 35 919 08	3 221 200	96 47 984 08	6	1
97 18 511 08	2 913	91 32 850 08	7	1	97 35 919 08	3 225 200	96 48 679 08	6	1
97 18 511 08	2 913 009	91 04 705 08	7	1	97 35 919 08	3 227 002	96 50 498 08	6	1
97 18 512 08	2 913	91 32 850 08	8	1	97 35 919 08	3 281	91 52 896 08	(6)	1
97 18 512 08	2 913 009	91 04 705 08	8	1	97 35 919 08	3 281	91 52 896 08	(6)	1
97 18 513 08	2 913	91 32 850 08	9	1	97 35 919 08	3 281	91 52 896 08	(11)	1
97 18 513 08	2 913 009	91 04 705 08	9	1	97 35 919 08	3 561 003	96 45 222 08	6	1

6.2.2009

etk_en_de_074515 LR 1600/2

842

LIEBHERRNumerical index
Numerischer Index

Item	Page	Assembly	Pos.	Quantity	Item	Page	Assembly	Pos.	Quantity
97 35 919 08	3 713 012	96 50 197 08	6	1	97 39 349	X1012059	10 12 059 0	169	1
97 35 919 08	3 714 013	96 59 083 08	9	1	97 39 351	X1012059	10 12 059 0	166	1
97 35 919 08	3 714 014	96 49 456 08	6	1	97 39 352	X1012059	10 12 059 0	165	1
97 35 919 08	3 714 025	96 49 269 08	9	1	97 39 353	X1012059	10 12 059 0	192	1
97 35 919 08	3 716 001	96 49 159 08	6	1	97 39 354	X1012059	10 12 059 0	240	1
97 36 626 08	2 913	91 32 850 08	16	1	97 39 355	X1012059	10 12 059 0	50	1
97 38 043 08	1 790 503	91 57 017 08	1	1	97 39 356	9 739 358	97 39 358	16	1
97 38 049 08	2 790 451	91 57 016 08	1	1	97 39 357	9 739 358	97 39 358	1	1
97 39 035	9 739 400	97 39 400	282	1	97 39 358	X1012059	10 12 059 0	115	1
97 39 036	9 739 035	97 39 035	1	1	97 39 360	X1012059	10 12 059 0	208	1
97 39 082	9 739 400	97 39 400	49	1	97 39 361	9 739 362	97 39 362	1	1
97 39 096	X1012059	10 12 059 0	2	1	97 39 362	X1012059	10 12 059 0	16	1
97 39 101	X1012059	10 12 059 0	28	1	97 39 365	9 739 368	97 39 368	3	1
97 39 102	X1012059	10 12 059 0	29	1	97 39 366	X1012059	10 12 059 0	229	1
97 39 118	X1012059	10 12 059 0	65	1	97 39 367	9 739 368	97 39 368	2	1
97 39 122	9 739 355	97 39 355	20	1	97 39 368	X1012059	10 12 059 0	1	1
97 39 126	X1012059	10 12 059 0	172	1	97 39 369	X1012059	10 12 059 0	101	1
97 39 127	X1012059	10 12 059 0	170	1	97 39 371	X1012059	10 12 059 0	150	1
97 39 129	X1012059	10 12 059 0	282	1	97 39 372	X1012059	10 12 059 0	56	1
97 39 140	X1012059	10 12 059 0	130	1	97 39 383	9 739 351	97 39 351	1	1
97 39 159	X1012059	10 12 059 0	205	1	97 39 386	X1012059	10 12 059 0	11	1
97 39 186	9 739 400	97 39 400	330	1	97 39 400	2 391 001	96 45 719 08	101	1
97 39 187	X1012059	10 12 059 0	46	6	97 39 403	9 739 400	97 39 400	71	1
97 39 188	X1012059	10 12 059 0	18	1	97 39 491	X1012059	10 12 059 0	140	1
97 39 209	X1012059	10 12 059 0	112	1	97 39 492	X1012059	10 12 059 0	143	1
97 39 210	X1012059	10 12 059 0	171	1	97 39 493	X1012059	10 12 059 0	210	1
97 39 242	X1012059	10 12 059 0	26	6	97 39 494	X1012059	10 12 059 0	190	1
97 39 243	X1012059	10 12 059 0	9	6	97 41 438 08	3 225	91 52 854 08	39	2
97 39 246	X1012059	10 12 059 0	40	6	97 41 439 08	3 220 500	91 52 849 08	29	1
97 39 248	X1012059	10 12 059 0	90	6	97 41 439 08	3 223	91 52 852 08	29	2
97 39 250	X1012059	10 12 059 0	250	1	97 41 439 08	3 223 010	91 52 853 08	29	2
97 39 256	X1012059	10 12 059 0	110	1	97 41 439 08	3 223 100	91 55 327 08	29	2
97 39 257	9 739 400	97 39 400	231	1	97 41 439 08	3 225	91 52 854 08	29	1
97 39 258	9 739 259	97 39 259	1	1	97 41 439 08	3 226	91 52 870 08	29	1
97 39 259	X1012059	10 12 059 0	93	1	97 41 439 08	3 227	91 52 873 08	29	2
97 39 260	9 739 261	97 39 261	10	1	97 41 439 08	3 227 008	91 52 872 08	29	2
97 39 261	9 739 262	97 39 262	6	1	97 41 439 08	3 227 200	91 53 519 08	29	2
97 39 261	9 739 266	97 39 266	6	1	97 41 439 08	3 713	91 57 749 08	57	3
97 39 262	X1012059	10 12 059 0	41	4	97 41 439 08	3 714	91 52 862 08	51	6
97 39 263	9 739 262	97 39 262	5	1	97 41 439 08	3 715 008	91 52 863 08	24	4
97 39 264	9 739 266	97 39 266	5	1	97 41 439 08	3 716	91 52 864 08	24	5
97 39 266	X1012059	10 12 059 0	42	2	97 41 440 08	3 220 500	91 52 849 08	30	1
97 39 267	X1012059	10 12 059 0	43	1	97 41 440 08	3 223	91 52 852 08	30	2
97 39 271	X1012059	10 12 059 0	126	1	97 41 440 08	3 223 010	91 52 853 08	30	2
97 39 276	X1012059	10 12 059 0	173	1	97 41 440 08	3 223 100	91 55 327 08	30	2
97 39 278	X1012059	10 12 059 0	73	1	97 41 440 08	3 225	91 52 854 08	28	1
97 39 281	X1012059	10 12 059 0	105	1	97 41 440 08	3 226	91 52 870 08	30	1
97 39 282	X1012059	10 12 059 0	107	1	97 41 440 08	3 227	91 52 873 08	30	2
97 39 286	9 739 491	97 39 491	10	1	97 41 440 08	3 227 008	91 52 872 08	30	2
97 39 287	X1012059	10 12 059 0	38	6	97 41 440 08	3 227 200	91 53 519 08	30	2
97 39 288	X1012059	10 12 059 0	131	1	97 41 440 08	3 713	91 57 749 08	58	1
97 39 292	X1012059	10 12 059 0	97	1	97 41 440 08	3 714	91 52 862 08	50	5
97 39 295	X1012059	10 12 059 0	180	1	97 41 440 08	3 715 008	91 52 863 08	25	2
97 39 296	X1012059	10 12 059 0	181	1	97 41 440 08	3 716	91 52 864 08	25	3
97 39 318	X1012059	10 12 059 0	231	1	97 41 664 08	1 632	91 52 389 08	7	1
97 39 322	9 739 386	97 39 386	11	1	97 42 123 08	1 631 100	91 52 388 08	13	6
97 39 326	9 739 400	97 39 400	230	1	97 43 187 08	3 747	91 52 950 08	6	2
97 39 341	X1012059	10 12 059 0	31	1	97 43 188 08	3 747	91 52 950 08	7	4
97 39 343	X1012059	10 12 059 0	195	1	97 43 189 08	3 747	91 52 950 08	8	4
97 39 344	X1012059	10 12 059 0	200	1	97 43 190 08	3 747	91 52 950 08	9	2

6.2.2009

etk_en_de_074515 LR 1600/2

843

LIEBHERRNumerical index
Numerischer Index

Item	Page	Assembly	Pos.	Quantity	Item	Page	Assembly	Pos.	Quantity
97 44 570 08	3 350	91 52 859 08	29	1	97 64 994 08	3 221	91 54 668 08	2	4
97 44 917 08	3 780 258	96 56 482 08	(1)	1	97 64 994 08	3 223	91 52 852 08	2	4
97 46 733 08	3 211	91 57 748 08	36	2	97 64 994 08	3 223 010	91 52 853 08	2	4
97 46 733 08	3 713	91 57 749 08	71	2	97 64 994 08	3 223 100	91 55 327 08	2	4
97 47 409 08	2 780 852	96 24 845 08	3	1	97 64 994 08	3 225	91 52 854 08	6	2
97 47 495 08	2 391 001	96 45 719 08	118	1	97 65 176 08	2 540	91 53 253 08	2	1
97 47 495 08	2 391 023	96 45 720 08	26	1	97 65 362 08	2 932 082	96 54 387 08	110	1
97 48 729 08	1 400	91 56 853 08	28	2	97 65 557 08	2 350	91 52 778 08	4	2
97 48 729 08	1 410 300	91 56 855 08	28	2	97 65 584 08	2 620	91 52 793 08	2	72
97 48 730 08	1 400	91 56 853 08	18	2	97 66 066 08	2 932 160	96 54 385 08	26	1
97 48 730 08	1 410 300	91 56 855 08	18	2	97 66 383 08	2 350	91 52 778 08	8	1
97 49 296 08	3 214	91 52 843 08	40	2	97 66 499 08	3 220 500	91 52 849 08	16	2
97 49 575 08	3 214	91 52 843 08	48	2	97 66 499 08	3 223	91 52 852 08	16	2
97 49 680 08	2 340	91 52 776 08	41	4	97 66 499 08	3 223 010	91 52 853 08	16	2
97 51 876 08	2 920 448	96 48 794 08	5	1	97 66 499 08	3 223 100	91 55 327 08	16	2
97 52 147 08	2 260	91 53 057 08	4	1	97 66 500 08	3 220 500	91 52 849 08	17	2
97 52 186 08	2 520	91 53 061 08	20	6	97 66 500 08	3 223	91 52 852 08	17	4
97 52 216 08	2 520 031	96 45 610 08	4	2	97 66 500 08	3 223 010	91 52 853 08	17	4
97 52 217 08	3 930 730	96 54 398 08	5	1	97 66 500 08	3 223 100	91 55 327 08	17	4
97 53 845 08	2 520	91 53 061 08	21	6	97 66 501 08	3 220 500	91 52 849 08	18	2
97 54 042 08	3 930 734	96 54 401 08	7	1	97 66 501 08	3 223	91 52 852 08	18	2
97 54 075 08	3 930 363	96 52 979 08	5	1	97 66 501 08	3 223 010	91 52 853 08	18	2
97 55 008 08	2 310	91 52 503 08	27	1	97 66 501 08	3 223 100	91 55 327 08	18	2
97 55 008 08	2 320	91 52 504 08	27	1	97 66 514 08	3 220 500	91 52 849 08	23	2
97 55 008 08	2 340	91 52 776 08	34	2	97 66 514 08	3 221	91 54 668 08	11	2
97 55 008 08	3 350	91 52 859 08	38	1	97 66 514 08	3 223	91 52 852 08	23	2
97 55 895 08	3 211	91 57 748 08	89	4	97 66 514 08	3 223 010	91 52 853 08	23	2
97 57 099 08	3 714	91 52 862 08	92	1	97 66 574 08	2 391 001	96 45 719 08	28	1
97 57 099 08	3 715 008	91 52 863 08	45	1	97 66 580 08	1 740	91 53 020 08	1	8
97 57 099 08	3 716	91 52 864 08	43	1	97 66 580 08	2 740	91 52 770 08	1	16
97 57 167 08	2 970	91 56 537 08	185	1	97 66 610 08	3 226	91 52 870 08	23	2
97 57 447 08	3 211	91 57 748 08	103	3	97 66 610 08	3 227	91 52 873 08	23	2
97 57 731 08	2 533 071	96 52 556 08	1	1	97 66 610 08	3 227 008	91 52 872 08	23	2
97 58 507 08	2 520	91 53 061 08	50	1	97 66 610 08	3 227 200	91 53 519 08	23	2
97 58 522 08	2 780 748	96 52 969 08	4	1	97 66 610 08	3 714	91 52 862 08	40	1
97 59 503 08	2 550	91 57 751 08	77	1	97 66 610 08	3 715 008	91 52 863 08	26	2
97 59 516 08	2 970	91 56 537 08	135	20	97 66 610 08	3 716	91 52 864 08	33	2
97 59 516 08	2 975 100	91 52 860 08	65	4	97 66 612 08	3 220 500	91 52 849 08	28	2
97 59 516 08	2 975 200	91 52 775 08	65	7	97 66 612 08	3 221	91 54 668 08	16	2
97 59 516 08	2 975 700	91 52 774 08	65	7	97 66 612 08	3 223	91 52 852 08	28	2
97 59 516 08	2 977	91 57 756 08	65	8	97 66 612 08	3 223 010	91 52 853 08	28	2
97 59 516 08	2 977 200	91 55 149 08	65	7	97 66 612 08	3 223 100	91 55 327 08	28	2
97 59 516 08	2 978 100	91 52 827 08	65	2	97 66 612 08	3 226	91 52 870 08	28	2
97 59 516 08	2 978 200	91 54 843 08	65	4	97 66 612 08	3 227	91 52 873 08	28	2
97 59 516 08	3 978 005	91 56 430 08	65	2	97 66 612 08	3 227 008	91 52 872 08	28	2
97 59 516 08	3 978 015	91 56 429 08	65	6	97 66 612 08	3 227 200	91 53 519 08	28	2
97 59 516 08	3 978 015	91 56 432 08	65	6	97 66 746 08	2 340	91 52 776 08	11	1
97 59 516 08	3 978 100	91 56 428 08	65	5	97 66 929 08	2 932 001	96 45 393 08	40	1
97 60 772 08	2 520	91 53 061 08	64	2	97 67 363 08	2 970	91 56 537 08	150	1
97 60 941 08	2 520 034	96 45 984 08	53	1	97 67 363 08	3 350	91 52 859 08	39	1
97 60 943 08	2 520 034	96 45 984 08	54	1	97 67 727 08	3 220 501	96 43 440 08	4	1
97 61 821 08	2 391 001	96 45 719 08	69	4	97 67 727 08	3 221 200	96 47 984 08	4	1
97 61 932 08	2 520	91 53 061 08	65	1	97 67 727 08	3 225 200	96 48 679 08	4	1
97 62 324 08	3 206	91 52 881 08	16	4	97 67 727 08	3 227 002	96 50 498 08	4	1
97 62 431 08	3 215 005	91 52 846 08	21	2	97 67 727 08	3 561 003	96 45 222 08	4	1
97 62 431 08	3 215 006	91 52 847 08	21	2	97 67 727 08	3 713 012	96 50 197 08	4	1
97 64 327 08	3 206	91 52 881 08	40	1	97 67 727 08	3 830	91 55 535 08	5	2
97 64 835 08	2 391 001	96 45 719 08	35	4	97 67 848 08	1 400 016	96 45 287 08	1	1
97 64 994 08	3 211	91 57 748 08	4	2	97 67 849 08	1 400 016	96 45 287 08	2	1
97 64 994 08	3 220 500	91 52 849 08	2	4	97 67 972 08	2 550	91 57 751 08	2	1

6.2.2009

etk_en_de_074515 LR 1600/2

844

LIEBHERRNumerical index
Numerischer Index

Item	Page	Assembly	Pos.	Quantity	Item	Page	Assembly	Pos.	Quantity
97 68 035 08	1 400	91 56 853 08	19	17	97 69 489 08	1 410 300	91 56 855 08	31	4
97 68 035 08	1 410 300	91 56 855 08	19	17	97 69 490 08	1 400	91 56 853 08	32	1
97 68 042 08	1 400	91 56 853 08	44	34	97 69 490 08	1 410 300	91 56 855 08	32	1
97 68 042 08	1 410 300	91 56 855 08	44	34	97 69 491 08	1 410 300	91 56 855 08	33	1
97 68 157 08	2 932 001	96 45 393 08	21	1	97 69 492 08	1 400	91 56 853 08	34	1
97 68 284 08	2 550	91 57 751 08	(2)	1	97 69 492 08	1 410 300	91 56 855 08	34	1
97 68 329 08	2 520 034	96 45 984 08	21	1	97 69 494 08	1 410 300	91 56 855 08	36	1
97 68 331 08	2 520 034	96 45 984 08	20	1	97 69 495 08	1 400	91 56 853 08	37	1
97 68 377 08	2 520	91 53 061 08	3	1	97 69 495 08	1 410 300	91 56 855 08	37	1
97 68 378 08	2 520	91 53 061 08	4	1	97 69 550 08	2 520	91 53 061 08	12	1
97 68 379 08	2 520	91 53 061 08	5	1	97 69 551 08	2 520	91 53 061 08	13	1
97 68 380 08	2 520 030	96 45 609 08	2	1	97 69 555 08	2 831	91 57 754 08	27	1
97 68 381 08	2 520 031	96 45 610 08	1	1	97 69 564 08	2 670	91 52 797 08	3	1
97 68 423 08	2 533 051	96 48 360 08	3	1	97 69 565 08	2 670	91 52 797 08	4	1
97 68 530 08	2 550 010	96 45 685 08	1	2	97 69 586 08	1 400	91 56 853 08	38	2
97 68 580 08	2 550	91 57 751 08	15	2	97 69 586 08	1 410 300	91 56 855 08	38	2
97 68 580 08	2 550 005	96 45 680 08	6	1	97 69 588 08	2 520 032	96 45 980 08	4	1
97 68 580 08	3 714 025	96 49 269 08	3	2	97 69 656 08	2 520 034	96 45 984 08	1	1
97 68 580 08	3 745 011	96 49 677 08	8	2	97 69 657 08	2 520 034	96 45 984 08	2	1
97 68 581 08	2 550 005	96 45 680 08	14	1	97 69 672 08	2 520	91 53 061 08	14	1
97 68 599 08	2 550	91 57 751 08	13	2	97 69 673 08	2 520	91 53 061 08	15	1
97 68 611 08	2 522	91 54 115 08	6	4	97 69 683 08	2 550 003	96 46 246 08	1	1
97 68 612 08	2 522	91 54 115 08	7	1	97 69 692 08	1 400	91 56 853 08	33	1
97 68 649 08	3 213	91 52 842 08	3	2	97 69 693 08	1 400	91 56 853 08	36	1
97 68 649 08	3 214	91 52 843 08	24	2	97 69 697 08	1 630	91 52 387 08	6	4
97 68 649 08	3 225	91 52 854 08	7	2	97 69 807 08	2 652	91 52 794 08	3	1
97 68 649 08	3 226	91 52 870 08	2	4	97 69 808 08	2 652	91 52 794 08	5	1
97 68 649 08	3 227	91 52 873 08	2	4	97 69 809 08	2 652	91 52 794 08	6	2
97 68 649 08	3 227 008	91 52 872 08	2	4	97 69 824 08	2 520 034	96 45 984 08	10	1
97 68 649 08	3 227 200	91 53 519 08	2	4	97 69 825 08	2 520 034	96 45 984 08	11	1
97 68 649 08	3 713	91 57 749 08	11	2	97 69 826 08	2 520 034	96 45 984 08	12	1
97 68 649 08	3 714	91 52 862 08	23	2	97 69 827 08	2 520 034	96 45 984 08	13	1
97 68 649 08	3 715 008	91 52 863 08	27	4	97 69 855 08	1 630	91 52 387 08	8	8
97 68 649 08	3 716	91 52 864 08	26	4	97 69 890 08	2 520 034	96 45 984 08	3	1
97 68 660 08	2 522 011	96 45 602 08	3	1	97 69 891 08	2 520 034	96 45 984 08	4	1
97 68 662 08	2 522 011	96 45 602 08	5	1	97 69 892 08	2 520 034	96 45 984 08	5	1
97 68 665 08	2 522 011	96 45 602 08	8	1	97 69 902 08	1 630	91 52 387 08	18	16
97 68 666 08	2 502	91 55 939 08	47	4	97 69 999 08	3 207	91 53 433 08	1	2
97 68 666 08	2 522 011	96 45 602 08	10	1	97 70 466 08	2 520	91 53 061 08	22	2
97 68 667 08	1 632	91 52 389 08	4	4	97 70 505 08	2 260	91 53 057 08	5	2
97 68 722 08	2 522 011	96 45 602 08	13	1	97 70 506 08	2 260	91 53 057 08	6	2
97 68 724 08	2 522 011	96 45 602 08	14	1	97 70 589 08	1 631 100	91 52 388 08	3	2
97 68 730 08	2 522	91 54 115 08	11	1	97 70 673 08	2 520	91 53 061 08	23	1
97 68 734 08	2 522	91 54 115 08	12	1	97 70 775 08	2 859	91 52 809 08	11	1
97 68 737 08	2 925 402	96 58 855 08	4	4	97 70 784 08	2 859	91 52 809 08	12	1
97 68 851 08	2 522	91 54 115 08	14	1	97 70 786 08	2 859	91 52 809 08	13	1
97 68 872 08	2 550	91 57 751 08	44	2	97 70 790 08	2 859	91 52 809 08	14	1
97 68 883 08	2 522 013	96 45 883 08	11	2	97 70 792 08	2 859	91 52 809 08	15	1
97 68 888 08	2 522 012	96 45 884 08	5	2	97 70 793 08	2 859	91 52 809 08	23	1
97 68 888 08	2 522 013	96 45 883 08	6	4	97 70 794 08	2 859	91 52 809 08	24	2
97 69 084 08	3 211	91 57 748 08	2	2	97 70 795 08	2 859	91 52 809 08	25	1
97 69 484 08	1 400	91 56 853 08	15	2	97 70 796 08	2 859	91 52 809 08	26	1
97 69 484 08	1 410 300	91 56 855 08	15	2	97 70 797 08	2 859	91 52 809 08	27	2
97 69 485 08	1 400	91 56 853 08	16	2	97 70 804 08	2 520 034	96 45 984 08	14	1
97 69 485 08	1 410 300	91 56 855 08	16	2	97 70 806 08	2 520 034	96 45 984 08	15	1
97 69 487 08	1 400	91 56 853 08	29	1	97 70 807 08	2 520 034	96 45 984 08	16	1
97 69 487 08	1 410 300	91 56 855 08	29	1	97 70 809 08	2 859	91 52 809 08	32	1
97 69 488 08	1 400	91 56 853 08	30	1	97 70 810 08	2 859	91 52 809 08	33	1
97 69 488 08	1 410 300	91 56 855 08	30	1	97 70 811 08	2 859	91 52 809 08	34	1
97 69 489 08	1 400	91 56 853 08	31	4	97 70 813 08	2 859	91 52 809 08	35	1

6.2.2009

etk_en_de_074515 LR 1600/2

845

LIEBHERRNumerical index
Numerischer Index

Item	Page	Assembly	Pos.	Quantity	Item	Page	Assembly	Pos.	Quantity
97 70 814 08	2 859	91 52 809 08	36	1	97 71 831 08	2 522 012	96 45 884 08	1	1
97 70 815 08	2 393 002	96 46 782 08	1	1	97 71 833 08	2 522 013	96 45 883 08	1	1
97 70 818 08	3 213	91 52 842 08	19	2	97 71 883 08	3 207 101	96 48 292 08	5	1
97 70 828 08	3 213	91 52 842 08	6	2	97 71 883 08	3 281	91 52 896 08	(2)	2
97 70 829 08	3 213	91 52 842 08	7	2	97 71 884 08	3 281	91 52 896 08	(2)	1
97 70 899 08	2 859 025	96 46 757 08	2	1	97 71 893 08	3 208 001	91 52 883 08	10	1
97 70 906 08	2 859 030	96 46 758 08	1	1	97 71 899 08	3 207 003	96 48 259 08	3	1
97 70 907 08	2 859	91 52 809 08	41	1	97 71 899 08	3 207 100	96 48 261 08	2	1
97 70 935 08	2 859 007	96 46 775 08	1	1	97 71 899 08	3 281	91 52 896 08	(3)	1
97 70 936 08	2 859 007	96 46 775 08	2	2	97 71 942 08	3 223	91 52 852 08	40	1
97 70 937 08	2 859 007	96 46 775 08	3	1	97 71 942 08	3 223 010	91 52 853 08	40	1
97 70 951 08	2 859 026	96 46 776 08	1	1	97 71 942 08	3 223 100	91 55 327 08	40	1
97 70 952 08	2 859 026	96 46 776 08	2	1	97 71 942 08	3 716	91 52 864 08	35	1
97 70 953 08	2 859 026	96 46 776 08	3	1	97 71 943 08	3 208 001	91 52 883 08	11	2
97 70 983 08	2 859 026	96 46 776 08	10	1	97 71 946 08	3 208 001	91 52 883 08	12	1
97 70 983 08	2 859 027	96 46 777 08	2	2	97 71 953 08	3 208 001	91 52 883 08	13	1
97 70 984 08	2 859 027	96 46 777 08	3	1	97 71 958 08	3 208 001	91 52 883 08	14	2
97 70 985 08	2 859 028	96 46 778 08	2	2	97 71 968 08	3 208 001	91 52 883 08	15	1
97 70 986 08	2 859 028	96 46 778 08	3	1	97 71 970 08	3 208 001	91 52 883 08	16	2
97 70 997 08	2 859 029	96 46 779 08	2	2	97 71 971 08	3 220 500	91 52 849 08	22	2
97 70 998 08	2 859 029	96 46 779 08	3	1	97 71 971 08	3 226	91 52 870 08	22	2
97 71 040 08	2 520 034	96 45 984 08	17	1	97 71 971 08	3 227	91 52 873 08	41	1
97 71 093 08	2 260 009	96 46 972 08	1	1	97 71 971 08	3 227 008	91 52 872 08	41	1
97 71 095 08	2 260	91 53 057 08	10	1	97 71 971 08	3 227 200	91 53 519 08	41	1
97 71 096 08	2 260	91 53 057 08	11	1	97 71 971 08	3 713 006	96 50 099 08	5	1
97 71 098 08	2 260	91 53 057 08	13	2	97 71 971 08	3 714	91 52 862 08	41	1
97 71 099 08	2 260	91 53 057 08	14	1	97 71 971 08	3 715 008	91 52 863 08	28	2
97 71 100 08	2 260	91 53 057 08	15	1	97 72 070 08	2 520	91 53 061 08	33	1
97 71 117 08	3 211	91 57 748 08	19	2	97 72 097 08	3 211 006	96 47 004 08	1	1
97 71 149 08	2 550 011	96 47 007 08	2	1	97 72 098 08	3 211 006	96 47 004 08	2	1
97 71 157 08	3 211	91 57 748 08	40	4	97 72 148 08	2 671 004	96 46 305 08	11	1
97 71 198 08	3 211 003	96 46 986 08	4	1	97 72 181 08	2 550	91 57 751 08	25	2
97 71 244 08	3 211 008	96 46 978 08	3	1	97 72 200 08	2 652	91 52 794 08	16	3
97 71 246 08	3 211 009	96 46 979 08	4	1	97 72 215 08	2 671	91 52 798 08	5	6
97 71 247 08	3 211 009	96 46 979 08	2	1	97 72 220 08	2 671	91 52 798 08	14	1
97 71 335 08	3 281	91 52 896 08	8	2	97 72 246 08	2 520 034	96 45 984 08	22	1
97 71 451 08	2 520 034	96 45 984 08	6	1	97 72 289 08	2 520 034	96 45 984 08	24	1
97 71 452 08	2 520 034	96 45 984 08	7	1	97 72 368 08	3 205	91 52 880 08	6	2
97 71 453 08	2 520 034	96 45 984 08	8	1	97 72 369 08	3 205	91 52 880 08	9	2
97 71 454 08	2 520 034	96 45 984 08	9	1	97 72 405 08	2 550 008	96 47 628 08	2	1
97 71 455 08	2 520 034	96 45 984 08	18	1	97 72 405 08	2 550 009	96 47 645 08	2	1
97 71 634 08	2 393 002	96 46 782 08	2	2	97 72 671 08	3 281	91 52 896 08	24	2
97 71 635 08	2 393 002	96 46 782 08	3	1	97 72 730 08	3 211 006	96 47 004 08	3	1
97 71 636 08	3 211	91 57 748 08	68	1	97 72 733 08	3 211 006	96 47 004 08	4	1
97 71 697 08	3 208 001	91 52 883 08	48	1	97 72 734 08	3 211 006	96 47 004 08	5	2
97 71 698 08	1 300 011	96 52 493 08	1	81	97 72 735 08	3 211 006	96 47 004 08	6	1
97 71 705 08	3 208 001	91 52 883 08	49	1	97 72 736 08	3 211 006	96 47 004 08	7	1
97 71 763 08	3 223	91 52 852 08	22	2	97 72 737 08	3 211 006	96 47 004 08	8	1
97 71 763 08	3 223 010	91 52 853 08	22	2	97 72 738 08	3 211 006	96 47 004 08	9	1
97 71 763 08	3 223 100	91 55 327 08	22	2	97 72 739 08	3 211 006	96 47 004 08	10	1
97 71 763 08	3 227	91 52 873 08	22	2	97 72 740 08	3 211 006	96 47 004 08	11	1
97 71 763 08	3 227 008	91 52 872 08	22	2	97 72 741 08	3 211 006	96 47 004 08	12	2
97 71 763 08	3 227 200	91 53 519 08	22	2	97 72 743 08	3 211 006	96 47 004 08	14	1
97 71 763 08	3 714	91 52 862 08	42	1	97 72 744 08	3 211 006	96 47 004 08	15	1
97 71 763 08	3 716	91 52 864 08	34	2	97 72 745 08	3 211 006	96 47 004 08	16	3
97 71 765 08	2 520	91 53 061 08	16	2	97 72 745 08	3 716	91 52 864 08	48	3
97 71 793 08	2 810 037	96 47 204 08	1	1	97 72 794 08	2 522 013	96 45 883 08	2	1
97 71 797 08	2 393 002	96 46 782 08	9	1	97 72 887 08	3 205	91 52 880 08	7	2
97 71 798 08	2 393 002	96 46 782 08	10	1	97 73 189 08	3 206	91 52 881 08	5	1
97 71 799 08	2 393 002	96 46 782 08	11	1	97 73 190 08	3 206	91 52 881 08	32	1

6.2.2009

etk_en_de_074515 LR 1600/2

846

LIEBHERRNumerical index
Numerischer Index

Item	Page	Assembly	Pos.	Quantity	Item	Page	Assembly	Pos.	Quantity
97 73 245 08	2 391 038	96 47 931 08	4	2	97 74 576 08	2 533 063	96 48 371 08	1	1
97 73 249 08	3 282 001	96 47 888 08	3	1	97 74 648 08	3 223 100	91 55 327 08	23	2
97 73 250 08	3 282 001	96 47 888 08	5	1	97 74 743 08	3 225	91 52 854 08	3	1
97 73 251 08	2 550	91 57 751 08	(2)	1	97 74 744 08	3 225	91 52 854 08	4	1
97 73 264 08	3 282 002	96 47 890 08	2	1	97 74 745 08	3 225	91 52 854 08	5	1
97 73 267 08	3 282 002	96 47 890 08	6	1	97 74 758 08	3 713	91 57 749 08	52	4
97 73 270 08	3 282 002	96 47 890 08	21	2	97 74 758 08	3 715 008	91 52 863 08	30	4
97 73 275 08	3 221	91 54 668 08	23	1	97 74 758 08	3 716	91 52 864 08	28	6
97 73 275 08	3 713 006	96 50 099 08	3	1	97 74 759 08	3 713	91 57 749 08	54	8
97 73 275 08	3 714	91 52 862 08	94	2	97 74 759 08	3 715 008	91 52 863 08	31	8
97 73 314 08	2 550	91 57 751 08	38	2	97 74 759 08	3 716	91 52 864 08	29	12
97 73 315 08	2 550	91 57 751 08	40	2	97 74 760 08	3 713	91 57 749 08	61	1
97 73 326 08	2 522	91 54 115 08	3	1	97 74 760 08	3 715 008	91 52 863 08	32	4
97 73 355 08	2 711	91 52 800 08	30	1	97 74 760 08	3 716	91 52 864 08	30	6
97 73 392 08	2 391 001	96 45 719 08	5	1	97 74 799 08	3 716 001	96 49 159 08	4	1
97 73 394 08	2 391 001	96 45 719 08	7	2	97 74 800 08	2 550 005	96 45 680 08	18	1
97 73 395 08	2 391 001	96 45 719 08	9	1	97 74 800 08	3 716 001	96 49 159 08	5	1
97 73 396 08	2 391 001	96 45 719 08	10	1	97 74 817 08	3 215 006	91 52 847 08	3	1
97 73 397 08	2 391 001	96 45 719 08	11	1	97 74 820 08	3 215 005	91 52 846 08	4	5
97 73 398 08	2 391 001	96 45 719 08	12	1	97 74 820 08	3 215 006	91 52 847 08	4	7
97 73 402 08	2 125	91 52 773 08	2	2	97 74 824 08	3 215 005	91 52 846 08	5	10
97 73 403 08	2 125	91 52 773 08	3	2	97 74 824 08	3 215 006	91 52 847 08	5	10
97 73 406 08	2 125	91 52 773 08	4	8	97 74 833 08	2 502	91 55 939 08	2	2
97 73 409 08	2 125	91 52 773 08	5	4	97 74 857 08	3 215 005	91 52 846 08	10	2
97 73 410 08	2 125	91 52 773 08	6	4	97 74 857 08	3 215 006	91 52 847 08	10	2
97 73 421 08	2 391 001	96 45 719 08	15	1	97 74 860 08	3 215 006	91 52 847 08	11	2
97 73 423 08	2 391 001	96 45 719 08	17	1	97 74 861 08	3 215 005	91 52 846 08	12	4
97 73 424 08	2 391 001	96 45 719 08	18	1	97 74 861 08	3 215 006	91 52 847 08	12	4
97 73 425 08	2 391 001	96 45 719 08	19	1	97 74 862 08	3 215 005	91 52 846 08	13	2
97 73 426 08	2 925 026	91 55 259 08	(5)	1	97 74 862 08	3 215 006	91 52 847 08	13	2
97 73 426 08	2 925 405	96 48 397 08	5	1	97 74 903 08	3 225	91 52 854 08	12	2
97 73 500 08	2 932 160	96 54 385 08	4	1	97 74 908 08	2 932 082	96 54 387 08	104	1
97 73 509 08	3 930 730	96 54 398 08	4	1	97 74 928 08	3 715 008	91 52 863 08	33	2
97 73 532 08	2 391 001	96 45 719 08	20	1	97 74 928 08	3 716	91 52 864 08	31	2
97 73 582 08	2 520	91 53 061 08	25	1	97 74 929 08	2 391 001	96 45 719 08	32	1
97 73 608 08	3 205	91 52 880 08	3	2	97 74 938 08	3 835 000	91 55 539 08	1	2
97 73 817 08	3 226	91 52 870 08	27	4	97 74 939 08	3 836 000	91 55 540 08	1	2
97 73 817 08	3 227	91 52 873 08	27	4	97 74 940 08	3 837	91 55 541 08	1	2
97 73 817 08	3 227 008	91 52 872 08	27	4	97 74 941 08	3 838 000	91 55 542 08	1	2
97 73 817 08	3 227 200	91 53 519 08	27	4	97 74 962 08	3 215 005	91 52 846 08	3	1
97 73 817 08	3 713	91 57 749 08	59	5	97 74 996 08	1 920 418	96 48 687 08	5	1
97 73 817 08	3 714	91 52 862 08	52	2	97 75 000 08	2 391 001	96 45 719 08	33	2
97 73 817 08	3 715 008	91 52 863 08	29	4	97 75 001 08	2 391 001	96 45 719 08	34	1
97 73 817 08	3 716	91 52 864 08	27	4	97 75 008 08	1 920 417	96 48 703 08	5	1
97 73 925 08	2 932 082	96 54 387 08	107	1	97 75 015 08	3 225	91 52 854 08	45	1
97 73 929 08	2 522 012	96 45 884 08	2	1	97 75 016 08	3 225	91 52 854 08	46	1
97 74 147 08	2 550	91 57 751 08	35	2	97 75 036 08	2 520	91 53 061 08	47	1
97 74 253 08	2 393	91 52 787 08	16	1	97 75 057 08	2 932 160	96 54 385 08	11	1
97 74 257 08	2 393	91 52 787 08	17	1	97 75 070 08	1 920 403	96 48 707 08	5	1
97 74 258 08	2 393	91 52 787 08	18	1	97 75 102 08	2 932 160	96 54 385 08	32	2
97 74 259 08	2 393	91 52 787 08	19	1	97 75 126 08	2 520	91 53 061 08	67	1
97 74 304 08	2 502	91 55 939 08	10	2	97 75 148 08	2 533 067	96 50 385 08	1	1
97 74 350 08	2 522	91 54 115 08	22	1	97 75 168 08	2 920 448	96 48 794 08	(1)	1
97 74 376 08	2 520 032	96 45 980 08	17	1	97 75 169 08	2 920 448	96 48 794 08	(2)	1
97 74 378 08	2 520 032	96 45 980 08	18	1	97 75 170 08	2 920 448	96 48 794 08	(3)	1
97 74 440 08	2 502	91 55 939 08	15	1	97 75 171 08	2 920 448	96 48 794 08	(4)	1
97 74 441 08	2 502	91 55 939 08	16	1	97 75 172 08	2 920 448	96 48 794 08	(5)	1
97 74 443 08	2 502	91 55 939 08	17	1	97 75 240 08	3 214	91 52 843 08	6	1
97 74 444 08	2 502	91 55 939 08	18	1	97 75 244 08	3 214	91 52 843 08	14	2
97 74 575 08	2 533 061	96 48 370 08	1	1	97 75 245 08	3 214	91 52 843 08	15	1

6.2.2009

etk_en_de_074515 LR 1600/2

847

LIEBHERRNumerical index
Numerischer Index

Item	Page	Assembly	Pos.	Quantity	Item	Page	Assembly	Pos.	Quantity
97 75 246 08	3 214	91 52 843 08	16	1	97 76 585 08	2 520 035	96 49 125 08	5	1
97 75 395 08	2 932 160	96 54 385 08	61	1	97 76 586 08	2 520 035	96 49 125 08	6	1
97 75 396 08	2 932 160	96 54 385 08	62	1	97 76 587 08	2 520 035	96 49 125 08	7	1
97 75 397 08	2 932 160	96 54 385 08	63	1	97 76 588 08	2 520 035	96 49 125 08	8	1
97 75 398 08	2 932 160	96 54 385 08	64	1	97 76 589 08	2 520 035	96 49 125 08	9	1
97 75 399 08	2 932 160	96 54 385 08	65	1	97 76 590 08	2 520 035	96 49 125 08	10	1
97 75 400 08	2 932 160	96 54 385 08	66	1	97 76 591 08	2 520 035	96 49 125 08	11	1
97 75 401 08	2 932 160	96 54 385 08	67	1	97 76 592 08	2 520 035	96 49 125 08	12	1
97 75 402 08	2 932 160	96 54 385 08	68	1	97 76 593 08	2 520 035	96 49 125 08	13	1
97 75 403 08	2 932 160	96 54 385 08	69	1	97 76 595 08	2 541	91 52 790 08	2	1
97 75 404 08	2 932 160	96 54 385 08	70	1	97 76 596 08	1 400	91 56 853 08	66	6
97 75 405 08	2 932 160	96 54 385 08	71	1	97 76 596 08	1 410 300	91 56 855 08	66	6
97 75 406 08	2 932 160	96 54 385 08	72	1	97 76 699 08	2 533 070	96 48 363 08	6	1
97 75 407 08	2 932 160	96 54 385 08	73	1	97 76 743 08	2 533 066	96 48 365 08	7	2
97 75 410 08	1 400	91 56 853 08	65	1	97 76 746 08	3 714 021	96 49 271 08	3	1
97 75 411 08	1 410 300	91 56 855 08	65	1	97 76 838 08	3 714	91 52 862 08	12	1
97 75 537 08	3 832	91 55 536 08	1	2	97 76 839 08	3 714	91 52 862 08	13	2
97 75 541 08	3 832 001	91 55 537 08	1	2	97 76 840 08	3 714	91 52 862 08	14	2
97 75 548 08	3 834	91 55 538 08	1	2	97 76 908 08	3 714	91 52 862 08	32	1
97 75 553 08	2 503 101	96 48 626 08	1	1	97 76 909 08	3 714	91 52 862 08	34	1
97 75 557 08	2 503 101	96 48 626 08	2	1	97 76 910 08	3 714	91 52 862 08	35	2
97 75 558 08	2 503 101	96 48 626 08	3	1	97 76 920 08	2 502	91 55 939 08	40	4
97 75 565 08	2 503 101	96 48 626 08	4	1	97 76 956 08	3 747	91 52 950 08	10	2
97 75 567 08	2 503 101	96 48 626 08	5	1	97 76 964 08	3 747	91 52 950 08	11	2
97 75 617 08	3 223 010	91 52 853 08	31	4	97 77 023 08	2 550 005	96 45 680 08	9	1
97 75 662 08	2 932 082	96 54 387 08	101	2	97 77 023 08	3 714 025	96 49 269 08	5	1
97 75 668 08	2 510 040	96 49 183 08	1	1	97 77 023 08	3 745 011	96 49 677 08	3	4
97 75 669 08	2 510 059	96 49 184 08	1	1	97 77 117 08	2 502	91 55 939 08	39	2
97 75 696 08	2 932 082	96 54 387 08	106	1	97 77 221 08	2 520 031	96 45 610 08	9	1
97 75 707 08	2 392	91 52 785 08	15	1	97 77 244 08	2 522 011	96 45 602 08	22	1
97 75 796 08	2 520	91 53 061 08	70	1	97 77 539 08	2 391 001	96 45 719 08	46	1
97 75 843 08	2 932 082	96 54 387 08	117	2	97 77 558 08	3 713 006	96 50 099 08	7	1
97 75 885 08	3 714 008	96 49 266 08	3	1	97 77 559 08	3 713 006	96 50 099 08	8	1
97 75 886 08	3 714 008	96 49 266 08	4	2	97 77 560 08	3 713 006	96 50 099 08	2	1
97 75 886 08	3 714 009	96 49 267 08	6	2	97 77 561 08	3 713 006	96 50 099 08	1	1
97 75 887 08	3 714 008	96 49 266 08	5	2	97 77 562 08	3 713 006	96 50 099 08	4	1
97 75 895 08	3 350	91 52 859 08	8	1	97 77 563 08	3 713 006	96 50 099 08	6	1
97 75 937 08	2 533 068	96 49 314 08	1	1	97 77 564 08	3 713 006	96 50 099 08	9	2
97 76 153 08	2 520 034	96 45 984 08	40	4	97 77 650 08	3 713	91 57 749 08	44	2
97 76 161 08	3 214	91 52 843 08	11	2	97 77 787 08	3 713 006	96 50 099 08	10	1
97 76 164 08	2 520 034	96 45 984 08	49	1	97 78 350 08	2 260	91 53 057 08	34	2
97 76 196 08	3 220 500	91 52 849 08	44	4	97 78 351 08	2 260	91 53 057 08	35	1
97 76 196 08	3 223	91 52 852 08	44	4	97 78 361 08	3 747	91 52 950 08	3	8
97 76 196 08	3 223 010	91 52 853 08	44	4	97 78 406 08	3 745 011	96 49 677 08	9	1
97 76 196 08	3 223 100	91 55 327 08	44	4	97 78 520 08	3 745	91 52 948 08	38	4
97 76 196 08	3 226	91 52 870 08	44	4	97 78 521 08	3 745	91 52 948 08	39	8
97 76 196 08	3 227	91 52 873 08	44	4	97 78 522 08	3 745	91 52 948 08	40	4
97 76 196 08	3 227 008	91 52 872 08	44	4	97 78 526 08	3 227	91 52 873 08	9	4
97 76 196 08	3 227 200	91 53 519 08	44	4	97 78 727 08	2 391 001	96 45 719 08	49	2
97 76 196 08	3 715 008	91 52 863 08	37	4	97 78 744 08	2 391 039	96 50 616 08	1	1
97 76 196 08	3 716	91 52 864 08	39	4	97 78 745 08	2 391 039	96 50 616 08	2	1
97 76 224 08	3 714 009	96 49 267 08	3	2	97 78 746 08	2 522 011	96 45 602 08	27	1
97 76 225 08	3 714 009	96 49 267 08	4	1	97 78 751 08	2 391 001	96 45 719 08	54	4
97 76 390 08	3 714 013	96 49 270 08	1	2	97 78 941 08	2 340	91 52 776 08	21	4
97 76 392 08	3 714 013	96 49 270 08	3	1	97 78 943 08	3 930 730	96 50 599 08	4	1
97 76 486 08	2 541 001	96 49 651 08	1	1	97 78 986 08	2 125	91 52 773 08	15	8
97 76 581 08	2 520 035	96 49 125 08	1	1	97 79 033 08	2 520 033	96 50 633 08	1	1
97 76 582 08	2 520 035	96 49 125 08	2	1	97 79 111 08	3 930 730	96 50 599 08	1	1
97 76 583 08	2 520 035	96 49 125 08	3	1	97 79 157 08	2 520	91 53 061 08	53	1
97 76 584 08	2 520 035	96 49 125 08	4	1	97 79 158 08	2 520	91 53 061 08	54	1

6.2.2009

etk_en_de_074515 LR 1600/2

848

LIEBHERRNumerical index
Numerischer Index

Item	Page	Assembly	Pos.	Quantity	Item	Page	Assembly	Pos.	Quantity
97 79 207 08	3 206	91 52 881 08	60	1	97 80 749 08	3 930 638	96 51 624 08	4	1
97 79 207 08	3 714	91 52 862 08	95	1	97 80 757 08	3 930 638	96 51 624 08	5	1
97 79 216 08	2 711	91 52 800 08	29	2	97 80 893 08	2 670	91 52 797 08	17	1
97 79 246 08	1 630	91 52 387 08	20	4	97 80 936 08	3 211	91 57 748 08	84	1
97 79 264 08	2 340	91 52 776 08	25	4	97 80 937 08	3 211	91 57 748 08	85	1
97 79 271 08	1 631 100	91 52 388 08	15	2	97 80 964 08	2 920 581	96 54 405 08	8	1
97 79 282 08	3 714	91 52 862 08	39	1	97 81 003 08	2 522 013	96 45 883 08	16	4
97 79 283 08	3 713	91 57 749 08	60	1	97 81 060 08	2 391 001	96 45 719 08	67	1
97 79 283 08	3 714	91 52 862 08	44	8	97 81 069 08	2 550	91 57 751 08	75	2
97 79 296 08	2 340	91 52 776 08	26	1	97 81 077 08	2 550	91 57 751 08	76	1
97 79 305 08	2 550 008	96 47 628 08	8	1	97 81 106 08	2 533 069	96 48 372 08	6	1
97 79 305 08	2 550 009	96 47 645 08	8	1	97 81 124 08	2 859	91 52 809 08	40	1
97 79 331 08	2 340	91 52 776 08	29	1	97 81 184 08	3 214	91 52 843 08	45	4
97 79 332 08	2 340	91 52 776 08	30	1	97 81 204 08	2 550	91 57 751 08	78	12
97 79 354 08	2 859 005	96 46 756 08	11	1	97 81 550 08	3 211	91 57 748 08	86	2
97 79 355 08	2 859 005	96 46 756 08	12	1	97 81 551 08	3 211	91 57 748 08	87	1
97 79 356 08	2 859 005	96 46 756 08	13	1	97 81 710 08	2 550	91 57 751 08	16	8
97 79 357 08	1 630	91 52 387 08	21	8	97 81 823 08	3 211	91 57 748 08	101	2
97 79 370 08	2 391	91 52 784 08	8	1	97 81 837 08	1 300	91 52 768 08	2	2
97 79 371 08	1 630	91 52 387 08	31	8	97 81 896 08	3 211	91 57 748 08	102	2
97 79 627 08	2 780 915	96 48 377 08	12	1	97 82 080 08	2 925 402	96 58 855 08	19	1
97 79 659 08	2 550 008	96 47 628 08	3	1	97 82 081 08	2 925 402	96 58 855 08	20	1
97 79 659 08	2 550 009	96 47 645 08	3	1	97 82 166 08	3 930 734	96 54 401 08	4	1
97 79 663 08	3 714	91 52 862 08	69	2	97 82 921 08	3 215 005	91 52 846 08	29	2
97 79 664 08	3 714	91 52 862 08	70	2	97 82 921 08	3 215 006	91 52 847 08	29	2
97 79 684 08	3 930 640	96 50 481 08	4	1	97 82 953 08	2 780 748	96 52 969 08	5	1
97 79 690 08	3 930 640	96 50 481 08	1	1	97 83 084 08	2 631	91 56 817 08	9	2
97 79 763 08	3 713	91 57 749 08	90	2	97 83 085 08	2 631	91 56 817 08	10	5
97 79 764 08	3 713	91 57 749 08	97	4	97 83 086 08	2 631	91 56 817 08	11	6
97 79 781 08	3 713	91 57 749 08	100	2	97 83 114 08	2 631	91 56 817 08	12	2
97 79 824 08	2 391 001	96 45 719 08	52	1	97 83 115 08	2 631	91 56 817 08	13	2
97 79 826 08	2 391 001	96 45 719 08	53	1	97 83 116 08	2 631	91 56 817 08	14	2
97 79 878 08	2 391 001	96 45 719 08	57	1	97 83 458 08	2 657	91 57 656 08	5	1
97 79 887 08	2 340	91 52 776 08	37	2	97 83 610 08	2 391 040	96 53 645 08	2	2
97 79 903 08	2 652	91 52 794 08	21	2	97 83 611 08	2 391 040	96 53 645 08	3	1
97 79 945 08	2 920 638	96 51 138 08	6	1	97 83 612 08	2 391 040	96 53 645 08	4	1
97 80 165 08	3 214	91 52 843 08	34	1	97 83 613 08	2 391 040	96 53 645 08	5	1
97 80 166 08	3 214	91 52 843 08	35	1	97 83 624 08	2 502	91 55 939 08	51	1
97 80 168 08	2 391 001	96 45 719 08	59	1	97 83 633 08	1 400	91 56 853 08	73	10
97 80 169 08	2 391 001	96 45 719 08	63	1	97 83 633 08	1 410 300	91 56 855 08	73	10
97 80 226 08	2 550 008	96 47 628 08	7	1	97 83 634 08	1 400	91 56 853 08	74	12
97 80 226 08	2 550 009	96 47 645 08	7	1	97 83 634 08	1 410 300	91 56 855 08	74	12
97 80 256 08	2 391 001	96 45 719 08	64	1	97 83 643 08	2 391 040	96 53 645 08	17	2
97 80 257 08	2 810	91 52 806 08	53	2	97 83 644 08	2 391 040	96 53 645 08	18	1
97 80 349 08	2 310	91 52 503 08	25	1	97 83 727 08	3 225 100	96 48 582 08	5	1
97 80 349 08	2 320	91 52 504 08	25	1	97 83 741 08	3 930 363	96 52 979 08	4	1
97 80 472 08	3 713	91 57 749 08	105	2	97 83 897 08	1 400	91 56 853 08	72	1
97 80 496 08	2 932 160	96 54 385 08	20	1	97 83 897 08	1 410 300	91 56 855 08	72	1
97 80 530 08	1 400	91 56 853 08	17	2	97 83 924 08	2 391 040	96 53 645 08	6	1
97 80 530 08	1 410 300	91 56 855 08	17	2	97 83 925 08	2 391 040	96 53 645 08	7	1
97 80 592 08	2 925 402	96 58 855 08	3	1	97 83 926 08	2 391 040	96 53 645 08	8	1
97 80 593 08	2 925 402	96 58 855 08	18	1	97 83 927 08	2 391 040	96 53 645 08	9	1
97 80 625 08	2 550	91 57 751 08	73	4	97 84 036 08	2 998	91 56 540 08	233	1
97 80 626 08	2 550	91 57 751 08	74	8	97 84 521 08	2 391	91 52 784 08	75	1
97 80 631 08	3 220 500	91 52 849 08	49	2	97 84 522 08	2 391 040	96 53 645 08	37	4
97 80 631 08	3 223	91 52 852 08	49	2	97 84 867 08	2 520	91 53 061 08	83	1
97 80 631 08	3 223 010	91 52 853 08	49	2	97 84 978 08	3 350	91 52 859 08	23	2
97 80 631 08	3 223 100	91 55 327 08	49	2	97 85 057 08	3 350	91 52 859 08	22	4
97 80 640 08	2 810	91 52 806 08	59	1	97 85 175 08	2 391 001	96 45 719 08	77	2
97 80 641 08	2 391 023	96 45 720 08	21	2	97 85 235 08	2 657	91 57 656 08	9	2

6.2.2009

etk_en_de_074515 LR 1600/2

849

LIEBHERRNumerical index
Numerischer Index

Item	Page	Assembly	Pos.	Quantity	Item	Page	Assembly	Pos.	Quantity
97 85 357 08	2 391 001	96 45 719 08	78	1	97 89 190 08	2 391 102	96 56 360 08	4	1
97 85 358 08	2 391 001	96 45 719 08	79	1	97 89 191 08	2 391 102	96 56 360 08	5	1
97 85 479 08	2 920 369	96 54 235 08	5	1	97 89 198 08	3 714 009	96 49 267 08	19	2
97 85 605 08	2 370	91 52 782 08	9	1	97 90 053 08	3 713	91 57 749 08	117	1
97 85 607 08	2 350	91 52 778 08	13	1	97 90 338 08	2 970	91 56 537 08	15	1
97 85 630 08	2 920 369	96 54 235 08	(160)	1	97 90 582 08	2 550	91 57 751 08	4	2
97 85 631 08	2 920 369	96 54 235 08	(158)	1	97 91 001 08	3 714	91 52 862 08	96	1
97 85 691 08	2 810	91 52 806 08	63	1	97 91 266 08	3 713	91 57 749 08	102	2
97 85 704 08	2 631 003	96 54 406 08	1	1	97 91 624 08	3 292	91 52 865 08	12	4
97 85 716 08	2 350	91 52 778 08	14	1	97 91 625 08	3 292	91 52 865 08	13	2
97 85 717 08	2 350	91 52 778 08	15	1	97 92 102 08	2 310	91 52 503 08	36	1
97 85 718 08	2 350	91 52 778 08	16	2	97 92 276 08	2 320	91 52 504 08	36	1
97 85 767 08	2 631	91 56 817 08	46	1	97 92 603 08	1 970	91 56 958 08	13	1
97 85 781 08	2 370	91 52 782 08	11	2	97 93 096 08	3 713	91 57 749 08	141	1
97 85 872 08	2 370	91 52 782 08	12	1	97 93 097 08	3 713	91 57 749 08	142	2
97 85 873 08	2 370	91 52 782 08	13	1	97 93 744 08	2 925 402	96 58 855 08	27	1
97 85 874 08	2 370	91 52 782 08	14	1	97 93 900 08	3 281	91 52 896 08	16	1
97 85 875 08	2 370	91 52 782 08	15	1	97 93 901 08	3 281	91 52 896 08	19	1
97 85 999 08	2 810	91 52 806 08	72	1	97 93 902 08	3 281	91 52 896 08	20	1
97 86 100 08	3 291	91 52 831 08	12	2	97 93 903 08	3 281	91 52 896 08	22	2
97 86 272 08	2 932 082	96 54 387 08	118	2	97 93 904 08	3 281	91 52 896 08	23	1
97 86 281 08	2 932 082	96 54 387 08	116	1	97 93 905 08	3 281	91 52 896 08	27	1
97 86 328 08	1 620	91 52 386 08	10	2	97 94 005 08	3 281	91 52 896 08	32	1
97 86 361 08	3 714	91 52 862 08	78	2	97 95 151 08	2 520	91 53 061 08	86	1
97 86 362 08	3 714	91 52 862 08	79	1	98 82 075	9 080 702	90 80 702	11	4
97 86 363 08	3 714	91 52 862 08	80	2	99 07 151 01	2 620	91 52 793 08	1	1
97 86 364 08	3 714	91 52 862 08	81	2	99 70 411 01	3 211 009	96 46 979 08	10	2
97 86 372 08	3 713	91 57 749 08	118	1					
97 86 531 08	3 211	91 57 748 08	88	2					
97 86 533 08	3 211	91 57 748 08	104	1					
97 86 675 08	2 520 034	96 45 984 08	23	1					
97 86 711 08	2 310	91 52 503 08	35	1					
97 86 711 08	2 320	91 52 504 08	35	1					
97 86 732 08	3 745	91 52 948 08	51	2					
97 86 742 08	1 631 100	91 52 388 08	16	2					
97 86 827 08	2 631	91 56 817 08	55	1					
97 86 922 08	3 206	91 52 881 08	14	1					
97 87 054 08	2 391 040	96 53 645 08	38	2					
97 87 754 08	3 713	91 57 749 08	113	1					
97 87 755 08	3 713	91 57 749 08	114	1					
97 87 756 08	3 713 013	96 57 159 08	1	1					
97 87 757 08	3 713	91 57 749 08	116	3					
97 87 760 08	3 713	91 57 749 08	130	2					
97 87 762 08	3 713	91 57 749 08	131	1					
97 87 763 08	3 713	91 57 749 08	132	1					
97 87 764 08	3 713	91 57 749 08	133	1					
97 87 765 08	3 713	91 57 749 08	134	1					
97 87 766 08	3 713	91 57 749 08	135	1					
97 88 000 08	3 715 008	91 52 863 08	38	6					
97 88 000 08	3 716	91 52 864 08	41	12					
97 88 106 08	3 211	91 57 748 08	3	2					
97 88 595 08	2 370	91 52 782 08	25	4					
97 88 595 08	2 810	91 52 806 08	77	12					
97 88 636 08	3 350	91 52 859 08	40	1					
97 88 637 08	3 350	91 52 859 08	41	1					
97 88 638 08	3 715 008	91 52 863 08	47	2					
97 88 785 08	3 215 005	91 52 846 08	33	10					
97 88 785 08	3 215 006	91 52 847 08	33	10					
97 88 842 08	2 550	91 57 751 08	85	2					
97 89 189 08	2 391 102	96 56 360 08	3	1					

6.2.2009

etk_en_de_074515 LR 1600/2

850

LIEBHERR

Numerical index
Numerischer Index

Description	Item	Pos.	Quantity	Page	Assembly	Description
232204 B 10 FST A3C	10 01 170 9	4	10	9 739 355	97 39 355	OIL COOLER ADD-ON
232204 B 14 FST A3C	10 01 171 0	7	1	9 739 243	97 39 243	PISTON COOLING
232204 DIN 137 B 30 A3C	42 50 518 08	33	4	2 810	91 52 806 08	CRANE DRIVER'S CABIN CPL.
A COLUMN CLADDING LEFT	97 69 656 08	1	1	2 520 034	96 45 984 08	INTERNAL LINING
A COLUMN CLADDING RIGHT	97 69 657 08	2	1	2 520 034	96 45 984 08	INTERNAL LINING
ABSORBER	10 65 048 8	66	1	X1029200	10 29 200 4	DRIVERS SEAT
ACCESS ALUMINIUM	97 70 589 08	3	2	1 631 100	91 52 388 08	CATWALK CRAW.TRACK TRA
ACCESS LADDER PRE-ASS.	96 54 406 08	52	1	2 631	91 56 817 08	SLEWING PLATFORM CATWAL
ACOUST. WARN. DISPLACEM.	91 56 389 08	341	1		LR 1600-2-0	
ACOUST.WARN. SLEWING G	91 05 067 08	358	1		LR 1600-2-0	
ACTUATING UNIT	57 13 664 08	95	1	X1065015	10 65 015 8	DRIVE UNIT
ACTUATION SPIKE	70 42 534 08	15	4	2 260 006	96 46 501 08	BATTERY BOX, PRE-ASSEMB
ACTUATION SPIKE	70 42 534 08	5	4	2 393 002	96 46 782 08	COVER COMPL.
ACTUATION SPIKE	70 42 534 08	6	7	2 859 005	96 46 756 08	FLAP PRE-ASS.
ACTUATION SPIKE	70 42 534 08	5	4	2 859 007	96 46 775 08	COVER COMPL.
ACTUATION SPIKE	70 42 534 08	11	4	2 859 025	96 46 757 08	GRIDIRON PRE-ASS.
ACTUATION SPIKE	70 42 534 08	5	4	2 859 026	96 46 776 08	COVER COMPL.
ACTUATION SPIKE	70 42 534 08	5	4	2 859 027	96 46 777 08	COVER COMPL.
ACTUATION SPIKE	70 42 534 08	5	4	2 859 028	96 46 778 08	COVER COMPL.
ACTUATION SPIKE	70 42 534 08	5	4	2 859 029	96 46 779 08	COVER COMPL.
ACTUATION SPIKE	70 42 534 08	10	2	2 859 030	96 46 758 08	COVER COMPL.
ACTUATION SPIKE	70 42 534 08	2	6	2 932 168	96 48 167 08	COVER COMPL.
ACTUATOR WELDED	92 90 527 08	3	1	1 991	91 52 510 08	ROTARY FEED THROUGH
ADAPTER BOARD CF-PCMCIA	10 46 740 3	5	1	2 533 050	96 48 359 08	EL.EQUIPMENT CABIN
ADAPTOR	96 51 859 08	(30)	1	2 925 026	91 55 259 08	ERG. CAMERA CONTROL
ADAPTOR	96 51 859 08	30	1	2 925 405	96 48 397 08	EQUIPMENT CAMERA CAB
ADAPTOR 18POL SPF	66 00 245 08	24	1	2 932 082	96 54 387 08	ASSEMBLY PARTS MOUNTIN
ADAPTOR KUNSSSTOFF	10 03 697 4	11	1	2 520 032	96 45 980 08	WINDSHIELD WASHER INSTAL
ADAPTOR REMACHING 42-LX3	97 90 338 08	15	1	2 970	91 56 537 08	HYDR
ADAPTOR RI11/4-EDX1 A3P	47 55 018 08	770	2	2 970	91 56 537 08	HYDR
ADAPTOR RI11/4-EDX3/4 A3P	47 55 014 08	780	2	2 970	91 56 537 08	HYDR
ADAPTOR RI3/4-EDX1 A3P	47 55 020 08	764	2	2 970	91 56 537 08	HYDR
ADD HEATING SUPERSTRUCT	91 52 790 08	134	1		LR 1600-2-0	
ADD WEIGHT 1TO SPF	91 55 527 08	317	4		LR 1600-2-0	
ADD-ON HOUSING 16POL.	60 56 171 08	28	2	2 920 369	96 54 235 08	TERMINAL BOX CPL.
ADD-ON HOUSING 16POL.	60 56 171 08	39	3	2 932 160	96 54 385 08	SWITCH CABINET
ADD-ON HOUSING 24POL.	60 56 172 08	32	1	2 920 369	96 54 235 08	TERMINAL BOX CPL.
ADD-ON HOUSING 24POL.	60 56 172 08	20	6	2 920 448	96 48 794 08	TERMINAL BOX CPL.
ADD-ON HOUSING 24POL.	60 56 172 08	38	8	2 932 160	96 54 385 08	SWITCH CABINET
ADD-ON HOUSING ALU/ZINK	10 47 566 6	28	1	2 932 160	96 54 385 08	SWITCH CABINET
ADD-ON HOUSING HAN 10 B	69 31 498 14	40	1	2 932 160	96 54 385 08	SWITCH CABINET
ADD-ON PARTS	97 39 278	73	1	X1012059	10 12 059 0	DIESEL ENGINE
ADD-ON PARTS EXTERNAL F	96 48 377 08	2	1	2 780 908	91 52 958 08	EXTERNAL FEED
ADD-ON PARTS LADEGERAET	96 48 379 08	4	1	2 835	91 52 807 08	BATTERY CHARGER
ADD. HYDR. SUPPORTING RA	91 52 509 08	32	1		LR 1600-2-0	
ADD.HYDR.S_RETAINING RAM	91 54 843 08	184	1		LR 1600-2-0	
ADDITIONAL HYDR.PUMP/WI	91 55 149 08	174	1		LR 1600-2-0	
ADDITIONAL HYDR.SLEWING P	91 57 756 08	173	1		LR 1600-2-0	
ADDITIONAL HYDRAULICS 2 D	91 52 780 08	118	1		LR 1600-2-0	
ADDITIONAL HYDRAULICS IN	91 56 429 08	600	1	3 716	91 52 864 08	D INTERMEDIATE SECTION
ADDITIONAL HYDRAULICS INT	91 56 432 08	600	1	3 715 008	91 52 863 08	D INTERMEDIATE SECTION
ADDITIONAL HYDRAULICS PU	91 54 795 08	176	1		LR 1600-2-0	
ADDITIONAL HYDRAULICS WI	91 52 775 08	108	1		LR 1600-2-0	
ADDITIONAL HYDRAULICS WI	91 52 774 08	106	1		LR 1600-2-0	
ADDITIONAL HYDRAULICS WI	91 52 860 08	225	1		LR 1600-2-0	
ADDL.HYDR.F.PIN PULLING D	92 27 489 08	6	1	3 790 006	96 19 989 08	PIN PULLING CYLINDER CPL.
ADDL.HYDR.F.PIN PULLING D	92 27 489 08	6	1	3 790 007	96 19 990 08	PIN PULLING CYLINDER CPL.
ADDL.HYDR.F.PIN PULLING D	96 50 495 08	14	1	2 125	91 52 773 08	PIN F.S-PIVOT SECTION SA F
ADDL.HYDRAULIC SB-HEAD PI	91 56 430 08	400	1	3 714	91 52 862 08	D HEAD SECTION
ADDNL. HYDR. F. ERECTING	91 57 881 08	120	1		LR 1600-2-0	

6.2.2009

etk_en_de_074515 LR 1600/2

851

LIEBHERRAlphabetical index
Alphabetischer Index

Description	Item	Pos.	Quantity	Page	Assembly	Description
ADDNL.HEATING, PRE-ASSE	96 49 651 08	1	1	2 541	91 52 790 08	ADD HEATING SUPERSTRUCT
ADDNL.HYDR.ERECTION DEV	91 52 796 08	142	1		LR 1600-2-0	
ADDNL.HYDR.RETAINING DEV	91 52 827 08	175	1		LR 1600-2-0	
ADHESIVE 50ML	81 12 017 08	6	1	9 739 129	97 39 129	COOLANT PREHEATING
ADHESIVE 50ML	81 12 017 08	6	1	9 739 349	97 39 349	CONNECTION F.WATER PIPE
ADHESIVE INSULATING STRIP	80 21 020 08	12	2.8	2 393 002	96 46 782 08	COVER COMPL.
ADHESIVE INSULATING STRIP	80 21 020 08	65	10.8	2 859	91 52 809 08	SOUND INSULATION
ADHESIVE INSULATING STRIP	80 21 020 08	9	3.7	2 859 007	96 46 775 08	COVER COMPL.
ADHESIVE INSULATING STRIP	80 21 020 08	9	5	2 859 026	96 46 776 08	COVER COMPL.
ADHESIVE INSULATING STRIP	80 21 020 08	9	5.7	2 859 027	96 46 777 08	COVER COMPL.
ADHESIVE INSULATING STRIP	80 21 020 08	9	4	2 859 028	96 46 778 08	COVER COMPL.
ADHESIVE INSULATING STRIP	80 21 020 08	10	4.3	2 859 029	96 46 779 08	COVER COMPL.
ADHESIVE LABELS	60 21 710 08	47	90	2 932 001	96 45 393 08	RELAY CONTROL SYSTEM
ADJUSTING SCREW M10X1X4	10 01 222 1	9	1	9 739 263	97 39 263	ROCKER ARM BEARING HOUS
ADJUSTING SCREW M10X1X4	10 01 222 1	9	1	9 739 264	97 39 264	ROCKER ARM BEARING HOUS
ADJUSTING SCREW M10X1X4	10 01 222 5	10	1	9 739 263	97 39 263	ROCKER ARM BEARING HOUS
ADJUSTING SCREW M10X1X4	10 01 222 5	10	1	9 739 264	97 39 264	ROCKER ARM BEARING HOUS
ADJUSTING SCREW M14X1X3	10 01 222 0	7	1	9 739 263	97 39 263	ROCKER ARM BEARING HOUS
ADJUSTING SCREW M14X1X3	10 01 222 0	7	1	9 739 264	97 39 264	ROCKER ARM BEARING HOUS
ADJUSTMENT	10 32 692 5	2	1	X1035924	10 35 924 6	VARIABLE PUMP
ADJUSTMENT	10 33 104 8	2	1	X1035924	10 35 924 1	VARIABLE PUMP
ADJUSTMENT	10 33 104 8	2	1	X1035924	10 35 924 2	VARIABLE PUMP
ADJUSTMENT	10 33 104 8	2	1	X1035925	10 35 925 0	VARIABLE PUMP
ADJUSTMENT	10 47 137 1	2	1	X1035924	10 35 924 3	VARIABLE PUMP
ADJUSTMENT	10 47 137 1	2	1	X1035924	10 35 924 4	VARIABLE PUMP
ADJUSTMENT	10 47 220 0	5	1	X1035924	10 35 924 7	VARIABLE PUMP
ADJUSTMENT	10 47 220 8	4	1	X1035924	10 35 924 8	VARIABLE PUMP
ADJUSTMENT	10 65 039 3	26	1	X1029200	10 29 200 4	DRIVERS SEAT
ADJUSTMENT	10 65 068 6	2	1	X1035924	10 35 924 9	VARIABLE PUMP
ADJUSTMENT	70 23 643	5	1	X1035924	10 35 924 8	VARIABLE PUMP
ADMISSION VALVE	10 22 234 7	1	2	9 739 261	97 39 261	CYLINDER HEAD
AERATION FILTER	51 06 673 08	3	1	2 671 004	96 46 305 08	OIL TANK PRE-ASS.
AIR BOTTLE 39,8L 10BAR ST	50 26 558 08	9	1	2 990	91 59 244 08	COMPRESSED AIR PLANT
AIR BOTTLE DIN 74281 20L 15	50 26 577 08	5	1	3 978 005	91 56 430 08	ADDL.HYDRAULIC SB-HEAD PI
AIR BOTTLE DIN 74281 4.5L 15.	50 29 871 08	6	1	2 990	91 59 244 08	COMPRESSED AIR PLANT
AIR COMPRESSOR	10 47 688 5	1	1	9 739 491	97 39 491	INSTALLATION BRAKE COMPR
AIR COMPRESSOR	10 65 049 0	85	1	X1029200	10 29 200 4	DRIVERS SEAT
AIR COND. COMPRESSOR A	97 39 371	150	1	X1012059	10 12 059 0	DIESEL ENGINE
AIR COND. UNIT SUPERSTRUC	91 57 754 08	320	1		LR 1600-2-0	
AIR CONDITIONING COMPRES	10 29 994 8	1	1	9 739 371	97 39 371	AIR COND. COMPRESSOR A
AIR CONDITIONING UNIT	10 22 811 2	1	1	2 540	91 53 253 08	CLIMA-HEATING INSTALLATIO
AIR DISTRIBUTOR	10 22 272 6	1	1	9 739 256	97 39 256	AIR SUCTION PIPE
AIR DRYER	50 26 573 08	21	1	2 990	91 59 244 08	COMPRESSED AIR PLANT
AIR DUCT PP SPF	97 71 765 08	16	2	2 520	91 53 061 08	CABIN, GLAZED
AIR ELBOW	10 01 242 0	202	1	2 391 001	96 45 719 08	DIESEL ENGINE, PRE-ASSEMB
AIR ELBOW	10 22 273 0	1	1	9 739 271	97 39 271	CONNECTING LINE
AIR FILTER PICO	55 17 203 08	1	1	2 393	91 52 787 08	AIR FILTER UNIT CPL.
AIR FILTER UNIT CPL.	91 52 787 08	125	1		LR 1600-2-0	
AIR GUIDE L PP SPF	97 69 550 08	12	1	2 520	91 53 061 08	CABIN, GLAZED
AIR GUIDE L PP SPF	97 69 672 08	14	1	2 520	91 53 061 08	CABIN, GLAZED
AIR GUIDE R PP SPF	97 69 551 08	13	1	2 520	91 53 061 08	CABIN, GLAZED
AIR GUIDE R PP SPF	97 69 673 08	15	1	2 520	91 53 061 08	CABIN, GLAZED
AIR INTAKE	96 17 591 08	39	2	2 391 001	96 45 719 08	DIESEL ENGINE, PRE-ASSEMB
AIR SUCTION PIPE	97 39 256	110	1	X1012059	10 12 059 0	DIESEL ENGINE
AIR SUCTION PIPE SPF	96 48 361 08	7	1	2 393	91 52 787 08	AIR FILTER UNIT CPL.
AIR SUCTION PIPE SPF	96 48 362 08	8	1	2 393	91 52 787 08	AIR FILTER UNIT CPL.
AIR-CRAFT & WIND WARNING	91 52 952 08	362	1		LR 1600-2-0	
ALARM 24V DC	61 40 047 08	(5)	1	2 920 559	96 47 914 08	LIMIT SWITCH AND SENSOR
ALLAN KEY DIN 911	79 00 236 08	8	1	1 750	91 52 394 08	TOOL
ANEMOMETER	10 47 043 3	1	1	X1042954	10 42 954 9	WIND VELOCITY TRANSMITTE

6.2.2009

etk_en_de_074515 LR 1600/2

852

LIEBHERRAlphabetical index
Alphabetischer Index

Description	Item	Pos.	Quantity	Page	Assembly	Description
ANGLE 1.5X151X54 FE//ZN20//	97 86 272 08	118	2	2 932 082	96 54 387 08	ASSEMBLY PARTS MOUNTIN
ANGLE 3X40X112 FE//ZN20//C	97 80 496 08	20	1	2 932 160	96 54 385 08	SWITCH CABINET
ANGLE 3X40X94	94 73 392 08	55	1	2 391 001	96 45 719 08	DIESEL ENGINE, PRE-ASSEMB
ANGLE 3X85X30	97 78 351 08	35	1	2 260	91 53 057 08	CUP SPRING CLUSTER
ANGLE 4X20X57	95 05 969 08	76	1	2 810	91 52 806 08	CRANE DRIVER'S CABIN CPL.
ANGLE 5x154x70	97 05 395 08	35	2	3 211	91 57 748 08	S PIVOT SECTION
ANGLE 5x154x70	97 05 395 08	72	2	3 713	91 57 749 08	D PIVOT SECTION
ANGLE JOINT DIN 71802 CS 13	72 50 066 08	13	1	9 739 357	97 39 357	EXHAUST GAS RECIRCUL.PRE
ANGLE JOINT DIN 71802 CS 16	72 50 069 08	16	2	2 391 040	96 53 645 08	CLUTCH ACTUATOR
ANGLE SCREW DRIVER GR.3	81 00 354 08	46	1	1 750	91 52 394 08	TOOL
ANGLE SOCKET 12-95	60 22 221 08	(648)	1	2 920 536	96 48 317 08	WIRING LIST F.ELECTR.AGG
ANGLE TRANSMITTER 360° SP	69 23 100 08	20	1	2 930	96 57 085 08	SENSOR ASSEMBLY SA-STAN
ANGLE TRANSMITTER 360° SP	69 23 100 08	(152)	1	3 930 138	96 54 377 08	ELECTRIC FOR S-PIVOT SECT
ANGLE TRANSMITTER 360° SP	69 23 100 08	(5)	1	3 930 576	96 48 381 08	EL.EQUIPMENT SW HEAD SE
ANGULAR GEAR	90 00 510 6	4	1	1 400	91 56 853 08	CRAWLER TRACK CARRIER LE
ANGULAR GEAR	90 00 510 6	80	1	1 410 300	91 56 855 08	CRAWLER CARRIER RIGHT CP
ANGULAR GEAR	90 00 521 4	80	1	1 400	91 56 853 08	CRAWLER TRACK CARRIER LE
ANGULAR GEAR	90 00 521 4	4	1	1 410 300	91 56 855 08	CRAWLER CARRIER RIGHT CP
ANTENNA	10 28 963 1	2	1	2 780 851	96 24 498 08	RADIO ANTENNA PRE-ASS.
ANTENNA 145MM	76 24 428	11	1	2 533 066	96 48 365 08	ELECTRIC ADD-ON PARTS CA
ANTI-SLIP SURFACE 150X300	97 28 594 08	17	2	2 730	91 52 802 08	BASE PLATE SLEWING PLATF
ANTIDAZZLE 242X171X55 SC	10 27 921 0	19	1	2 913	91 32 850 08	LICCON CONSOLE LCD2
APPLIANCE SOCKET	60 50 079 08	505	3	2 920 633	96 52 651 08	WIRING HARNESS
APPLIANCE SOCKET	69 18 092 08	(151)	1	2 920 369	96 54 235 08	TERMINAL BOX CPL.
APPLIANCE SOCKET	69 18 092 08	153	1	3 930 639	96 50 132 08	WIRES TERMINAL BOX CPL.
APPLIANCE SOCKET DIN 4365	60 52 106 08	507	15	2 920 633	96 52 651 08	WIRING HARNESS
ARM REST 310ERGO	77 41 197 08	1	1	2 502 007	96 22 822 08	ARM REST LEFT
ARM REST 310ERGO	77 41 198 08	1	1	2 502 008	96 22 823 08	ARM REST RIGHT
ARM REST LEFT	96 22 822 08	5	1	2 502	91 55 939 08	CONTROL STAND
ARM REST RIGHT	96 22 823 08	6	1	2 502	91 55 939 08	CONTROL STAND
ARM REST SUPPORT	97 16 366 08	2	1	2 502 007	96 22 822 08	ARM REST LEFT
ARM REST SUPPORT	97 16 366 08	2	1	2 502 008	96 22 823 08	ARM REST RIGHT
ARTICULATED HOOK WRENC	88 51 828 08	40	1	1 750	91 52 394 08	TOOL
ASH TRAY KUNSTSTOFF	10 29 199 7	33	1	2 520 034	96 45 984 08	INTERNAL LINING
ASSEMBLY FRAME 56TE	91 23 538 08	1	1	2 932 122	96 45 394 08	LICCON ASSEMBLY UNIT
ASSEMBLY PARTS MOUNTIN	96 54 387 08	3	1	2 932	91 57 750 08	BUILT-IN PARTS SWITCH BOX
AT-WATER PUMP WITH FAST	97 39 352	165	1	X1012059	10 12 059 0	DIESEL ENGINE
ATL ATTACHMENT	97 39 494	190	1	X1012059	10 12 059 0	DIESEL ENGINE
ATTACHABLE SLEEVE HOUSIN	60 23 198 08	513	1	2 920 633	96 52 651 08	WIRING HARNESS
ATTACHABLE SLEEVE HOUSI	60 22 097 08	508	3	2 920 633	96 52 651 08	WIRING HARNESS
ATTACHABLE SLEEVE HOUSI	60 22 097 08	(152)	1	2 932 001	96 45 393 08	RELAY CONTROL SYSTEM
ATTACHABLE SLEEVE HOUSI	60 22 097 08	517	2	2 932 224	96 54 389 08	CABLES MOUNTING PANEL C
ATTACHMENT CHAIN 0,85M 3	74 00 244 08	12	4	1 400	91 56 853 08	CRAWLER TRACK CARRIER LE
ATTACHMENT CHAIN 0,85M 3	74 00 244 08	12	4	1 410 300	91 56 855 08	CRAWLER CARRIER RIGHT CP
AUX.HYDR.CR.TRACK CARR.4	96 50 706 08	2	1	1 970	91 56 958 08	CRAWLER TRACK HYDRAULI
AUX.HYDR.CYLINDER SB-BW	91 56 431 08	400	1	3 714 016	96 49 797 08	TRACTION RAM PRE-ASS.
AUX.HYDR.PIN EXTRACTION D	91 44 034 08	2	1	3 790	91 08 481 08	BOLT EXTRACTION ATTACHM
AUXILIARY SWITCH UNIT	60 66 532 08	9	4	2 920 638	96 51 138 08	CONTROL DESK
AUXILIARY SWITCH UNIT	60 66 614 08	10	1	2 920 638	96 51 138 08	CONTROL DESK
AXLE 140.0X180 SPF	97 71 198 08	4	1	3 211 003	96 46 986 08	ROD CPL.
AXLE 150.0X2123 SPF	97 75 240 08	6	1	3 214	91 52 843 08	SW HEAD SECTION
AXLE 150.0X445 35NICRMOV12	97 68 035 08	19	17	1 400	91 56 853 08	CRAWLER TRACK CARRIER LE
AXLE 150.0X445 35NICRMOV12	97 68 035 08	19	17	1 410 300	91 56 855 08	CRAWLER CARRIER RIGHT CP
AXLE 16.0X76 FE//ZN20//C	97 79 659 08	3	1	2 550 008	96 47 628 08	RETAINER CPL.
AXLE 16.0X76 FE//ZN20//C	97 79 659 08	3	1	2 550 009	96 47 645 08	RETAINER CPL.
AXLE 219,1X40X245 SPF	95 66 984 08	3	1	3 225 100	96 48 582 08	BEARING CPL
AXLE 219,1X40X245 SPF	95 66 984 08	3	1	3 281	91 52 896 08	ERECTION FRAME
AXLE 219.1X1100 SPF	97 74 962 08	3	1	3 215 005	91 52 846 08	ROLLER SET
AXLE 219.1X1272 SPF	97 74 817 08	3	1	3 215 006	91 52 847 08	ROLLER SET
AXLE 219.1X140 SPF	97 76 746 08	3	1	3 714 021	96 49 271 08	ROLLER SEATING COMPL.

6.2.2009

etk_en_de_074515 LR 1600/2

853

LIEBHERRAlphabetical index
Alphabetischer Index

Description	Item	Pos.	Quantity	Page	Assembly	Description
AXLE 219.1X1612	97 69 807 08	3	1	2 652	91 52 794 08	ROLLER BEARING
AXLE 219.1X245	97 19 034 08	4	1	3 713	91 57 749 08	D PIVOT SECTION
AXLE 219.1X487 SPF	97 76 908 08	32	1	3 714	91 52 862 08	D HEAD SECTION
AXLE 219.1X870 SPF	97 71 893 08	10	1	3 208 001	91 52 883 08	F-HEAD SECTION
AXLE 220.0X2231 SPF	97 67 972 08	2	1	2 550	91 57 751 08	SA FRAME
AXLE 220.0X665 SPF	97 75 885 08	3	1	3 714 008	96 49 266 08	LUFFING PULLEY BLOCK COM
AXLE 220.0X745 SPF	97 76 225 08	4	1	3 714 009	96 49 267 08	LUFFING PULLEY BLOCK COM
AXLE 260.0X2407 SPF	97 76 838 08	12	1	3 714	91 52 862 08	D HEAD SECTION
AXLE 30.0X200 S355J2G3C+C	97 93 096 08	141	1	3 713	91 57 749 08	D PIVOT SECTION
AXLE 30.0X530 ST37.0	97 71 968 08	15	1	3 208 001	91 52 883 08	F-HEAD SECTION
AXLE 40.0X1247	97 74 860 08	11	2	3 215 006	91 52 847 08	ROLLER SET
AXLE 40.0X1446	97 71 244 08	3	1	3 211 008	96 46 978 08	SAFETY ROLLER CPL.
AXLE 45.0X1392 S355J2G3 FE//	97 71 246 08	4	1	3 211 009	96 46 979 08	SAFETY ROLLER CPL.
AXLE 50.0X100 SPF	97 80 226 08	7	1	2 550 008	96 47 628 08	RETAINER CPL.
AXLE 50.0X100 SPF	97 80 226 08	7	1	2 550 009	96 47 645 08	RETAINER CPL.
AXLE 50.0X910	97 71 953 08	13	1	3 208 001	91 52 883 08	F-HEAD SECTION
AXLE 55.0X292 SPF	97 48 730 08	18	2	1 400	91 56 853 08	CRAWLER TRACK CARRIER LE
AXLE 55.0X292 SPF	97 48 730 08	18	2	1 410 300	91 56 855 08	CRAWLER CARRIER RIGHT CP
AXLE HOLDER 10X140X40 S38	94 21 646 08	5	2	3 292	91 52 865 08	D OVERRUN PROTECTION
AXLE HOLDER 20X220X150 S	97 76 161 08	11	2	3 214	91 52 843 08	SW HEAD SECTION
AXLE HOLDER 25X50X290	94 83 965 08	23	17	1 400	91 56 853 08	CRAWLER TRACK CARRIER LE
AXLE HOLDER 25X50X290	94 83 965 08	23	17	1 410 300	91 56 855 08	CRAWLER CARRIER RIGHT CP
AXLE HOLDER 6X20X80	94 13 244 08	11	2	3 211	91 57 748 08	S PIVOT SECTION
AXLE HOLDER 6X20X80	94 13 244 08	13	4	3 350	91 52 859 08	WINCH 3
AXLE HOLDER LN 4/11 6X40X1	99 70 411 01	10	2	3 211 009	96 46 979 08	SAFETY ROLLER CPL.
AXLE RD30X786	93 88 891 08	8	3	3 714 009	96 49 267 08	LUFFING PULLEY BLOCK COM
AXLE RD40X1650	95 63 347 08	(2)	1	3 350	91 52 859 08	WINCH 3
BACK PART	10 49 234 5	1	1	X1029200	10 29 200 4	DRIVERS SEAT
BALL 3	10 01 183 1	5	2	9 739 243	97 39 243	PISTON COOLING
BALL DIN 5401 10	74 70 006 08	320	1	X1041101	10 41 101 5	TILTING-BACK SUPPORT
BALL DIN 5401 10	74 70 006 08	300	1	X1041101	10 41 101 8	TILTING-BACK SUPPORT
BALL DIN 5401 7	57 08 621 08	5	1	X1041267	10 41 267 8	END PLATE
BALL DIN 5401 8	74 70 004 08	520	1	X1041101	10 41 101 5	TILTING-BACK SUPPORT
BALL DIN 5401 8	74 70 004 08	440	1	X1041101	10 41 101 8	TILTING-BACK SUPPORT
BALL SOCKET	10 01 186 3	9	1	9 739 186	97 39 186	MOTOR BRAKE
BALL VALVE BK3-30S A3C SPF	51 10 634 08	52	2	2 970	91 56 537 08	HYDR
BALL VALVE BKH3/4" A3C	51 06 923 08	20	1	1 970	91 56 958 08	CRAWLER TRACK HYDRAULI
BALL VALVE BKH3/8" A3C	51 06 820 08	22	1	2 970	91 56 537 08	HYDR
BALL VALVE COMBINATION	10 42 471 6	26	2	2 970	91 56 537 08	HYDR
BALL VALVE DN8-1/4" MS	51 06 960 08	5	1	2 978 100	91 52 796 08	ADDNL.HYDR.ERECTION DEV
BALL VALVE DN8-1/4" MS	51 06 960 08	13	1	2 978 200	91 54 843 08	ADD.HYDR.S_RETAINING RAM
BALL VALVE DN8-1/4" MS	51 06 960 08	10	1	3 978 005	91 56 430 08	ADDL.HYDRAULIC SB-HEAD PI
BALLAST PALLET WELDED	96 49 614 08	1	1	3 745	91 52 948 08	SUSPENDED BALLAST
BAR LINKAGE CLIP	70 42 797 08	9	3	2 522 011	96 45 602 08	CLOSING DEVICE
BASE PART	60 66 620 08	1	1	2 780 244	91 52 951 08	EMERGENCY CUT-OFF CRAN
BASE PLATE SLEWING PLAT	91 52 802 08	150	1		LR 1600-2-0	
BATTERY BOX WELDED SPF	96 34 249 08	1	1	2 260 006	96 46 501 08	BATTERY BOX, PRE-ASSEMB
BATTERY BOX, PRE-ASSEMB	96 46 501 08	1	1	2 260	91 53 057 08	CUP SPRING CLUSTER
BATTERY CABLE 16	60 04 916 08	(329)	2.6	2 920 288	96 52 614 08	WIRING LIST F.SLEWING PLAT
BATTERY CABLE 50	60 04 912 08	(331)	1.4	2 920 815	96 49 300 08	WIRING LIST BATTERY BOX
BATTERY CABLE DIN 72551 95	60 04 918 08	(333)	11	2 920 536	96 48 317 08	WIRING LIST F.ELECTR.AGG
BATTERY CABLE DIN 72551 95	60 04 918 08	(333)	1	2 920 536	96 48 317 08	WIRING LIST F.ELECTR.AGG
BATTERY CABLE DIN 72551 95	60 04 918 08	(333)	0.9	2 920 815	96 49 300 08	WIRING LIST BATTERY BOX
BATTERY CABLE DIN 72551 95	60 04 918 08	(333)	2	2 920 815	96 49 300 08	WIRING LIST BATTERY BOX
BATTERY CABLE DIN 72551 95	60 04 918 08	(333)	0.16	2 920 815	96 49 300 08	WIRING LIST BATTERY BOX
BATTERY CHARGER 230V	91 52 807 08	156	1		LR 1600-2-0	
BATTERY EN 50342 12V 170A	10 11 258 4	15	2	2 920 083	96 48 319 08	ELECTRIC FOR BATTERY BOX
BATTERY TERMINAL CLAMP M	61 32 066 08	19	2	2 920 083	96 48 319 08	ELECTRIC FOR BATTERY BOX
BATTERY TERMINAL CLAMP	61 32 065 08	18	2	2 920 083	96 48 319 08	ELECTRIC FOR BATTERY BOX
BEAM	10 34 310 5	11	1	9 739 371	97 39 371	AIR COND. COMPRESSOR A

6.2.2009

etk_en_de_074515 LR 1600/2

854

LIEBHERRAlphabetical index
Alphabetischer Index

Description	Item	Pos.	Quantity	Page	Assembly	Description
BEAM	90 77 248	277	1	9 739 400	97 39 400	DIESEL ENGINE
BEAM RELAY 18 - 32V	63 01 022 08	52	1	2 932 001	96 45 393 08	RELAY CONTROL SYSTEM
BEARING	93 95 668 01	5	1	1 400	91 56 853 08	CRAWLER TRACK CARRIER LE
BEARING	93 95 668 01	5	1	1 410 300	91 56 855 08	CRAWLER CARRIER RIGHT CP
BEARING	93 95 675 01	6	1	1 400	91 56 853 08	CRAWLER TRACK CARRIER LE
BEARING	93 95 675 01	6	1	1 410 300	91 56 855 08	CRAWLER CARRIER RIGHT CP
BEARING 48X50 GUMMI 64CR	10 09 749 6	9	4	2 391 023	96 45 720 08	RADIATOR, PRE-ASSEMBLED
BEARING BLOCK PA6G	97 76 196 08	44	4	3 220 500	91 52 849 08	S INTERMEDIATE SECTION
BEARING BLOCK PA6G	97 76 196 08	44	4	3 223	91 52 852 08	S INTERMEDIATE SECTION
BEARING BLOCK PA6G	97 76 196 08	44	4	3 223 010	91 52 853 08	S INTERMEDIATE SECTION
BEARING BLOCK PA6G	97 76 196 08	44	4	3 223 100	91 55 327 08	S INTERMEDIATE SECTION
BEARING BLOCK PA6G	97 76 196 08	44	4	3 226	91 52 870 08	L INTERMEDIATE SECTION
BEARING BLOCK PA6G	97 76 196 08	44	4	3 227	91 52 873 08	L INTERMEDIATE SECTION
BEARING BLOCK PA6G	97 76 196 08	44	4	3 227 008	91 52 872 08	L INTERMEDIATE SECTION
BEARING BLOCK PA6G	97 76 196 08	44	4	3 227 200	91 53 519 08	LI INTERMEDIATE SECT. F-GU
BEARING BLOCK PA6G	97 76 196 08	37	4	3 715 008	91 52 863 08	D INTERMEDIATE SECTION
BEARING BLOCK PA6G	97 76 196 08	39	4	3 716	91 52 864 08	D INTERMEDIATE SECTION
BEARING BUSH 150X170X110	97 73 314 08	38	2	2 550	91 57 751 08	SA FRAME
BEARING BUSH 200X220X35 G	97 73 251 08	(2)	1	2 550	91 57 751 08	SA FRAME
BEARING BUSH 200X220X58 G	97 68 284 08	(2)	1	2 550	91 57 751 08	SA FRAME
BEARING BUSH 210X250X259	97 73 315 08	40	2	2 550	91 57 751 08	SA FRAME
BEARING CAP BOLT M14X1,5 1	90 77 199	2	2	9 739 287	97 39 287	MAIN ROD
BEARING CPL	96 45 603 08	10	2	2 550	91 57 751 08	SA FRAME
BEARING CPL	96 48 582 08	2	1	3 225	91 52 854 08	SL REDUCING SECTION
BEARING LEFT	96 49 043 08	3	1	3 214	91 52 843 08	SW HEAD SECTION
BEARING PLATE	28 30 209 08	52	1	2 550	91 57 751 08	SA FRAME
BEARING PLATE 10X60X120 P	93 54 692 08	2	2	3 714 017	96 50 752 08	SUPPORT CPL.
BEARING PLATE 10X60X90 P	93 22 470 08	47	4	3 211	91 57 748 08	S PIVOT SECTION
BEARING PLATE 10X60X90 P	93 22 470 08	27	8	3 713	91 57 749 08	D PIVOT SECTION
BEARING PLATE 15 X 60 X 810	97 64 327 08	40	1	3 206	91 52 881 08	PIVOT SECTION
BEARING PLATE 20X160X210	28 30 405 08	53	1	3 745	91 52 948 08	SUSPENDED BALLAST
BEARING RIGHT	96 49 044 08	4	1	3 214	91 52 843 08	SW HEAD SECTION
BEARING RING	57 01 135 08	3	1	5 701 129	57 01 129 08	DRIVING GEAR
BEARING STUB SHAFT 110.0X	97 73 250 08	5	1	3 282 001	96 47 888 08	F-STAY COMPL.
BEARING WELDED	96 45 611 08	(1)	1	2 550	91 57 751 08	SA FRAME
BEARING WELDED	96 48 584 08	1	1	3 225 100	96 48 582 08	BEARING CPL
BEARING WELDED	96 49 669 08	1	1	3 282 001	96 47 888 08	F-STAY COMPL.
BEARING WELDED	96 54 448 08	3	1	2 370	91 52 782 08	ERECTING WINCH
BELLOWS COUPLING	57 18 705 08	(60)	1	6 909 010	69 09 010 08	COLLECTING RING
BLANKING PLUG	10 01 262 8	6	2	9 739 354	97 39 354	FLYWHEEL HOUSING MOUNT
BLANKING PLUG	77 90 162 01	88	1	9 697 916	96 97 916 01	SLEWING GEAR
BLIND	10 41 336 1	37	1	2 520	91 53 061 08	CABIN, GLAZED
BLIND	10 41 336 2	38	1	2 520	91 53 061 08	CABIN, GLAZED
BLIND	10 41 336 4	39	1	2 520	91 53 061 08	CABIN, GLAZED
BLIND RIVET 3,0X3,2-5,0	70 42 121 08	10	2	2 913 005	96 20 731 08	INTERIOR HOUSING PRE-ASS.
BLIND RIVET 3,0X3,2-5,0	70 42 121 08	10	2	2 913 005	96 28 696 08	INTERIOR HOUSING PRE-ASS.
BLIND RIVET 3,0X3,2-5,0	70 42 121 08	41	50	2 932 001	96 45 393 08	RELAY CONTROL SYSTEM
BLIND RIVET 3,2X4,3-5,9	70 42 127 08	28	2	2 831	91 57 754 08	AIR COND. UNIT SUPERSTRU
BLIND RIVET 4,0X10,5	70 42 323 08	11	30	2 932 082	96 54 387 08	ASSEMBLY PARTS MOUNTIN
BLIND RIVET NUT M 8	41 30 065 08	24	5	2 520	91 53 061 08	CABIN, GLAZED
BLIND RIVET NUT M 8	41 30 065 08	18	2	2 522	91 54 115 08	SLIDING DOOR CPL.
BLIND RIVET NUT M 8	41 30 065 08	2	12	2 810 037	96 47 204 08	PEDAL CANTILEVER INSTALL
BLIND RIVET NUT M10 A3C	41 30 066 08	(2)	2	2 925 402	96 58 855 08	CAMERA EQUIPMENT SLEWI
BLIND RIVET NUT M5 ST VERZ	10 04 259 2	31	29	2 520	91 53 061 08	CABIN, GLAZED
BLIND RIVET NUT M5 ST VERZ	10 04 259 2	4	23	2 522	91 54 115 08	SLIDING DOOR CPL.
BLIND RIVET NUT M5 ST VERZ	10 04 259 2	36	8	2 533 070	96 48 363 08	CONTROLS AND FITTINGS RI
BLIND RIVET NUT M5 ST VERZ	10 04 259 2	86	6	2 932 082	96 54 387 08	ASSEMBLY PARTS MOUNTIN
BLIND RIVET NUT M6 ST VERZ	10 04 259 3	32	74	2 520	91 53 061 08	CABIN, GLAZED
BLIND RIVET NUT M6 ST VERZ	10 04 259 3	5	6	2 520 030	96 45 609 08	ROOF WINDOW PRE-ASS.
BLIND RIVET NUT M6 ST VERZ	10 04 259 3	14	1	2 533 066	96 48 365 08	ELECTRIC ADD-ON PARTS CA

6.2.2009

etk_en_de_074515 LR 1600/2

855

LIEBHERRAlphabetical index
Alphabetischer Index

Description	Item	Pos.	Quantity	Page	Assembly	Description
BLIND RIVET NUT M6 ST VERZ	10 04 259 3	3	5	2 810 037	96 47 204 08	PEDAL CANTILEVER INSTALL
BOARD CONTROL PANEL 40X	97 79 945 08	6	1	2 920 638	96 51 138 08	CONTROL DESK
BOLT EXTRACTION ATTACHM	91 08 481 08	344	1		LR 1600-2-0	
BOWDEN PULL SYSTEM L=130	10 42 458 1	18	1	2 522 011	96 45 602 08	CLOSING DEVICE
BOWL	70 30 235	14	1	7 027 481	70 27 481 03	WATER SEPARATOR
BOWLEN SEALING HNBR	10 29 417 0	9	1	7 027 481	70 27 481 03	WATER SEPARATOR
BOX NUT DIN 3870 AL10 A3P	47 74 015 08	593	1	2 990	91 59 244 08	COMPRESSED AIR PLANT
BOX NUT DIN 3870 AL12 A3P	47 74 016 08	20	1	2 391 038	96 47 931 08	OIL COOLER, PRE-ASSEMBLE
BOX NUT DIN 3870 AL12 A3P	47 74 016 08	593	1	2 970	91 56 537 08	HYDR
BOX NUT DIN 3870 AL15 A3P	47 74 012 08	582	2	2 970	91 56 537 08	HYDR
BOX NUT DIN 3870 AL18 A3P	47 74 024 08	591	1	2 970	91 56 537 08	HYDR
BOX NUT DIN 3870 AL22 A3P	47 74 026 08	584	2	2 970	91 56 537 08	HYDR
BOX NUT DIN 3870 AL28 A3P	47 74 017 08	586	2	2 970	91 56 537 08	HYDR
BOX NUT DIN 3870 AL28 A3P	47 74 017 08	598	1	2 978 200	91 54 843 08	ADD.HYDR.S_RETAINING RAM
BOX NUT DIN 3870 AL35 A3P	47 74 018 08	595	1	2 970	91 56 537 08	HYDR
BOX NUT DIN 3870 AL42 A3P	47 74 019 08	588	2	2 970	91 56 537 08	HYDR
BOX NUT DIN 3870 AS25 A3P	47 74 008 08	597	1	2 970	91 56 537 08	HYDR
BOX NUT DIN 3870 AS30 A3P	47 74 009 08	576	4	2 970	91 56 537 08	HYDR
BOX NUT DIN 3870 AS38	47 74 010 08	60	4	1 970	91 56 958 08	CRAWLER TRACK HYDRAULI
BOX NUT DIN 3870 AS38	47 74 010 08	573	10	2 970	91 56 537 08	HYDR
BOX NUT DIN 3870 AS6 A3P	47 74 001 08	590	2	2 990	91 59 244 08	COMPRESSED AIR PLANT
BRACE PLATE	92 53 054 08	1	1	1 641 014	92 53 053 08	SUPPORT PLATE COMPL.
BRACKET	10 65 067 0	2	1	X1035519	10 35 519 6	OIL AIR COOLER
BRACKET	96 51 811 08	26	1	2 652	91 52 794 08	ROLLER BEARING
BRACKET COMPL.	92 88 304 08	2	2	3 211 002	92 88 302 08	SAFETY ROLLER CPL.
BRACKET COMPL.	92 88 304 08	153	2	3 713	91 57 749 08	D PIVOT SECTION
BRACKET COMPL.	96 47 218 08	3	1	3 208 001	91 52 883 08	F-HEAD SECTION
BRACKET COMPL.	96 48 024 08	11	2	3 281	91 52 896 08	ERECTION FRAME
BRACKET COMPL.	96 48 027 08	21	2	3 281	91 52 896 08	ERECTION FRAME
BRACKET COMPL.	96 48 261 08	3	2	3 207	91 53 433 08	F-GUYING
BRACKET COMPL.	96 48 292 08	4	2	3 207	91 53 433 08	F-GUYING
BRACKET COMPL.	96 49 270 08	6	2	3 714	91 52 862 08	D HEAD SECTION
BRACKET COMPL.	96 49 456 08	2	2	3 714 009	96 49 267 08	LUFFING PULLEY BLOCK COM
BRACKET COMPL.	96 49 677 08	3	2	3 745	91 52 948 08	SUSPENDED BALLAST
BRACKET COMPL.	96 59 083 08	21	2	3 714 009	96 49 267 08	LUFFING PULLEY BLOCK COM
BRACKET COMPL. 0	96 47 187 08	2	2	3 208 001	91 52 883 08	F-HEAD SECTION
BRACKET COMPL. 0.50M	96 50 162 08	47	2	3 713	91 57 749 08	D PIVOT SECTION
BRACKET LEFT	97 75 565 08	4	1	2 503 101	96 48 626 08	SEAT
BRACKET LEFT SPF	97 23 411 08	3	1	2 502	91 55 939 08	CONTROL STAND
BRACKET RIGHT	97 75 567 08	5	1	2 503 101	96 48 626 08	SEAT
BRACKET RIGHT SPF	97 23 412 08	4	1	2 502	91 55 939 08	CONTROL STAND
BRACKET ST	10 21 652 9	60	1	2 831	91 57 754 08	AIR COND. UNIT SUPERSTRU
BRACKET WELDED	92 51 944 08	4	1	2 620	91 52 793 08	ROLLER SLEWING RING
BRACKET WELDED CONST.	92 16 964 08	2	1	2 925 204	92 16 990 08	CAMERA EQUIPMENT D-PIVOT
BRACKET WELDED CONST.	92 51 941 08	3	1	2 620	91 52 793 08	ROLLER SLEWING RING
BRACKET WELDED CONST.	96 17 503 08	2	2	3 291	91 52 831 08	S OVERRUN PROTECTION
BRACKET WELDED CONST.	96 17 503 08	7	2	3 292	91 52 865 08	D OVERRUN PROTECTION
BRACKET WELDED CONST.	96 42 805 08	2	2	2 670	91 52 797 08	FUEL TANK CPL.
BRACKET WELDED CONST.	96 44 626 08	1	2	2 730	91 52 802 08	BASE PLATE SLEWING PLATF
BRACKET WELDED CONST.	96 45 748 08	1	2	1 742	91 53 021 08	FIXAGE DU CONTREPOIDS CE
BRACKET WELDED CONST.	96 45 983 08	3	1	2 520 032	96 45 980 08	WINDSHIELD WASHER INSTAL
BRACKET WELDED CONST.	96 46 985 08	1	1	2 550 011	96 47 007 08	CONSOLE COMPL.
BRACKET WELDED CONST.	96 47 506 08	4	2	2 671	91 52 798 08	OIL RESERVOIR, COMPLETE
BRACKET WELDED CONST.	96 48 426 08	7	1	2 502	91 55 939 08	CONTROL STAND
BRACKET WELDED CONST.	96 48 437 08	12	2	2 502	91 55 939 08	CONTROL STAND
BRACKET WELDED CONST.	96 49 196 08	16	2	2 392	91 52 785 08	MUFFLER UNIT
BRACKET WELDED CONST.	96 49 689 08	2	4	3 747	91 52 950 08	CENTERING STANDARD
BRACKET WELDED CONST.	96 53 678 08	10	1	2 391 040	96 53 645 08	CLUTCH ACTUATOR
BRACKET WELDED CONST. FE	96 50 492 08	13	2	3 227 002	96 50 498 08	ROD CPL.
BRACKET WELDED CONST. H	96 52 910 08	1	1	2 790 455	91 57 005 08	TRANSPORT KEEPER

6.2.2009

etk_en_de_074515 LR 1600/2

856

LIEBHERRAlphabetical index
Alphabetischer Index

Description	Item	Pos.	Quantity	Page	Assembly	Description
BRACKET WELDED CONST. T	96 53 093 08	8	6	2 631	91 56 817 08	SLEWING PLATFORM CATWAL
BRACKET WELDED CONST. V	96 52 911 08	2	1	2 790 455	91 57 005 08	TRANSPORT KEEPER
BRACKET WELDED IN FRONT	96 51 810 08	25	1	2 652	91 52 794 08	ROLLER BEARING
BRACKET WITH BOARD	96 45 686 08	2	2	2 550 005	96 45 680 08	ROD CPL.
BRACKET WITH BOARD	96 45 687 08	3	2	2 550 005	96 45 680 08	ROD CPL.
BRACKET WITH BOARD	96 45 688 08	4	1	2 550 005	96 45 680 08	ROD CPL.
BRACKET WITH BOARD	96 48 337 08	1	2	3 207 101	96 48 292 08	BRACKET COMPL.
BRACKET WITH BOARD	96 49 464 08	1	2	3 714 014	96 49 456 08	BRACKET COMPL.
BRACKET WITH BOARD 0.25	96 45 231 08	2	2	3 220 501	96 43 440 08	ROD CPL.
BRACKET WITH BOARD 0.25	96 45 231 08	2	2	3 221 200	96 47 984 08	ROD CPL.
BRACKET WITH BOARD 0.25	96 45 231 08	2	2	3 225 200	96 48 679 08	ROD CPL.
BRACKET WITH BOARD 0.25	96 45 231 08	2	2	3 227 002	96 50 498 08	ROD CPL.
BRACKET WITH BOARD 0.25	96 45 231 08	2	2	3 561 003	96 45 222 08	ROD CPL.
BRACKET WITH BOARD 0.25	96 45 231 08	2	2	3 713 012	96 50 197 08	ROD CPL.
BRACKET WITH BOARD 0.25	96 45 231 08	1	2	3 714 013	96 59 083 08	BRACKET COMPL.
BRACKET WITH BOARD 0.25	96 45 232 08	3	1	3 220 501	96 43 440 08	ROD CPL.
BRACKET WITH BOARD 0.25	96 45 232 08	3	1	3 221 200	96 47 984 08	ROD CPL.
BRACKET WITH BOARD 0.25	96 45 232 08	3	1	3 225 200	96 48 679 08	ROD CPL.
BRACKET WITH BOARD 0.25	96 45 232 08	3	1	3 227 002	96 50 498 08	ROD CPL.
BRACKET WITH BOARD 0.25	96 45 232 08	3	1	3 561 003	96 45 222 08	ROD CPL.
BRACKET WITH BOARD 0.25	96 45 232 08	3	1	3 713 012	96 50 197 08	ROD CPL.
BRACKET WITH BOARD 0.25	96 45 232 08	2	1	3 714 013	96 59 083 08	BRACKET COMPL.
BRACKET WITH BOARD 0.25	96 48 595 08	2	2	3 716 001	96 49 159 08	ROD CPL.
BRACKET WITH BOARD 0.25	96 48 596 08	3	1	3 716 001	96 49 159 08	ROD CPL.
BRACKET WITH BOARD 0.25M	96 47 000 08	15	4	3 211	91 57 748 08	S PIVOT SECTION
BRACKET WITH BOARD 0.34	96 53 262 08	70	1	1 400	91 56 853 08	CRAWLER TRACK CARRIER LE
BRACKET WITH BOARD 0.34	96 53 262 08	70	1	1 410 300	91 56 855 08	CRAWLER CARRIER RIGHT CP
BRACKET WITH BOARD 0.34	96 53 263 08	71	1	1 400	91 56 853 08	CRAWLER TRACK CARRIER LE
BRACKET WITH BOARD 0.34	96 53 263 08	71	1	1 410 300	91 56 855 08	CRAWLER CARRIER RIGHT CP
BRACKET WITH BOARD 0.35M	96 49 611 08	2	2	3 714 025	96 49 269 08	ROD CPL.
BRACKET WITH BOARD 200	96 45 290 08	2	2	3 207 003	96 48 259 08	ROD CPL.
BRACKET WITH BOARD 200	96 45 290 08	1	2	3 207 100	96 48 261 08	BRACKET COMPL.
BRACKET WITH BOARD 200	96 45 290 08	(2)	2	3 281	91 52 896 08	ERECTION FRAME
BRACKET WITH BOARD 350	96 47 237 08	(1)	2	3 281	91 52 896 08	ERECTION FRAME
BRACKET WITH BOARD 350	96 47 239 08	(1)	2	3 281	91 52 896 08	ERECTION FRAME
BRACKET WITH BOARD 390	96 47 889 08	13	2	3 282 002	96 47 890 08	FAB-STAY
BRACKET,LEFT WELDED	96 48 438 08	13	1	2 502	91 55 939 08	CONTROL STAND
BRACKET,LEFT WELDED FE//	96 48 427 08	8	1	2 502	91 55 939 08	CONTROL STAND
BRACKET,RIGHT WELDED	96 48 439 08	14	1	2 502	91 55 939 08	CONTROL STAND
BRACKET,RIGHT WELDED FE//	96 48 428 08	9	1	2 502	91 55 939 08	CONTROL STAND
BRICK 50X242X242	97 43 188 08	7	4	3 747	91 52 950 08	CENTERING STANDARD
BRICK 50X242X242	97 43 189 08	8	4	3 747	91 52 950 08	CENTERING STANDARD
BRICK 50X255X280	97 76 964 08	11	2	3 747	91 52 950 08	CENTERING STANDARD
BRICK 50X279X255	97 43 187 08	6	2	3 747	91 52 950 08	CENTERING STANDARD
BRICK 50X280X255	97 43 190 08	9	2	3 747	91 52 950 08	CENTERING STANDARD
BRICK 50X280X255	97 76 956 08	10	2	3 747	91 52 950 08	CENTERING STANDARD
BRIDE DE BLOCAGE	96 51 407 08	2	1	2 925 402	96 58 855 08	CAMERA EQUIPMENT SLEWI
BRUSH SUPPORT	10 41 178 6	16	8	X1002800	10 02 800 2	CABLE REEL
BS HOUSING 24POL.	60 56 185 08	518	3	2 920 633	96 52 651 08	WIRING HARNESS
BUILD-IN SOCKET 24POL BU	69 24 016 08	(151)	1	2 920 369	96 54 235 08	TERMINAL BOX CPL.
BUILD-IN SOCKET 24POL BU	69 24 016 08	151	1	3 930 639	96 50 132 08	WIRES TERMINAL BOX CPL.
BUILD-IN SOCKET 24POL BU	69 24 016 08	(151)	1	3 930 640	96 50 481 08	TERMINAL BOX CPL.
BUILD-IN SOCKET 24POL STI	69 18 996 08	154	1	3 930 639	96 50 132 08	WIRES TERMINAL BOX CPL.
BUILD-IN SOCKET 24POL STI	69 18 996 08	(153)	1	3 930 640	96 50 481 08	TERMINAL BOX CPL.
BUILD-IN SOCKET 24POL STI	69 18 996 08	(501)	2	3 930 730	96 50 599 08	TERMINAL BOX CPL.
BUILT-IN KIT	10 02 217 1	4	1	2 932 001	96 45 393 08	RELAY CONTROL SYSTEM
BUILT-IN PARTS SWITCH BOX	91 57 750 08	165	1		LR 1600-2-0	
BUILT-IN SOCKET 2POL 16A	60 52 039 08	2	1	2 533 067	96 50 385 08	PLATE PRE-ASS.
BUILT-IN SOCKET 2POL 16A	60 52 039 08	3	2	2 920 257	92 78 689 08	TERMINAL BOX LIGHTING HO
BUILT-IN SOCKET 2POL 16A	60 52 039 08	51	1	2 932 001	96 45 393 08	RELAY CONTROL SYSTEM

6.2.2009

etk_en_de_074515 LR 1600/2

857

LIEBHERRAlphabetical index
Alphabetischer Index

Description	Item	Pos.	Quantity	Page	Assembly	Description
BURNER	10 29 012 4	17	1	X1004204	10 04 204 3	WATER HEATING SYSTEM
BUS LINE 4X1,0 SPF	60 03 452 08	371	2.05	2 920 633	96 52 651 08	WIRING HARNESS
BUS PCB	92 84 311 08	3	1	2 913 100	91 23 538 08	ASSEMBLY FRAME
BUSH	10 03 239 2	13	1	9 739 118	97 39 118	OIL LINE
BUSH	60 52 130 08	96	2	2 920 633	96 52 651 08	WIRING HARNESS
BUSH	60 52 130 08	96	2	2 920 636	96 51 854 08	LEAD
BUSH 100X130X170 GZ-CUZN	97 70 818 08	19	2	3 213	91 52 842 08	F-CONNECTING HEAD
BUSH 16.0X12 S355J2G3C+C	97 68 666 08	47	4	2 502	91 55 939 08	CONTROL STAND
BUSH 16.0X12 S355J2G3C+C	97 68 666 08	10	1	2 522 011	96 45 602 08	CLOSING DEVICE
BUSH 230X200X266 GZ-CUZN	97 69 084 08	2	2	3 211	91 57 748 08	S PIVOT SECTION
BUSH 240X280X175 GZ-ZUZN	97 76 392 08	3	1	3 714 013	96 49 270 08	BRACKET COMPL.
BUSH 80X100X70 GZ-CUZN25	70 43 346 08	25	2	2 810	91 52 806 08	CRANE DRIVER'S CABIN CPL.
BUSH 9X18X11	10 48 693 4	25	1	9 739 492	97 39 492	PIPELINE INSTALLATION
BUSH 9X18X15 ST35NBK	10 48 694 0	32	1	9 739 492	97 39 492	PIPELINE INSTALLATION
BUSH DIN 444 11X20X11,5 ST	10 34 329 9	14	2	9 739 344	97 39 344	GENERATOR, PRE-ASSEMBLE
BUSH INSERT	60 56 016 08	506	3	2 920 633	96 52 651 08	WIRING HARNESS
BUSH INSERT 16POL	60 56 086 08	29	1	2 920 369	96 54 235 08	TERMINAL BOX CPL.
BUSH INSERT 16POL	60 56 086 08	516	1	2 932 224	96 54 389 08	CABLES MOUNTING PANEL C
BUSH INSERT 40POL	60 56 021 08	30	1	2 920 369	96 54 235 08	TERMINAL BOX CPL.
BUSH INSERT 40POL	60 56 021 08	502	2	2 932 224	96 54 389 08	CABLES MOUNTING PANEL C
BUSH INSERT 64POL	60 56 088 08	25	1	2 920 369	96 54 235 08	TERMINAL BOX CPL.
BUSH INSERT 64POL	60 56 088 08	508	8	2 932 224	96 54 389 08	CABLES MOUNTING PANEL C
BUSH RD100X45 GZ-CUZN25	70 43 378 08	85	2	3 713	91 57 749 08	D PIVOT SECTION
BUSH RD100X45 GZ-CUZN25	97 88 106 08	3	2	3 211	91 57 748 08	S PIVOT SECTION
BUSH SUPPORT M1 E-6S	60 45 265 08	155	2	3 930 639	96 50 132 08	WIRES TERMINAL BOX CPL.
BUSH SUPPORT M1 E-6S	60 45 265 08	(154)	1	3 930 640	96 50 481 08	TERMINAL BOX CPL.
BUSH SUPPORT M1 E-6S	60 45 265 08	(503)	1	3 930 730	96 50 599 08	TERMINAL BOX CPL.
BUSHING SLEEVE 165X156 G	97 67 849 08	2	1	1 400 016	96 45 287 08	ROLLER BODY HALF CPL.
BUSHING SLEEVE RD70X68 G	70 43 316 08	2	1	1 400 017	92 51 976 08	ROLLER BODY HALF CPL.
BUTT STRAP	96 47 562 08	5	2	3 205	91 52 880 08	F-ASSEMBLY UNIT
BUTT STRAP 4X40X20	97 83 610 08	2	2	2 391 040	96 53 645 08	CLUTCH ACTUATOR
BUTT STRAP 8X113X108	97 83 611 08	3	1	2 391 040	96 53 645 08	CLUTCH ACTUATOR
BUTZEN 18-L A3P	47 77 001 08	592	1	2 970	91 56 537 08	HYDR
BUTZEN 22-L A3P	47 77 002 08	585	2	2 970	91 56 537 08	HYDR
BUTZEN 28-L A3P	47 77 008 08	587	2	2 970	91 56 537 08	HYDR
BUTZEN 28-L A3P	47 77 008 08	599	1	2 978 200	91 54 843 08	ADD.HYDR.S_RETAINING RAM
BUTZEN 30-S A3P	47 77 016 08	575	4	2 970	91 56 537 08	HYDR
CABIN SHEET METAL SECTI	91 55 303 08	71	1	2 520	91 53 061 08	CABIN, GLAZED
CABIN, GLAZED	91 53 061 08	1	1	2 810 001	96 43 597 08	CRANE DRIVER'S CABIN,PRE
CABLE 12M	61 40 376 08	11	1	2 925 002	96 58 856 08	EQUIPMENT CAMERA SUPER
CABLE 12M	61 40 382 08	(11)	1	2 925 218	91 60 840 08	CAMERA CONTROL WINCH 3
CABLE 6M	61 40 458 08	13	2	2 925 002	96 58 856 08	EQUIPMENT CAMERA SUPER
CABLE 9M	61 40 418 08	12	3	2 925 002	96 58 856 08	EQUIPMENT CAMERA SUPER
CABLE BOOM MOUNTING	97 39 326	230	1	9 739 400	97 39 400	DIESEL ENGINE
CABLE CHANNEL	60 14 058 08	44	0.63	2 932 001	96 45 393 08	RELAY CONTROL SYSTEM
CABLE CHANNEL	60 14 139 08	21	0.725	2 932 082	96 54 387 08	ASSEMBLY PARTS MOUNTIN
CABLE CHANNEL	60 14 142 08	45	1.295	2 932 082	96 54 387 08	ASSEMBLY PARTS MOUNTIN
CABLE CLAMP 6,5MM POLYA	70 42 805 08	19	3	2 522 011	96 45 602 08	CLOSING DEVICE
CABLE CLIP HOLDER	60 20 611 08	6	7	2 520 033	96 50 633 08	MONITOR CONSOLE
CABLE CLIP HOLDER	60 20 611 08	47	8	2 932 082	96 54 387 08	ASSEMBLY PARTS MOUNTIN
CABLE CONDUIT	60 30 245 08	223	3.83	2 920 633	96 52 651 08	WIRING HARNESS
CABLE CONDUIT	60 30 247 08	225	2.13	2 920 633	96 52 651 08	WIRING HARNESS
CABLE CONDUIT	60 30 249 08	227	2.03	2 920 633	96 52 651 08	WIRING HARNESS
CABLE CONDUIT	60 30 250 08	228	3.03	2 920 633	96 52 651 08	WIRING HARNESS
CABLE CONDUIT	60 30 252 08	226	4.66	2 920 633	96 52 651 08	WIRING HARNESS
CABLE CONDUIT	60 30 253 08	229	3.3	2 920 633	96 52 651 08	WIRING HARNESS
CABLE CONNECTOR	60 23 364 08	2	1	2 932 166	92 68 911 08	GROUND RAIL
CABLE DRUM	97 22 660 08	5	1	3 930 009	96 50 573 08	CABLE DRUM COMPL.
CABLE DRUM COMPL.	96 48 489 08	6	1	3 930 138	96 54 377 08	ELECTRIC FOR S-PIVOT SECT
CABLE DRUM COMPL.	96 50 573 08	8	1	3 930 731	96 48 374 08	ELECTRICS F BASE SECTION

6.2.2009

etk_en_de_074515 LR 1600/2

858

LIEBHERRAlphabetical index
Alphabetischer Index

Description	Item	Pos.	Quantity	Page	Assembly	Description
CABLE DRUM COMPL.	96 52 968 08	20	1	2 780 510	96 50 097 08	ELECTR.FOR BALLAST PALLE
CABLE DRUM M25X1,5 SPF	61 60 249 08	(151)	1	3 930 138	96 54 377 08	ELECTRIC FOR S-PIVOT SECT
CABLE HOLDER	72 00 144 08	40	6	3 715 008	91 52 863 08	D INTERMEDIATE SECTION
CABLE HOLDER	72 00 144 08	42	12	3 716	91 52 864 08	D INTERMEDIATE SECTION
CABLE HOLDER 2X22X90	95 36 500 08	31	8	2 310	91 52 503 08	WINCH 1
CABLE HOLDER 2X22X90	95 36 500 08	31	8	2 320	91 52 504 08	WINCH 2
CABLE HOLDER 2X22X90	95 36 500 08	152	2	2 391 001	96 45 719 08	DIESEL ENGINE, PRE-ASSEMB
CABLE HOLDER 2X22X90	95 36 500 08	(5)	5	2 550	91 57 751 08	SA FRAME
CABLE HOLDER 2X22X90	95 36 500 08	50	19	2 550	91 57 751 08	SA FRAME
CABLE HOLDER 2X22X90	95 36 500 08	61	3	2 810	91 52 806 08	CRANE DRIVER'S CABIN CPL.
CABLE HOLDER 2X22X90	95 36 500 08	31	13	3 350	91 52 859 08	WINCH 3
CABLE LIST DRIVER'S CABIN	96 48 364 08	6	1	2 533	91 52 789 08	EL.INSTRUMENTS F.CRANE D
CABLE LIST MAINS SUPPLY	96 48 376 08	3	1	2 780 908	91 52 958 08	EXTERNAL FEED
CABLE LUG 12 - 95	60 23 011 08	(99)	2	2 920 536	96 48 317 08	WIRING LIST F.ELECTR.AGG
CABLE LUG 12 - 95	60 23 011 08	(99)	1	2 920 815	96 49 300 08	WIRING LIST BATTERY BOX
CABLE LUG 4/2,5mm ² VERZ	60 23 061 08	31	2	2 920 369	96 54 235 08	TERMINAL BOX CPL.
CABLE LUG 4/2,5mm ² VERZ	60 23 061 08	31	2	2 920 448	96 48 794 08	TERMINAL BOX CPL.
CABLE LUG DIN 46234 10-50 V	60 22 082 08	(103)	2	2 920 815	96 49 300 08	WIRING LIST BATTERY BOX
CABLE LUG DIN 46234 8 - 16	60 23 114 08	(57)	2	2 920 288	96 52 614 08	WIRING LIST F.SLEWING PLAT
CABLE LUG DIN 46235 10 - 95	60 23 010 08	(80)	1	2 920 536	96 48 317 08	WIRING LIST F.ELECTR.AGG
CABLE LUG DIN 46235 10 - 95	60 23 010 08	(80)	2	2 920 815	96 49 300 08	WIRING LIST BATTERY BOX
CABLE LUG DIN 46235 10 - 95	60 23 010 08	(80)	1	2 920 815	96 49 300 08	WIRING LIST BATTERY BOX
CABLE LUG DIN 46235 10 - 95	60 23 010 08	(80)	2	2 920 815	96 49 300 08	WIRING LIST BATTERY BOX
CABLE LUG DIN 46237 0,25 - 1,	60 22 184 08	112	3	2 920 633	96 52 651 08	WIRING HARNESS
CABLE LUG DIN 46237 3,5/2,5m	60 22 060 08	32	1	3 930 009	96 50 573 08	CABLE DRUM COMPL.
CABLE LUG DIN 46237 6 - 2,5	60 22 061 08	34	1	3 930 009	96 50 573 08	CABLE DRUM COMPL.
CABLE LUG DIN 46237 6 - 2,5	60 22 179 08	34	2	2 920 369	96 54 235 08	TERMINAL BOX CPL.
CABLE LUG DIN 46237 6 - 2,5	60 22 179 08	34	2	2 920 448	96 48 794 08	TERMINAL BOX CPL.
CABLE MARKING	92 35 122 08	(500)	2	2 920 288	96 52 614 08	WIRING LIST F.SLEWING PLAT
CABLE MARKING	92 35 122 08	(500)	3	2 920 288	96 52 614 08	WIRING LIST F.SLEWING PLAT
CABLE MARKING	92 35 122 08	(500)	1	2 920 369	96 54 235 08	TERMINAL BOX CPL.
CABLE MARKING	92 35 122 08	(500)	1	2 920 369	96 54 235 08	TERMINAL BOX CPL.
CABLE MARKING	92 35 122 08	(500)	1	2 920 369	96 54 235 08	TERMINAL BOX CPL.
CABLE MARKING	92 35 122 08	(500)	3	2 920 369	96 54 235 08	TERMINAL BOX CPL.
CABLE MARKING	92 35 122 08	(500)	3	2 920 369	96 54 235 08	TERMINAL BOX CPL.
CABLE MARKING	92 35 122 08	(500)	2	2 920 536	96 48 317 08	WIRING LIST F.ELECTR.AGG
CABLE MARKING	92 35 122 08	(500)	2	2 920 536	96 48 317 08	WIRING LIST F.ELECTR.AGG
CABLE MARKING	92 35 122 08	(500)	2	2 920 581	96 54 405 08	TERMINAL BOX WINCH PRE-A
CABLE MARKING	92 35 122 08	(500)	2	2 920 581	96 54 405 08	TERMINAL BOX WINCH PRE-A
CABLE MARKING	92 35 122 08	(500)	1	2 920 581	96 54 405 08	TERMINAL BOX WINCH PRE-A
CABLE MARKING	92 35 122 08	(500)	1	2 920 581	96 54 405 08	TERMINAL BOX WINCH PRE-A
CABLE MARKING	92 35 122 08	500	53	2 920 633	96 52 651 08	WIRING HARNESS
CABLE MARKING	92 35 122 08	500	3	2 920 636	96 51 854 08	LEAD
CABLE MARKING	92 35 122 08	(500)	2	2 920 815	96 49 300 08	WIRING LIST BATTERY BOX
CABLE MARKING	92 35 122 08	(500)	2	2 920 815	96 49 300 08	WIRING LIST BATTERY BOX
CABLE MARKING	92 35 122 08	(500)	2	2 920 815	96 49 300 08	WIRING LIST BATTERY BOX
CABLE MARKING	92 35 122 08	(500)	3	2 920 815	96 49 300 08	WIRING LIST BATTERY BOX
CABLE MARKING	92 35 122 08	500	9	3 930 732	96 50 575 08	LEAD
CABLE MARKING	92 35 122 08	(500)	1	3 930 734	96 54 401 08	TERMINAL BOX
CABLE MK307.4,5	10 43 030 5	20	1	2 925 405	96 48 397 08	EQUIPMENT CAMERA CAB
CABLE PLUG 4POL 4A	10 32 483 0	515	1	2 920 633	96 52 651 08	WIRING HARNESS
CABLE PLUG KSB693/7P	10 02 527 8	(1)	1	2 925 002	96 58 856 08	EQUIPMENT CAMERA SUPER
CABLE REEL 30M 6POLIG SPF	10 02 800 2	5	1	2 780 524	96 52 968 08	CABLE DRUM COMPL.
CABLE SLEEVE 1,9-2,5 SILIKO	10 47 304 7	(707)	19	2 920 581	96 54 405 08	TERMINAL BOX WINCH PRE-A
CABLE SLEEVE 1,9-2,5 SILIKO	10 47 304 7	707	18	3 930 732	96 50 575 08	LEAD
CABLE SLEEVE 10-13	60 27 040 08	164	1	3 930 009	96 50 573 08	CABLE DRUM COMPL.
CABLE SLEEVE 15-19 SILIKON	10 47 305 2	(712)	2	2 920 536	96 48 317 08	WIRING LIST F.ELECTR.AGG
CABLE SLEEVE 15-19 SILIKON	10 47 305 2	(712)	2	2 920 536	96 48 317 08	WIRING LIST F.ELECTR.AGG
CABLE SLEEVE 15-19 SILIKON	10 47 305 2	(712)	2	2 920 815	96 49 300 08	WIRING LIST BATTERY BOX
CABLE SLEEVE 2,4-3,0 SILIKO	10 47 304 8	(708)	7	2 920 369	96 54 235 08	TERMINAL BOX CPL.

6.2.2009

etk_en_de_074515 LR 1600/2

859

LIEBHERRAlphabetical index
Alphabetischer Index

Description	Item	Pos.	Quantity	Page	Assembly	Description
CABLE SLEEVE 2,4-3,0 SILIKO	10 47 304 8	(708)	24	2 920 369	96 54 235 08	TERMINAL BOX CPL.
CABLE SLEEVE 2,4-3,0 SILIKO	10 47 304 8	(708)	16	2 920 369	96 54 235 08	TERMINAL BOX CPL.
CABLE SLEEVE 2,4-3,0 SILIKO	10 47 304 8	708	2	2 920 633	96 52 651 08	WIRING HARNESS
CABLE SLEEVE 2,4-3,0 SILIKO	10 47 304 8	708	28	3 930 732	96 50 575 08	LEAD
CABLE SLEEVE 2,4-3,0 SILIKO	10 47 304 8	(708)	14	3 930 734	96 54 401 08	TERMINAL BOX
CABLE SLEEVE 3,0-7,0/3,0/0,6	60 27 100 08	97	2	2 920 633	96 52 651 08	WIRING HARNESS
CABLE SLEEVE 3,0-7,0/3,0/0,6	60 27 100 08	(97)	25	3 930 138	96 54 377 08	ELECTRIC FOR S-PIVOT SECT
CABLE SLEEVE 3,0-7,0/3,0/0,6	60 27 100 08	97	4	3 930 732	96 50 575 08	LEAD
CABLE SLEEVE 5,0-7,0/5,0/0,7	60 27 101 08	(98)	2	2 920 288	96 52 614 08	WIRING LIST F.SLEWING PLAT
CABLE SLEEVE 5,0-7,0/5,0/0,7	60 27 101 08	(98)	2	2 920 815	96 49 300 08	WIRING LIST BATTERY BOX
CABLE SLEEVE 5,0-7,0/5,0/0,7	60 27 101 08	(98)	2	2 920 815	96 49 300 08	WIRING LIST BATTERY BOX
CABLE SLEEVE 5,0-7,0/5,0/0,7	60 27 101 08	(98)	2	2 920 815	96 49 300 08	WIRING LIST BATTERY BOX
CABLE SOCK 25	60 27 011 08	28	1	1 750	91 52 394 08	TOOL
CABLE SOCK 30	60 27 099 08	29	1	1 750	91 52 394 08	TOOL
CABLE SOCK 8 - 15 700	60 27 073 08	153	1	3 930 732	96 50 575 08	LEAD
CABLE TIE 2,5X102	60 32 022 08	13	2	2 780 852	96 24 845 08	GSM-MODULE PRE-ASS.LICCO
CABLE TIE 2,5X102	60 32 022 08	8	2	2 913 004	96 20 460 08	HOUSING PRE-ASSEMBLED
CABLE TIE 2,5X102	60 32 022 08	11	1	2 913 006	96 20 732 08	FAN PLATE PRE-ASS.
CABLE TIE 2,5X102	60 32 022 08	50	25	2 932 001	96 45 393 08	RELAY CONTROL SYSTEM
CABLE TIE 2,5X102	60 32 022 08	268	100	2 932 116	96 54 388 08	CABLING MOUNTING PLATE
CABLE TIE 2,5X102	60 32 022 08	261	5	3 930 363	96 52 979 08	TERMINAL BOX CPL.
CABLE TIE 2,5X102	60 32 022 08	217	10	3 930 734	96 54 401 08	TERMINAL BOX
CABLE TIE 3,5X150XSCHWARZ	10 34 342 4	9	5	9 739 366	97 39 366	FASTENING PIECES ASSEMBL
CABLE TIE 3,6X150	60 32 003 08	261	10	1 920 418	96 48 687 08	TERMINAL BOX CPL.
CABLE TIE 3,6X150	60 32 003 08	261	1	2 920 633	96 52 651 08	WIRING HARNESS
CABLE TIE 3,6X150	60 32 003 08	261	1	2 920 636	96 51 854 08	LEAD
CABLE TIE 3,6X150	60 32 003 08	261	100	2 932 116	96 54 388 08	CABLING MOUNTING PLATE
CABLE TIE 3,6X200	60 32 004 08	154	5	2 780 524	96 52 968 08	CABLE DRUM COMPL.
CABLE TIE 3,6X200	60 32 004 08	267	100	2 932 116	96 54 388 08	CABLING MOUNTING PLATE
CABLE TIE 4,6X385 PA6.6-SW	10 02 093 1	10	3	9 739 366	97 39 366	FASTENING PIECES ASSEMBL
CABLE TIE 4,6X385 PA6.6-SW	10 02 093 1	37	2	9 739 492	97 39 492	PIPELINE INSTALLATION
CABLES MOUNTING PANEL CP	96 54 389 08	2	1	2 932 116	96 54 388 08	CABLING MOUNTING PLATE
CABLES MOUNTING PLATES,P	96 54 390 08	2	1	2 932 224	96 54 389 08	CABLES MOUNTING PANEL C
CABLING MOUNTING PLATE S	96 54 388 08	5	1	2 932 082	96 54 387 08	ASSEMBLY PARTS MOUNTIN
CAGE NUT M5	41 30 026 08	87	8	2 932 082	96 54 387 08	ASSEMBLY PARTS MOUNTIN
CAGE NUT M5	41 30 038 08	6	8	2 932 001	96 45 393 08	RELAY CONTROL SYSTEM
CAGE NUT M5	41 30 038 08	19	13	2 932 160	96 54 385 08	SWITCH CABINET
CAGE NUT M5 ST	10 45 528 1	27	6	2 502	91 55 939 08	CONTROL STAND
CAGE NUT M6	41 30 027 08	44	4	2 502	91 55 939 08	CONTROL STAND
CAGE NUT M6	41 30 028 08	57	1	2 520 034	96 45 984 08	INTERNAL LINING
CAGE NUT M6	41 30 029 08	373	12	2 391 001	96 45 719 08	DIESEL ENGINE, PRE-ASSEMB
CAGE NUT M8	41 30 031 08	4	1	2 520 033	96 50 633 08	MONITOR CONSOLE
CAGE NUT M8	41 30 032 08	61	12	1 400	91 56 853 08	CRAWLER TRACK CARRIER LE
CAGE NUT M8	41 30 032 08	61	12	1 410 300	91 56 855 08	CRAWLER CARRIER RIGHT CP
CAGE NUT M8	41 30 032 08	53	21	2 859	91 52 809 08	SOUND INSULATION
CAMERA CONTROL WINCH 3	91 60 840 08	324	1		LR 1600-2-0	
CAMERA EQUIPMENT D-PIVO	92 16 990 08	12	1	2 925 218	91 60 840 08	CAMERA CONTROL WINCH 3
CAMERA EQUIPMENT SLEWIN	96 58 855 08	3	1	2 925 002	96 58 856 08	EQUIPMENT CAMERA SUPER
CAMERA MONITORING DB	91 60 728 08	322	1		LR 1600-2-0	
CAMERA SPF	61 40 436 08	17	3	2 925 002	96 58 856 08	EQUIPMENT CAMERA SUPER
CAMERA SPF	61 40 451 08	(17)	1	2 925 218	91 60 840 08	CAMERA CONTROL WINCH 3
CAMS SHAFT R-MOTORXD 287	10 34 284 2	44	1	X1012059	10 12 059 0	DIESEL ENGINE
CAP	10 66 332 8	2	1	X1004047	10 04 047 7	WINCH REVOLUTION TRANS
CAP NUT DIN 1587 M6 6 A2C	41 21 001 08	8	6	2 520 031	96 45 610 08	REAR WINDOW PRE-ASS.
CARRIER	96 54 709 08	8	2	2 810 001	96 43 597 08	CRANE DRIVER'S CABIN,PRE
CARRIER RAIL	97 03 448 08	149	1	2 391 001	96 45 719 08	DIESEL ENGINE, PRE-ASSEMB
CARRIER RAIL	97 03 448 08	92	18	3 211	91 57 748 08	S PIVOT SECTION
CARRIER RAIL	97 03 448 08	139	2	3 713	91 57 749 08	D PIVOT SECTION
CARRIER RAIL	97 03 448 08	86	4	3 714	91 52 862 08	D HEAD SECTION
CARRIER RAIL 140	95 41 173 08	7	1	2 310	91 52 503 08	WINCH 1

6.2.2009

etk_en_de_074515 LR 1600/2

860

LIEBHERRAlphabetical index
Alphabetischer Index

Description	Item	Pos.	Quantity	Page	Assembly	Description
CARRIER RAIL 140	95 41 173 08	7	1	2 320	91 52 504 08	WINCH 2
CARRIER RAIL 140	95 41 173 08	156	1	2 970	91 56 537 08	HYDR
CARRIER RAIL 140	95 41 173 08	13	4	2 978 100	91 52 796 08	ADDNL.HYDR.ERECTION DEV
CARRIER RAIL 140	95 41 173 08	33	2	3 350	91 52 859 08	WINCH 3
CARRIER RAIL 190	95 41 286 08	23	1	2 671 004	96 46 305 08	OIL TANK PRE-ASS.
CARRIER RAIL 240	95 41 174 08	30	2	2 310	91 52 503 08	WINCH 1
CARRIER RAIL 240	95 41 174 08	30	2	2 320	91 52 504 08	WINCH 2
CARRIER RAIL 240	95 41 174 08	151	1	2 391 001	96 45 719 08	DIESEL ENGINE, PRE-ASSEMB
CARRIER RAIL 240	95 41 174 08	94	6	3 211	91 57 748 08	S PIVOT SECTION
CARRIER RAIL 240	95 41 174 08	137	2	3 713	91 57 749 08	D PIVOT SECTION
CARRIER RAIL 240	95 41 174 08	84	2	3 714	91 52 862 08	D HEAD SECTION
CARRIER RAIL 340	95 41 175 08	29	1	2 310	91 52 503 08	WINCH 1
CARRIER RAIL 340	95 41 175 08	29	1	2 320	91 52 504 08	WINCH 2
CARRIER RAIL 340	95 41 175 08	33	2	2 340	91 52 776 08	WINCH 4 LUFFING GEAR
CARRIER RAIL 340	95 41 175 08	93	2	3 211	91 57 748 08	S PIVOT SECTION
CARRIER RAIL 340	95 41 175 08	34	2	3 350	91 52 859 08	WINCH 3
CARRIER RAIL 340	95 41 175 08	138	28	3 713	91 57 749 08	D PIVOT SECTION
CARRIER RAIL 340	95 41 175 08	85	9	3 714	91 52 862 08	D HEAD SECTION
CARRIER RAIL 340	95 41 175 08	39	6	3 715 008	91 52 863 08	D INTERMEDIATE SECTION
CARRIER RAIL 340	95 41 175 08	44	12	3 716	91 52 864 08	D INTERMEDIATE SECTION
CARRYING BOLT M8	40 97 109 08	3	2	2 859 030	96 46 758 08	COVER COMPL.
CARRYING ROLLER 80/5/20X51	74 90 120 08	150	1	3 713	91 57 749 08	D PIVOT SECTION
CARRYING ROLLER 80/5/20X95	74 90 102 08	1	1	3 211 002	92 88 302 08	SAFETY ROLLER CPL.
CARTOUCHE	57 13 523 08	1	1	5 026 573	50 26 573 08	AIR DRYER
CATWALK CRAW.TRACK TRAV	91 52 388 08	16	1		LR 1600-2-0	
CCD CAMERA 20GRAD	10 02 895 4	18	1	2 925 002	96 58 856 08	EQUIPMENT CAMERA SUPER
CELL RUBBER 16X8 ZELKAU	10 02 810 7	9	0.16	2 913 004	96 20 460 08	HOUSING PRE-ASSEMBLED
CELL RUBBER 20X12	26 21 043 08	12	4.6	2 932 160	96 54 385 08	SWITCH CABINET
CELL RUBBER 20X8	26 21 010 08	10	3.91	2 859 005	96 46 756 08	FLAP PRE-ASS.
CELL RUBBER 20X8	26 21 010 08	115	0.36	2 932 082	96 54 387 08	ASSEMBLY PARTS MOUNTIN
CELL RUBBER 25X4 NEOPREN	26 21 078 14	52	6	2 520	91 53 061 08	CABIN, GLAZED
CELL RUBBER 3X6X10M	26 21 089 08	20	0.36	2 670	91 52 797 08	FUEL TANK CPL.
CELL RUBBER 3X6X10M	26 21 089 08	7	0.18	2 913 006	96 20 732 08	FAN PLATE PRE-ASS.
CELL RUBBER 8X10	26 21 091 08	9	3.7	2 520 030	96 45 609 08	ROOF WINDOW PRE-ASS.
CENT. LUBRIC. SYSTEM SUP	91 52 800 08	147	1		LR 1600-2-0	
CENTER SECTION WELDED	96 45 385 08	1	1	1 130	91 52 377 08	CENTRAL SECTION CRAWLER
CENTER STUD	57 01 146 08	3	1	5 701 133	57 01 133 08	DRIVING GEAR
CENTERING STANDARD B	91 52 950 08	350	1		LR 1600-2-0	
CENTRAL BALLAST 8X7.5T	91 53 020 08	22	1		LR 1600-2-0	
CENTRAL SECTION CRAWLER	91 52 377 08	4	1		LR 1600-2-0	
CENTRAL UNIT C1 8X2A GEP	91 44 006 08	3	6	2 932 122	96 45 394 08	LICCON ASSEMBLY UNIT
CENTRAL UNIT C1 8X2A GEP	91 44 006 08	16	1	2 932 160	96 54 385 08	SWITCH CABINET
CENTRALIZED LUBRICATION S	91 52 392 08	20	1		LR 1600-2-0	
CHAIN DIN 763 6X42 0.2t UST	74 00 002 08	4	2	2 311 001	96 25 639 08	HOIST LIM.SWITCH PLUMMET
CHAIN DIN 763 6X42 0.2t UST	74 00 002 08	45	0.5	3 208 001	91 52 883 08	F-HEAD SECTION
CHAIN DIN 763 6X42 0.2t UST	74 00 002 08	33	1.2	3 745	91 52 948 08	SUSPENDED BALLAST
CHAIN SUSPENSION	74 00 219 08	2	2	2 730	91 52 802 08	BASE PLATE SLEWING PLATF
CHAIR BACK	97 75 558 08	3	1	2 503 101	96 48 626 08	SEAT
CHAMFERED RING	10 01 215 9	6	1	9 739 246	97 39 246	PISTON
CHANGE-OVER BLOCK SPF	10 28 786 3	10	2	2 970	91 56 537 08	HYDR
CHARGE AIR CORRUGATED H	55 17 025 08	124	2	2 391 001	96 45 719 08	DIESEL ENGINE, PRE-ASSEMB
CHARGE AIR PIPE SPF	96 48 500 08	25	1	2 391 001	96 45 719 08	DIESEL ENGINE, PRE-ASSEMB
CHARGE AIR PIPE SPF	96 48 501 08	26	1	2 391 001	96 45 719 08	DIESEL ENGINE, PRE-ASSEMB
CHARGED AIR TUBE BEND SP	97 25 170 08	27	1	2 391 001	96 45 719 08	DIESEL ENGINE, PRE-ASSEMB
CHARGER 230V/24V/8A SPF	61 33 018 08	2	1	2 835	91 52 807 08	BATTERY CHARGER
CHECK SCREW	57 15 610 08	16	2	5 113 086	51 13 086 08	PROPORTIONAL VALVE
CHECK SCREW	57 18 141 08	35	1	5 113 086	51 13 086 08	PROPORTIONAL VALVE
CHECK SCREW	57 19 037 08	45	1	5 113 086	51 13 086 08	PROPORTIONAL VALVE
CHECKING NUT DIN 444 B M1	10 34 329 6	17	1	9 739 344	97 39 344	GENERATOR, PRE-ASSEMBLE
CHEESE HEAD SCREW DIN 60	40 28 026 14	7	8	2 925 402	96 58 855 08	CAMERA EQUIPMENT SLEWI

6.2.2009

etk_en_de_074515 LR 1600/2

861

LIEBHERRAlphabetical index
Alphabetischer Index

Description	Item	Pos.	Quantity	Page	Assembly	Description
CIGARETTE LIGHTER	10 42 905 8	20	1	2 533 050	96 48 359 08	EL.EQUIPMENT CABIN
CIRCLIP DIN 127 A 10 VERZ	42 40 008 08	70	4	2 550	91 57 751 08	SA FRAME
CIRCLIP DIN 127 A 10 VERZ	42 40 008 08	10	14	X1035519	10 35 519 6	OIL AIR COOLER
CIRCLIP DIN 127 A 12 VERZ	42 40 009 08	4	2	3 211 002	92 88 302 08	SAFETY ROLLER CPL.
CIRCLIP DIN 127 A 12 VERZ	42 40 009 08	152	2	3 713	91 57 749 08	D PIVOT SECTION
CIRCLIP DIN 127 A 6 VERZ	42 40 005 08	12	3	2 920 200	96 44 536 08	ELECTRIC FOR WINCH 1
CIRCLIP DIN 127 A 6 VERZ	42 40 005 08	12	3	2 920 260	96 44 537 08	ELECTRIC FOR WINCH 2
CIRCLIP DIN 127 A 6 VERZ	42 40 005 08	12	3	2 920 334	96 44 538 08	ELECTRIC FOR WINCH 3
CIRCLIP DIN 127 A 6 VERZ	42 40 005 08	12	3	2 920 350	96 44 539 08	ELECTRIC FOR WINCH 4
CIRCLIP DIN 127 A 6 VERZ	42 40 005 08	66	10	2 970	91 56 537 08	HYDR
CIRCLIP DIN 127 A 6 VERZ	42 40 005 08	52	2	2 975 100	91 52 860 08	ADDITIONAL HYDRAULICS WI
CIRCLIP DIN 127 A 6 VERZ	42 40 005 08	53	4	2 975 200	91 52 775 08	ADDITIONAL HYDRAULICS WI
CIRCLIP DIN 127 A 6 VERZ	42 40 005 08	53	4	2 975 700	91 52 774 08	ADDITIONAL HYDRAULICS WI
CIRCLIP DIN 127 A 8 VERZ	42 40 007 08	9	2	1 970	91 56 958 08	CRAWLER TRACK HYDRAULI
CIRCLIP DIN 127 A 8 VERZ	42 40 007 08	36	16	3 713	91 57 749 08	D PIVOT SECTION
CIRCLIP DIN 127 A 8 VERZ	42 40 007 08	5	4	5 106 691	51 06 691 08	RETURN FILTER
CIRCLIP DIN 128 2 FST A2B	10 03 064 0	7	2	2 913 007	96 20 763 08	CONTROLLER UNIT
CIRCLIP DIN 128 A 5 VERZ	42 40 004 08	33	7	2 920 083	96 48 319 08	ELECTRIC FOR BATTERY BOX
CIRCLIP DIN 128 A 5 VERZ	42 40 004 08	269	2	2 920 638	96 51 138 08	CONTROL DESK
CIRCLIP DIN 128 A 8	42 40 607 08	12	14	X1035519	10 35 519 6	OIL AIR COOLER
CIRCLIP DIN 7980 6 VERZ	42 41 006 08	8	6	5 102 306	51 02 306 08	HYDRO MOTOR
CIRCULAR BEARING B40X30X	72 69 042 08	5	4	2 391 038	96 47 931 08	OIL COOLER, PRE-ASSEMBLE
CIRCULATING PUMP	10 29 012 1	2	1	X1004204	10 04 204 3	WATER HEATING SYSTEM
CIRCULATING PUMP	55 31 353 08	2	1	5 530 545	55 30 545 08	CIRCULATING PUMP
CIRCULATING PUMP U4846	55 30 545 08	6	1	2 540	91 53 253 08	CLIMA-HEATING INSTALLATIO
CLADDING REAR PANEL	97 70 807 08	16	1	2 520 034	96 45 984 08	INTERNAL LINING
CLAMP	60 52 155 08	503	1	2 920 633	96 52 651 08	WIRING HARNESS
CLAMP	60 52 155 08	153	1	2 920 636	96 51 854 08	LEAD
CLAMP	92 16 963 08	1	1	2 925 204	92 16 990 08	CAMERA EQUIPMENT D-PIVOT
CLAMP	96 23 820 08	24	1	2 925 402	96 58 855 08	CAMERA EQUIPMENT SLEWI
CLAMP 40x127x24	95 70 394 08	2	4	2 550 010	96 45 685 08	ROD
CLAMP G21MN5V SPF	38 00 707 08	15	2	3 227 002	96 50 498 08	ROD CPL.
CLAMP T ZN O	96 51 406 08	1	1	2 925 402	96 58 855 08	CAMERA EQUIPMENT SLEWI
CLAMP WELDED CONST.	96 45 803 08	3	1	2 522 012	96 45 884 08	GUIDE PRE-ASS.
CLAMP WELDED CONST.	96 46 046 08	4	1	2 522 013	96 45 883 08	GUIDE PRE-ASS.
CLAMP WELDED CONST.	96 46 388 08	54	4	2 550	91 57 751 08	SA FRAME
CLAMP WELDED CONST.	96 47 493 08	1	1	2 550 008	96 47 628 08	RETAINER CPL.
CLAMP WELDED CONST.	96 47 644 08	1	1	2 550 009	96 47 645 08	RETAINER CPL.
CLAMP WELDED CONST.	96 48 733 08	46	1	2 520	91 53 061 08	CABIN, GLAZED
CLAMP WELDED CONST.	96 49 299 08	9	1	3 350	91 52 859 08	WINCH 3
CLAMP WELDED CONST.	96 50 831 08	65	2	3 714	91 52 862 08	D HEAD SECTION
CLAMP WELDED CONST.	96 53 255 08	1	1	2 391 040	96 53 645 08	CLUTCH ACTUATOR
CLAMP WELDED CONST.	96 53 928 08	28	4	3 350	91 52 859 08	WINCH 3
CLAMP X5CRNI18-10 T ZN O	96 45 743 08	25	1	2 925 402	96 58 855 08	CAMERA EQUIPMENT SLEWI
CLAMP-HALF 4X18	60 20 014 08	146	4	2 391 001	96 45 719 08	DIESEL ENGINE, PRE-ASSEMB
CLAMP-HALF DIN 3015-1 10 PP	60 20 078 08	156	2	2 391 001	96 45 719 08	DIESEL ENGINE, PRE-ASSEMB
CLAMP-HALF DIN 3015-1 15 PP	60 20 081 08	49	2	2 502	91 55 939 08	CONTROL STAND
CLAMP-HALF DIN 3015-1 18 AL	60 20 022 08	139	4	2 391 001	96 45 719 08	DIESEL ENGINE, PRE-ASSEMB
CLAMP-HALF DIN 3015-1 18 PP	60 20 083 08	9	6	2 550 008	96 47 628 08	RETAINER CPL.
CLAMP-HALF DIN 3015-1 18 PP	60 20 083 08	9	6	2 550 009	96 47 645 08	RETAINER CPL.
CLAMP-HALF DIN 3015-1 L 0 R	73 65 090	21	2	2 978 100	91 52 796 08	ADDNL.HYDR.ERECTION DEV
CLAMP-HALF DIN 3015-1 L 2 R	73 62 946	19	6	2 978 100	91 52 796 08	ADDNL.HYDR.ERECTION DEV
CLAMP-HALF DIN 3015-1 L 3 R	70 05 052	138	10	2 391 001	96 45 719 08	DIESEL ENGINE, PRE-ASSEMB
CLAMP-HALF DIN 3015-1 L 3 R	70 05 052	18	12	3 780 751	91 52 952 08	AIR-CRAFT & WIND WARNING
CLAMP-HALF DIN 3015-1 L 4 R	60 20 089 08	23	40	2 978 100	91 52 796 08	ADDNL.HYDR.ERECTION DEV
CLAMP-HALF DIN 3015-1 L 5 R	60 20 091 08	116	4	2 391 001	96 45 719 08	DIESEL ENGINE, PRE-ASSEMB
CLAMP-HALF DIN 3015-1 L 5 R	60 20 092 08	51	20	3 978 005	91 56 430 08	ADDL.HYDRAULIC SB-HEAD PI
CLAMP-HALF DIN 3015-1 L 5 R	60 20 092 08	51	40	3 978 015	91 56 429 08	ADDITIONAL HYDRAULICS IN
CLAMP-HALF DIN 3015-1 L 5 R	60 20 092 08	51	40	3 978 015	91 56 432 08	ADDITIONAL HYDRAULICS IN
CLAMP-HALF DIN 3015-1 L5R 4	60 20 094 08	145	1	2 391 001	96 45 719 08	DIESEL ENGINE, PRE-ASSEMB

6.2.2009

etk_en_de_074515 LR 1600/2

862

LIEBHERRAlphabetical index
Alphabetischer Index

Description	Item	Pos.	Quantity	Page	Assembly	Description
CLAMP-HALF DIN 3015-1 L5R 4	60 20 094 08	26	2	2 671 004	96 46 305 08	OIL TANK PRE-ASS.
CLAMP-HALF DIN 3015-1 L6R 5	74 13 103	117	4	2 391 001	96 45 719 08	DIESEL ENGINE, PRE-ASSEMB
CLAMPING BOARD 6XM6	60 44 124 08	1	1	1 830 102	92 26 483 08	TERMINAL BOARD PRE-ASS.
CLAMPING DISK	10 47 043 4	3	1	X1042954	10 42 954 9	WIND VELOCITY TRANSMITTE
CLAMPING LEVER STAHL 5.8	10 01 719 2	5	4	2 925 402	96 58 855 08	CAMERA EQUIPMENT SLEWI
CLAMPING PIECE PA6G+OEL	97 68 737 08	4	4	2 925 402	96 58 855 08	CAMERA EQUIPMENT SLEWI
CLAMPING PROFILE EPDM	10 30 060 5	17	3.88	2 520	91 53 061 08	CABIN, GLAZED
CLAMPING PROFILE EPDM	10 30 060 5	18	2.1	2 520	91 53 061 08	CABIN, GLAZED
CLAMPING PROFILE EPDM/M	10 30 060 0	13	4.5	2 522	91 54 115 08	SLIDING DOOR CPL.
CLAW SINT-D39	90 78 321	5	1	9 739 248	97 39 248	INJECTOR
CLIMA-HEATING INSTALLATIO	91 53 253 08	10	1	2 520	91 53 061 08	CABIN, GLAZED
CLIP 23 ST	10 21 653 4	61	2	2 831	91 57 754 08	AIR COND. UNIT SUPERSTRU
CLOGGING INDICATOR	51 06 693 08	10	1	2 671 004	96 46 305 08	OIL TANK PRE-ASS.
CLOGGING INDICATOR	51 06 693 08	50	1	5 106 691	51 06 691 08	RETURN FILTER
CLOGGING INDICATOR	57 13 561 08	(4)	1	2 970	91 56 537 08	HYDR
CLOSE TOLERANCE GROOV	43 11 037 08	6	4	3 291	91 52 831 08	S OVERRUN PROTECTION
CLOSE TOLERANCE GROOV	43 11 037 08	11	4	3 292	91 52 865 08	D OVERRUN PROTECTION
CLOSING DEVICE SCHIEBET	96 45 602 08	10	1	2 522	91 54 115 08	SLIDING DOOR CPL.
CLOSING NIPPLE	51 15 062 08	13	1	2 990	91 59 244 08	COMPRESSED AIR PLANT
CLOSING PIN ST	10 34 246 3	4	1	2 522 011	96 45 602 08	CLOSING DEVICE
CLOSING RING	57 01 136 08	4	1	5 701 129	57 01 129 08	DRIVING GEAR
CLOSURE	70 42 624 08	53	1	3 206	91 52 881 08	PIVOT SECTION
CLOSURE	70 42 624 08	41	2	3 214	91 52 843 08	SW HEAD SECTION
CLUTCH ACTUATOR	96 53 645 08	13	1	2 391 001	96 45 719 08	DIESEL ENGINE, PRE-ASSEMB
COAT HOOK	59 10 501 08	32	2	2 520 034	96 45 984 08	INTERNAL LINING
COLLECTING PIPE	92 79 826 08	61	1	2 391 001	96 45 719 08	DIESEL ENGINE, PRE-ASSEMB
COLLECTING PIPE	92 79 826 08	140	2	2 970	91 56 537 08	HYDR
COLLECTING PIPE WELDED	92 15 428 08	141	1	2 970	91 56 537 08	HYDR
COLLECTING PIPE WELDED	92 57 933 08	62	1	2 391 001	96 45 719 08	DIESEL ENGINE, PRE-ASSEMB
COLLECTING RING 24V SPF	69 09 010 08	10	1	1 920 305	92 15 300 08	INSTALLAT.ROTOR+SLIPRING
COMBI PLIERS DIN 5244 180	79 00 315 08	12	1	1 750	91 52 394 08	TOOL
COMPRESSED AIR PLANT	91 59 244 08	177	1		LR 1600-2-0	
COMPRESSED-AIR CYLINDER	10 01 752 1	5	1	9 739 186	97 39 186	MOTOR BRAKE
COMPRESSED-AIR CYLINDER	10 33 276 5	12	1	9 739 357	97 39 357	EXHAUST GAS RECIRCUL.PRE
COMPRESSION PAD	24 01 915 02	15	1	2 391 040	96 53 645 08	CLUTCH ACTUATOR
COMPRESSION PAD	70 30 031 01	20	1	2 522 011	96 45 602 08	CLOSING DEVICE
COMPRESSION RING	50 29 326 08	48	1	2 393	91 52 787 08	AIR FILTER UNIT CPL.
COMPRESSION RING DR/R22	50 29 325 08	598	4	2 990	91 59 244 08	COMPRESSED AIR PLANT
COMPRESSION RING DR/R26	50 29 328 08	404	2	2 391 001	96 45 719 08	DIESEL ENGINE, PRE-ASSEMB
CONICAL BEARING 70NR11	10 29 198 9	6	4	2 810	91 52 806 08	CRANE DRIVER'S CABIN CPL.
CONNECTING CABLE 8 X 0,37	10 45 542 1	15	1	2 925 002	96 58 856 08	EQUIPMENT CAMERA SUPER
CONNECTING ELEMENT SPF	10 33 216 1	2	2	2 372	91 33 648 08	ROPE WITH ACCESSORIES
CONNECTING LINE	97 39 271	126	1	X1012059	10 12 059 0	DIESEL ENGINE
CONNECTING LINK PRE-ASS.	96 49 847 08	1	2	3 745 011	96 49 677 08	BRACKET COMPL.
CONNECTING LINK PRE-ASS.	96 48 638 08	1	2	3 830	91 55 535 08	SUPPLEMENTARY GUYING D
CONNECTING NIPPLE G 1/4"	57 17 230 08	3	1	5 123 682	51 23 682 08	MOUNTING - PISTON W. PUM
CONNECTING PIN WELDED	96 43 771 08	21	2	3 211	91 57 748 08	S PIVOT SECTION
CONNECTING PIN WELDED	96 43 771 08	15	8	3 220 500	91 52 849 08	S INTERMEDIATE SECTION
CONNECTING PIN WELDED	96 43 771 08	9	8	3 221	91 54 668 08	S INTERMEDIATE SECTION
CONNECTING PIN WELDED	96 43 771 08	15	8	3 223	91 52 852 08	S INTERMEDIATE SECTION
CONNECTING PIN WELDED	96 43 771 08	15	8	3 223 010	91 52 853 08	S INTERMEDIATE SECTION
CONNECTING PIN WELDED	96 43 771 08	15	8	3 223 100	91 55 327 08	S INTERMEDIATE SECTION
CONNECTING PIN WELDED	96 43 771 08	17	4	3 225	91 52 854 08	SL REDUCING SECTION
CONNECTING PIN WELDED	96 43 771 08	15	4	3 226	91 52 870 08	L INTERMEDIATE SECTION
CONNECTING PIN WELDED	96 43 771 08	15	8	3 227	91 52 873 08	L INTERMEDIATE SECTION
CONNECTING PIN WELDED	96 43 771 08	20	2	3 227 002	96 50 498 08	ROD CPL.
CONNECTING PIN WELDED	96 43 771 08	15	8	3 227 008	91 52 872 08	L INTERMEDIATE SECTION
CONNECTING PIN WELDED	96 43 771 08	15	10	3 227 200	91 53 519 08	LI INTERMEDIATE SECT. F-GU
CONNECTING PIN WELDED	96 43 771 08	53	4	3 713	91 57 749 08	D PIVOT SECTION
CONNECTING PIN WELDED	96 43 771 08	55	4	3 714	91 52 862 08	D HEAD SECTION

6.2.2009

etk_en_de_074515 LR 1600/2

863

LIEBHERRAlphabetical index
Alphabetischer Index

Description	Item	Pos.	Quantity	Page	Assembly	Description
CONNECTING PIN WELDED	96 43 771 08	4	8	3 715 008	91 52 863 08	D INTERMEDIATE SECTION
CONNECTING PIN WELDED	96 43 771 08	4	10	3 716	91 52 864 08	D INTERMEDIATE SECTION
CONNECTING PIN WELDED FE	96 47 595 08	12	1	3 211 003	96 46 986 08	ROD CPL.
CONNECTING ROD BEARING	10 01 215 0	3	1	9 739 287	97 39 287	MAIN ROD
CONNECTING ROD BEARING	10 01 215 2	52	1	9 739 287	97 39 287	MAIN ROD
CONNECTING ROD BEARING	10 01 215 3	53	1	9 739 287	97 39 287	MAIN ROD
CONNECTING ROD BEARING	10 01 215 4	54	1	9 739 287	97 39 287	MAIN ROD
CONNECTING ROD BEARING	10 01 215 5	55	1	9 739 287	97 39 287	MAIN ROD
CONNECTION BLOCK PSV4	96 40 276 08	1	1	5 133 090	51 13 090 08	SLIDE VALVE BLOCK
CONNECTION CABLE 10 X 0,1	10 45 478 3	(11)	1	2 925 026	91 55 259 08	ERG. CAMERA CONTROL
CONNECTION CABLE 10 X 0,1	10 45 478 3	11	1	2 925 405	96 48 397 08	EQUIPMENT CAMERA CAB
CONNECTION F.WATER PIPE	97 39 349	169	1	X1012059	10 12 059 0	DIESEL ENGINE
CONNECTION FLANGE	51 10 561 08	41	1	2 975 200	91 52 775 08	ADDITIONAL HYDRAULICS WI
CONNECTION FLANGE	51 10 561 08	41	1	2 975 700	91 52 774 08	ADDITIONAL HYDRAULICS WI
CONNECTION FLANGE 85X85	51 10 624 08	126	1	2 970	91 56 537 08	HYDR
CONNECTION FLANGE ALZNM	51 10 623 08	40	1	2 975 100	91 52 860 08	ADDITIONAL HYDRAULICS WI
CONNECTION PIECE	10 22 277 2	1	1	9 739 282	97 39 282	OVERFLOW-OIL LINE
CONNECTION PIECE	57 00 734 08	12	1	5 114 320	51 14 320 08	PRETENSIONING VALVE
CONNECTION PIECE M14X1,5/	77 43 832 08	17	8	1 711	91 52 392 08	CENTRALIZED LUBRICATION
CONNECTOR PLUG A	60 23 370 08	(153)	3	2 932 001	96 45 393 08	RELAY CONTROL SYSTEM
CONSOLE	10 01 749 3	2	1	9 739 186	97 39 186	MOTOR BRAKE
CONSOLE	10 34 317 4	1	1	9 739 360	97 39 360	MOTOR SUPPORT
CONSOLE	10 34 317 6	10	1	9 739 360	97 39 360	MOTOR SUPPORT
CONSOLE	10 34 331 8	13	1	9 739 371	97 39 371	AIR COND. COMPRESSOR A
CONSOLE	77 42 157 08	76	2	2 970	91 56 537 08	HYDR
CONSOLE	77 42 157 08	12	4	2 978 100	91 52 796 08	ADDNL.HYDR.ERECTION DEV
CONSOLE	92 17 245 08	1	1	3 745 002	92 17 236 08	SWITCH UNIT
CONSOLE	92 17 251 08	1	1	3 745 003	92 17 237 08	SWITCH UNIT
CONSOLE	96 50 735 08	93	1	3 713	91 57 749 08	D PIVOT SECTION
CONSOLE	96 50 968 08	95	1	3 713	91 57 749 08	D PIVOT SECTION
CONSOLE	96 56 719 08	50	2	3 223 100	91 55 327 08	S INTERMEDIATE SECTION
CONSOLE COMPL.	96 47 007 08	60	2	2 550	91 57 751 08	SA FRAME
CONTACT 0,5 - 1,0	60 23 003 08	(125)	14	2 920 369	96 54 235 08	TERMINAL BOX CPL.
CONTACT 0,5 - 1,0	60 23 003 08	(125)	9	2 920 369	96 54 235 08	TERMINAL BOX CPL.
CONTACT PIN	60 56 017 08	130	6	2 920 633	96 52 651 08	WIRING HARNESS
CONTACT RETAINING PIN 15	10 09 986 7	513	1	2 932 224	96 54 389 08	CABLES MOUNTING PANEL C
CONTACT RETAINING PIN 21	10 09 986 8	519	2	2 932 224	96 54 389 08	CABLES MOUNTING PANEL C
CONTAINER 2,5 KG	10 03 827 1	25	1	7 743 566	77 43 566 08	ELECTRIC PUMP
CONTAINER COVER	10 40 981 7	21	1	7 743 566	77 43 566 08	ELECTRIC PUMP
CONTAINER PLUG	57 00 662 08	4	1	5 028 065	50 28 065 08	EQUALIZING RESERVOIR
CONTROL BLOCK	51 13 005 08	23	1	2 970	91 56 537 08	HYDR
CONTROL BLOCK 350 BAR SP	10 42 440 2	19	1	2 970	91 56 537 08	HYDR
CONTROL BOX MB 618	10 33 264 0	10	1	2 925 002	96 58 856 08	EQUIPMENT CAMERA SUPER
CONTROL DESK A570	96 51 138 08	1	1	2 920 637	96 51 136 08	CONTROL DESK
CONTROL DESK DB	96 51 136 08	28	1	2 920	91 56 833 08	ELECTR. SYSTEM F.SLEWING
CONTROL ELEMENT	10 65 069 2	5	1	X1035924	10 35 924 9	VARIABLE PUMP
CONTROL GEAR	90 80 702	72	1	9 739 400	97 39 400	DIESEL ENGINE
CONTROL GEAR 24V	10 27 869 8	1	1	X1004204	10 04 204 3	WATER HEATING SYSTEM
CONTROL LEAD 19X0,5 SPF	60 04 640 08	(5)	14.86	2 920 581	96 54 405 08	TERMINAL BOX WINCH PRE-A
CONTROL LEAD 19X0,5 SPF	60 04 640 08	5	3.1	2 920 633	96 52 651 08	WIRING HARNESS
CONTROL LEAD 19X0,5 SPF	60 04 640 08	6	2.7	2 920 633	96 52 651 08	WIRING HARNESS
CONTROL LEAD 19X0,5 SPF	60 04 640 08	7	5.9	2 920 633	96 52 651 08	WIRING HARNESS
CONTROL LEAD 19X0,5 SPF	60 04 640 08	(5)	15.43	3 930 734	96 54 401 08	TERMINAL BOX
CONTROL LEAD 4X0,5 SPF	60 04 604 08	5	6.95	2 920 636	96 51 854 08	LEAD
CONTROL LEAD 8X0,5C+16X0	60 04 407 08	5	39.12	3 930 732	96 50 575 08	LEAD
CONTROL PARTS	97 39 187	46	6	X1012059	10 12 059 0	DIESEL ENGINE
CONTROL STAND	91 55 939 08	129	1		LR 1600-2-0	
CONTROL UNIT	10 29 184 0	5	1	X1035924	10 35 924 3	VARIABLE PUMP
CONTROL UNIT	10 29 184 0	5	1	X1035924	10 35 924 4	VARIABLE PUMP
CONTROL UNIT	10 47 138 4	5	1	X1035924	10 35 924 6	VARIABLE PUMP

6.2.2009

etk_en_de_074515 LR 1600/2

864

LIEBHERRAlphabetical index
Alphabetischer Index

Description	Item	Pos.	Quantity	Page	Assembly	Description
CONTROL UNIT	57 19 113 08	5	1	X1035924	10 35 924 1	VARIABLE PUMP
CONTROL UNIT	57 19 113 08	5	1	X1035924	10 35 924 2	VARIABLE PUMP
CONTROL VALVE	10 11 497 5	40	1	X1035925	10 35 925 1	VARIABLE PUMP
CONTROLLER BOARD KOMP.	10 04 375 9	20	1	2 913 005	96 28 696 08	INTERIOR HOUSING PRE-ASS.
CONTROLLER BOARD LSB-BS	10 04 375 7	1	1	2 913 007	96 20 763 08	CONTROLLER UNIT
CONTROLLER BOARD LSB-CP	10 04 376 0	2	1	2 913 007	96 20 763 08	CONTROLLER UNIT
CONTROLLER UNIT BSE-LSB	96 20 763 08	20	1	2 913 005	96 20 731 08	INTERIOR HOUSING PRE-ASS.
CONTROLS AND FITTINGS RI	96 48 363 08	5	1	2 533	91 52 789 08	EL.INSTRUMENTS F.CRANE D
CONVERTOR TTY-RS232	91 70 454 14	10	1	2 533 071	96 52 556 08	CONVERTOR
CONVERTOR TTY-RS232	96 52 556 08	8	1	2 533	91 52 789 08	EL.INSTRUMENTS F.CRANE D
COOLANT PIPE BEND	10 34 286 8	11	1	9 739 349	97 39 349	CONNECTION F.WATER PIPE
COOLANT PREHEATING	97 39 129	282	1	X1012059	10 12 059 0	DIESEL ENGINE
COOLANT PUMP	10 34 287 1	1	1	9 739 352	97 39 352	AT-WATER PUMP WITH FAST
COOLING AGENT R 134 A	86 16 012 08	8	2.2	2 831	91 57 754 08	AIR COND. UNIT SUPERSTRU
COOLING BODY 84X12X7,7 AL	10 00 812 5	13	1	2 913 005	96 20 731 08	INTERIOR HOUSING PRE-ASS.
COOLING BODY 84X12X7,7 AL	10 00 812 5	13	1	2 913 005	96 28 696 08	INTERIOR HOUSING PRE-ASS.
COOLING MEDIUM PIPELINE	97 39 351	166	1	X1012059	10 12 059 0	DIESEL ENGINE
COOLING WATER HOSE 10X4,	77 42 306 08	250	2	2 391 001	96 45 719 08	DIESEL ENGINE, PRE-ASSEMB
COOLING WATER HOSE 18X3,	77 42 329 08	20	20	2 540	91 53 253 08	CLIMA-HEATING INSTALLATIO
COOLING WATER HOSE 18X3,	77 42 329 08	17	10	2 541	91 52 790 08	ADD HEATING SUPERSTRUCT
COOLING WATER HOSE DN32	77 42 307 08	133	2	2 391 001	96 45 719 08	DIESEL ENGINE, PRE-ASSEMB
COOLING WATER LINE	10 01 231 4	1	1	9 739 127	97 39 127	WATER BLEEDER PIPELINE
COOLING WATER PREHEATIN	10 01 234 3	1	1	9 739 129	97 39 129	COOLANT PREHEATING
COUNTERSUNK SCREW DIN	40 86 013 08	98	9	2 550	91 57 751 08	SA FRAME
COUNTERSUNK SCREW DIN	40 86 062 08	346	2	2 391 001	96 45 719 08	DIESEL ENGINE, PRE-ASSEMB
COUNTERSUNK SCREW DIN	40 86 027 08	54	2	3 745	91 52 948 08	SUSPENDED BALLAST
COUNTERSUNK SCREW DIN 7	40 86 035 08	33	4	2 502	91 55 939 08	CONTROL STAND
COUNTERSUNK SCREW DIN 7	40 86 035 08	30	2	2 520	91 53 061 08	CABIN, GLAZED
COUNTERSUNK SCREW DIN 7	40 86 035 08	34	2	2 533 070	96 48 363 08	CONTROLS AND FITTINGS RI
COUNTERSUNK SCREW DIN	40 86 042 08	41	4	2 391 040	96 53 645 08	CLUTCH ACTUATOR
COUNTERSUNK SCREW DIN	40 86 040 08	57	2	2 631	91 56 817 08	SLEWING PLATFORM CATWAL
COUNTERSUNK SCREW DIN	40 86 040 08	4	1	2 780 851	96 24 498 08	RADIO ANTENNA PRE-ASS.
COUNTERSUNK SCREW DIN	40 86 040 08	8	1	2 780 852	96 24 845 08	GSM-MODULE PRE-ASS.LICCO
COUNTERSUNK SCREW DIN 7	40 86 002 08	5	8	2 510	91 52 788 08	TURNTABLE PANELLING
COUNTERSUNK SCREW DIN 7	40 86 002 08	4	4	2 510 040	96 49 183 08	DOOR COMPL.
COUNTERSUNK SCREW DIN 7	40 86 002 08	4	4	2 510 059	96 49 184 08	DOOR COMPL.
COUNTERSUNK SCREW DIN 7	40 86 002 08	25	4	2 522 011	96 45 602 08	CLOSING DEVICE
COUNTERSUNK SCREW DIN 7	40 86 002 08	10	16	2 932 160	96 54 385 08	SWITCH CABINET
COUNTERSUNK SCREW DIN 7	40 86 002 08	115	8	2 970	91 56 537 08	HYDR
COUNTERSUNK SCREW DIN 7	40 86 002 08	5	11	3 713 013	96 57 159 08	SHEET CPL.
COUNTERSUNK SCREW DIN 7	40 86 002 08	21	3	3 978 015	91 56 429 08	ADDITIONAL HYDRAULICS IN
COUNTERSUNK SCREW DIN 7	40 86 002 08	21	3	3 978 015	91 56 432 08	ADDITIONAL HYDRAULICS IN
COUNTERSUNK SCREW DIN 7	40 86 041 08	45	4	2 502	91 55 939 08	CONTROL STAND
COUNTERSUNK SCREW DIN 7	40 86 041 08	29	10	2 520	91 53 061 08	CABIN, GLAZED
COUNTERSUNK SCREW DIN 7	40 86 041 08	8	6	2 520 030	96 45 609 08	ROOF WINDOW PRE-ASS.
COUNTERSUNK SCREW DIN 7	40 86 041 08	5	4	2 520 031	96 45 610 08	REAR WINDOW PRE-ASS.
COUNTERSUNK SCREW DIN	40 86 036 08	25	1	2 522	91 54 115 08	SLIDING DOOR CPL.
COUNTERSUNK SCREW DIN 7	40 86 043 08	11	4	3 211 009	96 46 979 08	SAFETY ROLLER CPL.
COUNTERSUNK SCREW DIN 7	40 86 005 08	51	8	3 211	91 57 748 08	S PIVOT SECTION
COUNTERSUNK SCREW DIN 7	40 86 005 08	32	16	3 713	91 57 749 08	D PIVOT SECTION
COUNTERSUNK SCREW DIN 7	40 86 007 08	41	3	3 206	91 52 881 08	PIVOT SECTION
COUNTERSUNK SCREW DIN 7	40 86 007 08	3	4	3 714 017	96 50 752 08	SUPPORT CPL.
COUNTERSUNK SCREW DIN 7	40 86 008 08	53	2	2 550	91 57 751 08	SA FRAME
COUNTERSUNK SCREW DIN 7	40 86 010 08	20	4	2 502	91 55 939 08	CONTROL STAND
COUNTERSUNK SCREW DIN 7	40 86 049 08	20	4	2 370	91 52 782 08	ERECTING WINCH
COUNTERSUNK SCREW DIN 7	40 86 049 08	65	12	2 810	91 52 806 08	CRANE DRIVER'S CABIN CPL.
COUNTERSUNK SCREW DIN 9	40 04 016 08	17	8	2 260 006	96 46 501 08	BATTERY BOX, PRE-ASSEMB
COUNTERSUNK SCREW DIN	40 70 317 08	81	2	2 550	91 57 751 08	SA FRAME
COUNTERSUNK SCREW DIN 9	40 06 034 08	21	6	2 671 004	96 46 305 08	OIL TANK PRE-ASS.
COUNTERSUNK SCREW DIN 9	40 06 035 08	268	2	2 920 638	96 51 138 08	CONTROL DESK

6.2.2009

etk_en_de_074515 LR 1600/2

865

LIEBHERRAlphabetical index
Alphabetischer Index

Description	Item	Pos.	Quantity	Page	Assembly	Description
COUNTERSUNK SCREW ISO 7	40 70 608 08	4	8	2 913 102	92 32 870 08	FAN UNIT
COUNTERWEIGHT 16X7.5T +	91 52 770 08	152	1		LR 1600-2-0	
COUNTERWEIGHT SPF	38 82 792 08	2	6	2 740	91 52 770 08	COUNTERWEIGHT
COUNTERWEIGHT SPF	97 66 580 08	1	8	1 740	91 53 020 08	CENTRAL BALLAST
COUNTERWEIGHT SPF	97 66 580 08	1	16	2 740	91 52 770 08	COUNTERWEIGHT
COUPLING PLUG	77 43 727 08	17	24	2 711	91 52 800 08	CENT. LUBRIC. SYSTEM SUP
COUPLING PLUG 10-L	51 15 083 08	107	1	2 970	91 56 537 08	HYDR
COUPLING PLUG 10-L	51 15 083 08	7	1	2 970 081	96 50 495 08	ADDL.HYDR.F.PIN PULLING DE
COUPLING PLUG 10-L	51 15 083 08	20	2	2 975 100	91 52 860 08	ADDITIONAL HYDRAULICS WI
COUPLING PLUG 12-L	51 15 096 08	99	2	2 970	91 56 537 08	HYDR
COUPLING PLUG 12-L	51 15 096 08	35	2	2 975 100	91 52 860 08	ADDITIONAL HYDRAULICS WI
COUPLING PLUG 12-L	51 15 096 08	35	1	2 975 200	91 52 775 08	ADDITIONAL HYDRAULICS WI
COUPLING PLUG 12-L	51 15 096 08	35	1	2 975 700	91 52 774 08	ADDITIONAL HYDRAULICS WI
COUPLING PLUG 12-L	51 15 096 08	7	3	2 976 200	91 44 034 08	AUX.HYDR.PIN EXTRACTION
COUPLING PLUG 12-L	51 15 096 08	7	1	2 976 203	92 27 489 08	ADDL.HYDR.F.PIN PULLING DE
COUPLING PLUG 12-L	51 15 096 08	18	1	3 978 005	91 56 430 08	ADDL.HYDRAULIC SB-HEAD PI
COUPLING PLUG 12-L	51 15 096 08	13	1	3 978 015	91 56 429 08	ADDITIONAL HYDRAULICS IN
COUPLING PLUG 12-L	51 15 096 08	13	1	3 978 015	91 56 432 08	ADDITIONAL HYDRAULICS IN
COUPLING PLUG 12-S	51 15 013 08	23	1	1 970	91 56 958 08	CRAWLER TRACK HYDRAULI
COUPLING PLUG 15-L	51 15 004 08	105	4	2 970	91 56 537 08	HYDR
COUPLING PLUG 15-L	51 15 004 08	13	1	2 970 081	96 50 495 08	ADDL.HYDR.F.PIN PULLING DE
COUPLING PLUG 15-L	51 15 004 08	37	2	2 975 100	91 52 860 08	ADDITIONAL HYDRAULICS WI
COUPLING PLUG 15-L	51 15 004 08	11	1	2 976 200	91 44 034 08	AUX.HYDR.PIN EXTRACTION
COUPLING PLUG 15-L	51 15 004 08	24	2	2 977 200	91 55 149 08	ADDITIONAL HYDR.PUMP/WI
COUPLING PLUG 15-L	51 15 004 08	14	3	3 713 013	96 57 159 08	SHEET CPL.
COUPLING PLUG 16-S	51 15 086 08	41	2	1 970	91 56 958 08	CRAWLER TRACK HYDRAULI
COUPLING PLUG 16-S	51 15 086 08	94	2	2 970	91 56 537 08	HYDR
COUPLING PLUG 16-S	51 15 086 08	41	1	2 977	91 57 756 08	ADDITIONAL HYDR.SLEWING
COUPLING PLUG 16-S	51 15 086 08	43	1	2 977	91 57 756 08	ADDITIONAL HYDR.SLEWING
COUPLING PLUG 16-S	51 15 086 08	25	1	2 978 100	91 52 827 08	ADDNL.HYDR.RETAINING DEV
COUPLING PLUG 16-S	51 15 086 08	25	1	2 978 200	91 54 843 08	ADD.HYDR.S_RETAINING RAM
COUPLING PLUG 18-L	57 05 048 08	13	1	2 976 200	91 44 034 08	AUX.HYDR.PIN EXTRACTION
COUPLING PLUG 22-L	51 15 081 08	89	5	2 970	91 56 537 08	HYDR
COUPLING PLUG 22-L	51 15 081 08	30	1	2 975 100	91 52 860 08	ADDITIONAL HYDRAULICS WI
COUPLING PLUG 22-L	51 15 081 08	23	1	2 978 100	91 52 827 08	ADDNL.HYDR.RETAINING DEV
COUPLING PLUG 25-S	51 05 997 08	86	3	2 970	91 56 537 08	HYDR
COUPLING PLUG 25-S	51 05 997 08	27	1	2 975 100	91 52 860 08	ADDITIONAL HYDRAULICS WI
COUPLING PLUG 25-S	51 05 997 08	40	1	2 977	91 57 756 08	ADDITIONAL HYDR.SLEWING
COUPLING PLUG 25-S	51 05 997 08	26	2	2 978 100	91 52 796 08	ADDNL.HYDR.ERECTION DEV
COUPLING PLUG 25-S	51 05 997 08	21	1	2 978 100	91 52 827 08	ADDNL.HYDR.RETAINING DEV
COUPLING PLUG 28-L	51 15 011 08	37	2	1 970	91 56 958 08	CRAWLER TRACK HYDRAULI
COUPLING PLUG 28-L	51 15 011 08	91	1	2 970	91 56 537 08	HYDR
COUPLING PLUG 28-L	51 15 011 08	32	2	2 975 100	91 52 860 08	ADDITIONAL HYDRAULICS WI
COUPLING PLUG 28-L	51 15 011 08	37	1	2 977	91 57 756 08	ADDITIONAL HYDR.SLEWING
COUPLING PLUG 28-L	51 15 011 08	20	1	2 977 200	91 55 149 08	ADDITIONAL HYDR.PUMP/WI
COUPLING PLUG 28-L	51 15 011 08	33	1	3 978 100	91 56 428 08	HYDR. SUSPENDED BALLAST
COUPLING PLUG 30-S	51 15 108 08	31	1	3 978 100	91 56 428 08	HYDR. SUSPENDED BALLAST
COUPLING PLUG 38-S	51 15 123 08	33	4	1 970	91 56 958 08	CRAWLER TRACK HYDRAULI
COUPLING PLUG 38-S	51 15 123 08	82	6	2 970	91 56 537 08	HYDR
COUPLING PLUG 38-S	51 15 123 08	23	4	2 975 100	91 52 860 08	ADDITIONAL HYDRAULICS WI
COUPLING PLUG 38-S	51 15 123 08	33	4	2 977	91 57 756 08	ADDITIONAL HYDR.SLEWING
COUPLING PLUG 38-S	51 15 123 08	13	2	2 977 200	91 55 149 08	ADDITIONAL HYDR.PUMP/WI
COUPLING PLUG 38-S	51 15 123 08	14	1	3 978 005	91 56 430 08	ADDL.HYDRAULIC SB-HEAD PI
COUPLING PLUG 38-S	51 15 123 08	5	2	3 978 015	91 56 429 08	ADDITIONAL HYDRAULICS IN
COUPLING PLUG 38-S	51 15 123 08	5	2	3 978 015	91 56 432 08	ADDITIONAL HYDRAULICS IN
COUPLING PLUG BGR.8 35-L	51 15 185 08	46	1	2 977	91 57 756 08	ADDITIONAL HYDR.SLEWING
COUPLING SILIKON 60SH	10 42 823 9	128	1	2 391 001	96 45 719 08	DIESEL ENGINE, PRE-ASSEMB
COUPLING SLEEVE	51 15 184 08	96	1	2 970	91 56 537 08	HYDR
COUPLING SLEEVE	51 15 184 08	45	1	2 977	91 57 756 08	ADDITIONAL HYDR.SLEWING
COUPLING SLEEVE	77 43 726 08	18	14	2 711	91 52 800 08	CENT. LUBRIC. SYSTEM SUP

6.2.2009

etk_en_de_074515 LR 1600/2

866

LIEBHERRAlphabetical index
Alphabetischer Index

Description	Item	Pos.	Quantity	Page	Assembly	Description
COUPLING SLEEVE	77 43 726 08	13	1	3 713 013	96 57 159 08	SHEET CPL.
COUPLING SLEEVE 10-L	51 15 084 08	106	1	2 970	91 56 537 08	HYDR
COUPLING SLEEVE 10-L	51 15 084 08	5	2	2 970 081	96 50 495 08	ADDL.HYDR.F.PIN PULLING DE
COUPLING SLEEVE 10-L	51 15 084 08	19	1	2 975 100	91 52 860 08	ADDITIONAL HYDRAULICS WI
COUPLING SLEEVE 12-L	51 15 058 08	27	1	1 970	91 56 958 08	CRAWLER TRACK HYDRAULI
COUPLING SLEEVE 12-L	51 15 058 08	98	5	2 970	91 56 537 08	HYDR
COUPLING SLEEVE 12-L	51 15 058 08	33	2	2 975 100	91 52 860 08	ADDITIONAL HYDRAULICS WI
COUPLING SLEEVE 12-L	51 15 058 08	33	1	2 975 200	91 52 775 08	ADDITIONAL HYDRAULICS WI
COUPLING SLEEVE 12-L	51 15 058 08	33	1	2 975 700	91 52 774 08	ADDITIONAL HYDRAULICS WI
COUPLING SLEEVE 12-L	51 15 058 08	5	3	2 976 200	91 44 034 08	AUX.HYDR.PIN EXTRACTION
COUPLING SLEEVE 12-L	51 15 058 08	5	1	2 976 203	92 27 489 08	ADDL.HYDR.F.PIN PULLING DE
COUPLING SLEEVE 12-L	51 15 058 08	11	1	3 978 015	91 56 429 08	ADDITIONAL HYDRAULICS IN
COUPLING SLEEVE 12-L	51 15 058 08	11	1	3 978 015	91 56 432 08	ADDITIONAL HYDRAULICS IN
COUPLING SLEEVE 12-L	51 15 058 08	27	1	3 978 100	91 56 428 08	HYDR. SUSPENDED BALLAST
COUPLING SLEEVE 15-L	51 15 005 08	104	3	2 970	91 56 537 08	HYDR
COUPLING SLEEVE 15-L	51 15 005 08	11	2	2 970 081	96 50 495 08	ADDL.HYDR.F.PIN PULLING DE
COUPLING SLEEVE 15-L	51 15 005 08	37	1	2 975 200	91 52 775 08	ADDITIONAL HYDRAULICS WI
COUPLING SLEEVE 15-L	51 15 005 08	37	1	2 975 700	91 52 774 08	ADDITIONAL HYDRAULICS WI
COUPLING SLEEVE 16-S	51 15 059 08	39	2	1 970	91 56 958 08	CRAWLER TRACK HYDRAULI
COUPLING SLEEVE 16-S	51 15 059 08	92	2	2 970	91 56 537 08	HYDR
COUPLING SLEEVE 20-S	51 15 007 08	39	1	2 977	91 57 756 08	ADDITIONAL HYDR.SLEWING
COUPLING SLEEVE 22-L	51 15 082 08	88	3	2 970	91 56 537 08	HYDR
COUPLING SLEEVE 22-L	51 15 082 08	29	1	2 975 100	91 52 860 08	ADDITIONAL HYDRAULICS WI
COUPLING SLEEVE 22-L	51 15 082 08	29	1	2 975 200	91 52 775 08	ADDITIONAL HYDRAULICS WI
COUPLING SLEEVE 22-L	51 15 082 08	29	1	2 975 700	91 52 774 08	ADDITIONAL HYDRAULICS WI
COUPLING SLEEVE 25-S	51 05 996 08	84	6	2 970	91 56 537 08	HYDR
COUPLING SLEEVE 25-S	51 05 996 08	25	1	2 975 200	91 52 775 08	ADDITIONAL HYDRAULICS WI
COUPLING SLEEVE 25-S	51 05 996 08	25	1	2 975 700	91 52 774 08	ADDITIONAL HYDRAULICS WI
COUPLING SLEEVE 25-S	51 05 996 08	21	1	2 978 200	91 54 843 08	ADD.HYDR.S_RETAINING RAM
COUPLING SLEEVE 28-L	51 15 010 08	35	2	1 970	91 56 958 08	CRAWLER TRACK HYDRAULI
COUPLING SLEEVE 28-L	51 15 010 08	90	3	2 970	91 56 537 08	HYDR
COUPLING SLEEVE 28-L	51 15 010 08	31	1	2 975 100	91 52 860 08	ADDITIONAL HYDRAULICS WI
COUPLING SLEEVE 28-L	51 15 010 08	35	1	2 977	91 57 756 08	ADDITIONAL HYDR.SLEWING
COUPLING SLEEVE 28-L	51 15 010 08	23	2	2 978 200	91 54 843 08	ADD.HYDR.S_RETAINING RAM
COUPLING SLEEVE 38-S	51 15 122 08	31	4	1 970	91 56 958 08	CRAWLER TRACK HYDRAULI
COUPLING SLEEVE 38-S	51 15 122 08	80	4	2 970	91 56 537 08	HYDR
COUPLING SLEEVE 38-S	51 15 122 08	21	2	2 975 100	91 52 860 08	ADDITIONAL HYDRAULICS WI
COUPLING SLEEVE 38-S	51 15 122 08	21	2	2 975 200	91 52 775 08	ADDITIONAL HYDRAULICS WI
COUPLING SLEEVE 38-S	51 15 122 08	21	2	2 975 700	91 52 774 08	ADDITIONAL HYDRAULICS WI
COUPLING SLEEVE 38-S	51 15 122 08	31	4	2 977	91 57 756 08	ADDITIONAL HYDR.SLEWING
COUPLING SLEEVE 38-S	51 15 122 08	4	2	3 978 015	91 56 429 08	ADDITIONAL HYDRAULICS IN
COUPLING SLEEVE 38-S	51 15 122 08	4	2	3 978 015	91 56 432 08	ADDITIONAL HYDRAULICS IN
COUPLING SLEEVE 38-S	51 15 122 08	21	2	3 978 100	91 56 428 08	HYDR. SUSPENDED BALLAST
COUPLING SOCKET	60 50 127 08	7	1	2 780 915	96 48 377 08	ADD-ON PARTS EXTERNAL F
COUPLING SOCKET 90GR SP	68 00 008 08	(5)	1	2 920 581	96 54 405 08	TERMINAL BOX WINCH PRE-A
COUPLING SOCKET GERADE	68 00 017 08	(5)	1	2 920 288	96 52 614 08	WIRING LIST F.SLEWING PLAT
COUPLING SOCKET GERADE	68 00 017 08	(5)	1	2 920 581	96 54 405 08	TERMINAL BOX WINCH PRE-A
COUPLING SOCKET GERADE	68 00 017 08	(5)	1	2 920 581	96 54 405 08	TERMINAL BOX WINCH PRE-A
COUPLING SOCKET GERADE	68 00 017 08	8	1	2 920 633	96 52 651 08	WIRING HARNESS
COUPLING SOCKET GERADE	68 00 017 08	9	1	2 920 633	96 52 651 08	WIRING HARNESS
COUPLING SOCKET GERADE	68 00 017 08	10	1	2 920 633	96 52 651 08	WIRING HARNESS
COUPLING SOCKET GERADE	68 00 017 08	11	1	2 920 633	96 52 651 08	WIRING HARNESS
COUPLING SOCKET GERADE	68 00 017 08	372	1	2 920 633	96 52 651 08	WIRING HARNESS
COUPLING SOCKET GERADE	68 00 017 08	373	1	2 920 633	96 52 651 08	WIRING HARNESS
COUPLING SOCKET SPF	68 00 000 08	(6)	1	2 920 288	96 52 614 08	WIRING LIST F.SLEWING PLAT
COUPLING SOCKET SPF	68 00 014 08	374	1	2 920 633	96 52 651 08	WIRING HARNESS
COVER COMPL.	96 46 758 08	6	1	2 859	91 52 809 08	SOUND INSULATION
COVER COMPL.	96 46 775 08	16	1	2 859	91 52 809 08	SOUND INSULATION
COVER COMPL.	96 46 776 08	17	1	2 859	91 52 809 08	SOUND INSULATION
COVER COMPL.	96 46 777 08	18	1	2 859	91 52 809 08	SOUND INSULATION

6.2.2009

etk_en_de_074515 LR 1600/2

867

LIEBHERRAlphabetical index
Alphabetischer Index

Description	Item	Pos.	Quantity	Page	Assembly	Description
COVER COMPL.	96 46 778 08	19	1	2 859	91 52 809 08	SOUND INSULATION
COVER COMPL.	96 46 779 08	20	1	2 859	91 52 809 08	SOUND INSULATION
COVER COMPL.	96 46 782 08	6	1	2 393	91 52 787 08	AIR FILTER UNIT CPL.
COVER COMPL.	96 48 167 08	2	1	2 932 160	96 54 385 08	SWITCH CABINET
COVER CPL	96 50 546 08	51	1	2 391 001	96 45 719 08	DIESEL ENGINE, PRE-ASSEMB
COVER CPL	96 50 616 08	6	1	2 391	91 52 784 08	DIESEL ENGINE CPL.
COVER GLUED	96 48 168 08	1	1	2 932 168	96 48 167 08	COVER COMPL.
COVER HOOD	10 65 300 5	18	1	X1002800	10 02 800 2	CABLE REEL
COVER LID 28X30	59 15 709 08	77	2	2 520	91 53 061 08	CABIN, GLAZED
COVER PLATE WELDED	96 50 215 08	46	2	2 502	91 55 939 08	CONTROL STAND
COVER QC LOWER BAND LR 1	97 38 043 08	1	1	1 790 503	91 57 017 08	COVER
COVER QC OBERRING	91 57 016 08	429	1		LR 1600-2-0	
COVER QC UNTERRING	91 57 017 08	430	1		LR 1600-2-0	
COVER QC UPPER BAND LR 1	97 38 049 08	1	1	2 790 451	91 57 016 08	COVER
COVER ST. CONST.	96 49 873 08	2	1	2 520 033	96 50 633 08	MONITOR CONSOLE
COVER WELDED	96 36 694 08	10	1	3 745 011	96 49 677 08	BRACKET COMPL.
COVER WELDED	96 46 922 08	1	1	2 859 029	96 46 779 08	COVER COMPL.
COVER WELDED	96 49 083 08	68	1	2 520	91 53 061 08	CABIN, GLAZED
COVER/LID/CAP, PRE-ASSEMB	96 23 055 08	2	1	2 260 006	96 46 501 08	BATTERY BOX, PRE-ASSEMB
COVERING LEFT BOTTOM	97 69 824 08	10	1	2 520 034	96 45 984 08	INTERNAL LINING
COVERING RIGHT BOTTOM	97 69 825 08	11	1	2 520 034	96 45 984 08	INTERNAL LINING
CRAMP	60 27 417 08	275	6	1 920 403	96 48 707 08	TERMINAL BOX CPL.
CRAMP	60 27 417 08	275	6	1 920 417	96 48 703 08	TERMINAL BOX CPL.
CRAMP	60 27 417 08	274	10	3 930 363	96 52 979 08	TERMINAL BOX CPL.
CRAMP	60 27 417 08	274	12	3 930 640	96 50 481 08	TERMINAL BOX CPL.
CRANE DRIVER'S CABIN CPL.	91 52 806 08	153	1		LR 1600-2-0	
CRANE DRIVER'S CABIN,PRE-	96 43 597 08	1	1	2 810	91 52 806 08	CRANE DRIVER'S CABIN CPL.
CRANKCASE BREATHER	97 39 386	11	1	X1012059	10 12 059 0	DIESEL ENGINE
CRANKCASE CPL. R-MOTORX	97 39 368	1	1	X1012059	10 12 059 0	DIESEL ENGINE
CRANKSHAFT	97 39 101	28	1	X1012059	10 12 059 0	DIESEL ENGINE
CRANKSHAFT BEARINGS	97 39 102	29	1	X1012059	10 12 059 0	DIESEL ENGINE
CRANKSHAFT WHEEL	10 01 214 2	6	1	9 739 341	97 39 341	DRIVING PARTS
CRAWLER CARRIER RIGHT CP	91 56 855 08	11	1		LR 1600-2-0	
CRAWLER TRACK CARRIER L	96 53 235 08	(1)	1	1 400	91 56 853 08	CRAWLER TRACK CARRIER LE
CRAWLER TRACK CARRIER L	91 56 853 08	10	1		LR 1600-2-0	
CRAWLER TRACK CARRIER, L	96 53 234 08	1	1	1 400	91 56 853 08	CRAWLER TRACK CARRIER LE
CRAWLER TRACK CARRIER,	96 53 258 08	1	1	1 410 300	91 56 855 08	CRAWLER CARRIER RIGHT CP
CRAWLER TRACK CARRIER,	96 53 259 08	(1)	1	1 410 300	91 56 855 08	CRAWLER CARRIER RIGHT CP
CRAWLER TRACK HYDRAULI	91 56 958 08	31	1		LR 1600-2-0	
CRAWLER TRACK TRAVEL GE	91 52 375 08	2	1		LR 1600-2-0	
CRIMPING CONTACT	60 56 023 08	(602)	4	2 920 369	96 54 235 08	TERMINAL BOX CPL.
CRIMPING CONTACT	60 56 023 08	(602)	4	2 920 369	96 54 235 08	TERMINAL BOX CPL.
CRIMPING CONTACT	60 56 023 08	602	60	2 920 633	96 52 651 08	WIRING HARNESS
CRIMPING CONTACT 0,14 - 0,3	60 56 114 08	702	14	2 920 633	96 52 651 08	WIRING HARNESS
CRIMPING CONTACT 0,5	60 56 045 08	126	51	2 920 633	96 52 651 08	WIRING HARNESS
CRIMPING CONTACT 0,5	60 56 101 08	601	54	2 920 633	96 52 651 08	WIRING HARNESS
CRIMPING CONTACT 1,5	60 56 102 08	603	8	2 920 633	96 52 651 08	WIRING HARNESS
CROSS CONNECTING LINK W	96 48 639 08	3	2	3 830	91 55 535 08	SUPPLEMENTARY GUYING D
CROSS CONNECTING LINK W	96 48 640 08	2	2	3 830	91 55 535 08	SUPPLEMENTARY GUYING D
CROSS PIECE 30/30/30/30 G-A	10 44 099 0	49	1	2 520	91 53 061 08	CABIN, GLAZED
CROWN GEAR	10 01 219 1	2	1	9 739 250	97 39 250	FLYWHEEL
CUP SPRING CLUSTER	91 53 057 08	126	1		LR 1600-2-0	
CUSTOM CIRCUIT MODULE 2	96 48 302 08	(152)	1	1 920 418	96 48 687 08	TERMINAL BOX CPL.
CUSTOM CIRCUIT MODULE 2	96 48 302 08	(152)	1	2 780 748	96 52 969 08	TERMINAL BOX CPL.
CUSTOM CIRCUIT MODULE 2	96 48 302 08	(152)	1	3 930 363	96 52 979 08	TERMINAL BOX CPL.
CUSTOM CIRCUIT MODULE 2	96 48 302 08	156	1	3 930 639	96 50 132 08	WIRES TERMINAL BOX CPL.
CUSTOM CIRCUIT MODULE 2	96 48 302 08	(156)	1	3 930 640	96 50 481 08	TERMINAL BOX CPL.
CUSTOM CIRCUIT MODULE 2	96 48 302 08	(504)	1	3 930 730	96 50 599 08	TERMINAL BOX CPL.
CUTOFF RELAY	63 01 201 08	54	1	2 932 082	96 54 387 08	ASSEMBLY PARTS MOUNTIN
CUTOFF RELAY 24V	63 01 036 08	12	1	2 920 083	96 48 319 08	ELECTRIC FOR BATTERY BOX

6.2.2009

etk_en_de_074515 LR 1600/2

868

LIEBHERRAlphabetical index
Alphabetischer Index

Description	Item	Pos.	Quantity	Page	Assembly	Description
CYLINDER	57 01 144 08	1	1	5 701 133	57 01 133 08	DRIVING GEAR
CYLINDER 50/25-165	57 19 135 08	5	1	5 123 682	51 23 682 08	MOUNTING - PISTON W. PUM
CYLINDER BUSH	10 22 231 7	1	1	9 739 242	97 39 242	CYLINDER BUSH
CYLINDER BUSH	10 22 231 8	54	6	9 739 242	97 39 242	CYLINDER BUSH
CYLINDER BUSH	10 22 231 9	51	6	9 739 242	97 39 242	CYLINDER BUSH
CYLINDER BUSH	10 22 232 0	53	6	9 739 242	97 39 242	CYLINDER BUSH
CYLINDER BUSH	10 22 232 1	52	6	9 739 242	97 39 242	CYLINDER BUSH
CYLINDER BUSH	97 39 242	26	6	X1012059	10 12 059 0	DIESEL ENGINE
CYLINDER FAIRING	97 39 267	43	1	X1012059	10 12 059 0	DIESEL ENGINE
CYLINDER HEAD	97 39 261	6	1	9 739 262	97 39 262	CYLINDER HEAD
CYLINDER HEAD	97 39 261	6	1	9 739 266	97 39 266	CYLINDER HEAD
CYLINDER HEAD COVER	10 01 219 8	2	5	9 739 267	97 39 267	CYLINDER FAIRING
CYLINDER HEAD COVER	10 01 333 5	1	1	9 739 267	97 39 267	CYLINDER FAIRING
CYLINDER HEAD GASKET	10 03 231 8	7	1	9 739 262	97 39 262	CYLINDER HEAD
CYLINDER HEAD GASKET	10 03 231 8	7	1	9 739 266	97 39 266	CYLINDER HEAD
CYLINDER HEAD GASKET	10 03 231 8	80	1	X1022281	10 22 281 7	SEAL KIT CYLINDER HEAD
CYLINDER HEAD R-MOTOR	97 39 260	10	1	9 739 261	97 39 261	CYLINDER HEAD
CYLINDER HEAD R-MOTOR	97 39 262	41	4	X1012059	10 12 059 0	DIESEL ENGINE
CYLINDER HEAD R-MOTOR	97 39 266	42	2	X1012059	10 12 059 0	DIESEL ENGINE
CYLINDER SCREW	10 22 235 9	5	2	9 739 118	97 39 118	OIL LINE
CYLINDER SCREW DIN 6912 M	40 72 046 08	24	16	3 215 005	91 52 846 08	ROLLER SET
CYLINDER SCREW DIN 6912 M	40 72 046 08	24	16	3 215 006	91 52 847 08	ROLLER SET
CYLINDER SCREW DIN 6912	40 72 086 08	11	2	3 745 011	96 49 677 08	BRACKET COMPL.
CYLINDER SCREW DIN 6912 M	40 72 101 14	12	32	3 747	91 52 950 08	CENTERING STANDARD
CYLINDER SCREW DIN 7984	40 83 023 08	17	1	7 027 481	70 27 481 03	WATER SEPARATOR
CYLINDER SCREW DIN 7984 M	40 93 609 08	7	2	2 520 030	96 45 609 08	ROOF WINDOW PRE-ASS.
CYLINDER SCREW DIN 84 M3X	40 01 004 08	15	28	2 932 001	96 45 393 08	RELAY CONTROL SYSTEM
CYLINDER SCREW DIN 84 M3X	40 01 701 08	266	4	3 930 009	96 50 573 08	CABLE DRUM COMPL.
CYLINDER SCREW DIN 84 M3X	40 01 701 08	(268)	4	3 930 138	96 54 377 08	ELECTRIC FOR S-PIVOT SECT
CYLINDER SCREW DIN 84 M3X	40 01 701 08	280	16	3 930 638	96 51 624 08	TERMINAL BOX
CYLINDER SCREW DIN 84 M3X	40 01 701 08	154	10	3 930 640	96 50 481 08	TERMINAL BOX CPL.
CYLINDER SCREW DIN 84 M3X	40 01 701 08	266	10	3 930 730	96 50 599 08	TERMINAL BOX CPL.
CYLINDER SCREW DIN 84 M3	40 01 006 08	41	8	2 920 369	96 54 235 08	TERMINAL BOX CPL.
CYLINDER SCREW DIN 84 M3X	40 01 405 08	(153)	1	2 920 369	96 54 235 08	TERMINAL BOX CPL.
CYLINDER SCREW DIN 84 M3X	40 01 405 08	(153)	1	2 920 581	96 54 405 08	TERMINAL BOX WINCH PRE-A
CYLINDER SCREW DIN 84 M4X	40 01 018 08	48	56	2 932 160	96 54 385 08	SWITCH CABINET
CYLINDER SCREW DIN 84 M4X	40 01 020 08	(152)	1	2 920 369	96 54 235 08	TERMINAL BOX CPL.
CYLINDER SCREW DIN 84 M4X	40 01 020 08	(152)	1	2 920 369	96 54 235 08	TERMINAL BOX CPL.
CYLINDER SCREW DIN 84 M4X	40 01 020 08	280	12	2 920 369	96 54 235 08	TERMINAL BOX CPL.
CYLINDER SCREW DIN 84 M4X	40 01 020 08	280	24	2 920 448	96 48 794 08	TERMINAL BOX CPL.
CYLINDER SCREW DIN 84 M5X	40 01 033 08	28	4	2 260	91 53 057 08	CUP SPRING CLUSTER
CYLINDER SCREW DIN 84 M5X	40 01 033 08	4	4	2 260 009	96 46 972 08	FLAP PRE-ASS.
CYLINDER SCREW DIN 84 M5X	40 01 033 08	31	2	2 920 083	96 48 319 08	ELECTRIC FOR BATTERY BOX
CYLINDER SCREW DIN 84 M5X	40 01 034 08	4	4	2 780 915	96 48 377 08	ADD-ON PARTS EXTERNAL F
CYLINDER SCREW DIN 84 M5X	40 01 034 08	30	5	2 920 083	96 48 319 08	ELECTRIC FOR BATTERY BOX
CYLINDER SCREW DIN 84 M5X	40 01 034 08	(2)	3	3 780 258	96 56 482 08	ELECTRIC AIRCRAFT PROTE
CYLINDER SCREW DIN 84 M5X	40 01 036 08	29	2	2 932 082	96 54 387 08	ASSEMBLY PARTS MOUNTIN
CYLINDER SCREW DIN 84 M5X	40 01 041 08	6	3	1 100	91 52 375 08	CRAWLER TRACK TRAVEL G
CYLINDER SCREW DIN 84 M6X	40 01 054 08	12	12	2 932 082	96 54 387 08	ASSEMBLY PARTS MOUNTIN
CYLINDER SCREW DIN 84 M6X	40 01 054 08	15	2	5 026 126	50 26 126 08	SOLENOID VALVE
CYLINDER SCREW DIN 84 M8	51 07 977 08	22	1	5 114 176	51 14 176 08	PRESSURE LIMITING VALVE
CYLINDER SCREW DIN 84 M8	51 07 977 08	22	1	5 114 177	51 14 177 08	PRESSURE LIMITING VALVE
CYLINDER SCREW DIN 912 M1	40 43 097 08	340	4	X1041101	10 41 101 8	TILTING-BACK SUPPORT
CYLINDER SCREW DIN 912 M	40 42 120 08	7	8	2 350	91 52 778 08	SLEWING GEAR
CYLINDER SCREW DIN 912 M	40 42 120 08	342	12	2 391 001	96 45 719 08	DIESEL ENGINE, PRE-ASSEMB
CYLINDER SCREW DIN 912 M	40 42 120 08	546	12	2 970	91 56 537 08	HYDR
CYLINDER SCREW DIN 912 M1	40 43 126 08	26	8	9 697 916	96 97 916 01	SLEWING GEAR
CYLINDER SCREW DIN 912 M	40 42 152 08	56	32	1 970	91 56 958 08	CRAWLER TRACK HYDRAULI
CYLINDER SCREW DIN 912 M	40 42 152 08	56	8	1 970 161	96 50 706 08	AUX.HYDR.CR.TRACK CARR.4
CYLINDER SCREW DIN 912 M	40 42 152 08	555	28	2 970	91 56 537 08	HYDR

6.2.2009

etk_en_de_074515 LR 1600/2

869

LIEBHERRAlphabetical index
Alphabetischer Index

Description	Item	Pos.	Quantity	Page	Assembly	Description
CYLINDER SCREW DIN 912 M	40 42 156 08	47	4	2 975 100	91 52 860 08	ADDITIONAL HYDRAULICS WI
CYLINDER SCREW DIN 912 M	40 42 159 08	46	4	2 975 100	91 52 860 08	ADDITIONAL HYDRAULICS WI
CYLINDER SCREW DIN 912 M	40 43 263 08	6	2	3 211	91 57 748 08	S PIVOT SECTION
CYLINDER SCREW DIN 912 M	40 43 263 08	4	4	3 220 500	91 52 849 08	S INTERMEDIATE SECTION
CYLINDER SCREW DIN 912 M	40 43 263 08	4	4	3 221	91 54 668 08	S INTERMEDIATE SECTION
CYLINDER SCREW DIN 912 M	40 43 263 08	4	4	3 223	91 52 852 08	S INTERMEDIATE SECTION
CYLINDER SCREW DIN 912 M	40 43 263 08	4	4	3 223 010	91 52 853 08	S INTERMEDIATE SECTION
CYLINDER SCREW DIN 912 M	40 43 263 08	4	4	3 223 100	91 55 327 08	S INTERMEDIATE SECTION
CYLINDER SCREW DIN 912 M	40 43 263 08	16	2	3 225	91 52 854 08	SL REDUCING SECTION
CYLINDER SCREW DIN 912 M	40 42 242 08	46	2	1 400	91 56 853 08	CRAWLER TRACK CARRIER LE
CYLINDER SCREW DIN 912 M	40 42 242 08	46	2	1 410 300	91 56 855 08	CRAWLER CARRIER RIGHT CP
CYLINDER SCREW DIN 912 M	40 42 242 08	8	2	2 652	91 52 794 08	ROLLER BEARING
CYLINDER SCREW DIN 912 M2	40 43 246 08	103	2	3 713	91 57 749 08	D PIVOT SECTION
CYLINDER SCREW DIN 912 M3	40 42 002 08	11	2	2 780 852	96 24 845 08	GSM-MODULE PRE-ASS.LICCO
CYLINDER SCREW DIN 912 M	40 43 012 08	7	4	X1004047	10 04 047 7	WINCH REVOLUTION TRANS
CYLINDER SCREW DIN 912 M5	40 42 025 08	5	8	1 711	91 52 392 08	CENTRALIZED LUBRICATION
CYLINDER SCREW DIN 912 M5	40 42 025 08	7	10	2 711	91 52 800 08	CENT. LUBRIC. SYSTEM SUP
CYLINDER SCREW DIN 912 M	40 43 612 08	56	4	5 113 086	51 13 086 08	PROPORTIONAL VALVE
CYLINDER SCREW DIN 912 M	40 43 612 08	4	4	X1034282	10 34 282 3	PRESSURE CONTROL VALVE
CYLINDER SCREW DIN 912 M	40 43 028 08	65	16	1 970	91 56 958 08	CRAWLER TRACK HYDRAULI
CYLINDER SCREW DIN 912 M	51 07 466 08	15	8	5 113 086	51 13 086 08	PROPORTIONAL VALVE
CYLINDER SCREW DIN 912 M	40 43 601 08	5	4	2 975 000	91 57 881 08	ADDNL. HYDR. F. ERECTING W
CYLINDER SCREW DIN 912 M8	40 42 072 08	21	2	2 522	91 54 115 08	SLIDING DOOR CPL.
CYLINDER SCREW DIN 912 M8	40 42 072 08	32	78	3 211	91 57 748 08	S PIVOT SECTION
CYLINDER SCREW DIN 912 M8	40 42 072 08	73	6	3 713	91 57 749 08	D PIVOT SECTION
CYLINDER SCREW DIN EN ISO	54 01 790 08	11	2	3 714 008	96 49 266 08	LUFFING PULLEY BLOCK COM
CYLINDER SCREW ISO 4762	40 42 104 01	86	12	9 697 916	96 97 916 01	SLEWING GEAR
CYLINDER SCREW ISO 4762 M	40 42 014	7	2	5 102 354	51 02 354 08	HYDRO MOTOR
CYLINDER SCREW ISO 4762 M	49 00 537	37	8	3 745	91 52 948 08	SUSPENDE BALLAST
CYLINDER SCREW ISO 4762 M	46 00 132	542	6	2 970	91 56 537 08	HYDR
CYLINDER SCREW ISO 4762 M	46 00 132	(2)	4	2 970	91 56 537 08	HYDR
CYLINDER SCREW ISO 4762 M	46 00 132	563	20	2 976 200	91 52 780 08	ADDITIONAL HYDRAULICS
CYLINDER SCREW ISO 4762 M	46 00 132	568	8	2 976 700	91 54 795 08	ADDITIONAL HYDRAULICS P
CYLINDER SCREW ISO 4762 M	49 00 195	338	12	2 391 001	96 45 719 08	DIESEL ENGINE, PRE-ASSEMB
CYLINDER SCREW ISO 4762 M	46 00 331	14	4	2 392	91 52 785 08	MUFFLER UNIT
CYLINDER SCREW ISO 4762 M	46 00 143	10	4	5 102 354	51 02 354 08	HYDRO MOTOR
CYLINDER SCREW ISO 4762 M	10 35 370 5	13	2	X1041267	10 41 267 8	END PLATE
CYLINDER SCREW ISO 4762	40 42 132 01	22	12	X1065015	10 65 015 8	DRIVE UNIT
CYLINDER SCREW ISO 4762 M	40 42 030	24	8	X1065015	10 65 015 5	GEARBOX
CYLINDER SCREW ISO 4762 M	40 42 032	93	4	3 714	91 52 862 08	D HEAD SECTION
CYLINDER SCREW ISO 4762 M	40 42 035	20	4	2 671 004	96 46 305 08	OIL TANK PRE-ASS.
CYLINDER SCREW ISO 4762	40 00 784	4	6	3 978 100	91 56 428 08	HYDR. SUSPENDE BALLAST
CYLINDER SCREW ISO 4762 M	40 42 036	23	8	X1065015	10 65 015 8	DRIVE UNIT
CYLINDER SCREW ISO 4762 M	40 42 124 01	74	12	9 697 916	96 97 916 01	SLEWING GEAR
CYLINDER SCREW ISO 4762 M	24 00 551 02	10	4	3 978 100	91 56 428 08	HYDR. SUSPENDE BALLAST
CYLINDER SCREW ISO 4762 M	40 43 161 01	44	4	2 975 200	91 52 775 08	ADDITIONAL HYDRAULICS WI
CYLINDER SCREW ISO 4762 M	40 43 161 01	44	4	2 975 700	91 52 774 08	ADDITIONAL HYDRAULICS WI
CYLINDER SCREW ISO 4762 M	40 42 153 01	128	12	2 970	91 56 537 08	HYDR
CYLINDER SCREW ISO 4762 M	40 42 153 01	43	4	2 975 200	91 52 775 08	ADDITIONAL HYDRAULICS WI
CYLINDER SCREW ISO 4762 M	40 42 153 01	43	4	2 975 700	91 52 774 08	ADDITIONAL HYDRAULICS WI
CYLINDER SCREW ISO 4762	40 42 181 01	3	2	2 550 010	96 45 685 08	ROD
CYLINDER SCREW ISO 4762	40 42 183 01	1391	18	X1065015	10 65 015 5	GEARBOX
CYLINDER SCREW ISO 4762 M	46 00 329	11	24	3 350	91 52 859 08	WINCH 3
CYLINDER SCREW ISO 4762	40 43 169 01	63	10	X1065015	10 65 015 6	ROPE DRUM
CYLINDER SCREW ISO 4762 M	46 00 017	(37)	4	1 400	91 56 853 08	CRAWLER TRACK CARRIER LE
CYLINDER SCREW ISO 4762 M	46 00 017	73	4	2 970	91 56 537 08	HYDR
CYLINDER SCREW ISO 4762 M	46 00 017	20	8	X1065015	10 65 015 8	DRIVE UNIT
CYLINDER SCREW ISO 4762 M	46 00 237	10	8	2 340	91 52 776 08	WINCH 4 LUFFING GEAR
CYLINDER SCREW ISO 4762 M	40 42 175 01	22	6	2 652	91 52 794 08	ROLLER BEARING
CYLINDER SCREW ISO 4762 M	40 42 566 14	21	18	X1065015	10 65 015 5	GEARBOX

6.2.2009

etk_en_de_074515 LR 1600/2

870

LIEBHERRAlphabetical index
Alphabetischer Index

Description	Item	Pos.	Quantity	Page	Assembly	Description
CYLINDER SCREW ISO 4762 M	49 01 989	3	48	2 350	91 52 778 08	SLEWING GEAR
CYLINDER SCREW ISO 4762 M	46 30 212	5	2	3 213	91 52 842 08	F-CONNECTING HEAD
CYLINDER SCREW ISO 4762 M	46 30 212	26	2	3 214	91 52 843 08	SW HEAD SECTION
CYLINDER SCREW ISO 4762 M	46 30 212	15	2	3 225	91 52 854 08	SL REDUCING SECTION
CYLINDER SCREW ISO 4762 M	46 30 212	4	4	3 226	91 52 870 08	L INTERMEDIATE SECTION
CYLINDER SCREW ISO 4762 M	46 30 212	4	4	3 227	91 52 873 08	L INTERMEDIATE SECTION
CYLINDER SCREW ISO 4762 M	46 30 212	4	4	3 227 008	91 52 872 08	L INTERMEDIATE SECTION
CYLINDER SCREW ISO 4762 M	46 30 212	4	4	3 227 200	91 53 519 08	LI INTERMEDIATE SECT. F-GU
CYLINDER SCREW ISO 4762 M	46 30 212	12	2	3 713	91 57 749 08	D PIVOT SECTION
CYLINDER SCREW ISO 4762 M	46 30 212	24	2	3 714	91 52 862 08	D HEAD SECTION
CYLINDER SCREW ISO 4762 M	46 30 212	19	4	3 715 008	91 52 863 08	D INTERMEDIATE SECTION
CYLINDER SCREW ISO 4762 M	46 30 212	19	4	3 716	91 52 864 08	D INTERMEDIATE SECTION
CYLINDER SCREW ISO 4762 M	40 42 143 05	7	4	2 125	91 52 773 08	PIN F.S-PIVOT SECTION SA F
CYLINDER SCREW ISO 4762	10 12 438 50	17	4	2 533 066	96 48 365 08	ELECTRIC ADD-ON PARTS CA
CYLINDER SCREW ISO 4762	40 00 996	36	8	2 502	91 55 939 08	CONTROL STAND
CYLINDER SCREW ISO 4762	40 00 996	11	3	3 780 200	96 54 370 08	ELECTRIC WIND WARNING T
CYLINDER SCREW ISO 4762	46 00 387	89	54	2 932 082	96 54 387 08	ASSEMBLY PARTS MOUNTIN
CYLINDER SCREW ISO 4762	49 01 531	19	4	X1034282	10 34 282 3	PRESSURE CONTROL VALVE
CYLINDER SCREW ISO 4762	46 00 338	15	2	5 113 005	51 13 005 08	CONTROL BLOCK
CYLINDER SCREW ISO 4762	40 01 521	23	1	2 522	91 54 115 08	SLIDING DOOR CPL.
CYLINDER SCREW ISO 4762	40 01 521	48	4	2 975 200	91 52 775 08	ADDITIONAL HYDRAULICS WI
CYLINDER SCREW ISO 4762	40 01 521	48	4	2 975 700	91 52 774 08	ADDITIONAL HYDRAULICS WI
CYLINDER SCREW ISO 4762	40 01 308	34	24	2 502	91 55 939 08	CONTROL STAND
CYLINDER SCREW ISO 4762	40 01 308	18	2	2 540	91 53 253 08	CLIMA-HEATING INSTALLATIO
CYLINDER SCREW ISO 4762	24 00 465 02	23	4	2 520 032	96 45 980 08	WINDSHIELD WASHER INSTAL
CYLINDER SCREW ISO 4762	40 42 022 01	35	2	2 520	91 53 061 08	CABIN, GLAZED
CYLINDER SCREW ISO 4762	40 00 899	34	6	2 520	91 53 061 08	CABIN, GLAZED
CYLINDER SCREW ISO 4762	40 42 026 01	62	4	2 970	91 56 537 08	HYDR
CYLINDER SCREW ISO 4762	40 42 026 01	37	2	X1022811	10 22 811 2	AIR CONDITIONING UNIT
CYLINDER SCREW ISO 4762	49 00 626	48	4	2 502	91 55 939 08	CONTROL STAND
CYLINDER SCREW ISO 4762 M	10 66 372 5	2	4	5 114 651	51 14 651 08	DIRECTIONAL CONTROL VALV
CYLINDER SCREW ISO 4762 M	40 02 601	23	4	5 113 086	51 13 086 08	PROPORTIONAL VALVE
CYLINDER SCREW ISO 4762	46 00 049	8	2	2 522	91 54 115 08	SLIDING DOOR CPL.
CYLINDER SCREW ISO 4762	46 00 049	15	3	2 522 011	96 45 602 08	CLOSING DEVICE
CYLINDER SCREW ISO 4762	46 00 048	30	8	2 391 040	96 53 645 08	CLUTCH ACTUATOR
CYLINDER SCREW ISO 4762	46 00 048	7	6	5 102 306	51 02 306 08	HYDRO MOTOR
CYLINDER SCREW ISO 4762	46 00 048	8	2	9 080 702	90 80 702	CONTROL GEAR
CYLINDER SCREW ISO 4762	40 42 002	41	4	2 502	91 55 939 08	CONTROL STAND
CYLINDER SCREW ISO 4762	40 42 002	22	2	2 978 100	91 52 796 08	ADDNL.HYDR.ERECTION DEV
CYLINDER SCREW ISO 4762	40 42 002	(6)	3	3 780 258	96 56 482 08	ELECTRIC AIRCRAFT PROTE
CYLINDER SCREW ISO 4762	40 42 003	11	6	2 550 008	96 47 628 08	RETAINER CPL.
CYLINDER SCREW ISO 4762	40 42 003	11	6	2 550 009	96 47 645 08	RETAINER CPL.
CYLINDER SCREW ISO 4762	40 42 003	20	6	2 978 100	91 52 796 08	ADDNL.HYDR.ERECTION DEV
CYLINDER SCREW ISO 4762	40 42 003	3	1	9 079 185	90 79 185	TACHOMETER
CYLINDER SCREW ISO 4762	40 42 003	3	1	9 079 186	90 79 186	TACHOMETER
CYLINDER SCREW ISO 4762 M	49 01 159	(3)	4	X1035925	10 35 925 1	VARIABLE PUMP
CYLINDER SCREW ISO 4762	40 42 107	24	40	2 978 100	91 52 796 08	ADDNL.HYDR.ERECTION DEV
CYLINDER SCREW ISO 4762 M	46 00 340	27	8	5 102 380	51 02 380 08	HYDRO MOTOR
CYLINDER SCREW ISO 4762	46 00 384	50	2	2 502	91 55 939 08	CONTROL STAND
CYLINDER SCREW ISO 4762	46 00 384	20	6	3 780 751	91 52 952 08	AIR-CRAFT & WIND WARNING
CYLINDER SCREW ISO 4762	40 42 109	66	2	2 520	91 53 061 08	CABIN, GLAZED
CYLINDER SCREW ISO 4762	40 42 109	6	4	9 080 702	90 80 702	CONTROL GEAR
CYLINDER SCREW ISO 4762	46 00 091	27	2	2 671 004	96 46 305 08	OIL TANK PRE-ASS.
CYLINDER SCREW ISO 4762	46 00 091	54	20	3 978 005	91 56 430 08	ADDL.HYDRAULIC SB-HEAD PI
CYLINDER SCREW ISO 4762	46 00 091	54	40	3 978 015	91 56 429 08	ADDITIONAL HYDRAULICS IN
CYLINDER SCREW ISO 4762	46 00 091	54	40	3 978 015	91 56 432 08	ADDITIONAL HYDRAULICS IN
CYLINDER SCREW ISO 4762	46 00 091	38	3	X1022811	10 22 811 2	AIR CONDITIONING UNIT
CYLINDER SCREW ISO 4762	40 42 111	55	4	2 520 034	96 45 984 08	INTERNAL LINING
CYLINDER SCREW ISO 4762	40 02 418	351	8	2 391 001	96 45 719 08	DIESEL ENGINE, PRE-ASSEMB
CYLINDER SCREW ISO 4762 M	49 00 953	5	4	X1021769	10 21 769 5	LOWERING BRAKE VALVE

6.2.2009

etk_en_de_074515 LR 1600/2

871

LIEBHERRAlphabetical index
Alphabetischer Index

Description	Item	Pos.	Quantity	Page	Assembly	Description
CYLINDER SCREW ISO 4762	46 00 051	38	6	2 502	91 55 939 08	CONTROL STAND
CYLINDER SCREW ISO 4762	46 00 051	155	2	2 970	91 56 537 08	HYDR
CYLINDER SCREW ISO 4762	46 00 079	9	4	2 670	91 52 797 08	FUEL TANK CPL.
CYLINDER SCREW ISO 4762 M	49 01 217	4	4	X1021769	10 21 769 5	LOWERING BRAKE VALVE
CYLINDER SCREW ISO 4762	46 00 175	73	24	2 520	91 53 061 08	CABIN, GLAZED
CYLINDER SCREW ISO 4762 M	24 01 920 02	11	4	X1042440	10 42 440 2	CONTROL BLOCK
CYLINDER SCREW ISO 4762	40 01 620	45	8	3 713	91 57 749 08	D PIVOT SECTION
CYLINDER SCREW ISO 4762	40 42 044 05	50	5	X1047219	10 47 219 6	REGULATOR
CYLINDER SCREW ISO 4762	46 00 578	5	1	3 790 006	96 19 989 08	PIN PULLING CYLINDER CPL.
CYLINDER SCREW ISO 4762	46 00 578	5	1	3 790 007	96 19 990 08	PIN PULLING CYLINDER CPL.
CYLINDER SCREW ISO 4762	46 00 179	16	1	X1041267	10 41 267 8	END PLATE
CYLINDER SCREW M10X25 8.	10 01 122 8	4	4	9 739 278	97 39 278	ADD-ON PARTS
CYLINDER SCREW M10X40 8.	10 29 431 8	9	3	9 739 278	97 39 278	ADD-ON PARTS
CYLINDER SCREW M8X20 GA	10 01 251 3	6	6	9 739 358	97 39 358	EXHAUST GAS RECIRCUL.ATT
CYLINDER SCREW M8X25 10.9	10 22 272 5	10	6	9 739 357	97 39 357	EXHAUST GAS RECIRCUL.PRE
CYLINDER SCREW M8X30 8.8	10 34 226 5	12	1	9 739 356	97 39 356	PIPELINE INSTALLATION
CYLINDER SCREW M8X58 GA	10 01 251 4	8	2	9 739 358	97 39 358	EXHAUST GAS RECIRCUL.ATT
CYLINDRICAL ROLLER BEARIN	57 18 448 08	51	1	X1065015	10 65 015 5	GEARBOX
D HEAD SECTION	91 52 862 08	252	1		LR 1600-2-0	
D HEAD SECTION WELDED CO	96 49 265 08	1	1	3 714	91 52 862 08	D HEAD SECTION
D INTERMED. SECTION WELD.	96 48 588 08	1	1	3 715 008	91 52 863 08	D INTERMEDIATE SECTION
D INTERMED. SECTION WELD.	96 49 123 08	1	1	3 716	91 52 864 08	D INTERMEDIATE SECTION
D INTERMEDIATE SECTION 2	91 52 863 08	254	1		LR 1600-2-0	
D INTERMEDIATE SECTION 24	91 52 864 08	256	1		LR 1600-2-0	
D OVERRUN PROTECTION	91 52 865 08	258	1		LR 1600-2-0	
D PIVOT SECTION	91 57 749 08	250	1		LR 1600-2-0	
D PIVOT SECTION ELEC. EQUI	96 54 378 08	500	1	3 713	91 57 749 08	D PIVOT SECTION
D PIVOT SECTION WELDED	96 49 113 08	1	1	3 713	91 57 749 08	D PIVOT SECTION
DAMPING PISTON	51 07 974 08	7	1	5 114 176	51 14 176 08	PRESSURE LIMITING VALVE
DAMPING PISTON	51 07 974 08	7	1	5 114 177	51 14 177 08	PRESSURE LIMITING VALVE
DAMPING PISTON	51 07 974 08	6	1	5 114 320	51 14 320 08	PRETENSIONING VALVE
DASH BORD ARM REST LEFT	96 48 370 08	1	1	2 533 060	96 48 368 08	ELECTRIC FOR ARMREST LEF
DASH BORD ARM REST RIGH	96 48 371 08	1	1	2 533 062	96 48 369 08	ELECTRIC FOR ARMREST RI
DASHBOARD LINKS	97 74 575 08	1	1	2 533 061	96 48 370 08	DASH BORD ARM REST LEFT
DASHBOARD RECHTS	97 74 576 08	1	1	2 533 063	96 48 371 08	DASH BORD ARM REST RIGH
DATA LINE 2X1 SPF	60 04 425 08	14	6.95	2 920 633	96 52 651 08	WIRING HARNESS
DATALOGGER 24V LDL2 SPF	10 34 043 8	112	1	2 932 082	96 54 387 08	ASSEMBLY PARTS MOUNTIN
DEEP GROOVE BALL BEARIN	57 17 273 08	6	1	5 400 565	54 00 565 08	ROPE WINCH
DEEP GROOVE BALL BEARIN	10 11 483 8	38	1	6 909 010	69 09 010 08	COLLECTING RING
DEEP GROOVE BALL BEARIN	10 34 330 8	4	1	9 739 250	97 39 250	FLYWHEEL
DEEP GROOVE BALL BEARIN	54 05 073 08	37	1	6 909 010	69 09 010 08	COLLECTING RING
DEEP GROOVE BALL BEARING	74 51 288 08	4	2	3 745 002	92 17 236 08	SWITCH UNIT
DEEP GROOVE BALL BEARING	74 51 288 08	4	2	3 745 003	92 17 237 08	SWITCH UNIT
DEEP GROOVE BALL BEARING	74 51 215 08	30	1	X1065015	10 65 015 8	DRIVE UNIT
DEEP GROOVE BALL BEARING	74 51 960 08	53	1	X1065015	10 65 015 5	GEARBOX
DEEP GROOVE BALL BEARIN	74 51 295 01	4	2	2 522 012	96 45 884 08	GUIDE PRE-ASS.
DEEP GROOVE BALL BEARIN	74 51 295 01	5	8	2 522 013	96 45 883 08	GUIDE PRE-ASS.
DEEP GROOVE BALL BEARING	74 51 488 08	3	2	3 211 009	96 46 979 08	SAFETY ROLLER CPL.
DEEP GROOVE BALL BEARING	74 51 488 08	(3)	2	3 350	91 52 859 08	WINCH 3
DEEP GROOVE BALL BEARING	74 51 488 08	3	2	3 350 001	92 70 642 08	SAFETY ROLLER CPL.
DEEP GROOVE BALL BEARING	50 15 339 08	66	1	9 697 916	96 97 916 01	SLEWING GEAR
DEEP GROOVE BALL BEARING	74 51 604 08	1362	1	X1065015	10 65 015 5	GEARBOX
DEEP GROOVE BALL BEARING	74 51 684 08	2	1	3 206 002	96 47 960 08	LEVER COMPL.
DEEP GROOVE BALL BEARING	74 51 688 08	2	2	3 211 008	96 46 978 08	SAFETY ROLLER CPL.
DEVICE PLUG DIN 43650	60 50 066 08	509	1	2 920 633	96 52 651 08	WIRING HARNESS
DEVICE PLUG DIN 43650	60 50 066 08	2	1	5 114 445	51 14 445 08	DIRECTIONAL CONTROL VALV
DIAPHRAGM ACCUMULATOR	51 06 425 08	75	2	2 970	91 56 537 08	HYDR
DIAPHRAGM SOCKET	55 30 278 08	51	2	2 520	91 53 061 08	CABIN, GLAZED
DIAPHRAGM SOCKET	55 30 278 08	5	2	2 520 033	96 50 633 08	MONITOR CONSOLE
DIAPHRAGM SOCKET	55 30 278 08	12	4	2 540	91 53 253 08	CLIMA-HEATING INSTALLATIO

6.2.2009

etk_en_de_074515 LR 1600/2

872

LIEBHERRAlphabetical index
Alphabetischer Index

Description	Item	Pos.	Quantity	Page	Assembly	Description
DIESEL ENGINE CPL.	91 52 784 08	121	1		LR 1600-2-0	
DIESEL ENGINE D2876 LE131	10 12 059 0	1	1	9 739 400	97 39 400	DIESEL ENGINE
DIESEL ENGINE D846 A7	97 39 400	101	1	2 391 001	96 45 719 08	DIESEL ENGINE, PRE-ASSEMB
DIESEL ENGINE, PRE-ASSEMB	96 45 719 08	1	1	2 391	91 52 784 08	DIESEL ENGINE CPL.
DIODE 1000V 1A DO-41 SPF	66 00 331 08	3	1	2 932 515	96 45 911 08	INSERTION MODULE
DIODE MODULE	66 03 016 08	52	1	2 932 082	96 54 387 08	ASSEMBLY PARTS MOUNTIN
DIODE S 30V 0A2 DO-35 SPF	66 03 006 08	21	8	2 922 001	92 84 311 08	BUS PCB
DIODE VARISTOR MODULE SP	66 01 015 08	37	2	2 932 001	96 45 393 08	RELAY CONTROL SYSTEM
DIRECT-CURRENT MOTOR 24	10 01 469 1	8	1	7 743 566	77 43 566 08	ELECTRIC PUMP
DIRECTIONAL CONTROL VALV	10 45 104 9	7	1	X1042440	10 42 440 2	CONTROL BLOCK
DIRECTIONAL CONTROL VALV	10 47 082 9	4	1	X1042440	10 42 440 2	CONTROL BLOCK
DIRECTIONAL CONTROL VALV	51 13 022 08	55	3	2 970	91 56 537 08	HYDR
DIRECTIONAL CONTROL VALV	51 14 444 08	34	3	2 970	91 56 537 08	HYDR
DIRECTIONAL CONTROL VALV	51 14 444 08	4	1	2 975 100	91 52 860 08	ADDITIONAL HYDRAULICS WI
DIRECTIONAL CONTROL VALV	51 14 444 08	4	1	2 975 200	91 52 775 08	ADDITIONAL HYDRAULICS WI
DIRECTIONAL CONTROL VALV	51 14 444 08	4	1	2 975 700	91 52 774 08	ADDITIONAL HYDRAULICS WI
DIRECTIONAL CONTROL VALV	51 14 444 08	4	1	2 978 100	91 52 827 08	ADDNL.HYDR.RETAINING DEV
DIRECTIONAL CONTROL VALV	51 14 444 08	4	1	2 978 200	91 54 843 08	ADD.HYDR.S_RETAINING RAM
DIRECTIONAL CONTROL VALV	51 14 445 08	112	4	2 970	91 56 537 08	HYDR
DIRECTIONAL CONTROL VALV	51 14 498 08	2	2	3 978 005	91 56 430 08	ADDL.HYDRAULIC SB-HEAD PI
DIRECTIONAL CONTROL VALV	51 14 651 08	10	1	1 970	91 56 958 08	CRAWLER TRACK HYDRAULI
DIRECTIONAL CONTROL VALV	51 14 943 08	17	1	2 970	91 56 537 08	HYDR
DIRECTIONAL CONTROL VALV	57 10 349 08	3	1	3 978 100	91 56 428 08	HYDR. SUSPENDED BALLAST
DIRECTIONAL CONTROL VALV	10 42 393 8	4	1	2 975 000	91 57 881 08	ADDNL. HYDR. F. ERECTING W
DIRECTIONAL CTRL. VALVE	51 13 045 08	3	1	2 976 203	92 27 489 08	ADDL.HYDR.F.PIN PULLING DE
DIRECTIONAL CTRL. VALVE S	96 40 277 08	7	1	5 133 090	51 13 090 08	SLIDE VALVE BLOCK
DIRECTIONAL CTRL. VALVE	51 13 225 08	109	1	2 970	91 56 537 08	HYDR
DIRECTIONAL SEAT VALVE	51 13 087 08	111	2	2 970	91 56 537 08	HYDR
DIRECTIONAL SEAT VALVE	51 14 829 08	3	4	3 978 005	91 56 430 08	ADDL.HYDRAULIC SB-HEAD PI
DIRECTIONAL SEAT VALVE	51 14 988 08	25	1	2 970	91 56 537 08	HYDR
DISC SPRING	57 01 150 08	7	4	5 701 133	57 01 133 08	DRIVING GEAR
DISC SPRING DIN 2093 34X16,	72 08 002 08	25	4	2 502	91 55 939 08	CONTROL STAND
DISH MOUNTING	10 10 062 1	6	4	1 620	91 52 386 08	FIXING PARTS SLEWING RING
DISH MOUNTING	10 10 062 1	9	48	1 631 100	91 52 388 08	CATWALK CRAW.TRACK TRA
DISH MOUNTING	10 10 062 1	3	10	2 859 025	96 46 757 08	GRIDIRON PRE-ASS.
DISH MOUNTING	10 10 062 1	57	8	3 206	91 52 881 08	PIVOT SECTION
DISH MOUNTING	10 10 062 1	31	112	3 211	91 57 748 08	S PIVOT SECTION
DISH MOUNTING	10 10 062 1	37	9	3 214	91 52 843 08	SW HEAD SECTION
DISH MOUNTING	10 10 062 1	24	37	3 220 500	91 52 849 08	S INTERMEDIATE SECTION
DISH MOUNTING	10 10 062 1	12	24	3 221	91 54 668 08	S INTERMEDIATE SECTION
DISH MOUNTING	10 10 062 1	24	49	3 223	91 52 852 08	S INTERMEDIATE SECTION
DISH MOUNTING	10 10 062 1	24	49	3 223 010	91 52 853 08	S INTERMEDIATE SECTION
DISH MOUNTING	10 10 062 1	24	49	3 223 100	91 55 327 08	S INTERMEDIATE SECTION
DISH MOUNTING	10 10 062 1	41	37	3 225	91 52 854 08	SL REDUCING SECTION
DISH MOUNTING	10 10 062 1	24	25	3 226	91 52 870 08	L INTERMEDIATE SECTION
DISH MOUNTING	10 10 062 1	24	40	3 227	91 52 873 08	L INTERMEDIATE SECTION
DISH MOUNTING	10 10 062 1	24	32	3 227 008	91 52 872 08	L INTERMEDIATE SECTION
DISH MOUNTING	10 10 062 1	24	41	3 227 200	91 53 519 08	LI INTERMEDIATE SECT. F-GU
DISH MOUNTING	10 10 062 1	16	63	3 713	91 57 749 08	D PIVOT SECTION
DISH MOUNTING	10 10 062 1	45	51	3 714	91 52 862 08	D HEAD SECTION
DISH MOUNTING	10 10 062 1	5	48	3 715 008	91 52 863 08	D INTERMEDIATE SECTION
DISH MOUNTING	10 10 062 1	5	80	3 716	91 52 864 08	D INTERMEDIATE SECTION
DISH MOUNTING	10 10 062 1	27	16	3 745	91 52 948 08	SUSPENDED BALLAST
DISPLAY MD3072A-QUAD	10 45 478 2	(10)	1	2 925 026	91 55 259 08	ERG. CAMERA CONTROL
DISPLAY MD3072A-QUAD	10 45 478 2	10	1	2 925 405	96 48 397 08	EQUIPMENT CAMERA CAB
DISPLAY TFT PRE-ASS. TFT	96 20 762 08	21	1	2 913 005	96 20 731 08	INTERIOR HOUSING PRE-ASS.
DISPLAY TFT PRE-ASS. TFT	96 20 762 08	21	1	2 913 005	96 28 696 08	INTERIOR HOUSING PRE-ASS.
DISTANCE PIECE	96 47 596 08	2	1	3 205	91 52 880 08	F-ASSEMBLY UNIT
DISTANCE PIECE WELDED	96 49 272 08	8	2	3 714	91 52 862 08	D HEAD SECTION
DISTANCE PIECE WELDED	96 50 800 08	2	1	3 714 013	96 49 270 08	BRACKET COMPL.

6.2.2009

etk_en_de_074515 LR 1600/2

873

LIEBHERRAlphabetical index
Alphabetischer Index

Description	Item	Pos.	Quantity	Page	Assembly	Description
DISTRIBUTION BLOCK 3/4	77 43 859 08	2	1	2 711	91 52 800 08	CENT. LUBRIC. SYSTEM SUP
DISTRIBUTION BLOCK 3/6	10 47 036 7	4	1	2 711	91 52 800 08	CENT. LUBRIC. SYSTEM SUP
DISTRIBUTION BLOCK 4/3	77 43 860 08	3	1	2 711	91 52 800 08	CENT. LUBRIC. SYSTEM SUP
DISTRIBUTION BLOCK 4/8	77 43 862 08	5	1	2 711	91 52 800 08	CENT. LUBRIC. SYSTEM SUP
DISTRIBUTION BLOCK 7/12	10 47 036 8	3	2	1 711	91 52 392 08	CENTRALIZED LUBRICATION
DISTRIBUTION BLOCK 8/11	10 47 036 6	6	1	2 711	91 52 800 08	CENT. LUBRIC. SYSTEM SUP
DISTRIBUTION BLOCK 8/13	10 47 037 0	2	2	1 711	91 52 392 08	CENTRALIZED LUBRICATION
DISTRIBUTION STRIP	77 43 837 08	11	1	2 990	91 59 244 08	COMPRESSED AIR PLANT
DISTRIBUTOR BLOCK ALZNM	51 10 603 08	74	1	2 970	91 56 537 08	HYDR
DISTRIBUTOR GEARBOX SPF	10 35 659 9	102	1	2 391 001	96 45 719 08	DIESEL ENGINE, PRE-ASSEMB
DOOR COMPL.	96 49 183 08	2	1	2 510	91 52 788 08	TURNTABLE PANELLING
DOOR COMPL.	96 49 184 08	3	1	2 510	91 52 788 08	TURNTABLE PANELLING
DOOR CONTACT SWITCH	60 60 207 08	12	1	2 533 066	96 48 365 08	ELECTRIC ADD-ON PARTS CA
DOOR PANE ESG-GLAS SPF	97 68 851 08	14	1	2 522	91 54 115 08	SLIDING DOOR CPL.
DOSING PUMP	55 31 868 08	5	1	2 541	91 52 790 08	ADD HEATING SUPERSTRUCT
DOSING VALVE	10 30 300 5	1	1	X1034309	10 34 309 6	HIGH PRESSURE PUMP
DOUBLE GEAR PUMP SPF	51 21 370 08	114	1	2 391 001	96 45 719 08	DIESEL ENGINE, PRE-ASSEMB
DOUBLE NIPPLE R1/4"-M10X1	77 43 750 08	16	4	2 711	91 52 800 08	CENT. LUBRIC. SYSTEM SUP
DOUBLE RING SPANNER DIN	79 00 126 08	7	1	1 750	91 52 394 08	TOOL
DOUBLE-ENDED STUD M10X2	10 03 729 8	7	6	9 739 494	97 39 494	ATL ATTACHMENT
DOUBLE-ENDED STUD M10X3	10 28 710 4	5	4	9 739 494	97 39 494	ATL ATTACHMENT
DOUBLE-ENDED STUD M12X1	10 01 159 6	11	3	9 739 159	97 39 159	STARTER
DOUBLE-ENDED STUD M6X16	10 01 159 4	(2)	2	9 739 318	97 39 318	SENSOR ELEMENT
DOUBLE-ENDED STUD M8X15	10 47 689 0	4	1	9 739 491	97 39 491	INSTALLATION BRAKE COMPR
DOUBLE-HEADED SPANNER D	79 00 079 08	3	1	1 750	91 52 394 08	TOOL
DOUBLE-HEADED SPANNER D	79 00 039 08	4	1	1 750	91 52 394 08	TOOL
DOWEL PIN 8X40 ST	10 47 688 3	7	1	9 739 341	97 39 341	DRIVING PARTS
DOWEL PIN ISO 8752 10X60	43 20 111 08	62	2	X1065015	10 65 015 6	ROPE DRUM
DOWEL PIN ISO 8752 16X60	53 06 131 08	61	2	X1065015	10 65 015 6	ROPE DRUM
DOWEL PIN ISO 8752 4X28	43 20 025 08	4	4	1 641 014	92 53 053 08	SUPPORT PLATE COMPL.
DOWEL PIN ISO 8752 5X12	43 20 034 08	36	2	2 520	91 53 061 08	CABIN, GLAZED
DOWEL PIN ISO 8752 5X12	43 20 034 08	28	1	2 522 011	96 45 602 08	CLOSING DEVICE
DOWEL PIN ISO 8752 5X20	43 20 039 08	30	4	3 206	91 52 881 08	PIVOT SECTION
DOWEL PIN ISO 8752 5X32	43 20 045 08	14	2	2 522 013	96 45 883 08	GUIDE PRE-ASS.
DOWEL PIN ISO 8752 5X45	43 20 048 08	5	1	2 550 008	96 47 628 08	RETAINER CPL.
DOWEL PIN ISO 8752 5X45	43 20 048 08	5	1	2 550 009	96 47 645 08	RETAINER CPL.
DOWEL PIN ISO 8752 6X14	43 20 053 08	56	4	2 550	91 57 751 08	SA FRAME
DOWEL PIN ISO 8752 6X14	43 20 053 08	117	6	2 970	91 56 537 08	HYDR
DOWEL PIN ISO 8752 6X14	43 20 053 08	8	8	3 713 013	96 57 159 08	SHEET CPL.
DOWEL PIN ISO 8752 6X14	43 20 053 08	12	2	3 745 002	92 17 236 08	SWITCH UNIT
DOWEL PIN ISO 8752 6X14	43 20 053 08	24	2	3 978 015	91 56 429 08	ADDITIONAL HYDRAULICS IN
DOWEL PIN ISO 8752 6X14	43 20 053 08	24	2	3 978 015	91 56 432 08	ADDITIONAL HYDRAULICS IN
DOWEL PIN ISO 8752 6X20	43 20 057 08	13	2	2 391 040	96 53 645 08	CLUTCH ACTUATOR
DOWEL PIN ISO 8752 6X50 A2	43 20 067 08	8	2	2 925 402	96 58 855 08	CAMERA EQUIPMENT SLEWI
DOWEL PIN ISO 8752 8X60 ST	43 20 089 01	86	2	2 550	91 57 751 08	SA FRAME
DRAIN TAP	74 12 936	16	1	7 027 481	70 27 481 03	WATER SEPARATOR
DRAIN VALVE	10 03 290 6	23	1	9 739 361	97 39 361	OIL SUMP
DRAW CYLINDER 150/60-2300	10 41 102 1	2	1	2 657	91 57 656 08	MOUNTING EQUIPMENT CRAW
DRAW CYLINDER 310/120-500	10 42 959 8	1	1	3 714 016	96 49 797 08	TRACTION RAM PRE-ASS.
DRAWBAR WELDED	92 51 224 08	5	1	1 991	91 52 510 08	ROTARY FEED THROUGH
DRAWBAR WELDED	96 17 270 08	4	1	1 991	91 52 510 08	ROTARY FEED THROUGH
DRIVE FLANGE	60 60 126 08	6	1	2 920 200	96 44 536 08	ELECTRIC FOR WINCH 1
DRIVE FLANGE	60 60 126 08	6	1	2 920 260	96 44 537 08	ELECTRIC FOR WINCH 2
DRIVE FLANGE	60 60 126 08	6	1	2 920 334	96 44 538 08	ELECTRIC FOR WINCH 3
DRIVE FLANGE	60 60 126 08	6	1	2 920 350	96 44 539 08	ELECTRIC FOR WINCH 4
DRIVE SLEEVE	57 17 272 08	5	1	5 400 565	54 00 565 08	ROPE WINCH
DRIVE UNIT	10 65 015 8	24	1	X1035411	10 35 411 4	HOISTING WINCH
DRIVE WHEEL	10 22 275 2	5	1	9 739 278	97 39 278	ADD-ON PARTS
DRIVERS SEAT	10 29 200 4	1	1	2 502	91 55 939 08	CONTROL STAND
DRIVING GEAR	10 21 996 8	1	1	X1035925	10 35 925 1	VARIABLE PUMP

6.2.2009

etk_en_de_074515 LR 1600/2

874

LIEBHERRAlphabetical index
Alphabetischer Index

Description	Item	Pos.	Quantity	Page	Assembly	Description
DRIVING GEAR	10 32 692 4	1	1	X1035924	10 35 924 6	VARIABLE PUMP
DRIVING GEAR	10 33 104 7	1	1	X1035924	10 35 924 1	VARIABLE PUMP
DRIVING GEAR	10 33 104 7	1	1	X1035924	10 35 924 2	VARIABLE PUMP
DRIVING GEAR	10 33 104 7	1	1	X1035925	10 35 925 0	VARIABLE PUMP
DRIVING GEAR	10 47 137 0	1	1	X1035924	10 35 924 3	VARIABLE PUMP
DRIVING GEAR	10 47 138 0	1	1	X1035924	10 35 924 4	VARIABLE PUMP
DRIVING GEAR	10 47 218 5	1	1	X1035924	10 35 924 7	VARIABLE PUMP
DRIVING GEAR	10 47 220 4	1	1	X1035924	10 35 924 8	VARIABLE PUMP
DRIVING GEAR	10 65 006 5	1	1	5 102 354	51 02 354 08	HYDRO MOTOR
DRIVING GEAR	10 65 068 5	1	1	X1035924	10 35 924 9	VARIABLE PUMP
DRIVING GEAR	57 01 129 08	1	1	5 102 306	51 02 306 08	HYDRO MOTOR
DRIVING GEAR	57 01 133 08	1	1	5 701 129	57 01 129 08	DRIVING GEAR
DRIVING PARTS	97 39 341	31	1	X1012059	10 12 059 0	DIESEL ENGINE
DRIVING SHAFT	57 01 134 08	2	1	5 701 129	57 01 129 08	DRIVING GEAR
DRYER	57 14 890 08	4	1	2 831	91 57 754 08	AIR COND. UNIT SUPERSTRU
DS ASSEMBLY CYLINDER	57 19 136 08	(10)	1	5 123 682	51 23 682 08	MOUNTING - PISTON W. PUM
DS HYDRO CYLINDER	10 10 103 8	(999)	1	3 790 007	96 19 990 08	PIN PULLING CYLINDER CPL.
DS HYDRO CYLINDER	10 10 103 9	(999)	1	3 790 006	96 19 989 08	PIN PULLING CYLINDER CPL.
DS HYDRO CYLINDER	10 66 343 9	(999)	1	2 810	91 52 806 08	CRANE DRIVER'S CABIN CPL.
DS LOWERING BRAKE VALVE	10 65 006 8	99	1	X1021769	10 21 769 5	LOWERING BRAKE VALVE
DS RELAPSE SUPPORT	10 66 433 4	999	1	X1041101	10 41 101 5	TILTING-BACK SUPPORT
DS RELAPSE SUPPORT	10 66 444 9	999	1	X1041101	10 41 101 8	TILTING-BACK SUPPORT
DU BUSH	70 80 101 08	4	2	3 206	91 52 881 08	PIVOT SECTION
DUMMY PLUG W1050BS	96 56 664 08	16	1	2 920 369	96 54 235 08	TERMINAL BOX CPL.
DUMMY PLUG W909BS	96 55 366 08	17	1	2 920 369	96 54 235 08	TERMINAL BOX CPL.
DUMMY PLUG W909BS	96 56 665 08	15	1	2 920 369	96 54 235 08	TERMINAL BOX CPL.
DUMMY PLUG W988BS	96 52 267 08	320	1	3 930 638	96 51 624 08	TERMINAL BOX
DUMMY PLUG W989BS	96 52 272 08	330	1	3 930 638	96 51 624 08	TERMINAL BOX
DUST CAP	10 48 800 3	(1)	1	2 711	91 52 800 08	CENT. LUBRIC. SYSTEM SUP
DUST CAP	51 15 066 08	14	1	2 990	91 59 244 08	COMPRESSED AIR PLANT
DUST CAP	70 42 548 08	7	4	2 393 002	96 46 782 08	COVER COMPL.
DUST CAP	70 42 548 08	7	7	2 859 005	96 46 756 08	FLAP PRE-ASS.
DUST CAP	70 42 548 08	7	4	2 859 007	96 46 775 08	COVER COMPL.
DUST CAP	70 42 548 08	13	4	2 859 025	96 46 757 08	GRIDIRON PRE-ASS.
DUST CAP	70 42 548 08	7	4	2 859 026	96 46 776 08	COVER COMPL.
DUST CAP	70 42 548 08	7	4	2 859 027	96 46 777 08	COVER COMPL.
DUST CAP	70 42 548 08	7	4	2 859 028	96 46 778 08	COVER COMPL.
DUST CAP	70 42 548 08	7	4	2 859 029	96 46 779 08	COVER COMPL.
DUST CAP	70 42 548 08	12	2	2 859 030	96 46 758 08	COVER COMPL.
DUST CAP METALL	69 18 998 08	37	1	2 920 369	96 54 235 08	TERMINAL BOX CPL.
DUST CAP METALL	69 18 998 08	152	1	3 930 009	96 50 573 08	CABLE DRUM COMPL.
DUST CAP METALL	69 18 998 08	(172)	1	3 930 138	96 54 377 08	ELECTRIC FOR S-PIVOT SECT
DUST CAP METALL	69 18 998 08	289	2	3 930 638	96 51 624 08	TERMINAL BOX
DUST CAP METALL	69 18 998 08	280	2	3 930 730	96 50 599 08	TERMINAL BOX CPL.
DUST CAP METALL	69 24 000 08	(152)	1	2 920 369	96 54 235 08	TERMINAL BOX CPL.
DUST PLUG	10 48 800 2	(1)	1	2 711	91 52 800 08	CENT. LUBRIC. SYSTEM SUP
E/A-MODULE A SPF	66 01 020 08	113	1	2 932 082	96 54 387 08	ASSEMBLY PARTS MOUNTIN
ECROU HEXAGONAL AUTOFR	40 02 886	2	1	X1042954	10 42 954 9	WIND VELOCITY TRANSMITTE
EDGE PROTECTION	26 21 039 08	11	3.6	2 260 006	96 46 501 08	BATTERY BOX, PRE-ASSEMB
EDGE PROTECTION	26 21 039 08	9	1.75	2 391	91 52 784 08	DIESEL ENGINE CPL.
EDGE PROTECTION	26 21 039 08	42	1.3	2 520 034	96 45 984 08	INTERNAL LINING
EDGE PROTECTION	26 21 039 08	45	0.33	2 932 001	96 45 393 08	RELAY CONTROL SYSTEM
EDGE PROTECTION	26 21 039 08	43	2	2 932 082	96 54 387 08	ASSEMBLY PARTS MOUNTIN
EDGE PROTECTION	26 21 039 08	7	0.16	2 932 166	92 68 911 08	GROUND RAIL
EDGE PROTECTION	26 21 040 08	44	0.8	2 631	91 56 817 08	SLEWING PLATFORM CATWAL
EDGE PROTECTION	26 21 040 08	19	0.23	2 670	91 52 797 08	FUEL TANK CPL.
EDGE PROTECTION	26 21 040 08	48	0.8	2 810	91 52 806 08	CRANE DRIVER'S CABIN CPL.
EDGE PROTECTION	26 21 040 08	66	1.6	2 859	91 52 809 08	SOUND INSULATION
EDGE PROTECTION	26 21 040 08	10	3.27	2 859 007	96 46 775 08	COVER COMPL.
EDGE PROTECTION	26 21 053 08	64	9.6	2 859	91 52 809 08	SOUND INSULATION

6.2.2009

etk_en_de_074515 LR 1600/2

875

LIEBHERRAlphabetical index
Alphabetischer Index

Description	Item	Pos.	Quantity	Page	Assembly	Description
EDGE PROTECTION	26 21 053 08	9	0.16	2 859 029	96 46 779 08	COVER COMPL.
EL.BACKING PROTECTION D	96 51 078 08	500	1	3 292	91 52 865 08	D OVERRUN PROTECTION
EL.CHARGER F.BATTERY	96 48 378 08	3	1	2 835	91 52 807 08	BATTERY CHARGER
EL.EQUIPMENT CABIN DACH	96 48 360 08	3	1	2 533	91 52 789 08	EL.INSTRUMENTS F.CRANE D
EL.EQUIPMENT CABIN FRONT	96 48 359 08	2	1	2 533	91 52 789 08	EL.INSTRUMENTS F.CRANE D
EL.EQUIPMENT SAFETY RETAI	92 95 070 08	500	1	3 291	91 52 831 08	S OVERRUN PROTECTION
EL.EQUIPMENT SW HEAD SE	96 48 381 08	500	1	3 214	91 52 843 08	SW HEAD SECTION
EL.F-CONNECTING HEAD	96 48 380 08	500	1	3 213	91 52 842 08	F-CONNECTING HEAD
EL.INSTRUMENTS F.CRANE	91 52 789 08	133	1		LR 1600-2-0	
ELBOW	10 01 219 0	1	1	9 739 386	97 39 386	CRANKCASE BREATHER
ELBOW	10 01 230 1	1	1	9 739 126	97 39 126	THERMOSTAT HOUSING
ELBOW	10 01 230 2	1	1	9 739 349	97 39 349	CONNECTION F.WATER PIPE
ELBOW	10 22 237 4	1	1	9 739 276	97 39 276	WATER CONNECTION
ELBOW DN60 GUMMI	55 08 984 08	200	1	2 391 001	96 45 719 08	DIESEL ENGINE, PRE-ASSEMB
ELECT.EQUIPMENT THREAD	96 48 372 08	3	1	2 533 054	96 48 366 08	ELECTR. FOR CONTROL STAN
ELECTR. F-HEAD SECTION	96 48 375 08	500	1	3 208 001	91 52 883 08	F-HEAD SECTION
ELECTR. FOR CONTROL STAN	96 48 366 08	4	1	2 533	91 52 789 08	EL.INSTRUMENTS F.CRANE D
ELECTR. FOR HEAD SECTION	96 47 149 08	500	1	3 714	91 52 862 08	D HEAD SECTION
ELECTR. SYSTEM F.SLEWING	91 56 833 08	163	1		LR 1600-2-0	
ELECTR.CABLE 0,75Q PVC SP	60 04 140 08	(345)	0.32	2 920 369	96 54 235 08	TERMINAL BOX CPL.
ELECTR.CABLE 0,75Q PVC SP	60 04 140 08	(345)	0.32	2 920 369	96 54 235 08	TERMINAL BOX CPL.
ELECTR.CABLE 0,75Q PVC SP	60 04 140 08	345	22.2	2 920 633	96 52 651 08	WIRING HARNESS
ELECTR.CABLE DIN 72551 0,5	60 04 121 08	(344)	0.96	2 920 369	96 54 235 08	TERMINAL BOX CPL.
ELECTR.CABLE DIN 72551 1	60 04 341 08	20	3	2 780 320	91 05 067 08	ACOUST.WARN. SLEWING G
ELECTR.CABLE DIN 72551 1	60 04 341 08	(305)	3.84	2 920 369	96 54 235 08	TERMINAL BOX CPL.
ELECTR.CABLE DIN 72551 1	60 04 341 08	(305)	2.56	2 920 369	96 54 235 08	TERMINAL BOX CPL.
ELECTR.CABLE DIN 72551 1	60 04 341 08	305	453.6	2 920 633	96 52 651 08	WIRING HARNESS
ELECTR.CABLE DIN 72551 2,5	60 04 042 08	310	0.3	2 920 369	96 54 235 08	TERMINAL BOX CPL.
ELECTR.CABLE DIN 72551 2,5	60 04 042 08	310	0.3	2 920 448	96 48 794 08	TERMINAL BOX CPL.
ELECTR.CRAWLER SUPPORT	96 48 384 08	3	1	1 920 300	91 52 505 08	ELECTR.FOR CRAWLER CARR
ELECTR.CRAWLER SUPPORT	96 48 385 08	4	1	1 920 300	91 52 505 08	ELECTR.FOR CRAWLER CARR
ELECTR.F.FUEL TANK	96 45 717 08	2	1	2 670 002	96 45 352 08	FUEL TANK, PRE-ASSEMBLED
ELECTR.FOR BALLAST PALLE	96 50 097 08	10	1	2 780 100	96 50 096 08	ELECTRICS F.SUSPENDED BA
ELECTR.FOR CENTER SECTIO	96 48 383 08	2	1	1 920 300	91 52 505 08	ELECTR.FOR CRAWLER CARR
ELECTR.FOR CRAWLER CARR	91 52 505 08	28	1		LR 1600-2-0	
ELECTR.FOR SLEWING GEAR	96 47 474 08	500	1	2 350	91 52 778 08	SLEWING GEAR
ELECTRIC ADD-ON PARTS CA	96 48 365 08	7	1	2 533	91 52 789 08	EL.INSTRUMENTS F.CRANE D
ELECTRIC AIRCRAFT PROTE	96 56 482 08	11	1	3 780 751	91 52 952 08	AIR-CRAFT & WIND WARNING
ELECTRIC F. AGGREGATE	96 48 318 08	10	1	2 920	91 56 833 08	ELECTR. SYSTEM F.SLEWING
ELECTRIC FOR ARMREST LEF	96 48 368 08	1	1	2 533 054	96 48 366 08	ELECTR. FOR CONTROL STAN
ELECTRIC FOR ARMREST RI	96 48 369 08	2	1	2 533 054	96 48 366 08	ELECTR. FOR CONTROL STAN
ELECTRIC FOR BATTERY BOX	96 48 319 08	5	1	2 260 006	96 46 501 08	BATTERY BOX, PRE-ASSEMB
ELECTRIC FOR OIL COOLER	91 11 097 08	6	1	2 391 102	96 56 360 08	RADIATOR
ELECTRIC FOR S-PIVOT SECT	96 54 377 08	500	1	3 211	91 57 748 08	S PIVOT SECTION
ELECTRIC FOR SA - FRAME	96 54 379 08	500	1	2 550	91 57 751 08	SA FRAME
ELECTRIC FOR WINCH 1	96 44 536 08	500	1	2 310	91 52 503 08	WINCH 1
ELECTRIC FOR WINCH 2	96 44 537 08	500	1	2 320	91 52 504 08	WINCH 2
ELECTRIC FOR WINCH 3	96 44 538 08	500	1	3 350	91 52 859 08	WINCH 3
ELECTRIC FOR WINCH 4	96 44 539 08	500	1	2 340	91 52 776 08	WINCH 4 LUFFING GEAR
ELECTRIC PUMP	77 43 566 08	4	2	1 711	91 52 392 08	CENTRALIZED LUBRICATION
ELECTRIC PUMP S-EP4	10 32 716 7	1	1	2 711	91 52 800 08	CENT. LUBRIC. SYSTEM SUP
ELECTRIC WIND WARNING T	96 54 370 08	5	1	3 780 751	91 52 952 08	AIR-CRAFT & WIND WARNING
ELECTRICS F BASE SECTION	96 48 374 08	500	1	3 206	91 52 881 08	PIVOT SECTION
ELECTRICS F.SUSPENDED BA	96 50 096 08	500	1	3 745	91 52 948 08	SUSPENDED BALLAST
EMERGENCY CUT-OFF CRANE	91 52 951 08	352	1		LR 1600-2-0	
EMERGENCY CUT-OFF CRANE	96 41 461 08	4	1	2 533 051	96 48 360 08	EL.EQUIPMENT CABIN
EMERGENCY HAMMER	88 50 422 08	58	1	2 520 034	96 45 984 08	INTERNAL LINING
EMERGENCY SEAT	91 55 873 08	130	1		LR 1600-2-0	
EMERGENCY SHUT-DOWN D	10 47 515 0	55	1	2 932 082	96 54 387 08	ASSEMBLY PARTS MOUNTIN
EMERGENCY STOP	60 61 441 08	(2)	1	2 533 051	96 48 360 08	EL.EQUIPMENT CABIN

6.2.2009

etk_en_de_074515 LR 1600/2

876

LIEBHERRAlphabetical index
Alphabetischer Index

Description	Item	Pos.	Quantity	Page	Assembly	Description
EMPTY CASING	94 98 250 08	2	1	2 920 257	92 78 689 08	TERMINAL BOX LIGHTING HO
EMPTY CASING	97 14 228 08	5	1	2 920 581	96 54 405 08	TERMINAL BOX WINCH PRE-A
EMPTY CASING 160X160X90X	97 14 073 08	4	1	1 920 403	96 48 707 08	TERMINAL BOX CPL.
EMPTY CASING 160X160X90X	97 14 073 08	4	1	1 920 417	96 48 703 08	TERMINAL BOX CPL.
EMPTY CASING 160X160X90X0	97 58 522 08	4	1	2 780 748	96 52 969 08	TERMINAL BOX CPL.
EMPTY CASING 160X260X90X	97 79 111 08	1	1	3 930 730	96 50 599 08	TERMINAL BOX CPL.
EMPTY CASING 160X260X90X0	97 54 075 08	5	1	3 930 363	96 52 979 08	TERMINAL BOX CPL.
EMPTY CASING 160X360X90X	97 79 684 08	4	1	3 930 640	96 50 481 08	TERMINAL BOX CPL.
EMPTY CASING 160X360X90X	97 85 479 08	5	1	2 920 369	96 54 235 08	TERMINAL BOX CPL.
EMPTY CASING 160X560X90X	97 51 876 08	5	1	2 920 448	96 48 794 08	TERMINAL BOX CPL.
EMPTY CASING 160X560X90X0	97 54 042 08	7	1	3 930 734	96 54 401 08	TERMINAL BOX
EMPTY CASING 230X600X110X	97 52 217 08	5	1	3 930 730	96 54 398 08	TERMINAL BOX CPL.
EMPTY CASING 230X600X110X	97 80 749 08	4	1	3 930 638	96 51 624 08	TERMINAL BOX
EMPTY CASING 56 TE	61 10 011 08	2	1	2 913 100	91 23 538 08	ASSEMBLY FRAME
EMPTY CASING 75 110X55X0	97 57 731 08	1	1	2 533 071	96 52 556 08	CONVERTOR
EMPTY CASING DRILLED 230	97 13 661 08	3	1	1 920 418	96 48 687 08	TERMINAL BOX CPL.
END ANGLE	60 27 946 08	12	2	1 920 418	96 48 687 08	TERMINAL BOX CPL.
END ANGLE	60 27 946 08	7	2	2 780 748	96 52 969 08	TERMINAL BOX CPL.
END ANGLE	60 27 946 08	267	2	2 920 581	96 54 405 08	TERMINAL BOX WINCH PRE-A
END ANGLE	60 27 946 08	297	2	3 930 730	96 50 599 08	TERMINAL BOX CPL.
END ANGLE	60 27 946 08	281	4	3 930 730	96 54 398 08	TERMINAL BOX CPL.
END ANGLE	60 27 946 08	204	2	3 930 734	96 54 401 08	TERMINAL BOX
END CAP 34	55 31 811 08	4	1	2 541 001	96 49 651 08	ADDNL.HEATING, PRE-ASSE
END CAP 42,3	55 31 741 08	7	1	2 541	91 52 790 08	ADD HEATING SUPERSTRUCT
END HOLDER	60 21 101 08	9	5	2 932 082	96 54 387 08	ASSEMBLY PARTS MOUNTIN
END PLATE	10 41 267 8	21	1	5 133 090	51 13 090 08	SLIDE VALVE BLOCK
ENGINE BRACKET LEFT	96 48 468 08	2	1	2 391 001	96 45 719 08	DIESEL ENGINE, PRE-ASSEMB
ENGINE BRACKET RIGHT	96 48 457 08	3	1	2 391 001	96 45 719 08	DIESEL ENGINE, PRE-ASSEMB
ENGINE BRACKET WELDED	96 43 477 08	8	2	2 391 001	96 45 719 08	DIESEL ENGINE, PRE-ASSEMB
ENGINE CONTROL SENSORS	97 39 257	231	1	9 739 400	97 39 400	DIESEL ENGINE
EQUALIZING RESERVOIR	50 28 065 08	7	1	2 978 100	91 52 796 08	ADDNL.HYDR.ERECTION DEV
EQUALIZING RESERVOIR	50 28 065 08	12	1	2 978 100	91 52 827 08	ADDNL.HYDR.RETAINING DEV
EQUALIZING RESERVOIR	50 28 065 08	12	1	2 978 200	91 54 843 08	ADD.HYDR.S_RETAINING RAM
EQUALIZING RESERVOIR	50 28 073 08	12	2	1 970	91 56 958 08	CRAWLER TRACK HYDRAULI
EQUALIZING RESERVOIR	50 28 073 08	50	1	2 970	91 56 537 08	HYDR
EQUALIZING RESERVOIR	50 28 073 08	9	1	2 975 100	91 52 860 08	ADDITIONAL HYDRAULICS WI
EQUALIZING RESERVOIR	50 28 073 08	9	1	2 975 200	91 52 775 08	ADDITIONAL HYDRAULICS WI
EQUALIZING RESERVOIR	50 28 073 08	9	1	2 975 700	91 52 774 08	ADDITIONAL HYDRAULICS WI
EQUALIZING RESERVOIR	50 28 073 08	9	1	3 978 005	91 56 430 08	ADDL.HYDRAULIC SB-HEAD PI
EQUALIZING RESERVOIR	57 00 659 08	1	1	5 028 065	50 28 065 08	EQUALIZING RESERVOIR
EQUIPMENT CAMERA CAB	96 48 397 08	20	1	2 925 007	91 60 728 08	CAMERA MONITORING
EQUIPMENT CAMERA SUPERS	96 58 856 08	10	1	2 925 007	91 60 728 08	CAMERA MONITORING
EQUIPMENT CARRIER WELDE	96 46 563 08	50	1	2 391 001	96 45 719 08	DIESEL ENGINE, PRE-ASSEMB
EQUIPMENT MOUNTING 35MM	10 32 483 4	37	5	2 631	91 56 817 08	SLEWING PLATFORM CATWAL
ERECTING WINCH	91 52 782 08	119	1		LR 1600-2-0	
ERECTION FRAME	91 52 896 08	294	1		LR 1600-2-0	
ERG. CAMERA CONTROL	91 55 259 08	323	1		LR 1600-2-0	
ES PIN 8X16 VERZ	72 51 118 08	13	2	2 932 160	96 54 385 08	SWITCH CABINET
EXHAUST DUCT	10 01 240 0	7	1	9 739 358	97 39 358	EXHAUST GAS RECIRCUL.ATT
EXHAUST DUCT	10 22 237 3	4	1	9 739 358	97 39 358	EXHAUST GAS RECIRCUL.ATT
EXHAUST DUCT	10 22 237 6	10	1	9 739 358	97 39 358	EXHAUST GAS RECIRCUL.ATT
EXHAUST FLANGE ST	10 44 054 4	2	1	2 392	91 52 785 08	MUFFLER UNIT
EXHAUST GAS RECIRCUL.ATT	97 39 358	115	1	X1012059	10 12 059 0	DIESEL ENGINE
EXHAUST GAS RECIRCUL.PRE	97 39 357	1	1	9 739 358	97 39 358	EXHAUST GAS RECIRCUL.ATT
EXHAUST GAS TURBOCHAR	10 47 688 6	1	1	9 739 494	97 39 494	ATL ATTACHMENT
EXHAUST HOSE 38	55 30 541 08	6	2	2 541	91 52 790 08	ADD HEATING SUPERSTRUCT
EXHAUST HOSE 38	55 30 541 08	9	0.5	2 541 001	96 49 651 08	ADDNL.HEATING, PRE-ASSE
EXHAUST MUFFLER	55 31 872 08	7	1	2 541 001	96 49 651 08	ADDNL.HEATING, PRE-ASSE
EXHAUST NOZZLE	97 39 353	192	1	X1012059	10 12 059 0	DIESEL ENGINE
EXHAUST PIPE	10 22 237 7	1	1	9 739 295	97 39 295	EXHAUST PIPE

6.2.2009

etk_en_de_074515 LR 1600/2

877

LIEBHERRAlphabetical index
Alphabetischer Index

Description	Item	Pos.	Quantity	Page	Assembly	Description
EXHAUST PIPE	10 22 271 7	4	1	9 739 295	97 39 295	EXHAUST PIPE
EXHAUST PIPE	10 28 710 2	3	1	9 739 295	97 39 295	EXHAUST PIPE
EXHAUST PIPE	97 39 295	180	1	X1012059	10 12 059 0	DIESEL ENGINE
EXHAUST PIPE EDELSTAHL	10 43 037 0	4	1	2 392	91 52 785 08	MUFFLER UNIT
EXHAUST PIPE EDELSTAHL	10 43 037 1	6	2	2 392	91 52 785 08	MUFFLER UNIT
EXHAUST PIPE EDELSTAHL	10 43 037 2	5	1	2 392	91 52 785 08	MUFFLER UNIT
EXHAUST SILENCER 350X150	10 44 054 3	1	1	2 392	91 52 785 08	MUFFLER UNIT
EXHAUST TAIL PIPE EDELST	10 43 036 9	7	1	2 392	91 52 785 08	MUFFLER UNIT
EXPANSION BOLT 10.9 SPF	97 65 584 08	2	72	2 620	91 52 793 08	ROLLER SLEWING RING
EXPANSION BOLT M48X170 30	40 98 296 08	1	72	1 620	91 52 386 08	FIXING PARTS SLEWING RING
EXTENSION 35	77 43 735 08	14	8	2 711	91 52 800 08	CENT. LUBRIC. SYSTEM SUP
EXTENSION M10X1	77 43 734 08	7	46	1 711	91 52 392 08	CENTRALIZED LUBRICATION
EXTERNAL FEED 230V-110V	91 52 958 08	414	1		LR 1600-2-0	
EYE BOLT DIN 444 M12X150 6.	10 34 328 5	19	1	9 739 371	97 39 371	AIR COND. COMPRESSOR A
EYE BOLT DIN 444 M12X188 6.	10 34 328 8	13	1	9 739 344	97 39 344	GENERATOR, PRE-ASSEMBLE
F BASE SECTION WELDMENT	96 46 767 08	1	1	3 206	91 52 881 08	PIVOT SECTION
F-ASSEMBLY UNIT	91 52 880 08	282	1		LR 1600-2-0	
F-CONNECTING HEAD	91 52 842 08	202	1		LR 1600-2-0	
F-CONNECTING HEAD WELDE	96 46 750 08	1	1	3 213	91 52 842 08	F-CONNECTING HEAD
F-GUYING	91 53 433 08	286	1		LR 1600-2-0	
F-HEAD SECTION	91 52 883 08	288	1		LR 1600-2-0	
F-HEAD SECTION WELDM.	96 47 129 08	1	1	3 208 001	91 52 883 08	F-HEAD SECTION
F-STAY COMPL.	96 47 888 08	1	1	3 282	91 52 897 08	OVERRUN PROTECTION
FA FRAME WELDMENT	96 46 996 08	1	1	3 281	91 52 896 08	ERECTION FRAME
FAB-STAY	96 47 890 08	2	1	3 282	91 52 897 08	OVERRUN PROTECTION
FAN / BLOWER	61 07 145 08	2	1	2 913 004	96 20 460 08	HOUSING PRE-ASSEMBLED
FAN / BLOWER	61 07 146 08	2	2	2 913 006	96 20 732 08	FAN PLATE PRE-ASS.
FAN / BLOWER 80X80X25	61 03 886 14	3	2	2 913 102	92 32 870 08	FAN UNIT
FAN 24V	10 29 012 2	3	1	X1004204	10 04 204 3	WATER HEATING SYSTEM
FAN BLADE	10 65 067 6	7	1	X1035519	10 35 519 6	OIL AIR COOLER
FAN HOOD	10 65 067 1	3	1	X1035519	10 35 519 6	OIL AIR COOLER
FAN HUB D=168	95 70 468 08	4	2	2 391 023	96 45 720 08	RADIATOR, PRE-ASSEMBLED
FAN PLATE	92 99 370 08	1	1	2 913 006	96 20 732 08	FAN PLATE PRE-ASS.
FAN PLATE PRE-ASS.	96 20 732 08	1	1	2 913 005	96 20 731 08	INTERIOR HOUSING PRE-ASS.
FAN PLATE PRE-ASS.	96 20 732 08	1	1	2 913 005	96 28 696 08	INTERIOR HOUSING PRE-ASS.
FAN SCREEN 1X173X286 PENA	28 81 799 08	15	1	2 913 100	91 23 538 08	ASSEMBLY FRAME
FAN UNIT	92 32 870 08	11	1	2 913 100	91 23 538 08	ASSEMBLY FRAME
FASTENER	88 50 423 08	59	1	2 520 034	96 45 984 08	INTERNAL LINING
FASTENER	92 83 955 08	75	8	3 713	91 57 749 08	D PIVOT SECTION
FASTENING	10 22 273 8	9	1	9 739 248	97 39 248	INJECTOR
FASTENING CLAMP	55 31 352 08	1	1	5 530 545	55 30 545 08	CIRCULATING PUMP
FASTENING CLAMP	57 00 664 08	7	1	5 028 065	50 28 065 08	EQUALIZING RESERVOIR
FASTENING CLAMP 125X15 W	10 01 268 1	9	1	9 739 159	97 39 159	STARTER
FASTENING CLAMP 15,9	60 20 043 08	15	1	2 920 535	96 48 318 08	ELECTRIC F. AGGREGATE
FASTENING CLAMP D1-10X15	10 01 198 9	12	1	9 739 282	97 39 282	OVERFLOW-OIL LINE
FASTENING CLAMP DIN 3016-	10 34 229 7	6	1	9 739 356	97 39 356	PIPELINE INSTALLATION
FASTENING PIECES ASSEMBL	97 39 366	229	1	X1012059	10 12 059 0	DIESEL ENGINE
FAULT INDICATOR	10 42 995 2	19	2	7 743 566	77 43 566 08	ELECTRIC PUMP
FELT STRIP DIN 5419 5X4	26 11 007 08	5	1	5 718 420	57 18 420 08	FLANGE
FERRIMAGNET FERRIT	61 70 000 08	12	1	1 933 100	91 25 249 08	MAGNETIC LAMP
FILLISTER SOCKET HEAD SC	10 22 234 4	9	3	9 739 262	97 39 262	CYLINDER HEAD
FILLISTER SOCKET HEAD SC	10 22 234 4	9	3	9 739 266	97 39 266	CYLINDER HEAD
FILLISTER SOCKET HEAD SC	10 22 234 3	8	3	9 739 262	97 39 262	CYLINDER HEAD
FILLISTER SOCKET HEAD SC	10 22 234 3	8	3	9 739 266	97 39 266	CYLINDER HEAD
FILTER CARTRIDGE	51 06 711 08	38	4	2 970	91 56 537 08	HYDR
FILTER CARTRIDGE	51 06 711 08	12	1	2 975 100	91 52 860 08	ADDITIONAL HYDRAULICS WI
FILTER CARTRIDGE	51 06 711 08	12	1	2 975 200	91 52 775 08	ADDITIONAL HYDRAULICS WI
FILTER CARTRIDGE	51 06 711 08	12	1	2 975 700	91 52 774 08	ADDITIONAL HYDRAULICS WI
FILTER CARTRIDGE	51 06 711 08	7	1	2 978 100	91 52 827 08	ADDNL.HYDR.RETAINING DEV
FILTER CARTRIDGE	51 06 711 08	7	1	2 978 200	91 54 843 08	ADD.HYDR.S_RETAINING RAM

6.2.2009

etk_en_de_074515 LR 1600/2

878

LIEBHERRAlphabetical index
Alphabetischer Index

Description	Item	Pos.	Quantity	Page	Assembly	Description
FILTER COVER	57 08 320 08	2	1	5 106 691	51 06 691 08	RETURN FILTER
FILTER INSERT	10 03 762 3	(1)	1	2 970	91 56 537 08	HYDR
FILTER INSERT	51 06 692 08	1	1	5 106 691	51 06 691 08	RETURN FILTER
FILTER INSERT	51 06 718 08	(1)	1	2 671 004	96 46 305 08	OIL TANK PRE-ASS.
FILTER INSERT	57 17 556 08	1	1	5 517 203	55 17 203 08	AIR FILTER
FILTER INSERT KRAFTSTOFF	70 27 479	6	1	7 027 481	70 27 481 03	WATER SEPARATOR
FINGER WELDED	96 47 491 08	27	2	2 550	91 57 751 08	SA FRAME
FITTED SCREW M12X32 8.8	10 34 226 2	15	1	9 739 371	97 39 371	AIR COND. COMPRESSOR A
FIXAGE DU CONTREPOIDS CE	91 53 021 08	23	1		LR 1600-2-0	
FIXATION POINT	96 48 609 08	8	2	3 215 005	91 52 846 08	ROLLER SET
FIXATION POINT	96 48 609 08	8	2	3 215 006	91 52 847 08	ROLLER SET
FIXED BOOM RAISING DEVICE	10 65 048 3	28	1	X1029200	10 29 200 4	DRIVERS SEAT
FIXING OR FASTENING PART	78 89 018 08	19	4	2 370	91 52 782 08	ERECTING WINCH
FIXING OR FASTENING PART	78 89 018 08	70	12	2 810	91 52 806 08	CRANE DRIVER'S CABIN CPL.
FIXING PARTS ELECTRIC	96 48 328 08	40	1	2 920	91 56 833 08	ELECTR. SYSTEM F.SLEWING
FIXING PARTS SLEWING RING	91 52 386 08	13	1		LR 1600-2-0	
FIXING TAPE	54 01 368 08	42	1.7	X1065015	10 65 015 5	GEARBOX
FLAG RECEPTACLE	60 22 034 08	12	2	2 780 320	91 05 067 08	ACOUST.WARN. SLEWING G
FLAG RECEPTACLE	60 22 034 08	72	12	2 920 633	96 52 651 08	WIRING HARNESS
FLAME DETECTOR	10 29 012 3	16	1	X1004204	10 04 204 3	WATER HEATING SYSTEM
FLAME GLOW PLUG	10 01 246 3	1	1	9 739 140	97 39 140	FLAME STARTING SYSTEM
FLAME STARTING SYSTEM	97 39 140	130	1	X1012059	10 12 059 0	DIESEL ENGINE
FLANGE	10 01 271 4	17	2	9 739 361	97 39 361	OIL SUMP
FLANGE	10 01 271 5	2	1	9 739 035	97 39 035	LOCKING PIECES
FLANGE	10 01 271 5	2	1	9 739 129	97 39 129	COOLANT PREHEATING
FLANGE	10 22 275 1	2	1	9 739 278	97 39 278	ADD-ON PARTS
FLANGE	10 28 030 8	1	1	9 739 286	97 39 286	SCREW CAP
FLANGE	10 34 286 4	11	1	9 739 372	97 39 372	LUBRICATING OIL PUMP
FLANGE	10 34 334 0	12	1	9 739 349	97 39 349	CONNECTION F.WATER PIPE
FLANGE	57 18 420 08	22	1	X1035411	10 35 411 4	HOISTING WINCH
FLANGE 10X137X137	97 83 612 08	4	1	2 391 040	96 53 645 08	CLUTCH ACTUATOR
FLANGE FITTING A3P	51 01 416 08	19	1	2 391 038	96 47 931 08	OIL COOLER, PRE-ASSEMBLE
FLANGE FITTING A3P	51 01 417 08	17	1	2 391 038	96 47 931 08	OIL COOLER, PRE-ASSEMBLE
FLANGE HALF 1" A3P	51 05 869 08	545	8	2 970	91 56 537 08	HYDR
FLANGE HALF 2"	51 15 167 08	41	4	2 391 001	96 45 719 08	DIESEL ENGINE, PRE-ASSEMB
FLANGE HALF A3P	51 05 866 08	58	16	1 970	91 56 958 08	CRAWLER TRACK HYDRAULI
FLANGE HALF A3P	51 05 866 08	58	8	1 970 161	96 50 706 08	AUX.HYDR.CR.TRACK CARR.4
FLANGE HALF A3P	51 05 866 08	553	16	2 970	91 56 537 08	HYDR
FLANGE HALF A3P	51 05 866 08	41	4	2 975 100	91 52 860 08	ADDITIONAL HYDRAULICS WI
FLANGE HALF A3P	51 05 875 08	541	4	2 970	91 56 537 08	HYDR
FLANGE HALF A3P	51 05 875 08	561	12	2 976 200	91 52 780 08	ADDITIONAL HYDRAULICS
FLANGE HALF A3P	51 05 875 08	566	4	2 976 700	91 54 795 08	ADDITIONAL HYDRAULICS P
FLANGE JOINT	57 00 660 08	2	1	5 028 065	50 28 065 08	EQUALIZING RESERVOIR
FLANGE JOINT BUZ 12L CR6-F	47 77 005 08	594	1	2 970	91 56 537 08	HYDR
FLANGE JOINT BUZ 15L CR6-F	47 77 006 08	583	2	2 970	91 56 537 08	HYDR
FLANGE JOINT BUZ 25S CR6-F	47 77 015 08	598	1	2 970	91 56 537 08	HYDR
FLANGE JOINT BUZ 35L CR6-F	47 77 007 08	596	1	2 970	91 56 537 08	HYDR
FLANGE JOINT BUZ 42L CR6-F	47 77 009 08	589	2	2 970	91 56 537 08	HYDR
FLANGE JOINT EGE 10L G3/8A	47 19 043 08	732	5	2 970	91 56 537 08	HYDR
FLANGE JOINT EGE 10L G3/8A	47 19 043 08	609	1	2 975 100	91 52 860 08	ADDITIONAL HYDRAULICS WI
FLANGE JOINT EGE 10L G3/8A	47 19 043 08	622	1	2 975 200	91 52 775 08	ADDITIONAL HYDRAULICS WI
FLANGE JOINT EGE 10L G3/8A	47 19 043 08	622	1	2 975 700	91 52 774 08	ADDITIONAL HYDRAULICS WI
FLANGE JOINT EGE 10L G3/8A	47 19 043 08	602	1	2 978 100	91 52 827 08	ADDNL.HYDR.RETAINING DEV
FLANGE JOINT EGE 10L G3/8A	47 19 043 08	607	1	2 978 200	91 54 843 08	ADD.HYDR.S RETAINING RAM
FLANGE JOINT EGE 12S G1/2A	47 19 018 08	601	4	1 975 006	91 52 509 08	ADD. HYDR. SUPPORTING RA
FLANGE JOINT EGE 12S G1/2A	47 19 018 08	611	1	2 978 100	91 52 796 08	ADDNL.HYDR.ERECTION DEV
FLANGE JOINT EGESD10-LR-W	47 19 011 08	747	3	2 970	91 56 537 08	HYDR
FLANGE JOINT EGESD10-LR-W	47 19 011 08	616	1	2 975 100	91 52 860 08	ADDITIONAL HYDRAULICS WI
FLANGE JOINT EGESD10-LR-W	47 19 011 08	616	1	2 975 200	91 52 775 08	ADDITIONAL HYDRAULICS WI
FLANGE JOINT EGESD10-LR-W	47 19 011 08	616	1	2 975 700	91 52 774 08	ADDITIONAL HYDRAULICS WI

6.2.2009

etk_en_de_074515 LR 1600/2

879

LIEBHERRAlphabetical index
Alphabetischer Index

Description	Item	Pos.	Quantity	Page	Assembly	Description
FLANGE JOINT EGESD10-LR-W	47 19 011 08	619	1	2 978 100	91 52 827 08	ADDNL.HYDR.RETAINING DEV
FLANGE JOINT EGESD12-LR-W	47 19 012 08	756	1	2 970	91 56 537 08	HYDR
FLANGE JOINT EGESD12-LR-W	47 19 012 08	601	2	2 978 100	91 52 827 08	ADDNL.HYDR.RETAINING DEV
FLANGE JOINT EGESD12-LR-W	47 19 012 08	606	3	2 978 200	91 54 843 08	ADD.HYDR.S_RETAINING RAM
FLANGE JOINT EGESD12-LR-W	47 19 038 08	678	3	2 970	91 56 537 08	HYDR
FLANGE JOINT EGESD12-LR-W	47 19 038 08	613	1	2 978 200	91 54 843 08	ADD.HYDR.S_RETAINING RAM
FLANGE JOINT EGESD12-SR	47 19 005 08	643	1	2 978 100	91 52 827 08	ADDNL.HYDR.RETAINING DEV
FLANGE JOINT EGESD12-SR	47 19 005 08	608	1	2 978 200	91 54 843 08	ADD.HYDR.S_RETAINING RAM
FLANGE JOINT EGESD15-LM	47 19 042 08	8	1	2 670 002	96 45 352 08	FUEL TANK, PRE-ASSEMBLED
FLANGE JOINT EGESD15-LR-W	47 19 035 08	612	1	2 978 100	91 52 827 08	ADDNL.HYDR.RETAINING DEV
FLANGE JOINT EGESD16-SR	47 19 006 08	651	9	2 970	91 56 537 08	HYDR
FLANGE JOINT EGESD16-SR	47 19 006 08	603	3	2 975 000	91 57 881 08	ADDNL. HYDR. F. ERECTING W
FLANGE JOINT EGESD16-SR	47 19 006 08	610	8	3 978 005	91 56 430 08	ADDL.HYDRAULIC SB-HEAD PI
FLANGE JOINT EGESD16-SR	47 19 019 08	658	2	1 970	91 56 958 08	CRAWLER TRACK HYDRAULI
FLANGE JOINT EGESD18-LM	47 19 023 08	613	1	2 990	91 59 244 08	COMPRESSED AIR PLANT
FLANGE JOINT EGESD18-LR-W	47 19 013 08	793	1	2 970	91 56 537 08	HYDR
FLANGE JOINT EGESD20-SR	47 19 007 08	621	1	1 970	91 56 958 08	CRAWLER TRACK HYDRAULI
FLANGE JOINT EGESD20-SR	47 19 007 08	781	2	2 970	91 56 537 08	HYDR
FLANGE JOINT EGESD22-LR-W	47 19 014 08	623	2	2 970	91 56 537 08	HYDR
FLANGE JOINT EGESD25-SR	47 19 008 08	774	3	2 970	91 56 537 08	HYDR
FLANGE JOINT EGESD25-SR	47 19 008 08	613	1	3 978 100	91 56 428 08	HYDR. SUSPENDED BALLAST
FLANGE JOINT EGESD28-LR-W	47 19 015 08	760	1	2 970	91 56 537 08	HYDR
FLANGE JOINT EGESD30-SR	47 19 009 08	603	2	3 978 100	91 56 428 08	HYDR. SUSPENDED BALLAST
FLANGE JOINT EGESD35-LR-W	47 19 016 08	606	1	3 978 100	91 56 428 08	HYDR. SUSPENDED BALLAST
FLANGE JOINT EGESD42-LR-W	47 19 036 08	643	1	2 970	91 56 537 08	HYDR
FLANGE JOINT EGESD6-LM-W	47 19 020 08	645	2	1 970	91 56 958 08	CRAWLER TRACK HYDRAULI
FLANGE JOINT EGESD6-LM-W	47 19 020 08	603	2	1 970 161	96 50 706 08	AUX.HYDR.CR.TRACK CARR.4
FLANGE JOINT EGESD6-SR-W	47 19 003 08	42	1	2 711	91 52 800 08	CENT. LUBRIC. SYSTEM SUP
FLANGE JOINT EGESD6-SR-W	47 19 003 08	616	2	3 978 005	91 56 430 08	ADDL.HYDRAULIC SB-HEAD PI
FLANGE JOINT EL 16S CR6-F	47 23 315 08	754	5	2 970	91 56 537 08	HYDR
FLANGE JOINT EL 16S CR6-F	47 23 315 08	609	3	2 975 000	91 57 881 08	ADDNL. HYDR. F. ERECTING W
FLANGE JOINT EL 28L CR6-F	47 23 307 08	788	2	2 970	91 56 537 08	HYDR
FLANGE JOINT EL 28L CR6-F	47 23 307 08	623	1	2 975 100	91 52 860 08	ADDITIONAL HYDRAULICS WI
FLANGE JOINT EL 28L CR6-F	47 23 307 08	625	1	2 978 200	91 54 843 08	ADD.HYDR.S_RETAINING RAM
FLANGE JOINT EL 35L CR6-F	47 23 308 08	626	2	2 970	91 56 537 08	HYDR
FLANGE JOINT EL 35L CR6-F	47 23 308 08	608	1	3 978 100	91 56 428 08	HYDR. SUSPENDED BALLAST
FLANGE JOINT ELSD10-L A3P	47 23 302 08	728	20	2 970	91 56 537 08	HYDR
FLANGE JOINT ELSD10-L A3P	47 23 302 08	613	4	2 975 100	91 52 860 08	ADDITIONAL HYDRAULICS WI
FLANGE JOINT ELSD10-L A3P	47 23 302 08	617	4	2 975 200	91 52 775 08	ADDITIONAL HYDRAULICS WI
FLANGE JOINT ELSD10-L A3P	47 23 302 08	617	4	2 975 700	91 52 774 08	ADDITIONAL HYDRAULICS WI
FLANGE JOINT ELSD10-L A3P	47 23 302 08	603	2	2 978 100	91 52 796 08	ADDNL.HYDR.ERECTION DEV
FLANGE JOINT ELSD10-L A3P	47 23 302 08	618	2	2 978 100	91 52 827 08	ADDNL.HYDR.RETAINING DEV
FLANGE JOINT ELSD10-L A3P	47 23 302 08	609	1	2 978 200	91 54 843 08	ADD.HYDR.S_RETAINING RAM
FLANGE JOINT ELSD12-L A3P	47 23 303 08	649	11	2 970	91 56 537 08	HYDR
FLANGE JOINT ELSD12-L A3P	47 23 303 08	611	1	2 975 100	91 52 860 08	ADDITIONAL HYDRAULICS WI
FLANGE JOINT ELSD12-L A3P	47 23 303 08	611	2	2 975 200	91 52 775 08	ADDITIONAL HYDRAULICS WI
FLANGE JOINT ELSD12-L A3P	47 23 303 08	611	2	2 975 700	91 52 774 08	ADDITIONAL HYDRAULICS WI
FLANGE JOINT ELSD12-L A3P	47 23 303 08	617	2	2 978 100	91 52 827 08	ADDNL.HYDR.RETAINING DEV
FLANGE JOINT ELSD12-L A3P	47 23 303 08	615	4	2 978 200	91 54 843 08	ADD.HYDR.S_RETAINING RAM
FLANGE JOINT ELSD12-L A3P	47 23 303 08	624	1	3 978 005	91 56 430 08	ADDL.HYDRAULIC SB-HEAD PI
FLANGE JOINT ELSD12-S A3P	47 23 314 08	606	4	1 975 006	91 52 509 08	ADD. HYDR. SUPPORTING RA
FLANGE JOINT ELSD12-S A3P	47 23 314 08	602	1	2 978 200	91 54 843 08	ADD.HYDR.S_RETAINING RAM
FLANGE JOINT ELSD15-L A3P	47 23 304 08	614	1	2 978 100	91 52 827 08	ADDNL.HYDR.RETAINING DEV
FLANGE JOINT ELSD18-L A3P	47 23 305 08	610	1	1 970	91 56 958 08	CRAWLER TRACK HYDRAULI
FLANGE JOINT ELSD18-L A3P	47 23 305 08	633	1	2 970	91 56 537 08	HYDR
FLANGE JOINT ELSD18-L A3P	47 23 305 08	606	1	2 975 000	91 57 881 08	ADDNL. HYDR. F. ERECTING W
FLANGE JOINT ELSD18-L A3P	47 23 305 08	609	2	2 976 200	91 52 780 08	ADDITIONAL HYDRAULICS
FLANGE JOINT ELSD18-L A3P	47 23 305 08	617	1	2 978 200	91 54 843 08	ADD.HYDR.S_RETAINING RAM
FLANGE JOINT ELSD18-L A3P	47 23 305 08	623	1	2 990	91 59 244 08	COMPRESSED AIR PLANT
FLANGE JOINT ELSD20-S A3P	47 23 316 08	640	1	1 970	91 56 958 08	CRAWLER TRACK HYDRAULI

6.2.2009

etk_en_de_074515 LR 1600/2

880

LIEBHERRAlphabetical index
Alphabetischer Index

Description	Item	Pos.	Quantity	Page	Assembly	Description
FLANGE JOINT ELSD20-S A3P	47 23 316 08	644	3	2 970	91 56 537 08	HYDR
FLANGE JOINT ELSD22-L A3P	47 23 306 08	665	1	1 970	91 56 958 08	CRAWLER TRACK HYDRAULI
FLANGE JOINT ELSD22-L A3P	47 23 306 08	621	5	2 970	91 56 537 08	HYDR
FLANGE JOINT ELSD25-S A3P	47 23 317 08	762	6	2 970	91 56 537 08	HYDR
FLANGE JOINT ELSD25-S A3P	47 23 317 08	604	2	2 976 200	91 52 780 08	ADDITIONAL HYDRAULICS
FLANGE JOINT ELSD25-S A3P	47 23 317 08	615	1	3 978 100	91 56 428 08	HYDR. SUSPENDED BALLAST
FLANGE JOINT ELSD30-S A3P	47 23 318 08	758	3	2 970	91 56 537 08	HYDR
FLANGE JOINT ELSD38-S A3P	47 23 319 08	618	2	3 978 005	91 56 430 08	ADDL.HYDRAULIC SB-HEAD PI
FLANGE JOINT ELSD42-L A3P	47 23 311 08	608	1	1 970	91 56 958 08	CRAWLER TRACK HYDRAULI
FLANGE JOINT ELSD42-L A3P	47 23 311 08	603	10	2 970	91 56 537 08	HYDR
FLANGE JOINT ELSD6-L A3P	47 20 323 08	647	3	1 970	91 56 958 08	CRAWLER TRACK HYDRAULI
FLANGE JOINT ELSD6-S A3P	47 23 312 08	34	1	2 711	91 52 800 08	CENT. LUBRIC. SYSTEM SUP
FLANGE JOINT ELSD6-S A3P	47 23 312 08	769	3	2 970	91 56 537 08	HYDR
FLANGE JOINT ELSD6-S A3P	47 23 312 08	613	3	3 978 005	91 56 430 08	ADDL.HYDRAULIC SB-HEAD PI
FLANGE JOINT ELSD8-S A3P	47 23 300 08	680	2	2 970	91 56 537 08	HYDR
FLANGE JOINT ETSD10-L A3P	47 24 303 08	730	4	2 970	91 56 537 08	HYDR
FLANGE JOINT ETSD10-L A3P	47 24 303 08	641	1	2 978 100	91 52 827 08	ADDNL.HYDR.RETAINING DEV
FLANGE JOINT ETSD10-L A3P	47 24 303 08	626	1	2 990	91 59 244 08	COMPRESSED AIR PLANT
FLANGE JOINT ETSD10-S A3P	47 24 313 08	808	1	2 970	91 56 537 08	HYDR
FLANGE JOINT ETSD12-L A3P	47 24 302 08	674	4	2 970	91 56 537 08	HYDR
FLANGE JOINT ETSD12-L A3P	47 24 302 08	617	1	2 975 100	91 52 860 08	ADDITIONAL HYDRAULICS WI
FLANGE JOINT ETSD12-L A3P	47 24 302 08	621	1	2 978 100	91 52 796 08	ADDNL.HYDR.ERECTION DEV
FLANGE JOINT ETSD12-L A3P	47 24 302 08	611	2	2 978 200	91 54 843 08	ADD.HYDR.S_RETAINING RAM
FLANGE JOINT ETSD12-L A3P	47 24 302 08	622	1	3 978 005	91 56 430 08	ADDL.HYDRAULIC SB-HEAD PI
FLANGE JOINT ETSD12-S A3P	47 24 314 08	603	1	2 978 100	91 52 827 08	ADDNL.HYDR.RETAINING DEV
FLANGE JOINT ETSD15-L A3P	47 24 304 08	667	2	2 970	91 56 537 08	HYDR
FLANGE JOINT ETSD15-L A3P	47 24 304 08	610	1	2 978 100	91 52 827 08	ADDNL.HYDR.RETAINING DEV
FLANGE JOINT ETSD16-S A3P	47 24 315 08	615	2	1 970	91 56 958 08	CRAWLER TRACK HYDRAULI
FLANGE JOINT ETSD16-S A3P	47 24 315 08	783	5	2 970	91 56 537 08	HYDR
FLANGE JOINT ETSD16-S A3P	47 24 315 08	611	1	2 975 000	91 57 881 08	ADDNL. HYDR. F. ERECTING W
FLANGE JOINT ETSD18-L A3P	47 24 305 08	666	1	2 970	91 56 537 08	HYDR
FLANGE JOINT ETSD22-L A3P	47 24 306 08	619	4	2 970	91 56 537 08	HYDR
FLANGE JOINT ETSD22-L A3P	47 24 306 08	604	1	2 975 100	91 52 860 08	ADDITIONAL HYDRAULICS WI
FLANGE JOINT ETSD22-L A3P	47 24 306 08	614	1	2 975 200	91 52 775 08	ADDITIONAL HYDRAULICS WI
FLANGE JOINT ETSD22-L A3P	47 24 306 08	614	1	2 975 700	91 52 774 08	ADDITIONAL HYDRAULICS WI
FLANGE JOINT ETSD25-S A3P	47 24 317 08	653	2	2 970	91 56 537 08	HYDR
FLANGE JOINT ETSD28-L A3P	47 24 307 08	649	2	1 970	91 56 958 08	CRAWLER TRACK HYDRAULI
FLANGE JOINT ETSD28-L A3P	47 24 307 08	693	1	2 970	91 56 537 08	HYDR
FLANGE JOINT ETSD30-S A3P	47 24 318 08	661	3	2 970	91 56 537 08	HYDR
FLANGE JOINT ETSD30-S A3P	47 24 318 08	612	1	3 978 100	91 56 428 08	HYDR. SUSPENDED BALLAST
FLANGE JOINT ETSD42-L A3P	47 24 311 08	624	1	1 970	91 56 958 08	CRAWLER TRACK HYDRAULI
FLANGE JOINT ETSD42-L A3P	47 24 311 08	602	5	2 970	91 56 537 08	HYDR
FLANGE JOINT ETSD6-S A3P	47 24 312 08	33	1	2 711	91 52 800 08	CENT. LUBRIC. SYSTEM SUP
FLANGE JOINT ETSD6-S A3P	47 24 312 08	722	1	2 970	91 56 537 08	HYDR
FLANGE JOINT EV 25S M36X2	10 42 477 0	775	2	2 970	91 56 537 08	HYDR
FLANGE JOINT EV 28L M36X2	10 41 077 2	804	1	2 970	91 56 537 08	HYDR
FLANGE JOINT EV16S A3C	10 41 077 0	801	1	2 970	91 56 537 08	HYDR
FLANGE JOINT EWSD10-L A3P	47 25 302 08	635	16	2 970	91 56 537 08	HYDR
FLANGE JOINT EWSD10-L A3P	47 25 302 08	620	1	2 975 200	91 52 775 08	ADDITIONAL HYDRAULICS WI
FLANGE JOINT EWSD10-L A3P	47 25 302 08	620	1	2 975 700	91 52 774 08	ADDITIONAL HYDRAULICS WI
FLANGE JOINT EWSD10-L A3P	47 25 302 08	602	2	2 978 100	91 52 796 08	ADDNL.HYDR.ERECTION DEV
FLANGE JOINT EWSD10-L A3P	47 25 302 08	608	3	2 978 100	91 52 827 08	ADDNL.HYDR.RETAINING DEV
FLANGE JOINT EWSD10-L A3P	47 25 302 08	635	1	2 978 200	91 54 843 08	ADD.HYDR.S_RETAINING RAM
FLANGE JOINT EWSD10-L A3P	47 25 302 08	610	4	2 990	91 59 244 08	COMPRESSED AIR PLANT
FLANGE JOINT EWSD10-L A3P	47 25 302 08	602	1	3 978 100	91 56 428 08	HYDR. SUSPENDED BALLAST
FLANGE JOINT EWSD10-S A3	47 25 311 08	807	1	2 970	91 56 537 08	HYDR
FLANGE JOINT EWSD10-S A3	47 25 311 08	606	4	2 976 203	92 27 489 08	ADDL.HYDR.F.PIN PULLING DE
FLANGE JOINT EWSD12-L A3P	47 25 305 08	611	19	2 970	91 56 537 08	HYDR
FLANGE JOINT EWSD12-L A3P	47 25 305 08	610	2	2 975 100	91 52 860 08	ADDITIONAL HYDRAULICS WI
FLANGE JOINT EWSD12-L A3P	47 25 305 08	608	1	2 975 200	91 52 775 08	ADDITIONAL HYDRAULICS WI

6.2.2009

etk_en_de_074515 LR 1600/2

881

LIEBHERRAlphabetical index
Alphabetischer Index

Description	Item	Pos.	Quantity	Page	Assembly	Description
FLANGE JOINT EWSD12-L A3P	47 25 305 08	608	1	2 975 700	91 52 774 08	ADDITIONAL HYDRAULICS WI
FLANGE JOINT EWSD12-L A3P	47 25 305 08	607	1	2 976 200	91 52 780 08	ADDITIONAL HYDRAULICS
FLANGE JOINT EWSD12-L A3P	47 25 305 08	605	1	2 976 203	92 27 489 08	ADDL.HYDR.F.PIN PULLING DE
FLANGE JOINT EWSD12-L A3P	47 25 305 08	604	1	2 978 100	91 52 827 08	ADDNL.HYDR.RETAINING DEV
FLANGE JOINT EWSD12-L A3P	47 25 305 08	610	4	2 978 200	91 54 843 08	ADD.HYDR.S_RETAINING RAM
FLANGE JOINT EWSD12-L A3P	47 25 305 08	605	2	3 978 005	91 56 430 08	ADDL.HYDRAULIC SB-HEAD PI
FLANGE JOINT EWSD12-S A3	47 25 312 08	604	12	1 975 006	91 52 509 08	ADD. HYDR. SUPPORTING RA
FLANGE JOINT EWSD12-S A3	47 25 312 08	616	1	2 978 100	91 52 827 08	ADDNL.HYDR.RETAINING DEV
FLANGE JOINT EWSD12-S A3	47 25 312 08	601	1	2 978 200	91 54 843 08	ADD.HYDR.S_RETAINING RAM
FLANGE JOINT EWSD15-L A3P	47 25 307 08	7	2	2 670 002	96 45 352 08	FUEL TANK, PRE-ASSEMBLED
FLANGE JOINT EWSD15-L A3P	47 25 307 08	739	2	2 970	91 56 537 08	HYDR
FLANGE JOINT EWSD16-S A3	47 25 313 08	616	3	1 970	91 56 958 08	CRAWLER TRACK HYDRAULI
FLANGE JOINT EWSD16-S A3	47 25 313 08	784	8	2 970	91 56 537 08	HYDR
FLANGE JOINT EWSD16-S A3	47 25 313 08	606	1	2 978 100	91 52 796 08	ADDNL.HYDR.ERECTION DEV
FLANGE JOINT EWSD18-L A3P	47 25 304 08	612	1	1 970	91 56 958 08	CRAWLER TRACK HYDRAULI
FLANGE JOINT EWSD18-L A3P	47 25 304 08	402	2	2 391	91 52 784 08	DIESEL ENGINE CPL.
FLANGE JOINT EWSD18-L A3P	47 25 304 08	11	1	2 670 002	96 45 352 08	FUEL TANK, PRE-ASSEMBLED
FLANGE JOINT EWSD18-L A3P	47 25 304 08	631	5	2 970	91 56 537 08	HYDR
FLANGE JOINT EWSD18-L A3P	47 25 304 08	608	1	2 975 000	91 57 881 08	ADDNL. HYDR. F. ERECTING W
FLANGE JOINT EWSD18-L A3P	47 25 304 08	616	1	2 978 200	91 54 843 08	ADD.HYDR.S_RETAINING RAM
FLANGE JOINT EWSD18-L A3P	47 25 304 08	607	2	2 990	91 59 244 08	COMPRESSED AIR PLANT
FLANGE JOINT EWSD20-S A3	47 25 314 08	639	2	1 970	91 56 958 08	CRAWLER TRACK HYDRAULI
FLANGE JOINT EWSD20-S A3	47 25 314 08	711	3	2 970	91 56 537 08	HYDR
FLANGE JOINT EWSD20-S A3	47 25 314 08	604	1	3 978 019	91 56 431 08	AUX.HYDR.CYLINDER SB-BW
FLANGE JOINT EWSD22-L A3P	47 25 306 08	624	1	2 970	91 56 537 08	HYDR
FLANGE JOINT EWSD22-L A3P	47 25 306 08	625	1	2 975 100	91 52 860 08	ADDITIONAL HYDRAULICS WI
FLANGE JOINT EWSD25-S A3	47 25 317 08	701	6	2 970	91 56 537 08	HYDR
FLANGE JOINT EWSD25-S A3	47 25 317 08	603	1	2 975 200	91 52 775 08	ADDITIONAL HYDRAULICS WI
FLANGE JOINT EWSD25-S A3	47 25 317 08	603	1	2 975 700	91 52 774 08	ADDITIONAL HYDRAULICS WI
FLANGE JOINT EWSD25-S A3	47 25 317 08	606	2	2 976 200	91 52 780 08	ADDITIONAL HYDRAULICS
FLANGE JOINT EWSD25-S A3	47 25 317 08	629	1	2 978 200	91 54 843 08	ADD.HYDR.S_RETAINING RAM
FLANGE JOINT EWSD28-L A3P	47 25 303 08	622	10	2 970	91 56 537 08	HYDR
FLANGE JOINT EWSD28-L A3P	47 25 303 08	602	1	2 977	91 57 756 08	ADDITIONAL HYDR.SLEWING
FLANGE JOINT EWSD28-L A3P	47 25 303 08	626	1	2 978 200	91 54 843 08	ADD.HYDR.S_RETAINING RAM
FLANGE JOINT EWSD30-S A3	47 25 316 08	688	5	2 970	91 56 537 08	HYDR
FLANGE JOINT EWSD30-S A3	47 25 316 08	604	2	3 978 100	91 56 428 08	HYDR. SUSPENDED BALLAST
FLANGE JOINT EWSD35-L A3P	47 25 309 08	679	1	1 970	91 56 958 08	CRAWLER TRACK HYDRAULI
FLANGE JOINT EWSD35-L A3P	47 25 309 08	613	11	2 970	91 56 537 08	HYDR
FLANGE JOINT EWSD35-L A3P	47 25 309 08	607	1	3 978 100	91 56 428 08	HYDR. SUSPENDED BALLAST
FLANGE JOINT EWSD38-S A3	47 25 318 08	607	8	1 970	91 56 958 08	CRAWLER TRACK HYDRAULI
FLANGE JOINT EWSD38-S A3	47 25 318 08	718	13	2 970	91 56 537 08	HYDR
FLANGE JOINT EWSD38-S A3	47 25 318 08	607	2	2 975 200	91 52 775 08	ADDITIONAL HYDRAULICS WI
FLANGE JOINT EWSD38-S A3	47 25 318 08	607	2	2 975 700	91 52 774 08	ADDITIONAL HYDRAULICS WI
FLANGE JOINT EWSD38-S A3	47 25 318 08	601	1	2 977	91 57 756 08	ADDITIONAL HYDR.SLEWING
FLANGE JOINT EWSD42-L A3P	47 25 310 08	601	13	2 970	91 56 537 08	HYDR
FLANGE JOINT EWSD6-L A3P	47 25 300 08	605	2	1 970 161	96 50 706 08	AUX.HYDR.CR.TRACK CARR.4
FLANGE JOINT EWSD6-L A3P	47 25 300 08	46	2	2 393	91 52 787 08	AIR FILTER UNIT CPL.
FLANGE JOINT EWSD6-L A3P	47 25 300 08	628	4	2 990	91 59 244 08	COMPRESSED AIR PLANT
FLANGE JOINT EWSD6-S A3P	47 25 315 08	31	5	2 711	91 52 800 08	CENT. LUBRIC. SYSTEM SUP
FLANGE JOINT EWSD6-S A3P	47 25 315 08	22	1	2 932 160	96 54 385 08	SWITCH CABINET
FLANGE JOINT EWSD6-S A3P	47 25 315 08	660	11	2 970	91 56 537 08	HYDR
FLANGE JOINT EWSD6-S A3P	47 25 315 08	601	1	2 976 700	91 54 795 08	ADDITIONAL HYDRAULICS P
FLANGE JOINT EWSD6-S A3P	47 25 315 08	602	2	2 990	91 59 244 08	COMPRESSED AIR PLANT
FLANGE JOINT EWSD6-S A3P	47 25 315 08	625	2	3 978 005	91 56 430 08	ADDL.HYDRAULIC SB-HEAD PI
FLANGE JOINT EWSD8-S A3P	47 25 319 08	681	4	2 970	91 56 537 08	HYDR
FLANGE JOINT GA6-LM22X1,5	50 29 461 08	615	1	2 990	91 59 244 08	COMPRESSED AIR PLANT
FLANGE JOINT GE 12L M22X1	47 10 399 08	709	2	2 970	91 56 537 08	HYDR
FLANGE JOINT GE 12L M22X1	47 10 399 08	601	3	3 978 005	91 56 430 08	ADDL.HYDRAULIC SB-HEAD PI
FLANGE JOINT GE 12S G1/2A	47 10 326 08	603	4	1 975 006	91 52 509 08	ADD. HYDR. SUPPORTING RA
FLANGE JOINT GE 12S G1/2A	47 10 326 08	803	2	2 970	91 56 537 08	HYDR

6.2.2009

etk_en_de_074515 LR 1600/2

882

LIEBHERRAlphabetical index
Alphabetischer Index

Description	Item	Pos.	Quantity	Page	Assembly	Description
FLANGE JOINT GE 18L M22X1	47 10 311 08	616	11	2 970	91 56 537 08	HYDR
FLANGE JOINT GE 18L M22X1	47 10 311 08	606	4	2 990	91 59 244 08	COMPRESSED AIR PLANT
FLANGE JOINT GE6-LM12X1,5	47 66 077 08	45	2	2 393	91 52 787 08	AIR FILTER UNIT CPL.
FLANGE JOINT GE6-LM8X1K	77 43 748 08	13	2	2 711	91 52 800 08	CENT. LUBRIC. SYSTEM SUP
FLANGE JOINT GE6-LM8X1K	77 43 748 08	23	1	2 711	91 52 800 08	CENT. LUBRIC. SYSTEM SUP
FLANGE JOINT GEM10X1K	77 43 765 08	11	8	1 711	91 52 392 08	CENTRALIZED LUBRICATION
FLANGE JOINT GEO18-LM A3P	47 10 503 08	401	2	2 391	91 52 784 08	DIESEL ENGINE CPL.
FLANGE JOINT GR 15/6L CR6-F	47 50 303 08	646	2	1 970	91 56 958 08	CRAWLER TRACK HYDRAULI
FLANGE JOINT GR 15/6L CR6-F	47 50 303 08	604	3	1 970 161	96 50 706 08	AUX.HYDR.CR.TRACK CARR.4
FLANGE JOINT GR 15/8L CR6-F	47 50 322 08	9	1	2 670 002	96 45 352 08	FUEL TANK, PRE-ASSEMBLED
FLANGE JOINT GZ 18L CR6-F	47 00 104 08	669	2	2 970	91 56 537 08	HYDR
FLANGE JOINT GZ 18L CR6-F	47 00 104 08	607	1	2 975 000	91 57 881 08	ADDNL. HYDR. F. ERECTING W
FLANGE JOINT GZ 35L CR6-F	49 11 008 14	627	1	2 970	91 56 537 08	HYDR
FLANGE JOINT ISO 8434-1 GE	47 10 397 08	729	2	2 970	91 56 537 08	HYDR
FLANGE JOINT ISO 8434-1 GE	47 10 397 08	610	1	2 975 000	91 57 881 08	ADDNL. HYDR. F. ERECTING W
FLANGE JOINT ISO 8434-1 GE	47 10 397 08	606	1	2 975 100	91 52 860 08	ADDITIONAL HYDRAULICS WI
FLANGE JOINT ISO 8434-1 GE	47 10 397 08	624	1	2 975 200	91 52 775 08	ADDITIONAL HYDRAULICS WI
FLANGE JOINT ISO 8434-1 GE	47 10 397 08	624	1	2 975 700	91 52 774 08	ADDITIONAL HYDRAULICS WI
FLANGE JOINT ISO 8434-1 GE	47 10 397 08	601	2	2 976 200	91 52 780 08	ADDITIONAL HYDRAULICS
FLANGE JOINT ISO 8434-1 GE	47 10 397 08	609	2	2 990	91 59 244 08	COMPRESSED AIR PLANT
FLANGE JOINT ISO 8434-1 GE	47 10 328 08	767	1	2 970	91 56 537 08	HYDR
FLANGE JOINT ISO 8434-1 GE	47 10 328 08	604	2	2 976 203	92 27 489 08	ADDL.HYDR.F.PIN PULLING DE
FLANGE JOINT ISO 8434-1 GE	47 10 307 08	716	3	2 970	91 56 537 08	HYDR
FLANGE JOINT ISO 8434-1 GE	47 10 307 08	605	1	2 975 200	91 52 775 08	ADDITIONAL HYDRAULICS WI
FLANGE JOINT ISO 8434-1 GE	47 10 307 08	605	1	2 975 700	91 52 774 08	ADDITIONAL HYDRAULICS WI
FLANGE JOINT ISO 8434-1 GE	47 10 307 08	602	2	2 976 200	91 52 780 08	ADDITIONAL HYDRAULICS
FLANGE JOINT ISO 8434-1 GE	47 10 307 08	602	1	2 976 700	91 54 795 08	ADDITIONAL HYDRAULICS P
FLANGE JOINT REDSD10/6-L	47 54 310 08	753	1	2 970	91 56 537 08	HYDR
FLANGE JOINT REDSD10/6-L	47 54 310 08	627	1	2 990	91 59 244 08	COMPRESSED AIR PLANT
FLANGE JOINT REDSD12/10-L	47 54 314 08	755	3	2 970	91 56 537 08	HYDR
FLANGE JOINT REDSD12/10-L	47 54 314 08	622	1	2 978 100	91 52 796 08	ADDNL.HYDR.ERECTION DEV
FLANGE JOINT REDSD12/10-L	47 54 314 08	631	2	2 978 200	91 54 843 08	ADD.HYDR.S_RETAINING RAM
FLANGE JOINT REDSD12/6-S	47 54 329 08	607	4	1 975 006	91 52 509 08	ADD. HYDR. SUPPORTING RA
FLANGE JOINT REDSD12/6-S	47 54 329 08	607	1	2 978 100	91 52 827 08	ADDNL.HYDR.RETAINING DEV
FLANGE JOINT REDSD12/6-S	47 54 329 08	604	1	2 978 200	91 54 843 08	ADD.HYDR.S_RETAINING RAM
FLANGE JOINT REDSD15/10-L	47 54 301 08	776	1	2 970	91 56 537 08	HYDR
FLANGE JOINT REDSD15/10-L	47 54 301 08	601	3	2 970 081	96 50 495 08	ADDL.HYDR.F.PIN PULLING DE
FLANGE JOINT REDSD15/10-L	47 54 301 08	615	1	2 978 100	91 52 827 08	ADDNL.HYDR.RETAINING DEV
FLANGE JOINT REDSD15/12-L	47 54 318 08	708	5	2 970	91 56 537 08	HYDR
FLANGE JOINT REDSD15/12-L	47 54 318 08	623	1	2 975 200	91 52 775 08	ADDITIONAL HYDRAULICS WI
FLANGE JOINT REDSD15/12-L	47 54 318 08	623	1	2 975 700	91 52 774 08	ADDITIONAL HYDRAULICS WI
FLANGE JOINT REDSD15/12-L	47 54 318 08	602	1	2 976 200	91 44 034 08	AUX.HYDR.PIN EXTRACTION
FLANGE JOINT REDSD15/12-L	47 54 318 08	609	2	2 978 100	91 52 827 08	ADDNL.HYDR.RETAINING DEV
FLANGE JOINT REDSD16/10-S	47 54 335 08	609	1	2 978 100	91 52 796 08	ADDNL.HYDR.ERECTION DEV
FLANGE JOINT REDSD16/6-S	47 54 331 08	618	1	1 970	91 56 958 08	CRAWLER TRACK HYDRAULI
FLANGE JOINT REDSD16/6-S	47 54 331 08	751	5	2 970	91 56 537 08	HYDR
FLANGE JOINT REDSD16/6-S	47 54 331 08	612	1	2 975 000	91 57 881 08	ADDNL. HYDR. F. ERECTING W
FLANGE JOINT REDSD18/10-L	47 54 303 08	611	1	1 970	91 56 958 08	CRAWLER TRACK HYDRAULI
FLANGE JOINT REDSD18/10-L	47 54 303 08	634	2	2 970	91 56 537 08	HYDR
FLANGE JOINT REDSD18/10-L	47 54 303 08	636	1	2 978 200	91 54 843 08	ADD.HYDR.S_RETAINING RAM
FLANGE JOINT REDSD18/10-L	47 54 303 08	624	1	2 990	91 59 244 08	COMPRESSED AIR PLANT
FLANGE JOINT REDSD18/12-L	47 54 363 08	601	1	2 976 200	91 44 034 08	AUX.HYDR.PIN EXTRACTION
FLANGE JOINT REDSD18/12-L	47 54 363 08	610	2	2 976 200	91 52 780 08	ADDITIONAL HYDRAULICS
FLANGE JOINT REDSD18/15-L	47 54 356 08	403	1	2 391	91 52 784 08	DIESEL ENGINE CPL.
FLANGE JOINT REDSD18/15-L	47 54 356 08	738	1	2 970	91 56 537 08	HYDR
FLANGE JOINT REDSD18/15-L	47 54 356 08	614	1	2 975 000	91 57 881 08	ADDNL. HYDR. F. ERECTING W
FLANGE JOINT REDSD20/12-S	47 54 348 08	641	1	1 970	91 56 958 08	CRAWLER TRACK HYDRAULI
FLANGE JOINT REDSD22/10-L	47 54 308 08	621	1	2 975 100	91 52 860 08	ADDITIONAL HYDRAULICS WI
FLANGE JOINT REDSD22/12-L	47 54 361 08	659	1	1 970	91 56 958 08	CRAWLER TRACK HYDRAULI
FLANGE JOINT REDSD22/12-L	47 54 361 08	690	7	2 970	91 56 537 08	HYDR

6.2.2009

etk_en_de_074515 LR 1600/2

883

LIEBHERRAlphabetical index
Alphabetischer Index

Description	Item	Pos.	Quantity	Page	Assembly	Description
FLANGE JOINT REDSD22/12-L	47 54 361 08	605	1	2 975 100	91 52 860 08	ADDITIONAL HYDRAULICS WI
FLANGE JOINT REDSD22/12-L	47 54 361 08	602	1	2 975 200	91 52 775 08	ADDITIONAL HYDRAULICS WI
FLANGE JOINT REDSD22/12-L	47 54 361 08	602	1	2 975 700	91 52 774 08	ADDITIONAL HYDRAULICS WI
FLANGE JOINT REDSD22/12-L	47 54 361 08	640	1	2 978 100	91 52 827 08	ADDNL.HYDR.RETAINING DEV
FLANGE JOINT REDSD22/15-L	47 54 355 08	617	4	2 970	91 56 537 08	HYDR
FLANGE JOINT REDSD22/15-L	47 54 355 08	639	2	2 978 100	91 52 827 08	ADDNL.HYDR.RETAINING DEV
FLANGE JOINT REDSD22/18-L	47 54 360 08	625	1	2 970	91 56 537 08	HYDR
FLANGE JOINT REDSD25/16-S	47 54 328 08	652	1	2 970	91 56 537 08	HYDR
FLANGE JOINT REDSD28/18-L	47 54 309 08	694	1	2 970	91 56 537 08	HYDR
FLANGE JOINT REDSD28/18-L	47 54 309 08	627	1	2 978 200	91 54 843 08	ADD.HYDR.S_RETAINING RAM
FLANGE JOINT REDSD28/22-L	47 54 305 08	674	2	1 970	91 56 958 08	CRAWLER TRACK HYDRAULI
FLANGE JOINT REDSD28/22-L	47 54 305 08	699	1	2 970	91 56 537 08	HYDR
FLANGE JOINT REDSD28/22-L	47 54 305 08	624	1	2 975 100	91 52 860 08	ADDITIONAL HYDRAULICS WI
FLANGE JOINT REDSD35/18-L	47 54 312 08	691	5	2 970	91 56 537 08	HYDR
FLANGE JOINT REDSD35/22-L	47 54 315 08	630	3	2 970	91 56 537 08	HYDR
FLANGE JOINT REDSD35/28-L	47 54 304 08	642	11	2 970	91 56 537 08	HYDR
FLANGE JOINT REDSD35/28-L	47 54 304 08	609	1	3 978 100	91 56 428 08	HYDR. SUSPENDED BALLAST
FLANGE JOINT REDSD38/16-S	47 54 342 08	614	4	3 978 005	91 56 430 08	ADDL.HYDRAULIC SB-HEAD PI
FLANGE JOINT REDSD38/6-S	47 54 081 08	619	2	3 978 005	91 56 430 08	ADDL.HYDRAULIC SB-HEAD PI
FLANGE JOINT REDSD42/18-L	47 54 317 08	609	1	1 970	91 56 958 08	CRAWLER TRACK HYDRAULI
FLANGE JOINT REDSD42/18-L	47 54 317 08	647	1	2 970	91 56 537 08	HYDR
FLANGE JOINT REDSD42/22-L	47 54 316 08	648	1	2 970	91 56 537 08	HYDR
FLANGE JOINT REDSD42/35-L	47 54 367 08	603	1	1 970	91 56 958 08	CRAWLER TRACK HYDRAULI
FLANGE JOINT REDSD42/35-L	47 54 367 08	638	6	2 970	91 56 537 08	HYDR
FLANGE JOINT REDSDN10/6-S	47 54 320 08	806	1	2 970	91 56 537 08	HYDR
FLANGE JOINT REDSDN20/6-S	47 54 324 08	658	1	2 970	91 56 537 08	HYDR
FLANGE JOINT REDSDN25/20-	47 54 323 08	655	2	2 970	91 56 537 08	HYDR
FLANGE JOINT REDSDN25/6-S	47 54 337 08	786	2	2 970	91 56 537 08	HYDR
FLANGE JOINT REDSDN25/6-S	47 54 337 08	616	1	3 978 100	91 56 428 08	HYDR. SUSPENDED BALLAST
FLANGE JOINT REDSDN28/10-	47 54 354 08	740	2	2 970	91 56 537 08	HYDR
FLANGE JOINT REDSDN28/12-	47 54 357 08	623	2	1 970	91 56 958 08	CRAWLER TRACK HYDRAULI
FLANGE JOINT REDSDN28/12-	47 54 357 08	621	1	2 978 200	91 54 843 08	ADD.HYDR.S_RETAINING RAM
FLANGE JOINT REDSDN28/15-	47 54 345 08	789	2	2 970	91 56 537 08	HYDR
FLANGE JOINT REDSDN30/12-	47 54 340 08	613	1	2 978 100	91 52 796 08	ADDNL.HYDR.ERECTION DEV
FLANGE JOINT REDSDN30/16-	47 54 325 08	743	5	2 970	91 56 537 08	HYDR
FLANGE JOINT REDSDN30/25-	47 54 327 08	744	3	2 970	91 56 537 08	HYDR
FLANGE JOINT REDSDN30/25-	47 54 327 08	605	2	2 976 200	91 52 780 08	ADDITIONAL HYDRAULICS
FLANGE JOINT REDSDN30/25-	47 54 327 08	611	1	3 978 100	91 56 428 08	HYDR. SUSPENDED BALLAST
FLANGE JOINT REDSDN30/6-S	47 54 341 08	662	1	2 970	91 56 537 08	HYDR
FLANGE JOINT REDSDN38/25-	47 54 343 08	719	4	2 970	91 56 537 08	HYDR
FLANGE JOINT REDSDN42/28-	47 54 313 08	625	2	1 970	91 56 958 08	CRAWLER TRACK HYDRAULI
FLANGE JOINT REDSDN42/28-	47 54 313 08	604	6	2 970	91 56 537 08	HYDR
FLANGE JOINT RI G1/2AXG1/4	47 55 004 08	777	2	2 970	91 56 537 08	HYDR
FLANGE JOINT RSWS10-LM-W	47 66 102 08	604	1	2 975 200	91 52 775 08	ADDITIONAL HYDRAULICS WI
FLANGE JOINT RSWS10-LM-W	47 66 102 08	604	1	2 975 700	91 52 774 08	ADDITIONAL HYDRAULICS WI
FLANGE JOINT RSWS10-LR-W	47 32 305 08	655	1	1 970	91 56 958 08	CRAWLER TRACK HYDRAULI
FLANGE JOINT RSWS10-LR-W	47 32 305 08	657	10	2 970	91 56 537 08	HYDR
FLANGE JOINT RSWS10-SR-W	47 32 310 08	602	2	2 970 081	96 50 495 08	ADDL.HYDR.F.PIN PULLING DE
FLANGE JOINT RSWS10-SR-W	47 32 310 08	603	2	2 976 203	92 27 489 08	ADDL.HYDR.F.PIN PULLING DE
FLANGE JOINT RSWS12-SM-W	47 66 303 08	778	2	2 970	91 56 537 08	HYDR
FLANGE JOINT RSWS12-SR-W	47 66 115 08	602	8	1 975 006	91 52 509 08	ADD. HYDR. SUPPORTING RA
FLANGE JOINT RSWS16-SM-W	47 66 114 08	601	2	2 975 000	91 57 881 08	ADDNL. HYDR. F. ERECTING W
FLANGE JOINT RSWS16-SR-W	47 32 312 08	607	1	2 978 100	91 52 796 08	ADDNL.HYDR.ERECTION DEV
FLANGE JOINT RSWS20-SR-W	47 32 314 08	605	1	1 970	91 56 958 08	CRAWLER TRACK HYDRAULI
FLANGE JOINT RSWS22-LR-W	47 33 002 08	666	1	1 970	91 56 958 08	CRAWLER TRACK HYDRAULI
FLANGE JOINT RSWS42-LR-W	47 32 327 08	2	4	2 671 004	96 46 305 08	OIL TANK PRE-ASS.
FLANGE JOINT RSWS6-SM-W	47 32 303 08	704	4	2 970	91 56 537 08	HYDR
FLANGE JOINT RSWS6-SR-W	47 32 306 08	608	4	1 975 006	91 52 509 08	ADD. HYDR. SUPPORTING RA
FLANGE JOINT RSWS6-SR-W	47 32 306 08	22	2	2 711	91 52 800 08	CENT. LUBRIC. SYSTEM SUP
FLANGE JOINT RSWS6-SR-W	47 32 306 08	23	2	2 810	91 52 806 08	CRANE DRIVER'S CABIN CPL.

6.2.2009

etk_en_de_074515 LR 1600/2

884

LIEBHERRAlphabetical index
Alphabetischer Index

Description	Item	Pos.	Quantity	Page	Assembly	Description
FLANGE JOINT RSWS6-SR-W	47 32 306 08	771	1	2 970	91 56 537 08	HYDR
FLANGE JOINT SNV10-L A3P	47 00 101 08	748	2	2 970	91 56 537 08	HYDR
FLANGE JOINT SNV12-L A3P	47 00 113 08	633	2	1 970	91 56 958 08	CRAWLER TRACK HYDRAULI
FLANGE JOINT SNV12-L A3P	47 00 113 08	737	1	2 970	91 56 537 08	HYDR
FLANGE JOINT SNV12-L A3P	47 00 113 08	612	3	2 975 100	91 52 860 08	ADDITIONAL HYDRAULICS WI
FLANGE JOINT SNV12-L A3P	47 00 113 08	609	2	2 975 200	91 52 775 08	ADDITIONAL HYDRAULICS WI
FLANGE JOINT SNV12-L A3P	47 00 113 08	609	2	2 975 700	91 52 774 08	ADDITIONAL HYDRAULICS WI
FLANGE JOINT SNV12-L A3P	47 00 113 08	602	1	3 978 005	91 56 430 08	ADDL.HYDRAULIC SB-HEAD PI
FLANGE JOINT SNV12-S A3P	47 00 103 08	629	1	1 970	91 56 958 08	CRAWLER TRACK HYDRAULI
FLANGE JOINT SNV15-L A3P	47 00 112 08	672	1	2 970	91 56 537 08	HYDR
FLANGE JOINT SNV16-S A3P	47 00 108 08	675	2	1 970	91 56 958 08	CRAWLER TRACK HYDRAULI
FLANGE JOINT SNV16-S A3P	47 00 108 08	745	8	2 970	91 56 537 08	HYDR
FLANGE JOINT SNV20-S A3P	47 00 105 08	797	1	2 970	91 56 537 08	HYDR
FLANGE JOINT SNV25-S A3P	47 00 110 08	612	1	2 975 200	91 52 775 08	ADDITIONAL HYDRAULICS WI
FLANGE JOINT SNV25-S A3P	47 00 110 08	612	1	2 975 700	91 52 774 08	ADDITIONAL HYDRAULICS WI
FLANGE JOINT SNV30-S A3P	47 00 111 08	687	3	2 970	91 56 537 08	HYDR
FLANGE JOINT SNV38-S A3P	47 00 107 08	726	1	2 970	91 56 537 08	HYDR
FLANGE JOINT SNV38-S A3P	47 00 107 08	606	1	2 975 200	91 52 775 08	ADDITIONAL HYDRAULICS WI
FLANGE JOINT SNV38-S A3P	47 00 107 08	606	1	2 975 700	91 52 774 08	ADDITIONAL HYDRAULICS WI
FLANGE JOINT SNV38-S A3P	47 00 107 08	603	2	2 977	91 57 756 08	ADDITIONAL HYDR.SLEWING
FLANGE JOINT SNV42-L A3P	47 00 114 08	606	5	2 970	91 56 537 08	HYDR
FLANGE JOINT SNV6-S A3P	47 00 115 08	772	1	2 970	91 56 537 08	HYDR
FLANGE JOINT SNV6-S A3P	47 00 115 08	620	1	3 978 005	91 56 430 08	ADDL.HYDRAULIC SB-HEAD PI
FLANGE JOINT T 16S CR6-FRE	47 04 325 08	652	2	1 970	91 56 958 08	CRAWLER TRACK HYDRAULI
FLANGE JOINT T 16S CR6-FRE	47 04 325 08	791	1	2 970	91 56 537 08	HYDR
FLANGE JOINT T 16S CR6-FRE	47 04 325 08	608	1	2 978 100	91 52 796 08	ADDNL.HYDR.ERECTION DEV
FLANGE JOINT T 22L CR6-FRE	47 04 307 08	689	3	2 970	91 56 537 08	HYDR
FLANGE JOINT T 22L CR6-FRE	47 04 307 08	620	1	2 975 100	91 52 860 08	ADDITIONAL HYDRAULICS WI
FLANGE JOINT T 22L CR6-FRE	47 04 307 08	626	3	2 978 100	91 52 827 08	ADDNL.HYDR.RETAINING DEV
FLANGE JOINT TR 22/15/22L C	47 51 334 08	741	2	2 970	91 56 537 08	HYDR
FLANGE JOINT WE6-M10X1R	77 43 738 08	8	50	1 711	91 52 392 08	CENTRALIZED LUBRICATION
FLANGE JOINT WE6-M10X1R	77 43 738 08	(1)	1	2 711	91 52 800 08	CENT. LUBRIC. SYSTEM SUP
FLANGE JOINT WE6-M10X1R	77 43 738 08	(1)	1	2 711	91 52 800 08	CENT. LUBRIC. SYSTEM SUP
FLANGE JOINT WE6-M10X1R	77 43 738 08	(1)	1	2 711	91 52 800 08	CENT. LUBRIC. SYSTEM SUP
FLANGE JOINT WE6-M10X1R	77 43 738 08	12	22	2 711	91 52 800 08	CENT. LUBRIC. SYSTEM SUP
FLANGE JOINT WE6-M10X1R	77 43 738 08	15	1	2 711	91 52 800 08	CENT. LUBRIC. SYSTEM SUP
FLANGE JOINT X0	95 62 043 08	4	2	2 990	91 59 244 08	COMPRESSED AIR PLANT
FLANGE JOINT X0	95 62 043 08	605	1	2 990	91 59 244 08	COMPRESSED AIR PLANT
FLANGE JOINT XG10-L A3P	47 00 303 08	734	7	2 970	91 56 537 08	HYDR
FLANGE JOINT XG10-L A3P	47 00 303 08	610	1	2 978 100	91 52 796 08	ADDNL.HYDR.ERECTION DEV
FLANGE JOINT XG10-L A3P	47 00 303 08	633	1	2 978 100	91 52 827 08	ADDNL.HYDR.RETAINING DEV
FLANGE JOINT XG10-L A3P	47 00 303 08	622	1	3 978 100	91 56 428 08	HYDR. SUSPENDED BALLAST
FLANGE JOINT XG12-L A3P	47 00 304 08	725	4	2 970	91 56 537 08	HYDR
FLANGE JOINT XG12-L A3P	47 00 304 08	634	1	2 978 100	91 52 827 08	ADDNL.HYDR.RETAINING DEV
FLANGE JOINT XG12-L A3P	47 00 304 08	623	12	2 978 200	91 54 843 08	ADD.HYDR.S_RETAINING RAM
FLANGE JOINT XG12-L A3P	47 00 304 08	607	4	3 978 005	91 56 430 08	ADDL.HYDRAULIC SB-HEAD PI
FLANGE JOINT XG12-L A3P	47 00 304 08	602	2	3 978 015	91 56 429 08	ADDITIONAL HYDRAULICS IN
FLANGE JOINT XG12-L A3P	47 00 304 08	602	1	3 978 015	91 56 432 08	ADDITIONAL HYDRAULICS IN
FLANGE JOINT XG12-L A3P	47 00 304 08	607	2	3 978 019	91 56 431 08	AUX.HYDR.CYLINDER SB-BW
FLANGE JOINT XG12-L A3P	47 00 304 08	621	1	3 978 100	91 56 428 08	HYDR. SUSPENDED BALLAST
FLANGE JOINT XG12-S A3P	47 00 325 08	606	2	3 978 019	91 56 431 08	AUX.HYDR.CYLINDER SB-BW
FLANGE JOINT XG15-L A3P	47 00 305 08	724	3	2 970	91 56 537 08	HYDR
FLANGE JOINT XG15-L A3P	47 00 305 08	626	2	2 975 100	91 52 860 08	ADDITIONAL HYDRAULICS WI
FLANGE JOINT XG16-S A3P	47 00 327 08	620	10	1 970	91 56 958 08	CRAWLER TRACK HYDRAULI
FLANGE JOINT XG16-S A3P	47 00 327 08	790	1	2 970	91 56 537 08	HYDR
FLANGE JOINT XG16-S A3P	47 00 327 08	636	1	2 978 100	91 52 827 08	ADDNL.HYDR.RETAINING DEV
FLANGE JOINT XG18-L A3P	47 00 306 08	692	3	2 970	91 56 537 08	HYDR
FLANGE JOINT XG18-L A3P	47 00 306 08	617	4	2 990	91 59 244 08	COMPRESSED AIR PLANT
FLANGE JOINT XG20-S A3P	47 00 328 08	628	1	1 970	91 56 958 08	CRAWLER TRACK HYDRAULI
FLANGE JOINT XG20-S A3P	47 00 328 08	766	3	2 970	91 56 537 08	HYDR

6.2.2009

etk_en_de_074515 LR 1600/2

885

LIEBHERRAlphabetical index
Alphabetischer Index

Description	Item	Pos.	Quantity	Page	Assembly	Description
FLANGE JOINT XG20-S A3P	47 00 328 08	605	1	3 978 019	91 56 431 08	AUX.HYDR.CYLINDER SB-BW
FLANGE JOINT XG22-L A3P	47 00 307 08	736	1	2 970	91 56 537 08	HYDR
FLANGE JOINT XG22-L A3P	47 00 307 08	637	1	2 978 100	91 52 827 08	ADDNL.HYDR.RETAINING DEV
FLANGE JOINT XG22-L A3P	47 00 307 08	624	2	2 978 200	91 54 843 08	ADD.HYDR.S_RETAINING RAM
FLANGE JOINT XG25-S A3P	47 00 329 08	683	9	2 970	91 56 537 08	HYDR
FLANGE JOINT XG25-S A3P	47 00 329 08	638	1	2 978 100	91 52 827 08	ADDNL.HYDR.RETAINING DEV
FLANGE JOINT XG25-S A3P	47 00 329 08	622	6	2 978 200	91 54 843 08	ADD.HYDR.S_RETAINING RAM
FLANGE JOINT XG28-L A3P	47 00 308 08	626	6	1 970	91 56 958 08	CRAWLER TRACK HYDRAULI
FLANGE JOINT XG28-L A3P	47 00 308 08	697	5	2 970	91 56 537 08	HYDR
FLANGE JOINT XG28-L A3P	47 00 308 08	622	1	2 975 100	91 52 860 08	ADDITIONAL HYDRAULICS WI
FLANGE JOINT XG28-L A3P	47 00 308 08	619	3	2 978 200	91 54 843 08	ADD.HYDR.S_RETAINING RAM
FLANGE JOINT XG30-S A3P	47 00 330 08	686	2	2 970	91 56 537 08	HYDR
FLANGE JOINT XG30-S A3P	47 00 330 08	620	4	2 978 100	91 52 796 08	ADDNL.HYDR.ERECTION DEV
FLANGE JOINT XG35-L A3P	47 00 332 08	618	3	2 970	91 56 537 08	HYDR
FLANGE JOINT XG35-L A3P	47 00 332 08	619	1	3 978 100	91 56 428 08	HYDR. SUSPENDED BALLAST
FLANGE JOINT XG38-S A3P	47 00 331 08	601	12	1 970	91 56 958 08	CRAWLER TRACK HYDRAULI
FLANGE JOINT XG38-S A3P	47 00 331 08	705	43	2 970	91 56 537 08	HYDR
FLANGE JOINT XG38-S A3P	47 00 331 08	619	2	2 975 100	91 52 860 08	ADDITIONAL HYDRAULICS WI
FLANGE JOINT XG38-S A3P	47 00 331 08	621	4	3 978 005	91 56 430 08	ADDL.HYDRAULIC SB-HEAD PI
FLANGE JOINT XG38-S A3P	47 00 331 08	603	2	3 978 015	91 56 429 08	ADDITIONAL HYDRAULICS IN
FLANGE JOINT XG38-S A3P	47 00 331 08	618	1	3 978 100	91 56 428 08	HYDR. SUSPENDED BALLAST
FLANGE JOINT XG42-L A3P	47 00 309 08	628	7	2 970	91 56 537 08	HYDR
FLANGE JOINT XG6-S A3P	47 00 310 08	661	1	1 970	91 56 958 08	CRAWLER TRACK HYDRAULI
FLANGE JOINT XGA16-SR A3P	47 07 002 08	703	8	2 970	91 56 537 08	HYDR
FLANGE JOINT XGE10-LM-ED	47 10 305 08	23	2	2 391 023	96 45 720 08	RADIATOR, PRE-ASSEMBLED
FLANGE JOINT XGE10-LM-ED	47 10 305 08	664	5	2 970	91 56 537 08	HYDR
FLANGE JOINT XGE10-LM-ED	47 10 305 08	607	1	2 975 100	91 52 860 08	ADDITIONAL HYDRAULICS WI
FLANGE JOINT XGE10-LM-ED	47 10 398 08	620	1	2 990	91 59 244 08	COMPRESSED AIR PLANT
FLANGE JOINT XGE10-LR-ED	47 10 306 08	723	17	2 970	91 56 537 08	HYDR
FLANGE JOINT XGE10-LR-ED	47 10 306 08	614	2	2 975 100	91 52 860 08	ADDITIONAL HYDRAULICS WI
FLANGE JOINT XGE10-LR-ED	47 10 306 08	618	2	2 975 200	91 52 775 08	ADDITIONAL HYDRAULICS WI
FLANGE JOINT XGE10-LR-ED	47 10 306 08	618	2	2 975 700	91 52 774 08	ADDITIONAL HYDRAULICS WI
FLANGE JOINT XGE10-LR-ED	47 10 306 08	601	4	2 978 100	91 52 796 08	ADDNL.HYDR.ERECTION DEV
FLANGE JOINT XGE10-LR-ED	47 10 306 08	623	2	2 978 100	91 52 827 08	ADDNL.HYDR.RETAINING DEV
FLANGE JOINT XGE10-LR-ED	47 10 306 08	634	1	2 978 200	91 54 843 08	ADD.HYDR.S_RETAINING RAM
FLANGE JOINT XGE10-LR-ED	47 10 306 08	601	1	3 978 100	91 56 428 08	HYDR. SUSPENDED BALLAST
FLANGE JOINT XGE10-LR-ED3	47 10 396 08	746	5	2 970	91 56 537 08	HYDR
FLANGE JOINT XGE10-SR-ED1	47 10 045 14	805	1	2 970	91 56 537 08	HYDR
FLANGE JOINT XGE10-SR-ED1	47 10 045 14	602	2	3 978 019	91 56 431 08	AUX.HYDR.CYLINDER SB-BW
FLANGE JOINT XGE12-LM-ED	47 10 394 08	702	3	2 970	91 56 537 08	HYDR
FLANGE JOINT XGE12-LM-ED	47 10 394 08	618	1	2 975 100	91 52 860 08	ADDITIONAL HYDRAULICS WI
FLANGE JOINT XGE12-LM-ED	47 10 394 08	610	1	2 975 200	91 52 775 08	ADDITIONAL HYDRAULICS WI
FLANGE JOINT XGE12-LM-ED	47 10 394 08	610	1	2 975 700	91 52 774 08	ADDITIONAL HYDRAULICS WI
FLANGE JOINT XGE12-LR-ED	47 10 308 08	731	10	2 970	91 56 537 08	HYDR
FLANGE JOINT XGE12-LR-ED	47 10 308 08	608	1	2 975 100	91 52 860 08	ADDITIONAL HYDRAULICS WI
FLANGE JOINT XGE12-LR-ED	47 10 308 08	621	1	2 975 200	91 52 775 08	ADDITIONAL HYDRAULICS WI
FLANGE JOINT XGE12-LR-ED	47 10 308 08	621	1	2 975 700	91 52 774 08	ADDITIONAL HYDRAULICS WI
FLANGE JOINT XGE12-LR-ED	47 10 308 08	601	2	2 976 203	92 27 489 08	ADDL.HYDR.F.PIN PULLING DE
FLANGE JOINT XGE12-LR-ED	47 10 308 08	624	2	2 978 100	91 52 827 08	ADDNL.HYDR.RETAINING DEV
FLANGE JOINT XGE12-LR-ED1	47 10 348 08	677	4	2 970	91 56 537 08	HYDR
FLANGE JOINT XGE12-LR-ED1	47 10 348 08	614	1	2 978 100	91 52 796 08	ADDNL.HYDR.ERECTION DEV
FLANGE JOINT XGE12-LR-ED1	47 10 353 08	18	1	2 391 038	96 47 931 08	OIL COOLER, PRE-ASSEMBLE
FLANGE JOINT XGE12-LR-ED1	47 10 353 08	682	13	2 970	91 56 537 08	HYDR
FLANGE JOINT XGE12-LR-ED1	47 10 353 08	615	1	2 975 200	91 52 775 08	ADDITIONAL HYDRAULICS WI
FLANGE JOINT XGE12-LR-ED1	47 10 353 08	615	1	2 975 700	91 52 774 08	ADDITIONAL HYDRAULICS WI
FLANGE JOINT XGE12-LR-ED1	47 10 353 08	620	1	2 978 100	91 52 827 08	ADDNL.HYDR.RETAINING DEV
FLANGE JOINT XGE12-LR-ED1	47 10 353 08	635	1	2 978 100	91 52 827 08	ADDNL.HYDR.RETAINING DEV
FLANGE JOINT XGE12-LR-ED1	47 10 353 08	612	3	2 978 200	91 54 843 08	ADD.HYDR.S_RETAINING RAM
FLANGE JOINT XGE12-LR-ED1	47 10 353 08	604	4	3 978 005	91 56 430 08	ADDL.HYDRAULIC SB-HEAD PI
FLANGE JOINT XGE12-LR-ED1	47 10 353 08	603	1	3 978 019	91 56 431 08	AUX.HYDR.CYLINDER SB-BW

6.2.2009

etk_en_de_074515 LR 1600/2

886

LIEBHERRAlphabetical index
Alphabetischer Index

Description	Item	Pos.	Quantity	Page	Assembly	Description
FLANGE JOINT XGE15-LM-ED	47 10 309 08	24	2	2 391 023	96 45 720 08	RADIATOR, PRE-ASSEMBLED
FLANGE JOINT XGE15-LM-ED	47 10 309 08	6	1	2 670 002	96 45 352 08	FUEL TANK, PRE-ASSEMBLED
FLANGE JOINT XGE15-LM-ED	47 10 309 08	663	3	2 970	91 56 537 08	HYDR
FLANGE JOINT XGE15-LR-ED	47 10 310 08	27	1	1 750	91 52 394 08	TOOL
FLANGE JOINT XGE15-LR-ED	47 10 310 08	613	1	2 978 100	91 52 827 08	ADDNL.HYDR.RETAINING DEV
FLANGE JOINT XGE16-SR-ED	47 10 332 08	604	4	1 970	91 56 958 08	CRAWLER TRACK HYDRAULI
FLANGE JOINT XGE16-SR-ED	47 10 332 08	750	4	2 970	91 56 537 08	HYDR
FLANGE JOINT XGE16-SR-ED	47 10 332 08	604	3	2 975 000	91 57 881 08	ADDNL. HYDR. F. ERECTING W
FLANGE JOINT XGE16-SR-ED	47 10 332 08	605	1	2 978 100	91 52 796 08	ADDNL.HYDR.ERECTION DEV
FLANGE JOINT XGE16-SR-ED	47 10 332 08	601	1	3 978 019	91 56 431 08	AUX.HYDR.CYLINDER SB-BW
FLANGE JOINT XGE16-SR-ED3	47 10 331 08	657	6	1 970	91 56 958 08	CRAWLER TRACK HYDRAULI
FLANGE JOINT XGE16-SR-ED3	47 10 331 08	602	3	2 975 000	91 57 881 08	ADDNL. HYDR. F. ERECTING W
FLANGE JOINT XGE18-LM A3P	47 66 076 08	403	2	2 391 001	96 45 719 08	DIESEL ENGINE, PRE-ASSEMB
FLANGE JOINT XGE18-LM A3P	47 66 076 08	622	1	2 990	91 59 244 08	COMPRESSED AIR PLANT
FLANGE JOINT XGE18-LM-ED	47 10 370 08	25	2	2 391 023	96 45 720 08	RADIATOR, PRE-ASSEMBLED
FLANGE JOINT XGE18-LM-ED	47 10 370 08	10	1	2 670 002	96 45 352 08	FUEL TANK, PRE-ASSEMBLED
FLANGE JOINT XGE18-LM-ED	47 10 370 08	665	4	2 970	91 56 537 08	HYDR
FLANGE JOINT XGE18-LM-ED	47 10 370 08	611	2	2 976 200	91 52 780 08	ADDITIONAL HYDRAULICS
FLANGE JOINT XGE18-LM-ED	47 10 370 08	607	1	2 976 700	91 54 795 08	ADDITIONAL HYDRAULICS P
FLANGE JOINT XGE18-LM-ED	47 66 078 08	706	2	2 970	91 56 537 08	HYDR
FLANGE JOINT XGE18-LR-ED	47 10 312 08	614	1	1 970	91 56 958 08	CRAWLER TRACK HYDRAULI
FLANGE JOINT XGE18-LR-ED	47 10 312 08	614	1	2 978 200	91 54 843 08	ADD.HYDR.S. RETAINING RAM
FLANGE JOINT XGE18-LR-ED3	47 10 375 08	605	1	2 975 000	91 57 881 08	ADDNL. HYDR. F. ERECTING W
FLANGE JOINT XGE20-SM-ED	47 10 343 08	714	2	2 970	91 56 537 08	HYDR
FLANGE JOINT XGE20-SR-ED	47 10 334 08	656	3	1 970	91 56 958 08	CRAWLER TRACK HYDRAULI
FLANGE JOINT XGE20-SR-ED	47 10 334 08	609	1	3 978 019	91 56 431 08	AUX.HYDR.CYLINDER SB-BW
FLANGE JOINT XGE22-LM-ED	10 03 689 6	720	2	2 970	91 56 537 08	HYDR
FLANGE JOINT XGE22-LM-ED	47 10 313 08	643	2	1 970	91 56 958 08	CRAWLER TRACK HYDRAULI
FLANGE JOINT XGE22-LM-ED	47 10 313 08	601	2	1 970 161	96 50 706 08	AUX.HYDR.CR.TRACK CARR.4
FLANGE JOINT XGE22-LM-ED	47 10 313 08	615	6	2 970	91 56 537 08	HYDR
FLANGE JOINT XGE22-LM-ED	47 10 313 08	603	1	2 975 100	91 52 860 08	ADDITIONAL HYDRAULICS WI
FLANGE JOINT XGE22-LM-ED	47 10 313 08	613	1	2 975 200	91 52 775 08	ADDITIONAL HYDRAULICS WI
FLANGE JOINT XGE22-LM-ED	47 10 313 08	613	1	2 975 700	91 52 774 08	ADDITIONAL HYDRAULICS WI
FLANGE JOINT XGE22-LM-ED	47 10 313 08	606	1	2 976 700	91 54 795 08	ADDITIONAL HYDRAULICS P
FLANGE JOINT XGE22-LR-ED	47 10 314 08	621	2	2 978 100	91 52 827 08	ADDNL.HYDR.RETAINING DEV
FLANGE JOINT XGE25-SR-ED	47 10 336 08	763	7	2 970	91 56 537 08	HYDR
FLANGE JOINT XGE25-SR-ED	47 10 336 08	622	2	2 978 100	91 52 827 08	ADDNL.HYDR.RETAINING DEV
FLANGE JOINT XGE28-LM-ED	47 10 315 08	710	2	2 970	91 56 537 08	HYDR
FLANGE JOINT XGE28-LR-ED	47 10 316 08	606	2	1 970	91 56 958 08	CRAWLER TRACK HYDRAULI
FLANGE JOINT XGE28-LR-ED	47 10 316 08	787	2	2 970	91 56 537 08	HYDR
FLANGE JOINT XGE28-LR-ED	47 10 316 08	614	1	3 978 100	91 56 428 08	HYDR. SUSPENDED BALLAST
FLANGE JOINT XGE35-LM-ED	47 10 318 08	640	2	2 970	91 56 537 08	HYDR
FLANGE JOINT XGE35-LR-ED	47 10 345 08	802	2	2 970	91 56 537 08	HYDR
FLANGE JOINT XGE42-LM-ED	47 10 319 08	13	1	2 671 004	96 46 305 08	OIL TANK PRE-ASS.
FLANGE JOINT XGE42-LM-ED	47 10 319 08	637	1	2 970	91 56 537 08	HYDR
FLANGE JOINT XGE42-LR-ED	47 10 347 08	602	2	1 970	91 56 958 08	CRAWLER TRACK HYDRAULI
FLANGE JOINT XGE42-LR-ED	47 10 347 08	605	7	2 970	91 56 537 08	HYDR
FLANGE JOINT XGE6-LM-ED	47 10 301 08	604	4	2 990	91 59 244 08	COMPRESSED AIR PLANT
FLANGE JOINT XGE6-LR-ED A3	47 10 300 08	19	31	2 711	91 52 800 08	CENT. LUBRIC. SYSTEM SUP
FLANGE JOINT XGE6-LR-ED A3	47 10 300 08	749	2	2 970	91 56 537 08	HYDR
FLANGE JOINT XGE6-SM-ED	47 10 302 08	707	10	2 970	91 56 537 08	HYDR
FLANGE JOINT XGE6-SM-ED	47 10 302 08	605	1	2 976 700	91 54 795 08	ADDITIONAL HYDRAULICS P
FLANGE JOINT XGE6-SM-ED	47 10 302 08	611	2	2 990	91 59 244 08	COMPRESSED AIR PLANT
FLANGE JOINT XGE6-SR-ED	47 10 321 08	663	1	1 970	91 56 958 08	CRAWLER TRACK HYDRAULI
FLANGE JOINT XGE6-SR-ED	47 10 321 08	21	1	2 932 160	96 54 385 08	SWITCH CABINET
FLANGE JOINT XGE6-SR-ED	47 10 321 08	721	2	2 970	91 56 537 08	HYDR
FLANGE JOINT XGE6-SR-ED	47 10 321 08	603	1	2 990	91 59 244 08	COMPRESSED AIR PLANT
FLANGE JOINT XGE6-SR-ED	47 10 321 08	612	6	3 978 005	91 56 430 08	ADDL.HYDRAULIC SB-HEAD PI
FLANGE JOINT XGE8-SM-ED	47 10 322 08	684	2	2 970	91 56 537 08	HYDR
FLANGE JOINT XGE8-SR-ED	47 10 323 08	679	4	2 970	91 56 537 08	HYDR

6.2.2009

etk_en_de_074515 LR 1600/2

887

LIEBHERRAlphabetical index
Alphabetischer Index

Description	Item	Pos.	Quantity	Page	Assembly	Description
FLANGE JOINT XGEV30-SR-W	47 10 338 08	782	2	2 970	91 56 537 08	HYDR
FLANGE JOINT XGEV30-SR-W	47 10 338 08	610	1	3 978 100	91 56 428 08	HYDR. SUSPENDED BALLAST
FLANGE JOINT XGR12/10-L A3	47 50 315 08	798	1	2 970	91 56 537 08	HYDR
FLANGE JOINT XGR15/12-L A3	47 50 317 08	627	2	2 975 100	91 52 860 08	ADDITIONAL HYDRAULICS WI
FLANGE JOINT XGR16/12-S A3	47 50 325 08	605	8	1 975 006	91 52 509 08	ADD. HYDR. SUPPORTING RA
FLANGE JOINT XGR16/12-S A3	47 50 325 08	605	1	2 978 100	91 52 827 08	ADDNL.HYDR.RETAINING DEV
FLANGE JOINT XGR16/12-S A3	47 50 325 08	603	1	2 978 200	91 54 843 08	ADD.HYDR.S_RETAINING RAM
FLANGE JOINT XGR18/15-L A3	47 50 302 08	673	1	2 970	91 56 537 08	HYDR
FLANGE JOINT XGR20/16-S A3	47 50 336 08	656	4	2 970	91 56 537 08	HYDR
FLANGE JOINT XGR20/16-S A3	47 50 336 08	608	1	3 978 019	91 56 431 08	AUX.HYDR.CYLINDER SB-BW
FLANGE JOINT XGR25/16-S A3	47 50 328 08	785	6	2 970	91 56 537 08	HYDR
FLANGE JOINT XGR25/16-S A3	47 50 328 08	795	1	2 970	91 56 537 08	HYDR
FLANGE JOINT XGR28/18-L A3	47 50 311 08	794	1	2 970	91 56 537 08	HYDR
FLANGE JOINT XGR28/22-L A3	47 50 318 08	653	3	1 970	91 56 958 08	CRAWLER TRACK HYDRAULI
FLANGE JOINT XGR28/22-L A3	47 50 318 08	620	2	2 970	91 56 537 08	HYDR
FLANGE JOINT XGR28/22-L A3	47 50 318 08	628	1	2 975 100	91 52 860 08	ADDITIONAL HYDRAULICS WI
FLANGE JOINT XGR28/22-L A3	47 50 318 08	632	2	2 978 200	91 54 843 08	ADD.HYDR.S_RETAINING RAM
FLANGE JOINT XGR30/16-S A3	47 50 337 08	617	2	2 978 100	91 52 796 08	ADDNL.HYDR.ERECTION DEV
FLANGE JOINT XGR30/16-S A3	47 50 337 08	611	4	3 978 005	91 56 430 08	ADDL.HYDRAULIC SB-HEAD PI
FLANGE JOINT XGR30/20-S A3	47 50 340 08	606	4	3 978 005	91 56 430 08	ADDL.HYDRAULIC SB-HEAD PI
FLANGE JOINT XGR30/25-S A3	47 50 329 08	654	1	2 970	91 56 537 08	HYDR
FLANGE JOINT XGR30/25-S A3	47 50 329 08	619	2	2 978 100	91 52 796 08	ADDNL.HYDR.ERECTION DEV
FLANGE JOINT XGR35/22-L A3	47 50 312 08	696	1	2 970	91 56 537 08	HYDR
FLANGE JOINT XGR35/28-L A3	47 50 313 08	620	1	3 978 100	91 56 428 08	HYDR. SUSPENDED BALLAST
FLANGE JOINT XGR38/30-S A3	47 50 339 08	757	6	2 970	91 56 537 08	HYDR
FLANGE JOINT XGR38/30-S A3	47 50 339 08	605	4	3 978 100	91 56 428 08	HYDR. SUSPENDED BALLAST
FLANGE JOINT XGR42/28-L A3	47 50 310 08	695	1	2 970	91 56 537 08	HYDR
FLANGE JOINT XGR42/35-L A3	47 50 319 08	612	5	2 970	91 56 537 08	HYDR
FLANGE JOINT XSV10-L A3P	47 40 303 08	676	1	2 970	91 56 537 08	HYDR
FLANGE JOINT XSV15-L A3P	47 40 305 08	671	1	2 970	91 56 537 08	HYDR
FLANGE JOINT XSV16-S A3P	47 40 326 08	677	4	1 970	91 56 958 08	CRAWLER TRACK HYDRAULI
FLANGE JOINT XSV16-S A3P	47 40 326 08	616	4	1 975 006	91 52 509 08	ADD. HYDR. SUPPORTING RA
FLANGE JOINT XSV18-L A3P	47 40 307 08	668	1	2 970	91 56 537 08	HYDR
FLANGE JOINT XT10-L A3P	47 04 303 08	735	2	2 970	91 56 537 08	HYDR
FLANGE JOINT XT10-L A3P	47 04 303 08	628	1	2 978 100	91 52 827 08	ADDNL.HYDR.RETAINING DEV
FLANGE JOINT XT12-L A3P	47 04 304 08	800	1	2 970	91 56 537 08	HYDR
FLANGE JOINT XT12-L A3P	47 04 304 08	608	2	2 976 200	91 52 780 08	ADDITIONAL HYDRAULICS
FLANGE JOINT XT12-L A3P	47 04 304 08	627	1	2 978 100	91 52 827 08	ADDNL.HYDR.RETAINING DEV
FLANGE JOINT XT12-L A3P	47 04 304 08	630	2	2 978 200	91 54 843 08	ADD.HYDR.S_RETAINING RAM
FLANGE JOINT XT12-L A3P	47 04 304 08	617	2	3 978 005	91 56 430 08	ADDL.HYDRAULIC SB-HEAD PI
FLANGE JOINT XT15-L A3P	47 04 305 08	611	1	2 978 100	91 52 827 08	ADDNL.HYDR.RETAINING DEV
FLANGE JOINT XT25-S A3P	47 04 327 08	796	2	2 970	91 56 537 08	HYDR
FLANGE JOINT XT25-S A3P	47 04 327 08	625	1	2 978 100	91 52 827 08	ADDNL.HYDR.RETAINING DEV
FLANGE JOINT XT25-S A3P	47 04 327 08	628	1	2 978 200	91 54 843 08	ADD.HYDR.S_RETAINING RAM
FLANGE JOINT XT28-L A3P	47 04 308 08	651	2	1 970	91 56 958 08	CRAWLER TRACK HYDRAULI
FLANGE JOINT XT28-L A3P	47 04 308 08	698	3	2 970	91 56 537 08	HYDR
FLANGE JOINT XT28-L A3P	47 04 308 08	620	2	2 978 200	91 54 843 08	ADD.HYDR.S_RETAINING RAM
FLANGE JOINT XT30-S A3P	47 04 329 08	612	1	2 978 100	91 52 796 08	ADDNL.HYDR.ERECTION DEV
FLANGE JOINT XT35-L A3P	47 04 315 08	629	14	2 970	91 56 537 08	HYDR
FLANGE JOINT XT38-S A3P	47 04 330 08	650	4	1 970	91 56 958 08	CRAWLER TRACK HYDRAULI
FLANGE JOINT XT38-S A3P	47 04 330 08	717	3	2 970	91 56 537 08	HYDR
FLANGE JOINT XT38-S A3P	47 04 330 08	615	2	3 978 005	91 56 430 08	ADDL.HYDRAULIC SB-HEAD PI
FLANGE JOINT XT42-L A3P	47 04 314 08	607	7	2 970	91 56 537 08	HYDR
FLANGE JOINT XTR20/25/20-S	47 51 349 08	765	1	2 970	91 56 537 08	HYDR
FLANGE JOINT XW10-L A3P	47 02 303 08	779	1	2 970	91 56 537 08	HYDR
FLANGE JOINT XW10-L A3P	47 02 303 08	631	1	2 978 100	91 52 827 08	ADDNL.HYDR.RETAINING DEV
FLANGE JOINT XW12-L A3P	47 02 304 08	630	1	2 978 100	91 52 827 08	ADDNL.HYDR.RETAINING DEV
FLANGE JOINT XW16-S A3P	47 02 326 08	676	2	1 970	91 56 958 08	CRAWLER TRACK HYDRAULI
FLANGE JOINT XW16-S A3P	47 02 326 08	792	1	2 970	91 56 537 08	HYDR
FLANGE JOINT XW16-S A3P	47 02 326 08	618	1	2 978 100	91 52 796 08	ADDNL.HYDR.ERECTION DEV

6.2.2009

etk_en_de_074515 LR 1600/2

888

LIEBHERRAlphabetical index
Alphabetischer Index

Description	Item	Pos.	Quantity	Page	Assembly	Description
FLANGE JOINT XW16-S A3P	47 02 326 08	642	1	2 978 100	91 52 827 08	ADDNL.HYDR.RETAINING DEV
FLANGE JOINT XW18-L A3P	47 02 306 08	799	1	2 970	91 56 537 08	HYDR
FLANGE JOINT XW18-L A3P	47 02 306 08	601	1	2 990	91 59 244 08	COMPRESSED AIR PLANT
FLANGE JOINT XW22-L A3P	47 02 307 08	678	1	1 970	91 56 958 08	CRAWLER TRACK HYDRAULI
FLANGE JOINT XW22-L A3P	47 02 307 08	632	3	2 978 100	91 52 827 08	ADDNL.HYDR.RETAINING DEV
FLANGE JOINT XW25-S A3P	47 02 328 08	629	3	2 978 100	91 52 827 08	ADDNL.HYDR.RETAINING DEV
FLANGE JOINT XW28-L A3P	47 02 308 08	700	2	2 970	91 56 537 08	HYDR
FLANGE JOINT XW30-S A3P	47 02 330 08	715	1	2 970	91 56 537 08	HYDR
FLANGE JOINT XW35-L A3P	47 02 311 08	639	2	2 970	91 56 537 08	HYDR
FLANGE JOINT XW38-S A3P	47 02 334 08	727	1	2 970	91 56 537 08	HYDR
FLANGE JOINT XW38-S A3P	47 02 334 08	604	2	2 977	91 57 756 08	ADDITIONAL HYDR.SLEWING
FLANGE JOINT XW38-S A3P	47 02 334 08	623	2	3 978 005	91 56 430 08	ADDL.HYDRAULIC SB-HEAD PI
FLANGE JOINT XW42-L A3P	47 02 314 08	608	7	2 970	91 56 537 08	HYDR
FLANGE JOINT XWSV6-S A3P	47 42 021 08	32	1	2 711	91 52 800 08	CENT. LUBRIC. SYSTEM SUP
FLANGE POM	97 74 378 08	18	1	2 520 032	96 45 980 08	WINDSHIELD WASHER INSTAL
FLANGE SEALING	10 34 693 8	(5)	1	2 920 814	96 45 717 08	ELECTR.F.FUEL TANK
FLANGE SLEEVE 18X12X12 S	10 42 448 9	7	4	2 522 013	96 45 883 08	GUIDE PRE-ASS.
FLANGE STUB PIPE 38-S	51 15 177 08	571	4	2 970	91 56 537 08	HYDR
FLANGE STUB PIPE 38-S	51 15 178 08	52	4	1 970	91 56 958 08	CRAWLER TRACK HYDRAULI
FLANGE STUB PIPE 38-S	51 15 178 08	572	15	2 970	91 56 537 08	HYDR
FLANGE STUB PIPE 38-S	51 15 178 08	47	2	2 975 200	91 52 775 08	ADDITIONAL HYDRAULICS WI
FLANGE STUB PIPE 38-S	51 15 178 08	47	2	2 975 700	91 52 774 08	ADDITIONAL HYDRAULICS WI
FLANGED BOLT	10 22 236 1	6	1	9 739 256	97 39 256	AIR SUCTION PIPE
FLANGED BOLT	10 22 272 8	3	7	9 739 256	97 39 256	AIR SUCTION PIPE
FLANGED BOLT	10 22 273 7	7	1	9 739 248	97 39 248	INJECTOR
FLANGED BOLT	10 22 273 7	6	4	9 739 491	97 39 491	INSTALLATION BRAKE COMPR
FLANGED BOLT M10X55 X5NIC	10 03 034 6	6	2	9 739 295	97 39 295	EXHAUST PIPE
FLANGED BOLT M10X95	10 01 255 0	7	22	9 739 295	97 39 295	EXHAUST PIPE
FLANGED BOLT M8X40,5 AK 8	10 01 254 7	17	2	9 739 122	97 39 122	OIL COOLER
FLANGED BOLT M8X65,5 AK 8	10 01 254 9	18	2	9 739 122	97 39 122	OIL COOLER
FLAP	10 01 239 4	8	1	9 739 357	97 39 357	EXHAUST GAS RECIRCUL.PRE
FLAP GLUED SPF	96 46 809 08	1	1	2 859 005	96 46 756 08	FLAP PRE-ASS.
FLAP PRE-ASS.	96 46 756 08	4	1	2 859	91 52 809 08	SOUND INSULATION
FLAP PRE-ASS.	96 46 972 08	3	1	2 260	91 53 057 08	CUP SPRING CLUSTER
FLAP ST.CONST.	96 47 951 08	2	1	3 206	91 52 881 08	PIVOT SECTION
FLAT CAGE BEARING	50 15 271 08	9	1	5 400 565	54 00 565 08	ROPE WINCH
FLAT FUSE LINK 10A	60 40 071 08	75	22	2 932 082	96 54 387 08	ASSEMBLY PARTS MOUNTIN
FLAT FUSE LINK 15A	60 40 072 08	76	8	2 932 082	96 54 387 08	ASSEMBLY PARTS MOUNTIN
FLAT FUSE LINK 20A	60 40 073 08	77	5	2 932 082	96 54 387 08	ASSEMBLY PARTS MOUNTIN
FLAT FUSE LINK 25A	60 40 076 08	78	1	2 932 082	96 54 387 08	ASSEMBLY PARTS MOUNTIN
FLAT FUSE LINK 3A	60 40 077 08	72	6	2 932 082	96 54 387 08	ASSEMBLY PARTS MOUNTIN
FLAT FUSE LINK 5A	60 40 069 08	73	6	2 932 082	96 54 387 08	ASSEMBLY PARTS MOUNTIN
FLAT FUSE LINK 7,5A	60 40 070 08	74	20	2 932 082	96 54 387 08	ASSEMBLY PARTS MOUNTIN
FLAT GASKET	70 42 749 08	26	4	2 260 006	96 46 501 08	BATTERY BOX, PRE-ASSEMB
FLAT GASKET	70 42 749 08	27	4	2 260 006	96 46 501 08	BATTERY BOX, PRE-ASSEMB
FLAT GASKET	70 42 749 08	5	6	2 932 168	96 48 167 08	COVER COMPL.
FLAT PLUG 2,8	60 23 235 08	(124)	10	2 920 369	96 54 235 08	TERMINAL BOX CPL.
FLAT PLUG 2,8	60 23 235 08	(124)	7	2 920 369	96 54 235 08	TERMINAL BOX CPL.
FLAT PLUG 6,3 - 2,5 MS	60 23 048 08	9	2	2 913 102	92 32 870 08	FAN UNIT
FLAT PLUG HOUSING 18-POL	60 23 233 08	(151)	2	2 932 001	96 45 393 08	RELAY CONTROL SYSTEM
FLAT PLUG HOUSING 18-POL	60 23 233 08	503	34	2 932 224	96 54 389 08	CABLES MOUNTING PANEL C
FLAT PLUG HOUSING 2POL	60 23 059 08	8	1	2 913 102	92 32 870 08	FAN UNIT
FLAT PLUG HOUSING 6POL	60 23 256 08	514	6	2 932 224	96 54 389 08	CABLES MOUNTING PANEL C
FLOOR MAT 1188X829X28 PU	97 71 454 08	9	1	2 520 034	96 45 984 08	INTERNAL LINING
FLOOR MAT 1214X894X209 PU	97 71 453 08	8	1	2 520 034	96 45 984 08	INTERNAL LINING
FLOOR PLATE 2.0 M GS-18NI	97 71 698 08	1	81	1 300 011	96 52 493 08	FLOOR PLATES PRE-ASS.
FLOOR PLATES PRE-ASS.	96 52 493 08	1	1	1 300	91 52 768 08	FLOOR SHEET COMPL.
FLOOR SHEET COMPL. 2.0 M	91 52 768 08	6	2		LR 1600-2-0	
FLYWHEEL	10 22 233 9	1	1	9 739 250	97 39 250	FLYWHEEL
FLYWHEEL	97 39 250	250	1	X1012059	10 12 059 0	DIESEL ENGINE

6.2.2009

etk_en_de_074515 LR 1600/2

889

LIEBHERRAlphabetical index
Alphabetischer Index

Description	Item	Pos.	Quantity	Page	Assembly	Description
FLYWHEEL HOUSING	10 34 283 2	12	1	9 739 354	97 39 354	FLYWHEEL HOUSING MOUNT
FLYWHEEL HOUSING MOUNT	97 39 354	240	1	X1012059	10 12 059 0	DIESEL ENGINE
FOAM RUBBER BAND 15X5	26 21 051 08	13	1.76	2 393 002	96 46 782 08	COVER COMPL.
FOAM RUBBER BAND 15X5	26 21 051 08	11	0.78	2 510	91 52 788 08	TURNTABLE PANELLING
FOAM RUBBER BAND 15X5	26 21 051 08	14	2.24	2 859 030	96 46 758 08	COVER COMPL.
FOIL 0,2X3000 PE	80 10 029 08	272	1	2 920 638	96 51 138 08	CONTROL DESK
FOIL KEYPAD PRE-ASS.	96 20 599 08	1	1	2 913	91 32 850 08	LICCON CONSOLE LCD2
FOIL KEYPAD PRE-ASS.	96 20 599 08	1	1	2 913 009	91 04 705 08	LICCON CONSOLE LCD3
FOLDING BRACKET	96 50 486 08	52	1	3 745	91 52 948 08	SUSPENDED BALLAST
FOLDING BRACKET WELDED	96 50 130 08	28	1	3 713	91 57 749 08	D PIVOT SECTION
FOLDING BRACKET WELDED	96 50 131 08	29	1	3 713	91 57 749 08	D PIVOT SECTION
FOOT COMPLETE	96 50 697 08	51	2	3 214	91 52 843 08	SW HEAD SECTION
FOOT ROCKER SPF	10 29 731 0	11	2	2 533 050	96 48 359 08	EL.EQUIPMENT CABIN
FOOT SWITCH	60 66 035 08	15	1	2 533 050	96 48 359 08	EL.EQUIPMENT CABIN
FORCE MEASURING AXLE D	10 49 005 7	7	2	3 291	91 52 831 08	S OVERRUN PROTECTION
FORKED LINK DIN 71752 30X6	72 51 010 05	17	2	2 810	91 52 806 08	CRANE DRIVER'S CABIN CPL.
FORM HOSE	10 01 263 1	14	1	9 739 386	97 39 386	CRANKCASE BREATHER
FORM HOSE DN18X90°	55 31 731 08	14	2	2 540	91 53 253 08	CLIMA-HEATING INSTALLATIO
FORM HOSE DN18X90°	55 31 731 08	8	2	2 541	91 52 790 08	ADD HEATING SUPERSTRUCT
FORM HOSE DN18X90°	55 31 738 08	15	1	2 540	91 53 253 08	CLIMA-HEATING INSTALLATIO
FORM HOSE DN18X90°	55 31 738 08	11	1	2 541	91 52 790 08	ADD HEATING SUPERSTRUCT
FORM HOSE NW60X30GRAD	97 47 495 08	118	1	2 391 001	96 45 719 08	DIESEL ENGINE, PRE-ASSEMB
FORM HOSE NW60X30GRAD	97 47 495 08	26	1	2 391 023	96 45 720 08	RADIATOR, PRE-ASSEMBLED
FORM HOSE NW60X90° SPF	97 19 159 08	5	1	2 391 023	96 45 720 08	RADIATOR, PRE-ASSEMBLED
FORMCLIP AEHNL.DIN 11023	43 32 010 08	3	2	3 780 200	96 54 370 08	ELECTRIC WIND WARNING T
FORMCLIP AEHNL.DIN 11023	43 32 010 08	3	2	3 780 258	96 56 482 08	ELECTRIC AIRCRAFT PROTE
FRAME	96 46 755 08	3	1	2 859	91 52 809 08	SOUND INSULATION
FRAME	96 46 759 08	7	1	2 859	91 52 809 08	SOUND INSULATION
FRAME	96 46 760 08	8	1	2 859	91 52 809 08	SOUND INSULATION
FRAME	96 46 761 08	9	1	2 859	91 52 809 08	SOUND INSULATION
FRAME	96 48 159 08	10	1	2 859	91 52 809 08	SOUND INSULATION
FRAME 4X1029X189	97 70 784 08	12	1	2 859	91 52 809 08	SOUND INSULATION
FRAME 4X1150X608	97 70 775 08	11	1	2 859	91 52 809 08	SOUND INSULATION
FRAME WELDED	96 46 382 08	2	1	2 810	91 52 806 08	CRANE DRIVER'S CABIN CPL.
FRAME WELDED	96 46 971 08	2	1	2 260	91 53 057 08	CUP SPRING CLUSTER
FRAME WELDED	96 46 980 08	1	1	2 520 030	96 45 609 08	ROOF WINDOW PRE-ASS.
FRAME WELDED	96 47 500 08	1	1	3 205	91 52 880 08	F-ASSEMBLY UNIT
FRAME WELDED	96 49 182 08	1	1	2 510	91 52 788 08	TURNTABLE PANELLING
FRAME WELDED T ZN O	96 46 540 08	1	4	1 631 100	91 52 388 08	CATWALK CRAW.TRACK TRA
FRAME WELDED T ZN O	96 55 027 08	14	2	1 631 100	91 52 388 08	CATWALK CRAW.TRACK TRA
FRONT ELEMENT	60 66 525 08	8	4	2 920 638	96 51 138 08	CONTROL DESK
FRONT FRAME	69 26 004 08	8	1	2 913 003	96 20 599 08	FOIL KEYPAD PRE-ASS.
FRONT WINDOW ESG-GLAS	97 68 377 08	3	1	2 520	91 53 061 08	CABIN, GLAZED
FUEL FEED PUMP	10 22 274 8	3	1	X1034309	10 34 309 6	HIGH PRESSURE PUMP
FUEL FILTER	55 31 740 08	(1)	1	2 541	91 52 790 08	ADD HEATING SUPERSTRUCT
FUEL FILTER	97 39 258	1	1	9 739 259	97 39 259	FUEL FILTER
FUEL FILTER	97 39 259	93	1	X1012059	10 12 059 0	DIESEL ENGINE
FUEL FILTER ELEMENT	10 22 275 7	3	1	9 739 258	97 39 258	FUEL FILTER
FUEL HEATING	10 01 245 3	16	1	9 739 258	97 39 258	FUEL FILTER
FUEL HOSE	10 11 614 1	97	1	9 739 400	97 39 400	DIESEL ENGINE
FUEL HOSE	97 80 893 08	17	1	2 670	91 52 797 08	FUEL TANK CPL.
FUEL HOSE DI=4,5/DA=10,5	55 31 911 08	14	0.15	2 541	91 52 790 08	ADD HEATING SUPERSTRUCT
FUEL HOSE DN100	10 42 402 5	(1)	0.12	2 670	91 52 797 08	FUEL TANK CPL.
FUEL LINE	10 03 574 7	6	1	9 739 288	97 39 288	FUEL LINE
FUEL LINE	10 22 276 7	2	1	9 739 292	97 39 292	FUEL LINE
FUEL LINE	10 22 276 8	9	1	9 739 292	97 39 292	FUEL LINE
FUEL LINE	10 22 276 9	13	1	9 739 292	97 39 292	FUEL LINE
FUEL LINE	10 22 277 3	6	1	9 739 282	97 39 282	OVERFLOW-OIL LINE
FUEL LINE	10 22 277 4	7	1	9 739 282	97 39 282	OVERFLOW-OIL LINE
FUEL LINE	10 22 277 5	21	1	9 739 292	97 39 292	FUEL LINE

6.2.2009

etk_en_de_074515 LR 1600/2

890

LIEBHERRAlphabetical index
Alphabetischer Index

Description	Item	Pos.	Quantity	Page	Assembly	Description
FUEL LINE	10 28 515 3	10	1	9 739 288	97 39 288	FUEL LINE
FUEL LINE	97 39 288	131	1	X1012059	10 12 059 0	DIESEL ENGINE
FUEL LINE	97 39 292	97	1	X1012059	10 12 059 0	DIESEL ENGINE
FUEL TANK CPL.	91 52 797 08	143	1		LR 1600-2-0	
FUEL TANK WELDED CONSTR	96 45 354 08	1	1	2 670 002	96 45 352 08	FUEL TANK, PRE-ASSEMBLED
FUEL TANK, PRE-ASSEMBLED	96 45 352 08	1	1	2 670	91 52 797 08	FUEL TANK CPL.
FUNNEL RD200 WEISSBLECH	79 00 444 08	16	1	1 750	91 52 394 08	TOOL
FUS 10ML	86 55 016	109	1	9 080 702	90 80 702	CONTROL GEAR
FUSE BOX SMALL 6POL 24V	60 45 016 08	16	1	2 920 083	96 48 319 08	ELECTRIC FOR BATTERY BOX
FUSE BOX SMALL 6POL 24V	60 45 016 08	69	16	2 932 082	96 54 387 08	ASSEMBLY PARTS MOUNTIN
FUSE BOX SMALL 6POL 24V	60 45 016 08	33	2	2 932 160	96 54 385 08	SWITCH CABINET
GAS SPRING	59 10 670 08	23	1	2 502	91 55 939 08	CONTROL STAND
GAS SPRING 12X50 130N	10 41 287 1	6	2	2 520 030	96 45 609 08	ROOF WINDOW PRE-ASS.
GAS SPRING 23X270 350N	10 47 202 8	3	2	2 932 160	96 54 385 08	SWITCH CABINET
GASKET KIT INT.FLANGE LPV	10 47 221 9	(98)	1	X1035924	10 35 924 8	VARIABLE PUMP
GEAR WHEEL MOTOR	51 02 373 08	2	1	2 391 038	96 47 931 08	OIL COOLER, PRE-ASSEMBLE
GEARBOX	10 65 015 5	1	1	X1035411	10 35 411 4	HOISTING WINCH
GENERATOR, PRE-ASSEMBLE	97 39 343	195	1	X1012059	10 12 059 0	DIESEL ENGINE
GENERATOR, PRE-ASSEMBLE	97 39 344	200	1	X1012059	10 12 059 0	DIESEL ENGINE
GLARE SHIELD 4X567X55 AL	97 09 807 08	2	1	2 913 003	96 20 599 08	FOIL KEYPAD PRE-ASS.
GLUE 10ML	81 12 073 01	99	1	9 739 322	97 39 322	REPAIR KIT PIPE LINE
GLUE 10ML	81 12 073 01	104	1	9 739 386	97 39 386	CRANKCASE BREATHER
GLUE 250ML	86 55 023 23	104	1	9 739 035	97 39 035	LOCKING PIECES
GLUE 50ML	81 12 059 08	3	1	9 739 096	97 39 096	SCREW PLUG
GRATING 1007X567X30 GFK	97 77 563 08	6	1	3 713 006	96 50 099 08	GRATINGS
GRATING 1007X647X30 GFK	97 80 165 08	34	1	3 214	91 52 843 08	SW HEAD SECTION
GRATING 1007X647X30 GFK	97 80 166 08	35	1	3 214	91 52 843 08	SW HEAD SECTION
GRATING 1047X487X30 GFK	97 79 282 08	39	1	3 714	91 52 862 08	D HEAD SECTION
GRATING 1127X1007X30 GFK	97 77 558 08	7	1	3 713 006	96 50 099 08	GRATINGS
GRATING 1127X647X30 GFK	97 79 207 08	60	1	3 206	91 52 881 08	PIVOT SECTION
GRATING 1127X647X30 GFK	97 79 207 08	95	1	3 714	91 52 862 08	D HEAD SECTION
GRATING 1127X927X30 GFK	97 86 922 08	14	1	3 206	91 52 881 08	PIVOT SECTION
GRATING 1167X1007X30 GFK	97 75 015 08	45	1	3 225	91 52 854 08	SL REDUCING SECTION
GRATING 1167X687X30 GFK	97 75 016 08	46	1	3 225	91 52 854 08	SL REDUCING SECTION
GRATING 1327X447X30 GFK	97 72 738 08	9	1	3 211 006	96 47 004 08	GRATINGS
GRATING 1367X487X30 GFK	97 72 735 08	6	1	3 211 006	96 47 004 08	GRATINGS
GRATING 1367X487X30 GFK	97 72 736 08	7	1	3 211 006	96 47 004 08	GRATINGS
GRATING 1367X487X30 GFK	97 72 741 08	12	2	3 211 006	96 47 004 08	GRATINGS
GRATING 1367X807X30 GFK	97 73 275 08	23	1	3 221	91 54 668 08	S INTERMEDIATE SECTION
GRATING 1367X807X30 GFK	97 73 275 08	3	1	3 713 006	96 50 099 08	GRATINGS
GRATING 1367X807X30 GFK	97 73 275 08	94	2	3 714	91 52 862 08	D HEAD SECTION
GRATING 1407X327X30 GFK	97 77 561 08	1	1	3 713 006	96 50 099 08	GRATINGS
GRATING 1407X487X30 GFK	97 66 610 08	23	2	3 226	91 52 870 08	L INTERMEDIATE SECTION
GRATING 1407X487X30 GFK	97 66 610 08	23	2	3 227	91 52 873 08	L INTERMEDIATE SECTION
GRATING 1407X487X30 GFK	97 66 610 08	23	2	3 227 008	91 52 872 08	L INTERMEDIATE SECTION
GRATING 1407X487X30 GFK	97 66 610 08	23	2	3 227 200	91 53 519 08	LI INTERMEDIATE SECT. F-GU
GRATING 1407X487X30 GFK	97 66 610 08	40	1	3 714	91 52 862 08	D HEAD SECTION
GRATING 1407X487X30 GFK	97 66 610 08	26	2	3 715 008	91 52 863 08	D INTERMEDIATE SECTION
GRATING 1407X487X30 GFK	97 66 610 08	33	2	3 716	91 52 864 08	D INTERMEDIATE SECTION
GRATING 1527X447X30 GFK	97 72 730 08	3	1	3 211 006	96 47 004 08	GRATINGS
GRATING 1567X887X30 GFK	97 77 564 08	9	2	3 713 006	96 50 099 08	GRATINGS
GRATING 1607X1294X30 GFK	97 72 734 08	5	2	3 211 006	96 47 004 08	GRATINGS
GRATING 1927X1007X30 GFK	97 72 743 08	14	1	3 211 006	96 47 004 08	GRATINGS
GRATING 2007X807X30 GFK	97 72 744 08	15	1	3 211 006	96 47 004 08	GRATINGS
GRATING 2127X487X30 GFK	97 72 733 08	4	1	3 211 006	96 47 004 08	GRATINGS
GRATING 2127X487X30 GFK	97 77 559 08	8	1	3 713 006	96 50 099 08	GRATINGS
GRATING 2207X607X30 GFK	97 77 787 08	10	1	3 713 006	96 50 099 08	GRATINGS
GRATING 2207X807X30 GFK	97 71 971 08	22	2	3 220 500	91 52 849 08	S INTERMEDIATE SECTION
GRATING 2207X807X30 GFK	97 71 971 08	22	2	3 226	91 52 870 08	L INTERMEDIATE SECTION
GRATING 2207X807X30 GFK	97 71 971 08	41	1	3 227	91 52 873 08	L INTERMEDIATE SECTION

6.2.2009

etk_en_de_074515 LR 1600/2

891

LIEBHERRAlphabetical index
Alphabetischer Index

Description	Item	Pos.	Quantity	Page	Assembly	Description
GRATING 2207X807X30 GFK	97 71 971 08	41	1	3 227 008	91 52 872 08	L INTERMEDIATE SECTION
GRATING 2207X807X30 GFK	97 71 971 08	41	1	3 227 200	91 53 519 08	LI INTERMEDIATE SECT. F-GU
GRATING 2207X807X30 GFK	97 71 971 08	5	1	3 713 006	96 50 099 08	GRATINGS
GRATING 2207X807X30 GFK	97 71 971 08	41	1	3 714	91 52 862 08	D HEAD SECTION
GRATING 2207X807X30 GFK	97 71 971 08	28	2	3 715 008	91 52 863 08	D INTERMEDIATE SECTION
GRATING 2287X407X30 GFK	97 77 562 08	4	1	3 713 006	96 50 099 08	GRATINGS
GRATING 2287X807X30 GFK	97 71 942 08	40	1	3 223	91 52 852 08	S INTERMEDIATE SECTION
GRATING 2287X807X30 GFK	97 71 942 08	40	1	3 223 010	91 52 853 08	S INTERMEDIATE SECTION
GRATING 2287X807X30 GFK	97 71 942 08	40	1	3 223 100	91 55 327 08	S INTERMEDIATE SECTION
GRATING 2287X807X30 GFK	97 71 942 08	35	1	3 716	91 52 864 08	D INTERMEDIATE SECTION
GRATING 2327X487X30 GFK	97 74 745 08	5	1	3 225	91 52 854 08	SL REDUCING SECTION
GRATING 2447X487X30 GFK	97 72 097 08	1	1	3 211 006	96 47 004 08	GRATINGS
GRATING 2567X487X30 GFK	97 74 744 08	4	1	3 225	91 52 854 08	SL REDUCING SECTION
GRATING 2647X447X30 GFK	97 72 737 08	8	1	3 211 006	96 47 004 08	GRATINGS
GRATING 2647X487X30 GFK	97 66 514 08	23	2	3 220 500	91 52 849 08	S INTERMEDIATE SECTION
GRATING 2647X487X30 GFK	97 66 514 08	11	2	3 221	91 54 668 08	S INTERMEDIATE SECTION
GRATING 2647X487X30 GFK	97 66 514 08	23	2	3 223	91 52 852 08	S INTERMEDIATE SECTION
GRATING 2647X487X30 GFK	97 66 514 08	23	2	3 223 010	91 52 853 08	S INTERMEDIATE SECTION
GRATING 2647X487X30 GFK	97 74 648 08	23	2	3 223 100	91 55 327 08	S INTERMEDIATE SECTION
GRATING 2687X807X30 GFK	97 88 638 08	47	2	3 715 008	91 52 863 08	D INTERMEDIATE SECTION
GRATING 3167X807X30 GFK	97 77 560 08	2	1	3 713 006	96 50 099 08	GRATINGS
GRATING 3647X1007X30 GFK	97 72 098 08	2	1	3 211 006	96 47 004 08	GRATINGS
GRATING 3807X807X30 GFK	97 72 745 08	16	3	3 211 006	96 47 004 08	GRATINGS
GRATING 3807X807X30 GFK	97 72 745 08	48	3	3 716	91 52 864 08	D INTERMEDIATE SECTION
GRATING 3847X807X30 GFK	97 74 743 08	3	1	3 225	91 52 854 08	SL REDUCING SECTION
GRATING 4047X807X30 GFK	97 71 763 08	22	2	3 223	91 52 852 08	S INTERMEDIATE SECTION
GRATING 4047X807X30 GFK	97 71 763 08	22	2	3 223 010	91 52 853 08	S INTERMEDIATE SECTION
GRATING 4047X807X30 GFK	97 71 763 08	22	2	3 223 100	91 55 327 08	S INTERMEDIATE SECTION
GRATING 4047X807X30 GFK	97 71 763 08	22	2	3 227	91 52 873 08	L INTERMEDIATE SECTION
GRATING 4047X807X30 GFK	97 71 763 08	22	2	3 227 008	91 52 872 08	L INTERMEDIATE SECTION
GRATING 4047X807X30 GFK	97 71 763 08	22	2	3 227 200	91 53 519 08	LI INTERMEDIATE SECT. F-GU
GRATING 4047X807X30 GFK	97 71 763 08	42	1	3 714	91 52 862 08	D HEAD SECTION
GRATING 4047X807X30 GFK	97 71 763 08	34	2	3 716	91 52 864 08	D INTERMEDIATE SECTION
GRATING 447X367X30 GFK SP	97 72 739 08	10	1	3 211 006	96 47 004 08	GRATINGS
GRATING 447X367X30 GFK SP	97 72 740 08	11	1	3 211 006	96 47 004 08	GRATINGS
GRATING T1950X738X25/3 AL	97 70 899 08	2	1	2 859 025	96 46 757 08	GRIDIRON PRE-ASS.
GRATING-FRAME WELDED	96 46 810 08	1	1	2 859 025	96 46 757 08	GRIDIRON PRE-ASS.
GRATINGS	96 47 004 08	30	1	3 211	91 57 748 08	S PIVOT SECTION
GRATINGS	96 50 099 08	15	1	3 713	91 57 749 08	D PIVOT SECTION
GREASE NIPPLE	57 15 786 08	(1)	1	1 711	91 52 392 08	CENTRALIZED LUBRICATION
GREASE NIPPLE DIN 71412 A	77 43 040 08	13	4	2 125	91 52 773 08	PIN F.S-PIVOT SECTION SA F
GREASE NIPPLE DIN 71412 A	77 43 040 08	4	1	2 550 003	96 46 246 08	ROPE PULLEY CPL.
GREASE NIPPLE DIN 71412 A	77 43 040 08	4	1	2 652 007	92 68 928 08	ROPE PULLEY CPL.
GREASE NIPPLE DIN 71412 A	77 43 040 08	27	2	2 810	91 52 806 08	CRANE DRIVER'S CABIN CPL.
GREASE NIPPLE DIN 71412 A	77 43 040 08	41	3	3 208 001	91 52 883 08	F-HEAD SECTION
GREASE NIPPLE DIN 71412 A	77 43 040 08	106	2	3 211	91 57 748 08	S PIVOT SECTION
GREASE NIPPLE DIN 71412 A	77 43 040 08	10	2	3 213	91 52 842 08	F-CONNECTING HEAD
GREASE NIPPLE DIN 71412 A	77 43 040 08	10	2	3 214	91 52 843 08	SW HEAD SECTION
GREASE NIPPLE DIN 71412 A	77 43 040 08	6	2	3 292	91 52 865 08	D OVERRUN PROTECTION
GREASE NIPPLE DIN 71412 A	77 43 040 08	18	2	3 714	91 52 862 08	D HEAD SECTION
GREASE NIPPLE DIN 71412 A	77 43 040 08	401	1	5 718 420	57 18 420 08	FLANGE
GREASE NIPPLE DIN 71412 A	77 43 009 08	6	1	2 550 008	96 47 628 08	RETAINER CPL.
GREASE NIPPLE DIN 71412 A	77 43 009 08	6	1	2 550 009	96 47 645 08	RETAINER CPL.
GRIDIRON CARRIER LEFT 4X6	97 68 379 08	5	1	2 520	91 53 061 08	CABIN, GLAZED
GRIDIRON CARRIER RIGHT 4	97 68 378 08	4	1	2 520	91 53 061 08	CABIN, GLAZED
GRIDIRON PRE-ASS.	96 46 757 08	5	1	2 859	91 52 809 08	SOUND INSULATION
GRIDIRON T1020X240X30/2 S	72 58 067 08	5	2	1 620	91 52 386 08	FIXING PARTS SLEWING RING
GRIDIRON T1140X1260X30/2 S	97 79 271 08	15	2	1 631 100	91 52 388 08	CATWALK CRAW.TRACK TRA
GRIDIRON T1140X1260X30/2 S	97 86 742 08	16	2	1 631 100	91 52 388 08	CATWALK CRAW.TRACK TRA
GRIDIRON T1595X1260X30/2 S	72 58 549 08	2	4	1 631 100	91 52 388 08	CATWALK CRAW.TRACK TRA

6.2.2009

etk_en_de_074515 LR 1600/2

892

LIEBHERRAlphabetical index
Alphabetischer Index

Description	Item	Pos.	Quantity	Page	Assembly	Description
GRIDIRON T626X500X25/2 S23	72 58 469 08	25	2	3 745	91 52 948 08	SUSPENDED BALLAST
GRIP 10.0X750 S235JRG2 FE//	97 83 897 08	72	1	1 400	91 56 853 08	CRAWLER TRACK CARRIER LE
GRIP 10.0X750 S235JRG2 FE//	97 83 897 08	72	1	1 410 300	91 56 855 08	CRAWLER CARRIER RIGHT CP
GRIP BOLT	96 54 983 08	48	4	3 225	91 52 854 08	SL REDUCING SECTION
GRIP KUNSTSTOFF	70 42 545 08	8	1	2 260 006	96 46 501 08	BATTERY BOX, PRE-ASSEMB
GROMMET 10/12/17,5	60 27 013 08	5	2	2 810 037	96 47 204 08	PEDAL CANTILEVER INSTALL
GROMMET 4/6/9	60 27 024 08	10	1	2 913 102	92 32 870 08	FAN UNIT
GROUND RAIL	92 68 911 08	41	2	2 932 082	96 54 387 08	ASSEMBLY PARTS MOUNTIN
GRUB SCREW DIN 913 M10X1	40 44 022 08	530	1	X1041101	10 41 101 5	TILTING-BACK SUPPORT
GRUB SCREW DIN 913 M10X1	40 44 022 08	450	1	X1041101	10 41 101 8	TILTING-BACK SUPPORT
GRUB SCREW DIN 913 M10X4	40 44 031 08	4	1	2 502 007	96 22 822 08	ARM REST LEFT
GRUB SCREW DIN 913 M10X4	40 44 031 08	4	1	2 502 008	96 22 823 08	ARM REST RIGHT
GRUB SCREW DIN 913 M6X25	40 44 005 08	27	2	2 522	91 54 115 08	SLIDING DOOR CPL.
GRUB SCREW DIN 913 M6X35	51 07 533 08	9	1	5 711 301	57 11 301 08	PRESSURE LIMITING VALVE
GRUB SCREW DIN 913 M8X16	40 44 011 08	78	16	3 211	91 57 748 08	S PIVOT SECTION
GRUB SCREW DIN 914 M12X3	40 46 047 08	12	2	1 632	91 52 389 08	MECHANICAL SUPPORT
GRUB SCREW DIN 914 M6X16	40 46 005 08	20	2	3 213	91 52 842 08	F-CONNECTING HEAD
GRUB SCREW DIN 914 M8X10	40 46 013 08	540	4	X1041101	10 41 101 5	TILTING-BACK SUPPORT
GRUB SCREW DIN 914 M8X10	40 46 013 08	460	4	X1041101	10 41 101 8	TILTING-BACK SUPPORT
GRUB SCREW DIN 915 M16X4	40 48 046 08	23	5	X1065015	10 65 015 6	ROPE DRUM
GRUB SCREW DIN 915 M8X20	40 48 003 08	(4)	8	2 550	91 57 751 08	SA FRAME
GRUB SCREW DIN 915 M8X20	40 48 003 08	(5)	6	2 550	91 57 751 08	SA FRAME
GRUB SCREW DIN 915 M8X20	40 48 003 08	39	8	2 550	91 57 751 08	SA FRAME
GRUB SCREW M4	77 43 752 08	14	4	1 711	91 52 392 08	CENTRALIZED LUBRICATION
GSM MODULE LICCON 1	96 37 908 08	1	1	2 780 850	91 24 097 08	TELEDIAGNOSIS MODULE 1
GSM MODULE M1 TC63 QUAD	10 40 975 0	(10)	1	2 780 852	96 24 845 08	GSM-MODULE PRE-ASS.LICCO
GSM-MODULE PRE-ASS.LICCO	96 24 845 08	2	1	2 780 854	96 37 908 08	GSM MODULE LICCON 1
GSM-MODULE PROG. SPF	96 28 688 08	4	1	2 780 852	96 24 845 08	GSM-MODULE PRE-ASS.LICCO
GUIDE	97 71 833 08	1	1	2 522 013	96 45 883 08	GUIDE PRE-ASS.
GUIDE	97 72 794 08	2	1	2 522 013	96 45 883 08	GUIDE PRE-ASS.
GUIDE 306X48X37 ENAW6060-	97 74 304 08	10	2	2 502	91 55 939 08	CONTROL STAND
GUIDE G-ALSI10MG	97 71 831 08	1	1	2 522 012	96 45 884 08	GUIDE PRE-ASS.
GUIDE PIN	60 56 100 08	(157)	2	2 920 369	96 54 235 08	TERMINAL BOX CPL.
GUIDE PIN	60 56 100 08	(157)	2	2 920 369	96 54 235 08	TERMINAL BOX CPL.
GUIDE PIN	60 56 100 08	27	6	2 920 369	96 54 235 08	TERMINAL BOX CPL.
GUIDE PIN	60 56 100 08	23	10	2 920 448	96 48 794 08	TERMINAL BOX CPL.
GUIDE PIN	60 56 100 08	517	12	2 920 633	96 52 651 08	WIRING HARNESS
GUIDE PIN	60 56 100 08	52	21	2 932 160	96 54 385 08	SWITCH CABINET
GUIDE PLATE	57 01 145 08	2	1	5 701 133	57 01 133 08	DRIVING GEAR
GUIDE PRE-ASS. OBEN	96 45 884 08	26	1	2 520	91 53 061 08	CABIN, GLAZED
GUIDE PRE-ASS. UNTEN	96 45 883 08	27	1	2 520	91 53 061 08	CABIN, GLAZED
GUIDING BUSH	60 56 099 08	(156)	2	2 920 369	96 54 235 08	TERMINAL BOX CPL.
GUIDING BUSH	60 56 099 08	(156)	2	2 920 369	96 54 235 08	TERMINAL BOX CPL.
GUIDING BUSH	60 56 099 08	26	6	2 920 369	96 54 235 08	TERMINAL BOX CPL.
GUIDING BUSH	60 56 099 08	22	10	2 920 448	96 48 794 08	TERMINAL BOX CPL.
GUIDING BUSH	60 56 099 08	516	12	2 920 633	96 52 651 08	WIRING HARNESS
GUIDING BUSH	60 56 099 08	51	19	2 932 160	96 54 385 08	SWITCH CABINET
GUIDING CONE M3 MS SPF	66 00 420 08	13	6	2 922 001	92 84 311 08	BUS PCB
GUIDING CONE M5 PA6G SPF	66 00 419 08	12	1	2 922 001	92 84 311 08	BUS PCB
GUIDING PIECE	10 34 311 0	16	1	9 739 344	97 39 344	GENERATOR, PRE-ASSEMBLE
GUIDING PIPE	10 02 919 1	1	1	9 739 188	97 39 188	OIL-LEVEL GAUGE
HAMMER HEAD BOLT M8X15 4.	40 97 069 08	2	4	2 503 100	91 55 873 08	EMERGENCY SEAT
HAMMER HEAD BOLT M8X20 4.	40 97 070 08	32	2	2 310	91 52 503 08	WINCH 1
HAMMER HEAD BOLT M8X20 4.	40 97 070 08	32	2	2 320	91 52 504 08	WINCH 2
HAMMER HEAD BOLT M8X20 4.	40 97 070 08	152	2	2 970	91 56 537 08	HYDR
HAMMER HEAD BOLT M8X25 4.	40 97 066 08	14	2	2 391 102	96 56 360 08	RADIATOR
HAND GRIP	59 10 668 08	3	1	2 520 030	96 45 609 08	ROOF WINDOW PRE-ASS.
HAND GRIP WELDED	96 54 193 08	28	1	2 520	91 53 061 08	CABIN, GLAZED
HAND HAMMER 500G	79 00 303 08	9	1	1 750	91 52 394 08	TOOL
HAND HAMMER DIN 1041 1500	79 00 301 08	10	1	1 750	91 52 394 08	TOOL

6.2.2009

etk_en_de_074515 LR 1600/2

893

LIEBHERRAlphabetical index
Alphabetischer Index

Description	Item	Pos.	Quantity	Page	Assembly	Description
HAND LEVER PRESS VERZ.	79 00 420 08	18	1	1 750	91 52 394 08	TOOL
HAND RAIL WELDED STRUCT	96 47 099 08	65	4	3 211	91 57 748 08	S PIVOT SECTION
HANDGRIP 215X25X59,2X169	10 44 330 9	19	1	2 522	91 54 115 08	SLIDING DOOR CPL.
HANDLE CAP	57 18 247 08	1	1	6 060 950	60 60 950 08	MASTER SWITCH
HANDLE WELD.CONST.	92 10 795 08	5	1	2 550 011	96 47 007 08	CONSOLE COMPL.
HANDLE WELD.CONST.	92 10 795 08	4	4	2 790 455	91 57 005 08	TRANSPORT KEEPER
HANDLE WELD.CONST.	96 27 295 08	57	1	3 225	91 52 854 08	SL REDUCING SECTION
HANDLE WELD.CONST.	96 50 603 08	22	4	2 340	91 52 776 08	WINCH 4 LUFFING GEAR
HANDLE WELD.CONST. TZNO	96 53 092 08	7	1	2 631	91 56 817 08	SLEWING PLATFORM CATWAL
HANDPUMP ZPH1A/5PN500	57 17 080 08	1	1	5 123 682	51 23 682 08	MOUNTING - PISTON W. PUM
HEAT INSULATION PLATE	10 22 271 9	8	1	9 739 296	97 39 296	HEAT PROTECTION
HEAT INSULATION PLATE	10 22 272 3	15	1	9 739 296	97 39 296	HEAT PROTECTION
HEAT PROTECTION	97 39 296	181	1	X1012059	10 12 059 0	DIESEL ENGINE
HEATING HOSE 70	55 31 812 08	57	1.7	2 520	91 53 061 08	CABIN, GLAZED
HEATING HOSE 70	55 31 812 08	58	1.9	2 520	91 53 061 08	CABIN, GLAZED
HEATING HOSE 89 Rolle40m	55 30 182 08	59	0.16	2 520	91 53 061 08	CABIN, GLAZED
HEATING HOSE 89 Rolle40m	55 30 182 08	60	0.3	2 520	91 53 061 08	CABIN, GLAZED
HEATING HOSE 89 Rolle40m	55 30 182 08	61	0.13	2 520	91 53 061 08	CABIN, GLAZED
HEATING HOSE 89 Rolle40m	55 30 182 08	62	0.26	2 520	91 53 061 08	CABIN, GLAZED
HEATING HOSE 89 Rolle40m	55 30 182 08	63	1.62	2 520	91 53 061 08	CABIN, GLAZED
HEATING SYSTEM	50 26 514 08	2	1	5 026 573	50 26 573 08	AIR DRYER
HEATSHRINK SLEEVING 19-6,	60 30 167 08	(242)	0.03	2 920 581	96 54 405 08	TERMINAL BOX WINCH PRE-A
HEAVY FOIL MATTING 2X783X	97 79 354 08	11	1	2 859 005	96 46 756 08	FLAP PRE-ASS.
HEAVY FOIL MATTING 2X783X	97 79 356 08	13	1	2 859 005	96 46 756 08	FLAP PRE-ASS.
HEAVY FOIL MATTING 2X783X	97 79 355 08	12	1	2 859 005	96 46 756 08	FLAP PRE-ASS.
HEX BOLT	10 22 274 4	12	1	9 739 288	97 39 288	FUEL LINE
HEX BOLT	10 22 274 4	11	1	9 739 369	97 39 369	PRESSURE PIPE
HEX BOLT 7/16"X30 8.8 A3F	40 97 513 08	562	8	2 970	91 56 537 08	HYDR
HEX BOLT EN 1665 M10X20 10.	10 04 535 6	2	8	9 739 341	97 39 341	DRIVING PARTS
HEX BOLT EN 1665 M10X20 10.	10 04 535 6	3	2	9 739 344	97 39 344	GENERATOR, PRE-ASSEMBLE
HEX BOLT EN 1665 M5X10 10.	40 73 500 08	7	8	2 932 001	96 45 393 08	RELAY CONTROL SYSTEM
HEX BOLT EN 1665 M5X10 10.	40 73 500 08	36	18	2 932 082	96 54 387 08	ASSEMBLY PARTS MOUNTIN
HEX BOLT EN 1665 M5X16 10.	40 73 501 08	37	4	2 533 070	96 48 363 08	CONTROLS AND FITTINGS RI
HEX BOLT EN 1665 M5X16 10.	40 73 501 08	31	1	2 835 002	96 48 379 08	ADD-ON PARTS
HEX BOLT EN 1665 M5X16 10.	40 73 501 08	84	32	2 932 082	96 54 387 08	ASSEMBLY PARTS MOUNTIN
HEX BOLT EN 1665 M5X16 10.	40 73 501 08	5	13	2 932 160	96 54 385 08	SWITCH CABINET
HEX BOLT EN 1665 M6X16 8.8	40 73 502 08	40	2	2 520	91 53 061 08	CABIN, GLAZED
HEX BOLT EN 1665 M6X16 8.8	40 73 502 08	9	2	2 932 168	96 48 167 08	COVER COMPL.
HEX BOLT EN 1665 M8X140 10.	10 03 731 0	6	1	9 739 362	97 39 362	OIL SUMP
HEX BOLT EN 1665 M8X45 8.8	10 01 690 7	5	4	9 080 702	90 80 702	CONTROL GEAR
HEX BOLT ISO 4014 M10X40 10	40 62 011 08	26	7	3 208 001	91 52 883 08	F-HEAD SECTION
HEX BOLT ISO 4014 M10X40 8.	40 61 056	12	2	2 975 000	91 57 881 08	ADDNL. HYDR. F. ERECTING W
HEX BOLT ISO 4014 M10X50 8.	40 00 472	11	8	2 391 038	96 47 931 08	OIL COOLER, PRE-ASSEMBLE
HEX BOLT ISO 4014 M10X60 8.	49 01 053	38	4	3 281	91 52 896 08	ERECTION FRAME
HEX BOLT ISO 4014 M10X80 1	10 00 613 0	10	4	9 080 702	90 80 702	CONTROL GEAR
HEX BOLT ISO 4014 M12X120	46 00 247	11	4	2 392	91 52 785 08	MUFFLER UNIT
HEX BOLT ISO 4014 M12X150	40 61 076	81	2	3 211	91 57 748 08	S PIVOT SECTION
HEX BOLT ISO 4014 M12X200	46 00 887	10	1	2 550 008	96 47 628 08	RETAINER CPL.
HEX BOLT ISO 4014 M12X200	46 00 887	10	1	2 550 009	96 47 645 08	RETAINER CPL.
HEX BOLT ISO 4014 M12X50 8.	40 00 973	23	2	2 392	91 52 785 08	MUFFLER UNIT
HEX BOLT ISO 4014 M12X55 8.	46 00 047	35	3	3 206	91 52 881 08	PIVOT SECTION
HEX BOLT ISO 4014 M12X55 8.	46 00 047	27	6	3 208 001	91 52 883 08	F-HEAD SECTION
HEX BOLT ISO 4014 M12X55 8.	46 00 047	26	4	3 215 005	91 52 846 08	ROLLER SET
HEX BOLT ISO 4014 M12X55 8.	46 00 047	26	4	3 215 006	91 52 847 08	ROLLER SET
HEX BOLT ISO 4014 M12X60 8.	40 61 065	22	4	3 215 005	91 52 846 08	ROLLER SET
HEX BOLT ISO 4014 M12X60 8.	40 61 065	22	4	3 215 006	91 52 847 08	ROLLER SET
HEX BOLT ISO 4014 M12X75 8.	46 00 245	11	4	2 671	91 52 798 08	OIL RESERVOIR, COMPLETE
HEX BOLT ISO 4014 M12X75 8.	46 00 245	4	1	3 207 003	96 48 259 08	ROD CPL.
HEX BOLT ISO 4014 M12X75 8.	46 00 245	3	1	3 207 100	96 48 261 08	BRACKET COMPL.
HEX BOLT ISO 4014 M12X75 8.	46 00 245	(4)	1	3 281	91 52 896 08	ERECTION FRAME

6.2.2009

etk_en_de_074515 LR 1600/2

894

LIEBHERRAlphabetical index
Alphabetischer Index

Description	Item	Pos.	Quantity	Page	Assembly	Description
HEX BOLT ISO 4014 M12X80 8.	49 01 057	10	4	2 391 023	96 45 720 08	RADIATOR, PRE-ASSEMBLED
HEX BOLT ISO 4014 M14X60 1	40 62 036 08	48	4	3 745	91 52 948 08	SUSPENDED BALLAST
HEX BOLT ISO 4014 M16X100	46 00 038	336	8	2 391 001	96 45 719 08	DIESEL ENGINE, PRE-ASSEMB
HEX BOLT ISO 4014 M16X100	46 00 038	7	4	2 810	91 52 806 08	CRANE DRIVER'S CABIN CPL.
HEX BOLT ISO 4014 M16X130	40 61 179 01	4	4	2 730	91 52 802 08	BASE PLATE SLEWING PLATF
HEX BOLT ISO 4014 M16X130	40 61 179 01	2	1	3 207 101	96 48 292 08	BRACKET COMPL.
HEX BOLT ISO 4014 M16X130	40 61 179 01	(3)	2	3 281	91 52 896 08	ERECTION FRAME
HEX BOLT ISO 4014 M16X140	40 61 180 01	3	1	3 714 014	96 49 456 08	BRACKET COMPL.
HEX BOLT ISO 4014 M16X150	40 62 049 08	333	4	2 391 001	96 45 719 08	DIESEL ENGINE, PRE-ASSEMB
HEX BOLT ISO 4014 M16X160	40 62 051 08	49	13	1 400	91 56 853 08	CRAWLER TRACK CARRIER LE
HEX BOLT ISO 4014 M16X160	40 62 051 08	49	13	1 410 300	91 56 855 08	CRAWLER CARRIER RIGHT CP
HEX BOLT ISO 4014 M16X170	40 61 184 01	11	1	2 657	91 57 656 08	MOUNTING EQUIPMENT CRAW
HEX BOLT ISO 4014 M16X180	40 61 186 01	8	1	3 211 003	96 46 986 08	ROD CPL.
HEX BOLT ISO 4014 M16X180	40 61 186 01	9	1	3 220 501	96 43 440 08	ROD CPL.
HEX BOLT ISO 4014 M16X180	40 61 186 01	9	1	3 221 200	96 47 984 08	ROD CPL.
HEX BOLT ISO 4014 M16X180	40 61 186 01	9	1	3 225 200	96 48 679 08	ROD CPL.
HEX BOLT ISO 4014 M16X180	40 61 186 01	9	1	3 227 002	96 50 498 08	ROD CPL.
HEX BOLT ISO 4014 M16X180	40 61 186 01	9	1	3 561 003	96 45 222 08	ROD CPL.
HEX BOLT ISO 4014 M16X180	40 61 186 01	9	1	3 713 012	96 50 197 08	ROD CPL.
HEX BOLT ISO 4014 M16X180	40 61 186 01	4	2	3 714 013	96 49 270 08	BRACKET COMPL.
HEX BOLT ISO 4014 M16X180	40 61 186 01	5	1	3 714 013	96 59 083 08	BRACKET COMPL.
HEX BOLT ISO 4014 M16X180	40 61 186 01	9	1	3 716 001	96 49 159 08	ROD CPL.
HEX BOLT ISO 4014 M16X200	40 62 181 08	45	13	1 400	91 56 853 08	CRAWLER TRACK CARRIER LE
HEX BOLT ISO 4014 M16X200	40 62 181 08	45	13	1 410 300	91 56 855 08	CRAWLER CARRIER RIGHT CP
HEX BOLT ISO 4014 M16X60 8.	40 61 167 01	14	4	3 292	91 52 865 08	D OVERRUN PROTECTION
HEX BOLT ISO 4014 M16X70 8.	46 00 056	21	1	2 391 040	96 53 645 08	CLUTCH ACTUATOR
HEX BOLT ISO 4014 M16X90 10	40 62 044 08	16	4	3 227 002	96 50 498 08	ROD CPL.
HEX BOLT ISO 4014 M16X90 8.	46 00 332	(3)	1	3 281	91 52 896 08	ERECTION FRAME
HEX BOLT ISO 4014 M20X140	40 61 234 14	1272	18	X1065015	10 65 015 5	GEARBOX
HEX BOLT ISO 4014 M20X200	40 61 244 01	16	1	2 550 005	96 45 680 08	ROD CPL.
HEX BOLT ISO 4014 M20X220 1	46 35 436	15	4	3 745 011	96 49 677 08	BRACKET COMPL.
HEX BOLT ISO 4014 M20X220	40 61 246 01	2	1	1 632 032	96 20 093 08	SUPPORT PLATE COMPL.
HEX BOLT ISO 4014 M20X220	40 61 246 01	8	2	2 550 005	96 45 680 08	ROD CPL.
HEX BOLT ISO 4014 M20X220	40 61 246 01	6	1	3 714 025	96 49 269 08	ROD CPL.
HEX BOLT ISO 4014 M20X240	40 61 248 14	4	2	3 745 011	96 49 677 08	BRACKET COMPL.
HEX BOLT ISO 4014 M24X300	40 61 291 08	15	6	3 714 009	96 49 267 08	LUFFING PULLEY BLOCK COM
HEX BOLT ISO 4014 M24X370	10 04 097 9	55	35	1 400	91 56 853 08	CRAWLER TRACK CARRIER LE
HEX BOLT ISO 4014 M24X370	10 04 097 9	55	35	1 410 300	91 56 855 08	CRAWLER CARRIER RIGHT CP
HEX BOLT ISO 4014 M24X400	10 41 289 2	56	35	1 400	91 56 853 08	CRAWLER TRACK CARRIER LE
HEX BOLT ISO 4014 M24X400	10 41 289 2	56	35	1 410 300	91 56 855 08	CRAWLER CARRIER RIGHT CP
HEX BOLT ISO 4014 M6X40 8.8	40 01 928	33	2	3 220 500	91 52 849 08	S INTERMEDIATE SECTION
HEX BOLT ISO 4014 M6X40 8.8	40 01 928	33	4	3 223	91 52 852 08	S INTERMEDIATE SECTION
HEX BOLT ISO 4014 M6X40 8.8	40 01 928	33	4	3 223 010	91 52 853 08	S INTERMEDIATE SECTION
HEX BOLT ISO 4014 M6X40 8.8	40 01 928	33	4	3 223 100	91 55 327 08	S INTERMEDIATE SECTION
HEX BOLT ISO 4014 M6X40 8.8	40 01 928	31	2	3 225	91 52 854 08	SL REDUCING SECTION
HEX BOLT ISO 4014 M6X40 8.8	40 01 928	33	2	3 226	91 52 870 08	L INTERMEDIATE SECTION
HEX BOLT ISO 4014 M6X40 8.8	40 01 928	33	4	3 227	91 52 873 08	L INTERMEDIATE SECTION
HEX BOLT ISO 4014 M6X40 8.8	40 01 928	33	4	3 227 008	91 52 872 08	L INTERMEDIATE SECTION
HEX BOLT ISO 4014 M6X40 8.8	40 01 928	33	4	3 227 200	91 53 519 08	LI INTERMEDIATE SECT. F-GU
HEX BOLT ISO 4014 M6X40 8.8	40 01 928	59	10	3 714	91 52 862 08	D HEAD SECTION
HEX BOLT ISO 4014 M6X50 8.8	46 00 023	10	2	2 976 203	92 27 489 08	ADDL.HYDR.F.PIN PULLING DE
HEX BOLT ISO 4014 M6X50 8.8	46 00 023	56	5	3 211	91 57 748 08	S PIVOT SECTION
HEX BOLT ISO 4014 M6X60 8.8	40 01 929	6	4	3 715 008	91 52 863 08	D INTERMEDIATE SECTION
HEX BOLT ISO 4014 M6X60 8.8	40 01 929	6	6	3 716	91 52 864 08	D INTERMEDIATE SECTION
HEX BOLT ISO 4014 M6X65 8.8	46 00 356	36	15	3 220 500	91 52 849 08	S INTERMEDIATE SECTION
HEX BOLT ISO 4014 M6X65 8.8	46 00 356	20	12	3 221	91 54 668 08	S INTERMEDIATE SECTION
HEX BOLT ISO 4014 M6X65 8.8	46 00 356	36	18	3 223	91 52 852 08	S INTERMEDIATE SECTION
HEX BOLT ISO 4014 M6X65 8.8	46 00 356	36	18	3 223 010	91 52 853 08	S INTERMEDIATE SECTION
HEX BOLT ISO 4014 M6X65 8.8	46 00 356	36	18	3 223 100	91 55 327 08	S INTERMEDIATE SECTION
HEX BOLT ISO 4014 M6X65 8.8	46 00 356	43	15	3 225	91 52 854 08	SL REDUCING SECTION

6.2.2009

etk_en_de_074515 LR 1600/2

895

LIEBHERRAlphabetical index
Alphabetischer Index

Description	Item	Pos.	Quantity	Page	Assembly	Description
HEX BOLT ISO 4014 M6X65 8.8	46 00 356	36	15	3 226	91 52 870 08	L INTERMEDIATE SECTION
HEX BOLT ISO 4014 M6X65 8.8	46 00 356	36	18	3 227	91 52 873 08	L INTERMEDIATE SECTION
HEX BOLT ISO 4014 M6X65 8.8	46 00 356	36	18	3 227 008	91 52 872 08	L INTERMEDIATE SECTION
HEX BOLT ISO 4014 M6X65 8.8	46 00 356	36	18	3 227 200	91 53 519 08	LI INTERMEDIATE SECT. F-GU
HEX BOLT ISO 4014 M6X65 8.8	46 00 356	62	15	3 713	91 57 749 08	D PIVOT SECTION
HEX BOLT ISO 4014 M6X65 8.8	46 00 356	56	9	3 714	91 52 862 08	D HEAD SECTION
HEX BOLT ISO 4014 M6X65 8.8	46 00 356	18	16	3 715 008	91 52 863 08	D INTERMEDIATE SECTION
HEX BOLT ISO 4014 M6X65 8.8	46 00 356	18	19	3 716	91 52 864 08	D INTERMEDIATE SECTION
HEX BOLT ISO 4014 M6X75 8.8	49 81 024	60	11	3 714	91 52 862 08	D HEAD SECTION
HEX BOLT ISO 4014 M6X90 8.8	40 00 970	16	2	2 990	91 59 244 08	COMPRESSED AIR PLANT
HEX BOLT ISO 4014 M8X100 8.	46 00 310	9	3	2 350	91 52 778 08	SLEWING GEAR
HEX BOLT ISO 4014 M8X40 8.8	40 61 062	43	6	3 715 008	91 52 863 08	D INTERMEDIATE SECTION
HEX BOLT ISO 4014 M8X40 8.8	40 61 062	47	12	3 716	91 52 864 08	D INTERMEDIATE SECTION
HEX BOLT ISO 4014 M8X45 8.8	40 01 466	100	14	3 211	91 57 748 08	S PIVOT SECTION
HEX BOLT ISO 4014 M8X50 8.8	40 01 461	7	4	1 620	91 52 386 08	FIXING PARTS SLEWING RING
HEX BOLT ISO 4014 M8X50 8.8	40 01 461	25	2	3 208 001	91 52 883 08	F-HEAD SECTION
HEX BOLT ISO 4014 M8X50 8.8	40 01 461	75	44	3 211	91 57 748 08	S PIVOT SECTION
HEX BOLT ISO 4014 M8X50 8.8	40 01 461	76	16	3 713	91 57 749 08	D PIVOT SECTION
HEX BOLT ISO 4014 M8X50 8.8	40 01 461	31	8	3 745	91 52 948 08	SUSPENDED BALLAST
HEX BOLT ISO 4014 M8X55 8.8	40 61 024	10	48	1 631 100	91 52 388 08	CATWALK CRAW.TRACK TRA
HEX BOLT ISO 4014 M8X55 8.8	40 61 024	58	8	3 206	91 52 881 08	PIVOT SECTION
HEX BOLT ISO 4014 M8X55 8.8	40 61 024	36	9	3 214	91 52 843 08	SW HEAD SECTION
HEX BOLT ISO 4014 M8X55 8.8	40 61 024	25	45	3 220 500	91 52 849 08	S INTERMEDIATE SECTION
HEX BOLT ISO 4014 M8X55 8.8	40 61 024	13	36	3 221	91 54 668 08	S INTERMEDIATE SECTION
HEX BOLT ISO 4014 M8X55 8.8	40 61 024	25	49	3 223	91 52 852 08	S INTERMEDIATE SECTION
HEX BOLT ISO 4014 M8X55 8.8	40 61 024	25	49	3 223 010	91 52 853 08	S INTERMEDIATE SECTION
HEX BOLT ISO 4014 M8X55 8.8	40 61 024	25	49	3 223 100	91 55 327 08	S INTERMEDIATE SECTION
HEX BOLT ISO 4014 M8X55 8.8	40 61 024	35	47	3 225	91 52 854 08	SL REDUCING SECTION
HEX BOLT ISO 4014 M8X55 8.8	40 61 024	25	34	3 226	91 52 870 08	L INTERMEDIATE SECTION
HEX BOLT ISO 4014 M8X55 8.8	40 61 024	25	48	3 227	91 52 873 08	L INTERMEDIATE SECTION
HEX BOLT ISO 4014 M8X55 8.8	40 61 024	25	40	3 227 008	91 52 872 08	L INTERMEDIATE SECTION
HEX BOLT ISO 4014 M8X55 8.8	40 61 024	25	49	3 227 200	91 53 519 08	LI INTERMEDIATE SECT. F-GU
HEX BOLT ISO 4014 M8X55 8.8	40 61 024	17	73	3 713	91 57 749 08	D PIVOT SECTION
HEX BOLT ISO 4014 M8X55 8.8	40 61 024	46	55	3 714	91 52 862 08	D HEAD SECTION
HEX BOLT ISO 4014 M8X55 8.8	40 61 024	7	56	3 715 008	91 52 863 08	D INTERMEDIATE SECTION
HEX BOLT ISO 4014 M8X55 8.8	40 61 024	7	88	3 716	91 52 864 08	D INTERMEDIATE SECTION
HEX BOLT ISO 4017 M10X130	24 02 184 02	31	1	3 206	91 52 881 08	PIVOT SECTION
HEX BOLT ISO 4017 M10X16 8.	49 00 090	3	16	1 620	91 52 386 08	FIXING PARTS SLEWING RING
HEX BOLT ISO 4017 M10X16 8.	49 00 090	69	4	2 550	91 57 751 08	SA FRAME
HEX BOLT ISO 4017 M10X20 1	40 01 696	(56)	8	1 400	91 56 853 08	CRAWLER TRACK CARRIER LE
HEX BOLT ISO 4017 M10X20 1	40 01 696	9	16	2 810	91 52 806 08	CRANE DRIVER'S CABIN CPL.
HEX BOLT ISO 4017 M10X20 8.	40 65 166	7	4	2 671	91 52 798 08	OIL RESERVOIR, COMPLETE
HEX BOLT ISO 4017 M10X20 8.	40 65 166	12	8	2 730	91 52 802 08	BASE PLATE SLEWING PLATF
HEX BOLT ISO 4017 M10X20 8.	40 65 166	129	2	2 970	91 56 537 08	HYDR
HEX BOLT ISO 4017 M10X20 8.	40 65 093 08	6	8	2 670	91 52 797 08	FUEL TANK CPL.
HEX BOLT ISO 4017 M10X25 8.	40 65 164	5	6	2 350	91 52 778 08	SLEWING GEAR
HEX BOLT ISO 4017 M10X25 8.	40 65 164	7	12	2 370	91 52 782 08	ERECTING WINCH
HEX BOLT ISO 4017 M10X25 8.	40 65 164	344	4	2 391 001	96 45 719 08	DIESEL ENGINE, PRE-ASSEMB
HEX BOLT ISO 4017 M10X25 8.	40 65 164	20	4	2 393	91 52 787 08	AIR FILTER UNIT CPL.
HEX BOLT ISO 4017 M10X25 8.	40 65 164	19	4	2 631	91 56 817 08	SLEWING PLATFORM CATWAL
HEX BOLT ISO 4017 M10X25 8.	40 65 164	31	6	2 652	91 52 794 08	ROLLER BEARING
HEX BOLT ISO 4017 M10X25 8.	40 65 164	8	4	2 671 004	96 46 305 08	OIL TANK PRE-ASS.
HEX BOLT ISO 4017 M10X25 8.	40 65 164	14	12	2 810	91 52 806 08	CRANE DRIVER'S CABIN CPL.
HEX BOLT ISO 4017 M10X25 8.	40 65 164	16	4	2 925 204	92 16 990 08	CAMERA EQUIPMENT D-PIVOT
HEX BOLT ISO 4017 M10X25 8.	40 65 164	35	2	2 925 402	96 58 855 08	CAMERA EQUIPMENT SLEWI
HEX BOLT ISO 4017 M10X25 8.	40 65 164	7	5	3 206	91 52 881 08	PIVOT SECTION
HEX BOLT ISO 4017 M10X25 8.	40 65 164	71	16	3 714	91 52 862 08	D HEAD SECTION
HEX BOLT ISO 4017 M10X30 8.	40 00 828	67	12	1 400	91 56 853 08	CRAWLER TRACK CARRIER LE
HEX BOLT ISO 4017 M10X30 8.	40 00 828	67	12	1 410 300	91 56 855 08	CRAWLER CARRIER RIGHT CP
HEX BOLT ISO 4017 M10X30 8.	40 00 828	345	2	2 391 001	96 45 719 08	DIESEL ENGINE, PRE-ASSEMB

6.2.2009

etk_en_de_074515 LR 1600/2

896

LIEBHERRAlphabetical index
Alphabetischer Index

Description	Item	Pos.	Quantity	Page	Assembly	Description
HEX BOLT ISO 4017 M10X30 8.	40 00 828	35	24	2 631	91 56 817 08	SLEWING PLATFORM CATWAL
HEX BOLT ISO 4017 M10X30 8.	40 00 828	130	2	2 970	91 56 537 08	HYDR
HEX BOLT ISO 4017 M10X35 8.	49 00 112	9	4	2 730	91 52 802 08	BASE PLATE SLEWING PLATF
HEX BOLT ISO 4017 M10X35 8.	49 00 112	544	2	2 970	91 56 537 08	HYDR
HEX BOLT ISO 4017 M10X35 8.	49 00 112	564	4	2 976 200	91 52 780 08	ADDITIONAL HYDRAULICS
HEX BOLT ISO 4017 M10X35 8.	49 00 112	569	4	2 976 700	91 54 795 08	ADDITIONAL HYDRAULICS P
HEX BOLT ISO 4017 M10X35 8.	49 00 112	31	8	3 713	91 57 749 08	D PIVOT SECTION
HEX BOLT ISO 4017 M10X35 8.	49 00 112	11	4	X1035519	10 35 519 6	OIL AIR COOLER
HEX BOLT ISO 4017 M10X40 8.	46 00 122	339	12	2 391 001	96 45 719 08	DIESEL ENGINE, PRE-ASSEMB
HEX BOLT ISO 4017 M10X40 8.	46 00 122	23	2	3 206	91 52 881 08	PIVOT SECTION
HEX BOLT ISO 4017 M10X40 8.	46 00 122	48	4	3 211	91 57 748 08	S PIVOT SECTION
HEX BOLT ISO 4017 M10X45 8.	46 00 355	31	2	2 502	91 55 939 08	CONTROL STAND
HEX BOLT ISO 4017 M10X45 8.	46 00 355	9	10	X1035519	10 35 519 6	OIL AIR COOLER
HEX BOLT ISO 4017 M12X20 8.	49 00 120	10	8	1 630	91 52 387 08	HYDRAULIC SUPPORT
HEX BOLT ISO 4017 M12X20 8.	49 00 120	357	4	2 391	91 52 784 08	DIESEL ENGINE CPL.
HEX BOLT ISO 4017 M12X25 10	40 66 087 08	430	2	X1041101	10 41 101 8	TILTING-BACK SUPPORT
HEX BOLT ISO 4017 M12X30 8.	49 00 161	52	8	1 400	91 56 853 08	CRAWLER TRACK CARRIER LE
HEX BOLT ISO 4017 M12X30 8.	49 00 161	52	8	1 410 300	91 56 855 08	CRAWLER CARRIER RIGHT CP
HEX BOLT ISO 4017 M12X30 8.	49 00 161	173	8	2 970	91 56 537 08	HYDR
HEX BOLT ISO 4017 M12X30 8.	49 00 161	70	2	3 211	91 57 748 08	S PIVOT SECTION
HEX BOLT ISO 4017 M12X30 8.	49 00 161	8	8	3 213	91 52 842 08	F-CONNECTING HEAD
HEX BOLT ISO 4017 M12X30 8.	49 00 161	9	4	3 291	91 52 831 08	S OVERRUN PROTECTION
HEX BOLT ISO 4017 M12X30 8.	49 00 161	3	4	3 292	91 52 865 08	D OVERRUN PROTECTION
HEX BOLT ISO 4017 M12X30 8.	49 00 161	36	8	3 714	91 52 862 08	D HEAD SECTION
HEX BOLT ISO 4017 M12X30 8.	49 00 161	12	4	3 714 008	96 49 266 08	LUFFING PULLEY BLOCK COM
HEX BOLT ISO 4017 M12X35 8.	49 00 204	2	2	2 212	91 54 561 08	PUMP F.SLEWING GEAR
HEX BOLT ISO 4017 M12X35 8.	49 00 204	20	4	2 310	91 52 503 08	WINCH 1
HEX BOLT ISO 4017 M12X35 8.	49 00 204	20	4	2 320	91 52 504 08	WINCH 2
HEX BOLT ISO 4017 M12X35 8.	49 00 204	335	10	2 391 001	96 45 719 08	DIESEL ENGINE, PRE-ASSEMB
HEX BOLT ISO 4017 M12X35 8.	49 00 204	3	2	3 211 002	92 88 302 08	SAFETY ROLLER CPL.
HEX BOLT ISO 4017 M12X35 8.	49 00 204	16	4	3 292	91 52 865 08	D OVERRUN PROTECTION
HEX BOLT ISO 4017 M12X35 8.	49 00 204	24	8	3 350	91 52 859 08	WINCH 3
HEX BOLT ISO 4017 M12X35 8.	49 00 204	24	4	3 713	91 57 749 08	D PIVOT SECTION
HEX BOLT ISO 4017 M12X35 8.	49 00 204	151	2	3 713	91 57 749 08	D PIVOT SECTION
HEX BOLT ISO 4017 M12X35 8.	49 00 204	61	8	3 714	91 52 862 08	D HEAD SECTION
HEX BOLT ISO 4017 M12X40 1	46 00 366	12	12	3 214	91 52 843 08	SW HEAD SECTION
HEX BOLT ISO 4017 M12X40 8.	49 00 100	347	2	2 391 001	96 45 719 08	DIESEL ENGINE, PRE-ASSEMB
HEX BOLT ISO 4017 M12X40 8.	49 00 100	24	2	2 392	91 52 785 08	MUFFLER UNIT
HEX BOLT ISO 4017 M12X40 8.	49 00 100	548	4	2 970	91 56 537 08	HYDR
HEX BOLT ISO 4017 M12X40 8.	49 00 100	72	4	3 211	91 57 748 08	S PIVOT SECTION
HEX BOLT ISO 4017 M12X45 8.	46 00 158	15	1	1 991	91 52 510 08	ROTARY FEED THROUGH
HEX BOLT ISO 4017 M12X45 8.	46 00 158	12	2	2 340	91 52 776 08	WINCH 4 LUFFING GEAR
HEX BOLT ISO 4017 M12X45 8.	46 00 158	337	8	2 391 001	96 45 719 08	DIESEL ENGINE, PRE-ASSEMB
HEX BOLT ISO 4017 M12X45 8.	46 00 158	12	4	3 213	91 52 842 08	F-CONNECTING HEAD
HEX BOLT ISO 4017 M12X45 8.	46 00 158	28	4	3 214	91 52 843 08	SW HEAD SECTION
HEX BOLT ISO 4017 M12X45 8.	46 00 158	6	8	3 220 500	91 52 849 08	S INTERMEDIATE SECTION
HEX BOLT ISO 4017 M12X45 8.	46 00 158	6	8	3 221	91 54 668 08	S INTERMEDIATE SECTION
HEX BOLT ISO 4017 M12X45 8.	46 00 158	6	8	3 223	91 52 852 08	S INTERMEDIATE SECTION
HEX BOLT ISO 4017 M12X45 8.	46 00 158	6	8	3 223 010	91 52 853 08	S INTERMEDIATE SECTION
HEX BOLT ISO 4017 M12X45 8.	46 00 158	6	8	3 223 100	91 55 327 08	S INTERMEDIATE SECTION
HEX BOLT ISO 4017 M12X45 8.	46 00 158	25	8	3 225	91 52 854 08	SL REDUCING SECTION
HEX BOLT ISO 4017 M12X45 8.	46 00 158	6	8	3 226	91 52 870 08	L INTERMEDIATE SECTION
HEX BOLT ISO 4017 M12X45 8.	46 00 158	6	8	3 227	91 52 873 08	L INTERMEDIATE SECTION
HEX BOLT ISO 4017 M12X45 8.	46 00 158	6	8	3 227 008	91 52 872 08	L INTERMEDIATE SECTION
HEX BOLT ISO 4017 M12X45 8.	46 00 158	6	8	3 227 200	91 53 519 08	LI INTERMEDIATE SECT. F-GU
HEX BOLT ISO 4017 M12X45 8.	46 00 158	27	32	3 350	91 52 859 08	WINCH 3
HEX BOLT ISO 4017 M12X45 8.	46 00 158	27	4	3 714	91 52 862 08	D HEAD SECTION
HEX BOLT ISO 4017 M12X45 8.	46 00 158	17	8	3 715 008	91 52 863 08	D INTERMEDIATE SECTION
HEX BOLT ISO 4017 M12X45 8.	46 00 158	17	8	3 716	91 52 864 08	D INTERMEDIATE SECTION
HEX BOLT ISO 4017 M12X50 8.	46 00 156	4	8	2 391	91 52 784 08	DIESEL ENGINE CPL.

6.2.2009

etk_en_de_074515 LR 1600/2

897

LIEBHERRAlphabetical index
Alphabetischer Index

Description	Item	Pos.	Quantity	Page	Assembly	Description
HEX BOLT ISO 4017 M12X50 8.	46 00 156	42	8	3 350	91 52 859 08	WINCH 3
HEX BOLT ISO 4017 M12X55 8.	46 00 312	340	6	2 391 001	96 45 719 08	DIESEL ENGINE, PRE-ASSEMB
HEX BOLT ISO 4017 M14X40 8.	40 65 086 05	49	2	2 631	91 56 817 08	SLEWING PLATFORM CATWAL
HEX BOLT ISO 4017 M14X45 8.	40 65 145 01	57	8	1 970	91 56 958 08	CRAWLER TRACK HYDRAULI
HEX BOLT ISO 4017 M14X45 8.	40 65 145 01	57	8	1 970 161	96 50 706 08	AUX.HYDR.CR.TRACK CARR.4
HEX BOLT ISO 4017 M14X45 8.	40 65 145 01	556	4	2 970	91 56 537 08	HYDR
HEX BOLT ISO 4017 M14X45 8.	40 65 145 01	43	4	2 975 100	91 52 860 08	ADDITIONAL HYDRAULICS WI
HEX BOLT ISO 4017 M14X45 8.	40 65 145 01	44	4	2 975 100	91 52 860 08	ADDITIONAL HYDRAULICS WI
HEX BOLT ISO 4017 M14X65 1	46 01 349	28	8	1 630	91 52 387 08	HYDRAULIC SUPPORT
HEX BOLT ISO 4017 M16X20 8.	40 65 156 08	23	4	2 393	91 52 787 08	AIR FILTER UNIT CPL.
HEX BOLT ISO 4017 M16X30 8.	49 00 152	3	162	1 300 011	96 52 493 08	FLOOR PLATES PRE-ASS.
HEX BOLT ISO 4017 M16X30 8.	49 00 152	355	2	2 391 001	96 45 719 08	DIESEL ENGINE, PRE-ASSEMB
HEX BOLT ISO 4017 M16X30 8.	49 00 152	35	1	2 391 040	96 53 645 08	CLUTCH ACTUATOR
HEX BOLT ISO 4017 M16X30 8.	49 00 152	7	10	2 550	91 57 751 08	SA FRAME
HEX BOLT ISO 4017 M16X35 8.	49 00 123	54	4	1 400	91 56 853 08	CRAWLER TRACK CARRIER LE
HEX BOLT ISO 4017 M16X35 8.	49 00 123	54	4	1 410 300	91 56 855 08	CRAWLER CARRIER RIGHT CP
HEX BOLT ISO 4017 M16X35 8.	49 00 123	9	8	3 714 008	96 49 266 08	LUFFING PULLEY BLOCK COM
HEX BOLT ISO 4017 M16X35 8.	49 00 123	12	8	3 714 009	96 49 267 08	LUFFING PULLEY BLOCK COM
HEX BOLT ISO 4017 M16X35 8.	49 00 123	12	16	3 745	91 52 948 08	SUSPENDE BALLAST
HEX BOLT ISO 4017 M16X40 10	40 66 030 08	47	8	1 400	91 56 853 08	CRAWLER TRACK CARRIER LE
HEX BOLT ISO 4017 M16X40 10	40 66 030 08	47	8	1 410 300	91 56 855 08	CRAWLER CARRIER RIGHT CP
HEX BOLT ISO 4017 M16X40 10	40 66 030 08	7	26	2 652	91 52 794 08	ROLLER BEARING
HEX BOLT ISO 4017 M16X40 10	40 66 030 08	28	16	3 208 001	91 52 883 08	F-HEAD SECTION
HEX BOLT ISO 4017 M16X40 10	40 66 030 08	16	16	3 714	91 52 862 08	D HEAD SECTION
HEX BOLT ISO 4017 M16X40 8.	40 65 304 08	42	28	2 550	91 57 751 08	SA FRAME
HEX BOLT ISO 4017 M16X40 8.	49 00 153	8	16	2 125	91 52 773 08	PIN F.S-PIVOT SECTION SA F
HEX BOLT ISO 4017 M16X40 8.	49 00 153	5	16	2 550	91 57 751 08	SA FRAME
HEX BOLT ISO 4017 M16X40 8.	49 00 153	174	8	2 970	91 56 537 08	HYDR
HEX BOLT ISO 4017 M16X40 8.	49 00 153	51	2	3 223 100	91 55 327 08	S INTERMEDIATE SECTION
HEX BOLT ISO 4017 M16X45 8.	46 00 016	10	6	1 991	91 52 510 08	ROTARY FEED THROUGH
HEX BOLT ISO 4017 M16X45 8.	46 00 016	332	4	2 391 001	96 45 719 08	DIESEL ENGINE, PRE-ASSEMB
HEX BOLT ISO 4017 M16X45 8.	46 00 016	143	2	3 713	91 57 749 08	D PIVOT SECTION
HEX BOLT ISO 4017 M16X50 8.	46 00 189	6	12	1 631 100	91 52 388 08	CATWALK CRAW.TRACK TRA
HEX BOLT ISO 4017 M16X50 8.	46 00 189	334	4	2 391 001	96 45 719 08	DIESEL ENGINE, PRE-ASSEMB
HEX BOLT ISO 4017 M16X50 8.	46 00 189	50	4	2 810	91 52 806 08	CRANE DRIVER'S CABIN CPL.
HEX BOLT ISO 4017 M16X55 8.	46 00 044	18	2	3 214	91 52 843 08	SW HEAD SECTION
HEX BOLT ISO 4017 M16X60 8.	46 00 206	10	8	2 125	91 52 773 08	PIN F.S-PIVOT SECTION SA F
HEX BOLT ISO 4017 M20X25 8.	46 01 292	(68)	1	1 400	91 56 853 08	CRAWLER TRACK CARRIER LE
HEX BOLT ISO 4017 M20X30 8.	46 00 380	25	4	X1065015	10 65 015 8	DRIVE UNIT
HEX BOLT ISO 4017 M20X45 8.	46 00 020	13	8	1 991	91 52 510 08	ROTARY FEED THROUGH
HEX BOLT ISO 4017 M20X45 8.	46 00 020	10	6	2 310	91 52 503 08	WINCH 1
HEX BOLT ISO 4017 M20X45 8.	46 00 020	10	6	2 320	91 52 504 08	WINCH 2
HEX BOLT ISO 4017 M20X45 8.	46 00 020	6	6	3 350	91 52 859 08	WINCH 3
HEX BOLT ISO 4017 M20X55 8.	46 00 097	50	6	1 400	91 56 853 08	CRAWLER TRACK CARRIER LE
HEX BOLT ISO 4017 M20X55 8.	46 00 097	50	6	1 410 300	91 56 855 08	CRAWLER CARRIER RIGHT CP
HEX BOLT ISO 4017 M20X55 8.	46 00 097	341	20	2 391 001	96 45 719 08	DIESEL ENGINE, PRE-ASSEMB
HEX BOLT ISO 4017 M20X60 8.	40 65 211 01	11	4	2 310	91 52 503 08	WINCH 1
HEX BOLT ISO 4017 M20X60 8.	40 65 211 01	11	4	2 320	91 52 504 08	WINCH 2
HEX BOLT ISO 4017 M20X60 8.	40 65 211 01	7	4	3 350	91 52 859 08	WINCH 3
HEX BOLT ISO 4017 M20X70 1	40 66 043 08	48	8	1 400	91 56 853 08	CRAWLER TRACK CARRIER LE
HEX BOLT ISO 4017 M20X70 1	40 66 043 08	48	8	1 410 300	91 56 855 08	CRAWLER CARRIER RIGHT CP
HEX BOLT ISO 4017 M20X80 8.	40 65 215 01	6	1	3 206 002	96 47 960 08	LEVER COMPL.
HEX BOLT ISO 4017 M24X100	40 65 140 05	15	2	2 340	91 52 776 08	WINCH 4 LUFFING GEAR
HEX BOLT ISO 4017 M24X45 10	40 66 056 08	9	44	2 340	91 52 776 08	WINCH 4 LUFFING GEAR
HEX BOLT ISO 4017 M24X50 1	40 66 057 08	9	22	2 310	91 52 503 08	WINCH 1
HEX BOLT ISO 4017 M24X50 1	40 66 057 08	9	22	2 320	91 52 504 08	WINCH 2
HEX BOLT ISO 4017 M24X50 1	40 66 057 08	5	22	3 350	91 52 859 08	WINCH 3
HEX BOLT ISO 4017 M24X55 8.	40 65 232 01	51	34	1 400	91 56 853 08	CRAWLER TRACK CARRIER LE
HEX BOLT ISO 4017 M24X55 8.	40 65 232 01	51	34	1 410 300	91 56 855 08	CRAWLER CARRIER RIGHT CP
HEX BOLT ISO 4017 M24X55 8.	40 65 232 01	21	24	X1065015	10 65 015 6	ROPE DRUM

6.2.2009

etk_en_de_074515 LR 1600/2

898

LIEBHERRAlphabetical index
Alphabetischer Index

Description	Item	Pos.	Quantity	Page	Assembly	Description
HEX BOLT ISO 4017 M30X150	40 65 269 14	101	2	3 713	91 57 749 08	D PIVOT SECTION
HEX BOLT ISO 4017 M3X8 8.8	40 65 000 08	11	4	2 913	91 32 850 08	LICCON CONSOLE LCD2
HEX BOLT ISO 4017 M3X8 8.8	40 65 000 08	11	4	2 913 009	91 04 705 08	LICCON CONSOLE LCD3
HEX BOLT ISO 4017 M4X12 8.8	40 00 878	38	10	2 631	91 56 817 08	SLEWING PLATFORM CATWAL
HEX BOLT ISO 4017 M4X6 8.8	40 65 002 01	10	2	9 640 276	96 40 276 08	CONNECTION BLOCK
HEX BOLT ISO 4017 M4X8 8.8	40 65 002 14	35	4	2 533 070	96 48 363 08	CONTROLS AND FITTINGS RI
HEX BOLT ISO 4017 M4X8 8.8	40 65 002 14	(31)	4	2 925 026	91 55 259 08	ERG. CAMERA CONTROL
HEX BOLT ISO 4017 M4X8 8.8	40 65 002 14	31	4	2 925 405	96 48 397 08	EQUIPMENT CAMERA CAB
HEX BOLT ISO 4017 M5X10 8.8	40 65 060	23	28	2 260	91 53 057 08	CUP SPRING CLUSTER
HEX BOLT ISO 4017 M5X10 8.8	40 65 060	55	2	2 975 100	91 52 860 08	ADDITIONAL HYDRAULICS WI
HEX BOLT ISO 4017 M5X12 8.8	40 00 417	37	8	2 502	91 55 939 08	CONTROL STAND
HEX BOLT ISO 4017 M5X12 8.8	40 00 417	50	16	2 859	91 52 809 08	SOUND INSULATION
HEX BOLT ISO 4017 M5X12 8.8	40 00 417	8	8	2 859 025	96 46 757 08	GRIDIRON PRE-ASS.
HEX BOLT ISO 4017 M5X35 8.8	46 01 213	10	5	2 920 814	96 45 717 08	ELECTR.F.FUEL TANK
HEX BOLT ISO 4017 M6X10 8.8	40 65 103	18	4	2 978 200	91 54 843 08	ADD.HYDR.S_RETAINING RAM
HEX BOLT ISO 4017 M6X12 8.8	49 00 605	73	8	1 970	91 56 958 08	CRAWLER TRACK HYDRAULI
HEX BOLT ISO 4017 M6X12 8.8	49 00 605	65	10	2 970	91 56 537 08	HYDR
HEX BOLT ISO 4017 M6X12 8.8	49 00 605	51	2	2 975 100	91 52 860 08	ADDITIONAL HYDRAULICS WI
HEX BOLT ISO 4017 M6X12 8.8	49 00 605	52	4	2 975 200	91 52 775 08	ADDITIONAL HYDRAULICS WI
HEX BOLT ISO 4017 M6X12 8.8	49 00 605	52	4	2 975 700	91 52 774 08	ADDITIONAL HYDRAULICS WI
HEX BOLT ISO 4017 M6X16 8.8	40 65 099	19	2	2 260 006	96 46 501 08	BATTERY BOX, PRE-ASSEMB
HEX BOLT ISO 4017 M6X16 8.8	40 65 099	16	1	2 533 066	96 48 365 08	ELECTRIC ADD-ON PARTS CA
HEX BOLT ISO 4017 M6X16 8.8	40 65 099	5	1	2 913 004	96 20 460 08	HOUSING PRE-ASSEMBLED
HEX BOLT ISO 4017 M6X16 8.8	40 65 099	10	3	2 920 200	96 44 536 08	ELECTRIC FOR WINCH 1
HEX BOLT ISO 4017 M6X16 8.8	40 65 099	10	3	2 920 260	96 44 537 08	ELECTRIC FOR WINCH 2
HEX BOLT ISO 4017 M6X16 8.8	40 65 099	10	3	2 920 334	96 44 538 08	ELECTRIC FOR WINCH 3
HEX BOLT ISO 4017 M6X16 8.8	40 65 099	10	3	2 920 350	96 44 539 08	ELECTRIC FOR WINCH 4
HEX BOLT ISO 4017 M6X16 8.8	40 65 099	54	2	3 206	91 52 881 08	PIVOT SECTION
HEX BOLT ISO 4017 M6X16 8.8	40 65 099	42	4	3 214	91 52 843 08	SW HEAD SECTION
HEX BOLT ISO 4017 M6X20 8.8	40 00 829	66	8	1 970	91 56 958 08	CRAWLER TRACK HYDRAULI
HEX BOLT ISO 4017 M6X20 8.8	40 00 829	20	8	2 260	91 53 057 08	CUP SPRING CLUSTER
HEX BOLT ISO 4017 M6X20 8.8	40 00 829	22	4	2 260 006	96 46 501 08	BATTERY BOX, PRE-ASSEMB
HEX BOLT ISO 4017 M6X20 8.8	40 00 829	22	8	2 370	91 52 782 08	ERECTING WINCH
HEX BOLT ISO 4017 M6X20 8.8	40 00 829	13	2	2 391 023	96 45 720 08	RADIATOR, PRE-ASSEMBLED
HEX BOLT ISO 4017 M6X20 8.8	40 00 829	4	4	2 391 039	96 50 616 08	COVER CPL
HEX BOLT ISO 4017 M6X20 8.8	40 00 829	32	1	2 391 040	96 53 645 08	CLUTCH ACTUATOR
HEX BOLT ISO 4017 M6X20 8.8	40 00 829	7	4	2 510	91 52 788 08	TURNTABLE PANELLING
HEX BOLT ISO 4017 M6X20 8.8	40 00 829	15	8	2 522	91 54 115 08	SLIDING DOOR CPL.
HEX BOLT ISO 4017 M6X20 8.8	40 00 829	7	2	2 540	91 53 253 08	CLIMA-HEATING INSTALLATIO
HEX BOLT ISO 4017 M6X20 8.8	40 00 829	57	14	2 550	91 57 751 08	SA FRAME
HEX BOLT ISO 4017 M6X20 8.8	40 00 829	8	4	2 925 204	92 16 990 08	CAMERA EQUIPMENT D-PIVOT
HEX BOLT ISO 4017 M6X20 8.8	40 00 829	15	1	2 925 204	92 16 990 08	CAMERA EQUIPMENT D-PIVOT
HEX BOLT ISO 4017 M6X20 8.8	40 00 829	11	13	2 925 402	96 58 855 08	CAMERA EQUIPMENT SLEWI
HEX BOLT ISO 4017 M6X20 8.8	40 00 829	37	1	2 932 082	96 54 387 08	ASSEMBLY PARTS MOUNTIN
HEX BOLT ISO 4017 M6X20 8.8	40 00 829	27	4	3 206	91 52 881 08	PIVOT SECTION
HEX BOLT ISO 4017 M6X20 8.8	40 00 829	69	5	3 211	91 57 748 08	S PIVOT SECTION
HEX BOLT ISO 4017 M6X20 8.8	40 00 829	8	4	3 745 002	92 17 236 08	SWITCH UNIT
HEX BOLT ISO 4017 M6X20 8.8	40 00 829	8	4	3 745 003	92 17 237 08	SWITCH UNIT
HEX BOLT ISO 4017 M6X20 8.8	40 00 829	42	1	X1022811	10 22 811 2	AIR CONDITIONING UNIT
HEX BOLT ISO 4017 M6X25 8.8	49 00 539	17	16	2 391 023	96 45 720 08	RADIATOR, PRE-ASSEMBLED
HEX BOLT ISO 4017 M6X25 8.8	49 00 539	24	4	2 835 002	96 48 379 08	ADD-ON PARTS
HEX BOLT ISO 4017 M6X25 8.8	49 00 539	11	2	2 932 166	92 68 911 08	GROUND RAIL
HEX BOLT ISO 4017 M6X25 8.8	49 00 539	29	8	3 208 001	91 52 883 08	F-HEAD SECTION
HEX BOLT ISO 4017 M6X25 8.8	49 00 539	12	4	7 027 481	70 27 481 03	WATER SEPARATOR
HEX BOLT ISO 4017 M6X30 8.8	46 00 102	2	4	7 027 481	70 27 481 03	WATER SEPARATOR
HEX BOLT ISO 4017 M6X35 8.8	49 00 595	26	1	2 522	91 54 115 08	SLIDING DOOR CPL.
HEX BOLT ISO 4017 M6X50 8.8	46 00 532	17	2	1 991	91 52 510 08	ROTARY FEED THROUGH
HEX BOLT ISO 4017 M6X50 8.8	46 00 532	15	2	3 780 751	91 52 952 08	AIR-CRAFT & WIND WARNING
HEX BOLT ISO 4017 M6X60 8.8	40 65 055 08	24	2	X1042440	10 42 440 2	CONTROL BLOCK
HEX BOLT ISO 4017 M8X12 8.8	10 03 291 2	20	8	9 739 361	97 39 361	OIL SUMP

6.2.2009

etk_en_de_074515 LR 1600/2

899

LIEBHERRAlphabetical index
Alphabetischer Index

Description	Item	Pos.	Quantity	Page	Assembly	Description
HEX BOLT ISO 4017 M8X12 8.8	40 65 136	8	2	1 970	91 56 958 08	CRAWLER TRACK HYDRAULI
HEX BOLT ISO 4017 M8X12 8.8	40 65 136	63	8	1 970	91 56 958 08	CRAWLER TRACK HYDRAULI
HEX BOLT ISO 4017 M8X12 8.8	40 65 136	81	4	1 970	91 56 958 08	CRAWLER TRACK HYDRAULI
HEX BOLT ISO 4017 M8X12 8.8	40 65 136	15	4	2 391 102	96 56 360 08	RADIATOR
HEX BOLT ISO 4017 M8X12 8.8	40 65 136	22	2	2 393	91 52 787 08	AIR FILTER UNIT CPL.
HEX BOLT ISO 4017 M8X12 8.8	40 65 136	33	2	2 831	91 57 754 08	AIR COND. UNIT SUPERSTRU
HEX BOLT ISO 4017 M8X15 10.	40 66 005 08	17	8	2 392	91 52 785 08	MUFFLER UNIT
HEX BOLT ISO 4017 M8X16 8.8	49 00 188	53	18	1 400	91 56 853 08	CRAWLER TRACK CARRIER LE
HEX BOLT ISO 4017 M8X16 8.8	49 00 188	53	18	1 410 300	91 56 855 08	CRAWLER CARRIER RIGHT CP
HEX BOLT ISO 4017 M8X16 8.8	49 00 188	348	4	2 391 001	96 45 719 08	DIESEL ENGINE, PRE-ASSEMB
HEX BOLT ISO 4017 M8X16 8.8	49 00 188	16	8	2 510	91 52 788 08	TURNTABLE PANELLING
HEX BOLT ISO 4017 M8X16 8.8	49 00 188	44	6	2 520	91 53 061 08	CABIN, GLAZED
HEX BOLT ISO 4017 M8X16 8.8	49 00 188	7	4	2 522 012	96 45 884 08	GUIDE PRE-ASS.
HEX BOLT ISO 4017 M8X16 8.8	49 00 188	42	14	2 631	91 56 817 08	SLEWING PLATFORM CATWAL
HEX BOLT ISO 4017 M8X16 8.8	49 00 188	61	4	2 859	91 52 809 08	SOUND INSULATION
HEX BOLT ISO 4017 M8X16 8.8	49 00 188	27	28	3 211	91 57 748 08	S PIVOT SECTION
HEX BOLT ISO 4017 M8X16 8.8	49 00 188	14	8	3 350	91 52 859 08	WINCH 3
HEX BOLT ISO 4017 M8X16 8.8	49 00 188	124	33	3 713	91 57 749 08	D PIVOT SECTION
HEX BOLT ISO 4017 M8X16 8.8	49 00 188	87	12	3 714	91 52 862 08	D HEAD SECTION
HEX BOLT ISO 4017 M8X16 8.8	49 00 188	41	16	3 715 008	91 52 863 08	D INTERMEDIATE SECTION
HEX BOLT ISO 4017 M8X16 8.8	49 00 188	46	28	3 716	91 52 864 08	D INTERMEDIATE SECTION
HEX BOLT ISO 4017 M8X16 8.8	49 00 188	7	4	3 978 005	91 56 430 08	ADDL.HYDRAULIC SB-HEAD PI
HEX BOLT ISO 4017 M8X16 8.8	40 65 063 08	20	6	2 520 032	96 45 980 08	WINDSHIELD WASHER INSTAL
HEX BOLT ISO 4017 M8X18 8.8	46 00 334	17	24	2 260	91 53 057 08	CUP SPRING CLUSTER
HEX BOLT ISO 4017 M8X20 8.8	49 00 089	18	8	2 350	91 52 778 08	SLEWING GEAR
HEX BOLT ISO 4017 M8X20 8.8	49 00 089	16	4	2 370	91 52 782 08	ERECTING WINCH
HEX BOLT ISO 4017 M8X20 8.8	49 00 089	349	4	2 391 001	96 45 719 08	DIESEL ENGINE, PRE-ASSEMB
HEX BOLT ISO 4017 M8X20 8.8	49 00 089	15	12	2 391 023	96 45 720 08	RADIATOR, PRE-ASSEMBLED
HEX BOLT ISO 4017 M8X20 8.8	49 00 089	21	2	2 392	91 52 785 08	MUFFLER UNIT
HEX BOLT ISO 4017 M8X20 8.8	49 00 089	24	4	2 393	91 52 787 08	AIR FILTER UNIT CPL.
HEX BOLT ISO 4017 M8X20 8.8	49 00 089	47	13	2 631	91 56 817 08	SLEWING PLATFORM CATWAL
HEX BOLT ISO 4017 M8X20 8.8	49 00 089	68	4	2 810	91 52 806 08	CRANE DRIVER'S CABIN CPL.
HEX BOLT ISO 4017 M8X20 8.8	49 00 089	58	40	2 859	91 52 809 08	SOUND INSULATION
HEX BOLT ISO 4017 M8X20 8.8	49 00 089	4	1	2 925 204	92 16 990 08	CAMERA EQUIPMENT D-PIVOT
HEX BOLT ISO 4017 M8X20 8.8	49 00 089	9	9	2 925 402	96 58 855 08	CAMERA EQUIPMENT SLEWI
HEX BOLT ISO 4017 M8X20 8.8	49 00 089	14	2	2 932 160	96 54 385 08	SWITCH CABINET
HEX BOLT ISO 4017 M8X20 8.8	49 00 089	14	6	X1035519	10 35 519 6	OIL AIR COOLER
HEX BOLT ISO 4017 M8X22 8.8	50 26 189 08	9	2	2 522 012	96 45 884 08	GUIDE PRE-ASS.
HEX BOLT ISO 4017 M8X22 8.8	50 26 189 08	15	2	2 671	91 52 798 08	OIL RESERVOIR, COMPLETE
HEX BOLT ISO 4017 M8X22 8.8	50 26 189 08	4	12	2 810 001	96 43 597 08	CRANE DRIVER'S CABIN,PRE
HEX BOLT ISO 4017 M8X22 8.8	50 26 189 08	120	5	3 713	91 57 749 08	D PIVOT SECTION
HEX BOLT ISO 4017 M8X25 10.	40 66 042	17	4	2 350	91 52 778 08	SLEWING GEAR
HEX BOLT ISO 4017 M8X25 8.8	49 00 128	57	2	1 400	91 56 853 08	CRAWLER TRACK CARRIER LE
HEX BOLT ISO 4017 M8X25 8.8	49 00 128	57	2	1 410 300	91 56 855 08	CRAWLER CARRIER RIGHT CP
HEX BOLT ISO 4017 M8X25 8.8	49 00 128	24	12	1 630	91 52 387 08	HYDRAULIC SUPPORT
HEX BOLT ISO 4017 M8X25 8.8	49 00 128	21	4	1 991	91 52 510 08	ROTARY FEED THROUGH
HEX BOLT ISO 4017 M8X25 8.8	49 00 128	25	10	2 260	91 53 057 08	CUP SPRING CLUSTER
HEX BOLT ISO 4017 M8X25 8.8	49 00 128	9	3	2 260 006	96 46 501 08	BATTERY BOX, PRE-ASSEMB
HEX BOLT ISO 4017 M8X25 8.8	49 00 128	6	10	2 370	91 52 782 08	ERECTING WINCH
HEX BOLT ISO 4017 M8X25 8.8	49 00 128	350	10	2 391 001	96 45 719 08	DIESEL ENGINE, PRE-ASSEMB
HEX BOLT ISO 4017 M8X25 8.8	49 00 128	22	2	2 391 040	96 53 645 08	CLUTCH ACTUATOR
HEX BOLT ISO 4017 M8X25 8.8	49 00 128	10	8	2 391 102	96 56 360 08	RADIATOR
HEX BOLT ISO 4017 M8X25 8.8	49 00 128	21	8	2 393	91 52 787 08	AIR FILTER UNIT CPL.
HEX BOLT ISO 4017 M8X25 8.8	49 00 128	19	2	2 550	91 57 751 08	SA FRAME
HEX BOLT ISO 4017 M8X25 8.8	49 00 128	35	4	2 711	91 52 800 08	CENT. LUBRIC. SYSTEM SUP
HEX BOLT ISO 4017 M8X25 8.8	49 00 128	4	20	2 810 037	96 47 204 08	PEDAL CANTILEVER INSTALL
HEX BOLT ISO 4017 M8X25 8.8	49 00 128	60	5	2 859	91 52 809 08	SOUND INSULATION
HEX BOLT ISO 4017 M8X25 8.8	49 00 128	15	4	2 925 402	96 58 855 08	CAMERA EQUIPMENT SLEWI
HEX BOLT ISO 4017 M8X25 8.8	49 00 128	8	2	2 932 166	92 68 911 08	GROUND RAIL
HEX BOLT ISO 4017 M8X25 8.8	49 00 128	51	2	3 208 001	91 52 883 08	F-HEAD SECTION

6.2.2009

etk_en_de_074515 LR 1600/2

900

LIEBHERRAlphabetical index
Alphabetischer Index

Description	Item	Pos.	Quantity	Page	Assembly	Description
HEX BOLT ISO 4017 M8X25 8.8	49 00 128	53	8	3 211	91 57 748 08	S PIVOT SECTION
HEX BOLT ISO 4017 M8X25 8.8	49 00 128	16	2	3 213	91 52 842 08	F-CONNECTING HEAD
HEX BOLT ISO 4017 M8X25 8.8	49 00 128	21	2	3 214	91 52 843 08	SW HEAD SECTION
HEX BOLT ISO 4017 M8X25 8.8	49 00 128	60	2	3 281	91 52 896 08	ERECTION FRAME
HEX BOLT ISO 4017 M8X25 8.8	49 00 128	3	8	3 291	91 52 831 08	S OVERRUN PROTECTION
HEX BOLT ISO 4017 M8X25 8.8	49 00 128	8	8	3 292	91 52 865 08	D OVERRUN PROTECTION
HEX BOLT ISO 4017 M8X25 8.8	49 00 128	111	4	3 713	91 57 749 08	D PIVOT SECTION
HEX BOLT ISO 4017 M8X25 8.8	49 00 128	76	4	3 714	91 52 862 08	D HEAD SECTION
HEX BOLT ISO 4017 M8X25 8.8	49 00 128	28	8	3 745	91 52 948 08	SUSPENDED BALLAST
HEX BOLT ISO 4017 M8X25 8.8	49 00 128	13	4	X1035519	10 35 519 6	OIL AIR COOLER
HEX BOLT ISO 4017 M8X30 8.8	49 00 111	9	4	2 391 038	96 47 931 08	OIL COOLER, PRE-ASSEMBLE
HEX BOLT ISO 4017 M8X30 8.8	49 00 111	13	2	2 522 013	96 45 883 08	GUIDE PRE-ASS.
HEX BOLT ISO 4017 M8X30 8.8	49 00 111	68	4	2 859	91 52 809 08	SOUND INSULATION
HEX BOLT ISO 4017 M8X30 8.8	49 00 111	42	8	3 745	91 52 948 08	SUSPENDED BALLAST
HEX BOLT ISO 4017 M8X30 8.8	49 00 111	4	4	5 106 691	51 06 691 08	RETURN FILTER
HEX BOLT ISO 4017 M8X40 8.8	49 00 614	30	4	2 831	91 57 754 08	AIR COND. UNIT SUPERSTRU
HEX BOLT ISO 4017 M8X40 8.8	49 00 614	4	10	2 859 025	96 46 757 08	GRIDIRON PRE-ASS.
HEX BOLT ISO 4017 M8X45 8.8	40 01 667	15	4	X1035519	10 35 519 6	OIL AIR COOLER
HEX BOLT ISO 4017 M8X60 8.8	46 00 386	354	4	2 391 001	96 45 719 08	DIESEL ENGINE, PRE-ASSEMB
HEX BOLT ISO 4017 M8X60 8.8	46 00 386	46	6	3 214	91 52 843 08	SW HEAD SECTION
HEX BOLT M10X100 8.8 A3C	10 34 225 4	3	1	9 739 351	97 39 351	COOLING MEDIUM PIPELINE
HEX BOLT M10X75 8.8 MAN18	10 34 225 9	4	1	9 739 351	97 39 351	COOLING MEDIUM PIPELINE
HEX BOLT M12X50 8.8 A3C	10 34 318 3	18	1	9 739 344	97 39 344	GENERATOR, PRE-ASSEMBLE
HEX BOLT M16X30 8.8	10 03 719 1	5	1	9 739 210	97 39 210	LIQUID COOLING PIPELINE
HEX BOLT M16X45 10.9 ZNPH	10 34 318 6	5	8	9 739 341	97 39 341	DRIVING PARTS
HEX BOLT M6X12 8.8 MAN183-	10 01 135 8	4	2	9 739 140	97 39 140	FLAME STARTING SYSTEM
HEX BOLT M6X16 10.9 MAN18	10 34 225 7	7	1	9 739 356	97 39 356	PIPELINE INSTALLATION
HEX BOLT M8X20 10.9 MAN183	10 44 335 2	33	1	9 739 492	97 39 492	PIPELINE INSTALLATION
HEX BOLT M8X20 8.8	10 03 730 4	19	8	9 739 361	97 39 361	OIL SUMP
HEX BOLT M8X20 8.8	10 03 730 4	24	2	9 739 371	97 39 371	AIR COND. COMPRESSOR A
HEX BOLT M8X20 8.8	10 03 730 4	23	2	9 739 494	97 39 494	ATL ATTACHMENT
HEX BOLT M8X35 10.9 MAN183	10 44 336 5	31	1	9 739 492	97 39 492	PIPELINE INSTALLATION
HEX BOLT M8X43,5 8.8 A2C	10 01 250 7	4	12	9 739 267	97 39 267	CYLINDER FAIRING
HEX BOLT M8X70 10.9 MAN183	10 44 335 6	24	1	9 739 492	97 39 492	PIPELINE INSTALLATION
HEX BOLT M8X80 10.9 MAN18	10 22 272 9	5	4	9 739 256	97 39 256	AIR SUCTION PIPE
HEX CAP NUT	51 05 453 08	40	2	1 970	91 56 958 08	CRAWLER TRACK HYDRAULI
HEX CAP NUT	51 05 453 08	93	5	2 970	91 56 537 08	HYDR
HEX CAP NUT	51 05 453 08	12	2	2 970 081	96 50 495 08	ADDL.HYDR.F.PIN PULLING DE
HEX CAP NUT	51 05 453 08	38	1	2 975 200	91 52 775 08	ADDITIONAL HYDRAULICS WI
HEX CAP NUT	51 05 453 08	38	1	2 975 700	91 52 774 08	ADDITIONAL HYDRAULICS WI
HEX CAP NUT	51 05 453 08	42	1	2 977	91 57 756 08	ADDITIONAL HYDR.SLEWING
HEX CAP NUT	51 05 453 08	26	1	2 978 200	91 54 843 08	ADD.HYDR.S_RETAINING RAM
HEX CAP NUT	51 05 456 08	32	4	1 970	91 56 958 08	CRAWLER TRACK HYDRAULI
HEX CAP NUT	51 05 456 08	81	5	2 970	91 56 537 08	HYDR
HEX CAP NUT	51 05 456 08	22	2	2 975 100	91 52 860 08	ADDITIONAL HYDRAULICS WI
HEX CAP NUT	51 05 456 08	32	5	2 977	91 57 756 08	ADDITIONAL HYDR.SLEWING
HEX CAP NUT	51 05 456 08	6	2	3 978 015	91 56 429 08	ADDITIONAL HYDRAULICS IN
HEX CAP NUT	51 05 456 08	6	2	3 978 015	91 56 432 08	ADDITIONAL HYDRAULICS IN
HEX CAP NUT	51 05 458 08	36	2	1 970	91 56 958 08	CRAWLER TRACK HYDRAULI
HEX CAP NUT	51 05 458 08	85	12	2 970	91 56 537 08	HYDR
HEX CAP NUT	51 05 458 08	26	2	2 975 100	91 52 860 08	ADDITIONAL HYDRAULICS WI
HEX CAP NUT	51 05 458 08	36	2	2 977	91 57 756 08	ADDITIONAL HYDR.SLEWING
HEX CAP NUT	51 05 458 08	22	3	2 978 200	91 54 843 08	ADD.HYDR.S_RETAINING RAM
HEX CAP NUT	51 15 040 08	22	1	1 970	91 56 958 08	CRAWLER TRACK HYDRAULI
HEX CAP NUT	51 15 040 08	101	6	2 970	91 56 537 08	HYDR
HEX CAP NUT	51 15 040 08	6	2	2 970 081	96 50 495 08	ADDL.HYDR.F.PIN PULLING DE
HEX CAP NUT	51 15 040 08	34	3	2 975 100	91 52 860 08	ADDITIONAL HYDRAULICS WI
HEX CAP NUT	51 15 040 08	34	1	2 975 200	91 52 775 08	ADDITIONAL HYDRAULICS WI
HEX CAP NUT	51 15 040 08	34	1	2 975 700	91 52 774 08	ADDITIONAL HYDRAULICS WI
HEX CAP NUT	51 15 040 08	6	3	2 976 200	91 44 034 08	AUX.HYDR.PIN EXTRACTION

6.2.2009

etk_en_de_074515 LR 1600/2

901

LIEBHERRAlphabetical index
Alphabetischer Index

Description	Item	Pos.	Quantity	Page	Assembly	Description
HEX CAP NUT	51 15 040 08	6	1	2 976 203	92 27 489 08	ADDL.HYDR.F.PIN PULLING DE
HEX CAP NUT	51 15 040 08	12	1	3 978 015	91 56 429 08	ADDITIONAL HYDRAULICS IN
HEX CAP NUT	51 15 040 08	12	1	3 978 015	91 56 432 08	ADDITIONAL HYDRAULICS IN
HEX CAP NUT RD32X3 SPF	10 46 691 4	28	1	3 978 100	91 56 428 08	HYDR. SUSPENDED BALLAST
HEX CAP NUT RD54X4 SPF	10 46 691 6	26	1	2 975 200	91 52 775 08	ADDITIONAL HYDRAULICS WI
HEX CAP NUT RD54X4 SPF	10 46 691 6	30	1	2 975 200	91 52 775 08	ADDITIONAL HYDRAULICS WI
HEX CAP NUT RD54X4 SPF	10 46 691 6	26	1	2 975 700	91 52 774 08	ADDITIONAL HYDRAULICS WI
HEX CAP NUT RD54X4 SPF	10 46 691 6	30	1	2 975 700	91 52 774 08	ADDITIONAL HYDRAULICS WI
HEX CAP NUT RD79X4 SPF	10 46 691 7	22	2	2 975 200	91 52 775 08	ADDITIONAL HYDRAULICS WI
HEX CAP NUT RD79X4 SPF	10 46 691 7	22	2	2 975 700	91 52 774 08	ADDITIONAL HYDRAULICS WI
HEX CAP NUT RD79X4 SPF	10 46 691 7	22	2	3 978 100	91 56 428 08	HYDR. SUSPENDED BALLAST
HEX COLLAR NUT	10 22 273 2	6	4	9 739 494	97 39 494	ATL ATTACHMENT
HEX HEAD SCREW WITH FLA	10 47 688 8	3	1	9 739 491	97 39 491	INSTALLATION BRAKE COMPR
HEX HEAD SCREW WITH FLAN	10 34 226 7	4	19	9 739 362	97 39 362	OIL SUMP
HEX HEAD SCREW WITH FLAN	10 34 226 8	5	1	9 739 362	97 39 362	OIL SUMP
HEX NUT BM18X1,5 ZNPHR3F	10 22 275 3	6	1	9 739 278	97 39 278	ADD-ON PARTS
HEX NUT DIN 439 B M20 4 VER	41 01 012 08	7	1	3 206 002	96 47 960 08	LEVER COMPL.
HEX NUT DIN 439 B M5 4	51 10 017 08	19	2	2 540	91 53 253 08	CLIMA-HEATING INSTALLATIO
HEX NUT DIN 439 BM12X1 04 V	59 15 592 08	3	3	2 533 066	96 48 365 08	ELECTRIC ADD-ON PARTS CA
HEX NUT DIN 934 M10 10 VER	41 15 047 08	16	2	X1035519	10 35 519 6	OIL AIR COOLER
HEX NUT DIN 934 M10 8 VERZ	41 15 144 08	370	4	2 391 001	96 45 719 08	DIESEL ENGINE, PRE-ASSEMB
HEX NUT DIN 934 M10 8 VERZ	41 15 144 08	12	12	2 391 038	96 47 931 08	OIL COOLER, PRE-ASSEMBLE
HEX NUT DIN 934 M10 8 VERZ	41 15 144 08	24	2	2 391 040	96 53 645 08	CLUTCH ACTUATOR
HEX NUT DIN 934 M10 8 VERZ	41 15 144 08	32	2	2 502	91 55 939 08	CONTROL STAND
HEX NUT DIN 934 M10 8 VERZ	41 15 144 08	36	2	2 711	91 52 800 08	CENT. LUBRIC. SYSTEM SUP
HEX NUT DIN 934 M10 8 VERZ	41 15 144 08	17	4	2 925 204	92 16 990 08	CAMERA EQUIPMENT D-PIVOT
HEX NUT DIN 934 M10 8 VERZ	41 15 144 08	13	2	2 975 000	91 57 881 08	ADDNL. HYDR. F. ERECTING W
HEX NUT DIN 934 M10 8 VERZ	41 15 144 08	12	11	3 206	91 52 881 08	PIVOT SECTION
HEX NUT DIN 934 M10 8 VERZ	41 15 144 08	34	8	3 713	91 57 749 08	D PIVOT SECTION
HEX NUT DIN 934 M10 8 VERZ	41 15 144 08	73	16	3 714	91 52 862 08	D HEAD SECTION
HEX NUT DIN 934 M12 8 VERZ	41 15 143 08	16	1	1 991	91 52 510 08	ROTARY FEED THROUGH
HEX NUT DIN 934 M12 8 VERZ	41 15 143 08	22	4	2 310	91 52 503 08	WINCH 1
HEX NUT DIN 934 M12 8 VERZ	41 15 143 08	22	4	2 320	91 52 504 08	WINCH 2
HEX NUT DIN 934 M12 8 VERZ	41 15 143 08	5	8	2 391	91 52 784 08	DIESEL ENGINE CPL.
HEX NUT DIN 934 M12 8 VERZ	41 15 143 08	13	1	2 550 008	96 47 628 08	RETAINER CPL.
HEX NUT DIN 934 M12 8 VERZ	41 15 143 08	13	1	2 550 009	96 47 645 08	RETAINER CPL.
HEX NUT DIN 934 M12 8 VERZ	41 15 143 08	56	1	2 810	91 52 806 08	CRANE DRIVER'S CABIN CPL.
HEX NUT DIN 934 M12 8 VERZ	41 15 143 08	177	8	2 970	91 56 537 08	HYDR
HEX NUT DIN 934 M12 8 VERZ	41 15 143 08	13	4	3 213	91 52 842 08	F-CONNECTING HEAD
HEX NUT DIN 934 M12 8 VERZ	41 15 143 08	30	4	3 214	91 52 843 08	SW HEAD SECTION
HEX NUT DIN 934 M12 8 VERZ	41 15 143 08	8	8	3 220 500	91 52 849 08	S INTERMEDIATE SECTION
HEX NUT DIN 934 M12 8 VERZ	41 15 143 08	8	8	3 221	91 54 668 08	S INTERMEDIATE SECTION
HEX NUT DIN 934 M12 8 VERZ	41 15 143 08	8	8	3 223	91 52 852 08	S INTERMEDIATE SECTION
HEX NUT DIN 934 M12 8 VERZ	41 15 143 08	8	8	3 223 010	91 52 853 08	S INTERMEDIATE SECTION
HEX NUT DIN 934 M12 8 VERZ	41 15 143 08	8	8	3 223 100	91 55 327 08	S INTERMEDIATE SECTION
HEX NUT DIN 934 M12 8 VERZ	41 15 143 08	26	8	3 225	91 52 854 08	SL REDUCING SECTION
HEX NUT DIN 934 M12 8 VERZ	41 15 143 08	8	8	3 226	91 52 870 08	L INTERMEDIATE SECTION
HEX NUT DIN 934 M12 8 VERZ	41 15 143 08	8	8	3 227	91 52 873 08	L INTERMEDIATE SECTION
HEX NUT DIN 934 M12 8 VERZ	41 15 143 08	8	8	3 227 008	91 52 872 08	L INTERMEDIATE SECTION
HEX NUT DIN 934 M12 8 VERZ	41 15 143 08	8	8	3 227 200	91 53 519 08	LI INTERMEDIATE SECT. F-GU
HEX NUT DIN 934 M12 8 VERZ	41 15 143 08	18	48	3 350	91 52 859 08	WINCH 3
HEX NUT DIN 934 M12 8 VERZ	41 15 143 08	26	4	3 713	91 57 749 08	D PIVOT SECTION
HEX NUT DIN 934 M12 8 VERZ	41 15 143 08	29	4	3 714	91 52 862 08	D HEAD SECTION
HEX NUT DIN 934 M12 8 VERZ	41 15 143 08	8	8	3 715 008	91 52 863 08	D INTERMEDIATE SECTION
HEX NUT DIN 934 M12 8 VERZ	41 15 143 08	8	8	3 716	91 52 864 08	D INTERMEDIATE SECTION
HEX NUT DIN 934 M12 8 VERZ	41 15 143 08	11	4	3 978 100	91 56 428 08	HYDR. SUSPENDED BALLAST
HEX NUT DIN 934 M12X1 6 BL	41 15 197 08	37	2	2 932 160	96 54 385 08	SWITCH CABINET
HEX NUT DIN 934 M14 8 VERZ	41 15 083 08	29	16	1 630	91 52 387 08	HYDRAULIC SUPPORT
HEX NUT DIN 934 M14 8 VERZ	41 15 083 08	50	2	2 631	91 56 817 08	SLEWING PLATFORM CATWAL
HEX NUT DIN 934 M16 10 VER	41 15 050 08	34	2	2 652	91 52 794 08	ROLLER BEARING

6.2.2009

etk_en_de_074515 LR 1600/2

902

LIEBHERRAlphabetical index
Alphabetischer Index

Description	Item	Pos.	Quantity	Page	Assembly	Description
HEX NUT DIN 934 M16 10 VER	41 15 050 08	11	2	3 220 500	91 52 849 08	S INTERMEDIATE SECTION
HEX NUT DIN 934 M16 10 VER	41 15 050 08	11	2	3 223	91 52 852 08	S INTERMEDIATE SECTION
HEX NUT DIN 934 M16 10 VER	41 15 050 08	11	2	3 223 010	91 52 853 08	S INTERMEDIATE SECTION
HEX NUT DIN 934 M16 10 VER	41 15 050 08	11	4	3 223 100	91 55 327 08	S INTERMEDIATE SECTION
HEX NUT DIN 934 M16 10 VER	41 15 050 08	21	4	3 227 002	96 50 498 08	ROD CPL.
HEX NUT DIN 934 M16 8 VERZ	41 15 145 08	7	12	1 631 100	91 52 388 08	CATWALK CRAW.TRACK TRA
HEX NUT DIN 934 M16 8 VERZ	41 15 145 08	11	6	1 991	91 52 510 08	ROTARY FEED THROUGH
HEX NUT DIN 934 M16 8 VERZ	41 15 145 08	23	6	2 652	91 52 794 08	ROLLER BEARING
HEX NUT DIN 934 M16 8 VERZ	41 15 145 08	5	4	2 730	91 52 802 08	BASE PLATE SLEWING PLATF
HEX NUT DIN 934 M16 8 VERZ	41 15 145 08	52	4	2 810	91 52 806 08	CRANE DRIVER'S CABIN CPL.
HEX NUT DIN 934 M16 8 VERZ	41 15 145 08	11	2	3 745	91 52 948 08	SUSPENDED BALLAST
HEX NUT DIN 934 M20 8 VERZ	41 15 147 08	4	1	1 632 032	96 20 093 08	SUPPORT PLATE COMPL.
HEX NUT DIN 934 M20 8 VERZ	41 15 147 08	24	1	3 206	91 52 881 08	PIVOT SECTION
HEX NUT DIN 934 M24 8 A3C	41 15 149 08	16	2	2 340	91 52 776 08	WINCH 4 LUFFING GEAR
HEX NUT DIN 934 M3 8 A3C	41 15 157 08	15	10	2 922 001	92 84 311 08	BUS PCB
HEX NUT DIN 934 M3 8 A3C	41 15 157 08	18	28	2 932 001	96 45 393 08	RELAY CONTROL SYSTEM
HEX NUT DIN 934 M3 8 A3C	41 15 157 08	267	4	3 930 009	96 50 573 08	CABLE DRUM COMPL.
HEX NUT DIN 934 M3 8 A3C	41 15 157 08	(266)	4	3 930 138	96 54 377 08	ELECTRIC FOR S-PIVOT SECT
HEX NUT DIN 934 M3 8 A3C	41 15 157 08	284	16	3 930 638	96 51 624 08	TERMINAL BOX
HEX NUT DIN 934 M3 8 A3C	41 15 157 08	155	10	3 930 640	96 50 481 08	TERMINAL BOX CPL.
HEX NUT DIN 934 M3 8 A3C	41 15 157 08	267	10	3 930 730	96 50 599 08	TERMINAL BOX CPL.
HEX NUT DIN 934 M30 8 VERZ	41 15 152 08	14	32	3 747	91 52 950 08	CENTERING STANDARD
HEX NUT DIN 934 M4 8 A3C	41 15 142 08	26	2	2 522 011	96 45 602 08	CLOSING DEVICE
HEX NUT DIN 934 M4 8 A3C	41 15 142 08	7	8	2 913 102	92 32 870 08	FAN UNIT
HEX NUT DIN 934 M4 8 A3C	41 15 142 08	(153)	2	2 920 369	96 54 235 08	TERMINAL BOX CPL.
HEX NUT DIN 934 M4 8 A3C	41 15 142 08	(153)	2	2 920 369	96 54 235 08	TERMINAL BOX CPL.
HEX NUT DIN 934 M4 8 A3C	41 15 142 08	281	14	2 920 369	96 54 235 08	TERMINAL BOX CPL.
HEX NUT DIN 934 M4 8 A3C	41 15 142 08	281	26	2 920 448	96 48 794 08	TERMINAL BOX CPL.
HEX NUT DIN 934 M5 8 VERZ	41 15 148 08	7	9	1 100	91 52 375 08	CRAWLER TRACK TRAVEL G
HEX NUT DIN 934 M5 8 VERZ	41 15 148 08	15	8	1 711	91 52 392 08	CENTRALIZED LUBRICATION
HEX NUT DIN 934 M5 8 VERZ	41 15 148 08	18	8	2 260 006	96 46 501 08	BATTERY BOX, PRE-ASSEMB
HEX NUT DIN 934 M5 8 VERZ	41 15 148 08	8	10	2 711	91 52 800 08	CENT. LUBRIC. SYSTEM SUP
HEX NUT DIN 934 M5 8 VERZ	41 15 148 08	8	4	2 780 915	96 48 377 08	ADD-ON PARTS EXTERNAL F
HEX NUT DIN 934 M5 8 VERZ	41 15 148 08	34	2	2 835 002	96 48 379 08	ADD-ON PARTS
HEX NUT DIN 934 M5 8 VERZ	41 15 148 08	10	2	2 913 100	91 23 538 08	ASSEMBLY FRAME
HEX NUT DIN 934 M5 8 VERZ	41 15 148 08	32	7	2 920 083	96 48 319 08	ELECTRIC FOR BATTERY BOX
HEX NUT DIN 934 M5 8 VERZ	41 15 148 08	270	2	2 920 638	96 51 138 08	CONTROL DESK
HEX NUT DIN 934 M5 8 VERZ	41 15 148 08	18	1	2 922 001	92 84 311 08	BUS PCB
HEX NUT DIN 934 M5 8 VERZ	41 15 148 08	85	4	2 932 082	96 54 387 08	ASSEMBLY PARTS MOUNTIN
HEX NUT DIN 934 M6 8 VERZ	41 15 140 08	5	12	1 830 102	92 26 483 08	TERMINAL BOARD PRE-ASS.
HEX NUT DIN 934 M6 8 VERZ	41 15 140 08	67	8	1 970	91 56 958 08	CRAWLER TRACK HYDRAULI
HEX NUT DIN 934 M6 8 VERZ	41 15 140 08	75	8	1 970	91 56 958 08	CRAWLER TRACK HYDRAULI
HEX NUT DIN 934 M6 8 VERZ	41 15 140 08	18	2	1 991	91 52 510 08	ROTARY FEED THROUGH
HEX NUT DIN 934 M6 8 VERZ	41 15 140 08	24	8	2 370	91 52 782 08	ERECTING WINCH
HEX NUT DIN 934 M6 8 VERZ	41 15 140 08	9	12	2 510	91 52 788 08	TURNTABLE PANELLING
HEX NUT DIN 934 M6 8 VERZ	41 15 140 08	40	4	2 711	91 52 800 08	CENT. LUBRIC. SYSTEM SUP
HEX NUT DIN 934 M6 8 VERZ	41 15 140 08	75	5	2 810	91 52 806 08	CRANE DRIVER'S CABIN CPL.
HEX NUT DIN 934 M6 8 VERZ	41 15 140 08	22	8	2 835 002	96 48 379 08	ADD-ON PARTS
HEX NUT DIN 934 M6 8 VERZ	41 15 140 08	8	2	2 859 030	96 46 758 08	COVER COMPL.
HEX NUT DIN 934 M6 8 VERZ	41 15 140 08	6	2	2 913 004	96 20 460 08	HOUSING PRE-ASSEMBLED
HEX NUT DIN 934 M6 8 VERZ	41 15 140 08	9	7	2 925 204	92 16 990 08	CAMERA EQUIPMENT D-PIVOT
HEX NUT DIN 934 M6 8 VERZ	41 15 140 08	14	13	2 925 402	96 58 855 08	CAMERA EQUIPMENT SLEWI
HEX NUT DIN 934 M6 8 VERZ	41 15 140 08	38	1	2 932 082	96 54 387 08	ASSEMBLY PARTS MOUNTIN
HEX NUT DIN 934 M6 8 VERZ	41 15 140 08	6	4	2 932 166	92 68 911 08	GROUND RAIL
HEX NUT DIN 934 M6 8 VERZ	41 15 140 08	67	10	2 970	91 56 537 08	HYDR
HEX NUT DIN 934 M6 8 VERZ	41 15 140 08	53	2	2 975 100	91 52 860 08	ADDITIONAL HYDRAULICS WI
HEX NUT DIN 934 M6 8 VERZ	41 15 140 08	11	2	2 976 203	92 27 489 08	ADDL.HYDR.F.PIN PULLING DE
HEX NUT DIN 934 M6 8 VERZ	41 15 140 08	20	2	2 978 200	91 54 843 08	ADD.HYDR.S RETAINING RAM
HEX NUT DIN 934 M6 8 VERZ	41 15 140 08	56	2	3 206	91 52 881 08	PIVOT SECTION
HEX NUT DIN 934 M6 8 VERZ	41 15 140 08	6	11	3 713 013	96 57 159 08	SHEET CPL.

6.2.2009

etk_en_de_074515 LR 1600/2

903

LIEBHERRAlphabetical index
Alphabetischer Index

Description	Item	Pos.	Quantity	Page	Assembly	Description
HEX NUT DIN 934 M6 8 VERZ	41 15 140 08	9	4	3 745 002	92 17 236 08	SWITCH UNIT
HEX NUT DIN 934 M6 8 VERZ	41 15 140 08	9	4	3 745 003	92 17 237 08	SWITCH UNIT
HEX NUT DIN 934 M8 10 VERZ	41 15 046 08	21	4	2 370	91 52 782 08	ERECTING WINCH
HEX NUT DIN 934 M8 10 VERZ	41 15 046 08	66	12	2 810	91 52 806 08	CRANE DRIVER'S CABIN CPL.
HEX NUT DIN 934 M8 10 VERZ	41 15 046 08	10	4	2 932 166	92 68 911 08	GROUND RAIL
HEX NUT DIN 934 M8 8 A2C	41 15 141 08	26	12	1 630	91 52 387 08	HYDRAULIC SUPPORT
HEX NUT DIN 934 M8 8 A2C	41 15 141 08	19	33	2 260	91 53 057 08	CUP SPRING CLUSTER
HEX NUT DIN 934 M8 8 A2C	41 15 141 08	25	8	2 260 006	96 46 501 08	BATTERY BOX, PRE-ASSEMB
HEX NUT DIN 934 M8 8 A2C	41 15 141 08	34	2	2 310	91 52 503 08	WINCH 1
HEX NUT DIN 934 M8 8 A2C	41 15 141 08	34	2	2 320	91 52 504 08	WINCH 2
HEX NUT DIN 934 M8 8 A2C	41 15 141 08	19	12	2 350	91 52 778 08	SLEWING GEAR
HEX NUT DIN 934 M8 8 A2C	41 15 141 08	18	4	2 370	91 52 782 08	ERECTING WINCH
HEX NUT DIN 934 M8 8 A2C	41 15 141 08	371	10	2 391 001	96 45 719 08	DIESEL ENGINE, PRE-ASSEMB
HEX NUT DIN 934 M8 8 A2C	41 15 141 08	26	2	2 391 040	96 53 645 08	CLUTCH ACTUATOR
HEX NUT DIN 934 M8 8 A2C	41 15 141 08	11	12	2 391 102	96 56 360 08	RADIATOR
HEX NUT DIN 934 M8 8 A2C	41 15 141 08	20	2	2 392	91 52 785 08	MUFFLER UNIT
HEX NUT DIN 934 M8 8 A2C	41 15 141 08	31	12	2 393	91 52 787 08	AIR FILTER UNIT CPL.
HEX NUT DIN 934 M8 8 A2C	41 15 141 08	48	13	2 631	91 56 817 08	SLEWING PLATFORM CATWAL
HEX NUT DIN 934 M8 8 A2C	41 15 141 08	11	4	2 670	91 52 797 08	FUEL TANK CPL.
HEX NUT DIN 934 M8 8 A2C	41 15 141 08	69	4	2 810	91 52 806 08	CRANE DRIVER'S CABIN CPL.
HEX NUT DIN 934 M8 8 A2C	41 15 141 08	69	8	2 859	91 52 809 08	SOUND INSULATION
HEX NUT DIN 934 M8 8 A2C	41 15 141 08	5	2	2 925 204	92 16 990 08	CAMERA EQUIPMENT D-PIVOT
HEX NUT DIN 934 M8 8 A2C	41 15 141 08	6	12	2 925 402	96 58 855 08	CAMERA EQUIPMENT SLEWI
HEX NUT DIN 934 M8 8 A2C	41 15 141 08	15	8	2 978 100	91 52 796 08	ADDNL.HYDR.ERECTION DEV
HEX NUT DIN 934 M8 8 A2C	41 15 141 08	17	2	2 978 200	91 54 843 08	ADD.HYDR.S_RETAINING RAM
HEX NUT DIN 934 M8 8 A2C	41 15 141 08	17	2	2 990	91 59 244 08	COMPRESSED AIR PLANT
HEX NUT DIN 934 M8 8 A2C	41 15 141 08	33	21	3 713	91 57 749 08	D PIVOT SECTION
HEX NUT DIN 936 M10 8 VERZ	41 17 003 08	33	6	2 652	91 52 794 08	ROLLER BEARING
HEX NUT DIN 936 M20X1,5 8 V	41 17 209 08	33	4	1 630	91 52 387 08	HYDRAULIC SUPPORT
HEX NUT DIN 936 M24 8 VERZ	41 17 010 08	23	1	2 391 040	96 53 645 08	CLUTCH ACTUATOR
HEX NUT DIN 936 M30 8 VERZ	41 17 011 08	18	2	2 810	91 52 806 08	CRANE DRIVER'S CABIN CPL.
HEX NUT DIN 980 V M20 10 V	41 18 806 08	8	1	3 714 025	96 49 269 08	ROD CPL.
HEX NUT DIN 985 M10 10 VER	41 19 011 08	10	16	2 810	91 52 806 08	CRANE DRIVER'S CABIN CPL.
HEX NUT DIN 985 M10 8 VERZ	41 19 006 08	69	12	1 400	91 56 853 08	CRAWLER TRACK CARRIER LE
HEX NUT DIN 985 M10 8 VERZ	41 19 006 08	69	12	1 410 300	91 56 855 08	CRAWLER CARRIER RIGHT CP
HEX NUT DIN 985 M10 8 VERZ	41 19 006 08	100	9	2 550	91 57 751 08	SA FRAME
HEX NUT DIN 985 M10 8 VERZ	41 19 006 08	11	4	2 730	91 52 802 08	BASE PLATE SLEWING PLATF
HEX NUT DIN 985 M10 8 VERZ	41 19 006 08	13	2	3 206	91 52 881 08	PIVOT SECTION
HEX NUT DIN 985 M10 8 VERZ	41 19 006 08	32	7	3 208 001	91 52 883 08	F-HEAD SECTION
HEX NUT DIN 985 M10 8 VERZ	41 19 006 08	49	4	3 211	91 57 748 08	S PIVOT SECTION
HEX NUT DIN 985 M10 8 VERZ	41 19 006 08	40	4	3 281	91 52 896 08	ERECTION FRAME
HEX NUT DIN 985 M10 8 VERZ	41 19 006 08	35	8	3 745	91 52 948 08	SUSPENDED BALLAST
HEX NUT DIN 985 M12 8 A3C	41 19 007 08	14	2	2 340	91 52 776 08	WINCH 4 LUFFING GEAR
HEX NUT DIN 985 M12 8 A3C	41 19 007 08	361	8	2 391 001	96 45 719 08	DIESEL ENGINE, PRE-ASSEMB
HEX NUT DIN 985 M12 8 A3C	41 19 007 08	12	4	2 391 023	96 45 720 08	RADIATOR, PRE-ASSEMBLED
HEX NUT DIN 985 M12 8 A3C	41 19 007 08	38	11	3 206	91 52 881 08	PIVOT SECTION
HEX NUT DIN 985 M12 8 A3C	41 19 007 08	6	1	3 207 003	96 48 259 08	ROD CPL.
HEX NUT DIN 985 M12 8 A3C	41 19 007 08	5	1	3 207 100	96 48 261 08	BRACKET COMPL.
HEX NUT DIN 985 M12 8 A3C	41 19 007 08	33	6	3 208 001	91 52 883 08	F-HEAD SECTION
HEX NUT DIN 985 M12 8 A3C	41 19 007 08	73	8	3 211	91 57 748 08	S PIVOT SECTION
HEX NUT DIN 985 M12 8 A3C	41 19 007 08	32	4	3 215 005	91 52 846 08	ROLLER SET
HEX NUT DIN 985 M12 8 A3C	41 19 007 08	32	4	3 215 006	91 52 847 08	ROLLER SET
HEX NUT DIN 985 M12 8 A3C	41 19 007 08	(6)	1	3 281	91 52 896 08	ERECTION FRAME
HEX NUT DIN 985 M12 8 A3C	41 19 007 08	17	4	3 292	91 52 865 08	D OVERRUN PROTECTION
HEX NUT DIN 985 M12 8 A3C	41 19 007 08	14	4	3 714 008	96 49 266 08	LUFFING PULLEY BLOCK COM
HEX NUT DIN 985 M14 10 A3C	41 19 013 08	50	4	3 745	91 52 948 08	SUSPENDED BALLAST
HEX NUT DIN 985 M16 10 VER	41 19 014 08	362	4	2 391 001	96 45 719 08	DIESEL ENGINE, PRE-ASSEMB
HEX NUT DIN 985 M16 8 VERZ	41 19 009 08	4	162	1 300 011	96 52 493 08	FLOOR PLATES PRE-ASS.
HEX NUT DIN 985 M16 8 VERZ	41 19 009 08	25	1	2 391 040	96 53 645 08	CLUTCH ACTUATOR
HEX NUT DIN 985 M16 8 VERZ	41 19 009 08	4	2	2 550 010	96 45 685 08	ROD

6.2.2009

etk_en_de_074515 LR 1600/2

904

LIEBHERRAlphabetical index
Alphabetischer Index

Description	Item	Pos.	Quantity	Page	Assembly	Description
HEX NUT DIN 985 M16 8 VERZ	41 19 009 08	13	1	2 657	91 57 656 08	MOUNTING EQUIPMENT CRAW
HEX NUT DIN 985 M16 8 VERZ	41 19 009 08	3	1	3 207 101	96 48 292 08	BRACKET COMPL.
HEX NUT DIN 985 M16 8 VERZ	41 19 009 08	9	1	3 211 003	96 46 986 08	ROD CPL.
HEX NUT DIN 985 M16 8 VERZ	41 19 009 08	19	2	3 214	91 52 843 08	SW HEAD SECTION
HEX NUT DIN 985 M16 8 VERZ	41 19 009 08	10	1	3 220 501	96 43 440 08	ROD CPL.
HEX NUT DIN 985 M16 8 VERZ	41 19 009 08	10	1	3 221 200	96 47 984 08	ROD CPL.
HEX NUT DIN 985 M16 8 VERZ	41 19 009 08	10	1	3 225 200	96 48 679 08	ROD CPL.
HEX NUT DIN 985 M16 8 VERZ	41 19 009 08	10	1	3 227 002	96 50 498 08	ROD CPL.
HEX NUT DIN 985 M16 8 VERZ	41 19 009 08	(5)	2	3 281	91 52 896 08	ERECTION FRAME
HEX NUT DIN 985 M16 8 VERZ	41 19 009 08	(5)	1	3 281	91 52 896 08	ERECTION FRAME
HEX NUT DIN 985 M16 8 VERZ	41 19 009 08	15	4	3 292	91 52 865 08	D OVERRUN PROTECTION
HEX NUT DIN 985 M16 8 VERZ	41 19 009 08	10	1	3 561 003	96 45 222 08	ROD CPL.
HEX NUT DIN 985 M16 8 VERZ	41 19 009 08	10	1	3 713 012	96 50 197 08	ROD CPL.
HEX NUT DIN 985 M16 8 VERZ	41 19 009 08	6	2	3 714 013	96 49 270 08	BRACKET COMPL.
HEX NUT DIN 985 M16 8 VERZ	41 19 009 08	7	1	3 714 013	96 59 083 08	BRACKET COMPL.
HEX NUT DIN 985 M16 8 VERZ	41 19 009 08	5	1	3 714 014	96 49 456 08	BRACKET COMPL.
HEX NUT DIN 985 M16 8 VERZ	41 19 009 08	10	1	3 716 001	96 49 159 08	ROD CPL.
HEX NUT DIN 985 M20 10 A3C	41 19 024 08	11	2	2 550 005	96 45 680 08	ROD CPL.
HEX NUT DIN 985 M20 10 A3C	41 19 024 08	5	4	3 745 011	96 49 677 08	BRACKET COMPL.
HEX NUT DIN 985 M24 10 A3C	41 19 026 08	104	2	3 713	91 57 749 08	D PIVOT SECTION
HEX NUT DIN 985 M24 8 VERZ	41 19 025 08	17	6	3 714 009	96 49 267 08	LUFFING PULLEY BLOCK COM
HEX NUT DIN 985 M3 8 A3C	41 19 001 08	29	4	2 533 070	96 48 363 08	CONTROLS AND FITTINGS RI
HEX NUT DIN 985 M3 8 A3C	41 19 001 08	12	2	2 780 852	96 24 845 08	GSM-MODULE PRE-ASS.LICCO
HEX NUT DIN 985 M3 8 A3C	41 19 001 08	12	10	2 913	91 32 850 08	LICCON CONSOLE LCD2
HEX NUT DIN 985 M3 8 A3C	41 19 001 08	6	2	2 913 005	96 20 731 08	INTERIOR HOUSING PRE-ASS.
HEX NUT DIN 985 M3 8 A3C	41 19 001 08	6	2	2 913 005	96 28 696 08	INTERIOR HOUSING PRE-ASS.
HEX NUT DIN 985 M3 8 A3C	41 19 001 08	4	6	2 913 006	96 20 732 08	FAN PLATE PRE-ASS.
HEX NUT DIN 985 M3 8 A3C	41 19 001 08	12	10	2 913 009	91 04 705 08	LICCON CONSOLE LCD3
HEX NUT DIN 985 M3 8 A3C	41 19 001 08	44	8	2 920 369	96 54 235 08	TERMINAL BOX CPL.
HEX NUT DIN 985 M4 8 VERZ	41 19 002 08	40	10	2 631	91 56 817 08	SLEWING PLATFORM CATWAL
HEX NUT DIN 985 M4 8 VERZ	41 19 002 08	45	56	2 932 160	96 54 385 08	SWITCH CABINET
HEX NUT DIN 985 M4 8 VERZ	41 19 002 08	12	3	3 780 200	96 54 370 08	ELECTRIC WIND WARNING T
HEX NUT DIN 985 M5 8 VERZ	41 19 003 08	29	4	2 260	91 53 057 08	CUP SPRING CLUSTER
HEX NUT DIN 985 M5 8 VERZ	41 19 003 08	5	4	2 260 009	96 46 972 08	FLAP PRE-ASS.
HEX NUT DIN 985 M5 8 VERZ	41 19 003 08	43	4	2 391 040	96 53 645 08	CLUTCH ACTUATOR
HEX NUT DIN 985 M5 8 VERZ	41 19 003 08	33	2	2 533 070	96 48 363 08	CONTROLS AND FITTINGS RI
HEX NUT DIN 985 M5 8 VERZ	41 19 003 08	58	2	2 631	91 56 817 08	SLEWING PLATFORM CATWAL
HEX NUT DIN 985 M5 8 VERZ	41 19 003 08	5	1	2 780 851	96 24 498 08	RADIO ANTENNA PRE-ASS.
HEX NUT DIN 985 M5 8 VERZ	41 19 003 08	9	1	2 780 852	96 24 845 08	GSM-MODULE PRE-ASS.LICCO
HEX NUT DIN 985 M5 8 VERZ	41 19 003 08	51	16	2 859	91 52 809 08	SOUND INSULATION
HEX NUT DIN 985 M5 8 VERZ	41 19 003 08	4	8	2 859 005	96 46 756 08	FLAP PRE-ASS.
HEX NUT DIN 985 M5 8 VERZ	41 19 003 08	9	8	2 859 025	96 46 757 08	GRIDIRON PRE-ASS.
HEX NUT DIN 985 M5 8 VERZ	41 19 003 08	(3)	3	3 780 258	96 56 482 08	ELECTRIC AIRCRAFT PROTE
HEX NUT DIN 985 M6 8 VERZ	41 19 004 08	22	13	2 260	91 53 057 08	CUP SPRING CLUSTER
HEX NUT DIN 985 M6 8 VERZ	41 19 004 08	21	4	2 260 006	96 46 501 08	BATTERY BOX, PRE-ASSEMB
HEX NUT DIN 985 M6 8 VERZ	41 19 004 08	18	16	2 391 023	96 45 720 08	RADIATOR, PRE-ASSEMBLED
HEX NUT DIN 985 M6 8 VERZ	41 19 004 08	5	5	2 391 036	96 23 055 08	COVER/LID/CAP, PRE-ASSEMB
HEX NUT DIN 985 M6 8 VERZ	41 19 004 08	5	4	2 391 039	96 50 616 08	COVER CPL
HEX NUT DIN 985 M6 8 VERZ	41 19 004 08	33	1	2 391 040	96 53 645 08	CLUTCH ACTUATOR
HEX NUT DIN 985 M6 8 VERZ	41 19 004 08	16	12	2 393 002	96 46 782 08	COVER COMPL.
HEX NUT DIN 985 M6 8 VERZ	41 19 004 08	59	14	2 550	91 57 751 08	SA FRAME
HEX NUT DIN 985 M6 8 VERZ	41 19 004 08	14	6	2 932 166	92 68 911 08	GROUND RAIL
HEX NUT DIN 985 M6 8 VERZ	41 19 004 08	116	8	2 970	91 56 537 08	HYDR
HEX NUT DIN 985 M6 8 VERZ	41 19 004 08	29	4	3 206	91 52 881 08	PIVOT SECTION
HEX NUT DIN 985 M6 8 VERZ	41 19 004 08	30	8	3 208 001	91 52 883 08	F-HEAD SECTION
HEX NUT DIN 985 M6 8 VERZ	41 19 004 08	57	10	3 211	91 57 748 08	S PIVOT SECTION
HEX NUT DIN 985 M6 8 VERZ	41 19 004 08	44	4	3 214	91 52 843 08	SW HEAD SECTION
HEX NUT DIN 985 M6 8 VERZ	41 19 004 08	34	17	3 220 500	91 52 849 08	S INTERMEDIATE SECTION
HEX NUT DIN 985 M6 8 VERZ	41 19 004 08	18	12	3 221	91 54 668 08	S INTERMEDIATE SECTION
HEX NUT DIN 985 M6 8 VERZ	41 19 004 08	34	22	3 223	91 52 852 08	S INTERMEDIATE SECTION

6.2.2009

etk_en_de_074515 LR 1600/2

905

LIEBHERRAlphabetical index
Alphabetischer Index

Description	Item	Pos.	Quantity	Page	Assembly	Description
HEX NUT DIN 985 M6 8 VERZ	41 19 004 08	34	22	3 223 010	91 52 853 08	S INTERMEDIATE SECTION
HEX NUT DIN 985 M6 8 VERZ	41 19 004 08	34	22	3 223 100	91 55 327 08	S INTERMEDIATE SECTION
HEX NUT DIN 985 M6 8 VERZ	41 19 004 08	32	17	3 225	91 52 854 08	SL REDUCING SECTION
HEX NUT DIN 985 M6 8 VERZ	41 19 004 08	34	17	3 226	91 52 870 08	L INTERMEDIATE SECTION
HEX NUT DIN 985 M6 8 VERZ	41 19 004 08	34	22	3 227	91 52 873 08	L INTERMEDIATE SECTION
HEX NUT DIN 985 M6 8 VERZ	41 19 004 08	34	22	3 227 008	91 52 872 08	L INTERMEDIATE SECTION
HEX NUT DIN 985 M6 8 VERZ	41 19 004 08	34	22	3 227 200	91 53 519 08	LI INTERMEDIATE SECT. F-GU
HEX NUT DIN 985 M6 8 VERZ	41 19 004 08	63	15	3 713	91 57 749 08	D PIVOT SECTION
HEX NUT DIN 985 M6 8 VERZ	41 19 004 08	58	30	3 714	91 52 862 08	D HEAD SECTION
HEX NUT DIN 985 M6 8 VERZ	41 19 004 08	9	20	3 715 008	91 52 863 08	D INTERMEDIATE SECTION
HEX NUT DIN 985 M6 8 VERZ	41 19 004 08	9	25	3 716	91 52 864 08	D INTERMEDIATE SECTION
HEX NUT DIN 985 M6 8 VERZ	41 19 004 08	(7)	3	3 780 258	96 56 482 08	ELECTRIC AIRCRAFT PROTE
HEX NUT DIN 985 M6 8 VERZ	41 19 004 08	16	2	3 780 751	91 52 952 08	AIR-CRAFT & WIND WARNING
HEX NUT DIN 985 M6 8 VERZ	41 19 004 08	22	3	3 978 015	91 56 429 08	ADDITIONAL HYDRAULICS IN
HEX NUT DIN 985 M6 8 VERZ	41 19 004 08	22	3	3 978 015	91 56 432 08	ADDITIONAL HYDRAULICS IN
HEX NUT DIN 985 M8 10 VERZ	41 19 010 08	30	8	2 260	91 53 057 08	CUP SPRING CLUSTER
HEX NUT DIN 985 M8 10 VERZ	41 19 010 08	74	13	2 520	91 53 061 08	CABIN, GLAZED
HEX NUT DIN 985 M8 8 VERZ	41 19 005 08	62	2	1 400	91 56 853 08	CRAWLER TRACK CARRIER LE
HEX NUT DIN 985 M8 8 VERZ	41 19 005 08	62	2	1 410 300	91 56 855 08	CRAWLER CARRIER RIGHT CP
HEX NUT DIN 985 M8 8 VERZ	41 19 005 08	8	4	1 620	91 52 386 08	FIXING PARTS SLEWING RING
HEX NUT DIN 985 M8 8 VERZ	41 19 005 08	12	48	1 631 100	91 52 388 08	CATWALK CRAW.TRACK TRA
HEX NUT DIN 985 M8 8 VERZ	41 19 005 08	12	3	2 350	91 52 778 08	SLEWING GEAR
HEX NUT DIN 985 M8 8 VERZ	41 19 005 08	16	12	2 391 023	96 45 720 08	RADIATOR, PRE-ASSEMBLED
HEX NUT DIN 985 M8 8 VERZ	41 19 005 08	3	4	2 503 100	91 55 873 08	EMERGENCY SEAT
HEX NUT DIN 985 M8 8 VERZ	41 19 005 08	10	2	2 522 013	96 45 883 08	GUIDE PRE-ASS.
HEX NUT DIN 985 M8 8 VERZ	41 19 005 08	13	1	2 541 001	96 49 651 08	ADDNL.HEATING, PRE-ASSE
HEX NUT DIN 985 M8 8 VERZ	41 19 005 08	21	4	2 550	91 57 751 08	SA FRAME
HEX NUT DIN 985 M8 8 VERZ	41 19 005 08	4	4	2 631 003	96 54 406 08	ACCESS LADDER PRE-ASS.
HEX NUT DIN 985 M8 8 VERZ	41 19 005 08	17	2	2 671	91 52 798 08	OIL RESERVOIR, COMPLETE
HEX NUT DIN 985 M8 8 VERZ	41 19 005 08	6	6	2 810 001	96 43 597 08	CRANE DRIVER'S CABIN,PRE
HEX NUT DIN 985 M8 8 VERZ	41 19 005 08	54	77	2 859	91 52 809 08	SOUND INSULATION
HEX NUT DIN 985 M8 8 VERZ	41 19 005 08	6	10	2 859 025	96 46 757 08	GRIDIRON PRE-ASS.
HEX NUT DIN 985 M8 8 VERZ	41 19 005 08	5	2	2 859 030	96 46 758 08	COVER COMPL.
HEX NUT DIN 985 M8 8 VERZ	41 19 005 08	7	4	2 932 160	96 54 385 08	SWITCH CABINET
HEX NUT DIN 985 M8 8 VERZ	41 19 005 08	154	2	2 970	91 56 537 08	HYDR
HEX NUT DIN 985 M8 8 VERZ	41 19 005 08	46	11	3 206	91 52 881 08	PIVOT SECTION
HEX NUT DIN 985 M8 8 VERZ	41 19 005 08	31	4	3 208 001	91 52 883 08	F-HEAD SECTION
HEX NUT DIN 985 M8 8 VERZ	41 19 005 08	33	174	3 211	91 57 748 08	S PIVOT SECTION
HEX NUT DIN 985 M8 8 VERZ	41 19 005 08	17	2	3 213	91 52 842 08	F-CONNECTING HEAD
HEX NUT DIN 985 M8 8 VERZ	41 19 005 08	23	17	3 214	91 52 843 08	SW HEAD SECTION
HEX NUT DIN 985 M8 8 VERZ	41 19 005 08	35	41	3 220 500	91 52 849 08	S INTERMEDIATE SECTION
HEX NUT DIN 985 M8 8 VERZ	41 19 005 08	19	36	3 221	91 54 668 08	S INTERMEDIATE SECTION
HEX NUT DIN 985 M8 8 VERZ	41 19 005 08	35	51	3 223	91 52 852 08	S INTERMEDIATE SECTION
HEX NUT DIN 985 M8 8 VERZ	41 19 005 08	35	51	3 223 010	91 52 853 08	S INTERMEDIATE SECTION
HEX NUT DIN 985 M8 8 VERZ	41 19 005 08	35	51	3 223 100	91 55 327 08	S INTERMEDIATE SECTION
HEX NUT DIN 985 M8 8 VERZ	41 19 005 08	37	47	3 225	91 52 854 08	SL REDUCING SECTION
HEX NUT DIN 985 M8 8 VERZ	41 19 005 08	35	34	3 226	91 52 870 08	L INTERMEDIATE SECTION
HEX NUT DIN 985 M8 8 VERZ	41 19 005 08	35	39	3 227	91 52 873 08	L INTERMEDIATE SECTION
HEX NUT DIN 985 M8 8 VERZ	41 19 005 08	35	31	3 227 008	91 52 872 08	L INTERMEDIATE SECTION
HEX NUT DIN 985 M8 8 VERZ	41 19 005 08	35	49	3 227 200	91 53 519 08	LI INTERMEDIATE SECT. F-GU
HEX NUT DIN 985 M8 8 VERZ	41 19 005 08	62	2	3 281	91 52 896 08	ERECTION FRAME
HEX NUT DIN 985 M8 8 VERZ	41 19 005 08	4	8	3 291	91 52 831 08	S OVERRUN PROTECTION
HEX NUT DIN 985 M8 8 VERZ	41 19 005 08	9	8	3 292	91 52 865 08	D OVERRUN PROTECTION
HEX NUT DIN 985 M8 8 VERZ	41 19 005 08	18	173	3 713	91 57 749 08	D PIVOT SECTION
HEX NUT DIN 985 M8 8 VERZ	41 19 005 08	48	71	3 714	91 52 862 08	D HEAD SECTION
HEX NUT DIN 985 M8 8 VERZ	41 19 005 08	4	4	3 714 017	96 50 752 08	SUPPORT CPL.
HEX NUT DIN 985 M8 8 VERZ	41 19 005 08	10	74	3 715 008	91 52 863 08	D INTERMEDIATE SECTION
HEX NUT DIN 985 M8 8 VERZ	41 19 005 08	10	124	3 716	91 52 864 08	D INTERMEDIATE SECTION
HEX NUT DIN 985 M8 8 VERZ	41 19 005 08	30	24	3 745	91 52 948 08	SUSPENDED BALLAST
HEX NUT ISO 10511 M6 A2-70	41 19 030 08	22	8	2 925 402	96 58 855 08	CAMERA EQUIPMENT SLEWI

6.2.2009

etk_en_de_074515 LR 1600/2

906

LIEBHERRAlphabetical index
Alphabetischer Index

Description	Item	Pos.	Quantity	Page	Assembly	Description
HEX NUT ISO 4032 M10 8 A2E	41 15 031 03	15	2	X1041267	10 41 267 8	END PLATE
HEX NUT ISO 4032 M8 A2-70	51 07 374 08	18	1	X1041267	10 41 267 8	END PLATE
HEX NUT ISO 4035 M8 04 VER	41 01 203 08	17	2	2 522 011	96 45 602 08	CLOSING DEVICE
HEX NUT M10X1 -8	10 01 255 7	11	2	9 739 263	97 39 263	ROCKER ARM BEARING HOUS
HEX NUT M10X1 -8	10 01 255 7	11	2	9 739 264	97 39 264	ROCKER ARM BEARING HOUS
HEX NUT M12 04 A3C	10 34 227 9	20	2	9 739 371	97 39 371	AIR COND. COMPRESSOR A
HEX NUT M14X1	10 01 256 0	8	1	9 739 263	97 39 263	ROCKER ARM BEARING HOUS
HEX NUT M14X1	10 01 256 0	8	1	9 739 264	97 39 264	ROCKER ARM BEARING HOUS
HEX NUT M32X1,5 8	10 01 255 9	17	1	9 739 492	97 39 492	PIPELINE INSTALLATION
HEX NUT M8X10 MAN183-B1	10 47 690 5	5	1	9 739 491	97 39 491	INSTALLATION BRAKE COMPR
HEXALOBULAR HEAD SCREW	10 34 226 9	3	9	9 739 352	97 39 352	AT-WATER PUMP WITH FAST
HIGH PRESSURE PUMP	10 34 309 6	70	1	X1012059	10 12 059 0	DIESEL ENGINE
HINGE	70 42 281 08	2	2	2 510 040	96 49 183 08	DOOR COMPL.
HINGE	70 42 281 08	2	2	2 510 059	96 49 184 08	DOOR COMPL.
HINGE	70 42 559 08	81	4	2 932 082	96 54 387 08	ASSEMBLY PARTS MOUNTIN
HINGE	70 42 582 08	12	2	2 260 006	96 46 501 08	BATTERY BOX, PRE-ASSEMB
HINGE	70 42 598 08	42	2	2 520	91 53 061 08	CABIN, GLAZED
HINGE F6-1 STAHL	70 42 637 08	3	2	2 260 009	96 46 972 08	FLAP PRE-ASS.
HINGE F6-1 STAHL	70 42 637 08	7	4	2 859 025	96 46 757 08	GRIDIRON PRE-ASS.
HINGE F6-3 STAHL	70 42 619 08	2	4	2 859 005	96 46 756 08	FLAP PRE-ASS.
HINGED CONNECTOR 10,5X70	43 32 011 08	58	6	1 400	91 56 853 08	CRAWLER TRACK CARRIER LE
HINGED CONNECTOR 10,5X70	43 32 011 08	58	6	1 410 300	91 56 855 08	CRAWLER CARRIER RIGHT CP
HINGED CONNECTOR 10,5X70	43 32 011 08	30	4	1 630	91 52 387 08	HYDRAULIC SUPPORT
HINGED CONNECTOR DIN 11	43 32 001 08	16	8	2 631	91 56 817 08	SLEWING PLATFORM CATWAL
HINGED CONNECTOR DIN 11	43 32 001 08	16	4	2 730	91 52 802 08	BASE PLATE SLEWING PLATF
HINGED CONNECTOR DIN 11	43 32 001 08	31	1	2 925 402	96 58 855 08	CAMERA EQUIPMENT SLEWI
HINGED CONNECTOR DIN 11	43 32 001 08	63	2	3 211	91 57 748 08	S PIVOT SECTION
HINGED CONNECTOR DIN 11	43 32 001 08	50	4	3 214	91 52 843 08	SW HEAD SECTION
HINGED CONNECTOR DIN 11	43 32 001 08	13	2	3 220 500	91 52 849 08	S INTERMEDIATE SECTION
HINGED CONNECTOR DIN 11	43 32 001 08	13	2	3 223	91 52 852 08	S INTERMEDIATE SECTION
HINGED CONNECTOR DIN 11	43 32 001 08	13	2	3 223 010	91 52 853 08	S INTERMEDIATE SECTION
HINGED CONNECTOR DIN 11	43 32 001 08	13	2	3 223 100	91 55 327 08	S INTERMEDIATE SECTION
HINGED CONNECTOR DIN 11	43 32 001 08	42	2	3 713	91 57 749 08	D PIVOT SECTION
HINGED CONNECTOR DIN 11	43 32 002 08	5	20	1 631 100	91 52 388 08	CATWALK CRAW.TRACK TRA
HINGED CONNECTOR DIN 11	43 32 002 08	12	4	2 125	91 52 773 08	PIN F.S-PIVOT SECTION SA F
HINGED CONNECTOR DIN 11	43 32 002 08	93	1	2 550	91 57 751 08	SA FRAME
HINGED CONNECTOR DIN 11	43 32 002 08	40	2	3 208 001	91 52 883 08	F-HEAD SECTION
HINGED CONNECTOR DIN 11	43 32 002 08	52	4	3 225	91 52 854 08	SL REDUCING SECTION
HINGED CONNECTOR DIN 11	43 32 002 08	64	2	3 714	91 52 862 08	D HEAD SECTION
HINGED CONNECTOR DIN 11	43 32 003 08	79	2	1 400	91 56 853 08	CRAWLER TRACK CARRIER LE
HINGED CONNECTOR DIN 11	43 32 003 08	79	2	1 410 300	91 56 855 08	CRAWLER CARRIER RIGHT CP
HINGED CONNECTOR DIN 11	43 32 003 08	15	3	2 652	91 52 794 08	ROLLER BEARING
HINGED CONNECTOR DIN 11	43 32 003 08	7	2	3 713	91 57 749 08	D PIVOT SECTION
HINGED CONNECTOR DIN 11	43 32 008 08	14	2	3 215 005	91 52 846 08	ROLLER SET
HINGED CONNECTOR DIN 11	43 32 008 08	14	2	3 215 006	91 52 847 08	ROLLER SET
HINGED FRAME 15HE VERZ	61 10 470 08	1	1	2 932 001	96 45 393 08	RELAY CONTROL SYSTEM
HINGED HANDLE KUNSTSTOF	10 29 202 3	2	1	2 520 031	96 45 610 08	REAR WINDOW PRE-ASS.
HOIST LIM.SWITCH PLUMMET	96 25 639 08	3	1	2 311	91 52 834 08	ROPE WITH ACCESSORIES 1
HOIST LIM.SWITCH PLUMMET	96 25 639 08	3	1	2 312	91 52 835 08	ROPE WITH ACCESSORIES 2
HOISTING WINCH ZHP 4.29 SP	10 35 411 4	2	1	2 310	91 52 503 08	WINCH 1
HOISTING WINCH ZHP 4.29 SP	10 35 411 4	2	1	2 320	91 52 504 08	WINCH 2
HOISTING WINCH ZHP 4.29 SP	10 35 411 4	1	1	3 350	91 52 859 08	WINCH 3
HOLDER	10 01 229 5	7	1	9 739 118	97 39 118	OIL LINE
HOLDER	10 01 268 4	19	1	9 739 386	97 39 386	CRANKCASE BREATHER
HOLDER	10 01 268 5	3	1	9 739 140	97 39 140	FLAME STARTING SYSTEM
HOLDER	10 02 091 7	8	1	9 739 271	97 39 271	CONNECTING LINE
HOLDER	10 02 091 8	14	1	9 739 358	97 39 358	EXHAUST GAS RECIRCUL.ATT
HOLDER	10 02 092 1	1	1	9 739 366	97 39 366	FASTENING PIECES ASSEMBL
HOLDER	10 02 092 1	26	1	9 739 386	97 39 386	CRANKCASE BREATHER
HOLDER	10 02 095 5	7	4	9 739 366	97 39 366	FASTENING PIECES ASSEMBL

6.2.2009

etk_en_de_074515 LR 1600/2

907

LIEBHERRAlphabetical index
Alphabetischer Index

Description	Item	Pos.	Quantity	Page	Assembly	Description
HOLDER	10 03 718 2	4	1	9 739 210	97 39 210	LIQUID COOLING PIPELINE
HOLDER	10 28 506 8	2	1	9 739 366	97 39 366	FASTENING PIECES ASSEMBL
HOLDER	10 28 506 9	4	1	9 739 366	97 39 366	FASTENING PIECES ASSEMBL
HOLDER	10 28 507 0	11	1	9 739 356	97 39 356	PIPELINE INSTALLATION
HOLDER	10 28 507 0	6	1	9 739 366	97 39 366	FASTENING PIECES ASSEMBL
HOLDER	10 34 310 3	21	1	9 739 371	97 39 371	AIR COND. COMPRESSOR A
HOLDER	10 34 310 4	2	1	9 739 344	97 39 344	GENERATOR, PRE-ASSEMBLE
HOLDER	10 34 310 6	11	1	9 739 344	97 39 344	GENERATOR, PRE-ASSEMBLE
HOLDER	10 34 312 6	21	1	9 739 366	97 39 366	FASTENING PIECES ASSEMBL
HOLDER	10 34 312 8	22	1	9 739 366	97 39 366	FASTENING PIECES ASSEMBL
HOLDER	10 48 693 3	35	1	9 739 492	97 39 492	PIPELINE INSTALLATION
HOLDER	69 10 431 08	14	68	6 909 010	69 09 010 08	COLLECTING RING
HOLDER	89 01 014 08	31	1	2 520 034	96 45 984 08	INTERNAL LINING
HOLDER	90 80 704	1	1	9 080 702	90 80 702	CONTROL GEAR
HOLDER	90 80 706	2	1	9 080 702	90 80 702	CONTROL GEAR
HOLDER	97 52 186 08	20	6	2 520	91 53 061 08	CABIN, GLAZED
HOLDER	97 53 845 08	21	6	2 520	91 53 061 08	CABIN, GLAZED
HOLDER 4X20X80	94 66 007 08	68	2	2 550	91 57 751 08	SA FRAME
HOLDER 4X30X95	95 14 733 08	58	7	2 391 001	96 45 719 08	DIESEL ENGINE, PRE-ASSEMB
HOLDER ST	70 42 213 08	29	1	2 520 034	96 45 984 08	INTERNAL LINING
HOLDER X12CrNiS188	92 35 694 08	55	2	2 550	91 57 751 08	SA FRAME
HOLDER X12CrNiS188	92 35 694 08	11	1	3 745 002	92 17 236 08	SWITCH UNIT
HOLDER X12CrNiS188	92 35 694 08	11	1	3 745 003	92 17 237 08	SWITCH UNIT
HOLDER X12CrNiS188	92 35 704 08	25	1	3 206	91 52 881 08	PIVOT SECTION
HOLDING ANGLE 2X190X112	97 81 077 08	76	1	2 550	91 57 751 08	SA FRAME
HOLDING PLATE 4X155X50	97 81 204 08	78	12	2 550	91 57 751 08	SA FRAME
HOLLOW SCREW	10 01 272 8	2	6	9 739 127	97 39 127	WATER BLEEDER PIPELINE
HOLLOW SCREW	10 01 273 0	8	2	9 739 282	97 39 282	OVERFLOW-OIL LINE
HOLLOW SCREW	10 01 273 0	25	1	9 739 288	97 39 288	FUEL LINE
HOLLOW SCREW	10 01 273 0	4	6	9 739 292	97 39 292	FUEL LINE
HOLLOW SCREW	10 01 273 0	3	2	9 739 492	97 39 492	PIPELINE INSTALLATION
HOLLOW SCREW	10 22 232 3	6	1	9 739 243	97 39 243	PISTON COOLING
HOLLOW SCREW	10 22 276 0	2	5	9 739 281	97 39 281	OVERFLOW-OIL LINE
HOLLOW SCREW	10 22 276 3	6	1	9 739 281	97 39 281	OVERFLOW-OIL LINE
HOLLOW SCREW	10 28 515 6	18	1	9 739 288	97 39 288	FUEL LINE
HOLLOW SCREW	10 28 710 8	25	1	9 739 494	97 39 494	ATL ATTACHMENT
HOLLOW SCREW 10S	10 01 272 4	17	1	9 739 349	97 39 349	CONNECTION F.WATER PIPE
HOLLOW SCREW 12 A4D	10 01 200 7	6	1	9 739 355	97 39 355	OIL COOLER ADD-ON
HOLLOW SCREW M10X1X19E	10 01 272 6	15	1	9 739 288	97 39 288	FUEL LINE
HOLLOW SCREW M14X1,5X41,	10 22 277 0	10	1	9 739 282	97 39 282	OVERFLOW-OIL LINE
HOLLOW SCREW M14X1,5X41,	10 22 277 0	15	1	9 739 292	97 39 292	FUEL LINE
HOOD 1.5X411X555	97 29 088 08	18	1	2 550	91 57 751 08	SA FRAME
HOOD 1.5X411X555	97 29 088 08	50	1	3 208 001	91 52 883 08	F-HEAD SECTION
HOOD 1.5X411X555	97 29 088 08	52	1	3 211	91 57 748 08	S PIVOT SECTION
HOOD 1.5X411X555	97 29 088 08	15	1	3 213	91 52 842 08	F-CONNECTING HEAD
HOOD 1.5X411X555	97 29 088 08	20	1	3 214	91 52 843 08	SW HEAD SECTION
HOOD 1.5X831X448	95 47 461 08	110	1	3 713	91 57 749 08	D PIVOT SECTION
HOOD 1.5X831X448	95 47 461 08	75	1	3 714	91 52 862 08	D HEAD SECTION
HOOD 1.5X931X548	95 32 110 08	109	1	3 713	91 57 749 08	D PIVOT SECTION
HOOD 1.5X931X548	95 32 110 08	74	1	3 714	91 52 862 08	D HEAD SECTION
HOOD 2X298X327 FE//ZN20//C	97 80 592 08	3	1	2 925 402	96 58 855 08	CAMERA EQUIPMENT SLEWI
HOOD 2X333X329	97 14 477 08	15	1	2 657	91 57 656 08	MOUNTING EQUIPMENT CRAW
HOOK BLOCK 125 DM SPF	91 55 528 08	314	1		LR 1600-2-0	
HORIZONTAL TENSIONER	77 90 011 08	7	1	2 925 204	92 16 990 08	CAMERA EQUIPMENT D-PIVOT
HORN 335HZ 24V	61 40 031 08	9	1	2 533 066	96 48 365 08	ELECTRIC ADD-ON PARTS CA
HOSE	10 01 872 9	4	1	9 739 127	97 39 127	WATER BLEEDER PIPELINE
HOSE	51 05 010 08	121	1	2 391 001	96 45 719 08	DIESEL ENGINE, PRE-ASSEMB
HOSE 22X65 -1	10 01 263 2	28	1	9 739 494	97 39 494	ATL ATTACHMENT
HOSE 4	59 10 053 08	14	10	2 520 032	96 45 980 08	WINDSHIELD WASHER INSTAL
HOSE ASS CPL. 1SC 0,22M	96 51 592 08	313	1	2 997	91 56 539 08	HOSE LINES SUPERSTRUCT

6.2.2009

etk_en_de_074515 LR 1600/2

908

LIEBHERRAlphabetical index
Alphabetischer Index

Description	Item	Pos.	Quantity	Page	Assembly	Description
HOSE ASS CPL. 1SC 0,34M	92 67 113 08	197	1	2 997	91 56 539 08	HOSE LINES SUPERSTRUCT
HOSE ASS CPL. 1SC 0,3M	92 76 379 08	1406	1	2 975 061	96 47 201 08	HOSES WINCH 2
HOSE ASS CPL. 1SC 0,3M	92 76 379 08	1406	1	2 975 118	96 47 200 08	HOSES WINCH 1
HOSE ASS CPL. 1SC 0,48M	92 88 791 08	309	1	2 997	91 56 539 08	HOSE LINES SUPERSTRUCT
HOSE ASS CPL. 1SC 0,4M	92 60 254 08	342	1	2 997	91 56 539 08	HOSE LINES SUPERSTRUCT
HOSE ASS CPL. 1SC 0,58M	92 84 682 08	190	1	2 997	91 56 539 08	HOSE LINES SUPERSTRUCT
HOSE ASS CPL. 1SC 0,5M	92 60 981 08	1459	1	2 976 204	96 47 202 08	HOSE LINES 2 SLEWING GEA
HOSE ASS CPL. 1SC 0,64M	92 68 546 08	243	1	2 997	91 56 539 08	HOSE LINES SUPERSTRUCT
HOSE ASS CPL. 1SC 0,66M	92 61 198 08	307	1	2 997	91 56 539 08	HOSE LINES SUPERSTRUCT
HOSE ASS CPL. 1SC 0,66M	92 97 592 08	1452	1	2 976 701	96 47 196 08	HOSE LINES PUMP 12
HOSE ASS CPL. 1SC 0,6M	92 96 492 08	182	1	2 997	91 56 539 08	HOSE LINES SUPERSTRUCT
HOSE ASS CPL. 1SC 0,72M	92 76 816 08	386	1	2 997	91 56 539 08	HOSE LINES SUPERSTRUCT
HOSE ASS CPL. 1SC 0,72M	96 42 753 08	1466	1	2 976 204	96 47 202 08	HOSE LINES 2 SLEWING GEA
HOSE ASS CPL. 1SC 0,82M	92 63 790 08	333	1	2 997	91 56 539 08	HOSE LINES SUPERSTRUCT
HOSE ASS CPL. 1SC 0,88M	92 75 502 08	308	1	2 997	91 56 539 08	HOSE LINES SUPERSTRUCT
HOSE ASS CPL. 1SC 0,8M	96 25 348 08	219	1	2 997	91 56 539 08	HOSE LINES SUPERSTRUCT
HOSE ASS CPL. 1SC 0,96M	92 63 791 08	807	1	1 997	91 52 512 08	HOSE LINES CRAWLER
HOSE ASS CPL. 1SC 1,04M	92 93 776 08	385	1	2 997	91 56 539 08	HOSE LINES SUPERSTRUCT
HOSE ASS CPL. 1SC 1,0M	92 60 582 08	186	1	2 997	91 56 539 08	HOSE LINES SUPERSTRUCT
HOSE ASS CPL. 1SC 1,26M	92 80 465 08	304	1	2 997	91 56 539 08	HOSE LINES SUPERSTRUCT
HOSE ASS CPL. 1SC 1,2M	92 32 713 08	1460	1	2 976 204	96 47 202 08	HOSE LINES 2 SLEWING GEA
HOSE ASS CPL. 1SC 1,3M	96 52 075 08	343	1	2 997	91 56 539 08	HOSE LINES SUPERSTRUCT
HOSE ASS CPL. 1SC 1,46M	92 61 225 08	327	1	2 997	91 56 539 08	HOSE LINES SUPERSTRUCT
HOSE ASS CPL. 1SC 1,46M	92 76 122 08	271	1	2 997	91 56 539 08	HOSE LINES SUPERSTRUCT
HOSE ASS CPL. 1SC 2,0M	96 24 770 08	1223	1	2 978 101	96 47 912 08	HOSE LINES MOUNTING INST
HOSE ASS CPL. 1SC 2,3M	96 17 986 08	1385	1	2 975 191	96 48 196 08	HOSE LINES MOUNTING JACK
HOSE ASS CPL. 1SC 2,7M	92 76 383 08	326	1	2 997	91 56 539 08	HOSE LINES SUPERSTRUCT
HOSE ASS CPL. 1SN 0,2M	92 15 736 08	747	1	1 997	91 52 512 08	HOSE LINES CRAWLER
HOSE ASS CPL. 1SN 0,56M	92 13 504 08	384	1	2 997	91 56 539 08	HOSE LINES SUPERSTRUCT
HOSE ASS CPL. 1SN 0,56M	92 87 111 08	375	1	2 997	91 56 539 08	HOSE LINES SUPERSTRUCT
HOSE ASS CPL. 1SN 0,5M	92 15 391 08	231	1	2 997	91 56 539 08	HOSE LINES SUPERSTRUCT
HOSE ASS CPL. 1SN 0,7M	92 61 308 08	229	1	2 997	91 56 539 08	HOSE LINES SUPERSTRUCT
HOSE ASS CPL. 1SN 0,82M	96 52 068 08	228	1	2 997	91 56 539 08	HOSE LINES SUPERSTRUCT
HOSE ASS CPL. 1SN 0,84M	96 54 781 08	1481	1	2 977 005	96 48 195 08	HOSE LINES ADD HYDR
HOSE ASS CPL. 1SN 0,86M	92 26 313 08	221	1	2 997	91 56 539 08	HOSE LINES SUPERSTRUCT
HOSE ASS CPL. 1SN 0,8M	96 49 596 08	225	1	2 997	91 56 539 08	HOSE LINES SUPERSTRUCT
HOSE ASS CPL. 1SN 0,8M	96 49 599 08	235	1	2 997	91 56 539 08	HOSE LINES SUPERSTRUCT
HOSE ASS CPL. 1SN 0,94M	96 49 598 08	232	1	2 997	91 56 539 08	HOSE LINES SUPERSTRUCT
HOSE ASS CPL. 1SN 0,96M	92 97 527 08	226	1	2 997	91 56 539 08	HOSE LINES SUPERSTRUCT
HOSE ASS CPL. 1SN 0,98M	96 26 895 08	227	1	2 997	91 56 539 08	HOSE LINES SUPERSTRUCT
HOSE ASS CPL. 1SN 1,0M	92 76 051 08	377	1	2 997	91 56 539 08	HOSE LINES SUPERSTRUCT
HOSE ASS CPL. 1SN 1,0M	92 97 467 08	813	2	1 997	91 52 512 08	HOSE LINES CRAWLER
HOSE ASS CPL. 1SN 1,0M	92 97 467 08	234	1	2 997	91 56 539 08	HOSE LINES SUPERSTRUCT
HOSE ASS CPL. 1SN 1,2M	92 97 579 08	376	1	2 997	91 56 539 08	HOSE LINES SUPERSTRUCT
HOSE ASS CPL. 1SN 1,34M	96 49 595 08	223	1	2 997	91 56 539 08	HOSE LINES SUPERSTRUCT
HOSE ASS CPL. 1SN 1,36M	92 06 036 08	242	1	2 997	91 56 539 08	HOSE LINES SUPERSTRUCT
HOSE ASS CPL. 1SN 1,44M	96 49 594 08	222	1	2 997	91 56 539 08	HOSE LINES SUPERSTRUCT
HOSE ASS CPL. 1SN 1,55M	92 93 381 08	740	1	1 997	91 52 512 08	HOSE LINES CRAWLER
HOSE ASS CPL. 1SN 1,55M	96 27 618 08	389	1	2 997	91 56 539 08	HOSE LINES SUPERSTRUCT
HOSE ASS CPL. 1SN 1,55M	96 46 874 08	236	1	2 997	91 56 539 08	HOSE LINES SUPERSTRUCT
HOSE ASS CPL. 1SN 1,5M	96 54 337 08	1482	1	2 977 005	96 48 195 08	HOSE LINES ADD HYDR
HOSE ASS CPL. 1SN 1,6M	92 74 292 08	224	1	2 997	91 56 539 08	HOSE LINES SUPERSTRUCT
HOSE ASS CPL. 1SN 1,7M	92 75 706 08	1249	1	2 977 201	96 48 618 08	HOSES PUMP 6
HOSE ASS CPL. 1SN 1,7M	92 75 706 08	355	1	2 997	91 56 539 08	HOSE LINES SUPERSTRUCT
HOSE ASS CPL. 1SN 1,7M	92 87 633 08	357	1	2 997	91 56 539 08	HOSE LINES SUPERSTRUCT
HOSE ASS CPL. 1SN 1,95M	96 55 638 08	403	1	2 997	91 56 539 08	HOSE LINES SUPERSTRUCT
HOSE ASS CPL. 1SN 2,05M	92 96 216 08	237	1	2 997	91 56 539 08	HOSE LINES SUPERSTRUCT
HOSE ASS CPL. 1SN 2,1M	92 66 115 08	809	1	1 997	91 52 512 08	HOSE LINES CRAWLER
HOSE ASS CPL. 1SN 2,3M	92 96 157 08	1302	1	2 975 154	96 50 585 08	HOSES WINCH 3
HOSE ASS CPL. 1SN 2,3M	92 96 157 08	(1321)	1	3 978 100	91 56 428 08	HYDR. SUSPENDED BALLAST

6.2.2009

etk_en_de_074515 LR 1600/2

909

LIEBHERRAlphabetical index
Alphabetischer Index

Description	Item	Pos.	Quantity	Page	Assembly	Description
HOSE ASS CPL. 1SN 2,5M	92 60 668 08	1301	1	2 975 154	96 50 585 08	HOSES WINCH 3
HOSE ASS CPL. 1SN 2,6M	92 75 709 08	837	2	1 997	91 52 512 08	HOSE LINES CRAWLER
HOSE ASS CPL. 1SN 2,85M	96 55 637 08	402	1	2 997	91 56 539 08	HOSE LINES SUPERSTRUCT
HOSE ASS CPL. 1SN 3,0M	92 68 364 08	233	1	2 997	91 56 539 08	HOSE LINES SUPERSTRUCT
HOSE ASS CPL. 2755 0,46M	96 49 579 08	1210	1	2 978 204	96 47 114 08	HOSE LINES
HOSE ASS CPL. 2755 0,54M	92 25 870 08	1270	1	3 978 018	96 50 880 08	HOSE LINES PULL CYL
HOSE ASS CPL. 2755 0,54M	92 87 114 08	1211	1	2 978 204	96 47 114 08	HOSE LINES
HOSE ASS CPL. 2755 0,62M	92 18 495 08	391	1	2 997	91 56 539 08	HOSE LINES SUPERSTRUCT
HOSE ASS CPL. 2755 0,6M	92 22 817 08	359	1	2 997	91 56 539 08	HOSE LINES SUPERSTRUCT
HOSE ASS CPL. 2755 0,74M	96 51 591 08	1461	1	2 976 204	96 47 202 08	HOSE LINES 2 SLEWING GEA
HOSE ASS CPL. 2755 0,76M	96 43 235 08	392	1	2 997	91 56 539 08	HOSE LINES SUPERSTRUCT
HOSE ASS CPL. 2755 0,78M	92 60 732 08	358	1	2 997	91 56 539 08	HOSE LINES SUPERSTRUCT
HOSE ASS CPL. 2755 0,7M	92 28 969 08	382	1	2 997	91 56 539 08	HOSE LINES SUPERSTRUCT
HOSE ASS CPL. 2755 0,84M	96 51 573 08	1451	1	2 976 701	96 47 196 08	HOSE LINES PUMP 12
HOSE ASS CPL. 2755 0,86M	96 51 896 08	381	1	2 997	91 56 539 08	HOSE LINES SUPERSTRUCT
HOSE ASS CPL. 2755 0,88M	96 52 067 08	211	1	2 997	91 56 539 08	HOSE LINES SUPERSTRUCT
HOSE ASS CPL. 2755 0,8M	96 51 572 08	1450	1	2 976 701	96 47 196 08	HOSE LINES PUMP 12
HOSE ASS CPL. 2755 0,96M	92 45 280 08	1222	1	2 978 101	96 47 912 08	HOSE LINES MOUNTING INST
HOSE ASS CPL. 2755 0,9M	96 52 066 08	210	1	2 997	91 56 539 08	HOSE LINES SUPERSTRUCT
HOSE ASS CPL. 2755 1,02M	92 96 166 08	1462	1	2 976 204	96 47 202 08	HOSE LINES 2 SLEWING GEA
HOSE ASS CPL. 2755 1,04M	92 27 352 08	1483	1	2 977 005	96 48 195 08	HOSE LINES ADD HYDR
HOSE ASS CPL. 2755 1,06M	92 44 585 08	383	1	2 997	91 56 539 08	HOSE LINES SUPERSTRUCT
HOSE ASS CPL. 2755 1,0M	92 22 505 08	1313	2	2 978 107	96 50 433 08	HOSE LINES GUY MOUNTING
HOSE ASS CPL. 2755 1,12M	92 56 341 08	1221	1	2 978 101	96 47 912 08	HOSE LINES MOUNTING INST
HOSE ASS CPL. 2755 1,2M	96 51 561 08	212	1	2 997	91 56 539 08	HOSE LINES SUPERSTRUCT
HOSE ASS CPL. 2755 1,3M	92 40 956 08	746	1	1 997	91 52 512 08	HOSE LINES CRAWLER
HOSE ASS CPL. 2755 1,42M	92 80 222 08	1220	2	2 978 101	96 47 912 08	HOSE LINES MOUNTING INST
HOSE ASS CPL. 2755 1,55M	96 51 562 08	213	1	2 997	91 56 539 08	HOSE LINES SUPERSTRUCT
HOSE ASS CPL. 2755 1,65M	92 20 800 08	312	2	2 997	91 56 539 08	HOSE LINES SUPERSTRUCT
HOSE ASS CPL. 2755 1,75M	92 29 002 08	301	1	2 997	91 56 539 08	HOSE LINES SUPERSTRUCT
HOSE ASS CPL. 2755 1,7M	92 40 284 08	302	1	2 997	91 56 539 08	HOSE LINES SUPERSTRUCT
HOSE ASS CPL. 2755 1,8M	92 64 556 08	400	1	2 997	91 56 539 08	HOSE LINES SUPERSTRUCT
HOSE ASS CPL. 2755 1,9M	92 48 756 08	390	1	2 997	91 56 539 08	HOSE LINES SUPERSTRUCT
HOSE ASS CPL. 2755 2,05M	92 61 208 08	1455	1	2 976 204	96 47 202 08	HOSE LINES 2 SLEWING GEA
HOSE ASS CPL. 2755 2,2M	92 18 746 08	812	1	1 997	91 52 512 08	HOSE LINES CRAWLER
HOSE ASS CPL. 2755 2,35M	92 19 240 08	1456	1	2 976 204	96 47 202 08	HOSE LINES 2 SLEWING GEA
HOSE ASS CPL. 2755 2,3M	92 80 473 08	(1320)	1	3 978 100	91 56 428 08	HYDR. SUSPENDED BALLAST
HOSE ASS CPL. 2755 2,45M	96 54 735 08	1308	1	2 978 107	96 50 433 08	HOSE LINES GUY MOUNTING
HOSE ASS CPL. 2755 2,6M	92 60 420 08	1264	2	3 978 009	96 50 881 08	HOSE LINES D-HEAD SECTIO
HOSE ASS CPL. 2755 3,3M	92 44 929 08	1263	2	3 978 009	96 50 881 08	HOSE LINES D-HEAD SECTIO
HOSE ASS CPL. 2755 3,4M	96 20 654 08	802	4	1 997	91 52 512 08	HOSE LINES CRAWLER
HOSE ASS CPL. 2755 3,8M	92 87 562 08	(1880)	8	1 975 006	91 52 509 08	ADD. HYDR. SUPPORTING RA
HOSE ASS CPL. 2SN 0,23M	92 74 496 08	328	1	2 997	91 56 539 08	HOSE LINES SUPERSTRUCT
HOSE ASS CPL. 2SN 0,24M	96 52 045 08	122	1	2 997	91 56 539 08	HOSE LINES SUPERSTRUCT
HOSE ASS CPL. 2SN 0,25M	92 76 973 08	1405	1	2 975 061	96 47 201 08	HOSES WINCH 2
HOSE ASS CPL. 2SN 0,25M	92 76 973 08	1405	1	2 975 118	96 47 200 08	HOSES WINCH 1
HOSE ASS CPL. 2SN 0,28M	92 17 502 08	1161	1	2 975 154	96 50 585 08	HOSES WINCH 3
HOSE ASS CPL. 2SN 0,2M	92 80 057 08	185	1	2 997	91 56 539 08	HOSE LINES SUPERSTRUCT
HOSE ASS CPL. 2SN 0,32M	92 93 259 08	401	2	2 997	91 56 539 08	HOSE LINES SUPERSTRUCT
HOSE ASS CPL. 2SN 0,33M	92 09 765 08	398	1	2 997	91 56 539 08	HOSE LINES SUPERSTRUCT
HOSE ASS CPL. 2SN 0,33M	92 32 286 08	193	1	2 997	91 56 539 08	HOSE LINES SUPERSTRUCT
HOSE ASS CPL. 2SN 0,35M	92 66 576 08	188	1	2 997	91 56 539 08	HOSE LINES SUPERSTRUCT
HOSE ASS CPL. 2SN 0,35M	92 66 576 08	192	1	2 997	91 56 539 08	HOSE LINES SUPERSTRUCT
HOSE ASS CPL. 2SN 0,35M	92 76 161 08	1404	1	2 975 061	96 47 201 08	HOSES WINCH 2
HOSE ASS CPL. 2SN 0,35M	92 76 161 08	1404	1	2 975 118	96 47 200 08	HOSES WINCH 1
HOSE ASS CPL. 2SN 0,35M	92 87 660 08	394	1	2 997	91 56 539 08	HOSE LINES SUPERSTRUCT
HOSE ASS CPL. 2SN 0,41M	96 51 589 08	1402	1	2 975 061	96 47 201 08	HOSES WINCH 2
HOSE ASS CPL. 2SN 0,41M	96 51 589 08	1402	1	2 975 118	96 47 200 08	HOSES WINCH 1
HOSE ASS CPL. 2SN 0,42M	92 80 056 08	198	1	2 997	91 56 539 08	HOSE LINES SUPERSTRUCT
HOSE ASS CPL. 2SN 0,43M	96 51 596 08	329	1	2 997	91 56 539 08	HOSE LINES SUPERSTRUCT

6.2.2009

etk_en_de_074515 LR 1600/2

910

LIEBHERRAlphabetical index
Alphabetischer Index

Description	Item	Pos.	Quantity	Page	Assembly	Description
HOSE ASS CPL. 2SN 0,43M	96 51 596 08	330	1	2 997	91 56 539 08	HOSE LINES SUPERSTRUCT
HOSE ASS CPL. 2SN 0,46M	96 51 593 08	316	1	2 997	91 56 539 08	HOSE LINES SUPERSTRUCT
HOSE ASS CPL. 2SN 0,48M	92 99 231 08	1213	1	2 978 204	96 47 114 08	HOSE LINES
HOSE ASS CPL. 2SN 0,48M	96 22 558 08	1216	1	2 978 204	96 47 114 08	HOSE LINES
HOSE ASS CPL. 2SN 0,48M	96 51 588 08	196	1	2 997	91 56 539 08	HOSE LINES SUPERSTRUCT
HOSE ASS CPL. 2SN 0,48M	96 54 718 08	1272	1	3 978 018	96 50 880 08	HOSE LINES PULL CYL
HOSE ASS CPL. 2SN 0,4M	92 24 554 08	264	1	2 997	91 56 539 08	HOSE LINES SUPERSTRUCT
HOSE ASS CPL. 2SN 0,4M	92 24 554 08	397	1	2 997	91 56 539 08	HOSE LINES SUPERSTRUCT
HOSE ASS CPL. 2SN 0,4M	92 76 147 08	1382	1	2 975 191	96 48 196 08	HOSE LINES MOUNTING JACK
HOSE ASS CPL. 2SN 0,4M	92 80 060 08	331	1	2 997	91 56 539 08	HOSE LINES SUPERSTRUCT
HOSE ASS CPL. 2SN 0,4M	92 84 715 08	124	1	2 997	91 56 539 08	HOSE LINES SUPERSTRUCT
HOSE ASS CPL. 2SN 0,51M	92 93 119 08	1214	1	2 978 204	96 47 114 08	HOSE LINES
HOSE ASS CPL. 2SN 0,54M	92 96 122 08	379	1	2 997	91 56 539 08	HOSE LINES SUPERSTRUCT
HOSE ASS CPL. 2SN 0,54M	96 24 385 08	365	1	2 997	91 56 539 08	HOSE LINES SUPERSTRUCT
HOSE ASS CPL. 2SN 0,54M	96 29 580 08	215	1	2 997	91 56 539 08	HOSE LINES SUPERSTRUCT
HOSE ASS CPL. 2SN 0,56M	92 84 567 08	216	1	2 997	91 56 539 08	HOSE LINES SUPERSTRUCT
HOSE ASS CPL. 2SN 0,58M	92 93 262 08	1271	1	3 978 018	96 50 880 08	HOSE LINES PULL CYL
HOSE ASS CPL. 2SN 0,58M	96 54 722 08	1212	1	2 978 204	96 47 114 08	HOSE LINES
HOSE ASS CPL. 2SN 0,5M	92 68 659 08	265	1	2 997	91 56 539 08	HOSE LINES SUPERSTRUCT
HOSE ASS CPL. 2SN 0,62M	92 30 161 08	1160	1	2 975 154	96 50 585 08	HOSES WINCH 3
HOSE ASS CPL. 2SN 0,62M	92 76 164 08	125	1	2 997	91 56 539 08	HOSE LINES SUPERSTRUCT
HOSE ASS CPL. 2SN 0,62M	96 51 914 08	1215	1	2 978 204	96 47 114 08	HOSE LINES
HOSE ASS CPL. 2SN 0,62M	96 51 914 08	1217	1	2 978 204	96 47 114 08	HOSE LINES
HOSE ASS CPL. 2SN 0,64M	96 51 590 08	1403	1	2 975 061	96 47 201 08	HOSES WINCH 2
HOSE ASS CPL. 2SN 0,64M	96 51 590 08	1403	1	2 975 118	96 47 200 08	HOSES WINCH 1
HOSE ASS CPL. 2SN 0,66M	96 51 587 08	187	1	2 997	91 56 539 08	HOSE LINES SUPERSTRUCT
HOSE ASS CPL. 2SN 0,6M	92 80 058 08	366	1	2 997	91 56 539 08	HOSE LINES SUPERSTRUCT
HOSE ASS CPL. 2SN 0,6M	92 80 058 08	399	1	2 997	91 56 539 08	HOSE LINES SUPERSTRUCT
HOSE ASS CPL. 2SN 0,6M	92 88 897 08	354	1	2 997	91 56 539 08	HOSE LINES SUPERSTRUCT
HOSE ASS CPL. 2SN 0,72M	96 41 931 08	361	1	2 997	91 56 539 08	HOSE LINES SUPERSTRUCT
HOSE ASS CPL. 2SN 0,76M	92 88 711 08	1273	1	3 978 018	96 50 880 08	HOSE LINES PULL CYL
HOSE ASS CPL. 2SN 0,78M	92 76 428 08	184	1	2 997	91 56 539 08	HOSE LINES SUPERSTRUCT
HOSE ASS CPL. 2SN 0,78M	92 76 838 08	1384	1	2 975 191	96 48 196 08	HOSE LINES MOUNTING JACK
HOSE ASS CPL. 2SN 0,7M	92 65 600 08	(95)	2	2 976 203	92 27 489 08	ADDL.HYDR.F.PIN PULLING DE
HOSE ASS CPL. 2SN 0,7M	92 68 678 08	274	1	2 997	91 56 539 08	HOSE LINES SUPERSTRUCT
HOSE ASS CPL. 2SN 0,7M	96 33 357 08	1162	1	2 975 154	96 50 585 08	HOSES WINCH 3
HOSE ASS CPL. 2SN 0,7M	96 33 357 08	341	1	2 997	91 56 539 08	HOSE LINES SUPERSTRUCT
HOSE ASS CPL. 2SN 0,86M	96 41 973 08	1315	1	2 978 107	96 50 433 08	HOSE LINES GUY MOUNTING
HOSE ASS CPL. 2SN 0,86M	96 49 576 08	360	1	2 997	91 56 539 08	HOSE LINES SUPERSTRUCT
HOSE ASS CPL. 2SN 0,86M	96 51 917 08	320	1	2 997	91 56 539 08	HOSE LINES SUPERSTRUCT
HOSE ASS CPL. 2SN 0,88M	92 68 547 08	1314	1	2 978 107	96 50 433 08	HOSE LINES GUY MOUNTING
HOSE ASS CPL. 2SN 0,8M	92 27 451 08	1401	1	2 975 061	96 47 201 08	HOSES WINCH 2
HOSE ASS CPL. 2SN 0,8M	92 27 451 08	1401	1	2 975 118	96 47 200 08	HOSES WINCH 1
HOSE ASS CPL. 2SN 0,8M	92 27 451 08	362	1	2 997	91 56 539 08	HOSE LINES SUPERSTRUCT
HOSE ASS CPL. 2SN 0,8M	96 52 071 08	322	1	2 997	91 56 539 08	HOSE LINES SUPERSTRUCT
HOSE ASS CPL. 2SN 0,92M	92 76 776 08	393	1	2 997	91 56 539 08	HOSE LINES SUPERSTRUCT
HOSE ASS CPL. 2SN 0,92M	96 52 046 08	123	1	2 997	91 56 539 08	HOSE LINES SUPERSTRUCT
HOSE ASS CPL. 2SN 0,94M	92 80 363 08	332	1	2 997	91 56 539 08	HOSE LINES SUPERSTRUCT
HOSE ASS CPL. 2SN 0,9M	96 52 072 08	323	1	2 997	91 56 539 08	HOSE LINES SUPERSTRUCT
HOSE ASS CPL. 2SN 1,04M	92 99 672 08	1311	1	2 978 107	96 50 433 08	HOSE LINES GUY MOUNTING
HOSE ASS CPL. 2SN 1,06M	96 25 946 08	1310	1	2 978 107	96 50 433 08	HOSE LINES GUY MOUNTING
HOSE ASS CPL. 2SN 1,0M	92 80 300 08	1383	1	2 975 191	96 48 196 08	HOSE LINES MOUNTING JACK
HOSE ASS CPL. 2SN 1,0M	92 93 107 08	1164	1	2 975 154	96 50 585 08	HOSES WINCH 3
HOSE ASS CPL. 2SN 1,0M	92 93 328 08	1312	2	2 978 107	96 50 433 08	HOSE LINES GUY MOUNTING
HOSE ASS CPL. 2SN 1,1M	96 51 560 08	209	1	2 997	91 56 539 08	HOSE LINES SUPERSTRUCT
HOSE ASS CPL. 2SN 1,4M	92 87 596 08	1465	1	2 976 204	96 47 202 08	HOSE LINES 2 SLEWING GEA
HOSE ASS CPL. 2SN 1,55M	96 22 426 08	263	1	2 997	91 56 539 08	HOSE LINES SUPERSTRUCT
HOSE ASS CPL. 2SN 1,5M	96 31 722 08	1261	1	3 978 009	96 50 881 08	HOSE LINES D-HEAD SECTIO
HOSE ASS CPL. 2SN 1,5M	96 51 559 08	208	1	2 997	91 56 539 08	HOSE LINES SUPERSTRUCT
HOSE ASS CPL. 2SN 1,65M	96 55 636 08	217	1	2 997	91 56 539 08	HOSE LINES SUPERSTRUCT

6.2.2009

etk_en_de_074515 LR 1600/2

911

LIEBHERRAlphabetical index
Alphabetischer Index

Description	Item	Pos.	Quantity	Page	Assembly	Description
HOSE ASS CPL. 2SN 1,75M	92 09 806 08	261	1	2 997	91 56 539 08	HOSE LINES SUPERSTRUCT
HOSE ASS CPL. 2SN 1,75M	96 29 984 08	1287	1	3 978 016	96 50 878 08	HOSE LINES INTERM. SECTIO
HOSE ASS CPL. 2SN 1,7M	92 74 187 08	262	1	2 997	91 56 539 08	HOSE LINES SUPERSTRUCT
HOSE ASS CPL. 2SN 1,7M	96 31 723 08	(1282)	1	3 978 015	91 56 429 08	ADDITIONAL HYDRAULICS IN
HOSE ASS CPL. 2SN 1,85M	92 09 958 08	244	1	2 997	91 56 539 08	HOSE LINES SUPERSTRUCT
HOSE ASS CPL. 2SN 1,85M	92 76 030 08	1247	1	2 977 201	96 48 618 08	HOSES PUMP 6
HOSE ASS CPL. 2SN 1,85M	92 76 030 08	1248	1	2 977 201	96 48 618 08	HOSES PUMP 6
HOSE ASS CPL. 2SN 1,85M	92 87 626 08	338	1	2 997	91 56 539 08	HOSE LINES SUPERSTRUCT
HOSE ASS CPL. 2SN 1,9M	92 97 484 08	1169	1	2 975 154	96 50 585 08	HOSES WINCH 3
HOSE ASS CPL. 2SN 15,0M	92 87 559 08	90	4	2 976 200	91 44 034 08	AUX.HYDR.PIN EXTRACTION
HOSE ASS CPL. 2SN 15,0M	96 51 586 08	(1371)	2	2 970 081	96 50 495 08	ADDL.HYDR.F.PIN PULLING DE
HOSE ASS CPL. 2SN 2,0M	92 09 849 08	317	1	2 997	91 56 539 08	HOSE LINES SUPERSTRUCT
HOSE ASS CPL. 2SN 2,45M	92 76 036 08	1309	1	2 978 107	96 50 433 08	HOSE LINES GUY MOUNTING
HOSE ASS CPL. 2SN 2,55M	96 51 595 08	324	1	2 997	91 56 539 08	HOSE LINES SUPERSTRUCT
HOSE ASS CPL. 2SN 2,5M	92 76 848 08	1303	1	2 975 154	96 50 585 08	HOSES WINCH 3
HOSE ASS CPL. 2SN 2,5M	92 76 848 08	1304	1	2 975 154	96 50 585 08	HOSES WINCH 3
HOSE ASS CPL. 2SN 2,5M	92 97 568 08	339	2	2 997	91 56 539 08	HOSE LINES SUPERSTRUCT
HOSE ASS CPL. 2SN 2,5M	96 31 991 08	1307	1	2 978 107	96 50 433 08	HOSE LINES GUY MOUNTING
HOSE ASS CPL. 2SN 2,65M	96 32 001 08	838	2	1 997	91 52 512 08	HOSE LINES CRAWLER
HOSE ASS CPL. 2SN 2,7M	92 10 438 08	363	1	2 997	91 56 539 08	HOSE LINES SUPERSTRUCT
HOSE ASS CPL. 2SN 2,7M	96 52 073 08	325	1	2 997	91 56 539 08	HOSE LINES SUPERSTRUCT
HOSE ASS CPL. 2SN 3,0M	92 84 646 08	(1370)	2	2 970 081	96 50 495 08	ADDL.HYDR.F.PIN PULLING DE
HOSE ASS CPL. 2SN 3,6M	92 12 548 08	364	1	2 997	91 56 539 08	HOSE LINES SUPERSTRUCT
HOSE ASS CPL. 2SN 3,7M	96 47 681 08	1262	2	3 978 009	96 50 881 08	HOSE LINES D-HEAD SECTIO
HOSE ASS CPL. 2SN 7,9M	96 51 606 08	368	1	2 997	91 56 539 08	HOSE LINES SUPERSTRUCT
HOSE ASS CPL. 2TE 0,15M	96 27 578 08	1218	1	2 978 204	96 47 114 08	HOSE LINES
HOSE ASS CPL. 2TE 0,16M	96 54 309 08	1266	1	3 978 009	96 50 881 08	HOSE LINES D-HEAD SECTIO
HOSE ASS CPL. 2TE 0,22M	96 49 567 08	1224	1	2 978 101	96 47 912 08	HOSE LINES MOUNTING INST
HOSE ASS CPL. 2TE 0,26M	96 37 039 08	189	1	2 997	91 56 539 08	HOSE LINES SUPERSTRUCT
HOSE ASS CPL. 2TE 0,28M	96 54 283 08	396	1	2 997	91 56 539 08	HOSE LINES SUPERSTRUCT
HOSE ASS CPL. 2TE 0,32M	92 66 122 08	314	1	2 997	91 56 539 08	HOSE LINES SUPERSTRUCT
HOSE ASS CPL. 2TE 0,32M	92 76 407 08	1407	1	2 975 061	96 47 201 08	HOSES WINCH 2
HOSE ASS CPL. 2TE 0,32M	92 76 407 08	1407	1	2 975 118	96 47 200 08	HOSES WINCH 1
HOSE ASS CPL. 2TE 0,34M	92 80 398 08	178	1	2 997	91 56 539 08	HOSE LINES SUPERSTRUCT
HOSE ASS CPL. 2TE 0,34M	92 87 646 08	1458	1	2 976 204	96 47 202 08	HOSE LINES 2 SLEWING GEA
HOSE ASS CPL. 2TE 0,34M	92 87 646 08	1464	1	2 976 204	96 47 202 08	HOSE LINES 2 SLEWING GEA
HOSE ASS CPL. 2TE 0,34M	92 87 646 08	195	1	2 997	91 56 539 08	HOSE LINES SUPERSTRUCT
HOSE ASS CPL. 2TE 0,38M	92 87 508 08	120	1	2 997	91 56 539 08	HOSE LINES SUPERSTRUCT
HOSE ASS CPL. 2TE 0,3M	92 26 702 08	1219	1	2 978 204	96 47 114 08	HOSE LINES
HOSE ASS CPL. 2TE 0,3M	92 96 377 08	194	1	2 997	91 56 539 08	HOSE LINES SUPERSTRUCT
HOSE ASS CPL. 2TE 0,43M	92 87 642 08	191	1	2 997	91 56 539 08	HOSE LINES SUPERSTRUCT
HOSE ASS CPL. 2TE 0,43M	96 33 352 08	1408	1	2 975 061	96 47 201 08	HOSES WINCH 2
HOSE ASS CPL. 2TE 0,43M	96 33 352 08	1408	1	2 975 118	96 47 200 08	HOSES WINCH 1
HOSE ASS CPL. 2TE 0,45M	92 76 109 08	1409	1	2 975 061	96 47 201 08	HOSES WINCH 2
HOSE ASS CPL. 2TE 0,45M	92 76 109 08	1409	1	2 975 118	96 47 200 08	HOSES WINCH 1
HOSE ASS CPL. 2TE 0,46M	92 65 663 08	239	1	2 997	91 56 539 08	HOSE LINES SUPERSTRUCT
HOSE ASS CPL. 2TE 0,46M	92 84 526 08	1163	1	2 975 154	96 50 585 08	HOSES WINCH 3
HOSE ASS CPL. 2TE 0,47M	92 80 172 08	1454	1	2 976 701	96 47 196 08	HOSE LINES PUMP 12
HOSE ASS CPL. 2TE 0,47M	96 31 691 08	181	1	2 997	91 56 539 08	HOSE LINES SUPERSTRUCT
HOSE ASS CPL. 2TE 0,48M	92 87 505 08	745	1	1 997	91 52 512 08	HOSE LINES CRAWLER
HOSE ASS CPL. 2TE 0,48M	92 87 505 08	395	2	2 997	91 56 539 08	HOSE LINES SUPERSTRUCT
HOSE ASS CPL. 2TE 0,4M	92 60 954 08	257	1	2 997	91 56 539 08	HOSE LINES SUPERSTRUCT
HOSE ASS CPL. 2TE 0,4M	96 49 535 08	805	1	1 997	91 52 512 08	HOSE LINES CRAWLER
HOSE ASS CPL. 2TE 0,52M	92 96 106 08	808	1	1 997	91 52 512 08	HOSE LINES CRAWLER
HOSE ASS CPL. 2TE 0,52M	92 96 106 08	245	1	2 997	91 56 539 08	HOSE LINES SUPERSTRUCT
HOSE ASS CPL. 2TE 0,52M	96 51 604 08	351	1	2 997	91 56 539 08	HOSE LINES SUPERSTRUCT
HOSE ASS CPL. 2TE 0,54M	96 28 573 08	352	1	2 997	91 56 539 08	HOSE LINES SUPERSTRUCT
HOSE ASS CPL. 2TE 0,56M	92 87 641 08	1453	1	2 976 701	96 47 196 08	HOSE LINES PUMP 12
HOSE ASS CPL. 2TE 0,58M	92 69 908 08	353	1	2 997	91 56 539 08	HOSE LINES SUPERSTRUCT
HOSE ASS CPL. 2TE 0,58M	92 72 931 08	255	1	2 997	91 56 539 08	HOSE LINES SUPERSTRUCT

6.2.2009

etk_en_de_074515 LR 1600/2

912

LIEBHERRAlphabetical index
Alphabetischer Index

Description	Item	Pos.	Quantity	Page	Assembly	Description
HOSE ASS CPL. 2TE 0,5M	92 30 874 08	248	1	2 997	91 56 539 08	HOSE LINES SUPERSTRUCT
HOSE ASS CPL. 2TE 0,5M	92 60 417 08	256	1	2 997	91 56 539 08	HOSE LINES SUPERSTRUCT
HOSE ASS CPL. 2TE 0,5M	92 69 710 08	350	1	2 997	91 56 539 08	HOSE LINES SUPERSTRUCT
HOSE ASS CPL. 2TE 0,5M	96 49 593 08	254	1	2 997	91 56 539 08	HOSE LINES SUPERSTRUCT
HOSE ASS CPL. 2TE 0,62M	92 88 722 08	179	1	2 997	91 56 539 08	HOSE LINES SUPERSTRUCT
HOSE ASS CPL. 2TE 0,64M	92 76 825 08	121	1	2 997	91 56 539 08	HOSE LINES SUPERSTRUCT
HOSE ASS CPL. 2TE 0,64M	92 76 825 08	252	1	2 997	91 56 539 08	HOSE LINES SUPERSTRUCT
HOSE ASS CPL. 2TE 0,64M	96 39 296 08	380	1	2 997	91 56 539 08	HOSE LINES SUPERSTRUCT
HOSE ASS CPL. 2TE 0,66M	92 99 240 08	432	1	2 997	91 56 539 08	HOSE LINES SUPERSTRUCT
HOSE ASS CPL. 2TE 0,68M	96 40 959 08	1463	1	2 976 204	96 47 202 08	HOSE LINES 2 SLEWING GEA
HOSE ASS CPL. 2TE 0,68M	96 40 959 08	251	1	2 997	91 56 539 08	HOSE LINES SUPERSTRUCT
HOSE ASS CPL. 2TE 0,6M	92 65 511 08	1267	1	3 978 009	96 50 881 08	HOSE LINES D-HEAD SECTIO
HOSE ASS CPL. 2TE 0,6M	92 96 478 08	1172	1	2 975 154	96 50 585 08	HOSES WINCH 3
HOSE ASS CPL. 2TE 0,74M	96 38 237 08	199	1	2 997	91 56 539 08	HOSE LINES SUPERSTRUCT
HOSE ASS CPL. 2TE 0,74M	96 42 737 08	259	1	2 997	91 56 539 08	HOSE LINES SUPERSTRUCT
HOSE ASS CPL. 2TE 0,76M	92 26 284 08	247	1	2 997	91 56 539 08	HOSE LINES SUPERSTRUCT
HOSE ASS CPL. 2TE 0,82M	96 24 526 08	272	1	2 997	91 56 539 08	HOSE LINES SUPERSTRUCT
HOSE ASS CPL. 2TE 0,86M	92 64 932 08	180	1	2 997	91 56 539 08	HOSE LINES SUPERSTRUCT
HOSE ASS CPL. 2TE 0,86M	96 17 203 08	834	2	1 997	91 52 512 08	HOSE LINES CRAWLER
HOSE ASS CPL. 2TE 0,88M	96 47 719 08	238	1	2 997	91 56 539 08	HOSE LINES SUPERSTRUCT
HOSE ASS CPL. 2TE 0,88M	96 47 719 08	240	1	2 997	91 56 539 08	HOSE LINES SUPERSTRUCT
HOSE ASS CPL. 2TE 0,8M	92 66 066 08	183	1	2 997	91 56 539 08	HOSE LINES SUPERSTRUCT
HOSE ASS CPL. 2TE 0,8M	92 66 066 08	321	1	2 997	91 56 539 08	HOSE LINES SUPERSTRUCT
HOSE ASS CPL. 2TE 0,92M	92 87 176 08	249	1	2 997	91 56 539 08	HOSE LINES SUPERSTRUCT
HOSE ASS CPL. 2TE 0,96M	92 97 535 08	246	1	2 997	91 56 539 08	HOSE LINES SUPERSTRUCT
HOSE ASS CPL. 2TE 0,96M	92 97 535 08	356	1	2 997	91 56 539 08	HOSE LINES SUPERSTRUCT
HOSE ASS CPL. 2TE 0,98M	96 54 736 08	1316	1	2 978 107	96 50 433 08	HOSE LINES GUY MOUNTING
HOSE ASS CPL. 2TE 0,9M	92 76 814 08	337	1	2 997	91 56 539 08	HOSE LINES SUPERSTRUCT
HOSE ASS CPL. 2TE 0,9M	92 76 814 08	1265	1	3 978 009	96 50 881 08	HOSE LINES D-HEAD SECTIO
HOSE ASS CPL. 2TE 0,9M	92 84 719 08	367	1	2 997	91 56 539 08	HOSE LINES SUPERSTRUCT
HOSE ASS CPL. 2TE 1,04M	96 49 597 08	230	1	2 997	91 56 539 08	HOSE LINES SUPERSTRUCT
HOSE ASS CPL. 2TE 1,0M	92 80 170 08	334	1	2 997	91 56 539 08	HOSE LINES SUPERSTRUCT
HOSE ASS CPL. 2TE 1,0M	96 51 610 08	378	1	2 997	91 56 539 08	HOSE LINES SUPERSTRUCT
HOSE ASS CPL. 2TE 1,15M	92 76 775 08	373	1	2 997	91 56 539 08	HOSE LINES SUPERSTRUCT
HOSE ASS CPL. 2TE 1,18M	96 49 589 08	371	1	2 997	91 56 539 08	HOSE LINES SUPERSTRUCT
HOSE ASS CPL. 2TE 1,1M	92 35 237 08	1480	1	2 977 005	96 48 195 08	HOSE LINES ADD HYDR
HOSE ASS CPL. 2TE 1,1M	92 65 761 08	315	1	2 997	91 56 539 08	HOSE LINES SUPERSTRUCT
HOSE ASS CPL. 2TE 1,26M	92 70 110 08	310	1	2 997	91 56 539 08	HOSE LINES SUPERSTRUCT
HOSE ASS CPL. 2TE 1,34M	92 64 194 08	305	1	2 997	91 56 539 08	HOSE LINES SUPERSTRUCT
HOSE ASS CPL. 2TE 1,36M	92 64 954 08	258	1	2 997	91 56 539 08	HOSE LINES SUPERSTRUCT
HOSE ASS CPL. 2TE 1,3M	92 43 724 08	1170	1	2 975 154	96 50 585 08	HOSES WINCH 3
HOSE ASS CPL. 2TE 1,3M	92 60 465 08	804	1	1 997	91 52 512 08	HOSE LINES CRAWLER
HOSE ASS CPL. 2TE 1,3M	92 76 977 08	803	1	1 997	91 52 512 08	HOSE LINES CRAWLER
HOSE ASS CPL. 2TE 1,46M	92 65 763 08	273	1	2 997	91 56 539 08	HOSE LINES SUPERSTRUCT
HOSE ASS CPL. 2TE 1,46M	96 25 943 08	319	1	2 997	91 56 539 08	HOSE LINES SUPERSTRUCT
HOSE ASS CPL. 2TE 1,4M	92 72 524 08	372	1	2 997	91 56 539 08	HOSE LINES SUPERSTRUCT
HOSE ASS CPL. 2TE 1,55M	92 93 122 08	318	1	2 997	91 56 539 08	HOSE LINES SUPERSTRUCT
HOSE ASS CPL. 2TE 1,55M	96 51 567 08	253	1	2 997	91 56 539 08	HOSE LINES SUPERSTRUCT
HOSE ASS CPL. 2TE 1,6M	96 18 625 08	335	1	2 997	91 56 539 08	HOSE LINES SUPERSTRUCT
HOSE ASS CPL. 2TE 1,7M	92 61 392 08	260	1	2 997	91 56 539 08	HOSE LINES SUPERSTRUCT
HOSE ASS CPL. 2TE 1,85M	92 60 962 08	250	1	2 997	91 56 539 08	HOSE LINES SUPERSTRUCT
HOSE ASS CPL. 2TE 1,85M	92 76 750 08	806	1	1 997	91 52 512 08	HOSE LINES CRAWLER
HOSE ASS CPL. 2TE 1,95M	92 87 630 08	1171	1	2 975 154	96 50 585 08	HOSES WINCH 3
HOSE ASS CPL. 2TE 1,9M	92 80 485 08	1168	1	2 975 154	96 50 585 08	HOSES WINCH 3
HOSE ASS CPL. 2TE 2,05M	92 60 246 08	220	1	2 997	91 56 539 08	HOSE LINES SUPERSTRUCT
HOSE ASS CPL. 2TE 2,05M	96 54 724 08	1167	1	2 975 154	96 50 585 08	HOSES WINCH 3
HOSE ASS CPL. 2TE 2,0M	92 99 224 08	241	1	2 997	91 56 539 08	HOSE LINES SUPERSTRUCT
HOSE ASS CPL. 2TE 2,15M	92 61 222 08	832	2	1 997	91 52 512 08	HOSE LINES CRAWLER
HOSE ASS CPL. 2TE 2,1M	92 61 473 08	1457	1	2 976 204	96 47 202 08	HOSE LINES 2 SLEWING GEA
HOSE ASS CPL. 2TE 2,3M	92 88 607 08	336	1	2 997	91 56 539 08	HOSE LINES SUPERSTRUCT

6.2.2009

etk_en_de_074515 LR 1600/2

913

LIEBHERRAlphabetical index
Alphabetischer Index

Description	Item	Pos.	Quantity	Page	Assembly	Description
HOSE ASS CPL. 2TE 2,3M	92 88 763 08	388	1	2 997	91 56 539 08	HOSE LINES SUPERSTRUCT
HOSE ASS CPL. 2TE 2,4M	92 61 388 08	1380	1	2 975 191	96 48 196 08	HOSE LINES MOUNTING JACK
HOSE ASS CPL. 2TE 2,55M	92 76 918 08	374	1	2 997	91 56 539 08	HOSE LINES SUPERSTRUCT
HOSE ASS CPL. 2TE 2,5M	96 49 541 08	833	2	1 997	91 52 512 08	HOSE LINES CRAWLER
HOSE ASS CPL. 2TE 2,6M	92 93 167 08	1842	2	1 976 050	96 50 707 08	HOSES CRAWLER 4 DRIVES
HOSE ASS CPL. 2TE 2,7M	96 52 074 08	340	1	2 997	91 56 539 08	HOSE LINES SUPERSTRUCT
HOSE ASS CPL. 2TE 2,8M	92 71 131 08	1843	2	1 976 050	96 50 707 08	HOSES CRAWLER 4 DRIVES
HOSE ASS CPL. 2TE 3,2M	96 28 615 08	306	1	2 997	91 56 539 08	HOSE LINES SUPERSTRUCT
HOSE ASS CPL. 2TE 3,3M	92 61 496 08	311	1	2 997	91 56 539 08	HOSE LINES SUPERSTRUCT
HOSE ASS CPL. 2TE 3,3M	96 54 282 08	387	1	2 997	91 56 539 08	HOSE LINES SUPERSTRUCT
HOSE ASS CPL. 2TE 4,7M	92 97 516 08	431	1	2 997	91 56 539 08	HOSE LINES SUPERSTRUCT
HOSE ASS CPL. 2TE 5,0M	92 61 458 08	430	1	2 997	91 56 539 08	HOSE LINES SUPERSTRUCT
HOSE ASS CPL. GH134 1,9M	96 51 902 08	(1103)	1	2 831	91 57 754 08	AIR COND. UNIT SUPERSTRU
HOSE ASS CPL. GH134 2,7M	96 54 324 08	(1104)	1	2 831	91 57 754 08	AIR COND. UNIT SUPERSTRU
HOSE ASS CPL. GH134 2,8M	96 54 323 08	(1102)	1	2 831	91 57 754 08	AIR COND. UNIT SUPERSTRU
HOSE ASS CPL. GH134 3,6M	96 54 325 08	(1105)	1	2 831	91 57 754 08	AIR COND. UNIT SUPERSTRU
HOSE ASS CPL. GH134 8,0M	96 54 321 08	(1100)	1	2 831	91 57 754 08	AIR COND. UNIT SUPERSTRU
HOSE ASS CPL. GH134 8,1M	96 54 322 08	(1101)	1	2 831	91 57 754 08	AIR COND. UNIT SUPERSTRU
HOSE ASS CPL. GH466 0,48M	96 51 600 08	346	1	2 997	91 56 539 08	HOSE LINES SUPERSTRUCT
HOSE ASS CPL. GH466 0,62M	96 51 598 08	344	1	2 997	91 56 539 08	HOSE LINES SUPERSTRUCT
HOSE ASS CPL. GH466 0,62M	96 51 601 08	347	1	2 997	91 56 539 08	HOSE LINES SUPERSTRUCT
HOSE ASS CPL. GH466 0,74M	96 51 599 08	345	1	2 997	91 56 539 08	HOSE LINES SUPERSTRUCT
HOSE ASS CPL. GH466 0,78M	96 44 763 08	816	1	1 997	91 52 512 08	HOSE LINES CRAWLER
HOSE ASS CPL. GH466 0,88M	96 52 049 08	741	1	1 997	91 52 512 08	HOSE LINES CRAWLER
HOSE ASS CPL. GH466 0,88M	96 52 049 08	743	1	1 997	91 52 512 08	HOSE LINES CRAWLER
HOSE ASS CPL. GH466 0,92M	96 51 906 08	1486	1	2 977 005	96 48 195 08	HOSE LINES ADD HYDR
HOSE ASS CPL. GH466 1,02M	96 51 905 08	1484	1	2 977 005	96 48 195 08	HOSE LINES ADD HYDR
HOSE ASS CPL. GH466 1,08M	96 51 603 08	349	1	2 997	91 56 539 08	HOSE LINES SUPERSTRUCT
HOSE ASS CPL. GH466 1,0M	96 49 546 08	814	1	1 997	91 52 512 08	HOSE LINES CRAWLER
HOSE ASS CPL. GH466 1,0M	96 51 602 08	348	1	2 997	91 56 539 08	HOSE LINES SUPERSTRUCT
HOSE ASS CPL. GH466 1,12M	96 49 548 08	817	1	1 997	91 52 512 08	HOSE LINES CRAWLER
HOSE ASS CPL. GH466 1,12M	96 49 548 08	1487	1	2 977 005	96 48 195 08	HOSE LINES ADD HYDR
HOSE ASS CPL. GH466 1,15M	96 33 350 08	201	1	2 997	91 56 539 08	HOSE LINES SUPERSTRUCT
HOSE ASS CPL. GH466 1,1M	96 23 356 08	1485	1	2 977 005	96 48 195 08	HOSE LINES ADD HYDR
HOSE ASS CPL. GH466 1,32M	96 49 600 08	200	1	2 997	91 56 539 08	HOSE LINES SUPERSTRUCT
HOSE ASS CPL. GH466 1,34M	96 51 609 08	300	1	2 997	91 56 539 08	HOSE LINES SUPERSTRUCT
HOSE ASS CPL. GH466 1,34M	96 54 723 08	1166	1	2 975 154	96 50 585 08	HOSES WINCH 3
HOSE ASS CPL. GH466 1,36M	96 49 547 08	815	1	1 997	91 52 512 08	HOSE LINES CRAWLER
HOSE ASS CPL. GH466 1,46M	96 51 607 08	303	1	2 997	91 56 539 08	HOSE LINES SUPERSTRUCT
HOSE ASS CPL. GH466 1,46M	96 51 607 08	369	1	2 997	91 56 539 08	HOSE LINES SUPERSTRUCT
HOSE ASS CPL. GH466 1,4M	96 51 608 08	370	1	2 997	91 56 539 08	HOSE LINES SUPERSTRUCT
HOSE ASS CPL. GH466 1,5M	96 49 549 08	830	2	1 997	91 52 512 08	HOSE LINES CRAWLER
HOSE ASS CPL. GH466 1,5M	96 49 549 08	1165	1	2 975 154	96 50 585 08	HOSES WINCH 3
HOSE ASS CPL. GH466 1,5M	96 51 553 08	202	1	2 997	91 56 539 08	HOSE LINES SUPERSTRUCT
HOSE ASS CPL. GH466 1,6M	96 51 907 08	1245	2	2 977 201	96 48 618 08	HOSES PUMP 6
HOSE ASS CPL. GH466 1,75M	96 36 000 08	742	1	1 997	91 52 512 08	HOSE LINES CRAWLER
HOSE ASS CPL. GH466 1,75M	96 51 554 08	203	1	2 997	91 56 539 08	HOSE LINES SUPERSTRUCT
HOSE ASS CPL. GH466 1,7M	96 49 550 08	831	2	1 997	91 52 512 08	HOSE LINES CRAWLER
HOSE ASS CPL. GH466 1,85M	96 49 545 08	744	1	1 997	91 52 512 08	HOSE LINES CRAWLER
HOSE ASS CPL. GH466 1,8M	96 49 551 08	1840	2	1 976 050	96 50 707 08	HOSES CRAWLER 4 DRIVES
HOSE ASS CPL. GH466 2,05M	96 39 243 08	835	2	1 997	91 52 512 08	HOSE LINES CRAWLER
HOSE ASS CPL. GH466 2,0M	96 49 553 08	1841	2	1 976 050	96 50 707 08	HOSES CRAWLER 4 DRIVES
HOSE ASS CPL. GH466 2,35M	96 31 973 08	836	2	1 997	91 52 512 08	HOSE LINES CRAWLER
HOSE ASS CPL. GH466 2,35M	96 31 973 08	1300	2	2 975 154	96 50 585 08	HOSES WINCH 3
HOSE ASS CPL. GH506 0,62M	96 36 987 08	204	1	2 997	91 56 539 08	HOSE LINES SUPERSTRUCT
HOSE ASS CPL. GH506 0,62M	96 51 909 08	1244	1	2 977 201	96 48 618 08	HOSES PUMP 6
HOSE ASS CPL. GH506 0,74M	96 51 908 08	1243	1	2 977 201	96 48 618 08	HOSES PUMP 6
HOSE ASS CPL. GH506 0,7M	96 51 557 08	205	1	2 997	91 56 539 08	HOSE LINES SUPERSTRUCT
HOSE ASS CPL. GH506 1,3M	96 39 267 08	1260	2	3 978 009	96 50 881 08	HOSE LINES D-HEAD SECTIO
HOSE ASS CPL. GH506 1,44M	96 51 556 08	206	1	2 997	91 56 539 08	HOSE LINES SUPERSTRUCT

6.2.2009

etk_en_de_074515 LR 1600/2

914

LIEBHERRAlphabetical index
Alphabetischer Index

Description	Item	Pos.	Quantity	Page	Assembly	Description
HOSE ASS CPL. GH506 1,44M	96 52 047 08	207	1	2 997	91 56 539 08	HOSE LINES SUPERSTRUCT
HOSE ASS CPL. GH506 1,5M	96 54 719 08	(1280)	1	3 978 015	91 56 429 08	ADDITIONAL HYDRAULICS IN
HOSE ASS CPL. GH506 1,5M	96 54 719 08	(1281)	1	3 978 015	91 56 429 08	ADDITIONAL HYDRAULICS IN
HOSE ASS CPL. GH506 1,5M	96 54 719 08	1285	1	3 978 016	96 50 878 08	HOSE LINES INTERM. SECTIO
HOSE ASS CPL. GH506 1,5M	96 54 719 08	1286	1	3 978 016	96 50 878 08	HOSE LINES INTERM. SECTIO
HOSE ASS CPL. GH506 1,65M	96 28 576 08	214	1	2 997	91 56 539 08	HOSE LINES SUPERSTRUCT
HOSE ASS CPL. HPC 0,6M	92 14 563 08	451	1	2 997	91 56 539 08	HOSE LINES SUPERSTRUCT
HOSE ASS CPL. HPC 1,06M	96 51 948 08	452	1	2 997	91 56 539 08	HOSE LINES SUPERSTRUCT
HOSE ASS CPL. HPC 12,3M	96 54 779 08	455	1	2 997	91 56 539 08	HOSE LINES SUPERSTRUCT
HOSE ASS CPL. HPC 2,5M	92 93 211 08	871	2	1 997	91 52 512 08	HOSE LINES CRAWLER
HOSE ASS CPL. HPC 2,7M	96 52 070 08	453	1	2 997	91 56 539 08	HOSE LINES SUPERSTRUCT
HOSE ASS CPL. HPC 2,9M	96 38 619 08	450	1	2 997	91 56 539 08	HOSE LINES SUPERSTRUCT
HOSE ASS CPL. HPC 2,9M	96 38 619 08	454	1	2 997	91 56 539 08	HOSE LINES SUPERSTRUCT
HOSE ASS CPL. HPC 5,9M	92 09 034 08	870	2	1 997	91 52 512 08	HOSE LINES CRAWLER
HOSE ASS CPL. TFS 1,0M	92 12 619 08	275	1	2 997	91 56 539 08	HOSE LINES SUPERSTRUCT
HOSE ASS CPL. TFS 1,5M	96 23 354 08	(1366)	1	2 393	91 52 787 08	AIR FILTER UNIT CPL.
HOSE BEND 90°	10 03 717 3	2	2	9 739 210	97 39 210	LIQUID COOLING PIPELINE
HOSE CLAMP	55 31 023 08	15	6	2 541	91 52 790 08	ADD HEATING SUPERSTRUCT
HOSE CLAMP 100-104 ST	77 42 237 08	8	2	2 670	91 52 797 08	FUEL TANK CPL.
HOSE CLAMP 100-120 W3	55 08 494 08	132	8	2 391 001	96 45 719 08	DIESEL ENGINE, PRE-ASSEMB
HOSE CLAMP 100-120 W3	55 08 494 08	6	2	2 391 023	96 45 720 08	RADIATOR, PRE-ASSEMBLED
HOSE CLAMP 100-120 W3	55 08 494 08	16	4	2 670	91 52 797 08	FUEL TANK CPL.
HOSE CLAMP 100X120 12-W2	10 03 717 1	2	1	9 739 209	97 39 209	SUCTION NOZZLE
HOSE CLAMP 11-20	55 08 496 08	15	1	2 920 638	96 51 138 08	CONTROL DESK
HOSE CLAMP 130-150 W3	77 42 099 08	10	2	2 393	91 52 787 08	AIR FILTER UNIT CPL.
HOSE CLAMP 140-148 ST	77 42 118 08	11	1	2 393	91 52 787 08	AIR FILTER UNIT CPL.
HOSE CLAMP 158-166 ST	77 42 119 08	77	2	2 970	91 56 537 08	HYDR
HOSE CLAMP 160-180/12 W3	10 03 051 7	14	1	2 393	91 52 787 08	AIR FILTER UNIT CPL.
HOSE CLAMP 176-184 ST	77 42 283 08	11	2	2 978 100	91 52 796 08	ADDNL.HYDR.ERECTION DEV
HOSE CLAMP 24-38	77 42 040 08	5	1	2 541 001	96 49 651 08	ADDNL.HEATING, PRE-ASSE
HOSE CLAMP 26 CK75	10 01 267 1	16	2	9 739 386	97 39 386	CRANKCASE BREATHER
HOSE CLAMP 29	10 28 505 2	30	2	9 739 494	97 39 494	ATL ATTACHMENT
HOSE CLAMP 29 CK75	10 01 266 8	15	1	9 739 386	97 39 386	CRANKCASE BREATHER
HOSE CLAMP 32-50 W3	55 08 495 08	134	2	2 391 001	96 45 719 08	DIESEL ENGINE, PRE-ASSEMB
HOSE CLAMP 40-60 W3	55 08 380 08	52	4	2 520 034	96 45 984 08	INTERNAL LINING
HOSE CLAMP 44 CK75	10 01 267 4	21	5	9 739 492	97 39 492	PIPELINE INSTALLATION
HOSE CLAMP 60-80 W3	77 42 143 08	136	8	2 391 001	96 45 719 08	DIESEL ENGINE, PRE-ASSEMB
HOSE CLAMP 60-80 W3	77 42 143 08	7	2	2 391 023	96 45 720 08	RADIATOR, PRE-ASSEMBLED
HOSE CLAMP 60X80 12-W2	10 03 717 6	3	4	9 739 210	97 39 210	LIQUID COOLING PIPELINE
HOSE CLAMP 70/68-73/25 ST	10 65 265 7	135	6	2 391 001	96 45 719 08	DIESEL ENGINE, PRE-ASSEMB
HOSE CLAMP 72X20	77 42 139 08	12	1	2 671 004	96 46 305 08	OIL TANK PRE-ASS.
HOSE CLAMP 86-91X25 ST	77 42 279 08	148	8	2 391 001	96 45 719 08	DIESEL ENGINE, PRE-ASSEMB
HOSE CLAMP DIN 3017 A 32/50	55 31 684 08	15	2	2 520 032	96 45 980 08	WINDSHIELD WASHER INSTAL
HOSE CLAMP DIN 3017-1 21,5/	77 42 086 08	153	2	2 391 001	96 45 719 08	DIESEL ENGINE, PRE-ASSEMB
HOSE CLAMP DIN 3017-1 21,5/	77 42 086 08	13	17	2 540	91 53 253 08	CLIMA-HEATING INSTALLATIO
HOSE CLAMP DIN 3017-1 21,5/	77 42 086 08	16	12	2 541	91 52 790 08	ADD HEATING SUPERSTRUCT
HOSE CLAMP HRGB ST	77 42 830 08	12	3	2 393	91 52 787 08	AIR FILTER UNIT CPL.
HOSE CLAMP THREADED UN	60 24 400 08	4	1	2 920 257	92 78 689 08	TERMINAL BOX LIGHTING HO
HOSE DI=2/DA=5	55 30 187 08	12	10	2 541	91 52 790 08	ADD HEATING SUPERSTRUCT
HOSE DI=2/DA=5	55 30 187 08	13	2	2 541	91 52 790 08	ADD HEATING SUPERSTRUCT
HOSE DN130X100	95 58 181 08	4	1	2 393	91 52 787 08	AIR FILTER UNIT CPL.
HOSE DN18X2200	55 31 761 08	17	1	2 540	91 53 253 08	CLIMA-HEATING INSTALLATIO
HOSE DN18X2200	55 31 761 08	9	1	2 541	91 52 790 08	ADD HEATING SUPERSTRUCT
HOSE DN6,3	57 17 120 08	2	1	5 123 682	51 23 682 08	MOUNTING - PISTON W. PUM
HOSE DN65X5X450	97 72 148 08	11	1	2 671 004	96 46 305 08	OIL TANK PRE-ASS.
HOSE GUARD SPIRAL 26,5 ST	10 10 075 2	157	2.2	2 391 001	96 45 719 08	DIESEL ENGINE, PRE-ASSEMB
HOSE GUMMI	55 07 726 08	2	2	2 393	91 52 787 08	AIR FILTER UNIT CPL.
HOSE LINE	10 34 342 0	5	1	9 739 356	97 39 356	PIPELINE INSTALLATION
HOSE LINE DN10 1200	10 11 573 5	1	1	X1011614	10 11 614 1	FUEL HOSE
HOSE LINES	96 47 114 08	91	1	2 978 200	91 54 843 08	ADD.HYDR.S_RETAINING RAM

6.2.2009

etk_en_de_074515 LR 1600/2

915

LIEBHERRAlphabetical index
Alphabetischer Index

Description	Item	Pos.	Quantity	Page	Assembly	Description
HOSE LINES 2 SLEWING GEA	96 47 202 08	91	1	2 976 200	91 52 780 08	ADDITIONAL HYDRAULICS
HOSE LINES ADD HYDR	96 48 195 08	91	1	2 977	91 57 756 08	ADDITIONAL HYDR.SLEWING
HOSE LINES AIR FLAP	96 54 041 08	500	1	2 393	91 52 787 08	AIR FILTER UNIT CPL.
HOSE LINES BOLT EXTRACTIO	96 46 080 08	91	1	2 976 203	92 27 489 08	ADDL.HYDR.F.PIN PULLING DE
HOSE LINES BOLT EXTRACTIO	96 52 635 08	91	1	2 970 081	96 50 495 08	ADDL.HYDR.F.PIN PULLING DE
HOSE LINES CRAWLER	91 52 512 08	35	1		LR 1600-2-0	
HOSE LINES D-HEAD SECTIO	96 50 881 08	91	1	3 978 005	91 56 430 08	ADDL.HYDRAULIC SB-HEAD PI
HOSE LINES GUY MOUNTING	96 50 433 08	91	1	2 978 100	91 52 827 08	ADDNL.HYDR.RETAINING DEV
HOSE LINES INTERM. SECTIO	96 50 883 08	91	1	3 978 015	91 56 429 08	ADDITIONAL HYDRAULICS IN
HOSE LINES INTERM. SECTI	96 50 878 08	91	1	3 978 015	91 56 432 08	ADDITIONAL HYDRAULICS IN
HOSE LINES MOUNTING INST	96 47 912 08	91	1	2 978 100	91 52 796 08	ADDNL.HYDR.ERECTION DEV
HOSE LINES MOUNTING JACK	96 48 196 08	91	1	2 975 000	91 57 881 08	ADDNL. HYDR. F. ERECTING W
HOSE LINES PULL CYL	96 50 880 08	91	1	3 978 019	91 56 431 08	AUX.HYDR.CYLINDER SB-BW
HOSE LINES PUMP 12	96 47 196 08	91	1	2 976 700	91 54 795 08	ADDITIONAL HYDRAULICS P
HOSE LINES SUPERSTRUCT	91 56 539 08	179	1		LR 1600-2-0	
HOSE LINES SUPPORTING RA	96 47 504 08	91	1	1 975 006	91 52 509 08	ADD. HYDR. SUPPORTING RA
HOSE LINES SUSPENDED BA	96 56 946 08	91	1	3 978 100	91 56 428 08	HYDR. SUSPENDED BALLAST
HOSE N1-32	10 01 120 0	20	2	9 739 492	97 39 492	PIPELINE INSTALLATION
HOSE SLEEVE DN100X110	55 17 166 08	22	2	2 391 023	96 45 720 08	RADIATOR, PRE-ASSEMBLED
HOSE UNION 18 M24X 1,5 ST	10 34 334 3	8	1	9 739 351	97 39 351	COOLING MEDIUM PIPELINE
HOSE UNION 22-M26X1,5 ST	10 01 272 5	10	1	9 739 355	97 39 355	OIL COOLER ADD-ON
HOSE UNION JOINT M16X1,5 M	60 24 408 08	(7)	1	2 920 559	96 47 914 08	LIMIT SWITCH AND SENSOR
HOSE UNION JOINT M20X1,5 M	60 24 414 08	271	1	1 920 403	96 48 707 08	TERMINAL BOX CPL.
HOSE UNION JOINT M20X1,5 M	60 24 414 08	271	1	1 920 417	96 48 703 08	TERMINAL BOX CPL.
HOSE UNION JOINT M40X1,5 M	60 24 412 08	288	3	2 920 448	96 48 794 08	TERMINAL BOX CPL.
HOSE UNION JOINT M50X1,5 M	60 24 413 08	17	1	1 920 418	96 48 687 08	TERMINAL BOX CPL.
HOSE UNION JOINT M50X1,5 M	60 24 413 08	283	1	2 920 448	96 48 794 08	TERMINAL BOX CPL.
HOSES AIR CONDITIONING L	96 54 368 08	500	1	2 831	91 57 754 08	AIR COND. UNIT SUPERSTRU
HOSES CRAWLER 4 DRIVES	96 50 707 08	91	1	1 970 161	96 50 706 08	AUX.HYDR.CR.TRACK CARR.4
HOSES PUMP 6	96 48 618 08	91	1	2 977 200	91 55 149 08	ADDITIONAL HYDR.PUMP/WI
HOSES WINCH 1	96 47 200 08	91	1	2 975 700	91 52 774 08	ADDITIONAL HYDRAULICS WI
HOSES WINCH 2	96 47 201 08	91	1	2 975 200	91 52 775 08	ADDITIONAL HYDRAULICS WI
HOSES WINCH 3	96 50 585 08	91	1	2 975 100	91 52 860 08	ADDITIONAL HYDRAULICS WI
HOUSING	10 22 275 8	9	1	9 739 258	97 39 258	FUEL FILTER
HOUSING	51 07 969 08	1	1	5 114 176	51 14 176 08	PRESSURE LIMITING VALVE
HOUSING	51 07 969 08	1	1	5 114 177	51 14 177 08	PRESSURE LIMITING VALVE
HOUSING	57 00 092 08	1	1	5 026 126	50 26 126 08	SOLENOID VALVE
HOUSING	57 00 728 08	1	1	5 114 320	51 14 320 08	PRETENSIONING VALVE
HOUSING	57 01 130 08	3	1	5 102 306	51 02 306 08	HYDRO MOTOR
HOUSING	70 42 533 08	14	4	2 260 006	96 46 501 08	BATTERY BOX, PRE-ASSEMB
HOUSING	70 42 533 08	5	7	2 859 005	96 46 756 08	FLAP PRE-ASS.
HOUSING	70 42 566 08	4	4	2 393 002	96 46 782 08	COVER COMPL.
HOUSING	70 42 566 08	4	4	2 859 007	96 46 775 08	COVER COMPL.
HOUSING	70 42 566 08	10	4	2 859 025	96 46 757 08	GRIDIRON PRE-ASS.
HOUSING	70 42 566 08	4	4	2 859 026	96 46 776 08	COVER COMPL.
HOUSING	70 42 566 08	4	4	2 859 027	96 46 777 08	COVER COMPL.
HOUSING	70 42 566 08	4	4	2 859 028	96 46 778 08	COVER COMPL.
HOUSING	70 42 566 08	4	4	2 859 029	96 46 779 08	COVER COMPL.
HOUSING	70 42 566 08	9	2	2 859 030	96 46 758 08	COVER COMPL.
HOUSING	70 42 747 08	3	6	2 932 168	96 48 167 08	COVER COMPL.
HOUSING	92 99 369 08	1	1	2 913 004	96 20 460 08	HOUSING PRE-ASSEMBLED
HOUSING 10POL	60 23 328 08	(152)	1	2 920 369	96 54 235 08	TERMINAL BOX CPL.
HOUSING 14POL	60 23 360 08	(152)	1	2 920 369	96 54 235 08	TERMINAL BOX CPL.
HOUSING 14POL	60 23 360 08	507	12	2 932 224	96 54 389 08	CABLES MOUNTING PANEL C
HOUSING 15POL	10 09 986 3	512	1	2 932 224	96 54 389 08	CABLES MOUNTING PANEL C
HOUSING 1X400X273 DC01-A-	61 10 012 08	2	1	2 913 102	92 32 870 08	FAN UNIT
HOUSING 21 POL BRAUN	10 09 985 6	518	2	2 932 224	96 54 389 08	CABLES MOUNTING PANEL C
HOUSING 25POL SPF	60 23 223 08	510	7	2 932 224	96 54 389 08	CABLES MOUNTING PANEL C
HOUSING 4POL	60 23 313 08	515	13	2 932 224	96 54 389 08	CABLES MOUNTING PANEL C
HOUSING 6POL	60 23 255 08	520	2	2 932 224	96 54 389 08	CABLES MOUNTING PANEL C

6.2.2009

etk_en_de_074515 LR 1600/2

916

LIEBHERRAlphabetical index
Alphabetischer Index

Description	Item	Pos.	Quantity	Page	Assembly	Description
HOUSING 8POL	60 23 014 08	511	1	2 932 224	96 54 389 08	CABLES MOUNTING PANEL C
HOUSING PRE-ASSEMBLED	96 20 460 08	2	1	2 913	91 32 850 08	LICCON CONSOLE LCD2
HOUSING PRE-ASSEMBLED	96 20 460 08	2	1	2 913 009	91 04 705 08	LICCON CONSOLE LCD3
HOUSING SPF	97 58 507 08	50	1	2 520	91 53 061 08	CABIN, GLAZED
HUB	10 65 067 5	6	1	X1035519	10 35 519 6	OIL AIR COOLER
HUB	57 19 010 08	2	1	5 719 006	57 19 006 08	PUMP SUPPORT
HUB	57 19 055 08	4	1	2 212	91 54 561 08	PUMP F.SLEWING GEAR
HYDR	91 56 537 08	169	1		LR 1600-2-0	
HYDR. SUPPORT WELDMENT	96 45 817 08	1	2	1 630	91 52 387 08	HYDRAULIC SUPPORT
HYDR. SUPPORT WELDMENT	96 45 818 08	2	2	1 630	91 52 387 08	HYDRAULIC SUPPORT
HYDR. SUSPENDED BALLAST	91 56 428 08	400	1	3 713	91 57 749 08	D PIVOT SECTION
HYDRAULIC ADJUSTMENT	10 33 323 8	4	1	X1035924	10 35 924 7	VARIABLE PUMP
HYDRAULIC SUPPORT	91 52 387 08	15	1		LR 1600-2-0	
HYDRO CYLINDER 150/140-161	10 41 101 9	34	2	2 550	91 57 751 08	SA FRAME
HYDRO CYLINDER 55/32-400	51 23 497 08	31	1	2 810	91 52 806 08	CRANE DRIVER'S CABIN CPL.
HYDRO CYLINDER 75/30-100	10 32 632 3	16	2	2 810	91 52 806 08	CRANE DRIVER'S CABIN CPL.
HYDRO CYLINDER 75/30-260 -4	51 23 943 08	1	1	3 790 006	96 19 989 08	PIN PULLING CYLINDER CPL.
HYDRO CYLINDER 75/30-260 -4	51 23 944 08	1	1	3 790 007	96 19 990 08	PIN PULLING CYLINDER CPL.
HYDRO CYLINDER 80/40-400	10 41 102 2	1	1	2 125	91 52 773 08	PIN F.S-PIVOT SECTION SA F
HYDRO MOTOR SPF	51 02 306 08	2	1	2 370	91 52 782 08	ERECTING WINCH
HYDRO MOTOR SPF	51 02 354 08	2	2	2 350	91 52 778 08	SLEWING GEAR
HYDRO MOTOR SPF	51 02 380 08	2	2	2 391 023	96 45 720 08	RADIATOR, PRE-ASSEMBLED
HYDT.TUBE	10 22 236 5	8	1	9 739 355	97 39 355	OIL COOLER ADD-ON
HYDT.TUBE	10 28 710 5	21	1	9 739 494	97 39 494	ATL ATTACHMENT
HYDT.TUBE	10 28 710 7	29	1	9 739 494	97 39 494	ATL ATTACHMENT
IDENTIFICATION STRIP	60 27 426 08	503	0.25	3 930 363	96 52 979 08	TERMINAL BOX CPL.
IDENTIFICATION STRIP	60 27 426 08	14	0.1	3 930 640	96 50 481 08	TERMINAL BOX CPL.
IDENTIFICATION STRIP	60 27 426 08	503	0.56	3 930 730	96 54 398 08	TERMINAL BOX CPL.
IDENTIFICATION STRIP 1 - 250	60 27 437 08	263	1	2 920 581	96 54 405 08	TERMINAL BOX WINCH PRE-A
IDENTIFICATION STRIPS	60 27 629 08	19	1	2 932 082	96 54 387 08	ASSEMBLY PARTS MOUNTIN
IGNITION STARTER SWITCH 3	10 33 555 7	4	1	2 533 070	96 48 363 08	CONTROLS AND FITTINGS RI
INCLINATION TRANSMITTER	69 23 081 08	10	1	1 920 307	96 48 383 08	ELECTR.FOR CENTER SECTIO
INCLINATION TRANSMITTER	69 23 081 08	12	1	2 780 510	96 50 097 08	ELECTR.FOR BALLAST PALLE
INDUCT. SENSOR BT ASSEMB	96 17 565 08	2	1	2 920 559	96 47 914 08	LIMIT SWITCH AND SENSOR
INDUCTIVE SENSOR SPF	69 23 087 08	14	4	2 780 510	96 50 097 08	ELECTR.FOR BALLAST PALLE
INDUCTIVE SENSOR SPF	69 23 087 08	(1)	2	2 920 559	96 47 914 08	LIMIT SWITCH AND SENSOR
INDUCTIVE SENSOR SPF	69 23 087 08	15	2	2 930	96 57 085 08	SENSOR ASSEMBLY SA-STAN
INDUCTIVE SENSOR SPF	69 23 087 08	34	1	2 932 160	96 54 385 08	SWITCH CABINET
INDUCTIVE SENSOR SPF	69 23 087 08	151	2	3 930 501	96 51 078 08	EL.BACKING PROTECTION D
INDUCTIVE SENSOR SPF	69 23 087 08	151	2	3 930 713	92 95 070 08	EL.EQUIPMENT SAFETY RETAI
INDUCTIVE SENSOR SPF	69 23 087 08	(151)	1	3 930 731	96 48 374 08	ELECTRICS F BASE SECTION
INDUCTIVE SENSOR SPF	69 23 127 08	35	1	2 932 160	96 54 385 08	SWITCH CABINET
INFORMATION LABEL PVC 2	97 39 082	49	1	9 739 400	97 39 400	DIESEL ENGINE
INJECTION LINE	10 22 274 5	8	1	9 739 369	97 39 369	PRESSURE PIPE
INJECTION LINE	10 22 274 6	9	1	9 739 369	97 39 369	PRESSURE PIPE
INJECTION LINE	10 22 274 7	10	1	9 739 369	97 39 369	PRESSURE PIPE
INJECTOR	97 39 248	90	6	X1012059	10 12 059 0	DIESEL ENGINE
INJECTOR ASSY	10 22 019 8	1	1	9 739 248	97 39 248	INJECTOR
INPUT BOARD CPL. EP0	96 48 329 08	30	1	2 932 082	96 54 387 08	ASSEMBLY PARTS MOUNTIN
INPUT BOARD CPL. EP1	96 48 330 08	31	1	2 932 082	96 54 387 08	ASSEMBLY PARTS MOUNTIN
INPUT BOARD CPL. EP2	96 48 331 08	32	1	2 932 082	96 54 387 08	ASSEMBLY PARTS MOUNTIN
INPUT BOARD CPL. EP3	96 48 332 08	33	1	2 932 082	96 54 387 08	ASSEMBLY PARTS MOUNTIN
INPUT BOARD CPL. EP4	96 48 333 08	34	1	2 932 082	96 54 387 08	ASSEMBLY PARTS MOUNTIN
INPUT BOARD CPL. EP5	96 48 334 08	35	1	2 932 082	96 54 387 08	ASSEMBLY PARTS MOUNTIN
INSERT M20X1,5 NBR	60 24 219 08	(505)	1	2 920 288	96 52 614 08	WIRING LIST F.SLEWING PLAT
INSERTION BRIDGE	60 27 355 08	70	50	2 932 082	96 54 387 08	ASSEMBLY PARTS MOUNTIN
INSERTION MODULE	60 27 923 08	1	1	2 932 515	96 45 911 08	INSERTION MODULE
INSERTION MODULE	96 45 911 08	51	1	2 932 082	96 54 387 08	ASSEMBLY PARTS MOUNTIN
INSTALLAT.ROTOR+SLIPRING	92 15 300 08	2	1	1 991	91 52 510 08	ROTARY FEED THROUGH
INSTALLATION BRAKE COMPR	97 39 491	140	1	X1012059	10 12 059 0	DIESEL ENGINE

6.2.2009

etk_en_de_074515 LR 1600/2

917

LIEBHERRAlphabetical index
Alphabetischer Index

Description	Item	Pos.	Quantity	Page	Assembly	Description
INSULANT FLOOR PLATE	96 49 125 08	69	1	2 520	91 53 061 08	CABIN, GLAZED
INSULATING BODY	60 56 015 08	514	3	2 920 633	96 52 651 08	WIRING HARNESS
INSULATING BUSH KUNSTST	66 00 430 08	7	1	2 913 100	91 23 538 08	ASSEMBLY FRAME
INSULATING MAT 20X100X274	97 76 591 08	11	1	2 520 035	96 49 125 08	INSULANT FLOOR PLATE
INSULATING MAT 20X1206X32	97 70 937 08	3	1	2 859 007	96 46 775 08	COVER COMPL.
INSULATING MAT 20X123X288	97 76 590 08	10	1	2 520 035	96 49 125 08	INSULANT FLOOR PLATE
INSULATING MAT 20X1400X44	97 70 809 08	32	1	2 859	91 52 809 08	SOUND INSULATION
INSULATING MAT 20X155X429	97 76 582 08	2	1	2 520 035	96 49 125 08	INSULANT FLOOR PLATE
INSULATING MAT 20X182X747	97 76 588 08	8	1	2 520 035	96 49 125 08	INSULANT FLOOR PLATE
INSULATING MAT 20X195X747	97 76 585 08	5	1	2 520 035	96 49 125 08	INSULANT FLOOR PLATE
INSULATING MAT 20X213X280	97 76 592 08	12	1	2 520 035	96 49 125 08	INSULANT FLOOR PLATE
INSULATING MAT 20X215X451	97 76 593 08	13	1	2 520 035	96 49 125 08	INSULANT FLOOR PLATE
INSULATING MAT 20X229X810	97 76 584 08	4	1	2 520 035	96 49 125 08	INSULANT FLOOR PLATE
INSULATING MAT 20X229X810	97 76 586 08	6	1	2 520 035	96 49 125 08	INSULANT FLOOR PLATE
INSULATING MAT 20X294X986	97 76 587 08	7	1	2 520 035	96 49 125 08	INSULANT FLOOR PLATE
INSULATING MAT 20X348X786	97 76 581 08	1	1	2 520 035	96 49 125 08	INSULANT FLOOR PLATE
INSULATING MAT 20X380X894	97 76 583 08	3	1	2 520 035	96 49 125 08	INSULANT FLOOR PLATE
INSULATING MAT 20X451X986	97 76 589 08	9	1	2 520 035	96 49 125 08	INSULANT FLOOR PLATE
INSULATING MAT 20X793X635	97 70 984 08	3	1	2 859 027	96 46 777 08	COVER COMPL.
INSULATING MAT 20X798X443	97 70 986 08	3	1	2 859 028	96 46 778 08	COVER COMPL.
INSULATING MAT 20X798X445	97 71 635 08	3	1	2 393 002	96 46 782 08	COVER COMPL.
INSULATING MAT 20X798X643	97 70 953 08	3	1	2 859 026	96 46 776 08	COVER COMPL.
INSULATING MAT 20X953X442	97 70 796 08	26	1	2 859	91 52 809 08	SOUND INSULATION
INSULATING MAT 20X989X365	97 70 998 08	3	1	2 859 029	96 46 779 08	COVER COMPL.
INSULATING MAT 40X482X228	97 70 907 08	41	1	2 859	91 52 809 08	SOUND INSULATION
INSULATING MAT BOTTOM 9	97 18 507 08	6	1	2 913	91 32 850 08	LICCON CONSOLE LCD2
INSULATING MAT BOTTOM 9	97 18 507 08	6	1	2 913 009	91 04 705 08	LICCON CONSOLE LCD3
INSULATING MAT TOP 11.5X9	97 18 514 08	10	1	2 913	91 32 850 08	LICCON CONSOLE LCD2
INSULATING MAT TOP 11.5X9	97 18 514 08	10	1	2 913 009	91 04 705 08	LICCON CONSOLE LCD3
INSULATING MAT-LOCK 21X36	97 18 511 08	7	1	2 913	91 32 850 08	LICCON CONSOLE LCD2
INSULATING MAT-LOCK 21X36	97 18 511 08	7	1	2 913 009	91 04 705 08	LICCON CONSOLE LCD3
INSULATING MATERIAL 20X20	10 42 540 9	70	1.5	2 859	91 52 809 08	SOUND INSULATION
INSULATING MATERIAL 40X40	28 39 057 08	29	1	2 391 023	96 45 720 08	RADIATOR, PRE-ASSEMBLED
INSULATING MATERIAL 40X40	28 39 057 08	72	1	2 859	91 52 809 08	SOUND INSULATION
INSULATING RING	69 10 417 08	13	52	6 909 010	69 09 010 08	COLLECTING RING
INSULATING TUBE	10 28 710 6	27	1	9 739 494	97 39 494	ATL ATTACHMENT
INSULATING TUBE 10	60 30 004 08	204	0.92	2 920 633	96 52 651 08	WIRING HARNESS
INSULATING TUBE 12	60 30 005 08	205	0.4	2 920 633	96 52 651 08	WIRING HARNESS
INSULATING TUBE 14 -50°C.- 2	60 30 126 08	202	3.2	2 932 116	96 54 388 08	CABLING MOUNTING PLATE
INSULATING TUBE 6	60 30 002 08	202	28.96	2 920 633	96 52 651 08	WIRING HARNESS
INSULATING TUBE 8	60 30 003 08	203	22.31	2 920 633	96 52 651 08	WIRING HARNESS
INSULATING TUBE 8	60 30 003 08	201	4	2 932 116	96 54 388 08	CABLING MOUNTING PLATE
INSULATING TUBE DN25 0,8	10 48 691 7	30	1	9 739 492	97 39 492	PIPELINE INSTALLATION
INSULATION MAT RIGHT 19X9	97 18 513 08	9	1	2 913	91 32 850 08	LICCON CONSOLE LCD2
INSULATION MAT RIGHT 19X9	97 18 513 08	9	1	2 913 009	91 04 705 08	LICCON CONSOLE LCD3
INTERIOR HOUSING PRE-ASS.	96 20 731 08	4	1	2 913 009	91 04 705 08	LICCON CONSOLE LCD3
INTERIOR HOUSING PRE-ASS.	96 28 696 08	4	1	2 913	91 32 850 08	LICCON CONSOLE LCD2
INTERNAL LIGHT 6W 13-36V	10 34 285 4	8	2	2 533 066	96 48 365 08	ELECTRIC ADD-ON PARTS CA
INTERNAL LINING	96 45 984 08	11	1	2 520	91 53 061 08	CABIN, GLAZED
KEY PAD	69 18 849 08	1	1	2 913 003	96 20 599 08	FOIL KEYPAD PRE-ASS.
KEY RING 25	70 42 141 08	133	60	2 970	91 56 537 08	HYDR
KEY RING 25	70 42 141 08	67	10	2 975 100	91 52 860 08	ADDITIONAL HYDRAULICS WI
KEY RING 25	70 42 141 08	67	14	2 975 200	91 52 775 08	ADDITIONAL HYDRAULICS WI
KEY RING 25	70 42 141 08	67	14	2 975 700	91 52 774 08	ADDITIONAL HYDRAULICS WI
KEY RING 25	70 42 141 08	64	16	2 977	91 57 756 08	ADDITIONAL HYDR.SLEWING
KEY RING 25	70 42 141 08	67	10	2 977 200	91 55 149 08	ADDITIONAL HYDR.PUMP/WI
KEY RING 25	70 42 141 08	63	3	2 978 100	91 52 827 08	ADDNL.HYDR.RETAINING DEV
KEY RING 25	70 42 141 08	63	8	2 978 200	91 54 843 08	ADD.HYDR.S RETAINING RAM
KEY RING 25	70 42 141 08	63	5	3 978 005	91 56 430 08	ADDL.HYDRAULIC SB-HEAD PI
KEY RING 25	70 42 141 08	63	6	3 978 015	91 56 429 08	ADDITIONAL HYDRAULICS IN

6.2.2009

etk_en_de_074515 LR 1600/2

918

LIEBHERRAlphabetical index
Alphabetischer Index

Description	Item	Pos.	Quantity	Page	Assembly	Description
KEY RING 25	70 42 141 08	63	6	3 978 015	91 56 432 08	ADDITIONAL HYDRAULICS IN
KEY RING 25	70 42 141 08	63	10	3 978 100	91 56 428 08	HYDR. SUSPENDED BALLAST
KEYBOARD UNIT LSB-BKE SP	10 32 351 7	2	1	2 533 051	96 48 360 08	EL.EQUIPMENT CABIN
KEYBOARD UNIT LSB-TE PR	96 48 367 08	30	1	2 533 070	96 48 363 08	CONTROLS AND FITTINGS RI
KEYBOARD UNIT LSB-TE SPF	10 29 669 1	(2)	1	2 533 070	96 48 363 08	CONTROLS AND FITTINGS RI
KNOTTED-LINK CHAIN 2,8 GAL	74 00 006 08	155	1	3 930 732	96 50 575 08	LEAD
KNOTTED-LINK CHAIN DIN 56	74 00 008 08	7	0.25	1 632 032	96 20 093 08	SUPPORT PLATE COMPL.
KNOTTED-LINK CHAIN DIN 56	74 00 008 08	(266)	0.2	2 920 369	96 54 235 08	TERMINAL BOX CPL.
KNOTTED-LINK CHAIN DIN 56	74 00 008 08	(266)	0.2	2 920 369	96 54 235 08	TERMINAL BOX CPL.
KNOTTED-LINK CHAIN DIN 56	74 00 008 08	(266)	0.2	2 920 369	96 54 235 08	TERMINAL BOX CPL.
KNURLED SCREW M5X10 PA6	10 44 966 4	(33)	4	2 925 026	91 55 259 08	ERG. CAMERA CONTROL
KNURLED SCREW M5X10 PA6	10 44 966 4	33	4	2 925 405	96 48 397 08	EQUIPMENT CAMERA CAB
KNURLED SCREW M5X10 PA6	10 44 966 4	16	4	2 932 082	96 54 387 08	ASSEMBLY PARTS MOUNTIN
L INTERMEDIATE SECTION 24	91 52 872 08	272	1		LR 1600-2-0	
L INTERMEDIATE SECTION 242	91 52 870 08	268	1		LR 1600-2-0	
L INTERMEDIATE SECTION 24	91 52 873 08	273	1		LR 1600-2-0	
LABEL	10 47 561 9	3	1	2 780 244	91 52 951 08	EMERGENCY CUT-OFF CRAN
LABEL	55 30 310 08	20	1	2 831	91 57 754 08	AIR COND. UNIT SUPERSTRU
LABEL	77 25 885 08	6	1	2 780 915	96 48 377 08	ADD-ON PARTS EXTERNAL F
LABEL	97 03 200 08	182	1	2 970	91 56 537 08	HYDR
LABEL	97 03 208 08	181	1	2 970	91 56 537 08	HYDR
LABEL	97 05 729 08	183	1	2 970	91 56 537 08	HYDR
LABEL	97 08 391 08	14	1	1 970	91 56 958 08	CRAWLER TRACK HYDRAULI
LABEL	97 66 929 08	40	1	2 932 001	96 45 393 08	RELAY CONTROL SYSTEM
LABEL	97 75 168 08	(1)	1	2 920 448	96 48 794 08	TERMINAL BOX CPL.
LABEL	97 75 395 08	61	1	2 932 160	96 54 385 08	SWITCH CABINET
LABEL	97 75 397 08	63	1	2 932 160	96 54 385 08	SWITCH CABINET
LABEL	97 75 402 08	68	1	2 932 160	96 54 385 08	SWITCH CABINET
LABEL	97 75 403 08	69	1	2 932 160	96 54 385 08	SWITCH CABINET
LABEL	97 75 407 08	73	1	2 932 160	96 54 385 08	SWITCH CABINET
LABEL	97 85 630 08	(160)	1	2 920 369	96 54 235 08	TERMINAL BOX CPL.
LABEL	97 85 631 08	(158)	1	2 920 369	96 54 235 08	TERMINAL BOX CPL.
LABEL +S1020 ALU	97 78 943 08	4	1	3 930 730	96 50 599 08	TERMINAL BOX CPL.
LABEL +S1070 LEXAN	97 83 741 08	4	1	3 930 363	96 52 979 08	TERMINAL BOX CPL.
LABEL +S1090 ALU	97 80 964 08	8	1	2 920 581	96 54 405 08	TERMINAL BOX WINCH PRE-A
LABEL +S1100 LEXAN	97 82 953 08	5	1	2 780 748	96 52 969 08	TERMINAL BOX CPL.
LABEL +S980 ALU	97 80 757 08	5	1	3 930 638	96 51 624 08	TERMINAL BOX
LABEL 100X200 AL-BL 1MM	97 57 167 08	185	1	2 970	91 56 537 08	HYDR
LABEL 100X70X1 AL-BL	97 92 603 08	13	1	1 970	91 56 958 08	CRAWLER TRACK HYDRAULI
LABEL 110X70 LEXEDGE II	97 81 106 08	6	1	2 533 069	96 48 372 08	ELECT.EQUIPMENT THREAD
LABEL 2X190X100	97 42 123 08	13	6	1 631 100	91 52 388 08	CATWALK CRAW.TRACK TRA
LABEL 2X208X120	97 81 837 08	2	2	1 300	91 52 768 08	FLOOR SHEET COMPL.
LABEL 2X240X100	97 86 732 08	51	2	3 745	91 52 948 08	SUSPENDED BALLAST
LABEL 35X15 LEXEDGE II	97 75 169 08	(2)	1	2 920 448	96 48 794 08	TERMINAL BOX CPL.
LABEL 35X15 LEXEDGE II	97 75 170 08	(3)	1	2 920 448	96 48 794 08	TERMINAL BOX CPL.
LABEL 35X15 LEXEDGE II	97 75 171 08	(4)	1	2 920 448	96 48 794 08	TERMINAL BOX CPL.
LABEL 35X15 LEXEDGE II	97 75 172 08	(5)	1	2 920 448	96 48 794 08	TERMINAL BOX CPL.
LABEL 35X15 LEXEDGE II	97 75 396 08	62	1	2 932 160	96 54 385 08	SWITCH CABINET
LABEL 35X15 LEXEDGE II	97 75 398 08	64	1	2 932 160	96 54 385 08	SWITCH CABINET
LABEL 35X15 LEXEDGE II	97 75 399 08	65	1	2 932 160	96 54 385 08	SWITCH CABINET
LABEL 35X15 LEXEDGE II	97 75 400 08	66	1	2 932 160	96 54 385 08	SWITCH CABINET
LABEL 35X15 LEXEDGE II	97 75 401 08	67	1	2 932 160	96 54 385 08	SWITCH CABINET
LABEL 35X15 LEXEDGE II	97 75 404 08	70	1	2 932 160	96 54 385 08	SWITCH CABINET
LABEL 35X15 LEXEDGE II	97 75 405 08	71	1	2 932 160	96 54 385 08	SWITCH CABINET
LABEL 35X15 LEXEDGE II	97 75 406 08	72	1	2 932 160	96 54 385 08	SWITCH CABINET
LABEL 75X45 ALUMINIUM	97 69 555 08	27	1	2 831	91 57 754 08	AIR COND. UNIT SUPERSTRU
LABEL S1000	97 79 690 08	1	1	3 930 640	96 50 481 08	TERMINAL BOX CPL.
LABEL S1050 LEXAN	97 82 166 08	4	1	3 930 734	96 54 401 08	TERMINAL BOX
LABEL S200 LEXAN	97 74 996 08	5	1	1 920 418	96 48 687 08	TERMINAL BOX CPL.
LABEL S220 LEXAN	97 75 070 08	5	1	1 920 403	96 48 707 08	TERMINAL BOX CPL.

6.2.2009

etk_en_de_074515 LR 1600/2

919

LIEBHERRAlphabetical index
Alphabetischer Index

Description	Item	Pos.	Quantity	Page	Assembly	Description
LABEL S240 LEXAN	97 75 008 08	5	1	1 920 417	96 48 703 08	TERMINAL BOX CPL.
LABEL S910 LEXAN-SCHILD	97 73 509 08	4	1	3 930 730	96 54 398 08	TERMINAL BOX CPL.
LADDER 2,4M AL	78 89 047 08	41	2	3 745	91 52 948 08	SUSPENDED BALLAST
LADDER 8/2110X370 AL	78 89 054 08	29	1	3 211	91 57 748 08	S PIVOT SECTION
LADDER 8/2110X370 AL	78 89 054 08	67	1	3 713	91 57 749 08	D PIVOT SECTION
LADDER WELDED T ZN O	96 54 670 08	8	2	2 730	91 52 802 08	BASE PLATE SLEWING PLATF
LADDER WELDED TZNO	96 53 090 08	5	1	2 631	91 56 817 08	SLEWING PLATFORM CATWAL
LAMP SOCKET	60 61 445 08	21	2	2 533 070	96 48 363 08	CONTROLS AND FITTINGS RI
LAMPHOLDER	63 01 023 08	(151)	55	2 932 001	96 45 393 08	RELAY CONTROL SYSTEM
LASHING STRAP EN 12195-2	77 90 347 08	58	1	2 810	91 52 806 08	CRANE DRIVER'S CABIN CPL.
LASHING STRAP L=5M POLY	77 90 362 08	47	2	3 227 200	91 53 519 08	LI INTERMEDIATE SECT. F-GU
LATCH CLAMP	60 21 160 08	50	4	2 520 034	96 45 984 08	INTERNAL LINING
LEAD 2 X 1,5	60 03 420 08	11	3	2 780 320	91 05 067 08	ACOUST.WARN. SLEWING G
LEAD 2X1,5	60 03 673 08	12	9.37	2 920 633	96 52 651 08	WIRING HARNESS
LEAD 2X1,5	60 03 673 08	15	10.57	2 920 633	96 52 651 08	WIRING HARNESS
LEAD 2X1,5	60 03 673 08	16	8.77	2 920 633	96 52 651 08	WIRING HARNESS
LEAD 2X1,5	60 03 673 08	19	8.47	2 920 633	96 52 651 08	WIRING HARNESS
LEAD 8 X	10 32 684 4	28	1	2 533 070	96 48 363 08	CONTROLS AND FITTINGS RI
LEAD W1001	96 50 574 08	9	1	3 930 731	96 48 374 08	ELECTRICS F BASE SECTION
LEAD W1001A	96 50 575 08	6	1	3 930 009	96 50 573 08	CABLE DRUM COMPL.
LEAD W1002	96 50 478 08	6	1	3 930 640	96 50 481 08	TERMINAL BOX CPL.
LEAD W1003	96 50 572 08	7	1	3 930 731	96 48 374 08	ELECTRICS F BASE SECTION
LEAD W1023	96 50 641 08	7	1	3 930 730	96 50 599 08	TERMINAL BOX CPL.
LEAD W1050	96 54 402 08	480	1	3 930 734	96 54 401 08	TERMINAL BOX
LEAD W1051	96 52 804 08	470	1	3 930 734	96 54 401 08	TERMINAL BOX
LEAD W1052	96 53 010 08	31	1	3 930 363	96 52 979 08	TERMINAL BOX CPL.
LEAD W1053	96 54 483 08	430	1	3 930 734	96 54 401 08	TERMINAL BOX
LEAD W1056	96 50 276 08	(23)	1	2 925 218	91 60 840 08	CAMERA CONTROL WINCH 3
LEAD W1056	96 50 276 08	340	1	3 930 734	96 54 401 08	TERMINAL BOX
LEAD W1057	96 52 787 08	360	1	3 930 734	96 54 401 08	TERMINAL BOX
LEAD W1058	96 52 835 08	420	1	3 930 734	96 54 401 08	TERMINAL BOX
LEAD W1059	96 52 795 08	370	1	3 930 734	96 54 401 08	TERMINAL BOX
LEAD W1060	96 52 797 08	380	1	3 930 734	96 54 401 08	TERMINAL BOX
LEAD W1061	96 52 783 08	350	1	3 930 734	96 54 401 08	TERMINAL BOX
LEAD W1062A	96 52 798 08	390	1	3 930 734	96 54 401 08	TERMINAL BOX
LEAD W1062B	96 52 800 08	400	1	3 930 734	96 54 401 08	TERMINAL BOX
LEAD W1064	96 52 801 08	410	1	3 930 734	96 54 401 08	TERMINAL BOX
LEAD W1071	96 52 996 08	20	1	3 930 363	96 52 979 08	TERMINAL BOX CPL.
LEAD W1072	96 52 997 08	21	1	3 930 363	96 52 979 08	TERMINAL BOX CPL.
LEAD W1073	96 52 998 08	22	1	3 930 363	96 52 979 08	TERMINAL BOX CPL.
LEAD W1074	96 52 999 08	23	1	3 930 363	96 52 979 08	TERMINAL BOX CPL.
LEAD W1075	96 53 000 08	24	1	3 930 363	96 52 979 08	TERMINAL BOX CPL.
LEAD W1076	96 53 001 08	25	1	3 930 363	96 52 979 08	TERMINAL BOX CPL.
LEAD W1079	96 53 004 08	28	1	3 930 363	96 52 979 08	TERMINAL BOX CPL.
LEAD W1080	96 53 008 08	29	1	3 930 363	96 52 979 08	TERMINAL BOX CPL.
LEAD W1081	96 53 009 08	30	1	3 930 363	96 52 979 08	TERMINAL BOX CPL.
LEAD W1090	96 54 407 08	160	1	2 920 581	96 54 405 08	TERMINAL BOX WINCH PRE-A
LEAD W1091	96 51 848 08	150	1	2 920 581	96 54 405 08	TERMINAL BOX WINCH PRE-A
LEAD W1092	96 51 850 08	151	1	2 920 581	96 54 405 08	TERMINAL BOX WINCH PRE-A
LEAD W1093	96 51 855 08	153	1	2 920 581	96 54 405 08	TERMINAL BOX WINCH PRE-A
LEAD W1094	96 51 856 08	154	1	2 920 581	96 54 405 08	TERMINAL BOX WINCH PRE-A
LEAD W1095	96 51 854 08	152	1	2 920 581	96 54 405 08	TERMINAL BOX WINCH PRE-A
LEAD W1096	96 51 857 08	155	1	2 920 581	96 54 405 08	TERMINAL BOX WINCH PRE-A
LEAD W1140	96 52 970 08	10	1	2 780 524	96 52 968 08	CABLE DRUM COMPL.
LEAD W1140A	96 52 971 08	20	1	2 780 524	96 52 968 08	CABLE DRUM COMPL.
LEAD W1142	96 52 978 08	11	1	2 780 748	96 52 969 08	TERMINAL BOX CPL.
LEAD W1143	96 52 980 08	12	1	2 780 748	96 52 969 08	TERMINAL BOX CPL.
LEAD W1144	96 52 981 08	13	1	2 780 748	96 52 969 08	TERMINAL BOX CPL.
LEAD W1145	96 52 982 08	14	1	2 780 748	96 52 969 08	TERMINAL BOX CPL.
LEAD W1146	96 52 983 08	15	1	2 780 748	96 52 969 08	TERMINAL BOX CPL.

6.2.2009

etk_en_de_074515 LR 1600/2

920

LIEBHERRAlphabetical index
Alphabetischer Index

Description	Item	Pos.	Quantity	Page	Assembly	Description
LEAD W163	92 69 930 08	1	1	1 933 100	91 25 249 08	MAGNETIC LAMP
LEAD W221	96 48 719 08	10	1	1 920 403	96 48 707 08	TERMINAL BOX CPL.
LEAD W241	96 48 718 08	10	1	1 920 417	96 48 703 08	TERMINAL BOX CPL.
LEAD W319	96 52 559 08	11	1	2 533 071	96 52 556 08	CONVERTOR
LEAD W320	96 52 560 08	12	1	2 533 071	96 52 556 08	CONVERTOR
LEAD W330	96 52 929 08	10	1	2 920 288	96 52 614 08	WIRING LIST F.SLEWING PLAT
LEAD W331	96 52 930 08	11	1	2 920 288	96 52 614 08	WIRING LIST F.SLEWING PLAT
LEAD W332	96 52 931 08	12	1	2 920 288	96 52 614 08	WIRING LIST F.SLEWING PLAT
LEAD W333	96 52 932 08	13	1	2 920 288	96 52 614 08	WIRING LIST F.SLEWING PLAT
LEAD W334	96 52 933 08	14	1	2 920 288	96 52 614 08	WIRING LIST F.SLEWING PLAT
LEAD W336	96 54 268 08	21	1	2 920 369	96 54 235 08	TERMINAL BOX CPL.
LEAD W337	96 54 269 08	22	1	2 920 369	96 54 235 08	TERMINAL BOX CPL.
LEAD W338	96 54 270 08	23	1	2 920 369	96 54 235 08	TERMINAL BOX CPL.
LEAD W339	96 54 271 08	24	1	2 920 369	96 54 235 08	TERMINAL BOX CPL.
LEAD W50	10 46 727 5	20	1	6 909 010	69 09 010 08	COLLECTING RING
LEAD W540	96 52 934 08	15	1	2 920 288	96 52 614 08	WIRING LIST F.SLEWING PLAT
LEAD W560	96 52 935 08	16	1	2 920 288	96 52 614 08	WIRING LIST F.SLEWING PLAT
LEAD W571	96 52 936 08	18	1	2 920 288	96 52 614 08	WIRING LIST F.SLEWING PLAT
LEAD W634	96 24 499 08	6	1	2 780 852	96 24 845 08	GSM-MODULE PRE-ASS.LICCO
LEAD W635X1250	92 12 113 08	9	1	2 932 116	96 54 388 08	CABLING MOUNTING PLATE
LEAD W635X1600	92 17 086 08	8	4	2 932 116	96 54 388 08	CABLING MOUNTING PLATE
LEAD W635X1800	92 17 061 08	6	1	2 932 116	96 54 388 08	CABLING MOUNTING PLATE
LEAD W75	10 46 727 4	19	1	6 909 010	69 09 010 08	COLLECTING RING
LEAD W909	96 54 399 08	320	1	3 930 730	96 54 398 08	TERMINAL BOX CPL.
LEAD W910	96 54 400 08	330	1	3 930 730	96 54 398 08	TERMINAL BOX CPL.
LEAD W911	96 49 064 08	303	1	3 930 730	96 54 398 08	TERMINAL BOX CPL.
LEAD W913	96 49 055 08	420	1	3 930 730	96 54 398 08	TERMINAL BOX CPL.
LEAD W915	96 49 026 08	380	1	3 930 730	96 54 398 08	TERMINAL BOX CPL.
LEAD W916	96 49 027 08	390	1	3 930 730	96 54 398 08	TERMINAL BOX CPL.
LEAD W917	96 49 053 08	350	1	3 930 730	96 54 398 08	TERMINAL BOX CPL.
LEAD W918	96 49 052 08	310	1	3 930 730	96 54 398 08	TERMINAL BOX CPL.
LEAD W919	96 49 041 08	360	1	3 930 730	96 54 398 08	TERMINAL BOX CPL.
LEAD W920	96 49 047 08	370	1	3 930 730	96 54 398 08	TERMINAL BOX CPL.
LEAD W921	96 49 056 08	430	1	3 930 730	96 54 398 08	TERMINAL BOX CPL.
LEAD W923	96 50 211 08	440	1	3 930 730	96 54 398 08	TERMINAL BOX CPL.
LEAD W927	96 57 437 08	450	1	3 930 730	96 54 398 08	TERMINAL BOX CPL.
LEAD W928	96 57 438 08	460	1	3 930 730	96 54 398 08	TERMINAL BOX CPL.
LEAD W981	96 50 233 08	350	1	3 930 638	96 51 624 08	TERMINAL BOX
LEAD W982	96 50 235 08	360	1	3 930 638	96 51 624 08	TERMINAL BOX
LEAD W983	96 50 237 08	370	1	3 930 638	96 51 624 08	TERMINAL BOX
LEAD W985Y	96 52 546 08	8	1	3 780 751	91 52 952 08	AIR-CRAFT & WIND WARNING
LEAD WL934	96 51 045 08	4	1	3 780 258	96 56 482 08	ELECTRIC AIRCRAFT PROTE
LEAF RING	10 01 273 4	2	8	9 739 295	97 39 295	EXHAUST PIPE
LEFT-HAND INSULATING MAT	97 18 512 08	8	1	2 913	91 32 850 08	LICCON CONSOLE LCD2
LEFT-HAND INSULATING MAT	97 18 512 08	8	1	2 913 009	91 04 705 08	LICCON CONSOLE LCD3
LENS	60 72 126 08	1	1	6 071 131	60 71 131 08	TAIL BRAKE LIGHT
LEVEL PROBE SPF	10 22 814 3	8	1	2 391 023	96 45 720 08	RADIATOR, PRE-ASSEMBLED
LEVER	92 17 246 08	2	1	3 745 002	92 17 236 08	SWITCH UNIT
LEVER	92 17 246 08	2	1	3 745 003	92 17 237 08	SWITCH UNIT
LEVER ARM	10 41 278 8	13	1	X1041267	10 41 267 7	MANUAL ACTUATION
LEVER COMPL.	96 47 960 08	3	1	3 206	91 52 881 08	PIVOT SECTION
LEVER COMPL.	96 55 460 08	40	1	2 391 040	96 53 645 08	CLUTCH ACTUATOR
LEVER FASTENER	70 42 288 08	5	2	2 510 059	96 49 184 08	DOOR COMPL.
LEVER FASTENER	70 42 288 08	41	1	2 520	91 53 061 08	CABIN, GLAZED
LEVER WELDED	96 47 983 08	1	1	3 206 002	96 47 960 08	LEVER COMPL.
LI INTERMEDIATE SECT. F-GU	91 53 519 08	271	1		LR 1600-2-0	
LI INTERMEDIATE SECT.WELD	96 46 324 08	1	1	3 227 200	91 53 519 08	LI INTERMEDIATE SECT. F-GU
LI INTERMEDIATE SECT.WELD	96 44 853 08	1	1	3 227 008	91 52 872 08	L INTERMEDIATE SECTION
LI INTERMEDIATE SECT.WELD.	96 43 434 08	1	1	3 226	91 52 870 08	L INTERMEDIATE SECTION
LI INTERMEDIATE SECT.WELD	96 46 294 08	1	1	3 227	91 52 873 08	L INTERMEDIATE SECTION

6.2.2009

etk_en_de_074515 LR 1600/2

921

LIEBHERRAlphabetical index
Alphabetischer Index

Description	Item	Pos.	Quantity	Page	Assembly	Description
LI INTERMEDIATE SECTION 6.7	96 46 385 08	1	1	3 225	91 52 854 08	SL REDUCING SECTION
LICCON ASSEMBLY UNIT	96 45 394 08	5	1	2 932	91 57 750 08	BUILT-IN PARTS SWITCH BOX
LICCON CONSOLE LCD2 KO	91 32 850 08	2	2	2 533 050	96 48 359 08	EL.EQUIPMENT CABIN
LICCON CONSOLE LCD3 KRA	96 47 216 08	3	1	2 533 050	96 48 359 08	EL.EQUIPMENT CABIN
LICCON CONSOLE LCD3 LSB-	91 04 705 08	80	1	2 913 200	96 47 216 08	LICCON CONSOLE LCD3
LID	10 01 228 8	9	1	9 739 122	97 39 122	OIL COOLER
LID	10 01 245 1	5	1	9 739 258	97 39 258	FUEL FILTER
LID	10 01 245 2	7	1	9 739 258	97 39 258	FUEL FILTER
LID	10 28 635 3	11	1	1 920 418	96 48 687 08	TERMINAL BOX CPL.
LID	10 28 635 3	274	1	2 780 748	96 52 969 08	TERMINAL BOX CPL.
LID	10 28 635 3	266	1	2 920 581	96 54 405 08	TERMINAL BOX WINCH PRE-A
LID	10 28 635 3	262	1	3 930 638	96 51 624 08	TERMINAL BOX
LID	10 28 635 3	296	1	3 930 730	96 50 599 08	TERMINAL BOX CPL.
LID	10 28 635 3	280	2	3 930 730	96 54 398 08	TERMINAL BOX CPL.
LID	10 28 635 3	206	1	3 930 734	96 54 401 08	TERMINAL BOX
LID	60 27 617 08	62	1	2 932 082	96 54 387 08	ASSEMBLY PARTS MOUNTIN
LID	70 23 645	7	1	X1035924	10 35 924 8	VARIABLE PUMP
LID 1.5X954X977	97 75 796 08	70	1	2 520	91 53 061 08	CABIN, GLAZED
LID 2X341X116 ALMG3	97 17 070 08	3	1	2 913	91 32 850 08	LICCON CONSOLE LCD2
LID 2X341X116 ALMG3	97 17 070 08	3	1	2 913 009	91 04 705 08	LICCON CONSOLE LCD3
LID 5X490X490	97 66 383 08	8	1	2 350	91 52 778 08	SLEWING GEAR
LID ABS SPF	97 73 582 08	25	1	2 520	91 53 061 08	CABIN, GLAZED
LID GK-ALSI12CU	70 27 755	3	1	7 027 481	70 27 481 03	WATER SEPARATOR
LID PLATE 30X5X178/2 ST D9	60 20 015 08	147	2	2 391 001	96 45 719 08	DIESEL ENGINE, PRE-ASSEMB
LID RD190X6	93 55 088 08	7	3	3 745 011	96 49 677 08	BRACKET COMPL.
LID SAE-B	10 22 566 6	127	1	2 391 001	96 45 719 08	DIESEL ENGINE, PRE-ASSEMB
LID SEAL HNBR	10 29 417 1	4	1	7 027 481	70 27 481 03	WATER SEPARATOR
LIGHT BULB 1,2W 30V	60 70 087 08	10	4	2 533 061	96 48 370 08	DASH BORD ARM REST LEFT
LIGHT BULB 1,2W 30V	60 70 087 08	10	1	2 533 063	96 48 371 08	DASH BORD ARM REST RIGH
LIGHT BULB 1,2W 30V	60 70 087 08	17	12	2 533 070	96 48 363 08	CONTROLS AND FITTINGS RI
LIGHT BULB 1,2W 48V	60 70 117 08	23	1	2 533 070	96 48 363 08	CONTROLS AND FITTINGS RI
LIGHT BULB 35W 24V	60 70 091 08	11	1	1 933 100	91 25 249 08	MAGNETIC LAMP
LIGHT BULB DIN 72601 21W 24	60 70 217 08	4	2	2 920 931	96 59 398 08	WARNING LIGHT
LIGHT BULB DIN 72601 21W 24	60 70 217 08	2	1	6 071 131	60 71 131 08	TAIL BRAKE LIGHT
LIGHT BULB DIN 72601 5W 24	60 70 201 08	3	1	6 071 131	60 71 131 08	TAIL BRAKE LIGHT
LIGHT BULB DIN 72601 70W 24	60 70 211 08	21	3	2 925 002	96 58 856 08	EQUIPMENT CAMERA SUPER
LIGHT BULB DIN 72601 70W 24	60 70 211 08	(21)	1	2 925 218	91 60 840 08	CAMERA CONTROL WINCH 3
LIMIT STOP	51 07 457 08	29	1	5 113 086	51 13 086 08	PROPORTIONAL VALVE
LIMIT STOP 15X160X120 PA6	97 77 650 08	44	2	3 713	91 57 749 08	D PIVOT SECTION
LIMIT STOP ANGLE	10 01 752 9	4	1	9 739 186	97 39 186	MOTOR BRAKE
LIMIT STOP RING ST	10 29 198 8	8	4	2 810	91 52 806 08	CRANE DRIVER'S CABIN CPL.
LIMIT SWITCH AND SENSOR G	96 47 914 08	8	1	2 920	91 56 833 08	ELECTR. SYSTEM F.SLEWING
LIMIT SWITCH HUB-OBEN SPF	60 60 533 08	(7)	1	3 930 546	96 48 375 08	ELECTR. F-HEAD SECTION
LIMIT SWITCH HUB-OBEN SPF	60 60 533 08	(7)	2	3 930 576	96 48 381 08	EL.EQUIPMENT SW HEAD SE
LIMIT SWITCH SPF	60 60 531 08	16	1	2 930	96 57 085 08	SENSOR ASSEMBLY SA-STAN
LINE WITH PLUG W911A	96 49 011 08	(6)	1	3 930 138	96 54 377 08	ELECTRIC FOR S-PIVOT SECT
LINKAGE 4.0X106 ST	97 77 244 08	22	1	2 522 011	96 45 602 08	CLOSING DEVICE
LINKAGE 4.0X58 ST	97 68 662 08	5	1	2 522 011	96 45 602 08	CLOSING DEVICE
LINKAGE 4.0X72 ST	97 68 665 08	8	1	2 522 011	96 45 602 08	CLOSING DEVICE
LIQUEFIER AL	10 11 371 2	2	1	2 831	91 57 754 08	AIR COND. UNIT SUPERSTRU
LIQUID COOLING PIPELINE	10 03 716 9	1	1	9 739 210	97 39 210	LIQUID COOLING PIPELINE
LIQUID COOLING PIPELINE	10 47 689 5	1	1	9 739 492	97 39 492	PIPELINE INSTALLATION
LIQUID COOLING PIPELINE	10 47 690 7	7	1	9 739 492	97 39 492	PIPELINE INSTALLATION
LIQUID COOLING PIPELINE	97 39 210	171	1	X1012059	10 12 059 0	DIESEL ENGINE
LIQUID COOLING PIPELINE	97 39 383	1	1	9 739 351	97 39 351	COOLING MEDIUM PIPELINE
LOAD HOLDING VALVE	51 14 716 08	59	1	2 970	91 56 537 08	HYDR
LOAD HOLDING VALVE 280BA	10 21 831 0	58	2	2 970	91 56 537 08	HYDR
LOADING SHELL KUNSTSTOF	10 47 141 2	32	1	2 533 070	96 48 363 08	CONTROLS AND FITTINGS RI
LOCK BEARING	70 42 185 08	39	2	2 391 040	96 53 645 08	CLUTCH ACTUATOR
LOCK BEARING	70 42 185 08	56	1	2 631	91 56 817 08	SLEWING PLATFORM CATWAL

6.2.2009

etk_en_de_074515 LR 1600/2

922

LIEBHERRAlphabetical index
Alphabetischer Index

Description	Item	Pos.	Quantity	Page	Assembly	Description
LOCK NUT AM8-10	10 01 751 7	7	1	9 739 186	97 39 186	MOTOR BRAKE
LOCK NUT BM8-8	10 01 163 7	12	1	9 739 118	97 39 118	OIL LINE
LOCK NUT BM8-8	10 01 163 7	28	4	9 739 371	97 39 371	AIR COND. COMPRESSOR A
LOCK NUT M25X1,5 POLYAMI	10 04 269 6	20	2	2 780 915	96 48 377 08	ADD-ON PARTS EXTERNAL F
LOCK NUT PG9 MS	60 25 019 08	5	1	2 920 257	92 78 689 08	TERMINAL BOX LIGHTING HO
LOCK WASHER VS 10 VERZ	42 39 110 01	(57)	8	1 400	91 56 853 08	CRAWLER TRACK CARRIER LE
LOCK WASHER VS 12 VERZ	42 39 112 01	27	8	9 697 916	96 97 916 01	SLEWING GEAR
LOCK WASHER VS 12 VERZ	42 39 112 01	75	12	9 697 916	96 97 916 01	SLEWING GEAR
LOCK WITH FALLING LATCH	10 34 246 9	1	1	2 522 011	96 45 602 08	CLOSING DEVICE
LOCKING BAR 20X46X169	94 54 958 08	2	2	1 641 014	92 53 053 08	SUPPORT PLATE COMPL.
LOCKING PIECE	10 49 234 7	19	1	X1029200	10 29 200 4	DRIVERS SEAT
LOCKING PIECES	97 39 035	282	1	9 739 400	97 39 400	DIESEL ENGINE
LOCKING PLATE	57 00 100 08	20	1	5 026 126	50 26 126 08	SOLENOID VALVE
LOCKING PLATE 5X522X269	97 73 267 08	6	1	3 282 002	96 47 890 08	FAB-STAY
LOCKING RING AEHNL.DIN 98	10 22 093 7	25	1	X1035925	10 35 925 1	VARIABLE PUMP
LOCKING RING DIN 4 130X4	42 80 076 08	5	2	3 211 003	96 46 986 08	ROD CPL.
LOCKING RING DIN 471 100X3	42 80 067 08	14	4	2 550	91 57 751 08	SA FRAME
LOCKING RING DIN 471 100X3	42 80 067 08	7	1	2 550 005	96 45 680 08	ROD CPL.
LOCKING RING DIN 471 100X3	42 80 067 08	4	2	3 714 025	96 49 269 08	ROD CPL.
LOCKING RING DIN 471 100X3	42 80 067 08	6	2	3 745 011	96 49 677 08	BRACKET COMPL.
LOCKING RING DIN 471 100X4	42 80 119 01	(18)	5	1 400	91 56 853 08	CRAWLER TRACK CARRIER LE
LOCKING RING DIN 471 160X4	42 80 085 08	59	2	1 400	91 56 853 08	CRAWLER TRACK CARRIER LE
LOCKING RING DIN 471 160X4	42 80 085 08	59	2	1 410 300	91 56 855 08	CRAWLER CARRIER RIGHT CP
LOCKING RING DIN 471 200X4	42 80 093 08	9	5	3 214	91 52 843 08	SW HEAD SECTION
LOCKING RING DIN 471 200X4	42 80 093 08	4	2	3 225 100	96 48 582 08	BEARING CPL
LOCKING RING DIN 471 200X4	42 80 093 08	4	2	3 281	91 52 896 08	ERECTION FRAME
LOCKING RING DIN 471 200X4	42 80 093 08	5	2	3 713	91 57 749 08	D PIVOT SECTION
LOCKING RING DIN 471 200X4	42 80 093 08	33	1	3 714	91 52 862 08	D HEAD SECTION
LOCKING RING DIN 471 200X4	42 80 093 08	6	2	3 714 021	96 49 271 08	ROLLER SEATING COMPL.
LOCKING RING DIN 471 220X5	42 80 105 08	61	1	X1065015	10 65 015 5	GEARBOX
LOCKING RING DIN 471 25X1,2	42 80 021 08	29	2	2 550	91 57 751 08	SA FRAME
LOCKING RING DIN 471 25X1,2	42 80 021 08	13	2	2 550 005	96 45 680 08	ROD CPL.
LOCKING RING DIN 471 260X5	42 80 101 08	60	1	X1065015	10 65 015 5	GEARBOX
LOCKING RING DIN 471 270X5	42 80 103 08	3	2	2 550 003	96 46 246 08	ROPE PULLEY CPL.
LOCKING RING DIN 471 270X5	42 80 103 08	3	2	2 652 007	92 68 928 08	ROPE PULLEY CPL.
LOCKING RING DIN 471 340X6	42 80 113 08	62	1	X1065015	10 65 015 5	GEARBOX
LOCKING RING DIN 471 50X2	42 80 042 08	26	2	2 550	91 57 751 08	SA FRAME
LOCKING RING DIN 471 50X2	42 80 042 08	7	1	3 220 501	96 43 440 08	ROD CPL.
LOCKING RING DIN 471 50X2	42 80 042 08	7	1	3 221 200	96 47 984 08	ROD CPL.
LOCKING RING DIN 471 50X2	42 80 042 08	7	1	3 225 200	96 48 679 08	ROD CPL.
LOCKING RING DIN 471 50X2	42 80 042 08	7	1	3 227 002	96 50 498 08	ROD CPL.
LOCKING RING DIN 471 50X2	42 80 042 08	7	1	3 561 003	96 45 222 08	ROD CPL.
LOCKING RING DIN 471 50X2	42 80 042 08	7	1	3 713 012	96 50 197 08	ROD CPL.
LOCKING RING DIN 471 50X2	42 80 042 08	6	2	3 830	91 55 535 08	SUPPLEMENTARY GUYING D
LOCKING RING DIN 471 55X2	42 80 045 08	49	2	3 713	91 57 749 08	D PIVOT SECTION
LOCKING RING DIN 471 55X2	42 80 045 08	7	1	3 716 001	96 49 159 08	ROD CPL.
LOCKING RING DIN 471 55X3	53 01 333 08	15	1	2 550 005	96 45 680 08	ROD CPL.
LOCKING RING DIN 471 60X2	42 80 049 08	33	6	2 550	91 57 751 08	SA FRAME
LOCKING RING DIN 471 60X2	42 80 049 08	4	2	2 657	91 57 656 08	MOUNTING EQUIPMENT CRAW
LOCKING RING DIN 471 60X2	42 80 049 08	20	8	3 220 500	91 52 849 08	S INTERMEDIATE SECTION
LOCKING RING DIN 471 60X2	42 80 049 08	20	10	3 223	91 52 852 08	S INTERMEDIATE SECTION
LOCKING RING DIN 471 60X2	42 80 049 08	20	10	3 223 010	91 52 853 08	S INTERMEDIATE SECTION
LOCKING RING DIN 471 60X2	42 80 049 08	20	10	3 223 100	91 55 327 08	S INTERMEDIATE SECTION
LOCKING RING DIN 471 68X2,5	42 80 055 08	3	2	3 206 001	96 20 920 08	ROPE PULLEY CPL.
LOCKING RING DIN 471 70X2,5	42 80 056 08	16	2	3 215 005	91 52 846 08	ROLLER SET
LOCKING RING DIN 471 70X2,5	42 80 056 08	16	2	3 215 006	91 52 847 08	ROLLER SET
LOCKING RING DIN 471 70X4	40 01 447	(32)	3	1 400	91 56 853 08	CRAWLER TRACK CARRIER LE
LOCKING RING DIN 471 80X2,5	42 80 061 08	1343	1	X1065015	10 65 015 5	GEARBOX
LOCKING RING DIN 471 8X0,8	42 80 002 08	14	6	2 391 040	96 53 645 08	CLUTCH ACTUATOR
LOCKING RING DIN 471 8X0,8	42 80 002 08	6	2	2 522 012	96 45 884 08	GUIDE PRE-ASS.

6.2.2009

etk_en_de_074515 LR 1600/2

923

LIEBHERRAlphabetical index
Alphabetischer Index

Description	Item	Pos.	Quantity	Page	Assembly	Description
LOCKING RING DIN 471 8X0,8	42 80 002 08	8	8	2 522 013	96 45 883 08	GUIDE PRE-ASS.
LOCKING RING DIN 471 90X3	42 80 064 08	22	2	3 714	91 52 862 08	D HEAD SECTION
LOCKING RING DIN 471 90X3	42 80 064 08	41	1	X1065015	10 65 015 8	DRIVE UNIT
LOCKING RING DIN 471 95X3	42 80 065 08	15	2	3 714	91 52 862 08	D HEAD SECTION
LOCKING RING DIN 472 140X4	42 81 041 08	40	1	X1065015	10 65 015 8	DRIVE UNIT
LOCKING RING DIN 472 22X1	42 81 006 08	17	4	2 522 013	96 45 883 08	GUIDE PRE-ASS.
LOCKING RING DIN 472 300X5	50 15 497 08	4	1	5 718 420	57 18 420 08	FLANGE
LOCKING RING DIN 472 46X1,7	50 40 077 08	43	2	X1065015	10 65 015 8	DRIVE UNIT
LOCKING RING DIN 472 52X2	42 81 013 08	3	2	3 206 002	96 47 960 08	LEVER COMPL.
LOCKING RING DIN 472 540X8	10 65 017 7	41	1	X1065015	10 65 015 6	ROPE DRUM
LOCKING RING DIN 472 70X2,5	42 81 022 08	12	1	5 701 129	57 01 129 08	DRIVING GEAR
LOCKING RING DIN 472 80X2,5	42 81 025 08	4	1	5 400 565	54 00 565 08	ROPE WINCH
LOCKING RING DIN 984 54X2	10 00 942 4	(37)	2	X1035924	10 35 924 9	VARIABLE PUMP
LOCKING SCREW M14X45 12.9	10 34 226 6	3	8	9 739 360	97 39 360	MOTOR SUPPORT
LOCKING SCREW M8X20 10.9	10 01 752 6	3	2	9 739 186	97 39 186	MOTOR BRAKE
LOOM	10 11 922 6	(1)	1	9 739 400	97 39 400	DIESEL ENGINE
LOOM 3300MM	55 31 869 08	50	1	2 533 065	96 48 364 08	CABLE LIST DRIVER'S CABIN
LOUDSPEAKER 2,77V 86DBA	10 48 901 1	10	2	2 533 066	96 48 365 08	ELECTRIC ADD-ON PARTS CA
LOWERING BRAKE VALVE 42	10 46 565 9	12	1	3 978 019	91 56 431 08	AUX.HYDR.CYLINDER SB-BW
LOWERING BRAKE VALVE 420	10 21 769 5	2	1	2 978 100	91 52 796 08	ADDNL.HYDR.ERECTION DEV
LSB SENSOR TEST ADAPTER	91 05 061 08	10	1	2 932 116	96 54 388 08	CABLING MOUNTING PLATE
LUBRICATING OIL PUMP	10 02 919 2	1	1	9 739 372	97 39 372	LUBRICATING OIL PUMP
LUBRICATING OIL PUMP	97 39 372	56	1	X1012059	10 12 059 0	DIESEL ENGINE
LUBRICATION	10 01 732 5	6	1	9 739 187	97 39 187	CONTROL PARTS
LUFFING PULLEY BLOCK COM	96 49 266 08	2	1	3 714	91 52 862 08	D HEAD SECTION
LUFFING PULLEY BLOCK CO	96 49 267 08	3	1	3 714	91 52 862 08	D HEAD SECTION
LUFFING PULLEY BLOCK WE	96 49 290 08	1	1	3 714 008	96 49 266 08	LUFFING PULLEY BLOCK COM
LUFFING PULLEY BLOCK WE	96 49 455 08	1	1	3 714 009	96 49 267 08	LUFFING PULLEY BLOCK COM
LUG GE LL 16M26X1,5 ST A4C	10 22 280 4	20	1	9 739 491	97 39 491	INSTALLATION BRAKE COMPR
LUG L-10 WVE	10 22 276 6	1	1	9 739 292	97 39 292	FUEL LINE
LUG L-8 WVE	10 22 276 2	5	1	9 739 281	97 39 281	OVERFLOW-OIL LINE
LUMINOUS PUSH BUTTON C	60 61 437 08	24	7	2 533 070	96 48 363 08	CONTROLS AND FITTINGS RI
LUMINOUS SWITCH CONTACT	60 61 447 08	11	4	2 533 061	96 48 370 08	DASH BORD ARM REST LEFT
LUMINOUS SWITCH CONTACT	60 61 447 08	11	1	2 533 063	96 48 371 08	DASH BORD ARM REST RIGH
LUMINOUS SWITCH CONTACT	60 61 447 08	10	4	2 533 070	96 48 363 08	CONTROLS AND FITTINGS RI
MAGNET 24V	10 65 009 2	2	1	X1034282	10 34 282 3	PRESSURE CONTROL VALVE
MAGNET 24V	57 00 094 08	7	1	5 026 126	50 26 126 08	SOLENOID VALVE
MAGNET 24V	57 06 338 08	1	1	5 114 445	51 14 445 08	DIRECTIONAL CONTROL VALV
MAGNET 24V	57 06 338 08	1	1	5 114 498	51 14 498 08	DIRECTIONAL CONTROL VALV
MAGNET 24V	57 06 338 08	1	1	5 114 943	51 14 943 08	DIRECTIONAL CONTROL VALV
MAGNET 24V	57 16 137 08	(10)	1	2 970	91 56 537 08	HYDR
MAGNET 24V DC	10 42 953 2	5	1	5 114 651	51 14 651 08	DIRECTIONAL CONTROL VALV
MAGNET 24V DC	57 08 278 08	1	1	5 114 444	51 14 444 08	DIRECTIONAL CONTROL VALV
MAGNET COIL	57 19 101 08	435	2	5 713 626	57 13 626 08	PILOT VALVE
MAGNET COIL 24VDC 1,25A	57 17 127 08	1	2	5 113 022	51 13 022 08	DIRECTIONAL CONTROL VALV
MAGNET COIL 28V DC	57 08 179 08	1	2	5 710 349	57 10 349 08	DIRECTIONAL CONTROL VALV
MAGNETIC LAMP	91 25 249 08	42	1	1 750	91 52 394 08	TOOL
MAGNETIC LOCKING SLEEVE	57 00 093 08	5	1	5 026 126	50 26 126 08	SOLENOID VALVE
MAIN BEARING	10 01 208 3	6	7	9 739 102	97 39 102	CRANKSHAFT BEARINGS
MAIN BEARING D= -0,10MM	10 01 210 7	61	7	9 739 102	97 39 102	CRANKSHAFT BEARINGS
MAIN BEARING D= -0,50MM	10 01 210 9	63	7	9 739 102	97 39 102	CRANKSHAFT BEARINGS
MAIN BEARING D= -0,75MM	10 01 211 0	64	7	9 739 102	97 39 102	CRANKSHAFT BEARINGS
MAIN BEARING D= -1,00MM	10 01 211 2	65	7	9 739 102	97 39 102	CRANKSHAFT BEARINGS
MAIN BEARING R-MOTORXD2	10 01 208 8	62	7	9 739 102	97 39 102	CRANKSHAFT BEARINGS
MAIN ROD	10 22 233 7	1	1	9 739 287	97 39 287	MAIN ROD
MAIN ROD	97 39 287	38	6	X1012059	10 12 059 0	DIESEL ENGINE
MAINS RESISTOR 1K 5% 8X 9	63 50 855 08	20	2	2 922 001	92 84 311 08	BUS PCB
MAINS RESISTOR 22K 10% 8X	63 50 842 08	7	10	2 922 001	92 84 311 08	BUS PCB
MANDRIL RIVET 4X10,3	70 42 076 08	3	4	2 913 004	96 20 460 08	HOUSING PRE-ASSEMBLED
MANDRIL RIVET 4X10,3	70 42 076 08	23	8	2 932 001	96 45 393 08	RELAY CONTROL SYSTEM

6.2.2009

etk_en_de_074515 LR 1600/2

924

LIEBHERRAlphabetical index
Alphabetischer Index

Description	Item	Pos.	Quantity	Page	Assembly	Description
MANDRIL RIVET 4X10,3	70 42 076 08	49	42	2 932 082	96 54 387 08	ASSEMBLY PARTS MOUNTIN
MANUAL ACTUATION	10 41 267 7	9	1	5 133 090	51 13 090 08	SLIDE VALVE BLOCK
MANUAL ACTUATION	51 10 438 08	(8)	1	2 970	91 56 537 08	HYDR
MARKING STRIP	97 68 423 08	3	1	2 533 051	96 48 360 08	EL.EQUIPMENT CABIN
MASTER SWITCH SPF	60 60 950 08	5	1	2 533 060	96 48 368 08	ELECTRIC FOR ARMREST LEF
MASTER SWITCH SPF	60 60 950 08	5	1	2 533 062	96 48 369 08	ELECTRIC FOR ARMREST RI
MASTER SWITCH SPF	60 60 950 08	5	1	2 533 069	96 48 372 08	ELECT.EQUIPMENT THREAD
MEASURING CONNECTION BM	47 56 014 08	648	2	1 970	91 56 958 08	CRAWLER TRACK HYDRAULI
MEASURING CONNECTION BM	47 56 015 08	619	2	1 970	91 56 958 08	CRAWLER TRACK HYDRAULI
MEASURING CONNECTION BM	47 56 015 08	659	15	2 970	91 56 537 08	HYDR
MEASURING CONNECTION BM	47 56 015 08	613	1	2 975 000	91 57 881 08	ADDNL. HYDR. F. ERECTING W
MEASURING CONNECTION BM	47 56 015 08	603	1	2 976 700	91 54 795 08	ADDITIONAL HYDRAULICS P
MEASURING CONNECTION BM	47 56 015 08	644	1	2 978 100	91 52 827 08	ADDNL.HYDR.RETAINING DEV
MEASURING CONNECTION BM	47 56 015 08	605	1	2 978 200	91 54 843 08	ADD.HYDR.S_RETAINING RAM
MEASURING CONNECTION BM	47 56 015 08	617	1	3 978 100	91 56 428 08	HYDR. SUSPENDED BALLAST
MEASURING CONNECTION EM	47 56 026 08	641	10	2 970	91 56 537 08	HYDR
MEASURING CONNECTION GM	47 56 034 08	627	4	1 970	91 56 958 08	CRAWLER TRACK HYDRAULI
MEASURING CONNECTION GM	47 56 034 08	601	2	3 978 015	91 56 429 08	ADDITIONAL HYDRAULICS IN
MEASURING CONNECTION GM	47 56 034 08	601	2	3 978 015	91 56 432 08	ADDITIONAL HYDRAULICS IN
MEASURING CONNECTION M1	47 56 032 08	685	9	2 970	91 56 537 08	HYDR
MEASURING CONNECTION M1	47 56 032 08	604	2	2 976 700	91 54 795 08	ADDITIONAL HYDRAULICS P
MEASURING HOSE DN5 1000	47 09 018 08	33	3	1 750	91 52 394 08	TOOL
MEASURING HOSE DN5 2000	47 09 019 08	34	2	1 750	91 52 394 08	TOOL
MECHANIC ADDITIONAL SUPP	96 44 950 08	1	2	1 632	91 52 389 08	MECHANICAL SUPPORT
MECHANICAL SUPPORT	91 52 389 08	17	1		LR 1600-2-0	
MEGI BUFFER	72 66 113 08	54	1	2 810	91 52 806 08	CRANE DRIVER'S CABIN CPL.
MEGI BUFFER	72 66 122 08	42	1	2 810	91 52 806 08	CRANE DRIVER'S CABIN CPL.
MEGI BUFFER	72 66 127 08	14	1	2 925 204	92 16 990 08	CAMERA EQUIPMENT D-PIVOT
MEGI BUFFER 100X40-M16 NR	72 66 160 08	9	2	3 220 500	91 52 849 08	S INTERMEDIATE SECTION
MEGI BUFFER 100X40-M16 NR	72 66 160 08	9	2	3 223	91 52 852 08	S INTERMEDIATE SECTION
MEGI BUFFER 100X40-M16 NR	72 66 160 08	9	2	3 223 010	91 52 853 08	S INTERMEDIATE SECTION
MEGI BUFFER 100X40-M16 NR	72 66 160 08	9	2	3 223 100	91 55 327 08	S INTERMEDIATE SECTION
MEGI BUFFER 100X40-M16 NR	72 66 160 08	10	2	3 745	91 52 948 08	SUSPENDED BALLAST
MEGI BUFFER 18X7,5	72 66 167 08	10	4	2 510	91 52 788 08	TURNTABLE PANELLING
MEGI BUFFER 18X7,5	72 66 167 08	6	2	2 859 030	96 46 758 08	COVER COMPL.
MEGI BUFFER 30X20-M8 NR 60	72 66 156 08	2	4	2 391 102	96 56 360 08	RADIATOR
MEMORY CARD BSE 2GB CF-C	96 50 143 08	4	1	2 533 050	96 48 359 08	EL.EQUIPMENT CABIN
MICRO SWITCH	10 33 559 6	3	4	6 060 950	60 60 950 08	MASTER SWITCH
MINUTE RING	10 01 215 7	5	1	9 739 246	97 39 246	PISTON
MONITOR CONSOLE	96 50 633 08	9	1	2 520	91 53 061 08	CABIN, GLAZED
MONITOR CONSOLE PU SPF	97 79 033 08	1	1	2 520 033	96 50 633 08	MONITOR CONSOLE
MOTOR BRACKET	96 48 449 08	4	1	2 391 001	96 45 719 08	DIESEL ENGINE, PRE-ASSEMB
MOTOR BRACKET	96 49 935 08	44	1	2 391 001	96 45 719 08	DIESEL ENGINE, PRE-ASSEMB
MOTOR BRAKE	97 39 186	330	1	9 739 400	97 39 400	DIESEL ENGINE
MOTOR CONTROL DEVICE LH-	97 39 403	71	1	9 739 400	97 39 400	DIESEL ENGINE
MOTOR FLANGE	10 65 067 4	5	1	X1035519	10 35 519 6	OIL AIR COOLER
MOTOR OIL FILTER	10 01 228 7	13	1	9 739 122	97 39 122	OIL COOLER
MOTOR SUPPORT	97 39 360	208	1	X1012059	10 12 059 0	DIESEL ENGINE
MOULDING	60 52 128 08	502	1	2 920 633	96 52 651 08	WIRING HARNESS
MOULDING	60 52 128 08	152	1	2 920 636	96 51 854 08	LEAD
MOUNTING - PISTON W. PUM	51 23 682 08	11	1	1 410 300	91 56 855 08	CRAWLER CARRIER RIGHT CP
MOUNTING EQUIPMENT CRAW	91 57 656 08	139	1		LR 1600-2-0	
MOUNTING PARTS	10 65 040 3	49	1	X1029200	10 29 200 4	DRIVERS SEAT
MOUNTING PARTS	96 56 483 08	1	1	3 780 258	96 56 482 08	ELECTRIC AIRCRAFT PROTE
MOUNTING WELDED	96 46 304 08	2	1	2 652	91 52 794 08	ROLLER BEARING
MOUNTING WELDED	96 46 307 08	14	1	2 652	91 52 794 08	ROLLER BEARING
MOUNTING WELDED	96 47 021 08	1	1	3 211 009	96 46 979 08	SAFETY ROLLER CPL.
MOUSE SUBSTITUTE	10 32 683 8	27	1	2 533 070	96 48 363 08	CONTROLS AND FITTINGS RI
MUFFLER UNIT	91 52 785 08	124	1		LR 1600-2-0	
MULTIPLE PLUG SOCKET B 64	60 23 212 08	5	7	2 922 001	92 84 311 08	BUS PCB

6.2.2009

etk_en_de_074515 LR 1600/2

925

LIEBHERRAlphabetical index
Alphabetischer Index

Description	Item	Pos.	Quantity	Page	Assembly	Description
MUSHROOM PUSH-BUTTON	60 66 526 08	11	1	2 920 638	96 51 138 08	CONTROL DESK
NAME PLATE 20X8	60 27 614 08	12	10	2 932 166	92 68 911 08	GROUND RAIL
NAME PLATE 25,4X101,6	60 27 601 08	1	2	1 976 050	96 50 707 08	HOSES CRAWLER 4 DRIVES
NAME PLATE 25,4X101,6	60 27 601 08	1	15	1 997	91 52 512 08	HOSE LINES CRAWLER
NAME PLATE 25,4X101,6	60 27 601 08	(1)	1	2 393	91 52 787 08	AIR FILTER UNIT CPL.
NAME PLATE 25,4X101,6	60 27 601 08	(1)	6	2 831	91 57 754 08	AIR COND. UNIT SUPERSTRU
NAME PLATE 25,4X101,6	60 27 601 08	(1)	4	2 970 081	96 50 495 08	ADDL.HYDR.F.PIN PULLING DE
NAME PLATE 25,4X101,6	60 27 601 08	1	9	2 975 061	96 47 201 08	HOSES WINCH 2
NAME PLATE 25,4X101,6	60 27 601 08	1	9	2 975 118	96 47 200 08	HOSES WINCH 1
NAME PLATE 25,4X101,6	60 27 601 08	1	11	2 975 154	96 50 585 08	HOSES WINCH 3
NAME PLATE 25,4X101,6	60 27 601 08	1	4	2 975 191	96 48 196 08	HOSE LINES MOUNTING JACK
NAME PLATE 25,4X101,6	60 27 601 08	(1)	2	2 976 203	92 27 489 08	ADDL.HYDR.F.PIN PULLING DE
NAME PLATE 25,4X101,6	60 27 601 08	1	6	2 976 204	96 47 202 08	HOSE LINES 2 SLEWING GEA
NAME PLATE 25,4X101,6	60 27 601 08	1	1	2 976 701	96 47 196 08	HOSE LINES PUMP 12
NAME PLATE 25,4X101,6	60 27 601 08	1	1	2 977 005	96 48 195 08	HOSE LINES ADD HYDR
NAME PLATE 25,4X101,6	60 27 601 08	1	2	2 977 201	96 48 618 08	HOSES PUMP 6
NAME PLATE 25,4X101,6	60 27 601 08	1	2	2 978 101	96 47 912 08	HOSE LINES MOUNTING INST
NAME PLATE 25,4X101,6	60 27 601 08	1	6	2 978 107	96 50 433 08	HOSE LINES GUY MOUNTING
NAME PLATE 25,4X101,6	60 27 601 08	1	6	2 978 204	96 47 114 08	HOSE LINES
NAME PLATE 25,4X101,6	60 27 601 08	1	119	2 997	91 56 539 08	HOSE LINES SUPERSTRUCT
NAME PLATE 25,4X101,6	60 27 601 08	1	6	3 978 009	96 50 881 08	HOSE LINES D-HEAD SECTIO
NAME PLATE 25,4X101,6	60 27 601 08	(1)	1	3 978 015	91 56 429 08	ADDITIONAL HYDRAULICS IN
NAME PLATE 25,4X101,6	60 27 601 08	1	1	3 978 016	96 50 878 08	HOSE LINES INTERM. SECTIO
NAME PLATE 25,4X101,6	60 27 601 08	1	3	3 978 018	96 50 880 08	HOSE LINES PULL CYL
NAME PLATE 25,4X12,7	60 27 623 08	(980)	2	2 533 070	96 48 363 08	CONTROLS AND FITTINGS RI
NAME PLATE 25,4X165,1	60 27 603 08	(1)	8	1 975 006	91 52 509 08	ADD. HYDR. SUPPORTING RA
NAME PLATE 25,4X165,1	60 27 603 08	2	6	1 976 050	96 50 707 08	HOSES CRAWLER 4 DRIVES
NAME PLATE 25,4X165,1	60 27 603 08	2	33	1 997	91 52 512 08	HOSE LINES CRAWLER
NAME PLATE 25,4X165,1	60 27 603 08	2	8	2 975 154	96 50 585 08	HOSES WINCH 3
NAME PLATE 25,4X165,1	60 27 603 08	2	1	2 975 191	96 48 196 08	HOSE LINES MOUNTING JACK
NAME PLATE 25,4X165,1	60 27 603 08	2	6	2 976 204	96 47 202 08	HOSE LINES 2 SLEWING GEA
NAME PLATE 25,4X165,1	60 27 603 08	2	4	2 976 701	96 47 196 08	HOSE LINES PUMP 12
NAME PLATE 25,4X165,1	60 27 603 08	2	7	2 977 005	96 48 195 08	HOSE LINES ADD HYDR
NAME PLATE 25,4X165,1	60 27 603 08	2	5	2 977 201	96 48 618 08	HOSES PUMP 6
NAME PLATE 25,4X165,1	60 27 603 08	2	4	2 978 101	96 47 912 08	HOSE LINES MOUNTING INST
NAME PLATE 25,4X165,1	60 27 603 08	2	6	2 978 107	96 50 433 08	HOSE LINES GUY MOUNTING
NAME PLATE 25,4X165,1	60 27 603 08	2	4	2 978 204	96 47 114 08	HOSE LINES
NAME PLATE 25,4X165,1	60 27 603 08	2	117	2 997	91 56 539 08	HOSE LINES SUPERSTRUCT
NAME PLATE 25,4X165,1	60 27 603 08	2	6	3 978 009	96 50 881 08	HOSE LINES D-HEAD SECTIO
NAME PLATE 25,4X165,1	60 27 603 08	(2)	2	3 978 015	91 56 429 08	ADDITIONAL HYDRAULICS IN
NAME PLATE 25,4X165,1	60 27 603 08	2	2	3 978 016	96 50 878 08	HOSE LINES INTERM. SECTIO
NAME PLATE 25,4X165,1	60 27 603 08	2	1	3 978 018	96 50 880 08	HOSE LINES PULL CYL
NAME PLATE 25,4X165,1	60 27 603 08	(1)	2	3 978 100	91 56 428 08	HYDR. SUSPENDED BALLAST
NAME PLATE 70X40 POLYES	10 28 812 1	980	1	2 913 200	96 47 216 08	LICCON CONSOLE LCD3
NIPPLE PLATE 3.5x521x876 AL	97 00 272 08	1	1	2 859 028	96 46 778 08	COVER COMPL.
NIPPLE PLATE 3.5x721x876 AL	97 00 223 08	1	1	2 859 027	96 46 777 08	COVER COMPL.
NIPPLE PLATE 5X1372X491	97 70 935 08	1	1	2 859 007	96 46 775 08	COVER COMPL.
NIPPLE PLATE 5X878X723	97 70 951 08	1	1	2 859 026	96 46 776 08	COVER COMPL.
NON-RETURN VALVE	10 01 239 5	9	2	9 739 357	97 39 357	EXHAUST GAS RECIRCUL.PRE
NON-RETURN VALVE	10 34 334 2	2	1	9 739 356	97 39 356	PIPELINE INSTALLATION
NON-RETURN VALVE	10 45 104 8	6	1	X1042440	10 42 440 2	CONTROL BLOCK
NON-RETURN VALVE	51 04 087 08	37	1	2 970	91 56 537 08	HYDR
NON-RETURN VALVE	51 04 087 08	10	1	2 975 100	91 52 860 08	ADDITIONAL HYDRAULICS WI
NON-RETURN VALVE	51 04 087 08	10	1	2 975 200	91 52 775 08	ADDITIONAL HYDRAULICS WI
NON-RETURN VALVE	51 04 087 08	10	1	2 975 700	91 52 774 08	ADDITIONAL HYDRAULICS WI
NON-RETURN VALVE	51 04 121 08	18	1	1 970	91 56 958 08	CRAWLER TRACK HYDRAULI
NON-RETURN VALVE	51 04 121 08	20	1	2 970	91 56 537 08	HYDR
NON-RETURN VALVE	51 04 124 08	40	2	2 970	91 56 537 08	HYDR
NON-RETURN VALVE	51 04 124 08	14	1	2 975 200	91 52 775 08	ADDITIONAL HYDRAULICS WI
NON-RETURN VALVE	51 04 124 08	14	1	2 975 700	91 52 774 08	ADDITIONAL HYDRAULICS WI

6.2.2009

etk_en_de_074515 LR 1600/2

926

LIEBHERRAlphabetical index
Alphabetischer Index

Description	Item	Pos.	Quantity	Page	Assembly	Description
NON-RETURN VALVE	51 04 129 08	19	1	1 970	91 56 958 08	CRAWLER TRACK HYDRAULI
NON-RETURN VALVE	51 14 351 08	78	2	2 970	91 56 537 08	HYDR
NON-RETURN VALVE	51 14 535 08	35	3	2 970	91 56 537 08	HYDR
NON-RETURN VALVE	51 14 606 08	5	1	2 975 100	91 52 860 08	ADDITIONAL HYDRAULICS WI
NON-RETURN VALVE	51 14 606 08	5	1	2 975 200	91 52 775 08	ADDITIONAL HYDRAULICS WI
NON-RETURN VALVE	51 14 606 08	5	1	2 975 700	91 52 774 08	ADDITIONAL HYDRAULICS WI
NON-RETURN VALVE	51 14 769 08	18	1	2 970	91 56 537 08	HYDR
NON-RETURN VALVE	51 14 815 08	11	2	1 970	91 56 958 08	CRAWLER TRACK HYDRAULI
NON-RETURN VALVE	51 14 815 08	51	1	2 970	91 56 537 08	HYDR
NON-RETURN VALVE	51 14 815 08	8	1	2 975 100	91 52 860 08	ADDITIONAL HYDRAULICS WI
NON-RETURN VALVE	51 14 815 08	8	1	2 975 200	91 52 775 08	ADDITIONAL HYDRAULICS WI
NON-RETURN VALVE	51 14 815 08	8	1	2 975 700	91 52 774 08	ADDITIONAL HYDRAULICS WI
NON-RETURN VALVE	51 14 815 08	11	1	3 978 005	91 56 430 08	ADDL.HYDRAULIC SB-HEAD PI
NON-RETURN VALVE	51 14 820 08	27	2	2 970	91 56 537 08	HYDR
NON-RETURN VALVE	51 14 937 08	14	1	2 975 100	91 52 860 08	ADDITIONAL HYDRAULICS WI
NON-RETURN VALVE	51 14 982 08	8	1	3 978 100	91 56 428 08	HYDR. SUSPENDED BALLAST
NON-RETURN VALVE	57 19 038 08	48	1	5 113 086	51 13 086 08	PROPORTIONAL VALVE
NON-RETURN VALVE	59 10 556 08	16	2	2 520 032	96 45 980 08	WINDSHIELD WASHER INSTAL
NON-RETURN VALVE	76 22 803	(1)	1	2 711	91 52 800 08	CENT. LUBRIC. SYSTEM SUP
NON-RETURN VALVE	76 22 803	(2)	6	2 711	91 52 800 08	CENT. LUBRIC. SYSTEM SUP
NON-RETURN VALVE	76 22 803	(2)	6	2 711	91 52 800 08	CENT. LUBRIC. SYSTEM SUP
NON-RETURN VALVE	77 43 781 08	(1)	3	2 711	91 52 800 08	CENT. LUBRIC. SYSTEM SUP
NON-RETURN VALVE 350BAR	10 66 432 1	270	1	X1041101	10 41 101 5	TILTING-BACK SUPPORT
NON-RETURN VALVE 350BAR	10 66 432 1	250	1	X1041101	10 41 101 8	TILTING-BACK SUPPORT
NON-RETURN VALVE FE/ZN12	51 14 469 08	9	1	2 975 000	91 57 881 08	ADDNL. HYDR. F. ERECTING W
NOZZLE	10 22 232 2	4	1	9 739 243	97 39 243	PISTON COOLING
NOZZLE 0,4	51 07 543 08	5	2	2 990	91 59 244 08	COMPRESSED AIR PLANT
NOZZLE 0,4 MS	51 10 487 08	41	1	2 970	91 56 537 08	HYDR
NOZZLE 0,4 MS	51 10 487 08	8	1	2 978 100	91 52 827 08	ADDNL.HYDR.RETAINING DEV
NOZZLE 0,4 MS	51 10 487 08	8	1	2 978 200	91 54 843 08	ADD.HYDR.S_RETAINING RAM
NOZZLE 0,6	51 07 460 08	39	3	2 970	91 56 537 08	HYDR
NOZZLE 0,6	51 07 460 08	13	1	2 975 100	91 52 860 08	ADDITIONAL HYDRAULICS WI
NOZZLE 0,6	51 07 460 08	13	1	2 975 200	91 52 775 08	ADDITIONAL HYDRAULICS WI
NOZZLE 0,6	51 07 460 08	13	1	2 975 700	91 52 774 08	ADDITIONAL HYDRAULICS WI
NOZZLE 0,6 10.9	57 08 188 08	49	5	2 970	91 56 537 08	HYDR
NOZZLE D 1,5 M8X8 MS	51 10 575 08	3	2	2 976 200	91 52 780 08	ADDITIONAL HYDRAULICS
NOZZLE D=1,2	57 19 039 08	51	1	5 113 086	51 13 086 08	PROPORTIONAL VALVE
NRS CHECK VALVE	57 19 133 08	5	1	X1035925	10 35 925 0	VARIABLE PUMP
NUT	57 00 099 08	19	1	5 026 126	50 26 126 08	SOLENOID VALVE
NUT	57 10 772 08	(5)	1	2 975 700	91 52 774 08	ADDITIONAL HYDRAULICS WI
NUT	57 10 823 08	(5)	1	1 970	91 56 958 08	CRAWLER TRACK HYDRAULI
NUT	57 14 553 08	(1)	1	5 710 349	57 10 349 08	DIRECTIONAL CONTROL VALV
NUT GZ45-01	70 27 459	2	2	5 113 022	51 13 022 08	DIRECTIONAL CONTROL VALV
NUT M10 -8 A3C	10 01 427 8	10	1	9 739 159	97 39 159	STARTER
NUT M10 -8 A3C	10 01 427 8	8	1	9 739 186	97 39 186	MOTOR BRAKE
NUT M10 -8 A3C	10 01 427 8	6	1	9 739 344	97 39 344	GENERATOR, PRE-ASSEMBLE
NUT M12 8	10 02 092 2	10	2	9 739 344	97 39 344	GENERATOR, PRE-ASSEMBLE
NUT M12 8	10 02 092 2	20	1	9 739 344	97 39 344	GENERATOR, PRE-ASSEMBLE
NUT M12 CU	55 20 022 08	12	8	2 392	91 52 785 08	MUFFLER UNIT
NUT M12X1,5 8	10 01 163 2	3	3	9 739 159	97 39 159	STARTER
NUT M6 8	10 01 162 9	8	1	9 739 159	97 39 159	STARTER
NUT M6 8	10 01 162 9	13	1	9 739 288	97 39 288	FUEL LINE
NUT M6 8	10 01 162 9	8	4	9 739 292	97 39 292	FUEL LINE
NUT M6 8	10 01 162 9	(5)	2	9 739 318	97 39 318	SENSOR ELEMENT
NUT M6 8	10 01 162 9	10	1	9 739 356	97 39 356	PIPELINE INSTALLATION
NUT M6 VERZ	60 20 180 08	25	2	2 671 004	96 46 305 08	OIL TANK PRE-ASS.
NUT M6 VERZ	60 20 180 08	17	8	2 978 100	91 52 796 08	ADDNL.HYDR.ERECTION DEV
NUT M6 VERZ	60 20 180 08	55	20	3 978 005	91 56 430 08	ADDL.HYDRAULIC SB-HEAD PI
NUT M6 VERZ	60 20 180 08	55	40	3 978 015	91 56 429 08	ADDITIONAL HYDRAULICS IN
NUT M6 VERZ	60 20 180 08	55	40	3 978 015	91 56 432 08	ADDITIONAL HYDRAULICS IN

6.2.2009

etk_en_de_074515 LR 1600/2

927

LIEBHERRAlphabetical index
Alphabetischer Index

Description	Item	Pos.	Quantity	Page	Assembly	Description
NUT M8 8	10 01 163 1	11	1	9 739 210	97 39 210	LIQUID COOLING PIPELINE
NUT M8 8	10 01 163 1	22	1	9 739 386	97 39 386	CRANKCASE BREATHER
NUT M8 8	10 01 163 1	36	1	9 739 492	97 39 492	PIPELINE INSTALLATION
O RING	10 22 273 5	3	1	9 739 248	97 39 248	INJECTOR
O RING	10 22 273 5	73	1	X1022281	10 22 281 7	SEAL KIT CYLINDER HEAD
O RING 100X3 N-FPM1-70	10 33 210 8	11	1	9 739 278	97 39 278	ADD-ON PARTS
O RING 100X3 N-FPM1-70	10 33 210 8	2	1	X1034309	10 34 309 6	HIGH PRESSURE PUMP
O RING 10X3 FPM1-80-GN	10 01 192 5	8	1	9 739 278	97 39 278	ADD-ON PARTS
O RING 12X2 ACM1-60	10 01 263 7	11	1	9 739 122	97 39 122	OIL COOLER
O RING 130X4 ACM1-60	10 01 263 8	10	1	9 739 122	97 39 122	OIL COOLER
O RING 138X3,5 FPM1-70-GN	10 01 263 5	3	1	9 739 278	97 39 278	ADD-ON PARTS
O RING 144X4 FPM2-70	10 01 264 1	3	2	9 739 242	97 39 242	CYLINDER BUSH
O RING 23X2,5 FPM1-70-GN	10 01 192 0	4	2	9 739 263	97 39 263	ROCKER ARM BEARING HOUS
O RING 23X2,5 FPM1-70-GN	10 01 192 0	4	2	9 739 264	97 39 264	ROCKER ARM BEARING HOUS
O RING 30X3,5 N-NBR3-70	10 01 263 4	6	1	9 739 386	97 39 386	CRANKCASE BREATHER
O RING 48X3 B-NBR3-70	10 01 185 2	8	1	9 739 258	97 39 258	FUEL FILTER
O RING 59X3 B-FPM1-70	10 01 185 5	3	1	9 739 035	97 39 035	LOCKING PIECES
O RING 59X3 B-FPM1-70	10 01 185 5	3	1	9 739 129	97 39 129	COOLANT PREHEATING
O RING 60X4 B-NBR3-60	10 01 185 3	2	2	9 739 126	97 39 126	THERMOSTAT HOUSING
O RING 63X2,5 FPM1-70-GN	10 01 192 1	125	1	2 391 001	96 45 719 08	DIESEL ENGINE, PRE-ASSEMB
O RING 8X2 ACM1-60	10 01 263 6	12	1	9 739 122	97 39 122	OIL COOLER
O RING 91X4 N-NBR3-70	10 01 191 6	6	1	9 739 258	97 39 258	FUEL FILTER
O RING 9X3 N-FPM1-70-GN	10 01 191 9	10	1	9 739 248	97 39 248	INJECTOR
O RING 9X3 N-FPM1-70-GN	10 01 191 9	76	1	X1022281	10 22 281 7	SEAL KIT CYLINDER HEAD
O-RING 100X2,5 NBR70	72 64 351 08	144	1	2 391 001	96 45 719 08	DIESEL ENGINE, PRE-ASSEMB
O-RING 10X2 NBR70	72 64 065 08	(22)	1	X1042440	10 42 440 2	CONTROL BLOCK
O-RING 10X2,2 NBR70	50 29 332 08	47	1	2 393	91 52 787 08	AIR FILTER UNIT CPL.
O-RING 110X2 NBR70	72 64 234 01	5	1	X1004204	10 04 204 3	WATER HEATING SYSTEM
O-RING 120X3 NBR70	72 62 030 08	97	1	9 697 916	96 97 916 01	SLEWING GEAR
O-RING 125X3 NBR70	72 64 260 08	143	2	2 391 001	96 45 719 08	DIESEL ENGINE, PRE-ASSEMB
O-RING 12X2 NBR70	70 42 748 08	6	4	2 393 002	96 46 782 08	COVER COMPL.
O-RING 12X2 NBR70	70 42 748 08	9	7	2 859 005	96 46 756 08	FLAP PRE-ASS.
O-RING 12X2 NBR70	70 42 748 08	6	4	2 859 007	96 46 775 08	COVER COMPL.
O-RING 12X2 NBR70	70 42 748 08	12	4	2 859 025	96 46 757 08	GRIDIRON PRE-ASS.
O-RING 12X2 NBR70	70 42 748 08	6	4	2 859 026	96 46 776 08	COVER COMPL.
O-RING 12X2 NBR70	70 42 748 08	6	4	2 859 027	96 46 777 08	COVER COMPL.
O-RING 12X2 NBR70	70 42 748 08	6	4	2 859 028	96 46 778 08	COVER COMPL.
O-RING 12X2 NBR70	70 42 748 08	6	4	2 859 029	96 46 779 08	COVER COMPL.
O-RING 12X2 NBR70	70 42 748 08	11	2	2 859 030	96 46 758 08	COVER COMPL.
O-RING 12X2 NBR70	70 42 748 08	6	6	2 932 168	96 48 167 08	COVER COMPL.
O-RING 12X2,5 HNBR	74 12 937	15	1	7 027 481	70 27 481 03	WATER SEPARATOR
O-RING 135X3 NBR70	72 64 528 01	29	1	7 743 566	77 43 566 08	ELECTRIC PUMP
O-RING 14X1,1 NBR70	57 00 101 08	4	1	5 026 126	50 26 126 08	SOLENOID VALVE
O-RING 14X1,1 NBR70	57 00 101 08	3	2	5 114 498	51 14 498 08	DIRECTIONAL CONTROL VALV
O-RING 14X1,1 NBR70	57 00 101 08	3	2	5 114 943	51 14 943 08	DIRECTIONAL CONTROL VALV
O-RING 150X3 FPM70	57 16 648 08	(52)	1	1 400	91 56 853 08	CRAWLER TRACK CARRIER LE
O-RING 150X3 NBR70	51 85 781 08	142	5	2 391 001	96 45 719 08	DIESEL ENGINE, PRE-ASSEMB
O-RING 15X2 FPM80	57 12 342 08	23	4	X1035925	10 35 925 1	VARIABLE PUMP
O-RING 15X2 NBR90	51 45 424 08	43	1	X1041267	10 41 267 5	PRESSURE LIMITING VALVE
O-RING 167X2,5 NBR80	57 15 165 08	22	1	X1035925	10 35 925 1	VARIABLE PUMP
O-RING 174X4 NBR70	57 18 445 08	55	1	X1065015	10 65 015 8	DRIVE UNIT
O-RING 17X2 FPM70	57 10 826 08	(2)	1	1 970	91 56 958 08	CRAWLER TRACK HYDRAULI
O-RING 18X2,5 NBR70	72 64 069 08	(1)	1	2 391 038	96 47 931 08	OIL COOLER, PRE-ASSEMBLE
O-RING 19,4X2,5 HNBR	10 34 022 6	19	2	7 027 481	70 27 481 03	WATER SEPARATOR
O-RING 19X2,5 NBR70	72 64 241 08	(21)	2	X1042440	10 42 440 2	CONTROL BLOCK
O-RING 20,3X2,4 NBR70	50 29 329 08	597	4	2 990	91 59 244 08	COMPRESSED AIR PLANT
O-RING 200X3 NBR70	72 64 215 01	59	1	X1065015	10 65 015 8	DRIVE UNIT
O-RING 20X2 FPM70	57 10 820 08	(2)	1	1 970	91 56 958 08	CRAWLER TRACK HYDRAULI
O-RING 20X2 FPM70	57 10 820 08	(2)	1	1 970	91 56 958 08	CRAWLER TRACK HYDRAULI
O-RING 22,2X3 NBR70	54 01 843 08	16	1	5 400 565	54 00 565 08	ROPE WINCH

6.2.2009

etk_en_de_074515 LR 1600/2

928

LIEBHERRAlphabetical index
Alphabetischer Index

Description	Item	Pos.	Quantity	Page	Assembly	Description
O-RING 24X2 NBR70	72 64 306 08	32	2	X1042440	10 42 440 2	CONTROL BLOCK
O-RING 24X3 FPM70	57 10 774 08	(4)	1	3 978 100	91 56 428 08	HYDR. SUSPENDED BALLAST
O-RING 26X1,5 FPM70	57 10 821 08	(3)	1	1 970	91 56 958 08	CRAWLER TRACK HYDRAULI
O-RING 27,5X2,5 FPM70	57 06 810 08	(1)	1	5 114 943	51 14 943 08	DIRECTIONAL CONTROL VALV
O-RING 285X3 NBR70	57 15 514 08	58	1	X1065015	10 65 015 8	DRIVE UNIT
O-RING 29X3 NBR70	53 00 732 08	31	2	X1042440	10 42 440 2	CONTROL BLOCK
O-RING 29X4,5 NBR70	72 64 538 01	69	1	9 697 916	96 97 916 01	SLEWING GEAR
O-RING 320X3 NBR70	76 10 203 03	73	1	9 697 916	96 97 916 01	SLEWING GEAR
O-RING 32X3 FPM70	57 10 769 08	(2)	1	2 975 700	91 52 774 08	ADDITIONAL HYDRAULICS WI
O-RING 32X3 FPM70	57 10 769 08	(2)	1	3 978 100	91 56 428 08	HYDR. SUSPENDED BALLAST
O-RING 340X4 72 NBR 872	76 10 341 03	24	1	9 697 916	96 97 916 01	SLEWING GEAR
O-RING 39,7X3,5 NBR70	57 05 889 08	3	1	5 708 320	57 08 320 08	FILTER COVER
O-RING 40X3 FPM70	57 10 771 08	(4)	1	2 975 700	91 52 774 08	ADDITIONAL HYDRAULICS WI
O-RING 42X3 NBR90	72 64 212 08	19	1	2 520 032	96 45 980 08	WINDSHIELD WASHER INSTAL
O-RING 54X3 NBR70	72 64 055 08	68	1	9 697 916	96 97 916 01	SLEWING GEAR
O-RING 600X4 NBR 70	76 10 208 03	(2)	1	1 400	91 56 853 08	CRAWLER TRACK CARRIER LE
O-RING 6X1 NBR90	57 06 906 08	7	1	5 711 301	57 11 301 08	PRESSURE LIMITING VALVE
O-RING 6X1 NBR90	57 06 906 08	17	1	5 715 296	57 15 296 08	PRESSURE VALVE
O-RING 6X1 NBR90	57 06 906 08	22	1	7 743 566	77 43 566 08	ELECTRIC PUMP
O-RING 6X1,5 NBR90	51 07 129 08	11	3	5 114 498	51 14 498 08	DIRECTIONAL CONTROL VALV
O-RING 6X1,5 NBR90	51 07 129 08	11	3	5 114 943	51 14 943 08	DIRECTIONAL CONTROL VALV
O-RING 75X2,5 NBR70	52 12 028 08	22	1	5 102 380	51 02 380 08	HYDRO MOTOR
O-RING 78,97X3,53 FKM 70	10 22 070 7	6	1	5 102 354	51 02 354 08	HYDRO MOTOR
O-RING 98,02X3,53 S-FPM 75	73 72 303	(15)	1	5 102 354	51 02 354 08	HYDRO MOTOR
O-RING ARP 568 10,82X1,78 NB	51 07 181 08	27	1	5 113 005	51 13 005 08	CONTROL BLOCK
O-RING ARP 568 10,82X1,78 NB	51 07 181 08	12	3	5 719 113	57 19 113 08	CONTROL UNIT
O-RING ARP 568 10,82X1,78 NB	51 07 181 08	12	3	X1029184	10 29 184 0	CONTROL UNIT
O-RING ARP 568 10,82X1,78 NB	51 07 181 08	27	1	X1048973	10 48 973 4	PRESSURE LIMITING VALVE
O-RING ARP 568 10,82X1,78 NB	51 07 604 08	32	1	X1022811	10 22 811 2	AIR CONDITIONING UNIT
O-RING ARP 568 101,19X3,53	51 31 150 08	11	1	5 719 006	57 19 006 08	PUMP SUPPORT
O-RING ARP 568 11,89X1,98 N	57 11 305 08	8	1	5 711 301	57 11 301 08	PRESSURE LIMITING VALVE
O-RING ARP 568 12,37X2,62 NB	51 07 461 08	(1)	1	2 970	91 56 537 08	HYDR
O-RING ARP 568 12,37X2,62 NB	51 07 461 08	13	2	5 026 126	50 26 126 08	SOLENOID VALVE
O-RING ARP 568 12,37X2,62 NB	51 07 461 08	24	2	5 113 086	51 13 086 08	PROPORTIONAL VALVE
O-RING ARP 568 12,42X1,78 NB	51 45 915 08	26	2	5 715 142	57 15 142 08	TERMINAL BOARD
O-RING ARP 568 12,42X1,78 NB	51 45 915 08	15	2	5 719 113	57 19 113 08	CONTROL UNIT
O-RING ARP 568 12,42X1,78 NB	51 45 915 08	15	2	X1029184	10 29 184 0	CONTROL UNIT
O-RING ARP 568 12,42X1,78 NB	51 45 915 08	44	1	X1041267	10 41 267 7	MANUAL ACTUATION
O-RING ARP 568 133,02X2,62	57 07 108 08	9	1	5 715 142	57 15 142 08	TERMINAL BOARD
O-RING ARP 568 139,37X2,62	57 06 662 08	9	1	5 718 989	57 18 989 08	TERMINAL BOARD
O-RING ARP 568 145,72X2,62	51 85 009 08	26	1	X1035924	10 35 924 7	VARIABLE PUMP
O-RING ARP 568 148,49X5,33	51 45 275 08	13	1	5 106 691	51 06 691 08	RETURN FILTER
O-RING ARP 568 14X1,78 NBR9	51 57 106 08	31	1	X1022811	10 22 811 2	AIR CONDITIONING UNIT
O-RING ARP 568 158,42X2,62	57 12 398 08	9	1	5 719 030	57 19 030 08	TERMINAL BOARD
O-RING ARP 568 158,42X2,62	57 12 398 08	26	1	X1035924	10 35 924 8	VARIABLE PUMP
O-RING ARP 568 170,82X7 NB	57 05 883 08	8	1	5 106 691	51 06 691 08	RETURN FILTER
O-RING ARP 568 170,82X7 NB	57 05 883 08	1	1	5 708 320	57 08 320 08	FILTER COVER
O-RING ARP 568 2,9X1,78 NB	51 10 492 08	3	1	5 026 126	50 26 126 08	SOLENOID VALVE
O-RING ARP 568 20,29X2,62 NB	72 64 202 08	4	1	5 113 005	51 13 005 08	CONTROL BLOCK
O-RING ARP 568 23,4X3,53 NB	51 45 495 08	42	1	X1041267	10 41 267 5	PRESSURE LIMITING VALVE
O-RING ARP 568 23,52X1,78 N	57 06 523 08	25	1	5 113 005	51 13 005 08	CONTROL BLOCK
O-RING ARP 568 23,52X1,78 N	57 06 523 08	25	1	X1048973	10 48 973 4	PRESSURE LIMITING VALVE
O-RING ARP 568 24,99X3,53 NB	51 05 878 08	543	2	2 970	91 56 537 08	HYDR
O-RING ARP 568 24,99X3,53 NB	51 05 878 08	562	6	2 976 200	91 52 780 08	ADDITIONAL HYDRAULICS
O-RING ARP 568 24,99X3,53 NB	51 05 878 08	567	4	2 976 700	91 54 795 08	ADDITIONAL HYDRAULICS P
O-RING ARP 568 26,64X2,62 NB	57 00 488 08	17	2	5 719 113	57 19 113 08	CONTROL UNIT
O-RING ARP 568 26,64X2,62 NB	57 00 488 08	17	2	X1029184	10 29 184 0	CONTROL UNIT
O-RING ARP 568 29,82X2,62 NB	51 86 135 08	25	1	X1035924	10 35 924 1	VARIABLE PUMP
O-RING ARP 568 29,82X2,62 NB	51 86 135 08	25	1	X1035924	10 35 924 2	VARIABLE PUMP
O-RING ARP 568 29,82X2,62 NB	51 86 135 08	25	1	X1035924	10 35 924 6	VARIABLE PUMP

6.2.2009

etk_en_de_074515 LR 1600/2

929

LIEBHERRAlphabetical index
Alphabetischer Index

Description	Item	Pos.	Quantity	Page	Assembly	Description
O-RING ARP 568 29,82X2,62 NB	51 86 135 08	25	1	X1035925	10 35 925 0	VARIABLE PUMP
O-RING ARP 568 29,87X1,78 NB	51 07 478 08	39	2	5 113 086	51 13 086 08	PROPORTIONAL VALVE
O-RING ARP 568 29,87X1,78 NB	51 07 478 08	10	1	5 719 113	57 19 113 08	CONTROL UNIT
O-RING ARP 568 29,87X1,78 NB	51 07 478 08	10	1	X1029184	10 29 184 0	CONTROL UNIT
O-RING ARP 568 32,92X3,53 NB	51 05 870 08	547	4	2 970	91 56 537 08	HYDR
O-RING ARP 568 32,92X3,53 NB	51 05 870 08	(1)	1	2 970	91 56 537 08	HYDR
O-RING ARP 568 32,92X3,53 NB	51 05 870 08	(1)	1	2 970	91 56 537 08	HYDR
O-RING ARP 568 34,65X1,78 NB	51 07 399 08	43	1	X1041267	10 41 267 7	MANUAL ACTUATION
O-RING ARP 568 36,17X2,62 NB	72 64 252 08	50	1	X1041267	10 41 267 7	MANUAL ACTUATION
O-RING ARP 568 37,69X3,53 NB	51 05 867 08	53	12	1 970	91 56 958 08	CRAWLER TRACK HYDRAULI
O-RING ARP 568 37,69X3,53 NB	51 05 867 08	53	4	1 970 161	96 50 706 08	AUX.HYDR.CR.TRACK CARR.4
O-RING ARP 568 37,69X3,53 NB	51 05 867 08	127	4	2 970	91 56 537 08	HYDR
O-RING ARP 568 37,69X3,53 NB	51 05 867 08	554	20	2 970	91 56 537 08	HYDR
O-RING ARP 568 37,69X3,53 NB	51 05 867 08	560	2	2 970	91 56 537 08	HYDR
O-RING ARP 568 37,69X3,53 NB	51 05 867 08	45	4	2 975 100	91 52 860 08	ADDITIONAL HYDRAULICS WI
O-RING ARP 568 37,69X3,53 NB	51 05 867 08	42	3	2 975 200	91 52 775 08	ADDITIONAL HYDRAULICS WI
O-RING ARP 568 37,69X3,53 NB	51 05 867 08	42	3	2 975 700	91 52 774 08	ADDITIONAL HYDRAULICS WI
O-RING ARP 568 39,34X2,62 NB	72 64 191 08	25	1	X1035924	10 35 924 3	VARIABLE PUMP
O-RING ARP 568 39,34X2,62 NB	72 64 191 08	25	1	X1035924	10 35 924 4	VARIABLE PUMP
O-RING ARP 568 4,47X1,78 NB	51 31 192 08	50	1	5 113 086	51 13 086 08	PROPORTIONAL VALVE
O-RING ARP 568 47,22X3,53 NB	51 05 879 08	43	3	2 391 001	96 45 719 08	DIESEL ENGINE, PRE-ASSEMB
O-RING ARP 568 5,28X1,78 NB	72 64 266 08	49	2	5 113 086	51 13 086 08	PROPORTIONAL VALVE
O-RING ARP 568 52,07X2,62 NB	72 64 265 08	6	1	5 102 306	51 02 306 08	HYDRO MOTOR
O-RING ARP 568 56,74X3,53 NB	72 64 216 08	40	2	2 391 001	96 45 719 08	DIESEL ENGINE, PRE-ASSEMB
O-RING ARP 568 6,07X1,78 NB	72 64 196 08	20	1	5 715 296	57 15 296 08	PRESSURE VALVE
O-RING ARP 568 6,07X1,78 NB	51 07 384 08	441	4	5 713 626	57 13 626 08	PILOT VALVE
O-RING ARP 568 6,07X1,78 NB	51 07 384 08	16	1	5 719 113	57 19 113 08	CONTROL UNIT
O-RING ARP 568 6,07X1,78 NB	51 07 384 08	16	1	X1029184	10 29 184 0	CONTROL UNIT
O-RING ARP 568 63,09X3,53 NB	57 05 888 08	11	1	5 106 691	51 06 691 08	RETURN FILTER
O-RING ARP 568 64,77X2,62 NB	51 57 051 08	15	1	5 701 129	57 01 129 08	DRIVING GEAR
O-RING ARP 568 66,34X2,62 NB	51 45 042 08	(5)	1	X1035924	10 35 924 8	VARIABLE PUMP
O-RING ARP 568 75,87X2,62 NB	51 45 304 08	10	1	5 719 006	57 19 006 08	PUMP SUPPORT
O-RING ARP 568 85,32X3,53 NB	51 05 993 08	60	1	2 391 001	96 45 719 08	DIESEL ENGINE, PRE-ASSEMB
O-RING ARP 568 9,25X1,78 NB	51 07 190 08	26	1	5 113 005	51 13 005 08	CONTROL BLOCK
O-RING ARP 568 9,25X1,78 NB	51 07 190 08	26	1	X1048973	10 48 973 4	PRESSURE LIMITING VALVE
O-RING ARP 568 9,25X1,78 NB	51 07 386 08	26	2	5 718 989	57 18 989 08	TERMINAL BOARD
O-RING DIN 3770 25X2,5 FPM7	72 64 223 08	405	2	2 391 001	96 45 719 08	DIESEL ENGINE, PRE-ASSEMB
O-RING DIN 3771 17,17X1,78	73 81 103	4	2	9 079 186	90 79 186	TACHOMETER
O-RING DIN 3771 9,25X1,78 FP	73 80 574	5	4	X1034282	10 34 282 3	PRESSURE CONTROL VALVE
OIL AIR COOLER	10 33 421 5	1	1	2 391 102	96 56 360 08	RADIATOR
OIL AIR COOLER 75KW	10 35 519 6	1	1	2 391 038	96 47 931 08	OIL COOLER, PRE-ASSEMBLE
OIL COOLER	10 01 228 9	14	1	9 739 122	97 39 122	OIL COOLER
OIL COOLER	10 65 066 9	1	1	X1035519	10 35 519 6	OIL AIR COOLER
OIL COOLER	97 39 122	20	1	9 739 355	97 39 355	OIL COOLER ADD-ON
OIL COOLER ADD-ON	97 39 355	50	1	X1012059	10 12 059 0	DIESEL ENGINE
OIL COOLER, PRE-ASSEMBLE	96 47 931 08	130	1	2 391 001	96 45 719 08	DIESEL ENGINE, PRE-ASSEMB
OIL DRAIN PLUG M26X1,5	78 90 119 08	3	1	2 670 002	96 45 352 08	FUEL TANK, PRE-ASSEMBLED
OIL DRAIN PLUG M26X1,5	78 90 119 08	13	1	2 671	91 52 798 08	OIL RESERVOIR, COMPLETE
OIL DRAIN PLUG M26X1,5	78 90 119 08	5	1	2 671 004	96 46 305 08	OIL TANK PRE-ASS.
OIL DRAINING HOSE COMPL. 1	10 03 229 7	41	1	1 750	91 52 394 08	TOOL
OIL LINE	10 65 015 9	60	1	X1035411	10 35 411 4	HOISTING WINCH
OIL LINE	97 39 118	65	1	X1012059	10 12 059 0	DIESEL ENGINE
OIL RESERVOIR, COMPLETE	91 52 798 08	144	1		LR 1600-2-0	
OIL SEPARATOR	10 01 213 6	5	1	9 739 386	97 39 386	CRANKCASE BREATHER
OIL SIGHT GLASS R1"	77 43 201 08	4	1	2 671 004	96 46 305 08	OIL TANK PRE-ASS.
OIL SPLASH RING	10 34 283 6	1	1	9 739 341	97 39 341	DRIVING PARTS
OIL SUMP R-MOTORXD846 A7	97 39 361	1	1	9 739 362	97 39 362	OIL SUMP
OIL SUMP R-MOTORXD846 A7	97 39 362	16	1	X1012059	10 12 059 0	DIESEL ENGINE
OIL TANK PRE-ASS.	96 46 305 08	1	1	2 671	91 52 798 08	OIL RESERVOIR, COMPLETE
OIL TANK WELDED 600L - 564	96 46 306 08	1	1	2 671 004	96 46 305 08	OIL TANK PRE-ASS.

6.2.2009

etk_en_de_074515 LR 1600/2

930

LIEBHERRAlphabetical index
Alphabetischer Index

Description	Item	Pos.	Quantity	Page	Assembly	Description
OIL VALVE	54 02 537 14	520	1	X1065015	10 65 015 5	GEARBOX
OIL-LEVEL GAUGE	10 01 745 0	7	1	9 739 188	97 39 188	OIL-LEVEL GAUGE
OIL-LEVEL GAUGE	97 39 188	18	1	X1012059	10 12 059 0	DIESEL ENGINE
OIL-LEVEL GAUGE 11/8"	92 75 544 01	1	1	9 275 543	92 75 543 01	VENTILATION CONNECTING PI
OPERATING PANEL	96 46 505 08	2	1	2 533 070	96 48 363 08	CONTROLS AND FITTINGS RI
OPERATION	10 65 048 4	29	1	X1029200	10 29 200 4	DRIVERS SEAT
OUTLET JET D=82MM T=5 PA	55 31 932 08	36	9	2 520 034	96 45 984 08	INTERNAL LINING
OUTLET MANIFOLD	10 34 334 8	1	1	9 739 353	97 39 353	EXHAUST NOZZLE
OUTLET VALVE	10 22 234 8	2	2	9 739 261	97 39 261	CYLINDER HEAD
OUTPUT SHAFT	92 76 334 01	10	1	9 697 916	96 97 916 01	SLEWING GEAR
OUTSIDE HANDLE	10 42 458 2	2	1	2 522 011	96 45 602 08	CLOSING DEVICE
OVAL HEAD FLAT SCREW AE	10 41 285 1	27	5	2 260	91 53 057 08	CUP SPRING CLUSTER
OVAL HEAD FLAT SCREW AE	10 41 285 1	23	2	2 260 006	96 46 501 08	BATTERY BOX, PRE-ASSEMB
OVAL HEAD FLAT SCREW AE	10 41 285 1	4	5	2 391 036	96 23 055 08	COVER/LID/CAP, PRE-ASSEMB
OVAL HEAD FLAT SCREW AE	10 41 285 1	73	6	2 810	91 52 806 08	CRANE DRIVER'S CABIN CPL.
OVAL HEAD FLAT SCREW AE	10 41 285 1	21	8	2 925 402	96 58 855 08	CAMERA EQUIPMENT SLEWI
OVAL HEAD FLAT SCREW AE	10 41 285 2	14	8	2 393 002	96 46 782 08	COVER COMPL.
OVAL HEAD FLAT SCREW AE	10 41 285 2	15	10	2 522 013	96 45 883 08	GUIDE PRE-ASS.
OVAL HEAD FLAT SCREW AE	10 41 285 2	39	4	2 711	91 52 800 08	CENT. LUBRIC. SYSTEM SUP
OVAL HEAD FLAT SCREW AE	10 41 285 3	12	1	2 522 011	96 45 602 08	CLOSING DEVICE
OVAL HEAD FLAT SCREW AE	10 44 130 5	26	4	2 533 070	96 48 363 08	CONTROLS AND FITTINGS RI
OVAL HEAD FLAT SCREW AE	10 41 285 4	11	4	1 620	91 52 386 08	FIXING PARTS SLEWING RING
OVAL HEAD FLAT SCREW AE	10 41 285 4	62	8	1 970	91 56 958 08	CRAWLER TRACK HYDRAULI
OVAL HEAD FLAT SCREW AE	10 41 285 4	76	40	1 970	91 56 958 08	CRAWLER TRACK HYDRAULI
OVAL HEAD FLAT SCREW AE	10 41 285 4	13	30	2 310	91 52 503 08	WINCH 1
OVAL HEAD FLAT SCREW AE	10 41 285 4	13	30	2 320	91 52 504 08	WINCH 2
OVAL HEAD FLAT SCREW AE	10 41 285 4	20	47	2 340	91 52 776 08	WINCH 4 LUFFING GEAR
OVAL HEAD FLAT SCREW AE	10 41 285 4	353	8	2 391 001	96 45 719 08	DIESEL ENGINE, PRE-ASSEMB
OVAL HEAD FLAT SCREW AE	10 41 285 4	44	4	2 391 040	96 53 645 08	CLUTCH ACTUATOR
OVAL HEAD FLAT SCREW AE	10 41 285 4	3	4	2 540	91 53 253 08	CLIMA-HEATING INSTALLATIO
OVAL HEAD FLAT SCREW AE	10 41 285 4	(6)	5	2 550	91 57 751 08	SA FRAME
OVAL HEAD FLAT SCREW AE	10 41 285 4	23	40	2 550	91 57 751 08	SA FRAME
OVAL HEAD FLAT SCREW AE	10 41 285 4	12	2	2 550 008	96 47 628 08	RETAINER CPL.
OVAL HEAD FLAT SCREW AE	10 41 285 4	12	2	2 550 009	96 47 645 08	RETAINER CPL.
OVAL HEAD FLAT SCREW AE	10 41 285 4	16	4	2 657	91 57 656 08	MOUNTING EQUIPMENT CRAW
OVAL HEAD FLAT SCREW AE	10 41 285 4	7	4	2 670	91 52 797 08	FUEL TANK CPL.
OVAL HEAD FLAT SCREW AE	10 41 285 4	18	2	2 671	91 52 798 08	OIL RESERVOIR, COMPLETE
OVAL HEAD FLAT SCREW AE	10 41 285 4	24	2	2 671 004	96 46 305 08	OIL TANK PRE-ASS.
OVAL HEAD FLAT SCREW AE	10 41 285 4	60	7	2 810	91 52 806 08	CRANE DRIVER'S CABIN CPL.
OVAL HEAD FLAT SCREW AE	10 41 285 4	(5)	28	2 920	91 56 833 08	ELECTR. SYSTEM F.SLEWING
OVAL HEAD FLAT SCREW AE	10 41 285 4	14	8	2 978 100	91 52 796 08	ADDNL.HYDR.ERECTION DEV
OVAL HEAD FLAT SCREW AE	10 41 285 4	95	12	3 211	91 57 748 08	S PIVOT SECTION
OVAL HEAD FLAT SCREW AE	10 41 285 4	30	4	3 215 005	91 52 846 08	ROLLER SET
OVAL HEAD FLAT SCREW AE	10 41 285 4	30	4	3 215 006	91 52 847 08	ROLLER SET
OVAL HEAD FLAT SCREW AE	10 41 285 4	30	32	3 350	91 52 859 08	WINCH 3
OVAL HEAD FLAT SCREW AE	10 41 285 4	128	6	3 713	91 57 749 08	D PIVOT SECTION
OVAL HEAD FLAT SCREW AE	10 41 285 4	90	18	3 714	91 52 862 08	D HEAD SECTION
OVAL HEAD FLAT SCREW AEH	10 41 285 7	85	2	2 520	91 53 061 08	CABIN, GLAZED
OVAL HEAD FLAT SCREW AEH	10 41 285 7	19	4	2 541	91 52 790 08	ADD HEATING SUPERSTRUCT
OVAL HEAD FLAT SCREW AEH	10 41 285 7	11	4	2 541 001	96 49 651 08	ADDNL.HEATING, PRE-ASSE
OVAL HEAD FLAT SCREW AEH	10 41 285 7	53	4	2 631	91 56 817 08	SLEWING PLATFORM CATWAL
OVAL HEAD FLAT SCREW AEH	10 41 285 7	63	16	2 859	91 52 809 08	SOUND INSULATION
OVAL HEAD FLAT SCREW AEH	10 41 285 7	16	2	2 978 200	91 54 843 08	ADD.HYDR.S_RETAINING RAM
OVAL HEAD FLAT SCREW AEH	10 41 285 7	13	12	3 291	91 52 831 08	S OVERRUN PROTECTION
OVAL HEAD FLAT SCREW AEH	10 41 285 7	127	42	3 713	91 57 749 08	D PIVOT SECTION
OVAL HEAD FLAT SCREW AEH	10 41 286 1	331	4	2 391 001	96 45 719 08	DIESEL ENGINE, PRE-ASSEMB
OVAL HEAD FLAT SCREW AEH	10 41 286 1	79	2	2 520	91 53 061 08	CABIN, GLAZED
OVAL HEAD FLAT SCREW AEH	10 41 286 1	51	2	2 520 034	96 45 984 08	INTERNAL LINING
OVAL HEAD FLAT SCREW AEH	10 41 286 1	10	1	2 541 001	96 49 651 08	ADDNL.HEATING, PRE-ASSE
OVAL HEAD FLAT SCREW AEH	10 41 286 1	56	25	2 859	91 52 809 08	SOUND INSULATION

6.2.2009

etk_en_de_074515 LR 1600/2

931

LIEBHERRAlphabetical index
Alphabetischer Index

Description	Item	Pos.	Quantity	Page	Assembly	Description
OVAL HEAD FLAT SCREW ISO	10 45 069 3	80	6	2 520	91 53 061 08	CABIN, GLAZED
OVAL HEAD FLAT SCREW ISO	10 45 069 3	3	11	2 520 033	96 50 633 08	MONITOR CONSOLE
OVAL HEAD FLAT SCREW ISO	10 45 069 3	25	4	2 520 034	96 45 984 08	INTERNAL LINING
OVAL SCREW M6X12 10.9	10 33 615 7	20	6	2 391 040	96 53 645 08	CLUTCH ACTUATOR
OVERFLOW VALVE	10 27 976 0	9	1	9 739 281	97 39 281	OVERFLOW-OIL LINE
OVERFLOW VALVE	10 28 517 0	21	1	9 739 288	97 39 288	FUEL LINE
OVERFLOW VALVE	10 34 310 0	4	1	X1034309	10 34 309 6	HIGH PRESSURE PUMP
OVERFLOW VALVE	50 26 628 08	12	1	2 990	91 59 244 08	COMPRESSED AIR PLANT
OVERFLOW-OIL LINE	10 22 275 9	1	1	9 739 281	97 39 281	OVERFLOW-OIL LINE
OVERFLOW-OIL LINE	10 22 276 4	8	1	9 739 281	97 39 281	OVERFLOW-OIL LINE
OVERFLOW-OIL LINE	10 28 515 7	23	1	9 739 288	97 39 288	FUEL LINE
OVERFLOW-OIL LINE	97 39 281	105	1	X1012059	10 12 059 0	DIESEL ENGINE
OVERFLOW-OIL LINE	97 39 282	107	1	X1012059	10 12 059 0	DIESEL ENGINE
OVERHEAT PROTECTION	10 29 012 7	21	1	X1004204	10 04 204 3	WATER HEATING SYSTEM
OVERPRESSURE VALVE	10 01 228 3	9	1	9 739 372	97 39 372	LUBRICATING OIL PUMP
OVERPRESSURE VALVE	57 17 286 08	280	1	X1041101	10 41 101 5	TILTING-BACK SUPPORT
OVERPRESSURE VALVE	57 17 286 08	260	1	X1041101	10 41 101 8	TILTING-BACK SUPPORT
OVERPRESSURE VALVE 280	10 03 827 4	18	2	7 743 566	77 43 566 08	ELECTRIC PUMP
OVERRUN PROTECTION	91 52 897 08	296	1		LR 1600-2-0	
PADLOCK ABUS 62/40	88 52 515 08	31	1	2 391 040	96 53 645 08	CLUTCH ACTUATOR
PAN-HEAD SCREW AEHNL.IS	10 03 726 1	28	6	2 502	91 55 939 08	CONTROL STAND
PAN-HEAD SCREW AEHNL.IS	10 03 726 1	44	46	2 520 034	96 45 984 08	INTERNAL LINING
PAN-HEAD SCREW AEHNL.IS	10 03 726 1	5	27	2 522	91 54 115 08	SLIDING DOOR CPL.
PAN-HEAD SCREW AEHNL.IS	10 03 726 1	3	7	2 533 070	96 48 363 08	CONTROLS AND FITTINGS RI
PAN-HEAD SCREW AEHNL.ISO	40 97 053 08	43	4	2 502	91 55 939 08	CONTROL STAND
PAN-HEAD SCREW AEHNL.ISO	40 97 053 08	78	2	2 520	91 53 061 08	CABIN, GLAZED
PAN-HEAD SCREW AEHNL.ISO	40 97 053 08	46	6	2 520 034	96 45 984 08	INTERNAL LINING
PAN-HEAD SCREW DIN 7985 M	51 45 994 08	4	12	2 913 100	91 23 538 08	ASSEMBLY FRAME
PAN-HEAD SCREW DIN 7985 M	51 45 994 08	20	7	5 701 129	57 01 129 08	DRIVING GEAR
PAN-HEAD SCREW DIN 7985 M	55 31 699 08	39	4	X1022811	10 22 811 2	AIR CONDITIONING UNIT
PAN-HEAD SCREW DIN 7985 M	40 83 110 08	60	8	2 520 034	96 45 984 08	INTERNAL LINING
PAN-HEAD SCREW DIN 7985 M	55 31 619 08	12	4	2 913 100	91 23 538 08	ASSEMBLY FRAME
PAN-HEAD SCREW ISO 7045	40 83 112 08	4	4	2 913 003	96 20 599 08	FOIL KEYPAD PRE-ASS.
PAN-HEAD SCREW ISO 7045 M	10 03 064 2	6	2	2 913 007	96 20 763 08	CONTROLLER UNIT
PAN-HEAD SCREW ISO 7045	40 83 114 08	3	4	2 913 006	96 20 732 08	FAN PLATE PRE-ASS.
PAN-HEAD SCREW ISO 7045 M	40 83 115 08	3	8	2 913 005	96 20 731 08	INTERIOR HOUSING PRE-ASS.
PAN-HEAD SCREW ISO 7045 M	40 83 115 08	3	8	2 913 005	96 28 696 08	INTERIOR HOUSING PRE-ASS.
PAN-HEAD SCREW ISO 7045 M	40 83 115 08	4	3	2 913 007	96 20 763 08	CONTROLLER UNIT
PAN-HEAD SCREW ISO 7380	40 86 506 08	38	11	2 711	91 52 800 08	CENT. LUBRIC. SYSTEM SUP
PAN-HEAD SCREW ISO 7380	10 45 022 6	44	12	3 715 008	91 52 863 08	D INTERMEDIATE SECTION
PAN-HEAD SCREW ISO 7380	10 45 022 6	45	24	3 716	91 52 864 08	D INTERMEDIATE SECTION
PAN-HEAD SCREW M5X16 A2	10 02 823 7	356	8	2 391 001	96 45 719 08	DIESEL ENGINE, PRE-ASSEMB
PAN-HEAD SCREW M5X16 A2	10 02 823 7	3	8	2 859 005	96 46 756 08	FLAP PRE-ASS.
PAN-HEAD SCREW M6X16 S	40 97 043 08	17	4	2 393 002	96 46 782 08	COVER COMPL.
PAN-HEAD SCREW M6X16 S	40 97 043 08	76	13	2 520	91 53 061 08	CABIN, GLAZED
PAN-HEAD SCREW M6X16 S	40 97 043 08	21	6	2 520 032	96 45 980 08	WINDSHIELD WASHER INSTAL
PAN-HEAD SCREW M6X16 S	40 97 043 08	45	93	2 520 034	96 45 984 08	INTERNAL LINING
PAN-HEAD SCREW M6X16 S	40 97 043 08	5	4	2 533 051	96 48 360 08	EL.EQUIPMENT CABIN
PAN-HEAD SCREW M6X16 S	40 97 043 08	3	4	2 533 068	96 49 314 08	PREMOUNTED PLUG SOCKET
PAN-HEAD SCREW M6X16 S	40 97 043 08	(7)	2	2 925 026	91 55 259 08	ERG. CAMERA CONTROL
PAN-HEAD SCREW M6X16 S	40 97 043 08	7	2	2 925 405	96 48 397 08	EQUIPMENT CAMERA CAB
PAN-HEAD SCREW M8X20	40 97 041 08	26	8	2 260	91 53 057 08	CUP SPRING CLUSTER
PAN-HEAD SCREW M8X20	40 97 041 08	52	48	2 859	91 52 809 08	SOUND INSULATION
PAN-HEAD SCREW M8X20	40 97 041 08	97	12	3 211	91 57 748 08	S PIVOT SECTION
PAN-HEAD SCREW M8X35 A2	40 97 059 08	19	2	2 391 040	96 53 645 08	CLUTCH ACTUATOR
PAN-HEAD SCREW M8X35 A2	40 97 059 08	96	36	3 211	91 57 748 08	S PIVOT SECTION
PAN-HEAD SCREW M8X35 A2	40 97 059 08	126	20	3 713	91 57 749 08	D PIVOT SECTION
PAN-HEAD SCREW M8X35 A2	40 97 059 08	89	14	3 714	91 52 862 08	D HEAD SECTION
PANELLING	97 69 826 08	12	1	2 520 034	96 45 984 08	INTERNAL LINING
PANELLING ABS-TPU SPF	97 68 730 08	11	1	2 522	91 54 115 08	SLIDING DOOR CPL.

6.2.2009

etk_en_de_074515 LR 1600/2

932

LIEBHERRAlphabetical index
Alphabetischer Index

Description	Item	Pos.	Quantity	Page	Assembly	Description
PANELLING ABS-TPU SPF	97 68 734 08	12	1	2 522	91 54 115 08	SLIDING DOOR CPL.
PANELLING REST SPF	97 69 890 08	3	1	2 520 034	96 45 984 08	INTERNAL LINING
PANELLING REST SPF	97 69 891 08	4	1	2 520 034	96 45 984 08	INTERNAL LINING
PANELLING ROLLER BLIND SP	97 71 455 08	18	1	2 520 034	96 45 984 08	INTERNAL LINING
PANELLING ROOF SPF	97 71 040 08	17	1	2 520 034	96 45 984 08	INTERNAL LINING
PANELLING SPF	97 69 892 08	5	1	2 520 034	96 45 984 08	INTERNAL LINING
PANELLING,LEFT	97 70 806 08	15	1	2 520 034	96 45 984 08	INTERNAL LINING
PANELLING,LEFT SPF	97 69 827 08	13	1	2 520 034	96 45 984 08	INTERNAL LINING
PANELLING,RIGHT	97 70 804 08	14	1	2 520 034	96 45 984 08	INTERNAL LINING
PANELLING,STRUT LEFT SPF	97 71 451 08	6	1	2 520 034	96 45 984 08	INTERNAL LINING
PARALLEL PIN 16H8X24 ST.50	10 01 177 8	11	2	9 739 354	97 39 354	FLYWHEEL HOUSING MOUNT
PARALLEL PIN DIN 7 3M6X10 S	57 01 132 08	5	1	5 102 306	51 02 306 08	HYDRO MOTOR
PARALLEL PIN DIN 7 6M6X16 S	51 45 349 08	20	2	X1042440	10 42 440 2	CONTROL BLOCK
PARALLEL PIN DIN 7 6M6X32 S	43 06 047 08	7	1	2 522 011	96 45 602 08	CLOSING DEVICE
PASSAGE NIPPLE BLOCK	77 43 751 08	6	4	1 711	91 52 392 08	CENTRALIZED LUBRICATION
PASSAGE NIPPLE BLOCK	77 43 751 08	11	2	2 711	91 52 800 08	CENT. LUBRIC. SYSTEM SUP
PEDAL CANTILEVER INSTALL	96 47 204 08	3	1	2 810 001	96 43 597 08	CRANE DRIVER'S CABIN,PRE
PEDAL TRANSDUCER SPF	10 29 730 9	10	2	2 533 050	96 48 359 08	EL.EQUIPMENT CABIN
PENCIL-TYPE GLOW PLUG	10 29 012 5	18	1	X1004204	10 04 204 3	WATER HEATING SYSTEM
PENDULUM ROLLER BEARING	74 61 600 08	6	1	5 718 420	57 18 420 08	FLANGE
PERMANENT MAGNET	61 70 001 08	3	1	2 780 851	96 24 498 08	RADIO ANTENNA PRE-ASS.
PERMANENT MAGNET	61 70 001 08	7	1	2 780 852	96 24 845 08	GSM-MODULE PRE-ASS.LICCO
PERMANENT MAGNET	61 70 001 08	267	2	2 920 638	96 51 138 08	CONTROL DESK
PILOT VALVE	57 13 626 08	55	1	5 113 086	51 13 086 08	PROPORTIONAL VALVE
PIN	10 04 243 0	410	1	X1041101	10 41 101 5	TILTING-BACK SUPPORT
PIN	10 04 243 0	390	1	X1041101	10 41 101 8	TILTING-BACK SUPPORT
PIN	57 04 059 08	(1)	1	1 750	91 52 394 08	TOOL
PIN	60 52 129 08	95	2	2 920 633	96 52 651 08	WIRING HARNESS
PIN	60 52 129 08	95	1	2 920 636	96 51 854 08	LEAD
PIN 100.0X160 SPF	95 26 739 08	2	1	3 216 005	96 50 697 08	FOOT COMPLETE
PIN 100.0X185 SPF	97 76 840 08	14	2	3 714	91 52 862 08	D HEAD SECTION
PIN 100.0X215 SPF	97 74 861 08	12	4	3 215 005	91 52 846 08	ROLLER SET
PIN 100.0X215 SPF	97 74 861 08	12	4	3 215 006	91 52 847 08	ROLLER SET
PIN 100.0X225 35NICRMOV125	95 66 686 08	21	2	3 714	91 52 862 08	D HEAD SECTION
PIN 100.0X237 35NICRMOV125	97 68 649 08	3	2	3 213	91 52 842 08	F-CONNECTING HEAD
PIN 100.0X237 35NICRMOV125	97 68 649 08	24	2	3 214	91 52 843 08	SW HEAD SECTION
PIN 100.0X237 35NICRMOV125	97 68 649 08	7	2	3 225	91 52 854 08	SL REDUCING SECTION
PIN 100.0X237 35NICRMOV125	97 68 649 08	2	4	3 226	91 52 870 08	L INTERMEDIATE SECTION
PIN 100.0X237 35NICRMOV125	97 68 649 08	2	4	3 227	91 52 873 08	L INTERMEDIATE SECTION
PIN 100.0X237 35NICRMOV125	97 68 649 08	2	4	3 227 008	91 52 872 08	L INTERMEDIATE SECTION
PIN 100.0X237 35NICRMOV125	97 68 649 08	2	4	3 227 200	91 53 519 08	LI INTERMEDIATE SECT. F-GU
PIN 100.0X237 35NICRMOV125	97 68 649 08	11	2	3 713	91 57 749 08	D PIVOT SECTION
PIN 100.0X237 35NICRMOV125	97 68 649 08	23	2	3 714	91 52 862 08	D HEAD SECTION
PIN 100.0X237 35NICRMOV125	97 68 649 08	27	4	3 715 008	91 52 863 08	D INTERMEDIATE SECTION
PIN 100.0X237 35NICRMOV125	97 68 649 08	26	4	3 716	91 52 864 08	D INTERMEDIATE SECTION
PIN 100.0X390 SPF	97 72 369 08	9	2	3 205	91 52 880 08	F-ASSEMBLY UNIT
PIN 100.0X430 SPF	97 71 117 08	19	2	3 211	91 57 748 08	S PIVOT SECTION
PIN 100x210	97 03 556 08	7	2	3 714 008	96 49 266 08	LUFFING PULLEY BLOCK COM
PIN 105.0X230 SPF	97 78 406 08	9	1	3 745 011	96 49 677 08	BRACKET COMPL.
PIN 110.0X196 SPF	97 68 599 08	13	2	2 550	91 57 751 08	SA FRAME
PIN 110.0X214 SPF	97 68 580 08	15	2	2 550	91 57 751 08	SA FRAME
PIN 110.0X214 SPF	97 68 580 08	6	1	2 550 005	96 45 680 08	ROD CPL.
PIN 110.0X214 SPF	97 68 580 08	3	2	3 714 025	96 49 269 08	ROD CPL.
PIN 110.0X214 SPF	97 68 580 08	8	2	3 745 011	96 49 677 08	BRACKET COMPL.
PIN 110.0X265 SPF	97 70 828 08	6	2	3 213	91 52 842 08	F-CONNECTING HEAD
PIN 120.0X222 SPF	97 69 855 08	8	8	1 630	91 52 387 08	HYDRAULIC SUPPORT
PIN 120.0X237 SPF	97 64 994 08	4	2	3 211	91 57 748 08	S PIVOT SECTION
PIN 120.0X237 SPF	97 64 994 08	2	4	3 220 500	91 52 849 08	S INTERMEDIATE SECTION
PIN 120.0X237 SPF	97 64 994 08	2	4	3 221	91 54 668 08	S INTERMEDIATE SECTION
PIN 120.0X237 SPF	97 64 994 08	2	4	3 223	91 52 852 08	S INTERMEDIATE SECTION

6.2.2009

etk_en_de_074515 LR 1600/2

933

LIEBHERRAlphabetical index
Alphabetischer Index

Description	Item	Pos.	Quantity	Page	Assembly	Description
PIN 120.0X237 SPF	97 64 994 08	2	4	3 223 010	91 52 853 08	S INTERMEDIATE SECTION
PIN 120.0X237 SPF	97 64 994 08	2	4	3 223 100	91 55 327 08	S INTERMEDIATE SECTION
PIN 120.0X237 SPF	97 64 994 08	6	2	3 225	91 52 854 08	SL REDUCING SECTION
PIN 130.0X190 SPF	97 68 667 08	4	4	1 632	91 52 389 08	MECHANICAL SUPPORT
PIN 130.0X233 SPF	97 69 809 08	6	2	2 652	91 52 794 08	ROLLER BEARING
PIN 160.0X240 SPF	97 79 763 08	90	2	3 713	91 57 749 08	D PIVOT SECTION
PIN 170.0X260 SPF	97 69 484 08	15	2	1 400	91 56 853 08	CRAWLER TRACK CARRIER LE
PIN 170.0X260 SPF	97 69 484 08	15	2	1 410 300	91 56 855 08	CRAWLER CARRIER RIGHT CP
PIN 170.0X260 SPF	97 69 485 08	16	2	1 400	91 56 853 08	CRAWLER TRACK CARRIER LE
PIN 170.0X260 SPF	97 69 485 08	16	2	1 410 300	91 56 855 08	CRAWLER CARRIER RIGHT CP
PIN 19.0X76 FE//ZN20//C	97 68 883 08	11	2	2 522 013	96 45 883 08	GUIDE PRE-ASS.
PIN 20.0X255 T ZN O	97 79 357 08	21	8	1 630	91 52 387 08	HYDRAULIC SUPPORT
PIN 20.0X304	93 82 940 08	8	1	2 620	91 52 793 08	ROLLER SLEWING RING
PIN 220.0X455 SPF	97 73 402 08	2	2	2 125	91 52 773 08	PIN F.S-PIVOT SECTION SA F
PIN 220.0X455 SPF	97 73 403 08	3	2	2 125	91 52 773 08	PIN F.S-PIVOT SECTION SA F
PIN 25.0X204 T ZN O	94 26 891 08	28	2	2 550	91 57 751 08	SA FRAME
PIN 25.0X204 T ZN O	94 26 891 08	12	1	2 550 005	96 45 680 08	ROD CPL.
PIN 25.0X52	97 19 736 08	3	1	2 502 007	96 22 822 08	ARM REST LEFT
PIN 25.0X52	97 19 736 08	3	1	2 502 008	96 22 823 08	ARM REST RIGHT
PIN 30.0X220 S355J2G3 T ZN	97 74 759 08	54	8	3 713	91 57 749 08	D PIVOT SECTION
PIN 30.0X220 S355J2G3 T ZN	97 74 759 08	31	8	3 715 008	91 52 863 08	D INTERMEDIATE SECTION
PIN 30.0X220 S355J2G3 T ZN	97 74 759 08	29	12	3 716	91 52 864 08	D INTERMEDIATE SECTION
PIN 30.0X305 FE//ZN20//C	97 75 245 08	15	1	3 214	91 52 843 08	SW HEAD SECTION
PIN 30.0X515 FE//ZN20//C	97 75 246 08	16	1	3 214	91 52 843 08	SW HEAD SECTION
PIN 35.0X14 0 30CRNIMO8+QT	97 10 780 08	11	4	2 125	91 52 773 08	PIN F.S-PIVOT SECTION SA F
PIN 35.0X150 SPF	97 80 472 08	105	2	3 713	91 57 749 08	D PIVOT SECTION
PIN 35.0X236 SPF	97 83 727 08	5	1	3 225 100	96 48 582 08	BEARING CPL
PIN 35.0X320 FE//ZN20//C	97 80 530 08	17	2	1 400	91 56 853 08	CRAWLER TRACK CARRIER LE
PIN 35.0X320 FE//ZN20//C	97 80 530 08	17	2	1 410 300	91 56 855 08	CRAWLER CARRIER RIGHT CP
PIN 35.0X82	94 28 899 08	15	1	3 282 002	96 47 890 08	FAB-STAY
PIN 35.0X85 SPF	97 73 270 08	21	2	3 282 002	96 47 890 08	FAB-STAY
PIN 35.0x330	97 06 477 08	56	1	3 745	91 52 948 08	SUSPENDED BALLAST
PIN 35x178	97 04 625 08	92	1	2 550	91 57 751 08	SA FRAME
PIN 35x178	97 04 625 08	7	2	3 281	91 52 896 08	ERECTION FRAME
PIN 35x178	97 04 625 08	63	2	3 714	91 52 862 08	D HEAD SECTION
PIN 35x178	97 04 625 08	8	2	3 714 008	96 49 266 08	LUFFING PULLEY BLOCK COM
PIN 40.0X95 42CRMO4+QT	97 13 432 08	28	2	2 810	91 52 806 08	CRANE DRIVER'S CABIN CPL.
PIN 40x166	97 03 523 08	18	4	3 714 009	96 49 267 08	LUFFING PULLEY BLOCK COM
PIN 45.0X155 SPF	97 73 264 08	2	1	3 282 002	96 47 890 08	FAB-STAY
PIN 45.0X290	97 19 655 08	14	2	3 830	91 55 535 08	SUPPLEMENTARY GUYING D
PIN 45X158 SPF	94 00 692 08	89	1	2 550	91 57 751 08	SA FRAME
PIN 45X183 30CRNIMO8+QT	95 59 982 08	62	1	3 714	91 52 862 08	D HEAD SECTION
PIN 50.0X110 SPF	97 72 671 08	24	2	3 281	91 52 896 08	ERECTION FRAME
PIN 50.0X215 SPF	97 71 149 08	2	1	2 550 011	96 47 007 08	CONSOLE COMPL.
PIN 55.0X113 SPF	97 73 189 08	5	1	3 206	91 52 881 08	PIVOT SECTION
PIN 55.0X158	93 92 498 08	11	2	2 810	91 52 806 08	CRANE DRIVER'S CABIN CPL.
PIN 55.0X158	93 92 498 08	80	2	3 211	91 57 748 08	S PIVOT SECTION
PIN 55.0X160 SPF	97 72 181 08	25	2	2 550	91 57 751 08	SA FRAME
PIN 55.0X175 30CRNIMO8+QT	97 67 727 08	4	1	3 220 501	96 43 440 08	ROD CPL.
PIN 55.0X175 30CRNIMO8+QT	97 67 727 08	4	1	3 221 200	96 47 984 08	ROD CPL.
PIN 55.0X175 30CRNIMO8+QT	97 67 727 08	4	1	3 225 200	96 48 679 08	ROD CPL.
PIN 55.0X175 30CRNIMO8+QT	97 67 727 08	4	1	3 227 002	96 50 498 08	ROD CPL.
PIN 55.0X175 30CRNIMO8+QT	97 67 727 08	4	1	3 561 003	96 45 222 08	ROD CPL.
PIN 55.0X175 30CRNIMO8+QT	97 67 727 08	4	1	3 713 012	96 50 197 08	ROD CPL.
PIN 55.0X175 30CRNIMO8+QT	97 67 727 08	5	2	3 830	91 55 535 08	SUPPLEMENTARY GUYING D
PIN 55.0X210 30CRNIMO8+QT	95 28 920 08	16	4	3 211	91 57 748 08	S PIVOT SECTION
PIN 55.0X210 30CRNIMO8+QT	95 28 920 08	6	1	3 211 003	96 46 986 08	ROD CPL.
PIN 55.0X210 30CRNIMO8+QT	95 28 920 08	5	1	3 220 501	96 43 440 08	ROD CPL.
PIN 55.0X210 30CRNIMO8+QT	95 28 920 08	5	1	3 221 200	96 47 984 08	ROD CPL.
PIN 55.0X210 30CRNIMO8+QT	95 28 920 08	5	1	3 225 200	96 48 679 08	ROD CPL.

6.2.2009

etk_en_de_074515 LR 1600/2

934

LIEBHERRAlphabetical index
Alphabetischer Index

Description	Item	Pos.	Quantity	Page	Assembly	Description
PIN 55.0X210 30CRNIMO8+QT	95 28 920 08	5	1	3 227 002	96 50 498 08	ROD CPL.
PIN 55.0X210 30CRNIMO8+QT	95 28 920 08	5	1	3 561 003	96 45 222 08	ROD CPL.
PIN 55.0X210 30CRNIMO8+QT	95 28 920 08	5	1	3 713 012	96 50 197 08	ROD CPL.
PIN 55.0X210 30CRNIMO8+QT	95 28 920 08	10	2	3 714 009	96 49 267 08	LUFFING PULLEY BLOCK COM
PIN 55.0X210 30CRNIMO8+QT	95 28 920 08	3	2	3 714 013	96 59 083 08	BRACKET COMPL.
PIN 55.0X210 30CRNIMO8+QT	95 28 920 08	8	2	3 830	91 55 535 08	SUPPLEMENTARY GUYING D
PIN 55.0X445 SPF	97 79 764 08	97	4	3 713	91 57 749 08	D PIVOT SECTION
PIN 55.0X542 SPF	97 72 887 08	7	2	3 205	91 52 880 08	F-ASSEMBLY UNIT
PIN 65.0X171 SPF	97 68 581 08	14	1	2 550 005	96 45 680 08	ROD CPL.
PIN 65.0X177 SPF	97 74 799 08	4	1	3 716 001	96 49 159 08	ROD CPL.
PIN 65.0X182 SPF	97 85 235 08	9	2	2 657	91 57 656 08	MOUNTING EQUIPMENT CRAW
PIN 65.0X187 SPF	97 66 499 08	16	2	3 220 500	91 52 849 08	S INTERMEDIATE SECTION
PIN 65.0X187 SPF	97 66 499 08	16	2	3 223	91 52 852 08	S INTERMEDIATE SECTION
PIN 65.0X187 SPF	97 66 499 08	16	2	3 223 010	91 52 853 08	S INTERMEDIATE SECTION
PIN 65.0X187 SPF	97 66 499 08	16	2	3 223 100	91 55 327 08	S INTERMEDIATE SECTION
PIN 65.0X189 SPF	97 72 405 08	2	1	2 550 008	96 47 628 08	RETAINER CPL.
PIN 65.0X189 SPF	97 72 405 08	2	1	2 550 009	96 47 645 08	RETAINER CPL.
PIN 65.0X210 SPF	94 26 890 08	31	2	2 550	91 57 751 08	SA FRAME
PIN 65.0X220 SPF	97 74 800 08	18	1	2 550 005	96 45 680 08	ROD CPL.
PIN 65.0X220 SPF	97 74 800 08	5	1	3 716 001	96 49 159 08	ROD CPL.
PIN 65.0X240 SPF	97 09 155 08	19	2	3 225	91 52 854 08	SL REDUCING SECTION
PIN 65.0X258 SPF	97 74 147 08	35	2	2 550	91 57 751 08	SA FRAME
PIN 65.0X355 SPF	97 78 361 08	3	8	3 747	91 52 950 08	CENTERING STANDARD
PIN 65.0X375 SPF	97 74 903 08	12	2	3 225	91 52 854 08	SL REDUCING SECTION
PIN 65.0X435 35NICRMOV125	97 62 324 08	16	4	3 206	91 52 881 08	PIVOT SECTION
PIN 65.0X660 SPF	97 93 900 08	16	1	3 281	91 52 896 08	ERECTION FRAME
PIN 65.0X84 35NICRMOV125	95 71 127 08	87	4	3 713	91 57 749 08	D PIVOT SECTION
PIN 65x135	97 09 178 08	48	2	3 713	91 57 749 08	D PIVOT SECTION
PIN 70.0X170	97 20 177 08	6	2	3 207 101	96 48 292 08	BRACKET COMPL.
PIN 70.0X170	97 20 177 08	13	3	3 281	91 52 896 08	ERECTION FRAME
PIN 70.0X97 SPF	97 78 941 08	21	4	2 340	91 52 776 08	WINCH 4 LUFFING GEAR
PIN 75.0X166 SPF	97 74 862 08	13	2	3 215 005	91 52 846 08	ROLLER SET
PIN 75.0X166 SPF	97 74 862 08	13	2	3 215 006	91 52 847 08	ROLLER SET
PIN 75.0X195 SPF	97 72 368 08	6	2	3 205	91 52 880 08	F-ASSEMBLY UNIT
PIN 8.0X21	97 83 643 08	17	2	2 391 040	96 53 645 08	CLUTCH ACTUATOR
PIN 8.0X34	97 83 644 08	18	1	2 391 040	96 53 645 08	CLUTCH ACTUATOR
PIN 80.0X328 SPF	93 33 460 08	11	8	1 630	91 52 387 08	HYDRAULIC SUPPORT
PIN 85.0X120 SPF	95 67 585 08	2	2	3 292	91 52 865 08	D OVERRUN PROTECTION
PIN 85.0X150 SPF	97 73 608 08	3	2	3 205	91 52 880 08	F-ASSEMBLY UNIT
PIN 85x235	95 20 313 08	16	4	3 745	91 52 948 08	SUSPENDED BALLAST
PIN AEHN. ISO 2340 30X305X	45 00 333 08	23	2	3 211	91 57 748 08	S PIVOT SECTION
PIN CARRIER	60 45 266 08	(501)	1	2 920 288	96 52 614 08	WIRING LIST F.SLEWING PLAT
PIN COMPL.	96 36 836 08	19	4	3 745	91 52 948 08	SUSPENDED BALLAST
PIN CONTACT	60 45 192 08	(628)	3	2 920 288	96 52 614 08	WIRING LIST F.SLEWING PLAT
PIN DIN 1433 16X60X50 ST.50	45 00 191 08	3	2	1 641 014	92 53 053 08	SUPPORT PLATE COMPL.
PIN DIN 1433 20X175X160 ST.	45 00 239 08	19	4	3 227 002	96 50 498 08	ROD CPL.
PIN DIN 1433 30X140X125 ST.	45 00 330 08	4	1	3 714 021	96 49 271 08	ROLLER SEATING COMPL.
PIN DIN 1433 30X700X680 ST.	45 00 312 08	15	3	3 714 008	96 49 266 08	LUFFING PULLEY BLOCK COM
PIN DIN 1434 16H11X60X51 30	45 10 011 08	21	2	2 631	91 56 817 08	SLEWING PLATFORM CATWAL
PIN DIN 1434 20H11X55X46 30	45 10 012 08	67	8	3 211	91 57 748 08	S PIVOT SECTION
PIN DIN 1435 12H11X60X53 ST	45 12 144 08	61	4	2 550	91 57 751 08	SA FRAME
PIN DIN 1435 16H11X40X35 ST	45 12 412 08	45	4	3 211	91 57 748 08	S PIVOT SECTION
PIN DIN 1435 16H11X40X35 ST	45 12 412 08	154	4	3 713	91 57 749 08	D PIVOT SECTION
PIN DIN 1435 20H11X45X38 ST.	45 12 222 08	4	4	2 370	91 52 782 08	ERECTING WINCH
PIN DIN 1435 20H11X45X38 ST.	45 12 222 08	29	12	2 631	91 56 817 08	SLEWING PLATFORM CATWAL
PIN DIN 1435 20H11X75X66 ST	45 12 225 08	83	2	2 550	91 57 751 08	SA FRAME
PIN DIN 1435 20H11X75X66 ST	45 12 225 08	11	1	2 925 204	92 16 990 08	CAMERA EQUIPMENT D-PIVOT
PIN DIN 1435 20H11X75X66 ST	45 12 225 08	29	1	2 925 402	96 58 855 08	CAMERA EQUIPMENT SLEWI
PIN DIN 1435 20H11X75X66 ST	45 12 225 08	49	4	3 214	91 52 843 08	SW HEAD SECTION
PIN DIN 1435 20H11X75X66 ST	45 12 225 08	58	1	3 281	91 52 896 08	ERECTION FRAME

6.2.2009

etk_en_de_074515 LR 1600/2

935

LIEBHERRAlphabetical index
Alphabetischer Index

Description	Item	Pos.	Quantity	Page	Assembly	Description
PIN DIN 1435 25H11X110X100	45 12 272 08	39	4	2 810	91 52 806 08	CRANE DRIVER'S CABIN CPL.
PIN DIN 1435 25H11X110X100	45 12 272 08	49	4	3 225	91 52 854 08	SL REDUCING SECTION
PIN DIN 1435 25H11X70X60 ST.	45 12 269 08	2	4	2 671	91 52 798 08	OIL RESERVOIR, COMPLETE
PIN DIN 1435 25H11X75X65 ST.	45 12 264 08	13	2	2 670	91 52 797 08	FUEL TANK CPL.
PIN DIN 1435 40D10X80X68 ST	45 12 375 08	7	1	1 991	91 52 510 08	ROTARY FEED THROUGH
PIN DIN 1435 40H11X290X260	45 12 370 08	17	2	3 714 008	96 49 266 08	LUFFING PULLEY BLOCK COM
PIN DIN 1435 40H11X60X50 ST	45 12 372 08	6	4	1 991	91 52 510 08	ROTARY FEED THROUGH
PIN DIN 1436 20H11X85X78 30	45 14 223 08	12	4	3 220 500	91 52 849 08	S INTERMEDIATE SECTION
PIN DIN 1436 20H11X85X78 30	45 14 223 08	12	4	3 223	91 52 852 08	S INTERMEDIATE SECTION
PIN DIN 1436 20H11X85X78 30	45 14 223 08	12	4	3 223 010	91 52 853 08	S INTERMEDIATE SECTION
PIN DIN 1436 20H11X85X78 30	45 14 223 08	12	4	3 223 100	91 55 327 08	S INTERMEDIATE SECTION
PIN DIN 1436 20H11X90X80 ST	45 14 220 08	36	2	3 281	91 52 896 08	ERECTION FRAME
PIN DIN 1436 25H11X200X192	45 14 269 08	5	1	2 620	91 52 793 08	ROLLER SLEWING RING
PIN DIN 1436 30H11X105X97 30	45 14 308 08	4	20	1 631 100	91 52 388 08	CATWALK CRAW.TRACK TRA
PIN DIN 1436 30H11X140X130	45 14 304 08	37	2	3 713	91 57 749 08	D PIVOT SECTION
PIN DIN 1444 16H11X152X146	45 30 093 08	41	8	3 211	91 57 748 08	S PIVOT SECTION
PIN DIN 1444 16H11X162X157	45 30 083 08	45	8	3 220 500	91 52 849 08	S INTERMEDIATE SECTION
PIN DIN 1444 16H11X162X157	45 30 083 08	45	8	3 223	91 52 852 08	S INTERMEDIATE SECTION
PIN DIN 1444 16H11X162X157	45 30 083 08	45	8	3 223 010	91 52 853 08	S INTERMEDIATE SECTION
PIN DIN 1444 16H11X162X157	45 30 083 08	45	8	3 223 100	91 55 327 08	S INTERMEDIATE SECTION
PIN DIN 1444 16H11X162X157	45 30 083 08	45	8	3 226	91 52 870 08	L INTERMEDIATE SECTION
PIN DIN 1444 16H11X162X157	45 30 083 08	45	8	3 227	91 52 873 08	L INTERMEDIATE SECTION
PIN DIN 1444 16H11X162X157	45 30 083 08	45	8	3 227 008	91 52 872 08	L INTERMEDIATE SECTION
PIN DIN 1444 16H11X162X157	45 30 083 08	45	8	3 227 200	91 53 519 08	LI INTERMEDIATE SECT. F-GU
PIN DIN 1444 16H11X162X157	45 30 083 08	36	8	3 715 008	91 52 863 08	D INTERMEDIATE SECTION
PIN DIN 1444 16H11X162X157	45 30 083 08	38	8	3 716	91 52 864 08	D INTERMEDIATE SECTION
PIN DIN 1444 20H11X115X107	45 30 209 08	26	6	2 631	91 56 817 08	SLEWING PLATFORM CATWAL
PIN DIN 1444 20H11X115X107	45 30 209 08	62	4	3 211	91 57 748 08	S PIVOT SECTION
PIN DIN 1444 20H11X130X122	45 30 210 08	38	2	3 713	91 57 749 08	D PIVOT SECTION
PIN DIN 1444 20H11X170X162	45 30 221 08	10	2	3 205	91 52 880 08	F-ASSEMBLY UNIT
PIN DIN 1444 20H11X200X192	45 30 213 08	9	4	1 632	91 52 389 08	MECHANICAL SUPPORT
PIN DIN 1444 24H11X60X50 42	45 30 220 08	31	2	2 631	91 56 817 08	SLEWING PLATFORM CATWAL
PIN DIN 1444 24H11X60X50 42	45 30 220 08	13	4	2 730	91 52 802 08	BASE PLATE SLEWING PLATF
PIN DIN 1444 24H11X91X82 30	45 30 223 08	34	2	2 631	91 56 817 08	SLEWING PLATFORM CATWAL
PIN DIN 1444 30H11X220X210	45 30 300 08	76	2	1 400	91 56 853 08	CRAWLER TRACK CARRIER LE
PIN DIN 1444 30H11X220X210	45 30 300 08	76	2	1 410 300	91 56 855 08	CRAWLER CARRIER RIGHT CP
PIN DIN 1444 30H11X220X210	45 30 300 08	9	2	2 652	91 52 794 08	ROLLER BEARING
PIN DIN 1444 30H11X260X250	45 30 318 08	9	8	1 630	91 52 387 08	HYDRAULIC SUPPORT
PIN DIN 1444 30H11X70X58 30	94 00 689 08	11	1	2 620	91 52 793 08	ROLLER SLEWING RING
PIN DIN 1444 30H11X70X58 30	94 00 689 08	18	1	2 652	91 52 794 08	ROLLER BEARING
PIN DIN 1444 30H11X75X65 30	45 30 320 08	32	2	2 810	91 52 806 08	CRANE DRIVER'S CABIN CPL.
PIN DIN 1444 30H11X95X85 3	45 30 327 08	17	2	2 652	91 52 794 08	ROLLER BEARING
PIN DIN 1444 36H11X80X70 3	45 30 324 08	19	2	3 714	91 52 862 08	D HEAD SECTION
PIN DIN 1444 45H11X72X60 3	45 30 328 08	7	2	3 207 003	96 48 259 08	ROD CPL.
PIN DIN 1444 45H11X72X60 3	45 30 328 08	6	2	3 207 100	96 48 261 08	BRACKET COMPL.
PIN DIN 1444 45H11X72X60 3	45 30 328 08	(7)	2	3 281	91 52 896 08	ERECTION FRAME
PIN DIN 1444 50H11X162X150	45 30 448 08	15	2	3 205	91 52 880 08	F-ASSEMBLY UNIT
PIN DIN EN 22341 30H11X85X	45 12 305 08	2	1	3 790 006	96 19 989 08	PIN PULLING CYLINDER CPL.
PIN DIN EN 22341 30H11X85X	45 12 305 08	2	1	3 790 007	96 19 990 08	PIN PULLING CYLINDER CPL.
PIN F.S-PIVOT SECTION SA FR	91 52 773 08	102	1		LR 1600-2-0	
PIN INSERT 4/2POL -40°C	10 00 727 2	522	1	2 932 224	96 54 389 08	CABLES MOUNTING PANEL C
PIN INSERT 64POL	60 56 090 08	(151)	1	2 920 369	96 54 235 08	TERMINAL BOX CPL.
PIN INSERT 64POL	60 56 090 08	21	5	2 920 448	96 48 794 08	TERMINAL BOX CPL.
PIN ISO 2340 20X500X485 ST.	45 00 232 08	37	2	3 211	91 57 748 08	S PIVOT SECTION
PIN ISO 2340 20X500X485 ST.	45 00 232 08	68	2	3 713	91 57 749 08	D PIVOT SECTION
PIN ISO 2340 B30X200X180 30	45 25 412 08	66	2	3 714	91 52 862 08	D HEAD SECTION
PIN ISO 2340 B30X250X234 ST	45 25 413 08	6	1	3 713	91 57 749 08	D PIVOT SECTION
PIN ISO 2340 B40X1075X1045 S	45 25 485 08	11	2	3 215 005	91 52 846 08	ROLLER SET
PIN ISO 2341 30X120X6,3X110	10 04 126 0	12	2	2 670	91 52 797 08	FUEL TANK CPL.
PIN ISO 2341 B 30X115X105 3	10 47 124 9	49	4	3 206	91 52 881 08	PIVOT SECTION

6.2.2009

etk_en_de_074515 LR 1600/2

936

LIEBHERRAlphabetical index
Alphabetischer Index

Description	Item	Pos.	Quantity	Page	Assembly	Description
PIN ISO 2341 B18H11X75X68	10 42 572 5	20	1	3 206	91 52 881 08	PIVOT SECTION
PIN ISO 2341 B24H11X140X131	10 02 966 6	7	1	3 282 002	96 47 890 08	FAB-STAY
PIN PULLING CYLINDER CPL.	96 19 989 08	1	1	3 790	91 08 481 08	BOLT EXTRACTION ATTACHM
PIN PULLING CYLINDER CPL.	96 19 990 08	3	1	3 790	91 08 481 08	BOLT EXTRACTION ATTACHM
PIN RD30X255	94 04 740 08	44	2	3 206	91 52 881 08	PIVOT SECTION
PIN RD35X105 42CR	94 51 057 08	2	4	2 391	91 52 784 08	DIESEL ENGINE CPL.
PIN RD35X320	95 09 414 08	55	1	3 745	91 52 948 08	SUSPENDE BALLAST
PIN RD35X72	93 59 891 08	49	2	3 281	91 52 896 08	ERECTION FRAME
PIN RD35X85 30CR	94 56 112 08	12	8	1 630	91 52 387 08	HYDRAULIC SUPPORT
PIN RD40X105 30CRNIMO8+Q	93 22 268 08	13	4	1 400	91 56 853 08	CRAWLER TRACK CARRIER LE
PIN RD40X105 30CRNIMO8+Q	93 22 268 08	13	4	1 410 300	91 56 855 08	CRAWLER CARRIER RIGHT CP
PIN RD40X120	93 83 160 08	72	4	2 550	91 57 751 08	SA FRAME
PIN RD40X120	94 45 545 08	3	1	3 745 002	92 17 236 08	SWITCH UNIT
PIN RD40X120	94 45 545 08	3	1	3 745 003	92 17 237 08	SWITCH UNIT
PIN RD40X130 30CRNIMO8+Q	95 19 655 08	14	2	1 400	91 56 853 08	CRAWLER TRACK CARRIER LE
PIN RD40X130 30CRNIMO8+Q	95 19 655 08	14	2	1 410 300	91 56 855 08	CRAWLER CARRIER RIGHT CP
PIN RD40X75 30CRNIMO8+QT	95 60 974 08	18	2	3 206	91 52 881 08	PIVOT SECTION
PIN RD40X75 30CRNIMO8+QT	95 60 974 08	51	1	3 281	91 52 896 08	ERECTION FRAME
PIN RD40X92	93 35 587 08	19	2	2 810	91 52 806 08	CRANE DRIVER'S CABIN CPL.
PIN RD45X177	94 99 163 08	2	4	1 742	91 53 021 08	FIXAGE DU CONTREPOIDS CE
PIN RD45X177	94 99 163 08	11	2	3 830	91 55 535 08	SUPPLEMENTARY GUYING D
PIN RD50X120	94 57 205 08	60	2	3 211	91 57 748 08	S PIVOT SECTION
PIN RD50X135 30CRNIMO8+Q	95 36 201 08	10	1	3 282 002	96 47 890 08	FAB-STAY
PIN RD50X300	95 28 924 08	8	2	1 632	91 52 389 08	MECHANICAL SUPPORT
PIN RD50X90 30CR	95 54 699 08	59	2	3 211	91 57 748 08	S PIVOT SECTION
PIN RD60X170	95 36 392 08	3	1	2 657	91 57 656 08	MOUNTING EQUIPMENT CRAW
PIN RD60X220	93 73 829 08	3	4	2 790 455	91 57 005 08	TRANSPORT KEEPER
PIN RD65X232	95 50 681 08	75	2	1 400	91 56 853 08	CRAWLER TRACK CARRIER LE
PIN RD65X232	95 50 681 08	75	2	1 410 300	91 56 855 08	CRAWLER CARRIER RIGHT CP
PIN RD75X165 35NI	95 44 447 08	6	1	2 657	91 57 656 08	MOUNTING EQUIPMENT CRAW
PIN RD80X365	95 56 299 08	24	1	2 810	91 52 806 08	CRANE DRIVER'S CABIN CPL.
PIN W. HANDLE	96 48 349 08	48	1	3 206	91 52 881 08	PIVOT SECTION
PIN WELDED FE//ZN20//C	96 54 826 08	18	4	2 730	91 52 802 08	BASE PLATE SLEWING PLATF
PIPE 127MM EDELSTAHL	10 44 054 2	3	1	2 392	91 52 785 08	MUFFLER UNIT
PIPE CLAMP	10 01 265 5	11	1	9 739 288	97 39 288	FUEL LINE
PIPE CLAMP	10 22 274 3	7	1	9 739 369	97 39 369	PRESSURE PIPE
PIPE CLAMP 18 A4C	10 47 687 9	18	1	9 739 386	97 39 386	CRANKCASE BREATHER
PIPE CLAMP 32.2 UST37-2	10 01 265 3	23	3	9 739 492	97 39 492	PIPELINE INSTALLATION
PIPE CLAMP 33/20	77 42 250 08	6	1	2 541 001	96 49 651 08	ADDNL.HEATING, PRE-ASSE
PIPE CLAMP 43/20	77 42 217 08	18	3	2 541	91 52 790 08	ADD HEATING SUPERSTRUCT
PIPE CLAMP DIN 71555 60,5	10 03 723 0	7	1	9 739 210	97 39 210	LIQUID COOLING PIPELINE
PIPE CLAMP DIN 71555 60,5 A3	55 20 506 08	126	4	2 391 001	96 45 719 08	DIESEL ENGINE, PRE-ASSEMB
PIPE COMPL. 10X1,5X156	96 51 674 08	381	1	2 998	91 56 540 08	PIPELINES SUPERSTRUCTUR
PIPE COMPL. 10X1,5X166	96 51 741 08	190	1	2 978 102	96 47 913 08	PIPELINES MOUNTING DEVIC
PIPE COMPL. 10X1,5X1681	96 51 739 08	188	1	2 978 102	96 47 913 08	PIPELINES MOUNTING DEVIC
PIPE COMPL. 10X1,5X175	96 18 464 08	(373)	1	2 976 203	92 27 489 08	ADDL.HYDR.F.PIN PULLING DE
PIPE COMPL. 10X1,5X187	96 51 673 08	380	1	2 998	91 56 540 08	PIPELINES SUPERSTRUCTUR
PIPE COMPL. 10X1,5X1885	96 51 335 08	267	3	2 998	91 56 540 08	PIPELINES SUPERSTRUCTUR
PIPE COMPL. 10X1,5X190	92 09 706 08	(372)	1	2 976 203	92 27 489 08	ADDL.HYDR.F.PIN PULLING DE
PIPE COMPL. 10X1,5X2021	96 51 738 08	187	1	2 978 102	96 47 913 08	PIPELINES MOUNTING DEVIC
PIPE COMPL. 10X1,5X2374	96 55 083 08	507	1	2 978 108	96 44 195 08	PIPELINES DERR.
PIPE COMPL. 10X1,5X2394	96 55 056 08	480	1	3 978 106	96 50 885 08	PIPELINES SUSP. BALL. BASE
PIPE COMPL. 10X1,5X259	96 51 677 08	384	1	2 998	91 56 540 08	PIPELINES SUPERSTRUCTUR
PIPE COMPL. 10X1,5X289	96 51 758 08	152	1	2 978 205	96 47 115 08	PIPELINE S OVERRUN PROTE
PIPE COMPL. 10X1,5X300	96 51 676 08	383	1	2 998	91 56 540 08	PIPELINES SUPERSTRUCTUR
PIPE COMPL. 10X1,5X3082	96 55 058 08	482	1	2 975 155	96 50 586 08	PIPELINE WINCH
PIPE COMPL. 10X1,5X340	96 55 082 08	506	1	2 978 108	96 44 195 08	PIPELINES DERR.
PIPE COMPL. 10X1,5X376	96 51 759 08	153	1	2 978 205	96 47 115 08	PIPELINE S OVERRUN PROTE
PIPE COMPL. 10X1,5X604	96 51 723 08	432	1	2 998	91 56 540 08	PIPELINES SUPERSTRUCTUR
PIPE COMPL. 10X1,5X621	96 54 104 08	399	1	2 998	91 56 540 08	PIPELINES SUPERSTRUCTUR

6.2.2009

etk_en_de_074515 LR 1600/2

937

LIEBHERRAlphabetical index
Alphabetischer Index

Description	Item	Pos.	Quantity	Page	Assembly	Description
PIPE COMPL. 10X1,5X746	96 55 057 08	481	1	3 978 106	96 50 885 08	PIPELINES SUSP. BALL. BASE
PIPE COMPL. 10X1,5X768	96 51 740 08	189	1	2 978 102	96 47 913 08	PIPELINES MOUNTING DEVIC
PIPE COMPL. 10X1,5X86	96 55 087 08	511	1	2 978 108	96 44 195 08	PIPELINES DERR.
PIPE COMPL. 10X1,5X860	96 52 296 08	155	1	2 978 205	96 47 115 08	PIPELINE S OVERRUN PROTE
PIPE COMPL. 10X1,5X945	96 55 081 08	505	1	2 978 108	96 44 195 08	PIPELINES DERR.
PIPE COMPL. 10X1,5X966	96 53 057 08	400	1	2 998	91 56 540 08	PIPELINES SUPERSTRUCTUR
PIPE COMPL. 12X1,5X103	96 48 897 08	(761)	4	1 975 006	91 52 509 08	ADD. HYDR. SUPPORTING RA
PIPE COMPL. 12X1,5X1181	96 55 049 08	473	1	3 978 106	96 50 885 08	PIPELINES SUSP. BALL. BASE
PIPE COMPL. 12X1,5X1548	96 54 100 08	391	1	2 998	91 56 540 08	PIPELINES SUPERSTRUCTUR
PIPE COMPL. 12X1,5X168	96 51 671 08	378	2	2 998	91 56 540 08	PIPELINES SUPERSTRUCTUR
PIPE COMPL. 12X1,5X1786	96 55 032 08	218	1	3 978 010	96 50 882 08	PIPELINES DERR. HEAD SECT
PIPE COMPL. 12X1,5X1875	96 51 337 08	268	1	2 998	91 56 540 08	PIPELINES SUPERSTRUCTUR
PIPE COMPL. 12X1,5X1979	96 55 031 08	217	1	3 978 010	96 50 882 08	PIPELINES DERR. HEAD SECT
PIPE COMPL. 12X1,5X2027	96 54 146 08	209	1	3 978 010	96 50 882 08	PIPELINES DERR. HEAD SECT
PIPE COMPL. 12X1,5X2045	96 55 045 08	231	1	3 978 010	96 50 882 08	PIPELINES DERR. HEAD SECT
PIPE COMPL. 12X1,5X2092	96 55 030 08	216	1	3 978 010	96 50 882 08	PIPELINES DERR. HEAD SECT
PIPE COMPL. 12X1,5X2169	96 52 301 08	160	1	2 978 205	96 47 115 08	PIPELINE S OVERRUN PROTE
PIPE COMPL. 12X1,5X2215	96 52 303 08	162	1	2 978 205	96 47 115 08	PIPELINE S OVERRUN PROTE
PIPE COMPL. 12X1,5X2259	96 51 757 08	151	1	2 978 205	96 47 115 08	PIPELINE S OVERRUN PROTE
PIPE COMPL. 12X1,5X2329	96 52 302 08	161	1	2 978 205	96 47 115 08	PIPELINE S OVERRUN PROTE
PIPE COMPL. 12X1,5X2370	96 55 080 08	504	1	2 978 108	96 44 195 08	PIPELINES DERR.
PIPE COMPL. 12X1,5X2600	96 55 048 08	472	1	3 978 106	96 50 885 08	PIPELINES SUSP. BALL. BASE
PIPE COMPL. 12X1,5X261	96 51 338 08	269	1	2 998	91 56 540 08	PIPELINES SUPERSTRUCTUR
PIPE COMPL. 12X1,5X280	96 55 086 08	510	1	2 978 108	96 44 195 08	PIPELINES DERR.
PIPE COMPL. 12X1,5X291	96 52 313 08	437	1	2 998	91 56 540 08	PIPELINES SUPERSTRUCTUR
PIPE COMPL. 12X1,5X309	96 51 672 08	379	1	2 998	91 56 540 08	PIPELINES SUPERSTRUCTUR
PIPE COMPL. 12X1,5X329	96 55 079 08	503	1	2 978 108	96 44 195 08	PIPELINES DERR.
PIPE COMPL. 12X1,5X366	96 55 078 08	502	1	2 978 108	96 44 195 08	PIPELINES DERR.
PIPE COMPL. 12X1,5X4100	96 52 298 08	157	1	2 978 205	96 47 115 08	PIPELINE S OVERRUN PROTE
PIPE COMPL. 12X1,5X4111	96 52 299 08	158	1	2 978 205	96 47 115 08	PIPELINE S OVERRUN PROTE
PIPE COMPL. 12X1,5X4400	96 54 143 08	460	1	3 978 007	96 50 879 08	PIPELINES DERR. INT. SECT.
PIPE COMPL. 12X1,5X447	96 51 756 08	150	1	2 978 205	96 47 115 08	PIPELINE S OVERRUN PROTE
PIPE COMPL. 12X1,5X451	96 48 939 08	714	1	1 998	91 52 513 08	PIPELINES CRAWLER TYPE U
PIPE COMPL. 12X1,5X506	96 55 035 08	221	1	3 978 010	96 50 882 08	PIPELINES DERR. HEAD SECT
PIPE COMPL. 12X1,5X518	96 55 034 08	220	1	3 978 010	96 50 882 08	PIPELINES DERR. HEAD SECT
PIPE COMPL. 12X1,5X5190	96 55 088 08	(450)	1	3 978 015	91 56 429 08	ADDITIONAL HYDRAULICS IN
PIPE COMPL. 12X1,5X5190	96 55 089 08	(451)	1	3 978 015	91 56 429 08	ADDITIONAL HYDRAULICS IN
PIPE COMPL. 12X1,5X547	96 55 033 08	219	1	3 978 010	96 50 882 08	PIPELINES DERR. HEAD SECT
PIPE COMPL. 12X1,5X596	96 48 936 08	711	1	1 998	91 52 513 08	PIPELINES CRAWLER TYPE U
PIPE COMPL. 12X1,5X622	96 48 896 08	(760)	4	1 975 006	91 52 509 08	ADD. HYDR. SUPPORTING RA
PIPE COMPL. 12X1,5X829	96 51 760 08	154	1	2 978 205	96 47 115 08	PIPELINE S OVERRUN PROTE
PIPE COMPL. 12X1,5X3363	96 52 300 08	159	1	2 978 205	96 47 115 08	PIPELINE S OVERRUN PROTE
PIPE COMPL. 12X1,5X3663	96 52 297 08	156	1	2 978 205	96 47 115 08	PIPELINE S OVERRUN PROTE
PIPE COMPL. 15X1,5X1120	96 54 102 08	396	1	2 998	91 56 540 08	PIPELINES SUPERSTRUCTUR
PIPE COMPL. 15X1,5X2231	96 55 065 08	489	1	2 975 155	96 50 586 08	PIPELINE WINCH
PIPE COMPL. 15X1,5X2371	96 55 061 08	485	1	2 975 155	96 50 586 08	PIPELINE WINCH
PIPE COMPL. 15X1,5X520	96 51 663 08	370	1	2 998	91 56 540 08	PIPELINES SUPERSTRUCTUR
PIPE COMPL. 15X1,5X540	96 51 668 08	375	1	2 998	91 56 540 08	PIPELINES SUPERSTRUCTUR
PIPE COMPL. 15X1,5X621	96 55 085 08	509	1	2 978 108	96 44 195 08	PIPELINES DERR.
PIPE COMPL. 15X1,5X666	96 55 084 08	508	1	2 978 108	96 44 195 08	PIPELINES DERR.
PIPE COMPL. 15X1,5X682	96 54 099 08	374	1	2 998	91 56 540 08	PIPELINES SUPERSTRUCTUR
PIPE COMPL. 15X1,5X835	96 51 664 08	371	1	2 998	91 56 540 08	PIPELINES SUPERSTRUCTUR
PIPE COMPL. 16X2X1058	96 48 931 08	706	2	1 998	91 52 513 08	PIPELINES CRAWLER TYPE U
PIPE COMPL. 16X2X1122	96 51 656 08	363	1	2 998	91 56 540 08	PIPELINES SUPERSTRUCTUR
PIPE COMPL. 16X2X1714	96 55 070 08	494	1	2 978 108	96 44 195 08	PIPELINES DERR.
PIPE COMPL. 16X2X1882	96 55 067 08	491	1	2 978 108	96 44 195 08	PIPELINES DERR.
PIPE COMPL. 16X2X1919	96 51 753 08	147	1	2 978 205	96 47 115 08	PIPELINE S OVERRUN PROTE
PIPE COMPL. 16X2X2014	96 48 913 08	736	2	1 998	91 52 513 08	PIPELINES CRAWLER TYPE U
PIPE COMPL. 16X2X2228	96 51 737 08	186	1	2 978 102	96 47 913 08	PIPELINES MOUNTING DEVIC
PIPE COMPL. 16X2X2265	96 48 914 08	737	2	1 998	91 52 513 08	PIPELINES CRAWLER TYPE U

6.2.2009

etk_en_de_074515 LR 1600/2

938

LIEBHERRAlphabetical index
Alphabetischer Index

Description	Item	Pos.	Quantity	Page	Assembly	Description
PIPE COMPL. 16X2X2894	96 48 932 08	707	2	1 998	91 52 513 08	PIPELINES CRAWLER TYPE U
PIPE COMPL. 16X2X294	96 51 670 08	(377)	1	2 975 000	91 57 881 08	ADDNL. HYDR. F. ERECTING W
PIPE COMPL. 16X2X3017	96 53 059 08	361	1	2 998	91 56 540 08	PIPELINES SUPERSTRUCTUR
PIPE COMPL. 16X2X421	96 53 053 08	339	1	2 998	91 56 540 08	PIPELINES SUPERSTRUCTUR
PIPE COMPL. 16X2X495	96 51 736 08	185	1	2 978 102	96 47 913 08	PIPELINES MOUNTING DEVIC
PIPE COMPL. 16X2X535	96 51 655 08	362	1	2 998	91 56 540 08	PIPELINES SUPERSTRUCTUR
PIPE COMPL. 18X1,5X1095	96 51 346 08	238	1	2 998	91 56 540 08	PIPELINES SUPERSTRUCTUR
PIPE COMPL. 18X1,5X1195	96 51 701 08	410	1	2 998	91 56 540 08	PIPELINES SUPERSTRUCTUR
PIPE COMPL. 18X1,5X1383	96 51 752 08	146	1	2 978 205	96 47 115 08	PIPELINE S OVERRUN PROTE
PIPE COMPL. 18X1,5X1518	96 51 722 08	431	1	2 998	91 56 540 08	PIPELINES SUPERSTRUCTUR
PIPE COMPL. 18X1,5X2036	96 51 700 08	409	1	2 998	91 56 540 08	PIPELINES SUPERSTRUCTUR
PIPE COMPL. 18X1,5X3196	96 47 355 08	240	1	2 998	91 56 540 08	PIPELINES SUPERSTRUCTUR
PIPE COMPL. 18X1,5X384	96 51 345 08	237	1	2 998	91 56 540 08	PIPELINES SUPERSTRUCTUR
PIPE COMPL. 18X1,5X482	96 54 105 08	408	1	2 998	91 56 540 08	PIPELINES SUPERSTRUCTUR
PIPE COMPL. 18X1,5X859	96 51 348 08	241	1	2 998	91 56 540 08	PIPELINES SUPERSTRUCTUR
PIPE COMPL. 18X1,5X865	96 51 347 08	239	1	2 998	91 56 540 08	PIPELINES SUPERSTRUCTUR
PIPE COMPL. 20X2,5X1039	96 51 698 08	407	1	2 998	91 56 540 08	PIPELINES SUPERSTRUCTUR
PIPE COMPL. 20X2,5X1072	96 48 935 08	710	1	1 998	91 52 513 08	PIPELINES CRAWLER TYPE U
PIPE COMPL. 20X2,5X1553	96 51 697 08	406	1	2 998	91 56 540 08	PIPELINES SUPERSTRUCTUR
PIPE COMPL. 20X2,5X2296	96 51 696 08	405	1	2 998	91 56 540 08	PIPELINES SUPERSTRUCTUR
PIPE COMPL. 20X2,5X302	96 48 934 08	709	1	1 998	91 52 513 08	PIPELINES CRAWLER TYPE U
PIPE COMPL. 22X2,5X1009	96 51 339 08	270	1	2 998	91 56 540 08	PIPELINES SUPERSTRUCTUR
PIPE COMPL. 22X2,5X1130	96 55 069 08	493	1	2 978 108	96 44 195 08	PIPELINES DERR.
PIPE COMPL. 22X2,5X1300	96 55 059 08	483	1	2 975 155	96 50 586 08	PIPELINE WINCH
PIPE COMPL. 22X2,5X1342	96 55 060 08	484	1	2 975 155	96 50 586 08	PIPELINE WINCH
PIPE COMPL. 22X2,5X1509	96 51 680 08	389	1	2 998	91 56 540 08	PIPELINES SUPERSTRUCTUR
PIPE COMPL. 22X2,5X1530	96 55 072 08	496	1	2 978 108	96 44 195 08	PIPELINES DERR.
PIPE COMPL. 22X2,5X1599	96 51 340 08	271	1	2 998	91 56 540 08	PIPELINES SUPERSTRUCTUR
PIPE COMPL. 22X2,5X1685	96 51 681 08	390	1	2 998	91 56 540 08	PIPELINES SUPERSTRUCTUR
PIPE COMPL. 22X2,5X1776	96 55 068 08	492	1	2 978 108	96 44 195 08	PIPELINES DERR.
PIPE COMPL. 22X2,5X2407	96 55 077 08	501	1	2 978 108	96 44 195 08	PIPELINES DERR.
PIPE COMPL. 22X2,5X269	96 51 490 08	(281)	1	2 975 700	91 52 774 08	ADDITIONAL HYDRAULICS WI
PIPE COMPL. 22X2,5X360	96 55 076 08	500	1	2 978 108	96 44 195 08	PIPELINES DERR.
PIPE COMPL. 22X2,5X527	96 55 075 08	499	1	2 978 108	96 44 195 08	PIPELINES DERR.
PIPE COMPL. 22X2,5X904	96 48 938 08	713	1	1 998	91 52 513 08	PIPELINES CRAWLER TYPE U
PIPE COMPL. 25X3X1162	96 54 108 08	435	1	2 998	91 56 540 08	PIPELINES SUPERSTRUCTUR
PIPE COMPL. 25X3X1218	96 51 695 08	404	1	2 998	91 56 540 08	PIPELINES SUPERSTRUCTUR
PIPE COMPL. 25X3X1416	96 55 071 08	495	1	2 978 108	96 44 195 08	PIPELINES DERR.
PIPE COMPL. 25X3X1471	96 53 056 08	356	1	2 998	91 56 540 08	PIPELINES SUPERSTRUCTUR
PIPE COMPL. 25X3X1585	96 54 107 08	433	1	2 998	91 56 540 08	PIPELINES SUPERSTRUCTUR
PIPE COMPL. 25X3X1681	96 53 055 08	354	1	2 998	91 56 540 08	PIPELINES SUPERSTRUCTUR
PIPE COMPL. 25X3X1938	96 55 066 08	490	1	2 978 108	96 44 195 08	PIPELINES DERR.
PIPE COMPL. 25X3X200	96 51 751 08	145	1	2 978 205	96 47 115 08	PIPELINE S OVERRUN PROTE
PIPE COMPL. 25X3X2068	96 51 694 08	403	1	2 998	91 56 540 08	PIPELINES SUPERSTRUCTUR
PIPE COMPL. 25X3X2133	96 53 064 08	353	1	2 998	91 56 540 08	PIPELINES SUPERSTRUCTUR
PIPE COMPL. 25X3X2160	96 52 304 08	163	1	2 978 205	96 47 115 08	PIPELINE S OVERRUN PROTE
PIPE COMPL. 25X3X2240	96 54 090 08	346	1	2 998	91 56 540 08	PIPELINES SUPERSTRUCTUR
PIPE COMPL. 25X3X2376	96 55 074 08	498	1	2 978 108	96 44 195 08	PIPELINES DERR.
PIPE COMPL. 25X3X2414	96 51 678 08	385	1	2 998	91 56 540 08	PIPELINES SUPERSTRUCTUR
PIPE COMPL. 25X3X2435	96 53 063 08	357	1	2 998	91 56 540 08	PIPELINES SUPERSTRUCTUR
PIPE COMPL. 25X3X2489	96 53 060 08	359	1	2 998	91 56 540 08	PIPELINES SUPERSTRUCTUR
PIPE COMPL. 25X3X2664	96 52 307 08	166	1	2 978 205	96 47 115 08	PIPELINE S OVERRUN PROTE
PIPE COMPL. 25X3X2790	96 53 058 08	355	1	2 998	91 56 540 08	PIPELINES SUPERSTRUCTUR
PIPE COMPL. 25X3X3014	96 52 306 08	165	1	2 978 205	96 47 115 08	PIPELINE S OVERRUN PROTE
PIPE COMPL. 25X3X325	96 55 073 08	497	1	2 978 108	96 44 195 08	PIPELINES DERR.
PIPE COMPL. 25X3X3544	96 52 305 08	164	1	2 978 205	96 47 115 08	PIPELINE S OVERRUN PROTE
PIPE COMPL. 25X3X3800	96 54 091 08	347	1	2 998	91 56 540 08	PIPELINES SUPERSTRUCTUR
PIPE COMPL. 25X3X495	96 51 725 08	434	1	2 998	91 56 540 08	PIPELINES SUPERSTRUCTUR
PIPE COMPL. 25X3X551	96 53 062 08	360	1	2 998	91 56 540 08	PIPELINES SUPERSTRUCTUR
PIPE COMPL. 25X3X636	96 53 065 08	358	1	2 998	91 56 540 08	PIPELINES SUPERSTRUCTUR

6.2.2009

etk_en_de_074515 LR 1600/2

939

LIEBHERRAlphabetical index
Alphabetischer Index

Description	Item	Pos.	Quantity	Page	Assembly	Description
PIPE COMPL. 25X3X748	96 51 693 08	402	1	2 998	91 56 540 08	PIPELINES SUPERSTRUCTUR
PIPE COMPL. 25X3X778	96 51 692 08	401	1	2 998	91 56 540 08	PIPELINES SUPERSTRUCTUR
PIPE COMPL. 28X2X1115	96 54 094 08	344	1	2 998	91 56 540 08	PIPELINES SUPERSTRUCTUR
PIPE COMPL. 28X2X1186	96 51 665 08	372	1	2 998	91 56 540 08	PIPELINES SUPERSTRUCTUR
PIPE COMPL. 28X2X1216	96 51 544 08	352	1	2 998	91 56 540 08	PIPELINES SUPERSTRUCTUR
PIPE COMPL. 28X2X1315	96 51 755 08	149	1	2 978 205	96 47 115 08	PIPELINE S OVERRUN PROTE
PIPE COMPL. 28X2X137	96 51 750 08	144	1	2 978 205	96 47 115 08	PIPELINE S OVERRUN PROTE
PIPE COMPL. 28X2X1466	96 51 717 08	426	1	2 998	91 56 540 08	PIPELINES SUPERSTRUCTUR
PIPE COMPL. 28X2X1570	96 51 754 08	148	1	2 978 205	96 47 115 08	PIPELINE S OVERRUN PROTE
PIPE COMPL. 28X2X160	96 51 662 08	369	1	2 998	91 56 540 08	PIPELINES SUPERSTRUCTUR
PIPE COMPL. 28X2X1725	96 54 098 08	373	1	2 998	91 56 540 08	PIPELINES SUPERSTRUCTUR
PIPE COMPL. 28X2X1805	96 51 711 08	420	1	2 998	91 56 540 08	PIPELINES SUPERSTRUCTUR
PIPE COMPL. 28X2X1888	96 54 089 08	343	1	2 998	91 56 540 08	PIPELINES SUPERSTRUCTUR
PIPE COMPL. 28X2X1920	96 54 096 08	351	1	2 998	91 56 540 08	PIPELINES SUPERSTRUCTUR
PIPE COMPL. 28X2X2015	96 48 912 08	735	2	1 998	91 52 513 08	PIPELINES CRAWLER TYPE U
PIPE COMPL. 28X2X2191	96 54 093 08	349	1	2 998	91 56 540 08	PIPELINES SUPERSTRUCTUR
PIPE COMPL. 28X2X2256	96 48 911 08	734	2	1 998	91 52 513 08	PIPELINES CRAWLER TYPE U
PIPE COMPL. 28X2X2356	96 55 064 08	488	1	2 975 155	96 50 586 08	PIPELINE WINCH
PIPE COMPL. 28X2X2498	96 52 311 08	170	1	2 978 205	96 47 115 08	PIPELINE S OVERRUN PROTE
PIPE COMPL. 28X2X2882	96 48 927 08	705	2	1 998	91 52 513 08	PIPELINES CRAWLER TYPE U
PIPE COMPL. 28X2X2896	96 52 309 08	168	1	2 978 205	96 47 115 08	PIPELINE S OVERRUN PROTE
PIPE COMPL. 28X2X2917	96 52 308 08	167	1	2 978 205	96 47 115 08	PIPELINE S OVERRUN PROTE
PIPE COMPL. 28X2X3108	96 54 103 08	397	1	2 998	91 56 540 08	PIPELINES SUPERSTRUCTUR
PIPE COMPL. 28X2X3255	96 52 310 08	169	1	2 978 205	96 47 115 08	PIPELINE S OVERRUN PROTE
PIPE COMPL. 28X2X513	96 51 661 08	368	1	2 998	91 56 540 08	PIPELINES SUPERSTRUCTUR
PIPE COMPL. 28X2X829	96 54 097 08	366	1	2 998	91 56 540 08	PIPELINES SUPERSTRUCTUR
PIPE COMPL. 28X2X880	96 51 718 08	427	1	2 998	91 56 540 08	PIPELINES SUPERSTRUCTUR
PIPE COMPL. 28X2X945	96 53 066 08	367	1	2 998	91 56 540 08	PIPELINES SUPERSTRUCTUR
PIPE COMPL. 28X2X946	96 48 926 08	704	2	1 998	91 52 513 08	PIPELINES CRAWLER TYPE U
PIPE COMPL. 28X2X973	96 55 051 08	475	1	3 978 106	96 50 885 08	PIPELINES SUSP. BALL. BASE
PIPE COMPL. 30X4X115	96 53 054 08	340	2	2 998	91 56 540 08	PIPELINES SUPERSTRUCTUR
PIPE COMPL. 30X4X125	96 55 050 08	474	1	3 978 106	96 50 885 08	PIPELINES SUSP. BALL. BASE
PIPE COMPL. 30X4X1733	96 51 733 08	182	1	2 978 102	96 47 913 08	PIPELINES MOUNTING DEVIC
PIPE COMPL. 30X4X2042	96 55 042 08	228	1	3 978 010	96 50 882 08	PIPELINES DERR. HEAD SECT
PIPE COMPL. 30X4X2055	96 55 044 08	230	1	3 978 010	96 50 882 08	PIPELINES DERR. HEAD SECT
PIPE COMPL. 30X4X2154	96 55 041 08	227	1	3 978 010	96 50 882 08	PIPELINES DERR. HEAD SECT
PIPE COMPL. 30X4X2172	96 55 043 08	229	1	3 978 010	96 50 882 08	PIPELINES DERR. HEAD SECT
PIPE COMPL. 30X4X3030	96 54 121 08	386	1	2 998	91 56 540 08	PIPELINES SUPERSTRUCTUR
PIPE COMPL. 30X4X3221	96 51 734 08	183	1	2 978 102	96 47 913 08	PIPELINES MOUNTING DEVIC
PIPE COMPL. 30X4X3500	96 51 731 08	180	2	2 978 102	96 47 913 08	PIPELINES MOUNTING DEVIC
PIPE COMPL. 30X4X5473	96 51 735 08	184	2	2 978 102	96 47 913 08	PIPELINES MOUNTING DEVIC
PIPE COMPL. 30X4X654	96 51 732 08	181	1	2 978 102	96 47 913 08	PIPELINES MOUNTING DEVIC
PIPE COMPL. 35X2X1149	96 51 684 08	393	1	2 998	91 56 540 08	PIPELINES SUPERSTRUCTUR
PIPE COMPL. 35X2X1409	96 51 685 08	394	1	2 998	91 56 540 08	PIPELINES SUPERSTRUCTUR
PIPE COMPL. 35X2X1518	96 51 686 08	395	1	2 998	91 56 540 08	PIPELINES SUPERSTRUCTUR
PIPE COMPL. 35X2X1749	96 51 709 08	418	1	2 998	91 56 540 08	PIPELINES SUPERSTRUCTUR
PIPE COMPL. 35X2X1900	96 53 067 08	413	1	2 998	91 56 540 08	PIPELINES SUPERSTRUCTUR
PIPE COMPL. 35X2X2055	96 55 055 08	479	1	3 978 106	96 50 885 08	PIPELINES SUSP. BALL. BASE
PIPE COMPL. 35X2X2265	96 55 054 08	478	1	3 978 106	96 50 885 08	PIPELINES SUSP. BALL. BASE
PIPE COMPL. 35X2X483	96 53 051 08	364	1	2 998	91 56 540 08	PIPELINES SUPERSTRUCTUR
PIPE COMPL. 35X2X549	96 51 727 08	436	1	2 998	91 56 540 08	PIPELINES SUPERSTRUCTUR
PIPE COMPL. 35X2X652	96 53 061 08	419	1	2 998	91 56 540 08	PIPELINES SUPERSTRUCTUR
PIPE COMPL. 35X2X699	96 51 714 08	423	1	2 998	91 56 540 08	PIPELINES SUPERSTRUCTUR
PIPE COMPL. 35X2X720	96 51 689 08	398	1	2 998	91 56 540 08	PIPELINES SUPERSTRUCTUR
PIPE COMPL. 35X2X765	96 51 720 08	429	1	2 998	91 56 540 08	PIPELINES SUPERSTRUCTUR
PIPE COMPL. 35X2X828	96 54 101 08	392	1	2 998	91 56 540 08	PIPELINES SUPERSTRUCTUR
PIPE COMPL. 35X2X85	96 54 086 08	244	1	2 998	91 56 540 08	PIPELINES SUPERSTRUCTUR
PIPE COMPL. 35X2X914	96 54 088 08	338	1	2 998	91 56 540 08	PIPELINES SUPERSTRUCTUR
PIPE COMPL. 35X2X939	96 51 705 08	414	1	2 998	91 56 540 08	PIPELINES SUPERSTRUCTUR
PIPE COMPL. 35X2X95	96 53 052 08	365	1	2 998	91 56 540 08	PIPELINES SUPERSTRUCTUR

6.2.2009

etk_en_de_074515 LR 1600/2

940

LIEBHERRAlphabetical index
Alphabetischer Index

Description	Item	Pos.	Quantity	Page	Assembly	Description
PIPE COMPL. 35X2X990	96 51 721 08	430	1	2 998	91 56 540 08	PIPELINES SUPERSTRUCTUR
PIPE COMPL. 38X4X1013	96 51 350 08	(280)	1	2 975 700	91 52 774 08	ADDITIONAL HYDRAULICS WI
PIPE COMPL. 38X4X1049	96 48 922 08	700	2	1 998	91 52 513 08	PIPELINES CRAWLER TYPE U
PIPE COMPL. 38X4X1050	96 48 924 08	702	2	1 998	91 52 513 08	PIPELINES CRAWLER TYPE U
PIPE COMPL. 38X4X1133	96 51 336 08	266	1	2 998	91 56 540 08	PIPELINES SUPERSTRUCTUR
PIPE COMPL. 38X4X1141	96 51 519 08	327	1	2 998	91 56 540 08	PIPELINES SUPERSTRUCTUR
PIPE COMPL. 38X4X1213	96 51 506 08	314	1	2 998	91 56 540 08	PIPELINES SUPERSTRUCTUR
PIPE COMPL. 38X4X1232	96 51 515 08	323	1	2 998	91 56 540 08	PIPELINES SUPERSTRUCTUR
PIPE COMPL. 38X4X1243	96 51 522 08	330	1	2 998	91 56 540 08	PIPELINES SUPERSTRUCTUR
PIPE COMPL. 38X4X1264	96 51 520 08	328	1	2 998	91 56 540 08	PIPELINES SUPERSTRUCTUR
PIPE COMPL. 38X4X1369	96 51 334 08	265	1	2 998	91 56 540 08	PIPELINES SUPERSTRUCTUR
PIPE COMPL. 38X4X1595	96 53 050 08	325	1	2 998	91 56 540 08	PIPELINES SUPERSTRUCTUR
PIPE COMPL. 38X4X1602	96 51 527 08	335	1	2 998	91 56 540 08	PIPELINES SUPERSTRUCTUR
PIPE COMPL. 38X4X1608	96 53 048 08	321	1	2 998	91 56 540 08	PIPELINES SUPERSTRUCTUR
PIPE COMPL. 38X4X1632	96 51 510 08	318	1	2 998	91 56 540 08	PIPELINES SUPERSTRUCTUR
PIPE COMPL. 38X4X1648	96 51 526 08	334	1	2 998	91 56 540 08	PIPELINES SUPERSTRUCTUR
PIPE COMPL. 38X4X1670	96 51 511 08	319	1	2 998	91 56 540 08	PIPELINES SUPERSTRUCTUR
PIPE COMPL. 38X4X1698	96 54 148 08	211	1	3 978 010	96 50 882 08	PIPELINES DERR. HEAD SECT
PIPE COMPL. 38X4X1726	96 53 044 08	313	1	2 998	91 56 540 08	PIPELINES SUPERSTRUCTUR
PIPE COMPL. 38X4X1745	96 53 046 08	317	1	2 998	91 56 540 08	PIPELINES SUPERSTRUCTUR
PIPE COMPL. 38X4X1752	96 53 042 08	311	1	2 998	91 56 540 08	PIPELINES SUPERSTRUCTUR
PIPE COMPL. 38X4X1761	96 51 524 08	332	1	2 998	91 56 540 08	PIPELINES SUPERSTRUCTUR
PIPE COMPL. 38X4X1767	96 55 028 08	214	1	3 978 010	96 50 882 08	PIPELINES DERR. HEAD SECT
PIPE COMPL. 38X4X2010	96 51 507 08	315	1	2 998	91 56 540 08	PIPELINES SUPERSTRUCTUR
PIPE COMPL. 38X4X2025	96 51 491 08	300	1	2 998	91 56 540 08	PIPELINES SUPERSTRUCTUR
PIPE COMPL. 38X4X2030	96 53 041 08	310	1	2 998	91 56 540 08	PIPELINES SUPERSTRUCTUR
PIPE COMPL. 38X4X2035	96 48 909 08	732	2	1 998	91 52 513 08	PIPELINES CRAWLER TYPE U
PIPE COMPL. 38X4X2041	96 55 052 08	476	1	3 978 106	96 50 885 08	PIPELINES SUSP. BALL. BASE
PIPE COMPL. 38X4X2062	96 51 492 08	301	1	2 998	91 56 540 08	PIPELINES SUPERSTRUCTUR
PIPE COMPL. 38X4X2066	96 54 149 08	212	1	3 978 010	96 50 882 08	PIPELINES DERR. HEAD SECT
PIPE COMPL. 38X4X2133	96 54 150 08	213	1	3 978 010	96 50 882 08	PIPELINES DERR. HEAD SECT
PIPE COMPL. 38X4X2184	96 51 514 08	322	1	2 998	91 56 540 08	PIPELINES SUPERSTRUCTUR
PIPE COMPL. 38X4X2195	96 55 029 08	215	1	3 978 010	96 50 882 08	PIPELINES DERR. HEAD SECT
PIPE COMPL. 38X4X2200	96 55 053 08	477	1	3 978 106	96 50 885 08	PIPELINES SUSP. BALL. BASE
PIPE COMPL. 38X4X2224	96 48 908 08	731	2	1 998	91 52 513 08	PIPELINES CRAWLER TYPE U
PIPE COMPL. 38X4X2226	96 54 147 08	210	1	3 978 010	96 50 882 08	PIPELINES DERR. HEAD SECT
PIPE COMPL. 38X4X2308	96 48 910 08	733	2	1 998	91 52 513 08	PIPELINES CRAWLER TYPE U
PIPE COMPL. 38X4X2308	96 51 529 08	337	1	2 998	91 56 540 08	PIPELINES SUPERSTRUCTUR
PIPE COMPL. 38X4X2326	96 51 518 08	326	1	2 998	91 56 540 08	PIPELINES SUPERSTRUCTUR
PIPE COMPL. 38X4X2409	96 55 147 08	302	1	2 998	91 56 540 08	PIPELINES SUPERSTRUCTUR
PIPE COMPL. 38X4X2411	96 51 333 08	264	1	2 998	91 56 540 08	PIPELINES SUPERSTRUCTUR
PIPE COMPL. 38X4X2447	96 48 907 08	730	2	1 998	91 52 513 08	PIPELINES CRAWLER TYPE U
PIPE COMPL. 38X4X2571	96 51 523 08	331	1	2 998	91 56 540 08	PIPELINES SUPERSTRUCTUR
PIPE COMPL. 38X4X2609	96 55 148 08	303	1	2 998	91 56 540 08	PIPELINES SUPERSTRUCTUR
PIPE COMPL. 38X4X2674	96 55 063 08	487	1	2 975 155	96 50 586 08	PIPELINE WINCH
PIPE COMPL. 38X4X2700	96 55 062 08	486	1	2 975 155	96 50 586 08	PIPELINE WINCH
PIPE COMPL. 38X4X2737	96 51 521 08	329	1	2 998	91 56 540 08	PIPELINES SUPERSTRUCTUR
PIPE COMPL. 38X4X2763	96 51 525 08	333	1	2 998	91 56 540 08	PIPELINES SUPERSTRUCTUR
PIPE COMPL. 38X4X2779	96 48 923 08	701	2	1 998	91 52 513 08	PIPELINES CRAWLER TYPE U
PIPE COMPL. 38X4X2783	96 48 925 08	703	2	1 998	91 52 513 08	PIPELINES CRAWLER TYPE U
PIPE COMPL. 38X4X2843	96 51 528 08	336	1	2 998	91 56 540 08	PIPELINES SUPERSTRUCTUR
PIPE COMPL. 38X4X3213	96 58 312 08	307	1	2 998	91 56 540 08	PIPELINES SUPERSTRUCTUR
PIPE COMPL. 38X4X3240	96 51 496 08	305	1	2 998	91 56 540 08	PIPELINES SUPERSTRUCTUR
PIPE COMPL. 38X4X3272	96 53 045 08	316	1	2 998	91 56 540 08	PIPELINES SUPERSTRUCTUR
PIPE COMPL. 38X4X3302	96 53 043 08	312	1	2 998	91 56 540 08	PIPELINES SUPERSTRUCTUR
PIPE COMPL. 38X4X3645	96 51 497 08	306	1	2 998	91 56 540 08	PIPELINES SUPERSTRUCTUR
PIPE COMPL. 38X4X3935	96 55 047 08	471	1	3 978 106	96 50 885 08	PIPELINES SUSP. BALL. BASE
PIPE COMPL. 38X4X3974	96 51 495 08	304	1	2 998	91 56 540 08	PIPELINES SUPERSTRUCTUR
PIPE COMPL. 38X4X4000	96 53 049 08	324	1	2 998	91 56 540 08	PIPELINES SUPERSTRUCTUR
PIPE COMPL. 38X4X4004	96 53 047 08	320	1	2 998	91 56 540 08	PIPELINES SUPERSTRUCTUR

6.2.2009

etk_en_de_074515 LR 1600/2

941

LIEBHERRAlphabetical index
Alphabetischer Index

Description	Item	Pos.	Quantity	Page	Assembly	Description
PIPE COMPL. 38X4X4015	96 55 046 08	470	1	3 978 106	96 50 885 08	PIPELINES SUSP. BALL. BASE
PIPE COMPL. 38X4X4400	96 54 144 08	461	1	3 978 007	96 50 879 08	PIPELINES DERR. INT. SECT.
PIPE COMPL. 38X4X4400	96 54 145 08	462	1	3 978 007	96 50 879 08	PIPELINES DERR. INT. SECT.
PIPE COMPL. 38X4X495	96 51 332 08	263	1	2 998	91 56 540 08	PIPELINES SUPERSTRUCTUR
PIPE COMPL. 38X4X5190	96 55 090 08	(452)	1	3 978 015	91 56 429 08	ADDITIONAL HYDRAULICS IN
PIPE COMPL. 38X4X5190	96 55 091 08	(453)	1	3 978 015	91 56 429 08	ADDITIONAL HYDRAULICS IN
PIPE COMPL. 38X4X5190	96 55 092 08	(454)	1	3 978 015	91 56 429 08	ADDITIONAL HYDRAULICS IN
PIPE COMPL. 38X4X5190	96 55 093 08	(455)	1	3 978 015	91 56 429 08	ADDITIONAL HYDRAULICS IN
PIPE COMPL. 38X4X564	96 51 330 08	261	1	2 998	91 56 540 08	PIPELINES SUPERSTRUCTUR
PIPE COMPL. 38X4X572	96 51 331 08	262	1	2 998	91 56 540 08	PIPELINES SUPERSTRUCTUR
PIPE COMPL. 38X4X681	96 51 500 08	309	1	2 998	91 56 540 08	PIPELINES SUPERSTRUCTUR
PIPE COMPL. 38X4X779	96 51 329 08	260	1	2 998	91 56 540 08	PIPELINES SUPERSTRUCTUR
PIPE COMPL. 38X4X914	96 51 499 08	308	1	2 998	91 56 540 08	PIPELINES SUPERSTRUCTUR
PIPE COMPL. 42X3X1020	96 51 341 08	232	1	2 998	91 56 540 08	PIPELINES SUPERSTRUCTUR
PIPE COMPL. 42X3X1033	96 51 707 08	416	1	2 998	91 56 540 08	PIPELINES SUPERSTRUCTUR
PIPE COMPL. 42X3X1109	96 51 703 08	412	1	2 998	91 56 540 08	PIPELINES SUPERSTRUCTUR
PIPE COMPL. 42X3X115	96 54 106 08	415	1	2 998	91 56 540 08	PIPELINES SUPERSTRUCTUR
PIPE COMPL. 42X3X1279	96 54 095 08	350	1	2 998	91 56 540 08	PIPELINES SUPERSTRUCTUR
PIPE COMPL. 42X3X150	96 51 344 08	236	1	2 998	91 56 540 08	PIPELINES SUPERSTRUCTUR
PIPE COMPL. 42X3X1555	96 51 719 08	428	1	2 998	91 56 540 08	PIPELINES SUPERSTRUCTUR
PIPE COMPL. 42X3X200	96 51 343 08	235	1	2 998	91 56 540 08	PIPELINES SUPERSTRUCTUR
PIPE COMPL. 42X3X345	96 54 092 08	348	1	2 998	91 56 540 08	PIPELINES SUPERSTRUCTUR
PIPE COMPL. 42X3X508	96 51 708 08	417	1	2 998	91 56 540 08	PIPELINES SUPERSTRUCTUR
PIPE COMPL. 42X3X625	96 51 702 08	411	1	2 998	91 56 540 08	PIPELINES SUPERSTRUCTUR
PIPE COMPL. 42X3X732	96 51 716 08	425	1	2 998	91 56 540 08	PIPELINES SUPERSTRUCTUR
PIPE COMPL. 42X3X791	96 51 712 08	421	1	2 998	91 56 540 08	PIPELINES SUPERSTRUCTUR
PIPE COMPL. 42X3X796	96 54 087 08	243	1	2 998	91 56 540 08	PIPELINES SUPERSTRUCTUR
PIPE COMPL. 42X3X911	96 51 713 08	422	1	2 998	91 56 540 08	PIPELINES SUPERSTRUCTUR
PIPE COMPL. 42X3X935	96 51 715 08	424	1	2 998	91 56 540 08	PIPELINES SUPERSTRUCTUR
PIPE COMPL. 6X1X216	96 48 933 08	708	1	1 998	91 52 513 08	PIPELINES CRAWLER TYPE U
PIPE COMPL. 6X1X316	96 51 675 08	382	1	2 998	91 56 540 08	PIPELINES SUPERSTRUCTUR
PIPE COMPL. 6X1X387	96 55 037 08	223	1	3 978 010	96 50 882 08	PIPELINES DERR. HEAD SECT
PIPE COMPL. 6X1X525	96 55 038 08	224	1	3 978 010	96 50 882 08	PIPELINES DERR. HEAD SECT
PIPE COMPL. 6X1X555	96 55 039 08	225	1	3 978 010	96 50 882 08	PIPELINES DERR. HEAD SECT
PIPE COMPL. 6X1X563	96 55 040 08	226	1	3 978 010	96 50 882 08	PIPELINES DERR. HEAD SECT
PIPE COMPL. 6X1X773	96 48 898 08	(762)	4	1 975 006	91 52 509 08	ADD. HYDR. SUPPORTING RA
PIPE COMPL. 6X1X824	96 55 036 08	222	1	3 978 010	96 50 882 08	PIPELINES DERR. HEAD SECT
PIPE COMPL. 8X1X318	96 51 342 08	234	2	2 998	91 56 540 08	PIPELINES SUPERSTRUCTUR
PIPE ELBOW	57 00 661 08	3	1	5 028 065	50 28 065 08	EQUALIZING RESERVOIR
PIPE PRE-ASS.	96 47 854 08	22	1	2 671 004	96 46 305 08	OIL TANK PRE-ASS.
PIPE SOCKET	10 01 242 4	8	1	9 739 248	97 39 248	INJECTOR
PIPE SOCKET GSCK45	95 46 242 08	10	1	2 540	91 53 253 08	CLIMA-HEATING INSTALLATIO
PIPE WELDED	96 44 583 08	5	2	2 340	91 52 776 08	WINCH 4 LUFFING GEAR
PIPE WELDED	96 45 705 08	2	1	2 522	91 54 115 08	SLIDING DOOR CPL.
PIPE WELDED	96 48 606 08	31	1	2 391 001	96 45 719 08	DIESEL ENGINE, PRE-ASSEMB
PIPELINE	77 43 780 08	(2)	1	2 711	91 52 800 08	CENT. LUBRIC. SYSTEM SUP
PIPELINE INSTALLATION	97 39 356	16	1	9 739 358	97 39 358	EXHAUST GAS RECIRCUL.ATT
PIPELINE INSTALLATION	97 39 492	143	1	X1012059	10 12 059 0	DIESEL ENGINE
PIPELINE PIN PULLING CYLIN	96 46 081 08	90	1	2 976 203	92 27 489 08	ADDL.HYDR.F.PIN PULLING DE
PIPELINE S OVERRUN PROTE	96 47 115 08	93	1	2 978 200	91 54 843 08	ADD.HYDR.S. RETAINING RAM
PIPELINE WINCH I+II	96 51 219 08	93	1	2 975 200	91 52 775 08	ADDITIONAL HYDRAULICS WI
PIPELINE WINCH I+II	96 51 219 08	93	1	2 975 700	91 52 774 08	ADDITIONAL HYDRAULICS WI
PIPELINE WINCH III	96 50 586 08	93	1	2 975 100	91 52 860 08	ADDITIONAL HYDRAULICS WI
PIPELINES CRAWLER TYPE U	91 52 513 08	37	1		LR 1600-2-0	
PIPELINES DERR.	96 44 195 08	93	1	2 978 100	91 52 827 08	ADDNL.HYDR.RETAINING DEV
PIPELINES DERR. HEAD SECT	96 50 882 08	93	1	3 978 005	91 56 430 08	ADDL.HYDRAULIC SB-HEAD PI
PIPELINES DERR. INT. SECT.	96 50 884 08	93	1	3 978 015	91 56 429 08	ADDITIONAL HYDRAULICS IN
PIPELINES DERR. INT. SECT. 6	96 50 879 08	93	1	3 978 015	91 56 432 08	ADDITIONAL HYDRAULICS IN
PIPELINES ERECTION WINCH	96 47 540 08	93	1	2 975 000	91 57 881 08	ADDNL. HYDR. F. ERECTING W
PIPELINES MOUNTING DEVIC	96 47 913 08	93	1	2 978 100	91 52 796 08	ADDNL.HYDR.ERECTION DEV

6.2.2009

etk_en_de_074515 LR 1600/2

942

LIEBHERRAlphabetical index
Alphabetischer Index

Description	Item	Pos.	Quantity	Page	Assembly	Description
PIPELINES SUPERSTRUCTUR	91 56 540 08	181	1		LR 1600-2-0	
PIPELINES SUPPORTING RAM	96 47 505 08	93	1	1 975 006	91 52 509 08	ADD. HYDR. SUPPORTING RA
PIPELINES SUSP. BALL. BASE	96 50 885 08	93	1	3 978 100	91 56 428 08	HYDR. SUSPENDED BALLAST
PISTON	10 22 233 1	53	1	9 739 246	97 39 246	PISTON
PISTON	10 22 233 2	51	1	9 739 246	97 39 246	PISTON
PISTON	10 22 233 3	1	1	9 739 246	97 39 246	PISTON
PISTON	10 22 233 4	52	1	9 739 246	97 39 246	PISTON
PISTON	57 01 147 08	4	7	5 701 133	57 01 133 08	DRIVING GEAR
PISTON	97 39 246	40	6	X1012059	10 12 059 0	DIESEL ENGINE
PISTON BOLT	10 22 233 5	2	1	9 739 246	97 39 246	PISTON
PISTON COOLING	97 39 243	9	6	X1012059	10 12 059 0	DIESEL ENGINE
PIVOT BEARING 30	57 15 052 08	(9)	2	2 810	91 52 806 08	CRANE DRIVER'S CABIN CPL.
PIVOT SECTION	91 52 881 08	284	1		LR 1600-2-0	
PLANETARY GEAR	93 27 102 01	3	2	1 400	91 56 853 08	CRAWLER TRACK CARRIER LE
PLANETARY GEAR	93 27 102 01	3	2	1 410 300	91 56 855 08	CRAWLER CARRIER RIGHT CP
PLASTIC SPIRAL HOSE NW50	55 30 108 08	50	0.9	2 920 369	96 54 235 08	TERMINAL BOX CPL.
PLASTIC STRIP 13X45X710 P	93 72 005 08	97	3	2 550	91 57 751 08	SA FRAME
PLATE	96 54 011 08	21	1	3 350	91 52 859 08	WINCH 3
PLATE	96 54 012 08	20	1	3 350	91 52 859 08	WINCH 3
PLATE 1.5X100X100	93 97 306 08	14	7	3 225	91 52 854 08	SL REDUCING SECTION
PLATE 1.5X112X30	97 29 400 08	102	4	2 932 082	96 54 387 08	ASSEMBLY PARTS MOUNTIN
PLATE 1.5X1132X447	97 85 999 08	72	1	2 810	91 52 806 08	CRANE DRIVER'S CABIN CPL.
PLATE 1.5X1140X231	97 23 317 08	6	1	2 260 006	96 46 501 08	BATTERY BOX, PRE-ASSEMB
PLATE 1.5X1216X544	97 23 263 08	1	1	2 391 036	96 23 055 08	COVER/LID/CAP, PRE-ASSEMB
PLATE 1.5X131X10	97 73 326 08	3	1	2 522	91 54 115 08	SLIDING DOOR CPL.
PLATE 1.5X1489X232	97 70 814 08	36	1	2 859	91 52 809 08	SOUND INSULATION
PLATE 1.5X1577X366	97 71 093 08	1	1	2 260 009	96 46 972 08	FLAP PRE-ASS.
PLATE 1.5X158X338	97 29 623 08	103	1	2 932 082	96 54 387 08	ASSEMBLY PARTS MOUNTIN
PLATE 1.5X175X115	97 60 941 08	53	1	2 520 034	96 45 984 08	INTERNAL LINING
PLATE 1.5X1770X169	97 70 811 08	34	1	2 859	91 52 809 08	SOUND INSULATION
PLATE 1.5X1812X294	97 71 096 08	11	1	2 260	91 53 057 08	CUP SPRING CLUSTER
PLATE 1.5X191X111	97 26 606 08	105	2	2 932 082	96 54 387 08	ASSEMBLY PARTS MOUNTIN
PLATE 1.5X212X345	97 73 925 08	107	1	2 932 082	96 54 387 08	ASSEMBLY PARTS MOUNTIN
PLATE 1.5X219X84	97 75 001 08	34	1	2 391 001	96 45 719 08	DIESEL ENGINE, PRE-ASSEMB
PLATE 1.5X219X84	97 77 539 08	46	1	2 391 001	96 45 719 08	DIESEL ENGINE, PRE-ASSEMB
PLATE 1.5X240X140	97 75 937 08	1	1	2 533 068	96 49 314 08	PREMOUNTED PLUG SOCKET
PLATE 1.5X2576X755	97 71 095 08	10	1	2 260	91 53 057 08	CUP SPRING CLUSTER
PLATE 1.5X272X796	97 14 053 08	108	1	2 932 082	96 54 387 08	ASSEMBLY PARTS MOUNTIN
PLATE 1.5X283X325	97 75 696 08	106	1	2 932 082	96 54 387 08	ASSEMBLY PARTS MOUNTIN
PLATE 1.5X287X160	97 75 148 08	1	1	2 533 067	96 50 385 08	PLATE PRE-ASS.
PLATE 1.5X326X40	97 70 936 08	2	2	2 859 007	96 46 775 08	COVER COMPL.
PLATE 1.5X336X134	97 28 092 08	27	2	2 932 160	96 54 385 08	SWITCH CABINET
PLATE 1.5X389X269	97 76 699 08	6	1	2 533 070	96 48 363 08	CONTROLS AND FITTINGS RI
PLATE 1.5X399X35	97 75 662 08	101	2	2 932 082	96 54 387 08	ASSEMBLY PARTS MOUNTIN
PLATE 1.5X471X90	97 71 634 08	2	2	2 393 002	96 46 782 08	COVER COMPL.
PLATE 1.5X486X140	97 76 595 08	2	1	2 541	91 52 790 08	ADD HEATING SUPERSTRUCT
PLATE 1.5X493X622	97 72 289 08	24	1	2 520 034	96 45 984 08	INTERNAL LINING
PLATE 1.5X500X111	97 68 612 08	7	1	2 522	91 54 115 08	SLIDING DOOR CPL.
PLATE 1.5X60X39	97 74 350 08	22	1	2 522	91 54 115 08	SLIDING DOOR CPL.
PLATE 1.5X635X271 FE//ZN20//	97 86 281 08	116	1	2 932 082	96 54 387 08	ASSEMBLY PARTS MOUNTIN
PLATE 1.5X739X40	97 70 952 08	2	1	2 859 026	96 46 776 08	COVER COMPL.
PLATE 1.5X740X40	97 70 985 08	2	2	2 859 028	96 46 778 08	COVER COMPL.
PLATE 1.5X75X75	97 75 126 08	67	1	2 520	91 53 061 08	CABIN, GLAZED
PLATE 1.5X773X420	97 78 744 08	1	1	2 391 039	96 50 616 08	COVER CPL
PLATE 1.5X79X67 DC01 FE//ZN	97 74 908 08	104	1	2 932 082	96 54 387 08	ASSEMBLY PARTS MOUNTIN
PLATE 1.5X813X326	97 68 329 08	21	1	2 520 034	96 45 984 08	INTERNAL LINING
PLATE 1.5X817X297	97 77 221 08	9	1	2 520 031	96 45 610 08	REAR WINDOW PRE-ASS.
PLATE 1.5X848X40	97 70 997 08	2	2	2 859 029	96 46 779 08	COVER COMPL.
PLATE 1.5X85X54	97 86 675 08	23	1	2 520 034	96 45 984 08	INTERNAL LINING
PLATE 1.5X872X194	97 70 813 08	35	1	2 859	91 52 809 08	SOUND INSULATION

6.2.2009

etk_en_de_074515 LR 1600/2

943

LIEBHERRAlphabetical index
Alphabetischer Index

Description	Item	Pos.	Quantity	Page	Assembly	Description
PLATE 1.5X872X40 DC01	97 70 983 08	10	1	2 859 026	96 46 776 08	COVER COMPL.
PLATE 1.5X872X40 DC01	97 70 983 08	2	2	2 859 027	96 46 777 08	COVER COMPL.
PLATE 1.5X872X70	97 76 164 08	49	1	2 520 034	96 45 984 08	INTERNAL LINING
PLATE 1.5X949X398	97 78 745 08	2	1	2 391 039	96 50 616 08	COVER CPL
PLATE 1.5x60x47	97 07 173 08	(4)	4	2 550	91 57 751 08	SA FRAME
PLATE 10X100X163 FE//ZN20//	97 83 086 08	11	6	2 631	91 56 817 08	SLEWING PLATFORM CATWAL
PLATE 10X1250X80	97 41 440 08	30	1	3 220 500	91 52 849 08	S INTERMEDIATE SECTION
PLATE 10X1250X80	97 41 440 08	30	2	3 223	91 52 852 08	S INTERMEDIATE SECTION
PLATE 10X1250X80	97 41 440 08	30	2	3 223 010	91 52 853 08	S INTERMEDIATE SECTION
PLATE 10X1250X80	97 41 440 08	30	2	3 223 100	91 55 327 08	S INTERMEDIATE SECTION
PLATE 10X1250X80	97 41 440 08	28	1	3 225	91 52 854 08	SL REDUCING SECTION
PLATE 10X1250X80	97 41 440 08	30	1	3 226	91 52 870 08	L INTERMEDIATE SECTION
PLATE 10X1250X80	97 41 440 08	30	2	3 227	91 52 873 08	L INTERMEDIATE SECTION
PLATE 10X1250X80	97 41 440 08	30	2	3 227 008	91 52 872 08	L INTERMEDIATE SECTION
PLATE 10X1250X80	97 41 440 08	30	2	3 227 200	91 53 519 08	LI INTERMEDIATE SECT. F-GU
PLATE 10X1250X80	97 41 440 08	58	1	3 713	91 57 749 08	D PIVOT SECTION
PLATE 10X1250X80	97 41 440 08	50	5	3 714	91 52 862 08	D HEAD SECTION
PLATE 10X1250X80	97 41 440 08	25	2	3 715 008	91 52 863 08	D INTERMEDIATE SECTION
PLATE 10X1250X80	97 41 440 08	25	3	3 716	91 52 864 08	D INTERMEDIATE SECTION
PLATE 10X296X296	97 71 943 08	11	2	3 208 001	91 52 883 08	F-HEAD SECTION
PLATE 10X40X150	94 18 461 08	26	1	2 810	91 52 806 08	CRANE DRIVER'S CABIN CPL.
PLATE 10X549X280	97 76 909 08	34	1	3 714	91 52 862 08	D HEAD SECTION
PLATE 10x100x100	97 02 204 08	40	1	2 340	91 52 776 08	WINCH 4 LUFFING GEAR
PLATE 12X111X76	97 48 729 08	28	2	1 400	91 56 853 08	CRAWLER TRACK CARRIER LE
PLATE 12X111X76	97 48 729 08	28	2	1 410 300	91 56 855 08	CRAWLER CARRIER RIGHT CP
PLATE 12X120X120 SPF	97 70 829 08	7	2	3 213	91 52 842 08	F-CONNECTING HEAD
PLATE 12X120X532	97 75 895 08	8	1	3 350	91 52 859 08	WINCH 3
PLATE 12X337X120	97 88 636 08	40	1	3 350	91 52 859 08	WINCH 3
PLATE 12X471X120	97 88 637 08	41	1	3 350	91 52 859 08	WINCH 3
PLATE 15.0X113	97 77 117 08	39	2	2 502	91 55 939 08	CONTROL STAND
PLATE 15X200X200	97 76 839 08	13	2	3 714	91 52 862 08	D HEAD SECTION
PLATE 15X257X235	97 73 410 08	6	4	2 125	91 52 773 08	PIN F.S-PIVOT SECTION SA F
PLATE 15X303X246	97 69 586 08	38	2	1 400	91 56 853 08	CRAWLER TRACK CARRIER LE
PLATE 15X303X246	97 69 586 08	38	2	1 410 300	91 56 855 08	CRAWLER CARRIER RIGHT CP
PLATE 15X430X250	97 90 582 08	4	2	2 550	91 57 751 08	SA FRAME
PLATE 15X507X124	97 84 978 08	23	2	3 350	91 52 859 08	WINCH 3
PLATE 15X578X490	97 75 244 08	14	2	3 214	91 52 843 08	SW HEAD SECTION
PLATE 15X90X60	97 83 613 08	5	1	2 391 040	96 53 645 08	CLUTCH ACTUATOR
PLATE 15X930X362	97 66 746 08	11	1	2 340	91 52 776 08	WINCH 4 LUFFING GEAR
PLATE 15X964X235	97 85 057 08	22	4	3 350	91 52 859 08	WINCH 3
PLATE 1X108X9 ALMG3 H111	97 32 671 08	9	1	2 913 007	96 20 763 08	CONTROLLER UNIT
PLATE 1X142X55	97 72 215 08	5	6	2 671	91 52 798 08	OIL RESERVOIR, COMPLETE
PLATE 1X160X160	97 79 371 08	31	8	1 630	91 52 387 08	HYDRAULIC SUPPORT
PLATE 1X20X60	97 59 516 08	135	20	2 970	91 56 537 08	HYDR
PLATE 1X20X60	97 59 516 08	65	4	2 975 100	91 52 860 08	ADDITIONAL HYDRAULICS WI
PLATE 1X20X60	97 59 516 08	65	7	2 975 200	91 52 775 08	ADDITIONAL HYDRAULICS WI
PLATE 1X20X60	97 59 516 08	65	7	2 975 700	91 52 774 08	ADDITIONAL HYDRAULICS WI
PLATE 1X20X60	97 59 516 08	65	8	2 977	91 57 756 08	ADDITIONAL HYDR.SLEWING
PLATE 1X20X60	97 59 516 08	65	7	2 977 200	91 55 149 08	ADDITIONAL HYDR.PUMP/WI
PLATE 1X20X60	97 59 516 08	65	2	2 978 100	91 52 827 08	ADDNL.HYDR.RETAINING DEV
PLATE 1X20X60	97 59 516 08	65	4	2 978 200	91 54 843 08	ADD.HYDR.S_RETAINING RAM
PLATE 1X20X60	97 59 516 08	65	2	3 978 005	91 56 430 08	ADDL.HYDRAULIC SB-HEAD PI
PLATE 1X20X60	97 59 516 08	65	6	3 978 015	91 56 429 08	ADDITIONAL HYDRAULICS IN
PLATE 1X20X60	97 59 516 08	65	6	3 978 015	91 56 432 08	ADDITIONAL HYDRAULICS IN
PLATE 1X20X60	97 59 516 08	65	5	3 978 100	91 56 428 08	HYDR. SUSPENDED BALLAST
PLATE 1X285X126	97 74 443 08	17	1	2 502	91 55 939 08	CONTROL STAND
PLATE 1X285X126	97 74 444 08	18	1	2 502	91 55 939 08	CONTROL STAND
PLATE 1X350X136	97 71 799 08	11	1	2 393 002	96 46 782 08	COVER COMPL.
PLATE 1X35X22 ALMG3	61 10 022 08	5	1	2 913 003	96 20 599 08	FOIL KEYPAD PRE-ASS.
PLATE 1X467X259 ALMG3 H11	97 17 132 08	2	1	2 913 005	96 20 731 08	INTERIOR HOUSING PRE-ASS.

6.2.2009

etk_en_de_074515 LR 1600/2

944

LIEBHERRAlphabetical index
Alphabetischer Index

Description	Item	Pos.	Quantity	Page	Assembly	Description
PLATE 1X467X259 ALMG3 H11	97 17 132 08	2	1	2 913 005	96 28 696 08	INTERIOR HOUSING PRE-ASS.
PLATE 1X80X110	97 09 048 08	20	10	1 991	91 52 510 08	ROTARY FEED THROUGH
PLATE 1X95X78 ALMG3 H111	97 09 808 08	5	1	2 913	91 32 850 08	LICCON CONSOLE LCD2
PLATE 1X95X78 ALMG3 H111	97 09 808 08	5	1	2 913 009	91 04 705 08	LICCON CONSOLE LCD3
PLATE 1x120x100	97 03 987 08	10	2	3 350	91 52 859 08	WINCH 3
PLATE 2.5X199X102	97 80 641 08	21	2	2 391 023	96 45 720 08	RADIATOR, PRE-ASSEMBLED
PLATE 2.5X80X48	97 78 751 08	54	4	2 391 001	96 45 719 08	DIESEL ENGINE, PRE-ASSEMB
PLATE 2.5X86X86	97 76 153 08	40	4	2 520 034	96 45 984 08	INTERNAL LINING
PLATE 20X160X290	95 44 785 08	35	2	1 400	91 56 853 08	CRAWLER TRACK CARRIER LE
PLATE 20X160X290	95 44 785 08	35	2	1 410 300	91 56 855 08	CRAWLER CARRIER RIGHT CP
PLATE 20X260X260	97 74 857 08	10	2	3 215 005	91 52 846 08	ROLLER SET
PLATE 20X260X260	97 74 857 08	10	2	3 215 006	91 52 847 08	ROLLER SET
PLATE 20X311X106	97 83 633 08	73	10	1 400	91 56 853 08	CRAWLER TRACK CARRIER LE
PLATE 20X311X106	97 83 633 08	73	10	1 410 300	91 56 855 08	CRAWLER CARRIER RIGHT CP
PLATE 20X512X62	97 12 071 08	25	8	1 400	91 56 853 08	CRAWLER TRACK CARRIER LE
PLATE 20X512X62	97 12 071 08	25	8	1 410 300	91 56 855 08	CRAWLER CARRIER RIGHT CP
PLATE 20X61X358	97 72 200 08	16	3	2 652	91 52 794 08	ROLLER BEARING
PLATE 20X68X60	97 88 842 08	85	2	2 550	91 57 751 08	SA FRAME
PLATE 25X95X115	97 91 625 08	13	2	3 292	91 52 865 08	D OVERRUN PROTECTION
PLATE 2X100X100	95 62 979 08	1	2	1 100	91 52 375 08	CRAWLER TRACK TRAVEL G
PLATE 2X100X100	95 62 980 08	2	2	1 100	91 52 375 08	CRAWLER TRACK TRAVEL G
PLATE 2X100X100	95 62 981 08	3	2	1 100	91 52 375 08	CRAWLER TRACK TRAVEL G
PLATE 2X100X100	95 62 982 08	4	2	1 100	91 52 375 08	CRAWLER TRACK TRAVEL G
PLATE 2X1010X924	97 75 668 08	1	1	2 510 040	96 49 183 08	DOOR COMPL.
PLATE 2X103X117	97 60 772 08	64	2	2 520	91 53 061 08	CABIN, GLAZED
PLATE 2X103X40	97 26 310 08	1	1	2 780 851	96 24 498 08	RADIO ANTENNA PRE-ASS.
PLATE 2X105X105 DC01-A-M	97 04 902 08	17	2	3 205	91 52 880 08	F-ASSEMBLY UNIT
PLATE 2X110X109	97 75 843 08	117	2	2 932 082	96 54 387 08	ASSEMBLY PARTS MOUNTIN
PLATE 2X144X80 ST12.03	95 63 963 08	1	1	2 932 166	92 68 911 08	GROUND RAIL
PLATE 2X160X160	97 69 902 08	18	16	1 630	91 52 387 08	HYDRAULIC SUPPORT
PLATE 2X162X142 ALMG3 H11	97 65 362 08	110	1	2 932 082	96 54 387 08	ASSEMBLY PARTS MOUNTIN
PLATE 2X190X140	97 80 626 08	74	8	2 550	91 57 751 08	SA FRAME
PLATE 2X196X238	97 72 070 08	33	1	2 520	91 53 061 08	CABIN, GLAZED
PLATE 2X201X127 FE//ZN20//C	97 79 157 08	53	1	2 520	91 53 061 08	CABIN, GLAZED
PLATE 2X201X128 FE//ZN20//C	97 79 158 08	54	1	2 520	91 53 061 08	CABIN, GLAZED
PLATE 2X214X142 ALMG3 H11	97 47 409 08	3	1	2 780 852	96 24 845 08	GSM-MODULE PRE-ASS.LICCO
PLATE 2X215X100 FE//ZN20//C	97 86 328 08	10	2	1 620	91 52 386 08	FIXING PARTS SLEWING RING
PLATE 2X220X100	97 92 102 08	36	1	2 310	91 52 503 08	WINCH 1
PLATE 2X220X100	97 92 276 08	36	1	2 320	91 52 504 08	WINCH 2
PLATE 2X227X73 X5CRNI18-10	97 76 743 08	7	2	2 533 066	96 48 365 08	ELECTRIC ADD-ON PARTS CA
PLATE 2X228X100	97 44 570 08	29	1	3 350	91 52 859 08	WINCH 3
PLATE 2X228X100	97 86 711 08	35	1	2 310	91 52 503 08	WINCH 1
PLATE 2X228X100	97 86 711 08	35	1	2 320	91 52 504 08	WINCH 2
PLATE 2X2400X356	97 86 100 08	12	2	3 291	91 52 831 08	S OVERRUN PROTECTION
PLATE 2X2444X554	97 70 793 08	23	1	2 859	91 52 809 08	SOUND INSULATION
PLATE 2X248X326	95 63 998 08	3	1	2 925 204	92 16 990 08	CAMERA EQUIPMENT D-PIVOT
PLATE 2X251X134	97 65 176 08	2	1	2 540	91 53 253 08	CLIMA-HEATING INSTALLATIO
PLATE 2X274X212 FE//ZN20//C	97 86 372 08	118	1	3 713	91 57 749 08	D PIVOT SECTION
PLATE 2X287X171	97 73 426 08	(5)	1	2 925 026	91 55 259 08	ERG. CAMERA CONTROL
PLATE 2X287X171	97 73 426 08	5	1	2 925 405	96 48 397 08	EQUIPMENT CAMERA CAB
PLATE 2X341X363	97 33 034 08	28	1	2 925 402	96 58 855 08	CAMERA EQUIPMENT SLEWI
PLATE 2X50X75	97 18 510 08	39	1	3 206	91 52 881 08	PIVOT SECTION
PLATE 2X517X477	97 68 331 08	20	1	2 520 034	96 45 984 08	INTERNAL LINING
PLATE 2X55X21 FE//ZN20//C	97 68 660 08	3	1	2 522 011	96 45 602 08	CLOSING DEVICE
PLATE 2X616X222	97 76 486 08	1	1	2 541 001	96 49 651 08	ADDNL.HEATING, PRE-ASSE
PLATE 2X648X321	97 81 124 08	40	1	2 859	91 52 809 08	SOUND INSULATION
PLATE 2X661X530	97 71 798 08	10	1	2 393 002	96 46 782 08	COVER COMPL.
PLATE 2X67X47	97 78 746 08	27	1	2 522 011	96 45 602 08	CLOSING DEVICE
PLATE 2X719X599	97 71 797 08	9	1	2 393 002	96 46 782 08	COVER COMPL.
PLATE 2X749X420	97 79 370 08	8	1	2 391	91 52 784 08	DIESEL ENGINE CPL.

6.2.2009

etk_en_de_074515 LR 1600/2

945

LIEBHERRAlphabetical index
Alphabetischer Index

Description	Item	Pos.	Quantity	Page	Assembly	Description
PLATE 2X75X75 FE//ZN20//C	97 80 257 08	53	2	2 810	91 52 806 08	CRANE DRIVER'S CABIN CPL.
PLATE 2X77X20	97 83 927 08	9	1	2 391 040	96 53 645 08	CLUTCH ACTUATOR
PLATE 2X784X924	97 75 669 08	1	1	2 510 059	96 49 184 08	DOOR COMPL.
PLATE 2X817X486	97 70 673 08	23	1	2 520	91 53 061 08	CABIN, GLAZED
PLATE 2X875X546	97 70 906 08	1	1	2 859 030	96 46 758 08	COVER COMPL.
PLATE 2X90X110	97 25 222 08	26	1	3 206	91 52 881 08	PIVOT SECTION
PLATE 2X95X95	97 88 785 08	33	10	3 215 005	91 52 846 08	ROLLER SET
PLATE 2X95X95	97 88 785 08	33	10	3 215 006	91 52 847 08	ROLLER SET
PLATE 2X98X32 SPF	97 66 066 08	26	1	2 932 160	96 54 385 08	SWITCH CABINET
PLATE 2X990X104	97 28 766 08	3	1	2 391 036	96 23 055 08	COVER/LID/CAP, PRE-ASSEMB
PLATE 30X150X100	97 69 697 08	6	4	1 630	91 52 387 08	HYDRAULIC SUPPORT
PLATE 30X180X290	95 44 783 08	24	2	1 400	91 56 853 08	CRAWLER TRACK CARRIER LE
PLATE 30X180X290	95 44 783 08	24	2	1 410 300	91 56 855 08	CRAWLER CARRIER RIGHT CP
PLATE 30X270X160	97 79 903 08	21	2	2 652	91 52 794 08	ROLLER BEARING
PLATE 30X310X119	97 73 409 08	5	4	2 125	91 52 773 08	PIN F.S-PIVOT SECTION SA F
PLATE 35X1689X254	97 68 530 08	1	2	2 550 010	96 45 685 08	ROD
PLATE 35X904X404	97 76 390 08	1	2	3 714 013	96 49 270 08	BRACKET COMPL.
PLATE 3X100X110	97 87 054 08	38	2	2 391 040	96 53 645 08	CLUTCH ACTUATOR
PLATE 3X100X90	97 85 358 08	79	1	2 391 001	96 45 719 08	DIESEL ENGINE, PRE-ASSEMB
PLATE 3X101X70	97 83 116 08	14	2	2 631	91 56 817 08	SLEWING PLATFORM CATWAL
PLATE 3X1040X55	97 86 362 08	79	1	3 714	91 52 862 08	D HEAD SECTION
PLATE 3X106X42	97 59 503 08	77	1	2 550	91 57 751 08	SA FRAME
PLATE 3X110X93	97 79 878 08	57	1	2 391 001	96 45 719 08	DIESEL ENGINE, PRE-ASSEMB
PLATE 3X1155X55	97 87 766 08	135	1	3 713	91 57 749 08	D PIVOT SECTION
PLATE 3X1200X170	97 87 757 08	116	3	3 713	91 57 749 08	D PIVOT SECTION
PLATE 3X121X79	97 71 098 08	13	2	2 260	91 53 057 08	CUP SPRING CLUSTER
PLATE 3X144X80	97 07 719 08	72	1	2 391 001	96 45 719 08	DIESEL ENGINE, PRE-ASSEMB
PLATE 3X150X40	97 55 008 08	27	1	2 310	91 52 503 08	WINCH 1
PLATE 3X150X40	97 55 008 08	27	1	2 320	91 52 504 08	WINCH 2
PLATE 3X150X40	97 55 008 08	34	2	2 340	91 52 776 08	WINCH 4 LUFFING GEAR
PLATE 3X150X40	97 55 008 08	38	1	3 350	91 52 859 08	WINCH 3
PLATE 3X151X136	97 69 588 08	4	1	2 520 032	96 45 980 08	WINDSHIELD WASHER INSTAL
PLATE 3X157X156	95 70 054 08	2	1	3 780 200	96 54 370 08	ELECTRIC WIND WARNING T
PLATE 3X159X113	97 75 000 08	33	2	2 391 001	96 45 719 08	DIESEL ENGINE, PRE-ASSEMB
PLATE 3X1779X219	97 70 795 08	25	1	2 859	91 52 809 08	SOUND INSULATION
PLATE 3X190X60	97 15 627 08	105	2	3 211	91 57 748 08	S PIVOT SECTION
PLATE 3X192X187	97 23 319 08	7	1	2 260 006	96 46 501 08	BATTERY BOX, PRE-ASSEMB
PLATE 3X196X184	97 70 794 08	24	2	2 859	91 52 809 08	SOUND INSULATION
PLATE 3X200X150	97 02 854 08	11	1	2 780 324	91 56 389 08	ACOUST. WARN. DISPLACEM.
PLATE 3X200X150	97 02 854 08	(3)	1	2 920	91 56 833 08	ELECTR. SYSTEM F.SLEWING
PLATE 3X207X105	97 78 727 08	49	2	2 391 001	96 45 719 08	DIESEL ENGINE, PRE-ASSEMB
PLATE 3X2120X55	97 86 361 08	78	2	3 714	91 52 862 08	D HEAD SECTION
PLATE 3X212X34	97 79 305 08	8	1	2 550 008	96 47 628 08	RETAINER CPL.
PLATE 3X212X34	97 79 305 08	8	1	2 550 009	96 47 645 08	RETAINER CPL.
PLATE 3X220X176	97 93 905 08	27	1	3 281	91 52 896 08	ERECTION FRAME
PLATE 3X224X121 FE//ZN20//C	97 81 184 08	45	4	3 214	91 52 843 08	SW HEAD SECTION
PLATE 3X2260X511	97 32 004 08	77	2	3 211	91 57 748 08	S PIVOT SECTION
PLATE 3X2285X55 DC01	97 87 762 08	131	1	3 713	91 57 749 08	D PIVOT SECTION
PLATE 3X235X155	97 71 100 08	15	1	2 260	91 53 057 08	CUP SPRING CLUSTER
PLATE 3X26X26	97 19 742 08	22	2	2 502	91 55 939 08	CONTROL STAND
PLATE 3X270X308	97 79 627 08	12	1	2 780 915	96 48 377 08	ADD-ON PARTS EXTERNAL F
PLATE 3X280X154	97 15 521 08	49	1	2 550	91 57 751 08	SA FRAME
PLATE 3X280X170	97 72 246 08	22	1	2 520 034	96 45 984 08	INTERNAL LINING
PLATE 3X280X80	97 81 823 08	101	2	3 211	91 57 748 08	S PIVOT SECTION
PLATE 3X283X216	97 71 705 08	49	1	3 208 001	91 52 883 08	F-HEAD SECTION
PLATE 3X287X452 FE//ZN20//C	97 83 458 08	5	1	2 657	91 57 656 08	MOUNTING EQUIPMENT CRAW
PLATE 3X2895X55 DC01	97 87 763 08	132	1	3 713	91 57 749 08	D PIVOT SECTION
PLATE 3X3000X55 DC01	97 87 760 08	130	2	3 713	91 57 749 08	D PIVOT SECTION
PLATE 3X330X95	97 83 924 08	6	1	2 391 040	96 53 645 08	CLUTCH ACTUATOR
PLATE 3X353X300	97 44 917 08	(1)	1	3 780 258	96 56 482 08	ELECTRIC AIRCRAFT PROTE

6.2.2009

etk_en_de_074515 LR 1600/2

946

LIEBHERRAlphabetical index
Alphabetischer Index

Description	Item	Pos.	Quantity	Page	Assembly	Description
PLATE 3X366X104	97 74 440 08	15	1	2 502	91 55 939 08	CONTROL STAND
PLATE 3X366X104	97 74 441 08	16	1	2 502	91 55 939 08	CONTROL STAND
PLATE 3X380X225	97 73 394 08	7	2	2 391 001	96 45 719 08	DIESEL ENGINE, PRE-ASSEMB
PLATE 3X390X380	97 75 707 08	15	1	2 392	91 52 785 08	MUFFLER UNIT
PLATE 3X404X241	97 82 080 08	19	1	2 925 402	96 58 855 08	CAMERA EQUIPMENT SLEWI
PLATE 3X404X241	97 82 081 08	20	1	2 925 402	96 58 855 08	CAMERA EQUIPMENT SLEWI
PLATE 3X40X40 ST12.03	97 19 741 08	21	4	2 502	91 55 939 08	CONTROL STAND
PLATE 3X40X95	97 86 364 08	81	2	3 714	91 52 862 08	D HEAD SECTION
PLATE 3X437X272	97 71 099 08	14	1	2 260	91 53 057 08	CUP SPRING CLUSTER
PLATE 3X450X252	97 80 168 08	59	1	2 391 001	96 45 719 08	DIESEL ENGINE, PRE-ASSEMB
PLATE 3X45X120	95 37 609 08	4	1	2 310	91 52 503 08	WINCH 1
PLATE 3X45X120	95 37 609 08	4	1	2 320	91 52 504 08	WINCH 2
PLATE 3X45X120	95 37 609 08	82	1	3 714	91 52 862 08	D HEAD SECTION
PLATE 3X46X20 FE//ZN20//F	97 83 624 08	51	1	2 502	91 55 939 08	CONTROL STAND
PLATE 3X489X273	97 85 704 08	1	1	2 631 003	96 54 406 08	ACCESS LADDER PRE-ASS.
PLATE 3X60X70	97 80 640 08	59	1	2 810	91 52 806 08	CRANE DRIVER'S CABIN CPL.
PLATE 3X70X101	97 82 921 08	29	2	3 215 005	91 52 846 08	ROLLER SET
PLATE 3X70X101	97 82 921 08	29	2	3 215 006	91 52 847 08	ROLLER SET
PLATE 3X70X45	97 73 355 08	30	1	2 711	91 52 800 08	CENT. LUBRIC. SYSTEM SUP
PLATE 3X718X278	97 74 257 08	17	1	2 393	91 52 787 08	AIR FILTER UNIT CPL.
PLATE 3X770X55	97 87 764 08	133	1	3 713	91 57 749 08	D PIVOT SECTION
PLATE 3X80X1392	97 95 151 08	86	1	2 520	91 53 061 08	CABIN, GLAZED
PLATE 3X853X80	97 73 500 08	4	1	2 932 160	96 54 385 08	SWITCH CABINET
PLATE 3X85X210 FE//ZN20//C	97 67 363 08	150	1	2 970	91 56 537 08	HYDR
PLATE 3X85X210 FE//ZN20//C	97 67 363 08	39	1	3 350	91 52 859 08	WINCH 3
PLATE 3X880X55	97 86 363 08	80	2	3 714	91 52 862 08	D HEAD SECTION
PLATE 3X892X382	97 71 793 08	1	1	2 810 037	96 47 204 08	PEDAL CANTILEVER INSTALL
PLATE 3X90X103	97 85 357 08	78	1	2 391 001	96 45 719 08	DIESEL ENGINE, PRE-ASSEMB
PLATE 3X915X55	97 87 765 08	134	1	3 713	91 57 749 08	D PIVOT SECTION
PLATE 3X95X70	97 83 115 08	13	2	2 631	91 56 817 08	SLEWING PLATFORM CATWAL
PLATE 3x48x75	97 04 309 08	8	2	1 920 307	96 48 383 08	ELECTR.FOR CENTER SECTIO
PLATE 40X200X180	95 27 424 08	3	4	2 730	91 52 802 08	BASE PLATE SLEWING PLATF
PLATE 4X1001X183	97 70 810 08	33	1	2 859	91 52 809 08	SOUND INSULATION
PLATE 4X100X145	97 73 425 08	19	1	2 391 001	96 45 719 08	DIESEL ENGINE, PRE-ASSEMB
PLATE 4X1010X384	97 73 398 08	12	1	2 391 001	96 45 719 08	DIESEL ENGINE, PRE-ASSEMB
PLATE 4X103X20 S235JRG2	95 28 598 08	66	3	2 391 001	96 45 719 08	DIESEL ENGINE, PRE-ASSEMB
PLATE 4X1087X134	97 73 423 08	17	1	2 391 001	96 45 719 08	DIESEL ENGINE, PRE-ASSEMB
PLATE 4X1087X134	97 73 424 08	18	1	2 391 001	96 45 719 08	DIESEL ENGINE, PRE-ASSEMB
PLATE 4X110X80	97 03 502 08	79	2	2 550	91 57 751 08	SA FRAME
PLATE 4X110X80	97 03 502 08	25	2	2 711	91 52 800 08	CENT. LUBRIC. SYSTEM SUP
PLATE 4X110X89	97 66 574 08	28	1	2 391 001	96 45 719 08	DIESEL ENGINE, PRE-ASSEMB
PLATE 4X115X98	97 12 764 08	62	1	2 810	91 52 806 08	CRANE DRIVER'S CABIN CPL.
PLATE 4X1177X360	97 74 258 08	18	1	2 393	91 52 787 08	AIR FILTER UNIT CPL.
PLATE 4X119X70	97 86 827 08	55	1	2 631	91 56 817 08	SLEWING PLATFORM CATWAL
PLATE 4X120X187	97 69 564 08	3	1	2 670	91 52 797 08	FUEL TANK CPL.
PLATE 4X1320X547	97 69 693 08	36	1	1 400	91 56 853 08	CRAWLER TRACK CARRIER LE
PLATE 4X1322X547	97 69 494 08	36	1	1 410 300	91 56 855 08	CRAWLER CARRIER RIGHT CP
PLATE 4X1322X633	97 69 491 08	33	1	1 410 300	91 56 855 08	CRAWLER CARRIER RIGHT CP
PLATE 4X1322X633	97 69 692 08	33	1	1 400	91 56 853 08	CRAWLER TRACK CARRIER LE
PLATE 4X133X225	97 83 114 08	12	2	2 631	91 56 817 08	SLEWING PLATFORM CATWAL
PLATE 4X1390X487	97 52 147 08	4	1	2 260	91 53 057 08	CUP SPRING CLUSTER
PLATE 4X1400X207	97 80 937 08	85	1	3 211	91 57 748 08	S PIVOT SECTION
PLATE 4X140X30	97 79 264 08	25	4	2 340	91 52 776 08	WINCH 4 LUFFING GEAR
PLATE 4X140X30	97 80 169 08	63	1	2 391 001	96 45 719 08	DIESEL ENGINE, PRE-ASSEMB
PLATE 4X1445X192	97 71 636 08	68	1	3 211	91 57 748 08	S PIVOT SECTION
PLATE 4X148X85	97 83 926 08	8	1	2 391 040	96 53 645 08	CLUTCH ACTUATOR
PLATE 4X1540X297	97 71 157 08	40	4	3 211	91 57 748 08	S PIVOT SECTION
PLATE 4X155X134	97 70 790 08	14	1	2 859	91 52 809 08	SOUND INSULATION
PLATE 4X156X220	97 12 903 08	151	1	2 970	91 56 537 08	HYDR
PLATE 4X165X225	95 57 495 08	20	1	1 920 308	96 48 384 08	ELECTR.CRAWLER SUPPORT

6.2.2009

etk_en_de_074515 LR 1600/2

947

LIEBHERRAlphabetical index
Alphabetischer Index

Description	Item	Pos.	Quantity	Page	Assembly	Description
PLATE 4X165X225	95 57 495 08	20	1	1 920 309	96 48 385 08	ELECTR.CRAWLER SUPPORT
PLATE 4X165X225	95 57 495 08	23	1	3 745	91 52 948 08	SUSPENDED BALLAST
PLATE 4X167X25	97 78 521 08	39	8	3 745	91 52 948 08	SUSPENDED BALLAST
PLATE 4X170X157	95 70 439 08	24	1	2 711	91 52 800 08	CENT. LUBRIC. SYSTEM SUP
PLATE 4X173X102	97 85 767 08	46	1	2 631	91 56 817 08	SLEWING PLATFORM CATWAL
PLATE 4X174X191 FE//ZN20//C	97 83 085 08	10	5	2 631	91 56 817 08	SLEWING PLATFORM CATWAL
PLATE 4X174X72	97 02 120 08	4	1	2 260 006	96 46 501 08	BATTERY BOX, PRE-ASSEMB
PLATE 4X174X74	97 02 119 08	3	2	2 260 006	96 46 501 08	BATTERY BOX, PRE-ASSEMB
PLATE 4X178X30	97 85 175 08	77	2	2 391 001	96 45 719 08	DIESEL ENGINE, PRE-ASSEMB
PLATE 4X178X358	97 69 565 08	4	1	2 670	91 52 797 08	FUEL TANK CPL.
PLATE 4X189X430	97 80 256 08	64	1	2 391 001	96 45 719 08	DIESEL ENGINE, PRE-ASSEMB
PLATE 4X190X140	97 80 625 08	73	4	2 550	91 57 751 08	SA FRAME
PLATE 4X194X101	97 74 259 08	19	1	2 393	91 52 787 08	AIR FILTER UNIT CPL.
PLATE 4X205X450 FE//ZN20//C	97 88 000 08	38	6	3 715 008	91 52 863 08	D INTERMEDIATE SECTION
PLATE 4X205X450 FE//ZN20//C	97 88 000 08	41	12	3 716	91 52 864 08	D INTERMEDIATE SECTION
PLATE 4X209X189 FE//ZN20//C	97 83 084 08	9	2	2 631	91 56 817 08	SLEWING PLATFORM CATWAL
PLATE 4X209X275 FE//ZN20//C	97 78 526 08	9	4	3 227	91 52 873 08	L INTERMEDIATE SECTION
PLATE 4X20X500	95 37 411 08	91	1	3 211	91 57 748 08	S PIVOT SECTION
PLATE 4X20X500	95 37 411 08	119	1	3 713	91 57 749 08	D PIVOT SECTION
PLATE 4X20X500	95 37 411 08	91	1	3 714	91 52 862 08	D HEAD SECTION
PLATE 4X20X500	95 37 411 08	46	1	3 715 008	91 52 863 08	D INTERMEDIATE SECTION
PLATE 4X20X500	95 37 411 08	36	1	3 716	91 52 864 08	D INTERMEDIATE SECTION
PLATE 4X215X167	97 79 246 08	20	4	1 630	91 52 387 08	HYDRAULIC SUPPORT
PLATE 4X219X1068	97 73 397 08	11	1	2 391 001	96 45 719 08	DIESEL ENGINE, PRE-ASSEMB
PLATE 4X227X202	97 73 532 08	20	1	2 391 001	96 45 719 08	DIESEL ENGINE, PRE-ASSEMB
PLATE 4X2346X144	97 70 786 08	13	1	2 859	91 52 809 08	SOUND INSULATION
PLATE 4X243X155	97 72 220 08	14	1	2 671	91 52 798 08	OIL RESERVOIR, COMPLETE
PLATE 4X254X126	97 70 506 08	6	2	2 260	91 53 057 08	CUP SPRING CLUSTER
PLATE 4X256X130	97 80 349 08	25	1	2 310	91 52 503 08	WINCH 1
PLATE 4X256X130	97 80 349 08	25	1	2 320	91 52 504 08	WINCH 2
PLATE 4X2600X53	97 86 531 08	88	2	3 211	91 57 748 08	S PIVOT SECTION
PLATE 4X260X93	97 46 733 08	36	2	3 211	91 57 748 08	S PIVOT SECTION
PLATE 4X260X93	97 46 733 08	71	2	3 713	91 57 749 08	D PIVOT SECTION
PLATE 4X260X98	97 79 826 08	53	1	2 391 001	96 45 719 08	DIESEL ENGINE, PRE-ASSEMB
PLATE 4X2744X273	97 81 551 08	87	1	3 211	91 57 748 08	S PIVOT SECTION
PLATE 4X274X50	97 78 522 08	40	4	3 745	91 52 948 08	SUSPENDED BALLAST
PLATE 4X2834X53	97 81 550 08	86	2	3 211	91 57 748 08	S PIVOT SECTION
PLATE 4X283X127	97 85 781 08	11	2	2 370	91 52 782 08	ERECTING WINCH
PLATE 4X283X50	97 78 520 08	38	4	3 745	91 52 948 08	SUSPENDED BALLAST
PLATE 4X290X130	97 79 331 08	29	1	2 340	91 52 776 08	WINCH 4 LUFFING GEAR
PLATE 4X290X130	97 79 332 08	30	1	2 340	91 52 776 08	WINCH 4 LUFFING GEAR
PLATE 4X293X96	97 73 929 08	2	1	2 522 012	96 45 884 08	GUIDE PRE-ASS.
PLATE 4X30X105	95 36 969 08	48	1	2 550	91 57 751 08	SA FRAME
PLATE 4X30X105	95 36 969 08	28	2	2 711	91 52 800 08	CENT. LUBRIC. SYSTEM SUP
PLATE 4X310X120	97 57 099 08	92	1	3 714	91 52 862 08	D HEAD SECTION
PLATE 4X310X120	97 57 099 08	45	1	3 715 008	91 52 863 08	D INTERMEDIATE SECTION
PLATE 4X310X120	97 57 099 08	43	1	3 716	91 52 864 08	D INTERMEDIATE SECTION
PLATE 4X330X110	97 87 754 08	113	1	3 713	91 57 749 08	D PIVOT SECTION
PLATE 4X335X109	97 81 060 08	67	1	2 391 001	96 45 719 08	DIESEL ENGINE, PRE-ASSEMB
PLATE 4X351X333	97 93 744 08	27	1	2 925 402	96 58 855 08	CAMERA EQUIPMENT SLEWI
PLATE 4X352X345	97 25 209 08	22	1	3 206	91 52 881 08	PIVOT SECTION
PLATE 4X358X405	97 14 450 08	26	1	1 400	91 56 853 08	CRAWLER TRACK CARRIER LE
PLATE 4X358X405	97 14 596 08	26	1	1 410 300	91 56 855 08	CRAWLER CARRIER RIGHT CP
PLATE 4X369X224	97 10 255 08	2	4	1 620	91 52 386 08	FIXING PARTS SLEWING RING
PLATE 4X369X509	97 17 777 08	27	1	1 400	91 56 853 08	CRAWLER TRACK CARRIER LE
PLATE 4X369X509	97 17 950 08	27	1	1 410 300	91 56 855 08	CRAWLER CARRIER RIGHT CP
PLATE 4X382X120	97 80 593 08	18	1	2 925 402	96 58 855 08	CAMERA EQUIPMENT SLEWI
PLATE 4X389X287	97 69 492 08	34	1	1 400	91 56 853 08	CRAWLER TRACK CARRIER LE
PLATE 4X389X287	97 69 492 08	34	1	1 410 300	91 56 855 08	CRAWLER CARRIER RIGHT CP
PLATE 4X389X287	97 69 495 08	37	1	1 400	91 56 853 08	CRAWLER TRACK CARRIER LE

6.2.2009

etk_en_de_074515 LR 1600/2

948

LIEBHERRAlphabetical index
Alphabetischer Index

Description	Item	Pos.	Quantity	Page	Assembly	Description
PLATE 4X389X287	97 69 495 08	37	1	1 410 300	91 56 855 08	CRAWLER CARRIER RIGHT CP
PLATE 4X405X527	97 90 053 08	117	1	3 713	91 57 749 08	D PIVOT SECTION
PLATE 4X40X105	95 58 096 08	37	2	3 350	91 52 859 08	WINCH 3
PLATE 4X40X35	97 61 821 08	69	4	2 391 001	96 45 719 08	DIESEL ENGINE, PRE-ASSEMB
PLATE 4X40X78	97 70 797 08	27	2	2 859	91 52 809 08	SOUND INSULATION
PLATE 4X419X242 S315MC	97 75 410 08	65	1	1 400	91 56 853 08	CRAWLER TRACK CARRIER LE
PLATE 4X419X242 S315MC	97 75 411 08	65	1	1 410 300	91 56 855 08	CRAWLER CARRIER RIGHT CP
PLATE 4X450X100	97 57 447 08	103	3	3 211	91 57 748 08	S PIVOT SECTION
PLATE 4X453X40	97 79 216 08	29	2	2 711	91 52 800 08	CENT. LUBRIC. SYSTEM SUP
PLATE 4X470X271	97 79 824 08	52	1	2 391 001	96 45 719 08	DIESEL ENGINE, PRE-ASSEMB
PLATE 4X480X230	97 87 755 08	114	1	3 713	91 57 749 08	D PIVOT SECTION
PLATE 4X487X120	97 81 896 08	102	2	3 211	91 57 748 08	S PIVOT SECTION
PLATE 4X492X101	97 70 792 08	15	1	2 859	91 52 809 08	SOUND INSULATION
PLATE 4X492X116	97 79 887 08	37	2	2 340	91 52 776 08	WINCH 4 LUFFING GEAR
PLATE 4X498X192	97 74 929 08	32	1	2 391 001	96 45 719 08	DIESEL ENGINE, PRE-ASSEMB
PLATE 4X505X168	97 49 296 08	40	2	3 214	91 52 843 08	SW HEAD SECTION
PLATE 4X50X95	95 05 282 08	7	1	1 970	91 56 958 08	CRAWLER TRACK HYDRAULI
PLATE 4X529X368	97 85 691 08	63	1	2 810	91 52 806 08	CRANE DRIVER'S CABIN CPL.
PLATE 4X555X617	97 84 521 08	75	1	2 391	91 52 784 08	DIESEL ENGINE CPL.
PLATE 4X581X113	97 80 936 08	84	1	3 211	91 57 748 08	S PIVOT SECTION
PLATE 4X581X113	97 86 533 08	104	1	3 211	91 57 748 08	S PIVOT SECTION
PLATE 4X60X103	95 51 525 08	35	1	2 340	91 52 776 08	WINCH 4 LUFFING GEAR
PLATE 4X60X103	95 51 525 08	15	1	2 978 200	91 54 843 08	ADD.HYDR.S_RETAINING RAM
PLATE 4X60X103	95 51 525 08	35	1	3 350	91 52 859 08	WINCH 3
PLATE 4X60X103	97 15 061 08	6	1	2 310	91 52 503 08	WINCH 1
PLATE 4X60X103	97 15 061 08	6	1	2 320	91 52 504 08	WINCH 2
PLATE 4X60X224	97 81 069 08	75	2	2 550	91 57 751 08	SA FRAME
PLATE 4X611X119	97 70 505 08	5	2	2 260	91 53 057 08	CUP SPRING CLUSTER
PLATE 4X611X322	97 73 245 08	4	2	2 391 038	96 47 931 08	OIL COOLER, PRE-ASSEMBLE
PLATE 4X618X343	97 73 396 08	10	1	2 391 001	96 45 719 08	DIESEL ENGINE, PRE-ASSEMB
PLATE 4X650X443	97 15 345 08	32	1	3 214	91 52 843 08	SW HEAD SECTION
PLATE 4X650X479	97 74 253 08	16	1	2 393	91 52 787 08	AIR FILTER UNIT CPL.
PLATE 4X653X578	97 89 189 08	3	1	2 391 102	96 56 360 08	RADIATOR
PLATE 4X667X220	97 79 664 08	70	2	3 714	91 52 862 08	D HEAD SECTION
PLATE 4X680X383	97 15 435 08	9	1	1 920 307	96 48 383 08	ELECTR.FOR CENTER SECTIO
PLATE 4X711X637	97 89 190 08	4	1	2 391 102	96 56 360 08	RADIATOR
PLATE 4X747X370	97 79 663 08	69	2	3 714	91 52 862 08	D HEAD SECTION
PLATE 4X800X100	97 55 895 08	89	4	3 211	91 57 748 08	S PIVOT SECTION
PLATE 4X842X428	97 89 191 08	5	1	2 391 102	96 56 360 08	RADIATOR
PLATE 4X85X60	97 85 873 08	13	1	2 370	91 52 782 08	ERECTING WINCH
PLATE 4X86X60	97 85 872 08	12	1	2 370	91 52 782 08	ERECTING WINCH
PLATE 4X883X130	97 85 718 08	16	2	2 350	91 52 778 08	SLEWING GEAR
PLATE 4X900X225	97 87 756 08	1	1	3 713 013	96 57 159 08	SHEET CPL.
PLATE 4X90X12	94 99 977 08	9	4	2 932 160	96 54 385 08	SWITCH CABINET
PLATE 4X97X65	97 85 875 08	15	1	2 370	91 52 782 08	ERECTING WINCH
PLATE 4X97X77	97 85 874 08	14	1	2 370	91 52 782 08	ERECTING WINCH
PLATE 4X98X115	97 79 296 08	26	1	2 340	91 52 776 08	WINCH 4 LUFFING GEAR
PLATE 4x103x60	97 01 621 08	58	1	2 975 100	91 52 860 08	ADDITIONAL HYDRAULICS WI
PLATE 4x63x90 S235JRG2	95 41 137 08	6	2	2 510	91 52 788 08	TURNTABLE PANELLING
PLATE 4x73x30 S235JRG2	97 03 501 08	28	1	2 310	91 52 503 08	WINCH 1
PLATE 4x73x30 S235JRG2	97 03 501 08	28	1	2 320	91 52 504 08	WINCH 2
PLATE 4x73x30 S235JRG2	97 03 501 08	27	5	2 711	91 52 800 08	CENT. LUBRIC. SYSTEM SUP
PLATE 5X100X125	95 47 547 08	23	2	3 713	91 57 749 08	D PIVOT SECTION
PLATE 5X100X270	95 66 430 08	79	4	3 211	91 57 748 08	S PIVOT SECTION
PLATE 5X104X140	95 50 518 08	7	2	3 211	91 57 748 08	S PIVOT SECTION
PLATE 5X104X140	95 50 518 08	11	2	3 213	91 52 842 08	F-CONNECTING HEAD
PLATE 5X104X140	95 50 518 08	27	2	3 214	91 52 843 08	SW HEAD SECTION
PLATE 5X104X140	95 50 518 08	5	4	3 220 500	91 52 849 08	S INTERMEDIATE SECTION
PLATE 5X104X140	95 50 518 08	5	4	3 221	91 54 668 08	S INTERMEDIATE SECTION
PLATE 5X104X140	95 50 518 08	5	4	3 223	91 52 852 08	S INTERMEDIATE SECTION

6.2.2009

etk_en_de_074515 LR 1600/2

949

LIEBHERRAlphabetical index
Alphabetischer Index

Description	Item	Pos.	Quantity	Page	Assembly	Description
PLATE 5X104X140	95 50 518 08	5	4	3 223 010	91 52 853 08	S INTERMEDIATE SECTION
PLATE 5X104X140	95 50 518 08	5	4	3 223 100	91 55 327 08	S INTERMEDIATE SECTION
PLATE 5X104X140	95 50 518 08	24	4	3 225	91 52 854 08	SL REDUCING SECTION
PLATE 5X104X140	95 50 518 08	5	4	3 226	91 52 870 08	L INTERMEDIATE SECTION
PLATE 5X104X140	95 50 518 08	5	4	3 227	91 52 873 08	L INTERMEDIATE SECTION
PLATE 5X104X140	95 50 518 08	5	4	3 227 008	91 52 872 08	L INTERMEDIATE SECTION
PLATE 5X104X140	95 50 518 08	5	4	3 227 200	91 53 519 08	LI INTERMEDIATE SECT. F-GU
PLATE 5X104X140	95 50 518 08	26	2	3 714	91 52 862 08	D HEAD SECTION
PLATE 5X104X140	95 50 518 08	21	2	3 715 008	91 52 863 08	D INTERMEDIATE SECTION
PLATE 5X104X140	95 50 518 08	21	2	3 716	91 52 864 08	D INTERMEDIATE SECTION
PLATE 5X110X20	97 68 611 08	6	4	2 522	91 54 115 08	SLIDING DOOR CPL.
PLATE 5X1183X338	97 73 421 08	15	1	2 391 001	96 45 719 08	DIESEL ENGINE, PRE-ASSEMB
PLATE 5X120X30	97 62 431 08	21	2	3 215 005	91 52 846 08	ROLLER SET
PLATE 5X120X30	97 62 431 08	21	2	3 215 006	91 52 847 08	ROLLER SET
PLATE 5X130X125 FE//ZN20//C	97 75 887 08	5	2	3 714 008	96 49 266 08	LUFFING PULLEY BLOCK COM
PLATE 5X140X180	97 17 862 08	35	4	3 281	91 52 896 08	ERECTION FRAME
PLATE 5X150X101	97 74 928 08	33	2	3 715 008	91 52 863 08	D INTERMEDIATE SECTION
PLATE 5X150X101	97 74 928 08	31	2	3 716	91 52 864 08	D INTERMEDIATE SECTION
PLATE 5X1762X282	97 73 395 08	9	1	2 391 001	96 45 719 08	DIESEL ENGINE, PRE-ASSEMB
PLATE 5X1799X963	97 73 392 08	5	1	2 391 001	96 45 719 08	DIESEL ENGINE, PRE-ASSEMB
PLATE 5X208X162	97 33 032 08	(1)	1	2 925 402	96 58 855 08	CAMERA EQUIPMENT SLEWI
PLATE 5X263X60	97 79 283 08	60	1	3 713	91 57 749 08	D PIVOT SECTION
PLATE 5X263X60	97 79 283 08	44	8	3 714	91 52 862 08	D HEAD SECTION
PLATE 5X2668X259	97 69 490 08	32	1	1 400	91 56 853 08	CRAWLER TRACK CARRIER LE
PLATE 5X2668X259	97 69 490 08	32	1	1 410 300	91 56 855 08	CRAWLER CARRIER RIGHT CP
PLATE 5X3017X259	97 69 487 08	29	1	1 400	91 56 853 08	CRAWLER TRACK CARRIER LE
PLATE 5X3017X259	97 69 487 08	29	1	1 410 300	91 56 855 08	CRAWLER CARRIER RIGHT CP
PLATE 5X3017X259	97 69 488 08	30	1	1 400	91 56 853 08	CRAWLER TRACK CARRIER LE
PLATE 5X3017X259	97 69 488 08	30	1	1 410 300	91 56 855 08	CRAWLER CARRIER RIGHT CP
PLATE 5X311X106	97 83 634 08	74	12	1 400	91 56 853 08	CRAWLER TRACK CARRIER LE
PLATE 5X311X106	97 83 634 08	74	12	1 410 300	91 56 855 08	CRAWLER CARRIER RIGHT CP
PLATE 5X330X429	97 89 198 08	19	2	3 714 009	96 49 267 08	LUFFING PULLEY BLOCK COM
PLATE 5X393X60 S380MC	95 64 428 08	31	2	3 220 500	91 52 849 08	S INTERMEDIATE SECTION
PLATE 5X393X60 S380MC	95 64 428 08	31	4	3 223	91 52 852 08	S INTERMEDIATE SECTION
PLATE 5X393X60 S380MC	95 64 428 08	31	4	3 223 100	91 55 327 08	S INTERMEDIATE SECTION
PLATE 5X393X60 S380MC	95 64 428 08	30	2	3 225	91 52 854 08	SL REDUCING SECTION
PLATE 5X393X60 S380MC	95 64 428 08	31	2	3 226	91 52 870 08	L INTERMEDIATE SECTION
PLATE 5X393X60 S380MC	95 64 428 08	31	4	3 227	91 52 873 08	L INTERMEDIATE SECTION
PLATE 5X393X60 S380MC	95 64 428 08	31	4	3 227 008	91 52 872 08	L INTERMEDIATE SECTION
PLATE 5X393X60 S380MC	95 64 428 08	31	4	3 227 200	91 53 519 08	LI INTERMEDIATE SECT. F-GU
PLATE 5X393X60 S380MC	95 64 428 08	53	2	3 714	91 52 862 08	D HEAD SECTION
PLATE 5X393X60 S380MC	95 64 428 08	23	4	3 715 008	91 52 863 08	D INTERMEDIATE SECTION
PLATE 5X393X60 S380MC	95 64 428 08	23	6	3 716	91 52 864 08	D INTERMEDIATE SECTION
PLATE 5X410X41	97 78 350 08	34	2	2 260	91 53 057 08	CUP SPRING CLUSTER
PLATE 5X512X62	97 69 489 08	31	4	1 400	91 56 853 08	CRAWLER TRACK CARRIER LE
PLATE 5X512X62	97 69 489 08	31	4	1 410 300	91 56 855 08	CRAWLER CARRIER RIGHT CP
PLATE 5X60X388 FE//ZN20//C	97 75 617 08	31	4	3 223 010	91 52 853 08	S INTERMEDIATE SECTION
PLATE 5X691X300	97 74 820 08	4	5	3 215 005	91 52 846 08	ROLLER SET
PLATE 5X691X300	97 74 820 08	4	7	3 215 006	91 52 847 08	ROLLER SET
PLATE 5X82X50	97 71 697 08	48	1	3 208 001	91 52 883 08	F-HEAD SECTION
PLATE 5X878X523	97 70 815 08	1	1	2 393 002	96 46 782 08	COVER COMPL.
PLATE 5X90X57	97 76 596 08	66	6	1 400	91 56 853 08	CRAWLER TRACK CARRIER LE
PLATE 5X90X57	97 76 596 08	66	6	1 410 300	91 56 855 08	CRAWLER CARRIER RIGHT CP
PLATE 5X95X95	97 74 824 08	5	10	3 215 005	91 52 846 08	ROLLER SET
PLATE 5X95X95	97 74 824 08	5	10	3 215 006	91 52 847 08	ROLLER SET
PLATE 5X98X140	95 60 933 08	22	1	2 975 000	91 57 881 08	ADDNL. HYDR. F. ERECTING W
PLATE 6X128X166	95 51 017 08	171	2	2 970	91 56 537 08	HYDR
PLATE 6X90X123	95 40 177 08	172	2	2 970	91 56 537 08	HYDR
PLATE 6X90X22	97 18 723 08	6	1	3 206	91 52 881 08	PIVOT SECTION
PLATE 80X1380X475	97 76 224 08	3	2	3 714 009	96 49 267 08	LUFFING PULLEY BLOCK COM

6.2.2009

etk_en_de_074515 LR 1600/2

950

LIEBHERRAlphabetical index
Alphabetischer Index

Description	Item	Pos.	Quantity	Page	Assembly	Description
PLATE 8X115X115 FE//ZN20//C	97 93 903 08	22	2	3 281	91 52 896 08	ERECTION FRAME
PLATE 8X125X515	97 83 925 08	7	1	2 391 040	96 53 645 08	CLUTCH ACTUATOR
PLATE 8X25X160	95 32 809 08	67	2	2 859	91 52 809 08	SOUND INSULATION
PLATE 8X280X280 FE//ZN20//C	97 75 886 08	4	2	3 714 008	96 49 266 08	LUFFING PULLEY BLOCK COM
PLATE 8X280X280 FE//ZN20//C	97 75 886 08	6	2	3 714 009	96 49 267 08	LUFFING PULLEY BLOCK COM
PLATE 8X300X50	95 54 048 08	76	2	3 211	91 57 748 08	S PIVOT SECTION
PLATE 8X300X50	95 54 048 08	32	4	3 220 500	91 52 849 08	S INTERMEDIATE SECTION
PLATE 8X300X50	95 54 048 08	17	2	3 221	91 54 668 08	S INTERMEDIATE SECTION
PLATE 8X300X50	95 54 048 08	32	5	3 223	91 52 852 08	S INTERMEDIATE SECTION
PLATE 8X300X50	95 54 048 08	32	5	3 223 010	91 52 853 08	S INTERMEDIATE SECTION
PLATE 8X300X50	95 54 048 08	32	5	3 223 100	91 55 327 08	S INTERMEDIATE SECTION
PLATE 8X300X50	95 54 048 08	40	2	3 225	91 52 854 08	SL REDUCING SECTION
PLATE 8X300X50	95 54 048 08	32	4	3 226	91 52 870 08	L INTERMEDIATE SECTION
PLATE 8X300X50	95 54 048 08	32	5	3 227	91 52 873 08	L INTERMEDIATE SECTION
PLATE 8X300X50	95 54 048 08	32	5	3 227 008	91 52 872 08	L INTERMEDIATE SECTION
PLATE 8X300X50	95 54 048 08	32	8	3 227 200	91 53 519 08	LI INTERMEDIATE SECT. F-GU
PLATE 8X300X50	95 54 048 08	21	3	3 713	91 57 749 08	D PIVOT SECTION
PLATE 8X300X50	95 54 048 08	54	2	3 714	91 52 862 08	D HEAD SECTION
PLATE 8X300X50	95 54 048 08	22	4	3 715 008	91 52 863 08	D INTERMEDIATE SECTION
PLATE 8X300X50	95 54 048 08	22	8	3 716	91 52 864 08	D INTERMEDIATE SECTION
PLATE 8X369X382	97 85 716 08	14	1	2 350	91 52 778 08	SLEWING GEAR
PLATE 8X369X382	97 85 717 08	15	1	2 350	91 52 778 08	SLEWING GEAR
PLATE 8X407X110 T ZN O	97 74 758 08	52	4	3 713	91 57 749 08	D PIVOT SECTION
PLATE 8X407X110 T ZN O	97 74 758 08	30	4	3 715 008	91 52 863 08	D INTERMEDIATE SECTION
PLATE 8X407X110 T ZN O	97 74 758 08	28	6	3 716	91 52 864 08	D INTERMEDIATE SECTION
PLATE 8X40X246	97 73 817 08	27	4	3 226	91 52 870 08	L INTERMEDIATE SECTION
PLATE 8X40X246	97 73 817 08	27	4	3 227	91 52 873 08	L INTERMEDIATE SECTION
PLATE 8X40X246	97 73 817 08	27	4	3 227 008	91 52 872 08	L INTERMEDIATE SECTION
PLATE 8X40X246	97 73 817 08	27	4	3 227 200	91 53 519 08	LI INTERMEDIATE SECT. F-GU
PLATE 8X40X246	97 73 817 08	59	5	3 713	91 57 749 08	D PIVOT SECTION
PLATE 8X40X246	97 73 817 08	52	2	3 714	91 52 862 08	D HEAD SECTION
PLATE 8X40X246	97 73 817 08	29	4	3 715 008	91 52 863 08	D INTERMEDIATE SECTION
PLATE 8X40X246	97 73 817 08	27	4	3 716	91 52 864 08	D INTERMEDIATE SECTION
PLATE 8X83X83	97 64 835 08	35	4	2 391 001	96 45 719 08	DIESEL ENGINE, PRE-ASSEMB
PLATE 8X95X374	97 91 624 08	12	4	3 292	91 52 865 08	D OVERRUN PROTECTION
PLATE 8x40x276	97 08 336 08	27	4	3 220 500	91 52 849 08	S INTERMEDIATE SECTION
PLATE 8x40x276	97 08 336 08	15	4	3 221	91 54 668 08	S INTERMEDIATE SECTION
PLATE 8x40x276	97 08 336 08	27	4	3 223	91 52 852 08	S INTERMEDIATE SECTION
PLATE 8x40x276	97 08 336 08	27	4	3 223 010	91 52 853 08	S INTERMEDIATE SECTION
PLATE 8x40x276	97 08 336 08	27	4	3 223 100	91 55 327 08	S INTERMEDIATE SECTION
PLATE 8x40x276	97 08 336 08	34	4	3 225	91 52 854 08	SL REDUCING SECTION
PLATE ASSEMBLY BG-NR. PVC	97 35 919 08	(3)	1	2 550	91 57 751 08	SA FRAME
PLATE ASSEMBLY BG-NR. PVC	97 35 919 08	(3)	1	2 550	91 57 751 08	SA FRAME
PLATE ASSEMBLY BG-NR. PVC	97 35 919 08	5	1	2 550 005	96 45 680 08	ROD CPL.
PLATE ASSEMBLY BG-NR. PVC	97 35 919 08	11	1	3 207 003	96 48 259 08	ROD CPL.
PLATE ASSEMBLY BG-NR. PVC	97 35 919 08	8	1	3 207 100	96 48 261 08	BRACKET COMPL.
PLATE ASSEMBLY BG-NR. PVC	97 35 919 08	8	1	3 207 101	96 48 292 08	BRACKET COMPL.
PLATE ASSEMBLY BG-NR. PVC	97 35 919 08	14	1	3 211 003	96 46 986 08	ROD CPL.
PLATE ASSEMBLY BG-NR. PVC	97 35 919 08	6	1	3 220 501	96 43 440 08	ROD CPL.
PLATE ASSEMBLY BG-NR. PVC	97 35 919 08	6	1	3 221 200	96 47 984 08	ROD CPL.
PLATE ASSEMBLY BG-NR. PVC	97 35 919 08	6	1	3 225 200	96 48 679 08	ROD CPL.
PLATE ASSEMBLY BG-NR. PVC	97 35 919 08	6	1	3 227 002	96 50 498 08	ROD CPL.
PLATE ASSEMBLY BG-NR. PVC	97 35 919 08	(6)	1	3 281	91 52 896 08	ERECTION FRAME
PLATE ASSEMBLY BG-NR. PVC	97 35 919 08	(6)	1	3 281	91 52 896 08	ERECTION FRAME
PLATE ASSEMBLY BG-NR. PVC	97 35 919 08	(11)	1	3 281	91 52 896 08	ERECTION FRAME
PLATE ASSEMBLY BG-NR. PVC	97 35 919 08	6	1	3 561 003	96 45 222 08	ROD CPL.
PLATE ASSEMBLY BG-NR. PVC	97 35 919 08	6	1	3 713 012	96 50 197 08	ROD CPL.
PLATE ASSEMBLY BG-NR. PVC	97 35 919 08	9	1	3 714 013	96 59 083 08	BRACKET COMPL.
PLATE ASSEMBLY BG-NR. PVC	97 35 919 08	6	1	3 714 014	96 49 456 08	BRACKET COMPL.
PLATE ASSEMBLY BG-NR. PVC	97 35 919 08	9	1	3 714 025	96 49 269 08	ROD CPL.

6.2.2009

etk_en_de_074515 LR 1600/2

951

LIEBHERRAlphabetical index
Alphabetischer Index

Description	Item	Pos.	Quantity	Page	Assembly	Description
PLATE ASSEMBLY BG-NR. PVC	97 35 919 08	6	1	3 716 001	96 49 159 08	ROD CPL.
PLATE IDENTIFICATION NUMB	97 35 676 08	5	1	2 550 010	96 45 685 08	ROD
PLATE IDENTIFICATION NUMB	97 35 676 08	6	1	3 282 001	96 47 888 08	F-STAY COMPL.
PLATE IDENTIFICATION NUMB	97 35 676 08	7	1	3 714 013	96 49 270 08	BRACKET COMPL.
PLATE OPER. HOUR METER	97 12 910 08	58	1	2 932 082	96 54 387 08	ASSEMBLY PARTS MOUNTIN
PLATE PRE-ASS.	96 48 533 08	12	1	3 780 751	91 52 952 08	AIR-CRAFT & WIND WARNING
PLATE PRE-ASS.	96 48 552 08	1	1	2 932 082	96 54 387 08	ASSEMBLY PARTS MOUNTIN
PLATE PRE-ASS. DACH	96 50 385 08	1	1	2 533 051	96 48 360 08	EL.EQUIPMENT CABIN
PLATE RD120X2	95 36 382 08	16	2	3 205	91 52 880 08	F-ASSEMBLY UNIT
PLATE RD2X65	95 41 978 08	5	2	3 206 002	96 47 960 08	LEVER COMPL.
PLATE RD40X1	95 57 168 08	18	2	3 205	91 52 880 08	F-ASSEMBLY UNIT
PLATE RD70X2	94 90 229 08	9	1	3 207 003	96 48 259 08	ROD CPL.
PLATE RD70X2	94 90 229 08	26	2	3 281	91 52 896 08	ERECTION FRAME
PLATE RD70X2	94 90 229 08	(9)	2	3 281	91 52 896 08	ERECTION FRAME
PLATE WELDED	96 46 753 08	1	1	2 859	91 52 809 08	SOUND INSULATION
PLATE WELDED	96 46 754 08	2	1	2 859	91 52 809 08	SOUND INSULATION
PLATE WELDED	96 48 276 08	37	1	2 859	91 52 809 08	SOUND INSULATION
PLATE WELDED	96 48 277 08	38	1	2 859	91 52 809 08	SOUND INSULATION
PLATE WELDED	96 48 278 08	39	1	2 859	91 52 809 08	SOUND INSULATION
PLATE WELDED	96 48 607 08	6	1	3 215 005	91 52 846 08	ROLLER SET
PLATE WELDED	96 48 607 08	6	1	3 215 006	91 52 847 08	ROLLER SET
PLATE WELDED	96 48 608 08	7	1	3 215 005	91 52 846 08	ROLLER SET
PLATE WELDED	96 48 608 08	7	1	3 215 006	91 52 847 08	ROLLER SET
PLATE WELDED	96 49 851 08	2	1	3 745 011	96 49 677 08	BRACKET COMPL.
PLATE WELDED	96 52 917 08	81	1	2 520	91 53 061 08	CABIN, GLAZED
PLATE WELDED	96 53 131 08	82	1	2 520	91 53 061 08	CABIN, GLAZED
PLATE WELDED	96 54 179 08	1	2	2 657	91 57 656 08	MOUNTING EQUIPMENT CRAW
PLATE X0	95 56 681 08	26	1	2 310	91 52 503 08	WINCH 1
PLATE X0	95 56 681 08	26	1	2 320	91 52 504 08	WINCH 2
PLATE X0	95 56 681 08	36	1	2 340	91 52 776 08	WINCH 4 LUFFING GEAR
PLATE X0	95 56 681 08	(1)	4	2 920	91 56 833 08	ELECTR. SYSTEM F.SLEWING
PLATE X0	95 56 681 08	90	1	3 211	91 57 748 08	S PIVOT SECTION
PLATE X0	95 56 681 08	36	1	3 350	91 52 859 08	WINCH 3
PLATE X0	95 56 681 08	22	1	3 745	91 52 948 08	SUSPENDED BALLAST
PLATFORM	96 54 984 08	50	2	3 225	91 52 854 08	SL REDUCING SECTION
PLATFORM	96 56 268 08	19	1	2 730	91 52 802 08	BASE PLATE SLEWING PLATF
PLATFORM GROSS	96 53 086 08	1	3	2 631	91 56 817 08	SLEWING PLATFORM CATWAL
PLATFORM HINTEN	96 47 414 08	5	1	2 810	91 52 806 08	CRANE DRIVER'S CABIN CPL.
PLATFORM KLEIN	96 53 087 08	2	1	2 631	91 56 817 08	SLEWING PLATFORM CATWAL
PLATFORM T ZN O	96 53 121 08	7	1	2 730	91 52 802 08	BASE PLATE SLEWING PLATF
PLATFORM VORN	96 46 384 08	4	1	2 810	91 52 806 08	CRANE DRIVER'S CABIN CPL.
PLATFORM WELDED	92 36 315 08	26	2	3 745	91 52 948 08	SUSPENDED BALLAST
PLUG	10 47 638 3	(503)	1	2 920 288	96 52 614 08	WIRING LIST F.SLEWING PLAT
PLUG	92 03 811 08	512	1	2 920 633	96 52 651 08	WIRING HARNESS
PLUG	92 79 963 08	504	2	2 920 633	96 52 651 08	WIRING HARNESS
PLUG 12-POL	10 34 312 1	23	1	9 739 366	97 39 366	FASTENING PIECES ASSEMBL
PLUG 18POL SPF	60 23 250 08	(152)	12	2 932 001	96 45 393 08	RELAY CONTROL SYSTEM
PLUG 19-POL 22A	10 44 366 4	(151)	1	2 920 581	96 54 405 08	TERMINAL BOX WINCH PRE-A
PLUG 24POL 22A	10 44 365 8	152	1	3 930 732	96 50 575 08	LEAD
PLUG 24POL 22A	10 44 366 0	(151)	1	2 920 369	96 54 235 08	TERMINAL BOX CPL.
PLUG 46/38X19-59/51 CR2-70	10 01 263 0	5	1	9 739 354	97 39 354	FLYWHEEL HOUSING MOUNT
PLUG 8POL 24V	10 04 699 9	506	15	2 932 224	96 54 389 08	CABLES MOUNTING PANEL C
PLUG 8POL 24V	10 04 700 0	505	12	2 932 224	96 54 389 08	CABLES MOUNTING PANEL C
PLUG 8POL 24V	10 04 700 1	509	15	2 932 224	96 54 389 08	CABLES MOUNTING PANEL C
PLUG BASE 9-POL	63 01 229 08	504	41	2 932 224	96 54 389 08	CABLES MOUNTING PANEL C
PLUG CONTACT CPL.	92 01 005 08	15	2	2 631	91 56 817 08	SLEWING PLATFORM CATWAL
PLUG DIN 72585 7POL POLYBU	69 24 067 08	510	1	2 920 633	96 52 651 08	WIRING HARNESS
PLUG INSERT 40POL	60 56 022 08	(151)	1	2 920 369	96 54 235 08	TERMINAL BOX CPL.
PLUG M6	51 45 851 08	52	7	X1047219	10 47 219 6	REGULATOR
PLUG RD20X378	93 03 581 08	5	1	1 632 032	96 20 093 08	SUPPORT PLATE COMPL.

6.2.2009

etk_en_de_074515 LR 1600/2

952

LIEBHERRAlphabetical index
Alphabetischer Index

Description	Item	Pos.	Quantity	Page	Assembly	Description
PLUG SHELL 10-POL	10 02 156 7	(153)	1	2 920 369	96 54 235 08	TERMINAL BOX CPL.
PLUG SHELL 14POL	10 02 156 8	(153)	1	2 920 369	96 54 235 08	TERMINAL BOX CPL.
PLUG SHELL 14POL	60 23 365 08	3	6	2 932 166	92 68 911 08	GROUND RAIL
PLUG SHELL 18-POL	60 23 002 08	501	37	2 932 224	96 54 389 08	CABLES MOUNTING PANEL C
PLUG SHELL 4POL	60 23 359 08	523	1	2 932 224	96 54 389 08	CABLES MOUNTING PANEL C
PLUG SOCKET	51 05 696 08	26	1	1 750	91 52 394 08	TOOL
PLUG SOCKET BODY 4POL SS	60 52 516 08	501	1	2 920 633	96 52 651 08	WIRING HARNESS
PLUG SOCKET BODY 4POL SS	60 52 516 08	151	1	2 920 636	96 51 854 08	LEAD
PLUG T ZN K	92 47 131 08	37	1	2 810	91 52 806 08	CRANE DRIVER'S CABIN CPL.
PLUG T ZN K	92 47 131 08	66	8	3 211	91 57 748 08	S PIVOT SECTION
PLUG VSTI1"ED A3P	47 77 046 08	773	2	2 970	91 56 537 08	HYDR
PLUG VSTI1/2"ED A3P	47 77 042 08	752	1	2 970	91 56 537 08	HYDR
PLUG VSTI1/2"ED A3P	47 77 042 08	609	4	3 978 005	91 56 430 08	ADDL.HYDRAULIC SB-HEAD PI
PLUG VSTI1/2"ED A3P	47 77 042 08	3	1	X1021769	10 21 769 5	LOWERING BRAKE VALVE
PLUG VSTI1/4"ED A3P	47 77 040 77	330	2	X1041101	10 41 101 5	TILTING-BACK SUPPORT
PLUG VSTI1/4"ED A3P	47 77 040 77	310	2	X1041101	10 41 101 8	TILTING-BACK SUPPORT
PLUG VSTI1/8"ED ST A3C	51 07 415 08	3	1	5 113 086	51 13 086 08	PROPORTIONAL VALVE
PLUG VSTI1/4"ED A3P	47 77 054 08	16	3	9 640 276	96 40 276 08	CONNECTION BLOCK
PLUG VSTI1/4"ED A3P	47 77 054 08	4	1	X1041267	10 41 267 8	END PLATE
PLUG VSTI3/8"ED A3P	47 77 041 08	733	2	2 970	91 56 537 08	HYDR
PLUG VSTIM12X1,5ED A3P	47 77 043 08	51	1	2 393	91 52 787 08	AIR FILTER UNIT CPL.
PLUG VSTIM14X1,5ED A3P	47 77 049 08	15	1	X1042440	10 42 440 2	CONTROL BLOCK
PLUG VSTIM18X1,5ED A3P	47 77 051 08	644	2	1 970	91 56 958 08	CRAWLER TRACK HYDRAULI
PLUG VSTIM18X1,5ED A3P	47 77 051 08	602	2	1 970 161	96 50 706 08	AUX.HYDR.CR.TRACK CARR.4
PLUG VSTIM18X1,5ED A3P	47 77 051 08	4	1	2 670 002	96 45 352 08	FUEL TANK, PRE-ASSEMBLED
PLUG VSTIM18X1,5ED A3P	47 77 051 08	400	1	X1041101	10 41 101 5	TILTING-BACK SUPPORT
PLUG VSTIM18X1,5ED A3P	47 77 051 08	380	1	X1041101	10 41 101 8	TILTING-BACK SUPPORT
PLUG VSTIM22X1,5ED A3P	47 77 045 08	614	1	2 970	91 56 537 08	HYDR
PLUG VSTIM22X1,5ED A3P	47 77 045 08	616	2	2 990	91 59 244 08	COMPRESSED AIR PLANT
PLUG VSTIM22X1,5ED A3P	47 77 045 08	603	1	3 978 005	91 56 430 08	ADDL.HYDRAULIC SB-HEAD PI
PLUG VSTIM22X1,5ED A3P	47 77 045 08	580	1	X1041101	10 41 101 5	TILTING-BACK SUPPORT
PLUG VSTIM22X1,5ED A3P	47 77 045 08	490	1	X1041101	10 41 101 8	TILTING-BACK SUPPORT
PLUG VSTIM26X1,5ED A3P	47 77 058 08	712	1	2 970	91 56 537 08	HYDR
PLUG VSTIM27X2ED A3P	47 77 056 08	632	2	2 970	91 56 537 08	HYDR
PLUG VSTIM27X2ED A3P	47 77 056 08	89	1	9 697 916	96 97 916 01	SLEWING GEAR
PLUG VSTIM33X2ED A3P	47 77 052 08	713	2	2 970	91 56 537 08	HYDR
PLUG VSTIM33X2ED A3P	47 77 052 08	48	1	2 975 100	91 52 860 08	ADDITIONAL HYDRAULICS WI
PLUG VSTIM33X2ED A3P	47 77 052 08	45	1	2 975 200	91 52 775 08	ADDITIONAL HYDRAULICS WI
PLUG VSTIM33X2ED A3P	47 77 052 08	45	1	2 975 700	91 52 774 08	ADDITIONAL HYDRAULICS WI
PLUG VSTIM42X2ED A3P	47 77 048 08	(62)	3	1 400	91 56 853 08	CRAWLER TRACK CARRIER LE
PLUG VSTIM42X2ED A3P	47 77 048 08	13	1	X1042440	10 42 440 2	CONTROL BLOCK
PLUG VSTIM8X1ED	51 45 195 08	53	1	X1047219	10 47 219 6	REGULATOR
PLUG-IN CARD G0 COMM.SP.4	92 16 203 08	5	1	2 932 122	96 45 394 08	LICCON ASSEMBLY UNIT
PLUG-IN CARD G0Z0 PROG-SP	91 54 570 08	6	1	2 932 122	96 45 394 08	LICCON ASSEMBLY UNIT
PLUG-IN CARD G0Z1 PRPG.SP.	91 42 856 08	7	1	2 932 122	96 45 394 08	LICCON ASSEMBLY UNIT
PLUG-IN CARD G0Z2 PROG-S	91 42 857 08	8	1	2 932 122	96 45 394 08	LICCON ASSEMBLY UNIT
PLUG-IN CARD G0Z3 PROG-S	91 42 858 08	9	1	2 932 122	96 45 394 08	LICCON ASSEMBLY UNIT
PLUG-IN CARD G0Z4 PROG-S	91 42 859 08	10	1	2 932 122	96 45 394 08	LICCON ASSEMBLY UNIT
PLUG-IN CARD G0Z5 PROG-S	91 42 860 08	11	1	2 932 122	96 45 394 08	LICCON ASSEMBLY UNIT
PLUG-IN CONNECTOR	10 49 058 6	6	1	X1004047	10 04 047 7	WINCH REVOLUTION TRANS
PLUG-IN PIPE	10 01 273 3	21	1	9 739 349	97 39 349	CONNECTION F.WATER PIPE
PLUG-IN SLEEVE E10-8	77 20 023 08	595	1	2 990	91 59 244 08	COMPRESSED AIR PLANT
PLUG-IN SLEEVE E6-4	77 20 022 08	592	2	2 990	91 59 244 08	COMPRESSED AIR PLANT
POCKET KUNSTSTOFF	74 03 000 08	28	1	2 520 034	96 45 984 08	INTERNAL LINING
POCKET LOCK 27-29 SPF	77 39 399 08	2	1	2 311	91 52 834 08	ROPE WITH ACCESSORIES 1
POCKET LOCK 27-29 SPF	77 39 399 08	2	1	2 312	91 52 835 08	ROPE WITH ACCESSORIES 2
POCKET LOCK 27-29 SPF	77 39 399 08	2	1	2 313	91 52 836 08	ROPES FOR WINCHES 3
POT	10 27 991 9	2	1	5 517 203	55 17 203 08	AIR FILTER
POWER UNIT 4 GEPRUEFT	91 07 635 08	2	1	2 932 122	96 45 394 08	LICCON ASSEMBLY UNIT
POWER UNIT 4 GEPRUEFT	91 07 635 08	15	1	2 932 160	96 54 385 08	SWITCH CABINET

6.2.2009

etk_en_de_074515 LR 1600/2

953

LIEBHERRAlphabetical index
Alphabetischer Index

Description	Item	Pos.	Quantity	Page	Assembly	Description
PRECISION RESISTOR NTC -40	10 44 951 6	2	3	2 533 066	96 48 365 08	ELECTRIC ADD-ON PARTS CA
PREMOUNTED PLUG SOCKET	96 49 314 08	13	1	2 533 066	96 48 365 08	ELECTRIC ADD-ON PARTS CA
PRESSURE CONTROL VALVE	51 14 853 08	29	3	2 970	91 56 537 08	HYDR
PRESSURE CONTROL VALVE	10 34 282 3	61	1	2 970	91 56 537 08	HYDR
PRESSURE FILTER	51 06 715 08	71	1	2 970	91 56 537 08	HYDR
PRESSURE GAUGE 63	75 00 011 08	30	1	1 750	91 52 394 08	TOOL
PRESSURE GAUGE 63	75 00 018 08	31	2	1 750	91 52 394 08	TOOL
PRESSURE GAUGE 63	75 00 024 08	184	3	2 970	91 56 537 08	HYDR
PRESSURE GAUGE CONNECT	47 09 005 08	604	1	2 978 100	91 52 796 08	ADDNL.HYDR.ERECTION DEV
PRESSURE GAUGE CONNECT	47 09 008 08	32	3	1 750	91 52 394 08	TOOL
PRESSURE LIMITING VALVE	10 22 274 0	2	1	9 739 369	97 39 369	PRESSURE PIPE
PRESSURE LIMITING VALVE	10 41 267 5	2	1	5 133 090	51 13 090 08	SLIDE VALVE BLOCK
PRESSURE LIMITING VALVE	10 48 973 4	2	1	5 113 005	51 13 005 08	CONTROL BLOCK
PRESSURE LIMITING VALVE	51 14 176 08	113	1	2 970	91 56 537 08	HYDR
PRESSURE LIMITING VALVE	51 14 177 08	114	2	2 970	91 56 537 08	HYDR
PRESSURE LIMITING VALVE	51 14 177 08	6	1	2 978 100	91 52 796 08	ADDNL.HYDR.ERECTION DEV
PRESSURE LIMITING VALVE	51 14 177 08	10	1	2 978 100	91 52 827 08	ADDNL.HYDR.RETAINING DEV
PRESSURE LIMITING VALVE	51 14 177 08	10	1	2 978 200	91 54 843 08	ADD.HYDR.S_RETAINING RAM
PRESSURE LIMITING VALVE	51 14 333 08	8	1	2 975 000	91 57 881 08	ADDNL. HYDR. F. ERECTING W
PRESSURE LIMITING VALVE	51 14 562 08	7	1	3 978 100	91 56 428 08	HYDR. SUSPENDED BALLAST
PRESSURE LIMITING VALVE	51 14 568 08	30	2	2 970	91 56 537 08	HYDR
PRESSURE LIMITING VALVE	51 14 572 08	72	1	2 970	91 56 537 08	HYDR
PRESSURE LIMITING VALVE	57 11 301 08	31	1	5 113 086	51 13 086 08	PROPORTIONAL VALVE
PRESSURE LIMITING VALVE	57 12 325 08	2	1	5 718 989	57 18 989 08	TERMINAL BOARD
PRESSURE LIMITING VALVE	57 12 395 08	2	1	5 715 142	57 15 142 08	TERMINAL BOARD
PRESSURE LIMITING VALVE	57 12 395 08	2	1	5 719 030	57 19 030 08	TERMINAL BOARD
PRESSURE LIMITING VALVE	57 15 139 08	1	2	X1065068	10 65 068 8	TERMINAL BOARD
PRESSURE LIMITING VALVE	57 15 145 08	1	1	5 715 142	57 15 142 08	TERMINAL BOARD
PRESSURE LIMITING VALVE	57 15 147 08	4	1	5 715 142	57 15 142 08	TERMINAL BOARD
PRESSURE LIMITING VALVE	57 16 910 08	8	1	X1042440	10 42 440 2	CONTROL BLOCK
PRESSURE LIMITING VALVE	57 18 994 08	1	2	5 718 989	57 18 989 08	TERMINAL BOARD
PRESSURE LIMITING VALVE	57 19 033 08	1	2	5 719 030	57 19 030 08	TERMINAL BOARD
PRESSURE LIMITING VALVE	70 28 133	2	1	X1065068	10 65 068 8	TERMINAL BOARD
PRESSURE LIMITING VALVE 1	10 45 106 0	9	1	X1042440	10 42 440 2	CONTROL BLOCK
PRESSURE LIMITING VALVE 2	10 66 433 3	560	1	X1041101	10 41 101 5	TILTING-BACK SUPPORT
PRESSURE LIMITING VALVE 2	10 66 433 3	470	1	X1041101	10 41 101 8	TILTING-BACK SUPPORT
PRESSURE LINE	10 03 730 0	41	1	9 739 494	97 39 494	ATL ATTACHMENT
PRESSURE LINE	10 34 309 2	1	1	9 739 356	97 39 356	PIPELINE INSTALLATION
PRESSURE LINE	10 34 309 3	4	1	9 739 356	97 39 356	PIPELINE INSTALLATION
PRESSURE LINE	10 34 309 5	6	1	9 739 369	97 39 369	PRESSURE PIPE
PRESSURE PIPE	10 22 273 9	1	1	9 739 369	97 39 369	PRESSURE PIPE
PRESSURE PIPE	97 39 369	101	1	X1012059	10 12 059 0	DIESEL ENGINE
PRESSURE RELIEF VALVE	51 14 975 08	54	4	2 970	91 56 537 08	HYDR
PRESSURE SENS.RETAINING	96 47 916 08	3	1	2 978 100	91 52 827 08	ADDNL.HYDR.RETAINING DEV
PRESSURE SENS.RETAINING	96 47 917 08	3	1	2 978 200	91 54 843 08	ADD.HYDR.S_RETAINING RAM
PRESSURE SENS.RETAINING	96 47 918 08	4	1	2 970	91 56 537 08	HYDR
PRESSURE SENSOR	10 01 247 0	(1)	1	9 739 318	97 39 318	SENSOR ELEMENT
PRESSURE SENSOR	69 23 083 08	15	1	2 393	91 52 787 08	AIR FILTER UNIT CPL.
PRESSURE SENSOR 400/400	69 23 126 08	(1)	2	2 970	91 56 537 08	HYDR
PRESSURE SENSOR 400/400	69 23 126 08	(1)	2	2 978 100	91 52 827 08	ADDNL.HYDR.RETAINING DEV
PRESSURE SENSOR 400/400	69 23 126 08	(1)	2	2 978 200	91 54 843 08	ADD.HYDR.S_RETAINING RAM
PRESSURE SENSOR 750/750	69 23 128 08	(1)	5	2 970	91 56 537 08	HYDR
PRESSURE SENSOR ERECT. D	96 47 919 08	3	1	2 978 100	91 52 796 08	ADDNL.HYDR.ERECTION DEV
PRESSURE SENSOR SPF	69 23 125 08	(1)	2	2 978 100	91 52 796 08	ADDNL.HYDR.ERECTION DEV
PRESSURE SENSORS PUMPS	96 47 915 08	3	1	2 970	91 56 537 08	HYDR
PRESSURE SPRING	50 15 240 08	76	22	X1065015	10 65 015 8	DRIVE UNIT
PRESSURE SPRING	50 15 241 08	75	22	X1065015	10 65 015 8	DRIVE UNIT
PRESSURE SPRING	51 07 971 08	4	1	5 114 176	51 14 176 08	PRESSURE LIMITING VALVE
PRESSURE SPRING	51 07 971 08	2	1	5 114 320	51 14 320 08	PRETENSIONING VALVE
PRESSURE SPRING	51 07 975 08	9	1	5 114 176	51 14 176 08	PRESSURE LIMITING VALVE

6.2.2009

etk_en_de_074515 LR 1600/2

954

LIEBHERRAlphabetical index
Alphabetischer Index

Description	Item	Pos.	Quantity	Page	Assembly	Description
PRESSURE SPRING	51 07 975 08	9	1	5 114 177	51 14 177 08	PRESSURE LIMITING VALVE
PRESSURE SPRING	51 07 975 08	7	1	5 114 320	51 14 320 08	PRETENSIONING VALVE
PRESSURE SPRING	51 10 151 08	4	1	5 114 177	51 14 177 08	PRESSURE LIMITING VALVE
PRESSURE SPRING	56 00 192 08	6	1	2 522 011	96 45 602 08	CLOSING DEVICE
PRESSURE SPRING	57 00 095 08	8	1	5 026 126	50 26 126 08	SOLENOID VALVE
PRESSURE SPRING	57 06 304 08	4	1	2 550 008	96 47 628 08	RETAINER CPL.
PRESSURE SPRING	57 06 304 08	4	1	2 550 009	96 47 645 08	RETAINER CPL.
PRESSURE SPRING 1,9X6,9X2	51 07 359 08	6	1	5 711 301	57 11 301 08	PRESSURE LIMITING VALVE
PRESSURE SWITCH	51 06 769 08	44	1	2 970	91 56 537 08	HYDR
PRESSURE SWITCH	57 14 891 08	6	1	2 831	91 57 754 08	AIR COND. UNIT SUPERSTRU
PRESSURE SWITCH 20BAR SP	10 28 953 6	47	2	2 970	91 56 537 08	HYDR
PRESSURE SWITCH 20BAR SP	10 28 953 6	7	1	2 975 100	91 52 860 08	ADDITIONAL HYDRAULICS WI
PRESSURE SWITCH 20BAR SP	10 28 953 6	7	1	2 975 200	91 52 775 08	ADDITIONAL HYDRAULICS WI
PRESSURE SWITCH 20BAR SP	10 28 953 6	7	1	2 975 700	91 52 774 08	ADDITIONAL HYDRAULICS WI
PRESSURE SWITCH 8BAR SP	10 22 093 3	46	1	2 970	91 56 537 08	HYDR
PRESSURE SWITCH 8BAR SP	10 22 093 3	6	1	2 975 100	91 52 860 08	ADDITIONAL HYDRAULICS WI
PRESSURE SWITCH 8BAR SP	10 22 093 3	6	1	2 975 200	91 52 775 08	ADDITIONAL HYDRAULICS WI
PRESSURE SWITCH 8BAR SP	10 22 093 3	6	1	2 975 700	91 52 774 08	ADDITIONAL HYDRAULICS WI
PRESSURE TRANSMITTER	10 22 274 1	13	1	9 739 318	97 39 318	SENSOR ELEMENT
PRESSURE TRANSMITTER 0-5	10 01 274 0	(1)	1	9 739 318	97 39 318	SENSOR ELEMENT
PRESSURE TRANSMITTER B	96 36 406 08	90	1	3 978 019	91 56 431 08	AUX.HYDR.CYLINDER SB-BW
PRESSURE TRANSMITTER C	10 11 740 7	11	1	9 739 318	97 39 318	SENSOR ELEMENT
PRESSURE TRANSMITTER C	10 11 740 9	12	1	9 739 318	97 39 318	SENSOR ELEMENT
PRESSURE TRANSMITTER C	10 11 740 4	10	1	9 739 318	97 39 318	SENSOR ELEMENT
PRESSURE VALVE	57 15 296 08	8	1	5 113 086	51 13 086 08	PROPORTIONAL VALVE
PRETENSIONING VALVE	51 14 320 08	7	1	2 975 000	91 57 881 08	ADDNL. HYDR. F. ERECTING W
PRETENSIONING VALVE 30BA	51 13 082 08	11	1	2 978 100	91 52 827 08	ADDNL.HYDR.RETAINING DEV
PRETENSIONING VALVE 30BA	51 13 082 08	11	1	2 978 200	91 54 843 08	ADD.HYDR.S_RETAINING RAM
PRETENSIONING VALVE 30BA	10 46 788 6	19	4	1 975 006	91 52 509 08	ADD. HYDR. SUPPORTING RA
PRINTED CIRCUIT BOARD SP	66 10 179 08	4	1	2 922 001	92 84 311 08	BUS PCB
PROFIL CLAMP 108/25 A2-70	10 45 120 6	115	1	2 391 001	96 45 719 08	DIESEL ENGINE, PRE-ASSEMB
PROFILE CORD	50 15 070 14	41	1.6	X1065015	10 65 015 5	GEARBOX
PROFILE PACKING	10 03 234 8	2	1	9 739 242	97 39 242	CYLINDER BUSH
PROFILE RING PR10-S/L A3P	47 71 003 08	594	1	2 990	91 59 244 08	COMPRESSED AIR PLANT
PROFILE RING PR12-S/L A3P	47 71 004 08	21	1	2 391 038	96 47 931 08	OIL COOLER, PRE-ASSEMBLE
PROFILE RING PR6-S/L A3P	47 71 014 08	591	2	2 990	91 59 244 08	COMPRESSED AIR PLANT
PROPORTIONAL MAGNET	10 29 624 5	(1)	1	X1035925	10 35 925 1	VARIABLE PUMP
PROPORTIONAL MAGNET 24V	10 47 143 7	(2)	1	X1035924	10 35 924 6	VARIABLE PUMP
PROPORTIONAL MAGNET 24V	10 47 143 7	(1)	2	X1035924	10 35 924 9	VARIABLE PUMP
PROPORTIONAL MAGNET 24V	57 19 117 08	13	2	5 719 113	57 19 113 08	CONTROL UNIT
PROPORTIONAL MAGNET 24V	57 19 117 08	13	2	X1029184	10 29 184 0	CONTROL UNIT
PROPORTIONAL VALVE NG12	51 13 086 08	110	1	2 970	91 56 537 08	HYDR
PROTECTING CAP	77 90 201 08	2	6	1 830 102	92 26 483 08	TERMINAL BOARD PRE-ASS.
PROTECTING CAP MS	69 18 128 08	(152)	1	2 920 581	96 54 405 08	TERMINAL BOX WINCH PRE-A
PROTECTING CAP MS	69 18 129 08	39	1	2 920 369	96 54 235 08	TERMINAL BOX CPL.
PROTECTING CAP MS	69 18 129 08	290	1	3 930 638	96 51 624 08	TERMINAL BOX
PROTECTING CAP MS	69 18 129 08	(152)	1	3 930 734	96 54 401 08	TERMINAL BOX
PROTECTION PLATE	10 01 246 2	4	1	9 739 159	97 39 159	STARTER
PROTECTION PLATE 4X307X77	97 65 557 08	4	2	2 350	91 52 778 08	SLEWING GEAR
PROTECTION PLATE WELDED	96 44 241 08	18	1	2 310	91 52 503 08	WINCH 1
PROTECTION PLATE WELDED	96 44 241 08	18	1	2 320	91 52 504 08	WINCH 2
PROTECTION PLATE WELDED	96 44 242 08	19	1	2 310	91 52 503 08	WINCH 1
PROTECTION PLATE WELDED	96 44 242 08	19	1	2 320	91 52 504 08	WINCH 2
PROTECTION PLATE WELDED	96 50 779 08	32	1	2 340	91 52 776 08	WINCH 4 LUFFING GEAR
PROTECTION PLATE WELDED	96 50 778 08	31	1	2 340	91 52 776 08	WINCH 4 LUFFING GEAR
PROTECTIVE GRATING	10 65 067 2	4	1	X1035519	10 35 519 6	OIL AIR COOLER
PROTECTIVE GRATING	61 04 133 08	11	2	2 913 102	92 32 870 08	FAN UNIT
PROTECTIVE HOOD V2A	10 04 105 3	19	2	2 925 002	96 58 856 08	EQUIPMENT CAMERA SUPER
PROXIMITY SWITCH INDUKTIV	69 27 015 08	5	2	1 920 308	96 48 384 08	ELECTR.CRAWLER SUPPORT
PROXIMITY SWITCH INDUKTIV	69 27 015 08	5	2	1 920 309	96 48 385 08	ELECTR.CRAWLER SUPPORT

6.2.2009

etk_en_de_074515 LR 1600/2

955

LIEBHERRAlphabetical index
Alphabetischer Index

Description	Item	Pos.	Quantity	Page	Assembly	Description
PROXIMITY SWITCH INDUKTIV	69 27 015 08	(1)	2	2 350	91 52 778 08	SLEWING GEAR
PROXIMITY SWITCH M12X1	10 09 761 3	(2)	1	2 711	91 52 800 08	CENT. LUBRIC. SYSTEM SUP
PULL-BACK PLATE	57 01 138 08	7	1	5 701 129	57 01 129 08	DRIVING GEAR
PUMP	59 10 554 08	12	1	2 520 032	96 45 980 08	WINDSHIELD WASHER INSTAL
PUMP COVER	10 65 068 9	4	1	X1035924	10 35 924 9	VARIABLE PUMP
PUMP ELEMENT	10 03 827 2	17	2	7 743 566	77 43 566 08	ELECTRIC PUMP
PUMP F.SLEWING GEAR	91 54 561 08	123	1		LR 1600-2-0	
PUMP HOUSING	10 01 469 3	1	1	7 743 566	77 43 566 08	ELECTRIC PUMP
PUMP RETURN FLOW	77 43 728 08	1	2	1 711	91 52 392 08	CENTRALIZED LUBRICATION
PUMP RETURN FLOW	77 43 728 08	10	1	2 711	91 52 800 08	CENT. LUBRIC. SYSTEM SUP
PUMP SUPPORT	10 32 692 6	4	1	X1035924	10 35 924 6	VARIABLE PUMP
PUMP SUPPORT	57 19 006 08	7	1	X1035924	10 35 924 7	VARIABLE PUMP
PUSH BUTTON	10 47 561 7	2	1	2 780 244	91 52 951 08	EMERGENCY CUT-OFF CRAN
PUSH-BUTTON CAP FLACH G	60 61 439 08	13	4	2 533 061	96 48 370 08	DASH BORD ARM REST LEFT
PUSH-BUTTON CAP FLACH G	60 61 439 08	13	1	2 533 063	96 48 371 08	DASH BORD ARM REST RIGH
PUSH-BUTTON CAP FLACH G	60 61 439 08	9	17	2 533 070	96 48 363 08	CONTROLS AND FITTINGS RI
PUSH-BUTTON CAP FLACH K	60 61 444 08	7	2	2 533 061	96 48 370 08	DASH BORD ARM REST LEFT
PUSH-BUTTON CAP FLACH K	60 61 444 08	5	6	2 533 063	96 48 371 08	DASH BORD ARM REST RIGH
PUSH-BUTTON CAP FLACH K	60 61 444 08	12	4	2 533 070	96 48 363 08	CONTROLS AND FITTINGS RI
PUSH-BUTTON CAP FLACH RO	60 61 431 08	5	1	2 533 061	96 48 370 08	DASH BORD ARM REST LEFT
PUSH-BUTTON CAP FLACH RO	60 61 431 08	15	2	2 533 070	96 48 363 08	CONTROLS AND FITTINGS RI
PUSHER 25X25	60 61 430 08	6	7	2 533 061	96 48 370 08	DASH BORD ARM REST LEFT
PUSHER 25X25	60 61 430 08	6	7	2 533 063	96 48 371 08	DASH BORD ARM REST RIGH
PUSHER 25X25	60 61 430 08	14	23	2 533 070	96 48 363 08	CONTROLS AND FITTINGS RI
QUICK COUPLING FEMALE	57 17 231 08	4	1	5 123 682	51 23 682 08	MOUNTING - PISTON W. PUM
QUICK RELEASE PIN 20X100	10 45 165 0	38	4	2 340	91 52 776 08	WINCH 4 LUFFING GEAR
RADIAL PACKING SET DRIVE	10 33 111 6	(98)	1	X1035924	10 35 924 1	VARIABLE PUMP
RADIATOR	96 56 360 08	11	1	2 391	91 52 784 08	DIESEL ENGINE CPL.
RADIATOR UNIT AL	10 41 290 3	1	1	2 391 023	96 45 720 08	RADIATOR, PRE-ASSEMBLED
RADIATOR, PRE-ASSEMBLED	96 45 720 08	120	1	2 391 001	96 45 719 08	DIESEL ENGINE, PRE-ASSEMB
RADIO ANTENNA PRE-ASS.	96 24 498 08	1	1	2 780 854	96 37 908 08	GSM MODULE LICCON 1
RAIL PAIR	10 65 048 9	70	1	X1029200	10 29 200 4	DRIVERS SEAT
RAILING	96 53 088 08	3	1	2 631	91 56 817 08	SLEWING PLATFORM CATWAL
RAILING	96 53 089 08	4	1	2 631	91 56 817 08	SLEWING PLATFORM CATWAL
RAILING ALMG3	96 56 362 08	79	2	3 713	91 57 749 08	D PIVOT SECTION
RAILING ALMG3	96 56 363 08	80	2	3 713	91 57 749 08	D PIVOT SECTION
REAR REST HANDLE	10 49 234 8	21	1	X1029200	10 29 200 4	DRIVERS SEAT
REAR WINDOW ESG-GLAS SP	97 68 381 08	1	1	2 520 031	96 45 610 08	REAR WINDOW PRE-ASS.
REAR WINDOW PRE-ASS.	96 45 610 08	7	1	2 520	91 53 061 08	CABIN, GLAZED
RECEPTACLE FOR TABS 6,3 0,	60 22 037 08	(63)	3	2 920 581	96 54 405 08	TERMINAL BOX WINCH PRE-A
RECEPTACLE FOR TABS 6,3 0,	60 22 037 08	(63)	3	2 920 581	96 54 405 08	TERMINAL BOX WINCH PRE-A
RECEPTACLE FOR TABS 6,3 0,	60 22 037 08	(63)	3	2 920 581	96 54 405 08	TERMINAL BOX WINCH PRE-A
RECEPTACLE FOR TABS 6,3 0,	60 22 037 08	(63)	19	2 920 581	96 54 405 08	TERMINAL BOX WINCH PRE-A
RECEPTACLE FOR TABS 6,3 0,	60 22 037 08	63	3	2 920 636	96 51 854 08	LEAD
RECEPTACLE FOR TABS 6,3 0,	60 22 037 08	(63)	14	3 930 734	96 54 401 08	TERMINAL BOX
RECEPTACLE FOR TABS 6,3 1,	60 23 033 08	134	10	2 920 633	96 52 651 08	WIRING HARNESS
RECEPTACLE PRE-ASS.	96 23 819 08	26	1	2 925 402	96 58 855 08	CAMERA EQUIPMENT SLEWI
REDUCER M25X1,5/M16X1,5 P	10 04 464 8	15	2	2 780 915	96 48 377 08	ADD-ON PARTS EXTERNAL F
REDUCING PIECE 81,5/53,5 P	10 42 478 5	37	2	2 520 034	96 45 984 08	INTERNAL LINING
REDUCING SCREW GR 12/10L	24 72 399 02	3	1	X1011614	10 11 614 1	FUEL HOSE
REDUCING STUD ST MAN272	10 34 230 2	3	1	9 739 356	97 39 356	PIPELINE INSTALLATION
REDUCTION M20X1,5/M16X1,5	60 26 062 08	(6)	1	2 920 559	96 47 914 08	LIMIT SWITCH AND SENSOR
REDUCTION M25X1,5/M20X1,5	60 26 064 08	521	3	2 920 633	96 52 651 08	WIRING HARNESS
REDUCTION M25X1,5/M20X1,5	60 26 064 08	183	1	3 930 638	96 51 624 08	TERMINAL BOX
REDUCTION M32X1,5/M20X1,5	60 26 065 08	7	1	2 780 524	96 52 968 08	CABLE DRUM COMPL.
REDUCTION M32X1,5/M20X1,5	60 26 065 08	289	1	2 920 448	96 48 794 08	TERMINAL BOX CPL.
REDUCTION M32X1,5/M20X1,5	60 26 065 08	(155)	1	2 920 581	96 54 405 08	TERMINAL BOX WINCH PRE-A
REDUCTION M32X1,5/M20X1,5	60 26 065 08	(154)	1	3 930 734	96 54 401 08	TERMINAL BOX
REDUCTION M32X1,5/M25X1,5	60 26 066 08	157	1	3 930 732	96 50 575 08	LEAD
REGULATOR	10 47 219 6	3	1	X1035924	10 35 924 7	VARIABLE PUMP

6.2.2009

etk_en_de_074515 LR 1600/2

956

LIEBHERRAlphabetical index
Alphabetischer Index

Description	Item	Pos.	Quantity	Page	Assembly	Description
REGULATOR	10 47 219 6	3	1	X1035924	10 35 924 8	VARIABLE PUMP
REGULATOR	10 47 599 4	(1)	1	9 739 343	97 39 343	GENERATOR, PRE-ASSEMBLE
REGULATOR ELEMENT	10 47 220 2	3	1	X1047219	10 47 219 6	REGULATOR
REGULATOR ELEMENT	57 19 008 08	2	1	X1047219	10 47 219 6	REGULATOR
REINFORCED RUBBER HOSE	79 00 429 08	19	1	1 750	91 52 394 08	TOOL
RELAY	10 01 737 4	13	1	2 920 083	96 48 319 08	ELECTRIC FOR BATTERY BOX
RELAY 18-32V	63 01 021 08	42	51	2 932 001	96 45 393 08	RELAY CONTROL SYSTEM
RELAY 24V S=20A OE=10A 26X	63 01 215 08	26	24	2 932 082	96 54 387 08	ASSEMBLY PARTS MOUNTIN
RELAY 24V S=40A 26X26X24M	63 01 051 08	25	4	2 932 082	96 54 387 08	ASSEMBLY PARTS MOUNTIN
RELAY 24V S=40A OE=20A 26X	63 01 054 08	27	1	2 932 082	96 54 387 08	ASSEMBLY PARTS MOUNTIN
RELAY CONTROL SYSTEM	96 45 393 08	4	1	2 932	91 57 750 08	BUILT-IN PARTS SWITCH BOX
RELAY SUPPORT 1.5X725X51	97 68 157 08	21	1	2 932 001	96 45 393 08	RELAY CONTROL SYSTEM
REPAIR KIT	57 13 378 08	1	1	7 300 043	73 00 043 08	SHUT OFF DEVICE
REPAIR KIT PIPE LINE	97 39 322	11	1	9 739 386	97 39 386	CRANKCASE BREATHER
RESISTANCE MODULE PBTG	10 02 485 7	22	1	2 932 082	96 54 387 08	ASSEMBLY PARTS MOUNTIN
RESISTOR 15R 5% 50W	63 50 576 08	15	1	2 913 005	96 20 731 08	INTERIOR HOUSING PRE-ASS.
RESISTOR 15R 5% 50W	63 50 576 08	15	1	2 913 005	96 28 696 08	INTERIOR HOUSING PRE-ASS.
RESISTOR 1K 5% 3W 75PPM/K	63 50 585 08	2	1	2 932 515	96 45 911 08	INSERTION MODULE
RESISTOR 47R 10% 25W	63 50 170 08	46	10	2 932 001	96 45 393 08	RELAY CONTROL SYSTEM
RESISTOR 500R 0%1 2W5 SPF	63 50 515 08	4	2	2 932 515	96 45 911 08	INSERTION MODULE
REST WELDED	96 59 096 08	22	1	3 714 009	96 49 267 08	LUFFING PULLEY BLOCK COM
REST WELDED FE//ZN20//C	96 50 494 08	14	2	3 227 002	96 50 498 08	ROD CPL.
RESTRICTOR CAP	10 01 754 4	1	1	9 739 186	97 39 186	MOTOR BRAKE
RESTRICTOR CAP 130	55 17 068 08	3	1	2 393	91 52 787 08	AIR FILTER UNIT CPL.
RESTRICTOR VALVE	51 14 277 08	11	1	2 975 000	91 57 881 08	ADDNL. HYDR. F. ERECTING W
RETAINER CLIP 102-100 ST	77 42 229 08	137	1	2 391 001	96 45 719 08	DIESEL ENGINE, PRE-ASSEMB
RETAINER CLIP 128-136 ST	10 02 326 6	5	1	2 393	91 52 787 08	AIR FILTER UNIT CPL.
RETAINER CLIP 146-154 ST	77 42 831 08	10	3	2 392	91 52 785 08	MUFFLER UNIT
RETAINER CLIP 146-154 ST	77 42 831 08	13	2	2 393	91 52 787 08	AIR FILTER UNIT CPL.
RETAINER CLIP 59-62 ST	77 42 844 08	59	1	3 281	91 52 896 08	ERECTION FRAME
RETAINER CLIP 75/25	77 42 097 08	5	1	2 831	91 57 754 08	AIR COND. UNIT SUPERSTRU
RETAINER CLIP 77/20 ST	77 42 856 08	119	1	2 391 001	96 45 719 08	DIESEL ENGINE, PRE-ASSEMB
RETAINER CPL.	96 47 628 08	37	1	2 550	91 57 751 08	SA FRAME
RETAINER CPL.	96 47 645 08	36	1	2 550	91 57 751 08	SA FRAME
RETAINER CPL. S235JR	10 11 880 5	3	1	9 080 702	90 80 702	CONTROL GEAR
RETAINING NUT M16X1	60 20 422 08	18	4	2 533 070	96 48 363 08	CONTROLS AND FITTINGS RI
RETAINING NUT M16X1	60 20 422 08	32	1	2 932 001	96 45 393 08	RELAY CONTROL SYSTEM
RETAINING PLATE	10 34 310 7	7	1	9 739 344	97 39 344	GENERATOR, PRE-ASSEMBLE
RETAINING SPRING 3 VERZ	43 31 028 08	19	8	1 630	91 52 387 08	HYDRAULIC SUPPORT
RETAINING SPRING 3 VERZ	43 31 028 08	64	2	2 550	91 57 751 08	SA FRAME
RETAINING SPRING 3 VERZ	43 31 028 08	38	1	2 810	91 52 806 08	CRANE DRIVER'S CABIN CPL.
RETAINING SPRING 3 VERZ	43 31 028 08	44	14	3 211	91 57 748 08	S PIVOT SECTION
RETAINING SPRING 3 VERZ	43 31 028 08	46	4	3 220 500	91 52 849 08	S INTERMEDIATE SECTION
RETAINING SPRING 3 VERZ	43 31 028 08	46	4	3 223	91 52 852 08	S INTERMEDIATE SECTION
RETAINING SPRING 3 VERZ	43 31 028 08	46	4	3 223 010	91 52 853 08	S INTERMEDIATE SECTION
RETAINING SPRING 3 VERZ	43 31 028 08	46	4	3 223 100	91 55 327 08	S INTERMEDIATE SECTION
RETAINING SPRING 3 VERZ	43 31 028 08	46	4	3 226	91 52 870 08	L INTERMEDIATE SECTION
RETAINING SPRING 3 VERZ	43 31 028 08	46	4	3 227	91 52 873 08	L INTERMEDIATE SECTION
RETAINING SPRING 3 VERZ	43 31 028 08	46	4	3 227 008	91 52 872 08	L INTERMEDIATE SECTION
RETAINING SPRING 3 VERZ	43 31 028 08	46	8	3 227 200	91 53 519 08	LI INTERMEDIATE SECT. F-GU
RETAINING SPRING 3 VERZ	43 31 028 08	157	2	3 713	91 57 749 08	D PIVOT SECTION
RETAINING SPRING 3 VERZ	43 31 028 08	35	8	3 715 008	91 52 863 08	D INTERMEDIATE SECTION
RETAINING SPRING 3 VERZ	43 31 028 08	37	8	3 716	91 52 864 08	D INTERMEDIATE SECTION
RETAINING SPRING 4,5 VERZ	43 31 009 08	13	4	1 630	91 52 387 08	HYDRAULIC SUPPORT
RETAINING SPRING 4,5 VERZ	43 31 009 08	9	8	2 550	91 57 751 08	SA FRAME
RETAINING SPRING 4,5 VERZ	43 31 009 08	3	1	2 550 011	96 47 007 08	CONSOLE COMPL.
RETAINING SPRING 4,5 VERZ	43 31 009 08	52	2	3 206	91 52 881 08	PIVOT SECTION
RETAINING SPRING 4,5 VERZ	43 31 009 08	22	2	3 211	91 57 748 08	S PIVOT SECTION
RETAINING SPRING 4,5 VERZ	43 31 009 08	13	1	3 211 003	96 46 986 08	ROD CPL.
RETAINING SPRING 4,5 VERZ	43 31 009 08	21	8	3 220 500	91 52 849 08	S INTERMEDIATE SECTION

6.2.2009

etk_en_de_074515 LR 1600/2

957

LIEBHERRAlphabetical index
Alphabetischer Index

Description	Item	Pos.	Quantity	Page	Assembly	Description
RETAINING SPRING 4,5 VERZ	43 31 009 08	10	8	3 221	91 54 668 08	S INTERMEDIATE SECTION
RETAINING SPRING 4,5 VERZ	43 31 009 08	21	8	3 223	91 52 852 08	S INTERMEDIATE SECTION
RETAINING SPRING 4,5 VERZ	43 31 009 08	21	8	3 223 010	91 52 853 08	S INTERMEDIATE SECTION
RETAINING SPRING 4,5 VERZ	43 31 009 08	21	8	3 223 100	91 55 327 08	S INTERMEDIATE SECTION
RETAINING SPRING 4,5 VERZ	43 31 009 08	18	4	3 225	91 52 854 08	SL REDUCING SECTION
RETAINING SPRING 4,5 VERZ	43 31 009 08	21	4	3 226	91 52 870 08	L INTERMEDIATE SECTION
RETAINING SPRING 4,5 VERZ	43 31 009 08	21	4	3 227	91 52 873 08	L INTERMEDIATE SECTION
RETAINING SPRING 4,5 VERZ	43 31 009 08	17	2	3 227 002	96 50 498 08	ROD CPL.
RETAINING SPRING 4,5 VERZ	43 31 009 08	21	4	3 227 008	91 52 872 08	L INTERMEDIATE SECTION
RETAINING SPRING 4,5 VERZ	43 31 009 08	21	10	3 227 200	91 53 519 08	LI INTERMEDIATE SECT. F-GU
RETAINING SPRING 4,5 VERZ	43 31 009 08	55	12	3 713	91 57 749 08	D PIVOT SECTION
RETAINING SPRING 4,5 VERZ	43 31 009 08	31	8	3 714	91 52 862 08	D HEAD SECTION
RETAINING SPRING 4,5 VERZ	43 31 009 08	16	3	3 714 008	96 49 266 08	LUFFING PULLEY BLOCK COM
RETAINING SPRING 4,5 VERZ	43 31 009 08	9	6	3 714 009	96 49 267 08	LUFFING PULLEY BLOCK COM
RETAINING SPRING 4,5 VERZ	43 31 009 08	5	2	3 714 021	96 49 271 08	ROLLER SEATING COMPL.
RETAINING SPRING 4,5 VERZ	43 31 009 08	15	16	3 715 008	91 52 863 08	D INTERMEDIATE SECTION
RETAINING SPRING 4,5 VERZ	43 31 009 08	15	22	3 716	91 52 864 08	D INTERMEDIATE SECTION
RETAINING SPRING 4,5 VERZ	43 31 009 08	59	1	3 745	91 52 948 08	SUSPENDED BALLAST
RETAINING SPRING 4X68 VER	43 31 012 08	60	12	1 400	91 56 853 08	CRAWLER TRACK CARRIER LE
RETAINING SPRING 4X68 VER	43 31 012 08	60	12	1 410 300	91 56 855 08	CRAWLER CARRIER RIGHT CP
RETAINING SPRING 4X68 VER	43 31 012 08	10	4	1 632	91 52 389 08	MECHANICAL SUPPORT
RETAINING SPRING 4X68 VER	43 31 012 08	9	1	1 991	91 52 510 08	ROTARY FEED THROUGH
RETAINING SPRING 4X68 VER	43 31 012 08	21	1	3 206	91 52 881 08	PIVOT SECTION
RETAINING SPRING 4X68 VER	43 31 012 08	37	3	3 281	91 52 896 08	ERECTION FRAME
RETAINING SPRING 4X68 VER	43 31 012 08	8	1	3 282 002	96 47 890 08	FAB-STAY
RETAINING SPRING 4X68 VER	43 31 012 08	107	2	3 713	91 57 749 08	D PIVOT SECTION
RETAINING SPRING 5 VERZ	43 31 025 08	3	4	2 391	91 52 784 08	DIESEL ENGINE CPL.
RETAINING SPRING 5 VERZ	43 31 025 08	39	1	3 208 001	91 52 883 08	F-HEAD SECTION
RETAINING SPRING 5 VERZ	43 31 025 08	61	6	3 211	91 57 748 08	S PIVOT SECTION
RETAINING SPRING 5 VERZ	43 31 025 08	33	1	3 214	91 52 843 08	SW HEAD SECTION
RETAINING SPRING 5 VERZ	43 31 025 08	81	8	3 713	91 57 749 08	D PIVOT SECTION
RETAINING SPRING 5 VERZ	43 31 025 08	20	1	3 714	91 52 862 08	D HEAD SECTION
RETAINING SPRING 5 VERZ	43 31 025 08	18	2	3 714 008	96 49 266 08	LUFFING PULLEY BLOCK COM
RETAINING SPRING 5 VERZ	43 31 025 08	12	4	3 830	91 55 535 08	SUPPLEMENTARY GUYING D
RETAINING SPRING 6 A3C	43 31 050 08	11	4	1 632	91 52 389 08	MECHANICAL SUPPORT
RETAINING SPRING 6 A3C	43 31 050 08	8	8	3 205	91 52 880 08	F-ASSEMBLY UNIT
RETAINING SPRING 6 A3C	43 31 050 08	15	9	3 206	91 52 881 08	PIVOT SECTION
RETAINING SPRING 6 A3C	43 31 050 08	7	2	3 207 101	96 48 292 08	BRACKET COMPL.
RETAINING SPRING 6 A3C	43 31 050 08	14	3	3 281	91 52 896 08	ERECTION FRAME
RETAINING SPRING 6 A3C	43 31 050 08	11	1	3 282 002	96 47 890 08	FAB-STAY
RETAINING SPRING 6 A3C	43 31 050 08	21	4	3 745	91 52 948 08	SUSPENDED BALLAST
RETAINING SPRING 8 VERZ.	43 31 052 08	5	4	2 790 455	91 57 005 08	TRANSPORT KEEPER
RETAINING SPRING 8 VERZ.	43 31 052 08	20	2	3 211	91 57 748 08	S PIVOT SECTION
RETAINING SPRING 8 VERZ.	43 31 052 08	3	1	3 216 005	96 50 697 08	FOOT COMPLETE
RETAINING SPRING 8 VERZ.	43 31 052 08	14	1	3 745 011	96 49 677 08	BRACKET COMPL.
RETURN FILTER	51 06 691 08	9	1	2 671 004	96 46 305 08	OIL TANK PRE-ASS.
RETURN STRIP	77 43 758 08	21	2	2 711	91 52 800 08	CENT. LUBRIC. SYSTEM SUP
RIBBED HEX NUT M10 KL.10 Z	10 04 443 0	2	6	9 739 353	97 39 353	EXHAUST NOZZLE
RING	10 22 276 1	4	1	9 739 281	97 39 281	OVERFLOW-OIL LINE
RING	57 01 148 08	5	14	5 701 133	57 01 133 08	DRIVING GEAR
RING ADAPTER	10 01 271 0	4	5	9 739 282	97 39 282	OVERFLOW-OIL LINE
RING ADAPTER	10 01 271 0	3	7	9 739 292	97 39 292	FUEL LINE
RING ADAPTER	10 01 271 0	2	2	9 739 492	97 39 492	PIPELINE INSTALLATION
RING ADAPTER	10 01 271 1	14	1	9 739 288	97 39 288	FUEL LINE
RING ADAPTER	10 01 696 0	16	1	9 739 349	97 39 349	CONNECTION F.WATER PIPE
RING ADAPTER	10 11 610 9	7	1	X1011614	10 11 614 1	FUEL HOSE
RING ADAPTER	10 22 236 6	9	1	9 739 355	97 39 355	OIL COOLER ADD-ON
RING ADAPTER	10 28 515 5	17	1	9 739 288	97 39 288	FUEL LINE
RING ADAPTER 14MM	10 01 271 3	20	2	9 739 288	97 39 288	FUEL LINE
RING BOLT DIN 580 M10 C15E	40 26 002 08	2	3	2 790 451	91 57 016 08	COVER

6.2.2009

etk_en_de_074515 LR 1600/2

958

LIEBHERRAlphabetical index
Alphabetischer Index

Description	Item	Pos.	Quantity	Page	Assembly	Description
RING BOLT DIN 580 M12 C15E	40 26 003 08	5	2	2 670 002	96 45 352 08	FUEL TANK, PRE-ASSEMBLED
RING BOLT DIN 580 M12 C15E	40 26 003 08	17	2	2 671 004	96 46 305 08	OIL TANK PRE-ASS.
RING BOLT DIN 580 M24 C15E	40 26 007 08	6	4	1 632	91 52 389 08	MECHANICAL SUPPORT
RING FAN D=654	55 06 395 08	3	2	2 391 023	96 45 720 08	RADIATOR, PRE-ASSEMBLED
RING RD120X6	93 96 841 08	17	4	3 745	91 52 948 08	SUSPENDED BALLAST
RING RD84X23	93 87 145 08	4	1	3 282 001	96 47 888 08	F-STAY COMPL.
ROCKER ARM BEARING HOUS	10 22 235 1	2	1	9 739 263	97 39 263	ROCKER ARM BEARING HOUS
ROCKER ARM BEARING HOUS	10 22 235 2	2	1	9 739 264	97 39 264	ROCKER ARM BEARING HOUS
ROCKER ARM BEARING HOUS	97 39 263	5	1	9 739 262	97 39 262	CYLINDER HEAD
ROCKER ARM BEARING HOUS	97 39 264	5	1	9 739 266	97 39 266	CYLINDER HEAD
ROCKER AXLE	10 22 234 9	5	1	9 739 263	97 39 263	ROCKER ARM BEARING HOUS
ROCKER AXLE	10 22 234 9	5	1	9 739 264	97 39 264	ROCKER ARM BEARING HOUS
ROCKER AXLE	10 22 235 0	6	1	9 739 263	97 39 263	ROCKER ARM BEARING HOUS
ROCKER AXLE	10 22 235 0	6	1	9 739 264	97 39 264	ROCKER ARM BEARING HOUS
ROCKER LEVER	10 01 221 3	3	2	9 739 263	97 39 263	ROCKER ARM BEARING HOUS
ROCKER LEVER	10 01 221 3	3	2	9 739 264	97 39 264	ROCKER ARM BEARING HOUS
ROCKER WELDED	96 47 240 08	28	1	3 281	91 52 896 08	ERECTION FRAME
ROCKER WELDED	96 47 241 08	31	1	3 281	91 52 896 08	ERECTION FRAME
ROD	96 45 458 08	(1)	1	2 550	91 57 751 08	SA FRAME
ROD	96 45 685 08	1	1	2 550 005	96 45 680 08	ROD CPL.
ROD	96 45 819 08	3	4	1 630	91 52 387 08	HYDRAULIC SUPPORT
ROD	96 46 787 08	2	2	3 213	91 52 842 08	F-CONNECTING HEAD
ROD	96 48 680 08	1	1	3 225 200	96 48 679 08	ROD CPL.
ROD 1.99M	96 49 610 08	1	1	3 714 025	96 49 269 08	ROD CPL.
ROD 11.75 M	96 49 158 08	1	1	3 716 001	96 49 159 08	ROD CPL.
ROD 11.75M	96 45 230 08	1	1	3 227 002	96 50 498 08	ROD CPL.
ROD 11.75M	96 45 230 08	1	1	3 561 003	96 45 222 08	ROD CPL.
ROD 2.15M	96 50 198 08	1	1	3 713 012	96 50 197 08	ROD CPL.
ROD 2.45M	96 47 008 08	1	1	3 211 003	96 46 986 08	ROD CPL.
ROD 2.75 M	96 47 985 08	1	1	3 221 200	96 47 984 08	ROD CPL.
ROD 5.75 M	96 45 249 08	1	1	3 220 501	96 43 440 08	ROD CPL.
ROD CPL.	96 49 268 08	4	2	3 714	91 52 862 08	D HEAD SECTION
ROD CPL. 1 M	96 45 456 08	11	4	2 550	91 57 751 08	SA FRAME
ROD CPL. 1.075M	96 49 042 08	2	2	3 214	91 52 843 08	SW HEAD SECTION
ROD CPL. 12 M	96 45 222 08	42	2	3 223	91 52 852 08	S INTERMEDIATE SECTION
ROD CPL. 12 M	96 45 222 08	42	2	3 223 010	91 52 853 08	S INTERMEDIATE SECTION
ROD CPL. 12 M	96 45 222 08	42	2	3 223 100	91 55 327 08	S INTERMEDIATE SECTION
ROD CPL. 12 M	96 45 222 08	40	2	3 227 008	91 52 872 08	L INTERMEDIATE SECTION
ROD CPL. 12 M	96 45 222 08	40	2	3 227 200	91 53 519 08	LI INTERMEDIATE SECT. F-GU
ROD CPL. 12 M	96 45 222 08	2	2	3 716	91 52 864 08	D INTERMEDIATE SECTION
ROD CPL. 12 M	96 49 159 08	3	2	3 716	91 52 864 08	D INTERMEDIATE SECTION
ROD CPL. 12 M	96 50 498 08	40	2	3 227	91 52 873 08	L INTERMEDIATE SECTION
ROD CPL. 2.05M	96 45 680 08	12	2	2 550	91 57 751 08	SA FRAME
ROD CPL. 2.34M	96 49 269 08	5	2	3 714	91 52 862 08	D HEAD SECTION
ROD CPL. 2.3M	96 50 197 08	51	2	3 713	91 57 749 08	D PIVOT SECTION
ROD CPL. 2.975M	96 46 986 08	12	2	3 211	91 57 748 08	S PIVOT SECTION
ROD CPL. 3 M	96 47 984 08	24	2	3 221	91 54 668 08	S INTERMEDIATE SECTION
ROD CPL. 3.2M	96 45 288 08	33	2	3 281	91 52 896 08	ERECTION FRAME
ROD CPL. 5.15M	96 48 259 08	2	4	3 207	91 53 433 08	F-GUYING
ROD CPL. 6 M	96 43 440 08	42	2	3 220 500	91 52 849 08	S INTERMEDIATE SECTION
ROD CPL. 6 M	96 43 440 08	40	2	3 226	91 52 870 08	L INTERMEDIATE SECTION
ROD CPL. 6 M	96 43 440 08	2	2	3 715 008	91 52 863 08	D INTERMEDIATE SECTION
ROD CPL. 6 M	96 48 593 08	3	2	3 715 008	91 52 863 08	D INTERMEDIATE SECTION
ROD CPL. 6.75M	96 48 679 08	44	2	3 225	91 52 854 08	SL REDUCING SECTION
ROD WITH BOARD 0.43M	96 48 310 08	5	2	3 207	91 53 433 08	F-GUYING
ROD WITH BOARD 0.525M	96 47 009 08	2	2	3 211 003	96 46 986 08	ROD CPL.
ROD WITH BOARD 0.525M	96 47 010 08	3	1	3 211 003	96 46 986 08	ROD CPL.
ROD WITH BOARD 1.85M	96 46 998 08	13	4	3 211	91 57 748 08	S PIVOT SECTION
ROD WITH BOARD 1.85M	96 46 999 08	14	2	3 211	91 57 748 08	S PIVOT SECTION
ROD WITH BOARD 2.13M	96 48 354 08	6	2	3 207	91 53 433 08	F-GUYING

6.2.2009

etk_en_de_074515 LR 1600/2

959

LIEBHERRAlphabetical index
Alphabetischer Index

Description	Item	Pos.	Quantity	Page	Assembly	Description
ROD WITH BOARD 3200	96 45 289 08	(1)	1	3 281	91 52 896 08	ERECTION FRAME
ROD WITH BOARD 4950	96 48 260 08	1	1	3 207 003	96 48 259 08	ROD CPL.
ROD WITH BOARD 800	96 47 989 08	19	1	3 282 002	96 47 890 08	FAB-STAY
ROD WITH BOARD 800	96 47 990 08	24	2	3 282 002	96 47 890 08	FAB-STAY
ROLLER	10 66 425 0	430	1	X1041101	10 41 101 5	TILTING-BACK SUPPORT
ROLLER	10 66 425 0	410	1	X1041101	10 41 101 8	TILTING-BACK SUPPORT
ROLLER	92 17 259 08	6	2	3 745	91 52 948 08	SUSPENDED BALLAST
ROLLER	97 66 501 08	18	2	3 220 500	91 52 849 08	S INTERMEDIATE SECTION
ROLLER	97 66 501 08	18	2	3 223	91 52 852 08	S INTERMEDIATE SECTION
ROLLER	97 66 501 08	18	2	3 223 010	91 52 853 08	S INTERMEDIATE SECTION
ROLLER	97 66 501 08	18	2	3 223 100	91 55 327 08	S INTERMEDIATE SECTION
ROLLER 40.5X100X80 PA6G	94 37 683 08	17	10	3 215 005	91 52 846 08	ROLLER SET
ROLLER 40.5X100X80 PA6G	94 37 683 08	17	12	3 215 006	91 52 847 08	ROLLER SET
ROLLER 470X140 PA6GZAEHH	97 71 970 08	16	2	3 208 001	91 52 883 08	F-HEAD SECTION
ROLLER BEARING 200X270X8	74 65 067 08	2	1	2 550 003	96 46 246 08	ROPE PULLEY CPL.
ROLLER BEARING 200X270X8	74 65 067 08	2	1	2 652 007	92 68 928 08	ROPE PULLEY CPL.
ROLLER BEARING 68X40X38	74 59 008 08	2	1	3 206 001	96 20 920 08	ROPE PULLEY CPL.
ROLLER BEARING DREHBUE	91 52 794 08	138	1		LR 1600-2-0	
ROLLER BEARING WELDED	96 46 299 08	1	1	2 652	91 52 794 08	ROLLER BEARING
ROLLER BEARING WELDED	96 49 761 08	1	1	3 714 021	96 49 271 08	ROLLER SEATING COMPL.
ROLLER BODY HALF CPL.	92 51 976 08	10	4	1 400	91 56 853 08	CRAWLER TRACK CARRIER LE
ROLLER BODY HALF CPL.	92 51 976 08	10	4	1 410 300	91 56 855 08	CRAWLER CARRIER RIGHT CP
ROLLER BODY HALF CPL.	96 45 287 08	9	34	1 400	91 56 853 08	CRAWLER TRACK CARRIER LE
ROLLER BODY HALF CPL.	96 45 287 08	9	34	1 410 300	91 56 855 08	CRAWLER CARRIER RIGHT CP
ROLLER CORE HALF 34CRNI	97 67 848 08	1	1	1 400 016	96 45 287 08	ROLLER BODY HALF CPL.
ROLLER CORE RD230X70	95 44 255 08	1	1	1 400 017	92 51 976 08	ROLLER BODY HALF CPL.
ROLLER PA6G	97 66 500 08	17	2	3 220 500	91 52 849 08	S INTERMEDIATE SECTION
ROLLER PA6G	97 66 500 08	17	4	3 223	91 52 852 08	S INTERMEDIATE SECTION
ROLLER PA6G	97 66 500 08	17	4	3 223 010	91 52 853 08	S INTERMEDIATE SECTION
ROLLER PA6G	97 66 500 08	17	4	3 223 100	91 55 327 08	S INTERMEDIATE SECTION
ROLLER PA6G	97 68 888 08	5	2	2 522 012	96 45 884 08	GUIDE PRE-ASS.
ROLLER PA6G	97 68 888 08	6	4	2 522 013	96 45 883 08	GUIDE PRE-ASS.
ROLLER PA6G	97 80 631 08	49	2	3 220 500	91 52 849 08	S INTERMEDIATE SECTION
ROLLER PA6G	97 80 631 08	49	2	3 223	91 52 852 08	S INTERMEDIATE SECTION
ROLLER PA6G	97 80 631 08	49	2	3 223 010	91 52 853 08	S INTERMEDIATE SECTION
ROLLER PA6G	97 80 631 08	49	2	3 223 100	91 55 327 08	S INTERMEDIATE SECTION
ROLLER RD100X200 PA6G	93 24 583 08	43	2	3 206	91 52 881 08	PIVOT SECTION
ROLLER RD100X80 PA6G	28 81 883 08	8	2	3 713	91 57 749 08	D PIVOT SECTION
ROLLER RD180X98 PA6G	93 99 680 08	17	4	3 208 001	91 52 883 08	F-HEAD SECTION
ROLLER RD68X20 PA6G	28 30 961 08	34	2	3 206	91 52 881 08	PIVOT SECTION
ROLLER RD68X20 PA6G	28 30 961 08	23	3	3 208 001	91 52 883 08	F-HEAD SECTION
ROLLER RD75X120 PA6G	93 89 752 08	20	1	3 208 001	91 52 883 08	F-HEAD SECTION
ROLLER RD75X70 PA6G	93 26 439 08	42	5	3 208 001	91 52 883 08	F-HEAD SECTION
ROLLER RD80X40 PA6G	93 01 339 08	19	4	3 215 005	91 52 846 08	ROLLER SET
ROLLER RD80X40 PA6G	93 01 339 08	19	4	3 215 006	91 52 847 08	ROLLER SET
ROLLER SEATING COMPL.	96 49 271 08	7	1	3 714	91 52 862 08	D HEAD SECTION
ROLLER SET 300T	91 52 846 08	204	1		LR 1600-2-0	
ROLLER SET 320T	91 52 847 08	205	1		LR 1600-2-0	
ROLLER SET WELDED 300T	96 48 667 08	1	1	3 215 005	91 52 846 08	ROLLER SET
ROLLER SET WELDED 320T	96 48 526 08	1	1	3 215 006	91 52 847 08	ROLLER SET
ROLLER SLEWING RING	91 52 793 08	137	1		LR 1600-2-0	
ROLLER SLEWING RING	99 07 151 01	1	1	2 620	91 52 793 08	ROLLER SLEWING RING
ROLLER WELDED CONSTR.	92 70 643 08	1	1	3 350 001	92 70 642 08	SAFETY ROLLER CPL.
ROLLER X20CR13 X20CR13	97 81 003 08	16	4	2 522 013	96 45 883 08	GUIDE PRE-ASS.
ROLLING NOZZLE	10 29 201 3	35	10	2 520 034	96 45 984 08	INTERNAL LINING
ROOF WINDOW PRE-ASS.	96 45 609 08	6	1	2 520	91 53 061 08	CABIN, GLAZED
ROOF WINDOW SPF	97 68 380 08	2	1	2 520 030	96 45 609 08	ROOF WINDOW PRE-ASS.
ROPE 28MM 1050M -40°C SPF	10 41 082 0	1	1	2 311	91 52 834 08	ROPE WITH ACCESSORIES 1
ROPE 28MM 1050M -40°C SPF	10 41 082 0	1	1	2 312	91 52 835 08	ROPE WITH ACCESSORIES 2
ROPE 28MM 1200M -40°C SPF	10 41 082 4	1	1	2 313	91 52 836 08	ROPES FOR WINCHES 3

6.2.2009

etk_en_de_074515 LR 1600/2

960

LIEBHERRAlphabetical index
Alphabetischer Index

Description	Item	Pos.	Quantity	Page	Assembly	Description
ROPE 28MM 700M -40°C SPF	10 41 082 9	1	1	2 314	91 52 837 08	ROPE FOR WINCH 4
ROPE 28X7000	97 93 904 08	23	1	3 281	91 52 896 08	ERECTION FRAME
ROPE 34MM 1.525M	97 75 537 08	1	2	3 832	91 55 536 08	SUPPLEMENTARY GUYING D
ROPE 34MM 2.525M	97 75 541 08	1	2	3 832 001	91 55 537 08	SUPPLEMENTARY GUYING D
ROPE 34MM 3.525M	97 75 548 08	1	2	3 834	91 55 538 08	SUPPLEMENTARY GUYING D
ROPE 34MM 4.525M	97 74 938 08	1	2	3 835 000	91 55 539 08	SUPPLEMENTARY GUYING D
ROPE 34MM 5.525M	97 74 939 08	1	2	3 836 000	91 55 540 08	SUPPLEMENTARY GUYING D
ROPE 34MM 6.525M	97 74 940 08	1	2	3 837	91 55 541 08	SUPPLEMENTARY GUYING D
ROPE 34MM 7.525M	97 74 941 08	1	2	3 838 000	91 55 542 08	SUPPLEMENTARY GUYING D
ROPE 4X2416	97 73 190 08	32	1	3 206	91 52 881 08	PIVOT SECTION
ROPE 5x750	97 06 965 08	27	2	3 215 005	91 52 846 08	ROLLER SET
ROPE 5x750	97 06 965 08	27	2	3 215 006	91 52 847 08	ROLLER SET
ROPE 8MM 400M	10 03 825 9	1	1	2 372	91 33 648 08	ROPE WITH ACCESSORIES
ROPE CLAMP 24-26 GR.1"	77 39 091 08	37	1	1 750	91 52 394 08	TOOL
ROPE CLAMP DIN 1142 S26 V	77 39 118 08	38	1	1 750	91 52 394 08	TOOL
ROPE CLAMP DIN 1142 S30 V	77 39 132 08	45	1	1 750	91 52 394 08	TOOL
ROPE DIN 3055 2MM 2,3KN FE	77 34 003 08	64	3	2 631	91 56 817 08	SLEWING PLATFORM CATWAL
ROPE DIN 3055 2MM 2,3KN FE	77 34 003 08	79	1	2 810	91 52 806 08	CRANE DRIVER'S CABIN CPL.
ROPE DIN 3055 2MM 2,3KN FE	77 34 003 08	61	2	2 978 100	91 52 827 08	ADDNL.HYDR.RETAINING DEV
ROPE DIN 3055 2MM 2,3KN FE	77 34 003 08	55	1	3 225	91 52 854 08	SL REDUCING SECTION
ROPE DIN 3055 2MM 2,3KN FE	77 34 003 08	62	1.5	3 745	91 52 948 08	SUSPENDED BALLAST
ROPE DIN 3055 2MM 2,3KN FE	77 34 003 08	61	2	3 978 005	91 56 430 08	ADDL.HYDRAULIC SB-HEAD PI
ROPE DIN 3055 4MM 1,3M VER	10 45 067 1	23	4	1 630	91 52 387 08	HYDRAULIC SUPPORT
ROPE DRUM	10 65 015 6	21	1	X1035411	10 35 411 4	HOISTING WINCH
ROPE FOR WINCH 4	91 52 837 08	193	1		LR 1600-2-0	
ROPE GUARD WELDED	96 47 103 08	41	1	2 550	91 57 751 08	SA FRAME
ROPE GUARD WELDED	96 51 812 08	27	2	2 652	91 52 794 08	ROLLER BEARING
ROPE GUARD WELDED	96 51 813 08	28	1	2 652	91 52 794 08	ROLLER BEARING
ROPE GUARD WELDED	96 56 155 08	94	2	2 550	91 57 751 08	SA FRAME
ROPE GUARD WELDED	96 56 165 08	95	2	2 550	91 57 751 08	SA FRAME
ROPE GUARD WELDED	96 56 171 08	96	1	2 550	91 57 751 08	SA FRAME
ROPE GUARD WELDED	96 58 269 08	20	1	3 714 009	96 49 267 08	LUFFING PULLEY BLOCK COM
ROPE LOCK 28 SPF	77 39 401 08	44	1	1 750	91 52 394 08	TOOL
ROPE PULLEY / SHEAVE D=70	28 81 999 08	1	1	2 652 007	92 68 928 08	ROPE PULLEY CPL.
ROPE PULLEY / SHEAVE SPF	97 18 725 08	1	1	3 206 001	96 20 920 08	ROPE PULLEY CPL.
ROPE PULLEY ATTACHM. WEL	96 52 291 08	55	1	3 281	91 52 896 08	ERECTION FRAME
ROPE PULLEY CPL.	96 20 920 08	17	2	3 206	91 52 881 08	PIVOT SECTION
ROPE PULLEY CPL.	96 20 920 08	57	1	3 281	91 52 896 08	ERECTION FRAME
ROPE PULLEY CPL. SPF	92 68 928 08	6	4	3 208 001	91 52 883 08	F-HEAD SECTION
ROPE PULLEY CPL. SPF	92 68 928 08	2	10	3 215 005	91 52 846 08	ROLLER SET
ROPE PULLEY CPL. SPF	92 68 928 08	2	12	3 215 006	91 52 847 08	ROLLER SET
ROPE PULLEY CPL. SPF	92 68 928 08	2	1	3 281	91 52 896 08	ERECTION FRAME
ROPE PULLEY CPL. SPF	92 68 928 08	3	2	3 713	91 57 749 08	D PIVOT SECTION
ROPE PULLEY CPL. SPF	96 46 246 08	3	17	2 550	91 57 751 08	SA FRAME
ROPE PULLEY CPL. SPF	96 46 246 08	4	16	2 652	91 52 794 08	ROLLER BEARING
ROPE PULLEY CPL. SPF	96 46 246 08	5	4	3 214	91 52 843 08	SW HEAD SECTION
ROPE PULLEY CPL. SPF	96 46 246 08	2	2	3 225 100	96 48 582 08	BEARING CPL
ROPE PULLEY CPL. SPF	96 46 246 08	10	3	3 714	91 52 862 08	D HEAD SECTION
ROPE PULLEY CPL. SPF	96 46 246 08	2	7	3 714 008	96 49 266 08	LUFFING PULLEY BLOCK COM
ROPE PULLEY CPL. SPF	96 46 246 08	5	8	3 714 009	96 49 267 08	LUFFING PULLEY BLOCK COM
ROPE PULLEY CPL. SPF	96 46 246 08	2	1	3 714 021	96 49 271 08	ROLLER SEATING COMPL.
ROPE WINCH	54 00 018 08	7	4	1 630	91 52 387 08	HYDRAULIC SUPPORT
ROPE WINCH	54 00 569 08	5	1	3 208 001	91 52 883 08	F-HEAD SECTION
ROPE WINCH ZHP 4.13 SPF	54 00 565 08	1	1	2 370	91 52 782 08	ERECTING WINCH
ROPE WINCH ZHP 4.29 SPF	10 35 433 2	1	1	2 340	91 52 776 08	WINCH 4 LUFFING GEAR
ROPE WITH ACCESSORIES	91 33 648 08	198	1		LR 1600-2-0	
ROPE WITH ACCESSORIES 1	91 52 834 08	190	1		LR 1600-2-0	
ROPE WITH ACCESSORIES 2	91 52 835 08	191	1		LR 1600-2-0	
ROPES FOR WINCHES 3	91 52 836 08	192	1		LR 1600-2-0	
ROTARY ENCODER OPTISCH	69 23 091 08	11	1	1 920 305	92 15 300 08	INSTALLAT.ROTOR+SLIPRING

6.2.2009

etk_en_de_074515 LR 1600/2

961

LIEBHERRAlphabetical index
Alphabetischer Index

Description	Item	Pos.	Quantity	Page	Assembly	Description
ROTARY ENCODER OPTISCH	69 23 091 08	28	1	6 909 010	69 09 010 08	COLLECTING RING
ROTARY FEED THROUGH	91 52 510 08	33	1		LR 1600-2-0	
ROTARY FEED THROUGH SPF	10 04 262 0	1	1	1 991	91 52 510 08	ROTARY FEED THROUGH
ROTARY LOCK	60 61 433 08	19	2	2 533 070	96 48 363 08	CONTROLS AND FITTINGS RI
ROTARY LOCK	60 61 433 08	33	1	2 932 001	96 45 393 08	RELAY CONTROL SYSTEM
ROTARY SHAFT LIP SEAL DIN	57 15 512 08	53	1	X1065015	10 65 015 8	DRIVE UNIT
ROTARY SHAFT LIP SEAL DIN	57 15 521 08	31	1	X1065015	10 65 015 5	GEARBOX
ROTARY SHAFT LIP SEAL DIN	54 01 943 08	50	1	X1065015	10 65 015 8	DRIVE UNIT
ROTARY SHAFT LIP SEAL DIN	71 00 312 08	10	1	5 400 565	54 00 565 08	ROPE WINCH
ROTARY SHAFT LIP SEAL DIN	57 01 519 08	15	1	5 400 565	54 00 565 08	ROPE WINCH
ROTARY SHAFT LIP SEAL DIN	71 00 630 01	4	1	9 697 916	96 97 916 01	SLEWING GEAR
ROTARY SHAFT LIP SEAL DIN	57 07 018 08	(14)	1	5 102 354	51 02 354 08	HYDRO MOTOR
ROTARY SHAFT LIP SEAL DIN	71 00 241 08	64	2	9 697 916	96 97 916 01	SLEWING GEAR
ROTARY SHAFT LIP SEAL DIN	71 00 341 08	11	2	9 697 916	96 97 916 01	SLEWING GEAR
ROUND SLING DIN EN 1492-2 3	10 28 562 6	41	2	3 220 500	91 52 849 08	S INTERMEDIATE SECTION
ROUND SLING DIN EN 1492-2 3	10 28 562 6	41	2	3 223	91 52 852 08	S INTERMEDIATE SECTION
ROUND SLING DIN EN 1492-2 3	10 28 562 6	41	2	3 223 010	91 52 853 08	S INTERMEDIATE SECTION
ROUND SLING DIN EN 1492-2 3	10 28 562 6	41	2	3 223 100	91 55 327 08	S INTERMEDIATE SECTION
ROUND STEEL RD45X364	95 45 849 08	2	162	1 300 011	96 52 493 08	FLOOR PLATES PRE-ASS.
ROUND STRAND ROPE 10MM	10 65 281 3	39	1	3 214	91 52 843 08	SW HEAD SECTION
ROUND STRAND ROPE 10MM	10 65 281 4	83	2	3 713	91 57 749 08	D PIVOT SECTION
ROUND STRAND ROPE 10MM	10 65 244 0	43	2	3 223	91 52 852 08	S INTERMEDIATE SECTION
ROUND STRAND ROPE 10MM	10 65 244 0	43	2	3 223 010	91 52 853 08	S INTERMEDIATE SECTION
ROUND STRAND ROPE 10MM	10 65 244 0	43	2	3 223 100	91 55 327 08	S INTERMEDIATE SECTION
ROUND STRAND ROPE 10MM	10 65 244 0	43	2	3 227	91 52 873 08	L INTERMEDIATE SECTION
ROUND STRAND ROPE 10MM	10 65 244 0	43	2	3 227 008	91 52 872 08	L INTERMEDIATE SECTION
ROUND STRAND ROPE 10MM	10 65 244 0	43	2	3 227 200	91 53 519 08	LI INTERMEDIATE SECT. F-GU
ROUND STRAND ROPE 10MM	10 65 244 0	32	2	3 716	91 52 864 08	D INTERMEDIATE SECTION
ROUND STRAND ROPE 10MM	10 65 243 8	25	2	3 221	91 54 668 08	S INTERMEDIATE SECTION
ROUND STRAND ROPE 10MM	10 65 280 6	82	2	3 211	91 57 748 08	S PIVOT SECTION
ROUND STRAND ROPE 10MM	10 65 243 9	43	2	3 220 500	91 52 849 08	S INTERMEDIATE SECTION
ROUND STRAND ROPE 10MM	10 65 243 9	43	2	3 226	91 52 870 08	L INTERMEDIATE SECTION
ROUND STRAND ROPE 10MM	10 65 243 9	34	2	3 715 008	91 52 863 08	D INTERMEDIATE SECTION
ROUND STRAND ROPE 10MM	10 65 281 6	47	2	3 225	91 52 854 08	SL REDUCING SECTION
ROUND STRAND ROPE 10MM	10 65 281 8	43	2	3 714	91 52 862 08	D HEAD SECTION
RS PRESSURE FILTER DF...33	10 10 138 4	(3)	1	2 970	91 56 537 08	HYDR
RUBBER BELLOWS	10 65 048 5	48	1	X1029200	10 29 200 4	DRIVERS SEAT
RUBBER BELLOWS	57 19 123 08	2	1	6 060 950	60 60 950 08	MASTER SWITCH
RUBBER BUFFER 30X36 KAUT	10 04 050 2	33	1	2 925 402	96 58 855 08	CAMERA EQUIPMENT SLEWI
RUBBER BUMPER 32X32XM6	10 47 289 0	84	2	2 520	91 53 061 08	CABIN, GLAZED
RUBBER-METAL STOP BUFFE	72 66 158 08	8	2	2 260	91 53 057 08	CUP SPRING CLUSTER
RUNNING ROLLER PA6G	97 71 335 08	8	2	3 281	91 52 896 08	ERECTION FRAME
RUNNING ROLLER S355J2G3	97 69 683 08	1	1	2 550 003	96 46 246 08	ROPE PULLEY CPL.
S INTERMED.SECTION WELD	96 48 482 08	1	1	3 223 100	91 55 327 08	S INTERMEDIATE SECTION
S INTERMED.SECTION WELD	96 44 096 08	1	1	3 223	91 52 852 08	S INTERMEDIATE SECTION
S INTERMED.SECTION WELD.	96 43 376 08	1	1	3 220 500	91 52 849 08	S INTERMEDIATE SECTION
S INTERMED.SECTION WELD	96 45 126 08	1	1	3 223 010	91 52 853 08	S INTERMEDIATE SECTION
S INTERMED.SECTION WELD	96 47 979 08	1	1	3 221	91 54 668 08	S INTERMEDIATE SECTION
S INTERMEDIATE SECTION 12	91 55 327 08	213	1		LR 1600-2-0	
S INTERMEDIATE SECTION 28	91 52 852 08	210	2		LR 1600-2-0	
S INTERMEDIATE SECTION 2	91 52 849 08	207	1		LR 1600-2-0	
S INTERMEDIATE SECTION 28	91 52 853 08	211	3		LR 1600-2-0	
S INTERMEDIATE SECTION 2	91 54 668 08	212	1		LR 1600-2-0	
S OVERRUN PROTECTION	91 52 831 08	183	1		LR 1600-2-0	
S PIVOT SECTION 10M	91 57 748 08	201	1		LR 1600-2-0	
S PIVOT SECTION, WELD.CO	96 45 098 08	1	1	3 211	91 57 748 08	S PIVOT SECTION
SA FRAME	91 57 751 08	135	1		LR 1600-2-0	
SA FRAME WELDED CONSTR.	96 45 308 08	1	1	2 550	91 57 751 08	SA FRAME
SAE FLANGE 11/2"	51 15 026 08	42	6	2 391 001	96 45 719 08	DIESEL ENGINE, PRE-ASSEMB
SAE FLANGE CONNECTION	47 49 071 08	559	2	2 970	91 56 537 08	HYDR

6.2.2009

etk_en_de_074515 LR 1600/2

962

LIEBHERRAlphabetical index
Alphabetischer Index

Description	Item	Pos.	Quantity	Page	Assembly	Description
SAE FLANGE CONNECTION G	47 49 014 08	567	1	2 970	91 56 537 08	HYDR
SAE FLANGE CONNECTION G	47 49 019 08	564	1	2 970	91 56 537 08	HYDR
SAE FLANGE CONNECTION W	47 49 075 08	563	2	2 970	91 56 537 08	HYDR
SAE FLANGE CONNECTION W	47 49 069 08	565	4	2 970	91 56 537 08	HYDR
SAE SCREW-IN FLANGE A3P	51 15 125 08	3	2	2 391 038	96 47 931 08	OIL COOLER, PRE-ASSEMBLE
SAE-FLANGE HALF 11/4" A3P	51 15 162 08	561	4	2 970	91 56 537 08	HYDR
SAFETY PLUG W HINGE-LID 1	43 32 005 08	19	1	2 550 005	96 45 680 08	ROD CPL.
SAFETY PLUG W HINGE-LID 1	43 32 005 08	10	2	2 657	91 57 656 08	MOUNTING EQUIPMENT CRAW
SAFETY PLUG W HINGE-LID 1	43 32 005 08	17	4	3 211	91 57 748 08	S PIVOT SECTION
SAFETY PLUG W HINGE-LID 1	43 32 005 08	7	1	3 211 003	96 46 986 08	ROD CPL.
SAFETY PLUG W HINGE-LID 1	43 32 005 08	8	1	3 220 501	96 43 440 08	ROD CPL.
SAFETY PLUG W HINGE-LID 1	43 32 005 08	8	1	3 221 200	96 47 984 08	ROD CPL.
SAFETY PLUG W HINGE-LID 1	43 32 005 08	20	3	3 225	91 52 854 08	SL REDUCING SECTION
SAFETY PLUG W HINGE-LID 1	43 32 005 08	8	1	3 225 200	96 48 679 08	ROD CPL.
SAFETY PLUG W HINGE-LID 1	43 32 005 08	8	1	3 227 002	96 50 498 08	ROD CPL.
SAFETY PLUG W HINGE-LID 1	43 32 005 08	8	1	3 561 003	96 45 222 08	ROD CPL.
SAFETY PLUG W HINGE-LID 1	43 32 005 08	88	4	3 713	91 57 749 08	D PIVOT SECTION
SAFETY PLUG W HINGE-LID 1	43 32 005 08	8	1	3 713 012	96 50 197 08	ROD CPL.
SAFETY PLUG W HINGE-LID 1	43 32 005 08	11	2	3 714 009	96 49 267 08	LUFFING PULLEY BLOCK COM
SAFETY PLUG W HINGE-LID 1	43 32 005 08	4	2	3 714 013	96 59 083 08	BRACKET COMPL.
SAFETY PLUG W HINGE-LID 1	43 32 005 08	8	1	3 716 001	96 49 159 08	ROD CPL.
SAFETY PLUG W HINGE-LID 1	43 32 005 08	5	8	3 747	91 52 950 08	CENTERING STANDARD
SAFETY PLUG W HINGE-LID 1	43 32 005 08	9	2	3 830	91 55 535 08	SUPPLEMENTARY GUYING D
SAFETY PLUG W HINGE-LID 17	43 32 015 08	4	2	3 213	91 52 842 08	F-CONNECTING HEAD
SAFETY PLUG W HINGE-LID 17	43 32 015 08	25	2	3 214	91 52 843 08	SW HEAD SECTION
SAFETY PLUG W HINGE-LID 17	43 32 015 08	15	4	3 215 005	91 52 846 08	ROLLER SET
SAFETY PLUG W HINGE-LID 17	43 32 015 08	15	4	3 215 006	91 52 847 08	ROLLER SET
SAFETY PLUG W HINGE-LID 17	43 32 015 08	9	2	3 225	91 52 854 08	SL REDUCING SECTION
SAFETY PLUG W HINGE-LID 17	43 32 015 08	3	4	3 226	91 52 870 08	L INTERMEDIATE SECTION
SAFETY PLUG W HINGE-LID 17	43 32 015 08	3	4	3 227	91 52 873 08	L INTERMEDIATE SECTION
SAFETY PLUG W HINGE-LID 17	43 32 015 08	3	4	3 227 008	91 52 872 08	L INTERMEDIATE SECTION
SAFETY PLUG W HINGE-LID 17	43 32 015 08	3	4	3 227 200	91 53 519 08	LI INTERMEDIATE SECT. F-GU
SAFETY PLUG W HINGE-LID 17	43 32 015 08	13	2	3 713	91 57 749 08	D PIVOT SECTION
SAFETY PLUG W HINGE-LID 17	43 32 015 08	25	2	3 714	91 52 862 08	D HEAD SECTION
SAFETY PLUG W HINGE-LID 17	43 32 015 08	16	4	3 715 008	91 52 863 08	D INTERMEDIATE SECTION
SAFETY PLUG W HINGE-LID 17	43 32 015 08	16	4	3 716	91 52 864 08	D INTERMEDIATE SECTION
SAFETY PLUG W HINGE-LID 2	10 41 062 2	5	2	3 211	91 57 748 08	S PIVOT SECTION
SAFETY PLUG W HINGE-LID 2	10 41 062 2	3	4	3 220 500	91 52 849 08	S INTERMEDIATE SECTION
SAFETY PLUG W HINGE-LID 2	10 41 062 2	3	4	3 221	91 54 668 08	S INTERMEDIATE SECTION
SAFETY PLUG W HINGE-LID 2	10 41 062 2	3	4	3 223	91 52 852 08	S INTERMEDIATE SECTION
SAFETY PLUG W HINGE-LID 2	10 41 062 2	3	4	3 223 010	91 52 853 08	S INTERMEDIATE SECTION
SAFETY PLUG W HINGE-LID 2	10 41 062 2	3	4	3 223 100	91 55 327 08	S INTERMEDIATE SECTION
SAFETY PLUG W HINGE-LID 2	10 41 062 2	8	2	3 225	91 52 854 08	SL REDUCING SECTION
SAFETY PLUG W HINGE-LID 5X	43 32 013 08	18	8	3 227 002	96 50 498 08	ROD CPL.
SAFETY PLUG W HINGE-LID 8X	43 32 014 08	17	4	3 214	91 52 843 08	SW HEAD SECTION
SAFETY PLUG W HINGE-LID 8X	43 32 014 08	6	1	3 225 100	96 48 582 08	BEARING CPL
SAFETY PLUG W HINGE-LID 8X	43 32 014 08	97	2	3 714	91 52 862 08	D HEAD SECTION
SAFETY PLUG W HINGE-LID 8X	43 32 014 08	14	4	3 714 009	96 49 267 08	LUFFING PULLEY BLOCK COM
SAFETY PLUG W HINGE-LID 9,	43 32 004 08	3	4	1 742	91 53 021 08	FIXAGE DU CONTREPOIDS CE
SAFETY PLUG W HINGE-LID 9,	43 32 004 08	18	4	2 631	91 56 817 08	SLEWING PLATFORM CATWAL
SAFETY PLUG W HINGE-LID 9,	43 32 004 08	10	1	3 207 003	96 48 259 08	ROD CPL.
SAFETY PLUG W HINGE-LID 9,	43 32 004 08	7	2	3 207 100	96 48 261 08	BRACKET COMPL.
SAFETY ROLLER CPL.	92 88 302 08	10	1	3 211	91 57 748 08	S PIVOT SECTION
SAFETY ROLLER CPL.	96 46 978 08	8	1	3 211	91 57 748 08	S PIVOT SECTION
SAFETY ROLLER CPL.	96 46 979 08	9	1	3 211	91 57 748 08	S PIVOT SECTION
SAFETY ROLLER CPL. SPF	92 70 642 08	65	1	2 550	91 57 751 08	SA FRAME
SAFETY ROLLER CPL. SPF	96 18 667 08	4	2	3 350	91 52 859 08	WINCH 3
SAFETY ROLLER WELDED	92 38 783 08	(1)	1	3 350	91 52 859 08	WINCH 3
SAFETY STIRRUP S16 A3C	10 01 751 3	10	1	9 739 186	97 39 186	MOTOR BRAKE
SAFETY VALVE 17BAR	10 01 248 1	11	1	9 739 491	97 39 491	INSTALLATION BRAKE COMPR

6.2.2009

etk_en_de_074515 LR 1600/2

963

LIEBHERRAlphabetical index
Alphabetischer Index

Description	Item	Pos.	Quantity	Page	Assembly	Description
SASH LOCK SPF	70 42 710 08	2	2	2 260 009	96 46 972 08	FLAP PRE-ASS.
SCREEN 1,5X19,5X111	61 10 017 08	4	1	2 932 122	96 45 394 08	LICCON ASSEMBLY UNIT
SCREW	10 41 274 6	13	1	9 640 276	96 40 276 08	CONNECTION BLOCK
SCREW 3/8"-24NFX7 1/4" 12.9	10 35 393 0	(1)	4	2 970	91 56 537 08	HYDR
SCREW 4X12 ST VERZ	10 01 904 0	29	8	2 502	91 55 939 08	CONTROL STAND
SCREW 4X12 ST VERZ	10 01 904 0	5	4	2 540	91 53 253 08	CLIMA-HEATING INSTALLATIO
SCREW 4X12 ST VERZ	10 01 904 0	4	4	2 541	91 52 790 08	ADD HEATING SUPERSTRUCT
SCREW AEHNL.ISO 4017 UNC	40 97 516 08	343	8	2 391 001	96 45 719 08	DIESEL ENGINE, PRE-ASSEMB
SCREW CAP	10 01 212 9	2	1	9 739 354	97 39 354	FLYWHEEL HOUSING MOUNT
SCREW CAP	10 01 260 2	7	1	9 739 354	97 39 354	FLYWHEEL HOUSING MOUNT
SCREW CAP	10 01 333 6	5	1	9 739 267	97 39 267	CYLINDER FAIRING
SCREW CAP	51 06 623 08	2	1	5 708 320	57 08 320 08	FILTER COVER
SCREW CAP	97 39 286	10	1	9 739 491	97 39 491	INSTALLATION BRAKE COMPR
SCREW CAP	97 39 365	3	1	9 739 368	97 39 368	CRANKCASE CPL.
SCREW CAP	97 39 367	2	1	9 739 368	97 39 368	CRANKCASE CPL.
SCREW CAP SJ 355	97 39 036	1	1	9 739 035	97 39 035	LOCKING PIECES
SCREW CARABINER OVAL 130	10 47 304 0	3	2	2 311 001	96 25 639 08	HOIST LIM.SWITCH PLUMMET
SCREW CARABINER OVAL 130	10 47 304 0	44	1	3 208 001	91 52 883 08	F-HEAD SECTION
SCREW DRIVER 3,5	79 00 320 08	13	1	1 750	91 52 394 08	TOOL
SCREW DRIVER 4,5	88 52 004 08	14	1	1 750	91 52 394 08	TOOL
SCREW DRIVER 5,5	79 00 323 08	15	1	1 750	91 52 394 08	TOOL
SCREW FITTING ELEMENT X	93 75 014 08	4	2	2 976 200	91 52 780 08	ADDITIONAL HYDRAULICS
SCREW ISO 7045 M3X16 4.8 A2	40 84 007 01	4	2	2 913 005	96 20 731 08	INTERIOR HOUSING PRE-ASS.
SCREW ISO 7045 M3X16 4.8 A2	40 84 007 01	4	2	2 913 005	96 28 696 08	INTERIOR HOUSING PRE-ASS.
SCREW M10X130 8.8 A3C	10 01 127 2	4	1	9 739 344	97 39 344	GENERATOR, PRE-ASSEMBLE
SCREW M10X145 8.8 A3C	10 01 127 1	2	1	9 739 355	97 39 355	OIL COOLER ADD-ON
SCREW M10X170 8.8 A3C	10 01 127 4	3	1	9 739 355	97 39 355	OIL COOLER ADD-ON
SCREW M10X30 8.8	10 01 133 0	3	2	9 739 286	97 39 286	SCREW CAP
SCREW M10X30 8.8	10 01 133 0	12	1	9 739 344	97 39 344	GENERATOR, PRE-ASSEMBLE
SCREW M10X35 8.8	10 01 133 1	12	1	9 739 248	97 39 248	INJECTOR
SCREW M10X35 8.8	10 01 133 1	1	8	9 739 355	97 39 355	OIL COOLER ADD-ON
SCREW M10X35 8.8	10 01 133 1	14	1	9 739 371	97 39 371	AIR COND. COMPRESSOR A
SCREW M10X40 8.8 A3C	10 01 134 3	15	2	9 739 344	97 39 344	GENERATOR, PRE-ASSEMBLE
SCREW M10X54 12.9	10 01 250 3	9	13	9 739 354	97 39 354	FLYWHEEL HOUSING MOUNT
SCREW M10X65 10.9 A3C	10 01 133 7	4	1	9 739 271	97 39 271	CONNECTING LINE
SCREW M10X70 10.9	10 01 250 0	13	3	9 739 354	97 39 354	FLYWHEEL HOUSING MOUNT
SCREW M10X70 8.8	10 01 126 4	3	2	9 739 386	97 39 386	CRANKCASE BREATHER
SCREW M10X85 8.8 A3C	10 01 134 7	2	4	9 739 358	97 39 358	EXHAUST GAS RECIRCUL.ATT
SCREW M12X16 8.8 A3C	10 01 134 4	3	1	9 739 366	97 39 366	FASTENING PIECES ASSEMBL
SCREW M12X40 8.8 A3C	10 01 134 5	8	2	9 739 344	97 39 344	GENERATOR, PRE-ASSEMBLE
SCREW M12X40 8.8 A3C	10 01 134 5	17	1	9 739 371	97 39 371	AIR COND. COMPRESSOR A
SCREW M16X1,5X75 12.9	10 01 250 5	6	10	9 739 250	97 39 250	FLYWHEEL
SCREW M16X35 8.8	10 01 133 5	4	4	9 739 493	97 39 493	TRANSPORT DEVICE
SCREW M6X22 8.8	10 01 124 8	6	4	9 739 292	97 39 292	FUEL LINE
SCREW M8X105 8.8 A2C	10 01 126 1	4	2	9 739 349	97 39 349	CONNECTION F.WATER PIPE
SCREW M8X12 8.8	10 01 135 1	9	6	9 739 296	97 39 296	HEAT PROTECTION
SCREW M8X130 10.9	10 01 126 7	4	4	9 739 256	97 39 256	AIR SUCTION PIPE
SCREW M8X15	40 98 312 08	3	4	2 631 003	96 54 406 08	ACCESS LADDER PRE-ASS.
SCREW M8X16 8.8	10 01 136 0	4	3	9 739 035	97 39 035	LOCKING PIECES
SCREW M8X16 8.8	10 01 136 0	4	3	9 739 129	97 39 129	COOLANT PREHEATING
SCREW M8X16 8.8	10 01 136 0	8	5	9 739 366	97 39 366	FASTENING PIECES ASSEMBL
SCREW M8X18 8.8	10 01 124 9	5	6	9 739 352	97 39 352	AT-WATER PUMP WITH FAST
SCREW M8X18 8.8	10 01 124 9	20	1	9 739 386	97 39 386	CRANKCASE BREATHER
SCREW M8X20 8.8	10 01 134 9	17	1	9 739 296	97 39 296	HEAT PROTECTION
SCREW M8X22 8.8	10 01 125 0	4	2	9 739 354	97 39 354	FLYWHEEL HOUSING MOUNT
SCREW M8X22 8.8	10 01 125 0	12	4	9 739 358	97 39 358	EXHAUST GAS RECIRCUL.ATT
SCREW M8X22 8.8	10 01 125 0	22	2	9 739 371	97 39 371	AIR COND. COMPRESSOR A
SCREW M8X25 8.8	10 01 136 2	9	1	9 739 210	97 39 210	LIQUID COOLING PIPELINE
SCREW M8X25 8.8	10 01 136 2	12	1	9 739 371	97 39 371	AIR COND. COMPRESSOR A
SCREW M8X28 8.8 A2C	10 01 121 4	10	1	9 739 118	97 39 118	OIL LINE

6.2.2009

etk_en_de_074515 LR 1600/2

964

LIEBHERRAlphabetical index
Alphabetischer Index

Description	Item	Pos.	Quantity	Page	Assembly	Description
SCREW M8X35 10.9	10 01 133 9	7	1	9 739 256	97 39 256	AIR SUCTION PIPE
SCREW M8X35 8.8	10 01 125 2	3	1	9 739 349	97 39 349	CONNECTION F.WATER PIPE
SCREW M8X35 8.8	10 01 125 2	14	1	9 739 349	97 39 349	CONNECTION F.WATER PIPE
SCREW M8X40 8.8	10 01 125 3	9	1	9 739 118	97 39 118	OIL LINE
SCREW M8X40 8.8 A2C	10 01 148 8	14	1	9 739 357	97 39 357	EXHAUST GAS RECIRCUL.PRE
SCREW M8X40 8.8 A2C	10 01 148 8	26	4	9 739 371	97 39 371	AIR COND. COMPRESSOR A
SCREW M8X45 8.8	10 01 132 6	4	2	9 739 259	97 39 259	FUEL FILTER
SCREW M8X45 8.8	10 01 132 6	3	2	9 739 276	97 39 276	WATER CONNECTION
SCREW M8X55 8.8	10 01 132 8	3	2	9 739 126	97 39 126	THERMOSTAT HOUSING
SCREW M8X55 8.8	10 01 132 8	4	1	9 739 276	97 39 276	WATER CONNECTION
SCREW M8X55 8.8	10 01 132 8	10	3	9 739 372	97 39 372	LUBRICATING OIL PUMP
SCREW M8X55 8.8	10 01 133 4	3	2	9 739 271	97 39 271	CONNECTING LINE
SCREW M8X65 8.8 A2C	10 01 122 5	5	1	9 739 126	97 39 126	THERMOSTAT HOUSING
SCREW M8X65 8.8 A2C	10 01 122 5	4	2	9 739 369	97 39 369	PRESSURE PIPE
SCREW M8X90 8.8	10 01 126 2	2	2	9 739 259	97 39 259	FUEL FILTER
SCREW M8X95 8.8	10 02 919 3	5	1	9 739 369	97 39 369	PRESSURE PIPE
SCREW PLUG	10 41 274 8	19	1	9 640 276	96 40 276 08	CONNECTION BLOCK
SCREW PLUG	10 41 275 3	5	1	9 640 277	96 40 277 08	DIRECTIONAL CTRL. VALVE
SCREW PLUG	51 05 455 08	34	4	1 970	91 56 958 08	CRAWLER TRACK HYDRAULI
SCREW PLUG	51 05 455 08	83	6	2 970	91 56 537 08	HYDR
SCREW PLUG	51 05 455 08	34	5	2 977	91 57 756 08	ADDITIONAL HYDR.SLEWING
SCREW PLUG	51 05 455 08	14	2	2 977 200	91 55 149 08	ADDITIONAL HYDR.PUMP/WI
SCREW PLUG	51 05 455 08	15	1	3 978 005	91 56 430 08	ADDL.HYDRAULIC SB-HEAD PI
SCREW PLUG	57 17 778 08	55	1	5 102 380	51 02 380 08	HYDRO MOTOR
SCREW PLUG	97 39 096	2	1	X1012059	10 12 059 0	DIESEL ENGINE
SCREW PLUG AM16X1,5 ST A3	10 01 696 8	19	1	9 739 349	97 39 349	CONNECTION F.WATER PIPE
SCREW PLUG DIN 908 M10X1	46 00 319	60	4	X1065015	10 65 015 8	DRIVE UNIT
SCREW PLUG DIN 908 M12X1,5	51 07 192 08	122	1	X1065015	10 65 015 8	DRIVE UNIT
SCREW PLUG DIN 908 M16X1,5	40 41 001 08	7	1	5 113 005	51 13 005 08	CONTROL BLOCK
SCREW PLUG DIN 908 M18X1,5	40 41 002 08	(4)	2	2 810	91 52 806 08	CRANE DRIVER'S CABIN CPL.
SCREW PLUG DIN 908 M18X1,5	40 41 002 08	64	1	X1065015	10 65 015 8	DRIVE UNIT
SCREW PLUG DIN 908 M22X1,5	40 41 017 08	530	2	X1065015	10 65 015 5	GEARBOX
SCREW PLUG DIN 908 M22X1,5	40 41 016 08	24	1	9 739 491	97 39 491	INSTALLATION BRAKE COMPR
SCREW PLUG DIN 908 M30X1,5	40 41 007 08	462	4	X1065015	10 65 015 5	GEARBOX
SCREW PLUG M12X1,2 MS	60 24 255 08	152	1	2 780 748	96 52 969 08	TERMINAL BOX CPL.
SCREW PLUG M12X1,2 MS	60 24 255 08	271	1	3 930 638	96 51 624 08	TERMINAL BOX
SCREW PLUG M12X1,2 MS	60 24 255 08	152	2	3 930 640	96 50 481 08	TERMINAL BOX CPL.
SCREW PLUG M12X1,2 MS	60 24 255 08	214	1	3 930 734	96 54 401 08	TERMINAL BOX
SCREW PLUG M14X1,5 ST A3	10 01 161 2	2	2	9 739 282	97 39 282	OVERFLOW-OIL LINE
SCREW PLUG M14X1,5 ST A3	10 01 161 2	15	2	9 739 361	97 39 361	OIL SUMP
SCREW PLUG M16X1,5 MS	60 24 249 08	269	1	1 920 403	96 48 707 08	TERMINAL BOX CPL.
SCREW PLUG M16X1,5 MS	60 24 249 08	269	1	1 920 417	96 48 703 08	TERMINAL BOX CPL.
SCREW PLUG M16X1,5 MS	60 24 249 08	151	1	2 780 748	96 52 969 08	TERMINAL BOX CPL.
SCREW PLUG M16X1,5 MS	60 24 249 08	279	3	3 930 363	96 52 979 08	TERMINAL BOX CPL.
SCREW PLUG M16X1,5 MS	60 24 249 08	273	1	3 930 638	96 51 624 08	TERMINAL BOX
SCREW PLUG M16X1,5 MS	60 24 249 08	152	2	3 930 730	96 54 398 08	TERMINAL BOX CPL.
SCREW PLUG M16X15 9SMN	10 01 252 2	1	1	9 739 096	97 39 096	SCREW PLUG
SCREW PLUG M18 ST A3C	10 01 161 5	5	1	9 739 355	97 39 355	OIL COOLER ADD-ON
SCREW PLUG M20X1,5 MS	60 24 250 08	268	1	1 920 403	96 48 707 08	TERMINAL BOX CPL.
SCREW PLUG M20X1,5 MS	60 24 250 08	268	1	1 920 417	96 48 703 08	TERMINAL BOX CPL.
SCREW PLUG M20X1,5 MS	60 24 250 08	7	1	3 930 640	96 50 481 08	TERMINAL BOX CPL.
SCREW PLUG M20X1,5 MS	60 24 250 08	215	1	3 930 734	96 54 401 08	TERMINAL BOX
SCREW PLUG M22 5.8 ZNPHR3	10 34 227 2	6	1	9 739 351	97 39 351	COOLING MEDIUM PIPELINE
SCREW PLUG M22X1,5	10 34 023 6	13	2	7 027 481	70 27 481 03	WATER SEPARATOR
SCREW PLUG M22X1,5 A3P	50 29 401 08	596	2	2 990	91 59 244 08	COMPRESSED AIR PLANT
SCREW PLUG M25X1,5 MS	60 24 251 08	19	3	1 920 418	96 48 687 08	TERMINAL BOX CPL.
SCREW PLUG M25X1,5 MS	60 24 251 08	(159)	1	2 920 369	96 54 235 08	TERMINAL BOX CPL.
SCREW PLUG M25X1,5 MS	60 24 251 08	(160)	1	2 920 369	96 54 235 08	TERMINAL BOX CPL.
SCREW PLUG M25X1,5 MS	60 24 251 08	519	6	2 920 633	96 52 651 08	WIRING HARNESS
SCREW PLUG M25X1,5 MS	60 24 251 08	272	1	3 930 638	96 51 624 08	TERMINAL BOX

6.2.2009

etk_en_de_074515 LR 1600/2

965

LIEBHERRAlphabetical index
Alphabetischer Index

Description	Item	Pos.	Quantity	Page	Assembly	Description
SCREW PLUG M25X1,5 MS	60 24 251 08	157	1	3 930 730	96 50 599 08	TERMINAL BOX CPL.
SCREW PLUG M25X1,5 MS	60 24 251 08	158	1	3 930 730	96 50 599 08	TERMINAL BOX CPL.
SCREW PLUG M25X1,5 MS	60 24 251 08	220	3	3 930 734	96 54 401 08	TERMINAL BOX
SCREW PLUG M25X1,5X20 9S	10 01 252 6	7	1	9 739 361	97 39 361	OIL SUMP
SCREW PLUG M26X1,5 ST A3	10 01 161 9	9	2	9 739 361	97 39 361	OIL SUMP
SCREW PLUG M26X1,5 ST A3	10 01 161 9	21	2	9 739 491	97 39 491	INSTALLATION BRAKE COMPR
SCREW PLUG M32X1,5 MS	60 24 252 08	(154)	1	2 920 369	96 54 235 08	TERMINAL BOX CPL.
SCREW PLUG M32X1,5 MS	60 24 252 08	286	2	2 920 448	96 48 794 08	TERMINAL BOX CPL.
SCREW PLUG M32X1,5 MS	60 24 252 08	150	2	3 930 730	96 54 398 08	TERMINAL BOX CPL.
SCREW PLUG RD32X3 SPF	10 46 690 6	14	1	3 978 015	91 56 429 08	ADDITIONAL HYDRAULICS IN
SCREW PLUG RD32X3 SPF	10 46 690 6	14	1	3 978 015	91 56 432 08	ADDITIONAL HYDRAULICS IN
SCREW PLUG RD32X3 SPF	10 46 691 0	24	1	1 970	91 56 958 08	CRAWLER TRACK HYDRAULI
SCREW PLUG RD32X3 SPF	10 46 691 0	103	3	2 970	91 56 537 08	HYDR
SCREW PLUG RD32X3 SPF	10 46 691 0	8	1	2 970 081	96 50 495 08	ADDL.HYDR.F.PIN PULLING DE
SCREW PLUG RD32X3 SPF	10 46 691 0	36	4	2 975 100	91 52 860 08	ADDITIONAL HYDRAULICS WI
SCREW PLUG RD32X3 SPF	10 46 691 0	36	1	2 975 200	91 52 775 08	ADDITIONAL HYDRAULICS WI
SCREW PLUG RD32X3 SPF	10 46 691 0	36	1	2 975 700	91 52 774 08	ADDITIONAL HYDRAULICS WI
SCREW PLUG RD32X3 SPF	10 46 691 0	8	3	2 976 200	91 44 034 08	AUX.HYDR.PIN EXTRACTION
SCREW PLUG RD32X3 SPF	10 46 691 0	8	1	2 976 203	92 27 489 08	ADDL.HYDR.F.PIN PULLING DE
SCREW PLUG RD32X3 SPF	10 46 691 0	20	1	3 978 005	91 56 430 08	ADDL.HYDRAULIC SB-HEAD PI
SCREW PLUG RD36X3 SPF	10 46 690 7	38	2	2 975 100	91 52 860 08	ADDITIONAL HYDRAULICS WI
SCREW PLUG RD36X3 SPF	10 46 690 7	26	1	2 978 100	91 52 827 08	ADDNL.HYDR.RETAINING DEV
SCREW PLUG RD36X3 SPF	10 46 691 1	42	2	1 970	91 56 958 08	CRAWLER TRACK HYDRAULI
SCREW PLUG RD36X3 SPF	10 46 691 1	95	6	2 970	91 56 537 08	HYDR
SCREW PLUG RD36X3 SPF	10 46 691 1	14	1	2 970 081	96 50 495 08	ADDL.HYDR.F.PIN PULLING DE
SCREW PLUG RD36X3 SPF	10 46 691 1	12	1	2 976 200	91 44 034 08	AUX.HYDR.PIN EXTRACTION
SCREW PLUG RD36X3 SPF	10 46 691 1	44	1	2 977	91 57 756 08	ADDITIONAL HYDR.SLEWING
SCREW PLUG RD36X3 SPF	10 46 691 1	25	2	2 977 200	91 55 149 08	ADDITIONAL HYDR.PUMP/WI
SCREW PLUG RD54X4 SPF	10 46 690 8	39	2	2 975 100	91 52 860 08	ADDITIONAL HYDRAULICS WI
SCREW PLUG RD54X4 SPF	10 46 690 8	22	2	2 978 100	91 52 827 08	ADDNL.HYDR.RETAINING DEV
SCREW PLUG RD54X4 SPF	10 46 690 8	10	6	3 713 013	96 57 159 08	SHEET CPL.
SCREW PLUG RD54X4 SPF	10 46 690 8	32	2	3 978 100	91 56 428 08	HYDR. SUSPENDED BALLAST
SCREW PLUG RD54X4 SPF	10 46 691 2	38	2	1 970	91 56 958 08	CRAWLER TRACK HYDRAULI
SCREW PLUG RD54X4 SPF	10 46 691 2	87	8	2 970	91 56 537 08	HYDR
SCREW PLUG RD54X4 SPF	10 46 691 2	28	2	2 975 100	91 52 860 08	ADDITIONAL HYDRAULICS WI
SCREW PLUG RD54X4 SPF	10 46 691 2	14	1	2 976 200	91 44 034 08	AUX.HYDR.PIN EXTRACTION
SCREW PLUG RD54X4 SPF	10 46 691 2	38	2	2 977	91 57 756 08	ADDITIONAL HYDR.SLEWING
SCREW PLUG RD54X4 SPF	10 46 691 2	21	1	2 977 200	91 55 149 08	ADDITIONAL HYDR.PUMP/WI
SCREW PLUG RD54X4 SPF	10 46 691 2	28	2	2 978 100	91 52 796 08	ADDNL.HYDR.ERECTION DEV
SCREW PLUG RD79X4 SPF	10 46 690 9	25	2	2 975 100	91 52 860 08	ADDITIONAL HYDRAULICS WI
SCREW PLUG RD79X4 SPF	10 46 690 9	11	2	3 713 013	96 57 159 08	SHEET CPL.
SCREW PLUG RD79X4 SPF	10 46 690 9	7	2	3 978 015	91 56 429 08	ADDITIONAL HYDRAULICS IN
SCREW PLUG RD79X4 SPF	10 46 690 9	7	2	3 978 015	91 56 432 08	ADDITIONAL HYDRAULICS IN
SCREW PLUG RD79X4 SPF	10 46 691 3	24	2	2 975 100	91 52 860 08	ADDITIONAL HYDRAULICS WI
SCREW PLUG VSTI M22X1,5 C	47 75 104 01	2	7	9 697 916	96 97 916 01	SLEWING GEAR
SCREW PLUG VSTI M22X1,5 C	47 75 104 01	78	3	9 697 916	96 97 916 01	SLEWING GEAR
SCREW-ON CONNECTION	10 01 271 8	12	1	9 739 258	97 39 258	FUEL FILTER
SCREW-ON CONNECTION	10 01 272 2	2	1	9 739 494	97 39 494	ATL ATTACHMENT
SCREW-ON CONNECTION	10 29 720 4	2	2	9 739 322	97 39 322	REPAIR KIT PIPE LINE
SCREW-ON CONNECTION	94 79 067 08	48	5	2 970	91 56 537 08	HYDR
SCREW-ON CONNECTION L10	10 01 199 8	5	1	9 739 188	97 39 188	OIL-LEVEL GAUGE
SCREW-ON CONNECTION L10	10 01 199 8	5	2	9 739 492	97 39 492	PIPELINE INSTALLATION
SCREW-ON CONNECTION L12	10 01 200 4	14	1	9 739 258	97 39 258	FUEL FILTER
SCREW-ON CONNECTION L1	10 01 199 9	16	1	9 739 355	97 39 355	OIL COOLER ADD-ON
SCREW-ON CONNECTION L1	10 01 199 9	42	1	9 739 494	97 39 494	ATL ATTACHMENT
SCREW-ON CONNECTION M26	10 01 272 1	16	1	9 739 492	97 39 492	PIPELINE INSTALLATION
SCREW-ON HINGE	70 42 012 08	4	3	2 520 030	96 45 609 08	ROOF WINDOW PRE-ASS.
SCREW-ON HINGE	70 42 012 08	3	2	2 520 031	96 45 610 08	REAR WINDOW PRE-ASS.
SCREW-ON HINGE	70 42 012 08	8	4	2 932 160	96 54 385 08	SWITCH CABINET
SEAL	10 01 184 5	16	2	9 739 122	97 39 122	OIL COOLER

6.2.2009

etk_en_de_074515 LR 1600/2

966

LIEBHERRAlphabetical index
Alphabetischer Index

Description	Item	Pos.	Quantity	Page	Assembly	Description
SEAL	10 01 184 6	2	1	9 739 386	97 39 386	CRANKCASE BREATHER
SEAL	10 01 184 7	4	1	9 739 118	97 39 118	OIL LINE
SEAL	10 01 213 9	1	1	9 739 354	97 39 354	FLYWHEEL HOUSING MOUNT
SEAL	10 01 214 0	18	2	9 739 361	97 39 361	OIL SUMP
SEAL	10 01 229 8	15	1	9 739 122	97 39 122	OIL COOLER
SEAL	10 01 229 9	2	2	9 739 362	97 39 362	OIL SUMP
SEAL	10 01 234 5	12	2	9 739 126	97 39 126	THERMOSTAT HOUSING
SEAL	10 01 234 6	2	1	9 739 276	97 39 276	WATER CONNECTION
SEAL	10 01 234 6	2	1	9 739 349	97 39 349	CONNECTION F.WATER PIPE
SEAL	10 01 240 8	9	1	9 739 358	97 39 358	EXHAUST GAS RECIRCUL.ATT
SEAL	10 01 240 9	11	1	9 739 358	97 39 358	EXHAUST GAS RECIRCUL.ATT
SEAL	10 01 241 1	5	3	9 739 358	97 39 358	EXHAUST GAS RECIRCUL.ATT
SEAL	10 01 241 3	13	1	9 739 358	97 39 358	EXHAUST GAS RECIRCUL.ATT
SEAL	10 01 245 4	8	1	9 739 494	97 39 494	ATL ATTACHMENT
SEAL	10 01 264 3	8	1	9 739 361	97 39 361	OIL SUMP
SEAL	10 01 265 1	22	1	9 739 494	97 39 494	ATL ATTACHMENT
SEAL	10 01 333 7	6	1	9 739 267	97 39 267	CYLINDER FAIRING
SEAL	10 22 081 3	4	1	9 739 494	97 39 494	ATL ATTACHMENT
SEAL	10 22 234 5	3	6	9 739 267	97 39 267	CYLINDER FAIRING
SEAL	10 22 271 8	5	6	9 739 295	97 39 295	EXHAUST PIPE
SEAL	10 22 271 8	78	1	X1022281	10 22 281 7	SEAL KIT CYLINDER HEAD
SEAL	10 22 272 7	2	6	9 739 256	97 39 256	AIR SUCTION PIPE
SEAL	10 22 272 7	77	1	X1022281	10 22 281 7	SEAL KIT CYLINDER HEAD
SEAL	10 28 030 9	2	1	9 739 286	97 39 286	SCREW CAP
SEAL	10 29 787 6	(2)	1	X1035925	10 35 925 1	VARIABLE PUMP
SEAL	10 34 287 8	2	1	9 739 351	97 39 351	COOLING MEDIUM PIPELINE
SEAL	10 34 287 9	13	2	9 739 349	97 39 349	CONNECTION F.WATER PIPE
SEAL	10 34 288 0	2	1	9 739 352	97 39 352	AT-WATER PUMP WITH FAST
SEAL	10 66 332 9	3	1	X1004047	10 04 047 7	WINCH REVOLUTION TRANS
SEAL	69 18 222 08	40	1	2 920 369	96 54 235 08	TERMINAL BOX CPL.
SEAL	69 21 000 08	36	1	2 920 369	96 54 235 08	TERMINAL BOX CPL.
SEAL	69 21 000 08	155	1	3 930 009	96 50 573 08	CABLE DRUM COMPL.
SEAL	69 21 000 08	(171)	1	3 930 138	96 54 377 08	ELECTRIC FOR S-PIVOT SECT
SEAL	69 21 000 08	281	2	3 930 730	96 50 599 08	TERMINAL BOX CPL.
SEAL 0 PE	97 75 102 08	32	2	2 932 160	96 54 385 08	SWITCH CABINET
SEAL 120X60X 30	97 60 943 08	54	1	2 520 034	96 45 984 08	INTERNAL LINING
SEAL 78X64 30	97 61 932 08	65	1	2 520	91 53 061 08	CABIN, GLAZED
SEAL KIT	10 30 092 5	(999)	1	X1035924	10 35 924 3	VARIABLE PUMP
SEAL KIT	10 65 071 0	98	1	X1065068	10 65 068 8	TERMINAL BOARD
SEAL KIT	51 03 178 08	(1)	1	2 970	91 56 537 08	HYDR
SEAL KIT	55 31 355 08	4	1	5 530 545	55 30 545 08	CIRCULATING PUMP
SEAL KIT	57 05 881 08	999	1	5 106 691	51 06 691 08	RETURN FILTER
SEAL KIT	57 10 356 08	999	1	5 710 349	57 10 349 08	DIRECTIONAL CONTROL VALV
SEAL KIT	74 11 445	999	1	5 113 022	51 13 022 08	DIRECTIONAL CONTROL VALV
SEAL KIT ADJUSTMENT	10 33 111 7	(98)	1	X1035924	10 35 924 1	VARIABLE PUMP
SEAL KIT ADJUSTMENT	10 65 070 7	(98)	1	X1035924	10 35 924 9	VARIABLE PUMP
SEAL KIT CONNECTING BLOC	10 41 275 1	999	1	9 640 276	96 40 276 08	CONNECTION BLOCK
SEAL KIT CYLINDER HEAD	10 22 281 7	492	6	9 739 400	97 39 400	DIESEL ENGINE
SEAL KIT DIRECTIONAL VALV	10 42 478 6	(999)	1	2 970	91 56 537 08	HYDR
SEAL KIT F.PUMP	10 65 071 7	(98)	1	X1035924	10 35 924 9	VARIABLE PUMP
SEAL KIT F.REGULATOR	10 44 097 6	999	1	X1047219	10 47 219 6	REGULATOR
SEAL KIT GEAR WHEEL MOTO	10 49 389 0	(99)	1	2 391 038	96 47 931 08	OIL COOLER, PRE-ASSEMBLE
SEAL KIT HNBR70	70 27 982	999	1	7 027 481	70 27 481 03	WATER SEPARATOR
SEAL KIT WEGESCHIEBER	10 41 278 1	999	1	9 640 277	96 40 277 08	DIRECTIONAL CTRL. VALVE
SEALANT	10 01 117 2	11	1	9 739 262	97 39 262	CYLINDER HEAD
SEALANT	10 01 117 2	11	1	9 739 266	97 39 266	CYLINDER HEAD
SEALANT	10 01 117 2	2	1	9 739 271	97 39 271	CONNECTING LINE
SEALANT	10 01 117 2	2	1	9 739 491	97 39 491	INSTALLATION BRAKE COMPR
SEALANT	10 01 117 6	19	1	9 739 492	97 39 492	PIPELINE INSTALLATION
SEALANT A80MR HYLOMAR	87 00 028 08	(265)	0.01	3 930 138	96 54 377 08	ELECTRIC FOR S-PIVOT SECT

6.2.2009

etk_en_de_074515 LR 1600/2

967

LIEBHERRAlphabetical index
Alphabetischer Index

Description	Item	Pos.	Quantity	Page	Assembly	Description
SEALANT A80MR HYLOMAR	87 00 028 08	289	0.1	3 930 730	96 50 599 08	TERMINAL BOX CPL.
SEALING AND FILLING AGENT	87 00 018 08	7	1	2 810 001	96 43 597 08	CRANE DRIVER'S CABIN,PRE
SEALING FRAME	97 36 626 08	16	1	2 913	91 32 850 08	LICCON CONSOLE LCD2
SEALING FRAME 10X60X 185 P	97 25 613 08	38	10	2 520 034	96 45 984 08	INTERNAL LINING
SEALING FRAME RD92X20 DI=	97 25 615 08	39	3	2 520 034	96 45 984 08	INTERNAL LINING
SEALING INSERT 8MM VIERK	10 02 217 7	5	1	2 932 001	96 45 393 08	RELAY CONTROL SYSTEM
SEALING MATERIAL 50ML TUB	10 01 213 8	3	1	9 739 354	97 39 354	FLYWHEEL HOUSING MOUNT
SEALING NUT M6	51 07 534 08	10	1	5 711 301	57 11 301 08	PRESSURE LIMITING VALVE
SEALING NUT M6	51 07 534 08	11	1	X1048973	10 48 973 4	PRESSURE LIMITING VALVE
SEALING NUT M8	51 07 417 08	21	1	5 114 176	51 14 176 08	PRESSURE LIMITING VALVE
SEALING NUT M8	51 07 417 08	21	1	5 114 177	51 14 177 08	PRESSURE LIMITING VALVE
SEALING PLUG M 1-K	60 45 085 08	(502)	1	2 920 288	96 52 614 08	WIRING LIST F.SLEWING PLAT
SEALING PLUG M1-D	60 45 121 08	286	2	3 930 638	96 51 624 08	TERMINAL BOX
SEALING PLUG M1-D	60 45 121 08	(155)	1	3 930 640	96 50 481 08	TERMINAL BOX CPL.
SEALING PLUG M1-D	60 45 121 08	288	1	3 930 640	96 50 481 08	TERMINAL BOX CPL.
SEALING PLUG M1-D	60 45 121 08	153	1	3 930 730	96 50 599 08	TERMINAL BOX CPL.
SEALING PROFILE	26 21 047 08	154	0.85	2 391 001	96 45 719 08	DIESEL ENGINE, PRE-ASSEMB
SEALING PROFILE	26 21 047 08	18	0.69	2 393 002	96 46 782 08	COVER COMPL.
SEALING PROFILE	26 21 047 08	13	4.46	2 510	91 52 788 08	TURNTABLE PANELLING
SEALING PROFILE	26 21 821 01	315	8.36	9 907 151	99 07 151 01	ROLLER SLEWING RING
SEALING PROFILE	26 21 835 01	314	8.31	9 907 151	99 07 151 01	ROLLER SLEWING RING
SEALING PROFILE	59 15 078 08	12	4	2 510	91 52 788 08	TURNTABLE PANELLING
SEALING PROFILE 0 GUMMI 55	97 75 057 08	11	1	2 932 160	96 54 385 08	SWITCH CABINET
SEALING PROFILE GUMMI	26 21 067 08	71	10	2 859	91 52 809 08	SOUND INSULATION
SEALING RING	10 22 273 6	4	1	9 739 248	97 39 248	INJECTOR
SEALING RING	10 22 273 6	74	1	X1022281	10 22 281 7	SEAL KIT CYLINDER HEAD
SEALING RING	50 26 088 08	50	1	2 393	91 52 787 08	AIR FILTER UNIT CPL.
SEALING RING 10,7X16X1,5 S	10 01 186 4	16	2	9 739 288	97 39 288	FUEL LINE
SEALING RING 109X113X3	10 02 119 1	12	1	X1004204	10 04 204 3	WATER HEATING SYSTEM
SEALING RING 14,7X22X1,5 S	10 01 186 6	3	12	9 739 127	97 39 127	WATER BLEEDER PIPELINE
SEALING RING 14,7X22X1,5 S	10 01 186 6	6	1	9 739 188	97 39 188	OIL-LEVEL GAUGE
SEALING RING 14,7X22X1,5 S	10 01 186 6	15	1	9 739 258	97 39 258	FUEL FILTER
SEALING RING 14,7X22X1,5 S	10 01 186 6	12	1	9 739 281	97 39 281	OVERFLOW-OIL LINE
SEALING RING 14,7X22X1,5 S	10 01 186 6	3	11	9 739 282	97 39 282	OVERFLOW-OIL LINE
SEALING RING 14,7X22X1,5 S	10 01 186 6	19	5	9 739 288	97 39 288	FUEL LINE
SEALING RING 14,7X22X1,5 S	10 01 186 6	5	14	9 739 292	97 39 292	FUEL LINE
SEALING RING 14,7X22X1,5 S	10 01 186 6	18	2	9 739 349	97 39 349	CONNECTION F.WATER PIPE
SEALING RING 14,7X22X1,5 S	10 01 186 6	16	2	9 739 361	97 39 361	OIL SUMP
SEALING RING 14,7X22X1,5 S	10 01 186 6	4	6	9 739 492	97 39 492	PIPELINE INSTALLATION
SEALING RING 16,7X24X1,5 S	10 01 186 7	2	1	9 739 096	97 39 096	SCREW PLUG
SEALING RING 16,7X24X1,5 S	10 01 186 7	10	1	9 739 281	97 39 281	OVERFLOW-OIL LINE
SEALING RING 16,7X24X1,5 S	10 01 186 7	(2)	1	9 739 318	97 39 318	SENSOR ELEMENT
SEALING RING 16,7X24X1,5 S	10 01 186 7	(2)	1	9 739 318	97 39 318	SENSOR ELEMENT
SEALING RING 16,7X24X1,5 S	10 01 186 7	20	1	9 739 349	97 39 349	CONNECTION F.WATER PIPE
SEALING RING 16,7X24X1,5 S	10 01 186 7	7	3	9 739 355	97 39 355	OIL COOLER ADD-ON
SEALING RING 16,7X24X1,5 S	10 01 186 7	3	2	9 739 494	97 39 494	ATL ATTACHMENT
SEALING RING 18,7X26X1,5 S	10 01 186 8	(2)	1	9 739 318	97 39 318	SENSOR ELEMENT
SEALING RING 18,7X26X1,5 S	10 01 186 8	(2)	1	9 739 318	97 39 318	SENSOR ELEMENT
SEALING RING 18,7X26X1,5 S	10 01 186 8	13	1	9 739 355	97 39 355	OIL COOLER ADD-ON
SEALING RING 19,6X24,3X1,5	76 10 225 03	6	1	9 275 543	92 75 543 01	VENTILATION CONNECTING PI
SEALING RING 22,7X30X2 ST/	10 01 186 9	13	1	9 739 258	97 39 258	FUEL FILTER
SEALING RING 22,7X30X2 ST/	10 01 186 9	7	1	9 739 351	97 39 351	COOLING MEDIUM PIPELINE
SEALING RING 22,7X30X2 ST/	10 01 186 9	14	1	9 739 492	97 39 492	PIPELINE INSTALLATION
SEALING RING 24,7X32X2 ST/	10 01 184 2	9	1	9 739 351	97 39 351	COOLING MEDIUM PIPELINE
SEALING RING 26,7X34,93X2 S	10 01 187 0	11	1	9 739 355	97 39 355	OIL COOLER ADD-ON
SEALING RING 26,7X34,93X2 S	10 01 187 0	10	2	9 739 361	97 39 361	OIL SUMP
SEALING RING 26,7X34,93X2 S	10 01 187 0	12	1	9 739 491	97 39 491	INSTALLATION BRAKE COMPR
SEALING RING 26,7X34,93X2 S	10 01 187 0	26	2	9 739 494	97 39 494	ATL ATTACHMENT
SEALING RING 32,7X40X2 ST/	10 01 187 2	9	1	9 739 288	97 39 288	FUEL LINE
SEALING RING 32,7X40X2 ST/	10 01 187 2	15	2	9 739 492	97 39 492	PIPELINE INSTALLATION

6.2.2009

etk_en_de_074515 LR 1600/2

968

LIEBHERRAlphabetical index
Alphabetischer Index

Description	Item	Pos.	Quantity	Page	Assembly	Description
SEALING RING 8,7X14X1 ST/FP	10 01 187 1	3	12	9 739 281	97 39 281	OVERFLOW-OIL LINE
SEALING RING 8,7X14X1 ST/FP	10 01 187 1	79	2	X1022281	10 22 281 7	SEAL KIT CYLINDER HEAD
SEALING RING A22X27 CU	10 01 184 1	23	1	9 739 491	97 39 491	INSTALLATION BRAKE COMPR
SEALING RING A26X34 CU	10 03 730 5	22	3	9 739 491	97 39 491	INSTALLATION BRAKE COMPR
SEALING RING DIN 7603 A 10X	71 01 013 08	61	4	X1065015	10 65 015 8	DRIVE UNIT
SEALING RING DIN 7603 A 12X	71 01 017 08	123	1	X1065015	10 65 015 8	DRIVE UNIT
SEALING RING DIN 7603 A 12X	71 01 018 08	19	4	2 990	91 59 244 08	COMPRESSED AIR PLANT
SEALING RING DIN 7603 A 12X	71 01 020 08	49	1	2 393	91 52 787 08	AIR FILTER UNIT CPL.
SEALING RING DIN 7603 A 13X	71 01 023 08	(3)	1	2 391 102	96 56 360 08	RADIATOR
SEALING RING DIN 7603 A 14X	71 01 030 08	8	2	X1011614	10 11 614 1	FUEL HOSE
SEALING RING DIN 7603 A 14X	73 81 225 23	590	2	2 970	91 56 537 08	HYDR
SEALING RING DIN 7603 A 16X	71 01 034 08	8	1	5 113 005	51 13 005 08	CONTROL BLOCK
SEALING RING DIN 7603 A 16X	71 01 037 08	4	1	X1011614	10 11 614 1	FUEL HOSE
SEALING RING DIN 7603 A 18X	51 45 171 08	521	2	X1065015	10 65 015 5	GEARBOX
SEALING RING DIN 7603 A 18X	51 45 171 08	65	1	X1065015	10 65 015 8	DRIVE UNIT
SEALING RING DIN 7603 A 21X	71 01 044 08	13	1	5 114 320	51 14 320 08	PRETENSIONING VALVE
SEALING RING DIN 7603 A 21X	71 01 044 08	13	3	7 743 566	77 43 566 08	ELECTRIC PUMP
SEALING RING DIN 7603 A 22X	54 01 452 08	531	2	X1065015	10 65 015 5	GEARBOX
SEALING RING DIN 7603 A 24X	71 01 053 08	69	1	3 978 005	91 56 430 08	ADDL.HYDRAULIC SB-HEAD PI
SEALING RING DIN 7603 A 24X	71 01 053 08	69	2	3 978 015	91 56 429 08	ADDITIONAL HYDRAULICS IN
SEALING RING DIN 7603 A 24X	71 01 053 08	69	2	3 978 015	91 56 432 08	ADDITIONAL HYDRAULICS IN
SEALING RING DIN 7603 A 24X	71 01 053 08	69	1	3 978 100	91 56 428 08	HYDR. SUSPENDED BALLAST
SEALING RING DIN 7603 A 26X	71 01 061 08	12	1	2 671	91 52 798 08	OIL RESERVOIR, COMPLETE
SEALING RING DIN 7603 A 26X	71 01 060 08	20	1	2 990	91 59 244 08	COMPRESSED AIR PLANT
SEALING RING DIN 7603 A 27X	71 01 059 08	139	10	2 970	91 56 537 08	HYDR
SEALING RING DIN 7603 A 27X	71 01 059 08	63	6	2 975 100	91 52 860 08	ADDITIONAL HYDRAULICS WI
SEALING RING DIN 7603 A 27X	71 01 059 08	70	1	2 977	91 57 756 08	ADDITIONAL HYDR.SLEWING
SEALING RING DIN 7603 A 27X	71 01 059 08	70	1	2 978 100	91 52 827 08	ADDNL.HYDR.RETAINING DEV
SEALING RING DIN 7603 A 27X	71 01 059 08	62	1	2 978 200	91 54 843 08	ADD.HYDR.S_RETAINING RAM
SEALING RING DIN 7603 A 30X	50 15 366 08	463	4	X1065015	10 65 015 5	GEARBOX
SEALING RING DIN 7603 A 33X	71 01 070 08	138	10	2 970	91 56 537 08	HYDR
SEALING RING DIN 7603 A 33X	71 01 070 08	62	1	2 975 200	91 52 775 08	ADDITIONAL HYDRAULICS WI
SEALING RING DIN 7603 A 33X	71 01 070 08	62	1	2 975 700	91 52 774 08	ADDITIONAL HYDRAULICS WI
SEALING RING DIN 7603 A 33X	71 01 070 08	62	1	2 977 200	91 55 149 08	ADDITIONAL HYDR.PUMP/WI
SEALING RING DIN 7603 A 33X	71 01 070 08	69	1	2 978 100	91 52 827 08	ADDNL.HYDR.RETAINING DEV
SEALING RING DIN 7603 A 38X	71 01 072 08	137	20	2 970	91 56 537 08	HYDR
SEALING RING DIN 7603 A 38X	71 01 072 08	62	6	2 975 100	91 52 860 08	ADDITIONAL HYDRAULICS WI
SEALING RING DIN 7603 A 38X	71 01 072 08	61	1	2 975 200	91 52 775 08	ADDITIONAL HYDRAULICS WI
SEALING RING DIN 7603 A 38X	71 01 072 08	61	1	2 975 700	91 52 774 08	ADDITIONAL HYDRAULICS WI
SEALING RING DIN 7603 A 38X	71 01 072 08	69	2	2 977	91 57 756 08	ADDITIONAL HYDR.SLEWING
SEALING RING DIN 7603 A 38X	71 01 072 08	61	1	2 977 200	91 55 149 08	ADDITIONAL HYDR.PUMP/WI
SEALING RING DIN 7603 A 38X	71 01 072 08	68	1	2 978 100	91 52 827 08	ADDNL.HYDR.RETAINING DEV
SEALING RING DIN 7603 A 38X	71 01 072 08	67	2	3 978 100	91 56 428 08	HYDR. SUSPENDED BALLAST
SEALING RING DIN 7603 A 42X	71 01 075 08	136	3	2 970	91 56 537 08	HYDR
SEALING RING DIN 7603 A 42X	71 01 075 08	61	3	2 978 200	91 54 843 08	ADD.HYDR.S_RETAINING RAM
SEALING RING DIN 7603 A 48X	71 01 076 08	132	2	2 970	91 56 537 08	HYDR
SEALING RING DIN 7603 A 48X	71 01 076 08	68	1	2 977	91 57 756 08	ADDITIONAL HYDR.SLEWING
SEALING RING DIN 7603 A 4X8	51 10 089 08	9	2	9 640 276	96 40 276 08	CONNECTION BLOCK
SEALING RING DIN 7603 A 52X	71 01 077 08	131	10	2 970	91 56 537 08	HYDR
SEALING RING DIN 7603 A 52X	71 01 077 08	61	6	2 975 100	91 52 860 08	ADDITIONAL HYDRAULICS WI
SEALING RING DIN 7603 A 52X	71 01 077 08	63	2	2 975 200	91 52 775 08	ADDITIONAL HYDRAULICS WI
SEALING RING DIN 7603 A 52X	71 01 077 08	63	2	2 975 700	91 52 774 08	ADDITIONAL HYDRAULICS WI
SEALING RING DIN 7603 A 52X	71 01 077 08	67	4	2 977	91 57 756 08	ADDITIONAL HYDR.SLEWING
SEALING RING DIN 7603 A 52X	71 01 077 08	63	2	2 977 200	91 55 149 08	ADDITIONAL HYDR.PUMP/WI
SEALING RING DIN 7603 A 52X	71 01 077 08	68	2	3 978 005	91 56 430 08	ADDL.HYDRAULIC SB-HEAD PI
SEALING RING DIN 7603 A 52X	71 01 077 08	68	4	3 978 015	91 56 429 08	ADDITIONAL HYDRAULICS IN
SEALING RING DIN 7603 A 52X	71 01 077 08	68	4	3 978 015	91 56 432 08	ADDITIONAL HYDRAULICS IN
SEALING RING DIN 7603 A 52X	71 01 077 08	68	2	3 978 100	91 56 428 08	HYDR. SUSPENDED BALLAST
SEALING RING DIN 7603 A 6,5X	57 00 102 08	16	2	5 026 126	50 26 126 08	SOLENOID VALVE
SEALING RUBBER	54 01 323 08	141	1	5 400 565	54 00 565 08	ROPE WINCH

6.2.2009

etk_en_de_074515 LR 1600/2

969

LIEBHERRAlphabetical index
Alphabetischer Index

Description	Item	Pos.	Quantity	Page	Assembly	Description
SEALING RUBBER	54 01 323 08	200	1	5 400 565	54 00 565 08	ROPE WINCH
SEALING SET CONTROL UNIT	10 47 143 9	(98)	1	X1035924	10 35 924 6	VARIABLE PUMP
SEALING SET CONTROL UNIT	10 47 143 9	(98)	1	X1035924	10 35 924 9	VARIABLE PUMP
SEALING SET VALVE	10 66 373 0	999	1	5 114 651	51 14 651 08	DIRECTIONAL CONTROL VALV
SEARCHLIGHT	60 71 318 08	10	1	1 933 100	91 25 249 08	MAGNETIC LAMP
SEAT	96 48 626 08	1	1	2 503 100	91 55 873 08	EMERGENCY SEAT
SEAT	97 75 557 08	2	1	2 503 101	96 48 626 08	SEAT
SEAT ADJUSTMENT	10 41 120 7	2	1	X1035925	10 35 925 1	VARIABLE PUMP
SEAT BRACKET	97 75 553 08	1	1	2 503 101	96 48 626 08	SEAT
SEAT CUSHION	10 65 048 7	55	1	X1029200	10 29 200 4	DRIVERS SEAT
SENSOR	10 22 021 8	(1)	1	9 739 318	97 39 318	SENSOR ELEMENT
SENSOR ASSEMBLY	96 24 232 08	6	1	3 930 731	96 48 374 08	ELECTRICS F BASE SECTION
SENSOR ASSEMBLY S-HEAD	96 37 685 08	5	1	3 930 576	96 48 381 08	EL.EQUIPMENT SW HEAD SE
SENSOR ASSEMBLY SA-STAN	96 57 085 08	20	1	2 920 578	96 54 379 08	ELECTRIC FOR SA - FRAME
SENSOR ELEMENT	97 39 318	231	1	X1012059	10 12 059 0	DIESEL ENGINE
SENSOR FITTING ANGLE SEN	96 19 877 08	10	1	3 930 138	96 54 377 08	ELECTRIC FOR S-PIVOT SECT
SENSOR FITTING ANGLE SEN	96 19 877 08	5	1	3 930 330	96 54 378 08	D PIVOT SECTION ELEC. EQUI
SENSOR FITTING ANGLE SEN	96 19 877 08	10	1	3 930 421	96 47 149 08	ELECTR. FOR HEAD SECTION
SENSOR FITTING ANGLE SEN	96 19 877 08	10	1	3 930 575	96 48 380 08	EL.F-CONNECTING HEAD
SENSOR LIFT TOP LIMIT SWI	96 20 219 08	11	1	3 930 546	96 48 375 08	ELECTR. F-HEAD SECTION
SERRATED LOCK WASHER D	42 52 205 08	13	4	2 913	91 32 850 08	LICCON CONSOLE LCD2
SERRATED LOCK WASHER D	42 52 205 08	7	20	2 913 005	96 20 731 08	INTERIOR HOUSING PRE-ASS.
SERRATED LOCK WASHER D	42 52 205 08	7	12	2 913 005	96 28 696 08	INTERIOR HOUSING PRE-ASS.
SERRATED LOCK WASHER D	42 52 205 08	5	3	2 913 007	96 20 763 08	CONTROLLER UNIT
SERRATED LOCK WASHER D	42 52 205 08	13	4	2 913 009	91 04 705 08	LICCON CONSOLE LCD3
SERRATED LOCK WASHER D	42 52 205 08	17	28	2 932 001	96 45 393 08	RELAY CONTROL SYSTEM
SERRATED LOCK WASHER D	42 52 205 08	269	4	3 930 009	96 50 573 08	CABLE DRUM COMPL.
SERRATED LOCK WASHER D	42 52 205 08	157	10	3 930 640	96 50 481 08	TERMINAL BOX CPL.
SERRATED LOCK WASHER D	42 52 207 08	(155)	1	2 920 369	96 54 235 08	TERMINAL BOX CPL.
SERRATED LOCK WASHER D	42 52 207 08	(155)	1	2 920 369	96 54 235 08	TERMINAL BOX CPL.
SERRATED LOCK WASHER D	42 52 207 08	88	50	2 932 082	96 54 387 08	ASSEMBLY PARTS MOUNTIN
SERRATED LOCK WASHER D	42 52 207 08	(155)	1	3 930 138	96 54 377 08	ELECTRIC FOR S-PIVOT SECT
SERRATED LOCK WASHER D	42 52 208 08	3	4	2 780 915	96 48 377 08	ADD-ON PARTS EXTERNAL F
SERRATED LOCK WASHER D	42 52 208 08	32	1	2 835 002	96 48 379 08	ADD-ON PARTS
SERRATED LOCK WASHER D	42 52 208 08	40	4	2 932 082	96 54 387 08	ASSEMBLY PARTS MOUNTIN
SERRATED LOCK WASHER D	42 52 210 08	4	12	1 830 102	92 26 483 08	TERMINAL BOARD PRE-ASS.
SERRATED LOCK WASHER D	42 52 210 08	21	4	2 835 002	96 48 379 08	ADD-ON PARTS
SERRATED LOCK WASHER D	42 52 210 08	7	2	2 913 004	96 20 460 08	HOUSING PRE-ASSEMBLED
SERRATED LOCK WASHER D	42 52 210 08	39	1	2 932 082	96 54 387 08	ASSEMBLY PARTS MOUNTIN
SERVICE HOUR METER 12 - 24	69 18 022 08	57	1	2 932 082	96 54 387 08	ASSEMBLY PARTS MOUNTIN
SERVICE HOUR METER 24VD	69 17 985 08	3	1	2 533 067	96 50 385 08	PLATE PRE-ASS.
SERVOMOTOR	10 28 730 1	13	1	X1022811	10 22 811 2	AIR CONDITIONING UNIT
SET OF BRUSHES	10 01 243 7	11	1	9 739 258	97 39 258	FUEL FILTER
SET OF BRUSHES	55 31 354 08	3	1	5 530 545	55 30 545 08	CIRCULATING PUMP
SHACKLE 3,25T	10 28 319 6	18	2	3 292	91 52 865 08	D OVERRUN PROTECTION
SHACKLE 85t	10 02 211 1	47	4	3 745	91 52 948 08	SUSPENDED BALLAST
SHACKLE DIN 82101 1,6T NG 1,	77 39 334 08	57	2	2 810	91 52 806 08	CRANE DRIVER'S CABIN CPL.
SHACKLE DIN 82101 12T VERZ	77 39 284 08	35	4	1 750	91 52 394 08	TOOL
SHACKLE DIN 82101 25T VERZ	77 39 305 08	2	2	2 750 100	91 57 283 08	SLING GEAR ERECTION CRAW
SHACKLE DIN 82101 A 0,25 0,	77 39 335 08	14	4	1 630	91 52 387 08	HYDRAULIC SUPPORT
SHACKLE DIN 82101 A 0,25 0,	77 39 335 08	33	2	3 206	91 52 881 08	PIVOT SECTION
SHACKLE DIN 82101 A 0,25 0,	77 39 335 08	43	1	3 208 001	91 52 883 08	F-HEAD SECTION
SHACKLE DIN 82101 A 10 0,4T	77 39 300 08	28	2	3 215 005	91 52 846 08	ROLLER SET
SHACKLE DIN 82101 A 10 0,4T	77 39 300 08	28	2	3 215 006	91 52 847 08	ROLLER SET
SHAFT 40.0x1854	93 72 521 08	2	1	3 350 001	92 70 642 08	SAFETY ROLLER CPL.
SHAFT SEAL 22X35X6	57 15 168 08	20	1	5 102 380	51 02 380 08	HYDRO MOTOR
SHAFT SEAL 28X40X6 NBR	57 01 141 08	14	1	5 701 129	57 01 129 08	DRIVING GEAR
SHAFT SEAL 28X40X6.5/5.5 75	10 22 035 9	20	1	X1035925	10 35 925 1	VARIABLE PUMP
SHAFT SEAL BA 35X54X6	10 65 070 1	(38)	1	X1035924	10 35 924 9	VARIABLE PUMP
SHAFT SEAL DIN 3760 BA 50X	79 04 950 14	454	1	X1065015	10 65 015 5	GEARBOX

6.2.2009

etk_en_de_074515 LR 1600/2

970

LIEBHERRAlphabetical index
Alphabetischer Index

Description	Item	Pos.	Quantity	Page	Assembly	Description
SHEET	57 00 097 08	12	1	5 026 126	50 26 126 08	SOLENOID VALVE
SHEET 15X30X50 PA6G	28 81 762 08	12	1	1 920 305	92 15 300 08	INSTALLAT.ROTOR+SLIPRING
SHEET 50X20X2 PE	97 52 216 08	4	2	2 520 031	96 45 610 08	REAR WINDOW PRE-ASS.
SHEET CPL.	96 48 170 08	6	1	2 391 001	96 45 719 08	DIESEL ENGINE, PRE-ASSEMB
SHEET CPL.	96 51 071 08	56	1	2 391 001	96 45 719 08	DIESEL ENGINE, PRE-ASSEMB
SHEET CPL.	96 51 452 08	27	3	2 391 023	96 45 720 08	RADIATOR, PRE-ASSEMBLED
SHEET CPL.	96 51 459 08	28	3	2 391 023	96 45 720 08	RADIATOR, PRE-ASSEMBLED
SHEET CPL.	96 57 159 08	115	1	3 713	91 57 749 08	D PIVOT SECTION
SHEET GASKET	57 10 773 08	(1)	1	3 978 100	91 56 428 08	HYDR. SUSPENDED BALLAST
SHEET GASKET VITON	57 10 819 08	(1)	1	1 970	91 56 958 08	CRAWLER TRACK HYDRAULI
SHEET GASKET VITON	57 10 824 08	(1)	1	1 970	91 56 958 08	CRAWLER TRACK HYDRAULI
SHEET GASKET VITON	57 10 830 08	(1)	1	1 970	91 56 958 08	CRAWLER TRACK HYDRAULI
SHEET METAL NUT M8	41 30 070 08	19	2	2 391 023	96 45 720 08	RADIATOR, PRE-ASSEMBLED
SHEET METAL NUT M8	41 30 070 08	32	4	2 831	91 57 754 08	AIR COND. UNIT SUPERSTRU
SHEET METAL NUT M8	41 30 070 08	55	24	2 859	91 52 809 08	SOUND INSULATION
SHEET-METAL SCREW DIN 79	40 82 010 08	295	2	2 920 581	96 54 405 08	TERMINAL BOX WINCH PRE-A
SHEET-METAL SCREW DIN 79	40 82 010 08	273	2	3 930 730	96 54 398 08	TERMINAL BOX CPL.
SHEET-METAL SCREW DIN 79	40 82 010 08	210	2	3 930 734	96 54 401 08	TERMINAL BOX
SHEET-METAL SCREW DIN 798	55 31 687 08	17	2	2 932 160	96 54 385 08	SWITCH CABINET
SHEET-METAL SCREW DIN 798	55 31 687 08	159	2	3 930 640	96 50 481 08	TERMINAL BOX CPL.
SHEET-METAL SCREW DIN 798	55 31 687 08	272	2	3 930 730	96 50 599 08	TERMINAL BOX CPL.
SHEET-METAL SCREW DIN 798	55 31 687 08	17	6	X1035519	10 35 519 6	OIL AIR COOLER
SHEET-METAL SCREW DIN 798	59 10 059 08	47	20	2 520 034	96 45 984 08	INTERNAL LINING
SHIM	51 07 832 08	17	1	5 114 176	51 14 176 08	PRESSURE LIMITING VALVE
SHIM	51 07 832 08	17	1	5 114 177	51 14 177 08	PRESSURE LIMITING VALVE
SHIM FE//Zn20//C	96 49 841 08	26	2	2 502	91 55 939 08	CONTROL STAND
SHIM RING 58X70X0,1	57 01 142 08	17	2	5 701 129	57 01 129 08	DRIVING GEAR
SHIM RING 58X70X0,3	57 01 143 08	18	1	5 701 129	57 01 129 08	DRIVING GEAR
SHIM RING DIN 988 32X45X1	42 20 015 08	17	1	3 282 002	96 47 890 08	FAB-STAY
SHUT OFF DEVICE DN125	73 00 043 08	19	1	2 671 004	96 46 305 08	OIL TANK PRE-ASS.
SHUTDOWN VALVE	57 15 140 08	3	1	X1065068	10 65 068 8	TERMINAL BOARD
SHUTDOWN VALVE	57 15 146 08	3	1	5 715 142	57 15 142 08	TERMINAL BOARD
SHUTDOWN VALVE	57 18 995 08	3	1	5 718 989	57 18 989 08	TERMINAL BOARD
SHUTTER WELDED	96 49 441 08	19	1	2 520 034	96 45 984 08	INTERNAL LINING
SHUTTLE VALVE	10 41 276 3	6	1	9 640 277	96 40 277 08	DIRECTIONAL CTRL. VALVE
SHUTTLE VALVE	51 14 493 08	4	1	3 978 005	91 56 430 08	ADDL.HYDRAULIC SB-HEAD PI
SHUTTLE VALVE	51 14 689 08	108	4	2 970	91 56 537 08	HYDR
SHUTTLE VALVE	51 14 689 08	11	1	2 975 100	91 52 860 08	ADDITIONAL HYDRAULICS WI
SHUTTLE VALVE	51 14 689 08	11	1	2 975 200	91 52 775 08	ADDITIONAL HYDRAULICS WI
SHUTTLE VALVE	51 14 689 08	11	1	2 975 700	91 52 774 08	ADDITIONAL HYDRAULICS WI
SHUTTLE VALVE	51 14 689 08	5	1	2 978 100	91 52 827 08	ADDNL.HYDR.RETAINING DEV
SHUTTLE VALVE	51 14 689 08	5	1	2 978 200	91 54 843 08	ADD.HYDR.S_RETAINING RAM
SIDE PLATE WELDED CONSTR	96 44 562 08	3	1	2 340	91 52 776 08	WINCH 4 LUFFING GEAR
SIDE PLATE WELDED CONST	96 44 563 08	4	1	2 340	91 52 776 08	WINCH 4 LUFFING GEAR
SIEVE SLEEVE	57 00 663 08	5	1	5 028 065	50 28 065 08	EQUALIZING RESERVOIR
SIGNAL BELL LMB	96 21 541 08	8	1	2 920 559	96 47 914 08	LIMIT SWITCH AND SENSOR
SIGNAL LAMP	60 61 435 08	16	3	2 533 061	96 48 370 08	DASH BORD ARM REST LEFT
SIGNAL LAMP	60 61 435 08	7	1	2 533 063	96 48 371 08	DASH BORD ARM REST RIGH
SIGNAL LAMP	60 61 435 08	7	15	2 533 070	96 48 363 08	CONTROLS AND FITTINGS RI
SIGNAL LAMP	60 61 435 08	35	1	2 932 001	96 45 393 08	RELAY CONTROL SYSTEM
SIGNAL LAMP 24V DC ROT	10 01 646 5	6	1	3 780 258	96 56 482 08	ELECTRIC AIRCRAFT PROTE
SILENCER	50 26 616 08	22	1	2 990	91 59 244 08	COMPRESSED AIR PLANT
SINGLE STRAND SEALING 2	60 56 197 08	813	19	2 920 633	96 52 651 08	WIRING HARNESS
SINGLE STRAND SEALING DIN	60 56 200 08	820	4	2 920 633	96 52 651 08	WIRING HARNESS
SINGLE-END SPANNER DIN 8	88 51 322 08	5	1	1 750	91 52 394 08	TOOL
SINGLE-END SPANNER DIN 8	79 00 046 08	6	1	1 750	91 52 394 08	TOOL
SIPHON PIPE 76X6 NBR SPF	10 34 353 0	155	4	2 391 001	96 45 719 08	DIESEL ENGINE, PRE-ASSEMB
SIPHON PIPE 76X6 NBR SPF	10 34 353 0	268	2.4	2 997	91 56 539 08	HOSE LINES SUPERSTRUCT
SIPHON PIPE 76X6 NBR SPF	10 34 353 0	269	1.6	2 997	91 56 539 08	HOSE LINES SUPERSTRUCT
SIPHON PIPE 76X6 NBR SPF	10 34 353 0	270	0.22	2 997	91 56 539 08	HOSE LINES SUPERSTRUCT

6.2.2009

etk_en_de_074515 LR 1600/2

971

LIEBHERRAlphabetical index
Alphabetischer Index

Description	Item	Pos.	Quantity	Page	Assembly	Description
SIPHON PIPE NW60X6,5 NBR	10 04 167 5	266	1.1	2 997	91 56 539 08	HOSE LINES SUPERSTRUCT
SIPHON PIPE NW60X6,5 NBR	10 04 167 5	267	1.2	2 997	91 56 539 08	HOSE LINES SUPERSTRUCT
SL REDUCING SECTION 6.75	91 52 854 08	214	1		LR 1600-2-0	
SLEDGE HAMMER 5KG	88 50 341 08	11	1	1 750	91 52 394 08	TOOL
SLEEVE	57 11 303 08	2	1	5 711 301	57 11 301 08	PRESSURE LIMITING VALVE
SLEEVE	95 38 734 08	12	5	2 260	91 53 057 08	CUP SPRING CLUSTER
SLEEVE	95 38 734 08	28	10	2 340	91 52 776 08	WINCH 4 LUFFING GEAR
SLEEVE	95 38 734 08	10	4	2 391	91 52 784 08	DIESEL ENGINE CPL.
SLEEVE	95 38 734 08	30	11	2 391 001	96 45 719 08	DIESEL ENGINE, PRE-ASSEMB
SLEEVE	95 38 734 08	14	8	2 510	91 52 788 08	TURNTABLE PANELLING
SLEEVE	95 38 734 08	80	6	2 550	91 57 751 08	SA FRAME
SLEEVE	95 38 734 08	41	18	2 631	91 56 817 08	SLEWING PLATFORM CATWAL
SLEEVE	95 38 734 08	26	2	2 711	91 52 800 08	CENT. LUBRIC. SYSTEM SUP
SLEEVE	95 38 734 08	62	10	2 859	91 52 809 08	SOUND INSULATION
SLEEVE	95 38 734 08	17	4	2 925 402	96 58 855 08	CAMERA EQUIPMENT SLEWI
SLEEVE	95 38 734 08	98	72	3 211	91 57 748 08	S PIVOT SECTION
SLEEVE	95 38 734 08	32	7	3 350	91 52 859 08	WINCH 3
SLEEVE	95 38 734 08	123	61	3 713	91 57 749 08	D PIVOT SECTION
SLEEVE	95 38 734 08	83	48	3 714	91 52 862 08	D HEAD SECTION
SLEEVE	95 38 734 08	42	34	3 715 008	91 52 863 08	D INTERMEDIATE SECTION
SLEEVE	95 38 734 08	40	65	3 716	91 52 864 08	D INTERMEDIATE SECTION
SLEEVE 48X204 PA6	97 68 724 08	14	1	2 522 011	96 45 602 08	CLOSING DEVICE
SLEEVE 60.0X20 S355J2G3 FE	97 93 097 08	142	2	3 713	91 57 749 08	D PIVOT SECTION
SLEEVE CONTACT DIN 72585	60 23 395 08	647	4	2 920 633	96 52 651 08	WIRING HARNESS
SLEEVE CPL.	10 41 274 0	12	1	9 640 276	96 40 276 08	CONNECTION BLOCK
SLEIGH CPL.	96 47 880 08	3	2	2 522 013	96 45 883 08	GUIDE PRE-ASS.
SLEWING GEAR 2 DREHW.	91 52 778 08	117	1		LR 1600-2-0	
SLEWING GEAR DAT 450/1441	96 97 916 01	1	2	2 350	91 52 778 08	SLEWING GEAR
SLEWING PLATFORM CATWAL	91 56 817 08	132	1		LR 1600-2-0	
SLIDE 24.6X120 PA6	97 68 722 08	13	1	2 522 011	96 45 602 08	CLOSING DEVICE
SLIDE BLOCK CPL.	10 45 514 4	15	1	X1029200	10 29 200 4	DRIVERS SEAT
SLIDE VALVE BLOCK 4-FACH	51 13 090 08	16	1	1 970	91 56 958 08	CRAWLER TRACK HYDRAULI
SLIDING DOOR CPL.	91 54 115 08	2	1	2 520	91 53 061 08	CABIN, GLAZED
SLIDING PIECE L STEEL CONS	96 45 400 08	2	1	1 400	91 56 853 08	CRAWLER TRACK CARRIER LE
SLIDING PIECE STEEL CONS	96 45 401 08	2	1	1 410 300	91 56 855 08	CRAWLER CARRIER RIGHT CP
SLING GEAR ERECTION CRAW	91 57 283 08	148	1		LR 1600-2-0	
SLING ROPE 22.5T-12.1M VER	10 47 515 7	1	2	2 750 100	91 57 283 08	SLING GEAR ERECTION CRAW
SLING ROPE DIN 3088 7,7T-12	77 33 137 08	39	4	1 750	91 52 394 08	TOOL
SLING ROPE EN 13414 2,7T-6M	10 43 004 8	48	1	3 281	91 52 896 08	ERECTION FRAME
SLIP RING	10 41 178 0	14	1	X1002800	10 02 800 2	CABLE REEL
SLIP RING	10 41 178 1	15	7	X1002800	10 02 800 2	CABLE REEL
SLIP RING	57 14 224 08	9	4	6 909 010	69 09 010 08	COLLECTING RING
SLIP RING 60X2 2,5MM ²	10 11 484 3	11	46	6 909 010	69 09 010 08	COLLECTING RING
SLOTTED NUT M30X1,5	57 01 139 08	9	1	5 701 129	57 01 129 08	DRIVING GEAR
SMALL HILL COVERING SPF	97 71 452 08	7	1	2 520 034	96 45 984 08	INTERNAL LINING
SNAP HOOK DIN 5299 100X10	74 40 104 08	83	4	3 211	91 57 748 08	S PIVOT SECTION
SNAP HOOK DIN 5299 70X7 ST	74 40 100 08	3	3	2 790 451	91 57 016 08	COVER
SNAP HOOK DIN 5299 70X7 ST	74 40 100 08	34	2	3 745	91 52 948 08	SUSPENDED BALLAST
SNAP HOOK DIN 5299 80X8 ST	74 40 101 08	154	1	3 930 732	96 50 575 08	LEAD
SOCKET	10 21 947 7	4	1	2 533 067	96 50 385 08	PLATE PRE-ASS.
SOCKET	51 45 947 08	20	1	5 719 113	57 19 113 08	CONTROL UNIT
SOCKET	51 45 948 08	19	1	5 719 113	57 19 113 08	CONTROL UNIT
SOCKET 20A	10 42 905 7	5	1	2 533 067	96 50 385 08	PLATE PRE-ASS.
SOCKET 20A	10 42 905 7	2	1	2 533 068	96 49 314 08	PREMOUNTED PLUG SOCKET
SOCKET 2POL	60 52 082 08	(151)	1	2 920 815	96 49 300 08	WIRING LIST BATTERY BOX
SOCKET COMBINATION 16A M	60 52 157 08	1	1	2 780 915	96 48 377 08	ADD-ON PARTS EXTERNAL F
SOCKET GUMMI	59 10 555 08	13	1	2 520 032	96 45 980 08	WINDSHIELD WASHER INSTAL
SOCKET HD.SCREW 3X26X8,3	10 11 627 4	4	8	9 080 702	90 80 702	CONTROL GEAR
SOCKET SHELL 16POL	60 56 174 08	(159)	1	2 920 369	96 54 235 08	TERMINAL BOX CPL.
SOCKET SHELL 24POL.	60 56 176 08	(158)	1	2 920 369	96 54 235 08	TERMINAL BOX CPL.

6.2.2009

etk_en_de_074515 LR 1600/2

972

LIEBHERR
 Alphabetical index
 Alphabetischer Index

Description	Item	Pos.	Quantity	Page	Assembly	Description
SOCKET SHELL 24POL.	60 56 176 08	522	3	2 920 633	96 52 651 08	WIRING HARNESS
SOCKET TERMINAL STRIP 9PO	60 23 219 08	6	2	2 922 001	92 84 311 08	BUS PCB
SOCKET WRENCH GR.11/3	79 00 249 08	17	1	1 750	91 52 394 08	TOOL
SOFT GASKET PERBUNAN	71 02 004 08	59	4	1 970	91 56 958 08	CRAWLER TRACK HYDRAULI
SOFT GASKET PERBUNAN	71 02 004 08	574	30	2 970	91 56 537 08	HYDR
SOLENOID ARMATURE	57 00 096 08	9	1	5 026 126	50 26 126 08	SOLENOID VALVE
SOLENOID VALVE	10 01 245 8	2	1	9 739 140	97 39 140	FLAME STARTING SYSTEM
SOLENOID VALVE	50 26 126 08	9	1	2 393	91 52 787 08	AIR FILTER UNIT CPL.
SOLENOID VALVE	50 26 596 08	15	1	2 990	91 59 244 08	COMPRESSED AIR PLANT
SOLENOID VALVE 24V	10 34 300 3	4	1	2 540	91 53 253 08	CLIMA-HEATING INSTALLATIO
SOLENOID VALVE 24V	10 34 300 3	3	1	2 541	91 52 790 08	ADD HEATING SUPERSTRUCT
SOUND INSULATION	91 52 809 08	159	1		LR 1600-2-0	
SOUND TRANSMITTER 12-30	61 40 085 08	10	1	2 780 320	91 05 067 08	ACOUST.WARN. SLEWING G
SOUND TRANSMITTER 12-30	61 40 085 08	10	1	2 780 324	91 56 389 08	ACOUST. WARN. DISPLACEM.
SPACER BOLT B M6XM6X10 9S	10 01 253 1	5	1	9 739 159	97 39 159	STARTER
SPACER PIECE	10 22 277 6	22	1	9 739 292	97 39 292	FUEL LINE
SPACER PIECE	57 06 903 08	25	1	5 113 086	51 13 086 08	PROPORTIONAL VALVE
SPACER PIECE	57 11 304 08	5	1	5 711 301	57 11 301 08	PRESSURE LIMITING VALVE
SPACER PIPE RD65X76	95 44 254 08	21	2	1 400	91 56 853 08	CRAWLER TRACK CARRIER LE
SPACER PIPE RD65X76	95 44 254 08	21	2	1 410 300	91 56 855 08	CRAWLER CARRIER RIGHT CP
SPACER PLATE 3X84X15 DC0	97 76 920 08	40	4	2 502	91 55 939 08	CONTROL STAND
SPACER RING	10 01 261 7	5	1	9 739 250	97 39 250	FLYWHEEL
SPACER RING	90 80 288	2	1	9 079 186	90 79 186	TACHOMETER
SPACER RING	90 80 533	2	1	9 079 185	90 79 185	TACHOMETER
SPACER RING RD219,1X36	93 58 827 08	13	2	2 652	91 52 794 08	ROLLER BEARING
SPACER RING RD48X2	95 00 775 08	26	2	3 211	91 57 748 08	S PIVOT SECTION
SPACER RING RD48X3	94 15 400 08	5	1	3 745 002	92 17 236 08	SWITCH UNIT
SPACER RING RD48X3	94 15 400 08	5	1	3 745 003	92 17 237 08	SWITCH UNIT
SPACER SLEEVE 11X21X20	98 82 075	11	4	9 080 702	90 80 702	CONTROL GEAR
SPACER SLEEVE 21.3X27	97 71 899 08	3	1	3 207 003	96 48 259 08	ROD CPL.
SPACER SLEEVE 21.3X27	97 71 899 08	2	1	3 207 100	96 48 261 08	BRACKET COMPL.
SPACER SLEEVE 21.3X27	97 71 899 08	(3)	1	3 281	91 52 896 08	ERECTION FRAME
SPACER SLEEVE 25.0X39	97 71 884 08	(2)	1	3 281	91 52 896 08	ERECTION FRAME
SPACER SLEEVE 25.0X75	97 71 883 08	5	1	3 207 101	96 48 292 08	BRACKET COMPL.
SPACER SLEEVE 25.0X75	97 71 883 08	(2)	2	3 281	91 52 896 08	ERECTION FRAME
SPECIAL GREASE 100G TUBE	86 13 009 08	10	1	9 739 262	97 39 262	CYLINDER HEAD
SPECIAL GREASE 100G TUBE	86 13 009 08	12	1	9 739 263	97 39 263	ROCKER ARM BEARING HOUS
SPECIAL GREASE 100G TUBE	86 13 009 08	12	1	9 739 264	97 39 264	ROCKER ARM BEARING HOUS
SPECIAL GREASE 100G TUBE	86 13 009 08	10	1	9 739 266	97 39 266	CYLINDER HEAD
SPHERICAL CAP	60 61 440 08	17	3	2 533 061	96 48 370 08	DASH BORD ARM REST LEFT
SPHERICAL CAP	60 61 440 08	8	1	2 533 063	96 48 371 08	DASH BORD ARM REST RIGH
SPHERICAL CAP	60 61 440 08	8	13	2 533 070	96 48 363 08	CONTROLS AND FITTINGS RI
SPHERICAL CAP	60 61 440 08	34	1	2 932 001	96 45 393 08	RELAY CONTROL SYSTEM
SPHERICAL CAP	60 61 443 08	22	1	2 533 070	96 48 363 08	CONTROLS AND FITTINGS RI
SPHERICAL CAP	60 61 448 08	25	1	2 533 070	96 48 363 08	CONTROLS AND FITTINGS RI
SPHERICAL WASHER C 10,5	10 01 173 6	11	1	9 739 248	97 39 248	INJECTOR
SPHERICAL WASHER DIN 6319	10 01 173 8	6	1	9 739 248	97 39 248	INJECTOR
SPINDLE 180.0X1019	97 17 087 08	3	2	1 632	91 52 389 08	MECHANICAL SUPPORT
SPIRAL BACK-UP RING	54 01 844 08	20	1	5 400 565	54 00 565 08	ROPE WINCH
SPIRAL SPRING	57 01 989 08	12	2	X1002800	10 02 800 2	CABLE REEL
SPIRIT LEVEL	71 40 008 08	5	1	1 100	91 52 375 08	CRAWLER TRACK TRAVEL G
SPLIT PIN DIN 94 10X100 ST V	43 30 106 08	78	2	1 400	91 56 853 08	CRAWLER TRACK CARRIER LE
SPLIT PIN DIN 94 10X100 ST V	43 30 106 08	78	2	1 410 300	91 56 855 08	CRAWLER CARRIER RIGHT CP
SPLIT PIN DIN 94 10X100 ST V	43 30 106 08	17	1	3 281	91 52 896 08	ERECTION FRAME
SPLIT PIN DIN 94 10X71 ST V	43 30 101 08	90	1	2 550	91 57 751 08	SA FRAME
SPLIT PIN DIN 94 10X71 ST V	43 30 101 08	10	2	2 652	91 52 794 08	ROLLER BEARING
SPLIT PIN DIN 94 10X71 ST V	43 30 101 08	14	2	3 205	91 52 880 08	F-ASSEMBLY UNIT
SPLIT PIN DIN 94 10X71 ST V	43 30 101 08	8	1	3 207 003	96 48 259 08	ROD CPL.
SPLIT PIN DIN 94 10X71 ST V	43 30 101 08	19	2	3 208 001	91 52 883 08	F-HEAD SECTION
SPLIT PIN DIN 94 10X71 ST V	43 30 101 08	25	2	3 281	91 52 896 08	ERECTION FRAME

6.2.2009

etk_en_de_074515 LR 1600/2

973

LIEBHERRAlphabetical index
Alphabetischer Index

Description	Item	Pos.	Quantity	Page	Assembly	Description
SPLIT PIN DIN 94 10X71 ST V	43 30 101 08	(8)	2	3 281	91 52 896 08	ERECTION FRAME
SPLIT PIN DIN 94 10X71 ST V	43 30 101 08	98	8	3 713	91 57 749 08	D PIVOT SECTION
SPLIT PIN DIN 94 10X80 ST V	43 30 103 08	13	2	2 810	91 52 806 08	CRANE DRIVER'S CABIN CPL.
SPLIT PIN DIN 94 10X80 ST V	43 30 103 08	13	1	3 225	91 52 854 08	SL REDUCING SECTION
SPLIT PIN DIN 94 10X90 ST V	43 30 105 08	29	1	3 281	91 52 896 08	ERECTION FRAME
SPLIT PIN DIN 94 13X125 ST V	43 30 112 08	18	4	3 745	91 52 948 08	SUSPENDED BALLAST
SPLIT PIN DIN 94 13X160 ST V	43 30 115 08	4	4	3 205	91 52 880 08	F-ASSEMBLY UNIT
SPLIT PIN DIN 94 3,2X25 ST V	43 30 036 08	47	4	3 220 500	91 52 849 08	S INTERMEDIATE SECTION
SPLIT PIN DIN 94 3,2X25 ST V	43 30 036 08	47	4	3 223	91 52 852 08	S INTERMEDIATE SECTION
SPLIT PIN DIN 94 3,2X25 ST V	43 30 036 08	47	4	3 223 010	91 52 853 08	S INTERMEDIATE SECTION
SPLIT PIN DIN 94 3,2X25 ST V	43 30 036 08	47	4	3 223 100	91 55 327 08	S INTERMEDIATE SECTION
SPLIT PIN DIN 94 3,2X25 ST V	43 30 036 08	47	4	3 226	91 52 870 08	L INTERMEDIATE SECTION
SPLIT PIN DIN 94 3,2X25 ST V	43 30 036 08	47	4	3 227	91 52 873 08	L INTERMEDIATE SECTION
SPLIT PIN DIN 94 3,2X25 ST V	43 30 036 08	47	4	3 227 008	91 52 872 08	L INTERMEDIATE SECTION
SPLIT PIN DIN 94 4X25 ST VER	43 30 050 08	27	8	1 630	91 52 387 08	HYDRAULIC SUPPORT
SPLIT PIN DIN 94 4X25 ST VER	43 30 050 08	23	2	2 631	91 56 817 08	SLEWING PLATFORM CATWAL
SPLIT PIN DIN 94 4X25 ST VER	43 30 050 08	43	6	3 211	91 57 748 08	S PIVOT SECTION
SPLIT PIN DIN 94 4X25 ST VER	43 30 050 08	156	2	3 713	91 57 749 08	D PIVOT SECTION
SPLIT PIN DIN 94 4X32 ST VER	43 30 052 08	5	4	2 370	91 52 782 08	ERECTING WINCH
SPLIT PIN DIN 94 4X32 ST VER	43 30 052 08	62	2	2 550	91 57 751 08	SA FRAME
SPLIT PIN DIN 94 5X28 ST VER	43 30 063 08	28	12	2 631	91 56 817 08	SLEWING PLATFORM CATWAL
SPLIT PIN DIN 94 5X28 ST VER	43 30 063 08	11	2	3 205	91 52 880 08	F-ASSEMBLY UNIT
SPLIT PIN DIN 94 5X40 ST VER	43 30 065 08	13	1	2 925 204	92 16 990 08	CAMERA EQUIPMENT D-PIVOT
SPLIT PIN DIN 94 5X40 ST VER	43 30 065 08	39	14	3 211	91 57 748 08	S PIVOT SECTION
SPLIT PIN DIN 94 5X40 ST VER	43 30 065 08	70	4	3 713	91 57 749 08	D PIVOT SECTION
SPLIT PIN DIN 94 6,3X32 ST V	43 30 075 08	33	4	2 631	91 56 817 08	SLEWING PLATFORM CATWAL
SPLIT PIN DIN 94 6,3X32 ST V	43 30 075 08	30	16	2 652	91 52 794 08	ROLLER BEARING
SPLIT PIN DIN 94 6,3X32 ST V	43 30 075 08	15	4	2 730	91 52 802 08	BASE PLATE SLEWING PLATF
SPLIT PIN DIN 94 6,3X32 ST V	43 30 075 08	53	8	3 225	91 52 854 08	SL REDUCING SECTION
SPLIT PIN DIN 94 6,3X40 ST V	43 30 076 08	7	1	2 620	91 52 793 08	ROLLER SLEWING RING
SPLIT PIN DIN 94 6,3X40 ST V	43 30 076 08	3	4	2 671	91 52 798 08	OIL RESERVOIR, COMPLETE
SPLIT PIN DIN 94 6,3X45 ST V	43 30 077 08	14	4	2 670	91 52 797 08	FUEL TANK CPL.
SPLIT PIN DIN 94 6,3X45 ST V	43 30 077 08	21	4	3 208 001	91 52 883 08	F-HEAD SECTION
SPLIT PIN DIN 94 6,3X45 ST V	43 30 077 08	9	2	3 281	91 52 896 08	ERECTION FRAME
SPLIT PIN DIN 94 6,3X45 ST V	43 30 077 08	16	1	3 282 002	96 47 890 08	FAB-STAY
SPLIT PIN DIN 94 6,3X45 ST V	43 30 077 08	41	2	3 713	91 57 749 08	D PIVOT SECTION
SPLIT PIN DIN 94 6,3X45 ST V	43 30 077 08	15	4	3 745	91 52 948 08	SUSPENDED BALLAST
SPLIT PIN DIN 94 6,3X50 ST V	43 30 078 08	30	2	2 810	91 52 806 08	CRANE DRIVER'S CABIN CPL.
SPLIT PIN DIN 94 6,3X50 ST V	43 30 078 08	25	4	3 211	91 57 748 08	S PIVOT SECTION
SPLIT PIN DIN 94 6,3X50 ST V	43 30 078 08	14	2	3 220 500	91 52 849 08	S INTERMEDIATE SECTION
SPLIT PIN DIN 94 6,3X50 ST V	43 30 078 08	14	2	3 223	91 52 852 08	S INTERMEDIATE SECTION
SPLIT PIN DIN 94 6,3X50 ST V	43 30 078 08	14	2	3 223 010	91 52 853 08	S INTERMEDIATE SECTION
SPLIT PIN DIN 94 6,3X50 ST V	43 30 078 08	14	2	3 223 100	91 55 327 08	S INTERMEDIATE SECTION
SPLIT PIN DIN 94 6,3X50 ST V	43 30 078 08	50	2	3 281	91 52 896 08	ERECTION FRAME
SPLIT PIN DIN 94 6,3X56 ST V	43 30 079 08	51	2	3 206	91 52 881 08	PIVOT SECTION
SPLIT PIN DIN 94 6,3X90 ST V	43 30 085 08	45	2	3 206	91 52 881 08	PIVOT SECTION
SPLIT PIN DIN 94 8X100 ST V	43 30 097 08	16	4	1 630	91 52 387 08	HYDRAULIC SUPPORT
SPLIT PIN DIN 94 8X100 ST V	43 30 097 08	8	1	2 657	91 57 656 08	MOUNTING EQUIPMENT CRAW
SPLIT PIN DIN 94 8X50 ST VER	43 30 088 08	17	8	1 630	91 52 387 08	HYDRAULIC SUPPORT
SPLIT PIN DIN 94 8X50 ST VER	43 30 088 08	34	2	2 810	91 52 806 08	CRANE DRIVER'S CABIN CPL.
SPLIT PIN DIN 94 8X50 ST VER	43 30 088 08	4	3	3 282 002	96 47 890 08	FAB-STAY
SPLIT PIN DIN 94 8X50 ST VER	43 30 088 08	106	2	3 713	91 57 749 08	D PIVOT SECTION
SPLIT PIN DIN 94 8X50 ST VER	43 30 088 08	68	4	3 714	91 52 862 08	D HEAD SECTION
SPLIT PIN DIN 94 8X50 ST VER	43 30 088 08	60	1	3 745	91 52 948 08	SUSPENDED BALLAST
SPLIT PIN DIN 94 8X50 ST VER	43 30 088 08	4	1	3 790 006	96 19 989 08	PIN PULLING CYLINDER CPL.
SPLIT PIN DIN 94 8X50 ST VER	43 30 088 08	4	1	3 790 007	96 19 990 08	PIN PULLING CYLINDER CPL.
SPLIT PIN DIN 94 8X63 ST VER	43 30 090 08	8	4	1 991	91 52 510 08	ROTARY FEED THROUGH
SPLIT PIN DIN 94 8X63 ST VER	43 30 090 08	47	4	2 550	91 57 751 08	SA FRAME
SPLIT PIN DIN 94 8X63 ST VER	43 30 090 08	4	1	2 550 011	96 47 007 08	CONSOLE COMPL.
SPLIT PIN DIN 94 8X63 ST VER	43 30 090 08	20	2	2 652	91 52 794 08	ROLLER BEARING

6.2.2009

etk_en_de_074515 LR 1600/2

974

LIEBHERRAlphabetical index
Alphabetischer Index

Description	Item	Pos.	Quantity	Page	Assembly	Description
SPLIT PIN DIN 94 8X63 ST VER	43 30 090 08	21	2	2 810	91 52 806 08	CRANE DRIVER'S CABIN CPL.
SPLIT PIN DIN 94 8X63 ST VER	43 30 090 08	19	2	3 206	91 52 881 08	PIVOT SECTION
SPLIT PIN DIN 94 8X63 ST VER	43 30 090 08	18	2	3 215 005	91 52 846 08	ROLLER SET
SPLIT PIN DIN 94 8X63 ST VER	43 30 090 08	18	2	3 215 006	91 52 847 08	ROLLER SET
SPLIT PIN DIN 94 8X63 ST VER	43 30 090 08	52	1	3 281	91 52 896 08	ERECTION FRAME
SPLIT PIN DIN 94 8X63 ST VER	43 30 090 08	7	2	3 745 002	92 17 236 08	SWITCH UNIT
SPLIT PIN DIN 94 8X63 ST VER	43 30 090 08	7	2	3 745 003	92 17 237 08	SWITCH UNIT
SPONGE RUBBER 20X4 MOOS	26 21 031 08	30	0.064	2 502	91 55 939 08	CONTROL STAND
SPRING	57 08 310 08	9	1	5 106 691	51 06 691 08	RETURN FILTER
SPRING CUP	51 07 970 08	3	1	5 114 176	51 14 176 08	PRESSURE LIMITING VALVE
SPRING CUP	51 07 970 08	3	1	5 114 177	51 14 177 08	PRESSURE LIMITING VALVE
SPRING CUP	57 01 149 08	6	1	5 701 133	57 01 133 08	DRIVING GEAR
SPRING CUP 16MNCR5	90 78 515	6	4	9 739 261	97 39 261	CYLINDER HEAD
SPRING PIN	51 07 973 08	6	1	5 114 176	51 14 176 08	PRESSURE LIMITING VALVE
SPRING PIN	51 07 973 08	6	1	5 114 177	51 14 177 08	PRESSURE LIMITING VALVE
SPRING PIN	51 07 973 08	4	1	5 114 320	51 14 320 08	PRETENSIONING VALVE
SPRING PLUG 4 VERZ	43 32 062 08	8	1	1 632 032	96 20 093 08	SUPPORT PLATE COMPL.
SPRING PLUG 5 VERZ	43 32 063 08	84	2	2 550	91 57 751 08	SA FRAME
SPRING PLUG 5 VERZ	43 32 063 08	10	1	2 620	91 52 793 08	ROLLER SLEWING RING
SPRING PLUG 5 VERZ	43 32 063 08	41	4	2 810	91 52 806 08	CRANE DRIVER'S CABIN CPL.
SPRING PLUG 6 VERZ	43 32 064 08	13	1	2 620	91 52 793 08	ROLLER SLEWING RING
SPRING PLUG 6 VERZ	43 32 064 08	54	4	3 225	91 52 854 08	SL REDUCING SECTION
SPRING PLUG 6 VERZ	43 32 064 08	19	2	3 714 008	96 49 266 08	LUFFING PULLEY BLOCK COM
SPRING PLUG DIN 11024 B 2,5	43 32 060 08	31	2	3 215 005	91 52 846 08	ROLLER SET
SPRING PLUG DIN 11024 B 2,5	43 32 060 08	31	2	3 215 006	91 52 847 08	ROLLER SET
SPRING RING	10 22 233 6	3	2	9 739 246	97 39 246	PISTON
SPRING RING DIN 70951 47	42 42 017	(6)	2	2 810	91 52 806 08	CRANE DRIVER'S CABIN CPL.
SPRING X5CRNI18-10	97 84 867 08	83	1	2 520	91 53 061 08	CABIN, GLAZED
SPRING-LOADED LOCK VERZ	70 42 089 08	9	2	2 260	91 53 057 08	CUP SPRING CLUSTER
SPRING-LOADED LOCK VERZ	70 42 326 08	32	4	1 630	91 52 387 08	HYDRAULIC SUPPORT
SPUR WHEEL PA6G	96 89 130 01	17	1	2 340	91 52 776 08	WINCH 4 LUFFING GEAR
SQUARE WASHER	10 03 723 6	8	1	9 739 210	97 39 210	LIQUID COOLING PIPELINE
STAIR	96 54 367 08	45	1	2 631	91 56 817 08	SLEWING PLATFORM CATWAL
STAND WELDED	96 49 676 08	7	1	3 745	91 52 948 08	SUSPENDED BALLAST
STAND WELDED	96 49 679 08	9	1	3 745	91 52 948 08	SUSPENDED BALLAST
STANDOFF M3X13 ST SPF	66 00 460 08	8	12	2 922 001	92 84 311 08	BUS PCB
STANDOFF M3X4,7 STAHL VER	10 03 021 0	12	10	2 913 005	96 20 731 08	INTERIOR HOUSING PRE-ASS.
STANDOFF M3X4,7 STAHL VER	10 03 021 0	12	2	2 913 005	96 28 696 08	INTERIOR HOUSING PRE-ASS.
STANDOFF M3X5 ST SPF	66 00 422 08	10	4	2 922 001	92 84 311 08	BUS PCB
STANDOFF M3X6X12 ST SPF	66 00 428 08	9	4	2 922 001	92 84 311 08	BUS PCB
STANDOFF M3X8 STAHL VER	10 00 924 4	11	2	2 913 005	96 20 731 08	INTERIOR HOUSING PRE-ASS.
STANDOFF M3X8 STAHL VER	10 00 924 4	11	2	2 913 005	96 28 696 08	INTERIOR HOUSING PRE-ASS.
STANDOFF M3X8 STAHL VER	10 00 924 4	5	2	2 913 006	96 20 732 08	FAN PLATE PRE-ASS.
STANDOFF M3X8 STAHL VER	10 00 924 4	8	2	2 913 007	96 20 763 08	CONTROLLER UNIT
STANDOFF M4X30 VERZ	60 20 178 08	23	1	2 522 011	96 45 602 08	CLOSING DEVICE
STANDOFF M5X12 ST SPF	66 00 429 08	11	1	2 922 001	92 84 311 08	BUS PCB
STANDOFF M5X30	66 00 447 08	17	1	2 522	91 54 115 08	SLIDING DOOR CPL.
STANDOFF M6X50 ST VERZ	10 35 526 6	43	1	2 520 034	96 45 984 08	INTERNAL LINING
STAR HANDLE SCREW	10 44 362 5	24	2	2 502	91 55 939 08	CONTROL STAND
STARTER 6,6KW	97 39 159	205	1	X1012059	10 12 059 0	DIESEL ENGINE
STARTER KB24V 6,6KW	10 01 246 1	1	1	9 739 159	97 39 159	STARTER
STIFFENING PLATE	10 02 918 8	3	1	9 739 362	97 39 362	OIL SUMP
STOP BOLT NIROSTA	70 42 316 08	32	1	2 925 402	96 58 855 08	CAMERA EQUIPMENT SLEWI
STOPPER PLUG	26 47 366 02	30	1	2 932 160	96 54 385 08	SWITCH CABINET
STOPPER PLUG	69 24 049 08	811	1	2 920 636	96 51 854 08	LEAD
STOPPER PLUG 1,58	60 45 189 08	(812)	4	2 920 288	96 52 614 08	WIRING LIST F.SLEWING PLAT
STOPPER PLUG DIN 72585 7	69 24 057 08	822	3	2 920 633	96 52 651 08	WIRING HARNESS
STOPPER PLUG VST11/4"ED A3	47 77 040 08	664	1	1 970	91 56 958 08	CRAWLER TRACK HYDRAULI
STOPPER PLUG VST11/4"ED A3	47 77 040 08	761	5	2 970	91 56 537 08	HYDR
STOPPER PLUG VST11/4"ED A3	47 77 040 08	12	1	3 713 013	96 57 159 08	SHEET CPL.

6.2.2009

etk_en_de_074515 LR 1600/2

975

LIEBHERRAlphabetical index
Alphabetischer Index

Description	Item	Pos.	Quantity	Page	Assembly	Description
STOPPER PLUG VST11/4"ED A3	47 77 040 08	623	1	3 978 100	91 56 428 08	HYDR. SUSPENDED BALLAST
STOPPER PLUG VST11/4"ED A3	47 77 040 08	2	3	5 113 086	51 13 086 08	PROPORTIONAL VALVE
STOPPER PLUG VST11/4"ED A3	47 77 040 08	2	2	X1021769	10 21 769 5	LOWERING BRAKE VALVE
STOPPER PLUG VSTIM10X1E	47 77 055 08	608	3	2 990	91 59 244 08	COMPRESSED AIR PLANT
STRAINER FILTER	10 01 245 0	4	1	9 739 258	97 39 258	FUEL FILTER
STRAINER FILTER	10 34 659 9	1	1	X1021769	10 21 769 5	LOWERING BRAKE VALVE
STRIP CLIP 19X12	10 02 307 6	5	2	9 739 127	97 39 127	WATER BLEEDER PIPELINE
STRUT CYLINDER 190/160-850	10 41 080 3	4	4	1 630	91 52 387 08	HYDRAULIC SUPPORT
SUBPLATE	51 06 340 08	5	1	3 978 100	91 56 428 08	HYDR. SUSPENDED BALLAST
SUCTION BEND	10 01 247 7	18	1	9 739 492	97 39 492	PIPELINE INSTALLATION
SUCTION LINE JOINING	10 01 229 0	1	1	9 739 118	97 39 118	OIL LINE
SUCTION LINE JOINING	10 47 691 2	22	1	9 739 492	97 39 492	PIPELINE INSTALLATION
SUCTION LINE JOINING	10 48 691 6	26	1	9 739 492	97 39 492	PIPELINE INSTALLATION
SUCTION NOZZLE D 2876	10 03 716 3	1	1	9 739 209	97 39 209	SUCTION NOZZLE
SUCTION NOZZLE D 2876	97 39 209	112	1	X1012059	10 12 059 0	DIESEL ENGINE
SUCTION PIPE	96 47 510 08	9	1	2 671	91 52 798 08	OIL RESERVOIR, COMPLETE
SUCTION PIPE WELDED	96 50 520 08	48	1	2 391 001	96 45 719 08	DIESEL ENGINE, PRE-ASSEMB
SUCTION STUB PIPE WELDED	96 49 134 08	38	1	2 391 001	96 45 719 08	DIESEL ENGINE, PRE-ASSEMB
SUCTION STUB PIPE WELDED	96 50 514 08	47	1	2 391 001	96 45 719 08	DIESEL ENGINE, PRE-ASSEMB
SUCTION STUB PIPE WELDED	96 52 448 08	73	1	2 391 001	96 45 719 08	DIESEL ENGINE, PRE-ASSEMB
SUPPLEMENT CAMERA CAB	96 48 421 08	10	1	2 925 026	91 55 259 08	ERG. CAMERA CONTROL
SUPPLEMENT CAMERA WIND	96 59 125 08	10	1	2 925 218	91 60 840 08	CAMERA CONTROL WINCH 3
SUPPLEMENTARY GUYING DE	91 55 536 08	451	1		LR 1600-2-0	
SUPPLEMENTARY GUYING DE	91 55 537 08	452	1		LR 1600-2-0	
SUPPLEMENTARY GUYING DE	91 55 538 08	453	1		LR 1600-2-0	
SUPPLEMENTARY GUYING DE	91 55 539 08	454	1		LR 1600-2-0	
SUPPLEMENTARY GUYING DE	91 55 540 08	455	1		LR 1600-2-0	
SUPPLEMENTARY GUYING DE	91 55 541 08	456	1		LR 1600-2-0	
SUPPLEMENTARY GUYING DE	91 55 542 08	457	1		LR 1600-2-0	
SUPPLEMENTARY GUYING D	91 55 535 08	450	1		LR 1600-2-0	
SUPPORT	96 48 491 08	1	1	2 391 001	96 45 719 08	DIESEL ENGINE, PRE-ASSEMB
SUPPORT	96 53 864 08	88	1	2 550	91 57 751 08	SA FRAME
SUPPORT BRACKET WELDED	96 51 181 08	49	1	2 810	91 52 806 08	CRANE DRIVER'S CABIN CPL.
SUPPORT CPL.	96 50 752 08	38	2	3 714	91 52 862 08	D HEAD SECTION
SUPPORT FRAME WELDED ST	96 48 347 08	47	2	3 206	91 52 881 08	PIVOT SECTION
SUPPORT PLATE 1400X60 PA6	97 66 612 08	28	2	3 220 500	91 52 849 08	S INTERMEDIATE SECTION
SUPPORT PLATE 1400X60 PA6	97 66 612 08	16	2	3 221	91 54 668 08	S INTERMEDIATE SECTION
SUPPORT PLATE 1400X60 PA6	97 66 612 08	28	2	3 223	91 52 852 08	S INTERMEDIATE SECTION
SUPPORT PLATE 1400X60 PA6	97 66 612 08	28	2	3 223 010	91 52 853 08	S INTERMEDIATE SECTION
SUPPORT PLATE 1400X60 PA6	97 66 612 08	28	2	3 223 100	91 55 327 08	S INTERMEDIATE SECTION
SUPPORT PLATE 1400X60 PA6	97 66 612 08	28	2	3 226	91 52 870 08	L INTERMEDIATE SECTION
SUPPORT PLATE 1400X60 PA6	97 66 612 08	28	2	3 227	91 52 873 08	L INTERMEDIATE SECTION
SUPPORT PLATE 1400X60 PA6	97 66 612 08	28	2	3 227 008	91 52 872 08	L INTERMEDIATE SECTION
SUPPORT PLATE 1400X60 PA6	97 66 612 08	28	2	3 227 200	91 53 519 08	LI INTERMEDIATE SECT. F-GU
SUPPORT PLATE 15X50X900 P	28 81 951 08	71	2	2 550	91 57 751 08	SA FRAME
SUPPORT PLATE 15X60X1280	28 81 537 08	55	1	3 211	91 57 748 08	S PIVOT SECTION
SUPPORT PLATE 15X60X1318	28 81 766 08	64	1	3 211	91 57 748 08	S PIVOT SECTION
SUPPORT PLATE 15X60X980 P	28 81 926 08	22	2	3 208 001	91 52 883 08	F-HEAD SECTION
SUPPORT PLATE 60X1270 PA6	97 41 439 08	29	1	3 220 500	91 52 849 08	S INTERMEDIATE SECTION
SUPPORT PLATE 60X1270 PA6	97 41 439 08	29	2	3 223	91 52 852 08	S INTERMEDIATE SECTION
SUPPORT PLATE 60X1270 PA6	97 41 439 08	29	2	3 223 010	91 52 853 08	S INTERMEDIATE SECTION
SUPPORT PLATE 60X1270 PA6	97 41 439 08	29	2	3 223 100	91 55 327 08	S INTERMEDIATE SECTION
SUPPORT PLATE 60X1270 PA6	97 41 439 08	29	1	3 225	91 52 854 08	SL REDUCING SECTION
SUPPORT PLATE 60X1270 PA6	97 41 439 08	29	1	3 226	91 52 870 08	L INTERMEDIATE SECTION
SUPPORT PLATE 60X1270 PA6	97 41 439 08	29	2	3 227	91 52 873 08	L INTERMEDIATE SECTION
SUPPORT PLATE 60X1270 PA6	97 41 439 08	29	2	3 227 008	91 52 872 08	L INTERMEDIATE SECTION
SUPPORT PLATE 60X1270 PA6	97 41 439 08	29	2	3 227 200	91 53 519 08	LI INTERMEDIATE SECT. F-GU
SUPPORT PLATE 60X1270 PA6	97 41 439 08	57	3	3 713	91 57 749 08	D PIVOT SECTION
SUPPORT PLATE 60X1270 PA6	97 41 439 08	51	6	3 714	91 52 862 08	D HEAD SECTION
SUPPORT PLATE 60X1270 PA6	97 41 439 08	24	4	3 715 008	91 52 863 08	D INTERMEDIATE SECTION

6.2.2009

etk_en_de_074515 LR 1600/2

976

LIEBHERRAlphabetical index
Alphabetischer Index

Description	Item	Pos.	Quantity	Page	Assembly	Description
SUPPORT PLATE 60X1270 PA6	97 41 439 08	24	5	3 716	91 52 864 08	D INTERMEDIATE SECTION
SUPPORT PLATE 60X1520 PA6	97 41 438 08	39	2	3 225	91 52 854 08	SL REDUCING SECTION
SUPPORT PLATE COMPL.	92 53 053 08	5	4	1 630	91 52 387 08	HYDRAULIC SUPPORT
SUPPORT PLATE COMPL.	96 20 093 08	5	2	1 632	91 52 389 08	MECHANICAL SUPPORT
SUPPORT PLATE WELDED	96 20 102 08	1	1	1 632 032	96 20 093 08	SUPPORT PLATE COMPL.
SUPPORT TRESTLE	60 27 360 08	261	2	2 920 581	96 54 405 08	TERMINAL BOX WINCH PRE-A
SUPPORT TRESTLE	60 27 360 08	158	2	3 930 640	96 50 481 08	TERMINAL BOX CPL.
SUPPORT TRESTLE	60 27 360 08	271	2	3 930 730	96 50 599 08	TERMINAL BOX CPL.
SUPPORT TRESTLE	60 27 360 08	274	2	3 930 730	96 54 398 08	TERMINAL BOX CPL.
SUPPORT TRESTLE	60 27 360 08	205	2	3 930 734	96 54 401 08	TERMINAL BOX
SUPPORT TZNO	96 53 091 08	6	6	2 631	91 56 817 08	SLEWING PLATFORM CATWAL
SUPPORT WELDED	92 69 017 08	30	4	3 713	91 57 749 08	D PIVOT SECTION
SUPPORT WELDED	92 85 715 08	46	2	3 211	91 57 748 08	S PIVOT SECTION
SUPPORT WELDED	96 50 698 08	1	1	3 216 005	96 50 697 08	FOOT COMPLETE
SUPPORT WELDED	96 50 763 08	1	1	3 714 017	96 50 752 08	SUPPORT CPL.
SUPPORTING RING	57 10 770 08	(3)	1	2 975 700	91 52 774 08	ADDITIONAL HYDRAULICS WI
SUPPORTING RING	57 10 770 08	(3)	1	3 978 100	91 56 428 08	HYDR. SUSPENDED BALLAST
SUPPORTING RING	57 10 822 08	(4)	1	1 970	91 56 958 08	CRAWLER TRACK HYDRAULI
SUPPORTING RING	57 10 822 08	(3)	1	1 970	91 56 958 08	CRAWLER TRACK HYDRAULI
SUPPORTING RING	57 10 828 08	(3)	1	1 970	91 56 958 08	CRAWLER TRACK HYDRAULI
SUPPORTING RING DIN 988 S	42 20 075 08	(28)	3	1 400	91 56 853 08	CRAWLER TRACK CARRIER LE
SUPPORTING RING DIN 988 S	53 00 631 08	32	8	2 550	91 57 751 08	SA FRAME
SUPPORTING RING DIN 988 S	51 45 410 08	19	8	3 220 500	91 52 849 08	S INTERMEDIATE SECTION
SUPPORTING RING DIN 988 S	51 45 410 08	19	10	3 223	91 52 852 08	S INTERMEDIATE SECTION
SUPPORTING RING DIN 988 S	51 45 410 08	19	10	3 223 010	91 52 853 08	S INTERMEDIATE SECTION
SUPPORTING RING DIN 988 S	51 45 410 08	19	10	3 223 100	91 55 327 08	S INTERMEDIATE SECTION
SUSPENDED BALLAST	91 52 948 08	346	1		LR 1600-2-0	
SUSPENDED PUSH-BUTTON	60 66 523 08	7	1	2 920 638	96 51 138 08	CONTROL DESK
SUSPENSION EYE	10 22 277 7	5	1	9 739 493	97 39 493	TRANSPORT DEVICE
SUSPENSION EYE	10 29 431 6	2	1	9 739 493	97 39 493	TRANSPORT DEVICE
SUSPENSION RING	10 01 245 6	1	1	9 739 493	97 39 493	TRANSPORT DEVICE
SUSPENSION RING	10 01 734 7	3	1	9 739 493	97 39 493	TRANSPORT DEVICE
SW HEAD SECTION	91 52 843 08	203	1		LR 1600-2-0	
SW HEAD SECTION WELDMEN	96 46 991 08	1	1	3 214	91 52 843 08	SW HEAD SECTION
SWITCH CABINET	96 54 385 08	2	1	2 932	91 57 750 08	BUILT-IN PARTS SWITCH BOX
SWITCH CABINET WELDED	96 54 384 08	1	1	2 932 160	96 54 385 08	SWITCH CABINET
SWITCH UNIT	92 17 236 08	4	2	3 745	91 52 948 08	SUSPENDED BALLAST
SWITCH UNIT	92 17 237 08	5	2	3 745	91 52 948 08	SUSPENDED BALLAST
SWITCHING ELEMENT	69 27 014 08	7	1	2 913 003	96 20 599 08	FOIL KEYPAD PRE-ASS.
SWIVEL ARM WELDED	96 46 383 08	3	1	2 810	91 52 806 08	CRANE DRIVER'S CABIN CPL.
SWIVEL ELBOW	59 10 510 08	24	2	2 520 032	96 45 980 08	WINDSHIELD WASHER INSTAL
SWIVEL SCREW JOINT 76K 20	10 45 537 2	569	4	2 970	91 56 537 08	HYDR
SWIVEL SCREW JOINT DG108	51 05 521 08	570	2	2 970	91 56 537 08	HYDR
T-PIECE 18/18/18	55 31 281 08	11	1	2 540	91 53 253 08	CLIMA-HEATING INSTALLATIO
T-PIECE 18/18/18	55 31 281 08	10	1	2 541	91 52 790 08	ADD HEATING SUPERSTRUCT
T-PIECE 30X30X30 G-ALMG	10 28 570 1	48	2	2 520	91 53 061 08	CABIN, GLAZED
T-PIECE 30X30X30 G-ALMG	10 28 570 1	4	2	2 533 066	96 48 365 08	ELECTRIC ADD-ON PARTS CA
TACHOMETER	90 79 185	20	1	9 739 257	97 39 257	ENGINE CONTROL SENSORS
TACHOMETER	90 79 186	21	1	9 739 257	97 39 257	ENGINE CONTROL SENSORS
TACHOMETER HALL 0,3-1600	10 11 789 8	1	1	9 079 185	90 79 185	TACHOMETER
TACHOMETER HALL 0,3-1600	10 11 789 8	1	1	9 079 186	90 79 186	TACHOMETER
TAGS - TERMINAL BOX S10	96 48 795 08	4	1	2 920 448	96 48 794 08	TERMINAL BOX CPL.
TAIL BRAKE LIGHT	60 71 131 08	3	2	2 920 931	96 59 398 08	WARNING LIGHT
TANK SENSOR L=1000 SPF	78 90 151 08	5	1	2 920 814	96 45 717 08	ELECTR.F.FUEL TANK
TAPER	51 07 921 08	4	1	5 711 301	57 11 301 08	PRESSURE LIMITING VALVE
TAPERED ROLLER BEARING	57 01 140 08	10	1	5 701 129	57 01 129 08	DRIVING GEAR
TAPERED ROLLER BEARING D	74 62 026 01	12	1	9 697 916	96 97 916 01	SLEWING GEAR
TAPERED ROLLER BEARING D	74 62 237 01	3	1	9 697 916	96 97 916 01	SLEWING GEAR
TAPERED ROLLER BEARING	74 62 216 08	11	1	5 701 129	57 01 129 08	DRIVING GEAR
TAPPET PUSH ROD	10 01 707 9	4	2	9 739 187	97 39 187	CONTROL PARTS

6.2.2009

etk_en_de_074515 LR 1600/2

977

LIEBHERRAlphabetical index
Alphabetischer Index

Description	Item	Pos.	Quantity	Page	Assembly	Description
TELEDIAGNOSIS MODULE 1	91 24 097 08	354	1		LR 1600-2-0	
TELEDIAGNOSIS MODULE HA	89 96 346 08	3	1	2 780 854	96 37 908 08	GSM MODULE LICCON 1
TELESCOPE GUIDE RAIL 530	10 41 235 8	7	2	2 260	91 53 057 08	CUP SPRING CLUSTER
TEMPER. SENSOR HYDRAULI	96 47 922 08	14	1	2 970	91 56 537 08	HYDR
TEMPERATURE SENSOR	10 01 246 6	(1)	1	9 739 318	97 39 318	SENSOR ELEMENT
TEMPERATURE SENSOR	10 01 246 7	(1)	1	9 739 318	97 39 318	SENSOR ELEMENT
TEMPERATURE SENSOR	10 29 012 6	19	1	X1004204	10 04 204 3	WATER HEATING SYSTEM
TEMPERATURE SENSOR 2-9	69 11 831 08	(1)	1	2 970	91 56 537 08	HYDR
TEMPERATURE TEST	10 11 740 5	1	1	9 739 318	97 39 318	SENSOR ELEMENT
TEMPERATURE TEST	10 11 740 6	2	1	9 739 318	97 39 318	SENSOR ELEMENT
TENSION DYNAMOMETER 0-24	10 35 469 6	501	2	2 550	91 57 751 08	SA FRAME
TENSION DYNAMOMETER Z	10 28 861 0	11	2	3 714	91 52 862 08	D HEAD SECTION
TENSION SPRING	72 01 091 08	9	3	3 206	91 52 881 08	PIVOT SECTION
TENSION SPRING 0,8X8X26,5	10 44 376 9	24	2	2 522 011	96 45 602 08	CLOSING DEVICE
TENSIONING ROPE 13M	97 69 999 08	1	2	3 207	91 53 433 08	F-GUYING
TERMINAL BOARD	10 65 068 8	3	1	X1035924	10 35 924 9	VARIABLE PUMP
TERMINAL BOARD	51 06 295 08	63	1	2 970	91 56 537 08	HYDR
TERMINAL BOARD	51 06 318 08	56	3	2 970	91 56 537 08	HYDR
TERMINAL BOARD	51 10 583 08	6	1	2 975 000	91 57 881 08	ADDNL. HYDR. F. ERECTING W
TERMINAL BOARD	57 07 719 08	4	1	5 102 306	51 02 306 08	HYDRO MOTOR
TERMINAL BOARD	57 15 142 08	3	1	X1035924	10 35 924 1	VARIABLE PUMP
TERMINAL BOARD	57 15 142 08	3	1	X1035924	10 35 924 2	VARIABLE PUMP
TERMINAL BOARD	57 15 142 08	3	1	X1035925	10 35 925 0	VARIABLE PUMP
TERMINAL BOARD	57 18 989 08	3	1	X1035924	10 35 924 6	VARIABLE PUMP
TERMINAL BOARD	57 19 004 08	2	1	X1035924	10 35 924 7	VARIABLE PUMP
TERMINAL BOARD	57 19 030 08	3	1	X1035924	10 35 924 3	VARIABLE PUMP
TERMINAL BOARD	57 19 030 08	3	1	X1035924	10 35 924 4	VARIABLE PUMP
TERMINAL BOARD	70 23 640	2	1	X1035924	10 35 924 8	VARIABLE PUMP
TERMINAL BOARD PRE-ASS.	92 26 483 08	42	1	2 932 082	96 54 387 08	ASSEMBLY PARTS MOUNTIN
TERMINAL BOX CPL. +S1100	96 52 969 08	10	1	2 780 510	96 50 097 08	ELECTR.FOR BALLAST PALLE
TERMINAL BOX CPL. S10	96 48 794 08	1	1	2 920 443	96 54 236 08	TERMINAL BOX ELECTRICS S
TERMINAL BOX CPL. S1000	96 50 481 08	1	1	3 930 575	96 48 380 08	EL.F-CONNECTING HEAD
TERMINAL BOX CPL. S1020	96 50 599 08	1	1	3 930 546	96 48 375 08	ELECTR. F-HEAD SECTION
TERMINAL BOX CPL. S1070	96 52 979 08	1	1	3 930 421	96 47 149 08	ELECTR. FOR HEAD SECTION
TERMINAL BOX CPL. S11	96 54 235 08	2	1	2 920 443	96 54 236 08	TERMINAL BOX ELECTRICS S
TERMINAL BOX CPL. S200	96 48 687 08	2	1	1 920 307	96 48 383 08	ELECTR.FOR CENTER SECTIO
TERMINAL BOX CPL. S220 4X F	96 48 707 08	10	1	1 920 309	96 48 385 08	ELECTR.CRAWLER SUPPORT
TERMINAL BOX CPL. S240 4X	96 48 703 08	10	1	1 920 308	96 48 384 08	ELECTR.CRAWLER SUPPORT
TERMINAL BOX CPL. S910	96 54 398 08	9	1	3 930 138	96 54 377 08	ELECTRIC FOR S-PIVOT SECT
TERMINAL BOX ELECTRICS S	96 54 236 08	20	1	2 920	91 56 833 08	ELECTR. SYSTEM F.SLEWING
TERMINAL BOX LIGHTING HOI	92 78 689 08	523	1	2 920 633	96 52 651 08	WIRING HARNESS
TERMINAL BOX S1050	96 54 401 08	1	1	3 930 330	96 54 378 08	D PIVOT SECTION ELEC. EQUI
TERMINAL BOX S980	96 51 624 08	1	1	3 930 576	96 48 381 08	EL.EQUIPMENT SW HEAD SE
TERMINAL BOX WINCH PRE-	96 54 405 08	1	1	2 920 578	96 54 379 08	ELECTRIC FOR SA - FRAME
TERMINAL CLIP 39-42	55 30 542 08	8	3	2 541 001	96 49 651 08	ADDNL.HEATING, PRE-ASSE
TERMINAL HOUSING DIN 7258	69 24 062 08	511	1	2 920 633	96 52 651 08	WIRING HARNESS
TERMINAL MARKER	60 27 616 08	7	1	2 932 082	96 54 387 08	ASSEMBLY PARTS MOUNTIN
TERMINAL/CLAMP	10 28 635 4	274	12	1 920 403	96 48 707 08	TERMINAL BOX CPL.
TERMINAL/CLAMP	10 28 635 4	274	12	1 920 417	96 48 703 08	TERMINAL BOX CPL.
TERMINAL/CLAMP	10 28 635 4	(151)	47	1 920 418	96 48 687 08	TERMINAL BOX CPL.
TERMINAL/CLAMP	10 28 635 4	(151)	13	2 780 748	96 52 969 08	TERMINAL BOX CPL.
TERMINAL/CLAMP	10 28 635 4	260	21	2 920 581	96 54 405 08	TERMINAL BOX WINCH PRE-A
TERMINAL/CLAMP	10 28 635 4	63	2	2 932 082	96 54 387 08	ASSEMBLY PARTS MOUNTIN
TERMINAL/CLAMP	10 28 635 4	(151)	20	3 930 363	96 52 979 08	TERMINAL BOX CPL.
TERMINAL/CLAMP	10 28 635 4	152	36	3 930 639	96 50 132 08	WIRES TERMINAL BOX CPL.
TERMINAL/CLAMP	10 28 635 4	(152)	24	3 930 640	96 50 481 08	TERMINAL BOX CPL.
TERMINAL/CLAMP	10 28 635 4	(502)	28	3 930 730	96 50 599 08	TERMINAL BOX CPL.
TERMINAL/CLAMP	10 28 635 4	279	88	3 930 730	96 54 398 08	TERMINAL BOX CPL.
TERMINAL/CLAMP	10 28 635 4	(501)	47	3 930 734	96 54 401 08	TERMINAL BOX
TERMINAL/CLAMP	63 61 079 01	521	2	2 932 224	96 54 389 08	CABLES MOUNTING PANEL C

6.2.2009

etk_en_de_074515 LR 1600/2

978

LIEBHERRAlphabetical index
Alphabetischer Index

Description	Item	Pos.	Quantity	Page	Assembly	Description
TEST CONNECTION A3P	50 29 214 08	625	1	2 990	91 59 244 08	COMPRESSED AIR PLANT
THERMAL SWITCH 55-50GR.C	69 11 832 08	(2)	1	2 391 102	96 56 360 08	RADIATOR
THERMOSTAT	10 01 232 0	11	2	9 739 126	97 39 126	THERMOSTAT HOUSING
THERMOSTAT	57 18 677 08	44	1	X1022811	10 22 811 2	AIR CONDITIONING UNIT
THERMOSTAT HOUSING	97 39 126	172	1	X1012059	10 12 059 0	DIESEL ENGINE
THREAD FORM SCREW DIN 7	57 00 103 08	18	4	5 026 126	50 26 126 08	SOLENOID VALVE
THREADED BOLT 16F7X52X76	97 74 833 08	2	2	2 502	91 55 939 08	CONTROL STAND
THREADED BOLT 40.0X505	97 73 406 08	4	8	2 125	91 52 773 08	PIN F.S-PIVOT SECTION SA F
THREADED BOLT DIN 976 B M5	66 00 416 08	14	1	2 922 001	92 84 311 08	BUS PCB
THREADED BOLT RD30X365	95 44 784 08	20	6	1 400	91 56 853 08	CRAWLER TRACK CARRIER LE
THREADED BOLT RD30X365	95 44 784 08	20	6	1 410 300	91 56 855 08	CRAWLER CARRIER RIGHT CP
THREADED BUSH RD240X200	93 81 367 08	2	2	1 632	91 52 389 08	MECHANICAL SUPPORT
THREADED CABLE GLAND M	60 24 240 08	(151)	1	2 920 581	96 54 405 08	TERMINAL BOX WINCH PRE-A
THREADED CABLE GLAND M	60 24 240 08	(151)	1	2 920 581	96 54 405 08	TERMINAL BOX WINCH PRE-A
THREADED CABLE GLAND M	60 24 240 08	(151)	1	2 920 581	96 54 405 08	TERMINAL BOX WINCH PRE-A
THREADED CABLE GLAND M	60 24 241 08	267	2	1 920 403	96 48 707 08	TERMINAL BOX CPL.
THREADED CABLE GLAND M	60 24 241 08	267	2	1 920 417	96 48 703 08	TERMINAL BOX CPL.
THREADED CABLE GLAND M	60 24 241 08	72	3	2 520	91 53 061 08	CABIN, GLAZED
THREADED CABLE GLAND M	60 24 241 08	153	1	2 780 748	96 52 969 08	TERMINAL BOX CPL.
THREADED CABLE GLAND M	60 24 241 08	277	2	3 930 363	96 52 979 08	TERMINAL BOX CPL.
THREADED CABLE GLAND M	60 24 241 08	10	1	X1002800	10 02 800 2	CABLE REEL
THREADED CABLE GLAND M	60 24 242 08	8	2	2 780 524	96 52 968 08	CABLE DRUM COMPL.
THREADED CABLE GLAND M	60 24 242 08	290	1	2 920 448	96 48 794 08	TERMINAL BOX CPL.
THREADED CABLE GLAND M	60 24 242 08	(154)	2	2 920 581	96 54 405 08	TERMINAL BOX WINCH PRE-A
THREADED CABLE GLAND M	60 24 242 08	272	1	2 920 581	96 54 405 08	TERMINAL BOX WINCH PRE-A
THREADED CABLE GLAND M	60 24 242 08	520	3	2 920 633	96 52 651 08	WIRING HARNESS
THREADED CABLE GLAND M	60 24 242 08	(153)	2	3 930 734	96 54 401 08	TERMINAL BOX
THREADED CABLE GLAND M	60 24 242 08	3	1	X1002800	10 02 800 2	CABLE REEL
THREADED CABLE GLAND M	60 24 257 08	270	3	2 920 581	96 54 405 08	TERMINAL BOX WINCH PRE-A
THREADED CABLE GLAND M	60 24 257 08	276	3	3 930 363	96 52 979 08	TERMINAL BOX CPL.
THREADED CABLE GLAND M	60 24 257 08	279	1	3 930 638	96 51 624 08	TERMINAL BOX
THREADED CABLE GLAND M	60 24 260 08	(504)	1	2 920 288	96 52 614 08	WIRING LIST F.SLEWING PLAT
THREADED CABLE GLAND M	60 24 243 08	270	1	1 920 403	96 48 707 08	TERMINAL BOX CPL.
THREADED CABLE GLAND M	60 24 243 08	270	1	1 920 417	96 48 703 08	TERMINAL BOX CPL.
THREADED CABLE GLAND M	60 24 243 08	(269)	1	3 930 138	96 54 377 08	ELECTRIC FOR S-PIVOT SECT
THREADED CABLE GLAND M	60 24 258 08	156	1	3 930 732	96 50 575 08	LEAD
THREADED CABLE GLAND M	60 24 246 08	18	1	1 920 418	96 48 687 08	TERMINAL BOX CPL.
THREADED CABLE GLAND P	60 24 417 01	11	2	2 780 915	96 48 377 08	ADD-ON PARTS EXTERNAL F
THREADED CONNECTION	10 22 276 5	11	1	9 739 281	97 39 281	OVERFLOW-OIL LINE
THREADED DISK	10 41 278 9	6	1	X1041267	10 41 267 8	END PLATE
THREADED DISK	51 10 072 08	14	1	5 114 320	51 14 320 08	PRETENSIONING VALVE
THREADED PLATE 8X20X60	95 36 953 08	4	4	2 510	91 52 788 08	TURNTABLE PANELLING
THREADED PLATE 8X20X60	95 36 953 08	3	2	2 510 040	96 49 183 08	DOOR COMPL.
THREADED PLATE 8X20X60	95 36 953 08	3	2	2 510 059	96 49 184 08	DOOR COMPL.
THREADED ROD M10X120	95 45 915 08	11	1	2 391 040	96 53 645 08	CLUTCH ACTUATOR
THREADED ROD M10X120	95 45 915 08	10	1	3 206	91 52 881 08	PIVOT SECTION
THREE PHASE CURRENT GEN	10 03 240 2	1	1	9 739 343	97 39 343	GENERATOR, PRE-ASSEMBLE
THRUST WASHER	10 01 211 7	7	2	9 739 102	97 39 102	CRANKSHAFT BEARINGS
THRUST WASHER	10 01 211 8	71	2	9 739 102	97 39 102	CRANKSHAFT BEARINGS
THRUST WASHER	10 01 212 0	72	2	9 739 102	97 39 102	CRANKSHAFT BEARINGS
TIGHTENING ROLLER	10 34 330 9	2	1	9 739 371	97 39 371	AIR COND. COMPRESSOR A
TIGTENING STRAP 127	55 20 669 08	9	2	2 392	91 52 785 08	MUFFLER UNIT
TIGTENING STRAP 155,5//19	55 20 709 08	8	5	2 392	91 52 785 08	MUFFLER UNIT
TIGTENING STRAP 350X859X	10 04 160 5	19	2	2 392	91 52 785 08	MUFFLER UNIT
TIGTENING STRAP ST	77 42 105 08	10	2	2 990	91 59 244 08	COMPRESSED AIR PLANT
TIGTENING STRAP ST	77 42 105 08	6	2	3 978 005	91 56 430 08	ADDL.HYDRAULIC SB-HEAD PI
TIGTENING STRAP ST	77 42 113 08	7	1	2 990	91 59 244 08	COMPRESSED AIR PLANT
TILTING-BACK SUPPORT 150/1	10 41 101 5	1	2	3 291	91 52 831 08	S OVERRUN PROTECTION
TILTING-BACK SUPPORT 150/1	10 41 101 8	1	2	3 292	91 52 865 08	D OVERRUN PROTECTION
TIME RELAY SPF	63 01 013 08	53	2	2 932 082	96 54 387 08	ASSEMBLY PARTS MOUNTIN

6.2.2009

etk_en_de_074515 LR 1600/2

979

LIEBHERRAlphabetical index
Alphabetischer Index

Description	Item	Pos.	Quantity	Page	Assembly	Description
TIN M13	60 45 081 08	285	2	3 930 638	96 51 624 08	TERMINAL BOX
TIN M13	60 45 081 08	287	1	3 930 640	96 50 481 08	TERMINAL BOX CPL.
TIN M13	60 45 081 08	155	1	3 930 730	96 50 599 08	TERMINAL BOX CPL.
TONGUE	70 42 535 08	13	4	2 260 006	96 46 501 08	BATTERY BOX, PRE-ASSEMB
TONGUE	70 42 540 08	8	4	2 859 007	96 46 775 08	COVER COMPL.
TONGUE	70 42 551 08	8	4	2 393 002	96 46 782 08	COVER COMPL.
TONGUE	70 42 551 08	8	4	2 859 029	96 46 779 08	COVER COMPL.
TONGUE	70 42 553 08	8	7	2 859 005	96 46 756 08	FLAP PRE-ASS.
TONGUE	70 42 553 08	4	6	2 932 168	96 48 167 08	COVER COMPL.
TONGUE	70 42 562 08	13	2	2 859 030	96 46 758 08	COVER COMPL.
TONGUE	70 42 567 08	8	4	2 859 026	96 46 776 08	COVER COMPL.
TONGUE	70 42 567 08	8	4	2 859 027	96 46 777 08	COVER COMPL.
TONGUE	70 42 567 08	8	4	2 859 028	96 46 778 08	COVER COMPL.
TONGUE	70 42 590 08	14	4	2 859 025	96 46 757 08	GRIDIRON PRE-ASS.
TOOL	91 52 394 08	25	1		LR 1600-2-0	
TOOTH LOCK WASHER DIN 6	42 51 004 08	3	4	2 913 003	96 20 599 08	FOIL KEYPAD PRE-ASS.
TOOTH LOCK WASHER DIN 6	42 51 005 08	6	12	2 913 100	91 23 538 08	ASSEMBLY FRAME
TOOTH LOCK WASHER DIN 6	42 51 005 08	42	8	2 920 369	96 54 235 08	TERMINAL BOX CPL.
TOOTH LOCK WASHER DIN 6	42 51 005 08	17	10	2 922 001	92 84 311 08	BUS PCB
TOOTH LOCK WASHER DIN 6	42 51 005 08	(267)	4	3 930 138	96 54 377 08	ELECTRIC FOR S-PIVOT SECT
TOOTH LOCK WASHER DIN 6	42 51 005 08	283	16	3 930 638	96 51 624 08	TERMINAL BOX
TOOTH LOCK WASHER DIN 6	42 51 007 08	14	4	2 913 100	91 23 538 08	ASSEMBLY FRAME
TOOTH LOCK WASHER DIN 6	42 51 007 08	6	8	2 913 102	92 32 870 08	FAN UNIT
TOOTH LOCK WASHER DIN 6	42 51 007 08	282	12	2 920 369	96 54 235 08	TERMINAL BOX CPL.
TOOTH LOCK WASHER DIN 6	42 51 007 08	282	24	2 920 448	96 48 794 08	TERMINAL BOX CPL.
TOOTH LOCK WASHER DIN 6	42 51 007 08	46	56	2 932 160	96 54 385 08	SWITCH CABINET
TOOTHED BELT 12T5 445	10 48 983 6	1	1	X1022811	10 22 811 2	AIR CONDITIONING UNIT
TOP HAT RAIL 35X27X7,3X1	60 21 067 08	273	0.15	1 920 403	96 48 707 08	TERMINAL BOX CPL.
TOP HAT RAIL 35X27X7,3X1	60 21 067 08	273	0.15	1 920 417	96 48 703 08	TERMINAL BOX CPL.
TOP HAT RAIL 35X27X7,3X1	60 21 067 08	10	0.585	1 920 418	96 48 687 08	TERMINAL BOX CPL.
TOP HAT RAIL 35X27X7,3X1	60 21 067 08	273	0.15	2 780 748	96 52 969 08	TERMINAL BOX CPL.
TOP HAT RAIL 35X27X7,3X1	60 21 067 08	262	0.205	2 920 581	96 54 405 08	TERMINAL BOX WINCH PRE-A
TOP HAT RAIL 35X27X7,3X1	60 21 067 08	6	0.4	2 932 082	96 54 387 08	ASSEMBLY PARTS MOUNTIN
TOP HAT RAIL 35X27X7,3X1	60 21 067 08	8	0.1	2 932 082	96 54 387 08	ASSEMBLY PARTS MOUNTIN
TOP HAT RAIL 35X27X7,3X1	60 21 067 08	272	0.245	3 930 363	96 52 979 08	TERMINAL BOX CPL.
TOP HAT RAIL 35X27X7,3X1	60 21 067 08	261	0.58	3 930 638	96 51 624 08	TERMINAL BOX
TOP HAT RAIL 35X27X7,3X1	60 21 067 08	272	0.35	3 930 640	96 50 481 08	TERMINAL BOX CPL.
TOP HAT RAIL 35X27X7,3X1	60 21 067 08	298	0.245	3 930 730	96 50 599 08	TERMINAL BOX CPL.
TOP HAT RAIL 35X27X7,3X1	60 21 067 08	278	1.16	3 930 730	96 54 398 08	TERMINAL BOX CPL.
TOP HAT RAIL 35X27X7,3X1	60 21 067 08	202	0.55	3 930 734	96 54 401 08	TERMINAL BOX
TOUCH CONTACT TRANSMIT	60 61 434 08	12	3	2 533 061	96 48 370 08	DASH BORD ARM REST LEFT
TOUCH CONTACT TRANSMIT	60 61 434 08	20	2	2 533 070	96 48 363 08	CONTROLS AND FITTINGS RI
TOUCH CONTACT TRANSMITT	60 61 438 08	(3)	1	2 533 051	96 48 360 08	EL.EQUIPMENT CABIN
TOUCH CONTACT TRANSMITT	60 61 446 08	12	6	2 533 063	96 48 371 08	DASH BORD ARM REST RIGH
TOUCH CONTACT TRANSMITT	60 61 446 08	16	12	2 533 070	96 48 363 08	CONTROLS AND FITTINGS RI
TOUCH CONTACT TRANSMITT	60 61 446 08	31	3	2 932 001	96 45 393 08	RELAY CONTROL SYSTEM
TRACTION RAM PRE-ASS.	96 49 797 08	9	2	3 714	91 52 862 08	D HEAD SECTION
TRAILERS 25X2	95 05 568 08	134	30	2 970	91 56 537 08	HYDR
TRAILERS 25X2	95 05 568 08	66	5	2 975 100	91 52 860 08	ADDITIONAL HYDRAULICS WI
TRAILERS 25X2	95 05 568 08	66	7	2 975 200	91 52 775 08	ADDITIONAL HYDRAULICS WI
TRAILERS 25X2	95 05 568 08	66	7	2 975 700	91 52 774 08	ADDITIONAL HYDRAULICS WI
TRAILERS 25X2	95 05 568 08	63	16	2 977	91 57 756 08	ADDITIONAL HYDR.SLEWING
TRAILERS 25X2	95 05 568 08	66	5	2 977 200	91 55 149 08	ADDITIONAL HYDR.PUMP/WI
TRAILERS 25X2	95 05 568 08	64	3	2 978 100	91 52 827 08	ADDNL.HYDR.RETAINING DEV
TRAILERS 25X2	95 05 568 08	64	4	2 978 200	91 54 843 08	ADD.HYDR.S_RETAINING RAM
TRAILERS 25X2	95 05 568 08	64	3	3 978 005	91 56 430 08	ADDL.HYDRAULIC SB-HEAD PI
TRAILERS 25X2	95 05 568 08	64	6	3 978 015	91 56 429 08	ADDITIONAL HYDRAULICS IN
TRAILERS 25X2	95 05 568 08	64	6	3 978 015	91 56 432 08	ADDITIONAL HYDRAULICS IN
TRAILERS 25X2	95 05 568 08	64	5	3 978 100	91 56 428 08	HYDR. SUSPENDED BALLAST
TRANSITION CONNECTION PI	10 02 919 5	8	1	9 739 288	97 39 288	FUEL LINE

6.2.2009

etk_en_de_074515 LR 1600/2

980

LIEBHERRAlphabetical index
Alphabetischer Index

Description	Item	Pos.	Quantity	Page	Assembly	Description
TRANSITION CONNECTION PI	10 02 919 5	13	1	9 739 492	97 39 492	PIPELINE INSTALLATION
TRANSPORT DEVICE	97 39 493	210	1	X1012059	10 12 059 0	DIESEL ENGINE
TRANSPORT KEEPER QC	91 57 005 08	427	1		LR 1600-2-0	
TRAPEZOIDAL RING	10 01 216 0	4	1	9 739 246	97 39 246	PISTON
TREAD	97 85 605 08	9	1	2 370	91 52 782 08	ERECTING WINCH
TREAD	97 85 607 08	13	1	2 350	91 52 778 08	SLEWING GEAR
TREAD 2X40X400X120 AL SPF	78 89 017 08	64	2	2 810	91 52 806 08	CRANE DRIVER'S CABIN CPL.
TREAD 400X210X40 AL ELOXI	10 47 603 1	71	1	2 810	91 52 806 08	CRANE DRIVER'S CABIN CPL.
TUBE 101.6X1356	97 71 247 08	2	1	3 211 009	96 46 979 08	SAFETY ROLLER CPL.
TUBE 101.6X2799	97 73 249 08	3	1	3 282 001	96 47 888 08	F-STAY COMPL.
TUBE 10X1,5X1558	97 84 036 08	233	1	2 998	91 56 540 08	PIPELINES SUPERSTRUCTUR
TUBE 12.0X44	97 49 575 08	48	2	3 214	91 52 843 08	SW HEAD SECTION
TUBE 12X1,5X6	95 12 474 08	47	8	3 214	91 52 843 08	SW HEAD SECTION
TUBE 15.0X24 S355J2G3C+C	97 18 057 08	19	4	2 502	91 55 939 08	CONTROL STAND
TUBE 15X1,5X14	95 30 759 08	11	5	3 206	91 52 881 08	PIVOT SECTION
TUBE 16.0X22	97 18 575 08	36	3	3 206	91 52 881 08	PIVOT SECTION
TUBE 16.0X22	97 18 575 08	24	6	3 208 001	91 52 883 08	F-HEAD SECTION
TUBE 18 KUNSTSTOFF	55 31 730 08	16	2	2 540	91 53 253 08	CLIMA-HEATING INSTALLATIO
TUBE 20.0X33	97 88 595 08	25	4	2 370	91 52 782 08	ERECTING WINCH
TUBE 20.0X33	97 88 595 08	77	12	2 810	91 52 806 08	CRANE DRIVER'S CABIN CPL.
TUBE 20x3,6x42	97 06 963 08	20	4	3 215 005	91 52 846 08	ROLLER SET
TUBE 20x3,6x42	97 06 963 08	20	4	3 215 006	91 52 847 08	ROLLER SET
TUBE 219.1X88	97 76 910 08	35	2	3 714	91 52 862 08	D HEAD SECTION
TUBE 22X2,5X110	94 01 070 08	12	1	2 657	91 57 656 08	MOUNTING EQUIPMENT CRAW
TUBE 22X2,5X40	93 92 551 08	11	2	3 211 003	96 46 986 08	ROD CPL.
TUBE 22X2,5X40	93 92 551 08	12	2	3 220 501	96 43 440 08	ROD CPL.
TUBE 22X2,5X40	93 92 551 08	12	2	3 221 200	96 47 984 08	ROD CPL.
TUBE 22X2,5X40	93 92 551 08	12	2	3 225 200	96 48 679 08	ROD CPL.
TUBE 22X2,5X40	93 92 551 08	12	2	3 227 002	96 50 498 08	ROD CPL.
TUBE 22X2,5X40	93 92 551 08	12	2	3 561 003	96 45 222 08	ROD CPL.
TUBE 22X2,5X40	93 92 551 08	12	1	3 713 012	96 50 197 08	ROD CPL.
TUBE 22X2,5X40	93 92 551 08	8	2	3 714 013	96 59 083 08	BRACKET COMPL.
TUBE 22X2,5X40	93 92 551 08	12	2	3 716 001	96 49 159 08	ROD CPL.
TUBE 22X2,5X45	94 36 973 08	2	1	3 714 014	96 49 456 08	BRACKET COMPL.
TUBE 25X3,2X100	94 78 115 08	45	2	2 391 001	96 45 719 08	DIESEL ENGINE, PRE-ASSEMB
TUBE 30 Rolle20m PAK	55 31 594 08	3	0.33	2 541 001	96 49 651 08	ADDNL.HEATING, PRE-ASSE
TUBE 30.0X120	97 77 023 08	9	1	2 550 005	96 45 680 08	ROD CPL.
TUBE 30.0X120	97 77 023 08	5	1	3 714 025	96 49 269 08	ROD CPL.
TUBE 30.0X120	97 77 023 08	3	4	3 745 011	96 49 677 08	BRACKET COMPL.
TUBE 30.0X2863 X5CRNI18-10	97 70 466 08	22	2	2 520	91 53 061 08	CABIN, GLAZED
TUBE 30.0X495	97 75 036 08	47	1	2 520	91 53 061 08	CABIN, GLAZED
TUBE 30.0X690 ST37.0	97 71 958 08	14	2	3 208 001	91 52 883 08	F-HEAD SECTION
TUBE 30X4X40	94 12 040 08	17	2	2 550 005	96 45 680 08	ROD CPL.
TUBE 30X4X9	94 70 655 08	4	2	3 206 002	96 47 960 08	LEVER COMPL.
TUBE 33,7X8X15	94 99 872 08	36	4	2 391 001	96 45 719 08	DIESEL ENGINE, PRE-ASSEMB
TUBE 35X2X665 X5CRNI1810	95 70 053 08	1	1	3 780 200	96 54 370 08	ELECTRIC WIND WARNING T
TUBE 38.0X1716 T ZN O	97 69 808 08	5	1	2 652	91 52 794 08	ROLLER BEARING
TUBE 38.0X340 ST.37.0 TZNO	97 91 001 08	96	1	3 714	91 52 862 08	D HEAD SECTION
TUBE 38.0X540	97 15 586 08	30	1	3 714	91 52 862 08	D HEAD SECTION
TUBE 38.0X870 ST37.0	97 68 872 08	44	2	2 550	91 57 751 08	SA FRAME
TUBE 38X2,6X105 ST.37.0	95 27 658 08	22	4	1 400	91 56 853 08	CRAWLER TRACK CARRIER LE
TUBE 38X2,6X105 ST.37.0	95 27 658 08	22	4	1 410 300	91 56 855 08	CRAWLER CARRIER RIGHT CP
TUBE 48,3X3,2X14	95 61 143 08	6	1	3 745 002	92 17 236 08	SWITCH UNIT
TUBE 48,3X3,2X14	95 61 143 08	6	1	3 745 003	92 17 237 08	SWITCH UNIT
TUBE 48.3X92	97 78 986 08	15	8	2 125	91 52 773 08	PIN F.S-PIVOT SECTION SA F
TUBE 60.3X10 00	97 41 664 08	7	1	1 632	91 52 389 08	MECHANICAL SUPPORT
TUBE 65.0X10	97 93 902 08	20	1	3 281	91 52 896 08	ERECTION FRAME
TUBE 65.0X350	97 93 901 08	19	1	3 281	91 52 896 08	ERECTION FRAME
TUBE 65.0X39	97 94 005 08	32	1	3 281	91 52 896 08	ERECTION FRAME
TUBE 6X1,5 POLYAMID	77 43 737 08	9	120	1 711	91 52 392 08	CENTRALIZED LUBRICATION

6.2.2009

etk_en_de_074515 LR 1600/2

981

LIEBHERRAlphabetical index
Alphabetischer Index

Description	Item	Pos.	Quantity	Page	Assembly	Description
TUBE 6X1,5 POLYAMID	77 43 737 08	20	100	2 711	91 52 800 08	CENT. LUBRIC. SYSTEM SUP
TUBE 90.0X106 SPF	97 79 781 08	100	2	3 713	91 57 749 08	D PIVOT SECTION
TUBE CPL. RIGHT	96 51 174 08	8	1	3 214	91 52 843 08	SW HEAD SECTION
TUBE CPL.LEFT	96 51 173 08	7	1	3 214	91 52 843 08	SW HEAD SECTION
TUBE EPDM	97 74 376 08	17	1	2 520 032	96 45 980 08	WINDSHIELD WASHER INSTAL
TUBE RD101,6X10X1388	95 66 948 08	1	1	3 211 008	96 46 978 08	SAFETY ROLLER CPL.
TUBING COIL	77 43 835 08	10	14	1 711	91 52 392 08	CENTRALIZED LUBRICATION
TUBULAR RIVET DIN 7340 B2,5	44 33 003 08	19	14	2 922 001	92 84 311 08	BUS PCB
TUMBLER GS18NIMOCR36	97 11 958 08	7	2	1 400	91 56 853 08	CRAWLER TRACK CARRIER LE
TUMBLER GS18NIMOCR36	97 11 958 08	7	2	1 410 300	91 56 855 08	CRAWLER CARRIER RIGHT CP
TURNBUCKLE 1,59KN	77 39 170 08	63	2	2 550	91 57 751 08	SA FRAME
TURNBUCKLE 7/8"X12 163KN V	10 47 609 8	82	2	2 550	91 57 751 08	SA FRAME
TURNBUCKLE VERZ	10 42 540 8	1	1	3 282 002	96 47 890 08	FAB-STAY
TURNING KNOB	69 27 013 08	6	1	2 913 003	96 20 599 08	FOIL KEYPAD PRE-ASS.
TURNLOCK ACTUATOR	60 61 449 08	38	2	2 932 001	96 45 393 08	RELAY CONTROL SYSTEM
TURNTABLE PANELLING	91 52 788 08	131	1		LR 1600-2-0	
TWIST STOPPER	77 39 466 08	3	1	2 372	91 33 648 08	ROPE WITH ACCESSORIES
UMBRELLA RAIL	60 20 426 08	91	2	2 932 082	96 54 387 08	ASSEMBLY PARTS MOUNTIN
UNION NUT DIN 431 A-G1/4" 14	41 01 500 08	23	1	2 932 160	96 54 385 08	SWITCH CABINET
UNIVERSAL CONNECTING LIN	74 00 026 08	4	2	2 372	91 33 648 08	ROPE WITH ACCESSORIES
UNIVERSAL PERFORMANCE 3	78 89 058 08	2	1	2 631 003	96 54 406 08	ACCESS LADDER PRE-ASS.
UPPER FASTENING 52x26x3	72 58 100 08	26	4	2 831	91 57 754 08	AIR COND. UNIT SUPERSTRU
USIT RING U 6,7X10X1	51 45 080 08	18	1	7 027 481	70 27 481 03	WATER SEPARATOR
V-BELT 10 2AVX 1500 LA	10 34 342 2	21	1	9 739 344	97 39 344	GENERATOR, PRE-ASSEMBLE
V-BELT PULLEY	10 34 284 0	4	1	9 739 341	97 39 341	DRIVING PARTS
V-BELT PULLEY	10 34 313 1	2	1	9 739 343	97 39 343	GENERATOR, PRE-ASSEMBLE
V-BELT PULLEY	10 41 013 0	4	1	9 739 352	97 39 352	AT-WATER PUMP WITH FAST
V-BELT SET 2C 1325	10 34 229 2	29	1	9 739 371	97 39 371	AIR COND. COMPRESSOR A
VALVE	57 10 768 08	(1)	1	2 975 700	91 52 774 08	ADDITIONAL HYDRAULICS WI
VALVE	76 22 478	16	1	X1022811	10 22 811 2	AIR CONDITIONING UNIT
VALVE BRIDGE	10 01 706 2	1	1	9 739 187	97 39 187	CONTROL PARTS
VALVE BRIDGE	10 01 706 4	3	1	9 739 187	97 39 187	CONTROL PARTS
VALVE COLLET	10 10 164 9	9	8	9 739 261	97 39 261	CYLINDER HEAD
VALVE DIN 71401 C M14X1,5	73 00 009 08	74	1	2 391 001	96 45 719 08	DIESEL ENGINE, PRE-ASSEMB
VALVE INSERT	57 17 780 08	57	1	5 102 380	51 02 380 08	HYDRO MOTOR
VALVE LIFTER	10 01 711 0	5	2	9 739 187	97 39 187	CONTROL PARTS
VALVE SCREW	57 00 731 08	9	1	5 114 320	51 14 320 08	PRETENSIONING VALVE
VALVE SEAT	51 07 976 08	10	1	5 114 176	51 14 176 08	PRESSURE LIMITING VALVE
VALVE SEAT	51 07 976 08	10	1	5 114 177	51 14 177 08	PRESSURE LIMITING VALVE
VALVE SEAT	57 00 098 08	14	1	5 026 126	50 26 126 08	SOLENOID VALVE
VALVE SEAT	57 06 475 08	3	1	5 711 301	57 11 301 08	PRESSURE LIMITING VALVE
VALVE SEAT SLEEVE	57 17 779 08	56	1	5 102 380	51 02 380 08	HYDRO MOTOR
VALVE SPRING 4,25X28,35X63,	10 01 221 0	5	4	9 739 261	97 39 261	CYLINDER HEAD
VALVE STEM SEAL	10 01 224 7	3	4	9 739 261	97 39 261	CYLINDER HEAD
VALVE STEM SEAL	10 01 224 7	75	4	X1022281	10 22 281 7	SEAL KIT CYLINDER HEAD
VARIABLE DISPLACEMENT MO	10 42 876 6	2	2	2 340	91 52 776 08	WINCH 4 LUFFING GEAR
VARIABLE DISPLACEMENT M	10 35 482 8	3	1	2 310	91 52 503 08	WINCH 1
VARIABLE DISPLACEMENT M	10 35 482 8	3	1	2 320	91 52 504 08	WINCH 2
VARIABLE DISPLACEMENT MO	10 42 876 7	2	1	3 350	91 52 859 08	WINCH 3
VARIABLE DISPLACEMENT MO	10 42 876 8	8	2	1 400	91 56 853 08	CRAWLER TRACK CARRIER LE
VARIABLE DISPLACEMENT MO	10 42 876 8	8	2	1 410 300	91 56 855 08	CRAWLER CARRIER RIGHT CP
VARIABLE PUMP A11VO/40LI	10 35 924 7	110	1	2 391 001	96 45 719 08	DIESEL ENGINE, PRE-ASSEMB
VARIABLE PUMP A11VO/60RE	10 35 924 8	111	1	2 391 001	96 45 719 08	DIESEL ENGINE, PRE-ASSEMB
VARIABLE PUMP A4VG/125LI	10 35 924 3	105	1	2 391 001	96 45 719 08	DIESEL ENGINE, PRE-ASSEMB
VARIABLE PUMP A4VG/125RE	10 35 924 4	106	1	2 391 001	96 45 719 08	DIESEL ENGINE, PRE-ASSEMB
VARIABLE PUMP A4VG/28 LI	10 35 924 9	1	1	2 212	91 54 561 08	PUMP F.SLEWING GEAR
VARIABLE PUMP A4VG/56 LI	10 35 924 6	108	1	2 391 001	96 45 719 08	DIESEL ENGINE, PRE-ASSEMB
VARIABLE PUMP A4VG/90 LI	10 35 924 1	103	1	2 391 001	96 45 719 08	DIESEL ENGINE, PRE-ASSEMB
VARIABLE PUMP A4VG/90 LI	10 35 924 2	104	1	2 391 001	96 45 719 08	DIESEL ENGINE, PRE-ASSEMB
VARIABLE PUMP A4VG/90 LI	10 35 925 0	107	1	2 391 001	96 45 719 08	DIESEL ENGINE, PRE-ASSEMB

6.2.2009

etk_en_de_074515 LR 1600/2

982

LIEBHERRAlphabetical index
Alphabetischer Index

Description	Item	Pos.	Quantity	Page	Assembly	Description
VARIABLE PUMP PA10VO/45 L	10 35 925 1	109	1	2 391 001	96 45 719 08	DIESEL ENGINE, PRE-ASSEMB
VENTILATION	10 29 200 0	19	2	2 520	91 53 061 08	CABIN, GLAZED
VENTILATION CONNECTING PI	92 75 019 01	2	1	9 275 543	92 75 543 01	VENTILATION CONNECTING PI
VENTILATION CONNECTING PI	92 75 543 01	77	1	9 697 916	96 97 916 01	SLEWING GEAR
VENTILATION LINE	10 03 733 9	17	1	9 739 386	97 39 386	CRANKCASE BREATHER
VENTILATION LINE	10 29 720 3	1	1	9 739 322	97 39 322	REPAIR KIT PIPE LINE
VENTILATION SCREW	74 12 942	1	1	7 027 481	70 27 481 03	WATER SEPARATOR
VENTILATION SCREW G1/2"X	60 25 013 08	293	1	1 920 403	96 48 707 08	TERMINAL BOX CPL.
VENTILATION SCREW G1/2"X	60 25 013 08	293	1	1 920 417	96 48 703 08	TERMINAL BOX CPL.
VENTILATION SCREW G1/2"X	60 25 013 08	293	1	1 920 418	96 48 687 08	TERMINAL BOX CPL.
VENTILATION SCREW G1/2"X	60 25 013 08	9	1	2 780 524	96 52 968 08	CABLE DRUM COMPL.
VENTILATION SCREW G1/2"X	60 25 013 08	293	1	2 780 748	96 52 969 08	TERMINAL BOX CPL.
VENTILATION SCREW G1/2"X	60 25 013 08	293	1	2 920 369	96 54 235 08	TERMINAL BOX CPL.
VENTILATION SCREW G1/2"X	60 25 013 08	293	1	2 920 448	96 48 794 08	TERMINAL BOX CPL.
VENTILATION SCREW G1/2"X	60 25 013 08	293	1	2 920 581	96 54 405 08	TERMINAL BOX WINCH PRE-A
VENTILATION SCREW G1/2"X	60 25 013 08	286	1	3 930 363	96 52 979 08	TERMINAL BOX CPL.
VENTILATION SCREW G1/2"X	60 25 013 08	286	1	3 930 640	96 50 481 08	TERMINAL BOX CPL.
VENTILATION SCREW M20X1,5	10 48 866 2	293	1	3 930 638	96 51 624 08	TERMINAL BOX
VENTILATION SCREW M20X1,5	10 48 866 2	293	1	3 930 730	96 50 599 08	TERMINAL BOX CPL.
VENTILATION SCREW M20X1,5	10 48 866 2	286	1	3 930 730	96 54 398 08	TERMINAL BOX CPL.
VENTILATION SCREW M20X1,5	10 48 866 2	307	1	3 930 734	96 54 401 08	TERMINAL BOX
VENTILATION VALVE M10X1	57 18 446 08	69	1	X1065015	10 65 015 8	DRIVE UNIT
VIBRATION DAMPER	10 34 283 9	3	1	9 739 341	97 39 341	DRIVING PARTS
VIBRATION DAMPER	55 04 515 08	122	2	2 391 001	96 45 719 08	DIESEL ENGINE, PRE-ASSEMB
VIBRATION DAMPER	55 04 516 08	123	2	2 391 001	96 45 719 08	DIESEL ENGINE, PRE-ASSEMB
VOLTAGE REGULATOR 24/12D	61 40 205 08	11	1	2 533 070	96 48 363 08	CONTROLS AND FITTINGS RI
WALL OUTLET 19-POL SPF	10 44 366 5	(151)	1	3 930 734	96 54 401 08	TERMINAL BOX
WALL OUTLET 24-POL 22A SP	10 44 365 9	(170)	1	3 930 138	96 54 377 08	ELECTRIC FOR S-PIVOT SECT
WALL OUTLET 24-POL 22A SP	10 44 365 9	151	1	3 930 732	96 50 575 08	LEAD
WARM AIR HOSE DI 55MM PA	10 42 558 8	55	0.12	2 520	91 53 061 08	CABIN, GLAZED
WARM AIR HOSE DI 55MM PA	10 42 558 8	56	0.18	2 520	91 53 061 08	CABIN, GLAZED
WARM AIR HOSE DI 55MM PA	10 42 558 8	41	0.4	2 520 034	96 45 984 08	INTERNAL LINING
WARNING LIGHT 20-36V SPF	10 34 010 5	5	1	2 533 066	96 48 365 08	ELECTRIC ADD-ON PARTS CA
WARNING LIGHT LMB	96 59 398 08	35	1	2 920	91 56 833 08	ELECTR. SYSTEM F.SLEWING
WASHER	10 22 275 4	7	1	9 739 278	97 39 278	ADD-ON PARTS
WASHER	51 07 972 08	5	1	5 114 176	51 14 176 08	PRESSURE LIMITING VALVE
WASHER	51 07 972 08	5	1	5 114 177	51 14 177 08	PRESSURE LIMITING VALVE
WASHER	55 08 998 08	388	12	2 391 001	96 45 719 08	DIESEL ENGINE, PRE-ASSEMB
WASHER	57 00 729 08	3	1	5 114 320	51 14 320 08	PRETENSIONING VALVE
WASHER	57 01 137 08	5	1	5 701 129	57 01 129 08	DRIVING GEAR
WASHER	59 10 589 08	21	1	2 522 011	96 45 602 08	CLOSING DEVICE
WASHER	92 76 333 01	5	1	9 697 916	96 97 916 01	SLEWING GEAR
WASHER 1.5x58x58	97 02 665 08	67	2	2 550	91 57 751 08	SA FRAME
WASHER 100X2	94 33 992 08	77	2	1 400	91 56 853 08	CRAWLER TRACK CARRIER LE
WASHER 100X2	94 33 992 08	77	2	1 410 300	91 56 855 08	CRAWLER CARRIER RIGHT CP
WASHER 100X2	94 33 992 08	30	1	3 281	91 52 896 08	ERECTION FRAME
WASHER 10X100X100	97 91 266 08	102	2	3 713	91 57 749 08	D PIVOT SECTION
WASHER 11X22X5 9SMNPB28	10 01 256 6	6	1	9 739 271	97 39 271	CONNECTING LINE
WASHER 11X22X5 9SMNPB28	10 01 256 6	7	2	9 739 288	97 39 288	FUEL LINE
WASHER 11X23X6 9SMNPB28	10 01 694 9	10	3	9 739 354	97 39 354	FLYWHEEL HOUSING MOUNT
WASHER 12,5X24X4 C45K	10 01 256 7	19	1	9 739 344	97 39 344	GENERATOR, PRE-ASSEMBLE
WASHER 12X215X215 FE//ZN	94 23 101 08	6	2	3 714 008	96 49 266 08	LUFFING PULLEY BLOCK COM
WASHER 12X215X215 FE//ZN	94 23 101 08	7	2	3 714 009	96 49 267 08	LUFFING PULLEY BLOCK COM
WASHER 12X50X50 T ZN O	97 74 760 08	61	1	3 713	91 57 749 08	D PIVOT SECTION
WASHER 12X50X50 T ZN O	97 74 760 08	32	4	3 715 008	91 52 863 08	D INTERMEDIATE SECTION
WASHER 12X50X50 T ZN O	97 74 760 08	30	6	3 716	91 52 864 08	D INTERMEDIATE SECTION
WASHER 15,5X34X0,5 CK67V	10 01 256 3	4	4	9 739 261	97 39 261	CYLINDER HEAD
WASHER 219.1X34	97 71 946 08	12	1	3 208 001	91 52 883 08	F-HEAD SECTION
WASHER 2X100X100	97 18 386 08	18	16	3 211	91 57 748 08	S PIVOT SECTION
WASHER 2X110X110 DC01-A-	94 59 385 08	18	7	3 281	91 52 896 08	ERECTION FRAME

6.2.2009

etk_en_de_074515 LR 1600/2

983

LIEBHERRAlphabetical index
Alphabetischer Index

Description	Item	Pos.	Quantity	Page	Assembly	Description
WASHER 3X100X100 FE//ZN20	93 14 640 08	15	4	1 630	91 52 387 08	HYDRAULIC SUPPORT
WASHER 5X120X120	97 49 680 08	41	4	2 340	91 52 776 08	WINCH 4 LUFFING GEAR
WASHER 5X200X200 TZNO	97 81 710 08	16	8	2 550	91 57 751 08	SA FRAME
WASHER 5X36X36	94 10 542 08	29	8	3 745	91 52 948 08	SUSPENDED BALLAST
WASHER 5X40X40	97 84 522 08	37	4	2 391 040	96 53 645 08	CLUTCH ACTUATOR
WASHER 6,3X10,8X6 9SMNPB	10 01 699 2	(3)	2	9 739 318	97 39 318	SENSOR ELEMENT
WASHER 6,4X17X3 ST MAN183	10 34 375 2	9	1	9 739 356	97 39 356	PIPELINE INSTALLATION
WASHER 70X3	94 11 381 08	9	4	1 620	91 52 386 08	FIXING PARTS SLEWING RING
WASHER 70X3	94 11 381 08	11	48	1 631 100	91 52 388 08	CATWALK CRAW.TRACK TRA
WASHER 70X3	94 11 381 08	11	3	2 350	91 52 778 08	SLEWING GEAR
WASHER 70X3	94 11 381 08	5	10	2 859 025	96 46 757 08	GRIDIRON PRE-ASS.
WASHER 70X3	94 11 381 08	59	8	3 206	91 52 881 08	PIVOT SECTION
WASHER 70X3	94 11 381 08	34	62	3 211	91 57 748 08	S PIVOT SECTION
WASHER 70X3	94 11 381 08	38	9	3 214	91 52 843 08	SW HEAD SECTION
WASHER 70X3	94 11 381 08	26	55	3 220 500	91 52 849 08	S INTERMEDIATE SECTION
WASHER 70X3	94 11 381 08	14	44	3 221	91 54 668 08	S INTERMEDIATE SECTION
WASHER 70X3	94 11 381 08	26	56	3 223	91 52 852 08	S INTERMEDIATE SECTION
WASHER 70X3	94 11 381 08	26	56	3 223 010	91 52 853 08	S INTERMEDIATE SECTION
WASHER 70X3	94 11 381 08	26	56	3 223 100	91 55 327 08	S INTERMEDIATE SECTION
WASHER 70X3	94 11 381 08	38	53	3 225	91 52 854 08	SL REDUCING SECTION
WASHER 70X3	94 11 381 08	26	40	3 226	91 52 870 08	L INTERMEDIATE SECTION
WASHER 70X3	94 11 381 08	26	49	3 227	91 52 873 08	L INTERMEDIATE SECTION
WASHER 70X3	94 11 381 08	26	49	3 227 008	91 52 872 08	L INTERMEDIATE SECTION
WASHER 70X3	94 11 381 08	26	49	3 227 200	91 53 519 08	LI INTERMEDIATE SECT. F-GU
WASHER 70X3	94 11 381 08	20	103	3 713	91 57 749 08	D PIVOT SECTION
WASHER 70X3	94 11 381 08	47	65	3 714	91 52 862 08	D HEAD SECTION
WASHER 70X3	94 11 381 08	20	64	3 715 008	91 52 863 08	D INTERMEDIATE SECTION
WASHER 70X3	94 11 381 08	20	91	3 716	91 52 864 08	D INTERMEDIATE SECTION
WASHER 8,4X19X4 C45K	10 01 256 8	9	1	9 739 256	97 39 256	AIR SUCTION PIPE
WASHER 8,4X19X4 C45K	10 01 256 8	18	1	9 739 296	97 39 296	HEAT PROTECTION
WASHER 8,4X19X4 C45K	10 01 256 8	15	1	9 739 358	97 39 358	EXHAUST GAS RECIRCUL.ATT
WASHER 8,4X19X4 C45K	10 01 256 8	27	4	9 739 371	97 39 371	AIR COND. COMPRESSOR A
WASHER 8X185X185	97 68 042 08	44	34	1 400	91 56 853 08	CRAWLER TRACK CARRIER LE
WASHER 8X185X185	97 68 042 08	44	34	1 410 300	91 56 855 08	CRAWLER CARRIER RIGHT CP
WASHER 9X19X3	10 03 288 2	11	3	9 739 118	97 39 118	OIL LINE
WASHER A 10,5X20X2,0 200H	10 01 165 8	12	2	9 739 159	97 39 159	STARTER
WASHER A 10,5X20X2,0 200H	10 01 165 8	5	3	9 739 271	97 39 271	CONNECTING LINE
WASHER A 10,5X20X2,0 200H	10 01 165 8	10	3	9 739 278	97 39 278	ADD-ON PARTS
WASHER A 10,5X20X2,0 200H	10 01 165 8	4	2	9 739 286	97 39 286	SCREW CAP
WASHER A 10,5X20X2,0 200H	10 01 165 8	5	1	9 739 344	97 39 344	GENERATOR, PRE-ASSEMBLE
WASHER A 10,5X20X2,0 200H	10 01 165 8	5	2	9 739 351	97 39 351	COOLING MEDIUM PIPELINE
WASHER A 10,5X20X2,0 200H	10 01 165 8	3	4	9 739 358	97 39 358	EXHAUST GAS RECIRCUL.ATT
WASHER A 10,5X20X2,0 200H	10 01 165 8	4	2	9 739 386	97 39 386	CRANKCASE BREATHER
WASHER A 13X24X2,5 200HV	10 01 165 9	9	2	9 739 344	97 39 344	GENERATOR, PRE-ASSEMBLE
WASHER A 13X24X2,5 200HV	10 01 165 9	16	2	9 739 371	97 39 371	AIR COND. COMPRESSOR A
WASHER A 17,0 200HV A3C	10 03 722 6	6	1	9 739 210	97 39 210	LIQUID COOLING PIPELINE
WASHER A 5.3 ST MAN183-B1	10 22 279 4	8	2	9 739 356	97 39 356	PIPELINE INSTALLATION
WASHER A 6,4X12X1,6 200HV	10 01 165 3	7	2	9 739 159	97 39 159	STARTER
WASHER A 6,4X12X1,6 200HV	10 01 165 3	7	2	9 739 292	97 39 292	FUEL LINE
WASHER A 6,4X12X1,6 200HV	10 01 165 3	29	6	9 739 292	97 39 292	FUEL LINE
WASHER A 6,4X12X1,6 200HV	10 01 165 3	(4)	2	9 739 318	97 39 318	SENSOR ELEMENT
WASHER A 8,4X16X1,6 200HV	10 01 165 4	6	2	9 739 118	97 39 118	OIL LINE
WASHER A 8,4X16X1,6 200HV	10 01 165 4	4	3	9 739 126	97 39 126	THERMOSTAT HOUSING
WASHER A 8,4X16X1,6 200HV	10 01 165 4	6	1	9 739 186	97 39 186	MOTOR BRAKE
WASHER A 8,4X16X1,6 200HV	10 01 165 4	10	1	9 739 210	97 39 210	LIQUID COOLING PIPELINE
WASHER A 8,4X16X1,6 200HV	10 01 165 4	8	9	9 739 256	97 39 256	AIR SUCTION PIPE
WASHER A 8,4X16X1,6 200HV	10 01 165 4	3	2	9 739 259	97 39 259	FUEL FILTER
WASHER A 8,4X16X1,6 200HV	10 01 165 4	19	1	9 739 296	97 39 296	HEAT PROTECTION
WASHER A 8,4X16X1,6 200HV	10 01 165 4	5	5	9 739 349	97 39 349	CONNECTION F.WATER PIPE
WASHER A 8,4X16X1,6 200HV	10 01 165 4	15	1	9 739 349	97 39 349	CONNECTION F.WATER PIPE

6.2.2009

etk_en_de_074515 LR 1600/2

984

LIEBHERRAlphabetical index
Alphabetischer Index

Description	Item	Pos.	Quantity	Page	Assembly	Description
WASHER A 8,4X16X1,6 200HV	10 01 165 4	6	6	9 739 352	97 39 352	AT-WATER PUMP WITH FAST
WASHER A 8,4X16X1,6 200HV	10 01 165 4	13	1	9 739 356	97 39 356	PIPELINE INSTALLATION
WASHER A 8,4X16X1,6 200HV	10 01 165 4	11	6	9 739 357	97 39 357	EXHAUST GAS RECIRCUL.PRE
WASHER A 8,4X16X1,6 200HV	10 01 165 4	21	8	9 739 361	97 39 361	OIL SUMP
WASHER A 8,4X16X1,6 200HV	10 01 165 4	25	3	9 739 366	97 39 366	FASTENING PIECES ASSEMBL
WASHER A 8,4X16X1,6 200HV	10 01 165 4	23	4	9 739 371	97 39 371	AIR COND. COMPRESSOR A
WASHER A 8,4X16X1,6 200HV	10 01 165 4	12	3	9 739 372	97 39 372	LUBRICATING OIL PUMP
WASHER A 8,4X16X1,6 200HV	10 01 165 4	21	2	9 739 386	97 39 386	CRANKCASE BREATHER
WASHER A 8,4X16X1,6 200HV	10 01 165 4	34	2	9 739 492	97 39 492	PIPELINE INSTALLATION
WASHER A 8,4X16X1,6 200HV	10 01 165 4	24	2	9 739 494	97 39 494	ATL ATTACHMENT
WASHER CU	10 01 256 5	6	1	9 739 159	97 39 159	STARTER
WASHER DIN 125 A 10,5 MS	42 00 507 08	13	8	2 391 038	96 47 931 08	OIL COOLER, PRE-ASSEMBLE
WASHER DIN 125 A 10,5 MS	42 00 507 08	32	12	2 652	91 52 794 08	ROLLER BEARING
WASHER DIN 125 A 10,5 MS	42 00 507 08	36	18	3 208 001	91 52 883 08	F-HEAD SECTION
WASHER DIN 125 A 10.5 A2	50 09 175 08	68	24	1 400	91 56 853 08	CRAWLER TRACK CARRIER LE
WASHER DIN 125 A 10.5 A2	50 09 175 08	68	24	1 410 300	91 56 855 08	CRAWLER CARRIER RIGHT CP
WASHER DIN 125 A 10.5 A2	50 09 175 08	6	6	2 350	91 52 778 08	SLEWING GEAR
WASHER DIN 125 A 10.5 A2	50 09 175 08	5	8	2 670	91 52 797 08	FUEL TANK CPL.
WASHER DIN 125 A 10.5 A2	50 09 175 08	6	4	2 671	91 52 798 08	OIL RESERVOIR, COMPLETE
WASHER DIN 125 A 10.5 A2	50 09 175 08	10	12	2 730	91 52 802 08	BASE PLATE SLEWING PLATF
WASHER DIN 125 A 10.5 A2	50 09 175 08	15	18	2 810	91 52 806 08	CRANE DRIVER'S CABIN CPL.
WASHER DIN 125 A 13 MS	42 00 508 08	9	8	3 213	91 52 842 08	F-CONNECTING HEAD
WASHER DIN 125 A 13 MS	42 00 508 08	25	96	3 350	91 52 859 08	WINCH 3
WASHER DIN 125 A 13 MS	42 00 508 08	13	8	3 714 008	96 49 266 08	LUFFING PULLEY BLOCK COM
WASHER DIN 125 A 15 ST VER	42 00 018 08	51	4	2 631	91 56 817 08	SLEWING PLATFORM CATWAL
WASHER DIN 125 A 17 VERZ	42 00 019 08	5	4	1 641 014	92 53 053 08	SUPPORT PLATE COMPL.
WASHER DIN 125 A 17 VERZ	42 00 019 08	12	6	1 991	91 52 510 08	ROTARY FEED THROUGH
WASHER DIN 125 A 17 VERZ	42 00 019 08	9	24	2 125	91 52 773 08	PIN F.S-PIVOT SECTION SA F
WASHER DIN 125 A 17 VERZ	42 00 019 08	29	2	2 391 040	96 53 645 08	CLUTCH ACTUATOR
WASHER DIN 125 A 17 VERZ	42 00 019 08	44	4	2 393	91 52 787 08	AIR FILTER UNIT CPL.
WASHER DIN 125 A 17 VERZ	42 00 019 08	6	26	2 550	91 57 751 08	SA FRAME
WASHER DIN 125 A 17 VERZ	42 00 019 08	22	6	2 631	91 56 817 08	SLEWING PLATFORM CATWAL
WASHER DIN 125 A 17 VERZ	42 00 019 08	11	29	2 652	91 52 794 08	ROLLER BEARING
WASHER DIN 125 A 17 VERZ	42 00 019 08	14	2	2 657	91 57 656 08	MOUNTING EQUIPMENT CRAW
WASHER DIN 125 A 17 VERZ	42 00 019 08	6	4	2 730	91 52 802 08	BASE PLATE SLEWING PLATF
WASHER DIN 125 A 17 VERZ	42 00 019 08	51	8	2 810	91 52 806 08	CRANE DRIVER'S CABIN CPL.
WASHER DIN 125 A 17 VERZ	42 00 019 08	175	16	2 970	91 56 537 08	HYDR
WASHER DIN 125 A 17 VERZ	42 00 019 08	4	2	3 207 101	96 48 292 08	BRACKET COMPL.
WASHER DIN 125 A 17 VERZ	42 00 019 08	35	16	3 208 001	91 52 883 08	F-HEAD SECTION
WASHER DIN 125 A 17 VERZ	42 00 019 08	42	6	3 211	91 57 748 08	S PIVOT SECTION
WASHER DIN 125 A 17 VERZ	42 00 019 08	10	2	3 211 003	96 46 986 08	ROD CPL.
WASHER DIN 125 A 17 VERZ	42 00 019 08	13	4	3 214	91 52 843 08	SW HEAD SECTION
WASHER DIN 125 A 17 VERZ	42 00 019 08	10	2	3 220 500	91 52 849 08	S INTERMEDIATE SECTION
WASHER DIN 125 A 17 VERZ	42 00 019 08	11	2	3 220 501	96 43 440 08	ROD CPL.
WASHER DIN 125 A 17 VERZ	42 00 019 08	11	2	3 221 200	96 47 984 08	ROD CPL.
WASHER DIN 125 A 17 VERZ	42 00 019 08	10	2	3 223	91 52 852 08	S INTERMEDIATE SECTION
WASHER DIN 125 A 17 VERZ	42 00 019 08	10	2	3 223 010	91 52 853 08	S INTERMEDIATE SECTION
WASHER DIN 125 A 17 VERZ	42 00 019 08	10	4	3 223 100	91 55 327 08	S INTERMEDIATE SECTION
WASHER DIN 125 A 17 VERZ	42 00 019 08	11	2	3 225 200	96 48 679 08	ROD CPL.
WASHER DIN 125 A 17 VERZ	42 00 019 08	11	4	3 227 002	96 50 498 08	ROD CPL.
WASHER DIN 125 A 17 VERZ	42 00 019 08	(4)	4	3 281	91 52 896 08	ERECTION FRAME
WASHER DIN 125 A 17 VERZ	42 00 019 08	(4)	2	3 281	91 52 896 08	ERECTION FRAME
WASHER DIN 125 A 17 VERZ	42 00 019 08	12	24	3 350	91 52 859 08	WINCH 3
WASHER DIN 125 A 17 VERZ	42 00 019 08	11	2	3 561 003	96 45 222 08	ROD CPL.
WASHER DIN 125 A 17 VERZ	42 00 019 08	144	2	3 713	91 57 749 08	D PIVOT SECTION
WASHER DIN 125 A 17 VERZ	42 00 019 08	155	2	3 713	91 57 749 08	D PIVOT SECTION
WASHER DIN 125 A 17 VERZ	42 00 019 08	11	1	3 713 012	96 50 197 08	ROD CPL.
WASHER DIN 125 A 17 VERZ	42 00 019 08	17	16	3 714	91 52 862 08	D HEAD SECTION
WASHER DIN 125 A 17 VERZ	42 00 019 08	10	8	3 714 008	96 49 266 08	LUFFING PULLEY BLOCK COM
WASHER DIN 125 A 17 VERZ	42 00 019 08	13	8	3 714 009	96 49 267 08	LUFFING PULLEY BLOCK COM

6.2.2009

etk_en_de_074515 LR 1600/2

985

LIEBHERRAlphabetical index
Alphabetischer Index

Description	Item	Pos.	Quantity	Page	Assembly	Description
WASHER DIN 125 A 17 VERZ	42 00 019 08	5	2	3 714 013	96 49 270 08	BRACKET COMPL.
WASHER DIN 125 A 17 VERZ	42 00 019 08	6	2	3 714 013	96 59 083 08	BRACKET COMPL.
WASHER DIN 125 A 17 VERZ	42 00 019 08	4	2	3 714 014	96 49 456 08	BRACKET COMPL.
WASHER DIN 125 A 17 VERZ	42 00 019 08	11	2	3 716 001	96 49 159 08	ROD CPL.
WASHER DIN 125 A 17 VERZ	42 00 019 08	13	16	3 745	91 52 948 08	SUSPENDED BALLAST
WASHER DIN 125 A 19 ST VER	42 00 020 08	8	60	1 631 100	91 52 388 08	CATWALK CRAW.TRACK TRA
WASHER DIN 125 A 19 ST VER	42 00 020 08	24	6	2 652	91 52 794 08	ROLLER BEARING
WASHER DIN 125 A 25 ST VER	42 00 024 08	40	34	1 400	91 56 853 08	CRAWLER TRACK CARRIER LE
WASHER DIN 125 A 25 ST VER	42 00 024 08	40	34	1 410 300	91 56 855 08	CRAWLER CARRIER RIGHT CP
WASHER DIN 125 A 25 ST VER	42 00 024 08	32	14	2 631	91 56 817 08	SLEWING PLATFORM CATWAL
WASHER DIN 125 A 25 ST VER	42 00 024 08	14	8	2 730	91 52 802 08	BASE PLATE SLEWING PLATF
WASHER DIN 125 A 3.2 MS	42 00 501 08	268	4	3 930 009	96 50 573 08	CABLE DRUM COMPL.
WASHER DIN 125 A 3.2 MS	42 00 501 08	(154)	1	3 930 138	96 54 377 08	ELECTRIC FOR S-PIVOT SECT
WASHER DIN 125 A 3.2 MS	42 00 501 08	156	10	3 930 640	96 50 481 08	TERMINAL BOX CPL.
WASHER DIN 125 A 3.2 MS	42 00 501 08	268	10	3 930 730	96 50 599 08	TERMINAL BOX CPL.
WASHER DIN 125 A 3.2 ST VER	51 45 819 08	5	12	2 913 100	91 23 538 08	ASSEMBLY FRAME
WASHER DIN 125 A 3.7 ST VER	42 00 006 08	43	8	2 920 369	96 54 235 08	TERMINAL BOX CPL.
WASHER DIN 125 A 3.7 ST VER	42 00 006 08	16	10	2 922 001	92 84 311 08	BUS PCB
WASHER DIN 125 A 3.7 ST VER	42 00 006 08	30	20	2 932 001	96 45 393 08	RELAY CONTROL SYSTEM
WASHER DIN 125 A 3.7 ST VER	42 00 006 08	282	16	3 930 638	96 51 624 08	TERMINAL BOX
WASHER DIN 125 A 4.3 ST VER	42 00 007 08	4	4	2 913 004	96 20 460 08	HOUSING PRE-ASSEMBLED
WASHER DIN 125 A 4.3 ST VER	42 00 007 08	13	4	2 913 100	91 23 538 08	ASSEMBLY FRAME
WASHER DIN 125 A 4.3 ST VER	42 00 007 08	5	8	2 913 102	92 32 870 08	FAN UNIT
WASHER DIN 125 A 4.3 ST VER	42 00 007 08	(154)	4	2 920 369	96 54 235 08	TERMINAL BOX CPL.
WASHER DIN 125 A 4.3 ST VER	42 00 007 08	(154)	4	2 920 369	96 54 235 08	TERMINAL BOX CPL.
WASHER DIN 125 A 4.3 ST VER	42 00 007 08	279	16	2 920 369	96 54 235 08	TERMINAL BOX CPL.
WASHER DIN 125 A 4.3 ST VER	42 00 007 08	279	28	2 920 448	96 48 794 08	TERMINAL BOX CPL.
WASHER DIN 125 A 4.3 ST VER	42 00 007 08	39	8	2 932 001	96 45 393 08	RELAY CONTROL SYSTEM
WASHER DIN 125 A 4.3 ST VER	42 00 007 08	92	8	2 932 082	96 54 387 08	ASSEMBLY PARTS MOUNTIN
WASHER DIN 125 A 4.3 ST VER	42 00 007 08	47	56	2 932 160	96 54 385 08	SWITCH CABINET
WASHER DIN 125 A 5.3 VERZ	42 00 008 08	16	8	1 711	91 52 392 08	CENTRALIZED LUBRICATION
WASHER DIN 125 A 5.3 VERZ	42 00 008 08	16	8	2 260 006	96 46 501 08	BATTERY BOX, PRE-ASSEMB
WASHER DIN 125 A 5.3 VERZ	42 00 008 08	42	4	2 391 040	96 53 645 08	CLUTCH ACTUATOR
WASHER DIN 125 A 5.3 VERZ	42 00 008 08	35	8	2 502	91 55 939 08	CONTROL STAND
WASHER DIN 125 A 5.3 VERZ	42 00 008 08	24	1	2 522	91 54 115 08	SLIDING DOOR CPL.
WASHER DIN 125 A 5.3 VERZ	42 00 008 08	9	10	2 711	91 52 800 08	CENT. LUBRIC. SYSTEM SUP
WASHER DIN 125 A 5.3 VERZ	42 00 008 08	2	4	2 780 915	96 48 377 08	ADD-ON PARTS EXTERNAL F
WASHER DIN 125 A 5.3 VERZ	42 00 008 08	33	2	2 835 002	96 48 379 08	ADD-ON PARTS
WASHER DIN 125 A 5.3 VERZ	42 00 008 08	9	3	2 913 100	91 23 538 08	ASSEMBLY FRAME
WASHER DIN 125 A 5.3 VERZ	42 00 008 08	34	7	2 920 083	96 48 319 08	ELECTRIC FOR BATTERY BOX
WASHER DIN 125 A 5.3 VERZ	42 00 008 08	15	5	2 920 814	96 45 717 08	ELECTR.F.FUEL TANK
WASHER DIN 125 A 5.3 VERZ	42 00 008 08	56	2	2 975 100	91 52 860 08	ADDITIONAL HYDRAULICS WI
WASHER DIN 125 A 5.3 VERZ	42 00 008 08	(5)	3	3 780 258	96 56 482 08	ELECTRIC AIRCRAFT PROTE
WASHER DIN 125 A 5.3 VERZ	42 00 008 08	272	2	3 930 730	96 54 398 08	TERMINAL BOX CPL.
WASHER DIN 125 A 8.4 MS	42 00 506 08	37	4	2 711	91 52 800 08	CENT. LUBRIC. SYSTEM SUP
WASHER DIN 125 A8X16 ST V	42 00 012 08	39	18	1 400	91 56 853 08	CRAWLER TRACK CARRIER LE
WASHER DIN 125 A8X16 ST V	42 00 012 08	39	18	1 410 300	91 56 855 08	CRAWLER CARRIER RIGHT CP
WASHER DIN 125 A8X16 ST V	42 00 012 08	25	24	1 630	91 52 387 08	HYDRAULIC SUPPORT
WASHER DIN 125 A8X16 ST V	42 00 012 08	64	8	1 970	91 56 958 08	CRAWLER TRACK HYDRAULI
WASHER DIN 125 A8X16 ST V	42 00 012 08	82	4	1 970	91 56 958 08	CRAWLER TRACK HYDRAULI
WASHER DIN 125 A8X16 ST V	42 00 012 08	22	4	1 991	91 52 510 08	ROTARY FEED THROUGH
WASHER DIN 125 A8X16 ST V	42 00 012 08	18	57	2 260	91 53 057 08	CUP SPRING CLUSTER
WASHER DIN 125 A8X16 ST V	42 00 012 08	24	2	2 260 006	96 46 501 08	BATTERY BOX, PRE-ASSEMB
WASHER DIN 125 A8X16 ST V	42 00 012 08	33	2	2 310	91 52 503 08	WINCH 1
WASHER DIN 125 A8X16 ST V	42 00 012 08	33	2	2 320	91 52 504 08	WINCH 2
WASHER DIN 125 A8X16 ST V	42 00 012 08	20	24	2 350	91 52 778 08	SLEWING GEAR
WASHER DIN 125 A8X16 ST V	42 00 012 08	17	12	2 370	91 52 782 08	ERECTING WINCH
WASHER DIN 125 A8X16 ST V	42 00 012 08	15	10	2 391 038	96 47 931 08	OIL COOLER, PRE-ASSEMBLE
WASHER DIN 125 A8X16 ST V	42 00 012 08	12	12	2 391 102	96 56 360 08	RADIATOR
WASHER DIN 125 A8X16 ST V	42 00 012 08	4	4	2 503 100	91 55 873 08	EMERGENCY SEAT

6.2.2009

etk_en_de_074515 LR 1600/2

986

LIEBHERRAlphabetical index
Alphabetischer Index

Description	Item	Pos.	Quantity	Page	Assembly	Description
WASHER DIN 125 A8X16 ST V	42 00 012 08	20	2	2 522	91 54 115 08	SLIDING DOOR CPL.
WASHER DIN 125 A8X16 ST V	42 00 012 08	8	4	2 522 012	96 45 884 08	GUIDE PRE-ASS.
WASHER DIN 125 A8X16 ST V	42 00 012 08	9	2	2 522 013	96 45 883 08	GUIDE PRE-ASS.
WASHER DIN 125 A8X16 ST V	42 00 012 08	8	2	2 540	91 53 253 08	CLIMA-HEATING INSTALLATIO
WASHER DIN 125 A8X16 ST V	42 00 012 08	14	1	2 541 001	96 49 651 08	ADDNL.HEATING, PRE-ASSE
WASHER DIN 125 A8X16 ST V	42 00 012 08	20	6	2 550	91 57 751 08	SA FRAME
WASHER DIN 125 A8X16 ST V	42 00 012 08	43	40	2 631	91 56 817 08	SLEWING PLATFORM CATWAL
WASHER DIN 125 A8X16 ST V	42 00 012 08	5	4	2 631 003	96 54 406 08	ACCESS LADDER PRE-ASS.
WASHER DIN 125 A8X16 ST V	42 00 012 08	10	8	2 670	91 52 797 08	FUEL TANK CPL.
WASHER DIN 125 A8X16 ST V	42 00 012 08	67	20	2 810	91 52 806 08	CRANE DRIVER'S CABIN CPL.
WASHER DIN 125 A8X16 ST V	42 00 012 08	5	18	2 810 001	96 43 597 08	CRANE DRIVER'S CABIN,PRE
WASHER DIN 125 A8X16 ST V	42 00 012 08	34	4	2 831	91 57 754 08	AIR COND. UNIT SUPERSTRU
WASHER DIN 125 A8X16 ST V	42 00 012 08	59	104	2 859	91 52 809 08	SOUND INSULATION
WASHER DIN 125 A8X16 ST V	42 00 012 08	4	2	2 859 030	96 46 758 08	COVER COMPL.
WASHER DIN 125 A8X16 ST V	42 00 012 08	6	2	2 925 204	92 16 990 08	CAMERA EQUIPMENT D-PIVOT
WASHER DIN 125 A8X16 ST V	42 00 012 08	10	9	2 925 402	96 58 855 08	CAMERA EQUIPMENT SLEWI
WASHER DIN 125 A8X16 ST V	42 00 012 08	6	12	2 932 160	96 54 385 08	SWITCH CABINET
WASHER DIN 125 A8X16 ST V	42 00 012 08	13	4	2 932 166	92 68 911 08	GROUND RAIL
WASHER DIN 125 A8X16 ST V	42 00 012 08	153	2	2 970	91 56 537 08	HYDR
WASHER DIN 125 A8X16 ST V	42 00 012 08	38	8	3 208 001	91 52 883 08	F-HEAD SECTION
WASHER DIN 125 A8X16 ST V	42 00 012 08	28	12	3 211	91 57 748 08	S PIVOT SECTION
WASHER DIN 125 A8X16 ST V	42 00 012 08	18	4	3 213	91 52 842 08	F-CONNECTING HEAD
WASHER DIN 125 A8X16 ST V	42 00 012 08	22	10	3 214	91 52 843 08	SW HEAD SECTION
WASHER DIN 125 A8X16 ST V	42 00 012 08	39	8	3 220 500	91 52 849 08	S INTERMEDIATE SECTION
WASHER DIN 125 A8X16 ST V	42 00 012 08	39	8	3 223	91 52 852 08	S INTERMEDIATE SECTION
WASHER DIN 125 A8X16 ST V	42 00 012 08	39	8	3 223 010	91 52 853 08	S INTERMEDIATE SECTION
WASHER DIN 125 A8X16 ST V	42 00 012 08	39	8	3 223 100	91 55 327 08	S INTERMEDIATE SECTION
WASHER DIN 125 A8X16 ST V	42 00 012 08	36	31	3 225	91 52 854 08	SL REDUCING SECTION
WASHER DIN 125 A8X16 ST V	42 00 012 08	39	8	3 226	91 52 870 08	L INTERMEDIATE SECTION
WASHER DIN 125 A8X16 ST V	42 00 012 08	39	8	3 227	91 52 873 08	L INTERMEDIATE SECTION
WASHER DIN 125 A8X16 ST V	42 00 012 08	39	8	3 227 008	91 52 872 08	L INTERMEDIATE SECTION
WASHER DIN 125 A8X16 ST V	42 00 012 08	39	8	3 227 200	91 53 519 08	LI INTERMEDIATE SECT. F-GU
WASHER DIN 125 A8X16 ST V	42 00 012 08	61	4	3 281	91 52 896 08	ERECTION FRAME
WASHER DIN 125 A8X16 ST V	42 00 012 08	15	8	3 350	91 52 859 08	WINCH 3
WASHER DIN 125 A8X16 ST V	42 00 012 08	77	26	3 713	91 57 749 08	D PIVOT SECTION
WASHER DIN 125 A8X16 ST V	42 00 012 08	49	16	3 714	91 52 862 08	D HEAD SECTION
WASHER DIN 125 A8X16 ST V	42 00 012 08	5	4	3 714 017	96 50 752 08	SUPPORT CPL.
WASHER DIN 125 A8X16 ST V	42 00 012 08	11	8	3 715 008	91 52 863 08	D INTERMEDIATE SECTION
WASHER DIN 125 A8X16 ST V	42 00 012 08	11	8	3 716	91 52 864 08	D INTERMEDIATE SECTION
WASHER DIN 125 A8X16 ST V	42 00 012 08	43	8	3 745	91 52 948 08	SUSPENDE BALLAST
WASHER DIN 125 A8X16 ST V	42 00 012 08	6	4	5 106 691	51 06 691 08	RETURN FILTER
WASHER DIN 125 B 37 VERZ	42 00 033 08	57	1	3 745	91 52 948 08	SUSPENDE BALLAST
WASHER DIN 125 B 52 ST VER	42 00 040 08	13	2	3 205	91 52 880 08	F-ASSEMBLY UNIT
WASHER DIN 1440 14 ST VER	42 11 013 08	24	1	2 932 160	96 54 385 08	SWITCH CABINET
WASHER DIN 1440 26 ST VER	42 11 022 08	51	8	3 225	91 52 854 08	SL REDUCING SECTION
WASHER DIN 1440 32 ST VER	42 11 026 08	29	4	2 810	91 52 806 08	CRANE DRIVER'S CABIN CPL.
WASHER DIN 1440 33 ST VER	42 11 027 08	19	3	2 652	91 52 794 08	ROLLER BEARING
WASHER DIN 1440 45 ST VER	42 11 032 08	8	2	2 550	91 57 751 08	SA FRAME
WASHER DIN 1440 45 ST VER	42 11 032 08	12	2	2 652	91 52 794 08	ROLLER BEARING
WASHER DIN 1440 50 ST VER	42 11 033 08	4	8	3 747	91 52 950 08	CENTERING STANDARD
WASHER DIN 1440 8 ST VERZ	42 11 006 08	121	5	3 713	91 57 749 08	D PIVOT SECTION
WASHER DIN 1441 21 ST VER	42 12 013 08	30	2	2 631	91 56 817 08	SLEWING PLATFORM CATWAL
WASHER DIN 1441 21 ST VER	42 12 013 08	29	16	2 652	91 52 794 08	ROLLER BEARING
WASHER DIN 1441 21 ST VER	42 12 013 08	12	1	2 925 204	92 16 990 08	CAMERA EQUIPMENT D-PIVOT
WASHER DIN 1441 26 ST VER	42 12 016 08	30	2	2 550	91 57 751 08	SA FRAME
WASHER DIN 1441 26 ST VER	42 12 016 08	19	6	2 671	91 52 798 08	OIL RESERVOIR, COMPLETE
WASHER DIN 1441 26 ST VER	42 12 016 08	40	4	2 810	91 52 806 08	CRANE DRIVER'S CABIN CPL.
WASHER DIN 1441 31 ST VER	42 12 019 08	47	2	3 208 001	91 52 883 08	F-HEAD SECTION
WASHER DIN 1441 31 ST VER	42 12 019 08	24	4	3 211	91 57 748 08	S PIVOT SECTION
WASHER DIN 1441 31 ST VER	42 12 019 08	40	2	3 713	91 57 749 08	D PIVOT SECTION

6.2.2009

etk_en_de_074515 LR 1600/2

987

LIEBHERRAlphabetical index
Alphabetischer Index

Description	Item	Pos.	Quantity	Page	Assembly	Description
WASHER DIN 1441 31 ST VER	42 12 019 08	3	1	3 790 006	96 19 989 08	PIN PULLING CYLINDER CPL.
WASHER DIN 1441 31 ST VER	42 12 019 08	3	1	3 790 007	96 19 990 08	PIN PULLING CYLINDER CPL.
WASHER DIN 1441 41 ST A2C	42 12 024 08	66	4	2 550	91 57 751 08	SA FRAME
WASHER DIN 1441 41 ST A2C	42 12 024 08	91	3	2 550	91 57 751 08	SA FRAME
WASHER DIN 1441 41 ST A2C	42 12 024 08	20	2	2 810	91 52 806 08	CRANE DRIVER'S CABIN CPL.
WASHER DIN 1441 41 ST A2C	42 12 024 08	5	2	3 211 009	96 46 979 08	SAFETY ROLLER CPL.
WASHER DIN 433 17 ST	55 31 248 08	48	4	3 220 500	91 52 849 08	S INTERMEDIATE SECTION
WASHER DIN 433 17 ST	55 31 248 08	48	4	3 223	91 52 852 08	S INTERMEDIATE SECTION
WASHER DIN 433 17 ST	55 31 248 08	48	4	3 223 010	91 52 853 08	S INTERMEDIATE SECTION
WASHER DIN 433 17 ST	55 31 248 08	48	4	3 223 100	91 55 327 08	S INTERMEDIATE SECTION
WASHER DIN 433 17 ST	55 31 248 08	48	4	3 226	91 52 870 08	L INTERMEDIATE SECTION
WASHER DIN 433 17 ST	55 31 248 08	48	4	3 227	91 52 873 08	L INTERMEDIATE SECTION
WASHER DIN 433 17 ST	55 31 248 08	48	4	3 227 008	91 52 872 08	L INTERMEDIATE SECTION
WASHER DIN 440 V 9 ST VERZ	42 06 042 08	31	8	2 260	91 53 057 08	CUP SPRING CLUSTER
WASHER DIN 440 V 9 ST VERZ	42 06 042 08	43	2	2 393	91 52 787 08	AIR FILTER UNIT CPL.
WASHER DIN 6916 13 C45 VER	42 15 000 08	391	2	2 391 001	96 45 719 08	DIESEL ENGINE, PRE-ASSEMB
WASHER DIN 6916 17 C45 VER	42 15 002 08	42	26	1 400	91 56 853 08	CRAWLER TRACK CARRIER LE
WASHER DIN 6916 17 C45 VER	42 15 002 08	42	26	1 410 300	91 56 855 08	CRAWLER CARRIER RIGHT CP
WASHER DIN 6916 17 C45 VER	42 15 002 08	381	12	2 391 001	96 45 719 08	DIESEL ENGINE, PRE-ASSEMB
WASHER DIN 6916 21 C45 VER	42 15 003 08	389	4	2 391 001	96 45 719 08	DIESEL ENGINE, PRE-ASSEMB
WASHER DIN 6916 21 C45 VER	42 15 003 08	12	2	3 745 011	96 49 677 08	BRACKET COMPL.
WASHER DIN 6916 25 C45 VER	42 15 004 08	43	70	1 400	91 56 853 08	CRAWLER TRACK CARRIER LE
WASHER DIN 6916 25 C45 VER	42 15 004 08	43	70	1 410 300	91 56 855 08	CRAWLER CARRIER RIGHT CP
WASHER DIN 7349 10,5 ST V	42 16 006 08	36	24	2 631	91 56 817 08	SLEWING PLATFORM CATWAL
WASHER DIN 7349 13 ST VER	42 16 007 08	3	2	2 212	91 54 561 08	PUMP F.SLEWING GEAR
WASHER DIN 7349 13 ST VER	42 16 007 08	384	10	2 391 001	96 45 719 08	DIESEL ENGINE, PRE-ASSEMB
WASHER DIN 7349 13 ST VER	42 16 007 08	25	8	3 215 005	91 52 846 08	ROLLER SET
WASHER DIN 7349 13 ST VER	42 16 007 08	25	8	3 215 006	91 52 847 08	ROLLER SET
WASHER DIN 7349 17 ST VER	42 16 009 08	385	2	2 391 001	96 45 719 08	DIESEL ENGINE, PRE-ASSEMB
WASHER DIN 7349 17 ST VER	42 16 009 08	36	1	2 391 040	96 53 645 08	CLUTCH ACTUATOR
WASHER DIN 7349 17 ST VER	42 16 009 08	43	28	2 550	91 57 751 08	SA FRAME
WASHER DIN 7349 25 ST VER	42 16 013 08	16	12	3 714 009	96 49 267 08	LUFFING PULLEY BLOCK COM
WASHER DIN 7349 6,4 ST VER	42 16 004 08	32	5	2 260	91 53 057 08	CUP SPRING CLUSTER
WASHER DIN 7349 6,4 ST VER	42 16 004 08	6	5	2 391 036	96 23 055 08	COVER/LID/CAP, PRE-ASSEMB
WASHER DIN 7349 6,4 ST VER	42 16 004 08	13	13	2 925 402	96 58 855 08	CAMERA EQUIPMENT SLEWI
WASHER DIN 7349 8,4 ST VER	42 16 005 08	33	12	2 260	91 53 057 08	CUP SPRING CLUSTER
WASHER DIN 7349 8,4 ST VER	42 16 005 08	10	3	2 260 006	96 46 501 08	BATTERY BOX, PRE-ASSEMB
WASHER DIN 7349 8,4 ST VER	42 16 005 08	392	6	2 391 001	96 45 719 08	DIESEL ENGINE, PRE-ASSEMB
WASHER DIN 7349 8,4 ST VER	42 16 005 08	18	8	2 392	91 52 785 08	MUFFLER UNIT
WASHER DIN 7349 8,4 ST VER	42 16 005 08	15	8	2 510	91 52 788 08	TURNTABLE PANELLING
WASHER DIN 7349 8,4 ST VER	42 16 005 08	57	35	2 859	91 52 809 08	SOUND INSULATION
WASHER DIN 7349 8,4 ST VER	42 16 005 08	16	12	2 925 402	96 58 855 08	CAMERA EQUIPMENT SLEWI
WASHER DIN 7349 8,4 ST VER	42 16 005 08	99	55	3 211	91 57 748 08	S PIVOT SECTION
WASHER DIN 7349 8,4 ST VER	42 16 005 08	125	33	3 713	91 57 749 08	D PIVOT SECTION
WASHER DIN 7349 8,4 ST VER	42 16 005 08	88	12	3 714	91 52 862 08	D HEAD SECTION
WASHER DIN 7989 A 26 ST V	42 17 006 08	6	1	2 620	91 52 793 08	ROLLER SLEWING RING
WASHER DIN 7989 A 33 ST V	42 17 009 08	13	32	3 747	91 52 950 08	CENTERING STANDARD
WASHER DIN 7989 B 11 VERZ	42 17 005 08	12	4	2 541 001	96 49 651 08	ADDNL.HEATING, PRE-ASSE
WASHER DIN 9021 A 10,5 ST V	42 18 010 08	390	12	2 391 001	96 45 719 08	DIESEL ENGINE, PRE-ASSEMB
WASHER DIN 9021 A 10,5 ST V	42 18 010 08	14	12	2 391 038	96 47 931 08	OIL COOLER, PRE-ASSEMBLE
WASHER DIN 9021 A 10,5 ST V	42 18 010 08	41	4	2 393	91 52 787 08	AIR FILTER UNIT CPL.
WASHER DIN 9021 A 15 ST V	42 18 024 08	49	4	3 745	91 52 948 08	SUSPENDED BALLAST
WASHER DIN 9021 A 17 ST V	42 18 013 08	64	4	1 400	91 56 853 08	CRAWLER TRACK CARRIER LE
WASHER DIN 9021 A 17 ST V	42 18 013 08	64	4	1 410 300	91 56 855 08	CRAWLER CARRIER RIGHT CP
WASHER DIN 9021 A 17 ST V	42 18 013 08	52	2	3 223 100	91 55 327 08	S INTERMEDIATE SECTION
WASHER DIN 9021 A 4.3 ST V	42 18 005 08	39	10	2 631	91 56 817 08	SLEWING PLATFORM CATWAL
WASHER DIN 9021 A 4.3 ST V	42 18 005 08	(32)	4	2 925 026	91 55 259 08	ERG. CAMERA CONTROL
WASHER DIN 9021 A 4.3 ST V	42 18 005 08	32	4	2 925 405	96 48 397 08	EQUIPMENT CAMERA CAB
WASHER DIN 9021 A 5,3 ST V	42 18 006 08	24	28	2 260	91 53 057 08	CUP SPRING CLUSTER
WASHER DIN 9021 A 5,3 ST V	42 18 006 08	395	8	2 391 001	96 45 719 08	DIESEL ENGINE, PRE-ASSEMB

6.2.2009

etk_en_de_074515 LR 1600/2

988

LIEBHERRAlphabetical index
Alphabetischer Index

Description	Item	Pos.	Quantity	Page	Assembly	Description
WASHER DIN 9021 A 5,3 ST V	42 18 006 08	11	1	2 522 011	96 45 602 08	CLOSING DEVICE
WASHER DIN 9021 A 5,3 ST V	42 18 006 08	59	2	2 631	91 56 817 08	SLEWING PLATFORM CATWAL
WASHER DIN 9021 A 5,3 ST V	42 18 006 08	296	2	2 920 581	96 54 405 08	TERMINAL BOX WINCH PRE-A
WASHER DIN 9021 A 5,3 ST V	42 18 006 08	49	4	2 975 200	91 52 775 08	ADDITIONAL HYDRAULICS WI
WASHER DIN 9021 A 5,3 ST V	42 18 006 08	49	4	2 975 700	91 52 774 08	ADDITIONAL HYDRAULICS WI
WASHER DIN 9021 A 5,3 ST V	42 18 006 08	(4)	3	3 780 258	96 56 482 08	ELECTRIC AIRCRAFT PROTE
WASHER DIN 9021 A 5,3 ST V	42 18 006 08	160	2	3 930 640	96 50 481 08	TERMINAL BOX CPL.
WASHER DIN 9021 A 5,3 ST V	42 18 006 08	273	2	3 930 730	96 50 599 08	TERMINAL BOX CPL.
WASHER DIN 9021 A 5,3 ST V	42 18 006 08	218	2	3 930 734	96 54 401 08	TERMINAL BOX
WASHER DIN 9021 A 6.4 VERZ	42 18 007 08	34	2	2 391 040	96 53 645 08	CLUTCH ACTUATOR
WASHER DIN 9021 A 6.4 VERZ	42 18 007 08	8	8	2 510	91 52 788 08	TURNTABLE PANELLING
WASHER DIN 9021 A 6.4 VERZ	42 18 007 08	7	6	2 520 031	96 45 610 08	REAR WINDOW PRE-ASS.
WASHER DIN 9021 A 6.4 VERZ	42 18 007 08	16	8	2 522	91 54 115 08	SLIDING DOOR CPL.
WASHER DIN 9021 A 6.4 VERZ	42 18 007 08	15	1	2 533 066	96 48 365 08	ELECTRIC ADD-ON PARTS CA
WASHER DIN 9021 A 6.4 VERZ	42 18 007 08	58	28	2 550	91 57 751 08	SA FRAME
WASHER DIN 9021 A 6.4 VERZ	42 18 007 08	7	4	2 859 030	96 46 758 08	COVER COMPL.
WASHER DIN 9021 A 6.4 VERZ	42 18 007 08	23	8	2 925 402	96 58 855 08	CAMERA EQUIPMENT SLEWI
WASHER DIN 9021 A 6.4 VERZ	42 18 007 08	18	6	2 990	91 59 244 08	COMPRESSED AIR PLANT
WASHER DIN 9021 A 6.4 VERZ	42 18 007 08	55	2	3 206	91 52 881 08	PIVOT SECTION
WASHER DIN 9021 A 6.4 VERZ	42 18 007 08	37	16	3 208 001	91 52 883 08	F-HEAD SECTION
WASHER DIN 9021 A 6.4 VERZ	42 18 007 08	58	20	3 211	91 57 748 08	S PIVOT SECTION
WASHER DIN 9021 A 6.4 VERZ	42 18 007 08	37	17	3 220 500	91 52 849 08	S INTERMEDIATE SECTION
WASHER DIN 9021 A 6.4 VERZ	42 18 007 08	21	12	3 221	91 54 668 08	S INTERMEDIATE SECTION
WASHER DIN 9021 A 6.4 VERZ	42 18 007 08	37	22	3 223	91 52 852 08	S INTERMEDIATE SECTION
WASHER DIN 9021 A 6.4 VERZ	42 18 007 08	37	22	3 223 010	91 52 853 08	S INTERMEDIATE SECTION
WASHER DIN 9021 A 6.4 VERZ	42 18 007 08	37	22	3 223 100	91 55 327 08	S INTERMEDIATE SECTION
WASHER DIN 9021 A 6.4 VERZ	42 18 007 08	33	17	3 225	91 52 854 08	SL REDUCING SECTION
WASHER DIN 9021 A 6.4 VERZ	42 18 007 08	37	17	3 226	91 52 870 08	L INTERMEDIATE SECTION
WASHER DIN 9021 A 6.4 VERZ	42 18 007 08	37	22	3 227	91 52 873 08	L INTERMEDIATE SECTION
WASHER DIN 9021 A 6.4 VERZ	42 18 007 08	37	22	3 227 008	91 52 872 08	L INTERMEDIATE SECTION
WASHER DIN 9021 A 6.4 VERZ	42 18 007 08	37	22	3 227 200	91 53 519 08	LI INTERMEDIATE SECT. F-GU
WASHER DIN 9021 A 6.4 VERZ	42 18 007 08	5	16	3 291	91 52 831 08	S OVERRUN PROTECTION
WASHER DIN 9021 A 6.4 VERZ	42 18 007 08	10	8	3 292	91 52 865 08	D OVERRUN PROTECTION
WASHER DIN 9021 A 6.4 VERZ	42 18 007 08	64	16	3 713	91 57 749 08	D PIVOT SECTION
WASHER DIN 9021 A 6.4 VERZ	42 18 007 08	57	40	3 714	91 52 862 08	D HEAD SECTION
WASHER DIN 9021 A 6.4 VERZ	42 18 007 08	12	24	3 715 008	91 52 863 08	D INTERMEDIATE SECTION
WASHER DIN 9021 A 6.4 VERZ	42 18 007 08	12	31	3 716	91 52 864 08	D INTERMEDIATE SECTION
WASHER DIN 9021 A 8.4 VERZ	42 18 009 08	63	2	1 400	91 56 853 08	CRAWLER TRACK CARRIER LE
WASHER DIN 9021 A 8.4 VERZ	42 18 009 08	63	2	1 410 300	91 56 855 08	CRAWLER CARRIER RIGHT CP
WASHER DIN 9021 A 8.4 VERZ	42 18 009 08	10	3	2 350	91 52 778 08	SLEWING GEAR
WASHER DIN 9021 A 8.4 VERZ	42 18 009 08	21	4	2 350	91 52 778 08	SLEWING GEAR
WASHER DIN 9021 A 8.4 VERZ	42 18 009 08	387	22	2 391 001	96 45 719 08	DIESEL ENGINE, PRE-ASSEMB
WASHER DIN 9021 A 8.4 VERZ	42 18 009 08	28	4	2 391 040	96 53 645 08	CLUTCH ACTUATOR
WASHER DIN 9021 A 8.4 VERZ	42 18 009 08	13	14	2 391 102	96 56 360 08	RADIATOR
WASHER DIN 9021 A 8.4 VERZ	42 18 009 08	22	4	2 392	91 52 785 08	MUFFLER UNIT
WASHER DIN 9021 A 8.4 VERZ	42 18 009 08	42	26	2 393	91 52 787 08	AIR FILTER UNIT CPL.
WASHER DIN 9021 A 8.4 VERZ	42 18 009 08	75	7	2 520	91 53 061 08	CABIN, GLAZED
WASHER DIN 9021 A 8.4 VERZ	42 18 009 08	54	4	2 631	91 56 817 08	SLEWING PLATFORM CATWAL
WASHER DIN 9021 A 8.4 VERZ	42 18 009 08	31	4	2 831	91 57 754 08	AIR COND. UNIT SUPERSTRU
WASHER DIN 9021 A 8.4 VERZ	42 18 009 08	42	3	3 206	91 52 881 08	PIVOT SECTION
WASHER DIN 9021 A 8.4 VERZ	42 18 009 08	54	46	3 211	91 57 748 08	S PIVOT SECTION
WASHER DIN 9021 A 8.4 VERZ	42 18 009 08	38	8	3 220 500	91 52 849 08	S INTERMEDIATE SECTION
WASHER DIN 9021 A 8.4 VERZ	42 18 009 08	22	12	3 221	91 54 668 08	S INTERMEDIATE SECTION
WASHER DIN 9021 A 8.4 VERZ	42 18 009 08	38	40	3 223	91 52 852 08	S INTERMEDIATE SECTION
WASHER DIN 9021 A 8.4 VERZ	42 18 009 08	38	40	3 223 010	91 52 853 08	S INTERMEDIATE SECTION
WASHER DIN 9021 A 8.4 VERZ	42 18 009 08	38	40	3 223 100	91 55 327 08	S INTERMEDIATE SECTION
WASHER DIN 9021 A 8.4 VERZ	42 18 009 08	42	43	3 225	91 52 854 08	SL REDUCING SECTION
WASHER DIN 9021 A 8.4 VERZ	42 18 009 08	38	8	3 226	91 52 870 08	L INTERMEDIATE SECTION
WASHER DIN 9021 A 8.4 VERZ	42 18 009 08	38	24	3 227	91 52 873 08	L INTERMEDIATE SECTION
WASHER DIN 9021 A 8.4 VERZ	42 18 009 08	38	16	3 227 008	91 52 872 08	L INTERMEDIATE SECTION

6.2.2009

etk_en_de_074515 LR 1600/2

989

LIEBHERRAlphabetical index
Alphabetischer Index

Description	Item	Pos.	Quantity	Page	Assembly	Description
WASHER DIN 9021 A 8.4 VERZ	42 18 009 08	38	10	3 227 200	91 53 519 08	LI INTERMEDIATE SECT. F-GU
WASHER DIN 9021 A 8.4 VERZ	42 18 009 08	19	28	3 713	91 57 749 08	D PIVOT SECTION
WASHER DIN 9021 A 8.4 VERZ	42 18 009 08	77	8	3 714	91 52 862 08	D HEAD SECTION
WASHER DIN 9021 A 8.4 VERZ	42 18 009 08	13	48	3 715 008	91 52 863 08	D INTERMEDIATE SECTION
WASHER DIN 9021 A 8.4 VERZ	42 18 009 08	13	92	3 716	91 52 864 08	D INTERMEDIATE SECTION
WASHER DIN 9021 A 8.4 VERZ	42 18 009 08	8	4	3 978 005	91 56 430 08	ADDL.HYDRAULIC SB-HEAD PI
WASHER DIN EN ISO 7093-1 8	42 18 614 05	32	8	3 745	91 52 948 08	SUSPENDE BALLAST
WASHER ISO 7089 20 ST VER	42 00 021 01	(69)	1	1 400	91 56 853 08	CRAWLER TRACK CARRIER LE
WASHER ISO 7089 8 200HV-A2	42 00 607 05	16	4	2 671	91 52 798 08	OIL RESERVOIR, COMPLETE
WASHER ISO 7089 A 10.5 A3C	42 00 013 08	4	16	1 620	91 52 386 08	FIXING PARTS SLEWING RING
WASHER ISO 7089 A 10.5 A3C	42 00 013 08	27	2	2 391 040	96 53 645 08	CLUTCH ACTUATOR
WASHER ISO 7089 A 10.5 A3C	42 00 013 08	99	9	2 550	91 57 751 08	SA FRAME
WASHER ISO 7089 A 10.5 A3C	42 00 013 08	20	4	2 631	91 56 817 08	SLEWING PLATFORM CATWAL
WASHER ISO 7089 A 10.5 A3C	42 00 013 08	7	4	2 671 004	96 46 305 08	OIL TANK PRE-ASS.
WASHER ISO 7089 A 10.5 A3C	42 00 013 08	18	4	2 925 204	92 16 990 08	CAMERA EQUIPMENT D-PIVOT
WASHER ISO 7089 A 10.5 A3C	42 00 013 08	34	2	2 925 402	96 58 855 08	CAMERA EQUIPMENT SLEWI
WASHER ISO 7089 A 10.5 A3C	42 00 013 08	8	14	3 206	91 52 881 08	PIVOT SECTION
WASHER ISO 7089 A 10.5 A3C	42 00 013 08	50	8	3 211	91 57 748 08	S PIVOT SECTION
WASHER ISO 7089 A 10.5 A3C	42 00 013 08	39	8	3 281	91 52 896 08	ERECTION FRAME
WASHER ISO 7089 A 10.5 A3C	42 00 013 08	35	8	3 713	91 57 749 08	D PIVOT SECTION
WASHER ISO 7089 A 10.5 A3C	42 00 013 08	72	32	3 714	91 52 862 08	D HEAD SECTION
WASHER ISO 7089 A 10.5 A3C	42 00 013 08	36	16	3 745	91 52 948 08	SUSPENDE BALLAST
WASHER ISO 7089 A 10.5 A3C	42 00 013 08	9	4	9 080 702	90 80 702	CONTROL GEAR
WASHER ISO 7089 A 10.5 A3C	42 00 013 08	14	2	X1041267	10 41 267 8	END PLATE
WASHER ISO 7089 A 13 ST A3	42 00 016 08	34	8	1 630	91 52 387 08	HYDRAULIC SUPPORT
WASHER ISO 7089 A 13 ST A3	42 00 016 08	21	8	2 310	91 52 503 08	WINCH 1
WASHER ISO 7089 A 13 ST A3	42 00 016 08	21	8	2 320	91 52 504 08	WINCH 2
WASHER ISO 7089 A 13 ST A3	42 00 016 08	13	2	2 340	91 52 776 08	WINCH 4 LUFFING GEAR
WASHER ISO 7089 A 13 ST A3	42 00 016 08	13	16	2 392	91 52 785 08	MUFFLER UNIT
WASHER ISO 7089 A 13 ST A3	42 00 016 08	10	4	2 671	91 52 798 08	OIL RESERVOIR, COMPLETE
WASHER ISO 7089 A 13 ST A3	42 00 016 08	55	1	2 810	91 52 806 08	CRANE DRIVER'S CABIN CPL.
WASHER ISO 7089 A 13 ST A3	42 00 016 08	25	1	2 932 160	96 54 385 08	SWITCH CABINET
WASHER ISO 7089 A 13 ST A3	42 00 016 08	176	16	2 970	91 56 537 08	HYDR
WASHER ISO 7089 A 13 ST A3	42 00 016 08	37	6	3 206	91 52 881 08	PIVOT SECTION
WASHER ISO 7089 A 13 ST A3	42 00 016 08	5	2	3 207 003	96 48 259 08	ROD CPL.
WASHER ISO 7089 A 13 ST A3	42 00 016 08	4	2	3 207 100	96 48 261 08	BRACKET COMPL.
WASHER ISO 7089 A 13 ST A3	42 00 016 08	34	12	3 208 001	91 52 883 08	F-HEAD SECTION
WASHER ISO 7089 A 13 ST A3	42 00 016 08	71	8	3 211	91 57 748 08	S PIVOT SECTION
WASHER ISO 7089 A 13 ST A3	42 00 016 08	31	12	3 214	91 52 843 08	SW HEAD SECTION
WASHER ISO 7089 A 13 ST A3	42 00 016 08	23	4	3 215 005	91 52 846 08	ROLLER SET
WASHER ISO 7089 A 13 ST A3	42 00 016 08	23	4	3 215 006	91 52 847 08	ROLLER SET
WASHER ISO 7089 A 13 ST A3	42 00 016 08	(5)	2	3 281	91 52 896 08	ERECTION FRAME
WASHER ISO 7089 A 13 ST A3	42 00 016 08	10	4	3 291	91 52 831 08	S OVERRUN PROTECTION
WASHER ISO 7089 A 13 ST A3	42 00 016 08	4	4	3 292	91 52 865 08	D OVERRUN PROTECTION
WASHER ISO 7089 A 13 ST A3	42 00 016 08	37	28	3 714	91 52 862 08	D HEAD SECTION
WASHER ISO 7089 A 13 ST A3	42 00 016 08	12	4	3 978 100	91 56 428 08	HYDR. SUSPENDE BALLAST
WASHER ISO 7089 A 21 ST A3	42 00 021 08	41	4	1 400	91 56 853 08	CRAWLER TRACK CARRIER LE
WASHER ISO 7089 A 21 ST A3	42 00 021 08	41	4	1 410 300	91 56 855 08	CRAWLER CARRIER RIGHT CP
WASHER ISO 7089 A 21 ST A3	42 00 021 08	3	2	1 632 032	96 20 093 08	SUPPORT PLATE COMPL.
WASHER ISO 7089 A 21 ST A3	42 00 021 08	14	8	1 991	91 52 510 08	ROTARY FEED THROUGH
WASHER ISO 7089 A 21 ST A3	42 00 021 08	10	4	2 550 005	96 45 680 08	ROD CPL.
WASHER ISO 7089 A 21 ST A3	42 00 021 08	9	1	2 620	91 52 793 08	ROLLER SLEWING RING
WASHER ISO 7089 A 21 ST A3	42 00 021 08	27	12	2 631	91 56 817 08	SLEWING PLATFORM CATWAL
WASHER ISO 7089 A 21 ST A3	42 00 021 08	30	1	2 925 402	96 58 855 08	CAMERA EQUIPMENT SLEWI
WASHER ISO 7089 A 21 ST A3	42 00 021 08	38	14	3 211	91 57 748 08	S PIVOT SECTION
WASHER ISO 7089 A 21 ST A3	42 00 021 08	69	4	3 713	91 57 749 08	D PIVOT SECTION
WASHER ISO 7089 A 21 ST A3	42 00 021 08	7	2	3 714 025	96 49 269 08	ROD CPL.
WASHER ISO 7089 A 31 A3C	42 00 028 08	12	1	2 620	91 52 793 08	ROLLER SLEWING RING
WASHER ISO 7089 A 31 A3C	42 00 028 08	22	10	2 810	91 52 806 08	CRANE DRIVER'S CABIN CPL.
WASHER ISO 7089 A 31 A3C	42 00 028 08	22	2	3 282 002	96 47 890 08	FAB-STAY

6.2.2009

etk_en_de_074515 LR 1600/2

990

LIEBHERRAlphabetical index
Alphabetischer Index

Description	Item	Pos.	Quantity	Page	Assembly	Description
WASHER ISO 7089 A 31 A3C	42 00 028 08	67	4	3 714	91 52 862 08	D HEAD SECTION
WASHER ISO 7089 A 6.4 VERZ	42 00 009 08	3	6	1 830 102	92 26 483 08	TERMINAL BOARD PRE-ASS.
WASHER ISO 7089 A 6.4 VERZ	42 00 009 08	74	8	1 970	91 56 958 08	CRAWLER TRACK HYDRAULI
WASHER ISO 7089 A 6.4 VERZ	42 00 009 08	19	2	1 991	91 52 510 08	ROTARY FEED THROUGH
WASHER ISO 7089 A 6.4 VERZ	42 00 009 08	21	24	2 260	91 53 057 08	CUP SPRING CLUSTER
WASHER ISO 7089 A 6.4 VERZ	42 00 009 08	20	6	2 260 006	96 46 501 08	BATTERY BOX, PRE-ASSEMB
WASHER ISO 7089 A 6.4 VERZ	42 00 009 08	6	8	2 260 009	96 46 972 08	FLAP PRE-ASS.
WASHER ISO 7089 A 6.4 VERZ	42 00 009 08	23	16	2 370	91 52 782 08	ERECTING WINCH
WASHER ISO 7089 A 6.4 VERZ	42 00 009 08	6	8	2 391 039	96 50 616 08	COVER CPL
WASHER ISO 7089 A 6.4 VERZ	42 00 009 08	15	12	2 393 002	96 46 782 08	COVER COMPL.
WASHER ISO 7089 A 6.4 VERZ	42 00 009 08	42	4	2 502	91 55 939 08	CONTROL STAND
WASHER ISO 7089 A 6.4 VERZ	42 00 009 08	56	4	2 520 034	96 45 984 08	INTERNAL LINING
WASHER ISO 7089 A 6.4 VERZ	42 00 009 08	9	2	2 522	91 54 115 08	SLIDING DOOR CPL.
WASHER ISO 7089 A 6.4 VERZ	42 00 009 08	16	3	2 522 011	96 45 602 08	CLOSING DEVICE
WASHER ISO 7089 A 6.4 VERZ	42 00 009 08	9	2	2 540	91 53 253 08	CLIMA-HEATING INSTALLATIO
WASHER ISO 7089 A 6.4 VERZ	42 00 009 08	41	4	2 711	91 52 800 08	CENT. LUBRIC. SYSTEM SUP
WASHER ISO 7089 A 6.4 VERZ	42 00 009 08	23	12	2 835 002	96 48 379 08	ADD-ON PARTS
WASHER ISO 7089 A 6.4 VERZ	42 00 009 08	10	14	2 925 204	92 16 990 08	CAMERA EQUIPMENT D-PIVOT
WASHER ISO 7089 A 6.4 VERZ	42 00 009 08	12	13	2 925 402	96 58 855 08	CAMERA EQUIPMENT SLEWI
WASHER ISO 7089 A 6.4 VERZ	42 00 009 08	4	4	2 932 166	92 68 911 08	GROUND RAIL
WASHER ISO 7089 A 6.4 VERZ	42 00 009 08	8	4	2 932 168	96 48 167 08	COVER COMPL.
WASHER ISO 7089 A 6.4 VERZ	42 00 009 08	12	2	2 976 203	92 27 489 08	ADDL.HYDR.F.PIN PULLING DE
WASHER ISO 7089 A 6.4 VERZ	42 00 009 08	28	4	3 206	91 52 881 08	PIVOT SECTION
WASHER ISO 7089 A 6.4 VERZ	42 00 009 08	43	8	3 214	91 52 843 08	SW HEAD SECTION
WASHER ISO 7089 A 6.4 VERZ	42 00 009 08	10	8	3 745 002	92 17 236 08	SWITCH UNIT
WASHER ISO 7089 A 6.4 VERZ	42 00 009 08	10	8	3 745 003	92 17 237 08	SWITCH UNIT
WASHER ISO 7089 A 6.4 VERZ	42 00 009 08	17	6	3 780 751	91 52 952 08	AIR-CRAFT & WIND WARNING
WASHER ISO 7089 A 6.4 VERZ	42 00 009 08	23	3	3 978 015	91 56 429 08	ADDITIONAL HYDRAULICS IN
WASHER ISO 7089 A 6.4 VERZ	42 00 009 08	23	3	3 978 015	91 56 432 08	ADDITIONAL HYDRAULICS IN
WASHER ISO 7089 A 6.4 VERZ	42 00 009 08	7	8	7 027 481	70 27 481 03	WATER SEPARATOR
WASHER ISO 7089 A 6.4 VERZ	42 00 009 08	7	2	9 080 702	90 80 702	CONTROL GEAR
WASHER ISO 7089 A 6.4 VERZ	42 00 009 08	43	2	X1022811	10 22 811 2	AIR CONDITIONING UNIT
WASHER ISO 7089 A8.4X16 ST	46 00 373 03	17	1	X1041267	10 41 267 8	END PLATE
WASHER ISO 7093 A 6.4 A2	42 18 017 08	14	6	2 550 008	96 47 628 08	RETAINER CPL.
WASHER ISO 7093 A 6.4 A2	42 18 017 08	14	6	2 550 009	96 47 645 08	RETAINER CPL.
WASHER ISO 7093 A 6.4 A2	42 18 017 08	74	3	2 810	91 52 806 08	CRANE DRIVER'S CABIN CPL.
WASHER ISO 7093 A 6.4 A2	42 18 017 08	19	4	2 978 200	91 54 843 08	ADD.HYDR.S_RETAINING RAM
WASHER ISO 7093 A 6.4 A2	42 18 017 08	7	11	3 713 013	96 57 159 08	SHEET CPL.
WASHER ISO 7093-1 A 13 ST	42 18 011 08	23	8	2 310	91 52 503 08	WINCH 1
WASHER ISO 7093-1 A 13 ST	42 18 011 08	23	8	2 320	91 52 504 08	WINCH 2
WASHER ISO 7093-1 A 13 ST	42 18 011 08	386	4	2 391	91 52 784 08	DIESEL ENGINE CPL.
WASHER ISO 7093-1 A 13 ST	42 18 011 08	386	4	2 391 001	96 45 719 08	DIESEL ENGINE, PRE-ASSEMB
WASHER ISO 7093-1 A 13 ST	42 18 011 08	11	12	2 391 023	96 45 720 08	RADIATOR, PRE-ASSEMBLED
WASHER ISO 7093-1 A 13 ST	42 18 011 08	74	8	3 211	91 57 748 08	S PIVOT SECTION
WASHER ISO 7093-1 A 13 ST	42 18 011 08	14	8	3 213	91 52 842 08	F-CONNECTING HEAD
WASHER ISO 7093-1 A 13 ST	42 18 011 08	29	8	3 214	91 52 843 08	SW HEAD SECTION
WASHER ISO 7093-1 A 13 ST	42 18 011 08	7	16	3 220 500	91 52 849 08	S INTERMEDIATE SECTION
WASHER ISO 7093-1 A 13 ST	42 18 011 08	7	16	3 221	91 54 668 08	S INTERMEDIATE SECTION
WASHER ISO 7093-1 A 13 ST	42 18 011 08	7	16	3 223	91 52 852 08	S INTERMEDIATE SECTION
WASHER ISO 7093-1 A 13 ST	42 18 011 08	7	16	3 223 010	91 52 853 08	S INTERMEDIATE SECTION
WASHER ISO 7093-1 A 13 ST	42 18 011 08	7	16	3 223 100	91 55 327 08	S INTERMEDIATE SECTION
WASHER ISO 7093-1 A 13 ST	42 18 011 08	27	16	3 225	91 52 854 08	SL REDUCING SECTION
WASHER ISO 7093-1 A 13 ST	42 18 011 08	7	16	3 226	91 52 870 08	L INTERMEDIATE SECTION
WASHER ISO 7093-1 A 13 ST	42 18 011 08	7	16	3 227	91 52 873 08	L INTERMEDIATE SECTION
WASHER ISO 7093-1 A 13 ST	42 18 011 08	7	16	3 227 008	91 52 872 08	L INTERMEDIATE SECTION
WASHER ISO 7093-1 A 13 ST	42 18 011 08	7	16	3 227 200	91 53 519 08	LI INTERMEDIATE SECT. F-GU
WASHER ISO 7093-1 A 13 ST	42 18 011 08	25	4	3 713	91 57 749 08	D PIVOT SECTION
WASHER ISO 7093-1 A 13 ST	42 18 011 08	28	8	3 714	91 52 862 08	D HEAD SECTION
WASHER ISO 7093-1 A 13 ST	42 18 011 08	14	16	3 715 008	91 52 863 08	D INTERMEDIATE SECTION
WASHER ISO 7093-1 A 13 ST	42 18 011 08	14	16	3 716	91 52 864 08	D INTERMEDIATE SECTION

6.2.2009

etk_en_de_074515 LR 1600/2

991

LIEBHERRAlphabetical index
Alphabetischer Index

Description	Item	Pos.	Quantity	Page	Assembly	Description
WASHER M5 KUNSTSTOFF SP	66 00 414 08	8	1	2 913 100	91 23 538 08	ASSEMBLY FRAME
WASHER RD100X5	93 30 481 08	9	4	3 713	91 57 749 08	D PIVOT SECTION
WASHER RD100X6	93 97 916 08	18	2	3 208 001	91 52 883 08	F-HEAD SECTION
WASHER RD110X2	94 96 354 08	7	1	2 657	91 57 656 08	MOUNTING EQUIPMENT CRAW
WASHER RD150X1	94 67 863 08	17	4	2 550	91 57 751 08	SA FRAME
WASHER RD22X3	95 35 616 08	22	40	1 630	91 52 387 08	HYDRAULIC SUPPORT
WASHER RD25X6 PA6G SCHW	28 81 831 08	6	6	2 520 031	96 45 610 08	REAR WINDOW PRE-ASS.
WASHER RD40X4	95 36 317 08	14	2	2 391 023	96 45 720 08	RADIATOR, PRE-ASSEMBLED
WASHER RD44X2	93 94 608 08	15	10	2 670	91 52 797 08	FUEL TANK CPL.
WASHER RD44X2	93 94 608 08	50	4	3 206	91 52 881 08	PIVOT SECTION
WASHER RD44X2	93 94 608 08	39	4	3 713	91 57 749 08	D PIVOT SECTION
WASHER RD50X2	95 51 616 08	44	2	3 281	91 52 896 08	ERECTION FRAME
WASHER RD60X2	94 87 177 08	3	1	3 282 002	96 47 890 08	FAB-STAY
WASHER RD60X5	94 10 097 08	10	8	3 227	91 52 873 08	L INTERMEDIATE SECTION
WASHER RD65X8	93 24 016 08	14	4	3 745	91 52 948 08	SUSPENDED BALLAST
WASHER RD70X2	94 91 885 08	17	4	2 631	91 56 817 08	SLEWING PLATFORM CATWAL
WASHER RD70X2	94 91 885 08	53	1	3 281	91 52 896 08	ERECTION FRAME
WASHER RD80X5	94 95 827 08	12	2	2 810	91 52 806 08	CRANE DRIVER'S CABIN CPL.
WATER BASIN 8,0L KUNSTST	10 03 697 7	10	1	2 520 032	96 45 980 08	WINDSHIELD WASHER INSTAL
WATER BLEEDER PIPELINE	97 39 127	170	1	X1012059	10 12 059 0	DIESEL ENGINE
WATER CONNECTION	97 39 276	173	1	X1012059	10 12 059 0	DIESEL ENGINE
WATER DRAIN PLUG PA6G SP	60 25 012 08	292	1	1 920 403	96 48 707 08	TERMINAL BOX CPL.
WATER DRAIN PLUG PA6G SP	60 25 012 08	292	1	1 920 417	96 48 703 08	TERMINAL BOX CPL.
WATER DRAIN PLUG PA6G SP	60 25 012 08	292	2	1 920 418	96 48 687 08	TERMINAL BOX CPL.
WATER DRAIN PLUG PA6G SP	60 25 012 08	292	1	2 780 748	96 52 969 08	TERMINAL BOX CPL.
WATER DRAIN PLUG PA6G SP	60 25 012 08	292	1	2 920 369	96 54 235 08	TERMINAL BOX CPL.
WATER DRAIN PLUG PA6G SP	60 25 012 08	292	2	2 920 448	96 48 794 08	TERMINAL BOX CPL.
WATER DRAIN PLUG PA6G SP	60 25 012 08	292	1	2 920 581	96 54 405 08	TERMINAL BOX WINCH PRE-A
WATER DRAIN PLUG PA6G SP	60 25 012 08	18	2	2 932 160	96 54 385 08	SWITCH CABINET
WATER DRAIN PLUG PA6G SP	60 25 012 08	285	2	3 930 363	96 52 979 08	TERMINAL BOX CPL.
WATER DRAIN PLUG PA6G SP	60 25 012 08	292	1	3 930 638	96 51 624 08	TERMINAL BOX
WATER DRAIN PLUG PA6G SP	60 25 012 08	285	1	3 930 640	96 50 481 08	TERMINAL BOX CPL.
WATER DRAIN PLUG PA6G SP	60 25 012 08	292	1	3 930 730	96 50 599 08	TERMINAL BOX CPL.
WATER DRAIN PLUG PA6G SP	60 25 012 08	285	2	3 930 730	96 54 398 08	TERMINAL BOX CPL.
WATER DRAIN PLUG PA6G SP	60 25 012 08	308	3	3 930 734	96 54 401 08	TERMINAL BOX
WATER HEATING SYSTEM 24	10 04 204 3	2	1	2 541 001	96 49 651 08	ADDNL.HEATING, PRE-ASSE
WATER PIPE	96 48 528 08	29	1	2 391 001	96 45 719 08	DIESEL ENGINE, PRE-ASSEMB
WATER SEPARATOR	70 27 481 03	7	1	2 391	91 52 784 08	DIESEL ENGINE CPL.
WATER SOUND WASSER	10 34 675 2	20	2	7 027 481	70 27 481 03	WATER SEPARATOR
WEIGHT 43X70X245 EN-GJS4	38 82 832 08	1	1	2 311 001	96 25 639 08	HOIST LIM.SWITCH PLUMMET
WEIGHT EN-GJS400-18 FE//ZN	38 82 831 08	2	1	2 311 001	96 25 639 08	HOIST LIM.SWITCH PLUMMET
WELD SOCKET DKO 10L	51 06 290 08	636	8	2 970	91 56 537 08	HYDR
WELD SOCKET DKO 10L	51 06 290 08	615	2	2 975 100	91 52 860 08	ADDITIONAL HYDRAULICS WI
WELD SOCKET DKO 10L	51 06 290 08	619	2	2 975 200	91 52 775 08	ADDITIONAL HYDRAULICS WI
WELD SOCKET DKO 10L	51 06 290 08	619	2	2 975 700	91 52 774 08	ADDITIONAL HYDRAULICS WI
WELD SOCKET DKO 10L	51 06 290 08	606	2	2 978 100	91 52 827 08	ADDNL.HYDR.RETAINING DEV
WELD SOCKET DKO 10L	51 06 290 08	633	1	2 978 200	91 54 843 08	ADD.HYDR.S_RETAINING RAM
WINCH 1	91 52 503 08	103	1		LR 1600-2-0	
WINCH 2	91 52 504 08	104	1		LR 1600-2-0	
WINCH 3	91 52 859 08	223	1		LR 1600-2-0	
WINCH 4 LUFFING GEAR	91 52 776 08	111	1		LR 1600-2-0	
WINCH BEARING	96 43 852 08	1	1	2 310	91 52 503 08	WINCH 1
WINCH BEARING	96 43 852 08	1	1	2 320	91 52 504 08	WINCH 2
WINCH BEARING	96 49 298 08	3	1	3 350	91 52 859 08	WINCH 3
WINCH REVOLUTION TRANS	10 04 047 7	5	1	2 920 200	96 44 536 08	ELECTRIC FOR WINCH 1
WINCH REVOLUTION TRANS	10 04 047 7	5	1	2 920 260	96 44 537 08	ELECTRIC FOR WINCH 2
WINCH REVOLUTION TRANS	10 04 047 7	5	1	2 920 334	96 44 538 08	ELECTRIC FOR WINCH 3
WINCH REVOLUTION TRANS	10 04 047 7	5	1	2 920 350	96 44 539 08	ELECTRIC FOR WINCH 4
WIND VELOCITY TRANSMITTE	10 42 954 9	6	1	3 780 751	91 52 952 08	AIR-CRAFT & WIND WARNING
WINDSHIELD WASHER INSTA	96 45 980 08	8	1	2 520	91 53 061 08	CABIN, GLAZED

6.2.2009

etk_en_de_074515 LR 1600/2

992

LIEBHERRAlphabetical index
Alphabetischer Index

Description	Item	Pos.	Quantity	Page	Assembly	Description
WIPER ARM	10 29 201 4	8	1	2 520 032	96 45 980 08	WINDSHIELD WASHER INSTAL
WIPER ARM PARALELL	10 41 288 1	5	1	2 520 032	96 45 980 08	WINDSHIELD WASHER INSTAL
WIPER BLADE 1000	10 29 201 7	6	1	2 520 032	96 45 980 08	WINDSHIELD WASHER INSTAL
WIPER BLADE 700	10 29 201 6	9	1	2 520 032	96 45 980 08	WINDSHIELD WASHER INSTAL
WIPER FRAME 10	10 41 287 9	7	1	2 520 032	96 45 980 08	WINDSHIELD WASHER INSTAL
WIPER FRAME 12	10 41 288 0	2	1	2 520 032	96 45 980 08	WINDSHIELD WASHER INSTAL
WIPER MOTOR 55NM 24V	10 29 202 1	1	2	2 520 032	96 45 980 08	WINDSHIELD WASHER INSTAL
WIRE BRAID 0,5	60 01 312 08	341	0.32	3 930 732	96 50 575 08	LEAD
WIRE BRAID 0,5	60 01 313 08	342	1	3 930 009	96 50 573 08	CABLE DRUM COMPL.
WIRE CLIP	61 10 461 08	22	36	2 932 001	96 45 393 08	RELAY CONTROL SYSTEM
WIRE RING RD30X4	93 06 259 08	6	2	1 632 032	96 20 093 08	SUPPORT PLATE COMPL.
WIRE ROPE CLAMP DIN 3093 2	77 39 200 08	63	18	2 631	91 56 817 08	SLEWING PLATFORM CATWAL
WIRE ROPE CLAMP DIN 3093 2	77 39 200 08	78	4	2 810	91 52 806 08	CRANE DRIVER'S CABIN CPL.
WIRE ROPE CLAMP DIN 3093 2	77 39 200 08	62	3	2 978 100	91 52 827 08	ADDNL.HYDR.RETAINING DEV
WIRE ROPE CLAMP DIN 3093 2	77 39 200 08	56	8	3 225	91 52 854 08	SL REDUCING SECTION
WIRE ROPE CLAMP DIN 3093 2	77 39 200 08	61	8	3 745	91 52 948 08	SUSPENDED BALLAST
WIRE ROPE CLAMP DIN 3093 2	77 39 200 08	62	3	3 978 005	91 56 430 08	ADDL.HYDRAULIC SB-HEAD PI
WIRED END FERRULE 0,5X6 V	60 23 078 08	114	3	2 920 633	96 52 651 08	WIRING HARNESS
WIRED END FERRULE 10X12 V	60 23 084 08	105	3	2 920 633	96 52 651 08	WIRING HARNESS
WIRED END FERRULE 16X12 V	60 23 085 08	104	1	2 920 633	96 52 651 08	WIRING HARNESS
WIRED END FERRULE 1X6 V	60 23 077 08	86	42	2 920 633	96 52 651 08	WIRING HARNESS
WIRED END FERRULE DIN 462	60 23 080 08	13	2	2 780 320	91 05 067 08	ACOUST.WARN. SLEWING G
WIRES CPL. S2	96 49 211 08	2	1	2 932 001	96 45 393 08	RELAY CONTROL SYSTEM
WIRES CPL. S3	96 48 313 08	3	1	2 932 001	96 45 393 08	RELAY CONTROL SYSTEM
WIRES PRE-ASS. +S1070	96 53 012 08	(2)	1	3 930 363	96 52 979 08	TERMINAL BOX CPL.
WIRES PRE-ASS. -S1000	96 50 483 08	(2)	1	3 930 640	96 50 481 08	TERMINAL BOX CPL.
WIRES PRE-ASS. -S1020	96 50 643 08	(2)	1	3 930 730	96 50 599 08	TERMINAL BOX CPL.
WIRES PRE-ASS. -S980	96 50 045 08	2	1	3 930 639	96 50 132 08	WIRES TERMINAL BOX CPL.
WIRES PRE-ASS. S1050	96 54 485 08	(2)	1	3 930 734	96 54 401 08	TERMINAL BOX
WIRES PRE-ASS. S1100	96 53 013 08	(2)	1	2 780 748	96 52 969 08	TERMINAL BOX CPL.
WIRES PRE-ASS. S2	96 49 212 08	(2)	1	2 932 001	96 45 393 08	RELAY CONTROL SYSTEM
WIRES PRE-ASS. S200	96 51 072 08	(2)	1	1 920 418	96 48 687 08	TERMINAL BOX CPL.
WIRES PRE-ASS. S3	96 49 209 08	(2)	1	2 932 001	96 45 393 08	RELAY CONTROL SYSTEM
WIRES TERMINAL BOX CPL. +	96 53 011 08	32	1	3 930 363	96 52 979 08	TERMINAL BOX CPL.
WIRES TERMINAL BOX CPL.	96 50 482 08	8	1	3 930 640	96 50 481 08	TERMINAL BOX CPL.
WIRES TERMINAL BOX CPL.	96 50 642 08	8	1	3 930 730	96 50 599 08	TERMINAL BOX CPL.
WIRES TERMINAL BOX CPL.	96 54 484 08	2	1	3 930 734	96 54 401 08	TERMINAL BOX
WIRES TERMINAL BOX CPL.	96 52 977 08	1	1	2 780 748	96 52 969 08	TERMINAL BOX CPL.
WIRES TERMINAL BOX CPL. S	96 48 693 08	1	1	1 920 418	96 48 687 08	TERMINAL BOX CPL.
WIRES TERMINAL BOX CPL. S	96 50 132 08	2	1	3 930 638	96 51 624 08	TERMINAL BOX
WIRING DUCT 80X60/83,5X66/	63 81 092 01	20	0.62	2 932 082	96 54 387 08	ASSEMBLY PARTS MOUNTIN
WIRING HARNESS FOR INJEC	10 22 067 0	230	1	X1012059	10 12 059 0	DIESEL ENGINE
WIRING HARNESS W1063	96 44 547 08	20	1	2 920 334	96 44 538 08	ELECTRIC FOR WINCH 3
WIRING HARNESS W200	96 48 688 08	2	1	1 920 418	96 48 687 08	TERMINAL BOX CPL.
WIRING HARNESS W220	96 48 750 08	3	1	1 920 403	96 48 707 08	TERMINAL BOX CPL.
WIRING HARNESS W223	96 48 749 08	2	1	1 920 403	96 48 707 08	TERMINAL BOX CPL.
WIRING HARNESS W225	96 49 121 08	1	1	1 920 403	96 48 707 08	TERMINAL BOX CPL.
WIRING HARNESS W240	96 48 748 08	3	1	1 920 417	96 48 703 08	TERMINAL BOX CPL.
WIRING HARNESS W243	96 48 747 08	2	1	1 920 417	96 48 703 08	TERMINAL BOX CPL.
WIRING HARNESS W245	96 49 120 08	1	1	1 920 417	96 48 703 08	TERMINAL BOX CPL.
WIRING HARNESS W300	96 49 100 08	10	1	2 533 065	96 48 364 08	CABLE LIST DRIVER'S CABIN
WIRING HARNESS W301	96 49 101 08	11	1	2 533 065	96 48 364 08	CABLE LIST DRIVER'S CABIN
WIRING HARNESS W302	96 49 102 08	12	1	2 533 065	96 48 364 08	CABLE LIST DRIVER'S CABIN
WIRING HARNESS W305	96 49 103 08	13	1	2 533 065	96 48 364 08	CABLE LIST DRIVER'S CABIN
WIRING HARNESS W309	96 49 030 08	15	1	2 533 065	96 48 364 08	CABLE LIST DRIVER'S CABIN
WIRING HARNESS W310	96 49 105 08	16	1	2 533 065	96 48 364 08	CABLE LIST DRIVER'S CABIN
WIRING HARNESS W339A	96 55 363 08	18	1	2 920 369	96 54 235 08	TERMINAL BOX CPL.
WIRING HARNESS W339B	96 55 364 08	19	1	2 920 369	96 54 235 08	TERMINAL BOX CPL.
WIRING HARNESS W360	96 49 106 08	17	1	2 533 065	96 48 364 08	CABLE LIST DRIVER'S CABIN
WIRING HARNESS W390	96 55 952 08	19	1	2 920 288	96 52 614 08	WIRING LIST F.SLEWING PLAT

6.2.2009

etk_en_de_074515 LR 1600/2

993

LIEBHERRAlphabetical index
Alphabetischer Index

Description	Item	Pos.	Quantity	Page	Assembly	Description
WIRING HARNESS W500	96 52 651 08	5	1	2 920 288	96 52 614 08	WIRING LIST F.SLEWING PLAT
WIRING HARNESS W501	96 50 161 08	15	1	2 920 536	96 48 317 08	WIRING LIST F.ELECTR.AGG
WIRING HARNESS W521	96 44 545 08	20	1	2 920 200	96 44 536 08	ELECTRIC FOR WINCH 1
WIRING HARNESS W522	96 44 546 08	20	1	2 920 260	96 44 537 08	ELECTRIC FOR WINCH 2
WIRING HARNESS W524	96 44 548 08	20	1	2 920 350	96 44 539 08	ELECTRIC FOR WINCH 4
WIRING HARNESS W551	96 57 094 08	20	1	2 920 288	96 52 614 08	WIRING LIST F.SLEWING PLAT
WIRING HARNESS W570	96 51 115 08	1	1	2 920 638	96 51 138 08	CONTROL DESK
WIRING HARNESS W587	96 51 118 08	16	1	2 920 536	96 48 317 08	WIRING LIST F.ELECTR.AGG
WIRING HARNESS W589	96 51 126 08	18	1	2 920 536	96 48 317 08	WIRING LIST F.ELECTR.AGG
WIRING HARNESS W590	96 51 127 08	19	1	2 920 536	96 48 317 08	WIRING LIST F.ELECTR.AGG
WIRING HARNESS W591	96 48 799 08	11	1	2 920 815	96 49 300 08	WIRING LIST BATTERY BOX
WIRING HARNESS W592	96 51 129 08	12	1	2 920 815	96 49 300 08	WIRING LIST BATTERY BOX
WIRING HARNESS W593	96 51 130 08	13	1	2 920 815	96 49 300 08	WIRING LIST BATTERY BOX
WIRING HARNESS W596	96 51 131 08	14	1	2 920 815	96 49 300 08	WIRING LIST BATTERY BOX
WIRING HARNESS W620	96 51 040 08	(20)	1	2 835	91 52 807 08	BATTERY CHARGER
WIRING HARNESS W621	96 51 039 08	(10)	1	2 835	91 52 807 08	BATTERY CHARGER
WIRING HARNESS W647	96 20 761 08	10	1	2 913 006	96 20 732 08	FAN PLATE PRE-ASS.
WIRING HARNESS W648	96 20 750 08	9	1	2 913 003	96 20 599 08	FOIL KEYPAD PRE-ASS.
WIRING HARNESS W693	96 51 119 08	(1)	1	2 780 908	91 52 958 08	EXTERNAL FEED
WIRING HARNESS W811	96 48 390 08	10	1	2 780 244	91 52 951 08	EMERGENCY CUT-OFF CRAN
WIRING LIST BATTERY BOX	96 49 300 08	10	1	2 920 083	96 48 319 08	ELECTRIC FOR BATTERY BOX
WIRING LIST F.ELECTR.AGGR	96 48 317 08	10	1	2 920 535	96 48 318 08	ELECTRIC F. AGGREGATE
WIRING LIST F.SLEWING PLA	96 52 614 08	15	1	2 920	91 56 833 08	ELECTR. SYSTEM F.SLEWING
WORK FLOODLIGHT	60 71 509 08	20	3	2 925 002	96 58 856 08	EQUIPMENT CAMERA SUPER
WORK FLOODLIGHT	60 71 509 08	(20)	1	2 925 218	91 60 840 08	CAMERA CONTROL WINCH 3
WORK FLOODLIGHT 2X70W 24	10 42 527 1	6	2	2 533 066	96 48 365 08	ELECTRIC ADD-ON PARTS CA
WORKING LAMP	60 71 040 08	24	1	1 750	91 52 394 08	TOOL

Bezeichnung	Artikel	Pos.	Menge	Seite	Baugruppe	Bezeichnung
ABDECKBLECH SCHWK.	96 50 215 08	46	2	2 502	91 55 939 08	STEUERSTAND
ABDECKHAUBE	10 65 300 5	18	1	X1002800	10 02 800 2	LEITUNGSTROMMEL
ABDECKKAPPE 28X30	59 15 709 08	77	2	2 520	91 53 061 08	KABINE VERGLAST
ABDECKUNG QC OBERRING	91 57 016 08	429	1		LR 1600-2-0	LIEBHERR RAUPENKRAN LR 1
ABDECKUNG QC OBERRING	97 38 049 08	1	1	2 790 451	91 57 016 08	ABDECKUNG
ABDECKUNG QC UNTERRING	91 57 017 08	430	1		LR 1600-2-0	LIEBHERR RAUPENKRAN LR 1
ABDECKUNG QC UNTERRING	97 38 043 08	1	1	1 790 503	91 57 017 08	ABDECKUNG
ABDECKUNG SCHWK.	96 49 873 08	2	1	2 520 033	96 50 633 08	MONITORKONSOLE
ABDICHTGUMMI	54 01 323 08	141	1	5 400 565	54 00 565 08	SEILWINDE
ABDICHTGUMMI	54 01 323 08	200	1	5 400 565	54 00 565 08	SEILWINDE
ABDICHTPROFIL 0 GUMMI 55°	97 75 057 08	11	1	2 932 160	96 54 385 08	SCHALTSCHRANK MECH.
ABDICHTPROFIL GUMMI	26 21 067 08	71	10	2 859	91 52 809 08	GERAEUSCHDAEMMUNG
ABGASENDROHR EDELSTAHL	10 43 036 9	7	1	2 392	91 52 785 08	SCHALLDAEMPFERANLAGE
ABGASFLANSCH ST	10 44 054 4	2	1	2 392	91 52 785 08	SCHALLDAEMPFERANLAGE
ABGASKRUEMMER	10 34 334 8	1	1	9 739 353	97 39 353	ABGASSTUTZEN
ABGASLEITUNG	10 01 240 0	7	1	9 739 358	97 39 358	ABGASRUECKFUEHRUNG AN
ABGASLEITUNG	10 22 237 3	4	1	9 739 358	97 39 358	ABGASRUECKFUEHRUNG AN
ABGASLEITUNG	10 22 237 6	10	1	9 739 358	97 39 358	ABGASRUECKFUEHRUNG AN
ABGASROHR	10 22 237 7	1	1	9 739 295	97 39 295	ABGASROHR
ABGASROHR	10 22 271 7	4	1	9 739 295	97 39 295	ABGASROHR
ABGASROHR	10 28 710 2	3	1	9 739 295	97 39 295	ABGASROHR
ABGASROHR	97 39 295	180	1	X1012059	10 12 059 0	DIESELMOTOR
ABGASROHR EDELSTAHL	10 43 037 0	4	1	2 392	91 52 785 08	SCHALLDAEMPFERANLAGE
ABGASROHR EDELSTAHL	10 43 037 1	6	2	2 392	91 52 785 08	SCHALLDAEMPFERANLAGE
ABGASROHR EDELSTAHL	10 43 037 2	5	1	2 392	91 52 785 08	SCHALLDAEMPFERANLAGE
ABGASRUECKFUEHRUNG AN	97 39 358	115	1	X1012059	10 12 059 0	DIESELMOTOR
ABGASRUECKFUEHRUNG VO	97 39 357	1	1	9 739 358	97 39 358	ABGASRUECKFUEHRUNG AN
ABGASSCHALLDAEMPFER	55 31 872 08	7	1	2 541 001	96 49 651 08	ZUSATZHEIZUNG VORM.
ABGASSCHLAUCH 38	55 30 541 08	6	2	2 541	91 52 790 08	ZUSATZHEIZUNG OW
ABGASSCHLAUCH 38	55 30 541 08	9	0.5	2 541 001	96 49 651 08	ZUSATZHEIZUNG VORM.
ABGASSTUTZEN	97 39 353	192	1	X1012059	10 12 059 0	DIESELMOTOR
ABGASTURBOLADER	10 47 688 6	1	1	9 739 494	97 39 494	ATL-ANBAU
ABLAGE SCHWK.	96 59 096 08	22	1	3 714 009	96 49 267 08	VERSTELLFLASCHE KPL.
ABLAGE SCHWK. FE//ZN20//C	96 50 494 08	14	2	3 227 002	96 50 498 08	STANGE KPL.
ABLASSHAHN	74 12 936	16	1	7 027 481	70 27 481 03	WASSERABSCHIEDER
ABLASSVENTIL	10 03 290 6	23	1	9 739 361	97 39 361	OELWANNE
ABREISSSTOPFEN M6	51 45 851 08	52	7	X1047219	10 47 219 6	REGLER
ABSCHALTVENTIL	57 15 140 08	3	1	X1065068	10 65 068 8	ANSCHLUSSPLATTE
ABSCHALTVENTIL	57 15 146 08	3	1	5 715 142	57 15 142 08	ANSCHLUSSPLATTE
ABSCHALTVENTIL	57 18 995 08	3	1	5 718 989	57 18 989 08	ANSCHLUSSPLATTE
ABSPANNSEIL 13M	97 69 999 08	1	2	3 207	91 53 433 08	F-ABSPANNUNG
ABSPERRORGAN DN125	73 00 043 08	19	1	2 671 004	96 46 305 08	OELBEHAELTER VORM.
ABSTANDSBOLZEN M3X13 ST	66 00 460 08	8	12	2 922 001	92 84 311 08	BUSPLATINE
ABSTANDSBOLZEN M3X4,7 S	10 03 021 0	12	10	2 913 005	96 20 731 08	INNENGEHAEUSE VORM.
ABSTANDSBOLZEN M3X4,7 S	10 03 021 0	12	2	2 913 005	96 28 696 08	INNENGEHAEUSE VORM.
ABSTANDSBOLZEN M3X5 ST	66 00 422 08	10	4	2 922 001	92 84 311 08	BUSPLATINE
ABSTANDSBOLZEN M3X6X12	66 00 428 08	9	4	2 922 001	92 84 311 08	BUSPLATINE
ABSTANDSBOLZEN M3X8 STA	10 00 924 4	11	2	2 913 005	96 20 731 08	INNENGEHAEUSE VORM.
ABSTANDSBOLZEN M3X8 STA	10 00 924 4	11	2	2 913 005	96 28 696 08	INNENGEHAEUSE VORM.
ABSTANDSBOLZEN M3X8 STA	10 00 924 4	5	2	2 913 006	96 20 732 08	LUEFTERBLECH VORM.
ABSTANDSBOLZEN M3X8 STA	10 00 924 4	8	2	2 913 007	96 20 763 08	CONTROLLEREINHEIT
ABSTANDSBOLZEN M4X30 V	60 20 178 08	23	1	2 522 011	96 45 602 08	SCHLIESSANLAGE
ABSTANDSBOLZEN M5X12 ST	66 00 429 08	11	1	2 922 001	92 84 311 08	BUSPLATINE
ABSTANDSBOLZEN M5X30	66 00 447 08	17	1	2 522	91 54 115 08	SCHIEBETUER KPL.
ABSTANDSBOLZEN M6X50 ST	10 35 526 6	43	1	2 520 034	96 45 984 08	INNENVERKLEIDUNG
ABSTANDSHALTER	96 47 596 08	2	1	3 205	91 52 880 08	F-MONTAGEEINHEIT
ABSTECKBOLZEN SCHWK.	96 43 771 08	21	2	3 211	91 57 748 08	S-ANLENKSTUECK
ABSTECKBOLZEN SCHWK.	96 43 771 08	15	8	3 220 500	91 52 849 08	S-ZWISCHENSTUECK
ABSTECKBOLZEN SCHWK.	96 43 771 08	9	8	3 221	91 54 668 08	S-ZWISCHENSTUECK
ABSTECKBOLZEN SCHWK.	96 43 771 08	15	8	3 223	91 52 852 08	S-ZWISCHENSTUECK

6.2.2009

etk_en_de_074515 LR 1600/2

995

LIEBHERRAlphabetical index
Alphabetischer Index

Bezeichnung	Artikel	Pos.	Menge	Seite	Baugruppe	Bezeichnung
ABSTECKBOLZEN SCHWK.	96 43 771 08	15	8	3 223 010	91 52 853 08	S-ZWISCHENSTUECK
ABSTECKBOLZEN SCHWK.	96 43 771 08	15	8	3 223 100	91 55 327 08	S-ZWISCHENSTUECK
ABSTECKBOLZEN SCHWK.	96 43 771 08	17	4	3 225	91 52 854 08	SL-REDUZIERSTUECK
ABSTECKBOLZEN SCHWK.	96 43 771 08	15	4	3 226	91 52 870 08	LI-ZWISCHENSTUECK
ABSTECKBOLZEN SCHWK.	96 43 771 08	15	8	3 227	91 52 873 08	LI-ZWISCHENSTUECK
ABSTECKBOLZEN SCHWK.	96 43 771 08	20	2	3 227 002	96 50 498 08	STANGE KPL.
ABSTECKBOLZEN SCHWK.	96 43 771 08	15	8	3 227 008	91 52 872 08	LI-ZWISCHENSTUECK
ABSTECKBOLZEN SCHWK.	96 43 771 08	15	10	3 227 200	91 53 519 08	LI-ZWISCHENSTUECK F-ABSP
ABSTECKBOLZEN SCHWK.	96 43 771 08	53	4	3 713	91 57 749 08	D-ANLENKSTUECK
ABSTECKBOLZEN SCHWK.	96 43 771 08	55	4	3 714	91 52 862 08	D-KOPFSTUECK
ABSTECKBOLZEN SCHWK.	96 43 771 08	4	8	3 715 008	91 52 863 08	D-ZWISCHENSTUECK
ABSTECKBOLZEN SCHWK.	96 43 771 08	4	10	3 716	91 52 864 08	D-ZWISCHENSTUECK
ABSTECKBOLZEN SCHWK. FE	96 47 595 08	12	1	3 211 003	96 46 986 08	STANGE KPL.
ABSTUETZBOCK SCHWK.	96 48 347 08	47	2	3 206	91 52 881 08	F-ANLENKSTUECK
ABSTUETZKONSOLE SCHWK.	96 51 181 08	49	1	2 810	91 52 806 08	KRANFUEHRERKABINE KPL.
ABSTUETZPLATTE	92 53 054 08	1	1	1 641 014	92 53 053 08	ABSTUETZPLATTE KPL.
ABSTUETZPLATTE KPL.	92 53 053 08	5	4	1 630	91 52 387 08	HYDRAULISCHE ABSTUETZUN
ABSTUETZPLATTE KPL.	96 20 093 08	5	2	1 632	91 52 389 08	MECH.ZUSATZABSTUETZUNG
ABSTUETZPLATTE SCHWK.	96 20 102 08	1	1	1 632 032	96 20 093 08	ABSTUETZPLATTE KPL.
ABSTUETZZYLINDER 190/160-	10 41 080 3	4	4	1 630	91 52 387 08	HYDRAULISCHE ABSTUETZUN
ABTRIEBSWELLE	92 76 334 01	10	1	9 697 916	96 97 916 01	DREHWERK
ACHSE 140.0X180 SPF	97 71 198 08	4	1	3 211 003	96 46 986 08	STANGE KPL.
ACHSE 150.0X2123 SPF	97 75 240 08	6	1	3 214	91 52 843 08	SW-KOPFSTUECK
ACHSE 150.0X445 35NICRMOV	97 68 035 08	19	17	1 400	91 56 853 08	RAUPENTRAEGER KPL.LI.
ACHSE 150.0X445 35NICRMOV	97 68 035 08	19	17	1 410 300	91 56 855 08	RAUPENTRAEGER KPL.RE.
ACHSE 16.0X76 FE//ZN20//C	97 79 659 08	3	1	2 550 008	96 47 628 08	HALTER KPL.
ACHSE 16.0X76 FE//ZN20//C	97 79 659 08	3	1	2 550 009	96 47 645 08	HALTER KPL.
ACHSE 219,1X40X245 SPF	95 66 984 08	3	1	3 225 100	96 48 582 08	LAGERUNG KPL.
ACHSE 219,1X40X245 SPF	95 66 984 08	3	1	3 281	91 52 896 08	FA-BOCK
ACHSE 219.1X1100 SPF	97 74 962 08	3	1	3 215 005	91 52 846 08	ROLLENSATZ
ACHSE 219.1X1272 SPF	97 74 817 08	3	1	3 215 006	91 52 847 08	ROLLENSATZ
ACHSE 219.1X140 SPF	97 76 746 08	3	1	3 714 021	96 49 271 08	ROLLENLAGERUNG KPL.
ACHSE 219.1X1612	97 69 807 08	3	1	2 652	91 52 794 08	ROLLENLAGERUNG
ACHSE 219.1X245	97 19 034 08	4	1	3 713	91 57 749 08	D-ANLENKSTUECK
ACHSE 219.1X487 SPF	97 76 908 08	32	1	3 714	91 52 862 08	D-KOPFSTUECK
ACHSE 219.1X870 SPF	97 71 893 08	10	1	3 208 001	91 52 883 08	F-KOPFSTUECK
ACHSE 220.0X2231 SPF	97 67 972 08	2	1	2 550	91 57 751 08	SA-BOCK
ACHSE 220.0X665 SPF	97 75 885 08	3	1	3 714 008	96 49 266 08	VERSTELLFLASCHE KPL.
ACHSE 220.0X745 SPF	97 76 225 08	4	1	3 714 009	96 49 267 08	VERSTELLFLASCHE KPL.
ACHSE 260.0X2407 SPF	97 76 838 08	12	1	3 714	91 52 862 08	D-KOPFSTUECK
ACHSE 30.0X200 S355J2G3C+	97 93 096 08	141	1	3 713	91 57 749 08	D-ANLENKSTUECK
ACHSE 30.0X530 ST37.0	97 71 968 08	15	1	3 208 001	91 52 883 08	F-KOPFSTUECK
ACHSE 40.0X1247	97 74 860 08	11	2	3 215 006	91 52 847 08	ROLLENSATZ
ACHSE 40.0X1446	97 71 244 08	3	1	3 211 008	96 46 978 08	SCHUTZWALZE KPL.
ACHSE 45.0X1392 S355J2G3	97 71 246 08	4	1	3 211 009	96 46 979 08	SCHUTZWALZE KPL.
ACHSE 50.0X100 SPF	97 80 226 08	7	1	2 550 008	96 47 628 08	HALTER KPL.
ACHSE 50.0X100 SPF	97 80 226 08	7	1	2 550 009	96 47 645 08	HALTER KPL.
ACHSE 50.0X910	97 71 953 08	13	1	3 208 001	91 52 883 08	F-KOPFSTUECK
ACHSE 55.0X292 SPF	97 48 730 08	18	2	1 400	91 56 853 08	RAUPENTRAEGER KPL.LI.
ACHSE 55.0X292 SPF	97 48 730 08	18	2	1 410 300	91 56 855 08	RAUPENTRAEGER KPL.RE.
ACHSE RD30X786	93 88 891 08	8	3	3 714 009	96 49 267 08	VERSTELLFLASCHE KPL.
ACHSE RD40X1650	95 63 347 08	(2)	1	3 350	91 52 859 08	WINDE 3
ACHSHALTER 10X140X40 S38	94 21 646 08	5	2	3 292	91 52 865 08	D-RUECKHALTESICHERUNG
ACHSHALTER 20X220X150 S96	97 76 161 08	11	2	3 214	91 52 843 08	SW-KOPFSTUECK
ACHSHALTER 25X50X290	94 83 965 08	23	17	1 400	91 56 853 08	RAUPENTRAEGER KPL.LI.
ACHSHALTER 25X50X290	94 83 965 08	23	17	1 410 300	91 56 855 08	RAUPENTRAEGER KPL.RE.
ACHSHALTER 6X20X80	94 13 244 08	11	2	3 211	91 57 748 08	S-ANLENKSTUECK
ACHSHALTER 6X20X80	94 13 244 08	13	4	3 350	91 52 859 08	WINDE 3
ACHSHALTER LN 4/11 6X40X1	99 70 411 01	10	2	3 211 009	96 46 979 08	SCHUTZWALZE KPL.
ADAPTER	96 51 859 08	(30)	1	2 925 026	91 55 259 08	ERG.KAMERAUEBERWACHUN

6.2.2009

etk_en_de_074515 LR 1600/2

996

LIEBHERRAlphabetical index
Alphabetischer Index

Bezeichnung	Artikel	Pos.	Menge	Seite	Baugruppe	Bezeichnung
ADAPTER	96 51 859 08	30	1	2 925 405	96 48 397 08	AUSRUESTUNG KAMERA KAB
ADAPTER 18POL SPF	66 00 245 08	24	1	2 932 082	96 54 387 08	AUFBAUTEILE MONTAGETAPE
ADAPTER KUNSTSTOFF	10 03 697 4	11	1	2 520 032	96 45 980 08	SCHEIBENWISCHANLAGE EIN
ADAPTER NACHARBEIT 42-LX3	97 90 338 08	15	1	2 970	91 56 537 08	HYDRAULIK
ADAPTER RI11/4-EDX1 A3P	47 55 018 08	770	2	2 970	91 56 537 08	HYDRAULIK
ADAPTER RI11/4-EDX3/4 A3P	47 55 014 08	780	2	2 970	91 56 537 08	HYDRAULIK
ADAPTER RI3/4-EDX1 A3P	47 55 020 08	764	2	2 970	91 56 537 08	HYDRAULIK
ADAPTERKARTE CF-PCMCIA	10 46 740 3	5	1	2 533 050	96 48 359 08	ELEKTRIK KABINE
ADERENDHUELSE 0,5X6 VER	60 23 078 08	114	3	2 920 633	96 52 651 08	KABELSTRANG
ADERENDHUELSE 10X12 VER	60 23 084 08	105	3	2 920 633	96 52 651 08	KABELSTRANG
ADERENDHUELSE 16X12 VER	60 23 085 08	104	1	2 920 633	96 52 651 08	KABELSTRANG
ADERENDHUELSE 1X6 VERZ	60 23 077 08	86	42	2 920 633	96 52 651 08	KABELSTRANG
ADERENDHUELSE DIN 46228 1	60 23 080 08	13	2	2 780 320	91 05 067 08	AKUSTISCHE WARNUNG DRE
AGGREGATETRAEGER SCH	96 46 563 08	50	1	2 391 001	96 45 719 08	DIESELMOTOR VORM.
AKUST.WARNUNG VERFAHRE	91 56 389 08	341	1		LR 1600-2-0	LIEBHERR RAUPENKRAN LR 1
AKUSTISCHE WARNUNG DRE	91 05 067 08	358	1		LR 1600-2-0	LIEBHERR RAUPENKRAN LR 1
ANBAUGEHAEUSE 16POL.	60 56 171 08	28	2	2 920 369	96 54 235 08	KLEMMKASTEN KPL.
ANBAUGEHAEUSE 16POL.	60 56 171 08	39	3	2 932 160	96 54 385 08	SCHALTSCHRANK MECH.
ANBAUGEHAEUSE 24POL.	60 56 172 08	32	1	2 920 369	96 54 235 08	KLEMMKASTEN KPL.
ANBAUGEHAEUSE 24POL.	60 56 172 08	20	6	2 920 448	96 48 794 08	KLEMMKASTEN KPL.
ANBAUGEHAEUSE 24POL.	60 56 172 08	38	8	2 932 160	96 54 385 08	SCHALTSCHRANK MECH.
ANBAUGEHAEUSE ALU/ZINK	10 47 566 6	28	1	2 932 160	96 54 385 08	SCHALTSCHRANK MECH.
ANBAUGEHAEUSE HAN 10 B	69 31 498 14	40	1	2 932 160	96 54 385 08	SCHALTSCHRANK MECH.
ANBAUTEILE	97 39 278	73	1	X1012059	10 12 059 0	DIESELMOTOR
ANBAUTEILE FREMDEINSPEIS	96 48 377 08	2	1	2 780 908	91 52 958 08	FREMDEINSPEISUNG
ANBAUTEILE LADEGERAET	96 48 379 08	4	1	2 835	91 52 807 08	BATTERIELADEGERAET
ANHAENGEKETTE 0,85M 3T	74 00 244 08	12	4	1 400	91 56 853 08	RAUPENTRAEGER KPL.LI.
ANHAENGEKETTE 0,85M 3T	74 00 244 08	12	4	1 410 300	91 56 855 08	RAUPENTRAEGER KPL.RE.
ANHAENGER 25X2	95 05 568 08	134	30	2 970	91 56 537 08	HYDRAULIK
ANHAENGER 25X2	95 05 568 08	66	5	2 975 100	91 52 860 08	ZUSATZHYDRAULIK WINDE 3
ANHAENGER 25X2	95 05 568 08	66	7	2 975 200	91 52 775 08	ZUSATZHYDRAULIK WINDE 2
ANHAENGER 25X2	95 05 568 08	66	7	2 975 700	91 52 774 08	ZUSATZHYDRAULIK WINDE 1
ANHAENGER 25X2	95 05 568 08	63	16	2 977	91 57 756 08	ZUSATZHYDRAULIK DREHBUE
ANHAENGER 25X2	95 05 568 08	66	5	2 977 200	91 55 149 08	ZUSATZHYDR.PUMPE 5/WIND
ANHAENGER 25X2	95 05 568 08	64	3	2 978 100	91 52 827 08	ZUSATZHYDR.D-RUECKHALT
ANHAENGER 25X2	95 05 568 08	64	4	2 978 200	91 54 843 08	ZUSATZHYDR.S-RUECKHALTE
ANHAENGER 25X2	95 05 568 08	64	3	3 978 005	91 56 430 08	ZUSATZHYDRAULIK SB-KOPFS
ANHAENGER 25X2	95 05 568 08	64	6	3 978 015	91 56 429 08	ZUSATZHYDRAULIK ZWISCH
ANHAENGER 25X2	95 05 568 08	64	6	3 978 015	91 56 432 08	ZUSATZHYDRAULIK ZWISCH
ANHAENGER 25X2	95 05 568 08	64	5	3 978 100	91 56 428 08	HYDR.SCHWEBEBALLAST-AN
ANLAUFSCHIEBE	10 01 211 7	7	2	9 739 102	97 39 102	KURBELWELLENLAGERUNG
ANLAUFSCHIEBE	10 01 211 8	71	2	9 739 102	97 39 102	KURBELWELLENLAGERUNG
ANLAUFSCHIEBE	10 01 212 0	72	2	9 739 102	97 39 102	KURBELWELLENLAGERUNG
ANSAUGROHR	96 47 510 08	9	1	2 671	91 52 798 08	OELBEHAELTER KPL.
ANSAUGSTUTZEN D 2876	10 03 716 3	1	1	9 739 209	97 39 209	ANSAUGSTUTZEN
ANSAUGSTUTZEN D 2876	97 39 209	112	1	X1012059	10 12 059 0	DIESELMOTOR
ANSCHLAG	51 07 457 08	29	1	5 113 086	51 13 086 08	PROPORTIONALVENTIL
ANSCHLAG 15X160X120 PA6	97 77 650 08	44	2	3 713	91 57 749 08	D-ANLENKSTUECK
ANSCHLAGMITTEL MONTAGE	91 57 283 08	148	1		LR 1600-2-0	LIEBHERR RAUPENKRAN LR 1
ANSCHLAGSCHEIBE ST	10 29 198 8	8	4	2 810	91 52 806 08	KRANFUEHRERKABINE KPL.
ANSCHLAGSEIL 22.5T-12.1M V	10 47 515 7	1	2	2 750 100	91 57 283 08	ANSCHLAGMITTEL MONTAGE
ANSCHLAGSEIL DIN 3088 7,7T-	77 33 137 08	39	4	1 750	91 52 394 08	WERKZEUG
ANSCHLAGSEIL EN 13414 2,7	10 43 004 8	48	1	3 281	91 52 896 08	FA-BOCK
ANSCHLAGSWINKEL	10 01 752 9	4	1	9 739 186	97 39 186	MOTORBREMSE
ANSCHLUSSBLOCK PSV4	96 40 276 08	1	1	5 133 090	51 13 090 08	WEGESCHIEBERBLOCK
ANSCHLUSSFLANSCH	51 10 561 08	41	1	2 975 200	91 52 775 08	ZUSATZHYDRAULIK WINDE 2
ANSCHLUSSFLANSCH	51 10 561 08	41	1	2 975 700	91 52 774 08	ZUSATZHYDRAULIK WINDE 1
ANSCHLUSSFLANSCH 85X85	51 10 624 08	126	1	2 970	91 56 537 08	HYDRAULIK
ANSCHLUSSFLANSCH ALZNM	51 10 623 08	40	1	2 975 100	91 52 860 08	ZUSATZHYDRAULIK WINDE 3
ANSCHLUSSKABEL 10 X 0,14	10 45 478 3	(11)	1	2 925 026	91 55 259 08	ERG.KAMERAUEBERWACHUN

6.2.2009

etk_en_de_074515 LR 1600/2

997

LIEBHERRAlphabetical index
Alphabetischer Index

Bezeichnung	Artikel	Pos.	Menge	Seite	Baugruppe	Bezeichnung
ANSCHLUSSKABEL 10 X 0,14	10 45 478 3	11	1	2 925 405	96 48 397 08	AUSRUESTUNG KAMERA KAB
ANSCHLUSSNIPPEL G 1/4" M1	57 17 230 08	3	1	5 123 682	51 23 682 08	MONTAGEZYLINDER
ANSCHLUSSPLATTE	10 65 068 8	3	1	X1035924	10 35 924 9	VERSTELLPUMPE
ANSCHLUSSPLATTE	51 06 295 08	63	1	2 970	91 56 537 08	HYDRAULIK
ANSCHLUSSPLATTE	51 06 318 08	56	3	2 970	91 56 537 08	HYDRAULIK
ANSCHLUSSPLATTE	51 10 583 08	6	1	2 975 000	91 57 881 08	ZUSATZHYDRAULIK MONTAGE
ANSCHLUSSPLATTE	57 07 719 08	4	1	5 102 306	51 02 306 08	HYDROMOTOR
ANSCHLUSSPLATTE	57 15 142 08	3	1	X1035924	10 35 924 1	VERSTELLPUMPE
ANSCHLUSSPLATTE	57 15 142 08	3	1	X1035924	10 35 924 2	VERSTELLPUMPE
ANSCHLUSSPLATTE	57 15 142 08	3	1	X1035925	10 35 925 0	VERSTELLPUMPE
ANSCHLUSSPLATTE	57 18 989 08	3	1	X1035924	10 35 924 6	VERSTELLPUMPE
ANSCHLUSSPLATTE	57 19 004 08	2	1	X1035924	10 35 924 7	VERSTELLPUMPE
ANSCHLUSSPLATTE	57 19 030 08	3	1	X1035924	10 35 924 3	VERSTELLPUMPE
ANSCHLUSSPLATTE	57 19 030 08	3	1	X1035924	10 35 924 4	VERSTELLPUMPE
ANSCHLUSSPLATTE	70 23 640	2	1	X1035924	10 35 924 8	VERSTELLPUMPE
ANSCHLUSSSTECKER	60 23 370 08	(153)	3	2 932 001	96 45 393 08	RELAISSTEUERUNG
ANSCHLUSSSTUECK	10 22 277 2	1	1	9 739 282	97 39 282	LECKOELLEITUNG
ANSCHLUSSSTUECK	57 00 734 08	12	1	5 114 320	51 14 320 08	VORSPANNVENTIL
ANSCHLUSSSTUECK M14X1,5/	77 43 832 08	17	8	1 711	91 52 392 08	ZENTRALSCHMIERUNG RAUP
ANSCHRAUBSCHARNIER	70 42 012 08	4	3	2 520 030	96 45 609 08	DACHSCHEIBE VORM.
ANSCHRAUBSCHARNIER	70 42 012 08	3	2	2 520 031	96 45 610 08	HECKSCHEIBE VORM.
ANSCHRAUBSCHARNIER	70 42 012 08	8	4	2 932 160	96 54 385 08	SCHALTSCHRANK MECH.
ANSTEUERGERAET	10 29 184 0	5	1	X1035924	10 35 924 3	VERSTELLPUMPE
ANSTEUERGERAET	10 29 184 0	5	1	X1035924	10 35 924 4	VERSTELLPUMPE
ANSTEUERGERAET	10 47 138 4	5	1	X1035924	10 35 924 6	VERSTELLPUMPE
ANSTEUERGERAET	57 19 113 08	5	1	X1035924	10 35 924 1	VERSTELLPUMPE
ANSTEUERGERAET	57 19 113 08	5	1	X1035924	10 35 924 2	VERSTELLPUMPE
ANTENNE	10 28 963 1	2	1	2 780 851	96 24 498 08	FUNKANTENNE VORM.
ANTENNE 145MM	76 24 428	11	1	2 533 066	96 48 365 08	ELEKTRIK ANBAUTEILE KABIN
ANTIRUTSCHBELAG 150X300	97 28 594 08	17	2	2 730	91 52 802 08	GRUNDPLATTE DREHBUEHNE
ANTRIEB	10 65 015 8	24	1	X1035411	10 35 411 4	HUBWINDE
ANTRIEBSFLANSCH	60 60 126 08	6	1	2 920 200	96 44 536 08	ELEKTRIK WINDE 1
ANTRIEBSFLANSCH	60 60 126 08	6	1	2 920 260	96 44 537 08	ELEKTRIK WINDE 2
ANTRIEBSFLANSCH	60 60 126 08	6	1	2 920 334	96 44 538 08	ELEKTRIK WINDE 3
ANTRIEBSFLANSCH	60 60 126 08	6	1	2 920 350	96 44 539 08	ELEKTRIK WINDE 4
ANTRIEBSHUELSE	57 17 272 08	5	1	5 400 565	54 00 565 08	SEILWINDE
ANTRIEBSRAD	10 22 275 2	5	1	9 739 278	97 39 278	ANBAUTEILE
ANTRIEBSTEILE M.SCHWINGU	97 39 341	31	1	X1012059	10 12 059 0	DIESELMOTOR
ARBEITSSCHEINWERFER	60 71 509 08	20	3	2 925 002	96 58 856 08	AUSRUESTUNG KAMERA DRE
ARBEITSSCHEINWERFER	60 71 509 08	(20)	1	2 925 218	91 60 840 08	KAMERAUEBERWACHUNG WI
ARBEITSSCHEINWERFER 2X	10 42 527 1	6	2	2 533 066	96 48 365 08	ELEKTRIK ANBAUTEILE KABIN
ARMATUREN ARMLEHNE LI.	96 48 370 08	1	1	2 533 060	96 48 368 08	ELEKTRIK ARMLEHNE LI.
ARMATUREN ARMLEHNE RE.	96 48 371 08	1	1	2 533 062	96 48 369 08	ELEKTRIK ARMLEHNE RE.
ARMATUREN RE.	96 48 363 08	5	1	2 533	91 52 789 08	ELEKTRIK KRANFUEHRERKAB
ARMATURENBRETT LINKS	97 74 575 08	1	1	2 533 061	96 48 370 08	ARMATUREN ARMLEHNE LI.
ARMATURENBRETT RECHTS	97 74 576 08	1	1	2 533 063	96 48 371 08	ARMATUREN ARMLEHNE RE.
ARMLEHNE 310ERGO	77 41 197 08	1	1	2 502 007	96 22 822 08	ARMLEHNE LINKS
ARMLEHNE 310ERGO	77 41 198 08	1	1	2 502 008	96 22 823 08	ARMLEHNE RECHTS
ARMLEHNE LINKS	96 22 822 08	5	1	2 502	91 55 939 08	STUERSTAND
ARMLEHNE RECHTS	96 22 823 08	6	1	2 502	91 55 939 08	STUERSTAND
ARMLEHNENAUFPLAGE	97 16 366 08	2	1	2 502 007	96 22 822 08	ARMLEHNE LINKS
ARMLEHNENAUFPLAGE	97 16 366 08	2	1	2 502 008	96 22 823 08	ARMLEHNE RECHTS
ASCHENBECHER KUNSTSTOF	10 29 199 7	33	1	2 520 034	96 45 984 08	INNENVERKLEIDUNG
ATL-ANBAU	97 39 494	190	1	X1012059	10 12 059 0	DIESELMOTOR
AUFBAUTEILE MONTAGETAPE	96 54 387 08	3	1	2 932	91 57 750 08	EINBAUTEILE SCHALTSCHRAN
AUFHAENGOESE	10 22 277 7	5	1	9 739 493	97 39 493	TRANSPORTVORRICHTUNG
AUFHAENGOESE	10 29 431 6	2	1	9 739 493	97 39 493	TRANSPORTVORRICHTUNG
AUFHAENGOESE	10 01 245 6	1	1	9 739 493	97 39 493	TRANSPORTVORRICHTUNG
AUFHAENGOESE	10 01 734 7	3	1	9 739 493	97 39 493	TRANSPORTVORRICHTUNG
AUFLAGE 1400X60 PA6G	97 66 612 08	28	2	3 220 500	91 52 849 08	S-ZWISCHENSTUECK

6.2.2009

etk_en_de_074515 LR 1600/2

998

LIEBHERR
 Alphabetical index
 Alphabetischer Index

Bezeichnung	Artikel	Pos.	Menge	Seite	Baugruppe	Bezeichnung
AUFLAGE 1400X60 PA6G	97 66 612 08	16	2	3 221	91 54 668 08	S-ZWISCHENSTUECK
AUFLAGE 1400X60 PA6G	97 66 612 08	28	2	3 223	91 52 852 08	S-ZWISCHENSTUECK
AUFLAGE 1400X60 PA6G	97 66 612 08	28	2	3 223 010	91 52 853 08	S-ZWISCHENSTUECK
AUFLAGE 1400X60 PA6G	97 66 612 08	28	2	3 223 100	91 55 327 08	S-ZWISCHENSTUECK
AUFLAGE 1400X60 PA6G	97 66 612 08	28	2	3 226	91 52 870 08	LI-ZWISCHENSTUECK
AUFLAGE 1400X60 PA6G	97 66 612 08	28	2	3 227	91 52 873 08	LI-ZWISCHENSTUECK
AUFLAGE 1400X60 PA6G	97 66 612 08	28	2	3 227 008	91 52 872 08	LI-ZWISCHENSTUECK
AUFLAGE 1400X60 PA6G	97 66 612 08	28	2	3 227 200	91 53 519 08	LI-ZWISCHENSTUECK F-ABSP
AUFLAGE 15X50X900 PA6G	28 81 951 08	71	2	2 550	91 57 751 08	SA-BOCK
AUFLAGE 15X60X1280 PA6G	28 81 537 08	55	1	3 211	91 57 748 08	S-ANLENKSTUECK
AUFLAGE 15X60X1318 PA6G	28 81 766 08	64	1	3 211	91 57 748 08	S-ANLENKSTUECK
AUFLAGE 15X60X980 PA6G	28 81 926 08	22	2	3 208 001	91 52 883 08	F-KOPFSTUECK
AUFLAGE 60X1270 PA6G	97 41 439 08	29	1	3 220 500	91 52 849 08	S-ZWISCHENSTUECK
AUFLAGE 60X1270 PA6G	97 41 439 08	29	2	3 223	91 52 852 08	S-ZWISCHENSTUECK
AUFLAGE 60X1270 PA6G	97 41 439 08	29	2	3 223 010	91 52 853 08	S-ZWISCHENSTUECK
AUFLAGE 60X1270 PA6G	97 41 439 08	29	2	3 223 100	91 55 327 08	S-ZWISCHENSTUECK
AUFLAGE 60X1270 PA6G	97 41 439 08	29	1	3 225	91 52 854 08	SL-REDUZIERSTUECK
AUFLAGE 60X1270 PA6G	97 41 439 08	29	1	3 226	91 52 870 08	LI-ZWISCHENSTUECK
AUFLAGE 60X1270 PA6G	97 41 439 08	29	2	3 227	91 52 873 08	LI-ZWISCHENSTUECK
AUFLAGE 60X1270 PA6G	97 41 439 08	29	2	3 227 008	91 52 872 08	LI-ZWISCHENSTUECK
AUFLAGE 60X1270 PA6G	97 41 439 08	29	2	3 227 200	91 53 519 08	LI-ZWISCHENSTUECK F-ABSP
AUFLAGE 60X1270 PA6G	97 41 439 08	57	3	3 713	91 57 749 08	D-ANLENKSTUECK
AUFLAGE 60X1270 PA6G	97 41 439 08	51	6	3 714	91 52 862 08	D-KOPFSTUECK
AUFLAGE 60X1270 PA6G	97 41 439 08	24	4	3 715 008	91 52 863 08	D-ZWISCHENSTUECK
AUFLAGE 60X1270 PA6G	97 41 439 08	24	5	3 716	91 52 864 08	D-ZWISCHENSTUECK
AUFLAGE 60X1520 PA6G	97 41 438 08	39	2	3 225	91 52 854 08	SL-REDUZIERSTUECK
AUFLAGE KPL.	96 50 752 08	38	2	3 714	91 52 862 08	D-KOPFSTUECK
AUFLAGE SCHWK.	92 69 017 08	30	4	3 713	91 57 749 08	D-ANLENKSTUECK
AUFLAGE SCHWK.	92 85 715 08	46	2	3 211	91 57 748 08	S-ANLENKSTUECK
AUFLAGE SCHWK.	96 50 763 08	1	1	3 714 017	96 50 752 08	AUFLAGE KPL.
AUFLAGEBOCK	60 27 360 08	261	2	2 920 581	96 54 405 08	KLEMMKASTEN SA-BOCK VO
AUFLAGEBOCK	60 27 360 08	158	2	3 930 640	96 50 481 08	KLEMMKASTEN KPL.
AUFLAGEBOCK	60 27 360 08	271	2	3 930 730	96 50 599 08	KLEMMKASTEN KPL.
AUFLAGEBOCK	60 27 360 08	274	2	3 930 730	96 54 398 08	KLEMMKASTEN KPL.
AUFLAGEBOCK	60 27 360 08	205	2	3 930 734	96 54 401 08	KLEMMKASTEN
AUFNAHME VORM.	96 23 819 08	26	1	2 925 402	96 58 855 08	KAMERAANBAU DREHBUEHN
AUFSTIEG ALUMINIUM	97 70 589 08	3	2	1 631 100	91 52 388 08	LAUFSTEG RAUPENFAHRWER
AUFSTIEG VORM.	96 54 406 08	52	1	2 631	91 56 817 08	LAUFSTEG DREHBUEHNE
AUFSTIEGSTRIIT 2X40X400X1	78 89 017 08	64	2	2 810	91 52 806 08	KRANFUEHRERKABINE KPL.
AUFSTIEGSTRIIT 400X210X40	10 47 603 1	71	1	2 810	91 52 806 08	KRANFUEHRERKABINE KPL.
AUGENSCHRAUBE DIN 444 M1	10 34 328 5	19	1	9 739 371	97 39 371	KLIMAKOMPRESSOR ANBAU
AUGENSCHRAUBE DIN 444 M1	10 34 328 8	13	1	9 739 344	97 39 344	GENERATOR VORM.
AUSGLEICHSBEHAELTER	50 28 065 08	7	1	2 978 100	91 52 796 08	ZUSATZHYDR.MONTAGEEINR
AUSGLEICHSBEHAELTER	50 28 065 08	12	1	2 978 100	91 52 827 08	ZUSATZHYDR.D-RUECKHALT
AUSGLEICHSBEHAELTER	50 28 065 08	12	1	2 978 200	91 54 843 08	ZUSATZHYDR.S-RUECKHALTE
AUSGLEICHSBEHAELTER	50 28 073 08	12	2	1 970	91 56 958 08	HYDRAULIK RAUPE
AUSGLEICHSBEHAELTER	50 28 073 08	50	1	2 970	91 56 537 08	HYDRAULIK
AUSGLEICHSBEHAELTER	50 28 073 08	9	1	2 975 100	91 52 860 08	ZUSATZHYDRAULIK WINDE 3
AUSGLEICHSBEHAELTER	50 28 073 08	9	1	2 975 200	91 52 775 08	ZUSATZHYDRAULIK WINDE 2
AUSGLEICHSBEHAELTER	50 28 073 08	9	1	2 975 700	91 52 774 08	ZUSATZHYDRAULIK WINDE 1
AUSGLEICHSBEHAELTER	50 28 073 08	9	1	3 978 005	91 56 430 08	ZUSATZHYDRAULIK SB-KOPFS
AUSGLEICHSBEHAELTER	57 00 659 08	1	1	5 028 065	50 28 065 08	AUSGLEICHSBEHAELTER
AUSGLEICHSBLECH FE//ZN20//	96 49 841 08	26	2	2 502	91 55 939 08	STUERSTAND
AUSGLEICHSSCHEIBE	51 07 832 08	17	1	5 114 176	51 14 176 08	DRUCKBEGRENZUNGSVENTI
AUSGLEICHSSCHEIBE	51 07 832 08	17	1	5 114 177	51 14 177 08	DRUCKBEGRENZUNGSVENTI
AUSLASSVENTIL	10 22 234 8	2	2	9 739 261	97 39 261	ZYLINDERKOPF
AUSLAUFSCHLAUCH DN65X5X	97 72 148 08	11	1	2 671 004	96 46 305 08	OELBEHAELTER VORM.
AUSRUESTUNG KAMERA DRE	96 58 856 08	10	1	2 925 007	91 60 728 08	KAMERAUEBERWACHUNG
AUSRUESTUNG KAMERA KAB	96 48 397 08	20	1	2 925 007	91 60 728 08	KAMERAUEBERWACHUNG
AUSSENGRIFF	10 42 458 2	2	1	2 522 011	96 45 602 08	SCHLIESSANLAGE

6.2.2009

etk_en_de_074515 LR 1600/2

999

LIEBHERRAlphabetical index
Alphabetischer Index

Bezeichnung	Artikel	Pos.	Menge	Seite	Baugruppe	Bezeichnung
AUSSTELLGRIFF KUNSTSTOF	10 29 202 3	2	1	2 520 031	96 45 610 08	HECKSCHEIBE VORM.
AUSSTROEMDUESE D=82MM	55 31 932 08	36	9	2 520 034	96 45 984 08	INNENVERKLEIDUNG
BALLASTPALETTE SCHWK.	96 49 614 08	1	1	3 745	91 52 948 08	SCHWEBEBALLAST
BANDSCHELLE 19X12	10 02 307 6	5	2	9 739 127	97 39 127	WASSERENTLUEFTUNGSLEIT
BATTERIE EN 50342 12V 170A	10 11 258 4	15	2	2 920 083	96 48 319 08	ELEKTRIK BATTERIEKASTEN
BATTERIEKABEL 16	60 04 916 08	(329)	2.6	2 920 288	96 52 614 08	KABELLISTE DREHBUEHNE
BATTERIEKABEL 50	60 04 912 08	(331)	1.4	2 920 815	96 49 300 08	KABELLISTE BATTERIEKASTE
BATTERIEKABEL DIN 72551 95	60 04 918 08	(333)	11	2 920 536	96 48 317 08	KABELLISTE ELEKTRIK AGG
BATTERIEKABEL DIN 72551 95	60 04 918 08	(333)	1	2 920 536	96 48 317 08	KABELLISTE ELEKTRIK AGG
BATTERIEKABEL DIN 72551 95	60 04 918 08	(333)	0.9	2 920 815	96 49 300 08	KABELLISTE BATTERIEKASTE
BATTERIEKABEL DIN 72551 95	60 04 918 08	(333)	2	2 920 815	96 49 300 08	KABELLISTE BATTERIEKASTE
BATTERIEKABEL DIN 72551 95	60 04 918 08	(333)	0.16	2 920 815	96 49 300 08	KABELLISTE BATTERIEKASTE
BATTERIEKASTEN SCHWK. SP	96 34 249 08	1	1	2 260 006	96 46 501 08	BATTERIEKASTEN VORM.
BATTERIEKASTEN VORM.	96 46 501 08	1	1	2 260	91 53 057 08	BATTERIELAGERUNG
BATTERIEKLEMME MINUS VER	61 32 066 08	19	2	2 920 083	96 48 319 08	ELEKTRIK BATTERIEKASTEN
BATTERIEKLEMME PLUS VER	61 32 065 08	18	2	2 920 083	96 48 319 08	ELEKTRIK BATTERIEKASTEN
BATTERIELADEGERAET 230V	91 52 807 08	156	1		LR 1600-2-0	LIEBHERR RAUPENKRAN LR 1
BATTERIELAGERUNG	91 53 057 08	126	1		LR 1600-2-0	LIEBHERR RAUPENKRAN LR 1
BAUGRUPPENTRAEGER 56TE	91 23 538 08	1	1	2 932 122	96 45 394 08	LICCON MONTAGEEINHEIT
BEDIENKONSOLE	96 46 505 08	2	1	2 533 070	96 48 363 08	ARMATUREN RE.
BEDIENPULT A570	96 51 138 08	1	1	2 920 637	96 51 136 08	BEDIENPULT
BEDIENPULT DB	96 51 136 08	28	1	2 920	91 56 833 08	ELEKTRIK DREHBUEHNE
BEFESTIGUNG	10 22 273 8	9	1	9 739 248	97 39 248	EINSPRITZDUESE
BEFESTIGUNGSBAND	54 01 368 08	42	1.7	X1065015	10 65 015 5	GETRIEBE
BEFESTIGUNGSMATERIAL	10 65 040 3	49	1	X1029200	10 29 200 4	FAHRERSITZ
BEFESTIGUNGSMATERIAL	96 56 483 08	1	1	3 780 258	96 56 482 08	ELEKTRIK FLUGWARNSICHER
BEFESTIGUNGSMUTTER M16X	60 20 422 08	18	4	2 533 070	96 48 363 08	ARMATUREN RE.
BEFESTIGUNGSMUTTER M16X	60 20 422 08	32	1	2 932 001	96 45 393 08	RELAISSTEUERUNG
BEFESTIGUNGSOBERTEIL 52	72 58 100 08	26	4	2 831	91 57 754 08	KLIMAAANLAGE OW
BEFESTIGUNGSSCHELLE	55 31 352 08	1	1	5 530 545	55 30 545 08	UMWAE LZPUMPE
BEFESTIGUNGSSCHELLE	57 00 664 08	7	1	5 028 065	50 28 065 08	AUSGLEICHSBEHAELTER
BEFESTIGUNGSSCHELLE 15,9	60 20 043 08	15	1	2 920 535	96 48 318 08	ELEKTRIK AGGREGAT
BEFESTIGUNGSSTUECK KUN	78 89 018 08	19	4	2 370	91 52 782 08	MONTAGEWINDE
BEFESTIGUNGSSTUECK KUN	78 89 018 08	70	12	2 810	91 52 806 08	KRANFUEHRERKABINE KPL.
BEFESTIGUNGSTEILE ANBAU	97 39 366	229	1	X1012059	10 12 059 0	DIESELMOTOR
BEFESTIGUNGSTEILE DREH	91 52 386 08	13	1		LR 1600-2-0	LIEBHERR RAUPENKRAN LR 1
BEFESTIGUNGSTEILE ELEKT	96 48 328 08	40	1	2 920	91 56 833 08	ELEKTRIK DREHBUEHNE
BEHAELTER 2,5 KG	10 03 827 1	25	1	7 743 566	77 43 566 08	ELEKTROPUMPE
BEHAELTERABDECKKAPPE	10 40 981 7	21	1	7 743 566	77 43 566 08	ELEKTROPUMPE
BEHAELTERSTOPFEN	57 00 662 08	4	1	5 028 065	50 28 065 08	AUSGLEICHSBEHAELTER
BELUEFTUNGSFILTER	51 06 673 08	3	1	2 671 004	96 46 305 08	OELBEHAELTER VORM.
BESTUECKUNGSMODUL	60 27 923 08	1	1	2 932 515	96 45 911 08	BESTUECKUNGSMODUL
BESTUECKUNGSMODUL	96 45 911 08	51	1	2 932 082	96 54 387 08	AUFBAUTEILE MONTAGETAPE
BESTUECKUNGSMODUL 2	96 48 302 08	(152)	1	1 920 418	96 48 687 08	KLEMMKASTEN KPL.
BESTUECKUNGSMODUL 2	96 48 302 08	(152)	1	2 780 748	96 52 969 08	KLEMMKASTEN KPL.
BESTUECKUNGSMODUL 2	96 48 302 08	(152)	1	3 930 363	96 52 979 08	KLEMMKASTEN KPL.
BESTUECKUNGSMODUL 2	96 48 302 08	156	1	3 930 639	96 50 132 08	DRAEHTE KLEMMKASTEN KPL
BESTUECKUNGSMODUL 2	96 48 302 08	(156)	1	3 930 640	96 50 481 08	KLEMMKASTEN KPL.
BESTUECKUNGSMODUL 2	96 48 302 08	(504)	1	3 930 730	96 50 599 08	KLEMMKASTEN KPL.
BETAETIGUNG	10 65 048 4	29	1	X1029200	10 29 200 4	FAHRERSITZ
BETAETIGUNGSDORN	70 42 534 08	15	4	2 260 006	96 46 501 08	BATTERIEKASTEN VORM.
BETAETIGUNGSDORN	70 42 534 08	5	4	2 393 002	96 46 782 08	DECKEL KPL.
BETAETIGUNGSDORN	70 42 534 08	6	7	2 859 005	96 46 756 08	KLAPPE VORM.
BETAETIGUNGSDORN	70 42 534 08	5	4	2 859 007	96 46 775 08	DECKEL KPL.
BETAETIGUNGSDORN	70 42 534 08	11	4	2 859 025	96 46 757 08	GITTERROST VORM.
BETAETIGUNGSDORN	70 42 534 08	5	4	2 859 026	96 46 776 08	DECKEL KPL.
BETAETIGUNGSDORN	70 42 534 08	5	4	2 859 027	96 46 777 08	DECKEL KPL.
BETAETIGUNGSDORN	70 42 534 08	5	4	2 859 028	96 46 778 08	DECKEL KPL.
BETAETIGUNGSDORN	70 42 534 08	5	4	2 859 029	96 46 779 08	DECKEL KPL.
BETAETIGUNGSDORN	70 42 534 08	10	2	2 859 030	96 46 758 08	DECKEL KPL.

6.2.2009

etk_en_de_074515 LR 1600/2

1000

LIEBHERRAlphabetical index
Alphabetischer Index

Bezeichnung	Artikel	Pos.	Menge	Seite	Baugruppe	Bezeichnung
BETAETIGUNGSDORN	70 42 534 08	2	6	2 932 168	96 48 167 08	DECKEL KPL.
BETAETIGUNGSEINHEIT	57 13 664 08	95	1	X1065015	10 65 015 8	ANTRIEB
BETRIEBSSTUNDENZAEHLER	69 18 022 08	57	1	2 932 082	96 54 387 08	AUFBAUTEILE MONTAGETAPE
BETRIEBSSTUNDENZAEHLER	69 17 985 08	3	1	2 533 067	96 50 385 08	BLECH VORM.
BEZEICHNUNGSSCHILD 20X8	60 27 614 08	12	10	2 932 166	92 68 911 08	VERTEILER MASSE
BEZEICHNUNGSSCHILD 25,4X	60 27 601 08	1	2	1 976 050	96 50 707 08	SCHLAUCHLEITUNGEN RAUP
BEZEICHNUNGSSCHILD 25,4X	60 27 601 08	1	15	1 997	91 52 512 08	SCHLAUCHLEITUNGEN RAUP
BEZEICHNUNGSSCHILD 25,4X	60 27 601 08	(1)	1	2 393	91 52 787 08	LUFTFILTERANLAGE KPL.
BEZEICHNUNGSSCHILD 25,4X	60 27 601 08	(1)	6	2 831	91 57 754 08	KLIMAAANLAGE OW
BEZEICHNUNGSSCHILD 25,4X	60 27 601 08	(1)	4	2 970 081	96 50 495 08	ZUSATZHYDR.BOLZENZIEHZ
BEZEICHNUNGSSCHILD 25,4X	60 27 601 08	1	9	2 975 061	96 47 201 08	SCHLAUCHLEITUNGEN WIND
BEZEICHNUNGSSCHILD 25,4X	60 27 601 08	1	9	2 975 118	96 47 200 08	SCHLAUCHLEITUNGEN WIND
BEZEICHNUNGSSCHILD 25,4X	60 27 601 08	1	11	2 975 154	96 50 585 08	SCHLAUCHLEITUNGEN WIND
BEZEICHNUNGSSCHILD 25,4X	60 27 601 08	1	4	2 975 191	96 48 196 08	SCHLAUCHLEITUNGEN MONT
BEZEICHNUNGSSCHILD 25,4X	60 27 601 08	(1)	2	2 976 203	92 27 489 08	ZUSATZHYDR.BOLZENZIEHZ
BEZEICHNUNGSSCHILD 25,4X	60 27 601 08	1	6	2 976 204	96 47 202 08	SCHLAUCHLEITUNGEN 2 DR
BEZEICHNUNGSSCHILD 25,4X	60 27 601 08	1	1	2 976 701	96 47 196 08	SCHLAUCHLEITUNGEN PUM
BEZEICHNUNGSSCHILD 25,4X	60 27 601 08	1	1	2 977 005	96 48 195 08	SCHLAUCHLEITUNGEN ZUSA
BEZEICHNUNGSSCHILD 25,4X	60 27 601 08	1	2	2 977 201	96 48 618 08	SCHLAUCHLEITUNGEN PUMP
BEZEICHNUNGSSCHILD 25,4X	60 27 601 08	1	2	2 978 101	96 47 912 08	SCHLAUCHLEITUNGEN MONT
BEZEICHNUNGSSCHILD 25,4X	60 27 601 08	1	6	2 978 107	96 50 433 08	SCHLAUCHLEITUNGEN D-RU
BEZEICHNUNGSSCHILD 25,4X	60 27 601 08	1	6	2 978 204	96 47 114 08	SCHLAUCHLEITUNGEN S-RU
BEZEICHNUNGSSCHILD 25,4X	60 27 601 08	1	119	2 997	91 56 539 08	SCHLAUCHLEITUNGEN OBER
BEZEICHNUNGSSCHILD 25,4X	60 27 601 08	1	6	3 978 009	96 50 881 08	SCHLAUCHLEITUNGEN D-KO
BEZEICHNUNGSSCHILD 25,4X	60 27 601 08	(1)	1	3 978 015	91 56 429 08	ZUSATZHYDRAULIK ZWISCH
BEZEICHNUNGSSCHILD 25,4X	60 27 601 08	1	1	3 978 016	96 50 878 08	SCHLAUCHLEITUNGEN ZWIS
BEZEICHNUNGSSCHILD 25,4X	60 27 601 08	1	3	3 978 018	96 50 880 08	SCHLAUCHLEITUNGEN ZUGZY
BEZEICHNUNGSSCHILD 25,4	60 27 623 08	(980)	2	2 533 070	96 48 363 08	ARMATUREN RE.
BEZEICHNUNGSSCHILD 25,4X	60 27 603 08	(1)	8	1 975 006	91 52 509 08	ZUSATZHYDR.ABSTUETZZYL
BEZEICHNUNGSSCHILD 25,4X	60 27 603 08	2	6	1 976 050	96 50 707 08	SCHLAUCHLEITUNGEN RAUP
BEZEICHNUNGSSCHILD 25,4X	60 27 603 08	2	33	1 997	91 52 512 08	SCHLAUCHLEITUNGEN RAUP
BEZEICHNUNGSSCHILD 25,4X	60 27 603 08	2	8	2 975 154	96 50 585 08	SCHLAUCHLEITUNGEN WIND
BEZEICHNUNGSSCHILD 25,4X	60 27 603 08	2	1	2 975 191	96 48 196 08	SCHLAUCHLEITUNGEN MONT
BEZEICHNUNGSSCHILD 25,4X	60 27 603 08	2	6	2 976 204	96 47 202 08	SCHLAUCHLEITUNGEN 2 DR
BEZEICHNUNGSSCHILD 25,4X	60 27 603 08	2	4	2 976 701	96 47 196 08	SCHLAUCHLEITUNGEN PUM
BEZEICHNUNGSSCHILD 25,4X	60 27 603 08	2	7	2 977 005	96 48 195 08	SCHLAUCHLEITUNGEN ZUSA
BEZEICHNUNGSSCHILD 25,4X	60 27 603 08	2	5	2 977 201	96 48 618 08	SCHLAUCHLEITUNGEN PUMP
BEZEICHNUNGSSCHILD 25,4X	60 27 603 08	2	4	2 978 101	96 47 912 08	SCHLAUCHLEITUNGEN MONT
BEZEICHNUNGSSCHILD 25,4X	60 27 603 08	2	6	2 978 107	96 50 433 08	SCHLAUCHLEITUNGEN D-RU
BEZEICHNUNGSSCHILD 25,4X	60 27 603 08	2	4	2 978 204	96 47 114 08	SCHLAUCHLEITUNGEN S-RU
BEZEICHNUNGSSCHILD 25,4X	60 27 603 08	2	117	2 997	91 56 539 08	SCHLAUCHLEITUNGEN OBER
BEZEICHNUNGSSCHILD 25,4X	60 27 603 08	2	6	3 978 009	96 50 881 08	SCHLAUCHLEITUNGEN D-KO
BEZEICHNUNGSSCHILD 25,4X	60 27 603 08	(2)	2	3 978 015	91 56 429 08	ZUSATZHYDRAULIK ZWISCH
BEZEICHNUNGSSCHILD 25,4X	60 27 603 08	2	2	3 978 016	96 50 878 08	SCHLAUCHLEITUNGEN ZWIS
BEZEICHNUNGSSCHILD 25,4X	60 27 603 08	2	1	3 978 018	96 50 880 08	SCHLAUCHLEITUNGEN ZUGZY
BEZEICHNUNGSSCHILD 25,4X	60 27 603 08	(1)	2	3 978 100	91 56 428 08	HYDR.SCHWEBEBALLAST-AN
BEZEICHNUNGSSCHILD 70X4	10 28 812 1	980	1	2 913 200	96 47 216 08	LICCON KONSOLE LCD3
BEZEICHNUNGSSTREIFEN	60 27 629 08	19	1	2 932 082	96 54 387 08	AUFBAUTEILE MONTAGETAPE
BLECH 1.5X100X100	93 97 306 08	14	7	3 225	91 52 854 08	SL-REDUZIERSTUECK
BLECH 1.5X112X30	97 29 400 08	102	4	2 932 082	96 54 387 08	AUFBAUTEILE MONTAGETAPE
BLECH 1.5X1132X447	97 85 999 08	72	1	2 810	91 52 806 08	KRANFUEHRERKABINE KPL.
BLECH 1.5X1140X231	97 23 317 08	6	1	2 260 006	96 46 501 08	BATTERIEKASTEN VORM.
BLECH 1.5X1216X544	97 23 263 08	1	1	2 391 036	96 23 055 08	DECKEL VORM.
BLECH 1.5X131X10	97 73 326 08	3	1	2 522	91 54 115 08	SCHIEBETUER KPL.
BLECH 1.5X1489X232	97 70 814 08	36	1	2 859	91 52 809 08	GERAEUSCHDAEMMUNG
BLECH 1.5X1577X366	97 71 093 08	1	1	2 260 009	96 46 972 08	KLAPPE VORM.
BLECH 1.5X158X338	97 29 623 08	103	1	2 932 082	96 54 387 08	AUFBAUTEILE MONTAGETAPE
BLECH 1.5X175X115	97 60 941 08	53	1	2 520 034	96 45 984 08	INNENVERKLEIDUNG
BLECH 1.5X1770X169	97 70 811 08	34	1	2 859	91 52 809 08	GERAEUSCHDAEMMUNG
BLECH 1.5X1812X294	97 71 096 08	11	1	2 260	91 53 057 08	BATTERIELAGERUNG

6.2.2009

etk_en_de_074515 LR 1600/2

1001

LIEBHERRAlphabetical index
Alphabetischer Index

Bezeichnung	Artikel	Pos.	Menge	Seite	Baugruppe	Bezeichnung
BLECH 1.5X191X111	97 26 606 08	105	2	2 932 082	96 54 387 08	AUFBAUTEILE MONTAGETAPE
BLECH 1.5X212X345	97 73 925 08	107	1	2 932 082	96 54 387 08	AUFBAUTEILE MONTAGETAPE
BLECH 1.5X219X84	97 75 001 08	34	1	2 391 001	96 45 719 08	DIESELMOTOR VORM.
BLECH 1.5X219X84	97 77 539 08	46	1	2 391 001	96 45 719 08	DIESELMOTOR VORM.
BLECH 1.5X240X140	97 75 937 08	1	1	2 533 068	96 49 314 08	STECKDOSEN VORM.
BLECH 1.5X2576X755	97 71 095 08	10	1	2 260	91 53 057 08	BATTERIELAGERUNG
BLECH 1.5X272X796	97 14 053 08	108	1	2 932 082	96 54 387 08	AUFBAUTEILE MONTAGETAPE
BLECH 1.5X283X325	97 75 696 08	106	1	2 932 082	96 54 387 08	AUFBAUTEILE MONTAGETAPE
BLECH 1.5X287X160	97 75 148 08	1	1	2 533 067	96 50 385 08	BLECH VORM.
BLECH 1.5X326X40	97 70 936 08	2	2	2 859 007	96 46 775 08	DECKEL KPL.
BLECH 1.5X336X134	97 28 092 08	27	2	2 932 160	96 54 385 08	SCHALTSCHRANK MECH.
BLECH 1.5X389X269	97 76 699 08	6	1	2 533 070	96 48 363 08	ARMATUREN RE.
BLECH 1.5X399X35	97 75 662 08	101	2	2 932 082	96 54 387 08	AUFBAUTEILE MONTAGETAPE
BLECH 1.5X471X90	97 71 634 08	2	2	2 393 002	96 46 782 08	DECKEL KPL.
BLECH 1.5X486X140	97 76 595 08	2	1	2 541	91 52 790 08	ZUSATZHEIZUNG OW
BLECH 1.5X493X622	97 72 289 08	24	1	2 520 034	96 45 984 08	INNENVERKLEIDUNG
BLECH 1.5X500X111	97 68 612 08	7	1	2 522	91 54 115 08	SCHIEBETUER KPL.
BLECH 1.5X60X39	97 74 350 08	22	1	2 522	91 54 115 08	SCHIEBETUER KPL.
BLECH 1.5X635X271 FE//ZN20//	97 86 281 08	116	1	2 932 082	96 54 387 08	AUFBAUTEILE MONTAGETAPE
BLECH 1.5X739X40	97 70 952 08	2	1	2 859 026	96 46 776 08	DECKEL KPL.
BLECH 1.5X740X40	97 70 985 08	2	2	2 859 028	96 46 778 08	DECKEL KPL.
BLECH 1.5X75X75	97 75 126 08	67	1	2 520	91 53 061 08	KABINE VERGLAST
BLECH 1.5X773X420	97 78 744 08	1	1	2 391 039	96 50 616 08	HUTZE KPL
BLECH 1.5X79X67 DC01 FE//ZN	97 74 908 08	104	1	2 932 082	96 54 387 08	AUFBAUTEILE MONTAGETAPE
BLECH 1.5X813X326	97 68 329 08	21	1	2 520 034	96 45 984 08	INNENVERKLEIDUNG
BLECH 1.5X817X297	97 77 221 08	9	1	2 520 031	96 45 610 08	HECKSCHEIBE VORM.
BLECH 1.5X848X40	97 70 997 08	2	2	2 859 029	96 46 779 08	DECKEL KPL.
BLECH 1.5X85X54	97 86 675 08	23	1	2 520 034	96 45 984 08	INNENVERKLEIDUNG
BLECH 1.5X872X194	97 70 813 08	35	1	2 859	91 52 809 08	GERAEUSCHDAEMMUNG
BLECH 1.5X872X40 DC01	97 70 983 08	10	1	2 859 026	96 46 776 08	DECKEL KPL.
BLECH 1.5X872X40 DC01	97 70 983 08	2	2	2 859 027	96 46 777 08	DECKEL KPL.
BLECH 1.5X872X70	97 76 164 08	49	1	2 520 034	96 45 984 08	INNENVERKLEIDUNG
BLECH 1.5X949X398	97 78 745 08	2	1	2 391 039	96 50 616 08	HUTZE KPL
BLECH 1.5x60x47	97 07 173 08	(4)	4	2 550	91 57 751 08	SA-BOCK
BLECH 10X100X163 FE//ZN20//	97 83 086 08	11	6	2 631	91 56 817 08	LAUFSTEG DREHBUEHNE
BLECH 10X1250X80	97 41 440 08	30	1	3 220 500	91 52 849 08	S-ZWISCHENSTUECK
BLECH 10X1250X80	97 41 440 08	30	2	3 223	91 52 852 08	S-ZWISCHENSTUECK
BLECH 10X1250X80	97 41 440 08	30	2	3 223 010	91 52 853 08	S-ZWISCHENSTUECK
BLECH 10X1250X80	97 41 440 08	30	2	3 223 100	91 55 327 08	S-ZWISCHENSTUECK
BLECH 10X1250X80	97 41 440 08	28	1	3 225	91 52 854 08	SL-REDUZIERSTUECK
BLECH 10X1250X80	97 41 440 08	30	1	3 226	91 52 870 08	LI-ZWISCHENSTUECK
BLECH 10X1250X80	97 41 440 08	30	2	3 227	91 52 873 08	LI-ZWISCHENSTUECK
BLECH 10X1250X80	97 41 440 08	30	2	3 227 008	91 52 872 08	LI-ZWISCHENSTUECK
BLECH 10X1250X80	97 41 440 08	30	2	3 227 200	91 53 519 08	LI-ZWISCHENSTUECK F-ABSP
BLECH 10X1250X80	97 41 440 08	58	1	3 713	91 57 749 08	D-ANLENKSTUECK
BLECH 10X1250X80	97 41 440 08	50	5	3 714	91 52 862 08	D-KOPFSTUECK
BLECH 10X1250X80	97 41 440 08	25	2	3 715 008	91 52 863 08	D-ZWISCHENSTUECK
BLECH 10X1250X80	97 41 440 08	25	3	3 716	91 52 864 08	D-ZWISCHENSTUECK
BLECH 10X296X296	97 71 943 08	11	2	3 208 001	91 52 883 08	F-KOPFSTUECK
BLECH 10X40X150	94 18 461 08	26	1	2 810	91 52 806 08	KRANFUEHRERKABINE KPL.
BLECH 10X549X280	97 76 909 08	34	1	3 714	91 52 862 08	D-KOPFSTUECK
BLECH 10x100x100	97 02 204 08	40	1	2 340	91 52 776 08	WINDE 4 EINZIEHWERK
BLECH 12X111X76	97 48 729 08	28	2	1 400	91 56 853 08	RAUPENTRAEGER KPL.LI.
BLECH 12X111X76	97 48 729 08	28	2	1 410 300	91 56 855 08	RAUPENTRAEGER KPL.RE.
BLECH 12X120X120 SPF	97 70 829 08	7	2	3 213	91 52 842 08	F-ANSCHLUSSKOPF
BLECH 12X120X532	97 75 895 08	8	1	3 350	91 52 859 08	WINDE 3
BLECH 12X337X120	97 88 636 08	40	1	3 350	91 52 859 08	WINDE 3
BLECH 12X471X120	97 88 637 08	41	1	3 350	91 52 859 08	WINDE 3
BLECH 15.0X113	97 77 117 08	39	2	2 502	91 55 939 08	STUERSTAND
BLECH 15X200X200	97 76 839 08	13	2	3 714	91 52 862 08	D-KOPFSTUECK

6.2.2009

etk_en_de_074515 LR 1600/2

1002

LIEBHERRAlphabetical index
Alphabetischer Index

Bezeichnung	Artikel	Pos.	Menge	Seite	Baugruppe	Bezeichnung
BLECH 15X257X235	97 73 410 08	6	4	2 125	91 52 773 08	BOLZEN S-ANLENKST. UND S
BLECH 15X303X246	97 69 586 08	38	2	1 400	91 56 853 08	RAUPENTRAEGER KPL.LI.
BLECH 15X303X246	97 69 586 08	38	2	1 410 300	91 56 855 08	RAUPENTRAEGER KPL.RE.
BLECH 15X430X250	97 90 582 08	4	2	2 550	91 57 751 08	SA-BOCK
BLECH 15X507X124	97 84 978 08	23	2	3 350	91 52 859 08	WINDE 3
BLECH 15X578X490	97 75 244 08	14	2	3 214	91 52 843 08	SW-KOPFSTUECK
BLECH 15X90X60	97 83 613 08	5	1	2 391 040	96 53 645 08	KUPPLUNGSSTELLER
BLECH 15X930X362	97 66 746 08	11	1	2 340	91 52 776 08	WINDE 4 EINZIEHWERK
BLECH 15X964X235	97 85 057 08	22	4	3 350	91 52 859 08	WINDE 3
BLECH 1X108X9 ALMG3 H111	97 32 671 08	9	1	2 913 007	96 20 763 08	CONTROLLEREINHEIT
BLECH 1X142X55	97 72 215 08	5	6	2 671	91 52 798 08	OELBEHAELTER KPL.
BLECH 1X160X160	97 79 371 08	31	8	1 630	91 52 387 08	HYDRAULISCHE ABSTUETZUN
BLECH 1X20X60	97 59 516 08	135	20	2 970	91 56 537 08	HYDRAULIK
BLECH 1X20X60	97 59 516 08	65	4	2 975 100	91 52 860 08	ZUSATZHYDRAULIK WINDE 3
BLECH 1X20X60	97 59 516 08	65	7	2 975 200	91 52 775 08	ZUSATZHYDRAULIK WINDE 2
BLECH 1X20X60	97 59 516 08	65	7	2 975 700	91 52 774 08	ZUSATZHYDRAULIK WINDE 1
BLECH 1X20X60	97 59 516 08	65	8	2 977	91 57 756 08	ZUSATZHYDRAULIK DREHBUE
BLECH 1X20X60	97 59 516 08	65	7	2 977 200	91 55 149 08	ZUSATZHYDR.PUMPE 5/WIND
BLECH 1X20X60	97 59 516 08	65	2	2 978 100	91 52 827 08	ZUSATZHYDR.D-RUECKHALT
BLECH 1X20X60	97 59 516 08	65	4	2 978 200	91 54 843 08	ZUSATZHYDR.S-RUECKHALTE
BLECH 1X20X60	97 59 516 08	65	2	3 978 005	91 56 430 08	ZUSATZHYDRAULIK SB-KOPFS
BLECH 1X20X60	97 59 516 08	65	6	3 978 015	91 56 429 08	ZUSATZHYDRAULIK ZWISCH
BLECH 1X20X60	97 59 516 08	65	6	3 978 015	91 56 432 08	ZUSATZHYDRAULIK ZWISCH
BLECH 1X20X60	97 59 516 08	65	5	3 978 100	91 56 428 08	HYDR.SCHWEBEBALLAST-AN
BLECH 1X285X126	97 74 443 08	17	1	2 502	91 55 939 08	STEUERSTAND
BLECH 1X285X126	97 74 444 08	18	1	2 502	91 55 939 08	STEUERSTAND
BLECH 1X350X136	97 71 799 08	11	1	2 393 002	96 46 782 08	DECKEL KPL.
BLECH 1X35X22 ALMG3	61 10 022 08	5	1	2 913 003	96 20 599 08	FOLIENASTATUR VORM.
BLECH 1X467X259 ALMG3 H11	97 17 132 08	2	1	2 913 005	96 20 731 08	INNENGEHAEUSE VORM.
BLECH 1X467X259 ALMG3 H11	97 17 132 08	2	1	2 913 005	96 28 696 08	INNENGEHAEUSE VORM.
BLECH 1X80X110	97 09 048 08	20	10	1 991	91 52 510 08	DREHDURCHFUEHRUNG
BLECH 1X95X78 ALMG3 H111	97 09 808 08	5	1	2 913	91 32 850 08	LICCON KONSOLE LCD2
BLECH 1X95X78 ALMG3 H111	97 09 808 08	5	1	2 913 009	91 04 705 08	LICCON KONSOLE LCD3
BLECH 1x120x100	97 03 987 08	10	2	3 350	91 52 859 08	WINDE 3
BLECH 2.5X199X102	97 80 641 08	21	2	2 391 023	96 45 720 08	KUEHLER VORM.
BLECH 2.5X80X48	97 78 751 08	54	4	2 391 001	96 45 719 08	DIESELMOTOR VORM.
BLECH 2.5X86X86	97 76 153 08	40	4	2 520 034	96 45 984 08	INNENVERKLEIDUNG
BLECH 20X160X290	95 44 785 08	35	2	1 400	91 56 853 08	RAUPENTRAEGER KPL.LI.
BLECH 20X160X290	95 44 785 08	35	2	1 410 300	91 56 855 08	RAUPENTRAEGER KPL.RE.
BLECH 20X260X260	97 74 857 08	10	2	3 215 005	91 52 846 08	ROLLENSATZ
BLECH 20X260X260	97 74 857 08	10	2	3 215 006	91 52 847 08	ROLLENSATZ
BLECH 20X311X106	97 83 633 08	73	10	1 400	91 56 853 08	RAUPENTRAEGER KPL.LI.
BLECH 20X311X106	97 83 633 08	73	10	1 410 300	91 56 855 08	RAUPENTRAEGER KPL.RE.
BLECH 20X512X62	97 12 071 08	25	8	1 400	91 56 853 08	RAUPENTRAEGER KPL.LI.
BLECH 20X512X62	97 12 071 08	25	8	1 410 300	91 56 855 08	RAUPENTRAEGER KPL.RE.
BLECH 20X61X358	97 72 200 08	16	3	2 652	91 52 794 08	ROLLENLAGERUNG
BLECH 20X68X60	97 88 842 08	85	2	2 550	91 57 751 08	SA-BOCK
BLECH 25X95X115	97 91 625 08	13	2	3 292	91 52 865 08	D-RUECKHALTESICHERUNG
BLECH 2X100X100	95 62 979 08	1	2	1 100	91 52 375 08	RAUPENFAHRWERK KPL.
BLECH 2X100X100	95 62 980 08	2	2	1 100	91 52 375 08	RAUPENFAHRWERK KPL.
BLECH 2X100X100	95 62 981 08	3	2	1 100	91 52 375 08	RAUPENFAHRWERK KPL.
BLECH 2X100X100	95 62 982 08	4	2	1 100	91 52 375 08	RAUPENFAHRWERK KPL.
BLECH 2X1010X924	97 75 668 08	1	1	2 510 040	96 49 183 08	TUER VORM.
BLECH 2X103X117	97 60 772 08	64	2	2 520	91 53 061 08	KABINE VERGLAST
BLECH 2X103X40	97 26 310 08	1	1	2 780 851	96 24 498 08	FUNKANTENNE VORM.
BLECH 2X105X105 DC01-A-M	97 04 902 08	17	2	3 205	91 52 880 08	F-MONTAGEEINHEIT
BLECH 2X110X109	97 75 843 08	117	2	2 932 082	96 54 387 08	AUFBAUTEILE MONTAGETAPE
BLECH 2X144X80 ST12.03	95 63 963 08	1	1	2 932 166	92 68 911 08	VERTEILER MASSE
BLECH 2X160X160	97 69 902 08	18	16	1 630	91 52 387 08	HYDRAULISCHE ABSTUETZUN
BLECH 2X162X142 ALMG3 H11	97 65 362 08	110	1	2 932 082	96 54 387 08	AUFBAUTEILE MONTAGETAPE

6.2.2009

etk_en_de_074515 LR 1600/2

1003

LIEBHERRAlphabetical index
Alphabetischer Index

Bezeichnung	Artikel	Pos.	Menge	Seite	Baugruppe	Bezeichnung
BLECH 2X190X140	97 80 626 08	74	8	2 550	91 57 751 08	SA-BOCK
BLECH 2X196X238	97 72 070 08	33	1	2 520	91 53 061 08	KABINE VERGLAST
BLECH 2X201X127 FE//ZN20//C	97 79 157 08	53	1	2 520	91 53 061 08	KABINE VERGLAST
BLECH 2X201X128 FE//ZN20//C	97 79 158 08	54	1	2 520	91 53 061 08	KABINE VERGLAST
BLECH 2X214X142 ALMG3 H11	97 47 409 08	3	1	2 780 852	96 24 845 08	GSM-MODUL VORM.LICCON 1
BLECH 2X215X100 FE//ZN20//C	97 86 328 08	10	2	1 620	91 52 386 08	BEFESTIGUNGSTEILE DREH
BLECH 2X220X100	97 92 102 08	36	1	2 310	91 52 503 08	WINDE 1
BLECH 2X220X100	97 92 276 08	36	1	2 320	91 52 504 08	WINDE 2
BLECH 2X227X73 X5CRNI18-1	97 76 743 08	7	2	2 533 066	96 48 365 08	ELEKTRIK ANBAUTEILE KABIN
BLECH 2X228X100	97 44 570 08	29	1	3 350	91 52 859 08	WINDE 3
BLECH 2X228X100	97 86 711 08	35	1	2 310	91 52 503 08	WINDE 1
BLECH 2X228X100	97 86 711 08	35	1	2 320	91 52 504 08	WINDE 2
BLECH 2X2400X356	97 86 100 08	12	2	3 291	91 52 831 08	S-RUECKHALTESICHERUNG
BLECH 2X2444X554	97 70 793 08	23	1	2 859	91 52 809 08	GERAEUSCHDAEMMUNG
BLECH 2X248X326	95 63 998 08	3	1	2 925 204	92 16 990 08	KAMERAANBAU D-ANLENKS
BLECH 2X251X134	97 65 176 08	2	1	2 540	91 53 253 08	HEIZKLIMAGERAET EINBAU
BLECH 2X274X212 FE//ZN20//C	97 86 372 08	118	1	3 713	91 57 749 08	D-ANLENKSTUECK
BLECH 2X287X171	97 73 426 08	(5)	1	2 925 026	91 55 259 08	ERG.KAMERAUEBERWACHUN
BLECH 2X287X171	97 73 426 08	5	1	2 925 405	96 48 397 08	AUSRUESTUNG KAMERA KAB
BLECH 2X341X363	97 33 034 08	28	1	2 925 402	96 58 855 08	KAMERAANBAU DREHBUEHN
BLECH 2X50X75	97 18 510 08	39	1	3 206	91 52 881 08	F-ANLENKSTUECK
BLECH 2X517X477	97 68 331 08	20	1	2 520 034	96 45 984 08	INNENVERKLEIDUNG
BLECH 2X55X21 FE//ZN20//C	97 68 660 08	3	1	2 522 011	96 45 602 08	SCHLISSANLAGE
BLECH 2X616X222	97 76 486 08	1	1	2 541 001	96 49 651 08	ZUSATZHEIZUNG VORM.
BLECH 2X648X321	97 81 124 08	40	1	2 859	91 52 809 08	GERAEUSCHDAEMMUNG
BLECH 2X661X530	97 71 798 08	10	1	2 393 002	96 46 782 08	DECKEL KPL.
BLECH 2X67X47	97 78 746 08	27	1	2 522 011	96 45 602 08	SCHLISSANLAGE
BLECH 2X719X599	97 71 797 08	9	1	2 393 002	96 46 782 08	DECKEL KPL.
BLECH 2X749X420	97 79 370 08	8	1	2 391	91 52 784 08	DIESELMOTOR KPL.
BLECH 2X75X75 FE//ZN20//C	97 80 257 08	53	2	2 810	91 52 806 08	KRANFUEHRERKABINE KPL.
BLECH 2X77X20	97 83 927 08	9	1	2 391 040	96 53 645 08	KUPPLUNGSSTELLER
BLECH 2X784X924	97 75 669 08	1	1	2 510 059	96 49 184 08	TUER VORM.
BLECH 2X817X486	97 70 673 08	23	1	2 520	91 53 061 08	KABINE VERGLAST
BLECH 2X875X546	97 70 906 08	1	1	2 859 030	96 46 758 08	DECKEL KPL.
BLECH 2X90X110	97 25 222 08	26	1	3 206	91 52 881 08	F-ANLENKSTUECK
BLECH 2X95X95	97 88 785 08	33	10	3 215 005	91 52 846 08	ROLLENSATZ
BLECH 2X95X95	97 88 785 08	33	10	3 215 006	91 52 847 08	ROLLENSATZ
BLECH 2X98X32 SPF	97 66 066 08	26	1	2 932 160	96 54 385 08	SCHALTSCHRANK MECH.
BLECH 2X990X104	97 28 766 08	3	1	2 391 036	96 23 055 08	DECKEL VORM.
BLECH 30X150X100	97 69 697 08	6	4	1 630	91 52 387 08	HYDRAULISCHE ABSTUETZUN
BLECH 30X180X290	95 44 783 08	24	2	1 400	91 56 853 08	RAUPENTRAEGER KPL.LI.
BLECH 30X180X290	95 44 783 08	24	2	1 410 300	91 56 855 08	RAUPENTRAEGER KPL.RE.
BLECH 30X270X160	97 79 903 08	21	2	2 652	91 52 794 08	ROLLENLAGERUNG
BLECH 30X310X119	97 73 409 08	5	4	2 125	91 52 773 08	BOLZEN S-ANLENKST. UND S
BLECH 35X1689X254	97 68 530 08	1	2	2 550 010	96 45 685 08	STANGE VORM.
BLECH 35X904X404	97 76 390 08	1	2	3 714 013	96 49 270 08	LASCHE KPL.
BLECH 3X100X110	97 87 054 08	38	2	2 391 040	96 53 645 08	KUPPLUNGSSTELLER
BLECH 3X100X90	97 85 358 08	79	1	2 391 001	96 45 719 08	DIESELMOTOR VORM.
BLECH 3X101X70	97 83 116 08	14	2	2 631	91 56 817 08	LAUFSTEG DREHBUEHNE
BLECH 3X1040X55	97 86 362 08	79	1	3 714	91 52 862 08	D-KOPFSTUECK
BLECH 3X106X42	97 59 503 08	77	1	2 550	91 57 751 08	SA-BOCK
BLECH 3X110X93	97 79 878 08	57	1	2 391 001	96 45 719 08	DIESELMOTOR VORM.
BLECH 3X1155X55	97 87 766 08	135	1	3 713	91 57 749 08	D-ANLENKSTUECK
BLECH 3X1200X170	97 87 757 08	116	3	3 713	91 57 749 08	D-ANLENKSTUECK
BLECH 3X121X79	97 71 098 08	13	2	2 260	91 53 057 08	BATTERIELAGERUNG
BLECH 3X144X80	97 07 719 08	72	1	2 391 001	96 45 719 08	DIESELMOTOR VORM.
BLECH 3X150X40	97 55 008 08	27	1	2 310	91 52 503 08	WINDE 1
BLECH 3X150X40	97 55 008 08	27	1	2 320	91 52 504 08	WINDE 2
BLECH 3X150X40	97 55 008 08	34	2	2 340	91 52 776 08	WINDE 4 EINZIEHWERK
BLECH 3X150X40	97 55 008 08	38	1	3 350	91 52 859 08	WINDE 3

6.2.2009

etk_en_de_074515 LR 1600/2

1004

LIEBHERRAlphabetical index
Alphabetischer Index

Bezeichnung	Artikel	Pos.	Menge	Seite	Baugruppe	Bezeichnung
BLECH 3X151X136	97 69 588 08	4	1	2 520 032	96 45 980 08	SCHEIBENWISCHANLAGE EIN
BLECH 3X157X156	95 70 054 08	2	1	3 780 200	96 54 370 08	ELEKTRIK WINDWARNUNG T
BLECH 3X159X113	97 75 000 08	33	2	2 391 001	96 45 719 08	DIESELMOTOR VORM.
BLECH 3X1779X219	97 70 795 08	25	1	2 859	91 52 809 08	GERAEUSCHDAEMMUNG
BLECH 3X190X60	97 15 627 08	105	2	3 211	91 57 748 08	S-ANLENKSTUECK
BLECH 3X192X187	97 23 319 08	7	1	2 260 006	96 46 501 08	BATTERIEKASTEN VORM.
BLECH 3X196X184	97 70 794 08	24	2	2 859	91 52 809 08	GERAEUSCHDAEMMUNG
BLECH 3X200X150	97 02 854 08	11	1	2 780 324	91 56 389 08	AKUST.WARNUNG VERFAHRE
BLECH 3X200X150	97 02 854 08	(3)	1	2 920	91 56 833 08	ELEKTRIK DREHBUEHNE
BLECH 3X207X105	97 78 727 08	49	2	2 391 001	96 45 719 08	DIESELMOTOR VORM.
BLECH 3X2120X55	97 86 361 08	78	2	3 714	91 52 862 08	D-KOPFSTUECK
BLECH 3X212X34	97 79 305 08	8	1	2 550 008	96 47 628 08	HALTER KPL.
BLECH 3X212X34	97 79 305 08	8	1	2 550 009	96 47 645 08	HALTER KPL.
BLECH 3X220X176	97 93 905 08	27	1	3 281	91 52 896 08	FA-BOCK
BLECH 3X224X121 FE//ZN20//C	97 81 184 08	45	4	3 214	91 52 843 08	SW-KOPFSTUECK
BLECH 3X2260X511	97 32 004 08	77	2	3 211	91 57 748 08	S-ANLENKSTUECK
BLECH 3X2285X55 DC01	97 87 762 08	131	1	3 713	91 57 749 08	D-ANLENKSTUECK
BLECH 3X235X155	97 71 100 08	15	1	2 260	91 53 057 08	BATTERIELAGERUNG
BLECH 3X26X26	97 19 742 08	22	2	2 502	91 55 939 08	STEUERSTAND
BLECH 3X270X308	97 79 627 08	12	1	2 780 915	96 48 377 08	ANBAUTEILE FREMDEINSPEIS
BLECH 3X280X154	97 15 521 08	49	1	2 550	91 57 751 08	SA-BOCK
BLECH 3X280X170	97 72 246 08	22	1	2 520 034	96 45 984 08	INNENVERKLEIDUNG
BLECH 3X280X80	97 81 823 08	101	2	3 211	91 57 748 08	S-ANLENKSTUECK
BLECH 3X283X216	97 71 705 08	49	1	3 208 001	91 52 883 08	F-KOPFSTUECK
BLECH 3X287X452 FE//ZN20//C	97 83 458 08	5	1	2 657	91 57 656 08	MONTAGEEINRICHTUNG RA
BLECH 3X2895X55 DC01	97 87 763 08	132	1	3 713	91 57 749 08	D-ANLENKSTUECK
BLECH 3X3000X55 DC01	97 87 760 08	130	2	3 713	91 57 749 08	D-ANLENKSTUECK
BLECH 3X330X95	97 83 924 08	6	1	2 391 040	96 53 645 08	KUPPLUNGSSTELLER
BLECH 3X353X300	97 44 917 08	(1)	1	3 780 258	96 56 482 08	ELEKTRIK FLUGWARNSICHER
BLECH 3X366X104	97 74 440 08	15	1	2 502	91 55 939 08	STEUERSTAND
BLECH 3X366X104	97 74 441 08	16	1	2 502	91 55 939 08	STEUERSTAND
BLECH 3X380X225	97 73 394 08	7	2	2 391 001	96 45 719 08	DIESELMOTOR VORM.
BLECH 3X390X380	97 75 707 08	15	1	2 392	91 52 785 08	SCHALLDAEMPFERANLAGE
BLECH 3X404X241	97 82 080 08	19	1	2 925 402	96 58 855 08	KAMERAANBAU DREHBUEHN
BLECH 3X404X241	97 82 081 08	20	1	2 925 402	96 58 855 08	KAMERAANBAU DREHBUEHN
BLECH 3X40X40 ST12.03	97 19 741 08	21	4	2 502	91 55 939 08	STEUERSTAND
BLECH 3X40X95	97 86 364 08	81	2	3 714	91 52 862 08	D-KOPFSTUECK
BLECH 3X437X272	97 71 099 08	14	1	2 260	91 53 057 08	BATTERIELAGERUNG
BLECH 3X450X252	97 80 168 08	59	1	2 391 001	96 45 719 08	DIESELMOTOR VORM.
BLECH 3X45X120	95 37 609 08	4	1	2 310	91 52 503 08	WINDE 1
BLECH 3X45X120	95 37 609 08	4	1	2 320	91 52 504 08	WINDE 2
BLECH 3X45X120	95 37 609 08	82	1	3 714	91 52 862 08	D-KOPFSTUECK
BLECH 3X46X20 FE//ZN20//F	97 83 624 08	51	1	2 502	91 55 939 08	STEUERSTAND
BLECH 3X489X273	97 85 704 08	1	1	2 631 003	96 54 406 08	AUFSTIEG VORM.
BLECH 3X60X70	97 80 640 08	59	1	2 810	91 52 806 08	KRANFUEHRERKABINE KPL.
BLECH 3X70X101	97 82 921 08	29	2	3 215 005	91 52 846 08	ROLLENSATZ
BLECH 3X70X101	97 82 921 08	29	2	3 215 006	91 52 847 08	ROLLENSATZ
BLECH 3X70X45	97 73 355 08	30	1	2 711	91 52 800 08	ZENTRALSCHMIERANLAGE O
BLECH 3X718X278	97 74 257 08	17	1	2 393	91 52 787 08	LUFTFILTERANLAGE KPL.
BLECH 3X770X55	97 87 764 08	133	1	3 713	91 57 749 08	D-ANLENKSTUECK
BLECH 3X80X1392	97 95 151 08	86	1	2 520	91 53 061 08	KABINE VERGLAST
BLECH 3X853X80	97 73 500 08	4	1	2 932 160	96 54 385 08	SCHALTSCHRANK MECH.
BLECH 3X85X210 FE//ZN20//C	97 67 363 08	150	1	2 970	91 56 537 08	HYDRAULIK
BLECH 3X85X210 FE//ZN20//C	97 67 363 08	39	1	3 350	91 52 859 08	WINDE 3
BLECH 3X880X55	97 86 363 08	80	2	3 714	91 52 862 08	D-KOPFSTUECK
BLECH 3X892X382	97 71 793 08	1	1	2 810 037	96 47 204 08	PEDALTRAEGER EINBAU
BLECH 3X90X103	97 85 357 08	78	1	2 391 001	96 45 719 08	DIESELMOTOR VORM.
BLECH 3X915X55	97 87 765 08	134	1	3 713	91 57 749 08	D-ANLENKSTUECK
BLECH 3X95X70	97 83 115 08	13	2	2 631	91 56 817 08	LAUFSTEG DREHBUEHNE
BLECH 3x48x75	97 04 309 08	8	2	1 920 307	96 48 383 08	ELEKTRIK MITTELSTUECK

6.2.2009

etk_en_de_074515 LR 1600/2

1005

LIEBHERRAlphabetical index
Alphabetischer Index

Bezeichnung	Artikel	Pos.	Menge	Seite	Baugruppe	Bezeichnung
BLECH 40X200X180	95 27 424 08	3	4	2 730	91 52 802 08	GRUNDPLATTE DREHBUEHNE
BLECH 4X1001X183	97 70 810 08	33	1	2 859	91 52 809 08	GERAEUSCHDAEMMUNG
BLECH 4X100X145	97 73 425 08	19	1	2 391 001	96 45 719 08	DIESELMOTOR VORM.
BLECH 4X1010X384	97 73 398 08	12	1	2 391 001	96 45 719 08	DIESELMOTOR VORM.
BLECH 4X103X20 S235JRG2	95 28 598 08	66	3	2 391 001	96 45 719 08	DIESELMOTOR VORM.
BLECH 4X1087X134	97 73 423 08	17	1	2 391 001	96 45 719 08	DIESELMOTOR VORM.
BLECH 4X1087X134	97 73 424 08	18	1	2 391 001	96 45 719 08	DIESELMOTOR VORM.
BLECH 4X110X80	97 03 502 08	79	2	2 550	91 57 751 08	SA-BOCK
BLECH 4X110X80	97 03 502 08	25	2	2 711	91 52 800 08	ZENTRALSCHMIERANLAGE O
BLECH 4X110X89	97 66 574 08	28	1	2 391 001	96 45 719 08	DIESELMOTOR VORM.
BLECH 4X115X98	97 12 764 08	62	1	2 810	91 52 806 08	KRANFUEHRERKABINE KPL.
BLECH 4X1177X360	97 74 258 08	18	1	2 393	91 52 787 08	LUFTFILTERANLAGE KPL.
BLECH 4X119X70	97 86 827 08	55	1	2 631	91 56 817 08	LAUFSTEG DREHBUEHNE
BLECH 4X120X187	97 69 564 08	3	1	2 670	91 52 797 08	KRAFTSTOFFBEHAELTER KPL
BLECH 4X1320X547	97 69 693 08	36	1	1 400	91 56 853 08	RAUPENTRAEGER KPL.LI.
BLECH 4X1322X547	97 69 494 08	36	1	1 410 300	91 56 855 08	RAUPENTRAEGER KPL.RE.
BLECH 4X1322X633	97 69 491 08	33	1	1 410 300	91 56 855 08	RAUPENTRAEGER KPL.RE.
BLECH 4X1322X633	97 69 692 08	33	1	1 400	91 56 853 08	RAUPENTRAEGER KPL.LI.
BLECH 4X133X225	97 83 114 08	12	2	2 631	91 56 817 08	LAUFSTEG DREHBUEHNE
BLECH 4X1390X487	97 52 147 08	4	1	2 260	91 53 057 08	BATTERIELAGERUNG
BLECH 4X1400X207	97 80 937 08	85	1	3 211	91 57 748 08	S-ANLENKSTUECK
BLECH 4X140X30	97 79 264 08	25	4	2 340	91 52 776 08	WINDE 4 EINZIEHWERK
BLECH 4X140X30	97 80 169 08	63	1	2 391 001	96 45 719 08	DIESELMOTOR VORM.
BLECH 4X1445X192	97 71 636 08	68	1	3 211	91 57 748 08	S-ANLENKSTUECK
BLECH 4X148X85	97 83 926 08	8	1	2 391 040	96 53 645 08	KUPPLUNGSSTELLER
BLECH 4X1540X297	97 71 157 08	40	4	3 211	91 57 748 08	S-ANLENKSTUECK
BLECH 4X155X134	97 70 790 08	14	1	2 859	91 52 809 08	GERAEUSCHDAEMMUNG
BLECH 4X156X220	97 12 903 08	151	1	2 970	91 56 537 08	HYDRAULIK
BLECH 4X165X225	95 57 495 08	20	1	1 920 308	96 48 384 08	ELEKTRIK RAUPENTRAEGER
BLECH 4X165X225	95 57 495 08	20	1	1 920 309	96 48 385 08	ELEKTRIK RAUPENTRAEGER
BLECH 4X165X225	95 57 495 08	23	1	3 745	91 52 948 08	SCHWEBEBALLAST
BLECH 4X167X25	97 78 521 08	39	8	3 745	91 52 948 08	SCHWEBEBALLAST
BLECH 4X170X157	95 70 439 08	24	1	2 711	91 52 800 08	ZENTRALSCHMIERANLAGE O
BLECH 4X173X102	97 85 767 08	46	1	2 631	91 56 817 08	LAUFSTEG DREHBUEHNE
BLECH 4X174X191 FE//ZN20//C	97 83 085 08	10	5	2 631	91 56 817 08	LAUFSTEG DREHBUEHNE
BLECH 4X174X72	97 02 120 08	4	1	2 260 006	96 46 501 08	BATTERIEKASTEN VORM.
BLECH 4X174X74	97 02 119 08	3	2	2 260 006	96 46 501 08	BATTERIEKASTEN VORM.
BLECH 4X178X30	97 85 175 08	77	2	2 391 001	96 45 719 08	DIESELMOTOR VORM.
BLECH 4X178X358	97 69 565 08	4	1	2 670	91 52 797 08	KRAFTSTOFFBEHAELTER KPL
BLECH 4X189X430	97 80 256 08	64	1	2 391 001	96 45 719 08	DIESELMOTOR VORM.
BLECH 4X190X140	97 80 625 08	73	4	2 550	91 57 751 08	SA-BOCK
BLECH 4X194X101	97 74 259 08	19	1	2 393	91 52 787 08	LUFTFILTERANLAGE KPL.
BLECH 4X205X450 FE//ZN20//C	97 88 000 08	38	6	3 715 008	91 52 863 08	D-ZWISCHENSTUECK
BLECH 4X205X450 FE//ZN20//C	97 88 000 08	41	12	3 716	91 52 864 08	D-ZWISCHENSTUECK
BLECH 4X209X189 FE//ZN20//C	97 83 084 08	9	2	2 631	91 56 817 08	LAUFSTEG DREHBUEHNE
BLECH 4X209X275 FE//ZN20//C	97 78 526 08	9	4	3 227	91 52 873 08	LI-ZWISCHENSTUECK
BLECH 4X20X500	95 37 411 08	91	1	3 211	91 57 748 08	S-ANLENKSTUECK
BLECH 4X20X500	95 37 411 08	119	1	3 713	91 57 749 08	D-ANLENKSTUECK
BLECH 4X20X500	95 37 411 08	91	1	3 714	91 52 862 08	D-KOPFSTUECK
BLECH 4X20X500	95 37 411 08	46	1	3 715 008	91 52 863 08	D-ZWISCHENSTUECK
BLECH 4X20X500	95 37 411 08	36	1	3 716	91 52 864 08	D-ZWISCHENSTUECK
BLECH 4X215X167	97 79 246 08	20	4	1 630	91 52 387 08	HYDRAULISCHE ABSTUETZUN
BLECH 4X219X1068	97 73 397 08	11	1	2 391 001	96 45 719 08	DIESELMOTOR VORM.
BLECH 4X227X202	97 73 532 08	20	1	2 391 001	96 45 719 08	DIESELMOTOR VORM.
BLECH 4X2346X144	97 70 786 08	13	1	2 859	91 52 809 08	GERAEUSCHDAEMMUNG
BLECH 4X243X155	97 72 220 08	14	1	2 671	91 52 798 08	OELBEHAELTER KPL.
BLECH 4X254X126	97 70 506 08	6	2	2 260	91 53 057 08	BATTERIELAGERUNG
BLECH 4X256X130	97 80 349 08	25	1	2 310	91 52 503 08	WINDE 1
BLECH 4X256X130	97 80 349 08	25	1	2 320	91 52 504 08	WINDE 2
BLECH 4X2600X53	97 86 531 08	88	2	3 211	91 57 748 08	S-ANLENKSTUECK

6.2.2009

etk_en_de_074515 LR 1600/2

1006

LIEBHERRAlphabetical index
Alphabetischer Index

Bezeichnung	Artikel	Pos.	Menge	Seite	Baugruppe	Bezeichnung
BLECH 4X260X93	97 46 733 08	36	2	3 211	91 57 748 08	S-ANLENKSTUECK
BLECH 4X260X93	97 46 733 08	71	2	3 713	91 57 749 08	D-ANLENKSTUECK
BLECH 4X260X98	97 79 826 08	53	1	2 391 001	96 45 719 08	DIESELMOTOR VORM.
BLECH 4X2744X273	97 81 551 08	87	1	3 211	91 57 748 08	S-ANLENKSTUECK
BLECH 4X274X50	97 78 522 08	40	4	3 745	91 52 948 08	SCHWEBEBALLAST
BLECH 4X2834X53	97 81 550 08	86	2	3 211	91 57 748 08	S-ANLENKSTUECK
BLECH 4X283X127	97 85 781 08	11	2	2 370	91 52 782 08	MONTAGEWINDE
BLECH 4X283X50	97 78 520 08	38	4	3 745	91 52 948 08	SCHWEBEBALLAST
BLECH 4X290X130	97 79 331 08	29	1	2 340	91 52 776 08	WINDE 4 EINZIEHWERK
BLECH 4X290X130	97 79 332 08	30	1	2 340	91 52 776 08	WINDE 4 EINZIEHWERK
BLECH 4X293X96	97 73 929 08	2	1	2 522 012	96 45 884 08	FUEHRUNG VORM.
BLECH 4X30X105	95 36 969 08	48	1	2 550	91 57 751 08	SA-BOCK
BLECH 4X30X105	95 36 969 08	28	2	2 711	91 52 800 08	ZENTRALSCHMIERANLAGE O
BLECH 4X310X120	97 57 099 08	92	1	3 714	91 52 862 08	D-KOPFSTUECK
BLECH 4X310X120	97 57 099 08	45	1	3 715 008	91 52 863 08	D-ZWISCHENSTUECK
BLECH 4X310X120	97 57 099 08	43	1	3 716	91 52 864 08	D-ZWISCHENSTUECK
BLECH 4X330X110	97 87 754 08	113	1	3 713	91 57 749 08	D-ANLENKSTUECK
BLECH 4X335X109	97 81 060 08	67	1	2 391 001	96 45 719 08	DIESELMOTOR VORM.
BLECH 4X351X333	97 93 744 08	27	1	2 925 402	96 58 855 08	KAMERAANBAU DREHBUEHN
BLECH 4X352X345	97 25 209 08	22	1	3 206	91 52 881 08	F-ANLENKSTUECK
BLECH 4X358X405	97 14 450 08	26	1	1 400	91 56 853 08	RAUPENTRAEGER KPL.LI.
BLECH 4X358X405	97 14 596 08	26	1	1 410 300	91 56 855 08	RAUPENTRAEGER KPL.RE.
BLECH 4X369X224	97 10 255 08	2	4	1 620	91 52 386 08	BEFESTIGUNGSTEILE DREH
BLECH 4X369X509	97 17 777 08	27	1	1 400	91 56 853 08	RAUPENTRAEGER KPL.LI.
BLECH 4X369X509	97 17 950 08	27	1	1 410 300	91 56 855 08	RAUPENTRAEGER KPL.RE.
BLECH 4X382X120	97 80 593 08	18	1	2 925 402	96 58 855 08	KAMERAANBAU DREHBUEHN
BLECH 4X389X287	97 69 492 08	34	1	1 400	91 56 853 08	RAUPENTRAEGER KPL.LI.
BLECH 4X389X287	97 69 492 08	34	1	1 410 300	91 56 855 08	RAUPENTRAEGER KPL.RE.
BLECH 4X389X287	97 69 495 08	37	1	1 400	91 56 853 08	RAUPENTRAEGER KPL.LI.
BLECH 4X389X287	97 69 495 08	37	1	1 410 300	91 56 855 08	RAUPENTRAEGER KPL.RE.
BLECH 4X405X527	97 90 053 08	117	1	3 713	91 57 749 08	D-ANLENKSTUECK
BLECH 4X40X105	95 58 096 08	37	2	3 350	91 52 859 08	WINDE 3
BLECH 4X40X35	97 61 821 08	69	4	2 391 001	96 45 719 08	DIESELMOTOR VORM.
BLECH 4X40X78	97 70 797 08	27	2	2 859	91 52 809 08	GERAEUSCHDAEMMUNG
BLECH 4X419X242 S315MC	97 75 410 08	65	1	1 400	91 56 853 08	RAUPENTRAEGER KPL.LI.
BLECH 4X419X242 S315MC	97 75 411 08	65	1	1 410 300	91 56 855 08	RAUPENTRAEGER KPL.RE.
BLECH 4X450X100	97 57 447 08	103	3	3 211	91 57 748 08	S-ANLENKSTUECK
BLECH 4X453X40	97 79 216 08	29	2	2 711	91 52 800 08	ZENTRALSCHMIERANLAGE O
BLECH 4X470X271	97 79 824 08	52	1	2 391 001	96 45 719 08	DIESELMOTOR VORM.
BLECH 4X480X230	97 87 755 08	114	1	3 713	91 57 749 08	D-ANLENKSTUECK
BLECH 4X487X120	97 81 896 08	102	2	3 211	91 57 748 08	S-ANLENKSTUECK
BLECH 4X492X101	97 70 792 08	15	1	2 859	91 52 809 08	GERAEUSCHDAEMMUNG
BLECH 4X492X116	97 79 887 08	37	2	2 340	91 52 776 08	WINDE 4 EINZIEHWERK
BLECH 4X498X192	97 74 929 08	32	1	2 391 001	96 45 719 08	DIESELMOTOR VORM.
BLECH 4X505X168	97 49 296 08	40	2	3 214	91 52 843 08	SW-KOPFSTUECK
BLECH 4X50X95	95 05 282 08	7	1	1 970	91 56 958 08	HYDRAULIK RAUPE
BLECH 4X529X368	97 85 691 08	63	1	2 810	91 52 806 08	KRANFUEHRERKABINE KPL.
BLECH 4X555X617	97 84 521 08	75	1	2 391	91 52 784 08	DIESELMOTOR KPL.
BLECH 4X581X113	97 80 936 08	84	1	3 211	91 57 748 08	S-ANLENKSTUECK
BLECH 4X581X113	97 86 533 08	104	1	3 211	91 57 748 08	S-ANLENKSTUECK
BLECH 4X60X103	95 51 525 08	35	1	2 340	91 52 776 08	WINDE 4 EINZIEHWERK
BLECH 4X60X103	95 51 525 08	15	1	2 978 200	91 54 843 08	ZUSATZHYDR.S-RUECKHALTE
BLECH 4X60X103	95 51 525 08	35	1	3 350	91 52 859 08	WINDE 3
BLECH 4X60X103	97 15 061 08	6	1	2 310	91 52 503 08	WINDE 1
BLECH 4X60X103	97 15 061 08	6	1	2 320	91 52 504 08	WINDE 2
BLECH 4X60X224	97 81 069 08	75	2	2 550	91 57 751 08	SA-BOCK
BLECH 4X611X119	97 70 505 08	5	2	2 260	91 53 057 08	BATTERIELAGERUNG
BLECH 4X611X322	97 73 245 08	4	2	2 391 038	96 47 931 08	OELKUEHLER VORM.
BLECH 4X618X343	97 73 396 08	10	1	2 391 001	96 45 719 08	DIESELMOTOR VORM.
BLECH 4X650X443	97 15 345 08	32	1	3 214	91 52 843 08	SW-KOPFSTUECK

6.2.2009

etk_en_de_074515 LR 1600/2

1007

LIEBHERRAlphabetical index
Alphabetischer Index

Bezeichnung	Artikel	Pos.	Menge	Seite	Baugruppe	Bezeichnung
BLECH 4X650X479	97 74 253 08	16	1	2 393	91 52 787 08	LUFTFILTERANLAGE KPL.
BLECH 4X653X578	97 89 189 08	3	1	2 391 102	96 56 360 08	ZUSATZKUEHLER VORM.
BLECH 4X667X220	97 79 664 08	70	2	3 714	91 52 862 08	D-KOPFSTUECK
BLECH 4X680X383	97 15 435 08	9	1	1 920 307	96 48 383 08	ELEKTRIK MITTELSTUECK
BLECH 4X711X637	97 89 190 08	4	1	2 391 102	96 56 360 08	ZUSATZKUEHLER VORM.
BLECH 4X747X370	97 79 663 08	69	2	3 714	91 52 862 08	D-KOPFSTUECK
BLECH 4X800X100	97 55 895 08	89	4	3 211	91 57 748 08	S-ANLENKSTUECK
BLECH 4X842X428	97 89 191 08	5	1	2 391 102	96 56 360 08	ZUSATZKUEHLER VORM.
BLECH 4X85X60	97 85 873 08	13	1	2 370	91 52 782 08	MONTAGEWINDE
BLECH 4X86X60	97 85 872 08	12	1	2 370	91 52 782 08	MONTAGEWINDE
BLECH 4X883X130	97 85 718 08	16	2	2 350	91 52 778 08	DREHWERK
BLECH 4X900X225	97 87 756 08	1	1	3 713 013	96 57 159 08	BLECH KPL.
BLECH 4X90X12	94 99 977 08	9	4	2 932 160	96 54 385 08	SCHALTSCHRANK MECH.
BLECH 4X97X65	97 85 875 08	15	1	2 370	91 52 782 08	MONTAGEWINDE
BLECH 4X97X77	97 85 874 08	14	1	2 370	91 52 782 08	MONTAGEWINDE
BLECH 4X98X115	97 79 296 08	26	1	2 340	91 52 776 08	WINDE 4 EINZIEHWERK
BLECH 4x103x60	97 01 621 08	58	1	2 975 100	91 52 860 08	ZUSATZHYDRAULIK WINDE 3
BLECH 4x63x90 S235JRG2	95 41 137 08	6	2	2 510	91 52 788 08	DREHBUEHNENVERKLEIDUN
BLECH 4x73x30 S235JRG2	97 03 501 08	28	1	2 310	91 52 503 08	WINDE 1
BLECH 4x73x30 S235JRG2	97 03 501 08	28	1	2 320	91 52 504 08	WINDE 2
BLECH 4x73x30 S235JRG2	97 03 501 08	27	5	2 711	91 52 800 08	ZENTRALSCHMIERANLAGE O
BLECH 5X100X125	95 47 547 08	23	2	3 713	91 57 749 08	D-ANLENKSTUECK
BLECH 5X100X270	95 66 430 08	79	4	3 211	91 57 748 08	S-ANLENKSTUECK
BLECH 5X104X140	95 50 518 08	7	2	3 211	91 57 748 08	S-ANLENKSTUECK
BLECH 5X104X140	95 50 518 08	11	2	3 213	91 52 842 08	F-ANSCHLUSSKOPF
BLECH 5X104X140	95 50 518 08	27	2	3 214	91 52 843 08	SW-KOPFSTUECK
BLECH 5X104X140	95 50 518 08	5	4	3 220 500	91 52 849 08	S-ZWISCHENSTUECK
BLECH 5X104X140	95 50 518 08	5	4	3 221	91 54 668 08	S-ZWISCHENSTUECK
BLECH 5X104X140	95 50 518 08	5	4	3 223	91 52 852 08	S-ZWISCHENSTUECK
BLECH 5X104X140	95 50 518 08	5	4	3 223 010	91 52 853 08	S-ZWISCHENSTUECK
BLECH 5X104X140	95 50 518 08	5	4	3 223 100	91 55 327 08	S-ZWISCHENSTUECK
BLECH 5X104X140	95 50 518 08	24	4	3 225	91 52 854 08	SL-REDUZIERSTUECK
BLECH 5X104X140	95 50 518 08	5	4	3 226	91 52 870 08	LI-ZWISCHENSTUECK
BLECH 5X104X140	95 50 518 08	5	4	3 227	91 52 873 08	LI-ZWISCHENSTUECK
BLECH 5X104X140	95 50 518 08	5	4	3 227 008	91 52 872 08	LI-ZWISCHENSTUECK
BLECH 5X104X140	95 50 518 08	5	4	3 227 200	91 53 519 08	LI-ZWISCHENSTUECK F-ABSP
BLECH 5X104X140	95 50 518 08	26	2	3 714	91 52 862 08	D-KOPFSTUECK
BLECH 5X104X140	95 50 518 08	21	2	3 715 008	91 52 863 08	D-ZWISCHENSTUECK
BLECH 5X104X140	95 50 518 08	21	2	3 716	91 52 864 08	D-ZWISCHENSTUECK
BLECH 5X110X20	97 68 611 08	6	4	2 522	91 54 115 08	SCHIEBETUER KPL.
BLECH 5X1183X338	97 73 421 08	15	1	2 391 001	96 45 719 08	DIESELMOTOR VORM.
BLECH 5X120X30	97 62 431 08	21	2	3 215 005	91 52 846 08	ROLLENSATZ
BLECH 5X120X30	97 62 431 08	21	2	3 215 006	91 52 847 08	ROLLENSATZ
BLECH 5X130X125 FE//ZN20//C	97 75 887 08	5	2	3 714 008	96 49 266 08	VERSTELLFLASCHE KPL.
BLECH 5X140X180	97 17 862 08	35	4	3 281	91 52 896 08	FA-BOCK
BLECH 5X150X101	97 74 928 08	33	2	3 715 008	91 52 863 08	D-ZWISCHENSTUECK
BLECH 5X150X101	97 74 928 08	31	2	3 716	91 52 864 08	D-ZWISCHENSTUECK
BLECH 5X1762X282	97 73 395 08	9	1	2 391 001	96 45 719 08	DIESELMOTOR VORM.
BLECH 5X1799X963	97 73 392 08	5	1	2 391 001	96 45 719 08	DIESELMOTOR VORM.
BLECH 5X208X162	97 33 032 08	(1)	1	2 925 402	96 58 855 08	KAMERAANBAU DREHBUEHN
BLECH 5X263X60	97 79 283 08	60	1	3 713	91 57 749 08	D-ANLENKSTUECK
BLECH 5X263X60	97 79 283 08	44	8	3 714	91 52 862 08	D-KOPFSTUECK
BLECH 5X2668X259	97 69 490 08	32	1	1 400	91 56 853 08	RAUPENTRAEGER KPL.LI.
BLECH 5X2668X259	97 69 490 08	32	1	1 410 300	91 56 855 08	RAUPENTRAEGER KPL.RE.
BLECH 5X3017X259	97 69 487 08	29	1	1 400	91 56 853 08	RAUPENTRAEGER KPL.LI.
BLECH 5X3017X259	97 69 487 08	29	1	1 410 300	91 56 855 08	RAUPENTRAEGER KPL.RE.
BLECH 5X3017X259	97 69 488 08	30	1	1 400	91 56 853 08	RAUPENTRAEGER KPL.LI.
BLECH 5X3017X259	97 69 488 08	30	1	1 410 300	91 56 855 08	RAUPENTRAEGER KPL.RE.
BLECH 5X311X106	97 83 634 08	74	12	1 400	91 56 853 08	RAUPENTRAEGER KPL.LI.
BLECH 5X311X106	97 83 634 08	74	12	1 410 300	91 56 855 08	RAUPENTRAEGER KPL.RE.

6.2.2009

etk_en_de_074515 LR 1600/2

1008

LIEBHERRAlphabetical index
Alphabetischer Index

Bezeichnung	Artikel	Pos.	Menge	Seite	Baugruppe	Bezeichnung
BLECH 5X330X429	97 89 198 08	19	2	3 714 009	96 49 267 08	VERSTELLFLASCHE KPL.
BLECH 5X393X60 S380MC	95 64 428 08	31	2	3 220 500	91 52 849 08	S-ZWISCHENSTUECK
BLECH 5X393X60 S380MC	95 64 428 08	31	4	3 223	91 52 852 08	S-ZWISCHENSTUECK
BLECH 5X393X60 S380MC	95 64 428 08	31	4	3 223 100	91 55 327 08	S-ZWISCHENSTUECK
BLECH 5X393X60 S380MC	95 64 428 08	30	2	3 225	91 52 854 08	SL-REDUZIERSTUECK
BLECH 5X393X60 S380MC	95 64 428 08	31	2	3 226	91 52 870 08	LI-ZWISCHENSTUECK
BLECH 5X393X60 S380MC	95 64 428 08	31	4	3 227	91 52 873 08	LI-ZWISCHENSTUECK
BLECH 5X393X60 S380MC	95 64 428 08	31	4	3 227 008	91 52 872 08	LI-ZWISCHENSTUECK
BLECH 5X393X60 S380MC	95 64 428 08	31	4	3 227 200	91 53 519 08	LI-ZWISCHENSTUECK F-ABSP
BLECH 5X393X60 S380MC	95 64 428 08	53	2	3 714	91 52 862 08	D-KOPFSTUECK
BLECH 5X393X60 S380MC	95 64 428 08	23	4	3 715 008	91 52 863 08	D-ZWISCHENSTUECK
BLECH 5X393X60 S380MC	95 64 428 08	23	6	3 716	91 52 864 08	D-ZWISCHENSTUECK
BLECH 5X410X41	97 78 350 08	34	2	2 260	91 53 057 08	BATTERIELAGERUNG
BLECH 5X512X62	97 69 489 08	31	4	1 400	91 56 853 08	RAUPENTRAEGER KPL.LI.
BLECH 5X512X62	97 69 489 08	31	4	1 410 300	91 56 855 08	RAUPENTRAEGER KPL.RE.
BLECH 5X60X388 FE//ZN20//C	97 75 617 08	31	4	3 223 010	91 52 853 08	S-ZWISCHENSTUECK
BLECH 5X691X300	97 74 820 08	4	5	3 215 005	91 52 846 08	ROLLENSATZ
BLECH 5X691X300	97 74 820 08	4	7	3 215 006	91 52 847 08	ROLLENSATZ
BLECH 5X82X50	97 71 697 08	48	1	3 208 001	91 52 883 08	F-KOPFSTUECK
BLECH 5X878X523	97 70 815 08	1	1	2 393 002	96 46 782 08	DECKEL KPL.
BLECH 5X90X57	97 76 596 08	66	6	1 400	91 56 853 08	RAUPENTRAEGER KPL.LI.
BLECH 5X90X57	97 76 596 08	66	6	1 410 300	91 56 855 08	RAUPENTRAEGER KPL.RE.
BLECH 5X95X95	97 74 824 08	5	10	3 215 005	91 52 846 08	ROLLENSATZ
BLECH 5X95X95	97 74 824 08	5	10	3 215 006	91 52 847 08	ROLLENSATZ
BLECH 5X98X140	95 60 933 08	22	1	2 975 000	91 57 881 08	ZUSATZHYDRAULIK MONTAGE
BLECH 6X128X166	95 51 017 08	171	2	2 970	91 56 537 08	HYDRAULIK
BLECH 6X90X123	95 40 177 08	172	2	2 970	91 56 537 08	HYDRAULIK
BLECH 6X90X22	97 18 723 08	6	1	3 206	91 52 881 08	F-ANLENKSTUECK
BLECH 80X1380X475	97 76 224 08	3	2	3 714 009	96 49 267 08	VERSTELLFLASCHE KPL.
BLECH 8X115X115 FE//ZN20//C	97 93 903 08	22	2	3 281	91 52 896 08	FA-BOCK
BLECH 8X125X515	97 83 925 08	7	1	2 391 040	96 53 645 08	KUPPLUNGSSTELLER
BLECH 8X25X160	95 32 809 08	67	2	2 859	91 52 809 08	GERAEUSCHDAEMMUNG
BLECH 8X280X280 FE//ZN20//C	97 75 886 08	4	2	3 714 008	96 49 266 08	VERSTELLFLASCHE KPL.
BLECH 8X280X280 FE//ZN20//C	97 75 886 08	6	2	3 714 009	96 49 267 08	VERSTELLFLASCHE KPL.
BLECH 8X300X50	95 54 048 08	76	2	3 211	91 57 748 08	S-ANLENKSTUECK
BLECH 8X300X50	95 54 048 08	32	4	3 220 500	91 52 849 08	S-ZWISCHENSTUECK
BLECH 8X300X50	95 54 048 08	17	2	3 221	91 54 668 08	S-ZWISCHENSTUECK
BLECH 8X300X50	95 54 048 08	32	5	3 223	91 52 852 08	S-ZWISCHENSTUECK
BLECH 8X300X50	95 54 048 08	32	5	3 223 010	91 52 853 08	S-ZWISCHENSTUECK
BLECH 8X300X50	95 54 048 08	32	5	3 223 100	91 55 327 08	S-ZWISCHENSTUECK
BLECH 8X300X50	95 54 048 08	40	2	3 225	91 52 854 08	SL-REDUZIERSTUECK
BLECH 8X300X50	95 54 048 08	32	4	3 226	91 52 870 08	LI-ZWISCHENSTUECK
BLECH 8X300X50	95 54 048 08	32	5	3 227	91 52 873 08	LI-ZWISCHENSTUECK
BLECH 8X300X50	95 54 048 08	32	5	3 227 008	91 52 872 08	LI-ZWISCHENSTUECK
BLECH 8X300X50	95 54 048 08	32	8	3 227 200	91 53 519 08	LI-ZWISCHENSTUECK F-ABSP
BLECH 8X300X50	95 54 048 08	21	3	3 713	91 57 749 08	D-ANLENKSTUECK
BLECH 8X300X50	95 54 048 08	54	2	3 714	91 52 862 08	D-KOPFSTUECK
BLECH 8X300X50	95 54 048 08	22	4	3 715 008	91 52 863 08	D-ZWISCHENSTUECK
BLECH 8X300X50	95 54 048 08	22	8	3 716	91 52 864 08	D-ZWISCHENSTUECK
BLECH 8X369X382	97 85 716 08	14	1	2 350	91 52 778 08	DREHWERK
BLECH 8X369X382	97 85 717 08	15	1	2 350	91 52 778 08	DREHWERK
BLECH 8X407X110 T ZN O	97 74 758 08	52	4	3 713	91 57 749 08	D-ANLENKSTUECK
BLECH 8X407X110 T ZN O	97 74 758 08	30	4	3 715 008	91 52 863 08	D-ZWISCHENSTUECK
BLECH 8X407X110 T ZN O	97 74 758 08	28	6	3 716	91 52 864 08	D-ZWISCHENSTUECK
BLECH 8X40X246	97 73 817 08	27	4	3 226	91 52 870 08	LI-ZWISCHENSTUECK
BLECH 8X40X246	97 73 817 08	27	4	3 227	91 52 873 08	LI-ZWISCHENSTUECK
BLECH 8X40X246	97 73 817 08	27	4	3 227 008	91 52 872 08	LI-ZWISCHENSTUECK
BLECH 8X40X246	97 73 817 08	27	4	3 227 200	91 53 519 08	LI-ZWISCHENSTUECK F-ABSP
BLECH 8X40X246	97 73 817 08	59	5	3 713	91 57 749 08	D-ANLENKSTUECK
BLECH 8X40X246	97 73 817 08	52	2	3 714	91 52 862 08	D-KOPFSTUECK

6.2.2009

etk_en_de_074515 LR 1600/2

1009

LIEBHERRAlphabetical index
Alphabetischer Index

Bezeichnung	Artikel	Pos.	Menge	Seite	Baugruppe	Bezeichnung
BLECH 8X40X246	97 73 817 08	29	4	3 715 008	91 52 863 08	D-ZWISCHENSTUECK
BLECH 8X40X246	97 73 817 08	27	4	3 716	91 52 864 08	D-ZWISCHENSTUECK
BLECH 8X83X83	97 64 835 08	35	4	2 391 001	96 45 719 08	DIESELMOTOR VORM.
BLECH 8X95X374	97 91 624 08	12	4	3 292	91 52 865 08	D-RUECKHALTESICHERUNG
BLECH 8x40x276	97 08 336 08	27	4	3 220 500	91 52 849 08	S-ZWISCHENSTUECK
BLECH 8x40x276	97 08 336 08	15	4	3 221	91 54 668 08	S-ZWISCHENSTUECK
BLECH 8x40x276	97 08 336 08	27	4	3 223	91 52 852 08	S-ZWISCHENSTUECK
BLECH 8x40x276	97 08 336 08	27	4	3 223 010	91 52 853 08	S-ZWISCHENSTUECK
BLECH 8x40x276	97 08 336 08	27	4	3 223 100	91 55 327 08	S-ZWISCHENSTUECK
BLECH 8x40x276	97 08 336 08	34	4	3 225	91 52 854 08	SL-REDUZIERSTUECK
BLECH KPL.	96 48 170 08	6	1	2 391 001	96 45 719 08	DIESELMOTOR VORM.
BLECH KPL.	96 51 071 08	56	1	2 391 001	96 45 719 08	DIESELMOTOR VORM.
BLECH KPL.	96 51 452 08	27	3	2 391 023	96 45 720 08	KUEHLER VORM.
BLECH KPL.	96 51 459 08	28	3	2 391 023	96 45 720 08	KUEHLER VORM.
BLECH KPL.	96 57 159 08	115	1	3 713	91 57 749 08	D-ANLENKSTUECK
BLECH RD120X2	95 36 382 08	16	2	3 205	91 52 880 08	F-MONTAGEEINHEIT
BLECH RD2X65	95 41 978 08	5	2	3 206 002	96 47 960 08	HEBEL KPL.
BLECH RD40X1	95 57 168 08	18	2	3 205	91 52 880 08	F-MONTAGEEINHEIT
BLECH RD70X2	94 90 229 08	9	1	3 207 003	96 48 259 08	STANGE KPL.
BLECH RD70X2	94 90 229 08	26	2	3 281	91 52 896 08	FA-BOCK
BLECH RD70X2	94 90 229 08	(9)	2	3 281	91 52 896 08	FA-BOCK
BLECH SCHWK.	96 46 753 08	1	1	2 859	91 52 809 08	GERAEUSCHDAEMMUNG
BLECH SCHWK.	96 46 754 08	2	1	2 859	91 52 809 08	GERAEUSCHDAEMMUNG
BLECH SCHWK.	96 48 276 08	37	1	2 859	91 52 809 08	GERAEUSCHDAEMMUNG
BLECH SCHWK.	96 48 277 08	38	1	2 859	91 52 809 08	GERAEUSCHDAEMMUNG
BLECH SCHWK.	96 48 278 08	39	1	2 859	91 52 809 08	GERAEUSCHDAEMMUNG
BLECH SCHWK.	96 48 607 08	6	1	3 215 005	91 52 846 08	ROLLENSATZ
BLECH SCHWK.	96 48 607 08	6	1	3 215 006	91 52 847 08	ROLLENSATZ
BLECH SCHWK.	96 48 608 08	7	1	3 215 005	91 52 846 08	ROLLENSATZ
BLECH SCHWK.	96 48 608 08	7	1	3 215 006	91 52 847 08	ROLLENSATZ
BLECH SCHWK.	96 49 851 08	2	1	3 745 011	96 49 677 08	LASCHE KPL.
BLECH SCHWK.	96 52 917 08	81	1	2 520	91 53 061 08	KABINE VERGLAST
BLECH SCHWK.	96 53 131 08	82	1	2 520	91 53 061 08	KABINE VERGLAST
BLECH SCHWK.	96 54 179 08	1	2	2 657	91 57 656 08	MONTAGEEINRICHTUNG RA
BLECH VORM.	96 48 533 08	12	1	3 780 751	91 52 952 08	FLUG-U.WINDWARNUNG
BLECH VORM. DACH	96 50 385 08	1	1	2 533 051	96 48 360 08	ELEKTRIK KABINE
BLECH X0	95 56 681 08	26	1	2 310	91 52 503 08	WINDE 1
BLECH X0	95 56 681 08	26	1	2 320	91 52 504 08	WINDE 2
BLECH X0	95 56 681 08	36	1	2 340	91 52 776 08	WINDE 4 EINZIEHWERK
BLECH X0	95 56 681 08	(1)	4	2 920	91 56 833 08	ELEKTRIK DREHBUEHNE
BLECH X0	95 56 681 08	90	1	3 211	91 57 748 08	S-ANLENKSTUECK
BLECH X0	95 56 681 08	36	1	3 350	91 52 859 08	WINDE 3
BLECH X0	95 56 681 08	22	1	3 745	91 52 948 08	SCHWEBEBALLAST
BLECHMUTTER M8	41 30 070 08	19	2	2 391 023	96 45 720 08	KUEHLER VORM.
BLECHMUTTER M8	41 30 070 08	32	4	2 831	91 57 754 08	KLIMAAANLAGE OW
BLECHMUTTER M8	41 30 070 08	55	24	2 859	91 52 809 08	GERAEUSCHDAEMMUNG
BLECHSCHRAUBE DIN 7971 4	40 82 010 08	295	2	2 920 581	96 54 405 08	KLEMMKASTEN SA-BOCK VO
BLECHSCHRAUBE DIN 7971 4	40 82 010 08	273	2	3 930 730	96 54 398 08	KLEMMKASTEN KPL.
BLECHSCHRAUBE DIN 7971 4	40 82 010 08	210	2	3 930 734	96 54 401 08	KLEMMKASTEN
BLECHSCHRAUBE DIN 7981 4,	55 31 687 08	17	2	2 932 160	96 54 385 08	SCHALTSCHRANK MECH.
BLECHSCHRAUBE DIN 7981 4,	55 31 687 08	159	2	3 930 640	96 50 481 08	KLEMMKASTEN KPL.
BLECHSCHRAUBE DIN 7981 4,	55 31 687 08	272	2	3 930 730	96 50 599 08	KLEMMKASTEN KPL.
BLECHSCHRAUBE DIN 7981 4,	55 31 687 08	17	6	X1035519	10 35 519 6	OEL-LUFTKUEHLER
BLECHSCHRAUBE DIN 7982 3,	59 10 059 08	47	20	2 520 034	96 45 984 08	INNENVERKLEIDUNG
BLLENDE 1,5X19,5X111	61 10 017 08	4	1	2 932 122	96 45 394 08	LICCON MONTAGEEINHEIT
BLLENDE SCHWK.	96 49 441 08	19	1	2 520 034	96 45 984 08	INNENVERKLEIDUNG
BLENDENSCHUTZ 242X171X5	10 27 921 0	19	1	2 913	91 32 850 08	LICCON KONSOLE LCD2
BLENDENSCHUTZ 4X567X55 AL	97 09 807 08	2	1	2 913 003	96 20 599 08	FOLIENASTATUR VORM.
BLINDNIET 3,0X3,2-5,0	70 42 121 08	10	2	2 913 005	96 20 731 08	INNENGEHAEUSE VORM.
BLINDNIET 3,0X3,2-5,0	70 42 121 08	10	2	2 913 005	96 28 696 08	INNENGEHAEUSE VORM.

6.2.2009

etk_en_de_074515 LR 1600/2

1010

LIEBHERRAlphabetical index
Alphabetischer Index

Bezeichnung	Artikel	Pos.	Menge	Seite	Baugruppe	Bezeichnung
BLINDNIET 3,0X3,2-5,0	70 42 121 08	41	50	2 932 001	96 45 393 08	RELAISSTEUERUNG
BLINDNIET 3,2X4,3-5,9	70 42 127 08	28	2	2 831	91 57 754 08	KLIMAAANLAGE OW
BLINDNIET 4,0X10,5	70 42 323 08	11	30	2 932 082	96 54 387 08	AUFBAUTEILE MONTAGETAPE
BLINDNIETMÜTTER M 8	41 30 065 08	24	5	2 520	91 53 061 08	KABINE VERGLAST
BLINDNIETMÜTTER M 8	41 30 065 08	18	2	2 522	91 54 115 08	SCHIEBETUER KPL.
BLINDNIETMÜTTER M 8	41 30 065 08	2	12	2 810 037	96 47 204 08	PEDALTRAEGER EINBAU
BLINDNIETMÜTTER M10 A3C	41 30 066 08	(2)	2	2 925 402	96 58 855 08	KAMERAANBAU DREHBUEHN
BLINDNIETMÜTTER M5 ST VER	10 04 259 2	31	29	2 520	91 53 061 08	KABINE VERGLAST
BLINDNIETMÜTTER M5 ST VER	10 04 259 2	4	23	2 522	91 54 115 08	SCHIEBETUER KPL.
BLINDNIETMÜTTER M5 ST VER	10 04 259 2	36	8	2 533 070	96 48 363 08	ARMATUREN RE.
BLINDNIETMÜTTER M5 ST VER	10 04 259 2	86	6	2 932 082	96 54 387 08	AUFBAUTEILE MONTAGETAPE
BLINDNIETMÜTTER M6 ST VER	10 04 259 3	32	74	2 520	91 53 061 08	KABINE VERGLAST
BLINDNIETMÜTTER M6 ST VER	10 04 259 3	5	6	2 520 030	96 45 609 08	DACHSCHEIBE VORM.
BLINDNIETMÜTTER M6 ST VER	10 04 259 3	14	1	2 533 066	96 48 365 08	ELEKTRIK ANBAUTEILE KABIN
BLINDNIETMÜTTER M6 ST VER	10 04 259 3	3	5	2 810 037	96 47 204 08	PEDALTRAEGER EINBAU
BLINDSTECKER W1050BS	96 56 664 08	16	1	2 920 369	96 54 235 08	KLEMMKASTEN KPL.
BLINDSTECKER W909BS	96 55 366 08	17	1	2 920 369	96 54 235 08	KLEMMKASTEN KPL.
BLINDSTECKER W909BS	96 56 665 08	15	1	2 920 369	96 54 235 08	KLEMMKASTEN KPL.
BLINDSTECKER W988BS	96 52 267 08	320	1	3 930 638	96 51 624 08	KLEMMKASTEN
BLINDSTECKER W989BS	96 52 272 08	330	1	3 930 638	96 51 624 08	KLEMMKASTEN
BLINDSTOPFEN	26 47 366 02	30	1	2 932 160	96 54 385 08	SCHALTSCHRANK MECH.
BLINDSTOPFEN	69 24 049 08	811	1	2 920 636	96 51 854 08	LEITUNG
BLINDSTOPFEN 1,58	60 45 189 08	(812)	4	2 920 288	96 52 614 08	KABELLISTE DREHBUEHNE
BLINDSTOPFEN DIN 72585 7	69 24 057 08	822	3	2 920 633	96 52 651 08	KABELSTRANG
BLINDSTOPFEN VST11/4"ED A3	47 77 040 08	664	1	1 970	91 56 958 08	HYDRAULIK RAUPE
BLINDSTOPFEN VST11/4"ED A3	47 77 040 08	761	5	2 970	91 56 537 08	HYDRAULIK
BLINDSTOPFEN VST11/4"ED A3	47 77 040 08	12	1	3 713 013	96 57 159 08	BLECH KPL.
BLINDSTOPFEN VST11/4"ED A3	47 77 040 08	623	1	3 978 100	91 56 428 08	HYDR.SCHWEBEBALLAST-AN
BLINDSTOPFEN VST11/4"ED A3	47 77 040 08	2	3	5 113 086	51 13 086 08	PROPORTIONALVENTIL
BLINDSTOPFEN VST11/4"ED A3	47 77 040 08	2	2	X1021769	10 21 769 5	SENKBREMSVENTIL
BLINDSTOPFEN VSTM10X1E	47 77 055 08	608	3	2 990	91 59 244 08	DRUCKLUFTANLAGE
BOCK SCHWK.	96 49 676 08	7	1	3 745	91 52 948 08	SCHWEBEBALLAST
BOCK SCHWK.	96 49 679 08	9	1	3 745	91 52 948 08	SCHWEBEBALLAST
BODENMATTE 1188X829X28	97 71 454 08	9	1	2 520 034	96 45 984 08	INNENVERKLEIDUNG
BODENMATTE 1214X894X209	97 71 453 08	8	1	2 520 034	96 45 984 08	INNENVERKLEIDUNG
BODENPLATTE 2.0 M GS-18NI	97 71 698 08	1	81	1 300 011	96 52 493 08	BODENPLATTEN VORM.
BODENPLATTEN KPL. 2.0 M	91 52 768 08	6	2		LR 1600-2-0	LIEBHERR RAUPENKRAN LR 1
BODENPLATTEN VORM.	96 52 493 08	1	1	1 300	91 52 768 08	BODENPLATTEN KPL.
BOLZEN	10 04 243 0	410	1	X1041101	10 41 101 5	RUECKFALLSTUETZE
BOLZEN	10 04 243 0	390	1	X1041101	10 41 101 8	RUECKFALLSTUETZE
BOLZEN	57 04 059 08	(1)	1	1 750	91 52 394 08	WERKZEUG
BOLZEN 100.0X160 SPF	95 26 739 08	2	1	3 216 005	96 50 697 08	FUSS KPL.
BOLZEN 100.0X185 SPF	97 76 840 08	14	2	3 714	91 52 862 08	D-KOPFSTUECK
BOLZEN 100.0X215 SPF	97 74 861 08	12	4	3 215 005	91 52 846 08	ROLLENSATZ
BOLZEN 100.0X215 SPF	97 74 861 08	12	4	3 215 006	91 52 847 08	ROLLENSATZ
BOLZEN 100.0X225 35NICRM	95 66 686 08	21	2	3 714	91 52 862 08	D-KOPFSTUECK
BOLZEN 100.0X237 35NICRM	97 68 649 08	3	2	3 213	91 52 842 08	F-ANSCHLUSSKOPF
BOLZEN 100.0X237 35NICRM	97 68 649 08	24	2	3 214	91 52 843 08	SW-KOPFSTUECK
BOLZEN 100.0X237 35NICRM	97 68 649 08	7	2	3 225	91 52 854 08	SL-REDUZIERSTUECK
BOLZEN 100.0X237 35NICRM	97 68 649 08	2	4	3 226	91 52 870 08	LI-ZWISCHENSTUECK
BOLZEN 100.0X237 35NICRM	97 68 649 08	2	4	3 227	91 52 873 08	LI-ZWISCHENSTUECK
BOLZEN 100.0X237 35NICRM	97 68 649 08	2	4	3 227 008	91 52 872 08	LI-ZWISCHENSTUECK
BOLZEN 100.0X237 35NICRM	97 68 649 08	2	4	3 227 200	91 53 519 08	LI-ZWISCHENSTUECK F-ABSP
BOLZEN 100.0X237 35NICRM	97 68 649 08	11	2	3 713	91 57 749 08	D-ANLENKSTUECK
BOLZEN 100.0X237 35NICRM	97 68 649 08	23	2	3 714	91 52 862 08	D-KOPFSTUECK
BOLZEN 100.0X237 35NICRM	97 68 649 08	27	4	3 715 008	91 52 863 08	D-ZWISCHENSTUECK
BOLZEN 100.0X237 35NICRM	97 68 649 08	26	4	3 716	91 52 864 08	D-ZWISCHENSTUECK
BOLZEN 100.0X390 SPF	97 72 369 08	9	2	3 205	91 52 880 08	F-MONTAGEEINHEIT
BOLZEN 100.0X430 SPF	97 71 117 08	19	2	3 211	91 57 748 08	S-ANLENKSTUECK
BOLZEN 100x210	97 03 556 08	7	2	3 714 008	96 49 266 08	VERSTELLFLASCHE KPL.

6.2.2009

etk_en_de_074515 LR 1600/2

1011

LIEBHERRAlphabetical index
Alphabetischer Index

Bezeichnung	Artikel	Pos.	Menge	Seite	Baugruppe	Bezeichnung
BOLZEN 105.0X230 SPF	97 78 406 08	9	1	3 745 011	96 49 677 08	LASCHE KPL.
BOLZEN 110.0X196 SPF	97 68 599 08	13	2	2 550	91 57 751 08	SA-BOCK
BOLZEN 110.0X214 SPF	97 68 580 08	15	2	2 550	91 57 751 08	SA-BOCK
BOLZEN 110.0X214 SPF	97 68 580 08	6	1	2 550 005	96 45 680 08	STANGE KPL.
BOLZEN 110.0X214 SPF	97 68 580 08	3	2	3 714 025	96 49 269 08	STANGE KPL.
BOLZEN 110.0X214 SPF	97 68 580 08	8	2	3 745 011	96 49 677 08	LASCHE KPL.
BOLZEN 110.0X265 SPF	97 70 828 08	6	2	3 213	91 52 842 08	F-ANSCHLUSSKOPF
BOLZEN 120.0X222 SPF	97 69 855 08	8	8	1 630	91 52 387 08	HYDRAULISCHE ABSTUETZUN
BOLZEN 120.0X237 SPF	97 64 994 08	4	2	3 211	91 57 748 08	S-ANLENKSTUECK
BOLZEN 120.0X237 SPF	97 64 994 08	2	4	3 220 500	91 52 849 08	S-ZWISCHENSTUECK
BOLZEN 120.0X237 SPF	97 64 994 08	2	4	3 221	91 54 668 08	S-ZWISCHENSTUECK
BOLZEN 120.0X237 SPF	97 64 994 08	2	4	3 223	91 52 852 08	S-ZWISCHENSTUECK
BOLZEN 120.0X237 SPF	97 64 994 08	2	4	3 223 010	91 52 853 08	S-ZWISCHENSTUECK
BOLZEN 120.0X237 SPF	97 64 994 08	2	4	3 223 100	91 55 327 08	S-ZWISCHENSTUECK
BOLZEN 120.0X237 SPF	97 64 994 08	6	2	3 225	91 52 854 08	SL-REDUZIERSTUECK
BOLZEN 130.0X190 SPF	97 68 667 08	4	4	1 632	91 52 389 08	MECH.ZUSATZABSTUETZUNG
BOLZEN 130.0X233 SPF	97 69 809 08	6	2	2 652	91 52 794 08	ROLLENLAGERUNG
BOLZEN 160.0X240 SPF	97 79 763 08	90	2	3 713	91 57 749 08	D-ANLENKSTUECK
BOLZEN 170.0X260 SPF	97 69 484 08	15	2	1 400	91 56 853 08	RAUPENTRAEGER KPL.LI.
BOLZEN 170.0X260 SPF	97 69 484 08	15	2	1 410 300	91 56 855 08	RAUPENTRAEGER KPL.RE.
BOLZEN 170.0X260 SPF	97 69 485 08	16	2	1 400	91 56 853 08	RAUPENTRAEGER KPL.LI.
BOLZEN 170.0X260 SPF	97 69 485 08	16	2	1 410 300	91 56 855 08	RAUPENTRAEGER KPL.RE.
BOLZEN 19.0X76 FE//ZN20//C	97 68 883 08	11	2	2 522 013	96 45 883 08	FUEHRUNG VORM.
BOLZEN 20.0X255 T ZN O	97 79 357 08	21	8	1 630	91 52 387 08	HYDRAULISCHE ABSTUETZUN
BOLZEN 20.0X304	93 82 940 08	8	1	2 620	91 52 793 08	ROLLENDREHVERBINDUNG
BOLZEN 220.0X455 SPF	97 73 402 08	2	2	2 125	91 52 773 08	BOLZEN S-ANLENKST. UND S
BOLZEN 220.0X455 SPF	97 73 403 08	3	2	2 125	91 52 773 08	BOLZEN S-ANLENKST. UND S
BOLZEN 25.0X204 T ZN O	94 26 891 08	28	2	2 550	91 57 751 08	SA-BOCK
BOLZEN 25.0X204 T ZN O	94 26 891 08	12	1	2 550 005	96 45 680 08	STANGE KPL.
BOLZEN 25.0X52	97 19 736 08	3	1	2 502 007	96 22 822 08	ARMLEHNE LINKS
BOLZEN 25.0X52	97 19 736 08	3	1	2 502 008	96 22 823 08	ARMLEHNE RECHTS
BOLZEN 30.0X220 S355J2G3 T	97 74 759 08	54	8	3 713	91 57 749 08	D-ANLENKSTUECK
BOLZEN 30.0X220 S355J2G3 T	97 74 759 08	31	8	3 715 008	91 52 863 08	D-ZWISCHENSTUECK
BOLZEN 30.0X220 S355J2G3 T	97 74 759 08	29	12	3 716	91 52 864 08	D-ZWISCHENSTUECK
BOLZEN 30.0X305 FE//ZN20//C	97 75 245 08	15	1	3 214	91 52 843 08	SW-KOPFSTUECK
BOLZEN 30.0X515 FE//ZN20//C	97 75 246 08	16	1	3 214	91 52 843 08	SW-KOPFSTUECK
BOLZEN 35.0X14 0 30CRNIMO8	97 10 780 08	11	4	2 125	91 52 773 08	BOLZEN S-ANLENKST. UND S
BOLZEN 35.0X150 SPF	97 80 472 08	105	2	3 713	91 57 749 08	D-ANLENKSTUECK
BOLZEN 35.0X236 SPF	97 83 727 08	5	1	3 225 100	96 48 582 08	LAGERUNG KPL.
BOLZEN 35.0X320 FE//ZN20//C	97 80 530 08	17	2	1 400	91 56 853 08	RAUPENTRAEGER KPL.LI.
BOLZEN 35.0X320 FE//ZN20//C	97 80 530 08	17	2	1 410 300	91 56 855 08	RAUPENTRAEGER KPL.RE.
BOLZEN 35.0X82	94 28 899 08	15	1	3 282 002	96 47 890 08	FAB-STUETZE
BOLZEN 35.0X85 SPF	97 73 270 08	21	2	3 282 002	96 47 890 08	FAB-STUETZE
BOLZEN 35.0x330	97 06 477 08	56	1	3 745	91 52 948 08	SCHWEBEBALLAST
BOLZEN 35x178	97 04 625 08	92	1	2 550	91 57 751 08	SA-BOCK
BOLZEN 35x178	97 04 625 08	7	2	3 281	91 52 896 08	FA-BOCK
BOLZEN 35x178	97 04 625 08	63	2	3 714	91 52 862 08	D-KOPFSTUECK
BOLZEN 35x178	97 04 625 08	8	2	3 714 008	96 49 266 08	VERSTELLFLASCHE KPL.
BOLZEN 40.0X95 42CRMO4+Q	97 13 432 08	28	2	2 810	91 52 806 08	KRANFUEHRERKABINE KPL.
BOLZEN 40x166	97 03 523 08	18	4	3 714 009	96 49 267 08	VERSTELLFLASCHE KPL.
BOLZEN 45.0X155 SPF	97 73 264 08	2	1	3 282 002	96 47 890 08	FAB-STUETZE
BOLZEN 45.0X290	97 19 655 08	14	2	3 830	91 55 535 08	ZUSATZABSPANNUNG
BOLZEN 45X158 SPF	94 00 692 08	89	1	2 550	91 57 751 08	SA-BOCK
BOLZEN 45X183 30CRNIMO8	95 59 982 08	62	1	3 714	91 52 862 08	D-KOPFSTUECK
BOLZEN 50.0X110 SPF	97 72 671 08	24	2	3 281	91 52 896 08	FA-BOCK
BOLZEN 50.0X215 SPF	97 71 149 08	2	1	2 550 011	96 47 007 08	KONSOLE KPL.
BOLZEN 55.0X113 SPF	97 73 189 08	5	1	3 206	91 52 881 08	F-ANLENKSTUECK
BOLZEN 55.0X158	93 92 498 08	11	2	2 810	91 52 806 08	KRANFUEHRERKABINE KPL.
BOLZEN 55.0X158	93 92 498 08	80	2	3 211	91 57 748 08	S-ANLENKSTUECK
BOLZEN 55.0X160 SPF	97 72 181 08	25	2	2 550	91 57 751 08	SA-BOCK

6.2.2009

etk_en_de_074515 LR 1600/2

1012

LIEBHERRAlphabetical index
Alphabetischer Index

Bezeichnung	Artikel	Pos.	Menge	Seite	Baugruppe	Bezeichnung
BOLZEN 55.0X175 30CRNIMO8	97 67 727 08	4	1	3 220 501	96 43 440 08	STANGE KPL.
BOLZEN 55.0X175 30CRNIMO8	97 67 727 08	4	1	3 221 200	96 47 984 08	STANGE KPL.
BOLZEN 55.0X175 30CRNIMO8	97 67 727 08	4	1	3 225 200	96 48 679 08	STANGE KPL.
BOLZEN 55.0X175 30CRNIMO8	97 67 727 08	4	1	3 227 002	96 50 498 08	STANGE KPL.
BOLZEN 55.0X175 30CRNIMO8	97 67 727 08	4	1	3 561 003	96 45 222 08	STANGE KPL.
BOLZEN 55.0X175 30CRNIMO8	97 67 727 08	4	1	3 713 012	96 50 197 08	STANGE KPL.
BOLZEN 55.0X175 30CRNIMO8	97 67 727 08	5	2	3 830	91 55 535 08	ZUSATZABSPANNUNG
BOLZEN 55.0X210 30CRNIMO8	95 28 920 08	16	4	3 211	91 57 748 08	S-ANLENKSTUECK
BOLZEN 55.0X210 30CRNIMO8	95 28 920 08	6	1	3 211 003	96 46 986 08	STANGE KPL.
BOLZEN 55.0X210 30CRNIMO8	95 28 920 08	5	1	3 220 501	96 43 440 08	STANGE KPL.
BOLZEN 55.0X210 30CRNIMO8	95 28 920 08	5	1	3 221 200	96 47 984 08	STANGE KPL.
BOLZEN 55.0X210 30CRNIMO8	95 28 920 08	5	1	3 225 200	96 48 679 08	STANGE KPL.
BOLZEN 55.0X210 30CRNIMO8	95 28 920 08	5	1	3 227 002	96 50 498 08	STANGE KPL.
BOLZEN 55.0X210 30CRNIMO8	95 28 920 08	5	1	3 561 003	96 45 222 08	STANGE KPL.
BOLZEN 55.0X210 30CRNIMO8	95 28 920 08	5	1	3 713 012	96 50 197 08	STANGE KPL.
BOLZEN 55.0X210 30CRNIMO8	95 28 920 08	10	2	3 714 009	96 49 267 08	VERSTELLFLASCHE KPL.
BOLZEN 55.0X210 30CRNIMO8	95 28 920 08	3	2	3 714 013	96 59 083 08	LASCHE KPL.
BOLZEN 55.0X210 30CRNIMO8	95 28 920 08	8	2	3 830	91 55 535 08	ZUSATZABSPANNUNG
BOLZEN 55.0X445 SPF	97 79 764 08	97	4	3 713	91 57 749 08	D-ANLENKSTUECK
BOLZEN 55.0X542 SPF	97 72 887 08	7	2	3 205	91 52 880 08	F-MONTAGEEINHEIT
BOLZEN 65.0X171 SPF	97 68 581 08	14	1	2 550 005	96 45 680 08	STANGE KPL.
BOLZEN 65.0X177 SPF	97 74 799 08	4	1	3 716 001	96 49 159 08	STANGE KPL.
BOLZEN 65.0X182 SPF	97 85 235 08	9	2	2 657	91 57 656 08	MONTAGEEINRICHTUNG RA
BOLZEN 65.0X187 SPF	97 66 499 08	16	2	3 220 500	91 52 849 08	S-ZWISCHENSTUECK
BOLZEN 65.0X187 SPF	97 66 499 08	16	2	3 223	91 52 852 08	S-ZWISCHENSTUECK
BOLZEN 65.0X187 SPF	97 66 499 08	16	2	3 223 010	91 52 853 08	S-ZWISCHENSTUECK
BOLZEN 65.0X187 SPF	97 66 499 08	16	2	3 223 100	91 55 327 08	S-ZWISCHENSTUECK
BOLZEN 65.0X189 SPF	97 72 405 08	2	1	2 550 008	96 47 628 08	HALTER KPL.
BOLZEN 65.0X189 SPF	97 72 405 08	2	1	2 550 009	96 47 645 08	HALTER KPL.
BOLZEN 65.0X210 SPF	94 26 890 08	31	2	2 550	91 57 751 08	SA-BOCK
BOLZEN 65.0X220 SPF	97 74 800 08	18	1	2 550 005	96 45 680 08	STANGE KPL.
BOLZEN 65.0X220 SPF	97 74 800 08	5	1	3 716 001	96 49 159 08	STANGE KPL.
BOLZEN 65.0X240 SPF	97 09 155 08	19	2	3 225	91 52 854 08	SL-REDUZIERSTUECK
BOLZEN 65.0X258 SPF	97 74 147 08	35	2	2 550	91 57 751 08	SA-BOCK
BOLZEN 65.0X355 SPF	97 78 361 08	3	8	3 747	91 52 950 08	ZENTRIERUNG STANDARD
BOLZEN 65.0X375 SPF	97 74 903 08	12	2	3 225	91 52 854 08	SL-REDUZIERSTUECK
BOLZEN 65.0X435 35NICRMOV	97 62 324 08	16	4	3 206	91 52 881 08	F-ANLENKSTUECK
BOLZEN 65.0X660 SPF	97 93 900 08	16	1	3 281	91 52 896 08	FA-BOCK
BOLZEN 65.0X84 35NICRMOV	95 71 127 08	87	4	3 713	91 57 749 08	D-ANLENKSTUECK
BOLZEN 65x135	97 09 178 08	48	2	3 713	91 57 749 08	D-ANLENKSTUECK
BOLZEN 70.0X170	97 20 177 08	6	2	3 207 101	96 48 292 08	LASCHE KPL.
BOLZEN 70.0X170	97 20 177 08	13	3	3 281	91 52 896 08	FA-BOCK
BOLZEN 70.0X97 SPF	97 78 941 08	21	4	2 340	91 52 776 08	WINDE 4 EINZIEHWERK
BOLZEN 75.0X166 SPF	97 74 862 08	13	2	3 215 005	91 52 846 08	ROLLENSATZ
BOLZEN 75.0X166 SPF	97 74 862 08	13	2	3 215 006	91 52 847 08	ROLLENSATZ
BOLZEN 75.0X195 SPF	97 72 368 08	6	2	3 205	91 52 880 08	F-MONTAGEEINHEIT
BOLZEN 8.0X21	97 83 643 08	17	2	2 391 040	96 53 645 08	KUPPLUNGSSTELLER
BOLZEN 8.0X34	97 83 644 08	18	1	2 391 040	96 53 645 08	KUPPLUNGSSTELLER
BOLZEN 80.0X328 SPF	93 33 460 08	11	8	1 630	91 52 387 08	HYDRAULISCHE ABSTUETZUN
BOLZEN 85.0X120 SPF	95 67 585 08	2	2	3 292	91 52 865 08	D-RUECKHALTESICHERUNG
BOLZEN 85.0X150 SPF	97 73 608 08	3	2	3 205	91 52 880 08	F-MONTAGEEINHEIT
BOLZEN 85x235	95 20 313 08	16	4	3 745	91 52 948 08	SCHWEBEBALLAST
BOLZEN AEHN. ISO 2340 30X3	45 00 333 08	23	2	3 211	91 57 748 08	S-ANLENKSTUECK
BOLZEN DIN 1433 16X60X50 S	45 00 191 08	3	2	1 641 014	92 53 053 08	ABSTUETZPLATTE KPL.
BOLZEN DIN 1433 20X175X160	45 00 239 08	19	4	3 227 002	96 50 498 08	STANGE KPL.
BOLZEN DIN 1433 30X140X125	45 00 330 08	4	1	3 714 021	96 49 271 08	ROLLENLAGERUNG KPL.
BOLZEN DIN 1433 30X700X680	45 00 312 08	15	3	3 714 008	96 49 266 08	VERSTELLFLASCHE KPL.
BOLZEN DIN 1434 16H11X60X5	45 10 011 08	21	2	2 631	91 56 817 08	LAUFSTEG DREHBUEHNE
BOLZEN DIN 1434 20H11X55X4	45 10 012 08	67	8	3 211	91 57 748 08	S-ANLENKSTUECK
BOLZEN DIN 1435 12H11X60X5	45 12 144 08	61	4	2 550	91 57 751 08	SA-BOCK

6.2.2009

etk_en_de_074515 LR 1600/2

1013

LIEBHERRAlphabetical index
Alphabetischer Index

Bezeichnung	Artikel	Pos.	Menge	Seite	Baugruppe	Bezeichnung
BOLZEN DIN 1435 16H11X40X3	45 12 412 08	45	4	3 211	91 57 748 08	S-ANLENKSTUECK
BOLZEN DIN 1435 16H11X40X3	45 12 412 08	154	4	3 713	91 57 749 08	D-ANLENKSTUECK
BOLZEN DIN 1435 20H11X45X	45 12 222 08	4	4	2 370	91 52 782 08	MONTAGEWINDE
BOLZEN DIN 1435 20H11X45X	45 12 222 08	29	12	2 631	91 56 817 08	LAUFSTEG DREHBUEHNE
BOLZEN DIN 1435 20H11X75X6	45 12 225 08	83	2	2 550	91 57 751 08	SA-BOCK
BOLZEN DIN 1435 20H11X75X6	45 12 225 08	11	1	2 925 204	92 16 990 08	KAMERAANBAU D-ANLENKS
BOLZEN DIN 1435 20H11X75X6	45 12 225 08	29	1	2 925 402	96 58 855 08	KAMERAANBAU DREHBUEHN
BOLZEN DIN 1435 20H11X75X6	45 12 225 08	49	4	3 214	91 52 843 08	SW-KOPFSTUECK
BOLZEN DIN 1435 20H11X75X6	45 12 225 08	58	1	3 281	91 52 896 08	FA-BOCK
BOLZEN DIN 1435 25H11X110X	45 12 272 08	39	4	2 810	91 52 806 08	KRANFUEHRERKABINE KPL.
BOLZEN DIN 1435 25H11X110X	45 12 272 08	49	4	3 225	91 52 854 08	SL-REDUZIERSTUECK
BOLZEN DIN 1435 25H11X70X	45 12 269 08	2	4	2 671	91 52 798 08	OELBEHAELTER KPL.
BOLZEN DIN 1435 25H11X75X	45 12 264 08	13	2	2 670	91 52 797 08	KRAFTSTOFFBEHAELTER KPL
BOLZEN DIN 1435 40D10X80X6	45 12 375 08	7	1	1 991	91 52 510 08	DREHDURCHFUEHRUNG
BOLZEN DIN 1435 40H11X290	45 12 370 08	17	2	3 714 008	96 49 266 08	VERSTELLFLASCHE KPL.
BOLZEN DIN 1435 40H11X60X5	45 12 372 08	6	4	1 991	91 52 510 08	DREHDURCHFUEHRUNG
BOLZEN DIN 1436 20H11X85X7	45 14 223 08	12	4	3 220 500	91 52 849 08	S-ZWISCHENSTUECK
BOLZEN DIN 1436 20H11X85X7	45 14 223 08	12	4	3 223	91 52 852 08	S-ZWISCHENSTUECK
BOLZEN DIN 1436 20H11X85X7	45 14 223 08	12	4	3 223 010	91 52 853 08	S-ZWISCHENSTUECK
BOLZEN DIN 1436 20H11X85X7	45 14 223 08	12	4	3 223 100	91 55 327 08	S-ZWISCHENSTUECK
BOLZEN DIN 1436 20H11X90X8	45 14 220 08	36	2	3 281	91 52 896 08	FA-BOCK
BOLZEN DIN 1436 25H11X200X	45 14 269 08	5	1	2 620	91 52 793 08	ROLLENDREHVERBINDUNG
BOLZEN DIN 1436 30H11X105	45 14 308 08	4	20	1 631 100	91 52 388 08	LAUFSTEG RAUPENFAHRWER
BOLZEN DIN 1436 30H11X140	45 14 304 08	37	2	3 713	91 57 749 08	D-ANLENKSTUECK
BOLZEN DIN 1444 16H11X152X	45 30 093 08	41	8	3 211	91 57 748 08	S-ANLENKSTUECK
BOLZEN DIN 1444 16H11X162X	45 30 083 08	45	8	3 220 500	91 52 849 08	S-ZWISCHENSTUECK
BOLZEN DIN 1444 16H11X162X	45 30 083 08	45	8	3 223	91 52 852 08	S-ZWISCHENSTUECK
BOLZEN DIN 1444 16H11X162X	45 30 083 08	45	8	3 223 010	91 52 853 08	S-ZWISCHENSTUECK
BOLZEN DIN 1444 16H11X162X	45 30 083 08	45	8	3 223 100	91 55 327 08	S-ZWISCHENSTUECK
BOLZEN DIN 1444 16H11X162X	45 30 083 08	45	8	3 226	91 52 870 08	LI-ZWISCHENSTUECK
BOLZEN DIN 1444 16H11X162X	45 30 083 08	45	8	3 227	91 52 873 08	LI-ZWISCHENSTUECK
BOLZEN DIN 1444 16H11X162X	45 30 083 08	45	8	3 227 008	91 52 872 08	LI-ZWISCHENSTUECK
BOLZEN DIN 1444 16H11X162X	45 30 083 08	45	8	3 227 200	91 53 519 08	LI-ZWISCHENSTUECK F-ABSP
BOLZEN DIN 1444 16H11X162X	45 30 083 08	36	8	3 715 008	91 52 863 08	D-ZWISCHENSTUECK
BOLZEN DIN 1444 16H11X162X	45 30 083 08	38	8	3 716	91 52 864 08	D-ZWISCHENSTUECK
BOLZEN DIN 1444 20H11X115X	45 30 209 08	26	6	2 631	91 56 817 08	LAUFSTEG DREHBUEHNE
BOLZEN DIN 1444 20H11X115X	45 30 209 08	62	4	3 211	91 57 748 08	S-ANLENKSTUECK
BOLZEN DIN 1444 20H11X130	45 30 210 08	38	2	3 713	91 57 749 08	D-ANLENKSTUECK
BOLZEN DIN 1444 20H11X170X	45 30 221 08	10	2	3 205	91 52 880 08	F-MONTAGEEINHEIT
BOLZEN DIN 1444 20H11X200X	45 30 213 08	9	4	1 632	91 52 389 08	MECH.ZUSATZABSTUETZUNG
BOLZEN DIN 1444 24H11X60X5	45 30 220 08	31	2	2 631	91 56 817 08	LAUFSTEG DREHBUEHNE
BOLZEN DIN 1444 24H11X60X5	45 30 220 08	13	4	2 730	91 52 802 08	GRUNDPLATTE DREHBUEHNE
BOLZEN DIN 1444 24H11X91X8	45 30 223 08	34	2	2 631	91 56 817 08	LAUFSTEG DREHBUEHNE
BOLZEN DIN 1444 30H11X220X	45 30 300 08	76	2	1 400	91 56 853 08	RAUPENTRAEGER KPL.LI.
BOLZEN DIN 1444 30H11X220X	45 30 300 08	76	2	1 410 300	91 56 855 08	RAUPENTRAEGER KPL.RE.
BOLZEN DIN 1444 30H11X220X	45 30 300 08	9	2	2 652	91 52 794 08	ROLLENLAGERUNG
BOLZEN DIN 1444 30H11X260X	45 30 318 08	9	8	1 630	91 52 387 08	HYDRAULISCHE ABSTUETZUN
BOLZEN DIN 1444 30H11X70X5	94 00 689 08	11	1	2 620	91 52 793 08	ROLLENDREHVERBINDUNG
BOLZEN DIN 1444 30H11X70X5	94 00 689 08	18	1	2 652	91 52 794 08	ROLLENLAGERUNG
BOLZEN DIN 1444 30H11X75X6	45 30 320 08	32	2	2 810	91 52 806 08	KRANFUEHRERKABINE KPL.
BOLZEN DIN 1444 30H11X95X	45 30 327 08	17	2	2 652	91 52 794 08	ROLLENLAGERUNG
BOLZEN DIN 1444 36H11X80X	45 30 324 08	19	2	3 714	91 52 862 08	D-KOPFSTUECK
BOLZEN DIN 1444 45H11X72X	45 30 328 08	7	2	3 207 003	96 48 259 08	STANGE KPL.
BOLZEN DIN 1444 45H11X72X	45 30 328 08	6	2	3 207 100	96 48 261 08	LASCHE KPL.
BOLZEN DIN 1444 45H11X72X	45 30 328 08	(7)	2	3 281	91 52 896 08	FA-BOCK
BOLZEN DIN 1444 50H11X162X	45 30 448 08	15	2	3 205	91 52 880 08	F-MONTAGEEINHEIT
BOLZEN DIN EN 22341 30H11	45 12 305 08	2	1	3 790 006	96 19 989 08	BOLZENZIEHZYLINDER KPL.
BOLZEN DIN EN 22341 30H11	45 12 305 08	2	1	3 790 007	96 19 990 08	BOLZENZIEHZYLINDER KPL.
BOLZEN ISO 2340 20X500X485	45 00 232 08	37	2	3 211	91 57 748 08	S-ANLENKSTUECK
BOLZEN ISO 2340 20X500X485	45 00 232 08	68	2	3 713	91 57 749 08	D-ANLENKSTUECK

6.2.2009

etk_en_de_074515 LR 1600/2

1014

LIEBHERRAlphabetical index
Alphabetischer Index

Bezeichnung	Artikel	Pos.	Menge	Seite	Baugruppe	Bezeichnung
BOLZEN ISO 2340 B30X200X18	45 25 412 08	66	2	3 714	91 52 862 08	D-KOPFSTUECK
BOLZEN ISO 2340 B30X250X2	45 25 413 08	6	1	3 713	91 57 749 08	D-ANLENKSTUECK
BOLZEN ISO 2340 B40X1075X	45 25 485 08	11	2	3 215 005	91 52 846 08	ROLLENSATZ
BOLZEN ISO 2341 30X120X6,3	10 04 126 0	12	2	2 670	91 52 797 08	KRAFTSTOFFBEHAELTER KPL
BOLZEN ISO 2341 B 30X115X1	10 47 124 9	49	4	3 206	91 52 881 08	F-ANLENKSTUECK
BOLZEN ISO 2341 B18H11X75	10 42 572 5	20	1	3 206	91 52 881 08	F-ANLENKSTUECK
BOLZEN ISO 2341 B24H11X140	10 02 966 6	7	1	3 282 002	96 47 890 08	FAB-STUETZE
BOLZEN KPL.	96 36 836 08	19	4	3 745	91 52 948 08	SCHWEBEBALLAST
BOLZEN MIT GRIFF	96 48 349 08	48	1	3 206	91 52 881 08	F-ANLENKSTUECK
BOLZEN RD30X255	94 04 740 08	44	2	3 206	91 52 881 08	F-ANLENKSTUECK
BOLZEN RD35X105 42CR	94 51 057 08	2	4	2 391	91 52 784 08	DIESELMOTOR KPL.
BOLZEN RD35X320	95 09 414 08	55	1	3 745	91 52 948 08	SCHWEBEBALLAST
BOLZEN RD35X72	93 59 891 08	49	2	3 281	91 52 896 08	FA-BOCK
BOLZEN RD35X85 30CR	94 56 112 08	12	8	1 630	91 52 387 08	HYDRAULISCHE ABSTUETZUN
BOLZEN RD40X105 30CRNIM	93 22 268 08	13	4	1 400	91 56 853 08	RAUPENTRAEGER KPL.LI.
BOLZEN RD40X105 30CRNIM	93 22 268 08	13	4	1 410 300	91 56 855 08	RAUPENTRAEGER KPL.RE.
BOLZEN RD40X120	93 83 160 08	72	4	2 550	91 57 751 08	SA-BOCK
BOLZEN RD40X120	94 45 545 08	3	1	3 745 002	92 17 236 08	SCHALTEINHEIT
BOLZEN RD40X120	94 45 545 08	3	1	3 745 003	92 17 237 08	SCHALTEINHEIT
BOLZEN RD40X130 30CRNIM	95 19 655 08	14	2	1 400	91 56 853 08	RAUPENTRAEGER KPL.LI.
BOLZEN RD40X130 30CRNIM	95 19 655 08	14	2	1 410 300	91 56 855 08	RAUPENTRAEGER KPL.RE.
BOLZEN RD40X75 30CRNIMO8	95 60 974 08	18	2	3 206	91 52 881 08	F-ANLENKSTUECK
BOLZEN RD40X75 30CRNIMO8	95 60 974 08	51	1	3 281	91 52 896 08	FA-BOCK
BOLZEN RD40X92	93 35 587 08	19	2	2 810	91 52 806 08	KRANFUEHRERKABINE KPL.
BOLZEN RD45X177	94 99 163 08	2	4	1 742	91 53 021 08	ZENTRALBALLASTBEFESTIG
BOLZEN RD45X177	94 99 163 08	11	2	3 830	91 55 535 08	ZUSATZABSPANNUNG
BOLZEN RD50X120	94 57 205 08	60	2	3 211	91 57 748 08	S-ANLENKSTUECK
BOLZEN RD50X135 30CRNIM	95 36 201 08	10	1	3 282 002	96 47 890 08	FAB-STUETZE
BOLZEN RD50X300	95 28 924 08	8	2	1 632	91 52 389 08	MECH.ZUSATZABSTUETZUNG
BOLZEN RD50X90 30CR	95 54 699 08	59	2	3 211	91 57 748 08	S-ANLENKSTUECK
BOLZEN RD60X170	95 36 392 08	3	1	2 657	91 57 656 08	MONTAGEEINRICHTUNG RA
BOLZEN RD60X220	93 73 829 08	3	4	2 790 455	91 57 005 08	TRANSPORTABLAGE
BOLZEN RD65X232	95 50 681 08	75	2	1 400	91 56 853 08	RAUPENTRAEGER KPL.LI.
BOLZEN RD65X232	95 50 681 08	75	2	1 410 300	91 56 855 08	RAUPENTRAEGER KPL.RE.
BOLZEN RD75X165 35NI	95 44 447 08	6	1	2 657	91 57 656 08	MONTAGEEINRICHTUNG RA
BOLZEN RD80X365	95 56 299 08	24	1	2 810	91 52 806 08	KRANFUEHRERKABINE KPL.
BOLZEN S-ANLENKST. UND SA	91 52 773 08	102	1		LR 1600-2-0	LIEBHERR RAUPENKRAN LR 1
BOLZEN SCHWK. FE//ZN20//C	96 54 826 08	18	4	2 730	91 52 802 08	GRUNDPLATTE DREHBUEHNE
BOLZENZIEHEINRICHTUNG	91 08 481 08	344	1		LR 1600-2-0	LIEBHERR RAUPENKRAN LR 1
BOLZENZIEHZYLINDER KPL.	96 19 989 08	1	1	3 790	91 08 481 08	BOLZENZIEHEINRICHTUNG
BOLZENZIEHZYLINDER KPL.	96 19 990 08	3	1	3 790	91 08 481 08	BOLZENZIEHEINRICHTUNG
BOWDENZUG L=1300 FWK	10 42 458 1	18	1	2 522 011	96 45 602 08	SCHLIESSANLAGE
BOWLE	70 30 235	14	1	7 027 481	70 27 481 03	WASSERABSCHIEDER
BOWLENDICHTUNG HNBR	10 29 417 0	9	1	7 027 481	70 27 481 03	WASSERABSCHIEDER
BRENNER	10 29 012 4	17	1	X1004204	10 04 204 3	WASSERHEIZGERAET
BUCHSE	10 03 239 2	13	1	9 739 118	97 39 118	OELLEITUNG
BUCHSE	60 52 130 08	96	2	2 920 633	96 52 651 08	KABELSTRANG
BUCHSE	60 52 130 08	96	2	2 920 636	96 51 854 08	LEITUNG
BUCHSE 100X130X170 GZ-CU	97 70 818 08	19	2	3 213	91 52 842 08	F-ANSCHLUSSKOPF
BUCHSE 16.0X12 S355J2G3C+	97 68 666 08	47	4	2 502	91 55 939 08	STUERSTAND
BUCHSE 16.0X12 S355J2G3C+	97 68 666 08	10	1	2 522 011	96 45 602 08	SCHLIESSANLAGE
BUCHSE 230X200X266 GZ-CU	97 69 084 08	2	2	3 211	91 57 748 08	S-ANLENKSTUECK
BUCHSE 240X280X175 GZ-ZU	97 76 392 08	3	1	3 714 013	96 49 270 08	LASCHE KPL.
BUCHSE 80X100X70 GZ-CUZN	70 43 346 08	25	2	2 810	91 52 806 08	KRANFUEHRERKABINE KPL.
BUCHSE 9X18X11	10 48 693 4	25	1	9 739 492	97 39 492	ROHRLEITUNG ANBAU
BUCHSE 9X18X15 ST35NBK	10 48 694 0	32	1	9 739 492	97 39 492	ROHRLEITUNG ANBAU
BUCHSE DIN 444 11X20X11,5	10 34 329 9	14	2	9 739 344	97 39 344	GENERATOR VORM.
BUCHSE RD100X45 GZ-CUZN	70 43 378 08	85	2	3 713	91 57 749 08	D-ANLENKSTUECK
BUCHSE RD100X45 GZ-CUZN	97 88 106 08	3	2	3 211	91 57 748 08	S-ANLENKSTUECK
BUCHSENEINSATZ	60 56 016 08	506	3	2 920 633	96 52 651 08	KABELSTRANG

6.2.2009

etk_en_de_074515 LR 1600/2

1015

LIEBHERRAlphabetical index
Alphabetischer Index

Bezeichnung	Artikel	Pos.	Menge	Seite	Baugruppe	Bezeichnung
BUCHSENEINSATZ 16POL	60 56 086 08	29	1	2 920 369	96 54 235 08	KLEMMKASTEN KPL.
BUCHSENEINSATZ 16POL	60 56 086 08	516	1	2 932 224	96 54 389 08	DRAEHTE MONTAGETAFEL K
BUCHSENEINSATZ 40POL	60 56 021 08	30	1	2 920 369	96 54 235 08	KLEMMKASTEN KPL.
BUCHSENEINSATZ 40POL	60 56 021 08	502	2	2 932 224	96 54 389 08	DRAEHTE MONTAGETAFEL K
BUCHSENEINSATZ 64POL	60 56 088 08	25	1	2 920 369	96 54 235 08	KLEMMKASTEN KPL.
BUCHSENEINSATZ 64POL	60 56 088 08	508	8	2 932 224	96 54 389 08	DRAEHTE MONTAGETAFEL K
BUCHSENKONTAKT DIN 72585	60 23 395 08	647	4	2 920 633	96 52 651 08	KABELSTRANG
BUCHSENLEISTE 9POL SPF	60 23 219 08	6	2	2 922 001	92 84 311 08	BUSPLATINE
BUCHSENTRAEGER M1 E-6S	60 45 265 08	155	2	3 930 639	96 50 132 08	DRAEHTE KLEMMKASTEN KPL
BUCHSENTRAEGER M1 E-6S	60 45 265 08	(154)	1	3 930 640	96 50 481 08	KLEMMKASTEN KPL.
BUCHSENTRAEGER M1 E-6S	60 45 265 08	(503)	1	3 930 730	96 50 599 08	KLEMMKASTEN KPL.
BUEGEL	10 65 067 0	2	1	X1035519	10 35 519 6	OEL-LUFTKUEHLER
BUEGEL SCHWK.	92 51 944 08	4	1	2 620	91 52 793 08	ROLLENDREHVERBINDUNG
BUEGEL ST	10 21 652 9	60	1	2 831	91 57 754 08	KLIMAAANLAGE OW
BUERSTENHALTER	10 41 178 6	16	8	X1002800	10 02 800 2	LEITUNGSTROMMEL
BUNDLAGER 18X12X12 SINT	10 42 448 9	7	4	2 522 013	96 45 883 08	FUEHRUNG VORM.
BUNDSCHRAUBE	10 22 236 1	6	1	9 739 256	97 39 256	LUFTANSAUGROHR
BUNDSCHRAUBE	10 22 272 8	3	7	9 739 256	97 39 256	LUFTANSAUGROHR
BUNDSCHRAUBE	10 22 273 7	7	1	9 739 248	97 39 248	EINSPRITZDUESE
BUNDSCHRAUBE	10 22 273 7	6	4	9 739 491	97 39 491	LUFTPRESSER ANBAU
BUNDSCHRAUBE M10X55 X5N	10 03 034 6	6	2	9 739 295	97 39 295	ABGASROHR
BUNDSCHRAUBE M10X95	10 01 255 0	7	22	9 739 295	97 39 295	ABGASROHR
BUNDSCHRAUBE M8X40,5 AK	10 01 254 7	17	2	9 739 122	97 39 122	OELKUEHLER
BUNDSCHRAUBE M8X65,5 AK	10 01 254 9	18	2	9 739 122	97 39 122	OELKUEHLER
BUSLEITUNG 4X1,0 SPF	60 03 452 08	371	2.05	2 920 633	96 52 651 08	KABELSTRANG
BUSPLATINE	92 84 311 08	3	1	2 913 100	91 23 538 08	BAUGRUPPENTRAEGER
BUTZEN 18-L A3P	47 77 001 08	592	1	2 970	91 56 537 08	HYDRAULIK
BUTZEN 22-L A3P	47 77 002 08	585	2	2 970	91 56 537 08	HYDRAULIK
BUTZEN 28-L A3P	47 77 008 08	587	2	2 970	91 56 537 08	HYDRAULIK
BUTZEN 28-L A3P	47 77 008 08	599	1	2 978 200	91 54 843 08	ZUSATZHYDR.S-RUECKHALTE
BUTZEN 30-S A3P	47 77 016 08	575	4	2 970	91 56 537 08	HYDRAULIK
CCD-KAMERA 20GRAD	10 02 895 4	18	1	2 925 002	96 58 856 08	AUSRUESTUNG KAMERA DRE
CLIP 23 ST	10 21 653 4	61	2	2 831	91 57 754 08	KLIMAAANLAGE OW
CONTROLLERBOARD KOMP.	10 04 375 9	20	1	2 913 005	96 28 696 08	INNENGEHAEUSE VORM.
CONTROLLERBOARD LSB-BS	10 04 375 7	1	1	2 913 007	96 20 763 08	CONTROLLEREINHEIT
CONTROLLERBOARD LSB-CP	10 04 376 0	2	1	2 913 007	96 20 763 08	CONTROLLEREINHEIT
CONTROLLEREINHEIT BSE-LS	96 20 763 08	20	1	2 913 005	96 20 731 08	INNENGEHAEUSE VORM.
CRIMPKONTAKT	60 56 023 08	(602)	4	2 920 369	96 54 235 08	KLEMMKASTEN KPL.
CRIMPKONTAKT	60 56 023 08	(602)	4	2 920 369	96 54 235 08	KLEMMKASTEN KPL.
CRIMPKONTAKT	60 56 023 08	602	60	2 920 633	96 52 651 08	KABELSTRANG
CRIMPKONTAKT 0,14 - 0,37	60 56 114 08	702	14	2 920 633	96 52 651 08	KABELSTRANG
CRIMPKONTAKT 0,5	60 56 045 08	126	51	2 920 633	96 52 651 08	KABELSTRANG
CRIMPKONTAKT 0,5	60 56 101 08	601	54	2 920 633	96 52 651 08	KABELSTRANG
CRIMPKONTAKT 1,5	60 56 102 08	603	8	2 920 633	96 52 651 08	KABELSTRANG
D-ANLENKSTUECK	91 57 749 08	250	1		LR 1600-2-0	LIEBHERR RAUPENKRAN LR 1
D-ANLENKSTUECK SCHWK.	96 49 113 08	1	1	3 713	91 57 749 08	D-ANLENKSTUECK
D-KOPFSTUECK	91 52 862 08	252	1		LR 1600-2-0	LIEBHERR RAUPENKRAN LR 1
D-KOPFSTUECK SCHWK.	96 49 265 08	1	1	3 714	91 52 862 08	D-KOPFSTUECK
D-RUECKHALTESICHERUNG	91 52 865 08	258	1		LR 1600-2-0	LIEBHERR RAUPENKRAN LR 1
D-ZWISCHENSTUECK 2420.16	91 52 863 08	254	1		LR 1600-2-0	LIEBHERR RAUPENKRAN LR 1
D-ZWISCHENSTUECK 2420.20	91 52 864 08	256	1		LR 1600-2-0	LIEBHERR RAUPENKRAN LR 1
D-ZWISCHENSTUECK SCHWK.	96 48 588 08	1	1	3 715 008	91 52 863 08	D-ZWISCHENSTUECK
D-ZWISCHENSTUECK SCHWK.	96 49 123 08	1	1	3 716	91 52 864 08	D-ZWISCHENSTUECK
DACHFASENRING	10 01 215 9	6	1	9 739 246	97 39 246	KOLBEN
DACHSCHEIBE SPF	97 68 380 08	2	1	2 520 030	96 45 609 08	DACHSCHEIBE VORM.
DACHSCHEIBE VORM.	96 45 609 08	6	1	2 520	91 53 061 08	KABINE VERGLAST
DAEMMMATTE 20X100X274 PE	97 76 591 08	11	1	2 520 035	96 49 125 08	DAEMMUNG BODENBLECH
DAEMMMATTE 20X1206X326	97 70 937 08	3	1	2 859 007	96 46 775 08	DECKEL KPL.
DAEMMMATTE 20X123X288 PE	97 76 590 08	10	1	2 520 035	96 49 125 08	DAEMMUNG BODENBLECH
DAEMMMATTE 20X1400X442	97 70 809 08	32	1	2 859	91 52 809 08	GERAEUSCHDAEMMUNG

6.2.2009

etk_en_de_074515 LR 1600/2

1016

LIEBHERRAlphabetical index
Alphabetischer Index

Bezeichnung	Artikel	Pos.	Menge	Seite	Baugruppe	Bezeichnung
DAEMMMATTE 20X155X429 PE	97 76 582 08	2	1	2 520 035	96 49 125 08	DAEMMUNG BODENBLECH
DAEMMMATTE 20X182X747 PE	97 76 588 08	8	1	2 520 035	96 49 125 08	DAEMMUNG BODENBLECH
DAEMMMATTE 20X195X747 PE	97 76 585 08	5	1	2 520 035	96 49 125 08	DAEMMUNG BODENBLECH
DAEMMMATTE 20X213X280 PE	97 76 592 08	12	1	2 520 035	96 49 125 08	DAEMMUNG BODENBLECH
DAEMMMATTE 20X215X451 PE	97 76 593 08	13	1	2 520 035	96 49 125 08	DAEMMUNG BODENBLECH
DAEMMMATTE 20X229X810 PE	97 76 584 08	4	1	2 520 035	96 49 125 08	DAEMMUNG BODENBLECH
DAEMMMATTE 20X229X810 PE	97 76 586 08	6	1	2 520 035	96 49 125 08	DAEMMUNG BODENBLECH
DAEMMMATTE 20X294X986 PE	97 76 587 08	7	1	2 520 035	96 49 125 08	DAEMMUNG BODENBLECH
DAEMMMATTE 20X348X786 PE	97 76 581 08	1	1	2 520 035	96 49 125 08	DAEMMUNG BODENBLECH
DAEMMMATTE 20X380X894 PE	97 76 583 08	3	1	2 520 035	96 49 125 08	DAEMMUNG BODENBLECH
DAEMMMATTE 20X451X986 PE	97 76 589 08	9	1	2 520 035	96 49 125 08	DAEMMUNG BODENBLECH
DAEMMMATTE 20X793X635	97 70 984 08	3	1	2 859 027	96 46 777 08	DECKEL KPL.
DAEMMMATTE 20X798X443	97 70 986 08	3	1	2 859 028	96 46 778 08	DECKEL KPL.
DAEMMMATTE 20X798X445	97 71 635 08	3	1	2 393 002	96 46 782 08	DECKEL KPL.
DAEMMMATTE 20X798X643	97 70 953 08	3	1	2 859 026	96 46 776 08	DECKEL KPL.
DAEMMMATTE 20X953X442	97 70 796 08	26	1	2 859	91 52 809 08	GERAEUSCHDAEMMUNG
DAEMMMATTE 20X989X365	97 70 998 08	3	1	2 859 029	96 46 779 08	DECKEL KPL.
DAEMMMATTE 40X482X228	97 70 907 08	41	1	2 859	91 52 809 08	GERAEUSCHDAEMMUNG
DAEMMMATTE LINKS 19X94X	97 18 512 08	8	1	2 913	91 32 850 08	LICCON KONSOLE LCD2
DAEMMMATTE LINKS 19X94X	97 18 512 08	8	1	2 913 009	91 04 705 08	LICCON KONSOLE LCD3
DAEMMMATTE OBEN 11.5X94X	97 18 514 08	10	1	2 913	91 32 850 08	LICCON KONSOLE LCD2
DAEMMMATTE OBEN 11.5X94X	97 18 514 08	10	1	2 913 009	91 04 705 08	LICCON KONSOLE LCD3
DAEMMMATTE RECHTS 19X9	97 18 513 08	9	1	2 913	91 32 850 08	LICCON KONSOLE LCD2
DAEMMMATTE RECHTS 19X9	97 18 513 08	9	1	2 913 009	91 04 705 08	LICCON KONSOLE LCD3
DAEMMMATTE UNTEN 9X97X	97 18 507 08	6	1	2 913	91 32 850 08	LICCON KONSOLE LCD2
DAEMMMATTE UNTEN 9X97X	97 18 507 08	6	1	2 913 009	91 04 705 08	LICCON KONSOLE LCD3
DAEMMMATTE VERSCHLUSS	97 18 511 08	7	1	2 913	91 32 850 08	LICCON KONSOLE LCD2
DAEMMMATTE VERSCHLUSS	97 18 511 08	7	1	2 913 009	91 04 705 08	LICCON KONSOLE LCD3
DAEMMSTOFF 20X20X2000	10 42 540 9	70	1.5	2 859	91 52 809 08	GERAEUSCHDAEMMUNG
DAEMMSTOFF 40X40X2000	28 39 057 08	29	1	2 391 023	96 45 720 08	KUEHLER VORM.
DAEMMSTOFF 40X40X2000	28 39 057 08	72	1	2 859	91 52 809 08	GERAEUSCHDAEMMUNG
DAEMMUNG BODENBLECH	96 49 125 08	69	1	2 520	91 53 061 08	KABINE VERGLAST
DAEMPFER	10 65 048 8	66	1	X1029200	10 29 200 4	FAHRERSITZ
DAEMPFUNGSKOLBEN	51 07 974 08	7	1	5 114 176	51 14 176 08	DRUCKBEGRENZUNGSVENTI
DAEMPFUNGSKOLBEN	51 07 974 08	7	1	5 114 177	51 14 177 08	DRUCKBEGRENZUNGSVENTI
DAEMPFUNGSKOLBEN	51 07 974 08	6	1	5 114 320	51 14 320 08	VORSPANNVENTIL
DATENLEITUNG 2X1 SPF	60 04 425 08	14	6.95	2 920 633	96 52 651 08	KABELSTRANG
DATENLOGGER 24V LDL2 SPF	10 34 043 8	112	1	2 932 082	96 54 387 08	AUFBAUTEILE MONTAGETAPE
DAUERMAGNET	61 70 001 08	3	1	2 780 851	96 24 498 08	FUNKANTENNE VORM.
DAUERMAGNET	61 70 001 08	7	1	2 780 852	96 24 845 08	GSM-MODUL VORM.LICCON 1
DAUERMAGNET	61 70 001 08	267	2	2 920 638	96 51 138 08	BEDIENPULT
DECKEL	10 01 228 8	9	1	9 739 122	97 39 122	OELKUEHLER
DECKEL	10 01 245 1	5	1	9 739 258	97 39 258	KRAFTSTOFFFILTER
DECKEL	10 01 245 2	7	1	9 739 258	97 39 258	KRAFTSTOFFFILTER
DECKEL	10 28 635 3	11	1	1 920 418	96 48 687 08	KLEMMKASTEN KPL.
DECKEL	10 28 635 3	274	1	2 780 748	96 52 969 08	KLEMMKASTEN KPL.
DECKEL	10 28 635 3	266	1	2 920 581	96 54 405 08	KLEMMKASTEN SA-BOCK VO
DECKEL	10 28 635 3	262	1	3 930 638	96 51 624 08	KLEMMKASTEN
DECKEL	10 28 635 3	296	1	3 930 730	96 50 599 08	KLEMMKASTEN KPL.
DECKEL	10 28 635 3	280	2	3 930 730	96 54 398 08	KLEMMKASTEN KPL.
DECKEL	10 28 635 3	206	1	3 930 734	96 54 401 08	KLEMMKASTEN
DECKEL	60 27 617 08	62	1	2 932 082	96 54 387 08	AUFBAUTEILE MONTAGETAPE
DECKEL	70 23 645	7	1	X1035924	10 35 924 8	VERSTELLPUMPE
DECKEL 1.5X954X977	97 75 796 08	70	1	2 520	91 53 061 08	KABINE VERGLAST
DECKEL 2X341X116 ALMG3	97 17 070 08	3	1	2 913	91 32 850 08	LICCON KONSOLE LCD2
DECKEL 2X341X116 ALMG3	97 17 070 08	3	1	2 913 009	91 04 705 08	LICCON KONSOLE LCD3
DECKEL 5X490X490	97 66 383 08	8	1	2 350	91 52 778 08	DREHWERK
DECKEL ABS SPF	97 73 582 08	25	1	2 520	91 53 061 08	KABINE VERGLAST
DECKEL GEKLEBT	96 48 168 08	1	1	2 932 168	96 48 167 08	DECKEL KPL.
DECKEL GK-ALSI2CU	70 27 755	3	1	7 027 481	70 27 481 03	WASSERABSCHIEDER

6.2.2009

etk_en_de_074515 LR 1600/2

1017

LIEBHERRAlphabetical index
Alphabetischer Index

Bezeichnung	Artikel	Pos.	Menge	Seite	Baugruppe	Bezeichnung
DECKEL KPL.	96 46 758 08	6	1	2 859	91 52 809 08	GERAEUSCHDAEMMUNG
DECKEL KPL.	96 46 775 08	16	1	2 859	91 52 809 08	GERAEUSCHDAEMMUNG
DECKEL KPL.	96 46 776 08	17	1	2 859	91 52 809 08	GERAEUSCHDAEMMUNG
DECKEL KPL.	96 46 777 08	18	1	2 859	91 52 809 08	GERAEUSCHDAEMMUNG
DECKEL KPL.	96 46 778 08	19	1	2 859	91 52 809 08	GERAEUSCHDAEMMUNG
DECKEL KPL.	96 46 779 08	20	1	2 859	91 52 809 08	GERAEUSCHDAEMMUNG
DECKEL KPL.	96 46 782 08	6	1	2 393	91 52 787 08	LUFTFILTERANLAGE KPL.
DECKEL KPL.	96 48 167 08	2	1	2 932 160	96 54 385 08	SCHALTSCHRANK MECH.
DECKEL RD190X6	93 55 088 08	7	3	3 745 011	96 49 677 08	LASCHE KPL.
DECKEL SAE-B	10 22 566 6	127	1	2 391 001	96 45 719 08	DIESELMOTOR VORM.
DECKEL SCHWK.	96 36 694 08	10	1	3 745 011	96 49 677 08	LASCHE KPL.
DECKEL SCHWK.	96 46 922 08	1	1	2 859 029	96 46 779 08	DECKEL KPL.
DECKEL SCHWK.	96 49 083 08	68	1	2 520	91 53 061 08	KABINE VERGLAST
DECKEL VORM. SPF	96 23 055 08	2	1	2 260 006	96 46 501 08	BATTERIEKASTEN VORM.
DECKELDICHTUNG HNBR	10 29 417 1	4	1	7 027 481	70 27 481 03	WASSERABSCHIEDER
DECKPLATTE 30X5X178/2 ST D	60 20 015 08	147	2	2 391 001	96 45 719 08	DIESELMOTOR VORM.
DEHNSCHRAUBE 10.9 SPF	97 65 584 08	2	72	2 620	91 52 793 08	ROLLENDREHVERBINDUNG
DEHNSCHRAUBE M48X170 30	40 98 296 08	1	72	1 620	91 52 386 08	BEFESTIGUNGSTEILE DREH
DEICHSEL SCHWK.	92 51 224 08	5	1	1 991	91 52 510 08	DREHDURCHFUEHRUNG
DEICHSEL SCHWK.	96 17 270 08	4	1	1 991	91 52 510 08	DREHDURCHFUEHRUNG
DICHT-UND FUELLMASSE 100	87 00 018 08	7	1	2 810 001	96 43 597 08	KRANFUEHRERKABINE VORM
DICHTMITTEL	10 01 117 2	11	1	9 739 262	97 39 262	ZYLINDERKOPF
DICHTMITTEL	10 01 117 2	11	1	9 739 266	97 39 266	ZYLINDERKOPF
DICHTMITTEL	10 01 117 2	2	1	9 739 271	97 39 271	VERBINDUNGSLEITUNG
DICHTMITTEL	10 01 117 2	2	1	9 739 491	97 39 491	LUFTPRESSER ANBAU
DICHTMITTEL	10 01 117 6	19	1	9 739 492	97 39 492	ROHRLEITUNG ANBAU
DICHTMITTEL A80MR HYLOMA	87 00 028 08	(265)	0.01	3 930 138	96 54 377 08	ELEKTRIK S-ANLENKSTUECK
DICHTMITTEL A80MR HYLOMA	87 00 028 08	289	0.1	3 930 730	96 50 599 08	KLEMMKASTEN KPL.
DICHTMUTTER M6	51 07 534 08	10	1	5 711 301	57 11 301 08	DRUCKBEGRENZUNGSVENTI
DICHTMUTTER M6	51 07 534 08	11	1	X1048973	10 48 973 4	DRUCKBEGRENZUNGSVENTI
DICHTMUTTER M8	51 07 417 08	21	1	5 114 176	51 14 176 08	DRUCKBEGRENZUNGSVENTI
DICHTMUTTER M8	51 07 417 08	21	1	5 114 177	51 14 177 08	DRUCKBEGRENZUNGSVENTI
DICHTPROFIL	26 21 047 08	154	0.85	2 391 001	96 45 719 08	DIESELMOTOR VORM.
DICHTPROFIL	26 21 047 08	18	0.69	2 393 002	96 46 782 08	DECKEL KPL.
DICHTPROFIL	26 21 047 08	13	4.46	2 510	91 52 788 08	DREHBUEHNENVERKLEIDUN
DICHTPROFIL	26 21 821 01	315	8.36	9 907 151	99 07 151 01	ROLLENDREHVERBINDUNG
DICHTPROFIL	26 21 835 01	314	8.31	9 907 151	99 07 151 01	ROLLENDREHVERBINDUNG
DICHTPROFIL	59 15 078 08	12	4	2 510	91 52 788 08	DREHBUEHNENVERKLEIDUN
DICHTRAHMEN	97 36 626 08	16	1	2 913	91 32 850 08	LICCON KONSOLE LCD2
DICHTRAHMEN 10X60X 185 P	97 25 613 08	38	10	2 520 034	96 45 984 08	INNENVERKLEIDUNG
DICHTRAHMEN RD92X20 DI=80	97 25 615 08	39	3	2 520 034	96 45 984 08	INNENVERKLEIDUNG
DICHTRING	10 22 273 6	4	1	9 739 248	97 39 248	EINSPRITZDUESE
DICHTRING	10 22 273 6	74	1	X1022281	10 22 281 7	DS ZYLINDERKOPF
DICHTRING	50 26 088 08	50	1	2 393	91 52 787 08	LUFTFILTERANLAGE KPL.
DICHTRING 10,7X16X1,5 ST/FP	10 01 186 4	16	2	9 739 288	97 39 288	KRAFTSTOFFLEITUNG
DICHTRING 109X113X3	10 02 119 1	12	1	X1004204	10 04 204 3	WASSERHEIZGERAET
DICHTRING 14,7X22X1,5 ST/FP	10 01 186 6	3	12	9 739 127	97 39 127	WASSERENTLUEFTUNGSLEIT
DICHTRING 14,7X22X1,5 ST/FP	10 01 186 6	6	1	9 739 188	97 39 188	OELMESSSTAB
DICHTRING 14,7X22X1,5 ST/FP	10 01 186 6	15	1	9 739 258	97 39 258	KRAFTSTOFFFILTER
DICHTRING 14,7X22X1,5 ST/FP	10 01 186 6	12	1	9 739 281	97 39 281	LECKOELLEITUNG
DICHTRING 14,7X22X1,5 ST/FP	10 01 186 6	3	11	9 739 282	97 39 282	LECKOELLEITUNG
DICHTRING 14,7X22X1,5 ST/FP	10 01 186 6	19	5	9 739 288	97 39 288	KRAFTSTOFFLEITUNG
DICHTRING 14,7X22X1,5 ST/FP	10 01 186 6	5	14	9 739 292	97 39 292	KRAFTSTOFFLEITUNG
DICHTRING 14,7X22X1,5 ST/FP	10 01 186 6	18	2	9 739 349	97 39 349	WASSERLEITUNGSANSCHLUE
DICHTRING 14,7X22X1,5 ST/FP	10 01 186 6	16	2	9 739 361	97 39 361	OELWANNE
DICHTRING 14,7X22X1,5 ST/FP	10 01 186 6	4	6	9 739 492	97 39 492	ROHRLEITUNG ANBAU
DICHTRING 16,7X24X1,5 ST/FP	10 01 186 7	2	1	9 739 096	97 39 096	VERSCHLUSSSCHRAUBE
DICHTRING 16,7X24X1,5 ST/FP	10 01 186 7	10	1	9 739 281	97 39 281	LECKOELLEITUNG
DICHTRING 16,7X24X1,5 ST/FP	10 01 186 7	(2)	1	9 739 318	97 39 318	SENSORIK
DICHTRING 16,7X24X1,5 ST/FP	10 01 186 7	(2)	1	9 739 318	97 39 318	SENSORIK

6.2.2009

etk_en_de_074515 LR 1600/2

1018

LIEBHERRAlphabetical index
Alphabetischer Index

Bezeichnung	Artikel	Pos.	Menge	Seite	Baugruppe	Bezeichnung
DICHTRING 16,7X24X1,5 ST/FP	10 01 186 7	20	1	9 739 349	97 39 349	WASSERLEITUNGSANSCHLUE
DICHTRING 16,7X24X1,5 ST/FP	10 01 186 7	7	3	9 739 355	97 39 355	OELKUEHLER ANBAU
DICHTRING 16,7X24X1,5 ST/FP	10 01 186 7	3	2	9 739 494	97 39 494	ATL-ANBAU
DICHTRING 18,7X26X1,5 ST/FP	10 01 186 8	(2)	1	9 739 318	97 39 318	SENSORIK
DICHTRING 18,7X26X1,5 ST/FP	10 01 186 8	(2)	1	9 739 318	97 39 318	SENSORIK
DICHTRING 18,7X26X1,5 ST/FP	10 01 186 8	13	1	9 739 355	97 39 355	OELKUEHLER ANBAU
DICHTRING 19,6X24,3X1,5 NBR	76 10 225 03	6	1	9 275 543	92 75 543 01	ENTLUEFTUNGSSTUTZEN
DICHTRING 22,7X30X2 ST/FP	10 01 186 9	13	1	9 739 258	97 39 258	KRAFTSTOFFFILTER
DICHTRING 22,7X30X2 ST/FP	10 01 186 9	7	1	9 739 351	97 39 351	KUEHLMITTELEITUNG ANBA
DICHTRING 22,7X30X2 ST/FP	10 01 186 9	14	1	9 739 492	97 39 492	ROHRLEITUNG ANBAU
DICHTRING 24,7X32X2 ST/FP	10 01 184 2	9	1	9 739 351	97 39 351	KUEHLMITTELEITUNG ANBA
DICHTRING 26,7X34,93X2 ST/	10 01 187 0	11	1	9 739 355	97 39 355	OELKUEHLER ANBAU
DICHTRING 26,7X34,93X2 ST/	10 01 187 0	10	2	9 739 361	97 39 361	OELWANNE
DICHTRING 26,7X34,93X2 ST/	10 01 187 0	12	1	9 739 491	97 39 491	LUFTPRESSER ANBAU
DICHTRING 26,7X34,93X2 ST/	10 01 187 0	26	2	9 739 494	97 39 494	ATL-ANBAU
DICHTRING 32,7X40X2 ST/FP	10 01 187 2	9	1	9 739 288	97 39 288	KRAFTSTOFFLEITUNG
DICHTRING 32,7X40X2 ST/FP	10 01 187 2	15	2	9 739 492	97 39 492	ROHRLEITUNG ANBAU
DICHTRING 8,7X14X1 ST/FPM1	10 01 187 1	3	12	9 739 281	97 39 281	LECKOELLEITUNG
DICHTRING 8,7X14X1 ST/FPM1	10 01 187 1	79	2	X1022281	10 22 281 7	DS ZYLINDERKOPF
DICHTRING A22X27 CU	10 01 184 1	23	1	9 739 491	97 39 491	LUFTPRESSER ANBAU
DICHTRING A26X34 CU	10 03 730 5	22	3	9 739 491	97 39 491	LUFTPRESSER ANBAU
DICHTRING DIN 7603 A 10X13	71 01 013 08	61	4	X1065015	10 65 015 8	ANTRIEB
DICHTRING DIN 7603 A 12X16	71 01 017 08	123	1	X1065015	10 65 015 8	ANTRIEB
DICHTRING DIN 7603 A 12X17	71 01 018 08	19	4	2 990	91 59 244 08	DRUCKLUFTANLAGE
DICHTRING DIN 7603 A 12X18	71 01 020 08	49	1	2 393	91 52 787 08	LUFTFILTERANLAGE KPL.
DICHTRING DIN 7603 A 13X18	71 01 023 08	(3)	1	2 391 102	96 56 360 08	ZUSATZKUEHLER VORM.
DICHTRING DIN 7603 A 14X20	71 01 030 08	8	2	X1011614	10 11 614 1	KRAFTSTOFFSCHLAUCH
DICHTRING DIN 7603 A 14X20	73 81 225 23	590	2	2 970	91 56 537 08	HYDRAULIK
DICHTRING DIN 7603 A 16X20	71 01 034 08	8	1	5 113 005	51 13 005 08	STUEBERBLOCK
DICHTRING DIN 7603 A 16X22	71 01 037 08	4	1	X1011614	10 11 614 1	KRAFTSTOFFSCHLAUCH
DICHTRING DIN 7603 A 18X22	51 45 171 08	521	2	X1065015	10 65 015 5	GETRIEBE
DICHTRING DIN 7603 A 18X22	51 45 171 08	65	1	X1065015	10 65 015 8	ANTRIEB
DICHTRING DIN 7603 A 21X26	71 01 044 08	13	1	5 114 320	51 14 320 08	VORSPANNVENTIL
DICHTRING DIN 7603 A 21X26	71 01 044 08	13	3	7 743 566	77 43 566 08	ELEKTROPUMPE
DICHTRING DIN 7603 A 22X27	54 01 452 08	531	2	X1065015	10 65 015 5	GETRIEBE
DICHTRING DIN 7603 A 24X30	71 01 053 08	69	1	3 978 005	91 56 430 08	ZUSATZHYDRAULIK SB-KOPFS
DICHTRING DIN 7603 A 24X30	71 01 053 08	69	2	3 978 015	91 56 429 08	ZUSATZHYDRAULIK ZWISCH
DICHTRING DIN 7603 A 24X30	71 01 053 08	69	2	3 978 015	91 56 432 08	ZUSATZHYDRAULIK ZWISCH
DICHTRING DIN 7603 A 24X30	71 01 053 08	69	1	3 978 100	91 56 428 08	HYDR.SCHWEBEBALLAST-AN
DICHTRING DIN 7603 A 26X31	71 01 061 08	12	1	2 671	91 52 798 08	OELBEHAELTER KPL.
DICHTRING DIN 7603 A 26X32	71 01 060 08	20	1	2 990	91 59 244 08	DRUCKLUFTANLAGE
DICHTRING DIN 7603 A 27X32	71 01 059 08	139	10	2 970	91 56 537 08	HYDRAULIK
DICHTRING DIN 7603 A 27X32	71 01 059 08	63	6	2 975 100	91 52 860 08	ZUSATZHYDRAULIK WINDE 3
DICHTRING DIN 7603 A 27X32	71 01 059 08	70	1	2 977	91 57 756 08	ZUSATZHYDRAULIK DREHBUE
DICHTRING DIN 7603 A 27X32	71 01 059 08	70	1	2 978 100	91 52 827 08	ZUSATZHYDR.D-RUECKHALT
DICHTRING DIN 7603 A 27X32	71 01 059 08	62	1	2 978 200	91 54 843 08	ZUSATZHYDR.S-RUECKHALTE
DICHTRING DIN 7603 A 30X36	50 15 366 08	463	4	X1065015	10 65 015 5	GETRIEBE
DICHTRING DIN 7603 A 33X39	71 01 070 08	138	10	2 970	91 56 537 08	HYDRAULIK
DICHTRING DIN 7603 A 33X39	71 01 070 08	62	1	2 975 200	91 52 775 08	ZUSATZHYDRAULIK WINDE 2
DICHTRING DIN 7603 A 33X39	71 01 070 08	62	1	2 975 700	91 52 774 08	ZUSATZHYDRAULIK WINDE 1
DICHTRING DIN 7603 A 33X39	71 01 070 08	62	1	2 977 200	91 55 149 08	ZUSATZHYDR.PUMPE 5/WIND
DICHTRING DIN 7603 A 33X39	71 01 070 08	69	1	2 978 100	91 52 827 08	ZUSATZHYDR.D-RUECKHALT
DICHTRING DIN 7603 A 38X44	71 01 072 08	137	20	2 970	91 56 537 08	HYDRAULIK
DICHTRING DIN 7603 A 38X44	71 01 072 08	62	6	2 975 100	91 52 860 08	ZUSATZHYDRAULIK WINDE 3
DICHTRING DIN 7603 A 38X44	71 01 072 08	61	1	2 975 200	91 52 775 08	ZUSATZHYDRAULIK WINDE 2
DICHTRING DIN 7603 A 38X44	71 01 072 08	61	1	2 975 700	91 52 774 08	ZUSATZHYDRAULIK WINDE 1
DICHTRING DIN 7603 A 38X44	71 01 072 08	69	2	2 977	91 57 756 08	ZUSATZHYDRAULIK DREHBUE
DICHTRING DIN 7603 A 38X44	71 01 072 08	61	1	2 977 200	91 55 149 08	ZUSATZHYDR.PUMPE 5/WIND
DICHTRING DIN 7603 A 38X44	71 01 072 08	68	1	2 978 100	91 52 827 08	ZUSATZHYDR.D-RUECKHALT
DICHTRING DIN 7603 A 38X44	71 01 072 08	67	2	3 978 100	91 56 428 08	HYDR.SCHWEBEBALLAST-AN

6.2.2009

etk_en_de_074515 LR 1600/2

1019

LIEBHERRAlphabetical index
Alphabetischer Index

Bezeichnung	Artikel	Pos.	Menge	Seite	Baugruppe	Bezeichnung
DICHTRING DIN 7603 A 42X49	71 01 075 08	136	3	2 970	91 56 537 08	HYDRAULIK
DICHTRING DIN 7603 A 42X49	71 01 075 08	61	3	2 978 200	91 54 843 08	ZUSATZHYDR.S-RUECKHALTE
DICHTRING DIN 7603 A 48X55	71 01 076 08	132	2	2 970	91 56 537 08	HYDRAULIK
DICHTRING DIN 7603 A 48X55	71 01 076 08	68	1	2 977	91 57 756 08	ZUSATZHYDRAULIK DREHBUE
DICHTRING DIN 7603 A 4X8X1	51 10 089 08	9	2	9 640 276	96 40 276 08	ANSCHLUSSBLOCK
DICHTRING DIN 7603 A 52X60	71 01 077 08	131	10	2 970	91 56 537 08	HYDRAULIK
DICHTRING DIN 7603 A 52X60	71 01 077 08	61	6	2 975 100	91 52 860 08	ZUSATZHYDRAULIK WINDE 3
DICHTRING DIN 7603 A 52X60	71 01 077 08	63	2	2 975 200	91 52 775 08	ZUSATZHYDRAULIK WINDE 2
DICHTRING DIN 7603 A 52X60	71 01 077 08	63	2	2 975 700	91 52 774 08	ZUSATZHYDRAULIK WINDE 1
DICHTRING DIN 7603 A 52X60	71 01 077 08	67	4	2 977	91 57 756 08	ZUSATZHYDRAULIK DREHBUE
DICHTRING DIN 7603 A 52X60	71 01 077 08	63	2	2 977 200	91 55 149 08	ZUSATZHYDR.PUMPE 5/WIND
DICHTRING DIN 7603 A 52X60	71 01 077 08	68	2	3 978 005	91 56 430 08	ZUSATZHYDRAULIK SB-KOPFS
DICHTRING DIN 7603 A 52X60	71 01 077 08	68	4	3 978 015	91 56 429 08	ZUSATZHYDRAULIK ZWISCH
DICHTRING DIN 7603 A 52X60	71 01 077 08	68	4	3 978 015	91 56 432 08	ZUSATZHYDRAULIK ZWISCH
DICHTRING DIN 7603 A 52X60	71 01 077 08	68	2	3 978 100	91 56 428 08	HYDR.SCHWEBEBALLAST-AN
DICHTRING DIN 7603 A 6,5X11	57 00 102 08	16	2	5 026 126	50 26 126 08	MAGNETVENTIL
DICHTSATZ	10 30 092 5	(999)	1	X1035924	10 35 924 3	VERSTELLPUMPE
DICHTSATZ	51 03 178 08	(1)	1	2 970	91 56 537 08	HYDRAULIK
DICHTSATZ	55 31 355 08	4	1	5 530 545	55 30 545 08	UMWAEELZPUMPE
DICHTSATZ	57 05 881 08	999	1	5 106 691	51 06 691 08	RUECKLAUFFILTER
DICHTSATZ	57 10 356 08	999	1	5 710 349	57 10 349 08	WEGEVENTIL
DICHTSATZ	74 11 445	999	1	5 113 022	51 13 022 08	WEGEVENTIL
DICHTSATZ HNR70	70 27 982	999	1	7 027 481	70 27 481 03	WASSERABSCHIEDER
DICHTSATZ WEGESCHIEBER	10 41 278 1	999	1	9 640 277	96 40 277 08	WEGESCHIEBER
DICHTSCHEIBE	57 10 773 08	(1)	1	3 978 100	91 56 428 08	HYDR.SCHWEBEBALLAST-AN
DICHTSCHEIBE VITON	57 10 819 08	(1)	1	1 970	91 56 958 08	HYDRAULIK RAUPE
DICHTSCHEIBE VITON	57 10 824 08	(1)	1	1 970	91 56 958 08	HYDRAULIK RAUPE
DICHTSCHEIBE VITON	57 10 830 08	(1)	1	1 970	91 56 958 08	HYDRAULIK RAUPE
DICHTUNG	10 01 184 5	16	2	9 739 122	97 39 122	OELKUEHLER
DICHTUNG	10 01 184 6	2	1	9 739 386	97 39 386	KURBELGEHAEUSEENTLUEFT
DICHTUNG	10 01 184 7	4	1	9 739 118	97 39 118	OELLEITUNG
DICHTUNG	10 01 213 9	1	1	9 739 354	97 39 354	SCHWUNGRADGEHAEUSE AN
DICHTUNG	10 01 214 0	18	2	9 739 361	97 39 361	OELWANNE
DICHTUNG	10 01 229 8	15	1	9 739 122	97 39 122	OELKUEHLER
DICHTUNG	10 01 229 9	2	2	9 739 362	97 39 362	OELWANNE
DICHTUNG	10 01 234 5	12	2	9 739 126	97 39 126	THERMOSTATGEHAEUSE
DICHTUNG	10 01 234 6	2	1	9 739 276	97 39 276	WASSERANSCHLUSS
DICHTUNG	10 01 234 6	2	1	9 739 349	97 39 349	WASSERLEITUNGSANSCHLUE
DICHTUNG	10 01 240 8	9	1	9 739 358	97 39 358	ABGASRUECKFUEHRUNG AN
DICHTUNG	10 01 240 9	11	1	9 739 358	97 39 358	ABGASRUECKFUEHRUNG AN
DICHTUNG	10 01 241 1	5	3	9 739 358	97 39 358	ABGASRUECKFUEHRUNG AN
DICHTUNG	10 01 241 3	13	1	9 739 358	97 39 358	ABGASRUECKFUEHRUNG AN
DICHTUNG	10 01 245 4	8	1	9 739 494	97 39 494	ATL-ANBAU
DICHTUNG	10 01 264 3	8	1	9 739 361	97 39 361	OELWANNE
DICHTUNG	10 01 265 1	22	1	9 739 494	97 39 494	ATL-ANBAU
DICHTUNG	10 01 333 7	6	1	9 739 267	97 39 267	ZYLINDERKOPFHAUBE
DICHTUNG	10 22 081 3	4	1	9 739 494	97 39 494	ATL-ANBAU
DICHTUNG	10 22 234 5	3	6	9 739 267	97 39 267	ZYLINDERKOPFHAUBE
DICHTUNG	10 22 271 8	5	6	9 739 295	97 39 295	ABGASROHR
DICHTUNG	10 22 271 8	78	1	X1022281	10 22 281 7	DS ZYLINDERKOPF
DICHTUNG	10 22 272 7	2	6	9 739 256	97 39 256	LUFTANSAUGROHR
DICHTUNG	10 22 272 7	77	1	X1022281	10 22 281 7	DS ZYLINDERKOPF
DICHTUNG	10 28 030 9	2	1	9 739 286	97 39 286	VERSCHLUSSDECKEL
DICHTUNG	10 29 787 6	(2)	1	X1035925	10 35 925 1	VERSTELLPUMPE
DICHTUNG	10 34 287 8	2	1	9 739 351	97 39 351	KUEHLMITTELLEITUNG ANBA
DICHTUNG	10 34 287 9	13	2	9 739 349	97 39 349	WASSERLEITUNGSANSCHLUE
DICHTUNG	10 34 288 0	2	1	9 739 352	97 39 352	WASSERPUMPE MIT BEFEST.
DICHTUNG	10 66 332 9	3	1	X1004047	10 04 047 7	WINDENDREHGEBER
DICHTUNG	69 18 222 08	40	1	2 920 369	96 54 235 08	KLEMMKASTEN KPL.
DICHTUNG	69 21 000 08	36	1	2 920 369	96 54 235 08	KLEMMKASTEN KPL.

6.2.2009

etk_en_de_074515 LR 1600/2

1020

LIEBHERRAlphabetical index
Alphabetischer Index

Bezeichnung	Artikel	Pos.	Menge	Seite	Baugruppe	Bezeichnung
DICHTUNG	69 21 000 08	155	1	3 930 009	96 50 573 08	LEITUNGSTROMMEL KPL.
DICHTUNG	69 21 000 08	(171)	1	3 930 138	96 54 377 08	ELEKTRIK S-ANLENKSTUECK
DICHTUNG	69 21 000 08	281	2	3 930 730	96 50 599 08	KLEMMKASTEN KPL.
DICHTUNG 0 PE	97 75 102 08	32	2	2 932 160	96 54 385 08	SCHALTSCHRANK MECH.
DICHTUNG 120X60X 30	97 60 943 08	54	1	2 520 034	96 45 984 08	INNENVERKLEIDUNG
DICHTUNG 78X64 30	97 61 932 08	65	1	2 520	91 53 061 08	KABINE VERGLAST
DICHTUNGSMITTEL 50ML TUB	10 01 213 8	3	1	9 739 354	97 39 354	SCHWUNGRADGEHAEUSE AN
DIESELMOTOR D2876 LE131	10 12 059 0	1	1	9 739 400	97 39 400	DIESELMOTOR
DIESELMOTOR D846 A7	97 39 400	101	1	2 391 001	96 45 719 08	DIESELMOTOR VORM.
DIESELMOTOR KPL.	91 52 784 08	121	1		LR 1600-2-0	LIEBHERR RAUPENKRAN LR 1
DIESELMOTOR VORM.	96 45 719 08	1	1	2 391	91 52 784 08	DIESELMOTOR KPL.
DIODE 1000V 1A DO-41 SPF	66 00 331 08	3	1	2 932 515	96 45 911 08	BESTUECKUNGSMODUL
DIODE S 30V 0A2 DO-35 SPF	66 03 006 08	21	8	2 922 001	92 84 311 08	BUSPLATINE
DIODEN VARISTORENMODUL	66 01 015 08	37	2	2 932 001	96 45 393 08	RELAISSTEUERUNG
DIODENMODUL	66 03 016 08	52	1	2 932 082	96 54 387 08	AUFBAUTEILE MONTAGETAPE
DISPLAY MD3072A-QUAD	10 45 478 2	(10)	1	2 925 026	91 55 259 08	ERG.KAMERAUEBERWACHUN
DISPLAY MD3072A-QUAD	10 45 478 2	10	1	2 925 405	96 48 397 08	AUSRUESTUNG KAMERA KAB
DISPLAY VORM. TFT	96 20 762 08	21	1	2 913 005	96 20 731 08	INNENGEHAEUSE VORM.
DISPLAY VORM. TFT	96 20 762 08	21	1	2 913 005	96 28 696 08	INNENGEHAEUSE VORM.
DISTANZBLECH 3X84X15 DC0	97 76 920 08	40	4	2 502	91 55 939 08	STEUERSTAND
DISTANZBOLZEN B M6XM6X1	10 01 253 1	5	1	9 739 159	97 39 159	STARTER
DISTANZHUELSE 11X21X20	98 82 075	11	4	9 080 702	90 80 702	STEUERGERAET
DISTANZHUELSE 21.3X27	97 71 899 08	3	1	3 207 003	96 48 259 08	STANGE KPL.
DISTANZHUELSE 21.3X27	97 71 899 08	2	1	3 207 100	96 48 261 08	LASCHE KPL.
DISTANZHUELSE 21.3X27	97 71 899 08	(3)	1	3 281	91 52 896 08	FA-BOCK
DISTANZHUELSE 25.0X39	97 71 884 08	(2)	1	3 281	91 52 896 08	FA-BOCK
DISTANZHUELSE 25.0X75	97 71 883 08	5	1	3 207 101	96 48 292 08	LASCHE KPL.
DISTANZHUELSE 25.0X75	97 71 883 08	(2)	2	3 281	91 52 896 08	FA-BOCK
DISTANZRING	10 01 261 7	5	1	9 739 250	97 39 250	SCHWUNGRAD
DISTANZRING	90 80 288	2	1	9 079 186	90 79 186	DREHZAHLGEBER
DISTANZRING	90 80 533	2	1	9 079 185	90 79 185	DREHZAHLGEBER
DISTANZRING RD219,1X36	93 58 827 08	13	2	2 652	91 52 794 08	ROLLENLAGERUNG
DISTANZRING RD48X2	95 00 775 08	26	2	3 211	91 57 748 08	S-ANLENKSTUECK
DISTANZRING RD48X3	94 15 400 08	5	1	3 745 002	92 17 236 08	SCHALTEINHEIT
DISTANZRING RD48X3	94 15 400 08	5	1	3 745 003	92 17 237 08	SCHALTEINHEIT
DISTANZROHR RD65X76	95 44 254 08	21	2	1 400	91 56 853 08	RAUPENTRAEGER KPL.LI.
DISTANZROHR RD65X76	95 44 254 08	21	2	1 410 300	91 56 855 08	RAUPENTRAEGER KPL.RE.
DISTANZSTUECK	10 22 277 6	22	1	9 739 292	97 39 292	KRAFTSTOFFLEITUNG
DISTANZSTUECK	57 06 903 08	25	1	5 113 086	51 13 086 08	PROPORTIONALVENTIL
DISTANZSTUECK	57 11 304 08	5	1	5 711 301	57 11 301 08	DRUCKBEGRENZUNGSVENTI
DISTANZSTUECK SCHWK.	96 49 272 08	8	2	3 714	91 52 862 08	D-KOPFSTUECK
DISTANZSTUECK SCHWK.	96 50 800 08	2	1	3 714 013	96 49 270 08	LASCHE KPL.
DOPPELMAULSCHLUESSEL D	79 00 079 08	3	1	1 750	91 52 394 08	WERKZEUG
DOPPELMAULSCHLUESSEL D	79 00 039 08	4	1	1 750	91 52 394 08	WERKZEUG
DOPPELNIPPEL R1/4"-M10X1	77 43 750 08	16	4	2 711	91 52 800 08	ZENTRALSCHMIERANLAGE O
DOPPELRINGSCHLUESSEL DI	79 00 126 08	7	1	1 750	91 52 394 08	WERKZEUG
DOPPELZAHNRADPUMPE SPF	51 21 370 08	114	1	2 391 001	96 45 719 08	DIESELMOTOR VORM.
DORNNIET 4X10,3	70 42 076 08	3	4	2 913 004	96 20 460 08	GEHAEUSE VORM.
DORNNIET 4X10,3	70 42 076 08	23	8	2 932 001	96 45 393 08	RELAISSTEUERUNG
DORNNIET 4X10,3	70 42 076 08	49	42	2 932 082	96 54 387 08	AUFBAUTEILE MONTAGETAPE
DOSE M13	60 45 081 08	285	2	3 930 638	96 51 624 08	KLEMMKASTEN
DOSE M13	60 45 081 08	287	1	3 930 640	96 50 481 08	KLEMMKASTEN KPL.
DOSE M13	60 45 081 08	155	1	3 930 730	96 50 599 08	KLEMMKASTEN KPL.
DOSIERPUMPE	55 31 868 08	5	1	2 541	91 52 790 08	ZUSATZHEIZUNG OW
DRAEHTE KLEMMKASTEN KP	96 53 011 08	32	1	3 930 363	96 52 979 08	KLEMMKASTEN KPL.
DRAEHTE KLEMMKASTEN KPL	96 50 482 08	8	1	3 930 640	96 50 481 08	KLEMMKASTEN KPL.
DRAEHTE KLEMMKASTEN KPL	96 50 642 08	8	1	3 930 730	96 50 599 08	KLEMMKASTEN KPL.
DRAEHTE KLEMMKASTEN KPL	96 54 484 08	2	1	3 930 734	96 54 401 08	KLEMMKASTEN
DRAEHTE KLEMMKASTEN KPL	96 52 977 08	1	1	2 780 748	96 52 969 08	KLEMMKASTEN KPL.
DRAEHTE KLEMMKASTEN KP	96 48 693 08	1	1	1 920 418	96 48 687 08	KLEMMKASTEN KPL.

6.2.2009

etk_en_de_074515 LR 1600/2

1021

LIEBHERRAlphabetical index
Alphabetischer Index

Bezeichnung	Artikel	Pos.	Menge	Seite	Baugruppe	Bezeichnung
DRAEHTE KLEMMKASTEN KP	96 50 132 08	2	1	3 930 638	96 51 624 08	KLEMMKASTEN
DRAEHTE KPL. S2	96 49 211 08	2	1	2 932 001	96 45 393 08	RELAISSTEUERUNG
DRAEHTE KPL. S3	96 48 313 08	3	1	2 932 001	96 45 393 08	RELAISSTEUERUNG
DRAEHTE MONTAGETAFEL KP	96 54 389 08	2	1	2 932 116	96 54 388 08	VERKABELUNG MONTAGETA
DRAEHTE MONTAGETAFEL V	96 54 390 08	2	1	2 932 224	96 54 389 08	DRAEHTE MONTAGETAFEL K
DRAEHTE VORM. +S1070	96 53 012 08	(2)	1	3 930 363	96 52 979 08	KLEMMKASTEN KPL.
DRAEHTE VORM. -S1000	96 50 483 08	(2)	1	3 930 640	96 50 481 08	KLEMMKASTEN KPL.
DRAEHTE VORM. -S1020	96 50 643 08	(2)	1	3 930 730	96 50 599 08	KLEMMKASTEN KPL.
DRAEHTE VORM. -S980	96 50 045 08	2	1	3 930 639	96 50 132 08	DRAEHTE KLEMMKASTEN KPL
DRAEHTE VORM. S1050	96 54 485 08	(2)	1	3 930 734	96 54 401 08	KLEMMKASTEN
DRAEHTE VORM. S1100	96 53 013 08	(2)	1	2 780 748	96 52 969 08	KLEMMKASTEN KPL.
DRAEHTE VORM. S2	96 49 212 08	(2)	1	2 932 001	96 45 393 08	RELAISSTEUERUNG
DRAEHTE VORM. S200	96 51 072 08	(2)	1	1 920 418	96 48 687 08	KLEMMKASTEN KPL.
DRAEHTE VORM. S3	96 49 209 08	(2)	1	2 932 001	96 45 393 08	RELAISSTEUERUNG
DRAHTHALTER	61 10 461 08	22	36	2 932 001	96 45 393 08	RELAISSTEUERUNG
DRAHTRING RD30X4	93 06 259 08	6	2	1 632 032	96 20 093 08	ABSTUETZPLATTE KPL.
DRALLFAENGER	77 39 466 08	3	1	2 372	91 33 648 08	SEIL MONTAGEWINDE M.ZUB
DREHBUEHNENVERKLEIDUN	91 52 788 08	131	1		LR 1600-2-0	LIEBHERR RAUPENKRAN LR 1
DREHDURCHFUEHRUNG	91 52 510 08	33	1		LR 1600-2-0	LIEBHERR RAUPENKRAN LR 1
DREHDURCHFUEHRUNG SPF	10 04 262 0	1	1	1 991	91 52 510 08	DREHDURCHFUEHRUNG
DREHFALLENSCHLOSS	10 34 246 9	1	1	2 522 011	96 45 602 08	SCHLIESSANLAGE
DREHGEBER OPTISCH 360°	69 23 091 08	11	1	1 920 305	92 15 300 08	EINBAU SCHLEIFRINGKOERPE
DREHGEBER OPTISCH 360°	69 23 091 08	28	1	6 909 010	69 09 010 08	SCHLEIFRINGUEBERTRAEGE
DREHKNOPF	69 27 013 08	6	1	2 913 003	96 20 599 08	FOLIENSTATUR VORM.
DREHSCHLOSS	60 61 433 08	19	2	2 533 070	96 48 363 08	ARMATUREN RE.
DREHSCHLOSS	60 61 433 08	33	1	2 932 001	96 45 393 08	RELAISSTEUERUNG
DREHSCHLOSSBETAETIGER	60 61 449 08	38	2	2 932 001	96 45 393 08	RELAISSTEUERUNG
DREHSTROMGENERATOR 28V	10 03 240 2	1	1	9 739 343	97 39 343	GENERATOR VORM.
DREHVERSCHRAUBUNG 76K	10 45 537 2	569	4	2 970	91 56 537 08	HYDRAULIK
DREHVERSCHRAUBUNG DG1	51 05 521 08	570	2	2 970	91 56 537 08	HYDRAULIK
DREHWERK 2 DREHW.	91 52 778 08	117	1		LR 1600-2-0	LIEBHERR RAUPENKRAN LR 1
DREHWERK DAT 450/1441	96 97 916 01	1	2	2 350	91 52 778 08	DREHWERK
DREHZAHLGEBER	90 79 185	20	1	9 739 257	97 39 257	MOTORREGELUNGSSENSORIK
DREHZAHLGEBER	90 79 186	21	1	9 739 257	97 39 257	MOTORREGELUNGSSENSORIK
DREHZAHLGEBER HALL 0,3-16	10 11 789 8	1	1	9 079 185	90 79 185	DREHZAHLGEBER
DREHZAHLGEBER HALL 0,3-16	10 11 789 8	1	1	9 079 186	90 79 186	DREHZAHLGEBER
DROSSELKLAPPE	10 01 754 4	1	1	9 739 186	97 39 186	MOTORBREMSE
DROSSELKLAPPE 130	55 17 068 08	3	1	2 393	91 52 787 08	LUFTFILTERANLAGE KPL.
DROSSELVENTIL	51 14 277 08	11	1	2 975 000	91 57 881 08	ZUSATZHYDRAULIK MONTAGE
DRUCKAUFNEHMER 400/400	69 23 126 08	(1)	2	2 970	91 56 537 08	HYDRAULIK
DRUCKAUFNEHMER 400/400	69 23 126 08	(1)	2	2 978 100	91 52 827 08	ZUSATZHYDR.D-RUECKHALT
DRUCKAUFNEHMER 400/400	69 23 126 08	(1)	2	2 978 200	91 54 843 08	ZUSATZHYDR.S-RUECKHALTE
DRUCKAUFNEHMER 750/750	69 23 128 08	(1)	5	2 970	91 56 537 08	HYDRAULIK
DRUCKAUFNEHMER SPF	69 23 125 08	(1)	2	2 978 100	91 52 796 08	ZUSATZHYDR.MONTAGEEINR
DRUCKBEGRENZUNGSVENTI	10 22 274 0	2	1	9 739 369	97 39 369	DRUCKROHR
DRUCKBEGRENZUNGSVENTI	10 41 267 5	2	1	5 133 090	51 13 090 08	WEGESCHIEBERBLOCK
DRUCKBEGRENZUNGSVENTI	10 48 973 4	2	1	5 113 005	51 13 005 08	STUEBERBLOCK
DRUCKBEGRENZUNGSVENTI	51 14 176 08	113	1	2 970	91 56 537 08	HYDRAULIK
DRUCKBEGRENZUNGSVENTI	51 14 177 08	114	2	2 970	91 56 537 08	HYDRAULIK
DRUCKBEGRENZUNGSVENTI	51 14 177 08	6	1	2 978 100	91 52 796 08	ZUSATZHYDR.MONTAGEEINR
DRUCKBEGRENZUNGSVENTI	51 14 177 08	10	1	2 978 100	91 52 827 08	ZUSATZHYDR.D-RUECKHALT
DRUCKBEGRENZUNGSVENTI	51 14 177 08	10	1	2 978 200	91 54 843 08	ZUSATZHYDR.S-RUECKHALTE
DRUCKBEGRENZUNGSVENTI	51 14 333 08	8	1	2 975 000	91 57 881 08	ZUSATZHYDRAULIK MONTAGE
DRUCKBEGRENZUNGSVENTI	51 14 562 08	7	1	3 978 100	91 56 428 08	HYDR.SCHWEBEBALLAST-AN
DRUCKBEGRENZUNGSVENTI	51 14 568 08	30	2	2 970	91 56 537 08	HYDRAULIK
DRUCKBEGRENZUNGSVENTI	51 14 572 08	72	1	2 970	91 56 537 08	HYDRAULIK
DRUCKBEGRENZUNGSVENTI	57 11 301 08	31	1	5 113 086	51 13 086 08	PROPORTIONALVENTIL
DRUCKBEGRENZUNGSVENTI	57 12 325 08	2	1	5 718 989	57 18 989 08	ANSCHLUSSPLATTE
DRUCKBEGRENZUNGSVENTI	57 12 395 08	2	1	5 715 142	57 15 142 08	ANSCHLUSSPLATTE
DRUCKBEGRENZUNGSVENTI	57 12 395 08	2	1	5 719 030	57 19 030 08	ANSCHLUSSPLATTE

6.2.2009

etk_en_de_074515 LR 1600/2

1022

LIEBHERRAlphabetical index
Alphabetischer Index

Bezeichnung	Artikel	Pos.	Menge	Seite	Baugruppe	Bezeichnung
DRUCKBEGRENZUNGSVENTI	57 15 139 08	1	2	X1065068	10 65 068 8	ANSCHLUSSPLATTE
DRUCKBEGRENZUNGSVENTI	57 15 145 08	1	1	5 715 142	57 15 142 08	ANSCHLUSSPLATTE
DRUCKBEGRENZUNGSVENTI	57 15 147 08	4	1	5 715 142	57 15 142 08	ANSCHLUSSPLATTE
DRUCKBEGRENZUNGSVENTI	57 16 910 08	8	1	X1042440	10 42 440 2	STUEBERBLOCK
DRUCKBEGRENZUNGSVENTI	57 18 994 08	1	2	5 718 989	57 18 989 08	ANSCHLUSSPLATTE
DRUCKBEGRENZUNGSVENTI	57 19 033 08	1	2	5 719 030	57 19 030 08	ANSCHLUSSPLATTE
DRUCKBEGRENZUNGSVENTI	70 28 133	2	1	X1065068	10 65 068 8	ANSCHLUSSPLATTE
DRUCKBEGRENZUNGSVENTIL	10 45 106 0	9	1	X1042440	10 42 440 2	STUEBERBLOCK
DRUCKBEGRENZUNGSVENTIL	10 66 433 3	560	1	X1041101	10 41 101 5	RUECKFALLSTUETZE
DRUCKBEGRENZUNGSVENTIL	10 66 433 3	470	1	X1041101	10 41 101 8	RUECKFALLSTUETZE
DRUCKFEDER	50 15 240 08	76	22	X1065015	10 65 015 8	ANTRIEB
DRUCKFEDER	50 15 241 08	75	22	X1065015	10 65 015 8	ANTRIEB
DRUCKFEDER	51 07 971 08	4	1	5 114 176	51 14 176 08	DRUCKBEGRENZUNGSVENTI
DRUCKFEDER	51 07 971 08	2	1	5 114 320	51 14 320 08	VORSPANNVENTIL
DRUCKFEDER	51 07 975 08	9	1	5 114 176	51 14 176 08	DRUCKBEGRENZUNGSVENTI
DRUCKFEDER	51 07 975 08	9	1	5 114 177	51 14 177 08	DRUCKBEGRENZUNGSVENTI
DRUCKFEDER	51 07 975 08	7	1	5 114 320	51 14 320 08	VORSPANNVENTIL
DRUCKFEDER	51 10 151 08	4	1	5 114 177	51 14 177 08	DRUCKBEGRENZUNGSVENTI
DRUCKFEDER	56 00 192 08	6	1	2 522 011	96 45 602 08	SCHLISSANLAGE
DRUCKFEDER	57 00 095 08	8	1	5 026 126	50 26 126 08	MAGNETVENTIL
DRUCKFEDER	57 06 304 08	4	1	2 550 008	96 47 628 08	HALTER KPL.
DRUCKFEDER	57 06 304 08	4	1	2 550 009	96 47 645 08	HALTER KPL.
DRUCKFEDER 1,9X6,9X21,5	51 07 359 08	6	1	5 711 301	57 11 301 08	DRUCKBEGRENZUNGSVENTI
DRUCKFILTER	51 06 715 08	71	1	2 970	91 56 537 08	HYDRAULIK
DRUCKFUEHLER	10 01 247 0	(1)	1	9 739 318	97 39 318	SENSORIK
DRUCKGEBER	10 22 274 1	13	1	9 739 318	97 39 318	SENSORIK
DRUCKGEBER 0-5BAR	10 01 274 0	(1)	1	9 739 318	97 39 318	SENSORIK
DRUCKGEBER BW-B	96 36 406 08	90	1	3 978 019	91 56 431 08	ZUSATZHYDRAULIK ZYLINDER
DRUCKGEBER D-RUECKFALL	96 47 916 08	3	1	2 978 100	91 52 827 08	ZUSATZHYDR.D-RUECKHALT
DRUCKGEBER KPL.	10 11 740 7	11	1	9 739 318	97 39 318	SENSORIK
DRUCKGEBER KPL.	10 11 740 9	12	1	9 739 318	97 39 318	SENSORIK
DRUCKGEBER KPL. M18X1,5 0-	10 11 740 4	10	1	9 739 318	97 39 318	SENSORIK
DRUCKGEBER MONTAGEEINR	96 47 919 08	3	1	2 978 100	91 52 796 08	ZUSATZHYDR.MONTAGEEINR
DRUCKGEBER PUMPEN P1-5	96 47 915 08	3	1	2 970	91 56 537 08	HYDRAULIK
DRUCKGEBER S-RUECKFALL	96 47 917 08	3	1	2 978 200	91 54 843 08	ZUSATZHYDR.S-RUECKHALTE
DRUCKGEBER SA-RUECKFALL	96 47 918 08	4	1	2 970	91 56 537 08	HYDRAULIK
DRUCKLEITUNG	10 03 730 0	41	1	9 739 494	97 39 494	ATL-ANBAU
DRUCKLEITUNG	10 34 309 2	1	1	9 739 356	97 39 356	ROHRLEITUNG ANBAU
DRUCKLEITUNG	10 34 309 3	4	1	9 739 356	97 39 356	ROHRLEITUNG ANBAU
DRUCKLEITUNG	10 34 309 5	6	1	9 739 369	97 39 369	DRUCKROHR
DRUCKLUFTANLAGE	91 59 244 08	177	1		LR 1600-2-0	LIEBHERR RAUPENKRAN LR 1
DRUCKLUFTZYLINDER	10 01 752 1	5	1	9 739 186	97 39 186	MOTORBREMSE
DRUCKLUFTZYLINDER	10 33 276 5	12	1	9 739 357	97 39 357	ABGASRUECKFUEHRUNG VO
DRUCKMINDERVENTIL	51 14 975 08	54	4	2 970	91 56 537 08	HYDRAULIK
DRUCKREGELVENTIL	51 14 853 08	29	3	2 970	91 56 537 08	HYDRAULIK
DRUCKREGELVENTIL SPF	10 34 282 3	61	1	2 970	91 56 537 08	HYDRAULIK
DRUCKRING	50 29 326 08	48	1	2 393	91 52 787 08	LUFTFILTERANLAGE KPL.
DRUCKRING DR/R22X27	50 29 325 08	598	4	2 990	91 59 244 08	DRUCKLUFTANLAGE
DRUCKRING DR/R26X31	50 29 328 08	404	2	2 391 001	96 45 719 08	DIESELMOTOR VORM.
DRUCKROHR	10 22 273 9	1	1	9 739 369	97 39 369	DRUCKROHR
DRUCKROHR	97 39 369	101	1	X1012059	10 12 059 0	DIESELMOTOR
DRUCKSCHALTER	51 06 769 08	44	1	2 970	91 56 537 08	HYDRAULIK
DRUCKSCHALTER	57 14 891 08	6	1	2 831	91 57 754 08	KLIMAANLAGE OW
DRUCKSCHALTER 20BAR SPF	10 28 953 6	47	2	2 970	91 56 537 08	HYDRAULIK
DRUCKSCHALTER 20BAR SPF	10 28 953 6	7	1	2 975 100	91 52 860 08	ZUSATZHYDRAULIK WINDE 3
DRUCKSCHALTER 20BAR SPF	10 28 953 6	7	1	2 975 200	91 52 775 08	ZUSATZHYDRAULIK WINDE 2
DRUCKSCHALTER 20BAR SPF	10 28 953 6	7	1	2 975 700	91 52 774 08	ZUSATZHYDRAULIK WINDE 1
DRUCKSCHALTER 8BAR SPF	10 22 093 3	46	1	2 970	91 56 537 08	HYDRAULIK
DRUCKSCHALTER 8BAR SPF	10 22 093 3	6	1	2 975 100	91 52 860 08	ZUSATZHYDRAULIK WINDE 3
DRUCKSCHALTER 8BAR SPF	10 22 093 3	6	1	2 975 200	91 52 775 08	ZUSATZHYDRAULIK WINDE 2

6.2.2009

etk_en_de_074515 LR 1600/2

1023

LIEBHERRAlphabetical index
Alphabetischer Index

Bezeichnung	Artikel	Pos.	Menge	Seite	Baugruppe	Bezeichnung
DRUCKSCHALTER 8BAR SPF	10 22 093 3	6	1	2 975 700	91 52 774 08	ZUSATZHYDRAULIK WINDE 1
DRUCKSENSOR	69 23 083 08	15	1	2 393	91 52 787 08	LUFTFILTERANLAGE KPL.
DRUCKSTUECK	24 01 915 02	15	1	2 391 040	96 53 645 08	KUPPLUNGSSTELLER
DRUCKSTUECK	70 30 031 01	20	1	2 522 011	96 45 602 08	SCHLISSANLAGE
DRUCKTASTER	10 47 561 7	2	1	2 780 244	91 52 951 08	NOTAUS KRANFUEHRERKAB
DRUCKVENTIL	57 15 296 08	8	1	5 113 086	51 13 086 08	PROPORTIONALVENTIL
DRUECKER 25X25	60 61 430 08	6	7	2 533 061	96 48 370 08	ARMATUREN ARMLEHNE LI.
DRUECKER 25X25	60 61 430 08	6	7	2 533 063	96 48 371 08	ARMATUREN ARMLEHNE RE.
DRUECKER 25X25	60 61 430 08	14	23	2 533 070	96 48 363 08	ARMATUREN RE.
DS ANSCHLUSSBLOCK	10 41 275 1	999	1	9 640 276	96 40 276 08	ANSCHLUSSBLOCK
DS ANSCHLUSSPLATTE	10 47 221 9	(98)	1	X1035924	10 35 924 8	VERSTELLPUMPE
DS ANSCHLUSSPLATTE M.V	10 65 071 0	98	1	X1065068	10 65 068 8	ANSCHLUSSPLATTE
DS ANSTEUERGERAET	10 47 143 9	(98)	1	X1035924	10 35 924 6	VERSTELLPUMPE
DS ANSTEUERGERAET	10 47 143 9	(98)	1	X1035924	10 35 924 9	VERSTELLPUMPE
DS HYDROZYLINDER	10 10 103 8	(999)	1	3 790 007	96 19 990 08	BOLZENZIEHZYLINDER KPL.
DS HYDROZYLINDER	10 10 103 9	(999)	1	3 790 006	96 19 989 08	BOLZENZIEHZYLINDER KPL.
DS HYDROZYLINDER	10 66 343 9	(999)	1	2 810	91 52 806 08	KRANFUEHRERKABINE KPL.
DS MONTAGEZYLINDER	57 19 136 08	(10)	1	5 123 682	51 23 682 08	MONTAGEZYLINDER
DS PUMPE	10 65 071 7	(98)	1	X1035924	10 35 924 9	VERSTELLPUMPE
DS REGLER	10 44 097 6	999	1	X1047219	10 47 219 6	REGLER
DS RUECKFALLSTUETZE	10 66 433 4	999	1	X1041101	10 41 101 5	RUECKFALLSTUETZE
DS RUECKFALLSTUETZE	10 66 444 9	999	1	X1041101	10 41 101 8	RUECKFALLSTUETZE
DS SENKBREMSVENTIL	10 65 006 8	99	1	X1021769	10 21 769 5	SENBREMSVENTIL
DS TRIEBWELLE	10 33 111 6	(98)	1	X1035924	10 35 924 1	VERSTELLPUMPE
DS VENTIL	10 66 373 0	999	1	5 114 651	51 14 651 08	WEGEVENTIL
DS VERSTELLUNG	10 33 111 7	(98)	1	X1035924	10 35 924 1	VERSTELLPUMPE
DS VERSTELLUNG	10 65 070 7	(98)	1	X1035924	10 35 924 9	VERSTELLPUMPE
DS WEGEVENTIL	10 42 478 6	(999)	1	2 970	91 56 537 08	HYDRAULIK
DS ZAHNRADMOTOR	10 49 389 0	(99)	1	2 391 038	96 47 931 08	OELKUEHLER VORM.
DS ZYLINDERKOPF	10 22 281 7	492	6	9 739 400	97 39 400	DIESELMOTOR
DU-BUCHSE	70 80 101 08	4	2	3 206	91 52 881 08	F-ANLENKSTUECK
DUESE 0,4	51 07 543 08	5	2	2 990	91 59 244 08	DRUCKLUFTANLAGE
DUESE 0,4 MS	51 10 487 08	41	1	2 970	91 56 537 08	HYDRAULIK
DUESE 0,4 MS	51 10 487 08	8	1	2 978 100	91 52 827 08	ZUSATZHYDR.D-RUECKHALT
DUESE 0,4 MS	51 10 487 08	8	1	2 978 200	91 54 843 08	ZUSATZHYDR.S-RUECKHALTE
DUESE 0,6	51 07 460 08	39	3	2 970	91 56 537 08	HYDRAULIK
DUESE 0,6	51 07 460 08	13	1	2 975 100	91 52 860 08	ZUSATZHYDRAULIK WINDE 3
DUESE 0,6	51 07 460 08	13	1	2 975 200	91 52 775 08	ZUSATZHYDRAULIK WINDE 2
DUESE 0,6	51 07 460 08	13	1	2 975 700	91 52 774 08	ZUSATZHYDRAULIK WINDE 1
DUESE 0,6 10.9	57 08 188 08	49	5	2 970	91 56 537 08	HYDRAULIK
DUESE D 1,5 M8X8 MS	51 10 575 08	3	2	2 976 200	91 52 780 08	ZUSATZHYDRAULIK DREHWE
DUESE D=1,2	57 19 039 08	51	1	5 113 086	51 13 086 08	PROPORTIONALVENTIL
DURCHFUEHRUNGSTUELLE 1	60 27 013 08	5	2	2 810 037	96 47 204 08	PEDALTRAEGER EINBAU
DURCHFUEHRUNGSTUELLE 4/	60 27 024 08	10	1	2 913 102	92 32 870 08	LUEFTEREINHEIT
DURCHGANGSNIPPELBLOCK	77 43 751 08	6	4	1 711	91 52 392 08	ZENTRALSCHMIERUNG RAUP
DURCHGANGSNIPPELBLOCK	77 43 751 08	11	2	2 711	91 52 800 08	ZENTRALSCHMIERANLAGE O
E/A-MODUL A SPF	66 01 020 08	113	1	2 932 082	96 54 387 08	AUFBAUTEILE MONTAGETAPE
EINBAU SCHLEIFRINGKOERPE	92 15 300 08	2	1	1 991	91 52 510 08	DREHDURCHFUEHRUNG
EINBAUDOSE 24POL BU	69 24 016 08	(151)	1	2 920 369	96 54 235 08	KLEMMKASTEN KPL.
EINBAUDOSE 24POL BU	69 24 016 08	151	1	3 930 639	96 50 132 08	DRAEHTE KLEMMKASTEN KPL
EINBAUDOSE 24POL BU	69 24 016 08	(151)	1	3 930 640	96 50 481 08	KLEMMKASTEN KPL.
EINBAUDOSE 24POL STI	69 18 996 08	154	1	3 930 639	96 50 132 08	DRAEHTE KLEMMKASTEN KPL
EINBAUDOSE 24POL STI	69 18 996 08	(153)	1	3 930 640	96 50 481 08	KLEMMKASTEN KPL.
EINBAUDOSE 24POL STI	69 18 996 08	(501)	2	3 930 730	96 50 599 08	KLEMMKASTEN KPL.
EINBAUSATZ	10 02 217 1	4	1	2 932 001	96 45 393 08	RELAISSTEUERUNG
EINBAUSTECKDOSE 2POL 16	60 52 039 08	2	1	2 533 067	96 50 385 08	BLECH VORM.
EINBAUSTECKDOSE 2POL 16	60 52 039 08	3	2	2 920 257	92 78 689 08	KLEMMKASTEN BELEUCHTUN
EINBAUSTECKDOSE 2POL 16	60 52 039 08	51	1	2 932 001	96 45 393 08	RELAISSTEUERUNG
EINBAUTEILE SCHALTSCHRAN	91 57 750 08	165	1		LR 1600-2-0	LIEBHERR RAUPENKRAN LR 1
EINGANGSPLATINE KPL. EP0	96 48 329 08	30	1	2 932 082	96 54 387 08	AUFBAUTEILE MONTAGETAPE

6.2.2009

etk_en_de_074515 LR 1600/2

1024

LIEBHERRAlphabetical index
Alphabetischer Index

Bezeichnung	Artikel	Pos.	Menge	Seite	Baugruppe	Bezeichnung
EINGANGSPLATINE KPL. EP1	96 48 330 08	31	1	2 932 082	96 54 387 08	AUFBAUTEILE MONTAGETAPE
EINGANGSPLATINE KPL. EP2	96 48 331 08	32	1	2 932 082	96 54 387 08	AUFBAUTEILE MONTAGETAPE
EINGANGSPLATINE KPL. EP3	96 48 332 08	33	1	2 932 082	96 54 387 08	AUFBAUTEILE MONTAGETAPE
EINGANGSPLATINE KPL. EP4	96 48 333 08	34	1	2 932 082	96 54 387 08	AUFBAUTEILE MONTAGETAPE
EINGANGSPLATINE KPL. EP5	96 48 334 08	35	1	2 932 082	96 54 387 08	AUFBAUTEILE MONTAGETAPE
EINLASSVENTIL	10 22 234 7	1	2	9 739 261	97 39 261	ZYLINDERKOPF
EINLEGEBRUECKE	60 27 355 08	70	50	2 932 082	96 54 387 08	AUFBAUTEILE MONTAGETAPE
EINLEGESTREIFEN	97 68 423 08	3	1	2 533 051	96 48 360 08	ELEKTRIK KABINE
EINMAULSCHLUESSEL DIN 8	88 51 322 08	5	1	1 750	91 52 394 08	WERKZEUG
EINMAULSCHLUESSEL DIN 8	79 00 046 08	6	1	1 750	91 52 394 08	WERKZEUG
EINSCHRAUBSTUTZEN	10 01 271 8	12	1	9 739 258	97 39 258	KRAFTSTOFFFILTER
EINSCHRAUBSTUTZEN	10 01 272 2	2	1	9 739 494	97 39 494	ATL-ANBAU
EINSCHRAUBSTUTZEN	10 29 720 4	2	2	9 739 322	97 39 322	RS ROHRLEITUNG
EINSCHRAUBSTUTZEN	94 79 067 08	48	5	2 970	91 56 537 08	HYDRAULIK
EINSCHRAUBSTUTZEN L10 A	10 01 199 8	5	1	9 739 188	97 39 188	OELMESSSTAB
EINSCHRAUBSTUTZEN L10 A	10 01 199 8	5	2	9 739 492	97 39 492	ROHRLEITUNG ANBAU
EINSCHRAUBSTUTZEN L12 A	10 01 200 4	14	1	9 739 258	97 39 258	KRAFTSTOFFFILTER
EINSCHRAUBSTUTZEN L12A-M	10 01 199 9	16	1	9 739 355	97 39 355	OELKUEHLER ANBAU
EINSCHRAUBSTUTZEN L12A-M	10 01 199 9	42	1	9 739 494	97 39 494	ATL-ANBAU
EINSCHRAUBSTUTZEN M26X1	10 01 272 1	16	1	9 739 492	97 39 492	ROHRLEITUNG ANBAU
EINSCHUBKARTE G0 COMM.S	92 16 203 08	5	1	2 932 122	96 45 394 08	LICCON MONTAGEEINHEIT
EINSCHUBKARTE G0Z0 PROG-	91 54 570 08	6	1	2 932 122	96 45 394 08	LICCON MONTAGEEINHEIT
EINSCHUBKARTE G0Z1 PRPG	91 42 856 08	7	1	2 932 122	96 45 394 08	LICCON MONTAGEEINHEIT
EINSCHUBKARTE G0Z2 PROG	91 42 857 08	8	1	2 932 122	96 45 394 08	LICCON MONTAGEEINHEIT
EINSCHUBKARTE G0Z3 PROG	91 42 858 08	9	1	2 932 122	96 45 394 08	LICCON MONTAGEEINHEIT
EINSCHUBKARTE G0Z4 PROG	91 42 859 08	10	1	2 932 122	96 45 394 08	LICCON MONTAGEEINHEIT
EINSCHUBKARTE G0Z5 PROG	91 42 860 08	11	1	2 932 122	96 45 394 08	LICCON MONTAGEEINHEIT
EINSPRITZDUESE	97 39 248	90	6	X1012059	10 12 059 0	DIESELMOTOR
EINSPRITZLEITUNG	10 22 274 5	8	1	9 739 369	97 39 369	DRUCKROHR
EINSPRITZLEITUNG	10 22 274 6	9	1	9 739 369	97 39 369	DRUCKROHR
EINSPRITZLEITUNG	10 22 274 7	10	1	9 739 369	97 39 369	DRUCKROHR
EINSTECKHUELSE E10-8	77 20 023 08	595	1	2 990	91 59 244 08	DRUCKLUFTANLAGE
EINSTECKHUELSE E6-4	77 20 022 08	592	2	2 990	91 59 244 08	DRUCKLUFTANLAGE
EINSTELLSCHRAUBE M10X1X4	10 01 222 1	9	1	9 739 263	97 39 263	KIPPHEBELLAGERGEHAEUSE
EINSTELLSCHRAUBE M10X1X4	10 01 222 1	9	1	9 739 264	97 39 264	KIPPHEBELLAGERGEHAEUSE
EINSTELLSCHRAUBE M10X1X4	10 01 222 5	10	1	9 739 263	97 39 263	KIPPHEBELLAGERGEHAEUSE
EINSTELLSCHRAUBE M10X1X4	10 01 222 5	10	1	9 739 264	97 39 264	KIPPHEBELLAGERGEHAEUSE
EINSTELLSCHRAUBE M14X1X3	10 01 222 0	7	1	9 739 263	97 39 263	KIPPHEBELLAGERGEHAEUSE
EINSTELLSCHRAUBE M14X1X3	10 01 222 0	7	1	9 739 264	97 39 264	KIPPHEBELLAGERGEHAEUSE
EINZELADERABDICHTUNG 2	60 56 197 08	813	19	2 920 633	96 52 651 08	KABELSTRANG
EINZELADERABDICHTUNG DI	60 56 200 08	820	4	2 920 633	96 52 651 08	KABELSTRANG
EL.F-ANSCHLUSS KOPFSTUECK	96 48 380 08	500	1	3 213	91 52 842 08	F-ANSCHLUSSKOPF
ELEKTRIK AGGREGAT	96 48 318 08	10	1	2 920	91 56 833 08	ELEKTRIK DREHBUEHNE
ELEKTRIK ANBAUTEILE KABIN	96 48 365 08	7	1	2 533	91 52 789 08	ELEKTRIK KRANFUEHRERKAB
ELEKTRIK ARMATUR MS 3	96 48 372 08	3	1	2 533 054	96 48 366 08	ELEKTRIK STEUERSTAND
ELEKTRIK ARMLEHNE LI.	96 48 368 08	1	1	2 533 054	96 48 366 08	ELEKTRIK STEUERSTAND
ELEKTRIK ARMLEHNE RE.	96 48 369 08	2	1	2 533 054	96 48 366 08	ELEKTRIK STEUERSTAND
ELEKTRIK BALLASTPALETTE	96 50 097 08	10	1	2 780 100	96 50 096 08	ELEKTRIK SCHWEBEBALLAST
ELEKTRIK BATTERIEKASTEN	96 48 319 08	5	1	2 260 006	96 46 501 08	BATTERIEKASTEN VORM.
ELEKTRIK BATTERIELADEGER	96 48 378 08	3	1	2 835	91 52 807 08	BATTERIELADEGERAET
ELEKTRIK D-ANLENKSTUECK	96 54 378 08	500	1	3 713	91 57 749 08	D-ANLENKSTUECK
ELEKTRIK D-KOPFSTUECK	96 47 149 08	500	1	3 714	91 52 862 08	D-KOPFSTUECK
ELEKTRIK D-RUECKHALTESI	96 51 078 08	500	1	3 292	91 52 865 08	D-RUECKHALTESICHERUNG
ELEKTRIK DREHBUEHNE	91 56 833 08	163	1		LR 1600-2-0	LIEBHERR RAUPENKRAN LR 1
ELEKTRIK DREHWERK	96 47 474 08	500	1	2 350	91 52 778 08	DREHWERK
ELEKTRIK F-ANLENKSTUECK	96 48 374 08	500	1	3 206	91 52 881 08	F-ANLENKSTUECK
ELEKTRIK F-KOPFSTUECK	96 48 375 08	500	1	3 208 001	91 52 883 08	F-KOPFSTUECK
ELEKTRIK FLUGWARNSICHER	96 56 482 08	11	1	3 780 751	91 52 952 08	FLUG-U.WINDWARNUNG
ELEKTRIK KABINE DACH	96 48 360 08	3	1	2 533	91 52 789 08	ELEKTRIK KRANFUEHRERKAB
ELEKTRIK KABINE FRONT	96 48 359 08	2	1	2 533	91 52 789 08	ELEKTRIK KRANFUEHRERKAB

6.2.2009

etk_en_de_074515 LR 1600/2

1025

LIEBHERR
 Alphabetical index
 Alphabetischer Index

Bezeichnung	Artikel	Pos.	Menge	Seite	Baugruppe	Bezeichnung
ELEKTRIK KLEMMKASTEN DB	96 54 236 08	20	1	2 920	91 56 833 08	ELEKTRIK DREHBUEHNE
ELEKTRIK KRAFTSTOFFBEHA	96 45 717 08	2	1	2 670 002	96 45 352 08	KRAFTSTOFFBEHAELTER VO
ELEKTRIK KRANFUEHRERKAB	91 52 789 08	133	1		LR 1600-2-0	LIEBHERR RAUPENKRAN LR 1
ELEKTRIK MITTELSTUECK	96 48 383 08	2	1	1 920 300	91 52 505 08	ELEKTRIK RAUPE
ELEKTRIK OELKUEHLER	91 11 097 08	6	1	2 391 102	96 56 360 08	ZUSATZKUEHLER VORM.
ELEKTRIK RAUPE	91 52 505 08	28	1		LR 1600-2-0	LIEBHERR RAUPENKRAN LR 1
ELEKTRIK RAUPENTRAEGER	96 48 384 08	3	1	1 920 300	91 52 505 08	ELEKTRIK RAUPE
ELEKTRIK RAUPENTRAEGER	96 48 385 08	4	1	1 920 300	91 52 505 08	ELEKTRIK RAUPE
ELEKTRIK S-ANLENKSTUECK	96 54 377 08	500	1	3 211	91 57 748 08	S-ANLENKSTUECK
ELEKTRIK S-RUECKHALTESI	92 95 070 08	500	1	3 291	91 52 831 08	S-RUECKHALTESICHERUNG
ELEKTRIK SA-BOCK	96 54 379 08	500	1	2 550	91 57 751 08	SA-BOCK
ELEKTRIK SCHWEBEBALLAST	96 50 096 08	500	1	3 745	91 52 948 08	SCHWEBEBALLAST
ELEKTRIK STEUERSTAND	96 48 366 08	4	1	2 533	91 52 789 08	ELEKTRIK KRANFUEHRERKAB
ELEKTRIK SW-KOPFSTUECK	96 48 381 08	500	1	3 214	91 52 843 08	SW-KOPFSTUECK
ELEKTRIK WINDE 1	96 44 536 08	500	1	2 310	91 52 503 08	WINDE 1
ELEKTRIK WINDE 2	96 44 537 08	500	1	2 320	91 52 504 08	WINDE 2
ELEKTRIK WINDE 3	96 44 538 08	500	1	3 350	91 52 859 08	WINDE 3
ELEKTRIK WINDE 4	96 44 539 08	500	1	2 340	91 52 776 08	WINDE 4 EINZIEHWERK
ELEKTRIK WINDWARNUNG T	96 54 370 08	5	1	3 780 751	91 52 952 08	FLUG-U.WINDWARNUNG
ELEKTROPUMPE	77 43 566 08	4	2	1 711	91 52 392 08	ZENTRALSCHMIERUNG RAUP
ELEKTROPUMPE S-EP4	10 32 716 7	1	1	2 711	91 52 800 08	ZENTRALSCHMIERANLAGE O
ENDGEHAEUSE DIN 72585 8,	69 24 062 08	511	1	2 920 633	96 52 651 08	KABELSTRANG
ENDHALTER	60 21 101 08	9	5	2 932 082	96 54 387 08	AUFBAUTEILE MONTAGETAPE
ENDKAPPE 34	55 31 811 08	4	1	2 541 001	96 49 651 08	ZUSATZHEIZUNG VORM.
ENDKAPPE 42,3	55 31 741 08	7	1	2 541	91 52 790 08	ZUSATZHEIZUNG OW
ENDPLATTE	10 41 267 8	21	1	5 133 090	51 13 090 08	WEGESCHIEBERBLOCK
ENDSCHALTER HUB-OBEN SP	60 60 533 08	(7)	1	3 930 546	96 48 375 08	ELEKTRIK F-KOPFSTUECK
ENDSCHALTER HUB-OBEN SP	60 60 533 08	(7)	2	3 930 576	96 48 381 08	ELEKTRIK SW-KOPFSTUECK
ENDSCHALTER SPF	60 60 531 08	16	1	2 930	96 57 085 08	GEBERANBAU SA-BOCK
ENDSCHALTER U.GEBER AL	96 47 914 08	8	1	2 920	91 56 833 08	ELEKTRIK DREHBUEHNE
ENDWINKEL	60 27 946 08	12	2	1 920 418	96 48 687 08	KLEMMKASTEN KPL.
ENDWINKEL	60 27 946 08	7	2	2 780 748	96 52 969 08	KLEMMKASTEN KPL.
ENDWINKEL	60 27 946 08	267	2	2 920 581	96 54 405 08	KLEMMKASTEN SA-BOCK VO
ENDWINKEL	60 27 946 08	297	2	3 930 730	96 50 599 08	KLEMMKASTEN KPL.
ENDWINKEL	60 27 946 08	281	4	3 930 730	96 54 398 08	KLEMMKASTEN KPL.
ENDWINKEL	60 27 946 08	204	2	3 930 734	96 54 401 08	KLEMMKASTEN
ENTLUEFTUNG	10 29 200 0	19	2	2 520	91 53 061 08	KABINE VERGLAST
ENTLUEFTUNGSLEITUNG	10 03 733 9	17	1	9 739 386	97 39 386	KURBELGEHAEUSEENTLUEFT
ENTLUEFTUNGSLEITUNG	10 29 720 3	1	1	9 739 322	97 39 322	RS ROHRLEITUNG
ENTLUEFTUNGSSCHRAUBE	74 12 942	1	1	7 027 481	70 27 481 03	WASSERABSCHIEDER
ENTLUEFTUNGSSCHRAUBE	60 25 013 08	293	1	1 920 403	96 48 707 08	KLEMMKASTEN KPL.
ENTLUEFTUNGSSCHRAUBE	60 25 013 08	293	1	1 920 417	96 48 703 08	KLEMMKASTEN KPL.
ENTLUEFTUNGSSCHRAUBE	60 25 013 08	293	1	1 920 418	96 48 687 08	KLEMMKASTEN KPL.
ENTLUEFTUNGSSCHRAUBE	60 25 013 08	9	1	2 780 524	96 52 968 08	LEITUNGSTROMMEL KPL.
ENTLUEFTUNGSSCHRAUBE	60 25 013 08	293	1	2 780 748	96 52 969 08	KLEMMKASTEN KPL.
ENTLUEFTUNGSSCHRAUBE	60 25 013 08	293	1	2 920 369	96 54 235 08	KLEMMKASTEN KPL.
ENTLUEFTUNGSSCHRAUBE	60 25 013 08	293	1	2 920 448	96 48 794 08	KLEMMKASTEN KPL.
ENTLUEFTUNGSSCHRAUBE	60 25 013 08	293	1	2 920 581	96 54 405 08	KLEMMKASTEN SA-BOCK VO
ENTLUEFTUNGSSCHRAUBE	60 25 013 08	286	1	3 930 363	96 52 979 08	KLEMMKASTEN KPL.
ENTLUEFTUNGSSCHRAUBE	60 25 013 08	286	1	3 930 640	96 50 481 08	KLEMMKASTEN KPL.
ENTLUEFTUNGSSCHRAUBE M	10 48 866 2	293	1	3 930 638	96 51 624 08	KLEMMKASTEN
ENTLUEFTUNGSSCHRAUBE M	10 48 866 2	293	1	3 930 730	96 50 599 08	KLEMMKASTEN KPL.
ENTLUEFTUNGSSCHRAUBE M	10 48 866 2	286	1	3 930 730	96 54 398 08	KLEMMKASTEN KPL.
ENTLUEFTUNGSSCHRAUBE M	10 48 866 2	307	1	3 930 734	96 54 401 08	KLEMMKASTEN
ENTLUEFTUNGSSTUTZEN	92 75 019 01	2	1	9 275 543	92 75 543 01	ENTLUEFTUNGSSTUTZEN
ENTLUEFTUNGSSTUTZEN	92 75 543 01	77	1	9 697 916	96 97 916 01	DREHWERK
ENTLUEFTUNGSVENTIL M10X	57 18 446 08	69	1	X1065015	10 65 015 8	ANTRIEB
ENTWAESSERUNGSSTOPFEN	60 25 012 08	292	1	1 920 403	96 48 707 08	KLEMMKASTEN KPL.
ENTWAESSERUNGSSTOPFEN	60 25 012 08	292	1	1 920 417	96 48 703 08	KLEMMKASTEN KPL.
ENTWAESSERUNGSSTOPFEN	60 25 012 08	292	2	1 920 418	96 48 687 08	KLEMMKASTEN KPL.

6.2.2009

etk_en_de_074515 LR 1600/2

1026

LIEBHERRAlphabetical index
Alphabetischer Index

Bezeichnung	Artikel	Pos.	Menge	Seite	Baugruppe	Bezeichnung
ENTWAESSERUNGSSTOPFEN	60 25 012 08	292	1	2 780 748	96 52 969 08	KLEMMKASTEN KPL.
ENTWAESSERUNGSSTOPFEN	60 25 012 08	292	1	2 920 369	96 54 235 08	KLEMMKASTEN KPL.
ENTWAESSERUNGSSTOPFEN	60 25 012 08	292	2	2 920 448	96 48 794 08	KLEMMKASTEN KPL.
ENTWAESSERUNGSSTOPFEN	60 25 012 08	292	1	2 920 581	96 54 405 08	KLEMMKASTEN SA-BOCK VO
ENTWAESSERUNGSSTOPFEN	60 25 012 08	18	2	2 932 160	96 54 385 08	SCHALTSCHRANK MECH.
ENTWAESSERUNGSSTOPFEN	60 25 012 08	285	2	3 930 363	96 52 979 08	KLEMMKASTEN KPL.
ENTWAESSERUNGSSTOPFEN	60 25 012 08	292	1	3 930 638	96 51 624 08	KLEMMKASTEN
ENTWAESSERUNGSSTOPFEN	60 25 012 08	285	1	3 930 640	96 50 481 08	KLEMMKASTEN KPL.
ENTWAESSERUNGSSTOPFEN	60 25 012 08	292	1	3 930 730	96 50 599 08	KLEMMKASTEN KPL.
ENTWAESSERUNGSSTOPFEN	60 25 012 08	285	2	3 930 730	96 54 398 08	KLEMMKASTEN KPL.
ENTWAESSERUNGSSTOPFEN	60 25 012 08	308	3	3 930 734	96 54 401 08	KLEMMKASTEN
ERG.KAMERAUEBERWACHUN	91 55 259 08	323	1		LR 1600-2-0	LIEBHERR RAUPENKRAN LR 1
ERGAENZUNG KAMERA KABIN	96 48 421 08	10	1	2 925 026	91 55 259 08	ERG.KAMERAUEBERWACHUN
ERGAENZUNG KAMERA WIND	96 59 125 08	10	1	2 925 218	91 60 840 08	KAMERAUEBERWACHUNG WI
ES BOLZEN 8X16 VERZ	72 51 118 08	13	2	2 932 160	96 54 385 08	SCHALTSCHRANK MECH.
F-ABSPANNUNG	91 53 433 08	286	1		LR 1600-2-0	LIEBHERR RAUPENKRAN LR 1
F-ANLENKSTUECK	91 52 881 08	284	1		LR 1600-2-0	LIEBHERR RAUPENKRAN LR 1
F-ANLENKSTUECK SCHWK.	96 46 767 08	1	1	3 206	91 52 881 08	F-ANLENKSTUECK
F-ANSCHLUSSKOPF	91 52 842 08	202	1		LR 1600-2-0	LIEBHERR RAUPENKRAN LR 1
F-ANSCHLUSSKOPF SCHWK.	96 46 750 08	1	1	3 213	91 52 842 08	F-ANSCHLUSSKOPF
F-KOPFSTUECK	91 52 883 08	288	1		LR 1600-2-0	LIEBHERR RAUPENKRAN LR 1
F-KOPFSTUECK SCHWK.	96 47 129 08	1	1	3 208 001	91 52 883 08	F-KOPFSTUECK
F-MONTAGEEINHEIT	91 52 880 08	282	1		LR 1600-2-0	LIEBHERR RAUPENKRAN LR 1
F-RUECKHALTESICHERUNG	91 52 897 08	296	1		LR 1600-2-0	LIEBHERR RAUPENKRAN LR 1
F-STUETZE KPL.	96 47 888 08	1	1	3 282	91 52 897 08	F-RUECKHALTESICHERUNG
FA-BOCK	91 52 896 08	294	1		LR 1600-2-0	LIEBHERR RAUPENKRAN LR 1
FA-BOCK SCHWK.	96 46 996 08	1	1	3 281	91 52 896 08	FA-BOCK
FAB-STUETZE	96 47 890 08	2	1	3 282	91 52 897 08	F-RUECKHALTESICHERUNG
FAECHERSCHEIBE DIN 6798 J	42 52 205 08	13	4	2 913	91 32 850 08	LICCON KONSOLE LCD2
FAECHERSCHEIBE DIN 6798 J	42 52 205 08	7	20	2 913 005	96 20 731 08	INNENGEHAEUSE VORM.
FAECHERSCHEIBE DIN 6798 J	42 52 205 08	7	12	2 913 005	96 28 696 08	INNENGEHAEUSE VORM.
FAECHERSCHEIBE DIN 6798 J	42 52 205 08	5	3	2 913 007	96 20 763 08	CONTROLLEREINHEIT
FAECHERSCHEIBE DIN 6798 J	42 52 205 08	13	4	2 913 009	91 04 705 08	LICCON KONSOLE LCD3
FAECHERSCHEIBE DIN 6798 J	42 52 205 08	17	28	2 932 001	96 45 393 08	RELAISSTEUERUNG
FAECHERSCHEIBE DIN 6798 J	42 52 205 08	269	4	3 930 009	96 50 573 08	LEITUNGSTROMMEL KPL.
FAECHERSCHEIBE DIN 6798 J	42 52 205 08	157	10	3 930 640	96 50 481 08	KLEMMKASTEN KPL.
FAECHERSCHEIBE DIN 6798 J	42 52 207 08	(155)	1	2 920 369	96 54 235 08	KLEMMKASTEN KPL.
FAECHERSCHEIBE DIN 6798 J	42 52 207 08	(155)	1	2 920 369	96 54 235 08	KLEMMKASTEN KPL.
FAECHERSCHEIBE DIN 6798 J	42 52 207 08	88	50	2 932 082	96 54 387 08	AUFBAUTEILE MONTAGETAPE
FAECHERSCHEIBE DIN 6798 J	42 52 207 08	(155)	1	3 930 138	96 54 377 08	ELEKTRIK S-ANLENKSTUECK
FAECHERSCHEIBE DIN 6798 J	42 52 208 08	3	4	2 780 915	96 48 377 08	ANBAUTEILE FREMDEINSPEIS
FAECHERSCHEIBE DIN 6798 J	42 52 208 08	32	1	2 835 002	96 48 379 08	ANBAUTEILE
FAECHERSCHEIBE DIN 6798 J	42 52 208 08	40	4	2 932 082	96 54 387 08	AUFBAUTEILE MONTAGETAPE
FAECHERSCHEIBE DIN 6798 J	42 52 210 08	4	12	1 830 102	92 26 483 08	KLEMMBRETT VORM.
FAECHERSCHEIBE DIN 6798 J	42 52 210 08	21	4	2 835 002	96 48 379 08	ANBAUTEILE
FAECHERSCHEIBE DIN 6798 J	42 52 210 08	7	2	2 913 004	96 20 460 08	GEHAEUSE VORM.
FAECHERSCHEIBE DIN 6798 J	42 52 210 08	39	1	2 932 082	96 54 387 08	AUFBAUTEILE MONTAGETAPE
FAHRERSITZ	10 29 200 4	1	1	2 502	91 55 939 08	STUERSTAND
FALTENBALG	10 65 048 5	48	1	X1029200	10 29 200 4	FAHRERSITZ
FALTENBALG	57 19 123 08	2	1	6 060 950	60 60 950 08	MEISTERSCHALTER
FALTENBALGKUPPLUNG	57 18 705 08	(60)	1	6 909 010	69 09 010 08	SCHLEIFRINGUEBERTRAEGE
FASSUNG	63 01 023 08	(151)	55	2 932 001	96 45 393 08	RELAISSTEUERUNG
FEDER	57 08 310 08	9	1	5 106 691	51 06 691 08	RUECKLAUFFILTER
FEDER X5CRNI18-10	97 84 867 08	83	1	2 520	91 53 061 08	KABINE VERGLAST
FEDERBOLZEN	51 07 973 08	6	1	5 114 176	51 14 176 08	DRUCKBEGRENZUNGSVENTI
FEDERBOLZEN	51 07 973 08	6	1	5 114 177	51 14 177 08	DRUCKBEGRENZUNGSVENTI
FEDERBOLZEN	51 07 973 08	4	1	5 114 320	51 14 320 08	VORSPANNVENTIL
FEDERRIEGEL VERZ	70 42 089 08	9	2	2 260	91 53 057 08	BATTERIELAGERUNG
FEDERRIEGEL VERZ	70 42 326 08	32	4	1 630	91 52 387 08	HYDRAULISCHE ABSTUETZUN
FEDERRING DIN 127 A 10 VER	42 40 008 08	70	4	2 550	91 57 751 08	SA-BOCK

6.2.2009

etk_en_de_074515 LR 1600/2

1027

LIEBHERRAlphabetical index
Alphabetischer Index

Bezeichnung	Artikel	Pos.	Menge	Seite	Baugruppe	Bezeichnung
FEDERRING DIN 127 A 10 VER	42 40 008 08	10	14	X1035519	10 35 519 6	OEL-LUFTKUEHLER
FEDERRING DIN 127 A 12 VER	42 40 009 08	4	2	3 211 002	92 88 302 08	SCHUTZWALZE KPL.
FEDERRING DIN 127 A 12 VER	42 40 009 08	152	2	3 713	91 57 749 08	D-ANLENKSTUECK
FEDERRING DIN 127 A 6 VERZ	42 40 005 08	12	3	2 920 200	96 44 536 08	ELEKTRIK WINDE 1
FEDERRING DIN 127 A 6 VERZ	42 40 005 08	12	3	2 920 260	96 44 537 08	ELEKTRIK WINDE 2
FEDERRING DIN 127 A 6 VERZ	42 40 005 08	12	3	2 920 334	96 44 538 08	ELEKTRIK WINDE 3
FEDERRING DIN 127 A 6 VERZ	42 40 005 08	12	3	2 920 350	96 44 539 08	ELEKTRIK WINDE 4
FEDERRING DIN 127 A 6 VERZ	42 40 005 08	66	10	2 970	91 56 537 08	HYDRAULIK
FEDERRING DIN 127 A 6 VERZ	42 40 005 08	52	2	2 975 100	91 52 860 08	ZUSATZHYDRAULIK WINDE 3
FEDERRING DIN 127 A 6 VERZ	42 40 005 08	53	4	2 975 200	91 52 775 08	ZUSATZHYDRAULIK WINDE 2
FEDERRING DIN 127 A 6 VERZ	42 40 005 08	53	4	2 975 700	91 52 774 08	ZUSATZHYDRAULIK WINDE 1
FEDERRING DIN 127 A 8 VERZ	42 40 007 08	9	2	1 970	91 56 958 08	HYDRAULIK RAUPE
FEDERRING DIN 127 A 8 VERZ	42 40 007 08	36	16	3 713	91 57 749 08	D-ANLENKSTUECK
FEDERRING DIN 127 A 8 VERZ	42 40 007 08	5	4	5 106 691	51 06 691 08	RUECKLAUFFILTER
FEDERRING DIN 128 2 FST A2	10 03 064 0	7	2	2 913 007	96 20 763 08	CONTROLLEREINHEIT
FEDERRING DIN 128 A 5 VERZ	42 40 004 08	33	7	2 920 083	96 48 319 08	ELEKTRIK BATTERIEKASTEN
FEDERRING DIN 128 A 5 VERZ	42 40 004 08	269	2	2 920 638	96 51 138 08	BEDIENPULT
FEDERRING DIN 128 A 8	42 40 607 08	12	14	X1035519	10 35 519 6	OEL-LUFTKUEHLER
FEDERRING DIN 7980 6 VERZ	42 41 006 08	8	6	5 102 306	51 02 306 08	HYDROMOTOR
FEDERSCHEIBE B 10 FST A3C	10 01 170 9	4	10	9 739 355	97 39 355	OELKUEHLER ANBAU
FEDERSCHEIBE B 14 FST A3C	10 01 171 0	7	1	9 739 243	97 39 243	KOLBENKUEHLUNG
FEDERSCHEIBE DIN 137 B 30	42 50 518 08	33	4	2 810	91 52 806 08	KRANFUEHRERKABINE KPL.
FEDERSTECKER 4 VERZ	43 32 062 08	8	1	1 632 032	96 20 093 08	ABSTUETZPLATTE KPL.
FEDERSTECKER 5 VERZ	43 32 063 08	84	2	2 550	91 57 751 08	SA-BOCK
FEDERSTECKER 5 VERZ	43 32 063 08	10	1	2 620	91 52 793 08	ROLLENDREHVERBINDUNG
FEDERSTECKER 5 VERZ	43 32 063 08	41	4	2 810	91 52 806 08	KRANFUEHRERKABINE KPL.
FEDERSTECKER 6 VERZ	43 32 064 08	13	1	2 620	91 52 793 08	ROLLENDREHVERBINDUNG
FEDERSTECKER 6 VERZ	43 32 064 08	54	4	3 225	91 52 854 08	SL-REDUZIERSTUECK
FEDERSTECKER 6 VERZ	43 32 064 08	19	2	3 714 008	96 49 266 08	VERSTELLFLASCHE KPL.
FEDERSTECKER DIN 11024 B 2	43 32 060 08	31	2	3 215 005	91 52 846 08	ROLLENSATZ
FEDERSTECKER DIN 11024 B 2	43 32 060 08	31	2	3 215 006	91 52 847 08	ROLLENSATZ
FEDERTELLER	51 07 970 08	3	1	5 114 176	51 14 176 08	DRUCKBEGRENZUNGSVENTI
FEDERTELLER	51 07 970 08	3	1	5 114 177	51 14 177 08	DRUCKBEGRENZUNGSVENTI
FEDERTELLER	57 01 149 08	6	1	5 701 133	57 01 133 08	TRIEBWERK
FEDERTELLER 16MNCR5	90 78 515	6	4	9 739 261	97 39 261	ZYLINDERKOPF
FERNDIAGNOSE MODUL OW L	91 24 097 08	354	1		LR 1600-2-0	LIEBHERR RAUPENKRAN LR 1
FESTPUNKT	96 48 609 08	8	2	3 215 005	91 52 846 08	ROLLENSATZ
FESTPUNKT	96 48 609 08	8	2	3 215 006	91 52 847 08	ROLLENSATZ
FILTERDECKEL	57 08 320 08	2	1	5 106 691	51 06 691 08	RUECKLAUFFILTER
FILTEREINSATZ	10 03 762 3	(1)	1	2 970	91 56 537 08	HYDRAULIK
FILTEREINSATZ	51 06 692 08	1	1	5 106 691	51 06 691 08	RUECKLAUFFILTER
FILTEREINSATZ	51 06 718 08	(1)	1	2 671 004	96 46 305 08	OELBEHAELTER VORM.
FILTEREINSATZ	57 17 556 08	1	1	5 517 203	55 17 203 08	LUFTFILTER
FILTEREINSATZ KRAFTSTOFF	70 27 479	6	1	7 027 481	70 27 481 03	WASSERABSCHIEDER
FILTERPATRONE	51 06 711 08	38	4	2 970	91 56 537 08	HYDRAULIK
FILTERPATRONE	51 06 711 08	12	1	2 975 100	91 52 860 08	ZUSATZHYDRAULIK WINDE 3
FILTERPATRONE	51 06 711 08	12	1	2 975 200	91 52 775 08	ZUSATZHYDRAULIK WINDE 2
FILTERPATRONE	51 06 711 08	12	1	2 975 700	91 52 774 08	ZUSATZHYDRAULIK WINDE 1
FILTERPATRONE	51 06 711 08	7	1	2 978 100	91 52 827 08	ZUSATZHYDR.D-RUECKHALT
FILTERPATRONE	51 06 711 08	7	1	2 978 200	91 54 843 08	ZUSATZHYDR.S-RUECKHALTE
FILZSTREIFEN DIN 5419 5X4	26 11 007 08	5	1	5 718 420	57 18 420 08	FLANSCH
FINGER SCHWK.	96 47 491 08	27	2	2 550	91 57 751 08	SA-BOCK
FLACHDICHTUNG	70 42 749 08	26	4	2 260 006	96 46 501 08	BATTERIEKASTEN VORM.
FLACHDICHTUNG	70 42 749 08	27	4	2 260 006	96 46 501 08	BATTERIEKASTEN VORM.
FLACHDICHTUNG	70 42 749 08	5	6	2 932 168	96 48 167 08	DECKEL KPL.
FLACHGREIFER FERRIT	61 70 000 08	12	1	1 933 100	91 25 249 08	MAGNETLAMPE
FLACHKAEFIG	50 15 271 08	9	1	5 400 565	54 00 565 08	SEILWINDE
FLACHKOPFSCHRAUBE AEHN	10 03 726 1	28	6	2 502	91 55 939 08	STUERSTAND
FLACHKOPFSCHRAUBE AEHN	10 03 726 1	44	46	2 520 034	96 45 984 08	INNENVERKLEIDUNG
FLACHKOPFSCHRAUBE AEHN	10 03 726 1	5	27	2 522	91 54 115 08	SCHIEBETUER KPL.

6.2.2009

etk_en_de_074515 LR 1600/2

1028

LIEBHERRAlphabetical index
Alphabetischer Index

Bezeichnung	Artikel	Pos.	Menge	Seite	Baugruppe	Bezeichnung
FLACHKOPFSCHRAUBE AEHN	10 03 726 1	3	7	2 533 070	96 48 363 08	ARMATUREN RE.
FLACHKOPFSCHRAUBE AEH	40 97 053 08	43	4	2 502	91 55 939 08	STUERSTAND
FLACHKOPFSCHRAUBE AEH	40 97 053 08	78	2	2 520	91 53 061 08	KABINE VERGLAST
FLACHKOPFSCHRAUBE AEH	40 97 053 08	46	6	2 520 034	96 45 984 08	INNENVERKLEIDUNG
FLACHKOPFSCHRAUBE DIN 79	51 45 994 08	4	12	2 913 100	91 23 538 08	BAUGRUPPENTRAEGER
FLACHKOPFSCHRAUBE DIN 79	51 45 994 08	20	7	5 701 129	57 01 129 08	TRIEBWERK
FLACHKOPFSCHRAUBE DIN 79	55 31 699 08	39	4	X1022811	10 22 811 2	HEIZKLIMAGERAET
FLACHKOPFSCHRAUBE DIN 79	40 83 110 08	60	8	2 520 034	96 45 984 08	INNENVERKLEIDUNG
FLACHKOPFSCHRAUBE DIN 79	55 31 619 08	12	4	2 913 100	91 23 538 08	BAUGRUPPENTRAEGER
FLACHKOPFSCHRAUBE ISO 7	40 83 112 08	4	4	2 913 003	96 20 599 08	FOLIENASTATUR VORM.
FLACHKOPFSCHRAUBE ISO 70	10 03 064 2	6	2	2 913 007	96 20 763 08	CONTROLLEREINHEIT
FLACHKOPFSCHRAUBE ISO 7	40 83 114 08	3	4	2 913 006	96 20 732 08	LUEFTERBLECH VORM.
FLACHKOPFSCHRAUBE ISO 70	40 83 115 08	3	8	2 913 005	96 20 731 08	INNENGEHAEUSE VORM.
FLACHKOPFSCHRAUBE ISO 70	40 83 115 08	3	8	2 913 005	96 28 696 08	INNENGEHAEUSE VORM.
FLACHKOPFSCHRAUBE ISO 70	40 83 115 08	4	3	2 913 007	96 20 763 08	CONTROLLEREINHEIT
FLACHKOPFSCHRAUBE ISO 7	40 86 506 08	38	11	2 711	91 52 800 08	ZENTRALSCHMIERANLAGE O
FLACHKOPFSCHRAUBE ISO 7	10 45 022 6	44	12	3 715 008	91 52 863 08	D-ZWISCHENSTUECK
FLACHKOPFSCHRAUBE ISO 7	10 45 022 6	45	24	3 716	91 52 864 08	D-ZWISCHENSTUECK
FLACHKOPFSCHRAUBE M5X	10 02 823 7	356	8	2 391 001	96 45 719 08	DIESELMOTOR VORM.
FLACHKOPFSCHRAUBE M5X	10 02 823 7	3	8	2 859 005	96 46 756 08	KLAPPE VORM.
FLACHKOPFSCHRAUBE M6X	40 97 043 08	17	4	2 393 002	96 46 782 08	DECKEL KPL.
FLACHKOPFSCHRAUBE M6X	40 97 043 08	76	13	2 520	91 53 061 08	KABINE VERGLAST
FLACHKOPFSCHRAUBE M6X	40 97 043 08	21	6	2 520 032	96 45 980 08	SCHEIBENWISCHANLAGE EIN
FLACHKOPFSCHRAUBE M6X	40 97 043 08	45	93	2 520 034	96 45 984 08	INNENVERKLEIDUNG
FLACHKOPFSCHRAUBE M6X	40 97 043 08	5	4	2 533 051	96 48 360 08	ELEKTRIK KABINE
FLACHKOPFSCHRAUBE M6X	40 97 043 08	3	4	2 533 068	96 49 314 08	STECKDOSEN VORM.
FLACHKOPFSCHRAUBE M6X	40 97 043 08	(7)	2	2 925 026	91 55 259 08	ERG.KAMERAUEBERWACHUN
FLACHKOPFSCHRAUBE M6X	40 97 043 08	7	2	2 925 405	96 48 397 08	AUSRUESTUNG KAMERA KAB
FLACHKOPFSCHRAUBE M8X2	40 97 041 08	26	8	2 260	91 53 057 08	BATTERIELAGERUNG
FLACHKOPFSCHRAUBE M8X2	40 97 041 08	52	48	2 859	91 52 809 08	GERAEUSCHDAEMMUNG
FLACHKOPFSCHRAUBE M8X2	40 97 041 08	97	12	3 211	91 57 748 08	S-ANLENKSTUECK
FLACHKOPFSCHRAUBE M8X3	40 97 059 08	19	2	2 391 040	96 53 645 08	KUPPLUNGSSTELLER
FLACHKOPFSCHRAUBE M8X3	40 97 059 08	96	36	3 211	91 57 748 08	S-ANLENKSTUECK
FLACHKOPFSCHRAUBE M8X3	40 97 059 08	126	20	3 713	91 57 749 08	D-ANLENKSTUECK
FLACHKOPFSCHRAUBE M8X3	40 97 059 08	89	14	3 714	91 52 862 08	D-KOPFSTUECK
FLACHRUNDSCHRAUBE DIN	40 28 026 14	7	8	2 925 402	96 58 855 08	KAMERAANBAU DREHBUEHN
FLACHSICHERUNGSEINSATZ	60 40 071 08	75	22	2 932 082	96 54 387 08	AUFBAUTEILE MONTAGETAPE
FLACHSICHERUNGSEINSATZ	60 40 072 08	76	8	2 932 082	96 54 387 08	AUFBAUTEILE MONTAGETAPE
FLACHSICHERUNGSEINSATZ	60 40 073 08	77	5	2 932 082	96 54 387 08	AUFBAUTEILE MONTAGETAPE
FLACHSICHERUNGSEINSATZ	60 40 076 08	78	1	2 932 082	96 54 387 08	AUFBAUTEILE MONTAGETAPE
FLACHSICHERUNGSEINSATZ	60 40 077 08	72	6	2 932 082	96 54 387 08	AUFBAUTEILE MONTAGETAPE
FLACHSICHERUNGSEINSATZ	60 40 069 08	73	6	2 932 082	96 54 387 08	AUFBAUTEILE MONTAGETAPE
FLACHSICHERUNGSEINSATZ	60 40 070 08	74	20	2 932 082	96 54 387 08	AUFBAUTEILE MONTAGETAPE
FLACHSTECKER 2,8	60 23 235 08	(124)	10	2 920 369	96 54 235 08	KLEMMKASTEN KPL.
FLACHSTECKER 2,8	60 23 235 08	(124)	7	2 920 369	96 54 235 08	KLEMMKASTEN KPL.
FLACHSTECKER 6,3 - 2,5 MS	60 23 048 08	9	2	2 913 102	92 32 870 08	LUEFTEREINHEIT
FLACHSTECKERGEHAEUSE 1	60 23 233 08	(151)	2	2 932 001	96 45 393 08	RELAISSTEUERUNG
FLACHSTECKERGEHAEUSE 1	60 23 233 08	503	34	2 932 224	96 54 389 08	DRAEHTE MONTAGETAPEL K
FLACHSTECKERGEHAEUSE 2	60 23 059 08	8	1	2 913 102	92 32 870 08	LUEFTEREINHEIT
FLACHSTECKERGEHAEUSE 6	60 23 256 08	514	6	2 932 224	96 54 389 08	DRAEHTE MONTAGETAPEL K
FLACHSTECKHUELSE 6,3 0,3 -	60 22 037 08	(63)	3	2 920 581	96 54 405 08	KLEMMKASTEN SA-BOCK VO
FLACHSTECKHUELSE 6,3 0,3 -	60 22 037 08	(63)	3	2 920 581	96 54 405 08	KLEMMKASTEN SA-BOCK VO
FLACHSTECKHUELSE 6,3 0,3 -	60 22 037 08	(63)	3	2 920 581	96 54 405 08	KLEMMKASTEN SA-BOCK VO
FLACHSTECKHUELSE 6,3 0,3 -	60 22 037 08	(63)	19	2 920 581	96 54 405 08	KLEMMKASTEN SA-BOCK VO
FLACHSTECKHUELSE 6,3 0,3 -	60 22 037 08	63	3	2 920 636	96 51 854 08	LEITUNG
FLACHSTECKHUELSE 6,3 0,3 -	60 22 037 08	(63)	14	3 930 734	96 54 401 08	KLEMMKASTEN
FLACHSTECKHUELSE 6,3 1,0	60 23 033 08	134	10	2 920 633	96 52 651 08	KABELSTRANG
FLAMMGLUEHKERZE	10 01 246 3	1	1	9 739 140	97 39 140	FLAMMSTARTANLAGE
FLAMMSTARTANLAGE	97 39 140	130	1	X1012059	10 12 059 0	DIESELMOTOR
FLAMMWAECHTER	10 29 012 3	16	1	X1004204	10 04 204 3	WASSERHEIZGERAET

6.2.2009

etk_en_de_074515 LR 1600/2

1029

LIEBHERRAlphabetical index
Alphabetischer Index

Bezeichnung	Artikel	Pos.	Menge	Seite	Baugruppe	Bezeichnung
FLANSCH	10 01 271 4	17	2	9 739 361	97 39 361	OELWANNE
FLANSCH	10 01 271 5	2	1	9 739 035	97 39 035	VERSCHLUSSTEIL
FLANSCH	10 01 271 5	2	1	9 739 129	97 39 129	KUEHLMITTELVORWAERMUN
FLANSCH	10 22 275 1	2	1	9 739 278	97 39 278	ANBAUTEILE
FLANSCH	10 28 030 8	1	1	9 739 286	97 39 286	VERSCHLUSSDECKEL
FLANSCH	10 34 286 4	11	1	9 739 372	97 39 372	SCHMIEROELPUMPE
FLANSCH	10 34 334 0	12	1	9 739 349	97 39 349	WASSERLEITUNGSANSCHLUE
FLANSCH	57 18 420 08	22	1	X1035411	10 35 411 4	HUBWINDE
FLANSCH 10X137X137	97 83 612 08	4	1	2 391 040	96 53 645 08	KUPPLUNGSSTELLER
FLANSCH POM	97 74 378 08	18	1	2 520 032	96 45 980 08	SCHEIBENWISCHANLAGE EIN
FLANSCHDICHTUNG	10 34 693 8	(5)	1	2 920 814	96 45 717 08	ELEKTRIK KRAFTSTOFFBEHA
FLANSCHHAELFTE 1" A3P	51 05 869 08	545	8	2 970	91 56 537 08	HYDRAULIK
FLANSCHHAELFTE 2"	51 15 167 08	41	4	2 391 001	96 45 719 08	DIESELMOTOR VORM.
FLANSCHHAELFTE A3P	51 05 866 08	58	16	1 970	91 56 958 08	HYDRAULIK RAUPE
FLANSCHHAELFTE A3P	51 05 866 08	58	8	1 970 161	96 50 706 08	ZUSATZHYDR.RAUPENTRAEG
FLANSCHHAELFTE A3P	51 05 866 08	553	16	2 970	91 56 537 08	HYDRAULIK
FLANSCHHAELFTE A3P	51 05 866 08	41	4	2 975 100	91 52 860 08	ZUSATZHYDRAULIK WINDE 3
FLANSCHHAELFTE A3P	51 05 875 08	541	4	2 970	91 56 537 08	HYDRAULIK
FLANSCHHAELFTE A3P	51 05 875 08	561	12	2 976 200	91 52 780 08	ZUSATZHYDRAULIK DREHWE
FLANSCHHAELFTE A3P	51 05 875 08	566	4	2 976 700	91 54 795 08	ZUSATZHYDRAULIK PUMPE
FLANSCHSTUTZEN 38-S	51 15 177 08	571	4	2 970	91 56 537 08	HYDRAULIK
FLANSCHSTUTZEN 38-S	51 15 178 08	52	4	1 970	91 56 958 08	HYDRAULIK RAUPE
FLANSCHSTUTZEN 38-S	51 15 178 08	572	15	2 970	91 56 537 08	HYDRAULIK
FLANSCHSTUTZEN 38-S	51 15 178 08	47	2	2 975 200	91 52 775 08	ZUSATZHYDRAULIK WINDE 2
FLANSCHSTUTZEN 38-S	51 15 178 08	47	2	2 975 700	91 52 774 08	ZUSATZHYDRAULIK WINDE 1
FLANSCHVERSCHRAUBUNG	51 01 416 08	19	1	2 391 038	96 47 931 08	OELKUEHLER VORM.
FLANSCHVERSCHRAUBUNG	51 01 417 08	17	1	2 391 038	96 47 931 08	OELKUEHLER VORM.
FLUG-U.WINDWARNUNG	91 52 952 08	362	1		LR 1600-2-0	LIEBHERR RAUPENKRAN LR 1
FOLIE 0,2X3000 PE	80 10 029 08	272	1	2 920 638	96 51 138 08	BEDIENPULT
FOLIENASTATUR	69 18 849 08	1	1	2 913 003	96 20 599 08	FOLIENASTATUR VORM.
FOLIENASTATUR VORM.	96 20 599 08	1	1	2 913	91 32 850 08	LICCON KONSOLE LCD2
FOLIENASTATUR VORM.	96 20 599 08	1	1	2 913 009	91 04 705 08	LICCON KONSOLE LCD3
FORMCLIP AEHNL.DIN 11023	43 32 010 08	3	2	3 780 200	96 54 370 08	ELEKTRIK WINDWARNUNG T
FORMCLIP AEHNL.DIN 11023	43 32 010 08	3	2	3 780 258	96 56 482 08	ELEKTRIK FLUGWARNSICHER
FORMSCHLAUCH	10 01 263 1	14	1	9 739 386	97 39 386	KURBELGEHAEUSEENTLUEFT
FORMSCHLAUCH DN18X90°	55 31 731 08	14	2	2 540	91 53 253 08	HEIZKLIMAGERAET EINBAU
FORMSCHLAUCH DN18X90°	55 31 731 08	8	2	2 541	91 52 790 08	ZUSATZHEIZUNG OW
FORMSCHLAUCH DN18X90°	55 31 738 08	15	1	2 540	91 53 253 08	HEIZKLIMAGERAET EINBAU
FORMSCHLAUCH DN18X90°	55 31 738 08	11	1	2 541	91 52 790 08	ZUSATZHEIZUNG OW
FORMSCHLAUCH NW60X30G	97 47 495 08	118	1	2 391 001	96 45 719 08	DIESELMOTOR VORM.
FORMSCHLAUCH NW60X30G	97 47 495 08	26	1	2 391 023	96 45 720 08	KUEHLER VORM.
FORMSCHLAUCH NW60X90°	97 19 159 08	5	1	2 391 023	96 45 720 08	KUEHLER VORM.
FORMTEIL	60 52 128 08	502	1	2 920 633	96 52 651 08	KABELSTRANG
FORMTEIL	60 52 128 08	152	1	2 920 636	96 51 854 08	LEITUNG
FREMDEINSPEISUNG 230V-1	91 52 958 08	414	1		LR 1600-2-0	LIEBHERR RAUPENKRAN LR 1
FRONTELEMENT	60 66 525 08	8	4	2 920 638	96 51 138 08	BEDIENPULT
FRONTRAHMEN	69 26 004 08	8	1	2 913 003	96 20 599 08	FOLIENASTATUR VORM.
FRONTSCHIEBE ESG-GLAS SP	97 68 377 08	3	1	2 520	91 53 061 08	KABINE VERGLAST
FUEHRUNG	97 71 833 08	1	1	2 522 013	96 45 883 08	FUEHRUNG VORM.
FUEHRUNG	97 72 794 08	2	1	2 522 013	96 45 883 08	FUEHRUNG VORM.
FUEHRUNG 306X48X37 ENA	97 74 304 08	10	2	2 502	91 55 939 08	STEUERSTAND
FUEHRUNG G-ALSI10MG	97 71 831 08	1	1	2 522 012	96 45 884 08	FUEHRUNG VORM.
FUEHRUNG VORM. OBEN	96 45 884 08	26	1	2 520	91 53 061 08	KABINE VERGLAST
FUEHRUNG VORM. UNTEN	96 45 883 08	27	1	2 520	91 53 061 08	KABINE VERGLAST
FUEHRUNGSBUCHSE	60 56 099 08	(156)	2	2 920 369	96 54 235 08	KLEMMKASTEN KPL.
FUEHRUNGSBUCHSE	60 56 099 08	(156)	2	2 920 369	96 54 235 08	KLEMMKASTEN KPL.
FUEHRUNGSBUCHSE	60 56 099 08	26	6	2 920 369	96 54 235 08	KLEMMKASTEN KPL.
FUEHRUNGSBUCHSE	60 56 099 08	22	10	2 920 448	96 48 794 08	KLEMMKASTEN KPL.
FUEHRUNGSBUCHSE	60 56 099 08	516	12	2 920 633	96 52 651 08	KABELSTRANG
FUEHRUNGSBUCHSE	60 56 099 08	51	19	2 932 160	96 54 385 08	SCHALTSCHRANK MECH.

6.2.2009

etk_en_de_074515 LR 1600/2

1030

LIEBHERRAlphabetical index
Alphabetischer Index

Bezeichnung	Artikel	Pos.	Menge	Seite	Baugruppe	Bezeichnung
FUEHRUNGSKONUS M3 MS SP	66 00 420 08	13	6	2 922 001	92 84 311 08	BUSPLATINE
FUEHRUNGSKONUS M5 PA6G	66 00 419 08	12	1	2 922 001	92 84 311 08	BUSPLATINE
FUEHRUNGSROHR	10 02 919 1	1	1	9 739 188	97 39 188	OELMESSSTAB
FUEHRUNGSSTIFT	60 56 100 08	(157)	2	2 920 369	96 54 235 08	KLEMMKASTEN KPL.
FUEHRUNGSSTIFT	60 56 100 08	(157)	2	2 920 369	96 54 235 08	KLEMMKASTEN KPL.
FUEHRUNGSSTIFT	60 56 100 08	27	6	2 920 369	96 54 235 08	KLEMMKASTEN KPL.
FUEHRUNGSSTIFT	60 56 100 08	23	10	2 920 448	96 48 794 08	KLEMMKASTEN KPL.
FUEHRUNGSSTIFT	60 56 100 08	517	12	2 920 633	96 52 651 08	KABELSTRANG
FUEHRUNGSSTIFT	60 56 100 08	52	21	2 932 160	96 54 385 08	SCHALTSCHRANK MECH.
FUEHRUNGSSTUECK	10 34 311 0	16	1	9 739 344	97 39 344	GENERATOR VORM.
FUNKANTENNE VORM.	96 24 498 08	1	1	2 780 854	96 37 908 08	GSM-MODUL KPL.LICCON 1
FUSS KPL.	96 50 697 08	51	2	3 214	91 52 843 08	SW-KOPFSTUECK
FUSS SCHWK.	96 50 698 08	1	1	3 216 005	96 50 697 08	FUSS KPL.
FUSSTASTER	60 66 035 08	15	1	2 533 050	96 48 359 08	ELEKTRIK KABINE
FUSSWIPPE SPF	10 29 731 0	11	2	2 533 050	96 48 359 08	ELEKTRIK KABINE
GABELGELENK DIN 71752 30	72 51 010 05	17	2	2 810	91 52 806 08	KRANFUEHRERKABINE KPL.
GARDEROBENHAKEN	59 10 501 08	32	2	2 520 034	96 45 984 08	INNENVERKLEIDUNG
GASFEDER	59 10 670 08	23	1	2 502	91 55 939 08	STEUERSTAND
GASFEDER 12X50 130N	10 41 287 1	6	2	2 520 030	96 45 609 08	DACHSCHEIBE VORM.
GASFEDER 23X270 350N	10 47 202 8	3	2	2 932 160	96 54 385 08	SCHALTSCHRANK MECH.
GEBER HUB OBEN ENDSCHAL	96 20 219 08	11	1	3 930 546	96 48 375 08	ELEKTRIK F-KOPFSTUECK
GEBERANBAU ANLENKSTUEC	96 24 232 08	6	1	3 930 731	96 48 374 08	ELEKTRIK F-ANLENKSTUECK
GEBERANBAU S-KOPF	96 37 685 08	5	1	3 930 576	96 48 381 08	ELEKTRIK SW-KOPFSTUECK
GEBERANBAU SA-BOCK	96 57 085 08	20	1	2 920 578	96 54 379 08	ELEKTRIK SA-BOCK
GEBERANBAU WINKELGEBER	96 19 877 08	10	1	3 930 138	96 54 377 08	ELEKTRIK S-ANLENKSTUECK
GEBERANBAU WINKELGEBER	96 19 877 08	5	1	3 930 330	96 54 378 08	ELEKTRIK D-ANLENKSTUECK
GEBERANBAU WINKELGEBER	96 19 877 08	10	1	3 930 421	96 47 149 08	ELEKTRIK D-KOPFSTUECK
GEBERANBAU WINKELGEBER	96 19 877 08	10	1	3 930 575	96 48 380 08	EL.F-ANSCHLUSS KOPFSTUEC
GBLAESE 24V	10 29 012 2	3	1	X1004204	10 04 204 3	WASSERHEIZGERAET
GEGENGEWICHT 16X7.5T + 6X	91 52 770 08	152	1		LR 1600-2-0	LIEBHERR RAUPENKRAN LR 1
GEGENGEWICHT SPF	38 82 792 08	2	6	2 740	91 52 770 08	GEGENGEWICHT
GEGENGEWICHT SPF	97 66 580 08	1	8	1 740	91 53 020 08	ZENTRALBALLAST
GEGENGEWICHT SPF	97 66 580 08	1	16	2 740	91 52 770 08	GEGENGEWICHT
GEGENMUTTER M25X1,5 POL	10 04 269 6	20	2	2 780 915	96 48 377 08	ANBAUTEILE FREMDEINSPEIS
GEGENMUTTER PG9 MS	60 25 019 08	5	1	2 920 257	92 78 689 08	KLEMMKASTEN BELEUCHTUN
GEHAEUSE	10 22 275 8	9	1	9 739 258	97 39 258	KRAFTSTOFFFILTER
GEHAEUSE	51 07 969 08	1	1	5 114 176	51 14 176 08	DRUCKBEGRENZUNGSVENTI
GEHAEUSE	51 07 969 08	1	1	5 114 177	51 14 177 08	DRUCKBEGRENZUNGSVENTI
GEHAEUSE	57 00 092 08	1	1	5 026 126	50 26 126 08	MAGNETVENTIL
GEHAEUSE	57 00 728 08	1	1	5 114 320	51 14 320 08	VORSPANNVENTIL
GEHAEUSE	57 01 130 08	3	1	5 102 306	51 02 306 08	HYDROMOTOR
GEHAEUSE	70 42 533 08	14	4	2 260 006	96 46 501 08	BATTERIEKASTEN VORM.
GEHAEUSE	70 42 533 08	5	7	2 859 005	96 46 756 08	KLAPPE VORM.
GEHAEUSE	70 42 566 08	4	4	2 393 002	96 46 782 08	DECKEL KPL.
GEHAEUSE	70 42 566 08	4	4	2 859 007	96 46 775 08	DECKEL KPL.
GEHAEUSE	70 42 566 08	10	4	2 859 025	96 46 757 08	GITTERROST VORM.
GEHAEUSE	70 42 566 08	4	4	2 859 026	96 46 776 08	DECKEL KPL.
GEHAEUSE	70 42 566 08	4	4	2 859 027	96 46 777 08	DECKEL KPL.
GEHAEUSE	70 42 566 08	4	4	2 859 028	96 46 778 08	DECKEL KPL.
GEHAEUSE	70 42 566 08	4	4	2 859 029	96 46 779 08	DECKEL KPL.
GEHAEUSE	70 42 566 08	9	2	2 859 030	96 46 758 08	DECKEL KPL.
GEHAEUSE	70 42 747 08	3	6	2 932 168	96 48 167 08	DECKEL KPL.
GEHAEUSE	92 99 369 08	1	1	2 913 004	96 20 460 08	GEHAEUSE VORM.
GEHAEUSE 10POL	60 23 328 08	(152)	1	2 920 369	96 54 235 08	KLEMMKASTEN KPL.
GEHAEUSE 14POL	60 23 360 08	(152)	1	2 920 369	96 54 235 08	KLEMMKASTEN KPL.
GEHAEUSE 14POL	60 23 360 08	507	12	2 932 224	96 54 389 08	DRAEHTE MONTAGETAFEL K
GEHAEUSE 15POL	10 09 986 3	512	1	2 932 224	96 54 389 08	DRAEHTE MONTAGETAFEL K
GEHAEUSE 1X400X273 DC01-	61 10 012 08	2	1	2 913 102	92 32 870 08	LUEFTEREINHEIT
GEHAEUSE 21 POL BRAUN	10 09 985 6	518	2	2 932 224	96 54 389 08	DRAEHTE MONTAGETAFEL K
GEHAEUSE 25POL SPF	60 23 223 08	510	7	2 932 224	96 54 389 08	DRAEHTE MONTAGETAFEL K

6.2.2009

etk_en_de_074515 LR 1600/2

1031

LIEBHERRAlphabetical index
Alphabetischer Index

Bezeichnung	Artikel	Pos.	Menge	Seite	Baugruppe	Bezeichnung
GEHAEUSE 4POL	60 23 313 08	515	13	2 932 224	96 54 389 08	DRAEHTE MONTAGETAFEL K
GEHAEUSE 6POL	60 23 255 08	520	2	2 932 224	96 54 389 08	DRAEHTE MONTAGETAFEL K
GEHAEUSE 8POL	60 23 014 08	511	1	2 932 224	96 54 389 08	DRAEHTE MONTAGETAFEL K
GEHAEUSE SPF	97 58 507 08	50	1	2 520	91 53 061 08	KABINE VERGLAST
GEHAEUSE VORM.	96 20 460 08	2	1	2 913	91 32 850 08	LICCON KONSOLE LCD2
GEHAEUSE VORM.	96 20 460 08	2	1	2 913 009	91 04 705 08	LICCON KONSOLE LCD3
GELAENDER	96 53 088 08	3	1	2 631	91 56 817 08	LAUFSTEG DREHBUEHNE
GELAENDER	96 53 089 08	4	1	2 631	91 56 817 08	LAUFSTEG DREHBUEHNE
GELAENDER ALMG3	96 56 362 08	79	2	3 713	91 57 749 08	D-ANLENKSTUECK
GELAENDER ALMG3	96 56 363 08	80	2	3 713	91 57 749 08	D-ANLENKSTUECK
GELAENDER SCHWK.	96 47 099 08	65	4	3 211	91 57 748 08	S-ANLENKSTUECK
GELENKHAKENSCHLUESSEL	88 51 828 08	40	1	1 750	91 52 394 08	WERKZEUG
GELENKLAGER 30	57 15 052 08	(9)	2	2 810	91 52 806 08	KRANFUEHRERKABINE KPL.
GENERATOR VORM.	97 39 343	195	1	X1012059	10 12 059 0	DIESELMOTOR
GENERATOR VORM.	97 39 344	200	1	X1012059	10 12 059 0	DIESELMOTOR
GERAETEHALTER 35MM FED	10 32 483 4	37	5	2 631	91 56 817 08	LAUFSTEG DREHBUEHNE
GERAETESTECKDOSE	60 50 079 08	505	3	2 920 633	96 52 651 08	KABELSTRANG
GERAETESTECKDOSE	69 18 092 08	(151)	1	2 920 369	96 54 235 08	KLEMMKASTEN KPL.
GERAETESTECKDOSE	69 18 092 08	153	1	3 930 639	96 50 132 08	DRAEHTE KLEMMKASTEN KPL
GERAETESTECKDOSE DIN 43	60 52 106 08	507	15	2 920 633	96 52 651 08	KABELSTRANG
GERAETESTECKER DIN 43650	60 50 066 08	509	1	2 920 633	96 52 651 08	KABELSTRANG
GERAETESTECKER DIN 43650	60 50 066 08	2	1	5 114 445	51 14 445 08	WEGEVENTIL
GERAEUSCHDAEMMUNG	91 52 809 08	159	1		LR 1600-2-0	LIEBHERR RAUPENKRAN LR 1
GERAEUSCHDAEMPFER	50 26 616 08	22	1	2 990	91 59 244 08	DRUCKLUFTANLAGE
GESTAENGE 4.0X106 ST	97 77 244 08	22	1	2 522 011	96 45 602 08	SCHLIESSANLAGE
GESTAENGE 4.0X58 ST	97 68 662 08	5	1	2 522 011	96 45 602 08	SCHLIESSANLAGE
GESTAENGE 4.0X72 ST	97 68 665 08	8	1	2 522 011	96 45 602 08	SCHLIESSANLAGE
GESTAENGECLIP	70 42 797 08	9	3	2 522 011	96 45 602 08	SCHLIESSANLAGE
GETRIEBE	10 65 015 5	1	1	X1035411	10 35 411 4	HUBWINDE
GEWICHT 43X70X245 EN-GJS4	38 82 832 08	1	1	2 311 001	96 25 639 08	HUBENDSCHALTER GEWICHT
GEWICHT EN-GJS400-18 FE//	38 82 831 08	2	1	2 311 001	96 25 639 08	HUBENDSCHALTER GEWICHT
GEWINDEBOLZEN 16F7X52X7	97 74 833 08	2	2	2 502	91 55 939 08	STUERSTAND
GEWINDEBOLZEN 40.0X505	97 73 406 08	4	8	2 125	91 52 773 08	BOLZEN S-ANLENKST. UND S
GEWINDEBOLZEN DIN 976 B	66 00 416 08	14	1	2 922 001	92 84 311 08	BUSPLATINE
GEWINDEBOLZEN RD30X365	95 44 784 08	20	6	1 400	91 56 853 08	RAUPENTRAEGER KPL.LI.
GEWINDEBOLZEN RD30X365	95 44 784 08	20	6	1 410 300	91 56 855 08	RAUPENTRAEGER KPL.RE.
GEWINDEBUCHSE RD240X200	93 81 367 08	2	2	1 632	91 52 389 08	MECH.ZUSATZABSTUETZUNG
GEWINDEFORMSCHRAUBE D	57 00 103 08	18	4	5 026 126	50 26 126 08	MAGNETVENTIL
GEWINDEPLATTE 8X20X60	95 36 953 08	4	4	2 510	91 52 788 08	DREHBUEHNENVERKLEIDUN
GEWINDEPLATTE 8X20X60	95 36 953 08	3	2	2 510 040	96 49 183 08	TUER VORM.
GEWINDEPLATTE 8X20X60	95 36 953 08	3	2	2 510 059	96 49 184 08	TUER VORM.
GEWINDESCHEIBE	10 41 278 9	6	1	X1041267	10 41 267 8	ENDPLATTE
GEWINDESCHEIBE	51 10 072 08	14	1	5 114 320	51 14 320 08	VORSPANNVENTIL
GEWINDESTANGE M10X120	95 45 915 08	11	1	2 391 040	96 53 645 08	KUPPLUNGSSTELLER
GEWINDESTANGE M10X120	95 45 915 08	10	1	3 206	91 52 881 08	F-ANLENKSTUECK
GEWINDESTIFT DIN 913 M10X1	40 44 022 08	530	1	X1041101	10 41 101 5	RUECKFALLSTUETZE
GEWINDESTIFT DIN 913 M10X1	40 44 022 08	450	1	X1041101	10 41 101 8	RUECKFALLSTUETZE
GEWINDESTIFT DIN 913 M10X4	40 44 031 08	4	1	2 502 007	96 22 822 08	ARMLEHNE LINKS
GEWINDESTIFT DIN 913 M10X4	40 44 031 08	4	1	2 502 008	96 22 823 08	ARMLEHNE RECHTS
GEWINDESTIFT DIN 913 M6X2	40 44 005 08	27	2	2 522	91 54 115 08	SCHIEBETUER KPL.
GEWINDESTIFT DIN 913 M6X35	51 07 533 08	9	1	5 711 301	57 11 301 08	DRUCKBEGRENZUNGSVENTI
GEWINDESTIFT DIN 913 M8X16	40 44 011 08	78	16	3 211	91 57 748 08	S-ANLENKSTUECK
GEWINDESTIFT DIN 914 M12X3	40 46 047 08	12	2	1 632	91 52 389 08	MECH.ZUSATZABSTUETZUNG
GEWINDESTIFT DIN 914 M6X1	40 46 005 08	20	2	3 213	91 52 842 08	F-ANSCHLUSSKOPF
GEWINDESTIFT DIN 914 M8X1	40 46 013 08	540	4	X1041101	10 41 101 5	RUECKFALLSTUETZE
GEWINDESTIFT DIN 914 M8X1	40 46 013 08	460	4	X1041101	10 41 101 8	RUECKFALLSTUETZE
GEWINDESTIFT DIN 915 M16X4	40 48 046 08	23	5	X1065015	10 65 015 6	SEILTROMMEL
GEWINDESTIFT DIN 915 M8X2	40 48 003 08	(4)	8	2 550	91 57 751 08	SA-BOCK
GEWINDESTIFT DIN 915 M8X2	40 48 003 08	(5)	6	2 550	91 57 751 08	SA-BOCK
GEWINDESTIFT DIN 915 M8X2	40 48 003 08	39	8	2 550	91 57 751 08	SA-BOCK

6.2.2009

etk_en_de_074515 LR 1600/2

1032

LIEBHERRAlphabetical index
Alphabetischer Index

Bezeichnung	Artikel	Pos.	Menge	Seite	Baugruppe	Bezeichnung
GEWINDESTIFT M4	77 43 752 08	14	4	1 711	91 52 392 08	ZENTRALSCHMIERUNG RAUP
GEWINDESTUTZEN	10 22 276 5	11	1	9 739 281	97 39 281	LECKOELLEITUNG
GITTERROST 1007X567X30 GF	97 77 563 08	6	1	3 713 006	96 50 099 08	GITTERROSTE
GITTERROST 1007X647X30 GF	97 80 165 08	34	1	3 214	91 52 843 08	SW-KOPFSTUECK
GITTERROST 1007X647X30 GF	97 80 166 08	35	1	3 214	91 52 843 08	SW-KOPFSTUECK
GITTERROST 1047X487X30 GF	97 79 282 08	39	1	3 714	91 52 862 08	D-KOPFSTUECK
GITTERROST 1127X1007X30	97 77 558 08	7	1	3 713 006	96 50 099 08	GITTERROSTE
GITTERROST 1127X647X30 GF	97 79 207 08	60	1	3 206	91 52 881 08	F-ANLENKSTUECK
GITTERROST 1127X647X30 GF	97 79 207 08	95	1	3 714	91 52 862 08	D-KOPFSTUECK
GITTERROST 1127X927X30 GF	97 86 922 08	14	1	3 206	91 52 881 08	F-ANLENKSTUECK
GITTERROST 1167X1007X30	97 75 015 08	45	1	3 225	91 52 854 08	SL-REDUZIERSTUECK
GITTERROST 1167X687X30 GF	97 75 016 08	46	1	3 225	91 52 854 08	SL-REDUZIERSTUECK
GITTERROST 1327X447X30 GF	97 72 738 08	9	1	3 211 006	96 47 004 08	GITTERROSTE
GITTERROST 1367X487X30 GF	97 72 735 08	6	1	3 211 006	96 47 004 08	GITTERROSTE
GITTERROST 1367X487X30 GF	97 72 736 08	7	1	3 211 006	96 47 004 08	GITTERROSTE
GITTERROST 1367X487X30 GF	97 72 741 08	12	2	3 211 006	96 47 004 08	GITTERROSTE
GITTERROST 1367X807X30 GF	97 73 275 08	23	1	3 221	91 54 668 08	S-ZWISCHENSTUECK
GITTERROST 1367X807X30 GF	97 73 275 08	3	1	3 713 006	96 50 099 08	GITTERROSTE
GITTERROST 1367X807X30 GF	97 73 275 08	94	2	3 714	91 52 862 08	D-KOPFSTUECK
GITTERROST 1407X327X30 GF	97 77 561 08	1	1	3 713 006	96 50 099 08	GITTERROSTE
GITTERROST 1407X487X30 GF	97 66 610 08	23	2	3 226	91 52 870 08	LI-ZWISCHENSTUECK
GITTERROST 1407X487X30 GF	97 66 610 08	23	2	3 227	91 52 873 08	LI-ZWISCHENSTUECK
GITTERROST 1407X487X30 GF	97 66 610 08	23	2	3 227 008	91 52 872 08	LI-ZWISCHENSTUECK
GITTERROST 1407X487X30 GF	97 66 610 08	23	2	3 227 200	91 53 519 08	LI-ZWISCHENSTUECK F-ABSP
GITTERROST 1407X487X30 GF	97 66 610 08	40	1	3 714	91 52 862 08	D-KOPFSTUECK
GITTERROST 1407X487X30 GF	97 66 610 08	26	2	3 715 008	91 52 863 08	D-ZWISCHENSTUECK
GITTERROST 1407X487X30 GF	97 66 610 08	33	2	3 716	91 52 864 08	D-ZWISCHENSTUECK
GITTERROST 1527X447X30 GF	97 72 730 08	3	1	3 211 006	96 47 004 08	GITTERROSTE
GITTERROST 1567X887X30 GF	97 77 564 08	9	2	3 713 006	96 50 099 08	GITTERROSTE
GITTERROST 1607X1294X30	97 72 734 08	5	2	3 211 006	96 47 004 08	GITTERROSTE
GITTERROST 1927X1007X30	97 72 743 08	14	1	3 211 006	96 47 004 08	GITTERROSTE
GITTERROST 2007X807X30 GF	97 72 744 08	15	1	3 211 006	96 47 004 08	GITTERROSTE
GITTERROST 2127X487X30 GF	97 72 733 08	4	1	3 211 006	96 47 004 08	GITTERROSTE
GITTERROST 2127X487X30 GF	97 77 559 08	8	1	3 713 006	96 50 099 08	GITTERROSTE
GITTERROST 2207X607X30 GF	97 77 787 08	10	1	3 713 006	96 50 099 08	GITTERROSTE
GITTERROST 2207X807X30 GF	97 71 971 08	22	2	3 220 500	91 52 849 08	S-ZWISCHENSTUECK
GITTERROST 2207X807X30 GF	97 71 971 08	22	2	3 226	91 52 870 08	LI-ZWISCHENSTUECK
GITTERROST 2207X807X30 GF	97 71 971 08	41	1	3 227	91 52 873 08	LI-ZWISCHENSTUECK
GITTERROST 2207X807X30 GF	97 71 971 08	41	1	3 227 008	91 52 872 08	LI-ZWISCHENSTUECK
GITTERROST 2207X807X30 GF	97 71 971 08	41	1	3 227 200	91 53 519 08	LI-ZWISCHENSTUECK F-ABSP
GITTERROST 2207X807X30 GF	97 71 971 08	5	1	3 713 006	96 50 099 08	GITTERROSTE
GITTERROST 2207X807X30 GF	97 71 971 08	41	1	3 714	91 52 862 08	D-KOPFSTUECK
GITTERROST 2207X807X30 GF	97 71 971 08	28	2	3 715 008	91 52 863 08	D-ZWISCHENSTUECK
GITTERROST 2287X407X30 GF	97 77 562 08	4	1	3 713 006	96 50 099 08	GITTERROSTE
GITTERROST 2287X807X30 GF	97 71 942 08	40	1	3 223	91 52 852 08	S-ZWISCHENSTUECK
GITTERROST 2287X807X30 GF	97 71 942 08	40	1	3 223 010	91 52 853 08	S-ZWISCHENSTUECK
GITTERROST 2287X807X30 GF	97 71 942 08	40	1	3 223 100	91 55 327 08	S-ZWISCHENSTUECK
GITTERROST 2287X807X30 GF	97 71 942 08	35	1	3 716	91 52 864 08	D-ZWISCHENSTUECK
GITTERROST 2327X487X30 GF	97 74 745 08	5	1	3 225	91 52 854 08	SL-REDUZIERSTUECK
GITTERROST 2447X487X30 GF	97 72 097 08	1	1	3 211 006	96 47 004 08	GITTERROSTE
GITTERROST 2567X487X30 GF	97 74 744 08	4	1	3 225	91 52 854 08	SL-REDUZIERSTUECK
GITTERROST 2647X447X30 GF	97 72 737 08	8	1	3 211 006	96 47 004 08	GITTERROSTE
GITTERROST 2647X487X30 GF	97 66 514 08	23	2	3 220 500	91 52 849 08	S-ZWISCHENSTUECK
GITTERROST 2647X487X30 GF	97 66 514 08	11	2	3 221	91 54 668 08	S-ZWISCHENSTUECK
GITTERROST 2647X487X30 GF	97 66 514 08	23	2	3 223	91 52 852 08	S-ZWISCHENSTUECK
GITTERROST 2647X487X30 GF	97 66 514 08	23	2	3 223 010	91 52 853 08	S-ZWISCHENSTUECK
GITTERROST 2647X487X30 GF	97 74 648 08	23	2	3 223 100	91 55 327 08	S-ZWISCHENSTUECK
GITTERROST 2687X807X30 GF	97 88 638 08	47	2	3 715 008	91 52 863 08	D-ZWISCHENSTUECK
GITTERROST 3167X807X30 GF	97 77 560 08	2	1	3 713 006	96 50 099 08	GITTERROSTE
GITTERROST 3647X1007X30	97 72 098 08	2	1	3 211 006	96 47 004 08	GITTERROSTE

6.2.2009

etk_en_de_074515 LR 1600/2

1033

LIEBHERRAlphabetical index
Alphabetischer Index

Bezeichnung	Artikel	Pos.	Menge	Seite	Baugruppe	Bezeichnung
GITTERROST 3807X807X30 GF	97 72 745 08	16	3	3 211 006	96 47 004 08	GITTERROSTE
GITTERROST 3807X807X30 GF	97 72 745 08	48	3	3 716	91 52 864 08	D-ZWISCHENSTUECK
GITTERROST 3847X807X30 GF	97 74 743 08	3	1	3 225	91 52 854 08	SL-REDUZIERSTUECK
GITTERROST 4047X807X30 GF	97 71 763 08	22	2	3 223	91 52 852 08	S-ZWISCHENSTUECK
GITTERROST 4047X807X30 GF	97 71 763 08	22	2	3 223 010	91 52 853 08	S-ZWISCHENSTUECK
GITTERROST 4047X807X30 GF	97 71 763 08	22	2	3 223 100	91 55 327 08	S-ZWISCHENSTUECK
GITTERROST 4047X807X30 GF	97 71 763 08	22	2	3 227	91 52 873 08	LI-ZWISCHENSTUECK
GITTERROST 4047X807X30 GF	97 71 763 08	22	2	3 227 008	91 52 872 08	LI-ZWISCHENSTUECK
GITTERROST 4047X807X30 GF	97 71 763 08	22	2	3 227 200	91 53 519 08	LI-ZWISCHENSTUECK F-ABSP
GITTERROST 4047X807X30 GF	97 71 763 08	42	1	3 714	91 52 862 08	D-KOPFSTUECK
GITTERROST 4047X807X30 GF	97 71 763 08	34	2	3 716	91 52 864 08	D-ZWISCHENSTUECK
GITTERROST 447X367X30 GF	97 72 739 08	10	1	3 211 006	96 47 004 08	GITTERROSTE
GITTERROST 447X367X30 GF	97 72 740 08	11	1	3 211 006	96 47 004 08	GITTERROSTE
GITTERROST T1950X738X25/3	97 70 899 08	2	1	2 859 025	96 46 757 08	GITTERROST VORM.
GITTERROST VORM.	96 46 757 08	5	1	2 859	91 52 809 08	GERAEUSCHDAEMMUNG
GITTERROST-P T1020X240X30	72 58 067 08	5	2	1 620	91 52 386 08	BEFESTIGUNGSTEILE DREH
GITTERROST-P T1140X1260X	97 79 271 08	15	2	1 631 100	91 52 388 08	LAUFSTEG RAUPENFAHRWER
GITTERROST-P T1140X1260X	97 86 742 08	16	2	1 631 100	91 52 388 08	LAUFSTEG RAUPENFAHRWER
GITTERROST-P T1595X1260X	72 58 549 08	2	4	1 631 100	91 52 388 08	LAUFSTEG RAUPENFAHRWER
GITTERROST-P T626X500X25/2	72 58 469 08	25	2	3 745	91 52 948 08	SCHWEBEBALLAST
GITTERROSTE	96 47 004 08	30	1	3 211	91 57 748 08	S-ANLENKSTUECK
GITTERROSTE	96 50 099 08	15	1	3 713	91 57 749 08	D-ANLENKSTUECK
GITTERROSTRAHMEN SCHWK	96 46 810 08	1	1	2 859 025	96 46 757 08	GITTERROST VORM.
GLEICHSTROMMOTOR 24V	10 01 469 1	8	1	7 743 566	77 43 566 08	ELEKTROPUMPE
GLEITKLOTZ KPL.	10 45 514 4	15	1	X1029200	10 29 200 4	FAHRERSITZ
GLUEHLAMPE 1,2W 30V	60 70 087 08	10	4	2 533 061	96 48 370 08	ARMATUREN ARMLEHNE LI.
GLUEHLAMPE 1,2W 30V	60 70 087 08	10	1	2 533 063	96 48 371 08	ARMATUREN ARMLEHNE RE.
GLUEHLAMPE 1,2W 30V	60 70 087 08	17	12	2 533 070	96 48 363 08	ARMATUREN RE.
GLUEHLAMPE 1,2W 48V	60 70 117 08	23	1	2 533 070	96 48 363 08	ARMATUREN RE.
GLUEHLAMPE 35W 24V	60 70 091 08	11	1	1 933 100	91 25 249 08	MAGNETLAMPE
GLUEHLAMPE DIN 72601 21W	60 70 217 08	4	2	2 920 931	96 59 398 08	WARNLEUCHE
GLUEHLAMPE DIN 72601 21W	60 70 217 08	2	1	6 071 131	60 71 131 08	SCHLUSSBREMSLEUCHE
GLUEHLAMPE DIN 72601 5W	60 70 201 08	3	1	6 071 131	60 71 131 08	SCHLUSSBREMSLEUCHE
GLUEHLAMPE DIN 72601 70W	60 70 211 08	21	3	2 925 002	96 58 856 08	AUSRUESTUNG KAMERA DRE
GLUEHLAMPE DIN 72601 70W	60 70 211 08	(21)	1	2 925 218	91 60 840 08	KAMERAUEBERWACHUNG WI
GLUEHSTIFT	10 29 012 5	18	1	X1004204	10 04 204 3	WASSERHEIZGERAET
GRIFF 10.0X750 S235JRG2 FE//	97 83 897 08	72	1	1 400	91 56 853 08	RAUPENTRAEGER KPL.LI.
GRIFF 10.0X750 S235JRG2 FE//	97 83 897 08	72	1	1 410 300	91 56 855 08	RAUPENTRAEGER KPL.RE.
GRIFF KUNSTSTOFF	70 42 545 08	8	1	2 260 006	96 46 501 08	BATTERIEKASTEN VORM.
GRIFF SCHWK.	92 10 795 08	5	1	2 550 011	96 47 007 08	KONSOLE KPL.
GRIFF SCHWK.	92 10 795 08	4	4	2 790 455	91 57 005 08	TRANSPORTABLAGE
GRIFF SCHWK.	96 27 295 08	57	1	3 225	91 52 854 08	SL-REDUZIERSTUECK
GRIFF SCHWK.	96 50 603 08	22	4	2 340	91 52 776 08	WINDE 4 EINZIEHWERK
GRIFF SCHWK. TZNO	96 53 092 08	7	1	2 631	91 56 817 08	LAUFSTEG DREHBUEHNE
GRIFFBOLZEN	96 54 983 08	48	4	3 225	91 52 854 08	SL-REDUZIERSTUECK
GRIFFKAPPE	57 18 247 08	1	1	6 060 950	60 60 950 08	MEISTERSCHALTER
GRUNDPLATTE DREHBUEHN	91 52 802 08	150	1		LR 1600-2-0	LIEBHERR RAUPENKRAN LR 1
GSM-MODUL KPL.LICCON 1	96 37 908 08	1	1	2 780 850	91 24 097 08	FERNDIAGNOSE MODUL OW
GSM-MODUL PROG. SPF	96 28 688 08	4	1	2 780 852	96 24 845 08	GSM-MODUL VORM.LICCON 1
GSM-MODUL TC63 QUAD-BAN	10 40 975 0	(10)	1	2 780 852	96 24 845 08	GSM-MODUL VORM.LICCON 1
GSM-MODUL VORM.LICCON 1	96 24 845 08	2	1	2 780 854	96 37 908 08	GSM-MODUL KPL.LICCON 1
GUMMIPANZERSCHLAUCH 30	79 00 429 08	19	1	1 750	91 52 394 08	WERKZEUG
GUMMIPUFFER 32X32XM6 EL	10 47 289 0	84	2	2 520	91 53 061 08	KABINE VERGLAST
HAENGETASTER	60 66 523 08	7	1	2 920 638	96 51 138 08	BEDIENPULT
HAFTETIKETT	60 21 710 08	47	90	2 932 001	96 45 393 08	RELAISSTEUERUNG
HAKENFLASCHE 125 DM SPF	91 55 528 08	314	1		LR 1600-2-0	LIEBHERR RAUPENKRAN LR 1
HAKENVERSCHLUSS	70 42 624 08	53	1	3 206	91 52 881 08	F-ANLENKSTUECK
HAKENVERSCHLUSS	70 42 624 08	41	2	3 214	91 52 843 08	SW-KOPFSTUECK
HALTEBLECH	10 34 310 7	7	1	9 739 344	97 39 344	GENERATOR VORM.
HALTEGRIF 215X25X59,2X16	10 44 330 9	19	1	2 522	91 54 115 08	SCHIEBETUER KPL.

6.2.2009

etk_en_de_074515 LR 1600/2

1034

LIEBHERRAlphabetical index
Alphabetischer Index

Bezeichnung	Artikel	Pos.	Menge	Seite	Baugruppe	Bezeichnung
HALTEGRIFF SCHWK.	96 54 193 08	28	1	2 520	91 53 061 08	KABINE VERGLAST
HALTEPLATTE 4X155X50	97 81 204 08	78	12	2 550	91 57 751 08	SA-BOCK
HALTER	10 01 229 5	7	1	9 739 118	97 39 118	OELLEITUNG
HALTER	10 01 268 4	19	1	9 739 386	97 39 386	KURBELGEHAEUSEENTLUEFT
HALTER	10 01 268 5	3	1	9 739 140	97 39 140	FLAMMSTARTANLAGE
HALTER	10 02 091 7	8	1	9 739 271	97 39 271	VERBINDUNGSLEITUNG
HALTER	10 02 091 8	14	1	9 739 358	97 39 358	ABGASRUECKFUEHRUNG AN
HALTER	10 02 092 1	1	1	9 739 366	97 39 366	BEFESTIGUNGSTEILE ANBAU
HALTER	10 02 092 1	26	1	9 739 386	97 39 386	KURBELGEHAEUSEENTLUEFT
HALTER	10 02 095 5	7	4	9 739 366	97 39 366	BEFESTIGUNGSTEILE ANBAU
HALTER	10 03 718 2	4	1	9 739 210	97 39 210	KUEHLMITTELLEITUNG
HALTER	10 28 506 8	2	1	9 739 366	97 39 366	BEFESTIGUNGSTEILE ANBAU
HALTER	10 28 506 9	4	1	9 739 366	97 39 366	BEFESTIGUNGSTEILE ANBAU
HALTER	10 28 507 0	11	1	9 739 356	97 39 356	ROHRLEITUNG ANBAU
HALTER	10 28 507 0	6	1	9 739 366	97 39 366	BEFESTIGUNGSTEILE ANBAU
HALTER	10 34 310 3	21	1	9 739 371	97 39 371	KLIMAKOMPRESSOR ANBAU
HALTER	10 34 310 4	2	1	9 739 344	97 39 344	GENERATOR VORM.
HALTER	10 34 310 6	11	1	9 739 344	97 39 344	GENERATOR VORM.
HALTER	10 34 312 6	21	1	9 739 366	97 39 366	BEFESTIGUNGSTEILE ANBAU
HALTER	10 34 312 8	22	1	9 739 366	97 39 366	BEFESTIGUNGSTEILE ANBAU
HALTER	10 48 693 3	35	1	9 739 492	97 39 492	ROHRLEITUNG ANBAU
HALTER	69 10 431 08	14	68	6 909 010	69 09 010 08	SCHLEIFRINGUEBERTRAEGE
HALTER	89 01 014 08	31	1	2 520 034	96 45 984 08	INNENVERKLEIDUNG
HALTER	90 80 704	1	1	9 080 702	90 80 702	STEUERGERAET
HALTER	90 80 706	2	1	9 080 702	90 80 702	STEUERGERAET
HALTER	97 52 186 08	20	6	2 520	91 53 061 08	KABINE VERGLAST
HALTER	97 53 845 08	21	6	2 520	91 53 061 08	KABINE VERGLAST
HALTER 4X20X80	94 66 007 08	68	2	2 550	91 57 751 08	SA-BOCK
HALTER 4X30X95	95 14 733 08	58	7	2 391 001	96 45 719 08	DIESELMOTOR VORM.
HALTER KPL.	96 47 628 08	37	1	2 550	91 57 751 08	SA-BOCK
HALTER KPL.	96 47 645 08	36	1	2 550	91 57 751 08	SA-BOCK
HALTER KPL. S235JR	10 11 880 5	3	1	9 080 702	90 80 702	STEUERGERAET
HALTER SCHWK.	96 45 803 08	3	1	2 522 012	96 45 884 08	FUEHRUNG VORM.
HALTER SCHWK.	96 46 046 08	4	1	2 522 013	96 45 883 08	FUEHRUNG VORM.
HALTER SCHWK.	96 46 388 08	54	4	2 550	91 57 751 08	SA-BOCK
HALTER SCHWK.	96 47 493 08	1	1	2 550 008	96 47 628 08	HALTER KPL.
HALTER SCHWK.	96 47 644 08	1	1	2 550 009	96 47 645 08	HALTER KPL.
HALTER SCHWK.	96 48 733 08	46	1	2 520	91 53 061 08	KABINE VERGLAST
HALTER SCHWK.	96 49 299 08	9	1	3 350	91 52 859 08	WINDE 3
HALTER SCHWK.	96 50 831 08	65	2	3 714	91 52 862 08	D-KOPFSTUECK
HALTER SCHWK.	96 53 255 08	1	1	2 391 040	96 53 645 08	KUPPLUNGSSTELLER
HALTER SCHWK.	96 53 928 08	28	4	3 350	91 52 859 08	WINDE 3
HALTER ST	70 42 213 08	29	1	2 520 034	96 45 984 08	INNENVERKLEIDUNG
HALTER X12CrNiS188	92 35 694 08	55	2	2 550	91 57 751 08	SA-BOCK
HALTER X12CrNiS188	92 35 694 08	11	1	3 745 002	92 17 236 08	SCHALTEINHEIT
HALTER X12CrNiS188	92 35 694 08	11	1	3 745 003	92 17 237 08	SCHALTEINHEIT
HALTER X12CrNiS188	92 35 704 08	25	1	3 206	91 52 881 08	F-ANLENKSTUECK
HALTERUNG	88 50 423 08	59	1	2 520 034	96 45 984 08	INNENVERKLEIDUNG
HALTERUNG	92 83 955 08	75	8	3 713	91 57 749 08	D-ANLENKSTUECK
HALTERUNG SCHWK.	96 46 304 08	2	1	2 652	91 52 794 08	ROLLENLAGERUNG
HALTERUNG SCHWK.	96 46 307 08	14	1	2 652	91 52 794 08	ROLLENLAGERUNG
HALTERUNG SCHWK.	96 47 021 08	1	1	3 211 009	96 46 979 08	SCHUTZWALZE KPL.
HALTERUNGSSCHELLE 125X	10 01 268 1	9	1	9 739 159	97 39 159	STARTER
HALTERUNGSSCHELLE D1-10	10 01 198 9	12	1	9 739 282	97 39 282	LECKOELLEITUNG
HALTEWINKEL 2X190X112	97 81 077 08	76	1	2 550	91 57 751 08	SA-BOCK
HAMMERKOPFSCHRAUBE M8	40 97 069 08	2	4	2 503 100	91 55 873 08	NOTSITZ
HAMMERKOPFSCHRAUBE M8	40 97 070 08	32	2	2 310	91 52 503 08	WINDE 1
HAMMERKOPFSCHRAUBE M8	40 97 070 08	32	2	2 320	91 52 504 08	WINDE 2
HAMMERKOPFSCHRAUBE M8	40 97 070 08	152	2	2 970	91 56 537 08	HYDRAULIK
HAMMERKOPFSCHRAUBE M8	40 97 066 08	14	2	2 391 102	96 56 360 08	ZUSATZKUEHLER VORM.

6.2.2009

etk_en_de_074515 LR 1600/2

1035

LIEBHERRAlphabetical index
Alphabetischer Index

Bezeichnung	Artikel	Pos.	Menge	Seite	Baugruppe	Bezeichnung
HANDBETAETIGUNG	10 41 267 7	9	1	5 133 090	51 13 090 08	WEGESCHIEBERBLOCK
HANDBETAETIGUNG	51 10 438 08	(8)	1	2 970	91 56 537 08	HYDRAULIK
HANDGRIFF	59 10 668 08	3	1	2 520 030	96 45 609 08	DACHSCHEIBE VORM.
HANDHAMMER 500G	79 00 303 08	9	1	1 750	91 52 394 08	WERKZEUG
HANDHAMMER DIN 1041 1500	79 00 301 08	10	1	1 750	91 52 394 08	WERKZEUG
HANDHEBELPRESSE VERZ.	79 00 420 08	18	1	1 750	91 52 394 08	WERKZEUG
HANDPUMPE ZPH1A/5PN500	57 17 080 08	1	1	5 123 682	51 23 682 08	MONTAGEZYLINDER
HAUBE 1.5X411X555	97 29 088 08	18	1	2 550	91 57 751 08	SA-BOCK
HAUBE 1.5X411X555	97 29 088 08	50	1	3 208 001	91 52 883 08	F-KOPFSTUECK
HAUBE 1.5X411X555	97 29 088 08	52	1	3 211	91 57 748 08	S-ANLENKSTUECK
HAUBE 1.5X411X555	97 29 088 08	15	1	3 213	91 52 842 08	F-ANSCHLUSSKOPF
HAUBE 1.5X411X555	97 29 088 08	20	1	3 214	91 52 843 08	SW-KOPFSTUECK
HAUBE 1.5X831X448	95 47 461 08	110	1	3 713	91 57 749 08	D-ANLENKSTUECK
HAUBE 1.5X831X448	95 47 461 08	75	1	3 714	91 52 862 08	D-KOPFSTUECK
HAUBE 1.5X931X548	95 32 110 08	109	1	3 713	91 57 749 08	D-ANLENKSTUECK
HAUBE 1.5X931X548	95 32 110 08	74	1	3 714	91 52 862 08	D-KOPFSTUECK
HAUBE 2X298X327 FE//ZN20//	97 80 592 08	3	1	2 925 402	96 58 855 08	KAMERAANBAU DREHBUEHN
HAUBE 2X333X329	97 14 477 08	15	1	2 657	91 57 656 08	MONTAGEEINRICHTUNG RA
HAUPTLAGER	10 01 208 3	6	7	9 739 102	97 39 102	KURBELWELLENLAGERUNG
HAUPTLAGER D= -0,10MM	10 01 210 7	61	7	9 739 102	97 39 102	KURBELWELLENLAGERUNG
HAUPTLAGER D= -0,50MM	10 01 210 9	63	7	9 739 102	97 39 102	KURBELWELLENLAGERUNG
HAUPTLAGER D= -0,75MM	10 01 211 0	64	7	9 739 102	97 39 102	KURBELWELLENLAGERUNG
HAUPTLAGER D= -1,00MM	10 01 211 2	65	7	9 739 102	97 39 102	KURBELWELLENLAGERUNG
HAUPTLAGER R-MOTORXD287	10 01 208 8	62	7	9 739 102	97 39 102	KURBELWELLENLAGERUNG
HEBEL	92 17 246 08	2	1	3 745 002	92 17 236 08	SCHALTEINHEIT
HEBEL	92 17 246 08	2	1	3 745 003	92 17 237 08	SCHALTEINHEIT
HEBEL KPL.	96 47 960 08	3	1	3 206	91 52 881 08	F-ANLENKSTUECK
HEBEL KPL.	96 55 460 08	40	1	2 391 040	96 53 645 08	KUPPLUNGSSTELLER
HEBEL SCHWK.	96 47 983 08	1	1	3 206 002	96 47 960 08	HEBEL KPL.
HEBELSTANGE	10 41 278 8	13	1	X1041267	10 41 267 7	HANDBETAETIGUNG
HEBELVERSCHLUSS	70 42 288 08	5	2	2 510 059	96 49 184 08	TUER VORM.
HEBELVERSCHLUSS	70 42 288 08	41	1	2 520	91 53 061 08	KABINE VERGLAST
HECKSCHEIBE ESG-GLAS SP	97 68 381 08	1	1	2 520 031	96 45 610 08	HECKSCHEIBE VORM.
HECKSCHEIBE VORM.	96 45 610 08	7	1	2 520	91 53 061 08	KABINE VERGLAST
HEIZKLIMAGERAET	10 22 811 2	1	1	2 540	91 53 253 08	HEIZKLIMAGERAET EINBAU
HEIZKLIMAGERAET EINBAU	91 53 253 08	10	1	2 520	91 53 061 08	KABINE VERGLAST
HEIZUNG	50 26 514 08	2	1	5 026 573	50 26 573 08	LUFTTROCKNER
HEIZUNGSSCHLAUCH 70	55 31 812 08	57	1.7	2 520	91 53 061 08	KABINE VERGLAST
HEIZUNGSSCHLAUCH 70	55 31 812 08	58	1.9	2 520	91 53 061 08	KABINE VERGLAST
HEIZUNGSSCHLAUCH 89 Rolle	55 30 182 08	59	0.16	2 520	91 53 061 08	KABINE VERGLAST
HEIZUNGSSCHLAUCH 89 Rolle	55 30 182 08	60	0.3	2 520	91 53 061 08	KABINE VERGLAST
HEIZUNGSSCHLAUCH 89 Rolle	55 30 182 08	61	0.13	2 520	91 53 061 08	KABINE VERGLAST
HEIZUNGSSCHLAUCH 89 Rolle	55 30 182 08	62	0.26	2 520	91 53 061 08	KABINE VERGLAST
HEIZUNGSSCHLAUCH 89 Rolle	55 30 182 08	63	1.62	2 520	91 53 061 08	KABINE VERGLAST
HILFSSCHALTERBLOCK	60 66 532 08	9	4	2 920 638	96 51 138 08	BEDIENPULT
HILFSSCHALTERBLOCK	60 66 614 08	10	1	2 920 638	96 51 138 08	BEDIENPULT
HINWEISSCHILD PVC 2	97 39 082	49	1	9 739 400	97 39 400	DIESELMOTOR
HITZESCHUTZ	97 39 296	181	1	X1012059	10 12 059 0	DIESELMOTOR
HOCHDRUCKPUMPE	10 34 309 6	70	1	X1012059	10 12 059 0	DIESELMOTOR
HOEHENVERSTELLUNG	10 65 048 3	28	1	X1029200	10 29 200 4	FAHRERSITZ
HOHLSCHRAUBE	10 01 272 8	2	6	9 739 127	97 39 127	WASSERENTLUEFTUNGSLEIT
HOHLSCHRAUBE	10 01 273 0	8	2	9 739 282	97 39 282	LECKOELLEITUNG
HOHLSCHRAUBE	10 01 273 0	25	1	9 739 288	97 39 288	KRAFTSTOFFLEITUNG
HOHLSCHRAUBE	10 01 273 0	4	6	9 739 292	97 39 292	KRAFTSTOFFLEITUNG
HOHLSCHRAUBE	10 01 273 0	3	2	9 739 492	97 39 492	ROHRLEITUNG ANBAU
HOHLSCHRAUBE	10 22 232 3	6	1	9 739 243	97 39 243	KOLBENKUEHLUNG
HOHLSCHRAUBE	10 22 276 0	2	5	9 739 281	97 39 281	LECKOELLEITUNG
HOHLSCHRAUBE	10 22 276 3	6	1	9 739 281	97 39 281	LECKOELLEITUNG
HOHLSCHRAUBE	10 28 515 6	18	1	9 739 288	97 39 288	KRAFTSTOFFLEITUNG
HOHLSCHRAUBE	10 28 710 8	25	1	9 739 494	97 39 494	ATL-ANBAU

6.2.2009

etk_en_de_074515 LR 1600/2

1036

LIEBHERRAlphabetical index
Alphabetischer Index

Bezeichnung	Artikel	Pos.	Menge	Seite	Baugruppe	Bezeichnung
HOHLSCHRAUBE 10S	10 01 272 4	17	1	9 739 349	97 39 349	WASSERLEITUNGSANSCHLUE
HOHLSCHRAUBE 12 A4D	10 01 200 7	6	1	9 739 355	97 39 355	OELKUEHLER ANBAU
HOHLSCHRAUBE M10X1X19E	10 01 272 6	15	1	9 739 288	97 39 288	KRAFTSTOFFLEITUNG
HOHLSCHRAUBE M14X1,5X41,	10 22 277 0	10	1	9 739 282	97 39 282	LECKOELLEITUNG
HOHLSCHRAUBE M14X1,5X41,	10 22 277 0	15	1	9 739 292	97 39 292	KRAFTSTOFFLEITUNG
HORIZONTALSPANNER	77 90 011 08	7	1	2 925 204	92 16 990 08	KAMERAANBAU D-ANLENKS
HORN 335HZ 24V	61 40 031 08	9	1	2 533 066	96 48 365 08	ELEKTRIK ANBAUTEILE KABIN
HUBENDSCHALTER GEWICHT	96 25 639 08	3	1	2 311	91 52 834 08	SEIL F.WINDE 1
HUBENDSCHALTER GEWICHT	96 25 639 08	3	1	2 312	91 52 835 08	SEIL F.WINDE 2
HUBWINDE ZHP 4.29 SPF	10 35 411 4	2	1	2 310	91 52 503 08	WINDE 1
HUBWINDE ZHP 4.29 SPF	10 35 411 4	2	1	2 320	91 52 504 08	WINDE 2
HUBWINDE ZHP 4.29 SPF	10 35 411 4	1	1	3 350	91 52 859 08	WINDE 3
HUELSE	57 11 303 08	2	1	5 711 301	57 11 301 08	DRUCKBEGRENZUNGSVENTI
HUELSE	95 38 734 08	12	5	2 260	91 53 057 08	BATTERIELAGERUNG
HUELSE	95 38 734 08	28	10	2 340	91 52 776 08	WINDE 4 EINZIEHWERK
HUELSE	95 38 734 08	10	4	2 391	91 52 784 08	DIESELMOTOR KPL.
HUELSE	95 38 734 08	30	11	2 391 001	96 45 719 08	DIESELMOTOR VORM.
HUELSE	95 38 734 08	14	8	2 510	91 52 788 08	DREHBUEHNENVERKLEIDUN
HUELSE	95 38 734 08	80	6	2 550	91 57 751 08	SA-BOCK
HUELSE	95 38 734 08	41	18	2 631	91 56 817 08	LAUFSTEG DREHBUEHNE
HUELSE	95 38 734 08	26	2	2 711	91 52 800 08	ZENTRALSCHMIERANLAGE O
HUELSE	95 38 734 08	62	10	2 859	91 52 809 08	GERAEUSCHDAEMMUNG
HUELSE	95 38 734 08	17	4	2 925 402	96 58 855 08	KAMERAANBAU DREHBUEHN
HUELSE	95 38 734 08	98	72	3 211	91 57 748 08	S-ANLENKSTUECK
HUELSE	95 38 734 08	32	7	3 350	91 52 859 08	WINDE 3
HUELSE	95 38 734 08	123	61	3 713	91 57 749 08	D-ANLENKSTUECK
HUELSE	95 38 734 08	83	48	3 714	91 52 862 08	D-KOPFSTUECK
HUELSE	95 38 734 08	42	34	3 715 008	91 52 863 08	D-ZWISCHENSTUECK
HUELSE	95 38 734 08	40	65	3 716	91 52 864 08	D-ZWISCHENSTUECK
HUELSE 48X204 PA6	97 68 724 08	14	1	2 522 011	96 45 602 08	SCHLIESSANLAGE
HUELSE 60.0X20 S355J2G3 FE	97 93 097 08	142	2	3 713	91 57 749 08	D-ANLENKSTUECK
HUELSE KPL.	10 41 274 0	12	1	9 640 276	96 40 276 08	ANSCHLUSSBLOCK
HUTMUTTER DIN 1587 M6 6 A2	41 21 001 08	8	6	2 520 031	96 45 610 08	HECKSCHEIBE VORM.
HUTSCHIENE 35X27X7,3X1	60 21 067 08	273	0.15	1 920 403	96 48 707 08	KLEMMKASTEN KPL.
HUTSCHIENE 35X27X7,3X1	60 21 067 08	273	0.15	1 920 417	96 48 703 08	KLEMMKASTEN KPL.
HUTSCHIENE 35X27X7,3X1	60 21 067 08	10	0.585	1 920 418	96 48 687 08	KLEMMKASTEN KPL.
HUTSCHIENE 35X27X7,3X1	60 21 067 08	273	0.15	2 780 748	96 52 969 08	KLEMMKASTEN KPL.
HUTSCHIENE 35X27X7,3X1	60 21 067 08	262	0.205	2 920 581	96 54 405 08	KLEMMKASTEN SA-BOCK VO
HUTSCHIENE 35X27X7,3X1	60 21 067 08	6	0.4	2 932 082	96 54 387 08	AUFBAUTEILE MONTAGETAPE
HUTSCHIENE 35X27X7,3X1	60 21 067 08	8	0.1	2 932 082	96 54 387 08	AUFBAUTEILE MONTAGETAPE
HUTSCHIENE 35X27X7,3X1	60 21 067 08	272	0.245	3 930 363	96 52 979 08	KLEMMKASTEN KPL.
HUTSCHIENE 35X27X7,3X1	60 21 067 08	261	0.58	3 930 638	96 51 624 08	KLEMMKASTEN
HUTSCHIENE 35X27X7,3X1	60 21 067 08	272	0.35	3 930 640	96 50 481 08	KLEMMKASTEN KPL.
HUTSCHIENE 35X27X7,3X1	60 21 067 08	298	0.245	3 930 730	96 50 599 08	KLEMMKASTEN KPL.
HUTSCHIENE 35X27X7,3X1	60 21 067 08	278	1.16	3 930 730	96 54 398 08	KLEMMKASTEN KPL.
HUTSCHIENE 35X27X7,3X1	60 21 067 08	202	0.55	3 930 734	96 54 401 08	KLEMMKASTEN
HUTZE KPL	96 50 546 08	51	1	2 391 001	96 45 719 08	DIESELMOTOR VORM.
HUTZE KPL	96 50 616 08	6	1	2 391	91 52 784 08	DIESELMOTOR KPL.
HYDR.SCHWEBEBALLAST-AN	91 56 428 08	400	1	3 713	91 57 749 08	D-ANLENKSTUECK
HYDRAULIK	91 56 537 08	169	1		LR 1600-2-0	LIEBHERR RAUPENKRAN LR 1
HYDRAULIK RAUPE	91 56 958 08	31	1		LR 1600-2-0	LIEBHERR RAUPENKRAN LR 1
HYDRAULIKVERSTELLUNG	10 33 323 8	4	1	X1035924	10 35 924 7	VERSTELLPUMPE
HYDRAULISCHE ABSTUETZUN	91 52 387 08	15	1		LR 1600-2-0	LIEBHERR RAUPENKRAN LR 1
HYDRAULISCHE ABSTUETZUN	96 45 817 08	1	2	1 630	91 52 387 08	HYDRAULISCHE ABSTUETZUN
HYDRAULISCHE ABSTUETZUN	96 45 818 08	2	2	1 630	91 52 387 08	HYDRAULISCHE ABSTUETZUN
HYDROMOTOR SPF	51 02 306 08	2	1	2 370	91 52 782 08	MONTAGEWINDE
HYDROMOTOR SPF	51 02 354 08	2	2	2 350	91 52 778 08	DREHWERK
HYDROMOTOR SPF	51 02 380 08	2	2	2 391 023	96 45 720 08	KUEHLER VORM.
HYDROZYLINDER 150/140-161	10 41 101 9	34	2	2 550	91 57 751 08	SA-BOCK
HYDROZYLINDER 55/32-400 SP	51 23 497 08	31	1	2 810	91 52 806 08	KRANFUEHRERKABINE KPL.

6.2.2009

etk_en_de_074515 LR 1600/2

1037

LIEBHERRAlphabetical index
Alphabetischer Index

Bezeichnung	Artikel	Pos.	Menge	Seite	Baugruppe	Bezeichnung
HYDROZYLINDER 75/30-100 SP	10 32 632 3	16	2	2 810	91 52 806 08	KRANFUEHRERKABINE KPL.
HYDROZYLINDER 75/30-260 -4	51 23 943 08	1	1	3 790 006	96 19 989 08	BOLZENZIEHZYLINDER KPL.
HYDROZYLINDER 75/30-260 -4	51 23 944 08	1	1	3 790 007	96 19 990 08	BOLZENZIEHZYLINDER KPL.
HYDROZYLINDER 80/40-400 SP	10 41 102 2	1	1	2 125	91 52 773 08	BOLZEN S-ANLENKST. UND S
INBUSSCHLUESSEL DIN 911	79 00 236 08	8	1	1 750	91 52 394 08	WERKZEUG
INDUKTIVSENSOR BW MONTI	96 17 565 08	2	1	2 920 559	96 47 914 08	ENDSCHALTER U.GEBER AL
INDUKTIVSENSOR SPF	69 23 087 08	14	4	2 780 510	96 50 097 08	ELEKTRIK BALLASTPALETTE
INDUKTIVSENSOR SPF	69 23 087 08	(1)	2	2 920 559	96 47 914 08	ENDSCHALTER U.GEBER AL
INDUKTIVSENSOR SPF	69 23 087 08	15	2	2 930	96 57 085 08	GEBERANBAU SA-BOCK
INDUKTIVSENSOR SPF	69 23 087 08	34	1	2 932 160	96 54 385 08	SCHALTSCHRANK MECH.
INDUKTIVSENSOR SPF	69 23 087 08	151	2	3 930 501	96 51 078 08	ELEKTRIK D-RUECKHALTESIC
INDUKTIVSENSOR SPF	69 23 087 08	151	2	3 930 713	92 95 070 08	ELEKTRIK S-RUECKHALTESIC
INDUKTIVSENSOR SPF	69 23 087 08	(151)	1	3 930 731	96 48 374 08	ELEKTRIK F-ANLENKSTUECK
INDUKTIVSENSOR SPF	69 23 127 08	35	1	2 932 160	96 54 385 08	SCHALTSCHRANK MECH.
INJEKTOR	10 22 019 8	1	1	9 739 248	97 39 248	EINSPRITZDUESE
INJEKTORKABELBAUM	10 22 067 0	230	1	X1012059	10 12 059 0	DIESELMOTOR
INNENGEHAEUSE VORM.	96 20 731 08	4	1	2 913 009	91 04 705 08	LICCON KONSOLE LCD3
INNENGEHAEUSE VORM.	96 28 696 08	4	1	2 913	91 32 850 08	LICCON KONSOLE LCD2
INNENLEUCHTE 6W 13-36V	10 34 285 4	8	2	2 533 066	96 48 365 08	ELEKTRIK ANBAUTEILE KABIN
INNENVERKLEIDUNG	96 45 984 08	11	1	2 520	91 53 061 08	KABINE VERGLAST
ISOLIERBUCHSE KUNSTSTOF	66 00 430 08	7	1	2 913 100	91 23 538 08	BAUGRUPPENTRAEGER
ISOLIERKOERPER	60 56 015 08	514	3	2 920 633	96 52 651 08	KABELSTRANG
ISOLIERRING	69 10 417 08	13	52	6 909 010	69 09 010 08	SCHLEIFRINGUEBERTRAEGE
ISOLIERSCHLAUCH	10 28 710 6	27	1	9 739 494	97 39 494	ATL-ANBAU
ISOLIERSCHLAUCH 10	60 30 004 08	204	0.92	2 920 633	96 52 651 08	KABELSTRANG
ISOLIERSCHLAUCH 12	60 30 005 08	205	0.4	2 920 633	96 52 651 08	KABELSTRANG
ISOLIERSCHLAUCH 14 -50°C.-	60 30 126 08	202	3.2	2 932 116	96 54 388 08	VERKABELUNG MONTAGETA
ISOLIERSCHLAUCH 6	60 30 002 08	202	28.96	2 920 633	96 52 651 08	KABELSTRANG
ISOLIERSCHLAUCH 8	60 30 003 08	203	22.31	2 920 633	96 52 651 08	KABELSTRANG
ISOLIERSCHLAUCH 8	60 30 003 08	201	4	2 932 116	96 54 388 08	VERKABELUNG MONTAGETA
ISOLIERSCHLAUCH DN25 0,8	10 48 691 7	30	1	9 739 492	97 39 492	ROHRLEITUNG ANBAU
KABEL 12M	61 40 376 08	11	1	2 925 002	96 58 856 08	AUSRUESTUNG KAMERA DRE
KABEL 12M	61 40 382 08	(11)	1	2 925 218	91 60 840 08	KAMERAUEBERWACHUNG WI
KABEL 6M	61 40 458 08	13	2	2 925 002	96 58 856 08	AUSRUESTUNG KAMERA DRE
KABEL 9M	61 40 418 08	12	3	2 925 002	96 58 856 08	AUSRUESTUNG KAMERA DRE
KABEL MK307.4,5	10 43 030 5	20	1	2 925 405	96 48 397 08	AUSRUESTUNG KAMERA KAB
KABELBAUM	10 11 922 6	(1)	1	9 739 400	97 39 400	DIESELMOTOR
KABELBAUM 3300MM	55 31 869 08	50	1	2 533 065	96 48 364 08	KABELLISTE KRANFUEHRERK
KABELBAUM ANBAU	97 39 326	230	1	9 739 400	97 39 400	DIESELMOTOR
KABELBINDER 2,5X102	60 32 022 08	13	2	2 780 852	96 24 845 08	GSM-MODUL VORM.LICCON 1
KABELBINDER 2,5X102	60 32 022 08	8	2	2 913 004	96 20 460 08	GEHAEUSE VORM.
KABELBINDER 2,5X102	60 32 022 08	11	1	2 913 006	96 20 732 08	LUEFTERBLECH VORM.
KABELBINDER 2,5X102	60 32 022 08	50	25	2 932 001	96 45 393 08	RELAISSTEUERUNG
KABELBINDER 2,5X102	60 32 022 08	268	100	2 932 116	96 54 388 08	VERKABELUNG MONTAGETA
KABELBINDER 2,5X102	60 32 022 08	261	5	3 930 363	96 52 979 08	KLEMMKASTEN KPL.
KABELBINDER 2,5X102	60 32 022 08	217	10	3 930 734	96 54 401 08	KLEMMKASTEN
KABELBINDER 3,5X150XSCH	10 34 342 4	9	5	9 739 366	97 39 366	BEFESTIGUNGSTEILE ANBAU
KABELBINDER 3,6X150	60 32 003 08	261	10	1 920 418	96 48 687 08	KLEMMKASTEN KPL.
KABELBINDER 3,6X150	60 32 003 08	261	1	2 920 633	96 52 651 08	KABELSTRANG
KABELBINDER 3,6X150	60 32 003 08	261	1	2 920 636	96 51 854 08	LEITUNG
KABELBINDER 3,6X150	60 32 003 08	261	100	2 932 116	96 54 388 08	VERKABELUNG MONTAGETA
KABELBINDER 3,6X200	60 32 004 08	154	5	2 780 524	96 52 968 08	LEITUNGSTROMMEL KPL.
KABELBINDER 3,6X200	60 32 004 08	267	100	2 932 116	96 54 388 08	VERKABELUNG MONTAGETA
KABELBINDER 4,6X385 PA6.6	10 02 093 1	10	3	9 739 366	97 39 366	BEFESTIGUNGSTEILE ANBAU
KABELBINDER 4,6X385 PA6.6	10 02 093 1	37	2	9 739 492	97 39 492	ROHRLEITUNG ANBAU
KABELBINDERHALTER	60 20 611 08	6	7	2 520 033	96 50 633 08	MONITORKONSOLE
KABELBINDERHALTER	60 20 611 08	47	8	2 932 082	96 54 387 08	AUFBAUTEILE MONTAGETAPE
KABELHALTER	72 00 144 08	40	6	3 715 008	91 52 863 08	D-ZWISCHENSTUECK
KABELHALTER	72 00 144 08	42	12	3 716	91 52 864 08	D-ZWISCHENSTUECK
KABELHALTER 2X22X90	95 36 500 08	31	8	2 310	91 52 503 08	WINDE 1

6.2.2009

etk_en_de_074515 LR 1600/2

1038

LIEBHERRAlphabetical index
Alphabetischer Index

Bezeichnung	Artikel	Pos.	Menge	Seite	Baugruppe	Bezeichnung
KABELHALTER 2X22X90	95 36 500 08	31	8	2 320	91 52 504 08	WINDE 2
KABELHALTER 2X22X90	95 36 500 08	152	2	2 391 001	96 45 719 08	DIESELMOTOR VORM.
KABELHALTER 2X22X90	95 36 500 08	(5)	5	2 550	91 57 751 08	SA-BOCK
KABELHALTER 2X22X90	95 36 500 08	50	19	2 550	91 57 751 08	SA-BOCK
KABELHALTER 2X22X90	95 36 500 08	61	3	2 810	91 52 806 08	KRANFUEHRERKABINE KPL.
KABELHALTER 2X22X90	95 36 500 08	31	13	3 350	91 52 859 08	WINDE 3
KABELKANAL	60 14 058 08	44	0.63	2 932 001	96 45 393 08	RELAISSTEUERUNG
KABELKANAL	60 14 139 08	21	0.725	2 932 082	96 54 387 08	AUFBAUTEILE MONTAGETAPE
KABELKANAL	60 14 142 08	45	1.295	2 932 082	96 54 387 08	AUFBAUTEILE MONTAGETAPE
KABELLISTE BATTERIEKASTE	96 49 300 08	10	1	2 920 083	96 48 319 08	ELEKTRIK BATTERIEKASTEN
KABELLISTE DREHBUEHNE	96 52 614 08	15	1	2 920	91 56 833 08	ELEKTRIK DREHBUEHNE
KABELLISTE ELEKTRIK AGG	96 48 317 08	10	1	2 920 535	96 48 318 08	ELEKTRIK AGGREGAT
KABELLISTE FREMDEINSPEIS	96 48 376 08	3	1	2 780 908	91 52 958 08	FREMDEINSPEISUNG
KABELLISTE KRANFUEHRERK	96 48 364 08	6	1	2 533	91 52 789 08	ELEKTRIK KRANFUEHRERKAB
KABELMARKIERUNG	92 35 122 08	(500)	2	2 920 288	96 52 614 08	KABELLISTE DREHBUEHNE
KABELMARKIERUNG	92 35 122 08	(500)	3	2 920 288	96 52 614 08	KABELLISTE DREHBUEHNE
KABELMARKIERUNG	92 35 122 08	(500)	1	2 920 369	96 54 235 08	KLEMMKASTEN KPL.
KABELMARKIERUNG	92 35 122 08	(500)	1	2 920 369	96 54 235 08	KLEMMKASTEN KPL.
KABELMARKIERUNG	92 35 122 08	(500)	1	2 920 369	96 54 235 08	KLEMMKASTEN KPL.
KABELMARKIERUNG	92 35 122 08	(500)	3	2 920 369	96 54 235 08	KLEMMKASTEN KPL.
KABELMARKIERUNG	92 35 122 08	(500)	3	2 920 369	96 54 235 08	KLEMMKASTEN KPL.
KABELMARKIERUNG	92 35 122 08	(500)	2	2 920 536	96 48 317 08	KABELLISTE ELEKTRIK AGG
KABELMARKIERUNG	92 35 122 08	(500)	2	2 920 536	96 48 317 08	KABELLISTE ELEKTRIK AGG
KABELMARKIERUNG	92 35 122 08	(500)	2	2 920 581	96 54 405 08	KLEMMKASTEN SA-BOCK VO
KABELMARKIERUNG	92 35 122 08	(500)	2	2 920 581	96 54 405 08	KLEMMKASTEN SA-BOCK VO
KABELMARKIERUNG	92 35 122 08	(500)	1	2 920 581	96 54 405 08	KLEMMKASTEN SA-BOCK VO
KABELMARKIERUNG	92 35 122 08	(500)	1	2 920 581	96 54 405 08	KLEMMKASTEN SA-BOCK VO
KABELMARKIERUNG	92 35 122 08	500	53	2 920 633	96 52 651 08	KABELSTRANG
KABELMARKIERUNG	92 35 122 08	500	3	2 920 636	96 51 854 08	LEITUNG
KABELMARKIERUNG	92 35 122 08	(500)	2	2 920 815	96 49 300 08	KABELLISTE BATTERIEKASTE
KABELMARKIERUNG	92 35 122 08	(500)	2	2 920 815	96 49 300 08	KABELLISTE BATTERIEKASTE
KABELMARKIERUNG	92 35 122 08	(500)	2	2 920 815	96 49 300 08	KABELLISTE BATTERIEKASTE
KABELMARKIERUNG	92 35 122 08	(500)	3	2 920 815	96 49 300 08	KABELLISTE BATTERIEKASTE
KABELMARKIERUNG	92 35 122 08	500	9	3 930 732	96 50 575 08	LEITUNG
KABELMARKIERUNG	92 35 122 08	(500)	1	3 930 734	96 54 401 08	KLEMMKASTEN
KABELSCHLAUCH	60 30 245 08	223	3.83	2 920 633	96 52 651 08	KABELSTRANG
KABELSCHLAUCH	60 30 247 08	225	2.13	2 920 633	96 52 651 08	KABELSTRANG
KABELSCHLAUCH	60 30 249 08	227	2.03	2 920 633	96 52 651 08	KABELSTRANG
KABELSCHLAUCH	60 30 250 08	228	3.03	2 920 633	96 52 651 08	KABELSTRANG
KABELSCHLAUCH	60 30 252 08	226	4.66	2 920 633	96 52 651 08	KABELSTRANG
KABELSCHLAUCH	60 30 253 08	229	3.3	2 920 633	96 52 651 08	KABELSTRANG
KABELSCHUH 12 - 95	60 23 011 08	(99)	2	2 920 536	96 48 317 08	KABELLISTE ELEKTRIK AGG
KABELSCHUH 12 - 95	60 23 011 08	(99)	1	2 920 815	96 49 300 08	KABELLISTE BATTERIEKASTE
KABELSCHUH 4/2,5mm ² VERZ	60 23 061 08	31	2	2 920 369	96 54 235 08	KLEMMKASTEN KPL.
KABELSCHUH 4/2,5mm ² VERZ	60 23 061 08	31	2	2 920 448	96 48 794 08	KLEMMKASTEN KPL.
KABELSCHUH DIN 46234 10-50	60 22 082 08	(103)	2	2 920 815	96 49 300 08	KABELLISTE BATTERIEKASTE
KABELSCHUH DIN 46234 8 - 16	60 23 114 08	(57)	2	2 920 288	96 52 614 08	KABELLISTE DREHBUEHNE
KABELSCHUH DIN 46235 10 - 9	60 23 010 08	(80)	1	2 920 536	96 48 317 08	KABELLISTE ELEKTRIK AGG
KABELSCHUH DIN 46235 10 - 9	60 23 010 08	(80)	2	2 920 815	96 49 300 08	KABELLISTE BATTERIEKASTE
KABELSCHUH DIN 46235 10 - 9	60 23 010 08	(80)	1	2 920 815	96 49 300 08	KABELLISTE BATTERIEKASTE
KABELSCHUH DIN 46235 10 - 9	60 23 010 08	(80)	2	2 920 815	96 49 300 08	KABELLISTE BATTERIEKASTE
KABELSCHUH DIN 46237 0,25 -	60 22 184 08	112	3	2 920 633	96 52 651 08	KABELSTRANG
KABELSCHUH DIN 46237 3,5/2,	60 22 060 08	32	1	3 930 009	96 50 573 08	LEITUNGSTROMMEL KPL.
KABELSCHUH DIN 46237 6 - 2,	60 22 061 08	34	1	3 930 009	96 50 573 08	LEITUNGSTROMMEL KPL.
KABELSCHUH DIN 46237 6 - 2,	60 22 179 08	34	2	2 920 369	96 54 235 08	KLEMMKASTEN KPL.
KABELSCHUH DIN 46237 6 - 2,	60 22 179 08	34	2	2 920 448	96 48 794 08	KLEMMKASTEN KPL.
KABELSTECKER 4POL 4A	10 32 483 0	515	1	2 920 633	96 52 651 08	KABELSTRANG
KABELSTECKER KSB693/7P	10 02 527 8	(1)	1	2 925 002	96 58 856 08	AUSRUESTUNG KAMERA DRE
KABELSTRANG W1063	96 44 547 08	20	1	2 920 334	96 44 538 08	ELEKTRIK WINDE 3
KABELSTRANG W200	96 48 688 08	2	1	1 920 418	96 48 687 08	KLEMMKASTEN KPL.

6.2.2009

etk_en_de_074515 LR 1600/2

1039

LIEBHERRAlphabetical index
Alphabetischer Index

Bezeichnung	Artikel	Pos.	Menge	Seite	Baugruppe	Bezeichnung
KABELSTRANG W220	96 48 750 08	3	1	1 920 403	96 48 707 08	KLEMMKASTEN KPL.
KABELSTRANG W223	96 48 749 08	2	1	1 920 403	96 48 707 08	KLEMMKASTEN KPL.
KABELSTRANG W225	96 49 121 08	1	1	1 920 403	96 48 707 08	KLEMMKASTEN KPL.
KABELSTRANG W240	96 48 748 08	3	1	1 920 417	96 48 703 08	KLEMMKASTEN KPL.
KABELSTRANG W243	96 48 747 08	2	1	1 920 417	96 48 703 08	KLEMMKASTEN KPL.
KABELSTRANG W245	96 49 120 08	1	1	1 920 417	96 48 703 08	KLEMMKASTEN KPL.
KABELSTRANG W300	96 49 100 08	10	1	2 533 065	96 48 364 08	KABELLISTE KRANFUEHRERK
KABELSTRANG W301	96 49 101 08	11	1	2 533 065	96 48 364 08	KABELLISTE KRANFUEHRERK
KABELSTRANG W302	96 49 102 08	12	1	2 533 065	96 48 364 08	KABELLISTE KRANFUEHRERK
KABELSTRANG W305	96 49 103 08	13	1	2 533 065	96 48 364 08	KABELLISTE KRANFUEHRERK
KABELSTRANG W309	96 49 030 08	15	1	2 533 065	96 48 364 08	KABELLISTE KRANFUEHRERK
KABELSTRANG W310	96 49 105 08	16	1	2 533 065	96 48 364 08	KABELLISTE KRANFUEHRERK
KABELSTRANG W339A	96 55 363 08	18	1	2 920 369	96 54 235 08	KLEMMKASTEN KPL.
KABELSTRANG W339B	96 55 364 08	19	1	2 920 369	96 54 235 08	KLEMMKASTEN KPL.
KABELSTRANG W360	96 49 106 08	17	1	2 533 065	96 48 364 08	KABELLISTE KRANFUEHRERK
KABELSTRANG W390	96 55 952 08	19	1	2 920 288	96 52 614 08	KABELLISTE DREHBUEHNE
KABELSTRANG W500	96 52 651 08	5	1	2 920 288	96 52 614 08	KABELLISTE DREHBUEHNE
KABELSTRANG W501	96 50 161 08	15	1	2 920 536	96 48 317 08	KABELLISTE ELEKTRIK AGG
KABELSTRANG W521	96 44 545 08	20	1	2 920 200	96 44 536 08	ELEKTRIK WINDE 1
KABELSTRANG W522	96 44 546 08	20	1	2 920 260	96 44 537 08	ELEKTRIK WINDE 2
KABELSTRANG W524	96 44 548 08	20	1	2 920 350	96 44 539 08	ELEKTRIK WINDE 4
KABELSTRANG W551	96 57 094 08	20	1	2 920 288	96 52 614 08	KABELLISTE DREHBUEHNE
KABELSTRANG W570	96 51 115 08	1	1	2 920 638	96 51 138 08	BEDIENPULT
KABELSTRANG W587	96 51 118 08	16	1	2 920 536	96 48 317 08	KABELLISTE ELEKTRIK AGG
KABELSTRANG W589	96 51 126 08	18	1	2 920 536	96 48 317 08	KABELLISTE ELEKTRIK AGG
KABELSTRANG W590	96 51 127 08	19	1	2 920 536	96 48 317 08	KABELLISTE ELEKTRIK AGG
KABELSTRANG W591	96 48 799 08	11	1	2 920 815	96 49 300 08	KABELLISTE BATTERIEKASTE
KABELSTRANG W592	96 51 129 08	12	1	2 920 815	96 49 300 08	KABELLISTE BATTERIEKASTE
KABELSTRANG W593	96 51 130 08	13	1	2 920 815	96 49 300 08	KABELLISTE BATTERIEKASTE
KABELSTRANG W596	96 51 131 08	14	1	2 920 815	96 49 300 08	KABELLISTE BATTERIEKASTE
KABELSTRANG W620	96 51 040 08	(20)	1	2 835	91 52 807 08	BATTERIELADEGERAET
KABELSTRANG W621	96 51 039 08	(10)	1	2 835	91 52 807 08	BATTERIELADEGERAET
KABELSTRANG W647	96 20 761 08	10	1	2 913 006	96 20 732 08	LUEFTERBLECH VORM.
KABELSTRANG W648	96 20 750 08	9	1	2 913 003	96 20 599 08	FOLIENASTATUR VORM.
KABELSTRANG W693	96 51 119 08	(1)	1	2 780 908	91 52 958 08	FREMDEINSPEISUNG
KABELSTRANG W811	96 48 390 08	10	1	2 780 244	91 52 951 08	NOTAUS KRANFUEHRERKAB
KABELSTRUMPF 25	60 27 011 08	28	1	1 750	91 52 394 08	WERKZEUG
KABELSTRUMPF 30	60 27 099 08	29	1	1 750	91 52 394 08	WERKZEUG
KABELSTRUMPF 8 - 15 700	60 27 073 08	153	1	3 930 732	96 50 575 08	LEITUNG
KABELTROMMEL	97 22 660 08	5	1	3 930 009	96 50 573 08	LEITUNGSTROMMEL KPL.
KABELTROMMEL M25X1,5 SP	61 60 249 08	(151)	1	3 930 138	96 54 377 08	ELEKTRIK S-ANLENKSTUECK
KABELTUELLE 1,9-2,5 SILIKON	10 47 304 7	(707)	19	2 920 581	96 54 405 08	KLEMMKASTEN SA-BOCK VO
KABELTUELLE 1,9-2,5 SILIKON	10 47 304 7	707	18	3 930 732	96 50 575 08	LEITUNG
KABELTUELLE 10-13	60 27 040 08	164	1	3 930 009	96 50 573 08	LEITUNGSTROMMEL KPL.
KABELTUELLE 15-19 SILIKON	10 47 305 2	(712)	2	2 920 536	96 48 317 08	KABELLISTE ELEKTRIK AGG
KABELTUELLE 15-19 SILIKON	10 47 305 2	(712)	2	2 920 536	96 48 317 08	KABELLISTE ELEKTRIK AGG
KABELTUELLE 15-19 SILIKON	10 47 305 2	(712)	2	2 920 815	96 49 300 08	KABELLISTE BATTERIEKASTE
KABELTUELLE 2,4-3,0 SILIKON	10 47 304 8	(708)	7	2 920 369	96 54 235 08	KLEMMKASTEN KPL.
KABELTUELLE 2,4-3,0 SILIKON	10 47 304 8	(708)	24	2 920 369	96 54 235 08	KLEMMKASTEN KPL.
KABELTUELLE 2,4-3,0 SILIKON	10 47 304 8	(708)	16	2 920 369	96 54 235 08	KLEMMKASTEN KPL.
KABELTUELLE 2,4-3,0 SILIKON	10 47 304 8	708	2	2 920 633	96 52 651 08	KABELSTRANG
KABELTUELLE 2,4-3,0 SILIKON	10 47 304 8	708	28	3 930 732	96 50 575 08	LEITUNG
KABELTUELLE 2,4-3,0 SILIKON	10 47 304 8	(708)	14	3 930 734	96 54 401 08	KLEMMKASTEN
KABELTUELLE 3,0-7,0/3,0/0,6 S	60 27 100 08	97	2	2 920 633	96 52 651 08	KABELSTRANG
KABELTUELLE 3,0-7,0/3,0/0,6 S	60 27 100 08	(97)	25	3 930 138	96 54 377 08	ELEKTRIK S-ANLENKSTUECK
KABELTUELLE 3,0-7,0/3,0/0,6 S	60 27 100 08	97	4	3 930 732	96 50 575 08	LEITUNG
KABELTUELLE 5,0-7,0/5,0/0,7 S	60 27 101 08	(98)	2	2 920 288	96 52 614 08	KABELLISTE DREHBUEHNE
KABELTUELLE 5,0-7,0/5,0/0,7 S	60 27 101 08	(98)	2	2 920 815	96 49 300 08	KABELLISTE BATTERIEKASTE
KABELTUELLE 5,0-7,0/5,0/0,7 S	60 27 101 08	(98)	2	2 920 815	96 49 300 08	KABELLISTE BATTERIEKASTE
KABELTUELLE 5,0-7,0/5,0/0,7 S	60 27 101 08	(98)	2	2 920 815	96 49 300 08	KABELLISTE BATTERIEKASTE

6.2.2009

etk_en_de_074515 LR 1600/2

1040

LIEBHERRAlphabetical index
Alphabetischer Index

Bezeichnung	Artikel	Pos.	Menge	Seite	Baugruppe	Bezeichnung
KABELVERBINDER	60 23 364 08	2	1	2 932 166	92 68 911 08	VERTEILER MASSE
KABELVERSCHRAUBUNG M12	60 24 240 08	(151)	1	2 920 581	96 54 405 08	KLEMMKASTEN SA-BOCK VO
KABELVERSCHRAUBUNG M12	60 24 240 08	(151)	1	2 920 581	96 54 405 08	KLEMMKASTEN SA-BOCK VO
KABELVERSCHRAUBUNG M12	60 24 240 08	(151)	1	2 920 581	96 54 405 08	KLEMMKASTEN SA-BOCK VO
KABELVERSCHRAUBUNG M16	60 24 241 08	267	2	1 920 403	96 48 707 08	KLEMMKASTEN KPL.
KABELVERSCHRAUBUNG M16	60 24 241 08	267	2	1 920 417	96 48 703 08	KLEMMKASTEN KPL.
KABELVERSCHRAUBUNG M16	60 24 241 08	72	3	2 520	91 53 061 08	KABINE VERGLAST
KABELVERSCHRAUBUNG M16	60 24 241 08	153	1	2 780 748	96 52 969 08	KLEMMKASTEN KPL.
KABELVERSCHRAUBUNG M16	60 24 241 08	277	2	3 930 363	96 52 979 08	KLEMMKASTEN KPL.
KABELVERSCHRAUBUNG M16	60 24 241 08	10	1	X1002800	10 02 800 2	LEITUNGSTROMMEL
KABELVERSCHRAUBUNG M20	60 24 242 08	8	2	2 780 524	96 52 968 08	LEITUNGSTROMMEL KPL.
KABELVERSCHRAUBUNG M20	60 24 242 08	290	1	2 920 448	96 48 794 08	KLEMMKASTEN KPL.
KABELVERSCHRAUBUNG M20	60 24 242 08	(154)	2	2 920 581	96 54 405 08	KLEMMKASTEN SA-BOCK VO
KABELVERSCHRAUBUNG M20	60 24 242 08	272	1	2 920 581	96 54 405 08	KLEMMKASTEN SA-BOCK VO
KABELVERSCHRAUBUNG M20	60 24 242 08	520	3	2 920 633	96 52 651 08	KABELSTRANG
KABELVERSCHRAUBUNG M20	60 24 242 08	(153)	2	3 930 734	96 54 401 08	KLEMMKASTEN
KABELVERSCHRAUBUNG M20	60 24 242 08	3	1	X1002800	10 02 800 2	LEITUNGSTROMMEL
KABELVERSCHRAUBUNG M20	60 24 257 08	270	3	2 920 581	96 54 405 08	KLEMMKASTEN SA-BOCK VO
KABELVERSCHRAUBUNG M20	60 24 257 08	276	3	3 930 363	96 52 979 08	KLEMMKASTEN KPL.
KABELVERSCHRAUBUNG M20	60 24 257 08	279	1	3 930 638	96 51 624 08	KLEMMKASTEN
KABELVERSCHRAUBUNG M20	60 24 260 08	(504)	1	2 920 288	96 52 614 08	KABELLISTE DREHBUEHNE
KABELVERSCHRAUBUNG M25	60 24 243 08	270	1	1 920 403	96 48 707 08	KLEMMKASTEN KPL.
KABELVERSCHRAUBUNG M25	60 24 243 08	270	1	1 920 417	96 48 703 08	KLEMMKASTEN KPL.
KABELVERSCHRAUBUNG M25	60 24 243 08	(269)	1	3 930 138	96 54 377 08	ELEKTRIK S-ANLENKSTUECK
KABELVERSCHRAUBUNG M25	60 24 258 08	156	1	3 930 732	96 50 575 08	LEITUNG
KABELVERSCHRAUBUNG M50	60 24 246 08	18	1	1 920 418	96 48 687 08	KLEMMKASTEN KPL.
KABELVERSCHRAUBUNG POL	60 24 417 01	11	2	2 780 915	96 48 377 08	ANBAUTEILE FREMDEINSPEIS
KABINE BLECHTEILE	91 55 303 08	71	1	2 520	91 53 061 08	KABINE VERGLAST
KABINE VERGLAST	91 53 061 08	1	1	2 810 001	96 43 597 08	KRANFUEHRERKABINE VORM
KAFIGMUTTER M5	41 30 026 08	87	8	2 932 082	96 54 387 08	AUFBAUTEILE MONTAGETAPE
KAFIGMUTTER M5	41 30 038 08	6	8	2 932 001	96 45 393 08	RELAISSTEUERUNG
KAFIGMUTTER M5	41 30 038 08	19	13	2 932 160	96 54 385 08	SCHALTSCHRANK MECH.
KAFIGMUTTER M5 ST	10 45 528 1	27	6	2 502	91 55 939 08	STUERSTAND
KAFIGMUTTER M6	41 30 027 08	44	4	2 502	91 55 939 08	STUERSTAND
KAFIGMUTTER M6	41 30 028 08	57	1	2 520 034	96 45 984 08	INNENVERKLEIDUNG
KAFIGMUTTER M6	41 30 029 08	373	12	2 391 001	96 45 719 08	DIESELMOTOR VORM.
KAFIGMUTTER M8	41 30 031 08	4	1	2 520 033	96 50 633 08	MONITORKONSOLE
KAFIGMUTTER M8	41 30 032 08	61	12	1 400	91 56 853 08	RAUPENTRAEGER KPL.LI.
KAFIGMUTTER M8	41 30 032 08	61	12	1 410 300	91 56 855 08	RAUPENTRAEGER KPL.RE.
KAFIGMUTTER M8	41 30 032 08	53	21	2 859	91 52 809 08	GERAEUSCHDAEMMUNG
KAELTEMITTEL R 134 A	86 16 012 08	8	2.2	2 831	91 57 754 08	KLIMAAANLAGE OW
KALOTTE	60 61 440 08	17	3	2 533 061	96 48 370 08	ARMATUREN ARMLEHNE LI.
KALOTTE	60 61 440 08	8	1	2 533 063	96 48 371 08	ARMATUREN ARMLEHNE RE.
KALOTTE	60 61 440 08	8	13	2 533 070	96 48 363 08	ARMATUREN RE.
KALOTTE	60 61 440 08	34	1	2 932 001	96 45 393 08	RELAISSTEUERUNG
KALOTTE	60 61 443 08	22	1	2 533 070	96 48 363 08	ARMATUREN RE.
KALOTTE	60 61 448 08	25	1	2 533 070	96 48 363 08	ARMATUREN RE.
KAMERA SPF	61 40 436 08	17	3	2 925 002	96 58 856 08	AUSRUESTUNG KAMERA DRE
KAMERA SPF	61 40 451 08	(17)	1	2 925 218	91 60 840 08	KAMERAUEBERWACHUNG WI
KAMERAANBAU D-ANLENKS	92 16 990 08	12	1	2 925 218	91 60 840 08	KAMERAUEBERWACHUNG WI
KAMERAANBAU DREHBUEHN	96 58 855 08	3	1	2 925 002	96 58 856 08	AUSRUESTUNG KAMERA DRE
KAMERAUEBERWACHUNG DB	91 60 728 08	322	1		LR 1600-2-0	LIEBHERR RAUPENKRAN LR 1
KAMERAUEBERWACHUNG WI	91 60 840 08	324	1		LR 1600-2-0	LIEBHERR RAUPENKRAN LR 1
KANTENSCHUTZ	26 21 039 08	11	3.6	2 260 006	96 46 501 08	BATTERIEKASTEN VORM.
KANTENSCHUTZ	26 21 039 08	9	1.75	2 391	91 52 784 08	DIESELMOTOR KPL.
KANTENSCHUTZ	26 21 039 08	42	1.3	2 520 034	96 45 984 08	INNENVERKLEIDUNG
KANTENSCHUTZ	26 21 039 08	45	0.33	2 932 001	96 45 393 08	RELAISSTEUERUNG
KANTENSCHUTZ	26 21 039 08	43	2	2 932 082	96 54 387 08	AUFBAUTEILE MONTAGETAPE
KANTENSCHUTZ	26 21 039 08	7	0.16	2 932 166	92 68 911 08	VERTEILER MASSE
KANTENSCHUTZ	26 21 040 08	44	0.8	2 631	91 56 817 08	LAUFSTEG DREHBUEHNE

6.2.2009

etk_en_de_074515 LR 1600/2

1041

LIEBHERRAlphabetical index
Alphabetischer Index

Bezeichnung	Artikel	Pos.	Menge	Seite	Baugruppe	Bezeichnung
KANTENSCHUTZ	26 21 040 08	19	0.23	2 670	91 52 797 08	KRAFTSTOFFBEHAELTER KPL
KANTENSCHUTZ	26 21 040 08	48	0.8	2 810	91 52 806 08	KRANFUEHRERKABINE KPL.
KANTENSCHUTZ	26 21 040 08	66	1.6	2 859	91 52 809 08	GERAEUSCHDAEMMUNG
KANTENSCHUTZ	26 21 040 08	10	3.27	2 859 007	96 46 775 08	DECKEL KPL.
KANTENSCHUTZ	26 21 053 08	64	9.6	2 859	91 52 809 08	GERAEUSCHDAEMMUNG
KANTENSCHUTZ	26 21 053 08	9	0.16	2 859 029	96 46 779 08	DECKEL KPL.
KAPPE	10 66 332 8	2	1	X1004047	10 04 047 7	WINDENDREHGEBER
KARABINERHAKEN DIN 5299 1	74 40 104 08	83	4	3 211	91 57 748 08	S-ANLENKSTUECK
KARABINERHAKEN DIN 5299 7	74 40 100 08	3	3	2 790 451	91 57 016 08	ABDECKUNG
KARABINERHAKEN DIN 5299 7	74 40 100 08	34	2	3 745	91 52 948 08	SCHWEBEBALLAST
KARABINERHAKEN DIN 5299 8	74 40 101 08	154	1	3 930 732	96 50 575 08	LEITUNG
KARTUSCHE	57 13 523 08	1	1	5 026 573	50 26 573 08	LUFTTROCKNER
KEGEL	51 07 921 08	4	1	5 711 301	57 11 301 08	DRUCKBEGRENZUNGSVENTI
KEGELROLLENLAGER	57 01 140 08	10	1	5 701 129	57 01 129 08	TRIEBWERK
KEGELROLLENLAGER DIN 720	74 62 026 01	12	1	9 697 916	96 97 916 01	DREHWERK
KEGELROLLENLAGER DIN 720	74 62 237 01	3	1	9 697 916	96 97 916 01	DREHWERK
KEGELROLLENLAGER DIN 720	74 62 216 08	11	1	5 701 129	57 01 129 08	TRIEBWERK
KEILRIEMEN 10 2AVX 1500 LA	10 34 342 2	21	1	9 739 344	97 39 344	GENERATOR VORM.
KEILRIEMENSATZ 2C 1325	10 34 229 2	29	1	9 739 371	97 39 371	KLIMAKOMPRESSOR ANBAU
KEILRIEMENSCHLEIFE	10 34 284 0	4	1	9 739 341	97 39 341	ANTRIEBSTEILE M.SCHWINGU
KEILRIEMENSCHLEIFE	10 34 313 1	2	1	9 739 343	97 39 343	GENERATOR VORM.
KEILRIEMENSCHLEIFE	10 41 013 0	4	1	9 739 352	97 39 352	WASSERPUMPE MIT BEFEST.
KENNZEICHNUNGSKARTEN	60 27 426 08	503	0.25	3 930 363	96 52 979 08	KLEMMKASTEN KPL.
KENNZEICHNUNGSKARTEN	60 27 426 08	14	0.1	3 930 640	96 50 481 08	KLEMMKASTEN KPL.
KENNZEICHNUNGSKARTEN	60 27 426 08	503	0.56	3 930 730	96 54 398 08	KLEMMKASTEN KPL.
KENNZEICHNUNGSKARTEN 1	60 27 437 08	263	1	2 920 581	96 54 405 08	KLEMMKASTEN SA-BOCK VO
KETTE DIN 763 6X42 0.2t UST	74 00 002 08	4	2	2 311 001	96 25 639 08	HUBENDSCHALTER GEWICHT
KETTE DIN 763 6X42 0.2t UST	74 00 002 08	45	0.5	3 208 001	91 52 883 08	F-KOPFSTUECK
KETTE DIN 763 6X42 0.2t UST	74 00 002 08	33	1.2	3 745	91 52 948 08	SCHWEBEBALLAST
KETTENGEHAENGE	74 00 219 08	2	2	2 730	91 52 802 08	GRUNDPLATTE DREHBUEHNE
KFZ-LEITUNG 0,75Q PVC SPF	60 04 140 08	(345)	0.32	2 920 369	96 54 235 08	KLEMMKASTEN KPL.
KFZ-LEITUNG 0,75Q PVC SPF	60 04 140 08	(345)	0.32	2 920 369	96 54 235 08	KLEMMKASTEN KPL.
KFZ-LEITUNG 0,75Q PVC SPF	60 04 140 08	345	22.2	2 920 633	96 52 651 08	KABELSTRANG
KFZ-LEITUNG DIN 72551 0,5 SP	60 04 121 08	(344)	0.96	2 920 369	96 54 235 08	KLEMMKASTEN KPL.
KFZ-LEITUNG DIN 72551 1 SPF	60 04 341 08	20	3	2 780 320	91 05 067 08	AKUSTISCHE WARNUNG DRE
KFZ-LEITUNG DIN 72551 1 SPF	60 04 341 08	(305)	3.84	2 920 369	96 54 235 08	KLEMMKASTEN KPL.
KFZ-LEITUNG DIN 72551 1 SPF	60 04 341 08	(305)	2.56	2 920 369	96 54 235 08	KLEMMKASTEN KPL.
KFZ-LEITUNG DIN 72551 1 SPF	60 04 341 08	305	453.6	2 920 633	96 52 651 08	KABELSTRANG
KFZ-LEITUNG DIN 72551 2,5	60 04 042 08	310	0.3	2 920 369	96 54 235 08	KLEMMKASTEN KPL.
KFZ-LEITUNG DIN 72551 2,5	60 04 042 08	310	0.3	2 920 448	96 48 794 08	KLEMMKASTEN KPL.
KIPPEBEL	10 01 221 3	3	2	9 739 263	97 39 263	KIPPEBELLAGERGEHAEUSE
KIPPEBEL	10 01 221 3	3	2	9 739 264	97 39 264	KIPPEBELLAGERGEHAEUSE
KIPPEBELACHSE	10 22 234 9	5	1	9 739 263	97 39 263	KIPPEBELLAGERGEHAEUSE
KIPPEBELACHSE	10 22 234 9	5	1	9 739 264	97 39 264	KIPPEBELLAGERGEHAEUSE
KIPPEBELACHSE	10 22 235 0	6	1	9 739 263	97 39 263	KIPPEBELLAGERGEHAEUSE
KIPPEBELACHSE	10 22 235 0	6	1	9 739 264	97 39 264	KIPPEBELLAGERGEHAEUSE
KIPPEBELLAGERGEHAEUSE	10 22 235 1	2	1	9 739 263	97 39 263	KIPPEBELLAGERGEHAEUSE
KIPPEBELLAGERGEHAEUSE	10 22 235 2	2	1	9 739 264	97 39 264	KIPPEBELLAGERGEHAEUSE
KIPPEBELLAGERGEHAEUSE	97 39 263	5	1	9 739 262	97 39 262	ZYLINDERKOPF
KIPPEBELLAGERGEHAEUSE	97 39 264	5	1	9 739 266	97 39 266	ZYLINDERKOPF
KIPPRELAIS 18 - 32V	63 01 022 08	52	1	2 932 001	96 45 393 08	RELAISSTEUERUNG
KLAMMER	60 52 155 08	503	1	2 920 633	96 52 651 08	KABELSTRANG
KLAMMER	60 52 155 08	153	1	2 920 636	96 51 854 08	LEITUNG
KLAMMER 40x127x24	95 70 394 08	2	4	2 550 010	96 45 685 08	STANGE VORM.
KLAMMER G21MN5V SPF	38 00 707 08	15	2	3 227 002	96 50 498 08	STANGE KPL.
KLAPPE	10 01 239 4	8	1	9 739 357	97 39 357	ABGASRUECKFUEHRUNG VO
KLAPPE GEKLEBT SPF	96 46 809 08	1	1	2 859 005	96 46 756 08	KLAPPE VORM.
KLAPPE SCHWK.	96 47 951 08	2	1	3 206	91 52 881 08	F-ANLENKSTUECK
KLAPPE VORM.	96 46 756 08	4	1	2 859	91 52 809 08	GERAEUSCHDAEMMUNG
KLAPPE VORM.	96 46 972 08	3	1	2 260	91 53 057 08	BATTERIELAGERUNG

6.2.2009

etk_en_de_074515 LR 1600/2

1042

LIEBHERRAlphabetical index
Alphabetischer Index

Bezeichnung	Artikel	Pos.	Menge	Seite	Baugruppe	Bezeichnung
KLAPPKONSOLE	96 50 486 08	52	1	3 745	91 52 948 08	SCHWEBEBALLAST
KLAPPKONSOLE SCHWK.	96 50 130 08	28	1	3 713	91 57 749 08	D-ANLENKSTUECK
KLAPPKONSOLE SCHWK.	96 50 131 08	29	1	3 713	91 57 749 08	D-ANLENKSTUECK
KLAPPSTECKER 10,5X70	43 32 011 08	58	6	1 400	91 56 853 08	RAUPENTRAEGER KPL.LI.
KLAPPSTECKER 10,5X70	43 32 011 08	58	6	1 410 300	91 56 855 08	RAUPENTRAEGER KPL.RE.
KLAPPSTECKER 10,5X70	43 32 011 08	30	4	1 630	91 52 387 08	HYDRAULISCHE ABSTUETZUN
KLAPPSTECKER DIN 11023 5X	43 32 001 08	16	8	2 631	91 56 817 08	LAUFSTEG DREHBUEHNE
KLAPPSTECKER DIN 11023 5X	43 32 001 08	16	4	2 730	91 52 802 08	GRUNDPLATTE DREHBUEHNE
KLAPPSTECKER DIN 11023 5X	43 32 001 08	31	1	2 925 402	96 58 855 08	KAMERAANBAU DREHBUEHN
KLAPPSTECKER DIN 11023 5X	43 32 001 08	63	2	3 211	91 57 748 08	S-ANLENKSTUECK
KLAPPSTECKER DIN 11023 5X	43 32 001 08	50	4	3 214	91 52 843 08	SW-KOPFSTUECK
KLAPPSTECKER DIN 11023 5X	43 32 001 08	13	2	3 220 500	91 52 849 08	S-ZWISCHENSTUECK
KLAPPSTECKER DIN 11023 5X	43 32 001 08	13	2	3 223	91 52 852 08	S-ZWISCHENSTUECK
KLAPPSTECKER DIN 11023 5X	43 32 001 08	13	2	3 223 010	91 52 853 08	S-ZWISCHENSTUECK
KLAPPSTECKER DIN 11023 5X	43 32 001 08	13	2	3 223 100	91 55 327 08	S-ZWISCHENSTUECK
KLAPPSTECKER DIN 11023 5X	43 32 001 08	42	2	3 713	91 57 749 08	D-ANLENKSTUECK
KLAPPSTECKER DIN 11023 6X	43 32 002 08	5	20	1 631 100	91 52 388 08	LAUFSTEG RAUPENFAHRWER
KLAPPSTECKER DIN 11023 6X	43 32 002 08	12	4	2 125	91 52 773 08	BOLZEN S-ANLENKST. UND S
KLAPPSTECKER DIN 11023 6X	43 32 002 08	93	1	2 550	91 57 751 08	SA-BOCK
KLAPPSTECKER DIN 11023 6X	43 32 002 08	40	2	3 208 001	91 52 883 08	F-KOPFSTUECK
KLAPPSTECKER DIN 11023 6X	43 32 002 08	52	4	3 225	91 52 854 08	SL-REDUZIERSTUECK
KLAPPSTECKER DIN 11023 6X	43 32 002 08	64	2	3 714	91 52 862 08	D-KOPFSTUECK
KLAPPSTECKER DIN 11023 8X	43 32 003 08	79	2	1 400	91 56 853 08	RAUPENTRAEGER KPL.LI.
KLAPPSTECKER DIN 11023 8X	43 32 003 08	79	2	1 410 300	91 56 855 08	RAUPENTRAEGER KPL.RE.
KLAPPSTECKER DIN 11023 8X	43 32 003 08	15	3	2 652	91 52 794 08	ROLLENLAGERUNG
KLAPPSTECKER DIN 11023 8X	43 32 003 08	7	2	3 713	91 57 749 08	D-ANLENKSTUECK
KLAPPSTECKER DIN 11023 8X	43 32 008 08	14	2	3 215 005	91 52 846 08	ROLLENSATZ
KLAPPSTECKER DIN 11023 8X	43 32 008 08	14	2	3 215 006	91 52 847 08	ROLLENSATZ
KLEBER 50ML	81 12 017 08	6	1	9 739 129	97 39 129	KUEHLMITTELVORWAERMUN
KLEBER 50ML	81 12 017 08	6	1	9 739 349	97 39 349	WASSERLEITUNGSANSCHLUE
KLEBSTOFF 10ML	81 12 073 01	99	1	9 739 322	97 39 322	RS ROHRLEITUNG
KLEBSTOFF 10ML	81 12 073 01	104	1	9 739 386	97 39 386	KURBELGEHAEUSEENTLUEFT
KLEBSTOFF 250ML	86 55 023 23	104	1	9 739 035	97 39 035	VERSCHLUSSTEIL
KLEBSTOFF 50ML	81 12 059 08	3	1	9 739 096	97 39 096	VERSCHLUSSSCHRAUBE
KLEMMBRETT 6XM6	60 44 124 08	1	1	1 830 102	92 26 483 08	KLEMMBRETT VORM.
KLEMMBRETT VORM.	92 26 483 08	42	1	2 932 082	96 54 387 08	AUFBAUTEILE MONTAGETAPE
KLEMME	10 28 635 4	274	12	1 920 403	96 48 707 08	KLEMMKASTEN KPL.
KLEMME	10 28 635 4	274	12	1 920 417	96 48 703 08	KLEMMKASTEN KPL.
KLEMME	10 28 635 4	(151)	47	1 920 418	96 48 687 08	KLEMMKASTEN KPL.
KLEMME	10 28 635 4	(151)	13	2 780 748	96 52 969 08	KLEMMKASTEN KPL.
KLEMME	10 28 635 4	260	21	2 920 581	96 54 405 08	KLEMMKASTEN SA-BOCK VO
KLEMME	10 28 635 4	63	2	2 932 082	96 54 387 08	AUFBAUTEILE MONTAGETAPE
KLEMME	10 28 635 4	(151)	20	3 930 363	96 52 979 08	KLEMMKASTEN KPL.
KLEMME	10 28 635 4	152	36	3 930 639	96 50 132 08	DRAEHTE KLEMMKASTEN KPL
KLEMME	10 28 635 4	(152)	24	3 930 640	96 50 481 08	KLEMMKASTEN KPL.
KLEMME	10 28 635 4	(502)	28	3 930 730	96 50 599 08	KLEMMKASTEN KPL.
KLEMME	10 28 635 4	279	88	3 930 730	96 54 398 08	KLEMMKASTEN KPL.
KLEMME	10 28 635 4	(501)	47	3 930 734	96 54 401 08	KLEMMKASTEN
KLEMME	63 61 079 01	521	2	2 932 224	96 54 389 08	DRAEHTE MONTAGETAPEL K
KLEMMHAELFTE 4X18	60 20 014 08	146	4	2 391 001	96 45 719 08	DIESELMOTOR VORM.
KLEMMHAELFTE DIN 3015-1 1	60 20 078 08	156	2	2 391 001	96 45 719 08	DIESELMOTOR VORM.
KLEMMHAELFTE DIN 3015-1 1	60 20 081 08	49	2	2 502	91 55 939 08	STUERSTAND
KLEMMHAELFTE DIN 3015-1 18	60 20 022 08	139	4	2 391 001	96 45 719 08	DIESELMOTOR VORM.
KLEMMHAELFTE DIN 3015-1 1	60 20 083 08	9	6	2 550 008	96 47 628 08	HALTER KPL.
KLEMMHAELFTE DIN 3015-1 1	60 20 083 08	9	6	2 550 009	96 47 645 08	HALTER KPL.
KLEMMHAELFTE DIN 3015-1 L	73 65 090	21	2	2 978 100	91 52 796 08	ZUSATZHYDR.MONTAGEEINR
KLEMMHAELFTE DIN 3015-1 L	73 62 946	19	6	2 978 100	91 52 796 08	ZUSATZHYDR.MONTAGEEINR
KLEMMHAELFTE DIN 3015-1 L	70 05 052	138	10	2 391 001	96 45 719 08	DIESELMOTOR VORM.
KLEMMHAELFTE DIN 3015-1 L	70 05 052	18	12	3 780 751	91 52 952 08	FLUG-U.WINDWARNUNG
KLEMMHAELFTE DIN 3015-1 L	60 20 089 08	23	40	2 978 100	91 52 796 08	ZUSATZHYDR.MONTAGEEINR

6.2.2009

etk_en_de_074515 LR 1600/2

1043

LIEBHERRAlphabetical index
Alphabetischer Index

Bezeichnung	Artikel	Pos.	Menge	Seite	Baugruppe	Bezeichnung
KLEMMHAELFTE DIN 3015-1 L	60 20 091 08	116	4	2 391 001	96 45 719 08	DIESELMOTOR VORM.
KLEMMHAELFTE DIN 3015-1 L	60 20 092 08	51	20	3 978 005	91 56 430 08	ZUSATZHYDRAULIK SB-KOPFS
KLEMMHAELFTE DIN 3015-1 L	60 20 092 08	51	40	3 978 015	91 56 429 08	ZUSATZHYDRAULIK ZWISCH
KLEMMHAELFTE DIN 3015-1 L	60 20 092 08	51	40	3 978 015	91 56 432 08	ZUSATZHYDRAULIK ZWISCH
KLEMMHAELFTE DIN 3015-1 L	60 20 094 08	145	1	2 391 001	96 45 719 08	DIESELMOTOR VORM.
KLEMMHAELFTE DIN 3015-1 L	60 20 094 08	26	2	2 671 004	96 46 305 08	OELBEHAELTER VORM.
KLEMMHAELFTE DIN 3015-1 L	74 13 103	117	4	2 391 001	96 45 719 08	DIESELMOTOR VORM.
KLEMMHEBEL STAHL 5.8	10 01 719 2	5	4	2 925 402	96 58 855 08	KAMERAANBAU DREHBUEHN
KLEMMKASTEN BELEUCHTUN	92 78 689 08	523	1	2 920 633	96 52 651 08	KABELSTRANG
KLEMMKASTEN KPL. +S1100	96 52 969 08	10	1	2 780 510	96 50 097 08	ELEKTRIK BALLASTPALETTE
KLEMMKASTEN KPL. S10	96 48 794 08	1	1	2 920 443	96 54 236 08	ELEKTRIK KLEMMKASTEN DB
KLEMMKASTEN KPL. S1000	96 50 481 08	1	1	3 930 575	96 48 380 08	EL.F-ANSCHLUSS KOPFSTUECK
KLEMMKASTEN KPL. S1020	96 50 599 08	1	1	3 930 546	96 48 375 08	ELEKTRIK F-KOPFSTUECK
KLEMMKASTEN KPL. S1070	96 52 979 08	1	1	3 930 421	96 47 149 08	ELEKTRIK D-KOPFSTUECK
KLEMMKASTEN KPL. S11	96 54 235 08	2	1	2 920 443	96 54 236 08	ELEKTRIK KLEMMKASTEN DB
KLEMMKASTEN KPL. S200	96 48 687 08	2	1	1 920 307	96 48 383 08	ELEKTRIK MITTELSTUECK
KLEMMKASTEN KPL. S220 4X	96 48 707 08	10	1	1 920 309	96 48 385 08	ELEKTRIK RAUPENTRAEGER
KLEMMKASTEN KPL. S240 4X	96 48 703 08	10	1	1 920 308	96 48 384 08	ELEKTRIK RAUPENTRAEGER
KLEMMKASTEN KPL. S910	96 54 398 08	9	1	3 930 138	96 54 377 08	ELEKTRIK S-ANLENKSTUECK
KLEMMKASTEN S1050	96 54 401 08	1	1	3 930 330	96 54 378 08	ELEKTRIK D-ANLENKSTUECK
KLEMMKASTEN S980	96 51 624 08	1	1	3 930 576	96 48 381 08	ELEKTRIK SW-KOPFSTUECK
KLEMMKASTEN SA-BOCK VO	96 54 405 08	1	1	2 920 578	96 54 379 08	ELEKTRIK SA-BOCK
KLEMMKONSOLE	96 51 407 08	2	1	2 925 402	96 58 855 08	KAMERAANBAU DREHBUEHN
KLEMMPROFIL EPDM	10 30 060 5	17	3.88	2 520	91 53 061 08	KABINE VERGLAST
KLEMMPROFIL EPDM	10 30 060 5	18	2.1	2 520	91 53 061 08	KABINE VERGLAST
KLEMMPROFIL EPDM/MOOS	10 30 060 0	13	4.5	2 522	91 54 115 08	SCHIEBETUER KPL.
KLEMMSCHEIBE	10 47 043 4	3	1	X1042954	10 42 954 9	WINDGESCHWINDIGKEITSGE
KLEMMSCHELLE 39-42	55 30 542 08	8	3	2 541 001	96 49 651 08	ZUSATZHEIZUNG VORM.
KLEMMSTUECK PA6G+OEL	97 68 737 08	4	4	2 925 402	96 58 855 08	KAMERAANBAU DREHBUEHN
KLIMAANLAGE OW LR1600-2	91 57 754 08	320	1		LR 1600-2-0	LIEBHERR RAUPENKRAN LR 1
KLIMAKOMPRESSOR	10 29 994 8	1	1	9 739 371	97 39 371	KLIMAKOMPRESSOR ANBAU
KLIMAKOMPRESSOR ANBAU	97 39 371	150	1	X1012059	10 12 059 0	DIESELMOTOR
KLOTZ 50X242X242	97 43 188 08	7	4	3 747	91 52 950 08	ZENTRIERUNG STANDARD
KLOTZ 50X242X242	97 43 189 08	8	4	3 747	91 52 950 08	ZENTRIERUNG STANDARD
KLOTZ 50X255X280	97 76 964 08	11	2	3 747	91 52 950 08	ZENTRIERUNG STANDARD
KLOTZ 50X279X255	97 43 187 08	6	2	3 747	91 52 950 08	ZENTRIERUNG STANDARD
KLOTZ 50X280X255	97 43 190 08	9	2	3 747	91 52 950 08	ZENTRIERUNG STANDARD
KLOTZ 50X280X255	97 76 956 08	10	2	3 747	91 52 950 08	ZENTRIERUNG STANDARD
KNIESTUECK	57 00 661 08	3	1	5 028 065	50 28 065 08	AUSGLEICHSBEHAELTER
KNOTENKETTE 2,8 GALV.VERZ	74 00 006 08	155	1	3 930 732	96 50 575 08	LEITUNG
KNOTENKETTE DIN 5686 1,8X2	74 00 008 08	7	0.25	1 632 032	96 20 093 08	ABSTUETZPLATTE KPL.
KNOTENKETTE DIN 5686 1,8X2	74 00 008 08	(266)	0.2	2 920 369	96 54 235 08	KLEMMKASTEN KPL.
KNOTENKETTE DIN 5686 1,8X2	74 00 008 08	(266)	0.2	2 920 369	96 54 235 08	KLEMMKASTEN KPL.
KNOTENKETTE DIN 5686 1,8X2	74 00 008 08	(266)	0.2	2 920 369	96 54 235 08	KLEMMKASTEN KPL.
KOLBEN	10 22 233 1	53	1	9 739 246	97 39 246	KOLBEN
KOLBEN	10 22 233 2	51	1	9 739 246	97 39 246	KOLBEN
KOLBEN	10 22 233 3	1	1	9 739 246	97 39 246	KOLBEN
KOLBEN	10 22 233 4	52	1	9 739 246	97 39 246	KOLBEN
KOLBEN	57 01 147 08	4	7	5 701 133	57 01 133 08	TRIEBWERK
KOLBEN	97 39 246	40	6	X1012059	10 12 059 0	DIESELMOTOR
KOLBENBOLZEN	10 22 233 5	2	1	9 739 246	97 39 246	KOLBEN
KOLBENKUEHLUNG	97 39 243	9	6	X1012059	10 12 059 0	DIESELMOTOR
KOMBIZANGE DIN 5244 180	79 00 315 08	12	1	1 750	91 52 394 08	WERKZEUG
KONSOLE	10 01 749 3	2	1	9 739 186	97 39 186	MOTORBREMSE
KONSOLE	10 34 317 4	1	1	9 739 360	97 39 360	MOTORLAGERUNG
KONSOLE	10 34 317 6	10	1	9 739 360	97 39 360	MOTORLAGERUNG
KONSOLE	10 34 331 8	13	1	9 739 371	97 39 371	KLIMAKOMPRESSOR ANBAU
KONSOLE	77 42 157 08	76	2	2 970	91 56 537 08	HYDRAULIK
KONSOLE	77 42 157 08	12	4	2 978 100	91 52 796 08	ZUSATZHYDR.MONTAGEEINR
KONSOLE	92 17 245 08	1	1	3 745 002	92 17 236 08	SCHALTEINHEIT

6.2.2009

etk_en_de_074515 LR 1600/2

1044

LIEBHERRAlphabetical index
Alphabetischer Index

Bezeichnung	Artikel	Pos.	Menge	Seite	Baugruppe	Bezeichnung
KONSOLE	92 17 251 08	1	1	3 745 003	92 17 237 08	SCHALTEINHEIT
KONSOLE	96 50 735 08	93	1	3 713	91 57 749 08	D-ANLENKSTUECK
KONSOLE	96 50 968 08	95	1	3 713	91 57 749 08	D-ANLENKSTUECK
KONSOLE	96 56 719 08	50	2	3 223 100	91 55 327 08	S-ZWISCHENSTUECK
KONSOLE KPL.	96 47 007 08	60	2	2 550	91 57 751 08	SA-BOCK
KONSOLE LINKS	97 75 565 08	4	1	2 503 101	96 48 626 08	SITZ
KONSOLE LINKS SPF	97 23 411 08	3	1	2 502	91 55 939 08	STEUERSTAND
KONSOLE RECHTS	97 75 567 08	5	1	2 503 101	96 48 626 08	SITZ
KONSOLE RECHTS SPF	97 23 412 08	4	1	2 502	91 55 939 08	STEUERSTAND
KONSOLE SCHWK.	92 16 964 08	2	1	2 925 204	92 16 990 08	KAMERAANBAU D-ANLENKS
KONSOLE SCHWK.	92 51 941 08	3	1	2 620	91 52 793 08	ROLLENDREHVERBINDUNG
KONSOLE SCHWK.	96 17 503 08	2	2	3 291	91 52 831 08	S-RUECKHALTESICHERUNG
KONSOLE SCHWK.	96 17 503 08	7	2	3 292	91 52 865 08	D-RUECKHALTESICHERUNG
KONSOLE SCHWK.	96 42 805 08	2	2	2 670	91 52 797 08	KRAFTSTOFFBEHAELTER KPL
KONSOLE SCHWK.	96 44 626 08	1	2	2 730	91 52 802 08	GRUNDPLATTE DREHBUEHNE
KONSOLE SCHWK.	96 45 748 08	1	2	1 742	91 53 021 08	ZENTRALBALLASTBEFESTIG
KONSOLE SCHWK.	96 45 983 08	3	1	2 520 032	96 45 980 08	SCHEIBENWISCHANLAGE EIN
KONSOLE SCHWK.	96 46 985 08	1	1	2 550 011	96 47 007 08	KONSOLE KPL.
KONSOLE SCHWK.	96 47 506 08	4	2	2 671	91 52 798 08	OELBEHAELTER KPL.
KONSOLE SCHWK.	96 48 426 08	7	1	2 502	91 55 939 08	STEUERSTAND
KONSOLE SCHWK.	96 48 437 08	12	2	2 502	91 55 939 08	STEUERSTAND
KONSOLE SCHWK.	96 49 196 08	16	2	2 392	91 52 785 08	SCHALLDAEMPFERANLAGE
KONSOLE SCHWK.	96 49 689 08	2	4	3 747	91 52 950 08	ZENTRIERUNG STANDARD
KONSOLE SCHWK.	96 53 678 08	10	1	2 391 040	96 53 645 08	KUPPLUNGSSTELLER
KONSOLE SCHWK. FE//ZN20//	96 50 492 08	13	2	3 227 002	96 50 498 08	STANGE KPL.
KONSOLE SCHWK. HINTEN	96 52 910 08	1	1	2 790 455	91 57 005 08	TRANSPORTABLAGE
KONSOLE SCHWK. TZNO	96 53 093 08	8	6	2 631	91 56 817 08	LAUFSTEG DREHBUEHNE
KONSOLE SCHWK. VORN	96 52 911 08	2	1	2 790 455	91 57 005 08	TRANSPORTABLAGE
KONSOLE SCHWK.HI.	96 51 811 08	26	1	2 652	91 52 794 08	ROLLENLAGERUNG
KONSOLE SCHWK.LI.	96 48 438 08	13	1	2 502	91 55 939 08	STEUERSTAND
KONSOLE SCHWK.LI. FE//ZN20	96 48 427 08	8	1	2 502	91 55 939 08	STEUERSTAND
KONSOLE SCHWK.RE.	96 48 439 08	14	1	2 502	91 55 939 08	STEUERSTAND
KONSOLE SCHWK.RE. FE//ZN	96 48 428 08	9	1	2 502	91 55 939 08	STEUERSTAND
KONSOLE SCHWK.VORN	96 51 810 08	25	1	2 652	91 52 794 08	ROLLENLAGERUNG
KONTAKT 0,5 - 1,0	60 23 003 08	(125)	14	2 920 369	96 54 235 08	KLEMMKASTEN KPL.
KONTAKT 0,5 - 1,0	60 23 003 08	(125)	9	2 920 369	96 54 235 08	KLEMMKASTEN KPL.
KONTAKTSICHERUNGSSTIFT	10 09 986 7	513	1	2 932 224	96 54 389 08	DRAEHTE MONTAGETAFEL K
KONTAKTSICHERUNGSSTIFT	10 09 986 8	519	2	2 932 224	96 54 389 08	DRAEHTE MONTAGETAFEL K
KONTAKTSTIFT	60 56 017 08	130	6	2 920 633	96 52 651 08	KABELSTRANG
KONUSLAGER 70NR11	10 29 198 9	6	4	2 810	91 52 806 08	KRANFUEHRERKABINE KPL.
KRAFTMESSACHSE DRUCK 0	10 49 005 7	7	2	3 291	91 52 831 08	S-RUECKHALTESICHERUNG
KRAFTSTOFFBEHAELTER KPL	91 52 797 08	143	1		LR 1600-2-0	LIEBHERR RAUPENKRAN LR 1
KRAFTSTOFFBEHAELTER SCH	96 45 354 08	1	1	2 670 002	96 45 352 08	KRAFTSTOFFBEHAELTER VO
KRAFTSTOFFBEHAELTER VO	96 45 352 08	1	1	2 670	91 52 797 08	KRAFTSTOFFBEHAELTER KPL
KRAFTSTOFFFILTER	55 31 740 08	(1)	1	2 541	91 52 790 08	ZUSATZHEIZUNG OW
KRAFTSTOFFFILTER	97 39 258	1	1	9 739 259	97 39 259	KRAFTSTOFFFILTER
KRAFTSTOFFFILTER	97 39 259	93	1	X1012059	10 12 059 0	DIESELMOTOR
KRAFTSTOFFFILTEREINSATZ	10 22 275 7	3	1	9 739 258	97 39 258	KRAFTSTOFFFILTER
KRAFTSTOFFHEIZUNG	10 01 245 3	16	1	9 739 258	97 39 258	KRAFTSTOFFFILTER
KRAFTSTOFFLEITUNG	10 03 574 7	6	1	9 739 288	97 39 288	KRAFTSTOFFLEITUNG
KRAFTSTOFFLEITUNG	10 22 276 7	2	1	9 739 292	97 39 292	KRAFTSTOFFLEITUNG
KRAFTSTOFFLEITUNG	10 22 276 8	9	1	9 739 292	97 39 292	KRAFTSTOFFLEITUNG
KRAFTSTOFFLEITUNG	10 22 276 9	13	1	9 739 292	97 39 292	KRAFTSTOFFLEITUNG
KRAFTSTOFFLEITUNG	10 22 277 3	6	1	9 739 282	97 39 282	LECKOELLEITUNG
KRAFTSTOFFLEITUNG	10 22 277 4	7	1	9 739 282	97 39 282	LECKOELLEITUNG
KRAFTSTOFFLEITUNG	10 22 277 5	21	1	9 739 292	97 39 292	KRAFTSTOFFLEITUNG
KRAFTSTOFFLEITUNG	10 28 515 3	10	1	9 739 288	97 39 288	KRAFTSTOFFLEITUNG
KRAFTSTOFFLEITUNG	97 39 288	131	1	X1012059	10 12 059 0	DIESELMOTOR
KRAFTSTOFFLEITUNG	97 39 292	97	1	X1012059	10 12 059 0	DIESELMOTOR
KRAFTSTOFFOERDERPUMPE	10 22 274 8	3	1	X1034309	10 34 309 6	HOCHDRUCKPUMPE

6.2.2009

etk_en_de_074515 LR 1600/2

1045

LIEBHERRAlphabetical index
Alphabetischer Index

Bezeichnung	Artikel	Pos.	Menge	Seite	Baugruppe	Bezeichnung
KRAFTSTOFFSCHLAUCH	10 11 614 1	97	1	9 739 400	97 39 400	DIESELMOTOR
KRAFTSTOFFSCHLAUCH	97 80 893 08	17	1	2 670	91 52 797 08	KRAFTSTOFFBEHAELTER KPL
KRAFTSTOFFSCHLAUCH DI=4,	55 31 911 08	14	0.15	2 541	91 52 790 08	ZUSATZHEIZUNG OW
KRAFTSTOFFSCHLAUCH DN10	10 42 402 5	(1)	0.12	2 670	91 52 797 08	KRAFTSTOFFBEHAELTER KPL
KRAMPE	60 27 417 08	275	6	1 920 403	96 48 707 08	KLEMMKASTEN KPL.
KRAMPE	60 27 417 08	275	6	1 920 417	96 48 703 08	KLEMMKASTEN KPL.
KRAMPE	60 27 417 08	274	10	3 930 363	96 52 979 08	KLEMMKASTEN KPL.
KRAMPE	60 27 417 08	274	12	3 930 640	96 50 481 08	KLEMMKASTEN KPL.
KRANFUEHRERKABINE KPL.	91 52 806 08	153	1		LR 1600-2-0	LIEBHERR RAUPENKRAN LR 1
KRANFUEHRERKABINE VORM	96 43 597 08	1	1	2 810	91 52 806 08	KRANFUEHRERKABINE KPL.
KREUZLASCHE SCHWK.	96 48 639 08	3	2	3 830	91 55 535 08	ZUSATZABSPANNUNG
KREUZLASCHE SCHWK.	96 48 640 08	2	2	3 830	91 55 535 08	ZUSATZABSPANNUNG
KREUZSTUECK 30/30/30/30 G	10 44 099 0	49	1	2 520	91 53 061 08	KABINE VERGLAST
KRUEMMER	10 01 219 0	1	1	9 739 386	97 39 386	KURBELGEHAEUSEENTLUEFT
KRUEMMER	10 01 230 1	1	1	9 739 126	97 39 126	THERMOSTATGEHAEUSE
KRUEMMER	10 01 230 2	1	1	9 739 349	97 39 349	WASSERLEITUNGSANSCHLUE
KRUEMMER	10 22 237 4	1	1	9 739 276	97 39 276	WASSERANSCHLUSS
KRUEMMER DN60 GUMMI	55 08 984 08	200	1	2 391 001	96 45 719 08	DIESELMOTOR VORM.
KUEHLER VORM.	96 45 720 08	120	1	2 391 001	96 45 719 08	DIESELMOTOR VORM.
KUEHLERANLAGE AL	10 41 290 3	1	1	2 391 023	96 45 720 08	KUEHLER VORM.
KUEHLKOERPER 84X12X7,7 AL	10 00 812 5	13	1	2 913 005	96 20 731 08	INNENGEHAEUSE VORM.
KUEHLKOERPER 84X12X7,7 AL	10 00 812 5	13	1	2 913 005	96 28 696 08	INNENGEHAEUSE VORM.
KUEHLMITTELKRUEMMER	10 34 286 8	11	1	9 739 349	97 39 349	WASSERLEITUNGSANSCHLUE
KUEHLMITTELLEITUNG	10 03 716 9	1	1	9 739 210	97 39 210	KUEHLMITTELLEITUNG
KUEHLMITTELLEITUNG	10 47 689 5	1	1	9 739 492	97 39 492	ROHRLEITUNG ANBAU
KUEHLMITTELLEITUNG	10 47 690 7	7	1	9 739 492	97 39 492	ROHRLEITUNG ANBAU
KUEHLMITTELLEITUNG	97 39 210	171	1	X1012059	10 12 059 0	DIESELMOTOR
KUEHLMITTELLEITUNG	97 39 383	1	1	9 739 351	97 39 351	KUEHLMITTELLEITUNG ANBA
KUEHLMITTELLEITUNG ANBA	97 39 351	166	1	X1012059	10 12 059 0	DIESELMOTOR
KUEHLMITTELPUMPE	10 34 287 1	1	1	9 739 352	97 39 352	WASSERPUMPE MIT BEFEST.
KUEHLMITTELVORWAERMUN	97 39 129	282	1	X1012059	10 12 059 0	DIESELMOTOR
KUEHLWASSERLEITUNG	10 01 231 4	1	1	9 739 127	97 39 127	WASSERENTLUEFTUNGSLEIT
KUEHLWASSERSCHLAUCH 1	77 42 306 08	250	2	2 391 001	96 45 719 08	DIESELMOTOR VORM.
KUEHLWASSERSCHLAUCH 1	77 42 329 08	20	20	2 540	91 53 253 08	HEIZKLIMAGERAET EINBAU
KUEHLWASSERSCHLAUCH 1	77 42 329 08	17	10	2 541	91 52 790 08	ZUSATZHEIZUNG OW
KUEHLWASSERSCHLAUCH DN	77 42 307 08	133	2	2 391 001	96 45 719 08	DIESELMOTOR VORM.
KUEHLWASSERVORWAERM	10 01 234 3	1	1	9 739 129	97 39 129	KUEHLMITTELVORWAERMUN
KUGEL 3	10 01 183 1	5	2	9 739 243	97 39 243	KOLBENKUEHLUNG
KUGEL DIN 5401 10	74 70 006 08	320	1	X1041101	10 41 101 5	RUECKFALLSTUETZE
KUGEL DIN 5401 10	74 70 006 08	300	1	X1041101	10 41 101 8	RUECKFALLSTUETZE
KUGEL DIN 5401 7	57 08 621 08	5	1	X1041267	10 41 267 8	ENDPLATTE
KUGEL DIN 5401 8	74 70 004 08	520	1	X1041101	10 41 101 5	RUECKFALLSTUETZE
KUGEL DIN 5401 8	74 70 004 08	440	1	X1041101	10 41 101 8	RUECKFALLSTUETZE
KUGELHAHN BK3-30S A3C SP	51 10 634 08	52	2	2 970	91 56 537 08	HYDRAULIK
KUGELHAHN BKH3/4" A3C	51 06 923 08	20	1	1 970	91 56 958 08	HYDRAULIK RAUPE
KUGELHAHN BKH3/8" A3C	51 06 820 08	22	1	2 970	91 56 537 08	HYDRAULIK
KUGELHAHN DN8-1/4" MS	51 06 960 08	5	1	2 978 100	91 52 796 08	ZUSATZHYDR.MONTAGEEINR
KUGELHAHN DN8-1/4" MS	51 06 960 08	13	1	2 978 200	91 54 843 08	ZUSATZHYDR.S-RUECKHALTE
KUGELHAHN DN8-1/4" MS	51 06 960 08	10	1	3 978 005	91 56 430 08	ZUSATZHYDRAULIK SB-KOPFS
KUGELHAHNKOMBINATION DN	10 42 471 6	26	2	2 970	91 56 537 08	HYDRAULIK
KUGELPFANNE	10 01 186 3	9	1	9 739 186	97 39 186	MOTORBREMSE
KUGELSCHEIBE C 10,5	10 01 173 6	11	1	9 739 248	97 39 248	EINSPRITZDUESE
KUGELSCHEIBE DIN 6319 C 8.4	10 01 173 8	6	1	9 739 248	97 39 248	EINSPRITZDUESE
KUGELSPERRBOLZEN 20X100	10 45 165 0	38	4	2 340	91 52 776 08	WINDE 4 EINZIEHWERK
KUPPLUNG SILIKON 60SH	10 42 823 9	128	1	2 391 001	96 45 719 08	DIESELMOTOR VORM.
KUPPLUNGSDOSE	60 50 127 08	7	1	2 780 915	96 48 377 08	ANBAUTEILE FREMDEINSPEIS
KUPPLUNGSDOSE 90GR SPF	68 00 008 08	(5)	1	2 920 581	96 54 405 08	KLEMMKASTEN SA-BOCK VO
KUPPLUNGSDOSE GERADE	68 00 017 08	(5)	1	2 920 288	96 52 614 08	KABELLISTE DREHBUEHNE
KUPPLUNGSDOSE GERADE	68 00 017 08	(5)	1	2 920 581	96 54 405 08	KLEMMKASTEN SA-BOCK VO
KUPPLUNGSDOSE GERADE	68 00 017 08	(5)	1	2 920 581	96 54 405 08	KLEMMKASTEN SA-BOCK VO

6.2.2009

etk_en_de_074515 LR 1600/2

1046

LIEBHERRAlphabetical index
Alphabetischer Index

Bezeichnung	Artikel	Pos.	Menge	Seite	Baugruppe	Bezeichnung
KUPPLUNGSDOSE GERADE	68 00 017 08	8	1	2 920 633	96 52 651 08	KABELSTRANG
KUPPLUNGSDOSE GERADE	68 00 017 08	9	1	2 920 633	96 52 651 08	KABELSTRANG
KUPPLUNGSDOSE GERADE	68 00 017 08	10	1	2 920 633	96 52 651 08	KABELSTRANG
KUPPLUNGSDOSE GERADE	68 00 017 08	11	1	2 920 633	96 52 651 08	KABELSTRANG
KUPPLUNGSDOSE GERADE	68 00 017 08	372	1	2 920 633	96 52 651 08	KABELSTRANG
KUPPLUNGSDOSE GERADE	68 00 017 08	373	1	2 920 633	96 52 651 08	KABELSTRANG
KUPPLUNGSDOSE SPF	68 00 000 08	(6)	1	2 920 288	96 52 614 08	KABELLISTE DREHBUEHNE
KUPPLUNGSDOSE SPF	68 00 014 08	374	1	2 920 633	96 52 651 08	KABELSTRANG
KUPPLUNGSMUFFE	51 15 184 08	96	1	2 970	91 56 537 08	HYDRAULIK
KUPPLUNGSMUFFE	51 15 184 08	45	1	2 977	91 57 756 08	ZUSATZHYDRAULIK DREHBUE
KUPPLUNGSMUFFE	77 43 726 08	18	14	2 711	91 52 800 08	ZENTRALSCHMIERANLAGE O
KUPPLUNGSMUFFE	77 43 726 08	13	1	3 713 013	96 57 159 08	BLECH KPL.
KUPPLUNGSMUFFE 10-L	51 15 084 08	106	1	2 970	91 56 537 08	HYDRAULIK
KUPPLUNGSMUFFE 10-L	51 15 084 08	5	2	2 970 081	96 50 495 08	ZUSATZHYDR.BOLZENZIEHZ
KUPPLUNGSMUFFE 10-L	51 15 084 08	19	1	2 975 100	91 52 860 08	ZUSATZHYDRAULIK WINDE 3
KUPPLUNGSMUFFE 12-L	51 15 058 08	27	1	1 970	91 56 958 08	HYDRAULIK RAUPE
KUPPLUNGSMUFFE 12-L	51 15 058 08	98	5	2 970	91 56 537 08	HYDRAULIK
KUPPLUNGSMUFFE 12-L	51 15 058 08	33	2	2 975 100	91 52 860 08	ZUSATZHYDRAULIK WINDE 3
KUPPLUNGSMUFFE 12-L	51 15 058 08	33	1	2 975 200	91 52 775 08	ZUSATZHYDRAULIK WINDE 2
KUPPLUNGSMUFFE 12-L	51 15 058 08	33	1	2 975 700	91 52 774 08	ZUSATZHYDRAULIK WINDE 1
KUPPLUNGSMUFFE 12-L	51 15 058 08	5	3	2 976 200	91 44 034 08	ZUS.HYDR.BOLZENZIEHEINRI
KUPPLUNGSMUFFE 12-L	51 15 058 08	5	1	2 976 203	92 27 489 08	ZUSATZHYDR.BOLZENZIEHZ
KUPPLUNGSMUFFE 12-L	51 15 058 08	11	1	3 978 015	91 56 429 08	ZUSATZHYDRAULIK ZWISCH
KUPPLUNGSMUFFE 12-L	51 15 058 08	11	1	3 978 015	91 56 432 08	ZUSATZHYDRAULIK ZWISCH
KUPPLUNGSMUFFE 12-L	51 15 058 08	27	1	3 978 100	91 56 428 08	HYDR.SCHWEBEBALLAST-AN
KUPPLUNGSMUFFE 15-L	51 15 005 08	104	3	2 970	91 56 537 08	HYDRAULIK
KUPPLUNGSMUFFE 15-L	51 15 005 08	11	2	2 970 081	96 50 495 08	ZUSATZHYDR.BOLZENZIEHZ
KUPPLUNGSMUFFE 15-L	51 15 005 08	37	1	2 975 200	91 52 775 08	ZUSATZHYDRAULIK WINDE 2
KUPPLUNGSMUFFE 15-L	51 15 005 08	37	1	2 975 700	91 52 774 08	ZUSATZHYDRAULIK WINDE 1
KUPPLUNGSMUFFE 16-S	51 15 059 08	39	2	1 970	91 56 958 08	HYDRAULIK RAUPE
KUPPLUNGSMUFFE 16-S	51 15 059 08	92	2	2 970	91 56 537 08	HYDRAULIK
KUPPLUNGSMUFFE 20-S	51 15 007 08	39	1	2 977	91 57 756 08	ZUSATZHYDRAULIK DREHBUE
KUPPLUNGSMUFFE 22-L	51 15 082 08	88	3	2 970	91 56 537 08	HYDRAULIK
KUPPLUNGSMUFFE 22-L	51 15 082 08	29	1	2 975 100	91 52 860 08	ZUSATZHYDRAULIK WINDE 3
KUPPLUNGSMUFFE 22-L	51 15 082 08	29	1	2 975 200	91 52 775 08	ZUSATZHYDRAULIK WINDE 2
KUPPLUNGSMUFFE 22-L	51 15 082 08	29	1	2 975 700	91 52 774 08	ZUSATZHYDRAULIK WINDE 1
KUPPLUNGSMUFFE 25-S	51 05 996 08	84	6	2 970	91 56 537 08	HYDRAULIK
KUPPLUNGSMUFFE 25-S	51 05 996 08	25	1	2 975 200	91 52 775 08	ZUSATZHYDRAULIK WINDE 2
KUPPLUNGSMUFFE 25-S	51 05 996 08	25	1	2 975 700	91 52 774 08	ZUSATZHYDRAULIK WINDE 1
KUPPLUNGSMUFFE 25-S	51 05 996 08	21	1	2 978 200	91 54 843 08	ZUSATZHYDR.S-RUECKHALTE
KUPPLUNGSMUFFE 28-L	51 15 010 08	35	2	1 970	91 56 958 08	HYDRAULIK RAUPE
KUPPLUNGSMUFFE 28-L	51 15 010 08	90	3	2 970	91 56 537 08	HYDRAULIK
KUPPLUNGSMUFFE 28-L	51 15 010 08	31	1	2 975 100	91 52 860 08	ZUSATZHYDRAULIK WINDE 3
KUPPLUNGSMUFFE 28-L	51 15 010 08	35	1	2 977	91 57 756 08	ZUSATZHYDRAULIK DREHBUE
KUPPLUNGSMUFFE 28-L	51 15 010 08	23	2	2 978 200	91 54 843 08	ZUSATZHYDR.S-RUECKHALTE
KUPPLUNGSMUFFE 38-S	51 15 122 08	31	4	1 970	91 56 958 08	HYDRAULIK RAUPE
KUPPLUNGSMUFFE 38-S	51 15 122 08	80	4	2 970	91 56 537 08	HYDRAULIK
KUPPLUNGSMUFFE 38-S	51 15 122 08	21	2	2 975 100	91 52 860 08	ZUSATZHYDRAULIK WINDE 3
KUPPLUNGSMUFFE 38-S	51 15 122 08	21	2	2 975 200	91 52 775 08	ZUSATZHYDRAULIK WINDE 2
KUPPLUNGSMUFFE 38-S	51 15 122 08	21	2	2 975 700	91 52 774 08	ZUSATZHYDRAULIK WINDE 1
KUPPLUNGSMUFFE 38-S	51 15 122 08	31	4	2 977	91 57 756 08	ZUSATZHYDRAULIK DREHBUE
KUPPLUNGSMUFFE 38-S	51 15 122 08	4	2	3 978 015	91 56 429 08	ZUSATZHYDRAULIK ZWISCH
KUPPLUNGSMUFFE 38-S	51 15 122 08	4	2	3 978 015	91 56 432 08	ZUSATZHYDRAULIK ZWISCH
KUPPLUNGSMUFFE 38-S	51 15 122 08	21	2	3 978 100	91 56 428 08	HYDR.SCHWEBEBALLAST-AN
KUPPLUNGSSTECKER	77 43 727 08	17	24	2 711	91 52 800 08	ZENTRALSCHMIERANLAGE O
KUPPLUNGSSTECKER 10-L	51 15 083 08	107	1	2 970	91 56 537 08	HYDRAULIK
KUPPLUNGSSTECKER 10-L	51 15 083 08	7	1	2 970 081	96 50 495 08	ZUSATZHYDR.BOLZENZIEHZ
KUPPLUNGSSTECKER 10-L	51 15 083 08	20	2	2 975 100	91 52 860 08	ZUSATZHYDRAULIK WINDE 3
KUPPLUNGSSTECKER 12-L	51 15 096 08	99	2	2 970	91 56 537 08	HYDRAULIK
KUPPLUNGSSTECKER 12-L	51 15 096 08	35	2	2 975 100	91 52 860 08	ZUSATZHYDRAULIK WINDE 3

6.2.2009

etk_en_de_074515 LR 1600/2

1047

LIEBHERRAlphabetical index
Alphabetischer Index

Bezeichnung	Artikel	Pos.	Menge	Seite	Baugruppe	Bezeichnung
KUPPLUNGSSTECKER 12-L	51 15 096 08	35	1	2 975 200	91 52 775 08	ZUSATZHYDRAULIK WINDE 2
KUPPLUNGSSTECKER 12-L	51 15 096 08	35	1	2 975 700	91 52 774 08	ZUSATZHYDRAULIK WINDE 1
KUPPLUNGSSTECKER 12-L	51 15 096 08	7	3	2 976 200	91 44 034 08	ZUS.HYDR.BOLZENZIEHEINRI
KUPPLUNGSSTECKER 12-L	51 15 096 08	7	1	2 976 203	92 27 489 08	ZUSATZHYDR.BOLZENZIEHZ
KUPPLUNGSSTECKER 12-L	51 15 096 08	18	1	3 978 005	91 56 430 08	ZUSATZHYDRAULIK SB-KOPFS
KUPPLUNGSSTECKER 12-L	51 15 096 08	13	1	3 978 015	91 56 429 08	ZUSATZHYDRAULIK ZWISCH
KUPPLUNGSSTECKER 12-L	51 15 096 08	13	1	3 978 015	91 56 432 08	ZUSATZHYDRAULIK ZWISCH
KUPPLUNGSSTECKER 12-S	51 15 013 08	23	1	1 970	91 56 958 08	HYDRAULIK RAUPE
KUPPLUNGSSTECKER 15-L	51 15 004 08	105	4	2 970	91 56 537 08	HYDRAULIK
KUPPLUNGSSTECKER 15-L	51 15 004 08	13	1	2 970 081	96 50 495 08	ZUSATZHYDR.BOLZENZIEHZ
KUPPLUNGSSTECKER 15-L	51 15 004 08	37	2	2 975 100	91 52 860 08	ZUSATZHYDRAULIK WINDE 3
KUPPLUNGSSTECKER 15-L	51 15 004 08	11	1	2 976 200	91 44 034 08	ZUS.HYDR.BOLZENZIEHEINRI
KUPPLUNGSSTECKER 15-L	51 15 004 08	24	2	2 977 200	91 55 149 08	ZUSATZHYDR.PUMPE 5/WIND
KUPPLUNGSSTECKER 15-L	51 15 004 08	14	3	3 713 013	96 57 159 08	BLECH KPL.
KUPPLUNGSSTECKER 16-S	51 15 086 08	41	2	1 970	91 56 958 08	HYDRAULIK RAUPE
KUPPLUNGSSTECKER 16-S	51 15 086 08	94	2	2 970	91 56 537 08	HYDRAULIK
KUPPLUNGSSTECKER 16-S	51 15 086 08	41	1	2 977	91 57 756 08	ZUSATZHYDRAULIK DREHBUE
KUPPLUNGSSTECKER 16-S	51 15 086 08	43	1	2 977	91 57 756 08	ZUSATZHYDRAULIK DREHBUE
KUPPLUNGSSTECKER 16-S	51 15 086 08	25	1	2 978 100	91 52 827 08	ZUSATZHYDR.D-RUECKHALT
KUPPLUNGSSTECKER 16-S	51 15 086 08	25	1	2 978 200	91 54 843 08	ZUSATZHYDR.S-RUECKHALTE
KUPPLUNGSSTECKER 18-L	57 05 048 08	13	1	2 976 200	91 44 034 08	ZUS.HYDR.BOLZENZIEHEINRI
KUPPLUNGSSTECKER 22-L	51 15 081 08	89	5	2 970	91 56 537 08	HYDRAULIK
KUPPLUNGSSTECKER 22-L	51 15 081 08	30	1	2 975 100	91 52 860 08	ZUSATZHYDRAULIK WINDE 3
KUPPLUNGSSTECKER 22-L	51 15 081 08	23	1	2 978 100	91 52 827 08	ZUSATZHYDR.D-RUECKHALT
KUPPLUNGSSTECKER 25-S	51 05 997 08	86	3	2 970	91 56 537 08	HYDRAULIK
KUPPLUNGSSTECKER 25-S	51 05 997 08	27	1	2 975 100	91 52 860 08	ZUSATZHYDRAULIK WINDE 3
KUPPLUNGSSTECKER 25-S	51 05 997 08	40	1	2 977	91 57 756 08	ZUSATZHYDRAULIK DREHBUE
KUPPLUNGSSTECKER 25-S	51 05 997 08	26	2	2 978 100	91 52 796 08	ZUSATZHYDR.MONTAGEEINR
KUPPLUNGSSTECKER 25-S	51 05 997 08	21	1	2 978 100	91 52 827 08	ZUSATZHYDR.D-RUECKHALT
KUPPLUNGSSTECKER 28-L	51 15 011 08	37	2	1 970	91 56 958 08	HYDRAULIK RAUPE
KUPPLUNGSSTECKER 28-L	51 15 011 08	91	1	2 970	91 56 537 08	HYDRAULIK
KUPPLUNGSSTECKER 28-L	51 15 011 08	32	2	2 975 100	91 52 860 08	ZUSATZHYDRAULIK WINDE 3
KUPPLUNGSSTECKER 28-L	51 15 011 08	37	1	2 977	91 57 756 08	ZUSATZHYDRAULIK DREHBUE
KUPPLUNGSSTECKER 28-L	51 15 011 08	20	1	2 977 200	91 55 149 08	ZUSATZHYDR.PUMPE 5/WIND
KUPPLUNGSSTECKER 28-L	51 15 011 08	33	1	3 978 100	91 56 428 08	HYDR.SCHWEBEBALLAST-AN
KUPPLUNGSSTECKER 30-S	51 15 108 08	31	1	3 978 100	91 56 428 08	HYDR.SCHWEBEBALLAST-AN
KUPPLUNGSSTECKER 38-S	51 15 123 08	33	4	1 970	91 56 958 08	HYDRAULIK RAUPE
KUPPLUNGSSTECKER 38-S	51 15 123 08	82	6	2 970	91 56 537 08	HYDRAULIK
KUPPLUNGSSTECKER 38-S	51 15 123 08	23	4	2 975 100	91 52 860 08	ZUSATZHYDRAULIK WINDE 3
KUPPLUNGSSTECKER 38-S	51 15 123 08	33	4	2 977	91 57 756 08	ZUSATZHYDRAULIK DREHBUE
KUPPLUNGSSTECKER 38-S	51 15 123 08	13	2	2 977 200	91 55 149 08	ZUSATZHYDR.PUMPE 5/WIND
KUPPLUNGSSTECKER 38-S	51 15 123 08	14	1	3 978 005	91 56 430 08	ZUSATZHYDRAULIK SB-KOPFS
KUPPLUNGSSTECKER 38-S	51 15 123 08	5	2	3 978 015	91 56 429 08	ZUSATZHYDRAULIK ZWISCH
KUPPLUNGSSTECKER 38-S	51 15 123 08	5	2	3 978 015	91 56 432 08	ZUSATZHYDRAULIK ZWISCH
KUPPLUNGSSTECKER BGR.8	51 15 185 08	46	1	2 977	91 57 756 08	ZUSATZHYDRAULIK DREHBUE
KUPPLUNGSSTELLER	96 53 645 08	13	1	2 391 001	96 45 719 08	DIESELMOTOR VORM.
KURBELGEHAEUSE KPL. R-MO	97 39 368	1	1	X1012059	10 12 059 0	DIESELMOTOR
KURBELGEHAEUSEENTLUEFT	97 39 386	11	1	X1012059	10 12 059 0	DIESELMOTOR
KURBELWELLE	97 39 101	28	1	X1012059	10 12 059 0	DIESELMOTOR
KURBELWELLENLAGERUNG	97 39 102	29	1	X1012059	10 12 059 0	DIESELMOTOR
KURBELWELLENRAD	10 01 214 2	6	1	9 739 341	97 39 341	ANTRIEBSTEILE M.SCHWINGU
LADEGERAET 230V/24V/8A SP	61 33 018 08	2	1	2 835	91 52 807 08	BATTERIELADEGERAET
LADELUFT ROHRBOGEN SPF	97 25 170 08	27	1	2 391 001	96 45 719 08	DIESELMOTOR VORM.
LADELUFTKRUEMMER	10 01 242 0	202	1	2 391 001	96 45 719 08	DIESELMOTOR VORM.
LADELUFTKRUEMMER	10 22 273 0	1	1	9 739 271	97 39 271	VERBINDUNGSLEITUNG
LADELUFTROHR SPF	96 48 500 08	25	1	2 391 001	96 45 719 08	DIESELMOTOR VORM.
LADELUFTROHR SPF	96 48 501 08	26	1	2 391 001	96 45 719 08	DIESELMOTOR VORM.
LADELUFTWELLSCHLAUCH 10	55 17 025 08	124	2	2 391 001	96 45 719 08	DIESELMOTOR VORM.
LADESCHALE KUNSTSTOFF	10 47 141 2	32	1	2 533 070	96 48 363 08	ARMATUREN RE.
LAGER 48X50 GUMMI 64CR	10 09 749 6	9	4	2 391 023	96 45 720 08	KUEHLER VORM.

6.2.2009

etk_en_de_074515 LR 1600/2

1048

LIEBHERRAlphabetical index
Alphabetischer Index

Bezeichnung	Artikel	Pos.	Menge	Seite	Baugruppe	Bezeichnung
LAGER SCHWK.	96 49 669 08	1	1	3 282 001	96 47 888 08	F-STUETZE KPL.
LAGERBUCHSE 150X170X110	97 73 314 08	38	2	2 550	91 57 751 08	SA-BOCK
LAGERBUCHSE 200X220X35 G	97 73 251 08	(2)	1	2 550	91 57 751 08	SA-BOCK
LAGERBUCHSE 200X220X58 G	97 68 284 08	(2)	1	2 550	91 57 751 08	SA-BOCK
LAGERBUCHSE 210X250X259	97 73 315 08	40	2	2 550	91 57 751 08	SA-BOCK
LAGERKLOTZ PA6G	97 76 196 08	44	4	3 220 500	91 52 849 08	S-ZWISCHENSTUECK
LAGERKLOTZ PA6G	97 76 196 08	44	4	3 223	91 52 852 08	S-ZWISCHENSTUECK
LAGERKLOTZ PA6G	97 76 196 08	44	4	3 223 010	91 52 853 08	S-ZWISCHENSTUECK
LAGERKLOTZ PA6G	97 76 196 08	44	4	3 223 100	91 55 327 08	S-ZWISCHENSTUECK
LAGERKLOTZ PA6G	97 76 196 08	44	4	3 226	91 52 870 08	LI-ZWISCHENSTUECK
LAGERKLOTZ PA6G	97 76 196 08	44	4	3 227	91 52 873 08	LI-ZWISCHENSTUECK
LAGERKLOTZ PA6G	97 76 196 08	44	4	3 227 008	91 52 872 08	LI-ZWISCHENSTUECK
LAGERKLOTZ PA6G	97 76 196 08	44	4	3 227 200	91 53 519 08	LI-ZWISCHENSTUECK F-ABSP
LAGERKLOTZ PA6G	97 76 196 08	37	4	3 715 008	91 52 863 08	D-ZWISCHENSTUECK
LAGERKLOTZ PA6G	97 76 196 08	39	4	3 716	91 52 864 08	D-ZWISCHENSTUECK
LAGERPLATTE	28 30 209 08	52	1	2 550	91 57 751 08	SA-BOCK
LAGERPLATTE 10X60X120 PA6	93 54 692 08	2	2	3 714 017	96 50 752 08	AUFLAGE KPL.
LAGERPLATTE 10X60X90 PA6	93 22 470 08	47	4	3 211	91 57 748 08	S-ANLENKSTUECK
LAGERPLATTE 10X60X90 PA6	93 22 470 08	27	8	3 713	91 57 749 08	D-ANLENKSTUECK
LAGERPLATTE 15 X 60 X 810 P	97 64 327 08	40	1	3 206	91 52 881 08	F-ANLENKSTUECK
LAGERPLATTE 20X160X210	28 30 405 08	53	1	3 745	91 52 948 08	SCHWEBEBALLAST
LAGERRING	57 01 135 08	3	1	5 701 129	57 01 129 08	TRIEBWERK
LAGERUNG	93 95 668 01	5	1	1 400	91 56 853 08	RAUPENTRAEGER KPL.LI.
LAGERUNG	93 95 668 01	5	1	1 410 300	91 56 855 08	RAUPENTRAEGER KPL.RE.
LAGERUNG	93 95 675 01	6	1	1 400	91 56 853 08	RAUPENTRAEGER KPL.LI.
LAGERUNG	93 95 675 01	6	1	1 410 300	91 56 855 08	RAUPENTRAEGER KPL.RE.
LAGERUNG KPL.	96 45 603 08	10	2	2 550	91 57 751 08	SA-BOCK
LAGERUNG KPL.	96 48 582 08	2	1	3 225	91 52 854 08	SL-REDUZIERSTUECK
LAGERUNG LI.	96 49 043 08	3	1	3 214	91 52 843 08	SW-KOPFSTUECK
LAGERUNG RE.	96 49 044 08	4	1	3 214	91 52 843 08	SW-KOPFSTUECK
LAGERUNG SCHWK.	96 45 611 08	(1)	1	2 550	91 57 751 08	SA-BOCK
LAGERUNG SCHWK.	96 48 584 08	1	1	3 225 100	96 48 582 08	LAGERUNG KPL.
LAGERUNG SCHWK.	96 54 448 08	3	1	2 370	91 52 782 08	MONTAGEWINDE
LAGERZAPFEN 110.0X200	97 73 250 08	5	1	3 282 001	96 47 888 08	F-STUETZE KPL.
LAMELLENRING	10 01 273 4	2	8	9 739 295	97 39 295	ABGASROHR
LAMPENFASSUNG	60 61 445 08	21	2	2 533 070	96 48 363 08	ARMATUREN RE.
LASCHE	96 47 562 08	5	2	3 205	91 52 880 08	F-MONTAGEEINHEIT
LASCHE 4X40X20	97 83 610 08	2	2	2 391 040	96 53 645 08	KUPPLUNGSSTELLER
LASCHE 8X113X108	97 83 611 08	3	1	2 391 040	96 53 645 08	KUPPLUNGSSTELLER
LASCHE KPL.	92 88 304 08	2	2	3 211 002	92 88 302 08	SCHUTZWALZE KPL.
LASCHE KPL.	92 88 304 08	153	2	3 713	91 57 749 08	D-ANLENKSTUECK
LASCHE KPL.	96 47 218 08	3	1	3 208 001	91 52 883 08	F-KOPFSTUECK
LASCHE KPL.	96 48 024 08	11	2	3 281	91 52 896 08	FA-BOCK
LASCHE KPL.	96 48 027 08	21	2	3 281	91 52 896 08	FA-BOCK
LASCHE KPL.	96 48 261 08	3	2	3 207	91 53 433 08	F-ABSPANNUNG
LASCHE KPL.	96 48 292 08	4	2	3 207	91 53 433 08	F-ABSPANNUNG
LASCHE KPL.	96 49 270 08	6	2	3 714	91 52 862 08	D-KOPFSTUECK
LASCHE KPL.	96 49 456 08	2	2	3 714 009	96 49 267 08	VERSTELLFLASCHE KPL.
LASCHE KPL.	96 49 677 08	3	2	3 745	91 52 948 08	SCHWEBEBALLAST
LASCHE KPL.	96 59 083 08	21	2	3 714 009	96 49 267 08	VERSTELLFLASCHE KPL.
LASCHE KPL. 0	96 47 187 08	2	2	3 208 001	91 52 883 08	F-KOPFSTUECK
LASCHE KPL. 0.50M	96 50 162 08	47	2	3 713	91 57 749 08	D-ANLENKSTUECK
LASCHE MIT SCHILD	96 45 686 08	2	2	2 550 005	96 45 680 08	STANGE KPL.
LASCHE MIT SCHILD	96 45 687 08	3	2	2 550 005	96 45 680 08	STANGE KPL.
LASCHE MIT SCHILD	96 45 688 08	4	1	2 550 005	96 45 680 08	STANGE KPL.
LASCHE MIT SCHILD	96 48 337 08	1	2	3 207 101	96 48 292 08	LASCHE KPL.
LASCHE MIT SCHILD	96 49 464 08	1	2	3 714 014	96 49 456 08	LASCHE KPL.
LASCHE MIT SCHILD 0.25 M	96 45 231 08	2	2	3 220 501	96 43 440 08	STANGE KPL.
LASCHE MIT SCHILD 0.25 M	96 45 231 08	2	2	3 221 200	96 47 984 08	STANGE KPL.
LASCHE MIT SCHILD 0.25 M	96 45 231 08	2	2	3 225 200	96 48 679 08	STANGE KPL.

6.2.2009

etk_en_de_074515 LR 1600/2

1049

LIEBHERRAlphabetical index
Alphabetischer Index

Bezeichnung	Artikel	Pos.	Menge	Seite	Baugruppe	Bezeichnung
LASCHE MIT SCHILD 0.25 M	96 45 231 08	2	2	3 227 002	96 50 498 08	STANGE KPL.
LASCHE MIT SCHILD 0.25 M	96 45 231 08	2	2	3 561 003	96 45 222 08	STANGE KPL.
LASCHE MIT SCHILD 0.25 M	96 45 231 08	2	2	3 713 012	96 50 197 08	STANGE KPL.
LASCHE MIT SCHILD 0.25 M	96 45 231 08	1	2	3 714 013	96 59 083 08	LASCHE KPL.
LASCHE MIT SCHILD 0.25 M	96 45 232 08	3	1	3 220 501	96 43 440 08	STANGE KPL.
LASCHE MIT SCHILD 0.25 M	96 45 232 08	3	1	3 221 200	96 47 984 08	STANGE KPL.
LASCHE MIT SCHILD 0.25 M	96 45 232 08	3	1	3 225 200	96 48 679 08	STANGE KPL.
LASCHE MIT SCHILD 0.25 M	96 45 232 08	3	1	3 227 002	96 50 498 08	STANGE KPL.
LASCHE MIT SCHILD 0.25 M	96 45 232 08	3	1	3 561 003	96 45 222 08	STANGE KPL.
LASCHE MIT SCHILD 0.25 M	96 45 232 08	3	1	3 713 012	96 50 197 08	STANGE KPL.
LASCHE MIT SCHILD 0.25 M	96 45 232 08	2	1	3 714 013	96 59 083 08	LASCHE KPL.
LASCHE MIT SCHILD 0.25 M	96 48 595 08	2	2	3 716 001	96 49 159 08	STANGE KPL.
LASCHE MIT SCHILD 0.25 M	96 48 596 08	3	1	3 716 001	96 49 159 08	STANGE KPL.
LASCHE MIT SCHILD 0.25M	96 47 000 08	15	4	3 211	91 57 748 08	S-ANLENKSTUECK
LASCHE MIT SCHILD 0.34 M	96 53 262 08	70	1	1 400	91 56 853 08	RAUPENTRAEGER KPL.LI.
LASCHE MIT SCHILD 0.34 M	96 53 262 08	70	1	1 410 300	91 56 855 08	RAUPENTRAEGER KPL.RE.
LASCHE MIT SCHILD 0.34 M	96 53 263 08	71	1	1 400	91 56 853 08	RAUPENTRAEGER KPL.LI.
LASCHE MIT SCHILD 0.34 M	96 53 263 08	71	1	1 410 300	91 56 855 08	RAUPENTRAEGER KPL.RE.
LASCHE MIT SCHILD 0.35M	96 49 611 08	2	2	3 714 025	96 49 269 08	STANGE KPL.
LASCHE MIT SCHILD 200	96 45 290 08	2	2	3 207 003	96 48 259 08	STANGE KPL.
LASCHE MIT SCHILD 200	96 45 290 08	1	2	3 207 100	96 48 261 08	LASCHE KPL.
LASCHE MIT SCHILD 200	96 45 290 08	(2)	2	3 281	91 52 896 08	FA-BOCK
LASCHE MIT SCHILD 350	96 47 237 08	(1)	2	3 281	91 52 896 08	FA-BOCK
LASCHE MIT SCHILD 350	96 47 239 08	(1)	2	3 281	91 52 896 08	FA-BOCK
LASCHE MIT SCHILD 390	96 47 889 08	13	2	3 282 002	96 47 890 08	FAB-STUETZE
LASCHE VORM.	96 49 847 08	1	2	3 745 011	96 49 677 08	LASCHE KPL.
LASCHE VORM. 0.25M	96 48 638 08	1	2	3 830	91 55 535 08	ZUSATZABSPANNUNG
LASTHALTEVENTIL	51 14 716 08	59	1	2 970	91 56 537 08	HYDRAULIK
LASTHALTEVENTIL 280BAR 10	10 21 831 0	58	2	2 970	91 56 537 08	HYDRAULIK
LAUFBUCHSE 165X156 GZ-CU	97 67 849 08	2	1	1 400 016	96 45 287 08	ROLLENKOERPERHAELFTE K
LAUFBUCHSE RD70X68 GZ-CU	70 43 316 08	2	1	1 400 017	92 51 976 08	ROLLENKOERPERHAELFTE K
LAUFROLLE PA6G	97 71 335 08	8	2	3 281	91 52 896 08	FA-BOCK
LAUFROLLE S355J2G3	97 69 683 08	1	1	2 550 003	96 46 246 08	SEILROLLE KPL.
LAUFSTEG DREHBUEHNE	91 56 817 08	132	1		LR 1600-2-0	LIEBHERR RAUPENKRAN LR 1
LAUFSTEG RAUPENFAHRWER	91 52 388 08	16	1		LR 1600-2-0	LIEBHERR RAUPENKRAN LR 1
LAUTSPRECHER 2,77V 86DBA	10 48 901 1	10	2	2 533 066	96 48 365 08	ELEKTRIK ANBAUTEILE KABIN
LECKOELLEITUNG	10 22 275 9	1	1	9 739 281	97 39 281	LECKOELLEITUNG
LECKOELLEITUNG	10 22 276 4	8	1	9 739 281	97 39 281	LECKOELLEITUNG
LECKOELLEITUNG	10 28 515 7	23	1	9 739 288	97 39 288	KRAFTSTOFFLEITUNG
LECKOELLEITUNG	97 39 281	105	1	X1012059	10 12 059 0	DIESELMOTOR
LECKOELLEITUNG	97 39 282	107	1	X1012059	10 12 059 0	DIESELMOTOR
LEERGEHAEUSE	94 98 250 08	2	1	2 920 257	92 78 689 08	KLEMMKASTEN BELEUCHTUN
LEERGEHAEUSE	97 14 228 08	5	1	2 920 581	96 54 405 08	KLEMMKASTEN SA-BOCK VO
LEERGEHAEUSE 160X160X90X	97 14 073 08	4	1	1 920 403	96 48 707 08	KLEMMKASTEN KPL.
LEERGEHAEUSE 160X160X90X	97 14 073 08	4	1	1 920 417	96 48 703 08	KLEMMKASTEN KPL.
LEERGEHAEUSE 160X160X90	97 58 522 08	4	1	2 780 748	96 52 969 08	KLEMMKASTEN KPL.
LEERGEHAEUSE 160X260X90X	97 79 111 08	1	1	3 930 730	96 50 599 08	KLEMMKASTEN KPL.
LEERGEHAEUSE 160X260X90	97 54 075 08	5	1	3 930 363	96 52 979 08	KLEMMKASTEN KPL.
LEERGEHAEUSE 160X360X90X	97 79 684 08	4	1	3 930 640	96 50 481 08	KLEMMKASTEN KPL.
LEERGEHAEUSE 160X360X90X	97 85 479 08	5	1	2 920 369	96 54 235 08	KLEMMKASTEN KPL.
LEERGEHAEUSE 160X560X90X	97 51 876 08	5	1	2 920 448	96 48 794 08	KLEMMKASTEN KPL.
LEERGEHAEUSE 160X560X90	97 54 042 08	7	1	3 930 734	96 54 401 08	KLEMMKASTEN
LEERGEHAEUSE 230X600X11	97 52 217 08	5	1	3 930 730	96 54 398 08	KLEMMKASTEN KPL.
LEERGEHAEUSE 230X600X11	97 80 749 08	4	1	3 930 638	96 51 624 08	KLEMMKASTEN
LEERGEHAEUSE 56 TE	61 10 011 08	2	1	2 913 100	91 23 538 08	BAUGRUPPENTRAEGER
LEERGEHAEUSE 75 110X55X0	97 57 731 08	1	1	2 533 071	96 52 556 08	WANDLER
LEERGEHAEUSE GEBOHRT 2	97 13 661 08	3	1	1 920 418	96 48 687 08	KLEMMKASTEN KPL.
LEHNE	97 75 558 08	3	1	2 503 101	96 48 626 08	SITZ
LEISTE 13X45X710 PA6G	93 72 005 08	97	3	2 550	91 57 751 08	SA-BOCK
LEITER 2,4M AL	78 89 047 08	41	2	3 745	91 52 948 08	SCHWEBEBALLAST

6.2.2009

etk_en_de_074515 LR 1600/2

1050

LIEBHERRAlphabetical index
Alphabetischer Index

Bezeichnung	Artikel	Pos.	Menge	Seite	Baugruppe	Bezeichnung
LEITER 8/2110X370 AL	78 89 054 08	29	1	3 211	91 57 748 08	S-ANLENKSTUECK
LEITER 8/2110X370 AL	78 89 054 08	67	1	3 713	91 57 749 08	D-ANLENKSTUECK
LEITER SCHWK. T ZN O	96 54 670 08	8	2	2 730	91 52 802 08	GRUNDPLATTE DREHBUEHNE
LEITER SCHWK. TZNO	96 53 090 08	5	1	2 631	91 56 817 08	LAUFSTEG DREHBUEHNE
LEITERPLATTE SPF	66 10 179 08	4	1	2 922 001	92 84 311 08	BUSPLATINE
LEITUNG 2 X 1,5	60 03 420 08	11	3	2 780 320	91 05 067 08	AKUSTISCHE WARNUNG DRE
LEITUNG 2X1,5	60 03 673 08	12	9.37	2 920 633	96 52 651 08	KABELSTRANG
LEITUNG 2X1,5	60 03 673 08	15	10.57	2 920 633	96 52 651 08	KABELSTRANG
LEITUNG 2X1,5	60 03 673 08	16	8.77	2 920 633	96 52 651 08	KABELSTRANG
LEITUNG 2X1,5	60 03 673 08	19	8.47	2 920 633	96 52 651 08	KABELSTRANG
LEITUNG 8 X	10 32 684 4	28	1	2 533 070	96 48 363 08	ARMATUREN RE.
LEITUNG M.STECKER W911A	96 49 011 08	(6)	1	3 930 138	96 54 377 08	ELEKTRIK S-ANLENKSTUECK
LEITUNG W1001	96 50 574 08	9	1	3 930 731	96 48 374 08	ELEKTRIK F-ANLENKSTUECK
LEITUNG W1001A	96 50 575 08	6	1	3 930 009	96 50 573 08	LEITUNGSTROMMEL KPL.
LEITUNG W1002	96 50 478 08	6	1	3 930 640	96 50 481 08	KLEMMKASTEN KPL.
LEITUNG W1003	96 50 572 08	7	1	3 930 731	96 48 374 08	ELEKTRIK F-ANLENKSTUECK
LEITUNG W1023	96 50 641 08	7	1	3 930 730	96 50 599 08	KLEMMKASTEN KPL.
LEITUNG W1050	96 54 402 08	480	1	3 930 734	96 54 401 08	KLEMMKASTEN
LEITUNG W1051	96 52 804 08	470	1	3 930 734	96 54 401 08	KLEMMKASTEN
LEITUNG W1052	96 53 010 08	31	1	3 930 363	96 52 979 08	KLEMMKASTEN KPL.
LEITUNG W1053	96 54 483 08	430	1	3 930 734	96 54 401 08	KLEMMKASTEN
LEITUNG W1056	96 50 276 08	(23)	1	2 925 218	91 60 840 08	KAMERAUEBERWACHUNG WI
LEITUNG W1056	96 50 276 08	340	1	3 930 734	96 54 401 08	KLEMMKASTEN
LEITUNG W1057	96 52 787 08	360	1	3 930 734	96 54 401 08	KLEMMKASTEN
LEITUNG W1058	96 52 835 08	420	1	3 930 734	96 54 401 08	KLEMMKASTEN
LEITUNG W1059	96 52 795 08	370	1	3 930 734	96 54 401 08	KLEMMKASTEN
LEITUNG W1060	96 52 797 08	380	1	3 930 734	96 54 401 08	KLEMMKASTEN
LEITUNG W1061	96 52 783 08	350	1	3 930 734	96 54 401 08	KLEMMKASTEN
LEITUNG W1062A	96 52 798 08	390	1	3 930 734	96 54 401 08	KLEMMKASTEN
LEITUNG W1062B	96 52 800 08	400	1	3 930 734	96 54 401 08	KLEMMKASTEN
LEITUNG W1064	96 52 801 08	410	1	3 930 734	96 54 401 08	KLEMMKASTEN
LEITUNG W1071	96 52 996 08	20	1	3 930 363	96 52 979 08	KLEMMKASTEN KPL.
LEITUNG W1072	96 52 997 08	21	1	3 930 363	96 52 979 08	KLEMMKASTEN KPL.
LEITUNG W1073	96 52 998 08	22	1	3 930 363	96 52 979 08	KLEMMKASTEN KPL.
LEITUNG W1074	96 52 999 08	23	1	3 930 363	96 52 979 08	KLEMMKASTEN KPL.
LEITUNG W1075	96 53 000 08	24	1	3 930 363	96 52 979 08	KLEMMKASTEN KPL.
LEITUNG W1076	96 53 001 08	25	1	3 930 363	96 52 979 08	KLEMMKASTEN KPL.
LEITUNG W1079	96 53 004 08	28	1	3 930 363	96 52 979 08	KLEMMKASTEN KPL.
LEITUNG W1080	96 53 008 08	29	1	3 930 363	96 52 979 08	KLEMMKASTEN KPL.
LEITUNG W1081	96 53 009 08	30	1	3 930 363	96 52 979 08	KLEMMKASTEN KPL.
LEITUNG W1090	96 54 407 08	160	1	2 920 581	96 54 405 08	KLEMMKASTEN SA-BOCK VO
LEITUNG W1091	96 51 848 08	150	1	2 920 581	96 54 405 08	KLEMMKASTEN SA-BOCK VO
LEITUNG W1092	96 51 850 08	151	1	2 920 581	96 54 405 08	KLEMMKASTEN SA-BOCK VO
LEITUNG W1093	96 51 855 08	153	1	2 920 581	96 54 405 08	KLEMMKASTEN SA-BOCK VO
LEITUNG W1094	96 51 856 08	154	1	2 920 581	96 54 405 08	KLEMMKASTEN SA-BOCK VO
LEITUNG W1095	96 51 854 08	152	1	2 920 581	96 54 405 08	KLEMMKASTEN SA-BOCK VO
LEITUNG W1096	96 51 857 08	155	1	2 920 581	96 54 405 08	KLEMMKASTEN SA-BOCK VO
LEITUNG W1140	96 52 970 08	10	1	2 780 524	96 52 968 08	LEITUNGSTROMMEL KPL.
LEITUNG W1140A	96 52 971 08	20	1	2 780 524	96 52 968 08	LEITUNGSTROMMEL KPL.
LEITUNG W1142	96 52 978 08	11	1	2 780 748	96 52 969 08	KLEMMKASTEN KPL.
LEITUNG W1143	96 52 980 08	12	1	2 780 748	96 52 969 08	KLEMMKASTEN KPL.
LEITUNG W1144	96 52 981 08	13	1	2 780 748	96 52 969 08	KLEMMKASTEN KPL.
LEITUNG W1145	96 52 982 08	14	1	2 780 748	96 52 969 08	KLEMMKASTEN KPL.
LEITUNG W1146	96 52 983 08	15	1	2 780 748	96 52 969 08	KLEMMKASTEN KPL.
LEITUNG W163	92 69 930 08	1	1	1 933 100	91 25 249 08	MAGNETLAMPE
LEITUNG W221	96 48 719 08	10	1	1 920 403	96 48 707 08	KLEMMKASTEN KPL.
LEITUNG W241	96 48 718 08	10	1	1 920 417	96 48 703 08	KLEMMKASTEN KPL.
LEITUNG W319	96 52 559 08	11	1	2 533 071	96 52 556 08	WANDLER
LEITUNG W320	96 52 560 08	12	1	2 533 071	96 52 556 08	WANDLER
LEITUNG W330	96 52 929 08	10	1	2 920 288	96 52 614 08	KABELLISTE DREHBUEHNE

6.2.2009

etk_en_de_074515 LR 1600/2

1051

LIEBHERRAlphabetical index
Alphabetischer Index

Bezeichnung	Artikel	Pos.	Menge	Seite	Baugruppe	Bezeichnung
LEITUNG W331	96 52 930 08	11	1	2 920 288	96 52 614 08	KABELLISTE DREHBUEHNE
LEITUNG W332	96 52 931 08	12	1	2 920 288	96 52 614 08	KABELLISTE DREHBUEHNE
LEITUNG W333	96 52 932 08	13	1	2 920 288	96 52 614 08	KABELLISTE DREHBUEHNE
LEITUNG W334	96 52 933 08	14	1	2 920 288	96 52 614 08	KABELLISTE DREHBUEHNE
LEITUNG W336	96 54 268 08	21	1	2 920 369	96 54 235 08	KLEMMKASTEN KPL.
LEITUNG W337	96 54 269 08	22	1	2 920 369	96 54 235 08	KLEMMKASTEN KPL.
LEITUNG W338	96 54 270 08	23	1	2 920 369	96 54 235 08	KLEMMKASTEN KPL.
LEITUNG W339	96 54 271 08	24	1	2 920 369	96 54 235 08	KLEMMKASTEN KPL.
LEITUNG W50	10 46 727 5	20	1	6 909 010	69 09 010 08	SCHLEIFRINGUEBERTRAEGE
LEITUNG W540	96 52 934 08	15	1	2 920 288	96 52 614 08	KABELLISTE DREHBUEHNE
LEITUNG W560	96 52 935 08	16	1	2 920 288	96 52 614 08	KABELLISTE DREHBUEHNE
LEITUNG W571	96 52 936 08	18	1	2 920 288	96 52 614 08	KABELLISTE DREHBUEHNE
LEITUNG W634	96 24 499 08	6	1	2 780 852	96 24 845 08	GSM-MODUL VORM.LICCON 1
LEITUNG W635X1250	92 12 113 08	9	1	2 932 116	96 54 388 08	VERKABELUNG MONTAGETA
LEITUNG W635X1600	92 17 086 08	8	4	2 932 116	96 54 388 08	VERKABELUNG MONTAGETA
LEITUNG W635X1800	92 17 061 08	6	1	2 932 116	96 54 388 08	VERKABELUNG MONTAGETA
LEITUNG W75	10 46 727 4	19	1	6 909 010	69 09 010 08	SCHLEIFRINGUEBERTRAEGE
LEITUNG W909	96 54 399 08	320	1	3 930 730	96 54 398 08	KLEMMKASTEN KPL.
LEITUNG W910	96 54 400 08	330	1	3 930 730	96 54 398 08	KLEMMKASTEN KPL.
LEITUNG W911	96 49 064 08	303	1	3 930 730	96 54 398 08	KLEMMKASTEN KPL.
LEITUNG W913	96 49 055 08	420	1	3 930 730	96 54 398 08	KLEMMKASTEN KPL.
LEITUNG W915	96 49 026 08	380	1	3 930 730	96 54 398 08	KLEMMKASTEN KPL.
LEITUNG W916	96 49 027 08	390	1	3 930 730	96 54 398 08	KLEMMKASTEN KPL.
LEITUNG W917	96 49 053 08	350	1	3 930 730	96 54 398 08	KLEMMKASTEN KPL.
LEITUNG W918	96 49 052 08	310	1	3 930 730	96 54 398 08	KLEMMKASTEN KPL.
LEITUNG W919	96 49 041 08	360	1	3 930 730	96 54 398 08	KLEMMKASTEN KPL.
LEITUNG W920	96 49 047 08	370	1	3 930 730	96 54 398 08	KLEMMKASTEN KPL.
LEITUNG W921	96 49 056 08	430	1	3 930 730	96 54 398 08	KLEMMKASTEN KPL.
LEITUNG W923	96 50 211 08	440	1	3 930 730	96 54 398 08	KLEMMKASTEN KPL.
LEITUNG W927	96 57 437 08	450	1	3 930 730	96 54 398 08	KLEMMKASTEN KPL.
LEITUNG W928	96 57 438 08	460	1	3 930 730	96 54 398 08	KLEMMKASTEN KPL.
LEITUNG W981	96 50 233 08	350	1	3 930 638	96 51 624 08	KLEMMKASTEN
LEITUNG W982	96 50 235 08	360	1	3 930 638	96 51 624 08	KLEMMKASTEN
LEITUNG W983	96 50 237 08	370	1	3 930 638	96 51 624 08	KLEMMKASTEN
LEITUNG W985Y	96 52 546 08	8	1	3 780 751	91 52 952 08	FLUG-U.WINDWARNUNG
LEITUNG WL934	96 51 045 08	4	1	3 780 258	96 56 482 08	ELEKTRIK FLUGWARNSICHER
LEITUNGSHALTER 6,5MM POL	70 42 805 08	19	3	2 522 011	96 45 602 08	SCHLIESSANLAGE
LEITUNGSTROMMEL 30M 6PO	10 02 800 2	5	1	2 780 524	96 52 968 08	LEITUNGSTROMMEL KPL.
LEITUNGSTROMMEL KPL.	96 48 489 08	6	1	3 930 138	96 54 377 08	ELEKTRIK S-ANLENKSTUECK
LEITUNGSTROMMEL KPL.	96 50 573 08	8	1	3 930 731	96 48 374 08	ELEKTRIK F-ANLENKSTUECK
LEITUNGSTROMMEL KPL.	96 52 968 08	20	1	2 780 510	96 50 097 08	ELEKTRIK BALLASTPALETTE
LEUCHTMELDER	60 61 435 08	16	3	2 533 061	96 48 370 08	ARMATUREN ARMLEHNE LI.
LEUCHTMELDER	60 61 435 08	7	1	2 533 063	96 48 371 08	ARMATUREN ARMLEHNE RE.
LEUCHTMELDER	60 61 435 08	7	15	2 533 070	96 48 363 08	ARMATUREN RE.
LEUCHTMELDER	60 61 435 08	35	1	2 932 001	96 45 393 08	RELAISSTEUERUNG
LEUCHTSCHALTKONTAKTGEB	60 61 447 08	11	4	2 533 061	96 48 370 08	ARMATUREN ARMLEHNE LI.
LEUCHTSCHALTKONTAKTGEB	60 61 447 08	11	1	2 533 063	96 48 371 08	ARMATUREN ARMLEHNE RE.
LEUCHTSCHALTKONTAKTGEB	60 61 447 08	10	4	2 533 070	96 48 363 08	ARMATUREN RE.
LEUCHTTASTKONTAKTGEBER	60 61 437 08	24	7	2 533 070	96 48 363 08	ARMATUREN RE.
LI-ZWISCHENSTUECK 2420.10	91 52 872 08	272	1		LR 1600-2-0	LIEBHERR RAUPENKRAN LR 1
LI-ZWISCHENSTUECK 2420.10	91 52 870 08	268	1		LR 1600-2-0	LIEBHERR RAUPENKRAN LR 1
LI-ZWISCHENSTUECK 2420.12	91 52 873 08	273	1		LR 1600-2-0	LIEBHERR RAUPENKRAN LR 1
LI-ZWISCHENSTUECK F-ABSP	91 53 519 08	271	1		LR 1600-2-0	LIEBHERR RAUPENKRAN LR 1
LI-ZWISCHENSTUECK SCHWK	96 46 324 08	1	1	3 227 200	91 53 519 08	LI-ZWISCHENSTUECK F-ABSP
LI-ZWISCHENSTUECK SCHWK	96 44 853 08	1	1	3 227 008	91 52 872 08	LI-ZWISCHENSTUECK
LI-ZWISCHENSTUECK SCHWK.	96 43 434 08	1	1	3 226	91 52 870 08	LI-ZWISCHENSTUECK
LI-ZWISCHENSTUECK SCHWK	96 46 294 08	1	1	3 227	91 52 873 08	LI-ZWISCHENSTUECK
LIBELLE	71 40 008 08	5	1	1 100	91 52 375 08	RAUPENFAHRWERK KPL.
LICCON KONSOLE LCD2 KOMP	91 32 850 08	2	2	2 533 050	96 48 359 08	ELEKTRIK KABINE
LICCON KONSOLE LCD3 KRA	96 47 216 08	3	1	2 533 050	96 48 359 08	ELEKTRIK KABINE

6.2.2009

etk_en_de_074515 LR 1600/2

1052

LIEBHERRAlphabetical index
Alphabetischer Index

Bezeichnung	Artikel	Pos.	Menge	Seite	Baugruppe	Bezeichnung
LICCON KONSOLE LCD3 LSB-	91 04 705 08	80	1	2 913 200	96 47 216 08	LICCON KONSOLE LCD3
LICCON MONTAGEEINHEIT	96 45 394 08	5	1	2 932	91 57 750 08	EINBAUTEILE SCHALTSCHRAN
LICCON-FERNDIAGNOSE HA	89 96 346 08	3	1	2 780 854	96 37 908 08	GSM-MODUL KPL.LICCON 1
LICHTSCHEIBE	60 72 126 08	1	1	6 071 131	60 71 131 08	SCHLUSSBREMSLEUCHE
LINSENFLACHKOPFSCHRAUB	10 41 285 1	27	5	2 260	91 53 057 08	BATTERIELAGERUNG
LINSENFLACHKOPFSCHRAUB	10 41 285 1	23	2	2 260 006	96 46 501 08	BATTERIEKASTEN VORM.
LINSENFLACHKOPFSCHRAUB	10 41 285 1	4	5	2 391 036	96 23 055 08	DECKEL VORM.
LINSENFLACHKOPFSCHRAUB	10 41 285 1	73	6	2 810	91 52 806 08	KRANFUEHRERKABINE KPL.
LINSENFLACHKOPFSCHRAUB	10 41 285 1	21	8	2 925 402	96 58 855 08	KAMERAANBAU DREHBUEHN
LINSENFLACHKOPFSCHRAUB	10 41 285 2	14	8	2 393 002	96 46 782 08	DECKEL KPL.
LINSENFLACHKOPFSCHRAUB	10 41 285 2	15	10	2 522 013	96 45 883 08	FUEHRUNG VORM.
LINSENFLACHKOPFSCHRAUB	10 41 285 2	39	4	2 711	91 52 800 08	ZENTRALSCHMIERANLAGE O
LINSENFLACHKOPFSCHRAUB	10 41 285 3	12	1	2 522 011	96 45 602 08	SCHLIESSANLAGE
LINSENFLACHKOPFSCHRAUB	10 44 130 5	26	4	2 533 070	96 48 363 08	ARMATUREN RE.
LINSENFLACHKOPFSCHRAUB	10 41 285 4	11	4	1 620	91 52 386 08	BEFESTIGUNGSTEILE DREH
LINSENFLACHKOPFSCHRAUB	10 41 285 4	62	8	1 970	91 56 958 08	HYDRAULIK RAUPE
LINSENFLACHKOPFSCHRAUB	10 41 285 4	76	40	1 970	91 56 958 08	HYDRAULIK RAUPE
LINSENFLACHKOPFSCHRAUB	10 41 285 4	13	30	2 310	91 52 503 08	WINDE 1
LINSENFLACHKOPFSCHRAUB	10 41 285 4	13	30	2 320	91 52 504 08	WINDE 2
LINSENFLACHKOPFSCHRAUB	10 41 285 4	20	47	2 340	91 52 776 08	WINDE 4 EINZIEHWERK
LINSENFLACHKOPFSCHRAUB	10 41 285 4	353	8	2 391 001	96 45 719 08	DIESELMOTOR VORM.
LINSENFLACHKOPFSCHRAUB	10 41 285 4	44	4	2 391 040	96 53 645 08	KUPPLUNGSSTELLER
LINSENFLACHKOPFSCHRAUB	10 41 285 4	3	4	2 540	91 53 253 08	HEIZKLIMAGERAET EINBAU
LINSENFLACHKOPFSCHRAUB	10 41 285 4	(6)	5	2 550	91 57 751 08	SA-BOCK
LINSENFLACHKOPFSCHRAUB	10 41 285 4	23	40	2 550	91 57 751 08	SA-BOCK
LINSENFLACHKOPFSCHRAUB	10 41 285 4	12	2	2 550 008	96 47 628 08	HALTER KPL.
LINSENFLACHKOPFSCHRAUB	10 41 285 4	12	2	2 550 009	96 47 645 08	HALTER KPL.
LINSENFLACHKOPFSCHRAUB	10 41 285 4	16	4	2 657	91 57 656 08	MONTAGEEINRICHTUNG RA
LINSENFLACHKOPFSCHRAUB	10 41 285 4	7	4	2 670	91 52 797 08	KRAFTSTOFFBEHALTER KPL
LINSENFLACHKOPFSCHRAUB	10 41 285 4	18	2	2 671	91 52 798 08	OELBEHALTER KPL.
LINSENFLACHKOPFSCHRAUB	10 41 285 4	24	2	2 671 004	96 46 305 08	OELBEHALTER VORM.
LINSENFLACHKOPFSCHRAUB	10 41 285 4	60	7	2 810	91 52 806 08	KRANFUEHRERKABINE KPL.
LINSENFLACHKOPFSCHRAUB	10 41 285 4	(5)	28	2 920	91 56 833 08	ELEKTRIK DREHBUEHNE
LINSENFLACHKOPFSCHRAUB	10 41 285 4	14	8	2 978 100	91 52 796 08	ZUSATZHYDR.MONTAGEEINR
LINSENFLACHKOPFSCHRAUB	10 41 285 4	95	12	3 211	91 57 748 08	S-ANLENKSTUECK
LINSENFLACHKOPFSCHRAUB	10 41 285 4	30	4	3 215 005	91 52 846 08	ROLLENSATZ
LINSENFLACHKOPFSCHRAUB	10 41 285 4	30	4	3 215 006	91 52 847 08	ROLLENSATZ
LINSENFLACHKOPFSCHRAUB	10 41 285 4	30	32	3 350	91 52 859 08	WINDE 3
LINSENFLACHKOPFSCHRAUB	10 41 285 4	128	6	3 713	91 57 749 08	D-ANLENKSTUECK
LINSENFLACHKOPFSCHRAUB	10 41 285 4	90	18	3 714	91 52 862 08	D-KOPFSTUECK
LINSENFLACHKOPFSCHRAUB	10 41 285 7	85	2	2 520	91 53 061 08	KABINE VERGLAST
LINSENFLACHKOPFSCHRAUB	10 41 285 7	19	4	2 541	91 52 790 08	ZUSATZHEIZUNG OW
LINSENFLACHKOPFSCHRAUB	10 41 285 7	11	4	2 541 001	96 49 651 08	ZUSATZHEIZUNG VORM.
LINSENFLACHKOPFSCHRAUB	10 41 285 7	53	4	2 631	91 56 817 08	LAUFSTEG DREHBUEHNE
LINSENFLACHKOPFSCHRAUB	10 41 285 7	63	16	2 859	91 52 809 08	GERAEUSCHDAEMMUNG
LINSENFLACHKOPFSCHRAUB	10 41 285 7	16	2	2 978 200	91 54 843 08	ZUSATZHYDR.S-RUECKHALTE
LINSENFLACHKOPFSCHRAUB	10 41 285 7	13	12	3 291	91 52 831 08	S-RUECKHALTESICHERUNG
LINSENFLACHKOPFSCHRAUB	10 41 285 7	127	42	3 713	91 57 749 08	D-ANLENKSTUECK
LINSENFLACHKOPFSCHRAUB	10 41 286 1	331	4	2 391 001	96 45 719 08	DIESELMOTOR VORM.
LINSENFLACHKOPFSCHRAUB	10 41 286 1	79	2	2 520	91 53 061 08	KABINE VERGLAST
LINSENFLACHKOPFSCHRAUB	10 41 286 1	51	2	2 520 034	96 45 984 08	INNENVERKLEIDUNG
LINSENFLACHKOPFSCHRAUB	10 41 286 1	10	1	2 541 001	96 49 651 08	ZUSATZHEIZUNG VORM.
LINSENFLACHKOPFSCHRAUB	10 41 286 1	56	25	2 859	91 52 809 08	GERAEUSCHDAEMMUNG
LINSENFLACHKOPFSCHRAUB	10 45 069 3	80	6	2 520	91 53 061 08	KABINE VERGLAST
LINSENFLACHKOPFSCHRAUB	10 45 069 3	3	11	2 520 033	96 50 633 08	MONITORKONSOLE
LINSENFLACHKOPFSCHRAUB	10 45 069 3	25	4	2 520 034	96 45 984 08	INNENVERKLEIDUNG
LINSENSCHRAUBE M6X12 10.	10 33 615 7	20	6	2 391 040	96 53 645 08	KUPPLUNGSSTELLER
LITZE 0,5	60 01 312 08	341	0.32	3 930 732	96 50 575 08	LEITUNG
LITZE 0,5	60 01 313 08	342	1	3 930 009	96 50 573 08	LEITUNGSTROMMEL KPL.
LSB-SENSOR PRUEFADAPTE	91 05 061 08	10	1	2 932 116	96 54 388 08	VERKABELUNG MONTAGETA

6.2.2009

etk_en_de_074515 LR 1600/2

1053

LIEBHERRAlphabetical index
Alphabetischer Index

Bezeichnung	Artikel	Pos.	Menge	Seite	Baugruppe	Bezeichnung
LUEFTER	61 07 145 08	2	1	2 913 004	96 20 460 08	GEHAEUSE VORM.
LUEFTER	61 07 146 08	2	2	2 913 006	96 20 732 08	LUEFTERBLECH VORM.
LUEFTER 80X80X25	61 03 886 14	3	2	2 913 102	92 32 870 08	LUEFTEREINHEIT
LUEFTERBLECH	92 99 370 08	1	1	2 913 006	96 20 732 08	LUEFTERBLECH VORM.
LUEFTERBLECH VORM.	96 20 732 08	1	1	2 913 005	96 20 731 08	INNENGEHAEUSE VORM.
LUEFTERBLECH VORM.	96 20 732 08	1	1	2 913 005	96 28 696 08	INNENGEHAEUSE VORM.
LUEFTEREINHEIT	92 32 870 08	11	1	2 913 100	91 23 538 08	BAUGRUPPENTRAEGER
LUEFTERFLUEGEL	10 65 067 6	7	1	X1035519	10 35 519 6	OEL-LUFTKUEHLER
LUEFTERMASKE 1X173X286	28 81 799 08	15	1	2 913 100	91 23 538 08	BAUGRUPPENTRAEGER
LUEFTERNABE D=168	95 70 468 08	4	2	2 391 023	96 45 720 08	KUEHLER VORM.
LUFTANSAUGROHR	97 39 256	110	1	X1012059	10 12 059 0	DIESELMOTOR
LUFTANSAUGROHR SPF	96 48 361 08	7	1	2 393	91 52 787 08	LUFTFILTERANLAGE KPL.
LUFTANSAUGROHR SPF	96 48 362 08	8	1	2 393	91 52 787 08	LUFTFILTERANLAGE KPL.
LUFTBEHAELTER 39,8L 10BAR	50 26 558 08	9	1	2 990	91 59 244 08	DRUCKLUFTANLAGE
LUFTBEHAELTER DIN 74281 20	50 26 577 08	5	1	3 978 005	91 56 430 08	ZUSATZHYDRAULIK SB-KOPFS
LUFTBEHAELTER DIN 74281 4.	50 29 871 08	6	1	2 990	91 59 244 08	DRUCKLUFTANLAGE
LUFTFILTER PICO	55 17 203 08	1	1	2 393	91 52 787 08	LUFTFILTERANLAGE KPL.
LUFTFILTERANLAGE KPL.	91 52 787 08	125	1		LR 1600-2-0	LIEBHERR RAUPENKRAN LR 1
LUFTFUEHRUNG LI. PP SPF	97 69 550 08	12	1	2 520	91 53 061 08	KABINE VERGLAST
LUFTFUEHRUNG LI. PP SPF	97 69 672 08	14	1	2 520	91 53 061 08	KABINE VERGLAST
LUFTFUEHRUNG PP SPF	97 71 765 08	16	2	2 520	91 53 061 08	KABINE VERGLAST
LUFTFUEHRUNG RE. PP SPF	97 69 551 08	13	1	2 520	91 53 061 08	KABINE VERGLAST
LUFTFUEHRUNG RE. PP SPF	97 69 673 08	15	1	2 520	91 53 061 08	KABINE VERGLAST
LUFTPRESSER	10 47 688 5	1	1	9 739 491	97 39 491	LUFTPRESSER ANBAU
LUFTPRESSER	10 65 049 0	85	1	X1029200	10 29 200 4	FAHRERSITZ
LUFTPRESSER ANBAU	97 39 491	140	1	X1012059	10 12 059 0	DIESELMOTOR
LUFTTROCKNER	50 26 573 08	21	1	2 990	91 59 244 08	DRUCKLUFTANLAGE
LUFTVERTEILER	10 22 272 6	1	1	9 739 256	97 39 256	LUFTANSAUGROHR
MAGNET 24V	10 65 009 2	2	1	X1034282	10 34 282 3	DRUCKREGELVENTIL
MAGNET 24V	57 00 094 08	7	1	5 026 126	50 26 126 08	MAGNETVENTIL
MAGNET 24V	57 06 338 08	1	1	5 114 445	51 14 445 08	WEGEVENTIL
MAGNET 24V	57 06 338 08	1	1	5 114 498	51 14 498 08	WEGEVENTIL
MAGNET 24V	57 06 338 08	1	1	5 114 943	51 14 943 08	WEGEVENTIL
MAGNET 24V	57 16 137 08	(10)	1	2 970	91 56 537 08	HYDRAULIK
MAGNET 24V DC	10 42 953 2	5	1	5 114 651	51 14 651 08	WEGEVENTIL
MAGNET 24V DC	57 08 278 08	1	1	5 114 444	51 14 444 08	WEGEVENTIL
MAGNETANKER	57 00 096 08	9	1	5 026 126	50 26 126 08	MAGNETVENTIL
MAGNETLAMPE	91 25 249 08	42	1	1 750	91 52 394 08	WERKZEUG
MAGNETSCHLUSSHUELSE	57 00 093 08	5	1	5 026 126	50 26 126 08	MAGNETVENTIL
MAGNETSPULE	57 19 101 08	435	2	5 713 626	57 13 626 08	VORSTEUERVENTIL
MAGNETSPULE 24VDC 1,25A	57 17 127 08	1	2	5 113 022	51 13 022 08	WEGEVENTIL
MAGNETSPULE 28V DC	57 08 179 08	1	2	5 710 349	57 10 349 08	WEGEVENTIL
MAGNETVENTIL	10 01 245 8	2	1	9 739 140	97 39 140	FLAMMSTARTANLAGE
MAGNETVENTIL	50 26 126 08	9	1	2 393	91 52 787 08	LUFTFILTERANLAGE KPL.
MAGNETVENTIL	50 26 596 08	15	1	2 990	91 59 244 08	DRUCKLUFTANLAGE
MAGNETVENTIL 24V	10 34 300 3	4	1	2 540	91 53 253 08	HEIZKLIMAGERAET EINBAU
MAGNETVENTIL 24V	10 34 300 3	3	1	2 541	91 52 790 08	ZUSATZHEIZUNG OW
MANOMETER 63	75 00 011 08	30	1	1 750	91 52 394 08	WERKZEUG
MANOMETER 63	75 00 018 08	31	2	1 750	91 52 394 08	WERKZEUG
MANOMETER 63	75 00 024 08	184	3	2 970	91 56 537 08	HYDRAULIK
MANOMETERANSCHLUSS A3	47 09 005 08	604	1	2 978 100	91 52 796 08	ZUSATZHYDR.MONTAGEEINR
MANOMETERANSCHLUSS MA	47 09 008 08	32	3	1 750	91 52 394 08	WERKZEUG
MAUSERSATZ	10 32 683 8	27	1	2 533 070	96 48 363 08	ARMATUREN RE.
MECH.ZUSATZABSTUETZUNG	91 52 389 08	17	1		LR 1600-2-0	LIEBHERR RAUPENKRAN LR 1
MECH.ZUSATZABSTUETZUNG	96 44 950 08	1	2	1 632	91 52 389 08	MECH.ZUSATZABSTUETZUNG
MEGI-ANSCHLAGPUFFER 50	72 66 158 08	8	2	2 260	91 53 057 08	BATTERIELAGERUNG
MEGIPUFFER	72 66 113 08	54	1	2 810	91 52 806 08	KRANFUEHRERKABINE KPL.
MEGIPUFFER	72 66 122 08	42	1	2 810	91 52 806 08	KRANFUEHRERKABINE KPL.
MEGIPUFFER	72 66 127 08	14	1	2 925 204	92 16 990 08	KAMERAANBAU D-ANLENKS
MEGIPUFFER 100X40-M16 NR	72 66 160 08	9	2	3 220 500	91 52 849 08	S-ZWISCHENSTUECK

6.2.2009

etk_en_de_074515 LR 1600/2

1054

LIEBHERRAlphabetical index
Alphabetischer Index

Bezeichnung	Artikel	Pos.	Menge	Seite	Baugruppe	Bezeichnung
MEGIPUFFER 100X40-M16 NR	72 66 160 08	9	2	3 223	91 52 852 08	S-ZWISCHENSTUECK
MEGIPUFFER 100X40-M16 NR	72 66 160 08	9	2	3 223 010	91 52 853 08	S-ZWISCHENSTUECK
MEGIPUFFER 100X40-M16 NR	72 66 160 08	9	2	3 223 100	91 55 327 08	S-ZWISCHENSTUECK
MEGIPUFFER 100X40-M16 NR	72 66 160 08	10	2	3 745	91 52 948 08	SCHWEBEBALLAST
MEGIPUFFER 18X7,5	72 66 167 08	10	4	2 510	91 52 788 08	DREHBUEHNENVERKLEIDUN
MEGIPUFFER 18X7,5	72 66 167 08	6	2	2 859 030	96 46 758 08	DECKEL KPL.
MEGIPUFFER 30X20-M8 NR 60	72 66 156 08	2	4	2 391 102	96 56 360 08	ZUSATZKUEHLER VORM.
MEHRFACHDICHTENSATZ M2	60 24 219 08	(505)	1	2 920 288	96 52 614 08	KABELLISTE DREHBUEHNE
MEISTERSCHALTER SPF	60 60 950 08	5	1	2 533 060	96 48 368 08	ELEKTRIK ARMLEHNE LI.
MEISTERSCHALTER SPF	60 60 950 08	5	1	2 533 062	96 48 369 08	ELEKTRIK ARMLEHNE RE.
MEISTERSCHALTER SPF	60 60 950 08	5	1	2 533 069	96 48 372 08	ELEKTRIK ARMATUR
MEMBRANSPEICHER	51 06 425 08	75	2	2 970	91 56 537 08	HYDRAULIK
MEMBRANTUELLE	55 30 278 08	51	2	2 520	91 53 061 08	KABINE VERGLAST
MEMBRANTUELLE	55 30 278 08	5	2	2 520 033	96 50 633 08	MONITORKONSOLE
MEMBRANTUELLE	55 30 278 08	12	4	2 540	91 53 253 08	HEIZKLIMAGERAET EINBAU
MESSANSCHLUSS BMA3 6L	47 56 014 08	648	2	1 970	91 56 958 08	HYDRAULIK RAUPE
MESSANSCHLUSS BMA3 6S	47 56 015 08	619	2	1 970	91 56 958 08	HYDRAULIK RAUPE
MESSANSCHLUSS BMA3 6S	47 56 015 08	659	15	2 970	91 56 537 08	HYDRAULIK
MESSANSCHLUSS BMA3 6S	47 56 015 08	613	1	2 975 000	91 57 881 08	ZUSATZHYDRAULIK MONTAGE
MESSANSCHLUSS BMA3 6S	47 56 015 08	603	1	2 976 700	91 54 795 08	ZUSATZHYDRAULIK PUMPE
MESSANSCHLUSS BMA3 6S	47 56 015 08	644	1	2 978 100	91 52 827 08	ZUSATZHYDR.D-RUECKHALT
MESSANSCHLUSS BMA3 6S	47 56 015 08	605	1	2 978 200	91 54 843 08	ZUSATZHYDR.S-RUECKHALTE
MESSANSCHLUSS BMA3 6S	47 56 015 08	617	1	3 978 100	91 56 428 08	HYDR.SCHWEBEBALLAST-AN
MESSANSCHLUSS EMA3 1/4 C	47 56 026 08	641	10	2 970	91 56 537 08	HYDRAULIK
MESSANSCHLUSS GMA3 38S	47 56 034 08	627	4	1 970	91 56 958 08	HYDRAULIK RAUPE
MESSANSCHLUSS GMA3 38S	47 56 034 08	601	2	3 978 015	91 56 429 08	ZUSATZHYDRAULIK ZWISCH
MESSANSCHLUSS GMA3 38S	47 56 034 08	601	2	3 978 015	91 56 432 08	ZUSATZHYDRAULIK ZWISCH
MESSANSCHLUSS M12X1,5ED	47 56 032 08	685	9	2 970	91 56 537 08	HYDRAULIK
MESSANSCHLUSS M12X1,5ED	47 56 032 08	604	2	2 976 700	91 54 795 08	ZUSATZHYDRAULIK PUMPE
MESSERTRENNKLEMME	60 27 616 08	7	1	2 932 082	96 54 387 08	AUFBAUTEILE MONTAGETAPE
MESSSCHLAUCH DN5 1000	47 09 018 08	33	3	1 750	91 52 394 08	WERKZEUG
MESSSCHLAUCH DN5 2000	47 09 019 08	34	2	1 750	91 52 394 08	WERKZEUG
MESSSTUTZEN DKO 10L	51 06 290 08	636	8	2 970	91 56 537 08	HYDRAULIK
MESSSTUTZEN DKO 10L	51 06 290 08	615	2	2 975 100	91 52 860 08	ZUSATZHYDRAULIK WINDE 3
MESSSTUTZEN DKO 10L	51 06 290 08	619	2	2 975 200	91 52 775 08	ZUSATZHYDRAULIK WINDE 2
MESSSTUTZEN DKO 10L	51 06 290 08	619	2	2 975 700	91 52 774 08	ZUSATZHYDRAULIK WINDE 1
MESSSTUTZEN DKO 10L	51 06 290 08	606	2	2 978 100	91 52 827 08	ZUSATZHYDR.D-RUECKHALT
MESSSTUTZEN DKO 10L	51 06 290 08	633	1	2 978 200	91 54 843 08	ZUSATZHYDR.S-RUECKHALTE
MESSWIDERSTAND NTC -40/+	10 44 951 6	2	3	2 533 066	96 48 365 08	ELEKTRIK ANBAUTEILE KABIN
MIKROSCHALTER	10 33 559 6	3	4	6 060 950	60 60 950 08	MEISTERSCHALTER
MINUTENRING	10 01 215 7	5	1	9 739 246	97 39 246	KOLBEN
MITNEHMER SCHWK.	92 90 527 08	3	1	1 991	91 52 510 08	DREHDURCHFUEHRUNG
MITTELZAPFEN	57 01 146 08	3	1	5 701 133	57 01 133 08	TRIEBWERK
MONITORKONSOLE	96 50 633 08	9	1	2 520	91 53 061 08	KABINE VERGLAST
MONITORKONSOLE PU SPF	97 79 033 08	1	1	2 520 033	96 50 633 08	MONITORKONSOLE
MONTAGEEINRICHTUNG RA	91 57 656 08	139	1		LR 1600-2-0	LIEBHERR RAUPENKRAN LR 1
MONTAGELEUCHTE	60 71 040 08	24	1	1 750	91 52 394 08	WERKZEUG
MONTAGEPLATTE	51 06 340 08	5	1	3 978 100	91 56 428 08	HYDR.SCHWEBEBALLAST-AN
MONTAGEWINDE	91 52 782 08	119	1		LR 1600-2-0	LIEBHERR RAUPENKRAN LR 1
MONTAGEZYLINDER SPF	51 23 682 08	11	1	1 410 300	91 56 855 08	RAUPENTRAEGER KPL.RE.
MOOSGUMMI 20X4 MOOSGU	26 21 031 08	30	0.064	2 502	91 55 939 08	STUERSTAND
MOTORBREMSE	97 39 186	330	1	9 739 400	97 39 400	DIESELMOTOR
MOTORFLANSCH	10 65 067 4	5	1	X1035519	10 35 519 6	OEL-LUFTKUEHLER
MOTORKONSOLE	96 48 449 08	4	1	2 391 001	96 45 719 08	DIESELMOTOR VORM.
MOTORKONSOLE	96 49 935 08	44	1	2 391 001	96 45 719 08	DIESELMOTOR VORM.
MOTORKONSOLE LI.	96 48 468 08	2	1	2 391 001	96 45 719 08	DIESELMOTOR VORM.
MOTORKONSOLE RE.	96 48 457 08	3	1	2 391 001	96 45 719 08	DIESELMOTOR VORM.
MOTORKONSOLE SCHWK.	96 43 477 08	8	2	2 391 001	96 45 719 08	DIESELMOTOR VORM.
MOTORLAGERUNG	97 39 360	208	1	X1012059	10 12 059 0	DIESELMOTOR
MOTOROELFILTER	10 01 228 7	13	1	9 739 122	97 39 122	OELKUEHLER

6.2.2009

etk_en_de_074515 LR 1600/2

1055

LIEBHERRAlphabetical index
Alphabetischer Index

Bezeichnung	Artikel	Pos.	Menge	Seite	Baugruppe	Bezeichnung
MOTORREGELUNGSSENSORIK	97 39 257	231	1	9 739 400	97 39 400	DIESELMOTOR
MOTORSTEUERGERAET LH-	97 39 403	71	1	9 739 400	97 39 400	DIESELMOTOR
MUTTER	57 00 099 08	19	1	5 026 126	50 26 126 08	MAGNETVENTIL
MUTTER	57 10 772 08	(5)	1	2 975 700	91 52 774 08	ZUSATZHYDRAULIK WINDE 1
MUTTER	57 10 823 08	(5)	1	1 970	91 56 958 08	HYDRAULIK RAUPE
MUTTER GZ45-01	70 27 459	2	2	5 113 022	51 13 022 08	WEGEVENTIL
MUTTER M10 -8 A3C	10 01 427 8	10	1	9 739 159	97 39 159	STARTER
MUTTER M10 -8 A3C	10 01 427 8	8	1	9 739 186	97 39 186	MOTORBREMSE
MUTTER M10 -8 A3C	10 01 427 8	6	1	9 739 344	97 39 344	GENERATOR VORM.
MUTTER M12 8	10 02 092 2	10	2	9 739 344	97 39 344	GENERATOR VORM.
MUTTER M12 8	10 02 092 2	20	1	9 739 344	97 39 344	GENERATOR VORM.
MUTTER M12 CU	55 20 022 08	12	8	2 392	91 52 785 08	SCHALLDAEMPFERANLAGE
MUTTER M12X1,5 8	10 01 163 2	3	3	9 739 159	97 39 159	STARTER
MUTTER M6 8	10 01 162 9	8	1	9 739 159	97 39 159	STARTER
MUTTER M6 8	10 01 162 9	13	1	9 739 288	97 39 288	KRAFTSTOFFLEITUNG
MUTTER M6 8	10 01 162 9	8	4	9 739 292	97 39 292	KRAFTSTOFFLEITUNG
MUTTER M6 8	10 01 162 9	(5)	2	9 739 318	97 39 318	SENSORIK
MUTTER M6 8	10 01 162 9	10	1	9 739 356	97 39 356	ROHRLEITUNG ANBAU
MUTTER M6 VERZ	60 20 180 08	25	2	2 671 004	96 46 305 08	OELBEHAELTER VORM.
MUTTER M6 VERZ	60 20 180 08	17	8	2 978 100	91 52 796 08	ZUSATZHYDR.MONTAGEEINR
MUTTER M6 VERZ	60 20 180 08	55	20	3 978 005	91 56 430 08	ZUSATZHYDRAULIK SB-KOPFS
MUTTER M6 VERZ	60 20 180 08	55	40	3 978 015	91 56 429 08	ZUSATZHYDRAULIK ZWISCH
MUTTER M6 VERZ	60 20 180 08	55	40	3 978 015	91 56 432 08	ZUSATZHYDRAULIK ZWISCH
MUTTER M8 8	10 01 163 1	11	1	9 739 210	97 39 210	KUEHLMITTELLEITUNG
MUTTER M8 8	10 01 163 1	22	1	9 739 386	97 39 386	KURBELGEHAEUSEENTLUEFT
MUTTER M8 8	10 01 163 1	36	1	9 739 492	97 39 492	ROHRLEITUNG ANBAU
NABE	10 65 067 5	6	1	X1035519	10 35 519 6	OEL-LUFTKUEHLER
NABE	57 19 010 08	2	1	5 719 006	57 19 006 08	PUMPENTRAEGER
NABE	57 19 055 08	4	1	2 212	91 54 561 08	PUMPE F.DREHWERK
NAEHERUNGSSCHALTER IND	69 27 015 08	5	2	1 920 308	96 48 384 08	ELEKTRIK RAUPENTRAEGER
NAEHERUNGSSCHALTER IND	69 27 015 08	5	2	1 920 309	96 48 385 08	ELEKTRIK RAUPENTRAEGER
NAEHERUNGSSCHALTER IND	69 27 015 08	(1)	2	2 350	91 52 778 08	DREHWERK
NAEHERUNGSSCHALTER M1	10 09 761 3	(2)	1	2 711	91 52 800 08	ZENTRALSCHMIERANLAGE O
NEIGUNGSGEBER SPF	69 23 081 08	10	1	1 920 307	96 48 383 08	ELEKTRIK MITTELSTUECK
NEIGUNGSGEBER SPF	69 23 081 08	12	1	2 780 510	96 50 097 08	ELEKTRIK BALLASTPALETTE
NETZTEIL 4 GEPRUEFT	91 07 635 08	2	1	2 932 122	96 45 394 08	LICCON MONTAGEEINHEIT
NETZTEIL 4 GEPRUEFT	91 07 635 08	15	1	2 932 160	96 54 385 08	SCHALTSCHRANK MECH.
NIVEAUSONDE SPF	10 22 814 3	8	1	2 391 023	96 45 720 08	KUEHLER VORM.
NOCKENWELLE R-MOTORXD 2	10 34 284 2	44	1	X1012059	10 12 059 0	DIESELMOTOR
NOT-AUS SCHALTGERAET 24	10 47 515 0	55	1	2 932 082	96 54 387 08	AUFBAUTEILE MONTAGETAPE
NOT-AUS TASTE	60 61 441 08	(2)	1	2 533 051	96 48 360 08	ELEKTRIK KABINE
NOTAUS KRANFUEHRERKAB	91 52 951 08	352	1		LR 1600-2-0	LIEBHERR RAUPENKRAN LR 1
NOTAUS KRANFUEHRERKAB	96 41 461 08	4	1	2 533 051	96 48 360 08	ELEKTRIK KABINE
NOTHAMMER	88 50 422 08	58	1	2 520 034	96 45 984 08	INNENVERKLEIDUNG
NOTSITZ	91 55 873 08	130	1		LR 1600-2-0	LIEBHERR RAUPENKRAN LR 1
NRS RUECKSCHLAGVENTIL	57 19 133 08	5	1	X1035925	10 35 925 0	VERSTELLPUMPE
NUTMUTTER M30X1,5	57 01 139 08	9	1	5 701 129	57 01 129 08	TRIEBWERK
O-RING 100X2,5 NBR70	72 64 351 08	144	1	2 391 001	96 45 719 08	DIESELMOTOR VORM.
O-RING 10X2 NBR70	72 64 065 08	(22)	1	X1042440	10 42 440 2	STUEBERBLOCK
O-RING 10X2,2 NBR70	50 29 332 08	47	1	2 393	91 52 787 08	LUFTFILTERANLAGE KPL.
O-RING 110X2 NBR70	72 64 234 01	5	1	X1004204	10 04 204 3	WASSERHEIZGERAET
O-RING 120X3 NBR70	72 62 030 08	97	1	9 697 916	96 97 916 01	DREHWERK
O-RING 125X3 NBR70	72 64 260 08	143	2	2 391 001	96 45 719 08	DIESELMOTOR VORM.
O-RING 12X2 NBR70	70 42 748 08	6	4	2 393 002	96 46 782 08	DECKEL KPL.
O-RING 12X2 NBR70	70 42 748 08	9	7	2 859 005	96 46 756 08	KLAPPE VORM.
O-RING 12X2 NBR70	70 42 748 08	6	4	2 859 007	96 46 775 08	DECKEL KPL.
O-RING 12X2 NBR70	70 42 748 08	12	4	2 859 025	96 46 757 08	GITTERROST VORM.
O-RING 12X2 NBR70	70 42 748 08	6	4	2 859 026	96 46 776 08	DECKEL KPL.
O-RING 12X2 NBR70	70 42 748 08	6	4	2 859 027	96 46 777 08	DECKEL KPL.
O-RING 12X2 NBR70	70 42 748 08	6	4	2 859 028	96 46 778 08	DECKEL KPL.

6.2.2009

etk_en_de_074515 LR 1600/2

1056

LIEBHERRAlphabetical index
Alphabetischer Index

Bezeichnung	Artikel	Pos.	Menge	Seite	Baugruppe	Bezeichnung
O-RING 12X2 NBR70	70 42 748 08	6	4	2 859 029	96 46 779 08	DECKEL KPL.
O-RING 12X2 NBR70	70 42 748 08	11	2	2 859 030	96 46 758 08	DECKEL KPL.
O-RING 12X2 NBR70	70 42 748 08	6	6	2 932 168	96 48 167 08	DECKEL KPL.
O-RING 12X2,5 HNBR	74 12 937	15	1	7 027 481	70 27 481 03	WASSERABSCHIEDER
O-RING 135X3 NBR70	72 64 528 01	29	1	7 743 566	77 43 566 08	ELEKTROPUMPE
O-RING 14X1,1 NBR70	57 00 101 08	4	1	5 026 126	50 26 126 08	MAGNETVENTIL
O-RING 14X1,1 NBR70	57 00 101 08	3	2	5 114 498	51 14 498 08	WEGEVENTIL
O-RING 14X1,1 NBR70	57 00 101 08	3	2	5 114 943	51 14 943 08	WEGEVENTIL
O-RING 150X3 FPM70	57 16 648 08	(52)	1	1 400	91 56 853 08	RAUPENTRAEGER KPL.LI.
O-RING 150X3 NBR70	51 85 781 08	142	5	2 391 001	96 45 719 08	DIESELMOTOR VORM.
O-RING 15X2 FPM80	57 12 342 08	23	4	X1035925	10 35 925 1	VERSTELLPUMPE
O-RING 15X2 NBR90	51 45 424 08	43	1	X1041267	10 41 267 5	DRUCKBEGRENZUNGSVENTI
O-RING 167X2,5 NBR80	57 15 165 08	22	1	X1035925	10 35 925 1	VERSTELLPUMPE
O-RING 174X4 NBR70	57 18 445 08	55	1	X1065015	10 65 015 8	ANTRIEB
O-RING 17X2 FPM70	57 10 826 08	(2)	1	1 970	91 56 958 08	HYDRAULIK RAUPE
O-RING 18X2,5 NBR70	72 64 069 08	(1)	1	2 391 038	96 47 931 08	OELKUEHLER VORM.
O-RING 19,4X2,5 HNBR	10 34 022 6	19	2	7 027 481	70 27 481 03	WASSERABSCHIEDER
O-RING 19X2,5 NBR70	72 64 241 08	(21)	2	X1042440	10 42 440 2	STUEBERBLOCK
O-RING 20,3X2,4 NBR70	50 29 329 08	597	4	2 990	91 59 244 08	DRUCKLUFTANLAGE
O-RING 200X3 NBR70	72 64 215 01	59	1	X1065015	10 65 015 8	ANTRIEB
O-RING 20X2 FPM70	57 10 820 08	(2)	1	1 970	91 56 958 08	HYDRAULIK RAUPE
O-RING 20X2 FPM70	57 10 820 08	(2)	1	1 970	91 56 958 08	HYDRAULIK RAUPE
O-RING 22,2X3 NBR70	54 01 843 08	16	1	5 400 565	54 00 565 08	SEILWINDE
O-RING 24X2 NBR70	72 64 306 08	32	2	X1042440	10 42 440 2	STUEBERBLOCK
O-RING 24X3 FPM70	57 10 774 08	(4)	1	3 978 100	91 56 428 08	HYDR.SCHWEBEBALLAST-AN
O-RING 26X1,5 FPM70	57 10 821 08	(3)	1	1 970	91 56 958 08	HYDRAULIK RAUPE
O-RING 27,5X2,5 FPM70	57 06 810 08	(1)	1	5 114 943	51 14 943 08	WEGEVENTIL
O-RING 285X3 NBR70	57 15 514 08	58	1	X1065015	10 65 015 8	ANTRIEB
O-RING 29X3 NBR70	53 00 732 08	31	2	X1042440	10 42 440 2	STUEBERBLOCK
O-RING 29X4,5 NBR70	72 64 538 01	69	1	9 697 916	96 97 916 01	DREHWERK
O-RING 320X3 NBR70	76 10 203 03	73	1	9 697 916	96 97 916 01	DREHWERK
O-RING 32X3 FPM70	57 10 769 08	(2)	1	2 975 700	91 52 774 08	ZUSATZHYDRAULIK WINDE 1
O-RING 32X3 FPM70	57 10 769 08	(2)	1	3 978 100	91 56 428 08	HYDR.SCHWEBEBALLAST-AN
O-RING 340X4 72 NBR 872	76 10 341 03	24	1	9 697 916	96 97 916 01	DREHWERK
O-RING 39,7X3,5 NBR70	57 05 889 08	3	1	5 708 320	57 08 320 08	FILTERDECKEL
O-RING 40X3 FPM70	57 10 771 08	(4)	1	2 975 700	91 52 774 08	ZUSATZHYDRAULIK WINDE 1
O-RING 42X3 NBR90	72 64 212 08	19	1	2 520 032	96 45 980 08	SCHEIBENWISCHANLAGE EIN
O-RING 54X3 NBR70	72 64 055 08	68	1	9 697 916	96 97 916 01	DREHWERK
O-RING 600X4 NBR 70	76 10 208 03	(2)	1	1 400	91 56 853 08	RAUPENTRAEGER KPL.LI.
O-RING 6X1 NBR90	57 06 906 08	7	1	5 711 301	57 11 301 08	DRUCKBEGRENZUNGSVENTI
O-RING 6X1 NBR90	57 06 906 08	17	1	5 715 296	57 15 296 08	DRUCKVENTIL
O-RING 6X1 NBR90	57 06 906 08	22	1	7 743 566	77 43 566 08	ELEKTROPUMPE
O-RING 6X1,5 NBR90	51 07 129 08	11	3	5 114 498	51 14 498 08	WEGEVENTIL
O-RING 6X1,5 NBR90	51 07 129 08	11	3	5 114 943	51 14 943 08	WEGEVENTIL
O-RING 75X2,5 NBR70	52 12 028 08	22	1	5 102 380	51 02 380 08	HYDROMOTOR
O-RING 78,97X3,53 FKM 70	10 22 070 7	6	1	5 102 354	51 02 354 08	HYDROMOTOR
O-RING 98,02X3,53 S-FPM 75	73 72 303	(15)	1	5 102 354	51 02 354 08	HYDROMOTOR
O-RING ARP 568 10,82X1,78 NB	51 07 181 08	27	1	5 113 005	51 13 005 08	STUEBERBLOCK
O-RING ARP 568 10,82X1,78 NB	51 07 181 08	12	3	5 719 113	57 19 113 08	ANSTEUERGERAET
O-RING ARP 568 10,82X1,78 NB	51 07 181 08	12	3	X1029184	10 29 184 0	ANSTEUERGERAET
O-RING ARP 568 10,82X1,78 NB	51 07 181 08	27	1	X1048973	10 48 973 4	DRUCKBEGRENZUNGSVENTI
O-RING ARP 568 10,82X1,78 NB	51 07 604 08	32	1	X1022811	10 22 811 2	HEIZKLIMAGERAET
O-RING ARP 568 101,19X3,53	51 31 150 08	11	1	5 719 006	57 19 006 08	PUMPENTRAEGER
O-RING ARP 568 11,89X1,98 N	57 11 305 08	8	1	5 711 301	57 11 301 08	DRUCKBEGRENZUNGSVENTI
O-RING ARP 568 12,37X2,62 NB	51 07 461 08	(1)	1	2 970	91 56 537 08	HYDRAULIK
O-RING ARP 568 12,37X2,62 NB	51 07 461 08	13	2	5 026 126	50 26 126 08	MAGNETVENTIL
O-RING ARP 568 12,37X2,62 NB	51 07 461 08	24	2	5 113 086	51 13 086 08	PROPORTIONALVENTIL
O-RING ARP 568 12,42X1,78 NB	51 45 915 08	26	2	5 715 142	57 15 142 08	ANSCHLUSSPLATTE
O-RING ARP 568 12,42X1,78 NB	51 45 915 08	15	2	5 719 113	57 19 113 08	ANSTEUERGERAET
O-RING ARP 568 12,42X1,78 NB	51 45 915 08	15	2	X1029184	10 29 184 0	ANSTEUERGERAET

6.2.2009

etk_en_de_074515 LR 1600/2

1057

LIEBHERRAlphabetical index
Alphabetischer Index

Bezeichnung	Artikel	Pos.	Menge	Seite	Baugruppe	Bezeichnung
O-RING ARP 568 12,42X1,78 NB	51 45 915 08	44	1	X1041267	10 41 267 7	HANDBETAETIGUNG
O-RING ARP 568 133,02X2,62	57 07 108 08	9	1	5 715 142	57 15 142 08	ANSCHLUSSPLATTE
O-RING ARP 568 139,37X2,62	57 06 662 08	9	1	5 718 989	57 18 989 08	ANSCHLUSSPLATTE
O-RING ARP 568 145,72X2,62	51 85 009 08	26	1	X1035924	10 35 924 7	VERSTELLPUMPE
O-RING ARP 568 148,49X5,33	51 45 275 08	13	1	5 106 691	51 06 691 08	RUECKLAUFFILTER
O-RING ARP 568 14X1,78 NBR9	51 57 106 08	31	1	X1022811	10 22 811 2	HEIZKLIMAGERAET
O-RING ARP 568 158,42X2,62	57 12 398 08	9	1	5 719 030	57 19 030 08	ANSCHLUSSPLATTE
O-RING ARP 568 158,42X2,62	57 12 398 08	26	1	X1035924	10 35 924 8	VERSTELLPUMPE
O-RING ARP 568 170,82X7 NB	57 05 883 08	8	1	5 106 691	51 06 691 08	RUECKLAUFFILTER
O-RING ARP 568 170,82X7 NB	57 05 883 08	1	1	5 708 320	57 08 320 08	FILTERDECKEL
O-RING ARP 568 2,9X1,78 NB	51 10 492 08	3	1	5 026 126	50 26 126 08	MAGNETVENTIL
O-RING ARP 568 20,29X2,62 NB	72 64 202 08	4	1	5 113 005	51 13 005 08	STUEBERBLOCK
O-RING ARP 568 23,4X3,53 NB	51 45 495 08	42	1	X1041267	10 41 267 5	DRUCKBEGRENZUNGSVENTI
O-RING ARP 568 23,52X1,78 N	57 06 523 08	25	1	5 113 005	51 13 005 08	STUEBERBLOCK
O-RING ARP 568 23,52X1,78 N	57 06 523 08	25	1	X1048973	10 48 973 4	DRUCKBEGRENZUNGSVENTI
O-RING ARP 568 24,99X3,53 NB	51 05 878 08	543	2	2 970	91 56 537 08	HYDRAULIK
O-RING ARP 568 24,99X3,53 NB	51 05 878 08	562	6	2 976 200	91 52 780 08	ZUSATZHYDRAULIK DREHWE
O-RING ARP 568 24,99X3,53 NB	51 05 878 08	567	4	2 976 700	91 54 795 08	ZUSATZHYDRAULIK PUMPE
O-RING ARP 568 26,64X2,62 NB	57 00 488 08	17	2	5 719 113	57 19 113 08	ANSTEUERGERAET
O-RING ARP 568 26,64X2,62 NB	57 00 488 08	17	2	X1029184	10 29 184 0	ANSTEUERGERAET
O-RING ARP 568 29,82X2,62 NB	51 86 135 08	25	1	X1035924	10 35 924 1	VERSTELLPUMPE
O-RING ARP 568 29,82X2,62 NB	51 86 135 08	25	1	X1035924	10 35 924 2	VERSTELLPUMPE
O-RING ARP 568 29,82X2,62 NB	51 86 135 08	25	1	X1035924	10 35 924 6	VERSTELLPUMPE
O-RING ARP 568 29,82X2,62 NB	51 86 135 08	25	1	X1035925	10 35 925 0	VERSTELLPUMPE
O-RING ARP 568 29,87X1,78 NB	51 07 478 08	39	2	5 113 086	51 13 086 08	PROPORTIONALVENTIL
O-RING ARP 568 29,87X1,78 NB	51 07 478 08	10	1	5 719 113	57 19 113 08	ANSTEUERGERAET
O-RING ARP 568 29,87X1,78 NB	51 07 478 08	10	1	X1029184	10 29 184 0	ANSTEUERGERAET
O-RING ARP 568 32,92X3,53 NB	51 05 870 08	547	4	2 970	91 56 537 08	HYDRAULIK
O-RING ARP 568 32,92X3,53 NB	51 05 870 08	(1)	1	2 970	91 56 537 08	HYDRAULIK
O-RING ARP 568 32,92X3,53 NB	51 05 870 08	(1)	1	2 970	91 56 537 08	HYDRAULIK
O-RING ARP 568 34,65X1,78 NB	51 07 399 08	43	1	X1041267	10 41 267 7	HANDBETAETIGUNG
O-RING ARP 568 36,17X2,62 NB	72 64 252 08	50	1	X1041267	10 41 267 7	HANDBETAETIGUNG
O-RING ARP 568 37,69X3,53 NB	51 05 867 08	53	12	1 970	91 56 958 08	HYDRAULIK RAUPE
O-RING ARP 568 37,69X3,53 NB	51 05 867 08	53	4	1 970 161	96 50 706 08	ZUSATZHYDR.RAUPENTRAEG
O-RING ARP 568 37,69X3,53 NB	51 05 867 08	127	4	2 970	91 56 537 08	HYDRAULIK
O-RING ARP 568 37,69X3,53 NB	51 05 867 08	554	20	2 970	91 56 537 08	HYDRAULIK
O-RING ARP 568 37,69X3,53 NB	51 05 867 08	560	2	2 970	91 56 537 08	HYDRAULIK
O-RING ARP 568 37,69X3,53 NB	51 05 867 08	45	4	2 975 100	91 52 860 08	ZUSATZHYDRAULIK WINDE 3
O-RING ARP 568 37,69X3,53 NB	51 05 867 08	42	3	2 975 200	91 52 775 08	ZUSATZHYDRAULIK WINDE 2
O-RING ARP 568 37,69X3,53 NB	51 05 867 08	42	3	2 975 700	91 52 774 08	ZUSATZHYDRAULIK WINDE 1
O-RING ARP 568 39,34X2,62 NB	72 64 191 08	25	1	X1035924	10 35 924 3	VERSTELLPUMPE
O-RING ARP 568 39,34X2,62 NB	72 64 191 08	25	1	X1035924	10 35 924 4	VERSTELLPUMPE
O-RING ARP 568 4,47X1,78 NB	51 31 192 08	50	1	5 113 086	51 13 086 08	PROPORTIONALVENTIL
O-RING ARP 568 47,22X3,53 NB	51 05 879 08	43	3	2 391 001	96 45 719 08	DIESELMOTOR VORM.
O-RING ARP 568 5,28X1,78 NB	72 64 266 08	49	2	5 113 086	51 13 086 08	PROPORTIONALVENTIL
O-RING ARP 568 52,07X2,62 NB	72 64 265 08	6	1	5 102 306	51 02 306 08	HYDROMOTOR
O-RING ARP 568 56,74X3,53 NB	72 64 216 08	40	2	2 391 001	96 45 719 08	DIESELMOTOR VORM.
O-RING ARP 568 6,07X1,78 NB	72 64 196 08	20	1	5 715 296	57 15 296 08	DRUCKVENTIL
O-RING ARP 568 6,07X1,78 NB	51 07 384 08	441	4	5 713 626	57 13 626 08	VORSTEUERVENTIL
O-RING ARP 568 6,07X1,78 NB	51 07 384 08	16	1	5 719 113	57 19 113 08	ANSTEUERGERAET
O-RING ARP 568 6,07X1,78 NB	51 07 384 08	16	1	X1029184	10 29 184 0	ANSTEUERGERAET
O-RING ARP 568 63,09X3,53 NB	57 05 888 08	11	1	5 106 691	51 06 691 08	RUECKLAUFFILTER
O-RING ARP 568 64,77X2,62 NB	51 57 051 08	15	1	5 701 129	57 01 129 08	TRIEBWERK
O-RING ARP 568 66,34X2,62 NB	51 45 042 08	(5)	1	X1035924	10 35 924 8	VERSTELLPUMPE
O-RING ARP 568 75,87X2,62 NB	51 45 304 08	10	1	5 719 006	57 19 006 08	PUMPENTRAEGER
O-RING ARP 568 85,32X3,53 NB	51 05 993 08	60	1	2 391 001	96 45 719 08	DIESELMOTOR VORM.
O-RING ARP 568 9,25X1,78 NB	51 07 190 08	26	1	5 113 005	51 13 005 08	STUEBERBLOCK
O-RING ARP 568 9,25X1,78 NB	51 07 190 08	26	1	X1048973	10 48 973 4	DRUCKBEGRENZUNGSVENTI
O-RING ARP 568 9,25X1,78 NB	51 07 386 08	26	2	5 718 989	57 18 989 08	ANSCHLUSSPLATTE
O-RING DIN 3770 25X2,5 FPM7	72 64 223 08	405	2	2 391 001	96 45 719 08	DIESELMOTOR VORM.

6.2.2009

etk_en_de_074515 LR 1600/2

1058

LIEBHERRAlphabetical index
Alphabetischer Index

Bezeichnung	Artikel	Pos.	Menge	Seite	Baugruppe	Bezeichnung
O-RING DIN 3771 17,17X1,78	73 81 103	4	2	9 079 186	90 79 186	DREHZAHLGEBER
O-RING DIN 3771 9,25X1,78 FP	73 80 574	5	4	X1034282	10 34 282 3	DRUCKREGELVENTIL
OEL-LUFTKUEHLER	10 33 421 5	1	1	2 391 102	96 56 360 08	ZUSATZKUEHLER VORM.
OEL-LUFTKUEHLER 75KW	10 35 519 6	1	1	2 391 038	96 47 931 08	OELKUEHLER VORM.
OELABLASSSCHLAUCH KPL. 1	10 03 229 7	41	1	1 750	91 52 394 08	WERKZEUG
OELABLASSSCHRAUBE M26X	78 90 119 08	3	1	2 670 002	96 45 352 08	KRAFTSTOFFBEHAELTER VO
OELABLASSSCHRAUBE M26X	78 90 119 08	13	1	2 671	91 52 798 08	OELBEHAELTER KPL.
OELABLASSSCHRAUBE M26X	78 90 119 08	5	1	2 671 004	96 46 305 08	OELBEHAELTER VORM.
OELABSCHIEDER	10 01 213 6	5	1	9 739 386	97 39 386	KURBELGEHAEUSEENTLUEFT
OELBEHAELTER KPL.	91 52 798 08	144	1		LR 1600-2-0	LIEBHERR RAUPENKRAN LR 1
OELBEHAELTER SCHWK. 600L	96 46 306 08	1	1	2 671 004	96 46 305 08	OELBEHAELTER VORM.
OELBEHAELTER VORM.	96 46 305 08	1	1	2 671	91 52 798 08	OELBEHAELTER KPL.
OELKUEHLER	10 01 228 9	14	1	9 739 122	97 39 122	OELKUEHLER
OELKUEHLER	10 65 066 9	1	1	X1035519	10 35 519 6	OEL-LUFTKUEHLER
OELKUEHLER	97 39 122	20	1	9 739 355	97 39 355	OELKUEHLER ANBAU
OELKUEHLER ANBAU	97 39 355	50	1	X1012059	10 12 059 0	DIESELMOTOR
OELKUEHLER VORM.	96 47 931 08	130	1	2 391 001	96 45 719 08	DIESELMOTOR VORM.
OELLEITUNG	10 65 015 9	60	1	X1035411	10 35 411 4	HUBWINDE
OELLEITUNG	97 39 118	65	1	X1012059	10 12 059 0	DIESELMOTOR
OELMESSSTAB	10 01 745 0	7	1	9 739 188	97 39 188	OELMESSSTAB
OELMESSSTAB	97 39 188	18	1	X1012059	10 12 059 0	DIESELMOTOR
OELMESSSTAB 11/8"	92 75 544 01	1	1	9 275 543	92 75 543 01	ENTLUEFTUNGSSTUTZEN
OELRUECKLAUFLEITUNG	10 22 236 5	8	1	9 739 355	97 39 355	OELKUEHLER ANBAU
OELRUECKLAUFLEITUNG	10 28 710 5	21	1	9 739 494	97 39 494	ATL-ANBAU
OELRUECKLAUFLEITUNG	10 28 710 7	29	1	9 739 494	97 39 494	ATL-ANBAU
OELSPRITZDUESE	10 22 232 2	4	1	9 739 243	97 39 243	KOLBENKUEHLUNG
OELSTANDSAUGE R1"	77 43 201 08	4	1	2 671 004	96 46 305 08	OELBEHAELTER VORM.
OELVENTIL	54 02 537 14	520	1	X1065015	10 65 015 5	GETRIEBE
OELWANNE R-MOTORXD846 A	97 39 361	1	1	9 739 362	97 39 362	OELWANNE
OELWANNE R-MOTORXD846 A	97 39 362	16	1	X1012059	10 12 059 0	DIESELMOTOR
PARABEL-GUMMIPUFFER 30	10 04 050 2	33	1	2 925 402	96 58 855 08	KAMERAANBAU DREHBUEHN
PASSKERBSTIFT ISO 8745 6X	43 11 037 08	6	4	3 291	91 52 831 08	S-RUECKHALTESICHERUNG
PASSKERBSTIFT ISO 8745 6X	43 11 037 08	11	4	3 292	91 52 865 08	D-RUECKHALTESICHERUNG
PASSSCHEIBE 58X70X0,1	57 01 142 08	17	2	5 701 129	57 01 129 08	TRIEBWERK
PASSSCHEIBE 58X70X0,3	57 01 143 08	18	1	5 701 129	57 01 129 08	TRIEBWERK
PASSSCHEIBE DIN 988 32X45X	42 20 015 08	17	1	3 282 002	96 47 890 08	FAB-STUETZE
PASSSCHRAUBE M12X32 8.8	10 34 226 2	15	1	9 739 371	97 39 371	KLIMAKOMPRESSOR ANBAU
PEDALGEBER SPF	10 29 730 9	10	2	2 533 050	96 48 359 08	ELEKTRIK KABINE
PEDALTRAEGER EINBAU	96 47 204 08	3	1	2 810 001	96 43 597 08	KRANFUEHRERKABINE VORM
PENDELROLLENLAGER DIN 63	74 61 600 08	6	1	5 718 420	57 18 420 08	FLANSCH
PILZKOPFBAND 25MM PS18	80 21 020 08	12	2.8	2 393 002	96 46 782 08	DECKEL KPL.
PILZKOPFBAND 25MM PS18	80 21 020 08	65	10.8	2 859	91 52 809 08	GERAEUSCHDAEMMUNG
PILZKOPFBAND 25MM PS18	80 21 020 08	9	3.7	2 859 007	96 46 775 08	DECKEL KPL.
PILZKOPFBAND 25MM PS18	80 21 020 08	9	5	2 859 026	96 46 776 08	DECKEL KPL.
PILZKOPFBAND 25MM PS18	80 21 020 08	9	5.7	2 859 027	96 46 777 08	DECKEL KPL.
PILZKOPFBAND 25MM PS18	80 21 020 08	9	4	2 859 028	96 46 778 08	DECKEL KPL.
PILZKOPFBAND 25MM PS18	80 21 020 08	10	4.3	2 859 029	96 46 779 08	DECKEL KPL.
PILZTASTE	60 66 526 08	11	1	2 920 638	96 51 138 08	BEDIENPULT
PLANETENGETRIEBE	93 27 102 01	3	2	1 400	91 56 853 08	RAUPENTRAEGER KPL.LI.
PLANETENGETRIEBE	93 27 102 01	3	2	1 410 300	91 56 855 08	RAUPENTRAEGER KPL.RE.
PLATTE	57 00 097 08	12	1	5 026 126	50 26 126 08	MAGNETVENTIL
PLATTE 15X30X50 PA6G	28 81 762 08	12	1	1 920 305	92 15 300 08	EINBAU SCHLEIFRINGKOEPE
PLATTE 50X20X2 PE	97 52 216 08	4	2	2 520 031	96 45 610 08	HECKSCHEIBE VORM.
PLATTE VORM.	96 48 552 08	1	1	2 932 082	96 54 387 08	AUFBAUTEILE MONTAGETAPE
PLEUELLAGER	10 01 215 0	3	1	9 739 287	97 39 287	PLEUELSTANGE
PLEUELLAGER	10 01 215 2	52	1	9 739 287	97 39 287	PLEUELSTANGE
PLEUELLAGER	10 01 215 3	53	1	9 739 287	97 39 287	PLEUELSTANGE
PLEUELLAGER	10 01 215 4	54	1	9 739 287	97 39 287	PLEUELSTANGE
PLEUELLAGER	10 01 215 5	55	1	9 739 287	97 39 287	PLEUELSTANGE
PLEUELSCHRAUBE M14X1,5 1	90 77 199	2	2	9 739 287	97 39 287	PLEUELSTANGE

6.2.2009

etk_en_de_074515 LR 1600/2

1059

LIEBHERRAlphabetical index
Alphabetischer Index

Bezeichnung	Artikel	Pos.	Menge	Seite	Baugruppe	Bezeichnung
PLEUELSTANGE	10 22 233 7	1	1	9 739 287	97 39 287	PLEUELSTANGE
PLEUELSTANGE	97 39 287	38	6	X1012059	10 12 059 0	DIESELMOTOR
PODEST	96 54 984 08	50	2	3 225	91 52 854 08	SL-REDUZIERSTUECK
PODEST	96 56 268 08	19	1	2 730	91 52 802 08	GRUNDPLATTE DREHBUEHNE
PODEST GROSS	96 53 086 08	1	3	2 631	91 56 817 08	LAUFSTEG DREHBUEHNE
PODEST HINTEN	96 47 414 08	5	1	2 810	91 52 806 08	KRANFUEHRERKABINE KPL.
PODEST KLEIN	96 53 087 08	2	1	2 631	91 56 817 08	LAUFSTEG DREHBUEHNE
PODEST SCHWK.	92 36 315 08	26	2	3 745	91 52 948 08	SCHWEBEBALLAST
PODEST T ZN O	96 53 121 08	7	1	2 730	91 52 802 08	GRUNDPLATTE DREHBUEHNE
PODEST VORN	96 46 384 08	4	1	2 810	91 52 806 08	KRANFUEHRERKABINE KPL.
POLYFLEXROHR 127MM EDEL	10 44 054 2	3	1	2 392	91 52 785 08	SCHALLDAEMPFERANLAGE
PRATZE SINT-D39	90 78 321	5	1	9 739 248	97 39 248	EINSPRITZDUESE
PRESSKLEMME DIN 3093 2 AL	77 39 200 08	63	18	2 631	91 56 817 08	LAUFSTEG DREHBUEHNE
PRESSKLEMME DIN 3093 2 AL	77 39 200 08	78	4	2 810	91 52 806 08	KRANFUEHRERKABINE KPL.
PRESSKLEMME DIN 3093 2 AL	77 39 200 08	62	3	2 978 100	91 52 827 08	ZUSATZHYDR.D-RUECKHALT
PRESSKLEMME DIN 3093 2 AL	77 39 200 08	56	8	3 225	91 52 854 08	SL-REDUZIERSTUECK
PRESSKLEMME DIN 3093 2 AL	77 39 200 08	61	8	3 745	91 52 948 08	SCHWEBEBALLAST
PRESSKLEMME DIN 3093 2 AL	77 39 200 08	62	3	3 978 005	91 56 430 08	ZUSATZHYDRAULIK SB-KOPFS
PROFILDICHRING	10 03 234 8	2	1	9 739 242	97 39 242	ZYLINDERLAUFBUCHSE
PROFILRING PR10-S/L A3P	47 71 003 08	594	1	2 990	91 59 244 08	DRUCKLUFTANLAGE
PROFILRING PR12-S/L A3P	47 71 004 08	21	1	2 391 038	96 47 931 08	OELKUEHLER VORM.
PROFILRING PR6-S/L A3P	47 71 014 08	591	2	2 990	91 59 244 08	DRUCKLUFTANLAGE
PROFILSCHELLE 108/25 A2-70	10 45 120 6	115	1	2 391 001	96 45 719 08	DIESELMOTOR VORM.
PROFILSCHNUR	50 15 070 14	41	1.6	X1065015	10 65 015 5	GETRIEBE
PROPORTIONALMAGNET	10 29 624 5	(1)	1	X1035925	10 35 925 1	VERSTELLPUMPE
PROPORTIONALMAGNET 24V	10 47 143 7	(2)	1	X1035924	10 35 924 6	VERSTELLPUMPE
PROPORTIONALMAGNET 24V	10 47 143 7	(1)	2	X1035924	10 35 924 9	VERSTELLPUMPE
PROPORTIONALMAGNET 24V	57 19 117 08	13	2	5 719 113	57 19 113 08	ANSTEUERGERAET
PROPORTIONALMAGNET 24V	57 19 117 08	13	2	X1029184	10 29 184 0	ANSTEUERGERAET
PROPORTIONALVENTIL NG12	51 13 086 08	110	1	2 970	91 56 537 08	HYDRAULIK
PRUEFANSCHLUSS A3P	50 29 214 08	625	1	2 990	91 59 244 08	DRUCKLUFTANLAGE
PUMPE	59 10 554 08	12	1	2 520 032	96 45 980 08	SCHEIBENWISCHANLAGE EIN
PUMPE F.DREHWERK	91 54 561 08	123	1		LR 1600-2-0	LIEBHERR RAUPENKRAN LR 1
PUMPENDECKEL	10 65 068 9	4	1	X1035924	10 35 924 9	VERSTELLPUMPE
PUMPENELEMENT	10 03 827 2	17	2	7 743 566	77 43 566 08	ELEKTROPUMPE
PUMPENGEHAEUSE	10 01 469 3	1	1	7 743 566	77 43 566 08	ELEKTROPUMPE
PUMPENRUECKLAUF	77 43 728 08	1	2	1 711	91 52 392 08	ZENTRALSCHMIERUNG RAUP
PUMPENRUECKLAUF	77 43 728 08	10	1	2 711	91 52 800 08	ZENTRALSCHMIERANLAGE O
PUMPENTRAEGER	10 32 692 6	4	1	X1035924	10 35 924 6	VERSTELLPUMPE
PUMPENTRAEGER	57 19 006 08	7	1	X1035924	10 35 924 7	VERSTELLPUMPE
RADIALWELLENDICHRING D	57 15 512 08	53	1	X1065015	10 65 015 8	ANTRIEB
RADIALWELLENDICHRING DI	57 15 521 08	31	1	X1065015	10 65 015 5	GETRIEBE
RADIALWELLENDICHRING DI	54 01 943 08	50	1	X1065015	10 65 015 8	ANTRIEB
RADIALWELLENDICHRING DI	71 00 312 08	10	1	5 400 565	54 00 565 08	SEILWINDE
RADIALWELLENDICHRING D	57 01 519 08	15	1	5 400 565	54 00 565 08	SEILWINDE
RADIALWELLENDICHRING DI	71 00 630 01	4	1	9 697 916	96 97 916 01	DREHWERK
RADIALWELLENDICHRING DI	57 07 018 08	(14)	1	5 102 354	51 02 354 08	HYDROMOTOR
RADIALWELLENDICHRING D	71 00 241 08	64	2	9 697 916	96 97 916 01	DREHWERK
RADIALWELLENDICHRING DI	71 00 341 08	11	2	9 697 916	96 97 916 01	DREHWERK
RAENDELMUTTER	57 14 553 08	(1)	1	5 710 349	57 10 349 08	WEGEVENTIL
RAENDELSCHRAUBE M5X10	10 44 966 4	(33)	4	2 925 026	91 55 259 08	ERG.KAMERAUEBERWACHUN
RAENDELSCHRAUBE M5X10	10 44 966 4	33	4	2 925 405	96 48 397 08	AUSRUESTUNG KAMERA KAB
RAENDELSCHRAUBE M5X10	10 44 966 4	16	4	2 932 082	96 54 387 08	AUFBAUTEILE MONTAGETAPE
RAHMEN	96 46 755 08	3	1	2 859	91 52 809 08	GERAEUSCHDAEMMUNG
RAHMEN	96 46 759 08	7	1	2 859	91 52 809 08	GERAEUSCHDAEMMUNG
RAHMEN	96 46 760 08	8	1	2 859	91 52 809 08	GERAEUSCHDAEMMUNG
RAHMEN	96 46 761 08	9	1	2 859	91 52 809 08	GERAEUSCHDAEMMUNG
RAHMEN	96 48 159 08	10	1	2 859	91 52 809 08	GERAEUSCHDAEMMUNG
RAHMEN 4X1029X189	97 70 784 08	12	1	2 859	91 52 809 08	GERAEUSCHDAEMMUNG
RAHMEN 4X1150X608	97 70 775 08	11	1	2 859	91 52 809 08	GERAEUSCHDAEMMUNG

6.2.2009

etk_en_de_074515 LR 1600/2

1060

LIEBHERRAlphabetical index
Alphabetischer Index

Bezeichnung	Artikel	Pos.	Menge	Seite	Baugruppe	Bezeichnung
RAHMEN SCHWK.	96 46 382 08	2	1	2 810	91 52 806 08	KRANFUEHRERKABINE KPL.
RAHMEN SCHWK.	96 46 971 08	2	1	2 260	91 53 057 08	BATTERIELAGERUNG
RAHMEN SCHWK.	96 46 980 08	1	1	2 520 030	96 45 609 08	DACHSCHEIBE VORM.
RAHMEN SCHWK.	96 47 500 08	1	1	3 205	91 52 880 08	F-MONTAGEEINHEIT
RAHMEN SCHWK.	96 49 182 08	1	1	2 510	91 52 788 08	DREHBUEHNENVERKLEIDUN
RAHMEN SCHWK. T ZN O	96 46 540 08	1	4	1 631 100	91 52 388 08	LAUFSTEG RAUPENFAHRWER
RAHMEN SCHWK. T ZN O	96 55 027 08	14	2	1 631 100	91 52 388 08	LAUFSTEG RAUPENFAHRWER
RASTBOLZEN NIROSTA	70 42 316 08	32	1	2 925 402	96 58 855 08	KAMERAANBAU DREHBUEHN
RASTE	10 49 234 7	19	1	X1029200	10 29 200 4	FAHRERSITZ
RAUPENFAHRWERK KPL.	91 52 375 08	2	1		LR 1600-2-0	LIEBHERR RAUPENKRAN LR 1
RAUPENMITTELTEIL KPL.	91 52 377 08	4	1		LR 1600-2-0	LIEBHERR RAUPENKRAN LR 1
RAUPENMITTELTEIL SCHWK.	96 45 385 08	1	1	1 130	91 52 377 08	RAUPENMITTELTEIL KPL.
RAUPENTRAEGER KPL.LI.	91 56 853 08	10	1		LR 1600-2-0	LIEBHERR RAUPENKRAN LR 1
RAUPENTRAEGER KPL.RE.	91 56 855 08	11	1		LR 1600-2-0	LIEBHERR RAUPENKRAN LR 1
RAUPENTRAEGER LI.	96 53 234 08	1	1	1 400	91 56 853 08	RAUPENTRAEGER KPL.LI.
RAUPENTRAEGER RE.	96 53 258 08	1	1	1 410 300	91 56 855 08	RAUPENTRAEGER KPL.RE.
RAUPENTRAEGER SCHWK.LI.	96 53 235 08	(1)	1	1 400	91 56 853 08	RAUPENTRAEGER KPL.LI.
RAUPENTRAEGER SCHWK.RE	96 53 259 08	(1)	1	1 410 300	91 56 855 08	RAUPENTRAEGER KPL.RE.
REDUKTION M20X1,5/M16X1,5	60 26 062 08	(6)	1	2 920 559	96 47 914 08	ENDSCHALTER U.GEBER AL
REDUKTION M25X1,5/M20X1,5	60 26 064 08	521	3	2 920 633	96 52 651 08	KABELSTRANG
REDUKTION M25X1,5/M20X1,5	60 26 064 08	183	1	3 930 638	96 51 624 08	KLEMMKASTEN
REDUKTION M32X1,5/M20X1,5	60 26 065 08	7	1	2 780 524	96 52 968 08	LEITUNGSTROMMEL KPL.
REDUKTION M32X1,5/M20X1,5	60 26 065 08	289	1	2 920 448	96 48 794 08	KLEMMKASTEN KPL.
REDUKTION M32X1,5/M20X1,5	60 26 065 08	(155)	1	2 920 581	96 54 405 08	KLEMMKASTEN SA-BOCK VO
REDUKTION M32X1,5/M20X1,5	60 26 065 08	(154)	1	3 930 734	96 54 401 08	KLEMMKASTEN
REDUKTION M32X1,5/M25X1,5	60 26 066 08	157	1	3 930 732	96 50 575 08	LEITUNG
REDUZIERSTUECK 81,5/53,5 P	10 42 478 5	37	2	2 520 034	96 45 984 08	INNENVERKLEIDUNG
REDUZIERSTUTZEN ST MAN27	10 34 230 2	3	1	9 739 356	97 39 356	ROHRLEITUNG ANBAU
REDUZIERVERSCHRAUBUNG	10 04 464 8	15	2	2 780 915	96 48 377 08	ANBAUTEILE FREMDEINSPEIS
REGLER	10 47 219 6	3	1	X1035924	10 35 924 7	VERSTELLPUMPE
REGLER	10 47 219 6	3	1	X1035924	10 35 924 8	VERSTELLPUMPE
REGLER	10 47 599 4	(1)	1	9 739 343	97 39 343	GENERATOR VORM.
REGLERELEMENT	10 47 220 2	3	1	X1047219	10 47 219 6	REGLER
REGLERELEMENT	57 19 008 08	2	1	X1047219	10 47 219 6	REGLER
RELAIS	10 01 737 4	13	1	2 920 083	96 48 319 08	ELEKTRIK BATTERIEKASTEN
RELAIS 18-32V	63 01 021 08	42	51	2 932 001	96 45 393 08	RELAISSTEUERUNG
RELAIS 24V S=20A OE=10A 2	63 01 215 08	26	24	2 932 082	96 54 387 08	AUFBAUTEILE MONTAGETAPE
RELAIS 24V S=40A 26X26X24M	63 01 051 08	25	4	2 932 082	96 54 387 08	AUFBAUTEILE MONTAGETAPE
RELAIS 24V S=40A OE=20A 2	63 01 054 08	27	1	2 932 082	96 54 387 08	AUFBAUTEILE MONTAGETAPE
RELAISSTECKSOCKEL 9-POL	63 01 229 08	504	41	2 932 224	96 54 389 08	DRAEHTE MONTAGETAPEL K
RELAISSTEUERUNG	96 45 393 08	4	1	2 932	91 57 750 08	EINBAUTEILE SCHALTSCHRAN
RELAISTRAEGER 1.5X725X51	97 68 157 08	21	1	2 932 001	96 45 393 08	RELAISSTEUERUNG
REPARATURSATZ	57 13 378 08	1	1	7 300 043	73 00 043 08	ABSPERRORGAN
RIEGEL 20X46X169	94 54 958 08	2	2	1 641 014	92 53 053 08	ABSTUETZPLATTE KPL.
RIEGELKLEMME	60 21 160 08	50	4	2 520 034	96 45 984 08	INNENVERKLEIDUNG
RILLENKUGELLAGER	57 17 273 08	6	1	5 400 565	54 00 565 08	SEILWINDE
RILLENKUGELLAGER 50X65X7	10 11 483 8	38	1	6 909 010	69 09 010 08	SCHLEIFRINGUEBERTRAEGE
RILLENKUGELLAGER 6305-2	10 34 330 8	4	1	9 739 250	97 39 250	SCHWUNGRAD
RILLENKUGELLAGER DIN 625	54 05 073 08	37	1	6 909 010	69 09 010 08	SCHLEIFRINGUEBERTRAEGE
RILLENKUGELLAGER DIN 625	74 51 288 08	4	2	3 745 002	92 17 236 08	SCHALTEINHEIT
RILLENKUGELLAGER DIN 625	74 51 288 08	4	2	3 745 003	92 17 237 08	SCHALTEINHEIT
RILLENKUGELLAGER DIN 625	74 51 215 08	30	1	X1065015	10 65 015 8	ANTRIEB
RILLENKUGELLAGER DIN 625	74 51 960 08	53	1	X1065015	10 65 015 5	GETRIEBE
RILLENKUGELLAGER DIN 625	74 51 295 01	4	2	2 522 012	96 45 884 08	FUEHRUNG VORM.
RILLENKUGELLAGER DIN 625	74 51 295 01	5	8	2 522 013	96 45 883 08	FUEHRUNG VORM.
RILLENKUGELLAGER DIN 625	74 51 488 08	3	2	3 211 009	96 46 979 08	SCHUTZWALZE KPL.
RILLENKUGELLAGER DIN 625	74 51 488 08	(3)	2	3 350	91 52 859 08	WINDE 3
RILLENKUGELLAGER DIN 625	74 51 488 08	3	2	3 350 001	92 70 642 08	SCHUTZWALZE KPL.
RILLENKUGELLAGER DIN 625	50 15 339 08	66	1	9 697 916	96 97 916 01	DREHWERK

6.2.2009

etk_en_de_074515 LR 1600/2

1061

LIEBHERRAlphabetical index
Alphabetischer Index

Bezeichnung	Artikel	Pos.	Menge	Seite	Baugruppe	Bezeichnung
RILLENKUGELLAGER DIN 625	74 51 604 08	1362	1	X1065015	10 65 015 5	GETRIEBE
RILLENKUGELLAGER DIN 625	74 51 684 08	2	1	3 206 002	96 47 960 08	HEBEL KPL.
RILLENKUGELLAGER DIN 625	74 51 688 08	2	2	3 211 008	96 46 978 08	SCHUTZWALZE KPL.
RING	10 22 276 1	4	1	9 739 281	97 39 281	LECKOELLEITUNG
RING	57 01 148 08	5	14	5 701 133	57 01 133 08	TRIEBWERK
RING RD120X6	93 96 841 08	17	4	3 745	91 52 948 08	SCHWEBEBALLAST
RING RD84X23	93 87 145 08	4	1	3 282 001	96 47 888 08	F-STUETZE KPL.
RINGLUEFTER D=654	55 06 395 08	3	2	2 391 023	96 45 720 08	KUEHLER VORM.
RINGSCHRAUBE DIN 580 M10	40 26 002 08	2	3	2 790 451	91 57 016 08	ABDECKUNG
RINGSCHRAUBE DIN 580 M12	40 26 003 08	5	2	2 670 002	96 45 352 08	KRAFTSTOFFBEHAELTER VO
RINGSCHRAUBE DIN 580 M12	40 26 003 08	17	2	2 671 004	96 46 305 08	OELBEHAELTER VORM.
RINGSCHRAUBE DIN 580 M24	40 26 007 08	6	4	1 632	91 52 389 08	MECH.ZUSATZABSTUETZUNG
RINGSTUTZEN	10 01 271 0	4	5	9 739 282	97 39 282	LECKOELLEITUNG
RINGSTUTZEN	10 01 271 0	3	7	9 739 292	97 39 292	KRAFTSTOFFLEITUNG
RINGSTUTZEN	10 01 271 0	2	2	9 739 492	97 39 492	ROHRLEITUNG ANBAU
RINGSTUTZEN	10 01 271 1	14	1	9 739 288	97 39 288	KRAFTSTOFFLEITUNG
RINGSTUTZEN	10 01 696 0	16	1	9 739 349	97 39 349	WASSERLEITUNGSANSCHLUE
RINGSTUTZEN	10 11 610 9	7	1	X1011614	10 11 614 1	KRAFTSTOFFSCHLAUCH
RINGSTUTZEN	10 22 236 6	9	1	9 739 355	97 39 355	OELKUEHLER ANBAU
RINGSTUTZEN	10 28 515 5	17	1	9 739 288	97 39 288	KRAFTSTOFFLEITUNG
RINGSTUTZEN 14MM	10 01 271 3	20	2	9 739 288	97 39 288	KRAFTSTOFFLEITUNG
ROHR 101.6X1356	97 71 247 08	2	1	3 211 009	96 46 979 08	SCHUTZWALZE KPL.
ROHR 101.6X2799	97 73 249 08	3	1	3 282 001	96 47 888 08	F-STUETZE KPL.
ROHR 10X1,5X1558	97 84 036 08	233	1	2 998	91 56 540 08	ROHRLEITUNGEN OBERWAGE
ROHR 12.0X44	97 49 575 08	48	2	3 214	91 52 843 08	SW-KOPFSTUECK
ROHR 12X1,5X6	95 12 474 08	47	8	3 214	91 52 843 08	SW-KOPFSTUECK
ROHR 15.0X24 S355J2G3C+C	97 18 057 08	19	4	2 502	91 55 939 08	STUERSTAND
ROHR 15X1,5X14	95 30 759 08	11	5	3 206	91 52 881 08	F-ANLENKSTUECK
ROHR 16.0X22	97 18 575 08	36	3	3 206	91 52 881 08	F-ANLENKSTUECK
ROHR 16.0X22	97 18 575 08	24	6	3 208 001	91 52 883 08	F-KOPFSTUECK
ROHR 18 KUNSTSTOFF	55 31 730 08	16	2	2 540	91 53 253 08	HEIZKLIMAGERAET EINBAU
ROHR 20.0X33	97 88 595 08	25	4	2 370	91 52 782 08	MONTAGEWINDE
ROHR 20.0X33	97 88 595 08	77	12	2 810	91 52 806 08	KRANFUEHRERKABINE KPL.
ROHR 20x3,6x42	97 06 963 08	20	4	3 215 005	91 52 846 08	ROLLENSATZ
ROHR 20x3,6x42	97 06 963 08	20	4	3 215 006	91 52 847 08	ROLLENSATZ
ROHR 219.1X88	97 76 910 08	35	2	3 714	91 52 862 08	D-KOPFSTUECK
ROHR 22X2,5X110	94 01 070 08	12	1	2 657	91 57 656 08	MONTAGEEINRICHTUNG RA
ROHR 22X2,5X40	93 92 551 08	11	2	3 211 003	96 46 986 08	STANGE KPL.
ROHR 22X2,5X40	93 92 551 08	12	2	3 220 501	96 43 440 08	STANGE KPL.
ROHR 22X2,5X40	93 92 551 08	12	2	3 221 200	96 47 984 08	STANGE KPL.
ROHR 22X2,5X40	93 92 551 08	12	2	3 225 200	96 48 679 08	STANGE KPL.
ROHR 22X2,5X40	93 92 551 08	12	2	3 227 002	96 50 498 08	STANGE KPL.
ROHR 22X2,5X40	93 92 551 08	12	2	3 561 003	96 45 222 08	STANGE KPL.
ROHR 22X2,5X40	93 92 551 08	12	1	3 713 012	96 50 197 08	STANGE KPL.
ROHR 22X2,5X40	93 92 551 08	8	2	3 714 013	96 59 083 08	LASCHE KPL.
ROHR 22X2,5X40	93 92 551 08	12	2	3 716 001	96 49 159 08	STANGE KPL.
ROHR 22X2,5X45	94 36 973 08	2	1	3 714 014	96 49 456 08	LASCHE KPL.
ROHR 25X3,2X100	94 78 115 08	45	2	2 391 001	96 45 719 08	DIESELMOTOR VORM.
ROHR 30 Rolle20m PAK	55 31 594 08	3	0.33	2 541 001	96 49 651 08	ZUSATZHEIZUNG VORM.
ROHR 30.0X120	97 77 023 08	9	1	2 550 005	96 45 680 08	STANGE KPL.
ROHR 30.0X120	97 77 023 08	5	1	3 714 025	96 49 269 08	STANGE KPL.
ROHR 30.0X120	97 77 023 08	3	4	3 745 011	96 49 677 08	LASCHE KPL.
ROHR 30.0X2863 X5CRNI18-10	97 70 466 08	22	2	2 520	91 53 061 08	KABINE VERGLAST
ROHR 30.0X495	97 75 036 08	47	1	2 520	91 53 061 08	KABINE VERGLAST
ROHR 30.0X690 ST37.0	97 71 958 08	14	2	3 208 001	91 52 883 08	F-KOPFSTUECK
ROHR 30X4X40	94 12 040 08	17	2	2 550 005	96 45 680 08	STANGE KPL.
ROHR 30X4X9	94 70 655 08	4	2	3 206 002	96 47 960 08	HEBEL KPL.
ROHR 33,7X8X15	94 99 872 08	36	4	2 391 001	96 45 719 08	DIESELMOTOR VORM.
ROHR 35X2X665 X5CRNI1810	95 70 053 08	1	1	3 780 200	96 54 370 08	ELEKTRIK WINDWARNUNG T
ROHR 38.0X1716 T ZN O	97 69 808 08	5	1	2 652	91 52 794 08	ROLLENLAGERUNG

6.2.2009

etk_en_de_074515 LR 1600/2

1062

LIEBHERRAlphabetical index
Alphabetischer Index

Bezeichnung	Artikel	Pos.	Menge	Seite	Baugruppe	Bezeichnung
ROHR 38.0X340 ST.37.0 TZNO	97 91 001 08	96	1	3 714	91 52 862 08	D-KOPFSTUECK
ROHR 38.0X540	97 15 586 08	30	1	3 714	91 52 862 08	D-KOPFSTUECK
ROHR 38.0X870 ST37.0	97 68 872 08	44	2	2 550	91 57 751 08	SA-BOCK
ROHR 38X2,6X105 ST.37.0	95 27 658 08	22	4	1 400	91 56 853 08	RAUPENTRAEGER KPL.LI.
ROHR 38X2,6X105 ST.37.0	95 27 658 08	22	4	1 410 300	91 56 855 08	RAUPENTRAEGER KPL.RE.
ROHR 48,3X3,2X14	95 61 143 08	6	1	3 745 002	92 17 236 08	SCHALTEINHEIT
ROHR 48,3X3,2X14	95 61 143 08	6	1	3 745 003	92 17 237 08	SCHALTEINHEIT
ROHR 48.3X92	97 78 986 08	15	8	2 125	91 52 773 08	BOLZEN S-ANLENKST. UND S
ROHR 60.3X10 00	97 41 664 08	7	1	1 632	91 52 389 08	MECH.ZUSATZABSTUETZUNG
ROHR 65.0X10	97 93 902 08	20	1	3 281	91 52 896 08	FA-BOCK
ROHR 65.0X350	97 93 901 08	19	1	3 281	91 52 896 08	FA-BOCK
ROHR 65.0X39	97 94 005 08	32	1	3 281	91 52 896 08	FA-BOCK
ROHR 6X1,5 POLYAMID	77 43 737 08	9	120	1 711	91 52 392 08	ZENTRALSCHMIERUNG RAUP
ROHR 6X1,5 POLYAMID	77 43 737 08	20	100	2 711	91 52 800 08	ZENTRALSCHMIERANLAGE O
ROHR 90.0X106 SPF	97 79 781 08	100	2	3 713	91 57 749 08	D-ANLENKSTUECK
ROHR EPDM	97 74 376 08	17	1	2 520 032	96 45 980 08	SCHEIBENWISCHANLAGE EIN
ROHR KPL. 10X1,5X156	96 51 674 08	381	1	2 998	91 56 540 08	ROHRLEITUNGEN OBERWAGE
ROHR KPL. 10X1,5X166	96 51 741 08	190	1	2 978 102	96 47 913 08	ROHRLEITUNGEN MONTAGEE
ROHR KPL. 10X1,5X1681	96 51 739 08	188	1	2 978 102	96 47 913 08	ROHRLEITUNGEN MONTAGEE
ROHR KPL. 10X1,5X175	96 18 464 08	(373)	1	2 976 203	92 27 489 08	ZUSATZHYDR.BOLZENZIEHZ
ROHR KPL. 10X1,5X187	96 51 673 08	380	1	2 998	91 56 540 08	ROHRLEITUNGEN OBERWAGE
ROHR KPL. 10X1,5X1885	96 51 335 08	267	3	2 998	91 56 540 08	ROHRLEITUNGEN OBERWAGE
ROHR KPL. 10X1,5X190	92 09 706 08	(372)	1	2 976 203	92 27 489 08	ZUSATZHYDR.BOLZENZIEHZ
ROHR KPL. 10X1,5X2021	96 51 738 08	187	1	2 978 102	96 47 913 08	ROHRLEITUNGEN MONTAGEE
ROHR KPL. 10X1,5X2374	96 55 083 08	507	1	2 978 108	96 44 195 08	ROHRLEITUNGEN DERRICK
ROHR KPL. 10X1,5X2394	96 55 056 08	480	1	3 978 106	96 50 885 08	ROHRLEITUNGEN SCHWEBEB
ROHR KPL. 10X1,5X259	96 51 677 08	384	1	2 998	91 56 540 08	ROHRLEITUNGEN OBERWAGE
ROHR KPL. 10X1,5X289	96 51 758 08	152	1	2 978 205	96 47 115 08	ROHRLEITUNGEN S-RUECKH
ROHR KPL. 10X1,5X300	96 51 676 08	383	1	2 998	91 56 540 08	ROHRLEITUNGEN OBERWAGE
ROHR KPL. 10X1,5X3082	96 55 058 08	482	1	2 975 155	96 50 586 08	ROHRLEITUNGEN WINDE
ROHR KPL. 10X1,5X340	96 55 082 08	506	1	2 978 108	96 44 195 08	ROHRLEITUNGEN DERRICK
ROHR KPL. 10X1,5X376	96 51 759 08	153	1	2 978 205	96 47 115 08	ROHRLEITUNGEN S-RUECKH
ROHR KPL. 10X1,5X604	96 51 723 08	432	1	2 998	91 56 540 08	ROHRLEITUNGEN OBERWAGE
ROHR KPL. 10X1,5X621	96 54 104 08	399	1	2 998	91 56 540 08	ROHRLEITUNGEN OBERWAGE
ROHR KPL. 10X1,5X746	96 55 057 08	481	1	3 978 106	96 50 885 08	ROHRLEITUNGEN SCHWEBEB
ROHR KPL. 10X1,5X768	96 51 740 08	189	1	2 978 102	96 47 913 08	ROHRLEITUNGEN MONTAGEE
ROHR KPL. 10X1,5X86	96 55 087 08	511	1	2 978 108	96 44 195 08	ROHRLEITUNGEN DERRICK
ROHR KPL. 10X1,5X860	96 52 296 08	155	1	2 978 205	96 47 115 08	ROHRLEITUNGEN S-RUECKH
ROHR KPL. 10X1,5X945	96 55 081 08	505	1	2 978 108	96 44 195 08	ROHRLEITUNGEN DERRICK
ROHR KPL. 10X1,5X966	96 53 057 08	400	1	2 998	91 56 540 08	ROHRLEITUNGEN OBERWAGE
ROHR KPL. 12X1,5X103	96 48 897 08	(761)	4	1 975 006	91 52 509 08	ZUSATZHYDR.ABSTUETZZYL
ROHR KPL. 12X1,5X1181	96 55 049 08	473	1	3 978 106	96 50 885 08	ROHRLEITUNGEN SCHWEBEB
ROHR KPL. 12X1,5X1548	96 54 100 08	391	1	2 998	91 56 540 08	ROHRLEITUNGEN OBERWAGE
ROHR KPL. 12X1,5X168	96 51 671 08	378	2	2 998	91 56 540 08	ROHRLEITUNGEN OBERWAGE
ROHR KPL. 12X1,5X1786	96 55 032 08	218	1	3 978 010	96 50 882 08	ROHRLEITUNGEN DERR.KOP
ROHR KPL. 12X1,5X1875	96 51 337 08	268	1	2 998	91 56 540 08	ROHRLEITUNGEN OBERWAGE
ROHR KPL. 12X1,5X1979	96 55 031 08	217	1	3 978 010	96 50 882 08	ROHRLEITUNGEN DERR.KOP
ROHR KPL. 12X1,5X2027	96 54 146 08	209	1	3 978 010	96 50 882 08	ROHRLEITUNGEN DERR.KOP
ROHR KPL. 12X1,5X2045	96 55 045 08	231	1	3 978 010	96 50 882 08	ROHRLEITUNGEN DERR.KOP
ROHR KPL. 12X1,5X2092	96 55 030 08	216	1	3 978 010	96 50 882 08	ROHRLEITUNGEN DERR.KOP
ROHR KPL. 12X1,5X2169	96 52 301 08	160	1	2 978 205	96 47 115 08	ROHRLEITUNGEN S-RUECKH
ROHR KPL. 12X1,5X2215	96 52 303 08	162	1	2 978 205	96 47 115 08	ROHRLEITUNGEN S-RUECKH
ROHR KPL. 12X1,5X2259	96 51 757 08	151	1	2 978 205	96 47 115 08	ROHRLEITUNGEN S-RUECKH
ROHR KPL. 12X1,5X2329	96 52 302 08	161	1	2 978 205	96 47 115 08	ROHRLEITUNGEN S-RUECKH
ROHR KPL. 12X1,5X2370	96 55 080 08	504	1	2 978 108	96 44 195 08	ROHRLEITUNGEN DERRICK
ROHR KPL. 12X1,5X2600	96 55 048 08	472	1	3 978 106	96 50 885 08	ROHRLEITUNGEN SCHWEBEB
ROHR KPL. 12X1,5X261	96 51 338 08	269	1	2 998	91 56 540 08	ROHRLEITUNGEN OBERWAGE
ROHR KPL. 12X1,5X280	96 55 086 08	510	1	2 978 108	96 44 195 08	ROHRLEITUNGEN DERRICK
ROHR KPL. 12X1,5X291	96 52 313 08	437	1	2 998	91 56 540 08	ROHRLEITUNGEN OBERWAGE
ROHR KPL. 12X1,5X309	96 51 672 08	379	1	2 998	91 56 540 08	ROHRLEITUNGEN OBERWAGE

6.2.2009

etk_en_de_074515 LR 1600/2

1063

LIEBHERRAlphabetical index
Alphabetischer Index

Bezeichnung	Artikel	Pos.	Menge	Seite	Baugruppe	Bezeichnung
ROHR KPL. 12X1,5X329	96 55 079 08	503	1	2 978 108	96 44 195 08	ROHRLEITUNGEN DERRICK
ROHR KPL. 12X1,5X366	96 55 078 08	502	1	2 978 108	96 44 195 08	ROHRLEITUNGEN DERRICK
ROHR KPL. 12X1,5X4100	96 52 298 08	157	1	2 978 205	96 47 115 08	ROHRLEITUNGEN S-RUECKH
ROHR KPL. 12X1,5X4111	96 52 299 08	158	1	2 978 205	96 47 115 08	ROHRLEITUNGEN S-RUECKH
ROHR KPL. 12X1,5X4400	96 54 143 08	460	1	3 978 007	96 50 879 08	ROHRLEITUNGEN DERR.ZWI
ROHR KPL. 12X1,5X447	96 51 756 08	150	1	2 978 205	96 47 115 08	ROHRLEITUNGEN S-RUECKH
ROHR KPL. 12X1,5X451	96 48 939 08	714	1	1 998	91 52 513 08	ROHRLEITUNGEN RAUPE
ROHR KPL. 12X1,5X506	96 55 035 08	221	1	3 978 010	96 50 882 08	ROHRLEITUNGEN DERR.KOP
ROHR KPL. 12X1,5X518	96 55 034 08	220	1	3 978 010	96 50 882 08	ROHRLEITUNGEN DERR.KOP
ROHR KPL. 12X1,5X5190	96 55 088 08	(450)	1	3 978 015	91 56 429 08	ZUSATZHYDRAULIK ZWISCH
ROHR KPL. 12X1,5X5190	96 55 089 08	(451)	1	3 978 015	91 56 429 08	ZUSATZHYDRAULIK ZWISCH
ROHR KPL. 12X1,5X547	96 55 033 08	219	1	3 978 010	96 50 882 08	ROHRLEITUNGEN DERR.KOP
ROHR KPL. 12X1,5X596	96 48 936 08	711	1	1 998	91 52 513 08	ROHRLEITUNGEN RAUPE
ROHR KPL. 12X1,5X622	96 48 896 08	(760)	4	1 975 006	91 52 509 08	ZUSATZHYDR.ABSTUETZZYL
ROHR KPL. 12X1,5X829	96 51 760 08	154	1	2 978 205	96 47 115 08	ROHRLEITUNGEN S-RUECKH
ROHR KPL. 12X1,5X3363	96 52 300 08	159	1	2 978 205	96 47 115 08	ROHRLEITUNGEN S-RUECKH
ROHR KPL. 12X1,5X3663	96 52 297 08	156	1	2 978 205	96 47 115 08	ROHRLEITUNGEN S-RUECKH
ROHR KPL. 15X1,5X1120	96 54 102 08	396	1	2 998	91 56 540 08	ROHRLEITUNGEN OBERWAGE
ROHR KPL. 15X1,5X2231	96 55 065 08	489	1	2 975 155	96 50 586 08	ROHRLEITUNGEN WINDE
ROHR KPL. 15X1,5X2371	96 55 061 08	485	1	2 975 155	96 50 586 08	ROHRLEITUNGEN WINDE
ROHR KPL. 15X1,5X520	96 51 663 08	370	1	2 998	91 56 540 08	ROHRLEITUNGEN OBERWAGE
ROHR KPL. 15X1,5X540	96 51 668 08	375	1	2 998	91 56 540 08	ROHRLEITUNGEN OBERWAGE
ROHR KPL. 15X1,5X621	96 55 085 08	509	1	2 978 108	96 44 195 08	ROHRLEITUNGEN DERRICK
ROHR KPL. 15X1,5X666	96 55 084 08	508	1	2 978 108	96 44 195 08	ROHRLEITUNGEN DERRICK
ROHR KPL. 15X1,5X682	96 54 099 08	374	1	2 998	91 56 540 08	ROHRLEITUNGEN OBERWAGE
ROHR KPL. 15X1,5X835	96 51 664 08	371	1	2 998	91 56 540 08	ROHRLEITUNGEN OBERWAGE
ROHR KPL. 16X2X1058	96 48 931 08	706	2	1 998	91 52 513 08	ROHRLEITUNGEN RAUPE
ROHR KPL. 16X2X1122	96 51 656 08	363	1	2 998	91 56 540 08	ROHRLEITUNGEN OBERWAGE
ROHR KPL. 16X2X1714	96 55 070 08	494	1	2 978 108	96 44 195 08	ROHRLEITUNGEN DERRICK
ROHR KPL. 16X2X1882	96 55 067 08	491	1	2 978 108	96 44 195 08	ROHRLEITUNGEN DERRICK
ROHR KPL. 16X2X1919	96 51 753 08	147	1	2 978 205	96 47 115 08	ROHRLEITUNGEN S-RUECKH
ROHR KPL. 16X2X2014	96 48 913 08	736	2	1 998	91 52 513 08	ROHRLEITUNGEN RAUPE
ROHR KPL. 16X2X2228	96 51 737 08	186	1	2 978 102	96 47 913 08	ROHRLEITUNGEN MONTAGEE
ROHR KPL. 16X2X2265	96 48 914 08	737	2	1 998	91 52 513 08	ROHRLEITUNGEN RAUPE
ROHR KPL. 16X2X2894	96 48 932 08	707	2	1 998	91 52 513 08	ROHRLEITUNGEN RAUPE
ROHR KPL. 16X2X294	96 51 670 08	(377)	1	2 975 000	91 57 881 08	ZUSATZHYDRAULIK MONTAGE
ROHR KPL. 16X2X3017	96 53 059 08	361	1	2 998	91 56 540 08	ROHRLEITUNGEN OBERWAGE
ROHR KPL. 16X2X421	96 53 053 08	339	1	2 998	91 56 540 08	ROHRLEITUNGEN OBERWAGE
ROHR KPL. 16X2X495	96 51 736 08	185	1	2 978 102	96 47 913 08	ROHRLEITUNGEN MONTAGEE
ROHR KPL. 16X2X535	96 51 655 08	362	1	2 998	91 56 540 08	ROHRLEITUNGEN OBERWAGE
ROHR KPL. 18X1,5X1095	96 51 346 08	238	1	2 998	91 56 540 08	ROHRLEITUNGEN OBERWAGE
ROHR KPL. 18X1,5X1195	96 51 701 08	410	1	2 998	91 56 540 08	ROHRLEITUNGEN OBERWAGE
ROHR KPL. 18X1,5X1383	96 51 752 08	146	1	2 978 205	96 47 115 08	ROHRLEITUNGEN S-RUECKH
ROHR KPL. 18X1,5X1518	96 51 722 08	431	1	2 998	91 56 540 08	ROHRLEITUNGEN OBERWAGE
ROHR KPL. 18X1,5X2036	96 51 700 08	409	1	2 998	91 56 540 08	ROHRLEITUNGEN OBERWAGE
ROHR KPL. 18X1,5X3196	96 47 355 08	240	1	2 998	91 56 540 08	ROHRLEITUNGEN OBERWAGE
ROHR KPL. 18X1,5X384	96 51 345 08	237	1	2 998	91 56 540 08	ROHRLEITUNGEN OBERWAGE
ROHR KPL. 18X1,5X482	96 54 105 08	408	1	2 998	91 56 540 08	ROHRLEITUNGEN OBERWAGE
ROHR KPL. 18X1,5X859	96 51 348 08	241	1	2 998	91 56 540 08	ROHRLEITUNGEN OBERWAGE
ROHR KPL. 18X1,5X865	96 51 347 08	239	1	2 998	91 56 540 08	ROHRLEITUNGEN OBERWAGE
ROHR KPL. 20X2,5X1039	96 51 698 08	407	1	2 998	91 56 540 08	ROHRLEITUNGEN OBERWAGE
ROHR KPL. 20X2,5X1072	96 48 935 08	710	1	1 998	91 52 513 08	ROHRLEITUNGEN RAUPE
ROHR KPL. 20X2,5X1553	96 51 697 08	406	1	2 998	91 56 540 08	ROHRLEITUNGEN OBERWAGE
ROHR KPL. 20X2,5X2296	96 51 696 08	405	1	2 998	91 56 540 08	ROHRLEITUNGEN OBERWAGE
ROHR KPL. 20X2,5X302	96 48 934 08	709	1	1 998	91 52 513 08	ROHRLEITUNGEN RAUPE
ROHR KPL. 22X2,5X1009	96 51 339 08	270	1	2 998	91 56 540 08	ROHRLEITUNGEN OBERWAGE
ROHR KPL. 22X2,5X1130	96 55 069 08	493	1	2 978 108	96 44 195 08	ROHRLEITUNGEN DERRICK
ROHR KPL. 22X2,5X1300	96 55 059 08	483	1	2 975 155	96 50 586 08	ROHRLEITUNGEN WINDE
ROHR KPL. 22X2,5X1342	96 55 060 08	484	1	2 975 155	96 50 586 08	ROHRLEITUNGEN WINDE
ROHR KPL. 22X2,5X1509	96 51 680 08	389	1	2 998	91 56 540 08	ROHRLEITUNGEN OBERWAGE

6.2.2009

etk_en_de_074515 LR 1600/2

1064

LIEBHERRAlphabetical index
Alphabetischer Index

Bezeichnung	Artikel	Pos.	Menge	Seite	Baugruppe	Bezeichnung
ROHR KPL. 22X2,5X1530	96 55 072 08	496	1	2 978 108	96 44 195 08	ROHRLEITUNGEN DERRICK
ROHR KPL. 22X2,5X1599	96 51 340 08	271	1	2 998	91 56 540 08	ROHRLEITUNGEN OBERWAGE
ROHR KPL. 22X2,5X1685	96 51 681 08	390	1	2 998	91 56 540 08	ROHRLEITUNGEN OBERWAGE
ROHR KPL. 22X2,5X1776	96 55 068 08	492	1	2 978 108	96 44 195 08	ROHRLEITUNGEN DERRICK
ROHR KPL. 22X2,5X2407	96 55 077 08	501	1	2 978 108	96 44 195 08	ROHRLEITUNGEN DERRICK
ROHR KPL. 22X2,5X269	96 51 490 08	(281)	1	2 975 700	91 52 774 08	ZUSATZHYDRAULIK WINDE 1
ROHR KPL. 22X2,5X360	96 55 076 08	500	1	2 978 108	96 44 195 08	ROHRLEITUNGEN DERRICK
ROHR KPL. 22X2,5X527	96 55 075 08	499	1	2 978 108	96 44 195 08	ROHRLEITUNGEN DERRICK
ROHR KPL. 22X2,5X904	96 48 938 08	713	1	1 998	91 52 513 08	ROHRLEITUNGEN RAUPE
ROHR KPL. 25X3X1162	96 54 108 08	435	1	2 998	91 56 540 08	ROHRLEITUNGEN OBERWAGE
ROHR KPL. 25X3X1218	96 51 695 08	404	1	2 998	91 56 540 08	ROHRLEITUNGEN OBERWAGE
ROHR KPL. 25X3X1416	96 55 071 08	495	1	2 978 108	96 44 195 08	ROHRLEITUNGEN DERRICK
ROHR KPL. 25X3X1471	96 53 056 08	356	1	2 998	91 56 540 08	ROHRLEITUNGEN OBERWAGE
ROHR KPL. 25X3X1585	96 54 107 08	433	1	2 998	91 56 540 08	ROHRLEITUNGEN OBERWAGE
ROHR KPL. 25X3X1681	96 53 055 08	354	1	2 998	91 56 540 08	ROHRLEITUNGEN OBERWAGE
ROHR KPL. 25X3X1938	96 55 066 08	490	1	2 978 108	96 44 195 08	ROHRLEITUNGEN DERRICK
ROHR KPL. 25X3X200	96 51 751 08	145	1	2 978 205	96 47 115 08	ROHRLEITUNGEN S-RUECKH
ROHR KPL. 25X3X2068	96 51 694 08	403	1	2 998	91 56 540 08	ROHRLEITUNGEN OBERWAGE
ROHR KPL. 25X3X2133	96 53 064 08	353	1	2 998	91 56 540 08	ROHRLEITUNGEN OBERWAGE
ROHR KPL. 25X3X2160	96 52 304 08	163	1	2 978 205	96 47 115 08	ROHRLEITUNGEN S-RUECKH
ROHR KPL. 25X3X2240	96 54 090 08	346	1	2 998	91 56 540 08	ROHRLEITUNGEN OBERWAGE
ROHR KPL. 25X3X2376	96 55 074 08	498	1	2 978 108	96 44 195 08	ROHRLEITUNGEN DERRICK
ROHR KPL. 25X3X2414	96 51 678 08	385	1	2 998	91 56 540 08	ROHRLEITUNGEN OBERWAGE
ROHR KPL. 25X3X2435	96 53 063 08	357	1	2 998	91 56 540 08	ROHRLEITUNGEN OBERWAGE
ROHR KPL. 25X3X2489	96 53 060 08	359	1	2 998	91 56 540 08	ROHRLEITUNGEN OBERWAGE
ROHR KPL. 25X3X2664	96 52 307 08	166	1	2 978 205	96 47 115 08	ROHRLEITUNGEN S-RUECKH
ROHR KPL. 25X3X2790	96 53 058 08	355	1	2 998	91 56 540 08	ROHRLEITUNGEN OBERWAGE
ROHR KPL. 25X3X3014	96 52 306 08	165	1	2 978 205	96 47 115 08	ROHRLEITUNGEN S-RUECKH
ROHR KPL. 25X3X325	96 55 073 08	497	1	2 978 108	96 44 195 08	ROHRLEITUNGEN DERRICK
ROHR KPL. 25X3X3544	96 52 305 08	164	1	2 978 205	96 47 115 08	ROHRLEITUNGEN S-RUECKH
ROHR KPL. 25X3X3800	96 54 091 08	347	1	2 998	91 56 540 08	ROHRLEITUNGEN OBERWAGE
ROHR KPL. 25X3X495	96 51 725 08	434	1	2 998	91 56 540 08	ROHRLEITUNGEN OBERWAGE
ROHR KPL. 25X3X551	96 53 062 08	360	1	2 998	91 56 540 08	ROHRLEITUNGEN OBERWAGE
ROHR KPL. 25X3X636	96 53 065 08	358	1	2 998	91 56 540 08	ROHRLEITUNGEN OBERWAGE
ROHR KPL. 25X3X748	96 51 693 08	402	1	2 998	91 56 540 08	ROHRLEITUNGEN OBERWAGE
ROHR KPL. 25X3X778	96 51 692 08	401	1	2 998	91 56 540 08	ROHRLEITUNGEN OBERWAGE
ROHR KPL. 28X2X1115	96 54 094 08	344	1	2 998	91 56 540 08	ROHRLEITUNGEN OBERWAGE
ROHR KPL. 28X2X1186	96 51 665 08	372	1	2 998	91 56 540 08	ROHRLEITUNGEN OBERWAGE
ROHR KPL. 28X2X1216	96 51 544 08	352	1	2 998	91 56 540 08	ROHRLEITUNGEN OBERWAGE
ROHR KPL. 28X2X1315	96 51 755 08	149	1	2 978 205	96 47 115 08	ROHRLEITUNGEN S-RUECKH
ROHR KPL. 28X2X137	96 51 750 08	144	1	2 978 205	96 47 115 08	ROHRLEITUNGEN S-RUECKH
ROHR KPL. 28X2X1466	96 51 717 08	426	1	2 998	91 56 540 08	ROHRLEITUNGEN OBERWAGE
ROHR KPL. 28X2X1570	96 51 754 08	148	1	2 978 205	96 47 115 08	ROHRLEITUNGEN S-RUECKH
ROHR KPL. 28X2X160	96 51 662 08	369	1	2 998	91 56 540 08	ROHRLEITUNGEN OBERWAGE
ROHR KPL. 28X2X1725	96 54 098 08	373	1	2 998	91 56 540 08	ROHRLEITUNGEN OBERWAGE
ROHR KPL. 28X2X1805	96 51 711 08	420	1	2 998	91 56 540 08	ROHRLEITUNGEN OBERWAGE
ROHR KPL. 28X2X1888	96 54 089 08	343	1	2 998	91 56 540 08	ROHRLEITUNGEN OBERWAGE
ROHR KPL. 28X2X1920	96 54 096 08	351	1	2 998	91 56 540 08	ROHRLEITUNGEN OBERWAGE
ROHR KPL. 28X2X2015	96 48 912 08	735	2	1 998	91 52 513 08	ROHRLEITUNGEN RAUPE
ROHR KPL. 28X2X2191	96 54 093 08	349	1	2 998	91 56 540 08	ROHRLEITUNGEN OBERWAGE
ROHR KPL. 28X2X2256	96 48 911 08	734	2	1 998	91 52 513 08	ROHRLEITUNGEN RAUPE
ROHR KPL. 28X2X2356	96 55 064 08	488	1	2 975 155	96 50 586 08	ROHRLEITUNGEN WINDE
ROHR KPL. 28X2X2498	96 52 311 08	170	1	2 978 205	96 47 115 08	ROHRLEITUNGEN S-RUECKH
ROHR KPL. 28X2X2882	96 48 927 08	705	2	1 998	91 52 513 08	ROHRLEITUNGEN RAUPE
ROHR KPL. 28X2X2896	96 52 309 08	168	1	2 978 205	96 47 115 08	ROHRLEITUNGEN S-RUECKH
ROHR KPL. 28X2X2917	96 52 308 08	167	1	2 978 205	96 47 115 08	ROHRLEITUNGEN S-RUECKH
ROHR KPL. 28X2X3108	96 54 103 08	397	1	2 998	91 56 540 08	ROHRLEITUNGEN OBERWAGE
ROHR KPL. 28X2X3255	96 52 310 08	169	1	2 978 205	96 47 115 08	ROHRLEITUNGEN S-RUECKH
ROHR KPL. 28X2X513	96 51 661 08	368	1	2 998	91 56 540 08	ROHRLEITUNGEN OBERWAGE
ROHR KPL. 28X2X829	96 54 097 08	366	1	2 998	91 56 540 08	ROHRLEITUNGEN OBERWAGE

6.2.2009

etk_en_de_074515 LR 1600/2

1065

LIEBHERRAlphabetical index
Alphabetischer Index

Bezeichnung	Artikel	Pos.	Menge	Seite	Baugruppe	Bezeichnung
ROHR KPL. 28X2X880	96 51 718 08	427	1	2 998	91 56 540 08	ROHRLEITUNGEN OBERWAGE
ROHR KPL. 28X2X945	96 53 066 08	367	1	2 998	91 56 540 08	ROHRLEITUNGEN OBERWAGE
ROHR KPL. 28X2X946	96 48 926 08	704	2	1 998	91 52 513 08	ROHRLEITUNGEN RAUPE
ROHR KPL. 28X2X973	96 55 051 08	475	1	3 978 106	96 50 885 08	ROHRLEITUNGEN SCHWEBEB
ROHR KPL. 30X4X115	96 53 054 08	340	2	2 998	91 56 540 08	ROHRLEITUNGEN OBERWAGE
ROHR KPL. 30X4X125	96 55 050 08	474	1	3 978 106	96 50 885 08	ROHRLEITUNGEN SCHWEBEB
ROHR KPL. 30X4X1733	96 51 733 08	182	1	2 978 102	96 47 913 08	ROHRLEITUNGEN MONTAGEE
ROHR KPL. 30X4X2042	96 55 042 08	228	1	3 978 010	96 50 882 08	ROHRLEITUNGEN DERR.KOP
ROHR KPL. 30X4X2055	96 55 044 08	230	1	3 978 010	96 50 882 08	ROHRLEITUNGEN DERR.KOP
ROHR KPL. 30X4X2154	96 55 041 08	227	1	3 978 010	96 50 882 08	ROHRLEITUNGEN DERR.KOP
ROHR KPL. 30X4X2172	96 55 043 08	229	1	3 978 010	96 50 882 08	ROHRLEITUNGEN DERR.KOP
ROHR KPL. 30X4X3030	96 54 121 08	386	1	2 998	91 56 540 08	ROHRLEITUNGEN OBERWAGE
ROHR KPL. 30X4X3221	96 51 734 08	183	1	2 978 102	96 47 913 08	ROHRLEITUNGEN MONTAGEE
ROHR KPL. 30X4X3500	96 51 731 08	180	2	2 978 102	96 47 913 08	ROHRLEITUNGEN MONTAGEE
ROHR KPL. 30X4X5473	96 51 735 08	184	2	2 978 102	96 47 913 08	ROHRLEITUNGEN MONTAGEE
ROHR KPL. 30X4X654	96 51 732 08	181	1	2 978 102	96 47 913 08	ROHRLEITUNGEN MONTAGEE
ROHR KPL. 35X2X1149	96 51 684 08	393	1	2 998	91 56 540 08	ROHRLEITUNGEN OBERWAGE
ROHR KPL. 35X2X1409	96 51 685 08	394	1	2 998	91 56 540 08	ROHRLEITUNGEN OBERWAGE
ROHR KPL. 35X2X1518	96 51 686 08	395	1	2 998	91 56 540 08	ROHRLEITUNGEN OBERWAGE
ROHR KPL. 35X2X1749	96 51 709 08	418	1	2 998	91 56 540 08	ROHRLEITUNGEN OBERWAGE
ROHR KPL. 35X2X1900	96 53 067 08	413	1	2 998	91 56 540 08	ROHRLEITUNGEN OBERWAGE
ROHR KPL. 35X2X2055	96 55 055 08	479	1	3 978 106	96 50 885 08	ROHRLEITUNGEN SCHWEBEB
ROHR KPL. 35X2X2265	96 55 054 08	478	1	3 978 106	96 50 885 08	ROHRLEITUNGEN SCHWEBEB
ROHR KPL. 35X2X483	96 53 051 08	364	1	2 998	91 56 540 08	ROHRLEITUNGEN OBERWAGE
ROHR KPL. 35X2X549	96 51 727 08	436	1	2 998	91 56 540 08	ROHRLEITUNGEN OBERWAGE
ROHR KPL. 35X2X652	96 53 061 08	419	1	2 998	91 56 540 08	ROHRLEITUNGEN OBERWAGE
ROHR KPL. 35X2X699	96 51 714 08	423	1	2 998	91 56 540 08	ROHRLEITUNGEN OBERWAGE
ROHR KPL. 35X2X720	96 51 689 08	398	1	2 998	91 56 540 08	ROHRLEITUNGEN OBERWAGE
ROHR KPL. 35X2X765	96 51 720 08	429	1	2 998	91 56 540 08	ROHRLEITUNGEN OBERWAGE
ROHR KPL. 35X2X828	96 54 101 08	392	1	2 998	91 56 540 08	ROHRLEITUNGEN OBERWAGE
ROHR KPL. 35X2X85	96 54 086 08	244	1	2 998	91 56 540 08	ROHRLEITUNGEN OBERWAGE
ROHR KPL. 35X2X914	96 54 088 08	338	1	2 998	91 56 540 08	ROHRLEITUNGEN OBERWAGE
ROHR KPL. 35X2X939	96 51 705 08	414	1	2 998	91 56 540 08	ROHRLEITUNGEN OBERWAGE
ROHR KPL. 35X2X95	96 53 052 08	365	1	2 998	91 56 540 08	ROHRLEITUNGEN OBERWAGE
ROHR KPL. 35X2X990	96 51 721 08	430	1	2 998	91 56 540 08	ROHRLEITUNGEN OBERWAGE
ROHR KPL. 38X4X1013	96 51 350 08	(280)	1	2 975 700	91 52 774 08	ZUSATZHYDRAULIK WINDE 1
ROHR KPL. 38X4X1049	96 48 922 08	700	2	1 998	91 52 513 08	ROHRLEITUNGEN RAUPE
ROHR KPL. 38X4X1050	96 48 924 08	702	2	1 998	91 52 513 08	ROHRLEITUNGEN RAUPE
ROHR KPL. 38X4X1133	96 51 336 08	266	1	2 998	91 56 540 08	ROHRLEITUNGEN OBERWAGE
ROHR KPL. 38X4X1141	96 51 519 08	327	1	2 998	91 56 540 08	ROHRLEITUNGEN OBERWAGE
ROHR KPL. 38X4X1213	96 51 506 08	314	1	2 998	91 56 540 08	ROHRLEITUNGEN OBERWAGE
ROHR KPL. 38X4X1232	96 51 515 08	323	1	2 998	91 56 540 08	ROHRLEITUNGEN OBERWAGE
ROHR KPL. 38X4X1243	96 51 522 08	330	1	2 998	91 56 540 08	ROHRLEITUNGEN OBERWAGE
ROHR KPL. 38X4X1264	96 51 520 08	328	1	2 998	91 56 540 08	ROHRLEITUNGEN OBERWAGE
ROHR KPL. 38X4X1369	96 51 334 08	265	1	2 998	91 56 540 08	ROHRLEITUNGEN OBERWAGE
ROHR KPL. 38X4X1595	96 53 050 08	325	1	2 998	91 56 540 08	ROHRLEITUNGEN OBERWAGE
ROHR KPL. 38X4X1602	96 51 527 08	335	1	2 998	91 56 540 08	ROHRLEITUNGEN OBERWAGE
ROHR KPL. 38X4X1608	96 53 048 08	321	1	2 998	91 56 540 08	ROHRLEITUNGEN OBERWAGE
ROHR KPL. 38X4X1632	96 51 510 08	318	1	2 998	91 56 540 08	ROHRLEITUNGEN OBERWAGE
ROHR KPL. 38X4X1648	96 51 526 08	334	1	2 998	91 56 540 08	ROHRLEITUNGEN OBERWAGE
ROHR KPL. 38X4X1670	96 51 511 08	319	1	2 998	91 56 540 08	ROHRLEITUNGEN OBERWAGE
ROHR KPL. 38X4X1698	96 54 148 08	211	1	3 978 010	96 50 882 08	ROHRLEITUNGEN DERR.KOP
ROHR KPL. 38X4X1726	96 53 044 08	313	1	2 998	91 56 540 08	ROHRLEITUNGEN OBERWAGE
ROHR KPL. 38X4X1745	96 53 046 08	317	1	2 998	91 56 540 08	ROHRLEITUNGEN OBERWAGE
ROHR KPL. 38X4X1752	96 53 042 08	311	1	2 998	91 56 540 08	ROHRLEITUNGEN OBERWAGE
ROHR KPL. 38X4X1761	96 51 524 08	332	1	2 998	91 56 540 08	ROHRLEITUNGEN OBERWAGE
ROHR KPL. 38X4X1767	96 55 028 08	214	1	3 978 010	96 50 882 08	ROHRLEITUNGEN DERR.KOP
ROHR KPL. 38X4X2010	96 51 507 08	315	1	2 998	91 56 540 08	ROHRLEITUNGEN OBERWAGE
ROHR KPL. 38X4X2025	96 51 491 08	300	1	2 998	91 56 540 08	ROHRLEITUNGEN OBERWAGE
ROHR KPL. 38X4X2030	96 53 041 08	310	1	2 998	91 56 540 08	ROHRLEITUNGEN OBERWAGE

6.2.2009

etk_en_de_074515 LR 1600/2

1066

LIEBHERRAlphabetical index
Alphabetischer Index

Bezeichnung	Artikel	Pos.	Menge	Seite	Baugruppe	Bezeichnung
ROHR KPL. 38X4X2035	96 48 909 08	732	2	1 998	91 52 513 08	ROHRLEITUNGEN RAUPE
ROHR KPL. 38X4X2041	96 55 052 08	476	1	3 978 106	96 50 885 08	ROHRLEITUNGEN SCHWEBEB
ROHR KPL. 38X4X2062	96 51 492 08	301	1	2 998	91 56 540 08	ROHRLEITUNGEN OBERWAGE
ROHR KPL. 38X4X2066	96 54 149 08	212	1	3 978 010	96 50 882 08	ROHRLEITUNGEN DERR.KOP
ROHR KPL. 38X4X2133	96 54 150 08	213	1	3 978 010	96 50 882 08	ROHRLEITUNGEN DERR.KOP
ROHR KPL. 38X4X2184	96 51 514 08	322	1	2 998	91 56 540 08	ROHRLEITUNGEN OBERWAGE
ROHR KPL. 38X4X2195	96 55 029 08	215	1	3 978 010	96 50 882 08	ROHRLEITUNGEN DERR.KOP
ROHR KPL. 38X4X2200	96 55 053 08	477	1	3 978 106	96 50 885 08	ROHRLEITUNGEN SCHWEBEB
ROHR KPL. 38X4X2224	96 48 908 08	731	2	1 998	91 52 513 08	ROHRLEITUNGEN RAUPE
ROHR KPL. 38X4X2226	96 54 147 08	210	1	3 978 010	96 50 882 08	ROHRLEITUNGEN DERR.KOP
ROHR KPL. 38X4X2308	96 48 910 08	733	2	1 998	91 52 513 08	ROHRLEITUNGEN RAUPE
ROHR KPL. 38X4X2308	96 51 529 08	337	1	2 998	91 56 540 08	ROHRLEITUNGEN OBERWAGE
ROHR KPL. 38X4X2326	96 51 518 08	326	1	2 998	91 56 540 08	ROHRLEITUNGEN OBERWAGE
ROHR KPL. 38X4X2409	96 55 147 08	302	1	2 998	91 56 540 08	ROHRLEITUNGEN OBERWAGE
ROHR KPL. 38X4X2411	96 51 333 08	264	1	2 998	91 56 540 08	ROHRLEITUNGEN OBERWAGE
ROHR KPL. 38X4X2447	96 48 907 08	730	2	1 998	91 52 513 08	ROHRLEITUNGEN RAUPE
ROHR KPL. 38X4X2571	96 51 523 08	331	1	2 998	91 56 540 08	ROHRLEITUNGEN OBERWAGE
ROHR KPL. 38X4X2609	96 55 148 08	303	1	2 998	91 56 540 08	ROHRLEITUNGEN OBERWAGE
ROHR KPL. 38X4X2674	96 55 063 08	487	1	2 975 155	96 50 586 08	ROHRLEITUNGEN WINDE
ROHR KPL. 38X4X2700	96 55 062 08	486	1	2 975 155	96 50 586 08	ROHRLEITUNGEN WINDE
ROHR KPL. 38X4X2737	96 51 521 08	329	1	2 998	91 56 540 08	ROHRLEITUNGEN OBERWAGE
ROHR KPL. 38X4X2763	96 51 525 08	333	1	2 998	91 56 540 08	ROHRLEITUNGEN OBERWAGE
ROHR KPL. 38X4X2779	96 48 923 08	701	2	1 998	91 52 513 08	ROHRLEITUNGEN RAUPE
ROHR KPL. 38X4X2783	96 48 925 08	703	2	1 998	91 52 513 08	ROHRLEITUNGEN RAUPE
ROHR KPL. 38X4X2843	96 51 528 08	336	1	2 998	91 56 540 08	ROHRLEITUNGEN OBERWAGE
ROHR KPL. 38X4X3213	96 58 312 08	307	1	2 998	91 56 540 08	ROHRLEITUNGEN OBERWAGE
ROHR KPL. 38X4X3240	96 51 496 08	305	1	2 998	91 56 540 08	ROHRLEITUNGEN OBERWAGE
ROHR KPL. 38X4X3272	96 53 045 08	316	1	2 998	91 56 540 08	ROHRLEITUNGEN OBERWAGE
ROHR KPL. 38X4X3302	96 53 043 08	312	1	2 998	91 56 540 08	ROHRLEITUNGEN OBERWAGE
ROHR KPL. 38X4X3645	96 51 497 08	306	1	2 998	91 56 540 08	ROHRLEITUNGEN OBERWAGE
ROHR KPL. 38X4X3935	96 55 047 08	471	1	3 978 106	96 50 885 08	ROHRLEITUNGEN SCHWEBEB
ROHR KPL. 38X4X3974	96 51 495 08	304	1	2 998	91 56 540 08	ROHRLEITUNGEN OBERWAGE
ROHR KPL. 38X4X4000	96 53 049 08	324	1	2 998	91 56 540 08	ROHRLEITUNGEN OBERWAGE
ROHR KPL. 38X4X4004	96 53 047 08	320	1	2 998	91 56 540 08	ROHRLEITUNGEN OBERWAGE
ROHR KPL. 38X4X4015	96 55 046 08	470	1	3 978 106	96 50 885 08	ROHRLEITUNGEN SCHWEBEB
ROHR KPL. 38X4X4400	96 54 144 08	461	1	3 978 007	96 50 879 08	ROHRLEITUNGEN DERR.ZWI
ROHR KPL. 38X4X4400	96 54 145 08	462	1	3 978 007	96 50 879 08	ROHRLEITUNGEN DERR.ZWI
ROHR KPL. 38X4X495	96 51 332 08	263	1	2 998	91 56 540 08	ROHRLEITUNGEN OBERWAGE
ROHR KPL. 38X4X5190	96 55 090 08	(452)	1	3 978 015	91 56 429 08	ZUSATZHYDRAULIK ZWISCH
ROHR KPL. 38X4X5190	96 55 091 08	(453)	1	3 978 015	91 56 429 08	ZUSATZHYDRAULIK ZWISCH
ROHR KPL. 38X4X5190	96 55 092 08	(454)	1	3 978 015	91 56 429 08	ZUSATZHYDRAULIK ZWISCH
ROHR KPL. 38X4X5190	96 55 093 08	(455)	1	3 978 015	91 56 429 08	ZUSATZHYDRAULIK ZWISCH
ROHR KPL. 38X4X564	96 51 330 08	261	1	2 998	91 56 540 08	ROHRLEITUNGEN OBERWAGE
ROHR KPL. 38X4X572	96 51 331 08	262	1	2 998	91 56 540 08	ROHRLEITUNGEN OBERWAGE
ROHR KPL. 38X4X681	96 51 500 08	309	1	2 998	91 56 540 08	ROHRLEITUNGEN OBERWAGE
ROHR KPL. 38X4X779	96 51 329 08	260	1	2 998	91 56 540 08	ROHRLEITUNGEN OBERWAGE
ROHR KPL. 38X4X914	96 51 499 08	308	1	2 998	91 56 540 08	ROHRLEITUNGEN OBERWAGE
ROHR KPL. 42X3X1020	96 51 341 08	232	1	2 998	91 56 540 08	ROHRLEITUNGEN OBERWAGE
ROHR KPL. 42X3X1033	96 51 707 08	416	1	2 998	91 56 540 08	ROHRLEITUNGEN OBERWAGE
ROHR KPL. 42X3X1109	96 51 703 08	412	1	2 998	91 56 540 08	ROHRLEITUNGEN OBERWAGE
ROHR KPL. 42X3X115	96 54 106 08	415	1	2 998	91 56 540 08	ROHRLEITUNGEN OBERWAGE
ROHR KPL. 42X3X1279	96 54 095 08	350	1	2 998	91 56 540 08	ROHRLEITUNGEN OBERWAGE
ROHR KPL. 42X3X150	96 51 344 08	236	1	2 998	91 56 540 08	ROHRLEITUNGEN OBERWAGE
ROHR KPL. 42X3X1555	96 51 719 08	428	1	2 998	91 56 540 08	ROHRLEITUNGEN OBERWAGE
ROHR KPL. 42X3X200	96 51 343 08	235	1	2 998	91 56 540 08	ROHRLEITUNGEN OBERWAGE
ROHR KPL. 42X3X345	96 54 092 08	348	1	2 998	91 56 540 08	ROHRLEITUNGEN OBERWAGE
ROHR KPL. 42X3X508	96 51 708 08	417	1	2 998	91 56 540 08	ROHRLEITUNGEN OBERWAGE
ROHR KPL. 42X3X625	96 51 702 08	411	1	2 998	91 56 540 08	ROHRLEITUNGEN OBERWAGE
ROHR KPL. 42X3X732	96 51 716 08	425	1	2 998	91 56 540 08	ROHRLEITUNGEN OBERWAGE
ROHR KPL. 42X3X791	96 51 712 08	421	1	2 998	91 56 540 08	ROHRLEITUNGEN OBERWAGE

6.2.2009

etk_en_de_074515 LR 1600/2

1067

LIEBHERRAlphabetical index
Alphabetischer Index

Bezeichnung	Artikel	Pos.	Menge	Seite	Baugruppe	Bezeichnung
ROHR KPL. 42X3X796	96 54 087 08	243	1	2 998	91 56 540 08	ROHRLEITUNGEN OBERWAGE
ROHR KPL. 42X3X911	96 51 713 08	422	1	2 998	91 56 540 08	ROHRLEITUNGEN OBERWAGE
ROHR KPL. 42X3X935	96 51 715 08	424	1	2 998	91 56 540 08	ROHRLEITUNGEN OBERWAGE
ROHR KPL. 6X1X216	96 48 933 08	708	1	1 998	91 52 513 08	ROHRLEITUNGEN RAUPE
ROHR KPL. 6X1X316	96 51 675 08	382	1	2 998	91 56 540 08	ROHRLEITUNGEN OBERWAGE
ROHR KPL. 6X1X387	96 55 037 08	223	1	3 978 010	96 50 882 08	ROHRLEITUNGEN DERR.KOP
ROHR KPL. 6X1X525	96 55 038 08	224	1	3 978 010	96 50 882 08	ROHRLEITUNGEN DERR.KOP
ROHR KPL. 6X1X555	96 55 039 08	225	1	3 978 010	96 50 882 08	ROHRLEITUNGEN DERR.KOP
ROHR KPL. 6X1X563	96 55 040 08	226	1	3 978 010	96 50 882 08	ROHRLEITUNGEN DERR.KOP
ROHR KPL. 6X1X773	96 48 898 08	(762)	4	1 975 006	91 52 509 08	ZUSATZHYDR.ABSTUETZZYL
ROHR KPL. 6X1X824	96 55 036 08	222	1	3 978 010	96 50 882 08	ROHRLEITUNGEN DERR.KOP
ROHR KPL. 8X1X318	96 51 342 08	234	2	2 998	91 56 540 08	ROHRLEITUNGEN OBERWAGE
ROHR KPL.LI.	96 51 173 08	7	1	3 214	91 52 843 08	SW-KOPFSTUECK
ROHR KPL.RE.	96 51 174 08	8	1	3 214	91 52 843 08	SW-KOPFSTUECK
ROHR RD101,6X10X1388	95 66 948 08	1	1	3 211 008	96 46 978 08	SCHUTZWALZE KPL.
ROHR SCHWK.	96 44 583 08	5	2	2 340	91 52 776 08	WINDE 4 EINZIEHWERK
ROHR SCHWK.	96 45 705 08	2	1	2 522	91 54 115 08	SCHIEBETUER KPL.
ROHR SCHWK.	96 48 606 08	31	1	2 391 001	96 45 719 08	DIESELMOTOR VORM.
ROHR VORM.	96 47 854 08	22	1	2 671 004	96 46 305 08	OELBEHAELTER VORM.
ROHRLEITUNG	77 43 780 08	(2)	1	2 711	91 52 800 08	ZENTRALSCHMIERANLAGE O
ROHRLEITUNG ANBAU	97 39 356	16	1	9 739 358	97 39 358	ABGASRUECKFUEHRUNG AN
ROHRLEITUNG ANBAU	97 39 492	143	1	X1012059	10 12 059 0	DIESELMOTOR
ROHRLEITUNGEN ABSTUETZZ	96 47 505 08	93	1	1 975 006	91 52 509 08	ZUSATZHYDR.ABSTUETZZYL
ROHRLEITUNGEN BOLZENZIE	96 46 081 08	90	1	2 976 203	92 27 489 08	ZUSATZHYDR.BOLZENZIEHZ
ROHRLEITUNGEN DERR.KOP	96 50 882 08	93	1	3 978 005	91 56 430 08	ZUSATZHYDRAULIK SB-KOPFS
ROHRLEITUNGEN DERR.ZWIS	96 50 884 08	93	1	3 978 015	91 56 429 08	ZUSATZHYDRAULIK ZWISCH
ROHRLEITUNGEN DERR.ZWI	96 50 879 08	93	1	3 978 015	91 56 432 08	ZUSATZHYDRAULIK ZWISCH
ROHRLEITUNGEN DERRICK	96 44 195 08	93	1	2 978 100	91 52 827 08	ZUSATZHYDR.D-RUECKHALT
ROHRLEITUNGEN MONTAGEEI	96 47 913 08	93	1	2 978 100	91 52 796 08	ZUSATZHYDR.MONTAGEEINR
ROHRLEITUNGEN MONTAGE	96 47 540 08	93	1	2 975 000	91 57 881 08	ZUSATZHYDRAULIK MONTAGE
ROHRLEITUNGEN OBERWAGE	91 56 540 08	181	1		LR 1600-2-0	LIEBHERR RAUPENKRAN LR 1
ROHRLEITUNGEN RAUPE MIT	91 52 513 08	37	1		LR 1600-2-0	LIEBHERR RAUPENKRAN LR 1
ROHRLEITUNGEN S-RUECKHA	96 47 115 08	93	1	2 978 200	91 54 843 08	ZUSATZHYDR.S-RUECKHALTE
ROHRLEITUNGEN SCHWEBEB.	96 50 885 08	93	1	3 978 100	91 56 428 08	HYDR.SCHWEBEBALLAST-AN
ROHRLEITUNGEN WINDE I+II	96 51 219 08	93	1	2 975 200	91 52 775 08	ZUSATZHYDRAULIK WINDE 2
ROHRLEITUNGEN WINDE I+II	96 51 219 08	93	1	2 975 700	91 52 774 08	ZUSATZHYDRAULIK WINDE 1
ROHRLEITUNGEN WINDE III	96 50 586 08	93	1	2 975 100	91 52 860 08	ZUSATZHYDRAULIK WINDE 3
ROHRMUTTER DIN 431 A-G1/4	41 01 500 08	23	1	2 932 160	96 54 385 08	SCHALTSCHRANK MECH.
ROHRNIET DIN 7340 B2,5X0,3	44 33 003 08	19	14	2 922 001	92 84 311 08	BUSPLATINE
ROHRSCHELLE	10 01 265 5	11	1	9 739 288	97 39 288	KRAFTSTOFFLEITUNG
ROHRSCHELLE	10 22 274 3	7	1	9 739 369	97 39 369	DRUCKROHR
ROHRSCHELLE 18 A4C	10 47 687 9	18	1	9 739 386	97 39 386	KURBELGEHAEUSEENTLUEFT
ROHRSCHELLE 32.2 UST37-2	10 01 265 3	23	3	9 739 492	97 39 492	ROHRLEITUNG ANBAU
ROHRSCHELLE 33/20	77 42 250 08	6	1	2 541 001	96 49 651 08	ZUSATZHEIZUNG VORM.
ROHRSCHELLE 43/20	77 42 217 08	18	3	2 541	91 52 790 08	ZUSATZHEIZUNG OW
ROHRSCHELLE DIN 71555 60,	10 03 723 0	7	1	9 739 210	97 39 210	KUEHLMITTELLEITUNG
ROHRSCHELLE DIN 71555 60,	55 20 506 08	126	4	2 391 001	96 45 719 08	DIESELMOTOR VORM.
ROHRSTUTZEN	10 01 242 4	8	1	9 739 248	97 39 248	EINSPRITZDUESE
ROHRSTUTZEN GSCK45	95 46 242 08	10	1	2 540	91 53 253 08	HEIZKLIMAGERAET EINBAU
ROHRWENDEL	77 43 835 08	10	14	1 711	91 52 392 08	ZENTRALSCHMIERUNG RAUP
ROLLE	10 66 425 0	430	1	X1041101	10 41 101 5	RUECKFALLSTUETZE
ROLLE	10 66 425 0	410	1	X1041101	10 41 101 8	RUECKFALLSTUETZE
ROLLE	97 66 501 08	18	2	3 220 500	91 52 849 08	S-ZWISCHENSTUECK
ROLLE	97 66 501 08	18	2	3 223	91 52 852 08	S-ZWISCHENSTUECK
ROLLE	97 66 501 08	18	2	3 223 010	91 52 853 08	S-ZWISCHENSTUECK
ROLLE	97 66 501 08	18	2	3 223 100	91 55 327 08	S-ZWISCHENSTUECK
ROLLE 40.5X100X80 PA6G	94 37 683 08	17	10	3 215 005	91 52 846 08	ROLLENSATZ
ROLLE 40.5X100X80 PA6G	94 37 683 08	17	12	3 215 006	91 52 847 08	ROLLENSATZ
ROLLE 470X140 PA6GZAEHH	97 71 970 08	16	2	3 208 001	91 52 883 08	F-KOPFSTUECK
ROLLE PA6G	97 66 500 08	17	2	3 220 500	91 52 849 08	S-ZWISCHENSTUECK

6.2.2009

etk_en_de_074515 LR 1600/2

1068

LIEBHERRAlphabetical index
Alphabetischer Index

Bezeichnung	Artikel	Pos.	Menge	Seite	Baugruppe	Bezeichnung
ROLLE PA6G	97 66 500 08	17	4	3 223	91 52 852 08	S-ZWISCHENSTUECK
ROLLE PA6G	97 66 500 08	17	4	3 223 010	91 52 853 08	S-ZWISCHENSTUECK
ROLLE PA6G	97 66 500 08	17	4	3 223 100	91 55 327 08	S-ZWISCHENSTUECK
ROLLE PA6G	97 68 888 08	5	2	2 522 012	96 45 884 08	FUEHRUNG VORM.
ROLLE PA6G	97 68 888 08	6	4	2 522 013	96 45 883 08	FUEHRUNG VORM.
ROLLE PA6G	97 80 631 08	49	2	3 220 500	91 52 849 08	S-ZWISCHENSTUECK
ROLLE PA6G	97 80 631 08	49	2	3 223	91 52 852 08	S-ZWISCHENSTUECK
ROLLE PA6G	97 80 631 08	49	2	3 223 010	91 52 853 08	S-ZWISCHENSTUECK
ROLLE PA6G	97 80 631 08	49	2	3 223 100	91 55 327 08	S-ZWISCHENSTUECK
ROLLE RD100X200 PA6G	93 24 583 08	43	2	3 206	91 52 881 08	F-ANLENKSTUECK
ROLLE RD100X80 PA6G	28 81 883 08	8	2	3 713	91 57 749 08	D-ANLENKSTUECK
ROLLE RD180X98 PA6G	93 99 680 08	17	4	3 208 001	91 52 883 08	F-KOPFSTUECK
ROLLE RD68X20 PA6G	28 30 961 08	34	2	3 206	91 52 881 08	F-ANLENKSTUECK
ROLLE RD68X20 PA6G	28 30 961 08	23	3	3 208 001	91 52 883 08	F-KOPFSTUECK
ROLLE RD75X120 PA6G	93 89 752 08	20	1	3 208 001	91 52 883 08	F-KOPFSTUECK
ROLLE RD75X70 PA6G	93 26 439 08	42	5	3 208 001	91 52 883 08	F-KOPFSTUECK
ROLLE RD80X40 PA6G	93 01 339 08	19	4	3 215 005	91 52 846 08	ROLLENSATZ
ROLLE RD80X40 PA6G	93 01 339 08	19	4	3 215 006	91 52 847 08	ROLLENSATZ
ROLLE SCHWK.	92 70 643 08	1	1	3 350 001	92 70 642 08	SCHUTZWALZE KPL.
ROLLE X20CR13 X20CR13	97 81 003 08	16	4	2 522 013	96 45 883 08	FUEHRUNG VORM.
ROLLENDREHVERBINDUNG	91 52 793 08	137	1		LR 1600-2-0	LIEBHERR RAUPENKRAN LR 1
ROLLENDREHVERBINDUNG	99 07 151 01	1	1	2 620	91 52 793 08	ROLLENDREHVERBINDUNG
ROLLENKOERPER RD230X70	95 44 255 08	1	1	1 400 017	92 51 976 08	ROLLENKOERPERHAELFTE K
ROLLENKOERPERHAELFTE 34	97 67 848 08	1	1	1 400 016	96 45 287 08	ROLLENKOERPERHAELFTE K
ROLLENKOERPERHAELFTE K	92 51 976 08	10	4	1 400	91 56 853 08	RAUPENTRAEGER KPL.LI.
ROLLENKOERPERHAELFTE K	92 51 976 08	10	4	1 410 300	91 56 855 08	RAUPENTRAEGER KPL.RE.
ROLLENKOERPERHAELFTE K	96 45 287 08	9	34	1 400	91 56 853 08	RAUPENTRAEGER KPL.LI.
ROLLENKOERPERHAELFTE K	96 45 287 08	9	34	1 410 300	91 56 855 08	RAUPENTRAEGER KPL.RE.
ROLLENLAGERUNG DREHBUE	91 52 794 08	138	1		LR 1600-2-0	LIEBHERR RAUPENKRAN LR 1
ROLLENLAGERUNG KPL.	96 49 271 08	7	1	3 714	91 52 862 08	D-KOPFSTUECK
ROLLENLAGERUNG SCHWK.	96 46 299 08	1	1	2 652	91 52 794 08	ROLLENLAGERUNG
ROLLENLAGERUNG SCHWK.	96 49 761 08	1	1	3 714 021	96 49 271 08	ROLLENLAGERUNG KPL.
ROLLENSATZ 300T	91 52 846 08	204	1		LR 1600-2-0	LIEBHERR RAUPENKRAN LR 1
ROLLENSATZ 320T	91 52 847 08	205	1		LR 1600-2-0	LIEBHERR RAUPENKRAN LR 1
ROLLENSATZ SCHWK. 300T	96 48 667 08	1	1	3 215 005	91 52 846 08	ROLLENSATZ
ROLLENSATZ SCHWK. 320T	96 48 526 08	1	1	3 215 006	91 52 847 08	ROLLENSATZ
ROLLO	10 41 336 1	37	1	2 520	91 53 061 08	KABINE VERGLAST
ROLLO	10 41 336 2	38	1	2 520	91 53 061 08	KABINE VERGLAST
ROLLO	10 41 336 4	39	1	2 520	91 53 061 08	KABINE VERGLAST
RS DRUCKFILTER DF...330FG	10 10 138 4	(3)	1	2 970	91 56 537 08	HYDRAULIK
RS ROHRLEITUNG	97 39 322	11	1	9 739 386	97 39 386	KURBELGEHAEUSEENTLUEFT
RUECKENLEHNENGRIF	10 49 234 8	21	1	X1029200	10 29 200 4	FAHRERSITZ
RUECKENTEIL	10 49 234 5	1	1	X1029200	10 29 200 4	FAHRERSITZ
RUECKFALLSTUETZE 150/130	10 41 101 5	1	2	3 291	91 52 831 08	S-RUECKHALTESICHERUNG
RUECKFALLSTUETZE 150/140	10 41 101 8	1	2	3 292	91 52 865 08	D-RUECKHALTESICHERUNG
RUECKLAUFFILTER	51 06 691 08	9	1	2 671 004	96 46 305 08	OELBEHAELTER VORM.
RUECKLAUFLEISTE	77 43 758 08	21	2	2 711	91 52 800 08	ZENTRALSCHMIERANLAGE O
RUECKSCHLAGVENTIL	10 01 239 5	9	2	9 739 357	97 39 357	ABGASRUECKFUEHRUNG VO
RUECKSCHLAGVENTIL	10 34 334 2	2	1	9 739 356	97 39 356	ROHRLEITUNG ANBAU
RUECKSCHLAGVENTIL	10 45 104 8	6	1	X1042440	10 42 440 2	STUEBERBLOCK
RUECKSCHLAGVENTIL	51 04 087 08	37	1	2 970	91 56 537 08	HYDRAULIK
RUECKSCHLAGVENTIL	51 04 087 08	10	1	2 975 100	91 52 860 08	ZUSATZHYDRAULIK WINDE 3
RUECKSCHLAGVENTIL	51 04 087 08	10	1	2 975 200	91 52 775 08	ZUSATZHYDRAULIK WINDE 2
RUECKSCHLAGVENTIL	51 04 087 08	10	1	2 975 700	91 52 774 08	ZUSATZHYDRAULIK WINDE 1
RUECKSCHLAGVENTIL	51 04 121 08	18	1	1 970	91 56 958 08	HYDRAULIK RAUPE
RUECKSCHLAGVENTIL	51 04 121 08	20	1	2 970	91 56 537 08	HYDRAULIK
RUECKSCHLAGVENTIL	51 04 124 08	40	2	2 970	91 56 537 08	HYDRAULIK
RUECKSCHLAGVENTIL	51 04 124 08	14	1	2 975 200	91 52 775 08	ZUSATZHYDRAULIK WINDE 2
RUECKSCHLAGVENTIL	51 04 124 08	14	1	2 975 700	91 52 774 08	ZUSATZHYDRAULIK WINDE 1
RUECKSCHLAGVENTIL	51 04 129 08	19	1	1 970	91 56 958 08	HYDRAULIK RAUPE

6.2.2009

etk_en_de_074515 LR 1600/2

1069

LIEBHERRAlphabetical index
Alphabetischer Index

Bezeichnung	Artikel	Pos.	Menge	Seite	Baugruppe	Bezeichnung
RUECKSCHLAGVENTIL	51 14 351 08	78	2	2 970	91 56 537 08	HYDRAULIK
RUECKSCHLAGVENTIL	51 14 535 08	35	3	2 970	91 56 537 08	HYDRAULIK
RUECKSCHLAGVENTIL	51 14 606 08	5	1	2 975 100	91 52 860 08	ZUSATZHYDRAULIK WINDE 3
RUECKSCHLAGVENTIL	51 14 606 08	5	1	2 975 200	91 52 775 08	ZUSATZHYDRAULIK WINDE 2
RUECKSCHLAGVENTIL	51 14 606 08	5	1	2 975 700	91 52 774 08	ZUSATZHYDRAULIK WINDE 1
RUECKSCHLAGVENTIL	51 14 769 08	18	1	2 970	91 56 537 08	HYDRAULIK
RUECKSCHLAGVENTIL	51 14 815 08	11	2	1 970	91 56 958 08	HYDRAULIK RAUPE
RUECKSCHLAGVENTIL	51 14 815 08	51	1	2 970	91 56 537 08	HYDRAULIK
RUECKSCHLAGVENTIL	51 14 815 08	8	1	2 975 100	91 52 860 08	ZUSATZHYDRAULIK WINDE 3
RUECKSCHLAGVENTIL	51 14 815 08	8	1	2 975 200	91 52 775 08	ZUSATZHYDRAULIK WINDE 2
RUECKSCHLAGVENTIL	51 14 815 08	8	1	2 975 700	91 52 774 08	ZUSATZHYDRAULIK WINDE 1
RUECKSCHLAGVENTIL	51 14 815 08	11	1	3 978 005	91 56 430 08	ZUSATZHYDRAULIK SB-KOPFS
RUECKSCHLAGVENTIL	51 14 820 08	27	2	2 970	91 56 537 08	HYDRAULIK
RUECKSCHLAGVENTIL	51 14 937 08	14	1	2 975 100	91 52 860 08	ZUSATZHYDRAULIK WINDE 3
RUECKSCHLAGVENTIL	51 14 982 08	8	1	3 978 100	91 56 428 08	HYDR.SCHWEBEBALLAST-AN
RUECKSCHLAGVENTIL	57 19 038 08	48	1	5 113 086	51 13 086 08	PROPORTIONALVENTIL
RUECKSCHLAGVENTIL	59 10 556 08	16	2	2 520 032	96 45 980 08	SCHEIBENWISCHANLAGE EIN
RUECKSCHLAGVENTIL	76 22 803	(1)	1	2 711	91 52 800 08	ZENTRALSCHMIERANLAGE O
RUECKSCHLAGVENTIL	76 22 803	(2)	6	2 711	91 52 800 08	ZENTRALSCHMIERANLAGE O
RUECKSCHLAGVENTIL	76 22 803	(2)	6	2 711	91 52 800 08	ZENTRALSCHMIERANLAGE O
RUECKSCHLAGVENTIL	77 43 781 08	(1)	3	2 711	91 52 800 08	ZENTRALSCHMIERANLAGE O
RUECKSCHLAGVENTIL 350B	10 66 432 1	270	1	X1041101	10 41 101 5	RUECKFALLSTUETZE
RUECKSCHLAGVENTIL 350B	10 66 432 1	250	1	X1041101	10 41 101 8	RUECKFALLSTUETZE
RUECKSCHLAGVENTIL FE/ZN	51 14 469 08	9	1	2 975 000	91 57 881 08	ZUSATZHYDRAULIK MONTAGE
RUECKZUGPLATTE	57 01 138 08	7	1	5 701 129	57 01 129 08	TRIEBWERK
RUNDDICHTRING	10 22 273 5	3	1	9 739 248	97 39 248	EINSPRITZDUESE
RUNDDICHTRING	10 22 273 5	73	1	X1022281	10 22 281 7	DS ZYLINDERKOPF
RUNDDICHTRING 100X3 N-FP	10 33 210 8	11	1	9 739 278	97 39 278	ANBAUTEILE
RUNDDICHTRING 100X3 N-FP	10 33 210 8	2	1	X1034309	10 34 309 6	HOCHDRUCKPUMPE
RUNDDICHTRING 10X3 FPM1-	10 01 192 5	8	1	9 739 278	97 39 278	ANBAUTEILE
RUNDDICHTRING 12X2 ACM1	10 01 263 7	11	1	9 739 122	97 39 122	OELKUEHLER
RUNDDICHTRING 130X4 ACM1	10 01 263 8	10	1	9 739 122	97 39 122	OELKUEHLER
RUNDDICHTRING 138X3,5 FPM	10 01 263 5	3	1	9 739 278	97 39 278	ANBAUTEILE
RUNDDICHTRING 144X4 FPM2	10 01 264 1	3	2	9 739 242	97 39 242	ZYLINDERLAUFBUCHSE
RUNDDICHTRING 23X2,5 FPM	10 01 192 0	4	2	9 739 263	97 39 263	KIPPHEBELLAGERGEHAEUSE
RUNDDICHTRING 23X2,5 FPM	10 01 192 0	4	2	9 739 264	97 39 264	KIPPHEBELLAGERGEHAEUSE
RUNDDICHTRING 30X3,5 N-NB	10 01 263 4	6	1	9 739 386	97 39 386	KURBELGEHAEUSEENTLUEFT
RUNDDICHTRING 48X3 B-NB	10 01 185 2	8	1	9 739 258	97 39 258	KRAFTSTOFFFILTER
RUNDDICHTRING 59X3 B-FP	10 01 185 5	3	1	9 739 035	97 39 035	VERSCHLUSSTEIL
RUNDDICHTRING 59X3 B-FP	10 01 185 5	3	1	9 739 129	97 39 129	KUEHLMITTELVORWAERMUN
RUNDDICHTRING 60X4 B-NB	10 01 185 3	2	2	9 739 126	97 39 126	THERMOSTATGEHAEUSE
RUNDDICHTRING 63X2,5 FPM	10 01 192 1	125	1	2 391 001	96 45 719 08	DIESELMOTOR VORM.
RUNDDICHTRING 8X2 ACM1-6	10 01 263 6	12	1	9 739 122	97 39 122	OELKUEHLER
RUNDDICHTRING 91X4 N-NB	10 01 191 6	6	1	9 739 258	97 39 258	KRAFTSTOFFFILTER
RUNDDICHTRING 9X3 N-FPM1-	10 01 191 9	10	1	9 739 248	97 39 248	EINSPRITZDUESE
RUNDDICHTRING 9X3 N-FPM1-	10 01 191 9	76	1	X1022281	10 22 281 7	DS ZYLINDERKOPF
RUNDLAGER B40X30XM10	72 69 042 08	5	4	2 391 038	96 47 931 08	OELKUEHLER VORM.
RUNDLITZENSEIL 10MM 0,95M	10 65 281 3	39	1	3 214	91 52 843 08	SW-KOPFSTUECK
RUNDLITZENSEIL 10MM 1,75M	10 65 281 4	83	2	3 713	91 57 749 08	D-ANLENKSTUECK
RUNDLITZENSEIL 10MM 11,54	10 65 244 0	43	2	3 223	91 52 852 08	S-ZWISCHENSTUECK
RUNDLITZENSEIL 10MM 11,54	10 65 244 0	43	2	3 223 010	91 52 853 08	S-ZWISCHENSTUECK
RUNDLITZENSEIL 10MM 11,54	10 65 244 0	43	2	3 223 100	91 55 327 08	S-ZWISCHENSTUECK
RUNDLITZENSEIL 10MM 11,54	10 65 244 0	43	2	3 227	91 52 873 08	LI-ZWISCHENSTUECK
RUNDLITZENSEIL 10MM 11,54	10 65 244 0	43	2	3 227 008	91 52 872 08	LI-ZWISCHENSTUECK
RUNDLITZENSEIL 10MM 11,54	10 65 244 0	43	2	3 227 200	91 53 519 08	LI-ZWISCHENSTUECK F-ABSP
RUNDLITZENSEIL 10MM 11,54	10 65 244 0	32	2	3 716	91 52 864 08	D-ZWISCHENSTUECK
RUNDLITZENSEIL 10MM 2,54M	10 65 243 8	25	2	3 221	91 54 668 08	S-ZWISCHENSTUECK
RUNDLITZENSEIL 10MM 4,13M	10 65 280 6	82	2	3 211	91 57 748 08	S-ANLENKSTUECK
RUNDLITZENSEIL 10MM 5,54M	10 65 243 9	43	2	3 220 500	91 52 849 08	S-ZWISCHENSTUECK
RUNDLITZENSEIL 10MM 5,54M	10 65 243 9	43	2	3 226	91 52 870 08	LI-ZWISCHENSTUECK

6.2.2009

etk_en_de_074515 LR 1600/2

1070

LIEBHERRAlphabetical index
Alphabetischer Index

Bezeichnung	Artikel	Pos.	Menge	Seite	Baugruppe	Bezeichnung
RUNDLITZENSEIL 10MM 5,54M	10 65 243 9	34	2	3 715 008	91 52 863 08	D-ZWISCHENSTUECK
RUNDLITZENSEIL 10MM 6,3M	10 65 281 6	47	2	3 225	91 52 854 08	SL-REDUZIERSTUECK
RUNDLITZENSEIL 10MM 7,97M	10 65 281 8	43	2	3 714	91 52 862 08	D-KOPFSTUECK
RUNDSCHLINGE DIN EN 1492	10 28 562 6	41	2	3 220 500	91 52 849 08	S-ZWISCHENSTUECK
RUNDSCHLINGE DIN EN 1492	10 28 562 6	41	2	3 223	91 52 852 08	S-ZWISCHENSTUECK
RUNDSCHLINGE DIN EN 1492	10 28 562 6	41	2	3 223 010	91 52 853 08	S-ZWISCHENSTUECK
RUNDSCHLINGE DIN EN 1492	10 28 562 6	41	2	3 223 100	91 55 327 08	S-ZWISCHENSTUECK
RUNDSTAHL RD45X364	95 45 849 08	2	162	1 300 011	96 52 493 08	BODENPLATTEN VORM.
S-ANLENKSTUECK 10M	91 57 748 08	201	1		LR 1600-2-0	LIEBHERR RAUPENKRAN LR 1
S-ANLENKSTUECK SCHWK. 10	96 45 098 08	1	1	3 211	91 57 748 08	S-ANLENKSTUECK
S-RUECKHALTESICHERUNG	91 52 831 08	183	1		LR 1600-2-0	LIEBHERR RAUPENKRAN LR 1
S-ZWISCHENSTUECK 12 M 282	91 55 327 08	213	1		LR 1600-2-0	LIEBHERR RAUPENKRAN LR 1
S-ZWISCHENSTUECK 2825.20	91 52 852 08	210	2		LR 1600-2-0	LIEBHERR RAUPENKRAN LR 1
S-ZWISCHENSTUECK 2825.20	91 52 849 08	207	1		LR 1600-2-0	LIEBHERR RAUPENKRAN LR 1
S-ZWISCHENSTUECK 2825.25	91 52 853 08	211	3		LR 1600-2-0	LIEBHERR RAUPENKRAN LR 1
S-ZWISCHENSTUECK 2825.25	91 54 668 08	212	1		LR 1600-2-0	LIEBHERR RAUPENKRAN LR 1
S-ZWISCHENSTUECK SCHWK.	96 48 482 08	1	1	3 223 100	91 55 327 08	S-ZWISCHENSTUECK
S-ZWISCHENSTUECK SCHWK.	96 44 096 08	1	1	3 223	91 52 852 08	S-ZWISCHENSTUECK
S-ZWISCHENSTUECK SCHWK.	96 43 376 08	1	1	3 220 500	91 52 849 08	S-ZWISCHENSTUECK
S-ZWISCHENSTUECK SCHWK.	96 45 126 08	1	1	3 223 010	91 52 853 08	S-ZWISCHENSTUECK
S-ZWISCHENSTUECK SCHWK.	96 47 979 08	1	1	3 221	91 54 668 08	S-ZWISCHENSTUECK
SA-BOCK	91 57 751 08	135	1		LR 1600-2-0	LIEBHERR RAUPENKRAN LR 1
SA-BOCK SCHWK.	96 45 308 08	1	1	2 550	91 57 751 08	SA-BOCK
SAE-EINSCHRAUBFLANSCH	51 15 125 08	3	2	2 391 038	96 47 931 08	OELKUEHLER VORM.
SAE-FLANSCH 11/2"	51 15 026 08	42	6	2 391 001	96 45 719 08	DIESELMOTOR VORM.
SAE-FLANSCHHAELFTE 11/4"	51 15 162 08	561	4	2 970	91 56 537 08	HYDRAULIK
SAE-FLANSCHVERBINDUNG	47 49 071 08	559	2	2 970	91 56 537 08	HYDRAULIK
SAE-FLANSCHVERBINDUNG G	47 49 014 08	567	1	2 970	91 56 537 08	HYDRAULIK
SAE-FLANSCHVERBINDUNG G	47 49 019 08	564	1	2 970	91 56 537 08	HYDRAULIK
SAE-FLANSCHVERBINDUNG W	47 49 075 08	563	2	2 970	91 56 537 08	HYDRAULIK
SAE-FLANSCHVERBINDUNG W	47 49 069 08	565	4	2 970	91 56 537 08	HYDRAULIK
SAMMELROHR	92 79 826 08	61	1	2 391 001	96 45 719 08	DIESELMOTOR VORM.
SAMMELROHR	92 79 826 08	140	2	2 970	91 56 537 08	HYDRAULIK
SAMMELROHR SCHWK.	92 15 428 08	141	1	2 970	91 56 537 08	HYDRAULIK
SAMMELROHR SCHWK.	92 57 933 08	62	1	2 391 001	96 45 719 08	DIESELMOTOR VORM.
SAUGKRUEMMER	10 01 247 7	18	1	9 739 492	97 39 492	ROHRLEITUNG ANBAU
SAUGLEITUNG	10 01 229 0	1	1	9 739 118	97 39 118	OELLEITUNG
SAUGLEITUNG	10 47 691 2	22	1	9 739 492	97 39 492	ROHRLEITUNG ANBAU
SAUGLEITUNG	10 48 691 6	26	1	9 739 492	97 39 492	ROHRLEITUNG ANBAU
SAUGROHR SCHWK.	96 50 520 08	48	1	2 391 001	96 45 719 08	DIESELMOTOR VORM.
SAUGSCHLAUCH 76X6 NBR SP	10 34 353 0	155	4	2 391 001	96 45 719 08	DIESELMOTOR VORM.
SAUGSCHLAUCH 76X6 NBR SP	10 34 353 0	268	2.4	2 997	91 56 539 08	SCHLAUCHLEITUNGEN OBER
SAUGSCHLAUCH 76X6 NBR SP	10 34 353 0	269	1.6	2 997	91 56 539 08	SCHLAUCHLEITUNGEN OBER
SAUGSCHLAUCH 76X6 NBR SP	10 34 353 0	270	0.22	2 997	91 56 539 08	SCHLAUCHLEITUNGEN OBER
SAUGSCHLAUCH NW60X6,5	10 04 167 5	266	1.1	2 997	91 56 539 08	SCHLAUCHLEITUNGEN OBER
SAUGSCHLAUCH NW60X6,5	10 04 167 5	267	1.2	2 997	91 56 539 08	SCHLAUCHLEITUNGEN OBER
SAUGSTUTZEN	96 17 591 08	39	2	2 391 001	96 45 719 08	DIESELMOTOR VORM.
SAUGSTUTZEN SCHWK.	96 49 134 08	38	1	2 391 001	96 45 719 08	DIESELMOTOR VORM.
SAUGSTUTZEN SCHWK.	96 50 514 08	47	1	2 391 001	96 45 719 08	DIESELMOTOR VORM.
SAUGSTUTZEN SCHWK.	96 52 448 08	73	1	2 391 001	96 45 719 08	DIESELMOTOR VORM.
SCHAEKEL 3,25T	10 28 319 6	18	2	3 292	91 52 865 08	D-RUECKHALTESICHERUNG
SCHAEKEL 85t	10 02 211 1	47	4	3 745	91 52 948 08	SCHWEBEBALLAST
SCHAEKEL DIN 82101 1,6T NG	77 39 334 08	57	2	2 810	91 52 806 08	KRANFUEHRERKABINE KPL.
SCHAEKEL DIN 82101 12T VER	77 39 284 08	35	4	1 750	91 52 394 08	WERKZEUG
SCHAEKEL DIN 82101 25T VER	77 39 305 08	2	2	2 750 100	91 57 283 08	ANSCHLAGMITTEL MONTAGE
SCHAEKEL DIN 82101 A 0,25 0,	77 39 335 08	14	4	1 630	91 52 387 08	HYDRAULISCHE ABSTUETZUN
SCHAEKEL DIN 82101 A 0,25 0,	77 39 335 08	33	2	3 206	91 52 881 08	F-ANLENKSTUECK
SCHAEKEL DIN 82101 A 0,25 0,	77 39 335 08	43	1	3 208 001	91 52 883 08	F-KOPFSTUECK
SCHAEKEL DIN 82101 A 10 0,4	77 39 300 08	28	2	3 215 005	91 52 846 08	ROLLENSATZ
SCHAEKEL DIN 82101 A 10 0,4	77 39 300 08	28	2	3 215 006	91 52 847 08	ROLLENSATZ

6.2.2009

etk_en_de_074515 LR 1600/2

1071

LIEBHERRAlphabetical index
Alphabetischer Index

Bezeichnung	Artikel	Pos.	Menge	Seite	Baugruppe	Bezeichnung
SCHALLDAEMPFER 350X1500	10 44 054 3	1	1	2 392	91 52 785 08	SCHALLDAEMPFERANLAGE
SCHALLDAEMPFERANLAGE	91 52 785 08	124	1		LR 1600-2-0	LIEBHERR RAUPENKRAN LR 1
SCHALLGEBER 12-30VDC	61 40 085 08	10	1	2 780 320	91 05 067 08	AKUSTISCHE WARNUNG DRE
SCHALLGEBER 12-30VDC	61 40 085 08	10	1	2 780 324	91 56 389 08	AKUST.WARNUNG VERFAHRE
SCHALTEINHEIT	92 17 236 08	4	2	3 745	91 52 948 08	SCHWEBEBALLAST
SCHALTEINHEIT	92 17 237 08	5	2	3 745	91 52 948 08	SCHWEBEBALLAST
SCHALTELEMENT	69 27 014 08	7	1	2 913 003	96 20 599 08	FOLIENSTATUR VORM.
SCHALTSCHRANK MECH.	96 54 385 08	2	1	2 932	91 57 750 08	EINBAUTEILE SCHALTSCHRAN
SCHALTSCHRANK SCHWK.	96 54 384 08	1	1	2 932 160	96 54 385 08	SCHALTSCHRANK MECH.
SCHARNIER	70 42 281 08	2	2	2 510 040	96 49 183 08	TUER VORM.
SCHARNIER	70 42 281 08	2	2	2 510 059	96 49 184 08	TUER VORM.
SCHARNIER	70 42 559 08	81	4	2 932 082	96 54 387 08	AUFBAUTEILE MONTAGETAPE
SCHARNIER	70 42 582 08	12	2	2 260 006	96 46 501 08	BATTERIEKASTEN VORM.
SCHARNIER	70 42 598 08	42	2	2 520	91 53 061 08	KABINE VERGLAST
SCHARNIER F6-1 STAHL	70 42 637 08	3	2	2 260 009	96 46 972 08	KLAPPE VORM.
SCHARNIER F6-1 STAHL	70 42 637 08	7	4	2 859 025	96 46 757 08	GITTERROST VORM.
SCHARNIER F6-3 STAHL	70 42 619 08	2	4	2 859 005	96 46 756 08	KLAPPE VORM.
SCHEIBE	10 22 275 4	7	1	9 739 278	97 39 278	ANBAUTEILE
SCHEIBE	51 07 972 08	5	1	5 114 176	51 14 176 08	DRUCKBEGRENZUNGSVENTI
SCHEIBE	51 07 972 08	5	1	5 114 177	51 14 177 08	DRUCKBEGRENZUNGSVENTI
SCHEIBE	55 08 998 08	388	12	2 391 001	96 45 719 08	DIESELMOTOR VORM.
SCHEIBE	57 00 729 08	3	1	5 114 320	51 14 320 08	VORSPANNVENTIL
SCHEIBE	57 01 137 08	5	1	5 701 129	57 01 129 08	TRIEBWERK
SCHEIBE	59 10 589 08	21	1	2 522 011	96 45 602 08	SCHLISSANLAGE
SCHEIBE	92 76 333 01	5	1	9 697 916	96 97 916 01	DREHWERK
SCHEIBE 1.5x58x58	97 02 665 08	67	2	2 550	91 57 751 08	SA-BOCK
SCHEIBE 100X2	94 33 992 08	77	2	1 400	91 56 853 08	RAUPENTRAEGER KPL.LI.
SCHEIBE 100X2	94 33 992 08	77	2	1 410 300	91 56 855 08	RAUPENTRAEGER KPL.RE.
SCHEIBE 100X2	94 33 992 08	30	1	3 281	91 52 896 08	FA-BOCK
SCHEIBE 10X100X100	97 91 266 08	102	2	3 713	91 57 749 08	D-ANLENKSTUECK
SCHEIBE 11X22X5 9SMNPB28	10 01 256 6	6	1	9 739 271	97 39 271	VERBINDUNGSLEITUNG
SCHEIBE 11X22X5 9SMNPB28	10 01 256 6	7	2	9 739 288	97 39 288	KRAFTSTOFFLEITUNG
SCHEIBE 11X23X6 9SMNPB28	10 01 694 9	10	3	9 739 354	97 39 354	SCHWUNGRADGEHAEUSE AN
SCHEIBE 12,5X24X4 C45K	10 01 256 7	19	1	9 739 344	97 39 344	GENERATOR VORM.
SCHEIBE 12X215X215 FE//ZN	94 23 101 08	6	2	3 714 008	96 49 266 08	VERSTELLFLASCHE KPL.
SCHEIBE 12X215X215 FE//ZN	94 23 101 08	7	2	3 714 009	96 49 267 08	VERSTELLFLASCHE KPL.
SCHEIBE 12X50X50 T ZN O	97 74 760 08	61	1	3 713	91 57 749 08	D-ANLENKSTUECK
SCHEIBE 12X50X50 T ZN O	97 74 760 08	32	4	3 715 008	91 52 863 08	D-ZWISCHENSTUECK
SCHEIBE 12X50X50 T ZN O	97 74 760 08	30	6	3 716	91 52 864 08	D-ZWISCHENSTUECK
SCHEIBE 15,5X34X0,5 CK67V	10 01 256 3	4	4	9 739 261	97 39 261	ZYLINDERKOPF
SCHEIBE 219.1X34	97 71 946 08	12	1	3 208 001	91 52 883 08	F-KOPFSTUECK
SCHEIBE 2X100X100	97 18 386 08	18	16	3 211	91 57 748 08	S-ANLENKSTUECK
SCHEIBE 2X110X110 DC01-A-	94 59 385 08	18	7	3 281	91 52 896 08	FA-BOCK
SCHEIBE 3X100X100 FE//ZN20	93 14 640 08	15	4	1 630	91 52 387 08	HYDRAULISCHE ABSTUETZUN
SCHEIBE 5X120X120	97 49 680 08	41	4	2 340	91 52 776 08	WINDE 4 EINZIEHWERK
SCHEIBE 5X200X200 TZNO	97 81 710 08	16	8	2 550	91 57 751 08	SA-BOCK
SCHEIBE 5X36X36	94 10 542 08	29	8	3 745	91 52 948 08	SCHWEBEBALLAST
SCHEIBE 5X40X40	97 84 522 08	37	4	2 391 040	96 53 645 08	KUPPLUNGSSTELLER
SCHEIBE 6,3X10,8X6 9SMNPB	10 01 699 2	(3)	2	9 739 318	97 39 318	SENSORIK
SCHEIBE 6,4X17X3 ST MAN183	10 34 375 2	9	1	9 739 356	97 39 356	ROHRLEITUNG ANBAU
SCHEIBE 70X3	94 11 381 08	9	4	1 620	91 52 386 08	BEFESTIGUNGSTEILE DREH
SCHEIBE 70X3	94 11 381 08	11	48	1 631 100	91 52 388 08	LAUFSTEG RAUPENFAHRWER
SCHEIBE 70X3	94 11 381 08	11	3	2 350	91 52 778 08	DREHWERK
SCHEIBE 70X3	94 11 381 08	5	10	2 859 025	96 46 757 08	GITTERROST VORM.
SCHEIBE 70X3	94 11 381 08	59	8	3 206	91 52 881 08	F-ANLENKSTUECK
SCHEIBE 70X3	94 11 381 08	34	62	3 211	91 57 748 08	S-ANLENKSTUECK
SCHEIBE 70X3	94 11 381 08	38	9	3 214	91 52 843 08	SW-KOPFSTUECK
SCHEIBE 70X3	94 11 381 08	26	55	3 220 500	91 52 849 08	S-ZWISCHENSTUECK
SCHEIBE 70X3	94 11 381 08	14	44	3 221	91 54 668 08	S-ZWISCHENSTUECK
SCHEIBE 70X3	94 11 381 08	26	56	3 223	91 52 852 08	S-ZWISCHENSTUECK

6.2.2009

etk_en_de_074515 LR 1600/2

1072

LIEBHERRAlphabetical index
Alphabetischer Index

Bezeichnung	Artikel	Pos.	Menge	Seite	Baugruppe	Bezeichnung
SCHEIBE 70X3	94 11 381 08	26	56	3 223 010	91 52 853 08	S-ZWISCHENSTUECK
SCHEIBE 70X3	94 11 381 08	26	56	3 223 100	91 55 327 08	S-ZWISCHENSTUECK
SCHEIBE 70X3	94 11 381 08	38	53	3 225	91 52 854 08	SL-REDUZIERSTUECK
SCHEIBE 70X3	94 11 381 08	26	40	3 226	91 52 870 08	LI-ZWISCHENSTUECK
SCHEIBE 70X3	94 11 381 08	26	49	3 227	91 52 873 08	LI-ZWISCHENSTUECK
SCHEIBE 70X3	94 11 381 08	26	49	3 227 008	91 52 872 08	LI-ZWISCHENSTUECK
SCHEIBE 70X3	94 11 381 08	26	49	3 227 200	91 53 519 08	LI-ZWISCHENSTUECK F-ABSP
SCHEIBE 70X3	94 11 381 08	20	103	3 713	91 57 749 08	D-ANLENKSTUECK
SCHEIBE 70X3	94 11 381 08	47	65	3 714	91 52 862 08	D-KOPFSTUECK
SCHEIBE 70X3	94 11 381 08	20	64	3 715 008	91 52 863 08	D-ZWISCHENSTUECK
SCHEIBE 70X3	94 11 381 08	20	91	3 716	91 52 864 08	D-ZWISCHENSTUECK
SCHEIBE 8,4X19X4 C45K	10 01 256 8	9	1	9 739 256	97 39 256	LUFTANSAUGROHR
SCHEIBE 8,4X19X4 C45K	10 01 256 8	18	1	9 739 296	97 39 296	HITZESCHUTZ
SCHEIBE 8,4X19X4 C45K	10 01 256 8	15	1	9 739 358	97 39 358	ABGASRUECKFUEHRUNG AN
SCHEIBE 8,4X19X4 C45K	10 01 256 8	27	4	9 739 371	97 39 371	KLIMAKOMPRESSOR ANBAU
SCHEIBE 8X185X185	97 68 042 08	44	34	1 400	91 56 853 08	RAUPENTRAEGER KPL.LI.
SCHEIBE 8X185X185	97 68 042 08	44	34	1 410 300	91 56 855 08	RAUPENTRAEGER KPL.RE.
SCHEIBE 9X19X3	10 03 288 2	11	3	9 739 118	97 39 118	OELLEITUNG
SCHEIBE A 10,5X20X2,0 200H	10 01 165 8	12	2	9 739 159	97 39 159	STARTER
SCHEIBE A 10,5X20X2,0 200H	10 01 165 8	5	3	9 739 271	97 39 271	VERBINDUNGSLEITUNG
SCHEIBE A 10,5X20X2,0 200H	10 01 165 8	10	3	9 739 278	97 39 278	ANBAUTEILE
SCHEIBE A 10,5X20X2,0 200H	10 01 165 8	4	2	9 739 286	97 39 286	VERSCHLUSSDECKEL
SCHEIBE A 10,5X20X2,0 200H	10 01 165 8	5	1	9 739 344	97 39 344	GENERATOR VORM.
SCHEIBE A 10,5X20X2,0 200H	10 01 165 8	5	2	9 739 351	97 39 351	KUEHLMITTELEITUNG ANBA
SCHEIBE A 10,5X20X2,0 200H	10 01 165 8	3	4	9 739 358	97 39 358	ABGASRUECKFUEHRUNG AN
SCHEIBE A 10,5X20X2,0 200H	10 01 165 8	4	2	9 739 386	97 39 386	KURBELGEHAEUSEENTLUEFT
SCHEIBE A 13X24X2,5 200HV	10 01 165 9	9	2	9 739 344	97 39 344	GENERATOR VORM.
SCHEIBE A 13X24X2,5 200HV	10 01 165 9	16	2	9 739 371	97 39 371	KLIMAKOMPRESSOR ANBAU
SCHEIBE A 17,0 200HV A3C	10 03 722 6	6	1	9 739 210	97 39 210	KUEHLMITTELEITUNG
SCHEIBE A 5.3 ST MAN183-B1	10 22 279 4	8	2	9 739 356	97 39 356	ROHRLEITUNG ANBAU
SCHEIBE A 6,4X12X1,6 200HV	10 01 165 3	7	2	9 739 159	97 39 159	STARTER
SCHEIBE A 6,4X12X1,6 200HV	10 01 165 3	7	2	9 739 292	97 39 292	KRAFTSTOFFLEITUNG
SCHEIBE A 6,4X12X1,6 200HV	10 01 165 3	29	6	9 739 292	97 39 292	KRAFTSTOFFLEITUNG
SCHEIBE A 6,4X12X1,6 200HV	10 01 165 3	(4)	2	9 739 318	97 39 318	SENSORIK
SCHEIBE A 8,4X16X1,6 200HV	10 01 165 4	6	2	9 739 118	97 39 118	OELLEITUNG
SCHEIBE A 8,4X16X1,6 200HV	10 01 165 4	4	3	9 739 126	97 39 126	THERMOSTATGEHAEUSE
SCHEIBE A 8,4X16X1,6 200HV	10 01 165 4	6	1	9 739 186	97 39 186	MOTORBREMSE
SCHEIBE A 8,4X16X1,6 200HV	10 01 165 4	10	1	9 739 210	97 39 210	KUEHLMITTELEITUNG
SCHEIBE A 8,4X16X1,6 200HV	10 01 165 4	8	9	9 739 256	97 39 256	LUFTANSAUGROHR
SCHEIBE A 8,4X16X1,6 200HV	10 01 165 4	3	2	9 739 259	97 39 259	KRAFTSTOFFFILTER
SCHEIBE A 8,4X16X1,6 200HV	10 01 165 4	19	1	9 739 296	97 39 296	HITZESCHUTZ
SCHEIBE A 8,4X16X1,6 200HV	10 01 165 4	5	5	9 739 349	97 39 349	WASSERLEITUNGSANSCHLUE
SCHEIBE A 8,4X16X1,6 200HV	10 01 165 4	15	1	9 739 349	97 39 349	WASSERLEITUNGSANSCHLUE
SCHEIBE A 8,4X16X1,6 200HV	10 01 165 4	6	6	9 739 352	97 39 352	WASSERPUMPE MIT BEFEST.
SCHEIBE A 8,4X16X1,6 200HV	10 01 165 4	13	1	9 739 356	97 39 356	ROHRLEITUNG ANBAU
SCHEIBE A 8,4X16X1,6 200HV	10 01 165 4	11	6	9 739 357	97 39 357	ABGASRUECKFUEHRUNG VO
SCHEIBE A 8,4X16X1,6 200HV	10 01 165 4	21	8	9 739 361	97 39 361	OELWANNE
SCHEIBE A 8,4X16X1,6 200HV	10 01 165 4	25	3	9 739 366	97 39 366	BEFESTIGUNGSTEILE ANBAU
SCHEIBE A 8,4X16X1,6 200HV	10 01 165 4	23	4	9 739 371	97 39 371	KLIMAKOMPRESSOR ANBAU
SCHEIBE A 8,4X16X1,6 200HV	10 01 165 4	12	3	9 739 372	97 39 372	SCHMIEROELPUMPE
SCHEIBE A 8,4X16X1,6 200HV	10 01 165 4	21	2	9 739 386	97 39 386	KURBELGEHAEUSEENTLUEFT
SCHEIBE A 8,4X16X1,6 200HV	10 01 165 4	34	2	9 739 492	97 39 492	ROHRLEITUNG ANBAU
SCHEIBE A 8,4X16X1,6 200HV	10 01 165 4	24	2	9 739 494	97 39 494	ATL-ANBAU
SCHEIBE CU	10 01 256 5	6	1	9 739 159	97 39 159	STARTER
SCHEIBE DIN 125 A 10,5 MS	42 00 507 08	13	8	2 391 038	96 47 931 08	OELKUEHLER VORM.
SCHEIBE DIN 125 A 10,5 MS	42 00 507 08	32	12	2 652	91 52 794 08	ROLLENLAGERUNG
SCHEIBE DIN 125 A 10,5 MS	42 00 507 08	36	18	3 208 001	91 52 883 08	F-KOPFSTUECK
SCHEIBE DIN 125 A 10.5 A2	50 09 175 08	68	24	1 400	91 56 853 08	RAUPENTRAEGER KPL.LI.
SCHEIBE DIN 125 A 10.5 A2	50 09 175 08	68	24	1 410 300	91 56 855 08	RAUPENTRAEGER KPL.RE.
SCHEIBE DIN 125 A 10.5 A2	50 09 175 08	6	6	2 350	91 52 778 08	DREHWERK

6.2.2009

etk_en_de_074515 LR 1600/2

1073

LIEBHERRAlphabetical index
Alphabetischer Index

Bezeichnung	Artikel	Pos.	Menge	Seite	Baugruppe	Bezeichnung
SCHEIBE DIN 125 A 10.5 A2	50 09 175 08	5	8	2 670	91 52 797 08	KRAFTSTOFFBEHAELTER KPL
SCHEIBE DIN 125 A 10.5 A2	50 09 175 08	6	4	2 671	91 52 798 08	OELBEHAELTER KPL.
SCHEIBE DIN 125 A 10.5 A2	50 09 175 08	10	12	2 730	91 52 802 08	GRUNDPLATTE DREHBUEHNE
SCHEIBE DIN 125 A 10.5 A2	50 09 175 08	15	18	2 810	91 52 806 08	KRANFUEHRERKABINE KPL.
SCHEIBE DIN 125 A 13 MS	42 00 508 08	9	8	3 213	91 52 842 08	F-ANSCHLUSSKOPF
SCHEIBE DIN 125 A 13 MS	42 00 508 08	25	96	3 350	91 52 859 08	WINDE 3
SCHEIBE DIN 125 A 13 MS	42 00 508 08	13	8	3 714 008	96 49 266 08	VERSTELLFLASCHE KPL.
SCHEIBE DIN 125 A 15 ST VER	42 00 018 08	51	4	2 631	91 56 817 08	LAUFSTEG DREHBUEHNE
SCHEIBE DIN 125 A 17 VERZ	42 00 019 08	5	4	1 641 014	92 53 053 08	ABSTUETZPLATTE KPL.
SCHEIBE DIN 125 A 17 VERZ	42 00 019 08	12	6	1 991	91 52 510 08	DREHDURCHFUEHRUNG
SCHEIBE DIN 125 A 17 VERZ	42 00 019 08	9	24	2 125	91 52 773 08	BOLZEN S-ANLENKST. UND S
SCHEIBE DIN 125 A 17 VERZ	42 00 019 08	29	2	2 391 040	96 53 645 08	KUPPLUNGSSTELLER
SCHEIBE DIN 125 A 17 VERZ	42 00 019 08	44	4	2 393	91 52 787 08	LUFTFILTERANLAGE KPL.
SCHEIBE DIN 125 A 17 VERZ	42 00 019 08	6	26	2 550	91 57 751 08	SA-BOCK
SCHEIBE DIN 125 A 17 VERZ	42 00 019 08	22	6	2 631	91 56 817 08	LAUFSTEG DREHBUEHNE
SCHEIBE DIN 125 A 17 VERZ	42 00 019 08	11	29	2 652	91 52 794 08	ROLLENLAGERUNG
SCHEIBE DIN 125 A 17 VERZ	42 00 019 08	14	2	2 657	91 57 656 08	MONTAGEEINRICHTUNG RA
SCHEIBE DIN 125 A 17 VERZ	42 00 019 08	6	4	2 730	91 52 802 08	GRUNDPLATTE DREHBUEHNE
SCHEIBE DIN 125 A 17 VERZ	42 00 019 08	51	8	2 810	91 52 806 08	KRANFUEHRERKABINE KPL.
SCHEIBE DIN 125 A 17 VERZ	42 00 019 08	175	16	2 970	91 56 537 08	HYDRAULIK
SCHEIBE DIN 125 A 17 VERZ	42 00 019 08	4	2	3 207 101	96 48 292 08	LASCHE KPL.
SCHEIBE DIN 125 A 17 VERZ	42 00 019 08	35	16	3 208 001	91 52 883 08	F-KOPFSTUECK
SCHEIBE DIN 125 A 17 VERZ	42 00 019 08	42	6	3 211	91 57 748 08	S-ANLENKSTUECK
SCHEIBE DIN 125 A 17 VERZ	42 00 019 08	10	2	3 211 003	96 46 986 08	STANGE KPL.
SCHEIBE DIN 125 A 17 VERZ	42 00 019 08	13	4	3 214	91 52 843 08	SW-KOPFSTUECK
SCHEIBE DIN 125 A 17 VERZ	42 00 019 08	10	2	3 220 500	91 52 849 08	S-ZWISCHENSTUECK
SCHEIBE DIN 125 A 17 VERZ	42 00 019 08	11	2	3 220 501	96 43 440 08	STANGE KPL.
SCHEIBE DIN 125 A 17 VERZ	42 00 019 08	11	2	3 221 200	96 47 984 08	STANGE KPL.
SCHEIBE DIN 125 A 17 VERZ	42 00 019 08	10	2	3 223	91 52 852 08	S-ZWISCHENSTUECK
SCHEIBE DIN 125 A 17 VERZ	42 00 019 08	10	2	3 223 010	91 52 853 08	S-ZWISCHENSTUECK
SCHEIBE DIN 125 A 17 VERZ	42 00 019 08	10	4	3 223 100	91 55 327 08	S-ZWISCHENSTUECK
SCHEIBE DIN 125 A 17 VERZ	42 00 019 08	11	2	3 225 200	96 48 679 08	STANGE KPL.
SCHEIBE DIN 125 A 17 VERZ	42 00 019 08	11	4	3 227 002	96 50 498 08	STANGE KPL.
SCHEIBE DIN 125 A 17 VERZ	42 00 019 08	(4)	4	3 281	91 52 896 08	FA-BOCK
SCHEIBE DIN 125 A 17 VERZ	42 00 019 08	(4)	2	3 281	91 52 896 08	FA-BOCK
SCHEIBE DIN 125 A 17 VERZ	42 00 019 08	12	24	3 350	91 52 859 08	WINDE 3
SCHEIBE DIN 125 A 17 VERZ	42 00 019 08	11	2	3 561 003	96 45 222 08	STANGE KPL.
SCHEIBE DIN 125 A 17 VERZ	42 00 019 08	144	2	3 713	91 57 749 08	D-ANLENKSTUECK
SCHEIBE DIN 125 A 17 VERZ	42 00 019 08	155	2	3 713	91 57 749 08	D-ANLENKSTUECK
SCHEIBE DIN 125 A 17 VERZ	42 00 019 08	11	1	3 713 012	96 50 197 08	STANGE KPL.
SCHEIBE DIN 125 A 17 VERZ	42 00 019 08	17	16	3 714	91 52 862 08	D-KOPFSTUECK
SCHEIBE DIN 125 A 17 VERZ	42 00 019 08	10	8	3 714 008	96 49 266 08	VERSTELLFLASCHE KPL.
SCHEIBE DIN 125 A 17 VERZ	42 00 019 08	13	8	3 714 009	96 49 267 08	VERSTELLFLASCHE KPL.
SCHEIBE DIN 125 A 17 VERZ	42 00 019 08	5	2	3 714 013	96 49 270 08	LASCHE KPL.
SCHEIBE DIN 125 A 17 VERZ	42 00 019 08	6	2	3 714 013	96 59 083 08	LASCHE KPL.
SCHEIBE DIN 125 A 17 VERZ	42 00 019 08	4	2	3 714 014	96 49 456 08	LASCHE KPL.
SCHEIBE DIN 125 A 17 VERZ	42 00 019 08	11	2	3 716 001	96 49 159 08	STANGE KPL.
SCHEIBE DIN 125 A 17 VERZ	42 00 019 08	13	16	3 745	91 52 948 08	SCHWEBEBALLAST
SCHEIBE DIN 125 A 19 ST VER	42 00 020 08	8	60	1 631 100	91 52 388 08	LAUFSTEG RAUPENFAHRWER
SCHEIBE DIN 125 A 19 ST VER	42 00 020 08	24	6	2 652	91 52 794 08	ROLLENLAGERUNG
SCHEIBE DIN 125 A 25 ST VER	42 00 024 08	40	34	1 400	91 56 853 08	RAUPENTRAEGER KPL.LI.
SCHEIBE DIN 125 A 25 ST VER	42 00 024 08	40	34	1 410 300	91 56 855 08	RAUPENTRAEGER KPL.RE.
SCHEIBE DIN 125 A 25 ST VER	42 00 024 08	32	14	2 631	91 56 817 08	LAUFSTEG DREHBUEHNE
SCHEIBE DIN 125 A 25 ST VER	42 00 024 08	14	8	2 730	91 52 802 08	GRUNDPLATTE DREHBUEHNE
SCHEIBE DIN 125 A 3.2 MS	42 00 501 08	268	4	3 930 009	96 50 573 08	LEITUNGSTROMMEL KPL.
SCHEIBE DIN 125 A 3.2 MS	42 00 501 08	(154)	1	3 930 138	96 54 377 08	ELEKTRIK S-ANLENKSTUECK
SCHEIBE DIN 125 A 3.2 MS	42 00 501 08	156	10	3 930 640	96 50 481 08	KLEMMKASTEN KPL.
SCHEIBE DIN 125 A 3.2 MS	42 00 501 08	268	10	3 930 730	96 50 599 08	KLEMMKASTEN KPL.
SCHEIBE DIN 125 A 3.2 ST VER	51 45 819 08	5	12	2 913 100	91 23 538 08	BAUGRUPPENTRAEGER
SCHEIBE DIN 125 A 3.7 ST VER	42 00 006 08	43	8	2 920 369	96 54 235 08	KLEMMKASTEN KPL.

6.2.2009

etk_en_de_074515 LR 1600/2

1074

LIEBHERRAlphabetical index
Alphabetischer Index

Bezeichnung	Artikel	Pos.	Menge	Seite	Baugruppe	Bezeichnung
SCHEIBE DIN 125 A 3.7 ST VER	42 00 006 08	16	10	2 922 001	92 84 311 08	BUSPLATINE
SCHEIBE DIN 125 A 3.7 ST VER	42 00 006 08	30	20	2 932 001	96 45 393 08	RELAISSTEUERUNG
SCHEIBE DIN 125 A 3.7 ST VER	42 00 006 08	282	16	3 930 638	96 51 624 08	KLEMMKASTEN
SCHEIBE DIN 125 A 4.3 ST VER	42 00 007 08	4	4	2 913 004	96 20 460 08	GEHAEUSE VORM.
SCHEIBE DIN 125 A 4.3 ST VER	42 00 007 08	13	4	2 913 100	91 23 538 08	BAUGRUPPENTRAEGER
SCHEIBE DIN 125 A 4.3 ST VER	42 00 007 08	5	8	2 913 102	92 32 870 08	LUEFTEREINHEIT
SCHEIBE DIN 125 A 4.3 ST VER	42 00 007 08	(154)	4	2 920 369	96 54 235 08	KLEMMKASTEN KPL.
SCHEIBE DIN 125 A 4.3 ST VER	42 00 007 08	(154)	4	2 920 369	96 54 235 08	KLEMMKASTEN KPL.
SCHEIBE DIN 125 A 4.3 ST VER	42 00 007 08	279	16	2 920 369	96 54 235 08	KLEMMKASTEN KPL.
SCHEIBE DIN 125 A 4.3 ST VER	42 00 007 08	279	28	2 920 448	96 48 794 08	KLEMMKASTEN KPL.
SCHEIBE DIN 125 A 4.3 ST VER	42 00 007 08	39	8	2 932 001	96 45 393 08	RELAISSTEUERUNG
SCHEIBE DIN 125 A 4.3 ST VER	42 00 007 08	92	8	2 932 082	96 54 387 08	AUFBAUTEILE MONTAGETAPE
SCHEIBE DIN 125 A 4.3 ST VER	42 00 007 08	47	56	2 932 160	96 54 385 08	SCHALTSCHRANK MECH.
SCHEIBE DIN 125 A 5.3 VERZ	42 00 008 08	16	8	1 711	91 52 392 08	ZENTRALSCHMIERUNG RAUP
SCHEIBE DIN 125 A 5.3 VERZ	42 00 008 08	16	8	2 260 006	96 46 501 08	BATTERIEKASTEN VORM.
SCHEIBE DIN 125 A 5.3 VERZ	42 00 008 08	42	4	2 391 040	96 53 645 08	KUPPLUNGSSTELLER
SCHEIBE DIN 125 A 5.3 VERZ	42 00 008 08	35	8	2 502	91 55 939 08	STEUERSTAND
SCHEIBE DIN 125 A 5.3 VERZ	42 00 008 08	24	1	2 522	91 54 115 08	SCHIEBETUER KPL.
SCHEIBE DIN 125 A 5.3 VERZ	42 00 008 08	9	10	2 711	91 52 800 08	ZENTRALSCHMIERANLAGE O
SCHEIBE DIN 125 A 5.3 VERZ	42 00 008 08	2	4	2 780 915	96 48 377 08	ANBAUTEILE FREMDEINSPEIS
SCHEIBE DIN 125 A 5.3 VERZ	42 00 008 08	33	2	2 835 002	96 48 379 08	ANBAUTEILE
SCHEIBE DIN 125 A 5.3 VERZ	42 00 008 08	9	3	2 913 100	91 23 538 08	BAUGRUPPENTRAEGER
SCHEIBE DIN 125 A 5.3 VERZ	42 00 008 08	34	7	2 920 083	96 48 319 08	ELEKTRIK BATTERIEKASTEN
SCHEIBE DIN 125 A 5.3 VERZ	42 00 008 08	15	5	2 920 814	96 45 717 08	ELEKTRIK KRAFTSTOFFBEHA
SCHEIBE DIN 125 A 5.3 VERZ	42 00 008 08	56	2	2 975 100	91 52 860 08	ZUSATZHYDRAULIK WINDE 3
SCHEIBE DIN 125 A 5.3 VERZ	42 00 008 08	(5)	3	3 780 258	96 56 482 08	ELEKTRIK FLUGWARNSICHER
SCHEIBE DIN 125 A 5.3 VERZ	42 00 008 08	272	2	3 930 730	96 54 398 08	KLEMMKASTEN KPL.
SCHEIBE DIN 125 A 8.4 MS	42 00 506 08	37	4	2 711	91 52 800 08	ZENTRALSCHMIERANLAGE O
SCHEIBE DIN 125 A8X16 ST V	42 00 012 08	39	18	1 400	91 56 853 08	RAUPENTRAEGER KPL.LI.
SCHEIBE DIN 125 A8X16 ST V	42 00 012 08	39	18	1 410 300	91 56 855 08	RAUPENTRAEGER KPL.RE.
SCHEIBE DIN 125 A8X16 ST V	42 00 012 08	25	24	1 630	91 52 387 08	HYDRAULISCHE ABSTUETZUN
SCHEIBE DIN 125 A8X16 ST V	42 00 012 08	64	8	1 970	91 56 958 08	HYDRAULIK RAUPE
SCHEIBE DIN 125 A8X16 ST V	42 00 012 08	82	4	1 970	91 56 958 08	HYDRAULIK RAUPE
SCHEIBE DIN 125 A8X16 ST V	42 00 012 08	22	4	1 991	91 52 510 08	DREHDURCHFUEHRUNG
SCHEIBE DIN 125 A8X16 ST V	42 00 012 08	18	57	2 260	91 53 057 08	BATTERIELAGERUNG
SCHEIBE DIN 125 A8X16 ST V	42 00 012 08	24	2	2 260 006	96 46 501 08	BATTERIEKASTEN VORM.
SCHEIBE DIN 125 A8X16 ST V	42 00 012 08	33	2	2 310	91 52 503 08	WINDE 1
SCHEIBE DIN 125 A8X16 ST V	42 00 012 08	33	2	2 320	91 52 504 08	WINDE 2
SCHEIBE DIN 125 A8X16 ST V	42 00 012 08	20	24	2 350	91 52 778 08	DREHWERK
SCHEIBE DIN 125 A8X16 ST V	42 00 012 08	17	12	2 370	91 52 782 08	MONTAGEWINDE
SCHEIBE DIN 125 A8X16 ST V	42 00 012 08	15	10	2 391 038	96 47 931 08	OELKUEHLER VORM.
SCHEIBE DIN 125 A8X16 ST V	42 00 012 08	12	12	2 391 102	96 56 360 08	ZUSATZKUEHLER VORM.
SCHEIBE DIN 125 A8X16 ST V	42 00 012 08	4	4	2 503 100	91 55 873 08	NOTSITZ
SCHEIBE DIN 125 A8X16 ST V	42 00 012 08	20	2	2 522	91 54 115 08	SCHIEBETUER KPL.
SCHEIBE DIN 125 A8X16 ST V	42 00 012 08	8	4	2 522 012	96 45 884 08	FUEHRUNG VORM.
SCHEIBE DIN 125 A8X16 ST V	42 00 012 08	9	2	2 522 013	96 45 883 08	FUEHRUNG VORM.
SCHEIBE DIN 125 A8X16 ST V	42 00 012 08	8	2	2 540	91 53 253 08	HEIZKLIMAGERAET EINBAU
SCHEIBE DIN 125 A8X16 ST V	42 00 012 08	14	1	2 541 001	96 49 651 08	ZUSATZHEIZUNG VORM.
SCHEIBE DIN 125 A8X16 ST V	42 00 012 08	20	6	2 550	91 57 751 08	SA-BOCK
SCHEIBE DIN 125 A8X16 ST V	42 00 012 08	43	40	2 631	91 56 817 08	LAUFSTEG DREHBUEHNE
SCHEIBE DIN 125 A8X16 ST V	42 00 012 08	5	4	2 631 003	96 54 406 08	AUFSTIEG VORM.
SCHEIBE DIN 125 A8X16 ST V	42 00 012 08	10	8	2 670	91 52 797 08	KRAFTSTOFFBEHAELTER KPL
SCHEIBE DIN 125 A8X16 ST V	42 00 012 08	67	20	2 810	91 52 806 08	KRANFUEHRERKABINE KPL.
SCHEIBE DIN 125 A8X16 ST V	42 00 012 08	5	18	2 810 001	96 43 597 08	KRANFUEHRERKABINE VORM
SCHEIBE DIN 125 A8X16 ST V	42 00 012 08	34	4	2 831	91 57 754 08	KLIMAAANLAGE OW
SCHEIBE DIN 125 A8X16 ST V	42 00 012 08	59	104	2 859	91 52 809 08	GERAEUSCHDAEMMUNG
SCHEIBE DIN 125 A8X16 ST V	42 00 012 08	4	2	2 859 030	96 46 758 08	DECKEL KPL.
SCHEIBE DIN 125 A8X16 ST V	42 00 012 08	6	2	2 925 204	92 16 990 08	KAMERAANBAU D-ANLENKS
SCHEIBE DIN 125 A8X16 ST V	42 00 012 08	10	9	2 925 402	96 58 855 08	KAMERAANBAU DREHBUEHN
SCHEIBE DIN 125 A8X16 ST V	42 00 012 08	6	12	2 932 160	96 54 385 08	SCHALTSCHRANK MECH.

6.2.2009

etk_en_de_074515 LR 1600/2

1075

LIEBHERRAlphabetical index
Alphabetischer Index

Bezeichnung	Artikel	Pos.	Menge	Seite	Baugruppe	Bezeichnung
SCHEIBE DIN 125 A8X16 ST V	42 00 012 08	13	4	2 932 166	92 68 911 08	VERTEILER MASSE
SCHEIBE DIN 125 A8X16 ST V	42 00 012 08	153	2	2 970	91 56 537 08	HYDRAULIK
SCHEIBE DIN 125 A8X16 ST V	42 00 012 08	38	8	3 208 001	91 52 883 08	F-KOPFSTUECK
SCHEIBE DIN 125 A8X16 ST V	42 00 012 08	28	12	3 211	91 57 748 08	S-ANLENKSTUECK
SCHEIBE DIN 125 A8X16 ST V	42 00 012 08	18	4	3 213	91 52 842 08	F-ANSCHLUSSKOPF
SCHEIBE DIN 125 A8X16 ST V	42 00 012 08	22	10	3 214	91 52 843 08	SW-KOPFSTUECK
SCHEIBE DIN 125 A8X16 ST V	42 00 012 08	39	8	3 220 500	91 52 849 08	S-ZWISCHENSTUECK
SCHEIBE DIN 125 A8X16 ST V	42 00 012 08	39	8	3 223	91 52 852 08	S-ZWISCHENSTUECK
SCHEIBE DIN 125 A8X16 ST V	42 00 012 08	39	8	3 223 010	91 52 853 08	S-ZWISCHENSTUECK
SCHEIBE DIN 125 A8X16 ST V	42 00 012 08	39	8	3 223 100	91 55 327 08	S-ZWISCHENSTUECK
SCHEIBE DIN 125 A8X16 ST V	42 00 012 08	36	31	3 225	91 52 854 08	SL-REDUZIERSTUECK
SCHEIBE DIN 125 A8X16 ST V	42 00 012 08	39	8	3 226	91 52 870 08	LI-ZWISCHENSTUECK
SCHEIBE DIN 125 A8X16 ST V	42 00 012 08	39	8	3 227	91 52 873 08	LI-ZWISCHENSTUECK
SCHEIBE DIN 125 A8X16 ST V	42 00 012 08	39	8	3 227 008	91 52 872 08	LI-ZWISCHENSTUECK
SCHEIBE DIN 125 A8X16 ST V	42 00 012 08	39	8	3 227 200	91 53 519 08	LI-ZWISCHENSTUECK F-ABSP
SCHEIBE DIN 125 A8X16 ST V	42 00 012 08	61	4	3 281	91 52 896 08	FA-BOCK
SCHEIBE DIN 125 A8X16 ST V	42 00 012 08	15	8	3 350	91 52 859 08	WINDE 3
SCHEIBE DIN 125 A8X16 ST V	42 00 012 08	77	26	3 713	91 57 749 08	D-ANLENKSTUECK
SCHEIBE DIN 125 A8X16 ST V	42 00 012 08	49	16	3 714	91 52 862 08	D-KOPFSTUECK
SCHEIBE DIN 125 A8X16 ST V	42 00 012 08	5	4	3 714 017	96 50 752 08	AUFLAGE KPL.
SCHEIBE DIN 125 A8X16 ST V	42 00 012 08	11	8	3 715 008	91 52 863 08	D-ZWISCHENSTUECK
SCHEIBE DIN 125 A8X16 ST V	42 00 012 08	11	8	3 716	91 52 864 08	D-ZWISCHENSTUECK
SCHEIBE DIN 125 A8X16 ST V	42 00 012 08	43	8	3 745	91 52 948 08	SCHWEBEBALLAST
SCHEIBE DIN 125 A8X16 ST V	42 00 012 08	6	4	5 106 691	51 06 691 08	RUECKLAUFFILTER
SCHEIBE DIN 125 B 37 VERZ	42 00 033 08	57	1	3 745	91 52 948 08	SCHWEBEBALLAST
SCHEIBE DIN 125 B 52 ST VER	42 00 040 08	13	2	3 205	91 52 880 08	F-MONTAGEEINHEIT
SCHEIBE DIN 1440 14 ST VER	42 11 013 08	24	1	2 932 160	96 54 385 08	SCHALTSCHRANK MECH.
SCHEIBE DIN 1440 26 ST VER	42 11 022 08	51	8	3 225	91 52 854 08	SL-REDUZIERSTUECK
SCHEIBE DIN 1440 32 ST VER	42 11 026 08	29	4	2 810	91 52 806 08	KRANFUEHRERKABINE KPL.
SCHEIBE DIN 1440 33 ST VER	42 11 027 08	19	3	2 652	91 52 794 08	ROLLENLAGERUNG
SCHEIBE DIN 1440 45 ST VER	42 11 032 08	8	2	2 550	91 57 751 08	SA-BOCK
SCHEIBE DIN 1440 45 ST VER	42 11 032 08	12	2	2 652	91 52 794 08	ROLLENLAGERUNG
SCHEIBE DIN 1440 50 ST VER	42 11 033 08	4	8	3 747	91 52 950 08	ZENTRIERUNG STANDARD
SCHEIBE DIN 1440 8 ST VERZ	42 11 006 08	121	5	3 713	91 57 749 08	D-ANLENKSTUECK
SCHEIBE DIN 1441 21 ST VER	42 12 013 08	30	2	2 631	91 56 817 08	LAUFSTEG DREHBUEHNE
SCHEIBE DIN 1441 21 ST VER	42 12 013 08	29	16	2 652	91 52 794 08	ROLLENLAGERUNG
SCHEIBE DIN 1441 21 ST VER	42 12 013 08	12	1	2 925 204	92 16 990 08	KAMERAANBAU D-ANLENKS
SCHEIBE DIN 1441 26 ST VER	42 12 016 08	30	2	2 550	91 57 751 08	SA-BOCK
SCHEIBE DIN 1441 26 ST VER	42 12 016 08	19	6	2 671	91 52 798 08	OELBEHAELTER KPL.
SCHEIBE DIN 1441 26 ST VER	42 12 016 08	40	4	2 810	91 52 806 08	KRANFUEHRERKABINE KPL.
SCHEIBE DIN 1441 31 ST VER	42 12 019 08	47	2	3 208 001	91 52 883 08	F-KOPFSTUECK
SCHEIBE DIN 1441 31 ST VER	42 12 019 08	24	4	3 211	91 57 748 08	S-ANLENKSTUECK
SCHEIBE DIN 1441 31 ST VER	42 12 019 08	40	2	3 713	91 57 749 08	D-ANLENKSTUECK
SCHEIBE DIN 1441 31 ST VER	42 12 019 08	3	1	3 790 006	96 19 989 08	BOLZENZIEHZYLINDER KPL.
SCHEIBE DIN 1441 31 ST VER	42 12 019 08	3	1	3 790 007	96 19 990 08	BOLZENZIEHZYLINDER KPL.
SCHEIBE DIN 1441 41 ST A2C	42 12 024 08	66	4	2 550	91 57 751 08	SA-BOCK
SCHEIBE DIN 1441 41 ST A2C	42 12 024 08	91	3	2 550	91 57 751 08	SA-BOCK
SCHEIBE DIN 1441 41 ST A2C	42 12 024 08	20	2	2 810	91 52 806 08	KRANFUEHRERKABINE KPL.
SCHEIBE DIN 1441 41 ST A2C	42 12 024 08	5	2	3 211 009	96 46 979 08	SCHUTZWALZE KPL.
SCHEIBE DIN 433 17 ST	55 31 248 08	48	4	3 220 500	91 52 849 08	S-ZWISCHENSTUECK
SCHEIBE DIN 433 17 ST	55 31 248 08	48	4	3 223	91 52 852 08	S-ZWISCHENSTUECK
SCHEIBE DIN 433 17 ST	55 31 248 08	48	4	3 223 010	91 52 853 08	S-ZWISCHENSTUECK
SCHEIBE DIN 433 17 ST	55 31 248 08	48	4	3 223 100	91 55 327 08	S-ZWISCHENSTUECK
SCHEIBE DIN 433 17 ST	55 31 248 08	48	4	3 226	91 52 870 08	LI-ZWISCHENSTUECK
SCHEIBE DIN 433 17 ST	55 31 248 08	48	4	3 227	91 52 873 08	LI-ZWISCHENSTUECK
SCHEIBE DIN 433 17 ST	55 31 248 08	48	4	3 227 008	91 52 872 08	LI-ZWISCHENSTUECK
SCHEIBE DIN 440 V 9 ST VERZ	42 06 042 08	31	8	2 260	91 53 057 08	BATTERIELAGERUNG
SCHEIBE DIN 440 V 9 ST VERZ	42 06 042 08	43	2	2 393	91 52 787 08	LUFTFILTERANLAGE KPL.
SCHEIBE DIN 6916 13 C45 VER	42 15 000 08	391	2	2 391 001	96 45 719 08	DIESELMOTOR VORM.
SCHEIBE DIN 6916 17 C45 VER	42 15 002 08	42	26	1 400	91 56 853 08	RAUPENTRAEGER KPL.LI.

6.2.2009

etk_en_de_074515 LR 1600/2

1076

LIEBHERRAlphabetical index
Alphabetischer Index

Bezeichnung	Artikel	Pos.	Menge	Seite	Baugruppe	Bezeichnung
SCHEIBE DIN 6916 17 C45 VER	42 15 002 08	42	26	1 410 300	91 56 855 08	RAUPENTRAEGER KPL.RE.
SCHEIBE DIN 6916 17 C45 VER	42 15 002 08	381	12	2 391 001	96 45 719 08	DIESELMOTOR VORM.
SCHEIBE DIN 6916 21 C45 VER	42 15 003 08	389	4	2 391 001	96 45 719 08	DIESELMOTOR VORM.
SCHEIBE DIN 6916 21 C45 VER	42 15 003 08	12	2	3 745 011	96 49 677 08	LASCHE KPL.
SCHEIBE DIN 6916 25 C45 VER	42 15 004 08	43	70	1 400	91 56 853 08	RAUPENTRAEGER KPL.LI.
SCHEIBE DIN 6916 25 C45 VER	42 15 004 08	43	70	1 410 300	91 56 855 08	RAUPENTRAEGER KPL.RE.
SCHEIBE DIN 7349 10,5 ST V	42 16 006 08	36	24	2 631	91 56 817 08	LAUFSTEG DREHBUEHNE
SCHEIBE DIN 7349 13 ST VER	42 16 007 08	3	2	2 212	91 54 561 08	PUMPE F.DREHWERK
SCHEIBE DIN 7349 13 ST VER	42 16 007 08	384	10	2 391 001	96 45 719 08	DIESELMOTOR VORM.
SCHEIBE DIN 7349 13 ST VER	42 16 007 08	25	8	3 215 005	91 52 846 08	ROLLENSATZ
SCHEIBE DIN 7349 13 ST VER	42 16 007 08	25	8	3 215 006	91 52 847 08	ROLLENSATZ
SCHEIBE DIN 7349 17 ST VER	42 16 009 08	385	2	2 391 001	96 45 719 08	DIESELMOTOR VORM.
SCHEIBE DIN 7349 17 ST VER	42 16 009 08	36	1	2 391 040	96 53 645 08	KUPPLUNGSSTELLER
SCHEIBE DIN 7349 17 ST VER	42 16 009 08	43	28	2 550	91 57 751 08	SA-BOCK
SCHEIBE DIN 7349 25 ST VER	42 16 013 08	16	12	3 714 009	96 49 267 08	VERSTELLFLASCHE KPL.
SCHEIBE DIN 7349 6,4 ST VER	42 16 004 08	32	5	2 260	91 53 057 08	BATTERIELAGERUNG
SCHEIBE DIN 7349 6,4 ST VER	42 16 004 08	6	5	2 391 036	96 23 055 08	DECKEL VORM.
SCHEIBE DIN 7349 6,4 ST VER	42 16 004 08	13	13	2 925 402	96 58 855 08	KAMERAANBAU DREHBUEHN
SCHEIBE DIN 7349 8,4 ST VER	42 16 005 08	33	12	2 260	91 53 057 08	BATTERIELAGERUNG
SCHEIBE DIN 7349 8,4 ST VER	42 16 005 08	10	3	2 260 006	96 46 501 08	BATTERIEKASTEN VORM.
SCHEIBE DIN 7349 8,4 ST VER	42 16 005 08	392	6	2 391 001	96 45 719 08	DIESELMOTOR VORM.
SCHEIBE DIN 7349 8,4 ST VER	42 16 005 08	18	8	2 392	91 52 785 08	SCHALLDAEMPFERANLAGE
SCHEIBE DIN 7349 8,4 ST VER	42 16 005 08	15	8	2 510	91 52 788 08	DREHBUEHNENVERKLEIDUN
SCHEIBE DIN 7349 8,4 ST VER	42 16 005 08	57	35	2 859	91 52 809 08	GERAEUSCHDAEMMUNG
SCHEIBE DIN 7349 8,4 ST VER	42 16 005 08	16	12	2 925 402	96 58 855 08	KAMERAANBAU DREHBUEHN
SCHEIBE DIN 7349 8,4 ST VER	42 16 005 08	99	55	3 211	91 57 748 08	S-ANLENKSTUECK
SCHEIBE DIN 7349 8,4 ST VER	42 16 005 08	125	33	3 713	91 57 749 08	D-ANLENKSTUECK
SCHEIBE DIN 7349 8,4 ST VER	42 16 005 08	88	12	3 714	91 52 862 08	D-KOPFSTUECK
SCHEIBE DIN 7989 A 26 ST V	42 17 006 08	6	1	2 620	91 52 793 08	ROLLENDREHVERBINDUNG
SCHEIBE DIN 7989 A 33 ST V	42 17 009 08	13	32	3 747	91 52 950 08	ZENTRIERUNG STANDARD
SCHEIBE DIN 7989 B 11 VERZ	42 17 005 08	12	4	2 541 001	96 49 651 08	ZUSATZHEIZUNG VORM.
SCHEIBE DIN 9021 A 10,5 ST V	42 18 010 08	390	12	2 391 001	96 45 719 08	DIESELMOTOR VORM.
SCHEIBE DIN 9021 A 10,5 ST V	42 18 010 08	14	12	2 391 038	96 47 931 08	OELKUEHLER VORM.
SCHEIBE DIN 9021 A 10,5 ST V	42 18 010 08	41	4	2 393	91 52 787 08	LUFTFILTERANLAGE KPL.
SCHEIBE DIN 9021 A 15 ST V	42 18 024 08	49	4	3 745	91 52 948 08	SCHWEBEBALLAST
SCHEIBE DIN 9021 A 17 ST V	42 18 013 08	64	4	1 400	91 56 853 08	RAUPENTRAEGER KPL.LI.
SCHEIBE DIN 9021 A 17 ST V	42 18 013 08	64	4	1 410 300	91 56 855 08	RAUPENTRAEGER KPL.RE.
SCHEIBE DIN 9021 A 17 ST V	42 18 013 08	52	2	3 223 100	91 55 327 08	S-ZWISCHENSTUECK
SCHEIBE DIN 9021 A 4.3 ST V	42 18 005 08	39	10	2 631	91 56 817 08	LAUFSTEG DREHBUEHNE
SCHEIBE DIN 9021 A 4.3 ST V	42 18 005 08	(32)	4	2 925 026	91 55 259 08	ERG.KAMERAUEBERWACHUN
SCHEIBE DIN 9021 A 4.3 ST V	42 18 005 08	32	4	2 925 405	96 48 397 08	AUSRUESTUNG KAMERA KAB
SCHEIBE DIN 9021 A 5,3 ST V	42 18 006 08	24	28	2 260	91 53 057 08	BATTERIELAGERUNG
SCHEIBE DIN 9021 A 5,3 ST V	42 18 006 08	395	8	2 391 001	96 45 719 08	DIESELMOTOR VORM.
SCHEIBE DIN 9021 A 5,3 ST V	42 18 006 08	11	1	2 522 011	96 45 602 08	SCHLIESSANLAGE
SCHEIBE DIN 9021 A 5,3 ST V	42 18 006 08	59	2	2 631	91 56 817 08	LAUFSTEG DREHBUEHNE
SCHEIBE DIN 9021 A 5,3 ST V	42 18 006 08	296	2	2 920 581	96 54 405 08	KLEMMKASTEN SA-BOCK VO
SCHEIBE DIN 9021 A 5,3 ST V	42 18 006 08	49	4	2 975 200	91 52 775 08	ZUSATZHYDRAULIK WINDE 2
SCHEIBE DIN 9021 A 5,3 ST V	42 18 006 08	49	4	2 975 700	91 52 774 08	ZUSATZHYDRAULIK WINDE 1
SCHEIBE DIN 9021 A 5,3 ST V	42 18 006 08	(4)	3	3 780 258	96 56 482 08	ELEKTRIK FLUGWARNSICHER
SCHEIBE DIN 9021 A 5,3 ST V	42 18 006 08	160	2	3 930 640	96 50 481 08	KLEMMKASTEN KPL.
SCHEIBE DIN 9021 A 5,3 ST V	42 18 006 08	273	2	3 930 730	96 50 599 08	KLEMMKASTEN KPL.
SCHEIBE DIN 9021 A 5,3 ST V	42 18 006 08	218	2	3 930 734	96 54 401 08	KLEMMKASTEN
SCHEIBE DIN 9021 A 6.4 VERZ	42 18 007 08	34	2	2 391 040	96 53 645 08	KUPPLUNGSSTELLER
SCHEIBE DIN 9021 A 6.4 VERZ	42 18 007 08	8	8	2 510	91 52 788 08	DREHBUEHNENVERKLEIDUN
SCHEIBE DIN 9021 A 6.4 VERZ	42 18 007 08	7	6	2 520 031	96 45 610 08	HECKSCHEIBE VORM.
SCHEIBE DIN 9021 A 6.4 VERZ	42 18 007 08	16	8	2 522	91 54 115 08	SCHIEBETUER KPL.
SCHEIBE DIN 9021 A 6.4 VERZ	42 18 007 08	15	1	2 533 066	96 48 365 08	ELEKTRIK ANBAUTEILE KABIN
SCHEIBE DIN 9021 A 6.4 VERZ	42 18 007 08	58	28	2 550	91 57 751 08	SA-BOCK
SCHEIBE DIN 9021 A 6.4 VERZ	42 18 007 08	7	4	2 859 030	96 46 758 08	DECKEL KPL.
SCHEIBE DIN 9021 A 6.4 VERZ	42 18 007 08	23	8	2 925 402	96 58 855 08	KAMERAANBAU DREHBUEHN

6.2.2009

etk_en_de_074515 LR 1600/2

1077

LIEBHERRAlphabetical index
Alphabetischer Index

Bezeichnung	Artikel	Pos.	Menge	Seite	Baugruppe	Bezeichnung
SCHEIBE DIN 9021 A 6.4 VERZ	42 18 007 08	18	6	2 990	91 59 244 08	DRUCKLUFTANLAGE
SCHEIBE DIN 9021 A 6.4 VERZ	42 18 007 08	55	2	3 206	91 52 881 08	F-ANLENKSTUECK
SCHEIBE DIN 9021 A 6.4 VERZ	42 18 007 08	37	16	3 208 001	91 52 883 08	F-KOPFSTUECK
SCHEIBE DIN 9021 A 6.4 VERZ	42 18 007 08	58	20	3 211	91 57 748 08	S-ANLENKSTUECK
SCHEIBE DIN 9021 A 6.4 VERZ	42 18 007 08	37	17	3 220 500	91 52 849 08	S-ZWISCHENSTUECK
SCHEIBE DIN 9021 A 6.4 VERZ	42 18 007 08	21	12	3 221	91 54 668 08	S-ZWISCHENSTUECK
SCHEIBE DIN 9021 A 6.4 VERZ	42 18 007 08	37	22	3 223	91 52 852 08	S-ZWISCHENSTUECK
SCHEIBE DIN 9021 A 6.4 VERZ	42 18 007 08	37	22	3 223 010	91 52 853 08	S-ZWISCHENSTUECK
SCHEIBE DIN 9021 A 6.4 VERZ	42 18 007 08	37	22	3 223 100	91 55 327 08	S-ZWISCHENSTUECK
SCHEIBE DIN 9021 A 6.4 VERZ	42 18 007 08	33	17	3 225	91 52 854 08	SL-REDUZIERSTUECK
SCHEIBE DIN 9021 A 6.4 VERZ	42 18 007 08	37	17	3 226	91 52 870 08	LI-ZWISCHENSTUECK
SCHEIBE DIN 9021 A 6.4 VERZ	42 18 007 08	37	22	3 227	91 52 873 08	LI-ZWISCHENSTUECK
SCHEIBE DIN 9021 A 6.4 VERZ	42 18 007 08	37	22	3 227 008	91 52 872 08	LI-ZWISCHENSTUECK
SCHEIBE DIN 9021 A 6.4 VERZ	42 18 007 08	37	22	3 227 200	91 53 519 08	LI-ZWISCHENSTUECK F-ABSP
SCHEIBE DIN 9021 A 6.4 VERZ	42 18 007 08	5	16	3 291	91 52 831 08	S-RUECKHALTESICHERUNG
SCHEIBE DIN 9021 A 6.4 VERZ	42 18 007 08	10	8	3 292	91 52 865 08	D-RUECKHALTESICHERUNG
SCHEIBE DIN 9021 A 6.4 VERZ	42 18 007 08	64	16	3 713	91 57 749 08	D-ANLENKSTUECK
SCHEIBE DIN 9021 A 6.4 VERZ	42 18 007 08	57	40	3 714	91 52 862 08	D-KOPFSTUECK
SCHEIBE DIN 9021 A 6.4 VERZ	42 18 007 08	12	24	3 715 008	91 52 863 08	D-ZWISCHENSTUECK
SCHEIBE DIN 9021 A 6.4 VERZ	42 18 007 08	12	31	3 716	91 52 864 08	D-ZWISCHENSTUECK
SCHEIBE DIN 9021 A 8.4 VERZ	42 18 009 08	63	2	1 400	91 56 853 08	RAUPENTRAEGER KPL.LI.
SCHEIBE DIN 9021 A 8.4 VERZ	42 18 009 08	63	2	1 410 300	91 56 855 08	RAUPENTRAEGER KPL.RE.
SCHEIBE DIN 9021 A 8.4 VERZ	42 18 009 08	10	3	2 350	91 52 778 08	DREHWERK
SCHEIBE DIN 9021 A 8.4 VERZ	42 18 009 08	21	4	2 350	91 52 778 08	DREHWERK
SCHEIBE DIN 9021 A 8.4 VERZ	42 18 009 08	387	22	2 391 001	96 45 719 08	DIESELMOTOR VORM.
SCHEIBE DIN 9021 A 8.4 VERZ	42 18 009 08	28	4	2 391 040	96 53 645 08	KUPPLUNGSSTELLER
SCHEIBE DIN 9021 A 8.4 VERZ	42 18 009 08	13	14	2 391 102	96 56 360 08	ZUSATZKUEHLER VORM.
SCHEIBE DIN 9021 A 8.4 VERZ	42 18 009 08	22	4	2 392	91 52 785 08	SCHALLDAEMPFERANLAGE
SCHEIBE DIN 9021 A 8.4 VERZ	42 18 009 08	42	26	2 393	91 52 787 08	LUFTFILTERANLAGE KPL.
SCHEIBE DIN 9021 A 8.4 VERZ	42 18 009 08	75	7	2 520	91 53 061 08	KABINE VERGLAST
SCHEIBE DIN 9021 A 8.4 VERZ	42 18 009 08	54	4	2 631	91 56 817 08	LAUFSTEG DREHBUEHNE
SCHEIBE DIN 9021 A 8.4 VERZ	42 18 009 08	31	4	2 831	91 57 754 08	KLIMAANLAGE OW
SCHEIBE DIN 9021 A 8.4 VERZ	42 18 009 08	42	3	3 206	91 52 881 08	F-ANLENKSTUECK
SCHEIBE DIN 9021 A 8.4 VERZ	42 18 009 08	54	46	3 211	91 57 748 08	S-ANLENKSTUECK
SCHEIBE DIN 9021 A 8.4 VERZ	42 18 009 08	38	8	3 220 500	91 52 849 08	S-ZWISCHENSTUECK
SCHEIBE DIN 9021 A 8.4 VERZ	42 18 009 08	22	12	3 221	91 54 668 08	S-ZWISCHENSTUECK
SCHEIBE DIN 9021 A 8.4 VERZ	42 18 009 08	38	40	3 223	91 52 852 08	S-ZWISCHENSTUECK
SCHEIBE DIN 9021 A 8.4 VERZ	42 18 009 08	38	40	3 223 010	91 52 853 08	S-ZWISCHENSTUECK
SCHEIBE DIN 9021 A 8.4 VERZ	42 18 009 08	38	40	3 223 100	91 55 327 08	S-ZWISCHENSTUECK
SCHEIBE DIN 9021 A 8.4 VERZ	42 18 009 08	42	43	3 225	91 52 854 08	SL-REDUZIERSTUECK
SCHEIBE DIN 9021 A 8.4 VERZ	42 18 009 08	38	8	3 226	91 52 870 08	LI-ZWISCHENSTUECK
SCHEIBE DIN 9021 A 8.4 VERZ	42 18 009 08	38	24	3 227	91 52 873 08	LI-ZWISCHENSTUECK
SCHEIBE DIN 9021 A 8.4 VERZ	42 18 009 08	38	16	3 227 008	91 52 872 08	LI-ZWISCHENSTUECK
SCHEIBE DIN 9021 A 8.4 VERZ	42 18 009 08	38	10	3 227 200	91 53 519 08	LI-ZWISCHENSTUECK F-ABSP
SCHEIBE DIN 9021 A 8.4 VERZ	42 18 009 08	19	28	3 713	91 57 749 08	D-ANLENKSTUECK
SCHEIBE DIN 9021 A 8.4 VERZ	42 18 009 08	77	8	3 714	91 52 862 08	D-KOPFSTUECK
SCHEIBE DIN 9021 A 8.4 VERZ	42 18 009 08	13	48	3 715 008	91 52 863 08	D-ZWISCHENSTUECK
SCHEIBE DIN 9021 A 8.4 VERZ	42 18 009 08	13	92	3 716	91 52 864 08	D-ZWISCHENSTUECK
SCHEIBE DIN 9021 A 8.4 VERZ	42 18 009 08	8	4	3 978 005	91 56 430 08	ZUSATZHYDRAULIK SB-KOPFS
SCHEIBE DIN EN ISO 7093-1 8	42 18 614 05	32	8	3 745	91 52 948 08	SCHWEBEBALLAST
SCHEIBE ISO 7089 20 ST VER	42 00 021 01	(69)	1	1 400	91 56 853 08	RAUPENTRAEGER KPL.LI.
SCHEIBE ISO 7089 8 200HV-A2	42 00 607 05	16	4	2 671	91 52 798 08	OELBEHAELTER KPL.
SCHEIBE ISO 7089 A 10.5 A3C	42 00 013 08	4	16	1 620	91 52 386 08	BEFESTIGUNGSTEILE DREH
SCHEIBE ISO 7089 A 10.5 A3C	42 00 013 08	27	2	2 391 040	96 53 645 08	KUPPLUNGSSTELLER
SCHEIBE ISO 7089 A 10.5 A3C	42 00 013 08	99	9	2 550	91 57 751 08	SA-BOCK
SCHEIBE ISO 7089 A 10.5 A3C	42 00 013 08	20	4	2 631	91 56 817 08	LAUFSTEG DREHBUEHNE
SCHEIBE ISO 7089 A 10.5 A3C	42 00 013 08	7	4	2 671 004	96 46 305 08	OELBEHAELTER VORM.
SCHEIBE ISO 7089 A 10.5 A3C	42 00 013 08	18	4	2 925 204	92 16 990 08	KAMERAANBAU D-ANLENKS
SCHEIBE ISO 7089 A 10.5 A3C	42 00 013 08	34	2	2 925 402	96 58 855 08	KAMERAANBAU DREHBUEHN
SCHEIBE ISO 7089 A 10.5 A3C	42 00 013 08	8	14	3 206	91 52 881 08	F-ANLENKSTUECK

6.2.2009

etk_en_de_074515 LR 1600/2

1078

LIEBHERRAlphabetical index
Alphabetischer Index

Bezeichnung	Artikel	Pos.	Menge	Seite	Baugruppe	Bezeichnung
SCHEIBE ISO 7089 A 10.5 A3C	42 00 013 08	50	8	3 211	91 57 748 08	S-ANLENKSTUECK
SCHEIBE ISO 7089 A 10.5 A3C	42 00 013 08	39	8	3 281	91 52 896 08	FA-BOCK
SCHEIBE ISO 7089 A 10.5 A3C	42 00 013 08	35	8	3 713	91 57 749 08	D-ANLENKSTUECK
SCHEIBE ISO 7089 A 10.5 A3C	42 00 013 08	72	32	3 714	91 52 862 08	D-KOPFSTUECK
SCHEIBE ISO 7089 A 10.5 A3C	42 00 013 08	36	16	3 745	91 52 948 08	SCHWEBEBALLAST
SCHEIBE ISO 7089 A 10.5 A3C	42 00 013 08	9	4	9 080 702	90 80 702	STEUERGERAET
SCHEIBE ISO 7089 A 10.5 A3C	42 00 013 08	14	2	X1041267	10 41 267 8	ENDPLATTE
SCHEIBE ISO 7089 A 13 ST A3	42 00 016 08	34	8	1 630	91 52 387 08	HYDRAULISCHE ABSTUETZUN
SCHEIBE ISO 7089 A 13 ST A3	42 00 016 08	21	8	2 310	91 52 503 08	WINDE 1
SCHEIBE ISO 7089 A 13 ST A3	42 00 016 08	21	8	2 320	91 52 504 08	WINDE 2
SCHEIBE ISO 7089 A 13 ST A3	42 00 016 08	13	2	2 340	91 52 776 08	WINDE 4 EINZIEHWERK
SCHEIBE ISO 7089 A 13 ST A3	42 00 016 08	13	16	2 392	91 52 785 08	SCHALLDAEMPFERANLAGE
SCHEIBE ISO 7089 A 13 ST A3	42 00 016 08	10	4	2 671	91 52 798 08	OELBEHAELTER KPL.
SCHEIBE ISO 7089 A 13 ST A3	42 00 016 08	55	1	2 810	91 52 806 08	KRANFUEHRERKABINE KPL.
SCHEIBE ISO 7089 A 13 ST A3	42 00 016 08	25	1	2 932 160	96 54 385 08	SCHALTSCHRANK MECH.
SCHEIBE ISO 7089 A 13 ST A3	42 00 016 08	176	16	2 970	91 56 537 08	HYDRAULIK
SCHEIBE ISO 7089 A 13 ST A3	42 00 016 08	37	6	3 206	91 52 881 08	F-ANLENKSTUECK
SCHEIBE ISO 7089 A 13 ST A3	42 00 016 08	5	2	3 207 003	96 48 259 08	STANGE KPL.
SCHEIBE ISO 7089 A 13 ST A3	42 00 016 08	4	2	3 207 100	96 48 261 08	LASCHE KPL.
SCHEIBE ISO 7089 A 13 ST A3	42 00 016 08	34	12	3 208 001	91 52 883 08	F-KOPFSTUECK
SCHEIBE ISO 7089 A 13 ST A3	42 00 016 08	71	8	3 211	91 57 748 08	S-ANLENKSTUECK
SCHEIBE ISO 7089 A 13 ST A3	42 00 016 08	31	12	3 214	91 52 843 08	SW-KOPFSTUECK
SCHEIBE ISO 7089 A 13 ST A3	42 00 016 08	23	4	3 215 005	91 52 846 08	ROLLENSATZ
SCHEIBE ISO 7089 A 13 ST A3	42 00 016 08	23	4	3 215 006	91 52 847 08	ROLLENSATZ
SCHEIBE ISO 7089 A 13 ST A3	42 00 016 08	(5)	2	3 281	91 52 896 08	FA-BOCK
SCHEIBE ISO 7089 A 13 ST A3	42 00 016 08	10	4	3 291	91 52 831 08	S-RUECKHALTESICHERUNG
SCHEIBE ISO 7089 A 13 ST A3	42 00 016 08	4	4	3 292	91 52 865 08	D-RUECKHALTESICHERUNG
SCHEIBE ISO 7089 A 13 ST A3	42 00 016 08	37	28	3 714	91 52 862 08	D-KOPFSTUECK
SCHEIBE ISO 7089 A 13 ST A3	42 00 016 08	12	4	3 978 100	91 56 428 08	HYDR.SCHWEBEBALLAST-AN
SCHEIBE ISO 7089 A 21 ST A3	42 00 021 08	41	4	1 400	91 56 853 08	RAUPENTRAEGER KPL.LI.
SCHEIBE ISO 7089 A 21 ST A3	42 00 021 08	41	4	1 410 300	91 56 855 08	RAUPENTRAEGER KPL.RE.
SCHEIBE ISO 7089 A 21 ST A3	42 00 021 08	3	2	1 632 032	96 20 093 08	ABSTUETZPLATTE KPL.
SCHEIBE ISO 7089 A 21 ST A3	42 00 021 08	14	8	1 991	91 52 510 08	DREHDURCHFUEHRUNG
SCHEIBE ISO 7089 A 21 ST A3	42 00 021 08	10	4	2 550 005	96 45 680 08	STANGE KPL.
SCHEIBE ISO 7089 A 21 ST A3	42 00 021 08	9	1	2 620	91 52 793 08	ROLLENDREHVERBINDUNG
SCHEIBE ISO 7089 A 21 ST A3	42 00 021 08	27	12	2 631	91 56 817 08	LAUFSTEG DREHBUEHNE
SCHEIBE ISO 7089 A 21 ST A3	42 00 021 08	30	1	2 925 402	96 58 855 08	KAMERAANBAU DREHBUEHN
SCHEIBE ISO 7089 A 21 ST A3	42 00 021 08	38	14	3 211	91 57 748 08	S-ANLENKSTUECK
SCHEIBE ISO 7089 A 21 ST A3	42 00 021 08	69	4	3 713	91 57 749 08	D-ANLENKSTUECK
SCHEIBE ISO 7089 A 21 ST A3	42 00 021 08	7	2	3 714 025	96 49 269 08	STANGE KPL.
SCHEIBE ISO 7089 A 31 A3C	42 00 028 08	12	1	2 620	91 52 793 08	ROLLENDREHVERBINDUNG
SCHEIBE ISO 7089 A 31 A3C	42 00 028 08	22	10	2 810	91 52 806 08	KRANFUEHRERKABINE KPL.
SCHEIBE ISO 7089 A 31 A3C	42 00 028 08	22	2	3 282 002	96 47 890 08	FAB-STUETZE
SCHEIBE ISO 7089 A 31 A3C	42 00 028 08	67	4	3 714	91 52 862 08	D-KOPFSTUECK
SCHEIBE ISO 7089 A 6.4 VERZ	42 00 009 08	3	6	1 830 102	92 26 483 08	KLEMMBRETT VORM.
SCHEIBE ISO 7089 A 6.4 VERZ	42 00 009 08	74	8	1 970	91 56 958 08	HYDRAULIK RAUPE
SCHEIBE ISO 7089 A 6.4 VERZ	42 00 009 08	19	2	1 991	91 52 510 08	DREHDURCHFUEHRUNG
SCHEIBE ISO 7089 A 6.4 VERZ	42 00 009 08	21	24	2 260	91 53 057 08	BATTERIELAGERUNG
SCHEIBE ISO 7089 A 6.4 VERZ	42 00 009 08	20	6	2 260 006	96 46 501 08	BATTERIEKASTEN VORM.
SCHEIBE ISO 7089 A 6.4 VERZ	42 00 009 08	6	8	2 260 009	96 46 972 08	KLAPPE VORM.
SCHEIBE ISO 7089 A 6.4 VERZ	42 00 009 08	23	16	2 370	91 52 782 08	MONTAGEWINDE
SCHEIBE ISO 7089 A 6.4 VERZ	42 00 009 08	6	8	2 391 039	96 50 616 08	HUTZE KPL
SCHEIBE ISO 7089 A 6.4 VERZ	42 00 009 08	15	12	2 393 002	96 46 782 08	DECKEL KPL.
SCHEIBE ISO 7089 A 6.4 VERZ	42 00 009 08	42	4	2 502	91 55 939 08	STEUERSTAND
SCHEIBE ISO 7089 A 6.4 VERZ	42 00 009 08	56	4	2 520 034	96 45 984 08	INNENVERKLEIDUNG
SCHEIBE ISO 7089 A 6.4 VERZ	42 00 009 08	9	2	2 522	91 54 115 08	SCHIEBETUER KPL.
SCHEIBE ISO 7089 A 6.4 VERZ	42 00 009 08	16	3	2 522 011	96 45 602 08	SCHLIESSANLAGE
SCHEIBE ISO 7089 A 6.4 VERZ	42 00 009 08	9	2	2 540	91 53 253 08	HEIZKLIMAGERAET EINBAU
SCHEIBE ISO 7089 A 6.4 VERZ	42 00 009 08	41	4	2 711	91 52 800 08	ZENTRALSCHMIERANLAGE O
SCHEIBE ISO 7089 A 6.4 VERZ	42 00 009 08	23	12	2 835 002	96 48 379 08	ANBAUTEILE

6.2.2009

etk_en_de_074515 LR 1600/2

1079

LIEBHERRAlphabetical index
Alphabetischer Index

Bezeichnung	Artikel	Pos.	Menge	Seite	Baugruppe	Bezeichnung
SCHEIBE ISO 7089 A 6.4 VERZ	42 00 009 08	10	14	2 925 204	92 16 990 08	KAMERAANBAU D-ANLENKS
SCHEIBE ISO 7089 A 6.4 VERZ	42 00 009 08	12	13	2 925 402	96 58 855 08	KAMERAANBAU DREHBUEHN
SCHEIBE ISO 7089 A 6.4 VERZ	42 00 009 08	4	4	2 932 166	92 68 911 08	VERTEILER MASSE
SCHEIBE ISO 7089 A 6.4 VERZ	42 00 009 08	8	4	2 932 168	96 48 167 08	DECKEL KPL.
SCHEIBE ISO 7089 A 6.4 VERZ	42 00 009 08	12	2	2 976 203	92 27 489 08	ZUSATZHYDR.BOLZENZIEHZ
SCHEIBE ISO 7089 A 6.4 VERZ	42 00 009 08	28	4	3 206	91 52 881 08	F-ANLENKSTUECK
SCHEIBE ISO 7089 A 6.4 VERZ	42 00 009 08	43	8	3 214	91 52 843 08	SW-KOPFSTUECK
SCHEIBE ISO 7089 A 6.4 VERZ	42 00 009 08	10	8	3 745 002	92 17 236 08	SCHALTEINHEIT
SCHEIBE ISO 7089 A 6.4 VERZ	42 00 009 08	10	8	3 745 003	92 17 237 08	SCHALTEINHEIT
SCHEIBE ISO 7089 A 6.4 VERZ	42 00 009 08	17	6	3 780 751	91 52 952 08	FLUG-U.WINDWARNUNG
SCHEIBE ISO 7089 A 6.4 VERZ	42 00 009 08	23	3	3 978 015	91 56 429 08	ZUSATZHYDRAULIK ZWISCH
SCHEIBE ISO 7089 A 6.4 VERZ	42 00 009 08	23	3	3 978 015	91 56 432 08	ZUSATZHYDRAULIK ZWISCH
SCHEIBE ISO 7089 A 6.4 VERZ	42 00 009 08	7	8	7 027 481	70 27 481 03	WASSERABSCHIEDER
SCHEIBE ISO 7089 A 6.4 VERZ	42 00 009 08	7	2	9 080 702	90 80 702	STEUERGERAET
SCHEIBE ISO 7089 A 6.4 VERZ	42 00 009 08	43	2	X1022811	10 22 811 2	HEIZKLIMAGERAET
SCHEIBE ISO 7089 A8.4X16 ST	46 00 373 03	17	1	X1041267	10 41 267 8	ENDPLATTE
SCHEIBE ISO 7093 A 6.4 A2	42 18 017 08	14	6	2 550 008	96 47 628 08	HALTER KPL.
SCHEIBE ISO 7093 A 6.4 A2	42 18 017 08	14	6	2 550 009	96 47 645 08	HALTER KPL.
SCHEIBE ISO 7093 A 6.4 A2	42 18 017 08	74	3	2 810	91 52 806 08	KRANFUEHRERKABINE KPL.
SCHEIBE ISO 7093 A 6.4 A2	42 18 017 08	19	4	2 978 200	91 54 843 08	ZUSATZHYDR.S-RUECKHALTE
SCHEIBE ISO 7093 A 6.4 A2	42 18 017 08	7	11	3 713 013	96 57 159 08	BLECH KPL.
SCHEIBE ISO 7093-1 A 13 ST	42 18 011 08	23	8	2 310	91 52 503 08	WINDE 1
SCHEIBE ISO 7093-1 A 13 ST	42 18 011 08	23	8	2 320	91 52 504 08	WINDE 2
SCHEIBE ISO 7093-1 A 13 ST	42 18 011 08	386	4	2 391	91 52 784 08	DIESELMOTOR KPL.
SCHEIBE ISO 7093-1 A 13 ST	42 18 011 08	386	4	2 391 001	96 45 719 08	DIESELMOTOR VORM.
SCHEIBE ISO 7093-1 A 13 ST	42 18 011 08	11	12	2 391 023	96 45 720 08	KUEHLER VORM.
SCHEIBE ISO 7093-1 A 13 ST	42 18 011 08	74	8	3 211	91 57 748 08	S-ANLENKSTUECK
SCHEIBE ISO 7093-1 A 13 ST	42 18 011 08	14	8	3 213	91 52 842 08	F-ANSCHLUSSKOPF
SCHEIBE ISO 7093-1 A 13 ST	42 18 011 08	29	8	3 214	91 52 843 08	SW-KOPFSTUECK
SCHEIBE ISO 7093-1 A 13 ST	42 18 011 08	7	16	3 220 500	91 52 849 08	S-ZWISCHENSTUECK
SCHEIBE ISO 7093-1 A 13 ST	42 18 011 08	7	16	3 221	91 54 668 08	S-ZWISCHENSTUECK
SCHEIBE ISO 7093-1 A 13 ST	42 18 011 08	7	16	3 223	91 52 852 08	S-ZWISCHENSTUECK
SCHEIBE ISO 7093-1 A 13 ST	42 18 011 08	7	16	3 223 010	91 52 853 08	S-ZWISCHENSTUECK
SCHEIBE ISO 7093-1 A 13 ST	42 18 011 08	7	16	3 223 100	91 55 327 08	S-ZWISCHENSTUECK
SCHEIBE ISO 7093-1 A 13 ST	42 18 011 08	27	16	3 225	91 52 854 08	SL-REDUZIERSTUECK
SCHEIBE ISO 7093-1 A 13 ST	42 18 011 08	7	16	3 226	91 52 870 08	LI-ZWISCHENSTUECK
SCHEIBE ISO 7093-1 A 13 ST	42 18 011 08	7	16	3 227	91 52 873 08	LI-ZWISCHENSTUECK
SCHEIBE ISO 7093-1 A 13 ST	42 18 011 08	7	16	3 227 008	91 52 872 08	LI-ZWISCHENSTUECK
SCHEIBE ISO 7093-1 A 13 ST	42 18 011 08	7	16	3 227 200	91 53 519 08	LI-ZWISCHENSTUECK F-ABSP
SCHEIBE ISO 7093-1 A 13 ST	42 18 011 08	25	4	3 713	91 57 749 08	D-ANLENKSTUECK
SCHEIBE ISO 7093-1 A 13 ST	42 18 011 08	28	8	3 714	91 52 862 08	D-KOPFSTUECK
SCHEIBE ISO 7093-1 A 13 ST	42 18 011 08	14	16	3 715 008	91 52 863 08	D-ZWISCHENSTUECK
SCHEIBE ISO 7093-1 A 13 ST	42 18 011 08	14	16	3 716	91 52 864 08	D-ZWISCHENSTUECK
SCHEIBE M5 KUNSTSTOFF SP	66 00 414 08	8	1	2 913 100	91 23 538 08	BAUGRUPPENTRAEGER
SCHEIBE RD100X5	93 30 481 08	9	4	3 713	91 57 749 08	D-ANLENKSTUECK
SCHEIBE RD100X6	93 97 916 08	18	2	3 208 001	91 52 883 08	F-KOPFSTUECK
SCHEIBE RD110X2	94 96 354 08	7	1	2 657	91 57 656 08	MONTAGEEINRICHTUNG RA
SCHEIBE RD150X1	94 67 863 08	17	4	2 550	91 57 751 08	SA-BOCK
SCHEIBE RD22X3	95 35 616 08	22	40	1 630	91 52 387 08	HYDRAULISCHE ABSTUETZUN
SCHEIBE RD25X6 PA6G SCHW	28 81 831 08	6	6	2 520 031	96 45 610 08	HECKSCHEIBE VORM.
SCHEIBE RD40X4	95 36 317 08	14	2	2 391 023	96 45 720 08	KUEHLER VORM.
SCHEIBE RD44X2	93 94 608 08	15	10	2 670	91 52 797 08	KRAFTSTOFFBEHALTER KPL
SCHEIBE RD44X2	93 94 608 08	50	4	3 206	91 52 881 08	F-ANLENKSTUECK
SCHEIBE RD44X2	93 94 608 08	39	4	3 713	91 57 749 08	D-ANLENKSTUECK
SCHEIBE RD50X2	95 51 616 08	44	2	3 281	91 52 896 08	FA-BOCK
SCHEIBE RD60X2	94 87 177 08	3	1	3 282 002	96 47 890 08	FAB-STUETZE
SCHEIBE RD60X5	94 10 097 08	10	8	3 227	91 52 873 08	LI-ZWISCHENSTUECK
SCHEIBE RD65X8	93 24 016 08	14	4	3 745	91 52 948 08	SCHWEBEBALLAST
SCHEIBE RD70X2	94 91 885 08	17	4	2 631	91 56 817 08	LAUFSTEG DREHBUEHNE
SCHEIBE RD70X2	94 91 885 08	53	1	3 281	91 52 896 08	FA-BOCK

6.2.2009

etk_en_de_074515 LR 1600/2

1080

LIEBHERRAlphabetical index
Alphabetischer Index

Bezeichnung	Artikel	Pos.	Menge	Seite	Baugruppe	Bezeichnung
SCHEIBE RD80X5	94 95 827 08	12	2	2 810	91 52 806 08	KRANFUEHRERKABINE KPL.
SCHEIBENWISCHANLAGE EIN	96 45 980 08	8	1	2 520	91 53 061 08	KABINE VERGLAST
SCHEINWERFER	60 71 318 08	10	1	1 933 100	91 25 249 08	MAGNETLAMPE
SCHELLE DIN 3016-1 6 W1-EPD	10 34 229 7	6	1	9 739 356	97 39 356	ROHRLEITUNG ANBAU
SCHIEBER 24.6X120 PA6	97 68 722 08	13	1	2 522 011	96 45 602 08	SCHLISSANLAGE
SCHIEBESTUECK STAHLBAU	96 45 400 08	2	1	1 400	91 56 853 08	RAUPENTRAEGER KPL.LI.
SCHIEBESTUECK STAHLBAU	96 45 401 08	2	1	1 410 300	91 56 855 08	RAUPENTRAEGER KPL.RE.
SCHIEBETUER KPL.	91 54 115 08	2	1	2 520	91 53 061 08	KABINE VERGLAST
SCHIENENPAAR	10 65 048 9	70	1	X1029200	10 29 200 4	FAHRERSITZ
SCHILD	10 47 561 9	3	1	2 780 244	91 52 951 08	NOTAUS KRANFUEHRERKAB
SCHILD	55 30 310 08	20	1	2 831	91 57 754 08	KLIMAAANLAGE OW
SCHILD	77 25 885 08	6	1	2 780 915	96 48 377 08	ANBAUTEILE FREMDEINSPEIS
SCHILD	97 03 200 08	182	1	2 970	91 56 537 08	HYDRAULIK
SCHILD	97 03 208 08	181	1	2 970	91 56 537 08	HYDRAULIK
SCHILD	97 05 729 08	183	1	2 970	91 56 537 08	HYDRAULIK
SCHILD	97 08 391 08	14	1	1 970	91 56 958 08	HYDRAULIK RAUPE
SCHILD	97 66 929 08	40	1	2 932 001	96 45 393 08	RELAISSTEUERUNG
SCHILD	97 75 168 08	(1)	1	2 920 448	96 48 794 08	KLEMMKASTEN KPL.
SCHILD	97 75 395 08	61	1	2 932 160	96 54 385 08	SCHALTSCHRANK MECH.
SCHILD	97 75 397 08	63	1	2 932 160	96 54 385 08	SCHALTSCHRANK MECH.
SCHILD	97 75 402 08	68	1	2 932 160	96 54 385 08	SCHALTSCHRANK MECH.
SCHILD	97 75 403 08	69	1	2 932 160	96 54 385 08	SCHALTSCHRANK MECH.
SCHILD	97 75 407 08	73	1	2 932 160	96 54 385 08	SCHALTSCHRANK MECH.
SCHILD	97 85 630 08	(160)	1	2 920 369	96 54 235 08	KLEMMKASTEN KPL.
SCHILD	97 85 631 08	(158)	1	2 920 369	96 54 235 08	KLEMMKASTEN KPL.
SCHILD +S1020 ALU	97 78 943 08	4	1	3 930 730	96 50 599 08	KLEMMKASTEN KPL.
SCHILD +S1070 LEXAN	97 83 741 08	4	1	3 930 363	96 52 979 08	KLEMMKASTEN KPL.
SCHILD +S1090 ALU	97 80 964 08	8	1	2 920 581	96 54 405 08	KLEMMKASTEN SA-BOCK VO
SCHILD +S1100 LEXAN	97 82 953 08	5	1	2 780 748	96 52 969 08	KLEMMKASTEN KPL.
SCHILD +S980 ALU	97 80 757 08	5	1	3 930 638	96 51 624 08	KLEMMKASTEN
SCHILD 100X200 AL-BL 1MM	97 57 167 08	185	1	2 970	91 56 537 08	HYDRAULIK
SCHILD 100X70X1 AL-BL	97 92 603 08	13	1	1 970	91 56 958 08	HYDRAULIK RAUPE
SCHILD 110X70 LEXEDGE II	97 81 106 08	6	1	2 533 069	96 48 372 08	ELEKTRIK ARMATUR
SCHILD 2X190X100	97 42 123 08	13	6	1 631 100	91 52 388 08	LAUFSTEG RAUPENFAHRWER
SCHILD 2X208X120	97 81 837 08	2	2	1 300	91 52 768 08	BODENPLATTEN KPL.
SCHILD 2X240X100	97 86 732 08	51	2	3 745	91 52 948 08	SCHWEBEBALLAST
SCHILD 35X15 LEXEDGE II	97 75 169 08	(2)	1	2 920 448	96 48 794 08	KLEMMKASTEN KPL.
SCHILD 35X15 LEXEDGE II	97 75 170 08	(3)	1	2 920 448	96 48 794 08	KLEMMKASTEN KPL.
SCHILD 35X15 LEXEDGE II	97 75 171 08	(4)	1	2 920 448	96 48 794 08	KLEMMKASTEN KPL.
SCHILD 35X15 LEXEDGE II	97 75 172 08	(5)	1	2 920 448	96 48 794 08	KLEMMKASTEN KPL.
SCHILD 35X15 LEXEDGE II	97 75 396 08	62	1	2 932 160	96 54 385 08	SCHALTSCHRANK MECH.
SCHILD 35X15 LEXEDGE II	97 75 398 08	64	1	2 932 160	96 54 385 08	SCHALTSCHRANK MECH.
SCHILD 35X15 LEXEDGE II	97 75 399 08	65	1	2 932 160	96 54 385 08	SCHALTSCHRANK MECH.
SCHILD 35X15 LEXEDGE II	97 75 400 08	66	1	2 932 160	96 54 385 08	SCHALTSCHRANK MECH.
SCHILD 35X15 LEXEDGE II	97 75 401 08	67	1	2 932 160	96 54 385 08	SCHALTSCHRANK MECH.
SCHILD 35X15 LEXEDGE II	97 75 404 08	70	1	2 932 160	96 54 385 08	SCHALTSCHRANK MECH.
SCHILD 35X15 LEXEDGE II	97 75 405 08	71	1	2 932 160	96 54 385 08	SCHALTSCHRANK MECH.
SCHILD 35X15 LEXEDGE II	97 75 406 08	72	1	2 932 160	96 54 385 08	SCHALTSCHRANK MECH.
SCHILD 75X45 ALUMINIUM	97 69 555 08	27	1	2 831	91 57 754 08	KLIMAAANLAGE OW
SCHILD BAUGRUPPE BG-NR. P	97 35 919 08	(3)	1	2 550	91 57 751 08	SA-BOCK
SCHILD BAUGRUPPE BG-NR. P	97 35 919 08	(3)	1	2 550	91 57 751 08	SA-BOCK
SCHILD BAUGRUPPE BG-NR. P	97 35 919 08	5	1	2 550 005	96 45 680 08	STANGE KPL.
SCHILD BAUGRUPPE BG-NR. P	97 35 919 08	11	1	3 207 003	96 48 259 08	STANGE KPL.
SCHILD BAUGRUPPE BG-NR. P	97 35 919 08	8	1	3 207 100	96 48 261 08	LASCHE KPL.
SCHILD BAUGRUPPE BG-NR. P	97 35 919 08	8	1	3 207 101	96 48 292 08	LASCHE KPL.
SCHILD BAUGRUPPE BG-NR. P	97 35 919 08	14	1	3 211 003	96 46 986 08	STANGE KPL.
SCHILD BAUGRUPPE BG-NR. P	97 35 919 08	6	1	3 220 501	96 43 440 08	STANGE KPL.
SCHILD BAUGRUPPE BG-NR. P	97 35 919 08	6	1	3 221 200	96 47 984 08	STANGE KPL.
SCHILD BAUGRUPPE BG-NR. P	97 35 919 08	6	1	3 225 200	96 48 679 08	STANGE KPL.
SCHILD BAUGRUPPE BG-NR. P	97 35 919 08	6	1	3 227 002	96 50 498 08	STANGE KPL.

6.2.2009

etk_en_de_074515 LR 1600/2

1081

LIEBHERRAlphabetical index
Alphabetischer Index

Bezeichnung	Artikel	Pos.	Menge	Seite	Baugruppe	Bezeichnung
SCHILD BAUGRUPPE BG-NR. P	97 35 919 08	(6)	1	3 281	91 52 896 08	FA-BOCK
SCHILD BAUGRUPPE BG-NR. P	97 35 919 08	(6)	1	3 281	91 52 896 08	FA-BOCK
SCHILD BAUGRUPPE BG-NR. P	97 35 919 08	(11)	1	3 281	91 52 896 08	FA-BOCK
SCHILD BAUGRUPPE BG-NR. P	97 35 919 08	6	1	3 561 003	96 45 222 08	STANGE KPL.
SCHILD BAUGRUPPE BG-NR. P	97 35 919 08	6	1	3 713 012	96 50 197 08	STANGE KPL.
SCHILD BAUGRUPPE BG-NR. P	97 35 919 08	9	1	3 714 013	96 59 083 08	LASCHE KPL.
SCHILD BAUGRUPPE BG-NR. P	97 35 919 08	6	1	3 714 014	96 49 456 08	LASCHE KPL.
SCHILD BAUGRUPPE BG-NR. P	97 35 919 08	9	1	3 714 025	96 49 269 08	STANGE KPL.
SCHILD BAUGRUPPE BG-NR. P	97 35 919 08	6	1	3 716 001	96 49 159 08	STANGE KPL.
SCHILD BEDIENPULT 40X120	97 79 945 08	6	1	2 920 638	96 51 138 08	BEDIENPULT
SCHILD BETRIEBSSTUNDENZ	97 12 910 08	58	1	2 932 082	96 54 387 08	AUFBAUTEILE MONTAGETAPE
SCHILD IDENTNR. IDENT-NR	97 35 676 08	5	1	2 550 010	96 45 685 08	STANGE VORM.
SCHILD IDENTNR. IDENT-NR	97 35 676 08	6	1	3 282 001	96 47 888 08	F-STUETZE KPL.
SCHILD IDENTNR. IDENT-NR	97 35 676 08	7	1	3 714 013	96 49 270 08	LASCHE KPL.
SCHILD S1000	97 79 690 08	1	1	3 930 640	96 50 481 08	KLEMMKASTEN KPL.
SCHILD S1050 LEXAN	97 82 166 08	4	1	3 930 734	96 54 401 08	KLEMMKASTEN
SCHILD S200 LEXAN	97 74 996 08	5	1	1 920 418	96 48 687 08	KLEMMKASTEN KPL.
SCHILD S220 LEXAN	97 75 070 08	5	1	1 920 403	96 48 707 08	KLEMMKASTEN KPL.
SCHILD S240 LEXAN	97 75 008 08	5	1	1 920 417	96 48 703 08	KLEMMKASTEN KPL.
SCHILD S910 LEXAN-SCHILD	97 73 509 08	4	1	3 930 730	96 54 398 08	KLEMMKASTEN KPL.
SCHILDER KLEMMKASTEN S1	96 48 795 08	4	1	2 920 448	96 48 794 08	KLEMMKASTEN KPL.
SCHIRMSCHIENE	60 20 426 08	91	2	2 932 082	96 54 387 08	AUFBAUTEILE MONTAGETAPE
SCHLAUCH	10 01 872 9	4	1	9 739 127	97 39 127	WASSERENTLUEFTUNGSLEIT
SCHLAUCH	51 05 010 08	121	1	2 391 001	96 45 719 08	DIESELMOTOR VORM.
SCHLAUCH 22X65 -1	10 01 263 2	28	1	9 739 494	97 39 494	ATL-ANBAU
SCHLAUCH 4	59 10 053 08	14	10	2 520 032	96 45 980 08	SCHEIBENWISCHANLAGE EIN
SCHLAUCH DI=2/DA=5	55 30 187 08	12	10	2 541	91 52 790 08	ZUSATZHEIZUNG OW
SCHLAUCH DI=2/DA=5	55 30 187 08	13	2	2 541	91 52 790 08	ZUSATZHEIZUNG OW
SCHLAUCH DN130X100	95 58 181 08	4	1	2 393	91 52 787 08	LUFTFILTERANLAGE KPL.
SCHLAUCH DN18X2200	55 31 761 08	17	1	2 540	91 53 253 08	HEIZKLIMAGERAET EINBAU
SCHLAUCH DN18X2200	55 31 761 08	9	1	2 541	91 52 790 08	ZUSATZHEIZUNG OW
SCHLAUCH DN6,3	57 17 120 08	2	1	5 123 682	51 23 682 08	MONTAGEZYLINDER
SCHLAUCH GUMMI	55 07 726 08	2	2	2 393	91 52 787 08	LUFTFILTERANLAGE KPL.
SCHLAUCH KPL. 1SC 0,22M	96 51 592 08	313	1	2 997	91 56 539 08	SCHLAUCHLEITUNGEN OBER
SCHLAUCH KPL. 1SC 0,34M	92 67 113 08	197	1	2 997	91 56 539 08	SCHLAUCHLEITUNGEN OBER
SCHLAUCH KPL. 1SC 0,3M	92 76 379 08	1406	1	2 975 061	96 47 201 08	SCHLAUCHLEITUNGEN WIND
SCHLAUCH KPL. 1SC 0,3M	92 76 379 08	1406	1	2 975 118	96 47 200 08	SCHLAUCHLEITUNGEN WIND
SCHLAUCH KPL. 1SC 0,48M	92 88 791 08	309	1	2 997	91 56 539 08	SCHLAUCHLEITUNGEN OBER
SCHLAUCH KPL. 1SC 0,4M	92 60 254 08	342	1	2 997	91 56 539 08	SCHLAUCHLEITUNGEN OBER
SCHLAUCH KPL. 1SC 0,58M	92 84 682 08	190	1	2 997	91 56 539 08	SCHLAUCHLEITUNGEN OBER
SCHLAUCH KPL. 1SC 0,5M	92 60 981 08	1459	1	2 976 204	96 47 202 08	SCHLAUCHLEITUNGEN 2 DR
SCHLAUCH KPL. 1SC 0,64M	92 68 546 08	243	1	2 997	91 56 539 08	SCHLAUCHLEITUNGEN OBER
SCHLAUCH KPL. 1SC 0,66M	92 61 198 08	307	1	2 997	91 56 539 08	SCHLAUCHLEITUNGEN OBER
SCHLAUCH KPL. 1SC 0,66M	92 97 592 08	1452	1	2 976 701	96 47 196 08	SCHLAUCHLEITUNGEN PUM
SCHLAUCH KPL. 1SC 0,6M	92 96 492 08	182	1	2 997	91 56 539 08	SCHLAUCHLEITUNGEN OBER
SCHLAUCH KPL. 1SC 0,72M	92 76 816 08	386	1	2 997	91 56 539 08	SCHLAUCHLEITUNGEN OBER
SCHLAUCH KPL. 1SC 0,72M	96 42 753 08	1466	1	2 976 204	96 47 202 08	SCHLAUCHLEITUNGEN 2 DR
SCHLAUCH KPL. 1SC 0,82M	92 63 790 08	333	1	2 997	91 56 539 08	SCHLAUCHLEITUNGEN OBER
SCHLAUCH KPL. 1SC 0,88M	92 75 502 08	308	1	2 997	91 56 539 08	SCHLAUCHLEITUNGEN OBER
SCHLAUCH KPL. 1SC 0,8M	96 25 348 08	219	1	2 997	91 56 539 08	SCHLAUCHLEITUNGEN OBER
SCHLAUCH KPL. 1SC 0,96M	92 63 791 08	807	1	1 997	91 52 512 08	SCHLAUCHLEITUNGEN RAUP
SCHLAUCH KPL. 1SC 1,04M	92 93 776 08	385	1	2 997	91 56 539 08	SCHLAUCHLEITUNGEN OBER
SCHLAUCH KPL. 1SC 1,0M	92 60 582 08	186	1	2 997	91 56 539 08	SCHLAUCHLEITUNGEN OBER
SCHLAUCH KPL. 1SC 1,26M	92 80 465 08	304	1	2 997	91 56 539 08	SCHLAUCHLEITUNGEN OBER
SCHLAUCH KPL. 1SC 1,2M	92 32 713 08	1460	1	2 976 204	96 47 202 08	SCHLAUCHLEITUNGEN 2 DR
SCHLAUCH KPL. 1SC 1,3M	96 52 075 08	343	1	2 997	91 56 539 08	SCHLAUCHLEITUNGEN OBER
SCHLAUCH KPL. 1SC 1,46M	92 61 225 08	327	1	2 997	91 56 539 08	SCHLAUCHLEITUNGEN OBER
SCHLAUCH KPL. 1SC 1,46M	92 76 122 08	271	1	2 997	91 56 539 08	SCHLAUCHLEITUNGEN OBER
SCHLAUCH KPL. 1SC 2,0M	96 24 770 08	1223	1	2 978 101	96 47 912 08	SCHLAUCHLEITUNGEN MONT
SCHLAUCH KPL. 1SC 2,3M	96 17 986 08	1385	1	2 975 191	96 48 196 08	SCHLAUCHLEITUNGEN MONT

6.2.2009

etk_en_de_074515 LR 1600/2

1082

LIEBHERRAlphabetical index
Alphabetischer Index

Bezeichnung	Artikel	Pos.	Menge	Seite	Baugruppe	Bezeichnung
SCHLAUCH KPL. 1SC 2,7M	92 76 383 08	326	1	2 997	91 56 539 08	SCHLAUCHLEITUNGEN OBER
SCHLAUCH KPL. 1SN 0,2M	92 15 736 08	747	1	1 997	91 52 512 08	SCHLAUCHLEITUNGEN RAUP
SCHLAUCH KPL. 1SN 0,56M	92 13 504 08	384	1	2 997	91 56 539 08	SCHLAUCHLEITUNGEN OBER
SCHLAUCH KPL. 1SN 0,56M	92 87 111 08	375	1	2 997	91 56 539 08	SCHLAUCHLEITUNGEN OBER
SCHLAUCH KPL. 1SN 0,5M	92 15 391 08	231	1	2 997	91 56 539 08	SCHLAUCHLEITUNGEN OBER
SCHLAUCH KPL. 1SN 0,7M	92 61 308 08	229	1	2 997	91 56 539 08	SCHLAUCHLEITUNGEN OBER
SCHLAUCH KPL. 1SN 0,82M	96 52 068 08	228	1	2 997	91 56 539 08	SCHLAUCHLEITUNGEN OBER
SCHLAUCH KPL. 1SN 0,84M	96 54 781 08	1481	1	2 977 005	96 48 195 08	SCHLAUCHLEITUNGEN ZUSA
SCHLAUCH KPL. 1SN 0,86M	92 26 313 08	221	1	2 997	91 56 539 08	SCHLAUCHLEITUNGEN OBER
SCHLAUCH KPL. 1SN 0,8M	96 49 596 08	225	1	2 997	91 56 539 08	SCHLAUCHLEITUNGEN OBER
SCHLAUCH KPL. 1SN 0,8M	96 49 599 08	235	1	2 997	91 56 539 08	SCHLAUCHLEITUNGEN OBER
SCHLAUCH KPL. 1SN 0,94M	96 49 598 08	232	1	2 997	91 56 539 08	SCHLAUCHLEITUNGEN OBER
SCHLAUCH KPL. 1SN 0,96M	92 97 527 08	226	1	2 997	91 56 539 08	SCHLAUCHLEITUNGEN OBER
SCHLAUCH KPL. 1SN 0,98M	96 26 895 08	227	1	2 997	91 56 539 08	SCHLAUCHLEITUNGEN OBER
SCHLAUCH KPL. 1SN 1,0M	92 76 051 08	377	1	2 997	91 56 539 08	SCHLAUCHLEITUNGEN OBER
SCHLAUCH KPL. 1SN 1,0M	92 97 467 08	813	2	1 997	91 52 512 08	SCHLAUCHLEITUNGEN RAUP
SCHLAUCH KPL. 1SN 1,0M	92 97 467 08	234	1	2 997	91 56 539 08	SCHLAUCHLEITUNGEN OBER
SCHLAUCH KPL. 1SN 1,2M	92 97 579 08	376	1	2 997	91 56 539 08	SCHLAUCHLEITUNGEN OBER
SCHLAUCH KPL. 1SN 1,34M	96 49 595 08	223	1	2 997	91 56 539 08	SCHLAUCHLEITUNGEN OBER
SCHLAUCH KPL. 1SN 1,36M	92 06 036 08	242	1	2 997	91 56 539 08	SCHLAUCHLEITUNGEN OBER
SCHLAUCH KPL. 1SN 1,44M	96 49 594 08	222	1	2 997	91 56 539 08	SCHLAUCHLEITUNGEN OBER
SCHLAUCH KPL. 1SN 1,55M	92 93 381 08	740	1	1 997	91 52 512 08	SCHLAUCHLEITUNGEN RAUP
SCHLAUCH KPL. 1SN 1,55M	96 27 618 08	389	1	2 997	91 56 539 08	SCHLAUCHLEITUNGEN OBER
SCHLAUCH KPL. 1SN 1,55M	96 46 874 08	236	1	2 997	91 56 539 08	SCHLAUCHLEITUNGEN OBER
SCHLAUCH KPL. 1SN 1,5M	96 54 337 08	1482	1	2 977 005	96 48 195 08	SCHLAUCHLEITUNGEN ZUSA
SCHLAUCH KPL. 1SN 1,6M	92 74 292 08	224	1	2 997	91 56 539 08	SCHLAUCHLEITUNGEN OBER
SCHLAUCH KPL. 1SN 1,7M	92 75 706 08	1249	1	2 977 201	96 48 618 08	SCHLAUCHLEITUNGEN PUMP
SCHLAUCH KPL. 1SN 1,7M	92 75 706 08	355	1	2 997	91 56 539 08	SCHLAUCHLEITUNGEN OBER
SCHLAUCH KPL. 1SN 1,7M	92 87 633 08	357	1	2 997	91 56 539 08	SCHLAUCHLEITUNGEN OBER
SCHLAUCH KPL. 1SN 1,95M	96 55 638 08	403	1	2 997	91 56 539 08	SCHLAUCHLEITUNGEN OBER
SCHLAUCH KPL. 1SN 2,05M	92 96 216 08	237	1	2 997	91 56 539 08	SCHLAUCHLEITUNGEN OBER
SCHLAUCH KPL. 1SN 2,1M	92 66 115 08	809	1	1 997	91 52 512 08	SCHLAUCHLEITUNGEN RAUP
SCHLAUCH KPL. 1SN 2,3M	92 96 157 08	1302	1	2 975 154	96 50 585 08	SCHLAUCHLEITUNGEN WIND
SCHLAUCH KPL. 1SN 2,3M	92 96 157 08	(1321)	1	3 978 100	91 56 428 08	HYDR.SCHWEBEBALLAST-AN
SCHLAUCH KPL. 1SN 2,5M	92 60 668 08	1301	1	2 975 154	96 50 585 08	SCHLAUCHLEITUNGEN WIND
SCHLAUCH KPL. 1SN 2,6M	92 75 709 08	837	2	1 997	91 52 512 08	SCHLAUCHLEITUNGEN RAUP
SCHLAUCH KPL. 1SN 2,85M	96 55 637 08	402	1	2 997	91 56 539 08	SCHLAUCHLEITUNGEN OBER
SCHLAUCH KPL. 1SN 3,0M	92 68 364 08	233	1	2 997	91 56 539 08	SCHLAUCHLEITUNGEN OBER
SCHLAUCH KPL. 2755 0,46M	96 49 579 08	1210	1	2 978 204	96 47 114 08	SCHLAUCHLEITUNGEN S-RU
SCHLAUCH KPL. 2755 0,54M	92 25 870 08	1270	1	3 978 018	96 50 880 08	SCHLAUCHLEITUNGEN ZUGZY
SCHLAUCH KPL. 2755 0,54M	92 87 114 08	1211	1	2 978 204	96 47 114 08	SCHLAUCHLEITUNGEN S-RU
SCHLAUCH KPL. 2755 0,62M	92 18 495 08	391	1	2 997	91 56 539 08	SCHLAUCHLEITUNGEN OBER
SCHLAUCH KPL. 2755 0,6M	92 22 817 08	359	1	2 997	91 56 539 08	SCHLAUCHLEITUNGEN OBER
SCHLAUCH KPL. 2755 0,74M	96 51 591 08	1461	1	2 976 204	96 47 202 08	SCHLAUCHLEITUNGEN 2 DR
SCHLAUCH KPL. 2755 0,76M	96 43 235 08	392	1	2 997	91 56 539 08	SCHLAUCHLEITUNGEN OBER
SCHLAUCH KPL. 2755 0,78M	92 60 732 08	358	1	2 997	91 56 539 08	SCHLAUCHLEITUNGEN OBER
SCHLAUCH KPL. 2755 0,7M	92 28 969 08	382	1	2 997	91 56 539 08	SCHLAUCHLEITUNGEN OBER
SCHLAUCH KPL. 2755 0,84M	96 51 573 08	1451	1	2 976 701	96 47 196 08	SCHLAUCHLEITUNGEN PUM
SCHLAUCH KPL. 2755 0,86M	96 51 896 08	381	1	2 997	91 56 539 08	SCHLAUCHLEITUNGEN OBER
SCHLAUCH KPL. 2755 0,88M	96 52 067 08	211	1	2 997	91 56 539 08	SCHLAUCHLEITUNGEN OBER
SCHLAUCH KPL. 2755 0,8M	96 51 572 08	1450	1	2 976 701	96 47 196 08	SCHLAUCHLEITUNGEN PUM
SCHLAUCH KPL. 2755 0,96M	92 45 280 08	1222	1	2 978 101	96 47 912 08	SCHLAUCHLEITUNGEN MONT
SCHLAUCH KPL. 2755 0,9M	96 52 066 08	210	1	2 997	91 56 539 08	SCHLAUCHLEITUNGEN OBER
SCHLAUCH KPL. 2755 1,02M	92 96 166 08	1462	1	2 976 204	96 47 202 08	SCHLAUCHLEITUNGEN 2 DR
SCHLAUCH KPL. 2755 1,04M	92 27 352 08	1483	1	2 977 005	96 48 195 08	SCHLAUCHLEITUNGEN ZUSA
SCHLAUCH KPL. 2755 1,06M	92 44 585 08	383	1	2 997	91 56 539 08	SCHLAUCHLEITUNGEN OBER
SCHLAUCH KPL. 2755 1,0M	92 22 505 08	1313	2	2 978 107	96 50 433 08	SCHLAUCHLEITUNGEN D-RU
SCHLAUCH KPL. 2755 1,12M	92 56 341 08	1221	1	2 978 101	96 47 912 08	SCHLAUCHLEITUNGEN MONT
SCHLAUCH KPL. 2755 1,2M	96 51 561 08	212	1	2 997	91 56 539 08	SCHLAUCHLEITUNGEN OBER
SCHLAUCH KPL. 2755 1,3M	92 40 956 08	746	1	1 997	91 52 512 08	SCHLAUCHLEITUNGEN RAUP

6.2.2009

etk_en_de_074515 LR 1600/2

1083

LIEBHERRAlphabetical index
Alphabetischer Index

Bezeichnung	Artikel	Pos.	Menge	Seite	Baugruppe	Bezeichnung
SCHLAUCH KPL. 2755 1,42M	92 80 222 08	1220	2	2 978 101	96 47 912 08	SCHLAUCHLEITUNGEN MONT
SCHLAUCH KPL. 2755 1,55M	96 51 562 08	213	1	2 997	91 56 539 08	SCHLAUCHLEITUNGEN OBER
SCHLAUCH KPL. 2755 1,65M	92 20 800 08	312	2	2 997	91 56 539 08	SCHLAUCHLEITUNGEN OBER
SCHLAUCH KPL. 2755 1,75M	92 29 002 08	301	1	2 997	91 56 539 08	SCHLAUCHLEITUNGEN OBER
SCHLAUCH KPL. 2755 1,7M	92 40 284 08	302	1	2 997	91 56 539 08	SCHLAUCHLEITUNGEN OBER
SCHLAUCH KPL. 2755 1,8M	92 64 556 08	400	1	2 997	91 56 539 08	SCHLAUCHLEITUNGEN OBER
SCHLAUCH KPL. 2755 1,9M	92 48 756 08	390	1	2 997	91 56 539 08	SCHLAUCHLEITUNGEN OBER
SCHLAUCH KPL. 2755 2,05M	92 61 208 08	1455	1	2 976 204	96 47 202 08	SCHLAUCHLEITUNGEN 2 DR
SCHLAUCH KPL. 2755 2,2M	92 18 746 08	812	1	1 997	91 52 512 08	SCHLAUCHLEITUNGEN RAUP
SCHLAUCH KPL. 2755 2,35M	92 19 240 08	1456	1	2 976 204	96 47 202 08	SCHLAUCHLEITUNGEN 2 DR
SCHLAUCH KPL. 2755 2,3M	92 80 473 08	(1320)	1	3 978 100	91 56 428 08	HYDR.SCHWEBEBALLAST-AN
SCHLAUCH KPL. 2755 2,45M	96 54 735 08	1308	1	2 978 107	96 50 433 08	SCHLAUCHLEITUNGEN D-RU
SCHLAUCH KPL. 2755 2,6M	92 60 420 08	1264	2	3 978 009	96 50 881 08	SCHLAUCHLEITUNGEN D-KO
SCHLAUCH KPL. 2755 3,3M	92 44 929 08	1263	2	3 978 009	96 50 881 08	SCHLAUCHLEITUNGEN D-KO
SCHLAUCH KPL. 2755 3,4M	96 20 654 08	802	4	1 997	91 52 512 08	SCHLAUCHLEITUNGEN RAUP
SCHLAUCH KPL. 2755 3,8M	92 87 562 08	(1880)	8	1 975 006	91 52 509 08	ZUSATZHYDR.ABSTUETZZYL
SCHLAUCH KPL. 2SN 0,23M	92 74 496 08	328	1	2 997	91 56 539 08	SCHLAUCHLEITUNGEN OBER
SCHLAUCH KPL. 2SN 0,24M	96 52 045 08	122	1	2 997	91 56 539 08	SCHLAUCHLEITUNGEN OBER
SCHLAUCH KPL. 2SN 0,25M	92 76 973 08	1405	1	2 975 061	96 47 201 08	SCHLAUCHLEITUNGEN WIND
SCHLAUCH KPL. 2SN 0,25M	92 76 973 08	1405	1	2 975 118	96 47 200 08	SCHLAUCHLEITUNGEN WIND
SCHLAUCH KPL. 2SN 0,28M	92 17 502 08	1161	1	2 975 154	96 50 585 08	SCHLAUCHLEITUNGEN WIND
SCHLAUCH KPL. 2SN 0,2M	92 80 057 08	185	1	2 997	91 56 539 08	SCHLAUCHLEITUNGEN OBER
SCHLAUCH KPL. 2SN 0,32M	92 93 259 08	401	2	2 997	91 56 539 08	SCHLAUCHLEITUNGEN OBER
SCHLAUCH KPL. 2SN 0,33M	92 09 765 08	398	1	2 997	91 56 539 08	SCHLAUCHLEITUNGEN OBER
SCHLAUCH KPL. 2SN 0,33M	92 32 286 08	193	1	2 997	91 56 539 08	SCHLAUCHLEITUNGEN OBER
SCHLAUCH KPL. 2SN 0,35M	92 66 576 08	188	1	2 997	91 56 539 08	SCHLAUCHLEITUNGEN OBER
SCHLAUCH KPL. 2SN 0,35M	92 66 576 08	192	1	2 997	91 56 539 08	SCHLAUCHLEITUNGEN OBER
SCHLAUCH KPL. 2SN 0,35M	92 76 161 08	1404	1	2 975 061	96 47 201 08	SCHLAUCHLEITUNGEN WIND
SCHLAUCH KPL. 2SN 0,35M	92 76 161 08	1404	1	2 975 118	96 47 200 08	SCHLAUCHLEITUNGEN WIND
SCHLAUCH KPL. 2SN 0,35M	92 87 660 08	394	1	2 997	91 56 539 08	SCHLAUCHLEITUNGEN OBER
SCHLAUCH KPL. 2SN 0,41M	96 51 589 08	1402	1	2 975 061	96 47 201 08	SCHLAUCHLEITUNGEN WIND
SCHLAUCH KPL. 2SN 0,41M	96 51 589 08	1402	1	2 975 118	96 47 200 08	SCHLAUCHLEITUNGEN WIND
SCHLAUCH KPL. 2SN 0,42M	92 80 056 08	198	1	2 997	91 56 539 08	SCHLAUCHLEITUNGEN OBER
SCHLAUCH KPL. 2SN 0,43M	96 51 596 08	329	1	2 997	91 56 539 08	SCHLAUCHLEITUNGEN OBER
SCHLAUCH KPL. 2SN 0,43M	96 51 596 08	330	1	2 997	91 56 539 08	SCHLAUCHLEITUNGEN OBER
SCHLAUCH KPL. 2SN 0,46M	96 51 593 08	316	1	2 997	91 56 539 08	SCHLAUCHLEITUNGEN OBER
SCHLAUCH KPL. 2SN 0,48M	92 99 231 08	1213	1	2 978 204	96 47 114 08	SCHLAUCHLEITUNGEN S-RU
SCHLAUCH KPL. 2SN 0,48M	96 22 558 08	1216	1	2 978 204	96 47 114 08	SCHLAUCHLEITUNGEN S-RU
SCHLAUCH KPL. 2SN 0,48M	96 51 588 08	196	1	2 997	91 56 539 08	SCHLAUCHLEITUNGEN OBER
SCHLAUCH KPL. 2SN 0,48M	96 54 718 08	1272	1	3 978 018	96 50 880 08	SCHLAUCHLEITUNGEN ZUGZY
SCHLAUCH KPL. 2SN 0,4M	92 24 554 08	264	1	2 997	91 56 539 08	SCHLAUCHLEITUNGEN OBER
SCHLAUCH KPL. 2SN 0,4M	92 24 554 08	397	1	2 997	91 56 539 08	SCHLAUCHLEITUNGEN OBER
SCHLAUCH KPL. 2SN 0,4M	92 76 147 08	1382	1	2 975 191	96 48 196 08	SCHLAUCHLEITUNGEN MONT
SCHLAUCH KPL. 2SN 0,4M	92 80 060 08	331	1	2 997	91 56 539 08	SCHLAUCHLEITUNGEN OBER
SCHLAUCH KPL. 2SN 0,4M	92 84 715 08	124	1	2 997	91 56 539 08	SCHLAUCHLEITUNGEN OBER
SCHLAUCH KPL. 2SN 0,51M	92 93 119 08	1214	1	2 978 204	96 47 114 08	SCHLAUCHLEITUNGEN S-RU
SCHLAUCH KPL. 2SN 0,54M	92 96 122 08	379	1	2 997	91 56 539 08	SCHLAUCHLEITUNGEN OBER
SCHLAUCH KPL. 2SN 0,54M	96 24 385 08	365	1	2 997	91 56 539 08	SCHLAUCHLEITUNGEN OBER
SCHLAUCH KPL. 2SN 0,54M	96 29 580 08	215	1	2 997	91 56 539 08	SCHLAUCHLEITUNGEN OBER
SCHLAUCH KPL. 2SN 0,56M	92 84 567 08	216	1	2 997	91 56 539 08	SCHLAUCHLEITUNGEN OBER
SCHLAUCH KPL. 2SN 0,58M	92 93 262 08	1271	1	3 978 018	96 50 880 08	SCHLAUCHLEITUNGEN ZUGZY
SCHLAUCH KPL. 2SN 0,58M	96 54 722 08	1212	1	2 978 204	96 47 114 08	SCHLAUCHLEITUNGEN S-RU
SCHLAUCH KPL. 2SN 0,5M	92 68 659 08	265	1	2 997	91 56 539 08	SCHLAUCHLEITUNGEN OBER
SCHLAUCH KPL. 2SN 0,62M	92 30 161 08	1160	1	2 975 154	96 50 585 08	SCHLAUCHLEITUNGEN WIND
SCHLAUCH KPL. 2SN 0,62M	92 76 164 08	125	1	2 997	91 56 539 08	SCHLAUCHLEITUNGEN OBER
SCHLAUCH KPL. 2SN 0,62M	96 51 914 08	1215	1	2 978 204	96 47 114 08	SCHLAUCHLEITUNGEN S-RU
SCHLAUCH KPL. 2SN 0,62M	96 51 914 08	1217	1	2 978 204	96 47 114 08	SCHLAUCHLEITUNGEN S-RU
SCHLAUCH KPL. 2SN 0,64M	96 51 590 08	1403	1	2 975 061	96 47 201 08	SCHLAUCHLEITUNGEN WIND
SCHLAUCH KPL. 2SN 0,64M	96 51 590 08	1403	1	2 975 118	96 47 200 08	SCHLAUCHLEITUNGEN WIND
SCHLAUCH KPL. 2SN 0,66M	96 51 587 08	187	1	2 997	91 56 539 08	SCHLAUCHLEITUNGEN OBER

6.2.2009

etk_en_de_074515 LR 1600/2

1084

LIEBHERRAlphabetical index
Alphabetischer Index

Bezeichnung	Artikel	Pos.	Menge	Seite	Baugruppe	Bezeichnung
SCHLAUCH KPL. 2SN 0,6M	92 80 058 08	366	1	2 997	91 56 539 08	SCHLAUCHLEITUNGEN OBER
SCHLAUCH KPL. 2SN 0,6M	92 80 058 08	399	1	2 997	91 56 539 08	SCHLAUCHLEITUNGEN OBER
SCHLAUCH KPL. 2SN 0,6M	92 88 897 08	354	1	2 997	91 56 539 08	SCHLAUCHLEITUNGEN OBER
SCHLAUCH KPL. 2SN 0,72M	96 41 931 08	361	1	2 997	91 56 539 08	SCHLAUCHLEITUNGEN OBER
SCHLAUCH KPL. 2SN 0,76M	92 88 711 08	1273	1	3 978 018	96 50 880 08	SCHLAUCHLEITUNGEN ZUGZY
SCHLAUCH KPL. 2SN 0,78M	92 76 428 08	184	1	2 997	91 56 539 08	SCHLAUCHLEITUNGEN OBER
SCHLAUCH KPL. 2SN 0,78M	92 76 838 08	1384	1	2 975 191	96 48 196 08	SCHLAUCHLEITUNGEN MONT
SCHLAUCH KPL. 2SN 0,7M	92 65 600 08	(95)	2	2 976 203	92 27 489 08	ZUSATZHYDR.BOLZENZIEHZ
SCHLAUCH KPL. 2SN 0,7M	92 68 678 08	274	1	2 997	91 56 539 08	SCHLAUCHLEITUNGEN OBER
SCHLAUCH KPL. 2SN 0,7M	96 33 357 08	1162	1	2 975 154	96 50 585 08	SCHLAUCHLEITUNGEN WIND
SCHLAUCH KPL. 2SN 0,7M	96 33 357 08	341	1	2 997	91 56 539 08	SCHLAUCHLEITUNGEN OBER
SCHLAUCH KPL. 2SN 0,86M	96 41 973 08	1315	1	2 978 107	96 50 433 08	SCHLAUCHLEITUNGEN D-RU
SCHLAUCH KPL. 2SN 0,86M	96 49 576 08	360	1	2 997	91 56 539 08	SCHLAUCHLEITUNGEN OBER
SCHLAUCH KPL. 2SN 0,86M	96 51 917 08	320	1	2 997	91 56 539 08	SCHLAUCHLEITUNGEN OBER
SCHLAUCH KPL. 2SN 0,88M	92 68 547 08	1314	1	2 978 107	96 50 433 08	SCHLAUCHLEITUNGEN D-RU
SCHLAUCH KPL. 2SN 0,8M	92 27 451 08	1401	1	2 975 061	96 47 201 08	SCHLAUCHLEITUNGEN WIND
SCHLAUCH KPL. 2SN 0,8M	92 27 451 08	1401	1	2 975 118	96 47 200 08	SCHLAUCHLEITUNGEN WIND
SCHLAUCH KPL. 2SN 0,8M	92 27 451 08	362	1	2 997	91 56 539 08	SCHLAUCHLEITUNGEN OBER
SCHLAUCH KPL. 2SN 0,8M	96 52 071 08	322	1	2 997	91 56 539 08	SCHLAUCHLEITUNGEN OBER
SCHLAUCH KPL. 2SN 0,92M	92 76 776 08	393	1	2 997	91 56 539 08	SCHLAUCHLEITUNGEN OBER
SCHLAUCH KPL. 2SN 0,92M	96 52 046 08	123	1	2 997	91 56 539 08	SCHLAUCHLEITUNGEN OBER
SCHLAUCH KPL. 2SN 0,94M	92 80 363 08	332	1	2 997	91 56 539 08	SCHLAUCHLEITUNGEN OBER
SCHLAUCH KPL. 2SN 0,9M	96 52 072 08	323	1	2 997	91 56 539 08	SCHLAUCHLEITUNGEN OBER
SCHLAUCH KPL. 2SN 1,04M	92 99 672 08	1311	1	2 978 107	96 50 433 08	SCHLAUCHLEITUNGEN D-RU
SCHLAUCH KPL. 2SN 1,06M	96 25 946 08	1310	1	2 978 107	96 50 433 08	SCHLAUCHLEITUNGEN D-RU
SCHLAUCH KPL. 2SN 1,0M	92 80 300 08	1383	1	2 975 191	96 48 196 08	SCHLAUCHLEITUNGEN MONT
SCHLAUCH KPL. 2SN 1,0M	92 93 107 08	1164	1	2 975 154	96 50 585 08	SCHLAUCHLEITUNGEN WIND
SCHLAUCH KPL. 2SN 1,0M	92 93 328 08	1312	2	2 978 107	96 50 433 08	SCHLAUCHLEITUNGEN D-RU
SCHLAUCH KPL. 2SN 1,1M	96 51 560 08	209	1	2 997	91 56 539 08	SCHLAUCHLEITUNGEN OBER
SCHLAUCH KPL. 2SN 1,4M	92 87 596 08	1465	1	2 976 204	96 47 202 08	SCHLAUCHLEITUNGEN 2 DR
SCHLAUCH KPL. 2SN 1,55M	96 22 426 08	263	1	2 997	91 56 539 08	SCHLAUCHLEITUNGEN OBER
SCHLAUCH KPL. 2SN 1,5M	96 31 722 08	1261	1	3 978 009	96 50 881 08	SCHLAUCHLEITUNGEN D-KO
SCHLAUCH KPL. 2SN 1,5M	96 51 559 08	208	1	2 997	91 56 539 08	SCHLAUCHLEITUNGEN OBER
SCHLAUCH KPL. 2SN 1,65M	96 55 636 08	217	1	2 997	91 56 539 08	SCHLAUCHLEITUNGEN OBER
SCHLAUCH KPL. 2SN 1,75M	92 09 806 08	261	1	2 997	91 56 539 08	SCHLAUCHLEITUNGEN OBER
SCHLAUCH KPL. 2SN 1,75M	96 29 984 08	1287	1	3 978 016	96 50 878 08	SCHLAUCHLEITUNGEN ZWIS
SCHLAUCH KPL. 2SN 1,7M	92 74 187 08	262	1	2 997	91 56 539 08	SCHLAUCHLEITUNGEN OBER
SCHLAUCH KPL. 2SN 1,7M	96 31 723 08	(1282)	1	3 978 015	91 56 429 08	ZUSATZHYDRAULIK ZWISCH
SCHLAUCH KPL. 2SN 1,85M	92 09 958 08	244	1	2 997	91 56 539 08	SCHLAUCHLEITUNGEN OBER
SCHLAUCH KPL. 2SN 1,85M	92 76 030 08	1247	1	2 977 201	96 48 618 08	SCHLAUCHLEITUNGEN PUMP
SCHLAUCH KPL. 2SN 1,85M	92 76 030 08	1248	1	2 977 201	96 48 618 08	SCHLAUCHLEITUNGEN PUMP
SCHLAUCH KPL. 2SN 1,85M	92 87 626 08	338	1	2 997	91 56 539 08	SCHLAUCHLEITUNGEN OBER
SCHLAUCH KPL. 2SN 1,9M	92 97 484 08	1169	1	2 975 154	96 50 585 08	SCHLAUCHLEITUNGEN WIND
SCHLAUCH KPL. 2SN 15,0M	92 87 559 08	90	4	2 976 200	91 44 034 08	ZUS.HYDR.BOLZENZIEHEINRI
SCHLAUCH KPL. 2SN 15,0M	96 51 586 08	(1371)	2	2 970 081	96 50 495 08	ZUSATZHYDR.BOLZENZIEHZ
SCHLAUCH KPL. 2SN 2,0M	92 09 849 08	317	1	2 997	91 56 539 08	SCHLAUCHLEITUNGEN OBER
SCHLAUCH KPL. 2SN 2,45M	92 76 036 08	1309	1	2 978 107	96 50 433 08	SCHLAUCHLEITUNGEN D-RU
SCHLAUCH KPL. 2SN 2,55M	96 51 595 08	324	1	2 997	91 56 539 08	SCHLAUCHLEITUNGEN OBER
SCHLAUCH KPL. 2SN 2,5M	92 76 848 08	1303	1	2 975 154	96 50 585 08	SCHLAUCHLEITUNGEN WIND
SCHLAUCH KPL. 2SN 2,5M	92 76 848 08	1304	1	2 975 154	96 50 585 08	SCHLAUCHLEITUNGEN WIND
SCHLAUCH KPL. 2SN 2,5M	92 97 568 08	339	2	2 997	91 56 539 08	SCHLAUCHLEITUNGEN OBER
SCHLAUCH KPL. 2SN 2,5M	96 31 991 08	1307	1	2 978 107	96 50 433 08	SCHLAUCHLEITUNGEN D-RU
SCHLAUCH KPL. 2SN 2,65M	96 32 001 08	838	2	1 997	91 52 512 08	SCHLAUCHLEITUNGEN RAUP
SCHLAUCH KPL. 2SN 2,7M	92 10 438 08	363	1	2 997	91 56 539 08	SCHLAUCHLEITUNGEN OBER
SCHLAUCH KPL. 2SN 2,7M	96 52 073 08	325	1	2 997	91 56 539 08	SCHLAUCHLEITUNGEN OBER
SCHLAUCH KPL. 2SN 3,0M	92 84 646 08	(1370)	2	2 970 081	96 50 495 08	ZUSATZHYDR.BOLZENZIEHZ
SCHLAUCH KPL. 2SN 3,6M	92 12 548 08	364	1	2 997	91 56 539 08	SCHLAUCHLEITUNGEN OBER
SCHLAUCH KPL. 2SN 3,7M	96 47 681 08	1262	2	3 978 009	96 50 881 08	SCHLAUCHLEITUNGEN D-KO
SCHLAUCH KPL. 2SN 7,9M	96 51 606 08	368	1	2 997	91 56 539 08	SCHLAUCHLEITUNGEN OBER
SCHLAUCH KPL. 2TE 0,15M	96 27 578 08	1218	1	2 978 204	96 47 114 08	SCHLAUCHLEITUNGEN S-RU

6.2.2009

etk_en_de_074515 LR 1600/2

1085

LIEBHERRAlphabetical index
Alphabetischer Index

Bezeichnung	Artikel	Pos.	Menge	Seite	Baugruppe	Bezeichnung
SCHLAUCH KPL. 2TE 0,16M	96 54 309 08	1266	1	3 978 009	96 50 881 08	SCHLAUCHLEITUNGEN D-KO
SCHLAUCH KPL. 2TE 0,22M	96 49 567 08	1224	1	2 978 101	96 47 912 08	SCHLAUCHLEITUNGEN MONT
SCHLAUCH KPL. 2TE 0,26M	96 37 039 08	189	1	2 997	91 56 539 08	SCHLAUCHLEITUNGEN OBER
SCHLAUCH KPL. 2TE 0,28M	96 54 283 08	396	1	2 997	91 56 539 08	SCHLAUCHLEITUNGEN OBER
SCHLAUCH KPL. 2TE 0,32M	92 66 122 08	314	1	2 997	91 56 539 08	SCHLAUCHLEITUNGEN OBER
SCHLAUCH KPL. 2TE 0,32M	92 76 407 08	1407	1	2 975 061	96 47 201 08	SCHLAUCHLEITUNGEN WIND
SCHLAUCH KPL. 2TE 0,32M	92 76 407 08	1407	1	2 975 118	96 47 200 08	SCHLAUCHLEITUNGEN WIND
SCHLAUCH KPL. 2TE 0,34M	92 80 398 08	178	1	2 997	91 56 539 08	SCHLAUCHLEITUNGEN OBER
SCHLAUCH KPL. 2TE 0,34M	92 87 646 08	1458	1	2 976 204	96 47 202 08	SCHLAUCHLEITUNGEN 2 DR
SCHLAUCH KPL. 2TE 0,34M	92 87 646 08	1464	1	2 976 204	96 47 202 08	SCHLAUCHLEITUNGEN 2 DR
SCHLAUCH KPL. 2TE 0,34M	92 87 646 08	195	1	2 997	91 56 539 08	SCHLAUCHLEITUNGEN OBER
SCHLAUCH KPL. 2TE 0,38M	92 87 508 08	120	1	2 997	91 56 539 08	SCHLAUCHLEITUNGEN OBER
SCHLAUCH KPL. 2TE 0,3M	92 26 702 08	1219	1	2 978 204	96 47 114 08	SCHLAUCHLEITUNGEN S-RU
SCHLAUCH KPL. 2TE 0,3M	92 96 377 08	194	1	2 997	91 56 539 08	SCHLAUCHLEITUNGEN OBER
SCHLAUCH KPL. 2TE 0,43M	92 87 642 08	191	1	2 997	91 56 539 08	SCHLAUCHLEITUNGEN OBER
SCHLAUCH KPL. 2TE 0,43M	96 33 352 08	1408	1	2 975 061	96 47 201 08	SCHLAUCHLEITUNGEN WIND
SCHLAUCH KPL. 2TE 0,43M	96 33 352 08	1408	1	2 975 118	96 47 200 08	SCHLAUCHLEITUNGEN WIND
SCHLAUCH KPL. 2TE 0,45M	92 76 109 08	1409	1	2 975 061	96 47 201 08	SCHLAUCHLEITUNGEN WIND
SCHLAUCH KPL. 2TE 0,45M	92 76 109 08	1409	1	2 975 118	96 47 200 08	SCHLAUCHLEITUNGEN WIND
SCHLAUCH KPL. 2TE 0,46M	92 65 663 08	239	1	2 997	91 56 539 08	SCHLAUCHLEITUNGEN OBER
SCHLAUCH KPL. 2TE 0,46M	92 84 526 08	1163	1	2 975 154	96 50 585 08	SCHLAUCHLEITUNGEN WIND
SCHLAUCH KPL. 2TE 0,47M	92 80 172 08	1454	1	2 976 701	96 47 196 08	SCHLAUCHLEITUNGEN PUM
SCHLAUCH KPL. 2TE 0,47M	96 31 691 08	181	1	2 997	91 56 539 08	SCHLAUCHLEITUNGEN OBER
SCHLAUCH KPL. 2TE 0,48M	92 87 505 08	745	1	1 997	91 52 512 08	SCHLAUCHLEITUNGEN RAUP
SCHLAUCH KPL. 2TE 0,48M	92 87 505 08	395	2	2 997	91 56 539 08	SCHLAUCHLEITUNGEN OBER
SCHLAUCH KPL. 2TE 0,4M	92 60 954 08	257	1	2 997	91 56 539 08	SCHLAUCHLEITUNGEN OBER
SCHLAUCH KPL. 2TE 0,4M	96 49 535 08	805	1	1 997	91 52 512 08	SCHLAUCHLEITUNGEN RAUP
SCHLAUCH KPL. 2TE 0,52M	92 96 106 08	808	1	1 997	91 52 512 08	SCHLAUCHLEITUNGEN RAUP
SCHLAUCH KPL. 2TE 0,52M	92 96 106 08	245	1	2 997	91 56 539 08	SCHLAUCHLEITUNGEN OBER
SCHLAUCH KPL. 2TE 0,52M	96 51 604 08	351	1	2 997	91 56 539 08	SCHLAUCHLEITUNGEN OBER
SCHLAUCH KPL. 2TE 0,54M	96 28 573 08	352	1	2 997	91 56 539 08	SCHLAUCHLEITUNGEN OBER
SCHLAUCH KPL. 2TE 0,56M	92 87 641 08	1453	1	2 976 701	96 47 196 08	SCHLAUCHLEITUNGEN PUM
SCHLAUCH KPL. 2TE 0,58M	92 69 908 08	353	1	2 997	91 56 539 08	SCHLAUCHLEITUNGEN OBER
SCHLAUCH KPL. 2TE 0,58M	92 72 931 08	255	1	2 997	91 56 539 08	SCHLAUCHLEITUNGEN OBER
SCHLAUCH KPL. 2TE 0,5M	92 30 874 08	248	1	2 997	91 56 539 08	SCHLAUCHLEITUNGEN OBER
SCHLAUCH KPL. 2TE 0,5M	92 60 417 08	256	1	2 997	91 56 539 08	SCHLAUCHLEITUNGEN OBER
SCHLAUCH KPL. 2TE 0,5M	92 69 710 08	350	1	2 997	91 56 539 08	SCHLAUCHLEITUNGEN OBER
SCHLAUCH KPL. 2TE 0,5M	96 49 593 08	254	1	2 997	91 56 539 08	SCHLAUCHLEITUNGEN OBER
SCHLAUCH KPL. 2TE 0,62M	92 88 722 08	179	1	2 997	91 56 539 08	SCHLAUCHLEITUNGEN OBER
SCHLAUCH KPL. 2TE 0,64M	92 76 825 08	121	1	2 997	91 56 539 08	SCHLAUCHLEITUNGEN OBER
SCHLAUCH KPL. 2TE 0,64M	92 76 825 08	252	1	2 997	91 56 539 08	SCHLAUCHLEITUNGEN OBER
SCHLAUCH KPL. 2TE 0,64M	96 39 296 08	380	1	2 997	91 56 539 08	SCHLAUCHLEITUNGEN OBER
SCHLAUCH KPL. 2TE 0,66M	92 99 240 08	432	1	2 997	91 56 539 08	SCHLAUCHLEITUNGEN OBER
SCHLAUCH KPL. 2TE 0,68M	96 40 959 08	1463	1	2 976 204	96 47 202 08	SCHLAUCHLEITUNGEN 2 DR
SCHLAUCH KPL. 2TE 0,68M	96 40 959 08	251	1	2 997	91 56 539 08	SCHLAUCHLEITUNGEN OBER
SCHLAUCH KPL. 2TE 0,6M	92 65 511 08	1267	1	3 978 009	96 50 881 08	SCHLAUCHLEITUNGEN D-KO
SCHLAUCH KPL. 2TE 0,6M	92 96 478 08	1172	1	2 975 154	96 50 585 08	SCHLAUCHLEITUNGEN WIND
SCHLAUCH KPL. 2TE 0,74M	96 38 237 08	199	1	2 997	91 56 539 08	SCHLAUCHLEITUNGEN OBER
SCHLAUCH KPL. 2TE 0,74M	96 42 737 08	259	1	2 997	91 56 539 08	SCHLAUCHLEITUNGEN OBER
SCHLAUCH KPL. 2TE 0,76M	92 26 284 08	247	1	2 997	91 56 539 08	SCHLAUCHLEITUNGEN OBER
SCHLAUCH KPL. 2TE 0,82M	96 24 526 08	272	1	2 997	91 56 539 08	SCHLAUCHLEITUNGEN OBER
SCHLAUCH KPL. 2TE 0,86M	92 64 932 08	180	1	2 997	91 56 539 08	SCHLAUCHLEITUNGEN OBER
SCHLAUCH KPL. 2TE 0,86M	96 17 203 08	834	2	1 997	91 52 512 08	SCHLAUCHLEITUNGEN RAUP
SCHLAUCH KPL. 2TE 0,88M	96 47 719 08	238	1	2 997	91 56 539 08	SCHLAUCHLEITUNGEN OBER
SCHLAUCH KPL. 2TE 0,88M	96 47 719 08	240	1	2 997	91 56 539 08	SCHLAUCHLEITUNGEN OBER
SCHLAUCH KPL. 2TE 0,8M	92 66 066 08	183	1	2 997	91 56 539 08	SCHLAUCHLEITUNGEN OBER
SCHLAUCH KPL. 2TE 0,8M	92 66 066 08	321	1	2 997	91 56 539 08	SCHLAUCHLEITUNGEN OBER
SCHLAUCH KPL. 2TE 0,92M	92 87 176 08	249	1	2 997	91 56 539 08	SCHLAUCHLEITUNGEN OBER
SCHLAUCH KPL. 2TE 0,96M	92 97 535 08	246	1	2 997	91 56 539 08	SCHLAUCHLEITUNGEN OBER
SCHLAUCH KPL. 2TE 0,96M	92 97 535 08	356	1	2 997	91 56 539 08	SCHLAUCHLEITUNGEN OBER

6.2.2009

etk_en_de_074515 LR 1600/2

1086

LIEBHERRAlphabetical index
Alphabetischer Index

Bezeichnung	Artikel	Pos.	Menge	Seite	Baugruppe	Bezeichnung
SCHLAUCH KPL. 2TE 0,98M	96 54 736 08	1316	1	2 978 107	96 50 433 08	SCHLAUCHLEITUNGEN D-RU
SCHLAUCH KPL. 2TE 0,9M	92 76 814 08	337	1	2 997	91 56 539 08	SCHLAUCHLEITUNGEN OBER
SCHLAUCH KPL. 2TE 0,9M	92 76 814 08	1265	1	3 978 009	96 50 881 08	SCHLAUCHLEITUNGEN D-KO
SCHLAUCH KPL. 2TE 0,9M	92 84 719 08	367	1	2 997	91 56 539 08	SCHLAUCHLEITUNGEN OBER
SCHLAUCH KPL. 2TE 1,04M	96 49 597 08	230	1	2 997	91 56 539 08	SCHLAUCHLEITUNGEN OBER
SCHLAUCH KPL. 2TE 1,0M	92 80 170 08	334	1	2 997	91 56 539 08	SCHLAUCHLEITUNGEN OBER
SCHLAUCH KPL. 2TE 1,0M	96 51 610 08	378	1	2 997	91 56 539 08	SCHLAUCHLEITUNGEN OBER
SCHLAUCH KPL. 2TE 1,15M	92 76 775 08	373	1	2 997	91 56 539 08	SCHLAUCHLEITUNGEN OBER
SCHLAUCH KPL. 2TE 1,18M	96 49 589 08	371	1	2 997	91 56 539 08	SCHLAUCHLEITUNGEN OBER
SCHLAUCH KPL. 2TE 1,1M	92 35 237 08	1480	1	2 977 005	96 48 195 08	SCHLAUCHLEITUNGEN ZUSA
SCHLAUCH KPL. 2TE 1,1M	92 65 761 08	315	1	2 997	91 56 539 08	SCHLAUCHLEITUNGEN OBER
SCHLAUCH KPL. 2TE 1,26M	92 70 110 08	310	1	2 997	91 56 539 08	SCHLAUCHLEITUNGEN OBER
SCHLAUCH KPL. 2TE 1,34M	92 64 194 08	305	1	2 997	91 56 539 08	SCHLAUCHLEITUNGEN OBER
SCHLAUCH KPL. 2TE 1,36M	92 64 954 08	258	1	2 997	91 56 539 08	SCHLAUCHLEITUNGEN OBER
SCHLAUCH KPL. 2TE 1,3M	92 43 724 08	1170	1	2 975 154	96 50 585 08	SCHLAUCHLEITUNGEN WIND
SCHLAUCH KPL. 2TE 1,3M	92 60 465 08	804	1	1 997	91 52 512 08	SCHLAUCHLEITUNGEN RAUP
SCHLAUCH KPL. 2TE 1,3M	92 76 977 08	803	1	1 997	91 52 512 08	SCHLAUCHLEITUNGEN RAUP
SCHLAUCH KPL. 2TE 1,46M	92 65 763 08	273	1	2 997	91 56 539 08	SCHLAUCHLEITUNGEN OBER
SCHLAUCH KPL. 2TE 1,46M	96 25 943 08	319	1	2 997	91 56 539 08	SCHLAUCHLEITUNGEN OBER
SCHLAUCH KPL. 2TE 1,4M	92 72 524 08	372	1	2 997	91 56 539 08	SCHLAUCHLEITUNGEN OBER
SCHLAUCH KPL. 2TE 1,55M	92 93 122 08	318	1	2 997	91 56 539 08	SCHLAUCHLEITUNGEN OBER
SCHLAUCH KPL. 2TE 1,55M	96 51 567 08	253	1	2 997	91 56 539 08	SCHLAUCHLEITUNGEN OBER
SCHLAUCH KPL. 2TE 1,6M	96 18 625 08	335	1	2 997	91 56 539 08	SCHLAUCHLEITUNGEN OBER
SCHLAUCH KPL. 2TE 1,7M	92 61 392 08	260	1	2 997	91 56 539 08	SCHLAUCHLEITUNGEN OBER
SCHLAUCH KPL. 2TE 1,85M	92 60 962 08	250	1	2 997	91 56 539 08	SCHLAUCHLEITUNGEN OBER
SCHLAUCH KPL. 2TE 1,85M	92 76 750 08	806	1	1 997	91 52 512 08	SCHLAUCHLEITUNGEN RAUP
SCHLAUCH KPL. 2TE 1,95M	92 87 630 08	1171	1	2 975 154	96 50 585 08	SCHLAUCHLEITUNGEN WIND
SCHLAUCH KPL. 2TE 1,9M	92 80 485 08	1168	1	2 975 154	96 50 585 08	SCHLAUCHLEITUNGEN WIND
SCHLAUCH KPL. 2TE 2,05M	92 60 246 08	220	1	2 997	91 56 539 08	SCHLAUCHLEITUNGEN OBER
SCHLAUCH KPL. 2TE 2,05M	96 54 724 08	1167	1	2 975 154	96 50 585 08	SCHLAUCHLEITUNGEN WIND
SCHLAUCH KPL. 2TE 2,0M	92 99 224 08	241	1	2 997	91 56 539 08	SCHLAUCHLEITUNGEN OBER
SCHLAUCH KPL. 2TE 2,15M	92 61 222 08	832	2	1 997	91 52 512 08	SCHLAUCHLEITUNGEN RAUP
SCHLAUCH KPL. 2TE 2,1M	92 61 473 08	1457	1	2 976 204	96 47 202 08	SCHLAUCHLEITUNGEN 2 DR
SCHLAUCH KPL. 2TE 2,3M	92 88 607 08	336	1	2 997	91 56 539 08	SCHLAUCHLEITUNGEN OBER
SCHLAUCH KPL. 2TE 2,3M	92 88 763 08	388	1	2 997	91 56 539 08	SCHLAUCHLEITUNGEN OBER
SCHLAUCH KPL. 2TE 2,4M	92 61 388 08	1380	1	2 975 191	96 48 196 08	SCHLAUCHLEITUNGEN MONT
SCHLAUCH KPL. 2TE 2,55M	92 76 918 08	374	1	2 997	91 56 539 08	SCHLAUCHLEITUNGEN OBER
SCHLAUCH KPL. 2TE 2,5M	96 49 541 08	833	2	1 997	91 52 512 08	SCHLAUCHLEITUNGEN RAUP
SCHLAUCH KPL. 2TE 2,6M	92 93 167 08	1842	2	1 976 050	96 50 707 08	SCHLAUCHLEITUNGEN RAUP
SCHLAUCH KPL. 2TE 2,7M	96 52 074 08	340	1	2 997	91 56 539 08	SCHLAUCHLEITUNGEN OBER
SCHLAUCH KPL. 2TE 2,8M	92 71 131 08	1843	2	1 976 050	96 50 707 08	SCHLAUCHLEITUNGEN RAUP
SCHLAUCH KPL. 2TE 3,2M	96 28 615 08	306	1	2 997	91 56 539 08	SCHLAUCHLEITUNGEN OBER
SCHLAUCH KPL. 2TE 3,3M	92 61 496 08	311	1	2 997	91 56 539 08	SCHLAUCHLEITUNGEN OBER
SCHLAUCH KPL. 2TE 3,3M	96 54 282 08	387	1	2 997	91 56 539 08	SCHLAUCHLEITUNGEN OBER
SCHLAUCH KPL. 2TE 4,7M	92 97 516 08	431	1	2 997	91 56 539 08	SCHLAUCHLEITUNGEN OBER
SCHLAUCH KPL. 2TE 5,0M	92 61 458 08	430	1	2 997	91 56 539 08	SCHLAUCHLEITUNGEN OBER
SCHLAUCH KPL. GH134 1,9M	96 51 902 08	(1103)	1	2 831	91 57 754 08	KLIMAAANLAGE OW
SCHLAUCH KPL. GH134 2,7M	96 54 324 08	(1104)	1	2 831	91 57 754 08	KLIMAAANLAGE OW
SCHLAUCH KPL. GH134 2,8M	96 54 323 08	(1102)	1	2 831	91 57 754 08	KLIMAAANLAGE OW
SCHLAUCH KPL. GH134 3,6M	96 54 325 08	(1105)	1	2 831	91 57 754 08	KLIMAAANLAGE OW
SCHLAUCH KPL. GH134 8,0M	96 54 321 08	(1100)	1	2 831	91 57 754 08	KLIMAAANLAGE OW
SCHLAUCH KPL. GH134 8,1M	96 54 322 08	(1101)	1	2 831	91 57 754 08	KLIMAAANLAGE OW
SCHLAUCH KPL. GH466 0,48M	96 51 600 08	346	1	2 997	91 56 539 08	SCHLAUCHLEITUNGEN OBER
SCHLAUCH KPL. GH466 0,62M	96 51 598 08	344	1	2 997	91 56 539 08	SCHLAUCHLEITUNGEN OBER
SCHLAUCH KPL. GH466 0,62M	96 51 601 08	347	1	2 997	91 56 539 08	SCHLAUCHLEITUNGEN OBER
SCHLAUCH KPL. GH466 0,74M	96 51 599 08	345	1	2 997	91 56 539 08	SCHLAUCHLEITUNGEN OBER
SCHLAUCH KPL. GH466 0,78M	96 44 763 08	816	1	1 997	91 52 512 08	SCHLAUCHLEITUNGEN RAUP
SCHLAUCH KPL. GH466 0,88M	96 52 049 08	741	1	1 997	91 52 512 08	SCHLAUCHLEITUNGEN RAUP
SCHLAUCH KPL. GH466 0,88M	96 52 049 08	743	1	1 997	91 52 512 08	SCHLAUCHLEITUNGEN RAUP
SCHLAUCH KPL. GH466 0,92M	96 51 906 08	1486	1	2 977 005	96 48 195 08	SCHLAUCHLEITUNGEN ZUSA

6.2.2009

etk_en_de_074515 LR 1600/2

1087

LIEBHERRAlphabetical index
Alphabetischer Index

Bezeichnung	Artikel	Pos.	Menge	Seite	Baugruppe	Bezeichnung
SCHLAUCH KPL. GH466 1,02M	96 51 905 08	1484	1	2 977 005	96 48 195 08	SCHLAUCHLEITUNGEN ZUSA
SCHLAUCH KPL. GH466 1,08M	96 51 603 08	349	1	2 997	91 56 539 08	SCHLAUCHLEITUNGEN OBER
SCHLAUCH KPL. GH466 1,0M	96 49 546 08	814	1	1 997	91 52 512 08	SCHLAUCHLEITUNGEN RAUP
SCHLAUCH KPL. GH466 1,0M	96 51 602 08	348	1	2 997	91 56 539 08	SCHLAUCHLEITUNGEN OBER
SCHLAUCH KPL. GH466 1,12M	96 49 548 08	817	1	1 997	91 52 512 08	SCHLAUCHLEITUNGEN RAUP
SCHLAUCH KPL. GH466 1,12M	96 49 548 08	1487	1	2 977 005	96 48 195 08	SCHLAUCHLEITUNGEN ZUSA
SCHLAUCH KPL. GH466 1,15M	96 33 350 08	201	1	2 997	91 56 539 08	SCHLAUCHLEITUNGEN OBER
SCHLAUCH KPL. GH466 1,1M	96 23 356 08	1485	1	2 977 005	96 48 195 08	SCHLAUCHLEITUNGEN ZUSA
SCHLAUCH KPL. GH466 1,32M	96 49 600 08	200	1	2 997	91 56 539 08	SCHLAUCHLEITUNGEN OBER
SCHLAUCH KPL. GH466 1,34M	96 51 609 08	300	1	2 997	91 56 539 08	SCHLAUCHLEITUNGEN OBER
SCHLAUCH KPL. GH466 1,34M	96 54 723 08	1166	1	2 975 154	96 50 585 08	SCHLAUCHLEITUNGEN WIND
SCHLAUCH KPL. GH466 1,36M	96 49 547 08	815	1	1 997	91 52 512 08	SCHLAUCHLEITUNGEN RAUP
SCHLAUCH KPL. GH466 1,46M	96 51 607 08	303	1	2 997	91 56 539 08	SCHLAUCHLEITUNGEN OBER
SCHLAUCH KPL. GH466 1,46M	96 51 607 08	369	1	2 997	91 56 539 08	SCHLAUCHLEITUNGEN OBER
SCHLAUCH KPL. GH466 1,4M	96 51 608 08	370	1	2 997	91 56 539 08	SCHLAUCHLEITUNGEN OBER
SCHLAUCH KPL. GH466 1,5M	96 49 549 08	830	2	1 997	91 52 512 08	SCHLAUCHLEITUNGEN RAUP
SCHLAUCH KPL. GH466 1,5M	96 49 549 08	1165	1	2 975 154	96 50 585 08	SCHLAUCHLEITUNGEN WIND
SCHLAUCH KPL. GH466 1,5M	96 51 553 08	202	1	2 997	91 56 539 08	SCHLAUCHLEITUNGEN OBER
SCHLAUCH KPL. GH466 1,6M	96 51 907 08	1245	2	2 977 201	96 48 618 08	SCHLAUCHLEITUNGEN PUMP
SCHLAUCH KPL. GH466 1,75M	96 36 000 08	742	1	1 997	91 52 512 08	SCHLAUCHLEITUNGEN RAUP
SCHLAUCH KPL. GH466 1,75M	96 51 554 08	203	1	2 997	91 56 539 08	SCHLAUCHLEITUNGEN OBER
SCHLAUCH KPL. GH466 1,7M	96 49 550 08	831	2	1 997	91 52 512 08	SCHLAUCHLEITUNGEN RAUP
SCHLAUCH KPL. GH466 1,85M	96 49 545 08	744	1	1 997	91 52 512 08	SCHLAUCHLEITUNGEN RAUP
SCHLAUCH KPL. GH466 1,8M	96 49 551 08	1840	2	1 976 050	96 50 707 08	SCHLAUCHLEITUNGEN RAUP
SCHLAUCH KPL. GH466 2,05M	96 39 243 08	835	2	1 997	91 52 512 08	SCHLAUCHLEITUNGEN RAUP
SCHLAUCH KPL. GH466 2,0M	96 49 553 08	1841	2	1 976 050	96 50 707 08	SCHLAUCHLEITUNGEN RAUP
SCHLAUCH KPL. GH466 2,35M	96 31 973 08	836	2	1 997	91 52 512 08	SCHLAUCHLEITUNGEN RAUP
SCHLAUCH KPL. GH466 2,35M	96 31 973 08	1300	2	2 975 154	96 50 585 08	SCHLAUCHLEITUNGEN WIND
SCHLAUCH KPL. GH506 0,62M	96 36 987 08	204	1	2 997	91 56 539 08	SCHLAUCHLEITUNGEN OBER
SCHLAUCH KPL. GH506 0,62M	96 51 909 08	1244	1	2 977 201	96 48 618 08	SCHLAUCHLEITUNGEN PUMP
SCHLAUCH KPL. GH506 0,74M	96 51 908 08	1243	1	2 977 201	96 48 618 08	SCHLAUCHLEITUNGEN PUMP
SCHLAUCH KPL. GH506 0,7M	96 51 557 08	205	1	2 997	91 56 539 08	SCHLAUCHLEITUNGEN OBER
SCHLAUCH KPL. GH506 1,3M	96 39 267 08	1260	2	3 978 009	96 50 881 08	SCHLAUCHLEITUNGEN D-KO
SCHLAUCH KPL. GH506 1,44M	96 51 556 08	206	1	2 997	91 56 539 08	SCHLAUCHLEITUNGEN OBER
SCHLAUCH KPL. GH506 1,44M	96 52 047 08	207	1	2 997	91 56 539 08	SCHLAUCHLEITUNGEN OBER
SCHLAUCH KPL. GH506 1,5M	96 54 719 08	(1280)	1	3 978 015	91 56 429 08	ZUSATZHYDRAULIK ZWISCH
SCHLAUCH KPL. GH506 1,5M	96 54 719 08	(1281)	1	3 978 015	91 56 429 08	ZUSATZHYDRAULIK ZWISCH
SCHLAUCH KPL. GH506 1,5M	96 54 719 08	1285	1	3 978 016	96 50 878 08	SCHLAUCHLEITUNGEN ZWIS
SCHLAUCH KPL. GH506 1,5M	96 54 719 08	1286	1	3 978 016	96 50 878 08	SCHLAUCHLEITUNGEN ZWIS
SCHLAUCH KPL. GH506 1,65M	96 28 576 08	214	1	2 997	91 56 539 08	SCHLAUCHLEITUNGEN OBER
SCHLAUCH KPL. HPC 0,6M	92 14 563 08	451	1	2 997	91 56 539 08	SCHLAUCHLEITUNGEN OBER
SCHLAUCH KPL. HPC 1,06M	96 51 948 08	452	1	2 997	91 56 539 08	SCHLAUCHLEITUNGEN OBER
SCHLAUCH KPL. HPC 12,3M	96 54 779 08	455	1	2 997	91 56 539 08	SCHLAUCHLEITUNGEN OBER
SCHLAUCH KPL. HPC 2,5M	92 93 211 08	871	2	1 997	91 52 512 08	SCHLAUCHLEITUNGEN RAUP
SCHLAUCH KPL. HPC 2,7M	96 52 070 08	453	1	2 997	91 56 539 08	SCHLAUCHLEITUNGEN OBER
SCHLAUCH KPL. HPC 2,9M	96 38 619 08	450	1	2 997	91 56 539 08	SCHLAUCHLEITUNGEN OBER
SCHLAUCH KPL. HPC 2,9M	96 38 619 08	454	1	2 997	91 56 539 08	SCHLAUCHLEITUNGEN OBER
SCHLAUCH KPL. HPC 5,9M	92 09 034 08	870	2	1 997	91 52 512 08	SCHLAUCHLEITUNGEN RAUP
SCHLAUCH KPL. TFS 1,0M	92 12 619 08	275	1	2 997	91 56 539 08	SCHLAUCHLEITUNGEN OBER
SCHLAUCH KPL. TFS 1,5M	96 23 354 08	(1366)	1	2 393	91 52 787 08	LUFTFILTERANLAGE KPL.
SCHLAUCH N1-32	10 01 120 0	20	2	9 739 492	97 39 492	ROHRLEITUNG ANBAU
SCHLAUCHBOGEN 90°	10 03 717 3	2	2	9 739 210	97 39 210	KUEHLMITTELLEITUNG
SCHLAUCHLEITUNG	10 34 342 0	5	1	9 739 356	97 39 356	ROHRLEITUNG ANBAU
SCHLAUCHLEITUNG DN10 120	10 11 573 5	1	1	X1011614	10 11 614 1	KRAFTSTOFFSCHLAUCH
SCHLAUCHLEITUNGEN 2 DR	96 47 202 08	91	1	2 976 200	91 52 780 08	ZUSATZHYDRAULIK DREHWE
SCHLAUCHLEITUNGEN ABSTU	96 47 504 08	91	1	1 975 006	91 52 509 08	ZUSATZHYDR.ABSTUETZZYL
SCHLAUCHLEITUNGEN BOLZ	96 46 080 08	91	1	2 976 203	92 27 489 08	ZUSATZHYDR.BOLZENZIEHZ
SCHLAUCHLEITUNGEN BOLZ	96 52 635 08	91	1	2 970 081	96 50 495 08	ZUSATZHYDR.BOLZENZIEHZ
SCHLAUCHLEITUNGEN D-KOP	96 50 881 08	91	1	3 978 005	91 56 430 08	ZUSATZHYDRAULIK SB-KOPFS
SCHLAUCHLEITUNGEN D-RUE	96 50 433 08	91	1	2 978 100	91 52 827 08	ZUSATZHYDR.D-RUECKHALT

6.2.2009

etk_en_de_074515 LR 1600/2

1088

LIEBHERRAlphabetical index
Alphabetischer Index

Bezeichnung	Artikel	Pos.	Menge	Seite	Baugruppe	Bezeichnung
SCHLAUCHLEITUNGEN KLIMA	96 54 368 08	500	1	2 831	91 57 754 08	KLIMAAANLAGE OW
SCHLAUCHLEITUNGEN LUFTK	96 54 041 08	500	1	2 393	91 52 787 08	LUFTFILTERANLAGE KPL.
SCHLAUCHLEITUNGEN MON	96 47 912 08	91	1	2 978 100	91 52 796 08	ZUSATZHYDR.MONTAGEEINR
SCHLAUCHLEITUNGEN MON	96 48 196 08	91	1	2 975 000	91 57 881 08	ZUSATZHYDRAULIK MONTAGE
SCHLAUCHLEITUNGEN OBER	91 56 539 08	179	1		LR 1600-2-0	LIEBHERR RAUPENKRAN LR 1
SCHLAUCHLEITUNGEN PUM	96 47 196 08	91	1	2 976 700	91 54 795 08	ZUSATZHYDRAULIK PUMPE
SCHLAUCHLEITUNGEN PUMP	96 48 618 08	91	1	2 977 200	91 55 149 08	ZUSATZHYDR.PUMPE 5/WIND
SCHLAUCHLEITUNGEN RAUP	91 52 512 08	35	1		LR 1600-2-0	LIEBHERR RAUPENKRAN LR 1
SCHLAUCHLEITUNGEN RAUPE	96 50 707 08	91	1	1 970 161	96 50 706 08	ZUSATZHYDR.RAUPENTRAEG
SCHLAUCHLEITUNGEN S-RUE	96 47 114 08	91	1	2 978 200	91 54 843 08	ZUSATZHYDR.S-RUECKHALTE
SCHLAUCHLEITUNGEN SCH	96 56 946 08	91	1	3 978 100	91 56 428 08	HYDR.SCHWEBEBALLAST-AN
SCHLAUCHLEITUNGEN WIND	96 47 200 08	91	1	2 975 700	91 52 774 08	ZUSATZHYDRAULIK WINDE 1
SCHLAUCHLEITUNGEN WIND	96 47 201 08	91	1	2 975 200	91 52 775 08	ZUSATZHYDRAULIK WINDE 2
SCHLAUCHLEITUNGEN WIND	96 50 585 08	91	1	2 975 100	91 52 860 08	ZUSATZHYDRAULIK WINDE 3
SCHLAUCHLEITUNGEN ZUGZY	96 50 880 08	91	1	3 978 019	91 56 431 08	ZUSATZHYDRAULIK ZYLINDER
SCHLAUCHLEITUNGEN ZUSA	96 48 195 08	91	1	2 977	91 57 756 08	ZUSATZHYDRAULIK DREHBUE
SCHLAUCHLEITUNGEN ZWIS	96 50 883 08	91	1	3 978 015	91 56 429 08	ZUSATZHYDRAULIK ZWISCH
SCHLAUCHLEITUNGEN ZWISC	96 50 878 08	91	1	3 978 015	91 56 432 08	ZUSATZHYDRAULIK ZWISCH
SCHLAUCHMUFFE DN100X110	55 17 166 08	22	2	2 391 023	96 45 720 08	KUEHLER VORM.
SCHLAUCHSCHELLE	55 31 023 08	15	6	2 541	91 52 790 08	ZUSATZHEIZUNG OW
SCHLAUCHSCHELLE 100-104 S	77 42 237 08	8	2	2 670	91 52 797 08	KRAFTSTOFFBEHAELTER KPL
SCHLAUCHSCHELLE 100-120	55 08 494 08	132	8	2 391 001	96 45 719 08	DIESELMOTOR VORM.
SCHLAUCHSCHELLE 100-120	55 08 494 08	6	2	2 391 023	96 45 720 08	KUEHLER VORM.
SCHLAUCHSCHELLE 100-120	55 08 494 08	16	4	2 670	91 52 797 08	KRAFTSTOFFBEHAELTER KPL
SCHLAUCHSCHELLE 100X120	10 03 717 1	2	1	9 739 209	97 39 209	ANSAUGSTUTZEN
SCHLAUCHSCHELLE 11-20	55 08 496 08	15	1	2 920 638	96 51 138 08	BEDIENPULT
SCHLAUCHSCHELLE 130-150	77 42 099 08	10	2	2 393	91 52 787 08	LUFTFILTERANLAGE KPL.
SCHLAUCHSCHELLE 140-148 S	77 42 118 08	11	1	2 393	91 52 787 08	LUFTFILTERANLAGE KPL.
SCHLAUCHSCHELLE 158-166 S	77 42 119 08	77	2	2 970	91 56 537 08	HYDRAULIK
SCHLAUCHSCHELLE 160-180/	10 03 051 7	14	1	2 393	91 52 787 08	LUFTFILTERANLAGE KPL.
SCHLAUCHSCHELLE 176-184 S	77 42 283 08	11	2	2 978 100	91 52 796 08	ZUSATZHYDR.MONTAGEEINR
SCHLAUCHSCHELLE 24-38	77 42 040 08	5	1	2 541 001	96 49 651 08	ZUSATZHEIZUNG VORM.
SCHLAUCHSCHELLE 26 CK75	10 01 267 1	16	2	9 739 386	97 39 386	KURBELGEHAEUSEENTLUEFT
SCHLAUCHSCHELLE 29	10 28 505 2	30	2	9 739 494	97 39 494	ATL-ANBAU
SCHLAUCHSCHELLE 29 CK75	10 01 266 8	15	1	9 739 386	97 39 386	KURBELGEHAEUSEENTLUEFT
SCHLAUCHSCHELLE 32-50 W3	55 08 495 08	134	2	2 391 001	96 45 719 08	DIESELMOTOR VORM.
SCHLAUCHSCHELLE 40-60 W3	55 08 380 08	52	4	2 520 034	96 45 984 08	INNENVERKLEIDUNG
SCHLAUCHSCHELLE 44 CK75	10 01 267 4	21	5	9 739 492	97 39 492	ROHRLEITUNG ANBAU
SCHLAUCHSCHELLE 60-80 W3	77 42 143 08	136	8	2 391 001	96 45 719 08	DIESELMOTOR VORM.
SCHLAUCHSCHELLE 60-80 W3	77 42 143 08	7	2	2 391 023	96 45 720 08	KUEHLER VORM.
SCHLAUCHSCHELLE 60X80 12	10 03 717 6	3	4	9 739 210	97 39 210	KUEHLMITTELLEITUNG
SCHLAUCHSCHELLE 70/68-73/	10 65 265 7	135	6	2 391 001	96 45 719 08	DIESELMOTOR VORM.
SCHLAUCHSCHELLE 72X20	77 42 139 08	12	1	2 671 004	96 46 305 08	OELBEHAELTER VORM.
SCHLAUCHSCHELLE 86-91X25	77 42 279 08	148	8	2 391 001	96 45 719 08	DIESELMOTOR VORM.
SCHLAUCHSCHELLE DIN 3017	55 31 684 08	15	2	2 520 032	96 45 980 08	SCHEIBENWISCHANLAGE EIN
SCHLAUCHSCHELLE DIN 3017	77 42 086 08	153	2	2 391 001	96 45 719 08	DIESELMOTOR VORM.
SCHLAUCHSCHELLE DIN 3017	77 42 086 08	13	17	2 540	91 53 253 08	HEIZKLIMAGERAET EINBAU
SCHLAUCHSCHELLE DIN 3017	77 42 086 08	16	12	2 541	91 52 790 08	ZUSATZHEIZUNG OW
SCHLAUCHSCHELLE HRGB S	77 42 830 08	12	3	2 393	91 52 787 08	LUFTFILTERANLAGE KPL.
SCHLAUCHSCHELLENVERSCH	60 24 400 08	4	1	2 920 257	92 78 689 08	KLEMMKASTEN BELEUCHTUN
SCHLAUCHSCHUTZSPIRALE	10 10 075 2	157	2.2	2 391 001	96 45 719 08	DIESELMOTOR VORM.
SCHLAUCHSTUTZEN 18 M24X	10 34 334 3	8	1	9 739 351	97 39 351	KUEHLMITTELLEITUNG ANBA
SCHLAUCHSTUTZEN 22-M26	10 01 272 5	10	1	9 739 355	97 39 355	OELKUEHLER ANBAU
SCHLAUCHVERSCHRAUBUNG	60 24 408 08	(7)	1	2 920 559	96 47 914 08	ENDSCHALTER U.GEBER AL
SCHLAUCHVERSCHRAUBUNG	60 24 414 08	271	1	1 920 403	96 48 707 08	KLEMMKASTEN KPL.
SCHLAUCHVERSCHRAUBUNG	60 24 414 08	271	1	1 920 417	96 48 703 08	KLEMMKASTEN KPL.
SCHLAUCHVERSCHRAUBUNG	60 24 412 08	288	3	2 920 448	96 48 794 08	KLEMMKASTEN KPL.
SCHLAUCHVERSCHRAUBUNG	60 24 413 08	17	1	1 920 418	96 48 687 08	KLEMMKASTEN KPL.
SCHLAUCHVERSCHRAUBUNG	60 24 413 08	283	1	2 920 448	96 48 794 08	KLEMMKASTEN KPL.
SCHLEIFRING	10 41 178 0	14	1	X1002800	10 02 800 2	LEITUNGSTROMMEL

6.2.2009

etk_en_de_074515 LR 1600/2

1089

LIEBHERRAlphabetical index
Alphabetischer Index

Bezeichnung	Artikel	Pos.	Menge	Seite	Baugruppe	Bezeichnung
SCHLEIFRING	10 41 178 1	15	7	X1002800	10 02 800 2	LEITUNGSTROMMEL
SCHLEIFRING	57 14 224 08	9	4	6 909 010	69 09 010 08	SCHLEIFRINGUEBERTRAEGE
SCHLEIFRING 60X2 2,5MM²	10 11 484 3	11	46	6 909 010	69 09 010 08	SCHLEIFRINGUEBERTRAEGE
SCHLEIFRINGUEBERTRAEGE	69 09 010 08	10	1	1 920 305	92 15 300 08	EINBAU SCHLEIFRINGKOEPERE
SCHLIESSANLAGE SCHIEBET	96 45 602 08	10	1	2 522	91 54 115 08	SCHIEBETUER KPL.
SCHLISSBOLZEN ST	10 34 246 3	4	1	2 522 011	96 45 602 08	SCHLIESSANLAGE
SCHLITTEN KPL.	96 47 880 08	3	2	2 522 013	96 45 883 08	FUEHRUNG VORM.
SCHLUESSELRING 25	70 42 141 08	133	60	2 970	91 56 537 08	HYDRAULIK
SCHLUESSELRING 25	70 42 141 08	67	10	2 975 100	91 52 860 08	ZUSATZHYDRAULIK WINDE 3
SCHLUESSELRING 25	70 42 141 08	67	14	2 975 200	91 52 775 08	ZUSATZHYDRAULIK WINDE 2
SCHLUESSELRING 25	70 42 141 08	67	14	2 975 700	91 52 774 08	ZUSATZHYDRAULIK WINDE 1
SCHLUESSELRING 25	70 42 141 08	64	16	2 977	91 57 756 08	ZUSATZHYDRAULIK DREHBUE
SCHLUESSELRING 25	70 42 141 08	67	10	2 977 200	91 55 149 08	ZUSATZHYDR.PUMPE 5/WIND
SCHLUESSELRING 25	70 42 141 08	63	3	2 978 100	91 52 827 08	ZUSATZHYDR.D-RUECKHALT
SCHLUESSELRING 25	70 42 141 08	63	8	2 978 200	91 54 843 08	ZUSATZHYDR.S-RUECKHALTE
SCHLUESSELRING 25	70 42 141 08	63	5	3 978 005	91 56 430 08	ZUSATZHYDRAULIK SB-KOPFS
SCHLUESSELRING 25	70 42 141 08	63	6	3 978 015	91 56 429 08	ZUSATZHYDRAULIK ZWISCH
SCHLUESSELRING 25	70 42 141 08	63	6	3 978 015	91 56 432 08	ZUSATZHYDRAULIK ZWISCH
SCHLUESSELRING 25	70 42 141 08	63	10	3 978 100	91 56 428 08	HYDR.SCHWEBEBALLAST-AN
SCHLUSSBREMSLEUCHTE	60 71 131 08	3	2	2 920 931	96 59 398 08	WARNLEUCHTE
SCHMIERNIPPEL	57 15 786 08	(1)	1	1 711	91 52 392 08	ZENTRALSCHMIERUNG RAUP
SCHMIERNIPPEL DIN 71412 A	77 43 040 08	13	4	2 125	91 52 773 08	BOLZEN S-ANLENKST. UND S
SCHMIERNIPPEL DIN 71412 A	77 43 040 08	4	1	2 550 003	96 46 246 08	SEILROLLE KPL.
SCHMIERNIPPEL DIN 71412 A	77 43 040 08	4	1	2 652 007	92 68 928 08	SEILROLLE KPL.
SCHMIERNIPPEL DIN 71412 A	77 43 040 08	27	2	2 810	91 52 806 08	KRANFUEHRERKABINE KPL.
SCHMIERNIPPEL DIN 71412 A	77 43 040 08	41	3	3 208 001	91 52 883 08	F-KOPFSTUECK
SCHMIERNIPPEL DIN 71412 A	77 43 040 08	106	2	3 211	91 57 748 08	S-ANLENKSTUECK
SCHMIERNIPPEL DIN 71412 A	77 43 040 08	10	2	3 213	91 52 842 08	F-ANSCHLUSSKOPF
SCHMIERNIPPEL DIN 71412 A	77 43 040 08	10	2	3 214	91 52 843 08	SW-KOPFSTUECK
SCHMIERNIPPEL DIN 71412 A	77 43 040 08	6	2	3 292	91 52 865 08	D-RUECKHALTESICHERUNG
SCHMIERNIPPEL DIN 71412 A	77 43 040 08	18	2	3 714	91 52 862 08	D-KOPFSTUECK
SCHMIERNIPPEL DIN 71412 A	77 43 040 08	401	1	5 718 420	57 18 420 08	FLANSCH
SCHMIERNIPPEL DIN 71412 A	77 43 009 08	6	1	2 550 008	96 47 628 08	HALTER KPL.
SCHMIERNIPPEL DIN 71412 A	77 43 009 08	6	1	2 550 009	96 47 645 08	HALTER KPL.
SCHMIEROELPUMPE	10 02 919 2	1	1	9 739 372	97 39 372	SCHMIEROELPUMPE
SCHMIEROELPUMPE	97 39 372	56	1	X1012059	10 12 059 0	DIESELMOTOR
SCHMIERSTOFF	10 01 732 5	6	1	9 739 187	97 39 187	STEUERUNGSTEILE
SCHRAUBE	10 41 274 6	13	1	9 640 276	96 40 276 08	ANSCHLUSSBLOCK
SCHRAUBE 3/8"-24NFX7 1/4" 1	10 35 393 0	(1)	4	2 970	91 56 537 08	HYDRAULIK
SCHRAUBE 4X12 ST VERZ	10 01 904 0	29	8	2 502	91 55 939 08	STEUERSTAND
SCHRAUBE 4X12 ST VERZ	10 01 904 0	5	4	2 540	91 53 253 08	HEIZKLIMAGERAET EINBAU
SCHRAUBE 4X12 ST VERZ	10 01 904 0	4	4	2 541	91 52 790 08	ZUSATZHEIZUNG OW
SCHRAUBE AEHNL.ISO 4017 U	40 97 516 08	343	8	2 391 001	96 45 719 08	DIESELMOTOR VORM.
SCHRAUBE ISO 7045 M3X16 4.	40 84 007 01	4	2	2 913 005	96 20 731 08	INNENGEHAEUSE VORM.
SCHRAUBE ISO 7045 M3X16 4.	40 84 007 01	4	2	2 913 005	96 28 696 08	INNENGEHAEUSE VORM.
SCHRAUBE M10X130 8.8 A3C	10 01 127 2	4	1	9 739 344	97 39 344	GENERATOR VORM.
SCHRAUBE M10X145 8.8 A3C	10 01 127 1	2	1	9 739 355	97 39 355	OELKUEHLER ANBAU
SCHRAUBE M10X170 8.8 A3C	10 01 127 4	3	1	9 739 355	97 39 355	OELKUEHLER ANBAU
SCHRAUBE M10X30 8.8	10 01 133 0	3	2	9 739 286	97 39 286	VERSCHLUSSDECKEL
SCHRAUBE M10X30 8.8	10 01 133 0	12	1	9 739 344	97 39 344	GENERATOR VORM.
SCHRAUBE M10X35 8.8	10 01 133 1	12	1	9 739 248	97 39 248	EINSPRITZDUESE
SCHRAUBE M10X35 8.8	10 01 133 1	1	8	9 739 355	97 39 355	OELKUEHLER ANBAU
SCHRAUBE M10X35 8.8	10 01 133 1	14	1	9 739 371	97 39 371	KLIMAKOMPRESSOR ANBAU
SCHRAUBE M10X40 8.8 A3C	10 01 134 3	15	2	9 739 344	97 39 344	GENERATOR VORM.
SCHRAUBE M10X54 12.9	10 01 250 3	9	13	9 739 354	97 39 354	SCHWUNGRADGEHAEUSE AN
SCHRAUBE M10X65 10.9 A3C	10 01 133 7	4	1	9 739 271	97 39 271	VERBINDUNGSLEITUNG
SCHRAUBE M10X70 10.9	10 01 250 0	13	3	9 739 354	97 39 354	SCHWUNGRADGEHAEUSE AN
SCHRAUBE M10X70 8.8	10 01 126 4	3	2	9 739 386	97 39 386	KURBELGEHAEUSEENTLUEFT
SCHRAUBE M10X85 8.8 A3C	10 01 134 7	2	4	9 739 358	97 39 358	ABGASRUECKFUEHRUNG AN
SCHRAUBE M12X16 8.8 A3C	10 01 134 4	3	1	9 739 366	97 39 366	BEFESTIGUNGSTEILE ANBAU

6.2.2009

etk_en_de_074515 LR 1600/2

1090

LIEBHERRAlphabetical index
Alphabetischer Index

Bezeichnung	Artikel	Pos.	Menge	Seite	Baugruppe	Bezeichnung
SCHRAUBE M12X40 8.8 A3C	10 01 134 5	8	2	9 739 344	97 39 344	GENERATOR VORM.
SCHRAUBE M12X40 8.8 A3C	10 01 134 5	17	1	9 739 371	97 39 371	KLIMAKOMPRESSOR ANBAU
SCHRAUBE M16X1,5X75 12.9	10 01 250 5	6	10	9 739 250	97 39 250	SCHWUNGRAD
SCHRAUBE M16X35 8.8	10 01 133 5	4	4	9 739 493	97 39 493	TRANSPORTVORRICHTUNG
SCHRAUBE M6X22 8.8	10 01 124 8	6	4	9 739 292	97 39 292	KRAFTSTOFFLEITUNG
SCHRAUBE M8X105 8.8 A2C	10 01 126 1	4	2	9 739 349	97 39 349	WASSERLEITUNGSANSCHLUE
SCHRAUBE M8X12 8.8	10 01 135 1	9	6	9 739 296	97 39 296	HITZESCHUTZ
SCHRAUBE M8X130 10.9	10 01 126 7	4	4	9 739 256	97 39 256	LUFTANSAUGROHR
SCHRAUBE M8X15	40 98 312 08	3	4	2 631 003	96 54 406 08	AUFSTIEG VORM.
SCHRAUBE M8X16 8.8	10 01 136 0	4	3	9 739 035	97 39 035	VERSCHLUSSTEIL
SCHRAUBE M8X16 8.8	10 01 136 0	4	3	9 739 129	97 39 129	KUEHLMITTELVORWAERMUN
SCHRAUBE M8X16 8.8	10 01 136 0	8	5	9 739 366	97 39 366	BEFESTIGUNGSTEILE ANBAU
SCHRAUBE M8X18 8.8	10 01 124 9	5	6	9 739 352	97 39 352	WASSERPUMPE MIT BEFEST.
SCHRAUBE M8X18 8.8	10 01 124 9	20	1	9 739 386	97 39 386	KURBELGEHAEUSEENTLUEFT
SCHRAUBE M8X20 8.8	10 01 134 9	17	1	9 739 296	97 39 296	HITZESCHUTZ
SCHRAUBE M8X22 8.8	10 01 125 0	4	2	9 739 354	97 39 354	SCHWUNGRADGEHAEUSE AN
SCHRAUBE M8X22 8.8	10 01 125 0	12	4	9 739 358	97 39 358	ABGASRUECKFUEHRUNG AN
SCHRAUBE M8X22 8.8	10 01 125 0	22	2	9 739 371	97 39 371	KLIMAKOMPRESSOR ANBAU
SCHRAUBE M8X25 8.8	10 01 136 2	9	1	9 739 210	97 39 210	KUEHLMITTELLEITUNG
SCHRAUBE M8X25 8.8	10 01 136 2	12	1	9 739 371	97 39 371	KLIMAKOMPRESSOR ANBAU
SCHRAUBE M8X28 8.8 A2C	10 01 121 4	10	1	9 739 118	97 39 118	OELLEITUNG
SCHRAUBE M8X35 10.9	10 01 133 9	7	1	9 739 256	97 39 256	LUFTANSAUGROHR
SCHRAUBE M8X35 8.8	10 01 125 2	3	1	9 739 349	97 39 349	WASSERLEITUNGSANSCHLUE
SCHRAUBE M8X35 8.8	10 01 125 2	14	1	9 739 349	97 39 349	WASSERLEITUNGSANSCHLUE
SCHRAUBE M8X40 8.8	10 01 125 3	9	1	9 739 118	97 39 118	OELLEITUNG
SCHRAUBE M8X40 8.8 A2C	10 01 148 8	14	1	9 739 357	97 39 357	ABGASRUECKFUEHRUNG VO
SCHRAUBE M8X40 8.8 A2C	10 01 148 8	26	4	9 739 371	97 39 371	KLIMAKOMPRESSOR ANBAU
SCHRAUBE M8X45 8.8	10 01 132 6	4	2	9 739 259	97 39 259	KRAFTSTOFFFILTER
SCHRAUBE M8X45 8.8	10 01 132 6	3	2	9 739 276	97 39 276	WASSERANSCHLUSS
SCHRAUBE M8X55 8.8	10 01 132 8	3	2	9 739 126	97 39 126	THERMOSTATGEHAEUSE
SCHRAUBE M8X55 8.8	10 01 132 8	4	1	9 739 276	97 39 276	WASSERANSCHLUSS
SCHRAUBE M8X55 8.8	10 01 132 8	10	3	9 739 372	97 39 372	SCHMIEROELPUMPE
SCHRAUBE M8X55 8.8	10 01 133 4	3	2	9 739 271	97 39 271	VERBINDUNGSLEITUNG
SCHRAUBE M8X65 8.8 A2C	10 01 122 5	5	1	9 739 126	97 39 126	THERMOSTATGEHAEUSE
SCHRAUBE M8X65 8.8 A2C	10 01 122 5	4	2	9 739 369	97 39 369	DRUCKROHR
SCHRAUBE M8X90 8.8	10 01 126 2	2	2	9 739 259	97 39 259	KRAFTSTOFFFILTER
SCHRAUBE M8X95 8.8	10 02 919 3	5	1	9 739 369	97 39 369	DRUCKROHR
SCHRAUBENDREHER 3,5	79 00 320 08	13	1	1 750	91 52 394 08	WERKZEUG
SCHRAUBENDREHER 4,5	88 52 004 08	14	1	1 750	91 52 394 08	WERKZEUG
SCHRAUBENDREHER 5,5	79 00 323 08	15	1	1 750	91 52 394 08	WERKZEUG
SCHRAUBENSICHERUNG 10M	86 55 016	109	1	9 080 702	90 80 702	STEUERGERAET
SCHRAUBKAPPE	51 06 623 08	2	1	5 708 320	57 08 320 08	FILTERDECKEL
SCHRAUBKARABINER OVAL 1	10 47 304 0	3	2	2 311 001	96 25 639 08	HUBENDSCHALTER GEWICHT
SCHRAUBKARABINER OVAL 1	10 47 304 0	44	1	3 208 001	91 52 883 08	F-KOPFSTUECK
SCHRAUBSTOPFEN	10 41 275 3	5	1	9 640 277	96 40 277 08	WEGESCHIEBER
SCHRUMPFSCHLAUCH 19-6,0	60 30 167 08	(242)	0.03	2 920 581	96 54 405 08	KLEMMKASTEN SA-BOCK VO
SCHUTZBLECH	10 01 246 2	4	1	9 739 159	97 39 159	STARTER
SCHUTZBLECH 4X307X778	97 65 557 08	4	2	2 350	91 52 778 08	DREHWERK
SCHUTZBLECH SCHWK.	96 44 241 08	18	1	2 310	91 52 503 08	WINDE 1
SCHUTZBLECH SCHWK.	96 44 241 08	18	1	2 320	91 52 504 08	WINDE 2
SCHUTZBLECH SCHWK.	96 44 242 08	19	1	2 310	91 52 503 08	WINDE 1
SCHUTZBLECH SCHWK.	96 44 242 08	19	1	2 320	91 52 504 08	WINDE 2
SCHUTZBLECH SCHWK. LINK	96 50 779 08	32	1	2 340	91 52 776 08	WINDE 4 EINZIEHWERK
SCHUTZBLECH SCHWK. REC	96 50 778 08	31	1	2 340	91 52 776 08	WINDE 4 EINZIEHWERK
SCHUTZGITTER	10 65 067 2	4	1	X1035519	10 35 519 6	OEL-LUFTKUEHLER
SCHUTZGITTER	61 04 133 08	11	2	2 913 102	92 32 870 08	LUEFTEREINHEIT
SCHUTZHAUBE V2A	10 04 105 3	19	2	2 925 002	96 58 856 08	AUSRUESTUNG KAMERA DRE
SCHUTZKAPPE	77 90 201 08	2	6	1 830 102	92 26 483 08	KLEMMBRETT VORM.
SCHUTZKAPPE MS	69 18 128 08	(152)	1	2 920 581	96 54 405 08	KLEMMKASTEN SA-BOCK VO
SCHUTZKAPPE MS	69 18 129 08	39	1	2 920 369	96 54 235 08	KLEMMKASTEN KPL.

6.2.2009

etk_en_de_074515 LR 1600/2

1091

LIEBHERRAlphabetical index
Alphabetischer Index

Bezeichnung	Artikel	Pos.	Menge	Seite	Baugruppe	Bezeichnung
SCHUTZKAPPE MS	69 18 129 08	290	1	3 930 638	96 51 624 08	KLEMMKASTEN
SCHUTZKAPPE MS	69 18 129 08	(152)	1	3 930 734	96 54 401 08	KLEMMKASTEN
SCHUTZWALZE KPL.	92 88 302 08	10	1	3 211	91 57 748 08	S-ANLENKSTUECK
SCHUTZWALZE KPL.	96 46 978 08	8	1	3 211	91 57 748 08	S-ANLENKSTUECK
SCHUTZWALZE KPL.	96 46 979 08	9	1	3 211	91 57 748 08	S-ANLENKSTUECK
SCHUTZWALZE KPL. SPF	92 70 642 08	65	1	2 550	91 57 751 08	SA-BOCK
SCHUTZWALZE KPL. SPF	96 18 667 08	4	2	3 350	91 52 859 08	WINDE 3
SCHUTZWALZE SCHWK.	92 38 783 08	(1)	1	3 350	91 52 859 08	WINDE 3
SCHWEBEBALLAST	91 52 948 08	346	1		LR 1600-2-0	LIEBHERR RAUPENKRAN LR 1
SCHWENKARM SCHWK.	96 46 383 08	3	1	2 810	91 52 806 08	KRANFUEHRERKABINE KPL.
SCHWENKRAHMEN 15HE VER	61 10 470 08	1	1	2 932 001	96 45 393 08	RELAISSTEUERUNG
SCHWERFOLIENMATTE 2X78	97 79 354 08	11	1	2 859 005	96 46 756 08	KLAPPE VORM.
SCHWERFOLIENMATTE 2X78	97 79 356 08	13	1	2 859 005	96 46 756 08	KLAPPE VORM.
SCHWERFOLIENMATTE 2X78	97 79 355 08	12	1	2 859 005	96 46 756 08	KLAPPE VORM.
SCHWINGE SCHWK.	96 47 240 08	28	1	3 281	91 52 896 08	FA-BOCK
SCHWINGE SCHWK.	96 47 241 08	31	1	3 281	91 52 896 08	FA-BOCK
SCHWINGUNGSDAEMPFER	10 34 283 9	3	1	9 739 341	97 39 341	ANTRIEBSTEILE M.SCHWINGU
SCHWINGUNGSDAEMPFER	55 04 515 08	122	2	2 391 001	96 45 719 08	DIESELMOTOR VORM.
SCHWINGUNGSDAEMPFER	55 04 516 08	123	2	2 391 001	96 45 719 08	DIESELMOTOR VORM.
SCHWUNGRAD	10 22 233 9	1	1	9 739 250	97 39 250	SCHWUNGRAD
SCHWUNGRAD	97 39 250	250	1	X1012059	10 12 059 0	DIESELMOTOR
SCHWUNGRADGEHAEUSE	10 34 283 2	12	1	9 739 354	97 39 354	SCHWUNGRADGEHAEUSE AN
SCHWUNGRADGEHAEUSE AN	97 39 354	240	1	X1012059	10 12 059 0	DIESELMOTOR
SECHSKANTBUNDMUTTER	10 22 273 2	6	4	9 739 494	97 39 494	ATL-ANBAU
SECHSKANTHUTMUTTER M.K	40 02 886	2	1	X1042954	10 42 954 9	WINDGESCHWINDIGKEITSGE
SECHSKANTMUTTER BM18X1,	10 22 275 3	6	1	9 739 278	97 39 278	ANBAUTEILE
SECHSKANTMUTTER DIN 439	41 01 012 08	7	1	3 206 002	96 47 960 08	HEBEL KPL.
SECHSKANTMUTTER DIN 439	51 10 017 08	19	2	2 540	91 53 253 08	HEIZKLIMAGERAET EINBAU
SECHSKANTMUTTER DIN 439	59 15 592 08	3	3	2 533 066	96 48 365 08	ELEKTRIK ANBAUTEILE KABIN
SECHSKANTMUTTER DIN 934	41 15 047 08	16	2	X1035519	10 35 519 6	OEL-LUFTKUEHLER
SECHSKANTMUTTER DIN 934	41 15 144 08	370	4	2 391 001	96 45 719 08	DIESELMOTOR VORM.
SECHSKANTMUTTER DIN 934	41 15 144 08	12	12	2 391 038	96 47 931 08	OELKUEHLER VORM.
SECHSKANTMUTTER DIN 934	41 15 144 08	24	2	2 391 040	96 53 645 08	KUPPLUNGSSTELLER
SECHSKANTMUTTER DIN 934	41 15 144 08	32	2	2 502	91 55 939 08	STUERSTAND
SECHSKANTMUTTER DIN 934	41 15 144 08	36	2	2 711	91 52 800 08	ZENTRALSCHMIERANLAGE O
SECHSKANTMUTTER DIN 934	41 15 144 08	17	4	2 925 204	92 16 990 08	KAMERAANBAU D-ANLENKS
SECHSKANTMUTTER DIN 934	41 15 144 08	13	2	2 975 000	91 57 881 08	ZUSATZHYDRAULIK MONTAGE
SECHSKANTMUTTER DIN 934	41 15 144 08	12	11	3 206	91 52 881 08	F-ANLENKSTUECK
SECHSKANTMUTTER DIN 934	41 15 144 08	34	8	3 713	91 57 749 08	D-ANLENKSTUECK
SECHSKANTMUTTER DIN 934	41 15 144 08	73	16	3 714	91 52 862 08	D-KOPFSTUECK
SECHSKANTMUTTER DIN 934	41 15 143 08	16	1	1 991	91 52 510 08	DREHDURCHFUEHRUNG
SECHSKANTMUTTER DIN 934	41 15 143 08	22	4	2 310	91 52 503 08	WINDE 1
SECHSKANTMUTTER DIN 934	41 15 143 08	22	4	2 320	91 52 504 08	WINDE 2
SECHSKANTMUTTER DIN 934	41 15 143 08	5	8	2 391	91 52 784 08	DIESELMOTOR KPL.
SECHSKANTMUTTER DIN 934	41 15 143 08	13	1	2 550 008	96 47 628 08	HALTER KPL.
SECHSKANTMUTTER DIN 934	41 15 143 08	13	1	2 550 009	96 47 645 08	HALTER KPL.
SECHSKANTMUTTER DIN 934	41 15 143 08	56	1	2 810	91 52 806 08	KRANFUEHRERKABINE KPL.
SECHSKANTMUTTER DIN 934	41 15 143 08	177	8	2 970	91 56 537 08	HYDRAULIK
SECHSKANTMUTTER DIN 934	41 15 143 08	13	4	3 213	91 52 842 08	F-ANSCHLUSSKOPF
SECHSKANTMUTTER DIN 934	41 15 143 08	30	4	3 214	91 52 843 08	SW-KOPFSTUECK
SECHSKANTMUTTER DIN 934	41 15 143 08	8	8	3 220 500	91 52 849 08	S-ZWISCHENSTUECK
SECHSKANTMUTTER DIN 934	41 15 143 08	8	8	3 221	91 54 668 08	S-ZWISCHENSTUECK
SECHSKANTMUTTER DIN 934	41 15 143 08	8	8	3 223	91 52 852 08	S-ZWISCHENSTUECK
SECHSKANTMUTTER DIN 934	41 15 143 08	8	8	3 223 010	91 52 853 08	S-ZWISCHENSTUECK
SECHSKANTMUTTER DIN 934	41 15 143 08	8	8	3 223 100	91 55 327 08	S-ZWISCHENSTUECK
SECHSKANTMUTTER DIN 934	41 15 143 08	26	8	3 225	91 52 854 08	SL-REDUZIERSTUECK
SECHSKANTMUTTER DIN 934	41 15 143 08	8	8	3 226	91 52 870 08	LI-ZWISCHENSTUECK
SECHSKANTMUTTER DIN 934	41 15 143 08	8	8	3 227	91 52 873 08	LI-ZWISCHENSTUECK
SECHSKANTMUTTER DIN 934	41 15 143 08	8	8	3 227 008	91 52 872 08	LI-ZWISCHENSTUECK
SECHSKANTMUTTER DIN 934	41 15 143 08	8	8	3 227 200	91 53 519 08	LI-ZWISCHENSTUECK F-ABSP

6.2.2009

etk_en_de_074515 LR 1600/2

1092

LIEBHERRAlphabetical index
Alphabetischer Index

Bezeichnung	Artikel	Pos.	Menge	Seite	Baugruppe	Bezeichnung
SECHSKANTMUTTER DIN 934	41 15 143 08	18	48	3 350	91 52 859 08	WINDE 3
SECHSKANTMUTTER DIN 934	41 15 143 08	26	4	3 713	91 57 749 08	D-ANLENKSTUECK
SECHSKANTMUTTER DIN 934	41 15 143 08	29	4	3 714	91 52 862 08	D-KOPFSTUECK
SECHSKANTMUTTER DIN 934	41 15 143 08	8	8	3 715 008	91 52 863 08	D-ZWISCHENSTUECK
SECHSKANTMUTTER DIN 934	41 15 143 08	8	8	3 716	91 52 864 08	D-ZWISCHENSTUECK
SECHSKANTMUTTER DIN 934	41 15 143 08	11	4	3 978 100	91 56 428 08	HYDR.SCHWEBEBALLAST-AN
SECHSKANTMUTTER DIN 934	41 15 197 08	37	2	2 932 160	96 54 385 08	SCHALTSCHRANK MECH.
SECHSKANTMUTTER DIN 934	41 15 083 08	29	16	1 630	91 52 387 08	HYDRAULISCHE ABSTUETZUN
SECHSKANTMUTTER DIN 934	41 15 083 08	50	2	2 631	91 56 817 08	LAUFSTEG DREHBUEHNE
SECHSKANTMUTTER DIN 934	41 15 050 08	34	2	2 652	91 52 794 08	ROLLENLAGERUNG
SECHSKANTMUTTER DIN 934	41 15 050 08	11	2	3 220 500	91 52 849 08	S-ZWISCHENSTUECK
SECHSKANTMUTTER DIN 934	41 15 050 08	11	2	3 223	91 52 852 08	S-ZWISCHENSTUECK
SECHSKANTMUTTER DIN 934	41 15 050 08	11	2	3 223 010	91 52 853 08	S-ZWISCHENSTUECK
SECHSKANTMUTTER DIN 934	41 15 050 08	11	4	3 223 100	91 55 327 08	S-ZWISCHENSTUECK
SECHSKANTMUTTER DIN 934	41 15 050 08	21	4	3 227 002	96 50 498 08	STANGE KPL.
SECHSKANTMUTTER DIN 934	41 15 145 08	7	12	1 631 100	91 52 388 08	LAUFSTEG RAUPENFAHRWER
SECHSKANTMUTTER DIN 934	41 15 145 08	11	6	1 991	91 52 510 08	DREHDURCHFUEHRUNG
SECHSKANTMUTTER DIN 934	41 15 145 08	23	6	2 652	91 52 794 08	ROLLENLAGERUNG
SECHSKANTMUTTER DIN 934	41 15 145 08	5	4	2 730	91 52 802 08	GRUNDPLATTE DREHBUEHNE
SECHSKANTMUTTER DIN 934	41 15 145 08	52	4	2 810	91 52 806 08	KRANFUEHRERKABINE KPL.
SECHSKANTMUTTER DIN 934	41 15 145 08	11	2	3 745	91 52 948 08	SCHWEBEBALLAST
SECHSKANTMUTTER DIN 934	41 15 147 08	4	1	1 632 032	96 20 093 08	ABSTUETZPLATTE KPL.
SECHSKANTMUTTER DIN 934	41 15 147 08	24	1	3 206	91 52 881 08	F-ANLENKSTUECK
SECHSKANTMUTTER DIN 934	41 15 149 08	16	2	2 340	91 52 776 08	WINDE 4 EINZIEHWERK
SECHSKANTMUTTER DIN 934	41 15 157 08	15	10	2 922 001	92 84 311 08	BUSPLATINE
SECHSKANTMUTTER DIN 934	41 15 157 08	18	28	2 932 001	96 45 393 08	RELAISSTEUERUNG
SECHSKANTMUTTER DIN 934	41 15 157 08	267	4	3 930 009	96 50 573 08	LEITUNGSTROMMEL KPL.
SECHSKANTMUTTER DIN 934	41 15 157 08	(266)	4	3 930 138	96 54 377 08	ELEKTRIK S-ANLENKSTUECK
SECHSKANTMUTTER DIN 934	41 15 157 08	284	16	3 930 638	96 51 624 08	KLEMMKASTEN
SECHSKANTMUTTER DIN 934	41 15 157 08	155	10	3 930 640	96 50 481 08	KLEMMKASTEN KPL.
SECHSKANTMUTTER DIN 934	41 15 157 08	267	10	3 930 730	96 50 599 08	KLEMMKASTEN KPL.
SECHSKANTMUTTER DIN 934	41 15 152 08	14	32	3 747	91 52 950 08	ZENTRIERUNG STANDARD
SECHSKANTMUTTER DIN 934	41 15 142 08	26	2	2 522 011	96 45 602 08	SCHLIESSANLAGE
SECHSKANTMUTTER DIN 934	41 15 142 08	7	8	2 913 102	92 32 870 08	LUEFTEREINHEIT
SECHSKANTMUTTER DIN 934	41 15 142 08	(153)	2	2 920 369	96 54 235 08	KLEMMKASTEN KPL.
SECHSKANTMUTTER DIN 934	41 15 142 08	(153)	2	2 920 369	96 54 235 08	KLEMMKASTEN KPL.
SECHSKANTMUTTER DIN 934	41 15 142 08	281	14	2 920 369	96 54 235 08	KLEMMKASTEN KPL.
SECHSKANTMUTTER DIN 934	41 15 142 08	281	26	2 920 448	96 48 794 08	KLEMMKASTEN KPL.
SECHSKANTMUTTER DIN 934	41 15 148 08	7	9	1 100	91 52 375 08	RAUPENFAHRWERK KPL.
SECHSKANTMUTTER DIN 934	41 15 148 08	15	8	1 711	91 52 392 08	ZENTRALSCHMIERUNG RAUP
SECHSKANTMUTTER DIN 934	41 15 148 08	18	8	2 260 006	96 46 501 08	BATTERIEKASTEN VORM.
SECHSKANTMUTTER DIN 934	41 15 148 08	8	10	2 711	91 52 800 08	ZENTRALSCHMIERANLAGE O
SECHSKANTMUTTER DIN 934	41 15 148 08	8	4	2 780 915	96 48 377 08	ANBAUTEILE FREMDEINSPEIS
SECHSKANTMUTTER DIN 934	41 15 148 08	34	2	2 835 002	96 48 379 08	ANBAUTEILE
SECHSKANTMUTTER DIN 934	41 15 148 08	10	2	2 913 100	91 23 538 08	BAUGRUPPENTRAEGER
SECHSKANTMUTTER DIN 934	41 15 148 08	32	7	2 920 083	96 48 319 08	ELEKTRIK BATTERIEKASTEN
SECHSKANTMUTTER DIN 934	41 15 148 08	270	2	2 920 638	96 51 138 08	BEDIENPULT
SECHSKANTMUTTER DIN 934	41 15 148 08	18	1	2 922 001	92 84 311 08	BUSPLATINE
SECHSKANTMUTTER DIN 934	41 15 148 08	85	4	2 932 082	96 54 387 08	AUFBAUTEILE MONTAGETAPE
SECHSKANTMUTTER DIN 934	41 15 140 08	5	12	1 830 102	92 26 483 08	KLEMMBRETT VORM.
SECHSKANTMUTTER DIN 934	41 15 140 08	67	8	1 970	91 56 958 08	HYDRAULIK RAUPE
SECHSKANTMUTTER DIN 934	41 15 140 08	75	8	1 970	91 56 958 08	HYDRAULIK RAUPE
SECHSKANTMUTTER DIN 934	41 15 140 08	18	2	1 991	91 52 510 08	DREHDURCHFUEHRUNG
SECHSKANTMUTTER DIN 934	41 15 140 08	24	8	2 370	91 52 782 08	MONTAGEWINDE
SECHSKANTMUTTER DIN 934	41 15 140 08	9	12	2 510	91 52 788 08	DREHBUEHNENVERKLEIDUN
SECHSKANTMUTTER DIN 934	41 15 140 08	40	4	2 711	91 52 800 08	ZENTRALSCHMIERANLAGE O
SECHSKANTMUTTER DIN 934	41 15 140 08	75	5	2 810	91 52 806 08	KRANFUEHRERKABINE KPL.
SECHSKANTMUTTER DIN 934	41 15 140 08	22	8	2 835 002	96 48 379 08	ANBAUTEILE
SECHSKANTMUTTER DIN 934	41 15 140 08	8	2	2 859 030	96 46 758 08	DECKEL KPL.
SECHSKANTMUTTER DIN 934	41 15 140 08	6	2	2 913 004	96 20 460 08	GEHAEUSE VORM.

6.2.2009

etk_en_de_074515 LR 1600/2

1093

LIEBHERRAlphabetical index
Alphabetischer Index

Bezeichnung	Artikel	Pos.	Menge	Seite	Baugruppe	Bezeichnung
SECHSKANTMUTTER DIN 934	41 15 140 08	9	7	2 925 204	92 16 990 08	KAMERAANBAU D-ANLENKS
SECHSKANTMUTTER DIN 934	41 15 140 08	14	13	2 925 402	96 58 855 08	KAMERAANBAU DREHBUEHN
SECHSKANTMUTTER DIN 934	41 15 140 08	38	1	2 932 082	96 54 387 08	AUFBAUTEILE MONTAGETAPE
SECHSKANTMUTTER DIN 934	41 15 140 08	6	4	2 932 166	92 68 911 08	VERTEILER MASSE
SECHSKANTMUTTER DIN 934	41 15 140 08	67	10	2 970	91 56 537 08	HYDRAULIK
SECHSKANTMUTTER DIN 934	41 15 140 08	53	2	2 975 100	91 52 860 08	ZUSATZHYDRAULIK WINDE 3
SECHSKANTMUTTER DIN 934	41 15 140 08	11	2	2 976 203	92 27 489 08	ZUSATZHYDR.BOLZENZIEHZ
SECHSKANTMUTTER DIN 934	41 15 140 08	20	2	2 978 200	91 54 843 08	ZUSATZHYDR.S-RUECKHALTE
SECHSKANTMUTTER DIN 934	41 15 140 08	56	2	3 206	91 52 881 08	F-ANLENKSTUECK
SECHSKANTMUTTER DIN 934	41 15 140 08	6	11	3 713 013	96 57 159 08	BLECH KPL.
SECHSKANTMUTTER DIN 934	41 15 140 08	9	4	3 745 002	92 17 236 08	SCHALTEINHEIT
SECHSKANTMUTTER DIN 934	41 15 140 08	9	4	3 745 003	92 17 237 08	SCHALTEINHEIT
SECHSKANTMUTTER DIN 934	41 15 046 08	21	4	2 370	91 52 782 08	MONTAGEWINDE
SECHSKANTMUTTER DIN 934	41 15 046 08	66	12	2 810	91 52 806 08	KRANFUEHRERKABINE KPL.
SECHSKANTMUTTER DIN 934	41 15 046 08	10	4	2 932 166	92 68 911 08	VERTEILER MASSE
SECHSKANTMUTTER DIN 934	41 15 141 08	26	12	1 630	91 52 387 08	HYDRAULISCHE ABSTUETZUN
SECHSKANTMUTTER DIN 934	41 15 141 08	19	33	2 260	91 53 057 08	BATTERIELAGERUNG
SECHSKANTMUTTER DIN 934	41 15 141 08	25	8	2 260 006	96 46 501 08	BATTERIEKASTEN VORM.
SECHSKANTMUTTER DIN 934	41 15 141 08	34	2	2 310	91 52 503 08	WINDE 1
SECHSKANTMUTTER DIN 934	41 15 141 08	34	2	2 320	91 52 504 08	WINDE 2
SECHSKANTMUTTER DIN 934	41 15 141 08	19	12	2 350	91 52 778 08	DREHWERK
SECHSKANTMUTTER DIN 934	41 15 141 08	18	4	2 370	91 52 782 08	MONTAGEWINDE
SECHSKANTMUTTER DIN 934	41 15 141 08	371	10	2 391 001	96 45 719 08	DIESELMOTOR VORM.
SECHSKANTMUTTER DIN 934	41 15 141 08	26	2	2 391 040	96 53 645 08	KUPPLUNGSSTELLER
SECHSKANTMUTTER DIN 934	41 15 141 08	11	12	2 391 102	96 56 360 08	ZUSATZKUEHLER VORM.
SECHSKANTMUTTER DIN 934	41 15 141 08	20	2	2 392	91 52 785 08	SCHALLDAEMPFERANLAGE
SECHSKANTMUTTER DIN 934	41 15 141 08	31	12	2 393	91 52 787 08	LUFTFILTERANLAGE KPL.
SECHSKANTMUTTER DIN 934	41 15 141 08	48	13	2 631	91 56 817 08	LAUFSTEG DREHBUEHNE
SECHSKANTMUTTER DIN 934	41 15 141 08	11	4	2 670	91 52 797 08	KRAFTSTOFFBEHALTER KPL
SECHSKANTMUTTER DIN 934	41 15 141 08	69	4	2 810	91 52 806 08	KRANFUEHRERKABINE KPL.
SECHSKANTMUTTER DIN 934	41 15 141 08	69	8	2 859	91 52 809 08	GERAEUSCHDAEMMUNG
SECHSKANTMUTTER DIN 934	41 15 141 08	5	2	2 925 204	92 16 990 08	KAMERAANBAU D-ANLENKS
SECHSKANTMUTTER DIN 934	41 15 141 08	6	12	2 925 402	96 58 855 08	KAMERAANBAU DREHBUEHN
SECHSKANTMUTTER DIN 934	41 15 141 08	15	8	2 978 100	91 52 796 08	ZUSATZHYDR.MONTAGEEINR
SECHSKANTMUTTER DIN 934	41 15 141 08	17	2	2 978 200	91 54 843 08	ZUSATZHYDR.S-RUECKHALTE
SECHSKANTMUTTER DIN 934	41 15 141 08	17	2	2 990	91 59 244 08	DRUCKLUFTANLAGE
SECHSKANTMUTTER DIN 934	41 15 141 08	33	21	3 713	91 57 749 08	D-ANLENKSTUECK
SECHSKANTMUTTER DIN 936	41 17 003 08	33	6	2 652	91 52 794 08	ROLLENLAGERUNG
SECHSKANTMUTTER DIN 936	41 17 209 08	33	4	1 630	91 52 387 08	HYDRAULISCHE ABSTUETZUN
SECHSKANTMUTTER DIN 936	41 17 010 08	23	1	2 391 040	96 53 645 08	KUPPLUNGSSTELLER
SECHSKANTMUTTER DIN 936	41 17 011 08	18	2	2 810	91 52 806 08	KRANFUEHRERKABINE KPL.
SECHSKANTMUTTER DIN 980	41 18 806 08	8	1	3 714 025	96 49 269 08	STANGE KPL.
SECHSKANTMUTTER DIN 985	41 19 011 08	10	16	2 810	91 52 806 08	KRANFUEHRERKABINE KPL.
SECHSKANTMUTTER DIN 985	41 19 006 08	69	12	1 400	91 56 853 08	RAUPENTRAEGER KPL.LI.
SECHSKANTMUTTER DIN 985	41 19 006 08	69	12	1 410 300	91 56 855 08	RAUPENTRAEGER KPL.RE.
SECHSKANTMUTTER DIN 985	41 19 006 08	100	9	2 550	91 57 751 08	SA-BOCK
SECHSKANTMUTTER DIN 985	41 19 006 08	11	4	2 730	91 52 802 08	GRUNDPLATTE DREHBUEHNE
SECHSKANTMUTTER DIN 985	41 19 006 08	13	2	3 206	91 52 881 08	F-ANLENKSTUECK
SECHSKANTMUTTER DIN 985	41 19 006 08	32	7	3 208 001	91 52 883 08	F-KOPFSTUECK
SECHSKANTMUTTER DIN 985	41 19 006 08	49	4	3 211	91 57 748 08	S-ANLENKSTUECK
SECHSKANTMUTTER DIN 985	41 19 006 08	40	4	3 281	91 52 896 08	FA-BOCK
SECHSKANTMUTTER DIN 985	41 19 006 08	35	8	3 745	91 52 948 08	SCHWEBEBALLAST
SECHSKANTMUTTER DIN 985	41 19 007 08	14	2	2 340	91 52 776 08	WINDE 4 EINZIEHWERK
SECHSKANTMUTTER DIN 985	41 19 007 08	361	8	2 391 001	96 45 719 08	DIESELMOTOR VORM.
SECHSKANTMUTTER DIN 985	41 19 007 08	12	4	2 391 023	96 45 720 08	KUEHLER VORM.
SECHSKANTMUTTER DIN 985	41 19 007 08	38	11	3 206	91 52 881 08	F-ANLENKSTUECK
SECHSKANTMUTTER DIN 985	41 19 007 08	6	1	3 207 003	96 48 259 08	STANGE KPL.
SECHSKANTMUTTER DIN 985	41 19 007 08	5	1	3 207 100	96 48 261 08	LASCHE KPL.
SECHSKANTMUTTER DIN 985	41 19 007 08	33	6	3 208 001	91 52 883 08	F-KOPFSTUECK
SECHSKANTMUTTER DIN 985	41 19 007 08	73	8	3 211	91 57 748 08	S-ANLENKSTUECK

6.2.2009

etk_en_de_074515 LR 1600/2

1094

LIEBHERRAlphabetical index
Alphabetischer Index

Bezeichnung	Artikel	Pos.	Menge	Seite	Baugruppe	Bezeichnung
SECHSKANTMUTTER DIN 985	41 19 007 08	32	4	3 215 005	91 52 846 08	ROLLENSATZ
SECHSKANTMUTTER DIN 985	41 19 007 08	32	4	3 215 006	91 52 847 08	ROLLENSATZ
SECHSKANTMUTTER DIN 985	41 19 007 08	(6)	1	3 281	91 52 896 08	FA-BOCK
SECHSKANTMUTTER DIN 985	41 19 007 08	17	4	3 292	91 52 865 08	D-RUECKHALTESICHERUNG
SECHSKANTMUTTER DIN 985	41 19 007 08	14	4	3 714 008	96 49 266 08	VERSTELLFLASCHE KPL.
SECHSKANTMUTTER DIN 985	41 19 013 08	50	4	3 745	91 52 948 08	SCHWEBEBALLAST
SECHSKANTMUTTER DIN 985	41 19 014 08	362	4	2 391 001	96 45 719 08	DIESELMOTOR VORM.
SECHSKANTMUTTER DIN 985	41 19 009 08	4	162	1 300 011	96 52 493 08	BODENPLATTEN VORM.
SECHSKANTMUTTER DIN 985	41 19 009 08	25	1	2 391 040	96 53 645 08	KUPPLUNGSSTELLER
SECHSKANTMUTTER DIN 985	41 19 009 08	4	2	2 550 010	96 45 685 08	STANGE VORM.
SECHSKANTMUTTER DIN 985	41 19 009 08	13	1	2 657	91 57 656 08	MONTAGEEINRICHTUNG RA
SECHSKANTMUTTER DIN 985	41 19 009 08	3	1	3 207 101	96 48 292 08	LASCHE KPL.
SECHSKANTMUTTER DIN 985	41 19 009 08	9	1	3 211 003	96 46 986 08	STANGE KPL.
SECHSKANTMUTTER DIN 985	41 19 009 08	19	2	3 214	91 52 843 08	SW-KOPFSTUECK
SECHSKANTMUTTER DIN 985	41 19 009 08	10	1	3 220 501	96 43 440 08	STANGE KPL.
SECHSKANTMUTTER DIN 985	41 19 009 08	10	1	3 221 200	96 47 984 08	STANGE KPL.
SECHSKANTMUTTER DIN 985	41 19 009 08	10	1	3 225 200	96 48 679 08	STANGE KPL.
SECHSKANTMUTTER DIN 985	41 19 009 08	10	1	3 227 002	96 50 498 08	STANGE KPL.
SECHSKANTMUTTER DIN 985	41 19 009 08	(5)	2	3 281	91 52 896 08	FA-BOCK
SECHSKANTMUTTER DIN 985	41 19 009 08	(5)	1	3 281	91 52 896 08	FA-BOCK
SECHSKANTMUTTER DIN 985	41 19 009 08	15	4	3 292	91 52 865 08	D-RUECKHALTESICHERUNG
SECHSKANTMUTTER DIN 985	41 19 009 08	10	1	3 561 003	96 45 222 08	STANGE KPL.
SECHSKANTMUTTER DIN 985	41 19 009 08	10	1	3 713 012	96 50 197 08	STANGE KPL.
SECHSKANTMUTTER DIN 985	41 19 009 08	6	2	3 714 013	96 49 270 08	LASCHE KPL.
SECHSKANTMUTTER DIN 985	41 19 009 08	7	1	3 714 013	96 59 083 08	LASCHE KPL.
SECHSKANTMUTTER DIN 985	41 19 009 08	5	1	3 714 014	96 49 456 08	LASCHE KPL.
SECHSKANTMUTTER DIN 985	41 19 009 08	10	1	3 716 001	96 49 159 08	STANGE KPL.
SECHSKANTMUTTER DIN 985	41 19 024 08	11	2	2 550 005	96 45 680 08	STANGE KPL.
SECHSKANTMUTTER DIN 985	41 19 024 08	5	4	3 745 011	96 49 677 08	LASCHE KPL.
SECHSKANTMUTTER DIN 985	41 19 026 08	104	2	3 713	91 57 749 08	D-ANLENKSTUECK
SECHSKANTMUTTER DIN 985	41 19 025 08	17	6	3 714 009	96 49 267 08	VERSTELLFLASCHE KPL.
SECHSKANTMUTTER DIN 985	41 19 001 08	29	4	2 533 070	96 48 363 08	ARMATUREN RE.
SECHSKANTMUTTER DIN 985	41 19 001 08	12	2	2 780 852	96 24 845 08	GSM-MODUL VORM.LICCON 1
SECHSKANTMUTTER DIN 985	41 19 001 08	12	10	2 913	91 32 850 08	LICCON KONSOLE LCD2
SECHSKANTMUTTER DIN 985	41 19 001 08	6	2	2 913 005	96 20 731 08	INNENGEHAEUSE VORM.
SECHSKANTMUTTER DIN 985	41 19 001 08	6	2	2 913 005	96 28 696 08	INNENGEHAEUSE VORM.
SECHSKANTMUTTER DIN 985	41 19 001 08	4	6	2 913 006	96 20 732 08	LUEFTERBLECH VORM.
SECHSKANTMUTTER DIN 985	41 19 001 08	12	10	2 913 009	91 04 705 08	LICCON KONSOLE LCD3
SECHSKANTMUTTER DIN 985	41 19 001 08	44	8	2 920 369	96 54 235 08	KLEMMKASTEN KPL.
SECHSKANTMUTTER DIN 985	41 19 002 08	40	10	2 631	91 56 817 08	LAUFSTEG DREHBUEHNE
SECHSKANTMUTTER DIN 985	41 19 002 08	45	56	2 932 160	96 54 385 08	SCHALTSCHRANK MECH.
SECHSKANTMUTTER DIN 985	41 19 002 08	12	3	3 780 200	96 54 370 08	ELEKTRIK WINDWARNUNG T
SECHSKANTMUTTER DIN 985	41 19 003 08	29	4	2 260	91 53 057 08	BATTERIELAGERUNG
SECHSKANTMUTTER DIN 985	41 19 003 08	5	4	2 260 009	96 46 972 08	KLAPPE VORM.
SECHSKANTMUTTER DIN 985	41 19 003 08	43	4	2 391 040	96 53 645 08	KUPPLUNGSSTELLER
SECHSKANTMUTTER DIN 985	41 19 003 08	33	2	2 533 070	96 48 363 08	ARMATUREN RE.
SECHSKANTMUTTER DIN 985	41 19 003 08	58	2	2 631	91 56 817 08	LAUFSTEG DREHBUEHNE
SECHSKANTMUTTER DIN 985	41 19 003 08	5	1	2 780 851	96 24 498 08	FUNKANTENNE VORM.
SECHSKANTMUTTER DIN 985	41 19 003 08	9	1	2 780 852	96 24 845 08	GSM-MODUL VORM.LICCON 1
SECHSKANTMUTTER DIN 985	41 19 003 08	51	16	2 859	91 52 809 08	GERAEUSCHDAEMMUNG
SECHSKANTMUTTER DIN 985	41 19 003 08	4	8	2 859 005	96 46 756 08	KLAPPE VORM.
SECHSKANTMUTTER DIN 985	41 19 003 08	9	8	2 859 025	96 46 757 08	GITTERROST VORM.
SECHSKANTMUTTER DIN 985	41 19 003 08	(3)	3	3 780 258	96 56 482 08	ELEKTRIK FLUGWARNSICHER
SECHSKANTMUTTER DIN 985	41 19 004 08	22	13	2 260	91 53 057 08	BATTERIELAGERUNG
SECHSKANTMUTTER DIN 985	41 19 004 08	21	4	2 260 006	96 46 501 08	BATTERIEKASTEN VORM.
SECHSKANTMUTTER DIN 985	41 19 004 08	18	16	2 391 023	96 45 720 08	KUEHLER VORM.
SECHSKANTMUTTER DIN 985	41 19 004 08	5	5	2 391 036	96 23 055 08	DECKEL VORM.
SECHSKANTMUTTER DIN 985	41 19 004 08	5	4	2 391 039	96 50 616 08	HUTZE KPL
SECHSKANTMUTTER DIN 985	41 19 004 08	33	1	2 391 040	96 53 645 08	KUPPLUNGSSTELLER
SECHSKANTMUTTER DIN 985	41 19 004 08	16	12	2 393 002	96 46 782 08	DECKEL KPL.

6.2.2009

etk_en_de_074515 LR 1600/2

1095

LIEBHERRAlphabetical index
Alphabetischer Index

Bezeichnung	Artikel	Pos.	Menge	Seite	Baugruppe	Bezeichnung
SECHSKANTMUTTER DIN 985	41 19 004 08	59	14	2 550	91 57 751 08	SA-BOCK
SECHSKANTMUTTER DIN 985	41 19 004 08	14	6	2 932 166	92 68 911 08	VERTEILER MASSE
SECHSKANTMUTTER DIN 985	41 19 004 08	116	8	2 970	91 56 537 08	HYDRAULIK
SECHSKANTMUTTER DIN 985	41 19 004 08	29	4	3 206	91 52 881 08	F-ANLENKSTUECK
SECHSKANTMUTTER DIN 985	41 19 004 08	30	8	3 208 001	91 52 883 08	F-KOPFSTUECK
SECHSKANTMUTTER DIN 985	41 19 004 08	57	10	3 211	91 57 748 08	S-ANLENKSTUECK
SECHSKANTMUTTER DIN 985	41 19 004 08	44	4	3 214	91 52 843 08	SW-KOPFSTUECK
SECHSKANTMUTTER DIN 985	41 19 004 08	34	17	3 220 500	91 52 849 08	S-ZWISCHENSTUECK
SECHSKANTMUTTER DIN 985	41 19 004 08	18	12	3 221	91 54 668 08	S-ZWISCHENSTUECK
SECHSKANTMUTTER DIN 985	41 19 004 08	34	22	3 223	91 52 852 08	S-ZWISCHENSTUECK
SECHSKANTMUTTER DIN 985	41 19 004 08	34	22	3 223 010	91 52 853 08	S-ZWISCHENSTUECK
SECHSKANTMUTTER DIN 985	41 19 004 08	34	22	3 223 100	91 55 327 08	S-ZWISCHENSTUECK
SECHSKANTMUTTER DIN 985	41 19 004 08	32	17	3 225	91 52 854 08	SL-REDUZIERSTUECK
SECHSKANTMUTTER DIN 985	41 19 004 08	34	17	3 226	91 52 870 08	LI-ZWISCHENSTUECK
SECHSKANTMUTTER DIN 985	41 19 004 08	34	22	3 227	91 52 873 08	LI-ZWISCHENSTUECK
SECHSKANTMUTTER DIN 985	41 19 004 08	34	22	3 227 008	91 52 872 08	LI-ZWISCHENSTUECK
SECHSKANTMUTTER DIN 985	41 19 004 08	34	22	3 227 200	91 53 519 08	LI-ZWISCHENSTUECK F-ABSP
SECHSKANTMUTTER DIN 985	41 19 004 08	63	15	3 713	91 57 749 08	D-ANLENKSTUECK
SECHSKANTMUTTER DIN 985	41 19 004 08	58	30	3 714	91 52 862 08	D-KOPFSTUECK
SECHSKANTMUTTER DIN 985	41 19 004 08	9	20	3 715 008	91 52 863 08	D-ZWISCHENSTUECK
SECHSKANTMUTTER DIN 985	41 19 004 08	9	25	3 716	91 52 864 08	D-ZWISCHENSTUECK
SECHSKANTMUTTER DIN 985	41 19 004 08	(7)	3	3 780 258	96 56 482 08	ELEKTRIK FLUGWARNSICHER
SECHSKANTMUTTER DIN 985	41 19 004 08	16	2	3 780 751	91 52 952 08	FLUG-U.WINDWARNUNG
SECHSKANTMUTTER DIN 985	41 19 004 08	22	3	3 978 015	91 56 429 08	ZUSATZHYDRAULIK ZWISCH
SECHSKANTMUTTER DIN 985	41 19 004 08	22	3	3 978 015	91 56 432 08	ZUSATZHYDRAULIK ZWISCH
SECHSKANTMUTTER DIN 985	41 19 010 08	30	8	2 260	91 53 057 08	BATTERIELAGERUNG
SECHSKANTMUTTER DIN 985	41 19 010 08	74	13	2 520	91 53 061 08	KABINE VERGLAST
SECHSKANTMUTTER DIN 985	41 19 005 08	62	2	1 400	91 56 853 08	RAUPENTRAEGER KPL.LI.
SECHSKANTMUTTER DIN 985	41 19 005 08	62	2	1 410 300	91 56 855 08	RAUPENTRAEGER KPL.RE.
SECHSKANTMUTTER DIN 985	41 19 005 08	8	4	1 620	91 52 386 08	BEFESTIGUNGSTEILE DREH
SECHSKANTMUTTER DIN 985	41 19 005 08	12	48	1 631 100	91 52 388 08	LAUFSTEG RAUPENFAHRWER
SECHSKANTMUTTER DIN 985	41 19 005 08	12	3	2 350	91 52 778 08	DREHWERK
SECHSKANTMUTTER DIN 985	41 19 005 08	16	12	2 391 023	96 45 720 08	KUEHLER VORM.
SECHSKANTMUTTER DIN 985	41 19 005 08	3	4	2 503 100	91 55 873 08	NOTSITZ
SECHSKANTMUTTER DIN 985	41 19 005 08	10	2	2 522 013	96 45 883 08	FUEHRUNG VORM.
SECHSKANTMUTTER DIN 985	41 19 005 08	13	1	2 541 001	96 49 651 08	ZUSATZHEIZUNG VORM.
SECHSKANTMUTTER DIN 985	41 19 005 08	21	4	2 550	91 57 751 08	SA-BOCK
SECHSKANTMUTTER DIN 985	41 19 005 08	4	4	2 631 003	96 54 406 08	AUFSTIEG VORM.
SECHSKANTMUTTER DIN 985	41 19 005 08	17	2	2 671	91 52 798 08	OELBEHAELTER KPL.
SECHSKANTMUTTER DIN 985	41 19 005 08	6	6	2 810 001	96 43 597 08	KRANFUEHRERKABINE VORM
SECHSKANTMUTTER DIN 985	41 19 005 08	54	77	2 859	91 52 809 08	GERAEUSCHDAEMMUNG
SECHSKANTMUTTER DIN 985	41 19 005 08	6	10	2 859 025	96 46 757 08	GITTERROST VORM.
SECHSKANTMUTTER DIN 985	41 19 005 08	5	2	2 859 030	96 46 758 08	DECKEL KPL.
SECHSKANTMUTTER DIN 985	41 19 005 08	7	4	2 932 160	96 54 385 08	SCHALTSCHRANK MECH.
SECHSKANTMUTTER DIN 985	41 19 005 08	154	2	2 970	91 56 537 08	HYDRAULIK
SECHSKANTMUTTER DIN 985	41 19 005 08	46	11	3 206	91 52 881 08	F-ANLENKSTUECK
SECHSKANTMUTTER DIN 985	41 19 005 08	31	4	3 208 001	91 52 883 08	F-KOPFSTUECK
SECHSKANTMUTTER DIN 985	41 19 005 08	33	174	3 211	91 57 748 08	S-ANLENKSTUECK
SECHSKANTMUTTER DIN 985	41 19 005 08	17	2	3 213	91 52 842 08	F-ANSCHLUSSKOPF
SECHSKANTMUTTER DIN 985	41 19 005 08	23	17	3 214	91 52 843 08	SW-KOPFSTUECK
SECHSKANTMUTTER DIN 985	41 19 005 08	35	41	3 220 500	91 52 849 08	S-ZWISCHENSTUECK
SECHSKANTMUTTER DIN 985	41 19 005 08	19	36	3 221	91 54 668 08	S-ZWISCHENSTUECK
SECHSKANTMUTTER DIN 985	41 19 005 08	35	51	3 223	91 52 852 08	S-ZWISCHENSTUECK
SECHSKANTMUTTER DIN 985	41 19 005 08	35	51	3 223 010	91 52 853 08	S-ZWISCHENSTUECK
SECHSKANTMUTTER DIN 985	41 19 005 08	35	51	3 223 100	91 55 327 08	S-ZWISCHENSTUECK
SECHSKANTMUTTER DIN 985	41 19 005 08	37	47	3 225	91 52 854 08	SL-REDUZIERSTUECK
SECHSKANTMUTTER DIN 985	41 19 005 08	35	34	3 226	91 52 870 08	LI-ZWISCHENSTUECK
SECHSKANTMUTTER DIN 985	41 19 005 08	35	39	3 227	91 52 873 08	LI-ZWISCHENSTUECK
SECHSKANTMUTTER DIN 985	41 19 005 08	35	31	3 227 008	91 52 872 08	LI-ZWISCHENSTUECK
SECHSKANTMUTTER DIN 985	41 19 005 08	35	49	3 227 200	91 53 519 08	LI-ZWISCHENSTUECK F-ABSP

6.2.2009

etk_en_de_074515 LR 1600/2

1096

LIEBHERRAlphabetical index
Alphabetischer Index

Bezeichnung	Artikel	Pos.	Menge	Seite	Baugruppe	Bezeichnung
SECHSKANTMUTTER DIN 985	41 19 005 08	62	2	3 281	91 52 896 08	FA-BOCK
SECHSKANTMUTTER DIN 985	41 19 005 08	4	8	3 291	91 52 831 08	S-RUECKHALTESICHERUNG
SECHSKANTMUTTER DIN 985	41 19 005 08	9	8	3 292	91 52 865 08	D-RUECKHALTESICHERUNG
SECHSKANTMUTTER DIN 985	41 19 005 08	18	173	3 713	91 57 749 08	D-ANLENKSTUECK
SECHSKANTMUTTER DIN 985	41 19 005 08	48	71	3 714	91 52 862 08	D-KOPFSTUECK
SECHSKANTMUTTER DIN 985	41 19 005 08	4	4	3 714 017	96 50 752 08	AUFLAGE KPL.
SECHSKANTMUTTER DIN 985	41 19 005 08	10	74	3 715 008	91 52 863 08	D-ZWISCHENSTUECK
SECHSKANTMUTTER DIN 985	41 19 005 08	10	124	3 716	91 52 864 08	D-ZWISCHENSTUECK
SECHSKANTMUTTER DIN 985	41 19 005 08	30	24	3 745	91 52 948 08	SCHWEBEBALLAST
SECHSKANTMUTTER ISO 105	41 19 030 08	22	8	2 925 402	96 58 855 08	KAMERAANBAU DREHBUEHN
SECHSKANTMUTTER ISO 403	41 15 031 03	15	2	X1041267	10 41 267 8	ENDPLATTE
SECHSKANTMUTTER ISO 4032	51 07 374 08	18	1	X1041267	10 41 267 8	ENDPLATTE
SECHSKANTMUTTER ISO 4035	41 01 203 08	17	2	2 522 011	96 45 602 08	SCHLISSANLAGE
SECHSKANTMUTTER M10X1 -	10 01 255 7	11	2	9 739 263	97 39 263	KIPPHEBELLAGERGEHAEUSE
SECHSKANTMUTTER M10X1 -	10 01 255 7	11	2	9 739 264	97 39 264	KIPPHEBELLAGERGEHAEUSE
SECHSKANTMUTTER M12 04	10 34 227 9	20	2	9 739 371	97 39 371	KLIMAKOMPRESSOR ANBAU
SECHSKANTMUTTER M14X1	10 01 256 0	8	1	9 739 263	97 39 263	KIPPHEBELLAGERGEHAEUSE
SECHSKANTMUTTER M14X1	10 01 256 0	8	1	9 739 264	97 39 264	KIPPHEBELLAGERGEHAEUSE
SECHSKANTMUTTER M32X1,5	10 01 255 9	17	1	9 739 492	97 39 492	ROHRLEITUNG ANBAU
SECHSKANTMUTTER M8X10	10 47 690 5	5	1	9 739 491	97 39 491	LUFTPRESSER ANBAU
SECHSKANTRIPPENMUTTER	10 04 443 0	2	6	9 739 353	97 39 353	ABGASSTUTZEN
SECHSKANTSCHRAUBE	10 22 274 4	12	1	9 739 288	97 39 288	KRAFTSTOFFLEITUNG
SECHSKANTSCHRAUBE	10 22 274 4	11	1	9 739 369	97 39 369	DRUCKROHR
SECHSKANTSCHRAUBE 7/16"	40 97 513 08	562	8	2 970	91 56 537 08	HYDRAULIK
SECHSKANTSCHRAUBE EN 1	10 04 535 6	2	8	9 739 341	97 39 341	ANTRIEBSTEILE M.SCHWINGU
SECHSKANTSCHRAUBE EN 1	10 04 535 6	3	2	9 739 344	97 39 344	GENERATOR VORM.
SECHSKANTSCHRAUBE EN 16	40 73 500 08	7	8	2 932 001	96 45 393 08	RELAISSTEUERUNG
SECHSKANTSCHRAUBE EN 16	40 73 500 08	36	18	2 932 082	96 54 387 08	AUFBAUTEILE MONTAGETAPE
SECHSKANTSCHRAUBE EN 16	40 73 501 08	37	4	2 533 070	96 48 363 08	ARMATUREN RE.
SECHSKANTSCHRAUBE EN 16	40 73 501 08	31	1	2 835 002	96 48 379 08	ANBAUTEILE
SECHSKANTSCHRAUBE EN 16	40 73 501 08	84	32	2 932 082	96 54 387 08	AUFBAUTEILE MONTAGETAPE
SECHSKANTSCHRAUBE EN 16	40 73 501 08	5	13	2 932 160	96 54 385 08	SCHALTSCHRANK MECH.
SECHSKANTSCHRAUBE EN 1	40 73 502 08	40	2	2 520	91 53 061 08	KABINE VERGLAST
SECHSKANTSCHRAUBE EN 1	40 73 502 08	9	2	2 932 168	96 48 167 08	DECKEL KPL.
SECHSKANTSCHRAUBE EN 1	10 03 731 0	6	1	9 739 362	97 39 362	OELWANNE
SECHSKANTSCHRAUBE EN 1	10 01 690 7	5	4	9 080 702	90 80 702	STEUERGERAET
SECHSKANTSCHRAUBE ISO	40 62 011 08	26	7	3 208 001	91 52 883 08	F-KOPFSTUECK
SECHSKANTSCHRAUBE ISO	40 61 056	12	2	2 975 000	91 57 881 08	ZUSATZHYDRAULIK MONTAGE
SECHSKANTSCHRAUBE ISO	40 00 472	11	8	2 391 038	96 47 931 08	OELKUEHLER VORM.
SECHSKANTSCHRAUBE ISO	49 01 053	38	4	3 281	91 52 896 08	FA-BOCK
SECHSKANTSCHRAUBE ISO 4	10 00 613 0	10	4	9 080 702	90 80 702	STEUERGERAET
SECHSKANTSCHRAUBE ISO 4	46 00 247	11	4	2 392	91 52 785 08	SCHALLDAEMPFERANLAGE
SECHSKANTSCHRAUBE ISO 4	40 61 076	81	2	3 211	91 57 748 08	S-ANLENKSTUECK
SECHSKANTSCHRAUBE ISO 4	46 00 887	10	1	2 550 008	96 47 628 08	HALTER KPL.
SECHSKANTSCHRAUBE ISO 4	46 00 887	10	1	2 550 009	96 47 645 08	HALTER KPL.
SECHSKANTSCHRAUBE ISO	40 00 973	23	2	2 392	91 52 785 08	SCHALLDAEMPFERANLAGE
SECHSKANTSCHRAUBE ISO	46 00 047	35	3	3 206	91 52 881 08	F-ANLENKSTUECK
SECHSKANTSCHRAUBE ISO	46 00 047	27	6	3 208 001	91 52 883 08	F-KOPFSTUECK
SECHSKANTSCHRAUBE ISO	46 00 047	26	4	3 215 005	91 52 846 08	ROLLENSATZ
SECHSKANTSCHRAUBE ISO	46 00 047	26	4	3 215 006	91 52 847 08	ROLLENSATZ
SECHSKANTSCHRAUBE ISO	40 61 065	22	4	3 215 005	91 52 846 08	ROLLENSATZ
SECHSKANTSCHRAUBE ISO	40 61 065	22	4	3 215 006	91 52 847 08	ROLLENSATZ
SECHSKANTSCHRAUBE ISO	46 00 245	11	4	2 671	91 52 798 08	OELBEHAELTER KPL.
SECHSKANTSCHRAUBE ISO	46 00 245	4	1	3 207 003	96 48 259 08	STANGE KPL.
SECHSKANTSCHRAUBE ISO	46 00 245	3	1	3 207 100	96 48 261 08	LASCHE KPL.
SECHSKANTSCHRAUBE ISO	46 00 245	(4)	1	3 281	91 52 896 08	FA-BOCK
SECHSKANTSCHRAUBE ISO	49 01 057	10	4	2 391 023	96 45 720 08	KUEHLER VORM.
SECHSKANTSCHRAUBE ISO 4	40 62 036 08	48	4	3 745	91 52 948 08	SCHWEBEBALLAST
SECHSKANTSCHRAUBE ISO 4	46 00 038	336	8	2 391 001	96 45 719 08	DIESELMOTOR VORM.
SECHSKANTSCHRAUBE ISO 4	46 00 038	7	4	2 810	91 52 806 08	KRANFUEHRERKABINE KPL.

6.2.2009

etk_en_de_074515 LR 1600/2

1097

LIEBHERRAlphabetical index
Alphabetischer Index

Bezeichnung	Artikel	Pos.	Menge	Seite	Baugruppe	Bezeichnung
SECHSKANTSCHRAUBE ISO 4	40 61 179 01	4	4	2 730	91 52 802 08	GRUNDPLATTE DREHBUEHNE
SECHSKANTSCHRAUBE ISO 4	40 61 179 01	2	1	3 207 101	96 48 292 08	LASCHE KPL.
SECHSKANTSCHRAUBE ISO 4	40 61 179 01	(3)	2	3 281	91 52 896 08	FA-BOCK
SECHSKANTSCHRAUBE ISO 4	40 61 180 01	3	1	3 714 014	96 49 456 08	LASCHE KPL.
SECHSKANTSCHRAUBE ISO 4	40 62 049 08	333	4	2 391 001	96 45 719 08	DIESELMOTOR VORM.
SECHSKANTSCHRAUBE ISO 4	40 62 051 08	49	13	1 400	91 56 853 08	RAUPENTRAEGER KPL.LI.
SECHSKANTSCHRAUBE ISO 4	40 62 051 08	49	13	1 410 300	91 56 855 08	RAUPENTRAEGER KPL.RE.
SECHSKANTSCHRAUBE ISO 4	40 61 184 01	11	1	2 657	91 57 656 08	MONTAGEEINRICHTUNG RA
SECHSKANTSCHRAUBE ISO 4	40 61 186 01	8	1	3 211 003	96 46 986 08	STANGE KPL.
SECHSKANTSCHRAUBE ISO 4	40 61 186 01	9	1	3 220 501	96 43 440 08	STANGE KPL.
SECHSKANTSCHRAUBE ISO 4	40 61 186 01	9	1	3 221 200	96 47 984 08	STANGE KPL.
SECHSKANTSCHRAUBE ISO 4	40 61 186 01	9	1	3 225 200	96 48 679 08	STANGE KPL.
SECHSKANTSCHRAUBE ISO 4	40 61 186 01	9	1	3 227 002	96 50 498 08	STANGE KPL.
SECHSKANTSCHRAUBE ISO 4	40 61 186 01	9	1	3 561 003	96 45 222 08	STANGE KPL.
SECHSKANTSCHRAUBE ISO 4	40 61 186 01	9	1	3 713 012	96 50 197 08	STANGE KPL.
SECHSKANTSCHRAUBE ISO 4	40 61 186 01	4	2	3 714 013	96 49 270 08	LASCHE KPL.
SECHSKANTSCHRAUBE ISO 4	40 61 186 01	5	1	3 714 013	96 59 083 08	LASCHE KPL.
SECHSKANTSCHRAUBE ISO 4	40 61 186 01	9	1	3 716 001	96 49 159 08	STANGE KPL.
SECHSKANTSCHRAUBE ISO 4	40 62 181 08	45	13	1 400	91 56 853 08	RAUPENTRAEGER KPL.LI.
SECHSKANTSCHRAUBE ISO 4	40 62 181 08	45	13	1 410 300	91 56 855 08	RAUPENTRAEGER KPL.RE.
SECHSKANTSCHRAUBE ISO	40 61 167 01	14	4	3 292	91 52 865 08	D-RUECKHALTESICHERUNG
SECHSKANTSCHRAUBE ISO	46 00 056	21	1	2 391 040	96 53 645 08	KUPPLUNGSSTELLER
SECHSKANTSCHRAUBE ISO	40 62 044 08	16	4	3 227 002	96 50 498 08	STANGE KPL.
SECHSKANTSCHRAUBE ISO	46 00 332	(3)	1	3 281	91 52 896 08	FA-BOCK
SECHSKANTSCHRAUBE ISO 4	40 61 234 14	1272	18	X1065015	10 65 015 5	GETRIEBE
SECHSKANTSCHRAUBE ISO 4	40 61 244 01	16	1	2 550 005	96 45 680 08	STANGE KPL.
SECHSKANTSCHRAUBE ISO	46 35 436	15	4	3 745 011	96 49 677 08	LASCHE KPL.
SECHSKANTSCHRAUBE ISO 4	40 61 246 01	2	1	1 632 032	96 20 093 08	ABSTUETZPLATTE KPL.
SECHSKANTSCHRAUBE ISO 4	40 61 246 01	8	2	2 550 005	96 45 680 08	STANGE KPL.
SECHSKANTSCHRAUBE ISO 4	40 61 246 01	6	1	3 714 025	96 49 269 08	STANGE KPL.
SECHSKANTSCHRAUBE ISO 4	40 61 248 14	4	2	3 745 011	96 49 677 08	LASCHE KPL.
SECHSKANTSCHRAUBE ISO 4	40 61 291 08	15	6	3 714 009	96 49 267 08	VERSTELLFLASCHE KPL.
SECHSKANTSCHRAUBE ISO 4	10 04 097 9	55	35	1 400	91 56 853 08	RAUPENTRAEGER KPL.LI.
SECHSKANTSCHRAUBE ISO 4	10 04 097 9	55	35	1 410 300	91 56 855 08	RAUPENTRAEGER KPL.RE.
SECHSKANTSCHRAUBE ISO 4	10 41 289 2	56	35	1 400	91 56 853 08	RAUPENTRAEGER KPL.LI.
SECHSKANTSCHRAUBE ISO 4	10 41 289 2	56	35	1 410 300	91 56 855 08	RAUPENTRAEGER KPL.RE.
SECHSKANTSCHRAUBE ISO 4	40 01 928	33	2	3 220 500	91 52 849 08	S-ZWISCHENSTUECK
SECHSKANTSCHRAUBE ISO 4	40 01 928	33	4	3 223	91 52 852 08	S-ZWISCHENSTUECK
SECHSKANTSCHRAUBE ISO 4	40 01 928	33	4	3 223 010	91 52 853 08	S-ZWISCHENSTUECK
SECHSKANTSCHRAUBE ISO 4	40 01 928	33	4	3 223 100	91 55 327 08	S-ZWISCHENSTUECK
SECHSKANTSCHRAUBE ISO 4	40 01 928	31	2	3 225	91 52 854 08	SL-REDUZIERSTUECK
SECHSKANTSCHRAUBE ISO 4	40 01 928	33	2	3 226	91 52 870 08	LI-ZWISCHENSTUECK
SECHSKANTSCHRAUBE ISO 4	40 01 928	33	4	3 227	91 52 873 08	LI-ZWISCHENSTUECK
SECHSKANTSCHRAUBE ISO 4	40 01 928	33	4	3 227 008	91 52 872 08	LI-ZWISCHENSTUECK
SECHSKANTSCHRAUBE ISO 4	40 01 928	33	4	3 227 200	91 53 519 08	LI-ZWISCHENSTUECK F-ABSP
SECHSKANTSCHRAUBE ISO 4	40 01 928	59	10	3 714	91 52 862 08	D-KOPFSTUECK
SECHSKANTSCHRAUBE ISO 4	46 00 023	10	2	2 976 203	92 27 489 08	ZUSATZHYDR.BOLZENIEHZ
SECHSKANTSCHRAUBE ISO 4	46 00 023	56	5	3 211	91 57 748 08	S-ANLENKSTUECK
SECHSKANTSCHRAUBE ISO 4	40 01 929	6	4	3 715 008	91 52 863 08	D-ZWISCHENSTUECK
SECHSKANTSCHRAUBE ISO 4	40 01 929	6	6	3 716	91 52 864 08	D-ZWISCHENSTUECK
SECHSKANTSCHRAUBE ISO 4	46 00 356	36	15	3 220 500	91 52 849 08	S-ZWISCHENSTUECK
SECHSKANTSCHRAUBE ISO 4	46 00 356	20	12	3 221	91 54 668 08	S-ZWISCHENSTUECK
SECHSKANTSCHRAUBE ISO 4	46 00 356	36	18	3 223	91 52 852 08	S-ZWISCHENSTUECK
SECHSKANTSCHRAUBE ISO 4	46 00 356	36	18	3 223 010	91 52 853 08	S-ZWISCHENSTUECK
SECHSKANTSCHRAUBE ISO 4	46 00 356	36	18	3 223 100	91 55 327 08	S-ZWISCHENSTUECK
SECHSKANTSCHRAUBE ISO 4	46 00 356	43	15	3 225	91 52 854 08	SL-REDUZIERSTUECK
SECHSKANTSCHRAUBE ISO 4	46 00 356	36	15	3 226	91 52 870 08	LI-ZWISCHENSTUECK
SECHSKANTSCHRAUBE ISO 4	46 00 356	36	18	3 227	91 52 873 08	LI-ZWISCHENSTUECK
SECHSKANTSCHRAUBE ISO 4	46 00 356	36	18	3 227 008	91 52 872 08	LI-ZWISCHENSTUECK
SECHSKANTSCHRAUBE ISO 4	46 00 356	36	18	3 227 200	91 53 519 08	LI-ZWISCHENSTUECK F-ABSP

6.2.2009

etk_en_de_074515 LR 1600/2

1098

LIEBHERRAlphabetical index
Alphabetischer Index

Bezeichnung	Artikel	Pos.	Menge	Seite	Baugruppe	Bezeichnung
SECHSKANTSCHRAUBE ISO 4	46 00 356	62	15	3 713	91 57 749 08	D-ANLENKSTUECK
SECHSKANTSCHRAUBE ISO 4	46 00 356	56	9	3 714	91 52 862 08	D-KOPFSTUECK
SECHSKANTSCHRAUBE ISO 4	46 00 356	18	16	3 715 008	91 52 863 08	D-ZWISCHENSTUECK
SECHSKANTSCHRAUBE ISO 4	46 00 356	18	19	3 716	91 52 864 08	D-ZWISCHENSTUECK
SECHSKANTSCHRAUBE ISO 4	49 81 024	60	11	3 714	91 52 862 08	D-KOPFSTUECK
SECHSKANTSCHRAUBE ISO 4	40 00 970	16	2	2 990	91 59 244 08	DRUCKLUFTANLAGE
SECHSKANTSCHRAUBE ISO	46 00 310	9	3	2 350	91 52 778 08	DREHWERK
SECHSKANTSCHRAUBE ISO 4	40 61 062	43	6	3 715 008	91 52 863 08	D-ZWISCHENSTUECK
SECHSKANTSCHRAUBE ISO 4	40 61 062	47	12	3 716	91 52 864 08	D-ZWISCHENSTUECK
SECHSKANTSCHRAUBE ISO 4	40 01 466	100	14	3 211	91 57 748 08	S-ANLENKSTUECK
SECHSKANTSCHRAUBE ISO 4	40 01 461	7	4	1 620	91 52 386 08	BEFESTIGUNGSTEILE DREH
SECHSKANTSCHRAUBE ISO 4	40 01 461	25	2	3 208 001	91 52 883 08	F-KOPFSTUECK
SECHSKANTSCHRAUBE ISO 4	40 01 461	75	44	3 211	91 57 748 08	S-ANLENKSTUECK
SECHSKANTSCHRAUBE ISO 4	40 01 461	76	16	3 713	91 57 749 08	D-ANLENKSTUECK
SECHSKANTSCHRAUBE ISO 4	40 01 461	31	8	3 745	91 52 948 08	SCHWEBEBALLAST
SECHSKANTSCHRAUBE ISO 4	40 61 024	10	48	1 631 100	91 52 388 08	LAUFSTEG RAUPENFAHRWER
SECHSKANTSCHRAUBE ISO 4	40 61 024	58	8	3 206	91 52 881 08	F-ANLENKSTUECK
SECHSKANTSCHRAUBE ISO 4	40 61 024	36	9	3 214	91 52 843 08	SW-KOPFSTUECK
SECHSKANTSCHRAUBE ISO 4	40 61 024	25	45	3 220 500	91 52 849 08	S-ZWISCHENSTUECK
SECHSKANTSCHRAUBE ISO 4	40 61 024	13	36	3 221	91 54 668 08	S-ZWISCHENSTUECK
SECHSKANTSCHRAUBE ISO 4	40 61 024	25	49	3 223	91 52 852 08	S-ZWISCHENSTUECK
SECHSKANTSCHRAUBE ISO 4	40 61 024	25	49	3 223 010	91 52 853 08	S-ZWISCHENSTUECK
SECHSKANTSCHRAUBE ISO 4	40 61 024	25	49	3 223 100	91 55 327 08	S-ZWISCHENSTUECK
SECHSKANTSCHRAUBE ISO 4	40 61 024	35	47	3 225	91 52 854 08	SL-REDUZIERSTUECK
SECHSKANTSCHRAUBE ISO 4	40 61 024	25	34	3 226	91 52 870 08	LI-ZWISCHENSTUECK
SECHSKANTSCHRAUBE ISO 4	40 61 024	25	48	3 227	91 52 873 08	LI-ZWISCHENSTUECK
SECHSKANTSCHRAUBE ISO 4	40 61 024	25	40	3 227 008	91 52 872 08	LI-ZWISCHENSTUECK
SECHSKANTSCHRAUBE ISO 4	40 61 024	25	49	3 227 200	91 53 519 08	LI-ZWISCHENSTUECK F-ABSP
SECHSKANTSCHRAUBE ISO 4	40 61 024	17	73	3 713	91 57 749 08	D-ANLENKSTUECK
SECHSKANTSCHRAUBE ISO 4	40 61 024	46	55	3 714	91 52 862 08	D-KOPFSTUECK
SECHSKANTSCHRAUBE ISO 4	40 61 024	7	56	3 715 008	91 52 863 08	D-ZWISCHENSTUECK
SECHSKANTSCHRAUBE ISO 4	40 61 024	7	88	3 716	91 52 864 08	D-ZWISCHENSTUECK
SECHSKANTSCHRAUBE ISO 4	24 02 184 02	31	1	3 206	91 52 881 08	F-ANLENKSTUECK
SECHSKANTSCHRAUBE ISO	49 00 090	3	16	1 620	91 52 386 08	BEFESTIGUNGSTEILE DREH
SECHSKANTSCHRAUBE ISO	49 00 090	69	4	2 550	91 57 751 08	SA-BOCK
SECHSKANTSCHRAUBE ISO 4	40 01 696	(56)	8	1 400	91 56 853 08	RAUPENTRAEGER KPL.LI.
SECHSKANTSCHRAUBE ISO 4	40 01 696	9	16	2 810	91 52 806 08	KRANFUEHRERKABINE KPL.
SECHSKANTSCHRAUBE ISO	40 65 166	7	4	2 671	91 52 798 08	OELBEHAELTER KPL.
SECHSKANTSCHRAUBE ISO	40 65 166	12	8	2 730	91 52 802 08	GRUNDPLATTE DREHBUEHNE
SECHSKANTSCHRAUBE ISO	40 65 166	129	2	2 970	91 56 537 08	HYDRAULIK
SECHSKANTSCHRAUBE ISO	40 65 093 08	6	8	2 670	91 52 797 08	KRAFTSTOFFBEHAELTER KPL
SECHSKANTSCHRAUBE ISO	40 65 164	5	6	2 350	91 52 778 08	DREHWERK
SECHSKANTSCHRAUBE ISO	40 65 164	7	12	2 370	91 52 782 08	MONTAGEWINDE
SECHSKANTSCHRAUBE ISO	40 65 164	344	4	2 391 001	96 45 719 08	DIESELMOTOR VORM.
SECHSKANTSCHRAUBE ISO	40 65 164	20	4	2 393	91 52 787 08	LUFTFILTERANLAGE KPL.
SECHSKANTSCHRAUBE ISO	40 65 164	19	4	2 631	91 56 817 08	LAUFSTEG DREHBUEHNE
SECHSKANTSCHRAUBE ISO	40 65 164	31	6	2 652	91 52 794 08	ROLLENLAGERUNG
SECHSKANTSCHRAUBE ISO	40 65 164	8	4	2 671 004	96 46 305 08	OELBEHAELTER VORM.
SECHSKANTSCHRAUBE ISO	40 65 164	14	12	2 810	91 52 806 08	KRANFUEHRERKABINE KPL.
SECHSKANTSCHRAUBE ISO	40 65 164	16	4	2 925 204	92 16 990 08	KAMERAANBAU D-ANLENKS
SECHSKANTSCHRAUBE ISO	40 65 164	35	2	2 925 402	96 58 855 08	KAMERAANBAU DREHBUEHN
SECHSKANTSCHRAUBE ISO	40 65 164	7	5	3 206	91 52 881 08	F-ANLENKSTUECK
SECHSKANTSCHRAUBE ISO	40 65 164	71	16	3 714	91 52 862 08	D-KOPFSTUECK
SECHSKANTSCHRAUBE ISO	40 00 828	67	12	1 400	91 56 853 08	RAUPENTRAEGER KPL.LI.
SECHSKANTSCHRAUBE ISO	40 00 828	67	12	1 410 300	91 56 855 08	RAUPENTRAEGER KPL.RE.
SECHSKANTSCHRAUBE ISO	40 00 828	345	2	2 391 001	96 45 719 08	DIESELMOTOR VORM.
SECHSKANTSCHRAUBE ISO	40 00 828	35	24	2 631	91 56 817 08	LAUFSTEG DREHBUEHNE
SECHSKANTSCHRAUBE ISO	40 00 828	130	2	2 970	91 56 537 08	HYDRAULIK
SECHSKANTSCHRAUBE ISO	49 00 112	9	4	2 730	91 52 802 08	GRUNDPLATTE DREHBUEHNE
SECHSKANTSCHRAUBE ISO	49 00 112	544	2	2 970	91 56 537 08	HYDRAULIK

6.2.2009

etk_en_de_074515 LR 1600/2

1099

LIEBHERRAlphabetical index
Alphabetischer Index

Bezeichnung	Artikel	Pos.	Menge	Seite	Baugruppe	Bezeichnung
SECHSKANTSCHRAUBE ISO	49 00 112	564	4	2 976 200	91 52 780 08	ZUSATZHYDRAULIK DREHWE
SECHSKANTSCHRAUBE ISO	49 00 112	569	4	2 976 700	91 54 795 08	ZUSATZHYDRAULIK PUMPE
SECHSKANTSCHRAUBE ISO	49 00 112	31	8	3 713	91 57 749 08	D-ANLENKSTUECK
SECHSKANTSCHRAUBE ISO	49 00 112	11	4	X1035519	10 35 519 6	OEL-LUFTKUEHLER
SECHSKANTSCHRAUBE ISO	46 00 122	339	12	2 391 001	96 45 719 08	DIESELMOTOR VORM.
SECHSKANTSCHRAUBE ISO	46 00 122	23	2	3 206	91 52 881 08	F-ANLENKSTUECK
SECHSKANTSCHRAUBE ISO	46 00 122	48	4	3 211	91 57 748 08	S-ANLENKSTUECK
SECHSKANTSCHRAUBE ISO	46 00 355	31	2	2 502	91 55 939 08	STEUERSTAND
SECHSKANTSCHRAUBE ISO	46 00 355	9	10	X1035519	10 35 519 6	OEL-LUFTKUEHLER
SECHSKANTSCHRAUBE ISO	49 00 120	10	8	1 630	91 52 387 08	HYDRAULISCHE ABSTUETZUN
SECHSKANTSCHRAUBE ISO	49 00 120	357	4	2 391	91 52 784 08	DIESELMOTOR KPL.
SECHSKANTSCHRAUBE ISO	40 66 087 08	430	2	X1041101	10 41 101 8	RUECKFALLSTUETZE
SECHSKANTSCHRAUBE ISO	49 00 161	52	8	1 400	91 56 853 08	RAUPENTRAEGER KPL.LI.
SECHSKANTSCHRAUBE ISO	49 00 161	52	8	1 410 300	91 56 855 08	RAUPENTRAEGER KPL.RE.
SECHSKANTSCHRAUBE ISO	49 00 161	173	8	2 970	91 56 537 08	HYDRAULIK
SECHSKANTSCHRAUBE ISO	49 00 161	70	2	3 211	91 57 748 08	S-ANLENKSTUECK
SECHSKANTSCHRAUBE ISO	49 00 161	8	8	3 213	91 52 842 08	F-ANSCHLUSSKOPF
SECHSKANTSCHRAUBE ISO	49 00 161	9	4	3 291	91 52 831 08	S-RUECKHALTESICHERUNG
SECHSKANTSCHRAUBE ISO	49 00 161	3	4	3 292	91 52 865 08	D-RUECKHALTESICHERUNG
SECHSKANTSCHRAUBE ISO	49 00 161	36	8	3 714	91 52 862 08	D-KOPFSTUECK
SECHSKANTSCHRAUBE ISO	49 00 161	12	4	3 714 008	96 49 266 08	VERSTELLFLASCHE KPL.
SECHSKANTSCHRAUBE ISO	49 00 204	2	2	2 212	91 54 561 08	PUMPE F.DREHWERK
SECHSKANTSCHRAUBE ISO	49 00 204	20	4	2 310	91 52 503 08	WINDE 1
SECHSKANTSCHRAUBE ISO	49 00 204	20	4	2 320	91 52 504 08	WINDE 2
SECHSKANTSCHRAUBE ISO	49 00 204	335	10	2 391 001	96 45 719 08	DIESELMOTOR VORM.
SECHSKANTSCHRAUBE ISO	49 00 204	3	2	3 211 002	92 88 302 08	SCHUTZWALZE KPL.
SECHSKANTSCHRAUBE ISO	49 00 204	16	4	3 292	91 52 865 08	D-RUECKHALTESICHERUNG
SECHSKANTSCHRAUBE ISO	49 00 204	24	8	3 350	91 52 859 08	WINDE 3
SECHSKANTSCHRAUBE ISO	49 00 204	24	4	3 713	91 57 749 08	D-ANLENKSTUECK
SECHSKANTSCHRAUBE ISO	49 00 204	151	2	3 713	91 57 749 08	D-ANLENKSTUECK
SECHSKANTSCHRAUBE ISO	49 00 204	61	8	3 714	91 52 862 08	D-KOPFSTUECK
SECHSKANTSCHRAUBE ISO 4	46 00 366	12	12	3 214	91 52 843 08	SW-KOPFSTUECK
SECHSKANTSCHRAUBE ISO	49 00 100	347	2	2 391 001	96 45 719 08	DIESELMOTOR VORM.
SECHSKANTSCHRAUBE ISO	49 00 100	24	2	2 392	91 52 785 08	SCHALLDAEMPFERANLAGE
SECHSKANTSCHRAUBE ISO	49 00 100	548	4	2 970	91 56 537 08	HYDRAULIK
SECHSKANTSCHRAUBE ISO	49 00 100	72	4	3 211	91 57 748 08	S-ANLENKSTUECK
SECHSKANTSCHRAUBE ISO	46 00 158	15	1	1 991	91 52 510 08	DREHDURCHFUEHRUNG
SECHSKANTSCHRAUBE ISO	46 00 158	12	2	2 340	91 52 776 08	WINDE 4 EINZIEHWERK
SECHSKANTSCHRAUBE ISO	46 00 158	337	8	2 391 001	96 45 719 08	DIESELMOTOR VORM.
SECHSKANTSCHRAUBE ISO	46 00 158	12	4	3 213	91 52 842 08	F-ANSCHLUSSKOPF
SECHSKANTSCHRAUBE ISO	46 00 158	28	4	3 214	91 52 843 08	SW-KOPFSTUECK
SECHSKANTSCHRAUBE ISO	46 00 158	6	8	3 220 500	91 52 849 08	S-ZWISCHENSTUECK
SECHSKANTSCHRAUBE ISO	46 00 158	6	8	3 221	91 54 668 08	S-ZWISCHENSTUECK
SECHSKANTSCHRAUBE ISO	46 00 158	6	8	3 223	91 52 852 08	S-ZWISCHENSTUECK
SECHSKANTSCHRAUBE ISO	46 00 158	6	8	3 223 010	91 52 853 08	S-ZWISCHENSTUECK
SECHSKANTSCHRAUBE ISO	46 00 158	6	8	3 223 100	91 55 327 08	S-ZWISCHENSTUECK
SECHSKANTSCHRAUBE ISO	46 00 158	25	8	3 225	91 52 854 08	SL-REDUZIERSTUECK
SECHSKANTSCHRAUBE ISO	46 00 158	6	8	3 226	91 52 870 08	LI-ZWISCHENSTUECK
SECHSKANTSCHRAUBE ISO	46 00 158	6	8	3 227	91 52 873 08	LI-ZWISCHENSTUECK
SECHSKANTSCHRAUBE ISO	46 00 158	6	8	3 227 008	91 52 872 08	LI-ZWISCHENSTUECK
SECHSKANTSCHRAUBE ISO	46 00 158	6	8	3 227 200	91 53 519 08	LI-ZWISCHENSTUECK F-ABSP
SECHSKANTSCHRAUBE ISO	46 00 158	27	32	3 350	91 52 859 08	WINDE 3
SECHSKANTSCHRAUBE ISO	46 00 158	27	4	3 714	91 52 862 08	D-KOPFSTUECK
SECHSKANTSCHRAUBE ISO	46 00 158	17	8	3 715 008	91 52 863 08	D-ZWISCHENSTUECK
SECHSKANTSCHRAUBE ISO	46 00 158	17	8	3 716	91 52 864 08	D-ZWISCHENSTUECK
SECHSKANTSCHRAUBE ISO	46 00 156	4	8	2 391	91 52 784 08	DIESELMOTOR KPL.
SECHSKANTSCHRAUBE ISO	46 00 156	42	8	3 350	91 52 859 08	WINDE 3
SECHSKANTSCHRAUBE ISO	46 00 312	340	6	2 391 001	96 45 719 08	DIESELMOTOR VORM.
SECHSKANTSCHRAUBE ISO	40 65 086 05	49	2	2 631	91 56 817 08	LAUFSTEG DREHBUEHNE
SECHSKANTSCHRAUBE ISO	40 65 145 01	57	8	1 970	91 56 958 08	HYDRAULIK RAUPE

6.2.2009

etk_en_de_074515 LR 1600/2

1100

LIEBHERRAlphabetical index
Alphabetischer Index

Bezeichnung	Artikel	Pos.	Menge	Seite	Baugruppe	Bezeichnung
SECHSKANTSCHRAUBE ISO	40 65 145 01	57	8	1 970 161	96 50 706 08	ZUSATZHYDR.RAUPENTRAEG
SECHSKANTSCHRAUBE ISO	40 65 145 01	556	4	2 970	91 56 537 08	HYDRAULIK
SECHSKANTSCHRAUBE ISO	40 65 145 01	43	4	2 975 100	91 52 860 08	ZUSATZHYDRAULIK WINDE 3
SECHSKANTSCHRAUBE ISO	40 65 145 01	44	4	2 975 100	91 52 860 08	ZUSATZHYDRAULIK WINDE 3
SECHSKANTSCHRAUBE ISO 4	46 01 349	28	8	1 630	91 52 387 08	HYDRAULISCHE ABSTUETZUN
SECHSKANTSCHRAUBE ISO	40 65 156 08	23	4	2 393	91 52 787 08	LUFTFILTERANLAGE KPL.
SECHSKANTSCHRAUBE ISO	49 00 152	3	162	1 300 011	96 52 493 08	BODENPLATTEN VORM.
SECHSKANTSCHRAUBE ISO	49 00 152	355	2	2 391 001	96 45 719 08	DIESELMOTOR VORM.
SECHSKANTSCHRAUBE ISO	49 00 152	35	1	2 391 040	96 53 645 08	KUPPLUNGSSTELLER
SECHSKANTSCHRAUBE ISO	49 00 152	7	10	2 550	91 57 751 08	SA-BOCK
SECHSKANTSCHRAUBE ISO	49 00 123	54	4	1 400	91 56 853 08	RAUPENTRAEGER KPL.LI.
SECHSKANTSCHRAUBE ISO	49 00 123	54	4	1 410 300	91 56 855 08	RAUPENTRAEGER KPL.RE.
SECHSKANTSCHRAUBE ISO	49 00 123	9	8	3 714 008	96 49 266 08	VERSTELLFLASCHE KPL.
SECHSKANTSCHRAUBE ISO	49 00 123	12	8	3 714 009	96 49 267 08	VERSTELLFLASCHE KPL.
SECHSKANTSCHRAUBE ISO	49 00 123	12	16	3 745	91 52 948 08	SCHWEBEBALLAST
SECHSKANTSCHRAUBE ISO	40 66 030 08	47	8	1 400	91 56 853 08	RAUPENTRAEGER KPL.LI.
SECHSKANTSCHRAUBE ISO	40 66 030 08	47	8	1 410 300	91 56 855 08	RAUPENTRAEGER KPL.RE.
SECHSKANTSCHRAUBE ISO	40 66 030 08	7	26	2 652	91 52 794 08	ROLLENLAGERUNG
SECHSKANTSCHRAUBE ISO	40 66 030 08	28	16	3 208 001	91 52 883 08	F-KOPFSTUECK
SECHSKANTSCHRAUBE ISO	40 66 030 08	16	16	3 714	91 52 862 08	D-KOPFSTUECK
SECHSKANTSCHRAUBE ISO	40 65 304 08	42	28	2 550	91 57 751 08	SA-BOCK
SECHSKANTSCHRAUBE ISO	49 00 153	8	16	2 125	91 52 773 08	BOLZEN S-ANLENKST. UND S
SECHSKANTSCHRAUBE ISO	49 00 153	5	16	2 550	91 57 751 08	SA-BOCK
SECHSKANTSCHRAUBE ISO	49 00 153	174	8	2 970	91 56 537 08	HYDRAULIK
SECHSKANTSCHRAUBE ISO	49 00 153	51	2	3 223 100	91 55 327 08	S-ZWISCHENSTUECK
SECHSKANTSCHRAUBE ISO	46 00 016	10	6	1 991	91 52 510 08	DREHDURCHFUEHRUNG
SECHSKANTSCHRAUBE ISO	46 00 016	332	4	2 391 001	96 45 719 08	DIESELMOTOR VORM.
SECHSKANTSCHRAUBE ISO	46 00 016	143	2	3 713	91 57 749 08	D-ANLENKSTUECK
SECHSKANTSCHRAUBE ISO	46 00 189	6	12	1 631 100	91 52 388 08	LAUFSTEG RAUPENFAHRWER
SECHSKANTSCHRAUBE ISO	46 00 189	334	4	2 391 001	96 45 719 08	DIESELMOTOR VORM.
SECHSKANTSCHRAUBE ISO	46 00 189	50	4	2 810	91 52 806 08	KRANFUEHRERKABINE KPL.
SECHSKANTSCHRAUBE ISO	46 00 044	18	2	3 214	91 52 843 08	SW-KOPFSTUECK
SECHSKANTSCHRAUBE ISO	46 00 206	10	8	2 125	91 52 773 08	BOLZEN S-ANLENKST. UND S
SECHSKANTSCHRAUBE ISO	46 01 292	(68)	1	1 400	91 56 853 08	RAUPENTRAEGER KPL.LI.
SECHSKANTSCHRAUBE ISO	46 00 380	25	4	X1065015	10 65 015 8	ANTRIEB
SECHSKANTSCHRAUBE ISO	46 00 020	13	8	1 991	91 52 510 08	DREHDURCHFUEHRUNG
SECHSKANTSCHRAUBE ISO	46 00 020	10	6	2 310	91 52 503 08	WINDE 1
SECHSKANTSCHRAUBE ISO	46 00 020	10	6	2 320	91 52 504 08	WINDE 2
SECHSKANTSCHRAUBE ISO	46 00 020	6	6	3 350	91 52 859 08	WINDE 3
SECHSKANTSCHRAUBE ISO	46 00 097	50	6	1 400	91 56 853 08	RAUPENTRAEGER KPL.LI.
SECHSKANTSCHRAUBE ISO	46 00 097	50	6	1 410 300	91 56 855 08	RAUPENTRAEGER KPL.RE.
SECHSKANTSCHRAUBE ISO	46 00 097	341	20	2 391 001	96 45 719 08	DIESELMOTOR VORM.
SECHSKANTSCHRAUBE ISO	40 65 211 01	11	4	2 310	91 52 503 08	WINDE 1
SECHSKANTSCHRAUBE ISO	40 65 211 01	11	4	2 320	91 52 504 08	WINDE 2
SECHSKANTSCHRAUBE ISO	40 65 211 01	7	4	3 350	91 52 859 08	WINDE 3
SECHSKANTSCHRAUBE ISO 4	40 66 043 08	48	8	1 400	91 56 853 08	RAUPENTRAEGER KPL.LI.
SECHSKANTSCHRAUBE ISO 4	40 66 043 08	48	8	1 410 300	91 56 855 08	RAUPENTRAEGER KPL.RE.
SECHSKANTSCHRAUBE ISO	40 65 215 01	6	1	3 206 002	96 47 960 08	HEBEL KPL.
SECHSKANTSCHRAUBE ISO 4	40 65 140 05	15	2	2 340	91 52 776 08	WINDE 4 EINZIEHWERK
SECHSKANTSCHRAUBE ISO	40 66 056 08	9	44	2 340	91 52 776 08	WINDE 4 EINZIEHWERK
SECHSKANTSCHRAUBE ISO 4	40 66 057 08	9	22	2 310	91 52 503 08	WINDE 1
SECHSKANTSCHRAUBE ISO 4	40 66 057 08	9	22	2 320	91 52 504 08	WINDE 2
SECHSKANTSCHRAUBE ISO 4	40 66 057 08	5	22	3 350	91 52 859 08	WINDE 3
SECHSKANTSCHRAUBE ISO	40 65 232 01	51	34	1 400	91 56 853 08	RAUPENTRAEGER KPL.LI.
SECHSKANTSCHRAUBE ISO	40 65 232 01	51	34	1 410 300	91 56 855 08	RAUPENTRAEGER KPL.RE.
SECHSKANTSCHRAUBE ISO	40 65 232 01	21	24	X1065015	10 65 015 6	SEILTROMMEL
SECHSKANTSCHRAUBE ISO 4	40 65 269 14	101	2	3 713	91 57 749 08	D-ANLENKSTUECK
SECHSKANTSCHRAUBE ISO	40 65 000 08	11	4	2 913	91 32 850 08	LICCON KONSOLE LCD2
SECHSKANTSCHRAUBE ISO	40 65 000 08	11	4	2 913 009	91 04 705 08	LICCON KONSOLE LCD3
SECHSKANTSCHRAUBE ISO 4	40 00 878	38	10	2 631	91 56 817 08	LAUFSTEG DREHBUEHNE

6.2.2009

etk_en_de_074515 LR 1600/2

1101

LIEBHERRAlphabetical index
Alphabetischer Index

Bezeichnung	Artikel	Pos.	Menge	Seite	Baugruppe	Bezeichnung
SECHSKANTSCHRAUBE ISO	40 65 002 01	10	2	9 640 276	96 40 276 08	ANSCHLUSSBLOCK
SECHSKANTSCHRAUBE ISO	40 65 002 14	35	4	2 533 070	96 48 363 08	ARMATUREN RE.
SECHSKANTSCHRAUBE ISO	40 65 002 14	(31)	4	2 925 026	91 55 259 08	ERG.KAMERAUEBERWACHUN
SECHSKANTSCHRAUBE ISO	40 65 002 14	31	4	2 925 405	96 48 397 08	AUSRUESTUNG KAMERA KAB
SECHSKANTSCHRAUBE ISO 4	40 65 060	23	28	2 260	91 53 057 08	BATTERIELAGERUNG
SECHSKANTSCHRAUBE ISO 4	40 65 060	55	2	2 975 100	91 52 860 08	ZUSATZHYDRAULIK WINDE 3
SECHSKANTSCHRAUBE ISO 4	40 00 417	37	8	2 502	91 55 939 08	STUERSTAND
SECHSKANTSCHRAUBE ISO 4	40 00 417	50	16	2 859	91 52 809 08	GERAEUSCHDAEMMUNG
SECHSKANTSCHRAUBE ISO 4	40 00 417	8	8	2 859 025	96 46 757 08	GITTERROST VORM.
SECHSKANTSCHRAUBE ISO 4	46 01 213	10	5	2 920 814	96 45 717 08	ELEKTRIK KRAFTSTOFFBEHA
SECHSKANTSCHRAUBE ISO 4	40 65 103	18	4	2 978 200	91 54 843 08	ZUSATZHYDR.S-RUECKHALTE
SECHSKANTSCHRAUBE ISO 4	49 00 605	73	8	1 970	91 56 958 08	HYDRAULIK RAUPE
SECHSKANTSCHRAUBE ISO 4	49 00 605	65	10	2 970	91 56 537 08	HYDRAULIK
SECHSKANTSCHRAUBE ISO 4	49 00 605	51	2	2 975 100	91 52 860 08	ZUSATZHYDRAULIK WINDE 3
SECHSKANTSCHRAUBE ISO 4	49 00 605	52	4	2 975 200	91 52 775 08	ZUSATZHYDRAULIK WINDE 2
SECHSKANTSCHRAUBE ISO 4	49 00 605	52	4	2 975 700	91 52 774 08	ZUSATZHYDRAULIK WINDE 1
SECHSKANTSCHRAUBE ISO 4	40 65 099	19	2	2 260 006	96 46 501 08	BATTERIEKASTEN VORM.
SECHSKANTSCHRAUBE ISO 4	40 65 099	16	1	2 533 066	96 48 365 08	ELEKTRIK ANBAUTEILE KABIN
SECHSKANTSCHRAUBE ISO 4	40 65 099	5	1	2 913 004	96 20 460 08	GEHAEUSE VORM.
SECHSKANTSCHRAUBE ISO 4	40 65 099	10	3	2 920 200	96 44 536 08	ELEKTRIK WINDE 1
SECHSKANTSCHRAUBE ISO 4	40 65 099	10	3	2 920 260	96 44 537 08	ELEKTRIK WINDE 2
SECHSKANTSCHRAUBE ISO 4	40 65 099	10	3	2 920 334	96 44 538 08	ELEKTRIK WINDE 3
SECHSKANTSCHRAUBE ISO 4	40 65 099	10	3	2 920 350	96 44 539 08	ELEKTRIK WINDE 4
SECHSKANTSCHRAUBE ISO 4	40 65 099	54	2	3 206	91 52 881 08	F-ANLENKSTUECK
SECHSKANTSCHRAUBE ISO 4	40 65 099	42	4	3 214	91 52 843 08	SW-KOPFSTUECK
SECHSKANTSCHRAUBE ISO 4	40 00 829	66	8	1 970	91 56 958 08	HYDRAULIK RAUPE
SECHSKANTSCHRAUBE ISO 4	40 00 829	20	8	2 260	91 53 057 08	BATTERIELAGERUNG
SECHSKANTSCHRAUBE ISO 4	40 00 829	22	4	2 260 006	96 46 501 08	BATTERIEKASTEN VORM.
SECHSKANTSCHRAUBE ISO 4	40 00 829	22	8	2 370	91 52 782 08	MONTAGEWINDE
SECHSKANTSCHRAUBE ISO 4	40 00 829	13	2	2 391 023	96 45 720 08	KUEHLER VORM.
SECHSKANTSCHRAUBE ISO 4	40 00 829	4	4	2 391 039	96 50 616 08	HUTZE KPL
SECHSKANTSCHRAUBE ISO 4	40 00 829	32	1	2 391 040	96 53 645 08	KUPPLUNGSSTELLER
SECHSKANTSCHRAUBE ISO 4	40 00 829	7	4	2 510	91 52 788 08	DREHBUEHNENVERKLEIDUN
SECHSKANTSCHRAUBE ISO 4	40 00 829	15	8	2 522	91 54 115 08	SCHIEBETUER KPL.
SECHSKANTSCHRAUBE ISO 4	40 00 829	7	2	2 540	91 53 253 08	HEIZKLIMAGERAET EINBAU
SECHSKANTSCHRAUBE ISO 4	40 00 829	57	14	2 550	91 57 751 08	SA-BOCK
SECHSKANTSCHRAUBE ISO 4	40 00 829	8	4	2 925 204	92 16 990 08	KAMERAANBAU D-ANLENKS
SECHSKANTSCHRAUBE ISO 4	40 00 829	15	1	2 925 204	92 16 990 08	KAMERAANBAU D-ANLENKS
SECHSKANTSCHRAUBE ISO 4	40 00 829	11	13	2 925 402	96 58 855 08	KAMERAANBAU DREHBUEHN
SECHSKANTSCHRAUBE ISO 4	40 00 829	37	1	2 932 082	96 54 387 08	AUFBAUTEILE MONTAGETAPE
SECHSKANTSCHRAUBE ISO 4	40 00 829	27	4	3 206	91 52 881 08	F-ANLENKSTUECK
SECHSKANTSCHRAUBE ISO 4	40 00 829	69	5	3 211	91 57 748 08	S-ANLENKSTUECK
SECHSKANTSCHRAUBE ISO 4	40 00 829	8	4	3 745 002	92 17 236 08	SCHALTEINHEIT
SECHSKANTSCHRAUBE ISO 4	40 00 829	8	4	3 745 003	92 17 237 08	SCHALTEINHEIT
SECHSKANTSCHRAUBE ISO 4	40 00 829	42	1	X1022811	10 22 811 2	HEIZKLIMAGERAET
SECHSKANTSCHRAUBE ISO 4	49 00 539	17	16	2 391 023	96 45 720 08	KUEHLER VORM.
SECHSKANTSCHRAUBE ISO 4	49 00 539	24	4	2 835 002	96 48 379 08	ANBAUTEILE
SECHSKANTSCHRAUBE ISO 4	49 00 539	11	2	2 932 166	92 68 911 08	VERTEILER MASSE
SECHSKANTSCHRAUBE ISO 4	49 00 539	29	8	3 208 001	91 52 883 08	F-KOPFSTUECK
SECHSKANTSCHRAUBE ISO 4	49 00 539	12	4	7 027 481	70 27 481 03	WASSERABSCHIEDER
SECHSKANTSCHRAUBE ISO 4	46 00 102	2	4	7 027 481	70 27 481 03	WASSERABSCHIEDER
SECHSKANTSCHRAUBE ISO 4	49 00 595	26	1	2 522	91 54 115 08	SCHIEBETUER KPL.
SECHSKANTSCHRAUBE ISO 4	46 00 532	17	2	1 991	91 52 510 08	DREHDURCHFUEHRUNG
SECHSKANTSCHRAUBE ISO 4	46 00 532	15	2	3 780 751	91 52 952 08	FLUG-U.WINDWARNUNG
SECHSKANTSCHRAUBE ISO 4	40 65 055 08	24	2	X1042440	10 42 440 2	STUERBLOCK
SECHSKANTSCHRAUBE ISO 4	10 03 291 2	20	8	9 739 361	97 39 361	OELWANNE
SECHSKANTSCHRAUBE ISO 4	40 65 136	8	2	1 970	91 56 958 08	HYDRAULIK RAUPE
SECHSKANTSCHRAUBE ISO 4	40 65 136	63	8	1 970	91 56 958 08	HYDRAULIK RAUPE
SECHSKANTSCHRAUBE ISO 4	40 65 136	81	4	1 970	91 56 958 08	HYDRAULIK RAUPE
SECHSKANTSCHRAUBE ISO 4	40 65 136	15	4	2 391 102	96 56 360 08	ZUSATZKUEHLER VORM.

6.2.2009

etk_en_de_074515 LR 1600/2

1102

LIEBHERRAlphabetical index
Alphabetischer Index

Bezeichnung	Artikel	Pos.	Menge	Seite	Baugruppe	Bezeichnung
SECHSKANTSCHRAUBE ISO 4	40 65 136	22	2	2 393	91 52 787 08	LUFTFILTERANLAGE KPL.
SECHSKANTSCHRAUBE ISO 4	40 65 136	33	2	2 831	91 57 754 08	KLIMAAANLAGE OW
SECHSKANTSCHRAUBE ISO	40 66 005 08	17	8	2 392	91 52 785 08	SCHALLDAEMPFERANLAGE
SECHSKANTSCHRAUBE ISO 4	49 00 188	53	18	1 400	91 56 853 08	RAUPENTRAEGER KPL.LI.
SECHSKANTSCHRAUBE ISO 4	49 00 188	53	18	1 410 300	91 56 855 08	RAUPENTRAEGER KPL.RE.
SECHSKANTSCHRAUBE ISO 4	49 00 188	348	4	2 391 001	96 45 719 08	DIESELMOTOR VORM.
SECHSKANTSCHRAUBE ISO 4	49 00 188	16	8	2 510	91 52 788 08	DREHBUEHNENVERKLEIDUN
SECHSKANTSCHRAUBE ISO 4	49 00 188	44	6	2 520	91 53 061 08	KABINE VERGLAST
SECHSKANTSCHRAUBE ISO 4	49 00 188	7	4	2 522 012	96 45 884 08	FUEHRUNG VORM.
SECHSKANTSCHRAUBE ISO 4	49 00 188	42	14	2 631	91 56 817 08	LAUFSTEG DREHBUEHNE
SECHSKANTSCHRAUBE ISO 4	49 00 188	61	4	2 859	91 52 809 08	GERAEUSCHDAEMMUNG
SECHSKANTSCHRAUBE ISO 4	49 00 188	27	28	3 211	91 57 748 08	S-ANLENKSTUECK
SECHSKANTSCHRAUBE ISO 4	49 00 188	14	8	3 350	91 52 859 08	WINDE 3
SECHSKANTSCHRAUBE ISO 4	49 00 188	124	33	3 713	91 57 749 08	D-ANLENKSTUECK
SECHSKANTSCHRAUBE ISO 4	49 00 188	87	12	3 714	91 52 862 08	D-KOPFSTUECK
SECHSKANTSCHRAUBE ISO 4	49 00 188	41	16	3 715 008	91 52 863 08	D-ZWISCHENSTUECK
SECHSKANTSCHRAUBE ISO 4	49 00 188	46	28	3 716	91 52 864 08	D-ZWISCHENSTUECK
SECHSKANTSCHRAUBE ISO 4	49 00 188	7	4	3 978 005	91 56 430 08	ZUSATZHYDRAULIK SB-KOPFS
SECHSKANTSCHRAUBE ISO 4	40 65 063 08	20	6	2 520 032	96 45 980 08	SCHEIBENWISCHANLAGE EIN
SECHSKANTSCHRAUBE ISO 4	46 00 334	17	24	2 260	91 53 057 08	BATTERIELAGERUNG
SECHSKANTSCHRAUBE ISO 4	49 00 089	18	8	2 350	91 52 778 08	DREHWERK
SECHSKANTSCHRAUBE ISO 4	49 00 089	16	4	2 370	91 52 782 08	MONTAGEWINDE
SECHSKANTSCHRAUBE ISO 4	49 00 089	349	4	2 391 001	96 45 719 08	DIESELMOTOR VORM.
SECHSKANTSCHRAUBE ISO 4	49 00 089	15	12	2 391 023	96 45 720 08	KUEHLER VORM.
SECHSKANTSCHRAUBE ISO 4	49 00 089	21	2	2 392	91 52 785 08	SCHALLDAEMPFERANLAGE
SECHSKANTSCHRAUBE ISO 4	49 00 089	24	4	2 393	91 52 787 08	LUFTFILTERANLAGE KPL.
SECHSKANTSCHRAUBE ISO 4	49 00 089	47	13	2 631	91 56 817 08	LAUFSTEG DREHBUEHNE
SECHSKANTSCHRAUBE ISO 4	49 00 089	68	4	2 810	91 52 806 08	KRANFUEHRERKABINE KPL.
SECHSKANTSCHRAUBE ISO 4	49 00 089	58	40	2 859	91 52 809 08	GERAEUSCHDAEMMUNG
SECHSKANTSCHRAUBE ISO 4	49 00 089	4	1	2 925 204	92 16 990 08	KAMERAANBAU D-ANLENKS
SECHSKANTSCHRAUBE ISO 4	49 00 089	9	9	2 925 402	96 58 855 08	KAMERAANBAU DREHBUEHN
SECHSKANTSCHRAUBE ISO 4	49 00 089	14	2	2 932 160	96 54 385 08	SCHALTSCHRANK MECH.
SECHSKANTSCHRAUBE ISO 4	49 00 089	14	6	X1035519	10 35 519 6	OEL-LUFTKUEHLER
SECHSKANTSCHRAUBE ISO 4	50 26 189 08	9	2	2 522 012	96 45 884 08	FUEHRUNG VORM.
SECHSKANTSCHRAUBE ISO 4	50 26 189 08	15	2	2 671	91 52 798 08	OELBEHAELTER KPL.
SECHSKANTSCHRAUBE ISO 4	50 26 189 08	4	12	2 810 001	96 43 597 08	KRANFUEHRERKABINE VORM
SECHSKANTSCHRAUBE ISO 4	50 26 189 08	120	5	3 713	91 57 749 08	D-ANLENKSTUECK
SECHSKANTSCHRAUBE ISO	40 66 042	17	4	2 350	91 52 778 08	DREHWERK
SECHSKANTSCHRAUBE ISO 4	49 00 128	57	2	1 400	91 56 853 08	RAUPENTRAEGER KPL.LI.
SECHSKANTSCHRAUBE ISO 4	49 00 128	57	2	1 410 300	91 56 855 08	RAUPENTRAEGER KPL.RE.
SECHSKANTSCHRAUBE ISO 4	49 00 128	24	12	1 630	91 52 387 08	HYDRAULISCHE ABSTUETZUN
SECHSKANTSCHRAUBE ISO 4	49 00 128	21	4	1 991	91 52 510 08	DREHDURCHFUEHRUNG
SECHSKANTSCHRAUBE ISO 4	49 00 128	25	10	2 260	91 53 057 08	BATTERIELAGERUNG
SECHSKANTSCHRAUBE ISO 4	49 00 128	9	3	2 260 006	96 46 501 08	BATTERIEKASTEN VORM.
SECHSKANTSCHRAUBE ISO 4	49 00 128	6	10	2 370	91 52 782 08	MONTAGEWINDE
SECHSKANTSCHRAUBE ISO 4	49 00 128	350	10	2 391 001	96 45 719 08	DIESELMOTOR VORM.
SECHSKANTSCHRAUBE ISO 4	49 00 128	22	2	2 391 040	96 53 645 08	KUPPLUNGSSTELLER
SECHSKANTSCHRAUBE ISO 4	49 00 128	10	8	2 391 102	96 56 360 08	ZUSATZKUEHLER VORM.
SECHSKANTSCHRAUBE ISO 4	49 00 128	21	8	2 393	91 52 787 08	LUFTFILTERANLAGE KPL.
SECHSKANTSCHRAUBE ISO 4	49 00 128	19	2	2 550	91 57 751 08	SA-BOCK
SECHSKANTSCHRAUBE ISO 4	49 00 128	35	4	2 711	91 52 800 08	ZENTRALSCHMIERANLAGE O
SECHSKANTSCHRAUBE ISO 4	49 00 128	4	20	2 810 037	96 47 204 08	PEDALTRAEGER EINBAU
SECHSKANTSCHRAUBE ISO 4	49 00 128	60	5	2 859	91 52 809 08	GERAEUSCHDAEMMUNG
SECHSKANTSCHRAUBE ISO 4	49 00 128	15	4	2 925 402	96 58 855 08	KAMERAANBAU DREHBUEHN
SECHSKANTSCHRAUBE ISO 4	49 00 128	8	2	2 932 166	92 68 911 08	VERTEILER MASSE
SECHSKANTSCHRAUBE ISO 4	49 00 128	51	2	3 208 001	91 52 883 08	F-KOPFSTUECK
SECHSKANTSCHRAUBE ISO 4	49 00 128	53	8	3 211	91 57 748 08	S-ANLENKSTUECK
SECHSKANTSCHRAUBE ISO 4	49 00 128	16	2	3 213	91 52 842 08	F-ANSCHLUSSKOPF
SECHSKANTSCHRAUBE ISO 4	49 00 128	21	2	3 214	91 52 843 08	SW-KOPFSTUECK
SECHSKANTSCHRAUBE ISO 4	49 00 128	60	2	3 281	91 52 896 08	FA-BOCK

6.2.2009

etk_en_de_074515 LR 1600/2

1103

LIEBHERRAlphabetical index
Alphabetischer Index

Bezeichnung	Artikel	Pos.	Menge	Seite	Baugruppe	Bezeichnung
SECHSKANTSCHRAUBE ISO 4	49 00 128	3	8	3 291	91 52 831 08	S-RUECKHALTESICHERUNG
SECHSKANTSCHRAUBE ISO 4	49 00 128	8	8	3 292	91 52 865 08	D-RUECKHALTESICHERUNG
SECHSKANTSCHRAUBE ISO 4	49 00 128	111	4	3 713	91 57 749 08	D-ANLENKSTUECK
SECHSKANTSCHRAUBE ISO 4	49 00 128	76	4	3 714	91 52 862 08	D-KOPFSTUECK
SECHSKANTSCHRAUBE ISO 4	49 00 128	28	8	3 745	91 52 948 08	SCHWEBEBALLAST
SECHSKANTSCHRAUBE ISO 4	49 00 128	13	4	X1035519	10 35 519 6	OEL-LUFTKUEHLER
SECHSKANTSCHRAUBE ISO 4	49 00 111	9	4	2 391 038	96 47 931 08	OELKUEHLER VORM.
SECHSKANTSCHRAUBE ISO 4	49 00 111	13	2	2 522 013	96 45 883 08	FUEHRUNG VORM.
SECHSKANTSCHRAUBE ISO 4	49 00 111	68	4	2 859	91 52 809 08	GERAEUSCHDAEMMUNG
SECHSKANTSCHRAUBE ISO 4	49 00 111	42	8	3 745	91 52 948 08	SCHWEBEBALLAST
SECHSKANTSCHRAUBE ISO 4	49 00 111	4	4	5 106 691	51 06 691 08	RUECKLAUFFILTER
SECHSKANTSCHRAUBE ISO 4	49 00 614	30	4	2 831	91 57 754 08	KLIMAAANLAGE OW
SECHSKANTSCHRAUBE ISO 4	49 00 614	4	10	2 859 025	96 46 757 08	GITTERROST VORM.
SECHSKANTSCHRAUBE ISO 4	40 01 667	15	4	X1035519	10 35 519 6	OEL-LUFTKUEHLER
SECHSKANTSCHRAUBE ISO 4	46 00 386	354	4	2 391 001	96 45 719 08	DIESELMOTOR VORM.
SECHSKANTSCHRAUBE ISO 4	46 00 386	46	6	3 214	91 52 843 08	SW-KOPFSTUECK
SECHSKANTSCHRAUBE M10X	10 34 225 4	3	1	9 739 351	97 39 351	KUEHLMITTELEITUNG ANBA
SECHSKANTSCHRAUBE M10X	10 34 225 9	4	1	9 739 351	97 39 351	KUEHLMITTELEITUNG ANBA
SECHSKANTSCHRAUBE M12	10 34 318 3	18	1	9 739 344	97 39 344	GENERATOR VORM.
SECHSKANTSCHRAUBE M16	10 03 719 1	5	1	9 739 210	97 39 210	KUEHLMITTELEITUNG
SECHSKANTSCHRAUBE M16X	10 34 318 6	5	8	9 739 341	97 39 341	ANTRIEBSTEILE M.SCHWINGU
SECHSKANTSCHRAUBE M6X	10 01 135 8	4	2	9 739 140	97 39 140	FLAMMSTARTANLAGE
SECHSKANTSCHRAUBE M6X1	10 34 225 7	7	1	9 739 356	97 39 356	ROHRLEITUNG ANBAU
SECHSKANTSCHRAUBE M8X	10 44 335 2	33	1	9 739 492	97 39 492	ROHRLEITUNG ANBAU
SECHSKANTSCHRAUBE M8X2	10 03 730 4	19	8	9 739 361	97 39 361	OELWANNE
SECHSKANTSCHRAUBE M8X2	10 03 730 4	24	2	9 739 371	97 39 371	KLIMAKOMPRESSOR ANBAU
SECHSKANTSCHRAUBE M8X2	10 03 730 4	23	2	9 739 494	97 39 494	ATL-ANBAU
SECHSKANTSCHRAUBE M8X	10 44 336 5	31	1	9 739 492	97 39 492	ROHRLEITUNG ANBAU
SECHSKANTSCHRAUBE M8X4	10 01 250 7	4	12	9 739 267	97 39 267	ZYLINDERKOPFHAUBE
SECHSKANTSCHRAUBE M8X	10 44 335 6	24	1	9 739 492	97 39 492	ROHRLEITUNG ANBAU
SECHSKANTSCHRAUBE M8X8	10 22 272 9	5	4	9 739 256	97 39 256	LUFTANSAUGROHR
SECHSKANTSCHRAUBE MIT	10 47 688 8	3	1	9 739 491	97 39 491	LUFTPRESSER ANBAU
SECHSKANTSCHRAUBE MIT F	10 34 226 7	4	19	9 739 362	97 39 362	OELWANNE
SECHSKANTSCHRAUBE MIT F	10 34 226 8	5	1	9 739 362	97 39 362	OELWANNE
SECHSRUNDSCHRAUBE M8X	10 34 226 9	3	9	9 739 352	97 39 352	WASSERPUMPE MIT BEFEST.
SEIL 28MM 1050M -40°C SPF	10 41 082 0	1	1	2 311	91 52 834 08	SEIL F.WINDE 1
SEIL 28MM 1050M -40°C SPF	10 41 082 0	1	1	2 312	91 52 835 08	SEIL F.WINDE 2
SEIL 28MM 1200M -40°C SPF	10 41 082 4	1	1	2 313	91 52 836 08	SEIL F.WINDE 3
SEIL 28MM 700M -40°C SPF	10 41 082 9	1	1	2 314	91 52 837 08	SEIL F.WINDE 4
SEIL 28X7000	97 93 904 08	23	1	3 281	91 52 896 08	FA-BOCK
SEIL 34MM 1.525M	97 75 537 08	1	2	3 832	91 55 536 08	ZUSATZABSPANNUNG
SEIL 34MM 2.525M	97 75 541 08	1	2	3 832 001	91 55 537 08	ZUSATZABSPANNUNG
SEIL 34MM 3.525M	97 75 548 08	1	2	3 834	91 55 538 08	ZUSATZABSPANNUNG
SEIL 34MM 4.525M	97 74 938 08	1	2	3 835 000	91 55 539 08	ZUSATZABSPANNUNG
SEIL 34MM 5.525M	97 74 939 08	1	2	3 836 000	91 55 540 08	ZUSATZABSPANNUNG
SEIL 34MM 6.525M	97 74 940 08	1	2	3 837	91 55 541 08	ZUSATZABSPANNUNG
SEIL 34MM 7.525M	97 74 941 08	1	2	3 838 000	91 55 542 08	ZUSATZABSPANNUNG
SEIL 4X2416	97 73 190 08	32	1	3 206	91 52 881 08	F-ANLENKSTUECK
SEIL 5x750	97 06 965 08	27	2	3 215 005	91 52 846 08	ROLLENSATZ
SEIL 5x750	97 06 965 08	27	2	3 215 006	91 52 847 08	ROLLENSATZ
SEIL 8MM 400M	10 03 825 9	1	1	2 372	91 33 648 08	SEIL MONTAGEWINDE M.ZUB
SEIL DIN 3055 2MM 2,3KN FE	77 34 003 08	64	3	2 631	91 56 817 08	LAUFSTEG DREHBUEHNE
SEIL DIN 3055 2MM 2,3KN FE	77 34 003 08	79	1	2 810	91 52 806 08	KRANFUEHRERKABINE KPL.
SEIL DIN 3055 2MM 2,3KN FE	77 34 003 08	61	2	2 978 100	91 52 827 08	ZUSATZHYDR.D-RUECKHALT
SEIL DIN 3055 2MM 2,3KN FE	77 34 003 08	55	1	3 225	91 52 854 08	SL-REDUZIERSTUECK
SEIL DIN 3055 2MM 2,3KN FE	77 34 003 08	62	1.5	3 745	91 52 948 08	SCHWEBEBALLAST
SEIL DIN 3055 2MM 2,3KN FE	77 34 003 08	61	2	3 978 005	91 56 430 08	ZUSATZHYDRAULIK SB-KOPFS
SEIL DIN 3055 4MM 1,3M VERZI	10 45 067 1	23	4	1 630	91 52 387 08	HYDRAULISCHE ABSTUETZUN
SEIL F.WINDE 1	91 52 834 08	190	1		LR 1600-2-0	LIEBHERR RAUPENKRAN LR 1
SEIL F.WINDE 2	91 52 835 08	191	1		LR 1600-2-0	LIEBHERR RAUPENKRAN LR 1

6.2.2009

etk_en_de_074515 LR 1600/2

1104

LIEBHERRAlphabetical index
Alphabetischer Index

Bezeichnung	Artikel	Pos.	Menge	Seite	Baugruppe	Bezeichnung
SEIL F.WINDE 3	91 52 836 08	192	1		LR 1600-2-0	LIEBHERR RAUPENKRAN LR 1
SEIL F.WINDE 4	91 52 837 08	193	1		LR 1600-2-0	LIEBHERR RAUPENKRAN LR 1
SEIL MONTAGEWINDE M.ZUB	91 33 648 08	198	1		LR 1600-2-0	LIEBHERR RAUPENKRAN LR 1
SEILKLEMME 24-26 GR.1"	77 39 091 08	37	1	1 750	91 52 394 08	WERKZEUG
SEILKLEMME DIN 1142 S26 V	77 39 118 08	38	1	1 750	91 52 394 08	WERKZEUG
SEILKLEMME DIN 1142 S30 V	77 39 132 08	45	1	1 750	91 52 394 08	WERKZEUG
SEILROLLE D=700/620/270X75	28 81 999 08	1	1	2 652 007	92 68 928 08	SEILROLLE KPL.
SEILROLLE KPL.	96 20 920 08	17	2	3 206	91 52 881 08	F-ANLENKSTUECK
SEILROLLE KPL.	96 20 920 08	57	1	3 281	91 52 896 08	FA-BOCK
SEILROLLE KPL. SPF	92 68 928 08	6	4	3 208 001	91 52 883 08	F-KOPFSTUECK
SEILROLLE KPL. SPF	92 68 928 08	2	10	3 215 005	91 52 846 08	ROLLENSATZ
SEILROLLE KPL. SPF	92 68 928 08	2	12	3 215 006	91 52 847 08	ROLLENSATZ
SEILROLLE KPL. SPF	92 68 928 08	2	1	3 281	91 52 896 08	FA-BOCK
SEILROLLE KPL. SPF	92 68 928 08	3	2	3 713	91 57 749 08	D-ANLENKSTUECK
SEILROLLE KPL. SPF	96 46 246 08	3	17	2 550	91 57 751 08	SA-BOCK
SEILROLLE KPL. SPF	96 46 246 08	4	16	2 652	91 52 794 08	ROLLENLAGERUNG
SEILROLLE KPL. SPF	96 46 246 08	5	4	3 214	91 52 843 08	SW-KOPFSTUECK
SEILROLLE KPL. SPF	96 46 246 08	2	2	3 225 100	96 48 582 08	LAGERUNG KPL.
SEILROLLE KPL. SPF	96 46 246 08	10	3	3 714	91 52 862 08	D-KOPFSTUECK
SEILROLLE KPL. SPF	96 46 246 08	2	7	3 714 008	96 49 266 08	VERSTELLFLASCHE KPL.
SEILROLLE KPL. SPF	96 46 246 08	5	8	3 714 009	96 49 267 08	VERSTELLFLASCHE KPL.
SEILROLLE KPL. SPF	96 46 246 08	2	1	3 714 021	96 49 271 08	ROLLENLAGERUNG KPL.
SEILROLLE SPF	97 18 725 08	1	1	3 206 001	96 20 920 08	SEILROLLE KPL.
SEILROLLENHALTERUNG SCH	96 52 291 08	55	1	3 281	91 52 896 08	FA-BOCK
SEILSCHLOSS 28 SPF	77 39 401 08	44	1	1 750	91 52 394 08	WERKZEUG
SEILSCHUTZ SCHWK.	96 47 103 08	41	1	2 550	91 57 751 08	SA-BOCK
SEILSCHUTZ SCHWK.	96 51 812 08	27	2	2 652	91 52 794 08	ROLLENLAGERUNG
SEILSCHUTZ SCHWK.	96 51 813 08	28	1	2 652	91 52 794 08	ROLLENLAGERUNG
SEILSCHUTZ SCHWK.	96 56 155 08	94	2	2 550	91 57 751 08	SA-BOCK
SEILSCHUTZ SCHWK.	96 56 165 08	95	2	2 550	91 57 751 08	SA-BOCK
SEILSCHUTZ SCHWK.	96 56 171 08	96	1	2 550	91 57 751 08	SA-BOCK
SEILSCHUTZ SCHWK.	96 58 269 08	20	1	3 714 009	96 49 267 08	VERSTELLFLASCHE KPL.
SEILTROMMEL	10 65 015 6	21	1	X1035411	10 35 411 4	HUBWINDE
SEILWINDE	54 00 018 08	7	4	1 630	91 52 387 08	HYDRAULISCHE ABSTUETZUN
SEILWINDE	54 00 569 08	5	1	3 208 001	91 52 883 08	F-KOPFSTUECK
SEILWINDE ZHP 4.13 SPF	54 00 565 08	1	1	2 370	91 52 782 08	MONTAGEWINDE
SEILWINDE ZHP 4.29 SPF	10 35 433 2	1	1	2 340	91 52 776 08	WINDE 4 EINZIEHWERK
SEITENSCHIEBE LI. 4X603.5X8	97 68 379 08	5	1	2 520	91 53 061 08	KABINE VERGLAST
SEITENSCHIEBE RE. 4X1063X	97 68 378 08	4	1	2 520	91 53 061 08	KABINE VERGLAST
SEITENSCHIEBE SCHWK. LINK	96 44 562 08	3	1	2 340	91 52 776 08	WINDE 4 EINZIEHWERK
SEITENSCHIEBE SCHWK.RE.	96 44 563 08	4	1	2 340	91 52 776 08	WINDE 4 EINZIEHWERK
SENKBREMSVENTIL 420BAR 1	10 46 565 9	12	1	3 978 019	91 56 431 08	ZUSATZHYDRAULIK ZYLINDER
SENKBREMSVENTIL 420BAR	10 21 769 5	2	1	2 978 100	91 52 796 08	ZUSATZHYDR.MONTAGEEINR
SENKSCHRAUBE DIN 7991 M	40 86 013 08	98	9	2 550	91 57 751 08	SA-BOCK
SENKSCHRAUBE DIN 7991 M	40 86 062 08	346	2	2 391 001	96 45 719 08	DIESELMOTOR VORM.
SENKSCHRAUBE DIN 7991 M	40 86 027 08	54	2	3 745	91 52 948 08	SCHWEBEBALLAST
SENKSCHRAUBE DIN 7991 M5	40 86 035 08	33	4	2 502	91 55 939 08	STEUERSTAND
SENKSCHRAUBE DIN 7991 M5	40 86 035 08	30	2	2 520	91 53 061 08	KABINE VERGLAST
SENKSCHRAUBE DIN 7991 M5	40 86 035 08	34	2	2 533 070	96 48 363 08	ARMATUREN RE.
SENKSCHRAUBE DIN 7991 M	40 86 042 08	41	4	2 391 040	96 53 645 08	KUPPLUNGSSTELLER
SENKSCHRAUBE DIN 7991 M	40 86 040 08	57	2	2 631	91 56 817 08	LAUFSTEG DREHBUEHNE
SENKSCHRAUBE DIN 7991 M	40 86 040 08	4	1	2 780 851	96 24 498 08	FUNKANTENNE VORM.
SENKSCHRAUBE DIN 7991 M	40 86 040 08	8	1	2 780 852	96 24 845 08	GSM-MODUL VORM.LICCON 1
SENKSCHRAUBE DIN 7991 M6	40 86 002 08	5	8	2 510	91 52 788 08	DREHBUEHNENVERKLEIDUN
SENKSCHRAUBE DIN 7991 M6	40 86 002 08	4	4	2 510 040	96 49 183 08	TUER VORM.
SENKSCHRAUBE DIN 7991 M6	40 86 002 08	4	4	2 510 059	96 49 184 08	TUER VORM.
SENKSCHRAUBE DIN 7991 M6	40 86 002 08	25	4	2 522 011	96 45 602 08	SCHLIESSANLAGE
SENKSCHRAUBE DIN 7991 M6	40 86 002 08	10	16	2 932 160	96 54 385 08	SCHALTSCHRANK MECH.
SENKSCHRAUBE DIN 7991 M6	40 86 002 08	115	8	2 970	91 56 537 08	HYDRAULIK
SENKSCHRAUBE DIN 7991 M6	40 86 002 08	5	11	3 713 013	96 57 159 08	BLECH KPL.

6.2.2009

etk_en_de_074515 LR 1600/2

1105

LIEBHERRAlphabetical index
Alphabetischer Index

Bezeichnung	Artikel	Pos.	Menge	Seite	Baugruppe	Bezeichnung
SENKSCHEIBE DIN 7991 M6	40 86 002 08	21	3	3 978 015	91 56 429 08	ZUSATZHYDRAULIK ZWISCH
SENKSCHEIBE DIN 7991 M6	40 86 002 08	21	3	3 978 015	91 56 432 08	ZUSATZHYDRAULIK ZWISCH
SENKSCHEIBE DIN 7991 M6	40 86 041 08	45	4	2 502	91 55 939 08	STEUERSTAND
SENKSCHEIBE DIN 7991 M6	40 86 041 08	29	10	2 520	91 53 061 08	KABINE VERGLAST
SENKSCHEIBE DIN 7991 M6	40 86 041 08	8	6	2 520 030	96 45 609 08	DACHSCHEIBE VORM.
SENKSCHEIBE DIN 7991 M6	40 86 041 08	5	4	2 520 031	96 45 610 08	HECKSCHEIBE VORM.
SENKSCHEIBE DIN 7991 M	40 86 036 08	25	1	2 522	91 54 115 08	SCHIEBETUER KPL.
SENKSCHEIBE DIN 7991 M8	40 86 043 08	11	4	3 211 009	96 46 979 08	SCHUTZWALZE KPL.
SENKSCHEIBE DIN 7991 M8	40 86 005 08	51	8	3 211	91 57 748 08	S-ANLENKSTUECK
SENKSCHEIBE DIN 7991 M8	40 86 005 08	32	16	3 713	91 57 749 08	D-ANLENKSTUECK
SENKSCHEIBE DIN 7991 M8	40 86 007 08	41	3	3 206	91 52 881 08	F-ANLENKSTUECK
SENKSCHEIBE DIN 7991 M8	40 86 007 08	3	4	3 714 017	96 50 752 08	AUFLAGE KPL.
SENKSCHEIBE DIN 7991 M8	40 86 008 08	53	2	2 550	91 57 751 08	SA-BOCK
SENKSCHEIBE DIN 7991 M8	40 86 010 08	20	4	2 502	91 55 939 08	STEUERSTAND
SENKSCHEIBE DIN 7991 M8	40 86 049 08	20	4	2 370	91 52 782 08	MONTAGEWINDE
SENKSCHEIBE DIN 7991 M8	40 86 049 08	65	12	2 810	91 52 806 08	KRANFUEHRERKABINE KPL.
SENKSCHEIBE DIN 963 M5X	40 04 016 08	17	8	2 260 006	96 46 501 08	BATTERIEKASTEN VORM.
SENKSCHEIBE DIN 963 M8	40 70 317 08	81	2	2 550	91 57 751 08	SA-BOCK
SENKSCHEIBE DIN 964 M5X	40 06 034 08	21	6	2 671 004	96 46 305 08	OELBEHAELTER VORM.
SENKSCHEIBE DIN 964 M5X	40 06 035 08	268	2	2 920 638	96 51 138 08	BEDIENPULT
SENKSCHEIBE ISO 7046-1	40 70 608 08	4	8	2 913 102	92 32 870 08	LUEFTEREINHEIT
SENSOR	10 22 021 8	(1)	1	9 739 318	97 39 318	SENSORIK
SENSORIK	97 39 318	231	1	X1012059	10 12 059 0	DIESELMOTOR
SICHELBLECH SCHWK.	96 54 011 08	21	1	3 350	91 52 859 08	WINDE 3
SICHELBLECH SCHWK.	96 54 012 08	20	1	3 350	91 52 859 08	WINDE 3
SICHERHEITSKLAPPSTECKER	43 32 005 08	19	1	2 550 005	96 45 680 08	STANGE KPL.
SICHERHEITSKLAPPSTECKER	43 32 005 08	10	2	2 657	91 57 656 08	MONTAGEEINRICHTUNG RA
SICHERHEITSKLAPPSTECKER	43 32 005 08	17	4	3 211	91 57 748 08	S-ANLENKSTUECK
SICHERHEITSKLAPPSTECKER	43 32 005 08	7	1	3 211 003	96 46 986 08	STANGE KPL.
SICHERHEITSKLAPPSTECKER	43 32 005 08	8	1	3 220 501	96 43 440 08	STANGE KPL.
SICHERHEITSKLAPPSTECKER	43 32 005 08	8	1	3 221 200	96 47 984 08	STANGE KPL.
SICHERHEITSKLAPPSTECKER	43 32 005 08	20	3	3 225	91 52 854 08	SL-REDUZIERSTUECK
SICHERHEITSKLAPPSTECKER	43 32 005 08	8	1	3 225 200	96 48 679 08	STANGE KPL.
SICHERHEITSKLAPPSTECKER	43 32 005 08	8	1	3 227 002	96 50 498 08	STANGE KPL.
SICHERHEITSKLAPPSTECKER	43 32 005 08	8	1	3 561 003	96 45 222 08	STANGE KPL.
SICHERHEITSKLAPPSTECKER	43 32 005 08	88	4	3 713	91 57 749 08	D-ANLENKSTUECK
SICHERHEITSKLAPPSTECKER	43 32 005 08	8	1	3 713 012	96 50 197 08	STANGE KPL.
SICHERHEITSKLAPPSTECKER	43 32 005 08	11	2	3 714 009	96 49 267 08	VERSTELLFLASCHE KPL.
SICHERHEITSKLAPPSTECKER	43 32 005 08	4	2	3 714 013	96 59 083 08	LASCHE KPL.
SICHERHEITSKLAPPSTECKER	43 32 005 08	8	1	3 716 001	96 49 159 08	STANGE KPL.
SICHERHEITSKLAPPSTECKER	43 32 005 08	5	8	3 747	91 52 950 08	ZENTRIERUNG STANDARD
SICHERHEITSKLAPPSTECKER	43 32 005 08	9	2	3 830	91 55 535 08	ZUSATZABSPANNUNG
SICHERHEITSKLAPPSTECKER	43 32 015 08	4	2	3 213	91 52 842 08	F-ANSCHLUSSKOPF
SICHERHEITSKLAPPSTECKER	43 32 015 08	25	2	3 214	91 52 843 08	SW-KOPFSTUECK
SICHERHEITSKLAPPSTECKER	43 32 015 08	15	4	3 215 005	91 52 846 08	ROLLENSATZ
SICHERHEITSKLAPPSTECKER	43 32 015 08	15	4	3 215 006	91 52 847 08	ROLLENSATZ
SICHERHEITSKLAPPSTECKER	43 32 015 08	9	2	3 225	91 52 854 08	SL-REDUZIERSTUECK
SICHERHEITSKLAPPSTECKER	43 32 015 08	3	4	3 226	91 52 870 08	LI-ZWISCHENSTUECK
SICHERHEITSKLAPPSTECKER	43 32 015 08	3	4	3 227	91 52 873 08	LI-ZWISCHENSTUECK
SICHERHEITSKLAPPSTECKER	43 32 015 08	3	4	3 227 008	91 52 872 08	LI-ZWISCHENSTUECK
SICHERHEITSKLAPPSTECKER	43 32 015 08	3	4	3 227 200	91 53 519 08	LI-ZWISCHENSTUECK F-ABSP
SICHERHEITSKLAPPSTECKER	43 32 015 08	13	2	3 713	91 57 749 08	D-ANLENKSTUECK
SICHERHEITSKLAPPSTECKER	43 32 015 08	25	2	3 714	91 52 862 08	D-KOPFSTUECK
SICHERHEITSKLAPPSTECKER	43 32 015 08	16	4	3 715 008	91 52 863 08	D-ZWISCHENSTUECK
SICHERHEITSKLAPPSTECKER	43 32 015 08	16	4	3 716	91 52 864 08	D-ZWISCHENSTUECK
SICHERHEITSKLAPPSTECKER	10 41 062 2	5	2	3 211	91 57 748 08	S-ANLENKSTUECK
SICHERHEITSKLAPPSTECKER	10 41 062 2	3	4	3 220 500	91 52 849 08	S-ZWISCHENSTUECK
SICHERHEITSKLAPPSTECKER	10 41 062 2	3	4	3 221	91 54 668 08	S-ZWISCHENSTUECK
SICHERHEITSKLAPPSTECKER	10 41 062 2	3	4	3 223	91 52 852 08	S-ZWISCHENSTUECK
SICHERHEITSKLAPPSTECKER	10 41 062 2	3	4	3 223 010	91 52 853 08	S-ZWISCHENSTUECK

6.2.2009

etk_en_de_074515 LR 1600/2

1106

LIEBHERRAlphabetical index
Alphabetischer Index

Bezeichnung	Artikel	Pos.	Menge	Seite	Baugruppe	Bezeichnung
SICHERHEITSKLAPPSTECKER	10 41 062 2	3	4	3 223 100	91 55 327 08	S-ZWISCHENSTUECK
SICHERHEITSKLAPPSTECKER	10 41 062 2	8	2	3 225	91 52 854 08	SL-REDUZIERSTUECK
SICHERHEITSKLAPPSTECKER	43 32 013 08	18	8	3 227 002	96 50 498 08	STANGE KPL.
SICHERHEITSKLAPPSTECKER	43 32 014 08	17	4	3 214	91 52 843 08	SW-KOPFSTUECK
SICHERHEITSKLAPPSTECKER	43 32 014 08	6	1	3 225 100	96 48 582 08	LAGERUNG KPL.
SICHERHEITSKLAPPSTECKER	43 32 014 08	97	2	3 714	91 52 862 08	D-KOPFSTUECK
SICHERHEITSKLAPPSTECKER	43 32 014 08	14	4	3 714 009	96 49 267 08	VERSTELLFLASCHE KPL.
SICHERHEITSKLAPPSTECKER	43 32 004 08	3	4	1 742	91 53 021 08	ZENTRALBALLASTBEFESTIG
SICHERHEITSKLAPPSTECKER	43 32 004 08	18	4	2 631	91 56 817 08	LAUFSTEG DREHBUEHNE
SICHERHEITSKLAPPSTECKER	43 32 004 08	10	1	3 207 003	96 48 259 08	STANGE KPL.
SICHERHEITSKLAPPSTECKER	43 32 004 08	7	2	3 207 100	96 48 261 08	LASCHE KPL.
SICHERHEITSVENTIL 17BAR	10 01 248 1	11	1	9 739 491	97 39 491	LUFTPRESSER ANBAU
SICHERUNGSBLECH	57 00 100 08	20	1	5 026 126	50 26 126 08	MAGNETVENTIL
SICHERUNGSBLECH 5X522X26	97 73 267 08	6	1	3 282 002	96 47 890 08	FAB-STUETZE
SICHERUNGSBUEGEL S16 A3	10 01 751 3	10	1	9 739 186	97 39 186	MOTORBREMSE
SICHERUNGSDOSE 6POL 24V	60 45 016 08	16	1	2 920 083	96 48 319 08	ELEKTRIK BATTERIEKASTEN
SICHERUNGSDOSE 6POL 24V	60 45 016 08	69	16	2 932 082	96 54 387 08	AUFBAUTEILE MONTAGETAPE
SICHERUNGSDOSE 6POL 24V	60 45 016 08	33	2	2 932 160	96 54 385 08	SCHALTSCHRANK MECH.
SICHERUNGSFEDER 3 VERZ	43 31 028 08	19	8	1 630	91 52 387 08	HYDRAULISCHE ABSTUETZUN
SICHERUNGSFEDER 3 VERZ	43 31 028 08	64	2	2 550	91 57 751 08	SA-BOCK
SICHERUNGSFEDER 3 VERZ	43 31 028 08	38	1	2 810	91 52 806 08	KRANFUEHRERKABINE KPL.
SICHERUNGSFEDER 3 VERZ	43 31 028 08	44	14	3 211	91 57 748 08	S-ANLENKSTUECK
SICHERUNGSFEDER 3 VERZ	43 31 028 08	46	4	3 220 500	91 52 849 08	S-ZWISCHENSTUECK
SICHERUNGSFEDER 3 VERZ	43 31 028 08	46	4	3 223	91 52 852 08	S-ZWISCHENSTUECK
SICHERUNGSFEDER 3 VERZ	43 31 028 08	46	4	3 223 010	91 52 853 08	S-ZWISCHENSTUECK
SICHERUNGSFEDER 3 VERZ	43 31 028 08	46	4	3 223 100	91 55 327 08	S-ZWISCHENSTUECK
SICHERUNGSFEDER 3 VERZ	43 31 028 08	46	4	3 226	91 52 870 08	LI-ZWISCHENSTUECK
SICHERUNGSFEDER 3 VERZ	43 31 028 08	46	4	3 227	91 52 873 08	LI-ZWISCHENSTUECK
SICHERUNGSFEDER 3 VERZ	43 31 028 08	46	4	3 227 008	91 52 872 08	LI-ZWISCHENSTUECK
SICHERUNGSFEDER 3 VERZ	43 31 028 08	46	8	3 227 200	91 53 519 08	LI-ZWISCHENSTUECK F-ABSP
SICHERUNGSFEDER 3 VERZ	43 31 028 08	157	2	3 713	91 57 749 08	D-ANLENKSTUECK
SICHERUNGSFEDER 3 VERZ	43 31 028 08	35	8	3 715 008	91 52 863 08	D-ZWISCHENSTUECK
SICHERUNGSFEDER 3 VERZ	43 31 028 08	37	8	3 716	91 52 864 08	D-ZWISCHENSTUECK
SICHERUNGSFEDER 4,5 VERZ	43 31 009 08	13	4	1 630	91 52 387 08	HYDRAULISCHE ABSTUETZUN
SICHERUNGSFEDER 4,5 VERZ	43 31 009 08	9	8	2 550	91 57 751 08	SA-BOCK
SICHERUNGSFEDER 4,5 VERZ	43 31 009 08	3	1	2 550 011	96 47 007 08	KONSOLE KPL.
SICHERUNGSFEDER 4,5 VERZ	43 31 009 08	52	2	3 206	91 52 881 08	F-ANLENKSTUECK
SICHERUNGSFEDER 4,5 VERZ	43 31 009 08	22	2	3 211	91 57 748 08	S-ANLENKSTUECK
SICHERUNGSFEDER 4,5 VERZ	43 31 009 08	13	1	3 211 003	96 46 986 08	STANGE KPL.
SICHERUNGSFEDER 4,5 VERZ	43 31 009 08	21	8	3 220 500	91 52 849 08	S-ZWISCHENSTUECK
SICHERUNGSFEDER 4,5 VERZ	43 31 009 08	10	8	3 221	91 54 668 08	S-ZWISCHENSTUECK
SICHERUNGSFEDER 4,5 VERZ	43 31 009 08	21	8	3 223	91 52 852 08	S-ZWISCHENSTUECK
SICHERUNGSFEDER 4,5 VERZ	43 31 009 08	21	8	3 223 010	91 52 853 08	S-ZWISCHENSTUECK
SICHERUNGSFEDER 4,5 VERZ	43 31 009 08	21	8	3 223 100	91 55 327 08	S-ZWISCHENSTUECK
SICHERUNGSFEDER 4,5 VERZ	43 31 009 08	18	4	3 225	91 52 854 08	SL-REDUZIERSTUECK
SICHERUNGSFEDER 4,5 VERZ	43 31 009 08	21	4	3 226	91 52 870 08	LI-ZWISCHENSTUECK
SICHERUNGSFEDER 4,5 VERZ	43 31 009 08	21	4	3 227	91 52 873 08	LI-ZWISCHENSTUECK
SICHERUNGSFEDER 4,5 VERZ	43 31 009 08	17	2	3 227 002	96 50 498 08	STANGE KPL.
SICHERUNGSFEDER 4,5 VERZ	43 31 009 08	21	4	3 227 008	91 52 872 08	LI-ZWISCHENSTUECK
SICHERUNGSFEDER 4,5 VERZ	43 31 009 08	21	10	3 227 200	91 53 519 08	LI-ZWISCHENSTUECK F-ABSP
SICHERUNGSFEDER 4,5 VERZ	43 31 009 08	55	12	3 713	91 57 749 08	D-ANLENKSTUECK
SICHERUNGSFEDER 4,5 VERZ	43 31 009 08	31	8	3 714	91 52 862 08	D-KOPFSTUECK
SICHERUNGSFEDER 4,5 VERZ	43 31 009 08	16	3	3 714 008	96 49 266 08	VERSTELLFLASCHE KPL.
SICHERUNGSFEDER 4,5 VERZ	43 31 009 08	9	6	3 714 009	96 49 267 08	VERSTELLFLASCHE KPL.
SICHERUNGSFEDER 4,5 VERZ	43 31 009 08	5	2	3 714 021	96 49 271 08	ROLLENLAGERUNG KPL.
SICHERUNGSFEDER 4,5 VERZ	43 31 009 08	15	16	3 715 008	91 52 863 08	D-ZWISCHENSTUECK
SICHERUNGSFEDER 4,5 VERZ	43 31 009 08	15	22	3 716	91 52 864 08	D-ZWISCHENSTUECK
SICHERUNGSFEDER 4,5 VERZ	43 31 009 08	59	1	3 745	91 52 948 08	SCHWEBEBALLAST
SICHERUNGSFEDER 4X68 V	43 31 012 08	60	12	1 400	91 56 853 08	RAUPENTRAEGER KPL.LI.
SICHERUNGSFEDER 4X68 V	43 31 012 08	60	12	1 410 300	91 56 855 08	RAUPENTRAEGER KPL.RE.

6.2.2009

etk_en_de_074515 LR 1600/2

1107

LIEBHERRAlphabetical index
Alphabetischer Index

Bezeichnung	Artikel	Pos.	Menge	Seite	Baugruppe	Bezeichnung
SICHERUNGSFEDER 4X68 V	43 31 012 08	10	4	1 632	91 52 389 08	MECH.ZUSATZABSTUETZUNG
SICHERUNGSFEDER 4X68 V	43 31 012 08	9	1	1 991	91 52 510 08	DREHDURCHFUEHRUNG
SICHERUNGSFEDER 4X68 V	43 31 012 08	21	1	3 206	91 52 881 08	F-ANLENKSTUECK
SICHERUNGSFEDER 4X68 V	43 31 012 08	37	3	3 281	91 52 896 08	FA-BOCK
SICHERUNGSFEDER 4X68 V	43 31 012 08	8	1	3 282 002	96 47 890 08	FAB-STUETZE
SICHERUNGSFEDER 4X68 V	43 31 012 08	107	2	3 713	91 57 749 08	D-ANLENKSTUECK
SICHERUNGSFEDER 5 VERZ	43 31 025 08	3	4	2 391	91 52 784 08	DIESELMOTOR KPL.
SICHERUNGSFEDER 5 VERZ	43 31 025 08	39	1	3 208 001	91 52 883 08	F-KOPFSTUECK
SICHERUNGSFEDER 5 VERZ	43 31 025 08	61	6	3 211	91 57 748 08	S-ANLENKSTUECK
SICHERUNGSFEDER 5 VERZ	43 31 025 08	33	1	3 214	91 52 843 08	SW-KOPFSTUECK
SICHERUNGSFEDER 5 VERZ	43 31 025 08	81	8	3 713	91 57 749 08	D-ANLENKSTUECK
SICHERUNGSFEDER 5 VERZ	43 31 025 08	20	1	3 714	91 52 862 08	D-KOPFSTUECK
SICHERUNGSFEDER 5 VERZ	43 31 025 08	18	2	3 714 008	96 49 266 08	VERSTELLFLASCHE KPL.
SICHERUNGSFEDER 5 VERZ	43 31 025 08	12	4	3 830	91 55 535 08	ZUSATZABSPANNUNG
SICHERUNGSFEDER 6 A3C	43 31 050 08	11	4	1 632	91 52 389 08	MECH.ZUSATZABSTUETZUNG
SICHERUNGSFEDER 6 A3C	43 31 050 08	8	8	3 205	91 52 880 08	F-MONTAGEEINHEIT
SICHERUNGSFEDER 6 A3C	43 31 050 08	15	9	3 206	91 52 881 08	F-ANLENKSTUECK
SICHERUNGSFEDER 6 A3C	43 31 050 08	7	2	3 207 101	96 48 292 08	LASCHE KPL.
SICHERUNGSFEDER 6 A3C	43 31 050 08	14	3	3 281	91 52 896 08	FA-BOCK
SICHERUNGSFEDER 6 A3C	43 31 050 08	11	1	3 282 002	96 47 890 08	FAB-STUETZE
SICHERUNGSFEDER 6 A3C	43 31 050 08	21	4	3 745	91 52 948 08	SCHWEBEBALLAST
SICHERUNGSFEDER 8 VERZ.	43 31 052 08	5	4	2 790 455	91 57 005 08	TRANSPORTABLAGE
SICHERUNGSFEDER 8 VERZ.	43 31 052 08	20	2	3 211	91 57 748 08	S-ANLENKSTUECK
SICHERUNGSFEDER 8 VERZ.	43 31 052 08	3	1	3 216 005	96 50 697 08	FUSS KPL.
SICHERUNGSFEDER 8 VERZ.	43 31 052 08	14	1	3 745 011	96 49 677 08	LASCHE KPL.
SICHERUNGSMUTTER AM8-10	10 01 751 7	7	1	9 739 186	97 39 186	MOTORBREMSE
SICHERUNGSMUTTER BM8-8	10 01 163 7	12	1	9 739 118	97 39 118	OELLEITUNG
SICHERUNGSMUTTER BM8-8	10 01 163 7	28	4	9 739 371	97 39 371	KLIMAKOMPRESSOR ANBAU
SICHERUNGSRING AEHNL.DI	10 22 093 7	25	1	X1035925	10 35 925 1	VERSTELLPUMPE
SICHERUNGSRING DIN 4 130X	42 80 076 08	5	2	3 211 003	96 46 986 08	STANGE KPL.
SICHERUNGSRING DIN 471 10	42 80 067 08	14	4	2 550	91 57 751 08	SA-BOCK
SICHERUNGSRING DIN 471 10	42 80 067 08	7	1	2 550 005	96 45 680 08	STANGE KPL.
SICHERUNGSRING DIN 471 10	42 80 067 08	4	2	3 714 025	96 49 269 08	STANGE KPL.
SICHERUNGSRING DIN 471 10	42 80 067 08	6	2	3 745 011	96 49 677 08	LASCHE KPL.
SICHERUNGSRING DIN 471 10	42 80 119 01	(18)	5	1 400	91 56 853 08	RAUPENTRAEGER KPL.LI.
SICHERUNGSRING DIN 471 16	42 80 085 08	59	2	1 400	91 56 853 08	RAUPENTRAEGER KPL.LI.
SICHERUNGSRING DIN 471 16	42 80 085 08	59	2	1 410 300	91 56 855 08	RAUPENTRAEGER KPL.RE.
SICHERUNGSRING DIN 471 20	42 80 093 08	9	5	3 214	91 52 843 08	SW-KOPFSTUECK
SICHERUNGSRING DIN 471 20	42 80 093 08	4	2	3 225 100	96 48 582 08	LAGERUNG KPL.
SICHERUNGSRING DIN 471 20	42 80 093 08	4	2	3 281	91 52 896 08	FA-BOCK
SICHERUNGSRING DIN 471 20	42 80 093 08	5	2	3 713	91 57 749 08	D-ANLENKSTUECK
SICHERUNGSRING DIN 471 20	42 80 093 08	33	1	3 714	91 52 862 08	D-KOPFSTUECK
SICHERUNGSRING DIN 471 20	42 80 093 08	6	2	3 714 021	96 49 271 08	ROLLENLAGERUNG KPL.
SICHERUNGSRING DIN 471 22	42 80 105 08	61	1	X1065015	10 65 015 5	GETRIEBE
SICHERUNGSRING DIN 471 2	42 80 021 08	29	2	2 550	91 57 751 08	SA-BOCK
SICHERUNGSRING DIN 471 2	42 80 021 08	13	2	2 550 005	96 45 680 08	STANGE KPL.
SICHERUNGSRING DIN 471 26	42 80 101 08	60	1	X1065015	10 65 015 5	GETRIEBE
SICHERUNGSRING DIN 471 27	42 80 103 08	3	2	2 550 003	96 46 246 08	SEILROLLE KPL.
SICHERUNGSRING DIN 471 27	42 80 103 08	3	2	2 652 007	92 68 928 08	SEILROLLE KPL.
SICHERUNGSRING DIN 471 34	42 80 113 08	62	1	X1065015	10 65 015 5	GETRIEBE
SICHERUNGSRING DIN 471 5	42 80 042 08	26	2	2 550	91 57 751 08	SA-BOCK
SICHERUNGSRING DIN 471 5	42 80 042 08	7	1	3 220 501	96 43 440 08	STANGE KPL.
SICHERUNGSRING DIN 471 5	42 80 042 08	7	1	3 221 200	96 47 984 08	STANGE KPL.
SICHERUNGSRING DIN 471 5	42 80 042 08	7	1	3 225 200	96 48 679 08	STANGE KPL.
SICHERUNGSRING DIN 471 5	42 80 042 08	7	1	3 227 002	96 50 498 08	STANGE KPL.
SICHERUNGSRING DIN 471 5	42 80 042 08	7	1	3 561 003	96 45 222 08	STANGE KPL.
SICHERUNGSRING DIN 471 5	42 80 042 08	7	1	3 713 012	96 50 197 08	STANGE KPL.
SICHERUNGSRING DIN 471 5	42 80 042 08	6	2	3 830	91 55 535 08	ZUSATZABSPANNUNG
SICHERUNGSRING DIN 471 5	42 80 045 08	49	2	3 713	91 57 749 08	D-ANLENKSTUECK
SICHERUNGSRING DIN 471 5	42 80 045 08	7	1	3 716 001	96 49 159 08	STANGE KPL.

6.2.2009

etk_en_de_074515 LR 1600/2

1108

LIEBHERRAlphabetical index
Alphabetischer Index

Bezeichnung	Artikel	Pos.	Menge	Seite	Baugruppe	Bezeichnung
SICHERUNGSRING DIN 471 5	53 01 333 08	15	1	2 550 005	96 45 680 08	STANGE KPL.
SICHERUNGSRING DIN 471 6	42 80 049 08	33	6	2 550	91 57 751 08	SA-BOCK
SICHERUNGSRING DIN 471 6	42 80 049 08	4	2	2 657	91 57 656 08	MONTAGEEINRICHTUNG RA
SICHERUNGSRING DIN 471 6	42 80 049 08	20	8	3 220 500	91 52 849 08	S-ZWISCHENSTUECK
SICHERUNGSRING DIN 471 6	42 80 049 08	20	10	3 223	91 52 852 08	S-ZWISCHENSTUECK
SICHERUNGSRING DIN 471 6	42 80 049 08	20	10	3 223 010	91 52 853 08	S-ZWISCHENSTUECK
SICHERUNGSRING DIN 471 6	42 80 049 08	20	10	3 223 100	91 55 327 08	S-ZWISCHENSTUECK
SICHERUNGSRING DIN 471 6	42 80 055 08	3	2	3 206 001	96 20 920 08	SEILROLLE KPL.
SICHERUNGSRING DIN 471 7	42 80 056 08	16	2	3 215 005	91 52 846 08	ROLLENSATZ
SICHERUNGSRING DIN 471 7	42 80 056 08	16	2	3 215 006	91 52 847 08	ROLLENSATZ
SICHERUNGSRING DIN 471 7	40 01 447	(32)	3	1 400	91 56 853 08	RAUPENTRAEGER KPL.LI.
SICHERUNGSRING DIN 471 8	42 80 061 08	1343	1	X1065015	10 65 015 5	GETRIEBE
SICHERUNGSRING DIN 471 8X	42 80 002 08	14	6	2 391 040	96 53 645 08	KUPPLUNGSSTELLER
SICHERUNGSRING DIN 471 8X	42 80 002 08	6	2	2 522 012	96 45 884 08	FUEHRUNG VORM.
SICHERUNGSRING DIN 471 8X	42 80 002 08	8	8	2 522 013	96 45 883 08	FUEHRUNG VORM.
SICHERUNGSRING DIN 471 9	42 80 064 08	22	2	3 714	91 52 862 08	D-KOPFSTUECK
SICHERUNGSRING DIN 471 9	42 80 064 08	41	1	X1065015	10 65 015 8	ANTRIEB
SICHERUNGSRING DIN 471 9	42 80 065 08	15	2	3 714	91 52 862 08	D-KOPFSTUECK
SICHERUNGSRING DIN 472 14	42 81 041 08	40	1	X1065015	10 65 015 8	ANTRIEB
SICHERUNGSRING DIN 472 2	42 81 006 08	17	4	2 522 013	96 45 883 08	FUEHRUNG VORM.
SICHERUNGSRING DIN 472 30	50 15 497 08	4	1	5 718 420	57 18 420 08	FLANSCH
SICHERUNGSRING DIN 472 46	50 40 077 08	43	2	X1065015	10 65 015 8	ANTRIEB
SICHERUNGSRING DIN 472 5	42 81 013 08	3	2	3 206 002	96 47 960 08	HEBEL KPL.
SICHERUNGSRING DIN 472 54	10 65 017 7	41	1	X1065015	10 65 015 6	SEILTROMMEL
SICHERUNGSRING DIN 472 7	42 81 022 08	12	1	5 701 129	57 01 129 08	TRIEBWERK
SICHERUNGSRING DIN 472 8	42 81 025 08	4	1	5 400 565	54 00 565 08	SEILWINDE
SICHERUNGSRING DIN 984 5	10 00 942 4	(37)	2	X1035924	10 35 924 9	VERSTELLPUMPE
SICHERUNGSSCHEIBE VS 10	42 39 110 01	(57)	8	1 400	91 56 853 08	RAUPENTRAEGER KPL.LI.
SICHERUNGSSCHEIBE VS 12	42 39 112 01	27	8	9 697 916	96 97 916 01	DREHWERK
SICHERUNGSSCHEIBE VS 12	42 39 112 01	75	12	9 697 916	96 97 916 01	DREHWERK
SICHERUNGSSCHRAUBE M14	10 34 226 6	3	8	9 739 360	97 39 360	MOTORLAGERUNG
SICHERUNGSSCHRAUBE M8	10 01 752 6	3	2	9 739 186	97 39 186	MOTORBREMSE
SIEBFILTER	10 01 245 0	4	1	9 739 258	97 39 258	KRAFTSTOFFFILTER
SIEBFILTER	10 34 659 9	1	1	X1021769	10 21 769 5	SENKBREMSVENTIL
SIEBHUELSE	57 00 663 08	5	1	5 028 065	50 28 065 08	AUSGLEICHSBEHAELTER
SIGNALLEUCHE 24V DC ROT	10 01 646 5	6	1	3 780 258	96 56 482 08	ELEKTRIK FLUGWARNSICHER
SIGNALWECKER 24V DC	61 40 047 08	(5)	1	2 920 559	96 47 914 08	ENDSCHALTER U.GEBER AL
SIGNALWECKER LMB	96 21 541 08	8	1	2 920 559	96 47 914 08	ENDSCHALTER U.GEBER AL
SITZ	96 48 626 08	1	1	2 503 100	91 55 873 08	NOTSITZ
SITZ	97 75 557 08	2	1	2 503 101	96 48 626 08	SITZ
SITZKISSEN	10 65 048 7	55	1	X1029200	10 29 200 4	FAHRERSITZ
SITZKONSOLE	97 75 553 08	1	1	2 503 101	96 48 626 08	SITZ
SL-REDUZIERSTUECK 6.75 M	91 52 854 08	214	1		LR 1600-2-0	LIEBHERR RAUPENKRAN LR 1
SL-REDUZIERSTUECK SCHW	96 46 385 08	1	1	3 225	91 52 854 08	SL-REDUZIERSTUECK
SOCKELGEHAEUSE 24POL.	60 56 185 08	518	3	2 920 633	96 52 651 08	KABELSTRANG
SPANNBAND 127	55 20 669 08	9	2	2 392	91 52 785 08	SCHALLDAEMPFERANLAGE
SPANNBAND 155,5//19	55 20 709 08	8	5	2 392	91 52 785 08	SCHALLDAEMPFERANLAGE
SPANNBAND 350X859X30XA1K	10 04 160 5	19	2	2 392	91 52 785 08	SCHALLDAEMPFERANLAGE
SPANNBAND ST	77 42 105 08	10	2	2 990	91 59 244 08	DRUCKLUFTANLAGE
SPANNBAND ST	77 42 105 08	6	2	3 978 005	91 56 430 08	ZUSATZHYDRAULIK SB-KOPFS
SPANNBAND ST	77 42 113 08	7	1	2 990	91 59 244 08	DRUCKLUFTANLAGE
SPANNROLLE	10 34 330 9	2	1	9 739 371	97 39 371	KLIMAKOMPRESSOR ANBAU
SPANNSCHELLE 102-100 ST	77 42 229 08	137	1	2 391 001	96 45 719 08	DIESELMOTOR VORM.
SPANNSCHELLE 128-136 ST	10 02 326 6	5	1	2 393	91 52 787 08	LUFTFILTERANLAGE KPL.
SPANNSCHELLE 146-154 ST	77 42 831 08	10	3	2 392	91 52 785 08	SCHALLDAEMPFERANLAGE
SPANNSCHELLE 146-154 ST	77 42 831 08	13	2	2 393	91 52 787 08	LUFTFILTERANLAGE KPL.
SPANNSCHELLE 59-62 ST	77 42 844 08	59	1	3 281	91 52 896 08	FA-BOCK
SPANNSCHELLE 75/25	77 42 097 08	5	1	2 831	91 57 754 08	KLIMAAANLAGE OW
SPANNSCHELLE 77/20 ST	77 42 856 08	119	1	2 391 001	96 45 719 08	DIESELMOTOR VORM.
SPANNSCHLOSS 1,59KN	77 39 170 08	63	2	2 550	91 57 751 08	SA-BOCK

6.2.2009

etk_en_de_074515 LR 1600/2

1109

LIEBHERRAlphabetical index
Alphabetischer Index

Bezeichnung	Artikel	Pos.	Menge	Seite	Baugruppe	Bezeichnung
SPANNSCHLOSS 7/8"X12 163	10 47 609 8	82	2	2 550	91 57 751 08	SA-BOCK
SPANNSCHLOSS VERZ	10 42 540 8	1	1	3 282 002	96 47 890 08	FAB-STUETZE
SPANNSTIFT 8X40 ST	10 47 688 3	7	1	9 739 341	97 39 341	ANTRIEBSTEILE M.SCHWINGU
SPANNSTIFT ISO 8752 10X60	43 20 111 08	62	2	X1065015	10 65 015 6	SEILTROMMEL
SPANNSTIFT ISO 8752 16X60	53 06 131 08	61	2	X1065015	10 65 015 6	SEILTROMMEL
SPANNSTIFT ISO 8752 4X28	43 20 025 08	4	4	1 641 014	92 53 053 08	ABSTUETZPLATTE KPL.
SPANNSTIFT ISO 8752 5X12	43 20 034 08	36	2	2 520	91 53 061 08	KABINE VERGLAST
SPANNSTIFT ISO 8752 5X12	43 20 034 08	28	1	2 522 011	96 45 602 08	SCHLISSANLAGE
SPANNSTIFT ISO 8752 5X20	43 20 039 08	30	4	3 206	91 52 881 08	F-ANLENKSTUECK
SPANNSTIFT ISO 8752 5X32	43 20 045 08	14	2	2 522 013	96 45 883 08	FUEHRUNG VORM.
SPANNSTIFT ISO 8752 5X45	43 20 048 08	5	1	2 550 008	96 47 628 08	HALTER KPL.
SPANNSTIFT ISO 8752 5X45	43 20 048 08	5	1	2 550 009	96 47 645 08	HALTER KPL.
SPANNSTIFT ISO 8752 6X14	43 20 053 08	56	4	2 550	91 57 751 08	SA-BOCK
SPANNSTIFT ISO 8752 6X14	43 20 053 08	117	6	2 970	91 56 537 08	HYDRAULIK
SPANNSTIFT ISO 8752 6X14	43 20 053 08	8	8	3 713 013	96 57 159 08	BLECH KPL.
SPANNSTIFT ISO 8752 6X14	43 20 053 08	12	2	3 745 002	92 17 236 08	SCHALTEINHEIT
SPANNSTIFT ISO 8752 6X14	43 20 053 08	24	2	3 978 015	91 56 429 08	ZUSATZHYDRAULIK ZWISCH
SPANNSTIFT ISO 8752 6X14	43 20 053 08	24	2	3 978 015	91 56 432 08	ZUSATZHYDRAULIK ZWISCH
SPANNSTIFT ISO 8752 6X20	43 20 057 08	13	2	2 391 040	96 53 645 08	KUPPLUNGSSTELLER
SPANNSTIFT ISO 8752 6X50 A	43 20 067 08	8	2	2 925 402	96 58 855 08	KAMERAANBAU DREHBUEHN
SPANNSTIFT ISO 8752 8X60 S	43 20 089 01	86	2	2 550	91 57 751 08	SA-BOCK
SPANNUNGSREGLER 24/12DC	61 40 205 08	11	1	2 533 070	96 48 363 08	ARMATUREN RE.
SPEICHERKARTE BSE 2GB CF	96 50 143 08	4	1	2 533 050	96 48 359 08	ELEKTRIK KABINE
SPEZIALFETT 100G TUBE	86 13 009 08	10	1	9 739 262	97 39 262	ZYLINDERKOPF
SPEZIALFETT 100G TUBE	86 13 009 08	12	1	9 739 263	97 39 263	KIPPHEBELLAGERGEHAEUSE
SPEZIALFETT 100G TUBE	86 13 009 08	12	1	9 739 264	97 39 264	KIPPHEBELLAGERGEHAEUSE
SPEZIALFETT 100G TUBE	86 13 009 08	10	1	9 739 266	97 39 266	ZYLINDERKOPF
SPINDEL 180.0X1019	97 17 087 08	3	2	1 632	91 52 389 08	MECH.ZUSATZABSTUETZUNG
SPIRALBACKRING	54 01 844 08	20	1	5 400 565	54 00 565 08	SEILWINDE
SPIRALFEDER	57 01 989 08	12	2	X1002800	10 02 800 2	LEITUNGSTROMMEL
SPIRALSCHLAUCH NW50 KUN	55 30 108 08	50	0.9	2 920 369	96 54 235 08	KLEMMKASTEN KPL.
SPLINT DIN 94 10X100 ST VER	43 30 106 08	78	2	1 400	91 56 853 08	RAUPENTRAEGER KPL.LI.
SPLINT DIN 94 10X100 ST VER	43 30 106 08	78	2	1 410 300	91 56 855 08	RAUPENTRAEGER KPL.RE.
SPLINT DIN 94 10X100 ST VER	43 30 106 08	17	1	3 281	91 52 896 08	FA-BOCK
SPLINT DIN 94 10X71 ST VERZ	43 30 101 08	90	1	2 550	91 57 751 08	SA-BOCK
SPLINT DIN 94 10X71 ST VERZ	43 30 101 08	10	2	2 652	91 52 794 08	ROLLENLAGERUNG
SPLINT DIN 94 10X71 ST VERZ	43 30 101 08	14	2	3 205	91 52 880 08	F-MONTAGEEINHEIT
SPLINT DIN 94 10X71 ST VERZ	43 30 101 08	8	1	3 207 003	96 48 259 08	STANGE KPL.
SPLINT DIN 94 10X71 ST VERZ	43 30 101 08	19	2	3 208 001	91 52 883 08	F-KOPFSTUECK
SPLINT DIN 94 10X71 ST VERZ	43 30 101 08	25	2	3 281	91 52 896 08	FA-BOCK
SPLINT DIN 94 10X71 ST VERZ	43 30 101 08	(8)	2	3 281	91 52 896 08	FA-BOCK
SPLINT DIN 94 10X71 ST VERZ	43 30 101 08	98	8	3 713	91 57 749 08	D-ANLENKSTUECK
SPLINT DIN 94 10X80 ST VERZ	43 30 103 08	13	2	2 810	91 52 806 08	KRANFUEHRERKABINE KPL.
SPLINT DIN 94 10X80 ST VERZ	43 30 103 08	13	1	3 225	91 52 854 08	SL-REDUZIERSTUECK
SPLINT DIN 94 10X90 ST VERZ	43 30 105 08	29	1	3 281	91 52 896 08	FA-BOCK
SPLINT DIN 94 13X125 ST VER	43 30 112 08	18	4	3 745	91 52 948 08	SCHWEBEBALLAST
SPLINT DIN 94 13X160 ST VER	43 30 115 08	4	4	3 205	91 52 880 08	F-MONTAGEEINHEIT
SPLINT DIN 94 3,2X25 ST VER	43 30 036 08	47	4	3 220 500	91 52 849 08	S-ZWISCHENSTUECK
SPLINT DIN 94 3,2X25 ST VER	43 30 036 08	47	4	3 223	91 52 852 08	S-ZWISCHENSTUECK
SPLINT DIN 94 3,2X25 ST VER	43 30 036 08	47	4	3 223 010	91 52 853 08	S-ZWISCHENSTUECK
SPLINT DIN 94 3,2X25 ST VER	43 30 036 08	47	4	3 223 100	91 55 327 08	S-ZWISCHENSTUECK
SPLINT DIN 94 3,2X25 ST VER	43 30 036 08	47	4	3 226	91 52 870 08	LI-ZWISCHENSTUECK
SPLINT DIN 94 3,2X25 ST VER	43 30 036 08	47	4	3 227	91 52 873 08	LI-ZWISCHENSTUECK
SPLINT DIN 94 3,2X25 ST VER	43 30 036 08	47	4	3 227 008	91 52 872 08	LI-ZWISCHENSTUECK
SPLINT DIN 94 4X25 ST VERZ	43 30 050 08	27	8	1 630	91 52 387 08	HYDRAULISCHE ABSTUETZUN
SPLINT DIN 94 4X25 ST VERZ	43 30 050 08	23	2	2 631	91 56 817 08	LAUFSTEG DREHBUEHNE
SPLINT DIN 94 4X25 ST VERZ	43 30 050 08	43	6	3 211	91 57 748 08	S-ANLENKSTUECK
SPLINT DIN 94 4X25 ST VERZ	43 30 050 08	156	2	3 713	91 57 749 08	D-ANLENKSTUECK
SPLINT DIN 94 4X32 ST VERZ	43 30 052 08	5	4	2 370	91 52 782 08	MONTAGEWINDE
SPLINT DIN 94 4X32 ST VERZ	43 30 052 08	62	2	2 550	91 57 751 08	SA-BOCK

6.2.2009

etk_en_de_074515 LR 1600/2

1110

LIEBHERRAlphabetical index
Alphabetischer Index

Bezeichnung	Artikel	Pos.	Menge	Seite	Baugruppe	Bezeichnung
SPLINT DIN 94 5X28 ST VERZ	43 30 063 08	28	12	2 631	91 56 817 08	LAUFSTEG DREHBUEHNE
SPLINT DIN 94 5X28 ST VERZ	43 30 063 08	11	2	3 205	91 52 880 08	F-MONTAGEEINHEIT
SPLINT DIN 94 5X40 ST VERZ	43 30 065 08	13	1	2 925 204	92 16 990 08	KAMERAANBAU D-ANLENKS
SPLINT DIN 94 5X40 ST VERZ	43 30 065 08	39	14	3 211	91 57 748 08	S-ANLENKSTUECK
SPLINT DIN 94 5X40 ST VERZ	43 30 065 08	70	4	3 713	91 57 749 08	D-ANLENKSTUECK
SPLINT DIN 94 6,3X32 ST VER	43 30 075 08	33	4	2 631	91 56 817 08	LAUFSTEG DREHBUEHNE
SPLINT DIN 94 6,3X32 ST VER	43 30 075 08	30	16	2 652	91 52 794 08	ROLLENLAGERUNG
SPLINT DIN 94 6,3X32 ST VER	43 30 075 08	15	4	2 730	91 52 802 08	GRUNDPLATTE DREHBUEHNE
SPLINT DIN 94 6,3X32 ST VER	43 30 075 08	53	8	3 225	91 52 854 08	SL-REDUZIERSTUECK
SPLINT DIN 94 6,3X40 ST VER	43 30 076 08	7	1	2 620	91 52 793 08	ROLLENDREHVERBINDUNG
SPLINT DIN 94 6,3X40 ST VER	43 30 076 08	3	4	2 671	91 52 798 08	OELBEHAELTER KPL.
SPLINT DIN 94 6,3X45 ST VER	43 30 077 08	14	4	2 670	91 52 797 08	KRAFTSTOFFBEHAELTER KPL
SPLINT DIN 94 6,3X45 ST VER	43 30 077 08	21	4	3 208 001	91 52 883 08	F-KOPFSTUECK
SPLINT DIN 94 6,3X45 ST VER	43 30 077 08	9	2	3 281	91 52 896 08	FA-BOCK
SPLINT DIN 94 6,3X45 ST VER	43 30 077 08	16	1	3 282 002	96 47 890 08	FAB-STUETZE
SPLINT DIN 94 6,3X45 ST VER	43 30 077 08	41	2	3 713	91 57 749 08	D-ANLENKSTUECK
SPLINT DIN 94 6,3X45 ST VER	43 30 077 08	15	4	3 745	91 52 948 08	SCHWEBEBALLAST
SPLINT DIN 94 6,3X50 ST VER	43 30 078 08	30	2	2 810	91 52 806 08	KRANFUEHRERKABINE KPL.
SPLINT DIN 94 6,3X50 ST VER	43 30 078 08	25	4	3 211	91 57 748 08	S-ANLENKSTUECK
SPLINT DIN 94 6,3X50 ST VER	43 30 078 08	14	2	3 220 500	91 52 849 08	S-ZWISCHENSTUECK
SPLINT DIN 94 6,3X50 ST VER	43 30 078 08	14	2	3 223	91 52 852 08	S-ZWISCHENSTUECK
SPLINT DIN 94 6,3X50 ST VER	43 30 078 08	14	2	3 223 010	91 52 853 08	S-ZWISCHENSTUECK
SPLINT DIN 94 6,3X50 ST VER	43 30 078 08	14	2	3 223 100	91 55 327 08	S-ZWISCHENSTUECK
SPLINT DIN 94 6,3X50 ST VER	43 30 078 08	50	2	3 281	91 52 896 08	FA-BOCK
SPLINT DIN 94 6,3X56 ST VER	43 30 079 08	51	2	3 206	91 52 881 08	F-ANLENKSTUECK
SPLINT DIN 94 6,3X90 ST VER	43 30 085 08	45	2	3 206	91 52 881 08	F-ANLENKSTUECK
SPLINT DIN 94 8X100 ST VERZ	43 30 097 08	16	4	1 630	91 52 387 08	HYDRAULISCHE ABSTUETZUN
SPLINT DIN 94 8X100 ST VERZ	43 30 097 08	8	1	2 657	91 57 656 08	MONTAGEEINRICHTUNG RA
SPLINT DIN 94 8X50 ST VERZ	43 30 088 08	17	8	1 630	91 52 387 08	HYDRAULISCHE ABSTUETZUN
SPLINT DIN 94 8X50 ST VERZ	43 30 088 08	34	2	2 810	91 52 806 08	KRANFUEHRERKABINE KPL.
SPLINT DIN 94 8X50 ST VERZ	43 30 088 08	4	3	3 282 002	96 47 890 08	FAB-STUETZE
SPLINT DIN 94 8X50 ST VERZ	43 30 088 08	106	2	3 713	91 57 749 08	D-ANLENKSTUECK
SPLINT DIN 94 8X50 ST VERZ	43 30 088 08	68	4	3 714	91 52 862 08	D-KOPFSTUECK
SPLINT DIN 94 8X50 ST VERZ	43 30 088 08	60	1	3 745	91 52 948 08	SCHWEBEBALLAST
SPLINT DIN 94 8X50 ST VERZ	43 30 088 08	4	1	3 790 006	96 19 989 08	BOLZENZIEHZYLINDER KPL.
SPLINT DIN 94 8X50 ST VERZ	43 30 088 08	4	1	3 790 007	96 19 990 08	BOLZENZIEHZYLINDER KPL.
SPLINT DIN 94 8X63 ST VERZ	43 30 090 08	8	4	1 991	91 52 510 08	DREHDURCHFUEHRUNG
SPLINT DIN 94 8X63 ST VERZ	43 30 090 08	47	4	2 550	91 57 751 08	SA-BOCK
SPLINT DIN 94 8X63 ST VERZ	43 30 090 08	4	1	2 550 011	96 47 007 08	KONSOLE KPL.
SPLINT DIN 94 8X63 ST VERZ	43 30 090 08	20	2	2 652	91 52 794 08	ROLLENLAGERUNG
SPLINT DIN 94 8X63 ST VERZ	43 30 090 08	21	2	2 810	91 52 806 08	KRANFUEHRERKABINE KPL.
SPLINT DIN 94 8X63 ST VERZ	43 30 090 08	19	2	3 206	91 52 881 08	F-ANLENKSTUECK
SPLINT DIN 94 8X63 ST VERZ	43 30 090 08	18	2	3 215 005	91 52 846 08	ROLLENSATZ
SPLINT DIN 94 8X63 ST VERZ	43 30 090 08	18	2	3 215 006	91 52 847 08	ROLLENSATZ
SPLINT DIN 94 8X63 ST VERZ	43 30 090 08	52	1	3 281	91 52 896 08	FA-BOCK
SPLINT DIN 94 8X63 ST VERZ	43 30 090 08	7	2	3 745 002	92 17 236 08	SCHALTEINHEIT
SPLINT DIN 94 8X63 ST VERZ	43 30 090 08	7	2	3 745 003	92 17 237 08	SCHALTEINHEIT
SPRENGRING	10 22 233 6	3	2	9 739 246	97 39 246	KOLBEN
SPRENGRING DIN 70951 47	42 42 017	(6)	2	2 810	91 52 806 08	KRANFUEHRERKABINE KPL.
SPRITZRING	10 34 283 6	1	1	9 739 341	97 39 341	ANTRIEBSTEILE M.SCHWINGU
STANGE KPL.	96 49 268 08	4	2	3 714	91 52 862 08	D-KOPFSTUECK
STANGE KPL. 1 M	96 45 456 08	11	4	2 550	91 57 751 08	SA-BOCK
STANGE KPL. 1.075M	96 49 042 08	2	2	3 214	91 52 843 08	SW-KOPFSTUECK
STANGE KPL. 12 M	96 45 222 08	42	2	3 223	91 52 852 08	S-ZWISCHENSTUECK
STANGE KPL. 12 M	96 45 222 08	42	2	3 223 010	91 52 853 08	S-ZWISCHENSTUECK
STANGE KPL. 12 M	96 45 222 08	42	2	3 223 100	91 55 327 08	S-ZWISCHENSTUECK
STANGE KPL. 12 M	96 45 222 08	40	2	3 227 008	91 52 872 08	LI-ZWISCHENSTUECK
STANGE KPL. 12 M	96 45 222 08	40	2	3 227 200	91 53 519 08	LI-ZWISCHENSTUECK F-ABSP
STANGE KPL. 12 M	96 45 222 08	2	2	3 716	91 52 864 08	D-ZWISCHENSTUECK
STANGE KPL. 12 M	96 49 159 08	3	2	3 716	91 52 864 08	D-ZWISCHENSTUECK

6.2.2009

etk_en_de_074515 LR 1600/2

1111

LIEBHERRAlphabetical index
Alphabetischer Index

Bezeichnung	Artikel	Pos.	Menge	Seite	Baugruppe	Bezeichnung
STANGE KPL. 12 M	96 50 498 08	40	2	3 227	91 52 873 08	LI-ZWISCHENSTUECK
STANGE KPL. 2.05M	96 45 680 08	12	2	2 550	91 57 751 08	SA-BOCK
STANGE KPL. 2.34M	96 49 269 08	5	2	3 714	91 52 862 08	D-KOPFSTUECK
STANGE KPL. 2.3M	96 50 197 08	51	2	3 713	91 57 749 08	D-ANLENKSTUECK
STANGE KPL. 2.975M	96 46 986 08	12	2	3 211	91 57 748 08	S-ANLENKSTUECK
STANGE KPL. 3 M	96 47 984 08	24	2	3 221	91 54 668 08	S-ZWISCHENSTUECK
STANGE KPL. 3.2M	96 45 288 08	33	2	3 281	91 52 896 08	FA-BOCK
STANGE KPL. 5.15M	96 48 259 08	2	4	3 207	91 53 433 08	F-ABSPANNUNG
STANGE KPL. 6 M	96 43 440 08	42	2	3 220 500	91 52 849 08	S-ZWISCHENSTUECK
STANGE KPL. 6 M	96 43 440 08	40	2	3 226	91 52 870 08	LI-ZWISCHENSTUECK
STANGE KPL. 6 M	96 43 440 08	2	2	3 715 008	91 52 863 08	D-ZWISCHENSTUECK
STANGE KPL. 6 M	96 48 593 08	3	2	3 715 008	91 52 863 08	D-ZWISCHENSTUECK
STANGE KPL. 6.75M	96 48 679 08	44	2	3 225	91 52 854 08	SL-REDUZIERSTUECK
STANGE MIT SCHILD 0.43M	96 48 310 08	5	2	3 207	91 53 433 08	F-ABSPANNUNG
STANGE MIT SCHILD 0.525M	96 47 009 08	2	2	3 211 003	96 46 986 08	STANGE KPL.
STANGE MIT SCHILD 0.525M	96 47 010 08	3	1	3 211 003	96 46 986 08	STANGE KPL.
STANGE MIT SCHILD 1.85M	96 46 998 08	13	4	3 211	91 57 748 08	S-ANLENKSTUECK
STANGE MIT SCHILD 1.85M	96 46 999 08	14	2	3 211	91 57 748 08	S-ANLENKSTUECK
STANGE MIT SCHILD 2.13M	96 48 354 08	6	2	3 207	91 53 433 08	F-ABSPANNUNG
STANGE MIT SCHILD 3200	96 45 289 08	(1)	1	3 281	91 52 896 08	FA-BOCK
STANGE MIT SCHILD 4950	96 48 260 08	1	1	3 207 003	96 48 259 08	STANGE KPL.
STANGE MIT SCHILD 800	96 47 989 08	19	1	3 282 002	96 47 890 08	FAB-STUETZE
STANGE MIT SCHILD 800	96 47 990 08	24	2	3 282 002	96 47 890 08	FAB-STUETZE
STANGE SCHWK.	96 45 458 08	(1)	1	2 550	91 57 751 08	SA-BOCK
STANGE SCHWK.	96 45 819 08	3	4	1 630	91 52 387 08	HYDRAULISCHE ABSTUETZUN
STANGE SCHWK.	96 46 787 08	2	2	3 213	91 52 842 08	F-ANSCHLUSSKOPF
STANGE VORM.	96 45 685 08	1	1	2 550 005	96 45 680 08	STANGE KPL.
STANGE VORM.	96 48 680 08	1	1	3 225 200	96 48 679 08	STANGE KPL.
STANGE VORM. 1.99M	96 49 610 08	1	1	3 714 025	96 49 269 08	STANGE KPL.
STANGE VORM. 11.75 M	96 49 158 08	1	1	3 716 001	96 49 159 08	STANGE KPL.
STANGE VORM. 11.75M	96 45 230 08	1	1	3 227 002	96 50 498 08	STANGE KPL.
STANGE VORM. 11.75M	96 45 230 08	1	1	3 561 003	96 45 222 08	STANGE KPL.
STANGE VORM. 2.15M	96 50 198 08	1	1	3 713 012	96 50 197 08	STANGE KPL.
STANGE VORM. 2.45M	96 47 008 08	1	1	3 211 003	96 46 986 08	STANGE KPL.
STANGE VORM. 2.75 M	96 47 985 08	1	1	3 221 200	96 47 984 08	STANGE KPL.
STANGE VORM. 5.75 M	96 45 249 08	1	1	3 220 501	96 43 440 08	STANGE KPL.
STARTER 6,6KW	97 39 159	205	1	X1012059	10 12 059 0	DIESELMOTOR
STARTER KB24V 6,6KW	10 01 246 1	1	1	9 739 159	97 39 159	STARTER
STATIV SCHWK.	92 16 963 08	1	1	2 925 204	92 16 990 08	KAMERAANBAU D-ANLENKS
STATIV SCHWK.	96 23 820 08	24	1	2 925 402	96 58 855 08	KAMERAANBAU DREHBUEHN
STATIV SCHWK. T ZN O	96 51 406 08	1	1	2 925 402	96 58 855 08	KAMERAANBAU DREHBUEHN
STATIV SCHWK. X5CRNI18-10	96 45 743 08	25	1	2 925 402	96 58 855 08	KAMERAANBAU DREHBUEHN
STAUBKAPPE	10 48 800 3	(1)	1	2 711	91 52 800 08	ZENTRALSCHMIERANLAGE O
STAUBKAPPE	51 15 066 08	14	1	2 990	91 59 244 08	DRUCKLUFTANLAGE
STAUBKAPPE	70 42 548 08	7	4	2 393 002	96 46 782 08	DECKEL KPL.
STAUBKAPPE	70 42 548 08	7	7	2 859 005	96 46 756 08	KLAPPE VORM.
STAUBKAPPE	70 42 548 08	7	4	2 859 007	96 46 775 08	DECKEL KPL.
STAUBKAPPE	70 42 548 08	13	4	2 859 025	96 46 757 08	GITTERROST VORM.
STAUBKAPPE	70 42 548 08	7	4	2 859 026	96 46 776 08	DECKEL KPL.
STAUBKAPPE	70 42 548 08	7	4	2 859 027	96 46 777 08	DECKEL KPL.
STAUBKAPPE	70 42 548 08	7	4	2 859 028	96 46 778 08	DECKEL KPL.
STAUBKAPPE	70 42 548 08	7	4	2 859 029	96 46 779 08	DECKEL KPL.
STAUBKAPPE	70 42 548 08	12	2	2 859 030	96 46 758 08	DECKEL KPL.
STAUBKAPPE METALL	69 18 998 08	37	1	2 920 369	96 54 235 08	KLEMMKASTEN KPL.
STAUBKAPPE METALL	69 18 998 08	152	1	3 930 009	96 50 573 08	LEITUNGSTROMMEL KPL.
STAUBKAPPE METALL	69 18 998 08	(172)	1	3 930 138	96 54 377 08	ELEKTRIK S-ANLENKSTUECK
STAUBKAPPE METALL	69 18 998 08	289	2	3 930 638	96 51 624 08	KLEMMKASTEN
STAUBKAPPE METALL	69 18 998 08	280	2	3 930 730	96 50 599 08	KLEMMKASTEN KPL.
STAUBKAPPE METALL	69 24 000 08	(152)	1	2 920 369	96 54 235 08	KLEMMKASTEN KPL.
STAUBSTECKER	10 48 800 2	(1)	1	2 711	91 52 800 08	ZENTRALSCHMIERANLAGE O

6.2.2009

etk_en_de_074515 LR 1600/2

1112

LIEBHERRAlphabetical index
Alphabetischer Index

Bezeichnung	Artikel	Pos.	Menge	Seite	Baugruppe	Bezeichnung
STECKDOSE	10 21 947 7	4	1	2 533 067	96 50 385 08	BLECH VORM.
STECKDOSE	51 45 947 08	20	1	5 719 113	57 19 113 08	ANSTEUERGERAET
STECKDOSE	51 45 948 08	19	1	5 719 113	57 19 113 08	ANSTEUERGERAET
STECKDOSE 20A	10 42 905 7	5	1	2 533 067	96 50 385 08	BLECH VORM.
STECKDOSE 20A	10 42 905 7	2	1	2 533 068	96 49 314 08	STECKDOSEN VORM.
STECKDOSE 2POL	60 52 082 08	(151)	1	2 920 815	96 49 300 08	KABELLISTE BATTERIEKASTE
STECKDOSEN VORM.	96 49 314 08	13	1	2 533 066	96 48 365 08	ELEKTRIK ANBAUTEILE KABIN
STECKDOSENKOERPER 4POL	60 52 516 08	501	1	2 920 633	96 52 651 08	KABELSTRANG
STECKDOSENKOERPER 4POL	60 52 516 08	151	1	2 920 636	96 51 854 08	LEITUNG
STECKDOSENKOMBINATION 1	60 52 157 08	1	1	2 780 915	96 48 377 08	ANBAUTEILE FREMDEINSPEIS
STECKER	10 47 638 3	(503)	1	2 920 288	96 52 614 08	KABELLISTE DREHBUEHNE
STECKER	92 03 811 08	512	1	2 920 633	96 52 651 08	KABELSTRANG
STECKER	92 79 963 08	504	2	2 920 633	96 52 651 08	KABELSTRANG
STECKER 12-POL	10 34 312 1	23	1	9 739 366	97 39 366	BEFESTIGUNGSTEILE ANBAU
STECKER 18POL SPF	60 23 250 08	(152)	12	2 932 001	96 45 393 08	RELAISSTEUERUNG
STECKER 19-POL 22A	10 44 366 4	(151)	1	2 920 581	96 54 405 08	KLEMMKASTEN SA-BOCK VO
STECKER 24POL 22A	10 44 365 8	152	1	3 930 732	96 50 575 08	LEITUNG
STECKER 24POL 22A	10 44 366 0	(151)	1	2 920 369	96 54 235 08	KLEMMKASTEN KPL.
STECKER 8POL 24V	10 04 699 9	506	15	2 932 224	96 54 389 08	DRAEHTE MONTAGETAFEL K
STECKER 8POL 24V	10 04 700 0	505	12	2 932 224	96 54 389 08	DRAEHTE MONTAGETAFEL K
STECKER 8POL 24V	10 04 700 1	509	15	2 932 224	96 54 389 08	DRAEHTE MONTAGETAFEL K
STECKER DIN 72585 7POL PO	69 24 067 08	510	1	2 920 633	96 52 651 08	KABELSTRANG
STECKER KPL.	92 01 005 08	15	2	2 631	91 56 817 08	LAUFSTEG DREHBUEHNE
STECKER RD20X378	93 03 581 08	5	1	1 632 032	96 20 093 08	ABSTUETZPLATTE KPL.
STECKER T ZN K	92 47 131 08	37	1	2 810	91 52 806 08	KRANFUEHRERKABINE KPL.
STECKER T ZN K	92 47 131 08	66	8	3 211	91 57 748 08	S-ANLENKSTUECK
STECKEREINSATZ 40POL	60 56 022 08	(151)	1	2 920 369	96 54 235 08	KLEMMKASTEN KPL.
STECKERGEHAEUSE 10-POL	10 02 156 7	(153)	1	2 920 369	96 54 235 08	KLEMMKASTEN KPL.
STECKERGEHAEUSE 14POL	10 02 156 8	(153)	1	2 920 369	96 54 235 08	KLEMMKASTEN KPL.
STECKERGEHAEUSE 14POL	60 23 365 08	3	6	2 932 166	92 68 911 08	VERTEILER MASSE
STECKERGEHAEUSE 18-POL	60 23 002 08	501	37	2 932 224	96 54 389 08	DRAEHTE MONTAGETAFEL K
STECKERGEHAEUSE 4POL	60 23 359 08	523	1	2 932 224	96 54 389 08	DRAEHTE MONTAGETAFEL K
STECKERLEISTE B 64POL C	60 23 212 08	5	7	2 922 001	92 84 311 08	BUSPLATINE
STECKHUELSE	60 22 034 08	12	2	2 780 320	91 05 067 08	AKUSTISCHE WARNUNG DRE
STECKHUELSE	60 22 034 08	72	12	2 920 633	96 52 651 08	KABELSTRANG
STECKHUELSENGEHAEUSE	60 23 198 08	513	1	2 920 633	96 52 651 08	KABELSTRANG
STECKHUELSENGEHAEUSE 2	60 22 097 08	508	3	2 920 633	96 52 651 08	KABELSTRANG
STECKHUELSENGEHAEUSE 2	60 22 097 08	(152)	1	2 932 001	96 45 393 08	RELAISSTEUERUNG
STECKHUELSENGEHAEUSE 2	60 22 097 08	517	2	2 932 224	96 54 389 08	DRAEHTE MONTAGETAFEL K
STECKKUPPLUNGSMUFFE	57 17 231 08	4	1	5 123 682	51 23 682 08	MONTAGEZYLINDER
STECKROHR	10 01 273 3	21	1	9 739 349	97 39 349	WASSERLEITUNGSANSCHLUE
STECKSCHLUESSEL GR.11/3	79 00 249 08	17	1	1 750	91 52 394 08	WERKZEUG
STECKTUELLE	51 05 696 08	26	1	1 750	91 52 394 08	WERKZEUG
STECKVERBINDER	10 49 058 6	6	1	X1004047	10 04 047 7	WINDENDREHGEBER
STELLMOTOR	10 28 730 1	13	1	X1022811	10 22 811 2	HEIZKLIMAGERAET
STELLMUTTER DIN 444 B M12	10 34 329 6	17	1	9 739 344	97 39 344	GENERATOR VORM.
STELLSCHRAUBE	57 15 610 08	16	2	5 113 086	51 13 086 08	PROPORTIONALVENTIL
STELLSCHRAUBE	57 18 141 08	35	1	5 113 086	51 13 086 08	PROPORTIONALVENTIL
STELLSCHRAUBE	57 19 037 08	45	1	5 113 086	51 13 086 08	PROPORTIONALVENTIL
STERNGRIFFSCHRAUBE	10 44 362 5	24	2	2 502	91 55 939 08	STEUERSTAND
STUERBLOCK	51 13 005 08	23	1	2 970	91 56 537 08	HYDRAULIK
STUERBLOCK 350 BAR SPF	10 42 440 2	19	1	2 970	91 56 537 08	HYDRAULIK
STUERBOX MB 618	10 33 264 0	10	1	2 925 002	96 58 856 08	AUSRUESTUNG KAMERA DRE
STUERGERAET	90 80 702	72	1	9 739 400	97 39 400	DIESELMOTOR
STUERGERAET 24V	10 27 869 8	1	1	X1004204	10 04 204 3	WASSERHEIZGERAET
STUERLEITUNG 19X0,5 SPF	60 04 640 08	(5)	14.86	2 920 581	96 54 405 08	KLEMMKASTEN SA-BOCK VO
STUERLEITUNG 19X0,5 SPF	60 04 640 08	5	3.1	2 920 633	96 52 651 08	KABELSTRANG
STUERLEITUNG 19X0,5 SPF	60 04 640 08	6	2.7	2 920 633	96 52 651 08	KABELSTRANG
STUERLEITUNG 19X0,5 SPF	60 04 640 08	7	5.9	2 920 633	96 52 651 08	KABELSTRANG
STUERLEITUNG 19X0,5 SPF	60 04 640 08	(5)	15.43	3 930 734	96 54 401 08	KLEMMKASTEN

6.2.2009

etk_en_de_074515 LR 1600/2

1113

LIEBHERRAlphabetical index
Alphabetischer Index

Bezeichnung	Artikel	Pos.	Menge	Seite	Baugruppe	Bezeichnung
STEUERLEITUNG 4X0,5 SPF	60 04 604 08	5	6.95	2 920 636	96 51 854 08	LEITUNG
STEUERLEITUNG 8X0,5C+16X0	60 04 407 08	5	39.12	3 930 732	96 50 575 08	LEITUNG
STEUERPLATTE	57 01 145 08	2	1	5 701 133	57 01 133 08	TRIEBWERK
STEUERSTAND	91 55 939 08	129	1		LR 1600-2-0	LIEBHERR RAUPENKRAN LR 1
STEUERTEIL	10 65 069 2	5	1	X1035924	10 35 924 9	VERSTELLPUMPE
STEUERUNGSTEILE	97 39 187	46	6	X1012059	10 12 059 0	DIESELMOTOR
STEUERVENTIL	10 11 497 5	40	1	X1035925	10 35 925 1	VERSTELLPUMPE
STIFT	60 52 129 08	95	2	2 920 633	96 52 651 08	KABELSTRANG
STIFT	60 52 129 08	95	1	2 920 636	96 51 854 08	LEITUNG
STIFTEINSATZ 4/2POL -40°C	10 00 727 2	522	1	2 932 224	96 54 389 08	DRAEHTE MONTAGETAFEL K
STIFTEINSATZ 64POL	60 56 090 08	(151)	1	2 920 369	96 54 235 08	KLEMMKASTEN KPL.
STIFTEINSATZ 64POL	60 56 090 08	21	5	2 920 448	96 48 794 08	KLEMMKASTEN KPL.
STIFTKONTAKT	60 45 192 08	(628)	3	2 920 288	96 52 614 08	KABELLISTE DREHBUEHNE
STIFTSCHRAUBE M10X25	10 03 729 8	7	6	9 739 494	97 39 494	ATL-ANBAU
STIFTSCHRAUBE M10X35	10 28 710 4	5	4	9 739 494	97 39 494	ATL-ANBAU
STIFTSCHRAUBE M12X1,5X30	10 01 159 6	11	3	9 739 159	97 39 159	STARTER
STIFTSCHRAUBE M6X16 8.8 A2	10 01 159 4	(2)	2	9 739 318	97 39 318	SENSORIK
STIFTSCHRAUBE M8X150 10.9	10 47 689 0	4	1	9 739 491	97 39 491	LUFTPRESSER ANBAU
STIFTTRAEGER	60 45 266 08	(501)	1	2 920 288	96 52 614 08	KABELLISTE DREHBUEHNE
STIRNRAD PA6G	96 89 130 01	17	1	2 340	91 52 776 08	WINDE 4 EINZIEHWERK
STOERANZEIGE	10 42 995 2	19	2	7 743 566	77 43 566 08	ELEKTROPUMPE
STOESSELSTANGE	10 01 707 9	4	2	9 739 187	97 39 187	STEUERUNGSTEILE
STOPFEN 46/38X19-59/51 CR2	10 01 263 0	5	1	9 739 354	97 39 354	SCHWUNGRADGEHAEUSE AN
STOPFEN VST11"ED A3P	47 77 046 08	773	2	2 970	91 56 537 08	HYDRAULIK
STOPFEN VST11/2"ED A3P	47 77 042 08	752	1	2 970	91 56 537 08	HYDRAULIK
STOPFEN VST11/2"ED A3P	47 77 042 08	609	4	3 978 005	91 56 430 08	ZUSATZHYDRAULIK SB-KOPFS
STOPFEN VST11/2"ED A3P	47 77 042 08	3	1	X1021769	10 21 769 5	SENKBREMSVENTIL
STOPFEN VST11/4"ED A3P	47 77 040 77	330	2	X1041101	10 41 101 5	RUECKFALLSTUETZE
STOPFEN VST11/4"ED A3P	47 77 040 77	310	2	X1041101	10 41 101 8	RUECKFALLSTUETZE
STOPFEN VST11/8"ED ST A3C	51 07 415 08	3	1	5 113 086	51 13 086 08	PROPORTIONALVENTIL
STOPFEN VST11/4"ED A3P	47 77 054 08	16	3	9 640 276	96 40 276 08	ANSCHLUSSBLOCK
STOPFEN VST11/4"ED A3P	47 77 054 08	4	1	X1041267	10 41 267 8	ENDPLATTE
STOPFEN VST13/8"ED A3P	47 77 041 08	733	2	2 970	91 56 537 08	HYDRAULIK
STOPFEN VSTIM12X1,5ED A3	47 77 043 08	51	1	2 393	91 52 787 08	LUFTFILTERANLAGE KPL.
STOPFEN VSTIM14X1,5ED A3	47 77 049 08	15	1	X1042440	10 42 440 2	STUERBLOCK
STOPFEN VSTIM18X1,5ED A3	47 77 051 08	644	2	1 970	91 56 958 08	HYDRAULIK RAUPE
STOPFEN VSTIM18X1,5ED A3	47 77 051 08	602	2	1 970 161	96 50 706 08	ZUSATZHYDR.RAUPENTRAEG
STOPFEN VSTIM18X1,5ED A3	47 77 051 08	4	1	2 670 002	96 45 352 08	KRAFTSTOFFBEHALTER VO
STOPFEN VSTIM18X1,5ED A3	47 77 051 08	400	1	X1041101	10 41 101 5	RUECKFALLSTUETZE
STOPFEN VSTIM18X1,5ED A3	47 77 051 08	380	1	X1041101	10 41 101 8	RUECKFALLSTUETZE
STOPFEN VSTIM22X1,5ED A3	47 77 045 08	614	1	2 970	91 56 537 08	HYDRAULIK
STOPFEN VSTIM22X1,5ED A3	47 77 045 08	616	2	2 990	91 59 244 08	DRUCKLUFTANLAGE
STOPFEN VSTIM22X1,5ED A3	47 77 045 08	603	1	3 978 005	91 56 430 08	ZUSATZHYDRAULIK SB-KOPFS
STOPFEN VSTIM22X1,5ED A3	47 77 045 08	580	1	X1041101	10 41 101 5	RUECKFALLSTUETZE
STOPFEN VSTIM22X1,5ED A3	47 77 045 08	490	1	X1041101	10 41 101 8	RUECKFALLSTUETZE
STOPFEN VSTIM26X1,5ED A3	47 77 058 08	712	1	2 970	91 56 537 08	HYDRAULIK
STOPFEN VSTIM27X2ED A3P	47 77 056 08	632	2	2 970	91 56 537 08	HYDRAULIK
STOPFEN VSTIM27X2ED A3P	47 77 056 08	89	1	9 697 916	96 97 916 01	DREHWERK
STOPFEN VSTIM33X2ED A3P	47 77 052 08	713	2	2 970	91 56 537 08	HYDRAULIK
STOPFEN VSTIM33X2ED A3P	47 77 052 08	48	1	2 975 100	91 52 860 08	ZUSATZHYDRAULIK WINDE 3
STOPFEN VSTIM33X2ED A3P	47 77 052 08	45	1	2 975 200	91 52 775 08	ZUSATZHYDRAULIK WINDE 2
STOPFEN VSTIM33X2ED A3P	47 77 052 08	45	1	2 975 700	91 52 774 08	ZUSATZHYDRAULIK WINDE 1
STOPFEN VSTIM42X2ED A3P	47 77 048 08	(62)	3	1 400	91 56 853 08	RAUPENTRAEGER KPL.LI.
STOPFEN VSTIM42X2ED A3P	47 77 048 08	13	1	X1042440	10 42 440 2	STUERBLOCK
STOPFEN VSTIM8X1ED	51 45 195 08	53	1	X1047219	10 47 219 6	REGLER
STUETZE SCHWK.	96 48 491 08	1	1	2 391 001	96 45 719 08	DIESELMOTOR VORM.
STUETZE SCHWK.	96 53 864 08	88	1	2 550	91 57 751 08	SA-BOCK
STUETZE SCHWK. TZNO	96 53 091 08	6	6	2 631	91 56 817 08	LAUFSTEG DREHBUEHNE
STUETZRING	57 10 770 08	(3)	1	2 975 700	91 52 774 08	ZUSATZHYDRAULIK WINDE 1
STUETZRING	57 10 770 08	(3)	1	3 978 100	91 56 428 08	HYDR.SCHWEBEBALLAST-AN

6.2.2009

etk_en_de_074515 LR 1600/2

1114

LIEBHERRAlphabetical index
Alphabetischer Index

Bezeichnung	Artikel	Pos.	Menge	Seite	Baugruppe	Bezeichnung
STUETZRING	57 10 822 08	(4)	1	1 970	91 56 958 08	HYDRAULIK RAUPE
STUETZRING	57 10 822 08	(3)	1	1 970	91 56 958 08	HYDRAULIK RAUPE
STUETZRING	57 10 828 08	(3)	1	1 970	91 56 958 08	HYDRAULIK RAUPE
STUETZSCHEIBE DIN 988 S 17	42 20 075 08	(28)	3	1 400	91 56 853 08	RAUPENTRAEGER KPL.LI.
STUETZSCHEIBE DIN 988 S 60	53 00 631 08	32	8	2 550	91 57 751 08	SA-BOCK
STUETZSCHEIBE DIN 988 S 63	51 45 410 08	19	8	3 220 500	91 52 849 08	S-ZWISCHENSTUECK
STUETZSCHEIBE DIN 988 S 63	51 45 410 08	19	10	3 223	91 52 852 08	S-ZWISCHENSTUECK
STUETZSCHEIBE DIN 988 S 63	51 45 410 08	19	10	3 223 010	91 52 853 08	S-ZWISCHENSTUECK
STUETZSCHEIBE DIN 988 S 63	51 45 410 08	19	10	3 223 100	91 55 327 08	S-ZWISCHENSTUECK
STUETZSCHRAUBE M8	40 97 109 08	3	2	2 859 030	96 46 758 08	DECKEL KPL.
STUTZEN GE LL 16M26X1,5 ST	10 22 280 4	20	1	9 739 491	97 39 491	LUFTPRESSER ANBAU
STUTZEN L-10 WVE	10 22 276 6	1	1	9 739 292	97 39 292	KRAFTSTOFFLEITUNG
STUTZEN L-8 WVE	10 22 276 2	5	1	9 739 281	97 39 281	LECKOELLEITUNG
SW-KOPFSTUECK	91 52 843 08	203	1		LR 1600-2-0	LIEBHERR RAUPENKRAN LR 1
SW-KOPFSTUECK SCHWK.	96 46 991 08	1	1	3 214	91 52 843 08	SW-KOPFSTUECK
T-STUECK 18/18/18	55 31 281 08	11	1	2 540	91 53 253 08	HEIZKLIMAGERAET EINBAU
T-STUECK 18/18/18	55 31 281 08	10	1	2 541	91 52 790 08	ZUSATZHEIZUNG OW
T-STUECK 30X30X30 G-ALMG	10 28 570 1	48	2	2 520	91 53 061 08	KABINE VERGLAST
T-STUECK 30X30X30 G-ALMG	10 28 570 1	4	2	2 533 066	96 48 365 08	ELEKTRIK ANBAUTEILE KABIN
TANKSENSOR L=1000 SPF	78 90 151 08	5	1	2 920 814	96 45 717 08	ELEKTRIK KRAFTSTOFFBEHA
TASCHE KUNSTSTOFF	74 03 000 08	28	1	2 520 034	96 45 984 08	INNENVERKLEIDUNG
TASCHENSCHLOSS 27-29 SPF	77 39 399 08	2	1	2 311	91 52 834 08	SEIL F.WINDE 1
TASCHENSCHLOSS 27-29 SPF	77 39 399 08	2	1	2 312	91 52 835 08	SEIL F.WINDE 2
TASCHENSCHLOSS 27-29 SPF	77 39 399 08	2	1	2 313	91 52 836 08	SEIL F.WINDE 3
TASTATUREINHEIT LSB-BKE	10 32 351 7	2	1	2 533 051	96 48 360 08	ELEKTRIK KABINE
TASTATUREINHEIT LSB-TE PR	96 48 367 08	30	1	2 533 070	96 48 363 08	ARMATUREN RE.
TASTATUREINHEIT LSB-TE SP	10 29 669 1	(2)	1	2 533 070	96 48 363 08	ARMATUREN RE.
TASTERKAPPE FLACH GELB	60 61 439 08	13	4	2 533 061	96 48 370 08	ARMATUREN ARMLEHNE LI.
TASTERKAPPE FLACH GELB	60 61 439 08	13	1	2 533 063	96 48 371 08	ARMATUREN ARMLEHNE RE.
TASTERKAPPE FLACH GELB	60 61 439 08	9	17	2 533 070	96 48 363 08	ARMATUREN RE.
TASTERKAPPE FLACH KLAR	60 61 444 08	7	2	2 533 061	96 48 370 08	ARMATUREN ARMLEHNE LI.
TASTERKAPPE FLACH KLAR	60 61 444 08	5	6	2 533 063	96 48 371 08	ARMATUREN ARMLEHNE RE.
TASTERKAPPE FLACH KLAR	60 61 444 08	12	4	2 533 070	96 48 363 08	ARMATUREN RE.
TASTERKAPPE FLACH ROT	60 61 431 08	5	1	2 533 061	96 48 370 08	ARMATUREN ARMLEHNE LI.
TASTERKAPPE FLACH ROT	60 61 431 08	15	2	2 533 070	96 48 363 08	ARMATUREN RE.
TASTKONTAKTGEBER	60 61 434 08	12	3	2 533 061	96 48 370 08	ARMATUREN ARMLEHNE LI.
TASTKONTAKTGEBER	60 61 434 08	20	2	2 533 070	96 48 363 08	ARMATUREN RE.
TASTKONTAKTGEBER 2OE + 2	60 61 438 08	(3)	1	2 533 051	96 48 360 08	ELEKTRIK KABINE
TASTKONTAKTGEBER 2OE + 2	60 61 446 08	12	6	2 533 063	96 48 371 08	ARMATUREN ARMLEHNE RE.
TASTKONTAKTGEBER 2OE + 2	60 61 446 08	16	12	2 533 070	96 48 363 08	ARMATUREN RE.
TASTKONTAKTGEBER 2OE + 2	60 61 446 08	31	3	2 932 001	96 45 393 08	RELAISSTEUERUNG
TEILESATZ	10 01 243 7	11	1	9 739 258	97 39 258	KRAFTSTOFFFILTER
TEILESATZ	55 31 354 08	3	1	5 530 545	55 30 545 08	UMWAEELZPUMPE
TELESKOPSCHIENE 530X28X	10 41 235 8	7	2	2 260	91 53 057 08	BATTERIELAGERUNG
TELLERBEFESTIGUNG	10 10 062 1	6	4	1 620	91 52 386 08	BEFESTIGUNGSTEILE DREH
TELLERBEFESTIGUNG	10 10 062 1	9	48	1 631 100	91 52 388 08	LAUFSTEG RAUPENFAHRWER
TELLERBEFESTIGUNG	10 10 062 1	3	10	2 859 025	96 46 757 08	GITTERROST VORM.
TELLERBEFESTIGUNG	10 10 062 1	57	8	3 206	91 52 881 08	F-ANLENKSTUECK
TELLERBEFESTIGUNG	10 10 062 1	31	112	3 211	91 57 748 08	S-ANLENKSTUECK
TELLERBEFESTIGUNG	10 10 062 1	37	9	3 214	91 52 843 08	SW-KOPFSTUECK
TELLERBEFESTIGUNG	10 10 062 1	24	37	3 220 500	91 52 849 08	S-ZWISCHENSTUECK
TELLERBEFESTIGUNG	10 10 062 1	12	24	3 221	91 54 668 08	S-ZWISCHENSTUECK
TELLERBEFESTIGUNG	10 10 062 1	24	49	3 223	91 52 852 08	S-ZWISCHENSTUECK
TELLERBEFESTIGUNG	10 10 062 1	24	49	3 223 010	91 52 853 08	S-ZWISCHENSTUECK
TELLERBEFESTIGUNG	10 10 062 1	24	49	3 223 100	91 55 327 08	S-ZWISCHENSTUECK
TELLERBEFESTIGUNG	10 10 062 1	41	37	3 225	91 52 854 08	SL-REDUZIERSTUECK
TELLERBEFESTIGUNG	10 10 062 1	24	25	3 226	91 52 870 08	LI-ZWISCHENSTUECK
TELLERBEFESTIGUNG	10 10 062 1	24	40	3 227	91 52 873 08	LI-ZWISCHENSTUECK
TELLERBEFESTIGUNG	10 10 062 1	24	32	3 227 008	91 52 872 08	LI-ZWISCHENSTUECK
TELLERBEFESTIGUNG	10 10 062 1	24	41	3 227 200	91 53 519 08	LI-ZWISCHENSTUECK F-ABSP

6.2.2009

etk_en_de_074515 LR 1600/2

1115

LIEBHERRAlphabetical index
Alphabetischer Index

Bezeichnung	Artikel	Pos.	Menge	Seite	Baugruppe	Bezeichnung
TELLERBEFESTIGUNG	10 10 062 1	16	63	3 713	91 57 749 08	D-ANLENKSTUECK
TELLERBEFESTIGUNG	10 10 062 1	45	51	3 714	91 52 862 08	D-KOPFSTUECK
TELLERBEFESTIGUNG	10 10 062 1	5	48	3 715 008	91 52 863 08	D-ZWISCHENSTUECK
TELLERBEFESTIGUNG	10 10 062 1	5	80	3 716	91 52 864 08	D-ZWISCHENSTUECK
TELLERBEFESTIGUNG	10 10 062 1	27	16	3 745	91 52 948 08	SCHWEBEBALLAST
TELLERFEDER	57 01 150 08	7	4	5 701 133	57 01 133 08	TRIEBWERK
TELLERFEDER DIN 2093 34X1	72 08 002 08	25	4	2 502	91 55 939 08	STEUERSTAND
TEMPERATURFUEHLER	10 01 246 6	(1)	1	9 739 318	97 39 318	SENSORIK
TEMPERATURFUEHLER	10 29 012 6	19	1	X1004204	10 04 204 3	WASSERHEIZGERAET
TEMPERATURGEBER	10 01 246 7	(1)	1	9 739 318	97 39 318	SENSORIK
TEMPERATURGEBER 2-9VDC	69 11 831 08	(1)	1	2 970	91 56 537 08	HYDRAULIK
TEMPERATURGEBER HYDRA	96 47 922 08	14	1	2 970	91 56 537 08	HYDRAULIK
TEMPERATURSENSOR	10 11 740 5	1	1	9 739 318	97 39 318	SENSORIK
TEMPERATURSENSOR	10 11 740 6	2	1	9 739 318	97 39 318	SENSORIK
THERMOSCHALTER 55-50GR	69 11 832 08	(2)	1	2 391 102	96 56 360 08	ZUSATZKUEHLER VORM.
THERMOSTAT	10 01 232 0	11	2	9 739 126	97 39 126	THERMOSTATGEHAEUSE
THERMOSTAT	57 18 677 08	44	1	X1022811	10 22 811 2	HEIZKLIMAGERAET
THERMOSTATGEHAEUSE	97 39 126	172	1	X1012059	10 12 059 0	DIESELMOTOR
TOPF	10 27 991 9	2	1	5 517 203	55 17 203 08	LUFTFILTER
TRAEGER	10 34 310 5	11	1	9 739 371	97 39 371	KLIMAKOMPRESSOR ANBAU
TRAEGER	90 77 248	277	1	9 739 400	97 39 400	DIESELMOTOR
TRAEGER SCHWK.	96 54 709 08	8	2	2 810 001	96 43 597 08	KRANFUEHRERKABINE VORM
TRAGROLLE 80/5/20X510 ST.5	74 90 120 08	150	1	3 713	91 57 749 08	D-ANLENKSTUECK
TRAGROLLE 80/5/20X950 ST.5	74 90 102 08	1	1	3 211 002	92 88 302 08	SCHUTZWALZE KPL.
TRAGSCHIENE	97 03 448 08	149	1	2 391 001	96 45 719 08	DIESELMOTOR VORM.
TRAGSCHIENE	97 03 448 08	92	18	3 211	91 57 748 08	S-ANLENKSTUECK
TRAGSCHIENE	97 03 448 08	139	2	3 713	91 57 749 08	D-ANLENKSTUECK
TRAGSCHIENE	97 03 448 08	86	4	3 714	91 52 862 08	D-KOPFSTUECK
TRAGSCHIENE 140	95 41 173 08	7	1	2 310	91 52 503 08	WINDE 1
TRAGSCHIENE 140	95 41 173 08	7	1	2 320	91 52 504 08	WINDE 2
TRAGSCHIENE 140	95 41 173 08	156	1	2 970	91 56 537 08	HYDRAULIK
TRAGSCHIENE 140	95 41 173 08	13	4	2 978 100	91 52 796 08	ZUSATZHYDR.MONTAGEEINR
TRAGSCHIENE 140	95 41 173 08	33	2	3 350	91 52 859 08	WINDE 3
TRAGSCHIENE 190	95 41 286 08	23	1	2 671 004	96 46 305 08	OELBEHAELTER VORM.
TRAGSCHIENE 240	95 41 174 08	30	2	2 310	91 52 503 08	WINDE 1
TRAGSCHIENE 240	95 41 174 08	30	2	2 320	91 52 504 08	WINDE 2
TRAGSCHIENE 240	95 41 174 08	151	1	2 391 001	96 45 719 08	DIESELMOTOR VORM.
TRAGSCHIENE 240	95 41 174 08	94	6	3 211	91 57 748 08	S-ANLENKSTUECK
TRAGSCHIENE 240	95 41 174 08	137	2	3 713	91 57 749 08	D-ANLENKSTUECK
TRAGSCHIENE 240	95 41 174 08	84	2	3 714	91 52 862 08	D-KOPFSTUECK
TRAGSCHIENE 340	95 41 175 08	29	1	2 310	91 52 503 08	WINDE 1
TRAGSCHIENE 340	95 41 175 08	29	1	2 320	91 52 504 08	WINDE 2
TRAGSCHIENE 340	95 41 175 08	33	2	2 340	91 52 776 08	WINDE 4 EINZIEHWERK
TRAGSCHIENE 340	95 41 175 08	93	2	3 211	91 57 748 08	S-ANLENKSTUECK
TRAGSCHIENE 340	95 41 175 08	34	2	3 350	91 52 859 08	WINDE 3
TRAGSCHIENE 340	95 41 175 08	138	28	3 713	91 57 749 08	D-ANLENKSTUECK
TRAGSCHIENE 340	95 41 175 08	85	9	3 714	91 52 862 08	D-KOPFSTUECK
TRAGSCHIENE 340	95 41 175 08	39	6	3 715 008	91 52 863 08	D-ZWISCHENSTUECK
TRAGSCHIENE 340	95 41 175 08	44	12	3 716	91 52 864 08	D-ZWISCHENSTUECK
TRANSPORTABLAGE QC	91 57 005 08	427	1		LR 1600-2-0	LIEBHERR RAUPENKRAN LR 1
TRANSPORTVORRICHTUNG	97 39 493	210	1	X1012059	10 12 059 0	DIESELMOTOR
TRAPEZRING	10 01 216 0	4	1	9 739 246	97 39 246	KOLBEN
TRENNRELAIS	63 01 201 08	54	1	2 932 082	96 54 387 08	AUFBAUTEILE MONTAGETAPE
TRENNSCHALTRELAIS 24V	63 01 036 08	12	1	2 920 083	96 48 319 08	ELEKTRIK BATTERIEKASTEN
TREPPE	96 54 367 08	45	1	2 631	91 56 817 08	LAUFSTEG DREHBUEHNE
TRICHTER RD200 WEISSBLEC	79 00 444 08	16	1	1 750	91 52 394 08	WERKZEUG
TRIEBWELLE	57 01 134 08	2	1	5 701 129	57 01 129 08	TRIEBWERK
TRIEBWERK	10 21 996 8	1	1	X1035925	10 35 925 1	VERSTELLPUMPE
TRIEBWERK	10 32 692 4	1	1	X1035924	10 35 924 6	VERSTELLPUMPE
TRIEBWERK	10 33 104 7	1	1	X1035924	10 35 924 1	VERSTELLPUMPE

6.2.2009

etk_en_de_074515 LR 1600/2

1116

LIEBHERRAlphabetical index
Alphabetischer Index

Bezeichnung	Artikel	Pos.	Menge	Seite	Baugruppe	Bezeichnung
TRIEBWERK	10 33 104 7	1	1	X1035924	10 35 924 2	VERSTELLPUMPE
TRIEBWERK	10 33 104 7	1	1	X1035925	10 35 925 0	VERSTELLPUMPE
TRIEBWERK	10 47 137 0	1	1	X1035924	10 35 924 3	VERSTELLPUMPE
TRIEBWERK	10 47 138 0	1	1	X1035924	10 35 924 4	VERSTELLPUMPE
TRIEBWERK	10 47 218 5	1	1	X1035924	10 35 924 7	VERSTELLPUMPE
TRIEBWERK	10 47 220 4	1	1	X1035924	10 35 924 8	VERSTELLPUMPE
TRIEBWERK	10 65 006 5	1	1	5 102 354	51 02 354 08	HYDROMOTOR
TRIEBWERK	10 65 068 5	1	1	X1035924	10 35 924 9	VERSTELLPUMPE
TRIEBWERK	57 01 129 08	1	1	5 102 306	51 02 306 08	HYDROMOTOR
TRIEBWERK	57 01 133 08	1	1	5 701 129	57 01 129 08	TRIEBWERK
TRITT	97 85 605 08	9	1	2 370	91 52 782 08	MONTAGEWINDE
TRITT	97 85 607 08	13	1	2 350	91 52 778 08	DREHWERK
TROCKNER	57 14 890 08	4	1	2 831	91 57 754 08	KLIMAAANLAGE OW
TUELLE GUMMI	59 10 555 08	13	1	2 520 032	96 45 980 08	SCHEIBENWISCHANLAGE EIN
TUELLENGEHAEUSE 16POL	60 56 174 08	(159)	1	2 920 369	96 54 235 08	KLEMMKASTEN KPL.
TUELLENGEHAEUSE 24POL.	60 56 176 08	(158)	1	2 920 369	96 54 235 08	KLEMMKASTEN KPL.
TUELLENGEHAEUSE 24POL.	60 56 176 08	522	3	2 920 633	96 52 651 08	KABELSTRANG
TUER VORM.	96 49 183 08	2	1	2 510	91 52 788 08	DREHBUEHNENVERKLEIDUN
TUER VORM.	96 49 184 08	3	1	2 510	91 52 788 08	DREHBUEHNENVERKLEIDUN
TUERKONTAKTSCHALTER	60 60 207 08	12	1	2 533 066	96 48 365 08	ELEKTRIK ANBAUTEILE KABIN
TUERSCHEIBE ESG-GLAS SP	97 68 851 08	14	1	2 522	91 54 115 08	SCHIEBETUER KPL.
TURAS GS18NIMOCR36	97 11 958 08	7	2	1 400	91 56 853 08	RAUPENTRAEGER KPL.LI.
TURAS GS18NIMOCR36	97 11 958 08	7	2	1 410 300	91 56 855 08	RAUPENTRAEGER KPL.RE.
UEBERDRUCKVENTIL	10 01 228 3	9	1	9 739 372	97 39 372	SCHMIEROELPUMPE
UEBERDRUCKVENTIL	57 17 286 08	280	1	X1041101	10 41 101 5	RUECKFALLSTUETZE
UEBERDRUCKVENTIL	57 17 286 08	260	1	X1041101	10 41 101 8	RUECKFALLSTUETZE
UEBERDRUCKVENTIL 280BAR	10 03 827 4	18	2	7 743 566	77 43 566 08	ELEKTROPUMPE
UEBERGANGSSTUTZEN	10 02 919 5	8	1	9 739 288	97 39 288	KRAFTSTOFFLEITUNG
UEBERGANGSSTUTZEN	10 02 919 5	13	1	9 739 492	97 39 492	ROHRLEITUNG ANBAU
UEBERHITZUNGSSCHUTZ	10 29 012 7	21	1	X1004204	10 04 204 3	WASSERHEIZGERAET
UEBERSTROEMVENTIL	10 27 976 0	9	1	9 739 281	97 39 281	LECKOELLEITUNG
UEBERSTROEMVENTIL	10 28 517 0	21	1	9 739 288	97 39 288	KRAFTSTOFFLEITUNG
UEBERSTROEMVENTIL	10 34 310 0	4	1	X1034309	10 34 309 6	HOCHDRUCKPUMPE
UEBERSTROEMVENTIL	50 26 628 08	12	1	2 990	91 59 244 08	DRUCKLUFTANLAGE
UEBERWURFMUTTER DIN 38	47 74 015 08	593	1	2 990	91 59 244 08	DRUCKLUFTANLAGE
UEBERWURFMUTTER DIN 38	47 74 016 08	20	1	2 391 038	96 47 931 08	OELKUEHLER VORM.
UEBERWURFMUTTER DIN 38	47 74 016 08	593	1	2 970	91 56 537 08	HYDRAULIK
UEBERWURFMUTTER DIN 38	47 74 012 08	582	2	2 970	91 56 537 08	HYDRAULIK
UEBERWURFMUTTER DIN 38	47 74 024 08	591	1	2 970	91 56 537 08	HYDRAULIK
UEBERWURFMUTTER DIN 38	47 74 026 08	584	2	2 970	91 56 537 08	HYDRAULIK
UEBERWURFMUTTER DIN 38	47 74 017 08	586	2	2 970	91 56 537 08	HYDRAULIK
UEBERWURFMUTTER DIN 38	47 74 017 08	598	1	2 978 200	91 54 843 08	ZUSATZHYDR.S-RUECKHALTE
UEBERWURFMUTTER DIN 38	47 74 018 08	595	1	2 970	91 56 537 08	HYDRAULIK
UEBERWURFMUTTER DIN 38	47 74 019 08	588	2	2 970	91 56 537 08	HYDRAULIK
UEBERWURFMUTTER DIN 38	47 74 008 08	597	1	2 970	91 56 537 08	HYDRAULIK
UEBERWURFMUTTER DIN 38	47 74 009 08	576	4	2 970	91 56 537 08	HYDRAULIK
UEBERWURFMUTTER DIN 38	47 74 010 08	60	4	1 970	91 56 958 08	HYDRAULIK RAUPE
UEBERWURFMUTTER DIN 38	47 74 010 08	573	10	2 970	91 56 537 08	HYDRAULIK
UEBERWURFMUTTER DIN 387	47 74 001 08	590	2	2 990	91 59 244 08	DRUCKLUFTANLAGE
UMSCHALTBLOCK SPF	10 28 786 3	10	2	2 970	91 56 537 08	HYDRAULIK
UMWAE LZPUMPE	10 29 012 1	2	1	X1004204	10 04 204 3	WASSERHEIZGERAET
UMWAE LZPUMPE	55 31 353 08	2	1	5 530 545	55 30 545 08	UMWAE LZPUMPE
UMWAE LZPUMPE U4846	55 30 545 08	6	1	2 540	91 53 253 08	HEIZKLIMAGERAET EINBAU
UNIVERSALAUFTRITT 30X160X	78 89 058 08	2	1	2 631 003	96 54 406 08	AUFSTIEG VORM.
UNIVERSALVERBINDUNGSGL	74 00 026 08	4	2	2 372	91 33 648 08	SEIL MONTAGEWINDE M.ZUB
UNTERTEIL	60 66 620 08	1	1	2 780 244	91 52 951 08	NOTAUS KRANFUEHRERKAB
USIT-RING U 6,7X10X1	51 45 080 08	18	1	7 027 481	70 27 481 03	WASSERABSCHIEDER
VENTIL	57 10 768 08	(1)	1	2 975 700	91 52 774 08	ZUSATZHYDRAULIK WINDE 1
VENTIL	76 22 478	16	1	X1022811	10 22 811 2	HEIZKLIMAGERAET
VENTIL DIN 71401 C M14X1,5	73 00 009 08	74	1	2 391 001	96 45 719 08	DIESELMOTOR VORM.

6.2.2009

etk_en_de_074515 LR 1600/2

1117

LIEBHERRAlphabetical index
Alphabetischer Index

Bezeichnung	Artikel	Pos.	Menge	Seite	Baugruppe	Bezeichnung
VENTILATORHAUBE	10 65 067 1	3	1	X1035519	10 35 519 6	OEL-LUFTKUEHLER
VENTILBRUECKE	10 01 706 2	1	1	9 739 187	97 39 187	STEUERUNGSTEILE
VENTILBRUECKE	10 01 706 4	3	1	9 739 187	97 39 187	STEUERUNGSTEILE
VENTILEINSATZ	57 17 780 08	57	1	5 102 380	51 02 380 08	HYDROMOTOR
VENTILFEDER 4,25X28,35X63,	10 01 221 0	5	4	9 739 261	97 39 261	ZYLINDERKOPF
VENTILKEGELSTUECK	10 10 164 9	9	8	9 739 261	97 39 261	ZYLINDERKOPF
VENTILSCHAFTDICHTUNG	10 01 224 7	3	4	9 739 261	97 39 261	ZYLINDERKOPF
VENTILSCHAFTDICHTUNG	10 01 224 7	75	4	X1022281	10 22 281 7	DS ZYLINDERKOPF
VENTILSCHRAUBE	57 00 731 08	9	1	5 114 320	51 14 320 08	VORSPANNVENTIL
VENTILSITZ	51 07 976 08	10	1	5 114 176	51 14 176 08	DRUCKBEGRENZUNGSVENTI
VENTILSITZ	51 07 976 08	10	1	5 114 177	51 14 177 08	DRUCKBEGRENZUNGSVENTI
VENTILSITZ	57 00 098 08	14	1	5 026 126	50 26 126 08	MAGNETVENTIL
VENTILSITZ	57 06 475 08	3	1	5 711 301	57 11 301 08	DRUCKBEGRENZUNGSVENTI
VENTILSITZHUELSE	57 17 779 08	56	1	5 102 380	51 02 380 08	HYDROMOTOR
VENTILSTOESSEL	10 01 711 0	5	2	9 739 187	97 39 187	STEUERUNGSTEILE
VERBINDUNGSGLIED SPF	10 33 216 1	2	2	2 372	91 33 648 08	SEIL MONTAGEWINDE M.ZUB
VERBINDUNGSKABEL 8 X 0,37	10 45 542 1	15	1	2 925 002	96 58 856 08	AUSRUESTUNG KAMERA DRE
VERBINDUNGSLEITUNG	97 39 271	126	1	X1012059	10 12 059 0	DIESELMOTOR
VERDRAHTUNGSKANAL 80X6	63 81 092 01	20	0.62	2 932 082	96 54 387 08	AUFBAUTEILE MONTAGETAPE
VERFLUESSIGER AL	10 11 371 2	2	1	2 831	91 57 754 08	KLIMAAANLAGE OW
VERKABELUNG MONTAGETAPE	96 54 388 08	5	1	2 932 082	96 54 387 08	AUFBAUTEILE MONTAGETAPE
VERKLEIDUNG	97 69 826 08	12	1	2 520 034	96 45 984 08	INNENVERKLEIDUNG
VERKLEIDUNG A-SAEULE LI.	97 69 656 08	1	1	2 520 034	96 45 984 08	INNENVERKLEIDUNG
VERKLEIDUNG A-SAEULE RE.	97 69 657 08	2	1	2 520 034	96 45 984 08	INNENVERKLEIDUNG
VERKLEIDUNG ABLAGE SPF	97 69 890 08	3	1	2 520 034	96 45 984 08	INNENVERKLEIDUNG
VERKLEIDUNG ABLAGE SPF	97 69 891 08	4	1	2 520 034	96 45 984 08	INNENVERKLEIDUNG
VERKLEIDUNG ABS-TPU SPF	97 68 730 08	11	1	2 522	91 54 115 08	SCHIEBETUER KPL.
VERKLEIDUNG ABS-TPU SPF	97 68 734 08	12	1	2 522	91 54 115 08	SCHIEBETUER KPL.
VERKLEIDUNG DACH SPF	97 71 040 08	17	1	2 520 034	96 45 984 08	INNENVERKLEIDUNG
VERKLEIDUNG HOLM LI. SPF	97 71 451 08	6	1	2 520 034	96 45 984 08	INNENVERKLEIDUNG
VERKLEIDUNG HOLM RE. SPF	97 71 452 08	7	1	2 520 034	96 45 984 08	INNENVERKLEIDUNG
VERKLEIDUNG LI.	97 70 806 08	15	1	2 520 034	96 45 984 08	INNENVERKLEIDUNG
VERKLEIDUNG LI. SPF	97 69 827 08	13	1	2 520 034	96 45 984 08	INNENVERKLEIDUNG
VERKLEIDUNG OBEN RECHTS	97 70 804 08	14	1	2 520 034	96 45 984 08	INNENVERKLEIDUNG
VERKLEIDUNG ROLLO SPF	97 71 455 08	18	1	2 520 034	96 45 984 08	INNENVERKLEIDUNG
VERKLEIDUNG RUECKWAND	97 70 807 08	16	1	2 520 034	96 45 984 08	INNENVERKLEIDUNG
VERKLEIDUNG SPF	97 69 892 08	5	1	2 520 034	96 45 984 08	INNENVERKLEIDUNG
VERKLEIDUNG UNTEN LINKS	97 69 824 08	10	1	2 520 034	96 45 984 08	INNENVERKLEIDUNG
VERKLEIDUNG UNTEN RECHT	97 69 825 08	11	1	2 520 034	96 45 984 08	INNENVERKLEIDUNG
VERLAENGERUNG 35	77 43 735 08	14	8	2 711	91 52 800 08	ZENTRALSCHMIERANLAGE O
VERLAENGERUNG M10X1	77 43 734 08	7	46	1 711	91 52 392 08	ZENTRALSCHMIERUNG RAUP
VERSCHLUSSDECKEL	10 01 212 9	2	1	9 739 354	97 39 354	SCHWUNGRADGEHAEUSE AN
VERSCHLUSSDECKEL	10 01 260 2	7	1	9 739 354	97 39 354	SCHWUNGRADGEHAEUSE AN
VERSCHLUSSDECKEL	10 01 333 6	5	1	9 739 267	97 39 267	ZYLINDERKOPFFHAUBE
VERSCHLUSSDECKEL	97 39 286	10	1	9 739 491	97 39 491	LUFTPRESSER ANBAU
VERSCHLUSSDECKEL	97 39 365	3	1	9 739 368	97 39 368	KURBELGEHAEUSE KPL.
VERSCHLUSSDECKEL	97 39 367	2	1	9 739 368	97 39 368	KURBELGEHAEUSE KPL.
VERSCHLUSSDECKEL SJ 355	97 39 036	1	1	9 739 035	97 39 035	VERSCHLUSSTEIL
VERSCHLUSSEINSATZ 8MM V	10 02 217 7	5	1	2 932 001	96 45 393 08	RELAISSTEUERUNG
VERSCHLUSSKAPPE M 1-K	60 45 085 08	(502)	1	2 920 288	96 52 614 08	KABELLISTE DREHBUEHNE
VERSCHLUSSKAPPE M1-D	60 45 121 08	286	2	3 930 638	96 51 624 08	KLEMMKASTEN
VERSCHLUSSKAPPE M1-D	60 45 121 08	(155)	1	3 930 640	96 50 481 08	KLEMMKASTEN KPL.
VERSCHLUSSKAPPE M1-D	60 45 121 08	288	1	3 930 640	96 50 481 08	KLEMMKASTEN KPL.
VERSCHLUSSKAPPE M1-D	60 45 121 08	153	1	3 930 730	96 50 599 08	KLEMMKASTEN KPL.
VERSCHLUSSLAGER	70 42 185 08	39	2	2 391 040	96 53 645 08	KUPPLUNGSSTELLER
VERSCHLUSSLAGER	70 42 185 08	56	1	2 631	91 56 817 08	LAUFSTEG DREHBUEHNE
VERSCHLUSSMUTTER	51 05 453 08	40	2	1 970	91 56 958 08	HYDRAULIK RAUPE
VERSCHLUSSMUTTER	51 05 453 08	93	5	2 970	91 56 537 08	HYDRAULIK
VERSCHLUSSMUTTER	51 05 453 08	12	2	2 970 081	96 50 495 08	ZUSATZHYDR.BOLZENZIEHZ
VERSCHLUSSMUTTER	51 05 453 08	38	1	2 975 200	91 52 775 08	ZUSATZHYDRAULIK WINDE 2

6.2.2009

etk_en_de_074515 LR 1600/2

1118

LIEBHERRAlphabetical index
Alphabetischer Index

Bezeichnung	Artikel	Pos.	Menge	Seite	Baugruppe	Bezeichnung
VERSCHLUSSMUTTER	51 05 453 08	38	1	2 975 700	91 52 774 08	ZUSATZHYDRAULIK WINDE 1
VERSCHLUSSMUTTER	51 05 453 08	42	1	2 977	91 57 756 08	ZUSATZHYDRAULIK DREHBUE
VERSCHLUSSMUTTER	51 05 453 08	26	1	2 978 200	91 54 843 08	ZUSATZHYDR.S-RUECKHALTE
VERSCHLUSSMUTTER	51 05 456 08	32	4	1 970	91 56 958 08	HYDRAULIK RAUPE
VERSCHLUSSMUTTER	51 05 456 08	81	5	2 970	91 56 537 08	HYDRAULIK
VERSCHLUSSMUTTER	51 05 456 08	22	2	2 975 100	91 52 860 08	ZUSATZHYDRAULIK WINDE 3
VERSCHLUSSMUTTER	51 05 456 08	32	5	2 977	91 57 756 08	ZUSATZHYDRAULIK DREHBUE
VERSCHLUSSMUTTER	51 05 456 08	6	2	3 978 015	91 56 429 08	ZUSATZHYDRAULIK ZWISCH
VERSCHLUSSMUTTER	51 05 456 08	6	2	3 978 015	91 56 432 08	ZUSATZHYDRAULIK ZWISCH
VERSCHLUSSMUTTER	51 05 458 08	36	2	1 970	91 56 958 08	HYDRAULIK RAUPE
VERSCHLUSSMUTTER	51 05 458 08	85	12	2 970	91 56 537 08	HYDRAULIK
VERSCHLUSSMUTTER	51 05 458 08	26	2	2 975 100	91 52 860 08	ZUSATZHYDRAULIK WINDE 3
VERSCHLUSSMUTTER	51 05 458 08	36	2	2 977	91 57 756 08	ZUSATZHYDRAULIK DREHBUE
VERSCHLUSSMUTTER	51 05 458 08	22	3	2 978 200	91 54 843 08	ZUSATZHYDR.S-RUECKHALTE
VERSCHLUSSMUTTER	51 15 040 08	22	1	1 970	91 56 958 08	HYDRAULIK RAUPE
VERSCHLUSSMUTTER	51 15 040 08	101	6	2 970	91 56 537 08	HYDRAULIK
VERSCHLUSSMUTTER	51 15 040 08	6	2	2 970 081	96 50 495 08	ZUSATZHYDR.BOLZENZIEHZ
VERSCHLUSSMUTTER	51 15 040 08	34	3	2 975 100	91 52 860 08	ZUSATZHYDRAULIK WINDE 3
VERSCHLUSSMUTTER	51 15 040 08	34	1	2 975 200	91 52 775 08	ZUSATZHYDRAULIK WINDE 2
VERSCHLUSSMUTTER	51 15 040 08	34	1	2 975 700	91 52 774 08	ZUSATZHYDRAULIK WINDE 1
VERSCHLUSSMUTTER	51 15 040 08	6	3	2 976 200	91 44 034 08	ZUS.HYDR.BOLZENZIEHEINRI
VERSCHLUSSMUTTER	51 15 040 08	6	1	2 976 203	92 27 489 08	ZUSATZHYDR.BOLZENZIEHZ
VERSCHLUSSMUTTER	51 15 040 08	12	1	3 978 015	91 56 429 08	ZUSATZHYDRAULIK ZWISCH
VERSCHLUSSMUTTER	51 15 040 08	12	1	3 978 015	91 56 432 08	ZUSATZHYDRAULIK ZWISCH
VERSCHLUSSMUTTER RD32X	10 46 691 4	28	1	3 978 100	91 56 428 08	HYDR.SCHWEBEBALLAST-AN
VERSCHLUSSMUTTER RD54X	10 46 691 6	26	1	2 975 200	91 52 775 08	ZUSATZHYDRAULIK WINDE 2
VERSCHLUSSMUTTER RD54X	10 46 691 6	30	1	2 975 200	91 52 775 08	ZUSATZHYDRAULIK WINDE 2
VERSCHLUSSMUTTER RD54X	10 46 691 6	26	1	2 975 700	91 52 774 08	ZUSATZHYDRAULIK WINDE 1
VERSCHLUSSMUTTER RD54X	10 46 691 6	30	1	2 975 700	91 52 774 08	ZUSATZHYDRAULIK WINDE 1
VERSCHLUSSMUTTER RD79X	10 46 691 7	22	2	2 975 200	91 52 775 08	ZUSATZHYDRAULIK WINDE 2
VERSCHLUSSMUTTER RD79X	10 46 691 7	22	2	2 975 700	91 52 774 08	ZUSATZHYDRAULIK WINDE 1
VERSCHLUSSMUTTER RD79X	10 46 691 7	22	2	3 978 100	91 56 428 08	HYDR.SCHWEBEBALLAST-AN
VERSCHLUSSNIPPEL	51 15 062 08	13	1	2 990	91 59 244 08	DRUCKLUFTANLAGE
VERSCHLUSSRING	57 01 136 08	4	1	5 701 129	57 01 129 08	TRIEBWERK
VERSCHLUSSSCHRAUBE	10 41 274 8	19	1	9 640 276	96 40 276 08	ANSCHLUSSBLOCK
VERSCHLUSSSCHRAUBE	51 05 455 08	34	4	1 970	91 56 958 08	HYDRAULIK RAUPE
VERSCHLUSSSCHRAUBE	51 05 455 08	83	6	2 970	91 56 537 08	HYDRAULIK
VERSCHLUSSSCHRAUBE	51 05 455 08	34	5	2 977	91 57 756 08	ZUSATZHYDRAULIK DREHBUE
VERSCHLUSSSCHRAUBE	51 05 455 08	14	2	2 977 200	91 55 149 08	ZUSATZHYDR.PUMPE 5/WIND
VERSCHLUSSSCHRAUBE	51 05 455 08	15	1	3 978 005	91 56 430 08	ZUSATZHYDRAULIK SB-KOPFS
VERSCHLUSSSCHRAUBE	57 17 778 08	55	1	5 102 380	51 02 380 08	HYDROMOTOR
VERSCHLUSSSCHRAUBE	97 39 096	2	1	X1012059	10 12 059 0	DIESELMOTOR
VERSCHLUSSSCHRAUBE AM	10 01 696 8	19	1	9 739 349	97 39 349	WASSERLEITUNGSANSCHLUE
VERSCHLUSSSCHRAUBE DIN	46 00 319	60	4	X1065015	10 65 015 8	ANTRIEB
VERSCHLUSSSCHRAUBE DIN	51 07 192 08	122	1	X1065015	10 65 015 8	ANTRIEB
VERSCHLUSSSCHRAUBE DIN	40 41 001 08	7	1	5 113 005	51 13 005 08	STUEBERBLOCK
VERSCHLUSSSCHRAUBE DIN	40 41 002 08	(4)	2	2 810	91 52 806 08	KRANFUEHRERKABINE KPL.
VERSCHLUSSSCHRAUBE DIN	40 41 002 08	64	1	X1065015	10 65 015 8	ANTRIEB
VERSCHLUSSSCHRAUBE DIN	40 41 017 08	530	2	X1065015	10 65 015 5	GETRIEBE
VERSCHLUSSSCHRAUBE DIN	40 41 016 08	24	1	9 739 491	97 39 491	LUFTPRESSER ANBAU
VERSCHLUSSSCHRAUBE DIN	40 41 007 08	462	4	X1065015	10 65 015 5	GETRIEBE
VERSCHLUSSSCHRAUBE M12	60 24 255 08	152	1	2 780 748	96 52 969 08	KLEMMKASTEN KPL.
VERSCHLUSSSCHRAUBE M12	60 24 255 08	271	1	3 930 638	96 51 624 08	KLEMMKASTEN
VERSCHLUSSSCHRAUBE M12	60 24 255 08	152	2	3 930 640	96 50 481 08	KLEMMKASTEN KPL.
VERSCHLUSSSCHRAUBE M12	60 24 255 08	214	1	3 930 734	96 54 401 08	KLEMMKASTEN
VERSCHLUSSSCHRAUBE M14	10 01 161 2	2	2	9 739 282	97 39 282	LECKOELLEITUNG
VERSCHLUSSSCHRAUBE M14	10 01 161 2	15	2	9 739 361	97 39 361	OELWANNE
VERSCHLUSSSCHRAUBE M16	60 24 249 08	269	1	1 920 403	96 48 707 08	KLEMMKASTEN KPL.
VERSCHLUSSSCHRAUBE M16	60 24 249 08	269	1	1 920 417	96 48 703 08	KLEMMKASTEN KPL.
VERSCHLUSSSCHRAUBE M16	60 24 249 08	151	1	2 780 748	96 52 969 08	KLEMMKASTEN KPL.

6.2.2009

etk_en_de_074515 LR 1600/2

1119

LIEBHERRAlphabetical index
Alphabetischer Index

Bezeichnung	Artikel	Pos.	Menge	Seite	Baugruppe	Bezeichnung
VERSCHLUSSSCHRAUBE M16	60 24 249 08	279	3	3 930 363	96 52 979 08	KLEMMKASTEN KPL.
VERSCHLUSSSCHRAUBE M16	60 24 249 08	273	1	3 930 638	96 51 624 08	KLEMMKASTEN
VERSCHLUSSSCHRAUBE M16	60 24 249 08	152	2	3 930 730	96 54 398 08	KLEMMKASTEN KPL.
VERSCHLUSSSCHRAUBE M16	10 01 252 2	1	1	9 739 096	97 39 096	VERSCHLUSSSCHRAUBE
VERSCHLUSSSCHRAUBE M18	10 01 161 5	5	1	9 739 355	97 39 355	OELKUEHLER ANBAU
VERSCHLUSSSCHRAUBE M20	60 24 250 08	268	1	1 920 403	96 48 707 08	KLEMMKASTEN KPL.
VERSCHLUSSSCHRAUBE M20	60 24 250 08	268	1	1 920 417	96 48 703 08	KLEMMKASTEN KPL.
VERSCHLUSSSCHRAUBE M20	60 24 250 08	7	1	3 930 640	96 50 481 08	KLEMMKASTEN KPL.
VERSCHLUSSSCHRAUBE M20	60 24 250 08	215	1	3 930 734	96 54 401 08	KLEMMKASTEN
VERSCHLUSSSCHRAUBE M22	10 34 227 2	6	1	9 739 351	97 39 351	KUEHLMITTELLEITUNG ANBA
VERSCHLUSSSCHRAUBE M2	10 34 023 6	13	2	7 027 481	70 27 481 03	WASSERABSCHIEDER
VERSCHLUSSSCHRAUBE M2	50 29 401 08	596	2	2 990	91 59 244 08	DRUCKLUFTANLAGE
VERSCHLUSSSCHRAUBE M25	60 24 251 08	19	3	1 920 418	96 48 687 08	KLEMMKASTEN KPL.
VERSCHLUSSSCHRAUBE M25	60 24 251 08	(159)	1	2 920 369	96 54 235 08	KLEMMKASTEN KPL.
VERSCHLUSSSCHRAUBE M25	60 24 251 08	(160)	1	2 920 369	96 54 235 08	KLEMMKASTEN KPL.
VERSCHLUSSSCHRAUBE M25	60 24 251 08	519	6	2 920 633	96 52 651 08	KABELSTRANG
VERSCHLUSSSCHRAUBE M25	60 24 251 08	272	1	3 930 638	96 51 624 08	KLEMMKASTEN
VERSCHLUSSSCHRAUBE M25	60 24 251 08	157	1	3 930 730	96 50 599 08	KLEMMKASTEN KPL.
VERSCHLUSSSCHRAUBE M25	60 24 251 08	158	1	3 930 730	96 50 599 08	KLEMMKASTEN KPL.
VERSCHLUSSSCHRAUBE M25	60 24 251 08	220	3	3 930 734	96 54 401 08	KLEMMKASTEN
VERSCHLUSSSCHRAUBE M25	10 01 252 6	7	1	9 739 361	97 39 361	OELWANNE
VERSCHLUSSSCHRAUBE M26	10 01 161 9	9	2	9 739 361	97 39 361	OELWANNE
VERSCHLUSSSCHRAUBE M26	10 01 161 9	21	2	9 739 491	97 39 491	LUFTPRESSER ANBAU
VERSCHLUSSSCHRAUBE M32	60 24 252 08	(154)	1	2 920 369	96 54 235 08	KLEMMKASTEN KPL.
VERSCHLUSSSCHRAUBE M32	60 24 252 08	286	2	2 920 448	96 48 794 08	KLEMMKASTEN KPL.
VERSCHLUSSSCHRAUBE M32	60 24 252 08	150	2	3 930 730	96 54 398 08	KLEMMKASTEN KPL.
VERSCHLUSSSCHRAUBE RD3	10 46 690 6	14	1	3 978 015	91 56 429 08	ZUSATZHYDRAULIK ZWISCH
VERSCHLUSSSCHRAUBE RD3	10 46 690 6	14	1	3 978 015	91 56 432 08	ZUSATZHYDRAULIK ZWISCH
VERSCHLUSSSCHRAUBE RD3	10 46 691 0	24	1	1 970	91 56 958 08	HYDRAULIK RAUPE
VERSCHLUSSSCHRAUBE RD3	10 46 691 0	103	3	2 970	91 56 537 08	HYDRAULIK
VERSCHLUSSSCHRAUBE RD3	10 46 691 0	8	1	2 970 081	96 50 495 08	ZUSATZHYDR.BOLZENZIEHZ
VERSCHLUSSSCHRAUBE RD3	10 46 691 0	36	4	2 975 100	91 52 860 08	ZUSATZHYDRAULIK WINDE 3
VERSCHLUSSSCHRAUBE RD3	10 46 691 0	36	1	2 975 200	91 52 775 08	ZUSATZHYDRAULIK WINDE 2
VERSCHLUSSSCHRAUBE RD3	10 46 691 0	36	1	2 975 700	91 52 774 08	ZUSATZHYDRAULIK WINDE 1
VERSCHLUSSSCHRAUBE RD3	10 46 691 0	8	3	2 976 200	91 44 034 08	ZUS.HYDR.BOLZENZIEHEINRI
VERSCHLUSSSCHRAUBE RD3	10 46 691 0	8	1	2 976 203	92 27 489 08	ZUSATZHYDR.BOLZENZIEHZ
VERSCHLUSSSCHRAUBE RD3	10 46 691 0	20	1	3 978 005	91 56 430 08	ZUSATZHYDRAULIK SB-KOPFS
VERSCHLUSSSCHRAUBE RD3	10 46 690 7	38	2	2 975 100	91 52 860 08	ZUSATZHYDRAULIK WINDE 3
VERSCHLUSSSCHRAUBE RD3	10 46 690 7	26	1	2 978 100	91 52 827 08	ZUSATZHYDR.D-RUECKHALT
VERSCHLUSSSCHRAUBE RD3	10 46 691 1	42	2	1 970	91 56 958 08	HYDRAULIK RAUPE
VERSCHLUSSSCHRAUBE RD3	10 46 691 1	95	6	2 970	91 56 537 08	HYDRAULIK
VERSCHLUSSSCHRAUBE RD3	10 46 691 1	14	1	2 970 081	96 50 495 08	ZUSATZHYDR.BOLZENZIEHZ
VERSCHLUSSSCHRAUBE RD3	10 46 691 1	12	1	2 976 200	91 44 034 08	ZUS.HYDR.BOLZENZIEHEINRI
VERSCHLUSSSCHRAUBE RD3	10 46 691 1	44	1	2 977	91 57 756 08	ZUSATZHYDRAULIK DREHBUE
VERSCHLUSSSCHRAUBE RD3	10 46 691 1	25	2	2 977 200	91 55 149 08	ZUSATZHYDR.PUMPE 5/WIND
VERSCHLUSSSCHRAUBE RD5	10 46 690 8	39	2	2 975 100	91 52 860 08	ZUSATZHYDRAULIK WINDE 3
VERSCHLUSSSCHRAUBE RD5	10 46 690 8	22	2	2 978 100	91 52 827 08	ZUSATZHYDR.D-RUECKHALT
VERSCHLUSSSCHRAUBE RD5	10 46 690 8	10	6	3 713 013	96 57 159 08	BLECH KPL.
VERSCHLUSSSCHRAUBE RD5	10 46 690 8	32	2	3 978 100	91 56 428 08	HYDR.SCHWEBEBALLAST-AN
VERSCHLUSSSCHRAUBE RD5	10 46 691 2	38	2	1 970	91 56 958 08	HYDRAULIK RAUPE
VERSCHLUSSSCHRAUBE RD5	10 46 691 2	87	8	2 970	91 56 537 08	HYDRAULIK
VERSCHLUSSSCHRAUBE RD5	10 46 691 2	28	2	2 975 100	91 52 860 08	ZUSATZHYDRAULIK WINDE 3
VERSCHLUSSSCHRAUBE RD5	10 46 691 2	14	1	2 976 200	91 44 034 08	ZUS.HYDR.BOLZENZIEHEINRI
VERSCHLUSSSCHRAUBE RD5	10 46 691 2	38	2	2 977	91 57 756 08	ZUSATZHYDRAULIK DREHBUE
VERSCHLUSSSCHRAUBE RD5	10 46 691 2	21	1	2 977 200	91 55 149 08	ZUSATZHYDR.PUMPE 5/WIND
VERSCHLUSSSCHRAUBE RD5	10 46 691 2	28	2	2 978 100	91 52 796 08	ZUSATZHYDR.MONTAGEEINR
VERSCHLUSSSCHRAUBE RD7	10 46 690 9	25	2	2 975 100	91 52 860 08	ZUSATZHYDRAULIK WINDE 3
VERSCHLUSSSCHRAUBE RD7	10 46 690 9	11	2	3 713 013	96 57 159 08	BLECH KPL.
VERSCHLUSSSCHRAUBE RD7	10 46 690 9	7	2	3 978 015	91 56 429 08	ZUSATZHYDRAULIK ZWISCH
VERSCHLUSSSCHRAUBE RD7	10 46 690 9	7	2	3 978 015	91 56 432 08	ZUSATZHYDRAULIK ZWISCH

6.2.2009

etk_en_de_074515 LR 1600/2

1120

LIEBHERRAlphabetical index
Alphabetischer Index

Bezeichnung	Artikel	Pos.	Menge	Seite	Baugruppe	Bezeichnung
VERSCHLUSSSCHRAUBE RD7	10 46 691 3	24	2	2 975 100	91 52 860 08	ZUSATZHYDRAULIK WINDE 3
VERSCHLUSSSCHRAUBE VSTI	47 75 104 01	2	7	9 697 916	96 97 916 01	DREHWERK
VERSCHLUSSSCHRAUBE VSTI	47 75 104 01	78	3	9 697 916	96 97 916 01	DREHWERK
VERSCHLUSSSTOPFEN	10 01 262 8	6	2	9 739 354	97 39 354	SCHWUNGRADGEHAEUSE AN
VERSCHLUSSSTOPFEN	77 90 162 01	88	1	9 697 916	96 97 916 01	DREHWERK
VERSCHLUSSTEIL	97 39 035	282	1	9 739 400	97 39 400	DIESELMOTOR
VERSCHMUTZUNGSANZEIGE	51 06 693 08	10	1	2 671 004	96 46 305 08	OELBEHAELTER VORM.
VERSCHMUTZUNGSANZEIGE	51 06 693 08	50	1	5 106 691	51 06 691 08	RUECKLAUFFILTER
VERSCHMUTZUNGSANZEIGE	57 13 561 08	(4)	1	2 970	91 56 537 08	HYDRAULIK
VERSCHRAUBUNG	57 00 660 08	2	1	5 028 065	50 28 065 08	AUSGLEICHSBEHAELTER
VERSCHRAUBUNG BUZ 12L C	47 77 005 08	594	1	2 970	91 56 537 08	HYDRAULIK
VERSCHRAUBUNG BUZ 15L C	47 77 006 08	583	2	2 970	91 56 537 08	HYDRAULIK
VERSCHRAUBUNG BUZ 25S C	47 77 015 08	598	1	2 970	91 56 537 08	HYDRAULIK
VERSCHRAUBUNG BUZ 35L C	47 77 007 08	596	1	2 970	91 56 537 08	HYDRAULIK
VERSCHRAUBUNG BUZ 42L C	47 77 009 08	589	2	2 970	91 56 537 08	HYDRAULIK
VERSCHRAUBUNG EGE 10L G	47 19 043 08	732	5	2 970	91 56 537 08	HYDRAULIK
VERSCHRAUBUNG EGE 10L G	47 19 043 08	609	1	2 975 100	91 52 860 08	ZUSATZHYDRAULIK WINDE 3
VERSCHRAUBUNG EGE 10L G	47 19 043 08	622	1	2 975 200	91 52 775 08	ZUSATZHYDRAULIK WINDE 2
VERSCHRAUBUNG EGE 10L G	47 19 043 08	622	1	2 975 700	91 52 774 08	ZUSATZHYDRAULIK WINDE 1
VERSCHRAUBUNG EGE 10L G	47 19 043 08	602	1	2 978 100	91 52 827 08	ZUSATZHYDR.D-RUECKHALT
VERSCHRAUBUNG EGE 10L G	47 19 043 08	607	1	2 978 200	91 54 843 08	ZUSATZHYDR.S-RUECKHALTE
VERSCHRAUBUNG EGE 12S G	47 19 018 08	601	4	1 975 006	91 52 509 08	ZUSATZHYDR.ABSTUETZZYL
VERSCHRAUBUNG EGE 12S G	47 19 018 08	611	1	2 978 100	91 52 796 08	ZUSATZHYDR.MONTAGEEINR
VERSCHRAUBUNG EGESD10-	47 19 011 08	747	3	2 970	91 56 537 08	HYDRAULIK
VERSCHRAUBUNG EGESD10-	47 19 011 08	616	1	2 975 100	91 52 860 08	ZUSATZHYDRAULIK WINDE 3
VERSCHRAUBUNG EGESD10-	47 19 011 08	616	1	2 975 200	91 52 775 08	ZUSATZHYDRAULIK WINDE 2
VERSCHRAUBUNG EGESD10-	47 19 011 08	616	1	2 975 700	91 52 774 08	ZUSATZHYDRAULIK WINDE 1
VERSCHRAUBUNG EGESD10-	47 19 011 08	619	1	2 978 100	91 52 827 08	ZUSATZHYDR.D-RUECKHALT
VERSCHRAUBUNG EGESD12-	47 19 012 08	756	1	2 970	91 56 537 08	HYDRAULIK
VERSCHRAUBUNG EGESD12-	47 19 012 08	601	2	2 978 100	91 52 827 08	ZUSATZHYDR.D-RUECKHALT
VERSCHRAUBUNG EGESD12-	47 19 012 08	606	3	2 978 200	91 54 843 08	ZUSATZHYDR.S-RUECKHALTE
VERSCHRAUBUNG EGESD12-	47 19 038 08	678	3	2 970	91 56 537 08	HYDRAULIK
VERSCHRAUBUNG EGESD12-	47 19 038 08	613	1	2 978 200	91 54 843 08	ZUSATZHYDR.S-RUECKHALTE
VERSCHRAUBUNG EGESD12-	47 19 005 08	643	1	2 978 100	91 52 827 08	ZUSATZHYDR.D-RUECKHALT
VERSCHRAUBUNG EGESD12-	47 19 005 08	608	1	2 978 200	91 54 843 08	ZUSATZHYDR.S-RUECKHALTE
VERSCHRAUBUNG EGESD15-	47 19 042 08	8	1	2 670 002	96 45 352 08	KRAFTSTOFFBEHAELTER VO
VERSCHRAUBUNG EGESD15-	47 19 035 08	612	1	2 978 100	91 52 827 08	ZUSATZHYDR.D-RUECKHALT
VERSCHRAUBUNG EGESD16-	47 19 006 08	651	9	2 970	91 56 537 08	HYDRAULIK
VERSCHRAUBUNG EGESD16-	47 19 006 08	603	3	2 975 000	91 57 881 08	ZUSATZHYDRAULIK MONTAGE
VERSCHRAUBUNG EGESD16-	47 19 006 08	610	8	3 978 005	91 56 430 08	ZUSATZHYDRAULIK SB-KOPFS
VERSCHRAUBUNG EGESD16-	47 19 019 08	658	2	1 970	91 56 958 08	HYDRAULIK RAUPE
VERSCHRAUBUNG EGESD18-	47 19 023 08	613	1	2 990	91 59 244 08	DRUCKLUFTANLAGE
VERSCHRAUBUNG EGESD18-	47 19 013 08	793	1	2 970	91 56 537 08	HYDRAULIK
VERSCHRAUBUNG EGESD20-	47 19 007 08	621	1	1 970	91 56 958 08	HYDRAULIK RAUPE
VERSCHRAUBUNG EGESD20-	47 19 007 08	781	2	2 970	91 56 537 08	HYDRAULIK
VERSCHRAUBUNG EGESD22-	47 19 014 08	623	2	2 970	91 56 537 08	HYDRAULIK
VERSCHRAUBUNG EGESD25-	47 19 008 08	774	3	2 970	91 56 537 08	HYDRAULIK
VERSCHRAUBUNG EGESD25-	47 19 008 08	613	1	3 978 100	91 56 428 08	HYDR.SCHWEBEBALLAST-AN
VERSCHRAUBUNG EGESD28-	47 19 015 08	760	1	2 970	91 56 537 08	HYDRAULIK
VERSCHRAUBUNG EGESD30-	47 19 009 08	603	2	3 978 100	91 56 428 08	HYDR.SCHWEBEBALLAST-AN
VERSCHRAUBUNG EGESD35-	47 19 016 08	606	1	3 978 100	91 56 428 08	HYDR.SCHWEBEBALLAST-AN
VERSCHRAUBUNG EGESD42-	47 19 036 08	643	1	2 970	91 56 537 08	HYDRAULIK
VERSCHRAUBUNG EGESD6-	47 19 020 08	645	2	1 970	91 56 958 08	HYDRAULIK RAUPE
VERSCHRAUBUNG EGESD6-	47 19 020 08	603	2	1 970 161	96 50 706 08	ZUSATZHYDR.RAUPENTRAEG
VERSCHRAUBUNG EGESD6-	47 19 003 08	42	1	2 711	91 52 800 08	ZENTRALSCHMIERANLAGE O
VERSCHRAUBUNG EGESD6-	47 19 003 08	616	2	3 978 005	91 56 430 08	ZUSATZHYDRAULIK SB-KOPFS
VERSCHRAUBUNG EL 16S C	47 23 315 08	754	5	2 970	91 56 537 08	HYDRAULIK
VERSCHRAUBUNG EL 16S C	47 23 315 08	609	3	2 975 000	91 57 881 08	ZUSATZHYDRAULIK MONTAGE
VERSCHRAUBUNG EL 28L CR6	47 23 307 08	788	2	2 970	91 56 537 08	HYDRAULIK
VERSCHRAUBUNG EL 28L CR6	47 23 307 08	623	1	2 975 100	91 52 860 08	ZUSATZHYDRAULIK WINDE 3

6.2.2009

etk_en_de_074515 LR 1600/2

1121

LIEBHERRAlphabetical index
Alphabetischer Index

Bezeichnung	Artikel	Pos.	Menge	Seite	Baugruppe	Bezeichnung
VERSCHRAUBUNG EL 28L CR6	47 23 307 08	625	1	2 978 200	91 54 843 08	ZUSATZHYDR.S-RUECKHALTE
VERSCHRAUBUNG EL 35L CR6	47 23 308 08	626	2	2 970	91 56 537 08	HYDRAULIK
VERSCHRAUBUNG EL 35L CR6	47 23 308 08	608	1	3 978 100	91 56 428 08	HYDR.SCHWEBEBALLAST-AN
VERSCHRAUBUNG ELSD10-L	47 23 302 08	728	20	2 970	91 56 537 08	HYDRAULIK
VERSCHRAUBUNG ELSD10-L	47 23 302 08	613	4	2 975 100	91 52 860 08	ZUSATZHYDRAULIK WINDE 3
VERSCHRAUBUNG ELSD10-L	47 23 302 08	617	4	2 975 200	91 52 775 08	ZUSATZHYDRAULIK WINDE 2
VERSCHRAUBUNG ELSD10-L	47 23 302 08	617	4	2 975 700	91 52 774 08	ZUSATZHYDRAULIK WINDE 1
VERSCHRAUBUNG ELSD10-L	47 23 302 08	603	2	2 978 100	91 52 796 08	ZUSATZHYDR.MONTAGEEINR
VERSCHRAUBUNG ELSD10-L	47 23 302 08	618	2	2 978 100	91 52 827 08	ZUSATZHYDR.D-RUECKHALT
VERSCHRAUBUNG ELSD10-L	47 23 302 08	609	1	2 978 200	91 54 843 08	ZUSATZHYDR.S-RUECKHALTE
VERSCHRAUBUNG ELSD12-L	47 23 303 08	649	11	2 970	91 56 537 08	HYDRAULIK
VERSCHRAUBUNG ELSD12-L	47 23 303 08	611	1	2 975 100	91 52 860 08	ZUSATZHYDRAULIK WINDE 3
VERSCHRAUBUNG ELSD12-L	47 23 303 08	611	2	2 975 200	91 52 775 08	ZUSATZHYDRAULIK WINDE 2
VERSCHRAUBUNG ELSD12-L	47 23 303 08	611	2	2 975 700	91 52 774 08	ZUSATZHYDRAULIK WINDE 1
VERSCHRAUBUNG ELSD12-L	47 23 303 08	617	2	2 978 100	91 52 827 08	ZUSATZHYDR.D-RUECKHALT
VERSCHRAUBUNG ELSD12-L	47 23 303 08	615	4	2 978 200	91 54 843 08	ZUSATZHYDR.S-RUECKHALTE
VERSCHRAUBUNG ELSD12-L	47 23 303 08	624	1	3 978 005	91 56 430 08	ZUSATZHYDRAULIK SB-KOPFS
VERSCHRAUBUNG ELSD12-S	47 23 314 08	606	4	1 975 006	91 52 509 08	ZUSATZHYDR.ABSTUETZZYL
VERSCHRAUBUNG ELSD12-S	47 23 314 08	602	1	2 978 200	91 54 843 08	ZUSATZHYDR.S-RUECKHALTE
VERSCHRAUBUNG ELSD15-L	47 23 304 08	614	1	2 978 100	91 52 827 08	ZUSATZHYDR.D-RUECKHALT
VERSCHRAUBUNG ELSD18-L	47 23 305 08	610	1	1 970	91 56 958 08	HYDRAULIK RAUPE
VERSCHRAUBUNG ELSD18-L	47 23 305 08	633	1	2 970	91 56 537 08	HYDRAULIK
VERSCHRAUBUNG ELSD18-L	47 23 305 08	606	1	2 975 000	91 57 881 08	ZUSATZHYDRAULIK MONTAGE
VERSCHRAUBUNG ELSD18-L	47 23 305 08	609	2	2 976 200	91 52 780 08	ZUSATZHYDRAULIK DREHWE
VERSCHRAUBUNG ELSD18-L	47 23 305 08	617	1	2 978 200	91 54 843 08	ZUSATZHYDR.S-RUECKHALTE
VERSCHRAUBUNG ELSD18-L	47 23 305 08	623	1	2 990	91 59 244 08	DRUCKLUFTANLAGE
VERSCHRAUBUNG ELSD20-S	47 23 316 08	640	1	1 970	91 56 958 08	HYDRAULIK RAUPE
VERSCHRAUBUNG ELSD20-S	47 23 316 08	644	3	2 970	91 56 537 08	HYDRAULIK
VERSCHRAUBUNG ELSD22-L	47 23 306 08	665	1	1 970	91 56 958 08	HYDRAULIK RAUPE
VERSCHRAUBUNG ELSD22-L	47 23 306 08	621	5	2 970	91 56 537 08	HYDRAULIK
VERSCHRAUBUNG ELSD25-S	47 23 317 08	762	6	2 970	91 56 537 08	HYDRAULIK
VERSCHRAUBUNG ELSD25-S	47 23 317 08	604	2	2 976 200	91 52 780 08	ZUSATZHYDRAULIK DREHWE
VERSCHRAUBUNG ELSD25-S	47 23 317 08	615	1	3 978 100	91 56 428 08	HYDR.SCHWEBEBALLAST-AN
VERSCHRAUBUNG ELSD30-S	47 23 318 08	758	3	2 970	91 56 537 08	HYDRAULIK
VERSCHRAUBUNG ELSD38-S	47 23 319 08	618	2	3 978 005	91 56 430 08	ZUSATZHYDRAULIK SB-KOPFS
VERSCHRAUBUNG ELSD42-L	47 23 311 08	608	1	1 970	91 56 958 08	HYDRAULIK RAUPE
VERSCHRAUBUNG ELSD42-L	47 23 311 08	603	10	2 970	91 56 537 08	HYDRAULIK
VERSCHRAUBUNG ELSD6-L	47 20 323 08	647	3	1 970	91 56 958 08	HYDRAULIK RAUPE
VERSCHRAUBUNG ELSD6-S	47 23 312 08	34	1	2 711	91 52 800 08	ZENTRALSCHMIERANLAGE O
VERSCHRAUBUNG ELSD6-S	47 23 312 08	769	3	2 970	91 56 537 08	HYDRAULIK
VERSCHRAUBUNG ELSD6-S	47 23 312 08	613	3	3 978 005	91 56 430 08	ZUSATZHYDRAULIK SB-KOPFS
VERSCHRAUBUNG ELSD8-S	47 23 300 08	680	2	2 970	91 56 537 08	HYDRAULIK
VERSCHRAUBUNG ETSD10-L	47 24 303 08	730	4	2 970	91 56 537 08	HYDRAULIK
VERSCHRAUBUNG ETSD10-L	47 24 303 08	641	1	2 978 100	91 52 827 08	ZUSATZHYDR.D-RUECKHALT
VERSCHRAUBUNG ETSD10-L	47 24 303 08	626	1	2 990	91 59 244 08	DRUCKLUFTANLAGE
VERSCHRAUBUNG ETSD10-S	47 24 313 08	808	1	2 970	91 56 537 08	HYDRAULIK
VERSCHRAUBUNG ETSD12-L	47 24 302 08	674	4	2 970	91 56 537 08	HYDRAULIK
VERSCHRAUBUNG ETSD12-L	47 24 302 08	617	1	2 975 100	91 52 860 08	ZUSATZHYDRAULIK WINDE 3
VERSCHRAUBUNG ETSD12-L	47 24 302 08	621	1	2 978 100	91 52 796 08	ZUSATZHYDR.MONTAGEEINR
VERSCHRAUBUNG ETSD12-L	47 24 302 08	611	2	2 978 200	91 54 843 08	ZUSATZHYDR.S-RUECKHALTE
VERSCHRAUBUNG ETSD12-L	47 24 302 08	622	1	3 978 005	91 56 430 08	ZUSATZHYDRAULIK SB-KOPFS
VERSCHRAUBUNG ETSD12-S	47 24 314 08	603	1	2 978 100	91 52 827 08	ZUSATZHYDR.D-RUECKHALT
VERSCHRAUBUNG ETSD15-L	47 24 304 08	667	2	2 970	91 56 537 08	HYDRAULIK
VERSCHRAUBUNG ETSD15-L	47 24 304 08	610	1	2 978 100	91 52 827 08	ZUSATZHYDR.D-RUECKHALT
VERSCHRAUBUNG ETSD16-S	47 24 315 08	615	2	1 970	91 56 958 08	HYDRAULIK RAUPE
VERSCHRAUBUNG ETSD16-S	47 24 315 08	783	5	2 970	91 56 537 08	HYDRAULIK
VERSCHRAUBUNG ETSD16-S	47 24 315 08	611	1	2 975 000	91 57 881 08	ZUSATZHYDRAULIK MONTAGE
VERSCHRAUBUNG ETSD18-L	47 24 305 08	666	1	2 970	91 56 537 08	HYDRAULIK
VERSCHRAUBUNG ETSD22-L	47 24 306 08	619	4	2 970	91 56 537 08	HYDRAULIK
VERSCHRAUBUNG ETSD22-L	47 24 306 08	604	1	2 975 100	91 52 860 08	ZUSATZHYDRAULIK WINDE 3

6.2.2009

etk_en_de_074515 LR 1600/2

1122

LIEBHERRAlphabetical index
Alphabetischer Index

Bezeichnung	Artikel	Pos.	Menge	Seite	Baugruppe	Bezeichnung
VERSCHRAUBUNG ETSD22-L	47 24 306 08	614	1	2 975 200	91 52 775 08	ZUSATZHYDRAULIK WINDE 2
VERSCHRAUBUNG ETSD22-L	47 24 306 08	614	1	2 975 700	91 52 774 08	ZUSATZHYDRAULIK WINDE 1
VERSCHRAUBUNG ETSD25-S	47 24 317 08	653	2	2 970	91 56 537 08	HYDRAULIK
VERSCHRAUBUNG ETSD28-L	47 24 307 08	649	2	1 970	91 56 958 08	HYDRAULIK RAUPE
VERSCHRAUBUNG ETSD28-L	47 24 307 08	693	1	2 970	91 56 537 08	HYDRAULIK
VERSCHRAUBUNG ETSD30-S	47 24 318 08	661	3	2 970	91 56 537 08	HYDRAULIK
VERSCHRAUBUNG ETSD30-S	47 24 318 08	612	1	3 978 100	91 56 428 08	HYDR.SCHWEBEBALLAST-AN
VERSCHRAUBUNG ETSD42-L	47 24 311 08	624	1	1 970	91 56 958 08	HYDRAULIK RAUPE
VERSCHRAUBUNG ETSD42-L	47 24 311 08	602	5	2 970	91 56 537 08	HYDRAULIK
VERSCHRAUBUNG ETSD6-S	47 24 312 08	33	1	2 711	91 52 800 08	ZENTRALSCHMIERANLAGE O
VERSCHRAUBUNG ETSD6-S	47 24 312 08	722	1	2 970	91 56 537 08	HYDRAULIK
VERSCHRAUBUNG EV 25S M	10 42 477 0	775	2	2 970	91 56 537 08	HYDRAULIK
VERSCHRAUBUNG EV 28L M36	10 41 077 2	804	1	2 970	91 56 537 08	HYDRAULIK
VERSCHRAUBUNG EV16S A3	10 41 077 0	801	1	2 970	91 56 537 08	HYDRAULIK
VERSCHRAUBUNG EWSD10-L	47 25 302 08	635	16	2 970	91 56 537 08	HYDRAULIK
VERSCHRAUBUNG EWSD10-L	47 25 302 08	620	1	2 975 200	91 52 775 08	ZUSATZHYDRAULIK WINDE 2
VERSCHRAUBUNG EWSD10-L	47 25 302 08	620	1	2 975 700	91 52 774 08	ZUSATZHYDRAULIK WINDE 1
VERSCHRAUBUNG EWSD10-L	47 25 302 08	602	2	2 978 100	91 52 796 08	ZUSATZHYDR.MONTAGEEINR
VERSCHRAUBUNG EWSD10-L	47 25 302 08	608	3	2 978 100	91 52 827 08	ZUSATZHYDR.D-RUECKHALT
VERSCHRAUBUNG EWSD10-L	47 25 302 08	635	1	2 978 200	91 54 843 08	ZUSATZHYDR.S-RUECKHALTE
VERSCHRAUBUNG EWSD10-L	47 25 302 08	610	4	2 990	91 59 244 08	DRUCKLUFTANLAGE
VERSCHRAUBUNG EWSD10-L	47 25 302 08	602	1	3 978 100	91 56 428 08	HYDR.SCHWEBEBALLAST-AN
VERSCHRAUBUNG EWSD10-S	47 25 311 08	807	1	2 970	91 56 537 08	HYDRAULIK
VERSCHRAUBUNG EWSD10-S	47 25 311 08	606	4	2 976 203	92 27 489 08	ZUSATZHYDR.BOLZENZIEHZ
VERSCHRAUBUNG EWSD12-L	47 25 305 08	611	19	2 970	91 56 537 08	HYDRAULIK
VERSCHRAUBUNG EWSD12-L	47 25 305 08	610	2	2 975 100	91 52 860 08	ZUSATZHYDRAULIK WINDE 3
VERSCHRAUBUNG EWSD12-L	47 25 305 08	608	1	2 975 200	91 52 775 08	ZUSATZHYDRAULIK WINDE 2
VERSCHRAUBUNG EWSD12-L	47 25 305 08	608	1	2 975 700	91 52 774 08	ZUSATZHYDRAULIK WINDE 1
VERSCHRAUBUNG EWSD12-L	47 25 305 08	607	1	2 976 200	91 52 780 08	ZUSATZHYDRAULIK DREHWE
VERSCHRAUBUNG EWSD12-L	47 25 305 08	605	1	2 976 203	92 27 489 08	ZUSATZHYDR.BOLZENZIEHZ
VERSCHRAUBUNG EWSD12-L	47 25 305 08	604	1	2 978 100	91 52 827 08	ZUSATZHYDR.D-RUECKHALT
VERSCHRAUBUNG EWSD12-L	47 25 305 08	610	4	2 978 200	91 54 843 08	ZUSATZHYDR.S-RUECKHALTE
VERSCHRAUBUNG EWSD12-L	47 25 305 08	605	2	3 978 005	91 56 430 08	ZUSATZHYDRAULIK SB-KOPFS
VERSCHRAUBUNG EWSD12-S	47 25 312 08	604	12	1 975 006	91 52 509 08	ZUSATZHYDR.ABSTUETZZYL
VERSCHRAUBUNG EWSD12-S	47 25 312 08	616	1	2 978 100	91 52 827 08	ZUSATZHYDR.D-RUECKHALT
VERSCHRAUBUNG EWSD12-S	47 25 312 08	601	1	2 978 200	91 54 843 08	ZUSATZHYDR.S-RUECKHALTE
VERSCHRAUBUNG EWSD15-L	47 25 307 08	7	2	2 670 002	96 45 352 08	KRAFTSTOFFBEHAELTER VO
VERSCHRAUBUNG EWSD15-L	47 25 307 08	739	2	2 970	91 56 537 08	HYDRAULIK
VERSCHRAUBUNG EWSD16-S	47 25 313 08	616	3	1 970	91 56 958 08	HYDRAULIK RAUPE
VERSCHRAUBUNG EWSD16-S	47 25 313 08	784	8	2 970	91 56 537 08	HYDRAULIK
VERSCHRAUBUNG EWSD16-S	47 25 313 08	606	1	2 978 100	91 52 796 08	ZUSATZHYDR.MONTAGEEINR
VERSCHRAUBUNG EWSD18-L	47 25 304 08	612	1	1 970	91 56 958 08	HYDRAULIK RAUPE
VERSCHRAUBUNG EWSD18-L	47 25 304 08	402	2	2 391	91 52 784 08	DIESELMOTOR KPL.
VERSCHRAUBUNG EWSD18-L	47 25 304 08	11	1	2 670 002	96 45 352 08	KRAFTSTOFFBEHAELTER VO
VERSCHRAUBUNG EWSD18-L	47 25 304 08	631	5	2 970	91 56 537 08	HYDRAULIK
VERSCHRAUBUNG EWSD18-L	47 25 304 08	608	1	2 975 000	91 57 881 08	ZUSATZHYDRAULIK MONTAGE
VERSCHRAUBUNG EWSD18-L	47 25 304 08	616	1	2 978 200	91 54 843 08	ZUSATZHYDR.S-RUECKHALTE
VERSCHRAUBUNG EWSD18-L	47 25 304 08	607	2	2 990	91 59 244 08	DRUCKLUFTANLAGE
VERSCHRAUBUNG EWSD20-S	47 25 314 08	639	2	1 970	91 56 958 08	HYDRAULIK RAUPE
VERSCHRAUBUNG EWSD20-S	47 25 314 08	711	3	2 970	91 56 537 08	HYDRAULIK
VERSCHRAUBUNG EWSD20-S	47 25 314 08	604	1	3 978 019	91 56 431 08	ZUSATZHYDRAULIK ZYLINDER
VERSCHRAUBUNG EWSD22-L	47 25 306 08	624	1	2 970	91 56 537 08	HYDRAULIK
VERSCHRAUBUNG EWSD22-L	47 25 306 08	625	1	2 975 100	91 52 860 08	ZUSATZHYDRAULIK WINDE 3
VERSCHRAUBUNG EWSD25-S	47 25 317 08	701	6	2 970	91 56 537 08	HYDRAULIK
VERSCHRAUBUNG EWSD25-S	47 25 317 08	603	1	2 975 200	91 52 775 08	ZUSATZHYDRAULIK WINDE 2
VERSCHRAUBUNG EWSD25-S	47 25 317 08	603	1	2 975 700	91 52 774 08	ZUSATZHYDRAULIK WINDE 1
VERSCHRAUBUNG EWSD25-S	47 25 317 08	606	2	2 976 200	91 52 780 08	ZUSATZHYDRAULIK DREHWE
VERSCHRAUBUNG EWSD25-S	47 25 317 08	629	1	2 978 200	91 54 843 08	ZUSATZHYDR.S-RUECKHALTE
VERSCHRAUBUNG EWSD28-L	47 25 303 08	622	10	2 970	91 56 537 08	HYDRAULIK
VERSCHRAUBUNG EWSD28-L	47 25 303 08	602	1	2 977	91 57 756 08	ZUSATZHYDRAULIK DREHBUE

6.2.2009

etk_en_de_074515 LR 1600/2

1123

LIEBHERRAlphabetical index
Alphabetischer Index

Bezeichnung	Artikel	Pos.	Menge	Seite	Baugruppe	Bezeichnung
VERSCHRAUBUNG EWSD28-L	47 25 303 08	626	1	2 978 200	91 54 843 08	ZUSATZHYDR.S-RUECKHALTE
VERSCHRAUBUNG EWSD30-S	47 25 316 08	688	5	2 970	91 56 537 08	HYDRAULIK
VERSCHRAUBUNG EWSD30-S	47 25 316 08	604	2	3 978 100	91 56 428 08	HYDR.SCHWEBEBALLAST-AN
VERSCHRAUBUNG EWSD35-L	47 25 309 08	679	1	1 970	91 56 958 08	HYDRAULIK RAUPE
VERSCHRAUBUNG EWSD35-L	47 25 309 08	613	11	2 970	91 56 537 08	HYDRAULIK
VERSCHRAUBUNG EWSD35-L	47 25 309 08	607	1	3 978 100	91 56 428 08	HYDR.SCHWEBEBALLAST-AN
VERSCHRAUBUNG EWSD38-S	47 25 318 08	607	8	1 970	91 56 958 08	HYDRAULIK RAUPE
VERSCHRAUBUNG EWSD38-S	47 25 318 08	718	13	2 970	91 56 537 08	HYDRAULIK
VERSCHRAUBUNG EWSD38-S	47 25 318 08	607	2	2 975 200	91 52 775 08	ZUSATZHYDRAULIK WINDE 2
VERSCHRAUBUNG EWSD38-S	47 25 318 08	607	2	2 975 700	91 52 774 08	ZUSATZHYDRAULIK WINDE 1
VERSCHRAUBUNG EWSD38-S	47 25 318 08	601	1	2 977	91 57 756 08	ZUSATZHYDRAULIK DREHBUE
VERSCHRAUBUNG EWSD42-L	47 25 310 08	601	13	2 970	91 56 537 08	HYDRAULIK
VERSCHRAUBUNG EWSD6-L	47 25 300 08	605	2	1 970 161	96 50 706 08	ZUSATZHYDR.RAUPENTRAEG
VERSCHRAUBUNG EWSD6-L	47 25 300 08	46	2	2 393	91 52 787 08	LUFTFILTERANLAGE KPL.
VERSCHRAUBUNG EWSD6-L	47 25 300 08	628	4	2 990	91 59 244 08	DRUCKLUFTANLAGE
VERSCHRAUBUNG EWSD6-S	47 25 315 08	31	5	2 711	91 52 800 08	ZENTRALSCHMIERANLAGE O
VERSCHRAUBUNG EWSD6-S	47 25 315 08	22	1	2 932 160	96 54 385 08	SCHALTSCHRANK MECH.
VERSCHRAUBUNG EWSD6-S	47 25 315 08	660	11	2 970	91 56 537 08	HYDRAULIK
VERSCHRAUBUNG EWSD6-S	47 25 315 08	601	1	2 976 700	91 54 795 08	ZUSATZHYDRAULIK PUMPE
VERSCHRAUBUNG EWSD6-S	47 25 315 08	602	2	2 990	91 59 244 08	DRUCKLUFTANLAGE
VERSCHRAUBUNG EWSD6-S	47 25 315 08	625	2	3 978 005	91 56 430 08	ZUSATZHYDRAULIK SB-KOPFS
VERSCHRAUBUNG EWSD8-S	47 25 319 08	681	4	2 970	91 56 537 08	HYDRAULIK
VERSCHRAUBUNG GA6-LM22X	50 29 461 08	615	1	2 990	91 59 244 08	DRUCKLUFTANLAGE
VERSCHRAUBUNG GE 12L M	47 10 399 08	709	2	2 970	91 56 537 08	HYDRAULIK
VERSCHRAUBUNG GE 12L M	47 10 399 08	601	3	3 978 005	91 56 430 08	ZUSATZHYDRAULIK SB-KOPFS
VERSCHRAUBUNG GE 12S G1/	47 10 326 08	603	4	1 975 006	91 52 509 08	ZUSATZHYDR.ABSTUETZZYL
VERSCHRAUBUNG GE 12S G1/	47 10 326 08	803	2	2 970	91 56 537 08	HYDRAULIK
VERSCHRAUBUNG GE 18L M	47 10 311 08	616	11	2 970	91 56 537 08	HYDRAULIK
VERSCHRAUBUNG GE 18L M	47 10 311 08	606	4	2 990	91 59 244 08	DRUCKLUFTANLAGE
VERSCHRAUBUNG GE6-LM12X	47 66 077 08	45	2	2 393	91 52 787 08	LUFTFILTERANLAGE KPL.
VERSCHRAUBUNG GE6-LM8X1	77 43 748 08	13	2	2 711	91 52 800 08	ZENTRALSCHMIERANLAGE O
VERSCHRAUBUNG GE6-LM8X1	77 43 748 08	23	1	2 711	91 52 800 08	ZENTRALSCHMIERANLAGE O
VERSCHRAUBUNG GEM10X1	77 43 765 08	11	8	1 711	91 52 392 08	ZENTRALSCHMIERUNG RAUP
VERSCHRAUBUNG GEO18-LM	47 10 503 08	401	2	2 391	91 52 784 08	DIESELMOTOR KPL.
VERSCHRAUBUNG GR 15/6L C	47 50 303 08	646	2	1 970	91 56 958 08	HYDRAULIK RAUPE
VERSCHRAUBUNG GR 15/6L C	47 50 303 08	604	3	1 970 161	96 50 706 08	ZUSATZHYDR.RAUPENTRAEG
VERSCHRAUBUNG GR 15/8L C	47 50 322 08	9	1	2 670 002	96 45 352 08	KRAFTSTOFFBEHAELTER VO
VERSCHRAUBUNG GZ 18L C	47 00 104 08	669	2	2 970	91 56 537 08	HYDRAULIK
VERSCHRAUBUNG GZ 18L C	47 00 104 08	607	1	2 975 000	91 57 881 08	ZUSATZHYDRAULIK MONTAGE
VERSCHRAUBUNG GZ 35L C	49 11 008 14	627	1	2 970	91 56 537 08	HYDRAULIK
VERSCHRAUBUNG ISO 8434-1	47 10 397 08	729	2	2 970	91 56 537 08	HYDRAULIK
VERSCHRAUBUNG ISO 8434-1	47 10 397 08	610	1	2 975 000	91 57 881 08	ZUSATZHYDRAULIK MONTAGE
VERSCHRAUBUNG ISO 8434-1	47 10 397 08	606	1	2 975 100	91 52 860 08	ZUSATZHYDRAULIK WINDE 3
VERSCHRAUBUNG ISO 8434-1	47 10 397 08	624	1	2 975 200	91 52 775 08	ZUSATZHYDRAULIK WINDE 2
VERSCHRAUBUNG ISO 8434-1	47 10 397 08	624	1	2 975 700	91 52 774 08	ZUSATZHYDRAULIK WINDE 1
VERSCHRAUBUNG ISO 8434-1	47 10 397 08	601	2	2 976 200	91 52 780 08	ZUSATZHYDRAULIK DREHWE
VERSCHRAUBUNG ISO 8434-1	47 10 397 08	609	2	2 990	91 59 244 08	DRUCKLUFTANLAGE
VERSCHRAUBUNG ISO 8434-1	47 10 328 08	767	1	2 970	91 56 537 08	HYDRAULIK
VERSCHRAUBUNG ISO 8434-1	47 10 328 08	604	2	2 976 203	92 27 489 08	ZUSATZHYDR.BOLZENZIEHZ
VERSCHRAUBUNG ISO 8434-1	47 10 307 08	716	3	2 970	91 56 537 08	HYDRAULIK
VERSCHRAUBUNG ISO 8434-1	47 10 307 08	605	1	2 975 200	91 52 775 08	ZUSATZHYDRAULIK WINDE 2
VERSCHRAUBUNG ISO 8434-1	47 10 307 08	605	1	2 975 700	91 52 774 08	ZUSATZHYDRAULIK WINDE 1
VERSCHRAUBUNG ISO 8434-1	47 10 307 08	602	2	2 976 200	91 52 780 08	ZUSATZHYDRAULIK DREHWE
VERSCHRAUBUNG ISO 8434-1	47 10 307 08	602	1	2 976 700	91 54 795 08	ZUSATZHYDRAULIK PUMPE
VERSCHRAUBUNG REDSD10/	47 54 310 08	753	1	2 970	91 56 537 08	HYDRAULIK
VERSCHRAUBUNG REDSD10/	47 54 310 08	627	1	2 990	91 59 244 08	DRUCKLUFTANLAGE
VERSCHRAUBUNG REDSD12/1	47 54 314 08	755	3	2 970	91 56 537 08	HYDRAULIK
VERSCHRAUBUNG REDSD12/1	47 54 314 08	622	1	2 978 100	91 52 796 08	ZUSATZHYDR.MONTAGEEINR
VERSCHRAUBUNG REDSD12/1	47 54 314 08	631	2	2 978 200	91 54 843 08	ZUSATZHYDR.S-RUECKHALTE
VERSCHRAUBUNG REDSD12/	47 54 329 08	607	4	1 975 006	91 52 509 08	ZUSATZHYDR.ABSTUETZZYL

6.2.2009

etk_en_de_074515 LR 1600/2

1124

LIEBHERRAlphabetical index
Alphabetischer Index

Bezeichnung	Artikel	Pos.	Menge	Seite	Baugruppe	Bezeichnung
VERSCHRAUBUNG REDSD12/	47 54 329 08	607	1	2 978 100	91 52 827 08	ZUSATZHYDR.D-RUECKHALT
VERSCHRAUBUNG REDSD12/	47 54 329 08	604	1	2 978 200	91 54 843 08	ZUSATZHYDR.S-RUECKHALTE
VERSCHRAUBUNG REDSD15/1	47 54 301 08	776	1	2 970	91 56 537 08	HYDRAULIK
VERSCHRAUBUNG REDSD15/1	47 54 301 08	601	3	2 970 081	96 50 495 08	ZUSATZHYDR.BOLZENZIEHZ
VERSCHRAUBUNG REDSD15/1	47 54 301 08	615	1	2 978 100	91 52 827 08	ZUSATZHYDR.D-RUECKHALT
VERSCHRAUBUNG REDSD15/1	47 54 318 08	708	5	2 970	91 56 537 08	HYDRAULIK
VERSCHRAUBUNG REDSD15/1	47 54 318 08	623	1	2 975 200	91 52 775 08	ZUSATZHYDRAULIK WINDE 2
VERSCHRAUBUNG REDSD15/1	47 54 318 08	623	1	2 975 700	91 52 774 08	ZUSATZHYDRAULIK WINDE 1
VERSCHRAUBUNG REDSD15/1	47 54 318 08	602	1	2 976 200	91 44 034 08	ZUS.HYDR.BOLZENZIEHEINRI
VERSCHRAUBUNG REDSD15/1	47 54 318 08	609	2	2 978 100	91 52 827 08	ZUSATZHYDR.D-RUECKHALT
VERSCHRAUBUNG REDSD16/1	47 54 335 08	609	1	2 978 100	91 52 796 08	ZUSATZHYDR.MONTAGEEINR
VERSCHRAUBUNG REDSD16/	47 54 331 08	618	1	1 970	91 56 958 08	HYDRAULIK RAUPE
VERSCHRAUBUNG REDSD16/	47 54 331 08	751	5	2 970	91 56 537 08	HYDRAULIK
VERSCHRAUBUNG REDSD16/	47 54 331 08	612	1	2 975 000	91 57 881 08	ZUSATZHYDRAULIK MONTAGE
VERSCHRAUBUNG REDSD18/1	47 54 303 08	611	1	1 970	91 56 958 08	HYDRAULIK RAUPE
VERSCHRAUBUNG REDSD18/1	47 54 303 08	634	2	2 970	91 56 537 08	HYDRAULIK
VERSCHRAUBUNG REDSD18/1	47 54 303 08	636	1	2 978 200	91 54 843 08	ZUSATZHYDR.S-RUECKHALTE
VERSCHRAUBUNG REDSD18/1	47 54 303 08	624	1	2 990	91 59 244 08	DRUCKLUFTANLAGE
VERSCHRAUBUNG REDSD18/1	47 54 363 08	601	1	2 976 200	91 44 034 08	ZUS.HYDR.BOLZENZIEHEINRI
VERSCHRAUBUNG REDSD18/1	47 54 363 08	610	2	2 976 200	91 52 780 08	ZUSATZHYDRAULIK DREHWE
VERSCHRAUBUNG REDSD18/1	47 54 356 08	403	1	2 391	91 52 784 08	DIESELMOTOR KPL.
VERSCHRAUBUNG REDSD18/1	47 54 356 08	738	1	2 970	91 56 537 08	HYDRAULIK
VERSCHRAUBUNG REDSD18/1	47 54 356 08	614	1	2 975 000	91 57 881 08	ZUSATZHYDRAULIK MONTAGE
VERSCHRAUBUNG REDSD20/1	47 54 348 08	641	1	1 970	91 56 958 08	HYDRAULIK RAUPE
VERSCHRAUBUNG REDSD22/1	47 54 308 08	621	1	2 975 100	91 52 860 08	ZUSATZHYDRAULIK WINDE 3
VERSCHRAUBUNG REDSD22/1	47 54 361 08	659	1	1 970	91 56 958 08	HYDRAULIK RAUPE
VERSCHRAUBUNG REDSD22/1	47 54 361 08	690	7	2 970	91 56 537 08	HYDRAULIK
VERSCHRAUBUNG REDSD22/1	47 54 361 08	605	1	2 975 100	91 52 860 08	ZUSATZHYDRAULIK WINDE 3
VERSCHRAUBUNG REDSD22/1	47 54 361 08	602	1	2 975 200	91 52 775 08	ZUSATZHYDRAULIK WINDE 2
VERSCHRAUBUNG REDSD22/1	47 54 361 08	602	1	2 975 700	91 52 774 08	ZUSATZHYDRAULIK WINDE 1
VERSCHRAUBUNG REDSD22/1	47 54 361 08	640	1	2 978 100	91 52 827 08	ZUSATZHYDR.D-RUECKHALT
VERSCHRAUBUNG REDSD22/1	47 54 355 08	617	4	2 970	91 56 537 08	HYDRAULIK
VERSCHRAUBUNG REDSD22/1	47 54 355 08	639	2	2 978 100	91 52 827 08	ZUSATZHYDR.D-RUECKHALT
VERSCHRAUBUNG REDSD22/1	47 54 360 08	625	1	2 970	91 56 537 08	HYDRAULIK
VERSCHRAUBUNG REDSD25/1	47 54 328 08	652	1	2 970	91 56 537 08	HYDRAULIK
VERSCHRAUBUNG REDSD28/1	47 54 309 08	694	1	2 970	91 56 537 08	HYDRAULIK
VERSCHRAUBUNG REDSD28/1	47 54 309 08	627	1	2 978 200	91 54 843 08	ZUSATZHYDR.S-RUECKHALTE
VERSCHRAUBUNG REDSD28/2	47 54 305 08	674	2	1 970	91 56 958 08	HYDRAULIK RAUPE
VERSCHRAUBUNG REDSD28/2	47 54 305 08	699	1	2 970	91 56 537 08	HYDRAULIK
VERSCHRAUBUNG REDSD28/2	47 54 305 08	624	1	2 975 100	91 52 860 08	ZUSATZHYDRAULIK WINDE 3
VERSCHRAUBUNG REDSD35/1	47 54 312 08	691	5	2 970	91 56 537 08	HYDRAULIK
VERSCHRAUBUNG REDSD35/2	47 54 315 08	630	3	2 970	91 56 537 08	HYDRAULIK
VERSCHRAUBUNG REDSD35/2	47 54 304 08	642	11	2 970	91 56 537 08	HYDRAULIK
VERSCHRAUBUNG REDSD35/2	47 54 304 08	609	1	3 978 100	91 56 428 08	HYDR.SCHWEBEBALLAST-AN
VERSCHRAUBUNG REDSD38/1	47 54 342 08	614	4	3 978 005	91 56 430 08	ZUSATZHYDRAULIK SB-KOPFS
VERSCHRAUBUNG REDSD38/	47 54 081 08	619	2	3 978 005	91 56 430 08	ZUSATZHYDRAULIK SB-KOPFS
VERSCHRAUBUNG REDSD42/1	47 54 317 08	609	1	1 970	91 56 958 08	HYDRAULIK RAUPE
VERSCHRAUBUNG REDSD42/1	47 54 317 08	647	1	2 970	91 56 537 08	HYDRAULIK
VERSCHRAUBUNG REDSD42/2	47 54 316 08	648	1	2 970	91 56 537 08	HYDRAULIK
VERSCHRAUBUNG REDSD42/3	47 54 367 08	603	1	1 970	91 56 958 08	HYDRAULIK RAUPE
VERSCHRAUBUNG REDSD42/3	47 54 367 08	638	6	2 970	91 56 537 08	HYDRAULIK
VERSCHRAUBUNG REDSDN1	47 54 320 08	806	1	2 970	91 56 537 08	HYDRAULIK
VERSCHRAUBUNG REDSDN2	47 54 324 08	658	1	2 970	91 56 537 08	HYDRAULIK
VERSCHRAUBUNG REDSDN25	47 54 323 08	655	2	2 970	91 56 537 08	HYDRAULIK
VERSCHRAUBUNG REDSDN2	47 54 337 08	786	2	2 970	91 56 537 08	HYDRAULIK
VERSCHRAUBUNG REDSDN2	47 54 337 08	616	1	3 978 100	91 56 428 08	HYDR.SCHWEBEBALLAST-AN
VERSCHRAUBUNG REDSDN28	47 54 354 08	740	2	2 970	91 56 537 08	HYDRAULIK
VERSCHRAUBUNG REDSDN28	47 54 357 08	623	2	1 970	91 56 958 08	HYDRAULIK RAUPE
VERSCHRAUBUNG REDSDN28	47 54 357 08	621	1	2 978 200	91 54 843 08	ZUSATZHYDR.S-RUECKHALTE
VERSCHRAUBUNG REDSDN28	47 54 345 08	789	2	2 970	91 56 537 08	HYDRAULIK

6.2.2009

etk_en_de_074515 LR 1600/2

1125

LIEBHERRAlphabetical index
Alphabetischer Index

Bezeichnung	Artikel	Pos.	Menge	Seite	Baugruppe	Bezeichnung
VERSCHRAUBUNG REDSDN30	47 54 340 08	613	1	2 978 100	91 52 796 08	ZUSATZHYDR.MONTAGEEINR
VERSCHRAUBUNG REDSDN30	47 54 325 08	743	5	2 970	91 56 537 08	HYDRAULIK
VERSCHRAUBUNG REDSDN30	47 54 327 08	744	3	2 970	91 56 537 08	HYDRAULIK
VERSCHRAUBUNG REDSDN30	47 54 327 08	605	2	2 976 200	91 52 780 08	ZUSATZHYDRAULIK DREHWE
VERSCHRAUBUNG REDSDN30	47 54 327 08	611	1	3 978 100	91 56 428 08	HYDR.SCHWEBEBALLAST-AN
VERSCHRAUBUNG REDSDN3	47 54 341 08	662	1	2 970	91 56 537 08	HYDRAULIK
VERSCHRAUBUNG REDSDN38	47 54 343 08	719	4	2 970	91 56 537 08	HYDRAULIK
VERSCHRAUBUNG REDSDN42	47 54 313 08	625	2	1 970	91 56 958 08	HYDRAULIK RAUPE
VERSCHRAUBUNG REDSDN42	47 54 313 08	604	6	2 970	91 56 537 08	HYDRAULIK
VERSCHRAUBUNG RI G1/2AX	47 55 004 08	777	2	2 970	91 56 537 08	HYDRAULIK
VERSCHRAUBUNG RSWS10-	47 66 102 08	604	1	2 975 200	91 52 775 08	ZUSATZHYDRAULIK WINDE 2
VERSCHRAUBUNG RSWS10-	47 66 102 08	604	1	2 975 700	91 52 774 08	ZUSATZHYDRAULIK WINDE 1
VERSCHRAUBUNG RSWS10-	47 32 305 08	655	1	1 970	91 56 958 08	HYDRAULIK RAUPE
VERSCHRAUBUNG RSWS10-	47 32 305 08	657	10	2 970	91 56 537 08	HYDRAULIK
VERSCHRAUBUNG RSWS10-	47 32 310 08	602	2	2 970 081	96 50 495 08	ZUSATZHYDR.BOLZENZIEHZ
VERSCHRAUBUNG RSWS10-	47 32 310 08	603	2	2 976 203	92 27 489 08	ZUSATZHYDR.BOLZENZIEHZ
VERSCHRAUBUNG RSWS12-	47 66 303 08	778	2	2 970	91 56 537 08	HYDRAULIK
VERSCHRAUBUNG RSWS12-	47 66 115 08	602	8	1 975 006	91 52 509 08	ZUSATZHYDR.ABSTUETZZYL
VERSCHRAUBUNG RSWS16-	47 66 114 08	601	2	2 975 000	91 57 881 08	ZUSATZHYDRAULIK MONTAGE
VERSCHRAUBUNG RSWS16-	47 32 312 08	607	1	2 978 100	91 52 796 08	ZUSATZHYDR.MONTAGEEINR
VERSCHRAUBUNG RSWS20-	47 32 314 08	605	1	1 970	91 56 958 08	HYDRAULIK RAUPE
VERSCHRAUBUNG RSWS22-	47 33 002 08	666	1	1 970	91 56 958 08	HYDRAULIK RAUPE
VERSCHRAUBUNG RSWS42-	47 32 327 08	2	4	2 671 004	96 46 305 08	OELBEHAELTER VORM.
VERSCHRAUBUNG RSWS6-SM	47 32 303 08	704	4	2 970	91 56 537 08	HYDRAULIK
VERSCHRAUBUNG RSWS6-SR	47 32 306 08	608	4	1 975 006	91 52 509 08	ZUSATZHYDR.ABSTUETZZYL
VERSCHRAUBUNG RSWS6-SR	47 32 306 08	22	2	2 711	91 52 800 08	ZENTRALSCHMIERANLAGE O
VERSCHRAUBUNG RSWS6-SR	47 32 306 08	23	2	2 810	91 52 806 08	KRANFUEHRERKABINE KPL.
VERSCHRAUBUNG RSWS6-SR	47 32 306 08	771	1	2 970	91 56 537 08	HYDRAULIK
VERSCHRAUBUNG SNV10-L	47 00 101 08	748	2	2 970	91 56 537 08	HYDRAULIK
VERSCHRAUBUNG SNV12-L	47 00 113 08	633	2	1 970	91 56 958 08	HYDRAULIK RAUPE
VERSCHRAUBUNG SNV12-L	47 00 113 08	737	1	2 970	91 56 537 08	HYDRAULIK
VERSCHRAUBUNG SNV12-L	47 00 113 08	612	3	2 975 100	91 52 860 08	ZUSATZHYDRAULIK WINDE 3
VERSCHRAUBUNG SNV12-L	47 00 113 08	609	2	2 975 200	91 52 775 08	ZUSATZHYDRAULIK WINDE 2
VERSCHRAUBUNG SNV12-L	47 00 113 08	609	2	2 975 700	91 52 774 08	ZUSATZHYDRAULIK WINDE 1
VERSCHRAUBUNG SNV12-L	47 00 113 08	602	1	3 978 005	91 56 430 08	ZUSATZHYDRAULIK SB-KOPFS
VERSCHRAUBUNG SNV12-S	47 00 103 08	629	1	1 970	91 56 958 08	HYDRAULIK RAUPE
VERSCHRAUBUNG SNV15-L	47 00 112 08	672	1	2 970	91 56 537 08	HYDRAULIK
VERSCHRAUBUNG SNV16-S	47 00 108 08	675	2	1 970	91 56 958 08	HYDRAULIK RAUPE
VERSCHRAUBUNG SNV16-S	47 00 108 08	745	8	2 970	91 56 537 08	HYDRAULIK
VERSCHRAUBUNG SNV20-S	47 00 105 08	797	1	2 970	91 56 537 08	HYDRAULIK
VERSCHRAUBUNG SNV25-S	47 00 110 08	612	1	2 975 200	91 52 775 08	ZUSATZHYDRAULIK WINDE 2
VERSCHRAUBUNG SNV25-S	47 00 110 08	612	1	2 975 700	91 52 774 08	ZUSATZHYDRAULIK WINDE 1
VERSCHRAUBUNG SNV30-S	47 00 111 08	687	3	2 970	91 56 537 08	HYDRAULIK
VERSCHRAUBUNG SNV38-S	47 00 107 08	726	1	2 970	91 56 537 08	HYDRAULIK
VERSCHRAUBUNG SNV38-S	47 00 107 08	606	1	2 975 200	91 52 775 08	ZUSATZHYDRAULIK WINDE 2
VERSCHRAUBUNG SNV38-S	47 00 107 08	606	1	2 975 700	91 52 774 08	ZUSATZHYDRAULIK WINDE 1
VERSCHRAUBUNG SNV38-S	47 00 107 08	603	2	2 977	91 57 756 08	ZUSATZHYDRAULIK DREHBUE
VERSCHRAUBUNG SNV42-L	47 00 114 08	606	5	2 970	91 56 537 08	HYDRAULIK
VERSCHRAUBUNG SNV6-S A3	47 00 115 08	772	1	2 970	91 56 537 08	HYDRAULIK
VERSCHRAUBUNG SNV6-S A3	47 00 115 08	620	1	3 978 005	91 56 430 08	ZUSATZHYDRAULIK SB-KOPFS
VERSCHRAUBUNG T 16S CR6	47 04 325 08	652	2	1 970	91 56 958 08	HYDRAULIK RAUPE
VERSCHRAUBUNG T 16S CR6	47 04 325 08	791	1	2 970	91 56 537 08	HYDRAULIK
VERSCHRAUBUNG T 16S CR6	47 04 325 08	608	1	2 978 100	91 52 796 08	ZUSATZHYDR.MONTAGEEINR
VERSCHRAUBUNG T 22L CR6	47 04 307 08	689	3	2 970	91 56 537 08	HYDRAULIK
VERSCHRAUBUNG T 22L CR6	47 04 307 08	620	1	2 975 100	91 52 860 08	ZUSATZHYDRAULIK WINDE 3
VERSCHRAUBUNG T 22L CR6	47 04 307 08	626	3	2 978 100	91 52 827 08	ZUSATZHYDR.D-RUECKHALT
VERSCHRAUBUNG TR 22/15/2	47 51 334 08	741	2	2 970	91 56 537 08	HYDRAULIK
VERSCHRAUBUNG WE6-M10	77 43 738 08	8	50	1 711	91 52 392 08	ZENTRALSCHMIERUNG RAUP
VERSCHRAUBUNG WE6-M10	77 43 738 08	(1)	1	2 711	91 52 800 08	ZENTRALSCHMIERANLAGE O
VERSCHRAUBUNG WE6-M10	77 43 738 08	(1)	1	2 711	91 52 800 08	ZENTRALSCHMIERANLAGE O

6.2.2009

etk_en_de_074515 LR 1600/2

1126

LIEBHERRAlphabetical index
Alphabetischer Index

Bezeichnung	Artikel	Pos.	Menge	Seite	Baugruppe	Bezeichnung
VERSCHRAUBUNG WE6-M10	77 43 738 08	(1)	1	2 711	91 52 800 08	ZENTRALSCHMIERANLAGE O
VERSCHRAUBUNG WE6-M10	77 43 738 08	12	22	2 711	91 52 800 08	ZENTRALSCHMIERANLAGE O
VERSCHRAUBUNG WE6-M10	77 43 738 08	15	1	2 711	91 52 800 08	ZENTRALSCHMIERANLAGE O
VERSCHRAUBUNG X0	95 62 043 08	4	2	2 990	91 59 244 08	DRUCKLUFTANLAGE
VERSCHRAUBUNG X0	95 62 043 08	605	1	2 990	91 59 244 08	DRUCKLUFTANLAGE
VERSCHRAUBUNG XG10-L A3	47 00 303 08	734	7	2 970	91 56 537 08	HYDRAULIK
VERSCHRAUBUNG XG10-L A3	47 00 303 08	610	1	2 978 100	91 52 796 08	ZUSATZHYDR.MONTAGEEINR
VERSCHRAUBUNG XG10-L A3	47 00 303 08	633	1	2 978 100	91 52 827 08	ZUSATZHYDR.D-RUECKHALT
VERSCHRAUBUNG XG10-L A3	47 00 303 08	622	1	3 978 100	91 56 428 08	HYDR.SCHWEBEBALLAST-AN
VERSCHRAUBUNG XG12-L A3	47 00 304 08	725	4	2 970	91 56 537 08	HYDRAULIK
VERSCHRAUBUNG XG12-L A3	47 00 304 08	634	1	2 978 100	91 52 827 08	ZUSATZHYDR.D-RUECKHALT
VERSCHRAUBUNG XG12-L A3	47 00 304 08	623	12	2 978 200	91 54 843 08	ZUSATZHYDR.S-RUECKHALTE
VERSCHRAUBUNG XG12-L A3	47 00 304 08	607	4	3 978 005	91 56 430 08	ZUSATZHYDRAULIK SB-KOPFS
VERSCHRAUBUNG XG12-L A3	47 00 304 08	602	2	3 978 015	91 56 429 08	ZUSATZHYDRAULIK ZWISCH
VERSCHRAUBUNG XG12-L A3	47 00 304 08	602	1	3 978 015	91 56 432 08	ZUSATZHYDRAULIK ZWISCH
VERSCHRAUBUNG XG12-L A3	47 00 304 08	607	2	3 978 019	91 56 431 08	ZUSATZHYDRAULIK ZYLINDER
VERSCHRAUBUNG XG12-L A3	47 00 304 08	621	1	3 978 100	91 56 428 08	HYDR.SCHWEBEBALLAST-AN
VERSCHRAUBUNG XG12-S A3	47 00 325 08	606	2	3 978 019	91 56 431 08	ZUSATZHYDRAULIK ZYLINDER
VERSCHRAUBUNG XG15-L A3	47 00 305 08	724	3	2 970	91 56 537 08	HYDRAULIK
VERSCHRAUBUNG XG15-L A3	47 00 305 08	626	2	2 975 100	91 52 860 08	ZUSATZHYDRAULIK WINDE 3
VERSCHRAUBUNG XG16-S A3	47 00 327 08	620	10	1 970	91 56 958 08	HYDRAULIK RAUPE
VERSCHRAUBUNG XG16-S A3	47 00 327 08	790	1	2 970	91 56 537 08	HYDRAULIK
VERSCHRAUBUNG XG16-S A3	47 00 327 08	636	1	2 978 100	91 52 827 08	ZUSATZHYDR.D-RUECKHALT
VERSCHRAUBUNG XG18-L A3	47 00 306 08	692	3	2 970	91 56 537 08	HYDRAULIK
VERSCHRAUBUNG XG18-L A3	47 00 306 08	617	4	2 990	91 59 244 08	DRUCKLUFTANLAGE
VERSCHRAUBUNG XG20-S A3	47 00 328 08	628	1	1 970	91 56 958 08	HYDRAULIK RAUPE
VERSCHRAUBUNG XG20-S A3	47 00 328 08	766	3	2 970	91 56 537 08	HYDRAULIK
VERSCHRAUBUNG XG20-S A3	47 00 328 08	605	1	3 978 019	91 56 431 08	ZUSATZHYDRAULIK ZYLINDER
VERSCHRAUBUNG XG22-L A3	47 00 307 08	736	1	2 970	91 56 537 08	HYDRAULIK
VERSCHRAUBUNG XG22-L A3	47 00 307 08	637	1	2 978 100	91 52 827 08	ZUSATZHYDR.D-RUECKHALT
VERSCHRAUBUNG XG22-L A3	47 00 307 08	624	2	2 978 200	91 54 843 08	ZUSATZHYDR.S-RUECKHALTE
VERSCHRAUBUNG XG25-S A3	47 00 329 08	683	9	2 970	91 56 537 08	HYDRAULIK
VERSCHRAUBUNG XG25-S A3	47 00 329 08	638	1	2 978 100	91 52 827 08	ZUSATZHYDR.D-RUECKHALT
VERSCHRAUBUNG XG25-S A3	47 00 329 08	622	6	2 978 200	91 54 843 08	ZUSATZHYDR.S-RUECKHALTE
VERSCHRAUBUNG XG28-L A3	47 00 308 08	626	6	1 970	91 56 958 08	HYDRAULIK RAUPE
VERSCHRAUBUNG XG28-L A3	47 00 308 08	697	5	2 970	91 56 537 08	HYDRAULIK
VERSCHRAUBUNG XG28-L A3	47 00 308 08	622	1	2 975 100	91 52 860 08	ZUSATZHYDRAULIK WINDE 3
VERSCHRAUBUNG XG28-L A3	47 00 308 08	619	3	2 978 200	91 54 843 08	ZUSATZHYDR.S-RUECKHALTE
VERSCHRAUBUNG XG30-S A3	47 00 330 08	686	2	2 970	91 56 537 08	HYDRAULIK
VERSCHRAUBUNG XG30-S A3	47 00 330 08	620	4	2 978 100	91 52 796 08	ZUSATZHYDR.MONTAGEEINR
VERSCHRAUBUNG XG35-L A3	47 00 332 08	618	3	2 970	91 56 537 08	HYDRAULIK
VERSCHRAUBUNG XG35-L A3	47 00 332 08	619	1	3 978 100	91 56 428 08	HYDR.SCHWEBEBALLAST-AN
VERSCHRAUBUNG XG38-S A3	47 00 331 08	601	12	1 970	91 56 958 08	HYDRAULIK RAUPE
VERSCHRAUBUNG XG38-S A3	47 00 331 08	705	43	2 970	91 56 537 08	HYDRAULIK
VERSCHRAUBUNG XG38-S A3	47 00 331 08	619	2	2 975 100	91 52 860 08	ZUSATZHYDRAULIK WINDE 3
VERSCHRAUBUNG XG38-S A3	47 00 331 08	621	4	3 978 005	91 56 430 08	ZUSATZHYDRAULIK SB-KOPFS
VERSCHRAUBUNG XG38-S A3	47 00 331 08	603	2	3 978 015	91 56 429 08	ZUSATZHYDRAULIK ZWISCH
VERSCHRAUBUNG XG38-S A3	47 00 331 08	618	1	3 978 100	91 56 428 08	HYDR.SCHWEBEBALLAST-AN
VERSCHRAUBUNG XG42-L A3	47 00 309 08	628	7	2 970	91 56 537 08	HYDRAULIK
VERSCHRAUBUNG XG6-S A3P	47 00 310 08	661	1	1 970	91 56 958 08	HYDRAULIK RAUPE
VERSCHRAUBUNG XGAI6-SR	47 07 002 08	703	8	2 970	91 56 537 08	HYDRAULIK
VERSCHRAUBUNG XGE10-LM	47 10 305 08	23	2	2 391 023	96 45 720 08	KUEHLER VORM.
VERSCHRAUBUNG XGE10-LM	47 10 305 08	664	5	2 970	91 56 537 08	HYDRAULIK
VERSCHRAUBUNG XGE10-LM	47 10 305 08	607	1	2 975 100	91 52 860 08	ZUSATZHYDRAULIK WINDE 3
VERSCHRAUBUNG XGE10-LM	47 10 398 08	620	1	2 990	91 59 244 08	DRUCKLUFTANLAGE
VERSCHRAUBUNG XGE10-LR	47 10 306 08	723	17	2 970	91 56 537 08	HYDRAULIK
VERSCHRAUBUNG XGE10-LR	47 10 306 08	614	2	2 975 100	91 52 860 08	ZUSATZHYDRAULIK WINDE 3
VERSCHRAUBUNG XGE10-LR	47 10 306 08	618	2	2 975 200	91 52 775 08	ZUSATZHYDRAULIK WINDE 2
VERSCHRAUBUNG XGE10-LR	47 10 306 08	618	2	2 975 700	91 52 774 08	ZUSATZHYDRAULIK WINDE 1
VERSCHRAUBUNG XGE10-LR	47 10 306 08	601	4	2 978 100	91 52 796 08	ZUSATZHYDR.MONTAGEEINR

6.2.2009

etk_en_de_074515 LR 1600/2

1127

LIEBHERRAlphabetical index
Alphabetischer Index

Bezeichnung	Artikel	Pos.	Menge	Seite	Baugruppe	Bezeichnung
VERSCHRAUBUNG XGE10-LR	47 10 306 08	623	2	2 978 100	91 52 827 08	ZUSATZHYDR.D-RUECKHALT
VERSCHRAUBUNG XGE10-LR	47 10 306 08	634	1	2 978 200	91 54 843 08	ZUSATZHYDR.S-RUECKHALTE
VERSCHRAUBUNG XGE10-LR	47 10 306 08	601	1	3 978 100	91 56 428 08	HYDR.SCHWEBEBALLAST-AN
VERSCHRAUBUNG XGE10-LR	47 10 396 08	746	5	2 970	91 56 537 08	HYDRAULIK
VERSCHRAUBUNG XGE10-SR	47 10 045 14	805	1	2 970	91 56 537 08	HYDRAULIK
VERSCHRAUBUNG XGE10-SR	47 10 045 14	602	2	3 978 019	91 56 431 08	ZUSATZHYDRAULIK ZYLINDER
VERSCHRAUBUNG XGE12-LM	47 10 394 08	702	3	2 970	91 56 537 08	HYDRAULIK
VERSCHRAUBUNG XGE12-LM	47 10 394 08	618	1	2 975 100	91 52 860 08	ZUSATZHYDRAULIK WINDE 3
VERSCHRAUBUNG XGE12-LM	47 10 394 08	610	1	2 975 200	91 52 775 08	ZUSATZHYDRAULIK WINDE 2
VERSCHRAUBUNG XGE12-LM	47 10 394 08	610	1	2 975 700	91 52 774 08	ZUSATZHYDRAULIK WINDE 1
VERSCHRAUBUNG XGE12-LR	47 10 308 08	731	10	2 970	91 56 537 08	HYDRAULIK
VERSCHRAUBUNG XGE12-LR	47 10 308 08	608	1	2 975 100	91 52 860 08	ZUSATZHYDRAULIK WINDE 3
VERSCHRAUBUNG XGE12-LR	47 10 308 08	621	1	2 975 200	91 52 775 08	ZUSATZHYDRAULIK WINDE 2
VERSCHRAUBUNG XGE12-LR	47 10 308 08	621	1	2 975 700	91 52 774 08	ZUSATZHYDRAULIK WINDE 1
VERSCHRAUBUNG XGE12-LR	47 10 308 08	601	2	2 976 203	92 27 489 08	ZUSATZHYDR.BOLZENZIEHZ
VERSCHRAUBUNG XGE12-LR	47 10 308 08	624	2	2 978 100	91 52 827 08	ZUSATZHYDR.D-RUECKHALT
VERSCHRAUBUNG XGE12-LR	47 10 348 08	677	4	2 970	91 56 537 08	HYDRAULIK
VERSCHRAUBUNG XGE12-LR	47 10 348 08	614	1	2 978 100	91 52 796 08	ZUSATZHYDR.MONTAGEEINR
VERSCHRAUBUNG XGE12-LR	47 10 353 08	18	1	2 391 038	96 47 931 08	OELKUEHLER VORM.
VERSCHRAUBUNG XGE12-LR	47 10 353 08	682	13	2 970	91 56 537 08	HYDRAULIK
VERSCHRAUBUNG XGE12-LR	47 10 353 08	615	1	2 975 200	91 52 775 08	ZUSATZHYDRAULIK WINDE 2
VERSCHRAUBUNG XGE12-LR	47 10 353 08	615	1	2 975 700	91 52 774 08	ZUSATZHYDRAULIK WINDE 1
VERSCHRAUBUNG XGE12-LR	47 10 353 08	620	1	2 978 100	91 52 827 08	ZUSATZHYDR.D-RUECKHALT
VERSCHRAUBUNG XGE12-LR	47 10 353 08	635	1	2 978 100	91 52 827 08	ZUSATZHYDR.D-RUECKHALT
VERSCHRAUBUNG XGE12-LR	47 10 353 08	612	3	2 978 200	91 54 843 08	ZUSATZHYDR.S-RUECKHALTE
VERSCHRAUBUNG XGE12-LR	47 10 353 08	604	4	3 978 005	91 56 430 08	ZUSATZHYDRAULIK SB-KOPFS
VERSCHRAUBUNG XGE12-LR	47 10 353 08	603	1	3 978 019	91 56 431 08	ZUSATZHYDRAULIK ZYLINDER
VERSCHRAUBUNG XGE15-LM	47 10 309 08	24	2	2 391 023	96 45 720 08	KUEHLER VORM.
VERSCHRAUBUNG XGE15-LM	47 10 309 08	6	1	2 670 002	96 45 352 08	KRAFTSTOFFBEHAELTER VO
VERSCHRAUBUNG XGE15-LM	47 10 309 08	663	3	2 970	91 56 537 08	HYDRAULIK
VERSCHRAUBUNG XGE15-LR	47 10 310 08	27	1	1 750	91 52 394 08	WERKZEUG
VERSCHRAUBUNG XGE15-LR	47 10 310 08	613	1	2 978 100	91 52 827 08	ZUSATZHYDR.D-RUECKHALT
VERSCHRAUBUNG XGE16-SR	47 10 332 08	604	4	1 970	91 56 958 08	HYDRAULIK RAUPE
VERSCHRAUBUNG XGE16-SR	47 10 332 08	750	4	2 970	91 56 537 08	HYDRAULIK
VERSCHRAUBUNG XGE16-SR	47 10 332 08	604	3	2 975 000	91 57 881 08	ZUSATZHYDRAULIK MONTAGE
VERSCHRAUBUNG XGE16-SR	47 10 332 08	605	1	2 978 100	91 52 796 08	ZUSATZHYDR.MONTAGEEINR
VERSCHRAUBUNG XGE16-SR	47 10 332 08	601	1	3 978 019	91 56 431 08	ZUSATZHYDRAULIK ZYLINDER
VERSCHRAUBUNG XGE16-SR	47 10 331 08	657	6	1 970	91 56 958 08	HYDRAULIK RAUPE
VERSCHRAUBUNG XGE16-SR	47 10 331 08	602	3	2 975 000	91 57 881 08	ZUSATZHYDRAULIK MONTAGE
VERSCHRAUBUNG XGE18-LM	47 66 076 08	403	2	2 391 001	96 45 719 08	DIESELMOTOR VORM.
VERSCHRAUBUNG XGE18-LM	47 66 076 08	622	1	2 990	91 59 244 08	DRUCKLUFTANLAGE
VERSCHRAUBUNG XGE18-LM	47 10 370 08	25	2	2 391 023	96 45 720 08	KUEHLER VORM.
VERSCHRAUBUNG XGE18-LM	47 10 370 08	10	1	2 670 002	96 45 352 08	KRAFTSTOFFBEHAELTER VO
VERSCHRAUBUNG XGE18-LM	47 10 370 08	665	4	2 970	91 56 537 08	HYDRAULIK
VERSCHRAUBUNG XGE18-LM	47 10 370 08	611	2	2 976 200	91 52 780 08	ZUSATZHYDRAULIK DREHWE
VERSCHRAUBUNG XGE18-LM	47 10 370 08	607	1	2 976 700	91 54 795 08	ZUSATZHYDRAULIK PUMPE
VERSCHRAUBUNG XGE18-LM	47 66 078 08	706	2	2 970	91 56 537 08	HYDRAULIK
VERSCHRAUBUNG XGE18-LR	47 10 312 08	614	1	1 970	91 56 958 08	HYDRAULIK RAUPE
VERSCHRAUBUNG XGE18-LR	47 10 312 08	614	1	2 978 200	91 54 843 08	ZUSATZHYDR.S-RUECKHALTE
VERSCHRAUBUNG XGE18-LR	47 10 375 08	605	1	2 975 000	91 57 881 08	ZUSATZHYDRAULIK MONTAGE
VERSCHRAUBUNG XGE20-SM	47 10 343 08	714	2	2 970	91 56 537 08	HYDRAULIK
VERSCHRAUBUNG XGE20-SR	47 10 334 08	656	3	1 970	91 56 958 08	HYDRAULIK RAUPE
VERSCHRAUBUNG XGE20-SR	47 10 334 08	609	1	3 978 019	91 56 431 08	ZUSATZHYDRAULIK ZYLINDER
VERSCHRAUBUNG XGE22-LM	10 03 689 6	720	2	2 970	91 56 537 08	HYDRAULIK
VERSCHRAUBUNG XGE22-LM	47 10 313 08	643	2	1 970	91 56 958 08	HYDRAULIK RAUPE
VERSCHRAUBUNG XGE22-LM	47 10 313 08	601	2	1 970 161	96 50 706 08	ZUSATZHYDR.RAUPENTRAEG
VERSCHRAUBUNG XGE22-LM	47 10 313 08	615	6	2 970	91 56 537 08	HYDRAULIK
VERSCHRAUBUNG XGE22-LM	47 10 313 08	603	1	2 975 100	91 52 860 08	ZUSATZHYDRAULIK WINDE 3
VERSCHRAUBUNG XGE22-LM	47 10 313 08	613	1	2 975 200	91 52 775 08	ZUSATZHYDRAULIK WINDE 2
VERSCHRAUBUNG XGE22-LM	47 10 313 08	613	1	2 975 700	91 52 774 08	ZUSATZHYDRAULIK WINDE 1

6.2.2009

etk_en_de_074515 LR 1600/2

1128

LIEBHERRAlphabetical index
Alphabetischer Index

Bezeichnung	Artikel	Pos.	Menge	Seite	Baugruppe	Bezeichnung
VERSCHRAUBUNG XGE22-LM	47 10 313 08	606	1	2 976 700	91 54 795 08	ZUSATZHYDRAULIK PUMPE
VERSCHRAUBUNG XGE22-LR	47 10 314 08	621	2	2 978 100	91 52 827 08	ZUSATZHYDR.D-RUECKHALT
VERSCHRAUBUNG XGE25-SR	47 10 336 08	763	7	2 970	91 56 537 08	HYDRAULIK
VERSCHRAUBUNG XGE25-SR	47 10 336 08	622	2	2 978 100	91 52 827 08	ZUSATZHYDR.D-RUECKHALT
VERSCHRAUBUNG XGE28-LM	47 10 315 08	710	2	2 970	91 56 537 08	HYDRAULIK
VERSCHRAUBUNG XGE28-LR	47 10 316 08	606	2	1 970	91 56 958 08	HYDRAULIK RAUPE
VERSCHRAUBUNG XGE28-LR	47 10 316 08	787	2	2 970	91 56 537 08	HYDRAULIK
VERSCHRAUBUNG XGE28-LR	47 10 316 08	614	1	3 978 100	91 56 428 08	HYDR.SCHWEBEBALLAST-AN
VERSCHRAUBUNG XGE35-LM	47 10 318 08	640	2	2 970	91 56 537 08	HYDRAULIK
VERSCHRAUBUNG XGE35-LR	47 10 345 08	802	2	2 970	91 56 537 08	HYDRAULIK
VERSCHRAUBUNG XGE42-LM	47 10 319 08	13	1	2 671 004	96 46 305 08	OELBEHAELTER VORM.
VERSCHRAUBUNG XGE42-LM	47 10 319 08	637	1	2 970	91 56 537 08	HYDRAULIK
VERSCHRAUBUNG XGE42-LR	47 10 347 08	602	2	1 970	91 56 958 08	HYDRAULIK RAUPE
VERSCHRAUBUNG XGE42-LR	47 10 347 08	605	7	2 970	91 56 537 08	HYDRAULIK
VERSCHRAUBUNG XGE6-LM-E	47 10 301 08	604	4	2 990	91 59 244 08	DRUCKLUFTANLAGE
VERSCHRAUBUNG XGE6-LR-E	47 10 300 08	19	31	2 711	91 52 800 08	ZENTRALSCHMIERANLAGE O
VERSCHRAUBUNG XGE6-LR-E	47 10 300 08	749	2	2 970	91 56 537 08	HYDRAULIK
VERSCHRAUBUNG XGE6-SM-E	47 10 302 08	707	10	2 970	91 56 537 08	HYDRAULIK
VERSCHRAUBUNG XGE6-SM-E	47 10 302 08	605	1	2 976 700	91 54 795 08	ZUSATZHYDRAULIK PUMPE
VERSCHRAUBUNG XGE6-SM-E	47 10 302 08	611	2	2 990	91 59 244 08	DRUCKLUFTANLAGE
VERSCHRAUBUNG XGE6-SR-E	47 10 321 08	663	1	1 970	91 56 958 08	HYDRAULIK RAUPE
VERSCHRAUBUNG XGE6-SR-E	47 10 321 08	21	1	2 932 160	96 54 385 08	SCHALTSCHRANK MECH.
VERSCHRAUBUNG XGE6-SR-E	47 10 321 08	721	2	2 970	91 56 537 08	HYDRAULIK
VERSCHRAUBUNG XGE6-SR-E	47 10 321 08	603	1	2 990	91 59 244 08	DRUCKLUFTANLAGE
VERSCHRAUBUNG XGE6-SR-E	47 10 321 08	612	6	3 978 005	91 56 430 08	ZUSATZHYDRAULIK SB-KOPFS
VERSCHRAUBUNG XGE8-SM-E	47 10 322 08	684	2	2 970	91 56 537 08	HYDRAULIK
VERSCHRAUBUNG XGE8-SR-E	47 10 323 08	679	4	2 970	91 56 537 08	HYDRAULIK
VERSCHRAUBUNG XGEV30-	47 10 338 08	782	2	2 970	91 56 537 08	HYDRAULIK
VERSCHRAUBUNG XGEV30-	47 10 338 08	610	1	3 978 100	91 56 428 08	HYDR.SCHWEBEBALLAST-AN
VERSCHRAUBUNG XGR12/10-	47 50 315 08	798	1	2 970	91 56 537 08	HYDRAULIK
VERSCHRAUBUNG XGR15/12-	47 50 317 08	627	2	2 975 100	91 52 860 08	ZUSATZHYDRAULIK WINDE 3
VERSCHRAUBUNG XGR16/12-	47 50 325 08	605	8	1 975 006	91 52 509 08	ZUSATZHYDR.ABSTUETZZYL
VERSCHRAUBUNG XGR16/12-	47 50 325 08	605	1	2 978 100	91 52 827 08	ZUSATZHYDR.D-RUECKHALT
VERSCHRAUBUNG XGR16/12-	47 50 325 08	603	1	2 978 200	91 54 843 08	ZUSATZHYDR.S-RUECKHALTE
VERSCHRAUBUNG XGR18/15-	47 50 302 08	673	1	2 970	91 56 537 08	HYDRAULIK
VERSCHRAUBUNG XGR20/16-	47 50 336 08	656	4	2 970	91 56 537 08	HYDRAULIK
VERSCHRAUBUNG XGR20/16-	47 50 336 08	608	1	3 978 019	91 56 431 08	ZUSATZHYDRAULIK ZYLINDER
VERSCHRAUBUNG XGR25/16-	47 50 328 08	785	6	2 970	91 56 537 08	HYDRAULIK
VERSCHRAUBUNG XGR25/16-	47 50 328 08	795	1	2 970	91 56 537 08	HYDRAULIK
VERSCHRAUBUNG XGR28/18-	47 50 311 08	794	1	2 970	91 56 537 08	HYDRAULIK
VERSCHRAUBUNG XGR28/22-	47 50 318 08	653	3	1 970	91 56 958 08	HYDRAULIK RAUPE
VERSCHRAUBUNG XGR28/22-	47 50 318 08	620	2	2 970	91 56 537 08	HYDRAULIK
VERSCHRAUBUNG XGR28/22-	47 50 318 08	628	1	2 975 100	91 52 860 08	ZUSATZHYDRAULIK WINDE 3
VERSCHRAUBUNG XGR28/22-	47 50 318 08	632	2	2 978 200	91 54 843 08	ZUSATZHYDR.S-RUECKHALTE
VERSCHRAUBUNG XGR30/16-	47 50 337 08	617	2	2 978 100	91 52 796 08	ZUSATZHYDR.MONTAGEEINR
VERSCHRAUBUNG XGR30/16-	47 50 337 08	611	4	3 978 005	91 56 430 08	ZUSATZHYDRAULIK SB-KOPFS
VERSCHRAUBUNG XGR30/20-	47 50 340 08	606	4	3 978 005	91 56 430 08	ZUSATZHYDRAULIK SB-KOPFS
VERSCHRAUBUNG XGR30/25-	47 50 329 08	654	1	2 970	91 56 537 08	HYDRAULIK
VERSCHRAUBUNG XGR30/25-	47 50 329 08	619	2	2 978 100	91 52 796 08	ZUSATZHYDR.MONTAGEEINR
VERSCHRAUBUNG XGR35/22-	47 50 312 08	696	1	2 970	91 56 537 08	HYDRAULIK
VERSCHRAUBUNG XGR35/28-	47 50 313 08	620	1	3 978 100	91 56 428 08	HYDR.SCHWEBEBALLAST-AN
VERSCHRAUBUNG XGR38/30-	47 50 339 08	757	6	2 970	91 56 537 08	HYDRAULIK
VERSCHRAUBUNG XGR38/30-	47 50 339 08	605	4	3 978 100	91 56 428 08	HYDR.SCHWEBEBALLAST-AN
VERSCHRAUBUNG XGR42/28-	47 50 310 08	695	1	2 970	91 56 537 08	HYDRAULIK
VERSCHRAUBUNG XGR42/35-	47 50 319 08	612	5	2 970	91 56 537 08	HYDRAULIK
VERSCHRAUBUNG XSV10-L A3	47 40 303 08	676	1	2 970	91 56 537 08	HYDRAULIK
VERSCHRAUBUNG XSV15-L A3	47 40 305 08	671	1	2 970	91 56 537 08	HYDRAULIK
VERSCHRAUBUNG XSV16-S	47 40 326 08	677	4	1 970	91 56 958 08	HYDRAULIK RAUPE
VERSCHRAUBUNG XSV16-S	47 40 326 08	616	4	1 975 006	91 52 509 08	ZUSATZHYDR.ABSTUETZZYL
VERSCHRAUBUNG XSV18-L A3	47 40 307 08	668	1	2 970	91 56 537 08	HYDRAULIK

6.2.2009

etk_en_de_074515 LR 1600/2

1129

LIEBHERRAlphabetical index
Alphabetischer Index

Bezeichnung	Artikel	Pos.	Menge	Seite	Baugruppe	Bezeichnung
VERSCHRAUBUNG XT10-L A3	47 04 303 08	735	2	2 970	91 56 537 08	HYDRAULIK
VERSCHRAUBUNG XT10-L A3	47 04 303 08	628	1	2 978 100	91 52 827 08	ZUSATZHYDR.D-RUECKHALT
VERSCHRAUBUNG XT12-L A3	47 04 304 08	800	1	2 970	91 56 537 08	HYDRAULIK
VERSCHRAUBUNG XT12-L A3	47 04 304 08	608	2	2 976 200	91 52 780 08	ZUSATZHYDRAULIK DREHWE
VERSCHRAUBUNG XT12-L A3	47 04 304 08	627	1	2 978 100	91 52 827 08	ZUSATZHYDR.D-RUECKHALT
VERSCHRAUBUNG XT12-L A3	47 04 304 08	630	2	2 978 200	91 54 843 08	ZUSATZHYDR.S-RUECKHALTE
VERSCHRAUBUNG XT12-L A3	47 04 304 08	617	2	3 978 005	91 56 430 08	ZUSATZHYDRAULIK SB-KOPFS
VERSCHRAUBUNG XT15-L A3	47 04 305 08	611	1	2 978 100	91 52 827 08	ZUSATZHYDR.D-RUECKHALT
VERSCHRAUBUNG XT25-S A3	47 04 327 08	796	2	2 970	91 56 537 08	HYDRAULIK
VERSCHRAUBUNG XT25-S A3	47 04 327 08	625	1	2 978 100	91 52 827 08	ZUSATZHYDR.D-RUECKHALT
VERSCHRAUBUNG XT25-S A3	47 04 327 08	628	1	2 978 200	91 54 843 08	ZUSATZHYDR.S-RUECKHALTE
VERSCHRAUBUNG XT28-L A3	47 04 308 08	651	2	1 970	91 56 958 08	HYDRAULIK RAUPE
VERSCHRAUBUNG XT28-L A3	47 04 308 08	698	3	2 970	91 56 537 08	HYDRAULIK
VERSCHRAUBUNG XT28-L A3	47 04 308 08	620	2	2 978 200	91 54 843 08	ZUSATZHYDR.S-RUECKHALTE
VERSCHRAUBUNG XT30-S A3	47 04 329 08	612	1	2 978 100	91 52 796 08	ZUSATZHYDR.MONTAGEEINR
VERSCHRAUBUNG XT35-L A3	47 04 315 08	629	14	2 970	91 56 537 08	HYDRAULIK
VERSCHRAUBUNG XT38-S A3	47 04 330 08	650	4	1 970	91 56 958 08	HYDRAULIK RAUPE
VERSCHRAUBUNG XT38-S A3	47 04 330 08	717	3	2 970	91 56 537 08	HYDRAULIK
VERSCHRAUBUNG XT38-S A3	47 04 330 08	615	2	3 978 005	91 56 430 08	ZUSATZHYDRAULIK SB-KOPFS
VERSCHRAUBUNG XT42-L A3	47 04 314 08	607	7	2 970	91 56 537 08	HYDRAULIK
VERSCHRAUBUNG XTR20/25/2	47 51 349 08	765	1	2 970	91 56 537 08	HYDRAULIK
VERSCHRAUBUNG XW10-L A3	47 02 303 08	779	1	2 970	91 56 537 08	HYDRAULIK
VERSCHRAUBUNG XW10-L A3	47 02 303 08	631	1	2 978 100	91 52 827 08	ZUSATZHYDR.D-RUECKHALT
VERSCHRAUBUNG XW12-L A3	47 02 304 08	630	1	2 978 100	91 52 827 08	ZUSATZHYDR.D-RUECKHALT
VERSCHRAUBUNG XW16-S A3	47 02 326 08	676	2	1 970	91 56 958 08	HYDRAULIK RAUPE
VERSCHRAUBUNG XW16-S A3	47 02 326 08	792	1	2 970	91 56 537 08	HYDRAULIK
VERSCHRAUBUNG XW16-S A3	47 02 326 08	618	1	2 978 100	91 52 796 08	ZUSATZHYDR.MONTAGEEINR
VERSCHRAUBUNG XW16-S A3	47 02 326 08	642	1	2 978 100	91 52 827 08	ZUSATZHYDR.D-RUECKHALT
VERSCHRAUBUNG XW18-L A3	47 02 306 08	799	1	2 970	91 56 537 08	HYDRAULIK
VERSCHRAUBUNG XW18-L A3	47 02 306 08	601	1	2 990	91 59 244 08	DRUCKLUFTANLAGE
VERSCHRAUBUNG XW22-L A3	47 02 307 08	678	1	1 970	91 56 958 08	HYDRAULIK RAUPE
VERSCHRAUBUNG XW22-L A3	47 02 307 08	632	3	2 978 100	91 52 827 08	ZUSATZHYDR.D-RUECKHALT
VERSCHRAUBUNG XW25-S A3	47 02 328 08	629	3	2 978 100	91 52 827 08	ZUSATZHYDR.D-RUECKHALT
VERSCHRAUBUNG XW28-L A3	47 02 308 08	700	2	2 970	91 56 537 08	HYDRAULIK
VERSCHRAUBUNG XW30-S A3	47 02 330 08	715	1	2 970	91 56 537 08	HYDRAULIK
VERSCHRAUBUNG XW35-L A3	47 02 311 08	639	2	2 970	91 56 537 08	HYDRAULIK
VERSCHRAUBUNG XW38-S A3	47 02 334 08	727	1	2 970	91 56 537 08	HYDRAULIK
VERSCHRAUBUNG XW38-S A3	47 02 334 08	604	2	2 977	91 57 756 08	ZUSATZHYDRAULIK DREHBUE
VERSCHRAUBUNG XW38-S A3	47 02 334 08	623	2	3 978 005	91 56 430 08	ZUSATZHYDRAULIK SB-KOPFS
VERSCHRAUBUNG XW42-L A3	47 02 314 08	608	7	2 970	91 56 537 08	HYDRAULIK
VERSCHRAUBUNG XWSV6-S	47 42 021 08	32	1	2 711	91 52 800 08	ZENTRALSCHMIERANLAGE O
VERSCHRAUBUNGSKOERPER	93 75 014 08	4	2	2 976 200	91 52 780 08	ZUSATZHYDRAULIK DREHWE
VERSTEIFUNGSBLECH	10 02 918 8	3	1	9 739 362	97 39 362	OELWANNE
VERSTELLEINRICHTUNG	10 41 120 7	2	1	X1035925	10 35 925 1	VERSTELLPUMPE
VERSTELLFLASCHE KPL.	96 49 266 08	2	1	3 714	91 52 862 08	D-KOPFSTUECK
VERSTELLFLASCHE KPL. TZN	96 49 267 08	3	1	3 714	91 52 862 08	D-KOPFSTUECK
VERSTELLFLASCHE SCHWK.	96 49 290 08	1	1	3 714 008	96 49 266 08	VERSTELLFLASCHE KPL.
VERSTELLFLASCHE SCHWK.	96 49 455 08	1	1	3 714 009	96 49 267 08	VERSTELLFLASCHE KPL.
VERSTELLMOTOR A6VM 160	10 42 876 6	2	2	2 340	91 52 776 08	WINDE 4 EINZIEHWERK
VERSTELLMOTOR A6VM 200	10 35 482 8	3	1	2 310	91 52 503 08	WINDE 1
VERSTELLMOTOR A6VM 200	10 35 482 8	3	1	2 320	91 52 504 08	WINDE 2
VERSTELLMOTOR A6VM 200	10 42 876 7	2	1	3 350	91 52 859 08	WINDE 3
VERSTELLMOTOR A6VM 200	10 42 876 8	8	2	1 400	91 56 853 08	RAUPENTRAEGER KPL.LI.
VERSTELLMOTOR A6VM 200	10 42 876 8	8	2	1 410 300	91 56 855 08	RAUPENTRAEGER KPL.RE.
VERSTELLPUMPE A11VO/40LI	10 35 924 7	110	1	2 391 001	96 45 719 08	DIESELMOTOR VORM.
VERSTELLPUMPE A11VO/60R	10 35 924 8	111	1	2 391 001	96 45 719 08	DIESELMOTOR VORM.
VERSTELLPUMPE A4VG/125LI	10 35 924 3	105	1	2 391 001	96 45 719 08	DIESELMOTOR VORM.
VERSTELLPUMPE A4VG/125R	10 35 924 4	106	1	2 391 001	96 45 719 08	DIESELMOTOR VORM.
VERSTELLPUMPE A4VG/28 LI	10 35 924 9	1	1	2 212	91 54 561 08	PUMPE F.DREHWERK
VERSTELLPUMPE A4VG/56 LI	10 35 924 6	108	1	2 391 001	96 45 719 08	DIESELMOTOR VORM.

6.2.2009

etk_en_de_074515 LR 1600/2

1130

LIEBHERRAlphabetical index
Alphabetischer Index

Bezeichnung	Artikel	Pos.	Menge	Seite	Baugruppe	Bezeichnung
VERSTELLPUMPE A4VG/90 LI	10 35 924 1	103	1	2 391 001	96 45 719 08	DIESELMOTOR VORM.
VERSTELLPUMPE A4VG/90 LI	10 35 924 2	104	1	2 391 001	96 45 719 08	DIESELMOTOR VORM.
VERSTELLPUMPE A4VG/90 LI	10 35 925 0	107	1	2 391 001	96 45 719 08	DIESELMOTOR VORM.
VERSTELLPUMPE PA10VO/45	10 35 925 1	109	1	2 391 001	96 45 719 08	DIESELMOTOR VORM.
VERSTELLUNG	10 32 692 5	2	1	X1035924	10 35 924 6	VERSTELLPUMPE
VERSTELLUNG	10 33 104 8	2	1	X1035924	10 35 924 1	VERSTELLPUMPE
VERSTELLUNG	10 33 104 8	2	1	X1035924	10 35 924 2	VERSTELLPUMPE
VERSTELLUNG	10 33 104 8	2	1	X1035925	10 35 925 0	VERSTELLPUMPE
VERSTELLUNG	10 47 137 1	2	1	X1035924	10 35 924 3	VERSTELLPUMPE
VERSTELLUNG	10 47 137 1	2	1	X1035924	10 35 924 4	VERSTELLPUMPE
VERSTELLUNG	10 47 220 0	5	1	X1035924	10 35 924 7	VERSTELLPUMPE
VERSTELLUNG	10 47 220 8	4	1	X1035924	10 35 924 8	VERSTELLPUMPE
VERSTELLUNG	10 65 039 3	26	1	X1029200	10 29 200 4	FAHRERSITZ
VERSTELLUNG	10 65 068 6	2	1	X1035924	10 35 924 9	VERSTELLPUMPE
VERSTELLUNG	70 23 643	5	1	X1035924	10 35 924 8	VERSTELLPUMPE
VERTEILER MASSE	92 68 911 08	41	2	2 932 082	96 54 387 08	AUFBAUTEILE MONTAGETAPE
VERTEILERBLOCK ALZNMGC	51 10 603 08	74	1	2 970	91 56 537 08	HYDRAULIK
VERTEILERGETRIEBE SPF	10 35 659 9	102	1	2 391 001	96 45 719 08	DIESELMOTOR VORM.
VERTEILERKOMBINATION 3/4	77 43 859 08	2	1	2 711	91 52 800 08	ZENTRALSCHMIERANLAGE O
VERTEILERKOMBINATION 3/6	10 47 036 7	4	1	2 711	91 52 800 08	ZENTRALSCHMIERANLAGE O
VERTEILERKOMBINATION 4/3	77 43 860 08	3	1	2 711	91 52 800 08	ZENTRALSCHMIERANLAGE O
VERTEILERKOMBINATION 4/8	77 43 862 08	5	1	2 711	91 52 800 08	ZENTRALSCHMIERANLAGE O
VERTEILERKOMBINATION 7/1	10 47 036 8	3	2	1 711	91 52 392 08	ZENTRALSCHMIERUNG RAUP
VERTEILERKOMBINATION 8/1	10 47 036 6	6	1	2 711	91 52 800 08	ZENTRALSCHMIERANLAGE O
VERTEILERKOMBINATION 8/1	10 47 037 0	2	2	1 711	91 52 392 08	ZENTRALSCHMIERUNG RAUP
VERTEILERLEISTE	77 43 837 08	11	1	2 990	91 59 244 08	DRUCKLUFTANLAGE
VIERKANTSCHIEBE	10 03 723 6	8	1	9 739 210	97 39 210	KUEHLMITTELEITUNG
VORHAENGESCHLOSS ABUS	88 52 515 08	31	1	2 391 040	96 53 645 08	KUPPLUNGSSTELLER
VORREIBER SPF	70 42 710 08	2	2	2 260 009	96 46 972 08	KLAPPE VORM.
VORSCHLAGHAMMER 5KG	88 50 341 08	11	1	1 750	91 52 394 08	WERKZEUG
VORSPANNVENTIL	51 14 320 08	7	1	2 975 000	91 57 881 08	ZUSATZHYDRAULIK MONTAGE
VORSPANNVENTIL 30BAR	51 13 082 08	11	1	2 978 100	91 52 827 08	ZUSATZHYDR.D-RUECKHALT
VORSPANNVENTIL 30BAR	51 13 082 08	11	1	2 978 200	91 54 843 08	ZUSATZHYDR.S-RUECKHALTE
VORSPANNVENTIL 30BAR 40L/	10 46 788 6	19	4	1 975 006	91 52 509 08	ZUSATZHYDR.ABSTUETZZYL
VORSTEUERVENTIL	57 13 626 08	55	1	5 113 086	51 13 086 08	PROPORTIONALVENTIL
WAEHLZLAGER 200X270X80	74 65 067 08	2	1	2 550 003	96 46 246 08	SEILROLLE KPL.
WAEHLZLAGER 200X270X80	74 65 067 08	2	1	2 652 007	92 68 928 08	SEILROLLE KPL.
WAEHLZLAGER 68X40X38	74 59 008 08	2	1	3 206 001	96 20 920 08	SEILROLLE KPL.
WAERMESCHUTZBLECH	10 22 271 9	8	1	9 739 296	97 39 296	HITZESCHUTZ
WAERMESCHUTZBLECH	10 22 272 3	15	1	9 739 296	97 39 296	HITZESCHUTZ
WALZE	92 17 259 08	6	2	3 745	91 52 948 08	SCHWEBEBALLAST
WALZENDUESE	10 29 201 3	35	10	2 520 034	96 45 984 08	INNENVERKLEIDUNG
WANDLER TTY-RS232	91 70 454 14	10	1	2 533 071	96 52 556 08	WANDLER
WANDLER TTY-RS232	96 52 556 08	8	1	2 533	91 52 789 08	ELEKTRIK KRANFUEHRERKAB
WANDSTECKDOSE 19-POL SP	10 44 366 5	(151)	1	3 930 734	96 54 401 08	KLEMMKASTEN
WANDSTECKDOSE 24-POL 22	10 44 365 9	(170)	1	3 930 138	96 54 377 08	ELEKTRIK S-ANLENKSTUECK
WANDSTECKDOSE 24-POL 22	10 44 365 9	151	1	3 930 732	96 50 575 08	LEITUNG
WARMLUFTSCHLAUCH DI 55M	10 42 558 8	55	0.12	2 520	91 53 061 08	KABINE VERGLAST
WARMLUFTSCHLAUCH DI 55M	10 42 558 8	56	0.18	2 520	91 53 061 08	KABINE VERGLAST
WARMLUFTSCHLAUCH DI 55M	10 42 558 8	41	0.4	2 520 034	96 45 984 08	INNENVERKLEIDUNG
WARNLEUCHTE 20-36V SPF	10 34 010 5	5	1	2 533 066	96 48 365 08	ELEKTRIK ANBAUTEILE KABIN
WARNLEUCHTE LMB	96 59 398 08	35	1	2 920	91 56 833 08	ELEKTRIK DREHBUEHNE
WARZENBLECH 3.5x521x876	97 00 272 08	1	1	2 859 028	96 46 778 08	DECKEL KPL.
WARZENBLECH 3.5x721x876	97 00 223 08	1	1	2 859 027	96 46 777 08	DECKEL KPL.
WARZENBLECH 5X1372X491	97 70 935 08	1	1	2 859 007	96 46 775 08	DECKEL KPL.
WARZENBLECH 5X878X723	97 70 951 08	1	1	2 859 026	96 46 776 08	DECKEL KPL.
WASSERABSCHIEDER	70 27 481 03	7	1	2 391	91 52 784 08	DIESELMOTOR KPL.
WASSERANSCHLUSS	97 39 276	173	1	X1012059	10 12 059 0	DIESELMOTOR
WASSERBEHAELTER 8,0L KUN	10 03 697 7	10	1	2 520 032	96 45 980 08	SCHEIBENWISCHANLAGE EIN
WASSERENTLUEFTUNGSLEIT	97 39 127	170	1	X1012059	10 12 059 0	DIESELMOTOR

6.2.2009

etk_en_de_074515 LR 1600/2

1131

LIEBHERRAlphabetical index
Alphabetischer Index

Bezeichnung	Artikel	Pos.	Menge	Seite	Baugruppe	Bezeichnung
WASSERHEIZGERAET 24V	10 04 204 3	2	1	2 541 001	96 49 651 08	ZUSATZHEIZUNG VORM.
WASSERLEITUNGSANSCHLUE	97 39 349	169	1	X1012059	10 12 059 0	DIESELMOTOR
WASSERPUMPE MIT BEFEST.	97 39 352	165	1	X1012059	10 12 059 0	DIESELMOTOR
WASSERROHR SCHWK.	96 48 528 08	29	1	2 391 001	96 45 719 08	DIESELMOTOR VORM.
WASSERSONDE WASSER	10 34 675 2	20	2	7 027 481	70 27 481 03	WASSERABSCHIEDER
WECHSELVENTIL	10 41 276 3	6	1	9 640 277	96 40 277 08	WEGESCHIEBER
WECHSELVENTIL	51 14 493 08	4	1	3 978 005	91 56 430 08	ZUSATZHYDRAULIK SB-KOPFS
WECHSELVENTIL	51 14 689 08	108	4	2 970	91 56 537 08	HYDRAULIK
WECHSELVENTIL	51 14 689 08	11	1	2 975 100	91 52 860 08	ZUSATZHYDRAULIK WINDE 3
WECHSELVENTIL	51 14 689 08	11	1	2 975 200	91 52 775 08	ZUSATZHYDRAULIK WINDE 2
WECHSELVENTIL	51 14 689 08	11	1	2 975 700	91 52 774 08	ZUSATZHYDRAULIK WINDE 1
WECHSELVENTIL	51 14 689 08	5	1	2 978 100	91 52 827 08	ZUSATZHYDR.D-RUECKHALT
WECHSELVENTIL	51 14 689 08	5	1	2 978 200	91 54 843 08	ZUSATZHYDR.S-RUECKHALTE
WEGESCHIEBER	51 13 045 08	3	1	2 976 203	92 27 489 08	ZUSATZHYDR.BOLZENZIEHZ
WEGESCHIEBER SL3-41	96 40 277 08	7	1	5 133 090	51 13 090 08	WEGESCHIEBERBLOCK
WEGESCHIEBER SPF	51 13 225 08	109	1	2 970	91 56 537 08	HYDRAULIK
WEGESCHIEBERBLOCK 4-FAC	51 13 090 08	16	1	1 970	91 56 958 08	HYDRAULIK RAUPE
WEGESITZVENTIL	51 13 087 08	111	2	2 970	91 56 537 08	HYDRAULIK
WEGESITZVENTIL	51 14 829 08	3	4	3 978 005	91 56 430 08	ZUSATZHYDRAULIK SB-KOPFS
WEGESITZVENTIL	51 14 988 08	25	1	2 970	91 56 537 08	HYDRAULIK
WEGEVENTIL	10 45 104 9	7	1	X1042440	10 42 440 2	STUEBERBLOCK
WEGEVENTIL	10 47 082 9	4	1	X1042440	10 42 440 2	STUEBERBLOCK
WEGEVENTIL	51 13 022 08	55	3	2 970	91 56 537 08	HYDRAULIK
WEGEVENTIL	51 14 444 08	34	3	2 970	91 56 537 08	HYDRAULIK
WEGEVENTIL	51 14 444 08	4	1	2 975 100	91 52 860 08	ZUSATZHYDRAULIK WINDE 3
WEGEVENTIL	51 14 444 08	4	1	2 975 200	91 52 775 08	ZUSATZHYDRAULIK WINDE 2
WEGEVENTIL	51 14 444 08	4	1	2 975 700	91 52 774 08	ZUSATZHYDRAULIK WINDE 1
WEGEVENTIL	51 14 444 08	4	1	2 978 100	91 52 827 08	ZUSATZHYDR.D-RUECKHALT
WEGEVENTIL	51 14 444 08	4	1	2 978 200	91 54 843 08	ZUSATZHYDR.S-RUECKHALTE
WEGEVENTIL	51 14 445 08	112	4	2 970	91 56 537 08	HYDRAULIK
WEGEVENTIL	51 14 498 08	2	2	3 978 005	91 56 430 08	ZUSATZHYDRAULIK SB-KOPFS
WEGEVENTIL	51 14 651 08	10	1	1 970	91 56 958 08	HYDRAULIK RAUPE
WEGEVENTIL	51 14 943 08	17	1	2 970	91 56 537 08	HYDRAULIK
WEGEVENTIL	57 10 349 08	3	1	3 978 100	91 56 428 08	HYDR.SCHWEBEBALLAST-AN
WEGEVENTIL SPF	10 42 393 8	4	1	2 975 000	91 57 881 08	ZUSATZHYDRAULIK MONTAGE
WEICHDICHTUNG PERBUNAN	71 02 004 08	59	4	1 970	91 56 958 08	HYDRAULIK RAUPE
WEICHDICHTUNG PERBUNAN	71 02 004 08	574	30	2 970	91 56 537 08	HYDRAULIK
WELLE 40.0x1854	93 72 521 08	2	1	3 350 001	92 70 642 08	SCHUTZWALZE KPL.
WELLENDICHRING 22X35X6	57 15 168 08	20	1	5 102 380	51 02 380 08	HYDROMOTOR
WELLENDICHRING 28X40X6	57 01 141 08	14	1	5 701 129	57 01 129 08	TRIEBWERK
WELLENDICHRING 28X40X6.	10 22 035 9	20	1	X1035925	10 35 925 1	VERSTELLPUMPE
WELLENDICHRING BA 35X5	10 65 070 1	(38)	1	X1035924	10 35 924 9	VERSTELLPUMPE
WELLENDICHRING DIN 3760	79 04 950 14	454	1	X1065015	10 65 015 5	GETRIEBE
WERKZEUG	91 52 394 08	25	1		LR 1600-2-0	LIEBHERR RAUPENKRAN LR 1
WIDERSTAND 15R 5% 50W	63 50 576 08	15	1	2 913 005	96 20 731 08	INNENGEHAEUSE VORM.
WIDERSTAND 15R 5% 50W	63 50 576 08	15	1	2 913 005	96 28 696 08	INNENGEHAEUSE VORM.
WIDERSTAND 1K 5% 3W 75PP	63 50 585 08	2	1	2 932 515	96 45 911 08	BESTUECKUNGSMODUL
WIDERSTAND 47R 10% 25W	63 50 170 08	46	10	2 932 001	96 45 393 08	RELAISSTEUERUNG
WIDERSTAND 500R 0%1 2W5	63 50 515 08	4	2	2 932 515	96 45 911 08	BESTUECKUNGSMODUL
WIDERSTAND NW 1K 5% 8X 9	63 50 855 08	20	2	2 922 001	92 84 311 08	BUSPLATINE
WIDERSTAND NW 22K 10% 8X	63 50 842 08	7	10	2 922 001	92 84 311 08	BUSPLATINE
WIDERSTANDSMODUL PBTG	10 02 485 7	22	1	2 932 082	96 54 387 08	AUFBAUTEILE MONTAGETAPE
WINDE 1	91 52 503 08	103	1		LR 1600-2-0	LIEBHERR RAUPENKRAN LR 1
WINDE 2	91 52 504 08	104	1		LR 1600-2-0	LIEBHERR RAUPENKRAN LR 1
WINDE 3	91 52 859 08	223	1		LR 1600-2-0	LIEBHERR RAUPENKRAN LR 1
WINDE 4 EINZIEHWERK	91 52 776 08	111	1		LR 1600-2-0	LIEBHERR RAUPENKRAN LR 1
WINDENDREHGEBER SPF	10 04 047 7	5	1	2 920 200	96 44 536 08	ELEKTRIK WINDE 1
WINDENDREHGEBER SPF	10 04 047 7	5	1	2 920 260	96 44 537 08	ELEKTRIK WINDE 2
WINDENDREHGEBER SPF	10 04 047 7	5	1	2 920 334	96 44 538 08	ELEKTRIK WINDE 3
WINDENDREHGEBER SPF	10 04 047 7	5	1	2 920 350	96 44 539 08	ELEKTRIK WINDE 4

6.2.2009

etk_en_de_074515 LR 1600/2

1132

LIEBHERRAlphabetical index
Alphabetischer Index

Bezeichnung	Artikel	Pos.	Menge	Seite	Baugruppe	Bezeichnung
WINDENLAGERUNG SCHWK.	96 43 852 08	1	1	2 310	91 52 503 08	WINDE 1
WINDENLAGERUNG SCHWK.	96 43 852 08	1	1	2 320	91 52 504 08	WINDE 2
WINDENLAGERUNG SCHWK.	96 49 298 08	3	1	3 350	91 52 859 08	WINDE 3
WINDGESCHWINDIGKEITSGE	10 42 954 9	6	1	3 780 751	91 52 952 08	FLUG-U.WINDWARNUNG
WINDSTERN	10 47 043 3	1	1	X1042954	10 42 954 9	WINDGESCHWINDIGKEITSGE
WINKEL 1.5X151X54 FE//ZN20//	97 86 272 08	118	2	2 932 082	96 54 387 08	AUFBAUTEILE MONTAGETAPE
WINKEL 3X40X112 FE//ZN20//C	97 80 496 08	20	1	2 932 160	96 54 385 08	SCHALTSCHRANK MECH.
WINKEL 3X40X94	94 73 392 08	55	1	2 391 001	96 45 719 08	DIESELMOTOR VORM.
WINKEL 3X85X30	97 78 351 08	35	1	2 260	91 53 057 08	BATTERIELAGERUNG
WINKEL 4X20X57	95 05 969 08	76	1	2 810	91 52 806 08	KRANFUEHRERKABINE KPL.
WINKEL 5x154x70	97 05 395 08	35	2	3 211	91 57 748 08	S-ANLENKSTUECK
WINKEL 5x154x70	97 05 395 08	72	2	3 713	91 57 749 08	D-ANLENKSTUECK
WINKELGEBER 360° SPF	69 23 100 08	20	1	2 930	96 57 085 08	GEBERANBAU SA-BOCK
WINKELGEBER 360° SPF	69 23 100 08	(152)	1	3 930 138	96 54 377 08	ELEKTRIK S-ANLENKSTUECK
WINKELGEBER 360° SPF	69 23 100 08	(5)	1	3 930 576	96 48 381 08	ELEKTRIK SW-KOPFSTUECK
WINKELGELENK DIN 71802 CS	72 50 066 08	13	1	9 739 357	97 39 357	ABGASRUECKFUEHRUNG VO
WINKELGELENK DIN 71802 CS	72 50 069 08	16	2	2 391 040	96 53 645 08	KUPPLUNGSSTELLER
WINKELGETRIEBE	90 00 510 6	4	1	1 400	91 56 853 08	RAUPENTRAEGER KPL.LI.
WINKELGETRIEBE	90 00 510 6	80	1	1 410 300	91 56 855 08	RAUPENTRAEGER KPL.RE.
WINKELGETRIEBE	90 00 521 4	80	1	1 400	91 56 853 08	RAUPENTRAEGER KPL.LI.
WINKELGETRIEBE	90 00 521 4	4	1	1 410 300	91 56 855 08	RAUPENTRAEGER KPL.RE.
WINKELKABELSCHUH 12-95	60 22 221 08	(648)	1	2 920 536	96 48 317 08	KABELLISTE ELEKTRIK AGG
WINKELSCHRAUBENDREHER	81 00 354 08	46	1	1 750	91 52 394 08	WERKZEUG
WINKELSTUTZEN	59 10 510 08	24	2	2 520 032	96 45 980 08	SCHEIBENWISCHANLAGE EIN
WISCHERARM	10 29 201 4	8	1	2 520 032	96 45 980 08	SCHEIBENWISCHANLAGE EIN
WISCHERARM PARALELL	10 41 288 1	5	1	2 520 032	96 45 980 08	SCHEIBENWISCHANLAGE EIN
WISCHERBLATT 1000	10 29 201 7	6	1	2 520 032	96 45 980 08	SCHEIBENWISCHANLAGE EIN
WISCHERBLATT 700	10 29 201 6	9	1	2 520 032	96 45 980 08	SCHEIBENWISCHANLAGE EIN
WISCHERGESTAENGE 10	10 41 287 9	7	1	2 520 032	96 45 980 08	SCHEIBENWISCHANLAGE EIN
WISCHERGESTAENGE 12	10 41 288 0	2	1	2 520 032	96 45 980 08	SCHEIBENWISCHANLAGE EIN
WISCHERMOTOR 55NM 24V	10 29 202 1	1	2	2 520 032	96 45 980 08	SCHEIBENWISCHANLAGE EIN
ZAHNKRANZ	10 01 219 1	2	1	9 739 250	97 39 250	SCHWUNGRAD
ZAHNRADMOTOR	51 02 373 08	2	1	2 391 038	96 47 931 08	OELKUEHLER VORM.
ZAHNRIEMEN 12T5 445	10 48 983 6	1	1	X1022811	10 22 811 2	HEIZKLIMAGERAET
ZAHNSCHEIBE DIN 6797 A 2,7	42 51 004 08	3	4	2 913 003	96 20 599 08	FOLIENASTATUR VORM.
ZAHNSCHEIBE DIN 6797 A 3,2	42 51 005 08	6	12	2 913 100	91 23 538 08	BAUGRUPPENTRAEGER
ZAHNSCHEIBE DIN 6797 A 3,2	42 51 005 08	42	8	2 920 369	96 54 235 08	KLEMMKASTEN KPL.
ZAHNSCHEIBE DIN 6797 A 3,2	42 51 005 08	17	10	2 922 001	92 84 311 08	BUSPLATINE
ZAHNSCHEIBE DIN 6797 A 3,2	42 51 005 08	(267)	4	3 930 138	96 54 377 08	ELEKTRIK S-ANLENKSTUECK
ZAHNSCHEIBE DIN 6797 A 3,2	42 51 005 08	283	16	3 930 638	96 51 624 08	KLEMMKASTEN
ZAHNSCHEIBE DIN 6797 A 4,3	42 51 007 08	14	4	2 913 100	91 23 538 08	BAUGRUPPENTRAEGER
ZAHNSCHEIBE DIN 6797 A 4,3	42 51 007 08	6	8	2 913 102	92 32 870 08	LUEFTEREINHEIT
ZAHNSCHEIBE DIN 6797 A 4,3	42 51 007 08	282	12	2 920 369	96 54 235 08	KLEMMKASTEN KPL.
ZAHNSCHEIBE DIN 6797 A 4,3	42 51 007 08	282	24	2 920 448	96 48 794 08	KLEMMKASTEN KPL.
ZAHNSCHEIBE DIN 6797 A 4,3	42 51 007 08	46	56	2 932 160	96 54 385 08	SCHALTSCHRANK MECH.
ZEITRELAIS SPF	63 01 013 08	53	2	2 932 082	96 54 387 08	AUFBAUTEILE MONTAGETAPE
ZELLGUMMI 16X8 ZELLKAUTS	10 02 810 7	9	0.16	2 913 004	96 20 460 08	GEHAEUSE VORM.
ZELLGUMMI 20X12	26 21 043 08	12	4.6	2 932 160	96 54 385 08	SCHALTSCHRANK MECH.
ZELLGUMMI 20X8	26 21 010 08	10	3.91	2 859 005	96 46 756 08	KLAPPE VORM.
ZELLGUMMI 20X8	26 21 010 08	115	0.36	2 932 082	96 54 387 08	AUFBAUTEILE MONTAGETAPE
ZELLGUMMI 25X4 NEOPRENE	26 21 078 14	52	6	2 520	91 53 061 08	KABINE VERGLAST
ZELLGUMMI 3X6X10M	26 21 089 08	20	0.36	2 670	91 52 797 08	KRAFTSTOFFBEHAELTER KPL
ZELLGUMMI 3X6X10M	26 21 089 08	7	0.18	2 913 006	96 20 732 08	LUEFTERBLECH VORM.
ZELLGUMMI 8X10	26 21 091 08	9	3.7	2 520 030	96 45 609 08	DACHSCHEIBE VORM.
ZELLGUMMIBAND 15X5	26 21 051 08	13	1.76	2 393 002	96 46 782 08	DECKEL KPL.
ZELLGUMMIBAND 15X5	26 21 051 08	11	0.78	2 510	91 52 788 08	DREHBUEHNENVERKLEIDUN
ZELLGUMMIBAND 15X5	26 21 051 08	14	2.24	2 859 030	96 46 758 08	DECKEL KPL.
ZENTRALBALLAST 8X7.5T	91 53 020 08	22	1		LR 1600-2-0	LIEBHERR RAUPENKRAN LR 1
ZENTRALBALLASTBEFESTIG	91 53 021 08	23	1		LR 1600-2-0	LIEBHERR RAUPENKRAN LR 1
ZENTRALEINHEIT C1 8X2A G	91 44 006 08	3	6	2 932 122	96 45 394 08	LICCON MONTAGEEINHEIT

6.2.2009

etk_en_de_074515 LR 1600/2

1133

LIEBHERRAlphabetical index
Alphabetischer Index

Bezeichnung	Artikel	Pos.	Menge	Seite	Baugruppe	Bezeichnung
ZENTRALEINHEIT C1 8X2A G	91 44 006 08	16	1	2 932 160	96 54 385 08	SCHALTSCHRANK MECH.
ZENTRALSCHMIERANLAGE O	91 52 800 08	147	1		LR 1600-2-0	LIEBHERR RAUPENKRAN LR 1
ZENTRALSCHMIERUNG RAUP	91 52 392 08	20	1		LR 1600-2-0	LIEBHERR RAUPENKRAN LR 1
ZENTRIERUNG STANDARD B	91 52 950 08	350	1		LR 1600-2-0	LIEBHERR RAUPENKRAN LR 1
ZIGARETTENANZUENDER	10 42 905 8	20	1	2 533 050	96 48 359 08	ELEKTRIK KABINE
ZUENDSTARTSCHALTER 3S	10 33 555 7	4	1	2 533 070	96 48 363 08	ARMATUREN RE.
ZUGFEDER	72 01 091 08	9	3	3 206	91 52 881 08	F-ANLENKSTUECK
ZUGFEDER 0,8X8X26,5	10 44 376 9	24	2	2 522 011	96 45 602 08	SCHLIESSANLAGE
ZUGMESSLASCHE 0-2400KN S	10 35 469 6	501	2	2 550	91 57 751 08	SA-BOCK
ZUGMESSLASCHE ZUG 0-165	10 28 861 0	11	2	3 714	91 52 862 08	D-KOPFSTUECK
ZUGZYLINDER 150/60-2300 SP	10 41 102 1	2	1	2 657	91 57 656 08	MONTAGEEINRICHTUNG RA
ZUGZYLINDER 310/120-5000	10 42 959 8	1	1	3 714 016	96 49 797 08	ZUGZYLINDER VORM.
ZUGZYLINDER VORM.	96 49 797 08	9	2	3 714	91 52 862 08	D-KOPFSTUECK
ZUMESSVENTIL	10 30 300 5	1	1	X1034309	10 34 309 6	HOCHDRUCKPUMPE
ZUNGE	70 42 535 08	13	4	2 260 006	96 46 501 08	BATTERIEKASTEN VORM.
ZUNGE	70 42 540 08	8	4	2 859 007	96 46 775 08	DECKEL KPL.
ZUNGE	70 42 551 08	8	4	2 393 002	96 46 782 08	DECKEL KPL.
ZUNGE	70 42 551 08	8	4	2 859 029	96 46 779 08	DECKEL KPL.
ZUNGE	70 42 553 08	8	7	2 859 005	96 46 756 08	KLAPPE VORM.
ZUNGE	70 42 553 08	4	6	2 932 168	96 48 167 08	DECKEL KPL.
ZUNGE	70 42 562 08	13	2	2 859 030	96 46 758 08	DECKEL KPL.
ZUNGE	70 42 567 08	8	4	2 859 026	96 46 776 08	DECKEL KPL.
ZUNGE	70 42 567 08	8	4	2 859 027	96 46 777 08	DECKEL KPL.
ZUNGE	70 42 567 08	8	4	2 859 028	96 46 778 08	DECKEL KPL.
ZUNGE	70 42 590 08	14	4	2 859 025	96 46 757 08	GITTERROST VORM.
ZURRGURT EN 12195-2 6M 3	77 90 347 08	58	1	2 810	91 52 806 08	KRANFUEHRERKABINE KPL.
ZURRGURT L=5M POLYTEX	77 90 362 08	47	2	3 227 200	91 53 519 08	LI-ZWISCHENSTUECK F-ABSP
ZUS.HYDR.BOLZENZIEHEINR	91 44 034 08	2	1	3 790	91 08 481 08	BOLZENZIEHEINRICHTUNG
ZUSATZABSPANNUNG 2M	91 55 536 08	451	1		LR 1600-2-0	LIEBHERR RAUPENKRAN LR 1
ZUSATZABSPANNUNG 3M	91 55 537 08	452	1		LR 1600-2-0	LIEBHERR RAUPENKRAN LR 1
ZUSATZABSPANNUNG 4M	91 55 538 08	453	1		LR 1600-2-0	LIEBHERR RAUPENKRAN LR 1
ZUSATZABSPANNUNG 5M	91 55 539 08	454	1		LR 1600-2-0	LIEBHERR RAUPENKRAN LR 1
ZUSATZABSPANNUNG 6M	91 55 540 08	455	1		LR 1600-2-0	LIEBHERR RAUPENKRAN LR 1
ZUSATZABSPANNUNG 7M	91 55 541 08	456	1		LR 1600-2-0	LIEBHERR RAUPENKRAN LR 1
ZUSATZABSPANNUNG 8M	91 55 542 08	457	1		LR 1600-2-0	LIEBHERR RAUPENKRAN LR 1
ZUSATZABSPANNUNG LASC	91 55 535 08	450	1		LR 1600-2-0	LIEBHERR RAUPENKRAN LR 1
ZUSATZGEWICHT 1TO SPF	91 55 527 08	317	4		LR 1600-2-0	LIEBHERR RAUPENKRAN LR 1
ZUSATZHEIZUNG OW	91 52 790 08	134	1		LR 1600-2-0	LIEBHERR RAUPENKRAN LR 1
ZUSATZHEIZUNG VORM.	96 49 651 08	1	1	2 541	91 52 790 08	ZUSATZHEIZUNG OW
ZUSATZHYDR.ABSTUETZZYL	91 52 509 08	32	1		LR 1600-2-0	LIEBHERR RAUPENKRAN LR 1
ZUSATZHYDR.BOLZENZIEHZ	92 27 489 08	6	1	3 790 006	96 19 989 08	BOLZENZIEHZYLINDER KPL.
ZUSATZHYDR.BOLZENZIEHZ	92 27 489 08	6	1	3 790 007	96 19 990 08	BOLZENZIEHZYLINDER KPL.
ZUSATZHYDR.BOLZENZIEHZ	96 50 495 08	14	1	2 125	91 52 773 08	BOLZEN S-ANLENKST. UND S
ZUSATZHYDR.D-RUECKHALTE	91 52 827 08	175	1		LR 1600-2-0	LIEBHERR RAUPENKRAN LR 1
ZUSATZHYDR.MONTAGEEINR	91 52 796 08	142	1		LR 1600-2-0	LIEBHERR RAUPENKRAN LR 1
ZUSATZHYDR.PUMPE 5/WIND	91 55 149 08	174	1		LR 1600-2-0	LIEBHERR RAUPENKRAN LR 1
ZUSATZHYDR.RAUPENTRAE	96 50 706 08	2	1	1 970	91 56 958 08	HYDRAULIK RAUPE
ZUSATZHYDR.S-RUECKHALTE	91 54 843 08	184	1		LR 1600-2-0	LIEBHERR RAUPENKRAN LR 1
ZUSATZHYDRAULIK DREHBUE	91 57 756 08	173	1		LR 1600-2-0	LIEBHERR RAUPENKRAN LR 1
ZUSATZHYDRAULIK DREHW	91 52 780 08	118	1		LR 1600-2-0	LIEBHERR RAUPENKRAN LR 1
ZUSATZHYDRAULIK MONTAGE	91 57 881 08	120	1		LR 1600-2-0	LIEBHERR RAUPENKRAN LR 1
ZUSATZHYDRAULIK PUMPE D	91 54 795 08	176	1		LR 1600-2-0	LIEBHERR RAUPENKRAN LR 1
ZUSATZHYDRAULIK SB-KOPFS	91 56 430 08	400	1	3 714	91 52 862 08	D-KOPFSTUECK
ZUSATZHYDRAULIK WINDE 1	91 52 774 08	106	1		LR 1600-2-0	LIEBHERR RAUPENKRAN LR 1
ZUSATZHYDRAULIK WINDE 2	91 52 775 08	108	1		LR 1600-2-0	LIEBHERR RAUPENKRAN LR 1
ZUSATZHYDRAULIK WINDE 3	91 52 860 08	225	1		LR 1600-2-0	LIEBHERR RAUPENKRAN LR 1
ZUSATZHYDRAULIK ZWISCH	91 56 429 08	600	1	3 716	91 52 864 08	D-ZWISCHENSTUECK
ZUSATZHYDRAULIK ZWISCHE	91 56 432 08	600	1	3 715 008	91 52 863 08	D-ZWISCHENSTUECK
ZUSATZHYDRAULIK ZYLINDE	91 56 431 08	400	1	3 714 016	96 49 797 08	ZUGZYLINDER VORM.
ZUSATZKUEHLER VORM.	96 56 360 08	11	1	2 391	91 52 784 08	DIESELMOTOR KPL.

6.2.2009

etk_en_de_074515 LR 1600/2

1134

LIEBHERRAlphabetical index
Alphabetischer Index

Bezeichnung	Artikel	Pos.	Menge	Seite	Baugruppe	Bezeichnung
ZYLINDER	57 01 144 08	1	1	5 701 133	57 01 133 08	TRIEBWERK
ZYLINDER 50/25-165	57 19 135 08	5	1	5 123 682	51 23 682 08	MONTAGEZYLINDER
ZYLINDERFEDER 3X26X8,3X1	10 11 627 4	4	8	9 080 702	90 80 702	STEUERGERAET
ZYLINDERKOPF	97 39 261	6	1	9 739 262	97 39 262	ZYLINDERKOPF
ZYLINDERKOPF	97 39 261	6	1	9 739 266	97 39 266	ZYLINDERKOPF
ZYLINDERKOPF R-MOTOR	97 39 260	10	1	9 739 261	97 39 261	ZYLINDERKOPF
ZYLINDERKOPF R-MOTOR	97 39 262	41	4	X1012059	10 12 059 0	DIESELMOTOR
ZYLINDERKOPF R-MOTOR	97 39 266	42	2	X1012059	10 12 059 0	DIESELMOTOR
ZYLINDERKOPFDECKEL	10 01 219 8	2	5	9 739 267	97 39 267	ZYLINDERKOPFHAUBE
ZYLINDERKOPFDECKEL	10 01 333 5	1	1	9 739 267	97 39 267	ZYLINDERKOPFHAUBE
ZYLINDERKOPFDICHTUNG	10 03 231 8	7	1	9 739 262	97 39 262	ZYLINDERKOPF
ZYLINDERKOPFDICHTUNG	10 03 231 8	7	1	9 739 266	97 39 266	ZYLINDERKOPF
ZYLINDERKOPFDICHTUNG	10 03 231 8	80	1	X1022281	10 22 281 7	DS ZYLINDERKOPF
ZYLINDERKOPFHAUBE	97 39 267	43	1	X1012059	10 12 059 0	DIESELMOTOR
ZYLINDERKOPFSCHRAUBE M1	10 22 234 4	9	3	9 739 262	97 39 262	ZYLINDERKOPF
ZYLINDERKOPFSCHRAUBE M1	10 22 234 4	9	3	9 739 266	97 39 266	ZYLINDERKOPF
ZYLINDERKOPFSCHRAUBE M1	10 22 234 3	8	3	9 739 262	97 39 262	ZYLINDERKOPF
ZYLINDERKOPFSCHRAUBE M1	10 22 234 3	8	3	9 739 266	97 39 266	ZYLINDERKOPF
ZYLINDERLAUFBUCHSE	10 22 231 7	1	1	9 739 242	97 39 242	ZYLINDERLAUFBUCHSE
ZYLINDERLAUFBUCHSE	10 22 231 8	54	6	9 739 242	97 39 242	ZYLINDERLAUFBUCHSE
ZYLINDERLAUFBUCHSE	10 22 231 9	51	6	9 739 242	97 39 242	ZYLINDERLAUFBUCHSE
ZYLINDERLAUFBUCHSE	10 22 232 0	53	6	9 739 242	97 39 242	ZYLINDERLAUFBUCHSE
ZYLINDERLAUFBUCHSE	10 22 232 1	52	6	9 739 242	97 39 242	ZYLINDERLAUFBUCHSE
ZYLINDERLAUFBUCHSE	97 39 242	26	6	X1012059	10 12 059 0	DIESELMOTOR
ZYLINDERROLLENLAGER 375X	57 18 448 08	51	1	X1065015	10 65 015 5	GETRIEBE
ZYLINDERSCHRAUBE	10 22 235 9	5	2	9 739 118	97 39 118	OELLEITUNG
ZYLINDERSCHRAUBE DIN 69	40 72 046 08	24	16	3 215 005	91 52 846 08	ROLLENSATZ
ZYLINDERSCHRAUBE DIN 69	40 72 046 08	24	16	3 215 006	91 52 847 08	ROLLENSATZ
ZYLINDERSCHRAUBE DIN 691	40 72 086 08	11	2	3 745 011	96 49 677 08	LASCHE KPL.
ZYLINDERSCHRAUBE DIN 69	40 72 101 14	12	32	3 747	91 52 950 08	ZENTRIERUNG STANDARD
ZYLINDERSCHRAUBE DIN 798	40 83 023 08	17	1	7 027 481	70 27 481 03	WASSERABSCHIEDER
ZYLINDERSCHRAUBE DIN 79	40 93 609 08	7	2	2 520 030	96 45 609 08	DACHSCHEIBE VORM.
ZYLINDERSCHRAUBE DIN 84	40 01 004 08	15	28	2 932 001	96 45 393 08	RELAISSTEUERUNG
ZYLINDERSCHRAUBE DIN 84	40 01 701 08	266	4	3 930 009	96 50 573 08	LEITUNGSTROMMEL KPL.
ZYLINDERSCHRAUBE DIN 84	40 01 701 08	(268)	4	3 930 138	96 54 377 08	ELEKTRIK S-ANLENKSTUECK
ZYLINDERSCHRAUBE DIN 84	40 01 701 08	280	16	3 930 638	96 51 624 08	KLEMMKASTEN
ZYLINDERSCHRAUBE DIN 84	40 01 701 08	154	10	3 930 640	96 50 481 08	KLEMMKASTEN KPL.
ZYLINDERSCHRAUBE DIN 84	40 01 701 08	266	10	3 930 730	96 50 599 08	KLEMMKASTEN KPL.
ZYLINDERSCHRAUBE DIN 84	40 01 006 08	41	8	2 920 369	96 54 235 08	KLEMMKASTEN KPL.
ZYLINDERSCHRAUBE DIN 84	40 01 405 08	(153)	1	2 920 369	96 54 235 08	KLEMMKASTEN KPL.
ZYLINDERSCHRAUBE DIN 84	40 01 405 08	(153)	1	2 920 581	96 54 405 08	KLEMMKASTEN SA-BOCK VO
ZYLINDERSCHRAUBE DIN 84	40 01 018 08	48	56	2 932 160	96 54 385 08	SCHALTSCHRANK MECH.
ZYLINDERSCHRAUBE DIN 84	40 01 020 08	(152)	1	2 920 369	96 54 235 08	KLEMMKASTEN KPL.
ZYLINDERSCHRAUBE DIN 84	40 01 020 08	(152)	1	2 920 369	96 54 235 08	KLEMMKASTEN KPL.
ZYLINDERSCHRAUBE DIN 84	40 01 020 08	280	12	2 920 369	96 54 235 08	KLEMMKASTEN KPL.
ZYLINDERSCHRAUBE DIN 84	40 01 020 08	280	24	2 920 448	96 48 794 08	KLEMMKASTEN KPL.
ZYLINDERSCHRAUBE DIN 84	40 01 033 08	28	4	2 260	91 53 057 08	BATTERIELAGERUNG
ZYLINDERSCHRAUBE DIN 84	40 01 033 08	4	4	2 260 009	96 46 972 08	KLAPPE VORM.
ZYLINDERSCHRAUBE DIN 84	40 01 033 08	31	2	2 920 083	96 48 319 08	ELEKTRIK BATTERIEKASTEN
ZYLINDERSCHRAUBE DIN 84	40 01 034 08	4	4	2 780 915	96 48 377 08	ANBAUTEILE FREMDEINSPEIS
ZYLINDERSCHRAUBE DIN 84	40 01 034 08	30	5	2 920 083	96 48 319 08	ELEKTRIK BATTERIEKASTEN
ZYLINDERSCHRAUBE DIN 84	40 01 034 08	(2)	3	3 780 258	96 56 482 08	ELEKTRIK FLUGWARNSICHER
ZYLINDERSCHRAUBE DIN 84	40 01 036 08	29	2	2 932 082	96 54 387 08	AUFBAUTEILE MONTAGETAPE
ZYLINDERSCHRAUBE DIN 84	40 01 041 08	6	3	1 100	91 52 375 08	RAUPENFAHRWERK KPL.
ZYLINDERSCHRAUBE DIN 84	40 01 054 08	12	12	2 932 082	96 54 387 08	AUFBAUTEILE MONTAGETAPE
ZYLINDERSCHRAUBE DIN 84	40 01 054 08	15	2	5 026 126	50 26 126 08	MAGNETVENTIL
ZYLINDERSCHRAUBE DIN 84	51 07 977 08	22	1	5 114 176	51 14 176 08	DRUCKBEGRENZUNGSVENTI
ZYLINDERSCHRAUBE DIN 84	51 07 977 08	22	1	5 114 177	51 14 177 08	DRUCKBEGRENZUNGSVENTI
ZYLINDERSCHRAUBE DIN 912	40 43 097 08	340	4	X1041101	10 41 101 8	RUECKFALLSTUETZE
ZYLINDERSCHRAUBE DIN 912	40 42 120 08	7	8	2 350	91 52 778 08	DREHWERK

6.2.2009

etk_en_de_074515 LR 1600/2

1135

LIEBHERRAlphabetical index
Alphabetischer Index

Bezeichnung	Artikel	Pos.	Menge	Seite	Baugruppe	Bezeichnung
ZYLINDERSCHRAUBE DIN 912	40 42 120 08	342	12	2 391 001	96 45 719 08	DIESELMOTOR VORM.
ZYLINDERSCHRAUBE DIN 912	40 42 120 08	546	12	2 970	91 56 537 08	HYDRAULIK
ZYLINDERSCHRAUBE DIN 912	40 43 126 08	26	8	9 697 916	96 97 916 01	DREHWERK
ZYLINDERSCHRAUBE DIN 912	40 42 152 08	56	32	1 970	91 56 958 08	HYDRAULIK RAUPE
ZYLINDERSCHRAUBE DIN 912	40 42 152 08	56	8	1 970 161	96 50 706 08	ZUSATZHYDR.RAUPENTRAEG
ZYLINDERSCHRAUBE DIN 912	40 42 152 08	555	28	2 970	91 56 537 08	HYDRAULIK
ZYLINDERSCHRAUBE DIN 912	40 42 156 08	47	4	2 975 100	91 52 860 08	ZUSATZHYDRAULIK WINDE 3
ZYLINDERSCHRAUBE DIN 912	40 42 159 08	46	4	2 975 100	91 52 860 08	ZUSATZHYDRAULIK WINDE 3
ZYLINDERSCHRAUBE DIN 912	40 43 263 08	6	2	3 211	91 57 748 08	S-ANLENKSTUECK
ZYLINDERSCHRAUBE DIN 912	40 43 263 08	4	4	3 220 500	91 52 849 08	S-ZWISCHENSTUECK
ZYLINDERSCHRAUBE DIN 912	40 43 263 08	4	4	3 221	91 54 668 08	S-ZWISCHENSTUECK
ZYLINDERSCHRAUBE DIN 912	40 43 263 08	4	4	3 223	91 52 852 08	S-ZWISCHENSTUECK
ZYLINDERSCHRAUBE DIN 912	40 43 263 08	4	4	3 223 010	91 52 853 08	S-ZWISCHENSTUECK
ZYLINDERSCHRAUBE DIN 912	40 43 263 08	4	4	3 223 100	91 55 327 08	S-ZWISCHENSTUECK
ZYLINDERSCHRAUBE DIN 912	40 43 263 08	16	2	3 225	91 52 854 08	SL-REDUZIERSTUECK
ZYLINDERSCHRAUBE DIN 912	40 42 242 08	46	2	1 400	91 56 853 08	RAUPENTRAEGER KPL.LI.
ZYLINDERSCHRAUBE DIN 912	40 42 242 08	46	2	1 410 300	91 56 855 08	RAUPENTRAEGER KPL.RE.
ZYLINDERSCHRAUBE DIN 912	40 42 242 08	8	2	2 652	91 52 794 08	ROLLENLAGERUNG
ZYLINDERSCHRAUBE DIN 912	40 43 246 08	103	2	3 713	91 57 749 08	D-ANLENKSTUECK
ZYLINDERSCHRAUBE DIN 912	40 42 002 08	11	2	2 780 852	96 24 845 08	GSM-MODUL VORM.LICCON 1
ZYLINDERSCHRAUBE DIN 912	40 43 012 08	7	4	X1004047	10 04 047 7	WINDENDREHGEBER
ZYLINDERSCHRAUBE DIN 912	40 42 025 08	5	8	1 711	91 52 392 08	ZENTRALSCHMIERUNG RAUP
ZYLINDERSCHRAUBE DIN 912	40 42 025 08	7	10	2 711	91 52 800 08	ZENTRALSCHMIERANLAGE O
ZYLINDERSCHRAUBE DIN 912	40 43 612 08	56	4	5 113 086	51 13 086 08	PROPORTIONALVENTIL
ZYLINDERSCHRAUBE DIN 912	40 43 612 08	4	4	X1034282	10 34 282 3	DRUCKREGELVENTIL
ZYLINDERSCHRAUBE DIN 912	40 43 028 08	65	16	1 970	91 56 958 08	HYDRAULIK RAUPE
ZYLINDERSCHRAUBE DIN 912	51 07 466 08	15	8	5 113 086	51 13 086 08	PROPORTIONALVENTIL
ZYLINDERSCHRAUBE DIN 912	40 43 601 08	5	4	2 975 000	91 57 881 08	ZUSATZHYDRAULIK MONTAGE
ZYLINDERSCHRAUBE DIN 912	40 42 072 08	21	2	2 522	91 54 115 08	SCHIEBETUER KPL.
ZYLINDERSCHRAUBE DIN 912	40 42 072 08	32	78	3 211	91 57 748 08	S-ANLENKSTUECK
ZYLINDERSCHRAUBE DIN 912	40 42 072 08	73	6	3 713	91 57 749 08	D-ANLENKSTUECK
ZYLINDERSCHRAUBE DIN EN I	54 01 790 08	11	2	3 714 008	96 49 266 08	VERSTELLFLASCHE KPL.
ZYLINDERSCHRAUBE ISO 476	40 42 104 01	86	12	9 697 916	96 97 916 01	DREHWERK
ZYLINDERSCHRAUBE ISO 47	40 42 014	7	2	5 102 354	51 02 354 08	HYDROMOTOR
ZYLINDERSCHRAUBE ISO 47	49 00 537	37	8	3 745	91 52 948 08	SCHWEBEBALLAST
ZYLINDERSCHRAUBE ISO 47	46 00 132	542	6	2 970	91 56 537 08	HYDRAULIK
ZYLINDERSCHRAUBE ISO 47	46 00 132	(2)	4	2 970	91 56 537 08	HYDRAULIK
ZYLINDERSCHRAUBE ISO 47	46 00 132	563	20	2 976 200	91 52 780 08	ZUSATZHYDRAULIK DREHWE
ZYLINDERSCHRAUBE ISO 47	46 00 132	568	8	2 976 700	91 54 795 08	ZUSATZHYDRAULIK PUMPE
ZYLINDERSCHRAUBE ISO 47	49 00 195	338	12	2 391 001	96 45 719 08	DIESELMOTOR VORM.
ZYLINDERSCHRAUBE ISO 47	46 00 331	14	4	2 392	91 52 785 08	SCHALLDAEMPFERANLAGE
ZYLINDERSCHRAUBE ISO 47	46 00 143	10	4	5 102 354	51 02 354 08	HYDROMOTOR
ZYLINDERSCHRAUBE ISO 47	10 35 370 5	13	2	X1041267	10 41 267 8	ENDPLATTE
ZYLINDERSCHRAUBE ISO 476	40 42 132 01	22	12	X1065015	10 65 015 8	ANTRIEB
ZYLINDERSCHRAUBE ISO 47	40 42 030	24	8	X1065015	10 65 015 5	GETRIEBE
ZYLINDERSCHRAUBE ISO 47	40 42 032	93	4	3 714	91 52 862 08	D-KOPFSTUECK
ZYLINDERSCHRAUBE ISO 47	40 42 035	20	4	2 671 004	96 46 305 08	OELBEHAELTER VORM.
ZYLINDERSCHRAUBE ISO 476	40 00 784	4	6	3 978 100	91 56 428 08	HYDR.SCHWEBEBALLAST-AN
ZYLINDERSCHRAUBE ISO 47	40 42 036	23	8	X1065015	10 65 015 8	ANTRIEB
ZYLINDERSCHRAUBE ISO 47	40 42 124 01	74	12	9 697 916	96 97 916 01	DREHWERK
ZYLINDERSCHRAUBE ISO 47	24 00 551 02	10	4	3 978 100	91 56 428 08	HYDR.SCHWEBEBALLAST-AN
ZYLINDERSCHRAUBE ISO 47	40 43 161 01	44	4	2 975 200	91 52 775 08	ZUSATZHYDRAULIK WINDE 2
ZYLINDERSCHRAUBE ISO 47	40 43 161 01	44	4	2 975 700	91 52 774 08	ZUSATZHYDRAULIK WINDE 1
ZYLINDERSCHRAUBE ISO 47	40 42 153 01	128	12	2 970	91 56 537 08	HYDRAULIK
ZYLINDERSCHRAUBE ISO 47	40 42 153 01	43	4	2 975 200	91 52 775 08	ZUSATZHYDRAULIK WINDE 2
ZYLINDERSCHRAUBE ISO 47	40 42 153 01	43	4	2 975 700	91 52 774 08	ZUSATZHYDRAULIK WINDE 1
ZYLINDERSCHRAUBE ISO 476	40 42 181 01	3	2	2 550 010	96 45 685 08	STANGE VORM.
ZYLINDERSCHRAUBE ISO 476	40 42 183 01	1391	18	X1065015	10 65 015 5	GETRIEBE
ZYLINDERSCHRAUBE ISO 47	46 00 329	11	24	3 350	91 52 859 08	WINDE 3
ZYLINDERSCHRAUBE ISO 476	40 43 169 01	63	10	X1065015	10 65 015 6	SEILTROMMEL

6.2.2009

etk_en_de_074515 LR 1600/2

1136

LIEBHERRAlphabetical index
Alphabetischer Index

Bezeichnung	Artikel	Pos.	Menge	Seite	Baugruppe	Bezeichnung
ZYLINDERSCHRAUBE ISO 47	46 00 017	(37)	4	1 400	91 56 853 08	RAUPENTRAEGER KPL.LI.
ZYLINDERSCHRAUBE ISO 47	46 00 017	73	4	2 970	91 56 537 08	HYDRAULIK
ZYLINDERSCHRAUBE ISO 47	46 00 017	20	8	X1065015	10 65 015 8	ANTRIEB
ZYLINDERSCHRAUBE ISO 47	46 00 237	10	8	2 340	91 52 776 08	WINDE 4 EINZIEHWERK
ZYLINDERSCHRAUBE ISO 47	40 42 175 01	22	6	2 652	91 52 794 08	ROLLENLAGERUNG
ZYLINDERSCHRAUBE ISO 47	40 42 566 14	21	18	X1065015	10 65 015 5	GETRIEBE
ZYLINDERSCHRAUBE ISO 47	49 01 989	3	48	2 350	91 52 778 08	DREHWERK
ZYLINDERSCHRAUBE ISO 47	46 30 212	5	2	3 213	91 52 842 08	F-ANSCHLUSSKOPF
ZYLINDERSCHRAUBE ISO 47	46 30 212	26	2	3 214	91 52 843 08	SW-KOPFSTUECK
ZYLINDERSCHRAUBE ISO 47	46 30 212	15	2	3 225	91 52 854 08	SL-REDUZIERSTUECK
ZYLINDERSCHRAUBE ISO 47	46 30 212	4	4	3 226	91 52 870 08	LI-ZWISCHENSTUECK
ZYLINDERSCHRAUBE ISO 47	46 30 212	4	4	3 227	91 52 873 08	LI-ZWISCHENSTUECK
ZYLINDERSCHRAUBE ISO 47	46 30 212	4	4	3 227 008	91 52 872 08	LI-ZWISCHENSTUECK
ZYLINDERSCHRAUBE ISO 47	46 30 212	4	4	3 227 200	91 53 519 08	LI-ZWISCHENSTUECK F-ABSP
ZYLINDERSCHRAUBE ISO 47	46 30 212	12	2	3 713	91 57 749 08	D-ANLENKSTUECK
ZYLINDERSCHRAUBE ISO 47	46 30 212	24	2	3 714	91 52 862 08	D-KOPFSTUECK
ZYLINDERSCHRAUBE ISO 47	46 30 212	19	4	3 715 008	91 52 863 08	D-ZWISCHENSTUECK
ZYLINDERSCHRAUBE ISO 47	46 30 212	19	4	3 716	91 52 864 08	D-ZWISCHENSTUECK
ZYLINDERSCHRAUBE ISO 47	40 42 143 05	7	4	2 125	91 52 773 08	BOLZEN S-ANLENKST. UND S
ZYLINDERSCHRAUBE ISO 476	10 12 438 50	17	4	2 533 066	96 48 365 08	ELEKTRIK ANBAUTEILE KABIN
ZYLINDERSCHRAUBE ISO 476	40 00 996	36	8	2 502	91 55 939 08	STUERSTAND
ZYLINDERSCHRAUBE ISO 476	40 00 996	11	3	3 780 200	96 54 370 08	ELEKTRIK WINDWARNUNG T
ZYLINDERSCHRAUBE ISO 476	46 00 387	89	54	2 932 082	96 54 387 08	AUFBAUTEILE MONTAGETAPE
ZYLINDERSCHRAUBE ISO 476	49 01 531	19	4	X1034282	10 34 282 3	DRUCKREGELVENTIL
ZYLINDERSCHRAUBE ISO 476	46 00 338	15	2	5 113 005	51 13 005 08	STUECKERBLOCK
ZYLINDERSCHRAUBE ISO 476	40 01 521	23	1	2 522	91 54 115 08	SCHIEBETUER KPL.
ZYLINDERSCHRAUBE ISO 476	40 01 521	48	4	2 975 200	91 52 775 08	ZUSATZHYDRAULIK WINDE 2
ZYLINDERSCHRAUBE ISO 476	40 01 521	48	4	2 975 700	91 52 774 08	ZUSATZHYDRAULIK WINDE 1
ZYLINDERSCHRAUBE ISO 476	40 01 308	34	24	2 502	91 55 939 08	STUERSTAND
ZYLINDERSCHRAUBE ISO 476	40 01 308	18	2	2 540	91 53 253 08	HEIZKLIMAGERAET EINBAU
ZYLINDERSCHRAUBE ISO 476	24 00 465 02	23	4	2 520 032	96 45 980 08	SCHLEIBENWISCHANLAGE EIN
ZYLINDERSCHRAUBE ISO 476	40 42 022 01	35	2	2 520	91 53 061 08	KABINE VERGLAST
ZYLINDERSCHRAUBE ISO 476	40 00 899	34	6	2 520	91 53 061 08	KABINE VERGLAST
ZYLINDERSCHRAUBE ISO 476	40 42 026 01	62	4	2 970	91 56 537 08	HYDRAULIK
ZYLINDERSCHRAUBE ISO 476	40 42 026 01	37	2	X1022811	10 22 811 2	HEIZKLIMAGERAET
ZYLINDERSCHRAUBE ISO 476	49 00 626	48	4	2 502	91 55 939 08	STUERSTAND
ZYLINDERSCHRAUBE ISO 47	10 66 372 5	2	4	5 114 651	51 14 651 08	WEGEVENTIL
ZYLINDERSCHRAUBE ISO 47	40 02 601	23	4	5 113 086	51 13 086 08	PROPORTIONALVENTIL
ZYLINDERSCHRAUBE ISO 476	46 00 049	8	2	2 522	91 54 115 08	SCHIEBETUER KPL.
ZYLINDERSCHRAUBE ISO 476	46 00 049	15	3	2 522 011	96 45 602 08	SCHLIESSANLAGE
ZYLINDERSCHRAUBE ISO 476	46 00 048	30	8	2 391 040	96 53 645 08	KUPPLUNGSSTELLER
ZYLINDERSCHRAUBE ISO 476	46 00 048	7	6	5 102 306	51 02 306 08	HYDROMOTOR
ZYLINDERSCHRAUBE ISO 476	46 00 048	8	2	9 080 702	90 80 702	STUECKERGERAET
ZYLINDERSCHRAUBE ISO 476	40 42 002	41	4	2 502	91 55 939 08	STUERSTAND
ZYLINDERSCHRAUBE ISO 476	40 42 002	22	2	2 978 100	91 52 796 08	ZUSATZHYDR.MONTAGEEINR
ZYLINDERSCHRAUBE ISO 476	40 42 002	(6)	3	3 780 258	96 56 482 08	ELEKTRIK FLUGWARNSICHER
ZYLINDERSCHRAUBE ISO 476	40 42 003	11	6	2 550 008	96 47 628 08	HALTER KPL.
ZYLINDERSCHRAUBE ISO 476	40 42 003	11	6	2 550 009	96 47 645 08	HALTER KPL.
ZYLINDERSCHRAUBE ISO 476	40 42 003	20	6	2 978 100	91 52 796 08	ZUSATZHYDR.MONTAGEEINR
ZYLINDERSCHRAUBE ISO 476	40 42 003	3	1	9 079 185	90 79 185	DREHZAHLEBER
ZYLINDERSCHRAUBE ISO 476	40 42 003	3	1	9 079 186	90 79 186	DREHZAHLEBER
ZYLINDERSCHRAUBE ISO 47	49 01 159	(3)	4	X1035925	10 35 925 1	VERSTELLPUMPE
ZYLINDERSCHRAUBE ISO 476	40 42 107	24	40	2 978 100	91 52 796 08	ZUSATZHYDR.MONTAGEEINR
ZYLINDERSCHRAUBE ISO 47	46 00 340	27	8	5 102 380	51 02 380 08	HYDROMOTOR
ZYLINDERSCHRAUBE ISO 476	46 00 384	50	2	2 502	91 55 939 08	STUERSTAND
ZYLINDERSCHRAUBE ISO 476	46 00 384	20	6	3 780 751	91 52 952 08	FLUG-U.WINDWARNUNG
ZYLINDERSCHRAUBE ISO 476	40 42 109	66	2	2 520	91 53 061 08	KABINE VERGLAST
ZYLINDERSCHRAUBE ISO 476	40 42 109	6	4	9 080 702	90 80 702	STUECKERGERAET
ZYLINDERSCHRAUBE ISO 476	46 00 091	27	2	2 671 004	96 46 305 08	OELBEHAELTER VORM.
ZYLINDERSCHRAUBE ISO 476	46 00 091	54	20	3 978 005	91 56 430 08	ZUSATZHYDRAULIK SB-KOPFS

6.2.2009

etk_en_de_074515 LR 1600/2

1137

LIEBHERRAlphabetical index
Alphabetischer Index

Bezeichnung	Artikel	Pos.	Menge	Seite	Baugruppe	Bezeichnung
ZYLINDERSCHRAUBE ISO 476	46 00 091	54	40	3 978 015	91 56 429 08	ZUSATZHYDRAULIK ZWISCH
ZYLINDERSCHRAUBE ISO 476	46 00 091	54	40	3 978 015	91 56 432 08	ZUSATZHYDRAULIK ZWISCH
ZYLINDERSCHRAUBE ISO 476	46 00 091	38	3	X1022811	10 22 811 2	HEIZKLIMAGERAET
ZYLINDERSCHRAUBE ISO 476	40 42 111	55	4	2 520 034	96 45 984 08	INNENVERKLEIDUNG
ZYLINDERSCHRAUBE ISO 476	40 02 418	351	8	2 391 001	96 45 719 08	DIESELMOTOR VORM.
ZYLINDERSCHRAUBE ISO 47	49 00 953	5	4	X1021769	10 21 769 5	SENKBREMSVENTIL
ZYLINDERSCHRAUBE ISO 476	46 00 051	38	6	2 502	91 55 939 08	STEUERSTAND
ZYLINDERSCHRAUBE ISO 476	46 00 051	155	2	2 970	91 56 537 08	HYDRAULIK
ZYLINDERSCHRAUBE ISO 476	46 00 079	9	4	2 670	91 52 797 08	KRAFTSTOFFBEHAELTER KPL
ZYLINDERSCHRAUBE ISO 47	49 01 217	4	4	X1021769	10 21 769 5	SENKBREMSVENTIL
ZYLINDERSCHRAUBE ISO 476	46 00 175	73	24	2 520	91 53 061 08	KABINE VERGLAST
ZYLINDERSCHRAUBE ISO 47	24 01 920 02	11	4	X1042440	10 42 440 2	STUEBERBLOCK
ZYLINDERSCHRAUBE ISO 476	40 01 620	45	8	3 713	91 57 749 08	D-ANLENKSTUECK
ZYLINDERSCHRAUBE ISO 476	40 42 044 05	50	5	X1047219	10 47 219 6	REGLER
ZYLINDERSCHRAUBE ISO 476	46 00 578	5	1	3 790 006	96 19 989 08	BOLZENZIEHZYLINDER KPL.
ZYLINDERSCHRAUBE ISO 476	46 00 578	5	1	3 790 007	96 19 990 08	BOLZENZIEHZYLINDER KPL.
ZYLINDERSCHRAUBE ISO 476	46 00 179	16	1	X1041267	10 41 267 8	ENDPLATTE
ZYLINDERSCHRAUBE M10X25	10 01 122 8	4	4	9 739 278	97 39 278	ANBAUTEILE
ZYLINDERSCHRAUBE M10X40	10 29 431 8	9	3	9 739 278	97 39 278	ANBAUTEILE
ZYLINDERSCHRAUBE M8X20	10 01 251 3	6	6	9 739 358	97 39 358	ABGASRUECKFUEHRUNG AN
ZYLINDERSCHRAUBE M8X25	10 22 272 5	10	6	9 739 357	97 39 357	ABGASRUECKFUEHRUNG VO
ZYLINDERSCHRAUBE M8X30	10 34 226 5	12	1	9 739 356	97 39 356	ROHRLEITUNG ANBAU
ZYLINDERSCHRAUBE M8X58	10 01 251 4	8	2	9 739 358	97 39 358	ABGASRUECKFUEHRUNG AN
ZYLINDERSTIFT 16H8X24 ST.	10 01 177 8	11	2	9 739 354	97 39 354	SCHWUNGRADGEHAEUSE AN
ZYLINDERSTIFT DIN 7 3M6X10	57 01 132 08	5	1	5 102 306	51 02 306 08	HYDROMOTOR
ZYLINDERSTIFT DIN 7 6M6X16	51 45 349 08	20	2	X1042440	10 42 440 2	STUEBERBLOCK
ZYLINDERSTIFT DIN 7 6M6X32	43 06 047 08	7	1	2 522 011	96 45 602 08	SCHLIESSANLAGE