

# **LIEBHERR**

## **Crawler crane with lattice mast**

**LR 1800-1.0**

**LR 1800-1-0-000**

## **Operating instructions**

**BAL No.: 27200-07-02**

Serial No.	
Date	

### **ORIGINAL OPERATING INSTRUCTIONS**

**The operating instructions are part of the crane and must be followed!**

**The operating instructions must always be available within reach!**

**All local regulations for crane operation must be observed!**

**Liebherr-Werk Ehingen GmbH**

Dr.-Hans-Liebherr-Straße 1

**89584 Ehingen/Donau**

+49 (0) 7391 502-0

+49 (0) 7391 502-3399

info.lwe@liebherr.com

www.liebherr.com



# Preface

## Manufacturer

Liebherr-Werk Ehingen GmbH  
 Dr.-Hans-Liebherr-Straße 1  
 D-89584 Ehingen/Donau  
 +49 (0) 7391 502-0  
 +49 (0) 7391 502-3399  
 info.lwe@liebherr.com  
 www.liebherr.com

## California Proposition 65

Proposition 65 of the US State of California warns against chemicals that are known to cause cancer and birth defects or other reproductive harm.

For additional information, see the website: [www.P65Warnings.ca.gov](http://www.P65Warnings.ca.gov).

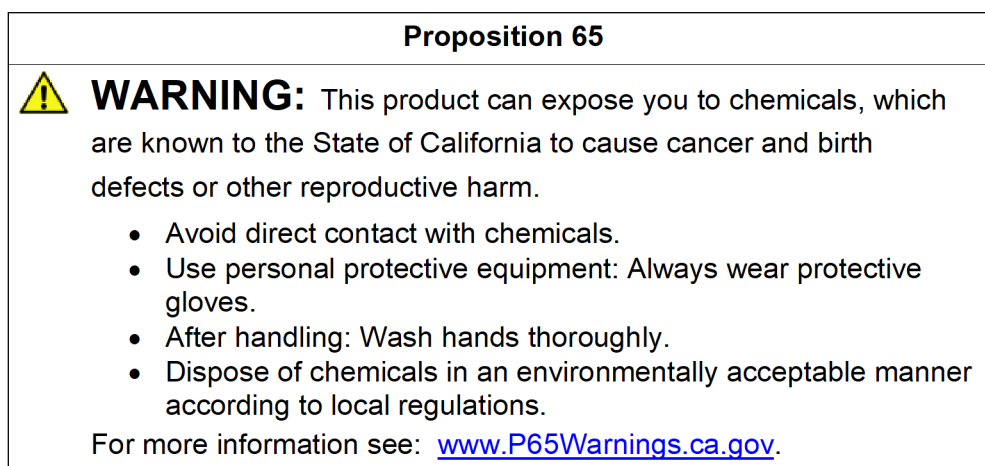


Fig.154660: Example of a Proposition 65 sign for USA: Chemicals

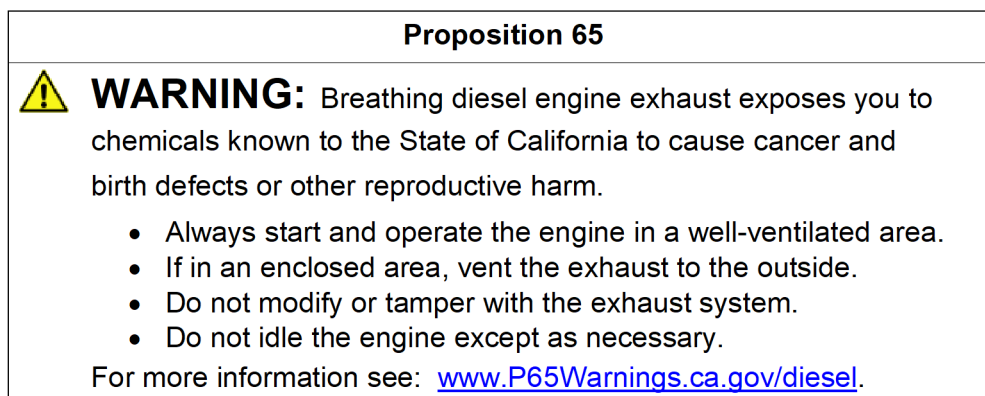


Fig.154661: Example of a Proposition 65 sign for USA: Diesel engine exhaust

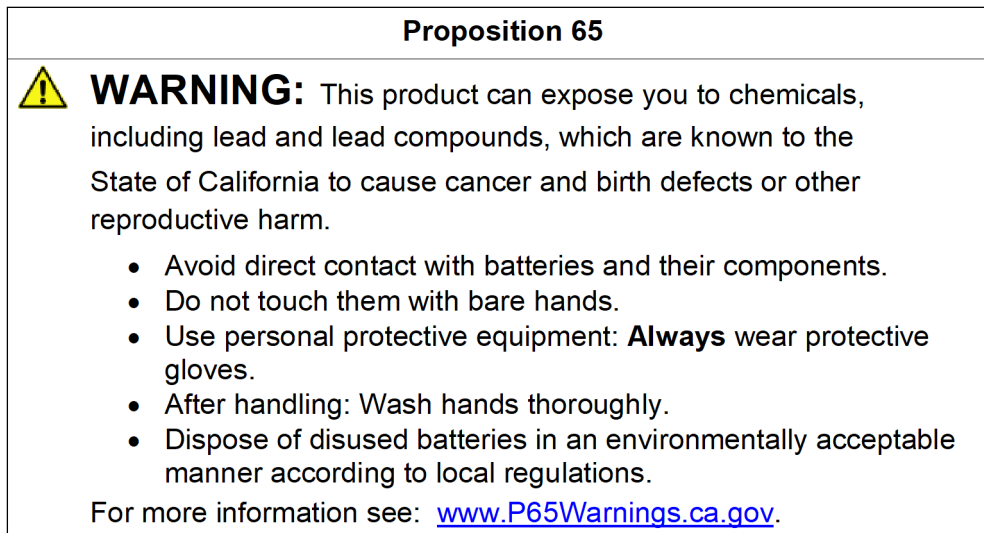


Fig.154662: Example of a Proposition 65 sign for USA: Lead and lead compounds

### General

This crane was built according to the state of technology and recognized safety technical regulations. Despite that, danger to body and life for the user and / or third persons or damage to the crane and / or other material assets is still possible.

This crane may only be used:

- When in a perfect technical condition.
- For the intended use.
- By authorized and trained personnel, who work in a safety and danger conscious way.
- When no safety relevant problems are present.
- When no modifications were made on the crane.

Any problems that could affect safety must be fixed immediately.

Modifications to the crane may only be made with written approval by Liebherr-Werk Ehingen GmbH.

### Data logger

This crane is equipped with a data recording device. Among others, the following data is recorded:




- date and time of day
- entered set up configuration of the crane
- actual load
- percentage of crane utilization
- boom radius (working radius)
- main boom angle, luffing jib angle
- total telescopic boom length, length of each telescopic section
- every actuation of bypass devices

The recorded data can be read with a respective software.

### Safety and warning display

The safety and warning display is directed to all persons who work with the crane or are located nearby. Failure to observe the safety and warning display can lead to accidents.


The terms **DANGER**, **WARNING**, **CAUTION** and **NOTICE** used in the crane documentation are intended to point out certain rules of conduct to all persons working with the crane or are located nearby.

Warning signs	Signal word	Explanation
	<b>DANGER</b>	Designates a dangerous situation which will lead to death or serious injury if it is not prevented. <sup>1)</sup>
	<b>WARNING</b>	Designates a dangerous situation which could lead to death or serious injury if it is not prevented. <sup>1)</sup>
	<b>CAUTION</b>	Designates a dangerous situation which could lead to slight or medium injury if it is not prevented. <sup>1)</sup>
	<b>NOTICE</b>	Designates a dangerous situation, which can lead to property damage if it is not prevented.

<sup>1)</sup> This could also result in property damage.

### Additional notes

The term **Note** is used in the crane documentation to make all persons working with the crane or are located nearby aware of useful information and tips.

Sign	Signal word	Explanation
	<b>Note</b>	Designates useful information and tips.

### Crane documentation

The crane documentation is comprised of:

- all supplied documents on paper and in digital form
- all supplied programs and applications
- the list of the crane documentation can be taken from the delivery note

The crane documentation:

- indicates how to use the crane safely
- supports the operators in using the permissible application possibilities of the crane
- provides information about the functionality of important components and systems



#### Note

Terminology in the crane documentation

Certain expressions are used in the crane documentation.

- ▶ In order to avoid misunderstandings, the same expressions should always be used.

If you find any errors or if any misunderstandings arise when reading the crane documentation, please contact Liebherr-Werk Ehingen GmbH immediately.



#### WARNING

Danger of accident due to incorrect operation of the crane!

Incorrect operation of the crane can lead to accidents.

Death, severe bodily injuries, property damage.

- ▶ Only authorized and trained personnel are permitted to work on the crane or have access to it.
- ▶ The crane documentation is part of the crane and must be accessible on the crane.
- ▶ The crane documentation and on-site regulations (such as accident prevention regulations) must be observed.

Using the crane documentation:

- **makes it easier** to become familiar with the crane.
- **avoids** problems due to improper operation.

Observing the crane documentation:

- **increases** reliability in use.
- **extends** the service life of the crane.
- **minimizes** repair costs and downtime.

The crane documentation must be accessible in the driver's cab or in the crane cab.



#### WARNING

Outdated version of crane documentation!

If subsequently supplied information, updates and addenda to the crane documentation are not observed and added, there is a danger of accident.

Death, severe bodily injuries, property damage.

- ▶ Add and observe all subsequently supplied information, updates and supplements for the crane documentation.
- ▶ Make sure that all involved persons always know of and understand the latest version of the crane documentation.

If there is any doubt regarding if the crane documentation is **not** up-to-date:

- ▶ Do **not** operate the crane. Contact Liebherr-Werk Ehingen GmbH.



#### WARNING

Crane documentation is not understood!

If parts of the crane documentation are not understood and the tasks are carried out on or with the crane, then there is a danger of accident.

Death, severe bodily injuries, property damage.

- ▶ Have any open questions clarified by Customer Service at Liebherr-Werk Ehingen GmbH before carrying out the respective task.

This documentation may not be reproduced or duplicated, distributed or used for purposes of the competition, neither completely nor in excerpts. All rights are expressly reserved in accordance with copyright laws.

All accident prevention regulations, operating instructions, load charts etc. are based on the intended use of the crane.

## Data tag

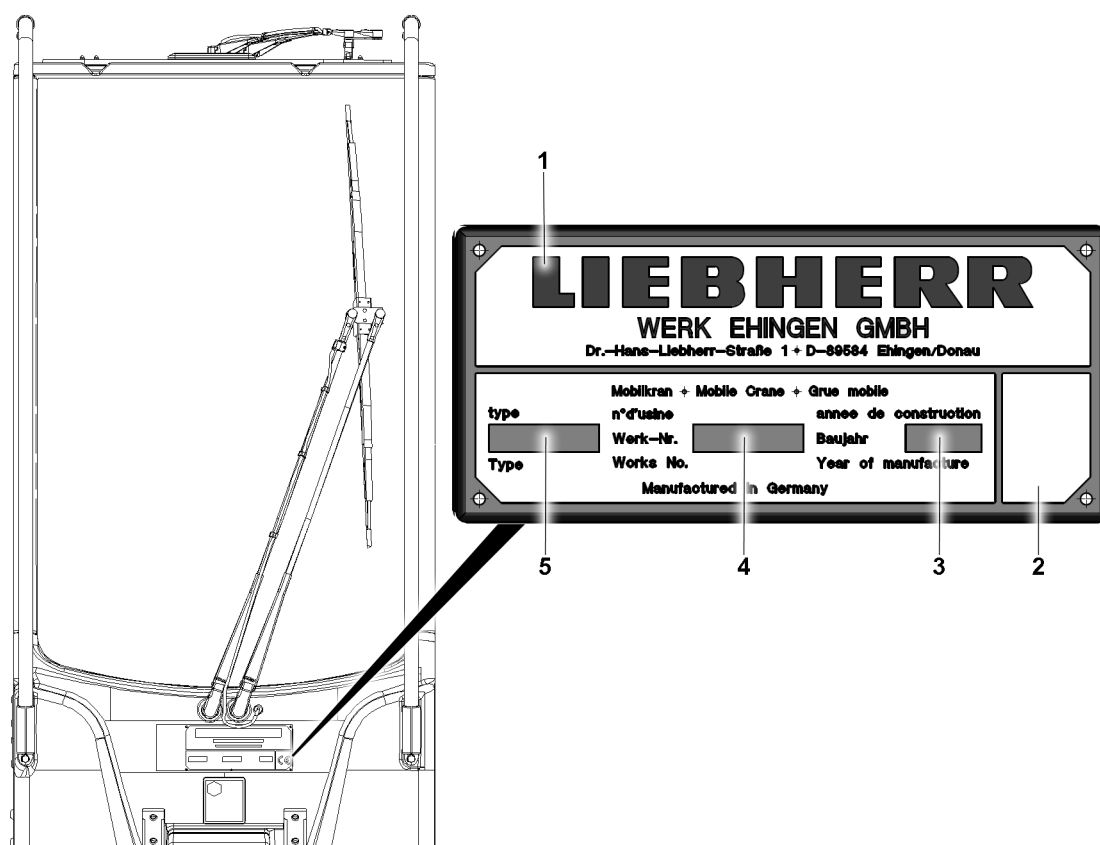


Fig.164277: Exemplary illustration: Data tag

- |   |                      |   |            |
|---|----------------------|---|------------|
| 1 | Manufacturer         | 4 | Serial no. |
| 2 | Markings             | 5 | Type       |
| 3 | Year of construction |   |            |

## Possible makings on the data tag

Depending on the regulation at the moment the crane is placed on the market, the data tag contains one of the following markings:



CE marking



Combined CE and UKCA marking



EAC marking



Without code

## CE marking

The CE marking is a mark according to EU laws:

- Cranes with CE markings are compliant with the European Directives applicable at the moment of placing the cranes on the market, and in particular European Machinery Directive 2006/42/EC and product standard EN 13000.
- Cranes that are operated outside the respective area of application of the European Machinery Directive do not require a CE marking.
- It is prohibited to market and operate cranes without a CE marking, and which do not meet the product-specific regulations valid in Europe, when a CE marking is specified for the country, especially in the single European market.
- European Union Directives prohibit operating cranes with a tipping load utilization of 85 % or a bypass device that does not comply with EN 13000 within the European Union or in countries that only permit a lower tipping load utilization! The local regulations apply. Cranes that do not comply with EN 13000 may not have the CE marking and therefore may not be operated in the European Union.

## UKCA marking

The UKCA marking is a mark according to the regulations of the United Kingdom (UK):

- UKCA marking (UK Conformity Assessed) is the British product marking for placing products on the market in Great Britain (England, Scotland and Wales). The CE marking still applies for North Ireland.
- Cranes with UKCA markings are compliant with the Directives of the United Kingdom applicable at the moment of placing the cranes on the market.

In the case of a combined CE/UKCA marking, a tag is applied in the crane cab with the name and address of the GB agent.



Fig.164279

## EAC marking

The EAC marking is a mark according to the Commonwealth of Independent States (CIS):

- Cranes with EAC markings are compliant with the Directives of the GUS applicable at the moment of placing the cranes on the market.

## Without marking

Cranes that are operated outside the respective area of application of the EU, CIS or UK are subject to the marking provisions applicable at the moment of placing the cranes on the market.

## EU Declaration of Conformity

Upon delivery of the equipment with a CE marking, the EU Declaration of Conformity according to Directive 2006/42/EC is provided directly after the cover sheet of the crane operating instructions. The EU Declaration of Conformity is valid in the following form and language in all countries of the European Union, as well as in countries that recognize the Directives of the European Union. Keep the EU Declaration of Conformity in a safe place.



**Note**

- ▶ This declaration of conformity is only valid when this mobile crane meets the directives and standards stated in this EU Declaration of Conformity. This applies especially for the programming and function of the safety-relevant overload protection. The CE marking must be removed if changes were made to the crane that do not conform to the stated directives and standards. These include in particular a tipping load utilization (85 % load charts) that are not permissible in Europe and a changed version of the bypass device for the overload protection.
- ▶ If this modified mobile crane is re-imported later into a country which is within the validity range of the EC machine directive, then the importer is responsible for the verification and the written confirmation, that the condition of the mobile crane at importation into the EC meets the directives and standards, which are stated in this declaration of conformity.
- ▶ The complete crane documentation must be complete and present in the official language of the community of the member state in which the machine is placed into service and / or where it is operated.
- ▶ For the verification and confirmation we recommend that the importer contacts the crane manufacturer or a person authorized by him.
- ▶ After written confirmation of the importer and the mobile crane manufacturer, the mobile crane may be labeled again with a CE marking and the EU Declaration of Conformity becomes valid again. Therefore the directives and standards valid at initial delivery continue to apply for this crane.

**LIEBHERR**

Original

**EU-Declaration of Conformity**

If changes are made to the machinery that were not approved in writing by Liebherr-Werk Ehingen GmbH, then this EU declaration of conformity becomes invalid.

This declaration of conformity is issued under the sole responsibility of the manufacturer.

Designation:	Mobile crane
Type:	_0001_
Serial number:	_0002_
Year of construction	_0003_
Nominal power of the diesel Engine:	_0004_ [kW] / _0005_ [rpm]
Representative measured sound power level $L_{WA}$ <sup>1)</sup> :	_0006_ [dB]
Guaranteed sound power level $L_{WA}$ <sup>1)</sup> :	_0007_ [dB]

We herewith declare that the above declared machine in its delivery condition complies with all relevant provisions of the following EU directives.

**1 EU Directives**

- 1.1 Directive 2006/42/EC of the European Parliament on machinery
- 1.2 Directive 2005/88/EC of the European Parliament amending the Directive 2000/14/EC relating to noise emission<sup>1)</sup>
- 1.3 Directive 2014/53/EU of the European Parliament relating to the making available on the market of radio equipment

Applied evaluation procedure according to Annex VIII of Directive 2000/14/EC  
 Notified body: TÜV SÜD Industrie Service GmbH, Westendstrasse 199, 80686 München, Germany;  
 Identification number: 0036

**2 Applied harmonized standards**

- 2.1 EN 13000:2010+A1:2014 Cranes – Mobile cranes

Manufacturer: Liebherr-Werk Ehingen GmbH, Dr.-Hans-Liebherr-Straße 1, 89584 Ehingen/Donau, Germany.

Person authorised to compile the technical file: Bernd Boos, Dr.-Hans-Liebherr-Straße 1, 89584 Ehingen/Donau, Germany, bernd.boos@liebherr.com.

\_\_\_\_\_  
 Bernd Boos  
 Head of Engineering Department

Ehingen, xx.xx.xxxx

<sup>1)</sup> during crane operation

*Fig.164285-en: Exemplary illustration of the crane's EU Declaration of Conformity*

**UK Declaration of Conformity**

Upon delivery of the equipment with a UKCA marking in Great Britain, the UK Declaration of Conformity according to The Supply of Machinery (Safety) Regulations 2008 is provided directly after the cover sheet of the crane operating instructions. The UK Declaration of Conformity is valid in the following

---

form and language in Great Britain (England, Scotland and Wales). Keep the UK Declaration of Conformity in a safe place.

For cranes with CE/UKCA marking that are not delivered to Great Britain: If necessary, please request a UK Declaration of Conformity from customer service at Liebherr-Werk Ehingen GmbH.

**Note**

- ▶ This declaration of conformity is only valid when this mobile crane meets the directives and standards stated in this UK Declaration of Conformity. This applies especially for the programming and function of the safety-relevant overload protection. The UKCA marking must be removed if changes were made to the crane that do not conform to the stated directives and standards.
-

**LIEBHERR**

Original

**UK-Declaration of Conformity****UK  
CA**

If changes are made to the machinery that were not approved in writing by Liebherr-Werk Ebingen GmbH, then this UK-declaration of conformity becomes invalid.  
This declaration of conformity is issued under the sole responsibility of the manufacturer.

Designation:	Mobile crane
Type:	_0001_
Serial number:	_0002_
Year of construction	_0003_
Nominal power of the diesel Engine:	_0004_ [kW] / _0005_ [rpm]
Representative measured sound power level $L_{WA}^{1)}$ :	_0006_ [dB]
Guaranteed sound power level $L_{WA}^{1)}$ :	_0007_ [dB]

We herewith declare that the above declared machine in its delivery condition complies with all relevant provisions of the following statutory requirements.

**1 Statutory requirements**

- 1.1 The Supply of Machinery (Safety) Regulations 2008, SI 2008 No. 1597
- 1.2 The Noise Emission in the Environment by Equipment for use Outdoors Regulations 2001, SI 2001 No. 1701
- 1.3 The Radio Equipment Regulations 2017, SI 2017 No. 1206

Applied evaluation procedure according to Schedule 11 of The Noise Emission in the Environment by Equipment for use Outdoors Regulations 2001, SI 2001 No. 1701<sup>1)</sup>

Approved body: TUV SUD BAPT Unlimited, Octagon House, Concorde Way, Segensworth North, Hampshire, PO15 5RL, United Kingdom; Identification number: 0168

**2 Applied designated standards**

- 2.1 EN 13000:2010+A1:2014 Cranes – Mobile cranes

Manufacturer: Liebherr-Werk Ebingen GmbH, Dr.-Hans-Liebherr-Straße 1, 89584 Ebingen/Donau, Germany.

Authorised representative of the manufacturer and person authorised to compile the technical file:  
Liebherr-Great Britain Ltd., Normandy Lane, Stratton Business Park, Biggleswade, SG18 8QB, United Kingdom,  
contact.ukca.lgb@liebherr.com

\_\_\_\_\_  
Bernd Boos  
Head of Engineering Department

Ebingen, xx.xx.xxxx

<sup>1)</sup> during crane operation

*Fig.164286-en: Exemplary illustration of the crane's UK Declaration of Conformity*

**Information for the REACH regulation of the European Union**

Based on the REACH regulation (EC) no. 1907/2006, article 33, there is an information requirement for substances of very high concern, hereafter indicated as SVHC. SVHC: Substance of Very High Concern.

Liebherr-Werk Ehingen GmbH uses its best judgment to avoid the use of these SVHC and to enable the customer to handle these substances safely.

When using the crane as intended, there is not expected to be any significant risk to human health or the environment.

According to information from suppliers and internal product information, Liebherr-Werk Ehingen GmbH is aware of SVHC that are present in more than 0.1 percent by weight in individual products of this vehicle.

For more information, contact REACH-LWE@liebherr.com.

### **Intended use**

Everyone who is involved in the use, operation, assembly, maintenance and inspection of the crane must read and use the crane documentation.

Only the following represents intended use:

- Lifting and lowering non-fixed loads vertically.
- Moving loads using the devices specified according to the crane documentation.
- Driving the crane with a suitable view or with a guide.
- Driving the crane with the equipment in place or with a suspended load only when the corresponding charts are available.

To do so, the weight, center of gravity and wind-exposed surface of the load must be known and observed. Permissible movement speeds and delay times must be observed.

The crane is used as intended when the following specifications and prerequisites are observed:

- Only operate the crane according to the set up configurations described in the crane documentation and that can be selected in the crane control.
- The entries and settings in the crane control match the actual set up configuration of the crane.
- The crane documentation includes: The operating instruction, load charts, wind speed charts, erection and take-down charts, job planner, assembly plans, rod plans, reeving plans, rigging plans.
- Comply with the crane documentation and the safety regulations, conditions, prerequisites, set up conditions and work steps it contains.
- Operate the crane within the permissible limit values, for example in compliance with the classification according to ISO 4301-1 and categorization according to ISO 4301-2, see chapter "Technical data".
- Operate the crane on ground that is suitable for the applied loads.
- Only allow access to the crane and operation of the crane by authorized and trained personnel.
- Operate the crane in a safety and danger conscious manner.
- Operate the crane in a perfect technical condition.
- The crane does not have safety-relevant problems.
- The roles of the people located near the crane are defined according to the crane documentation and known to all involved personnel.
- All involved personnel fulfill the personnel requirements according to their roles in the crane documentation.
- All involved personnel are aware of their areas of responsibility according to their roles in the crane documentation.
- All involved personnel act in a safety and danger conscious manner.
- Perform the maintenance and inspection work according to the specifications in the crane documentation. Have the required service work performed.
- Only use the equipment parts, components, spare parts and operating fluids approved in the crane documentation. This also applies for load hook und hook blocks.
- Comply with the national and regional regulations, for example regarding periodic inspections, safety distances when working with the crane, permissible travel conditions including axle loads for on-road driving.

Any other use or any use that exceeds what is indicated without the written declaration of consent from the manufacturer is unintended use.

## Unintended use

The manufacturer is **not** liable for damage caused by unintended use or improper use of the crane. Any associated risk is the sole responsibility of the owner, the operating company, the crane operator or the responsible person appointed by the operating company.

Unintended use includes, but is not limited to, the following:

- Operating the crane in an area exposed to explosion hazards.
- Operating the crane for dynamic uses, for example soil compaction, demolition balls.
- Using the crane at sports and recreational events, for example “bungee jumping” or “Dinner in the sky®”/“suspended restaurants”.
- Unloading or loading the crane suddenly, for example: Grab or dumping operation.
- Using the crane when the weight of the load is suspended on the crane is changed, for example by filling a container suspended on the load hook.
- Operation on a floating device if the conditions in chapter “Crane on a floating device” are not fulfilled and the written release by Liebherr-Werk Ehingen GmbH is not present.
- Operation of the crane when there are additional persons in addition to the crane operator outside of the crane cab, on the crane or in the danger zone. Exceptions to this are procedures allowed in the crane documentation.
- Pushing, pulling or lifting objects with the level control, sliding beams or the support cylinders.
- Rubbing or transversely pulling a load.
- Transporting personnel outside the driver's cab or in the crane cab.
- Transporting personnel with the carrying equipment or load handling equipment or on the load.
- Transporting personnel with work baskets, if the national and regional regulations are not observed, for example the responsible work safety organization.
- Transporting loads and objects on or to the side of the crane. Exceptions to this are the intended positions.

## Ambient temperature

The range of application of the crane is an ambient temperature from -20 °C to +50 °C. The use of the crane at ambient temperatures from +40 °C to +50 °C is connected to a reduction in drive performance and service life.

If the ambient temperature is lower than -20 °C the crane must be modified with “auxiliary equipment for working at low temperatures”.



### WARNING

Working at low temperatures without the corresponding auxiliary equipment!  
The crane components can be damaged and fail. The load can rip off.  
Death, severe bodily injuries, property damage.

If the crane is operated at an ambient temperature lower than -20 °C:

- ▶ Make sure that the crane is equipped with the corresponding “auxiliary equipment for working at low temperatures”. Comply with chapter 2.08.
- ▶ Use the operating fluids for the corresponding ambient temperature in time. Comply with the specifications in chapter 7.07.

## Cranes with electric mode

Electric mode is installed only for certain cranes.

The range of application of the crane is an ambient temperature from -20 °C to +40 °C and in diesel operation an ambient temperature from -20 °C to +50 °C. A use of the crane in diesel operation at ambient temperatures from +40 °C to +50 °C is connected to a reduction in drive performance and service life.

## Safety equipment

Special attention must be paid to the safety equipment built into the crane. The safety equipment must constantly be checked for functionality. The crane may not be operated if the safety equipment are not working or not working correctly.



### Note

Your motto must always be:

- ▶ **Safety first!**

The crane has been built in accordance with the European regulations for crane operation and travel operation and has been approved by the relevant authorities.

## Equipment and spare parts



### WARNING

Danger of fatal injury if original equipment parts are **not** used!

If the crane is operated with **non**-original equipment parts, the crane can fail.

Death, severe bodily injuries, property damage.

- ▶ Operate the crane only with original equipment parts!
- ▶ Crane operation with equipment parts that do **not** belong to the crane is prohibited!
- ▶ If there is any doubt about the origin of equipment parts, contact Customer Service at Liebherr-Werk Ehingen GmbH.



### WARNING

The crane permit and manufacturer's warranty will become void!

If any original installed parts are modified, manipulated or replaced (e.g. removal of parts, installation of non-original Liebherr parts), both the crane permit and the manufacturer's warranty will become void.

- ▶ Leave installed original parts unchanged.
- ▶ Do not remove installed original parts.
- ▶ Use only Original Liebherr spare parts.
- ▶ If there is any doubt about the origin of the spare parts, contact Customer Service at Liebherr-Werk Ehingen GmbH.

For ordering equipment parts and spare parts, always keep the crane number handy and provide it.

## Definition of directional data for mobile cranes

**Driving forward:** Driving with the driver's cab forward.

**Driving in reverse:** Driving with the taillights of the crane chassis forward.

**Front, rear, right, left** in the **driver's cab** refer to the crane chassis. The driver's cab is always in the front.

**Front, rear, right, left** in the **crane cab** refer to the crane superstructure. The front is always in the direction of the taken-down boom.

**0° crane superstructure slewing angle:** The boom points in the longitudinal direction to the rear over the rear of the vehicle.

**180° crane superstructure slewing angle:** The boom points in the longitudinal direction to the front over the driver's cab.

## Definition of directional data for crawler cranes

**Driving forward** driving forward from the view of the crane operator seated in the crane cab. Turntable in the 0° or 180° position.

**Driving reverse** driving backward from the view of the crane operator seated in the crane cab. Turntable in the 0° or 180° position.

**Front, rear, right, left** always orient themselves on the **crawler travel gear** from the position of the chain tension devices. The chain tension devices on the crawler travel gear are always on the front.

**Front, rear, right, left** refer to the direction of view of the crane operator seated in the **crane cab**. The front is always in the direction of the taken-down boom.

### Optional equipment and functions

The equipment marked with \* and the functions are optionally available and are **not** part of the standard crane (optional equipment).

### Conversion chart

	Initial unit	Multiplication factor	Target unit
<b>Length</b>	mm	0.03937	in
	in	25.4000	mm
	mm	0.00328	ft
	ft	304.8	mm
	cm	0.39370	in
	in	2.5400	cm
	cm	0.0328	ft
	ft	30.48	cm
	m	39.37	in
	in	0.0254	m
	<b>m</b>	<b>3.281</b>	<b>ft</b>
	<b>ft</b>	<b>0.3048</b>	<b>m</b>
	km	0.62137	mile
	mile	1.6093	km
	<b>Area</b>	cm <sup>2</sup>	0.155
in <sup>2</sup>		6.4516	cm <sup>2</sup>
<b>m<sup>2</sup></b>		<b>10.764</b>	<b>ft<sup>2</sup></b>
<b>ft<sup>2</sup></b>		<b>0.0929</b>	<b>m<sup>2</sup></b>



	Initial unit	Multiplication factor	Target unit
<b>Volume</b>	cm <sup>3</sup>	0.06102	in <sup>3</sup>
	in <sup>3</sup>	16.387	cm <sup>3</sup>
	m <sup>3</sup>	35.3147	ft <sup>3</sup>
	ft <sup>3</sup>	0.0283	m <sup>3</sup>
	l	0.001	m <sup>3</sup>
	m <sup>3</sup>	1000	l
	l	61.024	in <sup>3</sup>
	in <sup>3</sup>	0.016387	l
	l	0.0353	ft <sup>3</sup>
	ft <sup>3</sup>	28.32	l
	l	0.264178	US. liq. gal
	US. liq. gal	3.7853265	l
<b>Weight (mass)</b>	kg	2.20462	lb
	lb	0.45359	kg
	<b>t</b>	<b>2204.62</b>	<b>lb</b>
	<b>lb</b>	<b>0.0004536</b>	<b>t</b>
	t	1.1023	short ton US (tn. sh.)
	short ton US (tn. sh.)	0.90718	t
	<b>t</b>	<b>0.45359</b>	<b>kip</b>
	<b>kip</b>	<b>2.20462</b>	<b>t</b>
<b>Weight/length</b>	kg/m	0.055998	lb/in
	lb/in	17.857781	kg/m
	kg/m	0.67197	lb/ft
	lb/ft	1.48816	kg/m
<b>Force</b>	N	0.2248	lbf
	lbf	4.4483986	N
	<b>kN</b>	<b>224.809</b>	<b>lbf</b>
	<b>lbf</b>	<b>0.0044483986</b>	<b>kN</b>
<b>Turning moment</b>	Nm	8.85075	lbf·in
	lbf·in	0.112984	Nm
	Nm	0.73756	lbf·ft
	lbf·ft	1.3559	Nm
<b>Performance</b>	HP (DIN HP)	0.7355	kW
	kW	1.3596	HP (DIN HP)

LWE/LR 1800-1-0-000/27200-07-02/en

	Initial unit	Multiplication factor	Target unit
<b>Speed</b>	m/s	39.37	in/s
	in/s	0.0254	m/s
	<b>m/s</b>	<b>3.28084</b>	<b>ft/s</b>
	<b>ft/s</b>	<b>0.3048</b>	<b>m/s</b>
	km/h	0.62137	mph (mi/h)
	mph (mi/h)	1.60935	km/h
	m/s	2.2369	mph (mi/h)
	mph (mi/h)	0.44704	m/s
<b>Pressure</b>	kPa (kN/m <sup>2</sup> )	0.01	bar
	bar	100	kPa (kN/m <sup>2</sup> )
	bar	14.5038	psi
	psi	0.06895	bar
	<b>kPa (kN/m<sup>2</sup>)</b>	<b>0.145038</b>	<b>psi</b>
	<b>psi</b>	<b>6.894759</b>	<b>kPa (kN/m<sup>2</sup>)</b>
	N/cm <sup>2</sup>	1.450377	psi
	psi	0.6894759	N/cm <sup>2</sup>
	N/m <sup>2</sup>	0.000145038	psi
	psi	6894.759	N/m <sup>2</sup>
	t/m <sup>2</sup>	204.81	lbs/ft <sup>2</sup>
	lbs/ft <sup>2</sup>	0.0048828	t/m <sup>2</sup>
<b>Load-related area</b>	m <sup>2</sup> /t	0.004882	ft <sup>2</sup> /lbs
	ft <sup>2</sup> /lb	204.81	m <sup>2</sup> /t
<b>Temperature</b>	<b>°C</b>	<b>([°C] · 1.8) + 32</b>	<b>°F</b>
	<b>°F</b>	<b>([°F] - 32) / 1.8</b>	<b>°C</b>

Conversion chart

---

# Contents

## 1 Description of crane

---

1.01 Terminology	1
1 Component overview crawler travel gear	2
2 Turntable component overview	3
3 Winch component overview	4
4 Derrick ballast - suspended ballast component overview	5
5 Derrick ballast - ballast trailer component overview	6
6 Ground connection	6
7 Derrick boom component overview	7
8 Main boom component overview	8
9 S, SL-boom	10
10 SLF, SLAF-boom	12
11 SW1-boom	14
12 HSDBV, HSLDBV/B/BW-boom	16
13 HSDWB/BW/BV-boom	18
1.02 Product description	1
1 Crawler travel gear	2
2 Crane superstructure	2
3 Winches	3
4 Boom systems / boom combinations	4
5 Auxiliary equipment	4
1.03 Technical data	1
1 Dimensions	3
2 Operating and load conditions	4
3 Noise emission	4
4 Vibrations	4
5 Crane speeds	4
6 Crane surface pressure	5
7 Load handling equipment	5
8 Hoist ropes	5
9 Control ropes	5
10 Guy rope	5
11 Assembly rope	5
12 Dimensions and weights of the crane components	6
13 Crawler carrier	6
14 Crawler center section	6
15 Turntable without SA-frame	7
16 SA-frame with winch 4	7
17 Turntable with crawler center section with SA-frame	7
18 Crawler catwalk	8
19 Ballast frame for central ballast	8
20 Ascent	8
21 Mechanical auxiliary support	9
22 Winch 1	9
23 Winch 2	9

24	Counterweight platform	10
25	Ballast plate for central ballast	10
26	Ballast plate for counterweight and derrick ballast	10
27	H-pivot section 11 m	11
28	H-intermediate section 6 m	11
29	H-intermediate section 12 m	12
30	HS-reducer 9 m	12
31	S-intermediate section 6 m	13
32	S-intermediate section 12 m	13
33	S-end section 650 t	14
34	SL-reducer 6 m	14
35	L-intermediate section 6 m	15
36	L-intermediate section 12 m	15
37	L-end section 450 t	16
38	W-assembly unit 1	16
39	W-assembly unit 2	17
40	D-pivot section 10.5 m with winch 3 and luffing pulley block	17
41	D-intermediate section 6 m	18
42	D-intermediate section 12 m	18
43	D-end section 10.5 m	19
44	F-assembly unit without F-end section	19
45	F-assembly unit with F-end section	20
46	F-intermediate section 3 m	20
47	F-intermediate section 6 m	21
48	F-intermediate section 12 m	21
49	F-connector head	22
50	F-end section	22
51	Auxiliary guying fiber guy ropes	23
52	Roller set	23
53	Boom nose 25 t	24
54	Suspended ballast pallet	24
55	Pivot section BV suspended ballast guide (V-frame)	24
56	End section BV suspended ballast guide (V-frame)	25
57	Ballast trailer	25
58	Ballast trailer frame	26
59	Ballast trailer wheel set	26
60	Ballast trailer guide	26
61	Ballast trailer intermediate section	27
62	Ballast trailer adapter with pull rods	27
63	Roller cart	27

1.03.10	Outrigger pads	1
1	Description	2
2	Safety	2
3	Fastening the outrigger pad	5
4	Technical track pad data for cranes with a telescopic boom	8
5	Technical outrigger pad data for cranes with a lattice mast boom	24

## 2 Safety

2.03	Job planning	1
------	--------------	---

LWE/LR 1800-1-0-000/27200-07-02/en

1	Planning Crane operation	3
2.04	Technical safety instructions	1
1	Dangers on the crane	2
2	Safe working environment	4
3	Definition of roles	5
4	Instructions to personnel	11
5	Danger zone of the crane	12
6	Traffic endangerment and environmental damage	13
7	Endangering air traffic	13
8	Movement on the crane	14
9	Emergency exit - driver's cab	16
10	Emergency crane cab exit	16
11	Personal protective equipment	20
12	Supplied fire extinguisher	26
13	Securing persons to prevent them from falling	26
14	Saving personnel	28
15	Crane cab	28
16	Side window	36
17	Emergency hammer*	36
18	Transport	37
19	Fastening	40
20	Selecting the location	40
21	Slopes and excavations	44
22	Loads on the ground due to crane operation	47
23	Support	51
24	Alignment of the crane	53
25	Checking the safety measures	54
26	Safety instructions in case of an external power supply	55
27	Grounding for potential equalization	55
28	Working in the vicinity of transmitters	57
29	Crane operation in case of thunderstorms	58
30	Wind influences	59
31	Lifting a load with two cranes	66
32	Overlapping of working ranges of several cranes	68
33	Hand signals for guidance	69
34	Travel operation	77
35	Crane operation	79
36	Lifting of personnel	87
37	Securing personnel on shut off crane	89
38	Welding work on the load	91
2.04.10	Ladders	1
1	Intended use	2
2	Safety instructions	2
3	Safety signs	3
4	Ladder inspection	12
5	User guidelines	12
6	Assembling the ladder	14
7	Ladder access	25
2.05	Signs on the crane	1

1	Signs	2
2.05.10	Labeling of the load carriers	1
1	Identifications on the hook block or load hook	3
2	Identifications on single hook or double hook	4
3	Identifications on auxiliary weights	5
2.06	Fall protection equipment on the crane	1
1	Safety	2
2	Hook points	2
3	Safety ropes	3
4	Crawler travel gear	4
5	Turntable catwalks and railing	13
6	Additional step counterweight-bracket	24
7	H-pivot section	45
8	S-end section	49
9	D-end section	52
10	Counterweight bracket	53
11	Suspended ballast guide "V-frame"	56
12	Ballast trailer	59
13	Counterweights	79
2.07	Accesses to the crane	1
1	Safety	2
2	Ascending and descending the crawler travel gear	2
3	Removing the ladder from the transport retainer	4
4	Ascending and descending the turntable, "transport position"	5
5	Ascending and descending the crane cab, "transport position"	6
6	Ascending and descending the crane cab	7
7	Ascending and descending the turntable	8
8	Climbing up and down the turntable catwalk	9
9	Climbing up and down the catwalk turntable via the additional step	10
10	Climbing up and down the winch 4 assembly area	16
11	Ascending and descending winch 1 and 2	17
12	Ascending and descending the slewing ring connection assembly area	18
13	Ascending and descending the assembly area of winch 1 with an installed winch	19
14	Ascending and descending the counterweight platforms	20
15	Ascending and descending the counterweight plates	21
16	Ascending and descending the H-pivot section	22
17	Ascending and descending the D-pivot section	23
18	Ascending and descending the lattice sections	24
19	Ascending and descending the suspended ballast platform	25
20	Ascending and descending the suspended ballast plates	26
21	Ascending and descending the ballast trailer	27
22	Ascending and descending the control cabinet platform	28
23	Ascending and descending the ballast trailer guide	29
24	Ascending and descending the ballast trailer guide	30
25	Ascending and descending the ballast trailer plates	31
26	Walking surfaces and stepping surfaces	31
2.08	Working in low temperatures	1
1	Auxiliary equipment	2

2	Safety	2
3	Environmental / component temperature below -20 °C	3
4	Maintenance	7

#### 2.15 General technical safety instructions for operation with a ballast trailer 1

1	Safety instructions	2
2	Inspecting tires and disk wheels	3

#### 2.25 Crane on floating body 1

1	Non-intended use	2
2	Intended use	2
3	Floating device	2
4	Operating conditions	2
5	Crane transport on floating devices	3
6	Increased corrosion	4

### 3 Crane assembly

#### 3.01 Crawler carrier assembly 1

1	Safety	2
2	Component overview	4
3	Operating and control instruments	4
4	Fastening points	5
5	Hydraulic assembly support	6
6	Preparing the crawler carrier for assembly	10
7	Assembling the crawler carriers with SA-frame	11
8	Assembling the crawler carrier with the auxiliary crane	19
9	Establishing the connections to the crawler carriers	24
10	Preparing the crawler carrier for disassembly	26
11	Disassembling the crawler carrier with SA-frame	26
12	Disassembling the crawler carrier with the auxiliary crane	32
13	Disconnecting the connections to the crawler carriers	38

#### 3.02 Turntable assembly 1

1	Safety	2
2	Turntable fastening points	3
3	Assembling the fall protection equipment on the turntable	6
4	Lifting the turntable from the transport vehicle	7
5	Unpinning the pin from the transport position	8
6	Assembling the central ballast	8
7	Placing the turntable on the crawler center section	9
8	Pinning the turntable with the Quick Connection (QC)	11
9	Bringing the crane cab and cab platform into the operating position	13
10	Assembling the drawbar of the rotary connection on the turntable	14
11	Establishing the hydraulic connections	15
12	Establishing the electrical connections	16
13	Further assembly steps	16
14	Turning the turntable into the disassembly position	17
15	Reducing the central ballast for disassembly	17
16	Preparing the turntable for removal from the crawler center section	18
17	Disconnecting the electrical connections	18
18	Disconnecting the hydraulic connections	18

19	Disassembling the drawbar of the rotary connection on the turntable	19
20	Bringing the crane cab into the transport position	20
21	Unpinning the turntable with the quick connection (QC)	21
22	Lifting the turntable from the crawler center section	24
23	Bringing the pin into the transport position	25
24	Disassembling the fall protection equipment on the turntable	25
<b>3.03 Central ballast</b>		<b>1</b>
1	Safety	2
2	Components	3
3	Fastening points and weights	4
4	Central ballast combinations	5
5	Lifting the ballast plates together	9
6	Assembling the central ballast	9
7	Securing / releasing the central ballast	18
8	Disassembling the central ballast	21
<b>3.04 Mechanical auxiliary support</b>		<b>1</b>
1	Safety	2
2	Component overview	3
3	Fastening points	3
4	Assembling the mechanical auxiliary support	4
5	Disassembling the mechanical auxiliary support	6
<b>3.05 SA-frame assembly</b>		<b>1</b>
1	Safety	2
2	Component overview	3
3	SA-frame fastening points	4
4	Preparing the pin locations on the turntable	4
5	Pinning the SA-frame on the turntable	5
6	Pinning winch 4 on the turntable	8
7	Establishing the connections to the SA-frame	10
8	Pinning the pulley support with the turntable	11
9	Releasing the assembly cylinder	12
10	Assembling the guy rods	13
11	Disassembling the guy rods	14
12	Securing the assembly cylinder	15
13	Unpinning the pulley support on the turntable	16
14	Disconnecting the connections to the SA-frame	17
15	Unpinning winch 4 on the turntable	18
16	Unpinning the SA-frame on the turntable	20
<b>3.06 Assembly conditions</b>		<b>1</b>
1	Assembly conditions for operation on crawlers	2
<b>3.07 Winch assembly</b>		<b>1</b>
1	Winch assembly	2
<b>3.07.10 Winch 1 assembly</b>		<b>1</b>
1	Safety	2
2	Component overview	2
3	Winch 1 fastening points	2
4	Ascending / descending to the space of winch 1 and winch 2	3



5	Assembly winch 1	4
6	Establishing the connections from winch 1 to the turntable	9
7	Disconnecting the connections from winch 1 to the turntable	11
8	Disassembling winch 1	13
<b>3.07.20 Winch 2 assembly</b>		<b>1</b>
1	Safety	2
2	Component overview	2
3	Winch 2 fastening points	2
4	Ascending / descending to the space of winch 1 and winch 2	3
5	Assembly winch 2	4
6	Establishing the connections from winch 2 to the turntable	9
7	Winch 2 protective roller	11
8	Disconnecting the connections from winch 2 to the turntable	16
9	Disassembling winch 2	17
<b>3.07.30 Winch 3 assembly</b>		<b>1</b>
1	Safety	2
2	Component overview	2
3	D-pivot section fastening points	2
4	Winch 3 fastening points	3
5	Winch 3 assembly	4
6	Disassembling winch 3	10
<b>3.07.50 Winch 5 assembly</b>		<b>1</b>
1	Safety	2
2	Component overview	2
3	Winch 5 fastening points	2
4	Assembling winch 5	3
5	Assembling the H-pivot section on the turntable	16
6	Disassembling the H-pivot section on the turntable	16
7	Disassembling winch 5	16
8	Bringing winch 5 from the operating position into the transport position	26
9	Bringing winch 5 from the transport position into the operating position	29
<b>3.07.60 Winch 6 assembly</b>		<b>1</b>
1	Safety	2
2	Component overview	2
3	Winch 6 fastening points	2
4	Assembling winch 6	3
5	Assembling the H-pivot section on the turntable	12
6	Disassembling the H-pivot section on the turntable	13
7	Disassembling winch 6	13
8	Bringing winch 6 from the operating position into the transport position	20
9	Bringing winch 6 from the transport position into the operating position	23
10	Bringing winch 6 from transport position into the flat operating position	24
<b>3.80 Crane and crane component transport</b>		<b>1</b>
1	Safety	2
2	Crane, assembled	3
3	Crane components	3

---

## 4 Operation of crane superstructure

---

4.01 Operating and monitoring instruments on the crane superstructure	1
1 Crane cab exterior installation parts	2
2 Crane cab interior installation parts	3
3 Emergency equipment	4
4 Interfaces	5
5 Crane cab control units	6
6 Monitor control unit	7
7 Operating and control unit - BKE	7
8 BTT control unit	19
9 Drive assembly air conditioning system* control unit	19
10 Climate control system control unit	20
11 LICCON computer system control unit	23
12 Pedal carrier	23
13 Control platform	25
14 Instrument panel	42
15 Side panel	55
16 Turntable control units	57
17 Crawler travel gear control units	58
18 Control cabinet panel	58
19 External power supply	59
20 Drive assembly air conditioning system*	60
4.01.10 Touch display menu operation	1
1 Touch display	2
2 Operating variations	2
4.02 LICCON computer system	1
1 General	2
2 System start of the LICCON computer system	4
3 Operating elements on the LICCON monitors	6
4 <i>Set up</i> program	11
5 The <i>Crane operation</i> program on LICCON monitor 0	77
6 The <i>Crane operation</i> program on LICCON monitor 1	181
7 The <i>Crane operation</i> program on LICCON monitor 2	207
8 <i>Curve illustration</i> program	221
9 <i>Working range limitation</i> program	225
10 Master switch / pedal sensor speed reduction	233
11 Checking the gear oil fill level of the winches	241
12 Power Save mode and Stand-by mode in the LICCON computer system	245
4.03 Start up and shut down of crane	1
1 Safety	2
2 Crane start-up at low temperatures	2
3 Assembling the central ballast and assembly support	3
4 Assembling the turntable	3
5 Placing the extension ladder on the crane cab	3
6 Bringing the crane cab into the operating position	5
7 Bringing the cab platform into the operating position	6
8 Checking before start up	9
9 Diesel particle filter (DPF)*	20

10	Exhaust system cleaning procedure	25
11	Crane driver's seat	26
12	Control platform	31
13	Crane cab	33
14	Electrical external power supply	39
15	Jump starting the diesel engine	41
16	Preheating the hydraulic oil with Hydraulic oil preheating*	42
17	Starting the LICCON computer system (before engine start)	45
18	Starting and turning off the engine	46
19	Starting the LICCON computer system parallel to the engine	50
20	Bringing the crane cab into the transport position	50

4.04	Safety equipment	1
1	General	3
2	Crane geometry quick test	3
3	Overload protection quick test	3
4	LICCON computer system	3
5	Safety equipment on the crane	9

4.05	Crane operation	1
1	Description	2
2	Safety instructions	2
3	Prerequisites for crane operation	4
4	Master switch assignment	5
5	Locking / releasing the winch	6
6	Master switch functions	10
7	Changing the speed of the crane movement via the engine rpm	22
8	Spooling the hoist winches up / out (load lifting / load lowering)	24
9	Hoist winch in parallel operation	28
10	Luffing the boom system up / down	40
11	Turning the crane superstructure	44
12	Controlling the ballast functions (pull cylinder / derrick ballast guide / ballast automatic)	49
13	Assembly operating mode SA	61
14	Operating the ballast trailer support cylinders	63
15	Spooling the assembly winch up / out	65

4.06	Rope reeving	1
1	Wire ropes and rope end connections	2
2	Reeving in the hoist rope	5
3	Reeving in / reeving out the hook block, rope end connection in the standard version	8
4	Reeving in / reeving out the hook block, rope end connection with L-shaped rope lock	11
5	Attaching and removing the load hook*	15
6	Two-part hoist limit switch weight	18
7	One-part hoist limit switch weight	21
8	Assembling / disassembling the wedge lock	23
9	Rope reeving	35

4.07	Counterweight	1
1	Safety	2
2	Component overview	3
3	Fastening points	3
4	Permissible ballast assemblies	5

5	Ballast conditions	6
6	Climbing up / down the counterweight bracket	7
7	Assembling the counterweight brackets	8
8	Placing the ballast plates	10
9	Securing the counterweight	14
10	Releasing the counterweight	16
11	Removing the ballast plates	19
12	Disassembling the counterweight brackets	22
4.08 Working with a load		1
1	Safety instructions	3
2	Checks before starting to work with the crane	4
3	Telescoping crane movement	5
4	Taking on a load	7
5	Load weighing and load display	13
6	Crane operation	18
7	Ram work or pulling sheet piles	19
8	Crane rope pretension	20
4.10 Driving from the crane cab		1
1	Prerequisites for driving the crane (crawler operation)	2
2	Displays on the LICCON monitor	6
3	Preparing for driving the crane	10
4	Driving the crane: Load chart available	13
5	Driving the crane: No load chart is available	14
6	Driving the crane: Ballast trailer installed	18
7	Driving the crawler crane	20
4.15 Reeving plans		1
1	Reeving plans	2
4.20 Procedure for shut-off of crane movement		1
1	General	3
2	Instructions for resuming crane movement	17

## 5 Equipment

5.01 Technical safety instructions for assembly and disassembly		1
1	Equipment	2
2	Rope pulleys	2
3	Ropes	2
4	Fiber guy ropes	4
5	Control measures before crane operation	9
6	Relapse cylinders	11
7	Pneumatic springs	11
8	Manual rope winches	12
9	Weights	12
10	Guy rods	13
11	Auxiliary guying	14
12	Bypassing the overload protection	14
13	Bypassing the hoist top shut-off	16
14	Pin connections	17

15	Retaining elements	22
16	Assembling / disassembling	31
17	Erecting / taking-down	93
18	Walking on a boom component	97
5.02 SA-frame		1
1	Safety	2
2	Function and actuation	3
3	Performing the function checks	4
4	Erecting the SA-frame	5
5	Taking the SA-frame down	9
5.03 Boom systems		1
1	Boom components	2
2	Arrangement of intermediate sections and guy rods on the booms / boom systems	2
3	Wire rope auxiliary guying	5
4	Fiber guy rope auxiliary guying	15
5.05 Derrick boom		1
1	Component overview	2
2	Fastening points for derrick components	2
3	D-boom assembly on the crane	7
4	D-boom assembly on the ground	34
5	Flying D-boom assembly	37
6	Erecting the D-boom	43
7	D-boom disassembly on the crane	53
8	D-boom disassembly on the ground	80
9	Flying D-boom disassembly	82
5.07 Luffing jib - W-system		1
1	Safety	2
2	Component overview	4
3	Fastening points	4
4	Assembling	11
5	Information about erecting / taking down the boom system with the luffing jib	54
6	Erecting the boom system with luffing jib	60
7	Crane operation	68
8	Taking the boom system down with the luffing jib	69
9	Disassembling	79
5.10 Boom nose lattice boom		1
1	Safety	2
2	Component overview	3
3	Fastening points for boom nose 25 t	4
4	Assembling the boom nose 25 t	6
5	Crane operation	11
6	Disassembling the 25 t boom nose	14
5.13 Fixed jib – F-system		1
1	Component overview	2
2	F-jib fastening points	4
3	Assembling the F-jib	7
4	Erecting the boom	41

5	Operating the crane	43
6	Taking the boom down	44
7	Disassembling the F-jib	47
5.14 Roller set		1
1	Roller set component overview	2
2	Fastening points for roller set	3
3	Assembling the roller set / roller sets	4
4	Disassembling the roller set / roller sets	10
5.15 Roller cart		1
1	Roller cart	2
5.19 Hook blocks		1
1	Safety	2
2	Radio sending unit for the hook block incline indicator	2
3	Slack rope formation	3
4	Hook block or load hook fastening points for transport	4
5	Transporting the hook block or load hook with a forklift truck	5
6	Rope guard	5
7	Double hook block for single operation variation A	7
8	Double hook block for single operation variation B	11
9	Double hook block for parallel operation variation A	16
10	Double hook block for parallel operation variation B	23
11	Overview of the auxiliary weight fastening systems	31
12	Fastening system 1	34
13	Fastening system 2	36
14	Fastening system 3	38
15	Fastening system 4	40
5.19.10 Hook block incline sensors		1
1	General	2
2	Assembling the radio receiving unit	2
3	Assembling the radio sender unit on the hook block	5
4	Batteries in the radio sender unit	9
5	Radio sender unit and radio receiving unit park position	11
5.30 Pin pulling device		1
1	Product description	2
2	Component overview	2
3	Safety during assembly and disassembly	3
4	Pin pulling device (hydraulic aggregate with pin pulling cylinder)	4
5	Pin pulling device (battery-operated pin pulling cylinder)	15
6	Using the pin pulling cylinder or battery-operated pin pulling cylinder in the vertical position.	20
5.31 BTT - Operating element		1
1	BTT display / operating element	2
2	Settings and status displays on the BTT	15
3	BTT start menu	16
4	Selection overview	21
5	<i>Engine operation</i> menu	22
6	<i>Assembly support</i> menu	29
7	<i>Crawler carrier assembly</i> menu	34

8	<i>Crane cab / stepladder</i> menu	39
9	<i>Assembly functions</i> menu	43
10	<i>Crane floodlight</i> menu	46
11	<i>Test system</i> menu	47
12	BTT operation	51
13	Measures in case of problems	53

5.35	Derrick ballast - ballast trailer - M-BW	1
------	--	---

1	Description	2
2	Component overview	2
3	Fastening points	2
4	Radii	10
5	Stability and tipping safety	12
6	For your safety during assembly and disassembly	18
7	Prerequisites for assembly	23
8	Operating elements on the control panels	23
9	Assembling / disassembling the ballast trailer with the BTT-E	26
10	Assembling the ballast trailer	26
11	Preparing the ballast trailer for assembly on the crane	65
12	Assembling the ballast trailer on the crane	66
13	Ballasting the ballast trailer	84
14	Working with the ballast trailer	91
15	Removing ballast trailer ballast	173
16	Prerequisites for disassembly	178
17	Preparing the ballast trailer for disassembly from the crane	178
18	Disassembling the ballast trailer from the crane	179
19	Disassembling the ballast trailer	194
20	Emergency operation in case of a defective control module of the ballast trailer control	222
21	Ballast trailer maintenance intervals / maintenance instructions	229

5.36	Derrick ballast - suspended ballast	1
------	-------------------------------------	---

1	Content distributed in multiple chapters.	2
---	---	---

5.36.50	Ballast pallet - V-frame	1
---------	--------------------------	---

1	Safety	2
2	Product description	2
3	Component overview	4
4	Fastening points	7
5	Pull cylinder extension conditions	10
6	Permissible ballast assemblies	10
7	Derrick ballast radii	11
8	Permissible lifting heights	15
9	Assembling	24
10	Crane operation	74
11	Disassembling	115

5.36.90	Use of foreign ballast on ballast pallet	1
---------	--	---

1	Handling recommendation for the use of external ballast on Liebherr suspended ballast pallets	2
---	---	---

5.38	Main boom	1
------	-----------	---

1	Safety	2
---	--------	---

2	Component overview	3
3	Fastening points	3
4	Assembling	9
5	Assembling the S/SL boom at an incline	23
6	Assembling the boom system with the substructure	25
7	Performing the function checks	27
8	Erecting the boom system	28
9	Operating the crane	32
10	Disassembling	32
11	Disassembling the S/SL boom at an incline	46
12	Disassembling the boom system with the substructure	48
5.39 Main boom with derrick boom		1
1	Safety	2
2	Component overview	3
3	Fastening points	4
4	Assembling	10
5	Installing the boom system preassembled on the turntable	22
6	Assembling the boom system with the substructure	23
7	Assembling the main boom guying	25
8	Establishing the electrical connections on the boom end section	29
9	Performing the function checks	29
10	Erecting the boom system	30
11	Operating the crane	36
12	Disassembling	37
5.61 Roller cart		1
1	Component overview	2
2	Fastening points for the roller cart	2
3	Moving the roller cart	3
4	Crane assembly	4
5	Crane removal	7
5.70 Camera		1
1	Component overview	3
2	Safety guidelines	4
3	Assembling the camera	5
4	Assembling the cable drum on the auxiliary boom	7
5	Assembling the transmitter / receiver retainer	9
6	Establishing the electrical connections	11
7	Radio interference	14
8	Checking the electrical connections	15
9	Disconnecting the electrical connections	15
10	Transporting the camera	15
5.72 Outside drive aggregate		1
1	External drive assembly overview	2
2	Component overview	2
3	Fastening points for the drive assembly	4
4	Installing the drive assembly	5
5	Operating the drive assembly	12
6	Removing the drive assembly	20



5.75 Wind speed sensor / airplane warning light	1
1 Safety	2
2 Description	2
3 Transport	2
4 Wind speed sensor mounting positions	3
5 Wind speed sensor alignment / mounting	7
6 Wind speed sensor assembly	8
7 Wind speed sensor disassembly	10

## 6 Auxiliary equipment

6.01 Heater / engine preheating	1
1 Heater / engine preheating	2
6.02 Crane operator's cab heater / engine preheating / air conditioning system	1
1 Climate control system	2
2 Safety instructions	2
3 Climate control	4
4 Air distribution	12
5 Defrosting the window	13
6 Air supply	14
7 Set the auxiliary heater heat distribution	14
8 Operating the timer	15
9 Air heater*	17
10 Checking the fuel reserve	18
6.05 Emergency take down	1
1 Emergency control	2
2 Emergency control with assembly plate Variation 1 (V1)	9
3 Emergency control of slewing gear(s) with assembly plate Variation 1 (V1)	15
4 Emergency control with assembly plate(s) Variation 2 (V2)	19
5 Emergency control slewing gear(s) with assembly plate(s) Variation 2 (V2)	31
6 Completing emergency control	31
6.08 Radio remote control	1
1 Radio remote control	2

## 7 Maintenance and service

7.01 Maintenance and service - General	1
1 Safety	2
2 Warranty and coverage	7
3 Liebherr Customer Service	7
4 Taking an oil sample	8
5 Taking care of the crane	8
6 Storage	14
7 Recommendation for safe disposal	15
7.01.10 Service system	1
1 Description	2
2 Safety instructions	2
3 Calling up the service system	2
4 <i>Service system</i> operating interface	3

5	Service system function key line	5
6	Maintenance is due	5
7	Selecting the maintenance status	6
8	Resetting the maintenance status	7
7.02 Maintenance intervals - Crawler chassis		1
1	Maintenance and inspection schedule	2
7.02.50 Maintenance intervals - Ballast trailer		1
1	Maintenance and inspection schedule	2
7.03 Maintenance intervals - Crane superstructure		1
1	Maintenance and inspection schedule	2
7.03.50 Maintenance intervals - Crane boom		1
1	Maintenance and inspection schedule	2
7.04 Maintenance instructions - Crane chassis		1
1	Safety	2
2	Travel gear	2
3	Central lubrication system	7
4	Crawler carrier	7
5	Crawler chain	8
6	Hydraulic hose lines	21
7	Ladders	21
7.04.50 Maintenance instructions - Ballast trailer		1
1	Safety	2
2	Establishing the prerequisites for maintenance	2
3	Ballast trailer tires	2
4	Hydraulic hose lines	2
5	Slewing gear	3
6	Wheel set drive	6
7	Central lubrication system	10
7.05 Maintenance instructions - Crane superstructure		1
1	Safety	2
2	Establishing the prerequisites for maintenance	2
3	Fall protection equipment	2
4	Diesel engine	3
5	Cooling system	9
6	Fuel system	15
7	Urea system*	24
8	Exhaust system	27
9	Air filter system	29
10	Pump distributor gear	32
11	Central lubrication system	35
12	Slewing ring connection	42
13	Slewing gear	44
14	Winches	47
15	Assembly winch	50
16	Crane cab heating-air conditioner device	51
17	Crane cab auxiliary heater*	53

18	Air heater*	56
19	Drive assembly air conditioning system*	57
20	Hydraulic system	58
21	Hydraulic hose lines	66
22	Compressed air system	67
23	Electrical system	68
24	Window washing system	72
25	Ballast trailer*	73

7.05.50	Maintenance instructions - Crane boom	1
---------	---------------------------------------	---

1	Lattice mast boom	3
2	Rope pulleys and guide pulleys	3
3	Crane ropes	4

7.06	Fill quantities, lubrication chart	1
------	------------------------------------	---

1	Fill quantities	3
2	Lubrication schedule	4

7.07	Operating fluids and lubricants	1
------	---------------------------------	---

1	Specified service fluids and lubricants for Liebherr cranes	3
---	---	---

## 8 Inspections of cranes

8.01	Periodic crane inspections	1
------	----------------------------	---

1	General information	2
2	Inspecting load bearing crane structures, especially steel structures	4
3	Inspecting the locking system of the telescopic boom	89
4	Inspection of the screws in the adjustment plates	91
5	Checking the safety ropes and anchor points	92
6	Inspecting the load handling equipment and assembly aids	94
7	Inspecting of fastening equipment	94
8	Inspecting the hydro reservoir	95
9	Inspecting the relapse cylinders	95
10	Inspecting the rope pulleys	96
11	Inspecting the carrier rollers	97
12	Inspecting the extension conditions of sliding beams	98
13	Inspecting the inclination sensor	99
14	Inspecting the function of the overload protection	100
15	Inspecting the pin connections	100
16	Inspecting the slewing ring connection	101
17	Inspecting the mounting of the load bearing equipment	101
18	Inspecting the tele extension with eccentric, illustration 1	103
19	Inspecting the change over pulleys, illustration 2	104
20	Inspecting the oil and fuel tanks	104

8.03	Inspecting of winches	1
------	-----------------------	---

1	Inspecting the hoist and retracting winches	3
2	Inspection of the auxiliary reeving winch, recovery winch and spare wheel winch	5
3	Monitoring the winches	5

8.04	Inspection of crane wire ropes	1
------	--------------------------------	---

1	Crane ropes	3
2	Importance of inspection	3

3	Personal protective equipment	3
4	Inspection personnel qualification	3
5	Unscheduled inspection	3
6	Intervals	4
7	Areas	4
8	Documenting inspection results	5
9	Wire ropes and rope end connections	5
10	Degree of severity	8
11	Rope diameter abbreviations	8
12	Distortions and mechanical damage	8
13	Removal criteria overview	8
14	Checking for broken strands	10
15	Determining the number of broken wires	10
16	Checking the rope end connection	15
17	Checking the rope diameter	15
18	Corrosion	18
19	Corkscrew-like distortion	20
20	Basket formation	21
21	Protruding, distorted insert or strand	22
22	Loop formation	23
23	Kinking or rope loops pulled closed	24
24	Buckles	25
25	Effects of heat, arcs	26
26	Combined degree of severity	26
27	Flattenings	26
28	Current inspection checklist	31
<b>8.05 Inspection of load hooks</b>		<b>1</b>
1	Safety instructions	2
2	Inspection intervals	2
3	Checking the load hook	2
<b>8.06 Inspection of hydraulic hose lines</b>		<b>1</b>
1	Safety guidelines	3
2	Inspection intervals	3
3	Checking the end of the service life	3
4	Inspecting the hydraulic hose lines for damage	4
5	Inspecting the hydraulic hose lines for leaks	5
6	Documenting the inspection	5
7	Replacing hydraulic hose lines	5
<b>8.12 Inspection of safety controls on the relapse supports</b>		<b>1</b>
1	S-boom relapse retainer	2
2	D-boom relapse retainer	5
3	W-lattice jib relapse retainer	7
4	F-lattice jib relapse retainer	16
<b>8.14 Inspection of accumulator pressure in relapse cylinder</b>		<b>1</b>
1	Checking the accumulator pressure in the W-relapse cylinder	2
2	Checking the accumulator pressure in the W-relapse cylinder, WA-frame 1 on the ground	3
3	Checking the accumulator pressure in the W-relapse cylinder, W-boom luffed up	4

8.15 Inspection of guy rods	1
1 Safety guidelines	3
2 Inspection intervals	3
3 Checking the guy rods	3
8.16 Inspection of fiber guy ropes	1
1 Safety instructions	2
2 Inspection personnel qualification	2
3 Unscheduled inspection	2
4 Inspection intervals	2
5 Documentation	3
6 Inspecting the fiber guy ropes	3
8.17 Inspection of ladders	1
1 Safety instructions	3
2 Inspection intervals	3
3 Inspecting the ladders	3
4 Inspection sheet and check list	3
8.20 Country-specific content	1
1 Country-specific content	2
8.90 Inspection chart for cranes	1
1 Inspection chart for recurring inspections of Liebherr cranes	3

## 90 Appendix

90.01 Preface to the appendix	1
1 Foreword	3
90.05 Update confirmation	1
1 Change confirmation form	3
2 Update confirmation	3
3 Customer information	4

---

Empty page!

LWE/LR 1800-1-0-000/27200-07-02/en

---

# 1 Description of crane

LWE/LR 1800-1-0-000/27200-07-02/en

---

LWE/LR 1800-1-0-000/27200-07-02/en



# 1.01 Terminology

1	Component overview crawler travel gear	2
2	Turntable component overview	3
3	Winch component overview	4
4	Derrick ballast - suspended ballast component overview	5
5	Derrick ballast - ballast trailer component overview	6
6	Ground connection	6
7	Derrick boom component overview	7
8	Main boom component overview	8
9	S, SL-boom	10
10	SLF, SLAF-boom	12
11	SW1-boom	14
12	HSDBV, HSLDBV/B/BW-boom	16
13	HSDWB/BW/BV-boom	18

# 1 Component overview crawler travel gear

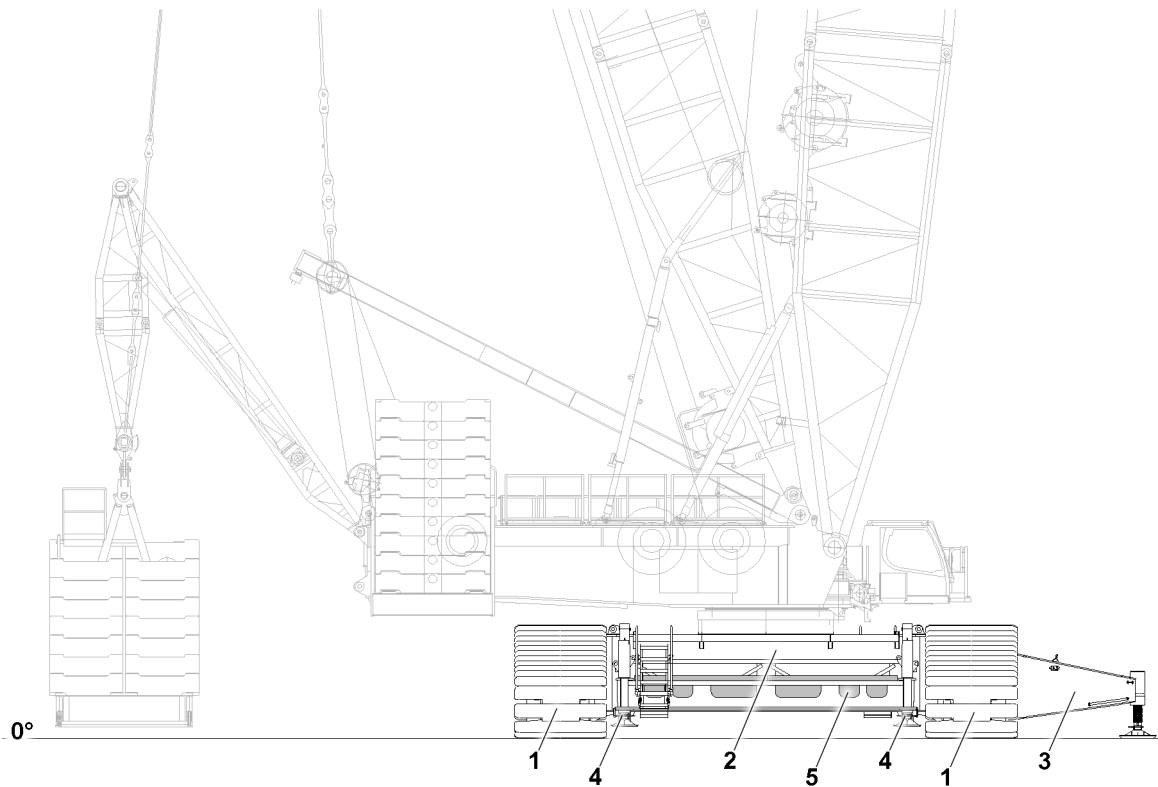


Fig.154401: Crawler travel gear

- |   |                              |   |                            |
|---|------------------------------|---|----------------------------|
| 1 | Crawler carrier              | 4 | Hydraulic assembly support |
| 2 | Crawler center section       | 5 | Central ballast            |
| 3 | Mechanical auxiliary support |   |                            |

## 2 Turntable component overview

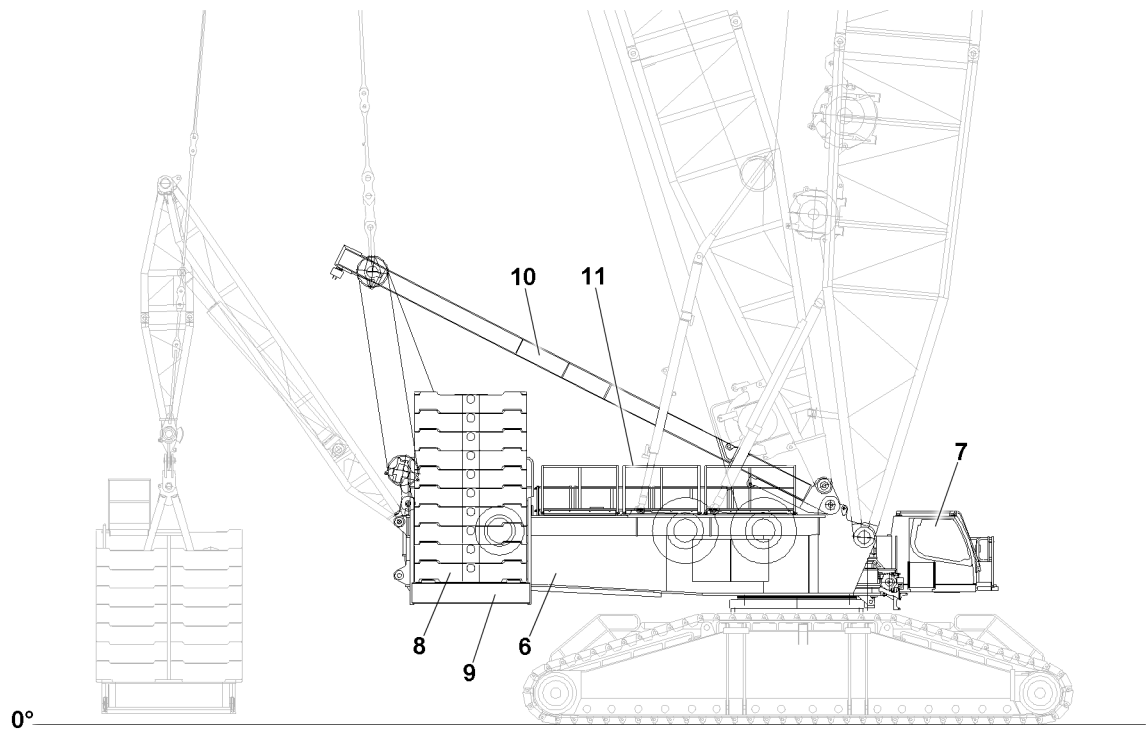


Fig.154400: Turntable

- |          |                      |           |                                |
|----------|----------------------|-----------|--------------------------------|
| <b>6</b> | Turntable            | <b>9</b>  | Console counterweight          |
| <b>7</b> | Crane operator's cab | <b>10</b> | SA-frame                       |
| <b>8</b> | Counterweight        | <b>11</b> | Turntable catwalks and railing |

### 3 Winch component overview

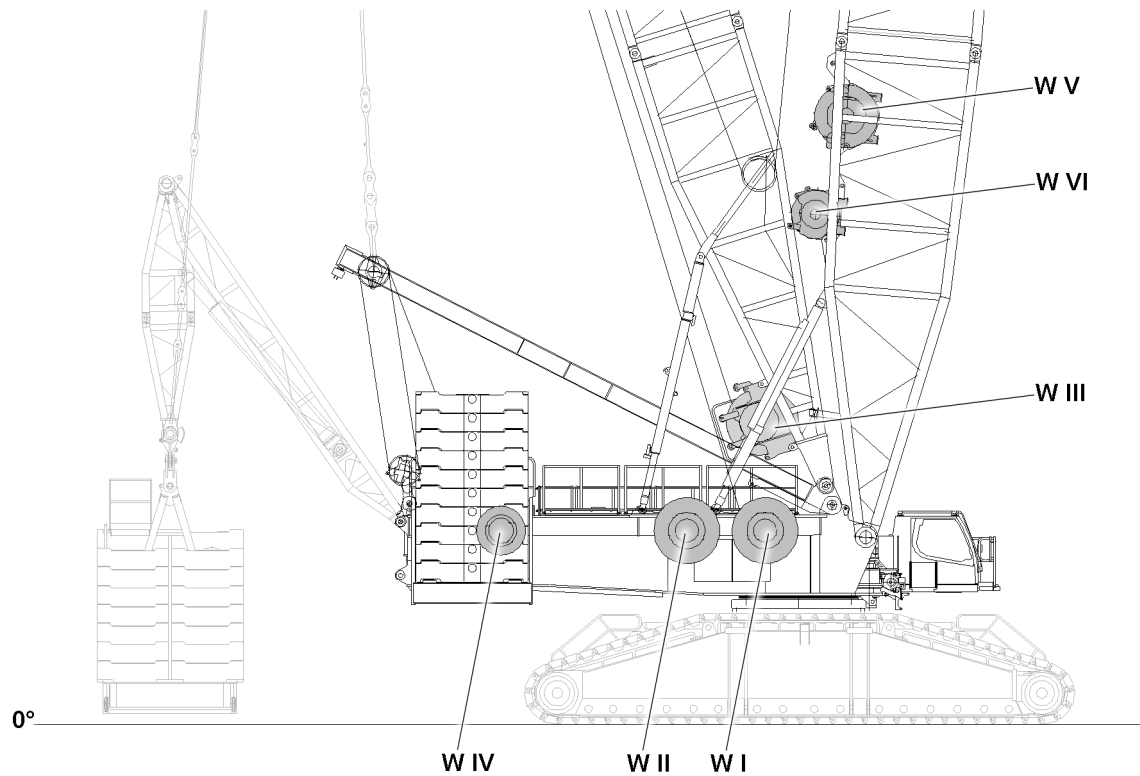


Fig.154402: Winches

**W I** Winch 1  
**W II** Winch 2  
**W III** Winch 3

**W IV** Winch 4  
**W V** Winch 5  
**W VI** Winch 6

## 4 Derrick ballast - suspended ballast component overview

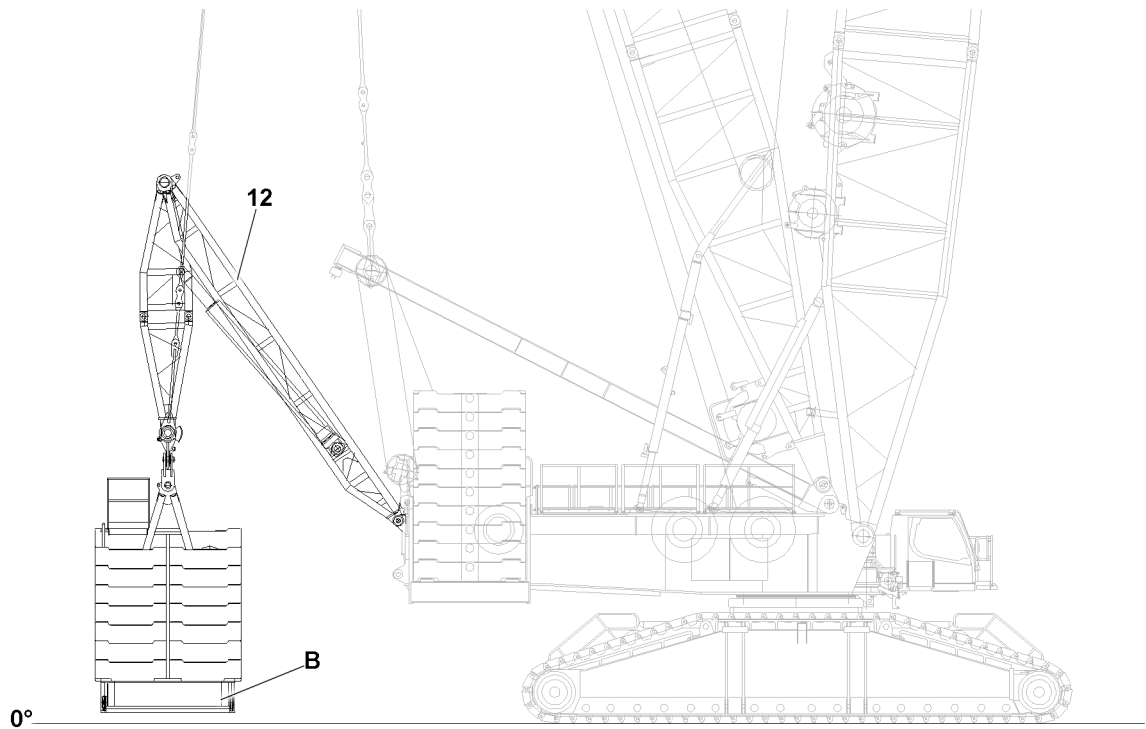


Fig.154403: Derrick ballast

12 "V-frame" suspended ballast guide

B Derrick ballast - suspended ballast

## 5 Derrick ballast - ballast trailer component overview

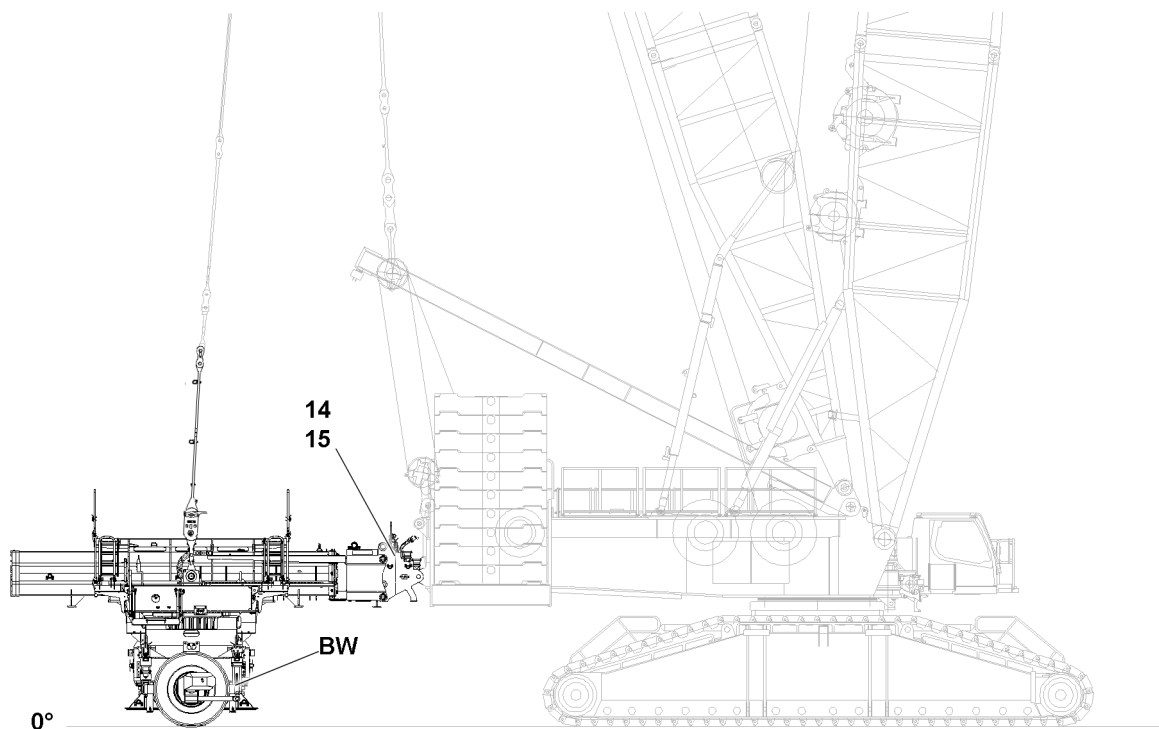


Fig.159038: Derrick ballast

- 14 Adapter
- 15 Intermediate section

**BW** Derrick ballast - ballast trailer

## 6 Ground connection

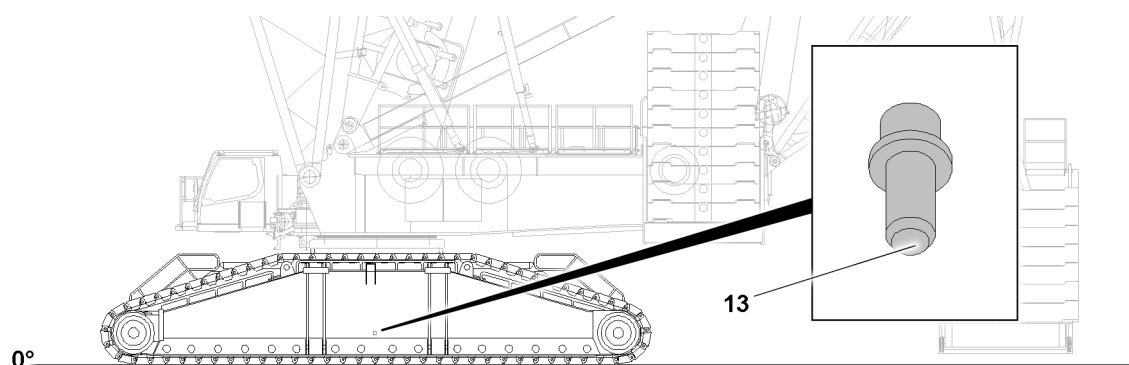


Fig.154404: Ground connection

- 13 Ground connection



### Note

Ground the crane:

- Observe and adhere to the instructions in chapter 2.04.

## 7 Derrick boom component overview

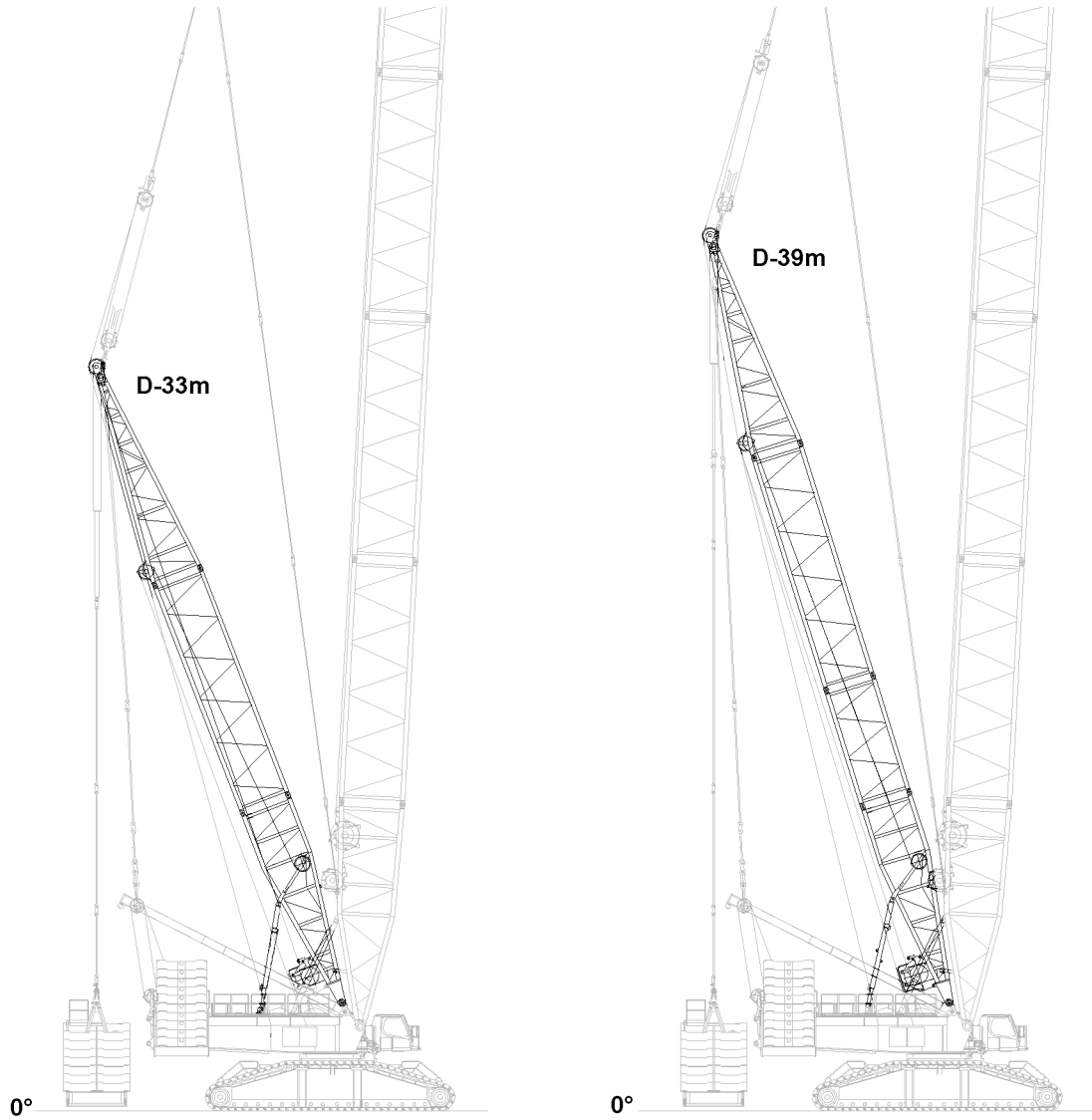


Fig.154411: Derrick boom component overview

**D** Derrick boom 33 m

**D** Derrick boom 39 m

LWE/LR 1800-1-0-000/27200-07-02/en

# 8 Main boom component overview

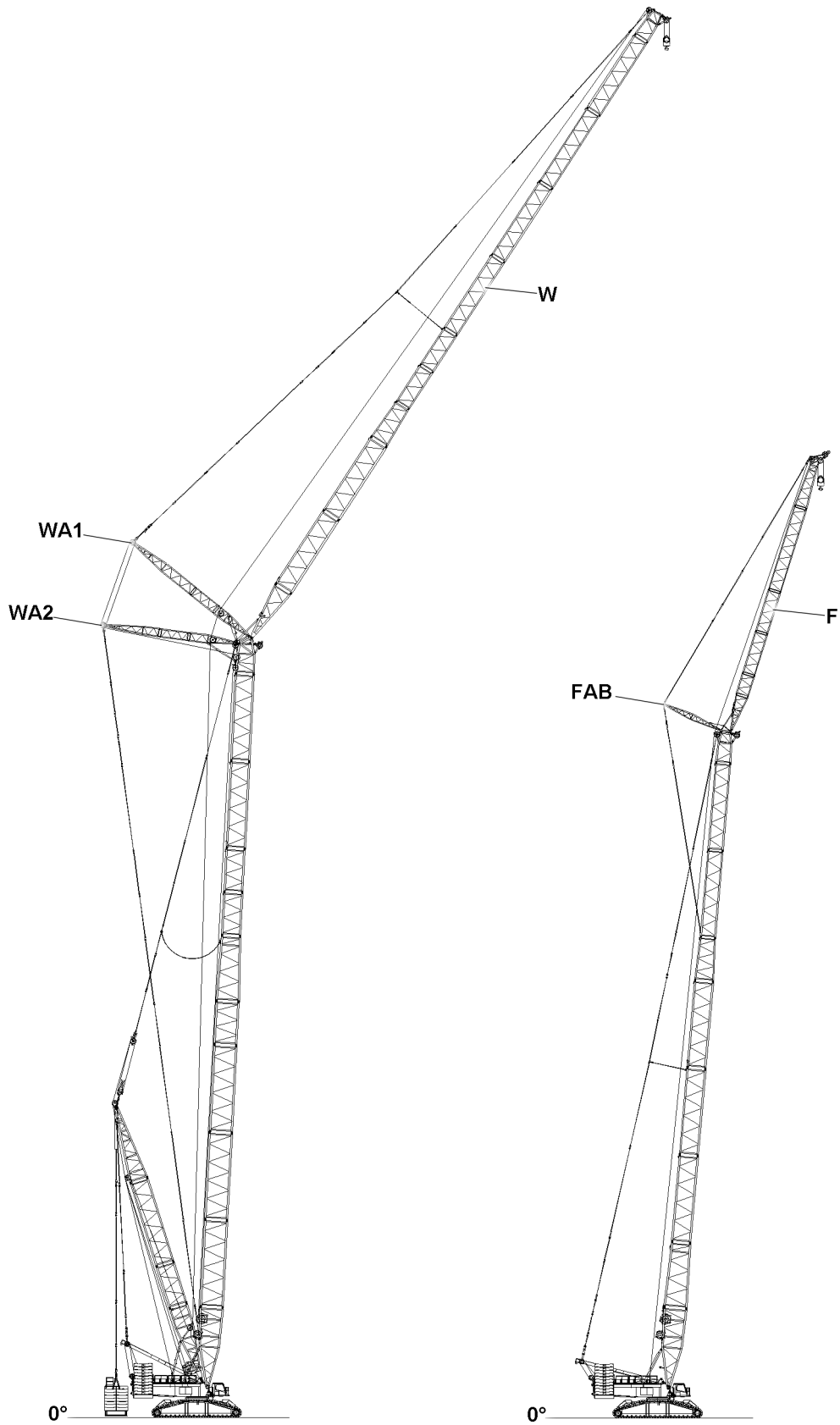


Fig.154410: Main boom component overview

LWE/LR 1800-1-0-000/27200-07-02/en



**WA1** WA-frame 1  
**WA2** WA-frame 2  
**W** Luffing lattice jib

**FAB** F-guying frame  
**F** Fixed lattice jib

# 9 S, SL-boom

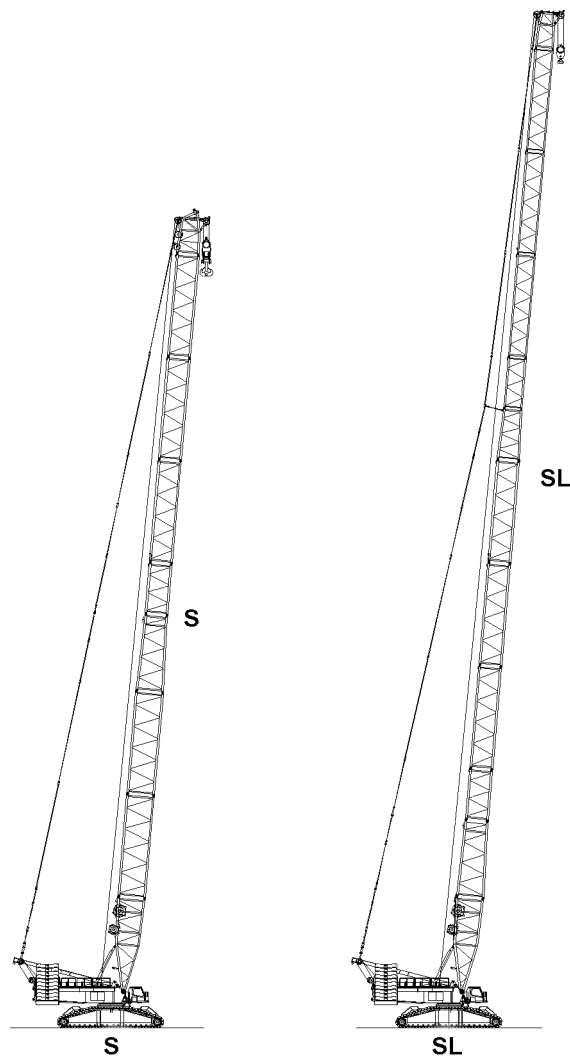


Fig.154405: S // SL boom combinations

LWE/LR 1800-1-0-000/27200-07-02/en

**WARNING**

The crane can topple over!

- ▶ Make sure that all boom systems are installed only according to the respective assembly chapters and the associated rod plans.
- ▶ Make sure that danger notes for assembly and for crane operation are observed and adhered to.
- ▶ The use of the following boom illustrations for assembly purposes is prohibited.

**S** Main boom

- Heavy-duty version
- With roller set / roller sets on the S-end section

**SL** Main boom

- Heavy-duty version, supplemented on top with light lattice sections **L**
- With roller set / roller sets on the L-end section

## 10 SLF, SLAF-boom

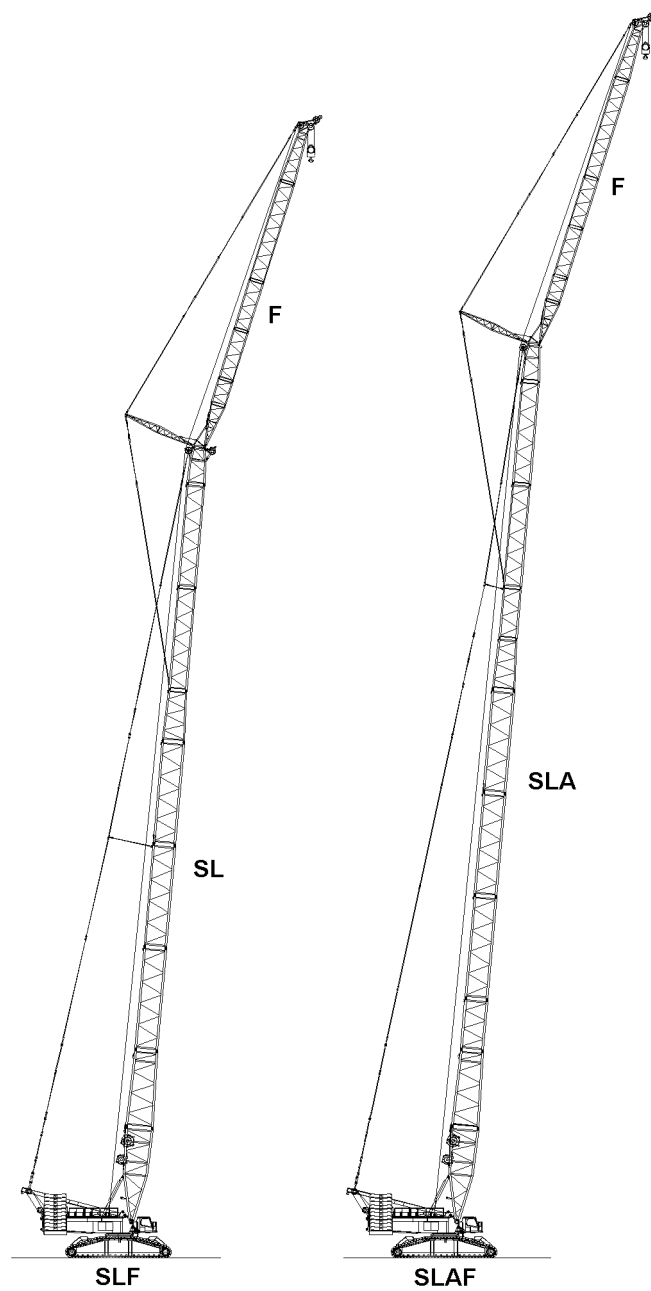


Fig.154406: SLF // SLAF-boom combination

LWE/LR 1800-1-0-000/27200-07-02/en

**WARNING**

The crane can topple over!

- ▶ Make sure that all boom systems are installed only according to the respective assembly chapters and the associated rod plans.
- ▶ Make sure that danger notes for assembly and for crane operation are observed and adhered to.
- ▶ The use of the following boom illustrations for assembly purposes is prohibited.

**SL** Main boom

- Heavy-duty version, supplemented on top with light lattice sections **L**
- With L-end section
- With roller set / roller sets on the L-end section

**SLA** Main boom

- Heavy-duty version, supplemented on top with light lattice sections **L**
- With F-connector head **A**

**F** Fixed lattice jib

- Light lattice sections **F**
- With F-end section
- With fiber guy ropes

# 11 SW1-boom

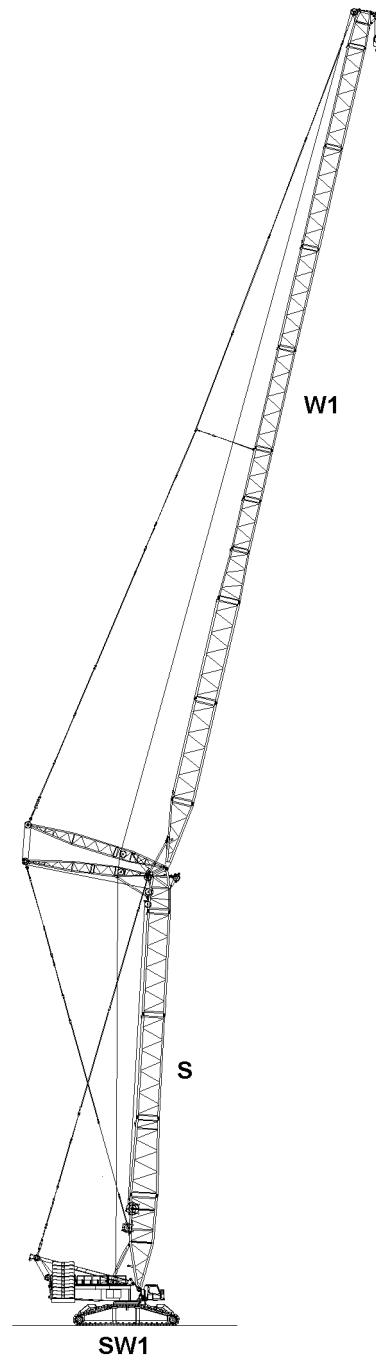


Fig.154407: SW1 - boom combination

LWE/LR 1800-1-0-000/27200-07-02/en

**WARNING**

The crane can topple over!

- ▶ Make sure that all boom systems are installed only according to the respective assembly chapters and the associated rod plans.
- ▶ Make sure that danger notes for assembly and for crane operation are observed and adhered to.
- ▶ The use of the following boom illustrations for assembly purposes is prohibited.

**SW1** Main boom

- Heavy-duty version
- Boom variant: **SW1**
- With roller set / roller sets on the S-end section

**W** Luffing lattice jib

- Heavy-duty version, supplemented on top with light lattice sections **L**

# 12 HSDBV, HSLDBV/B/BW-boom

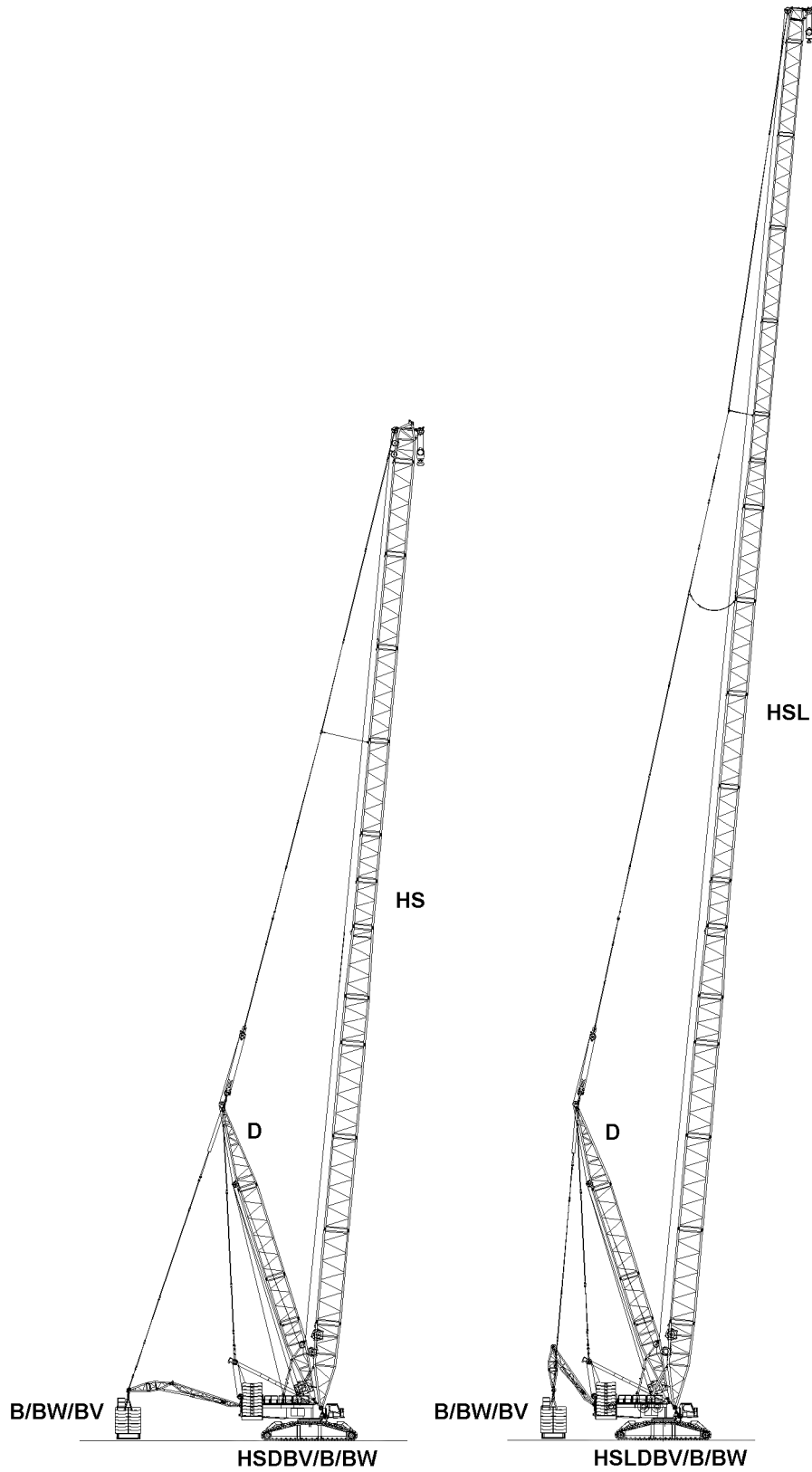


Fig.154408: HSDBV // HSLDBV/B/BW-boom combinations

LWE/LR 1800-1-0-000/27200-07-02/en



**WARNING**

The crane can topple over!

- ▶ Make sure that all boom systems are installed only according to the respective assembly chapters and the associated rod plans.
- ▶ Make sure that danger notes for assembly and for crane operation are observed and adhered to.
- ▶ The use of the following boom illustrations for assembly purposes is prohibited.

**HS** Main boom

- Heavy-duty version
- With roller set / roller sets on the S-end section

**HSL** Main boom

- Heavy-duty version, supplemented on top with light lattice sections **L**
- With roller set / roller sets on the L-end section

**D** Derrick boom

- Derrick-boom length 39 m
- Alone as an assembly device or in connection with **HSD, HSLD**

**BV** Suspended ballast guide

- "V-frame" suspended ballast guide

**B** Derrick ballast

- Suspended ballast

**BW** Derrick ballast

- Ballast trailer

## 13 HSDWB/BW/BV-boom

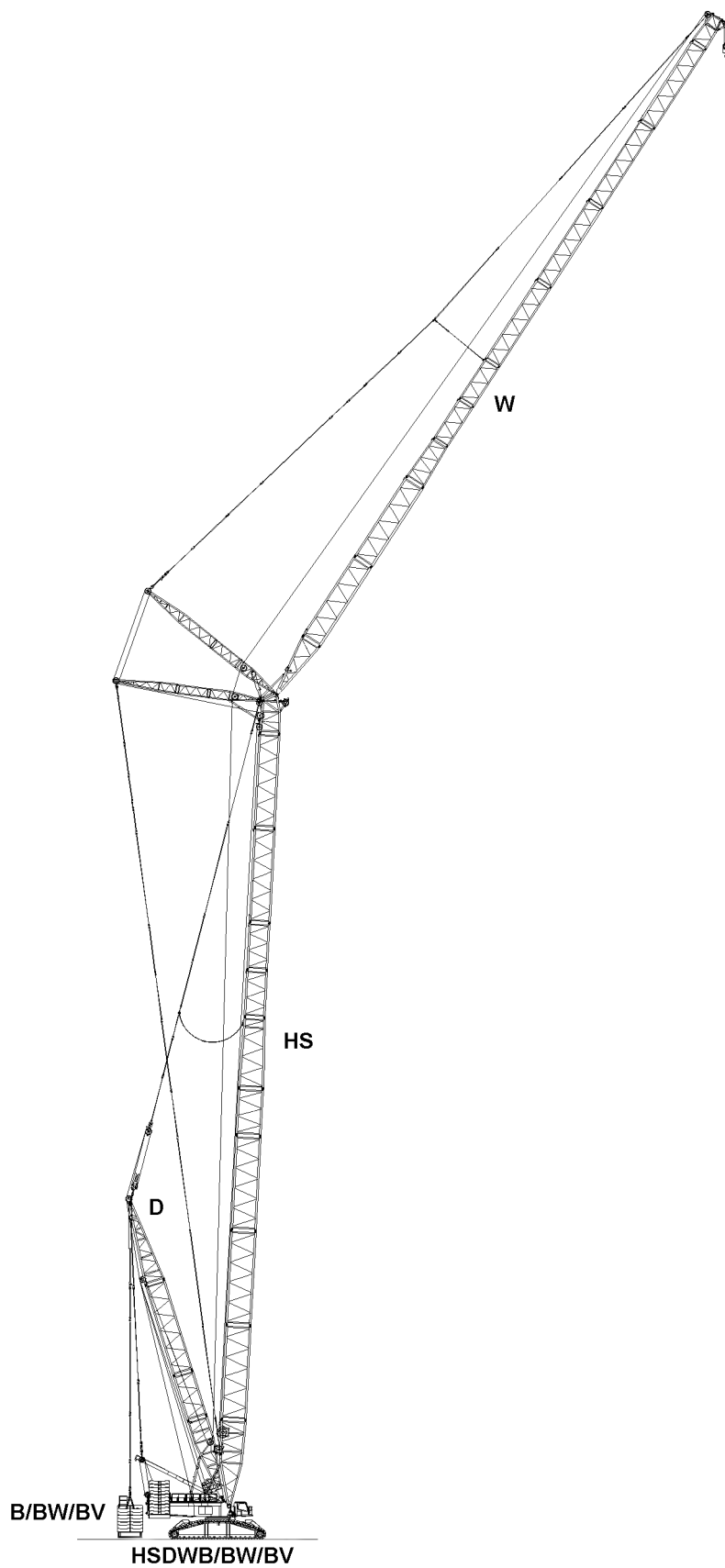


Fig.154409: HSDWB/BW/BV-boom combinations

LWE/LR 1800-1-0-000/27200-07-02/en

**WARNING**

The crane can topple over!

- ▶ Make sure that all boom systems are installed only according to the respective assembly chapters and the associated rod plans.
- ▶ Make sure that danger notes for assembly and for crane operation are observed and adhered to.
- ▶ The use of the following boom illustrations for assembly purposes is prohibited.

**HS** Main boom

- Heavy-duty version, supplemented on top with light lattice sections **L**
- With roller set / roller sets on the S-end section

**W** Luffing lattice jib

- Heavy-duty version, supplemented on top with light lattice sections **L**

**D** Derrick boom

- Derrick-boom length 39 m
- Alone as an assembly device or in connection with **HSD**

**BV** Suspended ballast guide

- "V-frame" suspended ballast guide

**B** Derrick ballast

- Suspended ballast

**BW** Derrick ballast

- Ballast trailer

---

Empty page!

LWE/LR 1800-1-0-000/27200-07-02/en

## 1.02 Product description

1	Crawler travel gear	2
2	Crane superstructure	2
3	Winches	3
4	Boom systems / boom combinations	4
5	Auxiliary equipment	4

# 1 Crawler travel gear

## 1.1 Frame

- In-house manufactured, distortion-resistant welded structure made from high-strength, close-grained structural steel.
- The crawler carriers can be removed and can be assembled / disassembled by the crane itself

## 1.2 Crawler travel gear

- Dirt protected crawler track with flat bottom pads
- Pad width: 2.0 m
- Pad width: 1.5 m
- Track width: 9.0 m

## 1.3 Drive

- Hydraulic travel drives with planetary gears
- The crawler chains can be controlled independently and in the opposite direction

## 1.4 Travel power

- Stepless speed from 0 km/h to 1.50 km/h

## 1.5 Central ballast

- 2 central ballast consoles each 5.0 t
- 6 central ballast plates each 10.0 t
- Total central ballast 70.0 t

# 2 Crane superstructure

## 2.1 Turntable frame

- In-house manufactured, distortion-resistant welded structure made from high-strength, close-grained structural steel.
- Connection to crawler travel gear via roller ring connection
- Turntable frame swingable by 360°

## 2.2 Diesel engine

- Number of cylinders: 8
- Engine output: 455 kW
- Make: LIEBHERR
- Water cooled



### Note

- ▶ Engine type, see also separate operating instructions for the diesel engine.

## 2.3 Crane cab

- Air conditioned crane cab, tiltable to the rear with safety glass
- Roof window with bullet-proof pane
- Standardized control units ergonomically located
- Thermostatically regulated warm water auxiliary heater

## 2.4 Crane control

- All crane movements are controlled by three 4-way master switches as well as two 2-way hand / foot levers
- All working movements can be actuated independently from each other

## 2.5 Assembly winch

- To reeve the ropes in

## 2.6 Slewing gear

- 2 slewing gears: hydraulically driven via axial piston displacement pumps and integrated planetary gear
- Disk brakes spring loaded and hydraulically vented
- Slewing speed can be steplessly regulated

## 2.7 Counterweight

- 2 counterweight consoles each 15.0 t
- 20 counterweight plates each 10.0 t
- Total counterweight 230.0 t

## 2.8 Safety equipment

- Hoist limit switch for hoist limitation
- Rope drum limit switch with 3 safety coils
- Safety valves against hose and pipe bursts
- Wind warning system
- Electronic incline display
- Airplane warning light

## 2.9 Electrical system

- Modern data bus technology
- 24 V DC
- 6 batteries, each 12 V / 70 Ah

## 3 Winches

- Winches hydraulically driven via axial piston variable displacement pumps and integrated planetary gear
- Disk brakes spring loaded and hydraulically vented

### 3.1 Winch 1

- Hoist winch

### 3.2 Winch 2

- Hoist winch

### 3.3 Winch 3

- Control winch for main boom for derrick operation

### 3.4 Winch 4

- Intake gear

### 3.5 Winch 5

- Adjustment luffing lattice jib

### 3.6 Winch 6

- Auxiliary hoist winch (boom nose)

## 4 Boom systems / boom combinations

### 4.1 Boom systems



---

**Note**

- ▶ See the Crane operating instructions, chapter 1.01.
- 

## 5 Auxiliary equipment

### 5.1 Mechanical auxiliary support

- To erect long boom combinations without derrick ballast

### 5.2 Hydraulic assembly support

- Lifting of basic machine for assembly / removal
- Consisting of 4 support cylinders, including support plates, installed on the central ballast consoles

### 5.3 Hydraulic assembly cylinder

- For self-assembly / disassembly of crawler travel gear



## 5.4 Pin pulling device

- Including mobile hydraulic aggregate
- For assembly / disassembly of the boom intermediate sections

---

Empty page!

LWE/LR 1800-1-0-000/27200-07-02/en

## 1.03 Technical data

1	Dimensions	3
2	Operating and load conditions	4
3	Noise emission	4
4	Vibrations	4
5	Crane speeds	4
6	Crane surface pressure	5
7	Load handling equipment	5
8	Hoist ropes	5
9	Control ropes	5
10	Guy rope	5
11	Assembly rope	5
12	Dimensions and weights of the crane components	6
13	Crawler carrier	6
14	Crawler center section	6
15	Turntable without SA-frame	7
16	SA-frame with winch 4	7
17	Turntable with crawler center section with SA-frame	7
18	Crawler catwalk	8
19	Ballast frame for central ballast	8
20	Ascent	8
21	Mechanical auxiliary support	9
22	Winch 1	9
23	Winch 2	9
24	Counterweight platform	10
25	Ballast plate for central ballast	10
26	Ballast plate for counterweight and derrick ballast	10
27	H-pivot section 11 m	11
28	H-intermediate section 6 m	11
29	H-intermediate section 12 m	12
30	HS-reducer 9 m	12
31	S-intermediate section 6 m	13
32	S-intermediate section 12 m	13
33	S-end section 650 t	14
34	SL-reducer 6 m	14
35	L-intermediate section 6 m	15
36	L-intermediate section 12 m	15
37	L-end section 450 t	16
38	W-assembly unit 1	16
39	W-assembly unit 2	17
40	D-pivot section 10.5 m with winch 3 and luffing pulley block	17
41	D-intermediate section 6 m	18
42	D-intermediate section 12 m	18
43	D-end section 10.5 m	19
44	F-assembly unit without F-end section	19
45	F-assembly unit with F-end section	20
46	F-intermediate section 3 m	20

47	F-intermediate section 6 m	21
48	F-intermediate section 12 m	21
49	F-connector head	22
50	F-end section	22
51	Auxiliary guying fiber guy ropes	23
52	Roller set	23
53	Boom nose 25 t	24
54	Suspended ballast pallet	24
55	Pivot section BV suspended ballast guide (V-frame)	24
56	End section BV suspended ballast guide (V-frame)	25
57	Ballast trailer	25
58	Ballast trailer frame	26
59	Ballast trailer wheel set	26
60	Ballast trailer guide	26
61	Ballast trailer intermediate section	27
62	Ballast trailer adapter with pull rods	27
63	Roller cart	27

# 1 Dimensions

All dimension data in meters

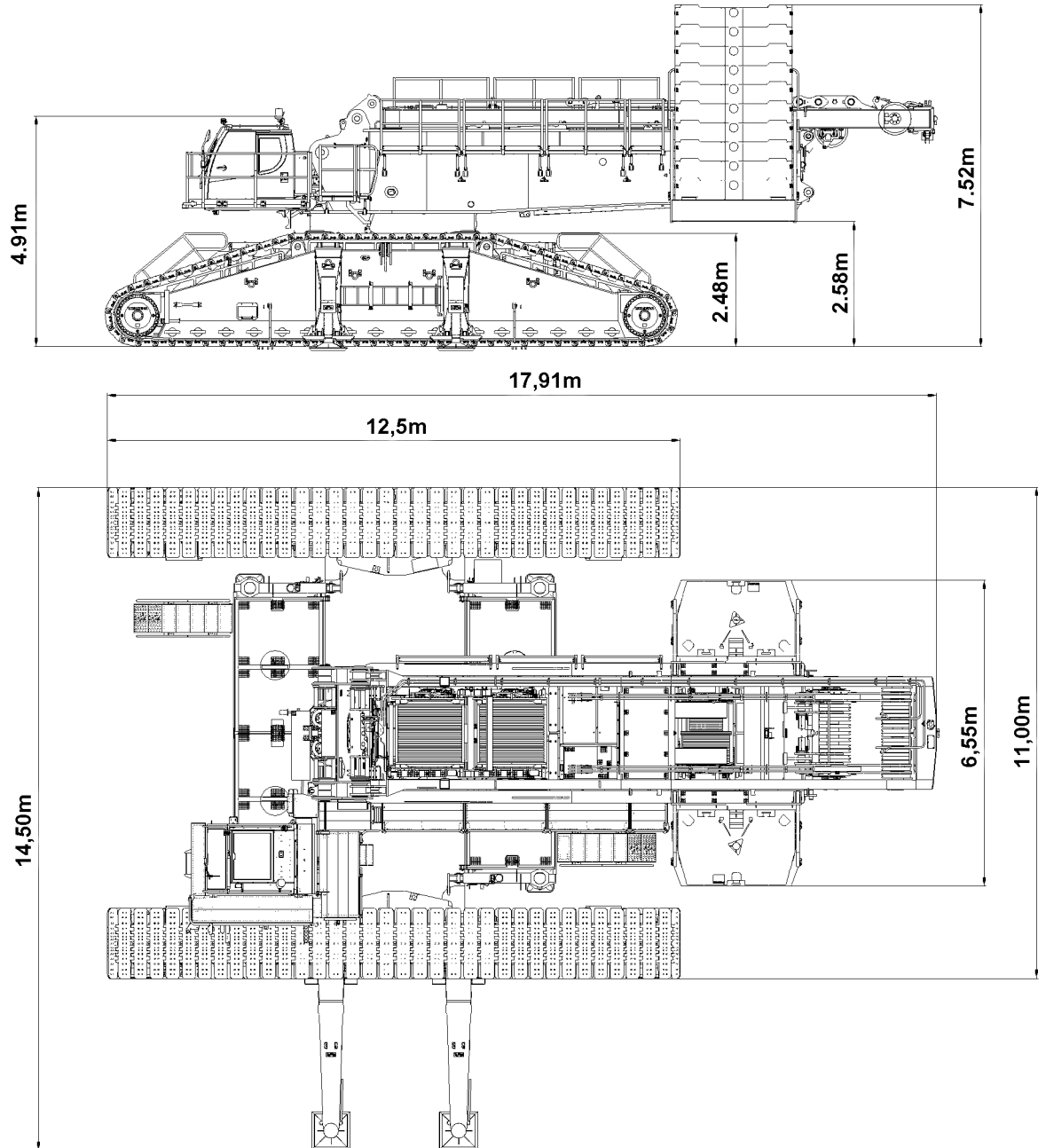


Fig.154448: Crane dimensions

LWE/LR 1800-1-0-000/27200-07-02/en

## 2 Operating and load conditions

Name	Value
Maximum number of operation cycles (N)	63000
Class according to ISO 4301-2	
Collective class according to ISO 4301-1	Q <sub>1</sub> = light k <sub>p</sub> = 0.125

*Operating and load conditions*

## 3 Noise emission

Control platform Crane cab	
Sound pressure level [L <sub>pA</sub> ], according to EN13000	73 db(A)

## 4 Vibrations

Vibrations transferred to the operator	Value
Total vibration value to which the upper body limbs are exposed	Not more than 2.5 m/s <sup>2</sup>
Effective value of weighted acceleration to which the entire body is exposed	Not more than 0.5 m/s <sup>2</sup>

## 5 Crane speeds

Drives	Speed
Winch 1	0 m/min to 114 m/min for a single strand
Winch 2	0 m/min to 114 m/min for a single strand
Winch 3	0 m/min to 125 m/min for a single strand
Winch 4	0 m/min 2 x to 75 m/min for a single strand
Winch 5	0 m/min to 135 m/min for a single strand
Winch 6	0 m/min to 137 m/min for a single strand

Drives	RPM
Slewing gear	0 rpm to 0.67 rpm

Drives	Speed (travel power)
2 drives per crawler carrier	0 km/h to 1.50 km/h

LWE/LR 1800-1-0-000/27200-07-02/en

## 6 Crane surface pressure



### Note

► Determination of the crane's surface pressure, see the LICCON job planner operating instructions.

## 7 Load handling equipment



### Note

► For load handling equipment, see the load chart manual.

## 8 Hoist ropes

	Rope diameter	Rope category number RCN
Winch 1	30 mm	See the rope certificate
Winch 2	30 mm	See the rope certificate
Winch 6	25 mm	See the rope certificate

## 9 Control ropes

	Rope diameter	Rope category number RCN
Winch 3	30 mm	See the rope certificate
Winch 4	28 mm	See the rope certificate
Winch 5	30 mm	See the rope certificate

## 10 Guy rope

	Rope diameter	Rope category number RCN
Auxiliary guying	40 mm	See the rope certificate

## 11 Assembly rope

	Rope diameter	Rope category number RCN
Assembly winch	8 mm	See the rope certificate

## 12 Dimensions and weights of the crane components



### WARNING

Danger of accidents when handling crane components / crane parts!

- ▶ Make sure that the actual weight is known before fastening crane components / crane parts.
- ▶ Check the weight label on the crane components / crane parts.
- ▶ Fasten crane components / crane parts solely with approved and sufficiently load bearing fastening equipment.
- ▶ Make sure that crane components / crane parts are fastened only on the intended fastening points.



### Note

- ▶ The following listed weights are reference values and may not match your crane exactly.
- ▶ The illustrations of crane components / crane parts are examples and may not apply exactly to your crane.

## 13 Crawler carrier

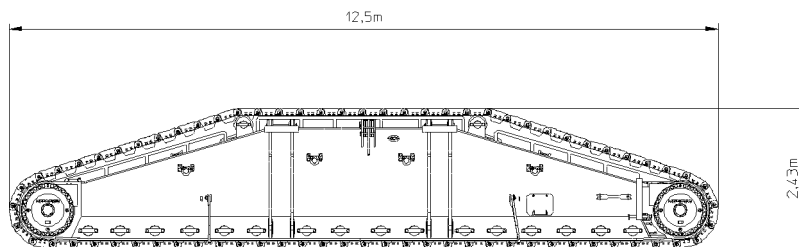


Fig.154412: Crawler carrier

Component	Weight	Width
Crawler carrier	50.0 t	1.50 m
Crawler carrier	60.0 t	2.00 m

## 14 Crawler center section

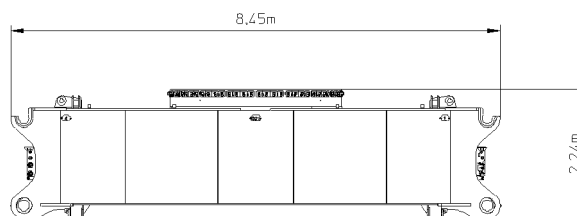


Fig.154416: Crawler center section

Component	Weight	Width
Crawler center section	30.0 t	3.05 m



## 15 Turntable without SA-frame

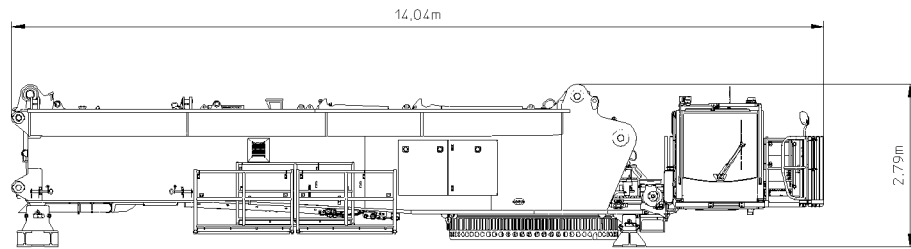


Fig.154414: Turntable without SA-frame

Component	Weight	Width
Turntable without SA-frame	48.3 t	3.00 m

## 16 SA-frame with winch 4

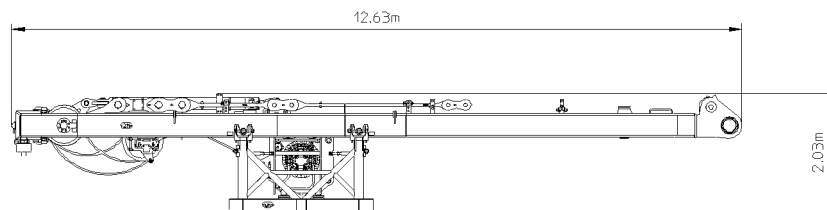


Fig.154415: SA-frame with winch 4

Component	Weight	Width
SA-frame with winch 4	23.0 t	2.71 m

## 17 Turntable with crawler center section with SA-frame

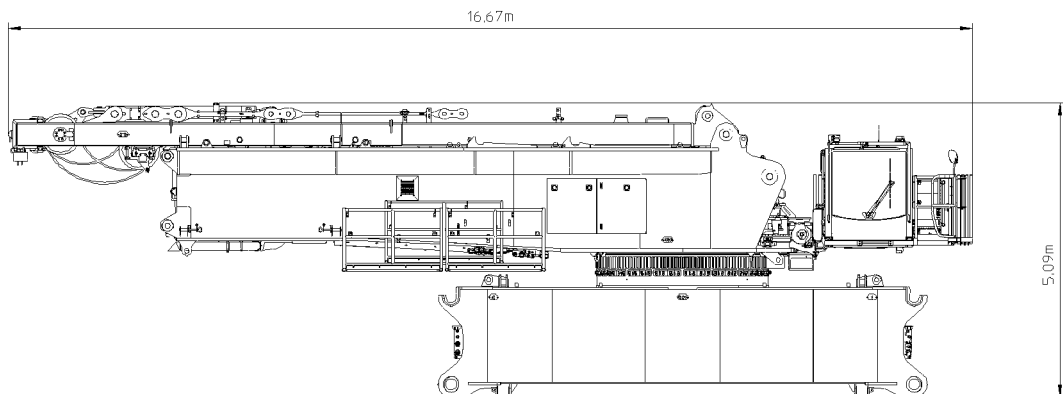


Fig.154413: Turntable with crawler center section with SA-frame

LWE/LR 1800-1-0-000/27200-07-02/en

Component	Weight	Width
Turntable with crawler center section with SA-frame	96.0 t	3.05 m

## 18 Crawler catwalk

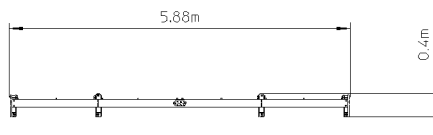


Fig.154417: Crawler catwalk

Component	Weight	Width
Crawler catwalk	0.8 t	2.12 m

## 19 Ballast frame for central ballast

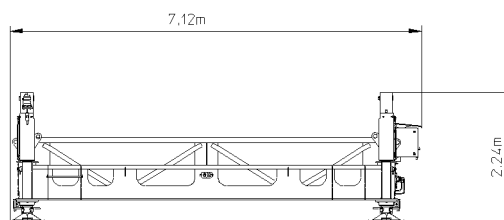


Fig.154420: Ballast frame for central ballast

Component	Weight	Width
Ballast frame for central ballast	6.1 t	2.31 m

## 20 Ascent

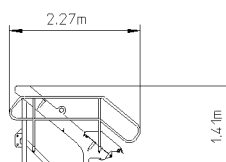


Fig.154418: Ascent

Component	Weight	Width
Ascent	0.2 t	0.83 m

## 21 Mechanical auxiliary support

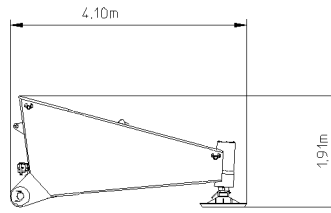


Fig.154419: Mechanical auxiliary support

Component	Weight	Width
Mechanical auxiliary support	2.4 t	0.82 m

## 22 Winch 1

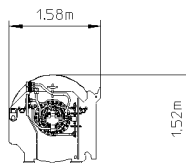


Fig.154421: Winch 1

Component	Weight	Width
Winch 1	11.0 t	1.90 m

## 23 Winch 2

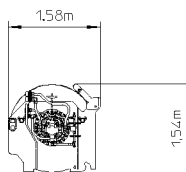


Fig.154422: Winch 2

Component	Weight	Width
Winch 2	11.0 t	1.90 m

LWE/LR 1800-1-0-000/27200-07-02/en

## 24 Counterweight platform

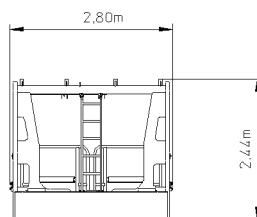


Fig.154423: Counterweight platform

Component	Weight	Width
Counterweight platform	15.0 t	2.04 m

## 25 Ballast plate for central ballast

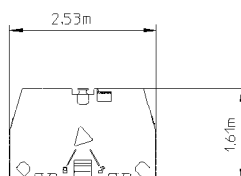


Fig.154424: Ballast plate for central ballast

Component	Weight	Width
Ballast plate	7.5 t	0.37 m
Ballast plate	10.0 t	0.47 m

## 26 Ballast plate for counterweight and derrick ballast

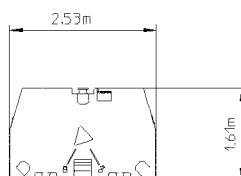


Fig.154424: Ballast plate for counterweight and derrick ballast

Component	Weight	Width
Ballast plate	10.0 t	0.47 m

## 27 H-pivot section 11 m

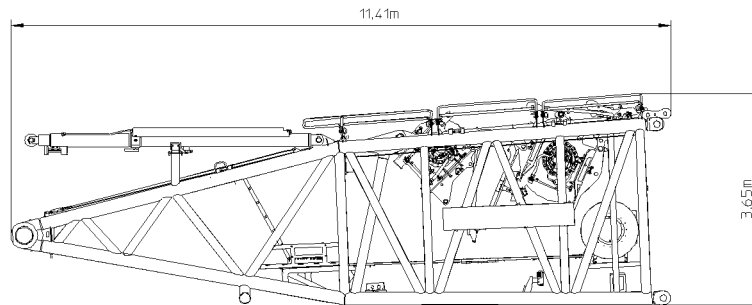


Fig.154425: H-pivot section 11 m

Component	Weight	Width
H-pivot section	21.5 t	3.49 m
H-pivot section with winch 5	31.2 t	3.49 m
H-pivot section with winch 6	25.8 t	3.49 m
H-pivot section with winch 5 and winch 6	35.5 t	3.49 m

## 28 H-intermediate section 6 m

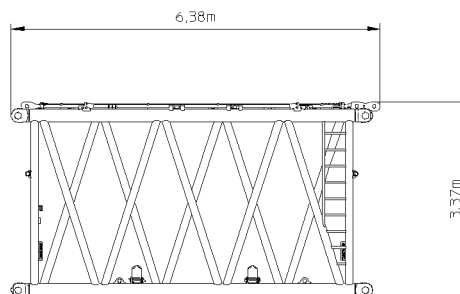


Fig.154426: H-intermediate section 6 m

Component	Weight	Width
H-intermediate section 6 m <b>3330.25</b>	6.2 t	3.49 m

LWE/LR 1800-1-0-000/27200-07-02/en

## 29 H-intermediate section 12 m

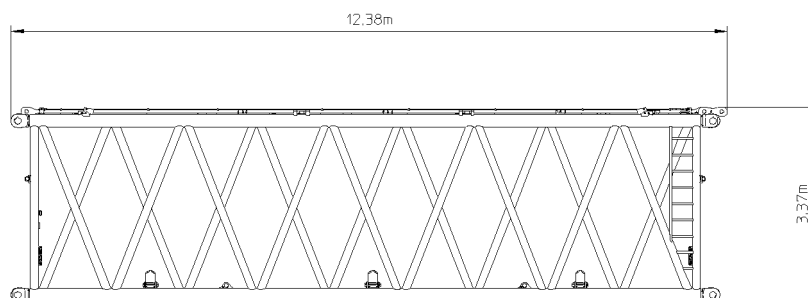


Fig.154427: H-intermediate section 12 m

Component	Weight	Width
H-intermediate section 12 m <b>3330.25</b>	10.9 t	3.49 m
H-intermediate section 12 m <b>3330.40</b>	13.5 t	3.49 m

## 30 HS-reducer 9 m

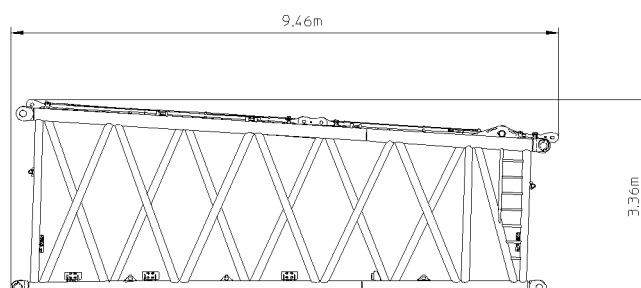


Fig.154428: HS-reducer 9 m

Component	Weight	Width
HS-reducer 9 m	10.0 t	3.49 m

## 31 S-intermediate section 6 m

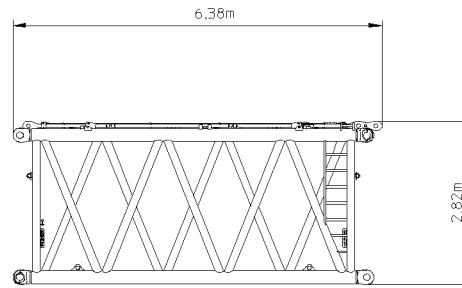


Fig.154429: S-intermediate section 6 m

Component	Weight	Width
S-intermediate section 6 m <b>2724.22</b>	5.2 t	3.00 m

## 32 S-intermediate section 12 m

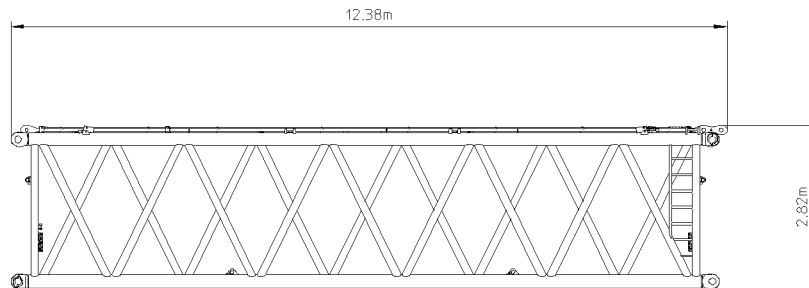


Fig.154430: S-intermediate section 12 m

Component	Weight	Width
S-intermediate section 12 m <b>2724.22</b>	9.7 t	3.00 m
S-intermediate section 12 m <b>2724.22A</b>	9.9 t	3.00 m
S-intermediate section 12 m <b>2724.22WF</b>	10.1 t	3.00 m

### 33 S-end section 650 t

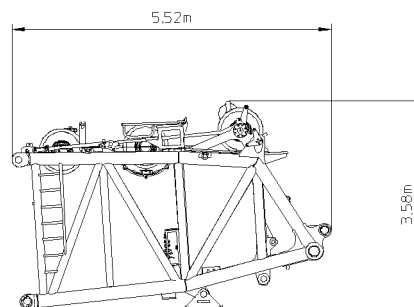


Fig.154431: S-end section 650 t

Component	Weight	Width
S-end section 650 t	10.0 t	3.00 m

### 34 SL-reducer 6 m

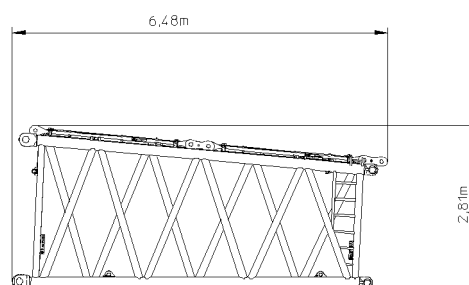


Fig.154432: SL-reducer 6 m

Component	Weight	Width
SL-reducer 6 m	3.7 t	3.00 m



### 35 L-intermediate section 6 m

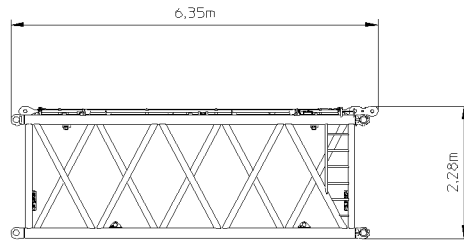


Fig.154433: L-intermediate section 6 m

Component	Weight	Width
L-intermediate section 6 m <b>2420.14</b>	3.1 t	2.59 m

### 36 L-intermediate section 12 m

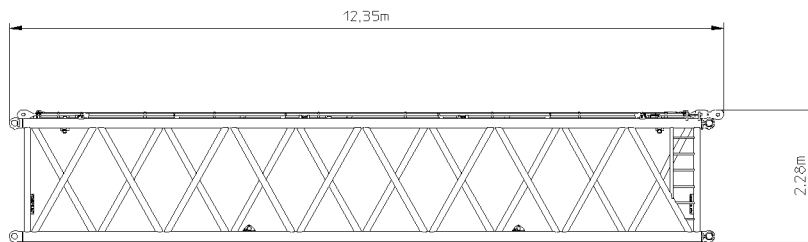


Fig.154434: L-intermediate section 12 m

Component	Weight	Width
L-intermediate section 12 m <b>2420.14</b>	5.4 t	2.59 m
L-intermediate section 12 m <b>2420.14F</b>	5.6 t	2.59 m

LWE/LR 1800-1-0-000/27200-07-02/en

## 37 L-end section 450 t

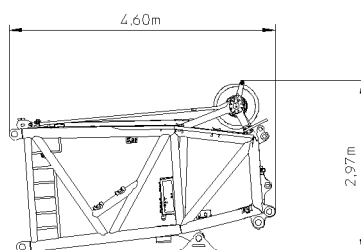


Fig.154435: L-end section 450 t

Component	Weight	Width
L-end section 450 t	5.0 t	2.58 m

## 38 W-assembly unit 1

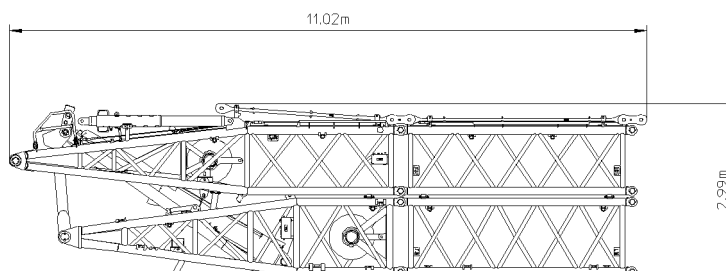


Fig.154436: W-assembly unit 1

Component	Weight	Width
W-assembly unit 1	12.0 t	2.87 m

### 39 W-assembly unit 2

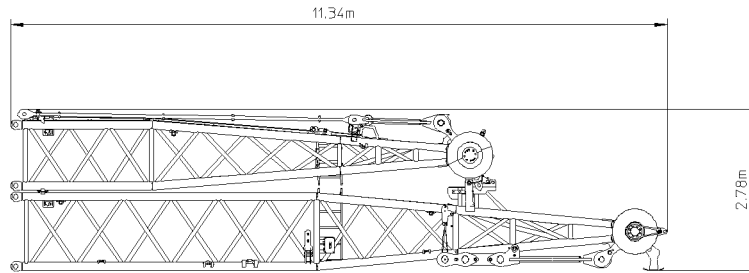


Fig.154437: W-assembly unit 2

Component	Weight	Width
W-assembly unit 2	9.2 t	2.55 m

### 40 D-pivot section 10.5 m with winch 3 and luffing pulley block

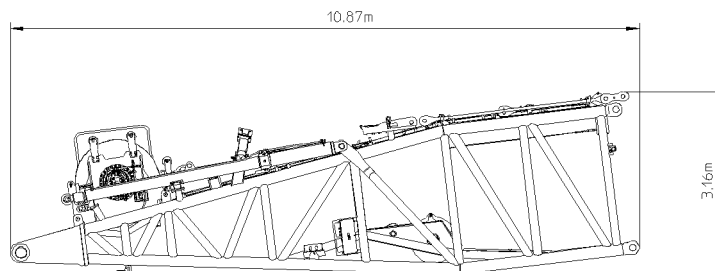


Fig.154438: D-pivot section 10.5 m with winch 3 and luffing pulley block

Component	Weight	Width
D-pivot section 10.5 m with winch 3 and luffing pulley block	31.6 t <sup>1)</sup>	3.00 m

1) The weight also takes into consideration: 2x D-relapse support

LWE/LR 1800-1-0-000/27200-07-02/en

## 41 D-intermediate section 6 m

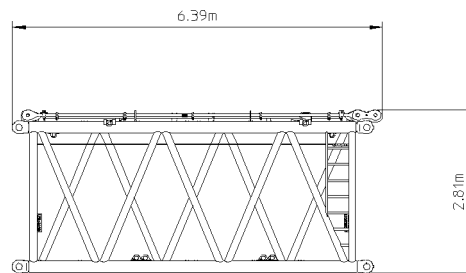


Fig.154439: D-intermediate section 6 m

Component	Weight	Width
D-intermediate section 6 m <b>2524.20</b>	5.3 t	2.70 m

## 42 D-intermediate section 12 m

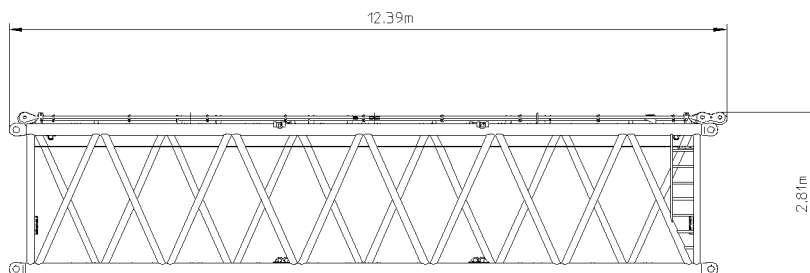


Fig.154440: D-intermediate section 12 m

Component	Weight	Width
D-intermediate section 12 m <b>2524.16</b>	8.9 t	2.70 m

### 43 D-end section 10.5 m

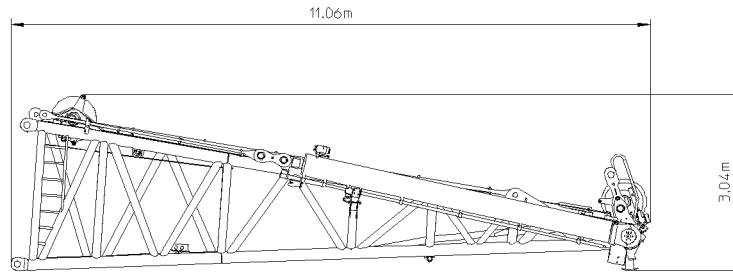


Fig.154441: D-end section 10.5 m

Component	Weight	Width
D-end section 10.5 m	17.6 t	2.70 m

### 44 F-assembly unit without F-end section

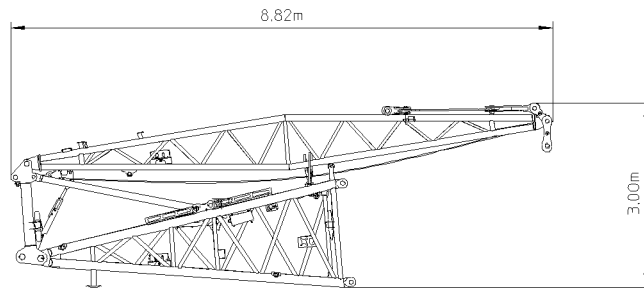


Fig.155866: F-assembly unit without F-end section

Component	Weight	Width
F-assembly unit without F-end section	3.3 t	2.34 m

LWE/LR 1800-1-0-000/27200-07-02/en

## 45 F-assembly unit with F-end section

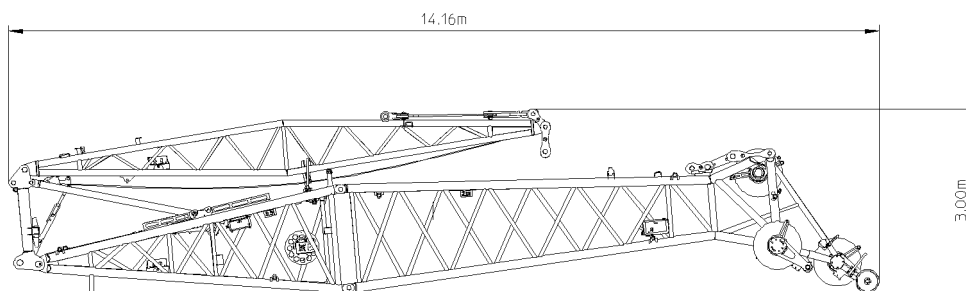


Fig.155867: F-assembly unit with F-end section

Component	Weight	Width
F-assembly unit with F-end section	6.2 t	2.34 m

## 46 F-intermediate section 3 m

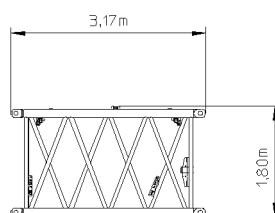


Fig.155868: F-intermediate section 3 m

Component	Weight	Width
F-intermediate section 3 m <b>2116.7</b>	0.8 t	2.24 m

## 47 F-intermediate section 6 m

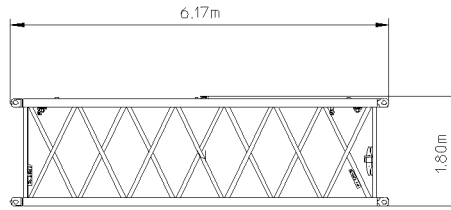


Fig.155869: F-intermediate section 6 m

Component	Weight	Width
F-intermediate section 6 m <b>2116.7</b>	1.2 t	2.24 m

## 48 F-intermediate section 12 m

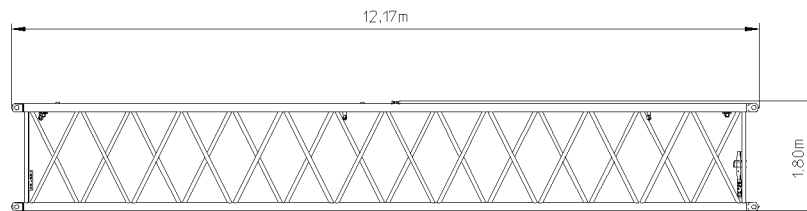


Fig.155870: F-intermediate section 12 m

Component	Weight	Width
F-intermediate section 12 m <b>2116.7</b>	2.1 t	2.24 m

LWE/LR 1800-1-0-000/27200-07-02/en

## 49 F-connector head

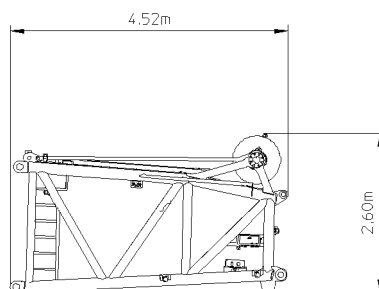


Fig.155871: F-connector head

Component	Weight	Width
F-connector head	3.3 t	2.58 m

## 50 F-end section

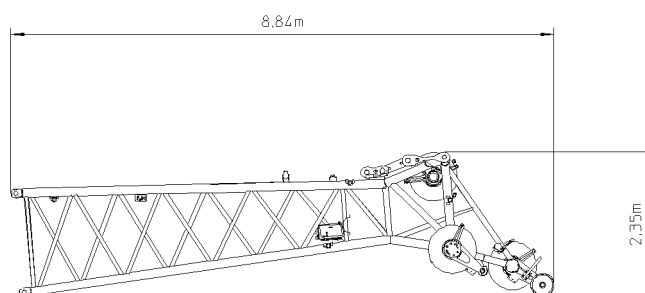


Fig.155872: F-end section

Component	Weight	Width
F-end section	2.9 t	2.24 m



## 51 Auxiliary guying fiber guy ropes

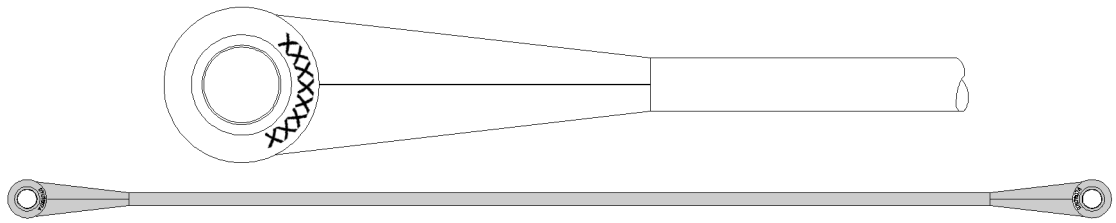


Fig.155873: Auxiliary guying fiber guy ropes

Component	Weight
Fiber guy rope $\varnothing$ 40 mm x 1.7 m	10.2 kg
Fiber guy rope $\varnothing$ 40 mm x 2.7 m	10.7 kg
Fiber guy rope $\varnothing$ 40 mm x 3.7 m	11.2 kg
Fiber guy rope $\varnothing$ 40 mm x 4.7 m	11.8 kg
Fiber guy rope $\varnothing$ 40 mm x 5.7 m	12.3 kg



### Note

► Observe the notes regarding the transport of the fiber guy ropes in chapter 2.04.

## 52 Roller set

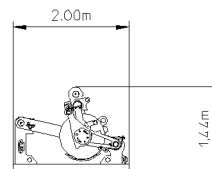


Fig.154442: Roller set

Component	Weight	Width
Roller set R9 (650 t)	2.2 t	1.29 m
Roller set R11 (650 t)	2.4 t	1.49 m

## 53 Boom nose 25 t

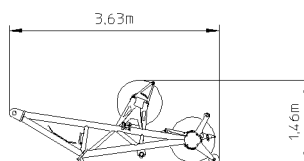


Fig.154443: Boom nose 25 t

Component	Weight	Width
Boom nose 25 t	0.6 t	0.94 m

## 54 Suspended ballast pallet

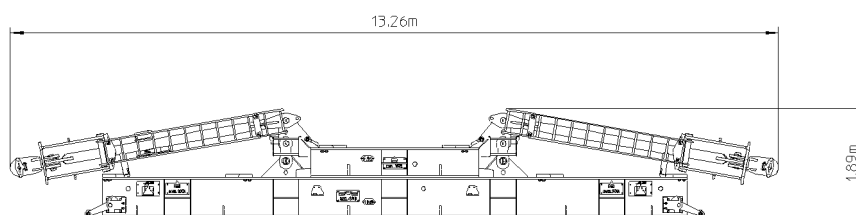


Fig.154444: Suspended ballast pallet

Component	Weight	Width
Suspended ballast pallet	19.4 t	3.00 m

## 55 Pivot section BV suspended ballast guide (V-frame)

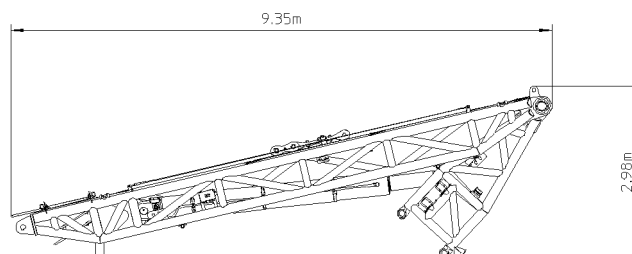


Fig.154445: Pivot section BV suspended ballast guide (V-frame)

Component	Weight	Width
Pivot section BV suspended ballast guide (V-frame)	11.5 t	2.91 m

## 56 End section BV suspended ballast guide (V-frame)

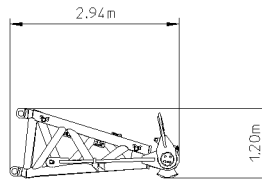


Fig.154446: End section BV suspended ballast guide (V-frame)

Component	Weight	Width
End section BV suspended ballast guide (V-frame)	2.9 t	4.09 m

## 57 Ballast trailer

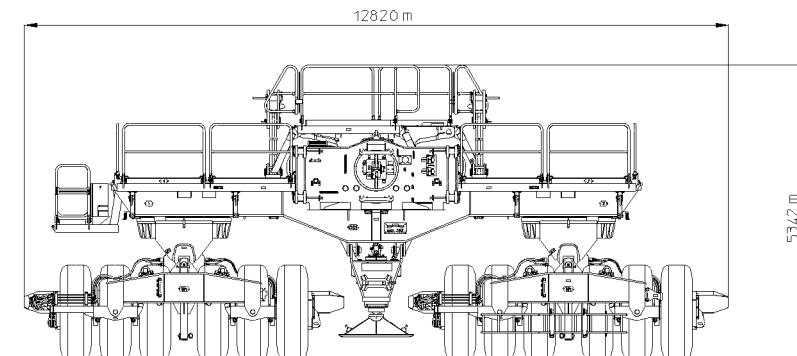


Fig.159039: Ballast trailer

Component	Weight	Width
Ballast trailer	83.0 t	8.45 m

## 58 Ballast trailer frame

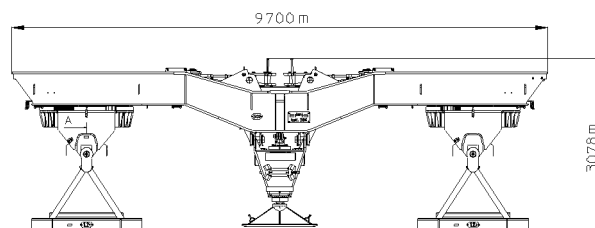


Fig.159043: Ballast trailer frame

Component	Weight	Width
Ballast trailer frame	32.5 t	3.00 m

## 59 Ballast trailer wheel set

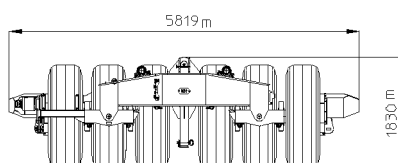


Fig.159044: Ballast trailer wheel set

Component	Weight	Width
Ballast trailer wheel set	16.0 t	2.43 m

## 60 Ballast trailer guide

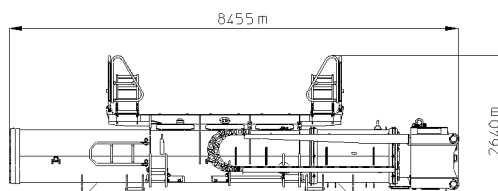


Fig.159042: Ballast trailer guide

Component	Weight	Width
Ballast trailer guide	21.0 t	8.45 m

## 61 Ballast trailer intermediate section

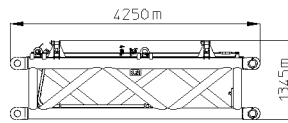


Fig.159040: Ballast trailer intermediate section

Component	Weight	Width
Ballast trailer intermediate section	3.2 t	3.06 m

## 62 Ballast trailer adapter with pull rods

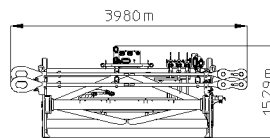


Fig.159041: Ballast trailer adapter with pull rods

Component	Weight	Width
Ballast trailer adapter with pull rods	2.06 t	1.01 m

## 63 Roller cart

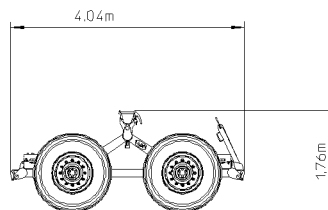


Fig.154447: Roller cart

Component	Weight	Width
Roller cart	4.0 t	2.24 m

LWE/LR 1800-1-0-000/27200-07-02/en

---

Empty page!

LWE/LR 1800-1-0-000/27200-07-02/en

## 1.03.10 Outrigger pads

1	Description	2
2	Safety	2
3	Fastening the outrigger pad	5
4	Technical track pad data for cranes with a telescopic boom	8
5	Technical outrigger pad data for cranes with a lattice mast boom	24

# 1 Description

By using the outrigger pads, the support load is distributed over a large area of the ground. Liebherr-Werk Ehingen GmbH offers different versions of outrigger pads. The outrigger pads suitable for the respective crane type can be taken via the corresponding LWE ID number from the following table "Track pads for support load distribution".

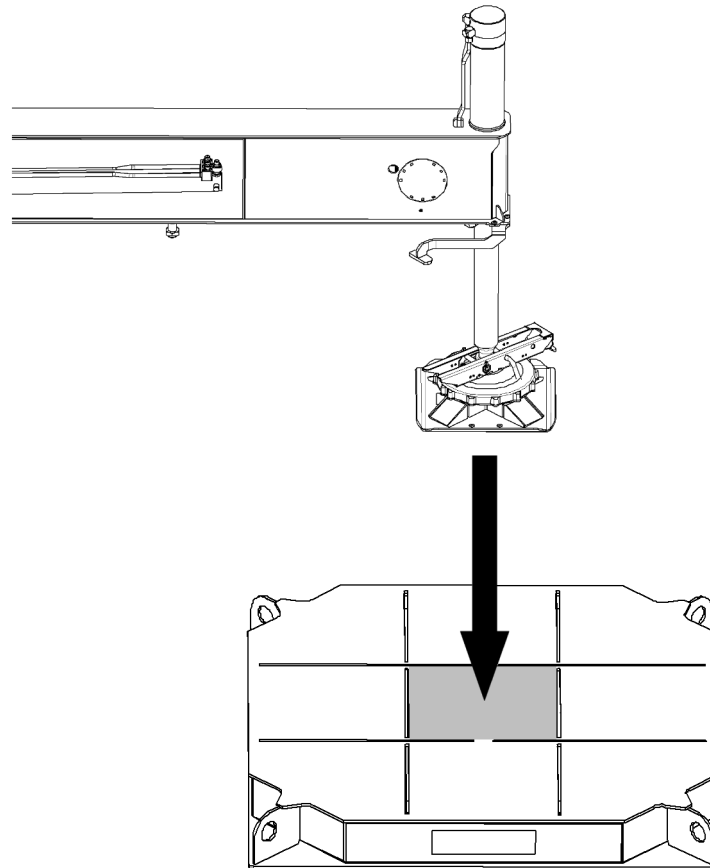


Fig.154813: Sample illustration of a outrigger pad for a crane with a telescopic boom

## 2 Safety

Before working with the outrigger pads, observe the safety instructions:

- General safety instructions, see chapter 2.04.
- Supporting the crane, see chapter 3.05.
- Installing and driving the outrigger pad (not for all crane types), see chapter 3.05.
- Assembling the outrigger pad (not for all crane types), see chapter 3.10.



### WARNING

Impermissible support plate substructure!

The crane can topple over.

Death, bodily injury, property damage.

- ▶ The ground must be able to safely absorb the occurring forces.
- ▶ Position a maximum of **one** support plate on **one** outrigger pad.
- ▶ Place the outrigger pads **centrally** below the support plates.
- ▶ The outrigger pad must be able to safely absorb the support force.



## 2.1 Placement width

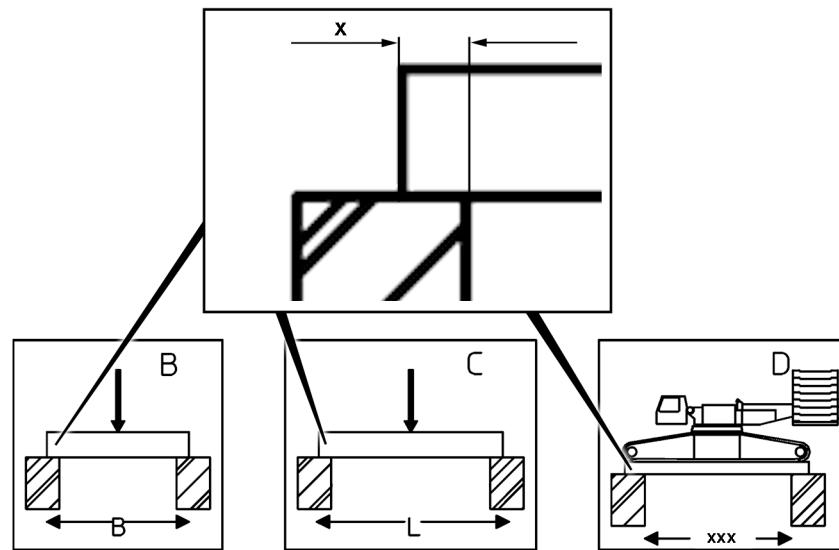


Fig.154918: Placement width  $x$



### WARNING

Placement width  $x$  **not** adhered to!  
The crane can topple over.  
Death, bodily injury, property damage.  
► Adhere to the placement width  $x$ .

## 2.2 Loads on the ground

When the crane is supported, significant forces (support forces) are transferred by the support cylinders via the support plates to the ground, see chapter 2.04. The same applies for crane operation on crawler. In this case, the forces (support forces) are transferred via the crawler plates to the ground.

- The ground must be able to safely withstand the resulting pressure. If the surface area of the crawler plates or support plates is inadequate, a substructure is required according to the load bearing capacity of the ground. Outrigger pads can be used for this.
- The support plate must be placed in the **center** on the outrigger pad. If off-center positioning is permitted, this is indicated for the corresponding outrigger pad with permissible support area.
- The required substructure for outrigger pads can be calculated from the load bearing capacity of the ground and the crawler pressures of the crane, see chapter 2.04. For the calculation examples, an even pressure distribution over the substructure surface is assumed.



### Note

- An even pressure distribution over the substructure surface can be obtained by centrally positioning the crawler or the support plates on the outrigger pad.

### 2.2.1 Permissible load configurations

Pressure forces distribute themselves differently on the ground depending on the support type and the support condition. The permissible load configurations are shown in the following illustration.

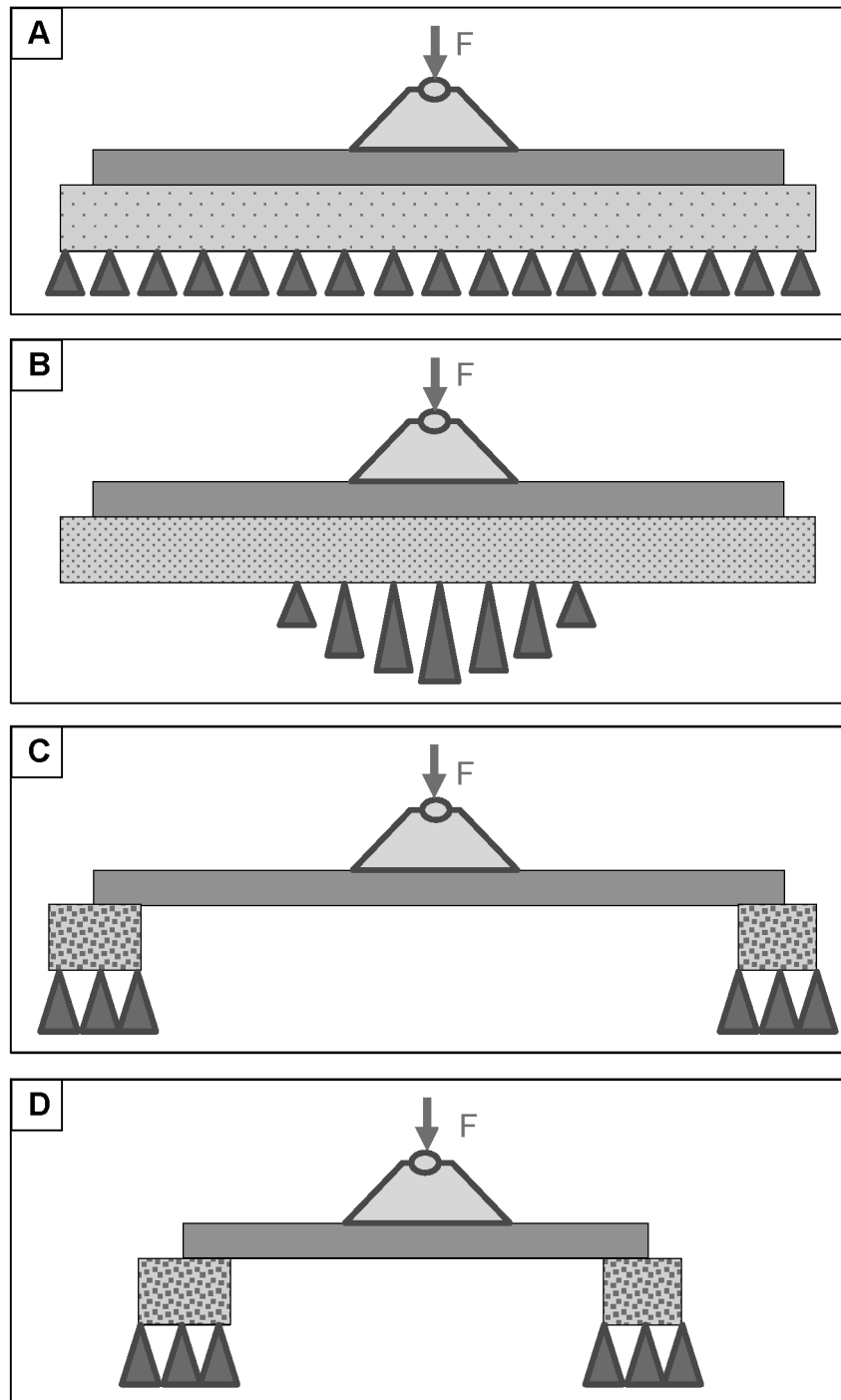


Fig.154921: Permissible load configurations

- |   |   |
|---|---|
| <b>A</b> Soft ground — even pressure distribution                       | <b>C</b> Bridge a cavity (longitudinal direction) — concentrated pressure distribution on the support surface |
| <b>B</b> Hard ground — concentrated pressure distribution in the middle | <b>D</b> Bridge a cavity (cross direction) — concentrated pressure distribution on the support surface        |

## 3 Fastening the outrigger pad



### WARNING

Incorrectly fastened outrigger pad!

Death, severe bodily injury, property damage.

- ▶ Fasten the outrigger pad in **all** fastening points.
- ▶ Use only approved and suitable fastening equipment.
- ▶ Always maintain a sufficient distance from the suspended load.
- ▶ Carry out all crane movements with a suspended load precisely and with caution.

Depending on the version, the outrigger pad can be fastened individually or in multiples in a stack. The number of outrigger pads permitted when fastening is specified in the chapter for the respective outrigger pads.

### 3.1 Fastening the individual outrigger pad

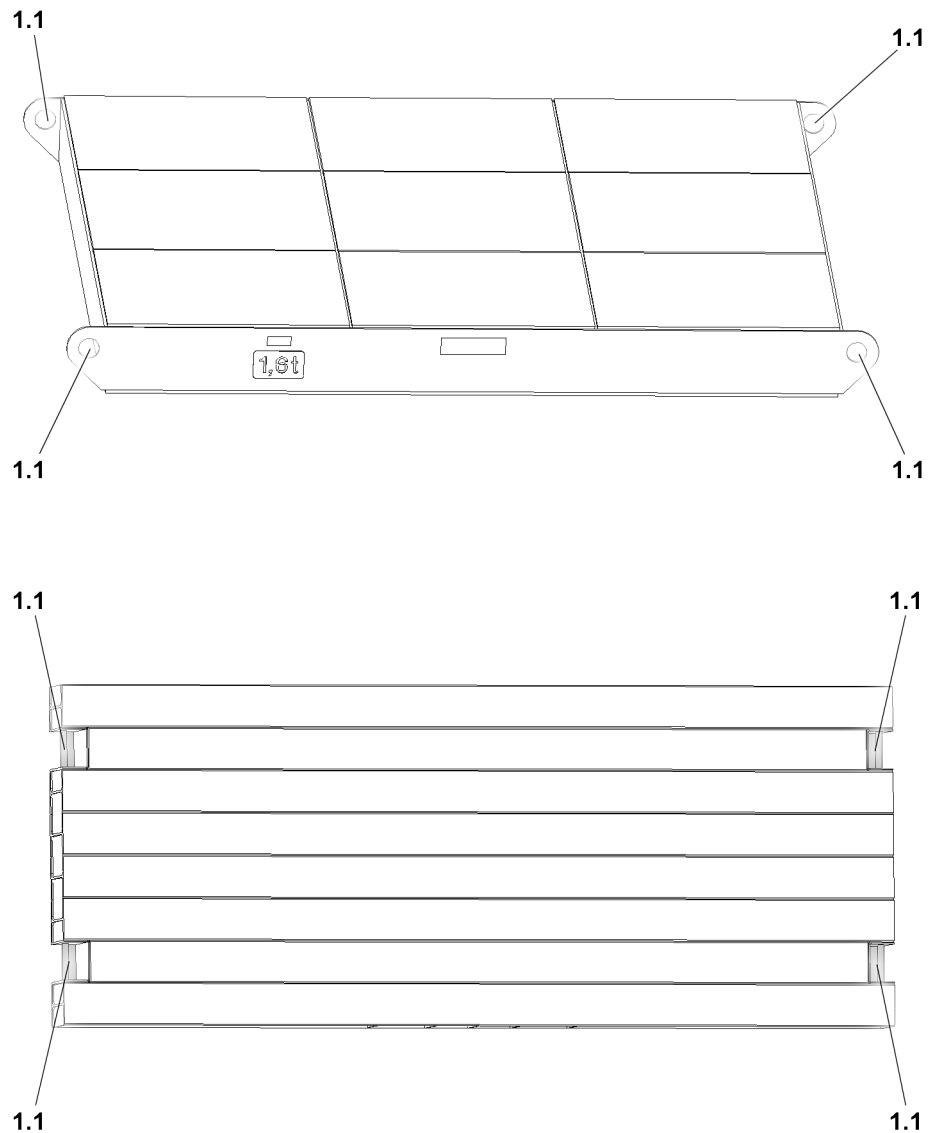
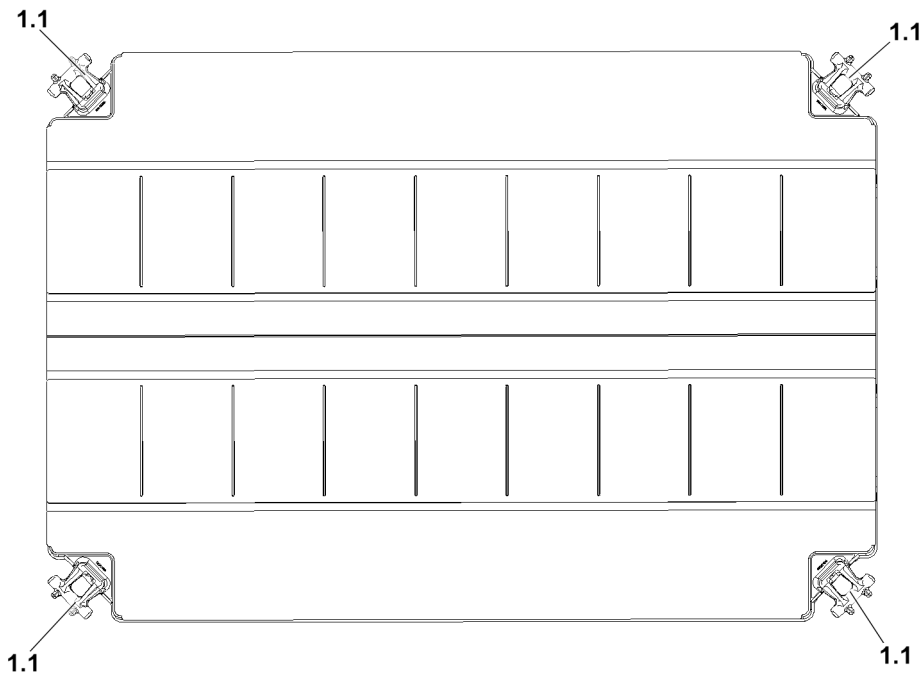


Fig. 154993: Fastening points on the outrigger pads are shown as an example

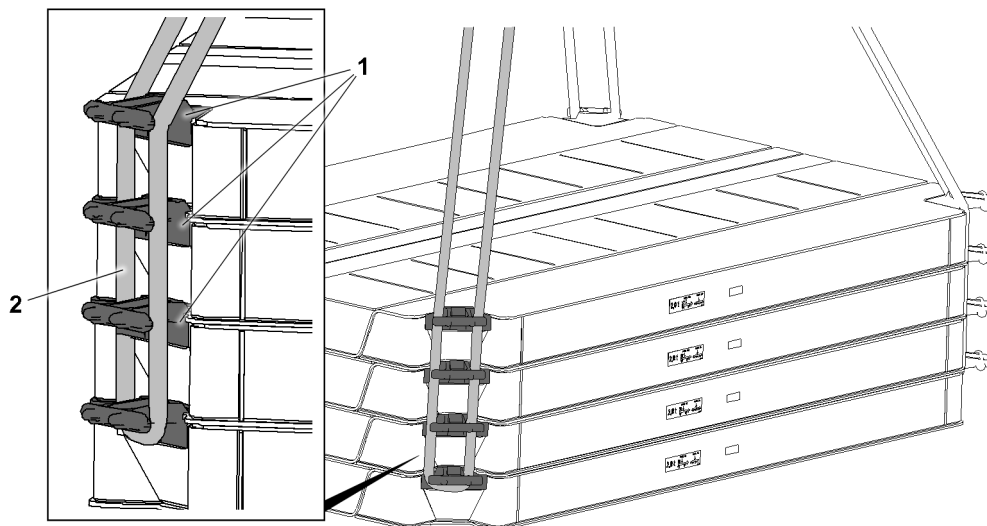
Fasten the outrigger pad in the fastening points 1.1.

## 3.2 Fastening the multiple outrigger pads



*Fig.162745: Fastening points on the outrigger pads are shown as an example*  
Fasten the outrigger pad in the fastening points 1.1.

### 3.2.1 Fastening multiple outrigger pads with a round sling



*Fig.162740: Fastening multiple outrigger pads with a round sling*

Fasten only the lowest outrigger pad.

When fastening with a round sling **2** make sure that the round sling **2** is located to the **side** on the fastening panel **1**.

### 3.2.2 Fastening multiple outrigger pads with a chain

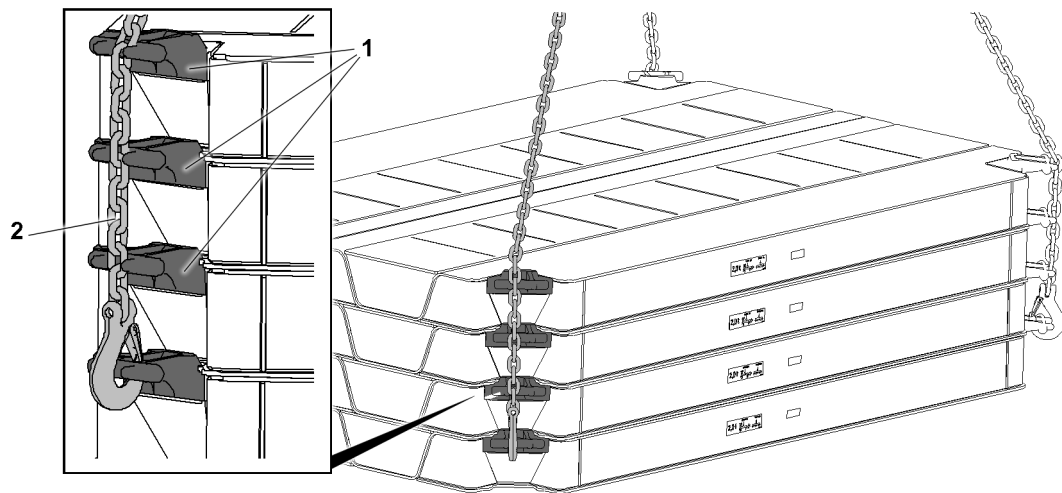


Fig.162742: Fastening multiple outrigger pads with a chain

Fasten only the lowest outrigger pad.

When fastening with a chain **2** make sure that the chain **2** is located to the **front** on the fastening panel **1**.

### 3.2.3 Stacking the outrigger pads

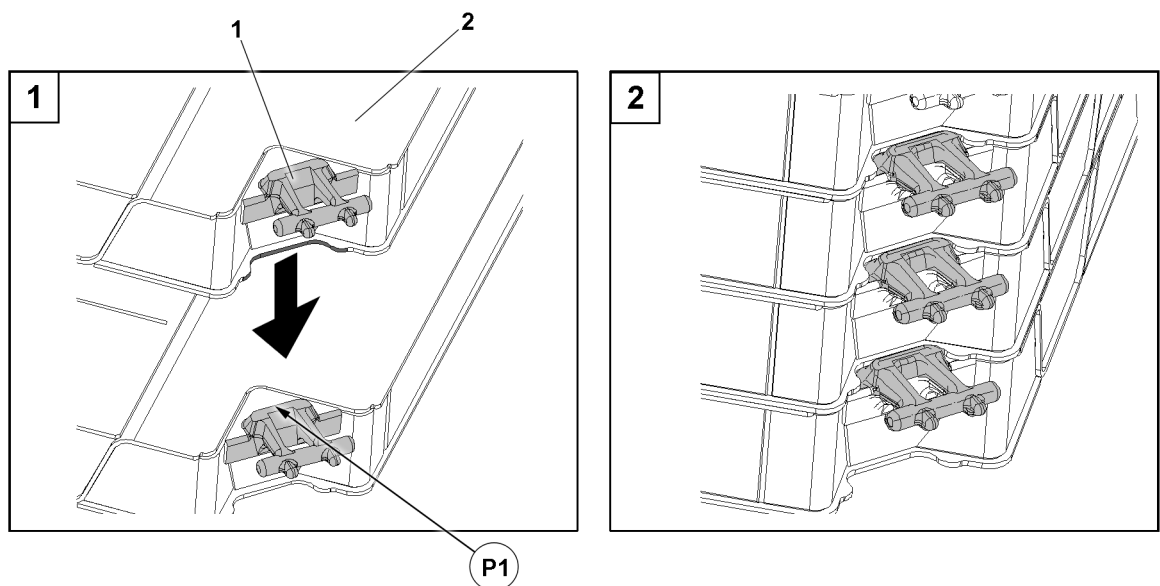


Fig.162744: Stacking the interlocking outrigger pads

Until the outrigger pads align on top of each other:

Position the upper outrigger pad **2** and lower carefully.

The fastening panels **1** are used when stacking the outrigger pads to establish an interlocking connection in position **P1**.

## 4 Technical track pad data for cranes with a telescopic boom

The following description of the outrigger pads only applies for supported crane operation.

The following outrigger pads are designed for all LWE support plates.

### 4.1 Outrigger pad LWE ID number 914786508

Observe the additional information:

- see section “Fastening the outrigger pads”.



#### WARNING

Incorrectly fastened outrigger pad!  
Death, severe bodily injury, property damage.

- Fasten a maximum of **one** outrigger pad.

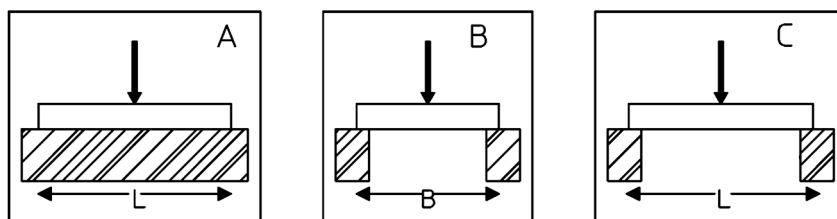


Fig.154815: Permissible support pressures

- A** The outrigger pad is placed completely on the surface
- B** The outrigger pad is positioned in the cross direction over a cavity
- C** The outrigger pad is placed in the longitudinal direction over a cavity

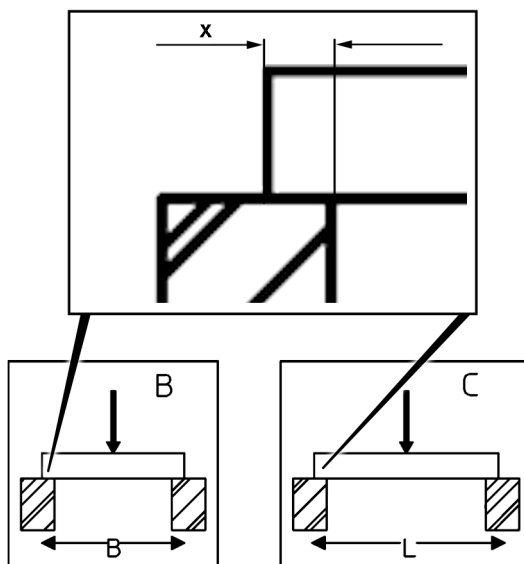


Fig.154911: Placement width  $x$

The placement width  $x$  must be at least 1.5 x height of the outrigger pad.

LWE ID number	Dimensions L x W x H <sup>1)</sup>	Surface	Mass	Permissible support pressures		
				A <sup>2)</sup>	B <sup>3)</sup>	C <sup>4)</sup>
914786508	1.0 x 1.0 x 0.12 m	1 m <sup>2</sup>	130 kg	100 t	100 t	100 t

*Outrigger pads for support load distribution*

- <sup>1)</sup> Dimensions in Length x Width x Height
- <sup>2)</sup> The outrigger pad is placed completely on the surface
- <sup>3)</sup> The outrigger pad is positioned in the cross direction over a cavity
- <sup>4)</sup> The outrigger pad is placed in the longitudinal direction over a cavity

## 4.2 Outrigger pad LWE ID number 914861908

Observe the additional information:  
 – see section “Fastening the outrigger pads”.



**WARNING**

Incorrectly fastened outrigger pad!  
 Death, severe bodily injury, property damage.  
 ► Fasten a maximum of **one** outrigger pad.

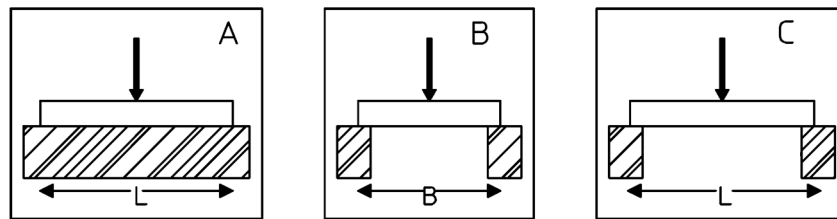


Fig.154815: Permissible support pressures

- A** The outrigger pad is placed completely on the surface
- B** The outrigger pad is positioned in the cross direction over a cavity
- C** The outrigger pad is placed in the longitudinal direction over a cavity

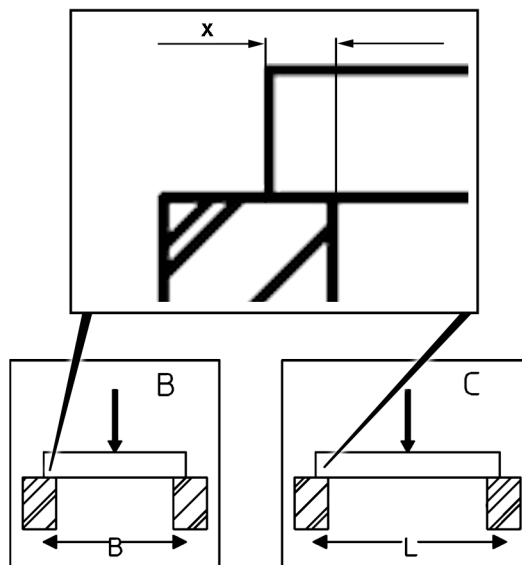


Fig.154911: Placement width x

The placement width x must be at least 1.5 x height of the outrigger pad.

LWE/LR 1800-1-0-000/27200-07-02/en

LWE ID number	Dimensions L x W x H <sup>1)</sup>	Surface	Mass	Permissible support pressures		
				A <sup>2)</sup>	B <sup>3)</sup>	C <sup>4)</sup>
914861908	1.4 x 1.2 x 0.122 m	1.68 m <sup>2</sup>	232 kg	130 t	130 t	130 t

#### Outrigger pads for support load distribution

<sup>1)</sup> Dimensions in Length x Width x Height

<sup>2)</sup> The outrigger pad is placed completely on the surface

<sup>3)</sup> The outrigger pad is positioned in the cross direction over a cavity

<sup>4)</sup> The outrigger pad is placed in the longitudinal direction over a cavity

### 4.3 Outrigger pad LWE ID number 914786808

Observe the additional information:

- see section “Fastening the outrigger pads”.



#### WARNING

Incorrectly fastened outrigger pad!  
Death, severe bodily injury, property damage.

- Fasten a maximum of **one** outrigger pad.

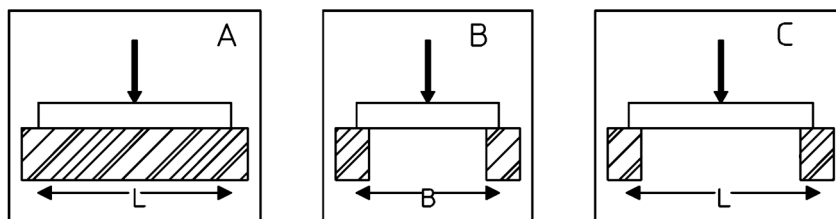


Fig.154815: Permissible support pressures

- A** The outrigger pad is placed completely on the surface
- B** The outrigger pad is positioned in the cross direction over a cavity
- C** The outrigger pad is placed in the longitudinal direction over a cavity

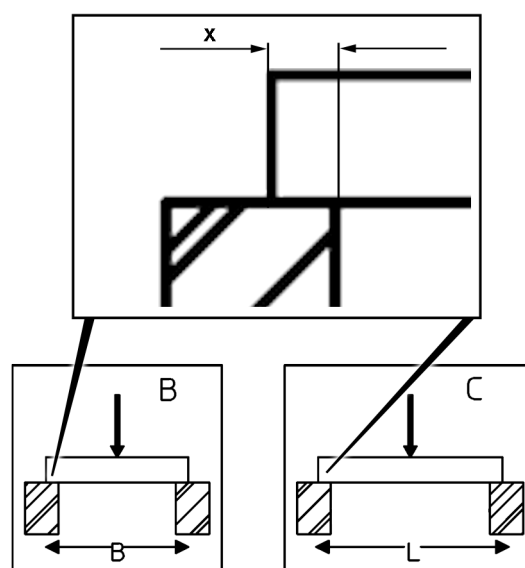


Fig.154911: Placement width  $x$

The placement width  $x$  must be at least 1.5 x height of the outrigger pad.



LWE ID number	Dimensions L x W x H <sup>1)</sup>	Surface	Mass	Permissible support pressures		
				A <sup>2)</sup>	B <sup>3)</sup>	C <sup>4)</sup>
914786808	2.0 x 1.8 x 0.2 m	3.6 m <sup>2</sup>	555 kg	210 t	210 t	210 t

*Outrigger pads for support load distribution*

- <sup>1)</sup> Dimensions in Length x Width x Height
- <sup>2)</sup> The outrigger pad is placed completely on the surface
- <sup>3)</sup> The outrigger pad is positioned in the cross direction over a cavity
- <sup>4)</sup> The outrigger pad is placed in the longitudinal direction over a cavity

### 4.4 Outrigger pad LWE ID number 915236308

Observe the additional information:  
 – see section “Fastening the outrigger pads”.



**WARNING**

Incorrectly fastened outrigger pad!  
 Death, severe bodily injury, property damage.  
 ► Fasten a maximum of **one** outrigger pad.

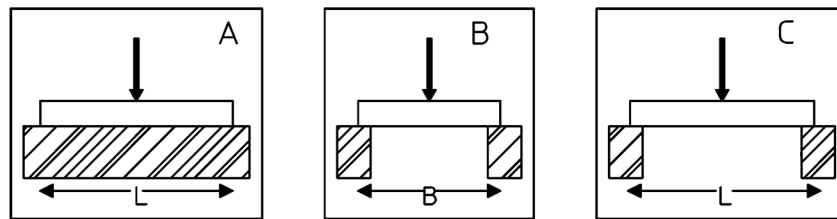


Fig.154815: Permissible support pressures

- A** The outrigger pad is placed completely on the surface
- B** The outrigger pad is positioned in the cross direction over a cavity
- C** The outrigger pad is placed in the longitudinal direction over a cavity

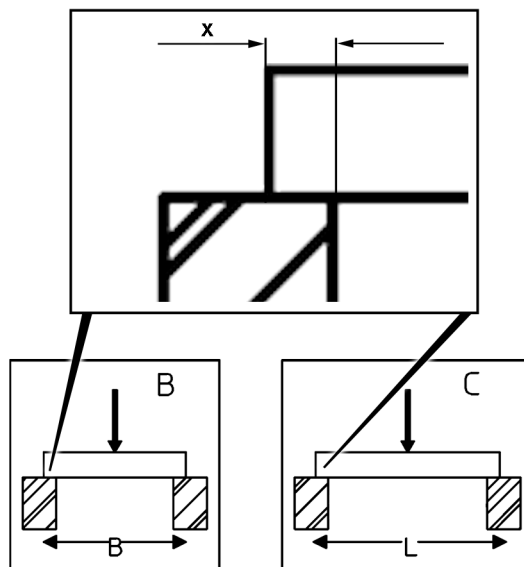


Fig.154911: Placement width x

The placement width x must be at least 1.5 x height of the outrigger pad.

LWE/LR 1800-1-0-000/27200-07-02/en

LWE ID number	Dimensions L x W x H <sup>1)</sup>	Surface	Mass	Permissible support pressures		
				A <sup>2)</sup>	B <sup>3)</sup>	C <sup>4)</sup>
915236308	2.5 x 2.4 x 0.25 m	6 m <sup>2</sup>	1600 kg	320 t	320 t	320 t

#### Outrigger pads for support load distribution

- 1) Dimensions in Length x Width x Height  
 2) The outrigger pad is placed completely on the surface  
 3) The outrigger pad is positioned in the cross direction over a cavity  
 4) The outrigger pad is placed in the longitudinal direction over a cavity

### 4.4.1 Positioning the support plate off-center on the outrigger pad

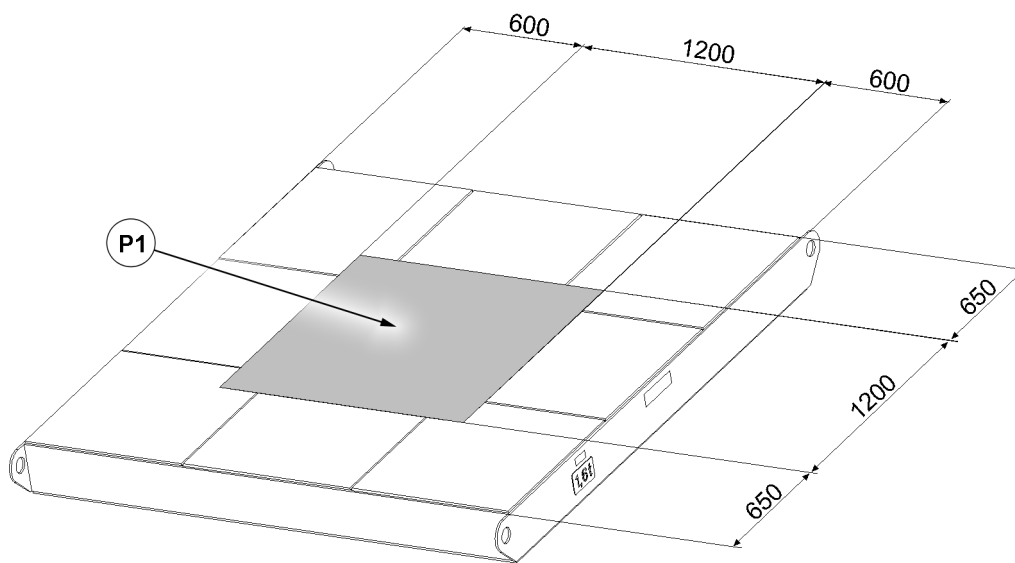


Fig.154923: Permissible placement surface for support plates

**P1** Support surface for support plates with permissible support pressure 320 t

An even pressure distribution over the substructure surface can be obtained by centrally positioning the support plates on the outrigger pad.



#### WARNING

Impermissible support plate substructure!  
 The crane can topple over.  
 Death, bodily injury, property damage.

- Place the outrigger pads **centrally** or according to the description under the support plates.

### 4.5 Outrigger pad LWE ID number 915236408/915464608

Observe the additional information:

- see section “Fastening the outrigger pads”.



#### WARNING

Incorrectly fastened outrigger pad!  
 Death, severe bodily injury, property damage.

- Fasten a maximum of **one** outrigger pad.

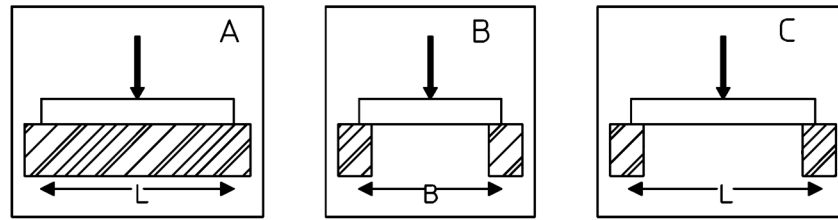


Fig.154815: Permissible support pressures

- A The outrigger pad is placed completely on the surface
- B The outrigger pad is positioned in the cross direction over a cavity
- C The outrigger pad is placed in the longitudinal direction over a cavity

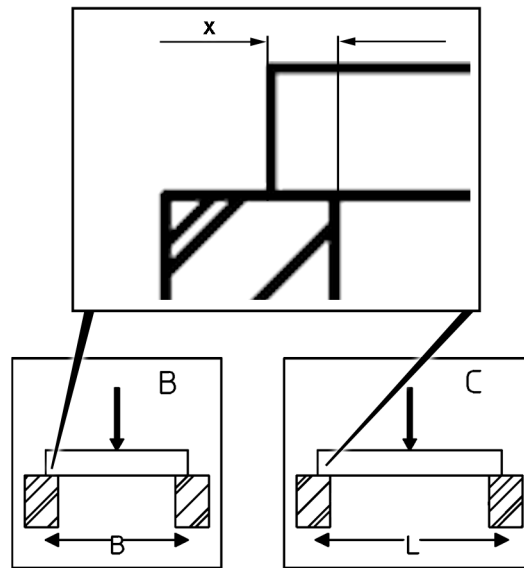


Fig.154911: Placement width x

The placement width x must be at least 1.5 x height of the outrigger pad.

LWE ID number	Dimensions L x W x H <sup>1)</sup>	Surface	Mass	Permissible support pressures		
				A <sup>2)</sup>	B <sup>3)</sup>	C <sup>4)</sup>
915236408/9154646 08	3.5 x 2.4 x 0.25 m	8.4 m <sup>2</sup>	2350 kg	320 t	320 t	320 t

**Outrigger pads for support load distribution**

- <sup>1)</sup> Dimensions in Length x Width x Height
- <sup>2)</sup> The outrigger pad is placed completely on the surface
- <sup>3)</sup> The outrigger pad is positioned in the cross direction over a cavity
- <sup>4)</sup> The outrigger pad is placed in the longitudinal direction over a cavity

LWE/LR 1800-1-0-000/27200-07-02/en

### 4.5.1 Positioning the support plate off-center on the outrigger pad

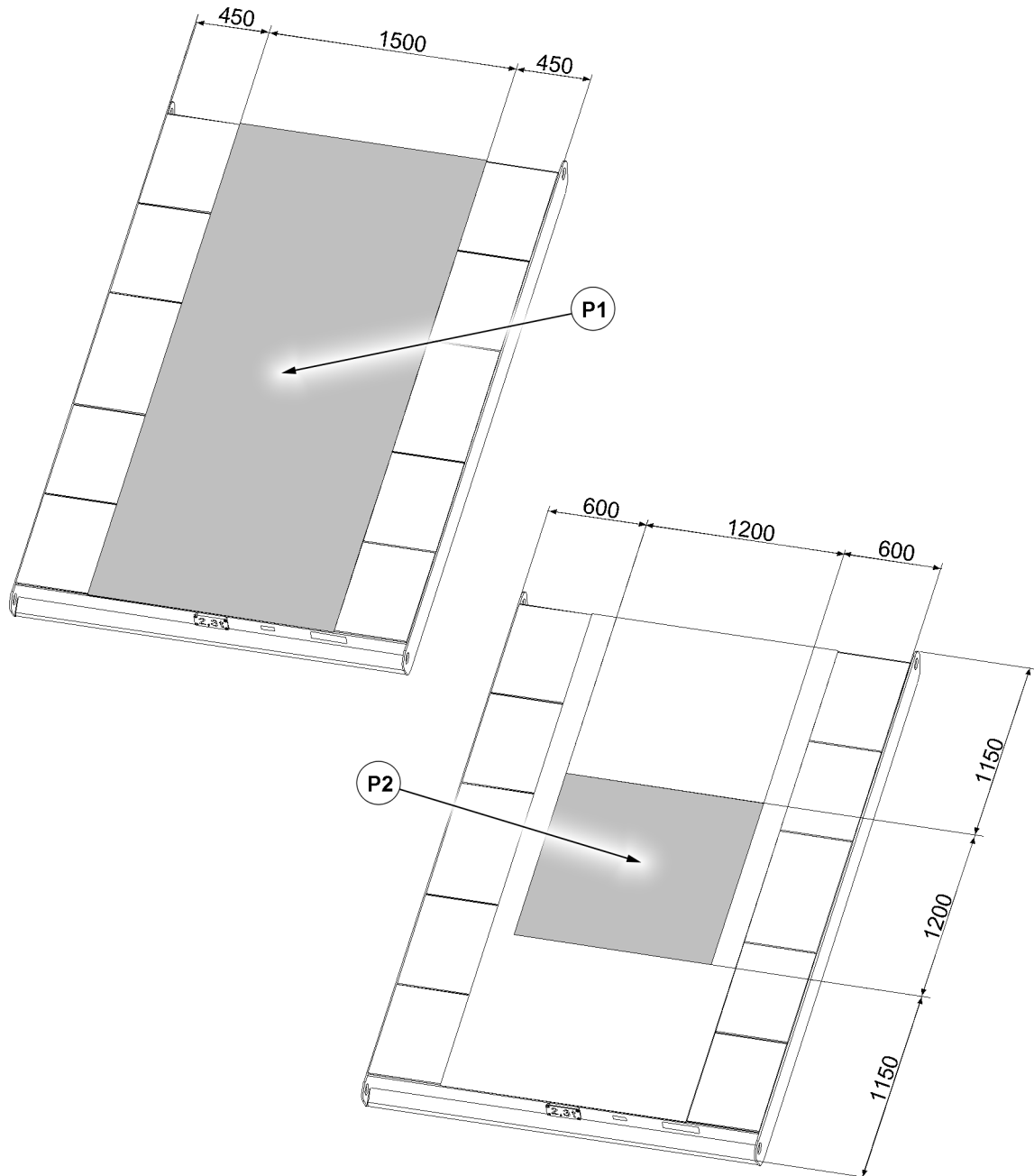


Fig. 154924: Permissible placement surface for support plates

**P1** Support surface for support plates with permissible support pressure up to 210 t

**P2** Support surface for support plates with permissible support pressure greater than 210 t up to 320 t

An even pressure distribution over the substructure surface can be obtained by centrally positioning the support plates on the outrigger pad.



#### WARNING

Impermissible support plate substructure!

The crane can topple over.

Death, bodily injury, property damage.

► Place the outrigger pads **centrally** or according to the description under the support plates.

### 4.6 Outrigger pad LWE ID number 919663108

Observe the additional information:  
 – see section “Fastening the outrigger pads”.



**WARNING**

- Incorrectly fastened outrigger pad!  
 Death, severe bodily injury, property damage.
- ▶ Fasten a maximum of **four** outrigger pads.
  - ▶ Fasten the fastening equipment only on the lowest outrigger pad.

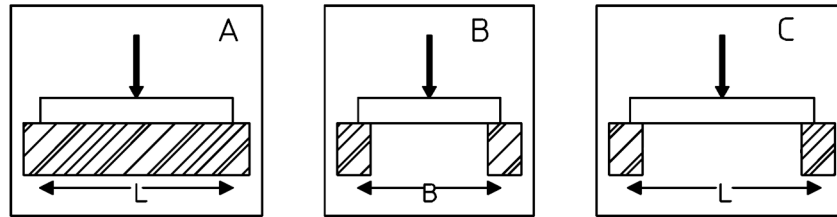


Fig.154815: Permissible support pressures

- A** The outrigger pad is placed completely on the surface
- B** The outrigger pad is positioned in the cross direction over a cavity
- C** The outrigger pad is placed in the longitudinal direction over a cavity

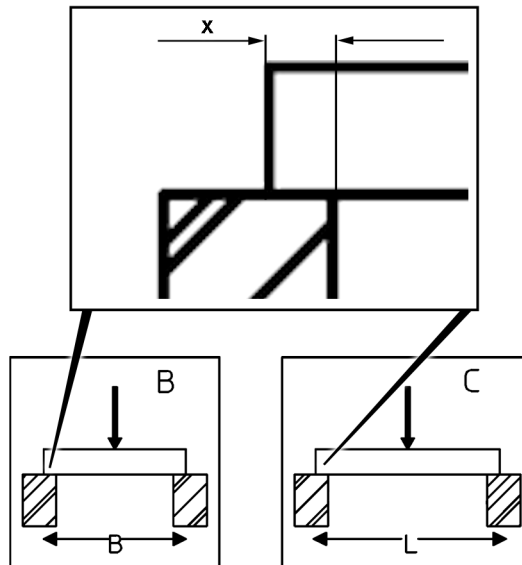


Fig.154911: Placement width x

The placement width **x** must be at least 2.5 x height of the outrigger pad.

LWE ID number	Dimensions L x W x H <sup>1)</sup>	Surface	Mass	Permissible support pressures		
				A <sup>2)</sup>	B <sup>3)</sup>	C <sup>4)</sup>
919663108	1.2 x 1.5 x 0.12 m	1.7 m <sup>2</sup>	270 kg	1100 kN	1100 kN	1100 kN

*Outrigger pads for support load distribution*

<sup>1)</sup> Dimensions in Length x Width x Height  
<sup>2)</sup> The outrigger pad is placed completely on the surface  
<sup>3)</sup> The outrigger pad is positioned in the cross direction over a cavity  
<sup>4)</sup> The outrigger pad is placed in the longitudinal direction over a cavity

LWE/LR 1800-1-0-000/27200-07-02/en

#### 4.6.1 Positioning the support plate off-center on the outrigger pad

Depending on the support surfaces of the outrigger pad, the support plates can be placed off-center on the outrigger pad.

##### Positioning the support plate off-center on the outrigger pad lying on the complete surface

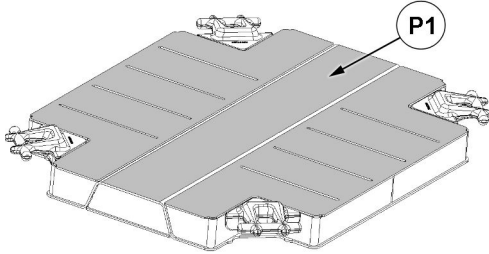


Fig. 162737: Permissible placement surface for support plates

**P1** Support surface for support plates with permissible support pressure 1100 kN

An even pressure distribution below the support surface can be obtained by centrally positioning the support plates on the outrigger pad.

##### Positioning the support plate off-center on the outrigger pad over a cavity

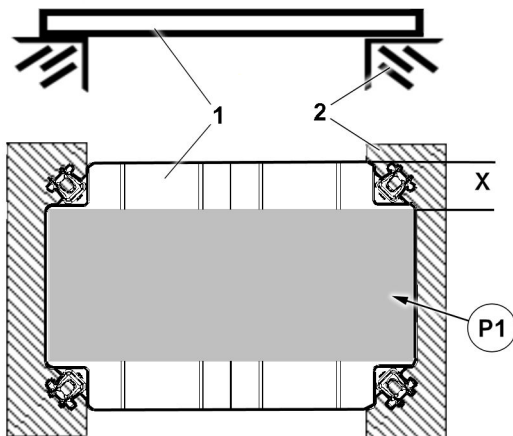


Fig. 162738: Exemplary illustration of a permissible placement surface for support plates

**1** Outrigger pad

**P1** Support surface for support plates with permissible support pressure 1100 kN

**2** Substructure

The distance **X** between the support plates and freely standing outrigger pad edge must be at least 2.5 x the height of the outrigger pad.

An even pressure distribution on the substructure surface can be obtained by centrally positioning the support plates on the outrigger pad.



#### WARNING

Impermissible support plate substructure!

The crane can topple over.

Death, bodily injury, property damage.

► Place the outrigger pads **centrally** or according to the description under the support plates.

## 4.7 Outrigger pad LWE ID number 919663508

Observe the additional information:

- see section “Fastening the outrigger pads”.



### WARNING

Incorrectly fastened outrigger pad!

Death, severe bodily injury, property damage.

- ▶ Fasten a maximum of **four** outrigger pads.
- ▶ Fasten the fastening equipment only on the lowest outrigger pad.

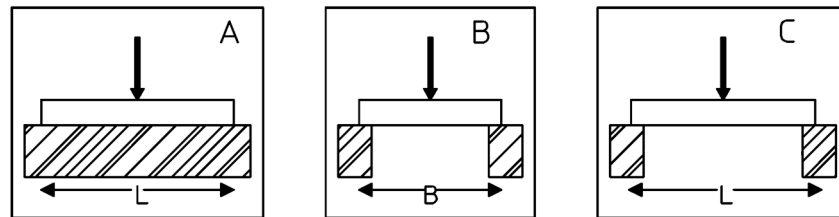


Fig.154815: Permissible support pressures

- A** The outrigger pad is placed completely on the surface
- B** The outrigger pad is positioned in the cross direction over a cavity
- C** The outrigger pad is placed in the longitudinal direction over a cavity

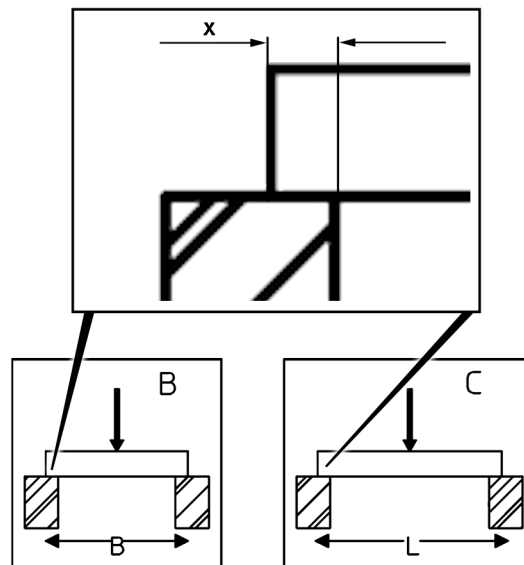


Fig.154911: Placement width  $x$

The placement width  $x$  must be at least  $1.5 \times$  height of the outrigger pad.

LWE ID number	Dimensions L x W x H <sup>1)</sup>	Surface	Mass	Permissible support pressures		
				A <sup>2)</sup>	B <sup>3)</sup>	C <sup>4)</sup>
919663508	2.4 x 1.6 x 0.19 m	3.8 m <sup>2</sup>	720 kg	1800 kN	1800 kN	1800 kN

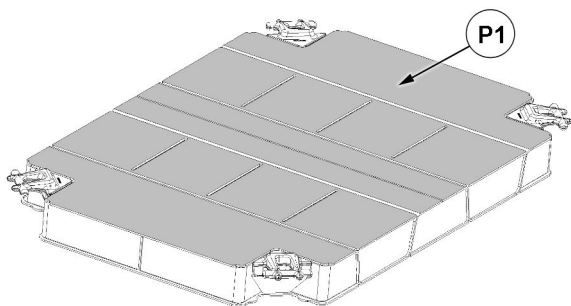
#### *Outrigger pads for support load distribution*

- 1) Dimensions in Length x Width x Height
- 2) The outrigger pad is placed completely on the surface
- 3) The outrigger pad is positioned in the cross direction over a cavity
- 4) The outrigger pad is placed in the longitudinal direction over a cavity

### 4.7.1 Positioning the support plate off-center on the outrigger pad

Depending on the support surfaces of the outrigger pad, the support plates can be placed off-center on the outrigger pad.

#### **Positioning the support plate off-center on the outrigger pad lying on the complete surface**



*Fig.162739: Permissible placement surface for support plates*

**P1** Support surface for support plates with permissible support pressure 1800 kN

An even pressure distribution below the support surface can be obtained by centrally positioning the support plates on the outrigger pad.



**Positioning the support plate off-center on the outrigger pad over a cavity**

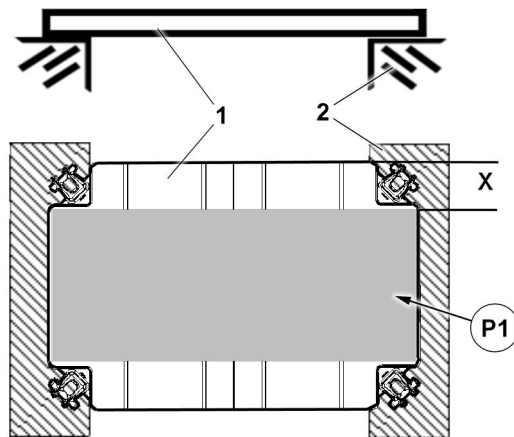


Fig.162738: Exemplary illustration of a permissible placement surface for support plates

- 1 Outrigger pad
- 2 Substructure
- P1 Support surface for support plates with permissible support pressure 1800 kN

The distance **X** between the support plates and freely standing outrigger pad edge must be at least 1.5 x the height of the outrigger pad.

An even pressure distribution on the substructure surface can be obtained by centrally positioning the support plates on the outrigger pad.



**WARNING**

Impermissible support plate substructure!  
The crane can topple over.  
Death, bodily injury, property damage.

- ▶ Place the outrigger pads **centrally** or according to the description under the support plates.

**4.8 Outrigger pad LWE ID number 919663608**

Observe the additional information:  
– see section “Fastening the outrigger pads”.



**WARNING**

Incorrectly fastened outrigger pad!  
Death, severe bodily injury, property damage.

- ▶ Fasten a maximum of **four** outrigger pads.
- ▶ Fasten the fastening equipment only on the lowest outrigger pad.

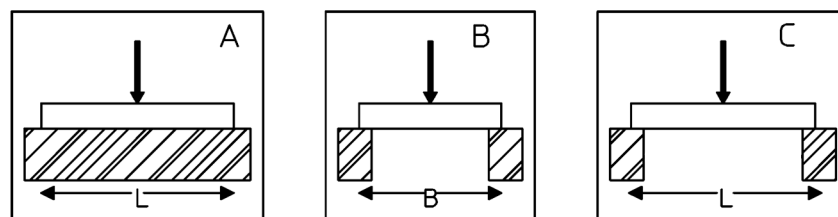


Fig.154815: Permissible support pressures

- A** The outrigger pad is placed completely on the surface
- C** The outrigger pad is placed in the longitudinal direction over a cavity

For continuation of legend for illustrations, see next page

LWE/LR 1800-1-0-000/27200-07-02/en

- B** The outrigger pad is positioned in the cross direction over a cavity

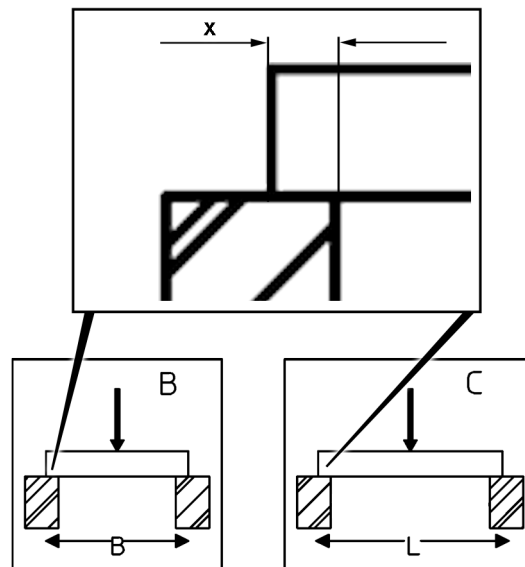


Fig.154911: Placement width  $x$

The placement width  $x$  must be at least 1.5 x height of the outrigger pad.

LWE ID number	Dimensions L x W x H <sup>1)</sup>	Surface	Mass	Permissible support pressures		
				A <sup>2)</sup>	B <sup>3)</sup>	C <sup>4)</sup>
919663608	2.4 x 2.4 x 0.21 m	5.7 m <sup>2</sup>	1200 kg	2100 kN	2100 kN	2100 kN

#### Outrigger pads for support load distribution

- 1) Dimensions in Length x Width x Height
- 2) The outrigger pad is placed completely on the surface
- 3) The outrigger pad is positioned in the cross direction over a cavity
- 4) The outrigger pad is placed in the longitudinal direction over a cavity

### 4.8.1 Positioning the support plate off-center on the outrigger pad

Depending on the support surfaces of the outrigger pad, the support plates can be placed off-center on the outrigger pad.

#### Positioning the support plate off-center on the outrigger pad lying on the complete surface

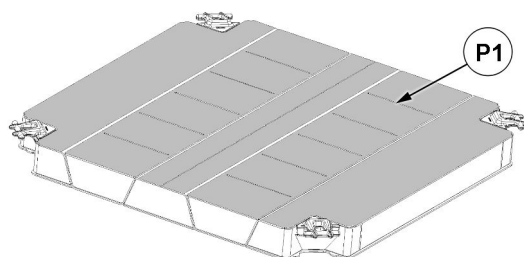


Fig.162741: Permissible placement surface for support plates

- P1** Support surface for support plates with permissible support pressure 2100 kN

An even pressure distribution below the support surface can be obtained by centrally positioning the support plates on the outrigger pad.

#### Positioning the support plate off-center on the outrigger pad over a cavity

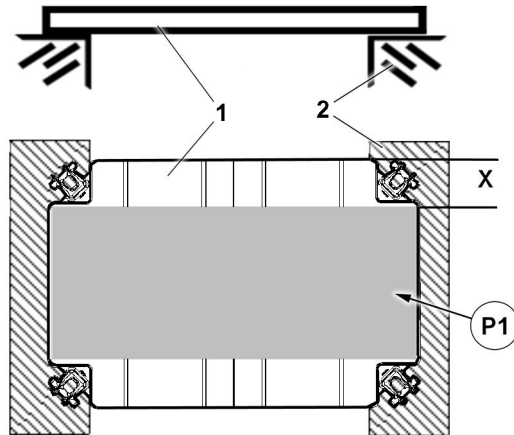


Fig.162738: Exemplary illustration of a permissible placement surface for support plates

1 Outrigger pad

P1 Support surface for support plates with permissible support pressure 2100 kN

2 Substructure

The distance **X** between the support plates and freely standing outrigger pad edge must be at least 1.5 x the height of the outrigger pad.

An even pressure distribution on the substructure surface can be obtained by centrally positioning the support plates on the outrigger pad.



#### WARNING

Impermissible support plate substructure!  
The crane can topple over.  
Death, bodily injury, property damage.

- ▶ Place the outrigger pads **centrally** or according to the description under the support plates.

## 4.9 Outrigger pad LWE ID number 919663708

Observe the additional information:

- see section “Fastening the outrigger pads”.



#### WARNING

Incorrectly fastened outrigger pad!  
Death, severe bodily injury, property damage.

- ▶ Fasten a maximum of **four** outrigger pads.
- ▶ Fasten the fastening equipment only on the lowest outrigger pad.

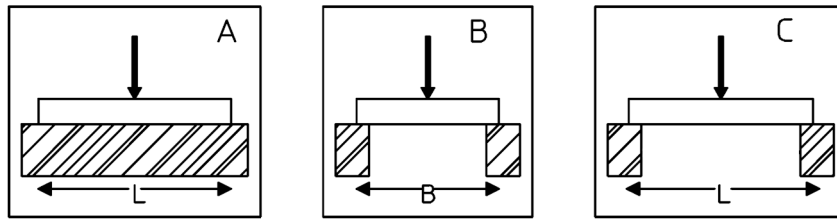


Fig.154815: Permissible support pressures

- A** The outrigger pad is placed completely on the surface
- B** The outrigger pad is positioned in the cross direction over a cavity
- C** The outrigger pad is placed in the longitudinal direction over a cavity

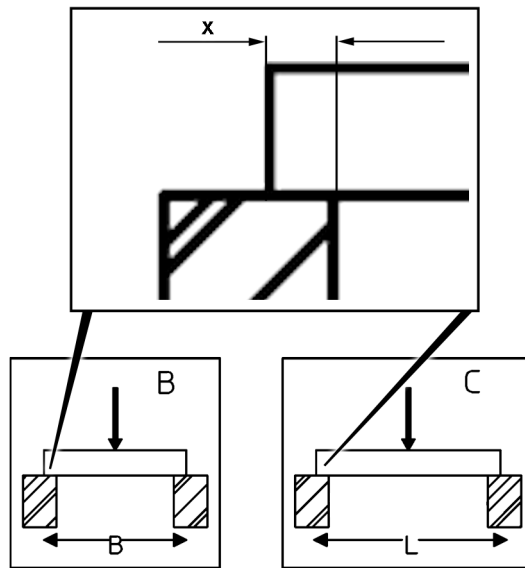


Fig.154911: Placement width x

The placement width  $x$  must be at least 1.5 x height of the outrigger pad.

LWE ID number	Dimensions L x W x H <sup>1)</sup>	Surface	Mass	Permissible support pressures		
				A <sup>2)</sup>	B <sup>3)</sup>	C <sup>4)</sup>
919663708	3.5 x 2.4 x 0.23 m	8.3 m <sup>2</sup>	2000 kg	3200 kN	3200 kN	3200 kN

**Outrigger pads for support load distribution**

- <sup>1)</sup> Dimensions in Length x Width x Height
- <sup>2)</sup> The outrigger pad is placed completely on the surface
- <sup>3)</sup> The outrigger pad is positioned in the cross direction over a cavity
- <sup>4)</sup> The outrigger pad is placed in the longitudinal direction over a cavity

**4.9.1 Positioning the support plate off-center on the outrigger pad**

Depending on the support surfaces of the outrigger pad, the support plates can be placed off-center on the outrigger pad.

LWE/LR 1800-1-0-000/27200-07-02/en

### Positioning the support plate off-center on the outrigger pad lying on the complete surface

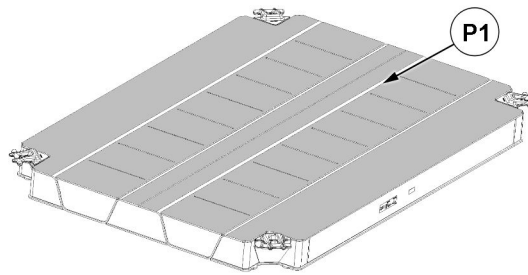


Fig.162743: Permissible placement surface for support plates

**P1** Support surface for support plates with permissible support pressure 3200 kN

An even pressure distribution below the support surface can be obtained by centrally positioning the support plates on the outrigger pad.

### Positioning the support plate off-center on the outrigger pad over a cavity

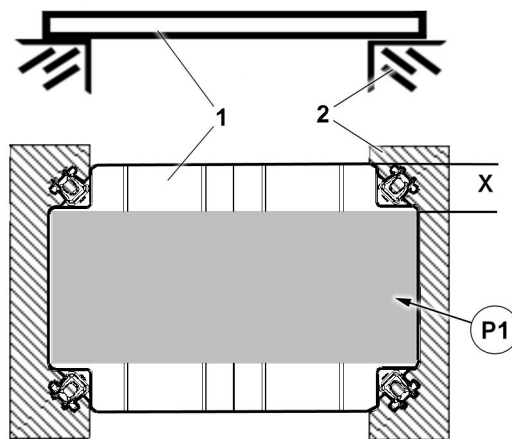


Fig.162738: Exemplary illustration of a permissible placement surface for support plates

**1** Outrigger pad

**P1** Support surface for support plates with permissible support pressure 3200 kN

**2** Substructure

The distance **X** between the support plates and freely standing outrigger pad edge must be at least 1.5 x the height of the outrigger pad.

An even pressure distribution on the substructure surface can be obtained by centrally positioning the support plates on the outrigger pad.



#### WARNING

Impermissible support plate substructure!  
The crane can topple over.  
Death, bodily injury, property damage.

► Place the outrigger pads **centrally** or according to the description under the support plates.

## 5 Technical outrigger pad data for cranes with a lattice mast boom

The following description of the outrigger pads only applies for supported crane operation and in crane operation on crawler.

### 5.1 Outrigger pad LWE ID number 914618608

Observe the additional information:

- Installing and driving the outrigger pad, see chapter 3.05.

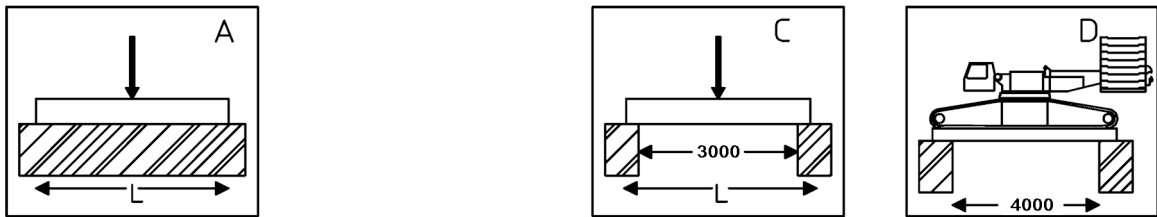


Fig.154942: Permissible support pressures

- A** The outrigger pad is placed completely on the surface
- C** The outrigger pad is placed in the longitudinal direction over a cavity
- D** The outrigger pad is placed in the longitudinal direction over a cavity and driven with the crawler crane



#### Note

- Driving the outrigger pads over a cavity is only permissible with the own weight of the crane (without a hoist load).

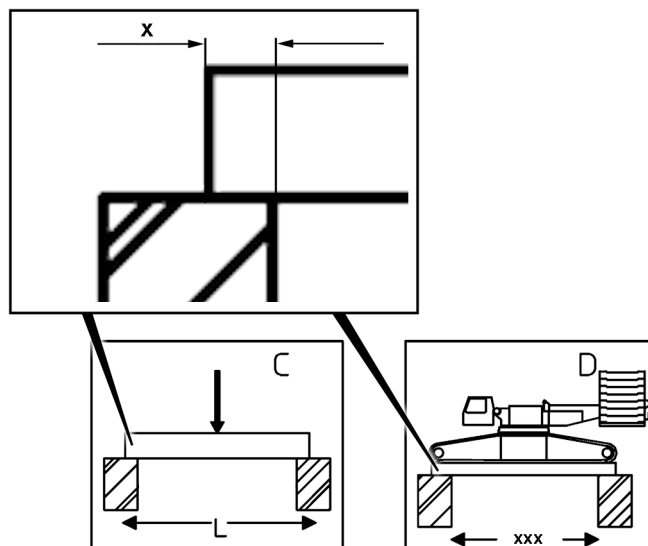


Fig.154941: Placement widths  $x$

- C** The placement width must be at least 1.5 m.
- D** The placement width must be at least 1.0 m.

LWE ID number	Dimensions L x W x H <sup>1)</sup>	Surface	Mass	Permissible support pressures			
				A <sup>2)</sup>	B <sup>3)</sup>	C <sup>4)</sup>	D <sup>5)</sup>
914618608	6.0 x 2.4 x 0.3 m	14.4 m <sup>2</sup>	7800 kg	4500 kN		4500 kN	

#### Outrigger pads for support load distribution

- <sup>1)</sup> Dimensions in Length x Width x Height
- <sup>2)</sup> The outrigger pad is placed completely on the surface
- <sup>3)</sup> The outrigger pad is positioned in the cross direction over a cavity
- <sup>4)</sup> The outrigger pad is placed in the longitudinal direction over a cavity
- <sup>5)</sup> The outrigger pad is placed in the longitudinal direction over a cavity and driven with the crawler crane

### 5.1.1 Positioning the support plate off-center on the outrigger pad

Off-center positioning is only permitted if the outrigger pad lies across the entire circumference (not only on two sides) on ground that is at least 100 mm wide.

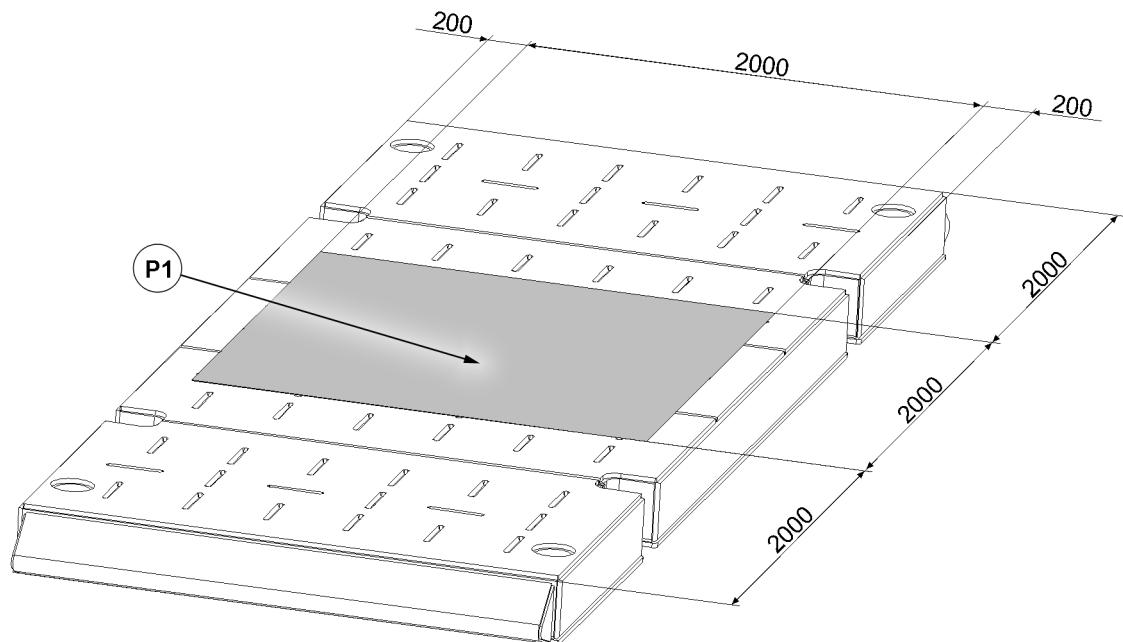


Fig.154926: Permissible placement surface for support plates

**P1** Support surface for support plates with permissible support pressure 4500 kN

An even pressure distribution over the substructure surface can be obtained by centrally positioning the support plates on the outrigger pad.



#### WARNING

Impermissible support plate substructure!  
The crane can topple over.  
Death, bodily injury, property damage.

- ▶ Place the outrigger pads **centrally** or according to the description under the support plates.

## 5.2 Outrigger pad LWE ID number 915696408

Observe the additional information:

- Outrigger pad assembly, see chapter 3.10.

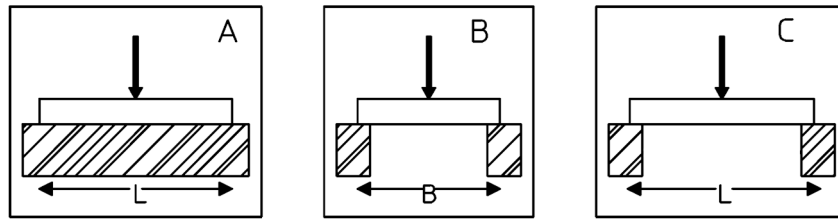


Fig.154815: Permissible support pressures

- A** The outrigger pad is placed completely on the surface
- B** The outrigger pad is positioned in the cross direction over a cavity
- C** The outrigger pad is placed in the longitudinal direction over a cavity

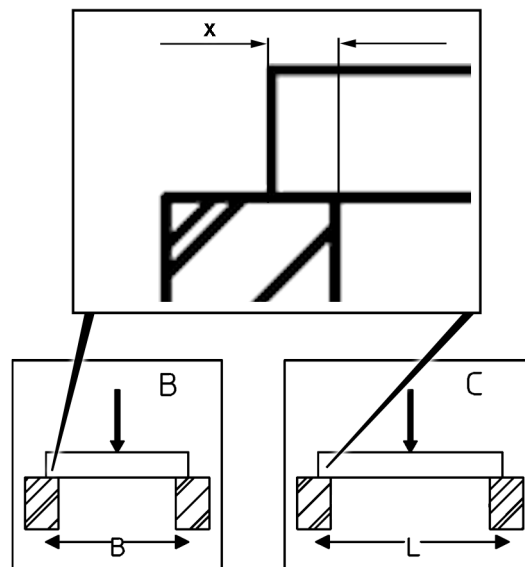


Fig.154911: Placement width  $x$

The placement width  $x$  must be at least 2.5 x height of the outrigger pad.

LWE ID number	Dimensions L x W x H <sup>1)</sup>	Surface	Mass	Permissible support pressures		
				A <sup>2)</sup>	B <sup>3)</sup>	C <sup>4)</sup>
915696408	4.0 x 2.4 x 0.25 m	9.6 m <sup>2</sup>	3300 kg	4500 kN	4500 kN	4500 kN

#### Outrigger pads for support load distribution

- <sup>1)</sup> Dimensions in Length x Width x Height
- <sup>2)</sup> The outrigger pad is placed completely on the surface
- <sup>3)</sup> The outrigger pad is positioned in the cross direction over a cavity
- <sup>4)</sup> The outrigger pad is placed according to the longitudinal direction over a cavity



### 5.3 Outrigger pad LWE ID number 918339808

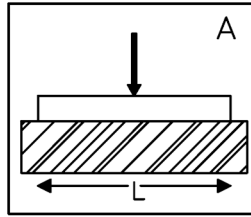


Fig.154917: Permissible support pressures

**A** The outrigger pad is placed completely on the surface

LWE ID number	Dimensions L x W x H <sup>1)</sup>	Surface	Mass	Permissible support pressures
				A <sup>2)</sup>
918339808	6.0 x 2.4 x 0.4 m	14.4 m <sup>2</sup>	7900 kg	2650 kN

*Outrigger pads for support load distribution*

<sup>1)</sup> Dimensions in Length x Width x Height

<sup>2)</sup> The outrigger pad is placed completely on the surface

LWE/LR 1800-1-0-000/27200-07-02/en

### 5.3.1 Positioning the support plate off-center on the outrigger pad

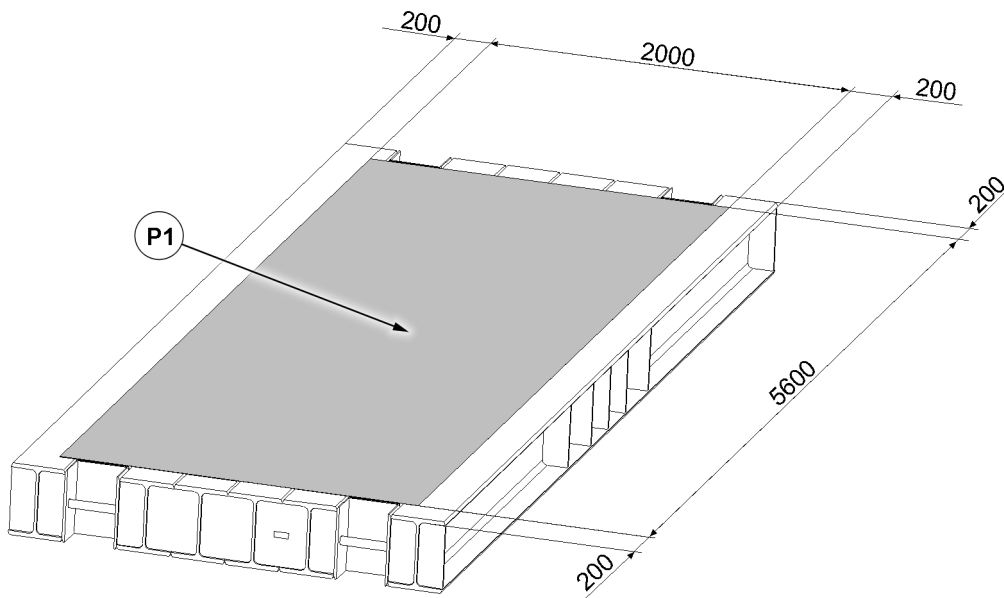


Fig.154925: Permissible placement surface for support plates

**P1** Support surface for support plates with permissible support pressure 2650 kN

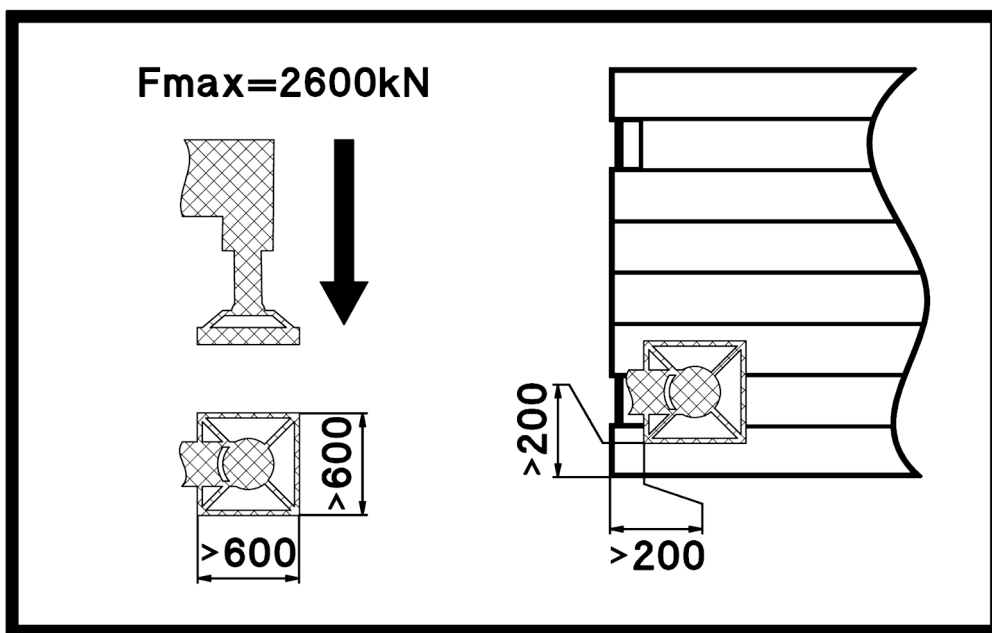


Fig.154913: The support plate is positioned off-center on the outrigger pad

LWE/LR 1800-1-0-000/27200-07-02/en

An even pressure distribution over the substructure surface can be obtained by centrally positioning the support plates on the outrigger pad.



#### WARNING

Impermissible support plate substructure!  
The crane can topple over.

Death, bodily injury, property damage.

- Place the outrigger pads **centrally** or according to the description under the support plates.

A support plate can be placed off-center on this outrigger pad. The minimum distance is 200 mm from the side edge of the outrigger pad. The side length of the support plate must be at least 600 mm.

### 5.3.2 Driving the outrigger pad in the cross direction with a crawler crane

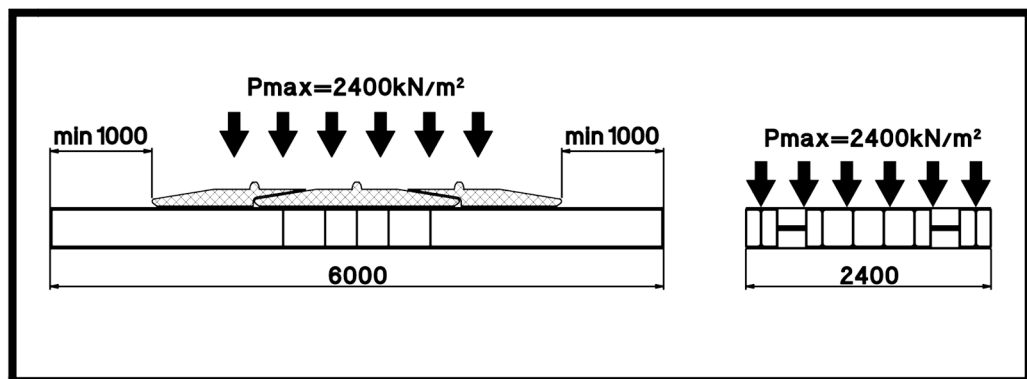


Fig.154912: Driving the outrigger pad in the cross direction with a crawler crane

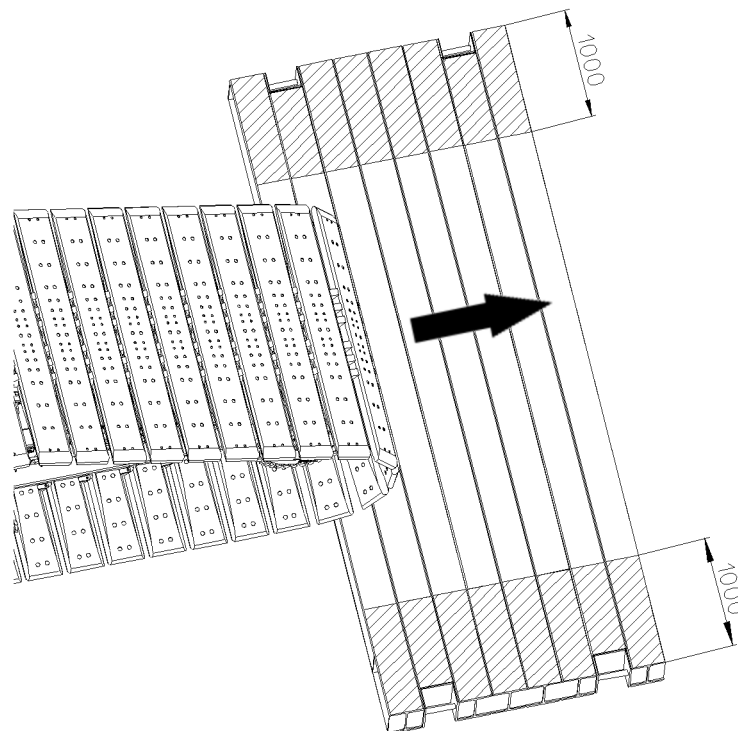


Fig.154922: Permissible driving range with the crawler crane

This outrigger pad can be driven in the cross direction with an approved crawler crane. The distance of at least 1000 mm to the side edges (longitudinal side) of the outrigger pad must be observed.

## 5.4 Outrigger pad LTE ID number 919427108

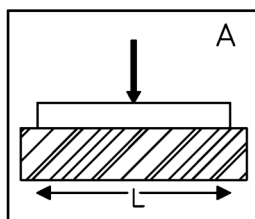


Fig.154917: Permissible support pressures

- A** The outrigger pad is placed completely on the surface



### Note

- Driving the outrigger pads over a cavity is only permissible with the own weight of the crane (without a hoist load).

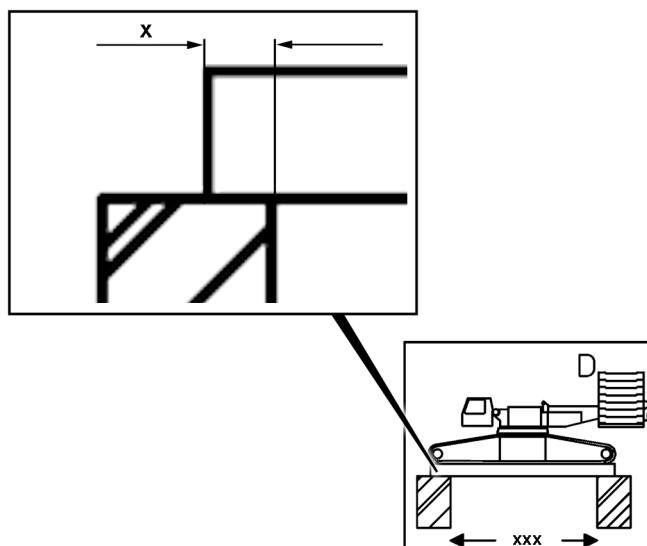


Fig.156550: Placement widths  $x$

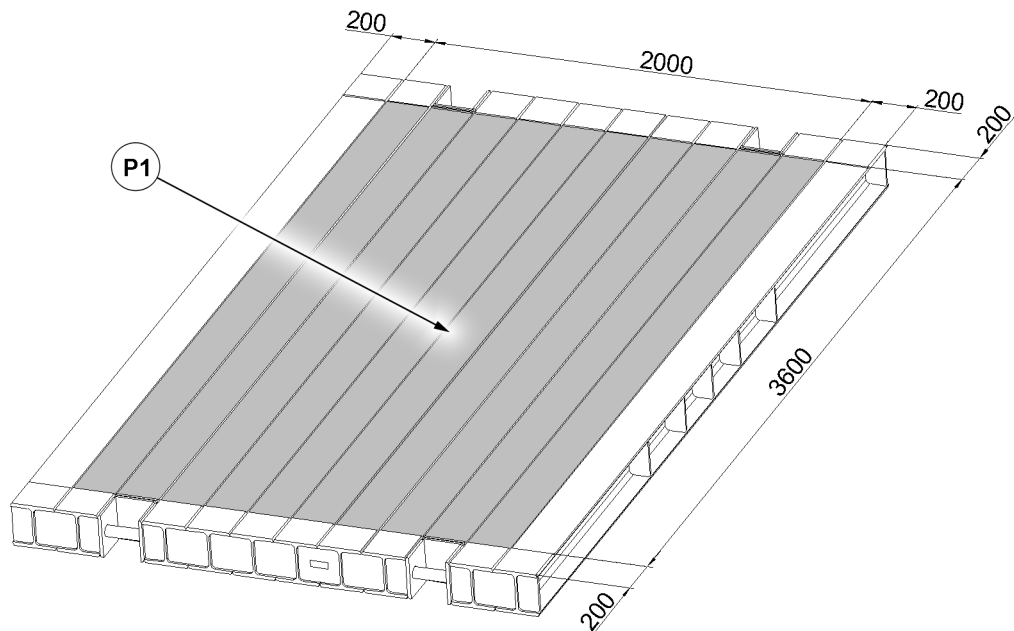
- D** The placement width must be at least 0.5 m .
- D** The cavity may be maximum 1.0 m .

LWE ID number	Dimensions L x W x H <sup>1)</sup>	Surface	Mass	Permissible support pressures	
				A <sup>2)</sup>	D <sup>3)</sup>
919427108	4.0 x 2.4 x 0.2 m	9.6 m <sup>2</sup>	3200 kg	2000 t for support plates with a placement surface of 0.6 x 0.6 m	
				3100 t for support plates with a placement surface of 0.7 x 0.7 m	

*Outrigger pads for support load distribution*

- <sup>1)</sup> Dimensions in Length x Width x Height
- <sup>2)</sup> The outrigger pad is placed completely on the surface
- <sup>3)</sup> The outrigger pad is placed in the longitudinal direction over a cavity and driven with the crawler crane

**5.4.1 Positioning the support plate off-center on the outrigger pad**



*Fig.156546: Permissible placement surface for support plates*

- P1** Support surface for support plates with placement surface of 600 x 600 mm with permissible support pressure of 2650 kN
- P1** Support surface for support plates with placement surface of 700 x 700 mm with permissible support pressure of 3100 kN

LWE/LR 1800-1-0-000/27200-07-02/en

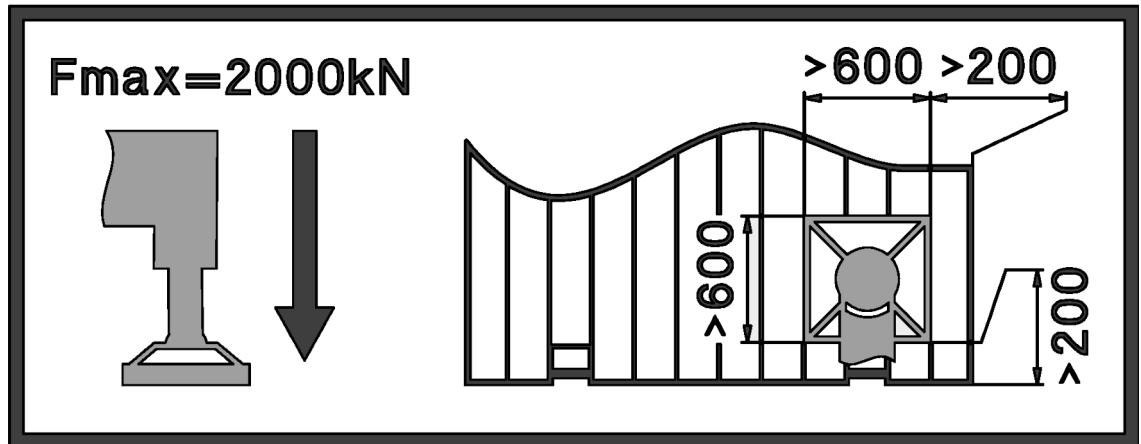


Fig.156549: The support plate is positioned off-center on the outrigger pad

An even pressure distribution over the substructure surface can be obtained by centrally positioning the support plates on the outrigger pad.



#### WARNING

Impermissible support plate substructure!  
The crane can topple over.  
Death, bodily injury, property damage.

► Place the outrigger pads **centrally** or according to the description under the support plates.

A support plate can be placed off-center on this outrigger pad. The minimum distance is 200 mm from the side edge of the outrigger pad. The side length of the support plate must be at least 600 mm.

#### 5.4.2 Driving the outrigger pad in the cross direction with a crawler crane

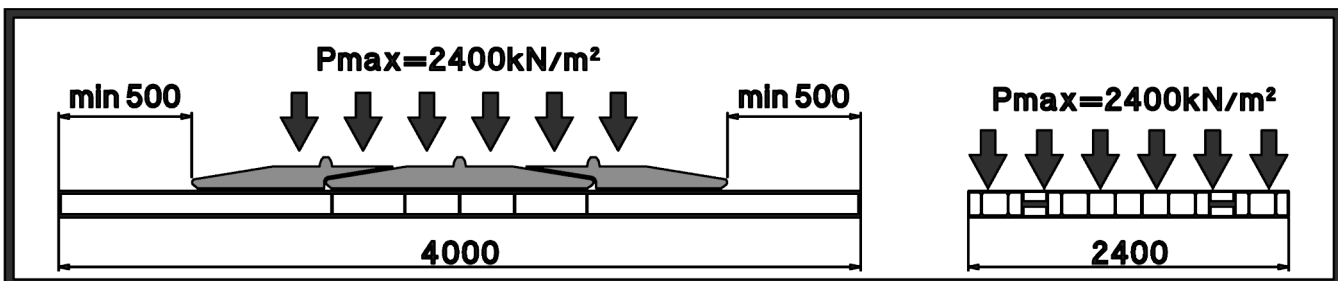


Fig.156548: Driving the outrigger pad in the cross direction with a crawler crane

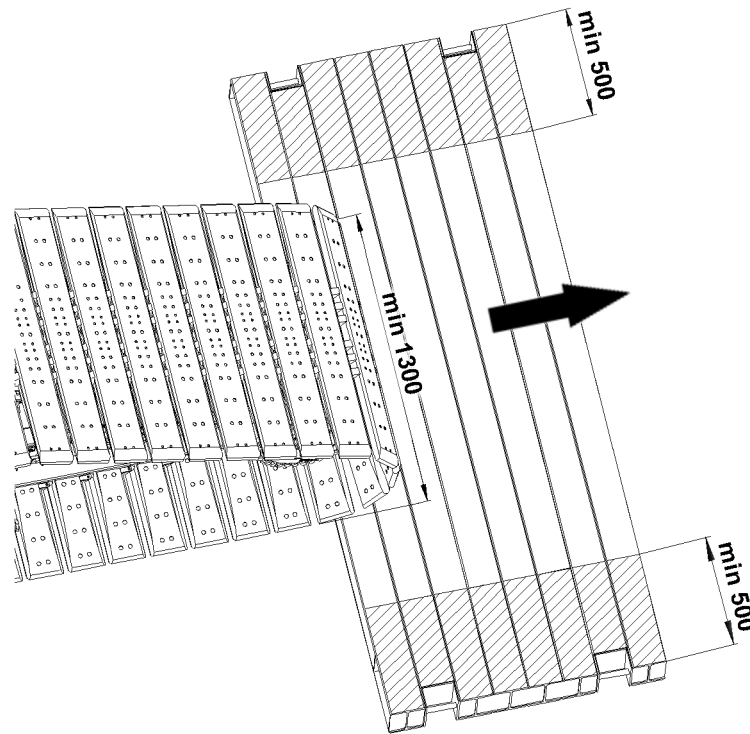


Fig.156547: Permissible driving range with the crawler crane

This outrigger pad can be driven in the cross direction with an approved crawler crane. The distance of at least 500 mm to the side edges (longitudinal side) of the outrigger pad must be observed. The support width of the crawler chain must be at least 1300 mm.

#### 5.4.3 Driving the outrigger pad in the cross direction over a cavity with a crawler crane

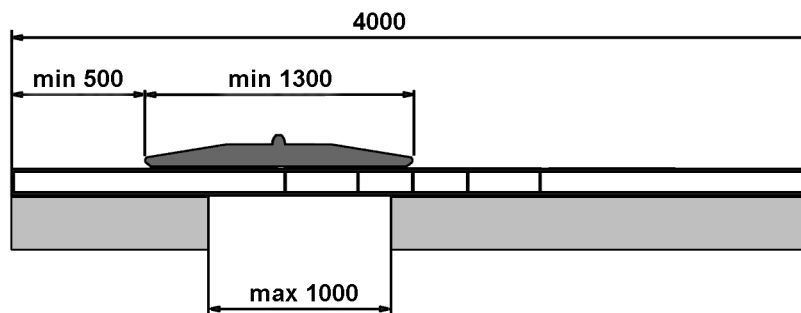


Fig.156551: Permissible driving range with the crawler crane

This outrigger pad can be driven in the cross direction over a cavity with an approved crawler crane. The distance of at least 500 mm to the side edges (longitudinal side) of the outrigger pad must be observed. The support width of the crawler chain must be at least 1300 mm. The cavity can have a maximum width of 1000 mm.

---

Empty page!

LWE/LR 1800-1-0-000/27200-07-02/en



---

## 2 Safety

LWE/LR 1800-1-0-000/27200-07-02/en

---

LWE/LR 1800-1-0-000/27200-07-02/en

## 2.03 Job planning

1 Planning Crane operation

---

3

LWE/LR 1800-1-0-000/27200-07-02/en

*Fig.195219*

LWE/LR 1800-1-0-000/27200-07-02/en

# 1 Planning Crane operation

In addition to a perfectly working crane and a well-trained crew, the **planning for crane operation** is an important principle for safe crane operation.



---

## WARNING

Missing information!

Death, severe bodily injuries, property damage.

► Obtain the required information and adhere to it.

---

Obtain the following information before crane operation and adhere to it:

- Type of crane operation
- National laws and regulations
- Height and width clearance measurements
- When mobile crane: Job site, distance and travel route
- Space prerequisites at the job site
- Electrical transmission lines with voltage data
- Movement restrictions caused by buildings
- Weight and dimensions of the load(s) to be lifted
- Geometric form and air resistance coefficient of the load(s) to be lifted
- Required lifting height and boom projection
- Ground bearing capacity at the job site
- Required space for the assembly and disassembly of the crane
- Weather data and weather forecasts

Assemble the equipment for crane operation:

- Hook block / load hook
- Auxiliary boom
- Fastening equipment
- Counterweight
- Base materials for support plates

---

Empty page!

LWE/LR 1800-1-0-000/27200-07-02/en

## 2.04 Technical safety instructions

1	Dangers on the crane	2
2	Safe working environment	4
3	Definition of roles	5
4	Instructions to personnel	11
5	Danger zone of the crane	12
6	Traffic endangerment and environmental damage	13
7	Endangering air traffic	13
8	Movement on the crane	14
9	Emergency exit - driver's cab	16
10	Emergency crane cab exit	16
11	Personal protective equipment	20
12	Supplied fire extinguisher	26
13	Securing persons to prevent them from falling	26
14	Saving personnel	28
15	Crane cab	28
16	Side window	36
17	Emergency hammer*	36
18	Transport	37
19	Fastening	40
20	Selecting the location	40
21	Slopes and excavations	44
22	Loads on the ground due to crane operation	47
23	Support	51
24	Alignment of the crane	53
25	Checking the safety measures	54
26	Safety instructions in case of an external power supply	55
27	Grounding for potential equalization	55
28	Working in the vicinity of transmitters	57
29	Crane operation in case of thunderstorms	58
30	Wind influences	59
31	Lifting a load with two cranes	66
32	Overlapping of working ranges of several cranes	68
33	Hand signals for guidance	69
34	Travel operation	77
35	Crane operation	79
36	Lifting of personnel	87
37	Securing personnel on shut off crane	89
38	Welding work on the load	91

**Note**

- ▶ The illustrations in this chapter are only examples. The illustrations may differ depending on the respective crane.

# 1 Dangers on the crane

## 1.1 Chemicals

Proposition 65 of the US State of California warns against chemicals that are known to cause cancer and birth defects or other reproductive harm. For additional information, see the website: [www.P65Warnings.ca.gov](http://www.P65Warnings.ca.gov)

<b>Proposition 65</b>	
	<p><b>WARNING:</b> This product can expose you to chemicals, which are known to the State of California to cause cancer and birth defects or other reproductive harm.</p> <ul style="list-style-type: none"> <li>• Avoid direct contact with chemicals.</li> <li>• Use personal protective equipment: Always wear protective gloves.</li> <li>• After handling: Wash hands thoroughly.</li> <li>• Dispose of chemicals in an environmentally acceptable manner according to local regulations.</li> </ul> <p>For more information see: <a href="http://www.P65Warnings.ca.gov">www.P65Warnings.ca.gov</a>.</p>

Fig.154660: Example of a Proposition 65 sign for USA: Chemicals

**WARNING**

Chemicals!

Damage to health such as cancer and birth defects or other reproductive harm.

- ▶ Avoid direct contact with chemicals.
- ▶ Use personal protective equipment: **Always** wear protective gloves.
- ▶ After handling: Wash hands thoroughly.
- ▶ Dispose of chemicals in an environmentally acceptable manner according to local regulations.

## 1.2 Diesel engine exhaust emissions

Proposition 65 of the US State of California warns against diesel engine exhaust emissions that are known to cause cancer and birth defects or other reproductive harm. For additional information, see the website: [www.P65Warnings.ca.gov/diesel](http://www.P65Warnings.ca.gov/diesel)




<b>Proposition 65</b>	
	<p><b>WARNING:</b> Breathing diesel engine exhaust exposes you to chemicals known to the State of California to cause cancer and birth defects or other reproductive harm.</p> <ul style="list-style-type: none"> <li>• Always start and operate the engine in a well-ventilated area.</li> <li>• If in an enclosed area, vent the exhaust to the outside.</li> <li>• Do not modify or tamper with the exhaust system.</li> <li>• Do not idle the engine except as necessary.</li> </ul> <p>For more information see: <a href="http://www.P65Warnings.ca.gov/diesel">www.P65Warnings.ca.gov/diesel</a>.</p>

Fig.154661: Example of a Proposition 65 sign for USA: Diesel engine exhaust emissions



### **WARNING**

Diesel engine exhaust emissions!

Damage to health such as cancer and birth defects or other reproductive harm.

- ▶ Always start and operate the diesel engine in properly ventilated spaces.
- ▶ If in enclosed areas: Direct the exhaust gas to the outside.
- ▶ Do not convert the exhaust system or make any other changes.
- ▶ Do not run the engine at idle speed for longer than necessary.

## 1.3 Lead and lead compounds

Proposition 65 of the US State of California warns against lead and lead compounds that are known to cause cancer and birth defects or other reproductive harm. For additional information, see the website: [www.P65Warnings.ca.gov](http://www.P65Warnings.ca.gov)


<b>Proposition 65</b>	
	<p><b>WARNING:</b> This product can expose you to chemicals, including lead and lead compounds, which are known to the State of California to cause cancer and birth defects or other reproductive harm.</p> <ul style="list-style-type: none"> <li>• Avoid direct contact with batteries and their components.</li> <li>• Do not touch them with bare hands.</li> <li>• Use personal protective equipment: <b>Always</b> wear protective gloves.</li> <li>• After handling: Wash hands thoroughly.</li> <li>• Dispose of disused batteries in an environmentally acceptable manner according to local regulations.</li> </ul> <p>For more information see: <a href="http://www.P65Warnings.ca.gov">www.P65Warnings.ca.gov</a>.</p>

Fig.154662: Example of a Proposition 65 sign for USA: Lead and lead compounds

**WARNING**

Batteries, battery poles, battery terminals and other battery components contain lead and lead compounds!

Damage to health such as birth defects and other reproductive harm.

- ▶ Avoid direct contact with batteries and their components.
- ▶ Do not touch them with bare hands.
- ▶ Use personal protective equipment: **Always** wear protective gloves.
- ▶ After handling: Wash hands thoroughly.
- ▶ Dispose of disused batteries in an environmentally acceptable manner according to local regulations.

## 1.4 Hydraulic oil, diesel fuel, operating fluids

**WARNING**

Due to technical defects or open tank covers, hydraulic oil, diesel fuel or service fluids spill out!

Dirt from the road and ground.

Traffic endangerment: Danger of skidding, death, severe bodily injuries.

Environmental pollution: Death, severe damage to health.

- ▶ Remedy the technical defect immediately.
- ▶ Securely close the tank cover after refueling.
- ▶ Immediately and thoroughly remove traces of hydraulic oil, diesel fuel, operating fluids.
- ▶ Avoid skin contact with hydraulic oil, diesel fuel and operating fluids.
- ▶ Wear personal protective equipment.

**WARNING**

Hot hydraulic oil! Hot service fluids!

Severe burns, severe scalds and severe bodily injuries.

- ▶ Before all work: Let hot hydraulic oil and hot operating fluids cool off.
- ▶ Avoid contact with hot hydraulic oil and hot operating fluids.
- ▶ Wear personal protective equipment.

## 1.5 Heated crane components

**WARNING**

Heated crane components! Hot surfaces!

Severe burns.

This applies in particular to exhaust systems, engines and transmissions.

- ▶ Let the components cool down before touching them.
- ▶ Proceed with special caution near heated crane components.
- ▶ Avoid skin contact with hot surfaces.
- ▶ Use personal protective equipment, such as protective gloves.

## 2 Safe working environment

A systematic procedure for creating a safe working environment must be ensured. The procedure must be followed for all components of crane use, regardless if it concerns an individual procedure or a group of repeating procedures.

All required preparations of the job site, assembly, disassembly, maintenance and driving the crane and the equipment must be understood as components of crane use. The following points concerning a systematic procedure for creating a safe working environment are effectively communicated to all involved parties.

The systematic procedure is as follows:

- Job planning: So that crane uses can be carried out safely, they must be planned in advance in consideration of all foreseeable risks. Planning is carried out by people with corresponding technical knowledge. In the case of repeated uses or routine uses, this planning is possibly required only for the first use. A check must be performed regularly if the factors of use or environmental conditions have changed. If the factors of use have changed, job planning must be performed again. The national and regional specifications on crane use must be observed. For example, the European Directive “Use of work equipment” and its implementation as a national or regional regulation, such as the “Operational safety regulation” in Germany.
- Selection, operational provision and use of suitable cranes and equipment: This concerns, for example, assembly tools, personal protective equipment (PPE), material for supporting the crane, load handling equipment and fastening equipment.
- Maintenance, testing and inspection of cranes and equipment: This concerns, for example, assembly tools, personal protective equipment (PPE), material for supporting the crane, load handling equipment and fastening equipment. Observe the national and regional regulations when checking the work equipment and cranes.
- Reasonable supervision by properly trained and competent personnel provided with the required authority.
- Provision of properly trained and competent personnel who fulfill all necessary requirements.
- Provision of properly trained and competent personnel who have received an explanation of their responsibilities and the responsibility of the others involved in crane use.
- Make sure that all required certificates and documents, such as, for example, crane test reports, qualification certifications for personnel, are valid, are available and demonstrate the required suitability.
- Cooperation with other authorities and test points for reaching the corresponding conformity with approvals.
- Cooperation with other trades and service providers with regard to crane use for preventing danger or protecting against danger, for example with additional crane operators and machine operators.
- Make sure, at all times, that unauthorized movements or unauthorized uses of the crane are prevented.
- Ensure safety for people who are not involved in crane use.
- Establish a communication system that is understood by everyone involved in crane use. For safety of crane use, all personnel must be able to communicate clearly in the same language.

### 3 Definition of roles

Safe crane operation depends on suitable personnel, for example.

Selection of personnel:

- Training certificates and evidence of practical experience are helpful when selecting competent personnel.
- Observe the national and regional regulations concerning personnel qualification.

All personnel have the following responsibilities:

- Personnel wear the personal protective equipment necessary for the respective work procedure in accordance with the Crane documentation and national and regional regulations.
- Personnel contact their supervisors when there are questions about the crane documentation or the information in the crane documentation is not sufficient.

All personnel must fulfil the following requirements:

- Personnel are physically and psychologically suitable to fulfil their roles, in particular with regard to vision, hearing, reflexes and a short reaction time.
- Personnel are **not** impaired by alcohol, drugs or other influences. Personnel who are impaired by alcohol, drugs or other influences may **not** be used.
- Personnel are able to fulfil the tasks assigned to them in a reliable manner.
- Personnel are trained according to the requirements.
- Personnel comply with the national and regional regulations on age. An exception to this are personnel who, for training purposes, are under the direct supervision of an authorized person.

All personnel must have the following qualifications and knowledge that are relevant for their individual scope of duties:

- Technical training and work experience.
- Knowledge of the use of suitable personnel protective equipment, especially fall protection equipment.
- Knowledge of the relevant standards, national and regional regulations, accident prevention regulations.
- Knowledge of the tasks and responsibilities of the involved persons.
- Ability to recognize and avoid possible dangers.

### 3.1 Understanding of roles

The roles in the following sections define the respective requirements and responsibilities. One person can fulfil multiple roles.

The roles of the people located near the crane must be defined at all times and be known to all involved personnel.

### 3.2 Manufacturer

The manufacturer has the following responsibilities:

- The manufacturer is responsible for the safety-related, proper condition of a new crane with accessories and crane documentation when handed over the first time to the operating company.
- The manufacturer documents all service work carried out by the manufacturer.
- The manufacturer offers training for crane operators, assembly personnel and maintenance personnel.
- The manufacturer offers services to support the operating company.

### 3.3 Operating company

The operating company can also be the owner of the crane.

The operating company has the following responsibilities:

- The operating company makes sure that the crane fulfils the national and regional regulations of the job site. If necessary, the crane must be changed, for example with signs, lighting, exhaust system, override protection.

When importing the crane into the United Kingdom, English crane documentation must also be provided. Examples are provided. If necessary, request them from the customer service at Liebherr-Werk Ehingen GmbH.

- The operating company is responsible for the safety-related, proper condition of the crane with accessories and complete crane documentation after hand over from the manufacturer.
- The crane documentation must be made available to personnel that work on and with the crane.
- The operating company makes sure that only trained personnel are used.
- The operating company provides the necessary personal protective equipment to all involved personnel. This responsibility includes all work on the crane and with the crane.
- When personnel are being trained, they must be suitably supervised.
- The responsible individuals make sure that personnel are efficiently organized, so that safe cooperation is ensured while working.
- The operating company checks at regular intervals that personnel are working in a safety-conscious manner.
- The operating company makes sure that when driving the crane on public roads, all national and regional traffic regulations as well as those required by the manufacturer are observed.
- The operating company commissions maintenance personnel and authorized and trained service personnel according to the maintenance and inspection schedule.
- The operating company appoints an authorized inspector. The operating company appoints an authorized inspector to perform the tests and maintenance required nationally, regionally and by Liebherr-Werk Ehingen GmbH. In this way the operating company ensures the further, safe and reliable operation of the crane.
- The operating company shall not make any alterations or repairs to load bearing or safety-relevant parts of the crane without consulting with the manufacturer and receiving written approval.

- The operating company makes sure that only original spare parts from Liebherr-Werk Ehingen GmbH are used.
- The operating company contacts customer service at Liebherr-Werk Ehingen GmbH when the information in the crane documentation is not sufficient.
- The operating company will inform the manufacturer of every safety-relevant incident that was caused directly by the crane, its components or by the crane documentation.

### 3.3.1 Transferring of responsibility

When the use of the crane is not carried out by the operating company, they must make sure that their areas of responsibility are contractually transferred to the organization using the crane.

### 3.3.2 Monitoring by a designated person

The operating company determines a “designated person” who is responsible for the monitoring of crane use.

The designated person is known to the crane operator and the involved persons located near crane use.

The designated person has the following tasks:

- The designated person assesses the use of the crane, so that the planning, selection of the crane or cranes, selection of the hoist gear and lifting equipment, support substructure, wind planning as well as instructions and supervision are ensured for the safe performance of the task. This includes consultation with other people responsible and guaranteeing the required cooperation with any other involved organizations.
- The designated person checks that the set up configuration was assembled properly before erection of the boom.
- The designated person makes sure that the tests and inspections as well as crane and equipment maintenance required nationally, regionally and by Liebherr-Werk Ehingen GmbH are carried out.
- The designated person makes sure that an effective procedure is in place for reporting defects and events as well as for carrying out the necessary corrective measures.
- The designated person is responsible for the organization and monitoring of crane use. The designated person assigns the role of crane operator and the other roles to competent people and assigns the role of crane operator as well as other roles and authorizes their activities.

The designated person receives the authority required for performance all their tasks in consultation with the crane operator. The designated person receives in particular the authority to stop operation when they believe that continuing operation could be dangerous.

## 3.4 Crane operator (crane driver)

The crane operator has the following responsibilities:

- The crane operator is responsible for the proper operation of the crane in compliance with the Crane documentation and within the framework of the systematic procedure for creating a safe working environment. See section “Safe working environment” in this chapter. This concerns both the lifting of loads as well as driving at the job site, and when required driving on public roads.
- The crane operator must always react only to the signal of the slinger or the guide, except in the case of a stop signal. The slinger or guide must be clearly recognizable. See section “Slinger” and section “Guide” in this chapter.
- The crane operator has read and understood the crane documentation.
- The crane operator operates the crane as intended within the limit values of the crane, depending on the weather and wind.
- The crane operator stops operation immediately when a safe method of operation is no longer possible, for example due to the weather and wind. The crane operator immediately initiates the required measures.
- The crane operator carries out all the tasks assigned to them by their role in the manufacturer’s maintenance and inspection plan.
- The crane operator uses only original spare parts from Liebherr-Werk Ehingen GmbH.
- The crane operator shall not make any alterations or repairs to the crane without consulting with the operating company and receiving written approval.

- The crane operator observes the national and regional regulations.
- When driving on public roads, the crane operator follows the national and regional traffic regulations.
- The crane operator establishes a travel condition that complies with the locally valid rules and the definitions in the crane documentation.
- When transferring the crane to another crane operator: All data and settings for which the last crane operator is responsible must be transferred to the new crane operator.
- The crane operator informs the operating company about every unsafe change to the crane.

The crane operator fulfils the following requirements:

- The crane operator fulfils the requirements in section “Slinger” and section “Guide”.
- The crane operator is physically capable of operating the crane in a safe manner.
- The crane operator provides the operating company with a health certificate that confirms that he is physically fit to operate the crane, if required by national or regional regulations.
- The crane operator is authorized to operate the crane.
- The crane operator is suitably trained with regard to the crane type to be operated. The crane operator has sufficient knowledge about the crane, the control and the safety equipment of the crane.
- The crane operator has the necessary knowledge to act independently in emergency situations and in the case of special events.
- The crane operator is trained in the use of and is familiar with all fire extinguishers on the crane.
- The crane operator is able to evaluate distances, heights and spaces.
- The crane operator is familiar with driving the crane from the driver's cab.
- Depending on the crane type, the crane operator is familiar with driving the crane from the crane cab.
- The crane operator is familiar with the maintenance and inspection schedule and the recommended procedures and preventive measures.
- The crane operator is familiar with the signal signs according to the regulations at the job site.

### 3.5 Slinger

The slinger has the following responsibilities:

- The slinger is responsible for fastening and loosening the load to or from the crane load carriers.
- The slinger is responsible for using the correct fastening equipment, load handling equipment and the correct equipment in compliance with the job planning for proper load handling.
- The slinger is responsible for guiding the load.
- When more than one slinger is present, at every moment only one slinger is responsible for the signal for releasing the load for the stroke.

The slinger fulfils the following requirements:

- The slinger fulfils the requirements in the section “Guide”.
- The slinger is physically able to use the load handling equipment, fastening equipment and the equipment.
- The slinger is physically able to guide the load.
- The slinger is authorized to give signal signs.
- The slinger is authorized to perform fastening operations.
- The slinger has received training in fastening techniques.
- The slinger has received training in securing against unforeseen unhooking of load handling equipment or fastening equipment.
- The slinger has received training in avoiding damage to load handling equipment and fastening equipment.
- The slinger is able to select the required load handling equipment, fastening equipment and equipment in a suitable condition for the load to be lifted.
- The slinger is aware of the weight of the load to be lifted with the dimensions and distance from the crane.
- The slinger is able to fasten balanced loads.
- The slinger is able to give precise and clear verbal instructions when audio devices are used (radio equipment, for example) and can use this equipment.

### 3.6 Guide

The guide has the following responsibilities:

- The guide is responsible for relaying the signal from the slinger to the crane operator.
- The guide is responsible for directing the crane movements, the load and travel movements.  
The guide must select a suitable position that ensures visual contact with the crane operator. If the guide does not have visual contact with the crane operator, the responsibility must be transferred to another guide.  
Alternatively, other suitable acoustic or visual methods can be used.
- When more than one guide is present, at every moment only one guide is responsible.
- If while the crane is being used, the responsibility for directing the crane movements, the load and the travel movements is transferred to another person, the guide must clearly notify the crane operator that the responsibility was transferred and to whom. Furthermore, the crane operator and the newly designated person must clearly indicate that they accept the transfer of the responsibility.

The guide fulfils the following requirements:

- The guide is authorized to give signal signs.
- The guide has received training in guidance and is familiar with the signal signs according to the regulations at the job site.
- The guide is able to evaluate distances, heights and spaces.
- The guide is able to safely guide the load.
- The guide is able to safely direct the crane movements, the load and the travel movements.
- The guide is aware of the hazards that can result from the crane movements, load, travel movements and conditions at the job site. The guide selects a safe working position for themselves.
- The guide is able to give precise and clear verbal instructions when audio devices are used (radio equipment, for example), and can use this equipment.

### 3.7 Assembly personnel

The assembly technician has the following responsibilities:

- The assembly technician is responsible for crane assembly and disassembly and for the equipment in compliance with the manufacturer's crane documentation.
- When two or more people are required for an activity, one person is appointed as the "responsible technician", to constantly monitor assembly and disassembly. The responsible technician is responsible for proper assembly and disassembly of the crane and the equipment.
- The assembly technician has read and understood the operating instructions, assembly plans, rod plans and all other documents necessary for assembly and disassembly.
- The assembly technician is aware of the weight of the load to be lifted and, in particular, of the crane components to be assembled, with the dimensions and distance from the crane.
- The assembly technician shall not make any alterations or repairs to the crane without consulting with the operating company and receiving written approval.
- The assembly technician carries out all the tasks assigned to them by their role in the manufacturer's maintenance and inspection plan.
- The assembly technician shall immediately clarify anything that is not clear with their supervisor.

The assembly technician fulfils the following requirements:

- The assembly technician fulfils the requirements in section "Slinger" and section "Guide".
- The assembly technician is physically able to use the load handling equipment, fastening equipment and the equipment as well as tools and work equipment.
- The assembly technician is able to work at heights in a confident and safe manner.
- The assembly technician has received suitable training in the assembly and disassembly and in the method of operating the crane type to be set up.
- The assembly technician has received suitable training in the erection and testing of the safety equipment on the crane to be set up.
- The assembly technician is familiar with the crane that is being assembled or disassembled by the assembly technician. The assembly technician is familiar with the resulting dangers.
- The assembly technician is familiar with the procedures and precautions for assembly and disassembly.
- The assembly technician is able to select the required load handling equipment, fastening equipment and equipment. The suitable condition of the load handling equipment, fastening equipment

and equipment depends on the load to be lifted, and in particular the crane components to be assembled.

- The assembly technician is able to fasten balanced loads in accordance with the crane documentation, and in particular with the crane components to be assembled.
- The assembly technician is familiar with the maintenance and inspection schedule and the recommended procedures and preventive measures.

### 3.8 Auxiliary operator

The auxiliary operator follows the instructions of the other defined roles. The activities of the auxiliary operator must be monitored by the other defined roles and checked at the end. The auxiliary operator is **not** authorized to make further decisions that go beyond the ancillary tasks assigned to them.

The auxiliary operator has the following responsibilities:

- The auxiliary operator supports the other defined roles during the work process by performing manual and supervisory tasks. These tasks include, for example, handing tools and auxiliary materials, aligning tools, connecting tool parts and auxiliary materials, as well as monitoring movements in hard to see areas.

The auxiliary operator fulfils the following requirements:

- The auxiliary operator knows the steps of the work procedure for which the auxiliary operator is providing support.
- The auxiliary operator has a technical understanding and knowledge of common tools.
- The auxiliary operator is capable of carrying out technical activities with tools and measuring equipment.
- The auxiliary operator is able to fulfil the ancillary activities assigned to them in a reliable manner.

### 3.9 Maintenance technician

The maintenance technician has the following responsibilities:

- The maintenance technician is responsible for the assigned crane maintenance according to the maintenance and inspection schedule and for guaranteeing safe and problem-free operation.
- The maintenance technician performs all required maintenance work in compliance with the manufacturer's maintenance and inspection schedule and within the framework of a systematic procedure for creating a safe working environment. See section "Safe working environment" in this chapter.
- The maintenance technician has read and understood the operating instructions and all other necessary documents.
- The maintenance technician uses only original spare parts from Liebherr-Werk Ehingen GmbH.

The maintenance technician fulfils the following requirements:

- The maintenance technician is physically able to use the load handling equipment, fastening equipment and the equipment.
- The maintenance technician is trained personnel with qualified training, who have the technical knowledge and experience required to perform the respective maintenance operations.
- The maintenance technician is properly trained and authorized, according to the obligations of the operating company. This includes participation in corresponding courses, when special equipment is used.
- The maintenance technician is familiar with the maintenance and inspection schedule and the recommended procedures and preventive measures.
- The maintenance technician is familiar with the crane to be serviced and the resulting dangers.

### 3.10 Authorized and trained service technician

The service technician has the following responsibilities:

- The service technician is responsible for carrying out the assigned crane maintenance and repairs to guarantee safe and satisfactory operation.
- The service technician performs all required work in compliance with the manufacturer's maintenance and inspection schedule and within the framework of a systematic procedure for creating a safe working environment. See section "Safe working environment" in this chapter.



- The service technician only carries out work for which the service technician was authorized and trained to carry out by Liebherr-Werk Ehingen GmbH or a Liebherr service point.

The service technician fulfils the following requirements:

- The service technician has comprehensive detailed knowledge about the components and systems.

### 3.11 Authorized inspector

The authorized inspector has the following responsibilities according to national and regional regulations:

- The authorized inspector carries out inspections and maintenance on the crane in accordance with the manufacturer's inspection schedule to guarantee further, safe and reliable crane operation.
- The performance of these inspections and maintenance requires particular technical competency and therefore **cannot** be performed by maintenance personnel or authorized and trained service personnel.
- The authorized inspector carries out acceptances and product certifications, on behalf of a notified body, according to the applicable, valid directives and standards.
- The authorized inspector provides the operating company with permission and approval for further use of the component and / or the crane.
- The authorized inspector has the authority to prohibit further use of the component and / or the crane.
- The authorized inspector documents the test results in a suitable document.

The authorized inspector fulfils the following requirements:

- The authorized inspector has the required knowledge for inspecting the components.
- The authorized inspector has experience in inspecting the components.
- The authorized inspector has knowledge about the valid standards, directives, national and regional regulations and accident prevention regulations.
- The authorized inspector fulfils the requirements according to national and regional regulations.
- If required by national or regional regulations: The authorized inspector is appointed by an independent accreditation body or similar.

## 4 Instructions to personnel

### 4.1 Before the start of crane operation

Carry out the following checks before starting to work with the crane:

- Make sure that job planner determines the set up configuration and positioning of the crane, use of supports and ground conditions.
- Make sure that the permissible crane utilization and the load carrying capacity of the ground is not exceeded.
- Check the proper assembly of the crane parts according to the crane documentation.
- Check all accessible ropes, rope end connections, winches, rope pulleys and hook blocks for visible defects.
- Check the displays for operating fluids and system parameters as well as the wind speed.
- If a BTT or radio remote control is present: Check the assignment of the BTT or the radio remote control with the crane.
- Check the safety equipment: For example overload protection, limit switch.
- Check the warning devices: Output of acoustic and optical warning signals.
- Check the function of the brakes.
- Ensure a good view of the load and working area.
- Ensure communication between the crane operator, slinger and guide. Make sure that the signals for communication between personnel are agreed upon prior to their use.
- Make sure that all control systems are in the neutral or idle position before starting the drive assembly.
- Make sure that only necessary persons are in the danger zone. For the rules, see section "Danger zone of the crane".

## 4.2 While working with the crane

Observe the following basic safety requirements while working with the crane:

- Make sure that personnel know how to proceed in the case of a storm or thunderstorm.
- After a potential lightning strike: Check the crane.
- Make sure that only necessary persons are in the danger zone. For the rules, see section “Danger zone of the crane”.
- The crane operator must give an acoustic warning sign prior to a lifting movement.
- The crane operator must exclude hazards by crane movements. The crane operator gives the warning signs at their own discretion and decides if the crane movements are stopped.
- Do not move loads over personnel.
- The crane operator monitors the load for all crane movements or the load lifting devices when moving the crane without a load. If observation is not possible, the crane can be controlled only with the aid of a guide.
- Only move loads attached by hand when the crane operator has received a clear sign from the slinger, the guide or another authorized person.
- Make sure that only properly fastened loads are carried.
- Make sure that the load or load handling equipment does not touch the boom.
- When a load is suspended on the crane, the crane operator must keep their hands near the control systems.
- In the case of an emergency, stop the crane movements and set down the load if necessary.
- Make sure that the crane movements are not shut off when multiple crane movements are controlled at the same time.
- Do **not** run up against end positions that are limited by a limit switch during operation.
- Do **not** drag the load on the ground. Make sure that the hook is located vertically over the center of gravity of the load. Only lift the load off the ground vertically and only with the hoist gear.
- In the limit ranges of the load chart and the overload protection: Proceed carefully. Prevent shut-offs.
- Make sure that the regulations are observed when bypassing the overload protection.
- Comply with the specifications for emergency operation.

## 4.3 Leaving the crane, ending work with the crane

Comply with the following basic safety requirements before leaving the crane:

- In the case of unpredictable weather conditions and exceedance of the maximum permissible wind speed, take down the equipment and boom. Telescope the telescopic boom in. If necessary: Adjust the set up configuration, dismantle the boom.
- Make sure that, with the help of the weather forecast, the permissible wind speed depending on the crane condition is not exceeded. Comply with the specifications in the wind speed charts, erection and take-down charts and in the load chart manual. If necessary: Adjust the set up configuration, dismantle the boom.
- Bring the control systems to the neutral or idle position before leaving the control platform.
- Turn the engine off.
- During take-down, protect the BTT or radio remote control against unauthorized turning on.
- Close the crane cab and if present the driver's cab.
- Observe the regulations concerning interrupting work with the crane with a set up crane.
- Observe the regulations concerning interrupting work with the crane with a set up crane out of operation.

# 5 Danger zone of the crane

## 5.1 Crane in operation

The danger zone of the crane is made up of the areas that are accessed during crane operation by the load or by movements of the crane or the crane components.

**WARNING**

Remaining in the danger zone!

Personnel within the danger zone can be hit by falling loads or components.

Personnel in the danger zone can be caught by moving crane components or loads.

Fatal or severe injuries can be the result.

- ▶ Warn any personnel in the danger zone with the crane warning device.
- ▶ After the warning is issued, wait and ensure that no personnel remains in the danger zone.
- ▶ If required, block off the danger zone at a safety distance.

## 5.2 Crane out of service

Take the crane out of service, failure to comply with the regulations represents considerable danger for the entire area around the crane.

**WARNING**

Actual wind speed higher than the wind speed permitted for the crane set up configuration!

Personnel in the danger zone can be hit by a toppling crane or crane components.

- ▶ Make sure that the condition of the crane complies with the regulations and the wind speed charts.
- ▶ If required, block off the danger zone at a safety distance.

**WARNING**

Icing on the boom!

Personnel within the danger zone can be hit by a falling ice.

- ▶ Make sure that there are no persons in the danger zone.
- ▶ If required, block off the danger zone at a safety distance.

## 6 Traffic endangerment and environmental damage

**WARNING**

Danger of slipping and skidding!

If the road becomes contaminated due to technical defects, open tank covers or leaking hydraulic oil, then this would pose a severe traffic endangerment.

Fatal accidents can result.

- ▶ Remove oil immediately and thoroughly.

## 7 Endangering air traffic

When working with crane, heights are reached which could endanger air traffic. This applies especially to areas near airports.

**WARNING**

Endangering air traffic!

If no protective measures are taken, this can result in endangerment to air traffic.

- ▶ Obtain approval from the agency responsible for air traffic.
- ▶ Observe the national and regional regulations. For example, in order to identify aviation obstructions.
- ▶ Carry out identification if required according to the national and regional regulations (for example with flags or warning signs).
- ▶ Assemble the airplane warning light on the boom head and turn it on.
- ▶ If the airplane warning lights is operated for a longer period of time, with the engine turned off, then the battery can be discharged and as the result the airplane warning light turns off. To prevent the battery from discharging, an external electrical power supply must be established.

## 8 Movement on the crane



### WARNING

Working at heights without suitable aids and fall protection equipment!

Danger of falling.

- ▶ Always use proper fall protection equipment according to national and regional regulations.
- ▶ Comply with the specifications in section "Personal protective equipment".
- ▶ Comply with the specifications in section "Aids for working at a height".
- ▶ Comply with the specifications for fall protection equipment on lattice sections and booms, see section "Securing persons to prevent them from falling".
- ▶ Comply with the specifications for the fall protection equipment, see chapter 2.06 and chapter 2.07.

When railings are available:

- ▶ Make sure that the railings are swung in and secured in the operating position.

When the railings are **not** assembled in the operating position:

- ▶ Make sure that personnel are secured with the supplied fall arrest system, see section "Personal protective equipment".

### 8.1 Aids for working at a height

All work at a height, when there is a danger of falling, must be carried out with suitable aids.

Part of the category "Aids for working at a height" are, for example:

- Work platforms
- Scaffolding
- Assembly platform
- Catwalks
- Ladders

When working at a height, working on a work platform, scaffolding, assembly platform, catwalk or similar is preferential to working on a ladder.



### WARNING

Persons not secured when working at a height!

Personnel can fall down. Death, severe bodily injuries.

When work platforms, scaffolding, catwalks or similar are not available and the work cannot be carried out from the ground:

- ▶ Secure personnel with the supplied fall arrest system to prevent falling.

When fall protection equipment such as hook points, safety ropes and fastening points are available on the crane:

- ▶ Secure personnel with the fall arrest system to the fall protection equipment. See chapter 2.06.

When stepping on a ladder:

- ▶ Do not hold any objects in your hands.
- ▶ Adhere to the 3-point support. See chapter 2.04.10.

Rules when using the aids:

- Step on the ladder only with clean shoes.
- Keep it free from heavy dirt deposits.
- Keep it free of snow and ice.

### 8.2 Accessible surfaces

Flat accessible surfaces have an anti-slip coating:

- Self-adhesive slip-resistant mats
- Sanding
- Painting

Accessible surfaces are, for example:

- Walking surfaces and stepping surfaces
- Stairs
- Ladders
- Gratings
- Platforms

Only step on the crane on the marked, accessible surfaces, see chapter 2.07.

Do **not** step on the driver's cab roof or crane cab roof, see chapter 2.05.



### WARNING

Danger of slipping and falling!

The traction of accessible surfaces and hand rails changes due to effects of the weather, such as wetness, snow, ice, frost and dirt.

Personnel can slip and fall down from the crane. Death, severe bodily injuries are possible.

The crane can be damaged.

- ▶ Step on the accessible surfaces only by taking the present conditions into account, such as icing in winter or dirt.
- ▶ Step or place a load only on the approved accessible surfaces.
- ▶ Comply with the specifications on the signs.
- ▶ Replace damaged safety signs (warning signs) immediately.



### WARNING

Slippery surfaces, lack of stability!

Personnel can fall down. Death, severe bodily injuries.

- ▶ Keep accessible surfaces free of objects and obstacles.
- ▶ Only step on accessible surfaces with a sufficiently clear height.
- ▶ Step on accessible surfaces only with clean shoes.
- ▶ Keep accessible surfaces free of heavy dirt, snow and ice!
- ▶ Stepping on accessible surfaces by persons, including tools and equipment, weighing more than 150 kg is prohibited.
- ▶ Do **not** step on damaged accessible surfaces.
- ▶ Replace any damaged or missing accessible surfaces immediately.
- ▶ Order the spare parts for accessible surfaces from Customer Service at Liebherr-Werk Ehingen GmbH.
- ▶ Do **not** trip over attachment parts.
- ▶ Personnel must wear an approved fall arrest system and protective equipment before performing any work on the crane superstructure.

When fall protection equipment is **not** in the assembly / disassembly position or personnel are on **non-accessible** surfaces:

- ▶ Personnel must hook themselves to the hook points and safety ropes with an approved fall arrest system to prevent falling.



### WARNING

Danger of tripping and falling!

When walking on a lattice boom / lattice section, there is a danger of tripping due to attachment parts.

Personnel can fall down. Death, severe bodily injuries.

- ▶ Personnel must hook themselves to the hook points and safety ropes with an approved fall arrest system to prevent falling.
- ▶ A grating is approved for a maximum of two people with a total weight of 150 kg including tools and equipment.
- ▶ No objects, such as boom components or a pin pulling aggregate may be placed or moved on the grating.

## 9 Emergency exit - driver's cab



### WARNING

The driver's cab **can** not be left using the normal path!  
 Danger of falling when exiting.  
 Crane damaged, inclined or tipped over: Increased danger of falling when exiting.

- ▶ Exit carefully in an emergency.

If the crane is damaged, inclined or tipped over:

- ▶ Accept help from others if possible.

The driver's cab can be exited through the driver's door or the passenger door.

### 9.1 Emergency exit through an open door

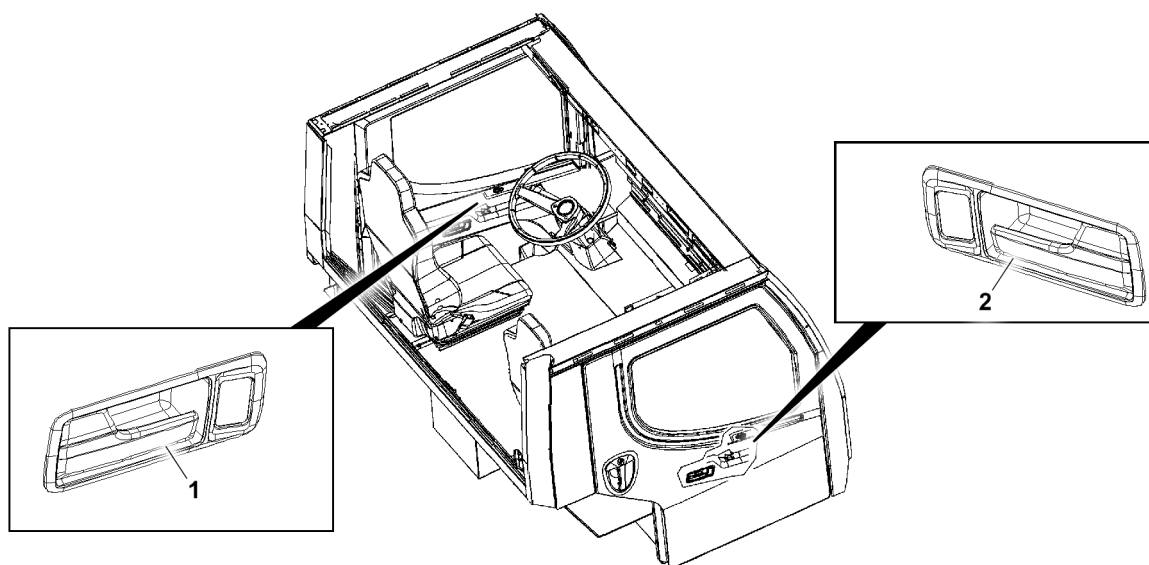


Fig.160365: Example of an emergency exit through an open door

Emergency exit through the open driver's door:

- Pull the door handle *to the left* 1 and open the driver's door.
- Leave the driver's cab through the driver's door.

Emergency exit through the open passenger door:

- Pull the door handle *to the right* 2 and open the passenger door.
- Leave the driver's cab through the passenger door.

## 10 Emergency crane cab exit



### WARNING

The crane cab **can** not be left using the normal path!  
 Danger of falling when exiting.  
 Crane damaged, inclined or tipped over: Increased danger of falling when exiting.

- ▶ Exit carefully in an emergency.

If the crane is damaged, inclined or tipped over:

- ▶ Accept help from others if possible.

The crane cab can be left in different ways depending on the type of crane:

- Emergency exit through the open cab door

- Emergency exit through the open front window
- Emergency exit through the roof window with emergency release
- Emergency exit through the side window with emergency release

**Note**

Each crane cab has at least a suitable window for an emergency exit.

- ▶ Windows with sufficiently large openings can be used as an emergency exit depending on the emergency situation.
- ▶ Some windows require an emergency release in order to create an opening large enough to climb through.

Not all windows can be used for an emergency exit:

- ▶ Some windows are kept small for safety reasons or secured, for example with a securing bracket.

## 10.1 Emergency exit through the open cab door

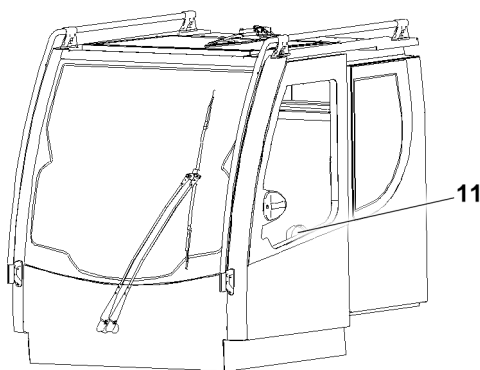


Fig.160389: Emergency exit through the open cab door

Emergency exit through the open cab door:

- Turn the inner door handle 11 and open the cab door.
- Leave the crane cab through the cab door.

## 10.2 Emergency exit through the open front window

For crane types with a tipping front window

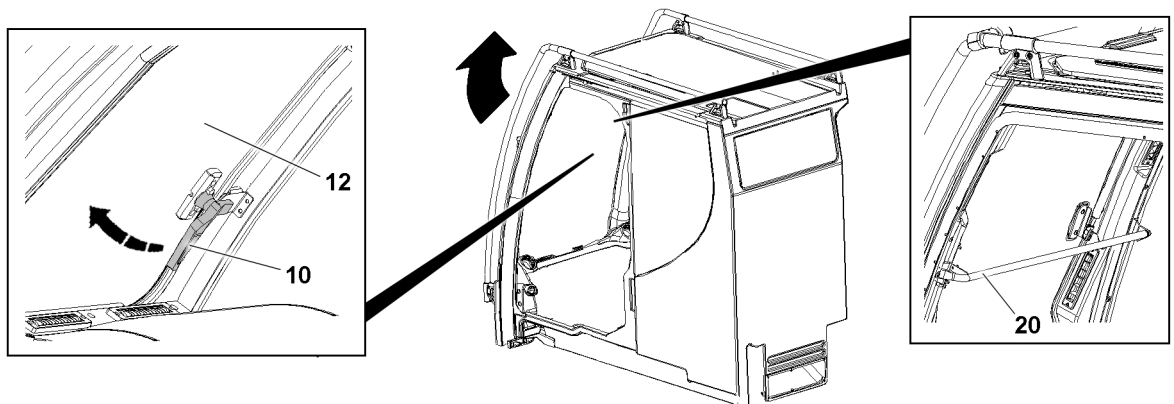


Fig.157680: Emergency exit through the open front window

**Note**

- ▶ The front windows 12 with a securing bracket 20 are not designed as an emergency exit.

- Release all turn handles **10** on the front window **12**.
- Open the front window **12**.
- Leave the crane cab through the front window **12**.

### 10.3 Emergency exit through the roof window with emergency release



#### Note

When the roof window is closed, the emergency release is difficult to operate.

- ▶ First open the roof window.

There are two variations of the emergency release:

- Window handle emergency release
- Gas pressure spring emergency release

#### 10.3.1 Emergency release on the window handle

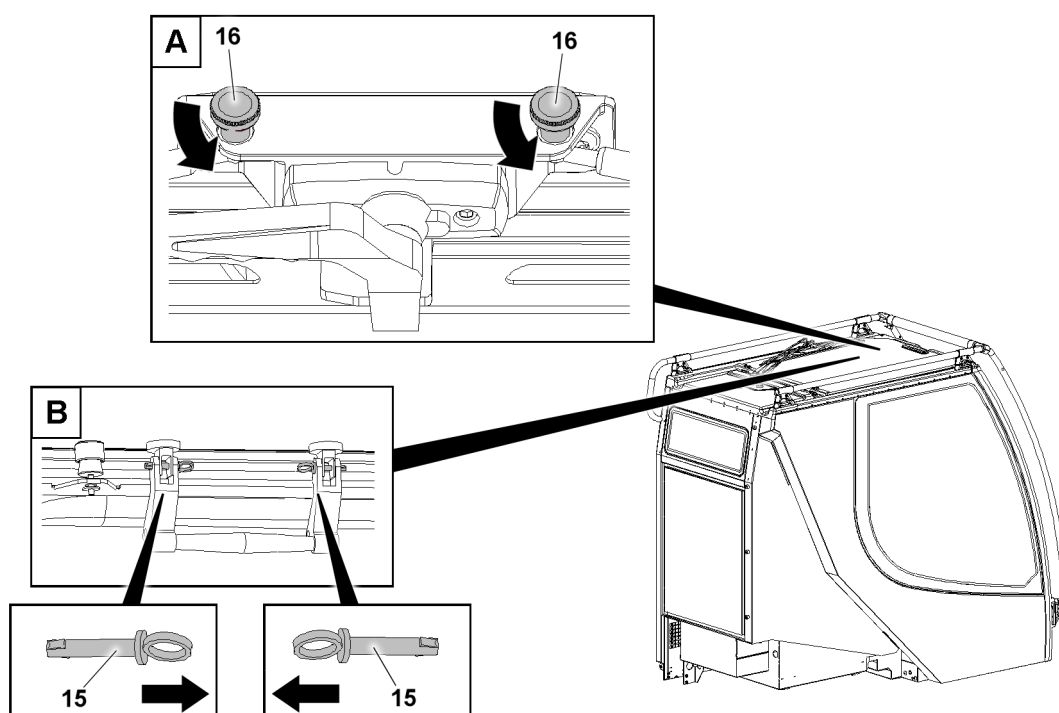


Fig.160655: Emergency release on the window handle

For crane types with an emergency release on the roof window:

- Open the roof window with the window handle.
- Operate the emergency release for the roof window, see variation A or variation B.

Variation A:

- Turn both thumbscrews **16** counterclockwise and release.

Variation B:

- Unpin both pins **15** by pulling them.
- Leave the crane cab through the roof window.



### 10.3.2 Gas pressure spring emergency release

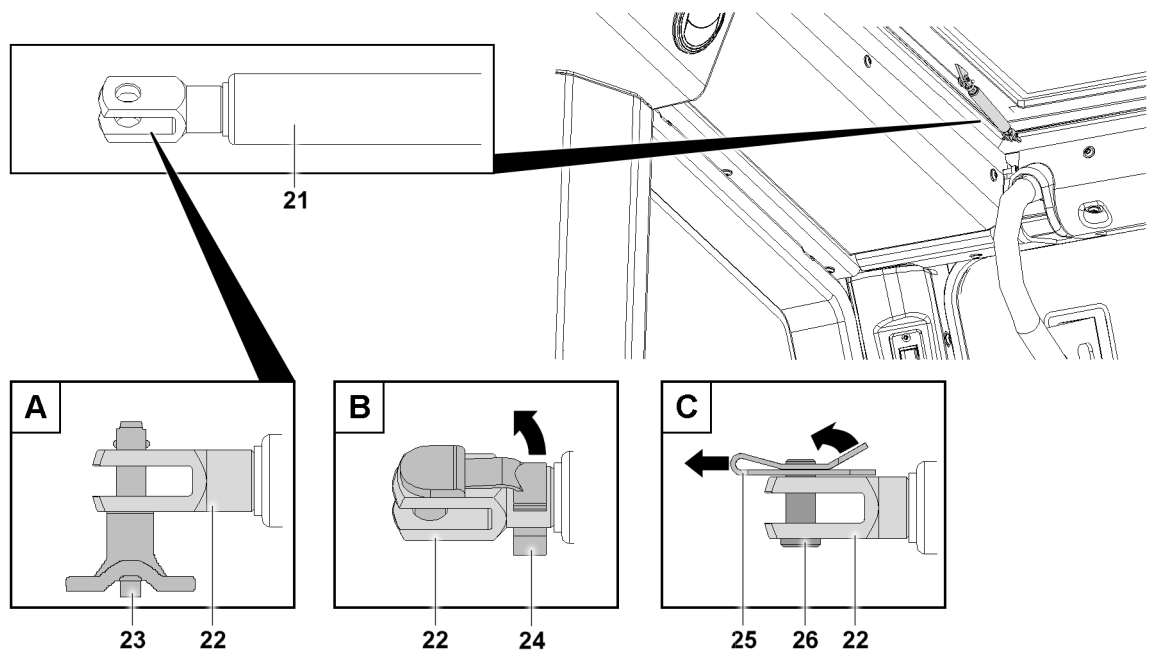


Fig.160604: Gas pressure spring emergency release

For crane types with an emergency release on the roof window:

- Open the roof window with the window handle.
- Operate the emergency release for the roof window on the gas pressure spring **21**, see variation A, variation B or Variation C:

Variation A:

- Release the ball locking pin **23** by pressing and holding the press button on the side of the handle.
- Unpin the ball locking pin **23** by pulling it out of the fork head **22**.

Variation B:

- Release the pin **24** on the fork head **22** by swinging it.
- Unpin the released pin **24** by pulling it out of the fork head **22**.

Variation C:

- Lift the retaining element **25** on the protruding part and push it away at the same time.
- Unpin the released pin **26** by pulling it out of the fork head **22**.
- Leave the crane cab through the roof window.

## 10.4 Emergency exit through the side window with emergency release

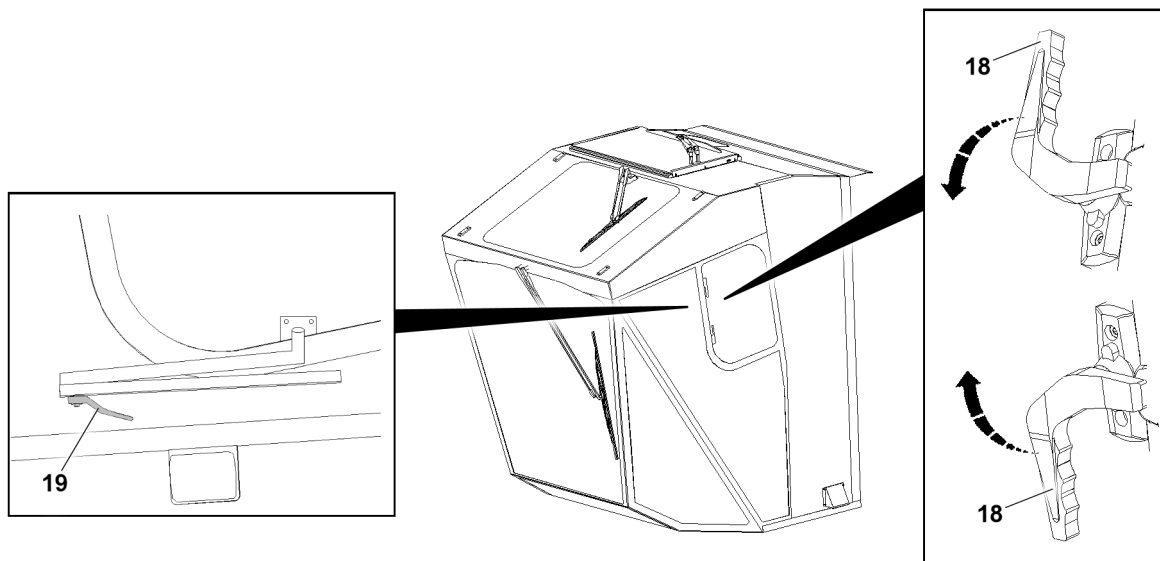


Fig.158755: Emergency exit through the side window with emergency release

For crane types with an emergency release on the side window:

- Release all turn handles **18** on the side window.
- Disassemble the clamping lever **19** on the side window.
- Open the side window completely.
- Leave the crane cab through the side window.

## 11 Personal protective equipment

Persons are exposed to various dangers when working on the crane.

Personal protective equipment is required when the risk assessment by the operating company has shown that risks cannot be avoided or sufficiently limited:

- By protective technical devices
- By organizational measures

When working on the crane, the required personal protective equipment according to national and regional regulations and accident prevention regulations must be provided and used.

Personal protective equipment protects against risks that can have severe results such as death or serious damage to health and injuries.

Personal protective equipment includes, for example:

- Supplied fall arrest system (safety harness and height safety equipment)
- Any supplied height rescue system
- Industrial helmet
- Safety shoes
- Protective gloves
- Safety goggles
- Warning apparel
- Hearing protection
- Respiratory protection

### 11.1 Rules for the use of personnel protective equipment

The operating company must ensure the following:

- Personal protective equipment is provided.

- Personnel are instructed in the use of personal protective equipment.
- The provided personal protective equipment is taken along and used.
- The operating instructions and maintenance instructions of the manufacturer for the personal protective equipment are observed and complied with.

Check and replace the personal protective equipment:

- Personal protective equipment is checked for damage and completeness before use.
- Defective or damaged personal protective equipment is replaced immediately with functioning protective equipment.
- Protective equipment is replaced when the maximum service life specified by the manufacture has been reached.
- Damaged fall arrest systems with height rescue systems will be replaced immediately and handed over to an authorized inspector.
- The product identifications are regularly checked for damage.
- Personal protective equipment with damaged product identification is replaced immediately.

## 11.2 Supplied fall arrest system

Personnel must work at a height often when working on the crane. Working at a height is connected with a risk of falling. Working at a height without suitable fall protection equipment can lead to serious injuries or death.

Always use proper fall protection equipment according to national and regional regulations.

A fall with a fall arrest system cannot exclude an injury. The fall arrest system reduces the severity of the injuries by catching the user during a free fall and limiting the impacts on the body from being caught.

When no other safety measures are possible for working in the presence of a fall hazard, the supplied fall arrest system must be used.

Rules for handling the fall arrest system:

- Utilize exclusively a fall arrest systems from Liebherr-Werk Ehingen GmbH.  
Or use fall arrest systems that correspond to the specifications that are listed in the Liebherr spare parts catalog of the respective crane.
- Do **not** use a damaged fall arrest system.
- Replace a damaged fall arrest system immediately with a new fall arrest system.
- Do **not** use the fall arrest system as fastening equipment for loads.

Protect the fall arrest system against the following external influences:

- Extreme temperatures
- Guiding the connecting devices over or around sharp edges
- Effects of chemicals
- Electrical influences
- Cuts, wear
- Climatic effects



### Note

If the fall arrest system (safety harness and height safety equipment) is not available or is damaged:

- ▶ Order it from Liebherr-Werk Ehingen GmbH.
- ▶ Or obtain a fall arrest systems that correspond to the specifications that are listed in the Liebherr spare parts catalog of the respective crane.

Identification and operating instructions:

- The supplied fall arrest system must be clearly and permanently identified.
- If the identification is no longer legible, then the supplied fall arrest system must be immediately replaced and handed over to an authorized inspector.

### 11.3 Components of the supplied fall arrest system

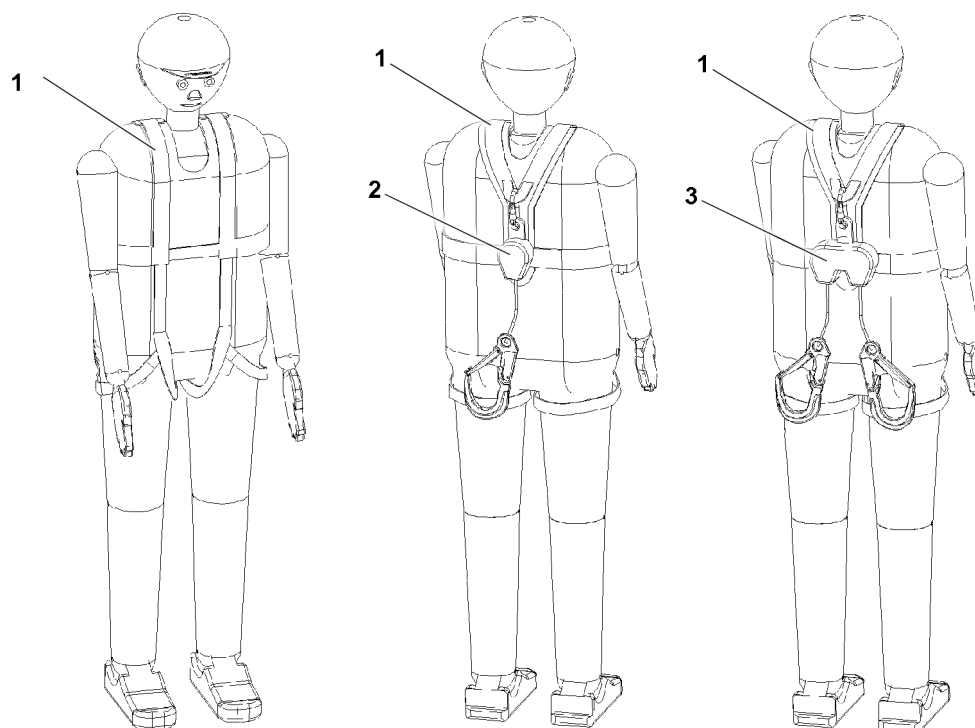


Fig.159819: Examples of a safety harness with height safety equipment

- 1 Safety harness  
 2 Height safety equipment, 1-strand  
 3 Height safety equipment, 2-strands

The fall arrest system consists of the following components:

- Safety harness
- Height safety equipment, 1-strand or 2-strands

Component	Description	Properties
Safety harness	<p>A safety harness is a body retaining device that is used in a fall arrest system.</p> <p>It consists of belt straps, fittings, buckles and other individual parts.</p> <p>The safety harness holds the body of the user after being caught from a fall.</p>	<p>It is approved according to <b>EN 361</b></p>

Component	Description	Properties
Height safety equipment, 1-strand	Height safety equipment with an extendable belt strap and snap hook with swivel  Provided for all cranes that do not have walking surfaces with safety ropes.	It is approved according to <b>EN 360</b> (for horizontal use and sharp edges).
Height safety equipment, 2-strands	Height safety equipment with two extendable belt straps and snap hooks with swivel  Provided for cranes with walking surfaces and two ropes as fastening device on the left and right hand side of the walking surface, for example lattice sections, lattice booms, telescopic booms or assembly units.	It is approved according to <b>EN 360</b> (for horizontal use and sharp edges).

#### *Components of the supplied fall arrest system*

The fall arrest system supplied by Liebherr-Werk Ebingen GmbH is designed in accordance with the crane structure.

Utilize exclusively a fall arrest system from Liebherr-Werk Ebingen GmbH.

Prior to use of the crane:

- Make sure that the fall arrest system is completely available and functional.
- Check the fall arrest system before use for visible defects. In the case of visible defects: Replace the fall arrest system immediately.

Rules for handling the fall arrest system:

- Comply with the specifications of the operating instructions for the fall arrest system.
- Check the fall arrest system before use for visible defects. In the case of visible defects: Replace the fall arrest system immediately.
- The fall arrest system must be worn where no other fall protection equipment, such as railings, can be installed for technical reasons.
- The fall arrest system is effective from a height of 2.5 m. The fall space must be free of obstacles.
- Do **not** change the configuration of the fall arrest system.
- Do **not** lengthen or shorten the fall arrest rope.
- A fall absorber is integrated in the height safety equipment. Do **not** use an additional fall absorbers.
- Fasten the fall arrest system only to the structural hook points, safety ropes and fastening points. See chapter 2.06.

Behavior in the case of a fall, damage or impairment of functionality:

- In the case of damage or impairment of the functionality: Have the fall arrest systems replaced immediately and checked by an authorized inspector.
- The fall arrest system may only be used further after written and documented approval.
- Fall arrest systems that are not longer approved may **not** be used. Unapproved fall arrest systems must be disposed of and replaced with new fall arrest systems.

Storage of the fall arrest system:

- Store the fall arrest system dry and without the effect of UV radiation in the corresponding transport bag.

The operating company must ensure the following:

- Personnel must be instructed at least once a year on how to use the supplied fall arrest system (safety harness and height safety equipment) with practical exercises. Performance of the instruction and exercises must be documented.
- The safety harness and height safety equipment must be checked at least once a year by an authorized inspector. The results must be documented in the fall arrest system inspection log book.

### 11.3.1 Using 1-strand height safety equipment

Fasten the fall arrest system with 1-strand height safety equipment only to the structural hook points and fastening points.

### 11.3.2 Using 2-strand height safety equipment

Fasten the fall arrest system with 2-strand height safety equipment only to the structural hook points, safety ropes and fastening points.

When two safety ropes are present on the booms, lattice sections or other components:

- **Only** use the height safety equipment with two belt straps.
- Per safety rope: Connect one belt strap with snap hook for the fall arrest system.
- When transferring to new safety equipment, a snap hook for the fall arrest system must **always** be connected.

## 11.4 Supplied height rescue system

The height rescue system is only supplied for certain crane types.

The height rescue system is an evacuation and rescue device. It is used to lift the fallen person to be able to unhook him from the height safety equipment and to lower him by rope.

The height rescue system consists of the following components:

- Rappelling rescue device
- Telescopic rod for connecting the snap hook to the safety harness

Component	Description	Properties
Rappelling rescue device	For rescuing a suspended person who cannot free themselves with their own strength.	It is approved according to <b>EN 361</b>
Snap hook	Connecting element	Trilock lock
Telescope rod with assembled carabiner retainer	As an aid for attaching the rescue rope	Extendable

#### *Components of the height rescue system*

The operating company must ensure the following:

- Personnel must be instructed at least once a year on how to use the height rescue system with practical exercises. Performance of the instruction and exercises must be documented.
- The height rescue system must be checked at least once a year by an authorized inspector. The results must be documented in the height rescue system inspection log.

Storage of the height rescue system:

- Store the height rescue system dry and without the effect of UV radiation in the corresponding transport bag.

Protect the height rescue system from external influences, for example:

- Extreme temperatures
- Effects of chemicals
- Electrical influences
- Cuts, wear
- Climatic effects

Before every use of the crane:

- Make sure that the height rescue system is completely available and functional.
- Check the height rescue system for visible defects. In the case of visible defects: Replace the height rescue system immediately.

Handling the height rescue system:

- Comply with the specifications of the operating instructions for the height rescue system.

- Do **not** change the configuration of the height rescue system.

Behavior in the case of a fall, damage or impairment of functionality:

- In the case of damage or impairment of the functionality: Do **not** use the height rescue system.
- In the case of damage or impairment of the functionality: Have the height rescue system replaced **immediately** and checked by an authorized inspector.
- After every use: Have the height rescue system checked immediately by an authorized inspector. The results must be documented in the height rescue system inspection log.
- The height rescue system may only be used further after written and documented approval.
- Height rescue systems that are no longer approved may **not** be used. Unapproved height rescue systems must be disposed of and replaced with new height rescue systems.

## 11.5 Further protective equipment

Required personal protective equipment must be provided and used according to national and regional regulations.

The protective equipment listed below is not provided.

Name	Description	Recommendation
Industrial helmet	Protection against head injuries, for example, due to: Striking, falling objects and oscillating objects	Industrial helmet with a chin strip should be preferred.
Protective gloves	Protection against pointed or sharp objects  Protection against hot surfaces or operating fluids  Protection against grazing, scratches	Depending on the task and the danger: Wear suitable protective gloves.  For example: Puncture resistant, abrasion resistant, heat-resistant, impermeable, slip-proof
Safety shoes	Protection against falling objects or components  Protection against slipping on slippery ground or accessible surfaces	Depending on the task and the danger: Wear suitable safety shoes.  For example: With toe protection, anti-slip soles, antistatic properties
Safety clothing, for example: Safety vest, safety jacket, safety pants	Make personnel more visible and recognizable.	Reflecting for better detection when dark  Fluorescent for better detection at a far distance during the day or in poor conditions of visibility
Safety goggles	Protection against eye injury, for example when working with a grease spraying system when greasing the boom or if other lubrication or operating fluids are sprayed.	Depending on the task and the danger: Wear suitable safety goggles.  For example, protection against:  Corrosive or pressurized fluids and projecting parts  UV-rays and sun

Name	Description	Recommendation
Hearing protection	Protection against damage to hearing due to noise	Selection depending on the volume and the necessary protection effect
Respiratory protection	Protection against damage to health due to dirty air, for example when working with a grease spraying system when greasing the boom or other lubrication or operating fluids that are sprayed.	Selection depending on the hazardous substance and duration of the activity  Respiratory protection covers the mouth and nose.

*Protective equipment*

## 12 Supplied fire extinguisher

Storage of the fire extinguisher:

- To protect against damage, store the fire extinguisher in its designated location.

Before crane operation and travel operation:

- Make sure that the fire extinguisher is always freely accessible and functional.

After use:

- Have the fire extinguisher refilled immediately or replaced.

Replace the fire extinguisher immediately, if:

- It has visible defects.
- The fire extinguisher does not function.
- The inspection term specified by the manufacturer has been exceeded.
- The maximum service life specified by the manufacture has been reached.

The operating company must ensure the following:

- Personnel must be instructed at least once a year on how to use the fire extinguisher with practical exercises. Performance of the instruction and exercises must be documented.
- The fire extinguisher must be checked by an authorized inspector according to the manufacturer's specifications and national and regional regulations. The results must be documented.
- Non-functional and used fire extinguishers must be immediately repaired or replaced.

## 13 Securing persons to prevent them from falling



### WARNING

Danger of falling!

- ▶ Wear the supplied fall arrest systems (safety harnesses and height safety equipment) correctly.
- ▶ When accessing a ladder, do not hold any objects in your hands.
- ▶ When accessing a ladder, adhere to the 3-point support. See the Crane operating instructions, chapter 2.04.10.

### 13.1 Working on the telescopic boom head and / or auxiliary boom

When performing assembly or disassembly work on a ladder, people can fall down:

- A second person must be present to hand the necessary items to the person on the ladder.

Reeve the hoist rope in or out on the pulley head:

- For ladder work, use the supplied ladder: For fastening and hook points, see the Crane operating instructions, chapter 2.06.
- For cranes that carry a ladder along **with** a hook device:  
Use the hook device to secure the ladder.



- For cranes that carry a ladder along **without** a hook device:  
Use the rigging belt to secure the ladder.
- When climbing up, personnel must ensure a 3-point support.
- If there is a danger of falling, personnel must connect themselves with the snap hooks of the fall arrest system in the fastening points and secure themselves against falling.

## 13.2 Walking on the telescopic boom



### WARNING

Danger of falling!

Personnel can fall down by slipping on the telescopic boom and be killed or severely injured!

- ▶ The telescopic boom may only be accessed if personnel are protected with suitable safety measures to prevent them from falling.
- ▶ If safety ropes are present on the telescopic boom, then personnel must connect themselves with the supplied fall arrest system to the safety ropes of the telescopic boom on the left and right with both snap hooks and secure themselves against falling.
- ▶ Without safety measures, it is **strictly** prohibited to step on the telescopic boom.

Assembly of the hoist rope or the TY-guying:

- During assembly, personnel must connect themselves to the fastening devices on the left and right with both snap hooks of the fall arrest system and secure themselves against falling.

## 13.3 Climbing up to the lattice sections or booms

Climbing the ladder:

- When climbing up, personnel must ensure a 3-point support.

Changing from a ladder to a catwalk **without** a transition aid:

- From a transition height above 1.8 m: **Before** transitioning, personnel must connect at least one snap hook of the fall arrest system to a safety rope and secure themselves against falling.

Changing from a ladder to a catwalk **with** a transition aid:

- **After** transitioning, personnel must hook at least one snap hook of the fall arrest system to a safety rope and secure themselves against falling.

## 13.4 Walking on lattice sections or booms

Walking on catwalks:

- When walking on catwalks, personnel must connect themselves to the safety ropes on the left and right with both snap hooks of the fall arrest system and secure themselves against falling.
- When transferring the fall arrest system to a new lattice section, personnel must be connected with at least one snap hook of the fall arrest system to safety equipment.

## 13.5 Working on lattice sections or booms

Pinning, unpinning the lattice sections or pull rods:

- During the pinning, unpinning of lattice sections or pull rods, personnel must connect themselves to the safety ropes on the left and right with both snap hooks of the fall arrest system and secure themselves against falling.

Fastening the lattice sections:

- When fastening the lattice sections, personnel must connect themselves to the safety ropes on the left and right with both snap hooks of the fall arrest system and secure themselves against falling.

## 13.6 Climbing down from lattice sections or booms

Accessing the ladder **without** a transition aid:

- From a transition height above 1.8 m: **Before** stepping on the ladder, personnel must connect at least one snap hook of the fall arrest system to a safety rope and secure themselves against falling.

- When stepping on the ladder, personnel must ensure a 3-point support.
- The snap hook of the fall arrest system may only be disconnected after standing safely on the ladder (3-point support).

Accessing the ladder **with** transition aid:

- When stepping on the ladder, personnel must ensure a 3-point support.

Climbing down the ladder:

- When climbing down, personnel must ensure a 3-point support.

## 14 Saving personnel

The height rescue system is only supplied with certain crane types.

The height rescue system, consisting of the rappelling rescue device, is an evacuation and rescue device. It is used to lift the fallen person to be able to unhook him from the height safety equipment and to lower him by rope.



### WARNING

Danger of falling!

- ▶ Personnel must be instructed and trained properly in the correct handling of the height rescue system. Annual practical instructions and drills must be carried out.
- ▶ The supplied height rescue system must be kept available.
- ▶ Comply with the manufacturer's documentation for the height rescue system.
- ▶ Have the height rescue system checked every year by an authorized inspector and the results documented in the inspection log.

### 14.1 First aid measures after rescue



### WARNING

Danger of fatal injury!

- ▶ After the rescue, the patient must be positioned with the upper body raised (in seated or squatting position).
- ▶ Immediate flat position or even shock position can be fatal.

## 15 Crane cab

The roof of the crane cab is not designed as a support surface.



### WARNING

Standing on the roof of the crane cab!

Persons on the roof of the crane cab can fall down, break through the roof or slide off.

- ▶ Do not access the roof of the crane cab.



### WARNING

The superstructure is in a position in which it is **no** longer safe to climb up to it and it is **no** longer possible to change the position of the superstructure to a safe ascent position!

People can fall down while ascending. Death, severe bodily injuries.

- ▶ Guarantee safe ascent / descent: Set up suitable climbing aids, such as a platform or ladder.

### 15.1 Extendible step\* for cranes on tires

An extendible step allows comfortable entry into the crane cab as well as safe exit from the crane cab to the crane chassis and safe access to the turntable.

The description for an “extendible step for cranes on tires” only applies for cranes that drive on tires.

Climbing up and down takes place via the ladder on the crane chassis. See chapter 2.07 “Accesses to the crane”.



### WARNING

Extendible step in the incorrect position!

Personnel can fall down. Death, severe bodily injuries.

- ▶ Make sure that the extendible step is in the correct position.

The extendible step must be **retracted** for:

- **Access to the crane cab below the cab door**

Access to the crane cab via the ladder from the ground or when directly descending from the crane cab via the ladder to the ground

- **Access to the crane cab in front of the crane cab**

Access to the crane cab via the ladder from the ground or when directly descending from the crane cab via the ladder to the ground

The extendible step must be **extended** for:

- **Access via an extendible step from the rear**

Access to the crane cab via the crane chassis or the crane superstructure

- **Accessing via the front step**

Access to the crane cab via the crane chassis or the crane superstructure

### 15.1.1 Access to the crane cab below the cab door

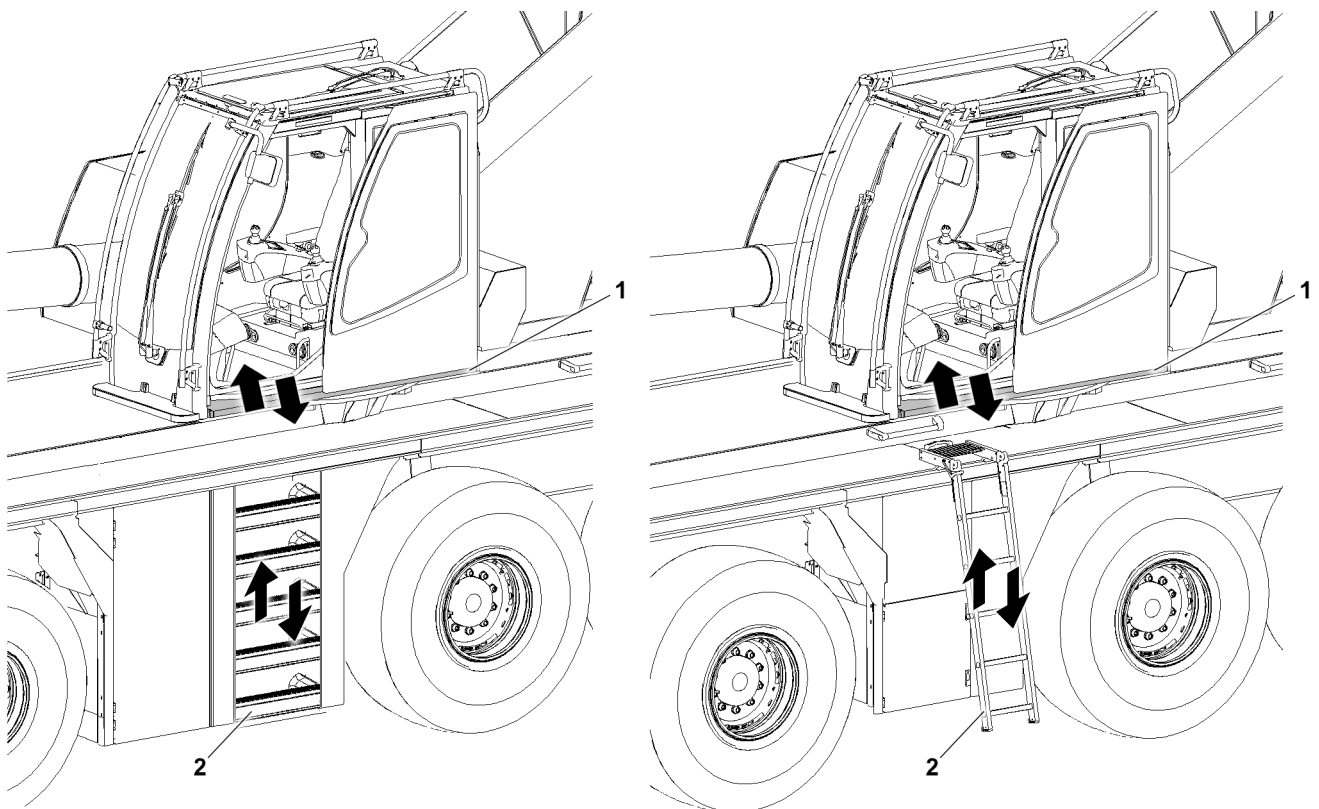


Fig.160754: Crane superstructure in the 180° position: Step **retracted**

1 Extendible step

2 Ladder / folding ladder

Prior to climbing up to the crane cab via the ladder **2** from the ground or before descending from the crane cab via the ladder **2** to the ground, the following prerequisites must be met:

- The crane superstructure is in the 180° position.
- In the case of a crane cab with incline adjustment: The crane cab is in the horizontal position.

- The extendible step **1** under the crane cab is **retracted**.
- The folding ladders **2** are in the ascent and descent position.

**WARNING**

Extendible step **1** in the incorrect position!  
Personnel can fall down. Death, severe bodily injuries.

- ▶ Make sure that the extendible step **1** is fully retracted.

**WARNING**

The step **1** **cannot** be retracted!  
People can fall during ascent and descent via the ladder **2**.  
Death, severe bodily injuries.

- ▶ Guarantee safe ascent / descent: Set up suitable climbing aids, such as a platform or ladder.

### 15.1.2 Access to the crane cab in front of the crane cab

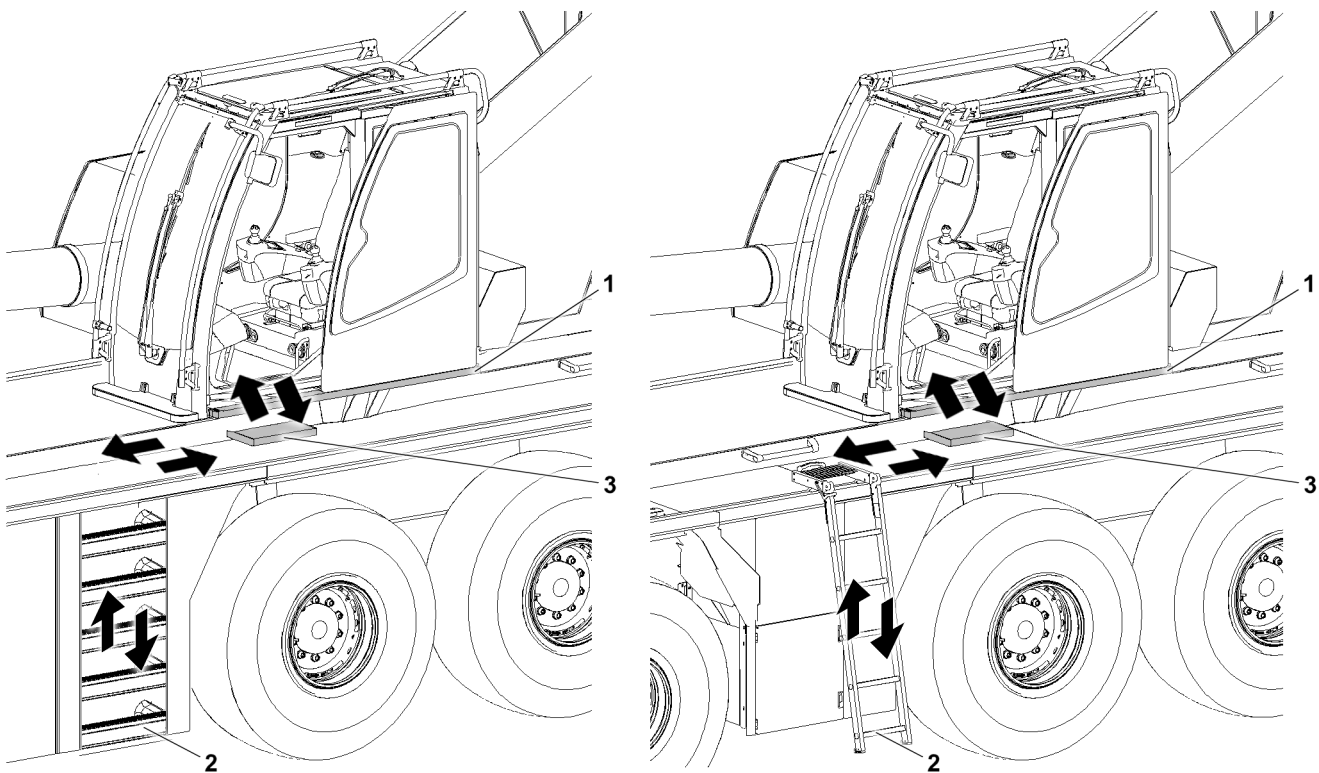


Fig.160768: Crane superstructure in the 180° position: Step **retracted**

- |                 |                         |                   |
|-----------------|-------------------------|-------------------|
| 1               | 2                       | 3                 |
| Extendible step | Ladder / folding ladder | Intermediate step |

The intermediate step **3** is installed only for certain crane types.

When accessing the crane cab, the following prerequisites must be met:

- The crane superstructure is in the 180° position.
- In the case of a crane cab with incline adjustment: The crane cab is in the horizontal position.
- The extendible step **1** is **retracted**.
- The folding ladders **2** are in the ascent and descent position.

**WARNING**

Extendible step **1** in the incorrect position!  
Personnel can fall down. Death, severe bodily injuries.

- ▶ Make sure that the extendible step **1** is fully retracted.

### 15.1.3 Access via an extendable step from the rear

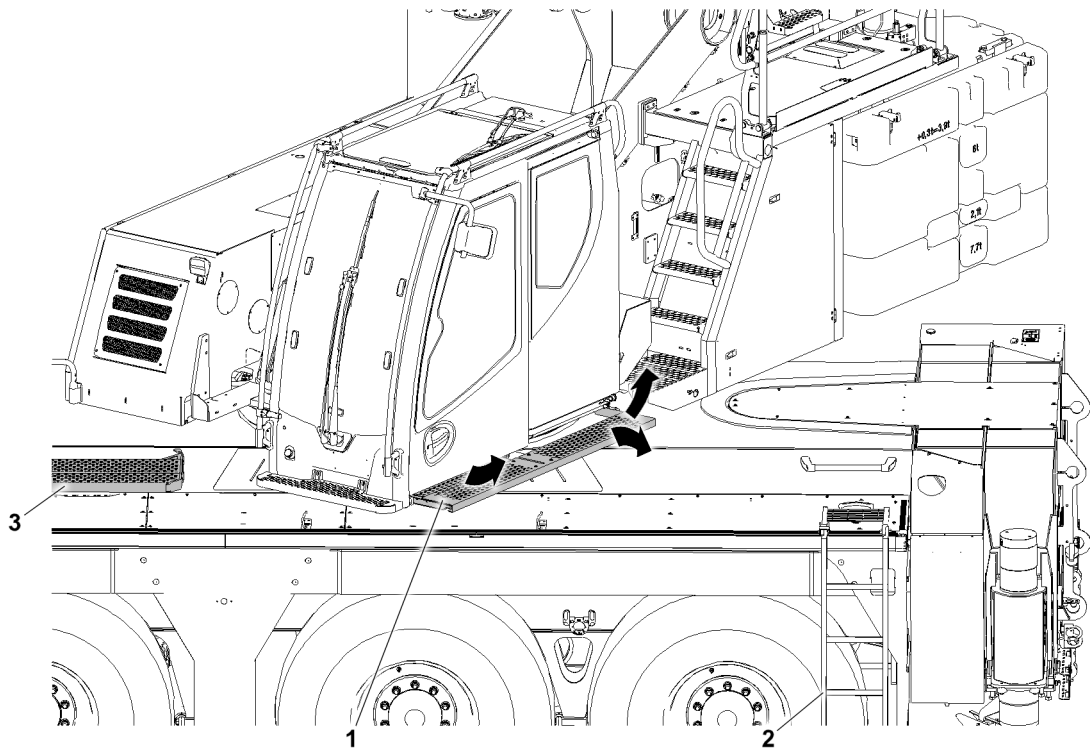


Fig.160756: Access via an extendable step from the rear

- |   |                 |   |                   |
|---|-----------------|---|-------------------|
| 1 | Extendable step | 3 | Intermediate step |
| 2 | Folding ladder  |   |                   |

The intermediate step **3** is installed only for certain crane types.

When accessing via an extendable step **1** from the rear, the following prerequisites must be met:

- Access to walkable surfaces of the crane chassis is ensured.
- The extendable step **1** **must** be extended.
- The **cab door** must be closed.
- In the case of a crane cab with incline adjustment: The crane cab is in the horizontal position.
- The folding ladders **2** are in the ascent and descent position.



#### WARNING

Extendable step **1** in the incorrect position!  
Personnel can fall down. Death, severe bodily injuries.

- ▶ Make sure that the extendable step **1** is fully extended.



#### WARNING

Cab door opened!  
The step depth of the extendable step **1** is too shallow.  
Personnel can fall down. Death, severe bodily injuries.

- ▶ Make sure that the cab door is closed completely.

### 15.1.4 Accessing via the front step

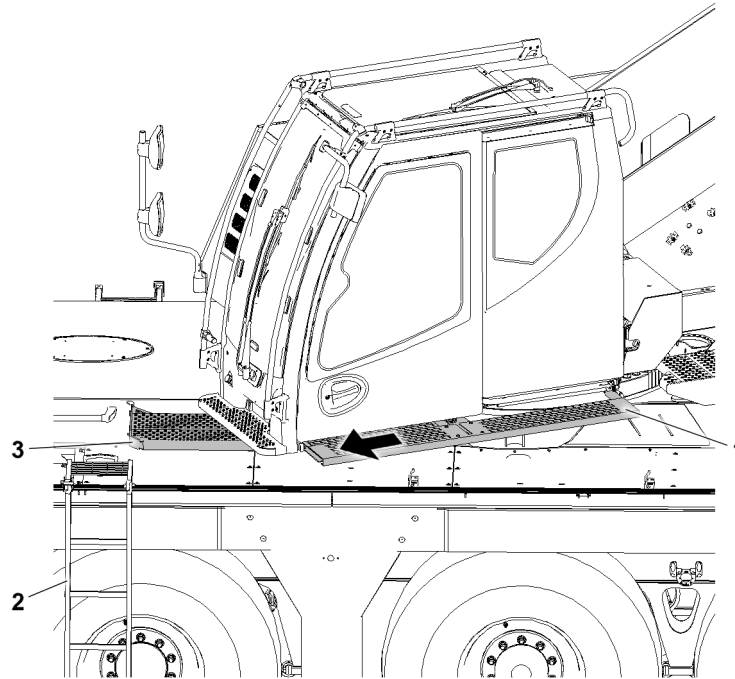


Fig.160757: Accessing via the front step

- |   |                 |   |                   |
|---|-----------------|---|-------------------|
| 1 | Extendible step | 3 | Intermediate step |
| 2 | Folding ladder  |   |                   |

The intermediate step **3** is installed only for certain crane types.

When accessing via the front step, the following prerequisites must be met:

- Access to walkable surfaces of the crane chassis is ensured.
- The extendible step **1** **must** be extended.
- In the case of a crane cab with incline adjustment: The crane cab is in the horizontal position.
- The folding ladders **2** are in the ascent and descent position.



#### WARNING

Extendible step **1** in the incorrect position!  
Personnel can fall down. Death, severe bodily injuries.

- ▶ Make sure that the extendible step **1** is fully extended.

## 15.2 Access for LTR cranes

An extendible step allows comfortable entry into the crane cab as well as exit from the crane cab during crane operation.

The description for an “extendible step for LTR cranes” only applies for LTR cranes.

### 15.2.1 Access for LTR 1060 and LTR 1100

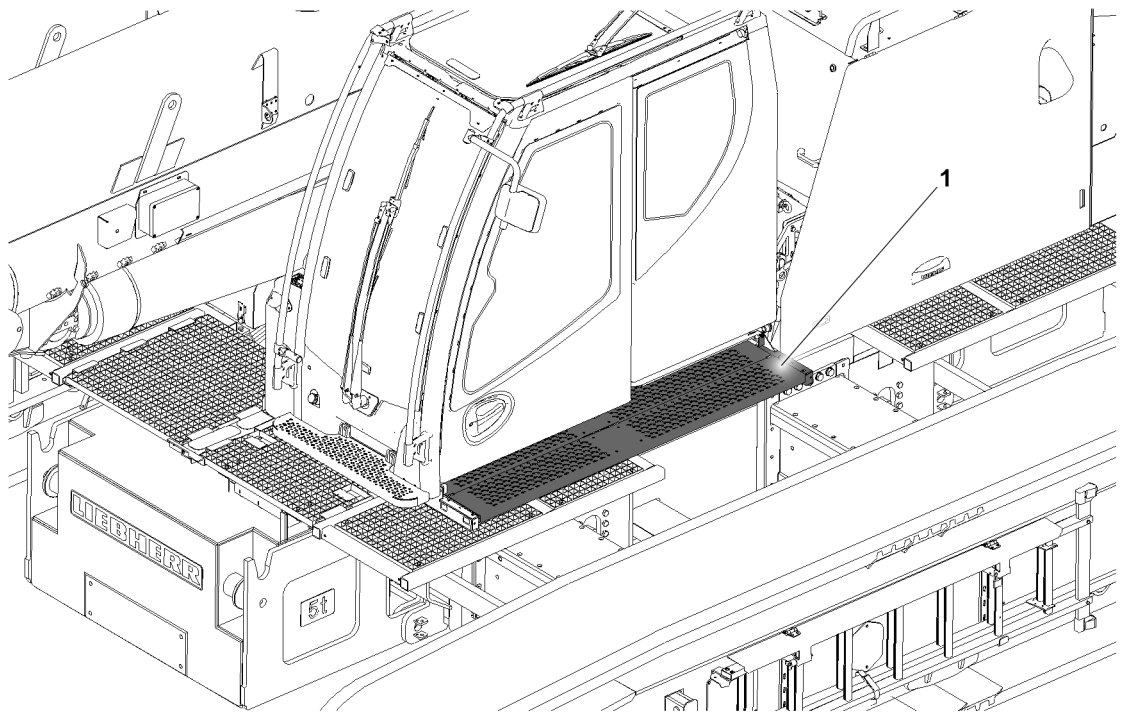


Fig.161886: Access for LTR 1060 and LTR 1100

#### 1 Extendible step

Climbing up and down takes place on the walking surfaces of the crawler chain. See chapter 2.07 "Accesses to the crane".

Before entering or exiting the crane cab, the following prerequisites must be met:

- The crane superstructure is in the 0° position (driving position).
- The crane is horizontally aligned.
- The crane cab is in the horizontal position.



#### WARNING

The superstructure is in a position in which it is **no** longer safe to climb up to it and it is **no** longer possible to change the position of the superstructure to a safe ascent position!  
People can fall down while ascending. Death, severe bodily injuries.

- ▶ Guarantee safe ascent / descent: Set up suitable climbing aids, such as a platform or ladder.



#### WARNING

The rise from the walking surface and cab floor is more than 300 mm !  
Personnel can fall down. Death, severe bodily injuries.

- ▶ Guarantee safe ascent and descent: Set up suitable climbing aids, such as a safety step.

## 15.2.2 Access for LTR 1220

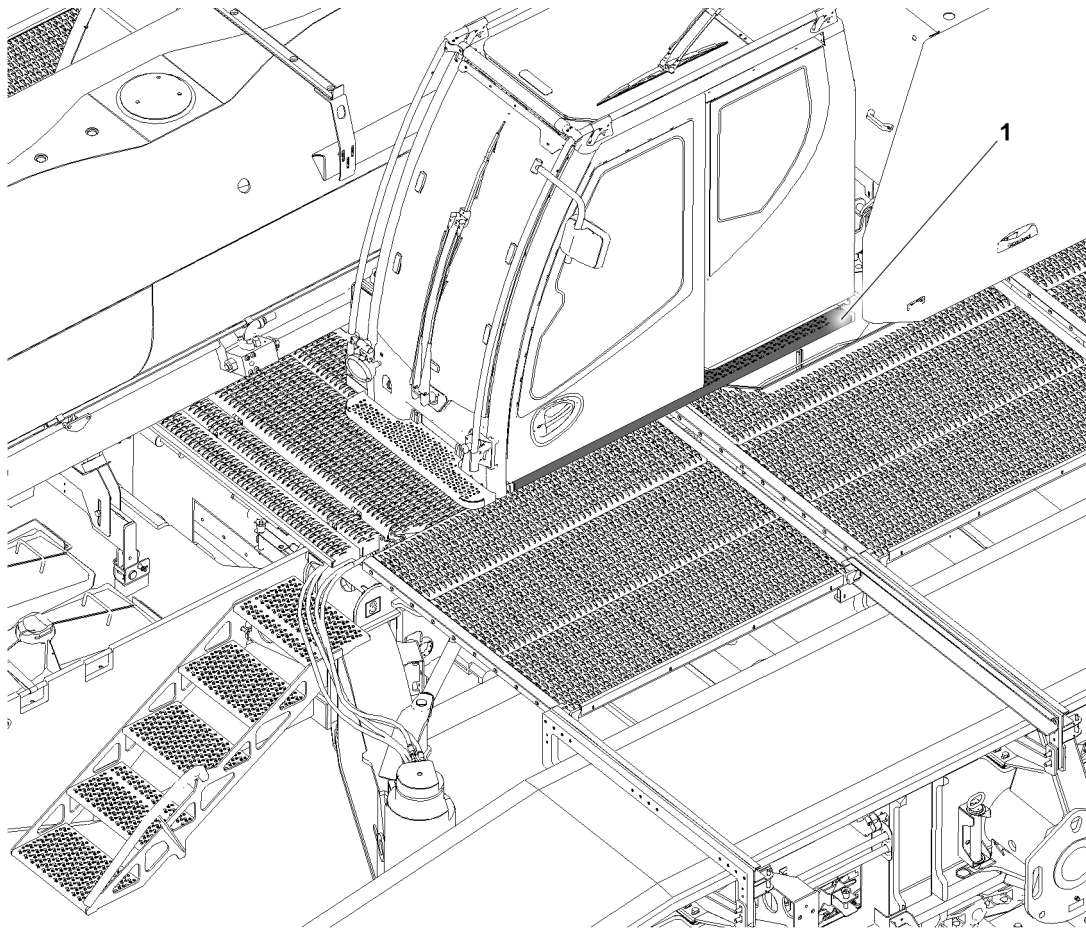


Fig.161887: Access for LTR 1220

### 1 Extendible step

Climbing up and down takes place on the walking surfaces of the crawler chain. See chapter 2.07 "Accesses to the crane".

Before entering or exiting the crane cab, the following prerequisites must be met:

- The crane superstructure is turned to the point where a safe access to walkable surfaces of the crane chassis is ensured.
- The crane is horizontally aligned.
- The crane cab is in the horizontal position.



### WARNING

The superstructure is in a position in which it is **no** longer safe to climb up to it and it is **no** longer possible to change the position of the superstructure to a safe ascent position! People can fall down while ascending. Death, severe bodily injuries.

- ▶ Guarantee safe ascent / descent: Set up suitable climbing aids, such as a platform or ladder.



### WARNING

The rise from the walking surface and cab floor is more than 300 mm ! Personnel can fall down. Death, severe bodily injuries.

- ▶ Guarantee safe ascent and descent: Set up suitable climbing aids, such as a safety step.



### 15.3 Crane cab with incline adjustment



#### WARNING

Danger of falling!

If the crane cab cannot be swung from an inclined position (for example 20° position) to the horizontal position, for example due to a problem, then utmost caution must be used when entering and exiting. Personnel can fall, death, severe bodily injuries.

- ▶ For safety reasons, we recommend making use of outside help.
- ▶ If necessary, have platforms or other suitable entry aids set up to ensure safe exit from the crane cab.



#### WARNING

Danger of accident!

If the door of the crane cab is opened in inclined position, then the door can move back suddenly. Hands can be crushed or injured.

- ▶ When the crane cab is in an inclined position, open the door carefully.

### 15.4 Crane cab with securing bracket

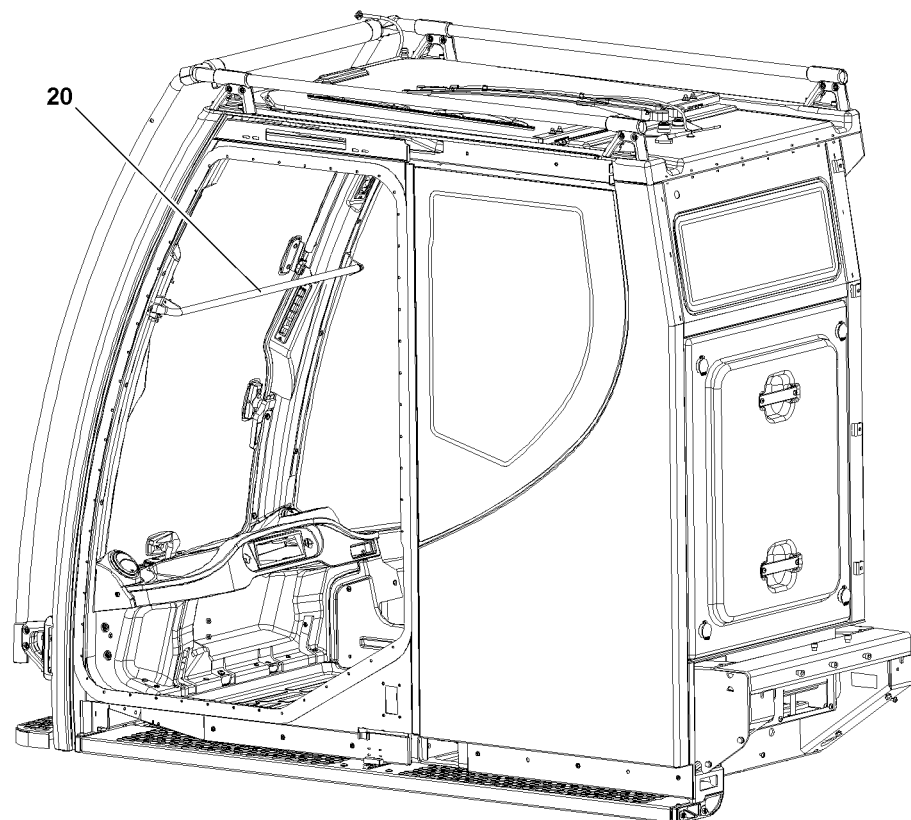


Fig.121158: Example of crane cab with securing bracket



#### Note

- ▶ The securing bracket **20** is installed to protect the crane operator from a danger of falling when the front window is open.

## 16 Side window



### WARNING

Close side window inadvertently!

Personnel can be crushed. Objects can be damaged!

- ▶ During closing, watch the side window pane as it moves up.
- ▶ Make sure that no persons are crushed or objects damaged.

## 17 Emergency hammer\*

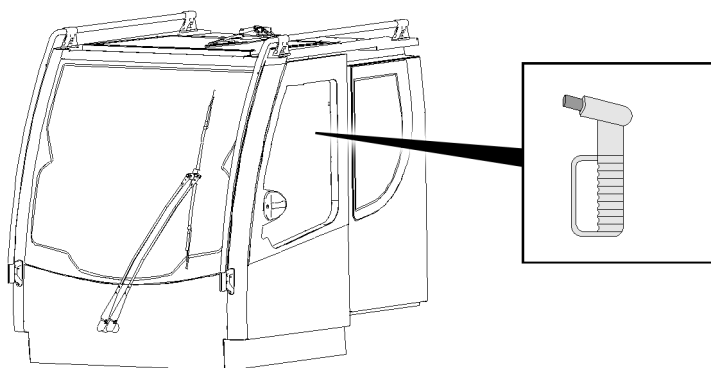


Fig.157682: The emergency hammer\* is shown as an example



### WARNING

Glass splinters and sharp broken edges!

If personnel is not suitably protected against glass splinters and sharp broken edges, serious bodily injury can result.

- ▶ Protect personnel when possible against glass splinters and sharp broken edges.
- ▶ When removing the destroyed glass pane, take the falling direction of the glass splinter into account.
- ▶ To climb through a destroyed glass pane, cover the broken edges or keep a distance.

### 17.1 Destruction of a glass pane

When an object suitable for destroying a glass panel is carried along, for example an emergency hammer\* (as shown in the example)



### WARNING

Glass splinters and sharp broken edges!

If personnel is not suitably protected against glass splinters when destroying a glass pane, serious bodily injury can result.

When a glass panel is destroyed:

- ▶ Cover your eyes and protect against glass splinters.

**Note**

- ▶ Glass panes breaker easier when the outer edge of the glass pane is struck.
- ▶ Cover your eyes when striking a pane.
- ▶ When striking a pane, go to a position if possible that offers protection from the falling glass splinters.
- ▶ When removing the destroyed glass splinters, use an object if possible and protect people against the glass splinters.
- ▶ When removing the destroyed glass pane, proceed from the top to the bottom and take the falling direction of the glass splinter into account.
- ▶ In the case of a glass pane made out of laminated safety glass, the incorporated film makes it is harder to create a large opening for climbing through. Select another pane if possible.

With suitable self-protection:

- Knock out the glass pane using a suitable object, such as an emergency hammer\*.
- Create a large enough opening.
- Climb through the opening carefully.

## 18 Transport

**WARNING**

Error during transport!

Death, severe bodily injuries, property damage.

- ▶ To avoid accidents, comply with the notes provided in the following sections.
- ▶ Observe the national and regional regulations on load securing.

**WARNING**

Falling of crane components!

If rigging devices are released and removed from crane components after transport, the crane components can slip or fall over.

Death, severe bodily injuries, property damage.

- ▶ Make sure that the crane components are fastened to the auxiliary crane after releasing the rigging devices.
- ▶ Make sure that the fastening equipment is tensioned before releasing the rigging devices on the crane components.

### 18.1 Crane and crane components

Follow the notes provided below to safely transport the crane and crane components:

- Close the crane cab and all cover doors.
- Use suitable transport vehicles.
- Use rigging devices with sufficient load capacity.
- Regularly check the rigging points and fastening points. See chapter 8.01.
- Properly support and secure the components on the transport vehicle.
- Use special transport devices. See chapter 3.80.
- Transporting a complete luffing lattice jib is prohibited.

### 18.2 Lattice sections

Follow the notes provided below to safely transport the telescoped lattice sections:

- Securely rig the lattice sections on the transport vehicle and secure them together in at least two independent points.
- When there are rigging points on the lattice sections: Secure each lattice section individually to the provided rigging points using suitable rigging elements and clamping elements on the transport vehicle.
- If there are no rigging points on the lattice sections: Secure each lattice section individually with suitable rigging devices and clamping elements to the transport vehicle.

## 18.3 Fiber guy ropes

The prerequisites for transporting the fiber guy ropes are closely connected with the prerequisites for storage.



### WARNING

Incorrect storage or transport of the fiber guy ropes!

Damage. The fiber guy ropes can rip.

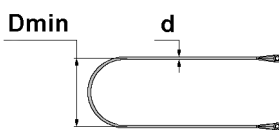
Death, severe bodily injuries, property damage.

- ▶ Comply with the instructions and conditions for storage and transport in this section.
- ▶ Inspect the fiber guy ropes regularly, see chapter 8.16.
- ▶ Comply with the maintenance intervals, see chapter 7.03.50.



Fig.160904: Twisting marking for a straight fiber guy rope, example of a twisted fiber guy rope!

- |   |                         |   |                             |
|---|-------------------------|---|-----------------------------|
| 1 | Straight fiber guy rope | 3 | Fiber guy rope twisted 180° |
| 2 | Twisting marking        | 4 | Fiber guy rope twisted 360° |



$$D_{min} = 20 \times d$$

Fig.160908: Fiber guy rope: Calculation of minimum permissible bending diameter

Formula element	Meaning
Dmin	Minimum permissible bending diameter
d	Rope diameter

*Minimum permissible bending diameter: Definition of the formula elements*

Make sure that the following instructions for storage and transport of fiber guy ropes are observed:

- Keep the fiber guy ropes free of ice and snow.
- Do **not** bend, knot, twist or sever the fiber guy ropes.
- The twist marking **2** is aligned straight along the entire rope length.
- Never fall below the minimum permissible bending diameter **Dmin** of **20 x** rope diameter **d**.

- Do **not** drag the fiber guy ropes over the ground, rough surfaces or sharp edges.
- Do **not** let the fiber guy ropes ball onto the ground or components.
- Do not place heavy loads on the rope.
- Do **not** allow heavy or sharp-edged objects fall onto the rope.
- Do **not** place the fiber guy ropes on sharp edges or pull them over sharp edges.
- Keep the fiber guy ropes away from hot surfaces, flames, lamps or other objects that radiate heat.
- Keep fiber guy ropes away from environments where grinding or welding takes place.
- Prevent contact with chemicals.
- Only fasten the fiber guy ropes in the permissible range with belt loops, see chapter 5.01.

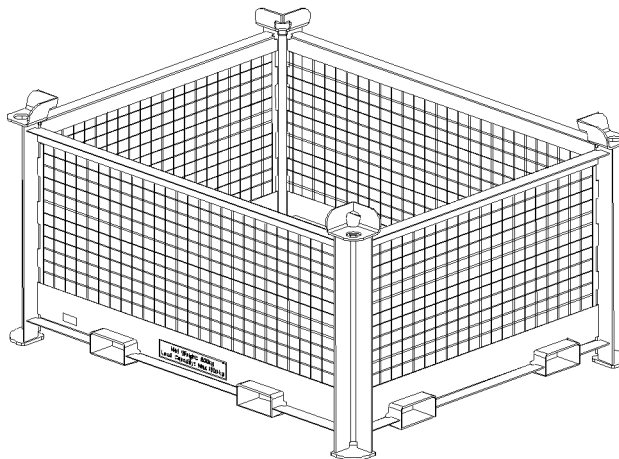


Fig.149503: Transport box for fiber guy ropes

The following factors can lead to damaging the fiber guy ropes:

- Moist and wet environment
- Temperatures below 0 °C

Make sure that the following conditions for storage and transport are observed:

- Do **not** bend rigidly frozen fiber guy ropes.
- Do **not** store fiber guy ropes that are rigidly frozen or covered with ice.
- Warm up and dry fiber guy ropes that are rigidly frozen or covered with ice at temperatures below 50 °C.
- Let wet fiber guy ropes dry in the air at approx. 20 °C prior to storage.
- Store and transport the fiber guy ropes only in the provided transport box.
- Do **not** store or transport fiber guy ropes together with other components.
- Store the fiber guy ropes in a dry and well-ventilated area.

When assembled fiber guy ropes are transported and stored as part of an assembly unit:

- All instructions for storage and transport of fiber guy ropes apply to the same extent.
- Make sure that the assembly unit is stored in a dry and well-ventilated area.
- If the assembly unit **cannot** be stored in a well-ventilated and dry area until the next assembly: Disassemble the fiber guy ropes.

## 18.4 Mobile cranes

Follow the notes provided below for the safe transport of mobile cranes:

- To ensure the largest possible frictional coefficient to the transport surface, clean the wheels before transport.
- When driving on the transport vehicle, check the easy movement of the vehicle with the aid of a guide to avoid hitting too hard.
- Apply the parking brake. See the Crane operating instructions, chapter 3.04.
- Lower the crane with the level control to obtain a center of gravity as low as possible. Level control, see the Crane operating instructions, chapter 3.03.
- Stopping the mobile crane: Place chocks behind the wheels. See the Crane operating instructions, chapter 2.04.
- Close the driver's cab.

## 18.5 Accelerating, changing the load

### NOTICE

Permissible acceleration exceeded!  
Damage to the crane.

- ▶ Observe the maximum permissible longitudinal acceleration of 1.0 g.
- ▶ Observe the maximum permissible lateral acceleration of 0.8 g.
- ▶ Offloading and running is prohibited during rail transport.

If higher accelerations are expected (sea transport, rail transport, maneuvering operation):

- ▶ Carry out the special measures to secure the crane and crane components.

### NOTICE

Frequent dynamic load change!  
Premature fatigue of load bearing crane components.

- ▶ Demount and properly secure components with large masses.
- ▶ Prior to transport: Have the rigging points and crane structures checked for damage by an authorized inspector. See chapter 8.01.

## 19 Fastening



### WARNING

Defective fastening equipment or fastening points!  
The load can fall down.

- ▶ Make sure that the fastening points and fastening equipment are in a perfect condition.
- ▶ Regularly check the rigging points and fastening points. See the Crane operating instructions, chapter 8.01.
- ▶ Check the fastening equipment regularly. See the Crane operating instructions, chapter 8.01.



### WARNING

Load bearing capacity of the fastening equipment is **not** sufficient!  
The load can fall down.

- ▶ Determine the weight of the crane component to be fastened.
- ▶ Fasten the components solely with approved and sufficiently load bearing fastening equipment.



### WARNING

Component incorrectly fastened!  
The load can fall down.

- ▶ Attach the components only to the intended fastening points.

## 20 Selecting the location

In the following illustrations 1 to 3 the possible situations are shown as an example.

It is very important to choose an appropriate site in order to prevent the danger of accidents.

It must always be possible to take down the crane in order to take it down in a timely manner in the case of unexpected weather conditions.

It must always be possible to position the crane in a safe out of operation position.

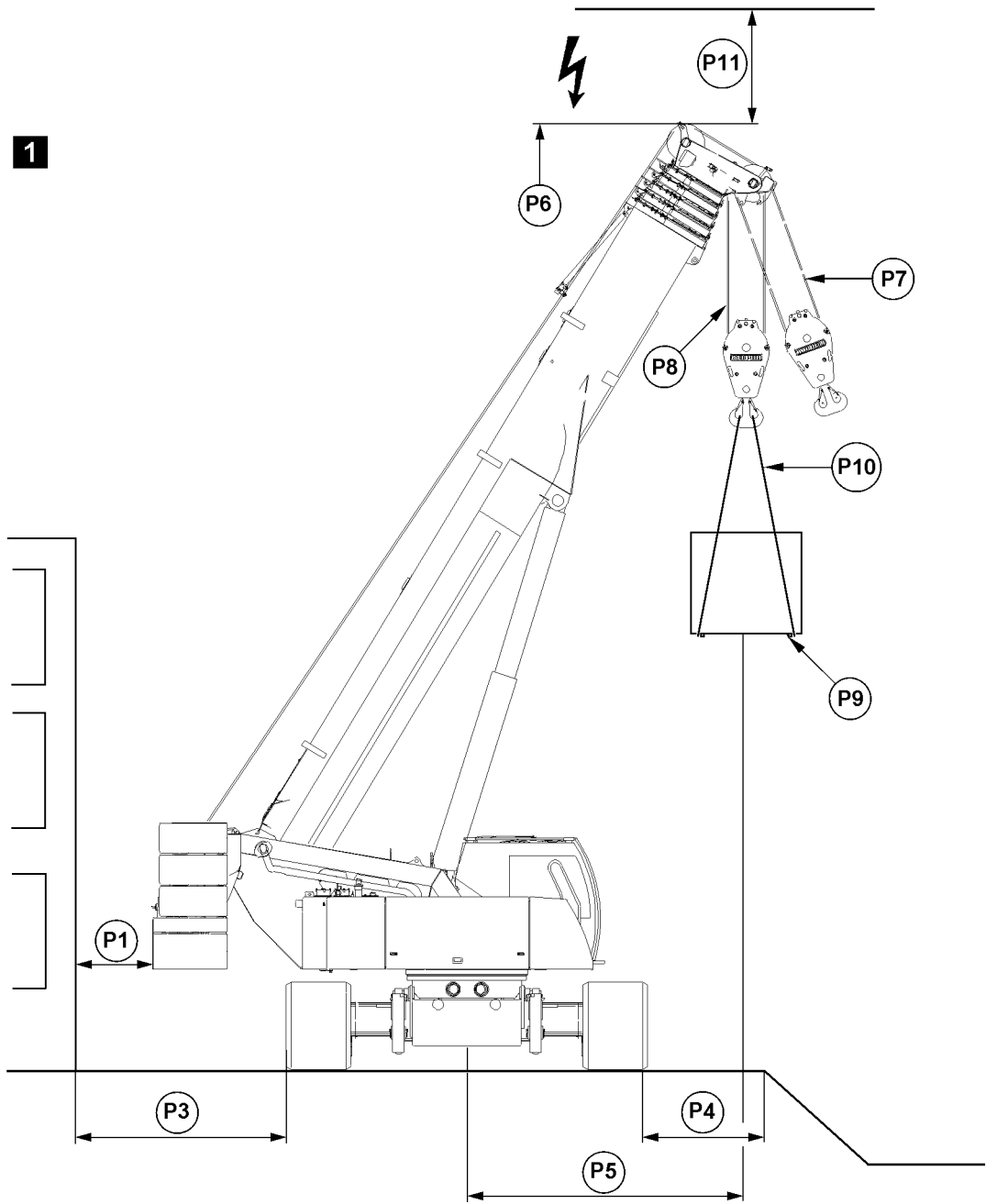


Fig.121166: Example of a crawler crane with telescopic boom

LWE/LR 1800-1-0-000/27200-07-02/en

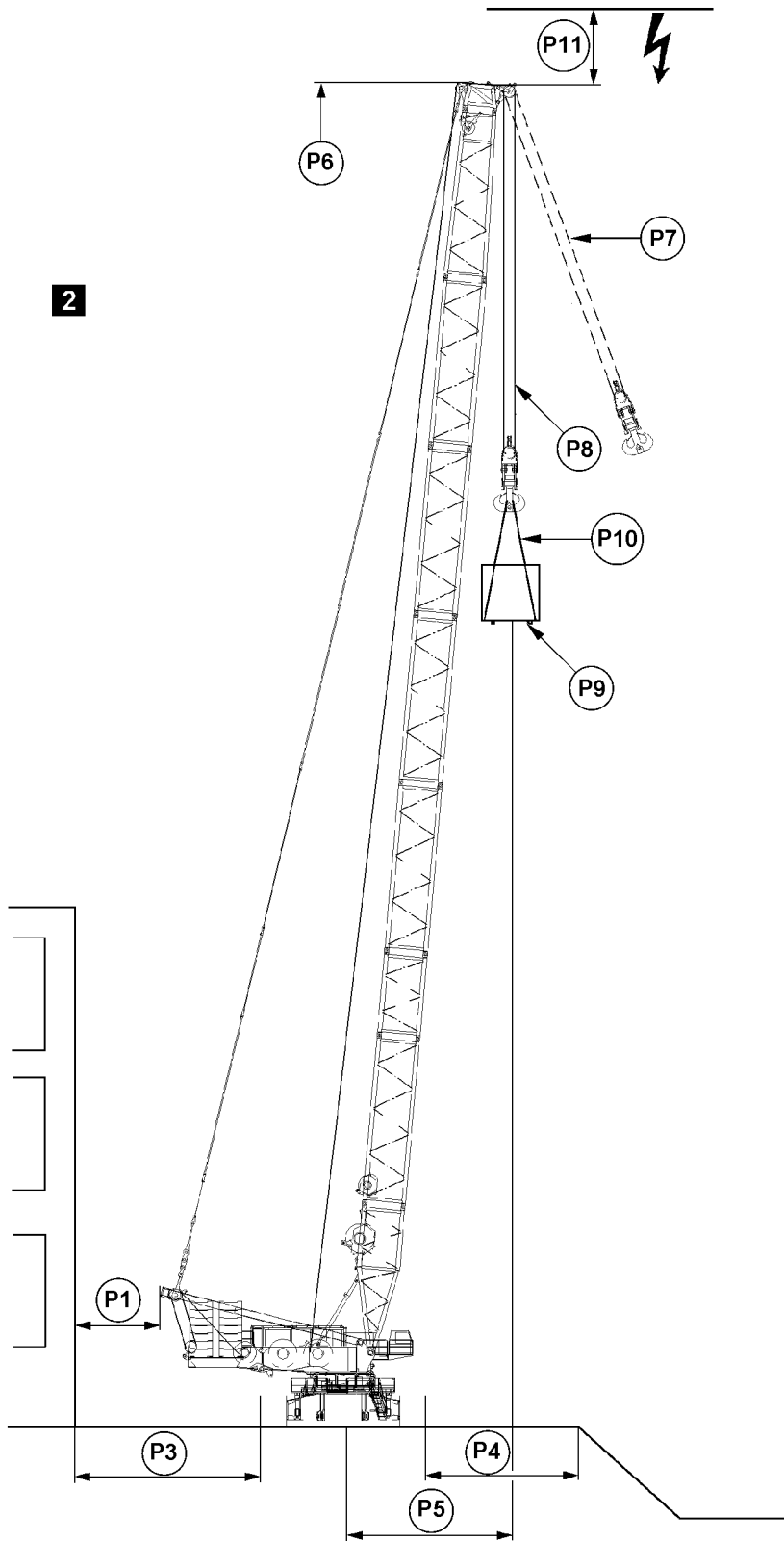


Fig.121167: Example of crawler crane with lattice mast boom

LWE/LR 1800-1-0-000/27200-07-02/en



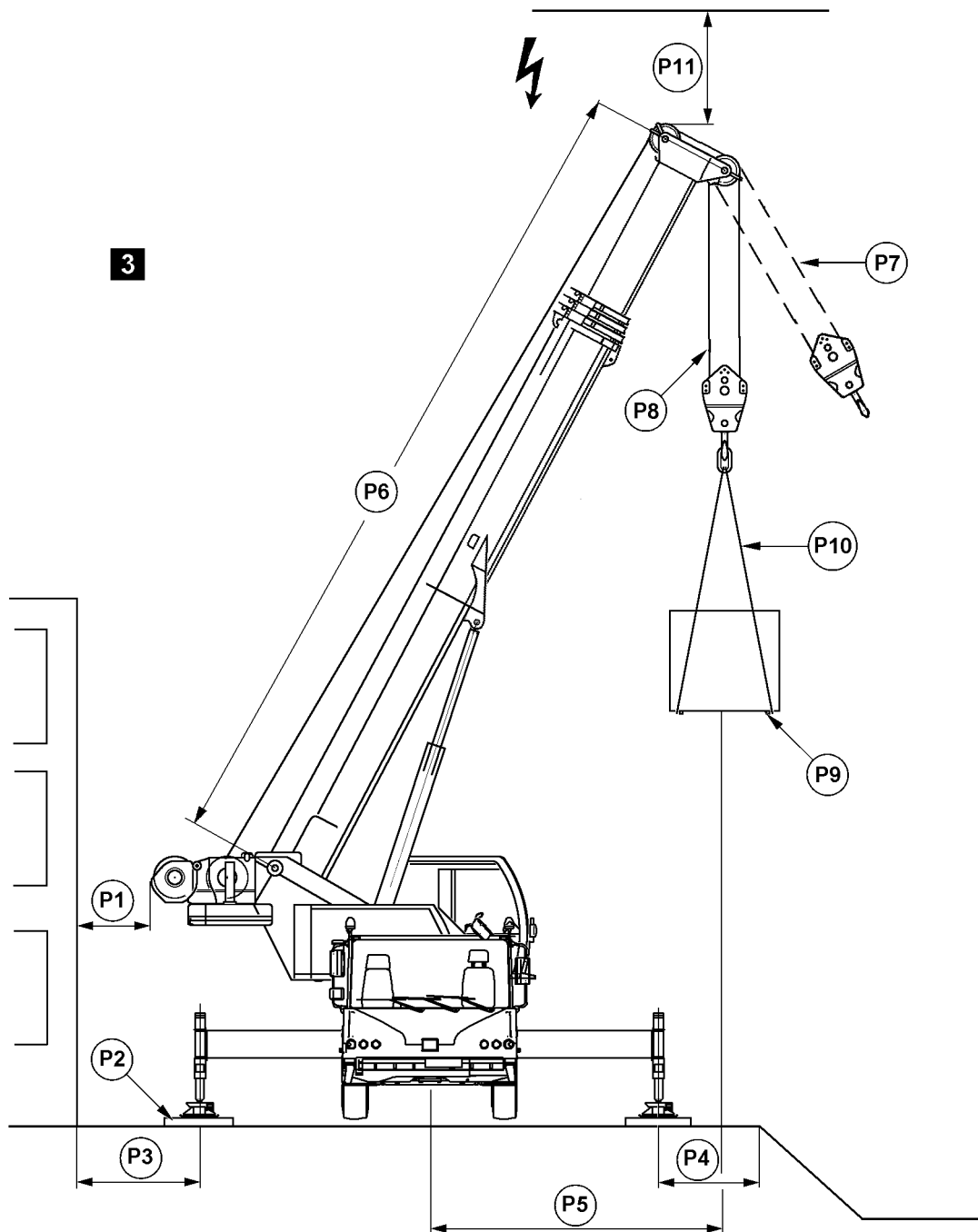


Fig.121168: Example of mobile cranes



### DANGER

Danger of accidents due to ground with **insufficient** load bearing capacity!

If the crane is supported or driven on ground with an **insufficient** load bearing capacity, then the crane can topple over and kill personnel.

- ▶ Only support or drive the crane on ground with a sufficient load bearing capacity.
- ▶ Act responsibly when planning and selecting the crane location and route.
- ▶ Comply with the following points.

Sign	When selecting the location of the crane, observe the following points:
P1	Select the placement location in such a way that crane movements can be carried out without collision and that the supports can be extended to the support base specified in the load charts  Make sure that no personnel is injured or killed  Always keep a safety distance of 0.5 m. If this is not possible, block the danger zone off
P2	When crane support is required: Support the crane correctly and support the support plates large enough according to the load bearing capacity of the ground and the placement location
P3	Maintain a safety distance from basements or similar
P4	Maintain a safety distance from slopes or similar
P5	Select a boom radius as low as possible
P6	Select the correct boom length for the load case
P7	Angular pull is prohibited
P8	Select the correct reeving of the hoist rope for the load case
P9	Keep in mind the weight and the wind-exposed surface of the load
P10	Select fastening equipment according to the weight of the load, the type of attachment and the incline angle
P11	Maintain sufficient distance from electrical overhead lines

## 21 Slopes and excavations

In the following illustrations 4 and 5 the possible situations are shown as an example.

The crane may not be set up too close to slopes or excavations. Maintain adequate safety distance **A** and safety distance **B** in accordance with the type of soil.

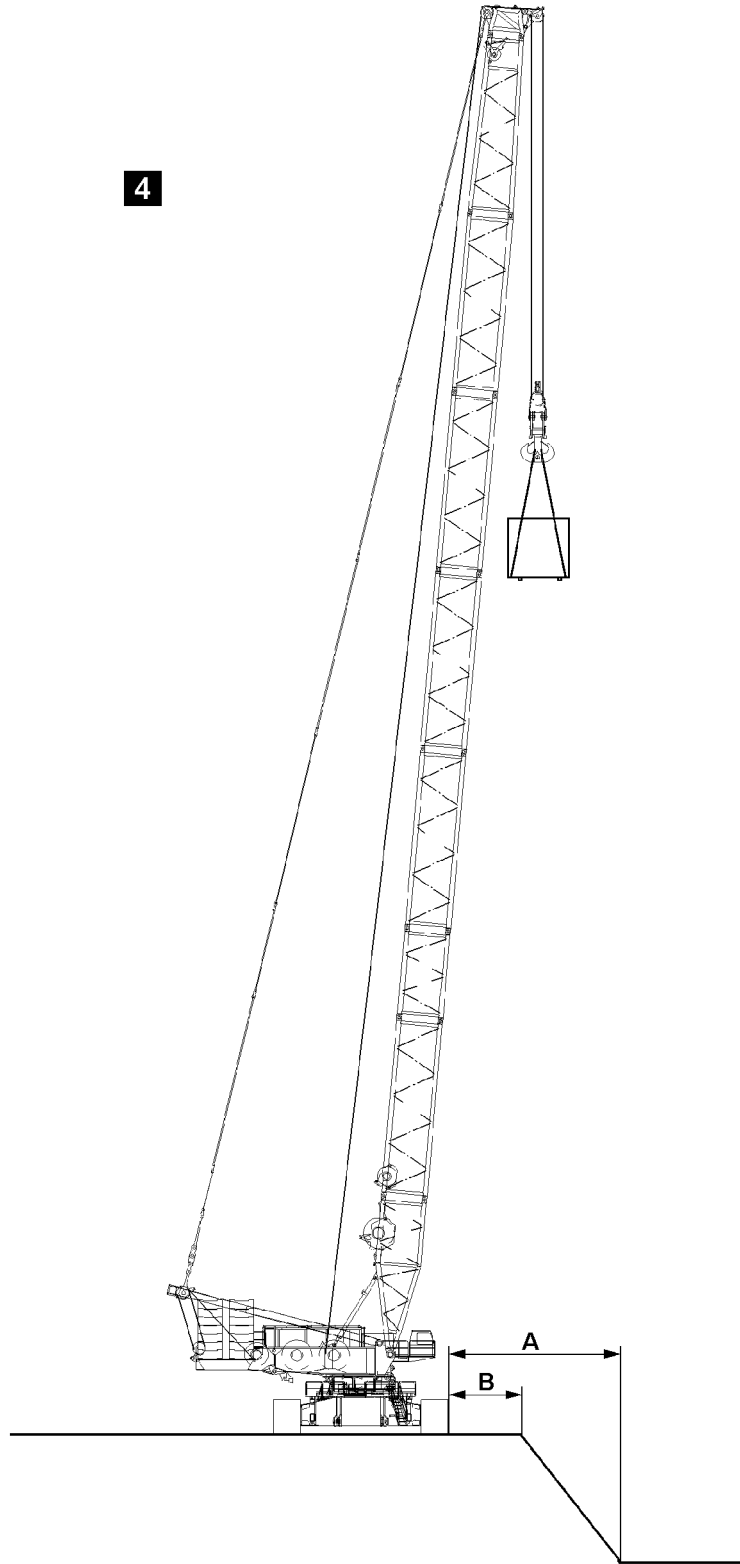


Fig.121162: Example of crawler cranes

- A** Distance from the bottom of excavation
- B** Distance from the excavation

LWE/LR 1800-1-0-000/27200-07-02/en

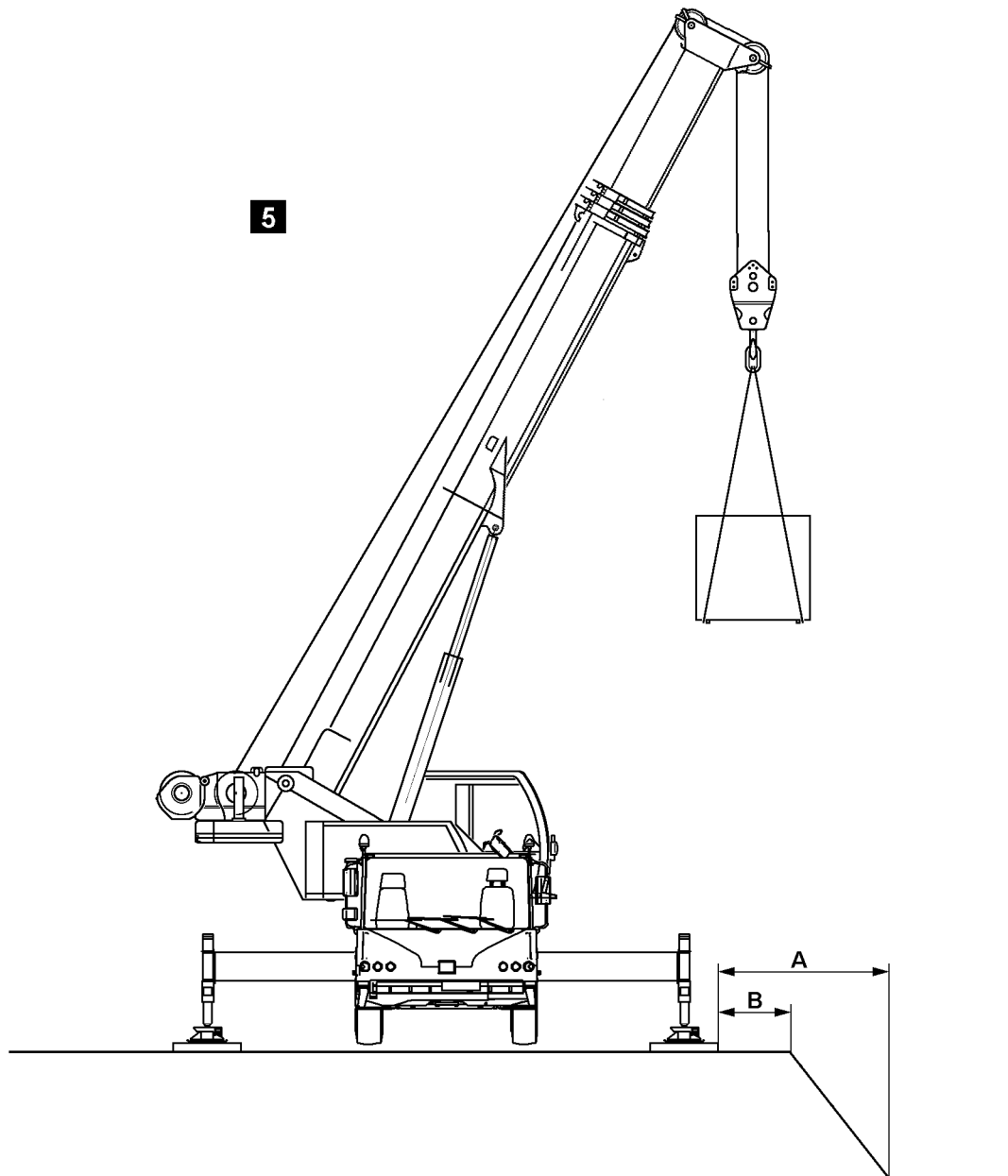


Fig.121163: Example of mobile cranes

- A** Distance from the bottom of excavation      **B** Distance from the excavation



**WARNING**

Safety distance **A** or safety distance **B** is too small!  
 The edge of the slope or the edge of the excavation can cave in.  
 The crane can topple over. Death, severe bodily injuries, property damage.  
 ► Maintain the safety distance **A** and safety distance **B**.

Have the safety distance **A** and safety distance **B** calculated by a soil expert or geologist.

## 22 Loads on the ground due to crane operation



### Note

- ▶ Take into account that on a crane with high counterweight the crawler pressures or support forces at low load can be higher than at high load.

### 22.1 Load burdens on the ground on cranes on crawlers

For cranes on crawlers significant forces are transferred via the outrigger pads of the crawlers into the ground (crawler pressures).

- The ground must be able to safely withstand the resulting pressure.
- If the surface of the outrigger pads is inadequate, then the crawlers must be supported according to the load bearing capacity of the ground.
- The required substructure can be calculated from the load bearing capacity of the ground and the crawler pressures of the crane.



### WARNING

Load bearing capacity of the ground insufficient!

The ground can give, the crane can topple over.

Death or severe bodily injuries.

- ▶ Support large enough, according to the load bearing capacity of the ground with suitable materials, such as wooden beams or steel plates.

To obtain an even pressure distribution over the substructure surface:

- ▶ Set the crawlers centered on the substructure.



### Note

- ▶ The respective ideal crawler pressure can be determined with the job planner program.

### 22.2 Load burdens on the ground on cranes on supports

When the crane is supported, significant forces (support forces) are transferred by the support cylinders via the support plates to the ground.

The ground must be able to safely withstand the resulting pressure.

If the support plate surface area is inadequate, then the support plates must be supported according to the load bearing capacity of the ground.

The required support surface areas can be calculated from the load bearing capacity of the ground and the support forces of the crane.



### WARNING

Load bearing capacity of the ground insufficient!

The ground can give, the crane can topple over.

Death or severe bodily injuries.

- ▶ Support large enough, according to the load bearing capacity of the ground with suitable materials, such as wooden beams or steel plates.

To obtain an even pressure distribution over the substructure surface:

- ▶ Set the support plates centered on the substructure.

## 22.3 Examples of the load bearing capacity of the ground

Soil type		Permissible ground pressure [kN/m <sup>2</sup> ]
1.	Organic ground: Peat, sludge, muck	0
2.	Uncompacted fill: Construction debris	0 to 100
3.	Non-cohesive ground: Sand, gravel, rocks and mix	200
4.	Cohesive soil:	
	a) Clayed silt, mixed with topsoil	120
	b) Silt, consisting of poor clay and coarse clay	130
	c) Plastic clay, consisting of potter's clay and fill	
	Stiff	90
	Semi-solid	140
	Solid	200
	d) Mixed granular ground, clay to sand, gravel and rocky areas	
	Stiff	150
	Semi-solid	220
	Solid	330
5.	Rock in evenly solid condition:	
	a) Brittle, with traces of decomposition	1500
	b) Not brittle	4000

*Examples: Permissible ground pressure of the ground*

If there is any doubt about the load bearing capacity of the ground at the placement location, soil tests must be carried out by an authorized inspector, for example with a ram penetrometer.

## 22.4 Calculation examples

The following are general calculation examples. The values are used only to explain the calculation steps. For the values specific to the crane, see the Crane operating instructions, chapter 1.03.

<b>Example: Calculation of ground pressure of support plates for cranes on supports</b>		□
Support force according to the Crane operating instructions, chapter 1.03 for example: 720 kN	720 kN	
Surface of square support plate with 550 mm side length according to the crane operating instructions, chapter 1.03, for example: $0.55 \text{ m} \times 0.55 \text{ m} = 0.3 \text{ m}^2$	0.3 m <sup>2</sup>	
80 % as the load bearing surface of the support plate: $0.3 \text{ m}^2 \times 0.8 = 0.24 \text{ m}^2$	0.24 m <sup>2</sup>	
Ground pressure = Support force / load bearing surface support plate	$720 \text{ kN} / 0.24 \text{ m}^2 = 3000 \text{ kN/m}^2$	
Ground pressure per support:	<b>3000 kN/m<sup>2</sup></b>	

*Example: Calculation of ground pressure*

- The value of the ground pressure is far higher than the permissible ground pressure for all types of granular soil.
- If this crane is utilized on bedrock, gravel type of ground, permissible ground pressure 200 kN/m<sup>2</sup>, then the support surface must be increased.

<b>Example: Calculation of required support surface for cranes on supports</b>		□
Support force according to the Crane operating instructions, chapter 1.03 for example: 720 kN	720 kN	
Ground pressure from chart <i>Permissible ground pressures</i> for example: 200 kN/m <sup>2</sup>	200 kN/m <sup>2</sup>	
Required support surface = Support force / permissible ground pressure	$720 \text{ kN} / 200 \text{ kN/m}^2 = 3.6 \text{ m}^2$	
Required support surface per support:	<b>3.6 m<sup>2</sup></b>	

*Example: Calculation of the support surface*

- The surface of the substructure for each support plate must be at least **3.6 m<sup>2</sup>**.
- The height of the substructure must be selected depending on the load distribution angle.



#### Note

- ▶ The corresponding ideal support forces can be determined with the Job planner.

## 22.5 LICCON job planner

The calculation of support forces and crawler pressures with the LICCON job planner are based on idealized assumptions: level and homogenous ground, rigid crane structure, no consideration in regard to wind.

Side deformations of the boom system due to wind, incline position and elastic compliance of the steel structure can lead to increase of support forces or increase of crawler pressures.

The determination of the values, taking wind load on the crane and the load into account, as well as the elastic deformation of the crane can only be carried out by the crane manufacturer or a person with suitable technical knowledge.

### 22.5.1 Example of a crane on crawler with derrick boom, suspended ballast and short (main) boom system

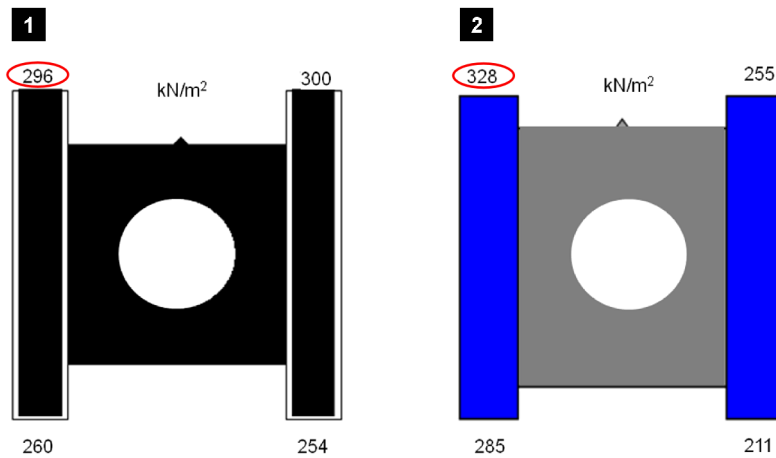


Fig.125052: Example of a crane on crawler with derrick boom, suspended ballast and short (main) boom system

**Illustration 1:** Idealized crawler pressures from Job planner calculated with the aid of a rigid body system and without considering the wind

**Illustration 2:** Idealized crawler pressures with consideration of elastic deformation and wind on crane and load

### 22.5.2 Example of crane on crawler with derrick boom, suspended ballast and long (main) boom system

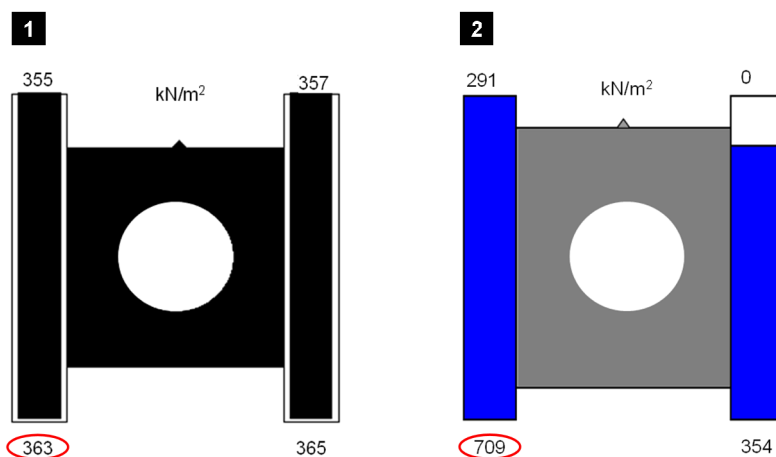


Fig.125053: Example of crane on crawler with derrick boom, suspended ballast and long (main) boom system

**Illustration 1:** Idealized crawler pressures from Job planner calculated with the aid of a rigid body system and without considering the wind

**Illustration 2:** Idealized crawler pressures with consideration of elastic deformation and wind on crane and load



### 22.5.3 Example of crane on supports

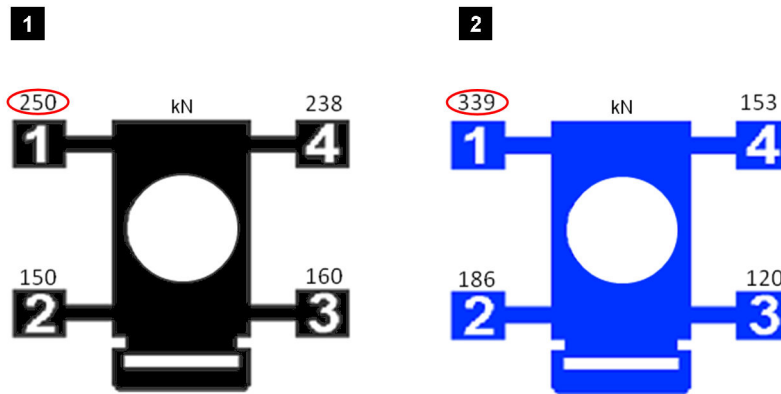


Fig.125054: Example of crane on supports

**Illustration 1:** Support forces from Job planner calculated with the aid of a rigid body system and without considering the wind

**Illustration 2:** Support forces with consideration of elastic deformation and wind on crane and load

## 23 Support

### 23.1 Support plates

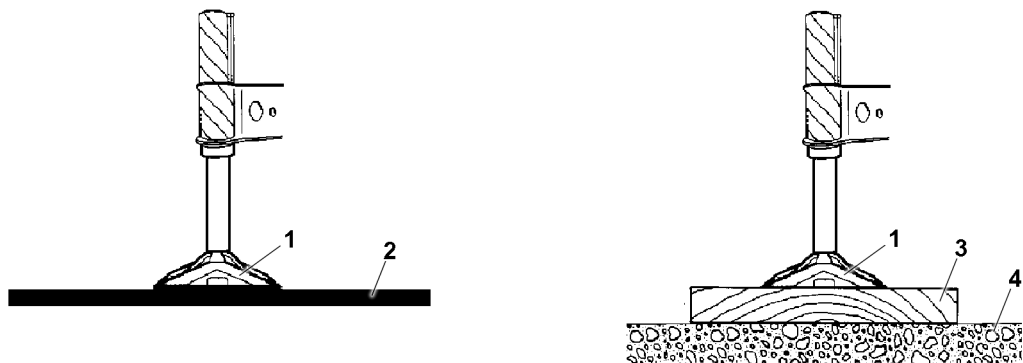


Fig.144244: Support plates

- 1 Support plate
- 2 Ground (**no** substructure necessary)
- 3 Substructure
- 4 Ground (substructure necessary)

When supporting the crane, the support plates must lie horizontally on the ground or on the substructure.



**WARNING**

The support plates are **not** lying horizontally!  
The crane can topple over, death, property damage.

- ▶ Before supporting the crane, align the support plates horizontally.

LWE/LR 1800-1-0-000/27200-07-02/en

## 23.2 Supporting the crane



### WARNING

The crane is **not** horizontally aligned!  
The crane can topple over, death, property damage.  
▶ Align the crane horizontally to 0.0° during the support procedure.



### DANGER

The crane can topple over!  
When actuating the supports with attached load and / or loaded derrick ballast guying, the incline and the force conditions of the entire boom system change.  
There is **no** shut-off by the LICCON overload protection.  
The crane can topple over.  
Personnel can be severely injured or killed.  
▶ When a load is suspended it is prohibited to actuate the support.  
▶ When the derrick ballast guying is loaded, it is prohibited to actuate the support.

It is absolutely essential that the crane be supported with the support base exactly in accordance with the load chart to ensure safe crane operation.

The correspondence of the support surfaces on the sliding beams must be observed to ensure proper force transfer between the sliding beams.

The crane may only be supported in these extension conditions.



### WARNING

The crane can topple over!  
If only the sliding beams on the load side are extended, then the crane can topple over and kill personnel.  
▶ Push all four sliding beams and support cylinders out according to the specifications in the load chart and pin them.  
▶ Do **not** support in intermediate positions between the support bases.  
▶ Pin the sliding beams to the support base according to the load chart.  
▶ Fully insert and secure the pins.



### WARNING

Risk of crane toppling due to incorrect extension of the sliding beams!  
The load suspended on the hook causes tension and deformation of the hoist rope and telescopic boom. The same applies for operation with lattice jib and guy ropes. If the load falls from the fastening ropes or if the fastening or hoist rope breaks in this situation, a sudden relief occurs. The boom snaps back quickly. This can cause the crane to topple over.  
Despite previous assumption, it might become necessary to swing the load to the opposite side. This can cause the crane to topple over.  
The boom and / or counterweight momentum may cause the crane to topple when turning out of the longitudinal vehicle direction.  
▶ Extend all four sliding beams and support cylinders according to the specifications in the load chart.

## 23.3 Supporting the crane with a *variable support*

When supporting the crane with a *variable support* special measures are required. These measures are described in detail in the Crane operating instructions, chapter 6.26.

## 24 Alignment of the crane

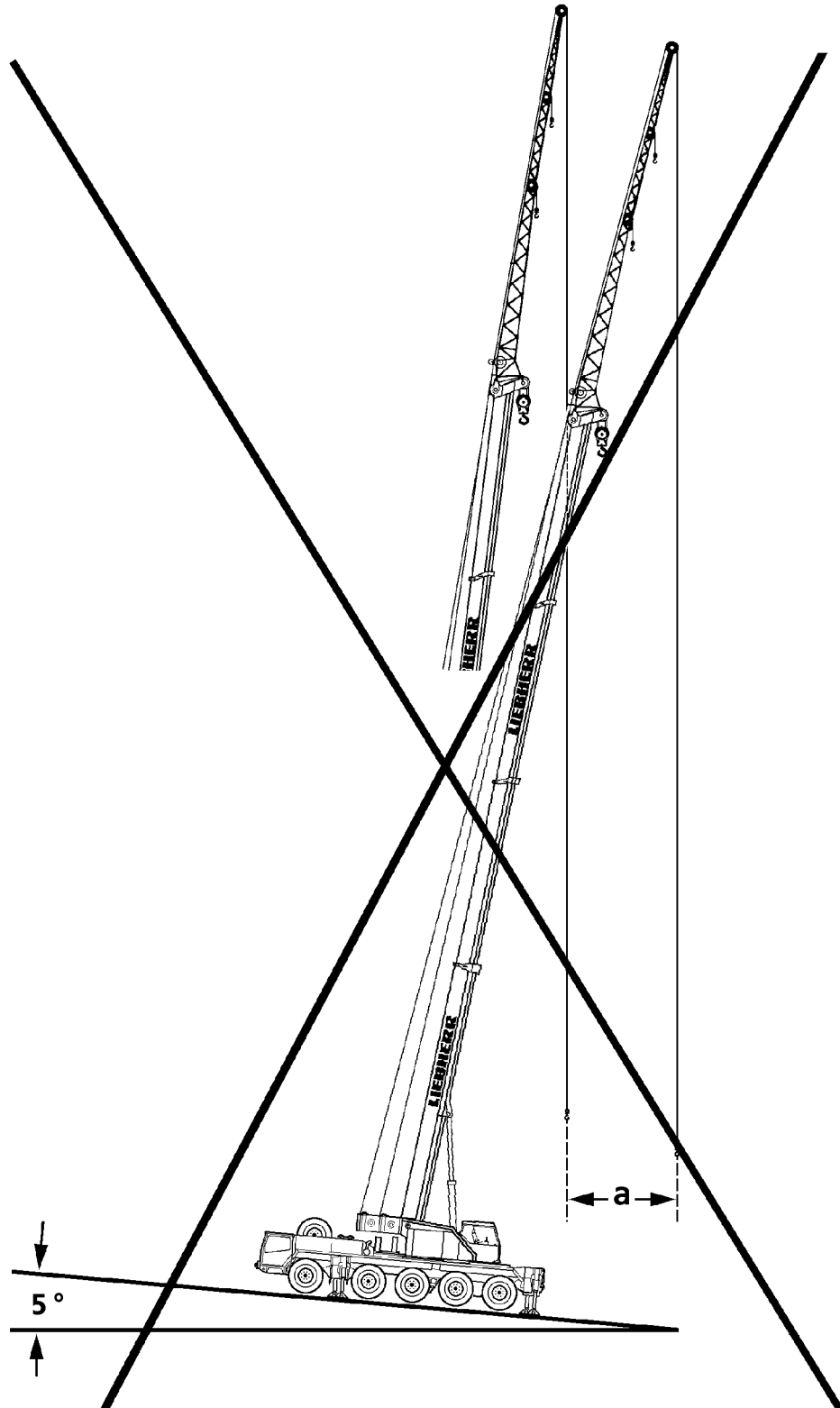


Fig.121164: Example of **non-permissible** incline position

In addition to the proper substructure for the supports, the horizontal alignment of the crane is of utmost importance for safe crane operation.

**DANGER**

The crane may fall over due to the incline position!

If the crane is positioned at an incline, and if the boom is turned towards the slope, then the boom radius is increased as a result.

It is possible that the slewing gear can no longer hold the crane superstructure and, in extreme cases, the crane can topple over.

Personnel can be severely injured or killed.

- ▶ Align the crane horizontally before starting crane operation.

If the horizontal alignment of the crane has to be readjusted:

- ▶ Set the load down on the ground before readjusting the crane.

For cranes on crawlers, readjustment is **not** possible:

- ▶ If possible, use load charts for limited terrain incline.

Example: At a boom length of 50 m, an incline position of the crane of only 5° with a boom radius of 10 m causes a radius increase of  $a = 4$  m.

## 25 Checking the safety measures

- The placement location has been selected so that all planned lifts included in the load chart for the erected set up configuration can be lifted.
- The load bearing capacity of the ground is adequate.
- There is a sufficient safety distance from excavations and slopes.
- It is ensured that there are no current-carrying lines within the working range of the crane.
- There are no obstacles that will hinder the required crane movements.
- The crane is horizontally aligned.
- When crane support is required:
  - All four sliding beams and support cylinders have been extended according to the support base given in the load chart.
  - The sliding beams have been secured with pins to prevent them from moving.
  - The support plates are pinned and secured in the operating position.
- On mobile cranes:
  - The axle suspension is blocked.
  - The axles are relieved, which means the tires do not touch the ground.

## 26 Safety instructions in case of an external power supply



Fig.197720

A potential danger exists when supplying a crane with an external power supply from a low voltage distribution system (100 V AC to 400 V AC).

A special electrical hazard is present when a protective conductor is interrupted (caused by the mechanical stress on flexible supply lines or the service connection), loose terminal connections, high wire or contact resistance, mixed up conductors, defective or missing protective equipment (FI / fault interrupters) in combination with a body contact on the crane.



### WARNING

Danger of fatal injury if the body conducts current!

Water and / or defective devices can cause hazardous stray voltages when touched. The person touching the crane is subject to lethal currents.

- ▶ The external supply cable must be in good working order.

Make sure that the external flexible supply cable is in good working order.

Where applicable, we recommend the use of a power isolating transformer.

## 27 Grounding for potential equalization

Have tasks regarding grounding performed by authorized and trained electricians.

- Crane grounding is done to establish the defined potential equalization between the crane that is electrically charged for any reason and the ground.
- Potential equalization protects people who are located near the crane. Potential equalization prevents currents from flowing through people who possibly touch a charged crane while standing on the ground.
- Potential equalization serves the purpose of protecting electronic components to prevent electrostatic charge.

- Grounding for potential equalization is not designed to protect crane components against extreme external influences (such as lightning).

## 27.1 Crane grounding

For crane types with a ground connection\*:

- Location of the ground connection\*, see chapter 1.01 or chapter 3.01.

For crane types without a ground connection for grounding of the crane:

- Properly connect the grounding with the crane.



### WARNING

Danger of fatal injury due to electric shock!

There is a danger of electrical shock, if the crane is not properly grounded.

- ▶ Properly ground the crane.
- ▶ Make sure that there is a potential equalization between the crane and the ground.

The crane must be grounded before start up.

Examples of extremely strong electromagnetic fields:

- Near transmitters (transmission equipment, radio and TV transmitters, radio stations, etc.)
- Near high frequency switching stations and high voltage lines.
- In case of severe possibility of thunderstorms or potential thunderstorms.

**Note:** As regards protecting a crane against lightning, grounding must be considered separately.

The crane can become electrostatically charged, especially if the crane is equipped with synthetic support mats or if the support mats are placed on insulating materials (such as wooden planks).

## 27.2 Grounding the load



### WARNING

Danger of fatal injury due to electric shock!

There is a danger of electrical shock, if the load is not properly grounded.

- ▶ Properly ground the load.
- ▶ Make sure that there is a potential equalization between the load and the ground.

The load must be grounded before start up:

- Near transmitters (radio and TV transmitters, radio stations, etc.).
- Near high frequency switching stations and high voltage lines.
- In case of severe possibility of thunderstorms or potential thunderstorms.

**Note:** As regards protecting the load against lightning, grounding must be considered separately.

The load can become electrostatically charged, even if the crane is grounded. This applies in particular if a hook block with pulleys made of synthetic material and non-conductive fastening equipment (for example plastic or manila ropes) are used.

## 28 Working in the vicinity of transmitters

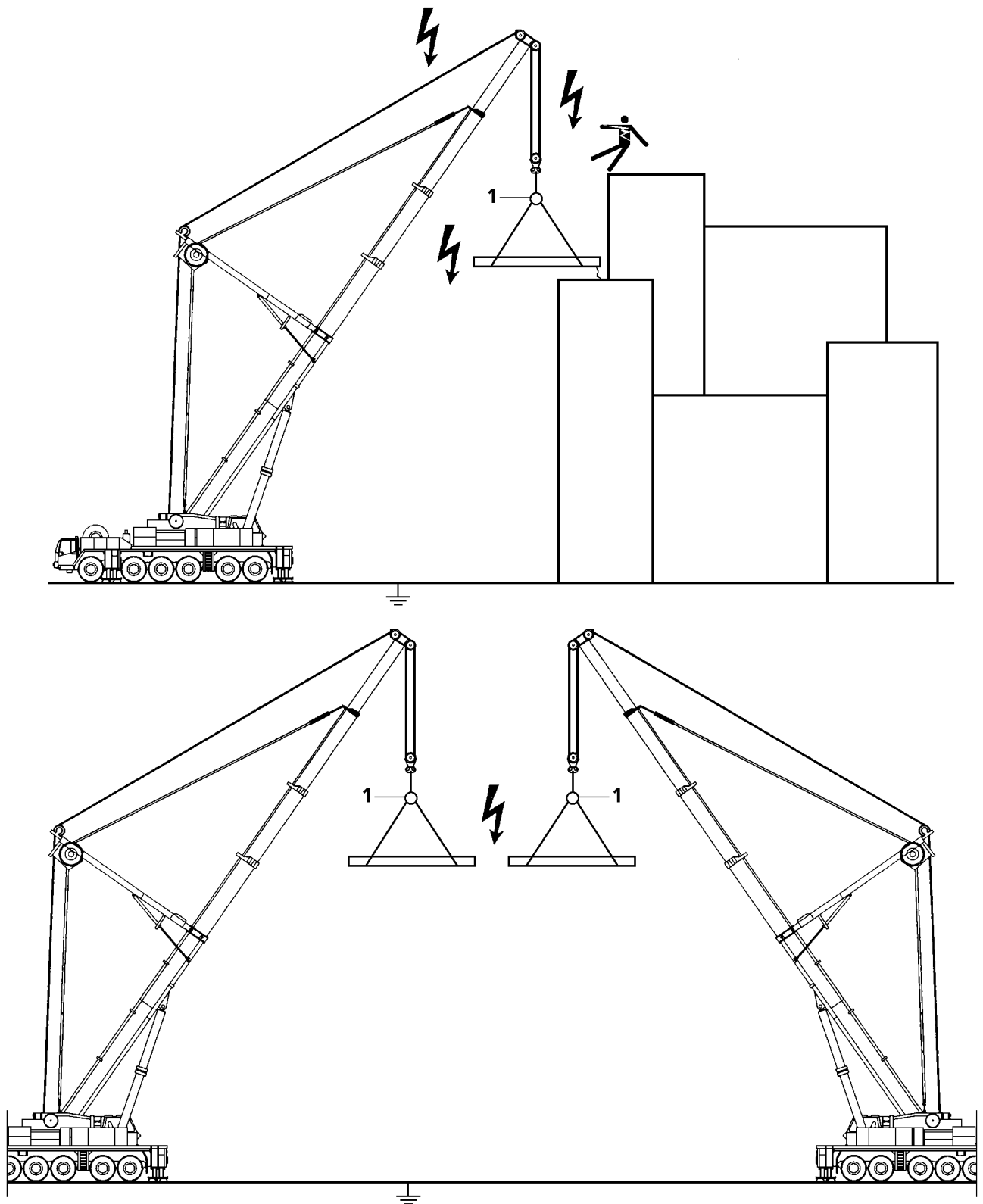


Fig.121165: Example of electrostatic charge

Strong electromagnetic fields are likely to be present if the construction site is close to a transmitter.

These electromagnetic fields can pose direct or indirect danger to persons or objects, for example:

- Effect on human organs due to temperature increase

- Danger of burns or inflammation due to temperature increase
- Spark or electric arc formation

**DANGER**

Danger due to electromagnetic fields!

- ▶ Before operating a crane in the vicinity of transmitters, be sure to: Consult with Liebherr-Werk Ehingen GmbH.
- ▶ In addition, involve an authorized and trained electrician with knowledge about high frequency fields.

High frequency (HF-) radiation from a transmitter requires extended work safety protection and special accident prevention regulations for personnel:

1. Each crane must be “fully” grounded. Check visually or use a simple continuity tester to ensure that the ladder, crane cab and rope pulleys are grounded.
2. All personnel working on the crane or with large metal objects must protect themselves from burns by wearing non-conductive synthetic gloves and suitable clothing while working.
3. There is no need to panic if you feel your hand warm up. Always work under the assumption that the respective workpiece, structural steel member or carrier is “hot”.
4. The temperature of objects affected by high frequency radiation depends on their “size”. Cranes, carriers and coverings, for example, are “hotter”.
5. Contact with other crane loads is not permitted when operating the crane (arcing). Since defects caused by burns considerably reduce the rope's load bearing capacity, any such occurrences must be reported immediately to customer service at Liebherr-Werk Ehingen GmbH so that the ropes can be inspected.
6. An insulator **1** is required at all times between the crane load hook and fastening equipment. It is strictly prohibited to remove this insulator **1**.
7. Do not touch the ropes above the insulator **1**.
8. Loads that are attached to the crane may not be touched by any unprotected parts of the body after the load has been lifted or set down.
9. Do not work with a bare upper torso or in short pants, this is prohibited.
10. To minimize absorption of high-frequency radiation, larger loads should be transported horizontally if possible.
11. Loads must be grounded, or additional insulation used (rubber material between the object and gloves) when manual work is required.
12. Use a suitable measuring instrument to check the “temperature” of the workpiece.  
For example, if 500 V can be measured on a workpiece at a distance of 1 cm to 2 cm, then the workpiece may not be touched with bare hands.  
The greater the distance, the higher the voltage is on the object:  
At 10 cm distance, approx. 600 V are present, at 30 cm distance approx. 2000 V are present.
13. When refueling the crane, it must be ensured that no sparks are created within a radius of 6 m by handling larger metallic parts or due to other work.
14. To avoid secondary accidents, use personal protective equipment when working on components that are high above the ground.
15. Any accidents and unexpected events must immediately be reported to the local construction supervisor and the safety engineer.

## 29 Crane operation in case of thunderstorms

**WARNING**

Danger of accident due to lightning!

Direct or indirect high current flow through the body.

Danger of falling when working above ground.

Death or severe bodily injuries.

- ▶ Make sure that there are no persons in the immediate area of the crane.
- ▶ Obtain the weather forecast for the entire period during which the crane will be used.
- ▶ Introduce safety measures in time.



In the case of weather where there may be lightning, observe the following specifications:

- Work on the crane is stopped.
- The load is set down.
- In the case of cranes with derrick ballast: The derrick ballast is set down, if possible.
- The boom is, if possible, telescoped in and / or taken down.
- The crane is in a safe condition.

Make sure that no persons are seeking protection in the immediate area of the crane.

Make sure that the danger zone of the crane is blocked off.

## 29.1 After a possible lightning strike to the crane

Lightning can cause many types of damage. For example, damage to casings, scorched cable or melting of metal components.

### 29.1.1 Checking the crane



#### **WARNING**

Damaged crane!

When crane damage is found:

- ▶ Crane operation with damaged components is prohibited.
- ▶ Repair the crane.



#### **WARNING**

Possible damage to the crane!

When crane damage cannot be excluded:

- ▶ Do not restart crane operation.
- ▶ Contact Customer Service at Liebherr-Werk Ehingen GmbH.

Step 1: Inspect the crane in detail, in particular perform a visual inspection for:

- Damage to the fiber guy ropes and plastic ropes.
- Damage to the hoist ropes and control ropes.
- Damage to cables, lines and hoses.
- Damage to hydraulic cylinders.

Step 2: If no damage is found during the visual inspection:

- Check the operation of the crane control, evaluate the error memory.

Step 3: If no damage was found in step 1 or step 2:

- Perform a function check for unusual behavior, vibrations and noise - control the slewing gear and winches slowly and pay attention to functionality and the generation of noise.
- Monitor the hydraulic cylinder for a long period of time for leakage.

## 29.2 Lightning: Protective measures for the crane and load

Protective measures regarding lightning / lightning protection for the crane and load, including optional grounding.

- Have the protective measures implemented by authorized and trained electricians with suitable knowledge about lightning protection.

## 30 Wind influences



#### **Note**

- ▶ The wind speeds are valid for a 360° wind direction for a 3-second wind gust at the highest point of the crane.

**WARNING**

Disregard of permissible wind speeds!

If the permissible wind speeds are disregarded, the crane can topple over. Personnel can be severely injured or killed.

- ▶ It is prohibited to erect the crane to measure the wind speed.
- ▶ Comply with the permissible wind speeds depending on the assembly / crane conditions, see following chart.

Assembly / crane conditions	Reference for permissible wind speed
Erection and take-down of various boom configurations	Wind speed charts and / or erection and take-down charts
Crane operation	Load chart manual
When the permissible wind speed according to the load charts is exceeded during crane operation, then <b>crane operation is prohibited</b> .	Wind speed charts
Interruption of crane operation when crane remains equipped	Wind speed charts
Crane out of operation, when crane remains equipped	Wind speed charts

**Note**

No wind speed charts available!

For a set up configuration for which no wind speed charts are available:

- ▶ Comply with the maximum permissible wind speeds in the load charts.

The wind load on the crane boom has **not** been taken into account for the planning of crane operation with the LICCON job planner.

- As a result, the actual values of the support force and / or the crawler pressure can be significantly higher than the values determined with the LICCON Job planner.
- The wind affecting the crane and the load, the elastic distortion of the crane structure, incline position as well as wind-exposed surface ( $A_w$ ) per ton of hoist load larger than 1.2 m<sup>2</sup>/t can significantly increase the support force and / or the crawler pressure.

**WARNING**

Increase of support force and / or the crawler pressure!

The resulting pressure on the ground becomes larger.

The permissible ground pressure can be exceeded.

- ▶ Do not exceed the permissible ground pressure.

**Note**

- ▶ The determining factor for all crane work in the actual wind speed at the job site of the crane.
- ▶ The current wind speed can be checked with the nearest weather bureau.
- ▶ The wind speed at the boom jib is higher than near the ground.
- ▶ Observe the national and regional regulations.

### 30.1 Wind speed charts for a *variable support*

For a *variable support*: Observe the wind speed charts according to the support base for the smallest extension length of the sliding beams.

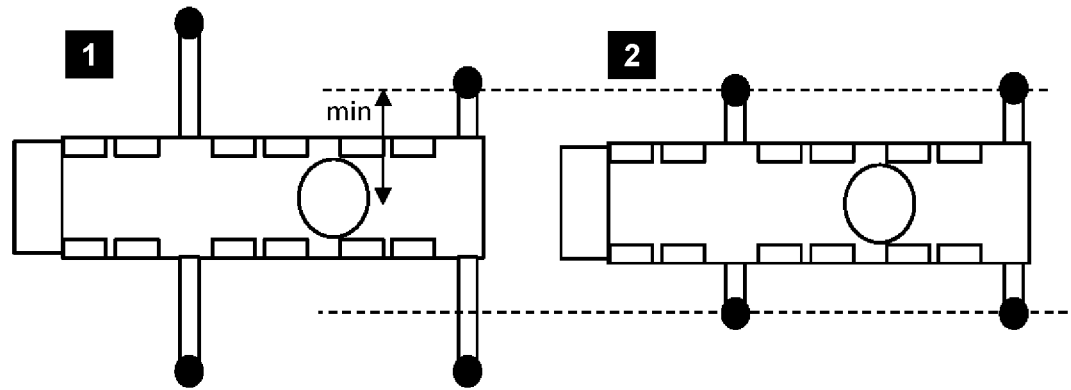


Fig.121577: Example of the selection of wind speed charts for a variable support

Example of the selection of wind speed charts for a *variable support*:

- The crane is supported with a *variable support* according to illustration 1.
- Select wind speed charts according to the support base in illustration 2.



#### Note

No wind speed charts available!

If the smallest extension length of a sliding beam is less than those of the wind speed charts on hand:

- ▶ Comply with the maximum permissible wind speeds in the load charts.

## 30.2 Wind speed, wind gust speed and wind direction

The depiction of the wind is made by statement of wind speed (wind force), wind gust speed and wind direction.

High above the ground, the wind is less influenced by the surface condition of the ground. In the lower layers of the atmosphere, the wind speed is reduced by the ground friction. One differentiates between roughness of terrain, influence of obstacles and influence of terrain contours. Vegetation, buildings etc. have great influence on the wind speed, wind gust speed and wind direction.

The site selection is thus especially important for wind measurement.

The wind speed, wind gust speed and wind direction are subject to significant time and local fluctuations. For that reason it is important to have reliable information regarding the expected wind speed, wind gust speed and wind direction during a load lift and to carry out exact wind measurements.

For mobile cranes, always assume a wind load of 360°. The determining factor is the “3 second gust speed” at the highest point of the boom.

## 30.3 Measurement of wind speed

The anemometer installed on the crane boom measures the wind speed on the boom jib and shows the current wind speed in the crane cab.

The function of the anemometer must be checked every time before erection of the boom by manually actuating the shell start for easy movement and proper function.

Before lifting a load, especially with large wind-exposed surface, the wind speed and the wind direction expected during the lift must be known. Information can be obtained for example from the local weather bureau. The determining factor is the “3-second gust speed” at the highest point of the boom.

**WARNING**

Overload of the crane!

The acoustic wind warning is only issued if the wind speed specified for the standard wind exposure surface in the load chart is exceeded (wind surface per ton load: 1 m<sup>2</sup>, drag coefficient: 1.2).

If the permissible wind speed must be reduced for loads due to large wind-exposed surfaces, no acoustic wind warning is issued.

There is no shut-off of crane movement.

- ▶ The wind-exposed surface and the wind resistance coefficient for the load to be lifted must be known.
- ▶ The maximum permissible wind speed specified in the load chart must be reduced for large wind exposure surfaces as described in the load chart manual chapter "Wind influences during crane operation".

To safely determination the wind speed, the crane must be turned 360° before use. The highest measured value while doing so must be compared with the "maximum permissible wind speed" for the load according to the load chart. Therefore the possibility that the result of the measurement is distorted due to nearby buildings, cranes or components is eliminated.

In gusty wind conditions, the probability of sudden high wind speed increases. In gusty wind conditions no loads with a large surface may be lifted.

**Note**

- ▶ If in doubt and in case of questions for further information and / or training in the area of "Wind influences in crane operation": Contact Customer Service at Liebherr-Werk Ehingen GmbH.

## 30.4 Conversion chart for wind force

**Note**

- ▶ The influence of the wind on the surrounding area is described clearly in the Beaufort scale to provide an orientation for the crane operator.
- ▶ The wind force of the Beaufort scale refers to the wind speed determined over 10 minutes at a height of 10 m.

Wind force		Wind speed		Effect of the wind Inland
Beaufort number	Designation	[m/s]	[km/h]	
0	Calm	0 to 0.2	1	Calm, smoke rises vertically
1	Slight air movement (draft)	0.3 to 1.5	1 to 5	Wind direction is shown only by observing the trail of smoke, not by the wind sock
2	Light breeze	1.6 to 3.3	6 to 11	Wind can be felt on the face, the leaves rustle, wind sock moves slightly
3	Gentle breeze	3.4 to 5.4	12 to 19	Leaves and small twigs in constant motion. Wind extends a flag
4	Moderate breeze	5.5 to 7.9	20 to 28	Swirls up dust and loose paper, moves twigs and thin branches
5	Fresh breeze	8.0 to 10.7	29 to 38	Small deciduous trees begin to sway, whitecaps form at sea
6	Strong breeze	10.8 to 13.8	39 to 49	Thicker branches move; telephone lines begin to whistle, umbrellas are difficult to use
7	Near gale	13.9 to 17.1	50 to 61	Entire trees swaying; difficult to walk into wind

Wind force		Wind speed		Effect of the wind Inland
Beaufort number	Designation	[m/s]	[km/h]	
8	Gale force wind	17.2 to 20.7	62 to 74	Breaks branches off trees, impedes walking in open areas considerably
9	Gale	20.8 to 24.4	75 to 88	Minor damage to property (chimney caps and roofing tile are blown off)
10	Severe storm	24.5 to 28.4	89 to 102	Trees are uprooted, significant damage to property
11	Violent storm	28.5 to 32.6	103 to 117	Extensive, widespread storm damage
12	Hurricane	32.7 and more	118 and more	Major destruction

Beaufort scale

## 30.5 Height-dependent wind speed



### Note

- ▶ The maximum permissible wind speed ( $v_{max}$ ) and the maximum permissible wind speed according to the load chart ( $v_{max\_TAB}$ ) always refer to the 3-second wind gust speed at the maximum height of the crane.
- ▶ Instead of the 3-second wind gust speed, weather information services often report a wind speed ( $v_m$ ) that is averaged over a time period of 10 minutes (so-called 10 minute average). It refers to the wind force on the Beaufort scale, normally to the medium value of the wind speed that is determined over a time period of 10 minutes at a height of 10 m above ground or above sea level.
- ▶ The 3-second wind gust speed at the maximum height of the crane that is the determining factor for the calculation is significantly higher than the average value of the wind speed that is determined over a time period of 10 minutes at a height of 10 m above ground.



### Note

- ▶ The following chart shows the 3-second wind gust speed depending on the height and the Beaufort number and / or the wind speed determined over a period of 10 minutes at a height of 10 m.
- ▶ With the aid of this chart, the 3-second wind gust speed can be determined for a certain height.

Beaufort number	3	4	5 <sup>a</sup>	5	6	7 <sup>a</sup>	7	8	9	10
$v_m$ [m/s <sup>b</sup> ]	5.4	7.9	<b>10.1</b>	10.7	13.8	<b>14.3</b>	17.1	20.7	24.4	28.4
$z$ [m]	$v(z)$ [m/s]									
10	7.6	11.1	<b>14.1</b>	15.0	19.3	<b>20.0</b>	23.9	29.0	34.2	39.8
20	8.1	11.9	<b>15.2</b>	16.1	20.7	<b>21.5</b>	25.7	31.1	36.6	42.7
30	8.5	12.4	<b>15.8</b>	16.8	21.6	<b>22.4</b>	26.8	32.4	38.2	44.5
40	8.7	12.8	<b>16.3</b>	17.3	22.3	<b>23.1</b>	27.6	33.4	39.4	45.8
50	8.9	13.1	<b>16.7</b>	17.7	22.8	<b>23.6</b>	28.3	34.2	40.3	46.9
60	9.1	13.3	<b>17.0</b>	18.0	23.3	<b>24.1</b>	28.8	34.9	41.1	47.9
70	9.3	13.5	<b>17.3</b>	18.3	23.6	<b>24.5</b>	29.3	35.5	41.8	48.7
80	9.4	13.7	<b>17.6</b>	18.6	24.0	<b>24.8</b>	29.7	36.0	42.4	49.4
90	9.5	13.9	<b>17.8</b>	18.8	24.3	<b>25.1</b>	30.1	36.4	42.9	50.0
100	9.6	14.1	<b>18.0</b>	19.1	24.6	<b>25.4</b>	30.4	36.9	43.4	50.6

Beaufort number	3	4	5 <sup>a</sup>	5	6	7 <sup>a</sup>	7	8	9	10
110	9.7	14.2	<b>18.2</b>	19.2	24.8	<b>25.7</b>	30.8	37.2	43.9	51.1
120	9.8	14.3	<b>18.3</b>	19.4	25.1	<b>25.9</b>	31.1	37.6	44.3	51.6
130	9.9	14.5	<b>18.5</b>	19.6	25.3	<b>26.2</b>	31.3	37.9	44.7	52.0
140	10.0	14.6	<b>18.7</b>	19.8	25.5	<b>26.4</b>	31.6	38.2	45.1	52.5
150	10.0	14.7	<b>18.8</b>	19.9	25.7	<b>26.6</b>	31.8	38.5	45.4	52.9
160	10.1	14.8	<b>18.9</b>	20.1	25.9	<b>26.8</b>	32.1	38.8	45.7	53.2
170	10.2	14.9	<b>19.1</b>	20.2	26.0	<b>27.0</b>	32.3	39.1	46.0	53.6
180	10.3	15.0	<b>19.2</b>	20.3	26.2	<b>27.1</b>	32.5	39.3	46.3	53.9
190	10.3	15.1	<b>19.3</b>	20.4	26.4	<b>27.3</b>	32.7	39.5	46.6	54.2
200	10.4	15.2	<b>19.4</b>	20.6	26.5	<b>27.4</b>	32.8	39.8	46.9	54.6
<sup>a</sup> Wind stages for the crane in operation: 1 light $v_m = 10.1 \text{ m/s}$ at $z = 10 \text{ m}$ $v(z) = 14.1 \text{ m/s}$ $q(z) = 125 \text{ N/m}^2$ 2 normal $v_m = 14.3 \text{ m/s}$ at $z = 10 \text{ m}$ $v(z) = 20.0 \text{ m/s}$ $q(z) = 250 \text{ N/m}^2$										
<sup>b</sup> Upper limit of the Beaufort scale										

3-second wind gust speed depending on the height and the Beaufort number and / or the wind speed determined over a time of 10 minutes at a height of 10 m

Sign	Unit	Definition
$v_m$	[m/s]	Wind speed determined over a time of 10 minutes at a height of 10 m
$z$	[m]	Height above level ground
$v(z)$	[m/s]	Speed effective at height $z$ , decisive for the calculation of a 3 second gust
$q(z)$	[N/m <sup>2</sup> ]	At a height $z$ effective quasi-static dynamic pressure, determined from $v(z)$

Symbol

## 30.6 Wind influences during erection and take-down



### WARNING

The crane can topple over!

If a boom or a boom system is erected or taken down and the expected wind speeds are higher than the maximum permissible wind speeds according to the wind speed chart, the crane can topple over and fatally injure personnel.

- ▶ If wind speeds are expected which are larger than the maximum permissible wind speeds for erection, then erection of the boom or erection of the boom system is prohibited.
- ▶ If wind speeds are expected, which are larger than the maximum permissible wind speeds for take-down, then the boom or the boom system must be taken down immediately.

**WARNING**

Wind speed higher than permissible!

When the permissible wind speed for "Crane out of operation" is higher than the permissible wind speed for take-down: Take-down of the boom is not permissible in case of an unexpected increase in wind speed.

The crane can topple over. Death, severe injury, property damage.

- ▶ If wind speeds are expected that are higher than the maximum permissible wind speeds for "Crane out of operation", then take the equipment and the boom down.
- ▶ Always take the boom down for safety reasons if weather conditions are unclear, see the Erection and take-down charts.
- ▶ Comply with the permissible wind speeds for take-down.

## 30.7 Wind influences during crane operation

**WARNING**

The crane can topple over!

Unforeseeable factors, such as sudden wind gusts on the crane and the load cannot be predicted precisely in advance.

- ▶ The size and shape of the load has a significant influence on the permissible wind speed during crane operation.
- ▶ Have professional job planning carried out by people with corresponding technical knowledge. All environmental conditions, such as the weather forecast and wind speeds, must be taken into account.
- ▶ Personnel with corresponding technical knowledge must have sufficient knowledge in the area of "Wind influences during crane operation".

**Note**

- ▶ Calculation examples are included in the load charts. For further information: Contact Customer Service at Liebherr-Werk Ehingen GmbH.

Depending on crane application, for example:

1. Lifting of large surfaced loads.
2. Working with long boom combinations.
3. Erection and take-down of boom combinations.

The crane operator must check with appropriate information sources about the expected wind speeds, at:

1. The start of crane operation.
2. Interruption of crane operation.
3. Resumption of crane operation.

**WARNING**

The crane can topple over!

If the crane is operated at wind speeds that are higher than the maximum permissible wind speeds according to the load chart, then the crane can topple over and kill personnel.

- ▶ If wind speeds are expected that are larger than the maximum permissible wind speeds for the equipped crane, then the equipment and the boom must be taken down.
- ▶ If wind speeds are expected that are higher than the maximum permissible winds speeds for crane operation, then it is prohibited to lift the load.

## 30.8 Wind influences for “Crane out of operation”



### WARNING

The crane can topple over. Death, severe injury, property damage!

If the crane is taken out of operation in the set up condition and the expected wind speeds are higher than the maximum permissible wind speeds according to the wind chart, then the crane can topple over and fatally injure personnel.

- ▶ If wind speeds are expected that are higher than the maximum permissible wind speeds for “Crane out of operation”, then take the equipment and the boom down.
- ▶ Always take the boom down for safety reasons if weather conditions are unclear, see the Erection and take-down charts.
- ▶ Comply with the permissible wind speeds for take-down.

## 31 Lifting a load with two cranes

Before lifting a load with two cranes, the operating company or a representative of the operating company must plan the use and indicate a “designated person”. The “designated person” must monitor the operation and remain in constant contact with the crane operators.



### WARNING

Overload and toppling of the cranes!

If the load is not lifted or lowered exactly evenly by both cranes, then the center of gravity changes.

The cranes can be overloaded and topple over.

Personnel can be killed or seriously injured.

- ▶ Make sure that the cranes are horizontally aligned.
- ▶ Observe the national and regional regulations.
- ▶ Determine the utilization degree of the cranes in operation, depending on the complexity of the load hoist.
- ▶ Plan for sufficient safety reserves.
- ▶ Avoid side load on the boom.
- ▶ Carry out crane movements synchronously and slowly.



### Note

- ▶ The total weight and the center of gravity of the load must be known exactly.
- ▶ Carry out the job planning in detail and with care.
- ▶ Avoid fastening points below the center of gravity of the load.

When the operational conditions or the work to be carried out require:

- ▶ Set up an assembly plan and operating instructions for the operation.

The drawing shows how the center of gravity for the load changes if the load is lifted or lowered unevenly. Even a slight incline of the load can cause the crane to be overloaded.

If the load on crane 2 ( $F_2$ ) is lowered, the load on crane 1 ( $F_1$ ) increases. Crane 1 can thereby be overloaded.



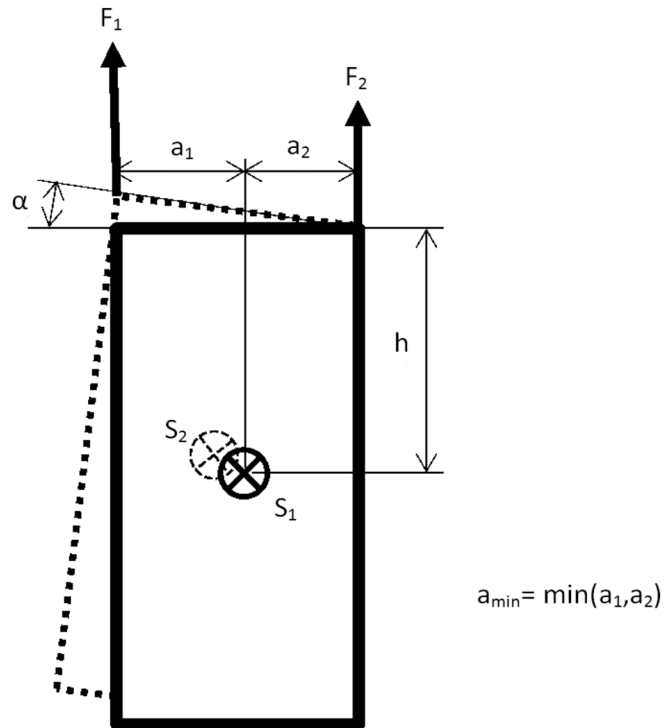


Fig.124126: Geometric conditions

<b>F<sub>1</sub></b>	Load on crane 1	<b>F<sub>2</sub></b>	Load on crane 2
<b>S<sub>1</sub></b>	Center of gravity of load	<b>S<sub>2</sub></b>	Center of gravity of load at incline position
<b>h</b>	Vertical distance between center of gravity of the load and the fastening points	<b>α</b>	Angle of load at incline position
<b>a<sub>1</sub></b>	Horizontal distance between center of gravity of load and fastening point crane 1	<b>a<sub>2</sub></b>	Horizontal distance between center of gravity of load and fastening point crane 2
<b>a<sub>min</sub></b>	Smallest horizontal distance between the center of gravity of the load and the fastening point (minimum from a <sub>1</sub> and a <sub>2</sub> )		

The following diagram shows the dependence of the ratio of  $h/a_{min}$  at a maximum permissible incline position of the load of 3° in reference to the permissible load utilization of cranes as a percentage.

LWE/LR 1800-1-0-000/27200-07-02/en



Fig. 124127: Maximum permissible load utilization

- x** Ratio of h to  $a_{min}$  **y** Maximum permissible load utilization as a percentage, if  $\alpha$  is smaller or equal to  $3^\circ$

Example: A ratio h to  $a_{min}$  of 6, when retaining the incline position of the load of maximum  $3^\circ$  results in a maximum permissible load utilization of both cranes of approx. 76 % each.

## 32 Overlapping of working ranges of several cranes



### WARNING

Danger of collision!

If the working ranges of several cranes overlap, there is a danger of collision.

Personnel can be injured or killed.

Significant property damage can result.

- ▶ The contractor or his representative must determine the work sequence in detail in advance.
- ▶ The contractor or his representative must ensure flawless communication between crane operators.
- ▶ The crane operators must ensure through calm operating mode, that no collisions occur due to uncontrolled movements. The crane operators must have been trained and instructed accordingly.

If the communication between the crane operators is not ensured by sound or visual connection, then suitable measures must be taken, such as using radio communication, guides or similar. When using derrick booms or TY-guying, it is necessary to proceed with extreme caution as these components protrude far past the rear turning radius of the turntable.



### Note

- ▶ If guides are used, then the signals must be agreed upon between them and the crane operators, see section "Hand signals for guidance".

## 33 Hand signals for guidance

For all crane movements, the crane operator must always keep the load as well as the crane hook or load handling equipment when the crane is not loaded, in his field of vision.



### WARNING

Danger of accident if standing under suspended loads!

- ▶ Always keep loads in sight.
- ▶ Standing under suspended loads is prohibited.

If this is not possible, the crane operator may only operate the crane if he is signed by an assigned guide.

The operator may be guided by hand signals or a two-way radio. It must be ensured that there are no misunderstandings.



### WARNING

Danger of accident caused by misunderstood hand signals!

- ▶ Hand signals must be mutually agreed upon and clearly executed.
- ▶ In any case, the **national and regional regulations** must be observed.

### 33.1 Hand signals

#### 33.1.1 Starting operation, follow my instructions

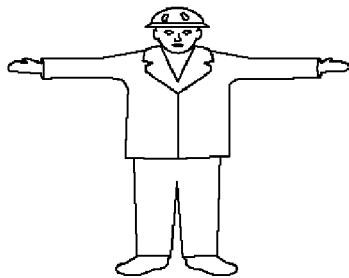


Fig.111700: Starting operation, follow my instructions

Both arms stretched out horizontally with hands open and palms directed to the front.

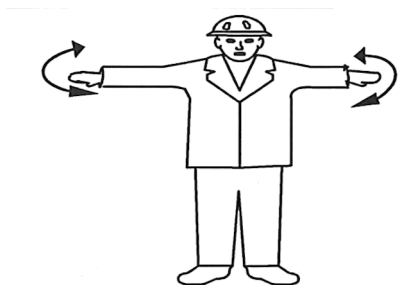
#### 33.1.2 Stop (normal stop)



Fig.144245: Stop (normal stop)

Arm stretched out, palm of hand facing down, move the arm horizontally backward and forward.

### 33.1.3 Emergency stop (quick stop)



*Fig.144246: Emergency stop (quick stop)*

Both arms stretched out, both hand palms facing down, move arms horizontally backward and forward.

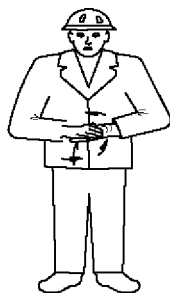
### 33.1.4 Ending operation, no longer follow my instructions



*Fig.111703: Ending operation, no longer follow my instructions*

Fold hands together at chest height in front of body.

### 33.1.5 Creeper gear or very slow movement

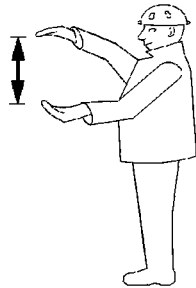


*Fig.111704: Creeper gear or very slow movement*

Rub palms together in circular motion. After this sign, all other applicable hand signals apply.

## 33.2 Vertical movements

### 33.2.1 Showing the vertical distance



*Fig.121364: Showing the vertical distance*

Both arms stretched out in front of the body one on top of the other, with opposing palms.

### 33.2.2 Lifting / lowering a load with even speed



*Fig.111706: Lifting / lowering a load with even speed*

Lift one arm overhead with closed hand and index finger pointing upward, with small horizontal circular movements with forearm.

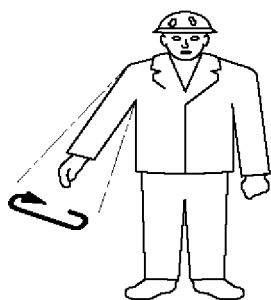
### 33.2.3 Lifting slowly



*Fig.121365: Lifting slowly*

Give lift signal with one hand, the other palm is not moving and positioned over the hand, which gives the signal.

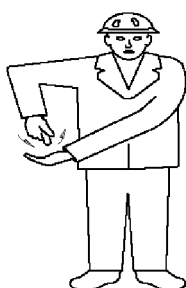
### 33.2.4 Lowering the load while stationary



*Fig.111708: Lowering the load while stationary*

Point one arm away from the body, downward, with hand closed and index finger pointing down. Make small circular movements with forearm.

### 33.2.5 Lowering slowly

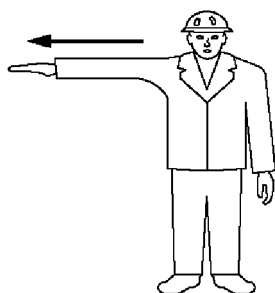


*Fig.121366: Lowering slowly*

Give lowering signal with one hand, do not move the other palm and hold it under the hand, pointing to the hand which gives the signal.

## 33.3 Horizontal movements

### 33.3.1 Driving / swinging in the specified direction



*Fig.111710: Driving / swinging in the specified direction*

Hold stretched out arm horizontally into the desired direction, with the hand open and the palm pointing down.

### 33.3.2 Moving away from me



Fig.111711: Moving away from me

Stretch out both arms simultaneously with forearms in front, with both hands open and the palms pointing down. Move the forearms repeatedly between the horizontal and vertical position up and down.

### 33.3.3 Moving toward me

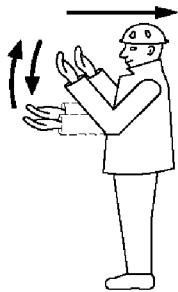


Fig.111712: Moving toward me

Stretch out both arms simultaneously with forearms vertically, with both hands open and the palms pointing to the rear. Move the forearms repeatedly up and down.

### 33.3.4 Moving both track chains

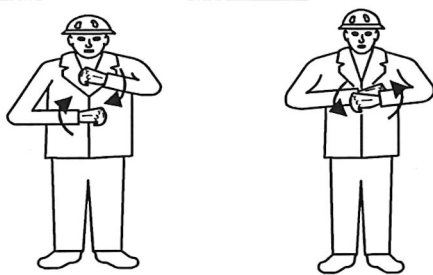


Fig.144247: Moving both track chains

Turn both fists around each other in front of the body in direction of the movement (forward or reverse).

### 33.3.5 Moving one crawler chain



Fig.144248: Moving one crawler chain

Lift one fist to show blockage of chain on one side. Turn the other fist vertically in front of the body to signal movement of the opposite chain.

### 33.3.6 Showing the horizontal distance

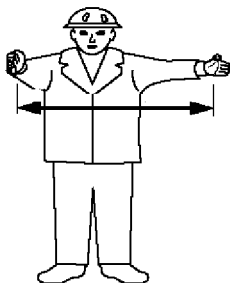


Fig.121380: Showing the horizontal distance

Keep both arms stretched out horizontally in front of the body with the palms opposite each other.

### 33.3.7 Transfer (between two cranes or two hooks)

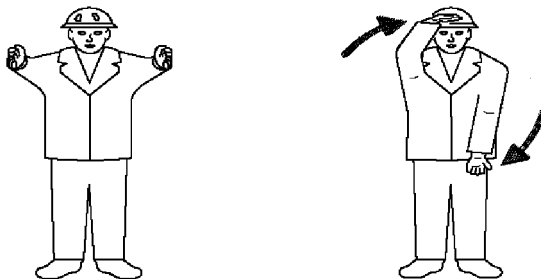


Fig.121368: Transfer (between two cranes or two hooks)

Hold both arms stretched out to the front, parallel and horizontally and turn by 90° in direction of the transfer.



#### WARNING

Load bearing capacity is **not** sufficient!  
The crane can topple over, death, property damage.

- ▶ Make sure that the load bearing capacity of the individual crane and hook is sufficient even if the transfer of the load is suddenly asymmetric.



## 33.4 Machine related movements

### 33.4.1 Lifting with main winch

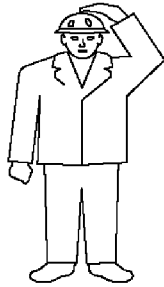


Fig.111719: *Lifting with main winch*

Place one hand on your head and hold the other arm on the side of the body.

After this signal, all other hand signals apply only for the main winch.



#### Note

- ▶ If two or more main winches are present, then the signaler can show the number of the crane by pointing to it or signal with one finger.

### 33.4.2 Lifting with the auxiliary winch

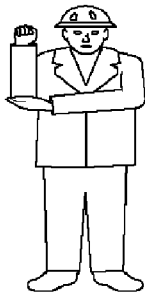


Fig.111720: *Lifting with the auxiliary winch*

Hold one forearm vertically with closed hand and touch the elbow of this arm with the other hand.

After this signal all other hand signals apply only for the auxiliary winch.

### 33.4.3 Lifting the boom

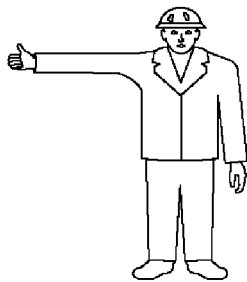
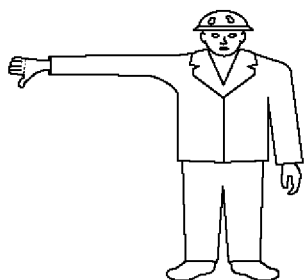


Fig.111721: *Lifting the boom*

Hold one arm horizontally with thumb directed upward.

### 33.4.4 Lowering the boom



*Fig.111722: Lowering the boom*

Hold one arm horizontally with thumb directed downward.

### 33.4.5 Extending the boom



*Fig.144249: Extending the boom*

Hold both hands (with closed fists) stretched out to the front, with both thumbs directed away from each other.

### 33.4.6 Retracting the boom



*Fig.144250: Retracting the boom*

Hold both hands (with closed fists) stretched out to the front, with both thumbs directed toward each other.

### 33.4.7 Lifting the boom and lower the load at the same time

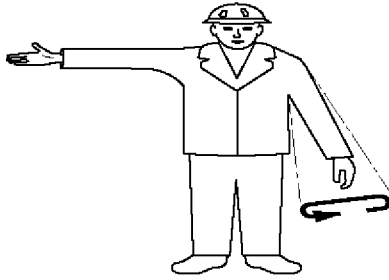


Fig.111725: Lifting the boom and lower the load at the same time

Hold one arm stretched out horizontally with thumb directed upward and stretch the other arm downward and away from the body, make small flat circles with the forearm.

### 33.4.8 Lowering the boom and lift the load at the same time

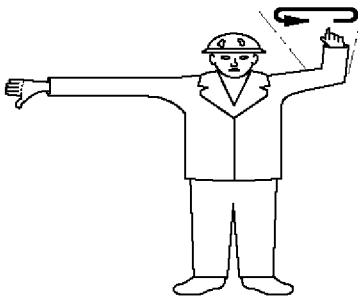


Fig.111726: Lowering the boom and lift the load at the same time

Hold one arm stretched out with thumb pointing down, stretch the other forearm upward and make small flat circles.

## 34 Travel operation

### 34.1 Starting to drive

Before starting to drive the crane

- Close all doors.
- Keep the doors closed during the travel operation.

## 34.2 Turning / driving in reverse



### WARNING

Danger of accidents when turning or driving in reverse!

When turning or driving in reverse, personnel can be overlooked and killed.

Objects can be severely damaged.

- ▶ When turning or driving in reverse, the driver must act in such a way that he does not endanger other traffic participants.
- ▶ The driver may only drive in reverse or back up when persons or devices are **not** endangered. If this can **not** be ensured, then he must use a guide.
- ▶ An acoustical back up warning device will never replace the guide.
- ▶ Make sure that there are no persons or objects behind the vehicle when driving in reverse.
- ▶ Make sure that no personnel is injured or even killed.
- ▶ Make sure that no objects are damaged.
- ▶ Driving in reverse is only permissible at a slow driving speed (maneuvering speed).
- ▶ Adhere to the national and regional regulations.

## 34.3 Driving with a trailer

Driving with a trailer depends on the weight of the mobile crane. The minimum weight of the mobile crane in trailer mode is 70 percent of the permissible total weight.

Number of axles	Permissible total weight of the mobile crane	Minimum weight of the mobile crane in trailer mode
4	48000 kg	Approx. 33000 kg
5	60000 kg	Approx. 42000 kg
6	72000 kg	Approx. 50000 kg

### 34.3.1 Driving with a reduced load

The load of the vehicle crane has been reduced to a range between the permissible total weight and the minimum weight for trailer mode. The load of the vehicle crane can be reduced by disassembling equipment.

The vehicle crane has a different, strong braking behavior. The vehicle crane can reeve out.

### 34.3.2 Driving with an extremely reduced load

The load of the vehicle crane has been reduced to the minimum weight for trailer mode or less. The load of the vehicle crane can be reduced extremely for example by disassembling the telescopic boom and by disassembling other equipment.



### WARNING

Driving with a trailer with an extremely reduced load!

The mobile crane has a different, strong braking behavior. The mobile crane can reeve out.

Danger of accident, death, property damage.

- ▶ In the case of an extremely reduced load, do **not** drive the crane vehicle with a trailer.

## 34.4 Stopping the mobile crane

Make sure that the following prerequisites are met:

- The mobile crane is standing on load bearing, level and tractive ground.
- The parking brake is applied.

**WARNING**

Parking brake is **not** applied!

The mobile crane can roll off, death, property damage.

- ▶ Park the mobile crane exclusively with applied parking brake.

- Turn off the ignition and pull out the ignition key.

When a battery master switch is present:

- Wait 10 seconds, turn off the battery master switch and pull out the switch cam.

**WARNING**

Downhill or uphill slope is too steep!

The mobile crane can roll off, death, property damage.

- ▶ Park the mobile crane at an downhill or uphill slope of no more than maximum 18 %.

Under the following conditions the mobile crane must be additionally secured with wheel chocks to prevent it from rolling off:

- The mobile crane is parked on a slope or an incline.
- The mobile crane is defective, particularly when the brake system is defective.

**WARNING**

Wedges incorrectly placed!

The mobile crane can roll off, death, property damage.

- ▶ So that the wedges have an immediate braking action and hold the mobile crane in park position:
  - Place all wedges tightly directly under the wheel.
- ▶ Place all specified wedges.
- ▶ All wedges must counteract the downhill slope force.

If necessary:

- Place the wedges.

## 35 Crane operation

### 35.1 Before starting to work

Before starting to work with the crane:

- Make sure that the cylinders are free of ice.
- Close all doors.
- Keep the doors closed during crane operation.

### 35.2 While working with the crane

**WARNING**

Defective crane!

Death, severe bodily injuries, property damage.

If an erroneous function of a crane movement is recognized during crane operation:

- ▶ Telescope the boom in all the way and take it down, find the source of the problem and remedy it.

**WARNING**

Relapse cylinder pressure loss!

The luffing lattice jib can luff uncontrollably.

If the luffing lattice jib is assembled

- ▶ Make sure that no persons or obstacles are in the luffing range or are located below the lattice jib.

**WARNING**

Relapse cylinder pressure loss!

The luffing lattice jib can luff uncontrollably due to slack rope on the luffing pulley block.

If an actuated luff down movement does not take place as expected:

- ▶ Immediately stop the luff down movement.
- ▶ Make sure that no slack rope has formed.

If slack rope has formed:

- ▶ Remedy the slack rope.

**NOTICE**

Freezing rain!

Property damage to the cylinder seals.

If freezing rain starts when working with the crane:

- ▶ Working with the crane is prohibited.
- ▶ Make sure that all cylinders are free of ice.

### 35.3 Crane operation with a load

**WARNING**

The crane can topple over!

If the crane is in a condition that is **not** operationally safe, the crane can topple over or crane components can fall down.

Personnel can be severely injured or killed.

- ▶ Before starting to work, the crane operator must ensure that the crane is in an operationally safe condition.
- ▶ If safe crane operation cannot be ensured by the crane operator, then crane operation is prohibited until an operationally safe condition for the crane is established.
- ▶ Safety equipment, for example: Load torque limiter, hoist limit switch, brakes must be fully functioning, otherwise crane operation is prohibited.

Make sure that the following prerequisites are met:

- The load torque limiter must be adjusted according to the current set up configuration of the crane.
- The loads given in the load chart may not be exceeded.
- The crane may never be subjected to a load that exceeds what is specified in the load charts.
- The weight, center of gravity and dimensions of the load to be lifted must be known.
- Load carriers, load handling equipment and fastening equipment must be sufficient for the specified requirements.

**Note**

- ▶ Subtract the weight of the hook block and the weight of the fastening equipment from the load specified in the load chart, see the following chart.

Example:		
Maximum permissible load according to the chart		30.000 t
Weight of the hook block	350 kg	- 0.350 t
Weight of the fastening rope	50 kg	- 0.050 t
Actual load capacity of the crane		= <b>29.600 t</b>

The weight of the load to be lifted, in this example, may not exceed **29.6 t**.

**DANGER**

There is a high danger of accident if the following points are not observed!

- ▶ Comply with the following points.

**There is considerable danger of accident if:**

- The load torque limiter is not set in accordance with the current crane set up configuration and is therefore not able to provide proper protection.
- The load torque limiter is defective or taken out of operation.
- The hoist limit switches are defective or not functioning.
- For crawler cranes and mobile cranes with luffing lattice jib:  
The angle sensor and the force test brackets are not functioning.
- For mobile cranes and crawler cranes with support:  
The sliding beams of the hydraulic support are not extended to the dimensions specified in the load chart.
- On crawler cranes:  
The crawlers are not supported with stable base material sufficiently large for the ground conditions.
- For mobile cranes and crawler cranes with support:  
The support plates are not supported with stable materials large enough for the ground conditions.
- Angular pull is performed.  
Angular pull to the side is particularly dangerous, because the boom has only minimal lateral resistance momentum.

**Angular pull is prohibited.**

- Load that is too heavy is attached during disassembly and hangs freely on the crane after release.
- The load hook is used to break away stuck loads.  
Even if the weight of a stuck load does not exceed the permissible load capacity, the crane can topple over backwards if the load is suddenly released due to the tension of the boom, which can cause it to tip backwards.
- Working when the wind is excessively strong.  
Adhere to the specifications in the load chart.
- The crane is not levelled and the load is swung in the direction of the slope.
- If improper control of crane movements cause the suspended load to swing like a pendulum.
- The loads and boom radii specified in the load charts are exceeded.
- When working in the vicinity of overhead electrical lines:
  - The overhead electrical lines are **not** turned off by authorized and trained electricians.
  - The danger zone was not covered or blocked off.

**WARNING**

Danger of current transfer!

If overhead electrical lines are not shut off or covered or blocked off, there is an increased danger of accident due to current transfer.

- ▶ Adhere to the safety distance according to the following chart.

If the crane becomes electrified despite having taken all necessary precautions, comply with the following points:

- ▶ Remain calm.
- ▶ Do not leave the crane cab or the driver's cab.
- ▶ Warn people outside: Stay in place and do not touch the crane.
- ▶ Move the crane away from the danger zone.

Nominal voltage	Safety distance	
Up to 50 kV	4 m	10 ft
Above 50 kV to 200 kV	5 m	15 ft
Above 200 kV to 350 kV	7 m	20 ft
Above 350 kV to 500 kV	8 m	25 ft

Nominal voltage	Safety distance	
Above 500 kV to 750 kV	11 m	35 ft
Above 750 kV to 1000 kV	14 m	45 ft
Above 1000 kV	Determination by the power supplier or an authorized and trained electrician	Determination by the power supplier or an authorized and trained electrician

*Safety distance to overhead electrical lines depending on the nominal voltage*

### 35.3.1 Counterweight and / or ballast

The type of counterweight and / or ballast required depends on the weight of the load to be lifted and the boom radius required for crane operation. The deciding factor for the selection of the counterweight and / or ballast is the specification in the corresponding load chart.



#### **WARNING**

The crane can topple over!

If the counterweight and / or ballast is not installed according to the load chart, the crane can topple over and fatally injure personnel.

- ▶ Install the counterweight and / or ballast according to the load chart.



### 35.3.2 Derrick ballast - suspended ballast

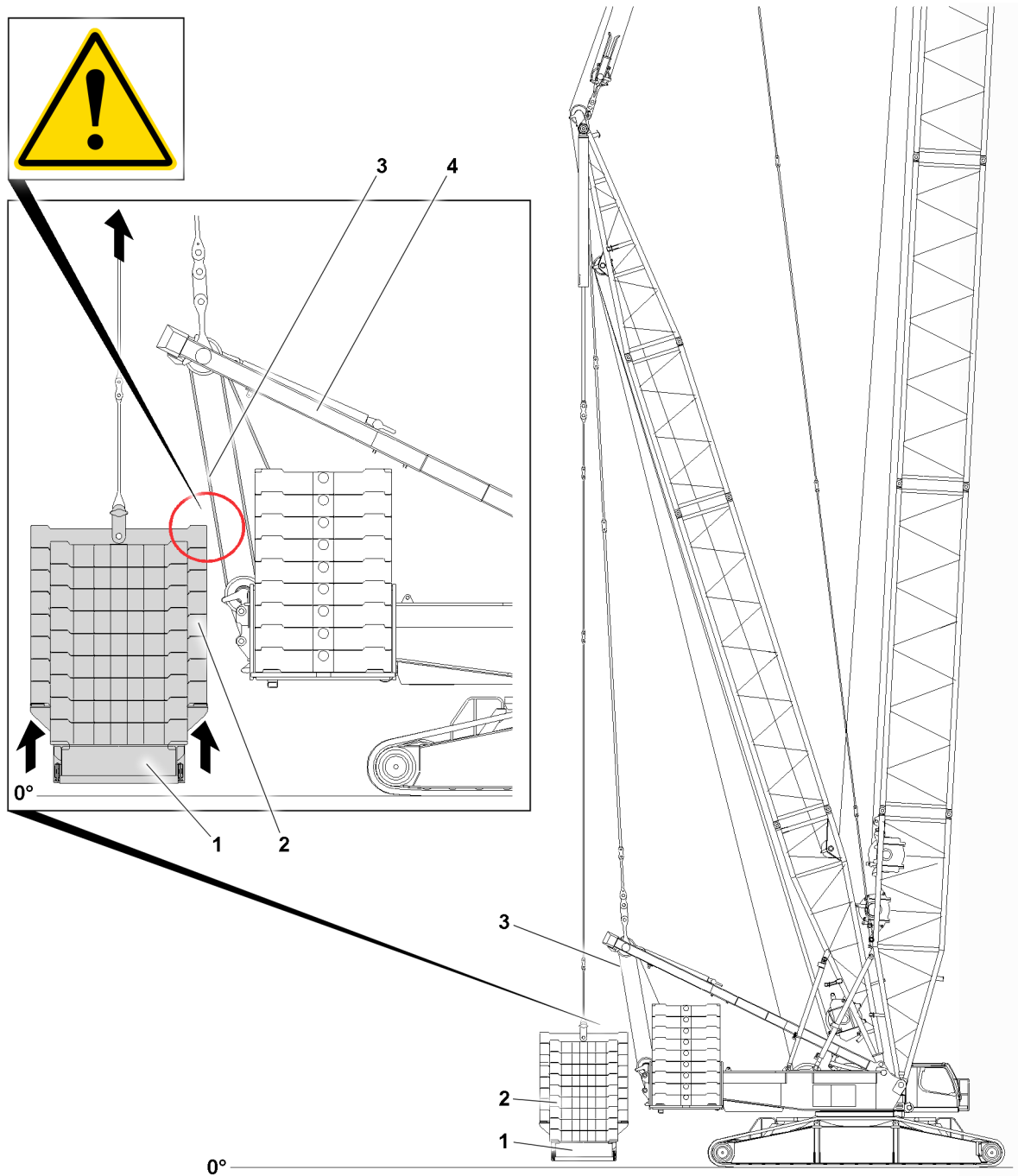


Fig.154801: Danger of collision when lifting the derrick ballast with small derrick ballast radii

- 1 Suspended ballast pallet
- 2 Derrick ballast plate
- 3 Winch 4 control rope
- 4 SA-frame

LWE/LR 1800-1-0-000/27200-07-02/en

**WARNING**

Danger of collision!

With small derrick ballast radii, the derrick ballast plates **2** can collide with the winch **4** control rope **3** when lifting the derrick ballast up off the ground.

Death, severe bodily injuries, property damage.

- ▶ Make sure that a guide monitors the lifting of the derrick ballast up off the ground.
- ▶ Adjust the lifting height of the derrick ballast.

### 35.3.3 Hoist gear, hoist rope

The lifting capability of the crane depends on the pull force of the hoist gear and the number of possible hoist rope reevings. When using a single strand, the crane can only lift a load that is pulled by the hoist gear.

If the load to be lifted is heavier than the pull force of the hoist gear, then the hoist rope must be reeved as needed according to the principle of a pulley between the pulley head on the boom and the hook block.

When reeving in, observe the specifications in the load chart manual and the crane operating instructions.

**WARNING**

Ripping of the hoist rope!

If the maximum pull force of the hoist gear is exceeded, the hoist rope can break or the hoist gear can be damaged.

The load can fall and kill personnel.

- ▶ Observe the maximum pull force of the hoist gear.

### 35.3.4 Hydraulically adjustable auxiliary boom

**WARNING**

Impermissible luffing of the auxiliary boom!

Damage to the auxiliary boom due to collision with the ground or other objects. Component failure. Death, severe bodily injuries, property damage.

- ▶ Do **not** luff the auxiliary boom down onto the ground or other objects by means of hydraulic adjustment.
- ▶ Do **not** luff the auxiliary boom down onto the ground or other objects by luffing the main boom down.

## 35.4 Interrupting crane operation

**WARNING**

Impermissible weather conditions!

If the crane is exposed to impermissible weather conditions during interruption of crane operation, situations can occur that could bring the crane into an unsafe condition.

Toppling crane, death, severe bodily injuries, property damage.

- ▶ Obtain the weather forecast for the entire period during which the crane is set up.

If the predicted wind speeds are above the permissible values according to the load chart and / or the wind speed chart:

- ▶ Take the boom and equipment down in time before impermissible wind speeds occur. See Crane operating instructions, wind speed charts and Erection and take down charts.

When wind conditions are present, which are above the permissible values of the wind speed chart and the boom can no longer be taken down:

- ▶ Make sure that there is no danger to persons, crane and surrounding area. Secure the crane and surrounding area of the crane far enough against access. Warn personnel in the surrounding area and bring them to safety.

A weather forecast includes information about:

- Changing weather conditions
- Wind
- Ice
- Precipitation
- Flooding
- Lightning



### WARNING

Defective crane!

Death, severe bodily injuries, property damage.

If a crane movement occurs during the interruption of crane operation:

- ▶ Make sure, when an unintentional crane movement occurs, for example as a result of leak, no danger for persons, crane and surrounding is created.

Leaks can occur all on pressurized hydraulic cylinders, for example on the following cylinders:

- Support cylinder
- Luffing cylinder
- Telescoping cylinder
- Control cylinder
- Relapse cylinders



### Note

- ▶ Movements can occur on hydraulic cylinders also as a result of changing oil temperature.



### WARNING

Set up crane is not supervised!

Situations during interruption of crane operation may occur that could cause the crane to become unsafe if left unsupervised.

Toppling crane, death, severe bodily injuries, property damage.

- ▶ Always observe the crane and keep it under control.

If the crane is in set up condition:

- ▶ Do **not** leave the crane.

If the crane can **not** be constantly kept under control:

- ▶ Take the equipment down and telescope the boom in and take it down.
- ▶ The boom on the crane may only be placed down if the predicted wind speeds according to the wind speed charts are less than the maximum permissible wind speeds during assembly and disassembly.
- ▶ Before the crane is unsupervised: Establish an emergency plan.
- ▶ Carry out the measures listed below.



### Note

- ▶ An emergency plan includes specifications regarding how the crane is brought into a safe condition if an unforeseen event occurs.

If possible:

- Take down and secure the equipment, see the erection and take-down charts.
- Telescope the boom in and secure it. The crane boom may only be telescoped when the prevalent wind speed is lower than the wind speed indicated in the load chart for the boom.
- Take the boom down and secure it. The crane boom may only be placed down if the wind speeds are lower than the maximum permitted wind speeds according to the wind speed charts or does not exceed them according to the assembly / disassembly instructions.

On mobile cranes:

- Lift the axles to the maximum position and block the hydraulic suspension.

On lattice mast cranes:

- Set the Derrick ballast, if present, down on the ground.

- Place the load completely on the ground and unhook it from the crane hook.
- Remove the fastening ropes from the hook.
- Place the load completely on the ground and unhook it from the crane hook.
- Remove the fastening ropes from the hook.

When the hook block remains installed:

- Lift the hook block into the highest position.
- Make sure that the hook block does not touch other crane parts or obstacles.
- Make sure that all measures were taken to keep the crane in a safe condition if something happens.
- If possible, turn the engines off.
- Set all control levers into neutral position or into a locked position.
- Turn all secondary systems off, except systems that are required for restart.
- Establish the energy supply and functionality of safety equipment.
- Close off all control devices, which are not in use.
- Disconnect all control devices, which are connected with cables, if possible, and secure them to prevent unauthorized use.
- Secure control devices without cables to prevent unauthorized use.
- Make sure that the batteries in control devices without cables are charged.
- Make sure that access to the crane and operation for unauthorized personnel is excluded: Lock the driver's cab and the crane cab.
- Secure all keys to prevent unauthorized access.

If the construction site has limited space:

- The decision not to take the boom down while the crane is unsupervised can only be made by an authorized and qualified crane operator, who is familiar with the construction site.
- Make sure that there is no danger to persons, the crane or its surroundings if an unforeseen event occurs.
- Make sure for the duration of the interruption of crane operation, that the predicted wind speeds do not exceed the permissible values for the respective set up configuration, see wind speed chart.
- If the wind speed charts do not provide values for the set up condition, the permissible wind speed in the load chart shall be observed.

If crane operation with a set up crane is interrupted:

- Make sure that personnel initiate measures in time to bring the crane into a safe condition if an event occurs.
- Make sure that there is no danger to persons, the crane or its surroundings if an unforeseen event occurs.

If the predicted wind speeds are above the permissible values:

- Bring the boom and equipment in time into a permissible condition before impermissible wind speeds occur, depending on the predicted wind speed, or take it down completely on the ground. See Crane operating instructions, wind speed charts and Erection and take down charts.
- Telescope the telescopic boom in and luff down to 0°. Position the boom and auxiliary boom, see the Crane operating instructions, wind speed charts and erection and take-down charts.

**Situations are for example:**

- Vandalism
- The ground giving way due to severe rain
- Melting ice under the supports
- Storm and thunderstorm
- Storm and wind
- Lightning
- Flooding
- Earthquakes
- Landslides
- Washouts
- For mobile cranes and crawler cranes with support:  
Yielding of support cylinders (leak, temperature changes)
- For cranes with a telescopic boom:  
Yielding of luffing cylinders (leak, temperature changes)

- Yielding of luffing lattice jib relapse cylinders (leak, temperature changes)

## 35.5 Resuming crane operation

Before resuming crane operation, the crane operator is obligated, among others, but not exclusively, to check the crane condition, the safety equipment, as well as the environmental conditions.



### WARNING

Danger of accident!

When the crane operator leaves the crane cab:

- ▶ Before resuming work, check the operating mode setting and reset, if necessary.

## 35.6 Ending crane operation

Before the crane operator may leave the crane, the following prerequisites must be met:

- Place the load fully on the ground and unhook from the crane hook.
- On crane with telescopic boom: Telescope the telescopic boom in all the way and take the boom down in the boom receptacle.
- For a crane with a lattice mast boom: Take the lattice mast boom down and disassemble if necessary.
- Bring the control lever (master switch) to the 0-position.
- Apply the parking brake on the crane chassis.
- Turn the engine off and pull out the ignition key.
- When a battery master switch is present: Wait ten minutes after removing the ignition key. After these ten seconds have passed, turn off the battery master switch and pull off the switch cam.
- Lock the crane cab.
- Secure the crane to prevent unauthorized use.
- For a mobile crane: Make sure that the driver's cab is **not** occupied. Lock the driver's cab. Secure the crane to prevent it from rolling off unintentionally, see section "Parking the vehicle".
- Make sure that there is no danger to persons, the crane or its surroundings if an unforeseen event occurs.

# 36 Lifting of personnel

## 36.1 Intended use

- The intended use of the crane is **lifting loads**.
- **Lifting personnel** is **not** part of the intended use of the crane.



### Note

- ▶ These instructions do **not** apply for work platforms that are attached on the crane boom and used to lift personnel. This situation is governed by international standards for mobile aerial work platforms.

**WARNING**

Unintended use of the cranes!

Personnel can be severely injured or killed.

- ▶ The crane is **not** intended to lift personnel.
- ▶ Lifting persons on the variable support is prohibited.
- ▶ The crane may **not** be used for recreational purposes and exhibitions, such as lifting personnel for shows, bungee jumping or Dinner in the sky.
- ▶ The crane may **not** be used for lifting of devices with personnel on them or under the device, such as lifting of tents.
- ▶ Exception: If lifting of personnel for special work situations is the least dangerous possibility to carry out the work, then personnel may be lifted or brought into a suspended position when using lifting cages (cherry pickers).

## 36.2 Prerequisites for lifting of personnel

Make sure that the following prerequisites are met:

- Lifting personnel with cranes is permitted by national and regional regulations of the country where this crane application is carried out.

**DANGER**

Lifting of personnel!

Accidents which occur when lifting personnel often result in severe injuries or even death.

- ▶ This exceptional application is within the scope of responsibility of the user and is only permitted if the requirements and instructions in the following sections are observed and adhered to.
- ▶ The operating company, a designated person for monitoring, the crane operator and other personnel must proceed especially carefully and in a safety conscious manner.
- ▶ Before the lifting procedure, a meeting must be held with all involved personnel.
- ▶ The following warning displays and safety regulations must be strictly observed.

### 36.2.1 Legal prerequisites

Make sure that the following prerequisites are met:

- Special arrangements were made for the use of the safety cage according to the requirements of national and regional regulations.
- If required by national or regional regulations: The use of the crane to lift personnel is reported to the state agency for occupational health and safety. The lifting procedure may possibly require a special permit.
- Before the implementation of the lifting procedure a work-specific risk analysis for the possibility of rescuing personnel in emergencies was defined with the aid of the evaluation.
- To rescue personnel in emergencies, precautionary measures must be present on the crane, if they are required by national and regional regulations.
- The measures for safe operation near power lines, depending on the conditions on the job site and the national and regional regulations, were observed and adhered to.

### 36.2.2 Prerequisites for crane equipment and accessories

Make sure that the following prerequisites are met:

- The hoist gear to lift personnel must also be able to be moved in emergency operation.
- Before lifting personnel, the crane was inspected. No damage was found.
- The safety cage is used according to national and regional regulations and according to the intended purpose.
- Before lifting personnel, the safety cage was carefully inspected. No damage was found.
- Every emergency rescue device was inspected and its operational readiness was determined, if required by national and regional regulations.
- Any hooks in use must be equipped with a latch that prevents the hook mouth from opening. According to national and regional regulations, the latch must be manually closable or lockable or must automatically close via a spring.

### 36.2.3 Inspecting before start up

- Make sure that the following inspections are made before starting up the lifting cage (cherry picker):
- On every new construction site and after every modification or repair: To ensure the operating safety of the lifting cage (cherry picker) and the lifting equipment, a test with 125 % of the nominal load carrying capacity of the lifting cage (cherry picker) without personnel must be carried out. During the test, the lifting cage (cherry picker) may only be lifted just above the ground.
  - A test lift with loaded lifting cage (cherry picker) without personnel must be carried out. The weight in the lifting cage (cherry picker) for the test lift must be at least as large as the weight of the personnel and the weight with the work equipment carried along. For this test lift, the course of all planned movements of the lifting procedure must be simulated.
  - This test lift must be carried out for every location on a construction site, where personnel must be carried.

### 36.2.4 Prerequisites for operation with lifting cage (cherry picker)

- Make sure that the following prerequisites are met for operation with safety cage:
- The personnel and technical prerequisites for safe use and operation of the emergency control of the crane are fulfilled.
  - The emergency control for emergency rescue of the person in the safety cage is operational.
  - The rope pull is limited to 50 % of the maximum rope pull.
  - The crane is utilized only to 50 % of its maximum load bearing capacity of the valid load chart.
  - Only the hoist gear lifting / lowering, turning and luffing crane movements may be performed.



#### WARNING

Superimposed crane movements with hydraulic auxiliary users!

Superimposed crane movements by actuating hydraulic auxiliary users can lead to the unwanted acceleration or deceleration of the safety cage movement.

- ▶ It is prohibited to superimpose crane movements with hydraulic auxiliary users to tilt the cab, for example.

## 37 Securing personnel on shut off crane

### 37.1 Terms and abbreviations

- PSAgA: Personal protective equipment to prevent falling
- HSG: Height safety device

### 37.2 Intended use

Cranes are **not** designed to protect personnel against falling.

When the following prerequisites are met, personnel protection may be permissible:

- A justified individual case is present.
- A project-specific written risk assessment and work procedure for the precise case by the employer is on hand.
- The specific safety measures are strictly adhered to.

Limitations for transport and operation:

- Transporting the secured person on the crane **from** job site and **to** job site is impermissible.
- Transporting the secured person on the crane **from** the job site and **to** the job site is permissible only in case of a rescue operation.
- Operation of the crane by the secured person is impermissible.
- The crane is stopped off and secured against any movement.

## 37.3 Prerequisites



### WARNING

Prerequisites for personnel protection are **not** met!  
Danger of accident. Death, severe bodily injuries.

- ▶ Carry out the personnel protection on the shut off crane only when **all** prerequisites in this section have been met.

Make sure that the following prerequisites are met:

- The national and regional regulations are observed.
- The written risk assessment shows:
  - Technical protective measures with at least the same protective effect are **not** available.
  - The normal fastening devices can **not** be used.
  - Personnel protection on the shut off crane is the safest and most useful method to carry out this work.
- Load transport and personnel protection occur independently of each other:
  - Do **not** carry out personnel protection at the same time as load transport. Simultaneous personnel transport is impermissible.
  - Riding along on the load is impermissible.
- Determination of fastening points and rescue plan for the precise case is on hand from the employer.

### 37.3.1 Personnel and qualification

Make sure that the following prerequisites for personnel and qualification are met:

- The crane operator is suitable and authorized to operate the crane.
- The person who is secured must be trained in handling the fall protection PPE.
- The following persons are present on the job site and separately instructed:
  - A supervisor
  - The crane operator
  - The required number of rescue staff according to the rescue plan
- Access protection, fall protection on the shut off crane is made in accordance with the project-specific risk assessment on hand and the measures to be taken.
- The supervisor monitors the safe execution of work. He may **not** take part in the work.
- An effective communication must be ensured between crane operator and the secured person.

### 37.3.2 PSAG, rescue equipment and tools

Make sure that the following prerequisites and measures are met:

- Use only the HSG (height safety device) according to EN 360 in connection with a safety harness according to EN 361 to secure the person.
- A connecting device is suited for the occurring stress on the edges, see the Manufacturer's documentation or device identification.
- Recurring inspections have been made. There are **no** visible defects.
- At least 1 m connecting device of the maximum possible extension length of the HSG (height safety device) must remain in the housing.
- Fasten the HSG (height safety device) with two separate connecting devices (for example securing on the crane hook and on the crane pulley block).
- Position the crane in such a way that the HSG (height safety device) is at least 5 m and plumb **over** the person being secured.
- Do **not** exceed the maximum permissible deflection of the HSG (height safety device)
- Keep the required clearance **below** the person being secured.
- All required objects (tools, building material) for the work are secured to prevent them from falling.



### 37.3.3 Crane

Make sure that the following prerequisites are met:

- The maintenance intervals and recurring crane inspections have been adhered to. There are **no** visible defects.
- The load on the crane hook in any possible position is at least 600 kg , see the Load chart (take the crane pulley block into account).
- Ensure a sufficient load bearing capacity: For the catching, pendular fall and possible angular pull load cases, adhere to the manufacturer's instructions.
- The crane is secured against movements and inadvertent movement (remote control is deactivated, crane control is activated).
- The overload protection is active.

### 37.4 Fastening device

Make sure that the following prerequisites are met:

- The crane hook is equipped with the hook safety.
- On the carrying device two connecting devices separated from each other can be fastened.
- HSG (height safety device) is redundantly fastened.
- Suitable fastening devices according to EN 795 Type B are on hand:
  - Round sling or fastening rope with steel core
  - Belt loop
- Textile components must be protected against greases, oils and other aggressive substances.
- Use only steel carabiners according to EN 362 with Tri-Lock function.

### 37.5 Rescue

An injured person must be lifted or lowered with the aid of the crane.

Carry out the following measures to ensure a safe rescue operation:

- Determine the rescue plan and rescue chain at the preparation of the mission.
- Ensure the rescue of a person involved in an accident immediately with locally available means and trained personnel.
- Have the rescue mission coordinated by another person, with visual and voice contact to the crane operator, additional personnel as well as to the person being rescued.

### 37.6 Additional risks

Make sure that the following risks are taken into account:

- Wind effect and environmental influences.
- Crushing and shearing points.
- Endangerment by additional cranes, for example material transport.

## 38 Welding work on the load



#### Note

- ▶ The load must also be grounded.

In case of welding work on the load, the screw clamp of the welding unit must be attached on the work piece to avoid current flow via hoist rope, crane superstructure or crane chassis.

---

Empty page!

LWE/LR 1800-1-0-000/27200-07-02/en

## 2.04.10 Ladders

1	Intended use	2
2	Safety instructions	2
3	Safety signs	3
4	Ladder inspection	12
5	User guidelines	12
6	Assembling the ladder	14
7	Ladder access	25

# 1 Intended use

Ladders are mobile work equipment that can be used in different locations. Ladders can be used to perform minor work at heights in cases where the use of other equipment would not be appropriate.

Ladders are designated for the ascent and descent of personnel.

Ladders may only be used as described. Any other use is considered unintended use and is therefore forbidden.

The manufacturer is **not** liable for damage caused by unintended use or improper usage.

## 2 Safety instructions

The ladders are built according to the present level of technology and recognized safety technical regulations. Despite that, during their use dangers to life and physical condition of the user and / or third parties can occur.

Ladders may exclusively be used in a flawless technical condition and according to their missions as well as with constant awareness of safety and dangers.

Changes to the structure may exclusively be made with written approval of the manufacturer.

The ladders that are illustrated are an example. Ladders with the same functional principle may appear differently.



### WARNING

Safety instructions not observed!

Personnel can fall, death, severe bodily injuries.

- ▶ Observe and adhere to the assembly and safety instructions for ladders.
- ▶ Observe and adhere to the safety signs on the ladders.
- ▶ Install and secure the ladders properly.
- ▶ Use ladders exclusively if you are healthy enough to do this.
- ▶ Climb up / down with the 3-point support.
- ▶ Use the rungs as handles.
- ▶ Step into the rungs deep enough.
- ▶ Never bring the ladder to a new position during use.
- ▶ Do not use damaged ladders and replace them immediately.
- ▶ Repair the ladder exclusively through authorized service facilities.

### 2.1 Ladder categories

Ladders are divided into two categories according to the most up-to-date specifications:

- Ladders for industrial use
- Ladders for private use

Ladders for industrial use are tested according to the strictest criteria. Only use ladders for industrial use.

Ladders are marked according to their category allocation by a corresponding pictogram. See section "Safety signs".

## 2.2 Stationary stability

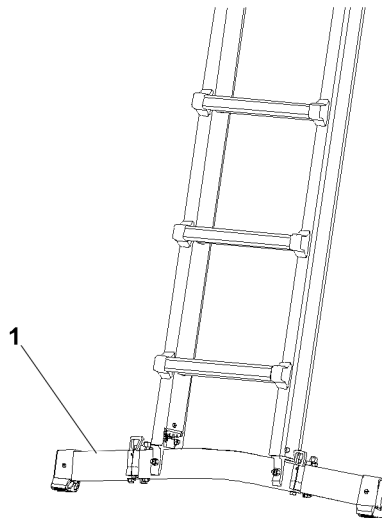


Fig.149993: Ladder with cross beam

According to the most up-to-date regulations, ladders with a length of more than 3 m must have a larger standing width. These ladders are equipped with a cross beam 1.

## 2.3 Retrofitting old ladders

It is not mandatory to retrofit old ladders. It is the responsibility of the industrial user to ensure, in accordance with the operational safety regulation by means of a risk assessment, that the safety of the work equipment is ensured for all work tasks.

Older ladders that no longer corresponds with the state of technology according to current regulations, can continue to be used, **if** their safety has been checked **and** guaranteed.




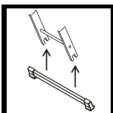

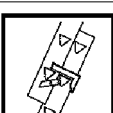
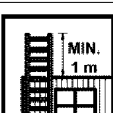

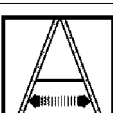
## 3 Safety signs

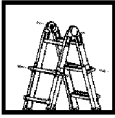
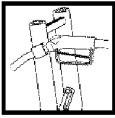






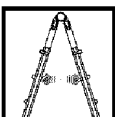
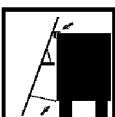


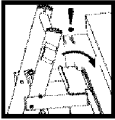
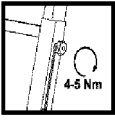








### Note

- ▶ The safety signs and instructions on the ladders must be complete and always legible.
- ▶ Observe and adhere to the manufacturer's operating instructions.


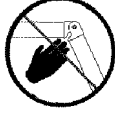








### 3.1 Symbols until the end of 2017

Sign	Explanation
	Read the operating instructions
	Maximum number of users on one ladder
	Maximum load
	In the case of ladders that have a cross beam, the cross beam must be assembled before the first use
	Correct set up angle 65° to 75°
	Before use: Engage the lift out safety
	Ladder overhang above the exit level
	Secure the upper / lower end of the ladder
	Before use: Tension the safety struts on stepladders




Sign	Explanation
	Before use: Engage the locking pin joints and pull pin locks
	To open / close the tank cover and to ascent / descent: Insert the fuel nozzle into the retainer.
	Before setting up the ladder: Fold out the platform.
	Before use: Check the ladder for damage
	Check the legs of the ladder
	Do not use the three uppermost rungs of an extension ladders as rungs to stand on
	Do not use the four uppermost rungs / steps of a stepladder without a platform to stand on
	Do not use the two uppermost rungs of a stepladder with integrated extension ladder as rungs to stand on
	If hinged ladders are used as stepladders: Spread the ladder legs to the stop
	Place the upper placement angle flat. Hold the belt on tension

Sign	Explanation
	Hook the hook on the platform of the refueling ladder on the vehicle
	Tightening the star knob on the beam extension tightly
	Do <b>not</b> use a damaged ladder
	Preclude any contaminants on the ground
	Make sure the upper end of the ladder is placed correctly. Place the ladder only on safe surfaces
	Only one person may climb up / down on any accessible leg of the ladder
	Avoid leaning out to the side. Keep the body's center of gravity between the ladder beams
	Face the ladder when climbing up / down the ladder
	Use the ladder only with suitable shoes
	Do not use a stepladder as a leaning ladder









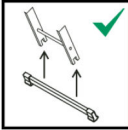









Sign	Explanation
	Do <b>not</b> use the inner section of multi-part hinged ladders without outer sections as a stepladder
	Crushing danger
	Set the ladder up on horizontal and solid ground
	Set the ladder up on solid ground
	Use the ladder in the correct set up direction
	Do not carry along bulky objects or objects over 10 kg on the ladder
	It is not permitted to step off the ladder to the side
	During transport, pay attention to danger due to power lines
	Do not use the ladder as a walkway
	Do not transport snow and ice shovels over the ladder Use hooks!










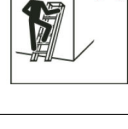
Sign	Explanation
	Danger due to shearing point
	Do not use the ladder with the cross beam folded in
	Do not use a ladder under the influence of drugs or alcohol
	Do not use a ladder to climb up to another lever
	Make sure that both ladder sections are opened completely and secured. Avoid an incorrect ladder position
	Only use the platform ladder with a locked spreader lock
	Only permissible ladder rungs / platforms may be used as standing and stepping surfaces. Other surfaces such as placement surfaces for cable clips or attachment hooks may <b>not</b> be used as standing and stepping surfaces
	If a crossbars is part of the delivery scope of the mobile platform ladder: Only use a mobile platform ladder with the crossbar assembled
	If auxiliary weights are part of the delivery scope of the mobile platform ladder: Only use the platform ladder with the auxiliary weights assembled

Sign	Explanation
	If a foot brake is installed on the mobile platform ladder: Use the foot brake
	Make sure that the joint is locked
	In unfavorable weather conditions, do <b>not</b> use the ladder in the open






### 3.2 Symbols from 2018

Sign	Explanation
	Danger of falling!
	Read the operating instructions
	Maximum load
	Ladder for professional use
	Ladder for private use
	Maximum number of users on one ladder

Sign	Explanation
	<p>In the case of ladders that have a cross beam, the cross beam must be assembled before the first use</p>
	<p>Correct set up angle 65° to 75°</p>
	<p>Always keep a firm grip: When ascending and descending and when working on the ladder</p>
	<p>Ladder overhang above the exit level</p>
	<p>Before use: Engage the lift guards</p>
	<p>Do <b>not</b> use a damaged ladder</p>
	<p>Only use the ladder with the cross beam folded out</p>
	<p>Prior to use: The hinges and locks must be engaged</p>
	<p>Use the ladder in the correct set up direction</p>
	<p>Only use the ladder with appropriate footwear</p>

Sign	Explanation
	<p>Do <b>not</b> use the ladder if physically impaired or under the influence of drugs or alcohol.</p>
	<p>Do <b>not</b> use the ladder on uneven or unsteady surface</p>
	<p>Do <b>not</b> use the ladder on a slippery or contaminated surface</p>
	<p>Do <b>not</b> place the ladder on unsuitable surfaces</p>
	<p>Do <b>not</b> carry along bulky objects or objects over 10 kg on the ladder</p>
	<p>Do <b>not</b> use the top three rungs as rungs to stand on</p>
	<p>Avoid leaning out to the side. Keep the body's center of gravity between the ladder beams</p>
	<p>Avoid working with a side load</p>
	<p>Climb up and down the ladder while facing it</p>
	<p>Do <b>not</b> use a stepladder as a leaning ladder</p>

LWE/LR 1800-1-0-000/27200-07-02/en

Sign	Explanation
	Prior to use: Tension the safety struts on stepladders
	For stepladders without a platform: Do <b>not</b> use the top two rungs as rungs to stand on
	It is not permitted to step off to the side from the ladder
	When transporting or using the ladder, be aware of any danger due to overhead wires
	Do <b>not</b> use the ladder as a walkway

## 4 Ladder inspection

Make sure that the following conditions are met:

- All ladders are inspected at least every 12 months. See chapter 8.17.
- The inspection may be made exclusively by authorized and trained expert personnel.
- The results of the inspection are documented.

## 5 User guidelines

Make sure that the following prerequisites are met before using the ladder:

- A risk evaluation had been made.  
The national legal regulations have been taken into account.
- People are physically able to use a ladder.
- The ladder is suited for the respective application.
- The ladder is complete and not damaged (visual inspection).
- The ladder is free of contaminants, such as:
  - Ice
  - Snow
  - Frost
  - Wet paint
  - Lubricants
- The legs of the ladders are not worn.
- Screws and connections have been checked for tight seating.
- The base is:

- Level
- Horizontal
- Slip-resistant
- Unmoveable

When climbing up the ladder:

- Set the ladder up in the correct set up angle.
- Secure the locking devices of the ladder.
- Tension the spreaders of the stepladder.
- Do **not** set up the ladder from above.
- Do **not** set the ladder on braces or steps.
- Avoid the risk of a collision with pedestrians, vehicles or doors.
- Place the leaning ladder only suitably stable contact surfaces with both rails.

When using the ladder:

- Make sure that no children are playing on the ladders.
- Subject the ladder to no more than maximum 150 kg.
- Use the ladder exclusively as described in section "Ladder access".
- Do **not** use the ladder outside in strong wind.
- Do **not** subject the ladder horizontally to excessive loads in side assembly work.
- Face the ladder when climbing up or down the ladder.
- Step on the ladder with suitable shoes.
- Do not use the ladder as a walkway.
- Secure the ladder to prevent it from being knocked over inadvertently.
- For leaning ladders, do not step on the uppermost three steps / rungs, in reference to the ladder placement point.
- For stepladders, do not step on the uppermost two steps / rungs.
- Do not work too long on the ladder without pauses. Tiredness is a safety risk.
- When working on a ladder, hold on tightly with one hand.

If this is not possible: Take additional safety measures, such as: use the WORK POSITIONING SYSTEM (WPS).

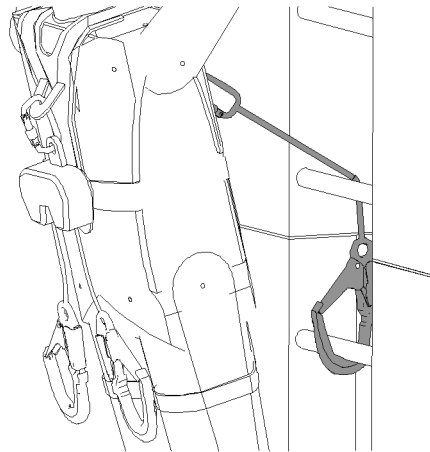


Fig.126746: Example of how to use the WPS

For repair, maintenance and storage of a ladder:

- Have repairs and maintenance made by expert personnel according to the manufacturer's instructions.
- Store the ladders according to the manufacturer's instructions.

Before transporting the ladders:

- Lock and secure the ladders in their provided transport retainers.

## 6 Assembling the ladder

### 6.1 Supplied cross beam

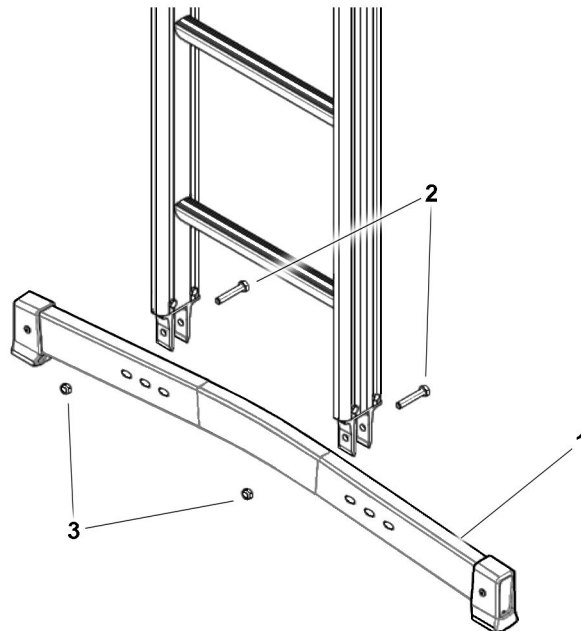


Fig.149565: Assembling the cross beam

Depending on the type of ladder and the delivery condition, the cross beam must be assembled prior to use.

Required tools:

- 2 x 13 mm wrenches
- The screws and nuts are included in the delivery scope.

Tightening torque:

- Approx. 8 Nm

- ▶ Position the cross beam **1** centrally between the cross beam fasteners.
- ▶ Secure the cross beam **1** with screws **2** and nuts **3**.
- ▶ Before using the ladder: Make sure that the screws **2** and nuts **3** are tightened correctly.



## 6.2 Folding cross beam

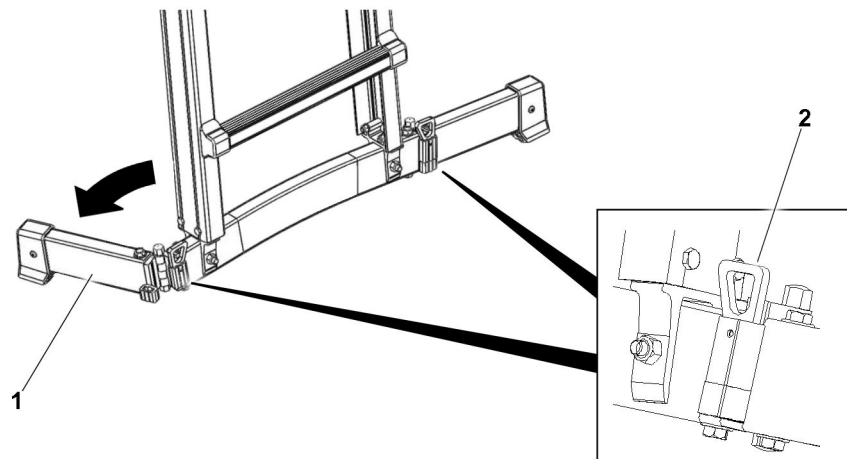


Fig.149566: Use the folding cross beam

Depending on the type of ladder, the folding cross beam must be brought into the operating position prior to use and brought to the transport position after use.

### 6.2.1 Bringing the cross beam into the operating position

- ▶ Swing the folding cross beam **1** on both sides into the operating position.
- ▶ Make sure that the retaining element **2** is engaged.
- ▶ Before using the ladder: Make sure that both retaining elements **2** have engaged.

### 6.2.2 Bringing the cross beam into the transport position

- ▶ Unlock the retaining element **2**.
- ▶ Swing the folding cross beam **1** on both sides into the transport position.
- ▶ Before storing the ladder: Make sure that both retaining elements **2** have engaged.

## 6.3 Cross beams for platform ladder

For platform ladders, the supplied cross beams must be assembled prior to use.

Required tools:

- 2 x 13 mm wrenches
- The screws and nuts are included in the delivery scope.

### 6.3.1 Assembling the cross beam without wheels

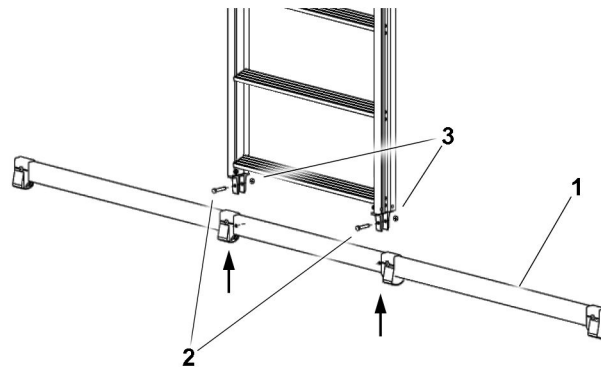


Fig.149595: Assembling the cross beam

- ▶ Position the cross beam 1 centrally between the cross beam fasteners.
- ▶ Secure the cross beam 1 with two screws 2 and two nuts 3.
- ▶ Tighten the screws 2 by hand.

### 6.3.2 Assembling the cross beam with wheels

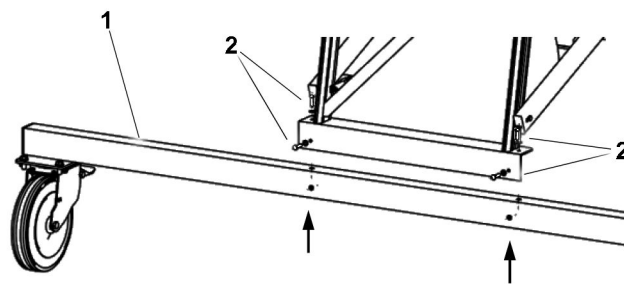


Fig.149596: Assembling the cross beam

- ▶ Position the cross beam 1 centrally between the cross beam fasteners.
- ▶ Secure the cross beam 1 with four screws 2 and four nuts.
- ▶ Tighten the screws 2 by hand.
- ▶ Before using the ladder: Make sure that all screws and nuts are correctly tightened.

## 6.4 Platform ladder

At least two people are required for ladder assembly and removal.

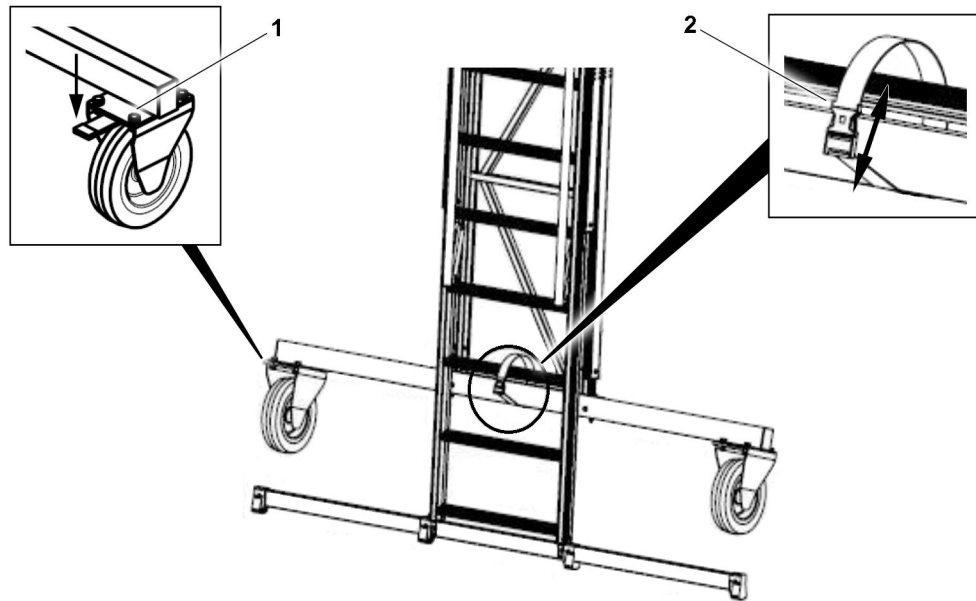
### 6.4.1 Assembling the platform ladder



#### WARNING

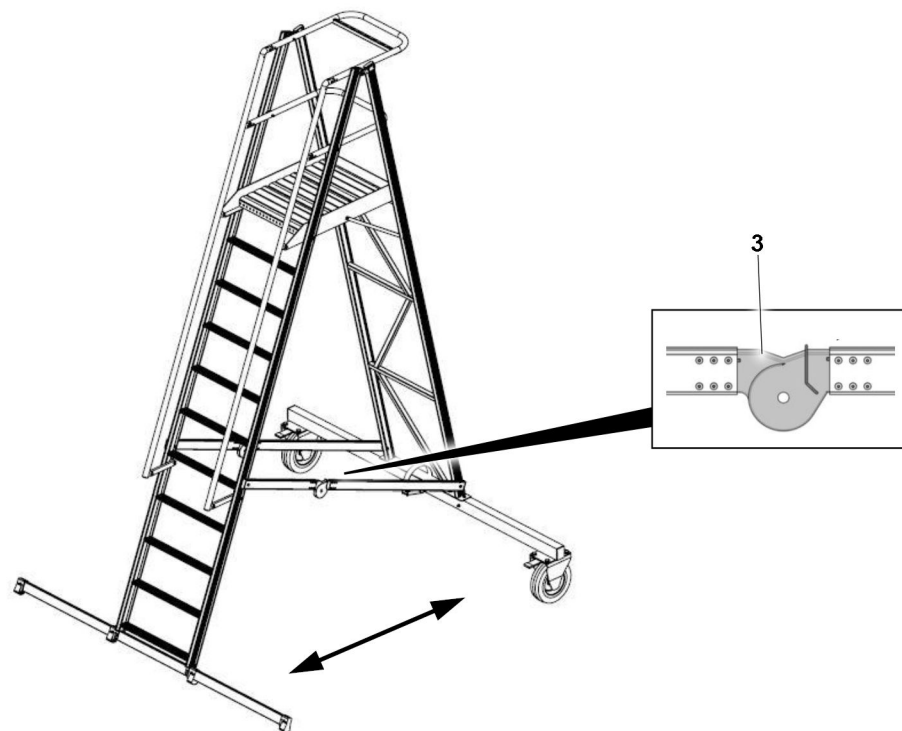
Platform ladder not correctly assembled!  
Personnel can fall down. Death, severe bodily injuries.

- ▶ Before the platform ladder is correctly assembled: Do **not** step on or load the platform ladder.



*Fig.149597: Preparing the ladder*

- ▶ Secure both pulleys **1**.
- ▶ Erect the ladder with two people.
- ▶ Release the rigging belt **2**.



*Fig.149598: Setting up the ladder*

- ▶ Each half of the ladder is held by a person.
- ▶ Until both hinges **3** engage audibly: Carefully guide the ladder halves away from each other. When doing so, the platform surface will fold out automatically.

**Result:**

- The ladder is now assembled.

## 6.4.2 Dismantling the platform ladder

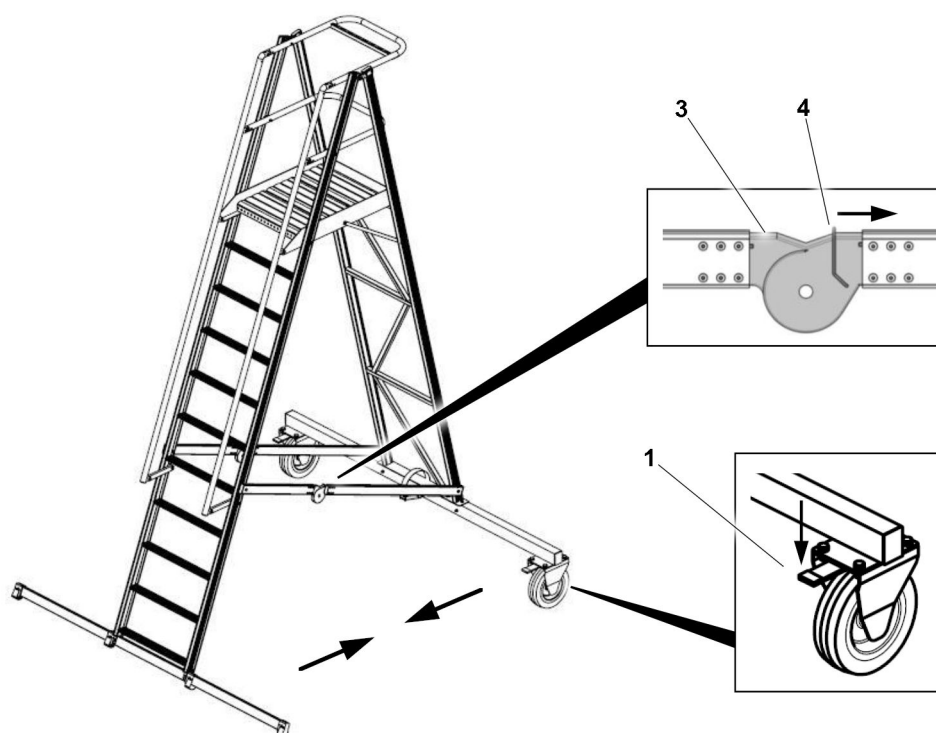


Fig.149599: Releasing the hinges

- ▶ Secure both pulleys 1.
- ▶ Unlock the locking bracket 4 in the hinge 3 on both sides.
- ▶ Each half of the ladder is held by a person.
- ▶ Carefully guide the ladder halves toward each other. When doing so, the platform surface will fold together automatically.

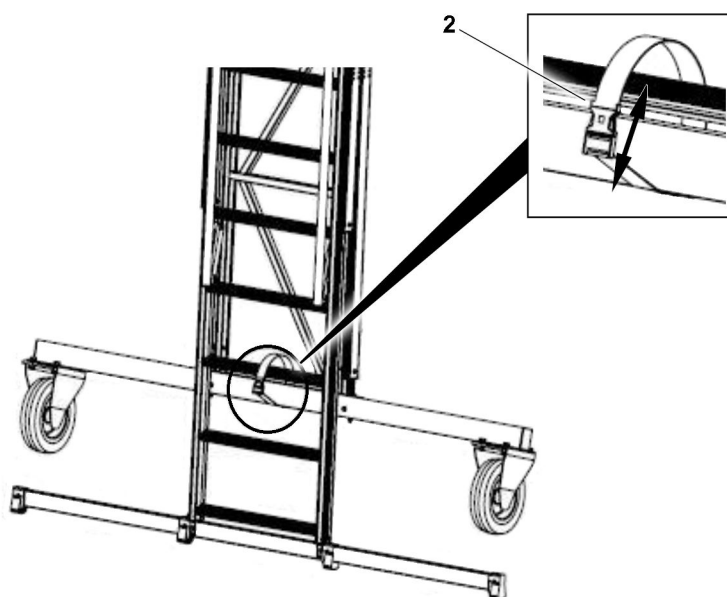


Fig.149600: Securing the ladder in the transport position

- ▶ Secure the rigging belt 2 on the cross beam and rung.
- ▶ Make sure that the clasp on the rigging belt 2 is closed.

**Result:**

- The ladder is dismantled and secured in the transport position.

## 6.5 Hinged ladders

The hinged ladder can be used as a leaning ladder or stepladder.

To adjust a part of the ladder, both hinges on opposite sides must be actuated.

### 6.5.1 Using a hinged ladder as a leaning ladder

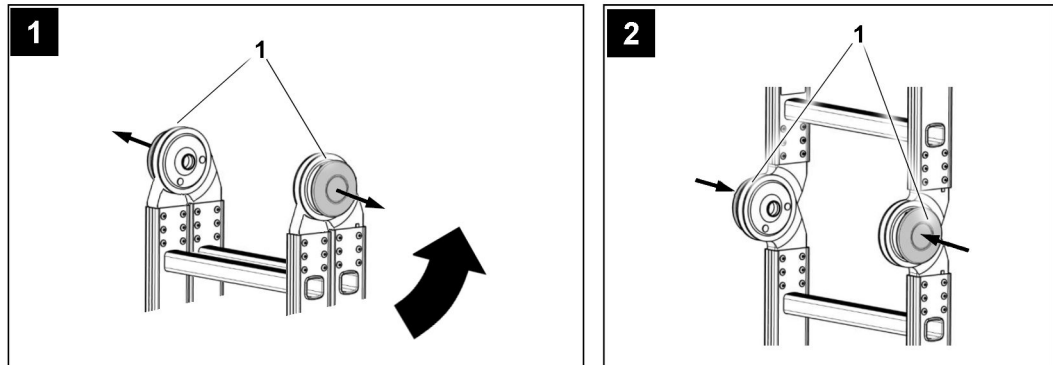


Fig.149567: Using a hinged ladder as a leaning ladder

- ▶ Release the hinges 1.
- ▶ Until the hinges 1 engage again: Spread out the legs to the stop.
- ▶ Before using the hinged ladder as a leaning ladder: Make sure that the hinges 1 have engaged.

### 6.5.2 Bringing the leaning ladder into the transport position

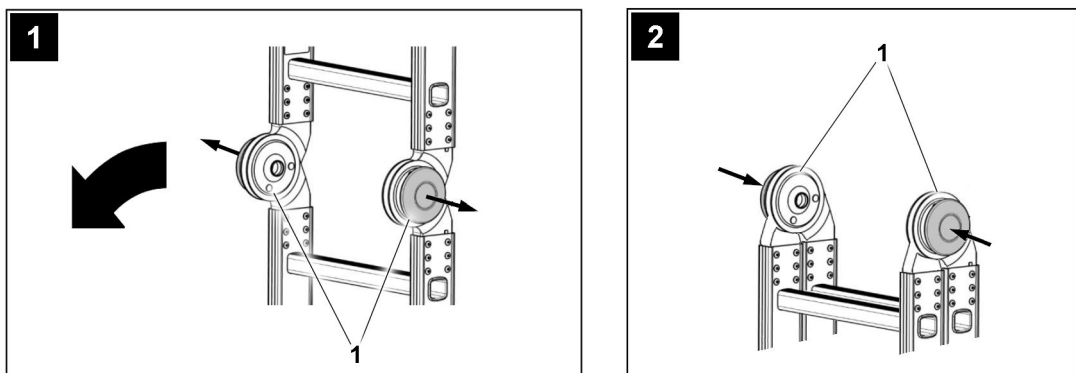


Fig.151625: Bringing the leaning ladder into the transport position

- ▶ Release the hinges 1.
- ▶ Until the legs lie together and the hinges 1 engage: Fold the legs together.

**Result:**

- The hinged ladder is now in the transport position. The hinged ladder can be stored.

### 6.5.3 Using a hinged ladders as a stepladder

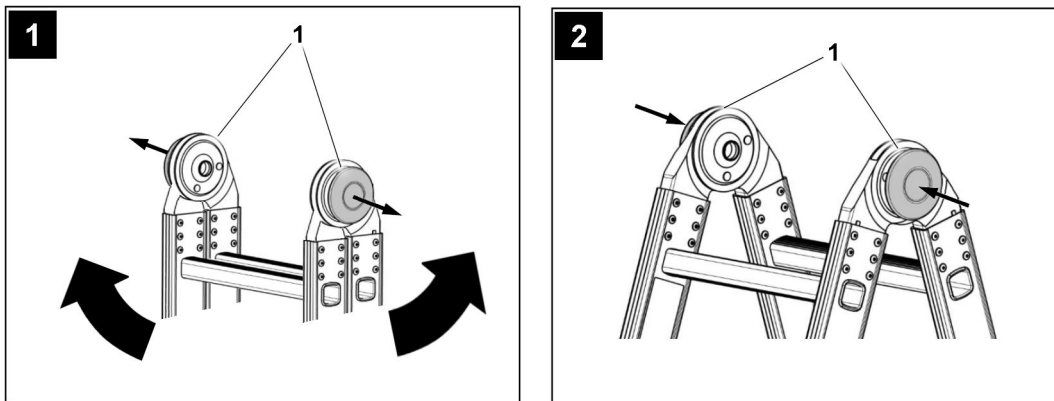


Fig.149568: Using a hinged ladders as a stepladder

- ▶ Release the hinges 1.
- ▶ Until the hinges 1 engage again: Spread out the legs.
- ▶ Before using the hinged ladder as a stepladder: Make sure that the hinges 1 have engaged.

### 6.5.4 Bringing the stepladder into the transport position

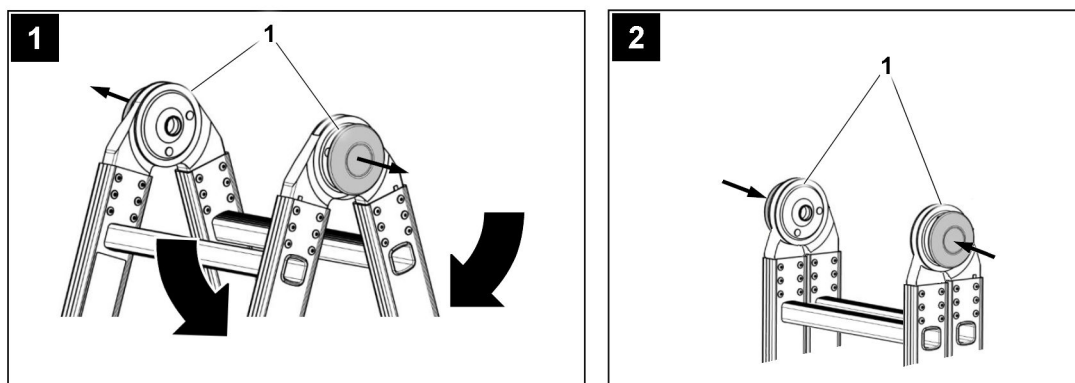


Fig.151607: Bringing the stepladder into the transport position

- ▶ Release the hinges 1.
- ▶ Until the legs lie together and the hinges 1 engage: Fold the legs together.

**Result:**

- The ladder is now in the transport position. The ladder can be stored.

## 6.6 Multi-purpose ladder with height adjustment

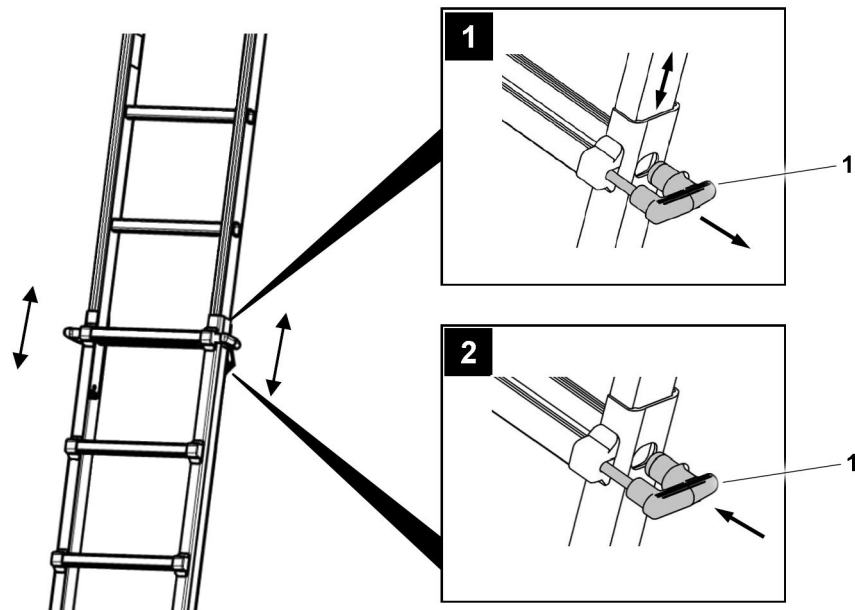


Fig.149570: Ladder with height adjustment

Multi-purpose ladders have a height adjustment device.

- ▶ Release the handle **1** on both sides.
- ▶ Pull out or push in the ladder to the desired length.
- ▶ Lock the ladder with the handle **1** on both sides.
- ▶ Before using the ladder: Make sure that both handles **1** have engaged.

## 6.7 Three-part multi-purpose ladder

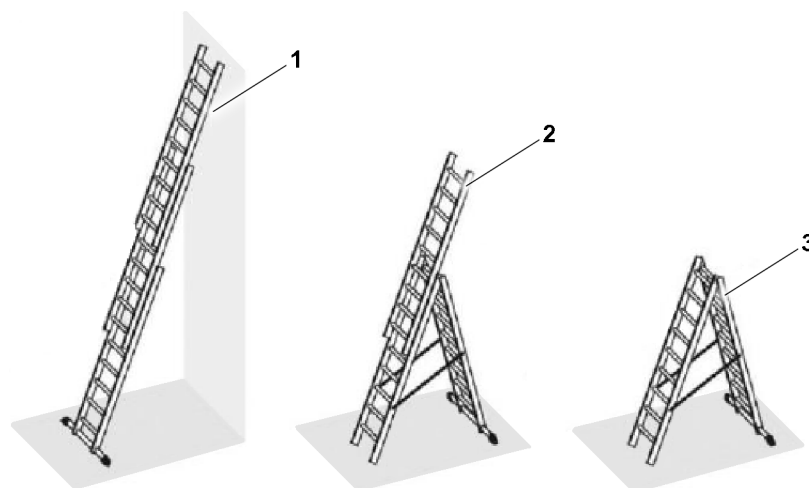
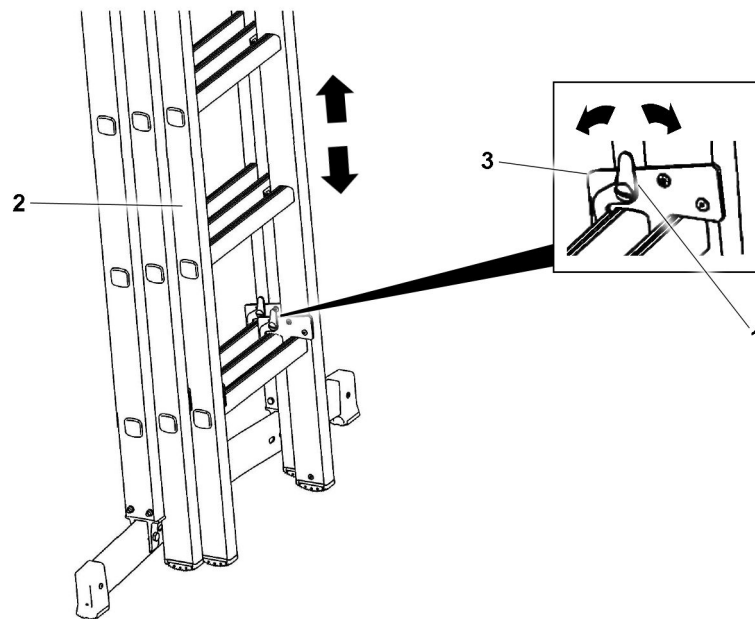


Fig.152833: Three-part multi-purpose ladder

The three-part multi-purpose ladder can be used as a leaning ladder **1**, stepladder with integrated extension ladder **2** or as a stepladder **3**.

### 6.7.1 Using the three-part multi-purpose ladder as a leaning ladder



*Fig.152834: Pushing out the ladder*

Push out the upper ladder section **2**:

- ▶ Release the lock **1**. Slightly lift up the upper ladder section **2** at the same time.
- ▶ Swing out the upper ladder section **2** and push it out to the desired length.
- ▶ Refit the securing hooks **3**.
- ▶ Make sure that the lock **1** engages.

Push out the middle ladder section:

- ▶ Pull out and lock the middle ladder section in the same manner.
- ▶ Make sure that the lock **1** engages.

**Result:**

- The ladder can now be used.

Push the ladder together:

- ▶ Push together and lock the middle ladder section.
- ▶ Subsequently push together and lock the upper ladder section.
- ▶ Make sure that the lock **1** engages.

**Result:**

- The ladder is now in the transport position. The ladder can be stored.



### 6.7.2 Using the three-part multi-purpose ladder as a stepladder

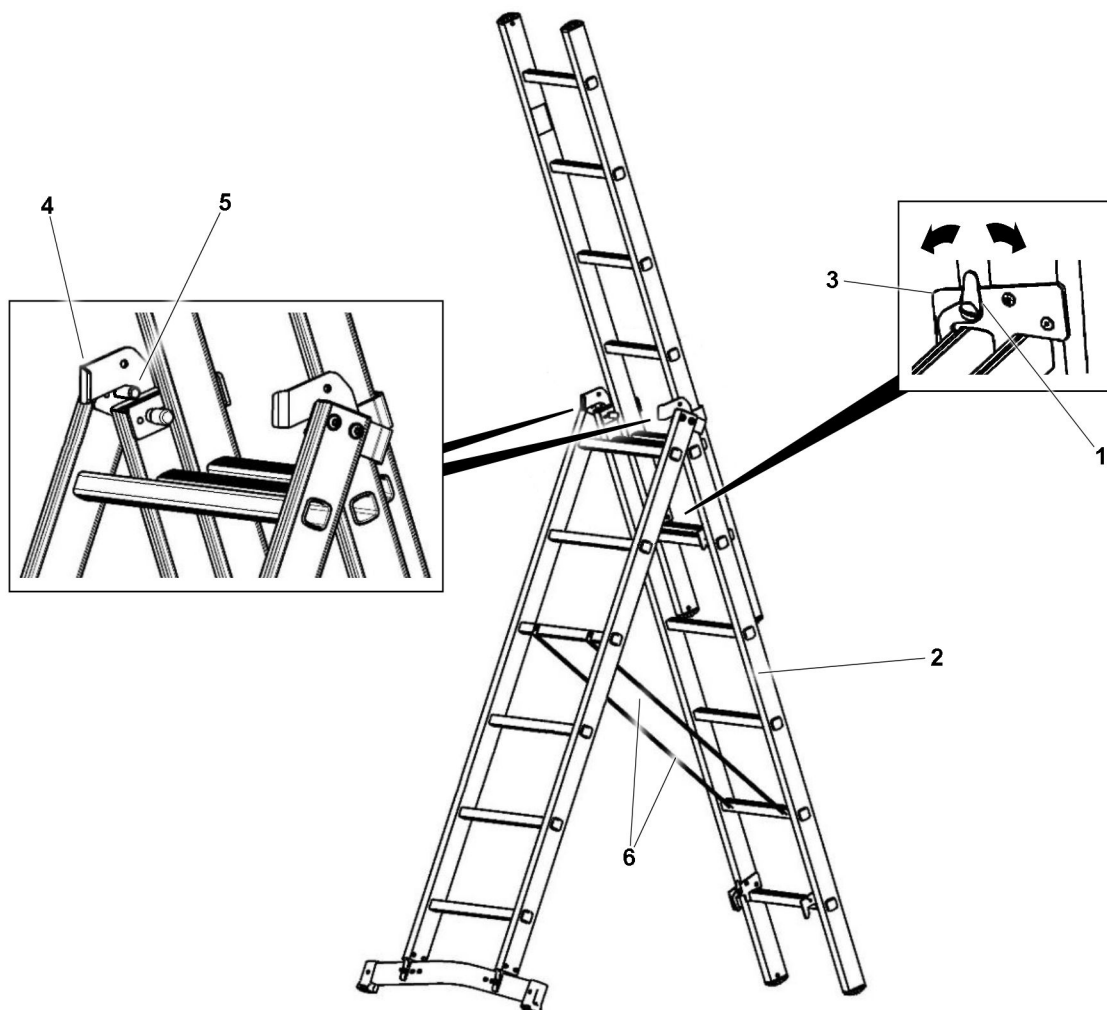


Fig.152835: Setting up the ladder

Push out the upper ladder section:

- ▶ Push out the upper ladder section to the desired length. See section “Using the three-part multi-purpose ladder as a leaning ladder”.

Swing out the middle ladder section **2**:

- ▶ Release the lock **1**. Slightly lift up the middle ladder section **2** at the same time.
- ▶ Until the contact point **5** of the bottom ladder section slides along the guide fitting **4** on both sides into the storage position: Spread out the legs.
- ▶ Make sure that the belt straps of the ladder locks **6** are tensioned.

**Result:**

- The ladder can now be used.

Bring the ladder into the transport position:

- ▶ Fold the middle and bottom ladder sections together.
- ▶ Push the upper ladder section together again.

**Result:**

- The ladder is now in the transport position. The ladder can be stored.

## 6.8 Extension ladder

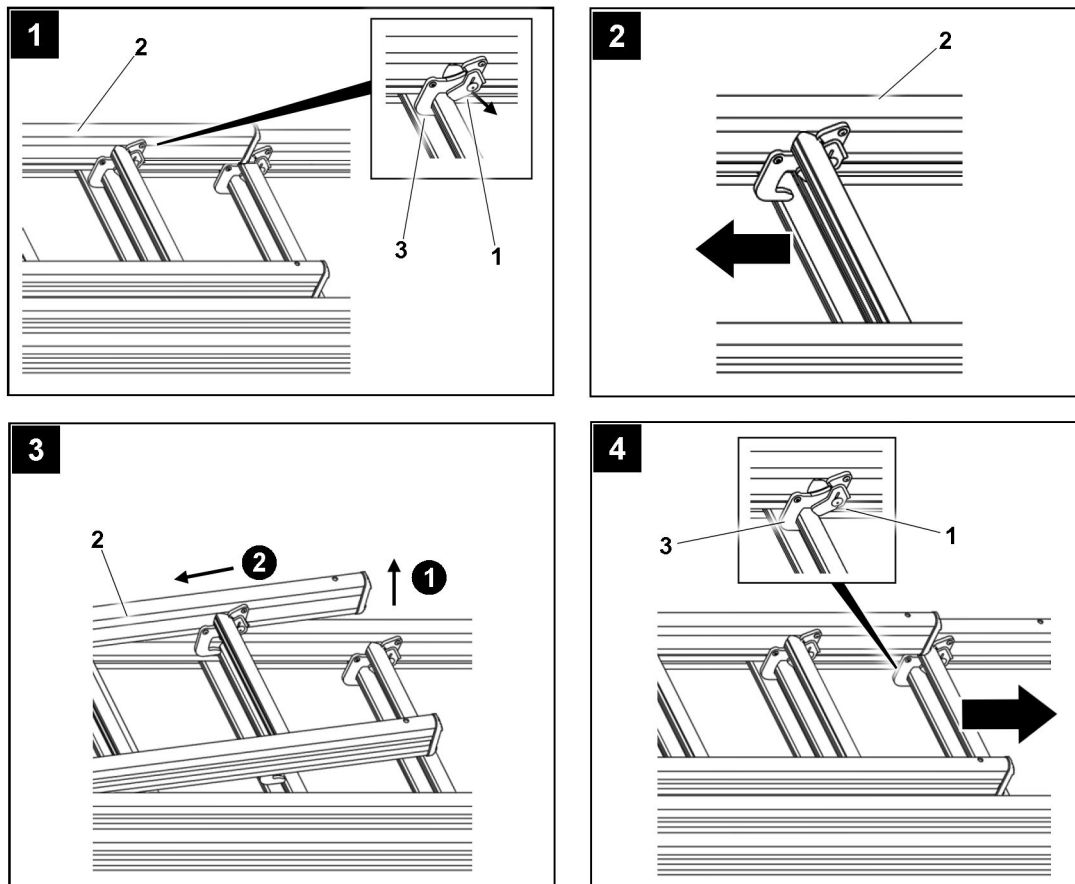


Fig.149569: Pushing out the ladder

Only pull out or push in the ladder when it is laid down.

Push out the upper ladder section:

- ▶ Release the lock 1 on the securing hook 3 on the upper ladder section 2.
- ▶ Move the upper ladder section 2 slightly at the same time.
- ▶ Now swing the ladder section 2 outward and push it out to the desired length.
- ▶ Refit the securing hooks 3.
- ▶ Make sure that the lock 1 re-engages.

Push out the middle ladder section:

- ▶ Pull out and lock the middle ladder section in the same manner.
- ▶ Make sure that the lock 1 engages.

**Result:**

- The ladder can now be used.

Push the extension ladder together:

- ▶ Push together and lock the middle ladder section.
- ▶ Subsequently push together and lock the upper ladder section.
- ▶ Make sure that the lock 1 engages.

**Result:**

- The ladder is now in the transport position. The ladder can be stored.

## 7 Ladder access

Wearing the personal protection equipment to prevent falling and the ladder safeguard depend on the type of work, among others.

### 7.1 Ladder safeguards

The ladder can be secured to prevent it from sliding away to the side by:

- Restraint device, for example: Tether or side stops on component
- Friction lock, for example: Rubber caps or plastic caps on the end of the ladder beam at direct placement on a surface

The ladder can be secured to prevent it from tipping to the rear by:

- The correct placement angle

### 7.2 3-point support

A 3-point support is ensured when:

- Two hands have a safe hold and one leg is standing safely.
- Two legs are standing safely and one hand has a safe hold.
- Two legs are standing safely in straddle position on a stepladder which can be accessed from both sides, on the third respective rungs / steps from the top. The user locks the ladder with the knees.
- Two legs are standing safely and at the same time, the body is leaned on higher rungs / steps of the leaning (extension) ladder. The center of gravity of the body must always be between the two ladder beams.
- A WORK POSITIONING SYSTEM (WPS) is used.

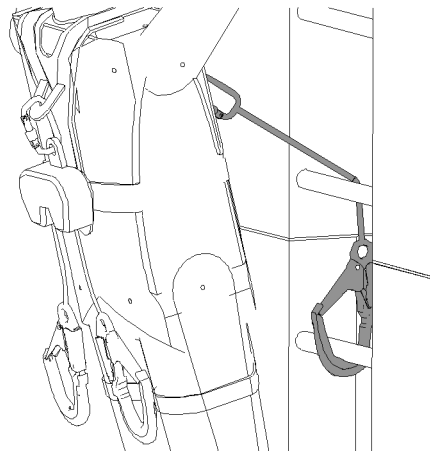


Fig.126746: Example of how to use the WPS

### 7.3 Light and / or heavy work

The following lists various light and heavy work

Examples for light work:

- Installing / removing retaining pins or spring retainers
- Fastening components, disengaging fastening equipment
- Pushing the transition aid out / in
- Establishing / disconnecting electrical or hydraulic connection between components
- Actuating the hand pump for the folding jib
- Reeving the auxiliary winch in / out
- Setting up / taking down foldable railings
- Carrying out maintenance and inspection work
- Refueling the crane chassis and / or crane superstructure

Examples for heavy work:

- Knocking the connector pins in / out
- Installing / removing the wind warning
- Reeving the hoist rope in / out
- Installing / removing the connector pin with assembly aid (hydraulic cylinder or mechanical assembly tool)
- Assembling / disassembling the rope lock

## 7.4 Using the stepladder

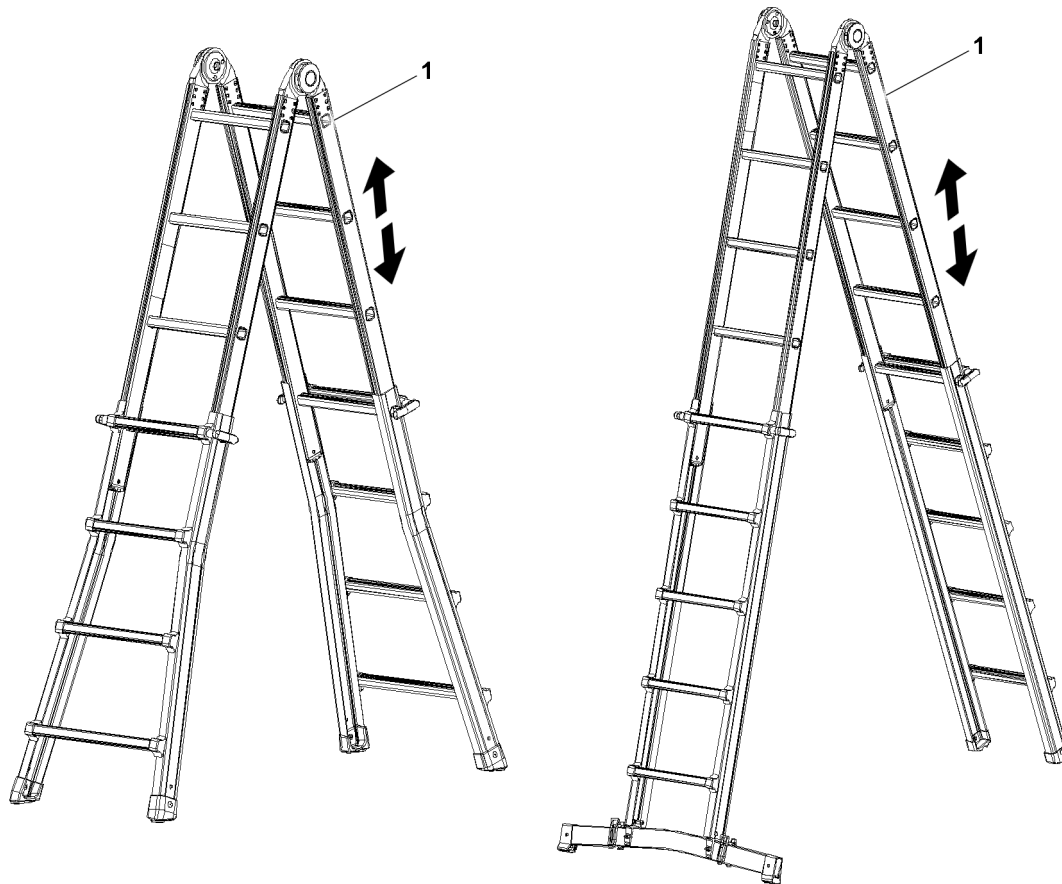


Fig.149996: Example of stepladders 1



### WARNING

Transitioning from a stepladder to other components!  
Personnel can fall, death, severe bodily injuries.

- ▶ Do **not** transition from a stepladder to other components.



### WARNING

3-point support not adhered to!  
Personnel can fall, death, severe bodily injuries.

- ▶ Adhere to the 3-point support.
- ▶ Adhere to the prerequisites and conditions for the use of stepladders.

Prerequisites for the use of stepladders 1:

- Make sure that the weight of the tool carried along does not weigh more than 10 kg.
- Make sure that stepladder 1 is set up stably.

Access	Work
Maximum rise to the third rung / step from the top	Maximum rise to the third rung / step from the top
3-point support required	3-point support required
	Rise to 1 m: Personal protective equipment to prevent falling not required
	Step height above 1 m to 7 m <b>Light work:</b> Personal protective equipment to prevent falling not required
	Step height above 1 m to 7 m <b>Heavy work:</b> Personal protective equipment to prevent falling required

*Conditions for access and work on stepladders 1*

## 7.5 Using the Leaning ladder

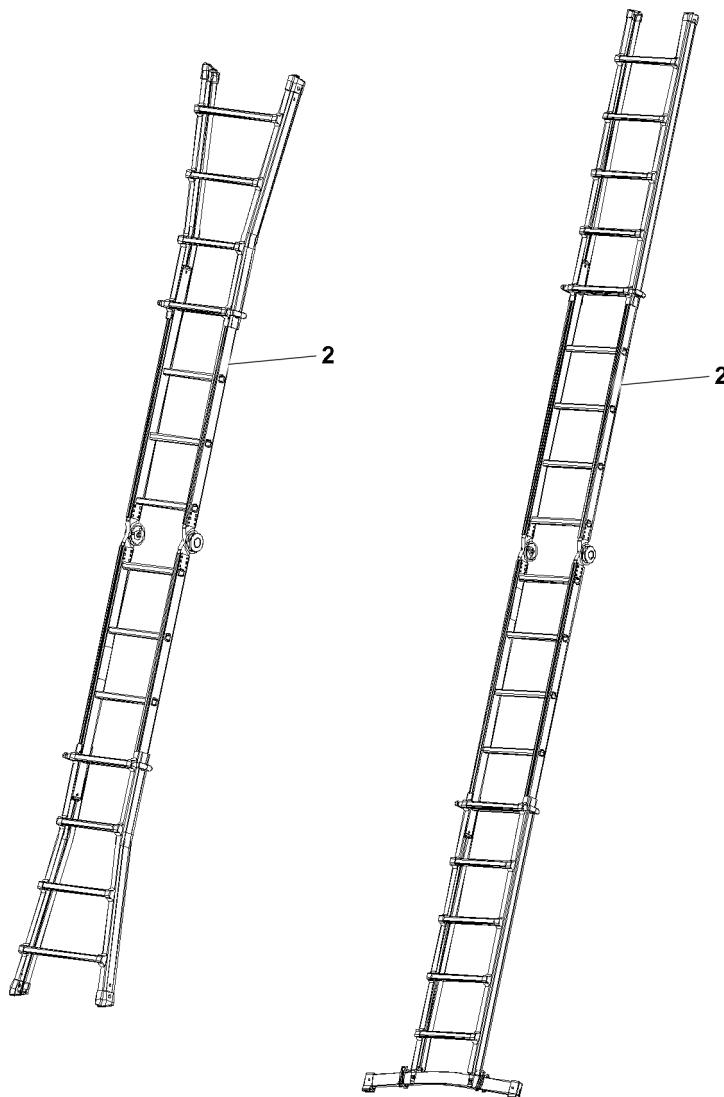


Fig.149997: Example of leaning ladders 2



### WARNING

3-point support not adhered to!  
Personnel can fall, death, severe bodily injuries.

- ▶ Adhere to the 3-point support.
- ▶ Adhere to the prerequisites and conditions for the use of leaning ladders.

### Prerequisites for the use of leaning ladders 2:

- Make sure that the 3-point support is complied with.
- Make sure that the leaning ladder 2 is positioned on a level placement surface.
- Make sure that the leaning ladder 2 is placed at an incline angle of 65° to 75° (approx. 1:4) to the horizontal.
- Make sure that the ladder overhang when leaning it on components is selected in such a way that the leaning ladder 2 is safely placed when subjected to a load / flexation due to ascending persons.
- Make sure that the weight of the tool carried along does not weigh more than 10 kg.

Access	Work
Maximum rise to the fourth rung / step from the top, in reference to the placement point	Maximum rise to the fourth rung / step from the top, in reference to the placement point
3-point support required	3-point support required
	Rise to 1 m: Ladder safeguard not required Personal protective equipment to prevent falling not required
	Step height above 1 m to 7 m <b>Light work:</b> Ladder safeguard required Personal protective equipment to prevent falling not required
	Step height above 1 m to 7 m <b>Heavy work:</b> Ladder safeguard and protection to prevent it from tipping to the rear required Personal protective equipment to prevent falling required

Conditions for access and work on leaning ladders 2

### 7.5.1 Using the leaning ladder without the conical end section

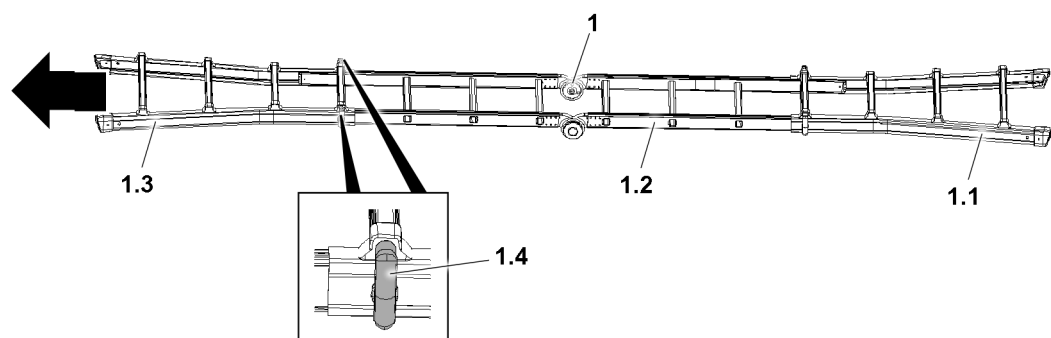


Fig.126873: Disassemble the conical end section 1.3.

The leaning ladder 1 consists of the following components:

- 1.1 Base
- 1.2 Center section
- 1.3 End section
- 1.4 Locks

When the conic end section 1.3 is wider than the leaning tube on the telescopic boom or the intended placement surface, the leaning ladder 1 cannot be placed fully expanded.

In order to position the leaning ladder 1 fully expanded, the end section 1.3 must be disassembled and removed.



#### CAUTION

Fingers in the spring range of the lock 1.4!  
Finger crushing when locking and unlocking.  
▶ Grip the lock 1.4 outside of the spring range.

- ▶ Release the locks **1.4** on the left and right.
- ▶ Slide the end section **1.3** out of the center section **1.2** and remove it.

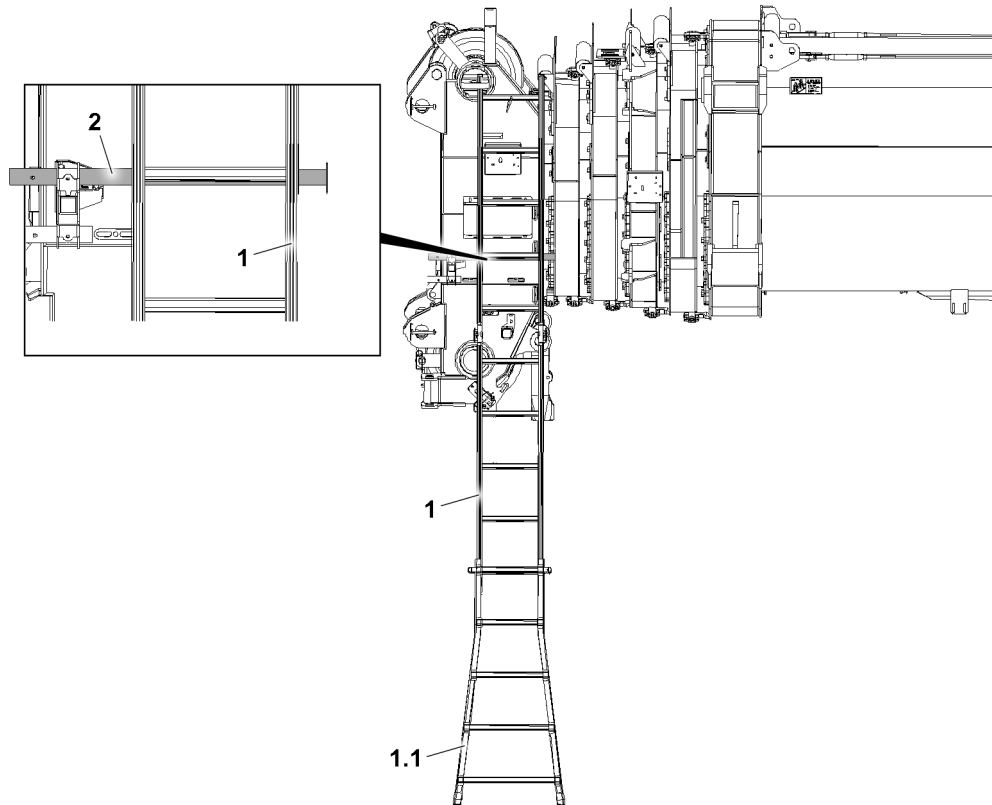


Fig.126874: Place the leaning ladder **1** on the leaning tube **2**

When placing the leaning ladder **1**, the base **1.1** must be placed on the ground.

- ▶ Place the leaning ladder **1** on the leaning tube **2** or the intended placement surface.



#### WARNING

The leaning ladder **1** is wider than the leaning tube **2** or the intended placement surface! The leaning ladder **1** can slip away when stepping on it and assembly personnel can fall down and be severely injured.

- ▶ When stepping on the leaning ladder **1** make sure that the leaning ladder **1** is **not** wider than the leaning tube **2** or the intended placement surface.
- ▶ Climb on the leaning ladder **1**. Carry out the assembly work.

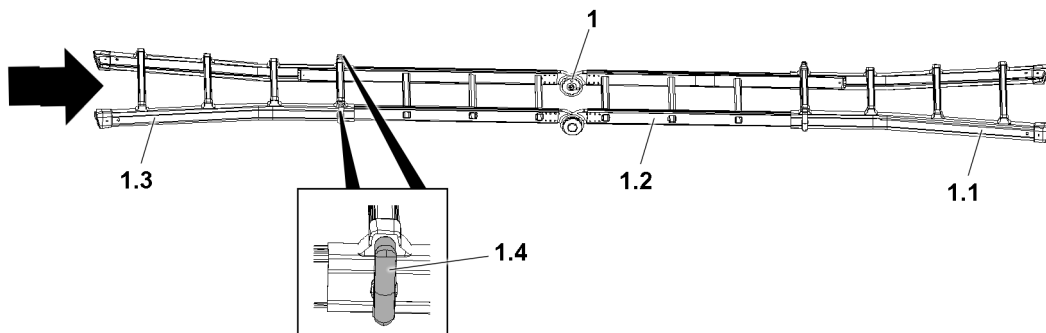


Fig.158064: Assemble the conical end section **1.3**.

Before leaving the jobsite, the conical end section **1.3** must be reinstalled.



**CAUTION**

Fingers in the spring range of the lock **1.4!**

Finger crushing when locking and unlocking.

- ▶ Grip the lock **1.4** outside of the spring range.
- 
- ▶ Release the lock **1.4** on the left and right.
  - ▶ Insert the end section **1.3** in the central section **1.2** and push them together.
  - ▶ Secure the leaning ladder **1** in the transport position on the crane.

### 7.5.2 Using the leaning ladder as a transition

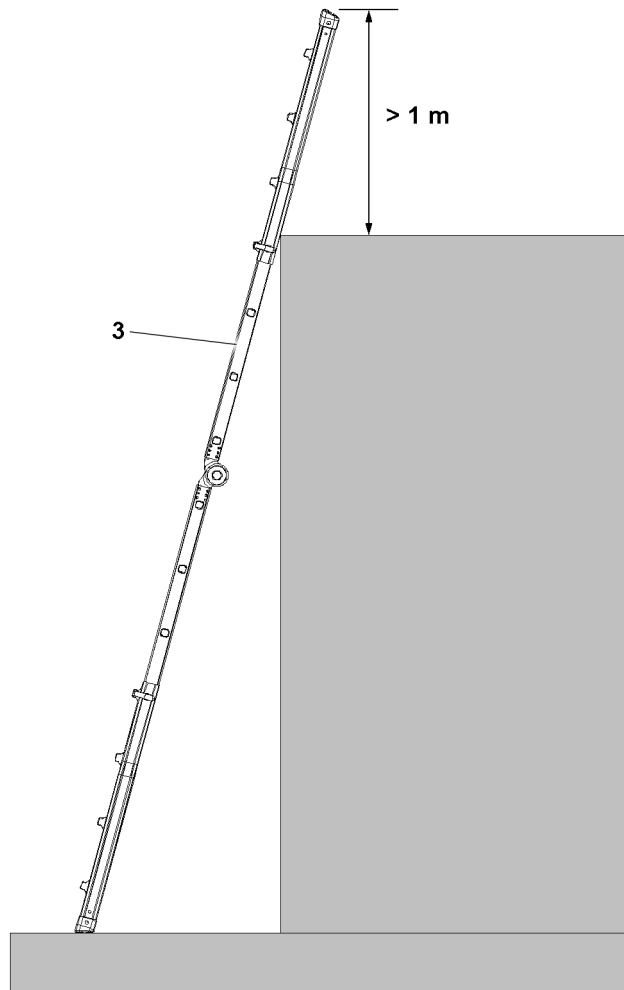


Fig.151626: Examples for leaning ladders with ladder overhang above the exit level

The leaning ladder can be used for transitioning.

**WARNING**

3-point support not adhered to!

Personnel can fall, death, severe bodily injuries.

- ▶ When transitioning, adhere to the 3-point support.
- ▶ Adhere to the prerequisites and conditions for the use of leaning ladders as a transition **3**.

Prerequisites for the use of leaning ladders as a transition **3**:

- Make sure that the leaning ladder **3** is positioned on a level placement surface.
- Make sure that the leaning ladder **3** is placed at an incline angle of 65° to 75° (approx. 1:4) to the horizontal.

- Make sure, for transitioning to higher work locations, when no other safehold possibilities are available, that the ladders beams of the leaning ladder go past the placement location by at least 1 m.
- Make sure that the transition area is slip-resistant.
- Make sure that the ladder position can be recognized from above.
- Make sure that the contact point of the ladder on the component is selected such that it will not be deformed or swing away due to the load of the person climbing up the ladder.
- Make sure that the weight of the tool carried along does not weigh more than 10 kg.

Access	Transition
Maximum rise to a rung / step below the placement edge	Maximum rise to a rung / step below the placement edge
3-point support required	3-point support required
Personal protective equipment to prevent falling not required	Personal protective equipment to prevent falling not required
	Rise to 1 m: Ladder safeguard not required
	Step height above 1 m to 7 m: Ladder safeguard required

*Conditions for access and transition to leaning ladders with transition 3*

### 7.5.3 Connecting and climbing up the leaning ladder

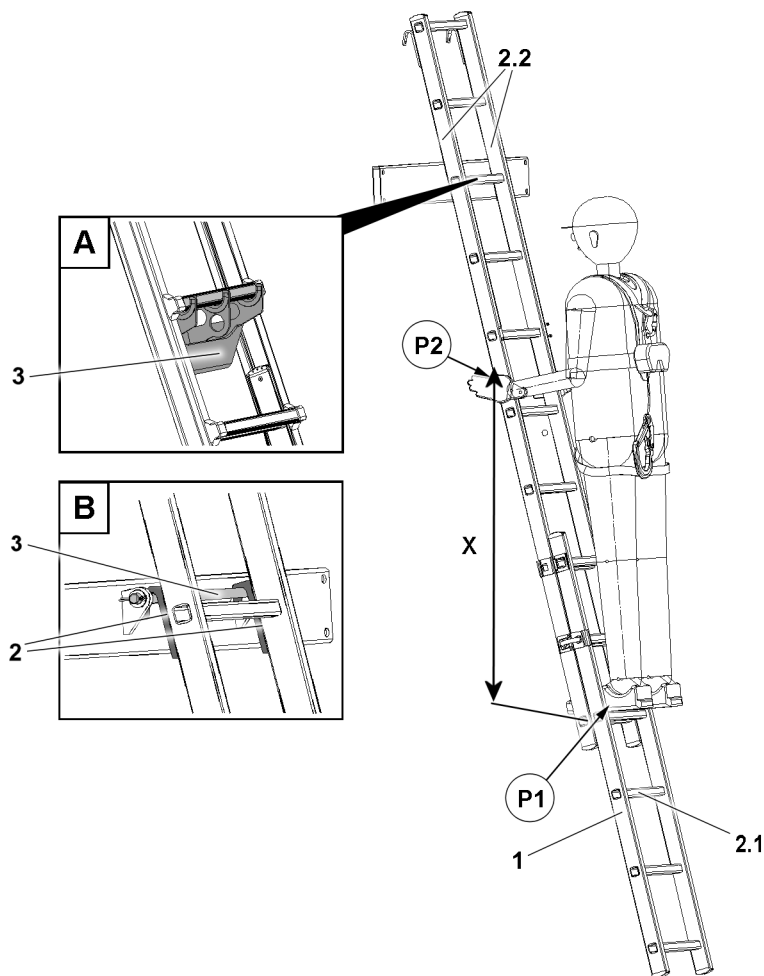


Fig.162714: Connecting the ladder to the suspension device

1	Leaning ladder	X	Length	2.1	Rung
2	Hook	P1	Standing position	2.2	Ladder beam
3	Suspension device	P2	Grip position		

Connected variations:

- Variation **A** rung **2.1** is connected to the suspension device **3**.
- Variation **B** hook **2** is connected to the suspension device **3**.

Prerequisites for the use of leaning ladders **1** when connected to the suspension device **3**:

- Make sure that leaning ladder **1** is set up stably.
- Make sure that the leaning ladder **1** is connected securely to the respective suspension device **3**.
- When ascending and descending: 3-point support observed.
- Make sure that the vertical mass **X** between the standing position **P1** on the rung **2.1** and the grip position **P2** on the ladder beam **2.2** is at least 1 m.
- Make sure that personnel holds the grip position **P2** on the ladder beam **2.2**.
- Do not use the rung **2.1** on the suspension device **3** as a standing position.
- Make sure that the last rung **2.1** below the suspension device **3** may only be used as a standing position if there is at least 1 m between the stopping position and the standing position.

Transition is only permissible if:

- The leaning ladder **1** is located at least 1 m above the higher work surface.
- **Or** safeholds are available when transitioning to the higher work surface.

**WARNING**

The leaning ladder **1** is not correctly connected and used!  
Personnel can fall, death, severe bodily injuries.

When the leaning ladder **1** is connected to the suspension device **3**:

- ▶ Adhere to the prerequisites and conditions for the use of the leaning ladder **1** in the suspension device **3**.
- ▶ Adhere to the 3-point support.

Access	Work
Maximum step height up to the last free rung below the suspension device <b>3</b>	Maximum step height up to the last free rung below the suspension device <b>3</b>
3-point support required	3-point support required
	Rise to 1 m: Personal protective equipment to prevent falling not required
	Step height above 1 m to 7 m <b>Light work:</b> Personal protective equipment to prevent falling not required
	Step height above 1 m to 7 m <b>Heavy work:</b> Personal protective equipment to prevent falling required

*Conditions for access and work on the leaning ladders **1** when connected to the suspension device **3**.*

## 7.6 Using the vertical ladder with transition aid

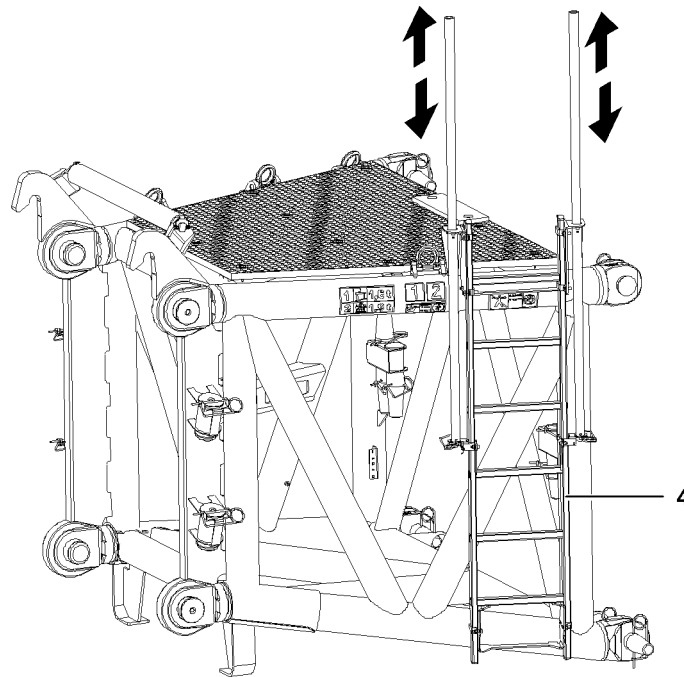


Fig.121178: Example for vertical ladder with transition aid



**WARNING**

Persons not secured!  
Personnel can fall, death, severe injuries.

When using vertical ladders with transition aid 4:

- ▶ Adhere to the 3-point support.

Before transitioning:

- ▶ Hook the personal protective equipment to prevent falling on a suitable location (for example: uppermost rung, safety rope or separate hook point).
- ▶ Adhere to the prerequisites and conditions for the use of vertical ladders with transition aid 4.

Prerequisites for the use of vertical ladders with transition aid 4:

- Make sure, a centered grip reachable from the transition edge and a possibility to support oneself with the second hand is present for transitioning.
- Make sure that the transition area is slip-resistant.
- Make sure that the ladder position can be recognized from above.
- Make sure that the weight of the tool carried along does not weigh more than 10 kg.

Access	Work
3-point support required	3-point support required
If necessary: Use a WORK POSITIONING SYSTEM (WPS) at a suitable hook point	If necessary: Use a WORK POSITIONING SYSTEM (WPS) at a suitable hook point

Conditions for access and work on vertical ladders with transition aid 4

LWE/LR 1800-1-0-000/27200-07-02/en

Ascent	Transition
3-point support required	3-point support required
Rise to 5 m: Personal protective equipment to prevent falling not required	Rise to 1.8 m: Without transition aid: Personal protective equipment to prevent falling not required
Rise above 5 m: Fall arrest system with moving along fall arrest device or back protection required	Rise above 1.8 m: Without transition aid: Personal protective equipment to prevent falling required

Conditions for ascent and transition to vertical ladders with / without transition aid 4

## 7.7 Using the platform ladder

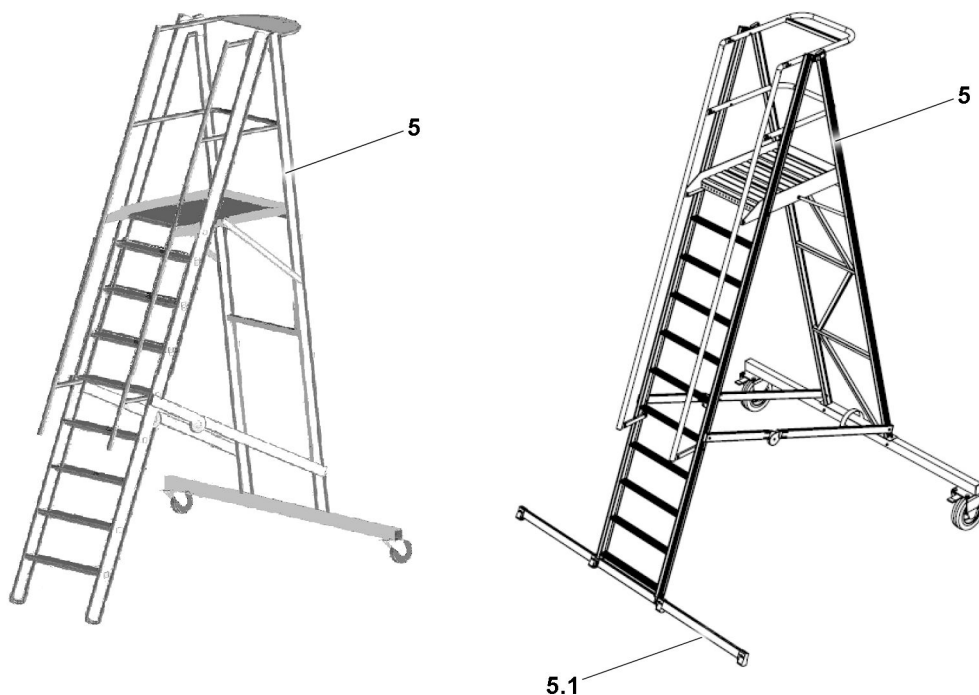


Fig. 149995: Example of platform ladders

A platform ladder **5** with a cross beam **5.1** offers more stability. It is recommended to use a platform ladder with a cross beam.



### WARNING

Transitioning from a platform ladder **5** to other components!  
Personnel can fall, death, severe bodily injuries.

- ▶ Do **not** transition from a platform ladder **5** to other components.



### WARNING

3-point support not adhered to!  
Personnel can fall, death, severe bodily injuries.

When using platform ladders **5**:

- ▶ Adhere to the 3-point support.
- ▶ Adhere to the prerequisite and conditions for the use of platform ladders **5**.

Prerequisite for the use of platform ladders **5**:

- Make sure that the weight of the tool carried along does not weigh more than 10 kg.

Access	Working on the ladder	Working on the platform
Maximum rise to platform height	Maximum rise to platform height	Maximum height: Platform height
3-point support required	3-point support required	
	Rise to 1 m: Personal protective equipment to prevent falling not required	
	Step height above 1 m to 7 m <b>Light work:</b> Personal protective equipment to prevent falling not required	Platform height <b>Light work:</b> Personal protective equipment to prevent falling not required
	Step height above 1 m to 7 m <b>Heavy work:</b> Personal protective equipment to prevent falling required	Platform height <b>Heavy work:</b> Personal protective equipment to prevent falling required

*Conditions for access and work on platform ladders 5*

---

Empty page!

LWE/LR 1800-1-0-000/27200-07-02/en



## 2.05 Signs on the crane

1 Signs

---

2

LWE/LR 1800-1-0-000/27200-07-02/en

# 1 Signs

## 1.1 Note regarding the signs

All signs must be complete and always legible. Replace any damaged or missing signs immediately.

Order damaged or missing signs from Customer Service at Liebherr-Werk Ehingen GmbH.

Always provide the ID no. when ordering. For example: 11952500.

Customer-specific special equipment\*: See the supplied spare parts catalog.

## 1.2 11952500 – California Proposition 65 Label

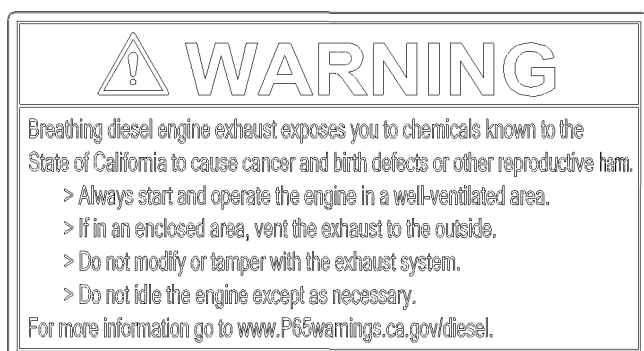


Fig.156191: California Proposition 65 Label



### WARNING

Diesel engine exhaust emissions!

Damage to health such as cancer and birth defects or other reproductive harm.

- ▶ Always start and operate the diesel engine in properly ventilated spaces.
- ▶ If a diesel engine is operated in a closed space: Direct the exhaust gas to the outside.
- ▶ Do not convert the exhaust system or make any other changes.
- ▶ Do not run the engine at idle speed for longer than necessary.

## 1.3 772563908 – Warning of high voltage



Fig.116269: Warning of high voltage



### Note

- ▶ Only for certain countries.

### 1.4 772564008 – Slewing range



Fig.116270: Slewing range



**Note**

► Only for certain countries.

### 1.5 772580408 – Limitation of maximum travel speed



Fig.106035: Limitation of maximum travel speed

### 1.6 Vehicle height

ID no.	Vehicle height
970610408	
970629508	
970596108	
970608708	
979459108	

Vehicle height

LWE/LR 1800-1-0-000/27200-07-02/en

**Note**

- ▶ Vehicle height x.x m (x.x ft).

## 1.7 97137170 – Luffing cylinder and counterweight collision

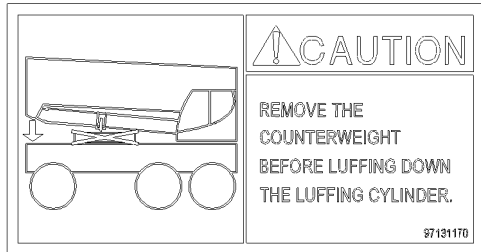


Fig.158141: Luffing cylinder and counterweight collision

**NOTICE**

Counterweight not disassembled from the crane chassis!

When taking the telescopic boom down, the luffing cylinder collides with the counterweight. Damage to the luffing cylinder and counterweight.

- ▶ Before taking the luffing cylinder down: Disassemble the counterweight.

## 1.8 97124295 – Load stop

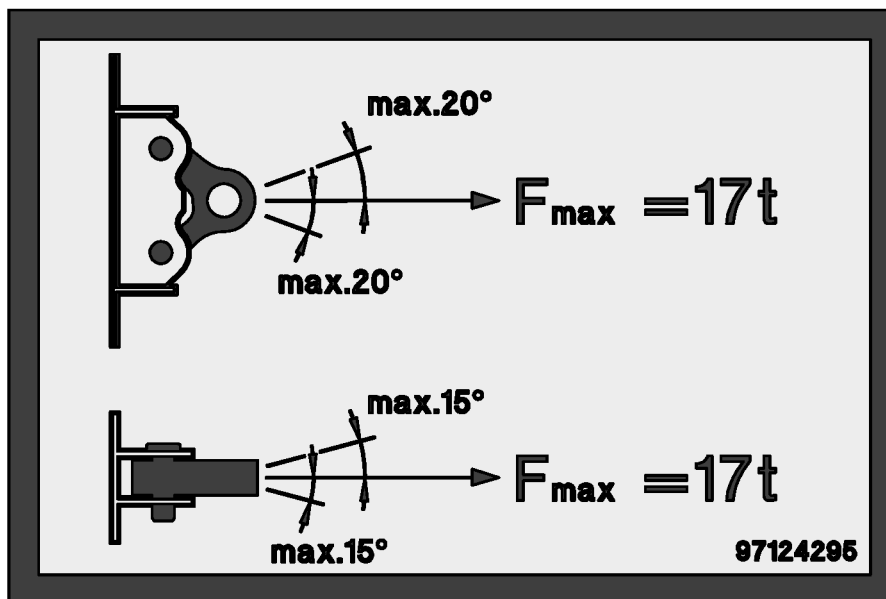


Fig.154929: Fastening the load according to the specifications on the sign

### 1.9 Assembly aid

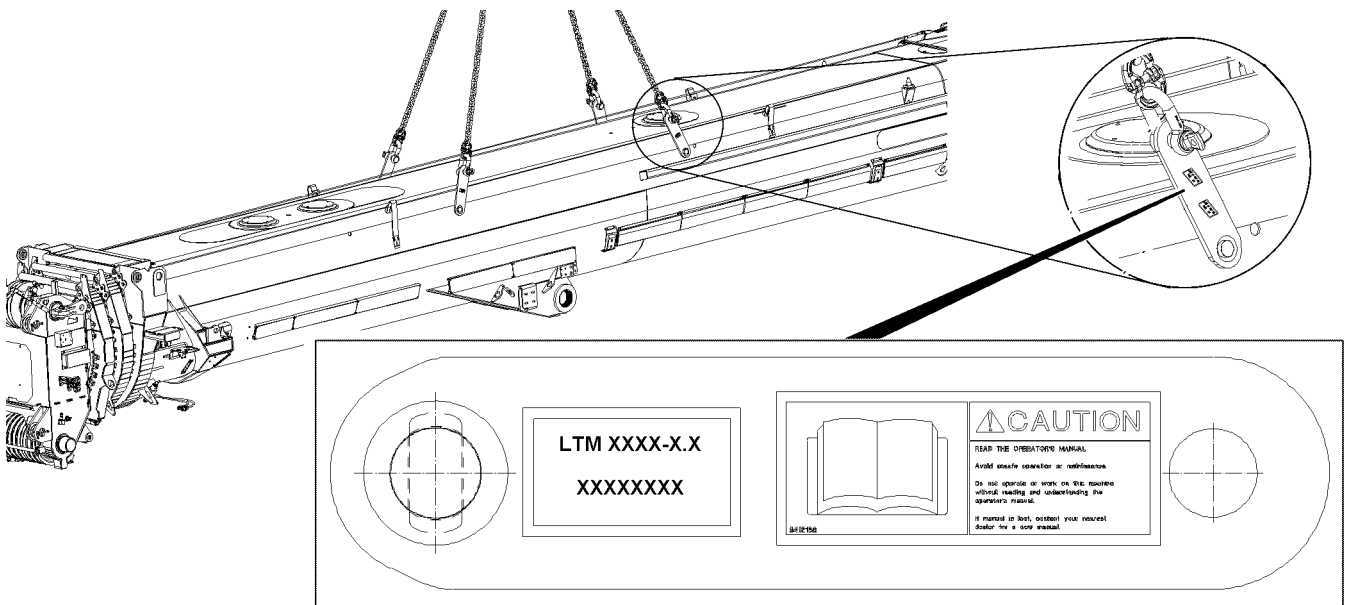


Fig.122741: Assembly aid



**WARNING**

Wrong assembly aids used!

The telescopic boom can fall down. Death, property damage.

- ▶ To assemble and disassemble the telescopic boom: Use solely the assembly aids that belong to the crane.

### 1.10 97127242 – Assembly aid

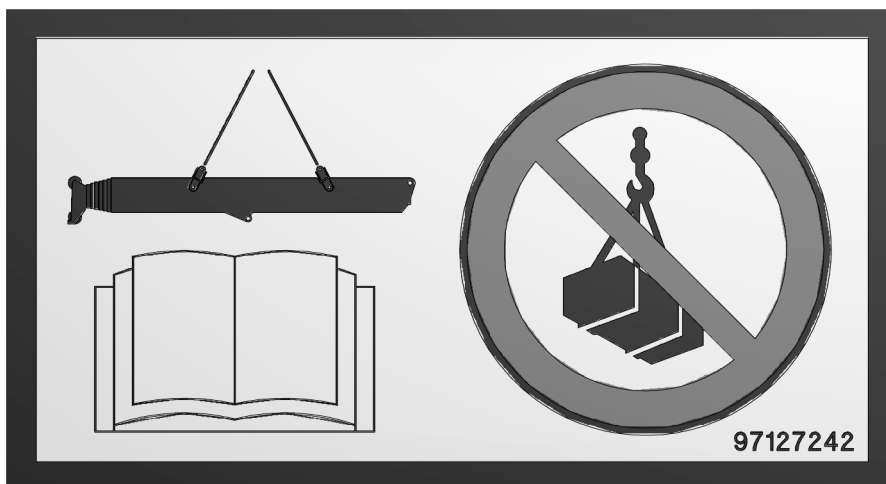


Fig.154928: Assembly aid



**WARNING**

Wrong assembly aids used!

The telescopic boom can fall down. Death, property damage.

- ▶ To assemble and disassemble the telescopic boom: Use solely the assembly aids that belong to the crane.
- ▶ Only use the assembly aids to assemble and disassemble the telescopic boom.

LWE/LR 1800-1-0-000/27200-07-02/en

## 1.11 97151252 – Hoist device

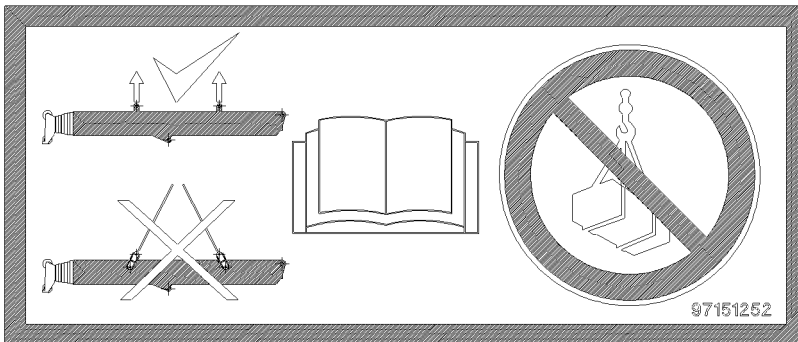


Fig.160978: Hoist device



### WARNING

Faulty assembly and disassembly!

The telescopic boom can fall down. Death, property damage.

- ▶ Use a hoist device to assemble and disassemble the telescopic boom.
- ▶ To assemble and disassemble the telescopic boom: Use solely the assembly aids that belong to the crane.
- ▶ Only use the assembly aids to assemble and disassemble the telescopic boom.
- ▶ Guide the fastening equipment for the assembly aid only in a vertical position.
- ▶ Angular pull with the fastening equipment and the assembly aid is **prohibited**.
- ▶ Replace lost or incomplete operating instructions immediately.
- ▶ Observe and adhere to the operating instructions.

## 1.12 97133617 – Hydraulic connection

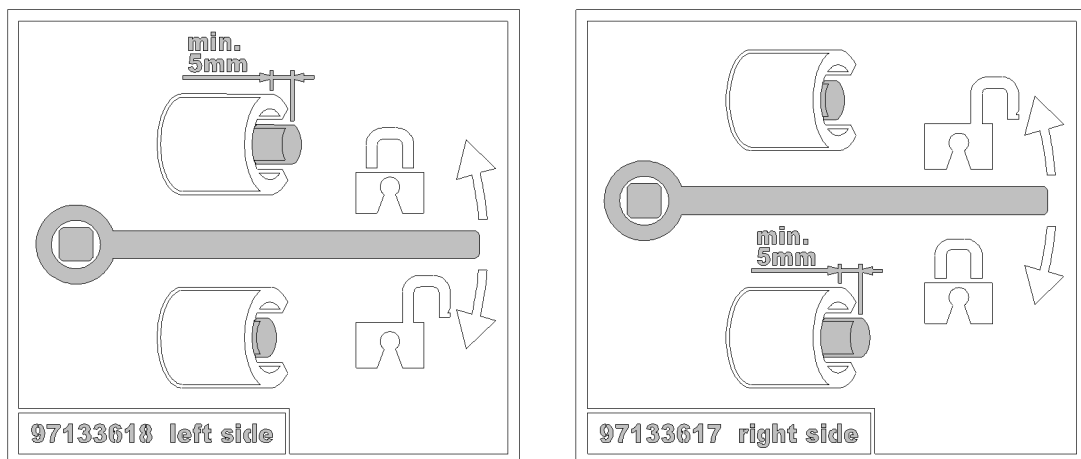


Fig.162452: Hydraulic connection

### NOTICE

The crawler center section and crawler carrier hydraulic lines are not completely connected!  
Emerging hydraulic oil, crawler carrier malfunction.

- ▶ The left and right side crawler center section and crawler carrier hydraulic lines are completely connected.
- ▶ After connecting the hydraulic lines: The threaded pins must project at least 5 mm over the sheath.

## 1.13 9412158 – Reading the operating instructions

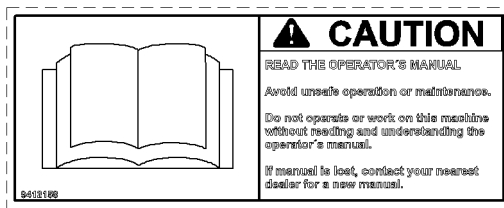


Fig.106048: Reading the operating instructions



### WARNING

Danger of accident due to non-observance of operating instructions!

If the operating instructions are not read or understood, then this can lead to unsafe operation and improper maintenance.

Accidents with bodily injuries and property damage can result.

- ▶ Operate the crane only if the contents of the operating instructions have been read and understood.
- ▶ Replace lost or incomplete operating instructions immediately.

## 1.14 97004046 – Safety harness, maximum two persons



Fig.115119: Safety harness, maximum two persons



### DANGER

Danger of accidents due to overloaded safety ropes!

If safety ropes are used by more than two persons, then the safety ropes can be overloaded and fail in case of an accident.

Personnel can be severely injured or killed.

- ▶ A maximum of two people may use the safety ropes on the left and right to secure themselves against falling.

## 1.15 97017585 – Falling telescopic boom during disassembly / assembly

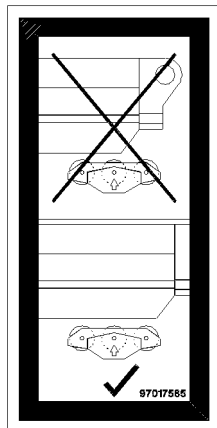


Fig.118467: Falling telescopic boom during disassembly / assembly



### WARNING

Death due to falling telescopic boom!

- Make sure that all pulleys are touching and supporting during the assembly and disassembly of the telescopic boom.

## 1.16 97018351 – Falling telescopic boom during transport

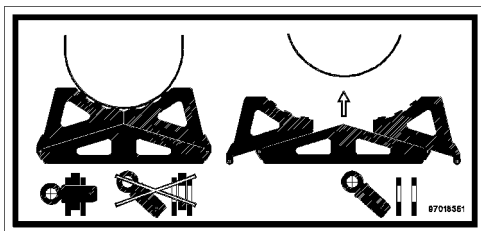


Fig.118466: Falling telescopic boom during transport



### WARNING

Fatal accidents due to falling telescopic boom during transport!

- Pin and secure the transport bracket on the left and right.

## 1.17 97018564 – Falling telescopic boom during transport

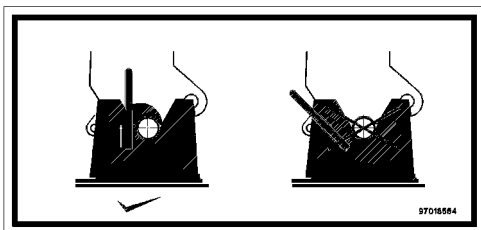


Fig.118533: Falling telescopic boom during transport



**WARNING**

Fatal accidents due to falling telescopic boom during transport!

- ▶ Lock the telescopic boom in the head receptacle.

## 1.18 97027147 – Overloading of the combi box is prohibited

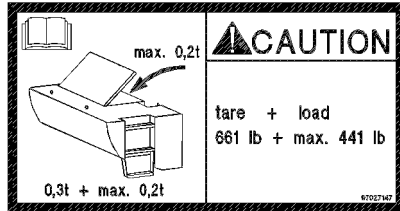


Fig.113829: Overloading of the combi box is prohibited

**WARNING**

Danger of overload!

If the combi box is subjected to a load of more than 0.2 t, the combi box can be damaged!

- ▶ The own weight of the combi box is 0.3 t and may be loaded with a maximum payload of 0.2 t.
- ▶ Load the combi box with a maximum weight of 0.2 t.

## 1.19 97036733 – Fastening point

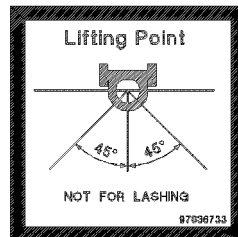


Fig.121184: Fastening point

**WARNING**

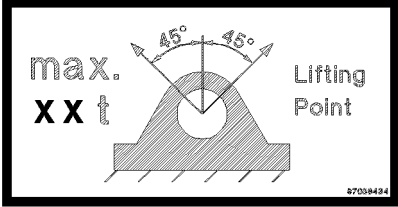
Damage to the fastening points!

- ▶ Use the fastening point solely to lift the load.
- ▶ Observe the maximum permissible fastening angle.

**Note**

- ▶ Fastening points and fastening angle

## 1.20 Suspended load fastening point

ID no.	Suspended load fastening point
97038434	 <p data-bbox="890 613 1082 645"><i>Fastening point</i></p>
97037482	
97039068	



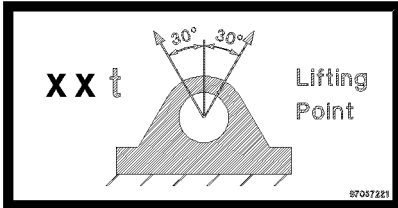
### WARNING

Mortal danger if the load falls down!

If the maximum suspended load or the maximum fastening angle is exceeded, the load can fall down and kill personnel.

- ▶ Observe the maximum permissible suspended load and fastening angle.

## 1.21 Suspended load fastening point

ID no.	Suspended load fastening point
97037221	 <p data-bbox="890 1442 1082 1473"><i>Fastening point</i></p>
97037223	



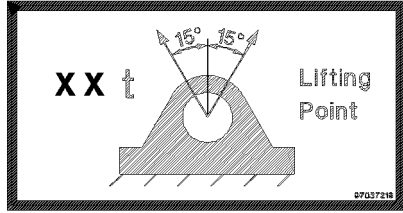
### WARNING

Mortal danger if the load falls down!

If the maximum suspended load or the maximum fastening angle is exceeded, the load can fall down and kill personnel.

- ▶ Observe the maximum permissible suspended load and fastening angle.

### 1.22 Suspended load fastening point

ID no.	Suspended load fastening point
97037219	 <p style="text-align: center;">Fastening point</p>



**WARNING**

Mortal danger if the load falls down!

If the maximum suspended load or the maximum fastening angle is exceeded, the load can fall down and kill personnel.

- ▶ Observe the maximum permissible suspended load and fastening angle.

### 1.23 97037625 – Suspended load Fastening points / rigging points

LIFTING AND LASHING			
Type III	Lashing Capacity		
	LC-N [daN]	LC-G [daN]	
4	4 000	2 800	
6,7	6 700	4 690	
10	10 000	7 000	
16	16 000	11 200	
31,5	31 500	22 050	

Fig.119988: Fastening points / rigging points



**Note**

- ▶ Fastening points and rigging points

### 1.24 9402377 – Fastening point / lifting point

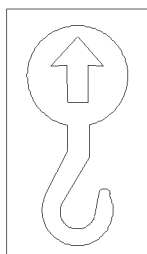


Fig.127586: Fastening point / lifting point



**Note**

- ▶ Fastening point / lifting point

LWE/LR 1800-1-0-000/27200-07-02/en

## 1.25 97140080 – Assembling the fixed lattice jib

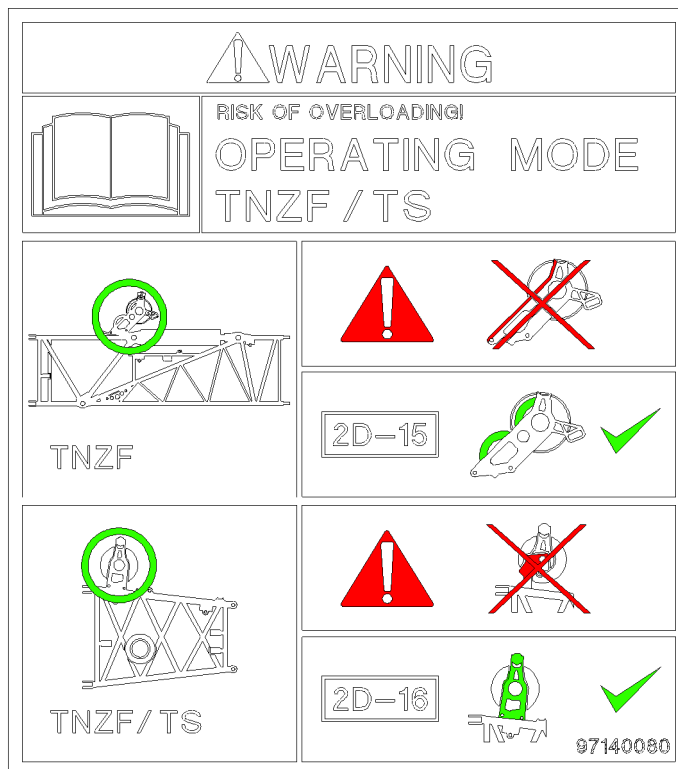


Fig.163345: Permissible components



### WARNING

Incorrect assembly of the lattice sections!  
The boom can break and the load can fall down.  
Death or severe bodily injuries.

- ▶ Assemble the lattice sections according to the separately supplied assembly drawings.
- ▶ Any other arrangement of the lattice sections than specified in the separately supplied assembly drawings is prohibited.
- ▶ Assemble the lattice jib according to its descriptions.

## 1.26 97106824 – Installing the N-assembly unit

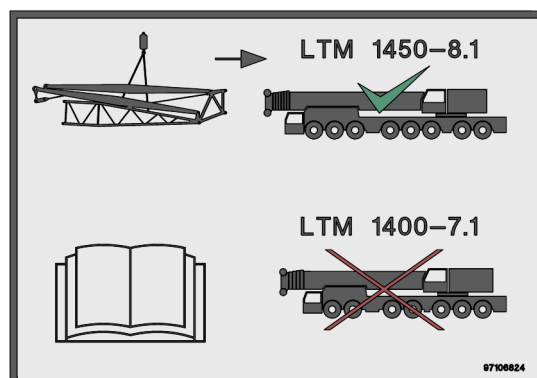


Fig.147594: Installing the N-assembly unit

**WARNING**

N-assembly unit installed on an impermissible crane type!  
Death, severe bodily injuries, property damage.

- ▶ Use N-assembly units marked with this sign only for crane type LTM 1450-8.1.
- ▶ Observe and adhere to the operating instructions.

## 1.27 97096132 – Fastening points for N-assembly unit

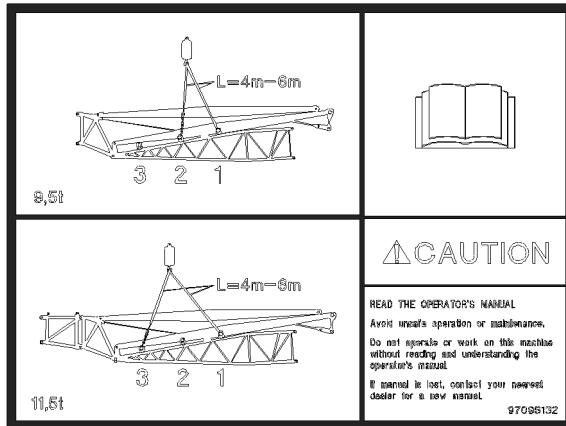


Fig.144774: N-assembly unit fastening points

**WARNING**

Incorrectly selected fastening points!

The N-assembly unit can tip over and kill personnel.

- ▶ Fasten the N-assembly unit only on the intended fastening points.
- ▶ Use fastening equipment with the correct strand length.
- ▶ Observe and adhere to the operating instructions.
- ▶ Replace lost or incomplete operating instructions immediately.

## 1.28 97036735 – Fastening point for lattice section

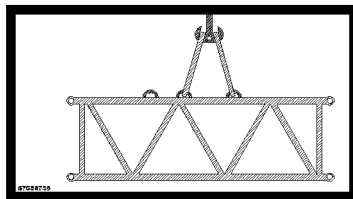


Fig.116266: Fastening point for lattice section

**Note**

- ▶ Fastening points for lattice section

## 1.29 97036736 – Fastening point for lattice sections

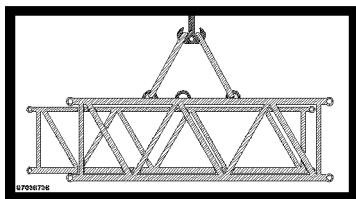


Fig.116267: Fastening point for lattice sections



### Note

- ▶ Fastening points for lattice sections

## 1.30 97038442 – Fastening point for lattice section

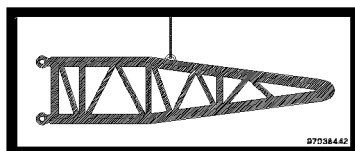


Fig.116288: Fastening point for lattice sections



### Note

- ▶ Fastening point for lattice section.

## 1.31 97038452 – Fastening point for lattice sections

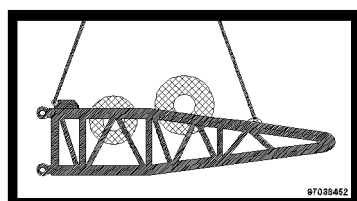


Fig.116289: Fastening point for lattice sections



### Note

- ▶ Fastening points for lattice sections

### 1.32 97038454 – Fastening point for lattice sections

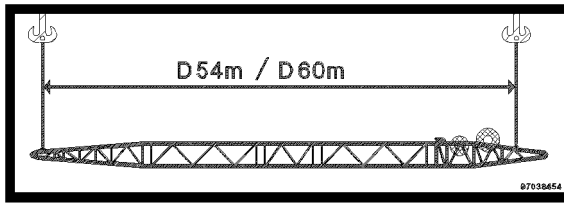


Fig.116290: Fastening point for lattice sections



#### Note

- ▶ Fastening points for lattice sections

### 1.33 97037871 – Fastening points for lattice sections

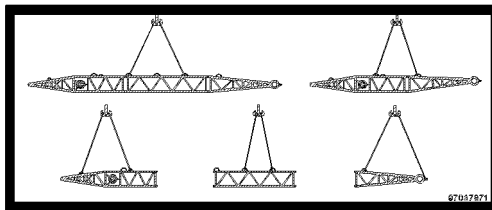


Fig.116292: Fastening points for lattice sections



#### Note

- ▶ Fastening points for lattice sections

### 1.34 97053410 – Fastening equipment

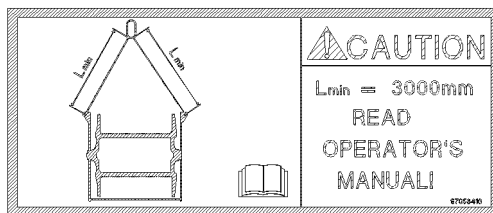


Fig.155031: Fastening equipment

#### NOTICE

The fastening equipment is too short!

The fastening equipment is overloaded, the load can fall down.

The assembly procedure cannot be carried out.

- ▶ Use fastening equipment with a minimum length of 3000 mm.
- ▶ Use only authorized fastening equipment with a suitable load bearing capacity.
- ▶ Observe and adhere to the operating instructions.

### 1.35 97057767 – Fastening points for lattice sections

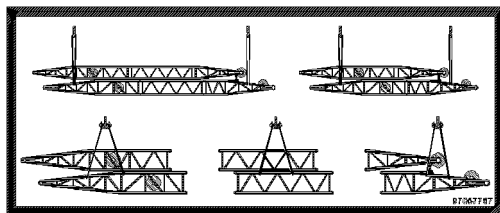


Fig.121181: Fastening points for lattice sections



#### Note

- ▶ Fastening points for lattice sections

### 1.36 97057524 – Fastening point for assembly of lattice sections

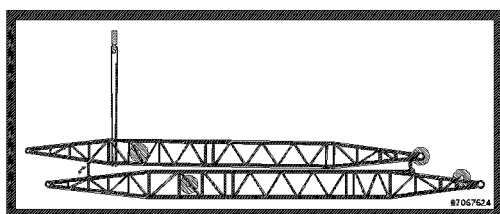


Fig.121182: Fastening point for assembly of lattice sections



#### Note

- ▶ Fastening point for assembly of lattice sections.

### 1.37 97057097 – Fastening point to turn the component

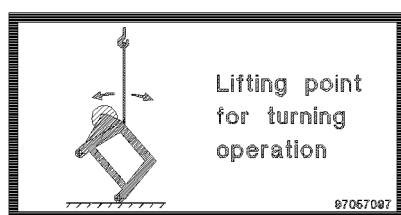


Fig.119987: Fastening point to turn the component



#### Note

- ▶ Fastening point to turn the component



### 1.38 97039035 – Assembly unit suspended load

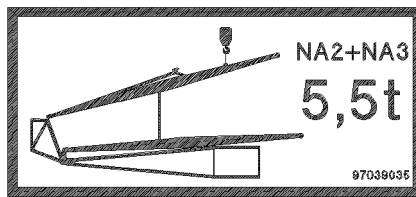


Fig.117348: Suspended load Assembly unit



#### Note

- ▶ Notice the suspended load.

### 1.39 97059339 – Suspended load Derrick pivot section

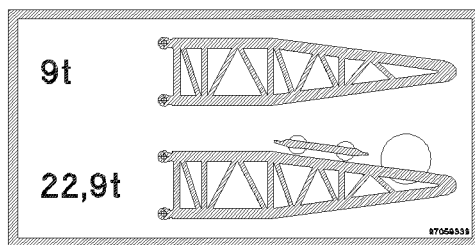


Fig.127469: Derrick pivot section suspended load



#### Note

- ▶ Derrick pivot section suspended load.
- ▶ Derrick pivot section suspended load with rope winch and luffing pulley block.

### 1.40 97068257 – Fastening point for end section

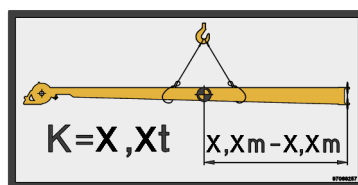


Fig.147595: Fastening point for end section

$K = \text{Weight in tons (t)}$

$X.X \text{ to } X.X = \text{Distance of center of gravity in meters (m)}$



#### WARNING

End section improperly fastened!

The end section can tip over and fall down.

Death, severe bodily injuries, property damage.

- ▶ Fasten the end section only with two hooks.
- ▶ Select the fastening point such that the center of gravity is located within the fastening points.

## 1.41 97095312 – Suspended load and fastening points for counterweight frame

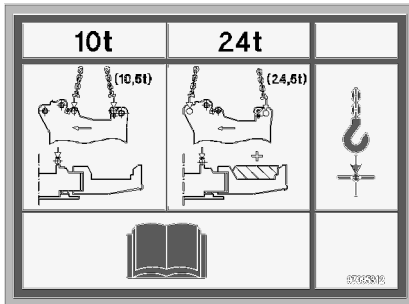


Fig.148126: Suspended load and fastening points for counterweight frame



### Note

- ▶ Observe the suspended load and fastening points for counterweight frame.
- ▶ Observe and adhere to the operating instructions.

## 1.42 97003109 – Accessing the step ladder



Fig.109032: Accessing the step ladder



### WARNING

Danger of falling!

If the step ladder is accessed before it is completely folded out, the assembly personnel can fall and be fatally injured.

- ▶ Before accessing the step ladder, fold the lowest step out.

## 1.43 97003110 – Folding the step ladder in and out



Fig.109033: Folding the step ladder in and out

**WARNING**

Danger of falling!

When folding the step ladder in or out or when driving the crane, no personnel may remain on the step ladder or within the entire danger zone! Personnel can fall from the step ladder or be killed as the step ladder folds in or out.

- ▶ Fold the step ladder in and out only if there are no persons in the danger zone.

### 1.44 97006167 – Identifying the support base

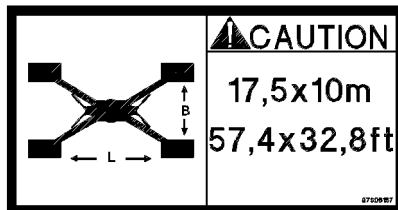


Fig.116285: Identifying the support base

**Note**

- ▶ The support beams are swung out / extended to a support base of 17.50 m x 10.0 m ; (57.4 ft x 32.8 ft)

### 1.45 97006167 – Identifying the support base

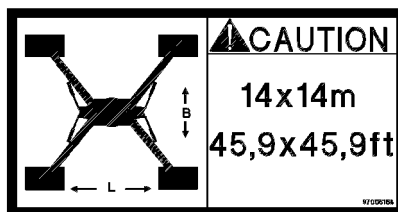


Fig.116286: Identifying the support base

**Note**

- ▶ The support beams are swung out / extended to a support base of 14.0 m x 14.0 m ; (45.9 ft x 45.9 ft ).

### 1.46 97008514 – Warning of head injuries



Fig.110550: Warning of head injuries

**WARNING**

Head injuries!

Due to falling parts, personnel can be killed or severely injured.

Hitting the head can cause injuries.

- ▶ Protect your head with a hard hat.
- ▶ Proceed in an aware and safe manner.

## 1.47 97009799 – Data logger

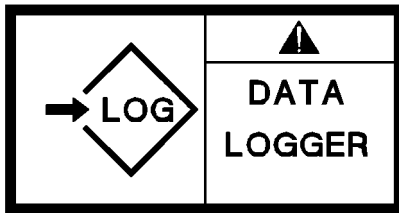


Fig.116261: Data logger

**Note**

- ▶ Data logger

## 1.48 97012949 – Maximum load

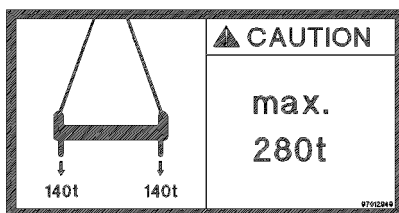


Fig.116263: Maximum load

**CAUTION**

Property damage due to overload!

If the cross beam is subjected to a higher load than permissible, damage can occur.

- ▶ Do not overload the cross beam.

## 1.49 97012095 – Maximum load

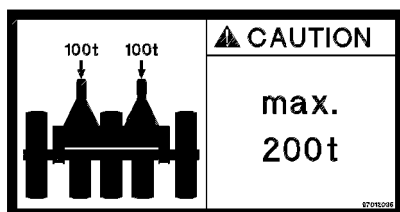


Fig.116265: Maximum load

**CAUTION**

Property damage due to overload!

If the roller cart is subjected to a higher load than permissible, damage can occur.

- ▶ Do not overload the roller cart.

## 1.50 97069053 – Storage boxes open

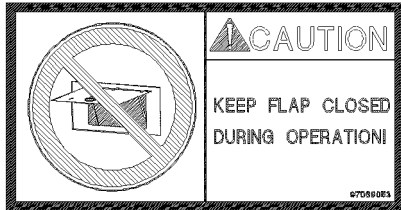


Fig.144736: Storage boxes open

**NOTICE**

Storage boxes open!

Damage of storage boxes.

- ▶ Before crane operation and before driving the crane, close the storage boxes.

## 1.51 97068370 – Closing the cab door

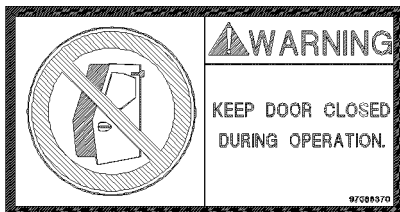


Fig.144737: Closing the cab door

**WARNING**

Cab door during crane operation **not** closed!

The crane operator can fall down.

Death, severe bodily injuries.

- ▶ Close the cab door during crane operation.

## 1.52 97053409 – Entanglement hazard during winch operation



Fig.144738: Entanglement hazard during winch operation

**DANGER**

Entanglement hazard during winch operation!  
Body parts can be caught and entangled.  
Death, severe bodily injuries, property damage.  
▶ Do **not** stand in the hazard area of the winch.

### 1.53 97011689 – Danger of crushing



Fig.111047: Danger of crushing

**DANGER**

Danger of fatal injury!  
▶ It is prohibited to remain in the danger zone of the cab.  
▶ Stay away from the movement range of the cab.

### 1.54 97011690 – Overload of crane cab is prohibited

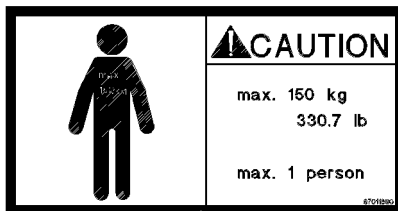


Fig.111048: Overloading the cab is prohibited

**WARNING**

Danger of overload!  
If the crane cab is subjected to a load of more than 150 kg then the crane cab or the telescoping arm can be damaged!  
▶ Only one person at a time may remain in the crane cab!  
▶ Do not subject the crane cab to a weight of more than 150 kg.

### 1.55 97016304 – Refueling

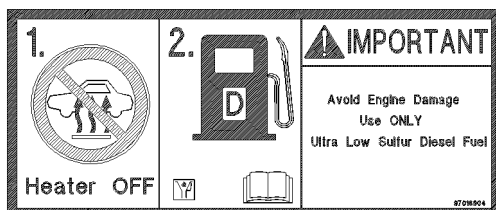


Fig.155029: Refueling

**WARNING**

Danger of fire and explosion!

- ▶ Turn the auxiliary heater\* off approx. 3 minutes before refueling the fuel tank.
- ▶ Before refueling the fuel tank, turn the engine off.

**NOTICE**

Property damage to the engine!

If incorrect fuel is added, the engine can be severely damaged.

- ▶ Refuel with fuel according to the Engine manufacturer's operating instructions.

## 1.56 97046488 – Corrosion inhibitor - antifreeze fluids

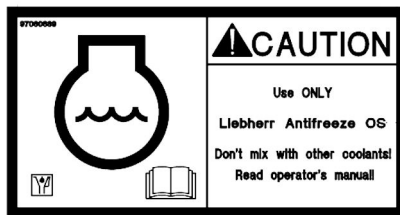


Fig.127585: Corrosion inhibitor - antifreeze fluids

**NOTICE**

Mixing of different corrosion inhibitor-antifreeze agents!

Damage to the cooling system.

- ▶ Fill the cooling system with corrosion inhibitor-antifreeze, see Service fill list.

## 1.57 97016392 – Crushing danger for feet



Fig.112474: Crushing danger for feet

**WARNING**

Crushing danger for feet!

Feet can be trapped or crushed.

- ▶ Keep feet away from the crushing area.

## 1.58 97012737 – Danger of accident



Fig.111748: Danger of accident



### WARNING

Danger of accident!

- ▶ Close the windshield when driving.

## 1.59 97023034 – Disassembling

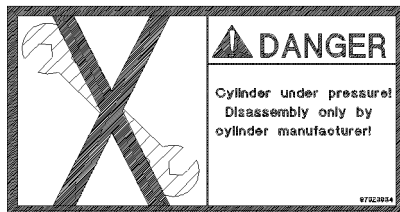


Fig.116264: Disassembling



### DANGER

Danger of fatal injury due to repair!

The cylinder is pressurized.

Disassembly of the cylinder can result in death or serious injuries.

- ▶ The cylinder may only be removed by the manufacturer.

## 1.60 97036732 – Access via 3-point support

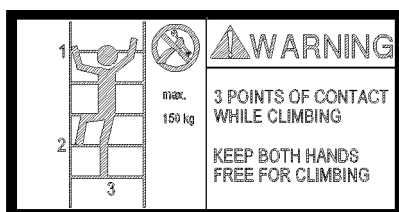


Fig.115172: Access via 3-point support



### DANGER

Access via 3-point support!

While climbing up and down via a ladder, assembly personnel can fall down and be injured severely.

- ▶ When climbing up and down, a 3-point support must be ensured.
- ▶ Use ladders only up to a weight of 150 kg.
- ▶ When climbing up and down, hands must be free.



A 3-point support is ensured when:

- Two legs are standing safely and one hand has a safe hold.
- Two hands have a safe hold and one leg is standing safely.

### 1.61 97003112 – Maximum suspended load

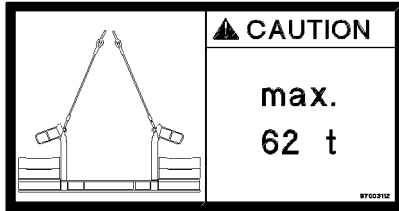


Fig.116282: Maximum suspended load



**WARNING**

Maximum suspended load!

If the maximum suspended load of 62 t is exceeded, the load can fall down and kill personnel.

- ▶ Observe the maximum permissible suspended load.

### 1.62 97036917 – Maximum suspended load

ID no.	Suspended load fastening point
97047630	
97036917	
97047630	
97077237	



**WARNING**

Mortal danger if the load falls down!

If the maximum suspended load is exceeded, the load can fall down and kill personnel.

- ▶ Observe the maximum permissible suspended load.

LWE/LR 1800-1-0-000/27200-07-02/en

### 1.63 97037383 – Urea

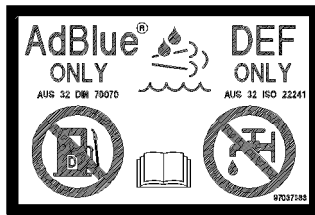


Fig.115173: Urea



#### CAUTION

Property damage due to incorrect operating fluids!  
When refilling urea and the urea that is specified by the engine manufacturer is not used, then damage can occur.

- ▶ Refill **exclusively** urea.
- ▶ See the engine manufacturer's operating instructions.

### 1.64 97037952 – Danger of fatal injury due to electric shock

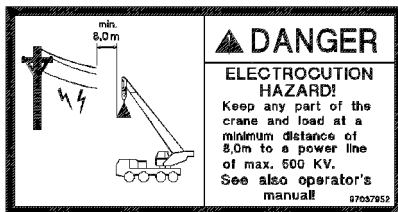


Fig.116280: Danger of fatal injury due to electric shock



#### DANGER

Danger of fatal injury due to electric shock!

If the boom or the hoist rope is powered with electric voltage, then death or severe injuries can occur if anyone touches the crane, the vehicle or the load.

- ▶ Keep a minimum distance of 8.0 m from current carrying parts.

### 1.65 97042730 – Falling luffing cylinder

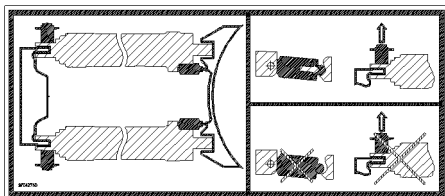


Fig.118465: Falling luffing cylinder



#### WARNING

Mortal danger if the luffing cylinders fall down!

- ▶ Make sure, before unpinning the luffing cylinder, that the erection cylinders are placed on both luffing cylinders.

## 1.66 97047810 – Pinning brackets

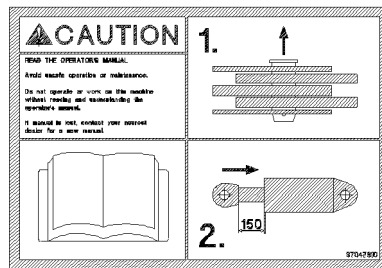


Fig.121709: Pinning brackets

### NOTICE

Damage to the brackets due to collision!

- ▶ Make sure, before pinning and unpinning, that the hydraulic cylinder is set to a distance of 150 mm.

## 1.67 97042797 – Overload of components

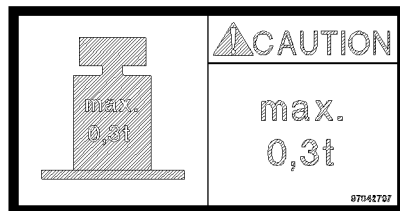


Fig.117347: Overload of components



### DANGER

Danger of falling due to overload!

If a component, such as a sliding beam platform, is subjected to a weight of more than 0.3 t, then the sliding beam platform can break.

Personnel can fall down and be severely injured or killed.

- ▶ Subject the component (sliding beam platform) to no more than maximum 0.3 t.

## 1.68 97041305 – Overload of components

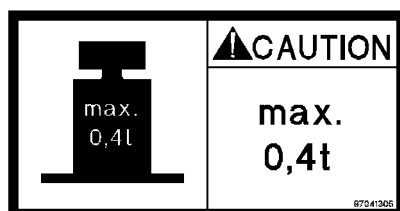


Fig.116792: Warning of overload of components



### DANGER

Danger of falling due to overload!

If a component, such as a sliding beam platform, is subjected to a weight of more than 0.4 t, then the sliding beam platform can break.

Personnel can fall down and be severely injured or killed.

- ▶ Subject the component (sliding beam platform) to no more than maximum 0.4 t.

## 1.69 97070905 – Disassembling the auxiliary jib (boom nose)

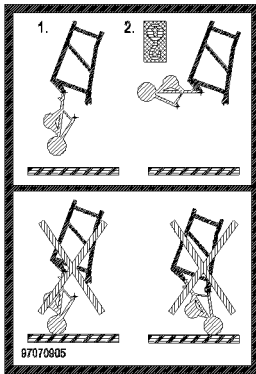


Fig.122645: Disassembling the auxiliary jib (boom nose)

### NOTICE

Property damage

Before taking the N-head down:

- ▶ Disassemble the auxiliary jib (boom nose).

## 1.70 97077304 – Positioning the outrigger pad

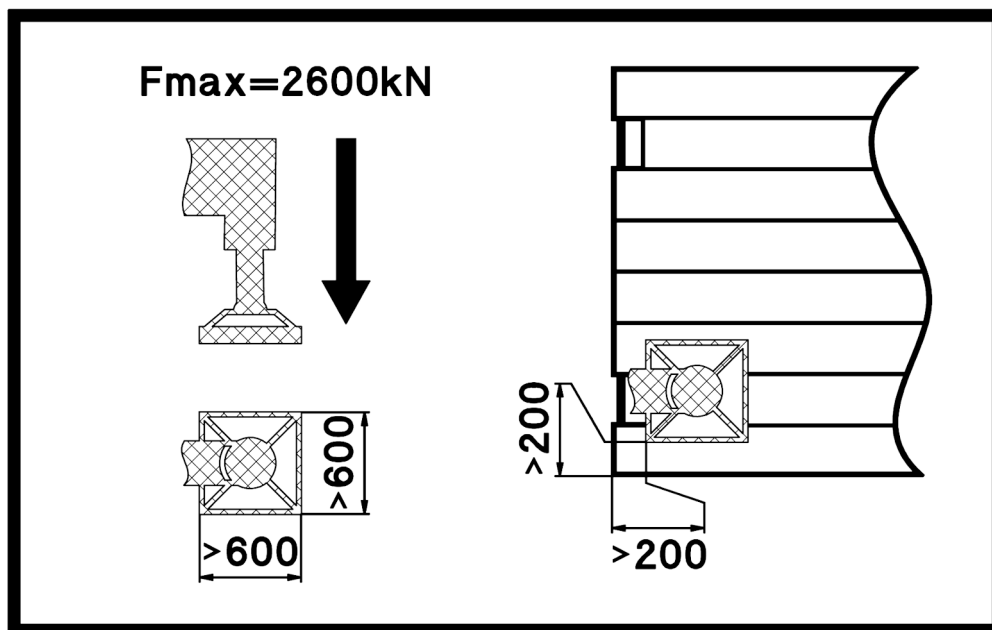


Fig.154913: Positioning the outrigger pad



### WARNING

Outrigger pad incorrectly positioned!  
The crane can topple over. Death, property damage.

- ▶ Position the outrigger pad **in the center** or according to the description in chapter 1.03.10 under the support plate.

### 1.71 9707704 – Driving with the outrigger pad

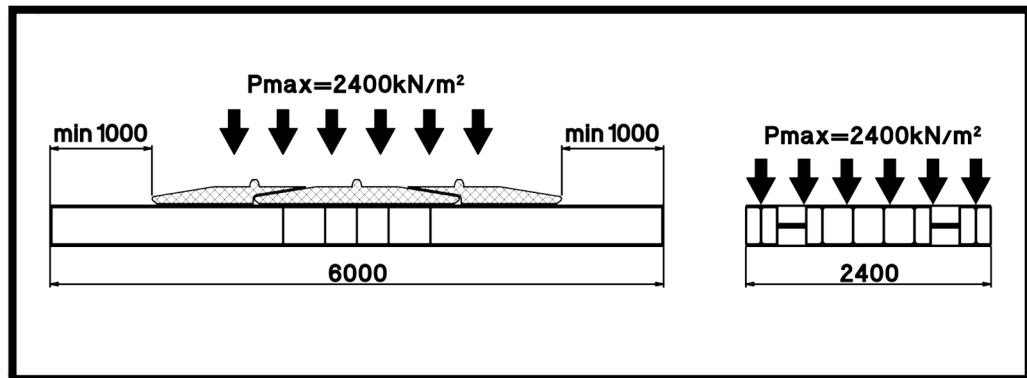


Fig.154912: Driving with the outrigger pad



**WARNING**

Outrigger pad incorrectly driven!  
The crane can topple over. Death, property damage.

- ▶ Drive with the outrigger pad according to the specifications on the sign.

### 1.72 Permissible support pressures on the outrigger pad [A-B-C]

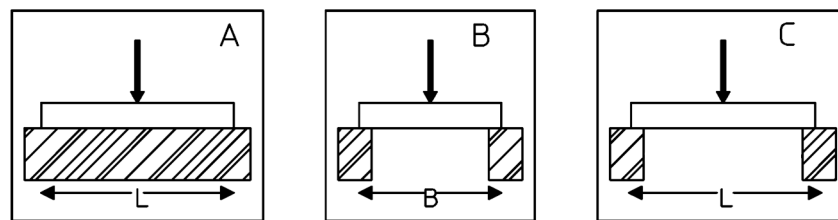


Fig.154815: Permissible support pressures on the outrigger pad for application cases [A-B-C]

### 1.73 Permissible support pressures on the outrigger pad [A-B-C-D]

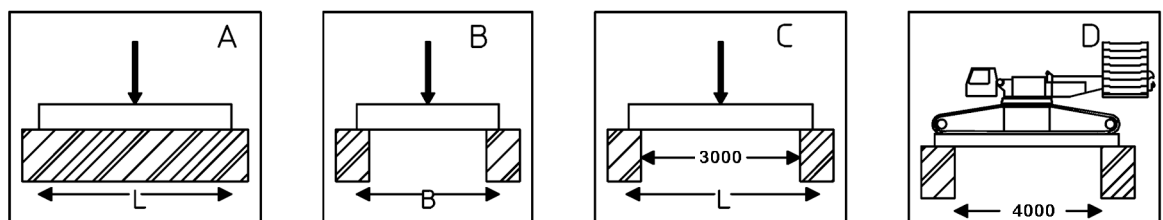


Fig.154816: Permissible support pressures on the outrigger pad for application cases [A-B-C-D]

LWE/LR 1800-1-0-000/27200-07-02/en

## 1.74 97033982 – Assembling / disassembling the Derrick pivot section

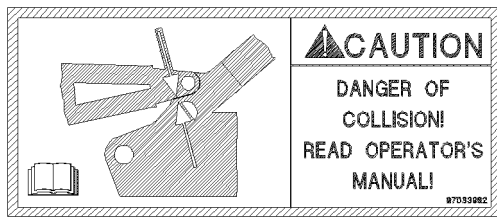


Fig.127470: Assembling / disassembling the Derrick pivot section

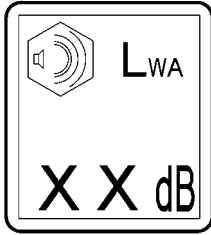
### NOTICE

Derrick pivot section assembly procedure carried out incorrectly!

Damage to the Derrick pivot section receptacle.

- ▶ Perform the assembly procedure according to the operating instructions.

## 1.75 Maximum sound power level

ID no.	Maximum sound power level
975809508	 <i>Maximum sound power level</i>
971693308	
971693408	
971693508	
971693608	



### Note

- ▶ The maximum sound power level can be read on the outside of the crane cab or in the CE declaration of conformity.

## 1.76 97097951 – Counterweight

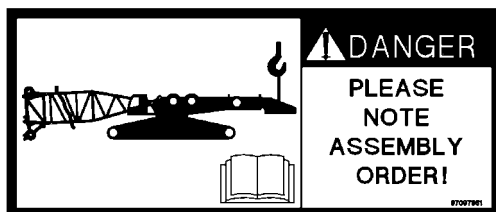


Fig.146805: Counterweight

**DANGER**

Counterweight not secured!  
Falling counterweight death, property damage.

- ▶ Observe and adhere to the operating instructions.
- ▶ Do not remove the auxiliary crane until the counterweight is pinned and secured on both sides with the turntable.

## 1.77 9710047 – Retaining pins for erection rack



Fig.158614: Retaining pins for erection rack

**DANGER**

Retaining pins not inserted!  
Falling ladder and erection rack, death, property damage.

- ▶ Before stepping on the erection rack ladder: Insert and secure the erection rack retaining pins.

## 1.78 97100629 – Connector pins for erection rack / guy rods



Fig.158615: Connector pins for erection rack / guy rods

**DANGER**

Unpin the erection rack / guy rods connector pins!  
Falling ladder and erection rack, death, property damage.

Before unpinning the erection rack / guy rods:

- ▶ Insert and secure the erection rack retaining pins.

## 1.79 97107101 – Unlocking the telescopic boom locking pin

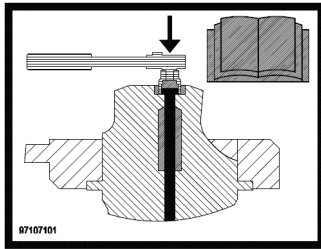


Fig.148421: Unlocking the telescopic boom locking pin



### Note

- ▶ The locking pin may be unlocked according to the operating instructions.
- ▶ Observe and adhere to the operating instructions.

## 1.80 97107199 – Do not unlock the telescopic boom locking pin

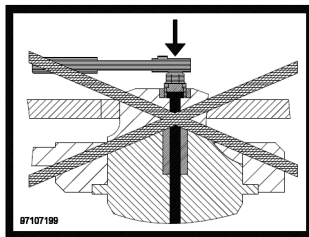


Fig.148422: Do not unlock the telescopic boom locking pin



### WARNING

Impermissible telescopic boom locking pin unlocked!  
The telescopic boom can retract in an uncontrolled manner.  
Death, severe bodily injuries, property damage.

If a locking pin is marked with this sign:

- ▶ **Never** unlock the locking pin.

## 1.81 97128894 – Counterweight and counterweight radius

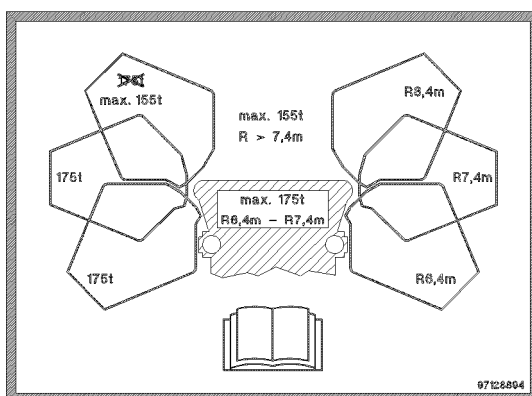


Fig.155030: Counterweight and counterweight radius



Counterweight radius	Maximum permissible counterweight
R- 6.4 m – R- 7.4 m	175.0 t
R- > 7.4 m	155.0 t

**Note**

- ▶ This notice sign indicates the maximum permissible counterweight for the different weight radii.
- ▶ Observe and adhere to the operating instructions.

## 1.82 97131530 – Reduced crawler crane track width

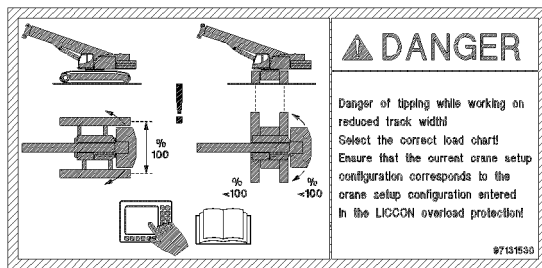


Fig.156174: Reduced crawler crane track width

**DANGER**

Danger of tipping when working with a reduced track width!

- ▶ Select the correct load chart.
- ▶ Make sure that the actual crane set up configuration and the set up configuration entered in the LICCON overload protection match.

## 1.83 977055908 – Fastening point for swingable sliding beam

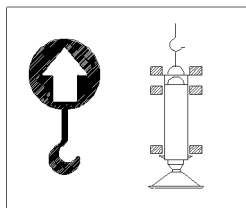


Fig.106894: Fastening point for swingable sliding beam

## 1.84 971494208 – Limitation of maximum travel speed

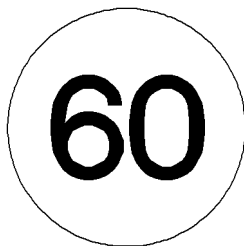


Fig.106034: Limitation of maximum travel speed

## 1.85 971539808 – Warning notice for unpinning the auxiliary boom on the pulley head

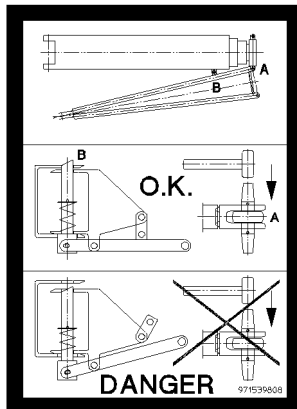


Fig.106040: Warning notice for unpinning the auxiliary boom on the pulley head



### **DANGER**

Danger of fatal injury!

If the auxiliary boom is not locked correctly to the pivot section, it can fall down. Personnel can be severely injured or killed.

- ▶ Unpinning the auxiliary boom on the pulley head is prohibited.

## 1.86 971539908 – Warning notice for unlocking the auxiliary boom

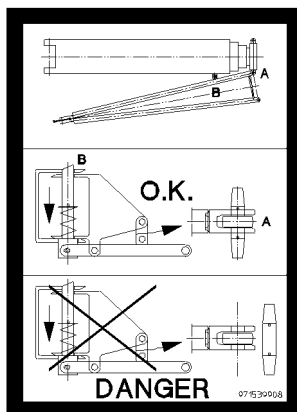


Fig.106041: Warning notice for unlocking the auxiliary boom



### **DANGER**

Danger of fatal injury!

If the auxiliary boom is not locked correctly to the pulley head, it can fall down. Personnel can be severely injured or killed.

- ▶ Unpinning the auxiliary boom on the pivot section is prohibited.

## 1.87 978673908 – Warning of suspended load

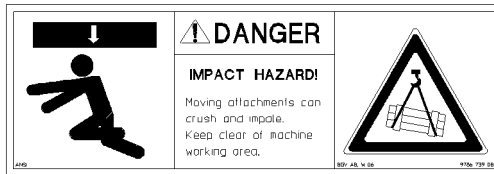


Fig.106026: Warning of suspended load



### DANGER

Danger of fatal injury under suspended load!

- ▶ Standing under suspended loads is prohibited.
- ▶ Stay away from the working range of the machine.

## 1.88 978674008 – Access for unauthorized personnel prohibited



Fig.106037: Access for unauthorized personnel prohibited



### DANGER

Danger of fatal injury!

If the crane or the working area is accessed by unauthorized personnel, life threatening injuries can occur as a result.

- ▶ It is prohibited for unauthorized personnel to enter the crane or the working area.

## 1.89 97039753 – Danger of stumbling

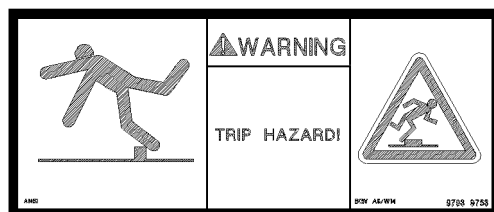


Fig.117346: Danger of stumbling



### WARNING

Danger of stumbling!

- ▶ Move with caution.

## 1.90 978674108 – Warning of crushing danger

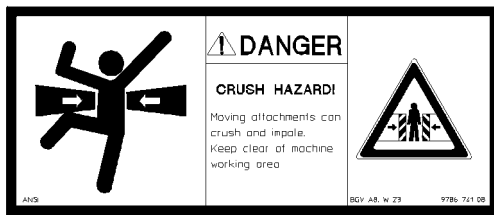


Fig.106027: Danger of crushing



### DANGER

Danger of fatal injury when remaining in areas with crushing danger!

- ▶ It is prohibited for anyone to remain in areas where there is a crushing danger.
- ▶ Stay away from the working range of the machine.

## 1.91 97016911 – Danger of collision

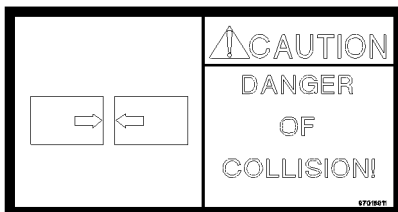


Fig.117344: Danger of collision

### NOTICE

Danger of collision!

- ▶ Avoid a collision.

## 1.92 978674308 – Radio remote control

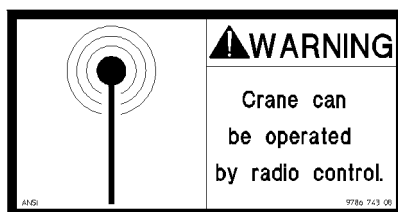


Fig.106047: Radio remote control



### WARNING

Danger of injury due to crane operation with radio remote control!

- ▶ The crane can be operated with radio remote control!
- ▶ During crane operation, it is prohibited for anyone to remain in the danger zone!

### 1.93 978674408 – Danger of burns to hands



Fig.106028: Danger of burns to hands



#### WARNING

Danger of burns when touching hot surfaces!

- ▶ Do not touch hot surfaces.

### 1.94 978674508 – Warning of rotating parts

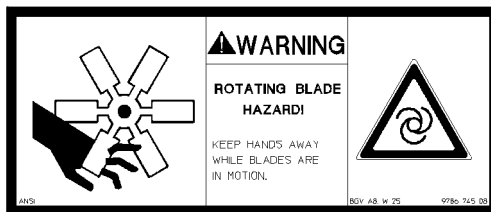


Fig.106029: Warning of rotating parts



#### WARNING

Rotating parts!

The rotating fan blade can cause finger and hand injuries.

- ▶ Keep your hands away from the rotating fan blade.

### 1.95 978674608 - Crushing danger for hands



Fig.106030: Crushing danger for hands



#### WARNING

Hazard area for hands!

Hands can be caught, trapped or crushed.

- ▶ Do not reach into the danger zone.

## 1.96 97164545 – Danger of injury for hands



Fig.162087: Danger of injury for hands



### WARNING

Hazard area for hands!  
Hands can be caught, trapped or crushed.  
▶ Do not reach into the danger zone.

## 1.97 97167874 – Danger of injury for hands by the rope drive

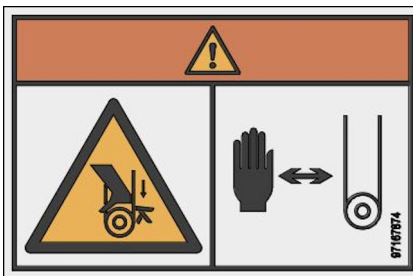


Fig.162086: Danger of injury for hands by the rope drive



### WARNING

Hazard area due to the rope drive!  
Hands can be caught, trapped or crushed due to the rope drive.  
▶ Do not reached in to the hazard area of the rope drive.

## 1.98 978674808 – Personal protective equipment



Fig.123900: Personal protective equipment



### DANGER

Working at a height!  
Danger of falling  
▶ Use personal protective equipment.

## 1.99 978674808 – Personal protective equipment

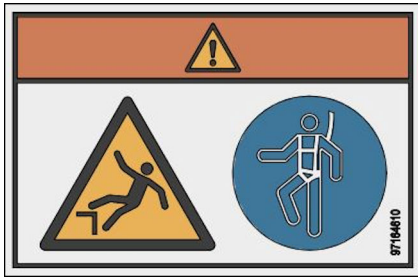


Fig.162085: Personal protective equipment



### **DANGER**

Working at a height!

Danger of falling

- ▶ Use personal protective equipment.

## 1.100 978674908 – Accessing the area is prohibited



Fig.106038: Accessing the area is prohibited



### **WARNING**

Danger of accident!

If the prohibited area is accessed, accidents can occur.

Personnel can be severely injured or killed.

- ▶ Do not access the prohibited area.

## 1.101 978675008 – Access prohibited



Fig.106039: Access prohibited



### **WARNING**

Danger of falling!

If the crane is accessed by unauthorized personnel, life threatening injuries can occur.

- ▶ Do not get on the crane.

### 1.102 97155791 – Rigging point



Fig.164359: Rigging point



#### WARNING

Incorrect use of the rigging point!

- ▶ Use the rigging point **only** for rigging.
- ▶ Do not lift the load on the rigging point.
- ▶ Observe and adhere to the operating instructions.

### 1.103 97165352 – Rigging point

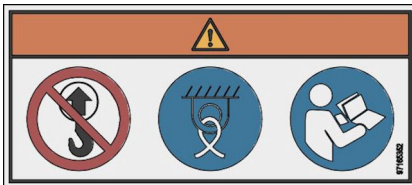


Fig.162088: Rigging point



#### WARNING

Incorrect use of the rigging point!

- ▶ Use the rigging point **only** for rigging.
- ▶ Do not lift the load on the rigging point.
- ▶ Observe and adhere to the operating instructions.

### 1.104 978687408 – Rigging point



Fig.112475: Rigging point



#### WARNING

Incorrect use of the rigging point!

- ▶ Use the rigging point **only** for rigging.
- ▶ Do not lift the load on the rigging point.
- ▶ Observe and adhere to the operating instructions.



## 1.105 97036734 – Rigging point

NOT FOR LIFTING!			
Type (t)	Lashing Capacity		
	LC-N (daN)	LC-Q (daN)	
4	4 000	2 000	
9,7	8 700	4 000	
10	10 000	7 000	
16	16 000	11 200	
31,5	31 500	22 050	

Fig.116287: Rigging point



### WARNING

Incorrect use of the rigging point!

- ▶ Use the rigging point **only** for rigging.
- ▶ Do not lift the load on the rigging point.
- ▶ Observe and adhere to the operating instructions.

## 1.106 978867108 – Danger of fatal injury due to electric shock

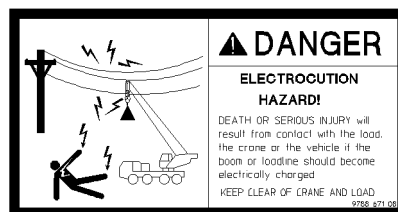


Fig.106814: Danger of fatal injury due to electric shock



### DANGER

Danger of fatal injury due to electric shock!

If the boom or the hoist rope is powered with electric voltage, then death or severe injuries can occur if anyone touches the crane, the vehicle or the load.

- ▶ Stay away from the crane and load.

## 1.107 97094940 – Spark catcher

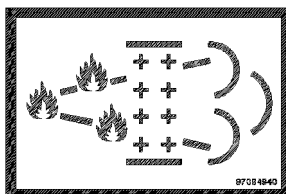


Fig.144735: Spark catcher



### Note

- ▶ The exhaust system is equipped with an integrated spark catcher.

## 1.108 979383308 – Oil change

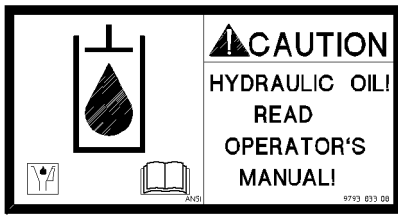


Fig.113827: Oil change



### CAUTION

Property damage due to oil change!

If the oil specified in the operating instructions is not used during the oil change, it can lead to damage.

- ▶ See the Crane operating instructions, chapter 7.07.

## 1.109 97160549 – Oil change

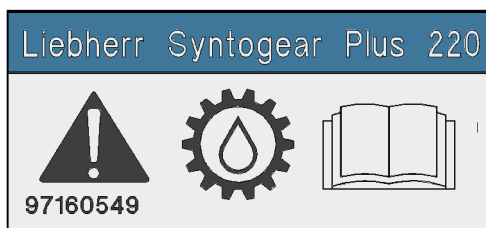


Fig.164360: Oil change



### CAUTION

Property damage due to oil change!

If the oil specified in the operating instructions is not used during the oil change, it can lead to damage.

- ▶ Use the specified oil.
- ▶ See the Crane operating instructions, chapter 7.07.

## 1.110 979561108 – Counterweight

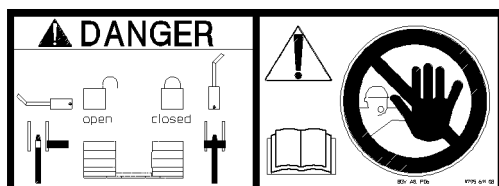


Fig.109026: Counterweight



### WARNING

The counterweight can fall down!

If the auxiliary crane is removed on the counterweight before the counterweight is locked on both sides with the turntable, then the counterweight will fall down and can fatally injure assembly personnel.

- ▶ Do not remove the auxiliary crane until the counterweight is locked and secured on both sides with the turntable. See chapter 4.07.

### 1.111 97001802 – Falling platform

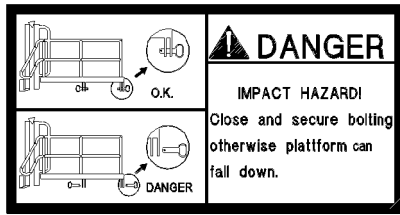


Fig.117345: Falling platform



**WARNING**

Falling platform!

- ▶ Pin and secure the platform in assembly / disassembly position.

### 1.112 973974408 - Transport weights of the components

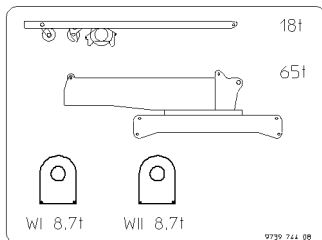


Fig.112440: Transport weights of the components

### 1.113 973974608 - Transport weights of the components

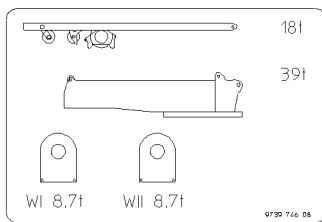


Fig.112441: Transport weights of the components

### 1.114 97011336 - Transport weights of the components

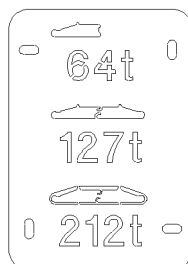


Fig.116271: Transport weights of the components

LWE/LR 1800-1-0-000/27200-07-02/en

### 1.115 97068839 - Transport weights of the components / fastening length of the fastening equipment

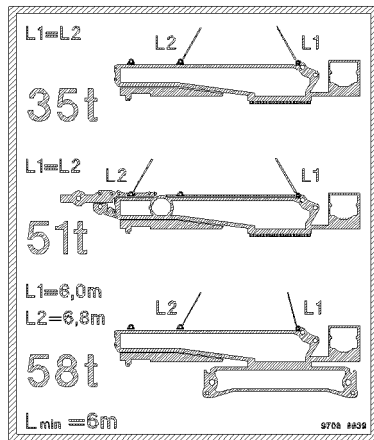
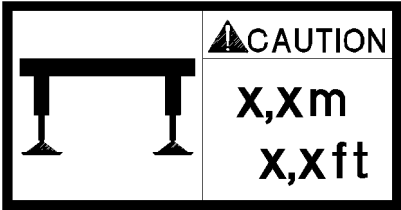


Fig.127587: Transport weights of the components / fastening length of the fastening equipment

### 1.116 Identification of sliding beam

ID no.	Identification of sliding beam
978675108	 <p data-bbox="817 1258 1158 1290">Identification of sliding beam</p>
978675208	
978772808	
978772908	
978809308	
978809408	
978809508	
978818408	
978818508	
978875908	
978902608	
978903108	
97029203	
978903208	
979126008	
979126108	
979210508	

LWE/LR 1800-1-0-000/27200-07-02/en

ID no.	Identification of sliding beam
979210608	
979210608	
979210708	
979309108	
979309208	
97019140	
97003224	
979410808	

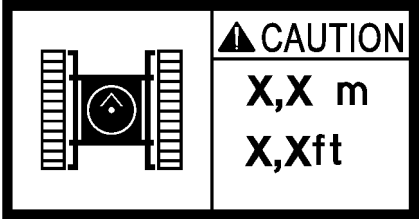
Identification of sliding beam



**Note**

► Extend the sliding beams to a support width of X.X m (X.X ft).

### 1.117 Identification of track width retracted

ID no.	Identification of track width retracted
97009840	 <p>Identification of track width</p>
97009841	
97017044	
97017045	
97017046	

Identification of track width



**Note**

► Track width retracted to x.xx m (x.x ft)

### 1.118 976624808 – Fastening the load

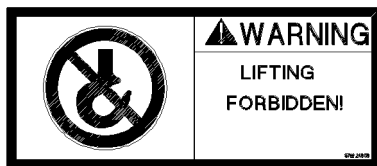


Fig.116283: Fastening the load

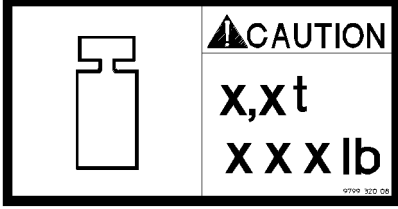
LWE/LR 1800-1-0-000/27200-07-02/en



**WARNING**

Fastening the load is prohibited!  
 If the load is lifted in this point, the load can fall down and kill personnel.  
 ▶ Lifting the load in unmarked locations is prohibited.

**1.119 Note of sliding beam weight**

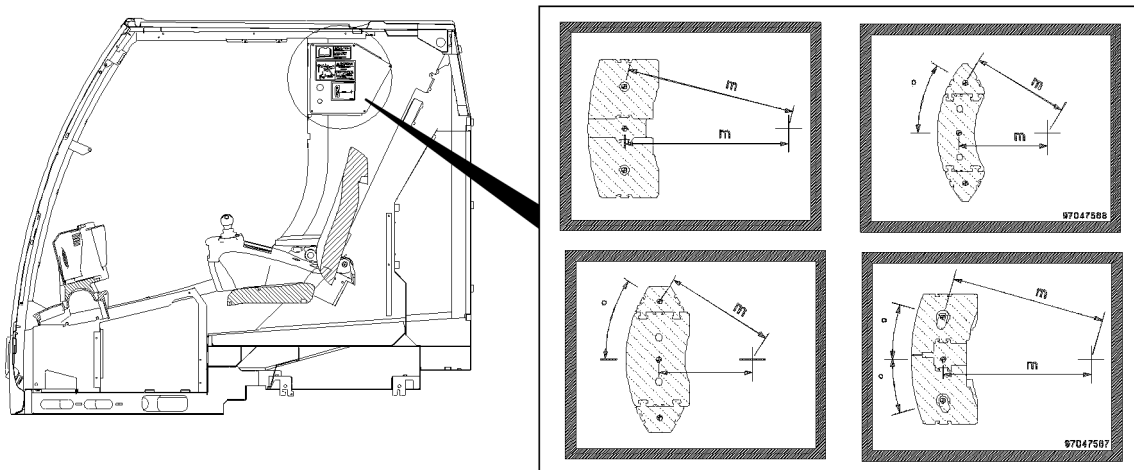
ID no.	Weight of sliding beams
979932008	 <p style="text-align: center;"><i>Weight of sliding beams</i></p>
979932108	
979932708	
979932808	



**Note**

▶ Pay attention to the weight of the sliding beams.

**1.120 Center of gravity of the counterweight**



*Fig.154058: Notice sign: Distance between center of gravity of counterweight and center of rotation*

The depicted notice sign are only examples and can differ depending on the crane type.

The notice signs are displayed in the crane operator's cab.



**Note**

▶ This notice sign indicates the distance between the center of rotation and the center of gravity of the counterweight.

LWE/LR 1800-1-0-000/27200-07-02/en

Notice sign: Distance between center of gravity of counterweight and center of rotation			
Crane type	ID number notice sign	Crane type	ID number notice sign
LTM 1030-2.1	97096584	LTM 1230-5.1	97103719
LTM 1040-2.1	97095218		97103720
LTM 1050-3.1	97094881	LTM 1250-5.1	97070214
LTM 1055-3.1	97047566		97070215
LTM 1060-3.1	97051053	LTM 1300-6.2	97064080
LTM 1070-4.1	97095971	LTM 1350-6.1	97128099
LTM 1090-4.1	97092106	LTM 1450-8.1	97093816
	97092109		
LTM 1095-5.1	97047565	LTC 1050-3.1	97095960
LTM 1100-4.2	97094364	LTF 1045-4.1	97095046
LTM 1100-5.2	97095763	LTF 1060-4.1	97096030
LTM 1130-5.1	97055765	LTR 1060	97128100
LTM 1160-5.2	97081129		

### 1.121 Minimum rope reeving / minimum hook block weight


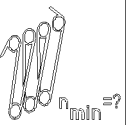

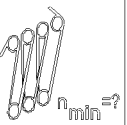

⚠ CAUTION					
LTM 1400-7.1			LTM 1450-8.1		
	 $W_{Tmin}=?$	 $n_{min}=?$		 $W_{Tmin}=?$	 $n_{min}=?$
TN			TN		
N-14,0m	3,1 t	n = 5	N-14,0m	3,1 t	n = 5
N-21,0m	2,6 t	n = 4	N-17,5m	2,6 t	n = 5
N-28,0m	1,4 t	n = 2	N-21,0m	2,6 t	n = 4
TN + 			N-24,5m	2,6 t	n = 4
N-14,0m	2,3 t	n = 3	N-28,0m	1,4 t	n = 2
N-21,0m	2,3 t	n = 2	TNH		
			N-14,0m	2,3 t	n = 3
			N-17,5m	1,8 t	n = 3
			N-21,0m	2,3 t	n = 2
			N-24,5m	1,8 t	n = 2

Fig.127972: Minimum rope reeving / minimum hook block weight with luffing lattice jib / boom nose



#### WARNING

Minimum rope reeving / minimum hook block weight not adhered to!

Too low hook block weight leads to the formation of slack rope.

Rope reeving too low, hoist rope is overloaded.

► Adhere to the hook block weight and hoist rope reeving.

Example: LTM 1400-7.1

With a luffing lattice jib TN **N-21 m**, a hook block with a weight of **2.6 t must** be installed and minimum rope reeving of **4** must be used.

With a luffing lattice jib **N-21 m** and boom nose, a hook block with a weight of **2.3 t must** be installed and minimum rope reeving of **2** must be used.



## 2.05.10 Labeling of the load carriers

1	Identifications on the hook block or load hook	3
2	Identifications on single hook or double hook	4
3	Identifications on auxiliary weights	5

*Fig.195219*

LWE/LR 1800-1-0-000/27200-07-02/en

# 1 Identifications on the hook block or load hook

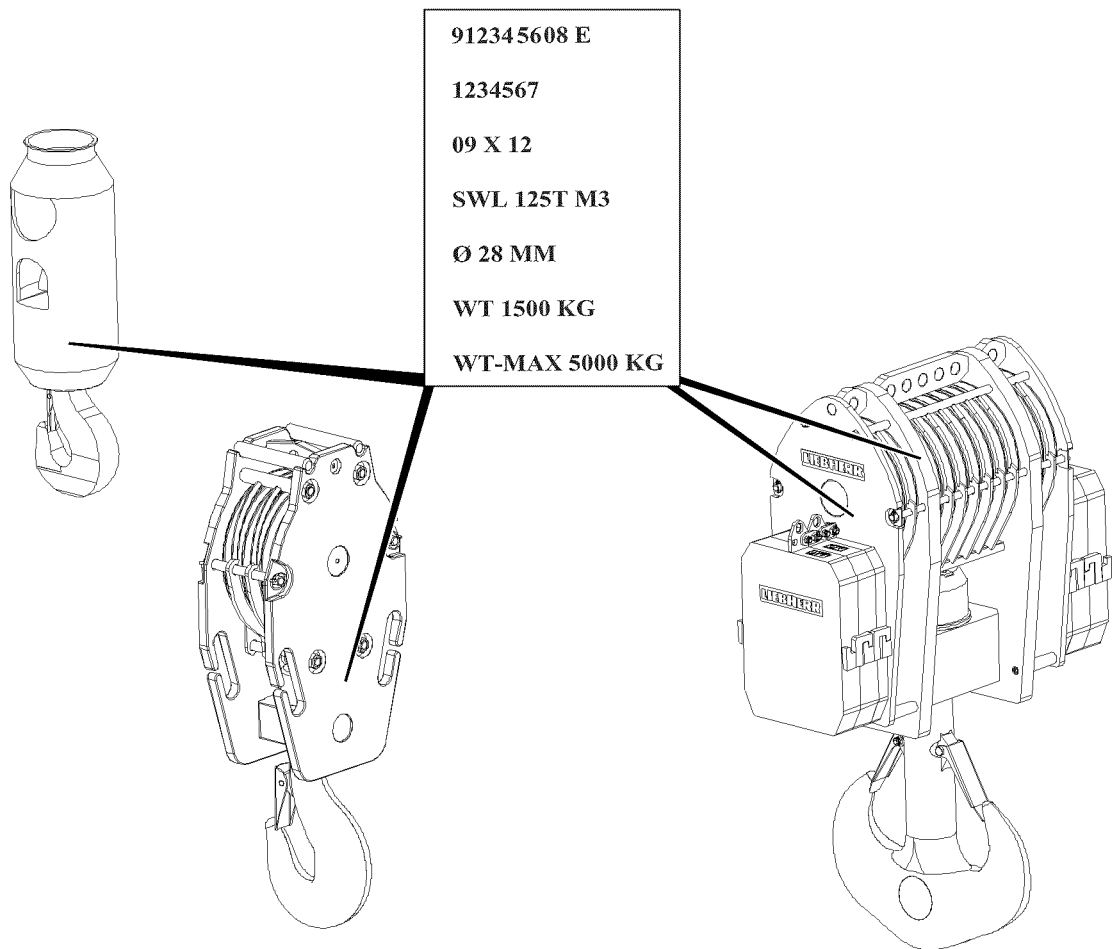


Fig.118509: Identifications on the hook block or load hook



## Note

- ▶ The load hooks and hook blocks approved for this crane type can be found in the load chart.
- ▶ The hook blocks shown are examples only and can deviate from the existing hook block.

Punch mark area	Explanation
912345608 E	Liebherr ID no., "E = entschärft (deburred)"
123456	Series or factory test number
09 X 12	Month of construction / supplier marks / year of construction
SWL 125T M3	SWL (Safe Working Load) = Load carrying capacity for power train group M3
Ø 28 mm	Hoist rope diameter
WT 1500 Kg	WT (Weight Tare) = Own weight (without auxiliary weights)

Punch mark area	Explanation
WT-MAX 5000 Kg	WT-Max = Maximum permissible own weight of lower pulley block and total number of progressively installed auxiliary weights
	Limits the number of installed auxiliary weights
	Determination via addition of assembled own weights (number of auxiliary weights + hook block)

Identifications on the hook block or load hook

## 2 Identifications on single hook or double hook

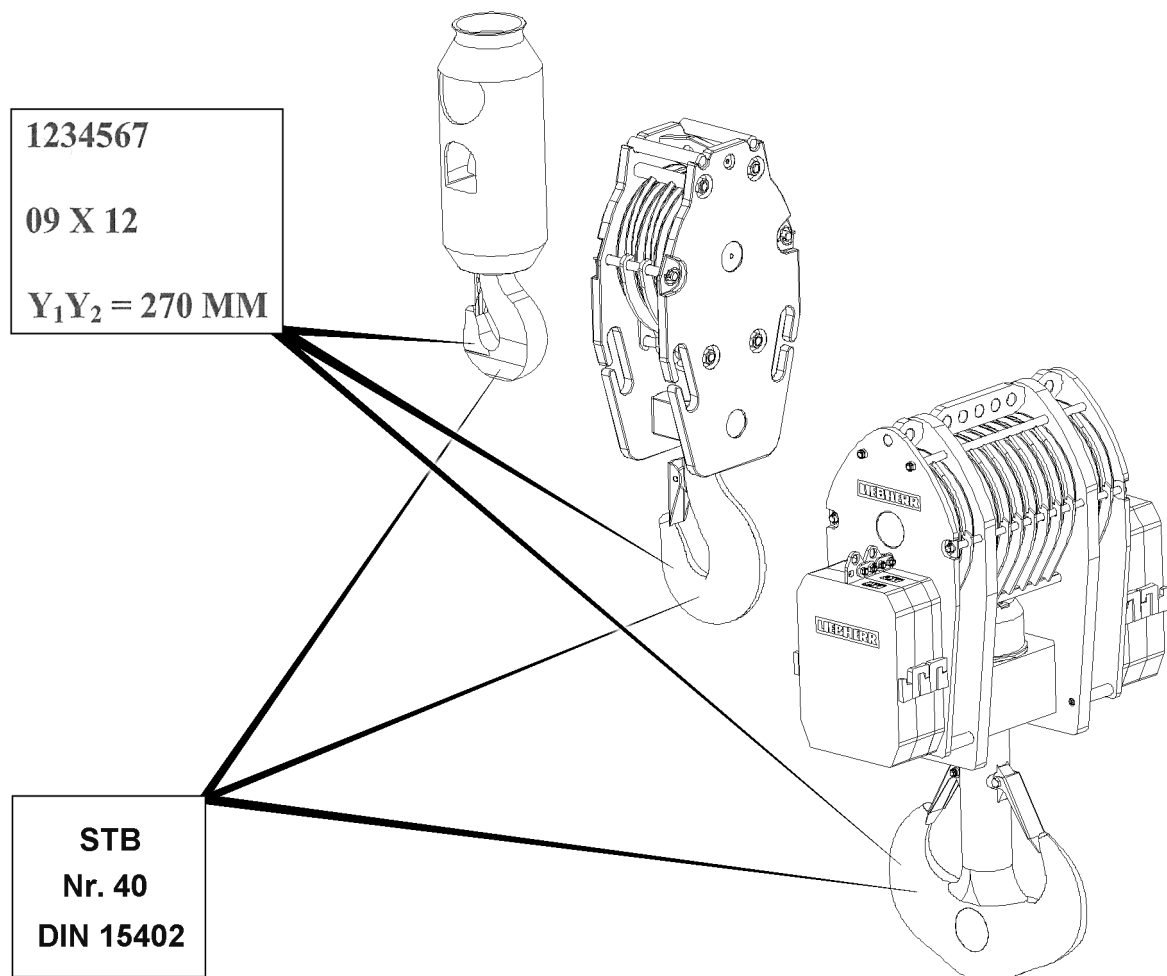


Fig.149061: Identifications on single hook or double hook

Punch mark area	Explanation
STB	Hook manufacturer
40-T	Hook number + strength class according to DIN 15 400
DIN	Hook shape according to DIN 15 401 /DIN 15 402
123456	Series or factory test number

Punch mark area	Explanation
09 X 12	Month of construction / supplier marks / year of construction
Y1Y2 = 270 mm	Dimension Y or dimension Y1 and dimension Y2 according to DIN (= Test dimensions for recurrent tests)

Identifications on single hook or double hook

### 3 Identifications on auxiliary weights

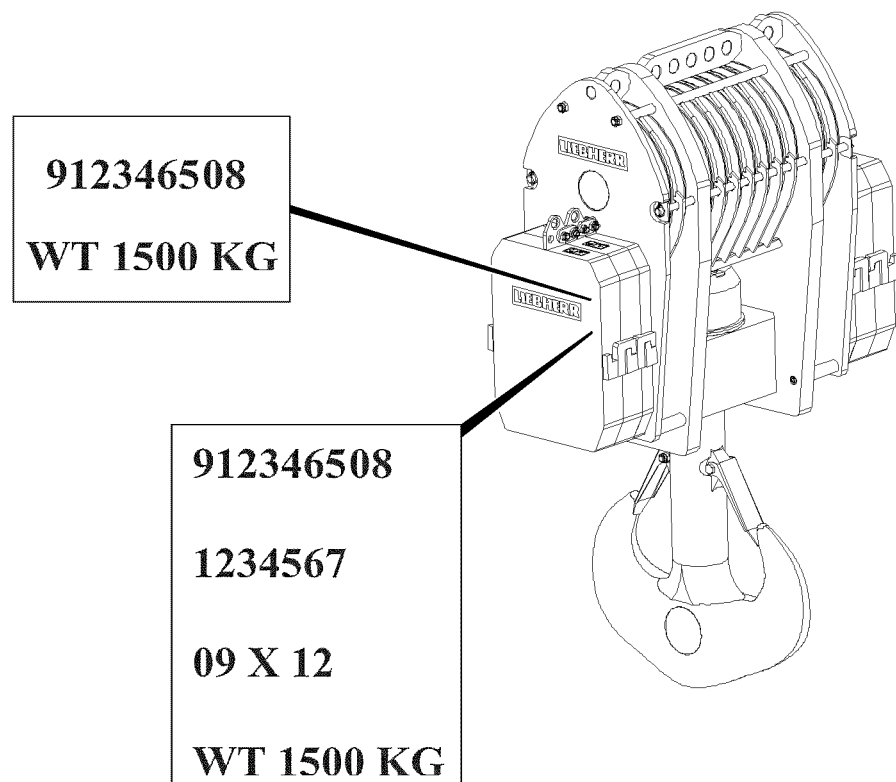


Fig.118511: Identifications on auxiliary weights



#### Note

- The own weight of the individual auxiliary weight is noted on the side on the respective auxiliary weight.

#### 3.1 Identifications on auxiliary weights at delivery

Punch mark area	Explanation
912346508	Liebherr ID no.
WT 1500 Kg	WT (Weight Tare) = Own weight of individual auxiliary weight

Identifications of auxiliary weights at delivery

### 3.2 Identifications on auxiliary weights for reorder

Punch mark area	Explanation
912346508	Liebherr ID no.
123456	Series or factory test number
09 X 12	Month of construction / supplier marks / year of construction
WT 1500 Kg	WT (Weight Tare) = Own weight of individual auxiliary weight

*Identifications of auxiliary weights at reorder*

## 2.06 Fall protection equipment on the crane

1	Safety	2
2	Hook points	2
3	Safety ropes	3
4	Crawler travel gear	4
5	Turntable catwalks and railing	13
6	Additional step counterweight-bracket	24
7	H-pivot section	45
8	S-end section	49
9	D-end section	52
10	Counterweight bracket	53
11	Suspended ballast guide "V-frame"	56
12	Ballast trailer	59
13	Counterweights	79

# 1 Safety

Before accessing the crane, observe the safety instructions.

- General safety information: See chapter 2.04.
- Information regarding personal protective equipment: See chapter 2.04.
- Information regarding the use of safety ropes: See chapter 2.04.
- Information regarding the use of ladders: See chapter 2.04.10.

## 2 Hook points

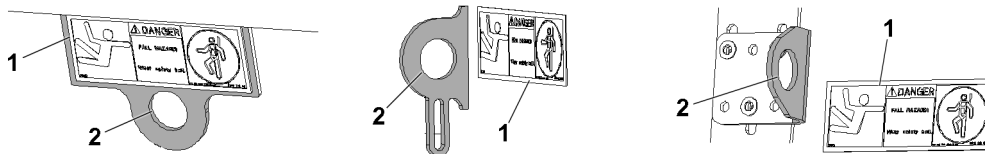


Fig.143168: Hook points shown as an example

Hook points **2** are installed on the various component groups. Assembly personnel must secure themselves to the hook points **2** to prevent falling.



Fig.128300: Sign 1 on the hook point

The hook points **2** are marked with signs **1**.



### WARNING

Assembly personnel **not** secured!  
 Assembly personnel can fall down.  
 Death, severe bodily injuries.

- ▶ Connect assembly personnel with the fall arrest system in the hook points **2** and secure them to prevent them from falling.

### NOTICE

The hook points can be ripped off!

- ▶ **Never** fasten loads or objects on the hook points.



### 3 Safety ropes

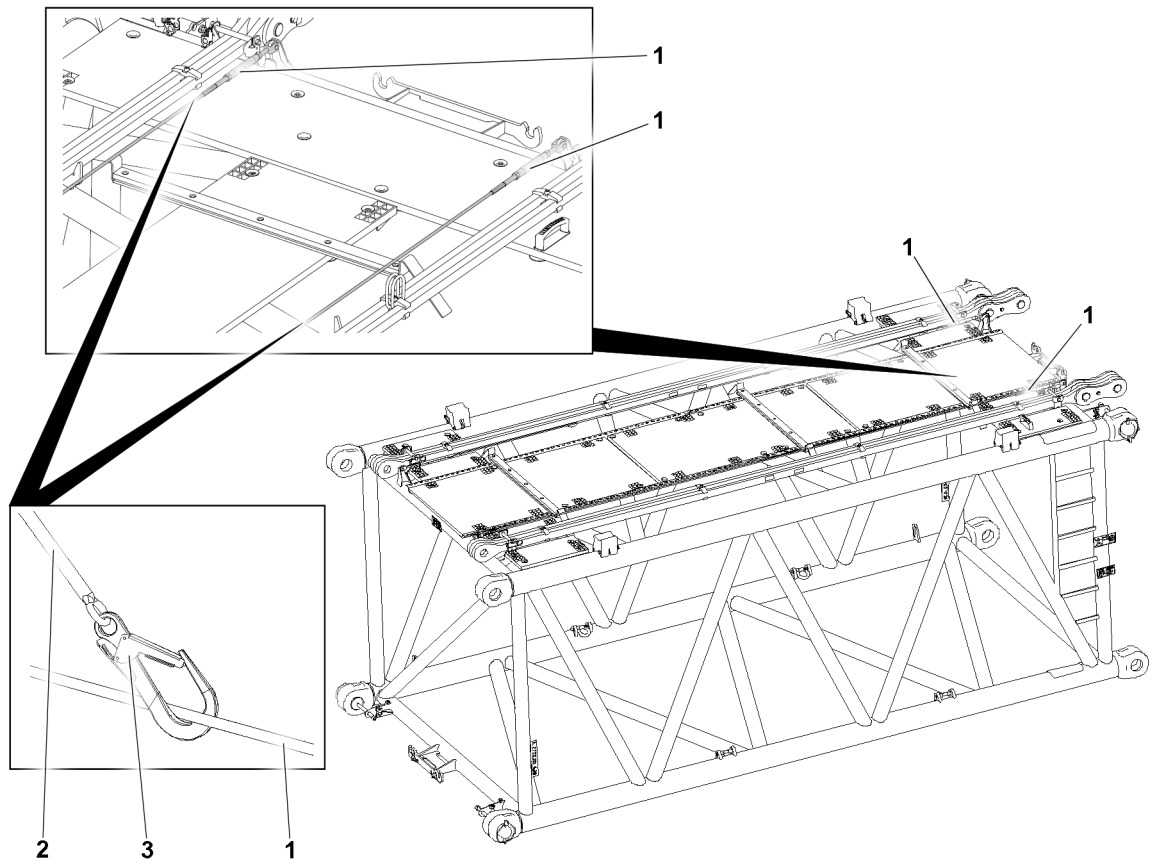


Fig.144910: Safety ropes shown as an example

If needed, the component groups with walking surfaces are equipped with safety ropes 1.

- If safety ropes 1 are present, assembly personnel must hang an approved fall arrest system 2 on the safety ropes 1 on both sides with two snap hooks 3 and secure themselves to avoid falling.
- No more than **maximum two persons** may hook themselves on the safety ropes 1 with the snap hooks 3.
- When transferring the snap hooks 3, one snap hook 3 must always be hooked on one safety rope 1.
- **Never** release both snap hooks 3 simultaneously from the safety ropes 1.



#### WARNING

Assembly personnel **not** secured!  
 Assembly personnel can fall down.  
 Death, severe bodily injuries.

- ▶ Hook assembly personnel with the fall arrest system on the safety rope 1 and secure them to prevent them from falling.

#### NOTICE

Ripping off of safety ropes!

- ▶ **Never** fasten loads or objects on the safety ropes.

**WARNING**

Danger of accident due to safety ropes strained by a fall!

If fall subjected safety ropes are not replaced after a fall, then the safety ropes can fail in case of another fall.

Death, severe bodily injury, property damage.

- ▶ **Expert personnel** must immediately replace any safety parts which were subjected in a fall and check the respective anchor points for damage.
- ▶ If the anchor points are damaged, they must be replaced immediately by **expert personnel**.
- ▶ The safety ropes and the respective anchor points may only be put into operation after a written release by **expert personnel**.

## 4 Crawler travel gear

### 4.1 Stairs

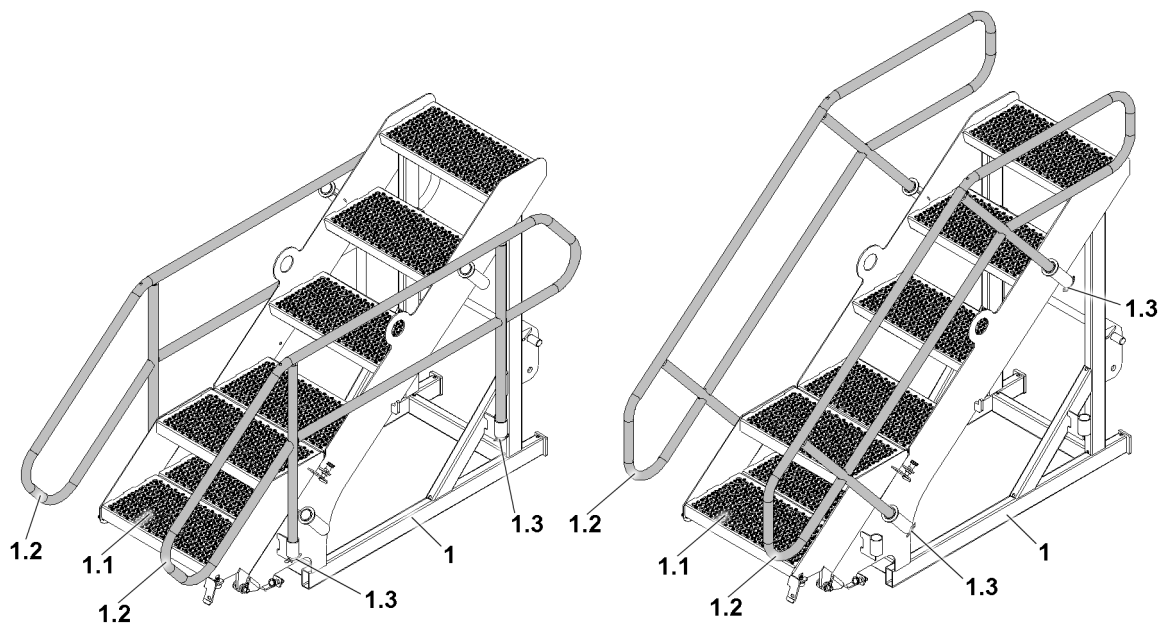


Fig.153466: Railing transport position / railing operating position

- |     |                        |     |                   |
|-----|------------------------|-----|-------------------|
| 1   | Stairs                 | 1.2 | Railing           |
| 1.1 | Stairs folding section | 1.3 | Retaining element |

**Note**

- ▶ The railings **1.2** are secured in the transport position and the operating position with a retaining element **1.3**.

### 4.1.1 Assembling the stairs

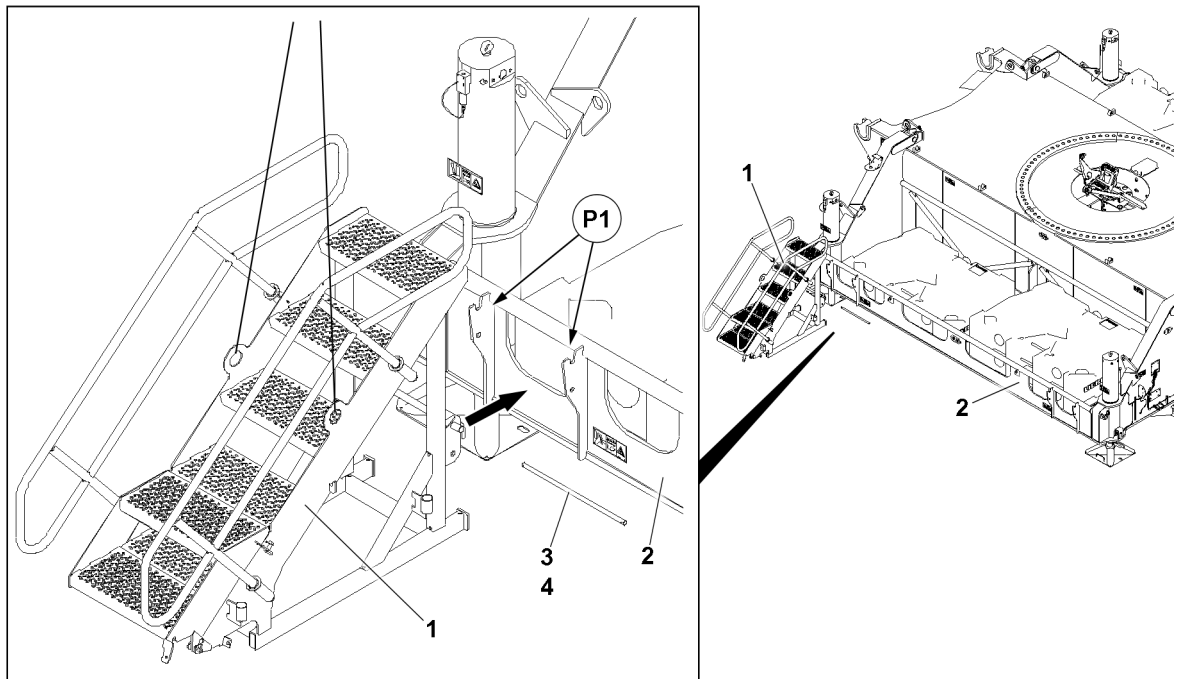


Fig.153458: Assembling the stairs



#### WARNING

Danger of crushing!

Death, severe bodily injuries, property damage.

- ▶ Make sure that there are no persons or obstacles within the danger zone when assembling the stairs.

Make sure that the following prerequisite is met:

- The central ballast brackets **2** are properly installed on the crawler center section.
- The rod **3** is unpinned on the central ballast bracket **2**.
- The railings are positioned and secured in the operating position.
- ▶ Fasten the stairs **1** to the auxiliary crane.
- ▶ Swing the stairs **1** with the auxiliary crane to the central ballast bracket **2**.

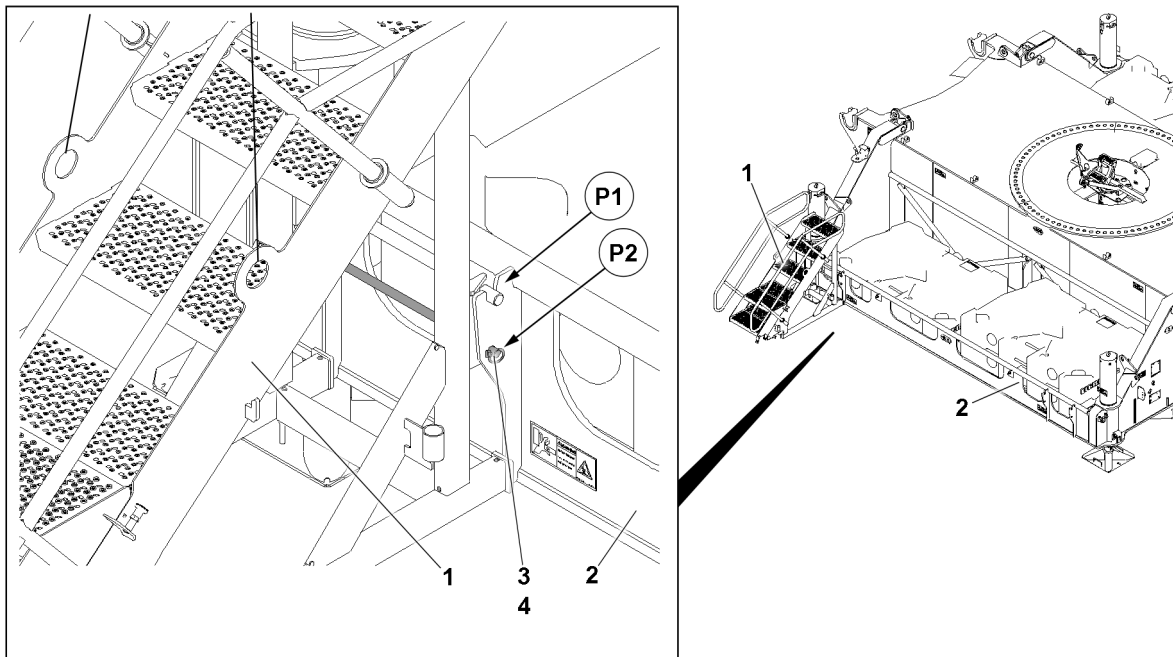


Fig.153459: Pinning the stairs



#### WARNING

Stairs **not** completely hooked!  
 Assembly personnel can fall down.  
 Death, severe bodily injuries.

- ▶ Fully connect and secure the stairs.
- ▶ Connect the stairs 1 to the central ballast bracket 2 in point P1.
- ▶ Pin the rod 3 in point P2 and secure with the retaining element 4.

#### Result:

- The stairs 1 are secured in the operating position.

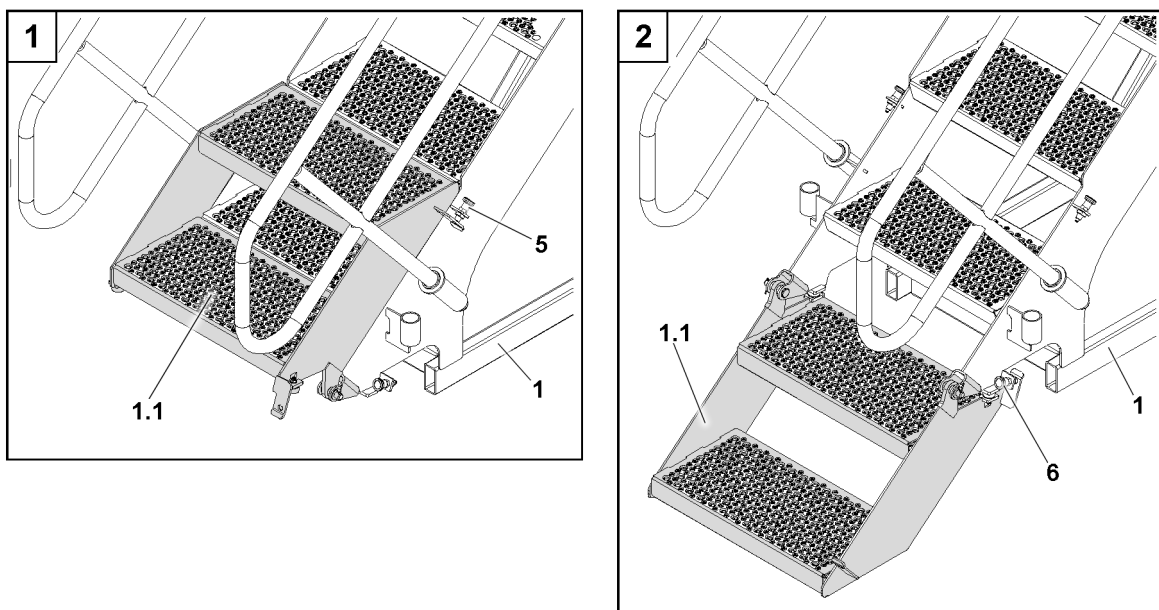


Fig.153460: Swinging the stairs folding section into the operating position

**WARNING**

Danger of crushed limbs!

When swinging the stair folding section **1.1**, fingers and hands can be crushed.

- ▶ Do not reach with your hands into the danger zone.
- 
- ▶ Pull and hold the detent pin **5**.
  - ▶ Fold the stairs folding section **1.1** down completely until the detent pin **6** engages.

**Result:**

- The stairs folding section **1.1** is in the operating position.

#### 4.1.2 Disassembling the stairs

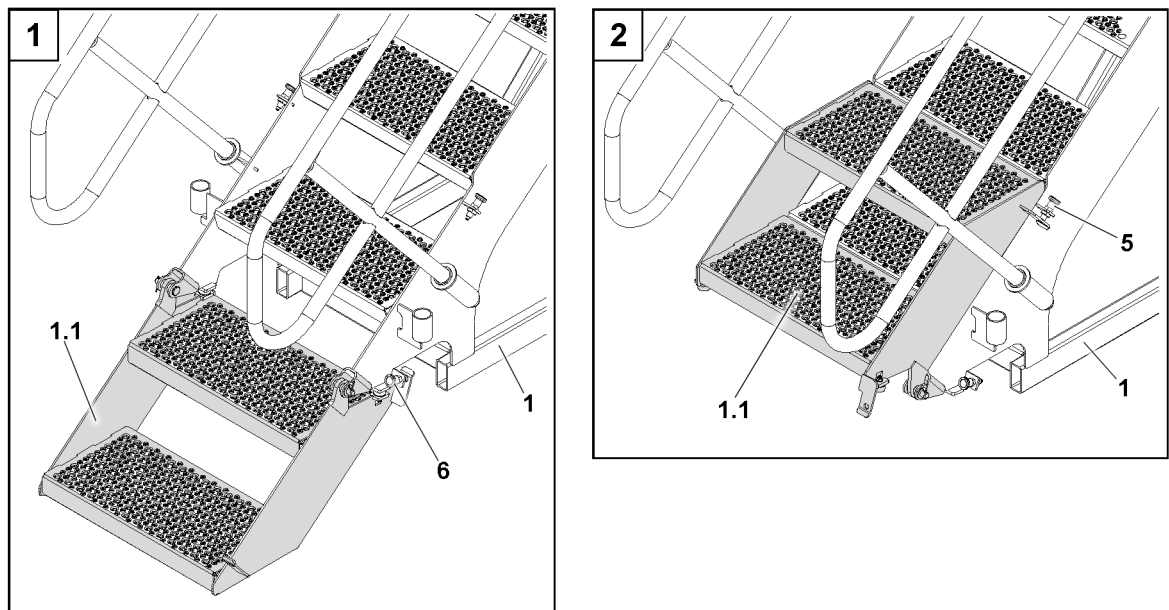


Fig.153461: Swinging the stair folding section into transport position

**WARNING**

Danger of crushing!

Death, severe bodily injuries, property damage.

- ▶ Make sure that there are no persons or obstacles within the danger zone when removing the stairs.

**WARNING**

Danger of crushed limbs!

When swinging the stair folding section **1.1**, fingers and hands can be crushed.

- ▶ Do not reach with your hands into the danger zone.
- 
- ▶ Pull and hold the detent pin **6**.
  - ▶ Fold the stairs folding section **1.1** up completely until the detent pin **5** engages.

**Result:**

- The stairs folding section **1.1** is in the transport position.

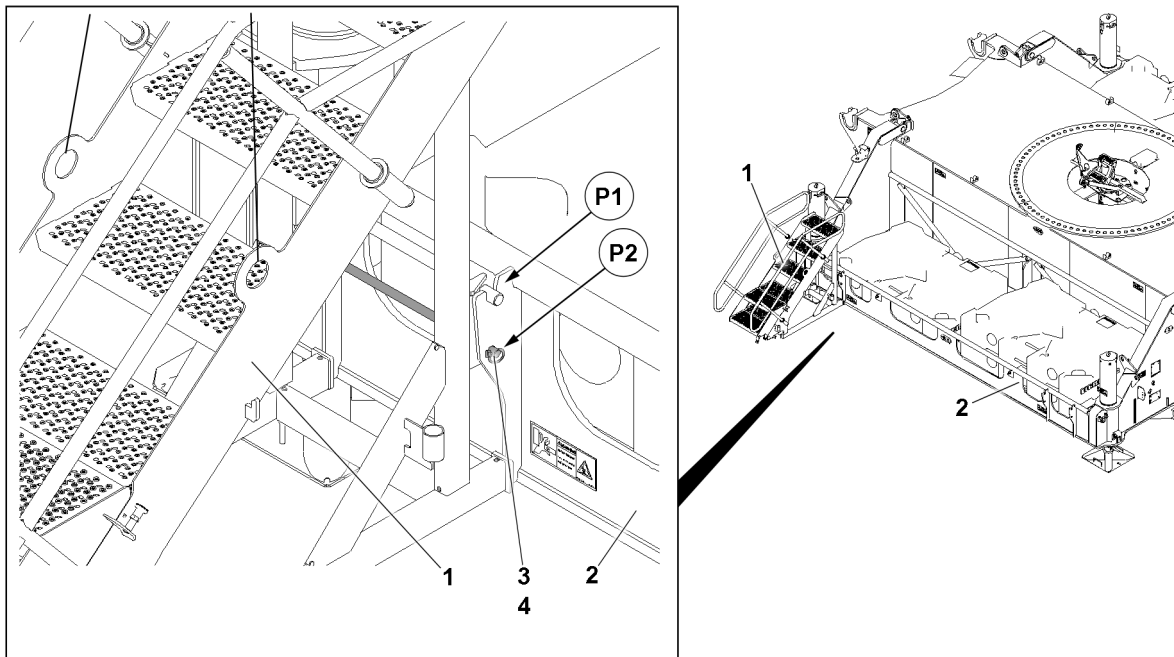


Fig.153459: Unpinning the stairs

- ▶ Fasten the stairs 1 to the auxiliary crane.
- ▶ Unpin the rod 3 in point P2.

**Result:**

- The stairs 1 are released.

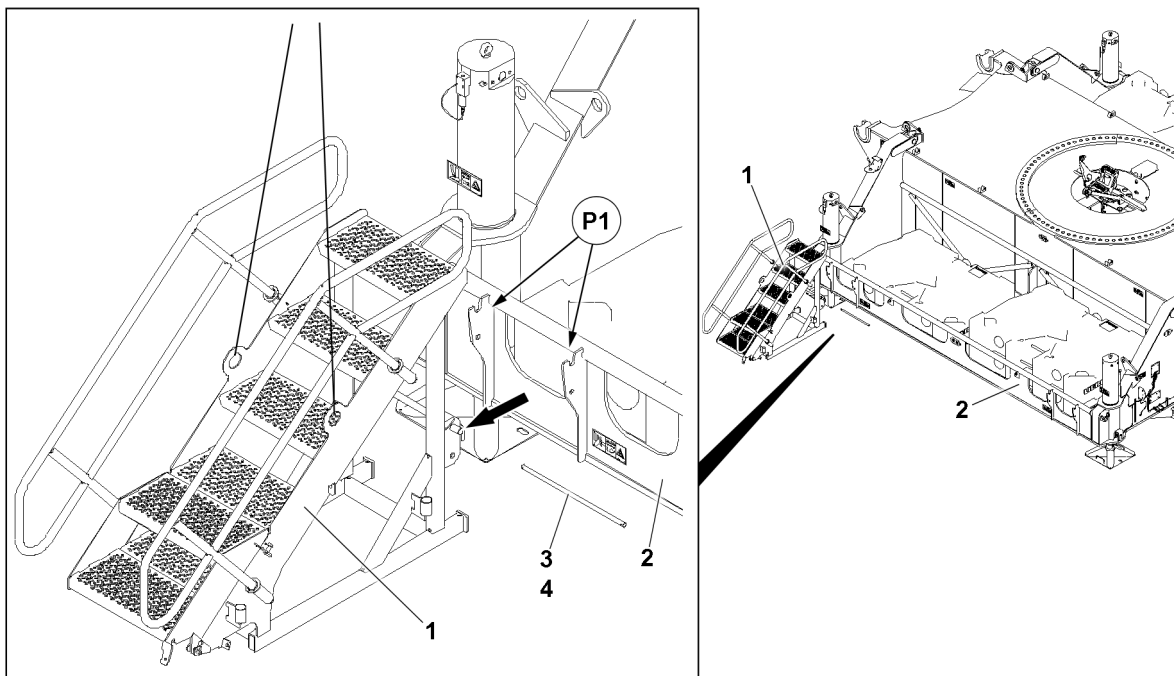


Fig.153462

- ▶ Lift the stairs 1 with the auxiliary crane.

When the stairs on the central ballast bracket 2 are disconnected in point P1:

- ▶ Swing out and take down the stairs 1 with the auxiliary crane.

## 4.2 Catwalk

### 4.2.1 Assembling the catwalks

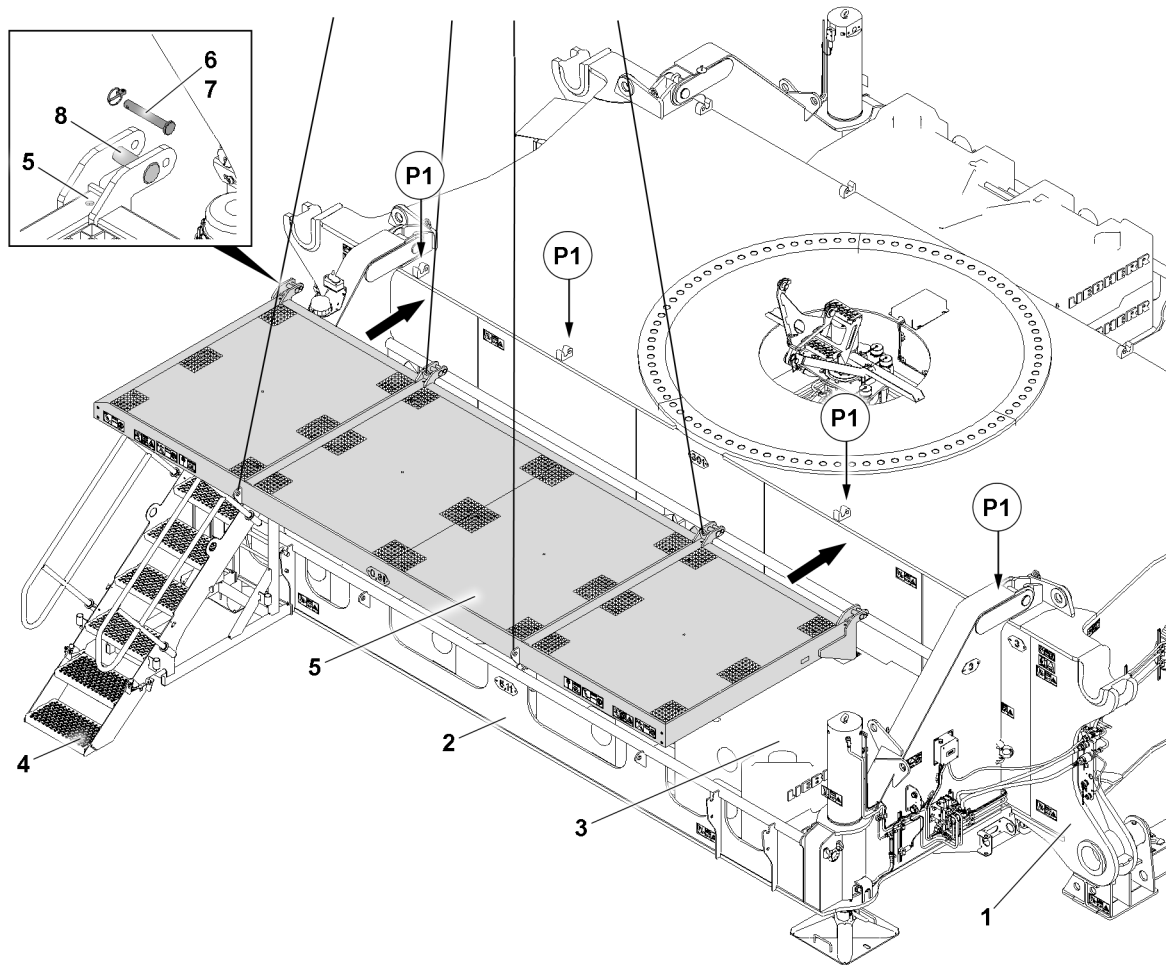


Fig.153463: Assembling the catwalk



#### WARNING

Danger of falling!

During assembly and disassembly of the catwalks, assembly personnel must be secured with appropriate aids to prevent them from falling.

Even during the assembly of protective devices there is a danger of falling.

Death, severe injury, property damage.

- ▶ Hang the personal protective equipment on the provided safety ropes.
- ▶ Keep a safety distance to edges.

Make sure that the following prerequisites are met:

- The central ballast brackets **2** are properly installed on the crawler center section.
- The central ballast **3** is placed according to the erection and take-down chart.
- The stairs **4** are properly assembled on the central ballast bracket **2**.
- Access is established to the crawler center section **1** via the leaning ladder, see chapter 2.07.
- ▶ Unpin the retaining pin **6** on the catwalk **5**.
- ▶ Fasten the catwalk **5** to the auxiliary crane.

**WARNING**

Danger of crushing!

Death, severe injury, property damage.

- ▶ Make sure that there are no persons or obstacles in the danger zone when swinging the catwalks in.
- 
- ▶ Swing the catwalk **5** in with the auxiliary crane to the crawler center section **1**.

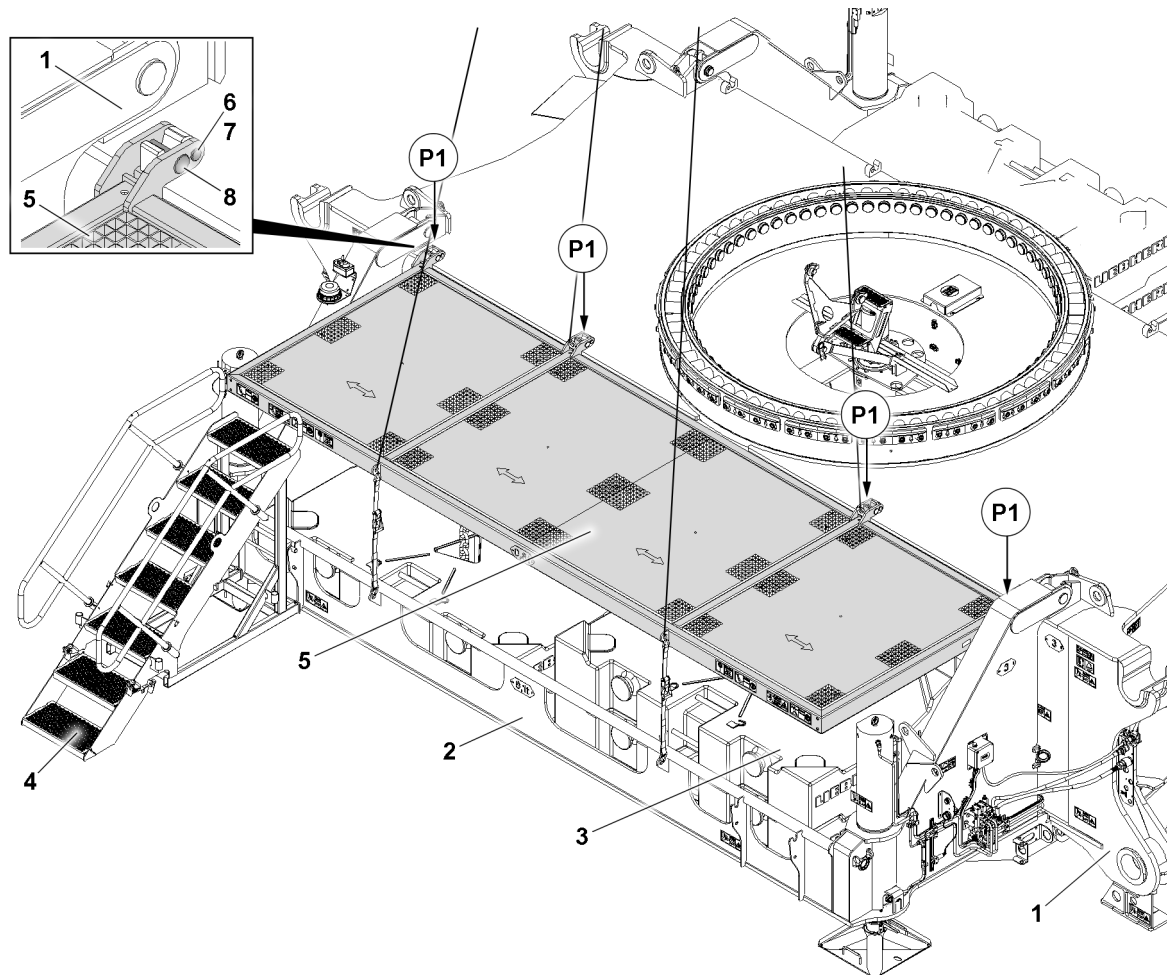


Fig.153464: Pinning the catwalk

- ▶ Connect the catwalk **5** with the hook pins **8** to the hooks on the crawler center section **1**.

When the catwalk **5** is properly connected:

- ▶ Insert the retaining pin **6** in all pin points **P1** and secure with the retaining element **7**.

**Result:**

- The catwalk **5** is properly assembled and secured.
- ▶ Remove the fastening equipment on the first catwalk **5**.

**Note**

- ▶ The assembly of the second catwalk is identical to the assembly procedure of the first catwalk.
- ▶ Assemble the second catwalk.
- ▶ Secure the catwalks with safety belts to the central ballast brackets **2**, see chapter 3.03.



## 4.2.2 Disassembling the catwalks

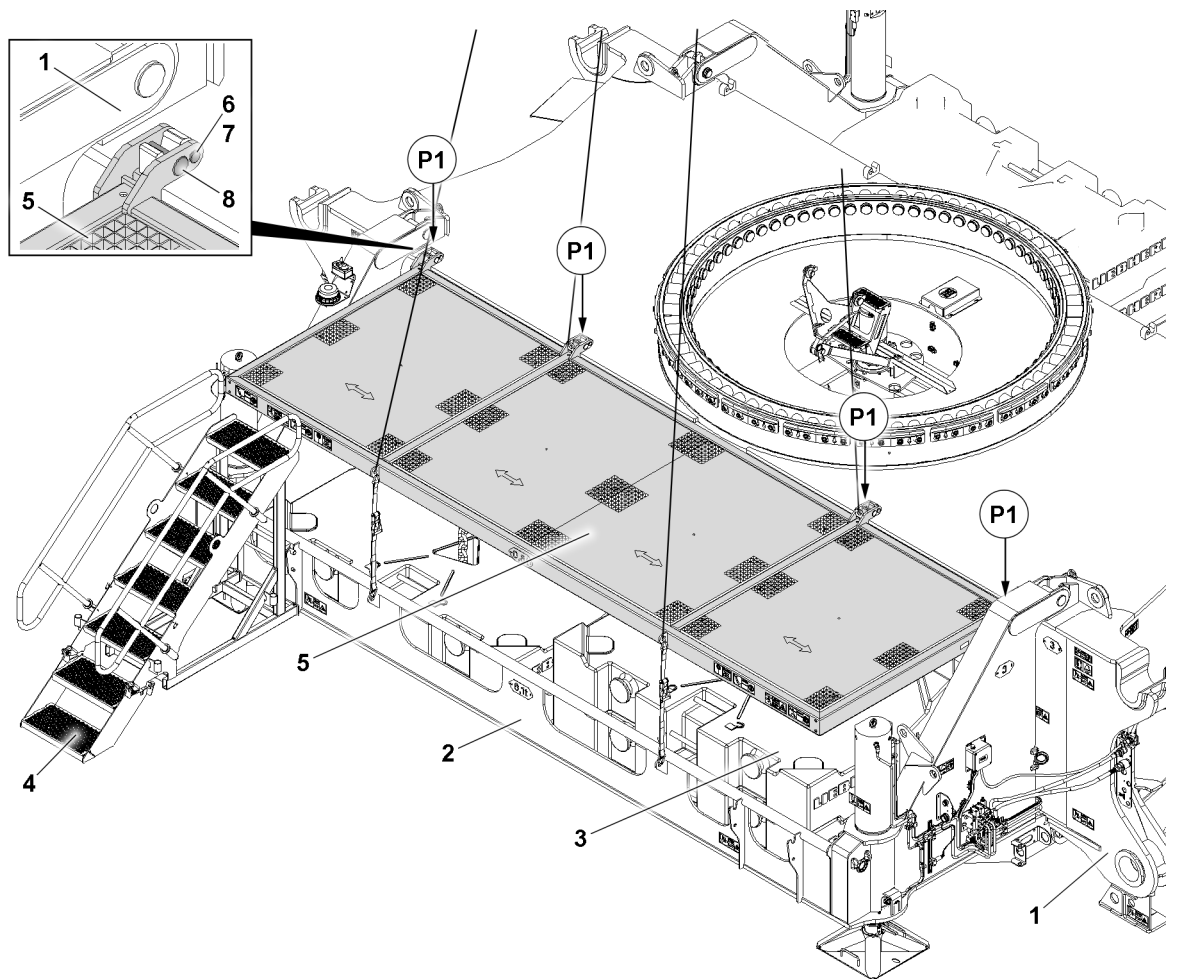


Fig.153464: Unpinning the catwalks



### WARNING

Danger of falling!

During assembly and disassembly of the catwalks, assembly personnel must be secured with appropriate aids to prevent them from falling.

Even during the assembly of protective devices there is a danger of falling.

Death, severe injury, property damage.

- ▶ Hang the personal protective equipment on the provided safety ropes.
- ▶ Keep a safety distance to edges.

Make sure that the following prerequisites are met:

- Safety belts are removed on the central ballast brackets **2**, see chapter 3.03.
- Access is established to the crawler center section **1** via the leaning ladder, see chapter 2.07.
- ▶ Fasten the catwalk **5** to the auxiliary crane.
- ▶ Tension the fastening equipment carefully using the auxiliary crane.
- ▶ Remove the retaining element **7** and unpin the retaining pins **6** in all pin points **P1**.

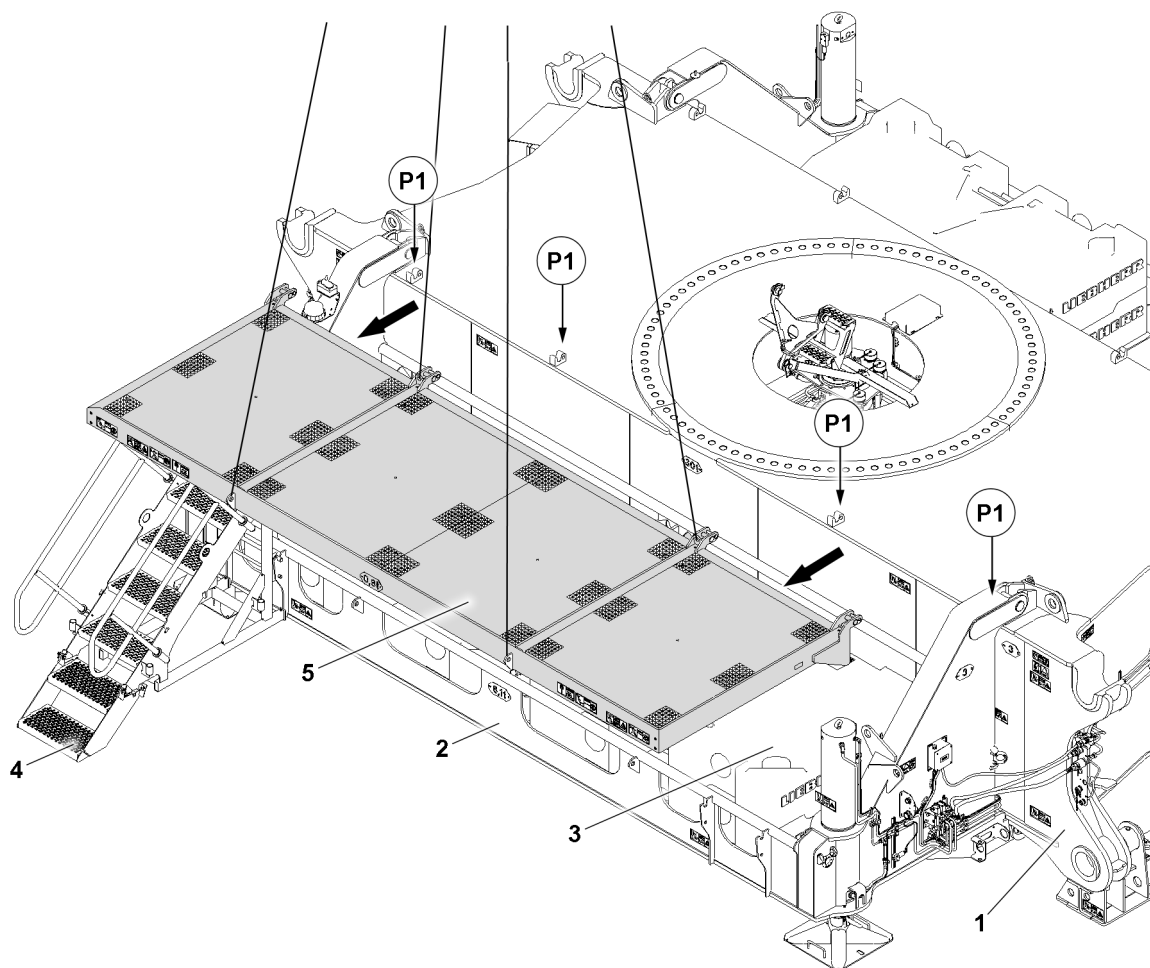


Fig.153465: Swinging the catwalk out



### WARNING

Danger of crushing!

Death, severe injury, property damage.

- ▶ Make sure that there are no persons or obstacles in the danger zone when swinging the catwalks out.

- ▶ Lift the catwalk **5** with the auxiliary crane and swing it out.
- ▶ Take the catwalk **5** down onto a load bearing substructure.
- ▶ Remove the fastening equipment on the first catwalk **5**.



### Note

- ▶ The procedure for the disassembly of the second catwalk is identical to the procedure for the first catwalk.
- ▶ Disassemble the second catwalk.

## 5 Turntable catwalks and railing



### WARNING

Danger of falling during the assembly and disassembly of the protective equipment and / or the fall protection equipment!

Death, severe bodily injuries, property damage.

- ▶ Use suitable and approved aids, such as working platforms.
- ▶ The assembly personnel must secure themselves during assembly and disassembly work with suitable aids to prevent them from falling.
- ▶ Use personal protective equipment.

### 5.1 Crane cab railing



### WARNING

Danger of accident due to incorrect assembly of the railings!

The railings can suddenly fold down.

Death, severe bodily injuries, property damage.

- ▶ Pin and secure the railing in the operating position.



### WARNING

Danger of accident due to non-assembled railings!

Assembly personnel can fall down.

Death, severe bodily injuries, property damage.

- ▶ Use suitable and approved aids, such as working platforms or lifting platforms.
- ▶ Secure assembly personnel with a fall arrest system to prevent falling.

#### 5.1.1 Railing in the crane cab transport retainer

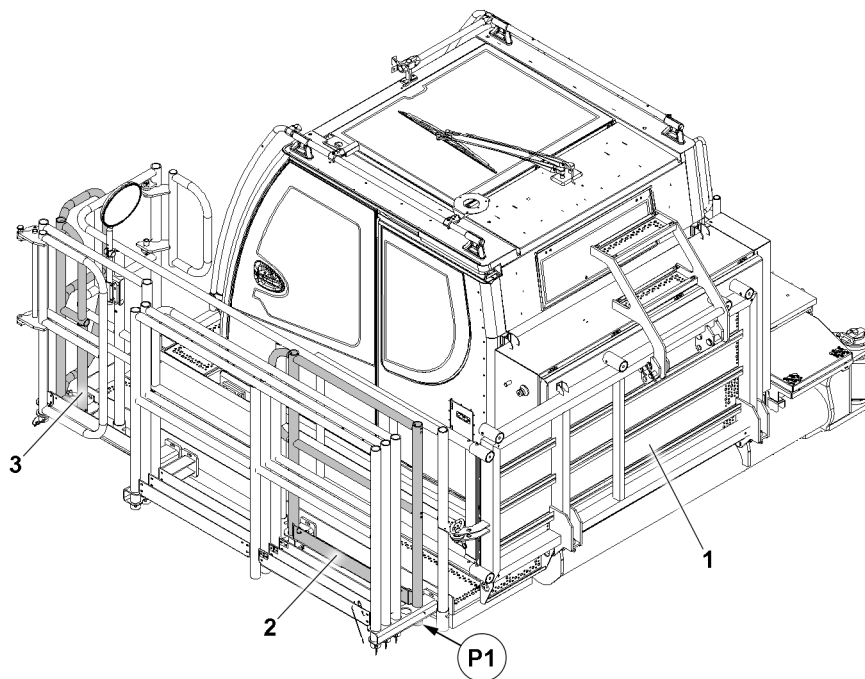


Fig.153480: Railing in the transport retainer

- 1 Catwalk
- 2 Railing

- 3 Railing

### 5.1.2 Assembling the railing on the crane cab

Make sure that the following prerequisites are met:

- The turntable is on the flatbed trailer.
- Appropriate aids, such as scaffolding or a work platform are available.
- The ladder is installed and secured in the operating position.
- The crane cab is assembled and secured in the operating position, see chapter 4.03.
- The catwalk **1** is assembled and secured in the operating position, see chapter 4.03.
- The railings are secured in the transport receptacle in position **P1**.

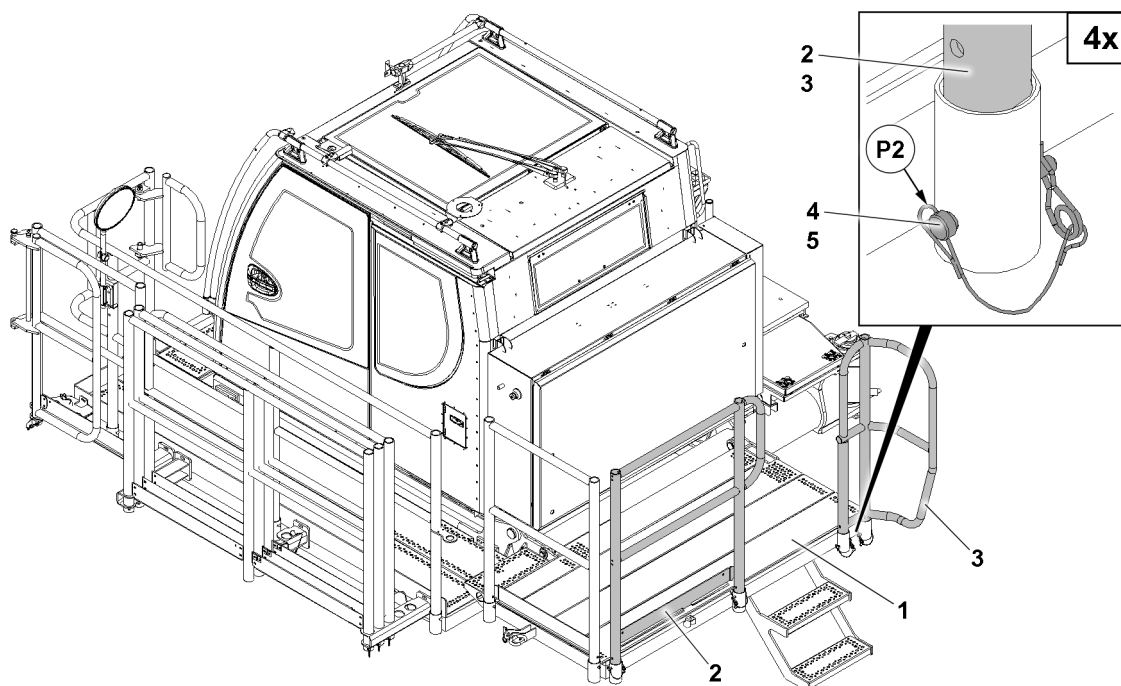


Fig.153481: Assembling the railing on the crane cab

- ▶ Remove the railing **2** from the transport retainer.
- ▶ Connect the railing **2** in position **P2** on the crane cab catwalk **1**.
- ▶ Secure the railing **2** in position **P2** with the pin **4** and the retaining element **5**.
- ▶ Remove the railing **3** from the transport retainer.
- ▶ Connect the railing **3** in position **P2** on the crane cab catwalk **1**.
- ▶ Secure the railing **3** in position **P2** with the pin **4** and the retaining element **5**.

## 5.2 Assembling the catwalks in the operating position

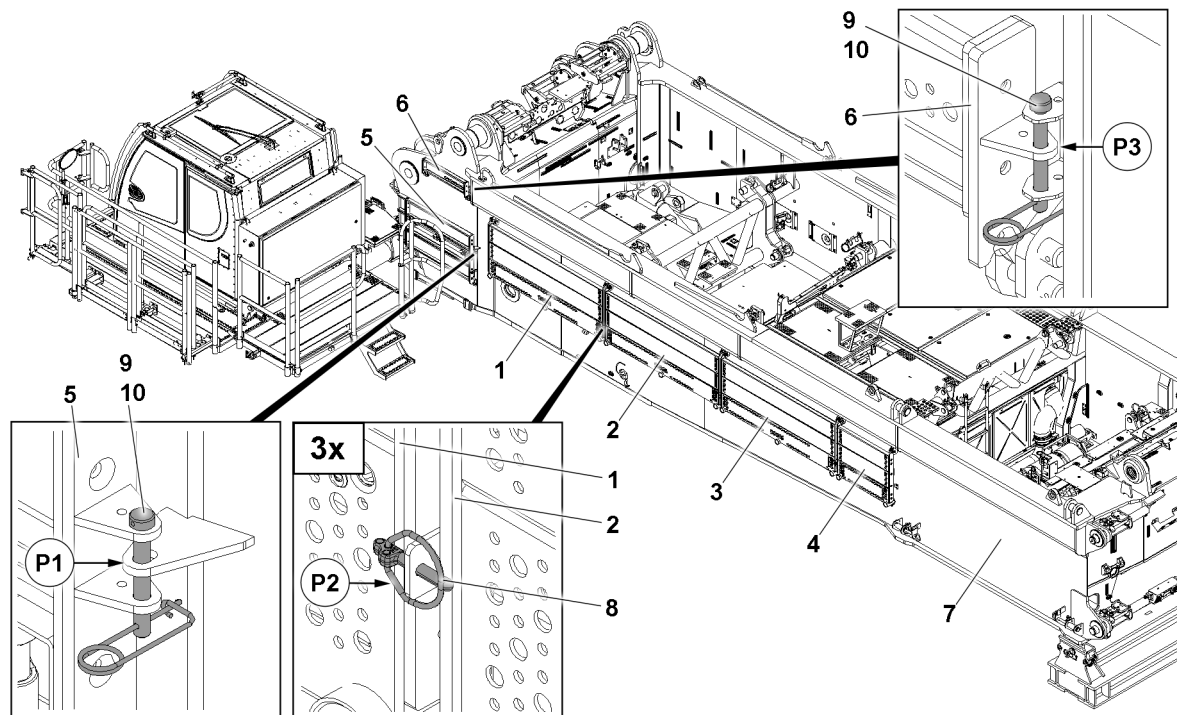


Fig.153482: Releasing the catwalks



### WARNING

Danger of accident due to incorrect assembly of the catwalks!  
The catwalks can suddenly fold down.  
Death, severe bodily injuries, property damage.

- ▶ Pin and secure the catwalks in the operating position.



### WARNING

Swinging components due to the release of the transport retainer!  
Death, severe bodily injuries, property damage.

- ▶ Hold components, for example the catwalk, in position after releasing from the transport retainer.
- ▶ Hold components, for example the ladder, in position after releasing from the transport retainer.
- ▶ Hold components, for example the support, in position after releasing from the transport retainer.
- ▶ Guide the components to the operating position and secure.



### Note

- ▶ Carry out the assembly of the catwalks **5** starting with the catwalk from the “front” to the “rear”.

Make sure that the following prerequisites are met:

- The turntable is on the flatbed trailer.
- Appropriate aids, such as scaffolding or a work platform are available.
- ▶ Release the catwalk **5** in the transport position in position **P1**: Loosen the pin **9** and retaining element **10**.
- ▶ Fold down the catwalk **5**.
- ▶ Release the catwalk **1**, catwalk **2**, catwalk **3** and catwalk **4** in the transport position (**3x**) in position **P2**: Release the retaining element **8**.
- ▶ Release the catwalk **6** in the transport position in position **P3**: Loosen the pin **9** and retaining element **10**.
- ▶ Fold down the catwalk **6**.

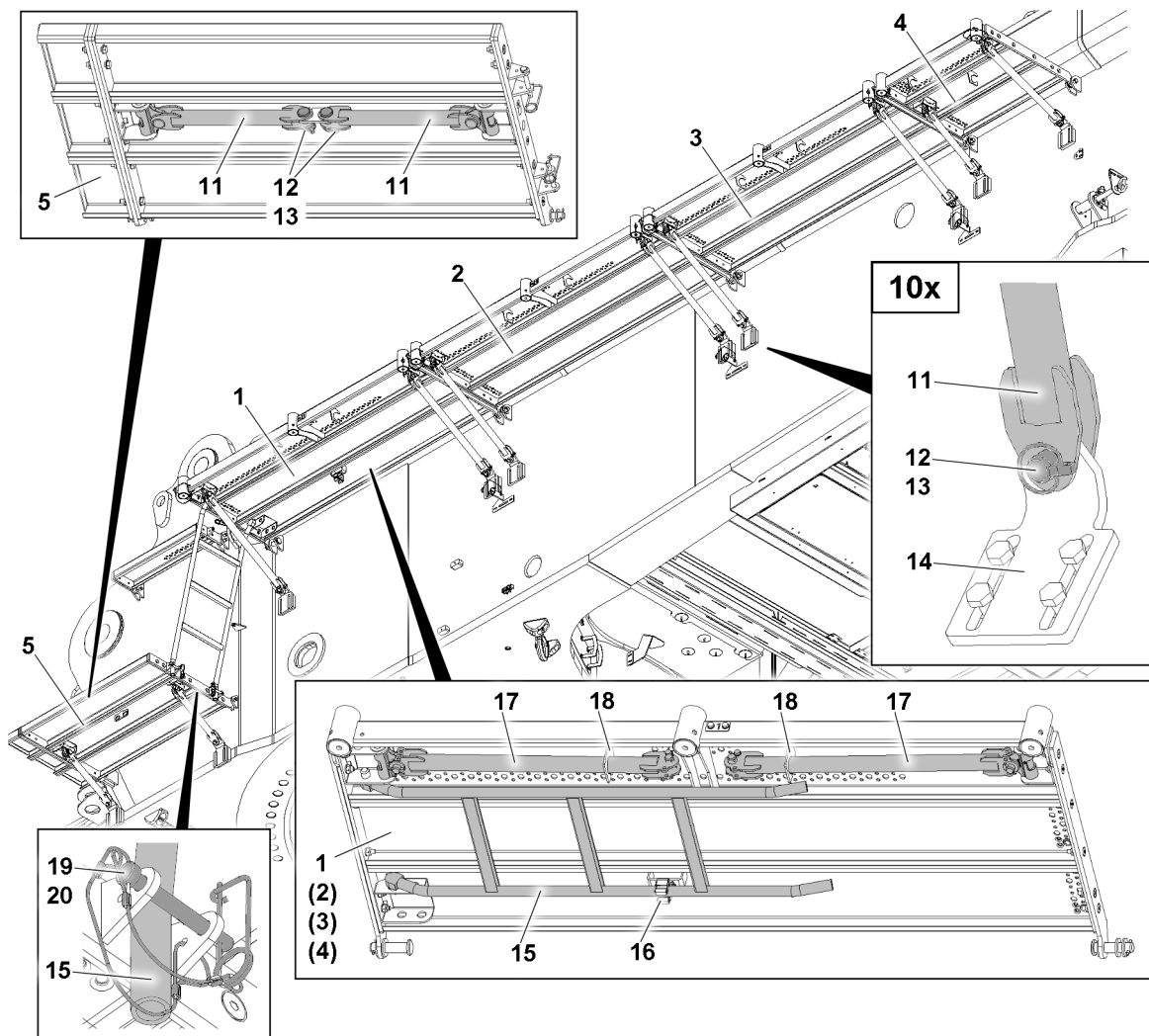


Fig.153483: Assembling the catwalks

Assemble the catwalk **5**.

- ▶ Remove the support **11** from the transport retainers: Remove the retaining element **13** and unpin the pin **12**.
- ▶ Secure the supports **11** on both sides to the retaining plate **14** with the pin **12** and the retaining element **13**.

Assemble the catwalk **1**.

- ▶ Release the ladder **15** on the underside of the catwalk **2** from the clamp mounting **16**.
- ▶ Remove the support **17** from the transport retainers **18**.
- ▶ Secure the supports **17** on both sides to the retaining plate **14** with the pin **12** and the retaining element **13**.
- ▶ Fasten the ladder **15** to the catwalk **5**: Insert the pin **19** on both sides and secure with the retaining element **20**.

Assemble the catwalk **2**, catwalk **3** and catwalk **4**.

- ▶ Remove the support **17** from the transport retainers **18**.
- ▶ Secure the supports **17** on both sides to the retaining plate **14** with the pin **12** and the retaining element **13**.

Assemble the catwalk **6**.

- ▶ The catwalk **6** is in the operating position after folding down.

### 5.3 Assembling the catwalks in the transport position



#### WARNING

Danger of accident due to incorrect disassembly of the catwalks!  
The catwalks can suddenly fold down.  
Death, severe bodily injuries, property damage.  
▶ Properly pin and secure the catwalks in the transport position.



#### WARNING

Swinging components due to releasing!  
Death, severe bodily injuries, property damage.  
▶ Hold components, for example the catwalk, in position after releasing.  
▶ Hold components, for example the ladder, in position after releasing.  
▶ Hold components, for example the support, in position after releasing.  
▶ Guide the components into the transport position and secure.



#### Note

▶ Carry out the disassembly of the catwalks starting with the catwalk 4 from the "rear" to the "front".

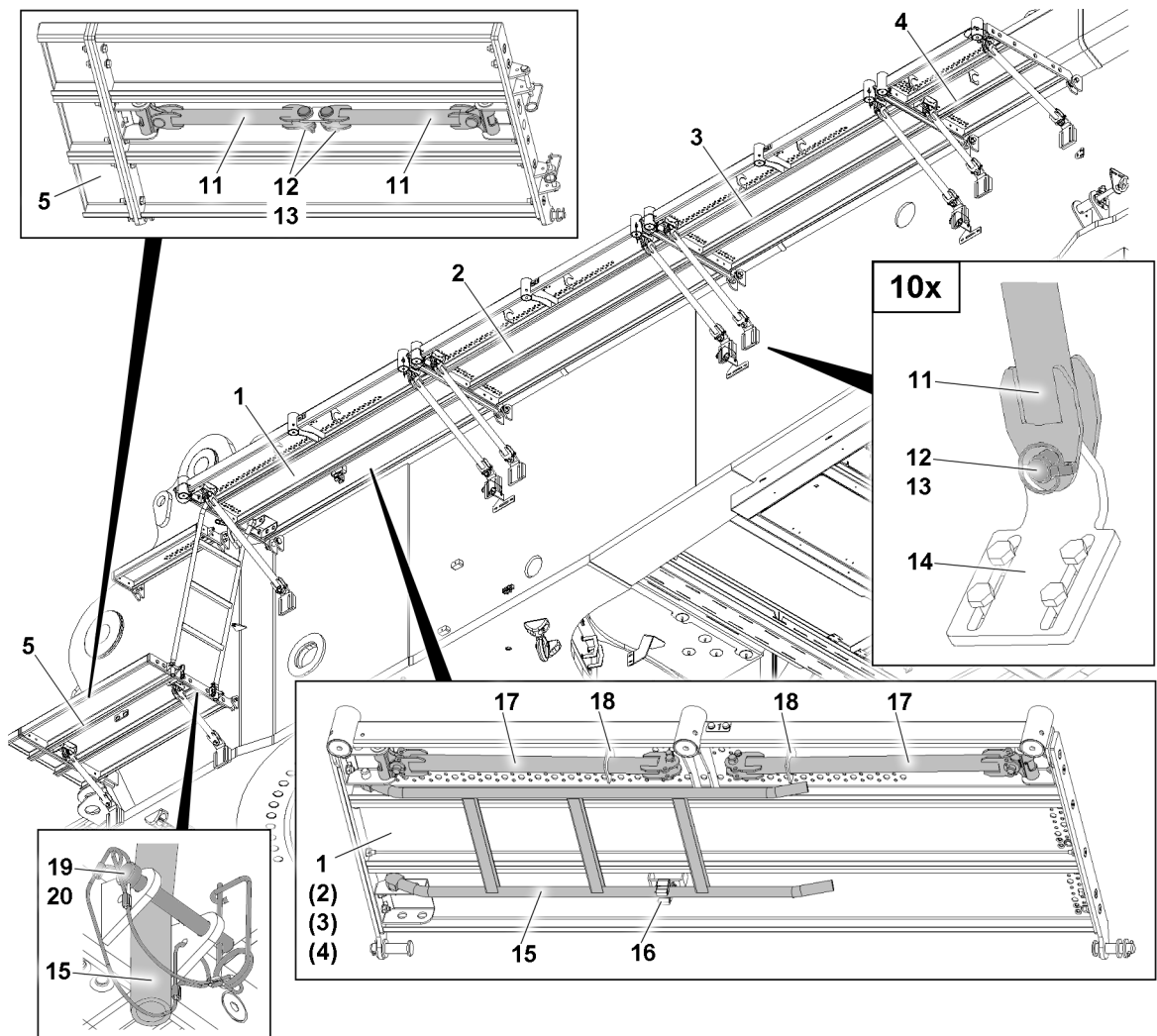


Fig.153483: Disassembling the catwalks

Disassemble the catwalk 4, catwalk 3 and catwalk 2.

▶ Release the supports 11 on the retaining plate 14 and place in the transport retainer 18.

- ▶ Fold down and secure the catwalks, see illustration “Securing the catwalks”.

Disassemble the catwalk 1.

- ▶ Release the ladder 15 from the catwalk 5: Loosen the pin 19 and retaining element 20.
- ▶ Release the supports 11 on the retaining plate 14 and place in the transport retainer 18.
- ▶ Clamp the ladder 15 in the clamp mounting 16.
- ▶ Fold down and secure the catwalk 1, see illustration “Securing the catwalks”.

Disassembling the catwalk 5

- ▶ Release the supports 11 on the retaining plate 14 and place in the transport retainer 18.
- ▶ Fold up and secure the catwalk 5, see illustration “Securing the catwalks”.

Disassemble the catwalk 6.

- ▶ Fold up and secure the catwalk 6, see illustration “Securing the catwalks”.

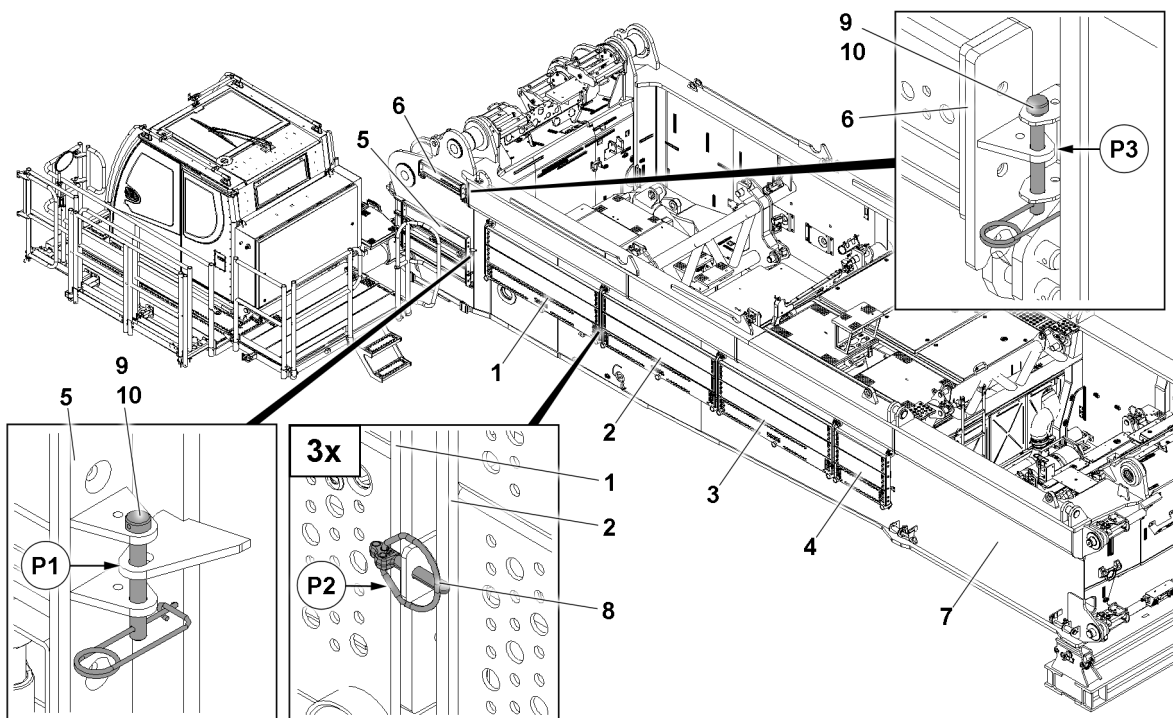


Fig.153482: Securing the catwalks

- ▶ Secure the catwalk 5 in the transport position in position P1: Insert the pin 9 and secure with the retaining element 10.
- ▶ Secure the catwalk 1, catwalk 2, catwalk 3 and catwalk 4 in the transport position (3x) in position P2: Attach the retaining element 8.
- ▶ Secure the catwalk 6 in the transport position in position P3: Insert the pin 9 and secure with the retaining element 10.

## 5.4 Catwalk railing



### WARNING

Danger of accident due to incorrect assembly of the railings!

The railings can suddenly fold down.

Death, severe bodily injuries, property damage.

- ▶ Pin and secure the railing in the operating position.



**WARNING**

Danger of accident due to non-assembled railings!

Assembly personnel can fall down.

Death, severe bodily injuries, property damage.

- ▶ Use suitable and approved aids, such as working platforms or lifting platforms.
- ▶ Secure assembly personnel with a fall arrest system to prevent falling.

**Note**

- ▶ Railings are marked with signs **5**, see image "Railing in the transport retainer".
- ▶ The numbering on the railings must be identical to the numbering on the catwalks.

### 5.4.1 Railing in the transport retainer

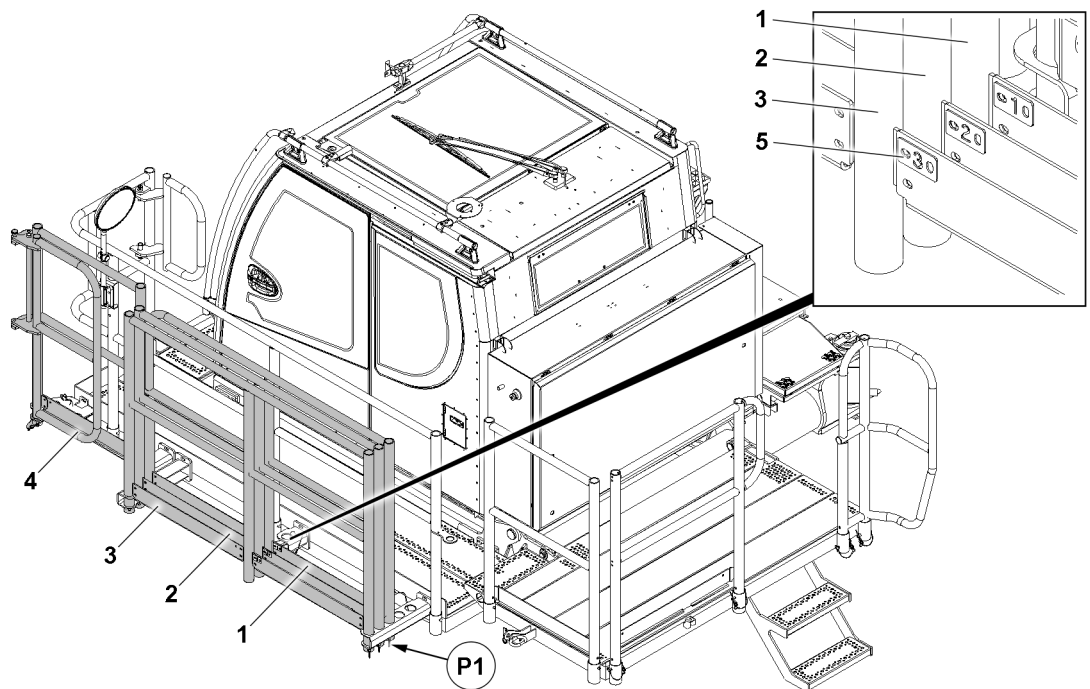


Fig.153484: Railing in the transport retainer

- |           |           |
|-----------|-----------|
| 1 Railing | 4 Railing |
| 2 Railing | 5 Sign    |
| 3 Railing |           |

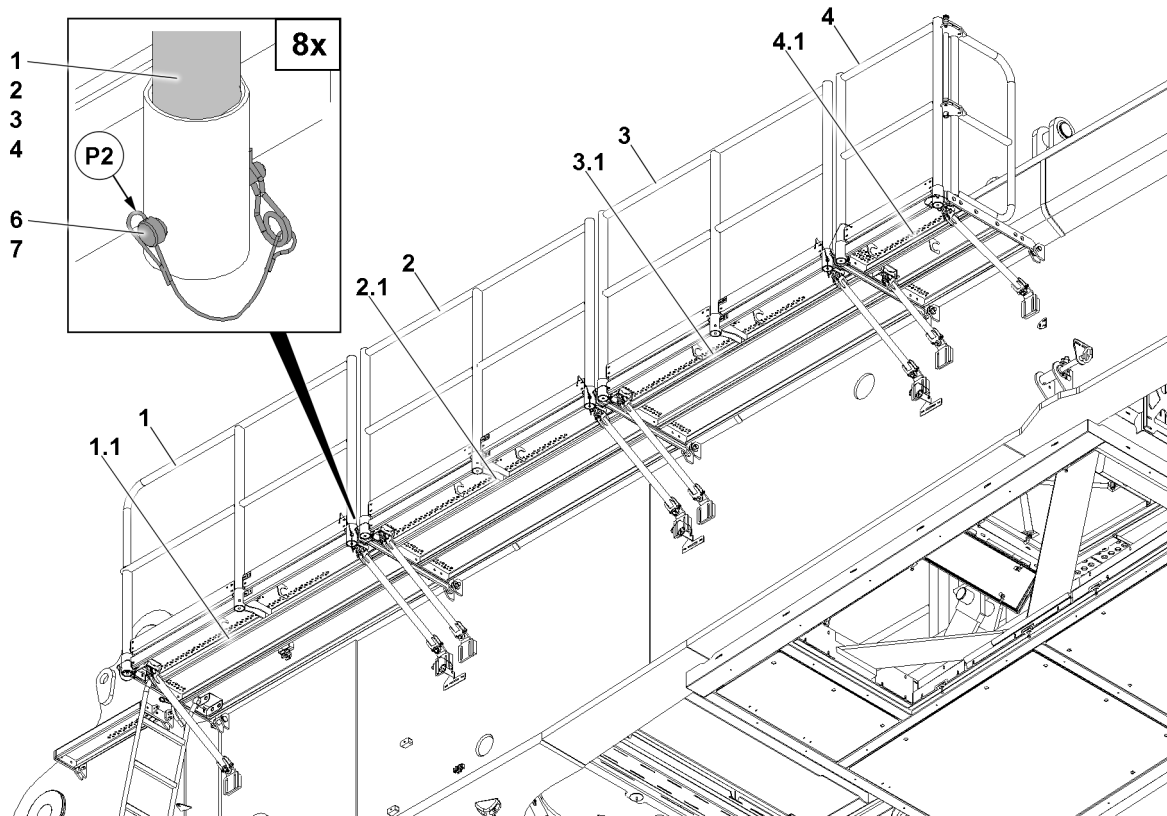
### 5.4.2 Assembling the railing in the operating position

Make sure that the following prerequisites are met:

- The railings are secured in the transport receptacle in position **P1**.
- The catwalks on the turntable are assembled and secured in the operating position.

**Note**

- ▶ Start disassembling the railings with the catwalk **1.1**.



*Fig.153485: Assembling the railings in the operating position*

Assemble the railing **1** on the catwalk **1.1**:

- ▶ Connect the railing **1** in position **P2** in the catwalks **1.1**.
- ▶ Secure the railing **1** in position **P2** with the pin **6** and the retaining element **7**.

Assemble the railing **2** on the catwalk **2.1**:

- ▶ Connect the railing **2** in position **P2** in the catwalk **2.1**.
- ▶ Secure the railing **2** in position **P2** with the pin **6** and the retaining element **7**.

Assemble the railing **3** on the catwalk **3.1**:

- ▶ Connect the railing **3** in position **P2** in the catwalk **3.1**.
- ▶ Secure the railing **3** in position **P2** with the pin **6** and the retaining element **7**.

Assemble the railing **4** on the catwalk **4.1**:

- ▶ Connect the railing **4** in position **P2** in the catwalk **4.1**.
- ▶ Secure the railing **4** in position **P2** with the pin **6** and the retaining element **7**.

### 5.4.3 Assembling the railing in the transport position

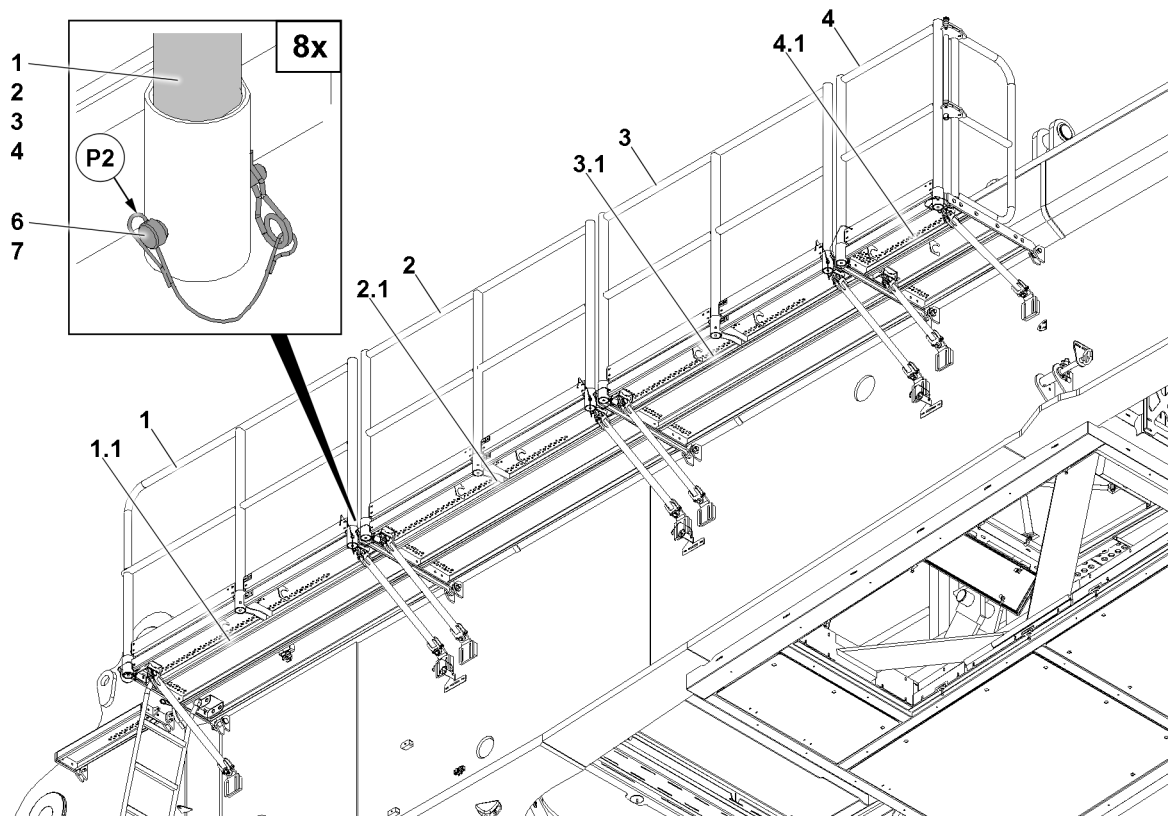


Fig.153485: Assembling the railings in the operating position



#### Note

- ▶ Start disassembling the railing with the catwalk 4.1.

Bring the railing 4 into the transport position:

- ▶ Release the railing 4 in position P2.
- ▶ Insert the railing 4 in the transport retainer on the cab, see image "Railing in the transport retainer".

Bring the railing 3 into the transport position:

- ▶ Release the railing 3 in position P2.
- ▶ Insert the railing 3 in the transport retainer on the cab, see image "Railing in the transport retainer".

Bring the railing 2 into the transport position:

- ▶ Release the railing 2 in position P2.
- ▶ Insert the railing 2 in the transport retainer on the cab, see image "Railing in the transport retainer".

Bring the railing 1 into the transport position:

- ▶ Release the railing 1 in position P2.
- ▶ Insert the railing 1 in the transport retainer on the cab, see image "Railing in the transport retainer".

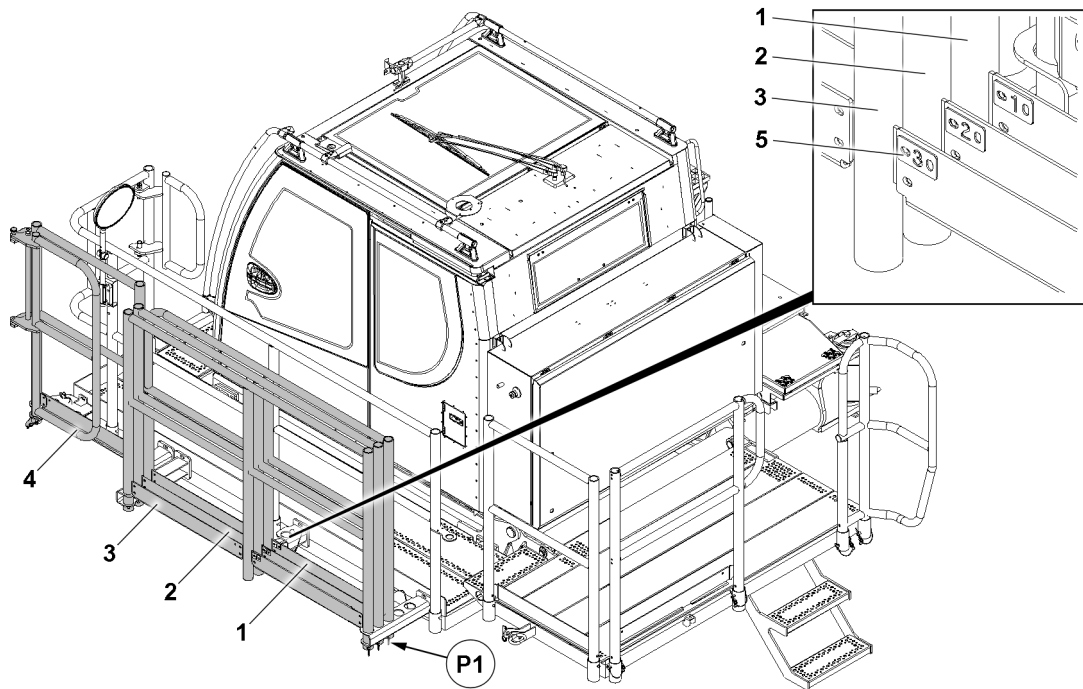


Fig.153484: Railing in the transport retainer

Secure the railings in the transport position:

- ▶ Secure the railing 4 in position P1.
- ▶ Secure the railing 3 in position P1.
- ▶ Secure the railing 2 in position P1.
- ▶ Secure the railing 1 in position P1.

## 5.5 Turntable railing



### WARNING

Danger of accident due to incorrect assembly of the railings!

The railings can suddenly fold down.

Death, severe bodily injuries, property damage.

- ▶ Pin and secure the railing in the operating position.



### WARNING

Danger of accident due to non-assembled railings!

Assembly personnel can fall down.

Death, severe bodily injuries, property damage.

- ▶ Use suitable and approved aids, such as working platforms or lifting platforms.
- ▶ Secure assembly personnel with a fall arrest system to prevent falling.



### Note

- ▶ The technical version of the three railings is identical.
- ▶ The assembly / disassembly of the three railings is identical and is described for one railing as an example.

Make sure that the following prerequisite is met:

- Appropriate aids, such as scaffolding or a work platform are available.

### 5.5.1 Assembling the railing on the turntable in the operating position

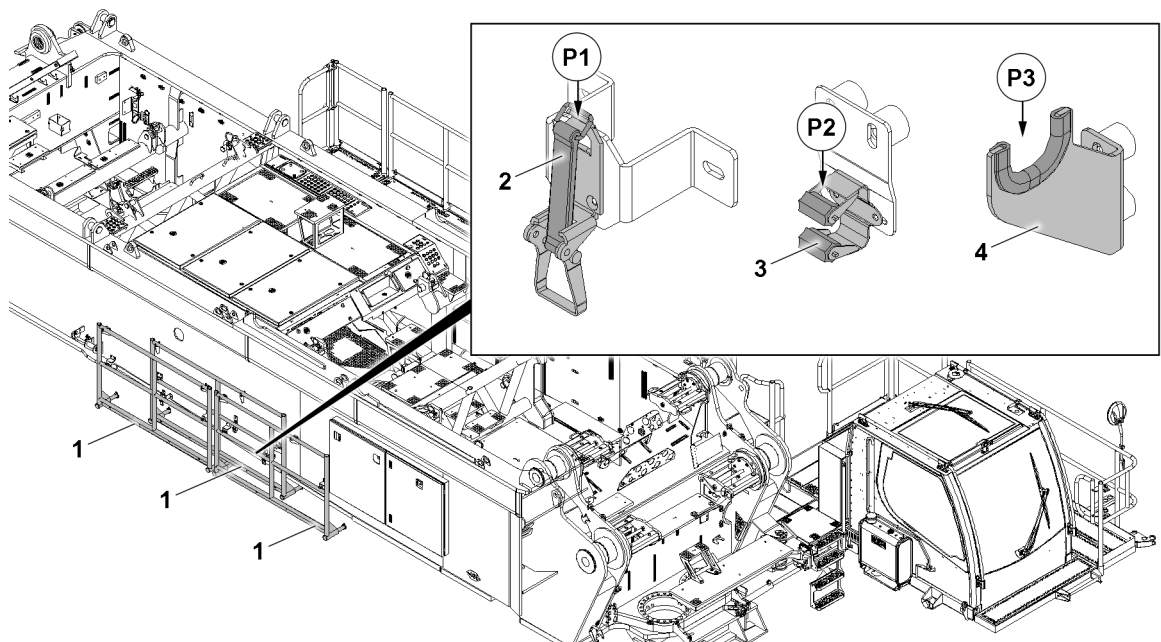


Fig.153486: Railing in the transport receptacle

- ▶ Release the lock 2 in position P1.
- ▶ Pull the railing 1 out of the clamp mounting 3 in position P2 and out of the retainer 4 in position P3.

### 5.5.2 Assembling the railing on the turntable in the transport position

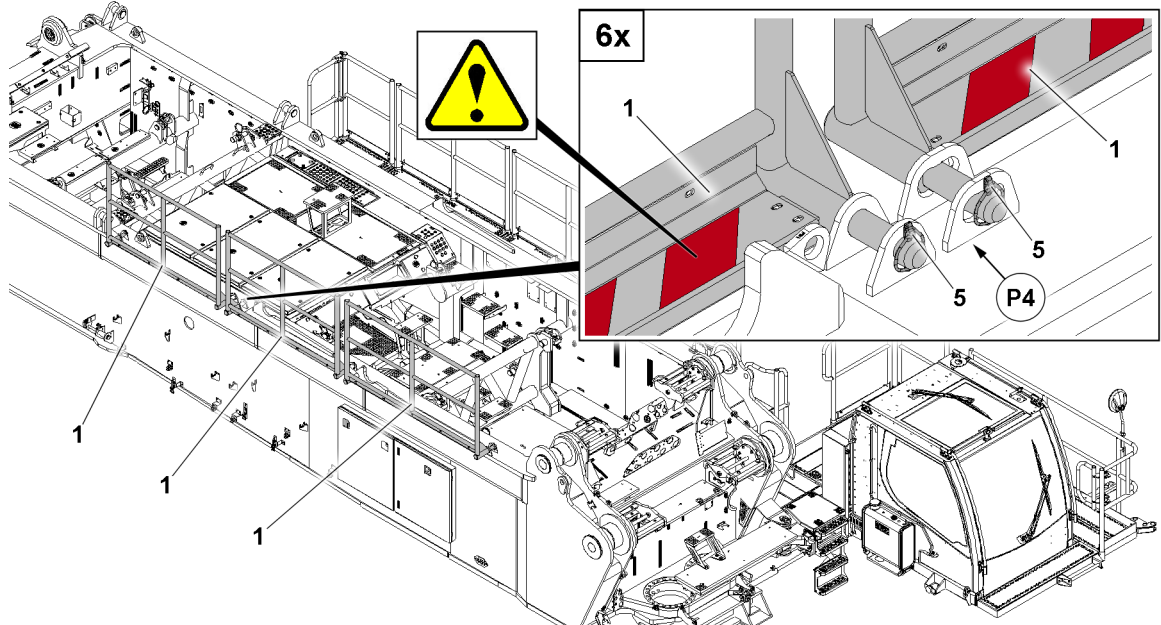


Fig.153487: Railing on turntable in operating position



#### WARNING

Danger of slipping due to small step depth!  
Death, severe bodily injuries.

- ▶ Always step on the walking surfaces with extreme caution.
- ▶ Insert the railing 1 in the receptacle in position P4 and secure with the retaining element 5.

## 6 Additional step counterweight-bracket



### WARNING

Working with unsuitable aids!  
Personnel can fall down.

- ▶ For all work at a height, use suitable and approved aids.
- ▶ If aids are not available and work cannot be carried out from the ground, then use the supplied fall arrest system to prevent falling, see chapter 2.04.



### Note

- ▶ Additional step consists of a platform and access ladder.

### 6.1 Platform fastening points

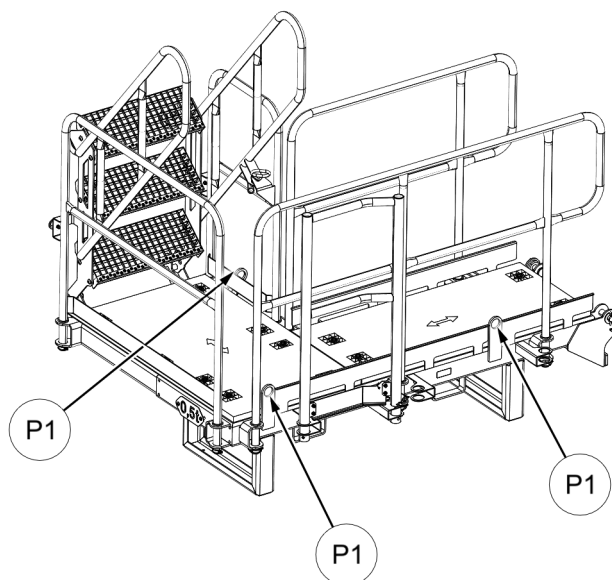


Fig.162682: Platform fastening points

**P1** (3x) Platform fastening points

## 6.2 Pinning the platform on the counterweight bracket

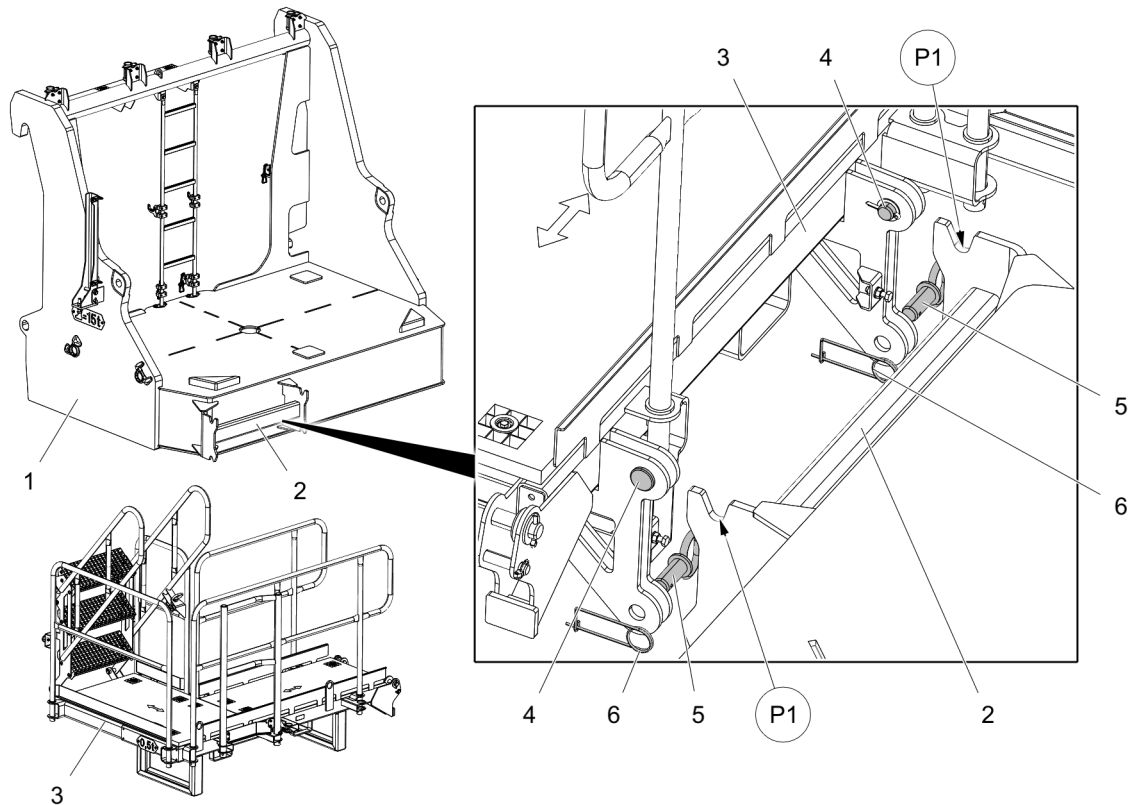


Fig.162691: Assembling the platform

- |          |                       |           |                   |
|----------|-----------------------|-----------|-------------------|
| <b>1</b> | Counterweight bracket | <b>5</b>  | Pin               |
| <b>2</b> | Retainer              | <b>6</b>  | Retaining element |
| <b>3</b> | Platform              | <b>P1</b> | Suspension point  |
| <b>4</b> | Pin                   |           |                   |

Make sure that the following prerequisites are met:

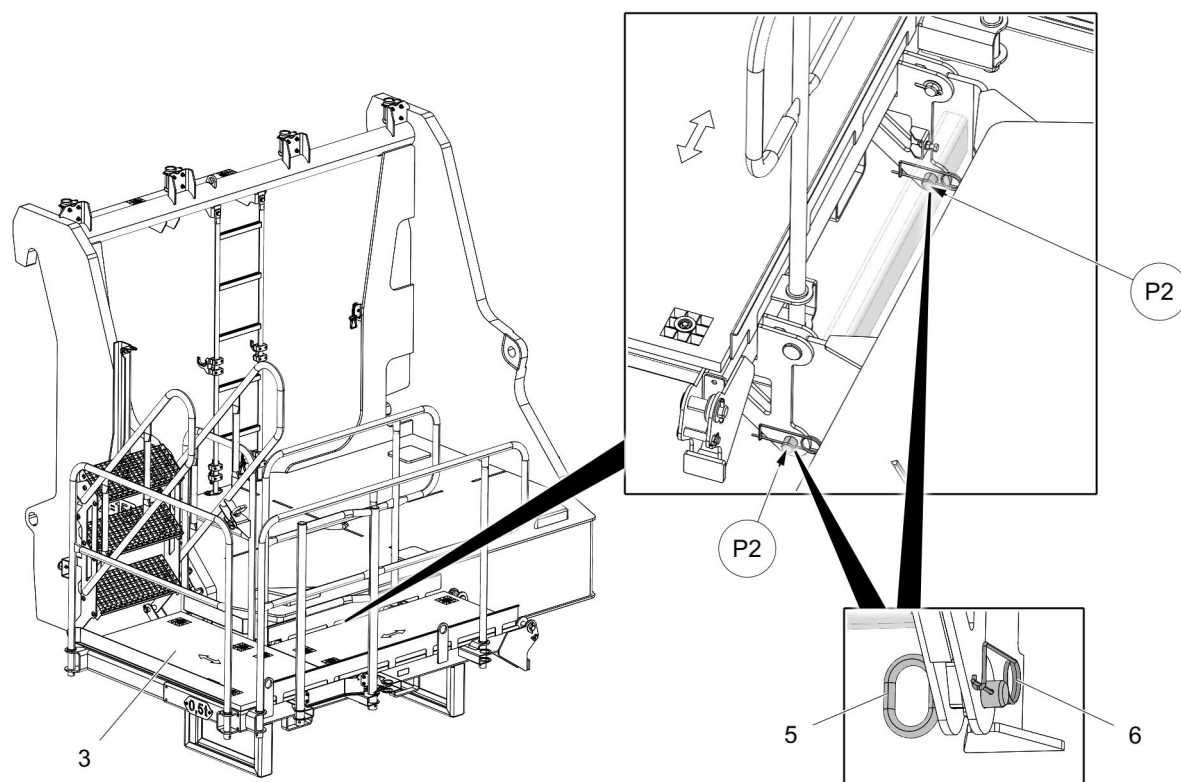
- The counterweight bracket is standing on the ground.
- The platform is standing on the ground.
- ▶ Remove the retaining element **6**.
- ▶ Unpin the pin **5**.
- ▶ Fasten the platform **3** to the auxiliary crane, see section “Platform fastening points”.



### WARNING

Swinging platform!  
Danger of crushed limbs.

- ▶ Keep hands out of the danger zone.
- ▶ Connect the platform **3** on both sides with the pin **4** in the suspension point **P1**.



*Fig.164707: Assembling the platform*

**3** Platform  
**5** Pin

**6** Retaining element  
**P2** Pin point

- ▶ Insert the pin **5** in the pin point **P2**.
- ▶ Secure the pin **5** with the retaining element **6**.

**Result:**

- The platform **3** is pinned to the retainer **2**.



### 6.3 Assembling the retaining bracket on the counterweight bracket

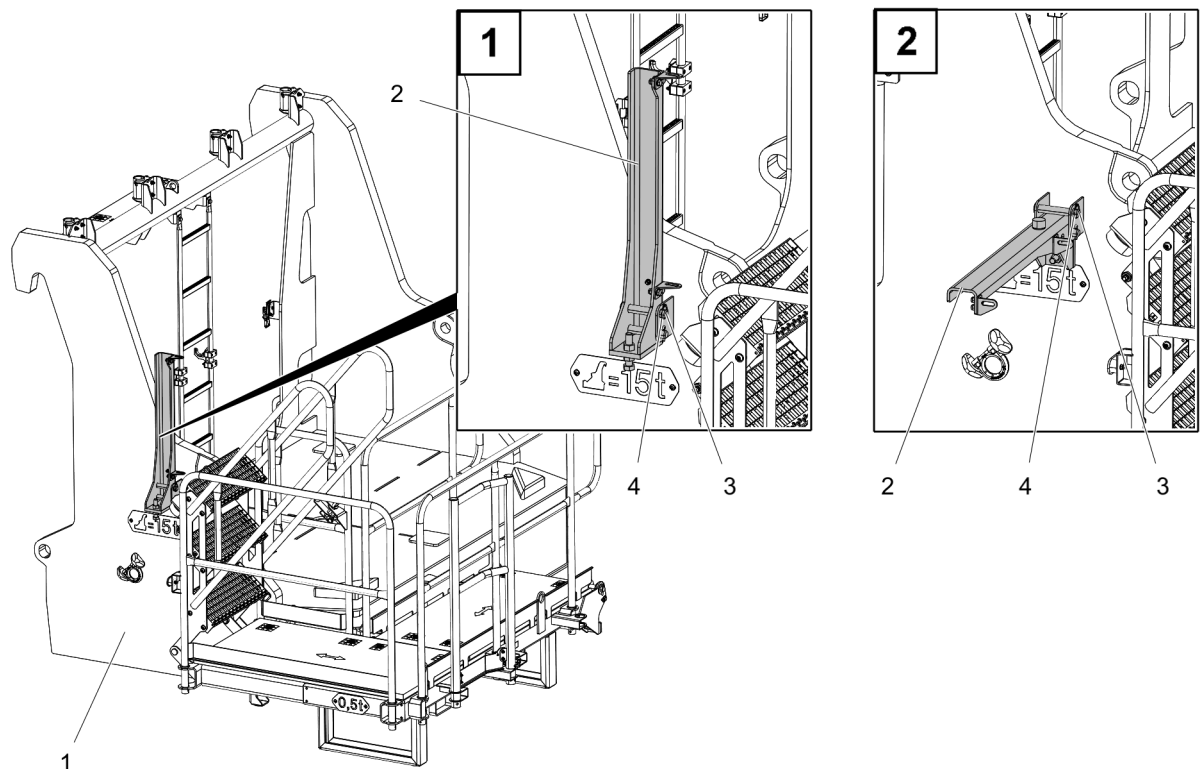


Fig.162686: Assembling the retaining bracket

- |   |                       |   |                   |
|---|-----------------------|---|-------------------|
| 1 | Counterweight bracket | 3 | Retaining pin     |
| 2 | Retaining bracket     | 4 | Retaining element |

Make sure that the following prerequisites are met:

- The counterweight bracket is standing on the ground.

- ▶ Remove the retaining element 4.
- ▶ Unpin the retaining pin 3.
- ▶ Fold the retaining bracket 2 down.
- ▶ Insert the retaining pin 3.
- ▶ Secure the retaining pin 3 with the retaining element 4.

**Result:**

- The retaining bracket 2 is in the operating position.

## 6.4 Assembling the counterweight bracket on the turntable

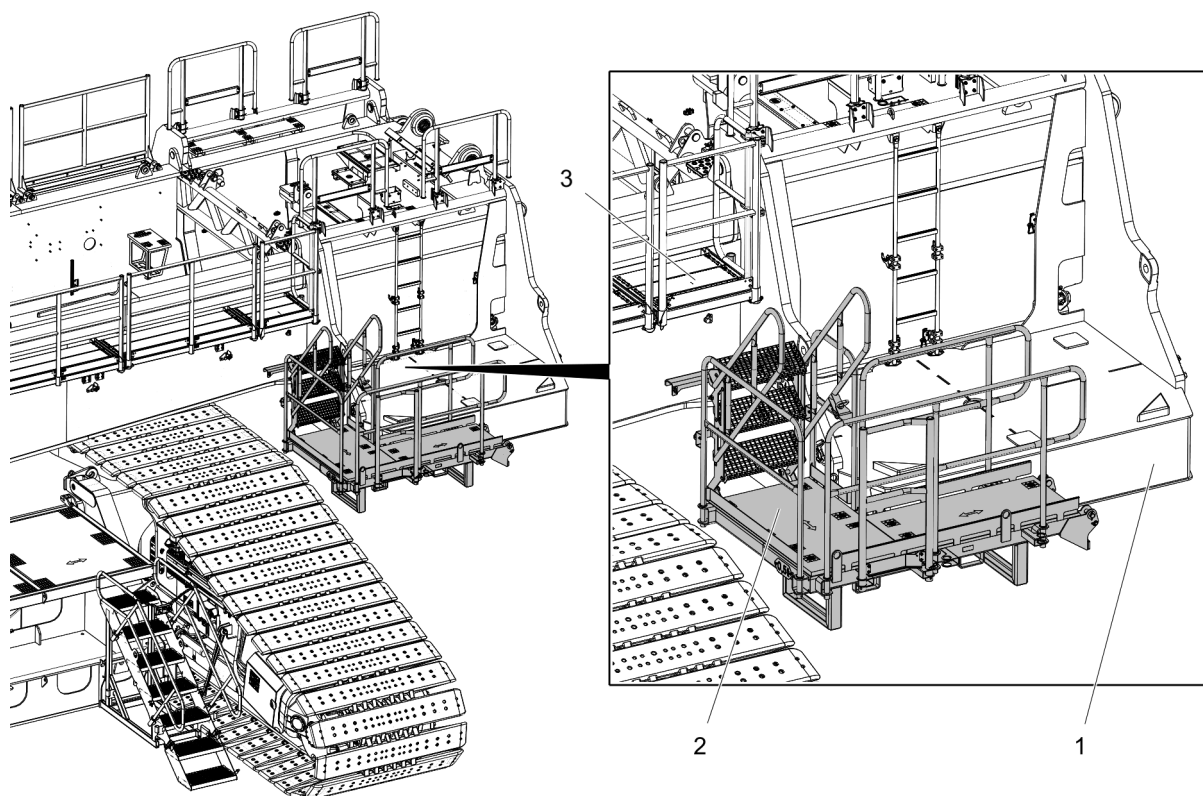


Fig.162689: Counterweight bracket on the turntable

- |  |                           |
|--|---------------------------|
| <p><b>1</b> Counterweight bracket</p> <p><b>2</b> Platform</p> | <p><b>3</b> Turntable</p> |
|--|---------------------------|

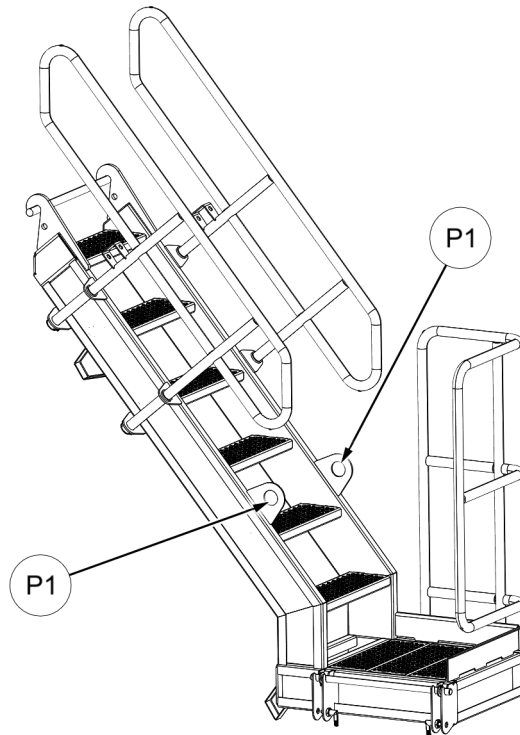


### Note

- ▶ The assembly of the counterweight bracket **1** is shown in Chapter 4.07 without a platform.
- ▶ Assemble the counterweight bracket **1** with the platform **2** assembled on the turntable **3**, see chapter 4.07.

## 6.5 Assembling the access stairs

### 6.5.1 Access stairs fastening points



*Fig.162681: Access stairs fastening points*

**P1** Access stairs fastening points

## 6.5.2 Connecting and pinning the access stairs

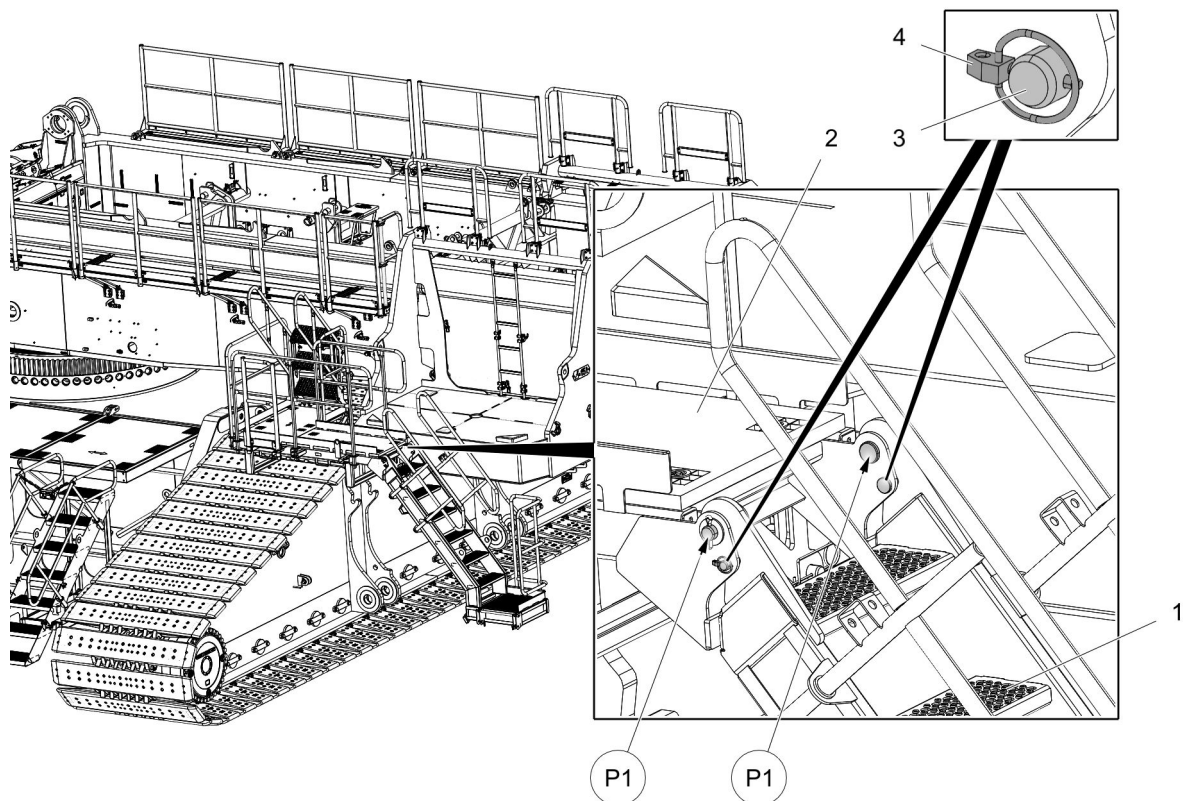


Fig.162688: Connecting and pinning the access stairs

- |   |               |    |                   |
|---|---------------|----|-------------------|
| 1 | Access stairs | 4  | Retaining element |
| 2 | Platform      | P1 | Suspension point  |
| 3 | Pin           |    |                   |

- ▶ Fasten the access stairs **1** to the auxiliary crane, see "Auxiliary crane fastening points".
- ▶ Lift the access stairs **1** with the auxiliary crane and swing it to the platform **2**.



### WARNING

Access stairs unsecured in the operating position!  
Assembly personnel can fall down.

- ▶ Fully connect and secure the access stairs.
- ▶ Connect the access stairs **1** to the platform **2** in the suspension point **P1**.
- ▶ Align the access stairs **1** with the auxiliary crane until the pin bores align.
- ▶ Insert the pin **3**.
- ▶ Secure the pin **3** with the retaining element **4**.

### 6.5.3 Assembling the ladder on the access stairs

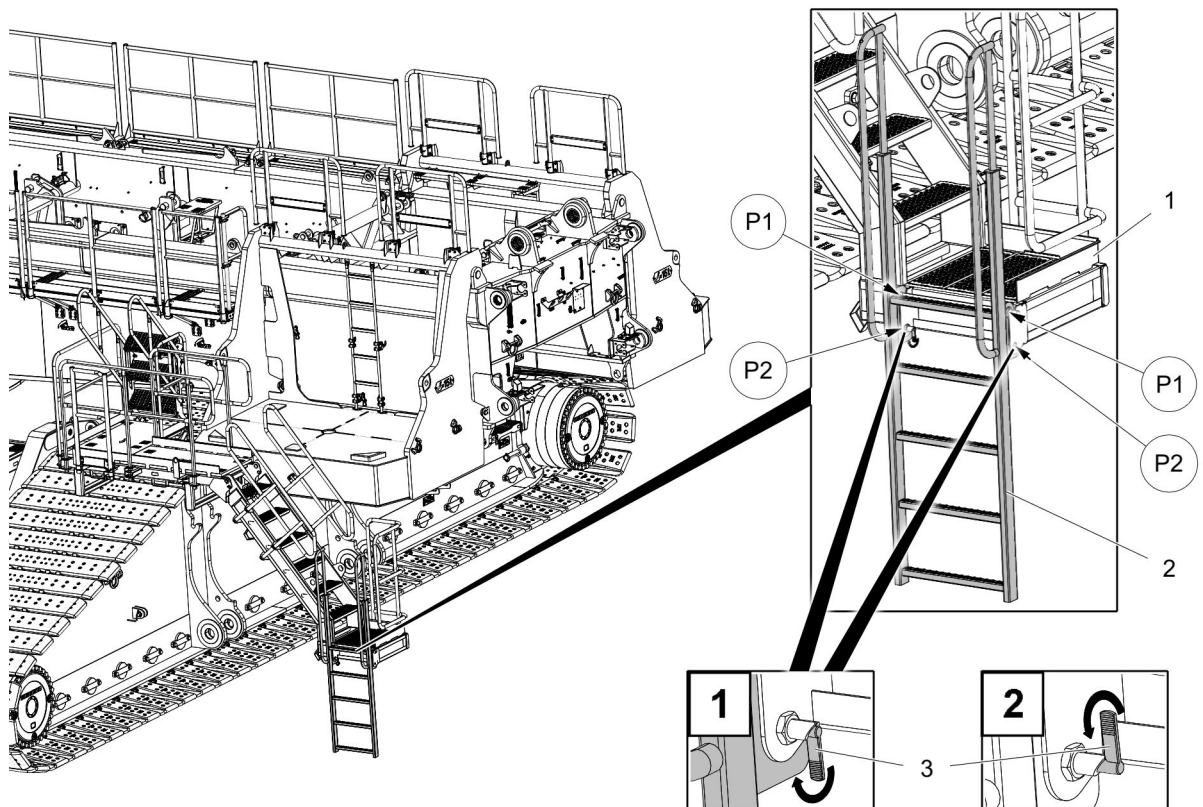


Fig.162687: Assembling the ladder on the access stairs

- |   |                   |    |                  |
|---|-------------------|----|------------------|
| 1 | Access stairs     | P1 | Suspension point |
| 2 | Ladder            | P2 | Pin bore         |
| 3 | Retaining element |    |                  |



#### WARNING

Hands in the danger zone!  
Danger of crushed limbs.

- ▶ Keep hands out of the danger zone.

- ▶ Release the retaining element 3.
- ▶ Connect the ladder 2 to the suspension points P1.
- ▶ Position the ladder 2 such that the pin bores P2 align.
- ▶ Close the retaining element 3.

#### Result:

- The ladder 2 is in the operating position.

## 6.6 Assembling the stairs

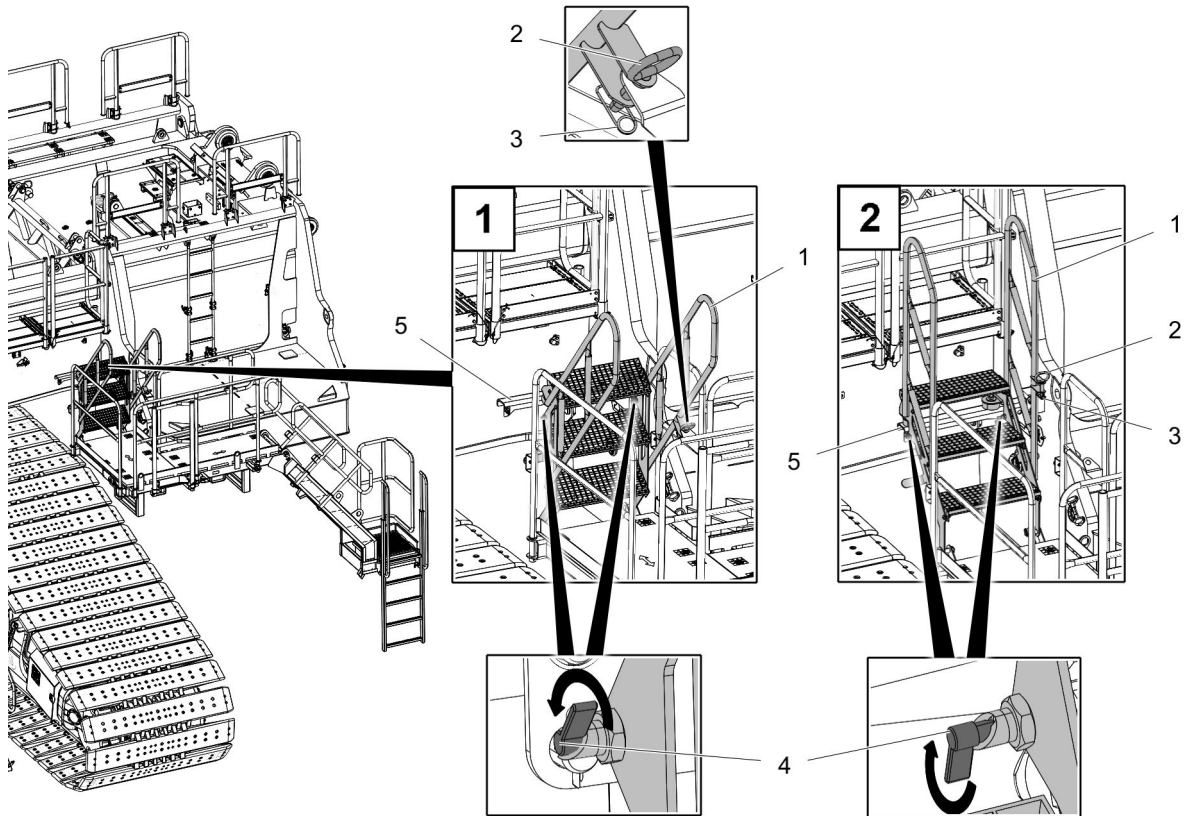


Fig.162693: Assembling the stairs

- |   |                   |   |                   |
|---|-------------------|---|-------------------|
| 1 | Stairs            | 4 | Retaining element |
| 2 | Pin               | 5 | Retaining bracket |
| 3 | Retaining element |   |                   |



### WARNING

Hands in the danger zone!  
Danger of crushed limbs.

- ▶ Keep hands out of the danger zone.

- ▶ Remove the retaining element 3.
- ▶ Unpin the pin 2.
- ▶ Release the retaining element 4.
- ▶ Swing the stairs 1 down until the stairs 1 are lying on the retaining bracket 5.
- ▶ Secure the stairs 1 with the retaining element 4 in the operating position.
- ▶ Insert the pin 2 in the park position.
- ▶ Secure the pin 2 with the retaining element 3.

### Result:

- The stairs 1 are in the operating position.

## 6.7 Replacing the railings for accessing the turntable

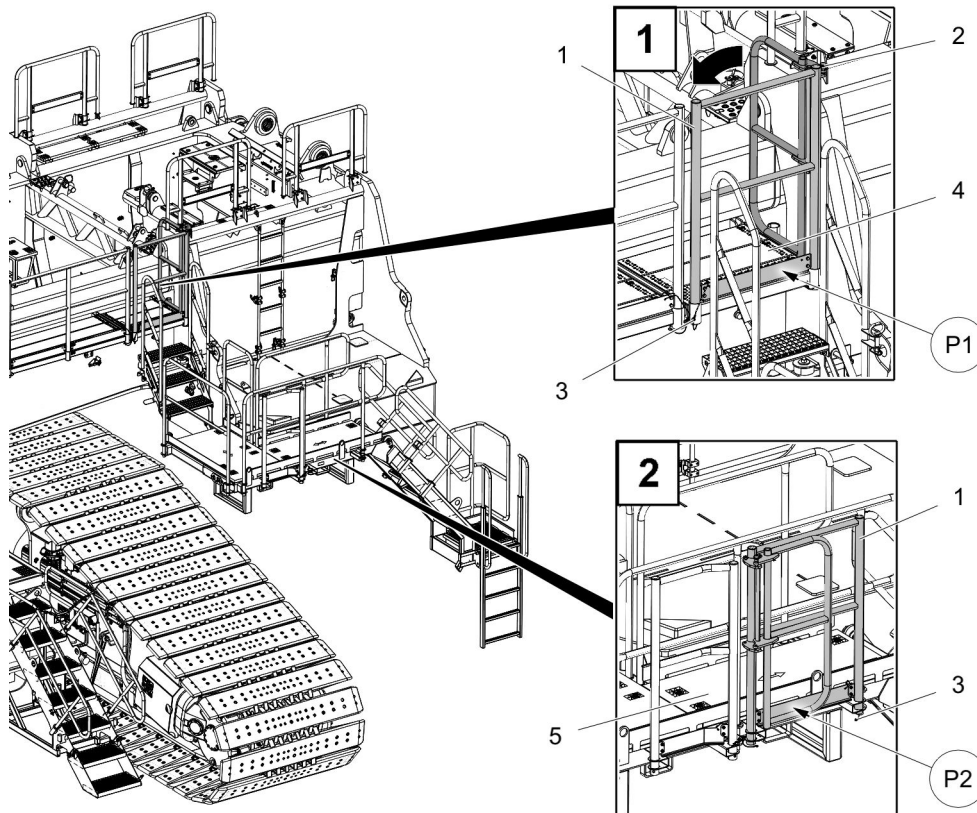


Fig.162684: Replacing the railing

- |          |                   |           |                    |
|----------|-------------------|-----------|--------------------|
| <b>1</b> | Railing           | <b>5</b>  | Platform           |
| <b>2</b> | Retaining element | <b>P1</b> | Operating position |
| <b>3</b> | Retaining element | <b>P2</b> | Park position      |
| <b>4</b> | Catwalk           |           |                    |

Make sure that the following prerequisites are met:

- The catwalks and railings on the turntable are assembled and secured in the operating position.
- The platform with access stairs is assembled and secured to the counterweight bracket.

- ▶ Release the retaining element **2**.
- ▶ Fold the railing folding section in.
- ▶ Release the railing **1**: Remove the retaining element **3**.
- ▶ Remove the railing **1** from the operating position **P1**.
- ▶ Position the railing **1** in the park position **P2**.
- ▶ Secure the railing **1** with the retaining element **3**.

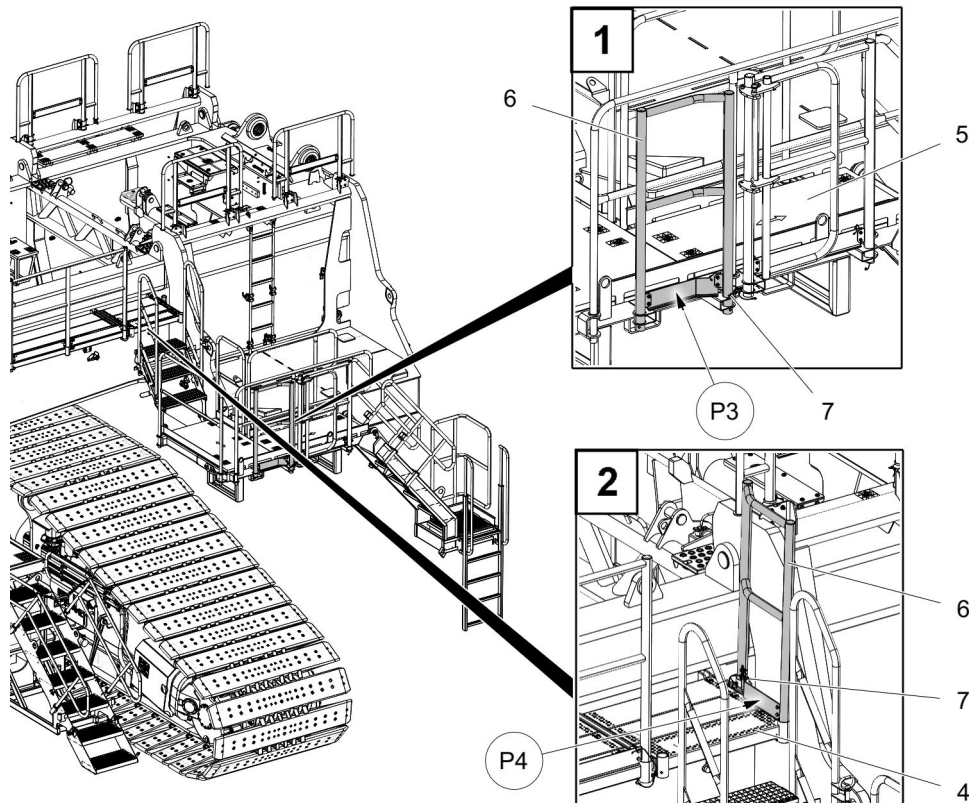


Fig.162685: Replacing the railing

4	Catwalk	7	Retaining element
5	Platform	P3	Park position
6	Railing	P4	Operating position

- ▶ Release the railing **6**: Remove the retaining element **7**.
- ▶ Remove the railing **6** from the park position **P3**.
- ▶ Position the railing **6** in the operating position **P4**.
- ▶ Secure the railing **6** with the retaining element **7**.

**Result:**

- The additional step is completely assembled.
- Keep in mind: Close off further accesses in a timely manner, see chapter 2.07.



**Note**

- ▶ In the case of deviation from the dimensions of the standard ballasting of the derrick ballast, freedom of movement between the additional step and the derrick ballast must be ensured.



## 6.8 Start disassembly: Resetting the railing on the turntable

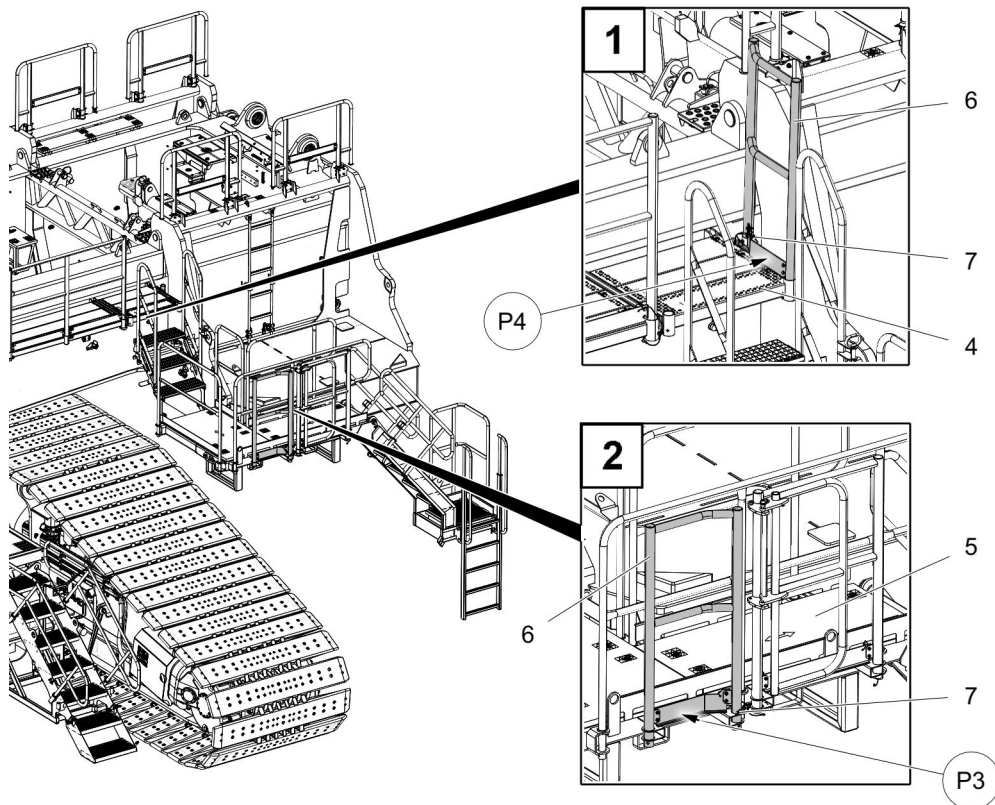


Fig.162694: Replacing the railing

- |                   |                              |
|-------------------|------------------------------|
| <b>4</b> Catwalk  | <b>7</b> Retaining element   |
| <b>5</b> Platform | <b>P3</b> Park position      |
| <b>6</b> Railing  | <b>P4</b> Operating position |

- ▶ Release the railing **6**: Remove the retaining element **7**.
- ▶ Remove the railing **6** from the operating position **P4**.
- ▶ Position the railing **6** in the park position **P3**.
- ▶ Secure the railing **6** with the retaining element **7**.

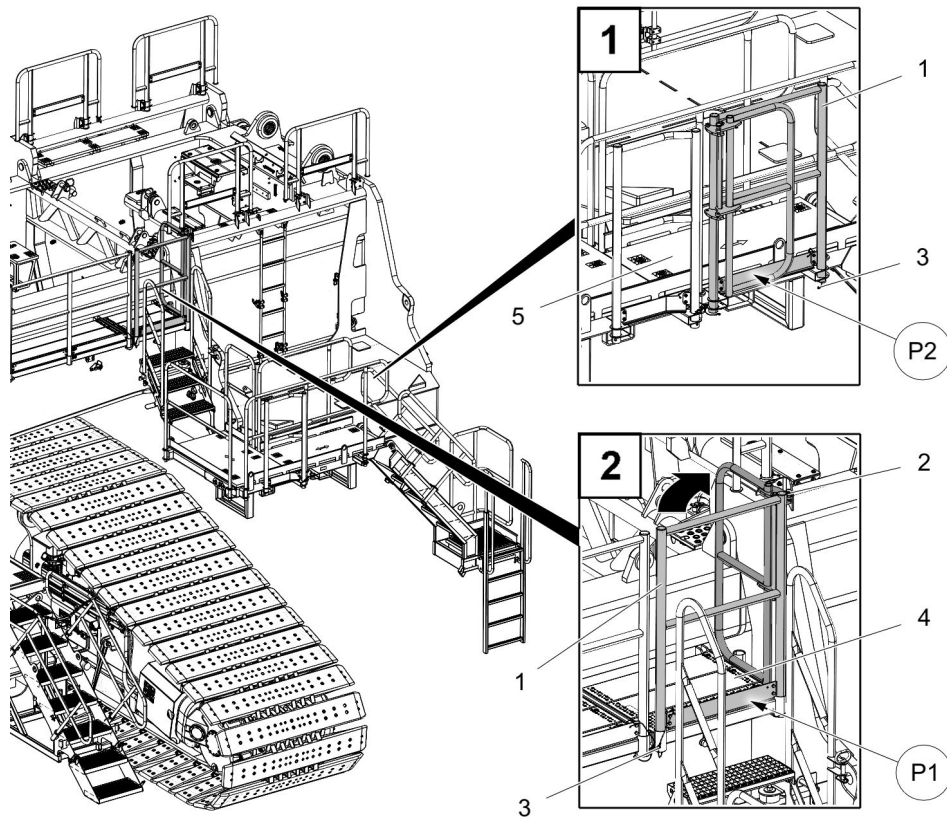


Fig.162695: Replacing the railing

- |   |                   |    |                    |
|---|-------------------|----|--------------------|
| 1 | Railing           | 5  | Platform           |
| 2 | Retaining element | P1 | Operating position |
| 3 | Cotter pin        | P2 | Park position      |
| 4 | Catwalk           |    |                    |

- ▶ Release the railing 1: Remove the retaining element 3.
- ▶ Remove the railing 1 from the park position P2.
- ▶ Position the railing 1 in the operating position P1.
- ▶ Secure the railing 1 with the retaining element 3.
- ▶ Release the retaining element 2.
- ▶ Fold the railing folding section out.

## 6.9 Disassembling the stairs

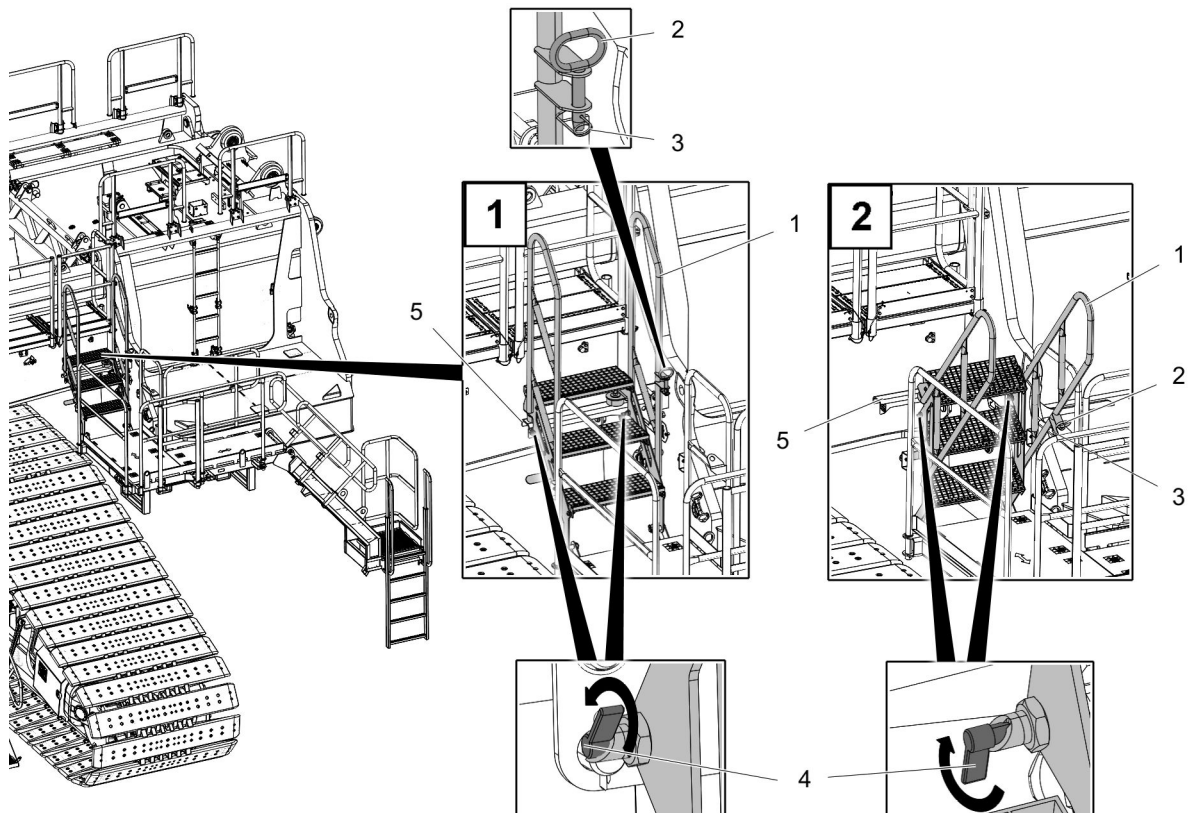


Fig.162696: Disassembling the stairs

- |   |                   |   |                   |
|---|-------------------|---|-------------------|
| 1 | Stairs            | 4 | Retaining element |
| 2 | Pin               | 5 | Retaining bracket |
| 3 | Retaining element |   |                   |



### WARNING

Hands in the danger zone!  
Danger of crushed limbs.

- ▶ Keep hands out of the danger zone.
- ▶ Remove the retaining element 3.
- ▶ Unpin the pin 2 from the park position.
- ▶ Release the stairs 1. Release the retaining element 4.
- ▶ Swing the stairs 1 upward.
- ▶ Pin the stairs 1 with the pin 2.
- ▶ Secure the pin 2 with the retaining element 3.

### Result:

- The stairs 1 are in the transport position.

## 6.10 Disassembling the access stairs

### 6.10.1 Disassembling the ladder on the access stairs

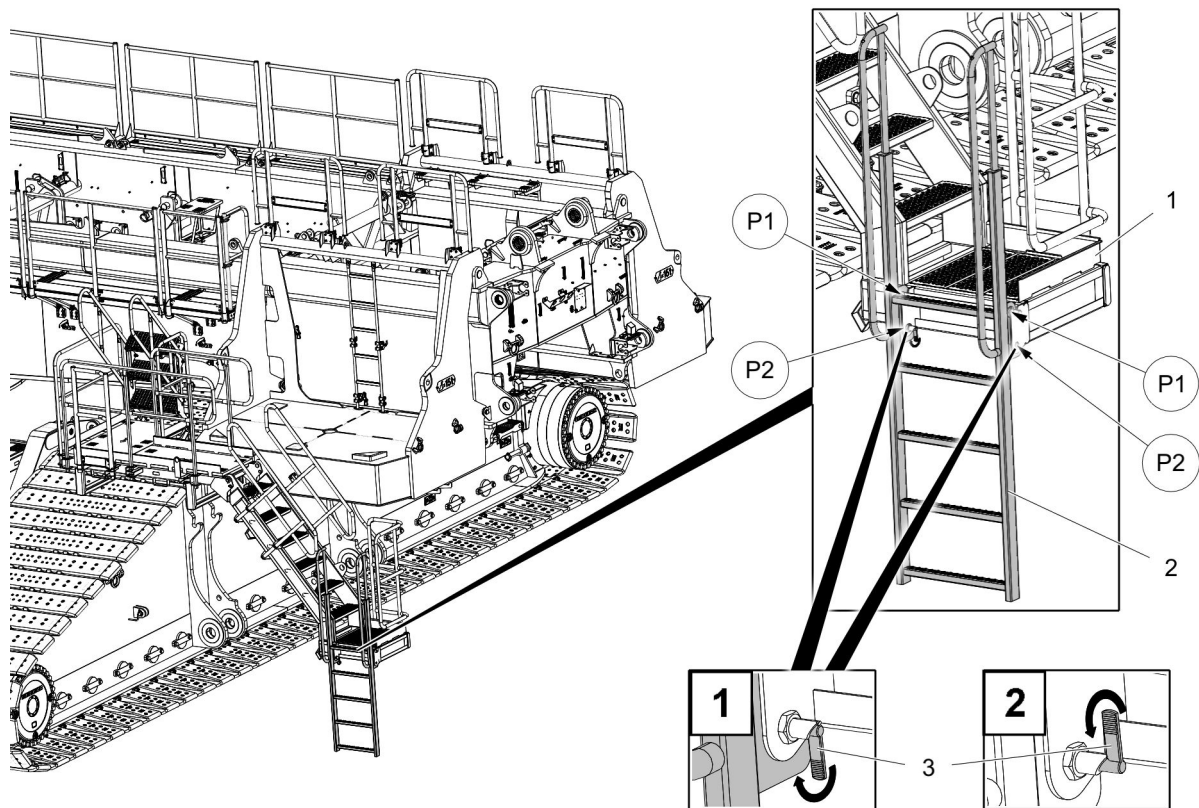


Fig.162687: Disassembling the ladder on the access stairs

- |   |                   |    |                  |
|---|-------------------|----|------------------|
| 1 | Access stairs     | P1 | Suspension point |
| 2 | Ladder            | P2 | Pin bore         |
| 3 | Retaining element |    |                  |

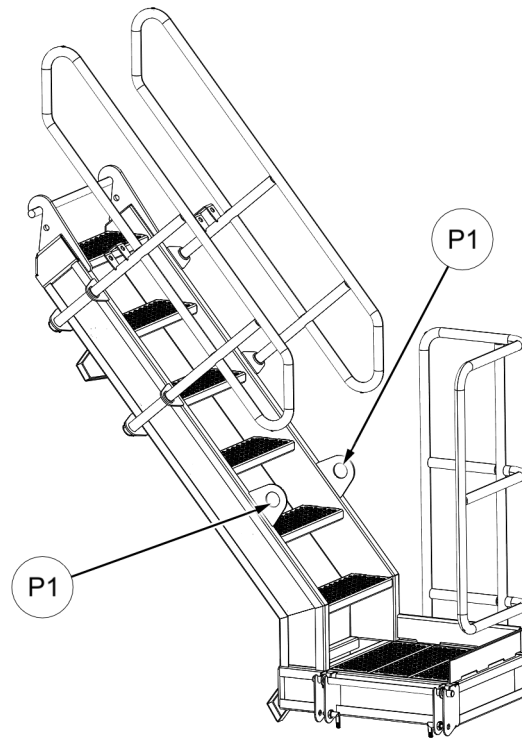


#### WARNING

Hands in the danger zone!  
Danger of crushed limbs.

- ▶ Keep hands out of the danger zone.
- 
- ▶ Release the retaining element 3.
  - ▶ Disconnect the ladder 2 from the suspension points P1.

### 6.10.2 Access stairs fastening points



*Fig.162681: Access stairs fastening points*

**P1** Access stairs fastening points

### 6.10.3 Unpinning and disconnecting the access stairs

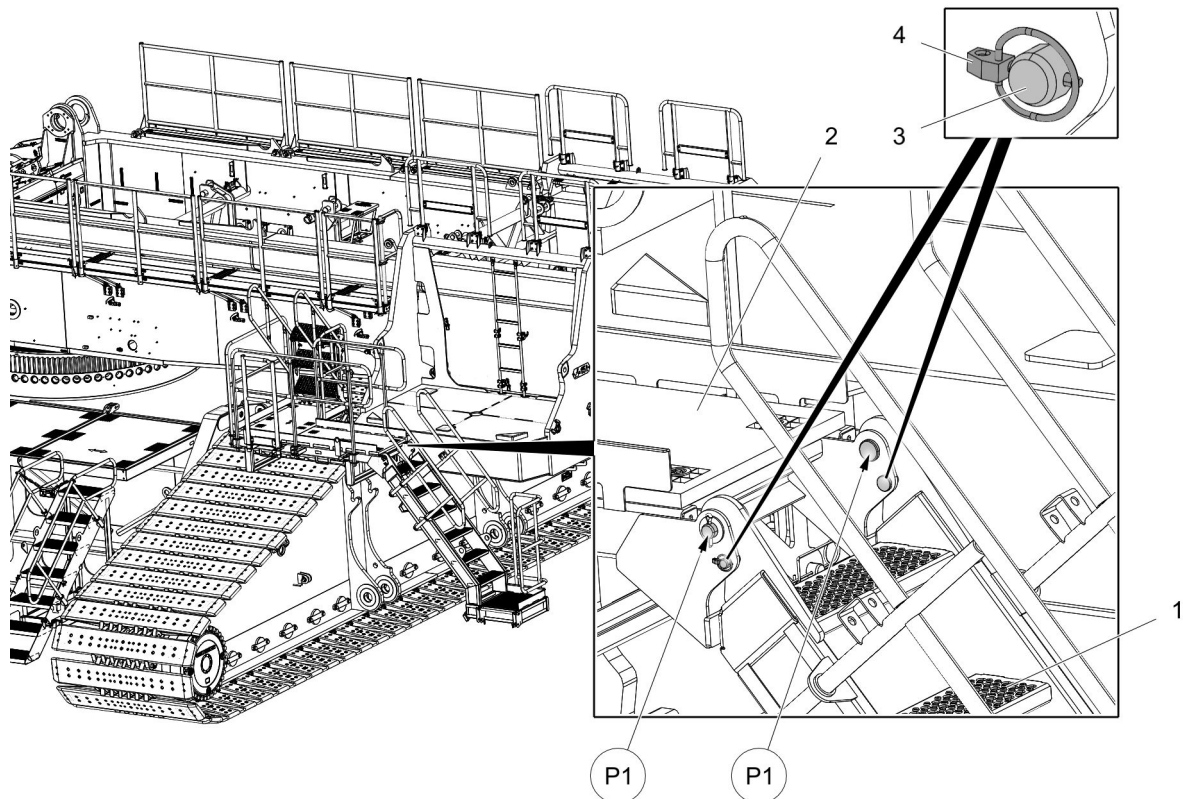


Fig.162688: Unpinning and disconnecting the access stairs

- |   |               |    |                   |
|---|---------------|----|-------------------|
| 1 | Access stairs | 4  | Retaining element |
| 2 | Platform      | P1 | Suspension point  |
| 3 | Pin           |    |                   |

- ▶ Fasten the access stairs **1** to the auxiliary crane, see "Auxiliary crane fastening points".
- ▶ Release the pin **3**: Remove the retaining element **4**.
- ▶ Unpin the pin **3**.



#### WARNING

Access stairs unsecured in the operating position!  
Assembly personnel can fall down.

- ▶ Fully connect and secure the access stairs.
- 
- ▶ Disconnect the access stairs **1** from the suspension point **P1**.
  - ▶ Lift the access stairs **1** with the auxiliary crane.
  - ▶ Swing the access stairs **1** out with the auxiliary crane and take them down.

## 6.11 Disassembling the counterweight bracket on the turntable

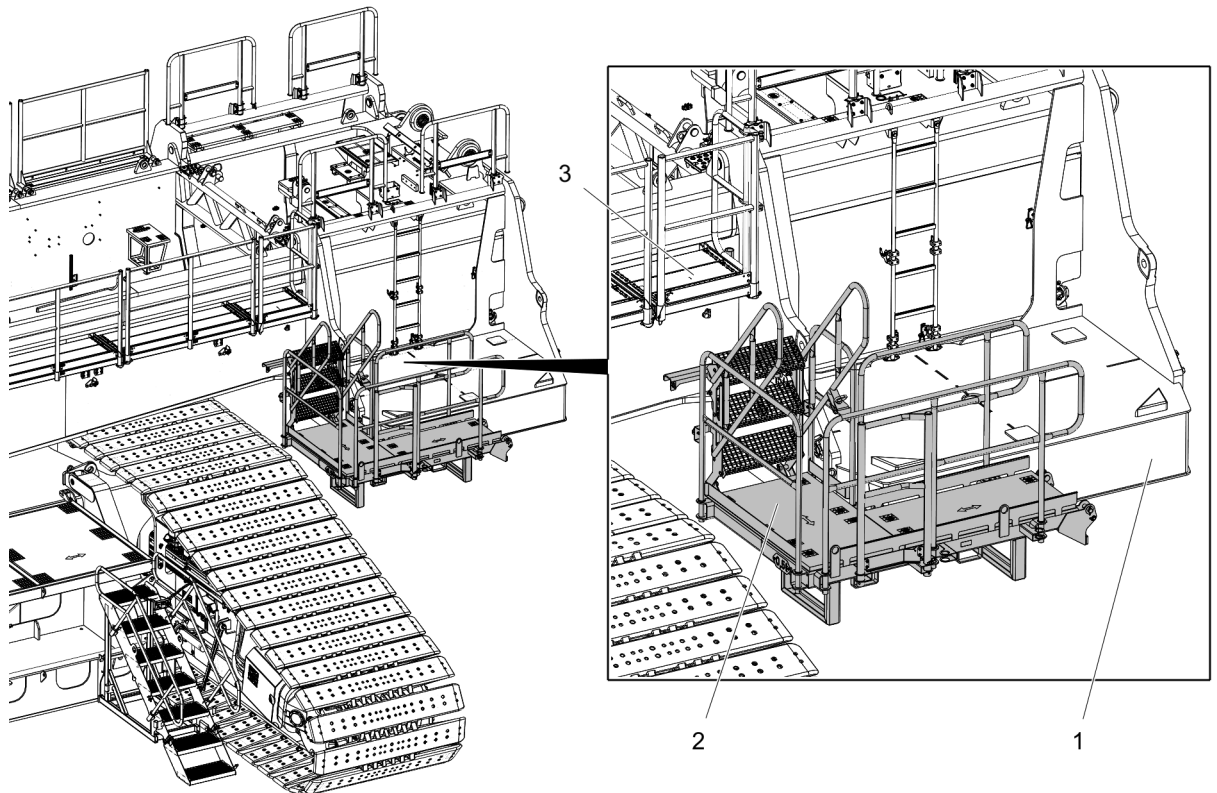


Fig.162689: Counterweight bracket on the turntable

- |          |                       |          |           |
|----------|-----------------------|----------|-----------|
| <b>1</b> | Counterweight bracket | <b>3</b> | Turntable |
| <b>2</b> | Platform              |          |           |



### Note

- ▶ The disassembly of the counterweight bracket **1** is shown in Chapter 4.07 without a platform.
- ▶ Disassemble the counterweight bracket **1** with the platform **2** assembled on the turntable **3**, see chapter 4.07.

## 6.12 Disassembling the retaining bracket on the counterweight bracket

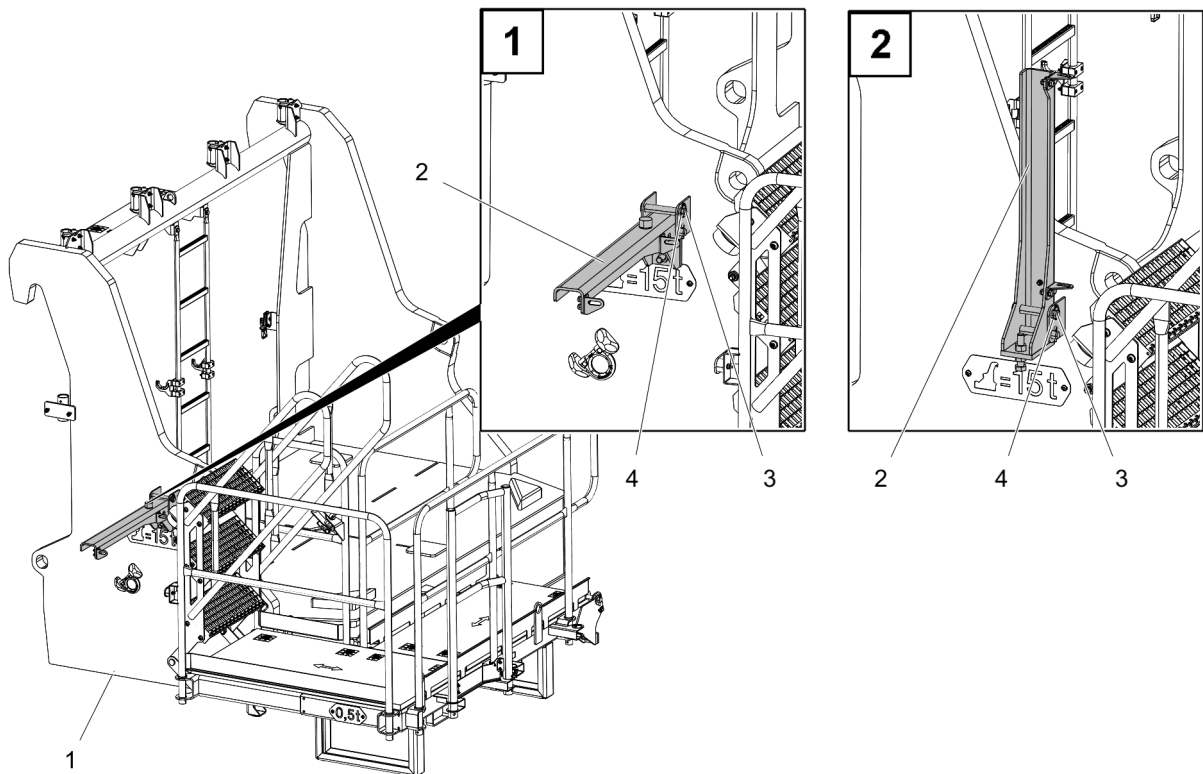


Fig.162698: Disassembling the retaining bracket

- |                                |                            |
|--------------------------------|----------------------------|
| <b>1</b> Counterweight bracket | <b>3</b> Retaining pin     |
| <b>2</b> Retaining bracket     | <b>4</b> Retaining element |

Make sure that the following prerequisites are met:

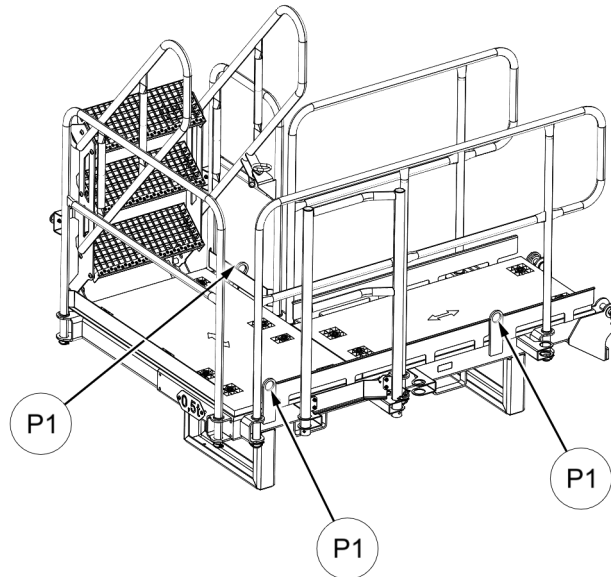
- The counterweight bracket is standing on the ground.
- ▶ Remove the retaining element **4**.
- ▶ Unpin the retaining pin **3**.
- ▶ Fold the retaining bracket **2** up.
- ▶ Insert the retaining pin **3**.
- ▶ Secure the retaining pin **3** with the retaining element **4**.

**Result:**

- The retaining bracket **2** is in the transport position.



## 6.13 Platform fastening points



*Fig.162682: Platform fastening points*

**P1** (3x) Platform fastening points

## 6.14 Disassembling the platform on the counterweight bracket

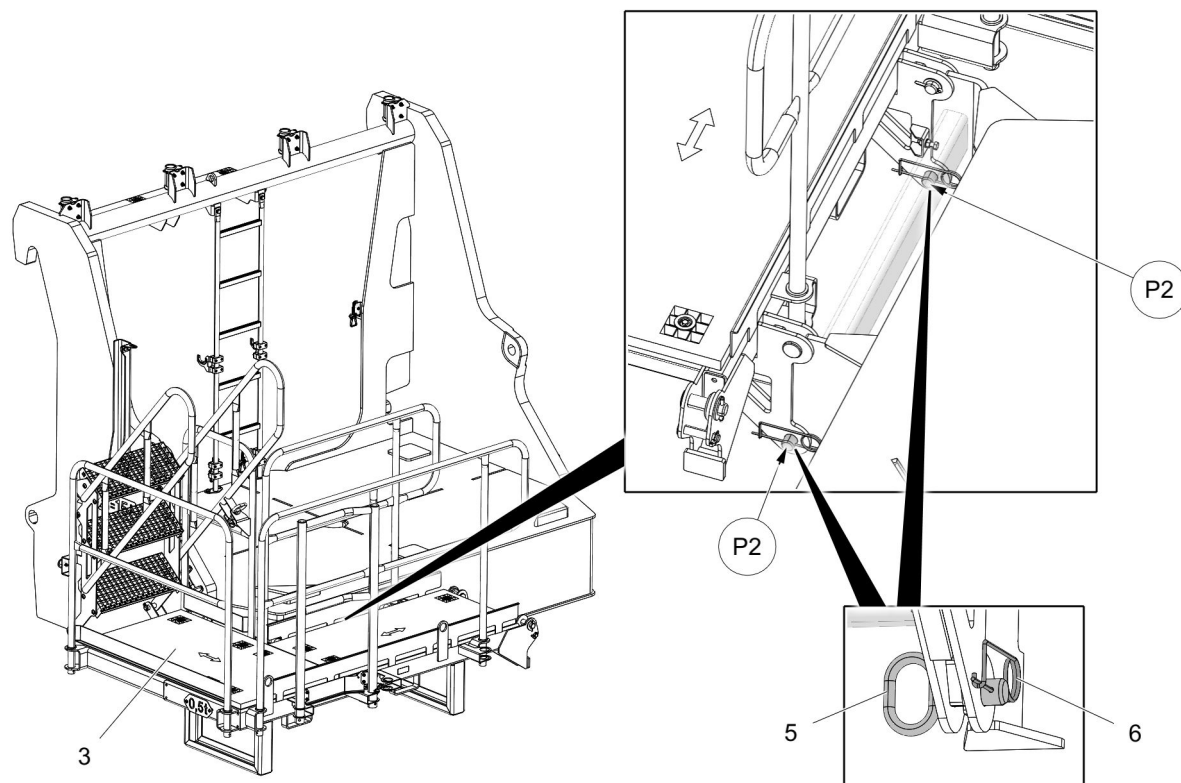


Fig.164707: Disassembling the platform

**3** Platform  
**5** Pin

**6** Retaining element  
**P2** Pin point

Make sure that the following prerequisites are met:

- The counterweight bracket is standing on the ground.
- ▶ Fasten the platform **3** to the auxiliary crane, see section “Platform fastening points”.
- ▶ Remove the retaining element **6**.
- ▶ Unpin the pin **5**.

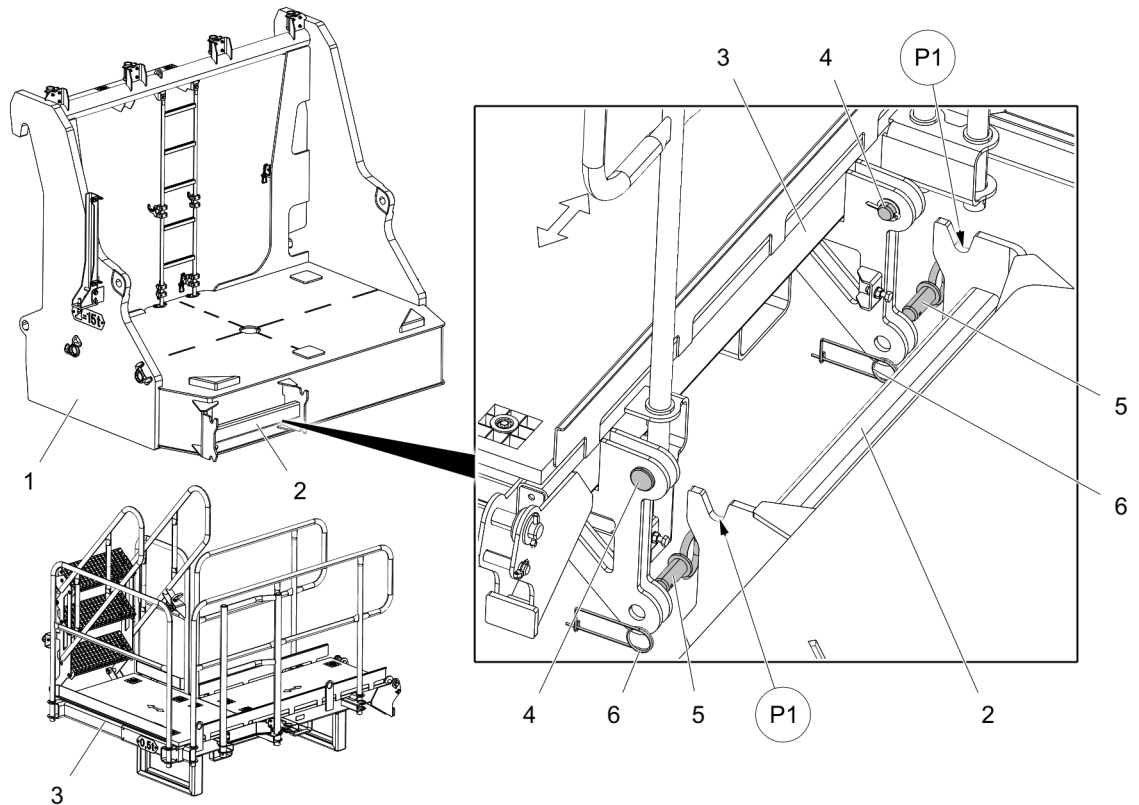


Fig.162691: Disassembling the platform

- |   |                       |    |                   |
|---|-----------------------|----|-------------------|
| 1 | Counterweight bracket | 5  | Pin               |
| 2 | Retainer              | 6  | Retaining element |
| 3 | Platform              | P1 | Suspension point  |
| 4 | Pin                   |    |                   |



### WARNING

Swinging platform!  
Danger of crushed limbs.

- ▶ Keep hands out of the danger zone.

- ▶ Disconnect the platform 3 with the auxiliary crane on the retainer 2 with the pin 4 from the suspension point P1.
- ▶ Swing out and take down the platform 3 with the auxiliary crane.

## 7 H-pivot section

### 7.1 Railings



### WARNING

Danger of accident due to incorrect assembly of the railings!  
The railings can suddenly fold down.  
Death, severe bodily injuries, property damage.

- ▶ Pin and secure the railing in the operating position.

**WARNING**

Danger of accident due to non-assembled railings!

Assembly personnel can fall down.

Death, severe bodily injuries, property damage.

- ▶ Use suitable and approved aids, such as working platforms or lifting platforms.
- ▶ Secure assembly personnel with a fall arrest system to prevent falling.

### 7.1.1 Assembling the railing in the operating position

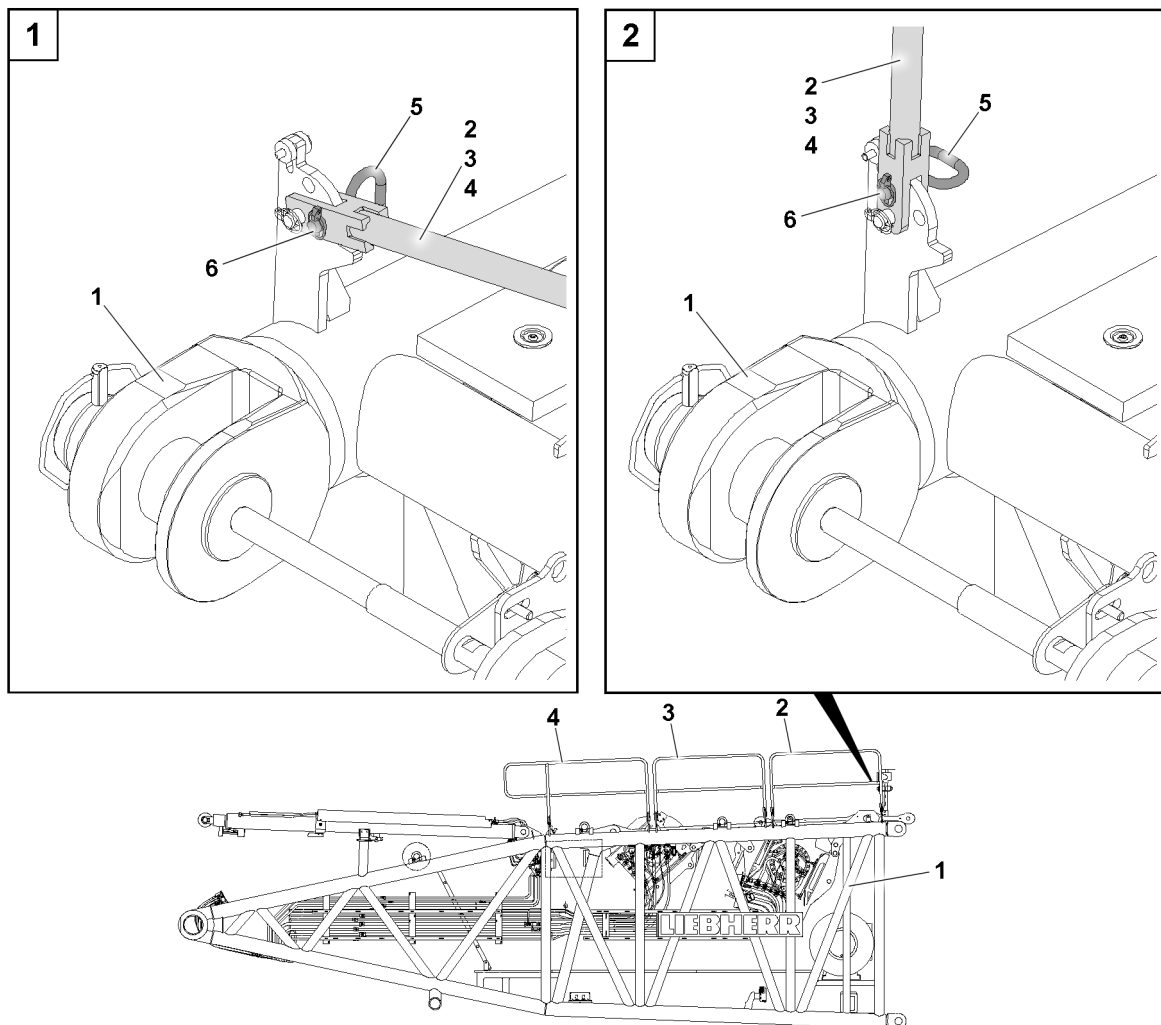


Fig.154354: H-pivot section railings

- ▶ Release the railing 2, railing 3, railing 4: Remove the retaining element 6 and unpin the socket pin 5.
- ▶ Fold the railings up.
- ▶ Secure the railings in the operating position: Insert the socket pin 5.
- ▶ Secure the socket pin 5 with the retaining element 6.

### 7.1.2 Assembling the railings in the transport retainer

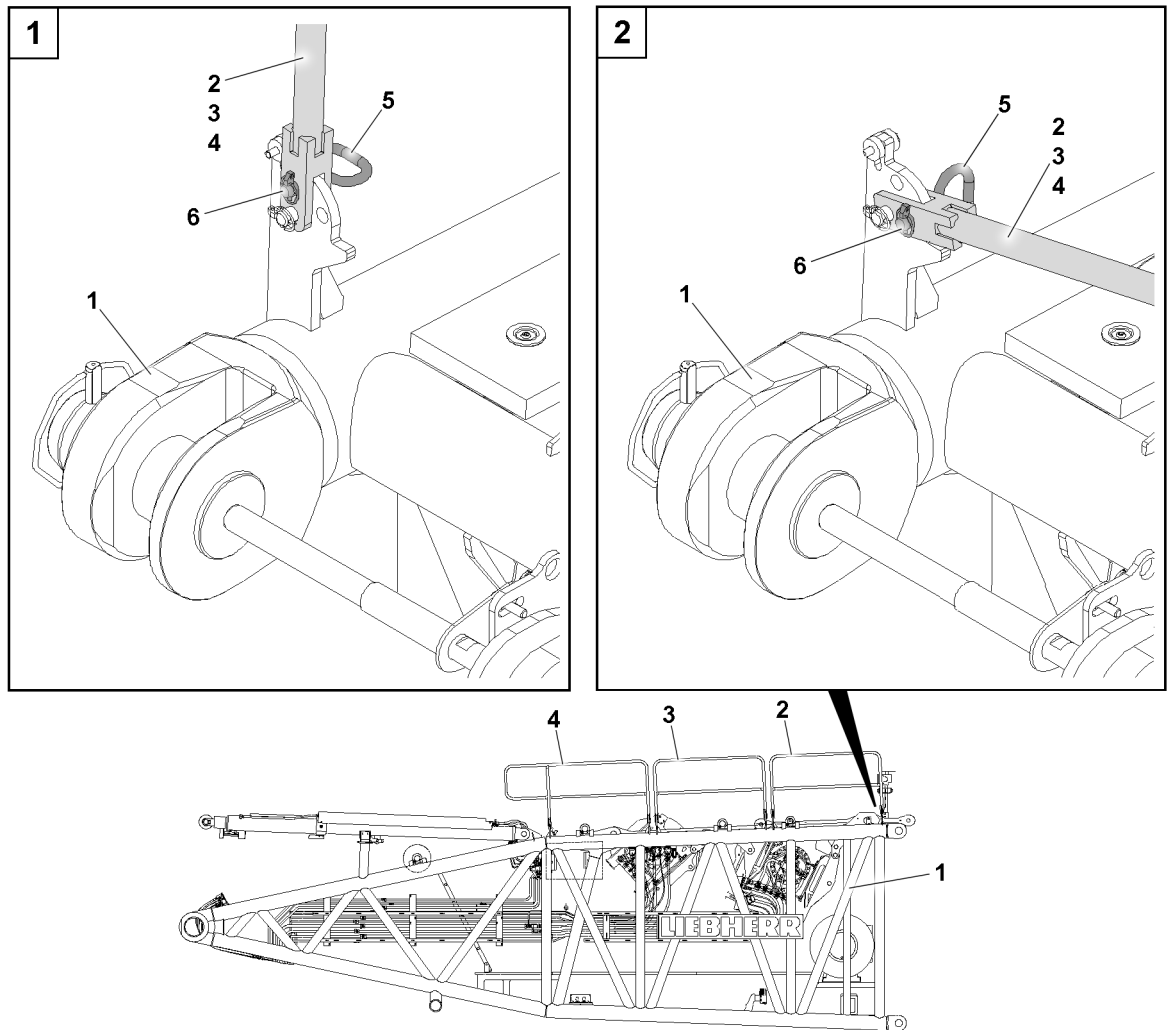


Fig.154355: H-pivot section railings

- ▶ Release the railing 2, railing 3, railing 4: Remove the retaining element 6 and unpin the socket pin 5.
- ▶ Fold the railings down.
- ▶ Secure the railings in the transport position: Insert the socket pin 5.
- ▶ Secure the socket pin 5 with the retaining element 6.

## 7.2 Safety ropes

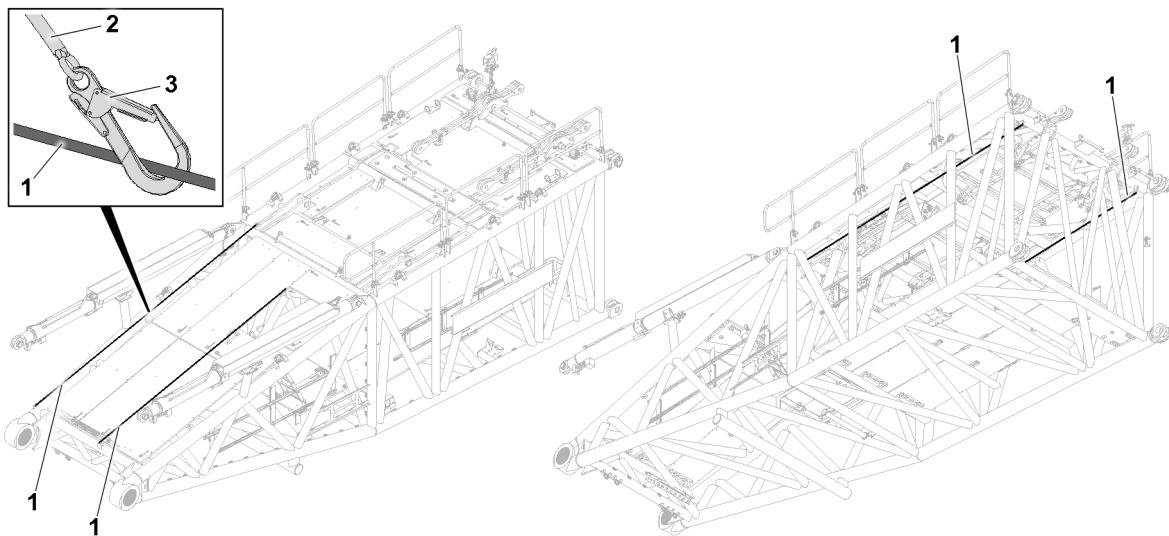


Fig.154356: H-pivot section safety ropes



### WARNING

Assembly personnel is not secured!  
 Assembly personnel can fall down.  
 Death, severe bodily injuries.

- ▶ Secure assembly personnel against falling.
- 
- ▶ Hook assembly personnel with the fall arrest system 2 to the safety rope 1 and secure them on the right and left with two snap hooks 3 to prevent them from falling.

## 7.3 Hook points

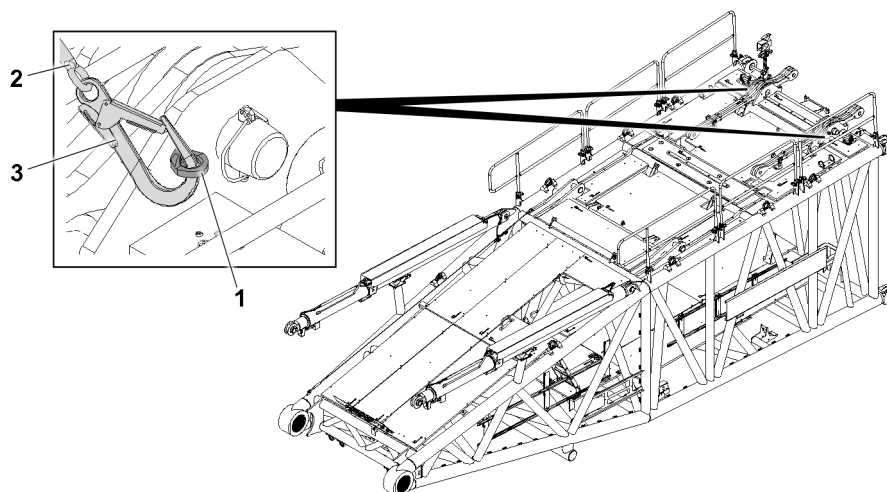


Fig.154357: Pivot section hook points

**WARNING**

Assembly personnel not secured!  
 Assembly personnel can fall down.  
 Death, severe bodily injuries.

- ▶ Secure assembly personnel during assembly and disassembly of the first intermediate section to protect against falling due to the incline position.
- 
- ▶ Hook assembly personnel with the fall arrest system **2** to the eyebolts **1** and secure them on the right and left with two snap hooks **3** to prevent them from falling.

## 8 S-end section

### 8.1 Railings

**WARNING**

Danger of accident due to incorrect assembly of the railings!  
 The railings can suddenly fold down.  
 Death, severe bodily injuries, property damage.

- ▶ Pin and secure the railing in the operating position.

**WARNING**

Danger of accident due to non-assembled railings!  
 Assembly personnel can fall down.  
 Death, severe bodily injuries, property damage.

- ▶ Use suitable and approved aids, such as working platforms or lifting platforms.
- ▶ Secure assembly personnel with a fall arrest system to prevent falling.

#### 8.1.1 Assembling the railing in the operating position

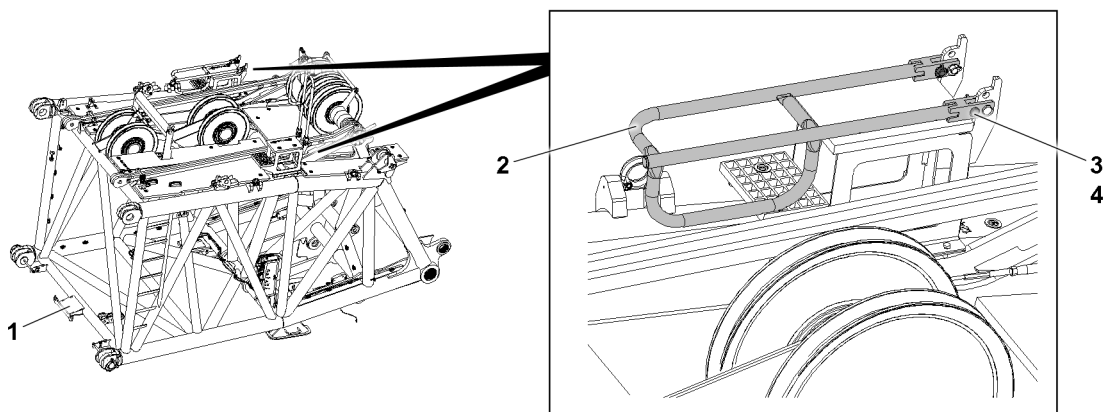


Fig.155864: S-end section railing

- ▶ Release the railing **2**: Remove the retaining element **4** and unpin the socket pin **3**.

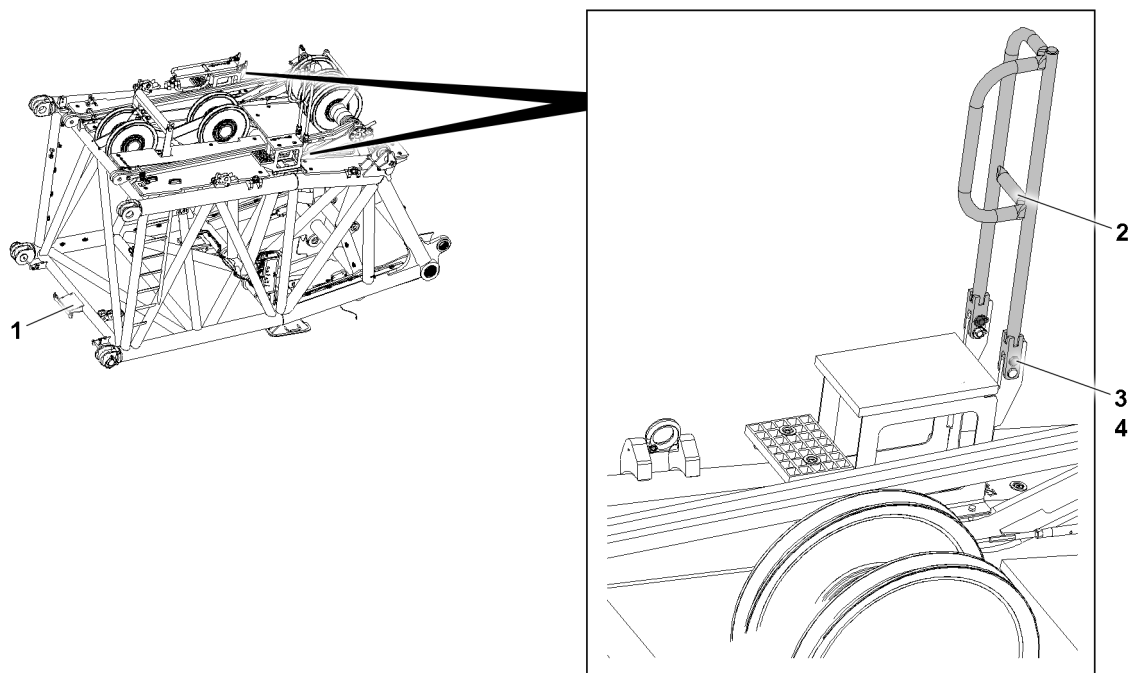


Fig.155865: S-end section railing



#### WARNING

Swinging components!

Death, severe bodily injuries, property damage.

- ▶ Hold components, for example the railing **2**, when swinging them until the respective end position is reached.
  - ▶ Swing the components into the operating position and secure.
- 
- ▶ Fold the railing **2** up.
  - ▶ Secure the railing **2** in the operating position: Insert the socket pin **3**.
  - ▶ Secure the socket pin **3** with the retaining element **4**.



### 8.1.2 Assembling the railing in the transport position

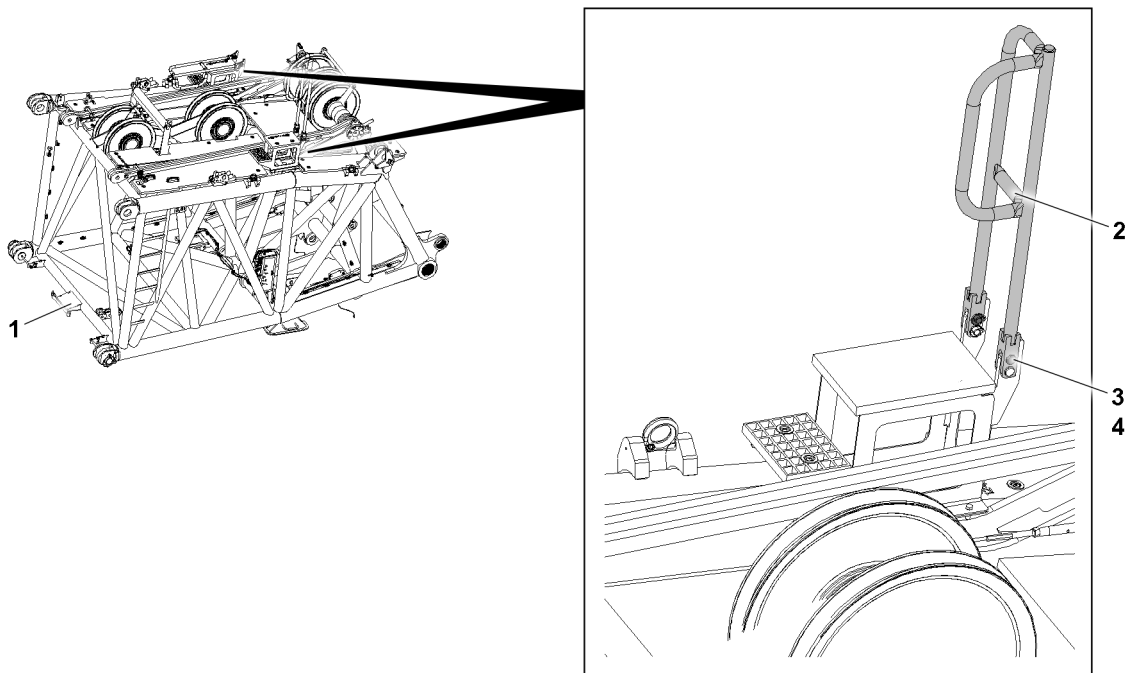


Fig. 155865: S-end section railing

- ▶ Release the railing 2: Remove the retaining element 4 and unpin the socket pin 3.

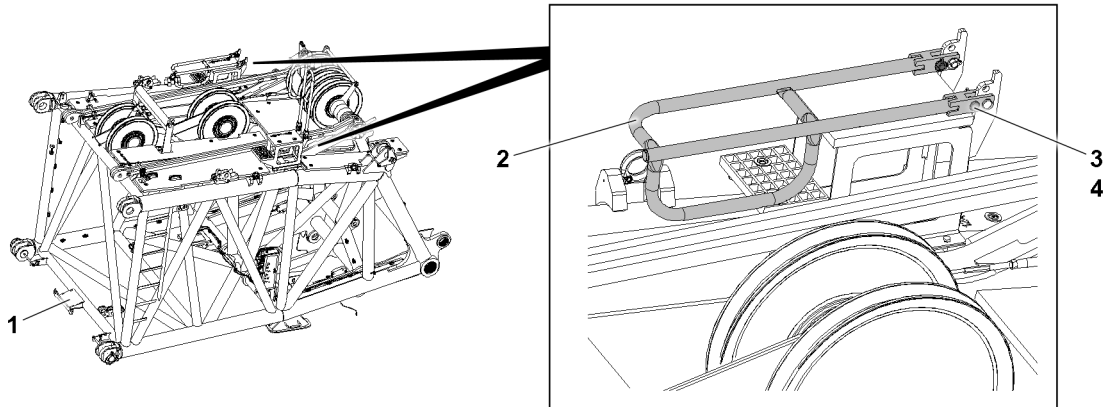


Fig. 155864: S-end section railing



#### WARNING

Swinging components!  
Death, severe bodily injuries, property damage.

- ▶ Hold components, for example the railing 2, when swinging them until the respective end position is reached.
  - ▶ Swing the components into the transport position and secure.
- 
- ▶ Fold the railing 2 down.
  - ▶ Secure the railing 2 in the transport position: Insert the socket pin 3.
  - ▶ Secure the socket pin 3 with the retaining element 4.

## 9 D-end section

### 9.1 Ladder

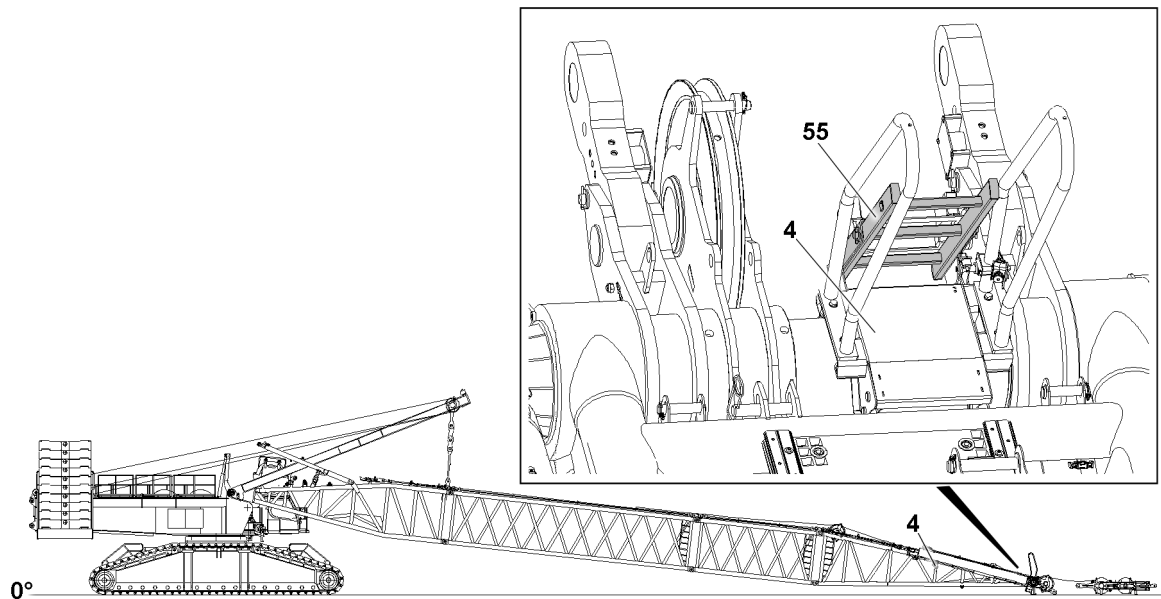


Fig.153400: Swinging the ladder into the operating position

The ladder **55** is locked in transport position with detent pins **56**.

- ▶ Swing the ladder into the operating position.

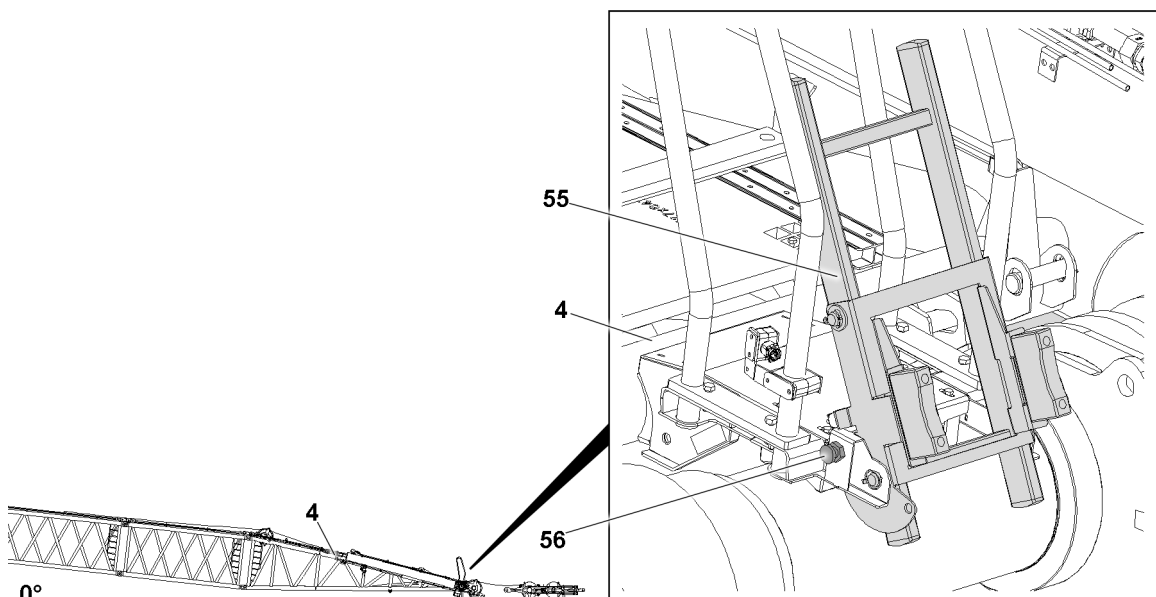


Fig.153401: Releasing the ladder



#### WARNING

Swinging components!  
Death, severe bodily injuries, property damage.

- ▶ Hold components, for example the ladder **55**, when swinging them until the respective end position is reached.
- ▶ Swing the components into the operating position and secure.

- ▶ Release the ladder **55** in the transport position: Pull up the detent pin **56** until the ladder **55** can be swung.

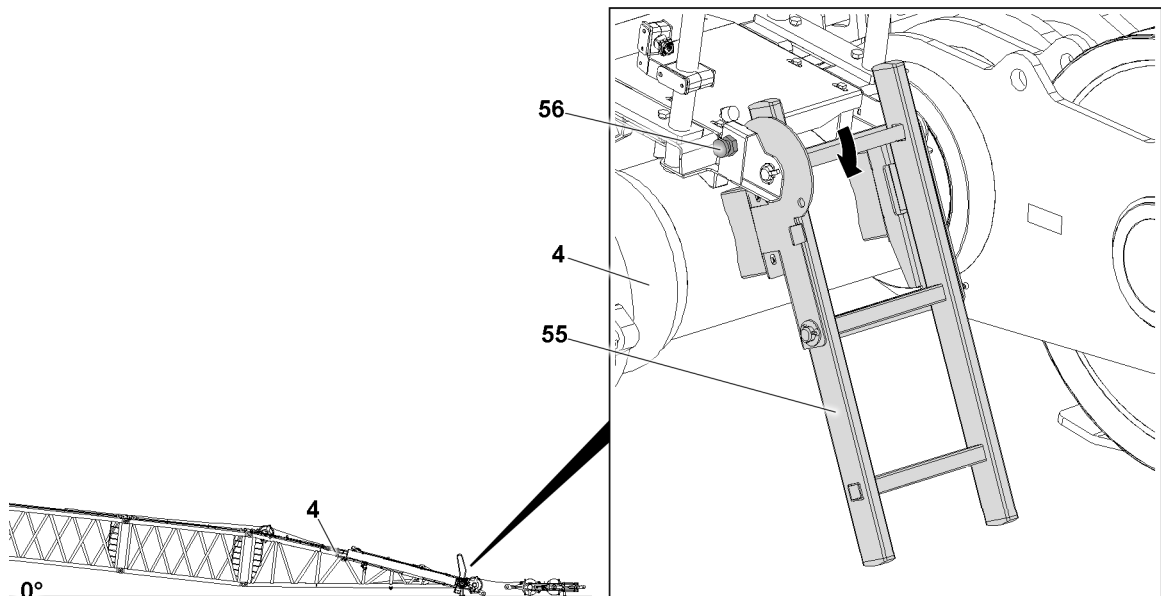


Fig.153402: Swinging the ladder

- ▶ Swing the ladder **55** into the operating position.
- ▶ Secure the ladder **55** in the operating position: Insert the detent pin **56**.

## 10 Counterweight bracket



### WARNING

Danger of accident due to incorrect assembly of the railings!  
The railings can suddenly fold down.

Death, severe bodily injuries, property damage.

- ▶ Pin and secure the railing in the operating position.



### WARNING

Danger of accident due to non-assembled railings!  
Assembly personnel can fall down.

Death, severe bodily injuries, property damage.

- ▶ Use suitable and approved aids, such as working platforms or lifting platforms.
- ▶ Secure assembly personnel with a fall arrest system to prevent falling.



### WARNING

Assembly personnel **not** secured!  
Assembly personnel can fall down.

Death, severe bodily injuries.

- ▶ Secure assembly personnel against falling.

## 10.1 Assembling the railing in the operating position

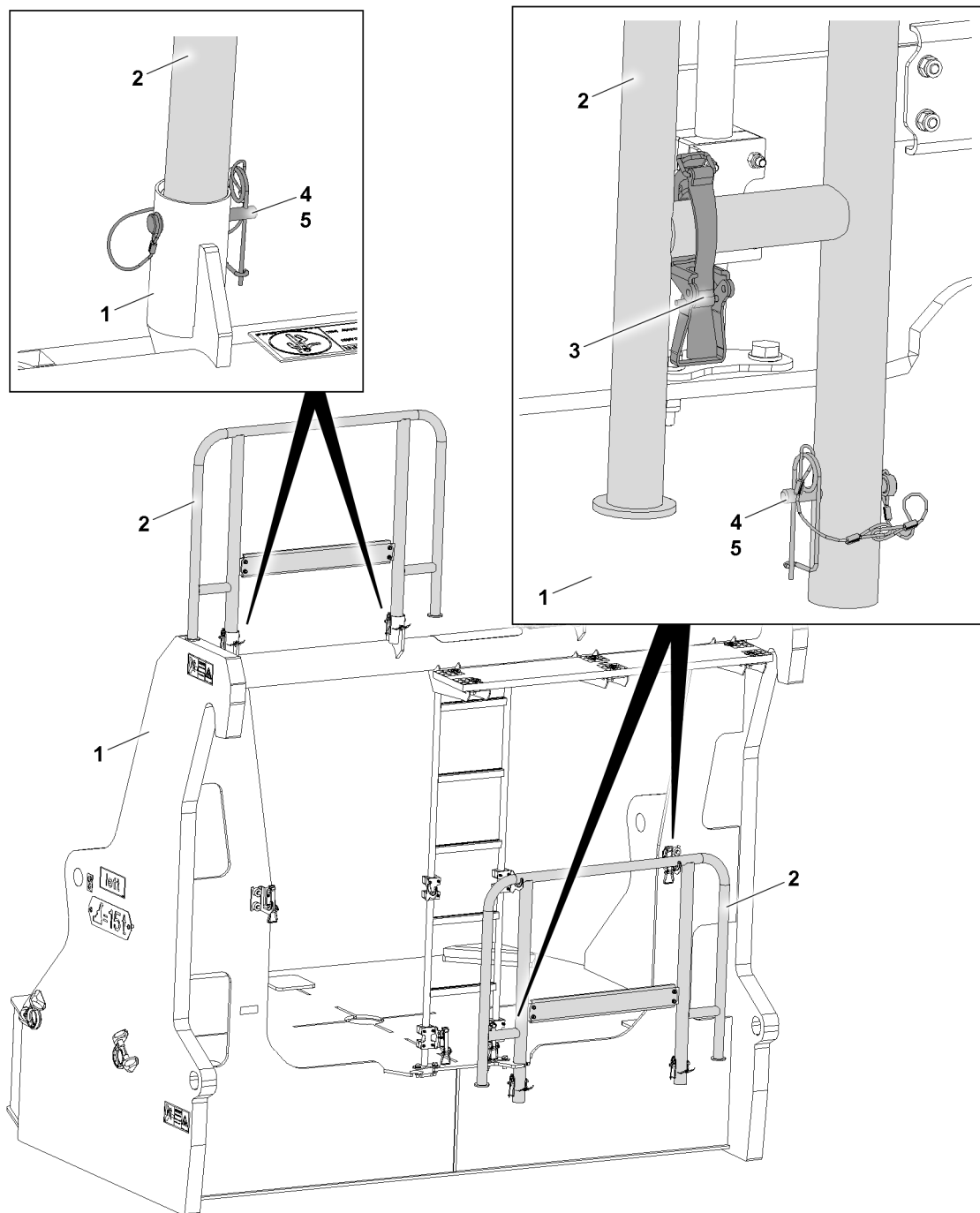


Fig.154329: Railings

- ▶ Release the lock 3.
- ▶ Remove the railing 2 from the transport retainers.
- ▶ Put the railing 2 on the counterweight bracket 1 in the operating position.
- ▶ Secure the railing 2 with the pin 4 and the retaining element 5.

## 10.2 Assembling the railing in the transport position

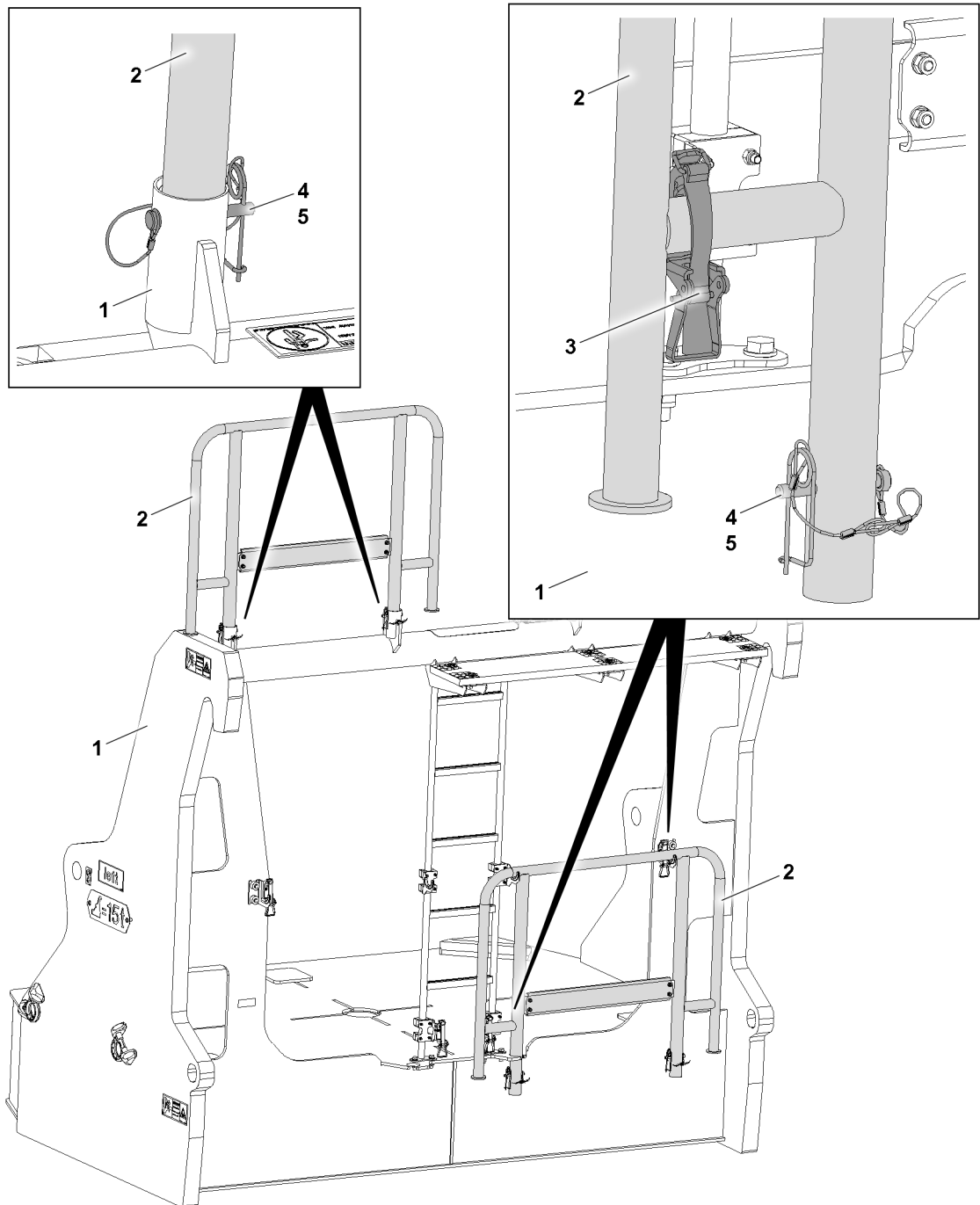


Fig.154329: Railings

- ▶ Release the railing 2: Remove the retaining element 5 and unpin the pin 4.
- ▶ Remove the railing 2 from the operating position.
- ▶ Connect the railing 2 to the counterweight bracket 1 in the transport position.
- ▶ Secure the railing 2 with the pin 4 and the retaining element 5.

# 11 Suspended ballast guide “V-frame”

## 11.1 Assembling the railing in the operating position

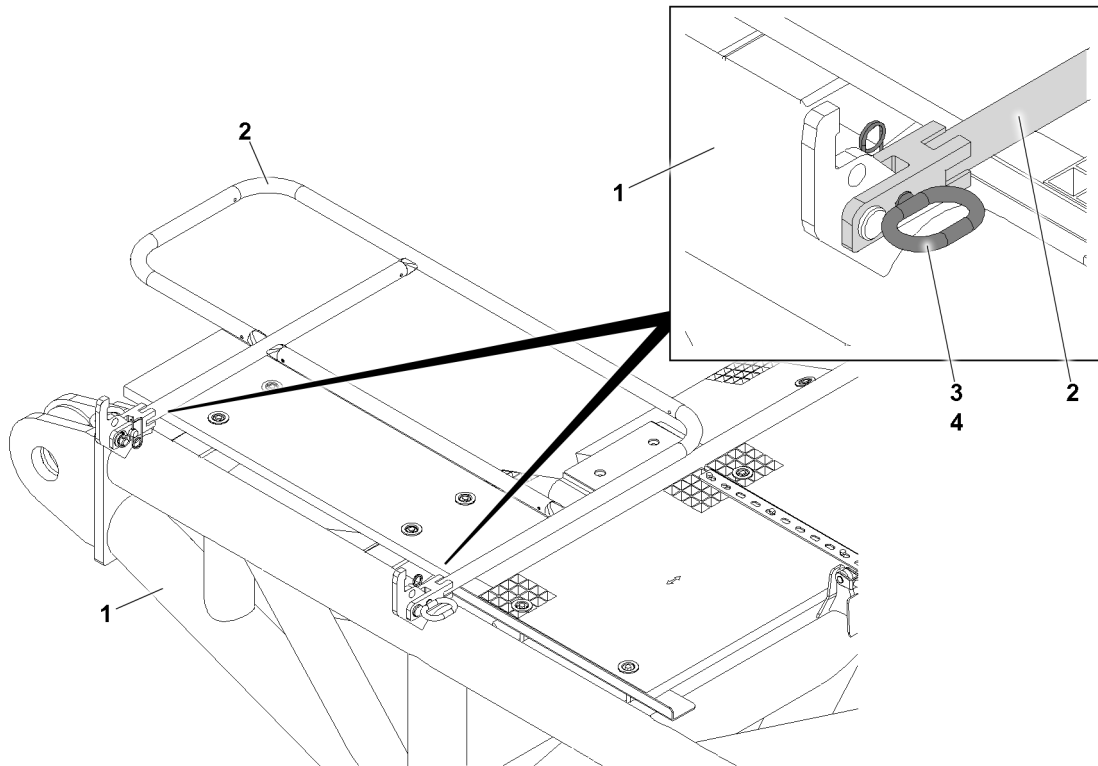


Fig.151474: Railings in the transport position

- ▶ Release the railings 2 in transport position: Remove the retaining element 4 and unpin the socket pin 3.

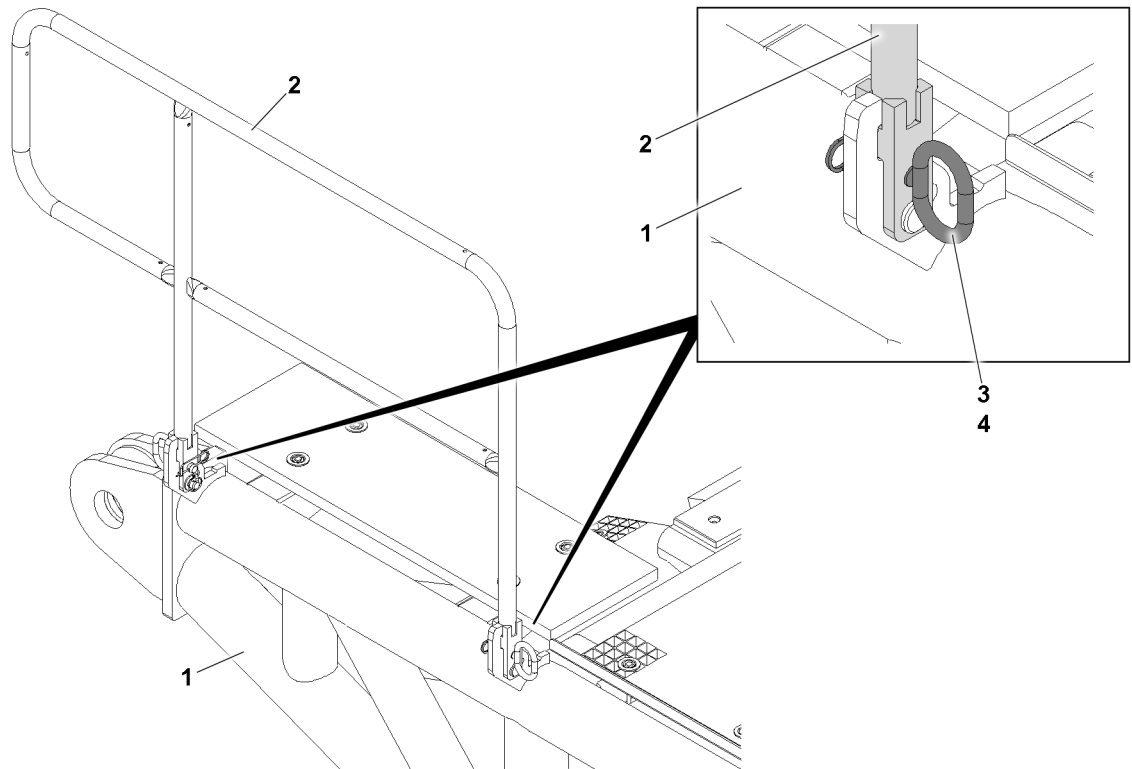


Fig.151475: Railing in the operating position



#### WARNING

Swinging components!

Death, severe bodily injuries, property damage.

- ▶ Hold components, for example the railing **2**, in the operating position after swinging.
  - ▶ Swing the components into the operating position and secure.
- 
- ▶ Swing the railing **2** into the operating position.
  - ▶ Secure the railing **2** in the operating position: Insert the socket pin **3** and secure with the retaining element **4**.

## 11.2 Assembling the railing in the transport position

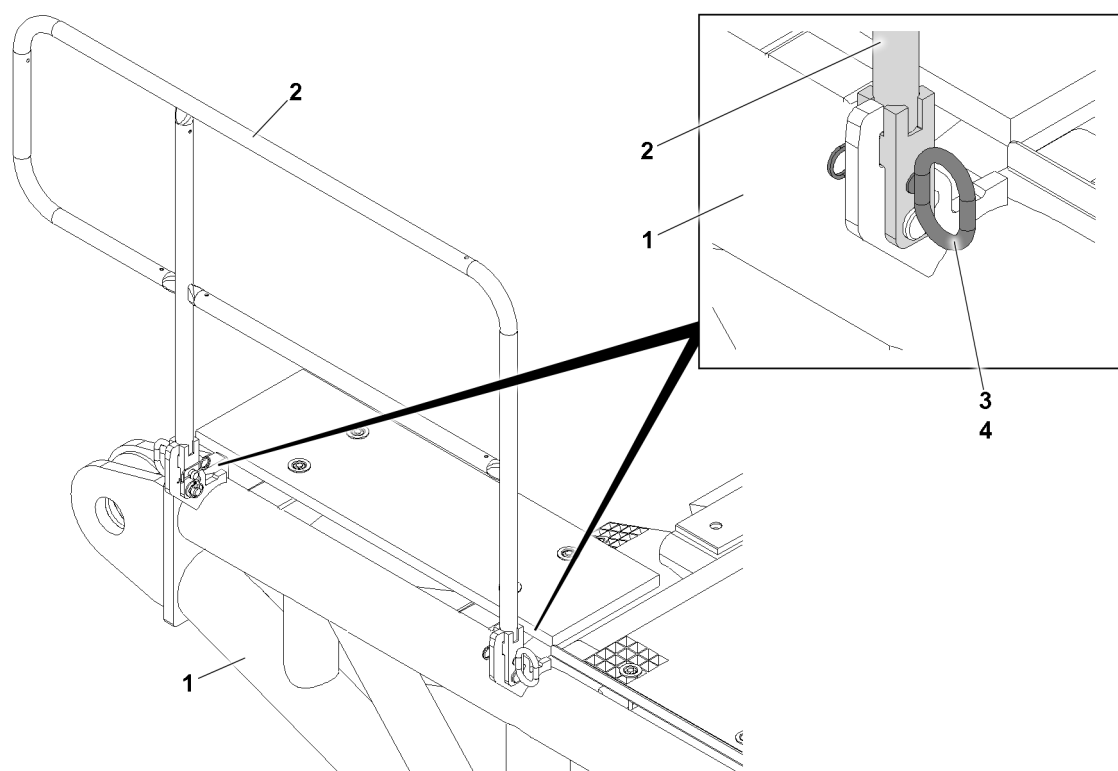


Fig.151475: Railing in the operating position



### WARNING

Swinging components due to releasing!  
Death, severe bodily injuries, property damage.

- ▶ Hold components, for example the railing **2**, in the operating position after releasing.
  - ▶ Swing the components into the transport position and secure.
- 
- ▶ Release the railing **2** in operating position: Remove the retaining element **4** and unpin the socket pin **3**.



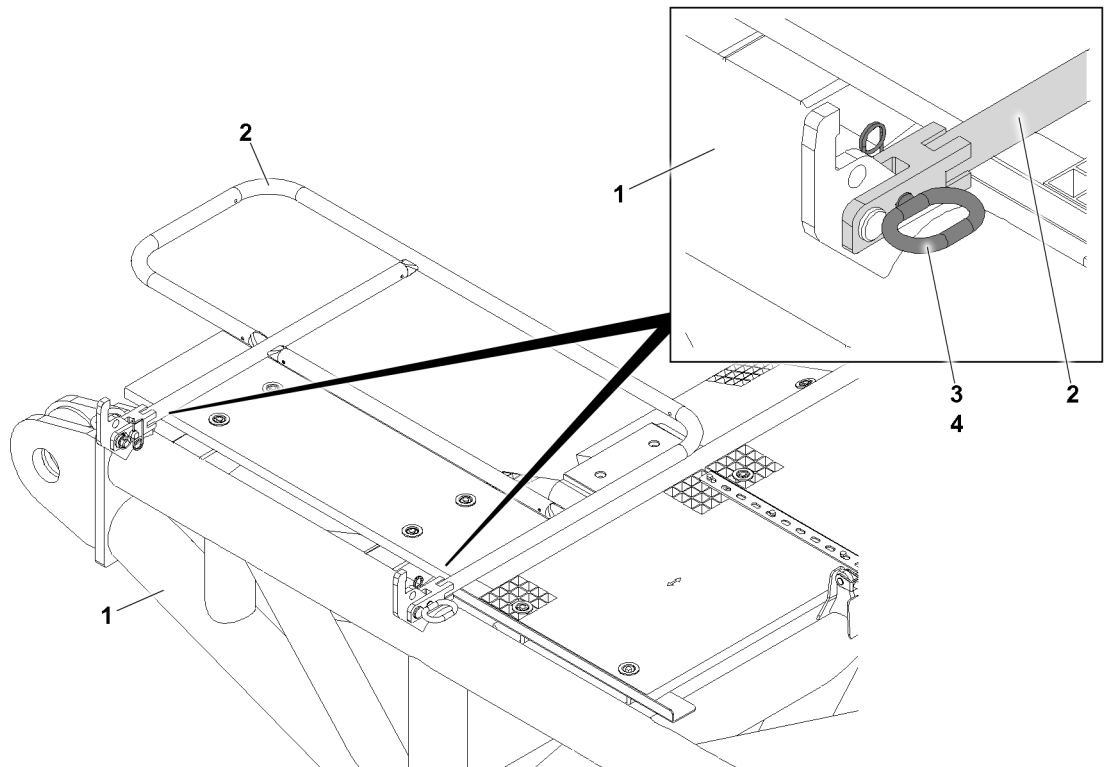


Fig.151474: Railings in the transport position

- ▶ Swing the railing **2** into the transport position.
- ▶ Secure the railings **2** in the transport position: Insert the socket pin **3** and secure with the retaining element **4**.

## 12 Ballast trailer

### 12.1 Railing on the adapter arm

The assembly and disassembly of the railings is identical and is described based on the example of one railing.



#### **WARNING**

Danger of falling!

During assembly and disassembly of the railing, personnel must be secured with appropriate aids to prevent them from falling.

Even during the assembly of protective devices there is a danger of falling.

Death, severe injury, property damage.

- ▶ Use personal protective equipment.

### 12.1.1 Swinging the railing into the operating position

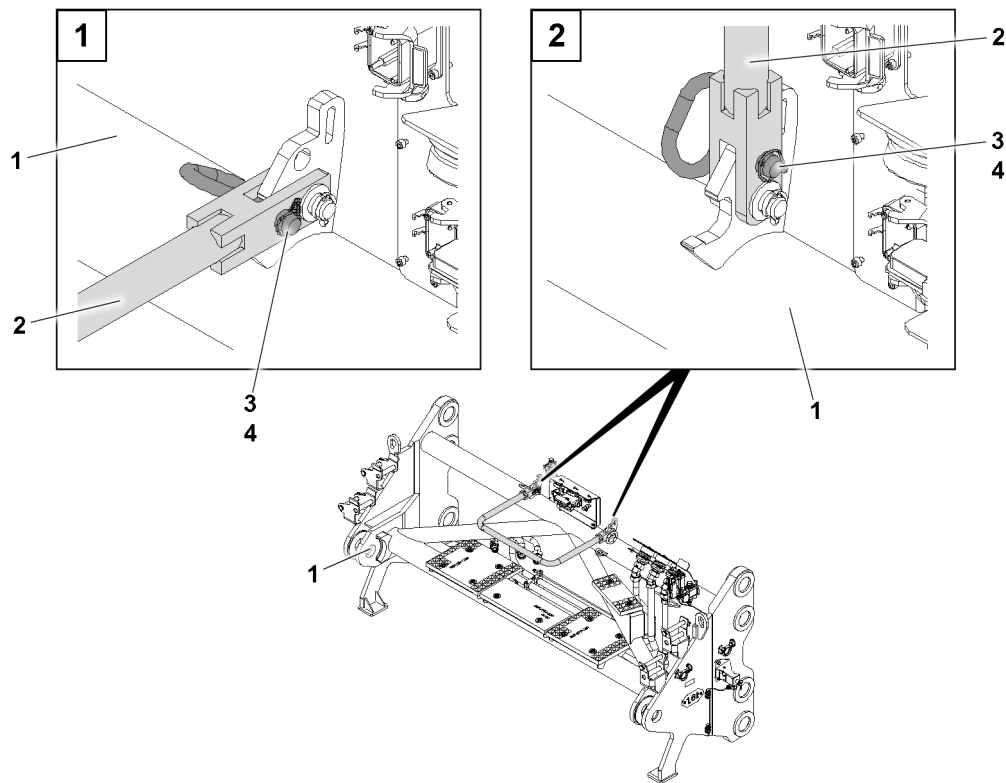


Fig.159012: Railings

- |   |         |   |                   |
|---|---------|---|-------------------|
| 1 | Adapter | 3 | Socket pin        |
| 2 | Railing | 4 | Retaining element |

The adapter 1 is equipped with a foldable railing 2.



#### WARNING

Danger of crushed limbs!

When swinging the railing, fingers and hands can be crushed.

- ▶ Do not reach with your hands into the danger zone.

The railing 2 is secured twice to the adapter 1. The securing procedure is described based on one socket pin as an example.

- ▶ Remove the retaining element 4.
- ▶ Unpin the socket pin 3.
- ▶ Swing the railing 2 into the operating position.
- ▶ Insert the socket pin 3.
- ▶ Secure the socket pin 3 with the retaining element 4.

#### Result:

- The railing 2 is secured in the operating position.

### 12.1.2 Swinging the railings into the transport position

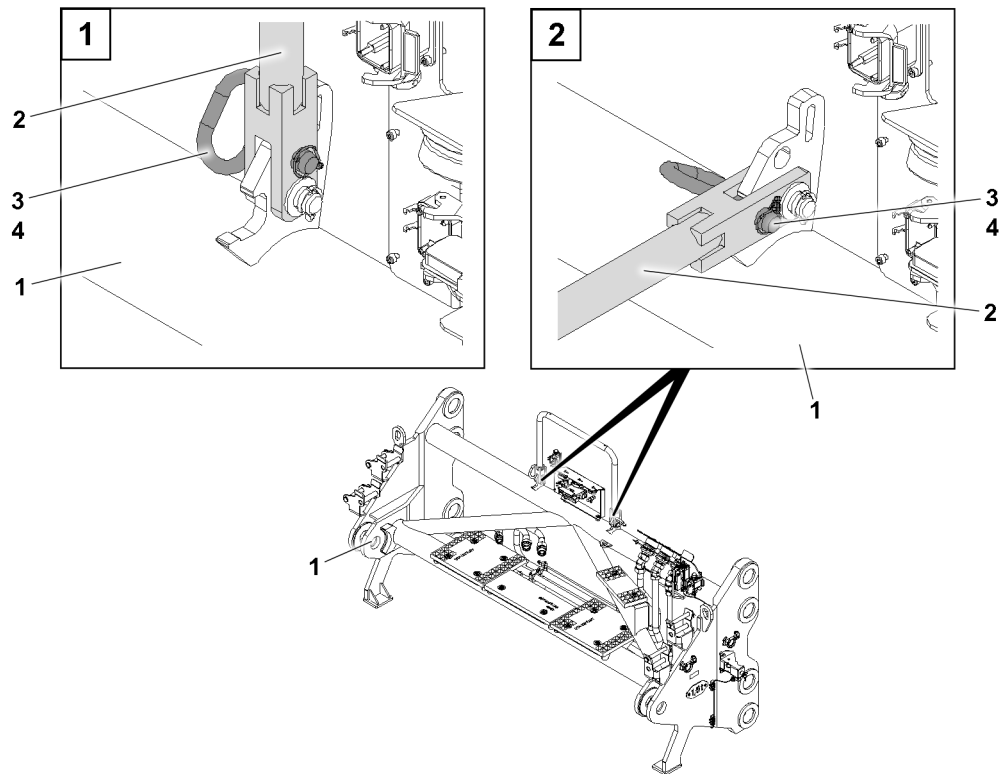


Fig.159018: Railings

- |   |         |   |                   |
|---|---------|---|-------------------|
| 1 | Adapter | 3 | Socket pin        |
| 2 | Railing | 4 | Retaining element |



#### WARNING

Danger of crushed limbs!

When swinging the railing, fingers and hands can be crushed.

- ▶ Do not reach with your hands into the danger zone.

The railing 2 is secured twice to the adapter 1. The unpinning procedure is described based on one socket pin as an example.

- ▶ Remove the retaining element 4.
- ▶ Unpin the socket pin 3.
- ▶ Swing the railing 2 into the transport position.
- ▶ Insert the socket pin 3.
- ▶ Secure the socket pin 3 with the retaining element 4.

#### Result:

- The railing 2 is secured in the transport position.

## 12.2 Railing on the platform

The platform 1 is equipped with a foldable railing 2 and with two foldable railings 3.

The assembly and disassembly of the railings is identical and is described based on the example of one railing.

**WARNING**

Danger of falling!

During assembly and disassembly of the railing, personnel must be secured with appropriate aids to prevent them from falling.

Even during the assembly of protective devices there is a danger of falling.

Death, severe injury, property damage.

► Use personal protective equipment.

### 12.2.1 Swinging the railing into the operating position

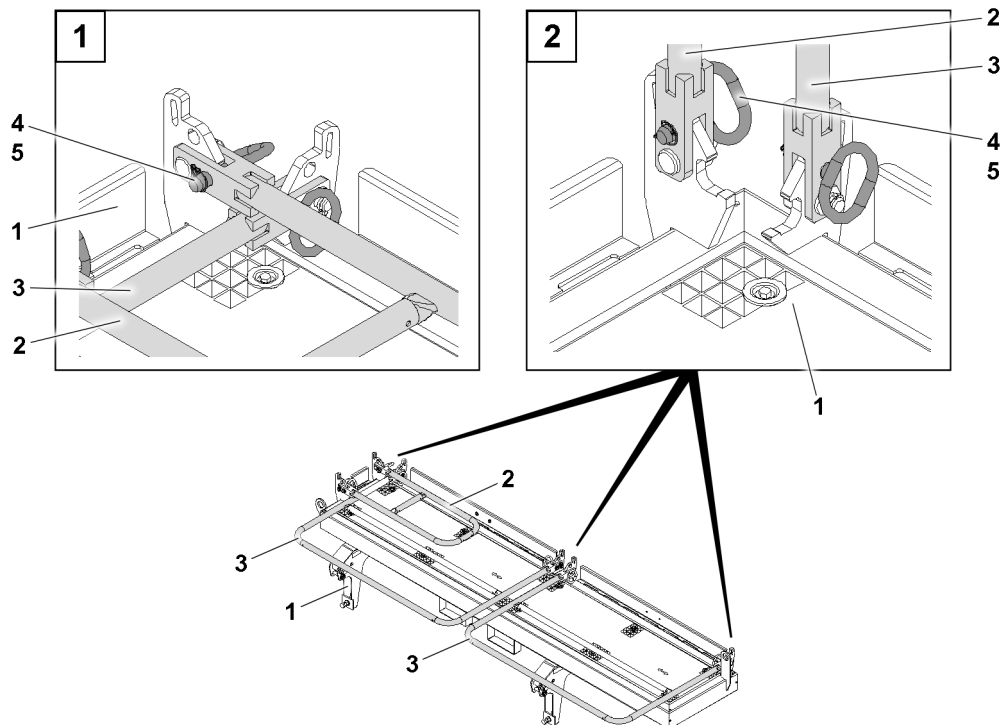


Fig.159013: Railings

- |   |          |   |                   |
|---|----------|---|-------------------|
| 1 | Platform | 4 | Socket pin        |
| 2 | Railing  | 5 | Retaining element |
| 3 | Railing  |   |                   |

The platform 1 is equipped with three foldable railings.

**WARNING**

Danger of crushed limbs!

When swinging the railing, fingers and hands can be crushed.

► Do not reach with your hands into the danger zone.

The railing 2 is secured twice to the platform 1. The securing procedure is described based on one socket pin as an example.

- Remove the retaining element 5.
- Unpin the socket pin 4.
- Swing the railing 2 into the operating position.
- Insert the socket pin 4.
- Secure the socket pin 4 with the retaining element 5.

**Result:**

- The railing 2 is secured in the operating position.
- Assemble the railing 3 the same way as described before.

## 12.2.2 Swinging the railings into the transport position

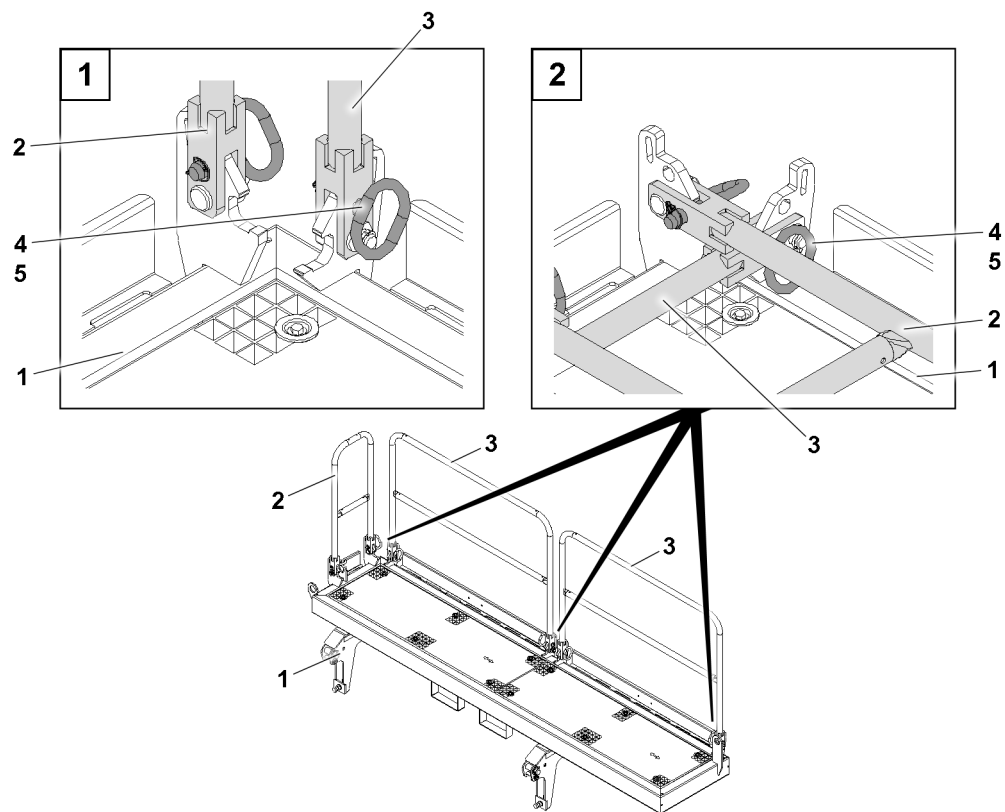


Fig.159019: Railings

- |   |          |   |                   |
|---|----------|---|-------------------|
| 1 | Platform | 4 | Socket pin        |
| 2 | Railing  | 5 | Retaining element |
| 3 | Railing  |   |                   |



### WARNING

Danger of crushed limbs!

When swinging the railing, fingers and hands can be crushed.

- ▶ Do not reach with your hands into the danger zone.

The railing **3** is secured twice to the platform **1**. The unpinning procedure is described based on one socket pin as an example.

- ▶ Remove the retaining element **5**.
- ▶ Unpin the socket pin **4**.
- ▶ Swing the railing **3** into the transport position.
- ▶ Insert the socket pin **4**.
- ▶ Secure the socket pin **4** with the retaining element **5**.

### Result:

- The railing **3** is secured in the transport position.
- ▶ Disassemble the railing **2** the same way as described before.

## 12.3 Railing on the control cabinet platform

The platform **1** is equipped with two foldable railings **3**.

The assembly and disassembly of the railings is identical and is described based on the example of one railing.

**WARNING**

Danger of falling!

During assembly and disassembly of the railing, personnel must be secured with appropriate aids to prevent them from falling.

Even during the assembly of protective devices there is a danger of falling.

Death, severe injury, property damage.

► Use personal protective equipment.

### 12.3.1 Swinging the railing into the operating position

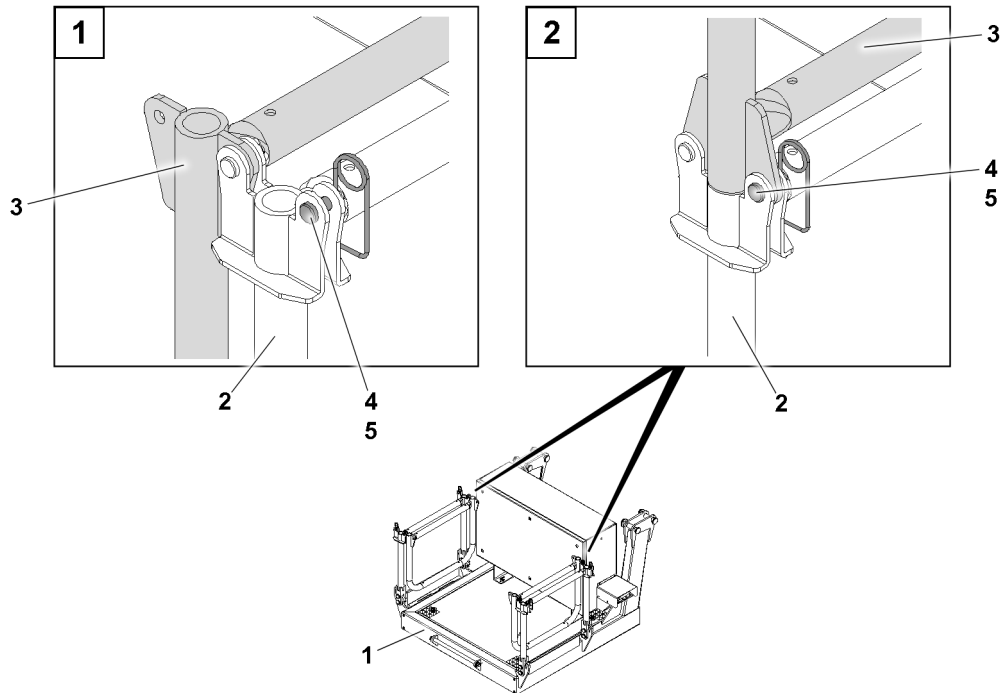


Fig.159014: Railings

- |   |                          |   |                   |
|---|--------------------------|---|-------------------|
| 1 | Control cabinet platform | 4 | Pin               |
| 2 | Railing                  | 5 | Retaining element |
| 3 | Railing                  |   |                   |

**WARNING**

Danger of crushed limbs!

When swinging the railing, fingers and hands can be crushed.

► Do not reach with your hands into the danger zone.

The railing **3** is secured twice to the railing **2**. The pinning procedure is described based on one pin as an example.

- Remove the retaining element **5**.
- Unpin the pin **4**.
- Swing the railing **3** into the operating position.
- Insert the pin **4**.
- Secure the pin **4** with the retaining element **5**.

**Result:**

- The railing **2** is secured in the operating position.

### 12.3.2 Swinging the railings into the transport position

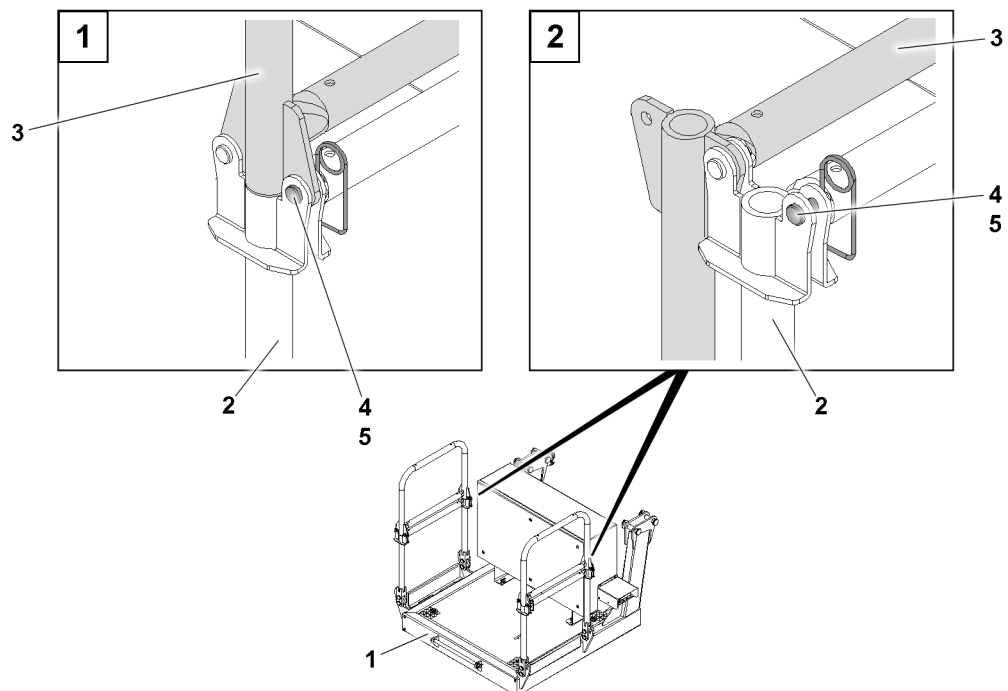


Fig.159020: Railings

- |   |                          |   |                   |
|---|--------------------------|---|-------------------|
| 1 | Control cabinet platform | 4 | Pin               |
| 2 | Railing                  | 5 | Retaining element |
| 3 | Railing                  |   |                   |



#### WARNING

Danger of crushed limbs!

When swinging the railing, fingers and hands can be crushed.

- ▶ Do not reach with your hands into the danger zone.

The railing 3 is secured twice to the railing 2. The unpinning procedure is described based on one pin as an example.

- ▶ Remove the retaining element 5.
- ▶ Unpin the pin 4.
- ▶ Swing the railing 3 into the transport position.
- ▶ Insert the pin 4 again.
- ▶ Secure the pin 4 with the retaining element 5.

## 12.4 Railing on ballast trailer guide

The ballast trailer guide 1 is equipped with three foldable railings 3.

The assembly and disassembly of the railings is identical and is described based on the example of one railing.



#### WARNING

Danger of falling!

During assembly and disassembly of the railing, personnel must be secured with appropriate aids to prevent them from falling.

Even during the assembly of protective devices there is a danger of falling.

Death, severe injury, property damage.

- ▶ Use personal protective equipment.

### 12.4.1 Swinging the railing into the operating position

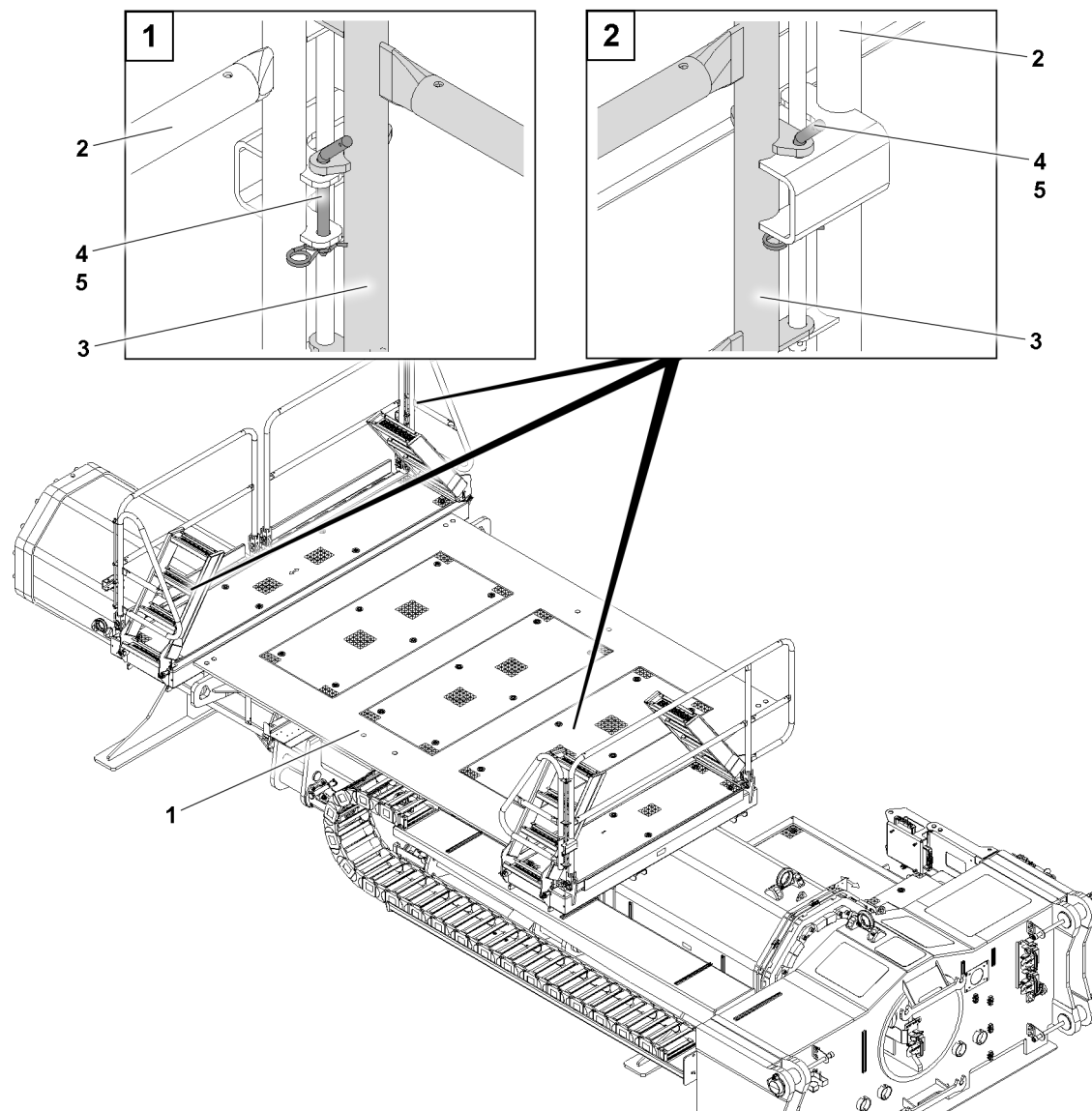


Fig.159015: Railings

- |   |                       |   |                   |
|---|-----------------------|---|-------------------|
| 1 | Ballast trailer guide | 4 | Socket pin        |
| 2 | Railing               | 5 | Retaining element |
| 3 | Railing               |   |                   |

The ballast trailer guide **1** is equipped with three foldable railings.



#### WARNING

Danger of crushed limbs!

When swinging the railing, fingers and hands can be crushed.

- ▶ Do not reach with your hands into the danger zone.

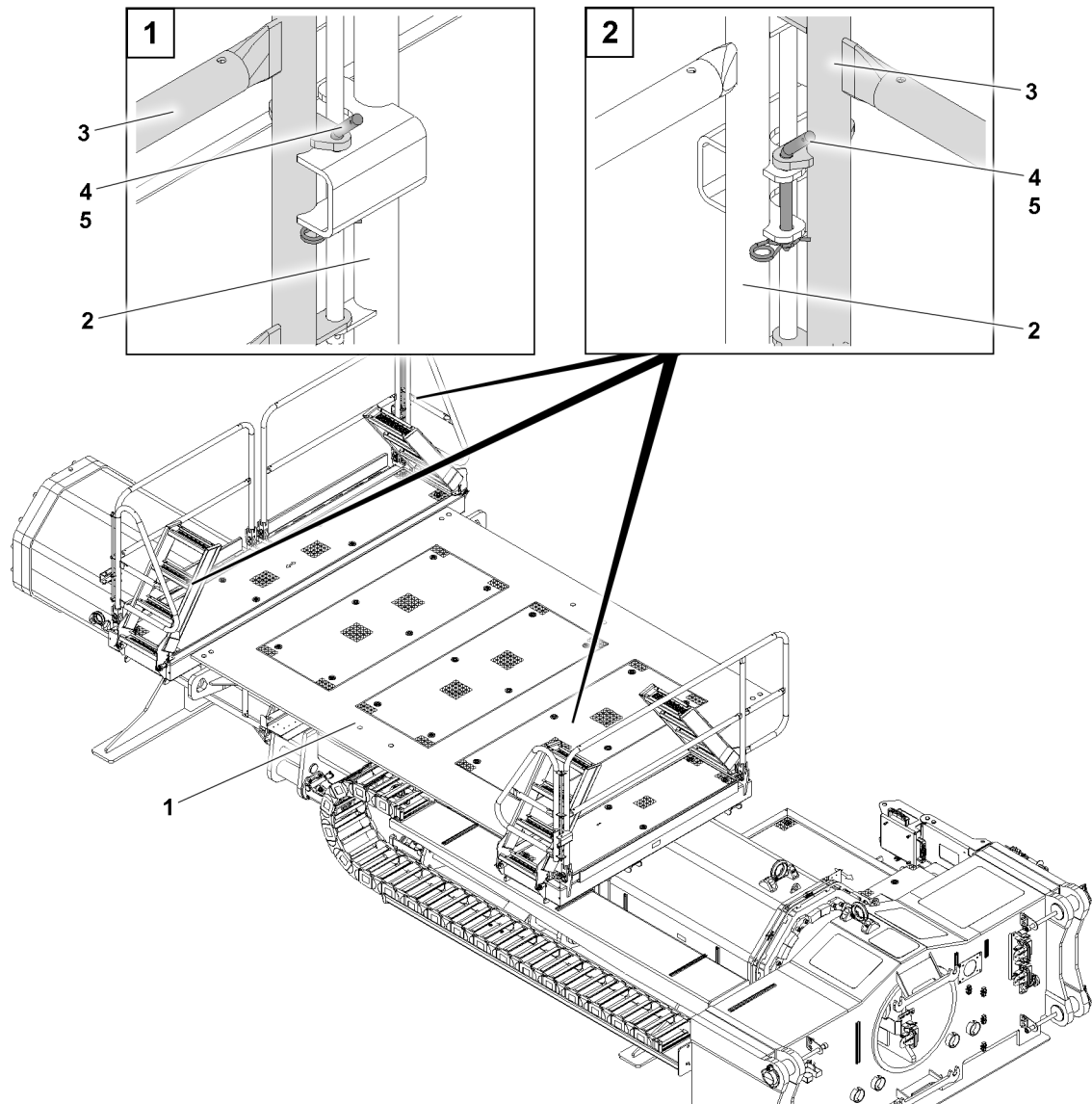
The railing **3** is secured once to the railing **2**. The securing procedure is described based on one socket pin as an example.

- ▶ Remove the retaining element **5**.
- ▶ Unpin the socket pin **4**.
- ▶ Swing the railing **3** into the operating position.
- ▶ Insert the socket pin **4**.
- ▶ Secure the socket pin **4** with the retaining element **5**.



**Result:**

- The railing **3** is secured in the operating position.

**12.4.2 Swinging the railings into the transport position***Fig.159021: Railings*

- |          |                       |          |                   |
|----------|-----------------------|----------|-------------------|
| <b>1</b> | Ballast trailer guide | <b>4</b> | Socket pin        |
| <b>2</b> | Railing               | <b>5</b> | Retaining element |
| <b>3</b> | Railing               |          |                   |

**WARNING**

Danger of crushed limbs!

When swinging the railing, fingers and hands can be crushed.

- ▶ Do not reach with your hands into the danger zone.

The railing **3** is secured once to the railing **2**. The unpinning procedure is described based on one socket pin as an example.

- ▶ Remove the retaining element **5**.
- ▶ Unpin the socket pin **4**.
- ▶ Swing the railing **3** into the transport position.

- ▶ Insert the socket pin **4**.
- ▶ Secure the socket pin **4** with the retaining element **5**.

**Result:**

- The railing **3** is secured in the transport position.

## 12.5 Railing on ballast trailer guide

The ballast trailer guide **1** is equipped with foldable railings **2**.

The assembly and disassembly of the railings is identical and is described based on the example of one railing.



---

**WARNING**

Danger of falling!

During assembly and disassembly of the railing, personnel must be secured with appropriate aids to prevent them from falling.

Even during the assembly of protective devices there is a danger of falling.

Death, severe injury, property damage.

- ▶ Use personal protective equipment.
-

### 12.5.1 Swinging the railing into the operating position

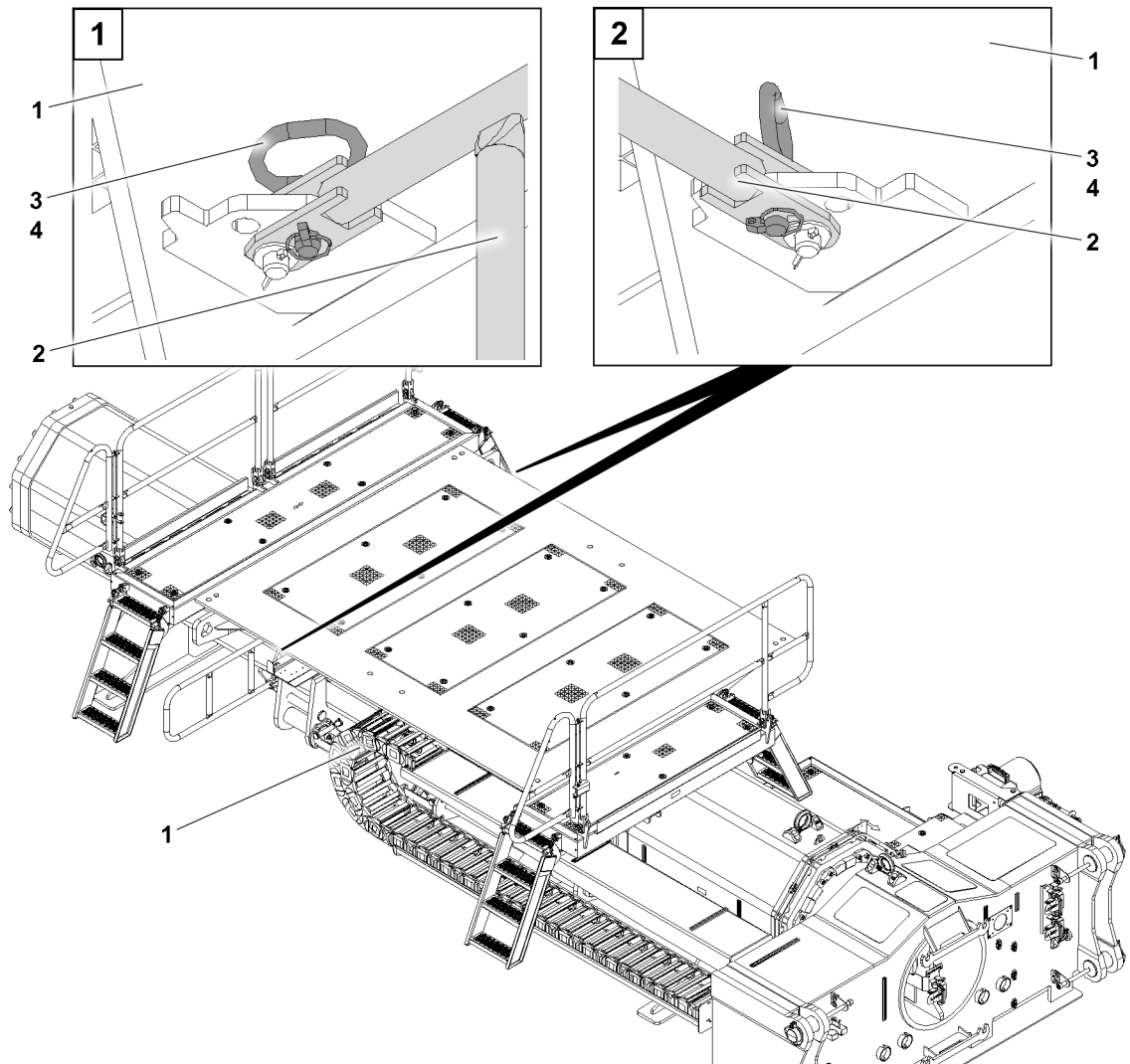


Fig.159017: Railings

- |   |                       |   |                   |
|---|-----------------------|---|-------------------|
| 1 | Ballast trailer guide | 3 | Socket pin        |
| 2 | Railing               | 4 | Retaining element |

The ballast trailer guide 1 is equipped with two foldable railings 2.



#### WARNING

Danger of crushed limbs!

When swinging the railing, fingers and hands can be crushed.

- ▶ Do not reach with your hands into the danger zone.

The railing 2 is secured twice to the ballast trailer guide 1. The securing procedure is described based on one socket pin as an example.

- ▶ Remove the retaining element 4.
- ▶ Unpin the socket pin 3.
- ▶ Swing the railing 3 into the operating position.
- ▶ Insert the socket pin 3.
- ▶ Secure the socket pin 3 with the retaining element 4.

#### Result:

- The railing 2 is secured in the operating position.

## 12.5.2 Swinging the railings into the transport position

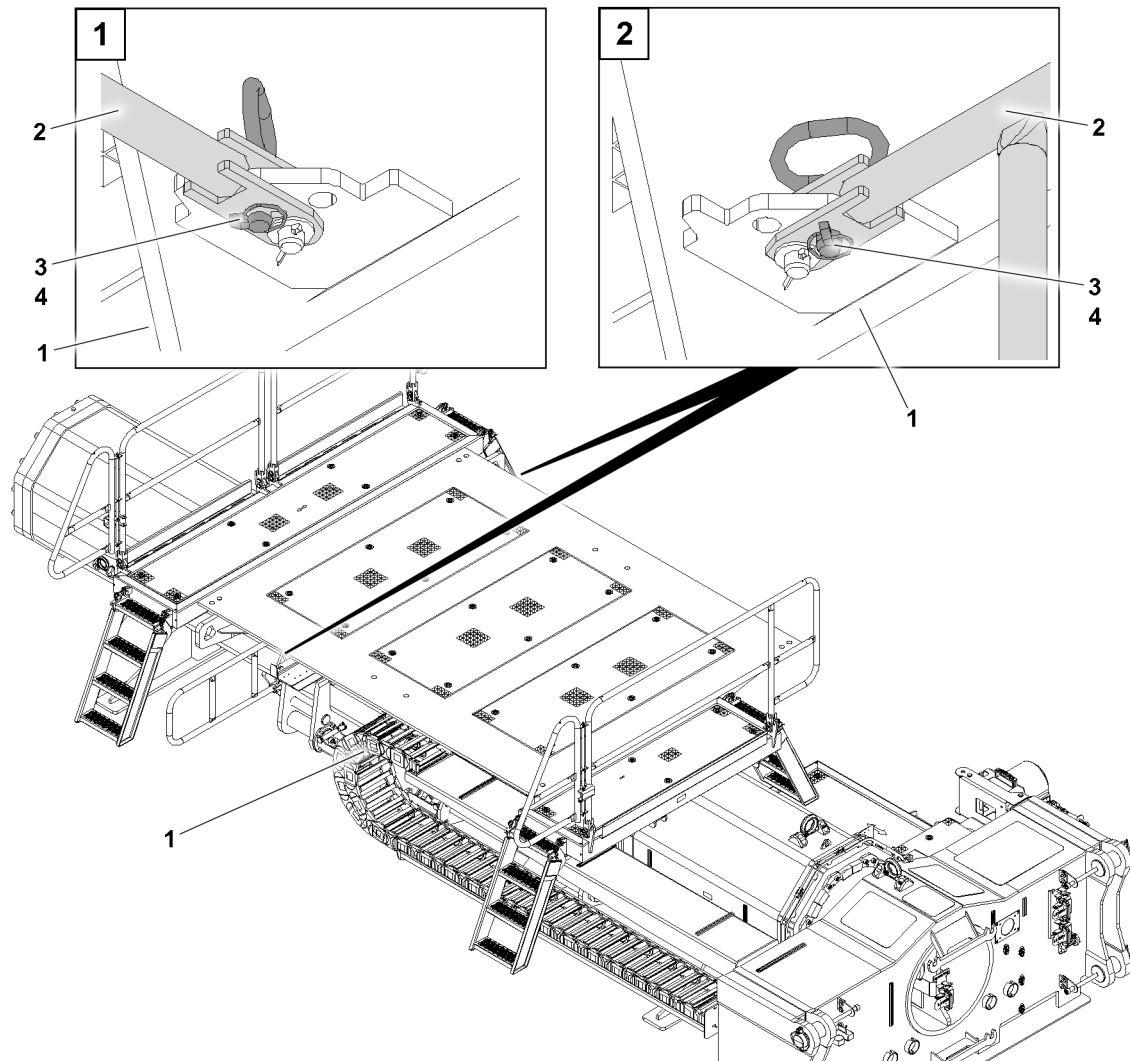


Fig. 159022: Railings

- |   |                       |   |                   |
|---|-----------------------|---|-------------------|
| 1 | Ballast trailer guide | 3 | Socket pin        |
| 2 | Railing               | 4 | Retaining element |



### WARNING

Danger of crushed limbs!

When swinging the railing, fingers and hands can be crushed.

- ▶ Do not reach with your hands into the danger zone.

The railing **2** is secured twice to the ballast trailer guide **1**. The unpinning procedure is described based on one socket pin as an example.

- ▶ Remove the retaining element **4**.
- ▶ Unpin the socket pin **3**.
- ▶ Swing the railing **2** into the transport position.
- ▶ Insert the socket pin **3**.
- ▶ Secure the socket pin **3** with the retaining element **4**.

### Result:

- The railing **2** is secured in the transport position.

## 12.6 Ladders on the ballast trailer guide

The ballast trailer guide **1** is equipped with four ladders **2**.

The ladders **2** are used for assembly personnel to ascend and descend the ballast trailer guide.

The assembly and disassembly of the ladders **2** is described based on the example of one ladder.

### NOTICE

Damage to ladder!

If the ladders **2** are in operating position before installation of the ballast trailer guide **1**, the ladders **2** can be damaged.

- ▶ Make sure that the ladders **2** are in transport position during installation of the ballast trailer guide **1**.

### 12.6.1 Swinging the ladder into the operating position

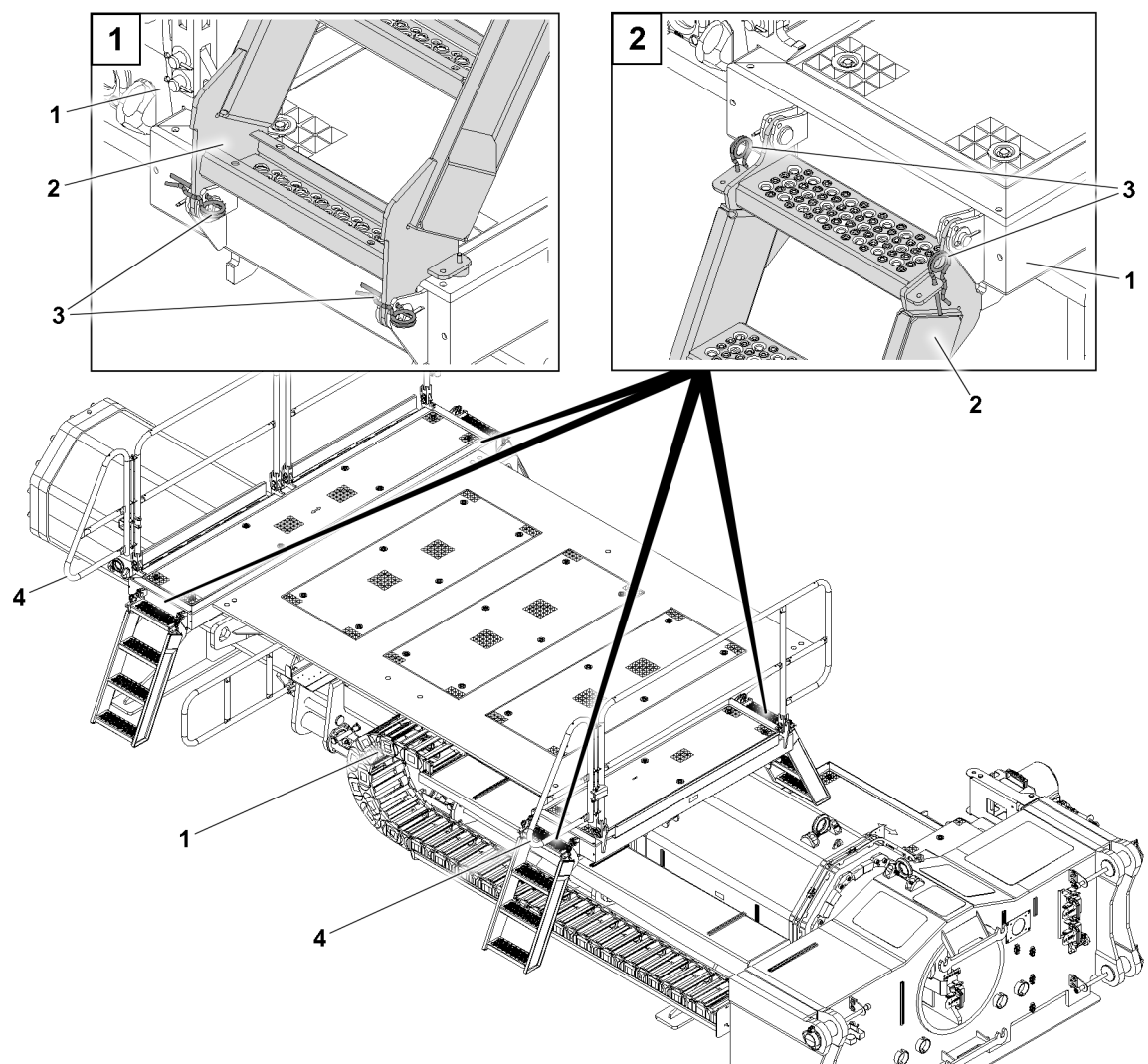


Fig.159016: Ladders

- |          |                       |          |                   |
|----------|-----------------------|----------|-------------------|
| <b>1</b> | Ballast trailer guide | <b>3</b> | Retaining element |
| <b>2</b> | Ladder                | <b>4</b> | Railing           |

Make sure that the following prerequisites are met:

- The ballast trailer guide **1** is installed.
- The railings **4** are open.

**WARNING**

Danger of crushing!

When swinging the ladder, it can fall down by itself due to its own weight.

Crushing injuries of limbs can occur.

Severe injuries.

- ▶ Hold the ladder **2** and swing it slowly into the operating position.

The ladder **2** is secured twice to the ballast trailer guide **1**. The pinning procedure is described based on one retaining element as an example.

- ▶ Remove the retaining element **3**.
- ▶ Swing the ladder **2** into the operating position.
- ▶ Assemble the retaining element **3** in the park position.

### 12.6.2 Swinging the ladder into the transport position

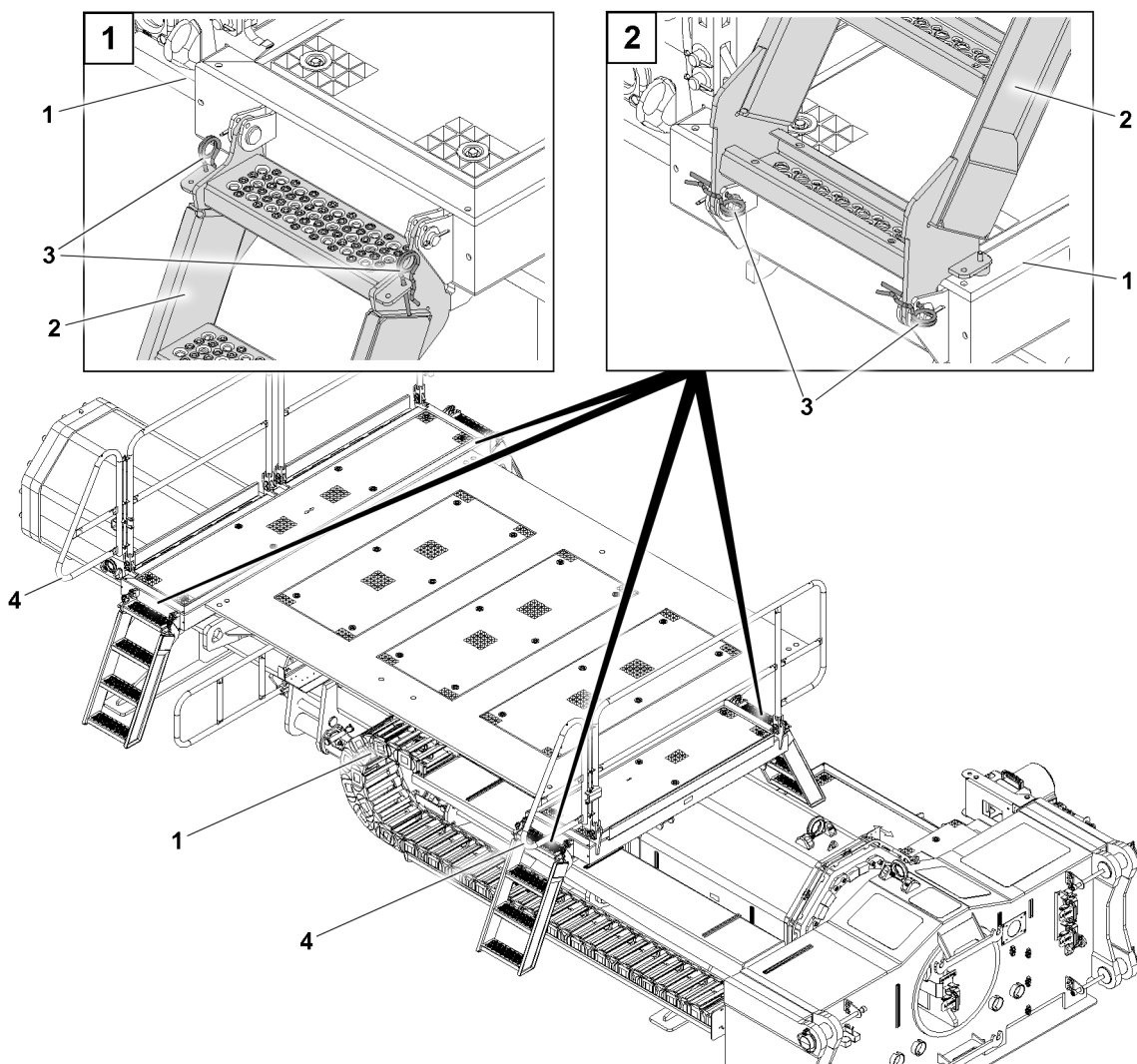


Fig.159023: Ladders

- |          |                       |          |                   |
|----------|-----------------------|----------|-------------------|
| <b>1</b> | Ballast trailer guide | <b>3</b> | Retaining element |
| <b>2</b> | Ladders               | <b>4</b> | Railing           |

Make sure that the following prerequisite is met:

- The railings **4** are open.

**WARNING**

Danger of crushing!

When swinging the ladder, it can fall down by itself due to its own weight. Crushing injuries of limbs can occur.

- ▶ Hold the ladder **2** and swing it slowly into the transport position.

The ladder **2** is secured twice to the ballast trailer guide **1**. The securing procedure is described based on one retaining element as an example.

- ▶ Remove the retaining element **3** from the park position.
- ▶ Swinging the ladder **2** into the transport position.
- ▶ Secure the ladder **2** with the retaining element **3**.

**Result:**

- The ladder **2** is secured in the transport position.

## 12.7 Extension ladder on the ballast trailer

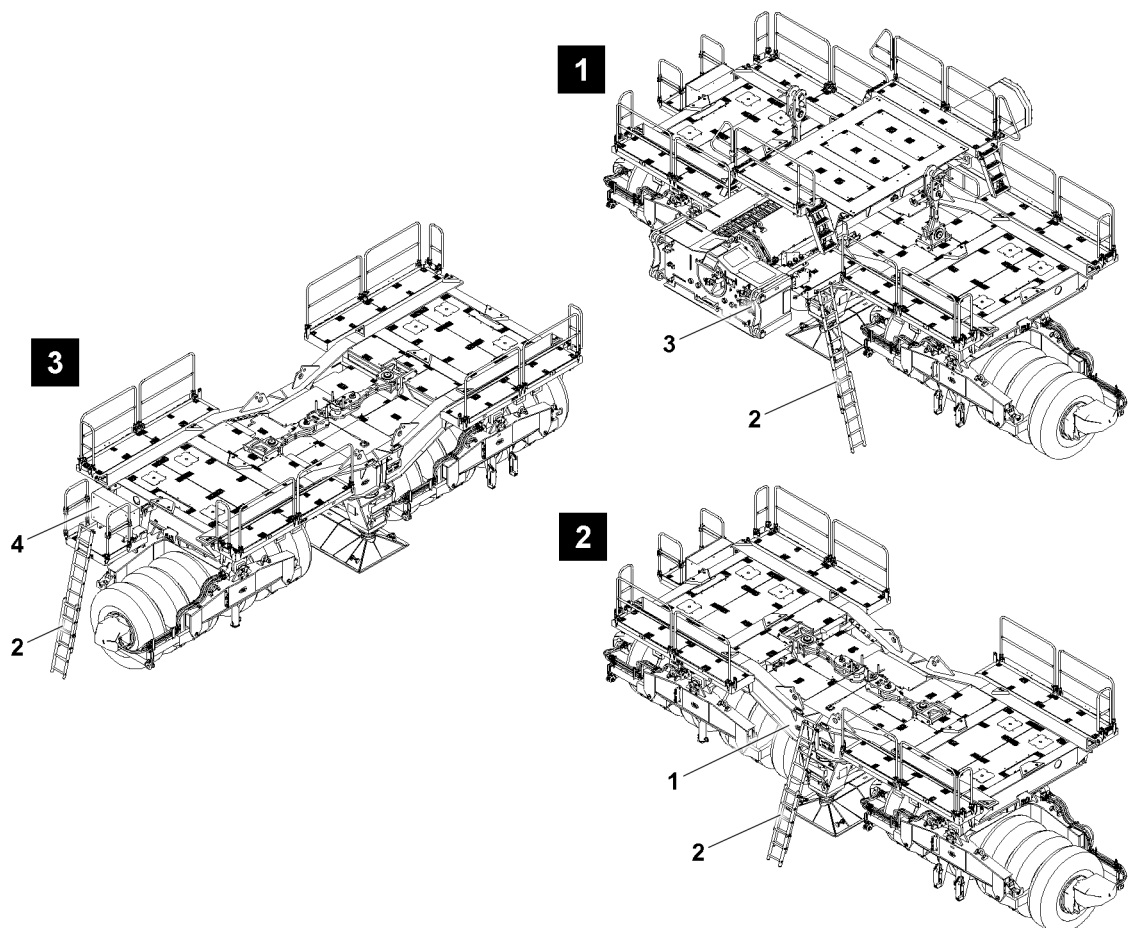


Fig.159025: Extension ladder

- |                           |                                |
|---------------------------|--------------------------------|
| <b>1</b> Ballast trailer  | <b>3</b> Ballast trailer guide |
| <b>2</b> Extension ladder | <b>4</b> Control cabinet       |

The extension ladder **2** is used for assembly personnel to ascend and descend the ballast trailer.

Area of operation of the extension ladder:

- Extension ladder on the ballast trailer **1**, see illustration **1**
- Extension ladder on ballast trailer guide **3**, see illustration **2**
- Extension ladder on control cabinet **4**, see illustration **3**

**Note**

- ▶ The weight of the extension ladder is 12.5 kg.

**WARNING**

Danger of falling!

Death, severe injury, property damage.

- ▶ When ascending and descending, assembly personnel must ensure a 3-point support.
- ▶ When ascending and descending, use rungs and ladder beams as handles.
- ▶ The assembly personnel must step into the rungs deep enough.

**NOTICE**

Danger of crushing!

During assembly and disassembly of the extension ladder fingers and hands can be crushed.

- ▶ Do not reach with your hands into the danger zone.
- ▶ Install the ladder solely from the ground.
- ▶ Step on the extension ladder only when the extension ladder is secured in the ascent and descent position.
- ▶ Observe the national regulations and standards regarding the use of rung ladders.

### 12.7.1 Preparing the ready-to-use / ready-to-transport extension ladder

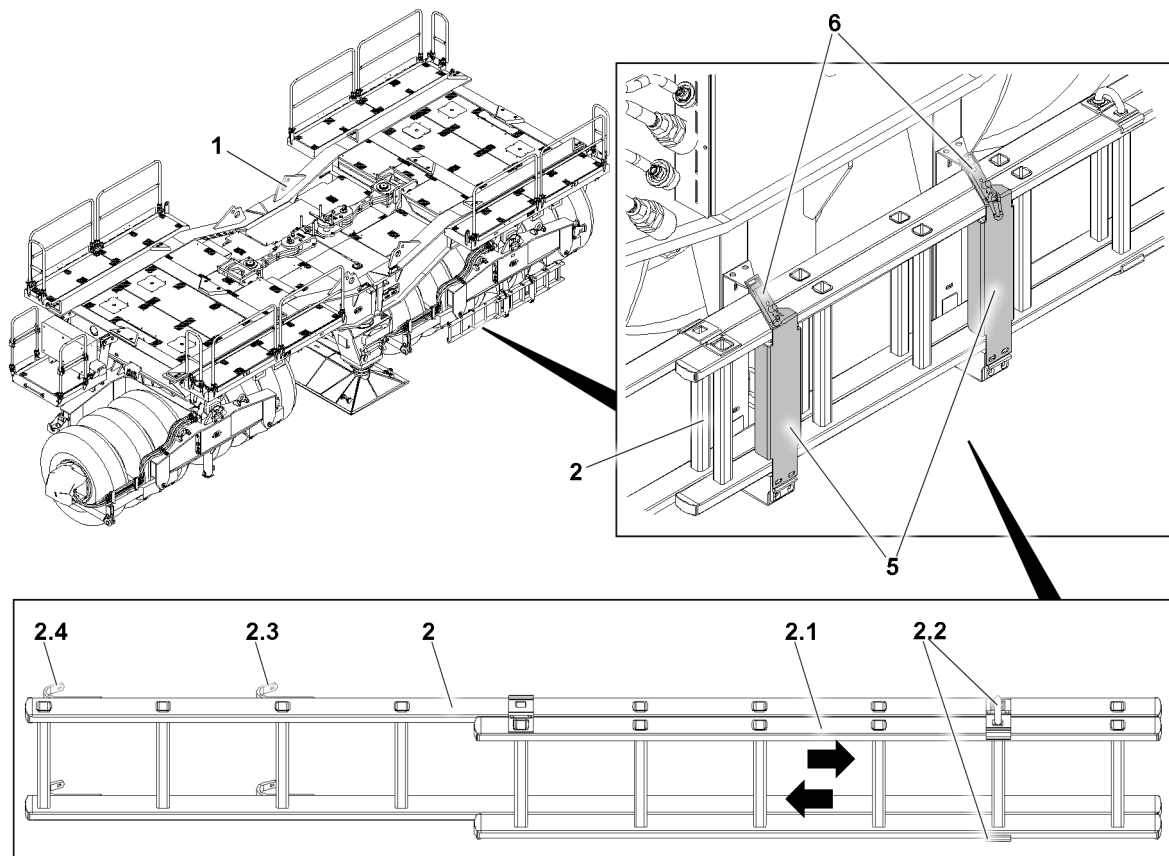


Fig.159024: Extension ladder

- |     |                          |     |            |
|-----|--------------------------|-----|------------|
| 2   | Extension ladder         | 2.4 | Hook       |
| 2.1 | Extension ladder section | 5   | Retainer   |
| 2.2 | Lock                     | 6   | Turnbuckle |
| 2.3 | Hook                     |     |            |

Make sure that the following prerequisite is met:

- The ballast trailer 1 is supported.



### Releasing the extension ladder from the transport position

---



#### WARNING

Danger of crushed limbs!

The extension ladder **2** can swing down by itself due to its own weight when it is opening. Fingers and hands can be crushed.

Severe injury, property damage.

▶ Before opening, hold the extension ladder **2** and swing the retainer **5** down slowly.

---

- ▶ Open both turnbuckles **6**.
- ▶ Swing the retainer **5**.
- ▶ Take the extension ladder **2** out.
- ▶ Swing the retainer **5** back up.
- ▶ Close both turnbuckles **6**.

### Pulling the extension ladder out

---



#### WARNING

Danger of crushed limbs!

When sliding the extension ladder section **2.1**, fingers and hands can be crushed.

▶ Do not reach with your hands into the danger zone.

---

- ▶ Pull the two sided lock **2.2** out and turn it to the side.
- ▶ Move the extension ladder section **2.1** one or more rungs.
- ▶ Turn and engage the two sided lock **2.2** again.

### Installing the extension ladder in the transport position

---



#### WARNING

Danger of crushed limbs!

The extension ladder **2** can swing down by itself due to its own weight during installation. Fingers and hands can be crushed.

Severe injury, property damage.

▶ Insert and hold the extension ladder **2** during installation. Swing the retainer **5** slowly upwards.

---

- ▶ Open both turnbuckles **6**.
- ▶ Swing the retainer **5** down.
- ▶ Insert the extension ladder **2**.
- ▶ Swing the retainer **5** back up.
- ▶ Close both turnbuckles **6**.

## 12.7.2 Extension ladder on the ballast trailer

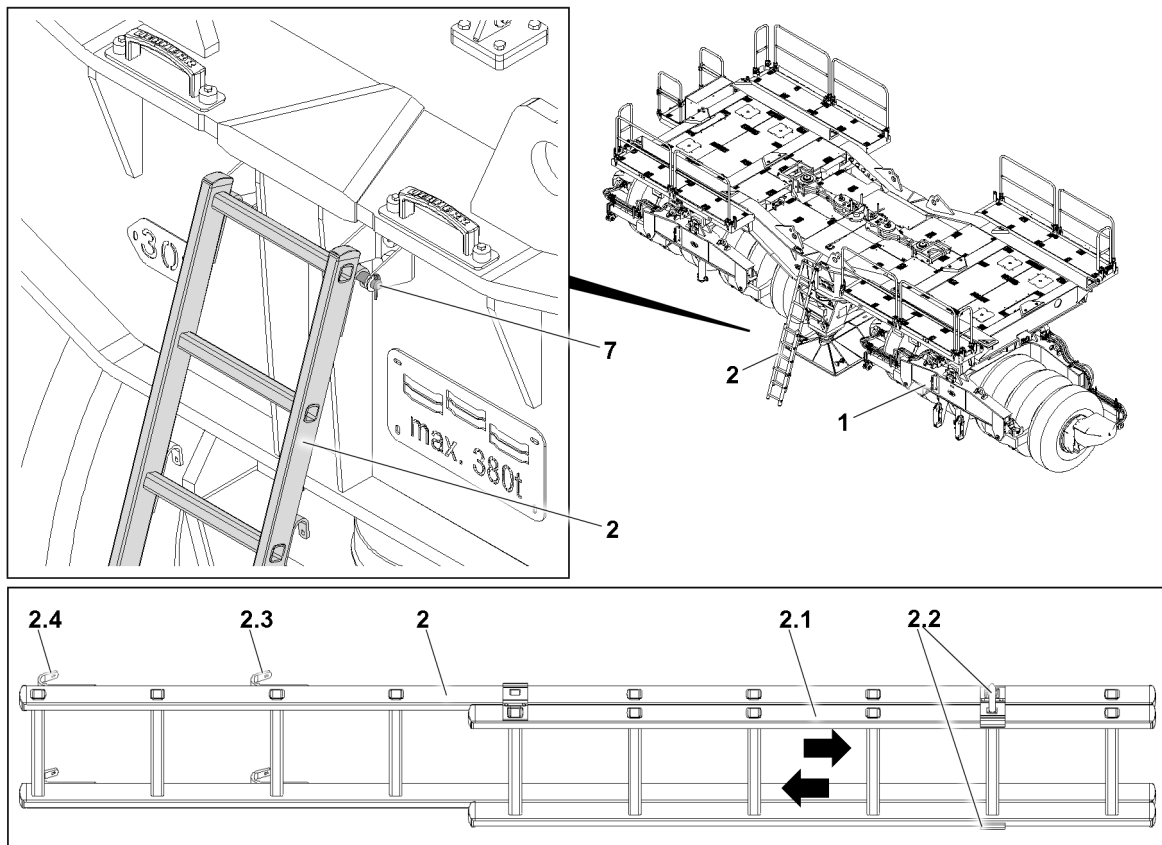


Fig. 159026: Extension ladder on the ballast trailer

- |     |                          |     |            |
|-----|--------------------------|-----|------------|
| 1   | Ballast trailer          | 2.3 | Hook       |
| 2   | Extension ladder         | 2.4 | Hook       |
| 2.1 | Extension ladder section | 7   | Receptacle |
| 2.2 | Lock                     |     |            |

Make sure that the following prerequisite is met:

- The ballast trailer 1 is supported.

### Hanging the extension ladder in the operating position

- ▶ Take the extension ladder 2 out of the transport position on the ballast trailer 1: see section “Preparing the ready-to-use / ready-to-transport extension ladder”.



### WARNING

Danger of crushed limbs!

When sliding the extension ladder section 2.1, fingers and hands can be crushed.

- ▶ Do not reach with your hands into the danger zone.
- ▶ Push the extension ladder section 2.1 by **one** rung, see section “Preparing the ready-to-use / ready-to-transport extension ladder”.
- ▶ Hang the extension ladder 2 with the hooks 2.4 on the receptacles 7 on the ballast trailer 1.

### Setting the extension ladder in the transport position

- ▶ Disconnect the extension ladder 2 with the hooks 2.4 from the ballast trailer 1.

**WARNING**

Danger of crushed limbs!

When sliding the extension ladder section **2.1**, fingers and hands can be crushed.

- ▶ Do not reach with your hands into the danger zone.
- 
- ▶ Move the extension ladder section **2.1** until it is flush with the extension ladder **2**, see section “Preparing the ready-to-use / ready-to-transport extension ladder”.
  - ▶ Fasten the extension ladder **2** in the transport position on the ballast trailer **1**, see section “Preparing the ready-to-use / ready-to-transport extension ladder”:

### 12.7.3 Extension ladder on the ballast trailer guide

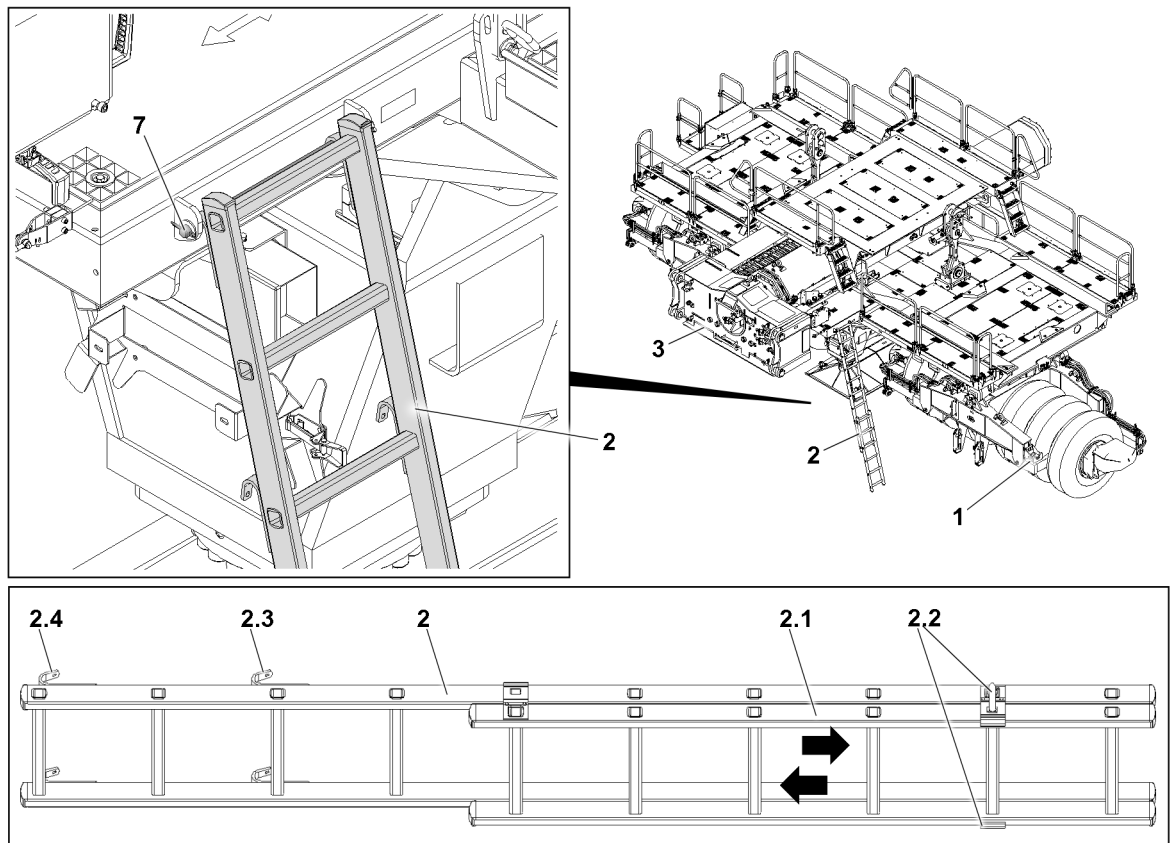


Fig. 159028: Extension ladder on the ballast trailer guide

<b>1</b> Ballast trailer	<b>2.3</b> Hook
<b>2</b> Extension ladder	<b>2.4</b> Hook
<b>2.1</b> Extension ladder section	<b>3</b> Ballast trailer guide
<b>2.2</b> Lock	<b>7</b> Receptacle

Make sure that the following prerequisite is met:

- The ballast trailer **1** is supported.

#### Hanging the extension ladder in the operating position

- ▶ Take the extension ladder **2** out of the transport position on the ballast trailer **1**: see section “Preparing the ready-to-use / ready-to-transport extension ladder”.

**WARNING**

Danger of crushed limbs!

When sliding the extension ladder section **2.1**, fingers and hands can be crushed.

- ▶ Do not reach with your hands into the danger zone.

- ▶ Push the extension ladder section **2.1** by **three** rungs, see section “Preparing the ready-to-use / ready-to-transport extension ladder”.
- ▶ Hang the extension ladder **2** with the hooks **2.4** on the receptacles **7** on the ballast trailer guide **3**.

### Setting the extension ladder in the transport position

- ▶ Disconnect the extension ladder **2** with the hooks **2.4** from the ballast trailer guide **3**.



#### WARNING

Danger of crushed limbs!

When sliding the extension ladder section **2.1**, fingers and hands can be crushed.

- ▶ Do not reach with your hands into the danger zone.
- ▶ Move the extension ladder section **2.1** until it is flush with the extension ladder **2**, see section “Preparing the ready-to-use / ready-to-transport extension ladder”.
- ▶ Fasten the extension ladder **2** in the transport position on the ballast trailer **1**, see section “Preparing the ready-to-use / ready-to-transport extension ladder”

## 12.7.4 Extension ladder on the control cabinet platform

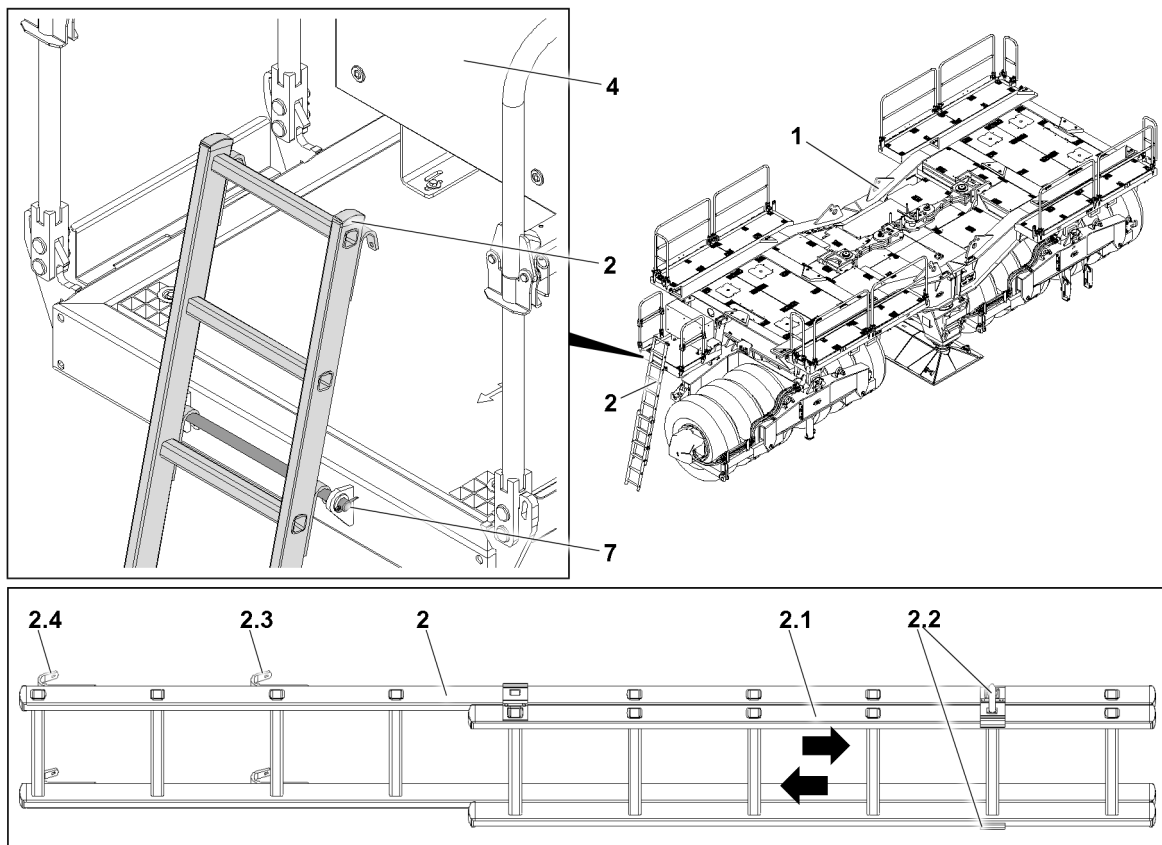


Fig.159027: Extension ladder on the control cabinet platform

- |                                     |                                   |
|-------------------------------------|-----------------------------------|
| <b>1</b> Ballast trailer            | <b>2.3</b> Hook                   |
| <b>2</b> Extension ladder           | <b>2.4</b> Hook                   |
| <b>2.1</b> Extension ladder section | <b>4</b> Control cabinet platform |
| <b>2.2</b> Lock                     | <b>7</b> Receptacle               |

Make sure that the following prerequisite is met:

- The ballast trailer **1** is supported.

### Hanging the extension ladder in the operating position

- ▶ Take the extension ladder **2** out of the transport position on the ballast trailer **1**: see section “Preparing the ready-to-use / ready-to-transport extension ladder”.



#### WARNING

Danger of crushed limbs!

When sliding the extension ladder section **2.1**, fingers and hands can be crushed.

- ▶ Do not reach with your hands into the danger zone.
- ▶ Push the extension ladder section **2.1** by **two** rungs, see section “Preparing the ready-to-use / ready-to-transport extension ladder”.
- ▶ Hang the extension ladder **2** with the hooks **2.3** on the receptacles **7** on the control cabinet platform **4**.

### Setting the extension ladder in the transport position

- ▶ Disconnect the extension ladder **2** with the hooks **2.3** from the control cabinet platform **4**.



#### WARNING

Danger of crushed limbs!

When sliding the extension ladder section **2.1**, fingers and hands can be crushed.

- ▶ Do not reach with your hands into the danger zone.
- ▶ Move the extension ladder section **2.1** until it is flush with the extension ladder **2**, see section “Preparing the ready-to-use / ready-to-transport extension ladder”.
- ▶ Fasten the extension ladder **2** in the transport position on the ballast trailer **1**, see section “Preparing the ready-to-use / ready-to-transport extension ladder”

## 13 Counterweights



#### WARNING

Assembly personnel **not** secured!

Assembly personnel can fall down.

Death, severe bodily injuries.

- ▶ Secure assembly personnel against falling.

### 13.1 Hook points

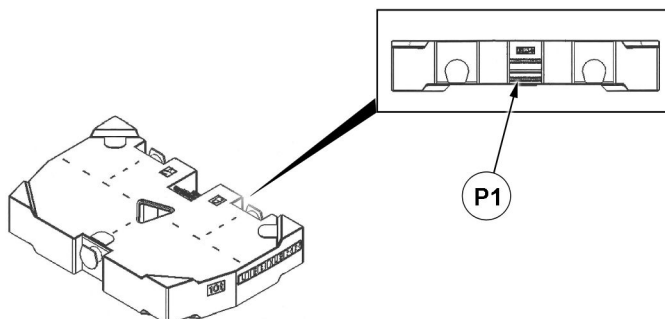


Fig.144909: Counterweight hook points

- ▶ Hook assembly personnel with the fall arrest system in position **1** and secure them to prevent them from falling.

---

Empty page!

LWE/LR 1800-1-0-000/27200-07-02/en

## 2.07 Accesses to the crane

1	Safety	2
2	Ascending and descending the crawler travel gear	2
3	Removing the ladder from the transport retainer	4
4	Ascending and descending the turntable, "transport position"	5
5	Ascending and descending the crane cab, "transport position"	6
6	Ascending and descending the crane cab	7
7	Ascending and descending the turntable	8
8	Climbing up and down the turntable catwalk	9
9	Climbing up and down the catwalk turntable via the additional step	10
10	Climbing up and down the winch 4 assembly area	16
11	Ascending and descending winch 1 and 2	17
12	Ascending and descending the slewing ring connection assembly area	18
13	Ascending and descending the assembly area of winch 1 with an installed winch	19
14	Ascending and descending the counterweight platforms	20
15	Ascending and descending the counterweight plates	21
16	Ascending and descending the H-pivot section	22
17	Ascending and descending the D-pivot section	23
18	Ascending and descending the lattice sections	24
19	Ascending and descending the suspended ballast platform	25
20	Ascending and descending the suspended ballast plates	26
21	Ascending and descending the ballast trailer	27
22	Ascending and descending the control cabinet platform	28
23	Ascending and descending the ballast trailer guide	29
24	Ascending and descending the ballast trailer guide	30
25	Ascending and descending the ballast trailer plates	31
26	Walking surfaces and stepping surfaces	31

# 1 Safety

Before accessing the crane, observe the safety instructions.

- General safety information: See chapter 2.04.
- Information regarding personal protective equipment: See chapter 2.04.
- Information regarding the use of ladders: See chapter 2.04.10.
- Information regarding available hook points: See chapter 2.06.



## WARNING

Slippery surfaces, lack of stability!

Personnel can fall down. Death, severe bodily injuries.

- ▶ Keep ladders, walking surfaces, stairs and stepping surfaces free of objects and obstacles.
- ▶ Only step on ladders, stairs, walking surfaces and stepping surfaces with sufficiently clear height.
- ▶ Only step on ladders, stairs, walking surfaces and stepping surfaces with clean shoes.
- ▶ Keep ladders, stairs, walking surfaces and stepping surfaces free of heavy dirt, snow and ice.
- ▶ Stepping on ladders, stairs, walking surfaces and stepping surfaces by persons, including tools and equipment, weighing more than 150 kg is prohibited.
- ▶ Do **not** step on damaged ladders, stairs, walking surfaces and stepping surfaces and replace them immediately.
- ▶ Do **not** trip over attachment parts.
- ▶ Personnel must wear an approved fall arrest system and protective equipment before performing any work on the crane superstructure.

When fall protection equipment is **not** in the assembly / disassembly position or personnel is on **non**-walking surfaces and stepping surfaces:

- ▶ Personnel must hook themselves to the hook points and safety ropes with an approved fall arrest system to prevent falling.

## NOTICE

The handles can be ripped off.

- ▶ Do **not** use handles as rigging points.
- ▶ Subject the handles to a maximum load of 100 kg.

# 2 Ascending and descending the crawler travel gear

Make sure that the following prerequisites are met:

- Personnel are wearing the personal protective equipment.
- The crawler travel gear is horizontally aligned.



## CAUTION

The access height from the ground is too high!

Personnel can fall, severe bodily injuries.

- ▶ Make sure that the first step is maximum 600 mm.
- ▶ Use a step for safe ascending and descending.



## 2.1 Swinging the stairs folding section into the operating position

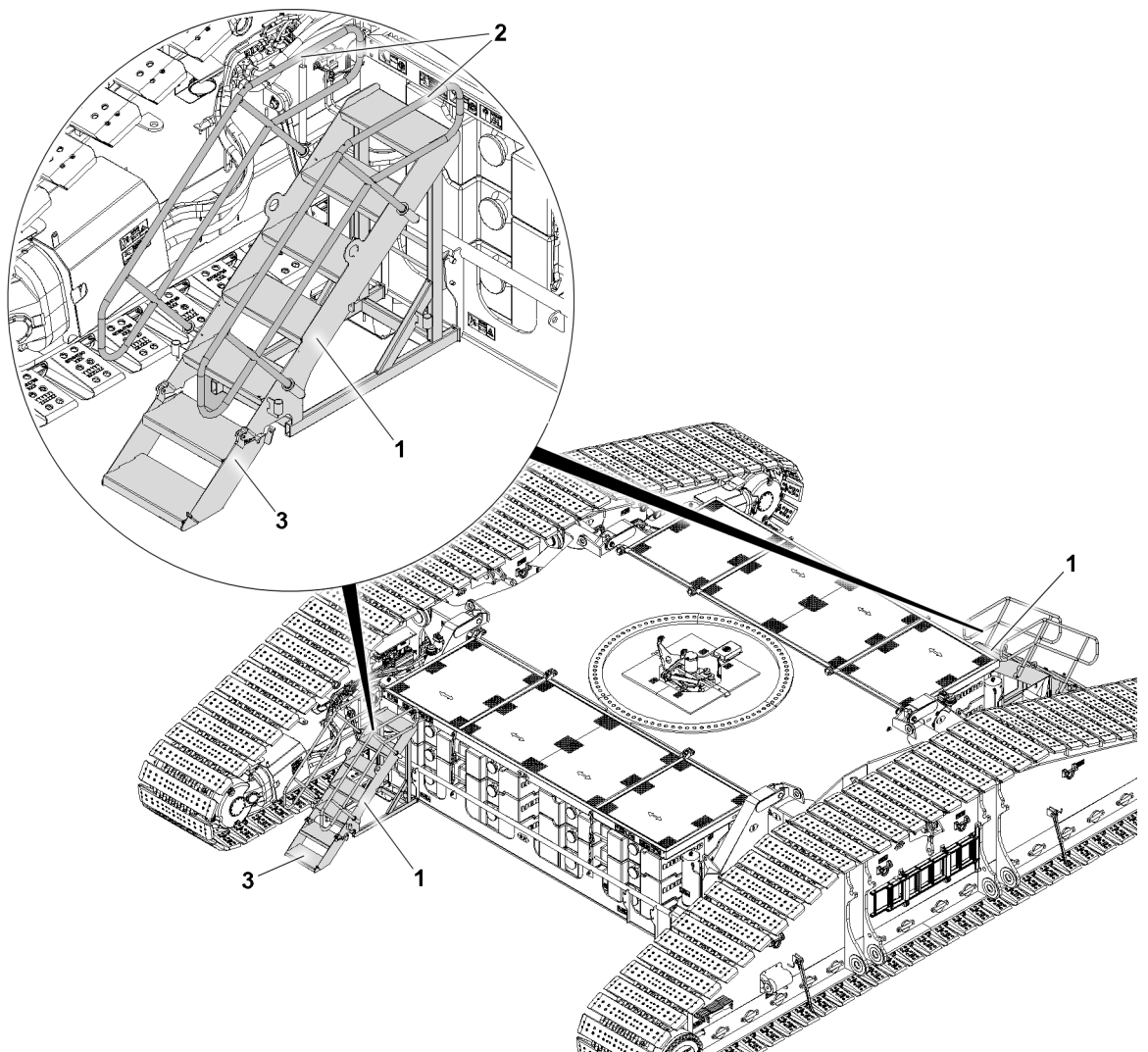


Fig.152002: Ascending and descending the crawler travel gear

The stair folding section **3** must be brought into the operating position before access.

Swing the stair folding section **3** into the operating position, see chapter 2.06.



### CAUTION

Moving parts!

Fingers and hands can be crushed. Severe bodily injuries

- ▶ Do **not** reach into the hinge area.
- ▶ Fold the stair folding section **3** out only from the ground.

## 2.2 Ascending and descending via the stairs

Before accessing the crane, observe the safety instructions, see section "Safety".

- ▶ When using the stairs **1**, secure personnel to the railing **2** to prevent falling.
- ▶ Always step on the stairs **1** with extreme caution.



### Note

- ▶ When climbing up and down as specified using the additional step, the access to the stairs **1** must be blocked off with the barrier chain, see section "Turntable access barrier".

### 3 Removing the ladder from the transport retainer

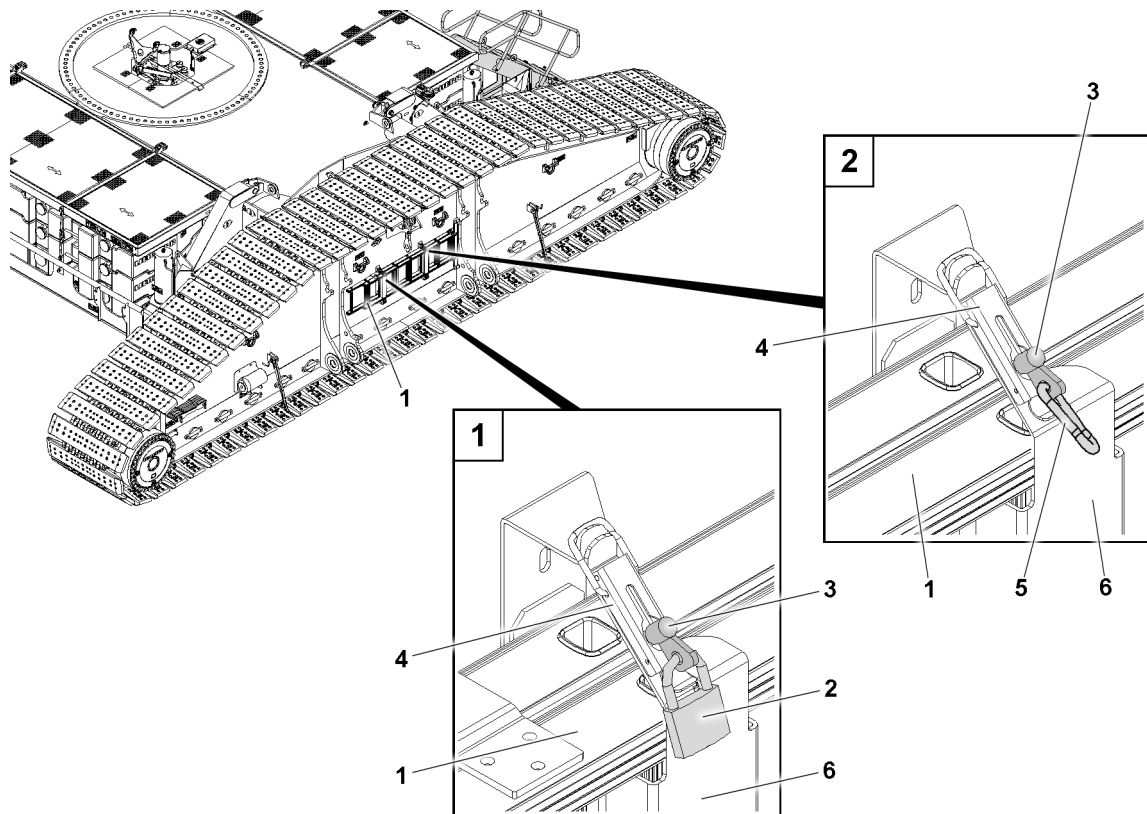


Fig.152029: Removing the ladder from the transport retainer, crawler travel gear

Make sure that the following prerequisites are met:

- Personnel are wearing the personal protective equipment.
- The crane is horizontally aligned.

For information regarding the use of ladders, see chapter 2.04.10.



#### WARNING

Falling ladder!

The ladder can fall down by itself due to its own weight when folding the transport retainer.  
Death, severe bodily injuries.

► When releasing the ladder, hold the ladder.

- Remove the padlock **2** on the locking latch **3**, see illustration **1**.
- Remove the retaining element **5** on the locking latch **3**, see illustration **2**.
- Turn the locking latch **2** 180° and open the lock **4**.
- Fold the transport retainers **6** down.
- Take the ladder **1** out of the retainer and set it on the ground.
- Fold up the transport retainers **6**.
- Close the lock **4** and turn the locking latch **2** 180°.
- Reinsert the padlock **2** and retaining element **5**.

## 4 Ascending and descending the turntable, “transport position”

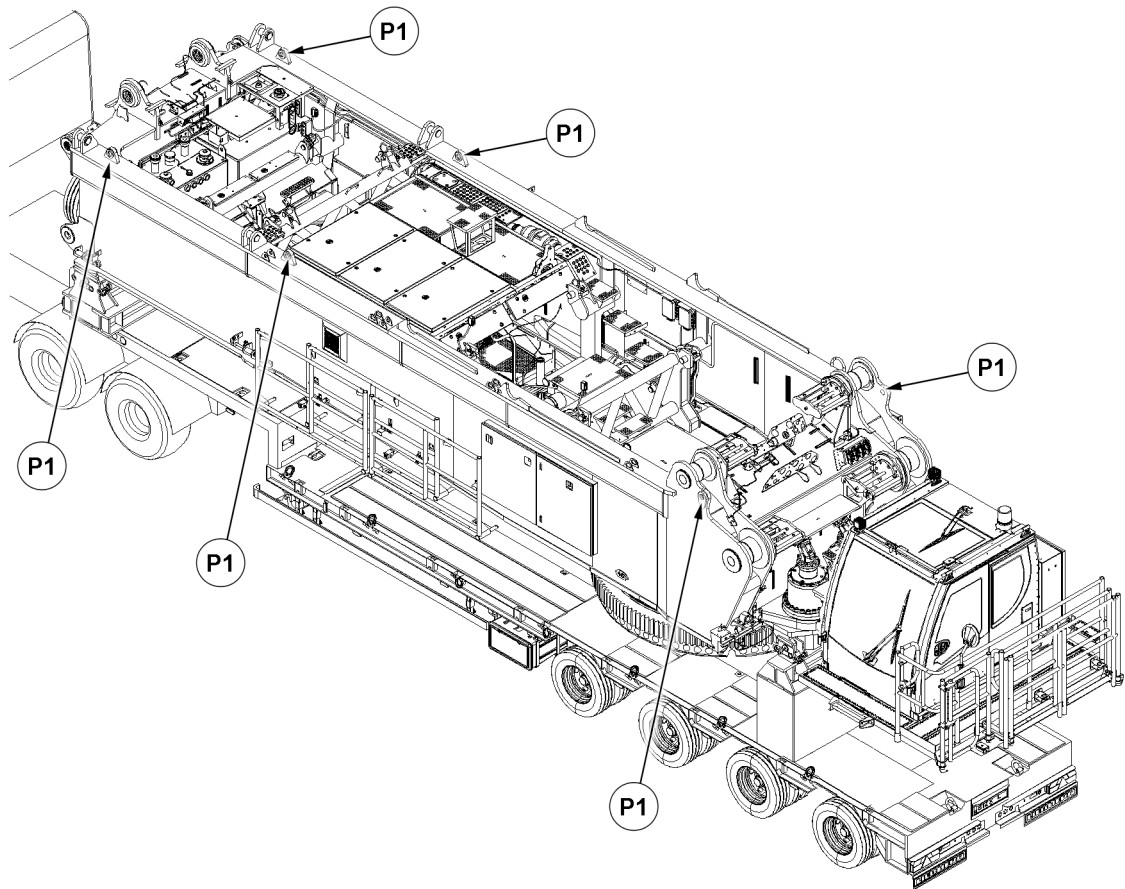


Fig.152036: Ascending and descending the turntable, “transport position”

Make sure that the following prerequisites are met:

- Personnel are wearing the personal protective equipment.
- A ladder, assembly scaffolding or a work platform is available.

Before accessing the crane, observe the safety instructions, see section “Safety”.

For information regarding the use of ladders, see chapter 2.04.10.

For information regarding the use of assembly scaffolding or a work platform, see the manufacturer’s documentation.

- ▶ Climb up and down the turntable in the transport position for fastening to the auxiliary crane is done using a ladder, assembly scaffolding or work platform.



### WARNING

Danger of falling!  
Death, severe bodily injuries.

- ▶ Walking on the upper belt of the turntable without the railings assembled is prohibited.
  - ▶ For each fastening point **P1** on the turntable, always assemble an extra auxiliary climbing aid such as a ladder, assembly scaffolding or work platform from the ground up.
- 
- ▶ Always step on the ladder, assembly scaffolding or work platform with extreme caution.

## 5 Ascending and descending the crane cab, “transport position”

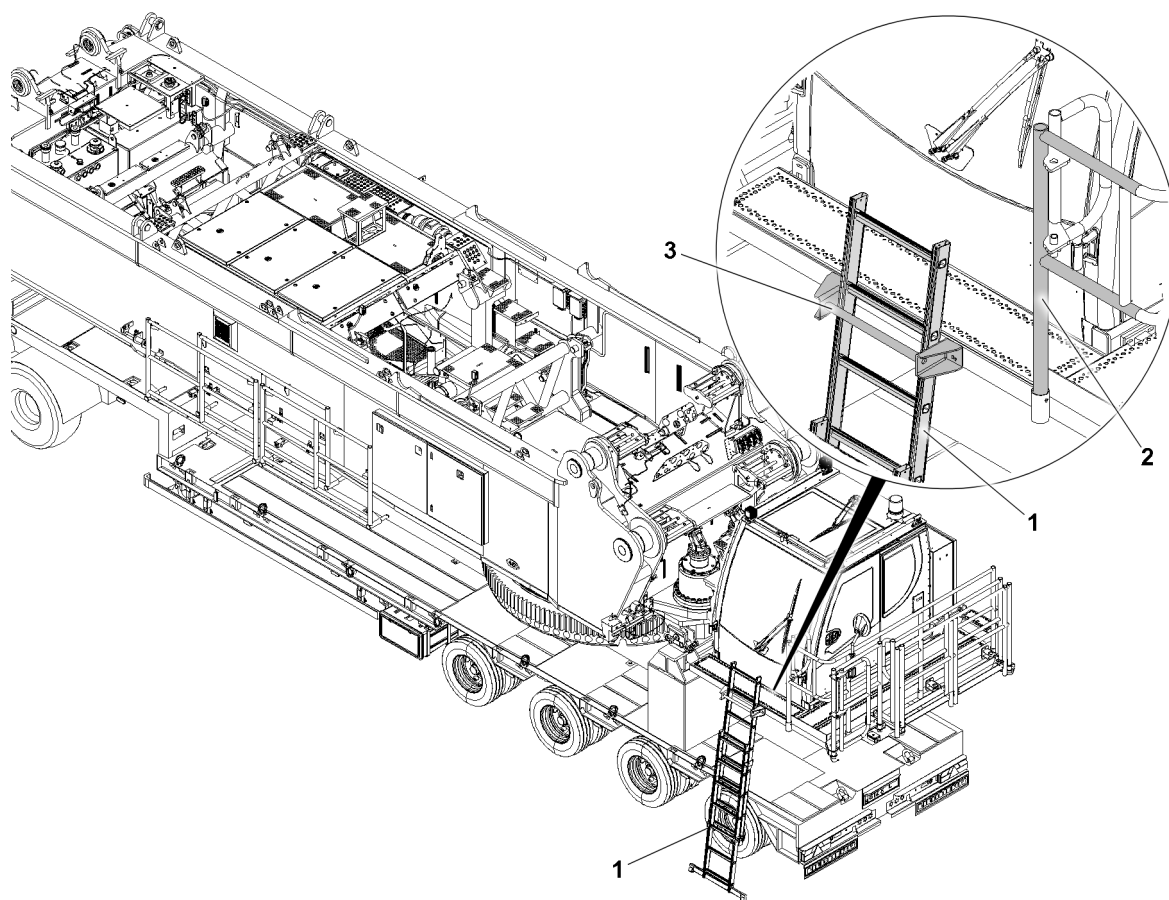


Fig.152035: Ascending and descending the crane cab, “transport position”

Make sure that the following prerequisites are met:

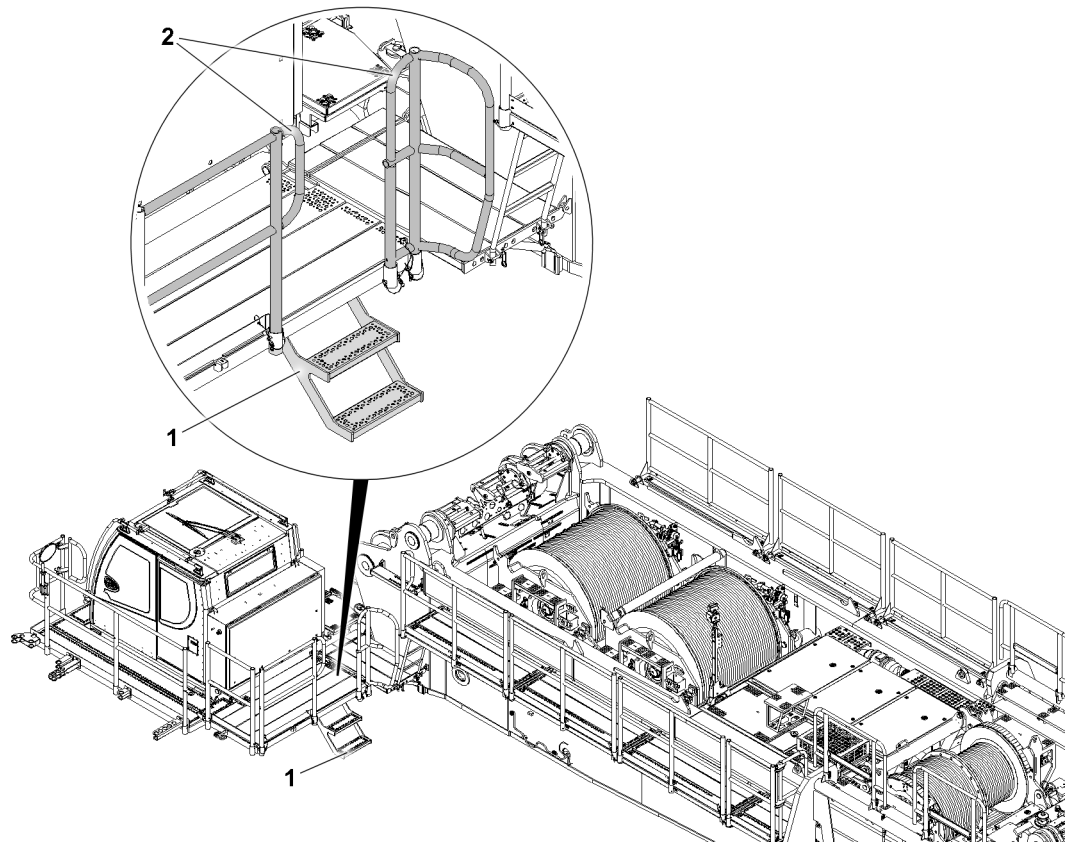
- Personnel are wearing the personal protective equipment.
- The ladder is properly positioned behind the mount **3**, see chapter 2.06.

Before accessing the crane, observe the safety instructions, see section “Safety”.

For information regarding the use of ladders, see chapter 2.04.10.

- ▶ When using the ladder **1**, secure personnel to the rungs of the ladder **1** and to the railing **2** to prevent falling.
- ▶ Always step on the ladder **1** with extreme caution.

## 6 Ascending and descending the crane cab



*Fig.152025: Ascending and descending the crane cab*

Make sure that the following prerequisites are met:

- Personnel are wearing the personal protective equipment.
- The crane is horizontally aligned.
- The turntable is assembled on the crawler travel gear.

Before accessing the crane, observe the safety instructions, see section “Safety”.

- ▶ When using the stairs **1**, secure personnel to the railing **2** to prevent falling.
- ▶ Always step on the stairs **1** with extreme caution.



### Note

- ▶ When climbing up and down as specified using the additional step, the access to the stairs **1** must be blocked off with the barrier chain, see section “Turntable access barrier”.

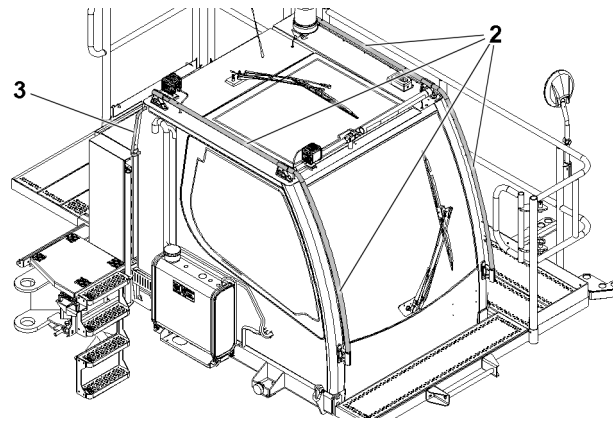


Fig.152030: Crane cab- handrail 2 and handle 3

## 7 Ascending and descending the turntable

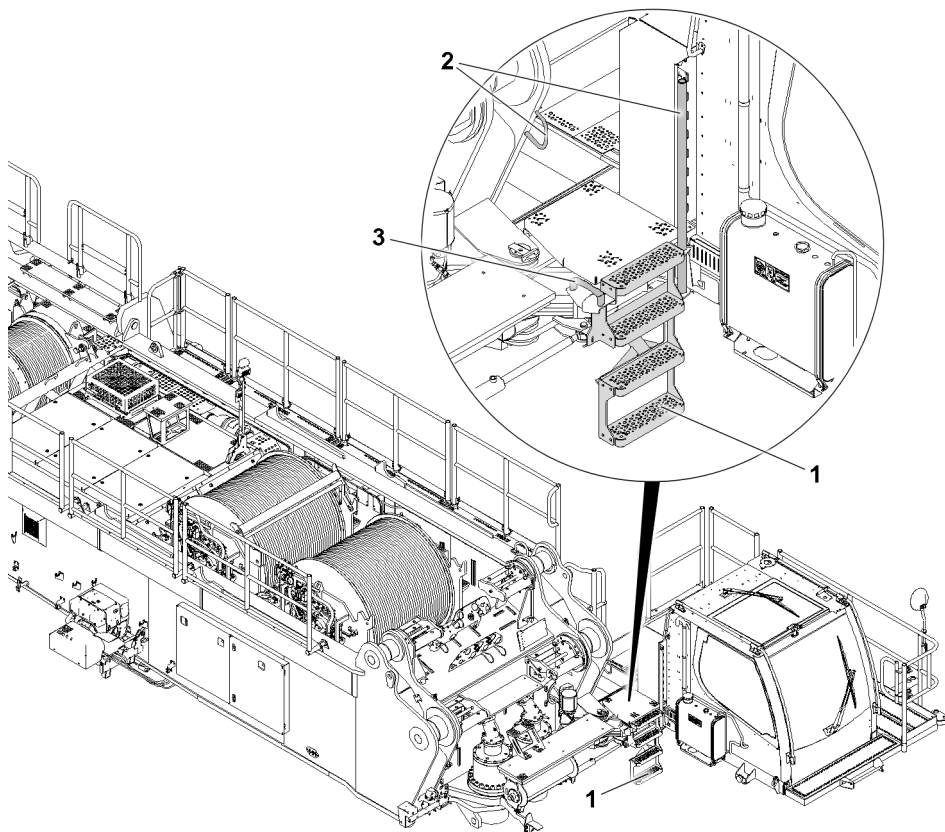


Fig.152026: Ascending and descending the crane superstructure

Make sure that the following prerequisites are met:

- Personnel are wearing the personal protective equipment.
- The crane is horizontally aligned.
- The turntable is assembled on the crawler travel gear.

Before accessing the crane, observe the safety instructions, see section “Safety”.

- ▶ When using the stairs 1, secure personnel to the railing 2 and the handle 3 to prevent falling.
- ▶ Always step on the stairs 1 with extreme caution.

**Note**

- ▶ When climbing up and down as specified using the additional step, the access to the stairs 1 must be blocked off with the barrier chain, see section “Turntable access barrier”.

## 8 Climbing up and down the turntable catwalk

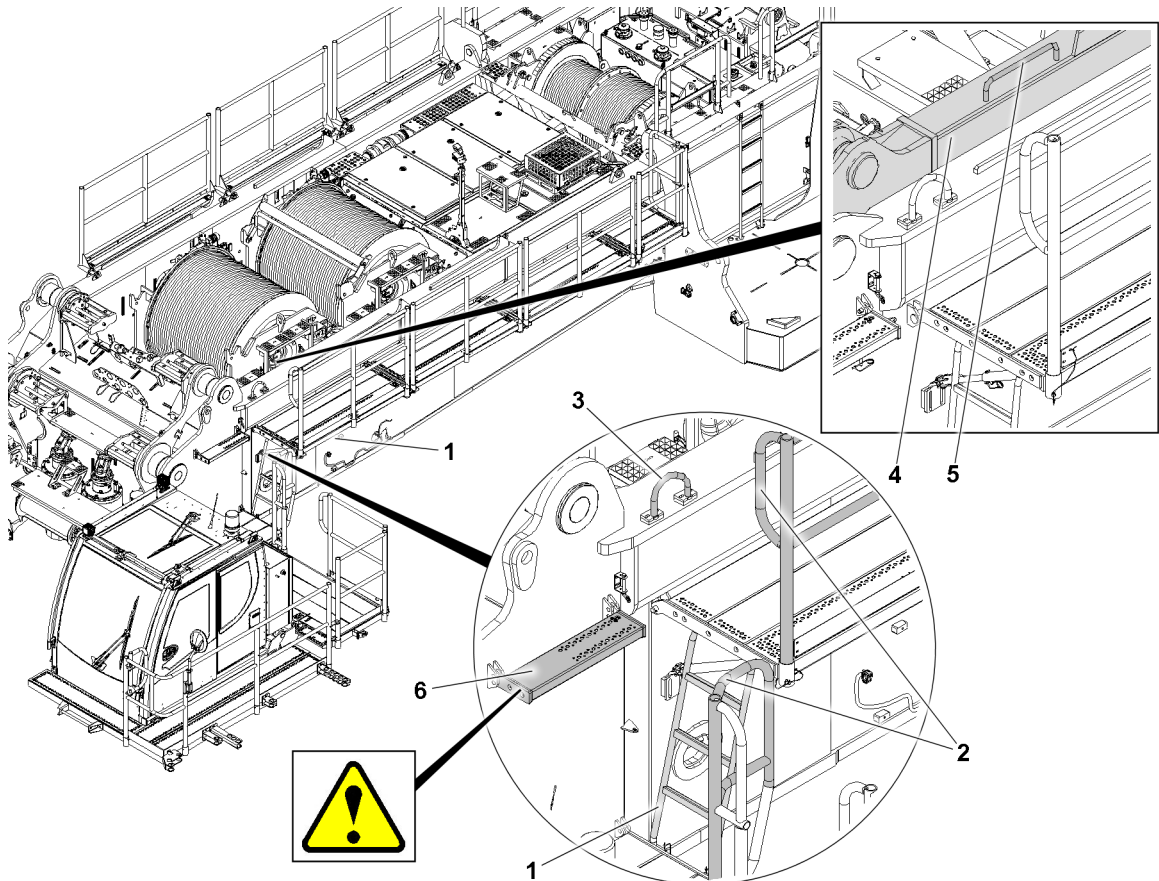


Fig.152027: Climbing up and down the turntable catwalk

Make sure that the following prerequisites are met:

- Personnel are wearing the personal protective equipment.
- The crane is horizontally aligned.
- The turntable is assembled on the crawler travel gear.

Before accessing the crane, observe the safety instructions, see section “Safety”.

For information regarding the use of ladders, see chapter 2.04.10.

**WARNING**

Hitting the catwalk 6 of the turntable!

Severe bodily injuries possible when using the ladder 1.

- ▶ Pay attention to the catwalk 6.
  - ▶ Personal protective equipment: Wear a hard hat.
- 
- ▶ When using the ladder 1, secure personnel to the rungs of the ladder 1, to the railing 2 and to the handle 3 to prevent falling.
  - ▶ If the SA-frame 4 is assembled, the handle 5 can be used when using the ladder 1.
  - ▶ Always step on the ladder 1 with extreme caution.

## 9 Climbing up and down the catwalk turntable via the additional step

In countries in which the use of the additional step is required, the other accesses to the crane may not be entered without the use of fall protection equipment.

The access to the crane without the use of fall protection equipment is only permitted using the additional step. The other accesses must be blocked off and secured against unauthorized entry.



### WARNING

Use of non-approved accesses!  
Danger of falling.

If required by the country of crane use:

- ▶ Use the additional step and block the other accesses.

### 9.1 Turntable access barrier



#### Note

- ▶ The barrier chains differ in length and must be attached to the provided locations.

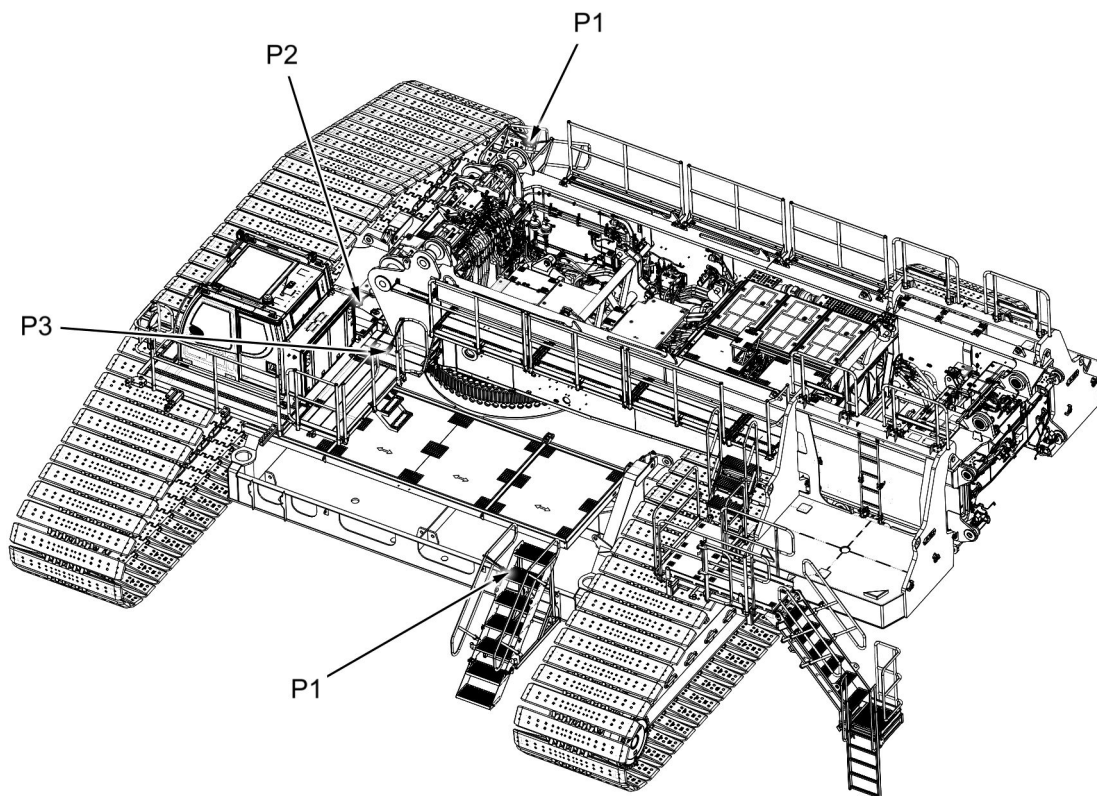
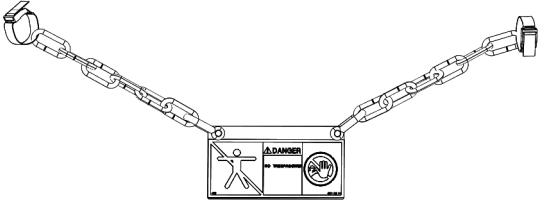
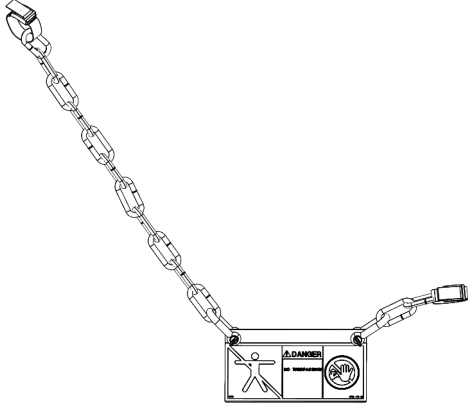
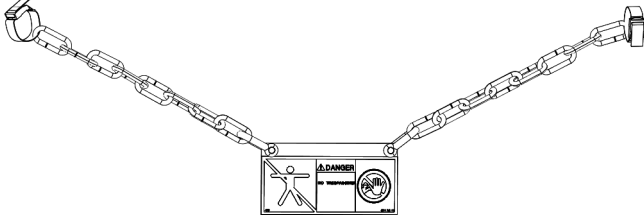


Fig.164708: Turntable access barrier



Position	Barrier chain		Quantity
P1	Stairs		2
P2	Passage		1
P3	Platform		1

Barrier chains

LWE/LR 1800-1-0-000/27200-07-02/en

### 9.1.1 Stairs barrier

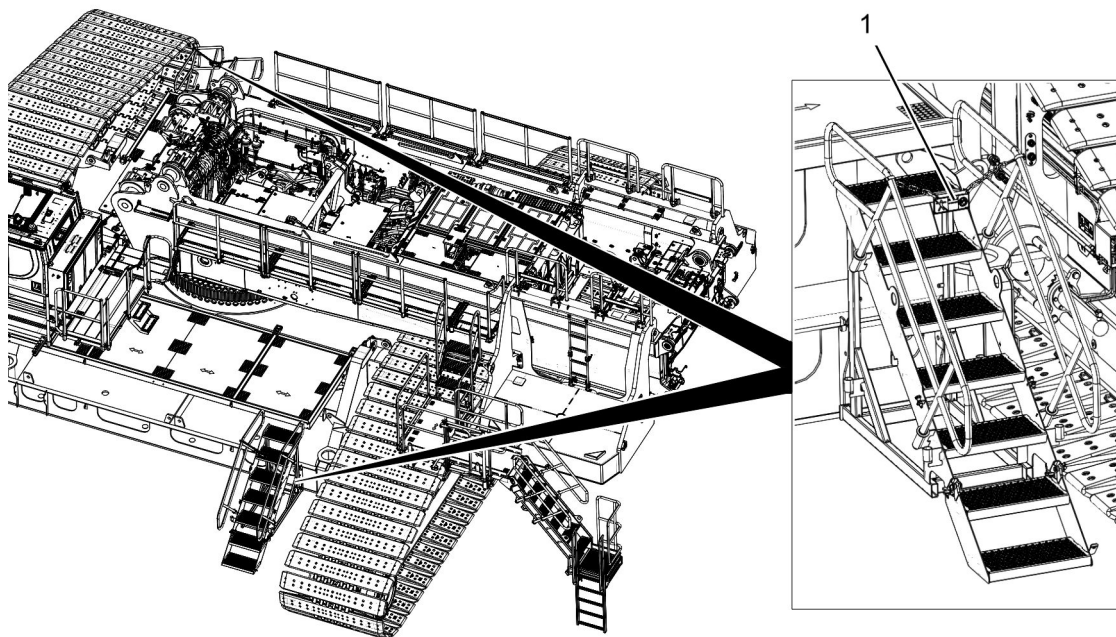


Fig.164705: Turntable access

1 Stairs barrier chain

- ▶ Place stairs barrier chains 1 on both steps, see also the chart "Barrier chains".



#### Note

- ▶ Climbing up to the crawler travel gear using the stairs, see section "Climbing up and down the crawler travel gear".

## 9.1.2 Crane cab and turntable barrier

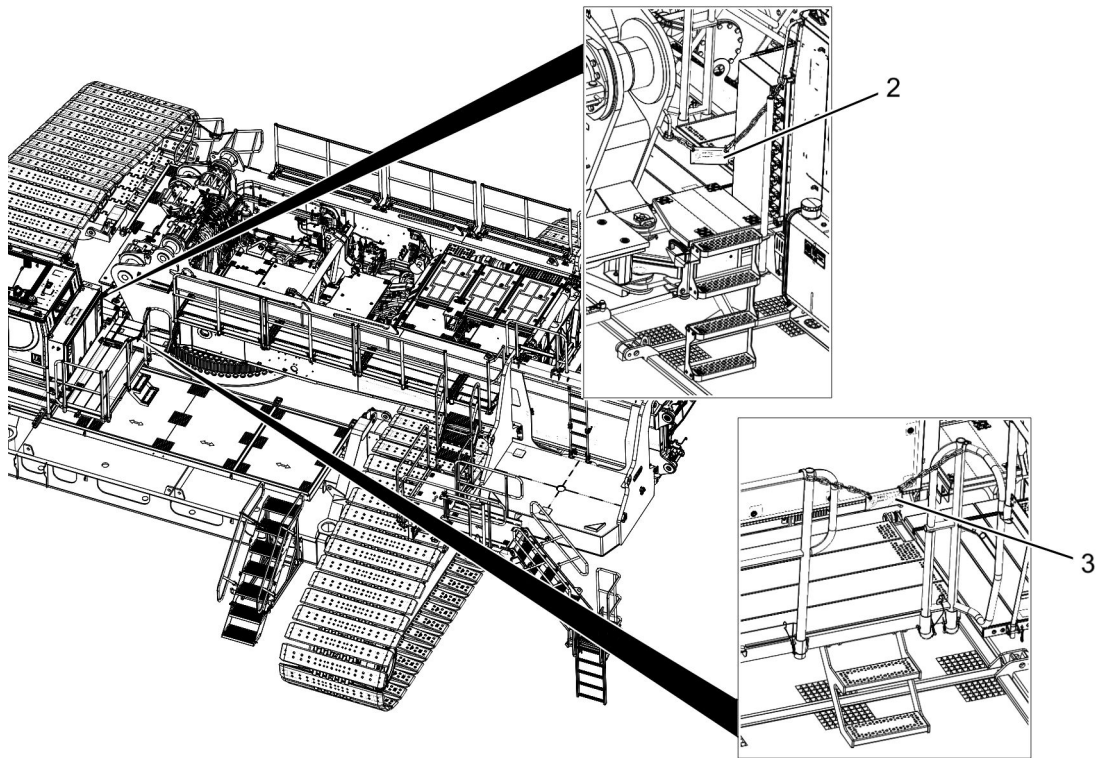


Fig.164706: Crane cab access

**2** Passage barrier chain

**3** Platform barrier chain

- ▶ Place a passage barrier chain **2** on the railing and handle, see also the chart "Barrier chains".



### Note

- ▶ Climbing up to the turntable using the stairs, see section "Climbing up and down the turntable".

- ▶ Place a platform barrier chain **3** on the railing, see also the chart "Barrier chains".



### Note

- ▶ Climbing up to the crane cab using the stairs, see section "Climbing up and down the crane cab".

## 9.2 Additional step

### 9.2.1 Climbing up and down the access stairs

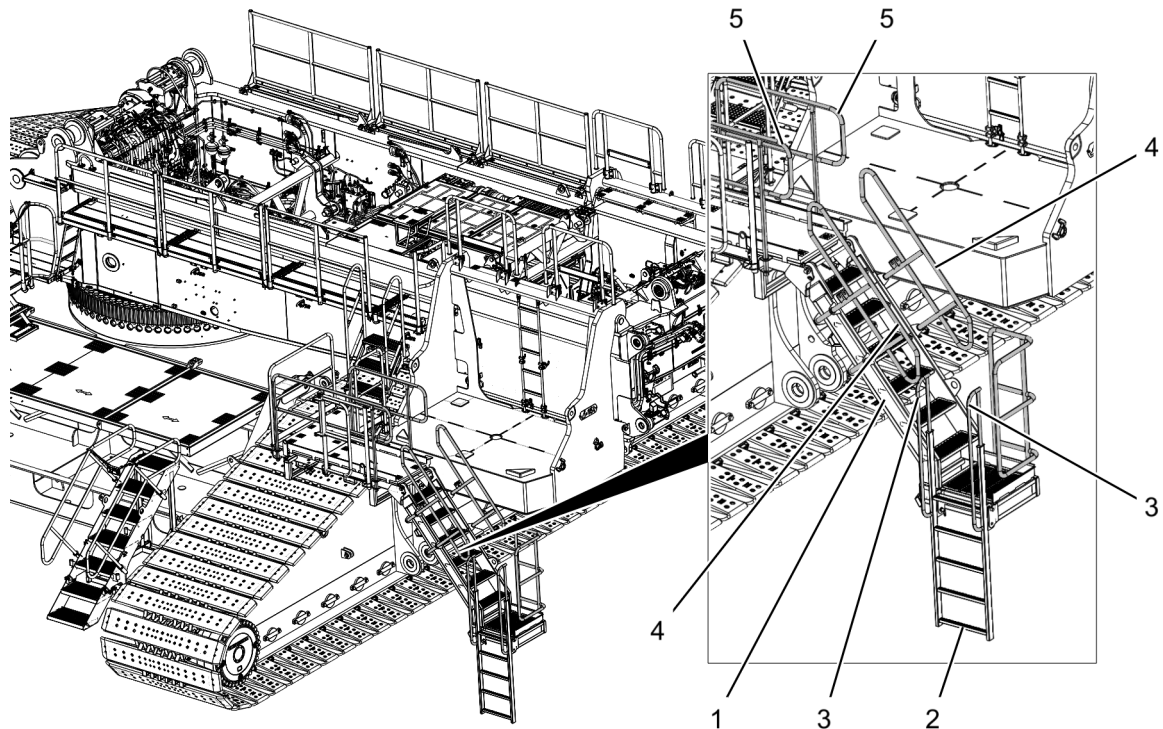


Fig.164700: Platform access

- |   |               |   |         |
|---|---------------|---|---------|
| 1 | Access stairs | 4 | Railing |
| 2 | Ladder        | 5 | Railing |
| 3 | Handle        |   |         |

Make sure that the following prerequisites are met:

- Barrier chains are installed.
- The ladder **2** is assembled and secured in the operating position, see chapter 2.06.

When climbing up the ladder **2** from the ground:

- ▶ Use the handle **3**.

When climbing up the access stairs **1** from the platform:

- ▶ Use the railing **4** and railing **5**.

When climbing down the access stairs **1** to the platform:

- ▶ Use the railing **4** and railing **5**.

When climbing down the ladder **2** to the ground:

- ▶ Use the handle **3**.

## 9.2.2 Climbing up and down the stairs

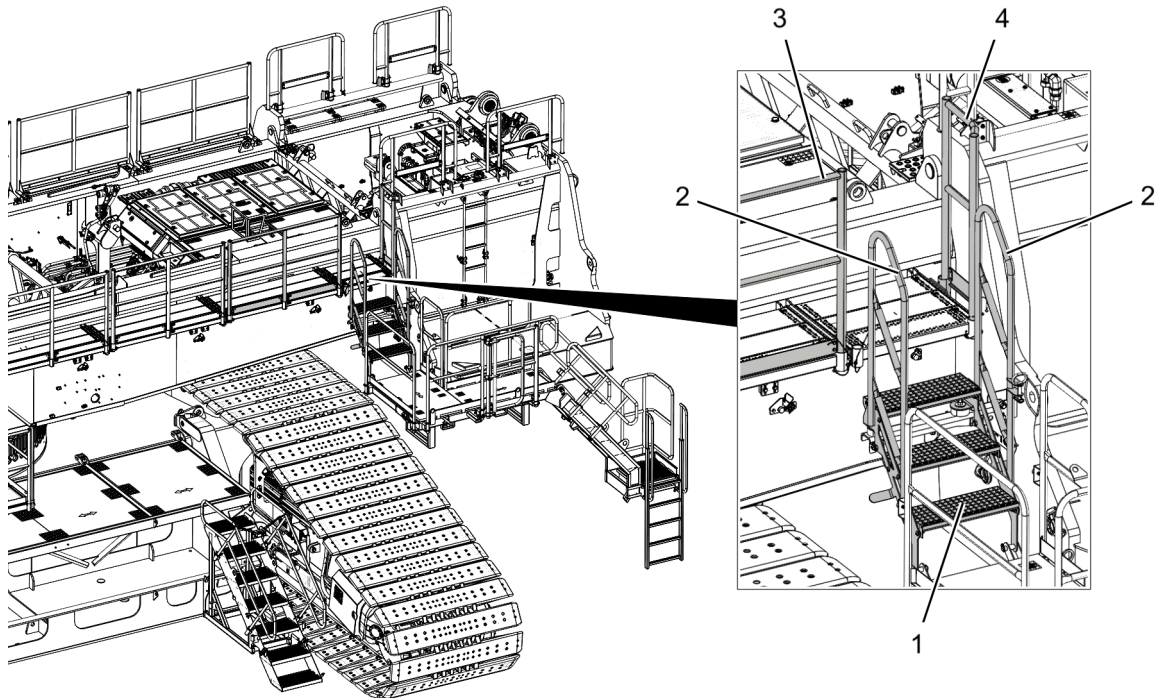


Fig.164701: Turntable access

- |          |         |          |         |
|----------|---------|----------|---------|
| <b>1</b> | Stairs  | <b>3</b> | Railing |
| <b>2</b> | Railing | <b>4</b> | Railing |

Make sure that the following prerequisites are met:

- The stairs **1** are assembled and secured in operating position, see chapter 2.06.

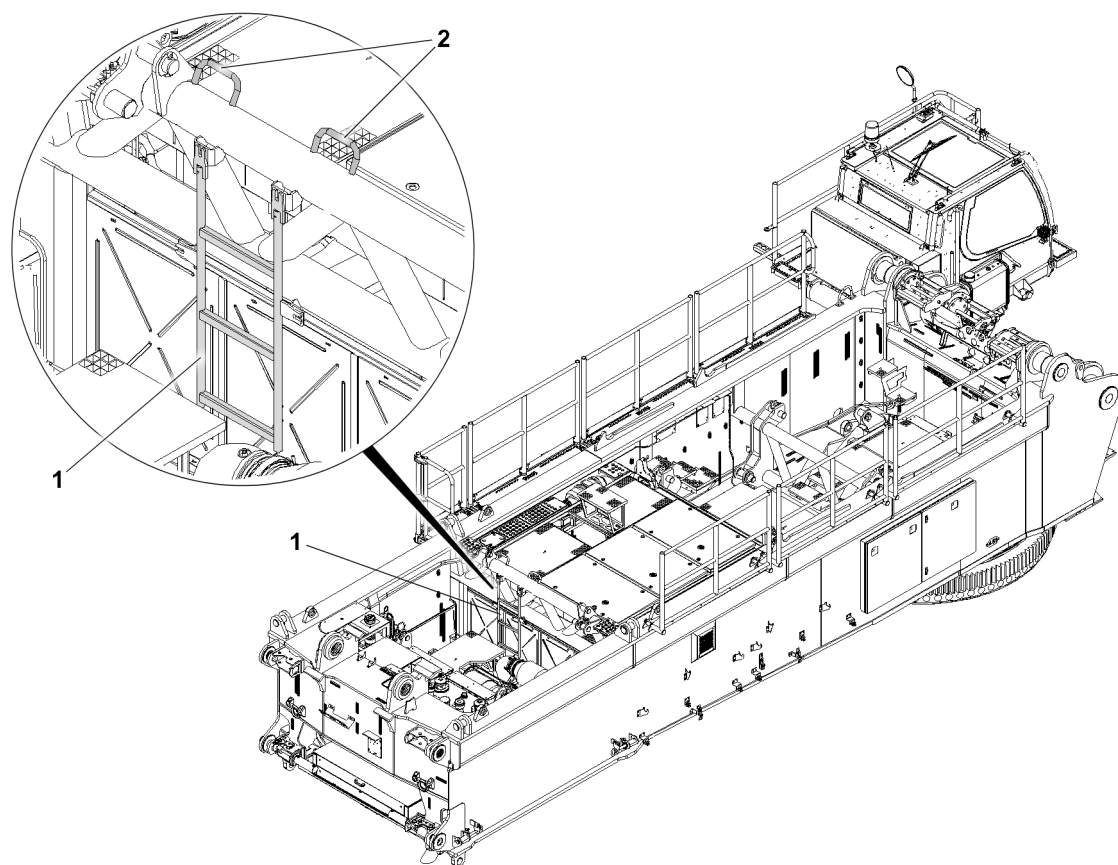
When climbing up the stairs **1** from the platform:

- ▶ Use the railing **2**, railing **3** and railing **4**.

When climbing down the stairs **1** to the platform:

- ▶ Use the railing **2**, railing **3** and railing **4**.

## 10 Climbing up and down the winch 4 assembly area



*Fig.152037: Climbing up and down the winch 4 assembly area*

Make sure that the following prerequisites are met:

- Personnel are wearing the personal protective equipment.
- The crane is horizontally aligned.
- The turntable is assembled on the crawler travel gear.

Before accessing the crane, observe the safety instructions, see section “Safety”.

For information regarding the use of ladders, see chapter 2.04.10.

- ▶ When using the ladder **1**, secure personnel to the rungs of the ladder **1** and to the handles **2** to prevent falling.
- ▶ Always step on the ladder **1** with extreme caution.

## 11 Ascending and descending winch 1 and 2

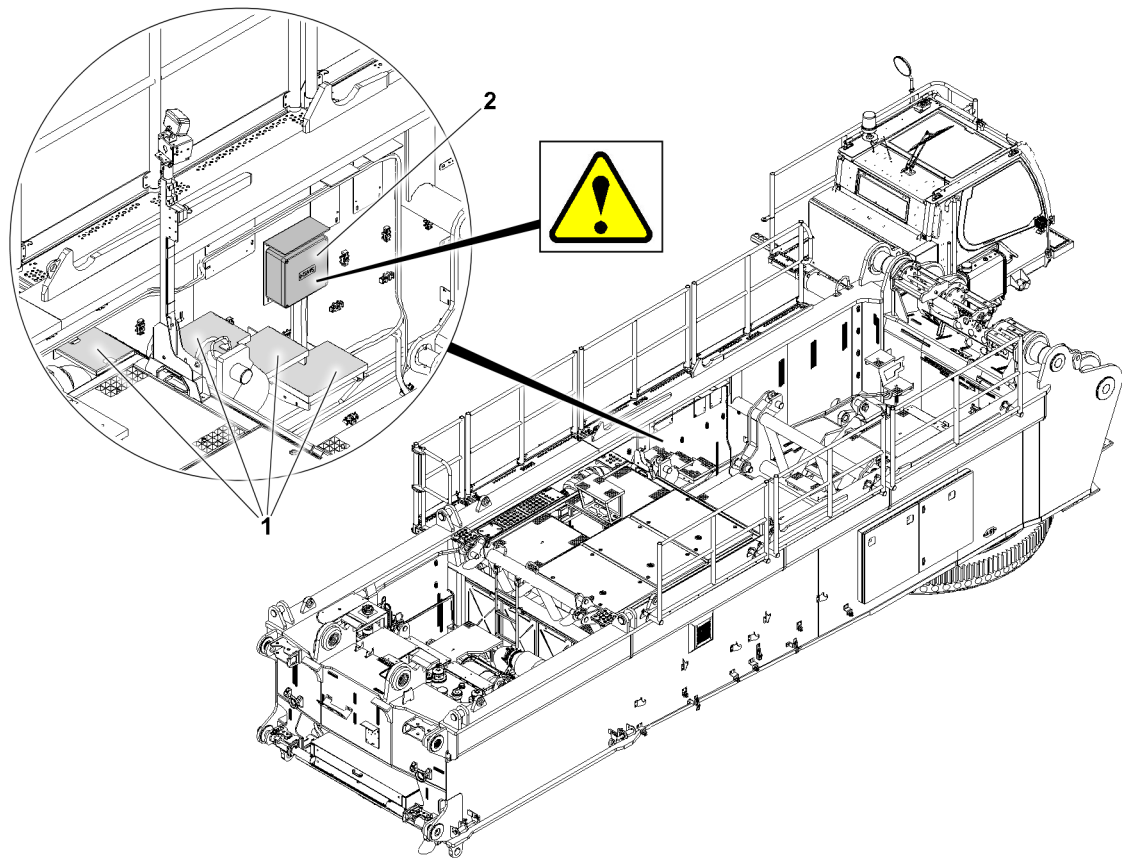


Fig.152038: Ascending and descending winch 1 and 2

Make sure that the following prerequisites are met:

- Personnel are wearing the personal protective equipment.
- The crane is horizontally aligned.
- The turntable is assembled on the crawler travel gear.

Before accessing the crane, observe the safety instructions, see section “Safety”.



### WARNING

Hitting the electrical box 2 of the turntable!

Severe bodily injuries possible when using the stairs 1.

- ▶ Pay attention to the electrical box 2.
- ▶ When using the stairs 1 and when changing from / to the walking surface, secure personnel to the available components to prevent falling.
- ▶ Always step on the stairs 1 with extreme caution.

## 12 Ascending and descending the slewing ring connection assembly area

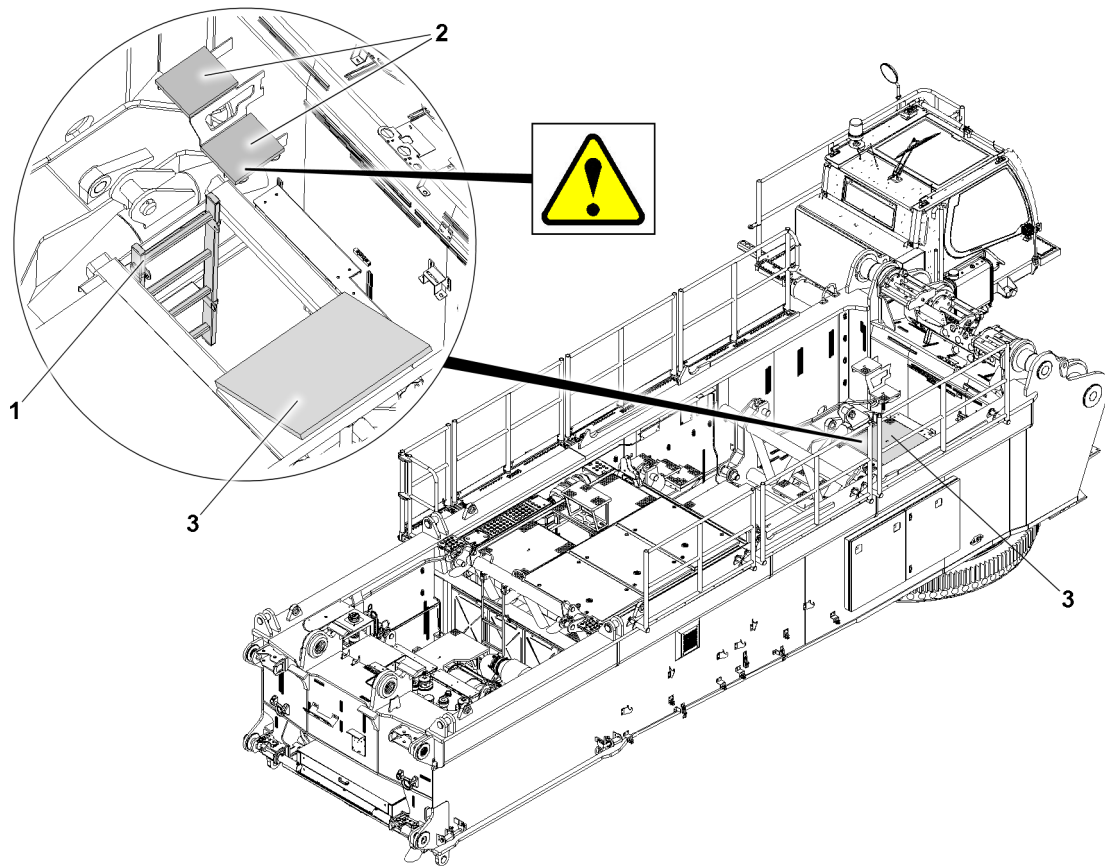


Fig.152039: Ascending and descending the slewing ring connection assembly area

Make sure that the following prerequisites are met:

- Personnel are wearing the personal protective equipment.
- The crane is horizontally aligned.
- The turntable is assembled on the crawler travel gear.

Before accessing the crane, observe the safety instructions, see section “Safety”.

For information regarding the use of ladders, see chapter 2.04.10.



### WARNING

Hitting the catwalk 2 of the turntable!

Severe bodily injuries possible when using the ladder 1.

- ▶ Pay attention to the catwalk 2. Personal protective equipment: Wear a hard hat.

- ▶ When using the ladder 1, secure personnel to the rungs of the ladder 1 and to the available components to prevent falling.
- ▶ Always step on the ladder 1 with extreme caution.



### WARNING

The grating flap 3 is open!

If the grating flap 3 is open, there is a danger that personnel can fall down.

Death, severe bodily injuries.

- ▶ After climbing off / on, close the grating flap 3.

- ▶ Open / close the grating flap 3, see chapter 2.06.



## 13 Ascending and descending the assembly area of winch 1 with an installed winch

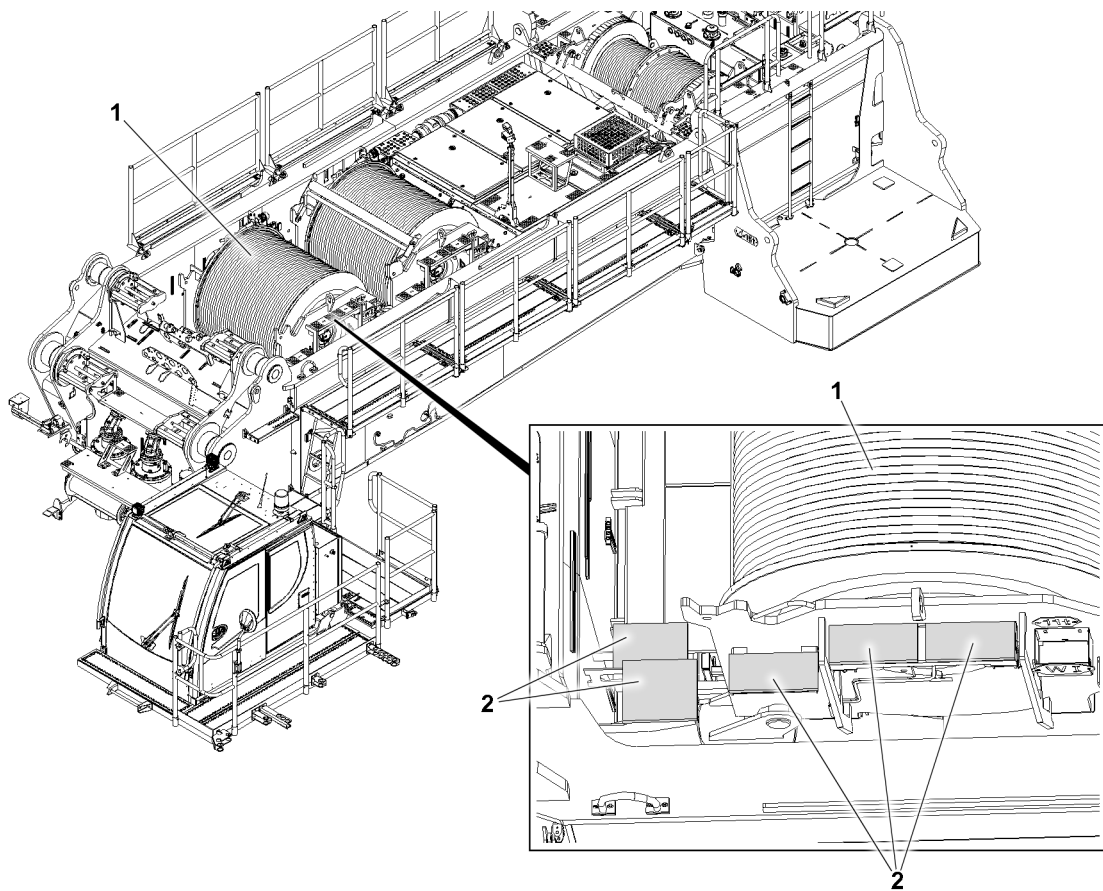


Fig.152040: Ascending and descending the assembly area of winch 1 1 with an installed winch

Make sure that the following prerequisites are met:

- Personnel are wearing the personal protective equipment.
- The crane is horizontally aligned.
- The turntable is assembled on the crawler travel gear.

Before accessing the crane, observe the safety instructions, see section “Safety”.

- ▶ When using the stairs 2, secure personnel to the available components to prevent falling.
- ▶ Always step on the stairs 2 with extreme caution.

## 14 Ascending and descending the counterweight platforms

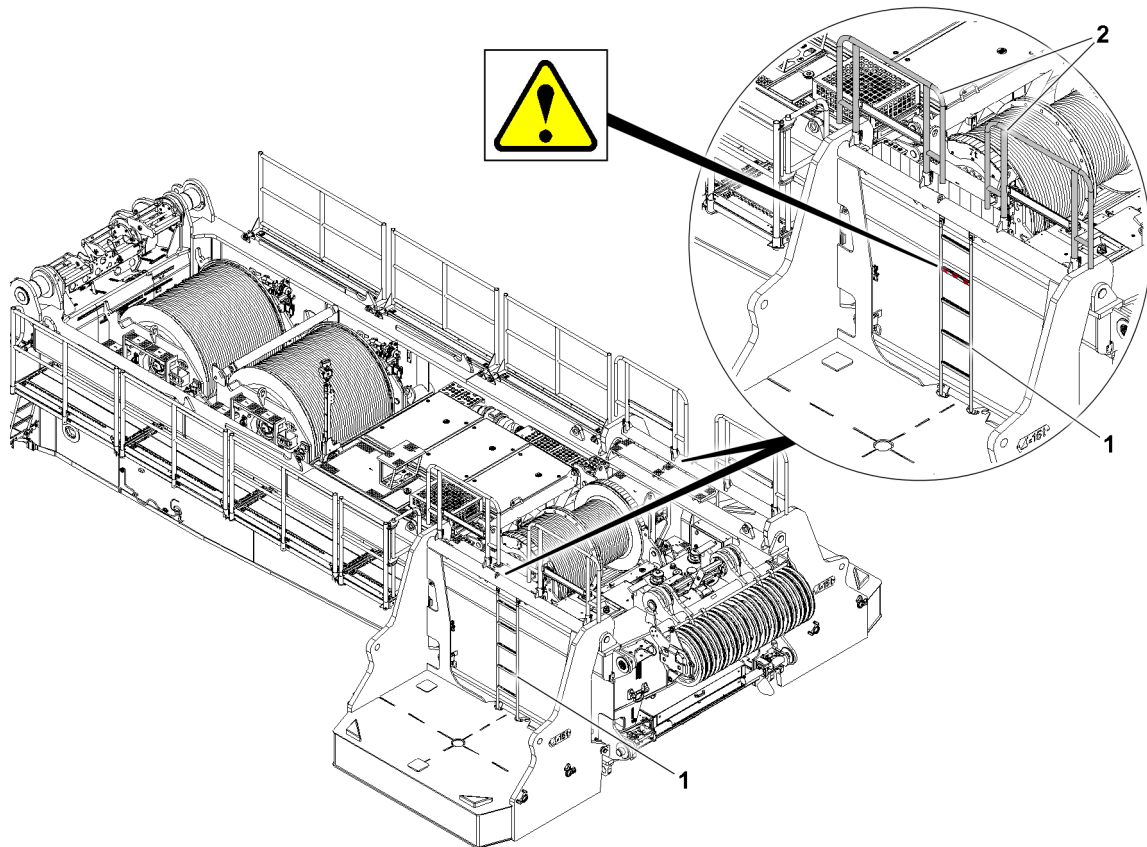


Fig.152028: Ascending and descending the counterweight platforms

Make sure that the following prerequisites are met:

- Personnel are wearing the personal protective equipment.
- The crane is horizontally aligned.

Before accessing the crane, observe the safety instructions, see section “Safety”.

For information regarding the use of ladders, see chapter 2.04.10.

- ▶ When using the ladder 1, secure personnel to the rungs of the ladder 1 and to the railing 2 to prevent falling.



### WARNING

Danger of slipping due to small step depth!  
Personnel can fall down. Death, severe bodily injuries.

- ▶ When climbing up the ladder 1, always use a 3-point support, see chapter 2.04.10.
- ▶ When climbing down the ladder 1, always use the 3-point support, see chapter 2.04.10.
- ▶ Always step on the ladder 1 with extreme caution.

## 15 Ascending and descending the counterweight plates

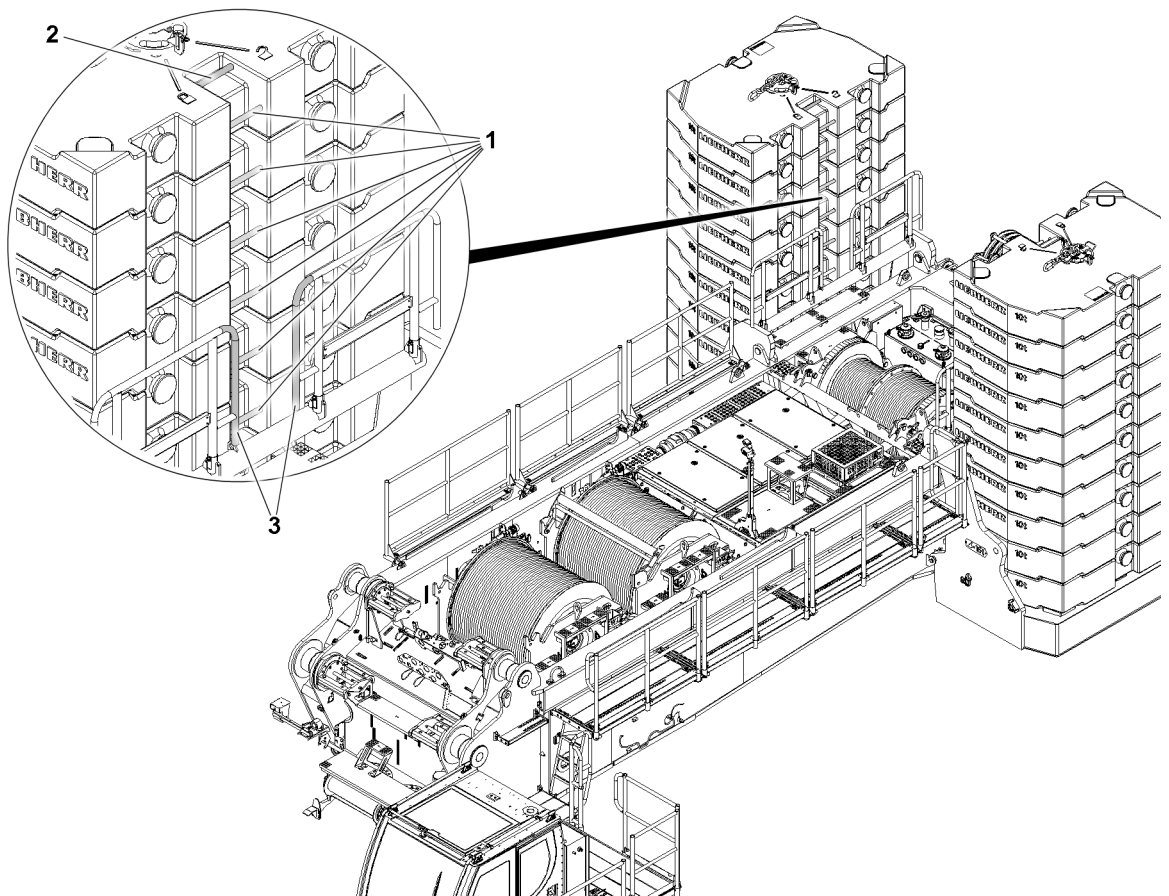


Fig.152041: Ascending and descending the counterweight plates

Make sure that the following prerequisites are met:

- Personnel are wearing the personal protective equipment.
- The crane is horizontally aligned.

Before accessing the counterweight plates, observe the safety instructions, see section “Safety”.

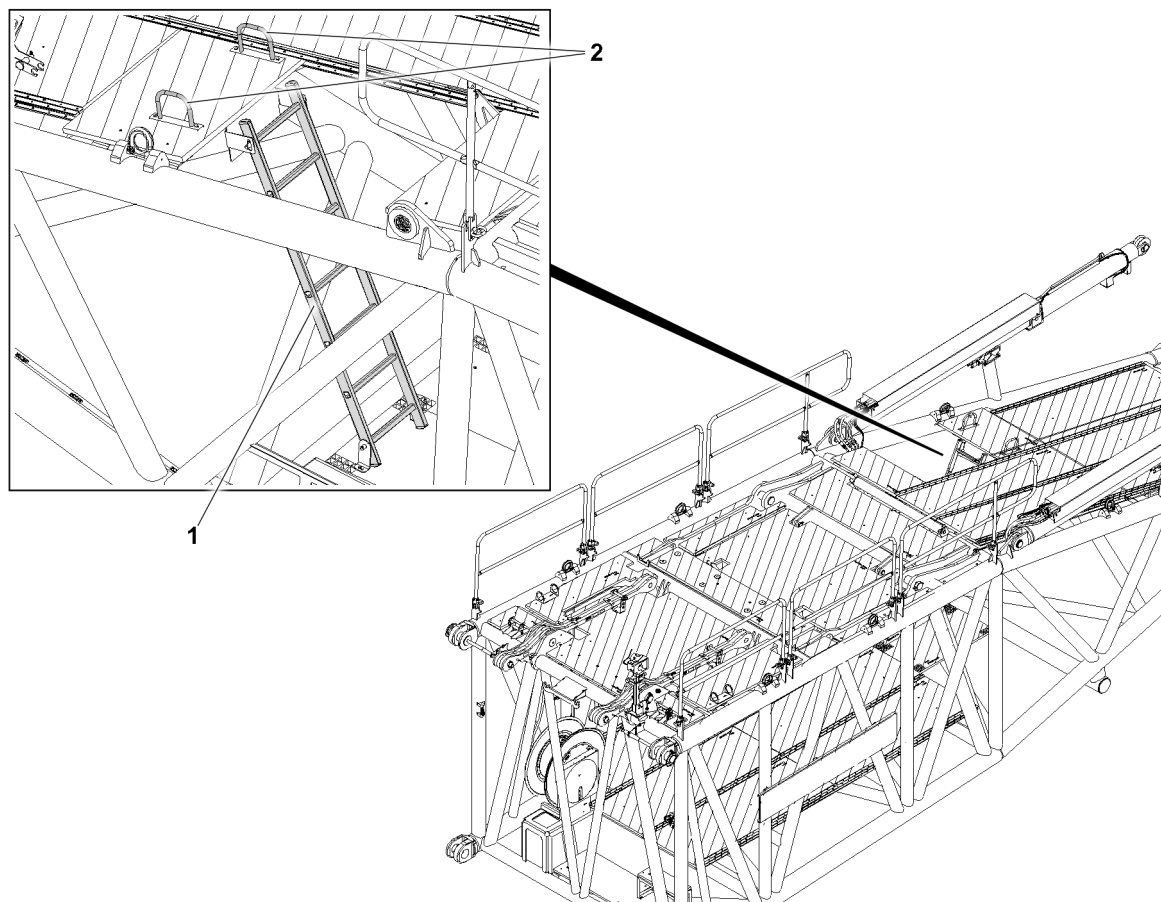
For information regarding the use of ladders, see chapter 2.04.10.



### Note

- ▶ The struts **1** on the stacked counterweight plates form a ladder.
- ▶ When using the ladder, secure personnel to the struts **1**, to the railing **3** and to the strut **2** to prevent falling.
- ▶ Always step on the ladder with extreme caution.

## 16 Ascending and descending the H-pivot section



*Fig.152042: Ascending and descending the H-pivot section*

Make sure that the following prerequisites are met:

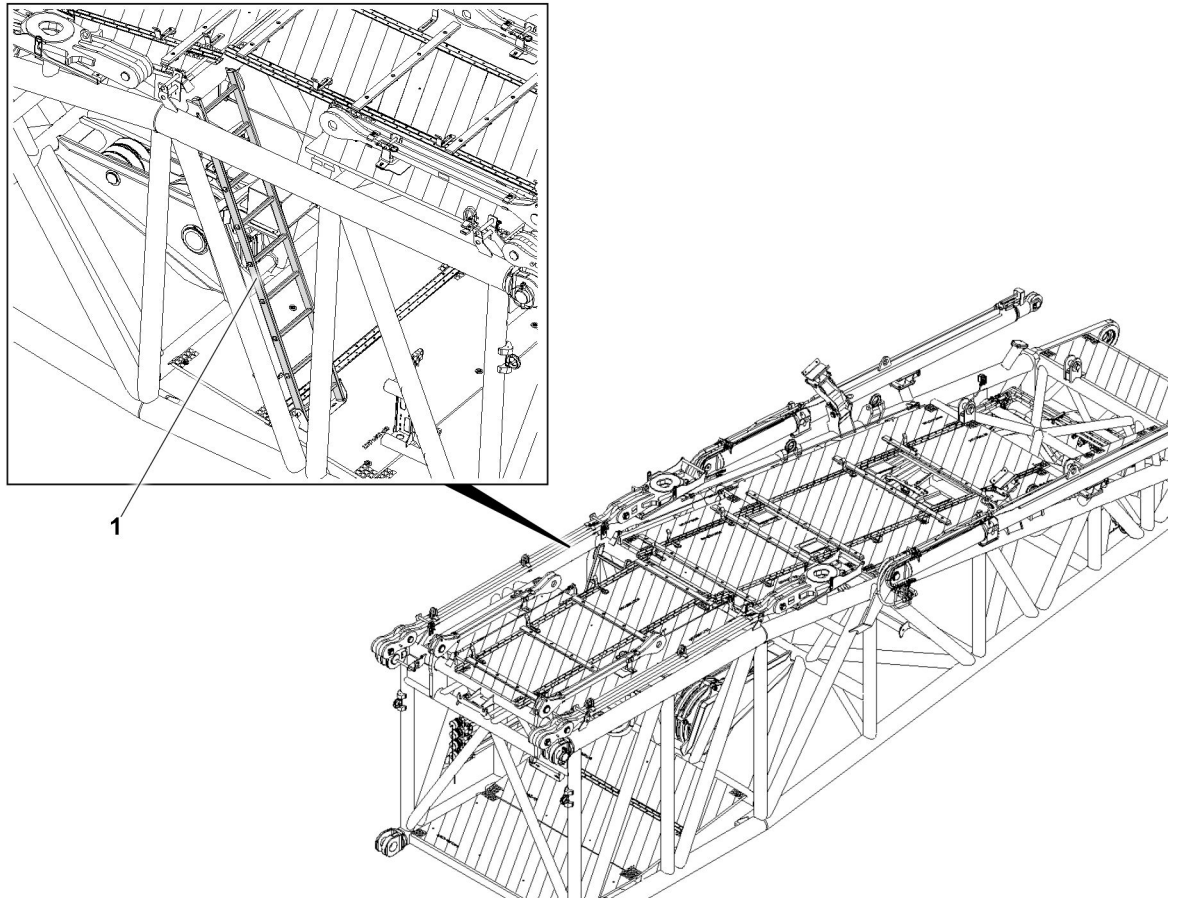
- Personnel are wearing the personal protective equipment.
- The lattice section is set down on a level surface.

Before accessing the H-pivot section, observe the safety instructions, see section “Safety”.

For information regarding the use of ladders, see chapter 2.04.10.

- ▶ When using the ladder **1**, secure personnel to the rungs of the ladder **1** to the handles **2** and to the available components to prevent falling.
- ▶ Always step on the ladder **1** with extreme caution.

## 17 Ascending and descending the D-pivot section



*Fig.152043: Ascending and descending the D-pivot section*

Make sure that the following prerequisites are met:

- Personnel are wearing the personal protective equipment.
- The lattice section is set down on a level surface.

Before accessing the D-pivot section, observe the safety instructions, see section “Safety”.

For information regarding the use of ladders, see chapter 2.04.10.

- ▶ When using the ladder **1**, secure personnel to the rungs of the ladder **1** and to the available components to prevent falling.
- ▶ Always step on the ladder **1** with extreme caution.

## 18 Ascending and descending the lattice sections

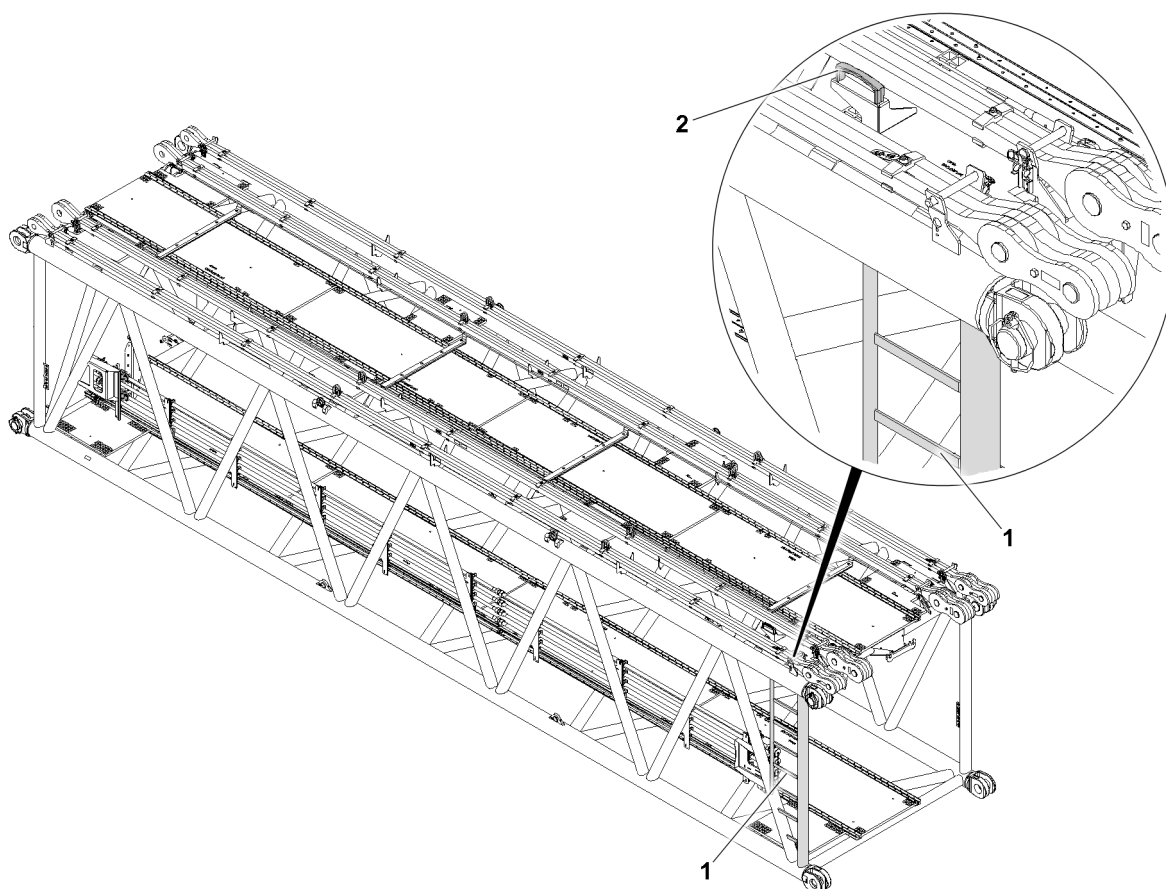


Fig.152034: Ascending and descending the lattice sections

Make sure that the following prerequisites are met:

- Personnel are wearing the personal protective equipment.
- The lattice section is set down on a level surface.

Before accessing the lattice sections, observe the safety instructions, see section “Safety”.

For information regarding the use of ladders, see chapter 2.04.10.



### Note

- ▶ The technical version of the ladders in all ladders is identical.
  - ▶ The use of the ladder 1 is described only for one lattice section.
- 
- ▶ When using the ladder 1, secure personnel to the rungs of the ladder 1 to the handle 2 and to the available components to prevent falling.
  - ▶ Always step on the ladder 1 with extreme caution.

## 19 Ascending and descending the suspended ballast platform

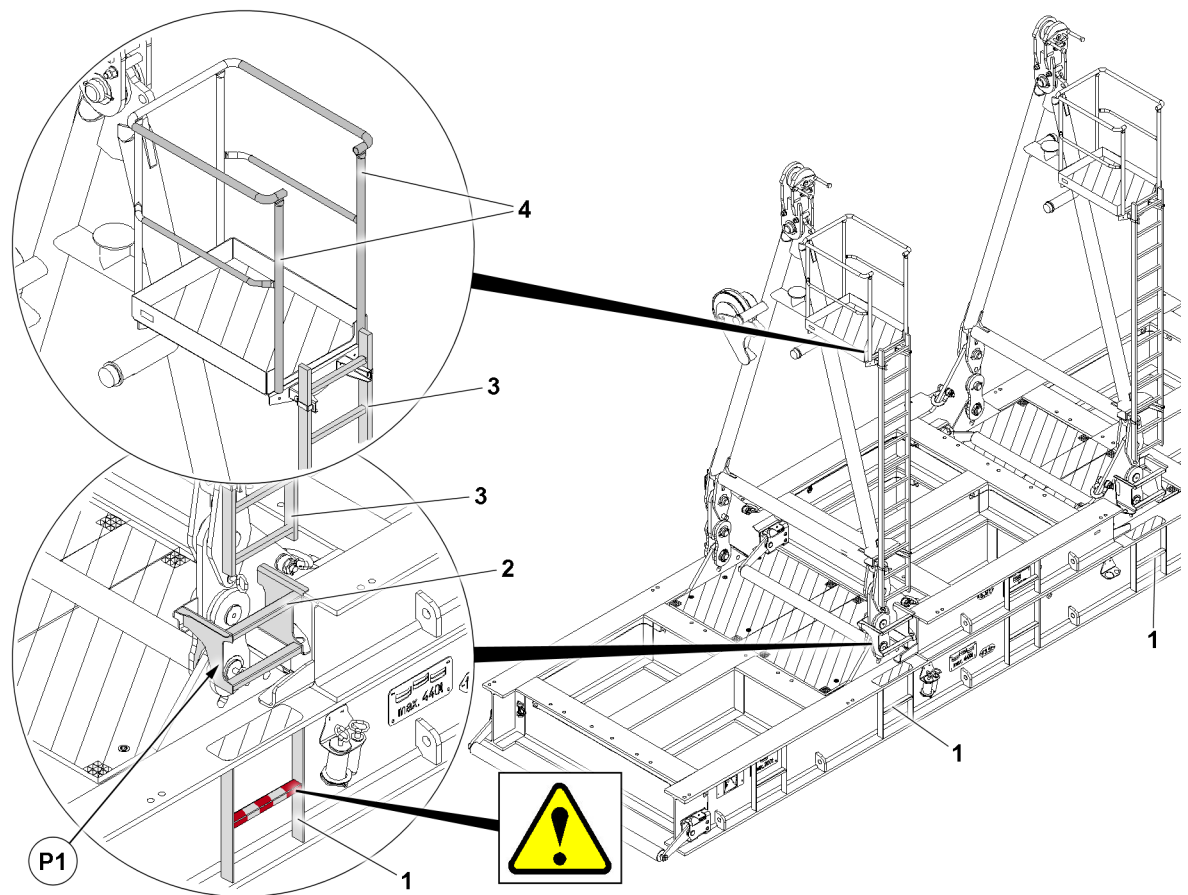


Fig.152032: Ascending and descending the suspended ballast platform

Make sure that the following prerequisites are met:

- Personnel are wearing the personal protective equipment.
- The suspended ballast is placed down on level ground and horizontally aligned.

Before accessing the suspended ballast platform, observe the safety instructions, see section “Safety”.

For information regarding the use of ladders, see chapter 2.04.10.



### WARNING

Danger of slipping due to small step depth!

Personnel can fall down. Death, severe bodily injuries.

- ▶ When climbing up the ladder 1, always use a 3-point support, see chapter 2.04.10.
  - ▶ When climbing down the ladder 1, always use the 3-point support, see chapter 2.04.10.
- 
- ▶ Always step on the ladder 1 with extreme caution.
  - ▶ When using the ladder 2 and when changing in point P1, secure personnel to the rungs of the ladder 3 to prevent falling.
  - ▶ When using the ladder 3, secure personnel to the rungs of the ladder 3 and to the railing 4 to prevent falling.

## 20 Ascending and descending the suspended ballast plates

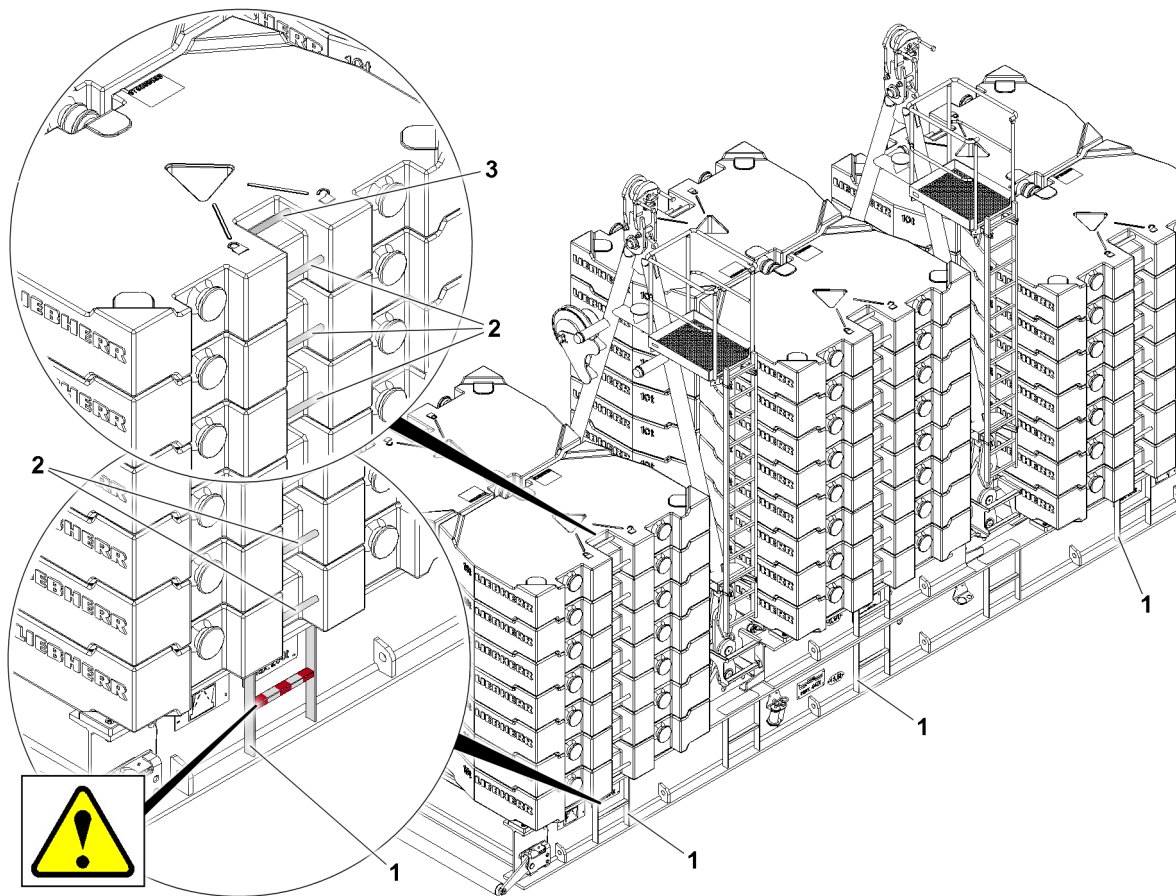


Fig.152033: Ascending and descending the suspended ballast plates

Make sure that the following prerequisites are met:

- Personnel are wearing the personal protective equipment.
- The suspended ballast is placed down on level ground and horizontally aligned.

Before accessing the suspended ballast plates, observe the safety instructions, see section “Safety”.

For information regarding the use of ladders, see chapter 2.04.10.



### WARNING

Danger of slipping due to small step depth!  
Personnel can fall down. Death, severe bodily injuries.

- ▶ When climbing up the ladder 1, always use a 3-point support, see chapter 2.04.10.
- ▶ When climbing down the ladder 1, always use the 3-point support, see chapter 2.04.10.

- ▶ Always step on the ladder 1 with extreme caution.

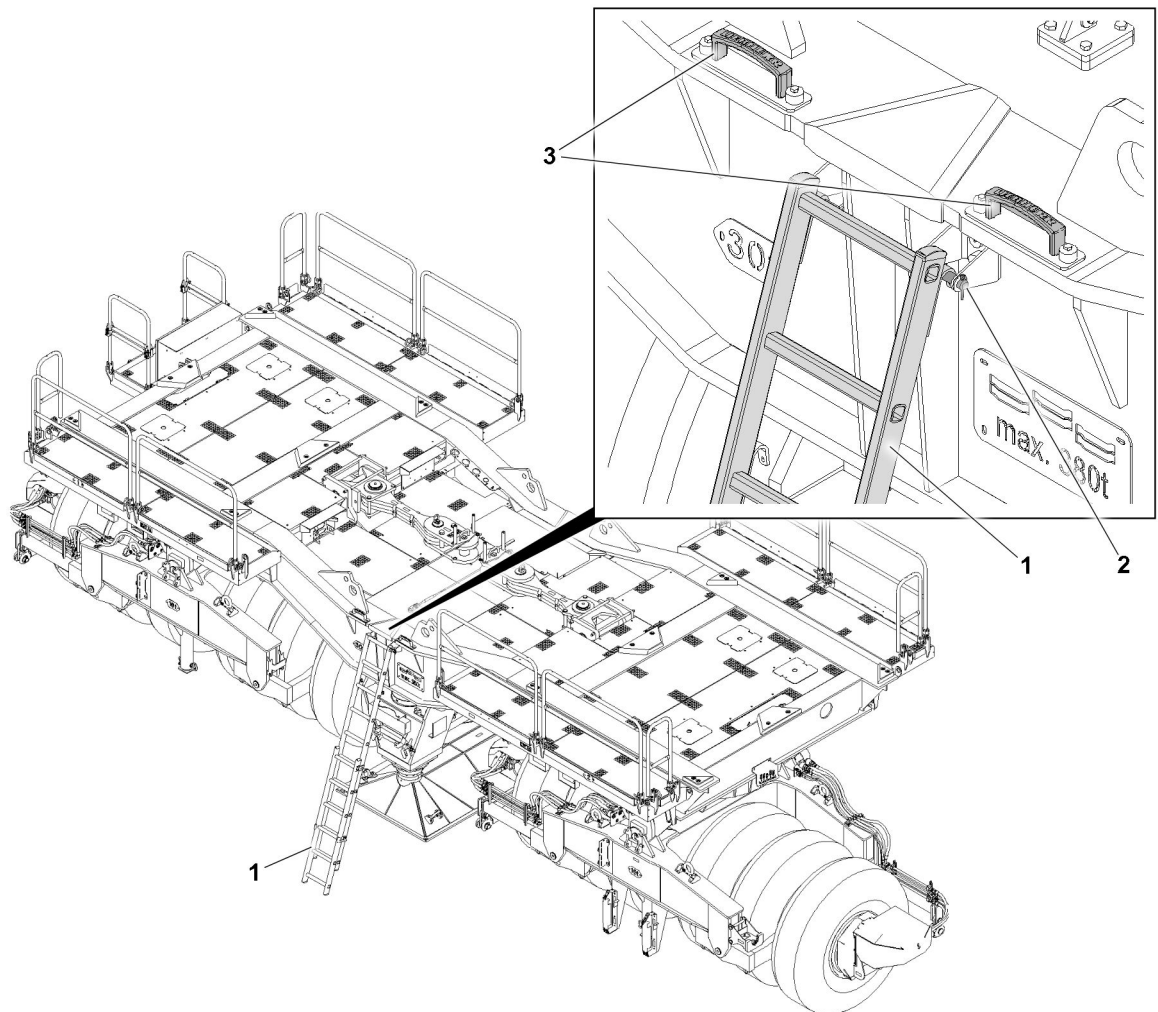


### Note

- ▶ The struts 2 on the stacked suspended ballast plates form a ladder.
- ▶ When using the ladder, secure personnel to the struts 2 and to the strut 3 to prevent falling.



## 21 Ascending and descending the ballast trailer



*Fig.159029: Ascending and descending the ballast trailer*

Make sure that the following prerequisites are met:

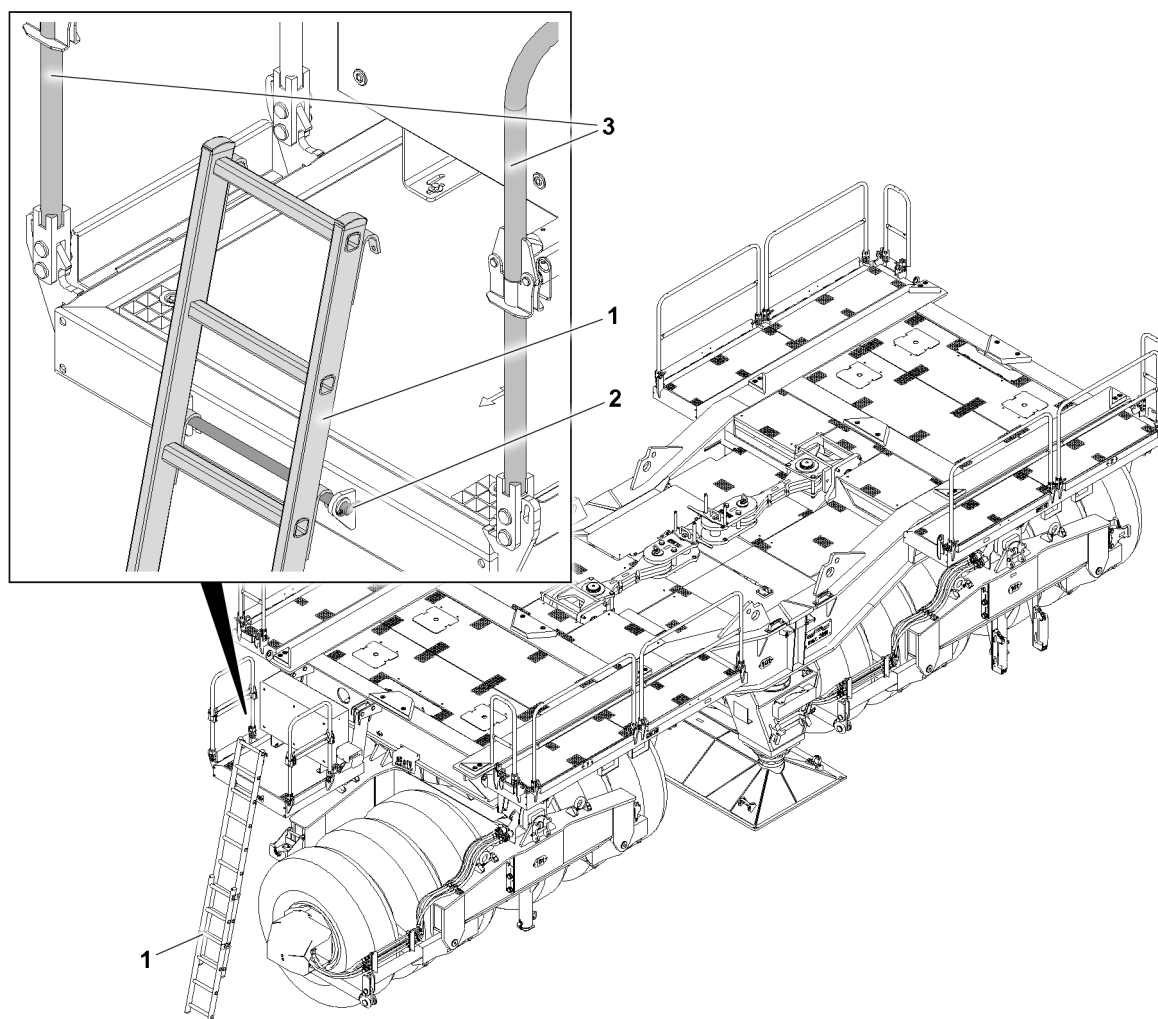
- Personnel are wearing the personal protective equipment.
- The ballast trailer is set down and supported on a level surface.
- The ladder **1** is hung securely with the hooks on the receptacles **2** on the ballast trailer.

Before accessing the ballast trailer, observe the safety instructions, see section “Safety”.

For information regarding the use of ladders, see chapter 2.04.10.

- ▶ When using the ladder **1**, secure personnel to the rungs of the ladder **1** and to the handles **3** to prevent falling.
- ▶ Always step on the ladder **1** with extreme caution.

## 22 Ascending and descending the control cabinet platform



*Fig.159030: Ascending and descending the control cabinet platform*

Make sure that the following prerequisites are met:

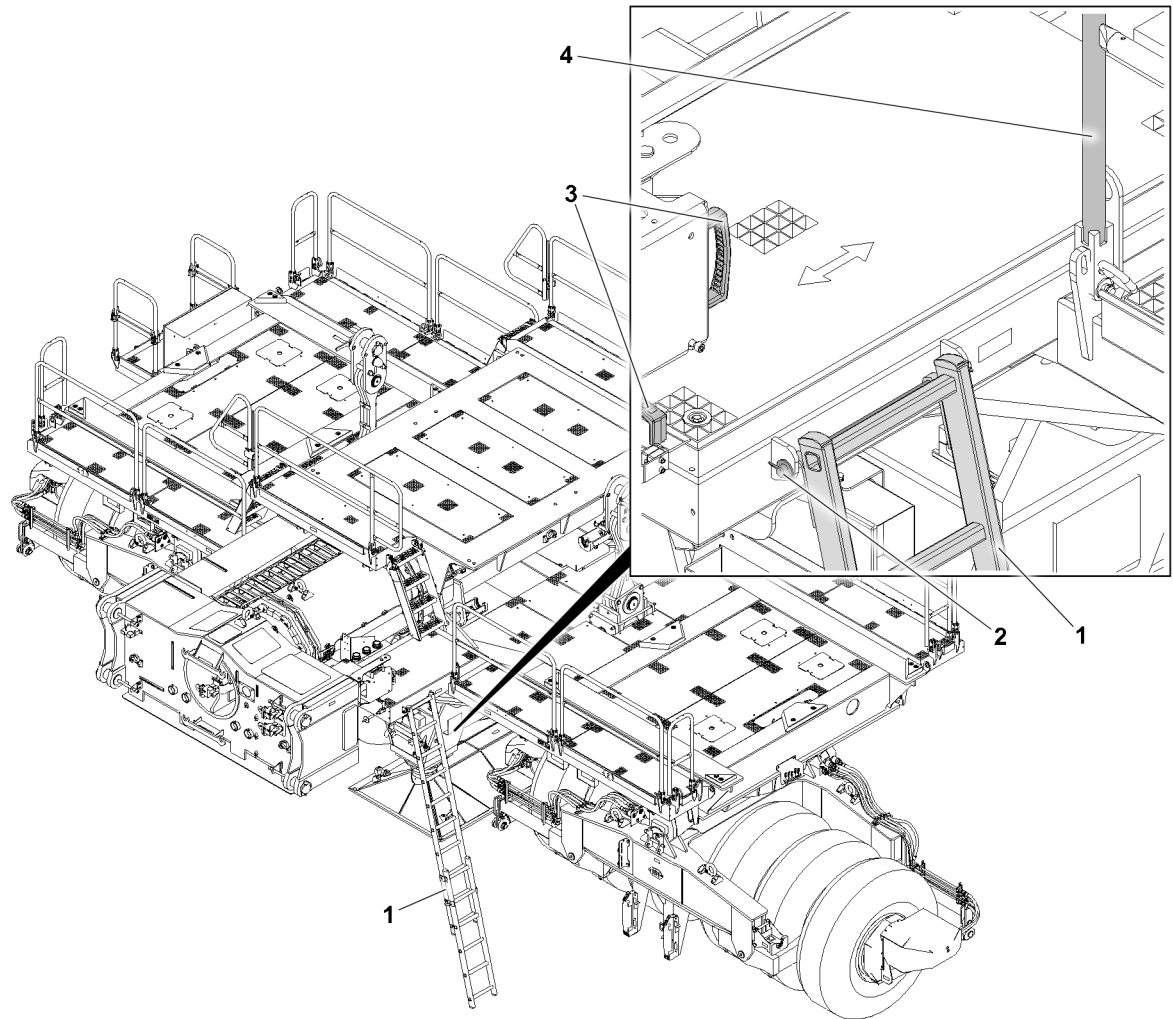
- Personnel are wearing the personal protective equipment.
- The ballast trailer is set down and supported on a level surface.
- The ladder **1** is hung securely with the hooks on the receptacle **2** on the control cabinet platform.

Before accessing the control cabinet platform, observe the safety instructions, see section “Safety”.

For information regarding the use of ladders, see chapter 2.04.10.

- ▶ When using the ladder **1**, secure personnel to the rungs of the ladder **1** and to the railings **3** to prevent falling.
- ▶ Always step on the ladder **1** with extreme caution.

## 23 Ascending and descending the ballast trailer guide



*Fig.159031: Ascending and descending the ballast trailer guide*

Make sure that the following prerequisites are met:

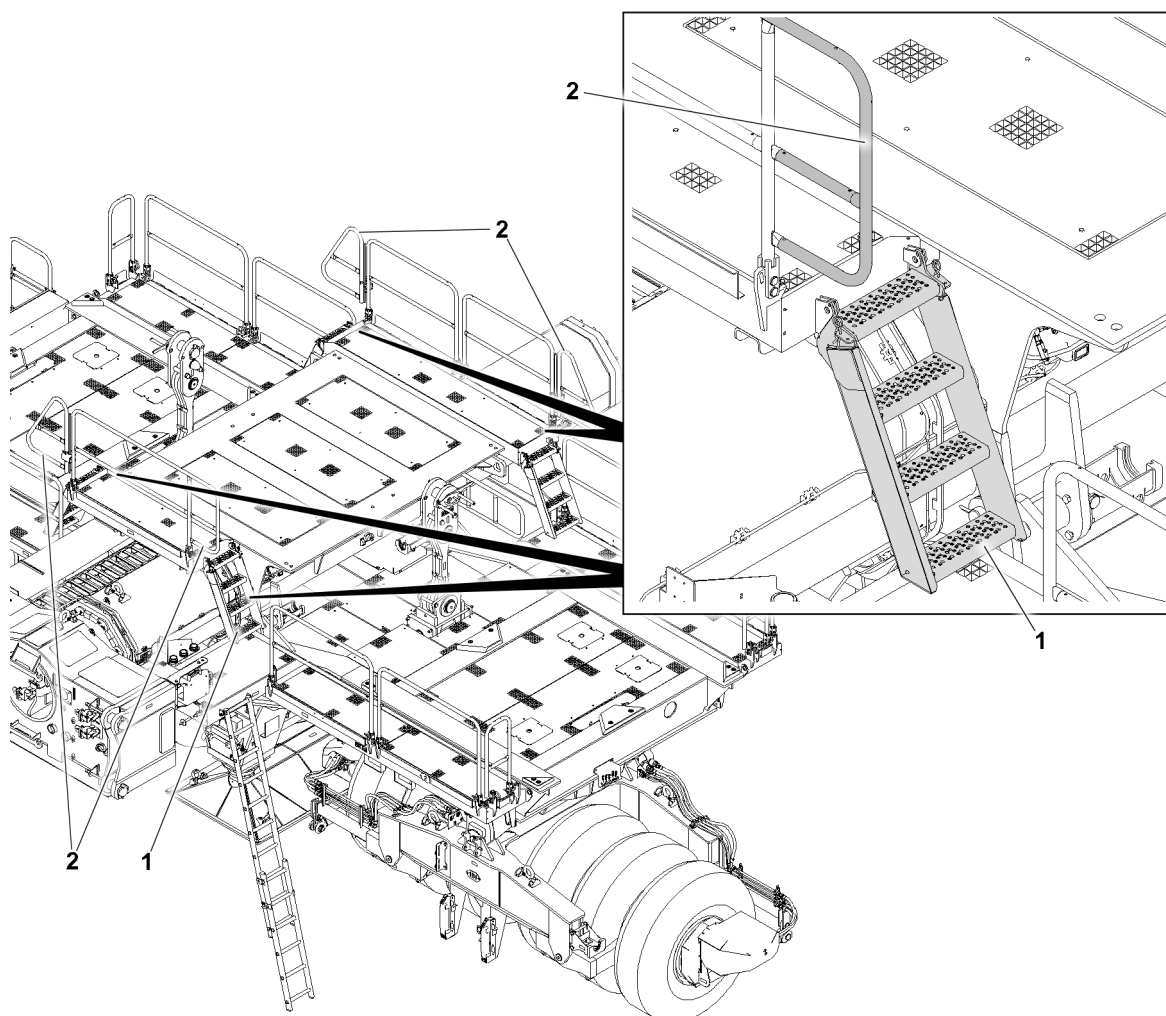
- Personnel are wearing the personal protective equipment.
- The ballast trailer is set down and supported on a level surface.
- The ladder **1** is hung securely with the hooks on the receptacle **2** on the ballast trailer guide.

Before accessing the ballast trailer guide, observe the safety instructions, see section “Safety”.

For information regarding the use of ladders, see chapter 2.04.10.

- ▶ When using the ladder **1**, secure personnel to the rungs of the ladder **1** and to the railings **4** and the handles **3** to prevent falling.
- ▶ Always step on the ladder **1** with extreme caution.

## 24 Ascending and descending the ballast trailer guide



*Fig.159032: Ascending and descending the ballast trailer guide*

Make sure that the following prerequisites are met:

- Personnel are wearing the personal protective equipment.
- The ballast trailer is set down and supported on a level surface.

Before accessing the ballast trailer guide, observe the safety instructions, see section “Safety”.

For information regarding the use of ladders, see chapter 2.04.10.

- ▶ When using the ladder **1**, secure personnel to the railing **2** to prevent falling.
- ▶ Always step on the ladder **1** with extreme caution.

## 25 Ascending and descending the ballast trailer plates

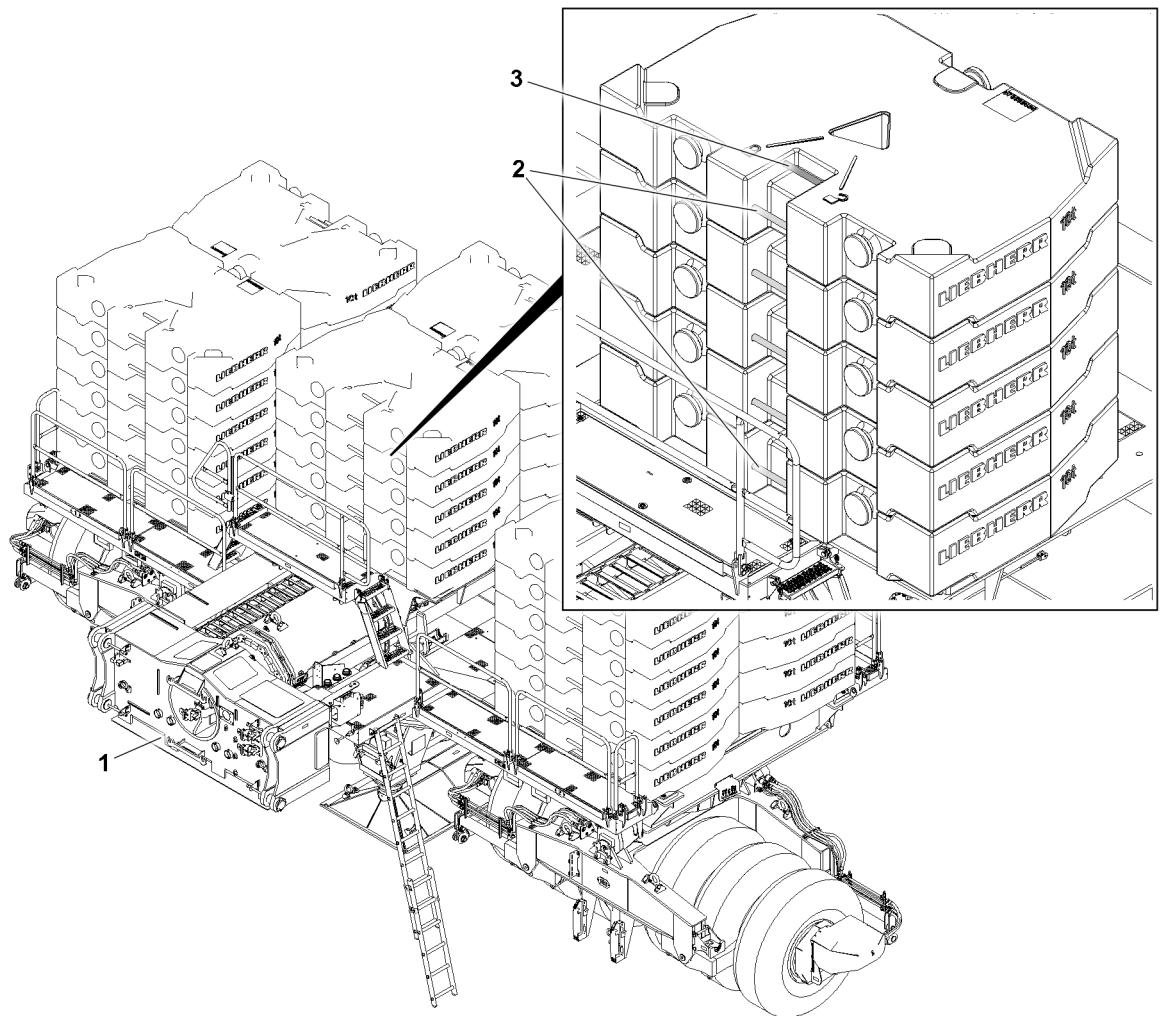


Fig.159033: Ascending and descending the ballast trailer plates

Make sure that the following prerequisites are met:

- Personnel are wearing the personal protective equipment.
- The suspended ballast is placed down on level ground and horizontally aligned.

Before accessing the suspended ballast plates, observe the safety instructions, see section “Safety”.

For information regarding the use of ladders, see chapter 2.04.10.



### Note

- ▶ The struts **2** on the stacked suspended ballast plates form a ladder.
- ▶ When using the ladder, secure personnel to the struts **2** and to the strut **3** to prevent falling.

## 26 Walking surfaces and stepping surfaces



### WARNING

Slippery surface!

Personnel can fall down. Death, severe bodily injuries.

- ▶ Only step on accessible surfaces.
- ▶ Stepping on non-accessible surfaces is **prohibited**.

**WARNING**

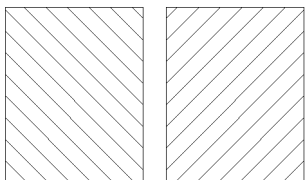
Danger of slipping due to small step depth!

Some walking surfaces and stepping surfaces on the crane have a small step depth.

Personnel can fall down. Death, severe bodily injuries.

- ▶ Step on the walking surfaces and stepping surfaces always with utmost caution.
- ▶ When walking on walking surfaces and stepping surfaces on the crane with a small step depth, always use a 3-point support, see chapter 2.04.10.

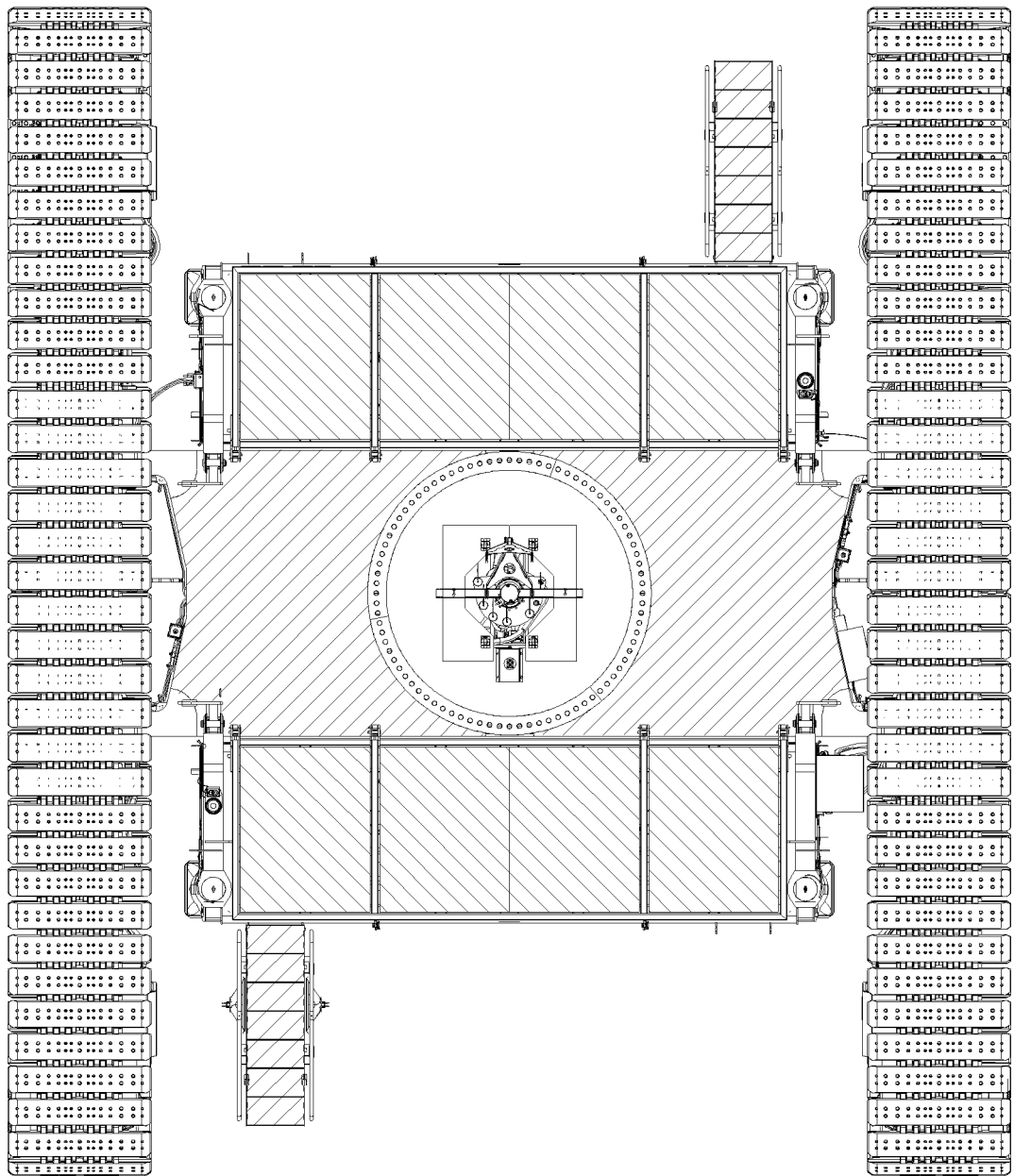
## 26.1 Accessible walking surfaces and stepping surfaces



*Fig.152031: Cross hatch*

The accessible walking surfaces and stepping surfaces are marked with cross hatches.

## 26.2 Crane chassis



*Fig.152001: Accessible walking surfaces and stepping surfaces*

LWE/LR 1800-1-0-000/27200-07-02/en

## 26.3 Crane superstructure

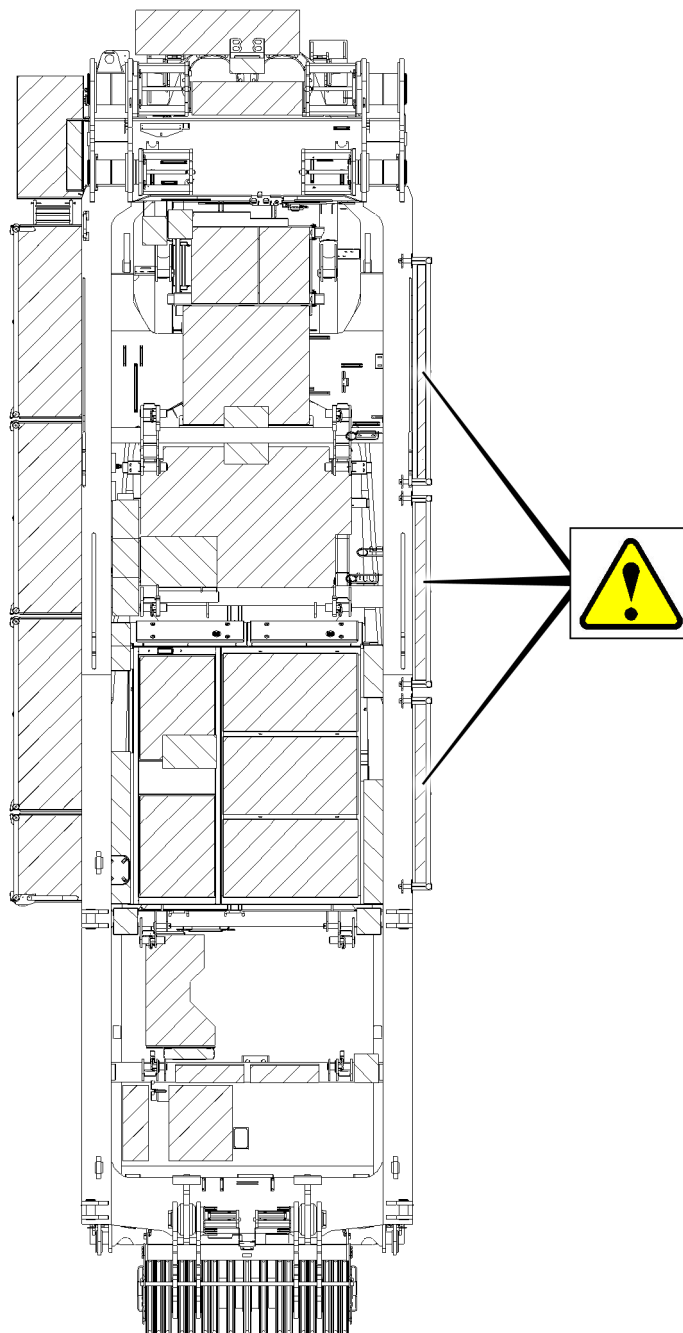


Fig.152003: Accessible walking surfaces and stepping surfaces



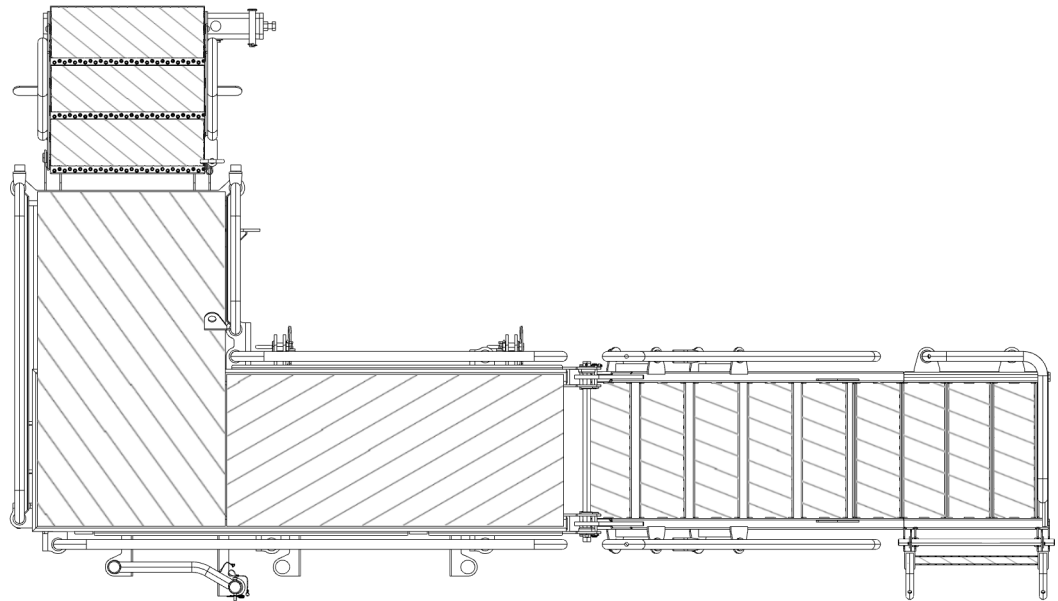
### WARNING

Danger of slipping due to small step depth!  
Personnel can fall down. Death, severe bodily injuries.

- ▶ Always walk with utmost caution on walking surfaces with a small step depth on the right upper belt of the turntable.
- ▶ When walking on walking surfaces with a small step depth on the right upper belt of the turntable, always use a 3-point support, see chapter 2.04.10.

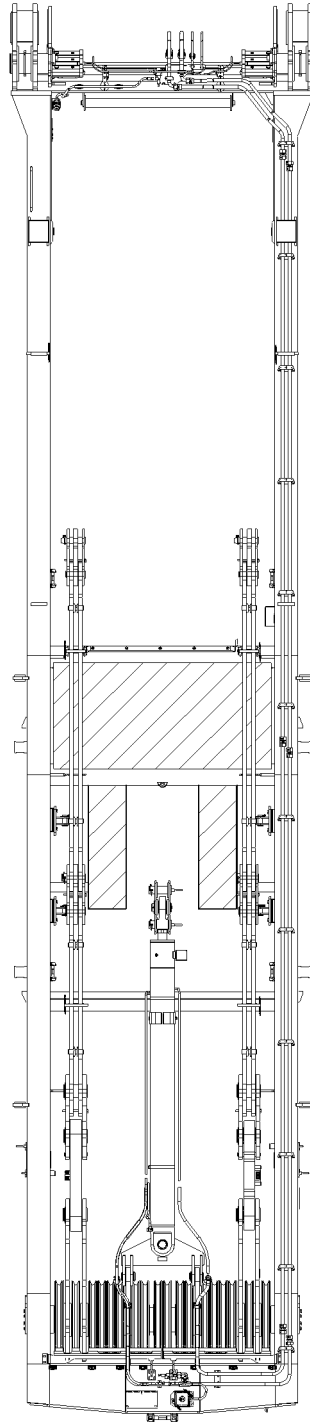


## 26.4 Additional step



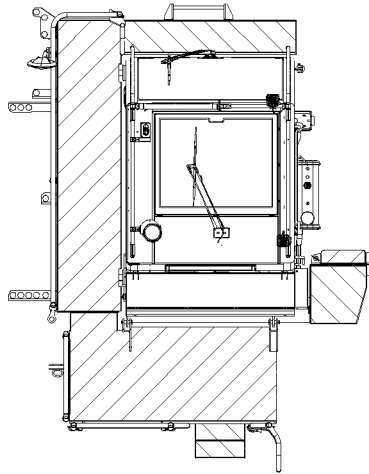
*Fig.162699: Accessible walking surfaces and stepping surfaces*

## 26.5 SA-frame



*Fig.152004: Accessible walking surfaces and stepping surfaces*

## 26.6 Crane cab



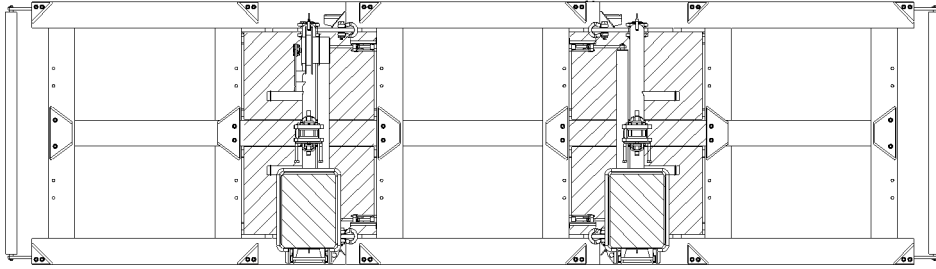
*Fig.152005: Accessible walking surfaces and stepping surfaces*

## 26.7 Winch 1; 2 and 4



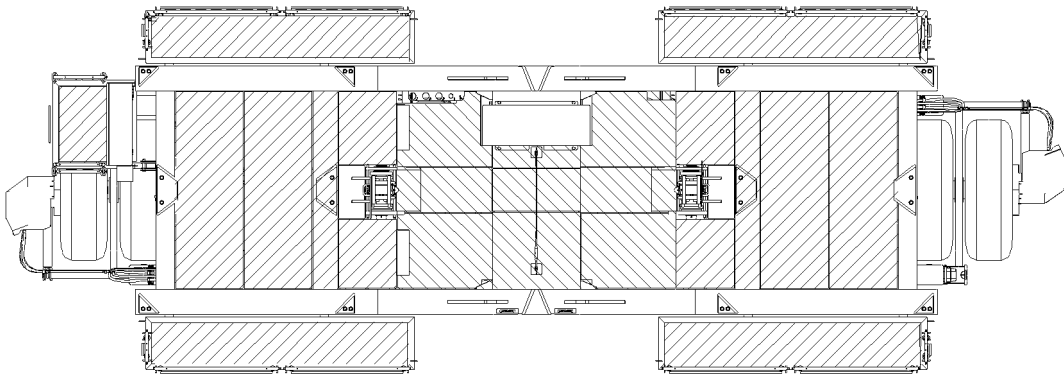
*Fig.152006: Accessible walking surfaces and stepping surfaces*

## 26.8 Suspended ballast



*Fig.152090: Accessible walking surfaces and stepping surfaces*

## 26.9 Ballast trailer



*Fig.159034: Accessible walking surfaces and stepping surfaces*

## 26.10 Ballast trailer guide

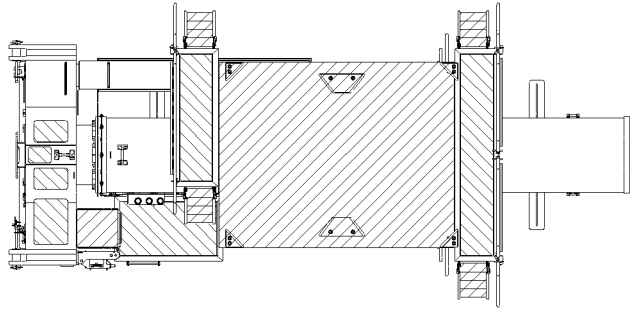


Fig.159035: Accessible walking surfaces and stepping surfaces

## 26.11 Intermediate section

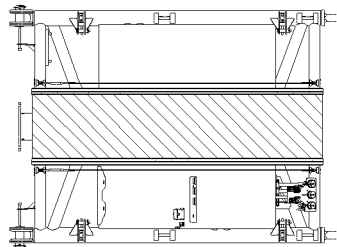


Fig.159036: Accessible walking surfaces and stepping surfaces

## 26.12 Adapter

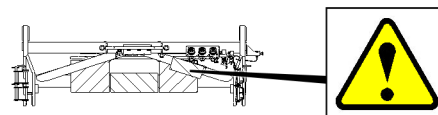


Fig.159037: Accessible walking surfaces and stepping surfaces



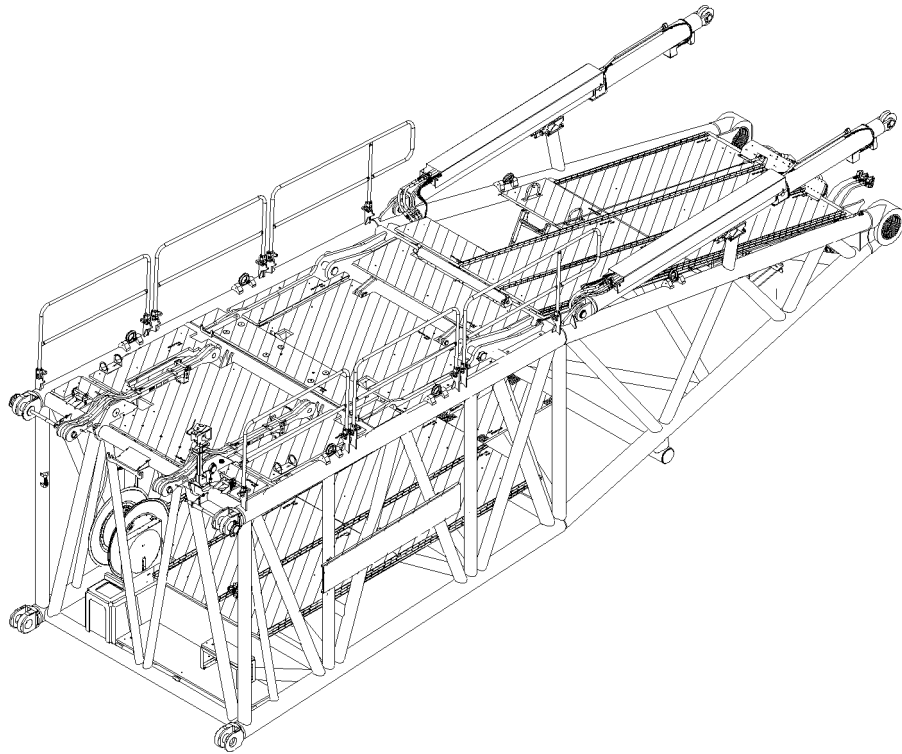
### WARNING

Danger of slipping due to small step depth!

Personnel can fall down. Death, severe bodily injuries.

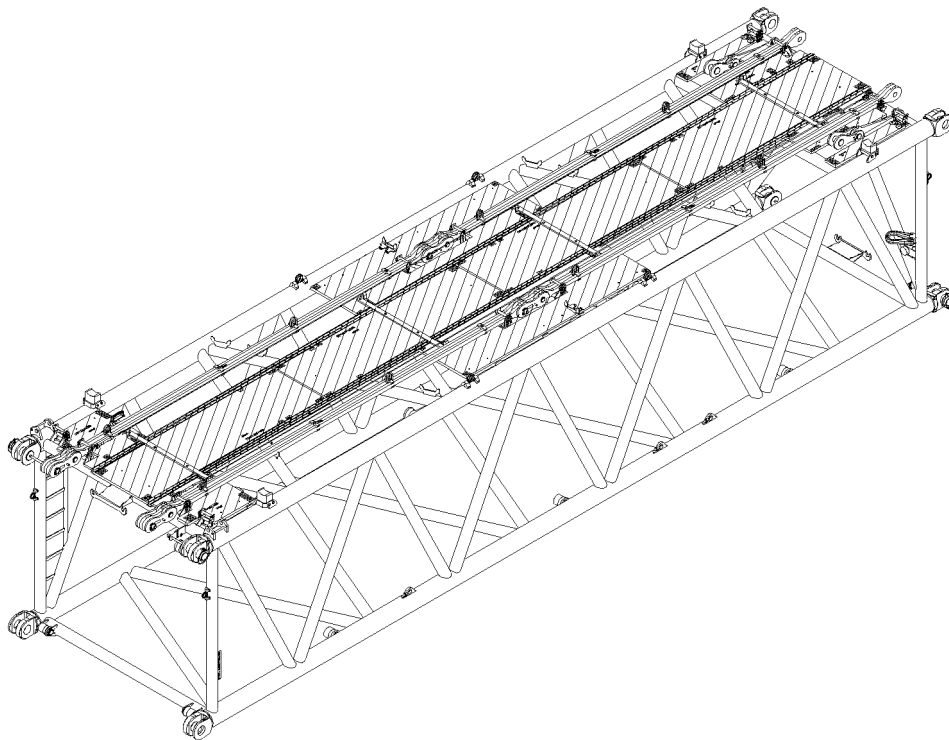
- ▶ Always walk with utmost caution on walking surfaces with a small step depth on the adapter.
- ▶ When walking on walking surfaces with a small step depth on the adapter, always use a 3-point support, see chapter 2.04.10.

## 26.13 H-pivot section



*Fig.152007: Accessible walking surfaces and stepping surfaces*

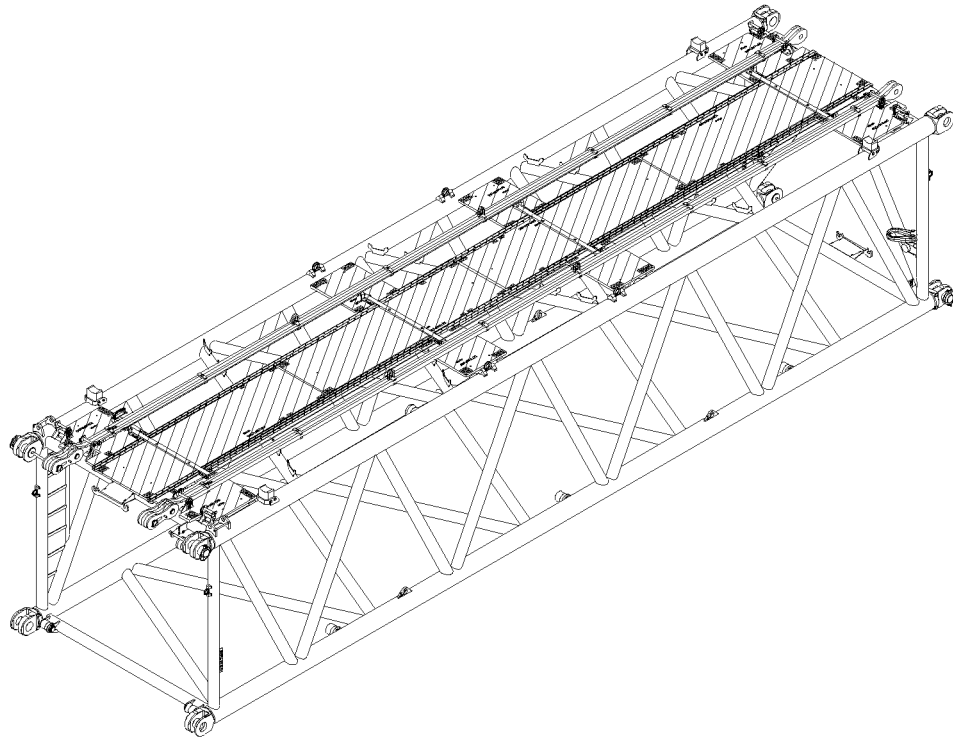
## 26.14 H-intermediate section



*Fig.152008: Accessible walking surfaces and stepping surfaces*

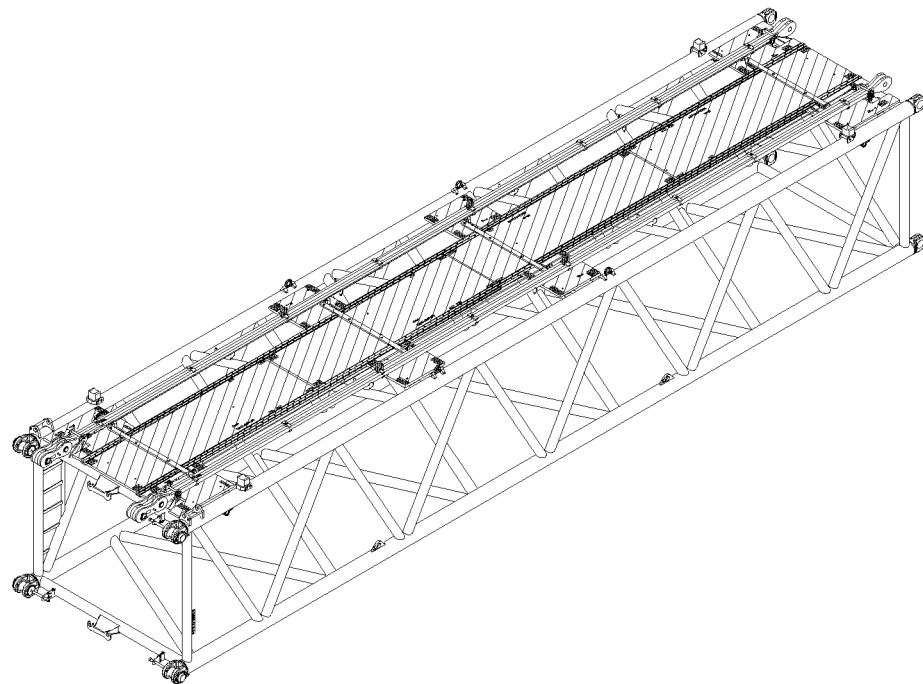
LWE/LR 1800-1-0-000/27200-07-02/en

## 26.15 S-intermediate section



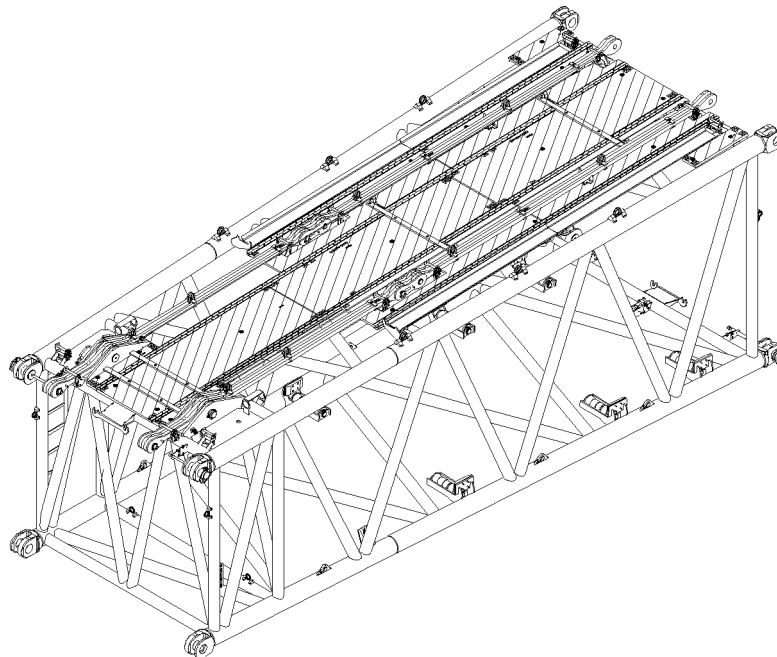
*Fig.152009: Accessible walking surfaces and stepping surfaces*

## 26.16 L-intermediate section



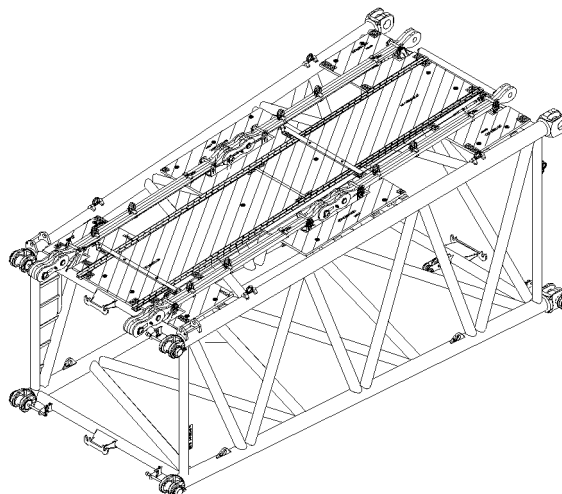
*Fig.152010: Accessible walking surfaces and stepping surfaces*

## 26.17 HS-reducer



*Fig.152011: Accessible walking surfaces and stepping surfaces*

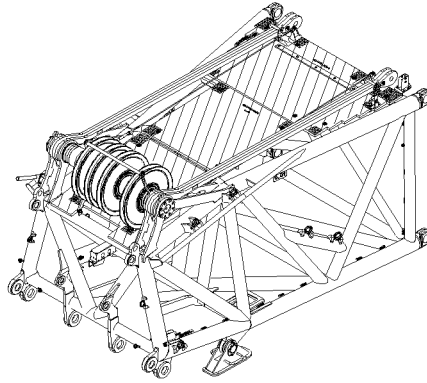
## 26.18 SL-reducer



*Fig.152012: Accessible walking surfaces and stepping surfaces*

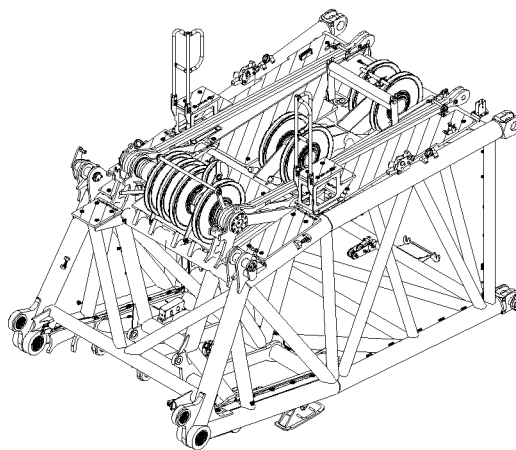


## 26.19 L-end section



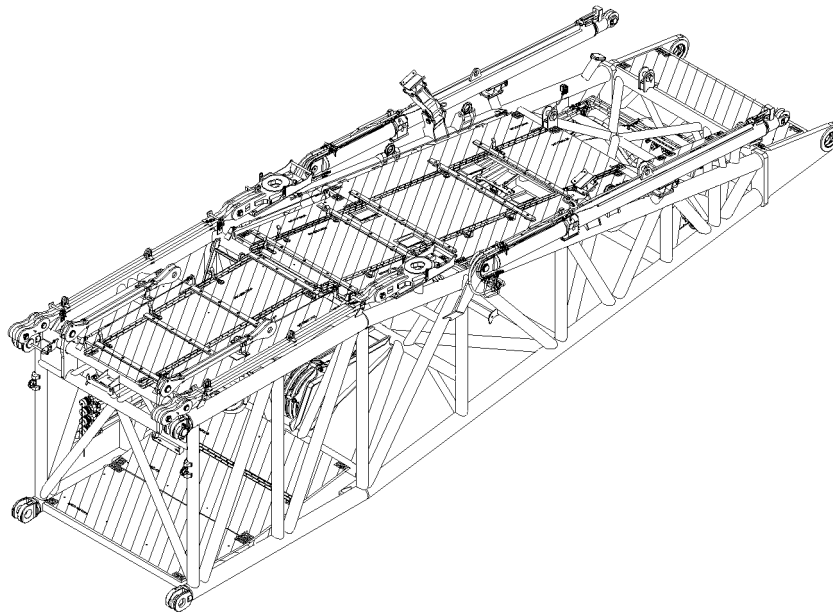
*Fig.152013: Accessible walking surfaces and stepping surfaces*

## 26.20 S-end section



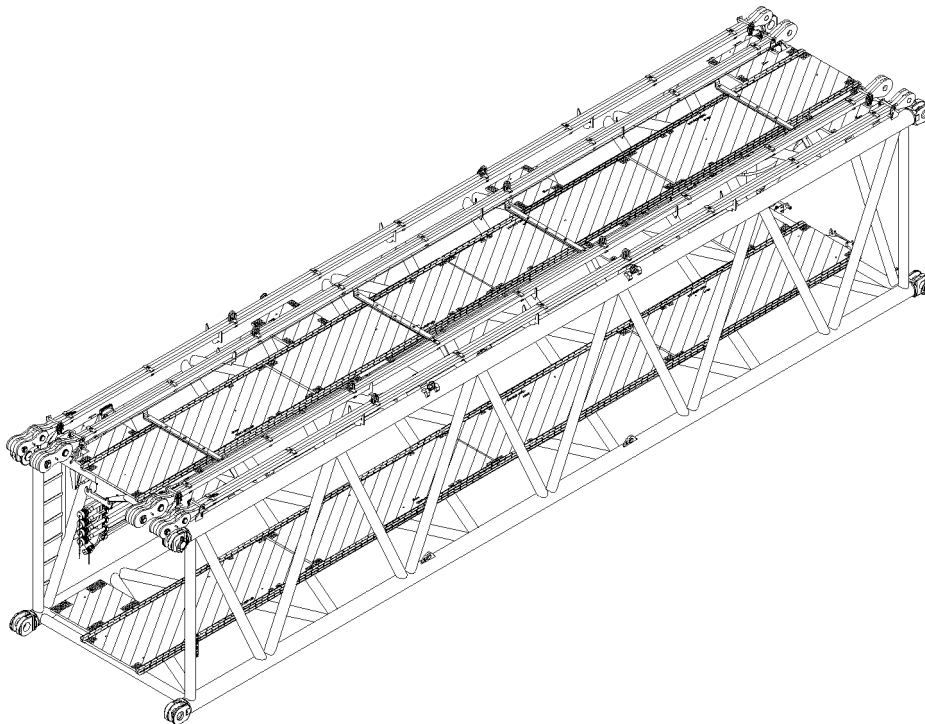
*Fig.152014: Accessible walking surfaces and stepping surfaces*

## 26.21 D-pivot section



*Fig.152015: Accessible walking surfaces and stepping surfaces*

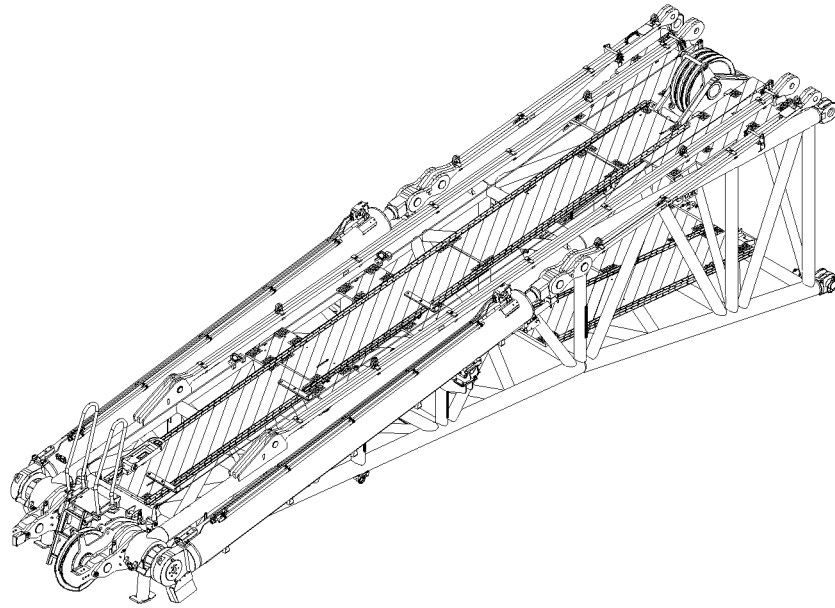
## 26.22 D-intermediate section



*Fig.152016: Accessible walking surfaces and stepping surfaces*

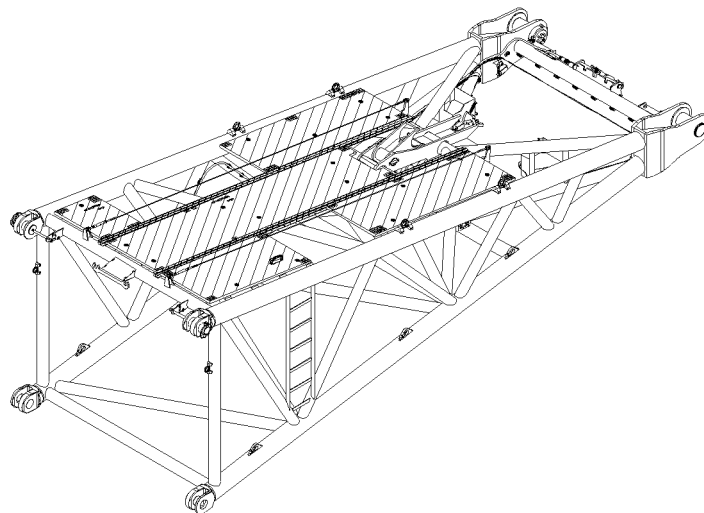
LWE/LR 1800-1-0-000/27200-07-02/en

## 26.23 D-end section



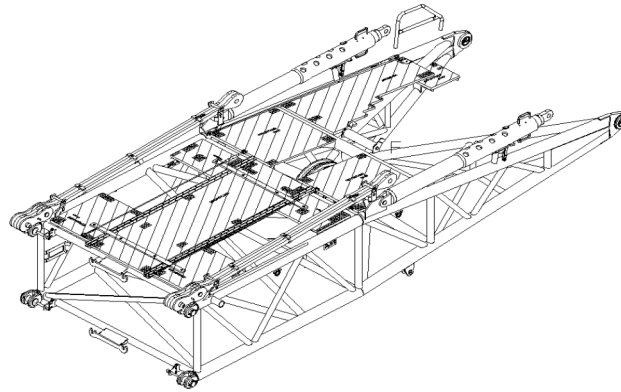
*Fig.152017: Accessible walking surfaces and stepping surfaces*

## 26.24 W-pivot section



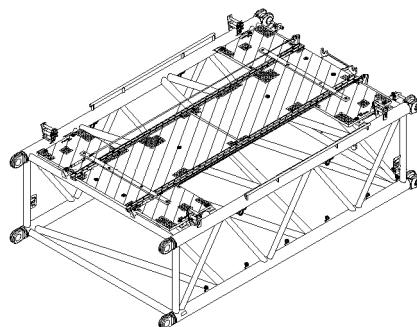
*Fig.152018: Accessible walking surfaces and stepping surfaces*

## 26.25 WA-frame 2 - pivot section



*Fig.152019: Accessible walking surfaces and stepping surfaces*

## 26.26 WA-frame 2 intermediate section



*Fig.152020: Accessible walking surfaces and stepping surfaces*

## 26.27 WA-frame 2, end section

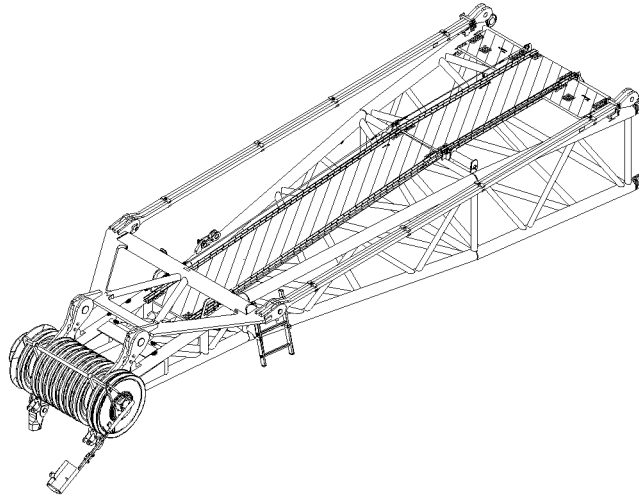


Fig.152021: Accessible walking surfaces and stepping surfaces

## 26.28 Counterweight platform

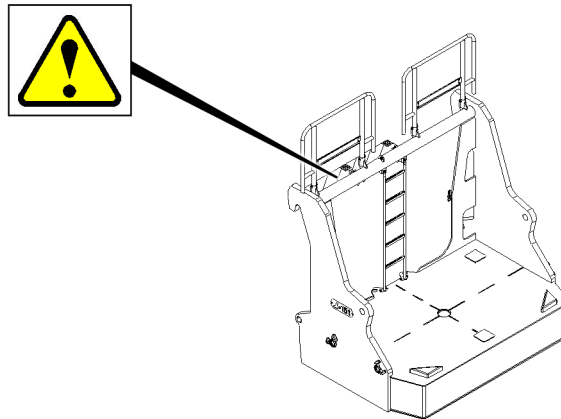


Fig.152023: Accessible walking surfaces and stepping surfaces

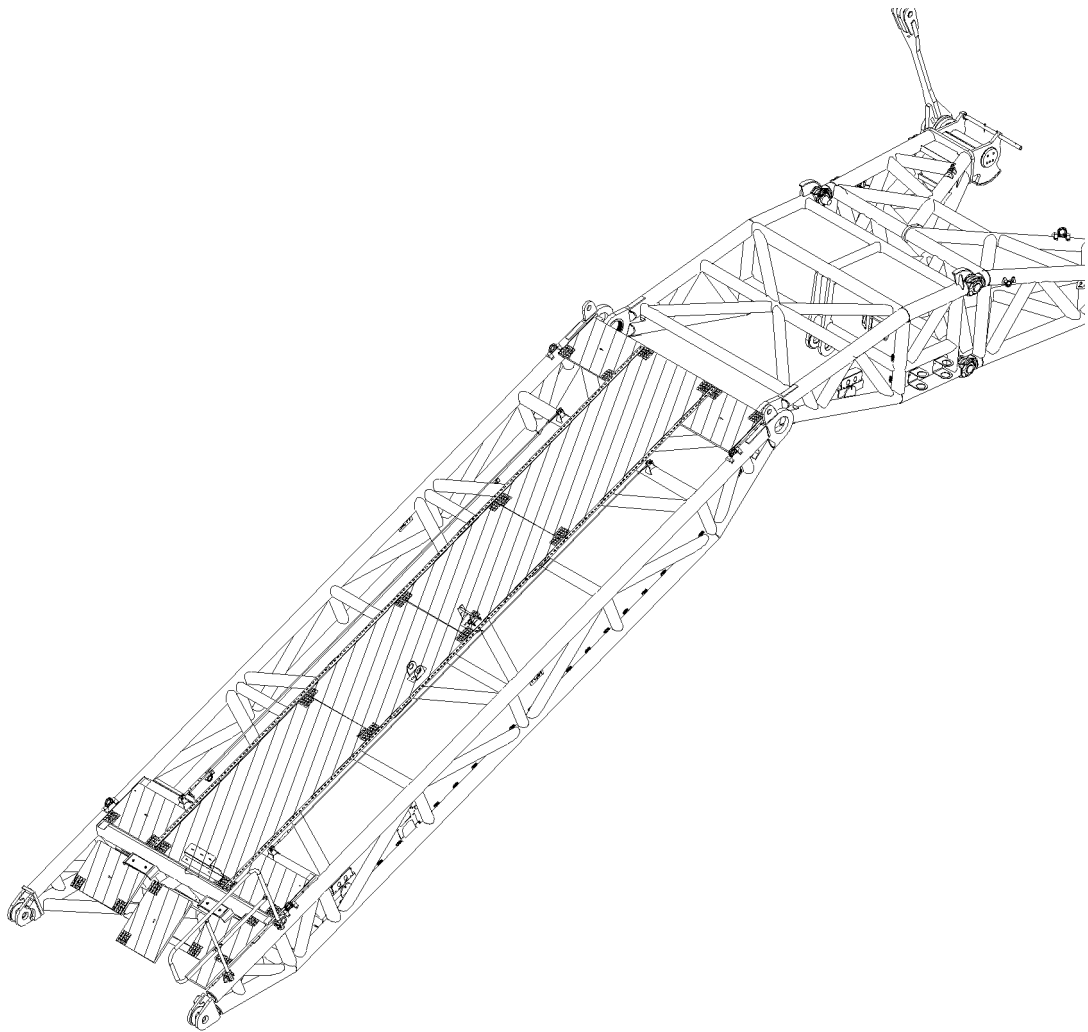


### WARNING

Danger of slipping due to small step depth!  
Personnel can fall down. Death, severe bodily injuries.

- ▶ Always walk with utmost caution on walking surfaces with a small step depth on the counterweight platform.
- ▶ When walking on walking surfaces with a small step depth on the counterweight platform, always use a 3-point support, see chapter 2.04.10.

## 26.29 Suspended ballast guide



*Fig.152022: Accessible walking surfaces and stepping surfaces*

## 2.08 Working in low temperatures

1	Auxiliary equipment	2
2	Safety	2
3	Environmental / component temperature below -20 °C	3
4	Maintenance	7

# 1 Auxiliary equipment

At ambient temperatures between -20 °C and +50 °C the crane can be operated and stored “without auxiliary equipment for working in low temperatures”.

At ambient temperatures below -20 °C , the crane must be modified and equipped with “auxiliary equipment for working at low temperatures”.



## WARNING

Working at low temperatures without the corresponding auxiliary equipment!  
The crane components can be damaged and fail. The load can rip off.  
Death, severe bodily injuries, property damage.

If the crane is operated at an ambient temperature lower than -20 °C:

- ▶ Make sure that the crane is equipped with the corresponding “auxiliary equipment for working at low temperatures”.
- ▶ Match the operating fluids in time to the ambient temperature.

# 2 Safety

Temperature changes cause technological changes to material properties in the case of steel / cast steel and many other materials.

Crane components made of steel / cast steel are very sensitive to sudden movements, impacts and shocks at decreasing negative temperatures.

This effect increases if the crane compacts are impacted with a load and / or large weights.

To ensure safe operation at low temperatures, the crane structure must be checked at short intervals for cracks.



## Note

- ▶ Observe and adhere to the instructions in chapter 8.01.



## DANGER

The crane can topple over!

Due to decreasing negative temperatures, crane components reach their technological load limits much earlier.

Crane components can break.

The crane can topple over.

Death, severe bodily injuries, property damage.

- ▶ For safe crane operation, the **temperature of the crane components is the deciding factor** and not the ambient temperature.
- ▶ For safe crane operation with component temperatures **down to -40 °C** , the crane must be equipped with “auxiliary equipment for working at low temperatures”.
- ▶ With component temperatures **below -40 °C** , do not operate the crane. In the case of doubt, contact Customer Service at Liebherr-Werk Ehingen GmbH.



## 3 Environmental / component temperature below -20 °C

### 3.1 Winter operation

Low temperatures, as well as snow, frost and ice can impair crane operation and cause problems on the crane.

Freezing takes place often at low temperatures.



#### WARNING

Snow, frost and ice on the accesses!

Personnel can fall from the accesses.

Death, severe bodily injuries, property damage.

- ▶ Remove the snow, frost and ice from all accesses, steps and catwalks.
- ▶ Remove the snow, frost and ice from the crane.

#### NOTICE

Snow, frost and ice on the crane components!

The crane components can be damaged and fail.

Cylinder seals can be destroyed by frozen piston rods.

- ▶ Remove the snow, frost and ice from the piston rods.
- ▶ Remove the snow, frost and ice from all rope pulleys and winches.
- ▶ Remove the snow, frost and ice from the hose drums and limit switches.



#### WARNING

Snow, frost and ice below the support plates or the crawler carriers!

The crane can slide.

Death, severe bodily injuries, property damage.

- ▶ Remove the snow, frost and ice on top and below the support plates.
- ▶ Remove the snow, frost and ice on top and below the crawler carrier.
- ▶ Remove the snow, frost and ice from the roadway.

Prerequisites for crane start up with component temperatures below -20 °C

- The hose drums and cables are easy to move.
- All rope pulleys are easily movable.
- The view from the crane cab is free.
- The mirrors are free of snow, frost and ice.
- Fastening equipment is approved for the ambient temperatures present.
- The load fastening points are approved for the ambient temperatures present.

### 3.2 Preheating time



#### WARNING

Limited crane control during radio operation!

In the case of falling negative temperatures, the LCD displays react increasingly slowly to changes made to images and icons on the displays.

In the case of minus temperatures below -25 °C, changes made to images and icons could be displayed with a considerable delay or not at all.

This can lead to dangerous situations if warnings are displayed with a delay.

Death, severe bodily injuries, property damage.

- ▶ If the component temperature of the radio remote control is below -25 °C: Preheat the radio remote control prior to start up.
- ▶ In the case of increasing sluggishness of the LCD displays during radio operation with temperatures below -25 °C: Warm up or preheat the radio remote control occasionally.

Crane components	Preheating time
Engine preheating up to start at -40 °C component temperature	45 minutes
Preheat the hydraulic system in the crane superstructure and the crane chassis	30 minutes
Preheat the crane cab / driver's cab for start up at the same time up to 5 °C	10 minutes
<b>Total preheating time</b>	<b>75 minutes</b>

- ▶ To ensure safe crane operation: Adhere to the preheating times.

### 3.3 Engine preheating

If the components temperature is lower than -20 °C the chassis engine and / or superstructure engine must be preheated before starting.

Depending on the crane type, a chassis engine and / or a superstructure engine is installed.

Pre-warming the chassis engine is described in chapter 6.01.

Pre-warming the superstructure engine is described in chapter 6.02.

- ▶ Preheat the chassis engine and / or the superstructure engine.
- ▶ Start the chassis engine and / or the superstructure engine.

When the chassis engine and / or the superstructure engine has reached its operating temperature:

- ▶ Turn off engine preheating.

### 3.4 Preheating the hydraulic oil

If the ambient temperature is lower than -20 °C the hydraulic oil must be preheated prior to crane operation.

#### NOTICE

Hydraulic oil **not** preheated!

The hydraulic system can be damaged during crane operation.

- ▶ Before starting crane operation, preheat the hydraulic oil to at least 20 °C.
- ▶ Retract and extend all the hydraulic cylinders in an unloaded state over the entire stroke multiple times.



#### WARNING

Persons in the area of the hoist movement!

Death, severe bodily injuries, property damage.

- ▶ Observe the area of the hoist movement.
- ▶ Make sure that there are **no** persons in the area of the hoist movement.

#### 3.4.1 Turning the hydraulic oil preheating on

Make sure that the following prerequisites are met:

- The engine is running.
- Hydraulic oil preheating is available.

Hydraulic oil preheating is described in chapter 4.03.

- ▶ Turn the hydraulic oil preheating on.

When the hydraulic oil is preheated:

- ▶ Turn the hydraulic oil preheating off.

#### 3.4.2 Supporting the crane

Supporting the crane vehicle is described in chapter 3.05.

All support plates must be supported with suitable and stable materials.

If moveable support plates are not available, the support plates must be supported **on one side of the crane** with greased polyamide plates.



#### WARNING

No movable support plates or crane **not** supported with greased polyamide plates!

The sliding beams can bend. The support plates can suddenly move to the side.

The load can oscillate.

Death, severe bodily injuries, property damage.

- ▶ Use moveable support plates.

If there are no movable support plates available:

- ▶ Support the support plates **on one side of the crane** with greased polyamide plates.

If not sure if the crane has been equipped with support cylinders for an operating temperature down to  $-40\text{ }^{\circ}\text{C}$ , contact Customer Service at Liebherr-Werk Ehingen GmbH.

If the crane is **not** equipped with support cylinders for an operating temperature down to  $-40\text{ }^{\circ}\text{C}$ :

- ▶ When supporting, extend the support cylinder a maximum of 50 %.

The wheels must not come in to contact with the ground after the crane is supported.

- ▶ Support the support plates when necessary.
- ▶ Support the crane.

### 3.4.3 Cranes with lattice mast boom

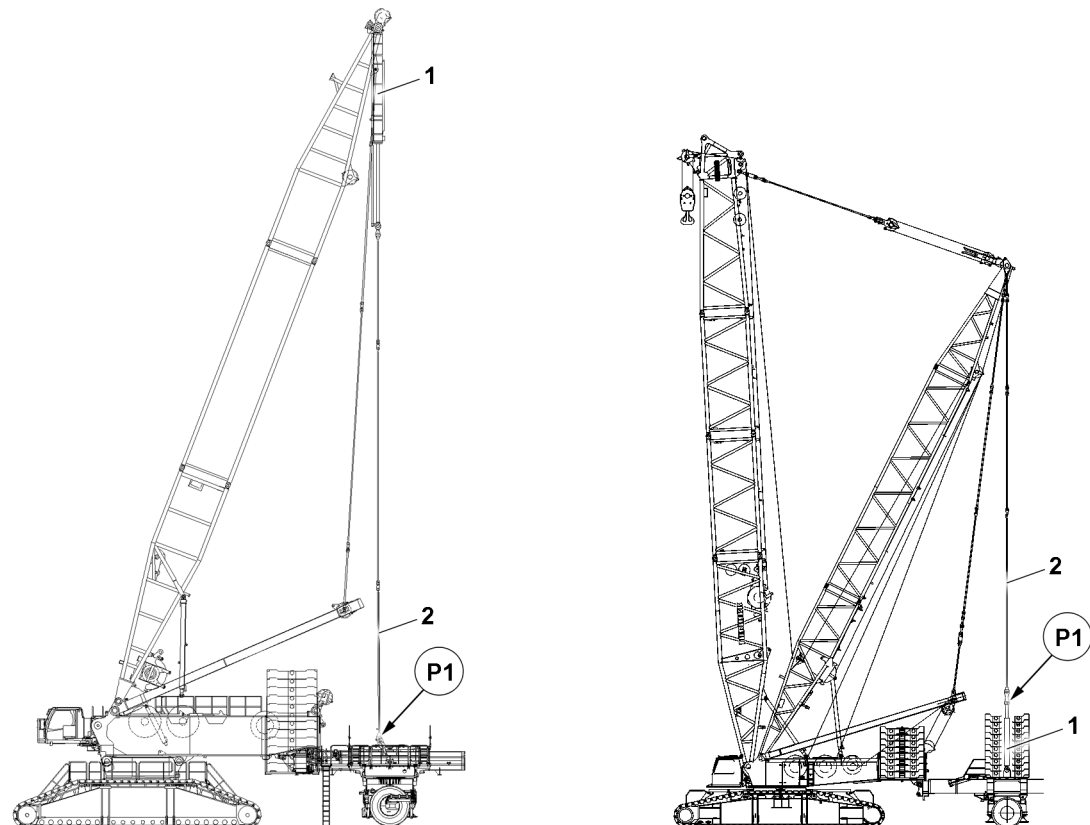


Fig.126875: Removing the guy rods on the derrick ballast

With component temperatures of less than  $-20\text{ }^{\circ}\text{C}$ , the pull cylinders must be preheated by means of retraction and extension. Before the pull cylinders can be preheated, the guy rods **2** must be removed in position **P1** on the derrick ballast.

Disassembly and assembly of the guy rods **2** on the derrick ballast is described in the Crane operating instructions, chapter 5.35 and chapter 5.36.

- ▶ Remove the guy rods **2** at position **P1** on the derrick ballast.

---

#### NOTICE

Danger of collision!

Damage of the guy rods, derrick ballast or other components.

- ▶ When retracting and extending the guy rods, avoid contact with other components.

- ▶ Retract and extend the pull cylinders **1** in an unloaded state over the entire stroke multiple times.

When additional hydraulic cylinders are installed on the crane with lattice mast:

- ▶ Retract and extend the hydraulic cylinders in an unloaded state over the entire stroke multiple times.

### 3.4.4 Cranes with a telescopic boom

Make sure that the following prerequisites are met:

- The crane is supported and horizontally aligned.
- There is no load on the hook.
- ▶ Retract and extend the luffing cylinder in an unloaded state over the entire stroke multiple times.
- ▶ Retract and extend the telescoping cylinder in an unloaded state over the entire stroke multiple times.

## 3.5 Assembling / disassembling the crane components

If the component temperature is lower than  $-20\text{ }^{\circ}\text{C}$ , there is an increased danger that in the case of impact and / or strong component contact that the crane components will be damaged as a result of their changed technological material properties. In particular counterweights and crane components made of cast steel are subject to a greater risk of damage due to impact at component temperatures below  $-20\text{ }^{\circ}\text{C}$ .

---

#### NOTICE

Striking of the crane component during assembly or disassembly!

Crane components can be damaged.

- ▶ Do **not** strike the crane component during assembly and disassembly.
  - ▶ Carry out all work slowly and with utmost caution.
- 

## 3.6 Reducing rope pull

When working with rope / component temperature below  $-20\text{ }^{\circ}\text{C}$ , Liebherr-Werk Ehingen GmbH recommends reducing the rope pull.

The rope pull on the hoist rope can be reduced by increasing the rope reeving.



#### Note

Increase of rope reeving!

Due to the increased rope reeving, the hoist rope length may not be sufficient for lowering the hook block to the ground.

- ▶ Pay attention to rope length.
- 

#### NOTICE

Rope reeving higher than specified in the load chart!

Danger of slack rope formation due to a too low hook block weight. Damage to the hoist rope.

- ▶ Increase the hook block weight accordingly.
  - ▶ Increase the rope reeving specified in the load chart.
  - ▶ If necessary: Increase the hook block weight.
-

### 3.7 Increasing the hook block weight

The calculation of the minimum required hook block weight is described in the load chart.

Rope / component temperature	Increasing the hook block weight
-21 °C to +30 °C	Increase the minimum required hook block weight by 10 %
-31 °C to +40 °C	Increase the minimum required hook block weight by 15 %

- ▶ Increase the required hook block weight depending on the rope or component temperature.
- ▶ Observe and adhere to the “hook block weight” charts.



#### Note

- ▶ Observe and comply with the permissible hook block weights for erection and take-down of the boom systems in the erection and take down charts.

### 3.8 Crane operation

In case of an ambient / component temperature below -20 °C , crane operation requires an anticipatory working procedure adapted to the weather conditions.



#### WARNING

Sudden acceleration and deceleration of crane movements!

Crane components can break.

Death, severe bodily injuries, property damage.

- ▶ Accelerate and decelerate crane movements sensitively and with utmost caution.

#### 3.8.1 Reducing the maximum load

##### Cranes with lattice mast boom

In the case of cranes with pull cylinders in the derrick ballast guying, if the component temperature is between -30 °C and -40 °C the maximum derrick ballast must be reduced. The maximum load is also reduced due to the reduction of the maximum derrick ballast.



#### Note

- ▶ Take load reduction into account during job planning.

- ▶ Reduce the maximum derrick ballast by 15 % in case of component temperatures between -30 °C and -40 °C.

##### Cranes with a telescopic boom

Cranes with a telescopic boom: For component temperatures between -30 °C and -40 °C the maximum load must be reduced.

- ▶ Reduce the maximum load by 15 % in the case of component temperatures between -30 °C and -40 °C.

## 4 Maintenance

### 4.1 Load bearing crane structures

Checking the load bearing crane structure is described in Chapter 8.01.

- ▶ The load bearing crane structure must be visually inspected more often at low temperatures.

## 4.2 Rope pulleys and hydraulic cylinders

Checking the rope pulleys and hydraulic cylinders is described in Chapter 8.01.

- ▶ Rope pulleys and hydraulic cylinders must be visually inspected more often at low temperatures.

## 2.15 General technical safety instructions for operation with a ballast trailer

1	Safety instructions	2
2	Inspecting tires and disk wheels	3

# 1 Safety instructions



## WARNING

Danger of falling!

- ▶ During assembly or disassembly work on the ballast trailer, assembly personnel must be secured with appropriate aids! If this is not observed, assembly personnel could fall and suffer life-threatening or fatal injuries!



## WARNING

Ballast trailer tipping danger!

If the following notes are not observed, the freestanding ballast trailer or the ballast trailer which needs to be disassembled can tip over.

Death, severe bodily injuries, property damage.

- ▶ The ballast trailer may only be parked on level ground with a sufficient load bearing capacity.
- ▶ The ballast trailer may only be unpinned from the crane and parked if there is corresponding ballast on the ballast trailer according to the assembly condition and the selected ballast trailer radius to ensure the stability of the ballast trailer.
- ▶ The ballast trailer may only be unpinned from the crane and parked if the support cylinders are extended and the tires are relieved.
- ▶ The ballast trailer may only be unpinned from the crane and parked if the strut on the support cylinders is pinned and secured.



## WARNING

Danger of fatal injury if the permissible travel speed is exceeded!

If the permissible travel speed is exceeded, the tires can be damaged.

Death, severe bodily injuries, property damage.

As a result, significant property damage can occur on the crane and on the ballast trailer.

- ▶ The travel speed of the ballast trailer when turning or driving with maximum ballast on the tires may be not more than maximum 1 km/h (0.28 m/s)



## WARNING

The crane can topple over if the level of the road differs!

Due to impermissible level differences between the ballast trailer roadway and the crane placement level, the entire crane system can be pulled back suddenly.

The relapse cylinders can run out to the block position. The relapse cylinders and the boom system can be damaged.

Depending on the distortion of the turntable and the load of the tires on the ballast trailer, a shut-off of crane movements may be activated with a retracted ballast trailer guide due to an excessive inclination of the ballast trailer (depending on the crane type and time of crane delivery), see chapter 4.02.

Death, severe bodily injuries, property damage.

- ▶ Do not exceed or fall below the permissible level difference between the ballast trailer road surface and the crane placement level.
- ▶ The travel path of the crane or the circular path of the ballast trailer must be level and of sufficient load bearing capacity.
- ▶ The permissible level difference of the ballast trailer travel path, in relation to the crane travel path for "towing" and "parallel driving" may not be exceeded depending on the crane type and the ballast trailer radius, see chapter 5.35 or chapter 5.35.10 or chapter 5.35.20.
- ▶ The permissible level difference of the ballast trailer travel path, in relation to the crane travel path for circular driving may not be exceeded depending on the crane type and the ballast trailer radius - based on a constant uphill incline or a constant downhill incline on a 90° turning range, see chapter 5.35 or chapter 5.35.10 or chapter 5.35.20.



**WARNING**

The crane can topple over!

If the following notes are not observed, the crane can topple over.

Death, severe bodily injuries, property damage.

- ▶ When lifting or lowering the ballast trailer, pay attention to the horizontal alignment of the ballast trailer.
- ▶ The assembly or disassembly work must be carried out according to chapter 5.35 **or** chapter 5.35.10 **or** chapter 5.35.20.

**NOTICE**

Damage to the ballast trailer, ballast trailer guide and / or the turntable!

If the ballast trailer inclination is too large or the level difference of the standing levels between the crane and ballast trailer are too large, this can cause damage to the ballast trailer, the ballast trailer guide and / or the turntable.

- ▶ Keep the ballast trailer inclination as small as possible.
- ▶ Do not exceed the maximum permissible level difference of the standing levels between the crane and the ballast trailer, see chapter 5.35 **or** chapter 5.35.10 **or** chapter 5.35.20.

**NOTICE**

Damage to the crane and the ballast trailer!

Due to steering movements on the crawler tracks during parallel travel, the crane and the ballast trailer can be significantly damaged.

- ▶ During parallel travel, steering the crawler travel gear is prohibited.
- ▶ For parallel travel, the side tire distortion on the wheel sets must be observed by an instructed person over the entire travel route of the crane. If the tires distort by more than 100 mm, then the position of the wheel sets must be corrected.

**Note**

General technical safety instructions!

- ▶ The ballast trailer guy rods must be assembled and secured according to the rod plan. The numbering on the rod plan must be identical to the numbering on the guy rods.

## 2 Inspecting tires and disk wheels

**Note**

- ▶ See chapter 8.01.

**WARNING**

Danger of fatal injury when using non-approved tires!

Due to the use of tires that are not explicitly approved by **LIEBHERR-Werk Ehingen GmbH**, uncontrollable operation conditions on the ballast trailer can occur due to the heavy load.

The tires can be destroyed and the ballast trailer as well as the crane can be significantly damaged. Death, severe bodily injuries, property damage.

- ▶ Use only spare tires that have been approved in writing by **LIEBHERR-Werk Ehingen GmbH**.
- ▶ Using spare tires that have been not explicitly approved in writing by **LIEBHERR-Werk Ehingen GmbH** is prohibited.

**NOTICE**

Damage to tires!

Due to external environmental influences (for example: rain, wind, snow, rime, frost, sun exposure) and the great weight load on the tires by the ballast trailer, the tires can become porous and the body can lose its original strength.

- ▶ The tires must be replaced according to the data of the tire manufacturer at least after 5 years, or if an authorized inspector of the tire manufacturer states in writing, after extensive inspection of the tires, that the tires can be utilized for an additional operation period stated by the expert representative.

**Note**

Tightening torque of ballast trailer tires!

- ▶ The tightening torque for the wheel nuts is 600 Nm.
- ▶ Check the wheel nuts according to the specified maintenance intervals for tight seating, see chapter 7.02.

## 2.1 Tires with air inflation

**It is imperative to comply with the following instructions:**

- After extended downtime, the inflation pressure must be checked before using the ballast trailer.
- The tires must be protected against UV rays during extended downtimes with tarps or wooden boards.

**Note**

Inflation pressure of the ballast trailer tires!

- ▶ The inflation pressure in all tires inflated with air that were approved in writing by **LIEBHERR-Werk Ehingen GmbH** is **10 bar**.
- ▶ Check the inflation pressure according to the specified maintenance intervals for tight seating, see chapter 7.02.

**WARNING**

Danger of accident due to damaged ballast trailer tires!

Due to extended downtime of the crane, when the ballast trailer tires are not relieved with supports, the tires can become irregular.

As a result, the tires can be destroyed and the ballast trailer as well as the crane can be significantly damaged.

Death, severe bodily injuries, property damage.

- ▶ During extended downtimes, the ballast trailer tires must always be relieved by the supports.

**WARNING**

Danger of accident due to damaged ballast trailer tires!

When driving the crane on insufficiently prepared ground, the tires can become damaged or punctured by large rocks or other foreign matter.

As a result, the ballast trailer as well as the crane can be significantly damaged.

Death, severe bodily injuries, property damage.

- ▶ The travel route of the crane or the ballast trailer must be level, of sufficient load bearing capacity and free of rocks or other foreign matter.
- ▶ The travel route of the crane must be walked off personally in advance by the crane operator.
- ▶ Rocks and other foreign matter on the travel route must be removed before starting to travel.
- ▶ If the crane operator cannot ensure that the ballast trailer tires may not be damaged when driving the crane, then the ballast trailer tires must be foamed with a special foam approved by **LIEBHERR-Werk Ehingen GmbH**. Contact **LIEBHERR-Werk Ehingen GmbH** in this regard.
- ▶ If you decide to foam the ballast trailer tires, then ballast trailer operation is only permissible if all tires of the ballast trailer have been foamed according to the specifications of **LIEBHERR-Werk Ehingen GmbH**.

## 2.2 Tires foamed with special foam

The tires of the ballast trailer are foamed with a special, high quality foam.

Due to extended downtime of the crane, when the ballast trailer tires are not relieved with supports, the tires can become irregular.

**It is imperative to comply with the following instructions:**

- Relieve the tires on the ballast trailer if it is at a standstill for more than 2 h via the support cylinders.
- The tires must be protected against UV rays during extended downtimes with tarps or wooden boards.



---

### WARNING

Danger of fatal injury when using non-approved tire fillings!

Due to the use of tire fillings that are not explicitly approved by **LIEBHERR-Werk Ehingen GmbH**, uncontrollable operation conditions on the ballast trailer can occur due to the heavy load.

The tires can be destroyed and the ballast trailer as well as the crane can be significantly damaged. Death, severe bodily injuries, property damage.

- ▶ Use of spare tires filled with water, air or special foam of lower quality is prohibited.
  - ▶ Using spare tires that have been not explicitly approved in writing by **LIEBHERR-Werk Ehingen GmbH** is prohibited.
- 



---

### WARNING

Danger of accident due to retreaded tires!

If tires foamed with the special foam are retreaded, the usage properties can be significantly changed in a negative manner.

The tires can be destroyed and the ballast trailer as well as the crane can be significantly damaged. Death, severe bodily injuries, property damage.

- ▶ Tires which are filled with special foam may not be retreaded, except if a written approval has been issued by the tire manufacturer.
-

---

Empty page!

LWE/LR 1800-1-0-000/27200-07-02/en

## 2.25 Crane on floating body

1	Non-intended use	2
2	Intended use	2
3	Floating device	2
4	Operating conditions	2
5	Crane transport on floating devices	3
6	Increased corrosion	4

# 1 Non-intended use



## WARNING

### Non-intended use!

The boom can break off. The crane can topple over.  
Death, severe injuries, property damage.

- ▶ Use the crane only as intended.
- ▶ Comply with the operating conditions and notes in this chapter.

Liebherr mobile cranes and crawler cranes are **not** designed for special requirements according to “EN 13852-2, Cranes - Offshore cranes” or other offshore specifications and regulations.

For a precise definition of **non**-intended use, see the preface.

# 2 Intended use

Liebherr mobile cranes and crawler cranes are only designed for assembly work and erection work and can only withstand a limited number of load cycles.

Liebherr mobile cranes and crawler cranes are designed for special properties and movements: Evenly distributed drive forces, only occasional operation and load conditions according to “EN 13000, Cranes - Mobile cranes” and comparable international standards.

For a precise definition of intended use, see the preface.

# 3 Floating device

The term floating device includes all floating devices such as barges and ships.

The floating device must fulfil the prerequisites for crane operation.

# 4 Operating conditions

## 4.1 Areas of responsibility for operating conditions

Observe the areas of responsibility:

- The crane contractor and crane operator are responsible for ensuring that the conditions for crane operation at the job site are fulfilled. Liebherr-Werk Ehingen GmbH strongly recommends involving a shipbuilding engineer.
- The correct functional, technical and static interaction between the crane and the floating device is the sole responsibility of the crane contractor and the crane operator.
- The correct functional, technical and static interaction between the crane and the floating device must be clarified and checked before operating the crane on a floating device.

## 4.2 Basic requirements

Observe the following to ensure the safe operation of the crane on floating devices:

- Comply with all country-specific, legal specifications and conditions.
- Perform a risk assessment according to the Occupational Safety and Health Act to ensure safe working conditions.
- Outrigger forces or crawler pressures generated by crane operation must be safely supported by the steel construction of the floating device.
- Assemble and operate the crane according to manufacturer specifications.
- Secure the crane to prevent it from slipping and lifting up.

- The conditions when working on a floating device must correspond with the conditions on land.
- Crane operation is only permissible in very calm waters and therefore on very calmly moving floating devices.
- Comply with the maximum permissible ground incline according to the load charts.
- Implement precautions that permit the boom system to be taken down at any time, for example if the wind and sea start to be strong.

#### 4.2.1 Floating device, supported

Observe the following additional notes to ensure the safe operation of the crane on supported floating devices:

- Design the supported floating device such that if the wind and sea start to be strong it will not cause the floating device to buoy upward.

#### 4.2.2 Floating device, not supported

Observe the following to ensure the safe operation of the crane on a **non** supported floating device:

- Crane operation on a **non** supported floating device is only permissible in very calm waters.
- Crane operation on a **non** supported floating device is only permissible with the main boom or alternatively a boom nose. No other additions on the main boom are permissible.
- Crane operation with the main boom in combination with the derrick ballast is only permitted with one derrick ballast that is set down and secured.

**Note:** The derrick ballast must be secured in all four horizontal directions (forward / backward / right / left). The height of the horizontal retainer must be implemented such that it is not possible to lift out by derrick ballast by lifting it. Keep in mind that the crane superstructure may not rotate.

- The incline of the floating device may **not** exceed the maximum permissible ground inclination of the crane according to the load chart.
- Before the crane is operated on the floating device: Calculate the incline of the floating device in the lateral direction and in the longitudinal direction in advance. The incline results from the interaction of the crane with the floating device.
- If the wind and sea start to be strong, the crane with the taken down boom system must also be secured against slipping and against oscillations.

## 5 Crane transport on floating devices

### 5.1 Areas of responsibility for crane transport on floating devices

Observe the areas of responsibility:

- The crane contractor is solely responsible for transporting the crane on a floating device.
- The crane contractor and crane operator are responsible for the assembly, securing and removal of the crane on the floating device.

### 5.2 Safety of crane transport on floating devices

Transport at sea can have a negative impact on the structural strength / stability and the fatigue limit of the crane.

Observe the following to ensure the safe transport of the crane on floating devices.

Secure the crane during “transport on a floating device” so that the following is prevented:

- Damage and releasing of components on the crane
- Slipping of the crane
- Inadvertent turning (swinging) of the crane superstructure
- Capsizing of the floating device

Make sure that the following measures are carried out prior to “transport on a floating device”:

- Take the boom system down and support it using adequate means.
- With telescope cranes:  
Disassemble the counterweight plates and secure on the floating device.

- Disassemble the separate counterweight brackets and secure on the floating device.
- With cranes with lattice mast / crawler cranes:
  - Secure the turntable using adequate means.
  - Disassemble the counterweight brackets and counterweight plates and secure on the floating device.
  - Disassemble the central ballast brackets and central ballast plates and secure on the floating device.
  - Support the installed counterweight brackets and counterweight plates separately using adequate means and secure against slipping.
  - Support the installed central ballast brackets and central ballast plates separately using adequate means and secure against slipping.
- Observe and adhere to the specifications for transporting the crane and the crane components, see chapter 3.80.

## 6 Increased corrosion

Extremely salty air near the sea can cause severe corrosion on the crane.

Increased corrosion can cause premature damage to the components (for example, the hydraulic cylinder, wire ropes, electrical and electronic components, driver's cab).

Submerging the hook block in water causes damage to the hook block and the rope.

The crane contractor and the crane operator are solely responsible for preventing severe corrosion.

Measures for preventing corrosion:

- Avoid direct contact between the crane and its components with salt water.
- Do **not** submerge the hook block in water.

Measures for detecting premature damage:

- Have the crane checked regularly and extensively by a qualified person.



---

## 3 Crane assembly

LWE/LR 1800-1-0-000/27200-07-02/en

---

LWE/LR 1800-1-0-000/27200-07-02/en

## 3.01 Crawler carrier assembly

1	Safety	2
2	Component overview	4
3	Operating and control instruments	4
4	Fastening points	5
5	Hydraulic assembly support	6
6	Preparing the crawler carrier for assembly	10
7	Assembling the crawler carriers with SA-frame	11
8	Assembling the crawler carrier with the auxiliary crane	19
9	Establishing the connections to the crawler carriers	24
10	Preparing the crawler carrier for disassembly	26
11	Disassembling the crawler carrier with SA-frame	26
12	Disassembling the crawler carrier with the auxiliary crane	32
13	Disconnecting the connections to the crawler carriers	38

# 1 Safety

Observe the safety instructions before assembly and disassembly:

- Information regarding work on the crane. See chapter 2.04.
- Information regarding personal protective equipment. See chapter 2.04.
- Information regarding fall protection equipment. See chapter 2.06.
- Information regarding accesses to the crane. See chapter 2.07.
- Information regarding accessible surfaces. See chapter 2.07.



## WARNING

Danger of falling!

During assembly / disassembly, inspection and maintenance work, assembly personnel must be secured with appropriate aids to prevent them from falling.

Death, severe bodily injuries, property damage.

- ▶ All work at a height, when there is a danger of falling, must be carried out with suitable aids.
- ▶ If aids are not available and work cannot be carried out from the ground, then assembly personnel must secure themselves with the supplied fall arrest system to prevent falling, see chapter 2.04.
- ▶ If fall protection equipment is available, then it must be used, see chapter 2.06.
- ▶ When lifting, lowering, swinging crane parts in and out, no persons may remain in the danger zone.
- ▶ If railings are present on the components, then they must be brought into the corresponding position and secured for assembly / disassembly work.
- ▶ Only step on the aids, ladders and catwalks with clean shoes.
- ▶ Keep aids, ladders and catwalks free of heavy dirt, snow and ice.
- ▶ During all assembly and disassembly work, maintenance work and inspections, travel or crane operation is prohibited.
- ▶ Remaining on a suspended load is prohibited.
- ▶ Stepping or walking on crane components and lattice sections, which have an incline of more than 20° is prohibited.
- ▶ For all assembly work, the crane operator of the main crane must be in voice contact with the crane operator / crane operators of the auxiliary crane / auxiliary cranes.
- ▶ For assembly / disassembly tasks, the crane operator may only initiate crane movements when the responsible guide has explicitly released the movement.



## WARNING

Danger of impact / crushing!

When assembling / disassembling crane components with the auxiliary crane, crane components can start to swing back and forth.

When lifting / lowering and positioning crane components, there is an increased danger of impact / crushing.

Death, severe bodily injuries, property damage.

- ▶ Make sure that personnel cannot be caught by components.
- ▶ When working in danger zones: Use aids to protect limbs.
- ▶ Guide components with suitable aids to minimize oscillation.



## DANGER

The components can fall down!

If the corresponding component is disengaged from the auxiliary crane before the corresponding component is pinned, then the corresponding component can fall down.

Death, severe bodily injuries, property damage.

- ▶ Do not detach the auxiliary crane until the respective component is pinned and secured.

**WARNING**

Danger of falling!

During assembly and disassembly of crane components, personnel must be secured with appropriate aids to prevent them from falling.

Death, severe bodily injuries, property damage.

- ▶ Use personal protective equipment.

**WARNING**

The crane can topple over!

If the SA-frame is assembled / disassembled or erected in the case of a supported crawler center section, the crane can topple over.

Death, severe bodily injuries, property damage.

- ▶ Only assemble / disassemble or erect the SA-frame when the crawler center section is lying on the substructure or is positioned on the crawlers.
- ▶ It is prohibited to assemble / disassemble or erect the SA-frame if the crawler center section is supported.

**Note**

- ▶ If an adjacent turntable is not installed, the hydraulic assembly support may be supplied and operated via an external hydraulic aggregate.

**NOTICE**

Environmental pollution due to hydraulic oil!

When retracting the assembly support, if an external hydraulic aggregate with a full hydraulic oil tank is used, then the hydraulic oil tank on the hydraulic aggregate can be flooded when retracting the assembly support.

Hydraulic oil can escape causing severe environmental pollution.

- ▶ Make sure that the hydraulic oil tank on the hydraulic aggregate has sufficient capacity to be able to safely contain the hydraulic oil of the assembly support.
- ▶ Make sure that the extension and retraction of the assembly support is carried out solely with the same hydraulic aggregate.
- ▶ Make sure that suitable measures are made to prevent an oil spill in the environment.

## 2 Component overview

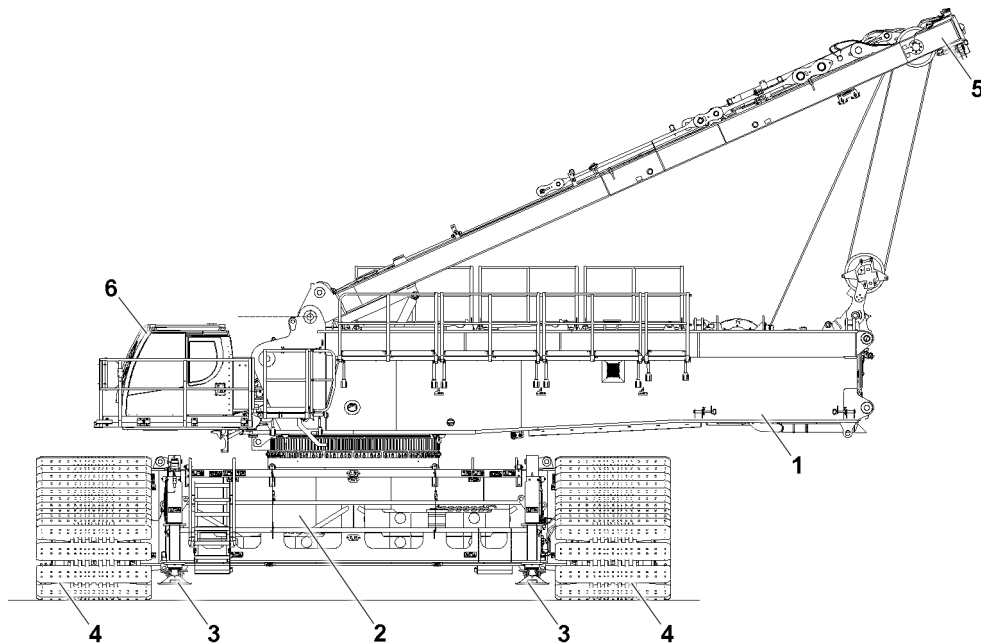


Fig.154306: Component overview



### Note

► Dimensions and weights, see chapter 1.03.

Position	Component
1	Turntable
2	Crawler center section
3	Hydraulic assembly support*
4	Crawler carrier with Outrigger pad 1500 mm (1.5 m) <b>or</b> outrigger pad 2000 mm (2.0 m) <b>or</b> outrigger pad 2400 mm (2.4 m)
5	SA-frame
6	Crane cab



### Note

The width of the outrigger pads is specified in the illustrations and the supplied drawings in millimeters (mm) or meters (m).

► Observe the measuring unit

## 3 Operating and control instruments

In addition to the fixed, installed operating elements, many functions are operated using the BTT or the radio remote control.

The relevant displays, for example the incline, the angle of the SA-frame or error messages appear on the LICCON monitor as well as on the BTT display.



#### Note

- ▶ For a description of the LICCON computer system, see chapter 4.02.

## 3.1 BTT

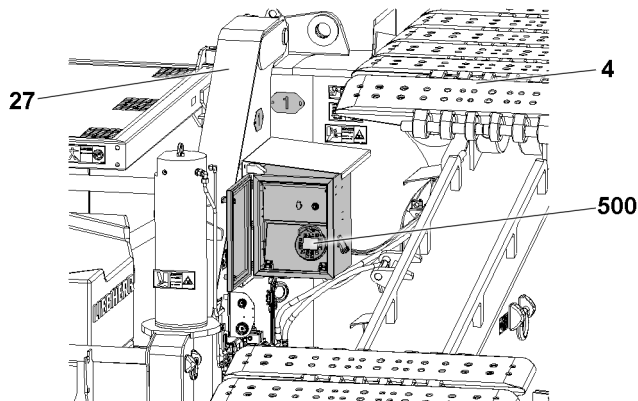


Fig.160404: BTT display / operating element position

The BTT **500** is a combined display / operating element for the crane.



#### Note

- ▶ For a description of the BTT, see chapter 5.31.
- ▶ Radio remote control operation (BTT with radio remote control console), see chapter 6.08.
- ▶ The BTT **500** is located in the control cabinet between the central ballast bracket **27** and the crawler carrier **4**, see illustration.
- ▶ Alternatively, the BTT can be stored in the crane cab, see chapter 4.01.

## 4 Fastening points



#### WARNING

Components incorrectly fastened!  
Death, severe bodily injuries, property damage.

- ▶ Fasten the components only in the intended fastening points on both sides.



#### WARNING

Fastening equipment can be ripped off!  
Death, severe bodily injuries, property damage.

- ▶ Make sure that the fastening equipment has a sufficient load carrying capacity and the required minimum length.
- ▶ Make sure that the auxiliary crane(s) have a sufficient load carrying capacity.
- ▶ Dimensions and weights, see chapter 1.03.
- ▶ Make sure that there are no persons in the danger zone.

**WARNING**

Overload of fastening points!

If the fastening points are overloaded, they can rip off and the component can fall down.  
Death, severe bodily injuries, property damage.

- ▶ Make sure that the fastening points are not overloaded.
- ▶ Observe the maximum permissible suspended loads.

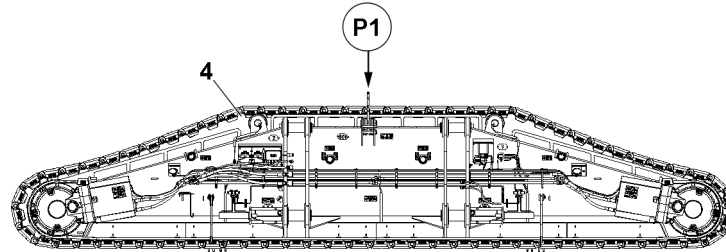


Fig.154307: Crawler carrier fastening points

Fastening points	Component
P1	Crawler carrier

**NOTICE**

Danger of property damage!

If the lashing lugs in point **P1** are not folded into the transport position after assembly with the auxiliary crane, then the crawler carrier and the hook points can be damaged later when driving the crane.

- ▶ Make sure that the lashing lugs in point **P1** are folded into the transport position after completion of the crawler carrier assembly.

## 5 Hydraulic assembly support

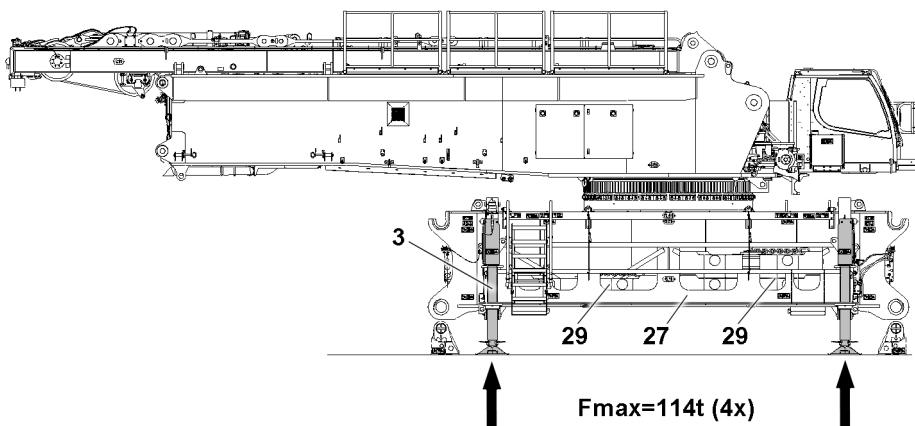


Fig.160405: Hydraulic assembly support

- 3** Hydraulic assembly support
- 27** Central ballast bracket

- 29** Ballast plates



**WARNING**

The crane can topple over!

If too much central ballast has been applied, the hydraulic assembly supports can be overloaded. If the crane is not supported by the crawler carriers, the height of the central ballast is limited.

- ▶ Make sure that a maximum of 30 t is placed on each central ballast bracket **27** as ballast plates. **29**
- ▶ Comply with Fmax of 114 t per support cylinder.

**Note**

- ▶ The support cylinders of the hydraulic assembly support **3** are integrated in the central ballast brackets **27**, see chapter 3.03.

Make sure that the following prerequisites are met:

- A maximum of 30 t is placed on each central ballast bracket **27** as ballast plates. **29**

## 5.1 Support plates

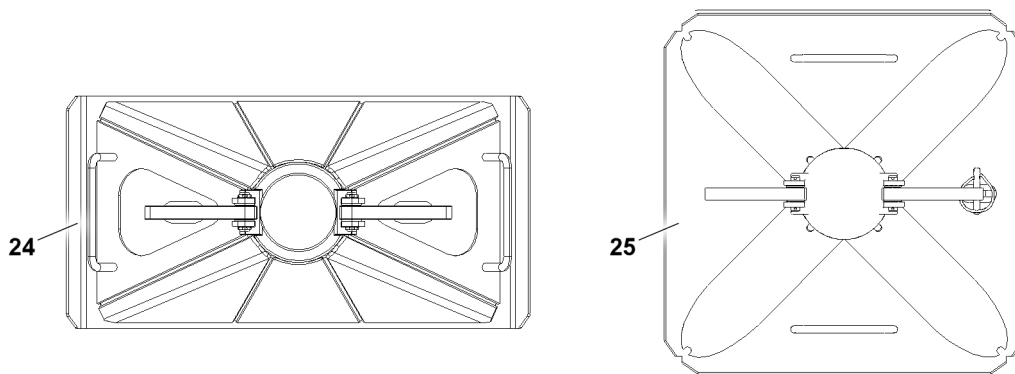


Fig.158777: Support plates

Position	Component
<b>24</b>	Rectangular support plate 700 mm x 350 mm
<b>25</b>	Square support plate 600 mm x 600 mm

**NOTICE**

Use of incorrect support plates!

When unsuitable or incorrectly aligned support plates are located on the assembly support, the support plate collides with the crawler carrier during assembly.

- ▶ Rectangular support plates **25** (600 mm x 600 mm ) may not be used in connection with 2400 mm outrigger pads.
- ▶ Square support plates **24** (700 mm x 350 mm) must be aligned in connection with 2400 mm outrigger pads.

**Note**

For crawler carriers with 2400 mm wide outrigger pads.

- ▶ Use and align rectangular support plates 700 mm x 350 mm.

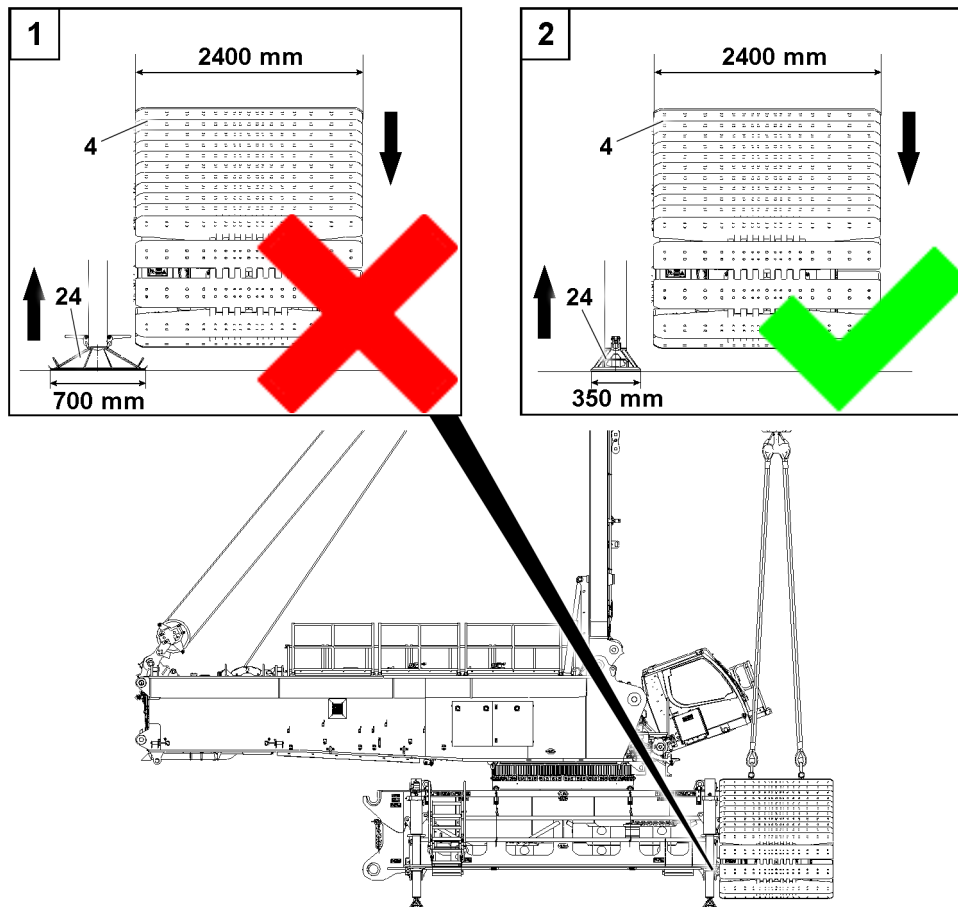


Fig.158741: Collision of crawler carrier 4 with incorrectly aligned support plates 24

#### NOTICE

Collision of support plates with crawler carrier!

When the rectangular support plates 24 with length 700 mm and width 350 mm are **not** correctly aligned, the support plates 24 collide with the crawler carrier 4 during assembly.

► Align the support plates 24.

### 5.1.1 Aligning rectangular support plates

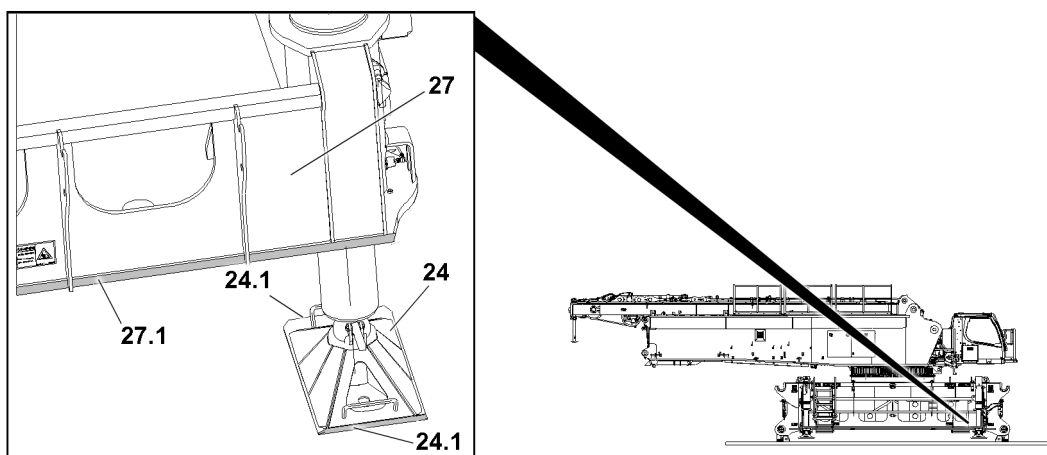


Fig.158742: Correctly aligned support plate 24 without installed crawler carrier.

The square support plates are correctly aligned when the short edge **24.1** (350 mm) is positioned parallel to the front lower edge **27.1** of the central ballast bracket **27**.

Before the hydraulic assembly support **3** is placed on the ground:

- ▶ Check if all four support plates **24** are correctly aligned.

When the support plates **24** are not aligned:

- ▶ Align the support plates **24**.

**Result:**

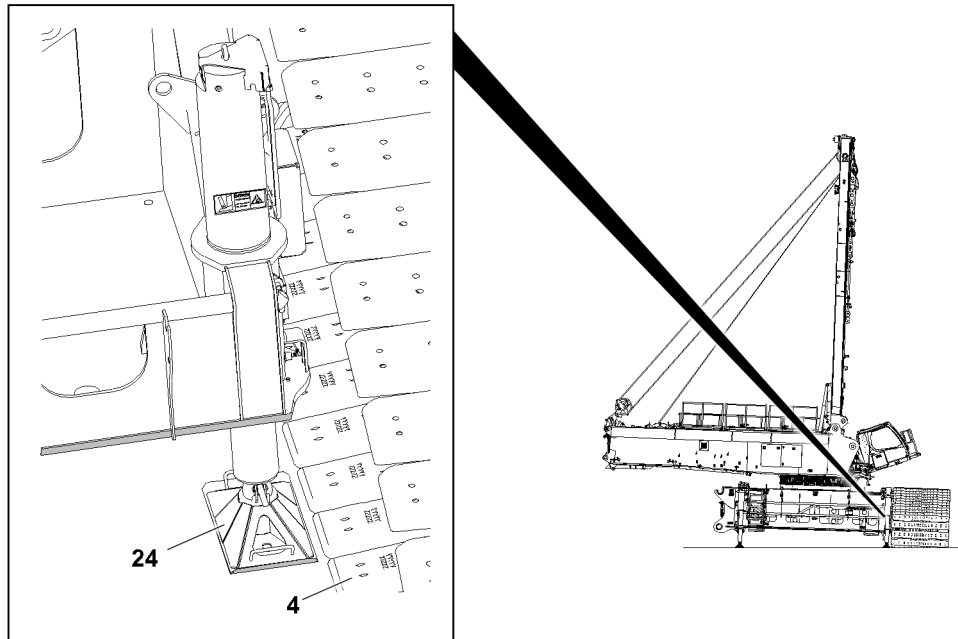


Fig.158775: Correctly aligned support plate **24** with installed crawler carrier **4**

- When putting the crane down later on the crawler carrier, there is sufficient distance between the support plate **24** and the crawler carrier **4**.

## 5.2 Transport receptacle

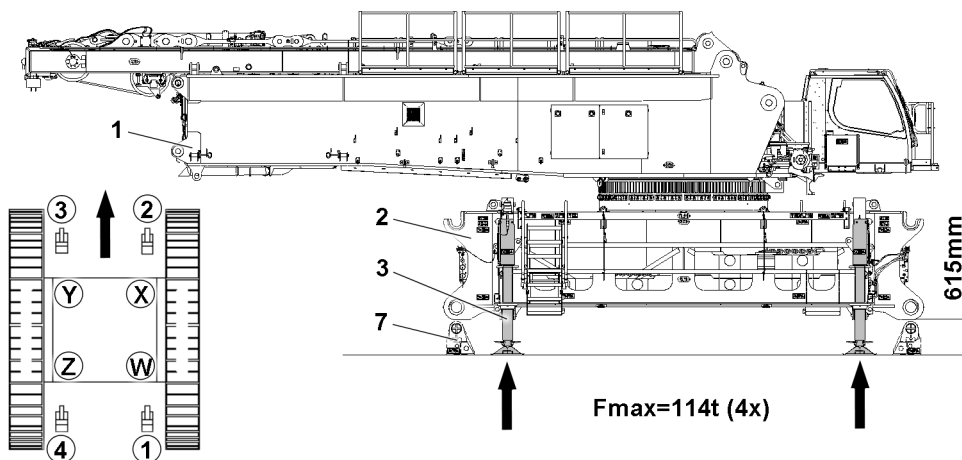


Fig.154310: Removing the transport receptacle

- ▶ If the transport receptacle **7** is installed, release the pin from the crawler center section **2**.

LWE/LR 1800-1-0-000/27200-07-02/en

- ▶ Extend the hydraulic assembly supports **3** and align the crane horizontally. Select the height such that the standard measure of 615 mm (lower edge of the bearing eye) is reached.

**Note**

Avoid the support cylinder block position.

During the support procedure, first lift the crane higher to be able to align the crane by retracting the support cylinder.

- ▶ Align the crane by retracting the support cylinder at least 30 mm.

When the support cylinders are extended very little, for example when there is a tall substructure:

- ▶ Make sure that the support cylinders are extended at least 50 mm.

- ▶ Remove the transport receptacle **7**.

## 6 Preparing the crawler carrier for assembly

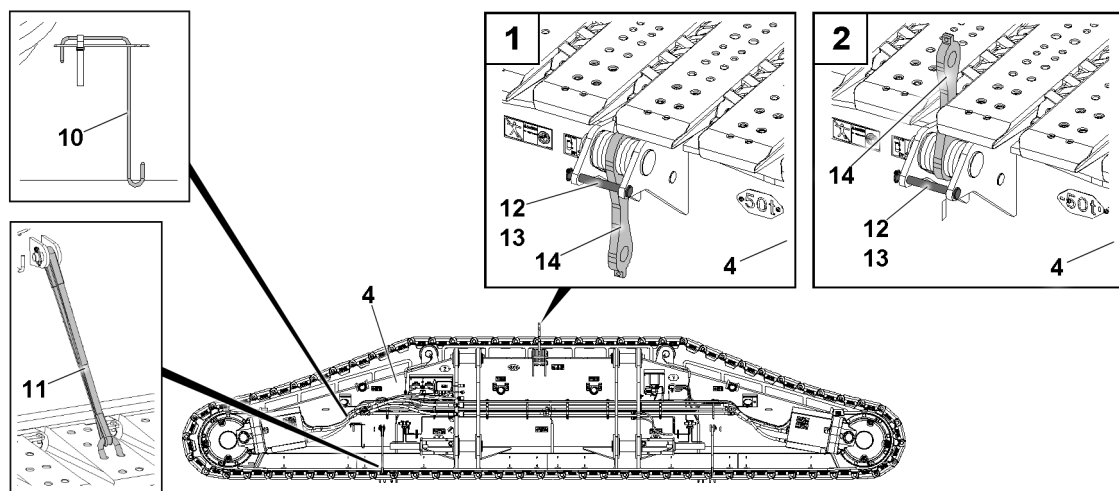


Fig. 154308: Crawler carrier

Make sure that the following prerequisite is met:

- The assembly location for the crane must be level and of adequate load bearing capacity.

**Note**

- ▶ The outrigger pads must be secured before assembly of the crawler carriers with the belts **11** to prevent sagging.

- ▶ Connect two belts **11** per crawler carrier side.

- ▶ Connect the belts **11** with the brackets on the outrigger pads.

**Note**

- ▶ The hook **10** is fastened in the transport position on the crawler carrier.

**Note**

- ▶ The lashing lugs **14** must be swung “up” into the assembly position between the outrigger pads.

- ▶ Remove the retaining element **13** and unpin the pin **12**.

- ▶ Swing the brackets **14** up with the hook **10**.

- ▶ Insert the pin **12** again and secure it with the retaining element **13**.

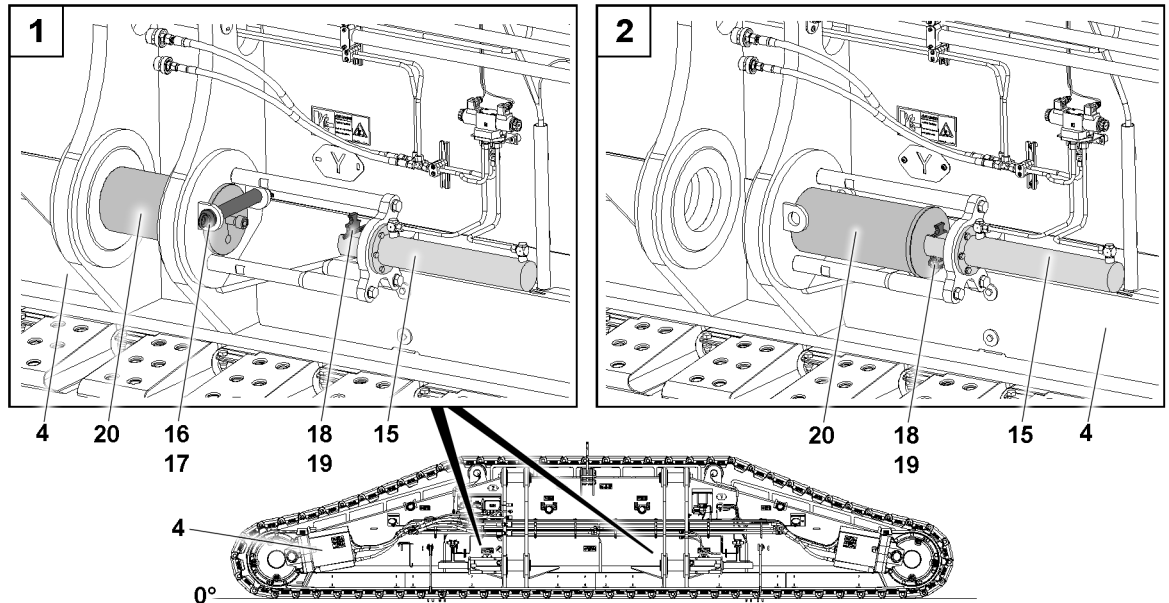


Fig.154309: Unpinning the pins for crawler carrier assembly

- ▶ Connect the hydraulic supply line to the external hydraulic aggregate, see the hydraulic diagram.
- ▶ Remove the retaining element 17 and unpin the retaining pin 16.
- ▶ Insert the retaining pin 16 in park position and secure it with retaining element 17.
- ▶ Remove the retaining element 19 and push the slide 18 up.
- ▶ Extend the pin pulling cylinder 15.
- ▶ Connect the piston rod head with the screw on the pin: Push the slide 18 down and secure with a retaining element 19.
- ▶ Unpin the pin 20 with the pin pulling cylinder 15.
- ▶ Disconnect the hydraulic supply line from the external hydraulic aggregate, see the hydraulic diagram.

## 7 Assembling the crawler carriers with SA-frame



### Note

In the case of crawler carriers with 2400 mm wide outrigger pads, it is recommended to perform assembly according to the section "Assembling the crawler carriers with the auxiliary crane".

- ▶ Only assemble crawler carriers with 1500 mm or 2000 mm wide outrigger pads with the SA-frame.
- ▶ The procedure is independent of the width of the outrigger pads.

### 7.1 Assembling the first crawler carrier with SA-frame



### Note

Crawler carrier installed on the wrong side.

- ▶ Note the identification on the crawler carrier and the crawler center section.



### Note

For assembly of the crawler carriers on the crawler center section, the assembly procedure and the process are identical for both crawler carrier sides from a certain point.

- ▶ Individual steps for the assembly of the crawler carrier are described as an example, observe the cross references.

**NOTICE**

Damage to the crane!

If the following instructions are not observed, the crane can be severely damaged when unloading the crawler carrier.

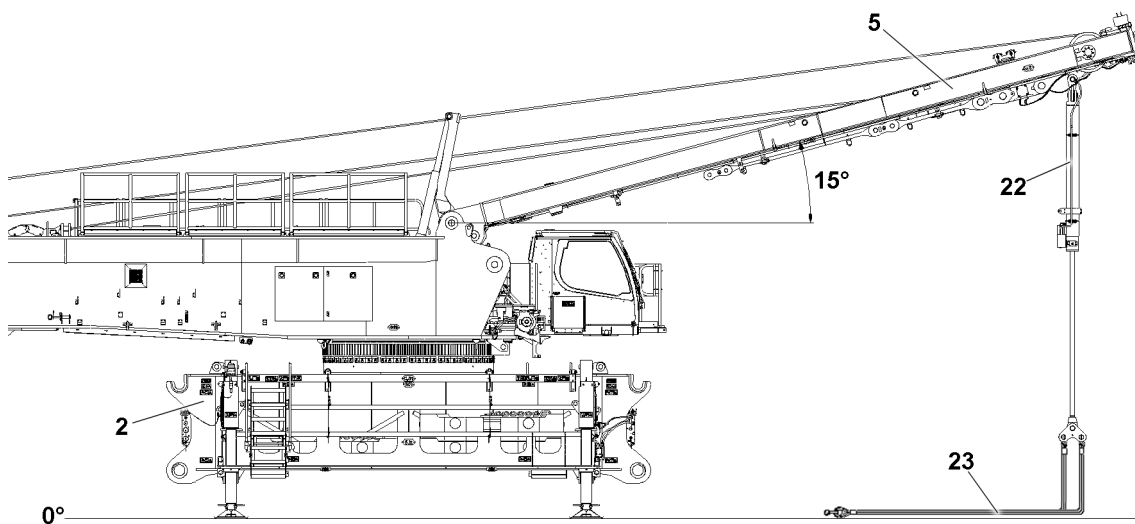
- ▶ The specifications in the load charts for SA-operation must be adhered to.

Make sure that the following prerequisites are met:

- A maximum of 30 t of ballast plates is placed on each central ballast bracket.
- The assembly support is extended to the standard measure of 615 mm (lower edge of the bearing eye), see section “Transport receptacle”.
- The outrigger pads of the crawler carrier are secured to prevent them from sagging.
- The SA-operating mode has been set and confirmed on the LICCON computer system.
- The SA-frame is erected to approx. 90°, see chapter 5.02.
- The crawler carriers are prepared for assembly, see section “Preparing the crawler carrier for assembly”.

**Note**

- ▶ The relevant displays, for example the incline, the angle of the SA-frame or error messages appear on the LICCON monitor as well as on the BTT display.



*Fig.154311: Assembling the fastening equipment*

- ▶ Lift the turntable and crawler center section **2** unit.
- ▶ Align the turntable and crawler center section **2** unit horizontally.
- ▶ Remove the substructure.
- ▶ Realign the access ladder.
- ▶ Luff the SA-frame **5** down to the front to 15°.

**Note**

If the assembly cylinder **22** is completely extended and the limit switch position is reached, the error display shuts off.

- ▶ The assembly cylinder **22** is not completely extended.
- ▶ Extend the assembly cylinder **22**.
- ▶ Pin and secure the fastening equipment **23** to the assembly cylinder **22**.

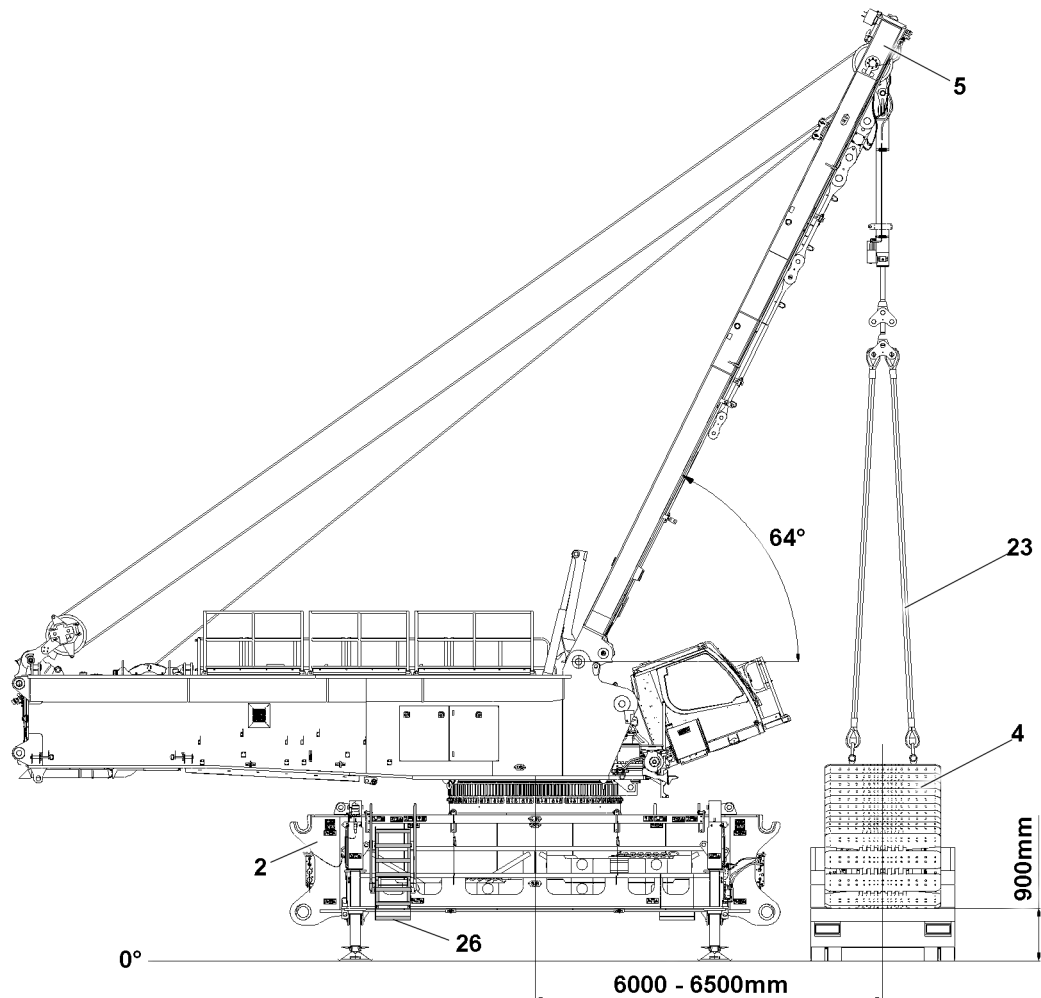


Fig.158743: Swinging the crawler carrier

- ▶ Tilt the crane cab up to the stop.



#### WARNING

Danger of collision!

When turning the turntable with the suspended crawler carrier, there is a danger of collision with the access ladder **26**.

Property damage.

- ▶ When turning the turntable with the suspended crawler carrier, disassemble the access ladder **26**.



#### WARNING

Danger of tipping the crane!

If the following instructions are not observed, the crane can tip over at assembly.

Death, severe bodily injuries, property damage.

- ▶ The maximum permissible distance of 6500 mm between the crawler carrier and the center of the turntable may not be exceeded.
  - ▶ The maximum permissible load on the assembly cylinder with a radius of 6500 mm may not exceed 60 t.
  - ▶ The maximum permitted height of the loading surface on the crawler carrier is 900 mm.
- 
- ▶ Fasten the fastening equipment **23** to the brackets of the crawler carrier, see section "Preparing the crawler carrier for assembly".
  - ▶ Lift the crawler carrier **4**.
  - ▶ Remove the transport vehicle.

**Note**

- ▶ When picking up the first crawler carrier, the turntable can be turned 360°.
- ▶ Carefully swing the crawler carrier 4 with the SA-frame up to the pin points on the crawler center section 2.

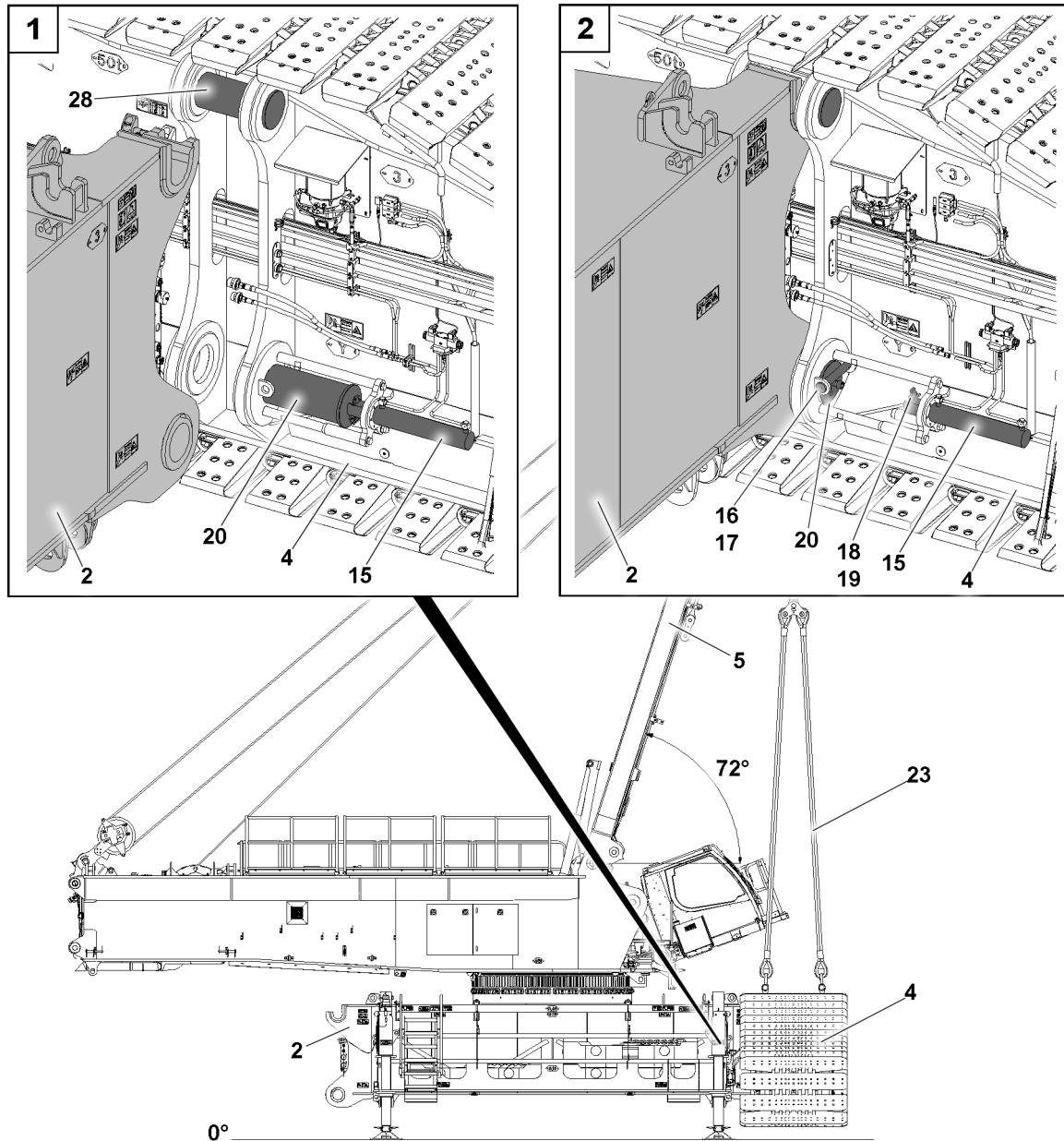


Fig.154313: Crawler carrier pinning

- ▶ Connect the crawler carrier 4 with pin 28 to the centerings on the crawler center section 2.
- ▶ Establish the hydraulic and electrical connections to the crawler carrier, see section "Establishing the connections to the crawler carriers".
- ▶ Insert the pin 20 with the pin pulling cylinder 15 to the stop: Extend the pin pulling cylinder 15.

**WARNING**

The pin is not secured!  
If the pins 20 are not secured, the pins can loosen up by themselves during crane operation. This can cause the crane to topple over.  
Death, severe bodily injuries, property damage.

- ▶ Make sure that the pins 20 are secured with the retaining pin 16.



- ▶ Remove the retaining element **17** and unpin the retaining pin **16** from the park position.
- ▶ Secure the pin **20**: Insert the retaining pin **16** in the operating position and secure it with the retaining element **17**.
- ▶ Remove the retaining element **19** and push the slide **18** up.
- ▶ Retract the pin pulling cylinder **15**.
- ▶ Push the slide **18** down and secure with a retaining element **19**.
- ▶ Pin the crawler carrier **4** on the other crawler carrier side with the crawler center section **2**.
- ▶ Remove the fastening equipment.

---

#### NOTICE

Damage to the brackets!

- ▶ After removing the fastening equipment, the brackets **14** must be swung down.
- 
- ▶ Swing the brackets **14** down, see section "Preparing the crawler carrier for assembly".

## 7.2 Assembling the second crawler carrier with the SA-frame



#### WARNING

The crane can topple over!

Depending on the assembly condition of the crane and the extension condition of the support cylinders, there can be very high support forces on the support cylinders.

Death, severe bodily injuries, property damage.

- ▶ Make sure that the ground under the support cylinders is able to safely take on the occurring support forces.
- ▶ Make sure that the support cylinders are supported with materials with a sufficiently high load bearing capacity, see chapter 2.04.
- ▶ Make sure that the support cylinders are retracted and / or extended evenly.
- ▶ When supporting or lowering the crawler center section pay attention to the horizontal alignment.



#### Note

For assembly of the crawler carriers on the crawler center section, the assembly procedure and the process are identical for both crawler carrier sides from a certain point.

- ▶ Individual steps for the assembly of the crawler carrier are described as an example, observe the cross references.
-

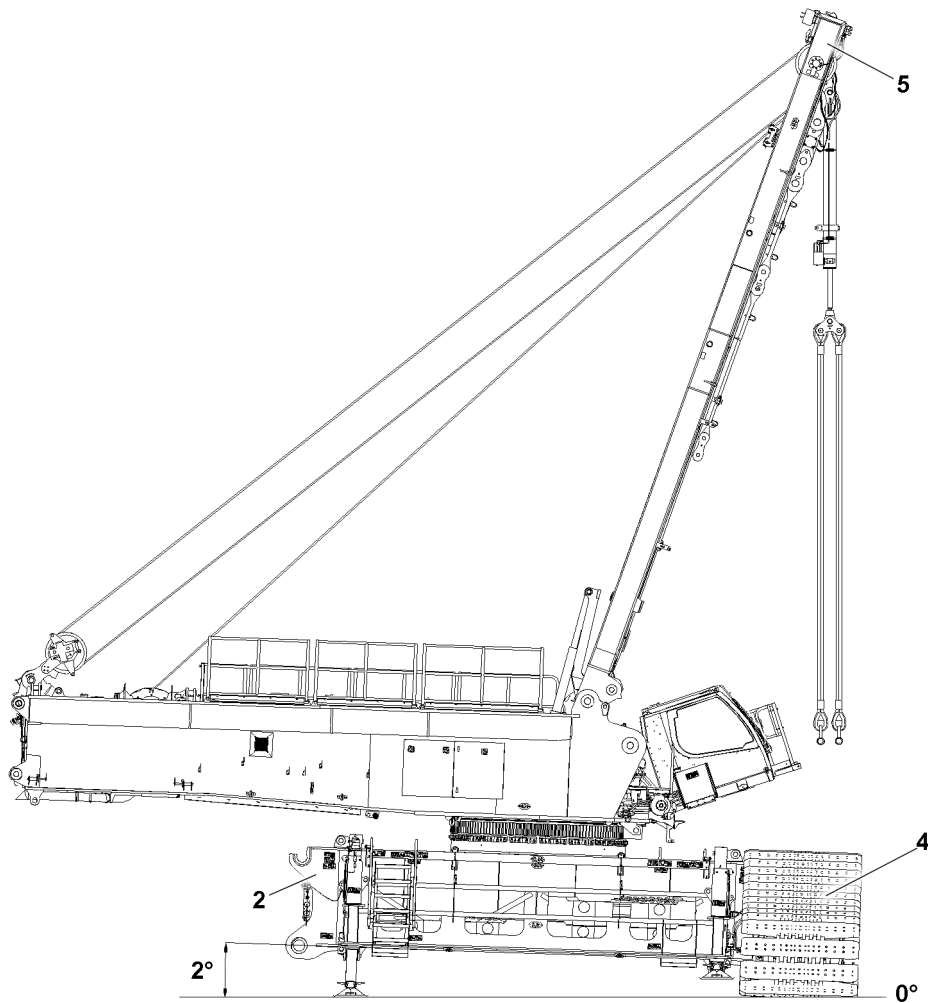


Fig.154314: First crawler carrier

Make sure that the following prerequisite is met:

- The first crawler carrier **4** is pinned and secured on the crawler center section **2**.

When the first crawler carrier is positioned on the ground:

- ▶ Fully retract the support cylinder on the side of the already assembled crawler carrier.

When the angle between the ground and the crawler center section is not 2°:

- ▶ Extend the support cylinder accordingly on the side without the crawler carrier.



### WARNING

Danger of tipping!

Before turning the turntable, if the first assembled crawler carrier is not positioned on the ground, there is a danger of tipping over.

Death, severe bodily injuries, property damage.

- ▶ The support cylinders on the side of the already installed crawler carrier have to be retracted completely.

- ▶ Turn the turntable 180°.

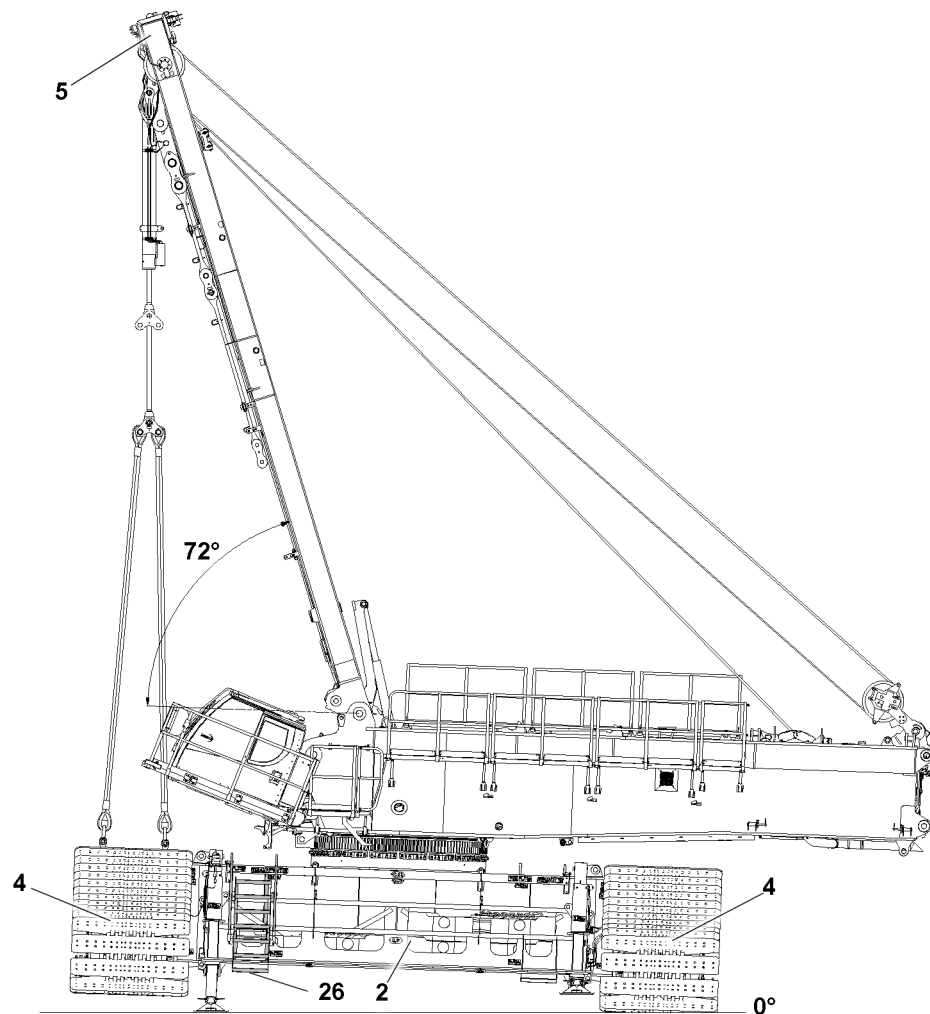


Fig.158744: Assembling the second crawler carrier, turntable in the 90° position to the side



### WARNING

Danger of tipping the crane!

If the following instructions are not observed, the crane can tip over at assembly.

Death, severe bodily injuries, property damage.

- ▶ The maximum permissible distance of 6500 mm between the crawler carrier and the center of the turntable may not be exceeded.
- ▶ The maximum permissible load on the assembly cylinder with a radius of 6500 mm may not exceed 60 t.
- ▶ The maximum permissible turning angle of the turntable, with reference to the 90° position to the side, may not exceed +/-70° when picking up the second crawler carrier.



### WARNING

Danger of collision!

When turning the turntable with the suspended crawler carrier, there is a danger of collision with the access ladder **26**.

Property damage.

- ▶ When turning the turntable with the suspended crawler carrier, disassemble the access ladder **26**.
- ▶ Assemble the second crawler carrier, see section "Assembling the first crawler carrier with the SA-frame".

## 7.3 Lowering the crane



### WARNING

Danger of accident due to improper substructure!  
Death, severe bodily injuries, property damage.

- ▶ The substructure must absorb the weight of the crane safely.
- ▶ The substructure must be made large enough for the ground conditions, with solid materials, such as wood, steel or concrete slabs, see chapter 2.04.

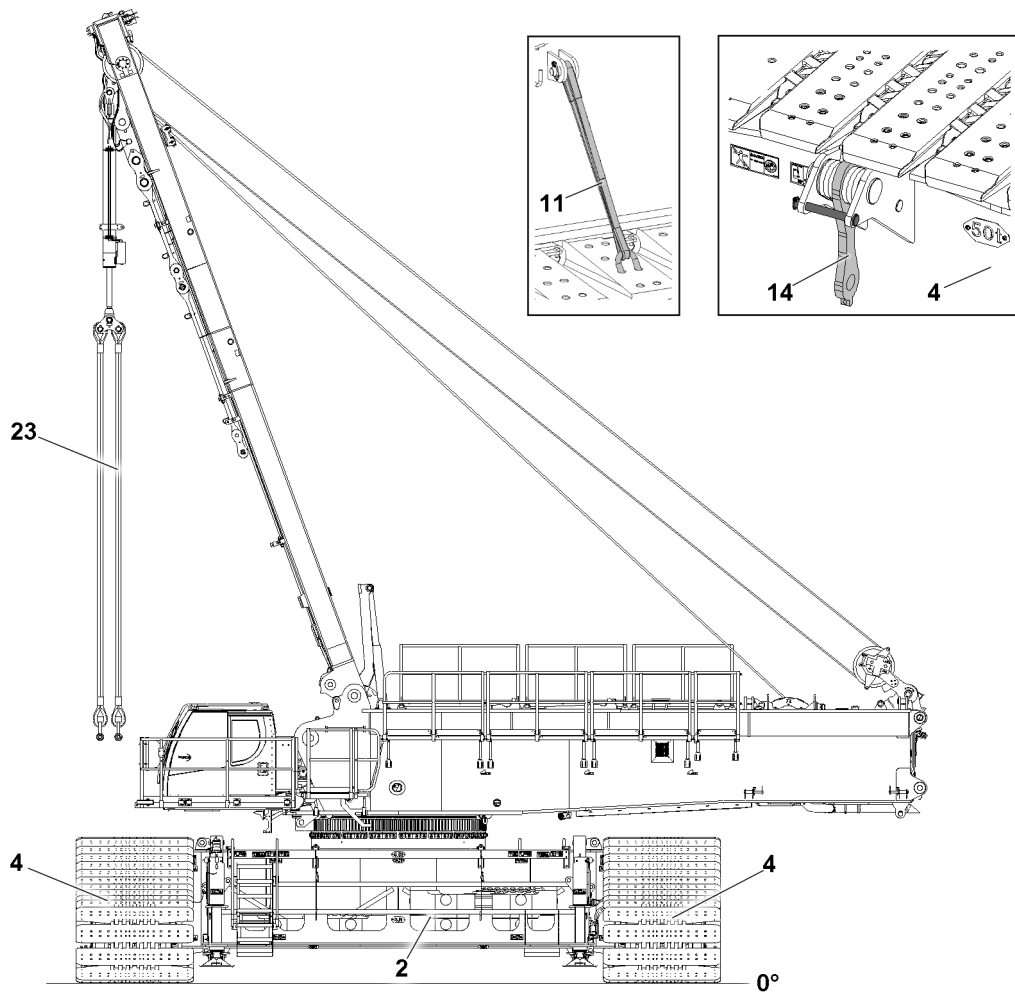


Fig.154316: Lowering the crane

Make sure that the following prerequisites are met:

- The second crawler carrier **4** is pinned and secured on the crawler center section.
- The brackets **14** are swung downwards.

- ▶ Retract the support cylinders completely.

### Result:

- Both crawler carriers **4** are positioned on the ground.
- ▶ Detach the belts **11** on the outrigger pads.
- ▶ The crane cab can be tilted as required.

**Note**

When both crawler carriers are on the ground, on the side of the assembly support, there is no longer a limit of maximum 30 t of ballast plates per central ballast bracket.

When the crane is positioned completely on the crawler travel gear:

- ▶ The central ballast can be increased according to the specifications.

## 8 Assembling the crawler carrier with the auxiliary crane

**Note**

In the case of crawler carriers with 2400 mm wide outrigger pads, it is recommended to perform assembly according to the section "Assembling the crawler carriers with the auxiliary crane".

- ▶ Crawler carriers with 1500 mm or 2000 mm wide outrigger pads can also be assembled with the auxiliary crane.
- ▶ The procedure is independent of the width of the outrigger pads.

### 8.1 Assembling the first crawler carrier with the auxiliary crane

**Note**

Crawler carrier installed on the wrong side.

- ▶ Note the identification on the crawler carrier and the crawler center section.

**Note**

For assembly of the crawler carriers on the crawler center section, the assembly procedure and the process are identical for both crawler carrier sides from a certain point.

- ▶ Individual steps for the assembly of the crawler carrier are described as an example, observe the cross references.

Make sure that the following prerequisites are met:

- A maximum of 30 t of ballast plates is placed on each central ballast bracket.
- The outrigger pads of the crawler carrier are secured to prevent them from sagging.
- The assembly support is extended to the standard measure of 615 mm (lower edge of the bearing eye), see section "Transport receptacle".
- The crawler center section is in a horizontal position.
- The transport receptacle has been removed.
- The crawler carriers are prepared for assembly, see section "Preparing the crawler carrier for assembly".
- The turntable with the SA-frame is connected with the crawler center section.
- The SA-operating mode has been set and confirmed on the LICCON computer system.
- The turntable is aligned such that the crawler carrier pin points are on the cab side.

**Note**

- ▶ The relevant displays, for example the incline, the angle of the SA-frame or error messages appear on the LICCON monitor as well as on the BTT display.

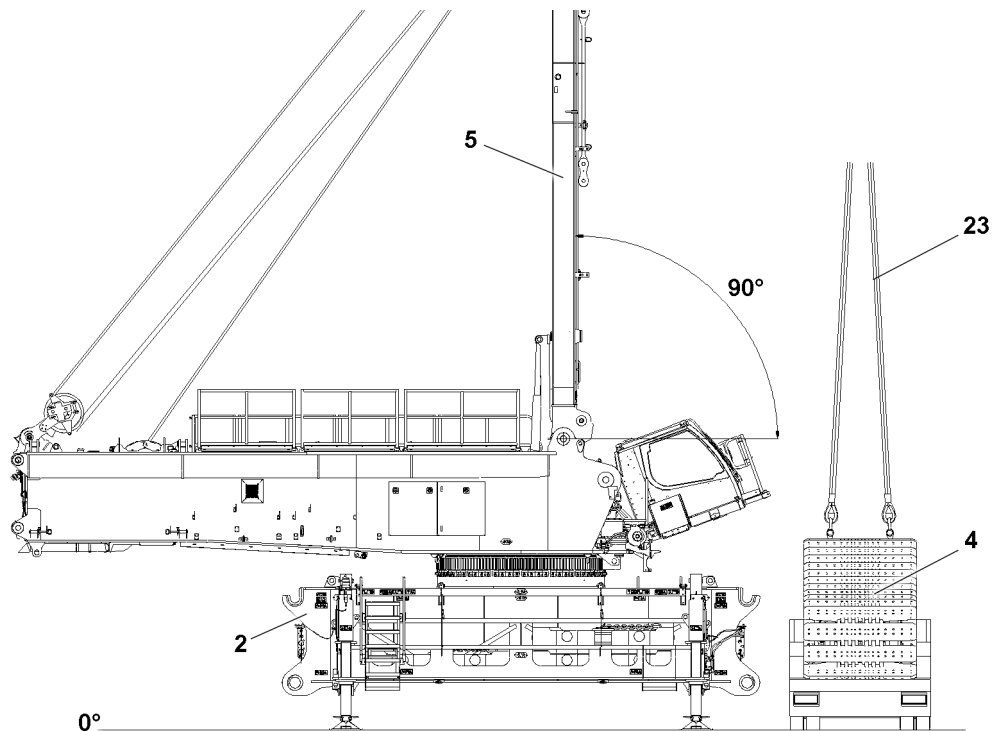


Fig.158733: Assembling with the auxiliary crane

- ▶ Erect the SA-frame **5** to 90°.
- ▶ Tilt the crane cab up to the stop.



#### WARNING

The crane can topple over!  
When fastening loads that are too heavy, the fastening equipment can fail.  
Death, severe bodily injuries, property damage.

- ▶ Make sure that the fastened load does not exceed a weight of 70 t.
- 
- ▶ Fasten the fastening equipment **23** to the brackets of the crawler carrier, see section “Preparing the crawler carrier for assembly”.
  - ▶ Lift the crawler carrier **4** with the auxiliary crane.
  - ▶ Remove the transport vehicle.



#### Note

- ▶ When picking up the first crawler carrier, the turntable can be turned 360°.
- 
- ▶ Carefully position the crawler carrier **4** with the auxiliary crane in the pin points on the crawler center section **2**.

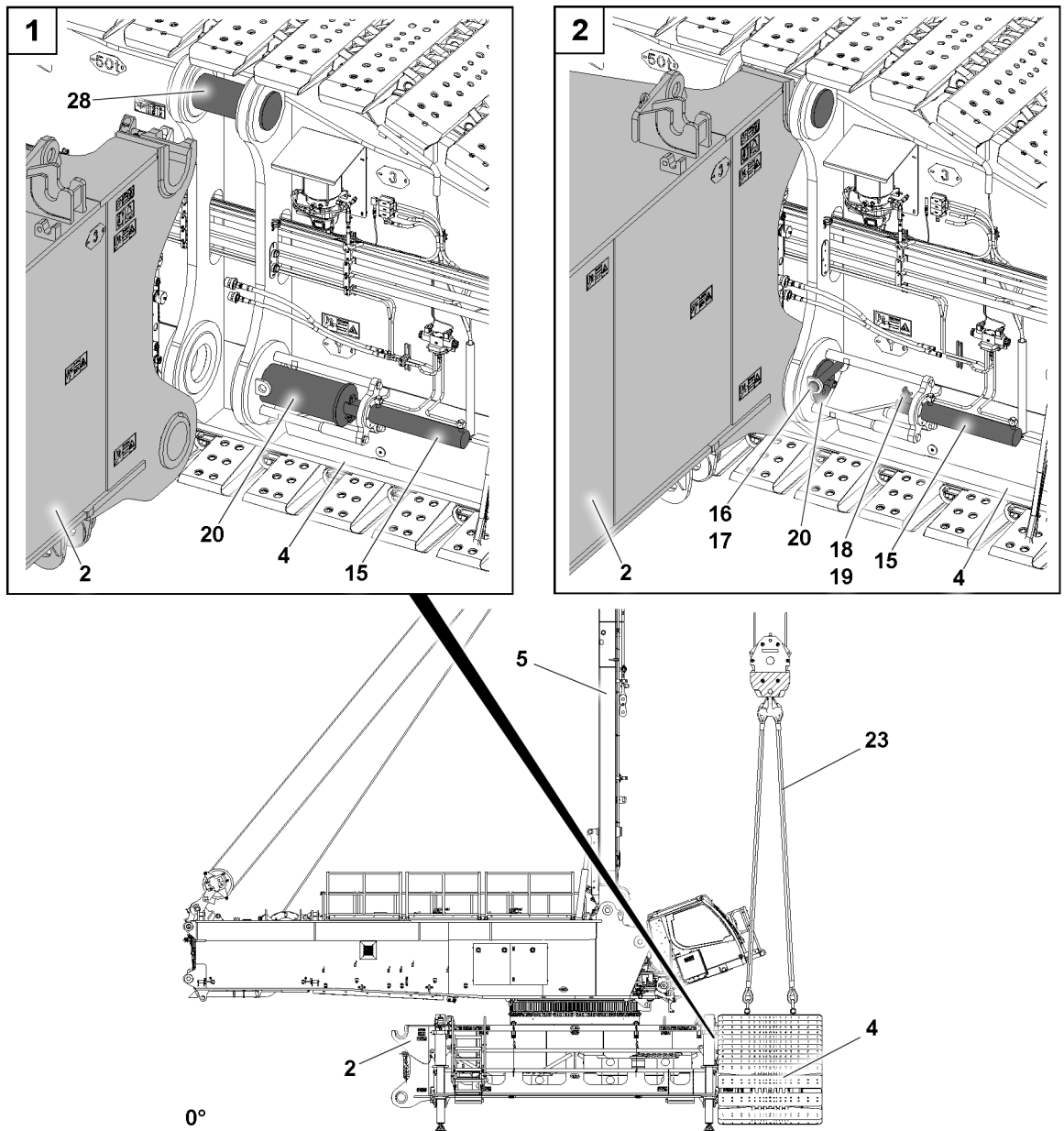


Fig.158734: Crawler carrier pinning

- ▶ Connect the crawler carrier 4 with pin 28 to the centerings on the crawler center section 2.
- ▶ Establish the hydraulic and electrical connections to the crawler carrier, see section “Establishing the connections to the crawler carriers”.
- ▶ Insert the pin 20 with the pin pulling cylinder 15 to the stop: Extend the pin pulling cylinder 15.



#### WARNING

The pin is not secured!

If the pins 20 are not secured, the pins can loosen up by themselves during crane operation. This can cause the crane to topple over.

Death, severe bodily injuries, property damage.

- ▶ Make sure that the pins 20 are secured with the retaining pin 16.
- 
- ▶ Remove the retaining element 17 and unpin the retaining pin 16 from the park position.
  - ▶ Secure the pin 20: Insert the retaining pin 16 in the operating position and secure it with the retaining element 17.
  - ▶ Remove the retaining element 19 and push the slide 18 up.
  - ▶ Retract the pin pulling cylinder 15.
  - ▶ Push the slide 18 down and secure with a retaining element 19.

- ▶ Pin the crawler carrier **4** on the other crawler carrier side with the crawler center section **2**.
- ▶ Remove the fastening equipment.

**NOTICE**

Damage to the brackets!

- ▶ After removing the fastening equipment, the brackets **14** must be swung down.
- ▶ Swing the brackets **14** down, see section "Preparing the crawler carrier for assembly".

## 8.2 Assembling the second crawler carrier with the auxiliary crane

**WARNING**

The crane can topple over!

Depending on the assembly condition of the crane and the extension condition of the support cylinders, there can be very high support forces on the support cylinders.

Death, severe bodily injuries, property damage.

- ▶ Make sure that the ground under the support cylinders is able to safely take on the occurring support forces.
- ▶ Make sure that the support cylinders are supported with materials with a sufficiently high load bearing capacity, see chapter 2.04.
- ▶ Make sure that the support cylinders are retracted and / or extended evenly.
- ▶ When supporting or lowering the crawler center section pay attention to the horizontal alignment.

**Note**

For assembly of the crawler carriers on the crawler center section, the assembly procedure and the process are identical for both crawler carrier sides from a certain point.

- ▶ Individual steps for the assembly of the crawler carrier are described as an example, observe the cross references.

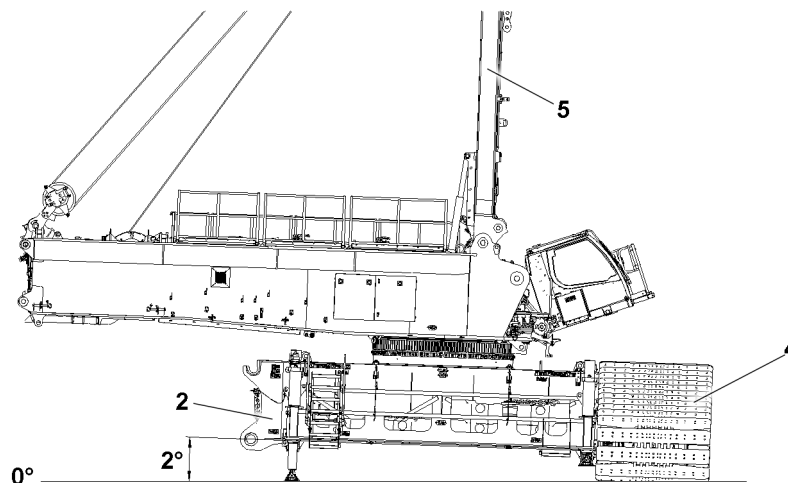


Fig.158735: Assembling the second crawler carrier with the auxiliary crane

Make sure that the following prerequisite is met:

- The first crawler carrier **4** is pinned and secured on the crawler center section **2**.

When the first crawler carrier is positioned on the ground:

- ▶ Fully retract the support cylinder on the side of the already assembled crawler carrier.

When the angle between the ground and the crawler center section is not 2°:

- ▶ Extend the support cylinder accordingly on the side without the crawler carrier.



**WARNING**

Danger of tipping!

Before turning the turntable, if the first assembled crawler carrier is not positioned on the ground, there is a danger of tipping over.

Death, severe bodily injuries, property damage.

- ▶ The support cylinders on the side of the already installed crawler carrier have to be retracted completely.
- 
- ▶ Turn the turntable 180°.

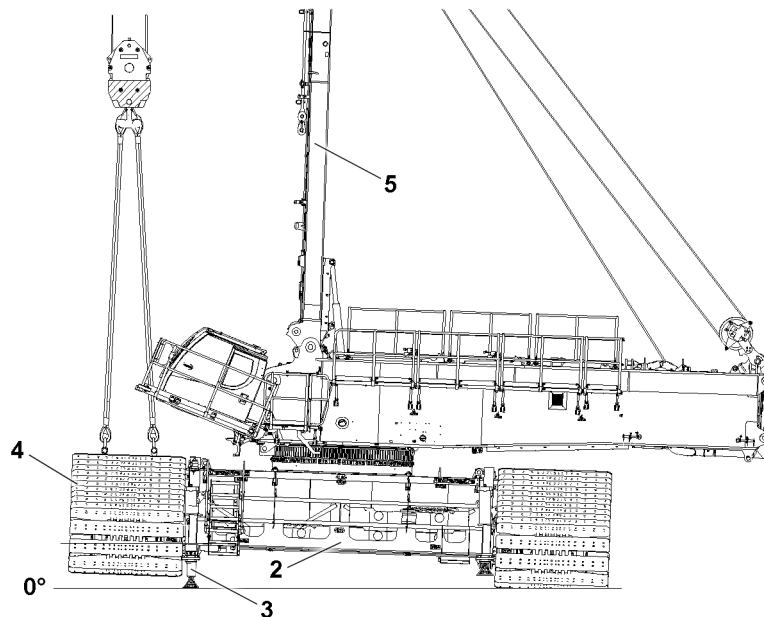


Fig.158736: Assembling the second crawler carrier

- ▶ Assemble the second crawler carrier, see section “Assembling the first crawler carrier with the auxiliary crane”.

### 8.3 Lowering the crane

**WARNING**

Danger of accident due to improper substructure!

Death, severe bodily injuries, property damage.

- ▶ The substructure must absorb the weight of the crane safely.
- ▶ Make the substructure large enough depending on the ground conditions. Use suitable materials such as wood, steel or concrete slabs, see chapter 2.04.

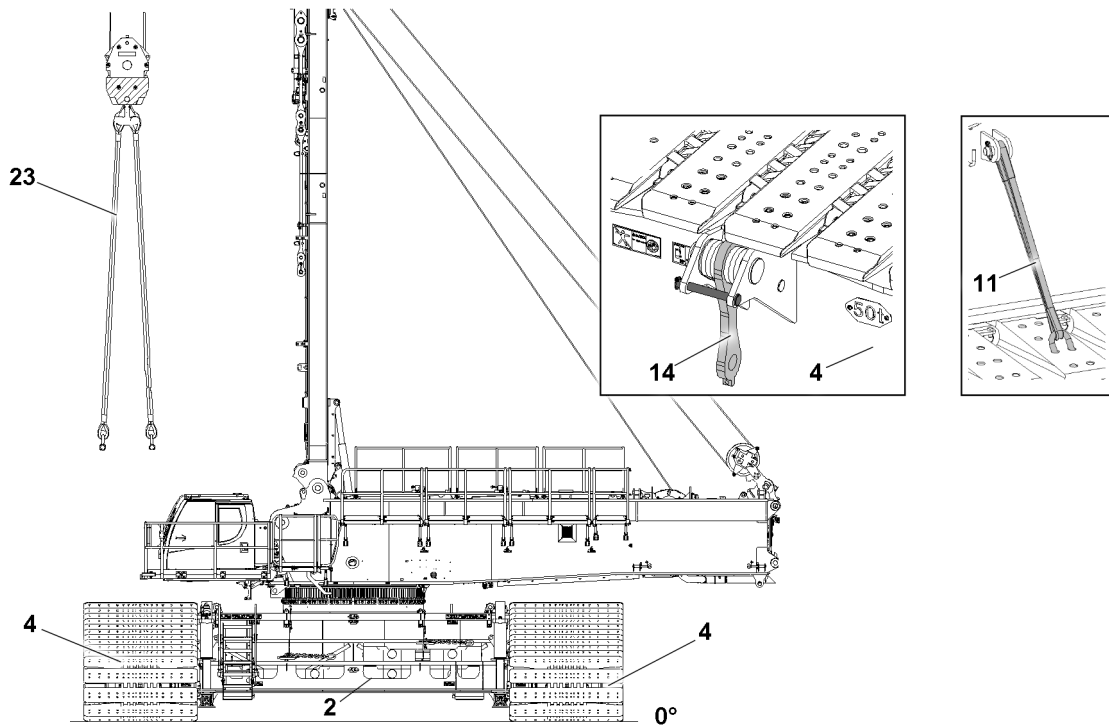


Fig.158737: Removing the fastening equipment from the crawler carrier

Make sure that the following prerequisites are met:

- The second crawler carrier **4** is pinned and secured on the crawler center section.
- The brackets **14** are swung down, see section “Preparing the crawler carrier for assembly”.
- ▶ Retract the support cylinders completely.

**Result:**

- Both crawler carriers **4** are positioned on the ground.
- ▶ Detach the belts **11** on the outrigger pads.
- ▶ The crane cab can be tilted as required.



**Note**

When both crawler carriers are on the ground, on the side of the assembly support, there is no longer a limit of maximum 30 t of ballast plates per central ballast bracket.

When the crane is positioned completely on the crawler travel gear:

- ▶ The central ballast can be increased according to the specifications.

## 9 Establishing the connections to the crawler carriers

### 9.1 Establishing the hydraulic connections

The hydraulic connections are established with quick couplings.

When connecting hydraulic lines with quick couplings, make sure that the coupling procedure is carried out correctly.

The matching quick couplings are marked.

**WARNING**

Pressure in the hydraulic lines!

If the pressure supply is not interrupted before connecting / releasing the hydraulic lines, the hydraulic oil can escape with high pressure.

Death, severe bodily injuries, property damage.

- ▶ Release the pressure in the hydraulic system before connecting / disconnecting: Interrupt the pressure supply and wait for a short time.

**WARNING**

Loss of pressure or leakage!

Incorrectly coupled or self-loosening quick couplings (particularly return lines) can result in serious accidents due to component failure.

Death, severe bodily injuries, property damage.

- ▶ Check that the quick couplings have been properly connected before using the crane.
- ▶ Connect the coupling components (sleeve and connector) and screw together with the knurled nut.
- ▶ Tighten the hydraulic coupling by hand. Turn the knurled nut until it reaches a tangible, fixed stop position.
- ▶ Establish the hydraulic connections, see the Hydraulic diagram.

## 9.2 Establishing the electrical connections

**Note**

- ▶ To establish the electrical connections, use the Electric wiring diagram.

- ▶ Establish the electrical connections.

**WARNING**

Malfunction if dummy plugs are not installed!

If the dummy plugs on the non-required electrical connections are not installed, then malfunctions or functional limitations can occur on the crane.

- ▶ Make sure that all non-required electrical connections, which have a dummy plug, are closed off with dummy plugs.
- ▶ Pay attention to the Electrical wiring diagram.
- ▶ As a rule, close off on-required electrical connections (for example for accessories which cannot be installed) with the respective dummy plugs.

**NOTICE**

Property damage due to dirt and / or corrosion!

If unnecessary electrical connections are not closed off with the respective protective caps, then dirt and / or corrosion can damage the electrical connections.

This could result in malfunctions.

- ▶ Make sure that all non-required electrical connections are always closed off properly.
- ▶ Pay attention to the Electrical wiring diagram.
- ▶ Close electrical connections, which have no dummy plugs, off properly with the corresponding protective caps.

## 9.3 Establishing the connections to the central lubrication system

- ▶ Establish the connections to the central lubrication system.

## 10 Preparing the crawler carrier for disassembly

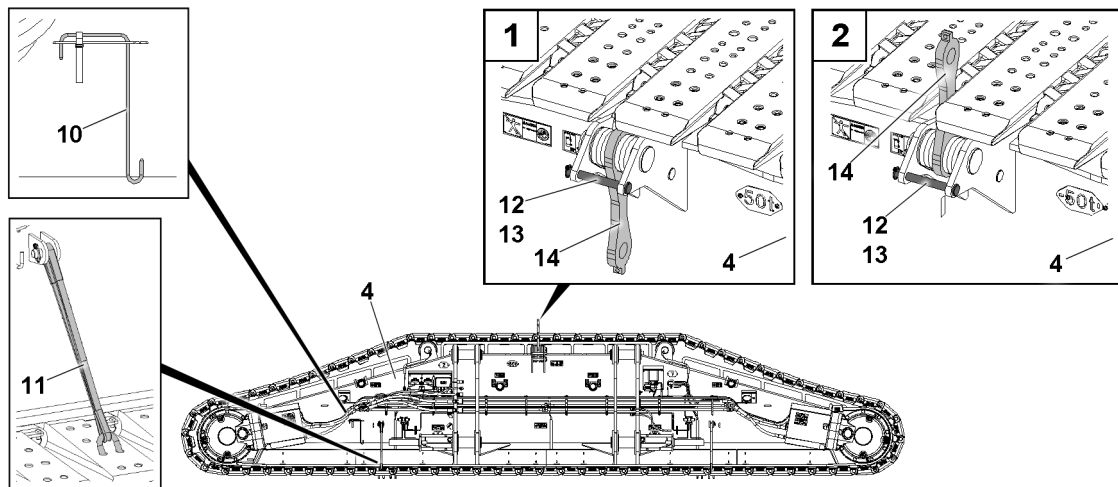


Fig.154308: Crawler carrier



### Note

- ▶ The outrigger pads must be secured before disassembly of the crawler carriers with the belts **11** to prevent them from sagging.
  - ▶ Connect two belts **11** per crawler carrier side.
- 
- ▶ Connect the belts **11** with the brackets on the outrigger pads.



### Note

- ▶ The hook **10** is fastened in the transport position on the crawler carrier.



### Note

- ▶ The lashing lugs **14** must be swung “up” into the assembly position between the outrigger pads.
- 
- ▶ Remove the retaining element **13** and unpin the pin **12**.
  - ▶ Swing the brackets **14** up with the hook **10**.
  - ▶ Insert the pin **12** again and secure it with the retaining element **13**.

## 11 Disassembling the crawler carrier with SA-frame



### WARNING

The crane can topple over!

If more than 30 t of central ballast is placed on each central ballast bracket during disassembly of the crawler carrier on the assembly support, the support cylinders of the assembly support can be overloaded.

- ▶ Make sure during disassembly of the crawler carrier on the assembly support that a maximum of 30 t is placed on each central ballast bracket.
- ▶ Central ballast of more than 30 t per central ballast bracket may only be applied when the crane is positioned on the crawler carrier.

## 11.1 Disassembling the first crawler carrier with the SA-frame



### Note

In the case of crawler carriers with 2400 mm wide outrigger pads, it is recommended to perform disassembly according to the section "Disassembling the crawler carriers with the auxiliary crane".

- ▶ Only disassemble crawler carriers with 1500 mm or 2000 mm wide outrigger pads with the SA-frame.
- ▶ The procedure is independent of the width of the outrigger pads.



### Note

For disassembly of the crawler carriers on the crawler center section, the assembly procedure and the process are identical for both crawler carrier sides from a certain point.

- ▶ Individual steps for the disassembly of the crawler carrier are described as an example, observe the cross references.

### NOTICE

Damage to the crane!

If the following instructions are not observed, the crane can be severely damaged when unloading the crawler carrier.

- ▶ The specifications in the load charts for SA-operation must be adhered to.

Make sure that the following prerequisites are met:

- When rectangular support plates are used, see section "Aligning rectangular support plates".
- The disassembly location must be level and have adequate load bearing capacity.
- The outrigger pads are secured to prevent them from sagging.
- Suitable material must be available for the substructure of the assembly supports.
- A maximum of 30 t of ballast plates is placed on each central ballast bracket.
- The SA-operating mode has been set and confirmed on the LICCON computer system.
- The crawler carriers are prepared for disassembly, see section "Preparing the crawler carrier for disassembly".



### Note

- ▶ The relevant displays, for example the incline, the angle of the SA-frame or error messages appear on the LICCON monitor as well as on the BTT display.

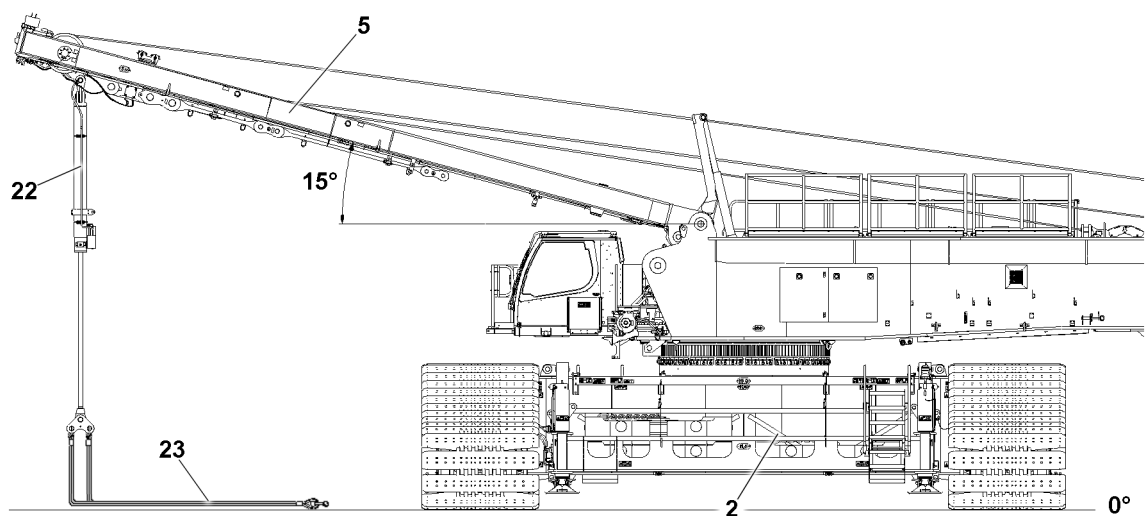


Fig.154319: Assembling the fastening equipment

- ▶ Luff the SA-frame 5 down to the front to 15°.

**Note**

If the assembly cylinder **22** is completely extended and the limit switch position is reached, the error display shuts off.

- ▶ The assembly cylinder **22** is not completely extended.
- 
- ▶ Extend the assembly cylinder **22**.
  - ▶ Pin and secure the fastening equipment **23** to the assembly cylinder **22**.

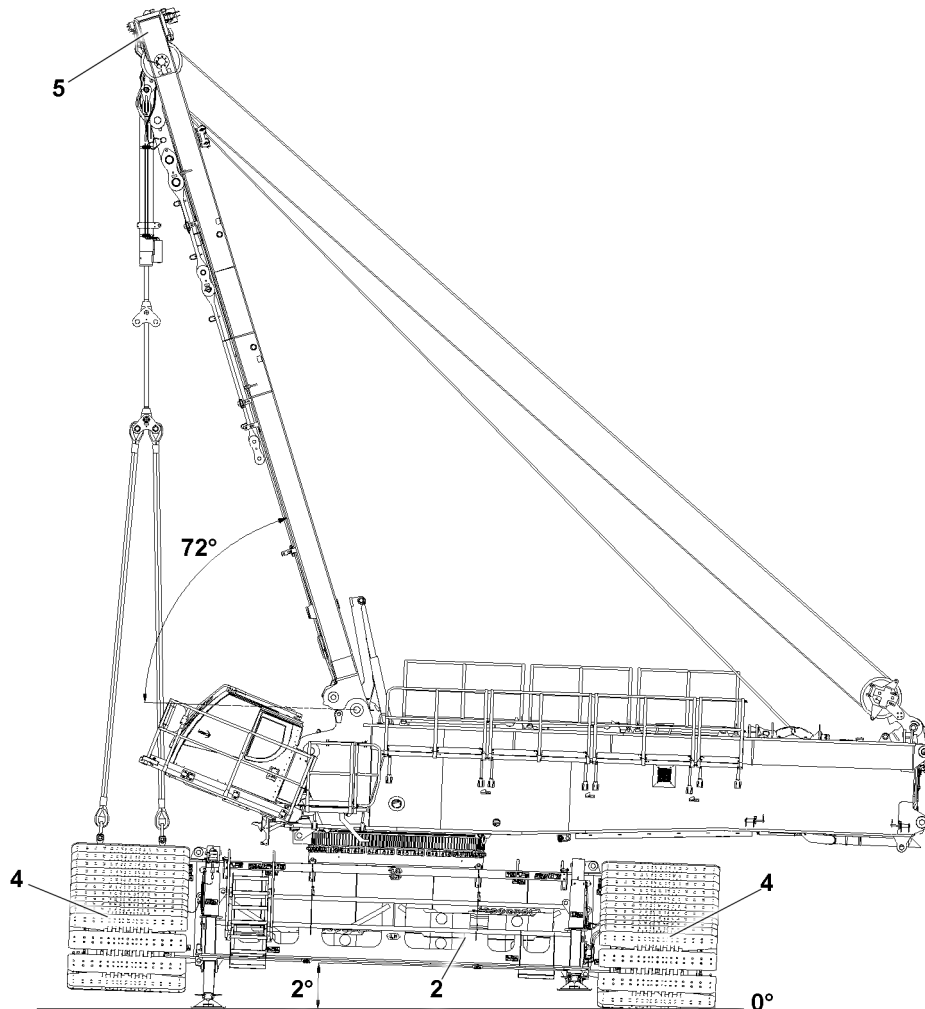


Fig.154320: Attaching the fastening equipment

**WARNING**

The crane can topple over!  
Death, severe bodily injuries, property damage.

- ▶ Make sure that the ground is level and of sufficient load bearing capacity if the hydraulic assembly support must be extended. Observe the ground conditions and maximum force  $F_{max.} = 114 \text{ t}$  per support.
  - ▶ When supporting or lowering the turntable / crawler center section unit, pay attention to the horizontal alignment.
  - ▶ The substructure must be able to safely absorb the weight of the crawler carrier, the turntable and the crawler center section.
  - ▶ The substructure must be made large enough for the ground conditions, with solid materials, such as wood, steel or concrete slabs, see chapter 2.04.
- 
- ▶ Support the crane with suitable materials.
  - ▶ Tilt the crane cab up to the stop.

- ▶ The hydraulic assembly support **3** on the side of the crawler carrier **4** which is being disassembled is extended until the angle between the ground and the crawler center section **2** is approximately  $2^\circ$ .
- ▶ Fasten the fastening equipment **23** to the brackets of the crawler carrier, see section "Preparing the crawler carrier for disassembly".

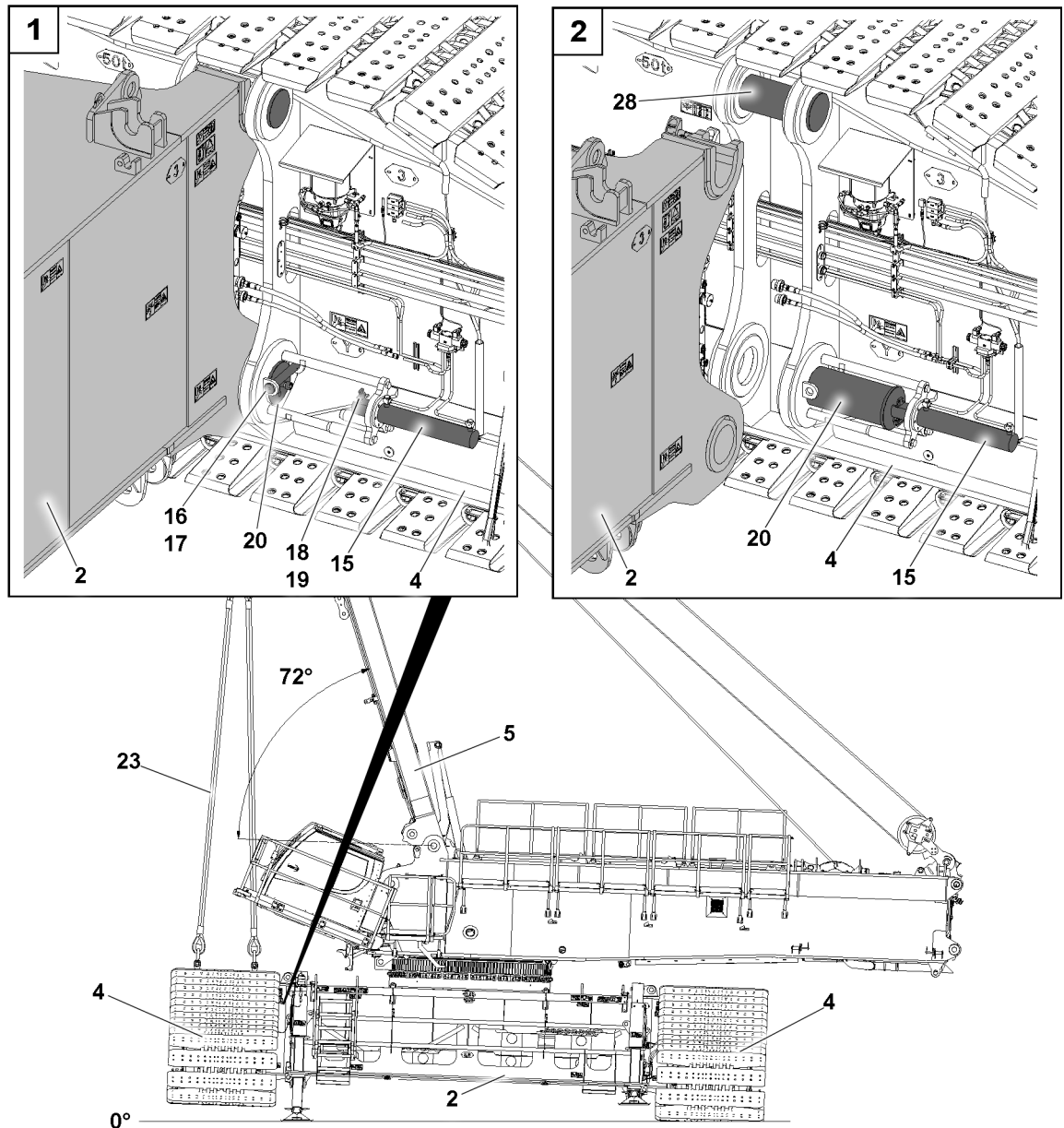


Fig.154321: Unpinning the crawler carrier on the crawler center section

- ▶ Tension the fastening equipment.
- ▶ Release the pin **20**: Remove the retaining element **17** and unpin the retaining pin **16**.
- ▶ Insert the retaining pin **16** in park position and secure it with retaining element **17**.
- ▶ Remove the retaining element **19** and push the slide **18** up.
- ▶ Extend the pin pulling cylinder **15**.
- ▶ Connect the piston rod head with the screw on the pin **20**: Push the slide **18** down and secure with a retaining element **19**.
- ▶ Unpin the pin **20** with the pin pulling cylinder **15** to the stop.
- ▶ Disconnect the hydraulic and electrical connections from the crawler carrier, see section "Disconnecting the connections from the crawler carriers".
- ▶ Unpin the crawler carrier **4** on the other crawler carrier side.

- ▶ Lift the crawler carrier **4** carefully with the SA-frame.

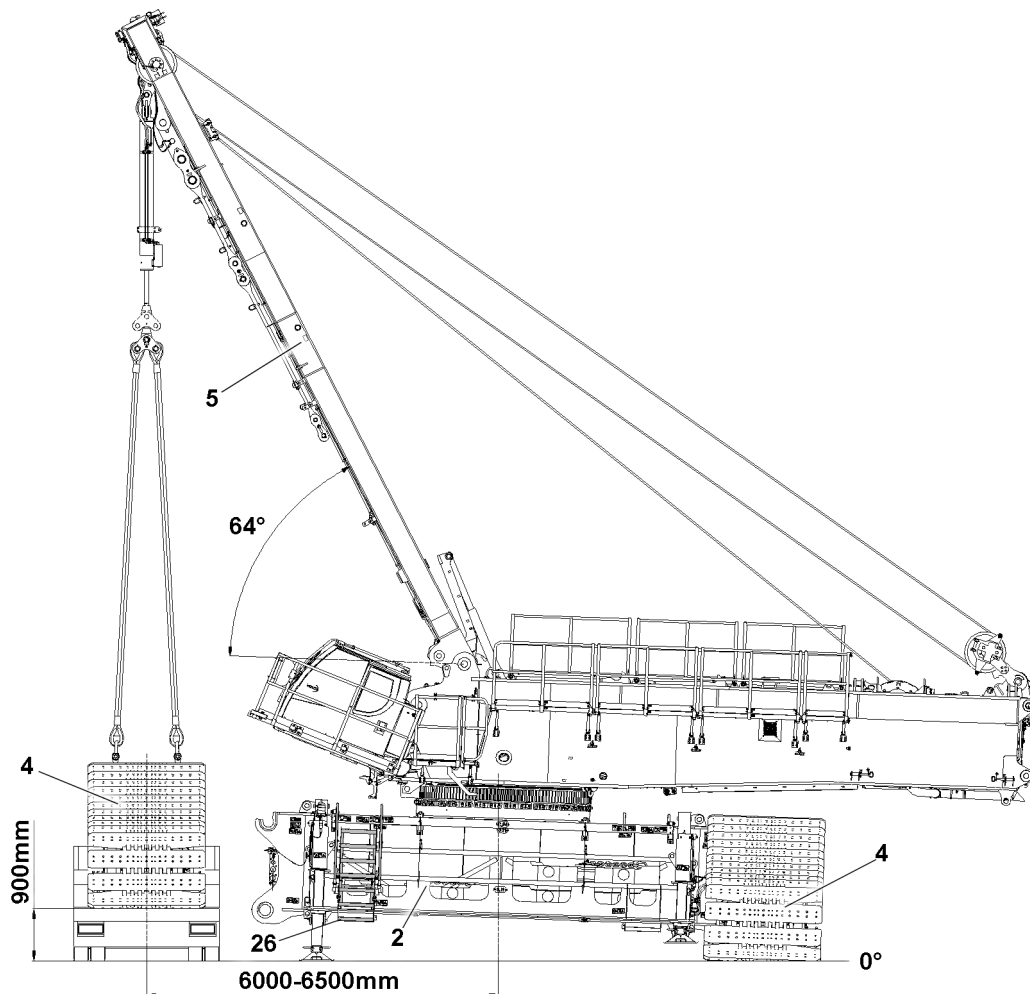


Fig.158745: Place the crawler carrier on the transport vehicle, turntable in the 90° position to the side



#### WARNING

Danger of tipping the crane!

If the following instructions are not observed, the crane can tip over during disassembly.

Death, severe bodily injuries, property damage.

- ▶ The maximum permissible distance of 6500 mm between the crawler carrier and the center of the turntable may not be exceeded.
- ▶ The maximum permissible load on the assembly cylinder with a radius of 6500 mm may not exceed 60 t.
- ▶ The maximum permissible turning angle of the turntable, with reference to the 90° position to the side, may not exceed +/-70°.
- ▶ The maximum permitted height of the loading surface on the crawler carrier is 900 mm.



#### WARNING

Danger of collision!

When turning the turntable with the suspended crawler carrier, there is a danger of collision with the access ladder **26**.

Property damage.

- ▶ When turning the turntable with the suspended crawler carrier, disassemble the access ladder **26**.

When the crawler carrier is raised lifted the fastening points:

- ▶ Swing the crawler carrier **4** out.
- ▶ Set the crawler carrier **4** on the transport vehicle.



- ▶ Remove the fastening equipment.
- ▶ Swing the brackets **14** down and secure, see section "Preparing the crawler carrier for disassembly".
- ▶ Reinsert the pin **20** to the stop: use an external hydraulic aggregate.
- ▶ Secure the crawler carrier **4** on the transport vehicle.

## 11.2 Disassembling the second crawler carrier with SA-frame

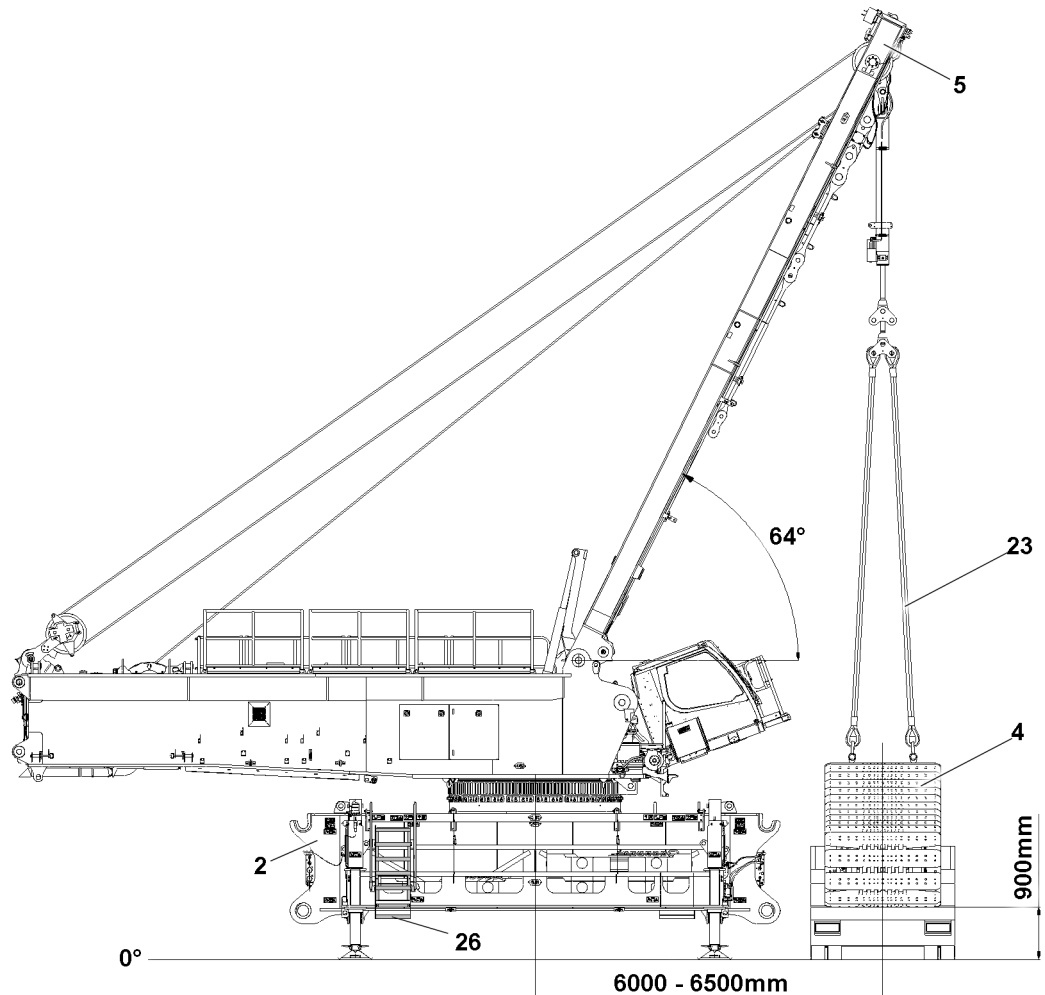


Fig.158746: Disassembling the second crawler carrier



### Note

For disassembly of the crawler carriers on the crawler center section, the assembly procedure and the process are identical for both crawler carrier sides from a certain point.

- ▶ Individual steps for the disassembly of the crawler carrier are described as an example, observe the cross references.

Make sure that the following prerequisite is met:

- The first crawler carrier has been disassembled.
- The SA-frame is erected.

**WARNING**

Danger of tipping!

Before turning the turntable, if the second crawler carrier is not placed on the ground, there is a danger of tipping over.

Death, severe bodily injuries, property damage.

- ▶ The support cylinders on the side of the crawler carrier that must still be disassembled must be completely retracted.
- ▶ Make sure that the crawler carrier is positioned on the ground.

- ▶ Turn the turntable 180°.

- ▶ Extend the opposite support cylinders until the crane is in a horizontal position.

When the crane is aligned horizontally:

- ▶ Extend all support cylinders completely.
- ▶ Align the crane horizontally.

**WARNING**

Danger of tipping the crane!

If the following instructions are not observed, the crane can tip over during disassembly.

Death, severe bodily injuries, property damage.

- ▶ The maximum permissible distance of 6500 mm between the crawler carrier and the center of the turntable may not be exceeded.
- ▶ The maximum permissible load on the assembly cylinder with a radius of 6500 mm may not exceed 60 t.
- ▶ The maximum permitted height of the loading surface on the crawler carrier is 900 mm.

**Note**

- ▶ When removing the second crawler carrier, the turntable can be turned 360°.

**WARNING**

Danger of collision!

When turning the turntable with the suspended crawler carrier, there is a danger of collision with the access ladder **26**.

Property damage.

- ▶ When turning the turntable with the suspended crawler carrier, disassemble the access ladder **26**.
- ▶ Disassemble the second crawler carrier, see section "Disassembling the first crawler carrier with the SA-frame".

## 12 Disassembling the crawler carrier with the auxiliary crane

**WARNING**

The crane can topple over!

If more than 30 t of central ballast is placed on each central ballast bracket during disassembly of the crawler carrier on the assembly support, the support cylinders of the assembly support can be overloaded.

- ▶ Make sure during disassembly of the crawler carrier on the assembly support that a maximum of 30 t is placed on each central ballast bracket.
- ▶ Central ballast of more than 30 t per central ballast bracket may only be applied when the crane is positioned on the crawler carrier.

## 12.1 Disassembling the first crawler carrier with the auxiliary crane



### Note

For disassembly of the crawler carriers on the crawler center section, the assembly procedure and the process are identical for both crawler carrier sides from a certain point.

- ▶ Individual steps for the disassembly of the crawler carrier are described as an example, observe the cross references.

Make sure that the following prerequisites are met:

- When rectangular support plates are used, see section “Aligning rectangular support plates”.
- The disassembly location must be level and have adequate load bearing capacity.
- The outrigger pads are secured to prevent them from sagging.
- Suitable material must be available for the substructure of the assembly supports.
- A maximum of 30 t of ballast plates is placed on each central ballast bracket.
- The SA-operating mode has been set and confirmed on the LICCON computer system.
- The crawler carriers are prepared for disassembly, see section “Preparing the crawler carrier for disassembly”.



### Note

- ▶ The relevant displays, for example the incline, the angle of the SA-frame or error messages appear on the LICCON monitor as well as on the BTT display.

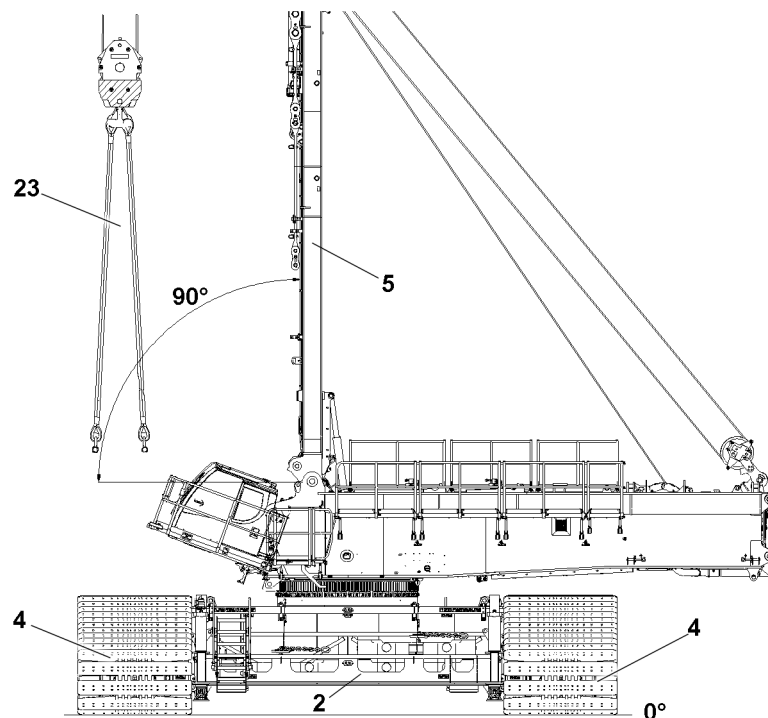


Fig.158738: Assembling the fastening equipment on the auxiliary crane

- ▶ Position SA-frame 5 up to 90°.
- ▶ Tilt the crane cab up to the stop.



### WARNING

The crane can topple over!

When fastening loads that are too heavy, the fastening equipment can fail.  
Death, severe bodily injuries, property damage.

- ▶ Make sure that the fastened load does not exceed a weight of 70 t.
- ▶ Connect the fastening equipment 23 to the auxiliary crane.

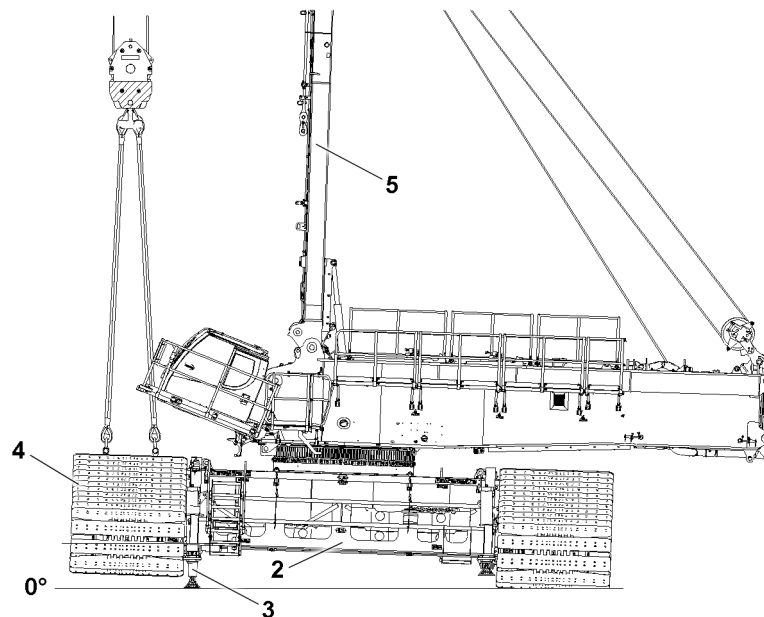


Fig.158736: Attaching the fastening equipment



#### WARNING

The crane can topple over!  
Death, severe bodily injuries, property damage.

- ▶ Make sure that the ground is level and of sufficient load bearing capacity if the hydraulic assembly support must be extended. Observe the ground conditions and maximum force  $F_{max.} = 114 \text{ t}$  per support.
  - ▶ When supporting or lowering the turntable / crawler center section unit, pay attention to the horizontal alignment.
  - ▶ The substructure must be able to safely absorb the weight of the crawler carrier, the turntable and the crawler center section.
  - ▶ The substructure must be made large enough for the ground conditions, with solid materials, such as wood, steel or concrete slabs, see chapter 2.04.
- 
- ▶ Support the crane with suitable materials.
  - ▶ The hydraulic assembly support **3** on the side of the crawler carrier **4** which is being disassembled is extended until the angle between the ground and the crawler center section **2** is approximately  $2^\circ$ .
  - ▶ Fasten the fastening equipment to the brackets of the crawler carrier, see section "Preparing the crawler carrier for disassembly".

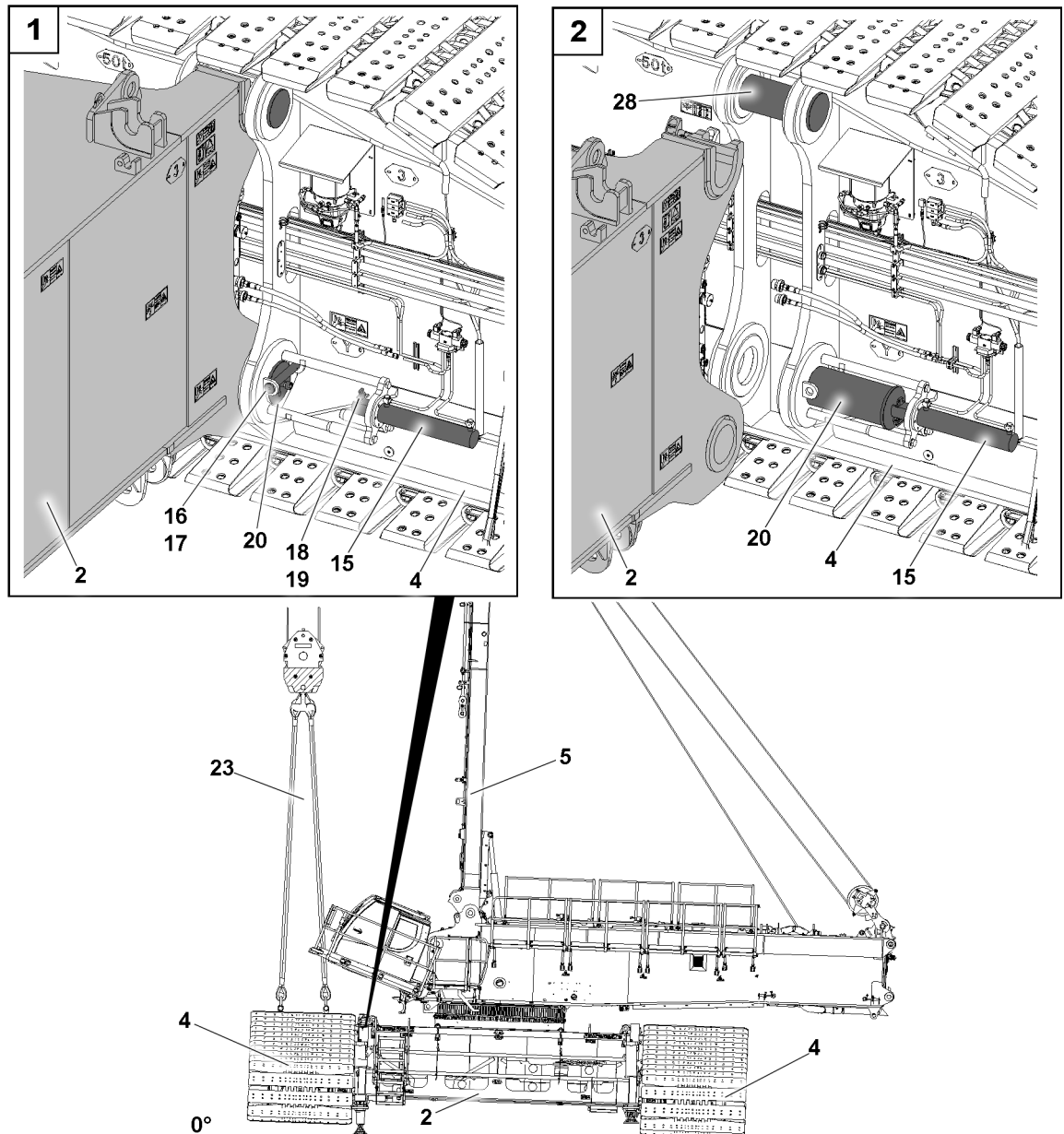
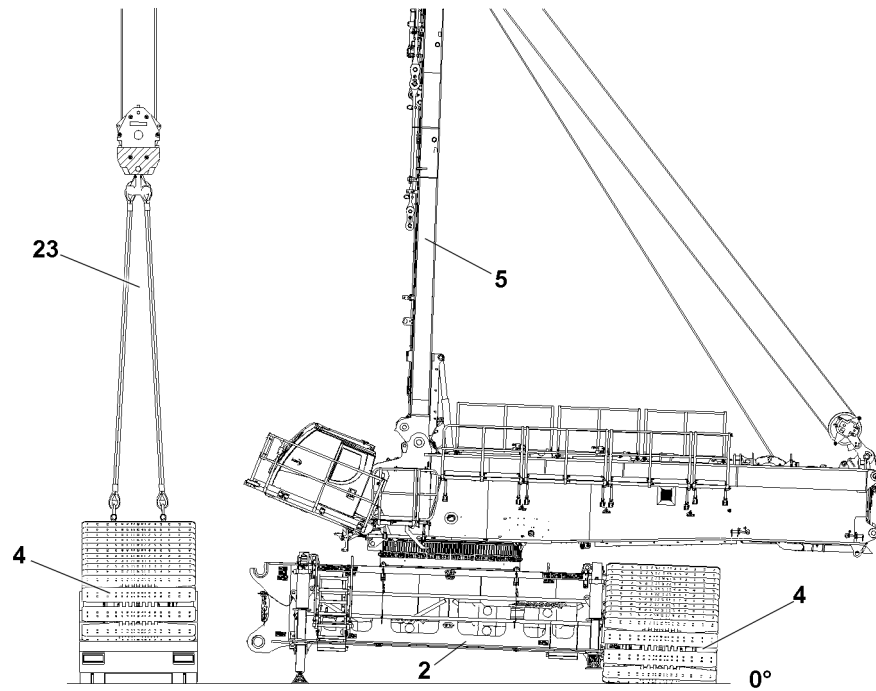


Fig.158739: Unpinning the crawler carrier on the crawler center section

- ▶ Tension the fastening equipment.
- ▶ Release the pin **20**: Remove the retaining element **17** and unpin the retaining pin **16**.
- ▶ Insert the retaining pin **16** in park position and secure it with retaining element **17**.
- ▶ Remove the retaining element **19** and push the slide **18** up.
- ▶ Extend the pin pulling cylinder **15**.
- ▶ Connect the piston rod head with the screw on the pin **20**: Push the slide **18** down and secure with a retaining element **19**.
- ▶ Unpin the pin **20** with the pin pulling cylinder **15** to the stop.
- ▶ Disconnect the hydraulic and electrical connections from the crawler carrier, see section “Disconnecting the connections from the crawler carriers”.
- ▶ Unpin the crawler carrier **4** on the other crawler carrier side.
- ▶ Lift the crawler carrier **4** carefully with the auxiliary crane.



*Fig.158740: Setting the crawler carrier on the transport vehicle*

When the crawler carrier is raised lifted the fastening points:

- ▶ Set the crawler carrier with the auxiliary crane **4** on the transport vehicle.
- ▶ Remove the fastening equipment.
- ▶ Swing the brackets **14** down and secure, see section “Preparing the crawler carrier for disassembly”.
- ▶ Reinsert the pin **20** to the stop: use an external hydraulic aggregate.
- ▶ Secure the crawler carrier **4** on the transport vehicle.

## 12.2 Removing the second crawler carrier with the auxiliary crane

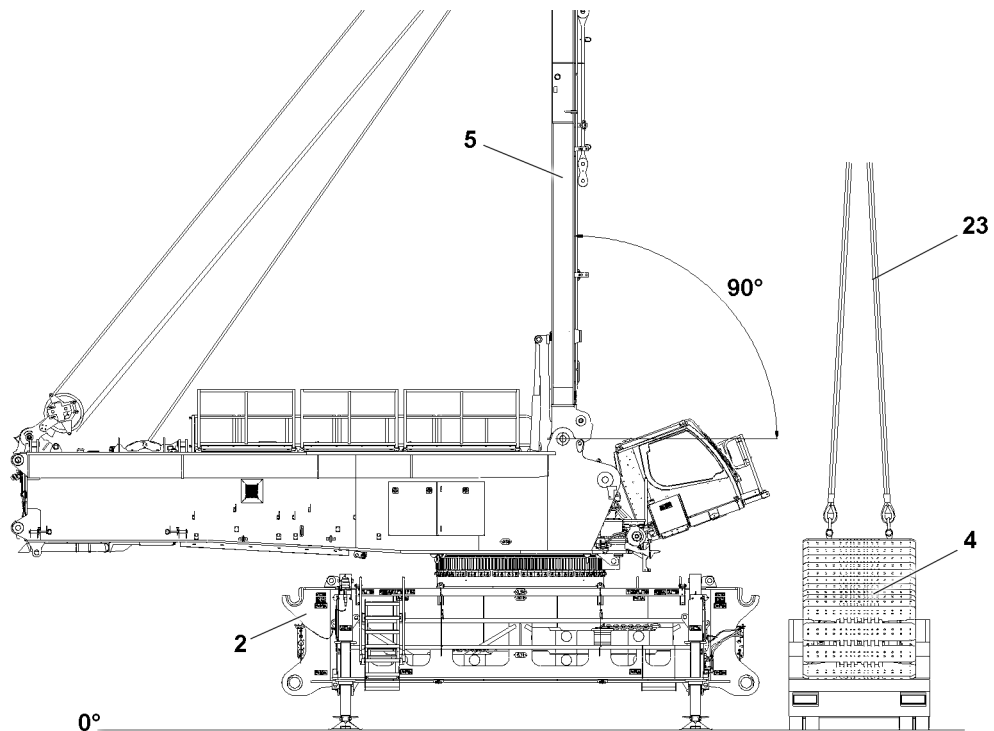


Fig.158733: Disassembling the second crawler carrier



### Note

For disassembly of the crawler carriers on the crawler center section, the assembly procedure and the process are identical for both crawler carrier sides from a certain point.

- ▶ Individual steps for the disassembly of the crawler carrier are described as an example, observe the cross references.

Make sure that the following prerequisite is met:

- The first crawler carrier has been disassembled.
- Erect the SA-frame to 90°.



### WARNING

Danger of tipping!

Before turning the turntable, if the second crawler carrier is not placed on the ground, there is a danger of tipping over.

Death, severe bodily injuries, property damage.

- ▶ The support cylinders on the side of the crawler carrier that must still be disassembled must be completely retracted.
- ▶ Make sure that the crawler carrier is positioned on the ground.

- ▶ Turn the turntable 180°.

- ▶ Extend the opposite support cylinders until the crane is in a horizontal position.

When the crane is aligned horizontally:

- ▶ Extend all support cylinders completely.
- ▶ Align the crane horizontally.



### Note

- ▶ When removing the second crawler carrier, the turntable can be turned 360°.

- ▶ Disassemble the second crawler carrier, see section “Disassembling the first crawler carrier with the auxiliary crane”.

## 13 Disconnecting the connections to the crawler carriers

### 13.1 Disconnecting the hydraulic connections

The hydraulic connections are established with quick couplings.

When disconnecting hydraulic lines with quick couplings, make sure that the uncoupling procedure is carried out correctly.



---

#### WARNING

Pressure in the hydraulic lines!

If the pressure supply is not interrupted before connecting / releasing the hydraulic lines, the hydraulic oil can escape with high pressure.

Death, severe bodily injuries, property damage.

▶ Release the pressure in the hydraulic system before connecting / disconnecting: Interrupt the pressure supply and wait for a short time.

- 
- ▶ Release the hydraulic coupling by hand.
  - ▶ Disconnect the hydraulic connections, see the Hydraulic diagram.
  - ▶ Protect the hydraulic connections from contamination with caps.

### 13.2 Disconnecting the electrical connections

---

#### NOTICE

Damage to the cable connections!

▶ Make sure that the electrical connections have been disconnected and properly stored before unpinning / lifting.

- 
- ▶ Disconnect the electrical connections, see the wiring diagram.
  - ▶ Store the electrical connections properly and protect them against damage.
  - ▶ Close the electrical connections off properly with dummy plugs or protective caps.

### 13.3 Disconnecting the connections to the central lubrication system

- ▶ Disconnect the connections to the central lubrication system.
- ▶ Use caps to protect the connections of the central lubrication system against contamination.



## 3.02 Turntable assembly

1	Safety	2
2	Turntable fastening points	3
3	Assembling the fall protection equipment on the turntable	6
4	Lifting the turntable from the transport vehicle	7
5	Unpinning the pin from the transport position	8
6	Assembling the central ballast	8
7	Placing the turntable on the crawler center section	9
8	Pinning the turntable with the Quick Connection (QC)	11
9	Bringing the crane cab and cab platform into the operating position	13
10	Assembling the drawbar of the rotary connection on the turntable	14
11	Establishing the hydraulic connections	15
12	Establishing the electrical connections	16
13	Further assembly steps	16
14	Turning the turntable into the disassembly position	17
15	Reducing the central ballast for disassembly	17
16	Preparing the turntable for removal from the crawler center section	18
17	Disconnecting the electrical connections	18
18	Disconnecting the hydraulic connections	18
19	Disassembling the drawbar of the rotary connection on the turntable	19
20	Bringing the crane cab into the transport position	20
21	Unpinning the turntable with the quick connection (QC)	21
22	Lifting the turntable from the crawler center section	24
23	Bringing the pin into the transport position	25
24	Disassembling the fall protection equipment on the turntable	25

# 1 Safety

Observe the safety instructions before assembly and disassembly:

- Information regarding work on the crane superstructure. See chapter 2.04.
- Information regarding personal protective equipment. See chapter 2.04.
- Information regarding fall protection equipment. See chapter 2.06.
- Information regarding accesses to the crane. See chapter 2.07.
- Information regarding accessible surfaces. See chapter 2.07.



## WARNING

Danger of falling!

During assembly / disassembly, inspection and maintenance work, assembly personnel must be secured with appropriate aids to prevent them from falling.

Death, severe bodily injuries, property damage.

- ▶ All work at a height, when there is a danger of falling, must be carried out with suitable aids.
- ▶ If aids are not available and work cannot be carried out from the ground, then assembly personnel must secure themselves with the supplied fall arrest system to prevent falling, see chapter 2.04.
- ▶ If fall protection equipment is available, then it must be used, see chapter 2.06.
- ▶ When lifting, lowering, swinging crane parts in and out, no persons may remain in the danger zone.
- ▶ If railings are present on the components, then they must be brought into the corresponding position and secured for assembly / disassembly work.
- ▶ It is prohibited to lean the ladder against the component being disassembled.
- ▶ Only step on the aids, ladders and catwalks with clean shoes.
- ▶ Keep aids, ladders and catwalks free of heavy dirt, snow, frost and ice.
- ▶ During all assembly and disassembly work, maintenance work and inspections, travel or crane operation is prohibited.
- ▶ Remaining on a suspended load is prohibited.
- ▶ Stepping or walking on crane components and lattice sections that have an incline of more than 20° is prohibited.
- ▶ For all assembly work, the crane driver of the main crane must be in voice contact with the crane driver / crane drivers of the auxiliary crane / auxiliary cranes.
- ▶ For assembly tasks, the crane driver may only initiate crane movements when the responsible guide has explicitly released the movement.



## WARNING

Danger of impact / crushing!

When assembling / disassembling crane components with the auxiliary crane, crane components can start to swing back and forth.

When lifting / lowering and positioning crane components, there is an increased danger of impact / crushing.

Death, severe bodily injuries, property damage.

- ▶ Make sure that personnel cannot be caught by components.
- ▶ Make sure that the crane is horizontally aligned.
- ▶ When working in danger zones: Use aids to protect limbs.
- ▶ Guide components with suitable aids to minimize oscillation.



## WARNING

Danger of accident due to sudden movements of components!

Operations / crane movements that are carried out without coordination between the crane operator, guide and assembly personnel can cause accidents!

- ▶ For all assembly work, observe the instructions of the guide! If necessary, use walkie-talkies.
- ▶ Continuously coordinate between the crane operator, guide and assembly personnel.
- ▶ Make sure that the danger zone can be viewed completely.

When moving components:

- ▶ Make sure that there are no persons in the danger zone.

**WARNING**

When lifting / lowering and positioning components, there is a danger of impacts / crushing!  
Personnel can be injured or killed!

- ▶ Make sure that personnel cannot be caught by components.

To protect limbs:

- ▶ Guide the components with suitable aids.

**DANGER**

The components can fall down!

If the corresponding component is disengaged from the auxiliary crane before the corresponding component is pinned, then the corresponding component can fall down.

If the corresponding component is unpinned before the corresponding component is attached by the auxiliary crane, the corresponding component can fall down.

Death, severe bodily injuries, property damage.

- ▶ Do not detach the auxiliary crane until the respective component is pinned and secured.
- ▶ Only unpin the corresponding component after the corresponding component is attached to the auxiliary crane.

**WARNING**

The crane can topple over!

Death, severe bodily injuries, property damage.

- ▶ Make sure that the crane turntable is not turned at the end of the assembly procedure.
- ▶ Turning is possibly only at a later assembly step, see chapter 3.01.

## 2 Turntable fastening points

For transport, the turntable can be separated from the crawler center section by means of the Quick Connection (QC). The turntable and the crawler center section are each transported on a separate transport vehicle.

**Note**

- ▶ If the turntable is not fit immediately on the crawler center section after lifting it off the transport vehicle, the turntable can be lifted with the transport receptacles from the transport vehicle and put down on level and load bearing ground.

**WARNING**

Turntable incorrectly fastened!

Life-threatening situations can arise if the turntable is incorrectly or improperly fastened.

The turntable can fall down, become unbalanced or move in an uncontrolled manner.

Death, severe bodily injuries, property damage.

- ▶ Fasten the turntable with the provided fastening equipment.
- ▶ Fasten the turntable in the provided fastening points.
- ▶ Make sure that the fastening equipment is properly fastened to the turntable and that it is secured sufficiently to prevent it from loosening up.

**WARNING**

Toppling of the turntable!

Death, severe bodily injuries, property damage.

- ▶ Make sure that the ground is level and of sufficient load bearing capacity if the turntable is to be placed on the ground with the transport receptacles.

## 2.1 Taking on a load with an auxiliary crane

### 2.1.1 Turntable and transport receptacles

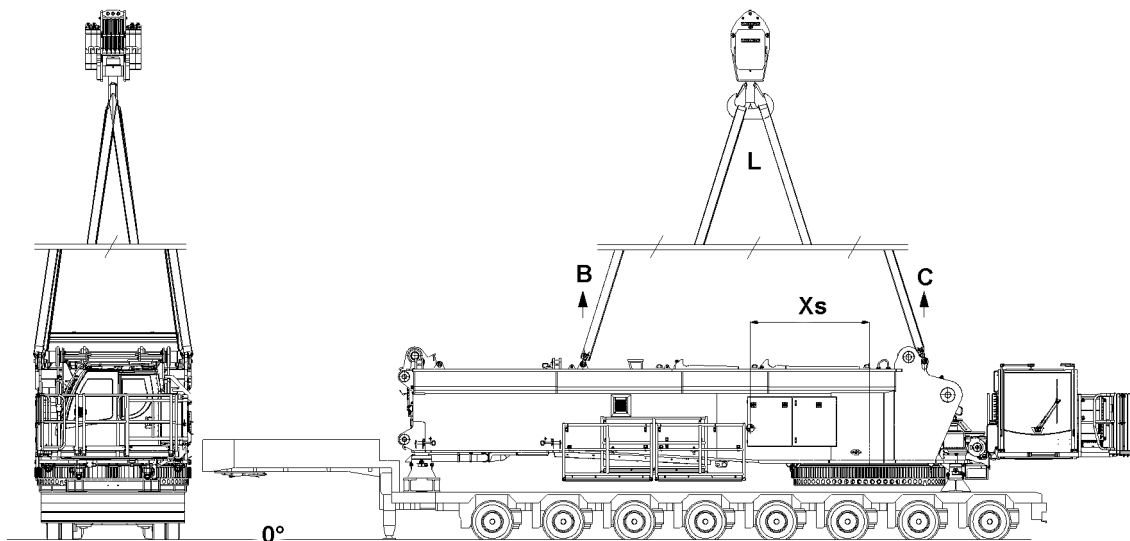


Fig.153470: Taking on a load: Turntable and transport receptacles

	Weight	Suspended load		Center of gravity	Length of fastening equipment
		B	C	Xs	L
Turntable with QC + Transport receptacles	48.30 t	24.60 t	23.70 t	2.28 m	10.00 m <sup>1)</sup>

<sup>1)</sup> Minimum length of fastening equipment

## 2.2 Taking on a load with two auxiliary cranes

### 2.2.1 Turntable with winch 1, winch 2 and transport receptacles

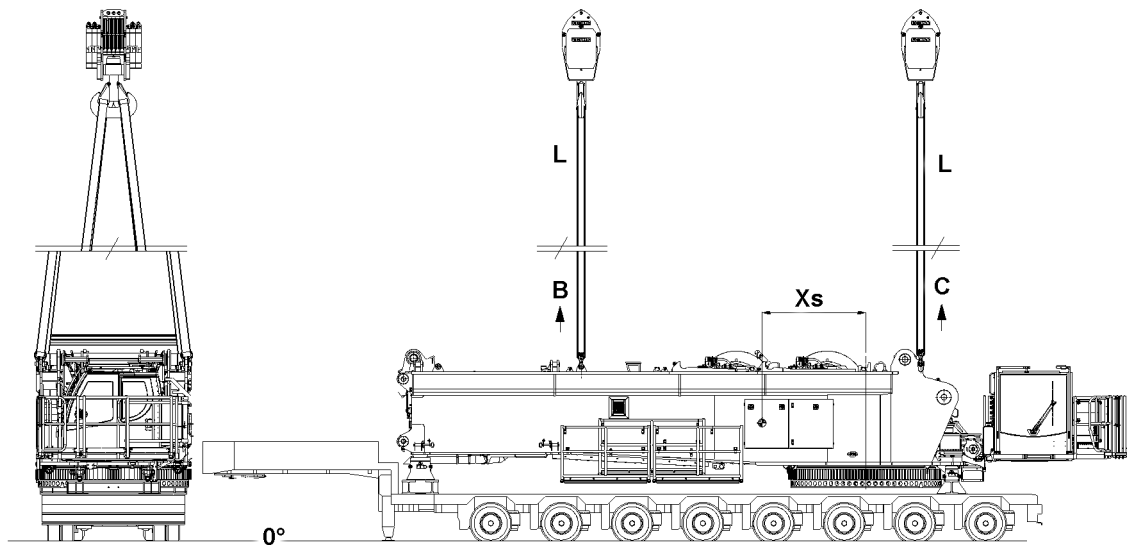


Fig.153471: Taking on a load: Turntable with winch 1, winch 2 and transport receptacles

	Weight	Suspended load		Center of gravity	Length of fastening equipment
		B	C	Xs	L
Turntable with QC + Transport receptacles + Winch 1 + Winch 2	69.80 t	33.50 t	36.30 t	2.08 m	10.00 m <sup>1)</sup>
Turntable with QC + Transport receptacles + Winch 1	59.00 t	27.60 t	31.40 t	2.00 m	10.00 m <sup>1)</sup>

<sup>1)</sup> Minimum length of fastening equipment

## 2.2.2 Turntable with SA-frame, pulley support, winch 4 and transport receptacles

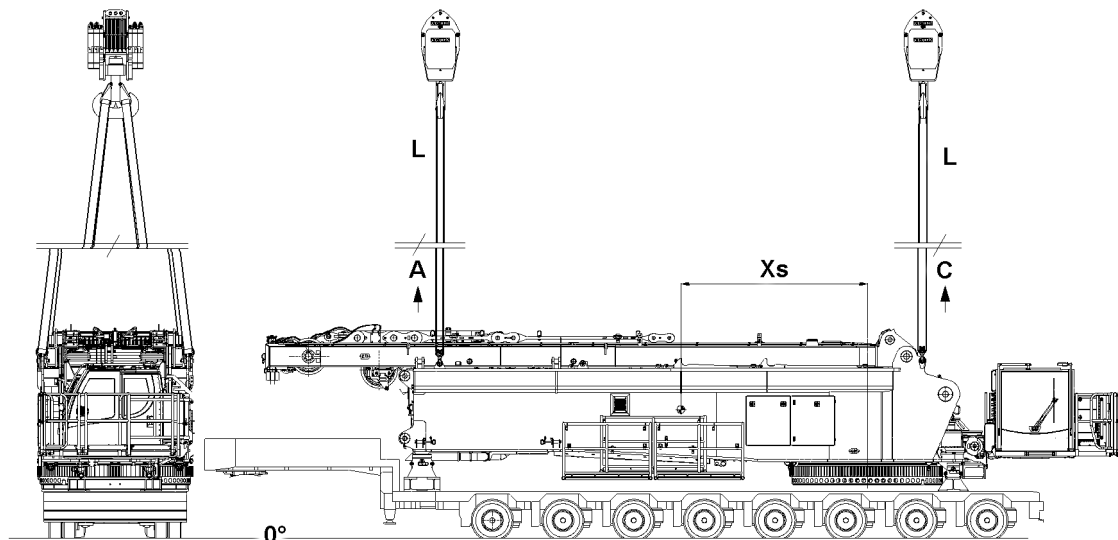


Fig.153472: Taking on a load: Turntable with SA-frame, pulley support, winch 4 and transport receptacles

	Weight	Suspended load		Center of gravity	Length of fastening equipment
		A	C	Xs	L
Turntable with QC + Transport receptacles + SA-frame + Pulley support + Winch 4	67.70 t	33.90 t	33.80 t	3.59 m	10.00 m <sup>1)</sup>

<sup>1)</sup> Minimum length of fastening equipment

## 3 Assembling the fall protection equipment on the turntable

Fall protection equipment includes, for example catwalks and railings.

- The ladders are described in chapter 2.04.10.
- The fall protection equipment on the crane is described in chapter 2.06.
- Accesses to the crane are described in chapter 2.07.



### WARNING

Chapter for assembly of the fall protection equipment not observed!  
Death, severe bodily injuries, property damage.

- ▶ Hazard notes as well as notes regarding the assembly and / or start up of catwalks and railings must be observed.
- ▶ Use suitable and approved aids, such as lifting platforms.

**Note**

- ▶ The crane cab and cab platform will be brought into the operating position at a later moment.

Assemble the fall protection equipment:

- If the turntable is put down from the transport vehicle onto ground with suitable load bearing capacity, assemble fall protection equipment on the turntable that was set down.
  - If the turntable is placed directly from the transport vehicle on to the crawler center section, assemble the fall protection equipment as long as the turntable is on the transport vehicle. Use aids, such as lifting platforms.
- ▶ Only assemble fall protection equipment in observance of the above specified chapters.

## 4 Lifting the turntable from the transport vehicle

If the turntable is not fit immediately on the crawler center section after lifting it off the transport vehicle, the transport receptacles can remain on the transport vehicle.

Make sure that the following prerequisites are met:

- At least one auxiliary crane is on hand.
- The crane cab is in the transport position.
- Fastening equipment with the required length is available, see the charts in section “Turntable fastening points”.
- The fastening equipment has a suitable load bearing capacity.
- The fastening equipment is pinned on the turntable, according to the data in the charts.

**Note**

- ▶ When fastening, take into account the fact that the turntable must be placed on the crawler center section.

**WARNING**

Turntable incorrectly fastened!

Accidents can occur if the turntable is incorrectly or improperly fastened.

The turntable can fall down, become unbalanced or move in an uncontrolled manner.

Death, severe bodily injuries, property damage.

- ▶ Fasten the turntable with the provided fastening equipment in the corresponding length, see section “Turntable fastening points”.
- ▶ Fasten the turntable in the provided fastening points.
- ▶ Make sure that the fastening equipment is properly fastened to the turntable and that it is secured sufficiently to prevent it from loosening up.

- ▶ Fasten the turntable properly to the auxiliary crane.

- ▶ Tension the fastening equipment.

When the fastening equipment is tensioned:

- ▶ Release the transport retainers on the transport receptacles.

When the transport retainers are released:

- ▶ Lift the turntable with the auxiliary crane from the transport vehicle.

## 5 Unpinning the pin from the transport position

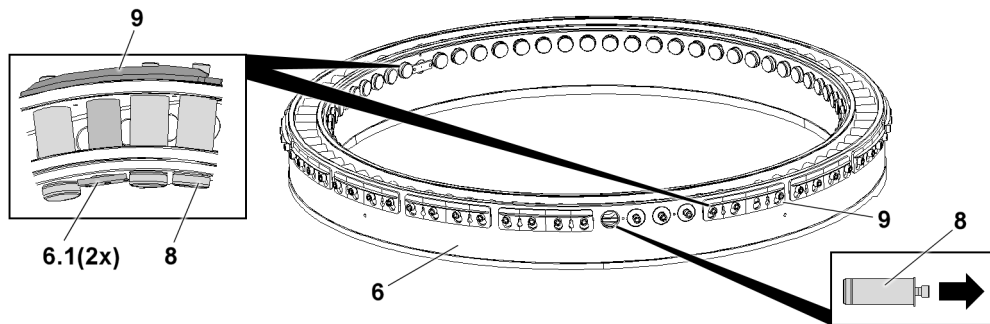


Fig.160624: Pin and securing bracket in the transport position

<b>6</b>	Lower ring	<b>8</b>	Pin
<b>6.1</b>	Centering pin	<b>9</b>	Securing bracket

Make sure that the following prerequisites are met:

- The cover hood is disassembled from the lower ring **6**.
- The turntable is disassembled.

- ▶ Disassemble the securing bracket **9** along the entire circumference of the lower ring **6**.



### Note

- ▶ The pins **8** must be easy to unpin without a pin pulling device.
- ▶ The two centering pins **6.1** of the roller ring connection are assembled permanently on the lower ring **6**.

- ▶ Unpin the pins **8** from the pin bores along the entire circumference of the lower ring **6**.
- ▶ Check the pin **8**, securing bracket **9** und Quick Connection (QC) for damage.
- ▶ Prepare the pin **8** and securing bracket **9** for further assembly.



### Note

- ▶ The pins **8** and pin bores must be lubricated with water repellent grease when pinning later.

## 6 Assembling the central ballast



### Note

- ▶ The assembly support is part of the central ballast.
- ▶ If the crane is placed on the assembly support, a maximum of 30 t of ballast plates is permissible per central ballast bracket.

- ▶ Assemble the central ballast according to chapter 3.03.



## 7 Placing the turntable on the crawler center section

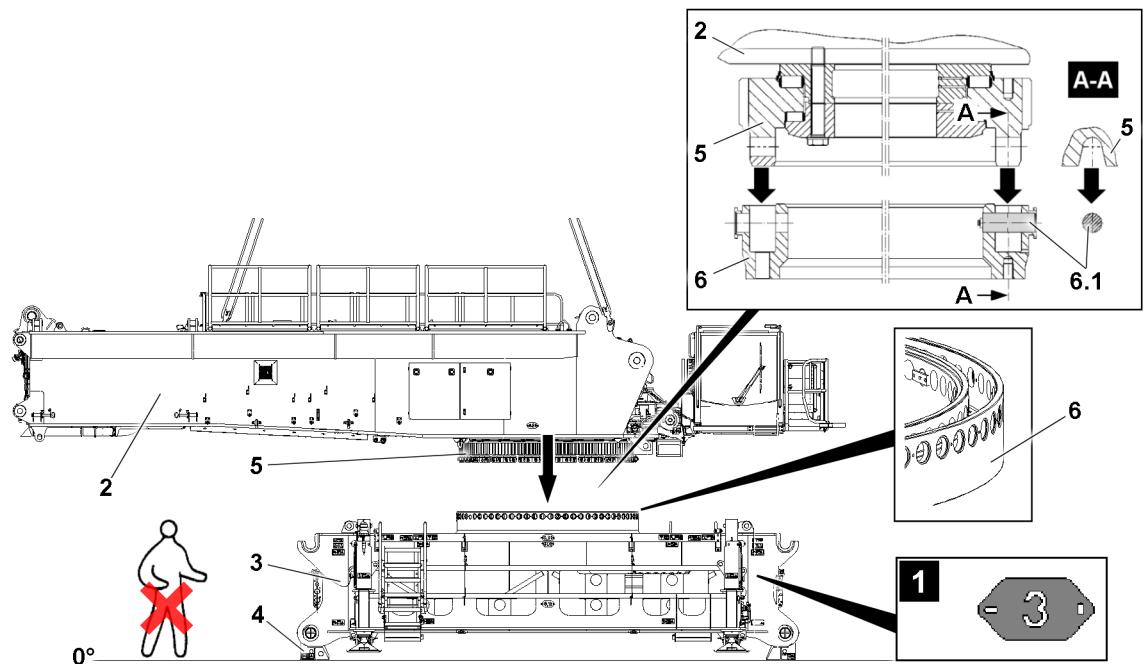


Fig.160613: Setting down the turntable

2	Turntable	5	Upper ring
3	Crawler center section	6	Lower ring
4	Transport receptacles	6.1	Centering pin

Make sure that the following prerequisites are met:

- The ground is level and of sufficient load bearing capacity.
- The crawler center section **3** is properly supported on the transport receptacle **4** and horizontally aligned.
- The turntable **2** does not hang horizontally on the auxiliary crane:
- The central ballast brackets are assembled, see chapter 3.03.
- The upper ring **5**, lower ring **6** and centering pin **6.1** are cleaned and greased.
- All pins are unpinned from the transport position.



### WARNING

Danger of fatal injury if anyone remains within the slewing range of the auxiliary crane or below the turntable!

When swinging in and lowering the turntable **2** onto the crawler center section **3**, people can be caught in the danger zone.

Death, severe bodily injuries, property damage.

- ▶ It is prohibited for anyone to remain within the slewing range of the auxiliary crane or under the turntable **2**.
- ▶ Make sure that there are no persons in the danger zone.



### WARNING

Crushing, sheering off of limbs!

During insertion and assembly of the upper ring **5** on the lower ring **6** of the roller ring connection, fingers and hands can be crushed or limbs can be severed.

- ▶ Keep limbs out of the danger zone.
- ▶ Swing the turntable **2** with the auxiliary crane over the crawler center section **3**.

**Note**

The turntable is aligned correctly on the crawler center section when the crane cab is located to the side of sign "3", see the illustration 1.

The centering pins **6.1** are not offset exactly 180°.

- ▶ If the turntable was removed in the correct position during the last disassemble, trouble-free erection is ensured.

**NOTICE**

Damage to the roller ring connection!

If the roller ring connection is dirty or insufficiently lubricated, it can be severely damaged during assembly.

A dirty or non-lubricated roller ring connection makes later disassembly considerably more difficult.

- ▶ Thoroughly clean and grease the upper ring **5**, lower ring **6** and the centering pins **6.1** before assembly.

- ▶ Place the turntable **2** on the crawler center section **3** such that the two pocket receptacles of the upper ring **5** retract into the two centering pins **6.1** of the lower ring **6**, see the sectional view **A-A**.

**WARNING**

Tipping of the turntable!

The center of gravity of the turntable **2** is outside the roller ring connection.

If the fastening equipment is not kept tensioned, the fitted turntable **2** can tip over.

Death, severe bodily injuries, property damage.

- ▶ Keep the fastening equipment tensioned until the pins of the Quick-Connection are properly inserted and secured.

- ▶ Lower the turntable **2** completely to the stop onto the crawler center section **3**, while keeping the fastening equipment tensioned.

## 8 Pinning the turntable with the Quick Connection (QC)

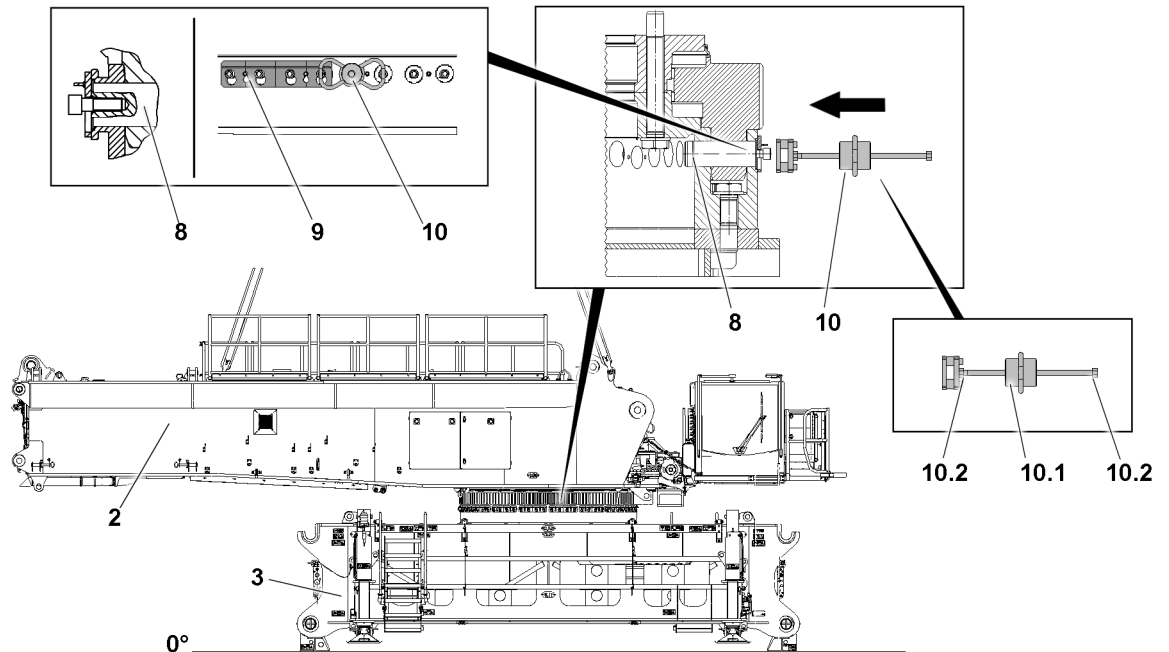


Fig.160617: Pinning the Quick-Connection (QC)

- |                                 |                              |
|---------------------------------|------------------------------|
| <b>2</b> Turntable              | <b>9</b> Securing bracket    |
| <b>3</b> Crawler center section | <b>10</b> Pin pulling device |
| <b>8</b> Pin                    |                              |



### WARNING

Error when using the pin pulling device!

Assembly personnel who are not standing safely can fall when using the pin pulling device **10**.

If the pin pulling device **10** is held incorrectly, there is danger of injury.

Death, severe bodily injuries, property damage.

- ▶ Use the pin pulling device **10** when standing safely.
- ▶ Hold the pin pulling device **10** on the provided grip / positions.
- ▶ Do not grip between the oscillating weight **10.1** and the stops **10.2**.

Make sure that the following prerequisites are met:

- The turntable **2** is properly aligned and positioned on the crawler center section **3**.
- The fastening equipment between the turntable **2** and the auxiliary crane / auxiliary cranes is tensioned.
- The pins **8** for the Quick-Connection (QC), are greased with water repellent grease and available.
- The securing brackets **9** for the Quick-Connection (QC) are available.
- The pin pulling device **10** is available.

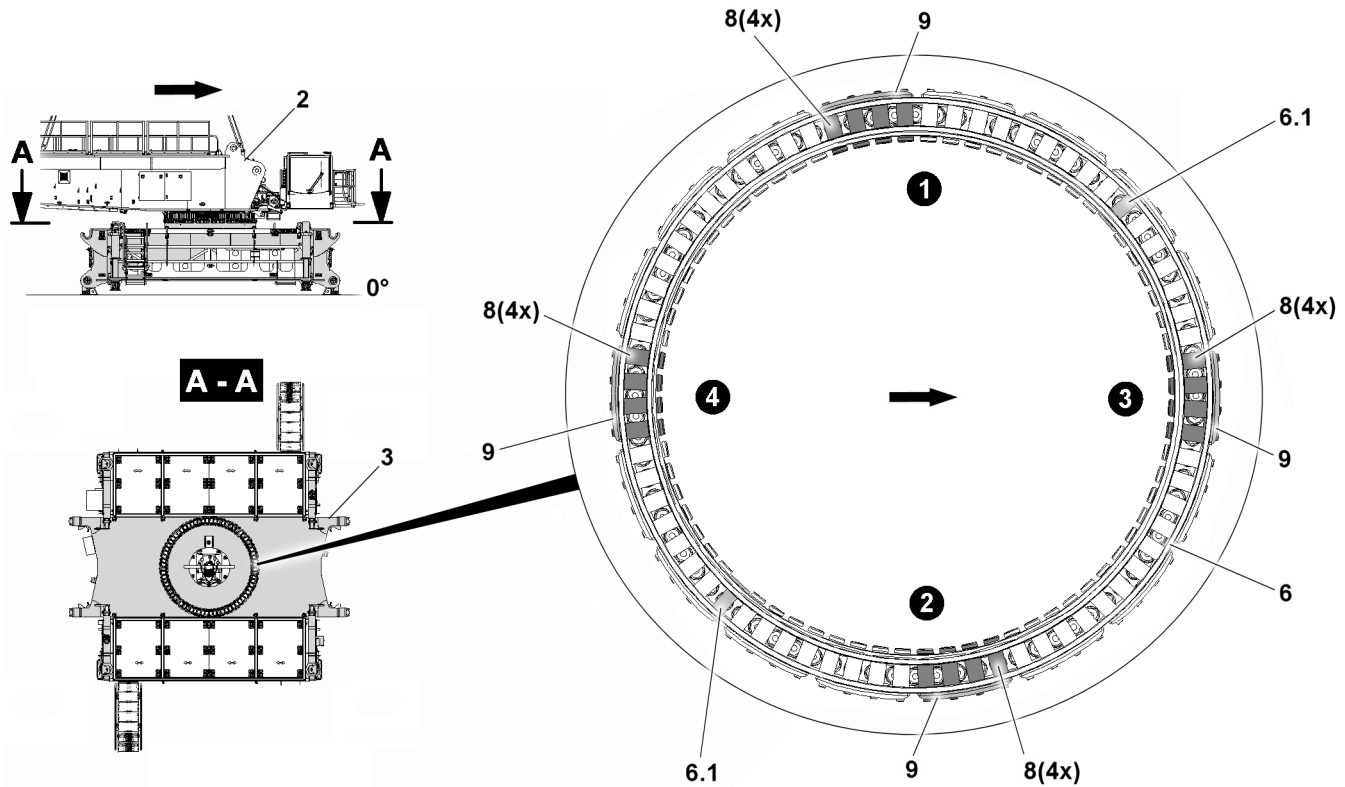


Fig. 160620: Sectional view for the pinning sequence

2	Turntable	6	Lower ring	8	Pin
3	Crawler center section	6.1	Centering pin	9	Securing bracket



### WARNING

Standing within or below an unpinned turntable!

If the turntable **2** and crawler center section **3** are not pinned together yet, the turntable **2** can tip over or oscillate.

People inside and below the turntable **2** could get caught.

When pinning, there is a danger of accident for personnel in the Quick Connection.

Death or severe bodily injuries.

If the turntable and crawler center section are not pinned together yet:

- ▶ Work from **outside** the turntable to insert the pins **8**: Carry out the operating step **1** and operating step **2** from a position next to the turntable.
- ▶ Carry out all further tasks after completing operating step **1** and operating step **2**.

- ▶ Operating step **1**: Insert the pins (4x) **8** on the left side of the turntable.
- ▶ Operating step **2**: Insert the pins (4x) **8** on the right side of the turntable.
- ▶ Operating step **3**: Insert the pins (4x) **8** on the front of the turntable
- ▶ Operating step **4**: Insert the pins (4x) **8** on the rear of the turntable
- ▶ Insert the pins **8** in the remaining free pin bores.

When the pins **8** cannot be fully inserted manually:

- ▶ Use a pin pulling device.

**WARNING**

The pin is not secured!

Unsecured pins **8** can become unpinned on their own.

The Quick Connection can fail, the turntable can release from the crawler travel gear.

Death, severe bodily injuries, property damage.

After inserting the pins **8**:

- ▶ Secure all pins **8** with the securing bracket **9**.

When all pins **8** are completely inserted:

- ▶ Attach the securing bracket **9** around the entire circumference of the Quick-Connection (QC).

**Result:**

- The pins **8** on the circumference of the Quick-Connection (QC) are secured to prevent them from loosening up by themselves.

When all pins **8** on the circumference of the Quick-Connection (QC) are properly pinned and secured:

- ▶ Remove the fastening equipment on the turntable **2**.

## 9 Bringing the crane cab and cab platform into the operating position

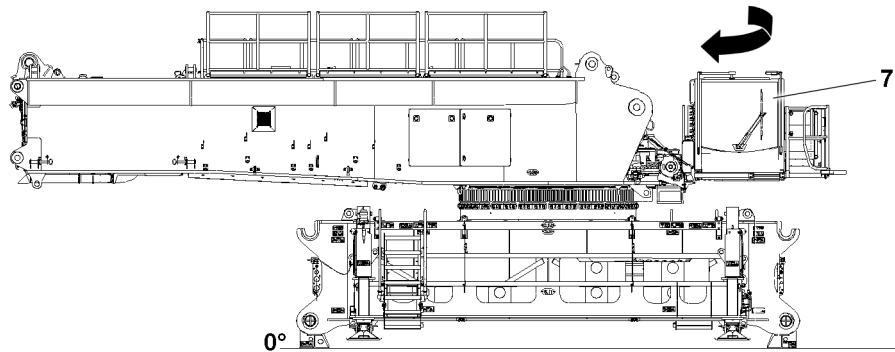


Fig.160627: Bringing the crane cab into the operating position

**WARNING**

Danger of accident when swinging the crane cab!

Limbs can be caught by the components when swinging the crane cab **7**.

Personnel can fall if the crane cab **7** is moved suddenly.

Death, severe bodily injuries, property damage.

- ▶ Make sure that no persons or objects are in the danger zone.
  - ▶ Make sure that the crane cab **7** is fastened to the respective end positions.
  - ▶ Use the available aids.
  - ▶ Remove the leaning ladder before swinging.
- 
- ▶ Bring the crane cab **7** into the operating position, see chapter 4.03.
  - ▶ Bring the crane cab platform into the operating position, see chapter 4.03.

## 10 Assembling the drawbar of the rotary connection on the turntable

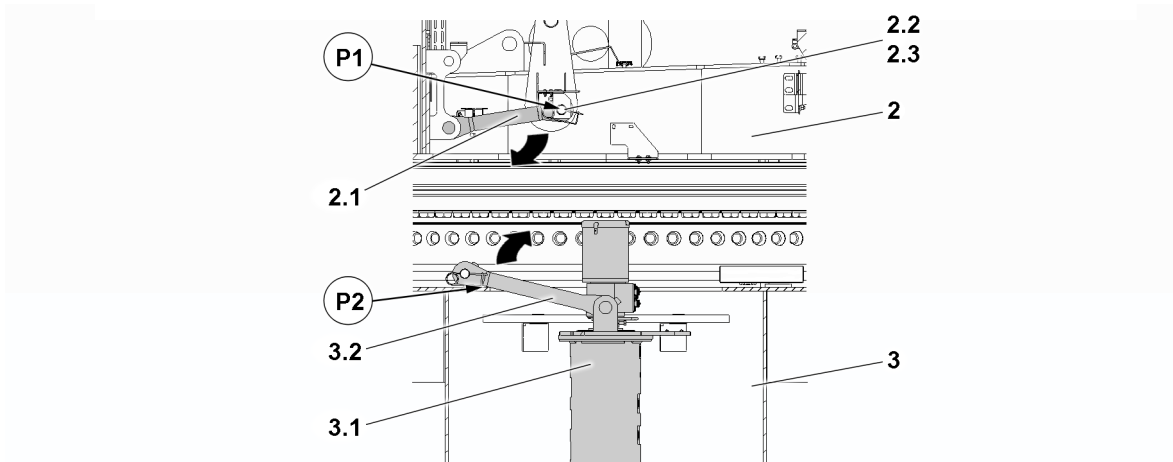


Fig.153476: Drawbar in the park position

2	Turntable	3	Crawler center section
2.1	Drawbar	3.1	Rotary connection
2.2	Pin	3.2	Drawbar
2.3	Retaining element		

When the turntable **2** is pinned and secured with the crawler center section **3** via the quick connection (QC), the drawbar **3.2** of the rotary connection must be pinned and secured with the drawbar **2.1** of the turntable.

Make sure that the following prerequisites are met:

- All pins on the circumference of the Quick-Connection (QC) are properly pinned and secured.
- The catwalks, platforms, ladders, crane cab and railings are assembled or in the operating position, see chapter 2.04.10, chapter 2.06 and chapter 2.07.
- The fastening equipment on the turntable has been removed.
- The drawbar **2.1** of the turntable **2** is pinned in point **P1**.
- The drawbar **3.2** of the rotary connection **3.1** is taken down on the crawler center section **3** in point **P2**.



### WARNING

Danger of falling from the turntable!

Death, severe bodily injuries.

Danger of falling due to stumbling or slipping during access or from the work position. Remove, set up or work around objects and equipment, for example a camera tripod that was set down or a railing.

Danger of falling due to tripping or slipping when accessing or leaving the work position due to a small step depth and different step heights due to structural conditions.

- ▶ Observe the danger notes in chapter 2.07.



### WARNING

Crushing danger due to the folding down of the drawbar **2.1**!

Severe bodily injuries, property damage.

- ▶ Make sure that when unpinning from the point **P1**, the drawbar **2.1** does not fold down by itself.

- ▶ Firmly hold the drawbar **2.1** and secure it against folding down.

When the drawbar **2.1** is secured against folding down by itself:

- ▶ Unpin the drawbar **2.1** in point **P1**: Remove the retaining element **2.3** and unpin the pin **2.2**.
- ▶ Lower the drawbar **2.1** and let it hang down.
- ▶ Reinsert the pin **2.2** in point **P1** and secure it with the retaining element **2.3**.

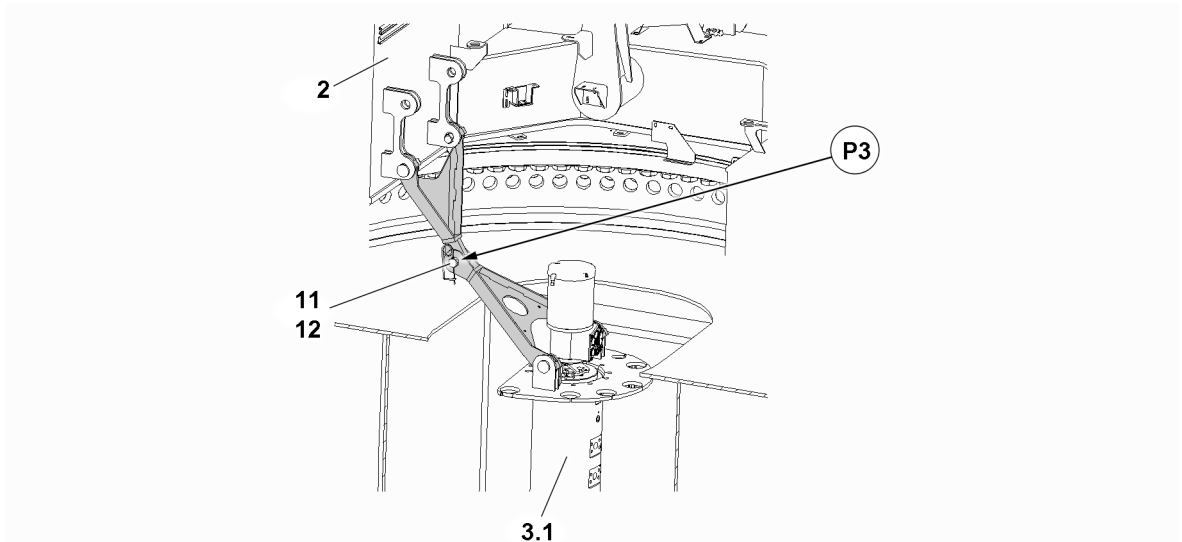


Fig.160614: Assembling the drawbar on the rotary connection

2	Turntable	11	Pin
3.1	Rotary connection	12	Retaining element

- ▶ Bring the drawbar of the turntable **2** and the rotary connection **3.1** together.

When the drawbar bores align in point **P3**:

- ▶ Insert the pin **11** and secure properly with the retaining element **12**.

## 11 Establishing the hydraulic connections

Make sure that the following prerequisite is met:

- The drawbar between the turntable and the rotary connection are properly pinned.

The hydraulic connections from the rotary connection in the crawler center section to the turntable are established with quick couplings.

When connecting hydraulic lines with quick couplings, make sure that the coupling procedure is carried out correctly.

The matching quick couplings are marked.



### WARNING

Pressure in the hydraulic lines!

If the pressure supply is not interrupted before connecting / releasing the hydraulic lines, the hydraulic oil can escape with high pressure.

Death, severe bodily injuries, property damage.

- ▶ Release the pressure in the hydraulic system before connecting / disconnecting: Interrupt the pressure supply and wait for a short time.



### WARNING

Loss of pressure or leakage!

Incorrectly coupled or self-loosening quick couplings (particularly return lines) can result in serious accidents due to component failure.

- ▶ Check that the quick couplings have been properly connected before using the crane.
- ▶ Connect the coupling components (sleeve and connector) and screw together with the knurled nut.
- ▶ Tighten the hydraulic coupling by hand. Turn the knurled nut until it reaches a tangible, fixed stop position.
- ▶ Establish the hydraulic connections, see the Hydraulic diagram.

## 12 Establishing the electrical connections



### Note

- ▶ To establish the electrical connections, use the Electric wiring diagram.

Make sure that the following prerequisite is met:

- The turntable is completely and properly assembled on the crawler center section.
- ▶ Establish the electrical connections.



### WARNING

Malfunction if dummy plugs are not installed!

If the dummy plugs on the non-required electrical connections are not installed, then malfunctions or functional limitations can occur on the crane.

- ▶ Make sure that all non-required electrical connections, which have a dummy plug, are closed off with dummy plugs.
  - ▶ Pay attention to the Electrical wiring diagram.
- 
- ▶ As a rule, close off on-required electrical connections (for example for accessories which cannot be installed) with the respective dummy plugs.

### NOTICE

Property damage due to dirt and / or corrosion!

If unnecessary electrical connections are not closed off with the respective protective caps, then dirt and / or corrosion can damage the electrical connections.

This could result in malfunctions.

- ▶ Make sure that all non-required electrical connections are always closed off properly.
  - ▶ Pay attention to the Electrical wiring diagram.
- 
- ▶ Close electrical connections, which have no dummy plugs, off properly with the corresponding protective caps.

## 13 Further assembly steps

### 13.1 Assembling the SA-frame



#### Note

- ▶ When the SA-frame is disassembled for transport.
- 
- ▶ Assemble the SA-frame according to chapter 3.05.

### 13.2 Assembling winch 1



#### Note

- ▶ When winch 1 is disassembled for transport.
- ▶ Winch 1 can be assembled with various prerequisites and conditions, see chapter 3.07.10

When winch 1 is not yet assembled:

- ▶ Assemble winch 1 according to chapter 3.07.10.

### 13.3 Assembling winch 2

When Winch 2 is used.



**Note**

- ▶ When winch 2 is disassembled for transport.
- ▶ Winch 2 can be assembled with various prerequisites and conditions, see chapter 3.07.20

When winch 2 is not yet assembled:

- ▶ Assemble winch 2 according to chapter 3.07.20.

## 14 Turning the turntable into the disassembly position

Make sure that the following prerequisite is met:

- The crane is in a condition in which the turntable may be turned.

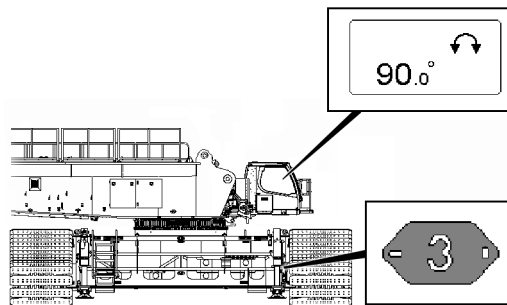


Fig.160628: Turning the turntable into the disassembly position

- ▶ Turn the turntable such that the crane cab is located to the side of sign “3”.

Align the turntable exactly:

- ▶ Align the turntable such that the turning angle on the LICCON monitor is exactly at 90°, see illustration.

**Note**

- ▶ If the turntable is turned to the disassembly position, the next assembly is ensured to be trouble-free.

## 15 Reducing the central ballast for disassembly

**Note**

- ▶ If the crane is placed on the assembly support, a maximum of 30 t of ballast plates is permissible per central ballast bracket.
- ▶ For information about central ballast, see chapter 3.03.

## 16 Preparing the turntable for removal from the crawler center section

Make sure that the following prerequisites are met:

- At least one auxiliary crane is on hand.
- The boom system is disassembled.
- The D-boom is disassembled.
- The counterweight is disassembled.
- The turntable is in the disassembly position.
- A maximum of 30 t of ballast plates is placed on each central ballast bracket.
- The crawler carriers on the crawler center section are disassembled.
- The crawler center section is horizontally aligned and taken down on transport receptacles.
- Fastening equipment with the required length is available, see the charts in section “Turntable fastening points”.
- The fastening equipment has a suitable load bearing capacity.
- The fastening equipment is pinned on the turntable, according to the data in the charts.
- Disassembly is carried out according to the transport condition.



### Note

#### Possible disassemblies according to the transport condition

When the SA-frame should be disassembled for transport:

- ▶ Disassemble the SA-frame according to chapter 3.05.

When winch 1 should be disassembled for transport:

- ▶ Disassemble winch 1 according to chapter 3.07.10.

When winch 2 should be disassembled for transport:

- ▶ Disassemble winch 2 according to chapter 3.07.20.

## 17 Disconnecting the electrical connections

Before unpinning the quick connection (QC), the electrical connections between the crawler center section and the turntable on the rotary connection must be separated.

### NOTICE

Damage to the cable connections!

- ▶ Make sure that the electrical connections have been disconnected and properly stored before unpinning / lifting the turntable from the crawler center section.
- ▶ Disconnect the electrical connections, use the Electric wiring diagram.
- ▶ Store the electrical connections properly and protect them against damage.
- ▶ Close the electrical connections off properly with dummy plugs or protective caps.

## 18 Disconnecting the hydraulic connections

The hydraulic connections are established with quick couplings.

When disconnecting hydraulic lines with quick couplings, make sure that the coupling procedure is carried out correctly.

**WARNING**

Pressure in the hydraulic lines!

If the pressure supply is not interrupted before connecting / releasing the hydraulic lines, the hydraulic oil can escape with high pressure.

Death, severe bodily injuries, property damage.

- ▶ Release the pressure in the hydraulic system before connecting / disconnecting: Interrupt the pressure supply and wait for a short time.
- 
- ▶ Release the hydraulic coupling by hand.
  - ▶ Disconnect the hydraulic connections, see the Hydraulic diagram.
  - ▶ Protect the hydraulic connections against contamination with caps.

## 19 Disassembling the drawbar of the rotary connection on the turntable

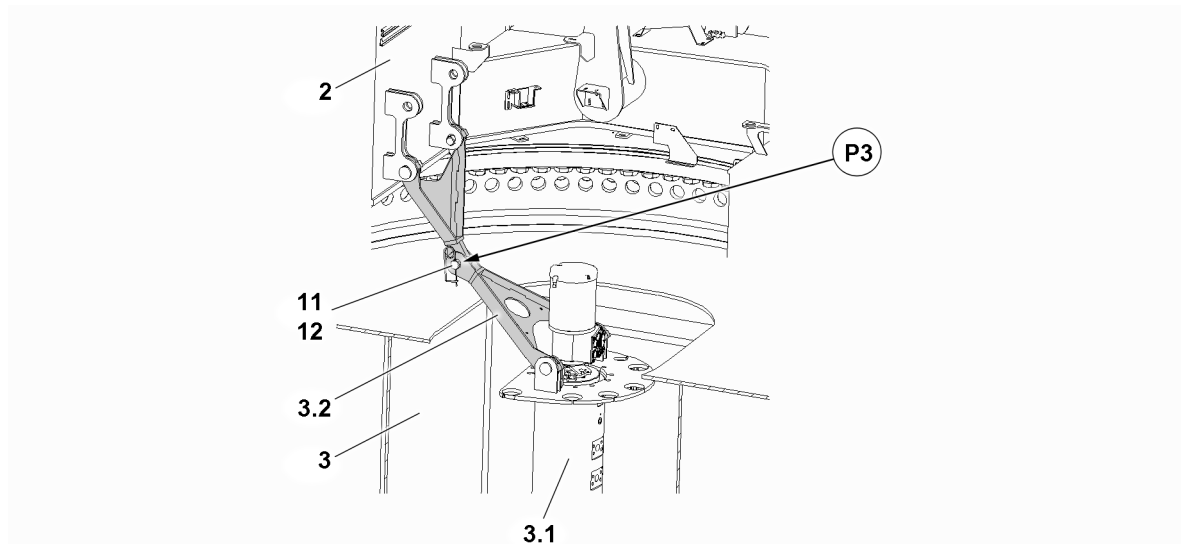


Fig.160625: Disassembling the drawbar

2	Turntable	3.2	Drawbar
2.1	Drawbar	11	Pin
3	Crawler center section	12	Retaining element
3.1	Rotary connection		

Make sure that the following prerequisites are met:

- All pins on the circumference of the Quick-Connection (QC) are pinned and secured.
- The catwalks, platforms, ladders, crane cab and railings are in the operating position, see chapter 2.04.10, chapter 2.06 and chapter 2.07.

**WARNING**

Danger of falling from the turntable!

Death, severe bodily injuries.

Danger of falling due to tripping or slipping when accessing or leaving the work position due to the taken down camera tripod for monitoring winch 1 and winch 2.

Danger of falling due to tripping or slipping when accessing or leaving the work position due to a small step depth and different step heights due to structural conditions.

- ▶ Observe the danger notes in chapter 2.07.
- 
- ▶ Unpin the drawbar 2.1 and drawbar 3.2 in point P3: Remove the retaining element 12 and unpin the pin 11.
  - ▶ Take down the drawbar 3.2 on the frames on the crawler center section 3.

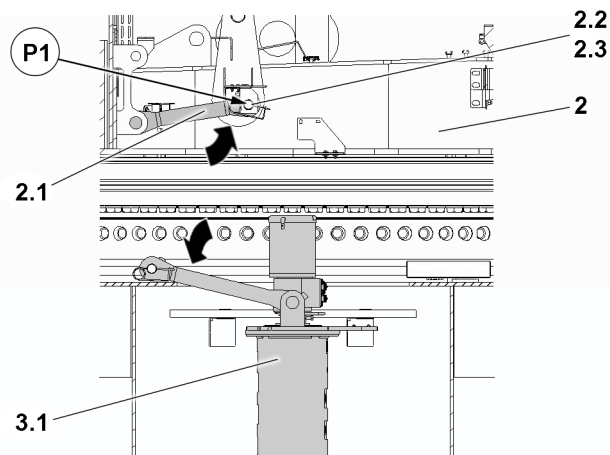


Fig.160616: Pinning the drawbar in the park position

2	Turntable	2.3	Retaining element
2.1	Drawbar	3.1	Rotary connection
2.2	Pin		

- ▶ Unpin the pin 2.2 from the park position in point P1.
- ▶ Lift the drawbar 2.1 and pin it in park position in point P1 with the pin 2.2 and secure with the retaining element 2.3.

**Result:**

- The electrical and hydraulic connections between the rotary connection 3.1 and the turntable 2 are disconnected.
- The drawbars between the rotary connection 3.1 and the turntable 2 are disconnected.

## 20 Bringing the crane cab into the transport position

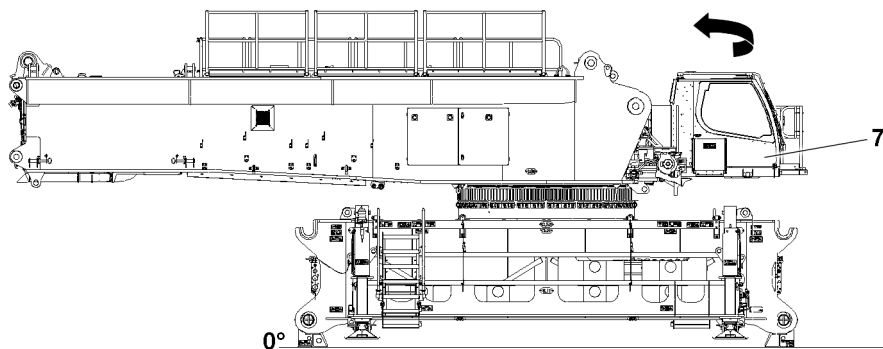


Fig.160626: Bringing the crane cab into the transport position



**WARNING**

Danger of accident when swinging the crane cab!

Limbs can be caught by the components when swinging the crane cab 7.

Personnel can fall if the crane cab 7 is moved suddenly.

Death, severe bodily injuries, property damage.

- ▶ Make sure that no persons or objects are in the danger zone.
  - ▶ Make sure that the crane cab 7 is fastened to the respective end positions.
  - ▶ Use the available aids.
  - ▶ Remove the leaning ladder before swinging.
- 
- ▶ Bring the crane cab into the transport position, see chapter 4.03.

## 21 Unpinning the turntable with the quick connection (QC)

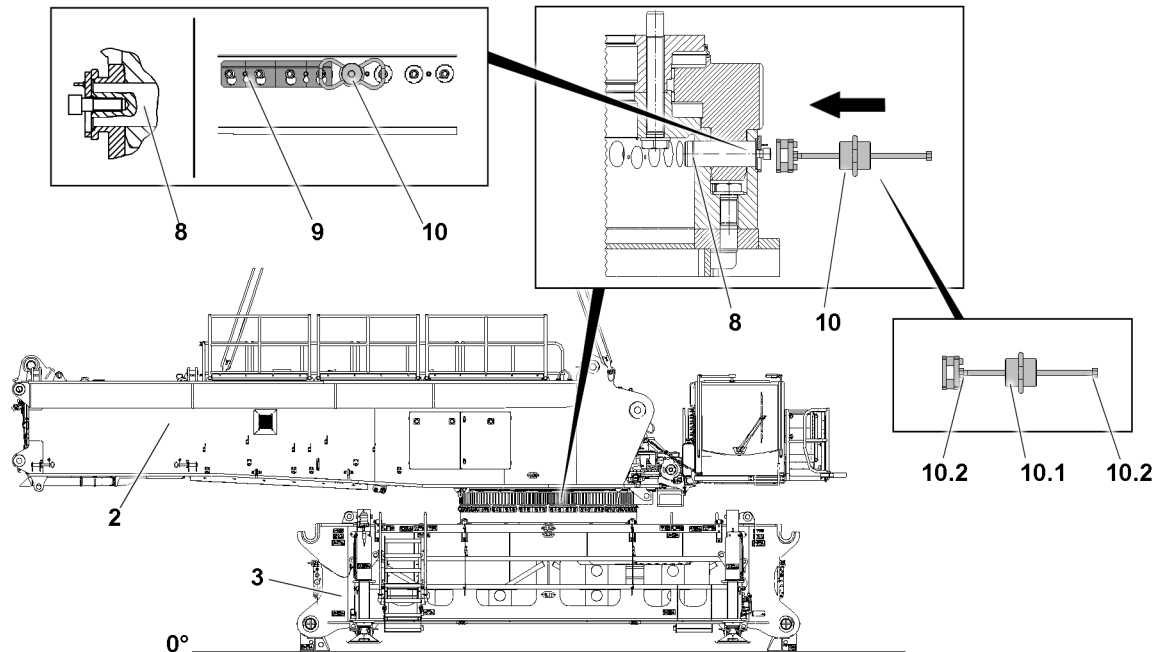


Fig.160617: Unpinning the turntable with the quick connection (QC)

- |   |                        |    |                    |
|---|------------------------|----|--------------------|
| 2 | Turntable              | 9  | Securing bracket   |
| 3 | Crawler center section | 10 | Pin pulling device |
| 8 | Pin                    |    |                    |



### WARNING

The turntable can fall down!  
If an unsecured turntable **2** is unpinned, the turntable **2** can fall down.  
Death, severe bodily injuries, property damage.

- ▶ Fasten the turntable **2** to the auxiliary crane and secure. Unpin the turntable **2** only afterward.



### WARNING

Turntable incorrectly fastened!  
Accidents can occur if the turntable **2** is incorrectly or improperly fastened.  
The turntable **2** can fall down, become unbalanced or move in an uncontrolled manner.  
Death, severe bodily injuries, property damage.

- ▶ Fasten the turntable **2** with the provided fastening equipment in the corresponding length, see section "Turntable fastening points".
- ▶ Fasten the turntable **2** in the provided fastening points.
- ▶ Make sure that the fastening equipment is properly fastened to the turntable **2** and that it is secured sufficiently to prevent it from loosening up.

▶ Fasten the turntable **2** properly to the auxiliary crane / auxiliary cranes, see section "Turntable fastening points".



**WARNING**

Tipping of the turntable!

The center of gravity of the turntable **2** is outside the roller ring connection.

If the fastening equipment is not kept tensioned, the fitted turntable **2** can tip over.

Death, severe bodily injuries, property damage.

► Always keep the fastening equipment tensioned.

► Tension the fastening equipment.

**NOTICE**

The connections on the rotary connection are not disconnected!

If not all connections are disconnected, the rotary connection will be damaged when lifting the turntable.

► Before lifting the turntable **2**, make sure that connections to the rotary connection are disconnected.

When the fastening equipment between the auxiliary crane and the turntable **2** is tensioned:

► Release the securing bracket **9** and remove it.

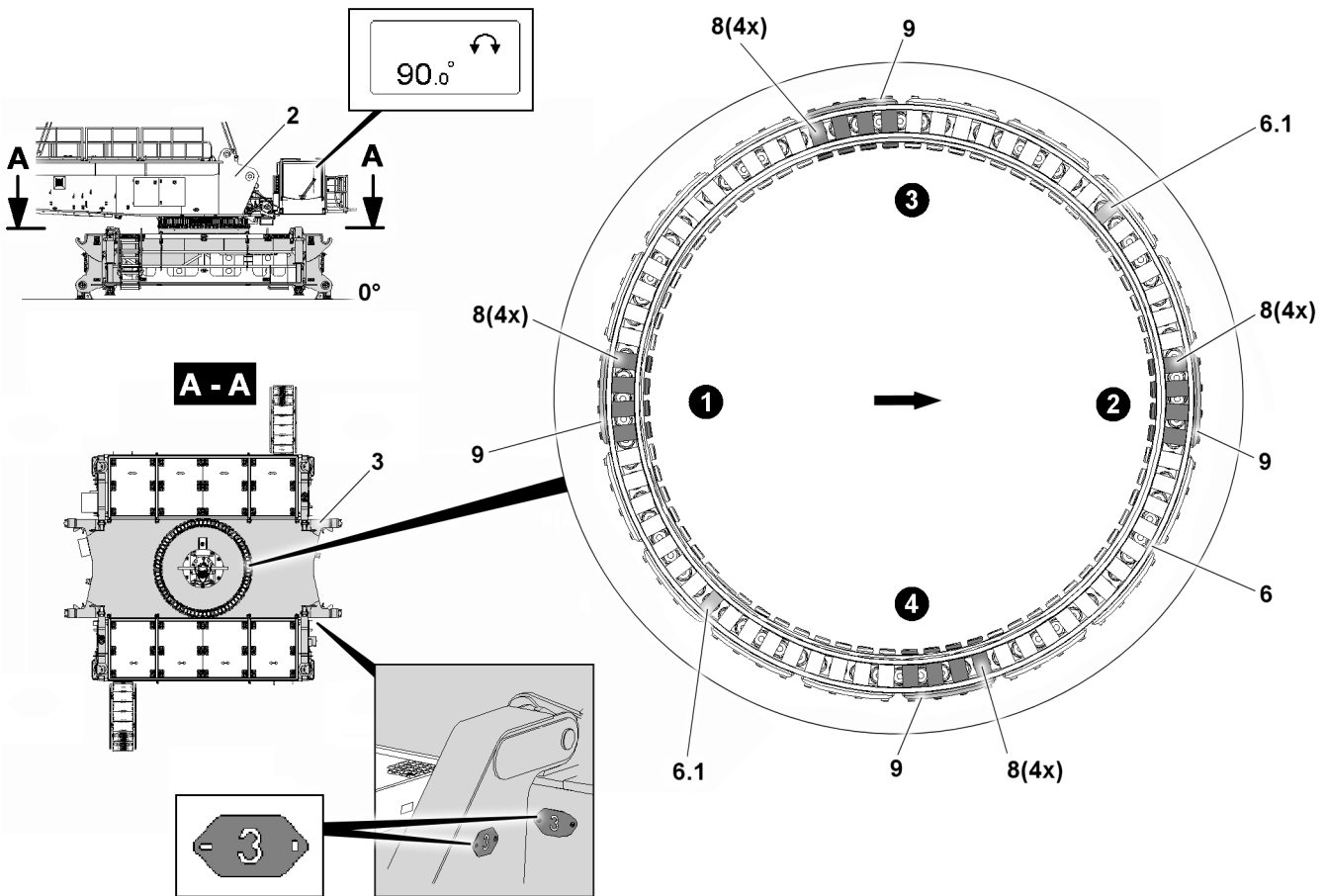


Fig.160619: Aligning the turntable on the crawler center section

- |                                 |                          |                           |
|---------------------------------|--------------------------|---------------------------|
| <b>2</b> Turntable              | <b>6</b> Lower ring      | <b>8</b> Pin              |
| <b>3</b> Crawler center section | <b>6.1</b> Centering pin | <b>9</b> Securing bracket |

LWE/LR 1800-1-0-000/27200-07-02/en

**WARNING**

Standing within or below an unpinned turntable!

If the turntable **2** and crawler center section **3** are no longer pinned together sufficiently, the turntable can tip over or oscillate.

Personnel within or under the turntable **2** can be caught.

Death or severe bodily injuries.

- ▶ Work from **outside** the turntable to unpin the pins **8**.
- ▶ Never unpin a pin **8** from the inside, for example using a punch.
- ▶ It is prohibited to remain in the inner area of the turntable **2**.
- ▶ After the operating step **1** has been performed, it is prohibited to remain under the turntable **2**.

**WARNING**

Forceful unpinning of jammed pins!

If a pin **8** cannot be unpinned using the pin pulling device **10**, it can be jammed.

If a jammed pin is unpinned in a forceful and violent manner without knowledge the cause of the jamming, this can have dangerous consequences. This applies in particular if it is the last pin **8** to be unpinned.

Death, severe bodily injuries, property damage.

If it is the last pin **8** to be unpinned:

- ▶ To be safe, insert two easy to move pins **8** on opposite sides back in the Quick Connection (QC).
- ▶ Before using increased force on the jammed pin **8** determine the cause of the jamming and remedy it.
- ▶ Loosen and unpin the jammed pin **8**.
- ▶ Only unpin the last pin **8** to be loosened when it is not jammed and can be easily unpinned from the outside.

**WARNING**

Error when using the pin pulling device!

Assembly personnel who are not standing safely can fall when using the pin pulling device **10**.

If the pin pulling device **10** is held incorrectly, there is danger of injury.

Death, severe bodily injuries, property damage.

- ▶ Use the pin pulling device **10** when standing safely.
- ▶ Hold the pin pulling device **10** on the provided grip / positions.
- ▶ Do not grip between the oscillating weight **10.1** and the stops **10.2**.

**Note**

- ▶ The turntable **2** is aligned correctly for disassembly when the crane cab is located to the side of sign "3" and the rotation angle on the LICCON monitor is at 90°.

- ▶ Unpin all **unmarked** pins **8**, see illustration.

**Result:**

- There are still 16 **marked** pins **8** to unpin.
- ▶ Operating step **1**: Unpin the pins (4x) **8** on the rear of the turntable.
- ▶ Operating step **2**: Unpin the pins (4x) **8** on the front of the turntable.
- ▶ Operating step **3**: Unpin the pins (4x) **8** on the left side of the turntable.
- ▶ Operating step **4**: Unpin the pins (4x) **8** on the right side of the turntable.

## 22 Lifting the turntable from the crawler center section

Make sure that the following prerequisites are met:

- The electrical connections between the crawler center section and the turntable are disconnected.
- The hydraulic connections between the crawler center section and the turntable are disconnected.
- The drawbar of the turntable is pinned in the park position.
- The pins on the Quick-Connection (QC) are completely unpinned.

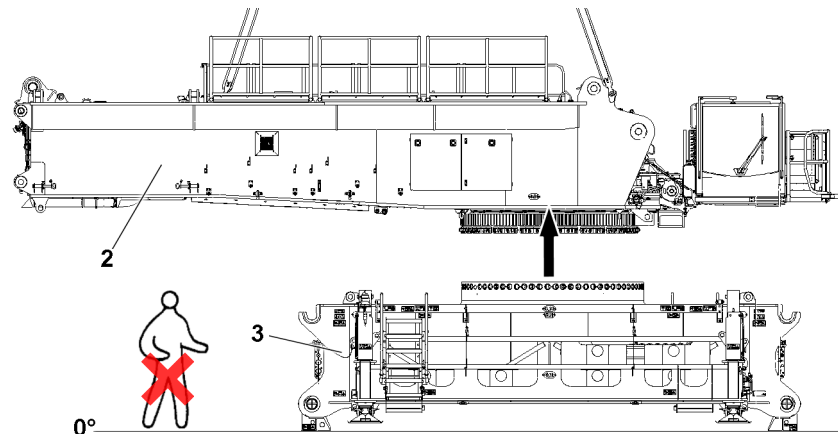


Fig.160610: Lifting the turntable from the crawler center section

2 Turntable

3 Crawler center section



### WARNING

Persons not at a safety distance!

When lifting and swinging the turntable **2** away with the auxiliary crane, there is a danger of accident in the nearby vicinity.

The turntable **2** can spring up, oscillate, tip over or fall down.

Objects and components can fall down from the turntable **2**.

Death or severe bodily injuries.

- ▶ Make sure that no persons are inside the Quick Connection.
- ▶ Make sure that no persons are below or directly next to the turntable **2**.
- ▶ Make sure that no persons are within the slewing range of the auxiliary crane or the turntable **2**.

### NOTICE

The pins on the Quick Connection (QC) are not unpinned!

If not all pins are unpinned, the Quick Connection (QC) will be damaged when lifting the turntable **2**.

- ▶ Before lifting the turntable **2**, make sure that all pins on the Quick Connection (QC) are fully unpinned.
- ▶ Carefully lift the turntable **2** from the crawler center section **3**.

When the turntable is lifted completely off the crawler center section **3**:

- ▶ Slowly swing the turntable **2** with the auxiliary crane away from the crawler center section **3**.
- ▶ Use the auxiliary crane to place the turntable **2** on the transport receptacles on the ground or on the transport vehicle.



## 23 Bringing the pin into the transport position

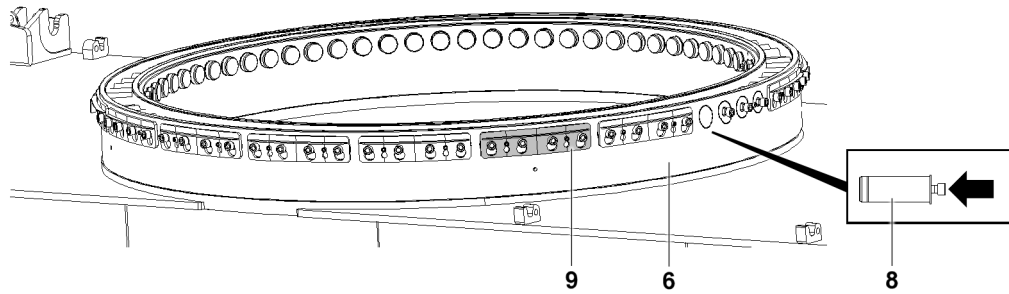


Fig.160606: Pin in the transport position

- |          |            |          |                  |
|----------|------------|----------|------------------|
| <b>6</b> | Lower ring | <b>9</b> | Securing bracket |
| <b>8</b> | Pin        |          |                  |

Make sure that the following prerequisites are met:

- The turntable is disassembled.



### Note

- ▶ The transport position for the pins **8** are located in the lower ring **6** of the roller ring connection.

- ▶ Insert the pins **8** in the pin bores of the lower ring **6**.
- ▶ Attach the securing bracket **9** along the entire circumference of the lower ring **6**.
- ▶ Attach the cover hood to the lower ring **6** properly.

## 24 Disassembling the fall protection equipment on the turntable

Fall protection equipment includes, for example catwalks and railings.

- The ladders are described in chapter 2.04.10.
- The fall protection equipment on the crane is described in chapter 2.06.
- Accesses to the crane are described in chapter 2.07.

Make sure that the following prerequisite is met:

- The crane cab is in the transport position.



### WARNING

Chapter for the disassembly of the fall protection equipment not observed!  
Death, severe bodily injuries, property damage.

- ▶ Hazard notes as well as notes regarding the disassembly and / or taking out of service of the catwalks and railings must be observed.
- ▶ Use suitable and approved aids, such as lifting platforms.



### Note

- ▶ The crane cab and cab platform will be brought into the transport position at a later moment.

Disassemble the fall protection equipment:

- If the turntable is put down from the crawler center section, disassemble the fall protection equipment on the turntable that was put down.
- If the turntable is placed directly from the transport vehicle onto the crawler center section, disassemble the fall protection equipment if the turntable is on the transport vehicle. Use aids, such as lifting platforms.

- ▶ Only disassemble fall protection equipment in observance of the above specified chapters.

## 3.03 Central ballast

1	Safety	2
2	Components	3
3	Fastening points and weights	4
4	Central ballast combinations	5
5	Lifting the ballast plates together	9
6	Assembling the central ballast	9
7	Securing / releasing the central ballast	18
8	Disassembling the central ballast	21

# 1 Safety

Observe the safety instructions before assembly and disassembly:

- Information regarding work on the crane superstructure. See chapter 2.04.
- Information regarding personal protective equipment. See chapter 2.04.
- Information regarding fall protection equipment. See chapter 2.06.
- Information regarding accesses to the crane. See chapter 2.07.
- Information regarding accessible surfaces. See chapter 2.07.



## WARNING

Danger of falling!

During assembly / disassembly, inspection and maintenance work, assembly personnel must be secured with appropriate aids to prevent them from falling.

Death, severe bodily injuries, property damage.

- ▶ All work at a height, when there is a danger of falling, must be carried out with suitable aids.
- ▶ If aids are not available and work cannot be carried out from the ground, then assembly personnel must secure themselves with the supplied fall arrest system to prevent falling, see chapter 2.04.
- ▶ If fall protection equipment is available, then it must be used, see chapter 2.06.
- ▶ When lifting, lowering, swinging crane parts in and out, no persons may remain in the danger zone.
- ▶ If railings are present on the components, then they must be brought into the corresponding position and secured for assembly / disassembly work.
- ▶ It is prohibited to lean the ladder against the component to be disassembled.
- ▶ Only step on the aids, ladders and catwalks with clean shoes.
- ▶ Keep aids, ladders and catwalks free of heavy dirt, snow, frost and ice.
- ▶ During all assembly and disassembly work, maintenance work and inspections, travel or crane operation is prohibited.
- ▶ Remaining on a suspended load is prohibited.
- ▶ Stepping or walking on crane components and lattice sections with an incline of more than 20° is prohibited.
- ▶ For all assembly work, the crane operator of the main crane must be in voice contact with the crane operator / crane operators of the auxiliary crane / auxiliary cranes.
- ▶ For the assembly / disassembly tasks, the crane operator may only initiate crane movements when the responsible guide has explicitly released the movement.



## WARNING

Danger of impact / crushing!

When assembling / disassembling crane components with the auxiliary crane, crane components can start to swing back and forth.

When lifting / lowering and positioning crane components, there is an increased danger of impact / crushing.

Death, severe bodily injuries, property damage.

- ▶ Make sure that personnel cannot be caught by components.
- ▶ When working in a danger zone: Use aids to protect limbs.
- ▶ Guide components with suitable aids to minimize oscillation.



## WARNING

Danger of accident due to sudden movements of components!

Operations / crane movements that are carried out without coordination between the crane operator, guide and assembly personnel can cause accidents!

- ▶ For all assembly work, observe the instructions of the guide! If necessary, use walkie-talkies.
- ▶ Continuously coordinate between the crane operator, guide and assembly personnel.
- ▶ Make sure that the danger zone can be viewed completely.

When moving components:

- ▶ Make sure that there are no persons in the danger zone.

**WARNING**

When lifting / lowering and positioning components, there is a danger of impacts / crushing!  
Personnel can be injured or killed!

- ▶ Make sure that personnel cannot be caught by components.

To protect limbs:

- ▶ Guide the components with suitable aids.

**DANGER**

The component can fall down!

If the corresponding component is disengaged from the auxiliary crane before the corresponding component is pinned, then the corresponding component can fall down.

If the corresponding component is unpinned before the corresponding component is attached by the auxiliary crane, the corresponding component can fall down.

Death, severe bodily injuries, property damage.

- ▶ Do not disconnect the auxiliary crane until the respective component is pinned and secured.
- ▶ Only unpin the corresponding component after the corresponding component is attached to the auxiliary crane.

**WARNING**

Danger of impact / crushing!

If anyone remains within the assembly / disassembly area of the ballast, they would be exposed to a danger of impact / crushing.

Death, severe bodily injuries, property damage.

- ▶ Make sure that there are no persons between the components to be assembled / disassembled and the crawler travel gear.

## 2 Components

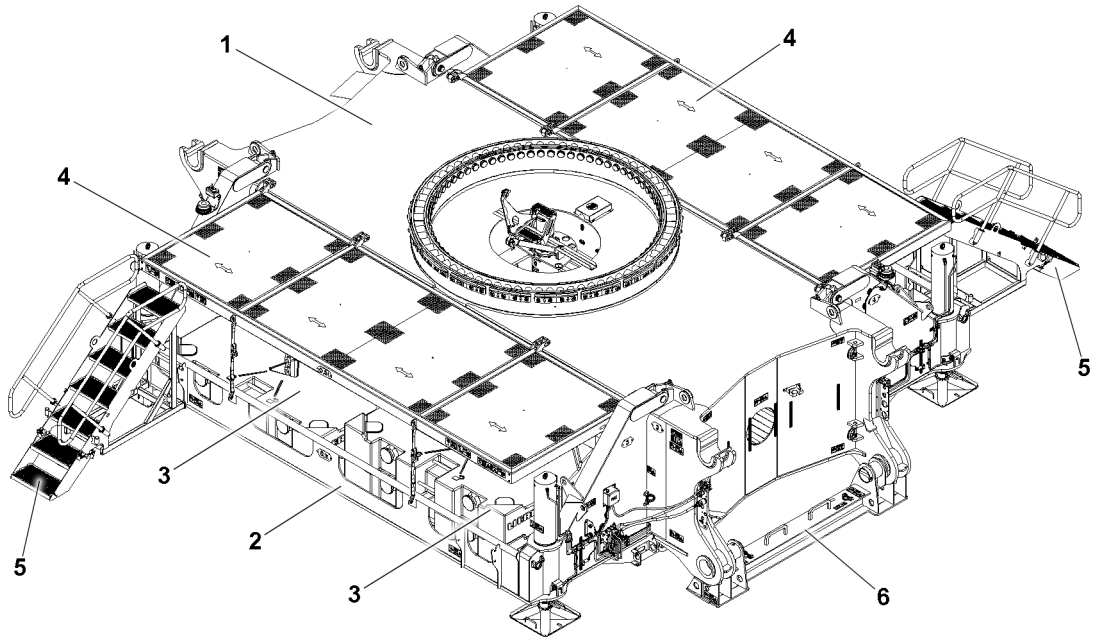


Fig. 153446

- |   |                                  |   |                      |
|---|----------------------------------|---|----------------------|
| 1 | Crawler center section           | 4 | Catwalk              |
| 2 | Central ballast brackets         | 5 | Stairs               |
| 3 | Ballast plate 5 t / 7.5 t / 10 t | 6 | Transport receptacle |

### 3 Fastening points and weights

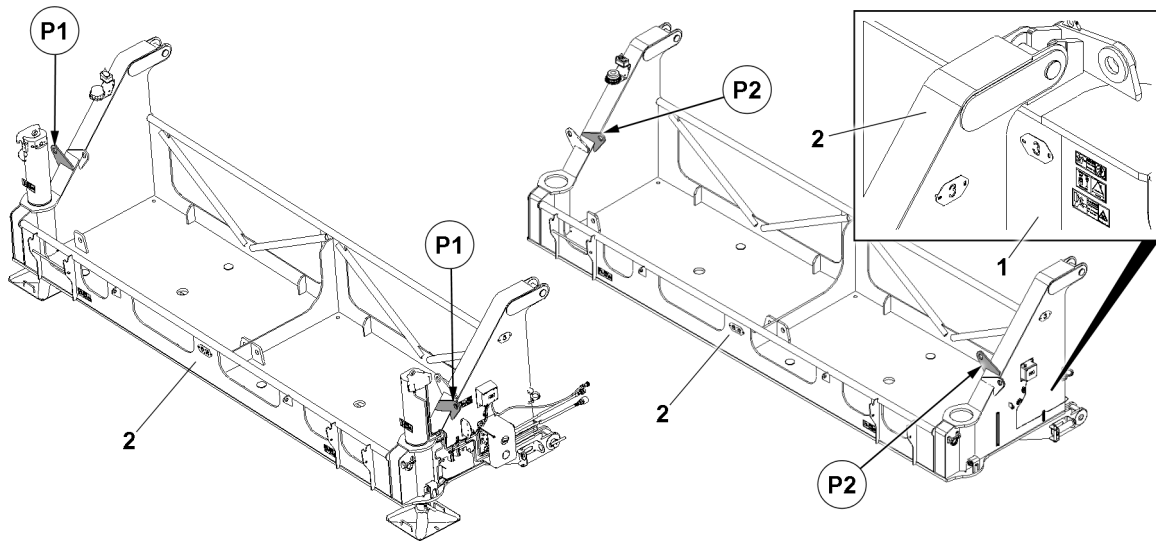


Fig.158751: Central ballast bracket



#### WARNING

Components incorrectly fastened!  
Death, severe bodily injuries, property damage.  
► Attach the components only to the intended fastening points.



#### Note

► The central ballast bracket 2 and crawler center section 1 are marked with numbers.  
► Observe the numbering for the assignment to the crawler center section 1, see illustration.

Fastening points	
P1	Central ballast bracket with hydraulic assembly support
P2	Central ballast bracket without hydraulic assembly support

#### Central ballast bracket fastening points

Weights	
5 t	Central ballast bracket without hydraulic assembly support
6.1 t <sup>1)</sup>	Central ballast bracket with hydraulic assembly support

#### Central ballast bracket weights

1) The additional weight due to the hydraulic assembly support is not taken into consideration for the set up of the central ballast.

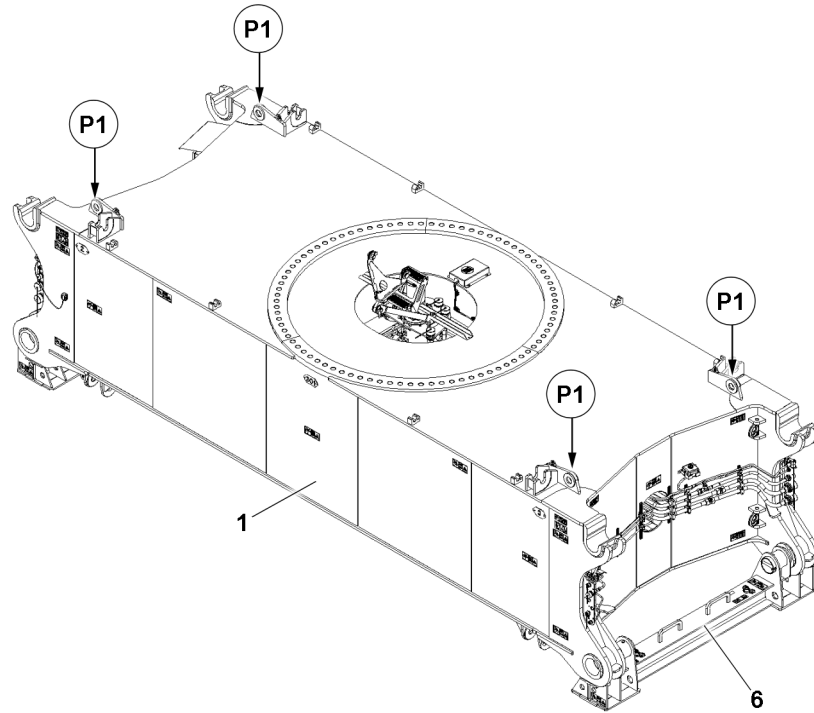


Fig.153469: Crawler center section on the transport receptacle

- 1** Crawler center section
- 6** Transport receptacle

Fastening points	
<b>P1</b>	Crawler center section

*Crawler center section fastening points*

Weights	
35 t	Crawler center section
0.9 t	Transport receptacle

*Crawler center section weights*

## 4 Central ballast combinations



**Note**

► Observe section “Placing the ballast plates” and section “Removing the ballast plates”.

LWE/LR 1800-1-0-000/27200-07-02/en

### 4.1 Ballast plates to be placed diagonally to each other

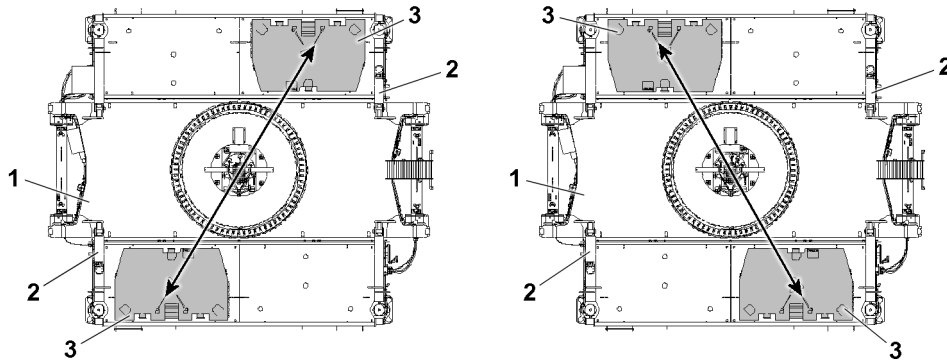


Fig.158747: Ballasting the central ballast: Examples for possibilities to place ballast plates diagonally to each other

- 1 Crawler center section
- 2 Central ballast bracket
- 3 Ballast plate 5 t / 7.5 t / 10 t

### 4.2 Ballast plate dimensions

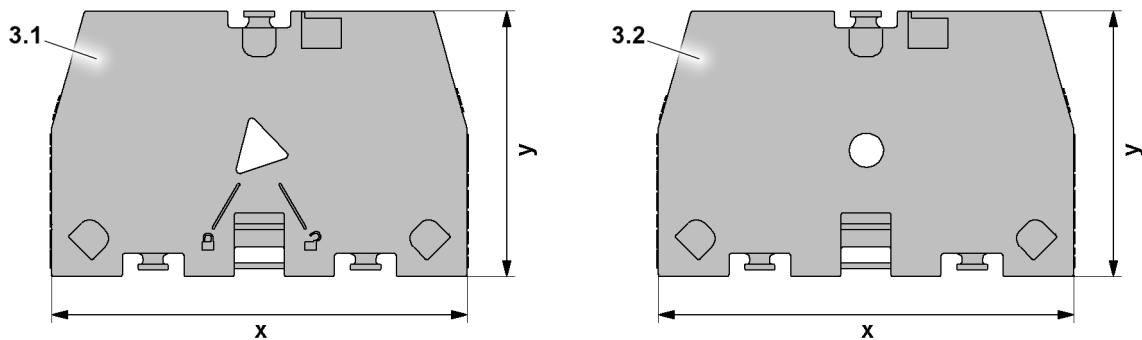


Fig.160398: Ballast plates with and without Twistlock

Ballast plate dimensions	
x	2500 mm
y	1600 mm

Ballast plates dimensions with and without Twistlock



**Note**

- Ballast plates with Twistlock **3.1** and ballast plates without Twistlock **3.2**.
- ▶ Ballast plates without Twistlock can differ slightly in height.

### 4.3 Central ballast assembly



**Note**

- ▶ Ballast plates with 5 t , 7.5 t and 10 t can be used combined.
- ▶ Examples of central ballast combinations with ballast plates 10 t are shown below.

LWE/LR 1800-1-0-000/27200-07-02/en



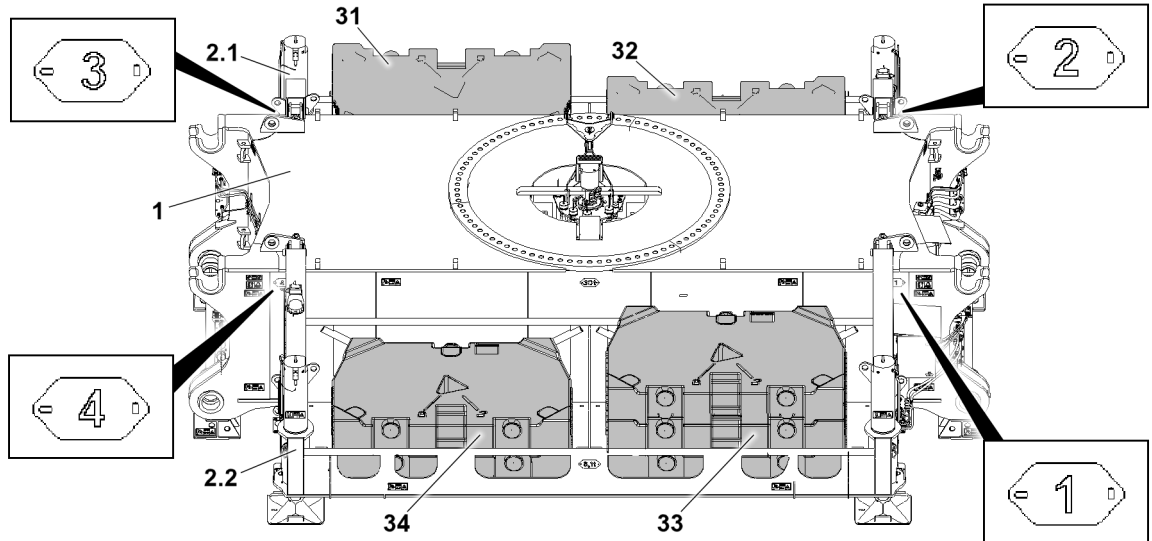


Fig.160399: Example: Crawler center section 1 with 110 t central ballast out of ballast plates with 10 t individual weight.

- |  |   |
|--|---|
| <b>1</b> Crawler center section            | <b>32</b> Central ballast stack (2x 10 t) |
| <b>2.1</b> Central ballast bracket (front) | <b>33</b> Central ballast stack (3x 10 t) |
| <b>2.2</b> Central ballast bracket (rear)  | <b>34</b> Central ballast stack (2x 10 t) |
| <b>31</b> Central ballast stack (3x 10 t)  |   |



**Note**

Correctly positioned ballast plates!

For example, the 110 t central ballast is comprised only of ballast plates with 10 t individual weight.

- ▶ The weight difference between the central ballast stack (3x 10 t) **31** and central ballast stack (2x 10 t) **32** of 10 t is not exceeded.
- ▶ The weight difference between the central ballast stack (3x 10 t) **33** and central ballast stack (2x 10 t) **34** of 10 t is not exceeded.
- ▶ The ballast plates are placed evenly and diagonally-symmetrically. In the case of a central ballast stack (3x 10 t) **31** and central ballast stack (3x 10 t) **33** each of the top ballast plates are placed diagonally with respect to each other.
- ▶ No weight difference between central ballast bracket (front) **2.1** and central ballast stack (rear) **2.2**.
- ▶ A weight difference between the central ballast bracket (front) **2.1** and central ballast bracket (rear) **2.2** is only permissible when placing / removing the ballast plates.

Central ballast	Composition	Individual weight	Quantity
0 t	-	-	-

Central ballast **without** central ballast brackets

Central ballast	Composition	Individual weight	Quantity
10 t	Central ballast bracket	5 t	No. 2

Central ballast **with** central ballast brackets

Central ballast	Composition	Individual weight	Quantity
30 t	Central ballast bracket	5 t	No. 2
	Ballast plate	10 t	No. 2

Central ballast combination 30 t

LWE/LR 1800-1-0-000/27200-07-02/en

Central ballast	Composition	Individual weight	Quantity
50 t	Central ballast bracket	5 t	No. 2
	Ballast plate	10 t	No. 4

*Central ballast combination 50 t*

Central ballast	Composition	Individual weight	Quantity
70 t	Central ballast bracket	5 t	No. 2
	Ballast plate	10 t	No. 6

*Central ballast combination 70 t*

Central ballast	Composition	Individual weight	Quantity
90 t <sup>1)</sup>	Central ballast bracket	5 t	No. 2
	Ballast plate	10 t	No. 8

*Central ballast combination 90 t*

1) Central ballast 90 t may only be applied when the crane is positioned on crawler carriers.

Central ballast	Composition	Individual weight	Quantity
110 t <sup>1)</sup>	Central ballast bracket	5 t	No. 2
	Ballast plate	10 t	No. 10

*Central ballast combination 110 t*

1) Central ballast 110 t may only be applied when the crane is positioned on crawler carriers.

Central ballast	Composition	Individual weight	Quantity
130 t <sup>1)</sup>	Central ballast bracket	5 t	No. 2
	Ballast plate	10 t	No. 12

*Central ballast combination 130 t*

1) Central ballast 130 t may only be applied when the crane is positioned on crawler carriers.

Various central ballast combinations can be positioned.

## 5 Lifting the ballast plates together

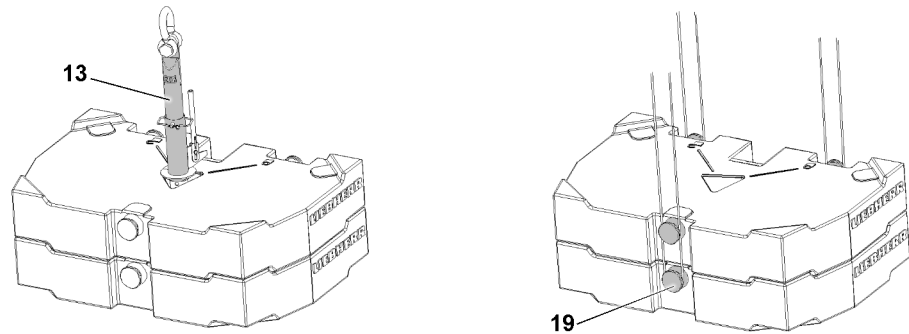


Fig.158753: Example: Lifting the ballast plates 10 t together

13 Twistlock receptacle stud

19 Bitt



### WARNING

Overload of the receptacle stud and ballast plates!

If more than the permissible number of ballast plates are lifted with the receptacle stud **13**, the receptacle stud **13** and the ballast plates will be overloaded and damaged!

If more than the permissible number of ballast plates are fastened with the bitt **19** and lifted, the bitt **19** will be overloaded and damaged.

The ballast plates can fall down.

Death, severe bodily injuries, property damage.

- ▶ Fasten and lift only the maximum permissible number of ballast plates per stroke.
- ▶ Observe the following chart!

Individual weight Ballast plate	Maximum number of same ballast plates per stroke over	
	Twistlock receptacle stud	Bitt
5.0 t	2	1
7.5 t	2	2
10.0 t	2	2

*Lifting the ballast plates*

## 6 Assembling the central ballast

Observe the section “safety”.

## 6.1 Assembling the central ballast brackets

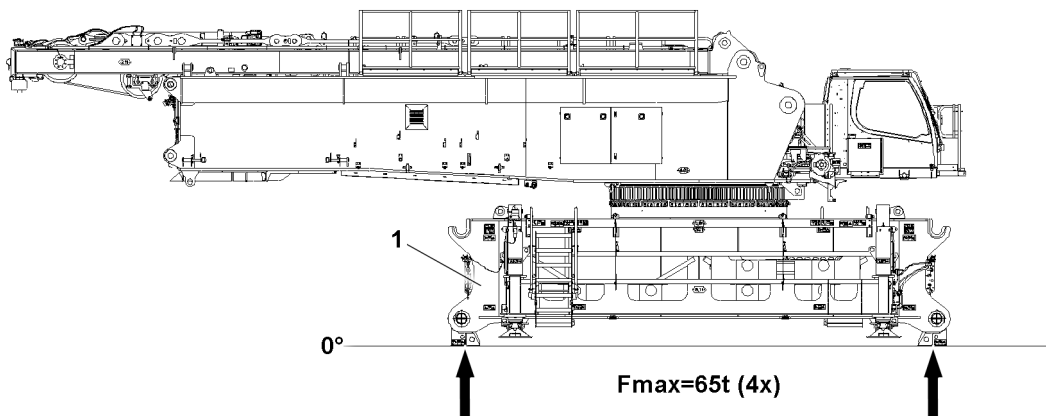


Fig.160396: Observe the maximum force  $F_{max} = 65 \text{ t}$  per bearing eye with continuous assembly.



### WARNING

The crane can topple over!  
Death, severe bodily injuries, property damage.

- ▶ Make sure that the ground is level and of sufficient load bearing capacity if a central ballast, turntable and SA-frame will be assembled on the crawler center section **1**. Observe the ground conditions and maximum force  $F_{max} = 65 \text{ t}$  per bearing eye, see illustration.

### 6.1.1 Setting up the crawler center section

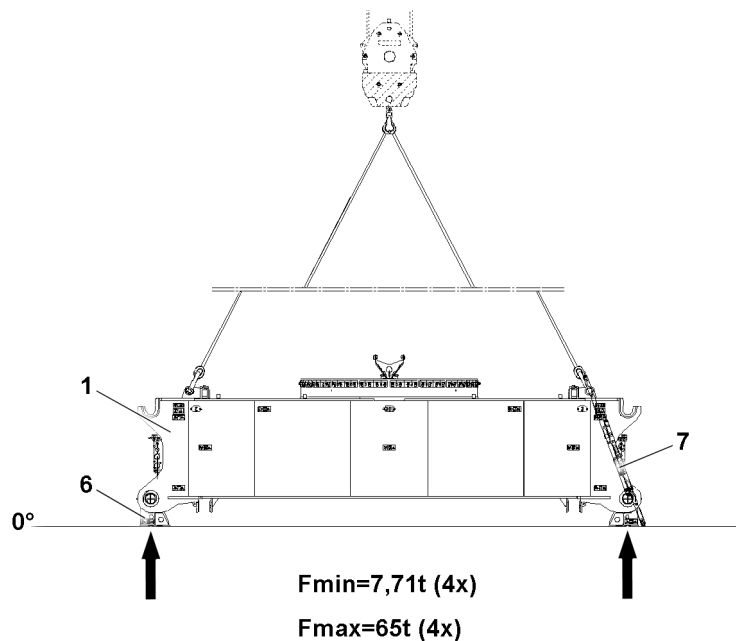


Fig.160397: Maximum force  $F_{max}$ .

**WARNING**

The crane can topple over!

Death, severe bodily injuries, property damage.

- ▶ Make sure that the ground is level and of sufficient load bearing capacity if the crawler center section **1** is to be placed with the transport receptacles **6** on the ground.
- ▶ Make sure that the ground is level and of sufficient load bearing capacity if a central ballast, turntable and SA-frame will be assembled on the crawler center section **1**. Observe the ground conditions and maximum force  $F_{max.} = 65 \text{ t}$  per bearing eye.

Make sure that the following prerequisites are met:

- At least one auxiliary crane is on hand.
- Fastening equipment with the required length, minimum 7000 mm, is available.
- The fastening equipment has a suitable load bearing capacity.

**Note**

- ▶ The crawler center section **1** without a transport receptacle **6** must be supported.
- ▶ For an optimal assembly procedure, the substructure must have a height of 240 mm.

- ▶ Fasten the crawler center section **1** properly to the auxiliary crane.
- ▶ Tension the fastening equipment.

When the fastening equipment is tensioned:

- ▶ Release the transport retainers on the transport receptacles.

When the transport retainers are released:

- ▶ Lift the crawler center section **1** with the auxiliary crane from the transport vehicle.
- ▶ Use the auxiliary crane to place the crawler center section **1** on the ground.
- ▶ Align the crawler center section **1** horizontally.
- ▶ Establish access to the crawler center section via the leaning ladder **7**, see chapter 2.07.

## 6.1.2 Assembling the first central ballast bracket

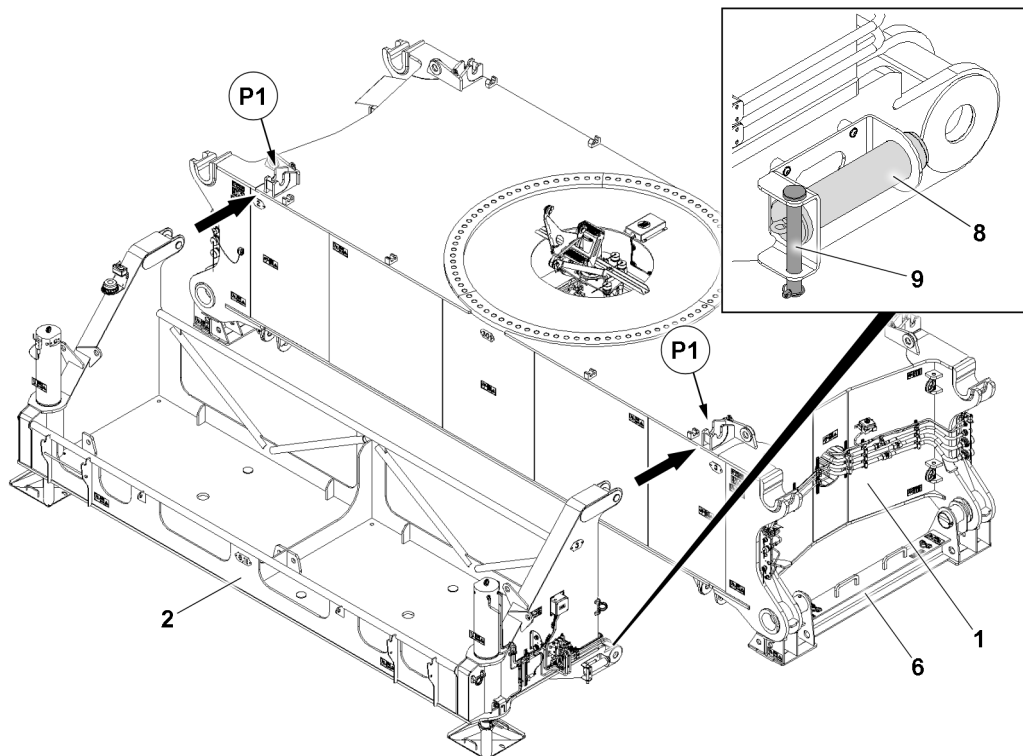


Fig.153452: Installing the central ballast bracket on the crawler center section

Make sure that the following prerequisites are met:

- The connector pin **8** and retaining pin **9** are in the park position.
  - There are no persons or objects in the assembly area of the central ballast brackets.
  - The crawler center section is horizontally aligned with the transport receptacle **6**.
  - Access is established to the crawler center section via the leaning ladder, see chapter 2.07.
- Fasten the central ballast bracket **2** to the auxiliary crane, see section “Fastening points and weights”.



### WARNING

Danger of crushing!  
Death, severe bodily injuries, property damage.

- Make sure, when swinging the central ballast brackets into the hook points on the crawler center section **1**, that there are no persons or objects within the danger zone.
- 
- Swing the central ballast bracket **2** in with the auxiliary crane to the hook points **P1**.

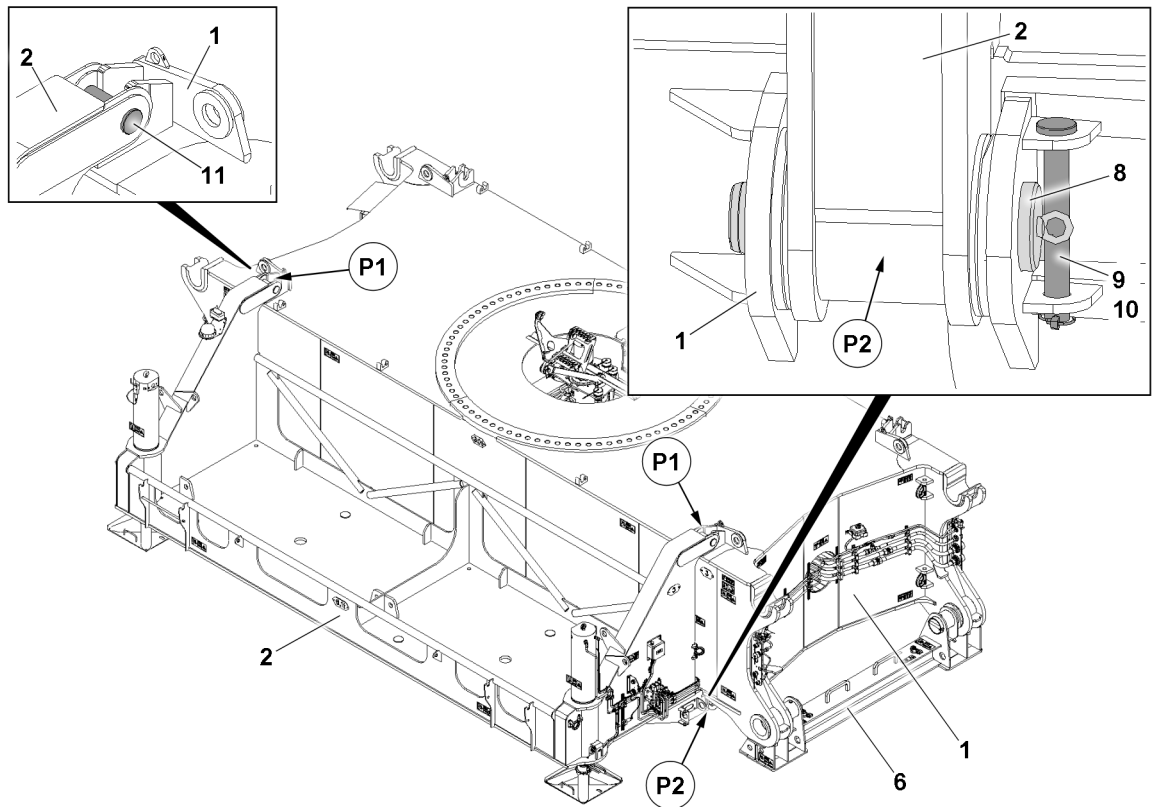


Fig.153453: Pinning the central ballast bracket on the crawler center section

- ▶ Connect the central ballast bracket **2** to the hook pins **11** on both sides.

When the central ballast bracket is properly connected to the hook pins **11**:

- ▶ Lower the central ballast bracket **2** with the auxiliary crane into the operating position.
- ▶ Insert the connector pin **8** on both sides in point **P2**.
- ▶ Secure the connector pin **8**: Insert the retaining pin **9** and secure with the retaining element **10**.

### 6.1.3 Assembling the second central ballast bracket



#### Note

- ▶ The procedure for the assembly of the second central ballast bracket is identical to the assembly of the first central ballast bracket.

Make sure that the following prerequisite is met:

- The first central ballast bracket is properly assembled and secured.
- ▶ Assemble the second central ballast bracket, see section “Assembling the first central ballast bracket”.

## 6.2 Placing the ballast plates



### WARNING

Danger of tipping the crane!

If the sequence and support locations are not observed when ballasting the central ballast, the crane can tip over!

Death, severe bodily injuries, property damage.

- ▶ Make sure that the ballast plates are always placed symmetrically, alternatively on the front and rear central ballast bracket.
- ▶ Make sure that the maximum weight difference between the central ballast stacks on the central ballast brackets does not exceed 10 t.
- ▶ Make sure that the ballast plates are placed evenly and diagonally-symmetrically.
- ▶ Make sure that the maximum weight difference between the central ballast brackets does not exceed 10 t.

If the necessary amount of central ballast on the central ballast bracket results in an uneven number of ballast plates:

- ▶ Make sure that each of the top ballast plates are placed diagonally with respect to each other.
- ▶ Observe the section "central ballast combinations"



### WARNING

The crane can topple over!

Incorrect central ballast is placed.

Death, severe bodily injuries, property damage.

When the erection / take-down chart applies:

- ▶ Always place the central ballast according to the erection / take-down chart.

When the assembly conditions apply:

- ▶ Always place the central ballast according to the assembly condition:

When the load chart applies:

- ▶ Always place the central ballast according to the load chart.



### WARNING

Risk of ballast plate breakage!

If the sequence is not observed when stacking the ballast plates, the ballast plates can be damaged or the stack can fall over.

Death, severe bodily injuries, property damage.

- ▶ When stacking the ballast plates, make sure that no more than 25 t is stacked on a 5 t ballast plate.



### WARNING

Damaged ballast plates!

Damage to the ballast plates can cause the fastening equipment to release.

Damaged ballast plates can break apart.

The ballast plates and components can fall down.

Death, severe bodily injuries, property damage.

- ▶ Do not use damaged ballast plates and replace them immediately.



### WARNING

Falling of the central ballast!

Lopsided stacked ballast plates create instability.

The ballast plates can tip from the central ballast brackets and cause the crane to topple over.

Death, severe bodily injuries, property damage.

- ▶ Make sure that the ballast plates are placed correctly in the centerings and are secured.



**WARNING**

The crane can topple over!

If more than 30 t of central ballast is placed on each central ballast bracket during assembly / disassembly of the crawler carrier on the assembly support, the support cylinders of the assembly support can be overloaded.

- ▶ Make sure during assembly / disassembly of the crawler carrier on the assembly support that a maximum of 30 t is placed on each central ballast bracket.
- ▶ Central ballast of more than 30 t per central ballast bracket may only be applied when the crane is positioned on the crawler carriers.

Make sure that the following prerequisite is met:

- The central ballast brackets are properly installed and secured on the crawler center section.

### 6.2.1 Placing the ballast plates, Twistlock fastening system

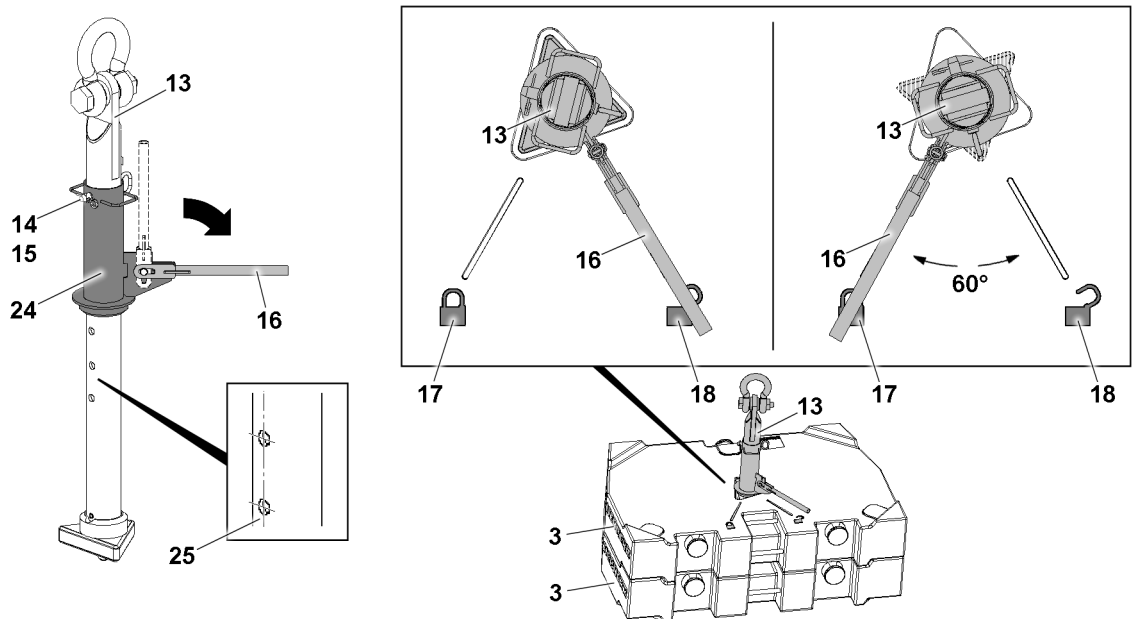


Fig.160403: Twistlock fastening system

**WARNING**

Overload of the receptacle stud and ballast plates!

If more than the permissible number of ballast plates **3** are lifted with the receptacle stud **13**, the receptacle stud **13** and the ballast plates **3** can be overloaded and damaged.

The ballast plates **3** can fall down.

Death, severe bodily injuries, property damage.

- ▶ Fasten only the maximum permissible number of ballast plates per stroke.
- ▶ Observe section "Lifting the ballast plates together".

**WARNING**

Damage to the receptacle stud and ballast plates!

If two ballast plates **3** are lifted that do not lie correctly in their centerings, the receptacle stud **13** and the ballast plates **3** can be damaged.

Damage can cause the ballast plates **3** to fall down.

Death, severe bodily injuries, property damage.

- ▶ Make sure that the ballast plates **3** to be lifted are placed correctly in the centerings.

**WARNING**

The Twistlock system opens by itself!

If the receptacle stud **13** is not correctly locked, the Twistlock system can open by itself!

The ballast plates **3** can fall down.

Death, severe bodily injuries, property damage.

- ▶ Make sure, when initiating a lift, that the lever **16** points directly to the “locked” icon **17**!

**Note**

- ▶ During a lift, the locked Twistlock system cannot release by itself due to its gravitational retention.
- ▶ During a lift, the locked Twistlock system cannot be released by hand due to its gravitational retention.

Before the receptacle stud **13** is guided into the ballast plates **3**, it must be ensured that the insertion length of the receptacle stud **13** is set correctly.

The insertion length of the receptacle stud **13** for the ballast plates **3** can be adjusted by hand.

If the insertion length of the receptacle stud **13** is to be adjusted:

- ▶ Release and unpin the pin **14**.
- ▶ Adjust the insertion length by moving the guide sleeve **24** to the desired value, observe the stages of the row of holes **25**.

**Note**

There are receptacle studs with different rows of holes.

- ▶ The correct receptacle stud **13** has a row of holes **25** with holes for 5 t / 7.5 t / 10 t / 15 t / 20 t.

- ▶ Insert the pin **14** and secure with the retaining element **15**.

**Result:**

- The receptacle stud **13** is adjusted.
- ▶ Fasten the receptacle stud **13** to the auxiliary crane and guide it into the ballast plate(s) **3**.
- ▶ Pull the lever **16** up and fold it down.
- ▶ Turn the receptacle stud **8** with the lever **16** 60° until it points to the “Locked” icon **17**.

**Note**

- ▶ The receptacle stud is locked by lifting the ballast plate(s).

- ▶ Lift the ballast plate(s) **3** with the receptacle stud **13** and take down carefully onto the centerings on the central ballast bracket or on another ballast plate **3**.

When the ballast plates **3** are taken down:

- ▶ Turn the receptacle stud **13** with the lever **16** 60° to the stop in direction of the “unlocked” icon **18**.

**Result:**

- The receptacle stud **13** is unlocked.
- ▶ Carefully pull out the receptacle stud **13**.

Until a maximum of 30 t per central ballast bracket is reached:

- ▶ Place the ballast plates **3** according to the specifications.

**Note**

- ▶ Central ballast of more than 30 t per central ballast bracket may only be applied when the crane is positioned on the crawler carriers.

- ▶ Secure the ballast plates **3**, see section “Securing / releasing the central ballast”.

## 6.2.2 Placing the ballast plates, bitt fastening points

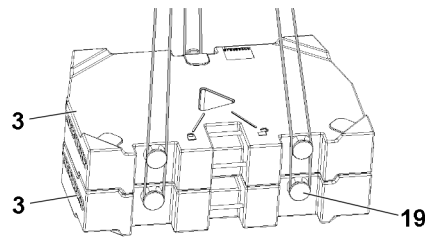


Fig.153451: Bitt fastening points



### WARNING

Overloaded bitt!

If more than the permissible number of ballast plates **3** are lifted together, the bitts **19** will be overloaded!

The ballast plates **3** can be damaged and fall down.

Death, severe bodily injuries, property damage.

- ▶ Fasten only the maximum permissible number of ballast plates per stroke.
- ▶ Observe section "Lifting the ballast plates together".



### WARNING

Incorrect handling of the fastening equipment!

If the fastening equipment is not attached correctly and / or if it is not secured sufficiently to prevent it from loosening up, the ballast plates **3** can fall down.

Death, severe bodily injuries, property damage.

- ▶ Make sure that the fastening equipment is correctly attached to the bitts **19** and that it is secured sufficiently to prevent it from loosening up.

- ▶ Fasten the ballast plates **3** to the auxiliary crane.

- ▶ Take the ballast plates **3** down on the centering devices of the central ballast bracket or another ballast plate.

Until a maximum of 30 t per central ballast bracket is reached:

- ▶ Place the ballast plates **3** according to the specifications.



### Note

- ▶ Central ballast of more than 30 t per central ballast bracket may only be applied when the crane is positioned on the crawler carriers.

- ▶ Secure the ballast plates **3**, see section "Securing / releasing the central ballast".

## 6.2.3 Assembling the stairs and catwalks

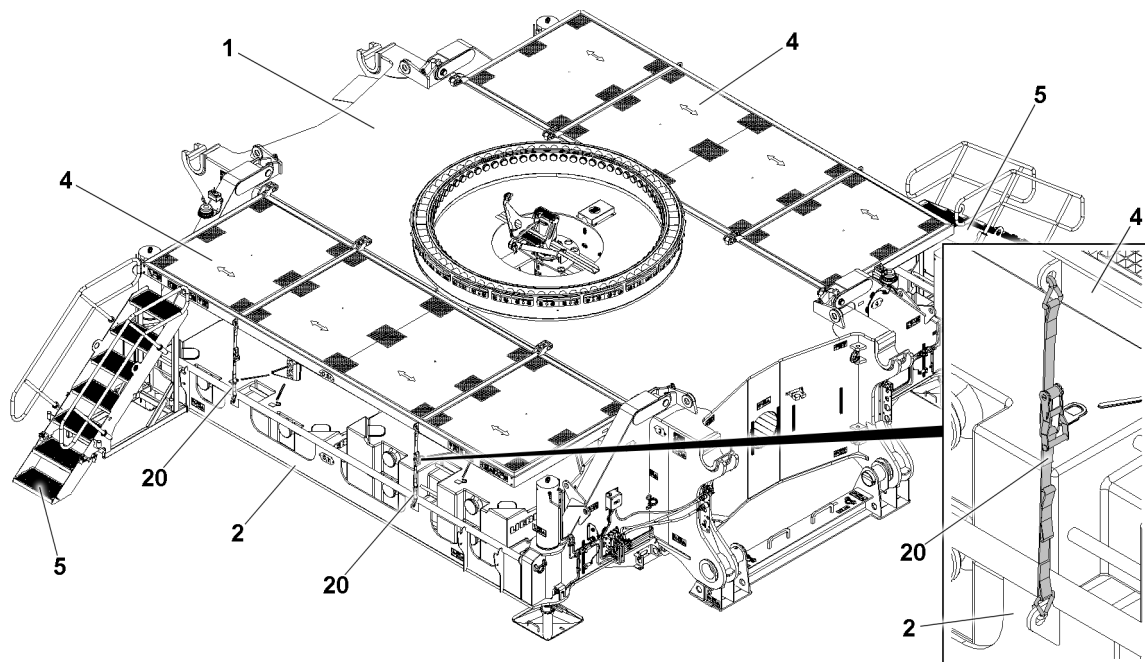


Fig.153454: Assembling the stairs and catwalks

- |   |                          |    |             |
|---|--------------------------|----|-------------|
| 1 | Crawler center section   | 5  | Stairs      |
| 2 | Central ballast brackets | 20 | Safety belt |
| 4 | Catwalk                  |    |             |

- ▶ Assemble the stairs **5**, see chapter 2.06.
- ▶ Assemble the catwalks **4**, see chapter 2.06.
- ▶ Secure the catwalks **4** with safety belts (2x) **20** to the central ballast bracket **2**.

## 7 Securing / releasing the central ballast



### WARNING

Unsecured central ballast!  
If the central ballast is not correctly secured, then it can fall down.  
Death, severe bodily injuries, property damage.

- ▶ Secure the complete central ballast.



### WARNING

The crane can topple over!  
Death, severe bodily injuries, property damage!

- ▶ Make sure that the assembly conditions in chapter 3.06 are observed.
- ▶ Make sure that the central ballast is installed according to the erection / take-down charts and the load charts.

## 7.1 Securing the central ballast

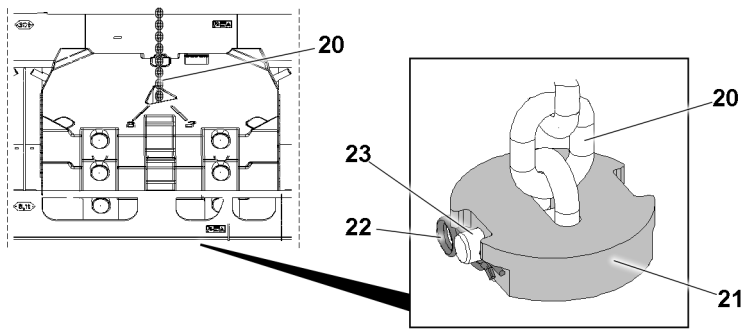


Fig.160400: Pinning the retaining chain at the bottom with the retaining plate

- ▶ Guide the retaining chain **20** with the auxiliary crane from top through the opening in the center of the ballast plates.
- ▶ Pinning the retaining chain **20** at the bottom with the retaining plate **21**: Insert the pin **23** and secure with the retaining element **22**.
- ▶ Tighten the retaining chain **20** with the auxiliary crane.

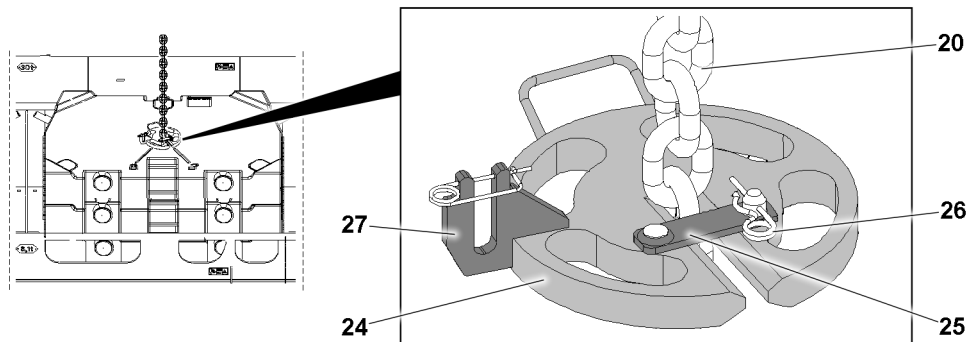


Fig.160401: Securing the retaining chain at the top with the retaining plate

- ▶ Securing the retaining chain **20** at the top with the retaining plate **24**.
- ▶ Secure the retaining plate **24** with the retaining plate **25**.
- ▶ Secure the retaining plate **25** with the retaining element **26**.

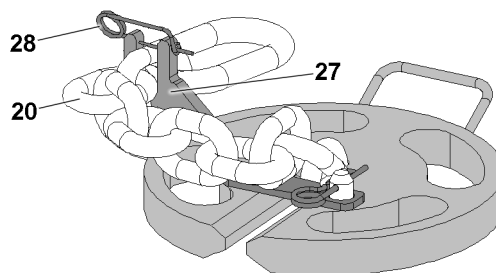


Fig.154337: Securing the chain overhang

### NOTICE

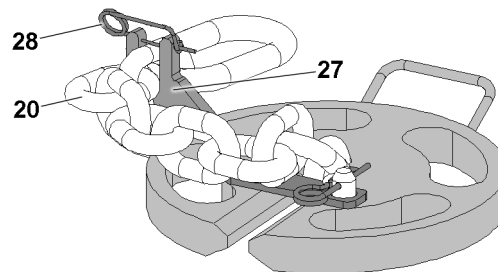
Unsecured chain overhang!

With a partial ballast, the chain overhang can fall down on the side!

- ▶ Secure the retaining chain **20** at the chain overhang to prevent it from falling down.

- ▶ In case of a chain overhang, connect the upper end of the retaining chain **20** to the fork **27** and secure with the retaining element **28** to prevent it from falling down!

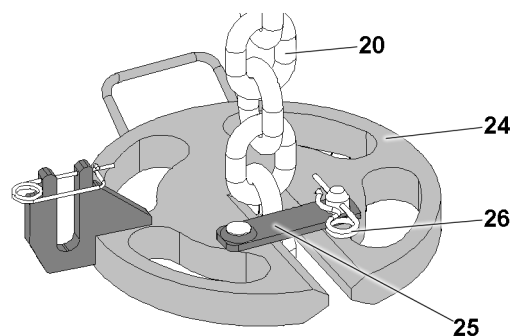
## 7.2 Releasing the central ballast



*Fig. 154337: Releasing the chain overhang*

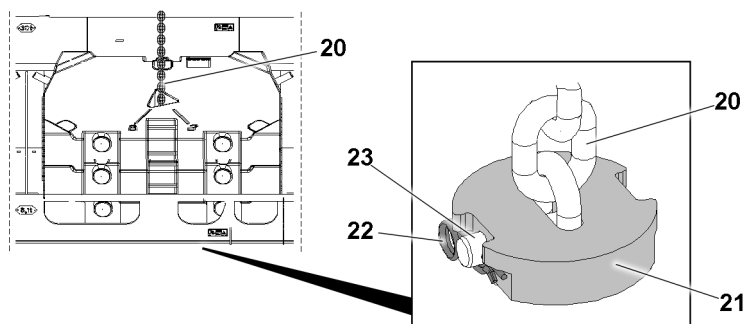
Make sure that the following prerequisite is met:

- The crane is horizontally aligned.
- ▶ Fasten the upper end of the retaining chain **20** to the auxiliary crane.
- ▶ Remove the retaining element **28**.
- ▶ Using the auxiliary crane, carefully pull the retaining chain **20** out of the fork **27** and tension.



*Fig. 154339: Releasing the retaining chain at the top*

- ▶ Release the retaining plate **25**: Remove the retaining element **26**.
- ▶ Remove the retaining plate **24**.
- ▶ Lower the retaining chain **20** with the auxiliary crane.



*Fig. 160400: Releasing the retaining chain at the top*

- ▶ Remove the retaining plate **21**: Release and unpin the pin **23**.
- ▶ Pull the retaining chain **20** with the auxiliary crane upward.

## 8 Disassembling the central ballast

Observe the section "safety".

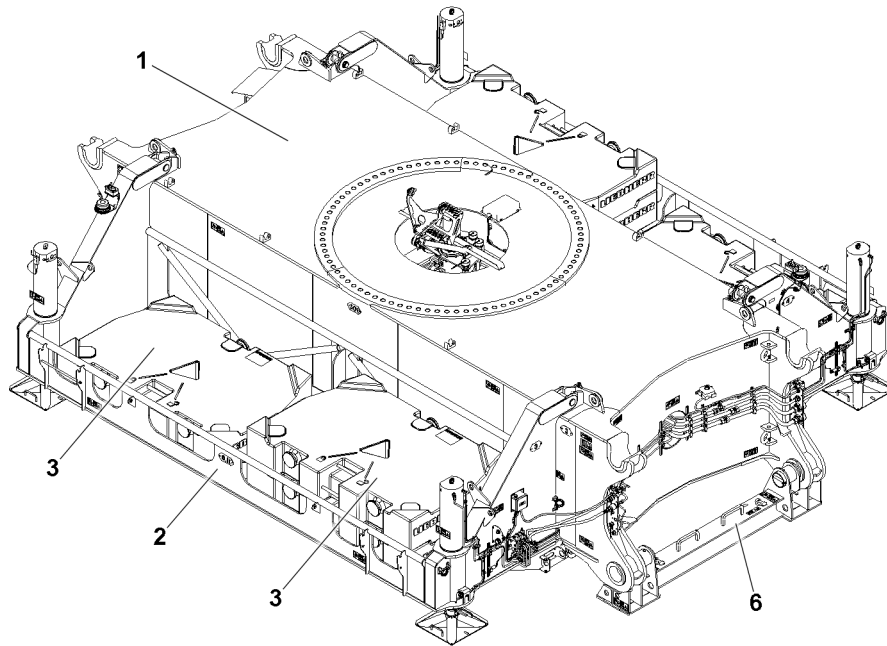


Fig.153455: Disassembling the central ballast

1	Crawler center section	3	Ballast plates
2	Central ballast bracket	6	Transport receptacle

Make sure that the following prerequisites are met:

- There is a maximum of 30 t on each central ballast bracket.
- Both crawler carriers are disassembled.
- The crawler center section 1 is horizontally aligned.
- Crawler center section 1 on the transport receptacle: The transport receptacle 6 is properly installed.
- Crawler center section without the transport receptacle 6: The crawler center section is properly supported with 240 mm.
- Access is established to the crawler center section via the leaning ladder, see chapter 2.07.
- The stairs are disassembled, see chapter 2.06.
- The ballast plates 3 are accessible, the catwalks are disassembled, see chapter 2.06.



### Note

- ▶ The crawler center section 1 without a transport receptacle 6 must be supported.
- ▶ For an optimal disassembly procedure, the substructure must have a height of 240 mm.

## 8.1 Removing the ballast plates



### WARNING

Toppling crane!

If the sequence and support locations are not observed when ballasting the central ballast, the crane can tip over!

Death, severe bodily injuries, property damage.

- ▶ Make sure that the ballast plates are always placed / removed symmetrically, alternatively on the front and rear central ballast bracket.
- ▶ Make sure that the maximum weight difference between the central ballast stacks on the central ballast brackets does not exceed 10 t.
- ▶ Make sure that the ballast plates are placed / removed evenly and diagonally-symmetrically.
- ▶ Make sure that the maximum weight difference between the central ballast brackets does not exceed 10 t.

If the necessary amount of central ballast on the central ballast bracket results in an uneven number of ballast plates:

- ▶ Make sure that each of the top ballast plates are placed diagonally with respect to each other.
- ▶ Observe the section "central ballast combinations"



### WARNING

Risk of ballast plate breakage!

If the sequence is not observed when stacking the ballast plates, the ballast plates can be damaged or the stack can fall over.

Death, severe bodily injuries, property damage.

- ▶ When stacking the ballast plates, make sure that no more than 25 t is stacked on a 5 t ballast plate.



### WARNING

Damaged ballast plates!

Damage to the ballast plates can cause the fastening equipment to release.

Damaged ballast plates can break apart.

The ballast plates and components can fall down.

Death, severe bodily injuries, property damage.

- ▶ Do not use damaged ballast plates and replace them immediately.



### WARNING

Falling of the central ballast!

Lopsided stacked ballast plates create instability.

The ballast plates can tip from the central ballast brackets and cause the crane to topple over.

Death, severe bodily injuries, property damage.

- ▶ Make sure that the ballast plates are placed correctly in the centerings and are secured.

Make sure that the following prerequisites are met:

- There are no persons or objects in the disassembly area of the central ballast brackets.
- The central ballast is released, see section "Securing / releasing the central ballast".



### 8.1.1 Removing the ballast plates, Twistlock fastening system

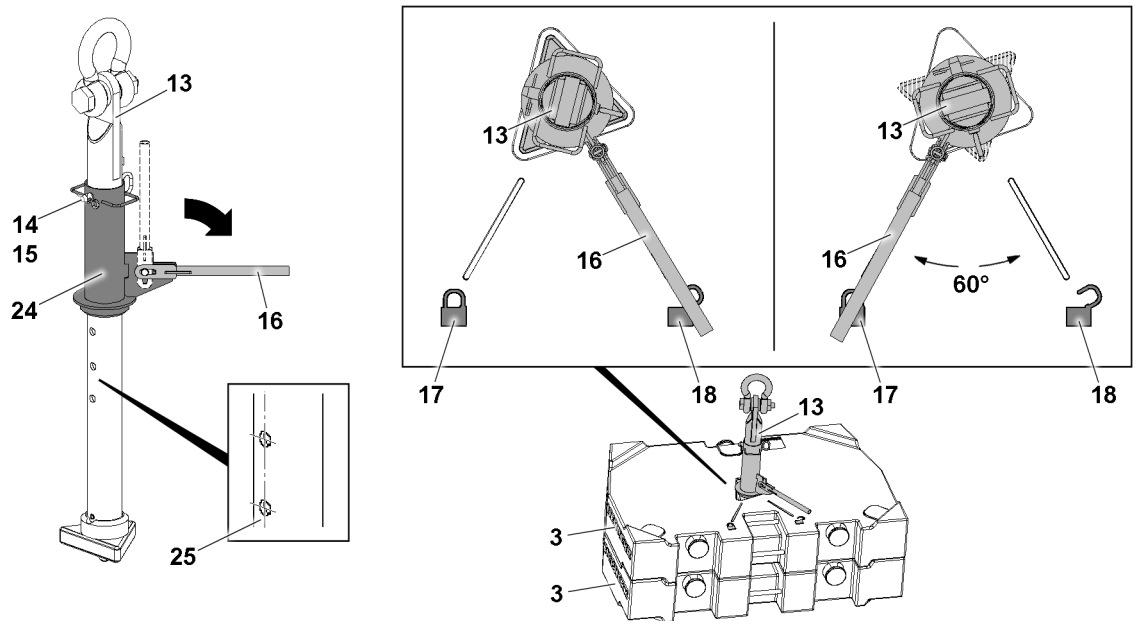


Fig.160403: Twistlock fastening system



#### WARNING

Overload of the receptacle stud and ballast plates!

If more than the permissible number of ballast plates **3** are lifted with the receptacle stud **13**, the receptacle stud **13** and the ballast plates **3** can be overloaded and damaged.

The ballast plates **3** can fall down.

Death, severe bodily injuries, property damage.

- ▶ Fasten only the maximum permissible number of ballast plates per stroke.
- ▶ Observe section “Lifting the ballast plates together”.



#### WARNING

Damage to the receptacle stud and ballast plates!

If two ballast plates **3** are lifted that do not lie correctly in their centerings, the receptacle stud **13** and the ballast plates **3** can be damaged.

Damage can cause the ballast plates **3** to fall down.

Death, severe bodily injuries, property damage.

- ▶ Make sure that the ballast plates **3** to be lifted are placed correctly in the centerings.



#### WARNING

The Twistlock system opens by itself!

If the receptacle stud **13** is not correctly locked, the Twistlock system can open by itself!

The ballast plates **3** can fall down.

Death, severe bodily injuries, property damage.

- ▶ Make sure, when initiating a lift, that the lever **16** points directly to the “locked” icon **17**!



#### Note

- ▶ During a lift, the locked Twistlock system cannot release by itself due to its gravitational retention.
- ▶ During a lift, the locked Twistlock system cannot be released by hand due to its gravitational retention.

Before the receptacle stud **13** is guided into the ballast plates **3**, it must be ensured that the insertion length of the receptacle stud **13** is set correctly.

The insertion length of the receptacle stud **13** for the ballast plates **3** can be adjusted by hand.

If the insertion length of the receptacle stud **8** is to be adjusted:

- ▶ Release and unpin the pin **14**.
- ▶ Adjust the insertion length by moving the guide sleeve **24** to the desired weight, observe the stages of the row of holes **25**.



#### Note

There are receptacle studs with different rows of holes.

- ▶ The correct receptacle stud **13** has a row of holes **25** with holes for 5 t / 7.5 t / 10 t / 15 t / 20 t.
- ▶ Insert the pin **14** and secure with the retaining element **15**.

#### Result:

- The receptacle stud **13** is adjusted.
- ▶ Fasten the receptacle stud **13** to the auxiliary crane and guide it into the ballast plate(s) **3**.
- ▶ Pull the lever **16** up and fold it down.
- ▶ Turn the receptacle stud **8** with the lever **16** 60° until it points to the “Locked” icon **17**.



#### Note

- ▶ The receptacle stud is locked by lifting the ballast plate(s).
- ▶ Lift the ballast plate(s) **3** with the receptacle stud **13** and take them down carefully on a suitable storage location.

When the ballast plates **3** are taken down:

- ▶ Turn the receptacle stud **13** with the lever **16** 60° to the stop in direction of the “unlocked” icon **18**.

#### Result:

- The receptacle stud **13** is unlocked.
- ▶ Carefully pull out the receptacle stud **13**.

### 8.1.2 Removing the ballast plates, fastening points: Bitt

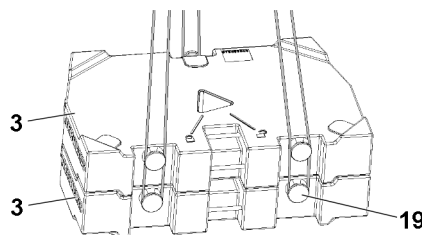


Fig.153451: Bitt fastening points



#### WARNING

Overloaded bitt!

If more than the permissible number of ballast plates **3** are lifted together, the bits **19** will be overloaded!

The ballast plates **3** can be damaged and fall down.

Death, severe bodily injuries, property damage.

- ▶ Fasten only the maximum permissible number of ballast plates per stroke.
- ▶ Observe section “Lifting the ballast plates together”.

**WARNING**

Incorrect handling of the fastening equipment!

If the fastening equipment is not attached correctly and / or if it is not secured sufficiently to prevent it from loosening up, the ballast plates **3** can fall down.

Death, severe bodily injuries, property damage.

- ▶ Make sure that the fastening equipment is correctly attached to the bits **19** and that it is secured sufficiently to prevent it from loosening up.

- ▶ Fasten the ballast plates **3** to the auxiliary crane.
- ▶ Lift the ballast plate(s) **3** and take them down carefully on a suitable storage location.

## 8.2 Disassembling the central ballast brackets

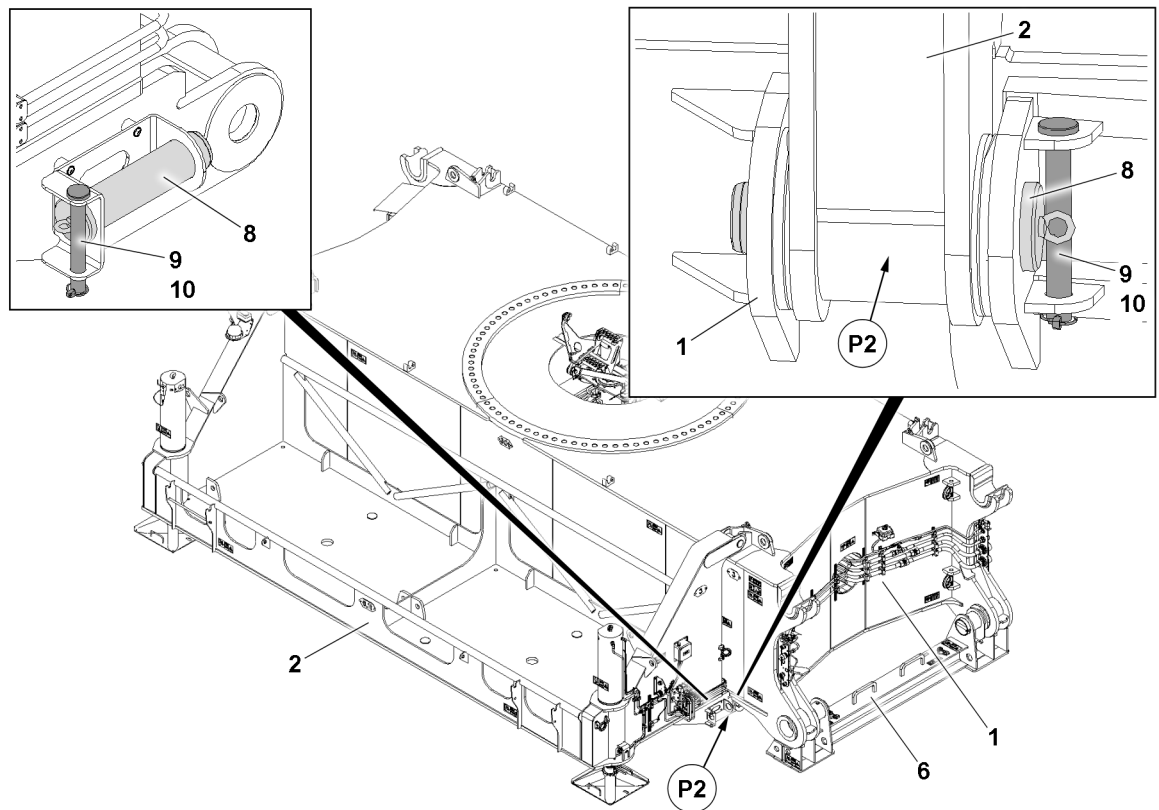


Fig.153456: Disassembling the central ballast brackets

1	Crawler center section	8	Connector pin
2	Central ballast brackets	9	Retaining pin
6	Transport receptacle	10	Retaining element

Make sure that the following prerequisite is met:

- The support cylinders of the hydraulic assembly support are retracted.

### 8.2.1 Disassembling the first central ballast bracket

- ▶ Release and unpin the retaining pin **9**.
- ▶ Unpin the connector pin **8** in point **P2**.
- ▶ Position the connector pin **8** in the transport receptacle and secure with the retaining pin **9** and retaining element **10**, see illustration.

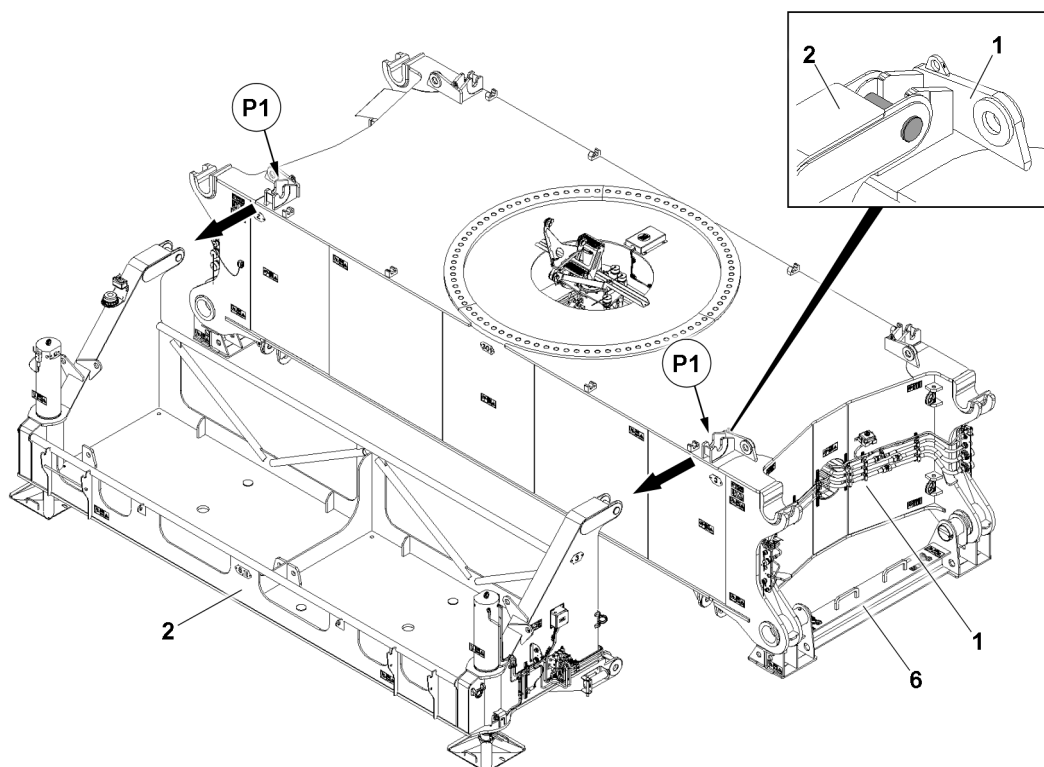


Fig.153457: Removing the central ballast bracket

- ▶ Fasten the central ballast bracket 2 to the auxiliary crane.
- ▶ Tension the fastening equipment with the auxiliary crane.
- ▶ Briefly swing out the central ballast bracket 2 with the auxiliary crane and connect it in point P1.
- ▶ Remove the central ballast bracket 2 with the auxiliary crane and take it down.

## 8.2.2 Disassembling the second central ballast bracket



### Note

- ▶ The procedure for the disassembly of the second central ballast bracket is identical to the disassembly of the first central ballast bracket.

Make sure that the following prerequisite is met:

- The first central ballast bracket is properly disassembled and removed.
- ▶ Disassemble the second central ballast bracket, see section “Disassembling the first central ballast bracket”.

## 3.04 Mechanical auxiliary support

1	Safety	2
2	Component overview	3
3	Fastening points	3
4	Assembling the mechanical auxiliary support	4
5	Disassembling the mechanical auxiliary support	6

# 1 Safety

Before assembly and disassembly observe the safety notes:

- Information regarding work on the crane. See chapter 2.04.
- Information regarding personal protective equipment. See chapter 2.04.



## WARNING

Danger of falling!

During assembly / disassembly, inspection and maintenance work, personnel must be secured with appropriate aids to prevent them from falling.

Death, severe bodily injuries, property damage.

- ▶ All work at a height, when there is a danger of falling, must be carried out with suitable aids.
- ▶ If aids are not available and work cannot be carried out from the ground, then assembly personnel must secure themselves with the supplied fall arrest system to prevent falling, see chapter 2.04.
- ▶ If fall protection equipment is available, then it must be used, see chapter 2.06.
- ▶ When lifting, lowering, swinging crane parts in and out, no persons may remain in the danger zone.
- ▶ If railings are present on the components, then they must be brought into the corresponding position and secured for assembly / disassembly work.
- ▶ Only step on the aids, ladders and catwalks with clean shoes.
- ▶ Keep aids, ladders and catwalks free of heavy dirt, snow and ice.
- ▶ During all assembly and disassembly work, maintenance work and inspections, travel or crane operation is prohibited.
- ▶ Remaining on a suspended load is prohibited.
- ▶ Stepping or walking on crane components and lattice sections, which have an incline of more than 20° is prohibited.
- ▶ For all assembly work, the crane operator of the main crane must be in voice contact with the crane operator / crane operators of the auxiliary crane / auxiliary cranes.
- ▶ For assembly / disassembly tasks, the crane operator may only initiate crane movements when the responsible guide has explicitly released the movement.



## WARNING

Danger of impact / crushing!

When installing / removing crane components with the auxiliary crane, crane components can start to swing back and forth.

When lifting / lowering and positioning crane components, there is an increased danger of impacts / crushing.

Death, severe bodily injuries, property damage.

- ▶ Make sure that personnel cannot be caught by components.
- ▶ When working in danger zones: Use aids to protect limbs.
- ▶ Guide components with suitable aids to minimize oscillation.



## DANGER

The components can fall down!

If the corresponding component is disengaged from the auxiliary crane before the corresponding component is pinned, then the corresponding component can fall down.

Death, severe bodily injuries, property damage.

- ▶ Do not disengage the auxiliary crane until the respective component is pinned and secured.



## WARNING

Danger of falling!

During assembly and disassembly of crane components, personnel must be secured with appropriate aids to prevent them from falling.

Death, severe bodily injuries, property damage.

- ▶ Use personal protective equipment.



**WARNING**

The crane can topple over!

If long boom combinations are erected or taken down without mechanical auxiliary support, then the crane can topple over.

Death, severe bodily injuries, property damage.

- ▶ Observe and adhere to the data in the erection and take-down charts.
- ▶ Install the mechanical auxiliary support only in pairs on the crawler carrier.
- ▶ Erection and / or take-down of long boom systems with only one installed support beam is prohibited.
- ▶ Use of the mechanical auxiliary support in crane operation is prohibited.



**Note**

- ▶ The assembly of the mechanical auxiliary support is only described for one support as an example!

## 2 Component overview



**Note**

- ▶ Dimensions and weights, see the Crane operating instructions, chapter 1.03.

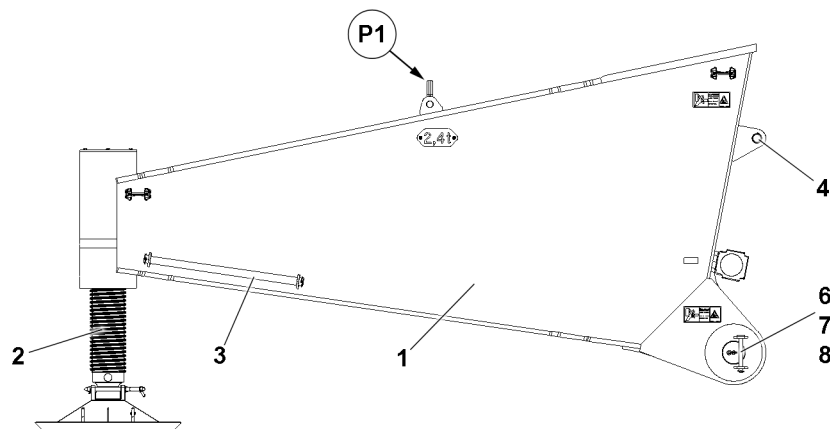


Fig.153442: Component overview

- |  |  |
|--|--|
| <ul style="list-style-type: none"> <li>1 Mechanical auxiliary support</li> <li>2 Spindle</li> <li>3 Rod</li> <li>4 Hook pin</li> </ul> | <ul style="list-style-type: none"> <li>6 Connector pin (2x)</li> <li>7 Retaining pin (2x)</li> <li>8 Retaining element (2x)</li> </ul> |
|--|--|

## 3 Fastening points



**WARNING**

Components incorrectly fastened!

Death, severe bodily injuries, property damage.

- ▶ Attach the components only on the intended fastening points.

Fastening point	
P1	Mechanical auxiliary support

LWE/LR 1800-1-0-000/27200-07-02/en

## 4 Assembling the mechanical auxiliary support

Make sure that the following prerequisites are met:

- The assembly of the crawler carriers is completed.
- The crane is horizontally aligned.
- The assembly supports are in the operating position.
- The ground has sufficient load bearing capacity in the area of the support plates.
- No personnel or objects are within the assembly area.
- An auxiliary crane is available.

### 4.1 Installing the mechanical auxiliary support on the crawler travel gear

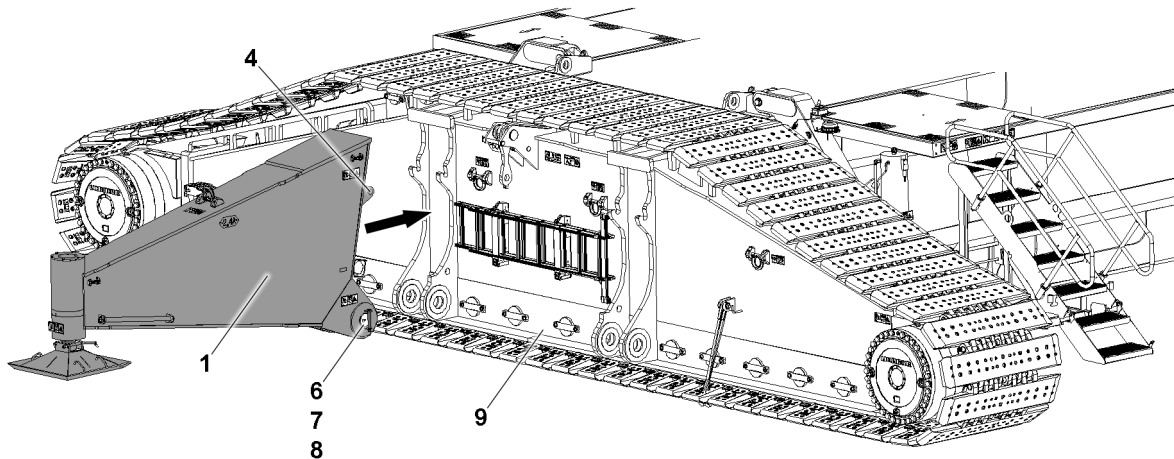


Fig.153443: Positioning the mechanical auxiliary support

- ▶ Fasten the mechanical auxiliary support 1 to the auxiliary crane, see section “Fastening points”.
- ▶ Swing the mechanical auxiliary support 1 in with the auxiliary crane to the assembly area on the crawler carrier 9.
- ▶ Unpin the retaining pin 7.
- ▶ Unpin the connector pin 6 on both sides.

#### Result:

- The mechanical auxiliary support 1 can be swung further to the pin locations.

#### NOTICE

Danger of property damage!

If the connector pins 6 are in the **pinned** position when swinging the mechanical auxiliary support 1, the components can be severely damaged.

- ▶ Make sure that the pins are unpinned on the mechanical auxiliary support.



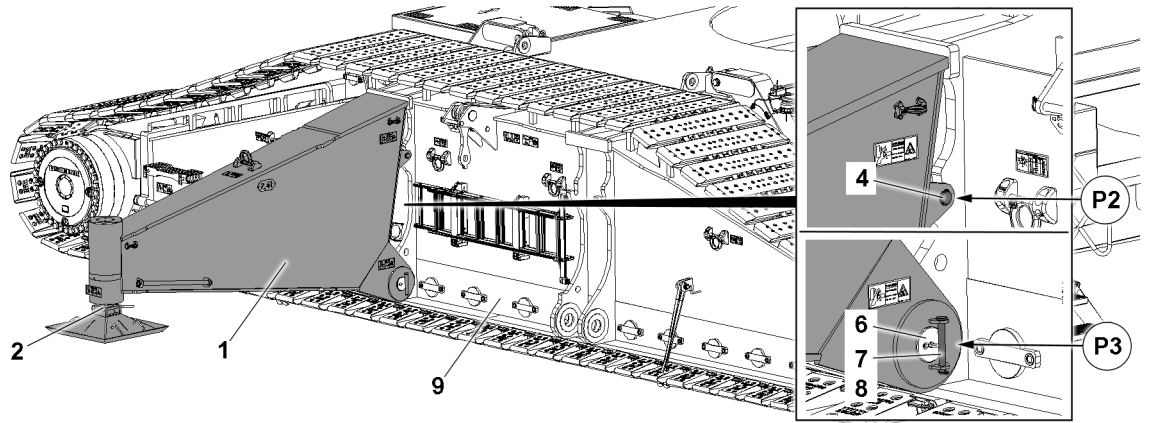


Fig. 153444: Pinning the mechanical auxiliary support

- ▶ Swing the mechanical auxiliary support 1 with the auxiliary crane to the assembly points.
- ▶ Connect the mechanical auxiliary support 1 with the hook pins 4 in point P2 with the hook points on the crawler carrier 9.

When the mechanical auxiliary support 1 is properly connected with the crawler carrier 9:

- ▶ Lower the mechanical auxiliary support 1 with the auxiliary crane into the operating position.

When the pin bores align in point P3:

- ▶ Insert the connector pin 6 on both sides.
- ▶ Secure the connector pin 6: Insert the retaining pins 7 and secure with the retaining elements 8.

**Result:**

- The first mechanical auxiliary support is pinned and secured on the crawler carrier.
- ▶ Remove the fastening equipment.
- ▶ Install the mechanical auxiliary support on the crawler carrier.

## 4.2 Adjusting the mechanical auxiliary support

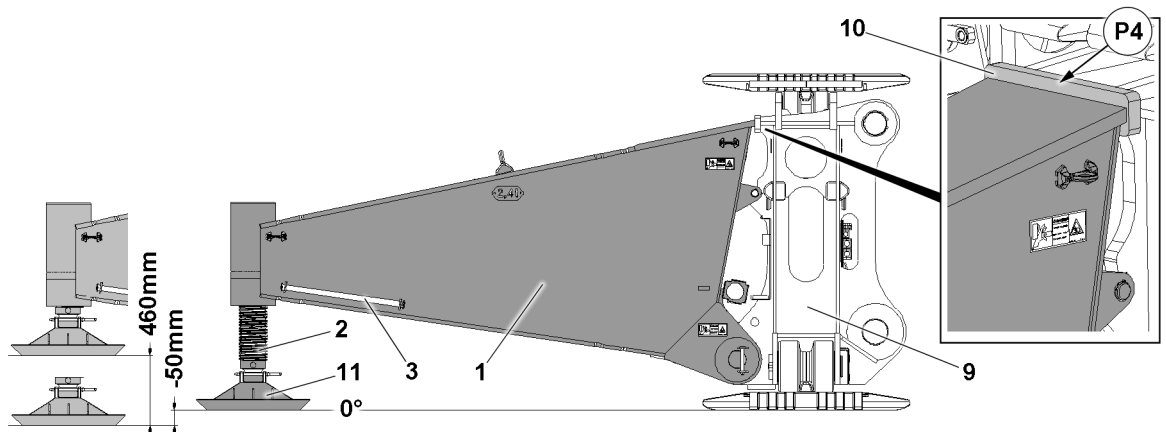


Fig. 153445: Adjusting the mechanical auxiliary support



**Note**

- ▶ The mechanical auxiliary support is only an erection and take down device.
- ▶ Due to the mechanical auxiliary support, the stability momentum of the crane increases toward the side, on which the auxiliary support is installed.

**DANGER**

The crane can topple over!

If the load momentum is increased in crane operation due to the use of the mechanical auxiliary support, the crane will tip over.

Death, severe bodily injuries, property damage.

- ▶ The increase of stability momentum through the mechanical auxiliary support may not be used to increase the load momentum.
- ▶ The use of the mechanical auxiliary support in crane operation is prohibited.
- ▶ Make sure that the mechanical auxiliary support is only used for erection and take-down of long boom systems.
- ▶ Support the support plates large enough for the ground conditions with solid materials, such as wood, steel or concrete slabs, see Crane operating instructions, chapter 2.04.

**WARNING**

Jerky movements during erection / take-down of the boom system!

If the mechanical auxiliary support **1** is not placed on the pressure plate **10** in point **P4** on the crawler carrier **9**, then the boom system can move jerkily during erection and / or take-down.

Death, severe bodily injuries, property damage.

- ▶ Turn the support plate **11** with the spindle **2** until the mechanical auxiliary supports **1** touch the pressure plate **10**.
- ▶ Remove the rod **3** from the transport retainer on the mechanical auxiliary support **1**.
- ▶ Insert the rod **3** into the bore on the spindle **2**.
- ▶ Support the support plate **11** properly with materials with load bearing capacity.
- ▶ Turn the spindle **2** downward until the support plate **11** makes surface contact with the substructure.

When the support plate **11** is laying on the substructure:

- ▶ Continue to turn the spindle **2** until the mechanical auxiliary support **1** is touching on the pressure plate **10**.
- ▶ Remove the rod **3** and install it in park position.
- ▶ Adjust the second support plate.

## 5 Disassembling the mechanical auxiliary support

**Note**

- ▶ The disassembly of the mechanical auxiliary support is only described for one support as an example!

Make sure that the following prerequisites are met:

- The main boom has been removed on the crane.
- The crane is horizontally aligned.
- The support plates are not in contact with the ground.
- An auxiliary crane is available.
- No personnel or objects are within the assembly area.

## 5.1 Removing the mechanical auxiliary support on the crawler travel gear

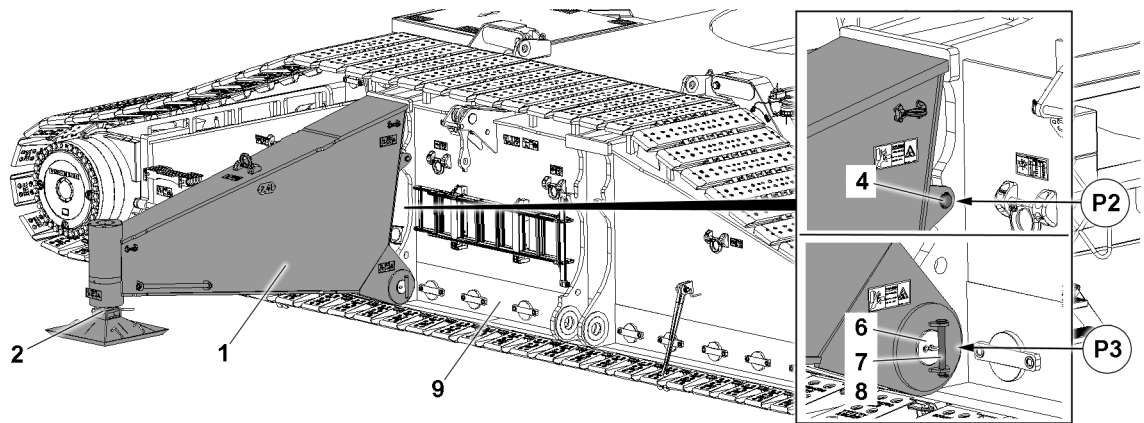


Fig.153444: Disassembling the mechanical auxiliary support

- ▶ Turn the spindle **2** completely up.
- ▶ Fasten the mechanical auxiliary support **1** to the auxiliary crane, see section “Fastening points”.
- ▶ Tension the fastening equipment.

When the fastening equipment is tensioned:

- ▶ Release the retaining pin **7** on both sides at point **P3** and unpin.

**Result:**

- The connector pin **6** is released.
- ▶ Unpin the connector pin **6** on both sides in point **P3**.

When all pins are unpinned:

- ▶ Carefully lift the mechanical auxiliary support **1** with the auxiliary crane and swing out.



### WARNING

Toppling mechanical auxiliary support!  
The support beams can fall over after placing.  
Death, severe bodily injuries, property damage.

- ▶ Secure the mechanical auxiliary support **1** immediately after placing it on the substructure or the flatbed trailer to prevent it from falling over.

- ▶ Place the mechanical auxiliary support **1** on the load bearing substructure.
- ▶ Secure the mechanical auxiliary support **1** immediately after setting it down to prevent it from falling over.

When the mechanical auxiliary support **1** is secured against falling over:

- ▶ Remove the auxiliary crane.
- ▶ Pin and secure all pins again on the mechanical auxiliary support **1**.
- ▶ Remove the second mechanical auxiliary support **1** on the crawler carrier and secure.

---

Empty page!

LWE/LR 1800-1-0-000/27200-07-02/en

## 3.05 SA-frame assembly

1	Safety	2
2	Component overview	3
3	SA-frame fastening points	4
4	Preparing the pin locations on the turntable	4
5	Pinning the SA-frame on the turntable	5
6	Pinning winch 4 on the turntable	8
7	Establishing the connections to the SA-frame	10
8	Pinning the pulley support with the turntable	11
9	Releasing the assembly cylinder	12
10	Assembling the guy rods	13
11	Disassembling the guy rods	14
12	Securing the assembly cylinder	15
13	Unpinning the pulley support on the turntable	16
14	Disconnecting the connections to the SA-frame	17
15	Unpinning winch 4 on the turntable	18
16	Unpinning the SA-frame on the turntable	20

# 1 Safety

## 1.1 General

Before assembly and disassembly observe the safety notes:

- Information regarding work on the crane superstructure. See chapter 2.04.
- Information regarding personal protective equipment. See chapter 2.04.
- Information regarding fall protection equipment. See chapter 2.06.
- Information regarding accesses to the crane. See chapter 2.07.
- Information regarding accessible surfaces. See chapter 2.07.



### WARNING

Danger of falling!

During assembly / disassembly, inspection and maintenance work, personnel must be secured with appropriate aids to prevent them from falling.

Death, severe bodily injuries, property damage.

- ▶ All work at a height, when there is a danger of falling, must be carried out with suitable aids.
- ▶ If aids are not available and work cannot be carried out from the ground, then assembly personnel must secure themselves with the supplied fall arrest system to prevent falling, see the Crane operating instructions, chapter 2.04.
- ▶ If fall protection equipment is available, then it must be used, see the Crane operating instructions, chapter 2.06.
- ▶ When lifting, lowering, swinging crane parts in and out, no persons may remain in the danger zone.
- ▶ If railings are present on the components, then they must be brought into the corresponding position and secured for assembly / disassembly work.
- ▶ Only step on the aids, ladders and catwalks with clean shoes.
- ▶ Keep aids, ladders and catwalks free of heavy dirt, snow and ice.
- ▶ During all assembly and disassembly work, maintenance work and inspections, travel or crane operation is prohibited.
- ▶ Remaining on a suspended load is prohibited.
- ▶ Stepping or walking on crane components and lattice sections, which have an incline of more than 20° is prohibited.
- ▶ For all assembly work, the crane operator of the main crane must be in voice contact with the crane operator / crane operators of the auxiliary crane / auxiliary cranes.
- ▶ For assembly / disassembly tasks, the crane operator may only initiate crane movements when the responsible guide has explicitly released the movement.



### WARNING

Danger of impact / crushing!

When installing / removing crane components with the auxiliary crane, crane components can start to swing back and forth.

When lifting / lowering and positioning crane components, there is an increased danger of impacts / crushing.

Death, severe bodily injuries, property damage.

- ▶ Make sure that personnel cannot be caught by components.
- ▶ When working in danger zones: Use aids to protect limbs.
- ▶ Guide components with suitable aids to minimize oscillation.



### DANGER

The components can fall down!

If the corresponding component is disengaged from the auxiliary crane before the corresponding component is pinned, then the corresponding component can fall down.

Death, severe bodily injuries, property damage.

- ▶ Do not disengage the auxiliary crane until the respective component is pinned and secured.



**WARNING**

Danger of falling!

During assembly and disassembly of crane components, personnel must be secured with appropriate aids to prevent them from falling.

Death, severe bodily injuries, property damage.

- ▶ Use personal protective equipment.



**WARNING**

The crane can topple over!

If the SA-frame is assembled / disassembled or erected in the case of a supported crawler center section, the crane can topple over.

Death, severe bodily injuries, property damage.

- ▶ Only assemble / disassemble or erect the SA-frame when the crawler center section is lying on the substructure or is positioned on the crawlers.
- ▶ It is prohibited to assemble / disassemble or erect the SA-frame if the crawler center section is supported.

## 2 Component overview



**Note**

- ▶ Dimensions and weights, see the Crane operating instructions, chapter 1.03.

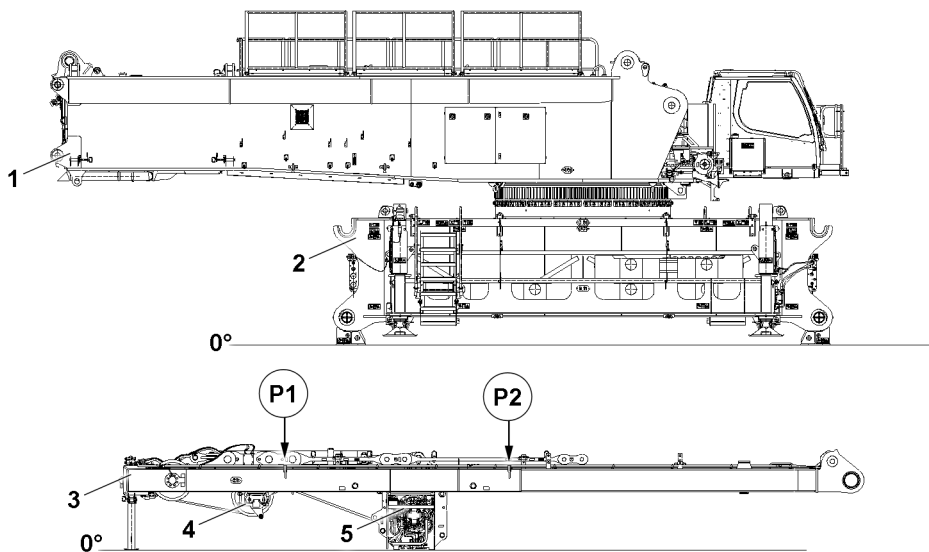


Fig.153488: Component overview

Position	Component
1	Turntable
2	Crawler center section
3	SA-frame
4	Pulley support
5	Winch 4

LWE/LR 1800-1-0-000/27200-07-02/en

### 3 SA-frame fastening points



#### WARNING

Component incorrectly fastened!

Life-threatening situations can arise due to improper or incorrect fastening of the corresponding components.

Death, severe bodily injuries, property damage.

► Fasten the components only on the intended fastening points on both sides.

Fastening points	
P1 and P2	SA-frame with winch 4 and pulley support

### 4 Preparing the pin locations on the turntable

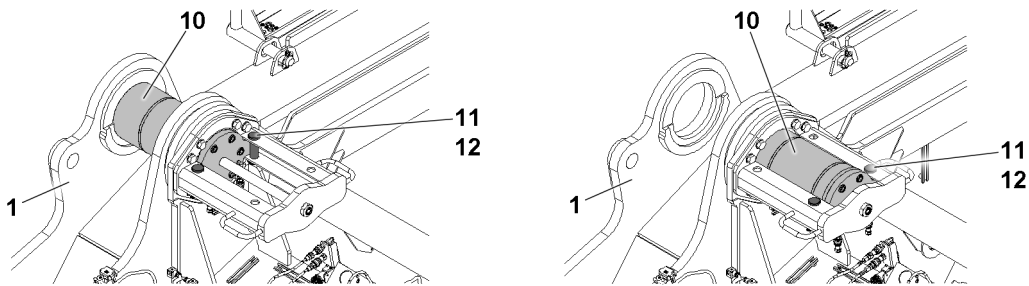


Fig.153489: Pin location

Make sure that the following prerequisites are met:

- The crawler center section is lying on the supporting bases or is standing in tracks.
- The crane is aligned horizontally.
- The crane engine is running.



#### Note

- Electrical connections, see the Electric wiring diagram.
- Hydraulic connections, see Hydraulic diagram.



#### WARNING

Danger of slipping, tripping and falling!

Death, severe bodily injuries.

Danger of slipping, tripping and falling when accessing or leaving the work position due to a small step depth and different step heights due to structural conditions.

► Observe the danger notes, see chapter 2.07.

- Release the pin 10: Remove the retaining element 12 on both sides and unpin the retaining pin 11.
- Unpin the pin 10.

#### Result:

- The pins 10 are prepared for assembly.



## 5 Pinning the SA-frame on the turntable

### 5.1 Fastening the SA-frame to the auxiliary crane

Make sure that the following prerequisite is met:

- An auxiliary crane with sufficient load bearing capacity is available.
- ▶ Fasten the fastening equipment to the SA-frame **3**, see section “SA-frame fastening points”.
- ▶ Tension the fastening equipment.

When the fastening equipment is tensioned:

- ▶ Release the rigging between the SA-frame **3** and the transport vehicle.
- ▶ Lift the SA-frame **3** with the auxiliary crane.

### 5.2 Swinging the support into operating position

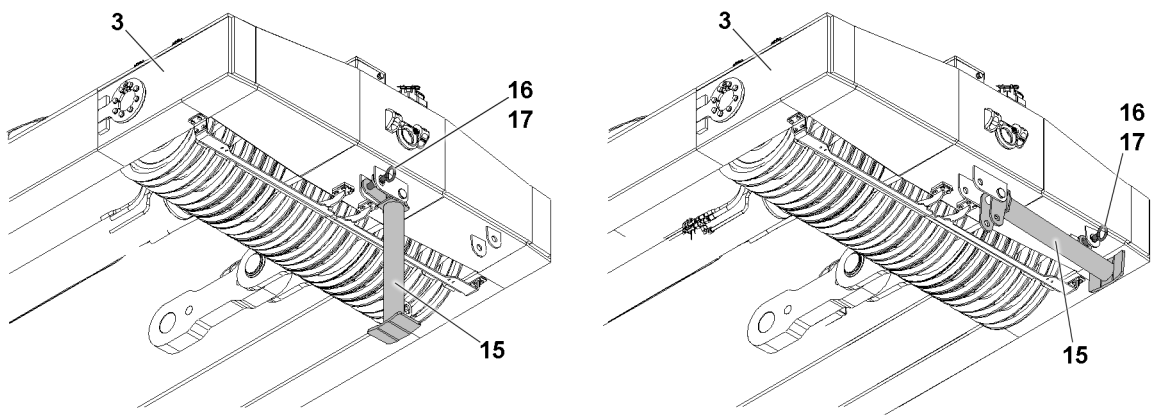


Fig.153490: Support

- ▶ Release the support **15** from the transport position: Remove the retaining element **17** and unpin the pin **16**.



#### WARNING

Support swinging down!

The support **15** can swing down during pinning.  
Death, severe bodily injuries, property damage.

- ▶ For safety reasons, carry out the pinning of the support always with **two** persons.
  - ▶ Make sure that there are no persons within the danger zone during the entire pin procedure.
- 
- ▶ Swing the support **15** into the park position.
  - ▶ Secure the support **15** in the park position: Insert the pin **16** and secure it with the retaining element **17**.

## 5.3 Pinning the SA-frame

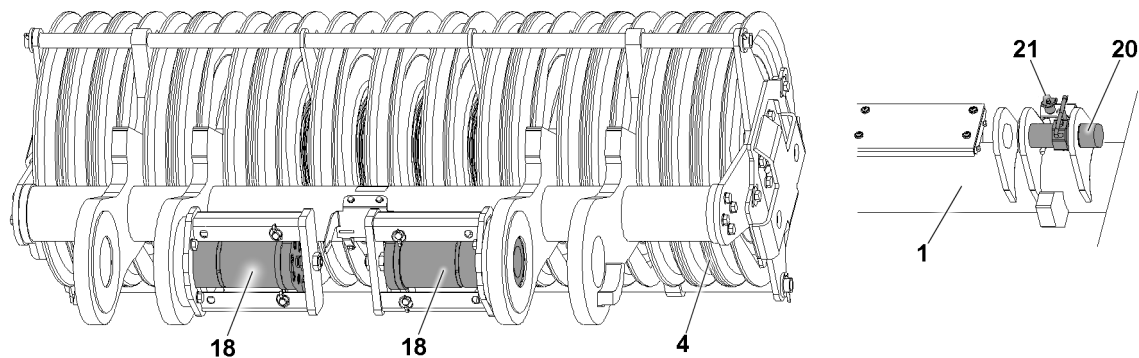


Fig.153491: Pin

Make sure that the following prerequisites are met:

- The pins **10** on the turntable for the installation of the SA-frame are unpinned.
- The pins **18** on the pulley support for installation on the turntable are unpinned.
- The pins **20** on the turntable for the installation of winch **4** are unpinned.
- The support **15** is in the park position.
- The camera for winch **1** has been taken down.
- The crane engine is running.

### NOTICE

Danger of property damage!

If the pin **10**, pin **20** and pin **18** are in the **pinned** position when retracting the SA-frame in the turntable, components can be severely damaged.

- ▶ Make sure that when retracting, the pins are in the **unpinned** position.

### NOTICE

Danger of property damage!

If the camera for winch **1** is in operating position - when swinging the SA-frame to the turntable - it will be damaged when retracting the SA-frame.

- ▶ Make sure that the camera for winch **1** is in transport position when retracting the SA-frame.



### WARNING

Danger of slipping, tripping and falling!

Death, severe bodily injuries.

Danger of slipping, tripping and falling when accessing or leaving the work position due to a small step depth and different step heights due to structural conditions.

- ▶ Observe the danger notes, see chapter 2.07.

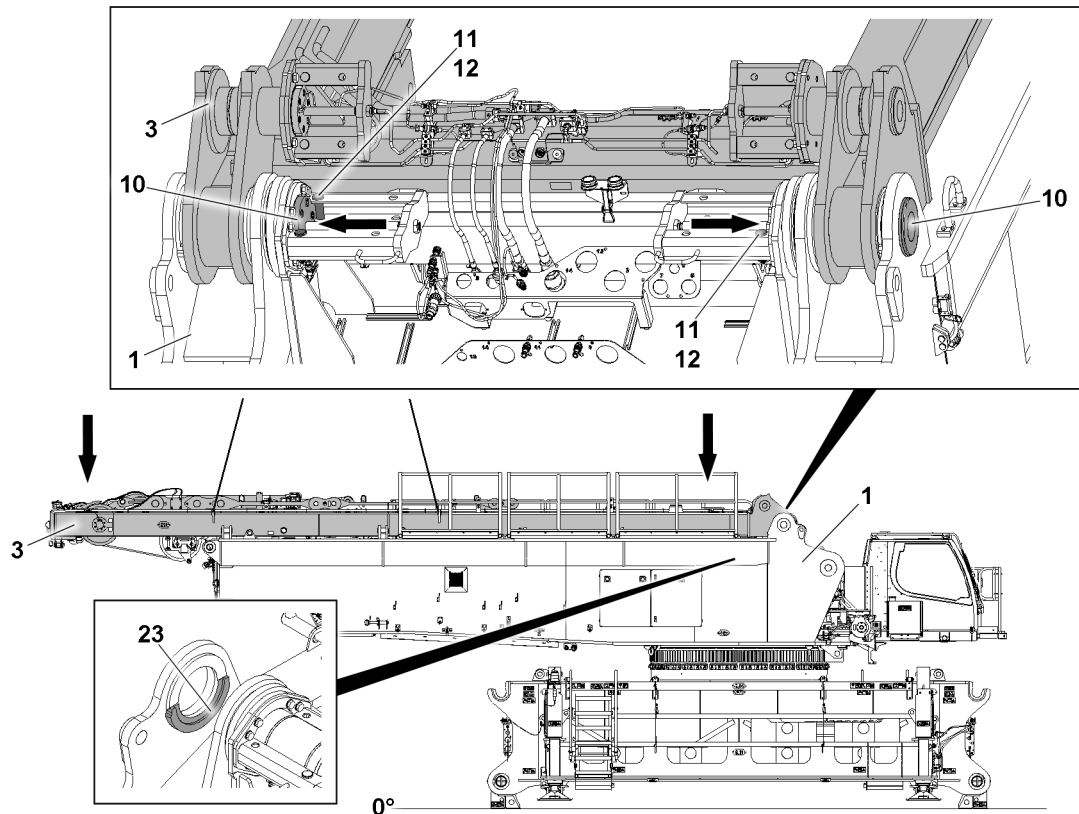


Fig.153492: Pinning the SA-frame

- ▶ Lift the SA-frame **3** with the auxiliary crane and position it on the turntable **1**.
- ▶ Place the SA-frame **3** in the centerings **23** on the turntable **1**.

**Result:**

- Align the pin bores.



**Note**

- ▶ The pinning procedure is the same for both sides of the SA-frame.
- ▶ Insert the pin **10**.



**WARNING**

The pin is not secured!  
If the pins **10** are not secured, the pins can loosen up by themselves during crane operation. This can cause the crane to topple over.  
Death, severe bodily injuries, property damage.

- ▶ Make sure that the pins **10** are secured with the retaining pin **11**.
- ▶ Secure the pin **10**: Insert the retaining pin **11** on both sides in the operating position and secure with the retaining element **12**.

When the SA-frame is pinned:

- ▶ Remove the fastening equipment on points **P2**, see section "Attachment points SA-frame".



**WARNING**

Danger of falling!  
Death, severe bodily injuries, property damage.

- ▶ The fastening equipment may only be removed on points **P1** with the aid of a work platform.
- ▶ Remove the fastening equipment on points **P1**, see section "Attachment points SA-frame".

## 6 Pinning winch 4 on the turntable

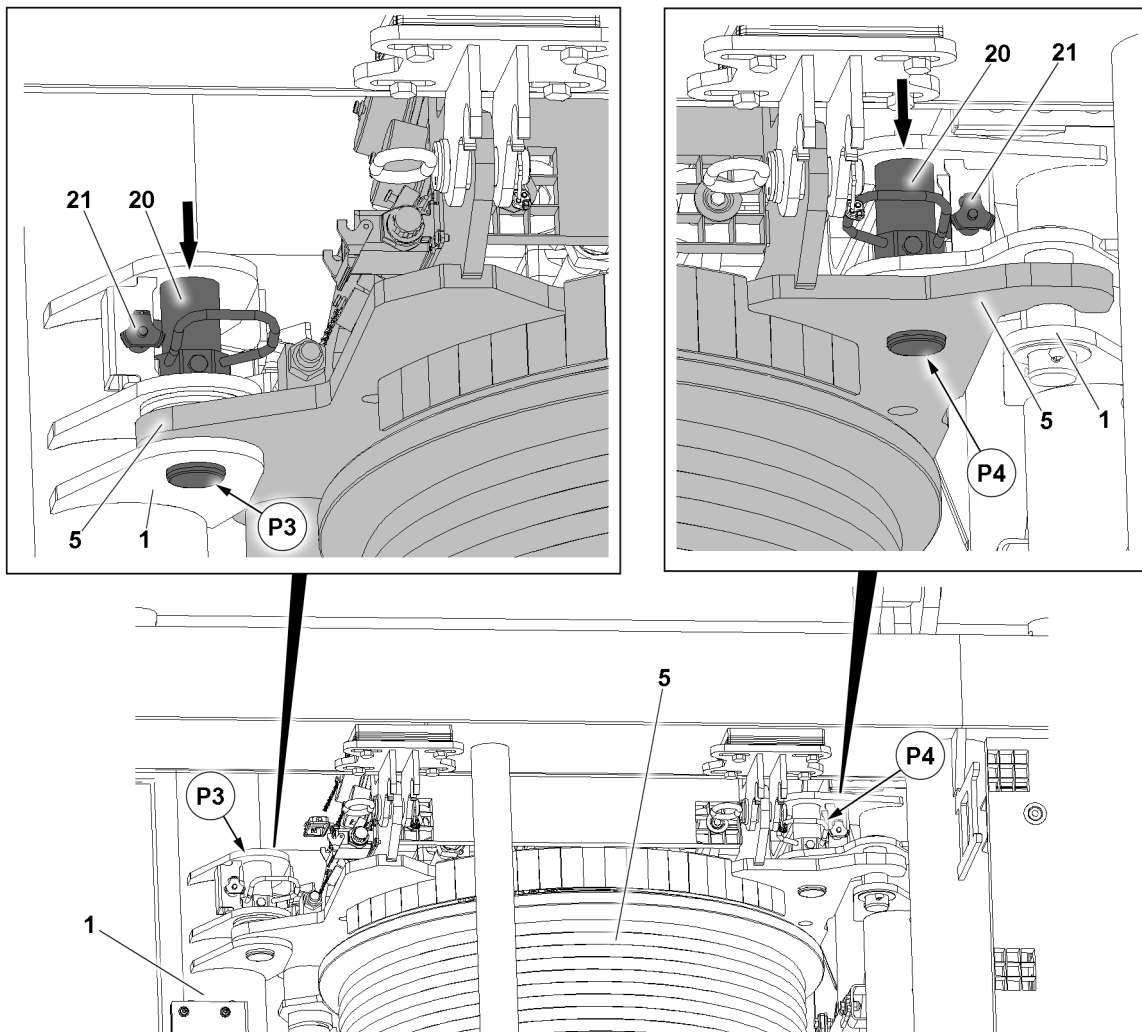


Fig.153496: Pinning winch 4

Make sure that the following prerequisites are met:

- The SA-frame is pinned on the turntable.
- The fastening equipment has been removed.



### Note

- ▶ The pinning procedure is the same for both sides of Winch 4.
- ▶ Unpin the ball locking pins **21** in point **P3** from the park position on both sides.



### WARNING

The pin is not secured!

If the pins **20** are not secured, the pins can loosen up by themselves during crane operation. This can cause the crane to topple over.

Death, severe bodily injuries, property damage.

- ▶ Make sure that the pins **20** are secured with ball locking pins **21**.
- ▶ Insert the pins **20** in the operating position in point **P3** on both sides.
- ▶ Secure the pin **20** in the operating position on both sides: Insert the ball locking pin **21** in the operating position.
- ▶ Unpin the ball locking pins **21** in point **P4** from the park position on both sides.

**WARNING**

The pin is not secured!

If the pins **20** are not secured, the pins can loosen up by themselves during crane operation. This can cause the crane to topple over.

Death, severe bodily injuries, property damage.

▶ Make sure that the pins **20** are secured with ball locking pins **21**.

▶ Insert the pins **20** in the operating position in point **P4** on both sides.

▶ Secure the pin **20** in the operating position on both sides: Insert the ball locking pin **21** in the operating position.

**Result:**

▷ Winch 4 is pinned and secured with the turntable **1**.

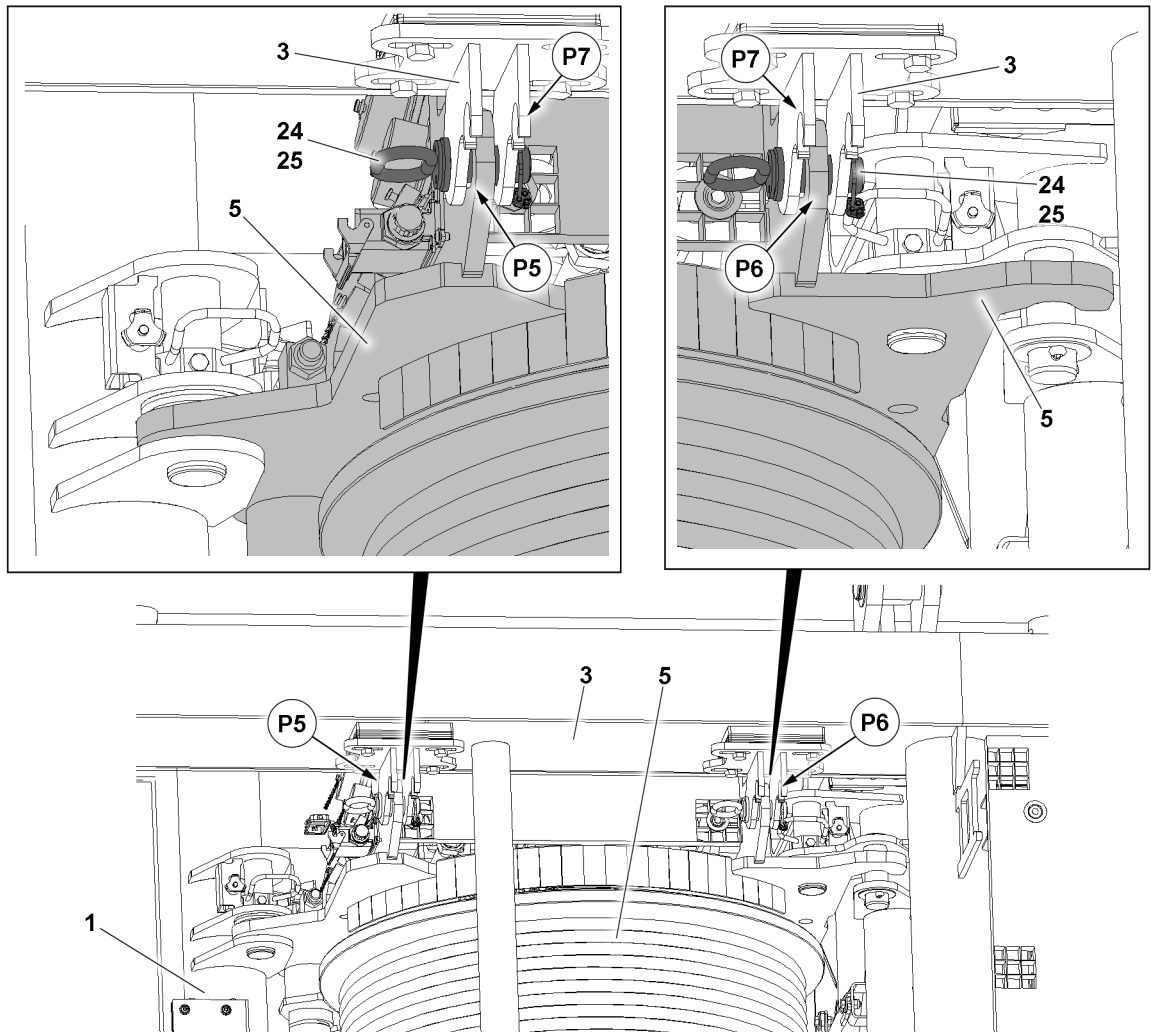


Fig.153497: Releasing winch 4

When winch 4 is pinned on the turntable and secured:

▶ Remove the retaining element **25** on both sides in point **P5** and unpin the connector pin **24**.

▶ Remove the retaining element **25** on both sides in point **P6** and unpin the connector pin **24**.

**Result:**

– Winch 4 is released from the SA-frame.

▶ Insert the connector pin **24** in points **P7** in the park position and secure with the retaining element **25**.

## 7 Establishing the connections to the SA-frame

Make sure that the following prerequisites are met:

- The SA-frame is installed, pinned and secured.
- Winch 4 is installed, pinned and secured.

### 7.1 Establishing the hydraulic connections

The hydraulic connections from the rotary connection in the crawler center section to the turntable is established with quick couplings.

When connecting hydraulic lines with quick couplings, make sure that the coupling procedure is carried out correctly.

The matching quick couplings are marked.



#### WARNING

Pressure in the hydraulic lines!

If the pressure supply is not interrupted before connecting / releasing the hydraulic lines, the hydraulic oil can escape with high pressure.

Death, severe bodily injuries, property damage.

- ▶ Release the pressure in the hydraulic system before connecting / disconnecting: Interrupt the pressure supply and wait for a short time.



#### WARNING

Loss of pressure or leakage!

Incorrectly coupled or self-loosening quick couplings (particularly return lines) can result in serious accidents due to component failure.

Death, severe bodily injuries, property damage.

- ▶ Check that the quick couplings have been properly connected before using the crane.
- ▶ Connect the coupling components (sleeve and connector) and screw together with the knurled nut.
- ▶ Tighten the hydraulic coupling by hand. Turn the knurled nut until it reaches a tangible, fixed stop position.
- ▶ Establish the hydraulic connections, see the Hydraulic diagram.

### 7.2 Establishing the electrical connections



#### Note

- ▶ To establish the electrical connections, use the Electric wiring diagram.
- ▶ Establish the electrical connections.



#### WARNING

Malfunction if dummy plugs are not installed!

If the dummy plugs on the non-required electrical connections are not installed, then malfunctions or functional limitations can occur on the crane.

- ▶ Make sure that all non-required electrical connections, which have a dummy plug, are closed off with dummy plugs.
- ▶ Pay attention to the Electrical wiring diagram.
- ▶ As a rule, close off on-required electrical connections (for example for accessories which cannot be installed) with the respective dummy plugs.

**NOTICE**

Property damage due to dirt and / or corrosion!

If non-required electrical connections are not closed off with the respective protective caps, then dirt and / or corrosion can damage the electrical connections.

This could result in malfunctions.

- ▶ Make sure that all non-required electrical connections are always closed off properly.
- ▶ Pay attention to the Electrical wiring diagram.

- ▶ Close electrical connections, which have no dummy plugs, properly off with the corresponding protective caps.

### 7.3 Establishing the connections to the central lubrication system

- ▶ Establish the connections to the central lubrication system.

## 8 Pinning the pulley support with the turntable

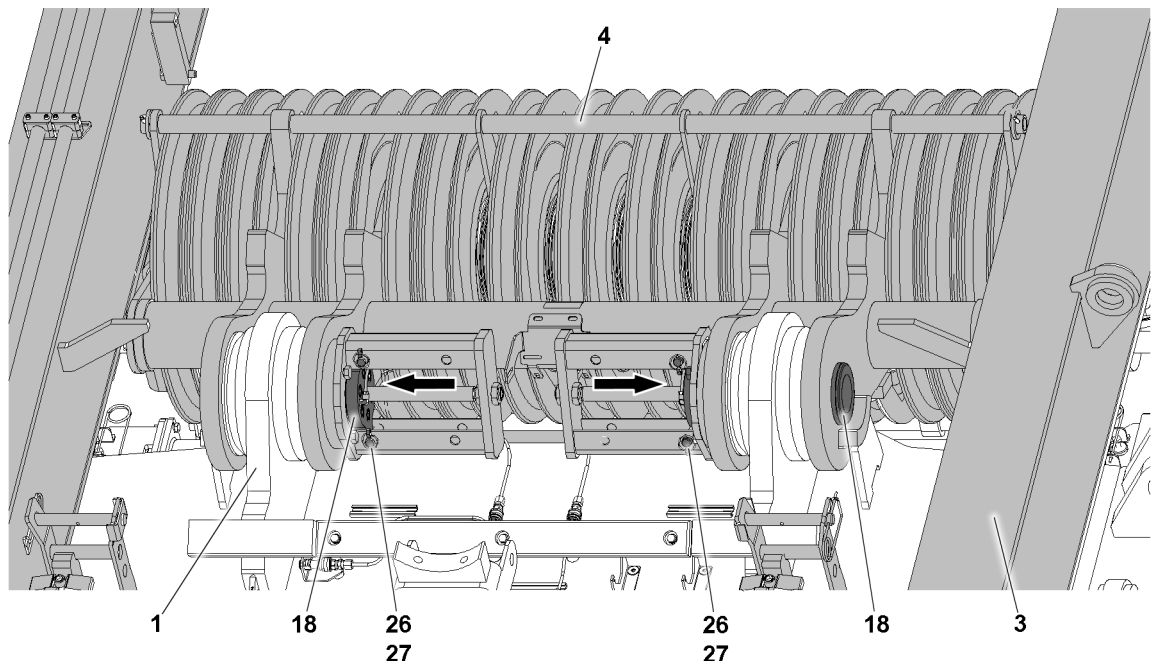


Fig.153498: Pinning roller bearings

Make sure that the following prerequisites are met:

- The hydraulic connections are established.
- The electrical connections are established.
- The connections of the central lubrication system are established.
- The crane engine is running.

**Note**

- ▶ The pinning procedure is the same for both sides of the pulley support.

- ▶ Insert the pin 18.

**Result:**

- The pulley support 4 is pinned with the turntable 1.

**WARNING**

The pin is not secured!

If the pins **18** are not secured, the pins can loosen up by themselves during crane operation. This can cause the crane to topple over.

Death, severe bodily injuries, property damage.

► Make sure that the pins **18** are secured with the retaining pin **26**.

► Secure the pin **18**: Insert the retaining pin **26** on both sides in the operating position and secure with the retaining element **27**.

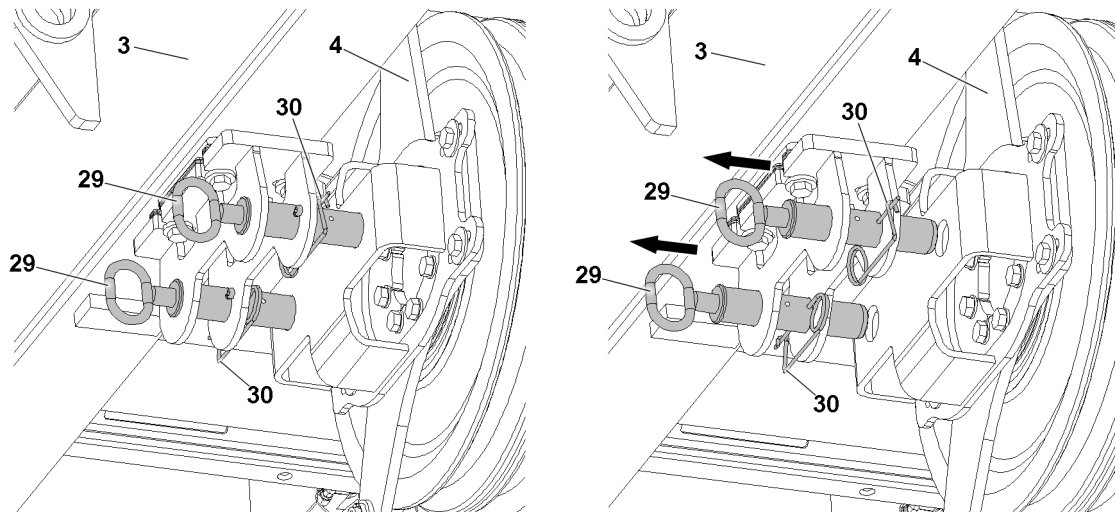


Fig.153499: Releasing the pulley support from the SA-frame

When pulley support **4** is pinned and secured on the turntable **1**:

- Release the pulley support **4** from the SA-frame: Remove the retaining element **30** on both sides out of the transport position and unpin the grip pin **29** to the stop.
- Secure the grip pin **29** in the park position with the retaining element **30** on both sides.

## 9 Releasing the assembly cylinder

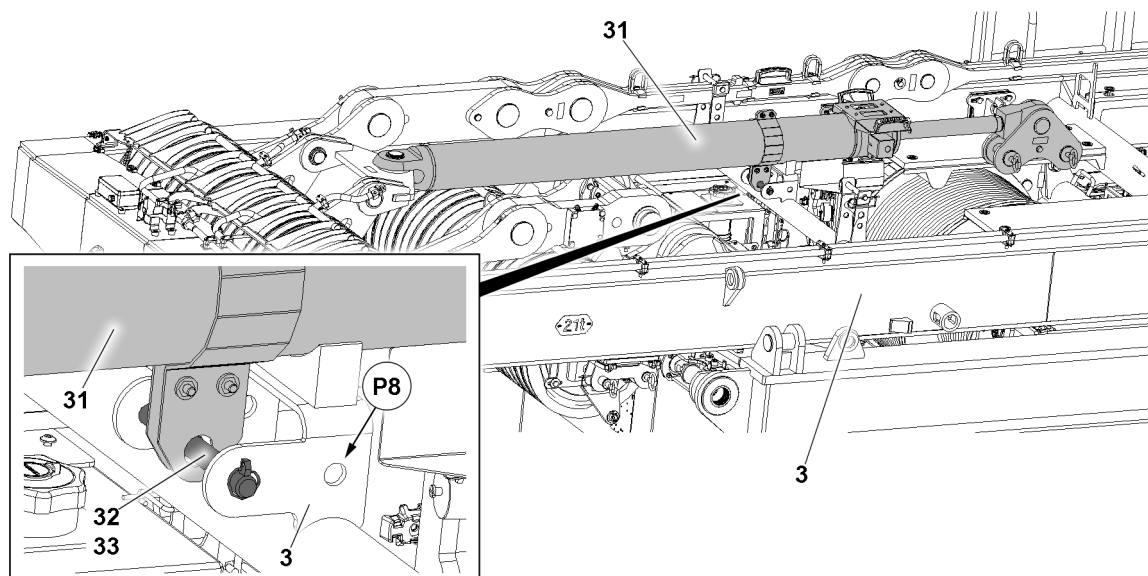


Fig.153500: Assembly cylinder transport retainer



If the assembly cylinder **31** on the SA-frame **3** is required for crawler assembly, then the transport retainer of the assembly cylinder must be removed.



### WARNING

Danger of accident due to the assembly cylinder!

If the SA-frame is erected to more than 90° after removing the transport retainer, then the assembly cylinder **31** swings forward by itself.

Death, severe bodily injuries, property damage.

- ▶ Make sure that no personnel is within the danger zone when erecting the SA-frame.
- ▶ Make sure that no objects or obstacles are within the danger zone.

- ▶ Remove the retaining element **33** and unpin the retaining pin **32** from the transport position.
- ▶ Insert the retaining pin **32** in the park position in point **P8** and secure with the retaining element **33**.

### Result:

- The assembly cylinder is prepared for crawler carrier assembly.

## 10 Assembling the guy rods

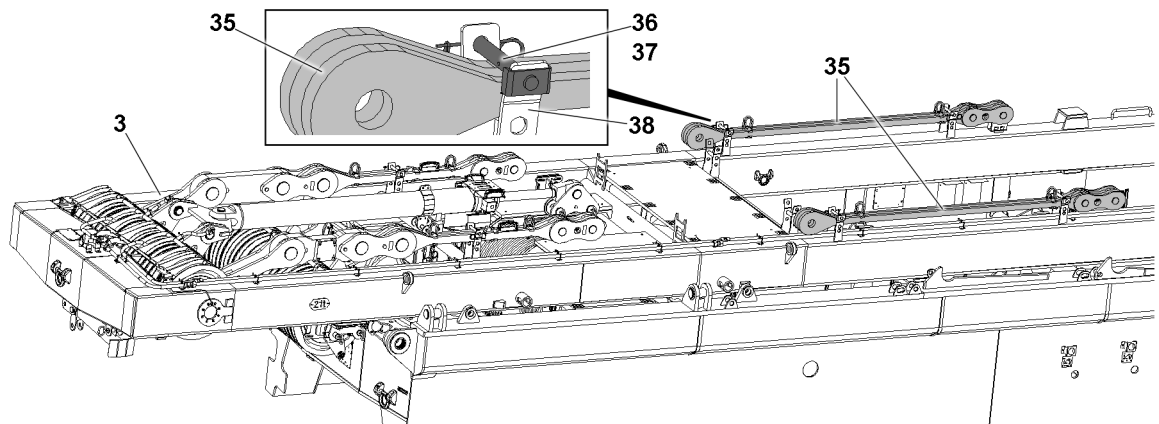


Fig.154299: Releasing the guy rods

If the guy rods **35** are needed on the SA-frame **3** for crane operation, the transport retainers must be removed from the guy rods and the guy rods must be re-pinned.



### WARNING

Danger of accident due to guy rods!

If the SA-frame is erected to more than 90° after removing the transport retainer, then the guy rods **35** swing forward by themselves.

Death, severe bodily injuries, property damage.

- ▶ Make sure that no personnel is within the danger zone when erecting the SA-frame.
- ▶ Make sure that no objects or obstacles are within the danger zone.

- ▶ Fasten the guy rods **35** to the auxiliary crane.
- ▶ Release the guy rods **35**: Remove the retaining element **36** from the retainer **38** and unpin the retaining pin **37**.

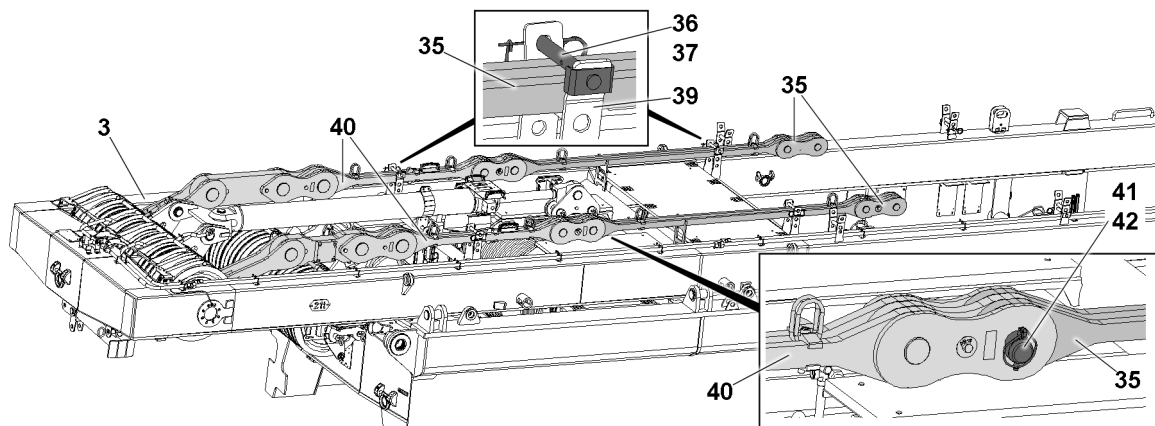


Fig.154300: Pinning the guy rods

- ▶ Lift the guy rods **35** with the auxiliary crane.
- ▶ Insert the guy rods **35** with the guy rods **40** in the retainer **39**.
- ▶ Pin the guy rods **35** with the guy rods **40**: Insert the pin **41** and secure it with the retaining element **42** in the operating position.

If the guy rods **35** are needed on the SA-frame **3** for crane operation:

- ▶ Release the guy rods **35** and the guy rods **40**: Remove the retaining element **36** from the retainer **39** and unpin the retaining pin **37**.
- ▶ Insert the retaining pins **37** in the retainer **38** and in the retainer **39** in the park position and secure with the retaining element **36**.

## 11 Disassembling the guy rods

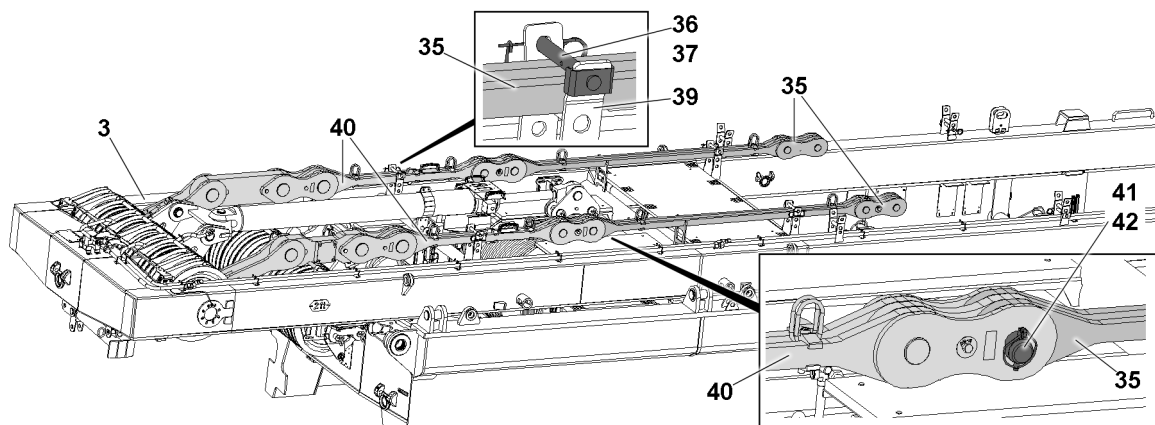


Fig.154301: Unpinning the guy rods

Make sure that the following prerequisite is met:

- The SA-frame is laying completely on the turntable.

- ▶ Secure the guy rods **40** to the retainer **39**: Insert the retaining pin **37** and secure with the retaining element **36** in the transport position.
- ▶ Fasten the guy rods **35** to the auxiliary crane.
- ▶ Unpin the guy rods **35** from the guy rods **40**: Remove the retaining element **42** and unpin the pin **41**.

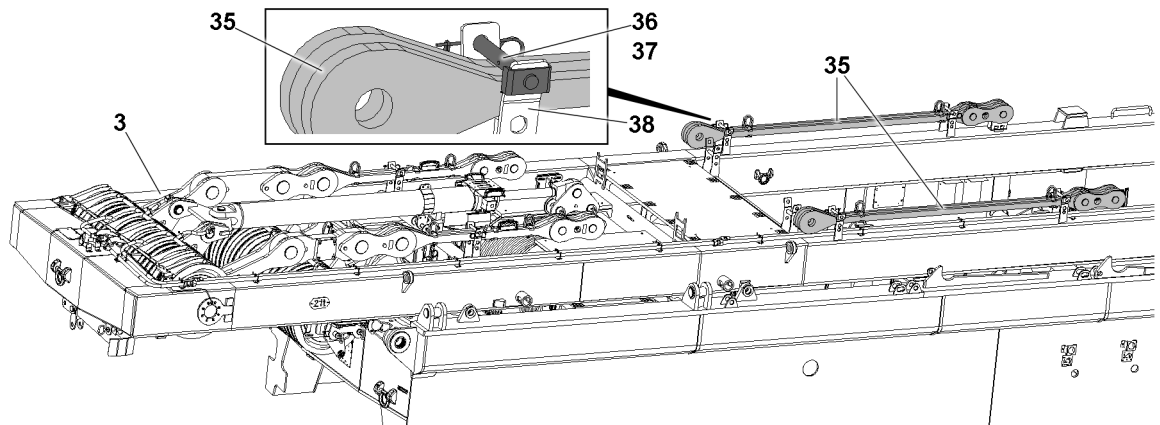


Fig.154299

- ▶ Lift the guy rods **35** with the auxiliary crane and place them in the transport position.
- ▶ Secure the guy rods **35** to the retainer **38**: Insert the retaining pin **37** and secure with the retaining element **36** in the transport position.
- ▶ Insert the pin **41** again in the guy rods **40** and secure with retaining element **42**.

## 12 Securing the assembly cylinder

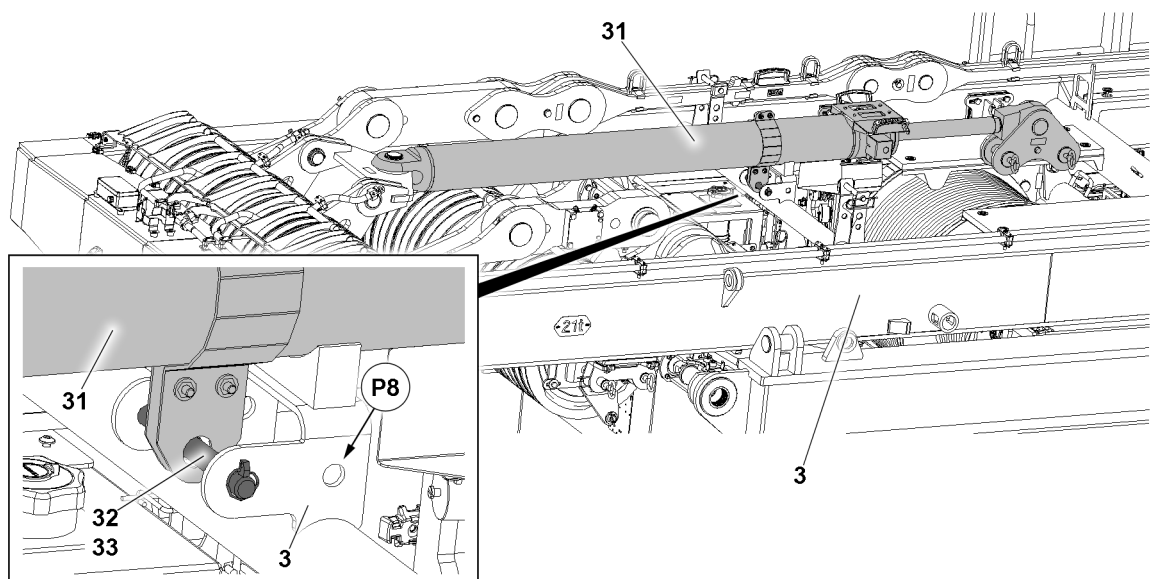


Fig.153500: Assembly cylinder transport retainer

- ▶ Remove the retaining element **33** and unpin the retaining pin **32** from the parking position in point **P8**.
- ▶ Insert the retaining pin **32** in the transport position and secure with the retaining element **33**.

### Result:

- The assembly cylinder **31** is secured for transport.

## 13 Unpinning the pulley support on the turntable

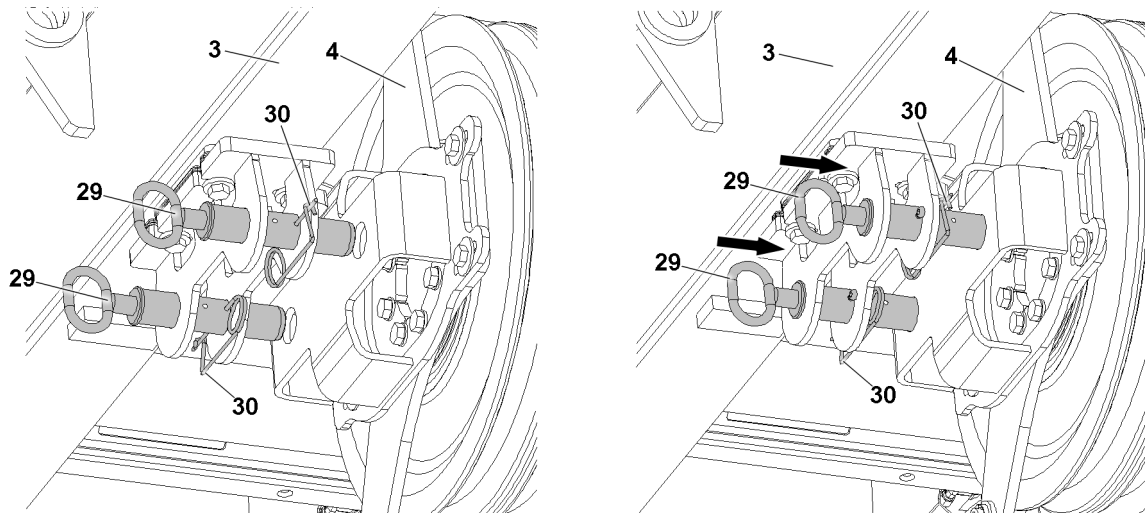


Fig.154302: Connecting the pulley support with the SA-frame

Make sure that the following prerequisite is met:

- The hydraulic connections are established.
- The crane engine is running.



### Note

- ▶ The unpinning procedure is the same for both sides of the pulley support.

- ▶ Connect the pulley support **4** with the SA-frame **3**: Remove the retaining element **30** on both sides out of the park position and insert the grip pin **29** to the stop.



### WARNING

The pin is not secured!

If the grip pins **29** are not secured, the pins can loosen up by themselves during transport operation. Death, severe bodily injuries, property damage.

- ▶ Make sure that the pins **29** are secured with the retaining element **30**.

- ▶ Secure the grip pin **29** on both sides with the spring retainer **30** in the transport position.

### Result:

- The pulley support **4** is pinned and secured on the SA-frame **3** for transport.

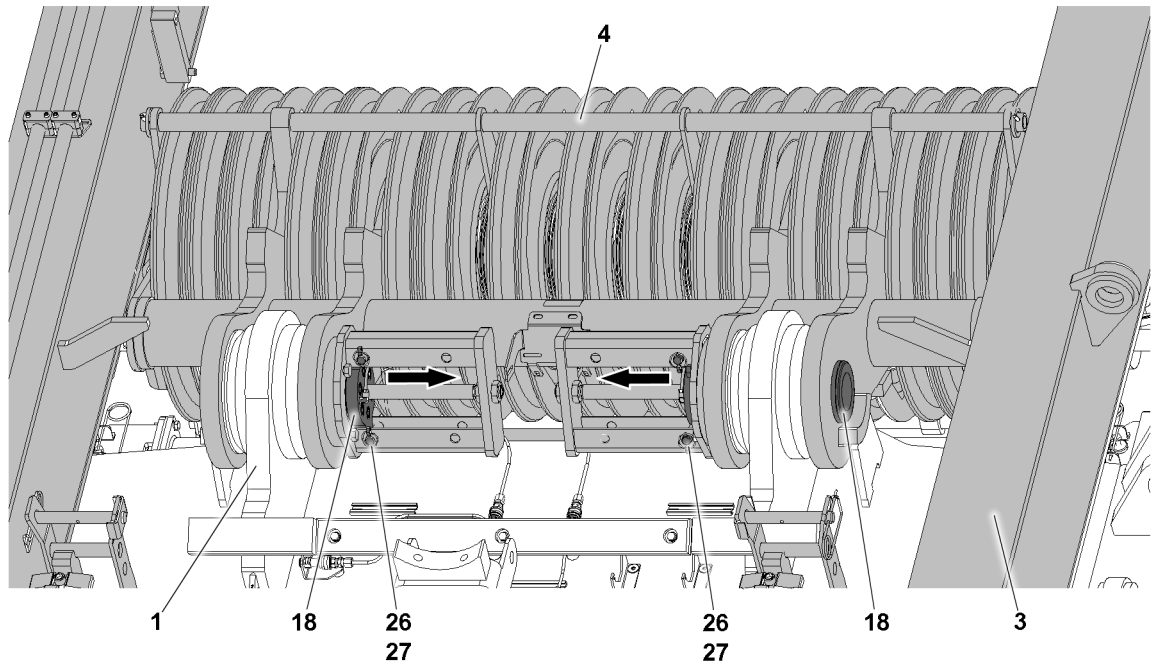


Fig.154303: Unpinning the pulley support

When the pulley support 4 is connected with the SA-frame 3, or the pins 29 are inserted:

- ▶ Remove the retaining element 27 on both sides out of the operating position and unpin the retaining pin 26.
- ▶ Unpin the pulley support 4 on the turntable 1 on both sides.
- ▶ Insert the retaining pin 26 on both sides in the transport position and secure with the retaining element 27.

## 14 Disconnecting the connections to the SA-frame

### 14.1 Disconnecting the hydraulic connections

The hydraulic connections are made with quick couplings.

When disconnecting hydraulic lines with quick couplings, make sure that the uncoupling procedure is carried out correctly.



#### WARNING

Pressure in the hydraulic lines!

If the pressure supply is not interrupted before connecting / releasing the hydraulic lines, the hydraulic oil can escape with high pressure.

Death, severe bodily injuries, property damage.

- ▶ Release the pressure in the hydraulic system before connecting / disconnecting: Interrupt the pressure supply and wait for a short time.
- ▶ Release the hydraulic coupling by hand.
- ▶ Disconnect the hydraulic connections, see the Hydraulic diagram.
- ▶ Protect the hydraulic connections from contamination with caps.

## 14.2 Disconnecting the electrical connections

### NOTICE

Damage to the cable connections!

- ▶ Make sure that the electrical connections have been disconnected and properly stored before unpinning / lifting.
- 
- ▶ Disconnect the electrical connections, see the Electric wiring diagram.
  - ▶ Store the electrical connections properly and protect them against damage.
  - ▶ Close the electrical connections off properly with dummy plugs or protective caps.

## 14.3 Disconnecting the connection to the central lubrication system

- ▶ Disconnect the connection to the central lubrication system.
- ▶ Protect the connections of the central lubrication system with caps from contamination.

## 15 Unpinning winch 4 on the turntable

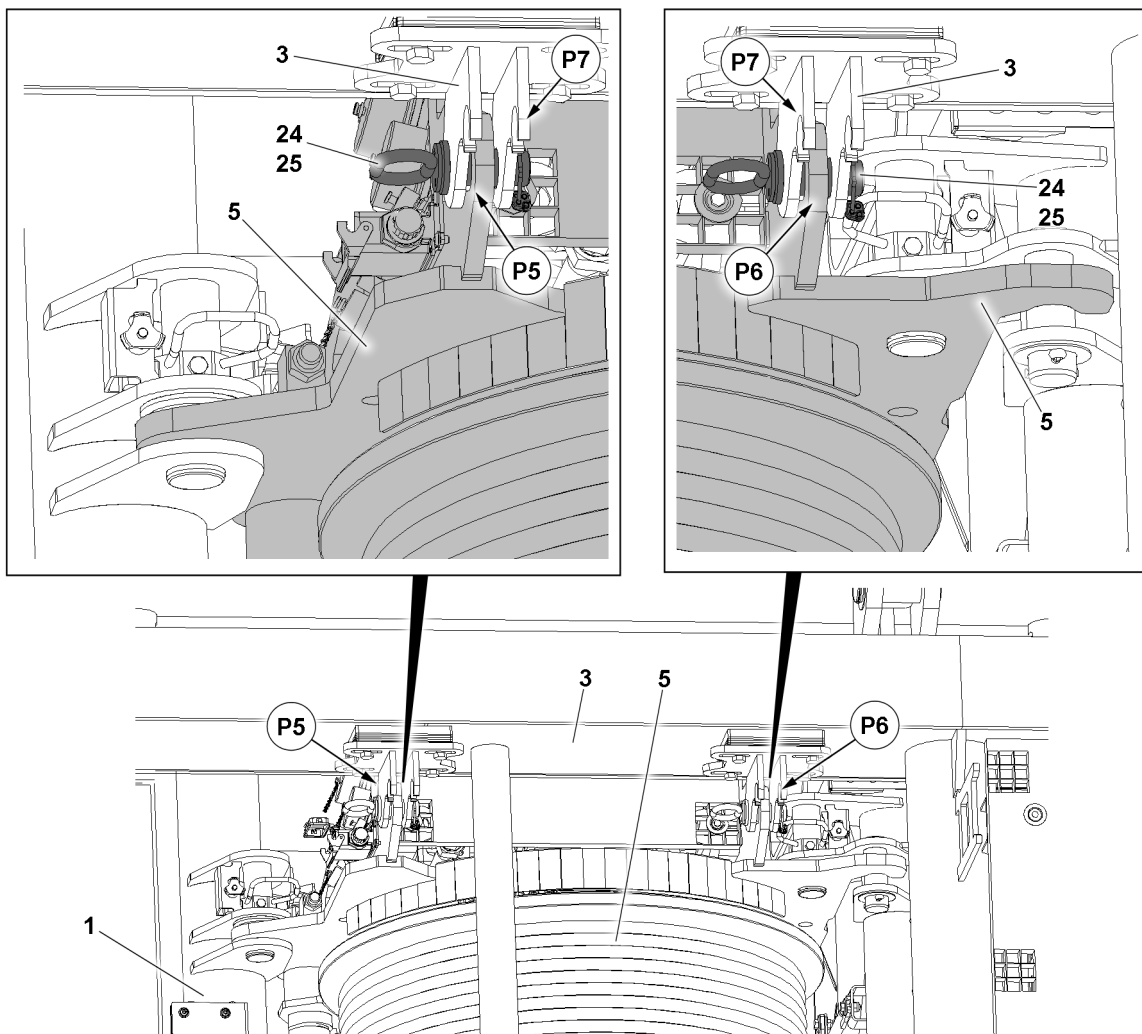


Fig.153497: Pinning winch 4



### Note

- ▶ The unpinning procedure is the same for both sides of Winch 4.

- ▶ Remove the retaining element **25** on both sides in points **P7** and unpin the connector pin **24** from the park position.

**WARNING**

The pin is not secured!

If the connector pins **24** are not secured, the pins can loosen up by themselves during transport. Death, severe bodily injuries, property damage.

- ▶ Make sure that the connector pins **24** are secured with the retaining element **25**.
- 
- ▶ Connect winch 4 with the SA-frame: Insert the connector pin **24** on both sides in point **P5** and point **P6** and secure with the retaining element **25**.

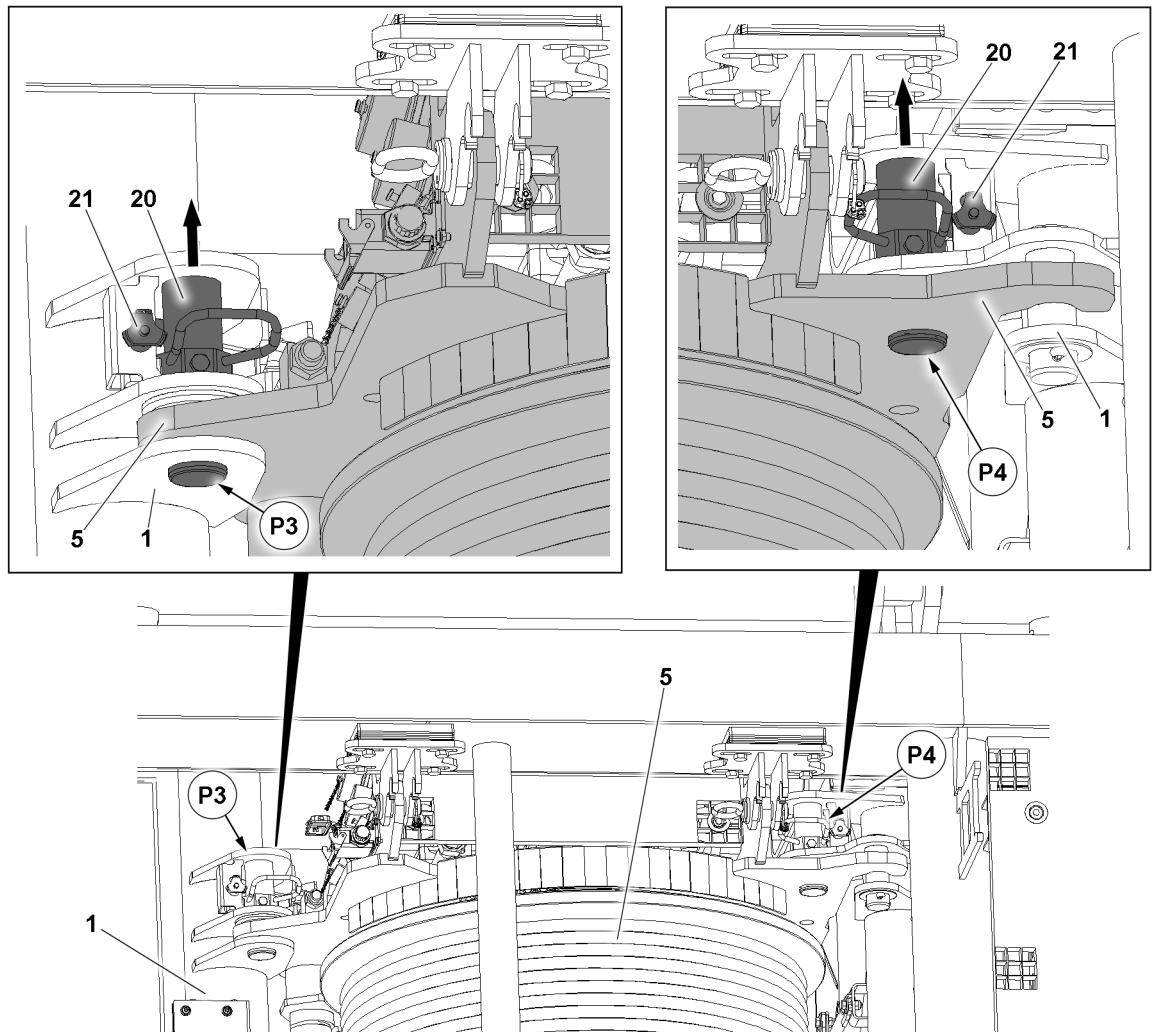


Fig.154304: Unpinning winch 4

When winch 4 is connected with the SA-frame 3:

- ▶ Remove the ball locking pins **21** in points **P3** on both sides and unpin the pin **20**.
- ▶ Secure the pin **20** in the transport position: Insert the ball locking pin **21** in the transport position.
- ▶ Remove the ball locking pins **21** in points **P4** on both sides and unpin the pin **20**.
- ▶ Secure the pin **20** in the transport position: Insert the ball locking pin **21** in the transport position.

**Result:**

- Winch 4 is separated from the turntable **1**.

## 16 Unpinning the SA-frame on the turntable

### 16.1 Fastening the SA-frame to the auxiliary crane

Make sure that the following prerequisite is met:

- An auxiliary crane with sufficient load bearing capacity is available.
- ▶ Fasten the fastening equipment in points **P2** to the SA-frame **3**, see section “SA-frame fastening points”.



#### WARNING

Danger of falling!

Death, severe bodily injuries, property damage.

- ▶ The fastening equipment may only be attached on points **P1** with the aid of a work platform.
- ▶ Fasten the fastening equipment in points **P1** to the SA-frame **1**, see section “SA-frame fastening points”.
- ▶ Tension the fastening equipment.

### 16.2 Unpinning the SA-frame

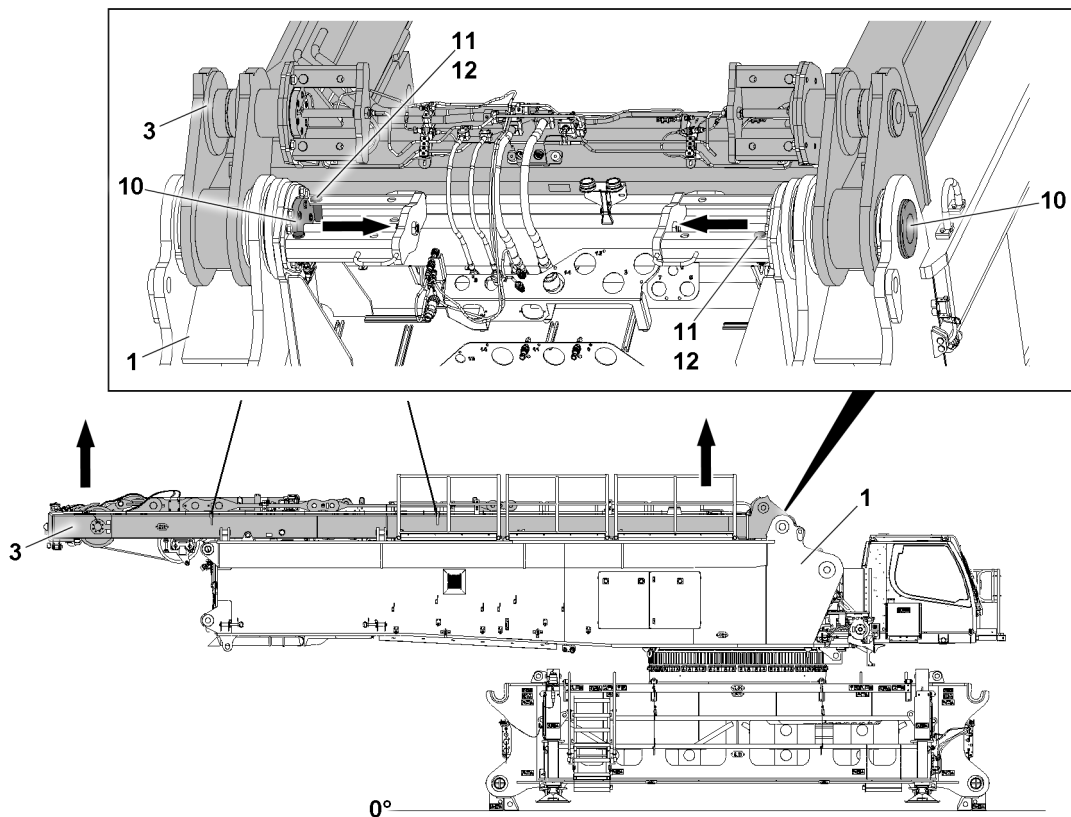


Fig.153493: Unpinning the SA-frame

Make sure that the following prerequisites are met:

- The hydraulic connections are disconnected.
- The electrical connections are disconnected.
- The connections of the central lubrication system are disconnected.
- The assembly cylinder is properly secured in the transport position.
- Winch 4 is pinned and secured with the SA-frame.
- The pulley support is pinned and secured with the SA-frame.
- The fastening equipment is tensioned.



- The crane engine is running.



**Note**

- ▶ The unpinning procedure is the same for both sides of the SA-frame.



**WARNING**

Danger of slipping, tripping and falling!  
Death, severe bodily injuries.

Danger of slipping, tripping and falling when accessing or leaving the work position due to a small step depth and different step heights due to structural conditions.

- ▶ Observe the danger notes, see chapter 2.07.

- ▶ Release the pin **10**: Remove the retaining element **12** on both sides and unpin the retaining pin **11**.
- ▶ Unpin the pin **10**.

**Result:**

- The SA-frame **3** can be removed.
- ▶ Lift the SA-frame **3** with the auxiliary crane, swing it and lower it until the support can be brought into transport position.

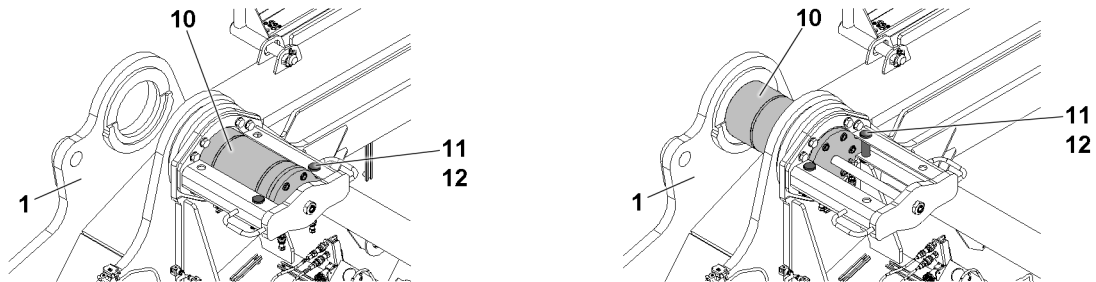


Fig.153494: Inserting the pin

- ▶ Insert the pins **10** again.

When the pins **10** are inserted:

- ▶ Insert the retaining pins **11** on both sides and secure with the retaining element **12**.

### 16.3 Swinging the support into the transport position

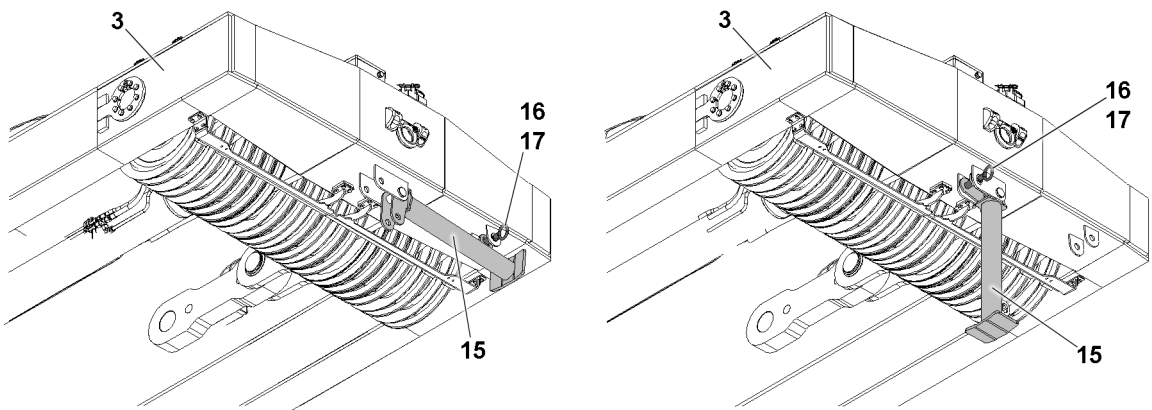


Fig.153495: Support

LWE/LR 1800-1-0-000/27200-07-02/en

**WARNING**

Support swinging down!

The support **15** can swing downward due to its own weight when unpinning it.

Death, severe bodily injuries, property damage.

- ▶ For safety reasons, **two** persons must always be used to unpin the support.
- ▶ Make sure that there are no persons within the danger zone during the entire unpinning procedure.

- ▶ Release the support **15** from the operating position: Remove the retaining element **17** and unpin the pin **16**.
- ▶ Swing the support **15** into the transport position.

**WARNING**

The pin is not secured!

If the pin **16** is not secured, the pin can loosen up by itself during transport.

Death, severe bodily injuries, property damage.

- ▶ Make sure that the pin **16** is secured with safety locking pin **17**.

- ▶ Secure the support **15** in the transport position: Insert the pin **16** and secure it with the retaining element **17**.

When the support **15** is swung into the transport position:

- ▶ Take the SA-frame **3** down on the ground or on the transport vehicle.

## 3.06 Assembly conditions

1 Assembly conditions for operation on crawlers

---

2

LWE/LR 1800-1-0-000/27200-07-02/en

# 1 Assembly conditions for operation on crawlers

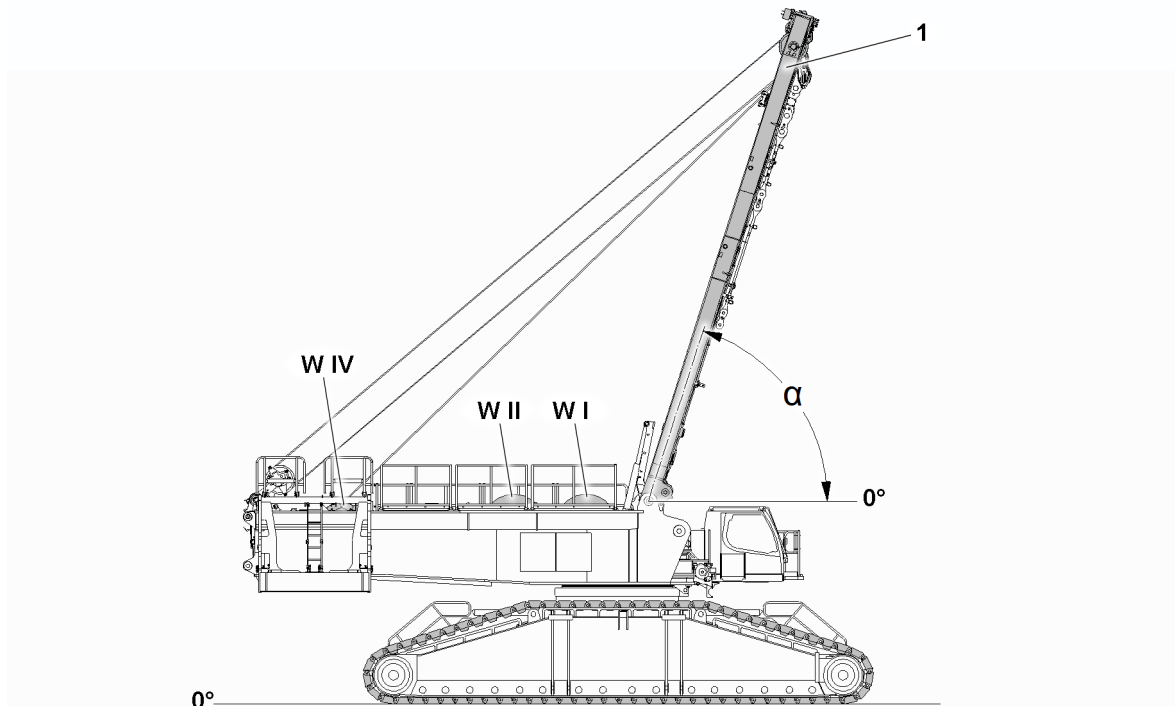


Fig.166594: Crane illustration

1 SA-frame

W II Winch 2

α SA-frame angle

W IV Winch 4

W I Winch 1



## WARNING

The crane can topple over!  
The crane can topple backwards during operation on crawlers.  
Death, severe bodily injuries, property damage.

- ▶ Observe the assembly conditions.
- ▶ Observe and apply the charts in this chapter only in combination.



## WARNING

Impermissible travel operation!

If the turntable ballast (counterweight) is installed, a crane can tip over in the assembly condition when driving.

If a pivot section is installed lying on the ground, a crane can be severely damaged in the assembly condition when driving.

Death, severe bodily injuries, property damage.

- ▶ Assembly conditions with installed turntable ballast are not permitted for travel operation.
- ▶ Assembly conditions with installed pivot section ballast are not permitted for travel operation.



## Note

Driving / changing over the crane in the assembly condition.

- ▶ Travel operation in the assembly condition is only possible without turntable ballast and without the pivot section.

## 1.1 Definition of assembly conditions

Assembly condition	SA-frame, angle $\alpha$	Winch I	Winch II	Winch IV	Pivot section <sup>1)</sup>
1	$> 90^\circ$	–	–	With rope	–
2	$\leq 90^\circ$	–	–	With rope	–
3	$> 90^\circ$	With rope	–	With rope	–
4	$\leq 90^\circ$	With rope	–	With rope	–
5	$> 90^\circ$	With rope	With rope	With rope	–
6	$\leq 90^\circ$	With rope	With rope	With rope	–
7	$> 90^\circ$	With rope	–	With rope	Installed (lies on <sup>2)</sup> )
8	$\leq 90^\circ$	With rope	–	With rope	Installed (lies on <sup>2)</sup> )

### Description of assembly conditions

1) Main boom pivot section or derrick boom pivot section

2) On the ground or, if necessary, on a substructure

SA-frame, angle $\alpha$	
Angle data	Description
$\alpha > 90^\circ$	<p><math>\alpha</math> greater than <math>90^\circ</math></p> <p><b>Note:</b> Applies until the SA-frame guide is taken down on the turntable.</p>
$\alpha \leq 90^\circ$	<p><math>\alpha</math> less than or equal to <math>90^\circ</math></p> <p><b>Note:</b> Applies until the SA-frame is set maximum to the front.</p>

### Description of angle data

## 1.2 Permissible turntable ballast / permissible ballast combinations



### Note

► Definition of assembly conditions, see section "Definition of assembly conditions".



### WARNING

The crane can topple over!

Death, severe bodily injuries, property damage.

► Observe the maximum permissible turntable ballast / permissible ballast combinations.

Assembly condition	Maximum permissible turntable ballast					
	360° slewing range on crawler travel gear 9.4 m x 9.0 m					
	For central ballast					
	130 t	90 t	70 t	50 t	30 t	10 t
1 <sup>1)</sup>	230 t	190 t	170 t	150 t	130 t	110 t
2 <sup>1)</sup>	230 t	210 t	190 t	170 t	150 t	130 t
3 <sup>1)</sup>	230 t	210 t	170 t	150 t	130 t	110 t
4 <sup>1)</sup>	230 t	230 t	210 t	190 t	170 t	150 t
5 <sup>1)</sup>	230 t	210 t	190 t	170 t	150 t	130 t

Assembly condition	Maximum permissible turntable ballast 360° slewing range on crawler travel gear 9.4 m x 9.0 m					
	For central ballast					
	130 t	90 t	70 t	50 t	30 t	10 t
6 <sup>1)</sup>	230 t	230 t	210 t	190 t	170 t	150 t
7 <sup>2)</sup>	230 t	210 t	190 t	170 t	150 t	130 t
8 <sup>2)</sup>	230 t	230 t	230 t	210 t	170 t	150 t

*Maximum permissible turntable ballast for assembly conditions on crawlers*

- 1) Anticipatory driving is possible in this assembly condition with 0 t turntable ballast.  
 2) Driving is not possible in this assembly condition.

## 3.07 Winch assembly

1 Winch assembly

---

2

LWE/LR 1800-1-0-000/27200-07-02/en

# 1 Winch assembly

**Note**

The assembly of the various winches is described in separate chapters.

- ▶ Observe the following chapter 3.07.xx (for example 3.07.10, 3.07.20...).



## 3.07.10 Winch 1 assembly

1	Safety	2
2	Component overview	2
3	Winch 1 fastening points	2
4	Ascending / descending to the space of winch 1 and winch 2	3
5	Assembly winch 1	4
6	Establishing the connections from winch 1 to the turntable	9
7	Disconnecting the connections from winch 1 to the turntable	11
8	Disassembling winch 1	13

# 1 Safety

Before assembly and disassembly of winch 2, observe the safety instructions:

- Information regarding work on the crane superstructure. See chapter 2.04.
- Information regarding personal protective equipment. See chapter 2.04.
- Information regarding the use of ladders. See chapter 2.04.10.
- Information regarding fall protection equipment. See chapter 2.06.
- Information regarding accesses to the crane. See chapter 2.07.
- Information regarding accessible surfaces. See chapter 2.07.
- Information regarding assembly conditions. See chapter 3.06.

## 2 Component overview



### Note

- ▶ Winch 1 dimensions and weights, see chapter 1.03.



### Note

- ▶ Winch 1 is marked with its own weight.

## 3 Winch 1 fastening points



### WARNING

Winch incorrectly fastened!

Life-threatening situations can arise if the winch is incorrectly or improperly fastened.  
Death, severe bodily injuries, property damage.

- ▶ Attach the winch only on the intended fastening points.
- ▶ Attach the fastening equipment on winch solely in connection with shackles.
- ▶ Make sure that the shackles and fastening equipment have sufficient load bearing capacity.
- ▶ Observe the technical safety instructions during assembly and disassembly, see Crane operating instructions, chapter 5.01.

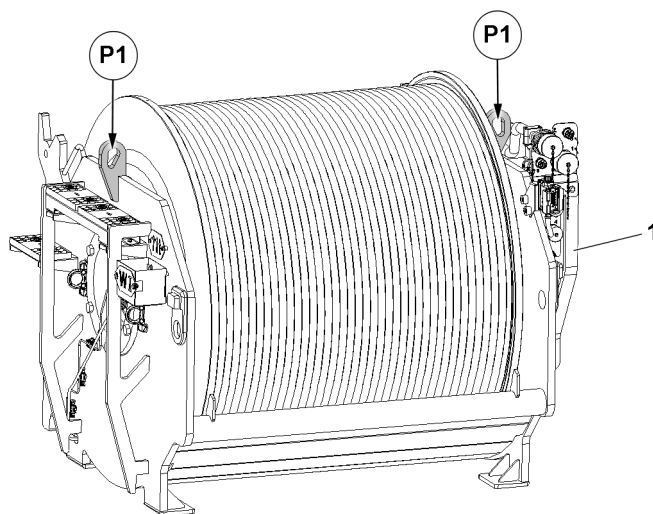


Fig.155206: Winch 1 fastening points

1 Winch 1

Fastening points	
P1	Winch 1

### 4 Ascending / descending to the space of winch 1 and winch 2

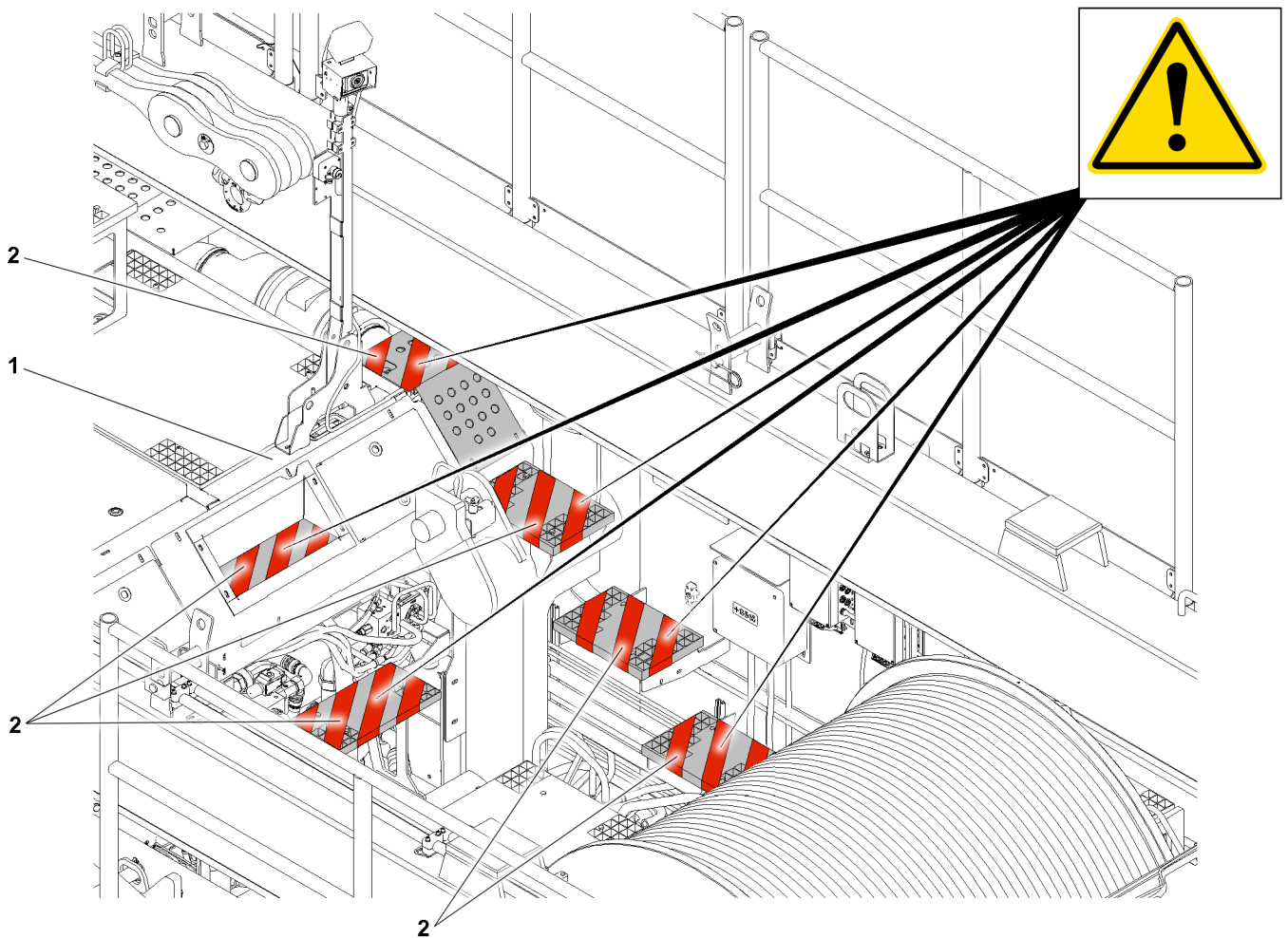


Fig.155207: Ascending / descending to the space of winch 1 and winch 2 (SA-frame is placed on the turntable in the illustration)

- 1 Turntable
- 2 Steps

To pin winch 1 to the turntable 1, assembly personal must climb down from the level of the motor cover using the steps 2 to the assembly space of winch 1 and winch 2. After pinning winch 1, they must climb up again using the steps 2 to the level of the motor cover of the turntable.



**WARNING**

Small step depth!  
 Death, severe bodily injuries.  
 ► Always step on the steps 2 with extreme caution.

LWE/LR 1800-1-0-000/27200-07-02/en

**WARNING**

Different step heights!

Death, severe bodily injuries.

- ▶ Always step on the steps **2** with extreme caution.

- ▶ Step on the steps **2** with extreme caution.

## 5 Assembly winch 1

**WARNING**

Danger of falling!

During assembly / disassembly, inspection and maintenance work, assembly personnel must be secured with appropriate aids to prevent them from falling.

Death, severe bodily injuries, property damage.

- ▶ All work at a height, when there is a danger of falling, must be carried out with suitable aids.
- ▶ If aids are not available and work cannot be carried out from the ground, then assembly personnel must secure themselves with the supplied fall arrest system to prevent falling, see chapter 2.04.
- ▶ If fall protection equipment is available, then it must be used, see chapter 2.06.
- ▶ When lifting, lowering, swinging crane parts in and out, no persons may remain in the danger zone.
- ▶ When closing or opening boom systems during boom assembly or boom disassembly, no persons may remain on the boom system or in the danger zone.
- ▶ If railings are present on the components, then they must be brought into the corresponding position and secured for assembly / disassembly work.
- ▶ Only step on the aids, ladders and catwalks with clean shoes.
- ▶ Keep aids, ladders and catwalks free of heavy dirt, snow, frost and ice.
- ▶ During all assembly and disassembly work, maintenance work and inspections, travel or crane operation is prohibited.
- ▶ Remaining on a suspended load is prohibited.
- ▶ Stepping or walking on crane components and lattice sections that have an incline of more than 20° is prohibited.
- ▶ For all assembly work, the crane driver of the main crane must be in voice contact with the crane driver / crane drivers of the auxiliary crane / auxiliary cranes.
- ▶ For assembly tasks, the crane driver may only initiate crane movements when the responsible guide has explicitly released the movement.

**WARNING**

Danger of impact / crushing!

When installing / removing crane components with the auxiliary crane, crane components can start to swing back and forth.

When lifting / lowering and positioning crane components, there is an increased danger of impacts / crushing.

Death, severe bodily injuries, property damage.

- ▶ Make sure that personnel cannot be caught by components.
- ▶ Make sure that the crane is horizontally aligned.
- ▶ When working in danger zones: Use aids to protect limbs.
- ▶ Guide components with suitable aids to minimize oscillation.

**DANGER**

The components can fall down!

If the corresponding component is disengaged from the auxiliary crane before the corresponding component is pinned, then the corresponding component can fall down.

Death, severe bodily injuries, property damage.

- ▶ Do not disengage the auxiliary crane until the respective component is pinned and secured.

## 5.1 Assembling winch 1

Winch 1 can be installed on the turntable with varying prerequisites / conditions. The following describes the assembly based on condition 3 as an example.

Make sure that the following prerequisites are met:

- Condition 1: Turntable without SA-frame.  
**or:**
- Condition 2: The SA-frame is assembled on the turntable and completely taken down (180° position).  
**or:**
- Condition 3: The SA-frame is assembled on the turntable and erected to 156°.
- The counterweight is assembled on the turntable according to “Assembly conditions on crawlers”, see chapter 3.06.

### 5.1.1 Lifting winch 1 from the flatbed trailer



#### WARNING

Danger of accident during assembly of winch 1!  
Death, severe bodily injuries, property damage.

- ▶ Make sure that winch 1 is secured with an auxiliary rope to prevent it from swinging.
- 
- ▶ Fasten the fastening equipment to the fastening points properly, see section “Winch 1 fastening points”.
  - ▶ Bring the fastening equipment to “tension” with the auxiliary crane.
  - ▶ Release and remove the transport retainers on the flatbed trailer.



#### WARNING

Falling components!  
When lifting winch 1 from the flatbed trailer, components or winch 1 can fall down.  
Death, severe bodily injuries, property damage.

- ▶ Make sure that there are no persons within the danger zone.
- 
- ▶ Lift winch 1 with the auxiliary crane from the flatbed trailer.

## 5.1.2 Swinging in and positioning winch 1

Make sure that the following prerequisites are met:

- The crane is horizontally aligned.
- The ground is able to safely take on the entire operating weight of the crane including the load to be lifted.
- Gratings, catwalks and fall protection equipment are properly installed.
- Access stairs to the catwalks are properly installed.
- The access stairs to the cab platform are in operating position.
- An auxiliary crane with a suitable load-bearing capacity is available.
- The connector pins **4** in points **P2** are fully unpinned on both sides.
- The connector pins **4** are secured in the "unpinned" position with ball locking pins **5**, point **P8**.

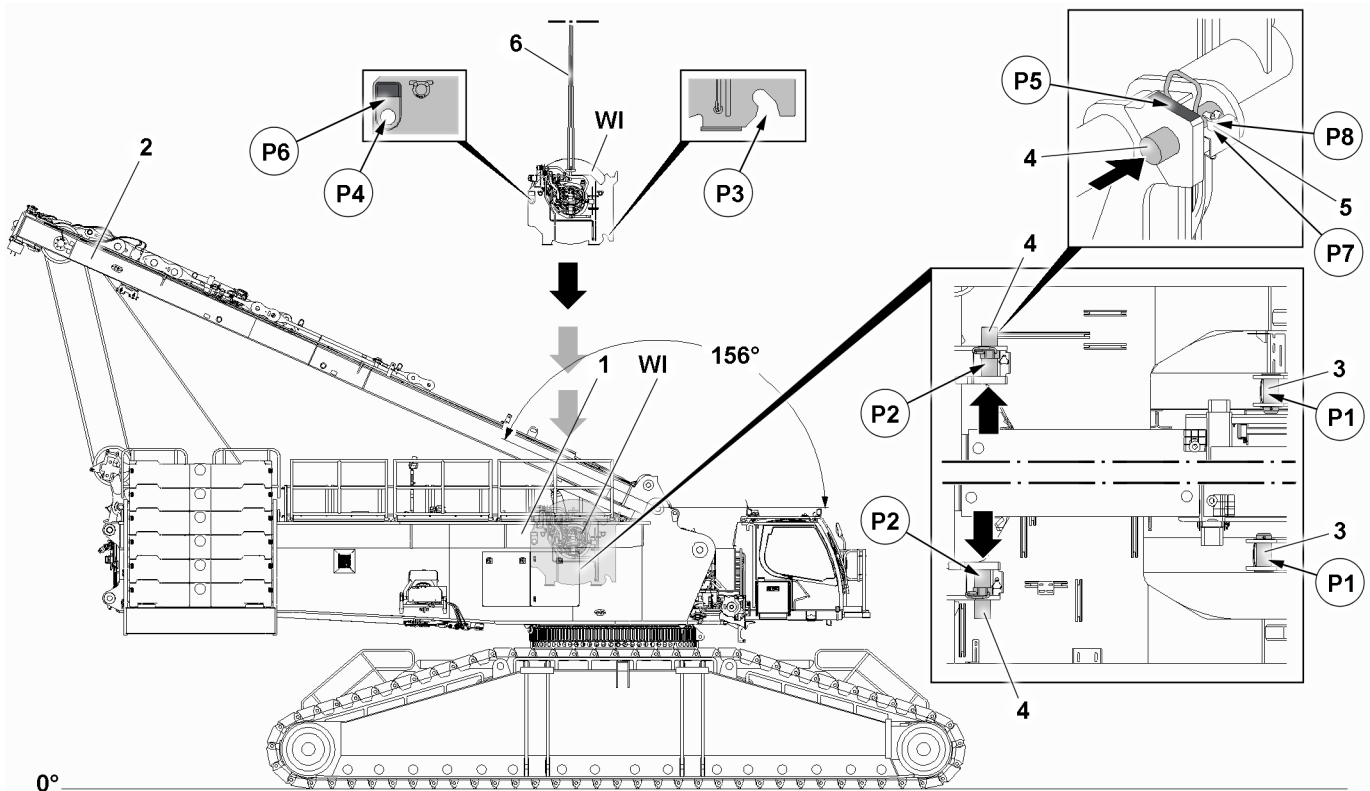


Fig.155209: Positioning winch 1 in the turntable

<b>WI</b> Winch 1	<b>3</b> Centering pin	<b>6</b> Fastening equipment
<b>1</b> Turntable	<b>4</b> Connector pin	
<b>2</b> SA-frame	<b>5</b> Ball locking pin	



### WARNING

Danger of accident when swinging in and lowering winch 1!  
When swinging in and lowering winch 1 **WI** on the turntable **1**, limbs can be crushed or even severed. Death, severe bodily injuries, property damage.

- ▶ Make sure that there is no personnel in the danger zone.
- ▶ Do not reach with your hands into the danger zone.

### NOTICE

Property damage!

If the following notes are not observed, damage can result to the crane or winch 1 **WI**.

- ▶ Make sure that winch 1 **WI** does not bump against the SA-frame **2** when lowering into the turntable **1**.
- ▶ Make sure that winch 1 **WI** does not bump against the turntable when lowering into the turntable **1**.

**Note**

- ▶ The guide must be in constant visual and acoustic contact with the crane operator.

**Note**

- ▶ Pay attention to exact alignment of winch 1 **WI** to the installation position or the pocket receptacles, point **P3**, to the centering pins **3**.
- ▶ Before lowering, bring winch 1 **WI** into position so that the pocket receptacles, point **P3**, are above the centering pins **3** at point **P1**.

- ▶ Swing winch 1 **WI** in with the auxiliary crane to the turntable **1**.
- ▶ Position and align winch 1 **WI**.

When winch 1 **WI** is aligned:

- ▶ Slowly and carefully lower winch 1 **WI** into the turntable frame.
- ▶ Set winch 1 **WI** with the centerings on both sides, points **P3**, on the centering pins **3** at point **P1**.
- ▶ Continue to lower winch 1 **WI** until the locating surfaces **P6** rest completely on the mounting plates **P5**.

**Result:**

- Winch 1 **WI** is positioned and inserted in the winch frame.
- ▶ Pin winch 1, see section “Pinning winch 1 **WI**”.

### 5.1.3 Pinning winch 1

Make sure that the following prerequisites are met:

- Winch 1 **WI** is resting with the centerings **P3** on both sides on the centering pins **3** at point **P1**.
- Winch 1 **WI** is resting with the locating surfaces **P6** on both sides on the mounting plates **P5**.

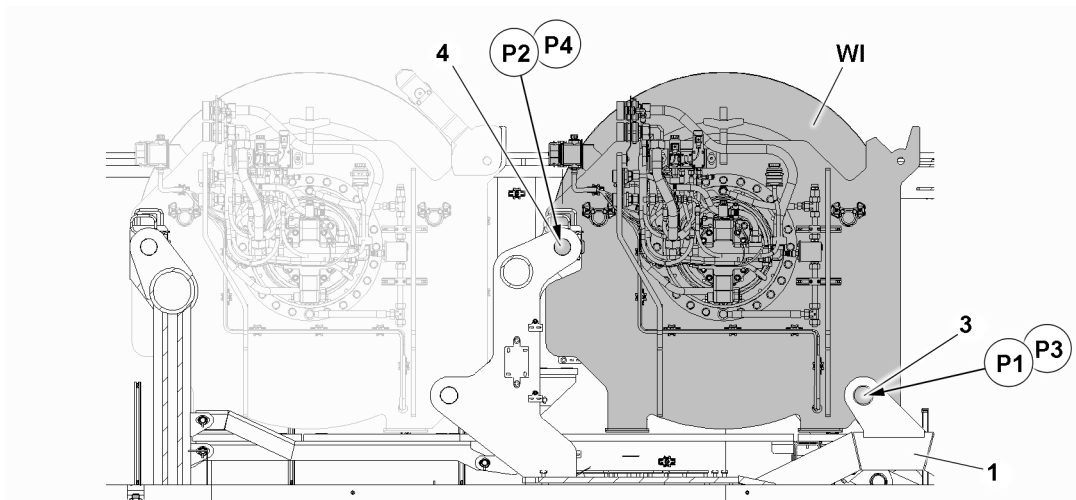


Fig.155210: Inserting winch 1 **WI** in the turntable

<b>WI</b> Winch 1	<b>3</b> Centering pin
<b>1</b> Turntable	<b>4</b> Connector pin

- ▶ Release the connector pin **4**: Remove the ball locking pin **5** at point **P8**.
- ▶ Pin the connector pins **4** completely on both sides.

**WARNING**

The pins can loosen up by themselves!

If the connector pins **4** are not properly secured, they can come loose. The load call fall down. Death, severe bodily injuries, property damage.

- ▶ Secure the connector pins **4** immediately after pinning with ball locking pins **5**.

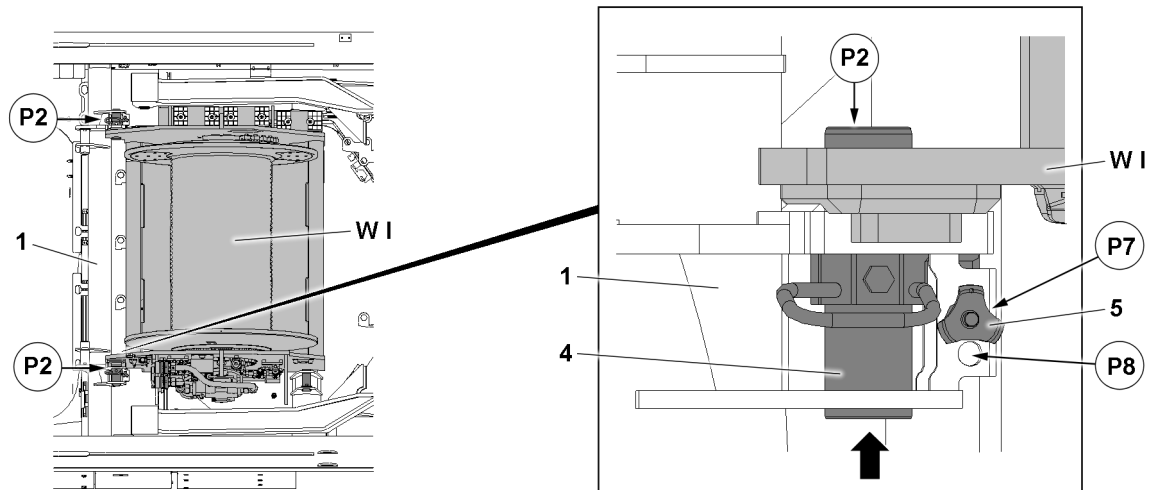


Fig.155211: Pinning winch 1 in the turntable

**W I** Winch 1  
**1** Turntable

**4** Connector pin  
**5** Ball locking pin

When the connector pins **4** on winch 1 are completely pinned on both sides:

- ▶ Secure the connector pins **4** immediately on both sides: Insert the ball locking pins **5** completely in point **P7**.

**Result:**

- The connector pins **4** are properly secured.
- Winch 1 **W I** is properly secured.
- ▶ Release the fastening equipment on winch 1 **W I**.
- ▶ Remove the auxiliary crane.



## 6 Establishing the connections from winch 1 to the turntable



### WARNING

Danger of falling!

During assembly / disassembly, inspection and maintenance work, assembly personnel must be secured with appropriate aids to prevent them from falling.

Death, severe bodily injuries, property damage.

- ▶ All work at a height, when there is a danger of falling, must be carried out with suitable aids.
- ▶ If aids are not available and work cannot be carried out from the ground, then assembly personnel must secure themselves with the supplied fall arrest system to prevent falling, see chapter 2.04.
- ▶ If fall protection equipment is available, then it must be used, see chapter 2.06.
- ▶ When lifting, lowering, swinging crane parts in and out, no persons may remain in the danger zone.
- ▶ When closing or opening boom systems during boom assembly or boom disassembly, no persons may remain on the boom system or in the danger zone.
- ▶ If railings are present on the components, then they must be brought into the corresponding position and secured for assembly / disassembly work.
- ▶ Only step on the aids, ladders and catwalks with clean shoes.
- ▶ Keep aids, ladders and catwalks free of heavy dirt, snow, frost and ice.
- ▶ During all assembly and disassembly work, maintenance work and inspections, travel or crane operation is prohibited.
- ▶ Remaining on a suspended load is prohibited.
- ▶ Stepping or walking on crane components and lattice sections that have an incline of more than 20° is prohibited.
- ▶ For all assembly work, the crane driver of the main crane must be in voice contact with the crane driver / crane drivers of the auxiliary crane / auxiliary cranes.
- ▶ For assembly tasks, the crane driver may only initiate crane movements when the responsible guide has explicitly released the movement.



### WARNING

Danger of impact / crushing!

When installing / removing crane components with the auxiliary crane, crane components can start to swing back and forth.

When lifting / lowering and positioning crane components, there is an increased danger of impacts / crushing.

Death, severe bodily injuries, property damage.

- ▶ Make sure that personnel cannot be caught by components.
- ▶ Make sure that the crane is horizontally aligned.
- ▶ When working in danger zones: Use aids to protect limbs.
- ▶ Guide components with suitable aids to minimize oscillation.



### DANGER

The components can fall down!

If the corresponding component is disengaged from the auxiliary crane before the corresponding component is pinned, then the corresponding component can fall down.

Death, severe bodily injuries, property damage.

- ▶ Do not disengage the auxiliary crane until the respective component is pinned and secured.

## 6.1 Establishing the connections



### Note

- ▶ Establish the connections to winch 1 only when winch 1 is properly installed and secured on the turntable.

Make sure that the following prerequisite is met:

- The winch 1 is properly installed, pinned and secured.

### 6.1.1 Establishing the hydraulic connections to the winch



### Note

- ▶ After the hydraulic connections to the winch are established, the expansion tank must be checked and emptied.

The hydraulic connections for the winch are made with quick couplings.

When connecting hydraulic lines with quick couplings, make sure that the coupling procedure is carried out correctly.



### WARNING

Pressure in the hydraulic lines!

If the pressure supply is not interrupted before connecting / releasing the hydraulic lines, the hydraulic oil can escape with high pressure.

Death, severe bodily injuries, property damage.

- ▶ Release the pressure in the hydraulic system before connecting / disconnecting: Interrupt the pressure supply and wait for a short time.



### WARNING

Loss of pressure or leakage!

Incorrectly coupled or self-loosening quick couplings (particularly return lines) can result in serious accidents due to component failure.

- ▶ Check that the quick couplings have been properly connected before using the crane.
- ▶ Connect the coupling components (sleeve and connector) and screw together with the knurled nut.
- ▶ Tighten the hydraulic coupling by hand. Turn the knurled nut until it reaches a tangible, fixed stop position.
- ▶ Establish the hydraulic connections to the winch.

### 6.1.2 Establishing the electrical connections to the winch

- ▶ Establish the electrical connections to the winch, see the Electric wiring diagram.



### WARNING

Malfunction if dummy plugs are not installed!

If the dummy plugs on the non-required electrical connections are not installed, then malfunctions or functional limitations can occur on the crane.

- ▶ Make sure that all non-required electrical connections, which have a dummy plug, are closed off with dummy plugs.
- ▶ Pay attention to the Electrical wiring diagram.
- ▶ As a rule, close off on-required electrical connections (for example for accessories which cannot be installed) with the respective dummy plugs.

**NOTICE**

Property damage due to dirt and / or corrosion!

If non-required electrical connections are not closed off with the respective protective caps, then dirt and / or corrosion can damage the electrical connections.

This could result in malfunctions.

- ▶ Make sure that all non-required electrical connections are always closed off properly.
- ▶ Pay attention to the Electrical wiring diagram.

- ▶ Close electrical connections, which have no dummy plugs, properly off with the corresponding protective caps.

**6.1.3 Establishing the connections of the central lubrication system to the winch**

- ▶ Establish the connections of the central lubrication system to the winch.

**7 Disconnecting the connections from winch 1 to the turntable****WARNING**

Danger of falling!

During assembly / disassembly, inspection and maintenance work, assembly personnel must be secured with appropriate aids to prevent them from falling.

Death, severe bodily injuries, property damage.

- ▶ All work at a height, when there is a danger of falling, must be carried out with suitable aids.
- ▶ If aids are not available and work cannot be carried out from the ground, then assembly personnel must secure themselves with the supplied fall arrest system to prevent falling, see chapter 2.04.
- ▶ If fall protection equipment is available, then it must be used, see chapter 2.06.
- ▶ When lifting, lowering, swinging crane parts in and out, no persons may remain in the danger zone.
- ▶ When closing or opening boom systems during boom assembly or boom disassembly, no persons may remain on the boom system or in the danger zone.
- ▶ If railings are present on the components, then they must be brought into the corresponding position and secured for assembly / disassembly work.
- ▶ Only step on the aids, ladders and catwalks with clean shoes.
- ▶ Keep aids, ladders and catwalks free of heavy dirt, snow, frost and ice.
- ▶ During all assembly and disassembly work, maintenance work and inspections, travel or crane operation is prohibited.
- ▶ Remaining on a suspended load is prohibited.
- ▶ Stepping or walking on crane components and lattice sections that have an incline of more than 20° is prohibited.
- ▶ For all assembly work, the crane driver of the main crane must be in voice contact with the crane driver / crane drivers of the auxiliary crane / auxiliary cranes.
- ▶ For assembly tasks, the crane driver may only initiate crane movements when the responsible guide has explicitly released the movement.

**WARNING**

Danger of impact / crushing!

When installing / removing crane components with the auxiliary crane, crane components can start to swing back and forth.

When lifting / lowering and positioning crane components, there is an increased danger of impacts / crushing.

Death, severe bodily injuries, property damage.

- ▶ Make sure that personnel cannot be caught by components.
- ▶ Make sure that the crane is horizontally aligned.
- ▶ When working in danger zones: Use aids to protect limbs.
- ▶ Guide components with suitable aids to minimize oscillation.

**DANGER**

The components can fall down!

If the corresponding component is disengaged from the auxiliary crane before the corresponding component is pinned, then the corresponding component can fall down.

Death, severe bodily injuries, property damage.

- ▶ Do not disengage the auxiliary crane until the respective component is pinned and secured.

## 7.1 Disconnecting the connections

Make sure that the following prerequisites are met:

- The hoist rope is completely spooled up to the winch.
- The hoist rope is secured on the winch to prevent it from spooling out by itself.

### 7.1.1 Disconnecting the hydraulic connections to the winch

When releasing hydraulic lines with quick couplings, make sure that the uncoupling procedure is carried out correctly.

**WARNING**

Pressure in the hydraulic lines!

If the pressure supply is not interrupted before connecting / releasing the hydraulic lines, the hydraulic oil can escape with high pressure.

Death, severe bodily injuries, property damage.

- ▶ Release the pressure in the hydraulic system before connecting / disconnecting: Interrupt the pressure supply and wait for a short time.
- ▶ Release the hydraulic coupling by hand.
- ▶ Disconnect the hydraulic connections to the winch.
- ▶ Close the hydraulic hoses and hydraulic lines off properly with the intended caps.
- ▶ Bring the hydraulic hoses in park position for transport and secure them properly.

### 7.1.2 Disconnecting the electrical connections to the winch

- ▶ Disconnect the electrical connections to the winch.
- ▶ Close the electrical connections properly off with the intended caps.

### 7.1.3 Disconnecting the connections of the central lubrication system to the winch

- ▶ Disconnect the connections to the winch.
- ▶ Close the lube line connections properly off with the intended caps.

## 8 Disassembling winch 1



### WARNING

Danger of falling!

During assembly / disassembly, inspection and maintenance work, assembly personnel must be secured with appropriate aids to prevent them from falling.

Death, severe bodily injuries, property damage.

- ▶ All work at a height, when there is a danger of falling, must be carried out with suitable aids.
- ▶ If aids are not available and work cannot be carried out from the ground, then assembly personnel must secure themselves with the supplied fall arrest system to prevent falling, see chapter 2.04.
- ▶ If fall protection equipment is available, then it must be used, see chapter 2.06.
- ▶ When lifting, lowering, swinging crane parts in and out, no persons may remain in the danger zone.
- ▶ When closing or opening boom systems during boom assembly or boom disassembly, no persons may remain on the boom system or in the danger zone.
- ▶ If railings are present on the components, then they must be brought into the corresponding position and secured for assembly / disassembly work.
- ▶ Only step on the aids, ladders and catwalks with clean shoes.
- ▶ Keep aids, ladders and catwalks free of heavy dirt, snow, frost and ice.
- ▶ During all assembly and disassembly work, maintenance work and inspections, travel or crane operation is prohibited.
- ▶ Remaining on a suspended load is prohibited.
- ▶ Stepping or walking on crane components and lattice sections that have an incline of more than 20° is prohibited.
- ▶ For all assembly work, the crane driver of the main crane must be in voice contact with the crane driver / crane drivers of the auxiliary crane / auxiliary cranes.
- ▶ For assembly tasks, the crane driver may only initiate crane movements when the responsible guide has explicitly released the movement.



### WARNING

Danger of impact / crushing!

When installing / removing crane components with the auxiliary crane, crane components can start to swing back and forth.

When lifting / lowering and positioning crane components, there is an increased danger of impacts / crushing.

Death, severe bodily injuries, property damage.

- ▶ Make sure that personnel cannot be caught by components.
- ▶ Make sure that the crane is horizontally aligned.
- ▶ When working in danger zones: Use aids to protect limbs.
- ▶ Guide components with suitable aids to minimize oscillation.



### DANGER

The components can fall down!

If the corresponding component is disengaged from the auxiliary crane before the corresponding component is pinned, then the corresponding component can fall down.

Death, severe bodily injuries, property damage.

- ▶ Do not disengage the auxiliary crane until the respective component is pinned and secured.

### 8.1 Unpinning winch 1

Make sure that the following prerequisites are met:

- The hydraulic connections are properly disconnected and closed off.
- The electrical connections are properly disconnected and closed off.
- The connections of the central lubrication system are properly disconnected and closed off.
- An auxiliary crane with a suitable load-bearing capacity is available.

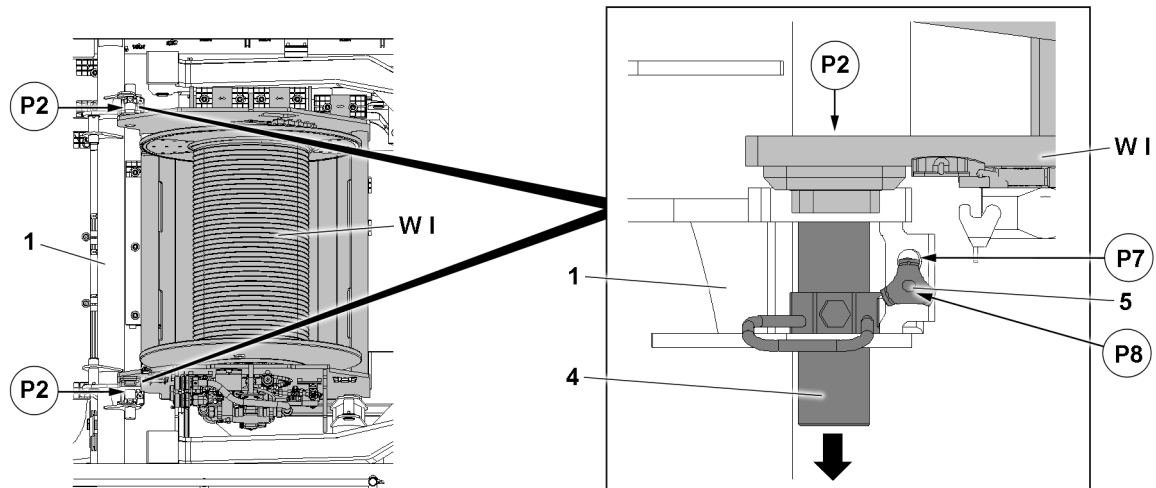


Fig.155212: Unpinning winch 1 WI on the turntable

WI Winch 1  
1 Turntable

4 Connector pin  
5 Ball locking pin



### WARNING

Danger of accident due to incorrect fastening!  
Life-threatening situations can arise if the winch 1 WI is incorrectly or improperly fastened.  
Death, severe bodily injuries, property damage.

- ▶ The fastening equipment may only be fastened on winch 1 WI at the intended fastening points.
- ▶ Make sure that the fastening equipment is properly attached on winch 1 WI and that it is properly secured to prevent it from loosening up.

- ▶ Attach the fastening equipment on both sides on winch 1 WI, see section "Winch 1 fastening points".

When the fastening equipment is properly fastened to winch 1 WI:

- ▶ Bring the fastening equipment carefully to "tension" with the auxiliary crane.

When the fastening equipment is tensioned:

- ▶ Release the connector pins 4 on both sides: Remove the ball locking pin 5.
- ▶ Secure the connector pins 4 in the "unpinned" position with ball locking pins 5: Insert the ball locking pins 5 completely in point P8.

### Result:

- The connector pins 4 are secured in the "unpinned" position.
- Winch 1 WI is unpinned on the turntable 1.

## 8.2 Lifting winch 1 from the turntable

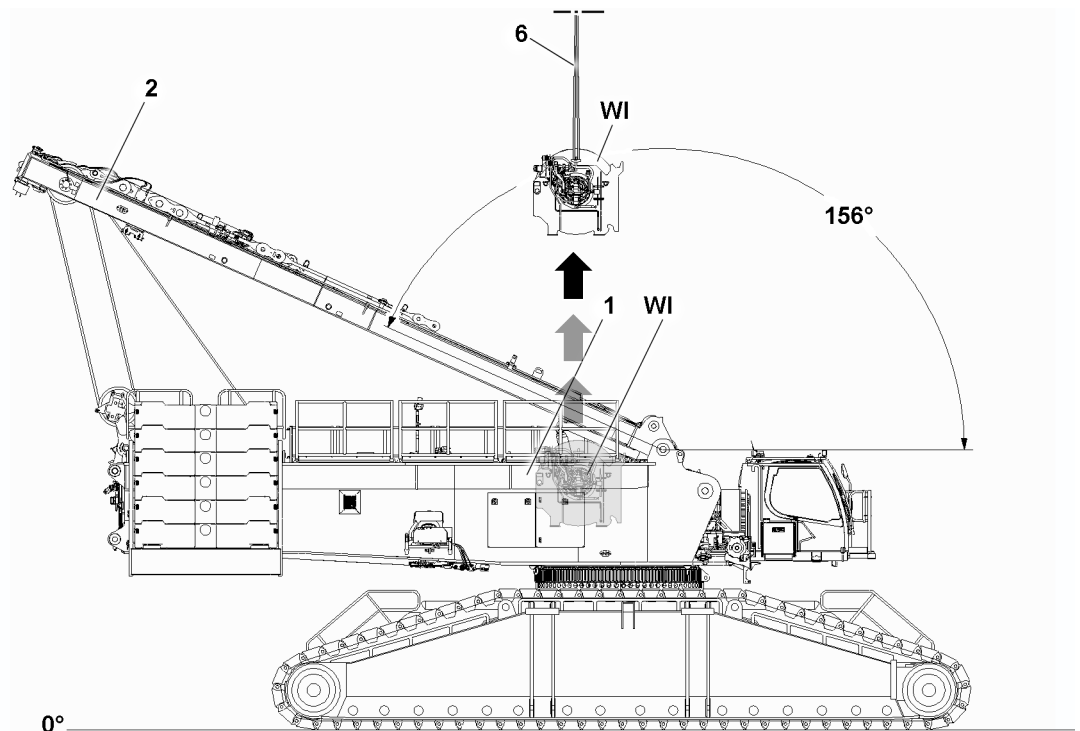


Fig.155213: Lifting winch 1 **WI** from the turntable

**WI** Winch 1

**1** Turntable

Make sure that the following prerequisites are met:

- The SA-frame **2** is erected to 156°.
- The counterweight is assembled on the turntable **1** according to “Assembly conditions on crawlers”, see chapter 3.06.
- Winch 2 is disassembled on the turntable **1**.
- Winch 1 **WI** is properly unpinned on the turntable **1**.



### WARNING

Falling components!

When lifting winch 1 **WI** on the turntable **1**, components or winch 1 **WI** can fall down. Death, severe bodily injuries, property damage.

- ▶ Make sure that there are no persons within the danger zone.

- ▶ Carefully lift winch 1 **WI** from the turntable **1** with the auxiliary crane.



### WARNING

Toppling winch!

When setting winch 1 **WI** on the ground, the winch can sink into the ground and fall over. Death, severe bodily injuries, property damage.

- ▶ Make sure that the ground has sufficient load bearing capacity to safely absorb the weight of the winch.

- ▶ Swing winch 1 **WI** out with the auxiliary crane and set it on the ground on a suitable substructure.  
**or**  
Swing winch 1 **WI** out with the auxiliary crane and set it on the flatbed trailer.

When winch 1 **WI** has been set down properly:

- ▶ Remove the auxiliary crane.

---

Empty page!

LWE/LR 1800-1-0-000/27200-07-02/en



## 3.07.20 Winch 2 assembly

1	Safety	2
2	Component overview	2
3	Winch 2 fastening points	2
4	Ascending / descending to the space of winch 1 and winch 2	3
5	Assembly winch 2	4
6	Establishing the connections from winch 2 to the turntable	9
7	Winch 2 protective roller	11
8	Disconnecting the connections from winch 2 to the turntable	16
9	Disassembling winch 2	17

# 1 Safety

Before assembly and disassembly of winch 2, observe the safety instructions:

- Information regarding work on the crane superstructure. See chapter 2.04.
- Information regarding personal protective equipment. See chapter 2.04.
- Information regarding the use of ladders. See chapter 2.04.10.
- Information regarding fall protection equipment. See chapter 2.06.
- Information regarding accesses to the crane. See chapter 2.07.
- Information regarding accessible surfaces. See chapter 2.07.
- Information regarding assembly conditions. See chapter 3.06.

## 2 Component overview



### Note

- ▶ Winch 2 dimensions and weights, see chapter 1.03.



### Note

- ▶ Winch 2 is marked with its own weight.

## 3 Winch 2 fastening points



### WARNING

Winch incorrectly fastened!

Life-threatening situations can arise if the winch is incorrectly or improperly fastened.  
Death, severe bodily injuries, property damage.

- ▶ Attach the winch only on the intended fastening points.
- ▶ Attach the fastening equipment on winch solely in connection with shackles.
- ▶ Make sure that the shackles and fastening equipment have sufficient load bearing capacity.
- ▶ Observe the technical safety instructions during assembly and disassembly, see chapter 5.01.

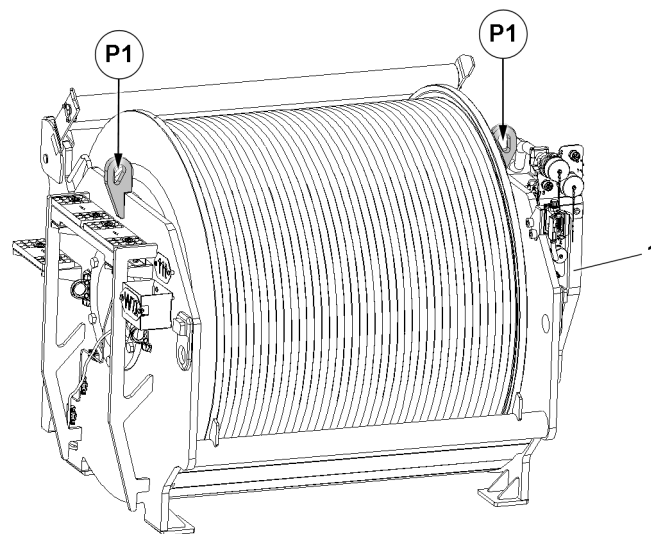


Fig.155214: Winch 2 fastening points

1 Winch 2

Fastening points	
P1	Winch 2

## 4 Ascending / descending to the space of winch 1 and winch 2

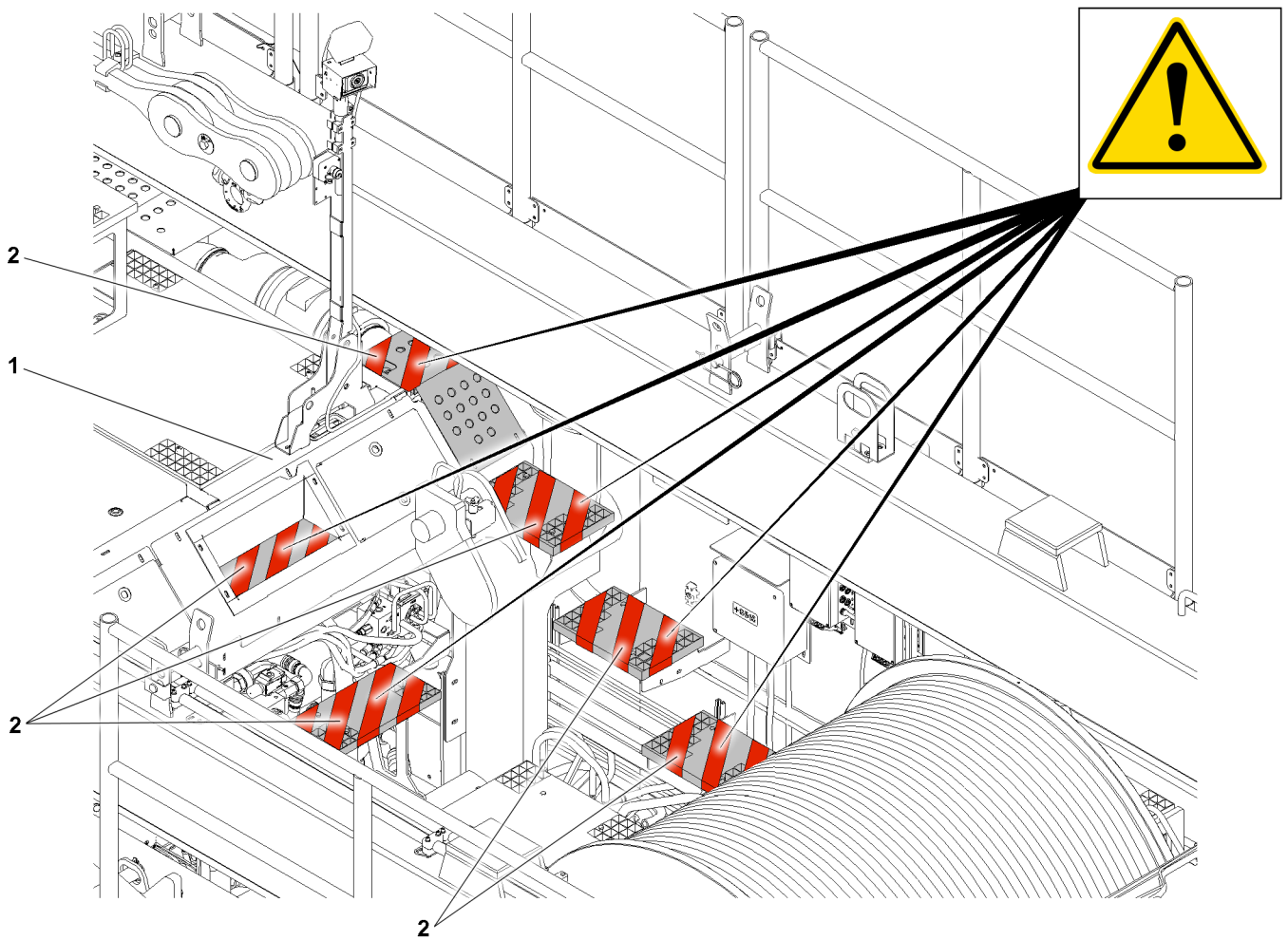


Fig.155207: Ascending / descending to the space of winch 1 and winch 2 (SA-frame is placed on the turntable in the illustration)

- 1 Turntable
- 2 Steps

To pin winch 2 to the turntable 1, assembly personal must climb down from the level of the motor cover using the steps 2 to the assembly space of winch 1 and winch 2. After pinning winch 2, they must climb up again using the steps 2 to the level of the motor cover of the turntable.



**WARNING**

Small step depth!  
 Death, severe bodily injuries.  
 ► Always step on the steps 2 with extreme caution.

LWE/LR 1800-1-0-000/27200-07-02/en

**WARNING**

Different step heights!

Death, severe bodily injuries.

- ▶ Always step on the steps **2** with extreme caution.

- ▶ Step on the steps **2** with extreme caution.

## 5 Assembly winch 2

**WARNING**

Danger of falling!

During assembly / disassembly, inspection and maintenance work, assembly personnel must be secured with appropriate aids to prevent them from falling.

Death, severe bodily injuries, property damage.

- ▶ All work at a height, when there is a danger of falling, must be carried out with suitable aids.
- ▶ If aids are not available and work cannot be carried out from the ground, then assembly personnel must secure themselves with the supplied fall arrest system to prevent falling, see chapter 2.04.
- ▶ If fall protection equipment is available, then it must be used, see chapter 2.06.
- ▶ When lifting, lowering, swinging crane parts in and out, no persons may remain in the danger zone.
- ▶ When closing or opening boom systems during boom assembly or boom disassembly, no persons may remain on the boom system or in the danger zone.
- ▶ If railings are present on the components, then they must be brought into the corresponding position and secured for assembly / disassembly work.
- ▶ Only step on the aids, ladders and catwalks with clean shoes.
- ▶ Keep aids, ladders and catwalks free of heavy dirt, snow, frost and ice.
- ▶ During all assembly and disassembly work, maintenance work and inspections, travel or crane operation is prohibited.
- ▶ Remaining on a suspended load is prohibited.
- ▶ Stepping or walking on crane components and lattice sections that have an incline of more than 20° is prohibited.
- ▶ For all assembly work, the crane driver of the main crane must be in voice contact with the crane driver / crane drivers of the auxiliary crane / auxiliary cranes.
- ▶ For assembly tasks, the crane driver may only initiate crane movements when the responsible guide has explicitly released the movement.

**WARNING**

Danger of impact / crushing!

When installing / removing crane components with the auxiliary crane, crane components can start to swing back and forth.

When lifting / lowering and positioning crane components, there is an increased danger of impacts / crushing.

Death, severe bodily injuries, property damage.

- ▶ Make sure that personnel cannot be caught by components.
- ▶ Make sure that the crane is horizontally aligned.
- ▶ When working in danger zones: Use aids to protect limbs.
- ▶ Guide components with suitable aids to minimize oscillation.

**DANGER**

The components can fall down!

If the corresponding component is disengaged from the auxiliary crane before the corresponding component is pinned, then the corresponding component can fall down.

Death, severe bodily injuries, property damage.

- ▶ Do not disengage the auxiliary crane until the respective component is pinned and secured.

## 5.1 Assembling winch 2

Winch 2 can be installed on the turntable with varying prerequisites / conditions. The following describes the assembly based on condition 3 as an example.

Make sure that the following prerequisites are met:

- Condition 1: Turntable without SA-frame.  
**or:**
- Condition 2: The SA-frame is assembled on the turntable and completely taken down (180° position).  
**or:**
- Condition 3: The SA-frame is assembled on the turntable and erected to 160°.
- The counterweight is assembled on the turntable according to “Assembly conditions on crawlers”, see chapter 3.06.

### 5.1.1 Lifting winch 2 from the flatbed trailer



#### WARNING

Danger of accident during assembly of winch 2!  
Death, severe bodily injuries, property damage.

- ▶ Make sure that winch 2 is secured with an auxiliary rope to prevent it from swinging.
- 
- ▶ Fasten the fastening equipment to the fastening points properly, see section “Winch 2 fastening points”.
  - ▶ Bring the fastening equipment to “tension” with the auxiliary crane.
  - ▶ Release and remove the transport retainers on the flatbed trailer.



#### WARNING

Falling components!  
When lifting winch 2 from the flatbed trailer, components or winch 2 can fall down.  
Death, severe bodily injuries, property damage.

- ▶ Make sure that there are no persons within the danger zone.
- 
- ▶ Lift winch 2 with the auxiliary crane from the flatbed trailer.

## 5.1.2 Swinging in and positioning winch 2

Make sure that the following prerequisites are met:

- The crane is horizontally aligned.
- The ground is able to safely take on the entire operating weight of the crane including the load to be lifted.
- Gratings, catwalks and fall protection equipment are properly installed.
- Access stairs to the catwalks are properly installed.
- The access stairs to the cab platform are in operating position.
- An auxiliary crane with a suitable load-bearing capacity is available.
- Winch 1 **WI** is properly assembled and secured on the turntable.
- The connector pins **4** in points **P2** are fully unpinned on both sides.
- The connector pins **4** are secured in the "unpinned" position with ball locking pins **5**, point **P8**.

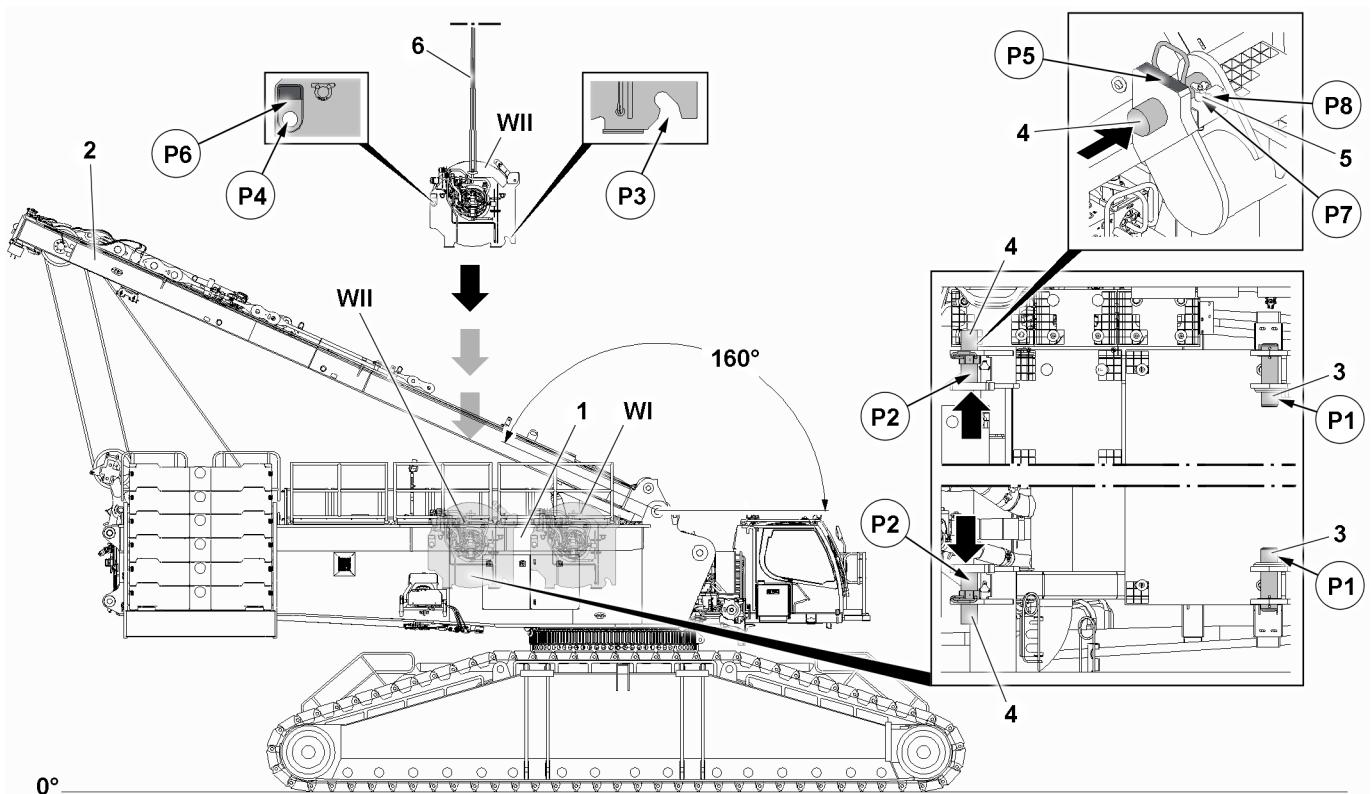


Fig.155215: Positioning winch 2 in the turntable

<b>WI</b> Winch 1	<b>2</b> SA-frame	<b>5</b> Ball locking pin
<b>WII</b> Winch 2	<b>3</b> Centering pin	<b>6</b> Fastening equipment
<b>1</b> Turntable	<b>4</b> Connector pin	



### WARNING

Danger of accident when swinging in and lowering winch 2!  
When swinging in and lowering winch 2 **WII** on the turntable **1**, limbs can be crushed or even severed. Death, severe bodily injuries, property damage.

- ▶ Make sure that there is no personnel in the danger zone.
- ▶ Do not reach with your hands into the danger zone.

### NOTICE

Property damage!

If the following notes are not observed, damage can result to the crane or winch 2 **WII**.

- ▶ Make sure that winch 2 **WII** does not bump against the SA-frame **2** when lowering into the turntable **1**.
- ▶ Make sure that winch 2 **WII** does not bump against the turntable when lowering into the turntable **1**.

**Note**

- ▶ The guide must be in constant visual and acoustic contact with the crane operator.

**Note**

- ▶ Pay attention to exact alignment of winch 2 **WII** to the installation position or the pocket receptacles, point **P3**, to the centering pins **3**.
- ▶ Before lowering, bring winch 2 **WII** into position so that the pocket receptacles, point **P3**, are above the centering pins **3** at point **P1**.

- ▶ Swing winch 2 **WII** in with the auxiliary crane to the turntable **1**.
- ▶ Position and align winch 2 **WII**.

When winch 2 **WII** is aligned:

- ▶ Slowly and carefully lower winch 2 **WII** into the turntable frame.
- ▶ Set winch 2 **WII** with the centerings on both sides, points **P3**, on the centering pins **3** at point **P1**.
- ▶ Continue to lower winch 2 **WII** until the locating surfaces **P6** rest completely on the mounting plates **P5**.

**Result:**

- Winch 2 **WII** is positioned and inserted in the winch frame.
- ▶ Pin winch 2, see section “Pinning winch 2 **WII**”.

### 5.1.3 Pinning winch 2

Make sure that the following prerequisites are met:

- Winch 2 **WII** is resting with the centerings **P3** on both sides on the centering pins **3** at point **P1**.
- Winch 2 **WII** is resting with the locating surfaces **P6** on both sides on the mounting plates **P5**.

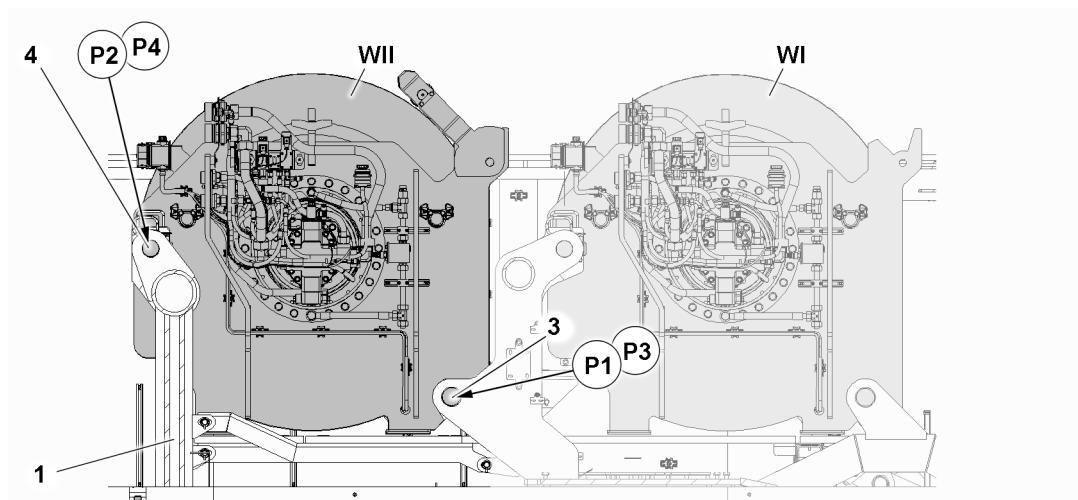


Fig.155216: Inserting winch 2 **WII** in the turntable

<b>WI</b>	Winch 1	<b>3</b>	Centering pin
<b>WII</b>	Winch 2	<b>4</b>	Connector pin
<b>1</b>	Turntable		

- ▶ Release the connector pin **4**: Remove the ball locking pin **5** at point **P8**.
- ▶ Pin the connector pins **4** completely on both sides.

**WARNING**

The pins can loosen up by themselves!

If the connector pins **4** are not properly secured, they can come loose. The load call fall down. Death, severe bodily injuries, property damage.

- ▶ Secure the connector pins **4** immediately after pinning with ball locking pins **5**.

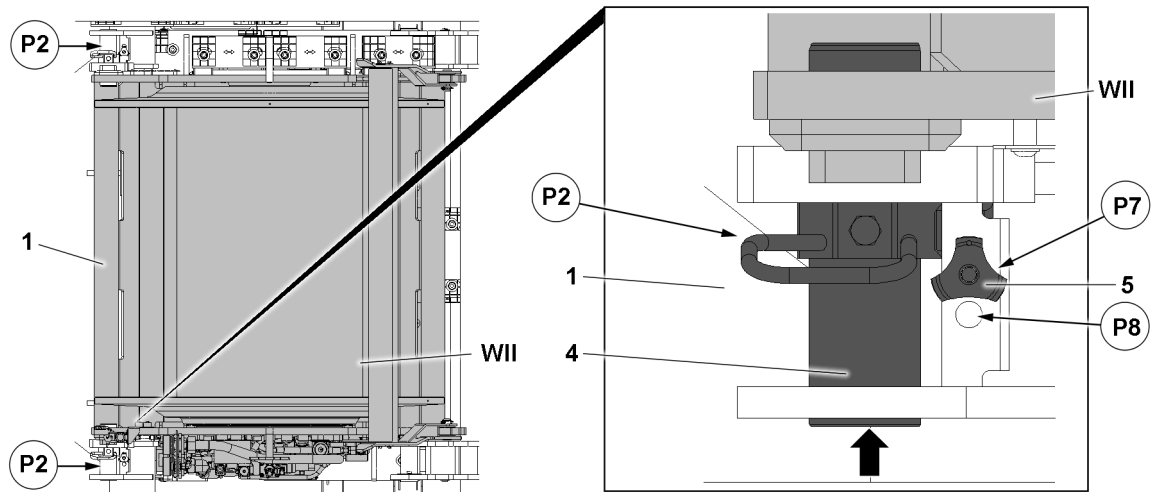


Fig.155217: Pinning winch 2 in the turntable

**WII** Winch 2  
**1** Turntable

**4** Connector pin  
**5** Ball locking pin

When the connector pins **4** on winch 2 are completely pinned on both sides:

- ▶ Secure the connector pins **4** immediately on both sides: Insert the ball locking pins **5** completely in point **P7**.

**Result:**

- The connector pins **4** are properly secured.
- Winch 2 **WII** is properly secured.
- ▶ Release the fastening equipment on winch 2 **WII**.
- ▶ Remove the auxiliary crane.



## 6 Establishing the connections from winch 2 to the turntable



### WARNING

Danger of falling!

During assembly / disassembly, inspection and maintenance work, assembly personnel must be secured with appropriate aids to prevent them from falling.

Death, severe bodily injuries, property damage.

- ▶ All work at a height, when there is a danger of falling, must be carried out with suitable aids.
- ▶ If aids are not available and work cannot be carried out from the ground, then assembly personnel must secure themselves with the supplied fall arrest system to prevent falling, see chapter 2.04.
- ▶ If fall protection equipment is available, then it must be used, see chapter 2.06.
- ▶ When lifting, lowering, swinging crane parts in and out, no persons may remain in the danger zone.
- ▶ When closing or opening boom systems during boom assembly or boom disassembly, no persons may remain on the boom system or in the danger zone.
- ▶ If railings are present on the components, then they must be brought into the corresponding position and secured for assembly / disassembly work.
- ▶ Only step on the aids, ladders and catwalks with clean shoes.
- ▶ Keep aids, ladders and catwalks free of heavy dirt, snow, frost and ice.
- ▶ During all assembly and disassembly work, maintenance work and inspections, travel or crane operation is prohibited.
- ▶ Remaining on a suspended load is prohibited.
- ▶ Stepping or walking on crane components and lattice sections that have an incline of more than 20° is prohibited.
- ▶ For all assembly work, the crane driver of the main crane must be in voice contact with the crane driver / crane drivers of the auxiliary crane / auxiliary cranes.
- ▶ For assembly tasks, the crane driver may only initiate crane movements when the responsible guide has explicitly released the movement.



### WARNING

Danger of impact / crushing!

When installing / removing crane components with the auxiliary crane, crane components can start to swing back and forth.

When lifting / lowering and positioning crane components, there is an increased danger of impacts / crushing.

Death, severe bodily injuries, property damage.

- ▶ Make sure that personnel cannot be caught by components.
- ▶ Make sure that the crane is horizontally aligned.
- ▶ When working in danger zones: Use aids to protect limbs.
- ▶ Guide components with suitable aids to minimize oscillation.



### DANGER

The components can fall down!

If the corresponding component is disengaged from the auxiliary crane before the corresponding component is pinned, then the corresponding component can fall down.

Death, severe bodily injuries, property damage.

- ▶ Do not disengage the auxiliary crane until the respective component is pinned and secured.

## 6.1 Establishing the connections



### Note

- ▶ Establish the connections to winch 2 only when winch 2 is properly installed and secured on the turntable.

Make sure that the following prerequisite is met:

- The winch 2 is properly installed, pinned and secured.

### 6.1.1 Establishing the hydraulic connections to the winch



### Note

- ▶ After the hydraulic connections to the winch are established, the expansion tank must be checked and emptied.

The hydraulic connections for the winch are made with quick couplings.

When connecting hydraulic lines with quick couplings, make sure that the coupling procedure is carried out correctly.



### WARNING

Pressure in the hydraulic lines!

If the pressure supply is not interrupted before connecting / releasing the hydraulic lines, the hydraulic oil can escape with high pressure.

Death, severe bodily injuries, property damage.

- ▶ Release the pressure in the hydraulic system before connecting / disconnecting: Interrupt the pressure supply and wait for a short time.



### WARNING

Loss of pressure or leakage!

Incorrectly coupled or self-loosening quick couplings (particularly return lines) can result in serious accidents due to component failure.

- ▶ Check that the quick couplings have been properly connected before using the crane.
- ▶ Connect the coupling components (sleeve and connector) and screw together with the knurled nut.
- ▶ Tighten the hydraulic coupling by hand. Turn the knurled nut until it reaches a tangible, fixed stop position.
- ▶ Establish the hydraulic connections to the winch.

### 6.1.2 Establishing the electrical connections to the winch

- ▶ Establish the electrical connections to the winch, see the Electric wiring diagram.



### WARNING

Malfunction if dummy plugs are not installed!

If the dummy plugs on the non-required electrical connections are not installed, then malfunctions or functional limitations can occur on the crane.

- ▶ Make sure that all non-required electrical connections, which have a dummy plug, are closed off with dummy plugs.
- ▶ Pay attention to the Electrical wiring diagram.
- ▶ As a rule, close off on-required electrical connections (for example for accessories which cannot be installed) with the respective dummy plugs.

**NOTICE**

Property damage due to dirt and / or corrosion!

If non-required electrical connections are not closed off with the respective protective caps, then dirt and / or corrosion can damage the electrical connections.

This could result in malfunctions.

- ▶ Make sure that all non-required electrical connections are always closed off properly.
  - ▶ Pay attention to the Electrical wiring diagram.
- 
- ▶ Close electrical connections, which have no dummy plugs, properly off with the corresponding protective caps.

**6.1.3 Establishing the connections of the central lubrication system to the winch**

- ▶ Establish the connections of the central lubrication system to the winch.

## 7 Winch 2 protective roller

The protective roller on winch 2 is used in the assembly position when reeving the hoist rope of winch 2 in / out to deflect the hoist rope of winch 2 over winch 1 and therefore prevent property damage to winch 1 and the hoist rope.

The protective roller on winch 2 is used in the assembly position when reeving in the control rope of winch 4 (intake gear), to deflect the control rope of winch 4 over winch 2 and winch 1 and prevent property damage.

### 7.1 Bringing the protective roller on winch 2 into the assembly position; reeving in the hoist rope

Make sure that the following prerequisites are met:

- Winch 1 is properly assembled in the turntable.
- Winch 2 is properly assembled in the turntable.
- The hydraulic connections to winch 1 **WI** and winch 2 **WII** are established.
- The electrical connections to winch 1 **WI** and winch 2 **WII** are established.
- The connections of the central lubrication system to winch 1 **WI** and winch 2 **WII** are established.

**WARNING**

Danger of crushing when folding the protective roller!

Severe bodily injuries due to crushing.

- ▶ Use personal protective equipment.
- ▶ When folding the protective roller **8**, do not hold it near the stop, point **P1**.
- ▶ Make sure after folding that the protective roller **8** lies fully on the stop, point **P1**.

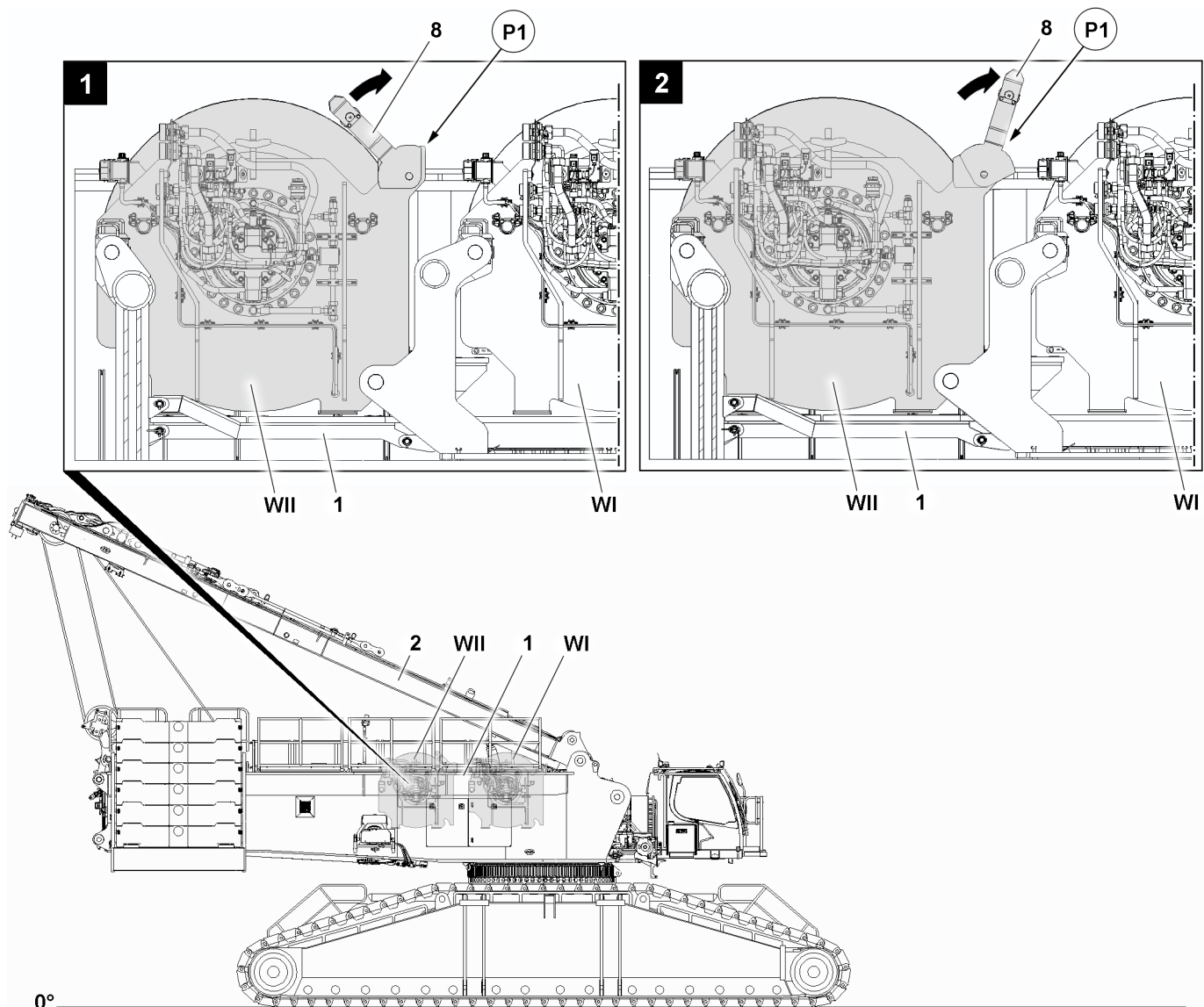


Fig.155218: Bringing the protective roller 8 on winch 2 WII into the assembly position

- ▶ Fold the protective roller 8 in the direction of the arrow to the assembly position stop P1, illustration 1.

**Result:**

- The protective roller 8 is in the assembly position, illustration 2.

When the D-boom on the crane and the D-guying between the SA-frame and the D-boom are assembled:

- ▶ Pull the hoist rope from winch 2 WII for reeving in over the protective roller 8, see illustration 2 and chapter 5.05.

**or:**

When the main boom on the crane and the main boom guying between the SA-frame and the boom are assembled:

- ▶ Pull the hoist rope of winch 2 WII for reeving in over the protective roller 8, illustration 2.

## 7.2 Bringing the protective roller on winch 2 into the operating position, crane operation

Make sure that the following prerequisites are met:

- Winch 1 **WI** is properly reeved in.
- Winch 2 **WII** is properly reeved in.
- The boom system is erected and in the operating position.

### NOTICE

Danger of property damage!

- ▶ Make sure that the protective roller **8** is changed to the operating position after reeving in the hoist rope of winch 2 **WII** and after the successful erection of the boom system, see illustration 2.

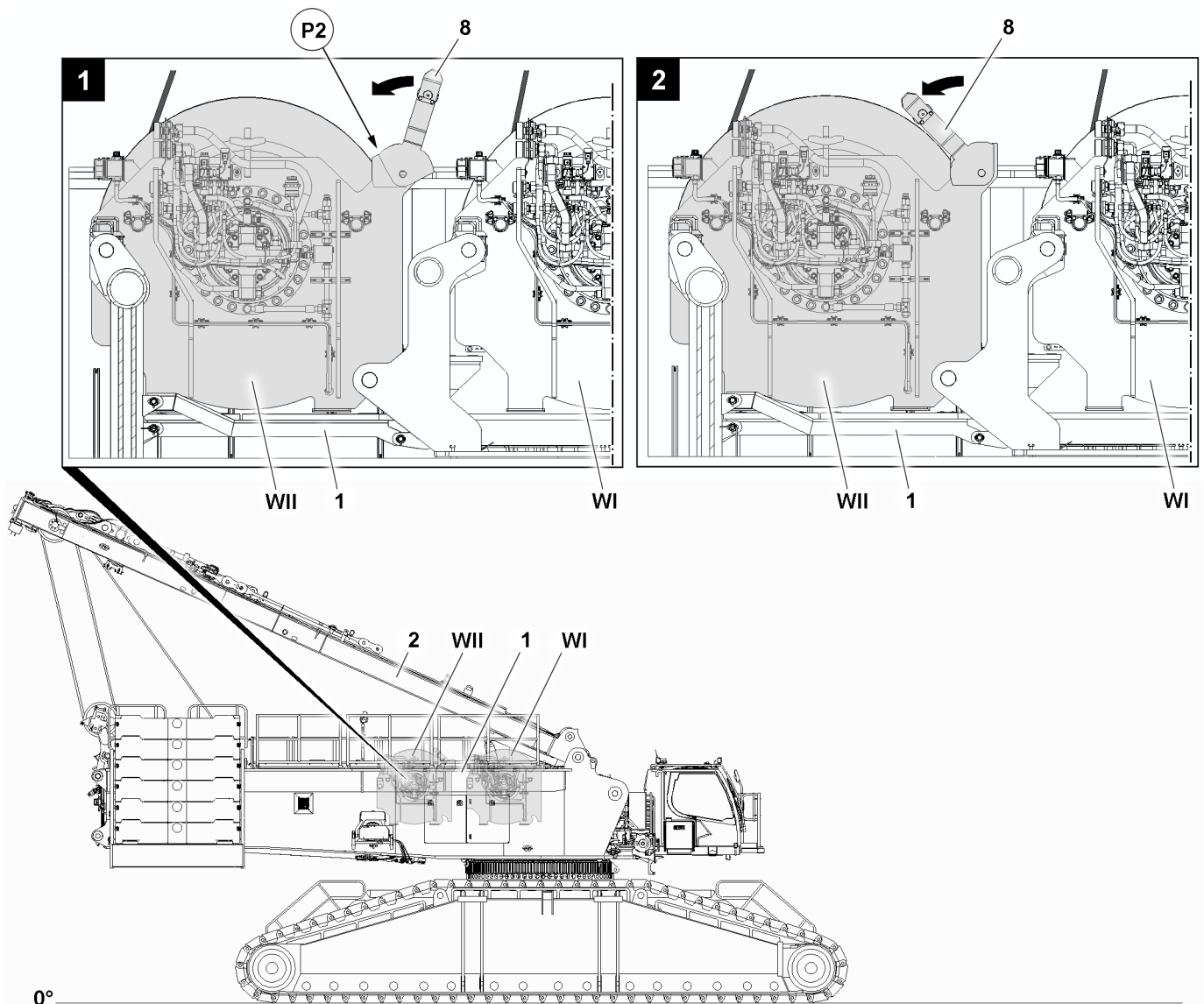


### WARNING

Danger of crushing when folding the protective roller **8**!

Severe bodily injuries due to crushing.

- ▶ Use personal protective equipment.
- ▶ When folding the protective roller **8**, do not hold it near the stop, point **P2**.



LWE/LR 1800-1-0-000/27200-07-02/en

Fig.155219: Bringing the protective roller **8.1** on winch 2 **WII** into the operating position

- ▶ Fold the protective roller **8** in the direction of the arrow to the operating position stop **P2**, illustration 1.

**Result:**

- The protective roller **8** is in the operating position, illustration 2.

### 7.3 Bringing the protective roller on winch 2 into the operating position, crane operation with the D-boom

Make sure that the following prerequisites are met:

- Winch 1 is properly reeved in on the D-boom.
- Winch 2 is properly reeved in on the D-boom.

**WARNING**

Automatic folding of the protective roller due to the hoist rope of winch 1!

If the D-boom is erected in the operating position and the protective roller **8** is still in the assembly position, then the protective roller **8** will be folded in an uncontrolled manner into the operating position by the hoist rope **7.1** of winch 1 **WI**.

Death, severe bodily injuries, property damage.

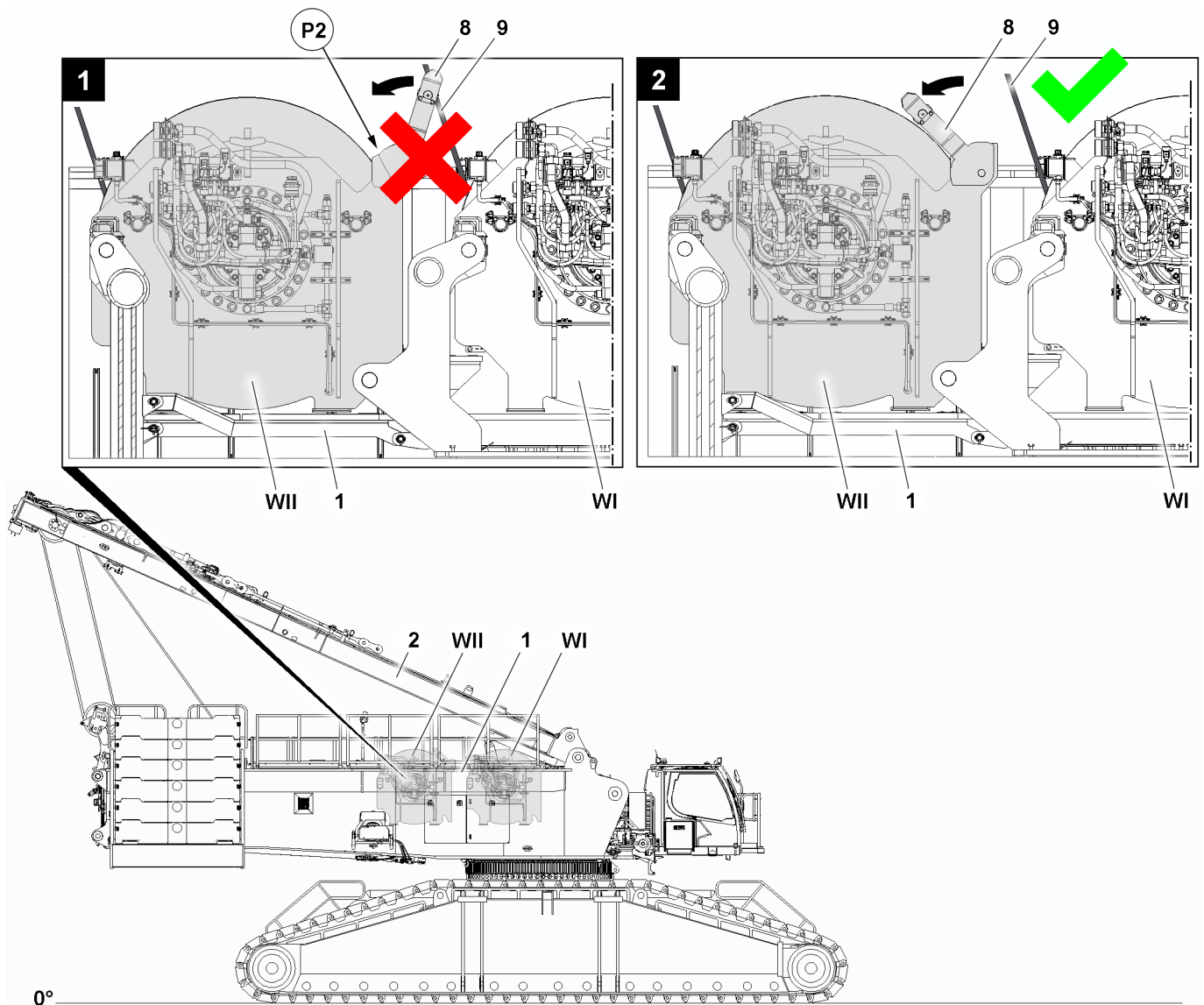
- ▶ Make sure that the protective roller **8** is folded into the operating position before the D-boom reaches the operating position.
- ▶ Make sure that there are no persons within the danger zone of the winches.

**WARNING**

Danger of crushing when folding the protective roller!

Severe bodily injuries due to crushing.

- ▶ Use personal protective equipment.
- ▶ When folding the protective roller **8**, do not hold it near the stop, point **P2**.



*Fig.155220: Bringing the protective roller 8 on winch 2 8 into the operating position prior to contact between the hoist rope 9 and the protective roller 8*

Before the hoist rope 9 makes contact with the protective roller, illustration 1:

- ▶ Stop the D-boom erection procedure.
- ▶ Fold the protective roller 8 in the direction of the arrow to the operating position stop P2.

**Result:**

- The protective roller 8 is in the operating position, illustration 2.

## 8 Disconnecting the connections from winch 2 to the turntable



### WARNING

Danger of falling!

During assembly / disassembly, inspection and maintenance work, assembly personnel must be secured with appropriate aids to prevent them from falling.

Death, severe bodily injuries, property damage.

- ▶ All work at a height, when there is a danger of falling, must be carried out with suitable aids.
- ▶ If aids are not available and work cannot be carried out from the ground, then assembly personnel must secure themselves with the supplied fall arrest system to prevent falling, see chapter 2.04.
- ▶ If fall protection equipment is available, then it must be used, see chapter 2.06.
- ▶ When lifting, lowering, swinging crane parts in and out, no persons may remain in the danger zone.
- ▶ When closing or opening boom systems during boom assembly or boom disassembly, no persons may remain on the boom system or in the danger zone.
- ▶ If railings are present on the components, then they must be brought into the corresponding position and secured for assembly / disassembly work.
- ▶ Only step on the aids, ladders and catwalks with clean shoes.
- ▶ Keep aids, ladders and catwalks free of heavy dirt, snow, frost and ice.
- ▶ During all assembly and disassembly work, maintenance work and inspections, travel or crane operation is prohibited.
- ▶ Remaining on a suspended load is prohibited.
- ▶ Stepping or walking on crane components and lattice sections that have an incline of more than 20° is prohibited.
- ▶ For all assembly work, the crane driver of the main crane must be in voice contact with the crane driver / crane drivers of the auxiliary crane / auxiliary cranes.
- ▶ For assembly tasks, the crane driver may only initiate crane movements when the responsible guide has explicitly released the movement.



### WARNING

Danger of impact / crushing!

When installing / removing crane components with the auxiliary crane, crane components can start to swing back and forth.

When lifting / lowering and positioning crane components, there is an increased danger of impacts / crushing.

Death, severe bodily injuries, property damage.

- ▶ Make sure that personnel cannot be caught by components.
- ▶ Make sure that the crane is horizontally aligned.
- ▶ When working in danger zones: Use aids to protect limbs.
- ▶ Guide components with suitable aids to minimize oscillation.



### DANGER

The components can fall down!

If the corresponding component is disengaged from the auxiliary crane before the corresponding component is pinned, then the corresponding component can fall down.

Death, severe bodily injuries, property damage.

- ▶ Do not disengage the auxiliary crane until the respective component is pinned and secured.

### 8.1 Disconnecting the connections

Make sure that the following prerequisites are met:

- The hoist rope is completely spooled up to the winch.
- The hoist rope is secured on the winch to prevent it from spooling out by itself.



### 8.1.1 Disconnecting the hydraulic connections to the winch

When releasing hydraulic lines with quick couplings, make sure that the uncoupling procedure is carried out correctly.



#### WARNING

Pressure in the hydraulic lines!

If the pressure supply is not interrupted before connecting / releasing the hydraulic lines, the hydraulic oil can escape with high pressure.

Death, severe bodily injuries, property damage.

- ▶ Release the pressure in the hydraulic system before connecting / disconnecting: Interrupt the pressure supply and wait for a short time.
- ▶ Release the hydraulic coupling by hand.
- ▶ Disconnect the hydraulic connections to the winch.
- ▶ Close the hydraulic hoses and hydraulic lines off properly with the intended caps.
- ▶ Bring the hydraulic hoses in park position for transport and secure them properly.

### 8.1.2 Disconnecting the electrical connections to the winch

- ▶ Disconnect the electrical connections to the winch.
- ▶ Close the electrical connections properly off with the intended caps.

### 8.1.3 Disconnecting the connections of the central lubrication system to the winch

- ▶ Disconnect the connections to the winch.
- ▶ Close the lube line connections properly off with the intended caps.

## 9 Disassembling winch 2



#### WARNING

Danger of falling!

During assembly / disassembly, inspection and maintenance work, assembly personnel must be secured with appropriate aids to prevent them from falling.

Death, severe bodily injuries, property damage.

- ▶ All work at a height, when there is a danger of falling, must be carried out with suitable aids.
- ▶ If aids are not available and work cannot be carried out from the ground, then assembly personnel must secure themselves with the supplied fall arrest system to prevent falling, see chapter 2.04.
- ▶ If fall protection equipment is available, then it must be used, see chapter 2.06.
- ▶ When lifting, lowering, swinging crane parts in and out, no persons may remain in the danger zone.
- ▶ When closing or opening boom systems during boom assembly or boom disassembly, no persons may remain on the boom system or in the danger zone.
- ▶ If railings are present on the components, then they must be brought into the corresponding position and secured for assembly / disassembly work.
- ▶ Only step on the aids, ladders and catwalks with clean shoes.
- ▶ Keep aids, ladders and catwalks free of heavy dirt, snow, frost and ice.
- ▶ During all assembly and disassembly work, maintenance work and inspections, travel or crane operation is prohibited.
- ▶ Remaining on a suspended load is prohibited.
- ▶ Stepping or walking on crane components and lattice sections that have an incline of more than 20° is prohibited.
- ▶ For all assembly work, the crane driver of the main crane must be in voice contact with the crane driver / crane drivers of the auxiliary crane / auxiliary cranes.
- ▶ For assembly tasks, the crane driver may only initiate crane movements when the responsible guide has explicitly released the movement.

**WARNING**

Danger of impact / crushing!

When installing / removing crane components with the auxiliary crane, crane components can start to swing back and forth.

When lifting / lowering and positioning crane components, there is an increased danger of impacts / crushing.

Death, severe bodily injuries, property damage.

- ▶ Make sure that personnel cannot be caught by components.
- ▶ Make sure that the crane is horizontally aligned.
- ▶ When working in danger zones: Use aids to protect limbs.
- ▶ Guide components with suitable aids to minimize oscillation.

**DANGER**

The components can fall down!

If the corresponding component is disengaged from the auxiliary crane before the corresponding component is pinned, then the corresponding component can fall down.

Death, severe bodily injuries, property damage.

- ▶ Do not disengage the auxiliary crane until the respective component is pinned and secured.

## 9.1 Unpinning winch 2

Make sure that the following prerequisites are met:

- The hydraulic connections are properly disconnected and closed off.
- The electrical connections are properly disconnected and closed off.
- The connections of the central lubrication system are properly disconnected and closed off.
- An auxiliary crane with a suitable load-bearing capacity is available.

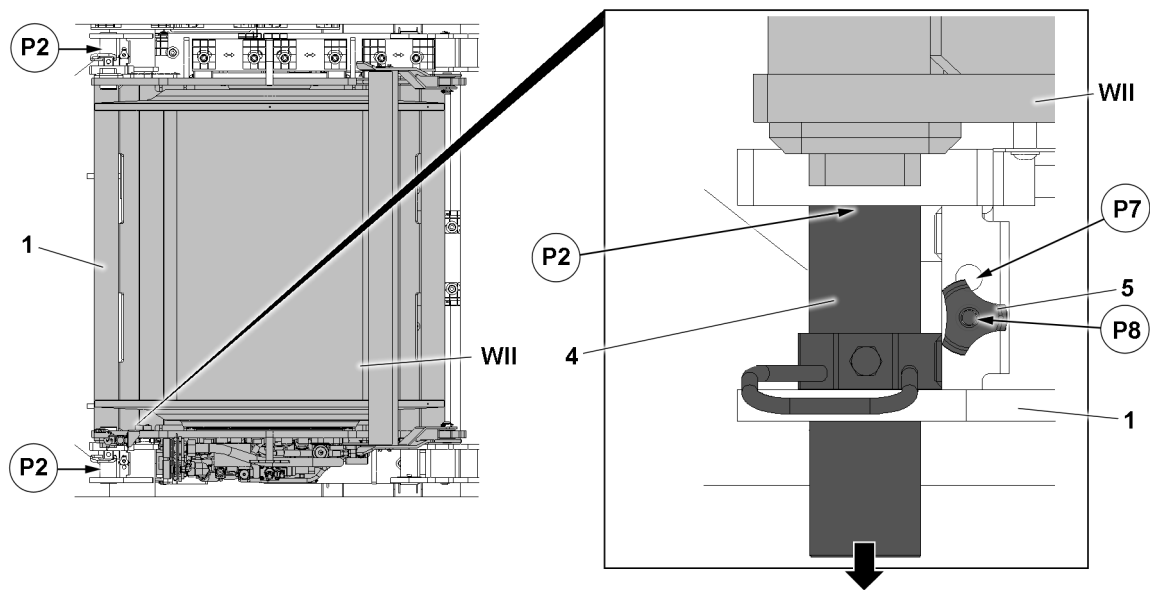


Fig.155221: Unpinning winch 2 **WII** on the turntable

**WII** Winch 2  
**1** Turntable

**4** Connector pin  
**5** Ball locking pin

**WARNING**

Danger of accident due to incorrect fastening!

Life-threatening situations can arise if the winch 2 **WII** is incorrectly or improperly fastened.

Death, severe bodily injuries, property damage.

- ▶ The fastening equipment may only be fastened on winch 2 **WII** at the intended fastening points.
- ▶ Make sure that the fastening equipment is properly attached on winch 2 **WII** and that it is properly secured to prevent it from loosening up.

- ▶ Attach the fastening equipment on both sides on winch 2 **WII**, see section “Winch 2 fastening points”.

When the fastening equipment is properly fastened to winch 2 **WII**:

- ▶ Bring the fastening equipment carefully to “tension” with the auxiliary crane.

When the fastening equipment is tensioned:

- ▶ Release the connector pins **4** on both sides: Remove the ball locking pin **5**.
- ▶ Secure the connector pins **4** in the “unpinned” position with ball locking pins **5**: Insert the ball locking pins **5** completely in point **P8**.

**Result:**

- The connector pins **4** are secured in the “unpinned” position.
- Winch 2 **WII** is unpinned on the turntable **1**.

## 9.2 Lifting winch 2 from the turntable

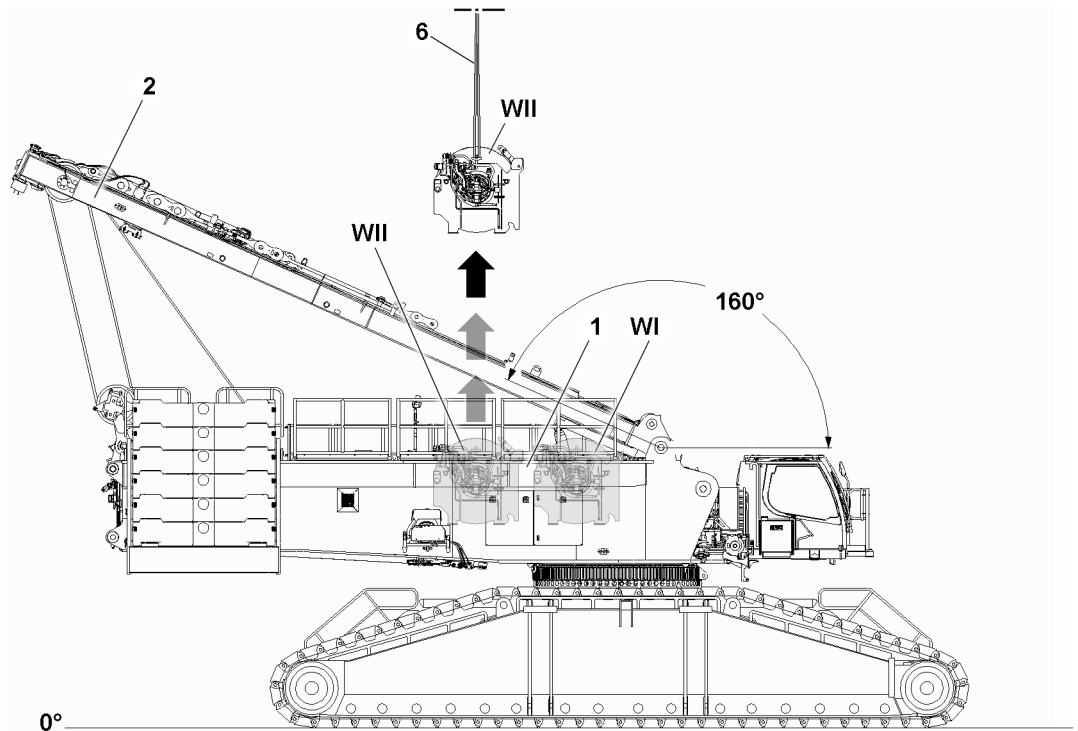


Fig.155222: Lifting winch 2 **WII** from the turntable

**WII** Winch 2

**1** Turntable

Make sure that the following prerequisites are met:

- The SA-frame **2** is erected to 160°.
- The counterweight is assembled on the turntable **1** according to “Assembly conditions on crawlers”, see chapter 3.06.
- Winch 2 **WII** is properly unpinned on the turntable **1**.

**WARNING**

Falling components!

When lifting winch 2 **WII** on the turntable 1, components or winch 2 **WII** can fall down.

Death, severe bodily injuries, property damage.

- ▶ Make sure that there are no persons within the danger zone.

- ▶ Carefully lift winch 2 **WII** from the turntable 1 with the auxiliary crane.

**WARNING**

Toppling winch!

When setting winch 2 **WII** on the ground, the winch can sink into the ground and fall over.

Death, severe bodily injuries, property damage.

- ▶ Make sure that the ground has sufficient load bearing capacity to safely absorb the weight of the winch.

- ▶ Swing winch 2 **WII** out with the auxiliary crane and set it on the ground on a suitable substructure.

**or**

Swing winch 2 **WII** out with the auxiliary crane and set it on the flatbed trailer.

When winch 2 **WII** has been set down properly:

- ▶ Remove the auxiliary crane.

## 3.07.30 Winch 3 assembly

1	Safety	2
2	Component overview	2
3	D-pivot section fastening points	2
4	Winch 3 fastening points	3
5	Winch 3 assembly	4
6	Disassembling winch 3	10

# 1 Safety

Observe the safety instructions before assembly and disassembly of winch 3:

- Information regarding work on the crane superstructure. See chapter 2.04.
- Information regarding personal protective equipment. See chapter 2.04.
- Information regarding the use of ladders. See chapter 2.04.10.
- Information regarding fall protection equipment. See chapter 2.06.
- Information regarding accesses to the crane. See chapter 2.07.
- Information regarding accessible surfaces. See chapter 2.07.
- Information regarding the assembly conditions. See chapter 3.06.

## 2 Component overview

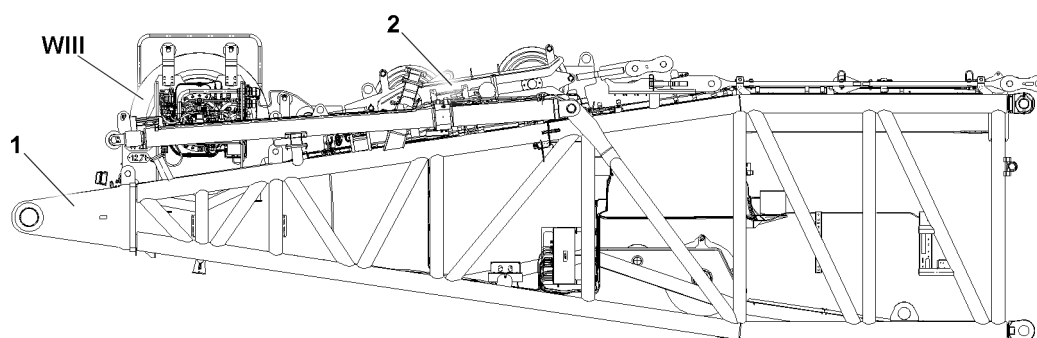


Fig.159647: Component overview

- |   |                      |                     |
|---|----------------------|---------------------|
| 1 | D-pivot section      | <b>WIII</b> Winch 3 |
| 2 | Luffing pulley block |                     |



### Note

- ▶ Weights of winch 3 **WIII**, D-pivot section **1** and the luffing pulley block **2**, see chapter 1.03.



### Note

- ▶ Winch 3 **WIII** is marked with its own weight.

## 3 D-pivot section fastening points



### WARNING

D-pivot section incorrectly fastened!

Life-threatening situations can arise if the D-pivot section is incorrectly or improperly fastened. Death, severe bodily injuries, property damage.

- ▶ Fasten the D-pivot section only on the intended fastening points.
- ▶ Fasten the fastening equipment to the D-pivot section only in connection with shackles.
- ▶ Make sure that the shackles and fastening equipment have a sufficient load bearing capacity.
- ▶ Observe the technical safety instructions during assembly and disassembly, see chapter 5.01.

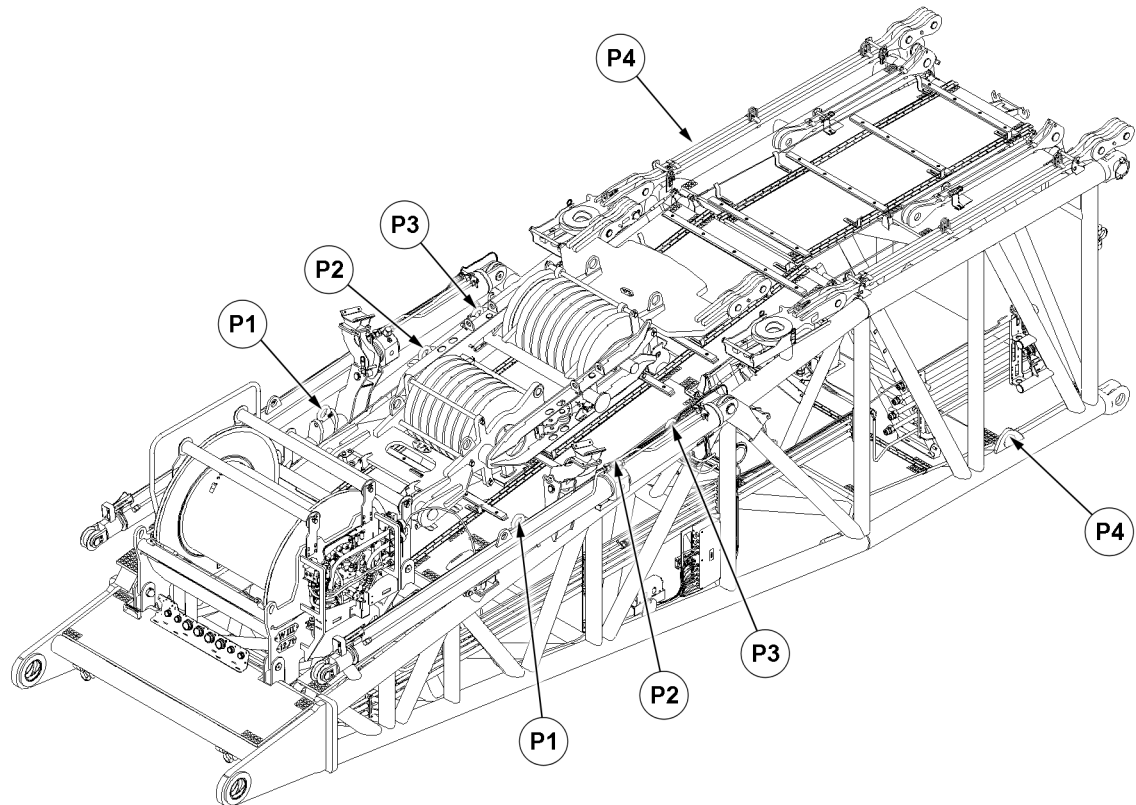


Fig.159646: D-pivot section fastening points (illustration with winch 3)

Fastening points	
P1 and P2	D-pivot section with winch 3
P3	D-pivot section without winch 3 installed
P4	D-boom completely assembled

## 4 Winch 3 fastening points



### WARNING

Winch incorrectly fastened!

Life-threatening situations can arise if the winch is incorrectly or improperly fastened. Death, severe bodily injuries, property damage.

- ▶ Attach the winch only on the intended fastening points.
- ▶ Attach the fastening equipment on winch solely in connection with shackles.
- ▶ Make sure that the shackles and fastening equipment have a sufficient load bearing capacity.
- ▶ Observe the technical safety instructions during assembly and disassembly, see chapter 5.01.

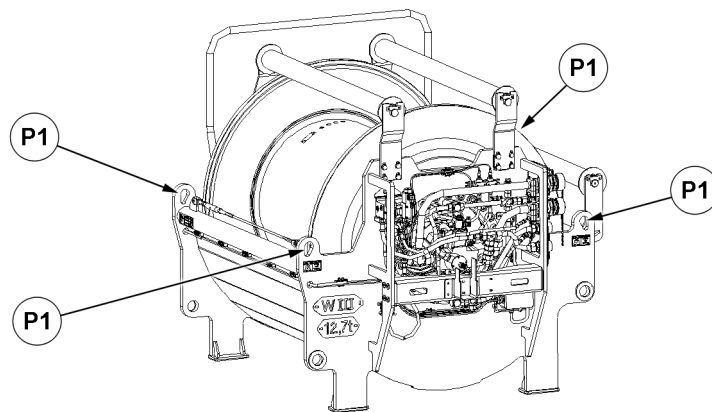


Fig.159644: Winch 3 fastening points

Fastening points	
P1	Winch 3

## 5 Winch 3 assembly



### Note

- ▶ The description in this section may only be used when winch 3 is delivered separately from the D-pivot section to the assembly and / or job location of the crane.



### WARNING

#### Danger of falling!

During assembly / disassembly, inspection and maintenance work, assembly personnel must be secured with appropriate aids to prevent them from falling.

Death, severe bodily injuries, property damage.

- ▶ All work at a height, when there is a danger of falling, must be carried out with suitable aids.
- ▶ If aids are not available and work cannot be carried out from the ground, then assembly personnel must secure themselves with the supplied fall arrest system to prevent falling, see chapter 2.04.
- ▶ If fall protection equipment is available, then it must be used, see chapter 2.06.
- ▶ When lifting, lowering, swinging crane parts in and out, no persons may remain in the danger zone.
- ▶ If railings are present on the components, then they must be brought into the corresponding position and secured for assembly / disassembly work.
- ▶ It is prohibited to lean the ladder against the component being disassembled.
- ▶ Only step on the aids, ladders and catwalks with clean shoes.
- ▶ Keep aids, ladders and catwalks free of heavy dirt, snow, frost and ice.
- ▶ During all assembly and disassembly work, maintenance work and inspections, travel or crane operation is prohibited.
- ▶ Remaining on a suspended load is prohibited.
- ▶ Stepping or walking on crane components and lattice sections, which have an incline of more than 20° is prohibited.
- ▶ For all assembly work, the crane operator of the main crane must be in voice contact with the crane operator / crane operators of the auxiliary crane / auxiliary cranes.
- ▶ For assembly / disassembly tasks, the crane operator may only initiate crane movements when the responsible guide has explicitly released the movement.



**WARNING**

Danger of impact / crushing!

If anyone remains within the assembly / disassembly area of winch 3, they would be exposed to a danger of impact / crushing.

When assembling / disassembling crane components with the auxiliary crane, crane components can start to swing back and forth.

When lifting / lowering and positioning crane components, there is an increased danger of impact / crushing.

Death, severe bodily injuries, property damage.

- ▶ Make sure that there are no persons between the components which are to be assembled / disassembled.
- ▶ Make sure that personnel cannot be caught by components.
- ▶ When working in danger zones: Use aids to protect limbs.
- ▶ Guide components with suitable aids to minimize oscillation.

**DANGER**

The components can fall down!

If the corresponding component is disengaged from the auxiliary crane before the corresponding component is pinned, then the corresponding component can fall down.

Death, severe bodily injuries, property damage.

- ▶ Do not detach the auxiliary crane until the respective component is pinned and secured.

## 5.1 Assembling winch 3

**WARNING**

Danger of accident during assembly of winch 3!

Death, severe bodily injuries, property damage.

- ▶ Make sure that the following prerequisites are met for the assembly of winch 3.

Make sure that the following prerequisite is met:

- An auxiliary crane with a suitable load-bearing capacity is available.

### 5.1.1 Lifting the D-pivot section from the transport vehicle

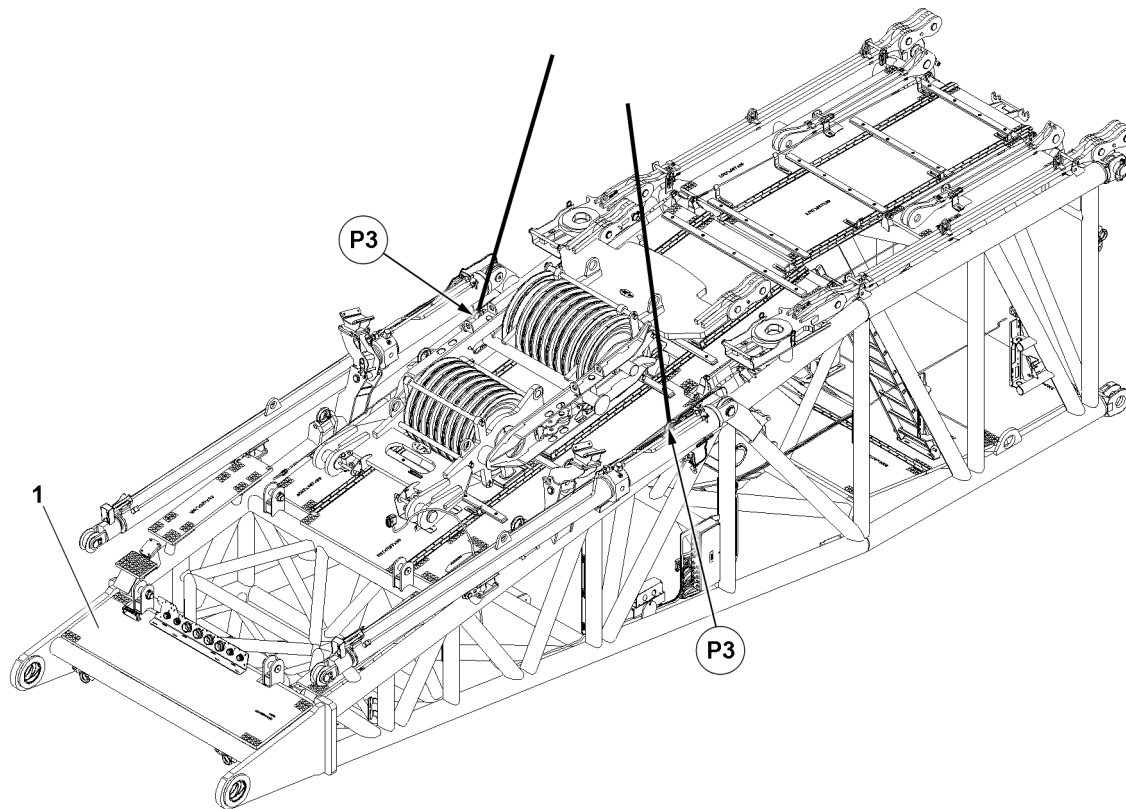


Fig.159648: Lifting the D-pivot section without winch 3 from the transport vehicle



#### WARNING

Danger of accident due to incorrect fastening!

Life-threatening situations can arise if the D-pivot section is incorrectly or improperly fastened. Death, severe bodily injuries, property damage.

- ▶ Fasten the D-pivot section without winch 3 only to the fastening points (position **P3**).
- ▶ Make sure that the fastening equipment is correctly fastened to the fastening points (position **P3**) and that it is secured sufficiently to prevent it from loosening up.

- ▶ Fasten the fastening equipment (position **P3**) to the fastening points.
- ▶ Use the auxiliary crane to "tension" the fastening equipment.
- ▶ Release and remove the transport retainers on the transport vehicle.



#### WARNING

Falling components!

When lifting the D-pivot section **1** from the transport vehicle, components or the D-pivot section **1** could start to oscillate or fall down.

Death, severe bodily injuries, property damage.

- ▶ Make sure that there are no persons within the danger zone.



#### WARNING

Tipping of the D-pivot section due to an incorrectly dimensioned substructure!

Death, severe bodily injuries, property damage.

- ▶ Dimension the substructure according to the weight of the D-pivot section with winch 3, see chapter 1.03.

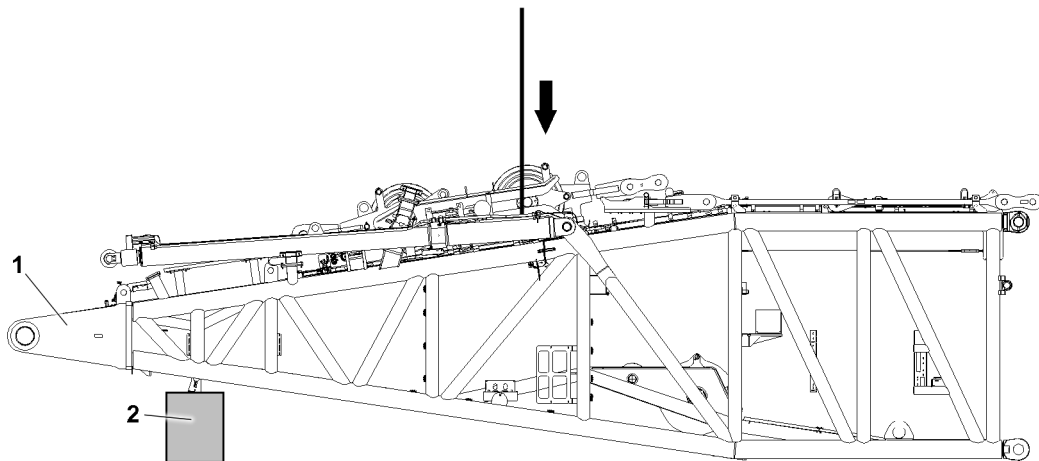


Fig.159649: Putting down the D-pivot section without winch 3

- ▶ Build up the substructure 2 for the D-pivot section 1 approx. 700 mm.
- ▶ Lift the D-pivot section 1 with the auxiliary crane from the transport vehicle.
- ▶ Place the D-pivot section 1 on the ground and on the substructure 2.

### 5.1.2 Lifting winch 3 from the transport vehicle

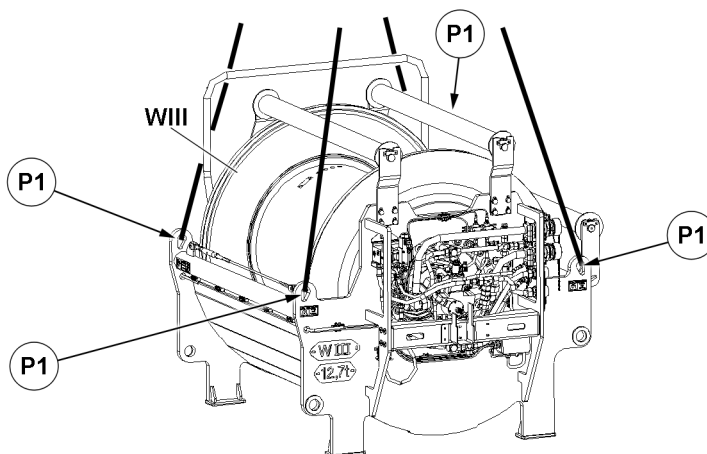


Fig.159650: Lifting winch 3 from the transport vehicle



#### WARNING

Danger of accident due to incorrect fastening!  
Life-threatening situations can arise if the winch 3 is incorrectly or improperly fastened.  
Death, severe bodily injuries, property damage.

- ▶ Fasten winch 3 only to the fastening points (position **P1**).
- ▶ Make sure that the fastening equipment is correctly fastened to the fastening points (position **P1**) and that it is secured sufficiently to prevent it from loosening up.

- ▶ Fasten the fastening equipment (position **P1**) to the fastening points.
- ▶ Use the auxiliary crane to "tension" the fastening equipment.
- ▶ Release and remove the transport retainers on the transport vehicle.



#### WARNING

Falling components!  
When lifting winch 3 from the transport vehicle, components or winch 3 can start to oscillate or fall down.

- ▶ Make sure that there are no persons within the danger zone.

- ▶ Lift winch 3 **WIII** with the auxiliary crane from the transport vehicle.

### 5.1.3 Positioning winch 3

Make sure that the following prerequisite is met:

- The pin and safety locking pin are removed from the pin points of winch 3.
- The D-pivot section is supported.

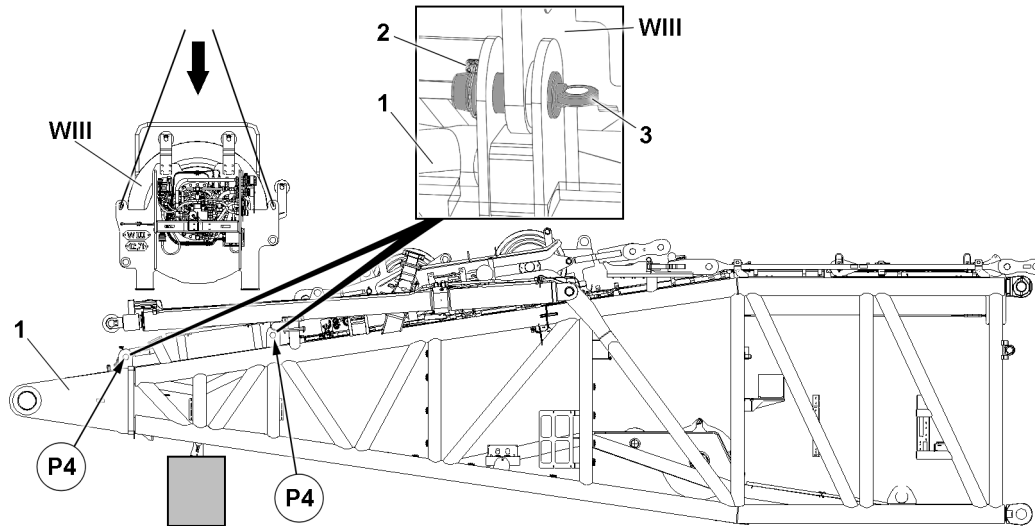


Fig.159645: Assembling winch 3



#### WARNING

Danger of accident when swinging in and lowering winch 3!

When swinging in and lowering winch 3 in the assembly opening of the D-pivot section, limbs can be crushed or even severed.

Death, severe bodily injuries, property damage.

- ▶ Make sure that there is no personnel in the danger zone.
- ▶ Do not reach with your hands into the danger zone.

#### NOTICE

Property damage!

If the following notes are not observed, damage can result to the crane or winch 3.

- ▶ When retracting winch 3, it must be ensured that winch 3 does not hit against the D-pivot section.



#### Note

- ▶ The guide must be in constant visual and acoustic contact with the crane operator.



#### Note

- ▶ Pay attention to the exact alignment of winch 3 to the installation position.

- ▶ Swing winch 3 **WIII** in with the auxiliary crane to the D-pivot section **1**.

- ▶ Position and align winch 3 **WIII**.

When winch 3 **WIII** is aligned:

- ▶ Lower winch 3 **WIII** into the assembly opening using the auxiliary crane until the pin bores of winch 3 **WIII** aligned with the pin bores on the D-pivot section **1** for winch 3 **WIII** in position **P4** on both sides.

When the pin bores align:

- ▶ Pin winch 3 **WIII** with four pins **3** from the outside to the inside and secure with the safety locking pins **2**.
- ▶ Remove the auxiliary crane.

## 5.2 Establishing the hydraulic connections to winch 3

Make sure that the following prerequisite is met:

- Winch 3 **WIII** is properly installed, pinned and secured.

### 5.2.1 Establishing the hydraulic connections to winch 3



#### Note

- ▶ After the hydraulic connections to the winch are established, the expansion tank must be checked and emptied.

The hydraulic connections for the winch are made with quick couplings.

When connecting hydraulic lines with quick couplings, make sure that the coupling procedure is carried out correctly.



#### WARNING

Pressure in the hydraulic lines!

If the pressure supply is not interrupted before connecting / releasing the hydraulic lines, the hydraulic oil can escape with high pressure.

Death, severe bodily injuries, property damage.

- ▶ Release the pressure in the hydraulic system before connecting / disconnecting: Interrupt the pressure supply and wait for a short time.



#### WARNING

Loss of pressure or leakage!

Incorrectly coupled or self-loosening quick couplings (particularly return lines) can result in serious accidents due to component failure.

- ▶ Check that the quick couplings have been properly connected before using the crane.
- ▶ Connect the coupling components (sleeve and connector) and screw together with the knurled nut.

#### Problem remedy

Is it not possible to assemble the coupling components due to the high pressure?

When the D-relapse cylinder in the D-pivot section is connected hydraulically with the crane:

- ▶ Turn the engine off.
- ▶ Turn the ball valve for the D-relapse cylinder to the horizontal position for approx 1 second, extend the D-relapse cylinder, see chapter 5.05
- ▶ Turn the ball valve for the D-relapse cylinder to the vertical position for approx 1 second, the hydraulic pressure decreases. Retracting the D-relapse cylinder, see chapter 5.05
- ▶ Turning the ball valve to the STOP position (45°).

- ▶ Tighten the hydraulic coupling by hand. Turn the knurled nut until it reaches a tangible, fixed stop position.
- ▶ Establish the hydraulic connections to the winch.

### 5.2.2 Establishing the electrical connections to winch 3

- ▶ Establish the electrical connections to winch 3, see the wiring diagram.



#### WARNING

Malfunction if dummy plugs are not installed!

If the dummy plugs on the non-required electrical connections are not installed, then malfunctions or functional limitations can occur on the crane.

- ▶ Make sure that all non-required electrical connections, which have a dummy plug, are closed off with dummy plugs.
- ▶ Pay attention to the Electrical wiring diagram.

- ▶ As a rule, close off on-required electrical connections (for example for accessories which cannot be installed) with the respective dummy plugs.

---

#### NOTICE

Property damage due to dirt and / or corrosion!

If unnecessary electrical connections are not closed off with the respective protective caps, then dirt and / or corrosion can damage the electrical connections.

This could result in malfunctions.

- ▶ Make sure that all non-required electrical connections are always closed off properly.
  - ▶ Pay attention to the Electrical wiring diagram.
- 
- ▶ Close electrical connections, which have no dummy plugs, off properly with the corresponding protective caps.

### 5.2.3 Establishing the connections of the central lubrication system to winch 3

- ▶ Establish the connections of the central lubrication system to the winch.

## 5.3 Assembling the D-boom



#### Note

- ▶ Assemble the D-boom, see chapter 5.05.
- 

## 5.4 Assembling the luffing pulley block



#### Note

- ▶ Assemble the luffing pulley block, see chapter 5.05.
- 



#### WARNING

Falling down of the upper pulley block!

Death, severe bodily injuries, property damage.

- ▶ Make sure that the upper pulley block is only disconnected from the lower pulley block if the rope of winch 3 is properly reeved in on the luffing pulley block and secured to the fixed point of the lower pulley block, see the Reeving plan.
- 

## 5.5 Reeving in the S-or main-boom adjustment (luffing pulley block)



#### Note

- ▶ Reeving in the S-or main-boom adjustment (luffing pulley block), see the reeving plan.
- 

## 6 Disassembling winch 3



#### Note

- ▶ The description in this section only has to be used when winch 3 is to be transported separately from the D-pivot section.
-

**WARNING**

Danger of falling!

During assembly / disassembly, inspection and maintenance work, assembly personnel must be secured with appropriate aids to prevent them from falling.

Death, severe bodily injuries, property damage.

- ▶ All work at a height, when there is a danger of falling, must be carried out with suitable aids.
- ▶ If aids are not available and work cannot be carried out from the ground, then assembly personnel must secure themselves with the supplied fall arrest system to prevent falling, see chapter 2.04.
- ▶ If fall protection equipment is available, then it must be used, see chapter 2.06.
- ▶ When lifting, lowering, swinging crane parts in and out, no persons may remain in the danger zone.
- ▶ If railings are present on the components, then they must be brought into the corresponding position and secured for assembly / disassembly work.
- ▶ It is prohibited to lean the ladder against the component being disassembled.
- ▶ Only step on the aids, ladders and catwalks with clean shoes.
- ▶ Keep aids, ladders and catwalks free of heavy dirt, snow, frost and ice.
- ▶ During all assembly and disassembly work, maintenance work and inspections, travel or crane operation is prohibited.
- ▶ Remaining on a suspended load is prohibited.
- ▶ Stepping or walking on crane components and lattice sections, which have an incline of more than 20° is prohibited.
- ▶ For all assembly work, the crane operator of the main crane must be in voice contact with the crane operator / crane operators of the auxiliary crane / auxiliary cranes.
- ▶ For assembly / disassembly tasks, the crane operator may only initiate crane movements when the responsible guide has explicitly released the movement.

**WARNING**

Danger of impact / crushing!

If anyone remains within the assembly / disassembly area of winch 3, they would be exposed to a danger of impact / crushing.

When assembling / disassembling crane components with the auxiliary crane, crane components can start to swing back and forth.

When lifting / lowering and positioning crane components, there is an increased danger of impact / crushing.

Death, severe bodily injuries, property damage.

- ▶ Make sure that there are no persons between the components which are to be assembled / disassembled.
- ▶ Make sure that personnel cannot be caught by components.
- ▶ When working in danger zones: Use aids to protect limbs.
- ▶ Guide components with suitable aids to minimize oscillation.

**DANGER**

The components can fall down!

If the corresponding component is disengaged from the auxiliary crane before the corresponding component is pinned, then the corresponding component can fall down.

Death, severe bodily injuries, property damage.

- ▶ Do not detach the auxiliary crane until the respective component is pinned and secured.

## 6.1 Putting down D-pivot section with winch 3

Make sure that the following prerequisites are met:

- The luffing pulley block is reeved out and secured to the D-pivot section.
- The D-pivot section is disassembled from the crane.

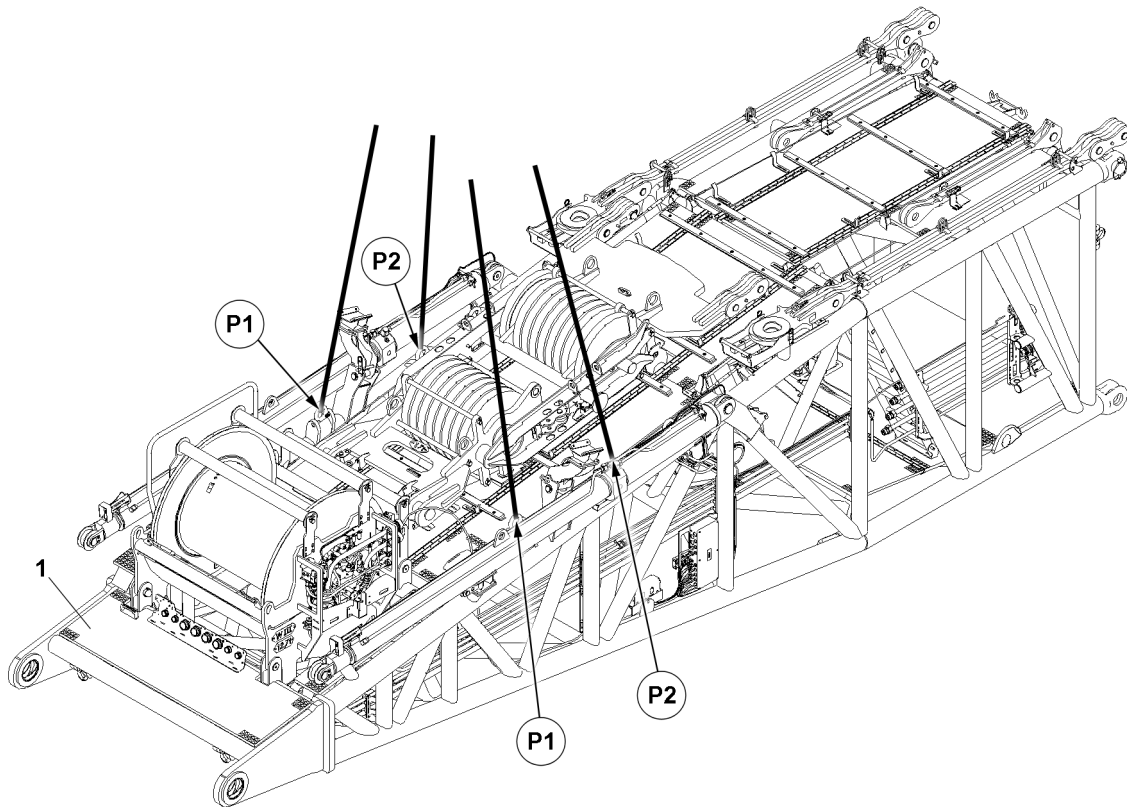


Fig.159652: Fastening the D-pivot section with winch 3



#### WARNING

Danger of accident due to incorrect fastening!

Life-threatening situations can arise if the D-pivot section **1** is incorrectly or improperly fastened. Death, severe bodily injuries, property damage.

- ▶ Fasten the D-pivot section **1** with winch 3 only to the fastening points (position **P1** and position **P2**).
- ▶ Make sure that the fastening equipment is correctly fastened to the fastening points (position **P1** and position **P2**) and that it is secured sufficiently to prevent it from loosening up.

- ▶ Fasten the fastening equipment to the fastening points (position **P1** and position **P2**) to the fastening points.
- ▶ Use the auxiliary crane to “tension” the fastening equipment.



#### WARNING

Falling components!

When lifting the D-pivot section **1**, components or the D-pivot section **1** could start to oscillate or fall down.

Death, severe bodily injuries, property damage.

- ▶ Make sure that there are no persons within the danger zone.



#### WARNING

Tipping of the D-pivot section due to an incorrectly dimensioned substructure!

Death, severe bodily injuries, property damage.

- ▶ Dimension the substructure according to the weight of the D-pivot section with winch 3, see chapter 1.03.



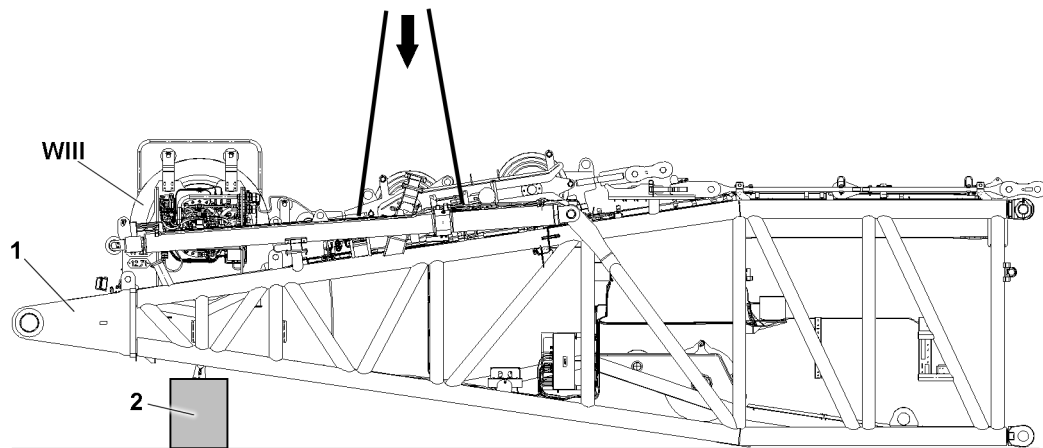


Fig.159653: Putting down the D-pivot section

- ▶ Build up the substructure 2 for the D-pivot section 1 approx. 700 mm.
- ▶ Lift the D-pivot section 1 and place it on the ground and on the substructure 2.

## 6.2 Disconnecting the connections to winch 3

Make sure that the following prerequisites are met:

- The upper pulley block is secured properly to the lower pulley block.
- The luffing pulley block is properly reeved out.
- The rope of winch 3 is completely spooled out.
- The rope of winch 3 is secured against spooling out by itself.

### 6.2.1 Disconnecting the hydraulic connections to winch 3

When releasing hydraulic lines with quick couplings, make sure that the coupling procedure is carried out correctly.



#### WARNING

Pressure in the hydraulic lines!

If the pressure supply is not interrupted before connecting / releasing the hydraulic lines, the hydraulic oil can escape with high pressure.

Death, severe bodily injuries, property damage.

- ▶ Release the pressure in the hydraulic system before connecting / disconnecting: Interrupt the pressure supply and wait for a short time.

- ▶ Release the hydraulic coupling by hand.
- ▶ Disconnect the hydraulic connections to the winch.

#### Problem remedy

Is it not possible to disconnect the coupling components due to the high pressure?

When the D-relapse cylinder in the D-pivot section is connected hydraulically with the crane:

- ▶ Turn the engine off.
- ▶ Turn the ball valve for the D-relapse cylinder to the horizontal position for approx 1 second, extend the D-relapse cylinder, see chapter 5.05
- ▶ Turn the ball valve for the D-relapse cylinder to the vertical position for approx 1 second, the hydraulic pressure decreases. Retracting the D-relapse cylinder, see chapter 5.05
- ▶ Turning the ball valve to the STOP position (45°).

- ▶ Close the hydraulic hoses and hydraulic lines off properly with the provided caps.
- ▶ Bring the hydraulic hoses into the park position for transport and secure them properly.

### 6.2.2 Disconnecting the electrical connections to winch 3

- ▶ Disconnect the electrical connections to the winch.

- ▶ Close the electrical connections off properly with the provided caps.

### 6.2.3 Disconnecting the connections of the central lubrication system to winch 3

- ▶ Disconnect the connections to the winch.
- ▶ Close the lubrication line connections off properly with the provided caps.

## 6.3 Disassembling winch 3

### 6.3.1 Lifting winch 3 out of the D-pivot section

Make sure that the following prerequisites are met:

- The hydraulic connections are properly disconnected and closed off.
- The electrical connections are properly disconnected and closed off.
- The connections of the central lubrication system are properly disconnected and closed off.
- An auxiliary crane with a suitable load-bearing capacity is available.

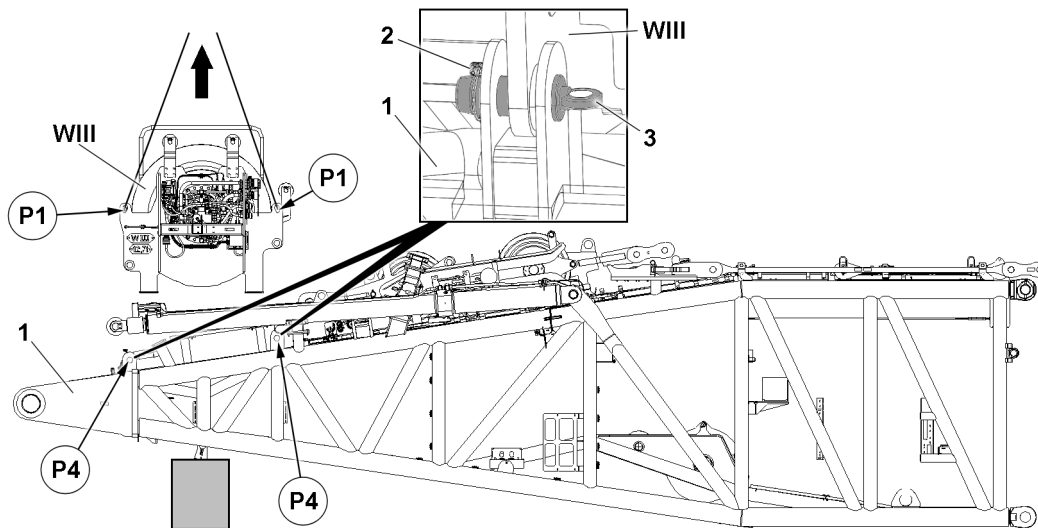


Fig.159651: Disassembling winch 3



#### WARNING

Danger of accident due to incorrect fastening!

Life-threatening situations can arise if the winch 3 is incorrectly or improperly fastened. Death, severe bodily injuries, property damage.

- ▶ The fastening equipment may only be fastened to winch 3 in the intended fastening points.
- ▶ Make sure that the fastening equipment is properly attached to winch 3 and that it is secured sufficiently to prevent it from loosening up.



#### WARNING

Falling components!

When lifting winch 3 on the D-pivot section, components or winch 3 can fall down. Death, severe bodily injuries, property damage.

- ▶ Make sure that there are no persons within the danger zone.



#### WARNING

Toppling winch!

When setting winch 3 on the ground, the winch can sink into the ground and fall over. Death, severe bodily injuries, property damage.

- ▶ Make sure that the ground has sufficient load bearing capacity to safely absorb the weight of winch 3.

- ▶ Fasten the fastening equipment on both sides to winch 3 **WIII** in position **P1**.

When the fastening equipment is properly fastened to winch 3 **WIII**:

- ▶ “Tension” the fastening equipment carefully using the auxiliary crane.

When the fastening equipment is tensioned:

- ▶ Remove the safety locking pin **2** on both sides in position **P4**.
- ▶ Unpin four pin **3**.
- ▶ Lift winch 3 **WIII** carefully with the auxiliary crane onto the D-pivot section **1**.
- ▶ Swing winch 3 **WIII** out with the auxiliary crane and set it on the ground on a suitable substructure.  
**or**  
Swing winch 3 **WIII** out with the auxiliary crane and set it on the transport vehicle.

When winch 3 **WIII** has been set down properly:

- ▶ Remove the auxiliary crane.
- ▶ Insert four pins **3** in winch 3 **WIII** and secure with safety locking pins **2**.

### 6.3.2 Setting the D-pivot section down

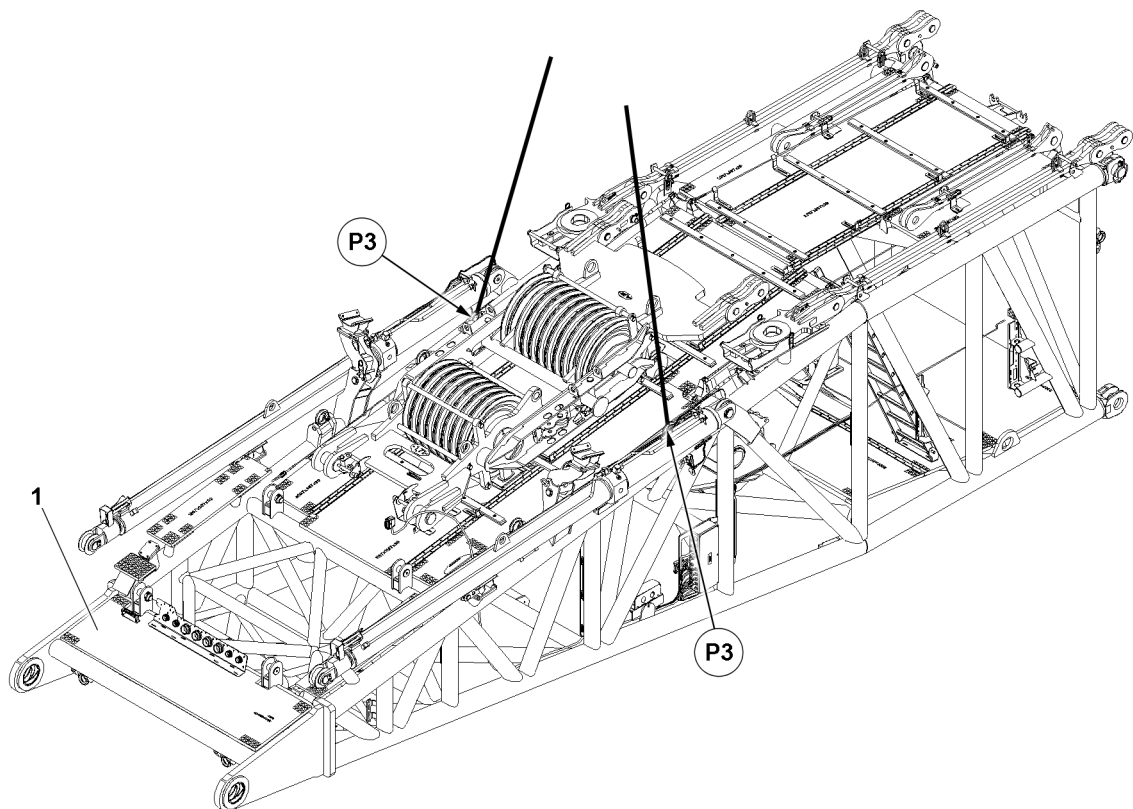


Fig.159648: Fastening the D-pivot section



#### WARNING

Danger of accident due to incorrect fastening!

Life-threatening situations can arise if the D-pivot section is incorrectly or improperly fastened.

Death, severe bodily injuries, property damage.

- ▶ Fasten the D-pivot section only to the fastening points (position **P3**).
  - ▶ Make sure that the fastening equipment is correctly fastened to the fastening points (position **P3**) and that it is secured sufficiently to prevent it from loosening up.
- 
- ▶ Fasten the fastening equipment (position **P3**) to the fastening points.
  - ▶ Use the auxiliary crane to “tension” the fastening equipment.

**WARNING**

Falling components!

When lifting the D-pivot section 1, components or the D-pivot section 1 could start to oscillate or fall down.

Death, severe bodily injuries, property damage.

- ▶ Make sure that there are no persons within the danger zone.

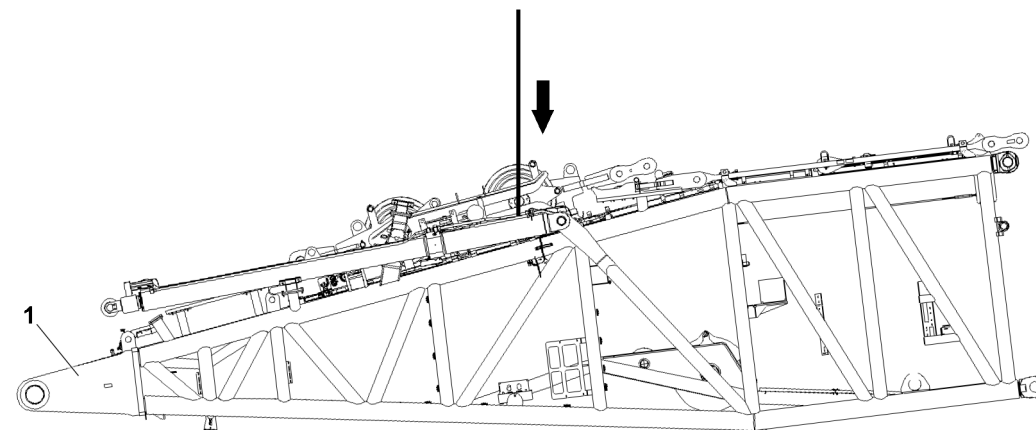


Fig.159654: Setting the D-pivot section down

- ▶ Lift the D-pivot section 1 with the auxiliary crane and set it on the ground on a suitable substructure.

**or**

Lift the D-pivot section 1 with the auxiliary crane and set it down on the transport vehicle.

When the D-pivot section 1 has been set down properly:

- ▶ Remove the auxiliary crane.

## 3.07.50 Winch 5 assembly

1	Safety	2
2	Component overview	2
3	Winch 5 fastening points	2
4	Assembling winch 5	3
5	Assembling the H-pivot section on the turntable	16
6	Disassembling the H-pivot section on the turntable	16
7	Disassembling winch 5	16
8	Bringing winch 5 from the operating position into the transport position	26
9	Bringing winch 5 from the transport position into the operating position	29

# 1 Safety

Before assembly and disassembly of winch 5, observe the safety instructions:

- Information regarding work on the crane superstructure. See chapter 2.04.
- Information regarding personal protective equipment. See chapter 2.04.
- Information about securing persons to prevent them from falling. See chapter 2.04.
- Information regarding the use of ladders. See chapter 2.04.10.
- Information regarding fall protection equipment. See chapter 2.06.
- Information regarding accesses to the crane. See chapter 2.07.
- Information regarding accessible surfaces. See chapter 2.07.

## 2 Component overview

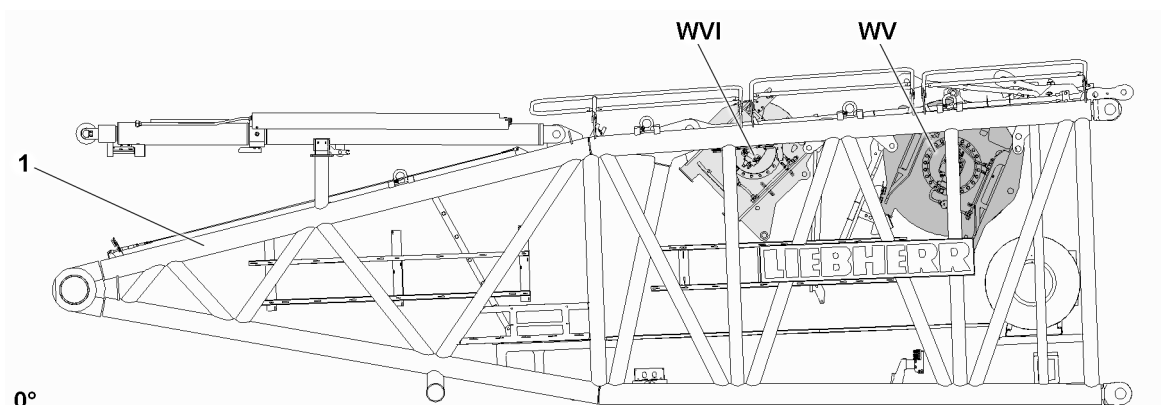


Fig.155501: H-pivot section 1 with winches (winch 5 **WV**, winch 6 **WVI** and relapse cylinders

1 H-pivot section

**WVI** Winch 6

**WV** Winch 5



### Note

- ▶ Dimensions and weights of winch 5 **WV**, see chapter 1.03.



### Note

- ▶ Winch 5 **WV** is marked with its own weight.

## 3 Winch 5 fastening points



### WARNING

Winch incorrectly fastened!

Life-threatening situations can arise if the winch is incorrectly or improperly fastened.

Death, severe bodily injuries, property damage.

- ▶ Attach the winch only on the intended fastening points.
- ▶ Attach the fastening equipment on winch solely in connection with shackles.
- ▶ Make sure that the shackles and fastening equipment have sufficient load bearing capacity.
- ▶ Observe the technical safety instructions during assembly and disassembly, see Crane operating instructions, chapter 5.01.

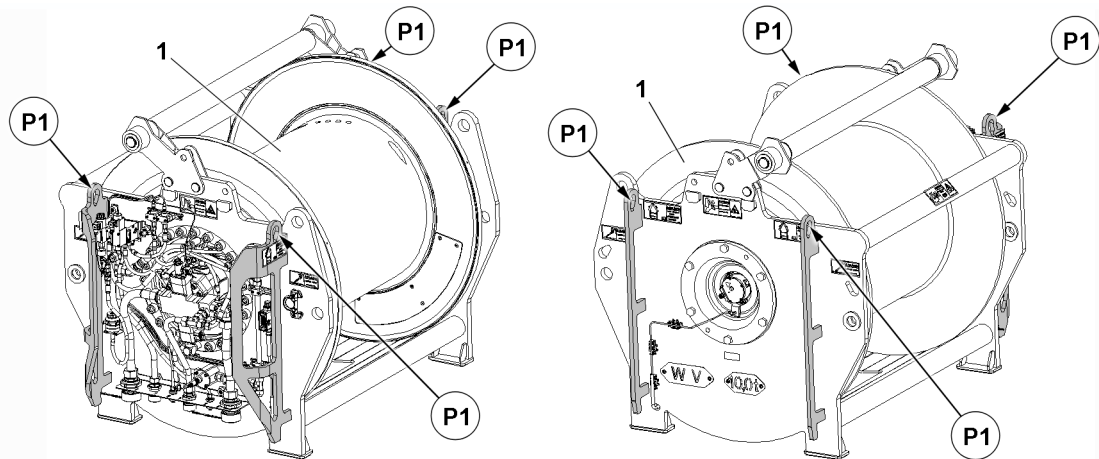


Fig.155502: Winch 5 fastening points // View from left and right

1 Winch 5

P1 Fastening point

Fastening points	
P1	Winch 5

## 4 Assembling winch 5



### WARNING

Danger of falling!

During assembly / disassembly, inspection and maintenance work, assembly personnel must be secured with appropriate aids to prevent them from falling.

Death, severe bodily injuries, property damage.

- ▶ All work at a height, when there is a danger of falling, must be carried out with suitable aids.
- ▶ If aids are not available and work cannot be carried out from the ground, then assembly personnel must secure themselves with the supplied fall arrest system to prevent falling, see chapter 2.04.
- ▶ If fall protection equipment is available, then it must be used, see chapter 2.06.
- ▶ When lifting, lowering, swinging crane parts in and out, no persons may remain in the danger zone.
- ▶ When closing or opening boom systems during boom assembly or boom disassembly, no persons may remain on the boom system or in the danger zone.
- ▶ If railings are present on the components, then they must be brought into the corresponding position and secured for assembly / disassembly work.
- ▶ Only step on the aids, ladders and catwalks with clean shoes.
- ▶ Keep aids, ladders and catwalks free of heavy dirt, snow, frost and ice.
- ▶ During all assembly and disassembly work, maintenance work and inspections, travel or crane operation is prohibited.
- ▶ Remaining on a suspended load is prohibited.
- ▶ Stepping or walking on crane components and lattice sections that have an incline of more than 20° is prohibited.
- ▶ For all assembly work, the crane driver of the main crane must be in voice contact with the crane driver / crane drivers of the auxiliary crane / auxiliary cranes.
- ▶ For assembly tasks, the crane driver may only initiate crane movements when the responsible guide has explicitly released the movement.

**WARNING**

Danger of impact / crushing!

When installing / removing crane components with the auxiliary crane, crane components can start to swing back and forth.

When lifting / lowering and positioning crane components, there is an increased danger of impacts / crushing.

Death, severe bodily injuries, property damage.

- ▶ Make sure that personnel cannot be caught by components.
- ▶ Make sure that the crane is horizontally aligned.
- ▶ When working in danger zones: Use aids to protect limbs.
- ▶ Guide components with suitable aids to minimize oscillation.

**DANGER**

The components can fall down!

If the corresponding component is disengaged from the auxiliary crane before the corresponding component is pinned, then the corresponding component can fall down.

Death, severe bodily injuries, property damage.

- ▶ Do not disengage the auxiliary crane until the respective component is pinned and secured.

## 4.1 Assembling winch 5

### 4.1.1 Disassembling the H-guy rods on the H-pivot section

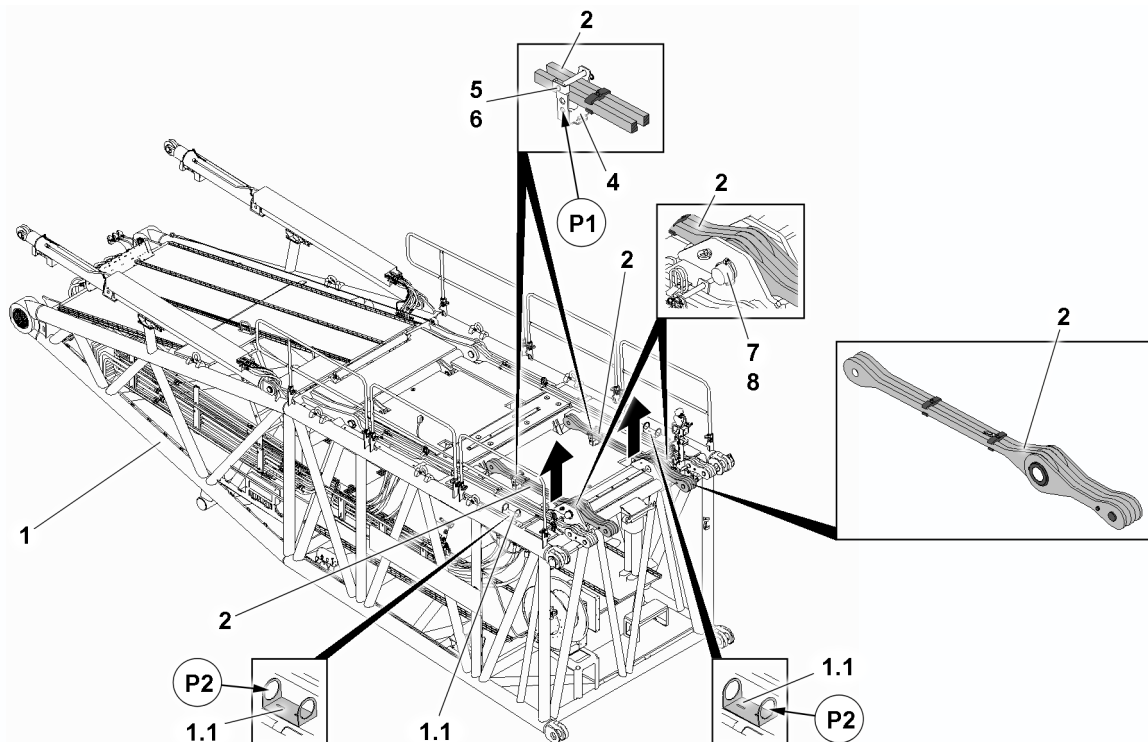


Fig.155503: Disassembling the H-guy rods 2 on the H-pivot section 1

- |     |                         |    |                         |
|-----|-------------------------|----|-------------------------|
| 1   | H-pivot section         | 6  | Retaining element       |
| 1.1 | Park position for pin 7 | 7  | Pin                     |
| 2   | Two-part H-guy rod      | 8  | Retaining element       |
| 4   | Transport retainer      | P1 | Park position for pin 5 |
| 5   | Pin                     | P2 | Park position for pin 7 |



Make sure that the following prerequisites are met:

- The H-pivot section **1** is lying completely on the ground.
  - The winch assembly opening of winch 5 is properly closed off by the grating.
  - The winch assembly opening of winch 6 is properly closed off by the grating.
  - The railings on the H-pivot section are in the operating position, see chapter 2.06.
  - Gratings, catwalks and fall protection equipment are properly installed.
  - The access ladder is properly assembled.
  - An auxiliary crane with a suitable load-bearing capacity is available.
- ▶ Access the H-pivot section **1**, see chapter 2.07.



#### Note

- ▶ The disassembly of the H-guy rods **2** is described based on the example of one guy rod.
- ▶ The disassembly of the second H-guy rod is carried out in the same manner.



#### WARNING

Danger of crushing!

During assembly of the H-guy rod **2**, hands and / or limbs could be crushed.

Death, severe bodily injuries, property damage.

- ▶ When swinging in and positioning the H-guy rod **2**, do not reach into the assembly area.
- ▶ Wear personal protective equipment.

- ▶ Fasten the first H-guy rod **2** properly to the auxiliary crane.

When the H-guy rod **2** is properly fastened to the auxiliary crane:

- ▶ Remove the transport retainer for the H-guy rod **2**: Remove the retaining element **6** in the pin **5** and unpin the pin **5**.
- ▶ Insert the pin **5** in the transport receptacle **4** in point **P1** and secure properly with the retaining element **6**.
- ▶ Remove the retaining element **8** in the pin **7** and unpin the pin **7**.
- ▶ Insert the pin **7** in the transport receptacle **1.1** in point **P2** and secure properly with the retaining element **8**.

#### Result:

- The H-guy rod **2** is unpinned.
- ▶ Lift the first H-guy rod **2** using the auxiliary crane from the H-pivot section **1** and take down onto the substructure on the ground.



#### Note

- ▶ The disassembly of the second H-guy rod is to be carried out in the same manner as the disassembly of the first H-guy rod.
- ▶ Disassemble the second H-guy rod **2** and use the auxiliary crane to lift it off the H-pivot section **1**.

### 4.1.2 Folding the grating into the installation position of winch 5



#### Note

- ▶ If winch 5 is not installed in transport condition of the H-pivot section **1**, then the installation / assembly opening of winch 5 on the H-pivot section is closed off with a grating **10**.
- ▶ The grating **10** must be unpinned for the installation of winch 5 on the H-pivot section **1** on one side in points **P1** and must be folded down and secured properly in this position.

Make sure that the following prerequisites are met:

- No personnel is present on the grating **10**.
- The H-guy rods are disassembled on the H-pivot section **1**.
- No winch is assembled on the H-pivot section.
- The pins **7** are inserted on both sides in the transport receptacle **1.1** and properly secured with the retaining element **8**.
- A second person is present for assembly support.
- An auxiliary crane with an adequate load-bearing capacity is available.

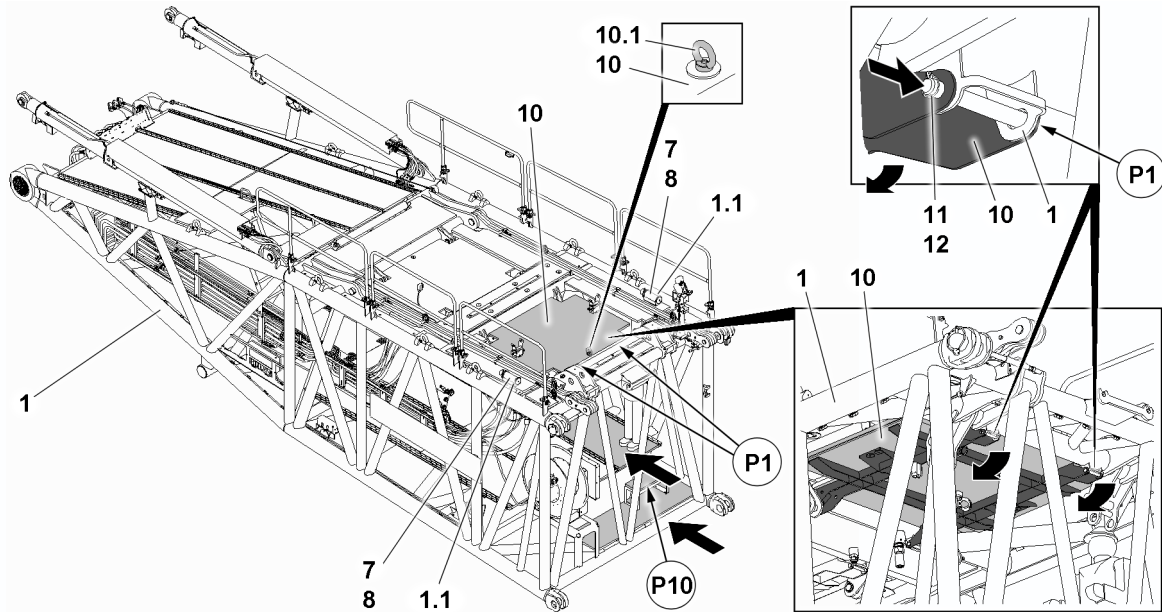


Fig.155504: Folding the grating **10** down

<b>1</b>	H-pivot section	<b>10.1</b>	Ring nut
<b>1.1</b>	Pin park position	<b>11</b>	Pin
<b>7</b>	Pin	<b>12</b>	Retaining element
<b>8</b>	Retaining element	<b>P1</b>	Pin point
<b>10</b>	Grating	<b>P10</b>	Assembly personnel access, bottom platform

- ▶ Properly fasten the grating **10** to the ring nut **10.1** on the auxiliary crane.

When the grating **10** is properly fastened to the auxiliary crane:

- ▶ Carefully tension the fastening equipment.
- ▶ Unpin the pin **11**: Remove the retaining element **12** on both sides and unpin the pin **11** on both sides.



### WARNING

Danger of accident due to the grating!

When lowering the grating **10**, people can fall down.

Death, severe bodily injuries, property damage.

- ▶ Make sure before lowering the grating **10** that no people are located on the grating.
- ▶ Make sure that there are no persons within the slewing range of the grating **10**.

When the pins **11** are unpinned on both sides:

- ▶ Lower the grating **10** slowly with the auxiliary crane about 10 cm.

When the grating **10** has been lowered about 10 cm:

- ▶ Stop the lowering procedure of the grating **10**.
- ▶ Insert the pins **11** on both sides in the pin points in the grating **10** and properly secure with the retaining element **12**.
- ▶ Lower the grating **10** completely with the auxiliary crane.

**Note**

- For reasons of better illustration, the grating **16** above the installation opening of winch 6 is removed on the H-pivot section **1**.

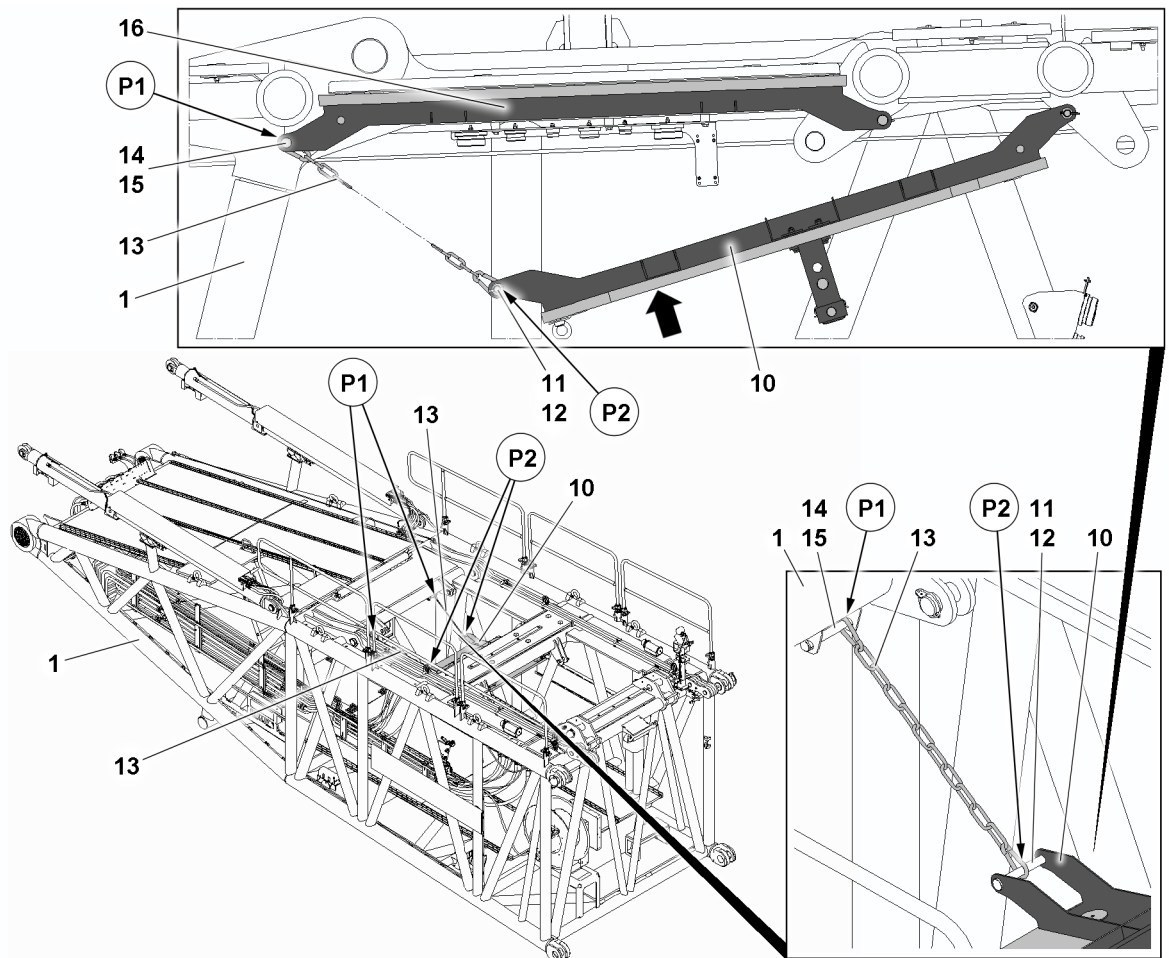


Fig.155505: Grating **10** in the assembly position

- |                             |  |
|-----------------------------|--|
| <b>1</b> H-pivot section    | <b>14</b> Pin                          |
| <b>10</b> Winch 5 grating   | <b>15</b> Retaining element            |
| <b>11</b> Pin               | <b>16</b> Winch 6 grating              |
| <b>12</b> Retaining element | <b>P1</b> Chain hanger fastening point |
| <b>13</b> Chain hanger      | <b>P2</b> Chain hanger fastening point |

When the grating **10** is lowered completely:

- Remove the fastening equipment from the ring nut **10.1** and swing the auxiliary crane out.

The grating **10** must be moved into the assembly position (direction of the grating **16**), held there and fastened with two chain hangers **13**.

**NOTICE**

Damage to the grating **10**!

If the grating **10** is secured in the assembly position with only one chain hanger **13**, the grating **10** can be permanently damaged due to twisting.

- Always secure the grating **10** with two chain hangers **13**.

- Move the grating **10** manually to the assembly position (direction of the arrow) and hold it there.
- Fix the grating **10** in the assembly position: Hang the chain hangers **13** on both sides with snap hook in point **P1** and point **P2**.

When the grating **10** is properly secured in the assembly position:

- Lower the grating **10** until the grating is securely held by the chain hangers.

- ▶ Remove the auxiliary crane.

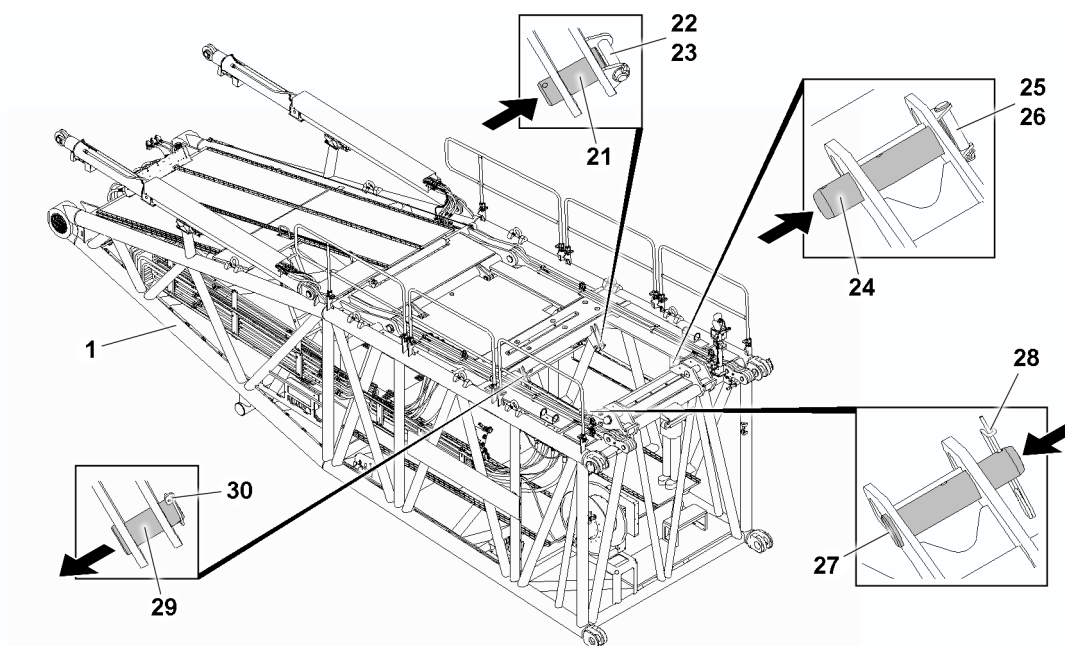


Fig.155506: Preparing the H-pivot section 1 for winch 5 installation

1	H-pivot section	26	Retaining element
21	Connector pin	27	Connector pin
22	Retaining pin	28	Retaining element
23	Retaining element	29	Connector pin
24	Connector pin	30	Retaining element
25	Retaining pin		

- ▶ Release the connector pin 21, connector pin 24, connector pin 27 and connector pin 29: Remove the retaining elements and retaining pins.
- ▶ Completely unpin the connector pin 21, connector pin 24, connector pin 27 and connector pin 29.
- ▶ Take down the connector pins, retaining pins and retaining elements.

**Result:**

- The H-pivot section 1 is prepared for winch 5 assembly.

### 4.1.3 Lifting winch 5 from the flatbed trailer

Make sure that the following prerequisites are met:

- The minimum length of the fastening equipment is 3000 mm.
- Pay attention to the labels on the components.

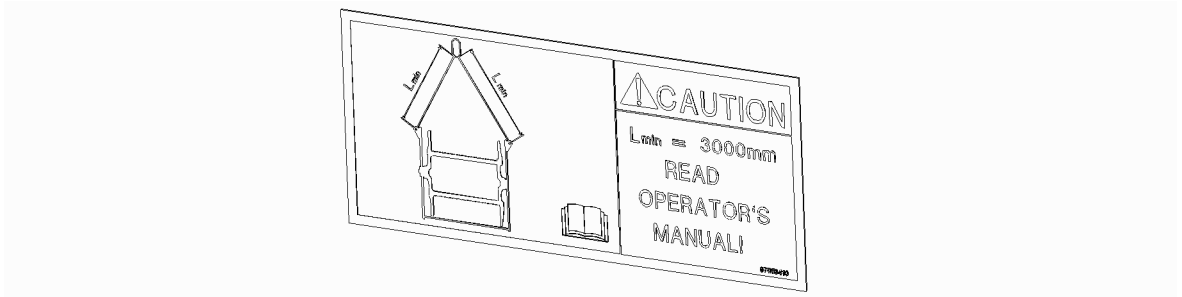


Fig.155507: Labels - minimum length of the fastening equipment 3000 mm



#### WARNING

Danger of accident during assembly of winch 5!  
Death, severe bodily injuries, property damage.

- ▶ Make sure that winch 5 is secured with an auxiliary rope to prevent it from swinging during transport with the auxiliary crane.
- 
- ▶ Fasten the fastening equipment to the fastening points properly, see section “Winch 5 fastening points”.
  - ▶ Bring the fastening equipment to “tension” with the auxiliary crane.
  - ▶ Release and remove the transport retainers on the flatbed trailer.



#### WARNING

Falling components!

When lifting winch 5 from the flatbed trailer, components or winch 5 can fall down.  
Death, severe bodily injuries, property damage.

- ▶ Make sure that there are no persons within the danger zone.
- 
- ▶ Lift winch 5 with the auxiliary crane from the flatbed trailer.
  - ▶ Swing winch 5 in with the auxiliary crane for assembly on the S-pivot section.
- or**
- Use the auxiliary crane to place winch 5 on the substructure on the ground.

#### 4.1.4 Swinging in and positioning winch 5

Make sure that the following prerequisites are met:

- The H-pivot section **1** is lying completely on the ground.
- Winch 6 is not assembled on the H-pivot section.
- The winch assembly opening of winch 6 is properly closed off by the grating.
- The railings on the H-pivot section **1** are in the operating position.
- The ground is able to safely take on the entire weight of the H-pivot section **1** inclusive of winch **5 WV** to be assembled.
- Gratings, catwalks and fall protection equipment are properly installed.
- The access ladder is properly assembled.
- An auxiliary crane with a suitable load-bearing capacity is available.

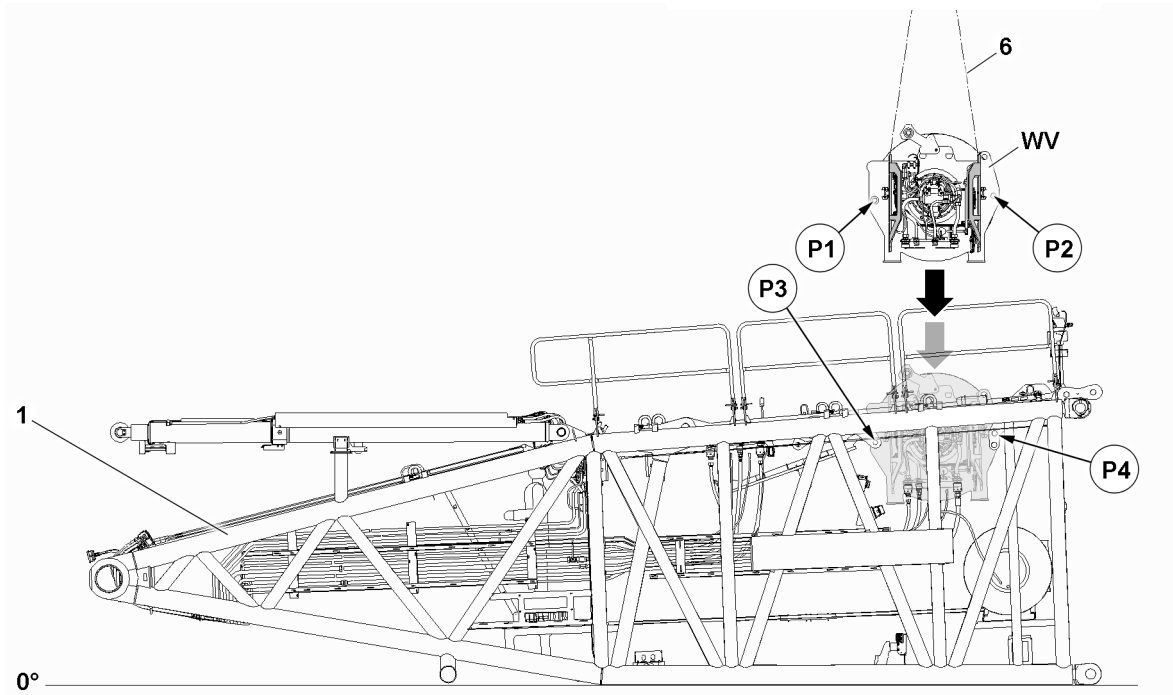


Fig.155508: Positioning winch 5 **WV** on the H-pivot section **1**

<b>WV</b> Winch 5	<b>P2</b> Pin point
<b>1</b> H-pivot section	<b>P3</b> Pin point
<b>6</b> Fastening equipment	<b>P4</b> Pin point
<b>P1</b> Pin point	



#### WARNING

Danger of accident when swinging in and lowering winch 5!

When swinging in and lowering winch 5 **WV** on the H-pivot section **1**, limbs can be crushed or even severed.

Death, severe bodily injuries, property damage.

- ▶ Make sure that there is no personnel in the danger zone.
- ▶ Do not reach with your hands into the danger zone.

#### NOTICE

Property damage!

If the following notes are not observed, damage can result to the H-pivot section **1** or winch 5 **WV**.

- ▶ Make sure that winch 5 **WV** does not bump against the H-pivot section when lowering into the H-pivot section **1**.



**Note**

- ▶ The guide must be in constant visual and acoustic contact with the crane operator.



**Note**

- ▶ Pay attention to the exact alignment of winch 5 **WV** with respect to the installation position on the H-pivot section **1**.

- ▶ Swing winch 5 **WV** in with the auxiliary crane to the H-pivot section **1**.
- ▶ Position and align winch 5 **WV** over the installation opening on the H-pivot section **1**.

When winch 5 **WV** is aligned:

- ▶ Slowly and carefully lower winch 5 **WV** into the H-pivot section **1**.
- ▶ Lower winch 5 **WV** until the bores, point **P1**, align with the bores point **P3**.

### 4.1.5 Assembling winch 5 in the operating position

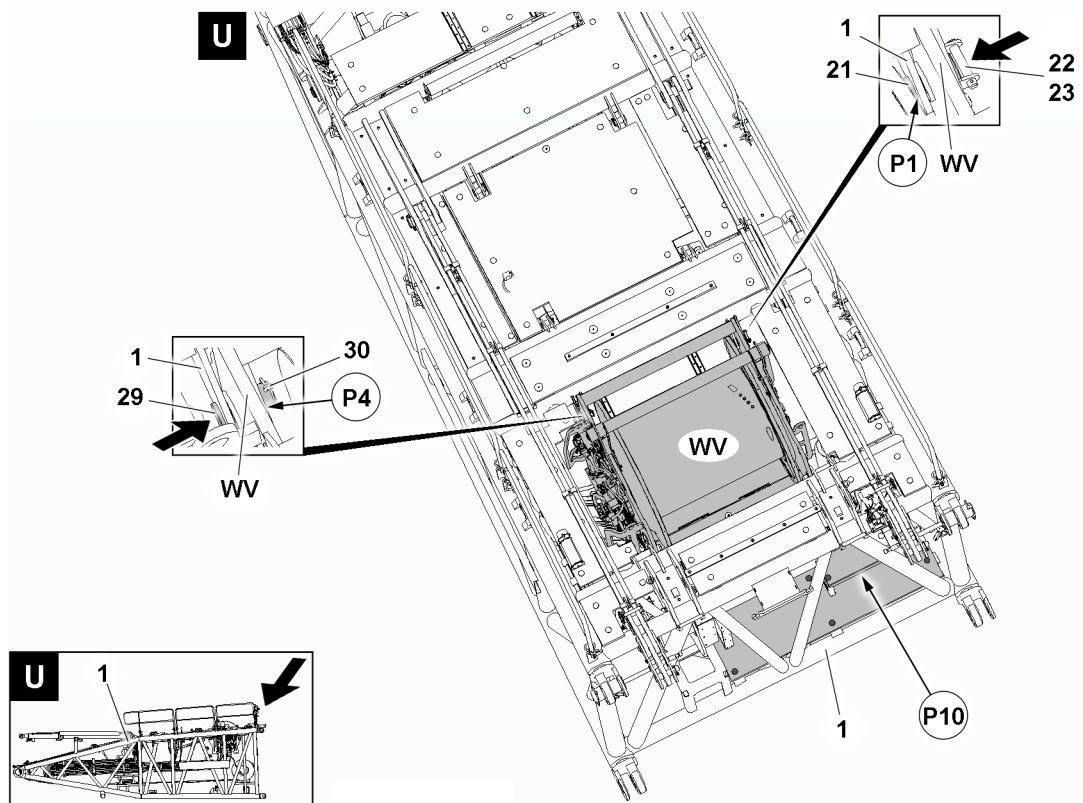


Fig.155509: Pinning winch 5 **WV** on the H-pivot section **1** in the operating position

- |                             |   |
|-----------------------------|---|
| <b>WV</b> Winch 5           | <b>30</b> Retaining element                           |
| <b>1</b> H-pivot section    | <b>P1</b> Pin point                                   |
| <b>21</b> Connector pin     | <b>P4</b> Pin point                                   |
| <b>22</b> Retaining pin     | <b>P10</b> Assembly personnel access, bottom platform |
| <b>23</b> Retaining element | <b>U</b> Orientation aid / direction of vision        |
| <b>29</b> Connector pin     |   |

LWE/LR 1800-1-0-000/27200-07-02/en

**WARNING**

The connector pins can loosen up by themselves!  
If the connector pins are not properly secured, they can come loose.  
Death, severe bodily injuries, property damage.

- ▶ Secure all connector pins immediately after pinning with retaining pins and / or retaining elements.

Make sure that the following prerequisites are met:

- The bores of winch 5 **WV** align with the bores of H-pivot section **1**.
- Winch 5 **WV** must be pinned from the “bottom platform” by assembly personnel.

When the bores between winch 5 **WV** and the receptacles in the H-pivot section **1** align in point **P1** and point **P4**:

- ▶ Completely insert the connector pin **21** in point **P1** from the outside to the inside.
- ▶ Properly secure the connector pin **21** with the retaining pin **22** and retaining element **23**.
- ▶ Completely insert the connector pin **29** in point **P4** from the outside to the inside.
- ▶ Properly secure the connector pin **29** with the retaining element **30**.

When the connector pin **21** and connector pin **29** are properly pinned and secured:

- ▶ Lift or lower winch 5 **WV** with the auxiliary crane until the pin bores align in point **P20**.

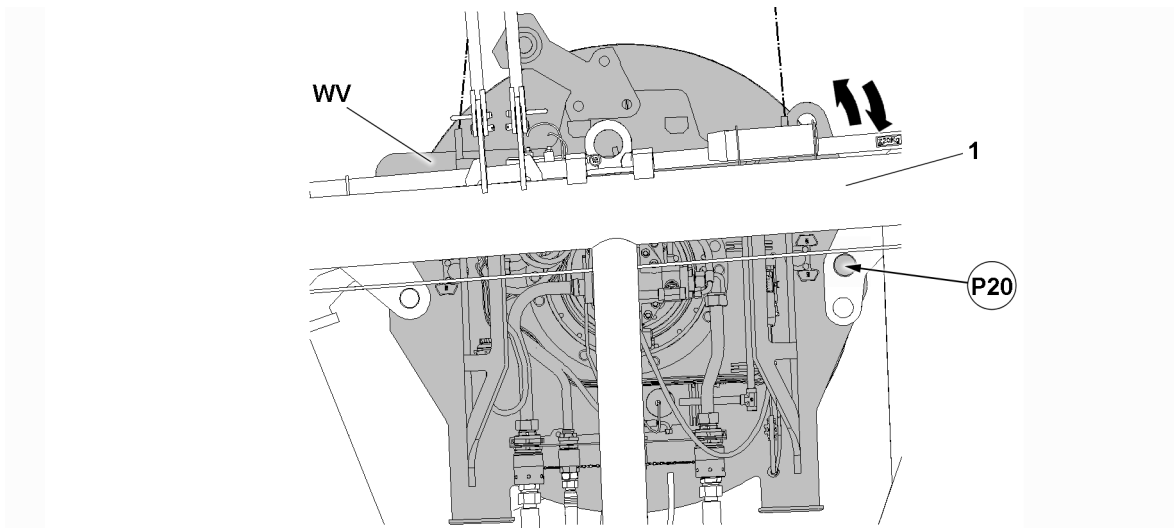


Fig.155510: Winch 5 **WV** in the H-pivot section **1**

**1** H-pivot section

**P20** Pinning operating position

**WV** Winch 5

When the bores between winch 5 **WV** and the receptacles in the H-pivot section **1** align in point **P20**:

- ▶ Completely insert the connector pin **24** in point **P2** from the outside to the inside.



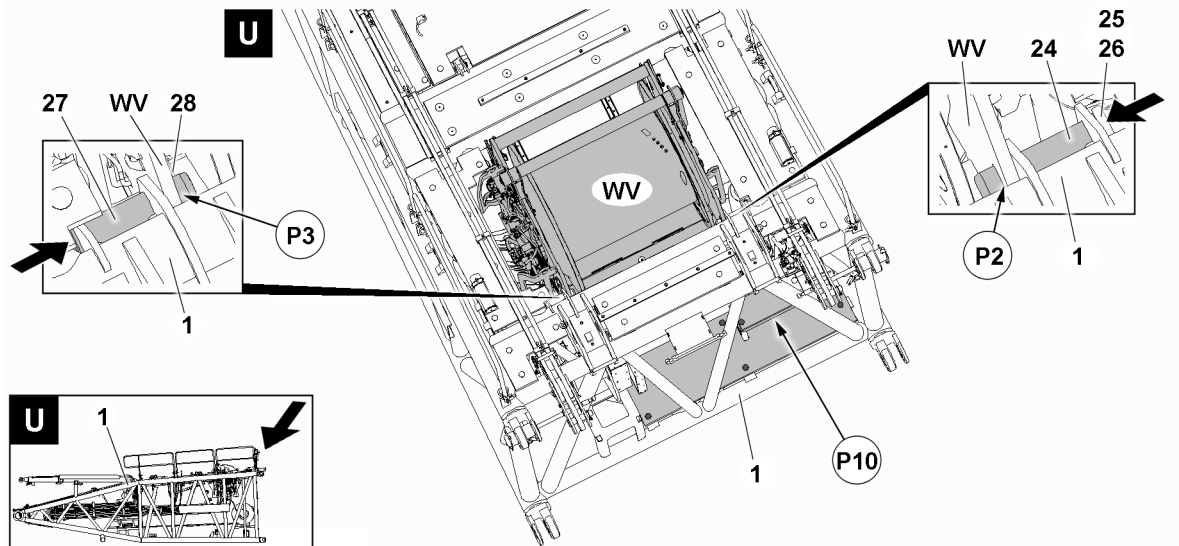


Fig.155511: Pinning winch 5 **WV** on the H-pivot section **1** in the operating position

<b>WV</b> Winch 5	<b>28</b> Retaining element
<b>1</b> H-pivot section	<b>P2</b> Pin point
<b>24</b> Connector pin	<b>P3</b> Pin point
<b>25</b> Retaining pin	<b>P10</b> Assembly personnel access, bottom platform
<b>26</b> Retaining element	<b>U</b> Orientation aid / direction of vision
<b>27</b> Connector pin	

- ▶ Properly secure the connector pin **24** with the retaining pin **25** and retaining element **26**.
- ▶ Completely insert the connector pin **27** in point **P3** from the outside to the inside.
- ▶ Properly secure the connector pin **27** with the retaining element **28**.

**Result:**

- The connector pins are properly pinned and secured.
- Winch 5 **WV** is properly installed in the operating position.
- ▶ Release the fastening equipment on winch 5 **WV**.
- ▶ Remove the auxiliary crane.

#### 4.1.6 Establishing the hydraulic connections to winch 5



**Note**

- ▶ Establish the connections to winch 5 only when winch 5 is properly installed and secured.

Make sure that the following prerequisite is met:

- The winch 5 is properly installed, pinned and secured.

##### Establishing the hydraulic connections to the winch



**Note**

- ▶ After the hydraulic connections to the winch are established, the expansion tank must be checked and emptied.

The hydraulic connections for the winch are made with quick couplings.

When connecting hydraulic lines with quick couplings, make sure that the coupling procedure is carried out correctly.

**WARNING**

Pressure in the hydraulic lines!

If the pressure supply is not interrupted before connecting / releasing the hydraulic lines, the hydraulic oil can escape with high pressure.

Death, severe bodily injuries, property damage.

- ▶ Release the pressure in the hydraulic system before connecting / disconnecting: Interrupt the pressure supply and wait for a short time.

**WARNING**

Loss of pressure or leakage!

Incorrectly coupled or self-loosening quick couplings (particularly return lines) can result in serious accidents due to component failure.

- ▶ Check that the quick couplings have been properly connected before using the crane.
- ▶ Connect the coupling components (sleeve and connector) and screw together with the knurled nut.
- ▶ Tighten the hydraulic coupling by hand. Turn the knurled nut until it reaches a tangible, fixed stop position.
- ▶ Establish the hydraulic connections to the winch.

**Establishing the electrical connections to the winch**

- ▶ Establish the electrical connections to the winch, see the Electric wiring diagram.

**WARNING**

Malfunction if dummy plugs are not installed!

If the dummy plugs on the non-required electrical connections are not installed, then malfunctions or functional limitations can occur on the crane.

- ▶ Make sure that all non-required electrical connections, which have a dummy plug, are closed off with dummy plugs.
- ▶ Pay attention to the Electrical wiring diagram.
- ▶ As a rule, close off on-required electrical connections (for example for accessories which cannot be installed) with the respective dummy plugs.

**NOTICE**

Property damage due to dirt and / or corrosion!

If non-required electrical connections are not closed off with the respective protective caps, then dirt and / or corrosion can damage the electrical connections.

This could result in malfunctions.

- ▶ Make sure that all non-required electrical connections are always closed off properly.
- ▶ Pay attention to the Electrical wiring diagram.
- ▶ Close electrical connections, which have no dummy plugs, properly off with the corresponding protective caps.

**Establishing the connections of the central lubrication system to the winch**

- ▶ Establish the connections of the central lubrication system to the winch.

**Result:**

- Winch 5 is properly assembled on the H-pivot section.

### 4.1.7 Assembling the H-guy rods on the H-pivot section

Make sure that the following prerequisites are met:

- The H-pivot section **1** is lying completely on the ground.
- Winch 5 **WV** is properly assembled and secured in the operating position.
- The winch assembly opening of winch 6 is properly closed off by the grating.
- The railings on the H-pivot section are in the operating position, see chapter 2.06.
- Gratings, catwalks and fall protection equipment are properly installed.
- The access ladder is properly assembled.
- An auxiliary crane with a suitable load-bearing capacity is available.

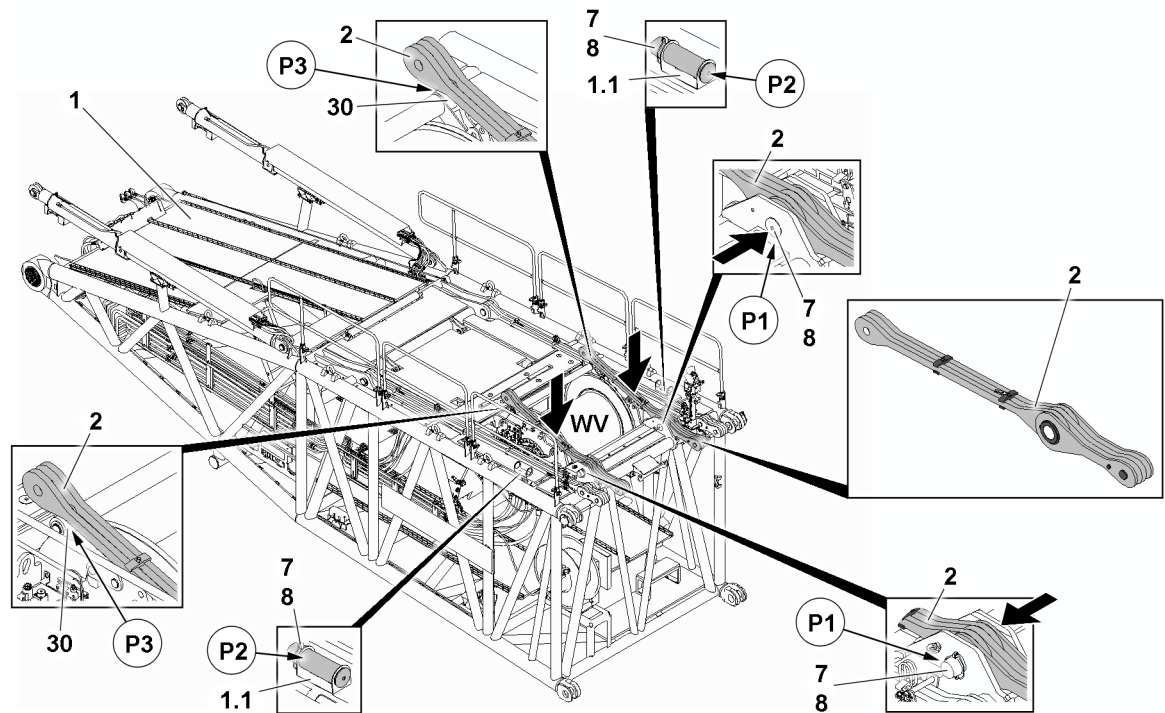


Fig.155904: Assembling the H-guy rods on the H-pivot section 1

<b>1</b>	H-pivot section	<b>30</b>	Pulley
<b>1.1</b>	Park position for pin 7	<b>P1</b>	Rod pin point
<b>2</b>	Two-part H-guy rod	<b>P2</b>	Pin park position
<b>7</b>	Pin	<b>P3</b>	Pulley contact point
<b>8</b>	Retaining element		

- ▶ Access the H-pivot section **1**, see chapter 2.07.



#### Note

- ▶ The assembly of the H-guy rods **2** is described based on the example of one guy rod.
- ▶ The assembly of the second H-guy rod is carried out in the same manner.



#### WARNING

Danger of crushing!

During assembly of the H-guy rod **2**, hands and / or limbs could be crushed.  
Death, severe bodily injuries, property damage.

- ▶ When swinging in and positioning the H-guy rod **2**, go not reach into the assembly area.
- ▶ Wear personal protective equipment.

- ▶ Fasten the first H-guy rod **2** properly to the auxiliary crane.

**Note**

- ▶ When swinging in and positioning the H-guy rod **2**, make sure that the H-guy rod **2** with the longer rod element is lying on the pulley **30** in point **P3**.

When the H-guy rod **2** is properly fastened to the auxiliary crane:

- ▶ Swing in the H-guy rod **2** with the auxiliary crane to the H-pivot section **1** and position it with the hollow axle in the pin point **P1**.

When the hollow axle and the pin bore align in the pin point **P1**:

- ▶ Release the pins **7** from the park position **1.1** in point **P2** and unpin.
- ▶ Insert the pin **7** in pin position **P1** from the inside to the outside and properly secure with the retaining element **8**.

**Result:**

- The H-guy rod **2** is properly pinned and secured.

**Note**

- ▶ The assembly of the second H-guy rod is to be carried out in the same manner as the assembly of the first H-guy rod.

- ▶ Properly assemble the second H-guy rod **2**.

## 5 Assembling the H-pivot section on the turntable

**Note**

- ▶ Assembling the H-pivot section on the turntable, see chapter 5.38 and Chapter 5.39.10.

## 6 Disassembling the H-pivot section on the turntable

**Note**

- ▶ Disassembling the H-pivot section on the turntable, see chapter 5.38 and Chapter 5.39.10.

## 7 Disassembling winch 5

**Note**

- ▶ The description in this section is only used when winch 5 is to be transported separately from the H-pivot section.

**WARNING**

Danger of falling!

During assembly / disassembly, inspection and maintenance work, assembly personnel must be secured with appropriate aids to prevent them from falling.

Death, severe bodily injuries, property damage.

- ▶ All work at a height, when there is a danger of falling, must be carried out with suitable aids.
- ▶ If aids are not available and work cannot be carried out from the ground, then assembly personnel must secure themselves with the supplied fall arrest system to prevent falling, see chapter 2.04.
- ▶ If fall protection equipment is available, then it must be used, see chapter 2.06.
- ▶ When lifting, lowering, swinging crane parts in and out, no persons may remain in the danger zone.
- ▶ When closing or opening boom systems during boom assembly or boom disassembly, no persons may remain on the boom system or in the danger zone.
- ▶ If railings are present on the components, then they must be brought into the corresponding position and secured for assembly / disassembly work.
- ▶ Only step on the aids, ladders and catwalks with clean shoes.
- ▶ Keep aids, ladders and catwalks free of heavy dirt, snow, frost and ice.
- ▶ During all assembly and disassembly work, maintenance work and inspections, travel or crane operation is prohibited.
- ▶ Remaining on a suspended load is prohibited.
- ▶ Stepping or walking on crane components and lattice sections that have an incline of more than 20° is prohibited.
- ▶ For all assembly work, the crane driver of the main crane must be in voice contact with the crane driver / crane drivers of the auxiliary crane / auxiliary cranes.
- ▶ For assembly tasks, the crane driver may only initiate crane movements when the responsible guide has explicitly released the movement.

**WARNING**

Danger of impact / crushing!

When installing / removing crane components with the auxiliary crane, crane components can start to swing back and forth.

When lifting / lowering and positioning crane components, there is an increased danger of impacts / crushing.

Death, severe bodily injuries, property damage.

- ▶ Make sure that personnel cannot be caught by components.
- ▶ Make sure that the crane is horizontally aligned.
- ▶ When working in danger zones: Use aids to protect limbs.
- ▶ Guide components with suitable aids to minimize oscillation.

**DANGER**

The components can fall down!

If the corresponding component is disengaged from the auxiliary crane before the corresponding component is pinned, then the corresponding component can fall down.

Death, severe bodily injuries, property damage.

- ▶ Do not disengage the auxiliary crane until the respective component is pinned and secured.

## 7.1 Disconnecting the connections to winch 5

Make sure that the following prerequisites are met:

- The hoist rope is completely spooled up to the winch.
- The hoist rope is secured on the winch to prevent it from spooling out by itself.

### 7.1.1 Disconnecting the hydraulic connections to the winch

When releasing hydraulic lines with quick couplings, make sure that the uncoupling procedure is carried out correctly.

**WARNING**

Pressure in the hydraulic lines!

If the pressure supply is not interrupted before connecting / releasing the hydraulic lines, the hydraulic oil can escape with high pressure.

Death, severe bodily injuries, property damage.

- ▶ Release the pressure in the hydraulic system before connecting / disconnecting: Interrupt the pressure supply and wait for a short time.
- 
- ▶ Release the hydraulic coupling by hand.
  - ▶ Disconnect the hydraulic connections to the winch.
  - ▶ Close the hydraulic hoses and hydraulic lines off properly with the intended caps.
  - ▶ Bring the hydraulic hoses in park position for transport and secure them properly.

### 7.1.2 Disconnecting the electrical connections to the winch

- ▶ Disconnect the electrical connections to the winch.
- ▶ Close the electrical connections properly off with the intended caps.

### 7.1.3 Disconnecting the connections of the central lubrication system to the winch

- ▶ Disconnect the connections to the winch.
- ▶ Close the lube line connections properly off with the intended caps.

## 7.2 Disassembling winch 5

### 7.2.1 Disassembling the H-guy rods on the H-pivot section

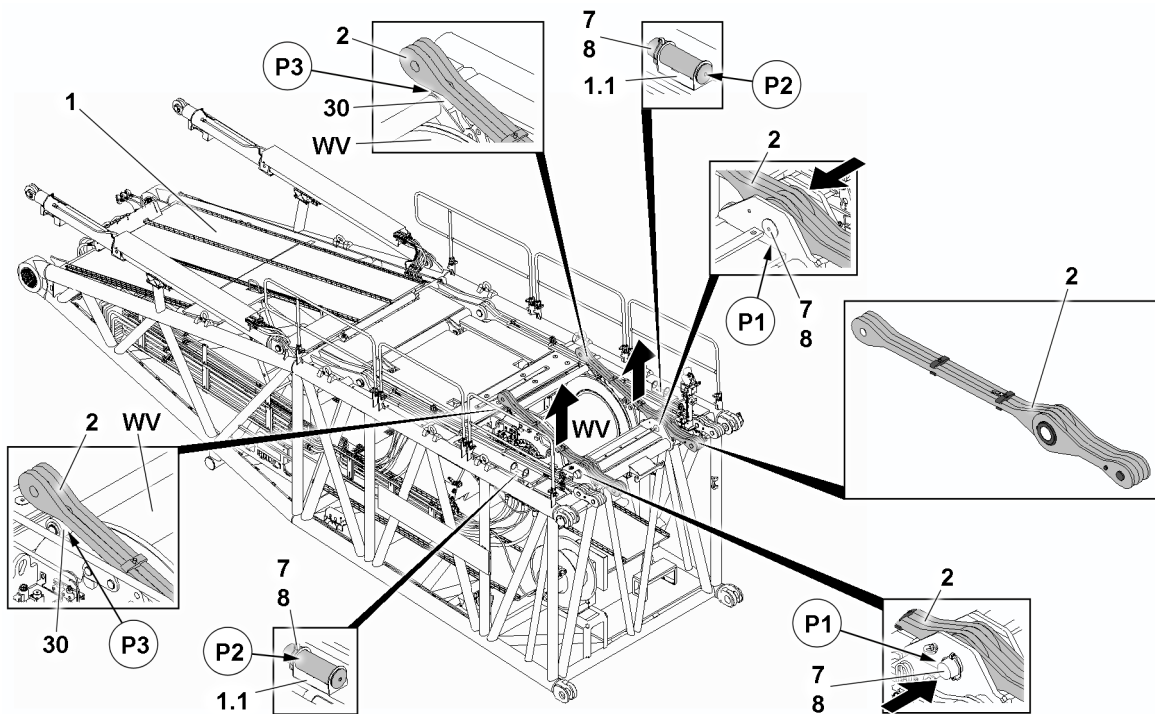


Fig.155910: Disassembling the H-guy rods 2 on the H-pivot section 1

- |     |                         |    |                      |
|-----|-------------------------|----|----------------------|
| 1   | H-pivot section         | 30 | Pulley               |
| 1.1 | Park position for pin 7 | WV | Winch 5              |
| 2   | Two-part H-guy rod      | P1 | Rod pin point        |
| 7   | Pin                     | P2 | Pin park position    |
| 8   | Retaining element       | P3 | Pulley contact point |

Make sure that the following prerequisites are met:

- The H-pivot section **1** is lying completely on the ground.
  - Winch 5 **WV** is properly assembled on the H-pivot section **1**.
  - The winch assembly opening of winch 6 is properly closed off by the grating.
  - The railings on the H-pivot section are in the operating position, see chapter 2.06.
  - Gratings, catwalks and fall protection equipment are properly installed.
  - The access ladder is properly assembled.
  - An auxiliary crane with a suitable load-bearing capacity is available.
- ▶ Access the H-pivot section **1**, see chapter 2.07.



#### Note

- ▶ The disassembly of the H-guy rods **2** is described based on the example of one guy rod.
- ▶ The disassembly of the second H-guy rod is carried out in the same manner.



#### WARNING

Danger of crushing!

When lifting the H-guy rods **2**, limbs can be crushed or severed.

Death, severe bodily injuries, property damage.

- ▶ Make sure that the H-guy rods **2** are fastened such that they do not fold together when lifting with the auxiliary crane.

- ▶ Fasten the first H-guy rod **2** properly to the auxiliary crane.

When the H-guy rod **2** is properly fastened to the auxiliary crane:

- ▶ Carefully “tension” the fastening equipment.
- ▶ Remove the retaining element **8** in the pin **7** and unpin the pin **7**.
- ▶ Insert the pin **7** in the transport receptacle **1.1** in point **P2** and secure properly with the retaining element **8**.

#### Result:

- The H-guy rod **2** is unpinned.
- ▶ Lift the first H-guy rod **2** using the auxiliary crane from the H-pivot section **1** and take down onto the substructure on the ground.



#### Note

- ▶ The disassembly of the second H-guy rod is to be carried out in the same manner as the disassembly of the first H-guy rod.
- ▶ Disassemble the second H-guy rod **2** and use the auxiliary crane to lift it off the H-pivot section **1**.

## 7.2.2 Unpinning winch 5

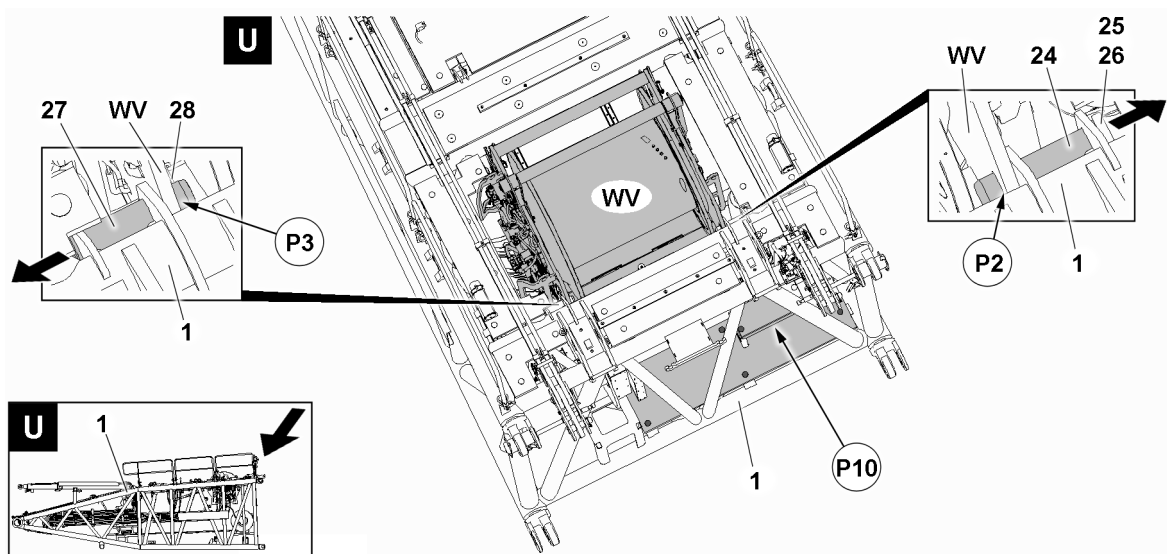


Fig.155512: Unpinning winch 5 **WV** on the H-pivot section **1**

<b>WV</b> Winch 5	<b>27</b> Connector pin
<b>1</b> H-pivot section	<b>28</b> Retaining element
<b>24</b> Connector pin	<b>P2</b> Pin point
<b>25</b> Retaining pin	<b>P3</b> Pin point
<b>26</b> Retaining element	<b>P10</b> Assembly personnel access, bottom platform

Make sure that the following prerequisites are met:

- The H-pivot section **1** is lying completely on the ground.
- The winch assembly opening of winch 6 is properly closed off by the grating.
- The railings on the H-pivot section **1** are in the operating position, see chapter 2.06.
- Gratings, catwalks and fall protection equipment are properly installed.
- The access ladder is properly assembled.
- The H-guy rods are disassembled on the H-pivot section.
- The hydraulic connections are properly disconnected and closed off.
- The electrical connections are properly disconnected and closed off.
- The connections of the central lubrication system are properly disconnected and closed off.
- An auxiliary crane with a suitable load-bearing capacity is available.



### WARNING

Danger of accident due to incorrect fastening!

Life-threatening situations can arise if the winch 5 is incorrectly or improperly fastened.

Death, severe bodily injuries, property damage.

- ▶ The fastening equipment may be attached to the winch only on the intended fastening points.
- ▶ Make sure that the fastening equipment is properly attached to winch 5 and that it is secured sufficiently to prevent it from loosening up.
- ▶ Standing in the danger zone, especially under a suspended load, is prohibited.

- ▶ Fasten the fastening equipment on both sides on winch 5 **WV**, see section “Winch 5 fastening points”.

When the fastening equipment is properly fastened on winch 5:

- ▶ Bring the fastening equipment carefully to “tension” with the auxiliary crane.

When the fastening equipment is tensioned:

- ▶ Release the connector pin **24**: Remove the retaining element **26** and unpin the retaining pin **25** in point **P2**.



When the retaining pin **25** is unpinned in point **P2**:

- ▶ Unpin the connector pins **24** completely.
- ▶ Release the connector pin **27**: Remove the retaining element **28**.

When the connector pin **27** in point **P3** is released:

- ▶ Unpin the connector pins **27** completely.

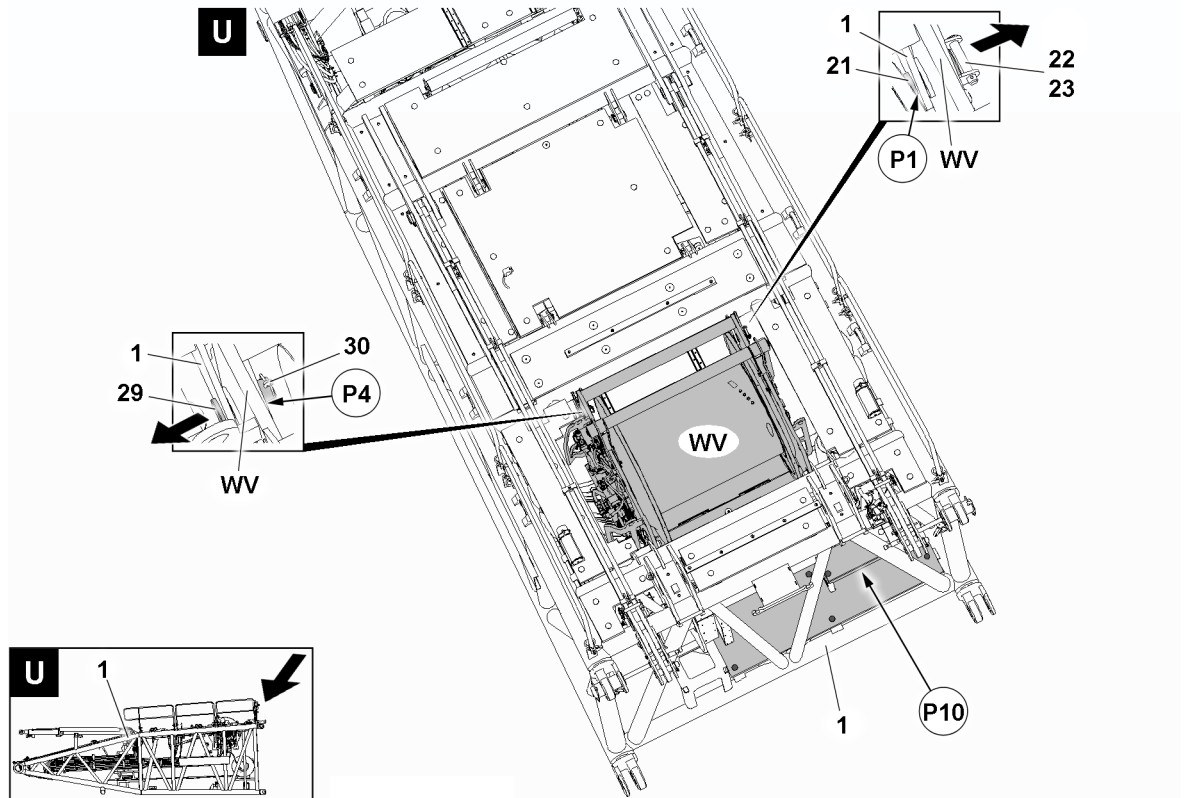


Fig.155905: Unpinning winch 5 **WV** on the H-pivot section **1**

<b>WV</b> Winch 5	<b>30</b> Retaining element
<b>1</b> H-pivot section	<b>P1</b> Pin point
<b>21</b> Connector pin	<b>P4</b> Pin point
<b>22</b> Retaining pin	<b>P10</b> Assembly personnel access, bottom platform
<b>23</b> Retaining element	<b>U</b> Orientation aid / direction of vision
<b>29</b> Connector pin	

- ▶ Release the connector pin **21**: Remove the retaining element **23** and unpin the retaining pin **22** in point **P1**.

When the retaining pin **22** is unpinned in point **P1**:

- ▶ Unpin the connector pins **21** completely.
- ▶ Release the connector pin **29**: Remove the retaining element **30**.

When the connector pin **29** in point **P4** is released:

- ▶ Unpin the connector pins **29** completely.

**Result:**

- Winch 5 **WV** is completely unpinned on the H-pivot section **1**.

### 7.2.3 Lifting winch 5 out of the H-pivot section

Make sure that the following prerequisites are met:

- Winch 5 **WV** is properly unpinned on the H-pivot section 1.
- All connections to winch 5 **WV** are disconnected.

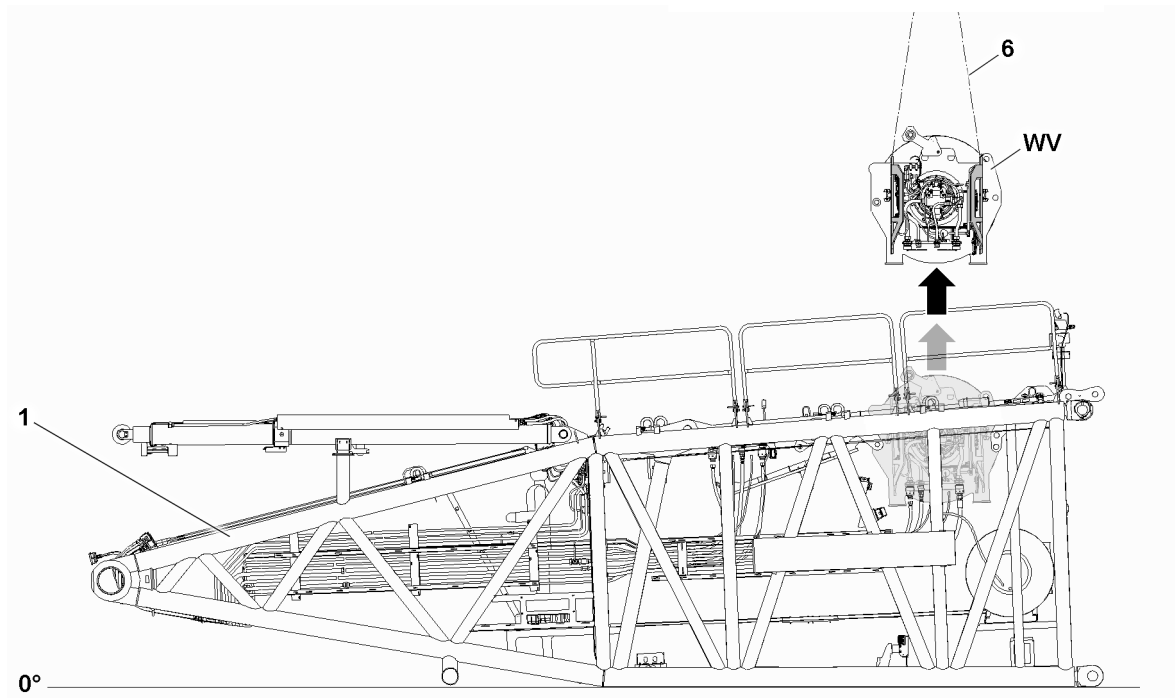


Fig.155906: Lifting winch 5 **WV** out of the H-pivot section 1

**WV** Winch 5

**6** Fastening equipment

**1** H-pivot section



#### WARNING

Falling components!

When lifting winch 5 **WV** on the H-pivot section 1, components or winch 5 can fall down.  
Death, severe bodily injuries, property damage.

- ▶ Make sure that there are no persons within the danger zone.

- ▶ Lift winch 5 **WV** carefully out with the auxiliary crane on the H-pivot section 1.



#### WARNING

Toppling winch!

When setting winch 5 **WV** on the ground, the winch can sink into the ground and fall over.  
Death, severe bodily injuries, property damage.

- ▶ Make sure that winch 5 **WV** is properly supported.
- ▶ Make sure that the ground has sufficient load bearing capacity and can safely pick up the weight of winch 5 **WV**.

- ▶ Swing winch 5 **WV** out with the auxiliary crane and set it on the ground on a suitable substructure.  
**or**  
Swing winch 5 **WV** out with the auxiliary crane and set it on the transport vehicle.

When winch 5 has been set down properly:

- ▶ Remove the auxiliary crane.

## 7.2.4 Inserting the connector pins for transport

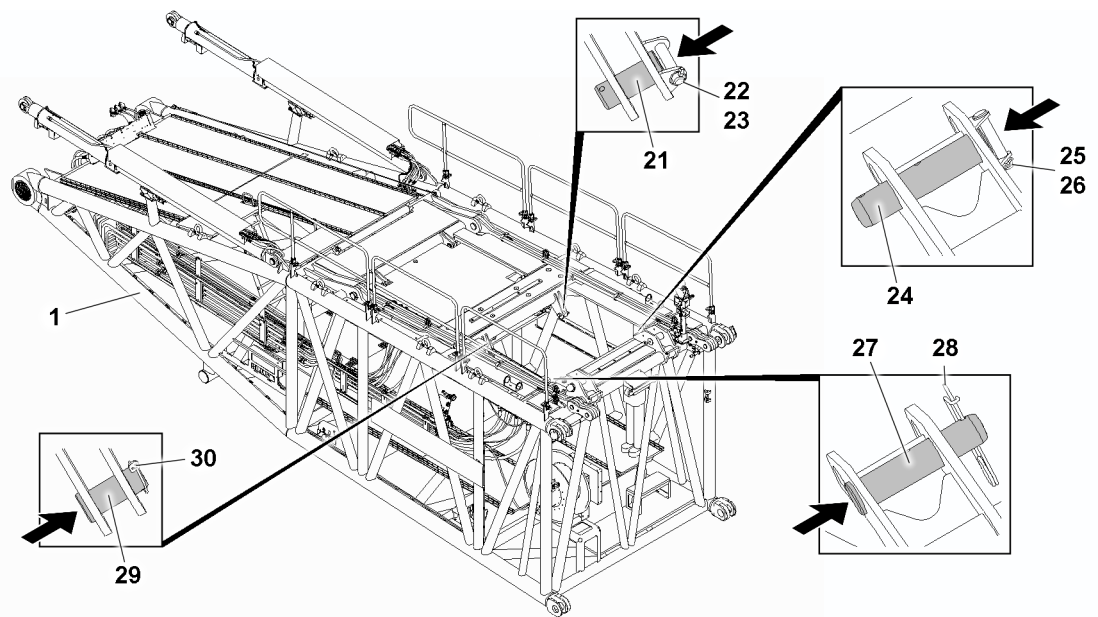


Fig.155907: Inserting the connector pin in the H-pivot section 1

1	H-pivot section	26	Retaining element
21	Connector pin	27	Connector pin
22	Retaining pin	28	Retaining element
23	Retaining element	29	Connector pin
24	Connector pin	30	Retaining element
25	Retaining pin		

- ▶ Insert connector pin **21**, connector pin **24**, connector pin **27** and connector pin **29** back in the pin bores in the H-pivot section **1** and secure with the relative retaining element.

## 7.2.5 Closing the assembly opening of winch 5



### WARNING

Falling assembly personnel!

If the assembly opening of winch 5 is not properly closed off and secured after disassembly of the winch, then assembly personnel can fall down.

Death, severe bodily injuries, property damage.

- ▶ Make sure, after disassembly of winch 5, that the assembly opening is properly closed off and secured with the grating **10**.



### Note

- ▶ For reasons of better illustration, the grating above the installation opening of winch 6 is removed on the H-pivot section **1**.



### Note

- ▶ Assembly personnel access via the bottom platform **P10**

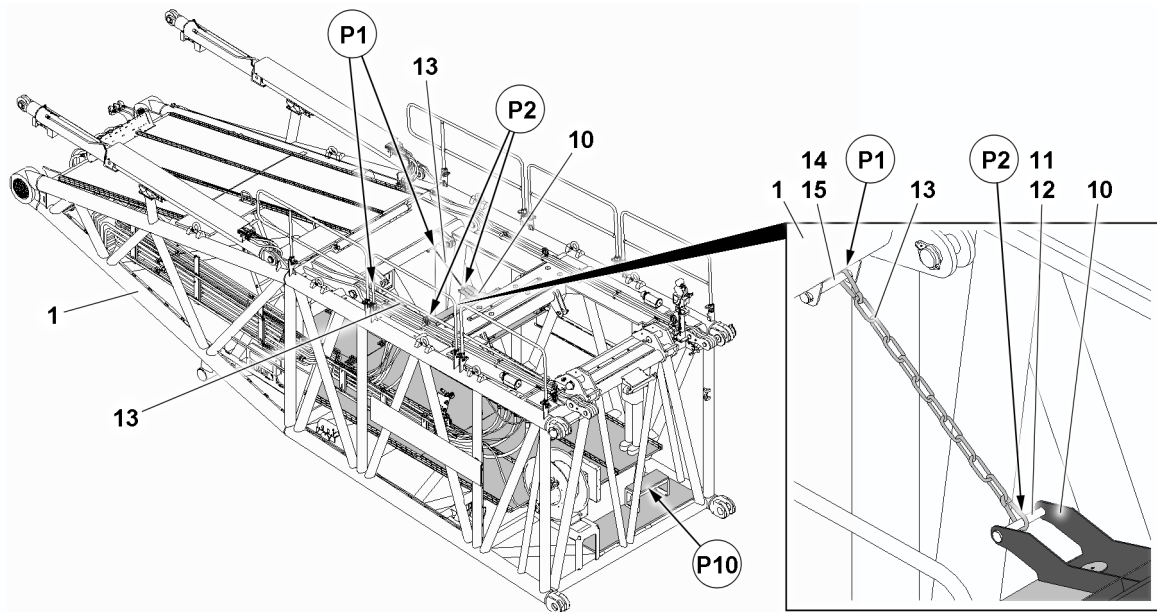


Fig.155908: Blocking the assembly opening of winch 5

- |    |                   |     |  |
|----|-------------------|-----|--|
| 1  | H-pivot section   | 14  | Pin  |
| 10 | Grating           | 15  | Retaining element                          |
| 11 | Pin               | P1  | Hook points, H-pivot section 1             |
| 12 | Retaining element | P2  | Hook points, grating 10                    |
| 13 | Chain hanger      | P10 | Assembly personnel access, bottom platform |

- ▶ First person: Hold the grating 10 in the transport position.
- ▶ Second person: Release both chain hangers 13.

When both chain hangers between the H-pivot section 1 and grating 10 are removed:

- ▶ Swing the grating 10 down carefully and slowly.

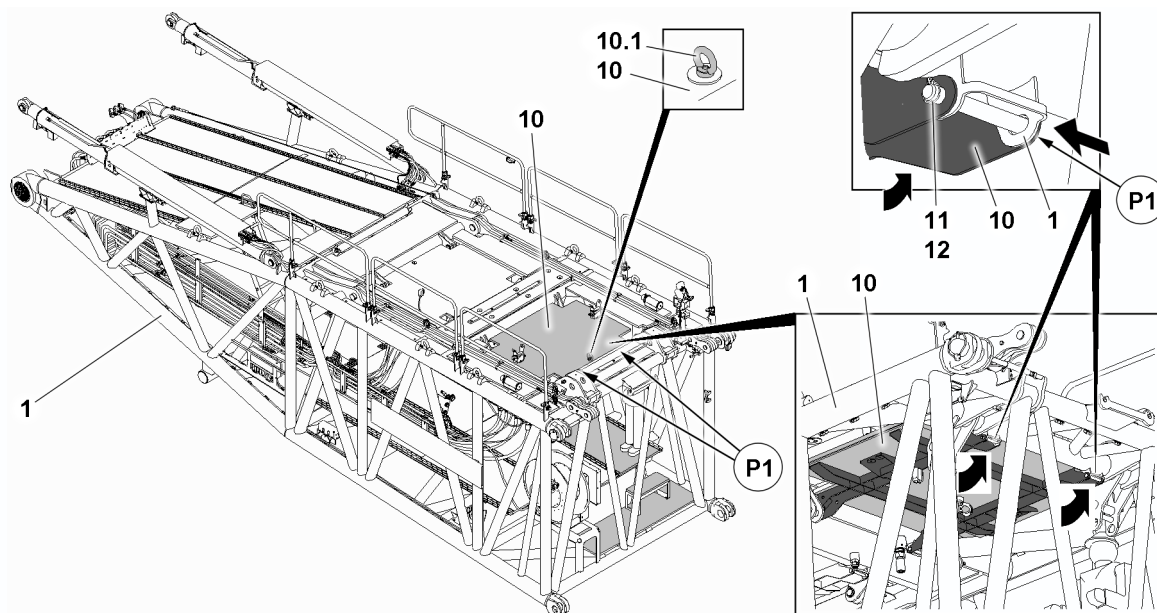


Fig.155909: Blocking the assembly opening of winch 5

- |      |                 |    |                   |
|------|-----------------|----|-------------------|
| 1    | H-pivot section | 11 | Pin               |
| 10   | Grating         | 12 | Retaining element |
| 10.1 | Ring nut        | P1 | Pin point         |

- ▶ Swing the grating **10** up and block the winch 5 assembly opening.  
or  
Fasten the fastening equipment to the ring nut **10.1** and lift and block the grating **10** with the auxiliary crane.

When the winch 5 assembly opening is closed off:

- ▶ Properly pin and secure the grating **10** in the upper position: Insert the pin **11** in point **P1** on both sides and properly secure with the retaining element **12**.

**Result:**

- Close off the assembly opening of winch 5 is using the grating **10**.

## 7.2.6 Assembling the H-guy rods on the H-pivot section

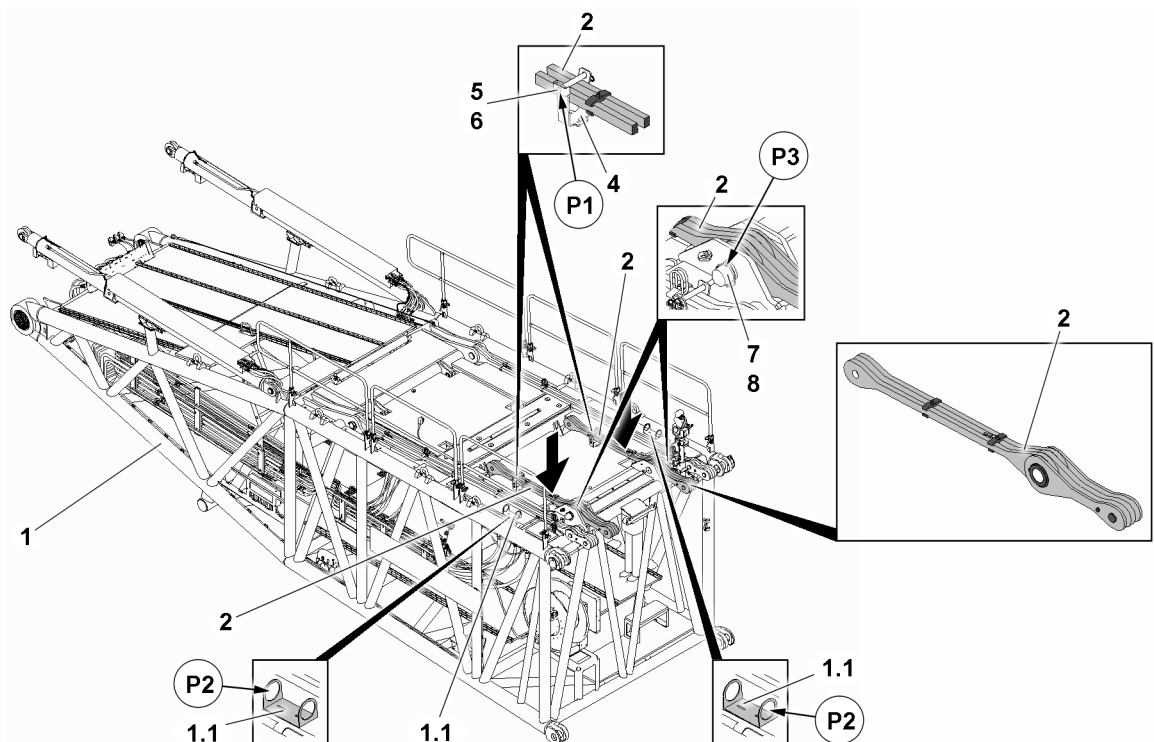


Fig.155911: Assembling the H-guy rods on the H-pivot section 1

1	H-pivot section	7	Pin
1.1	Park position for pin 7	8	Retaining element
2	Two-part H-guy rod	P1	Park position for pin 5
4	Transport retainer	P2	Park position for pin 7
5	Pin	P3	Rod pin point 2
6	Retaining element		

Make sure that the following prerequisites are met:

- The H-pivot section **1** is lying completely on the ground.
- Winch 5 is disassembled.
- The winch assembly opening of winch 5 is properly closed off.
- The railings on the H-pivot section are in the operating position, see chapter 2.06.
- Gratings, catwalks and fall protection equipment are properly installed.
- The access ladder is properly assembled.
- An auxiliary crane with a suitable load-bearing capacity is available.
- ▶ Access the H-pivot section **1**, see chapter 2.07.

**Note**

- ▶ The assembly of the H-guy rods **2** is described based on the example of one guy rod.
- ▶ The assembly of the second H-guy rod is carried out in the same manner.

- ▶ Fasten the first H-guy rod **2** properly to the auxiliary crane.

**Note**

- ▶ When swinging in and positioning the H-guy rod **2**, make sure that the H-guy rod **2** with the longer rod element is taken down in the transport retainer **4**.

**WARNING**

Danger of crushing!

During assembly of the H-guy rod **2**, hands and / or limbs could be crushed.

Death, severe bodily injuries, property damage.

- ▶ When swinging in and positioning the H-guy rod **2**, do not reach into the assembly area.
- ▶ Wear personal protective equipment.

When the H-guy rod **2** is properly fastened to the auxiliary crane:

- ▶ Swing in the H-guy rod **2** with the auxiliary crane to the H-pivot section **1** and position it with the hollow axle in the pin point **P3**.

When the hollow axle and the pin bore align in the pin point **P3**:

- ▶ Release the pins **7** from the park position **1.1** in point **P2** and unpin.
- ▶ Insert the pin **7** in the pin position **P3** from the inside to the outside and properly secure with the retaining element **8**.

**Result:**

- The H-guy rod **2** is properly pinned and secured.
- ▶ Unpin the pin **5** from the transport retainer and insert it properly in point **P1** and secure with the retaining element **6**.

**Result:**

- The H-guy rod **2** is properly secured in the transport position.

**Note**

- ▶ The assembly of the second H-guy rod is to be carried out in the same manner as the assembly of the first H-guy rod.

- ▶ Properly assemble the second H-guy rod **2**.

## 8 Bringing winch 5 from the operating position into the transport position

**Note**

- ▶ If winch 5 remains installed in the H-pivot section during transport, winch 5 must be lowered into the transport position.

**WARNING**

Permissible transport weight exceeded!

Death, severe bodily injuries, property damage.

- ▶ Pay attention to the country-specific transport weights and axle load specifications for the transport vehicles.
- ▶ The freight forwarder / transport company is responsible for complying with the country-specific transport weights and axle load specifications.

Make sure that the following prerequisites are met:

- The H-pivot section **1** is lying completely on the ground.
- The railings on the H-pivot section are in the operating position.
- Gratings, catwalks and fall protection equipment are properly installed.
- The access ladder is properly assembled.
- An auxiliary crane with a suitable load-bearing capacity is available.

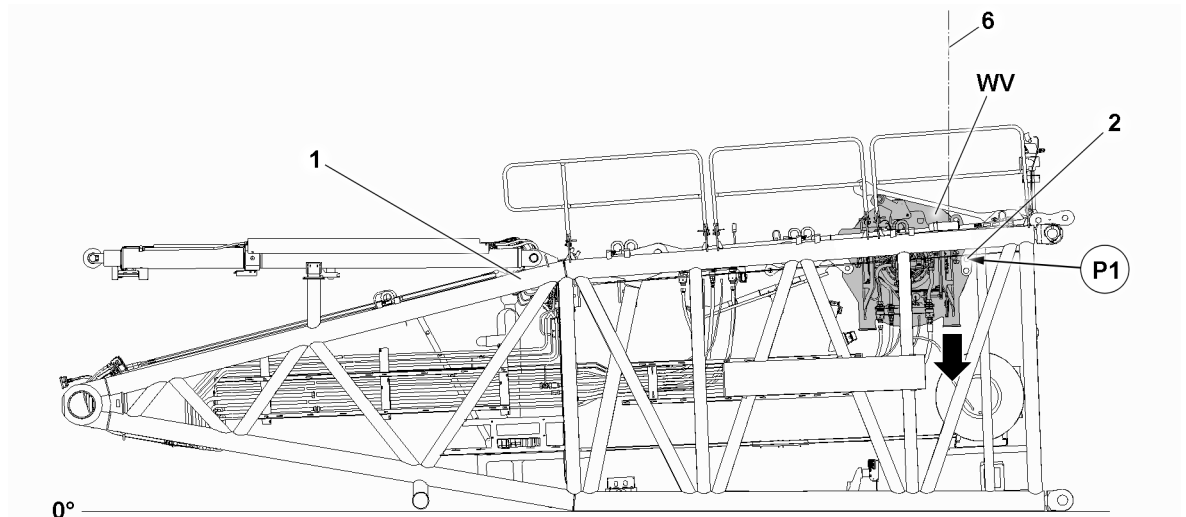


Fig.155912: Fastening winch 5 **WV** to the auxiliary crane and unpinning

- |          |                     |           |                                      |
|----------|---------------------|-----------|--------------------------------------|
| <b>1</b> | H-pivot section     | <b>WV</b> | Winch 5                              |
| <b>2</b> | Pin                 | <b>P1</b> | Winch 5 operating position pin point |
| <b>6</b> | Fastening equipment |           |                                      |



#### Note

- ▶ During the lowering procedure of winch 5 **WV** from the operating to the transport position, all hydraulic and electrical connections as well as the central lubrication connection remain connected with winch 5 **WV**.

- ▶ Properly fasten winch 5 **WV** to the front fastening points on the auxiliary crane.



#### WARNING

Danger of accident due to winch 5!

If the pins **2** in point **P1** are unpinned on both sides and the fastening equipment **6** is not tensioned, then winch 5 **WV** can suddenly swing downward.

Death, severe bodily injuries, property damage.

- ▶ Make sure that the fastening equipment **6** is tensioned before the pins are unpinned on both sides in point **P1**.
- ▶ Make sure that no personnel is within the danger zone when unpinning winch 5.

When winch 5 is properly fastened to the auxiliary crane:

- ▶ Carefully tension the fastening equipment **6**.

When the fastening equipment is tensioned:

- ▶ Release the pins **2** on both sides in point **P1** and unpin.
- ▶ Lower winch 5 **WV** with the auxiliary crane into the transport position until the upper pin bores of winch 5 align with the pin bores in point **P2**.

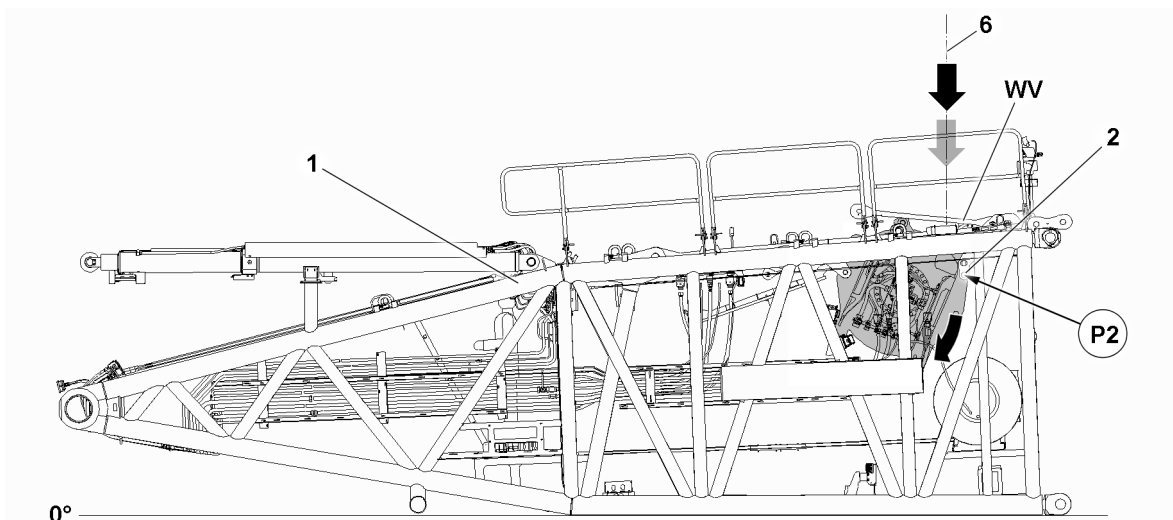


Fig.155913: Lowering winch 5 **WV** with the auxiliary crane into the transport position

- |   |                     |           |                                      |
|---|---------------------|-----------|--------------------------------------|
| 1 | H-pivot section     | <b>WV</b> | Winch 5                              |
| 2 | Pin                 | <b>P2</b> | Winch 5 transport position pin point |
| 6 | Fastening equipment |           |                                      |

When the pin bores align in point **P2**:

- ▶ Insert the pins **2** completely on both sides.
- ▶ Secure the pins **2** on both sides with the corresponding retaining element.

When winch 5 **WV** is properly pinned and secured in the transport position:

- ▶ Remove the auxiliary crane and the fastening equipment **6** on winch 5 **WV**.



## 9 Bringing winch 5 from the transport position into the operating position

Make sure that the following prerequisites are met:

- The H-pivot section **1** is lying completely on the ground.
- The railings on the H-pivot section are in the operating position.
- Gratings, catwalks and fall protection equipment are properly installed.
- The access ladder is properly assembled.
- An auxiliary crane with a suitable load-bearing capacity is available.

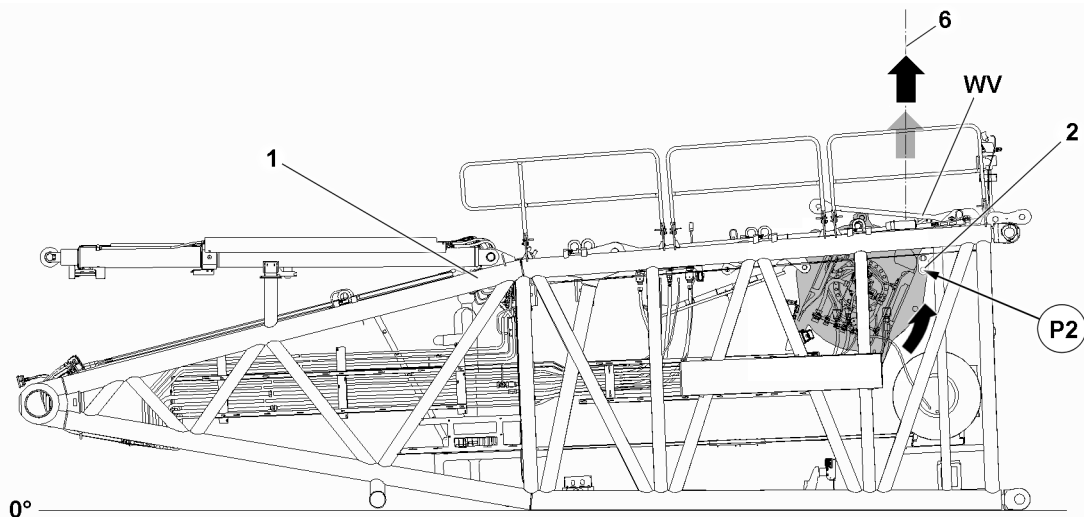


Fig.155936: Fastening winch 5 **WV** to the auxiliary crane and unpinning

<b>1</b>	H-pivot section	<b>WV</b>	Winch 5
<b>2</b>	Pin	<b>P2</b>	Winch 5 transport position pin point
<b>6</b>	Fastening equipment		



### Note

- ▶ During the lifting procedure of winch 5 **WV** from the transport into the operating position, all hydraulic and electrical connections as well as the central lubrication connection remain connected with winch 5 **WV**.
- ▶ Properly fasten winch 5 **WV** to the front fastening points on the auxiliary crane.



### WARNING

Danger of accident due to winch 5!

If the pins **2** in point **P2** are unpinned on both sides and the fastening equipment **6** is not tensioned, then winch 5 **WV** can suddenly swing downward.

Death, severe bodily injuries, property damage.

- ▶ Make sure that the fastening equipment **6** is tensioned before the pins are unpinned on both sides in point **P2**.
- ▶ Make sure that no personnel is within the danger zone when unpinning winch 5.

When winch 5 is properly fastened to the auxiliary crane:

- ▶ Carefully tension the fastening equipment **6**.

When the fastening equipment is tensioned:

- ▶ Release the pins **2** on both sides in point **P2** and unpin.
- ▶ Lift winch 5 **WV** with the auxiliary crane into the transport position until the lower pin bores of winch 5 align with the pin bores in point **P1**.

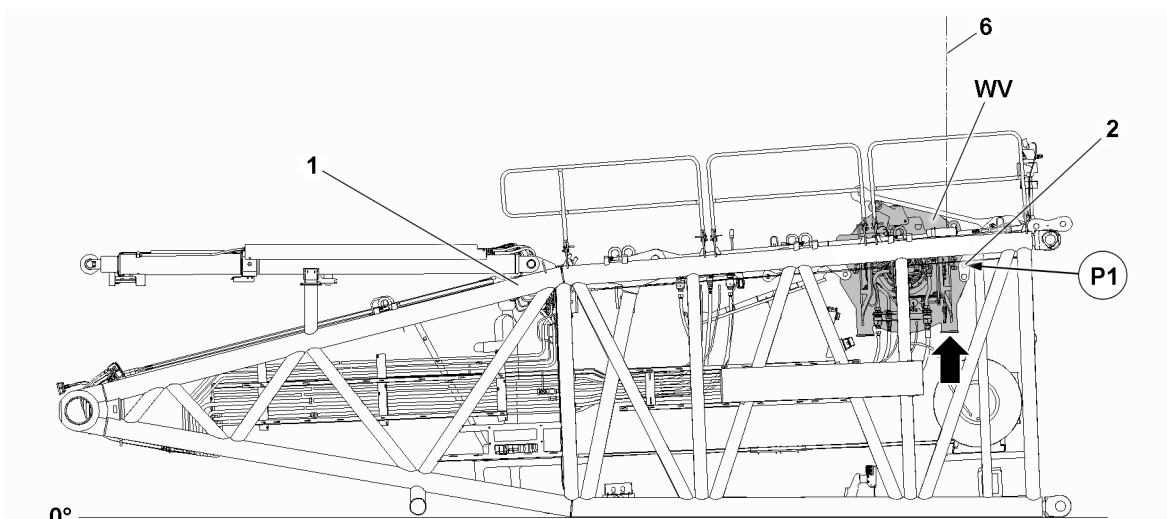


Fig.155937: Lifting winch 5 **WV** with the auxiliary crane into the operating position

- |   |                     |           |                                      |
|---|---------------------|-----------|--------------------------------------|
| 1 | H-pivot section     | <b>WV</b> | Winch 5                              |
| 2 | Pin                 | <b>P1</b> | Winch 5 operating position pin point |
| 6 | Fastening equipment |           |                                      |

When the pin bores align in point **P1**:

- ▶ Insert the pins **2** completely on both sides.
- ▶ Secure the pins **2** on both sides with the corresponding retaining element.

When winch 5 **WV** is properly pinned and secured in the operating position:

- ▶ Remove the auxiliary crane and the fastening equipment **6** on winch 5 **WV**.

## 3.07.60 Winch 6 assembly

1	Safety	2
2	Component overview	2
3	Winch 6 fastening points	2
4	Assembling winch 6	3
5	Assembling the H-pivot section on the turntable	12
6	Disassembling the H-pivot section on the turntable	13
7	Disassembling winch 6	13
8	Bringing winch 6 from the operating position into the transport position	20
9	Bringing winch 6 from the transport position into the operating position	23
10	Bringing winch 6 from transport position into the flat operating position	24

# 1 Safety

Before assembly and disassembly of winch 6, observe the safety instructions:

- Information regarding work on the crane superstructure. See chapter 2.04.
- Information regarding personal protective equipment. See chapter 2.04.
- Information about securing persons to prevent them from falling. See chapter 2.04.
- Information regarding the use of ladders. See chapter 2.04.10.
- Information regarding fall protection equipment. See chapter 2.06.
- Information regarding accesses to the crane. See chapter 2.07.
- Information regarding accessible surfaces. See chapter 2.07.

## 2 Component overview

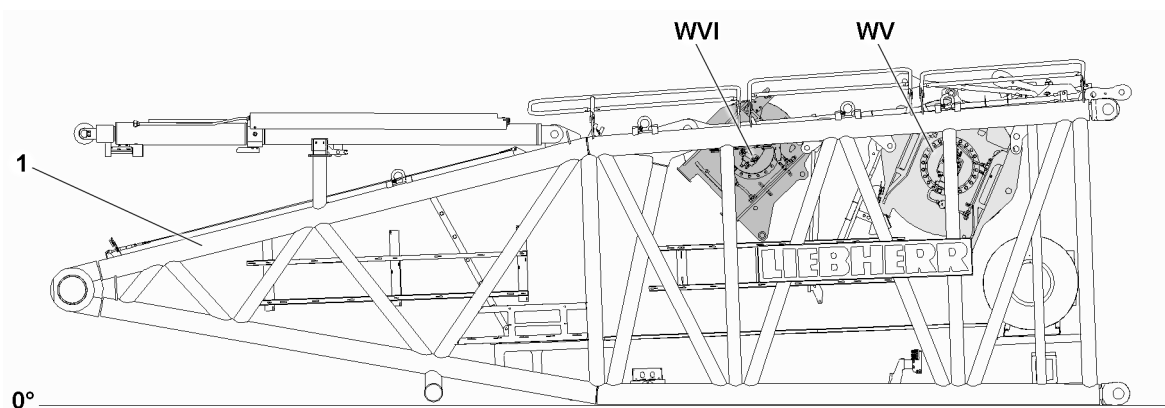


Fig.156000: H-pivot section 1 with winches (winch 5 WV, winch 6 WVI and relapse cylinders)

1 H-pivot section

WVI Winch 6

WV Winch 5



### Note

- ▶ Dimensions and weights of winch 6 WVI, see chapter 1.03.



### Note

- ▶ Winch 6 WVI is marked with its own weight.

## 3 Winch 6 fastening points



### WARNING

Winch incorrectly fastened!

Life-threatening situations can arise if the winch is incorrectly or improperly fastened.

Death, severe bodily injuries, property damage.

- ▶ Attach the winch only on the intended fastening points.
- ▶ Attach the fastening equipment on winch solely in connection with shackles.
- ▶ Make sure that the shackles and fastening equipment have sufficient load bearing capacity.
- ▶ Observe the technical safety instructions during assembly and disassembly, see Crane operating instructions, chapter 5.01.

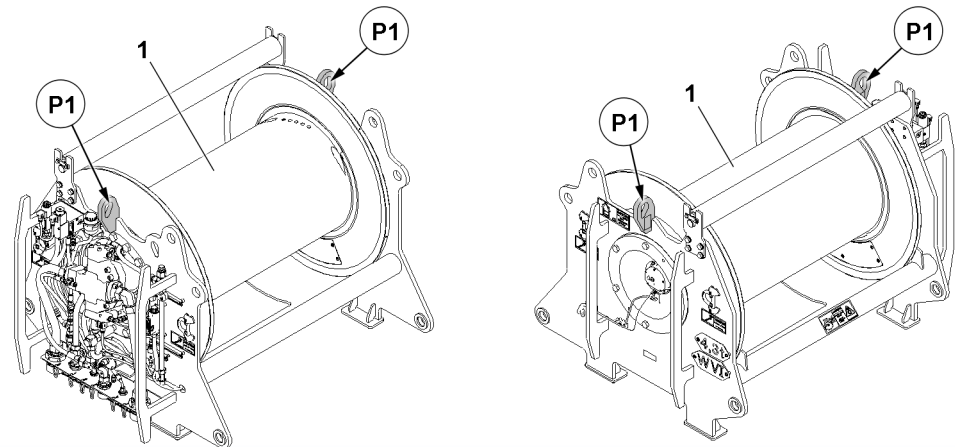


Fig.156001: Winch 6 fastening points // View from left and right

1 Winch 6

P1 Fastening point

Fastening points	
P1	Winch 6

## 4 Assembling winch 6



### WARNING

Danger of falling!

During assembly / disassembly, inspection and maintenance work, assembly personnel must be secured with appropriate aids to prevent them from falling.

Death, severe bodily injuries, property damage.

- ▶ All work at a height, when there is a danger of falling, must be carried out with suitable aids.
- ▶ If aids are not available and work cannot be carried out from the ground, then assembly personnel must secure themselves with the supplied fall arrest system to prevent falling, see chapter 2.04.
- ▶ If fall protection equipment is available, then it must be used, see chapter 2.06.
- ▶ When lifting, lowering, swinging crane parts in and out, no persons may remain in the danger zone.
- ▶ When closing or opening boom systems during boom assembly or boom disassembly, no persons may remain on the boom system or in the danger zone.
- ▶ If railings are present on the components, then they must be brought into the corresponding position and secured for assembly / disassembly work.
- ▶ Only step on the aids, ladders and catwalks with clean shoes.
- ▶ Keep aids, ladders and catwalks free of heavy dirt, snow, frost and ice.
- ▶ During all assembly and disassembly work, maintenance work and inspections, travel or crane operation is prohibited.
- ▶ Remaining on a suspended load is prohibited.
- ▶ Stepping or walking on crane components and lattice sections that have an incline of more than 20° is prohibited.
- ▶ For all assembly work, the crane driver of the main crane must be in voice contact with the crane driver / crane drivers of the auxiliary crane / auxiliary cranes.
- ▶ For assembly tasks, the crane driver may only initiate crane movements when the responsible guide has explicitly released the movement.

**WARNING**

Danger of impact / crushing!

When installing / removing crane components with the auxiliary crane, crane components can start to swing back and forth.

When lifting / lowering and positioning crane components, there is an increased danger of impacts / crushing.

Death, severe bodily injuries, property damage.

- ▶ Make sure that personnel cannot be caught by components.
- ▶ Make sure that the crane is horizontally aligned.
- ▶ When working in danger zones: Use aids to protect limbs.
- ▶ Guide components with suitable aids to minimize oscillation.

**DANGER**

The components can fall down!

If the corresponding component is disengaged from the auxiliary crane before the corresponding component is pinned, then the corresponding component can fall down.

Death, severe bodily injuries, property damage.

- ▶ Do not disengage the auxiliary crane until the respective component is pinned and secured.

## 4.1 Assembling winch 6

### 4.1.1 Folding the grating into the installation position of winch 6

**Note**

- ▶ If winch 6 is not installed in transport condition of the H-pivot section **1**, then the installation / assembly opening of winch 6 on the H-pivot section is closed off with a grating **10**.
- ▶ The grating **10** must be unpinned for the installation of winch 6 on the H-pivot section **1** on one side in points **P1** and must be folded down and secured properly in this position.

Make sure that the following prerequisites are met:

- No personnel is present on the grating **10**.
- The H-guy rods are disassembled on the H-pivot section **1**.
- No winch is assembled on the H-pivot section.
- A second person is present for assembly support.
- An auxiliary crane with an adequate load-bearing capacity is available.

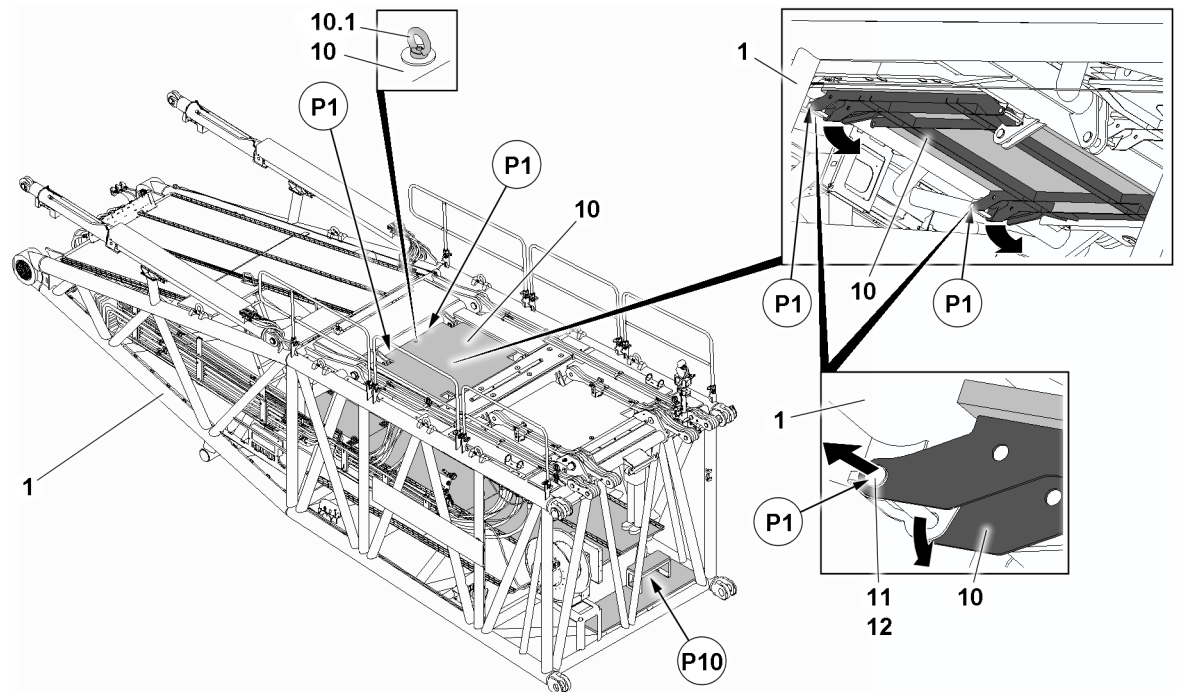


Fig.156002: Folding the grating **10** down

<b>1</b> H-pivot section	<b>11</b> Pin
<b>8</b> Retaining element	<b>12</b> Retaining element
<b>10</b> Grating	<b>P1</b> Pin point
<b>10.1</b> Ring nut	<b>P10</b> Assembly personnel access, bottom platform

- ▶ Properly fasten the grating **10** to the ring nut **10.1** on the auxiliary crane.

When the grating **10** is properly fastened to the auxiliary crane:

- ▶ Carefully tension the fastening equipment.
- ▶ Unpin the pin **11**: Remove the retaining element **12** on both sides and unpin the pin **11** on both sides.



### WARNING

Danger of accident due to the grating!

When lowering the grating **10**, people can fall down.

Death, severe bodily injuries, property damage.

- ▶ Make sure before lowering the grating **10** that no people are located on the grating.
- ▶ Make sure that there are no persons within the slewing range of the grating **10**.

When the pins **11** are unpinned on both sides:

- ▶ Lower the grating **10** slowly with the auxiliary crane about 10 cm.

When the grating **10** has been lowered about 10 cm:

- ▶ Stop the lowering procedure of the grating **10**.
- ▶ Insert the pins **11** on both sides in the pin points in the grating **10** and properly secure with the retaining element **12**.
- ▶ Lower the grating **10** completely with the auxiliary crane.

**Note**

- For reasons of better illustration, the grating **16** above the installation opening of winch 5 is removed on the H-pivot section **1** in the following main view.

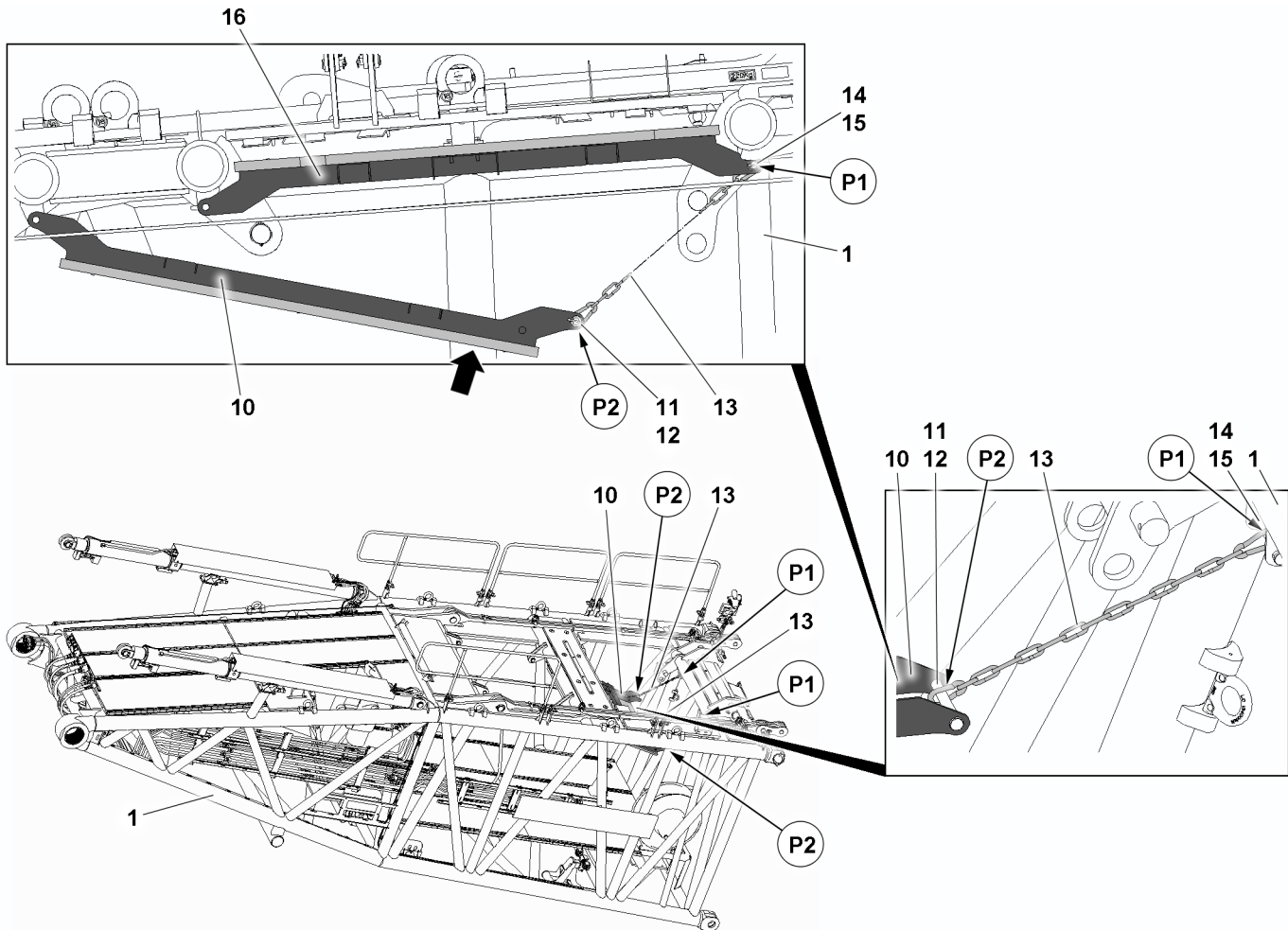


Fig.156003: Grating 10 in the assembly position

<b>1</b>	H-pivot section	<b>13</b>	Chain hanger	<b>P1</b>	Chain hanger fastening point
<b>10</b>	Winch 6 grating	<b>14</b>	Pin	<b>P2</b>	Chain hanger fastening point
<b>11</b>	Pin	<b>15</b>	Retaining element		
<b>12</b>	Retaining element	<b>16</b>	Winch 5 grating		

When the grating **10** is lowered completely:

- Remove the fastening equipment from the ring nut **10.1** and swing the auxiliary crane out.

The grating **10** must be moved into the assembly position (direction of the grating **16**), held there and fastened with two chain hangers **13**.

**NOTICE**

**Damage to the grating 10!**

If the grating **10** is secured in the assembly position with only one chain hanger **13**, the grating **10** can be permanently damaged due to twisting.

- Always secure the grating **10** with two chain hangers **13**.

- Move the grating **10** manually to the assembly position (direction of the arrow) and hold it there.
- Fix the grating **10** in the assembly position: Hang the chain hangers **13** on both sides with snap hook in point **P1** and point **P2**.

When the grating **10** is properly secured in the assembly position:

- Until the grating **10** is securely held by the chain hangers **13**: Lower the grating **10**.



- ▶ Remove the auxiliary crane.

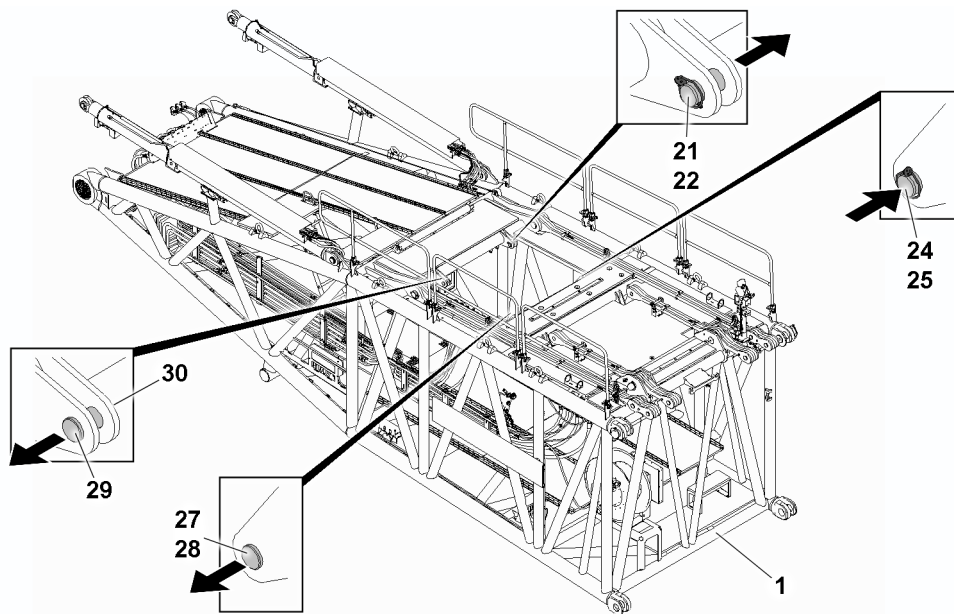


Fig.156004: Preparing the H-pivot section 1 for winch 6 installation

1	H-pivot section	27	Connector pin
21	Connector pin	28	Retaining element
22	Retaining element	29	Connector pin
24	Connector pin	30	Retaining element
25	Retaining element		

- ▶ Release the connector pin **21**, connector pin **24**, connector pin **27** and connector pin **29**: Remove the retaining elements.
- ▶ Completely unpin the connector pin **21**, connector pin **24**, connector pin **27** and connector pin **29**.
- ▶ Take down the connector pins and retaining elements.

**Result:**

- The H-pivot section **1** is prepared for winch 6 assembly.

### 4.1.2 Lifting winch 6 from the flatbed trailer

Make sure that the following prerequisites are met:

- The minimum length of the fastening equipment is 3000 mm.
- Pay attention to the labels on the components.

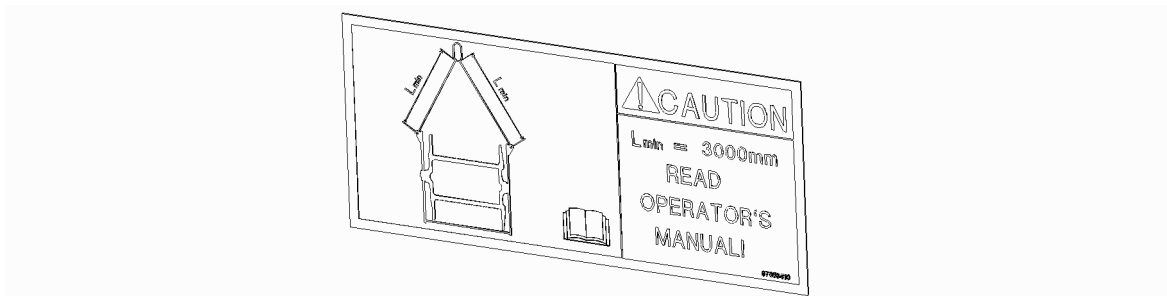


Fig.155507: Labels - minimum length of the fastening equipment 3000 mm



#### WARNING

Danger of accident during assembly of winch 6!  
Death, severe bodily injuries, property damage.

- ▶ Make sure that winch 6 is secured with an auxiliary rope to prevent it from swinging during transport with the auxiliary crane.
- 
- ▶ Fasten the fastening equipment to the fastening points properly, see section “Winch 6 fastening points”.
  - ▶ Bring the fastening equipment to “tension” with the auxiliary crane.
  - ▶ Release and remove the transport retainers on the flatbed trailer.



#### WARNING

Falling components!  
When lifting winch 6 from the flatbed trailer, components or winch 6 can fall down.  
Death, severe bodily injuries, property damage.

- ▶ Make sure that there are no persons within the danger zone.
- 
- ▶ Lift winch 6 with the auxiliary crane from the flatbed trailer.
  - ▶ Swing winch 6 in with the auxiliary crane for assembly on the S-pivot section.
- or**
- ▶ Use the auxiliary crane to place winch 6 on the substructure on the ground.

### 4.1.3 Swinging in and positioning winch 6

Make sure that the following prerequisites are met:

- The H-pivot section **1** is lying completely on the ground.
- The railings on the H-pivot section **1** are in the operating position.
- The ground is able to safely take on the entire weight of the H-pivot section **1** inclusive of winch **6 WVI** to be assembled.
- Gratings, catwalks and fall protection equipment are properly installed.
- The access ladder is properly assembled.
- An auxiliary crane with a suitable load-bearing capacity is available.

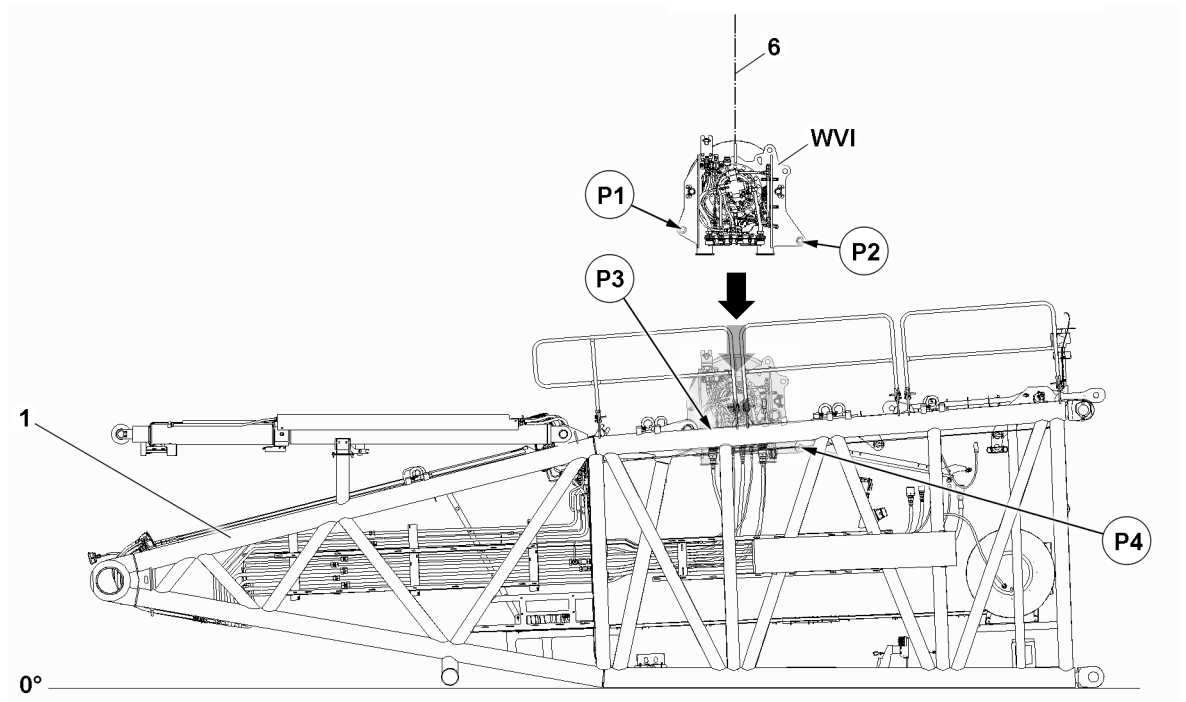


Fig.156005: Positioning winch 6 **WVI** on the H-pivot section **1**

<b>WVI</b> Winch 6	<b>P2</b> Winch 6 pin point
<b>1</b> H-pivot section	<b>P3</b> H-pivot section pin point
<b>6</b> Fastening equipment	<b>P4</b> H-pivot section pin point
<b>P1</b> Winch 6 pin point	



#### WARNING

Danger of accident when swinging in and lowering winch 6!

When swinging in and lowering winch 6 **WVI** on the H-pivot section **1**, limbs can be crushed or even severed.

Death, severe bodily injuries, property damage.

- ▶ Make sure that there is no personnel in the danger zone.
- ▶ Do not reach with your hands into the danger zone.

#### NOTICE

Property damage!

If the following notes are not observed, damage can result to the H-pivot section **1** or winch 6 **WVI**.

- ▶ Make sure that winch 6 **WVI** does not bump against the H-pivot section when lowering into the H-pivot section **1**.



#### Note

- ▶ The guide must be in constant visual and acoustic contact with the crane operator.

**Note**

- ▶ Pay attention to the exact alignment of winch 6 **WVI** with respect to the installation position on the H-pivot section **1**.

- ▶ Swing winch 6 **WVI** in with the auxiliary crane to the H-pivot section **1**.
- ▶ Position and align winch 6 **WVI** over the installation opening on the H-pivot section **1**.

When winch 6 **WVI** is aligned:

- ▶ Slowly and carefully lower winch 6 **WVI** into the H-pivot section **1**.
- ▶ Until the bores, point **P1**, align with the bores point **P3**: Lower winch 6 **WVI**.

#### 4.1.4 Assembling winch 6 in the operating position

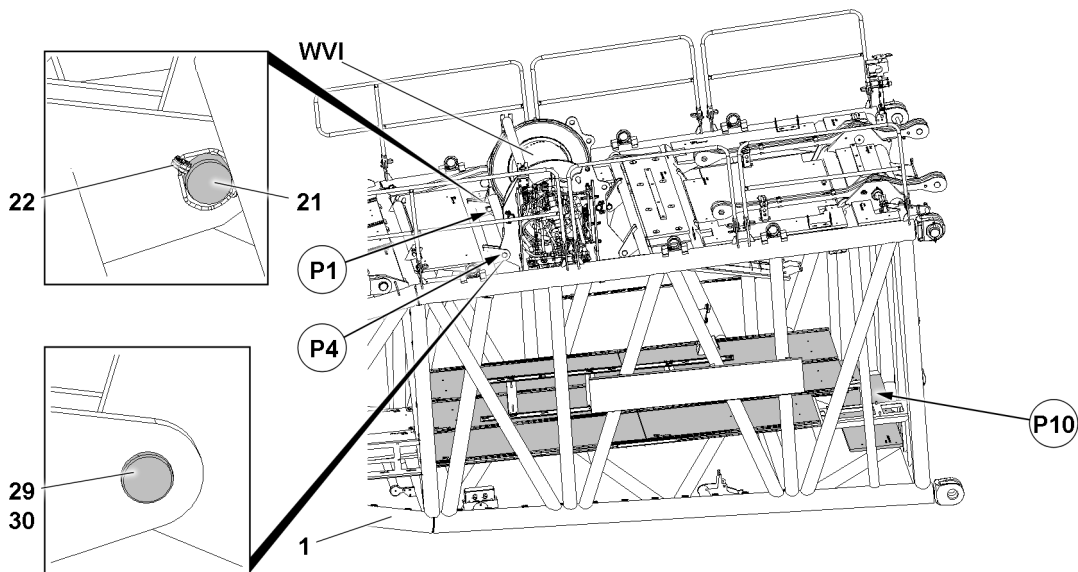


Fig.156006: Pinning winch 6 **WVI** on the H-pivot section **1** in the operating position

<b>WVI</b> Winch 6	<b>30</b> Retaining element
<b>1</b> H-pivot section	<b>P1</b> Pin point
<b>21</b> Connector pin	<b>P4</b> Pin point
<b>22</b> Retaining element	<b>P10</b> Assembly personnel access, bottom platform
<b>29</b> Connector pin	

**WARNING**

The connector pins can loosen up by themselves!  
If the connector pins are not properly secured, they can come loose.  
Death, severe bodily injuries, property damage.

- ▶ Secure all connector pins immediately after pinning with retaining pins and / or retaining elements.

Make sure that the following prerequisites are met:

- The bores of winch 6 **WVI** align with the bores of H-pivot section **1**.
- Winch 6 **WVI** must be pinned from the “bottom platform” by assembly personnel.

When the bores between winch 6 **WVI** and the receptacles in the H-pivot section **1** align in point **P1** and point **P4**:

- ▶ Completely insert the connector pin **21** in point **P1** from the outside to the inside.
- ▶ Properly secure the connector pin **21** with the retaining element **22**.
- ▶ Completely insert the connector pin **29** in point **P4** from the outside to the inside.
- ▶ Properly secure the connector pin **29** with the retaining element **30**.

When the connector pin **21** and connector pin **29** are properly pinned and secured:

- ▶ Until the pin bores align in point **P20**: Use the auxiliary crane to lift or lower winch 6 **WVI**

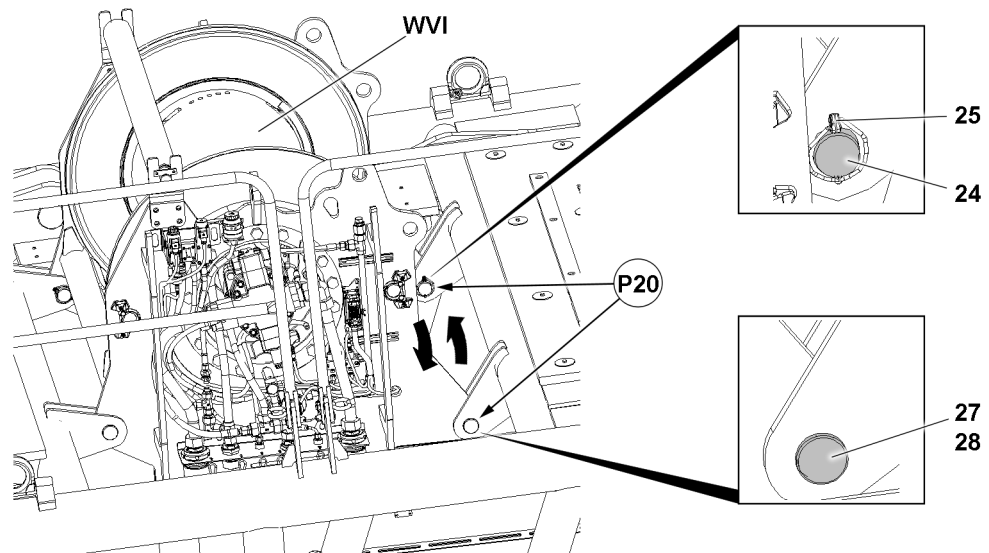


Fig.156007: Winch 6 **WVI** in the H-pivot section 1

**WVI** Winch 6

**P20** Pinning operating position

When the bores between winch 6 **WVI** and the receptacles in the H-pivot section 1 align in point **P20**:

- ▶ Completely insert the connector pin **24** from the outside to the inside.
- ▶ Properly secure the connector pin **24** with the retaining element **25**.
- ▶ Completely insert the connector pin **27** from the outside to the inside.
- ▶ Properly secure the connector pin **27** with the retaining element **28**.

**Result:**

- The connector pins are properly pinned and secured.
- Winch 6 **WVI** is properly installed in the operating position.
- ▶ Release the fastening equipment on winch 6 **WVI**.
- ▶ Remove the auxiliary crane.

#### 4.1.5 Establishing the hydraulic connections to winch 6



**Note**

- ▶ Establish the connections to winch 6 only when winch 6 is properly installed and secured.

Make sure that the following prerequisite is met:

- The winch 6 is properly installed, pinned and secured.

#### Establishing the hydraulic connections to the winch



**Note**

- ▶ After the hydraulic connections to the winch are established, the expansion tank must be checked and emptied.

The hydraulic connections for the winch are made with quick couplings.

When connecting hydraulic lines with quick couplings, make sure that the coupling procedure is carried out correctly.

**WARNING**

Pressure in the hydraulic lines!

If the pressure supply is not interrupted before connecting / releasing the hydraulic lines, the hydraulic oil can escape with high pressure.

Death, severe bodily injuries, property damage.

- ▶ Release the pressure in the hydraulic system before connecting / disconnecting: Interrupt the pressure supply and wait for a short time.

**WARNING**

Loss of pressure or leakage!

Incorrectly coupled or self-loosening quick couplings (particularly return lines) can result in serious accidents due to component failure.

- ▶ Check that the quick couplings have been properly connected before using the crane.
- ▶ Connect the coupling components (sleeve and connector) and screw together with the knurled nut.
- ▶ Tighten the hydraulic coupling by hand. Turn the knurled nut until it reaches a tangible, fixed stop position.
- ▶ Establish the hydraulic connections to the winch.

**Establishing the electrical connections to the winch**

- ▶ Establish the electrical connections to the winch, see the Electric wiring diagram.

**WARNING**

Malfunction if dummy plugs are not installed!

If the dummy plugs on the non-required electrical connections are not installed, then malfunctions or functional limitations can occur on the crane.

- ▶ Make sure that all non-required electrical connections, which have a dummy plug, are closed off with dummy plugs.
- ▶ Pay attention to the Electrical wiring diagram.
- ▶ As a rule, close off on-required electrical connections (for example for accessories which cannot be installed) with the respective dummy plugs.

**NOTICE**

Property damage due to dirt and / or corrosion!

If non-required electrical connections are not closed off with the respective protective caps, then dirt and / or corrosion can damage the electrical connections.

This could result in malfunctions.

- ▶ Make sure that all non-required electrical connections are always closed off properly.
- ▶ Pay attention to the Electrical wiring diagram.
- ▶ Close electrical connections, which have no dummy plugs, properly off with the corresponding protective caps.

**Establishing the connections of the central lubrication system to the winch**

- ▶ Establish the connections of the central lubrication system to the winch.

**Result:**

- Winch 6 is properly assembled on the H-pivot section.

## 5 Assembling the H-pivot section on the turntable

**Note**

- ▶ Assembling the H-pivot section on the turntable, see chapter 5.38 and Chapter 5.39.10.

## 6 Disassembling the H-pivot section on the turntable



### Note

- ▶ Disassembling the H-pivot section on the turntable, see chapter 5.38 and Chapter 5.39.10.

## 7 Disassembling winch 6



### Note

- ▶ The description in this section is only used when winch 6 is to be transported separately from the H-pivot section.



### WARNING

Danger of falling!

During assembly / disassembly, inspection and maintenance work, assembly personnel must be secured with appropriate aids to prevent them from falling.

Death, severe bodily injuries, property damage.

- ▶ All work at a height, when there is a danger of falling, must be carried out with suitable aids.
- ▶ If aids are not available and work cannot be carried out from the ground, then assembly personnel must secure themselves with the supplied fall arrest system to prevent falling, see chapter 2.04.
- ▶ If fall protection equipment is available, then it must be used, see chapter 2.06.
- ▶ When lifting, lowering, swinging crane parts in and out, no persons may remain in the danger zone.
- ▶ When closing or opening boom systems during boom assembly or boom disassembly, no persons may remain on the boom system or in the danger zone.
- ▶ If railings are present on the components, then they must be brought into the corresponding position and secured for assembly / disassembly work.
- ▶ Only step on the aids, ladders and catwalks with clean shoes.
- ▶ Keep aids, ladders and catwalks free of heavy dirt, snow, frost and ice.
- ▶ During all assembly and disassembly work, maintenance work and inspections, travel or crane operation is prohibited.
- ▶ Remaining on a suspended load is prohibited.
- ▶ Stepping or walking on crane components and lattice sections that have an incline of more than 20° is prohibited.
- ▶ For all assembly work, the crane driver of the main crane must be in voice contact with the crane driver / crane drivers of the auxiliary crane / auxiliary cranes.
- ▶ For assembly tasks, the crane driver may only initiate crane movements when the responsible guide has explicitly released the movement.



### WARNING

Danger of impact / crushing!

When installing / removing crane components with the auxiliary crane, crane components can start to swing back and forth.

When lifting / lowering and positioning crane components, there is an increased danger of impacts / crushing.

Death, severe bodily injuries, property damage.

- ▶ Make sure that personnel cannot be caught by components.
- ▶ Make sure that the crane is horizontally aligned.
- ▶ When working in danger zones: Use aids to protect limbs.
- ▶ Guide components with suitable aids to minimize oscillation.

**DANGER**

The components can fall down!

If the corresponding component is disengaged from the auxiliary crane before the corresponding component is pinned, then the corresponding component can fall down.

Death, severe bodily injuries, property damage.

- ▶ Do not disengage the auxiliary crane until the respective component is pinned and secured.

## 7.1 Disconnecting the connections to winch 6

Make sure that the following prerequisites are met:

- The hoist rope is completely spooled up to the winch.
- The hoist rope is secured on the winch to prevent it from spooling out by itself.

### 7.1.1 Disconnecting the hydraulic connections to the winch

When releasing hydraulic lines with quick couplings, make sure that the uncoupling procedure is carried out correctly.

**WARNING**

Pressure in the hydraulic lines!

If the pressure supply is not interrupted before connecting / releasing the hydraulic lines, the hydraulic oil can escape with high pressure.

Death, severe bodily injuries, property damage.

- ▶ Release the pressure in the hydraulic system before connecting / disconnecting: Interrupt the pressure supply and wait for a short time.
- ▶ Release the hydraulic coupling by hand.
- ▶ Disconnect the hydraulic connections to the winch.
- ▶ Close the hydraulic hoses and hydraulic lines off properly with the intended caps.
- ▶ Bring the hydraulic hoses in park position for transport and secure them properly.

### 7.1.2 Disconnecting the electrical connections to the winch

- ▶ Disconnect the electrical connections to the winch.
- ▶ Close the electrical connections properly off with the intended caps.

### 7.1.3 Disconnecting the connections of the central lubrication system to the winch

- ▶ Disconnect the connections to the winch.
- ▶ Close the lube line connections properly off with the intended caps.



## 7.2 Disassembling winch 6

### 7.2.1 Unpinning winch 6

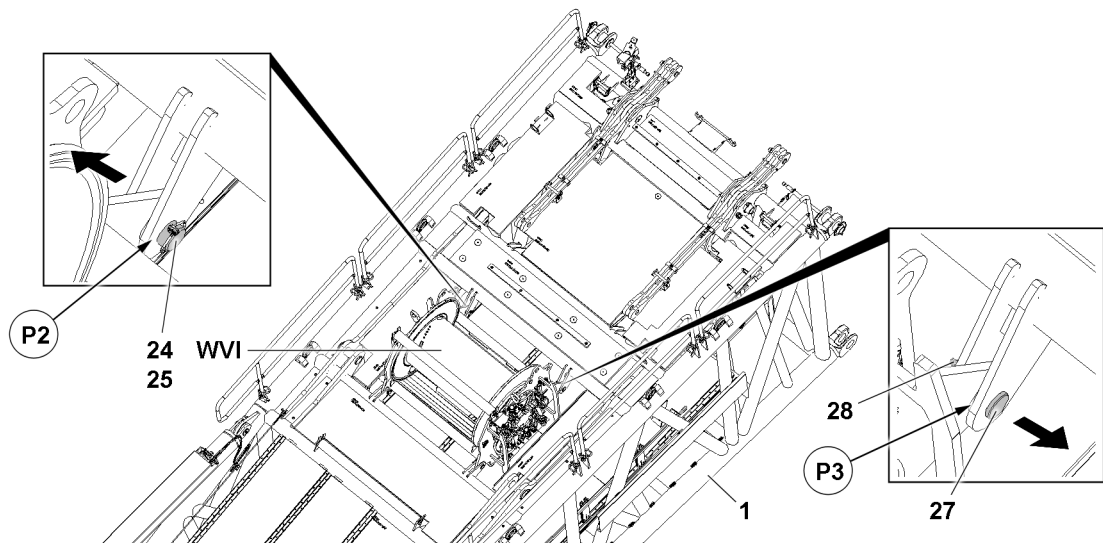


Fig.156011: Unpinning winch 6 **WVI** on the H-pivot section **1**

<b>WVI</b> Winch 6	<b>27</b> Connector pin
<b>1</b> H-pivot section	<b>28</b> Retaining element
<b>24</b> Connector pin	<b>P2</b> Pin point
<b>25</b> Retaining element	<b>P3</b> Pin point

Make sure that the following prerequisites are met:

- The H-pivot section **1** is lying completely on the ground.
- The winch assembly opening of winch 5 is properly closed off by the grating.
- The railings on the H-pivot section **1** are in the operating position, see chapter 2.06.
- Gratings, catwalks and fall protection equipment are properly installed.
- The access ladder is properly assembled.
- The hydraulic connections are properly disconnected and closed off.
- The electrical connections are properly disconnected and closed off.
- The connections of the central lubrication system are properly disconnected and closed off.
- An auxiliary crane with a suitable load-bearing capacity is available.



#### WARNING

Danger of accident due to incorrect fastening!

Life-threatening situations can arise if the winch 6 is incorrectly or improperly fastened.

Death, severe bodily injuries, property damage.

- ▶ The fastening equipment may be attached on the winch only on the intended fastening points.
- ▶ Make sure that the fastening equipment is properly attached on winch 6 and that it is secured sufficiently to prevent it from loosening up.
- ▶ Standing in the danger zone, especially under a suspended load, is prohibited.

- ▶ Fasten the fastening equipment on both sides on winch 6 **WVI**, see section “Winch 6 fastening points”.

When the fastening equipment is properly fastened on winch 6:

- ▶ Bring the fastening equipment carefully to “tension” with the auxiliary crane.

When the fastening equipment is tensioned:

- ▶ Release the connector pin **24**: Remove the retaining element **25**.

When the connector pin **24** in point **P2** is released:

- ▶ Unpin the connector pins **24** completely.
- ▶ Release the connector pin **27**: Remove the retaining element **28**.

When the connector pin **27** in point **P3** is released:

- ▶ Unpin the connector pins **27** completely.

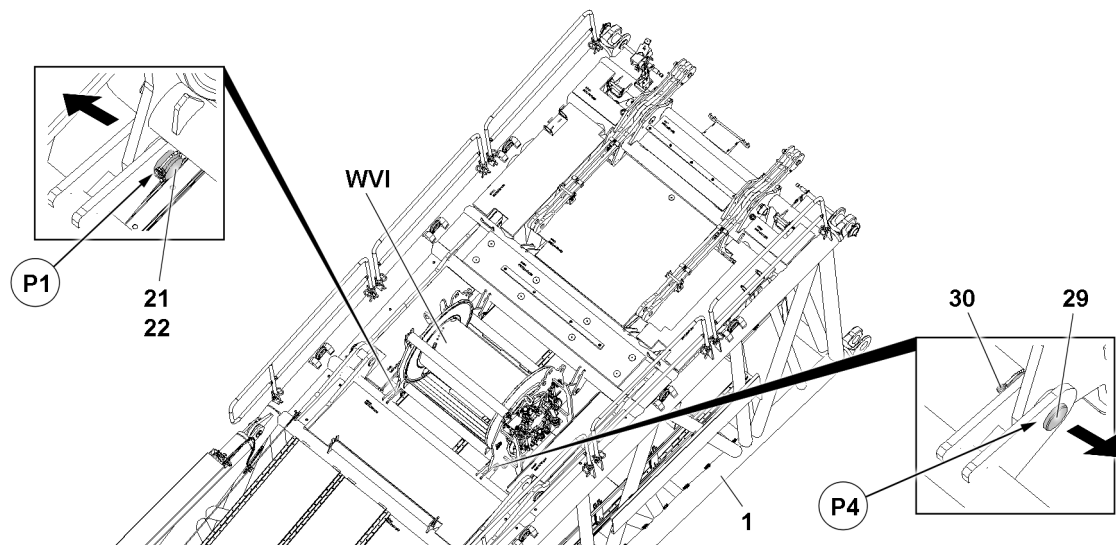


Fig.156012: Unpinning winch 6 **WVI** on the H-pivot section **1**

<b>WVI</b> Winch 6	<b>29</b> Connector pin
<b>1</b> H-pivot section	<b>30</b> Retaining element
<b>21</b> Connector pin	<b>P1</b> Pin point
<b>22</b> Retaining element	<b>P4</b> Pin point

- ▶ Release the connector pin **21**: Remove the retaining element **22**.

When the connector pin **21** in point **P1** is released:

- ▶ Unpin the connector pins **21** completely.
- ▶ Release the connector pin **29**: Remove the retaining element **30**.

When the connector pin **29** in point **P4** is released:

- ▶ Unpin the connector pins **29** completely.

**Result:**

- Winch 6 **WVI** is completely unpinned on the H-pivot section **1**.

## 7.2.2 Lifting winch 6 out of the H-pivot section

Make sure that the following prerequisites are met:

- Winch 6 **WVI** is properly unpinned on the H-pivot section 1.
- All connections to winch 6 **WVI** are disconnected.

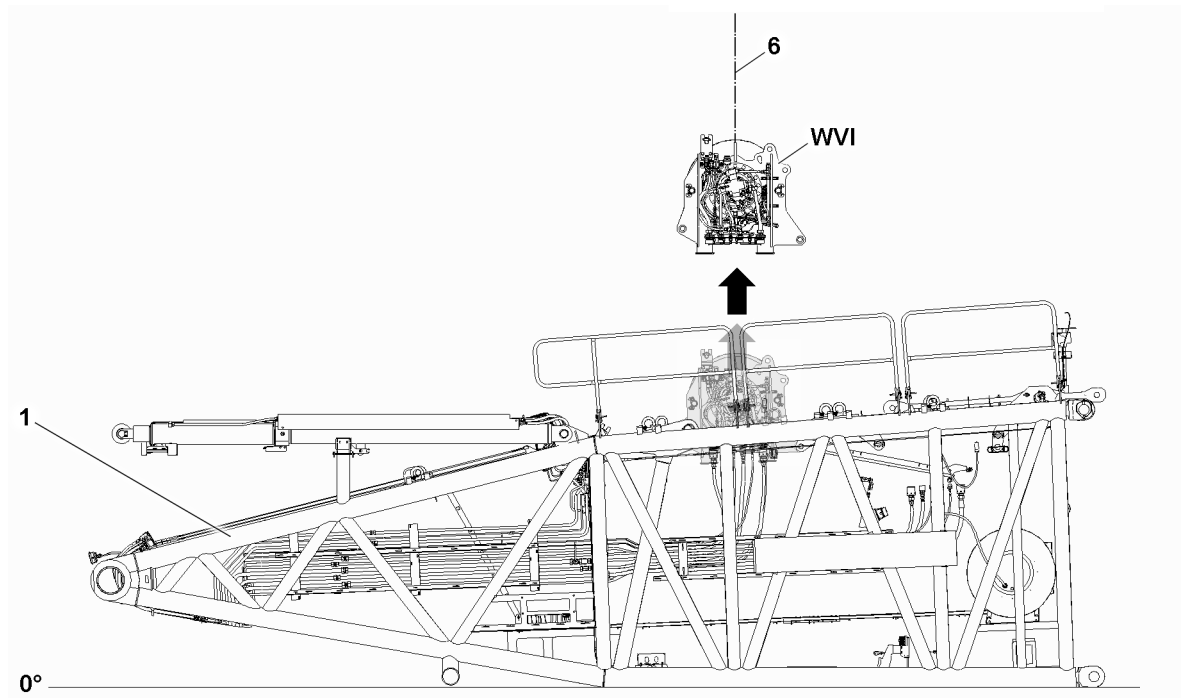


Fig.156013: Lifting winch 6 **WVI** out of the H-pivot section 1

**WVI** Winch 6

**6** Fastening equipment

**1** H-pivot section



### WARNING

Falling components!

When lifting winch 6 **WVI** on the H-pivot section 1, components or winch 6 can fall down.  
Death, severe bodily injuries, property damage.

- ▶ Make sure that there are no persons within the danger zone.

- ▶ Lift winch 6 **WVI** carefully out with the auxiliary crane on the H-pivot section 1.



### WARNING

Toppling winch!

When setting winch 6 **WVI** on the ground, the winch can sink into the ground and fall over.  
Death, severe bodily injuries, property damage.

- ▶ Make sure that winch 6 **WVI** is properly supported.
- ▶ Make sure that the ground has sufficient load bearing capacity and can safely pick up the weight of winch 6 **WVI**.

- ▶ Swing winch 6 **WVI** out with the auxiliary crane and set it on the ground on a suitable substructure.  
**or**  
Swing winch 6 **WVI** out with the auxiliary crane and set it on the transport vehicle.

When winch 6 **WVI** has been set down properly:

- ▶ Remove the auxiliary crane.

### 7.2.3 Inserting the connector pins for transport

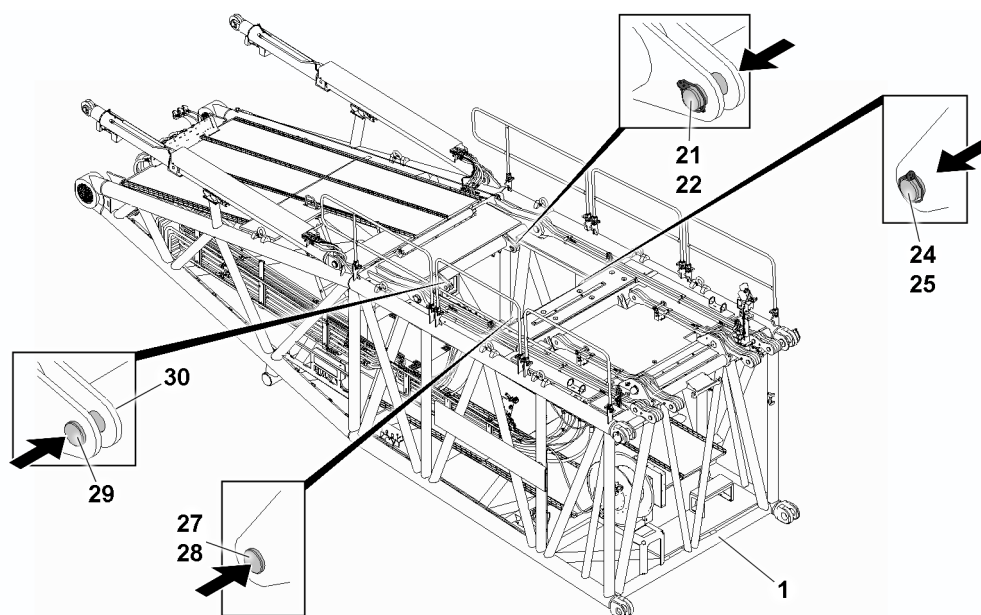


Fig.156014: Inserting the connector pin in the H-pivot section 1

1	H-pivot section	27	Connector pin
21	Connector pin	28	Retaining element
22	Retaining element	29	Connector pin
24	Connector pin	30	Retaining element
25	Retaining element		

- ▶ Insert connector pin 21, connector pin 24, connector pin 27 and connector pin 29 back in the pin bores in the H-pivot section 1 and secure with the relative retaining element.

### 7.2.4 Closing the assembly opening of winch 6



#### WARNING

Falling assembly personnel!

If the assembly opening of winch 6 is not properly closed off and secured after disassembly of the winch, then assembly personnel can fall down.

Death, severe bodily injuries, property damage.

- ▶ Make sure, after disassembly of winch 6, that the assembly opening is properly closed off and secured with the grating 10.



#### Note

- ▶ For reasons of better illustration, the grating above the installation opening of winch 5 is removed on the H-pivot section 1 in the following main view.



#### Note

- ▶ Assembly personnel access via the bottom platform.

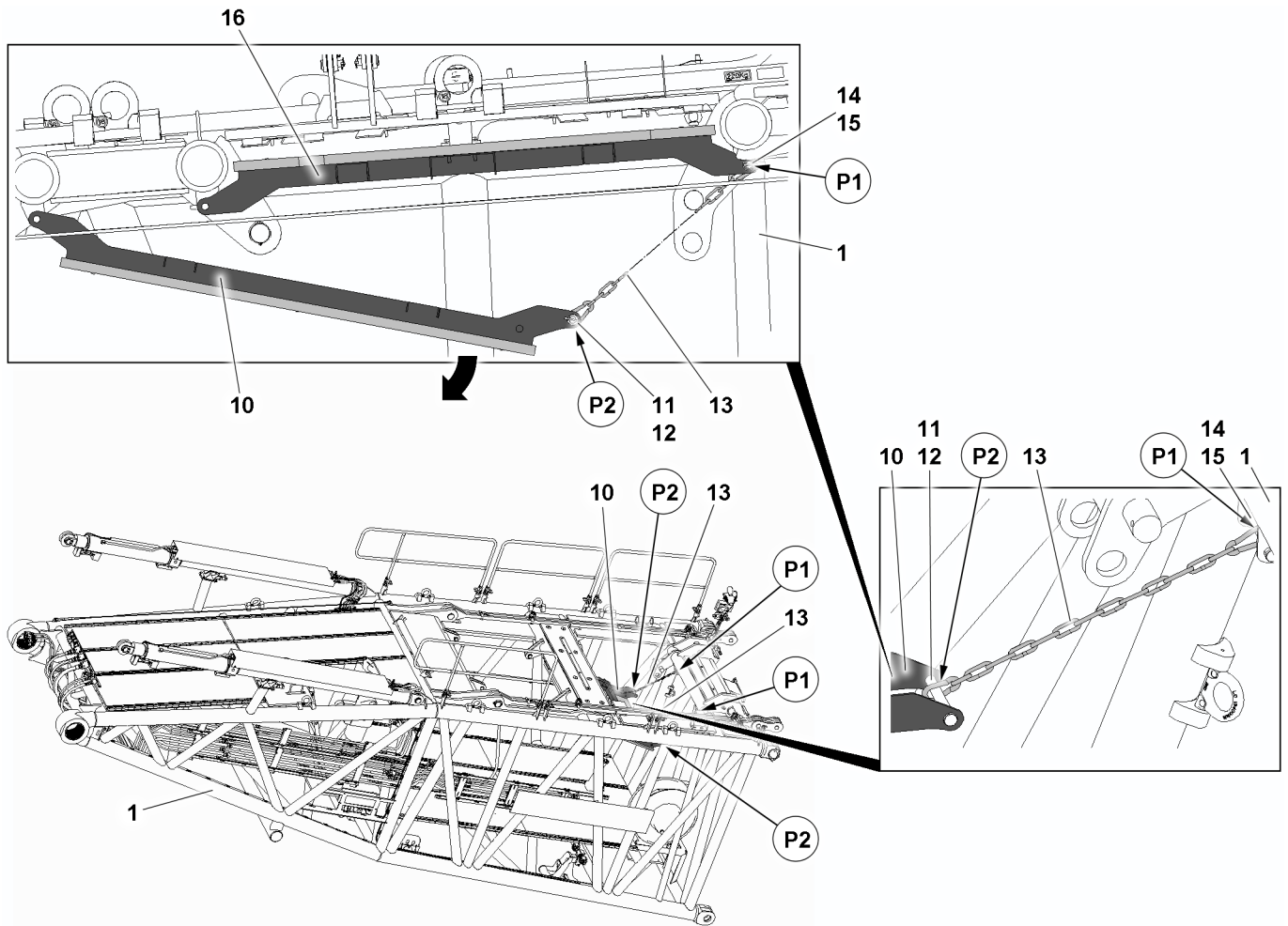


Fig.156015: Blocking the assembly opening of winch 6

<b>1</b>	H-pivot section	<b>12</b>	Retaining element	<b>15</b>	Retaining element
<b>10</b>	Grating	<b>13</b>	Chain hanger	<b>P1</b>	Hook points, H-pivot section 1
<b>11</b>	Pin	<b>14</b>	Pin	<b>P2</b>	Hook points, grating 10

- ▶ First person: Hold the grating **10** in the transport position.
- ▶ Second person: Release both chain hangers **13**.

When both chain hangers between the H-pivot section **1** and grating **10** are removed:

- ▶ Swing the grating **10** down carefully and slowly.

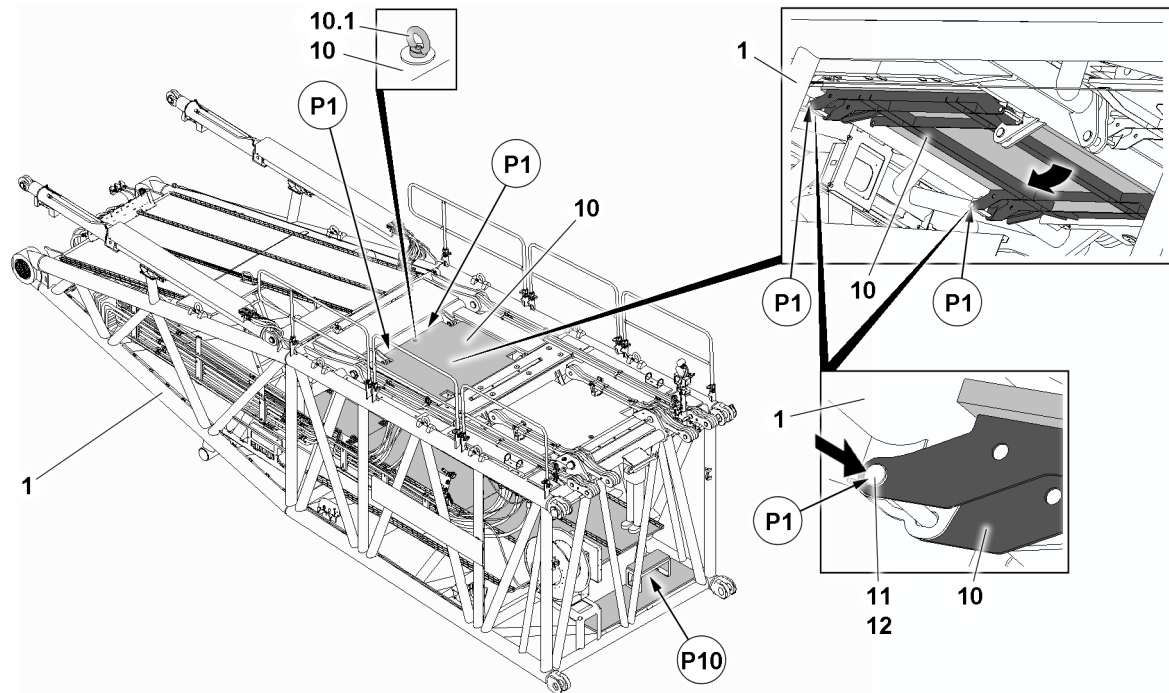


Fig.156016: Blocking the assembly opening of winch 6

- |      |                 |     |  |
|------|-----------------|-----|--|
| 1    | H-pivot section | 12  | Retaining element                          |
| 10   | Grating         | P1  | Pin point                                  |
| 10.1 | Ring nut        | P10 | Assembly personnel access, bottom platform |
| 11   | Pin             |     |  |

- Swing the grating 10 up and close the winch 6 assembly opening.

or

Fasten the fastening equipment to the ring nut 10.1 and lift and block the grating 10 with the auxiliary crane.

When the winch 6 assembly opening is closed off:

- Properly pin and secure the grating 10 in the upper position: Insert the pin 11 in point P1 on both sides and properly secure with the retaining element 12.

**Result:**

- Close off the assembly opening of winch 6 is using the grating 10.

## 8 Bringing winch 6 from the operating position into the transport position



### Note

- If winch 6 remains installed in the H-pivot section during transport, winch 6 must be lowered into the transport position.



### WARNING

Permissible transport weight exceeded!  
Death, severe bodily injuries, property damage.

- Pay attention to the country-specific transport weights and axle load specifications for the transport vehicles.
- The freight forwarder / transport company is responsible for complying with the country-specific transport weights and axle load specifications.

Make sure that the following prerequisites are met:

- The H-pivot section **1** is lying completely on the ground.
- The railings on the H-pivot section are in the operating position.
- Gratings, catwalks and fall protection equipment are properly installed.
- The access ladder is properly assembled.
- An auxiliary crane with a suitable load-bearing capacity is available.

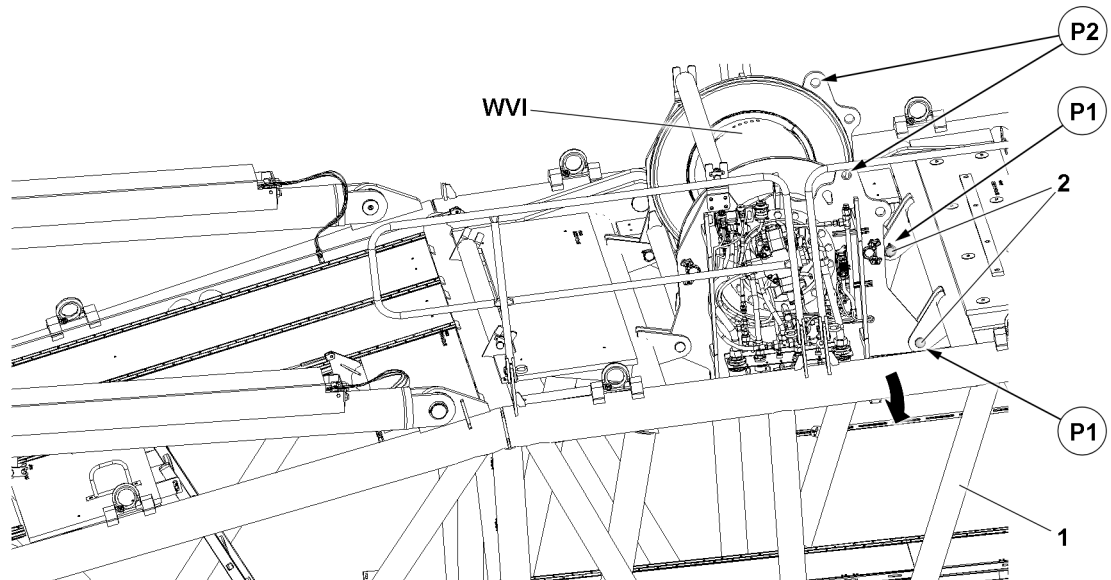


Fig.156018: Fastening winch 6 **WVI** to the auxiliary crane and unpinning

**1** H-pivot section  
**2** Pin  
**WVI** Winch 6

**P1** Winch 6 operating position pin point  
**P2** Winch 6 transport position pin point



#### Note

- ▶ When lowering winch 6 **WVI** from the operating to the transport position, all hydraulic and electrical connections as well as the central lubrication connection remain connected with winch 6 **WVI**.
- ▶ Properly fasten winch 6 **WVI** to the fastening points on the auxiliary crane.



#### WARNING

Danger of accident due to winch 6!

If the pins **2** in point **P1** are unpinned on both sides and the fastening equipment is not tensioned, then winch 6 **WVI** can suddenly swing downward.

Death, severe bodily injuries, property damage.

- ▶ Make sure that the fastening equipment is tensioned before the pins are unpinned on both sides in point **P1**.
- ▶ Make sure that no personnel is within the danger zone when unpinning winch 6 **WVI**.

When winch 6 is properly fastened to the auxiliary crane:

- ▶ Carefully tension the fastening equipment.

When the fastening equipment is tensioned:

- ▶ Release the pins **2** on both sides in point **P1** and unpin.
- ▶ Until the upper pin bores of winch 6 **WVI** align with the pin bores in point **P2**: Lower winch 6 **WVI** with the auxiliary crane into the transport position.

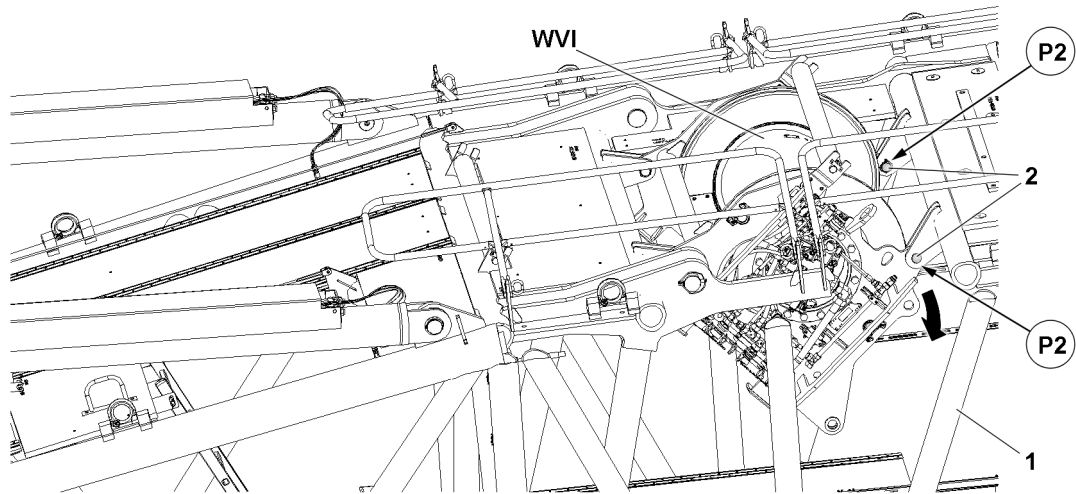


Fig.156019: Lowering winch 6 **WVI** with the auxiliary crane into the transport position

- 1 H-pivot section  
2 Pin

- WVI** Winch 6  
**P2** Winch 6 transport position pin point

When the pin bores align in point **P2**:

- ▶ Insert the pins **2** completely on both sides from the outside to the inside.
- ▶ Secure the pins **2** on both sides with the corresponding retaining element.

When winch 6 **WVI** is properly pinned and secured in the transport position:

- ▶ Remove the auxiliary crane and the fastening equipment on winch 6 **WVI**.



## 9 Bringing winch 6 from the transport position into the operating position

Make sure that the following prerequisites are met:

- The H-pivot section **1** is lying completely on the ground.
- The railings on the H-pivot section are in the operating position.
- Gratings, catwalks and fall protection equipment are properly installed.
- The access ladder is properly assembled.
- An auxiliary crane with a suitable load-bearing capacity is available.

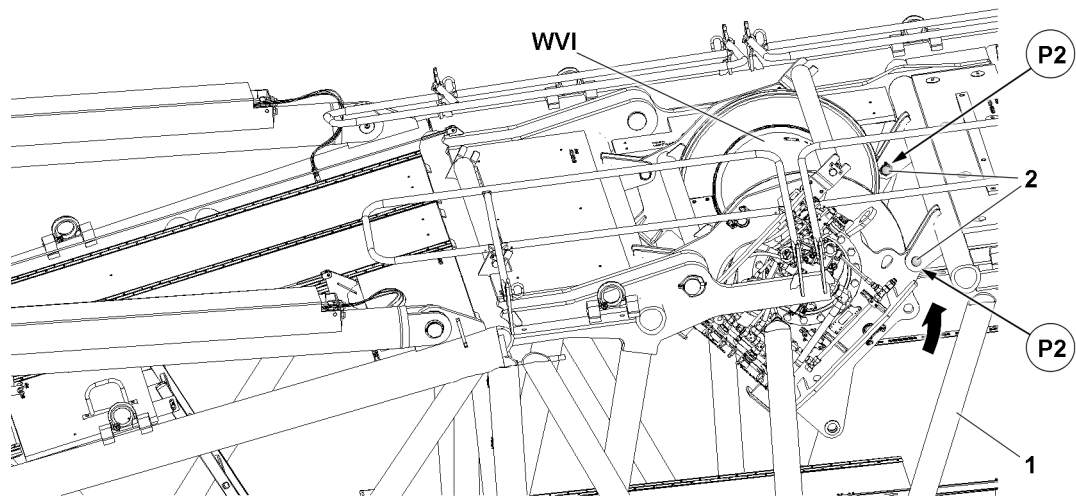


Fig.156020: Fastening winch 6 **WVI** to the auxiliary crane and unpinning

- 1** H-pivot section  
**2** Pin

- WVI** Winch 6  
**P2** Winch 6 transport position pin point



### Note

- ▶ During the lifting procedure of winch 6 **WVI** from the transport into the operating position, all hydraulic and electrical connections as well as the central lubrication connection remain connected with winch 6 **WV**.

- ▶ Properly fasten winch 6 **WVI** to the fastening points on the auxiliary crane.



### WARNING

Danger of accident due to winch 6!

If the pins **2** in point **P2** are unpinned on both sides and the fastening equipment is not tensioned, then winch 6 **WVI** can suddenly swing downward.

Death, severe bodily injuries, property damage.

- ▶ Make sure that the fastening equipment is tensioned before the pins are unpinned on both sides in point **P2**.
- ▶ Make sure that no personnel is within the danger zone when unpinning winch 6 **WVI**.

When winch 6 **WVI** is properly fastened to the auxiliary crane:

- ▶ Carefully tension the fastening equipment.

When the fastening equipment is tensioned:

- ▶ Release the pins **2** on both sides in point **P2** and unpin.
- ▶ Until the lower pin bores align for the operating position of winch 6 **WVI**: Lift winch 6 **WVI** with the auxiliary crane into the transport position.

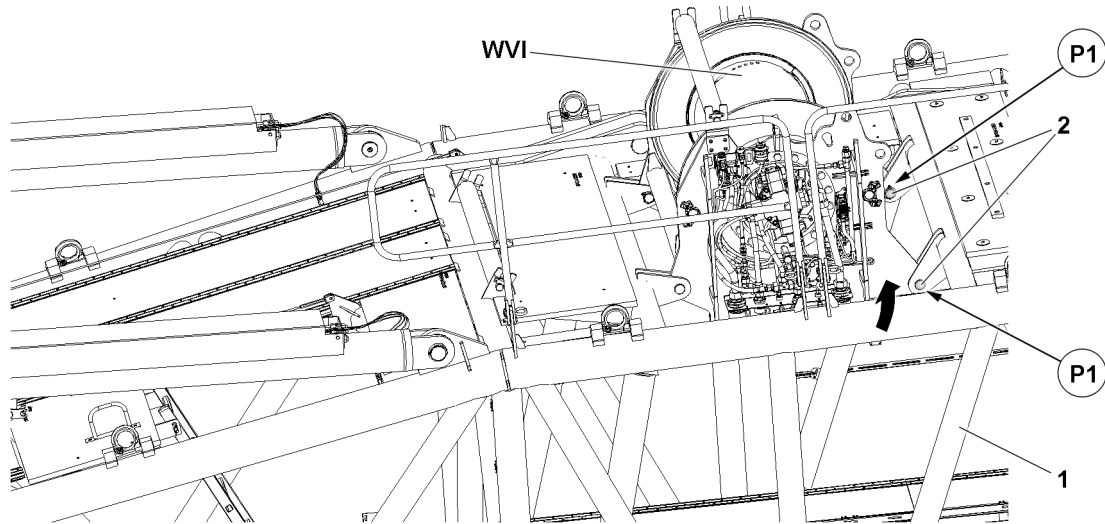


Fig.156021: Lifting winch 6 **WVI** with the auxiliary crane into the operating position

- 1 H-pivot section  
2 Pin

- WVI** Winch 6  
**P1** Winch 6 operating position pin point

When the pin bores align in point **P1**:

- ▶ Insert the pins **2** completely on both sides from the outside to the inside.
- ▶ Secure the pins **2** on both sides with the corresponding retaining element.

When winch 6 **WVI** is properly pinned and secured in the operating position:

- ▶ Remove the auxiliary crane and the fastening equipment on winch 6 **WVI**.

## 10 Bringing winch 6 from transport position into the flat operating position

Winch 6 must be brought into the flat operating position in the following operating condition:

- Parallel operation of winch 1 and winch 2 in combination with main boom operation without derrick and winch (e.g. S/ SL/ SLF) with operating position below 45°.

In the flat operating position, the oil measurement probe displays an incorrect oil level for winch 6. To make sure that there is sufficient oil in winch 6 in the flat operating position, the oil level must be checked during the assembly procedure using the dipstick. To do so, winch 6 must be in the operating position and the H-pivot section must be at 0°.

### NOTICE

Oil check in the flat operating position!

Property damage.

An incorrect oil level is displayed when checking the oil in the flat operating position using the oil measurement probe.

- ▶ Only check the oil of winch 6 in the operating position during the assembly procedure using the dipstick.

Make sure that the following prerequisites are met:

- The H-pivot section **1** is lying completely on the ground.
- The railings on the H-pivot section are in the operating position.
- Gratings, catwalks and fall protection equipment are properly installed.
- The access ladder is properly assembled.
- An auxiliary crane with a suitable load-bearing capacity is available.
- The oil level is checked.

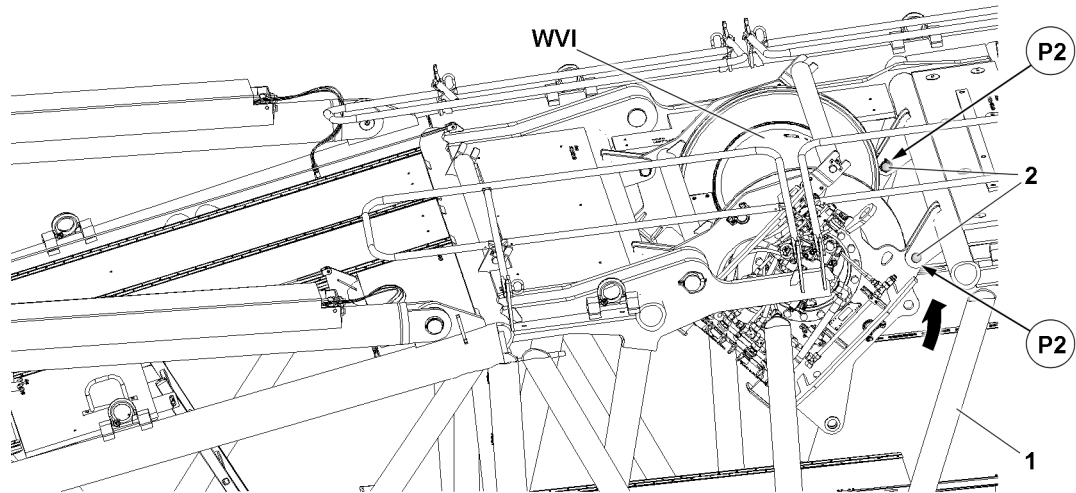


Fig.156020: Fastening winch 6 **WVI** to the auxiliary crane and unpinning

- 1** H-pivot section  
**2** Pin

- WVI** Winch 6  
**P2** Winch 6 transport position pin point



#### Note

- ▶ During the lifting procedure of winch 6 **WVI** from the transport into the flat operating position, all hydraulic and electrical connections as well as the central lubrication connection remain connected with winch 6 **WVI**.

- ▶ Properly fasten winch 6 **WVI** to the fastening points on the auxiliary crane.



#### WARNING

Danger of accident due to winch 6!

If the pins **2** in point **P2** are unpinned on both sides and the fastening equipment is not tensioned, then winch 6 **WVI** can suddenly swing downward.

Death, severe bodily injuries, property damage.

- ▶ Make sure that the fastening equipment is tensioned before the pins are unpinned on both sides in point **P2**.
- ▶ Make sure that no personnel is within the danger zone when unpinning winch 6 **WVI**.

When winch 6 **WVI** is properly fastened to the auxiliary crane:

- ▶ Carefully tension the fastening equipment.

When the fastening equipment is tensioned:

- ▶ Release the pins **2** on both sides in point **P2** and unpin.
- ▶ Until the lower pin bores align for the flat operating position of winch 6 **WVI**: Lift winch 6 **WVI** with the auxiliary crane into the flat operating position.

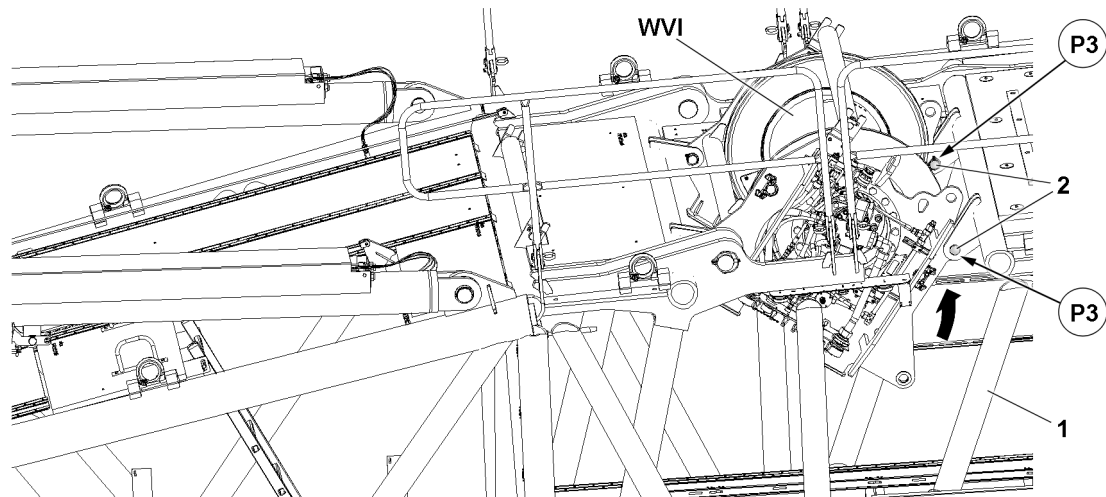


Fig.156008: Lifting winch 6 **WVI** with the auxiliary crane into the flat operating position

- 1 H-pivot section  
2 Pin

**WVI** Winch 6

**P3** Winch 6 flat operating position pin point

When the pin bores align in point **P3**:

- ▶ Insert the pins **2** completely on both sides from the outside to the inside.
- ▶ Secure the pins **2** on both sides with the corresponding retaining element.

When winch 6 **WVI** is properly pinned and secured in the flat operating position:

- ▶ Remove the auxiliary crane and the fastening equipment on winch 6 **WVI**.

## 3.80 Crane and crane component transport

1	Safety	2
2	Crane, assembled	3
3	Crane components	3

# 1 Safety

Observe and adhere to the transport safety instructions. See chapter 2.04.

## 1.1 Forms of transport

Observe and adhere to the specifications for the respective form of transport:

- Road transport
- Rail transport
- Ship transport
- Air transport

## 1.2 Transport company

The transport company is responsible for fulfilling the following prerequisites:

- Loading on the transport vehicle must be positioned taking into consideration the applicable permissible axle loads in the respective countries.
- Suitable rigging devices are provided.
- The transport location is even, level in horizontal direction and of sufficient load bearing capacity.
- A guide is present.

## 1.3 Rigging plans



### WARNING

Missing or deficient securing of the load!

Danger of accident. The crane components can slip and fall down.

Death, severe bodily injuries, property damage.

- ▶ Observe and adhere to the rigging plan specifications, see rigging plans.
- ▶ Fasten the tension belts or tension chains on rigging points according to the rigging plan.
- ▶ Adhere to the angles, radii and tension surfaces according to the rigging plan and the signs in the rigging points.

## 1.4 Rigging points



### WARNING

Impermissible use of the rigging points and rigging eyehooks!

The rigging points and rigging eyehooks can fail. The crane or components can fall from the transport vehicle.

Death, severe bodily injuries, property damage.

- ▶ Use the eyehooks only for rigging the crane or components.
- ▶ Do **not** use the eyehooks to lift the crane or components.
- ▶ Do **not** use the eyehooks to lift loads.
- ▶ Observe and adhere to the maximum permissible rigging forces.
- ▶ Make sure that eyehooks of the transport vehicle correspond at least to the load carrying capacity of the rigging device.

Eyehooks are designed only for road transport.

For certain crane components, specific rigging plans are available for rail transport.

## 1.5 Transport vehicle

Observe and adhere to the following notes for safe transport:

- Use a suitable transport vehicle.
- Establish the greatest possible frictional coefficient to the transport surface: Prior to transport, clean the support surfaces of the crane components.
- The loading surface must be free of snow, ice, grease and be well-swept.

## 1.6 Rigging device

Observe and adhere to the following notes for safe transport:

- Use a rigging device with a sufficient load capacity.
- Use the rigging belts and rigging chains in application of the respectively valid regulations for loading and load retention.

## 1.7 Substructure

To avoid accidents, observe the following notes regarding anti-slip mats:

- Comply with the minimum friction value, minimum load bearing capacity and minimum thickness of the anti-slip mats.
- Replace the anti-slip mats when one of the following criteria is fulfilled:
  - Permanent deformation or pressure marks
  - Cracks
  - Abrasion on the surface
  - Broken out material area
  - Swollen areas
  - Damage due to contact with aggressive materials
  - Brittleness
  - Function-impairing contaminants

To avoid accidents, observe the following notes regarding wood:

- Wood with a minimum quality of “spruce” is to be used.

# 2 Crane, assembled

## 2.1 Rigging plans

When the crawler crane must be luffed down completely:

- ▶ Contact Customer Service at Liebherr-Werk Ehingen GmbH.

# 3 Crane components

## 3.1 Rigging plans

Rig the crane components , see the rigging plans.

## 3.2 Rigging

The signs in the rigging points are described in chapter 2.05.

- ▶ Observe and comply with the specifications on the rigging plans.
- ▶ Secure the crane or the crane components with tension belts or tension chains in the rigging points.
- ▶ Attach the tension belts or tension chains to the transport vehicle.

---

Empty page!

LWE/LR 1800-1-0-000/27200-07-02/en



---

## 4 Operation of crane superstructure

LWE/LR 1800-1-0-000/27200-07-02/en

---

LWE/LR 1800-1-0-000/27200-07-02/en

## 4.01 Operating and monitoring instruments on the crane superstructure

1	Crane cab exterior installation parts	2
2	Crane cab interior installation parts	3
3	Emergency equipment	4
4	Interfaces	5
5	Crane cab control units	6
6	Monitor control unit	7
7	Operating and control unit - BKE	7
8	BTT control unit	19
9	Drive assembly air conditioning system* control unit	19
10	Climate control system control unit	20
11	LICCON computer system control unit	23
12	Pedal carrier	23
13	Control platform	25
14	Instrument panel	42
15	Side panel	55
16	Turntable control units	57
17	Crawler travel gear control units	58
18	Control cabinet panel	58
19	External power supply	59
20	Drive assembly air conditioning system*	60

# 1 Crane cab exterior installation parts

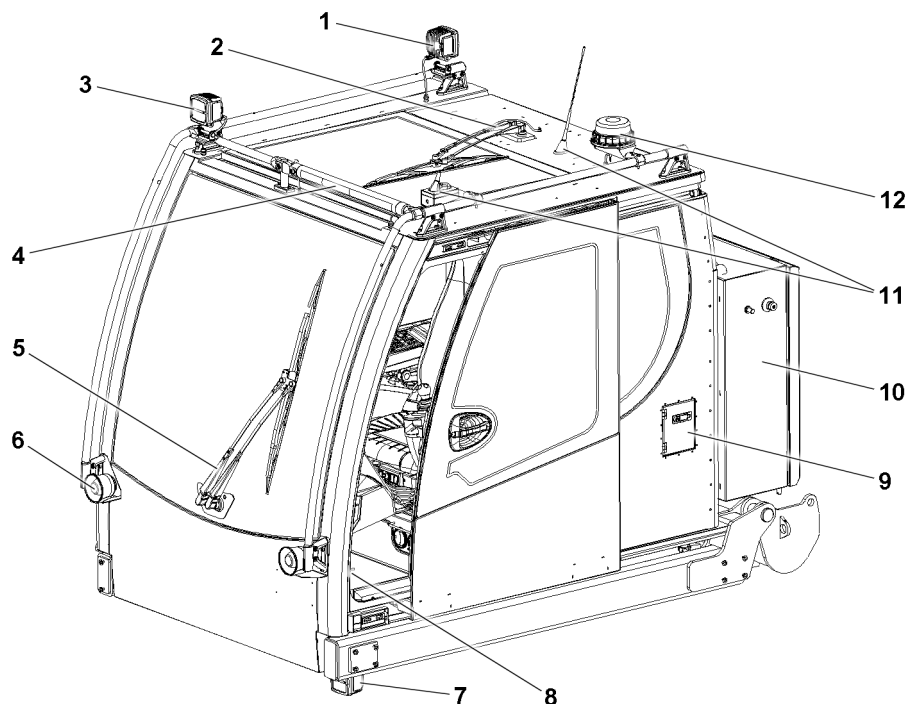


Fig.151480: Crane cab installation parts assignment

- 1 Floodlight, crane cab rear
- 2 Window wiper for roof window
- 3 Floodlight, crane cab front
- 4 Three color light
- 5 Window wiper front window
- 6 Speaker
- 7 Floodlight, crane cab bottom
- 8 Door contact switch
- 9 Reservoir for window cleaning fluid
- 10 Control cabinet
- 11 Antenna
- 12 Rotating beacon

## 2 Crane cab interior installation parts

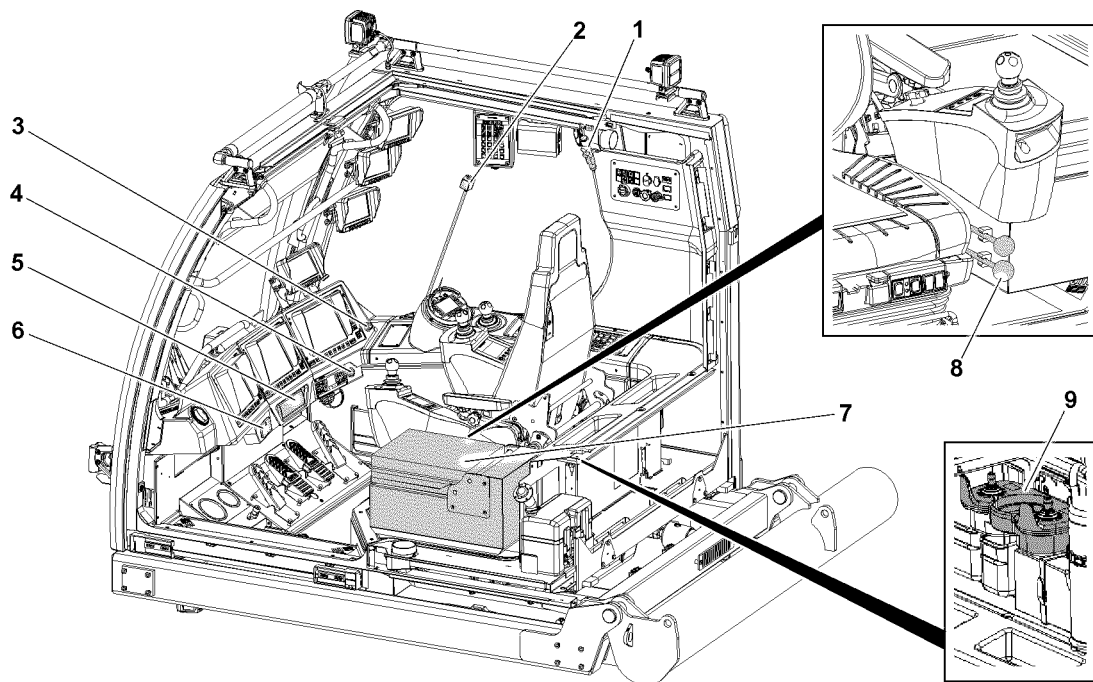


Fig.155101: Interior equipment assignment

- 1 Microphone\*
- 2 Reading lights
- 3 Cigarette lighter
- 4 Crane cab ignition switch
  - There is an additional ignition switch on the crawler travel gear. If the crawler travel gear and turntable are electrically connected, both ignition switches must be turned on in order to turn on the ignition. To turn off the ignition, turning off one ignition switch is sufficient (series connection).
- 5 Radio
- 6 Ashtray
- 7 Auxiliary seat
  - With storage compartment
  - The auxiliary seat is only designed for use when the crane is stationary and may not be used as a seat during crane operation / travel operation.
- 8 Pedal sensor manual control lever
- 9 Radio remote control panel



### Note

- For a detailed description of the BTT in connection with the radio remote control console **9**, see chapter 6.08.

### 3 Emergency equipment

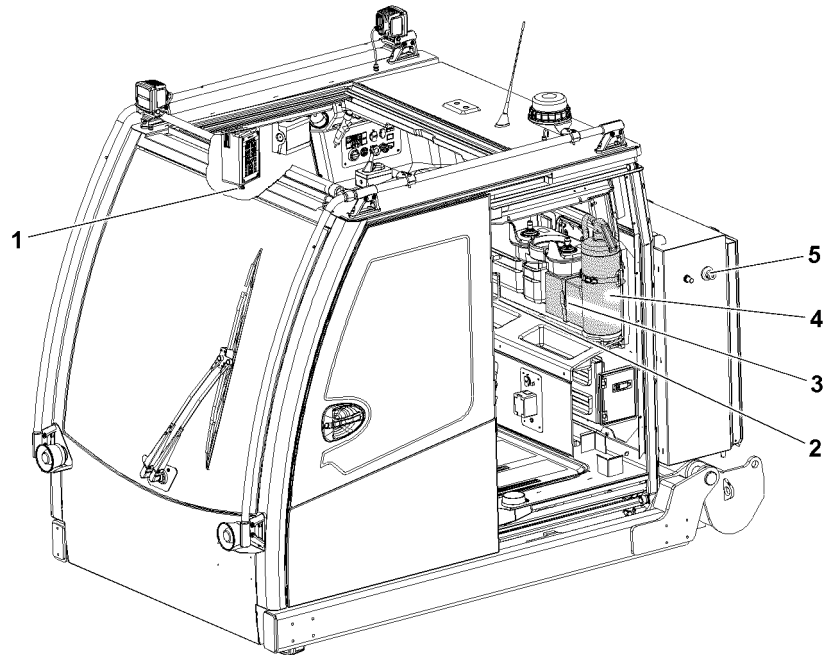


Fig.151481: Emergency equipment assignment

- 1 EMERGENCY STOP switch - crane cab interior
- 2 Emergency hammer
- 3 First aid kit
- 4 Fire extinguisher
- 5 EMERGENCY STOP switch - crane cab exterior

## 4 Interfaces

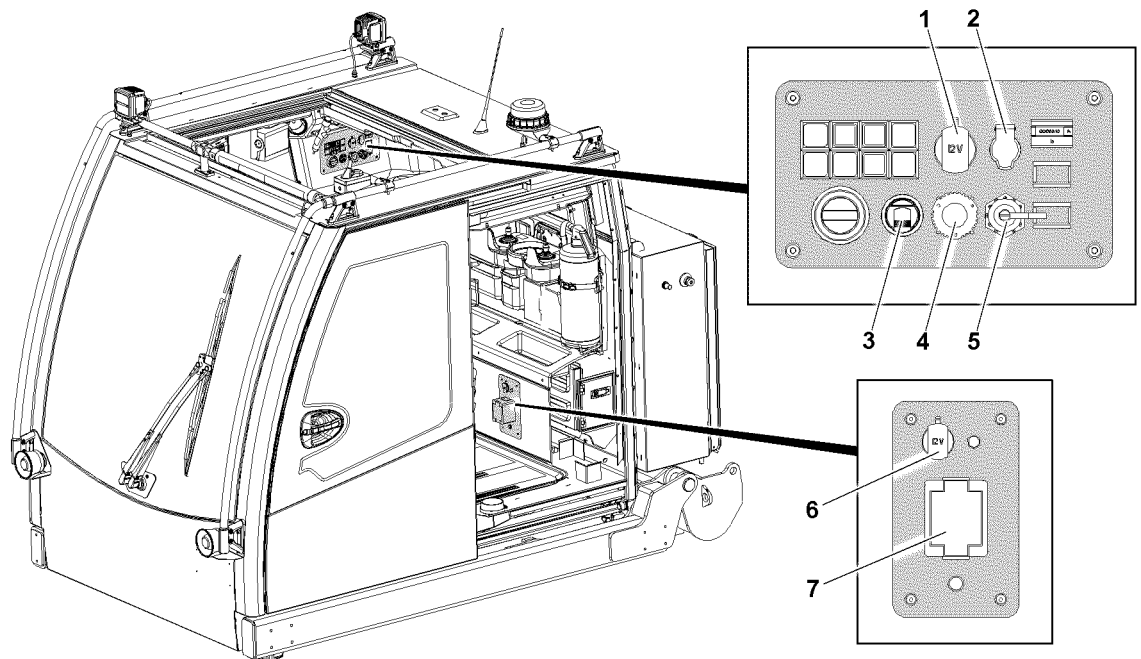


Fig.151482: Interface assignment

- 1 12 V socket
- 2 24 V socket
- 3 USB socket
- 4 Engine diagnostics socket
- 5 LAN socket
- 6 12 V socket
- 7 230 V socket\*

## 5 Crane cab control units

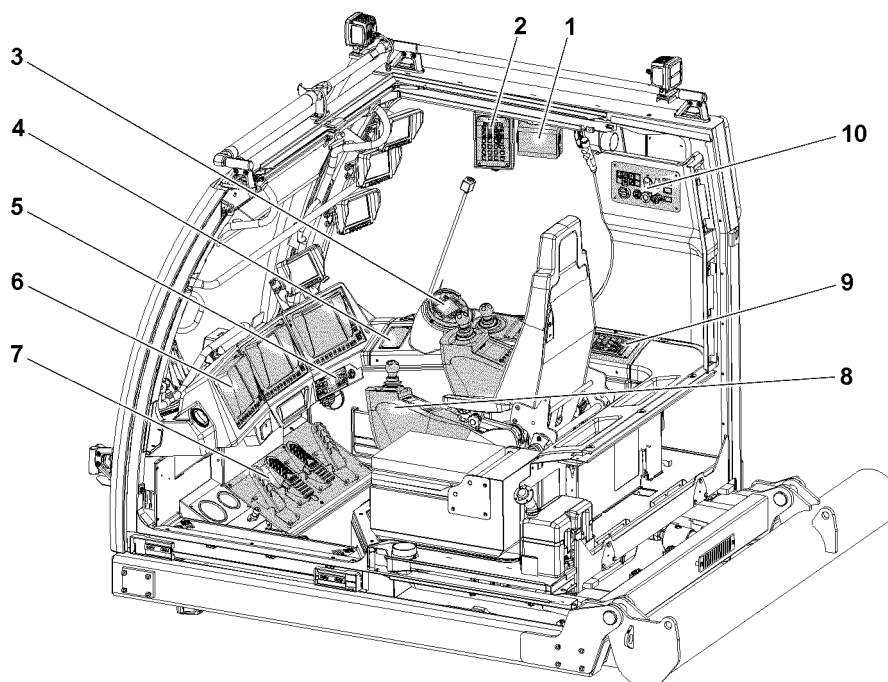


Fig.151483: Crane cab control units

The following control units are in the crane cab:

- 1 Monitor control unit
- 2 Operating and control unit - BKE
- 3 *Crane cab* charging cradle
  - **Note:** There is an additional charging cradle for the BTT on the crawler travel gear
  - For the automatic registration of the BTT on the crane superstructure, the BTT must be in the *crane cab* charging cradle when the ignition is turned on
  - To recharge the rechargeable battery, the BTT must be plugged into a charging cradle:
    - *Crane cab* charging cradle
    - *Crawler travel gear* charging cradle
- 4 Drive assembly air conditioning system\* control unit
- 5 Climate control system control unit
- 6 LICCON computer system control unit
- 7 Pedal carrier
- 8 Control platform
- 9 Instrument panel
- 10 Side panel



## 6 Monitor control unit

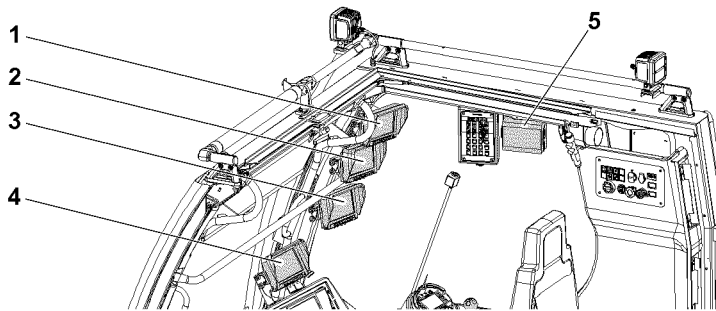


Fig.151485: Camera monitoring assignment



### WARNING

Unavailable camera view!

The individual camera views in the monitors can be changed over or masked.

The camera objective can become dirty, fogged up or otherwise impaired in the sight window.

Incorrectly set or dirty floodlights can impair camera monitoring.

- ▶ Always allow to show required camera views.
- ▶ Remedy any impairments of picture quality of camera views immediately.

Location of monitors in the crane cab:

- 1 Monitor 1
- 2 Monitor 2
- 3 Monitor 3
- 4 Monitor 4

For description of the monitor control unit 5, see the documentation from the manufacturer.

For a description of the monitor operating buttons, see documentation from the manufacturer.

Assignment of cameras to monitors, see the Electrical wiring diagram.

## 7 Operating and control unit - BKE

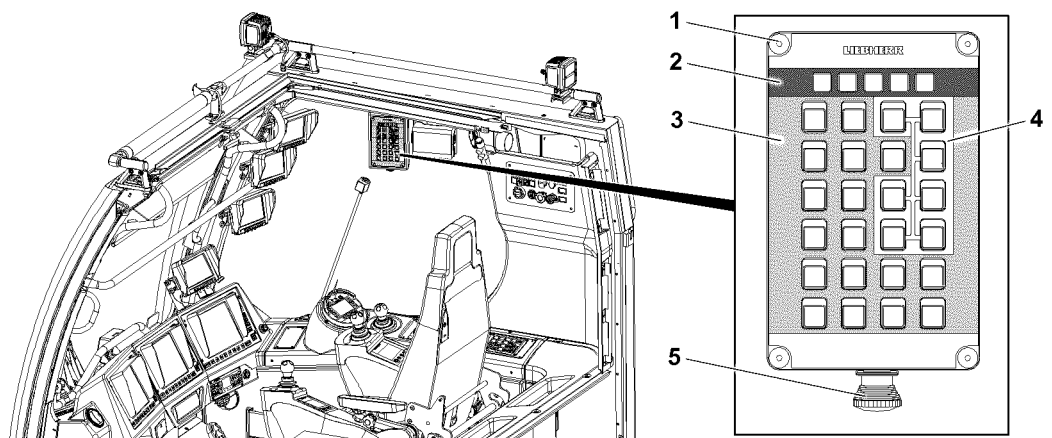


Fig.151486: Operating and control unit - BKE assignment

## 7.1 Operating console



### Note

► The indicator lights as well as the operating buttons are described in detail in the following sections.

- 1 Operating console
  - Housing with indicator lights and buttons
- 2 Indicator lights on the BKE
- 3 Operating buttons on the BKE
- 4 Operating buttons on the BKE
  - Operating buttons with release actuations
- 5 EMERGENCY STOP switch - crane cab interior
  - Impact switch

## 7.2 Indicator lights on the BKE

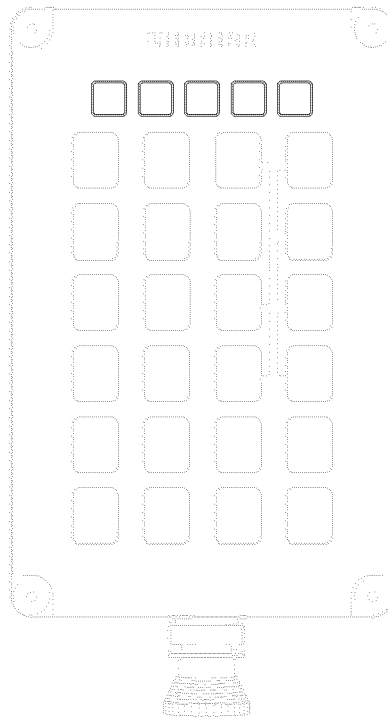






Fig.151933: Indicator lights on the BKE

Position	Indicator light	LED	Description
1.2	 Engine monitoring Aggregate 1 or aggregate 2	Orange	Engine not ready to start, engine preheating active
		Orange blinking	Engine ready to start
		Off	Engine is running (after engine has been started)
		Red	The engine is running, the alternator does not charge
		Red blinking	Engine is running in emergency operation

Position	Indicator light	LED condition	Description
3	 Central lubrication 1 for: Hoist winches, control winches SA-frame, slewing ring, pin S/D	Yellow + red (orange)	Functional readiness (shown after engine start for 1.5 s)
		Yellow	Lubrication active
		Red / red blinking	Error / problem
		Off	Central lubrication not active

Position	Indicator light	LED condition	Description
4	 Central lubrication 2 for: Ballast trailer	Yellow + red (orange)	Functional readiness (shown after engine start for 1.5 s)
		Yellow	Lubrication active
		Red	Error / problem
		Off	Central lubrication not active

Position	Indicator light	LED condition	Description
5	 Central lubrication 3 for: Crawler travel gear	Yellow + red (orange)	Functional readiness (shown after engine start for 1.5 s)
		Yellow	Lubrication active
		Red	Error / problem
		Off	Central lubrication not active

## 7.3 Operating buttons on the BKE

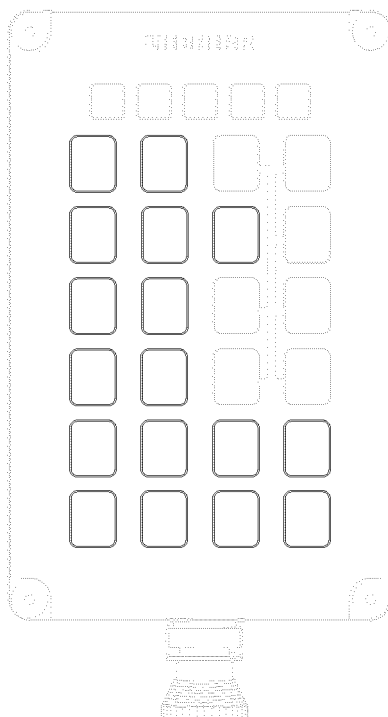




Fig.151934: Operating buttons on the BKE





### Note


- With the LEDs in the operating buttons, operating conditions and problems can be recognized quickly and reliably by the crane driver.


Position	Operating button	Function	LED	Description
1	 Washer pump front window	On		Clean the front window: By pressing and holding the operating button
		Off		By releasing the operating button
		<b>Note:</b>		After releasing the operating button, three additional wipe movements are carried out before the wiper blades return to their original position.

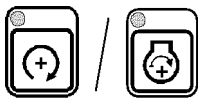
Position	Operating button	Function	LED	Description
2	 Washer pump Roof window	On		Clean roof window: By pressing and holding the operating button
		Off		By releasing the operating button
		<b>Note:</b>		After releasing the operating button, three additional wipe movements are carried out before the wiper blades return to their original position.

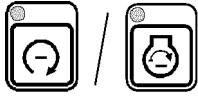
Position	Operating button	Function	LED	Description
3	 Window wiper front window	On	Lights up	By momentarily pressing the operating button (less than one second). By momentarily pressing it further, the interval stage changes incrementally.
		Intermittent	Lights up	There are different interval stages:  1. Interval stage: Wipe with long pauses 2. Interval stage: Wipe with short pauses 3. Wipe continuously off
		Off	Off	By pressing the operating button longer (more than one second until a beep sounds)  <b>or</b> By pressing the operating button briefly (less than one second) several times until the LED turns off <sup>1)</sup>

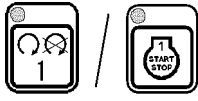
Position	Operating button	Function	LED	Description
4	 Window wiper for roof window	On	Lights up	By momentarily pressing the operating button (less than one second). By momentarily pressing it further, the interval stage changes incrementally.
		Intermittent	Lights up	There are different interval stages:  1. Interval stage: Wipe with long pauses 2. Interval stage: Wipe with short pauses 3. Wipe continuously off
		Off	Off	By pressing the operating button longer (more than one second until a beep sounds)  <b>or</b> By pressing the operating button briefly (less than one second) several times until the LED turns off <sup>1)</sup>


Position	Operating button	Function	LED	Description
5	 Auxiliary users pressure supply	On	Lights up	By pressing the operating button
		Off	Off	By pressing the operating button
		Error	Blinks	Error / problem
				<b>Note:</b> For all functions that are actuated with the hydraulic manual control levers, the pressure supply for the auxiliary users must be turned on.

Position	Operating button	Function	LED	Description
6	 Intermediate lubrication central lubrication system	On	Lights up	By pressing the operating button, an intermediate lubrication is carried out, then the function turns off.
		Off	Off	Automatically after completion of intermediate lubrication
		Error	Blinks	Error / problem


Position	Operating button	Function	LED	Description
7		Increase	Lights up	By pressing and holding the operating button or By momentarily pressing (less than one second) the rpm changes incrementally by 50 rpm
		Lock	Off	By releasing the operating button
		Error	Blinks	Error / problem
	Increase the engine rpm			



Position	Operating button	Function	LED	Description
8		Lower	Lights up	By pressing and holding the operating button or By momentarily pressing (less than one second) the rpm is lowered incrementally by 50 rpm
		Lock	Off	By releasing the operating button
		Error	Blinks	Error / problem
	Lower engine rpm			



Position	Operating button	Function	LED	Description
9		Start	Lights up	Start turned off crane engine: By pressing and holding the button, until the engine is running
		Turn off	Off	Turn the started crane engine off: By pressing the operating button
		Error	Blinks	Crane engine nominal rpm not reached
				<b>Note:</b> If the crane engine is turned off via this operating button when the ignition is turned on, then stand-by mode is started in the LICCON computer system.
	Engine START / STOP			


Position	Operating button	Function	LED	Description
10	 Airplane warning light	On	Lights up	By pressing the button  <b>Note:</b> To identify aviation obstructions. The airplane warning light can also be actuated when the ignition is "Off", by pressing the button longer than one second. Pressing it again switches the next shift stage.  <b>Note:</b> The light signal illuminates or blinks depending on the airplane warning light version.
		On	Blinks (1 Hz)	By pressing the button  <b>Note:</b> Only on crane types with switchable airplane warning light*: If the LED blinks continuously once per second, the airplane warning light is in blinking mode
		Off	Off	By pressing the button
		Error	Blinks (2 Hz)	<b>Note:</b> Only on crane types with airplane warning light monitoring: Error / problem: If the LED blinks continuously twice per second, there is a detected airplane warning error





Position	Operating button	Function	LED	Description
11	  Interior lighting crane cab	On		By opening the door  <b>or</b> By momentarily pressing the operating button (less than one second). By momentarily pressing it further, the dimmer stage changes incrementally.
		Dim		There are different dimmer stages: 1. Dimmer stage 75 % 2. Dimmer stage 50 % 3. Dimmer stage 25 % 4. Interior lighting continuously off
		Off		By pressing the operating button longer (more than one second)  <b>or</b> By pressing the operating button briefly (less than one second) several times until the interior lighting turns off  <b>or</b> If the following conditions are present simultaneously for longer than 30 seconds: – Crane operator's seat not occupied – Crane cab door closed – Crane engine off


Position	Operating button	Function	LED	Description
12	 /   Floodlight camera	On	Lights up	By pressing the operating button
		Off	Off	By pressing the operating button
		Error	Blinks	Error / problem


Position	Operating button	Function	LED	Description
13	 /   Crawler travel gear floodlight	On	Lights up	By pressing the operating button
		Off	Off	By pressing the operating button
		Error	Blinks	Error / problem


Position	Operating button	Function	LED	Description
14		On	Lights up	By pressing the operating button
		Off	Off	By pressing the operating button
		Error	Blinks	Error / problem
	Ladder floodlight			


Position	Operating button	Function	LED	Description
15		On	Lights up	By pressing the operating button
		Off	Off	By pressing the operating button
		Error	Blinks	Error / problem
	Turntable floodlight			


Position	Operating button	Function	LED	Description
16		On	Lights up	By pressing the operating button
		Off	Off	By pressing the operating button
		Error	Blinks	Error / problem
	Pivot section floodlight			

Position	Operating button	Function	LED	Description
17		On	Lights up	By pressing the operating button
		Off	Off	By pressing the operating button
		Error	Blinks	Error / problem
	Lift the pivot section floodlight			

Position	Operating button	Function	LED	Description
18		On	Lights up	By pressing the operating button
		Off	Off	By pressing the operating button
		Error	Blinks	Error / problem
	Lower the pivot section floodlight			

Position	Operating button	Function	LED	Description
19		On	Lights up	By pressing the operating button
		Off	Off	By pressing the operating button
		Error	Blinks	Error / problem
	Crane cab outside area floodlight			

Position	Operating button	Function	LED	Description
20	 Crane cab front outside area floodlight	On	Lights up	By pressing the operating button
		Off	Off	By pressing the operating button
		Error	Blinks	Error / problem

Position	Operating button	Function	LED	Description
21	 Crane cab rear outside area floodlight	On	Lights up	By pressing the operating button
		Off	Off	By pressing the operating button
		Error	Blinks	Error / problem

### 7.4 Operating buttons on the BKE with release actuations

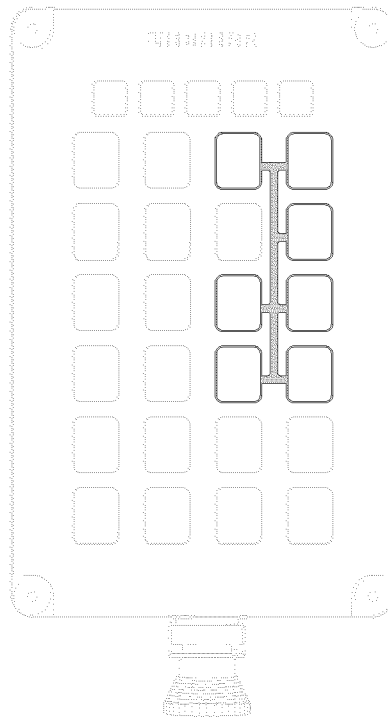


Fig.151935: Operating buttons on the BKE with release actuations




**Note**

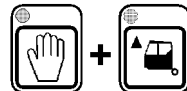
- ▶ The following functions require the activation of the enable button.
- ▶ The enable button is active for 20 seconds. If the operating button is pressed during this time, the release time is reset to 30 seconds. The release stops after 20 seconds.
- ▶ A function is triggered by activation of the enable button and then pressing the corresponding operating button.
- ▶ For the listed key combinations, hold the corresponding operating button until the desired end position is reached.


LWE/LR 1800-1-0-000/27200-07-02/en


**Note**


- With the LEDs in the operating buttons, operating conditions and problems can be recognized quickly and reliably by the crane driver.

Position	Key combination	Function	LED	Description
1	 Enable button	On	Lights up	Press the enable button, within 30 seconds the functions which require a release must now be activated.
		Off	Off	By pressing the button <b>or</b> Automatically after 30 seconds when no operating button is pressed, a release is required.

Position	Key combination	Function	LED	Description
2	 Lift the crane cab	On	Lights up	By pressing and holding the operating button lift the crane cab on the front to the desired position
		Lock	Off	By releasing the operating button
		Error	Blinks	Error / problem

Position	Key combination	Function	LED	Description
3	 Lower the crane cab	On	Lights up	By pressing and holding the operating button lower the crane cab on the front to the desired position
		Lock	Off	By releasing the operating button
		Error	Blinks	Error / problem

Position	Key combination	Function	LED	Description
4	 Swing the crane cab in	On	Lights up	Function inactive
		Off	Off	Error / problem
		Error	Blinks	The crane cab is swung in

Position	Key combination	Function	LED	Description
5	 Swing the crane cab out	On	Lights up	Function inactive
		Off	Off	Error / problem
		Error	Blinks	The crane cab is swung out

## 8 BTT control unit

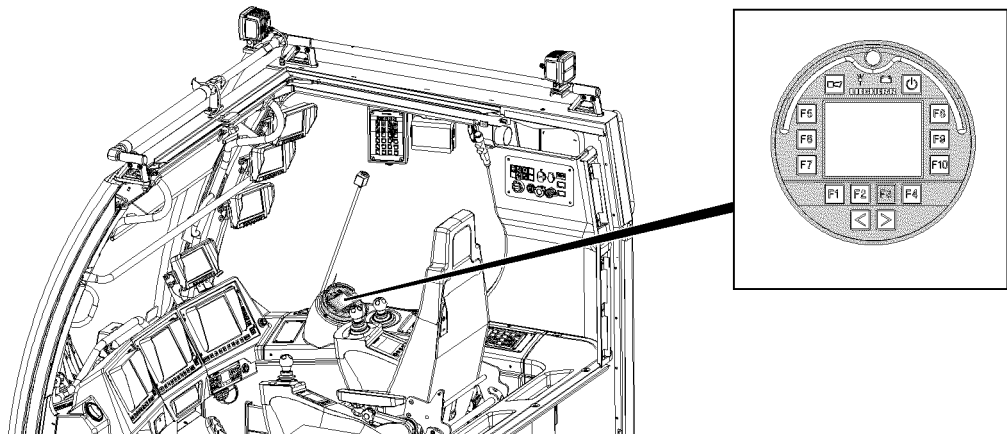


Fig.151498: BTT control unit

For a description of the BTT control unit, see chapter 5.31.



### Note

- ▶ Alternatively, the BTT can be stowed in the crawler travel gear control cabinet, see section “Crawler travel gear control units”.

## 9 Drive assembly air conditioning system\* control unit

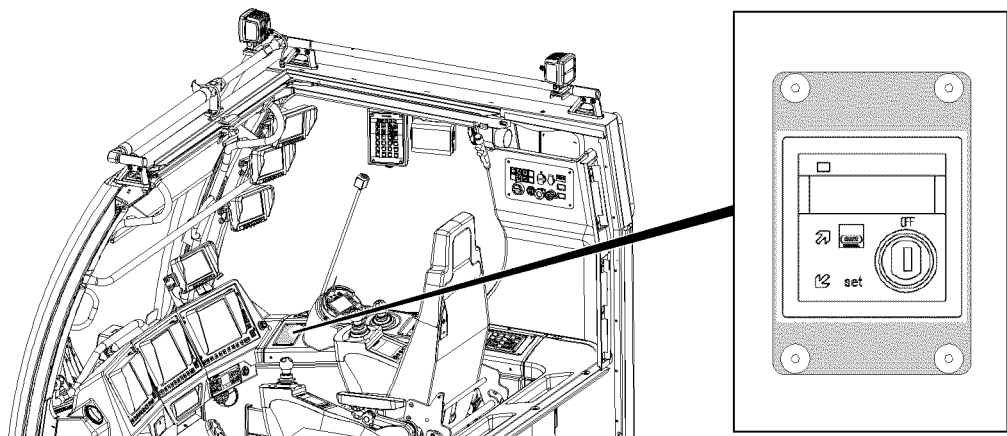


Fig.151490: Drive assembly air conditioning system\* control unit

For description of the drive assembly air conditioning system\* control unit, see the documentation from the manufacturer.

## 10 Climate control system control unit

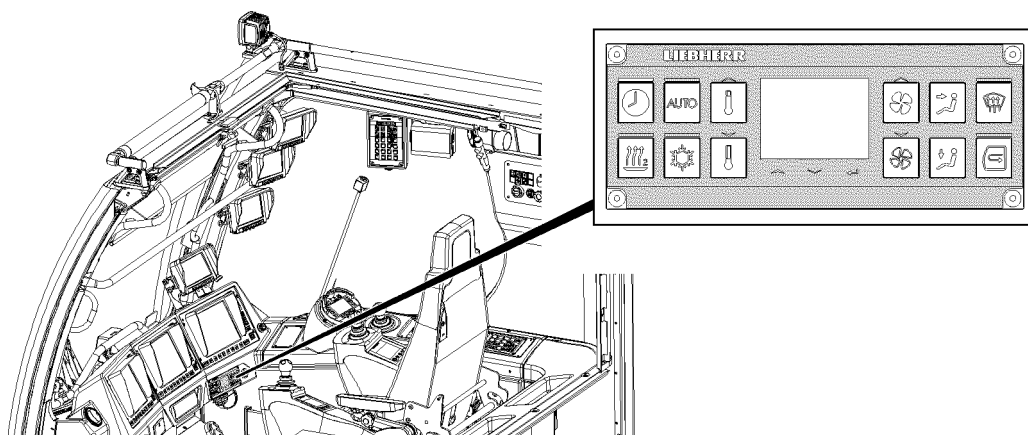





Fig.151487: Climate control system control unit


### 10.1 Climate control system control unit buttons


For a description of the climate control system control unit, see Chapter 6.02.


Position	Operating button	Description
1		Timer


Position	Operating button	Description
2		Automatic operation


Position	Operating button	Description
3		Crane cab / engine preheating* auxiliary heater


Position	Operating button	Description
4		Climate control system*


Position	Operating button	Description
5		Increase temperature


Position	Operating button	Description
6		Decrease temperature


Position	Operating button	Description
7		Increase blower stage

Position	Operating button	Description
8		Decrease blower stage

Position	Operating button	Description
9		Air distribution for head area

Position	Icon	Description
10		Air distribution for floorboard area

Position	Operating button	Description
11		Front window defrosting

Position	Operating button	Description
12		Recirculating air

## 10.2 Climate control system control unit display

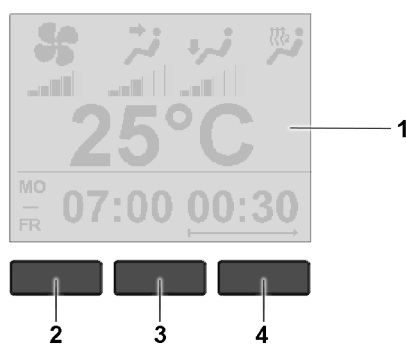


Fig.155118: Display with buttons

- |   |                  |   |                    |
|---|------------------|---|--------------------|
| 1 | Display          | 3 | Down selection key |
| 2 | Up selection key | 4 | Confirm entry key  |



## 11 LICCON computer system control unit

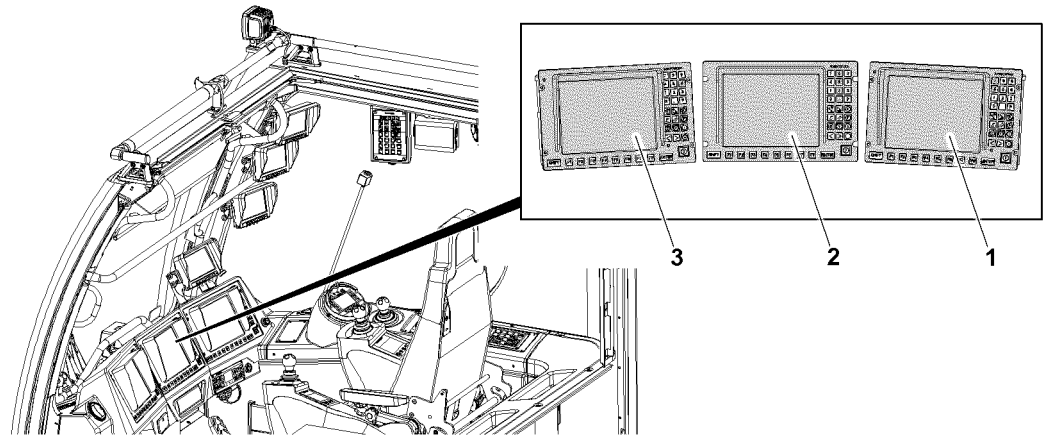


Fig.151489: LICCON computer system assignment

For a description of the LICCON computer system, see chapter 4.02.

- 1 LICCON monitor 0
  - User interface for entry of equipment configurations and for crane operation
- 2 LICCON monitor 1
  - User interface for operation with “derrick” boom
- 3 LICCON monitor 2
  - User interface for “SB-pallet or ballast trailer operation”

## 12 Pedal carrier

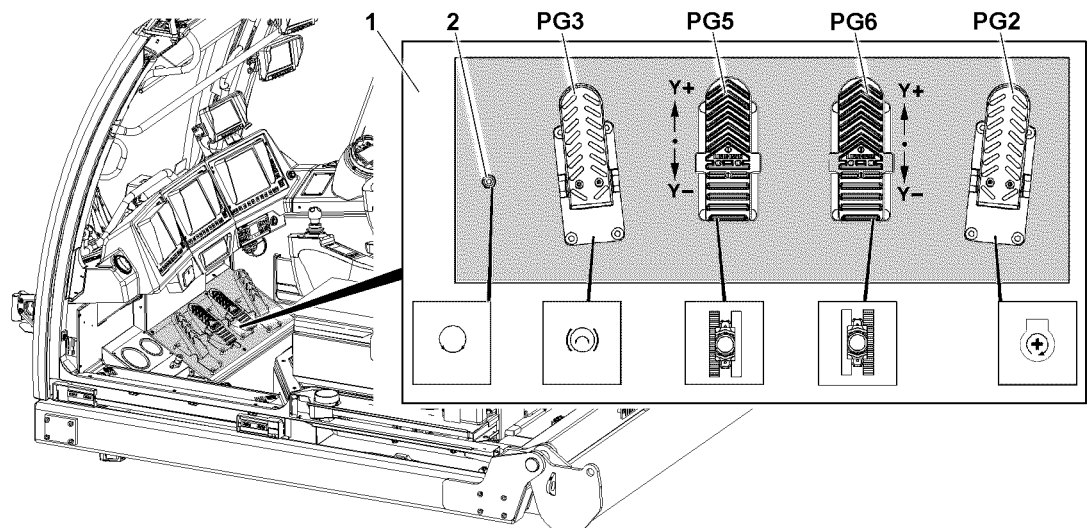







Fig.151491: Pedal carrier assignment 1

Position	Operating element	Description
2	 Foot rocker	Slewing gear freewheeling

Position	Operating element	Description
PG3	 Pedal sensor	Slewing gear brake

Position	Operating element	Description
PG5	 Pedal sensor	Drive the crawler forward or backward on the left hand side

Position	Operating element	Description
PG6	 Pedal sensor	Drive the crawler forward or backward on the right hand side

Position	Operating element	Description
PG2	 Pedal sensor	Engine regulation

## 13 Control platform

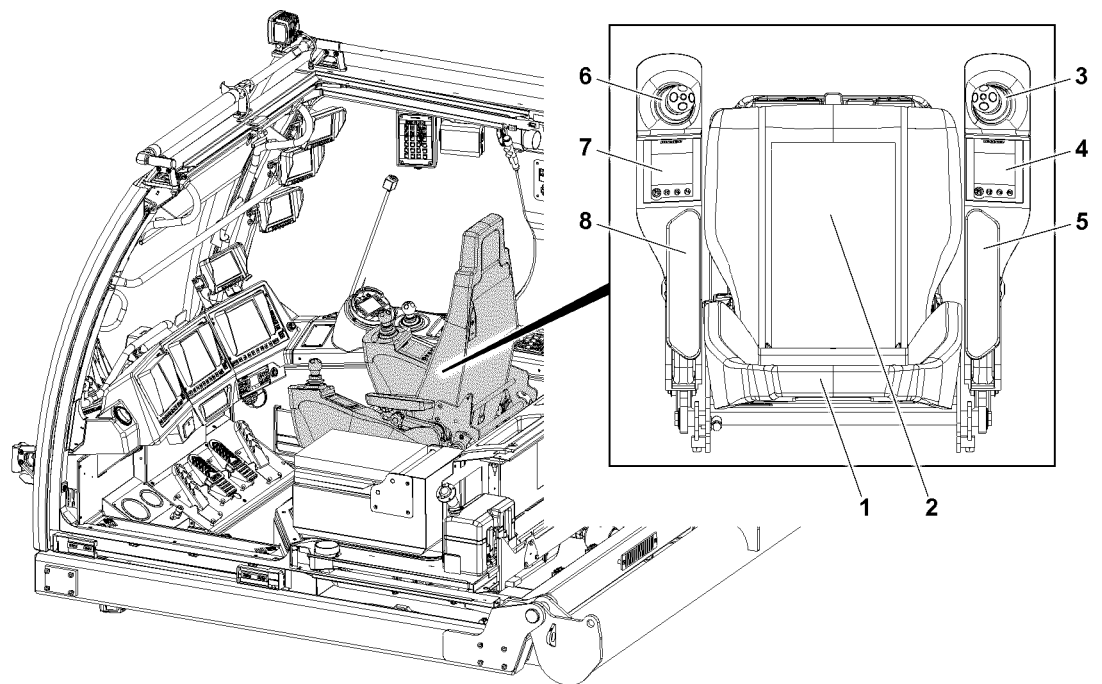


Fig.151492: Control platform assignment

The control platform consists of the following elements:

- 1 Crane operator's seat
- 2 Seat contact button
- 3 Master switch MS1
- 4 Touch display TE1
- 5 Right armrest
- 6 Master switch MS2
- 7 Touch display TE2
- 8 Left armrest

### 13.1 Crane operator's seat

For a detailed description of operating elements to adjust the crane operator's seat, see the Crane operating instructions, chapter 4.03.

#### 13.1.1 Seat contact button

Function of the seat contact button, see the Crane operating instructions, chapter 4.04.

## 13.2 Master switch MS1

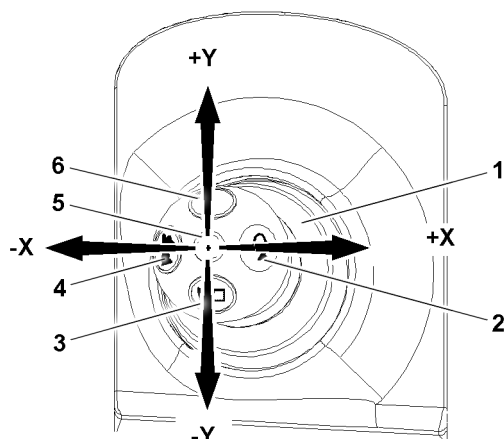


Fig.151494: Master switch MS1 assignment



### WARNING

Change of master switch assignment!

The assignment of the master switches to the respective units on the crane can change, depending on the set up configuration and winch application.

- ▶ Select the correct master switch assignment.
- ▶ Check the assignment before actuating the master switch on the TE.

#### 1 Master switch MS1

- The functions for the master switch MS1 depend on the set up configuration and the selected master switch assignment on the touch display TE1.



### Note

- ▶ Pressing the button **2** will lock the engine regulation in the current position.

#### 2 Button

- Locking the engine regulation of the superstructure engine  
The idling speed can be increased up to the maximum rpm.
- Can be “overridden” by the engine regulation (gas pedal).
- With continued actuation of the engine regulation (gas pedal), the current rpm is taken over.
- By pressing the button **4** with the engine regulation (gas pedal) **NOT actuated**, the manual throttle is cancelled.
- If the engine rpm is locked, a “+” appears on the LICCON monitor on the “dynamic engine rpm display” (travel operation) and the “dynamic load utilization bar display” (crane operation).
- Delete the lock by touching the gas pedal momentarily.

#### 3 Button

- Horn

#### 4 Button

- “Power Plus” activation, crane operation

#### 5 Vibration sensor

- Turn sensor and winches

#### 6 Button

- Bypass of the seat contact button
- **Or:** When the seat contact button is actuated: Activation of the vibration sensor **5**

## 13.3 Touch display TE1

### 13.3.1 Touch display TE1 function buttons

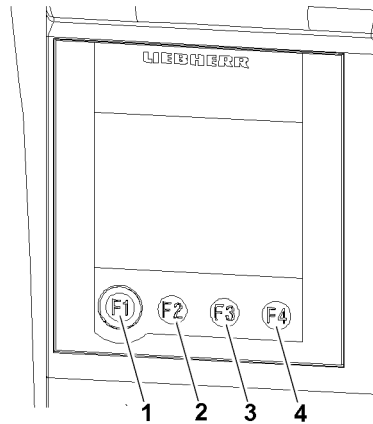


Fig.151496: Touch display TE1 assignment

Operating the touch display, see the Crane operating instructions, chapter 4.01.10.

- 1 F1 key
  - On the touch display TE1, no function
- 2 F2 key
  - Change to the “Lock winch” menu




#### Note

- ▶ The winch status (winch activated / blocked) can be seen on the touch display. Blocked winches are recognizable on the icon.


- 3 F3 key
  - Change master switch assignment; identification via letters in the icon.  
The number of possible master switch assignments depends on the set up configuration configured in the LICCON computer system.  
**Conditions:** Master switch MS1, master switch MS2 and master switch MS3 are not actuated.
- 4 F4 key
  - If a touch function of the assembly winch is activated on the touch display: Spool assembly winch out, spool up or constantly spool up.  
When parallel operation winch 1 || winch 2 is activated: “Adjust the winches”


### 13.3.2 TE1 touch display main menu: Functions and assignment

Position	Icon	Touch display TE1 assignment
1.01		Display of the master switch with deflection directions: Icon visible in the main menu on every touch display


Position	Icon	Touch display TE1 assignment
1.02		Identification of the master switch assignment in the center of icon, for example "D"


#### TE1 touch display main menu: Touch functions


Position	Icon	Touch display TE1 main menu assignment: Touch functions
1.10		Adjusting winch 1 and winch 2


Position	Icon	Touch display TE1 main menu assignment: Touch functions
1.11		Winch 1 and winch 2 are adjusted



#### TE1 touch display main menu: Winch assignment



Position	Icon	Touch display TE1 main menu assignment: Winches
1.20		Spool winch 1 up


Position	Icon	Touch display TE1 main menu assignment: Winches
1.21		Spool winch 1 out, display of maximum winch speed as a percentage


Position	Icon	Touch display TE1 main menu assignment: Winches
1.22		Spool winch 1 and winch 2 up in parallel operation

Position	Icon	Touch display TE1 main menu assignment: Winches
1.23		Spool winch 1 and winch 2 out in parallel operation, display of maximum winch speed as a percentage


Position	Icon	Touch display TE1 main menu assignment: Winches
1.24		Winch 1 is blocked
		<b>Note:</b> If a winch is blocked, the “spool winch up” and “spool winch out” functions can <b>NOT</b> be carried out!


Position	Icon	Touch display TE1 main menu assignment: Winches
1.25		Parallel operation of winch 1 and winch 2 is blocked
		<b>Note:</b> If the parallel operation is blocked, the “spool winch up” and “spool winch out” functions can <b>NOT</b> be carried out!


Position	Icon	Touch display TE1 main menu assignment: Winches
1.26		Spool winch 4 up


Position	Icon	Touch display TE1 main menu assignment: Winches
1.27		Spool winch 4 out, display of maximum winch speed as a percentage


#### TE1 touch display main menu: Boom and equipment assignment


Position	Icon	Touch display TE1 main menu assignment: Boom and equipment
1.30		Luff the main boom up


Position	Icon	Touch display TE1 main menu assignment: Boom and equipment
1.31		Luff the main boom down; display of maximum winch speed as a percentage


Position	Icon	Touch display TE1 main menu assignment: Boom and equipment
1.32		Luff the luffing jib up


Position	Icon	Touch display TE1 main menu assignment: Boom and equipment
1.33		Luff the luffing jib down; display of maximum winch speed as a percentage


Position	Icon	Touch display TE1 main menu assignment: Boom and equipment
1.34		Luff the main boom up


Position	Icon	Touch display TE1 main menu assignment: Boom and equipment
1.35		Luff the main boom down; display of maximum winch speed as a percentage

Position	Icon	Touch display TE1 main menu assignment: Boom and equipment
1.36		Luff the main boom up


Position	Icon	Touch display TE1 main menu assignment: Boom and equipment
1.37		Luff the main boom down; display of maximum winch speed as a percentage

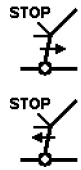
Position	Icon	Touch display TE1 main menu assignment: Boom and equipment
1.38		Luff the luffing jib up


Position	Icon	Touch display TE1 main menu assignment: Boom and equipment
1.39		Luff the luffing jib down; display of maximum winch speed as a percentage


Position	Icon	Touch display TE1 main menu assignment: Boom and equipment
1.40		Luff the main boom up





Position	Icon	Touch display TE1 main menu assignment: Boom and equipment
1.41		Luff the main boom down; display of maximum winch speed as a percentage


Position	Icon	Touch display TE1 main menu assignment: Boom and equipment
1.42		<p>If a crane movement is blocked, the “luffing up” and “luffing down” functions can <b>NOT</b> be carried out!</p> <p><b>Note:</b></p> <p>Boom and equipment: Crane movement is blocked, example SW, “luff luffing jib up” and “luff luffing jib down” can <b>NOT</b> be carried out.</p>


Position	Icon	Touch display TE1 main menu assignment: Boom and equipment
1.43		Lower the derrick ballast: Extend pull cylinder A and pull cylinder B

Position	Icon	Touch display TE1 main menu assignment: Boom and equipment
1.44		Lift the derrick ballast: Retract pull cylinder A and pull cylinder B

Position	Icon	Touch display TE1 main menu assignment: Boom and equipment
1.45		Lift / lower the derrick ballast: Lock pull cylinder A

Position	Icon	Touch display TE1 main menu assignment: Boom and equipment
1.46		Lift / lower the derrick ballast: Lock pull cylinder B

Position	Icon	Touch display TE1 main menu assignment: Boom and equipment
1.47		Ballast automatic* - Lower the derrick ballast: Extend pull cylinder A and pull cylinder B

Position	Icon	Touch display TE1 main menu assignment: Boom and equipment
1.48		Ballast automatic* - Lift the derrick ballast: Retract pull cylinder A and pull cylinder B

### 13.3.3 Touch display TE1 “Block winch” menu

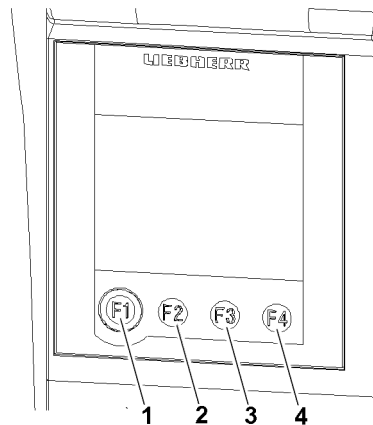


Fig.151496: Touch display TE1 assignment

The crane operator has the possibility to block a winch that is not needed in the “Block winch” menu.



#### Note


- ▶ “Touching” a touch function activates the function.
- ▶ Only an activated winch can be blocked or released with the F4 key **4**.
- ▶ The touch display changes 20 seconds after the last button actuation in the main menu.

#### Touch display TE1 “Block winch” menu: Function key assignment


The “Block winch” menu is accessed via touch display TE1.


- 1** F1 key
  - Change to the main menu
- 2** F2 key
  - No function in this menu
- 3** F3 key
  - No function in this menu
- 4** F4 key
  - Block / release the winch: When the winch is blocked, the winch is shown as in icon **1.67**.


#### Touch display TE1 “Block winch” menu: Assignment


Position	Icon	Touch display TE1 “Block winch” menu assignment
1.60		Block the selected winches


#### Touch display TE1 “Block winch” menu: Touch functions


Position	Icon	Touch display TE1 menu “Block winch” touch functions
1.61		Winch 1


Position	Icon	Touch display TE1 menu "Block winch" touch functions
1.62		Winch 2

Position	Icon	Touch display TE1 menu "Block winch" touch functions
1.63		Winch 3

Position	Icon	Touch display TE1 menu "Block winch" touch functions
1.64		Winch 4

Position	Icon	Touch display TE1 menu "Block winch" touch functions
1.65		Winch 5

Position	Icon	Touch display TE1 menu "Block winch" touch functions
1.66		Winch 6

Position	Icon	Touch display TE1 menu "Block winch" touch functions
1.67		Winch 3 is blocked

## 13.4 Master switch MS2

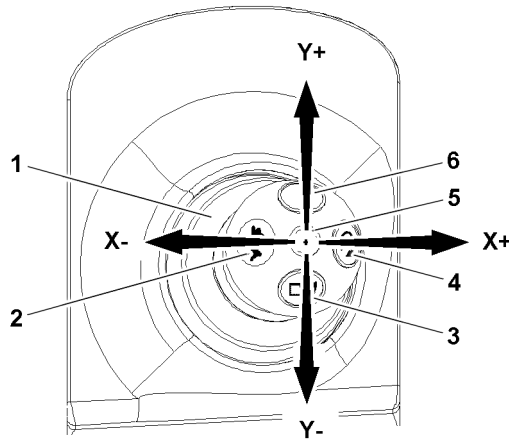


Fig.151493: Master switch MS2 assignment



### WARNING

Change of master switch assignment!

The assignment of the master switches to the respective units on the crane can change, depending on the set up configuration and winch application.

- ▶ Select the correct master switch assignment.
- ▶ Check the assignment before actuating the master switch on the TE.

- 1 Master switch MS2
  - The functions for the master switch MS2 depend on the set up configuration and the selected master switch assignment on the touch display TE2.
- 2 Button
  - “Power Plus” activation, crane operation
- 3 Button
  - Horn



### Note

- ▶ Pressing the button 4 will lock the engine regulation in the current position.

- 4 Button
  - Locking the engine regulation of the superstructure engine  
The idling speed can be increased up to the maximum rpm.
  - Can be “overridden” by the engine regulation (gas pedal).
  - With continued actuation of the engine regulation (gas pedal), the current rpm is taken over.
  - By pressing the button 4 with the engine regulation (gas pedal) **NOT actuated**, the manual throttle is cancelled.
  - If the engine rpm is locked, a “+” appears on the LICCON monitor on the “dynamic engine rpm display” (travel operation) and the “dynamic load utilization bar display” (crane operation).
  - Delete the lock by touching the gas pedal momentarily.
- 5 Vibration sensor
  - Turn sensor and winches
- 6 Button
  - Bypass of the seat contact button
  - **Or:** When the seat contact button is actuated: Activation of the vibration sensor 5

## 13.5 Touch display TE2

### 13.5.1 Touch display TE2 function buttons

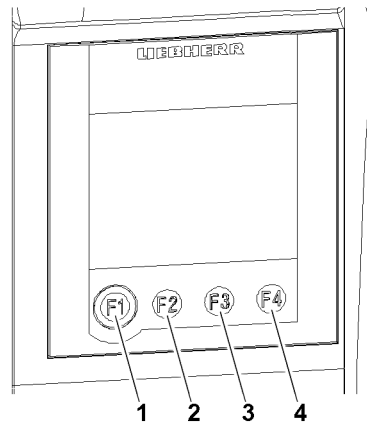


Fig.151495: Touch display TE2 assignment

Operating the touch display, see the Crane operating instructions, chapter 4.01.10.

- 1 F1 key
  - You can change to the next menu in this sequence:
    - “Floodlight” menu
    - “Hydraulic oil preheating / DPF filter” menu
- 2 F2 key
  - On the touch display TE2 main menu, no function
- 3 F3 key
  - Open / close the slewing gear brake
  - or**
  - Ballast automatic off / on
- 4 F4 key
  - Spool the assembly winch out / up
  - Luffing in with suspended load (icon **2.13**), see Crane operating instructions, chapter 4.20


### 13.5.2 TE2 touch display main menu: Functions and assignment


Position	Icon	Touch display TE2 assignment
2.01		Display of the master switch with deflection directions: Icon visible in the main menu on every touch display


#### TE2 touch display main menu: Touch functions

Position	Icon	Touch display TE2 main menu assignment: Touch functions
2.10		Spool the assembly winch up


LWE/LR 1800-1-0-000/27200-07-02/en


Position	Icon	Touch display TE2 main menu assignment: Touch functions
2.11		Spool the assembly winch out


Position	Icon	Touch display TE2 main menu assignment: Touch functions
2.12		Spool the assembly winch up constantly


Position	Icon	Touch display TE2 main menu assignment: Touch functions
2.13	LMB 	Luff in with a suspended load



#### TE2 touch display main menu: Winch assignment

Position	Icon	Touch display TE2 main menu assignment: Winches
2.20		Spool winch 2 up


Position	Icon	Touch display TE2 main menu assignment: Winches
2.21		Spool winch 2 out; display of maximum winch speed as a percentage


Position	Icon	Touch display TE2 main menu assignment: Winches
2.22		Spool winch 6 up


Position	Icon	Touch display TE2 main menu assignment: Winches
2.23		Spool winch 6 out; display of maximum winch speed as a percentage


Position	Icon	Touch display TE2 main menu assignment: Winches
2.24	Note:	If a winch is blocked, the “spool winch up” and “spool winch out” functions can <b>NOT</b> be carried out!
	 	Winch 2 is blocked


**TE2 touch display main menu: Slewing gear and equipment assignment**

Position	Icon	Touch display TE2 main menu assignment: Slewing gear / equipment
2.30		Turn the slewing gear to the left


Position	Icon	Touch display TE2 main menu assignment: Slewing gear / equipment
2.31		Turn the slewing gear to the right, display of maximum slewing gear speed as a percentage


Position	Icon	Touch display TE2 main menu assignment: Slewing gear / equipment
2.32		The slewing gear brake is released


Position	Icon	Touch display TE2 main menu assignment: Slewing gear / equipment
2.33		The slewing gear brake is applied


Position	Icon	Touch display TE2 main menu assignment: Slewing gear / equipment
2.35		Ballast automatic can be turned off

LWE/LR 1800-1-0-000/27200-07-02/en

Position	Icon	Touch display TE2 main menu assignment: Slewing gear / equipment
2.36		Extend the assembly cylinder

Position	Icon	Touch display TE2 main menu assignment: Slewing gear / equipment
2.37		Retract the assembly cylinder

Position	Icon	Touch display TE2 main menu assignment: Slewing gear / equipment
2.38		Increase the derrick ballast boom radius: The derrick ballast guide extends

Position	Icon	Touch display TE2 main menu assignment: Slewing gear / equipment
2.39		Decrease the derrick ballast boom radius: The derrick ballast guide retracts

### 13.5.3 Touch display TE2 “floodlight” menu

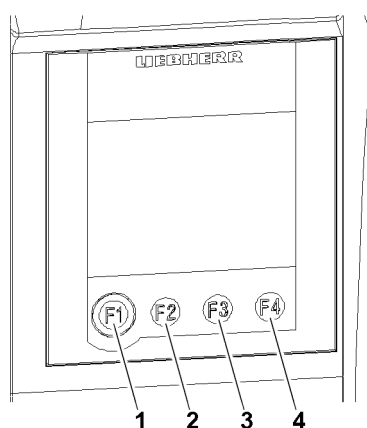


Fig.151495: Touch display TE2 assignment



#### Note

- ▶ The floodlight on the S-pivot section is assembled together with the zoom camera on one control drive.
- ▶ The alignment and the adjustment of the working floodlight transfers automatically to the zoom camera.
- ▶ Functions of the zoom camera, see section “Control unit camera monitoring”



In the floodlight menu, the crane driver has the opportunity to manually align the floodlight to suit the current load or the planned working range. In crane operation, the previously aligned floodlight changes its position according to the movement direction of the load (load-following) or the working range (fixed to working range).




#### Note


- ▶ The floodlight menu is only available if the floodlight is installed and connected.
- ▶ “Touching” a touch function activates the function.
- ▶ Only an activated function can be turned on or off with the F4 key 4.
- ▶ The touch display changes 20 seconds after the last button actuation in the main menu.

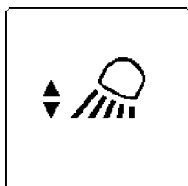
#### Touch display TE2 “floodlight” menu: Function key assignment

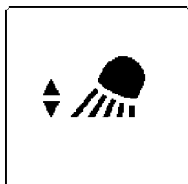
- 1 F1 key
  - Switch to the next menu
- 2 F2 key
  - **No** function
- 3 F3 key
  - One hook position: **without** function
  - From two hook positions: Select the hook position
- 4 F4 key
  - Turn the floodlight on / off

#### Touch display TE2 “floodlight” menu: Assignment

Position	Icon	TE “Working floodlight” menu assignment
2.50		Turn the floodlight on / off.

Position	Icon	TE “Working floodlight” menu assignment
2.51		From two hook positions: Select the hook position.


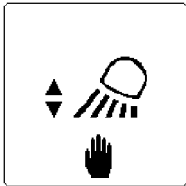
Position	Icon	TE “Working floodlight” menu assignment
2.52		Status display: The status display shows the different icons, depending on the selected function. This example shows the working floodlights turned off.


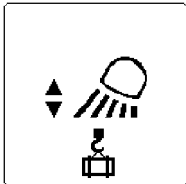
Position	Icon	TE “Working floodlight” menu assignment
2.53		Status display: The status display shows the different icons, depending on the selected function. This example shows the working floodlights turned on.


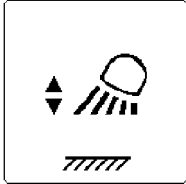
## Touch display TE2 “floodlight” menu: Touch functions

**Note**

- ▶ Before the desired operating mode of the floodlight is selected, set the initial position of the floodlight manually.
- ▶ Set the initial position: In the “Manual floodlight” operating mode, deflect master switch MS2 in direction Y+ or Y-.

Position	Icon	TE “Working floodlight” menu touch functions	Status display
2.54		Align the working floodlight “manually”.	

Position	Icon	TE “Working floodlight” menu touch functions	Status display
2.55		Set working floodlight “following the load” (icon shows sample setting for load position 5).	

Position	Icon	TE “Working floodlight” menu touch functions	Status display
2.56		Set working floodlight “fixed to working range”.	

### 13.5.4 Touch display TE2 “Hydraulic oil preheating / DPF filter” menu

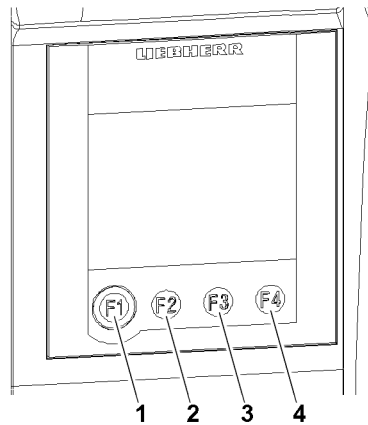


Fig.151495: Touch display TE2 assignment



**Note**

- ▶ “Touching” a touch function activates the function.
- ▶ Only an activated function can be turned on or off with the F4 key 4.
- ▶ The touch display changes 20 seconds after the last button actuation in the main menu.

**Touch display TE2 “Hydraulic oil preheating / DPF filter” menu: Function key assignment**

- 1 F1 key
  - Switch to the next menu
- 2 F2 key
  - **No** function
- 3 F3 key
  - **No** function
- 4 F4 key
  - Turn function on / off


**Touch display TE2 “Hydraulic oil preheating / DPF filter” menu: Assignment**


Position	Icon	TE “Hydraulic oil preheating / DPF filter” menu assignment
2.60		Turn selected function on / off

**Touch display TE2 “Hydraulic oil preheating / DPF filter” menu: Touch functions**

Position	Icon	TE “Hydraulic oil preheating / DPF filter” menu touch functions
2.65		Select / deselect <i>Hydraulic oil preheating</i> function

LWE/LR 1800-1-0-000/27200-07-02/en

Position	Icon	TE “Hydraulic oil preheating / DPF filter” menu touch functions
2.66		Select / deselect <i>Regeneration at a standstill of the diesel particle filter</i> function

Position	Icon	TE “Hydraulic oil preheating / DPF filter” menu touch functions
2.67		Select / deselect <i>Disable diesel particle filter regeneration at a standstill</i> function

## 14 Instrument panel

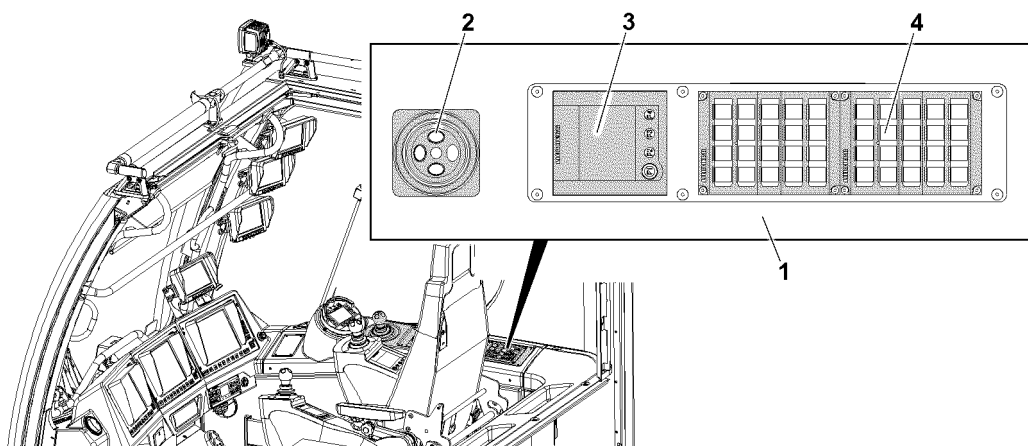


Fig.151497: Instrument panel operating elements

The instrument panel 1 consists of the following elements:

- 2 Master switch MS3
- 3 Touch display TE3
- 4 Keypad
  - Indicator lights and operating buttons

## 14.1 Master switch MS3

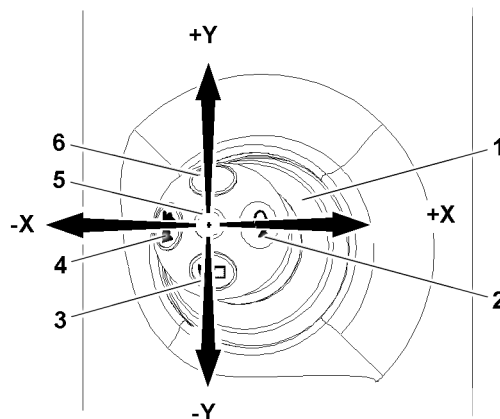


Fig.151499: Master switch MS3 assignment



### WARNING

Change of master switch assignment!

The assignment of the master switches to the respective units on the crane can change, depending on the set up configuration and winch application.

- ▶ Select the correct master switch assignment.



### Note

- ▶ For description of the functions of the master switches, see the Crane operating instructions, chapter 4.05.

#### 1 Master switch MS3



### Note

- ▶ Pressing the button **2** will lock the engine regulation in the current position.

#### 2 Button

- Locking the engine regulation of the superstructure engine  
The idling speed can be increased up to the maximum rpm.
- Can be “overridden” by the engine regulation (gas pedal).
- With continued actuation of the engine regulation (gas pedal), the current rpm is taken over.
- By pressing the button **4** with the engine regulation (gas pedal) **NOT actuated**, the manual throttle is cancelled.
- If the engine rpm is locked, a “+” appears on the LICCON monitor on the “dynamic engine rpm display” (travel operation) and the “dynamic load utilization bar display” (crane operation).
- Delete the lock by touching the gas pedal momentarily.

#### 3 Button

- Horn

#### 4 Button

- “Power Plus” activation, crane operation

#### 5 Vibration sensor

- Turn sensor and winches

#### 6 Button

- Bypass of the seat contact button
- **Or:** When the seat contact button is actuated: Activation of the vibration sensor **5**

## 14.2 Touch display TE3

### 14.2.1 Touch display TE3 function buttons

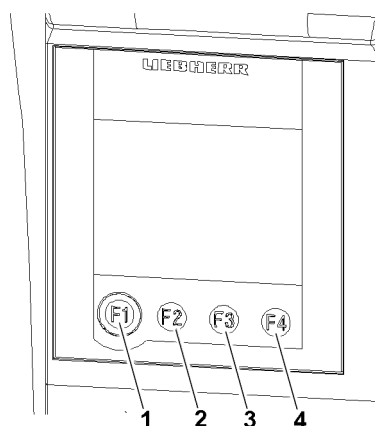


Fig.151496: Touch display TE3 assignment

- 1 F1 key
  - Change to the Automatic selection menu
- 2 F2 key
  - No function on TE3
- 3 F3 key
  - Derrick ballast operation on master switch on / off



#### WARNING


Incorrect travel direction!



When the crawler operation icon travel direction is incorrectly interpreted, the crane moves into the wrong direction! Danger of accident!

► Before driving the crawler, make sure that the travel gear moves in the expected direction!



- 4 F4 key
  - TE3 main menu: Crawlers retract / extend
  - Automatic selection menu: Automatic on / off



### 14.2.2 TE3 touch display main menu: Functions and assignment



Position	Icon	TE3 assignment
3.01		Display of the master switch with deflection directions: Continuously visible icon on every touch display with active master switch assignment

Position	Icon	TE3 assignment: Derrick ballast operation function via master switch
3.02		Turn on derrick ballast operation via master switch <b>Note:</b> Switching takes place through function key <b>F3</b> , operation takes place through master switch MS1 and master switch MS2
3.03		Turn off derrick ballast operation via master switch <b>Note:</b> Switching takes place through function key <b>F3</b>


### 14.2.3 Touch display TE3 “Drive crawler” menu: Touch functions


Position	Icon	TE3 main menu: Touch functions
3.10		Drive crawler, crawler operation deactivated
		Drive crawler, crawler operation activated, icon blinks


Position	Icon	TE3 main menu: Touch functions
3.11		Drive crawler, rapid gear deactivated
		Drive crawler, rapid gear activated, icon blinks


Position	Icon	TE3 main menu: Touch functions
3.12		Drive crawler, parallel operation deactivated
		Drive crawler, parallel operation activated, icon blinks


### 14.2.4 TE3 touch display main menu: Winch assignment

Position	Icon	TE3 main menu: Winch assignment
3.20		Not available on all crane types: Spool winch 5 out; display of maximum winch speed as a percentage


Position	Icon	TE3 main menu: Winch assignment
3.21		Not available on all crane types: Spool winch 5 up


Position	Icon	TE3 main menu: Winch assignment
3.22		Spool winch 6 out; display of maximum winch speed as a percentage


Position	Icon	TE3 main menu: Winch assignment
3.23		Spool winch 6 up

Position	Icon	TE3 main menu: Winch assignment
3.24		<b>Note:</b> If a winch is blocked, the “spool winch up” and “spool winch out” functions can <b>NOT</b> be carried out!
		Winch 6 blocked


#### 14.2.5 TE3 touch display main menu: Boom and equipment assignment


Position	Icon	TE3 main menu: Boom and equipment assignment
3.30		Luff SW – luffing jib up


Position	Icon	TE3 main menu: Boom and equipment assignment
3.31		Luff SW – luffing jib down; display of maximum winch speed as a percentage


Position	Icon	TE3 main menu: Boom and equipment assignment
3.32		Luff SW – main boom up





Position	Icon	TE3 main menu: Boom and equipment assignment
3.33		Luff SW – main boom down; display of maximum winch speed as a percentage


Position	Icon	TE3 main menu: Boom and equipment assignment
3.34		Luff SD – derrick boom up


Position	Icon	TE3 main menu: Boom and equipment assignment
3.35		Luff SD – derrick boom down; display of maximum winch speed as a percentage

Position	Icon	TE3 main menu: Boom and equipment assignment
3.36		Luff SDW – luffing jib up

Position	Icon	TE3 main menu: Boom and equipment assignment
3.37		Luff SDW – luffing jib down; display of maximum winch speed as a percentage


Position	Icon	TE3 main menu: Boom and equipment assignment
3.38		Luff SDW – derrick boom up


Position	Icon	TE3 main menu: Boom and equipment assignment
3.39		Luff SDW – derrick boom down; display of maximum winch speed as a percentage


Position	Icon	TE3 main menu: Boom and equipment assignment
3.40	<b>Note:</b> If a crane movement is blocked, the “luffing up” and “luffing down” functions can <b>NOT</b> be carried out!	
		Boom and equipment: Crane movement is blocked, example SDW, “luff up derrick boom” and “luff down derrick boom” can <b>NOT</b> be carried out.


LWE/LR 1800-1-0-000/27200-07-02/en

### 14.2.6 TE3 touch display main menu: Ballast trailer support assignment

Position	Icon	TE3 main menu: Ballast trailer support assignment
3.50		Extend the support ballast trailer at the front and at the rear. Support the ballast trailer.


Position	Icon	TE3 main menu: Ballast trailer support assignment
3.51		Retract the support ballast trailer at the front and at the rear. Lower the ballast trailer on the wheels.

Position	Icon	TE3 main menu: Ballast trailer support assignment
3.52		Support cylinder blocked at the front.





Position	Icon	TE3 main menu: Ballast trailer support assignment
3.53		Support cylinder blocked at the rear.





### 14.2.7 Touch display TE3 automatic programs menu

#### Touch display TE3 automatic programs menu: Assignment





Position	Icon	TE3 ballast automatic menu: Automatic program on / off
3.60		Selected automatic program on / off

**Touch display TE3 automatic programs menu: Touch functions**


Position	Icon	TE3 ballast automatic menu: <i>Ballast trailer ballast automatic</i>
3.61		<i>Ballast trailer ballast automatic not selected and turned off</i>
		<i>Ballast trailer ballast automatic not selected and turned on</i>
		<i>Ballast trailer ballast automatic selected, turned off and can be turned on</i>
		<i>Ballast trailer ballast automatic selected, turned on and can be turned off</i>
<p><b>Note:</b> When turning the ballast automatic on, a saved value (current F1-force and / or ballast trailer incline) is set. As soon as the ballast trailer guide is adjusted, the ballast automatic controls the pull cylinder to regulate that the actual value is maintained with respect to the saved value (situation dependent F1-force or ballast trailer incline).</p>		


Position	Icon	TE3 ballast automatic menu: <i>Suspended ballast guide adjustment ballast automatic</i>
3.62		<i>Suspended ballast guide adjustment ballast automatic not selected and turned off</i>
		<i>Suspended ballast guide adjustment ballast automatic not selected and turned on</i>
		<i>Suspended ballast guide adjustment ballast automatic selected, turned off and can be turned on</i>
		<i>Suspended ballast guide adjustment ballast automatic selected, turned on and can be turned off</i>
<p><b>Note:</b> When turning the ballast automatic on, a saved value (calculated current height difference of the suspended ballast with respect to the crane placement surface) is set. As soon as the suspended ballast guide is adjusted, the ballast automatic controls the activated pull cylinder to regulate that the actual value is maintained with respect to the saved value.</p>		


LWE/LR 1800-1-0-000/27200-07-02/en


Position	Icon	TE3 ballast automatic menu: <i>Suspended ballast derrick adjustment</i> ballast automatic
3.63		<i>Suspended ballast derrick adjustment</i> ballast automatic not selected and turned off
		<i>Suspended ballast derrick adjustment</i> ballast automatic not selected and turned on
		<i>Suspended ballast derrick adjustment</i> ballast automatic selected, turned off and can be turned on
		<i>Suspended ballast derrick adjustment</i> ballast automatic selected, turned on and can be turned off
<p><b>Note:</b> When turning the ballast automatic on, a saved value (calculated current height difference of the suspended ballast with respect to the crane placement surface) is set. As soon as the derrick boom is adjusted, the ballast automatic controls the activated pull cylinder to regulate that the actual value is maintained with respect to the saved value.</p>		


## 14.3 Keypad


Position	Operating element	Function	LED	Description
1	 Lift the derrick ballast	Off		Releasing the button interrupts the movement
		On		Pressing and holding the button lifts the derrick ballast


Position	Operating element	Function	LED	Description
2	 Lower the derrick ballast	Off		Releasing the button interrupts the movement
		On		Pressing and holding the button lowers the derrick ballast

Position	Operating element	Function	LED	Description
3	 Block derrick ballast - pull cylinder <b>A</b>	Off		Releasing the button releases the pull cylinder <b>A</b> on the derrick ballast
		On		Pressing and holding the button blocks the pull cylinder <b>A</b> on the derrick ballast

Position	Operating element	Function	LED	Description
4	 Block derrick ballast - pull cylinder <b>B</b>	Off		Releasing the button releases the pull cylinder <b>B</b> on the derrick ballast
		On		Pressing and holding the button blocks the pull cylinder <b>B</b> on the derrick ballast


Position	Operating element	Function	LED	Description
5	 Retract the derrick ballast guide	Off		Releasing the button interrupts the movement
		On		Pressing and holding the button retracts the derrick ballast


Position	Operating element	Function	LED	Description
6	 Extend the derrick ballast guide	Off		Releasing the button interrupts the movement
		On		Pressing and holding the button extends the derrick ballast.


Position	Operating element	Function	Beacon	Description
7	 Derrick ballast lifted <sup>1)</sup>	Off	Off	By pressing the operating button
		On <sup>2)</sup>	On	<b>Note:</b> Function only for derrick ballast versions without ground contact monitoring


1) For a detailed description see the Crane operating instructions, chapter 5.35.


2) If the *Derrick ballast lifted* operating button is pressed, the derrick ballast is shown lifted up in the LICCON monitor, see the Crane operating instructions, chapter 4.02.


Position	Operating element	Function	Beacon	Description
8	 Crane cab ladder up operating button	Up	–	By pressing the operating button
				<b>Note:</b> As long as the operating button is pressed, the ladder moves up until the upper end position of the ladder is reached.


Position	Operating element	Function	Beacon	Description
9	 Crane cab ladder down operating button	Down	–	By pressing the operating button
				<b>Note:</b> As long as the operating button is pressed, the ladder moves down until the lower end position of the ladder is reached.


Position	Operating element	Function	Beacon	Description
10	  Winch gear oil level measurement operating button	On	–	Oil levels of all installed winches are checked. If the oil fill level is too low on one winch, then this is shown in the respective winch icon. The display remains active until the oil level sensor reports a correct fill level.  <b>NOTICE!:</b> Property damage! If a winch is actuated when the “oil fill level is too low” then there is <b>no</b> shut-off of the winch movement. An operating error message appears.


Position	Operating element	Function	LED	Description
11	  Retract the front ballast trailer support cylinder	Off		Releasing the button interrupts the movement
		On		Press and hold the button: Support cylinder retracts in the front


Position	Operating element	Function	LED	Description
12	  Extend the front ballast trailer support cylinder	Off		Releasing the button interrupts the movement
		On		Press and hold the button: Support cylinder extends in the front


Position	Operating element	Function	LED	Description
13	  Retract the rear ballast trailer support cylinder	Off		Releasing the button interrupts the movement
		On		Press and hold the button: Support cylinder retracts in the rear


Position	Operating element	Function	LED	Description
14	  Extend the rear ballast trailer support cylinder	Off		Releasing the button interrupts the movement
		On		Press and hold the button: Support cylinder extends in the rear


Position	Operating element	Function	LED	Description
15	  Ballast trailer circular travel	On	Blinks	Press and hold the button: Turn the wheels sets into Circular driving position
			Lights up	The wheel sets are in the Circular driving position

Position	Operating element	Function	LED	Description
16	 Ballast trailer towing	On	Blinks	Press and hold the button: Sets the wheel sets into Towing position
			Lights up	The wheel sets are in the Towing position

Position	Operating element	Function	LED	Description
17	 Parallel travel ballast trailer	On	Blinks	Press and hold the button: Turn the wheels sets into Parallel driving position
			Lights up	The wheel sets are in the Parallel driving position

Position	Operating element	Function	LED	Description
18	 Manual steering correction to the left	On	Lights up	Operating mode Manual steering correction: When pressing and holding the button, the wheel sets turn to the left to drive in tight construction sites.

Position	Operating element	Function	LED	Description
19	 Manual steering correction to the right	On	Lights up	Operating mode Manual steering correction: When pressing and holding the button, the wheel sets turn to the right to drive in tight construction sites

Position	Operating element	Function	Beacon	Description
20	 Ballast trailer drive switch	On	On	By actuating the switch: Drive for ballast trailer is added See the Crane operating instructions, chapter 5.35
		Off	Off	By actuating the switch: Drive for ballast trailer is turned off

## 14.4 Indicator lights



### Note


- ▶ The “Urea” indicator light **1** is only available on engines which are equipped with a SCR exhaust aftertreatment system.
- ▶ If a warning occurrence is present, the indicator light lights up or blinks and a signal sounds.

**WARNING**

Insufficient Urea in the Urea reservoir or faulty function in the SCR exhaust aftertreatment system!  
Due to insufficient Urea level or faulty function in the SCR system, a reduction in engine power can be activated by the engine control or a start block of the engine can be triggered.


The crane operation can be limited.

- ▶ Add missing Urea in the Urea reservoir in time.
- ▶ Remedy faulty function in the SCR system immediately.
- ▶ Observe the national / regional regulations valid on the job site.

Position	Indicator light	Function	LED	Description
1	 Urea		Off	Urea is available
			Statically on	Urea is getting low or faulty function of the exhaust aftertreatment
			<b>Note:</b>	Add urea or remedy the malfunction of the exhaust aftertreatment.
			Blinks	Urea almost empty or faulty function of the exhaust aftertreatment
			<b>Note:</b>	Add urea immediately or remedy the faulty function of the exhaust aftertreatment.

**Note**

- ▶ The “SCR exhaust aftertreatment” indicator light **2** is only available on engines which are equipped with a SCR exhaust aftertreatment system.
- ▶ If a warning occurrence is present, the indicator light lights up or blinks and a signal sounds.

Position	Indicator light	Function	LED	Description
2	 Exhaust aftertreatment		Off	Exhaust aftertreatment is OK
			Blinks	Advance warning: Exhaust aftertreatment
			Statically on	Exhaust aftertreatment is no longer ensured



# 15 Side panel

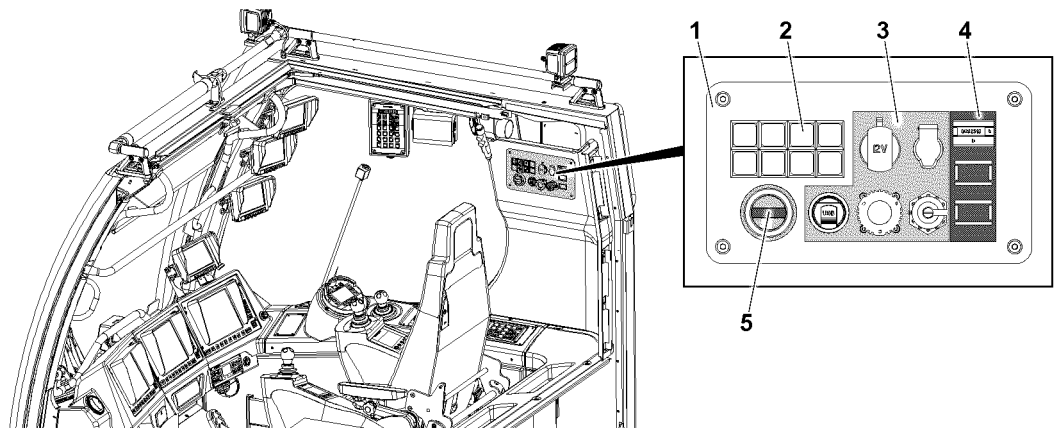


Fig.151926: Side panel assignment


The side panel 1 consists of the following elements:

- 2 Keypad
  - Indicator lights and operating buttons
- 3 Sockets
- 4 Operating hour meter



Up to three operating hour meters can be present

- Diesel engine operating hour meter
- Winch W1 operating hour meter
- Winch W2 operating hour meter
- 5 Air heater\*


## 15.1 Keypad


Position	Indicator light	Function	LED	Description
1	 Request engine stop		<b>Note:</b>	Pay attention to the system error, remedy the cause of the error immediately, turn the engine off if necessary.
			Lights up or blinks	In case of a warning occurrence

LWE/LR 1800-1-0-000/27200-07-02/en

Position	Operating element	Function	LED	Description
2	 Boom on ground indicator light	–	Lights up	Boom on ground function is active
		–	Off	Boom on ground function is inactive
3	 Boom on ground key button <sup>1)</sup>	On	–	Turn on by pressing the on key button - the boom on ground function is active, the boom on ground indicator light lights up
		Off	–	Turn off by pressing the off key button - the boom on ground function is inactive, the boom on ground indicator light turns off

1) For a supplementary description, see chapter 4.20


Position	Operating element	Function	LED	Description
4	 Mirror heater	On	Lights up	By pressing the button
		Off	Off	By pressing the button


Position	Operating element	Function	LED	Description
5	 Remote diagnostics module (GSM module)*	On	Lights up	By pressing the button
		Off	Off	By pressing the button


## 15.2 Sockets

Sockets, see section “Interfaces”

## 15.3 Operating hour meter

Position	Operating element	Description
1	 Operating hour meter	Diesel engine operating hours display

Position	Operating element	Description
2	 Operating hour meter*	Winch W1 operating hours display

Position	Operating element	Description
3	 Operating hour meter*	Winch W2 operating hours display

### 15.4 Air heater\*

For description of the air heater\*, see the documentation from the manufacturer.




**WARNING**

Danger of explosion!

Death. Severe bodily injuries. Property damage.

► For the maintenance and safety instructions for the air heater\*, see the documentation from the manufacturer.

Position	Operating element	Function	LED	Description
1	 Air heater* rotary switch	On	Lights up	Turn on by pressing the rotary switch
		Off	Off	Turn off by pressing the rotary switch
		Error	Blinks	Error / problem

## 16 Turntable control units

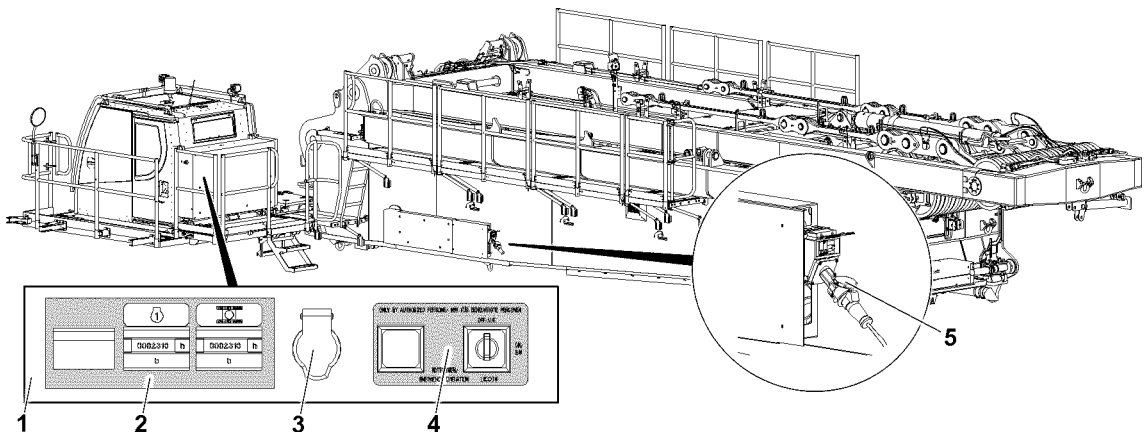


Fig.151929: Control cabinet panel and control unit operating element external power supply assignment

The following control units are on the turntable:

- 1 Control cabinet panel
- 5 External power supply

The control cabinet panel 1 consists of the following elements:

- 2 Operating hour meter
- 3 Interface
- 4 Keypad
  - Key switch

LWE/LR 1800-1-0-000/27200-07-02/en

## 17 Crawler travel gear control units

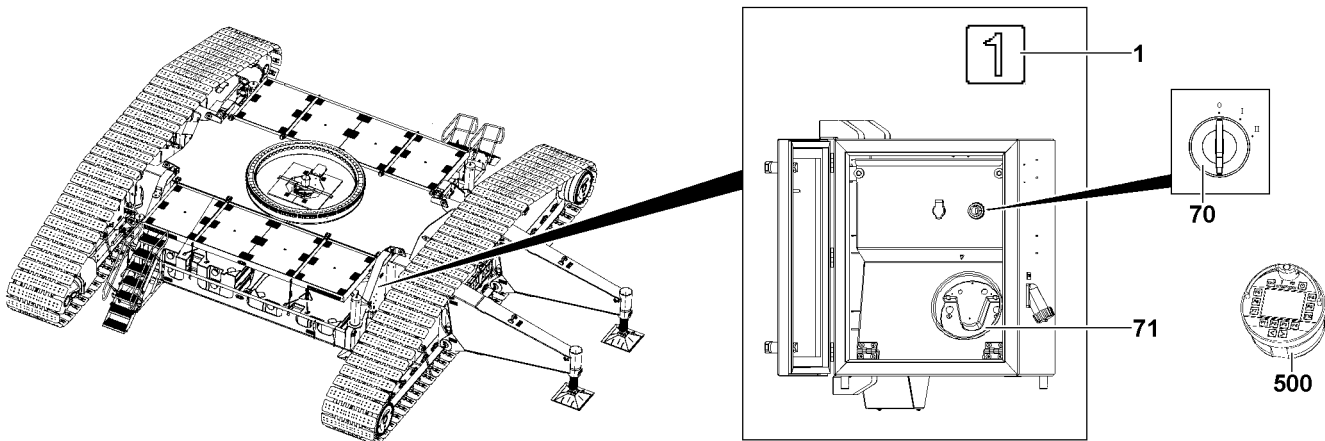


Fig.153752: Radio remote control operation: Crawler travel gear operating and control instruments

The control cabinet with the crawler travel gear control units is located on the right side of the rear central ballast bracket below the sign 1.

### 70 Crawler travel gear ignition switch

- There is an additional ignition switch in the crane cab. If the crawler travel gear and turntable are electrically connected, both ignition switches must be turned on in order to turn on the ignition. To turn off the ignition, turning off one ignition switch is sufficient (series connection).

### 71 Crawler travel gear charging cradle

- For the automatic registration of the BTT on the crawler travel gear, the BTT must be in the *crawler travel gear* charging cradle when the ignition is turned on by the *crawler travel gear* ignition switch 70
- To recharge the rechargeable battery, the BTT 500 must be plugged into a charging cradle:
  - Crane cab charging cradle
  - Crawler travel gear charging cradle




### Note


- ▶ For a detailed description of the BTT, see chapter 5.31.
- ▶ For a detailed description of the BTT in connection with the radio remote control console, see chapter 6.08.

## 18 Control cabinet panel


### 18.1 Operating hour meter

Assignment according to signs, for example additional display of diesel engine operating hours.


Position	Operating element	Description
1	 Operating hour meter*	Diesel engine operating hours display  <b>Note:</b> Can also be installed in the crane cab.

Position	Operating element	Description
2	 Operating hour meter	Crawler operating hours display

## 18.2 Interface

Position	Operating element	Description
1	 Socket	24 V

## 18.3 Keypad

Position	Operating element	Function	LED	Description
1	 Key switch LMB emergency operation	On		By actuating the switch
		Off		By actuating the switch


## 19 External power supply



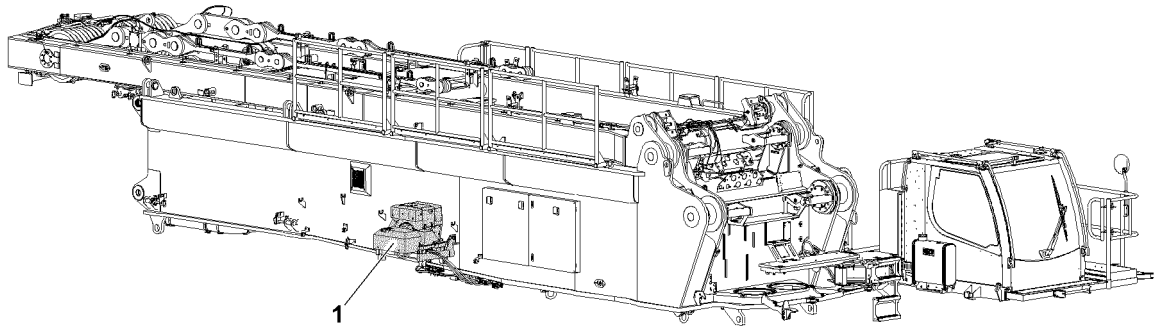
### WARNING

Danger of fatal injury due to electric shock!  
 Death. Severe bodily injuries. Property damage.

► Safety instructions for the external power supply, see chapter 2.04.

Position	Operating element	Description
1	 Socket	External power supply 110 V / 230 V

## 20 Drive assembly air conditioning system\*



*Fig.151930: Drive assembly air conditioning system\**

For a description of the drive assembly air conditioning system\* 1, see chapter 5.72.

## 4.01.10 Touch display menu operation

1	Touch display	2
2	Operating variations	2

# 1 Touch display

The touch displays are combined display and operating elements.

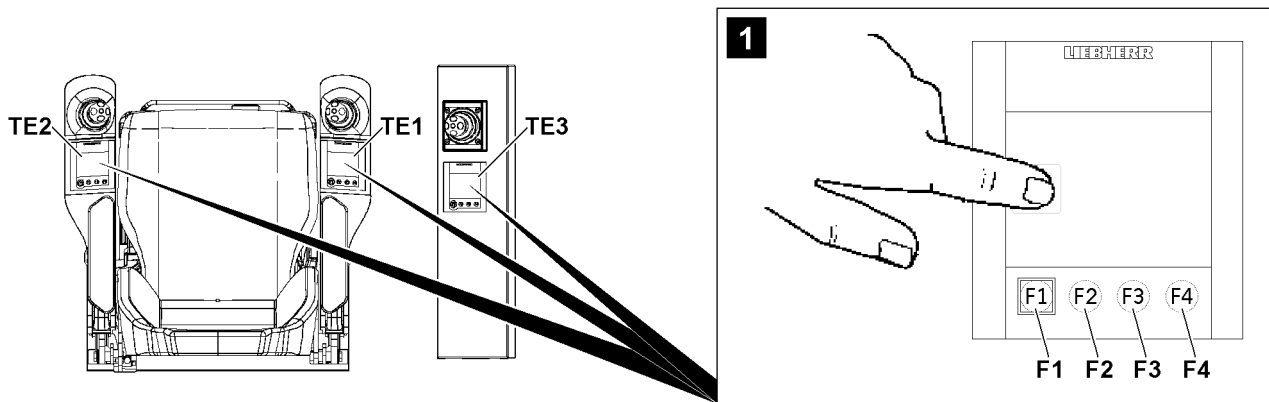


Fig.156276: F-keys on the touch display

Various menus are opened using the touch display **TE1**, touch display **TE2** and touch display **TE3**.

In these menus, various crane functions are:

- selected
- deselected
- turned on
- turned off
- directly controlled

The touch display is operated using the F-keys **F1-F4** and the touch functions.

The touch functions are performed by pressing the corresponding icon with a finger tip, see illustration 1.

## 2 Operating variations

Depending on the function, operation takes place using one of the following variations:

- Operating the function with the F-keys
- Operating the function using the touch function
- Select the function using the touch function and then operate using the F-keys

### 2.1 Operating the function with the F-keys

In this section, the variation is explained using the *close the slewing gear brake* function.

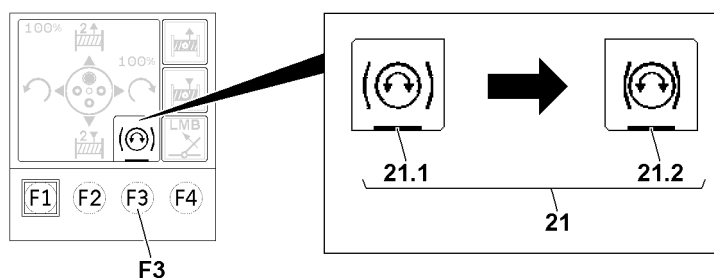


Fig.156272: Example: Closing the slewing gear brake

Make sure that the following prerequisite is met:

- The corresponding display is shown on the touch display.



- ▶ Press the F key **F3**

**Result:**

- The display of the *slewing gear brake* icon **21** changes from *slewing gear brake open 21.1* to *slewing gear brake closed 21.2*.
- Close the slewing gear brake is set.

## 2.2 Operating the function using the touch function

In this section, the variation is explained using the a function for the setting of the floodlight.

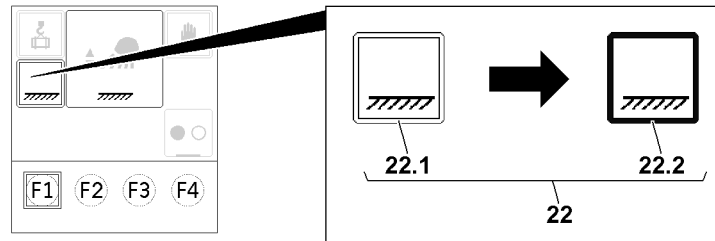


Fig.156273: Example: Adjusting the floodlight

Make sure that the following prerequisite is met:

- The corresponding display is shown on the touch display.

- ▶ Tap the *illuminate the work area* icon **22**.

**Result:**

- The frame around the *illuminate the work area* icon **22** switches from an empty frame **22.1** to a filled frame **22.2**.
- The illuminate the work area setting is selected.

## 2.3 Select the function using the touch function and then operate using the F-keys

In this section, the two different operating sequences of the variation is explained.

- Operating sequence 1: Example based on the *turning the hydraulic oil preheating on* function
- Operating sequence 2: Example based on the *spool the assembly winch up* function

### 2.3.1 Operating sequence 1

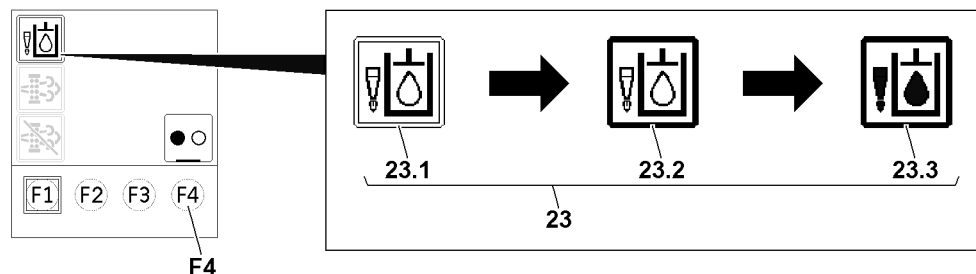


Fig.156274: Operating sequence 1: Example based on the turning the hydraulic oil preheating on function

Make sure that the following prerequisite is met:

- The corresponding display is shown on the touch display.

- ▶ Tap the hydraulic oil preheating icon **23**.

**Result:**

- The frame around the hydraulic oil preheating icon **23** switches from an empty frame **23.1** to a filled frame **23.2**.
- Hydraulic oil prewarming is preselected.

▶ Press the F key **F4**

**Result:**

- The display of the hydraulic oil preheating icon **23** switches with the filled frame **23.2** to hydraulic oil preheating turned on **23.3**.
- Hydraulic oil preheating is turned on.

### 2.3.2 Operating sequence 2

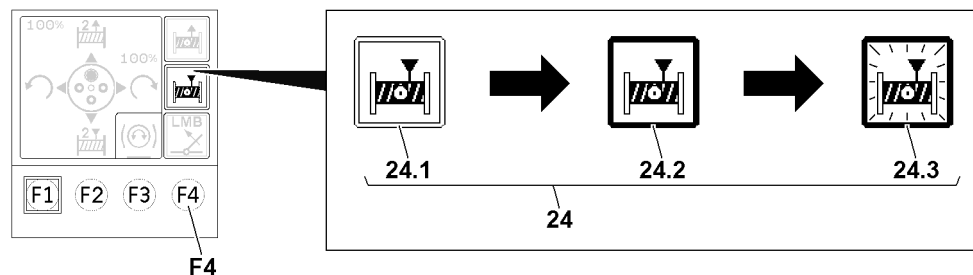


Fig.156275: Operating sequence 2: Example based on the spool the assembly winch up function

Make sure that the following prerequisite is met:

- The corresponding display is shown on the touch display.

▶ Tap the spool the assembly winch up icon **24**.

**Result:**

- The frame of the *spool the assembly winch up* icon **24** switches from an empty frame **24.1** to a filled frame **24.2**.
- *Spool the assembly winch up* is preselected.

▶ Press and hold the F key **F4**.

**Result:**

- The display with the filled frame **24.2** starts to blink **24.3**.
- *The assembly winch spools up*.

## 4.02 LICCON computer system

1	General	2
2	System start of the LICCON computer system	4
3	Operating elements on the LICCON monitors	6
4	<i>Set up</i> program	11
5	The <i>Crane operation</i> program on LICCON monitor 0	77
6	The <i>Crane operation</i> program on LICCON monitor 1	181
7	The <i>Crane operation</i> program on LICCON monitor 2	207
8	<i>Curve illustration</i> program	221
9	<i>Working range limitation</i> program	225
10	Master switch / pedal sensor speed reduction	233
11	Checking the gear oil fill level of the winches	241
12	Power Save mode and Stand-by mode in the LICCON computer system	245

# 1 General



## Note

- ▶ The illustrations, icons and monitor illustrations in this chapter are only examples.
- ▶ The numerical values in the individual icons and charts do not have to necessarily match the crane exactly.
- ▶ Numbers and letters can be replaced by place holders.
- ▶ The display and assignment of the icons can deviate, depending on the set up configuration, operating status and configuration of the crane.
- ▶ In addition, many of the illustrations show the maximum configuration of the LICCON monitor with icons.
- ▶ During crane operation, an identical display will **not** appear on the LICCON monitor.

The LICCON computer system is a computer system for controlling and monitoring mobile and crawler cranes. In addition to the use of overload protection and load bearing capacity display there are a number of application programs that can be used for controlling and monitoring the crane movements.

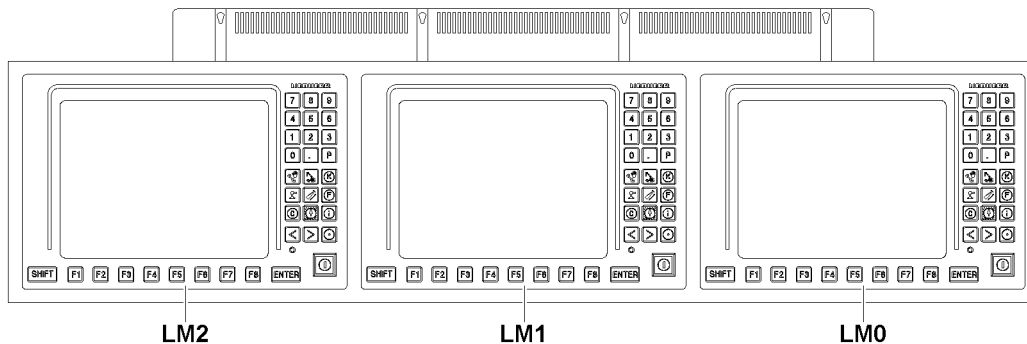


Fig.119921: Three LICCON monitors

The LICCON computer system is visualized among other possibilities via three LICCON monitors:

- **LM0** LICCON monitor 0
  - Located on the right side of the monitor
- **LM1** LICCON monitor 1
  - Located in the center of the monitor
- **LM2** LICCON monitor 2
  - Located on the left side of the monitor



## Note

- ▶ The electrical and electronic components are linked via data bus transmission technology (Liebherr-System-Bus = LSB).

## 1.1 Overload protection

The overload protection includes limiters and displays (for example load capacity displays), which also alert to danger conditions via acoustical and optical warning signals.

The computer controlled part of the overload protection is called the LICCON overload protection. The LICCON overload protection is set by entering the set up configuration in the LICCON computer system.

The LICCON overload protection works, among other possibilities, according to the principle of comparing the current and actual load with the maximum load (also *Maximum load according to the load chart and reeving*) of the crane.

### 1.1.1 Acoustic and optical warning signals

The crane is equipped with acoustical and optical warning device to warn crane operator, auxiliary personnel and any person nearby.

Overview of acoustic / optical warnings, see Crane operating instructions, chapter 4.20.

### 1.1.2 Actual load

The actual load is determined by recording changing dimensions, the set up configuration and situational influences.

The **load on the crane** results from the load momentum, boom momentum as well as environmental and mechanical influences. The occurring moments and forces are measured and processed by the LICCON computer system.

The **load momentum** results from load and boom radius. The load includes load, fastening equipment and hook block / load hook. The boom radius is calculated with aid of the angle sensor information (boom angle) and the length of the boom system. This also takes into account the boom deflection due to its own weight and the weight of the load.

The **boom momentum** is calculated from the length of the boom system, the crane data (boom weights) and angle sensor information (boom angle).

**Environmental and mechanical influences** are recorded, determined and taken into account individually.

### 1.1.3 Maximum load according to the load chart and reeving



#### Note

- The *Maximum load according to load chart and reeving* is also called *Maximum load* in the description.

The crane data such as load charts (also called load capacity charts), boom weights and geometry data is stored in the central data memory of the LICCON computer system.

The *maximum load according to load chart and reeving* value (maximum load) is constantly determined, based on the load charts, for the set up configuration, the set reeving, the calculated boom radius and additional influences.

### 1.1.4 Comparison

The *actual load* value and *maximum load* value are compared. When they approach the specified limit, an advance warning is issued by the overload protection. If this limit is exceeded, the overload protection turns the load moment increasing crane movements off.

## 1.2 Error messages

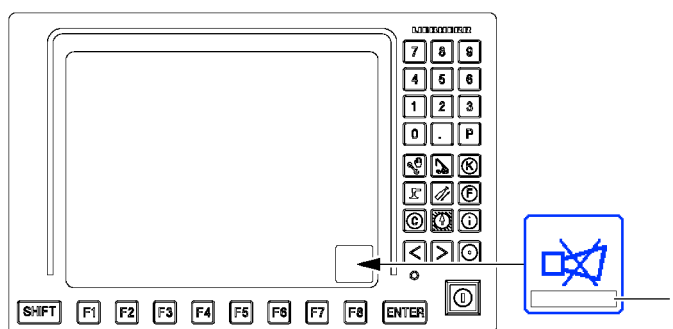


Fig. 119922: Error message display

The LICCON computer system monitors the crane permanently for operating and system errors.

If operating and / or system errors occur, error messages **1** are displayed. Error messages appear in the *Horn* icon of the LICCON monitor.



#### Note

- ▶ Always pay attention to error messages **1**.
- ▶ For procedure in case of error messages, see the Diagnostics manual and the respective chapter in the Crane operating instructions.

## 2 System start of the LICCON computer system

There are two operating modes for the LICCON computer system:

- The LICCON computer system in normal mode (crane engine turned on).
- LICCON computer system in Stand-by mode (crane engine turned off).

Start normal mode:

- System start of LICCON computer system in connection with a started crane engine.

Start Stand-by mode:

- See section “Power-Save mode and Stand-by mode in the LICCON computer system”.

### 2.1 LICCON monitors at system start

After turning the ignition on, the LICCON computer system boots up and carries out a self test.

After successful self test and system start of the LICCON computer system, each LICCON monitor changes to a separate view.



#### Note

If an error is detected during the system start of the LICCON computer system, an error message appears on the LICCON monitor.

- ▶ Consult Liebherr Customer Service if an error occurs during system start.

#### 2.1.1 LICCON monitor 0

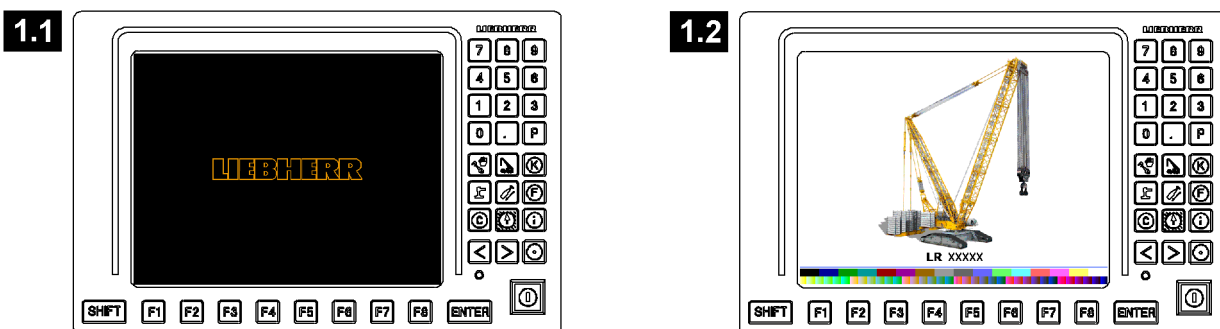


Fig.161581: LICCON Monitor 0 system start

During the self test and system start, the start screen appears, see illustration 1.1.

After a successful starting procedure, a wall paper of the crane appears on **LICCON monitor 0** for a few seconds, see illustration 1.2.

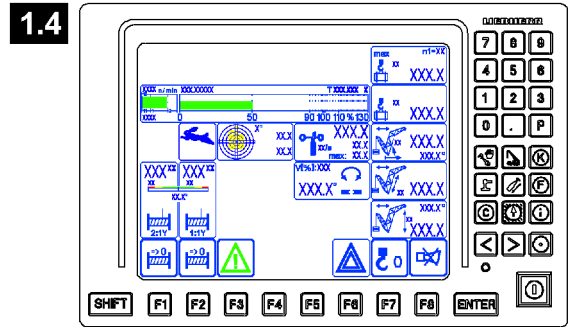
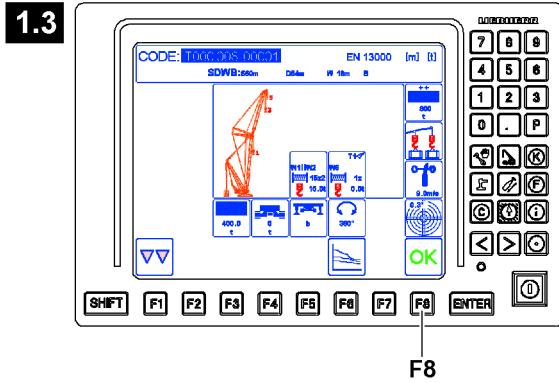


Fig.119936: LICCON monitor 0 system start completed

When the last set up configuration appears (see example illustration 1.3), then system start on LICCON monitor 0 is completed.

The existing set up configuration or a newly entered set up configuration must be confirmed with the function key F8.

Then the Crane operation operating screen appears on the LICCON monitor 0, see illustration 1.4.

### 2.1.2 LICCON monitor 1

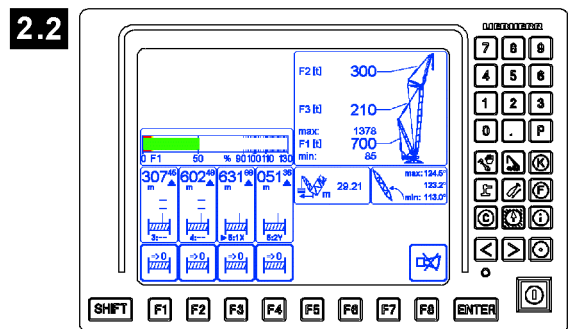
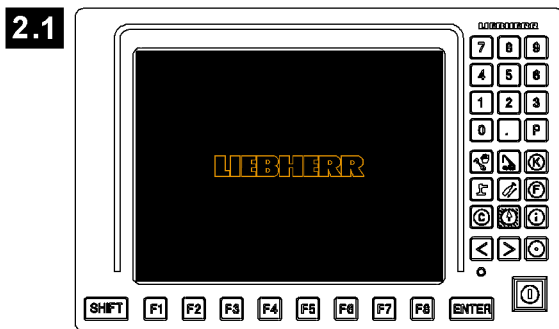


Fig.161582: LICCON Monitor 1 system start

During the self test and system start, the start screen appears, see illustration 2.1.

After a successful starting procedure, the corresponding operating screen appears on LICCON monitor 1, see example illustration 2.2.

### 2.1.3 LICCON monitor 2

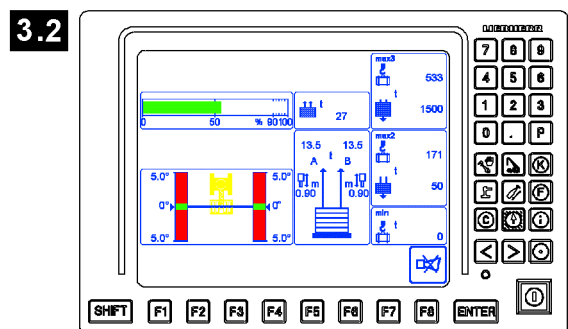
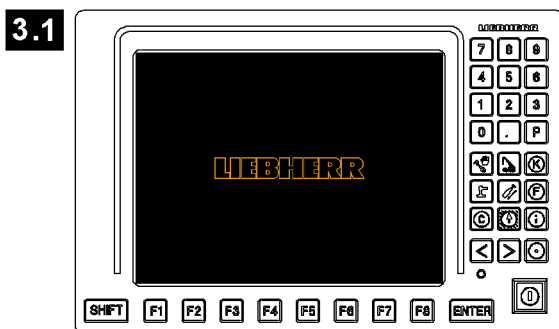


Fig.161583: LICCON monitor 2 system start

During the self test and system start, the start screen appears, see illustration 3.1.

After a successful starting procedure, the corresponding operating screen appears on LICCON monitor 1, see example illustration 3.2.

LWE/LR-1800-1-0-000/27200-07-02/en

### 3 Operating elements on the LICCON monitors

All LICCON monitors are optically the same, the installation location is the deciding factor for the function of the operating elements.

In addition, the functions of the individual monitor operating elements are program-dependent and can differ, depending on the currently running LICCON program. This will be described in more detail in the description of the individual LICCON programs.

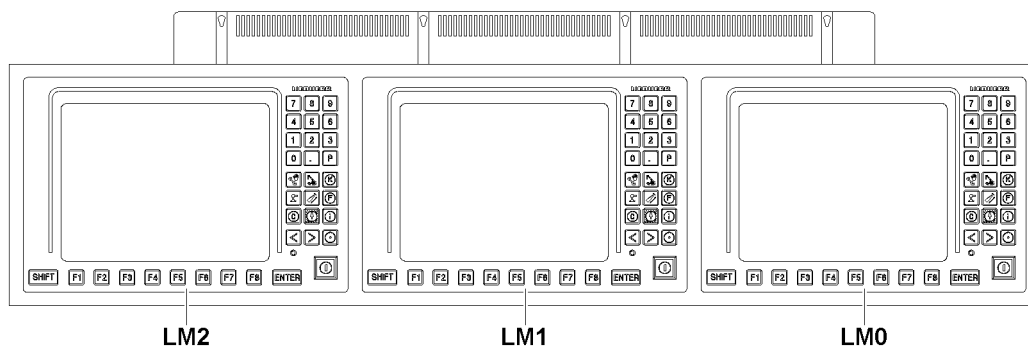


Fig.119921: Three LICCON monitors

- LM0** LICCON monitor 0
  - Located on the right side of the monitor
- LM1** LICCON monitor 1
  - Located in the center of the monitor
- LM2** LICCON monitor 2
  - Located on the left side of the monitor



### 3.1 Operating element on LICCON monitor 0

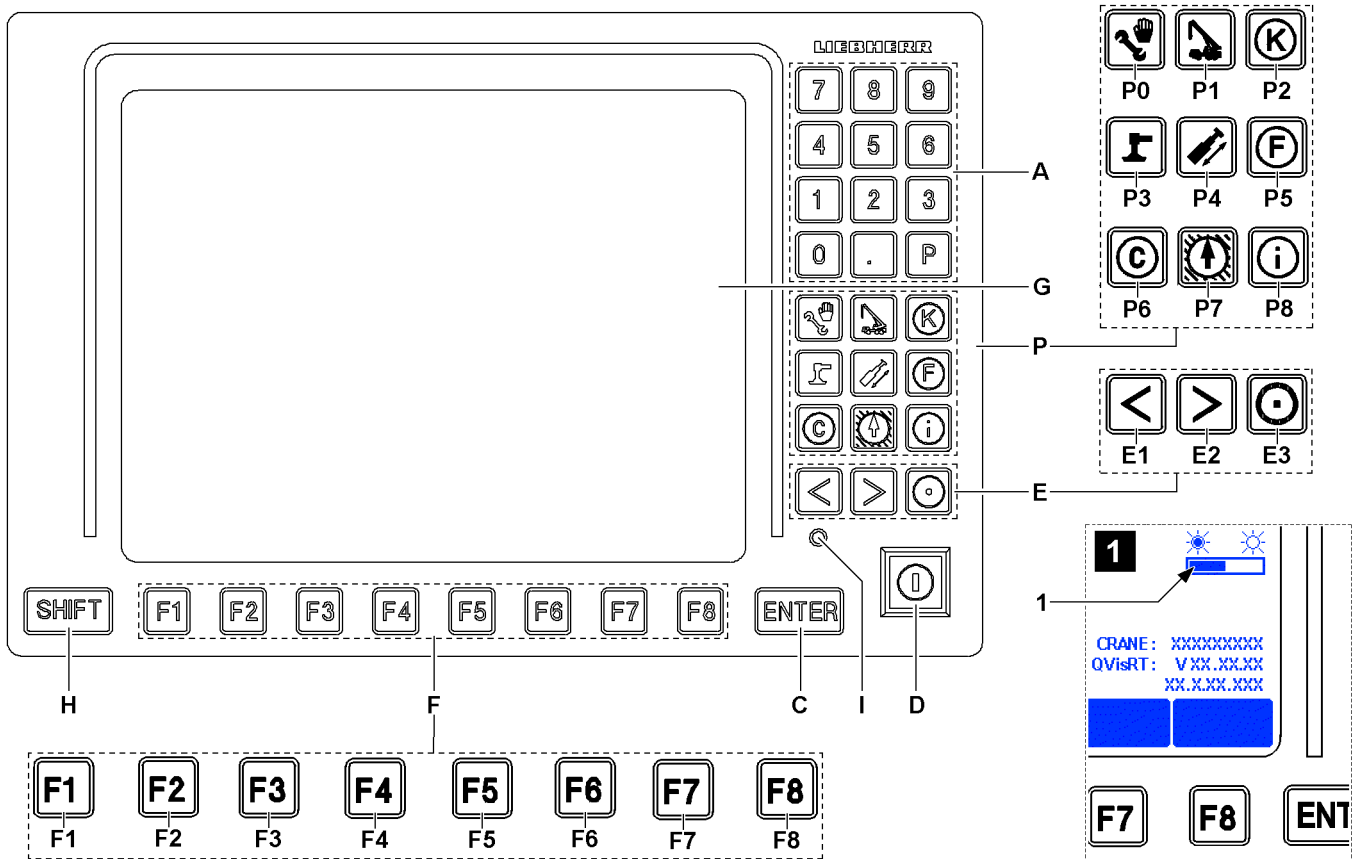


Fig.120677: Operating element on LICCON monitor 0

- A** Keypad
  - The function is program dependent
- P** Program keys
  - Selection of the individual LICCON programs
- P0** Set up
  - Call up the *Set up* program
- P1** Crane operation
  - Call up the *Crane operation* program
- P2** Chart illustration of load charts
  - Call up the *Curve illustration* program
- P3** —
  - Program key not assigned.
- P4** —
  - Program key not assigned.
- P5** —
  - Program key not assigned.
- P6** —
  - Program key not assigned.
- P7** Working range limitation\*
  - Call up the *Working range limitation* program
- P8** BSE test system
  - Call up the *BSE test system* program
  - **Note:** Description of the BSE test system, see the Diagnostics manual.

LWE/LR 1800-1-0-000/27200-07-02/en

- C** ENTER key
  - Confirmation of changes in the running program
- D** Set up key
  - Zero position (not actuated):  
Normal operation.
  - Touching:  
The *Exceedance of shut off limits of LICCON overload protection* function is released and / or the hoist limit switch is bypassed




---

**Note**

- ▶ By pressing the set up key **D**, all erection / take-down procedures can be carried out within the erection / take-down charts, for which no load charts are available.
- 

- E** Special function keys
    - The functions of the special function keys are program-dependent and are further explained in the description of the individual LICCON programs.
    - **Monitor brightness adjustment:**
      - Press **E3** (hold down) and **E1**: Change night design incrementally
      - Press **E3** (hold down) and **E2**: Brightness setting in several stages  
The brightness setting can be made from all available programs (for example: set up, crane operation).
- 


**Note**

Automatic brightness adjustment of the LICCON monitor

The brightness of the LICCON monitor can be adapted to the existing light conditions automatically or manually.

The current brightness setting of the LICCON monitor can be seen via the bar display **1** on the starting screen of the *BSE test system program* (illustration 1).

- ▶ Press the *BSE test system* button **P8** to call up the *BSE test system* program.
  - ▶ With the *medium brightness* brightness setting, automatic brightness adjustment is **activated**.
  - ▶ With the *lowest brightness* brightness setting, automatic brightness adjustment is **inactive**.
  - ▶ With the *highest brightness* brightness setting, automatic brightness adjustment is **inactive**.
- 

- F** Function keys
  - The function keys should always be viewed in conjunction with the function key icon line on the display **G**.
- G** Display
  - A program-dependent operating screen appears on the display
- H** SHIFT key
  - Second-level key assignments, for example Supervisory function
- I** Indicator light
  - Indicator light for the monitor supply voltage

## 3.2 Operating element on LICCON monitor 1

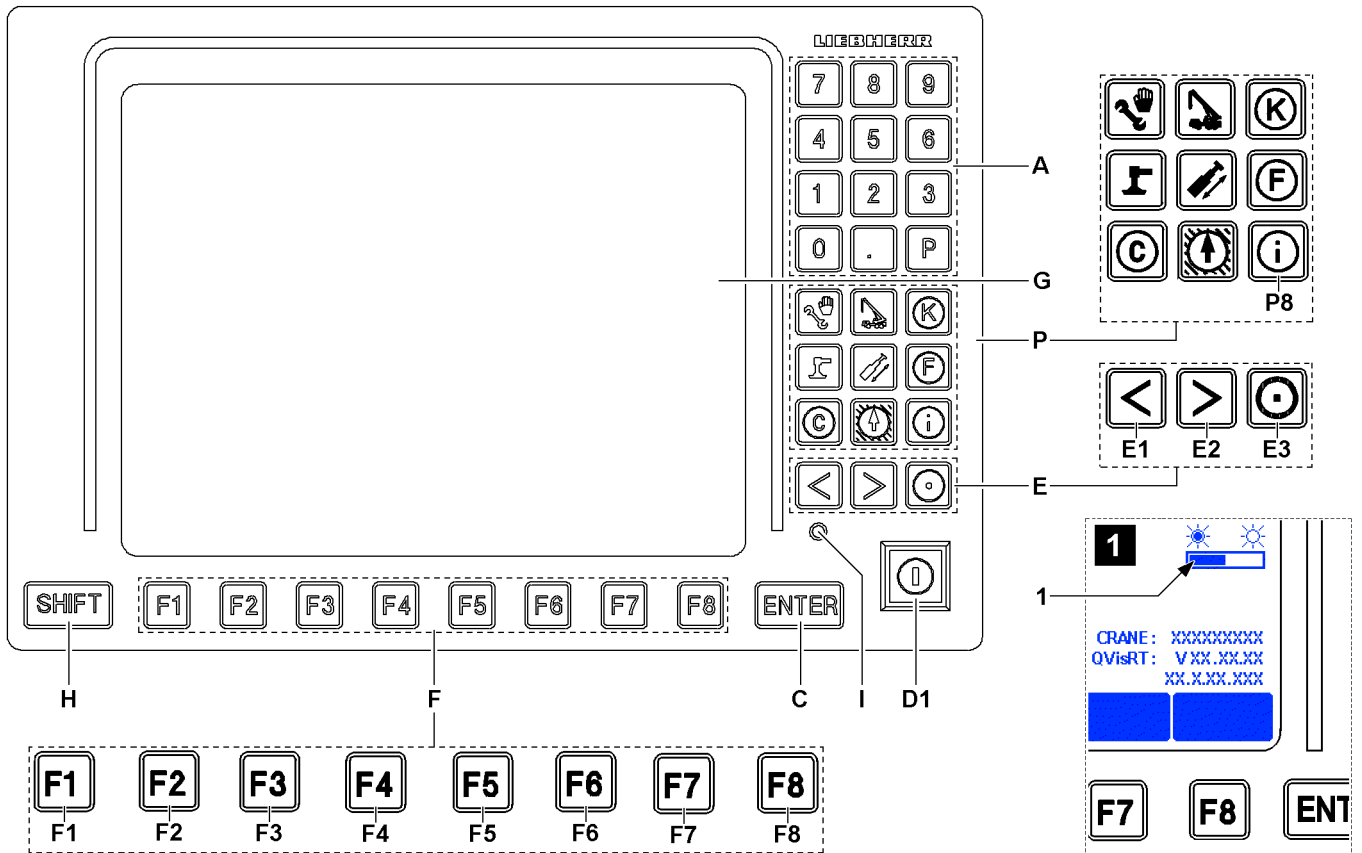


Fig.125385: Operating element on LICCON monitor 1

- A** Keypad
  - The function is program dependent
- P** Program keys
  - Only the *BSE test system* program key **P8** with function
- P8** BSE test system
  - Call up the *BSE test system* program
  - **Note:** Description of the BSE test system, see the Diagnostics manual.
- C** ENTER key
  - Confirmation of changes in the running program
- D1** Key button
  - No function
- E** Special function keys
  - The functions of the special function keys are program-dependent and are further explained in the description of the individual LICCON programs.
  - **Monitor brightness adjustment:**
    - Press **E3** (hold down) and **E1**: Change night design incrementally
    - Press **E3** (hold down) and **E2**: Brightness setting in several stages
  - The brightness setting can be made from all available programs (for example: set up, crane operation). The current brightness setting of the LICCON monitor can be seen via the bar display **1** on the starting screen of the *BSE test system program* (illustration **1**).
  - **Note:** See also section “Operating elements on LICCON monitor 0”
- F** Function keys
  - The function keys should always be viewed in conjunction with the function key icon line on the display **G**.

- G** Display
  - A program-dependent operating screen appears on the display
- H** SHIFT key
  - Second-level key assignments, for example Supervisory function
- I** Indicator light
  - Indicator light for the monitor supply voltage

### 3.3 Operating element on LICCON monitor 2

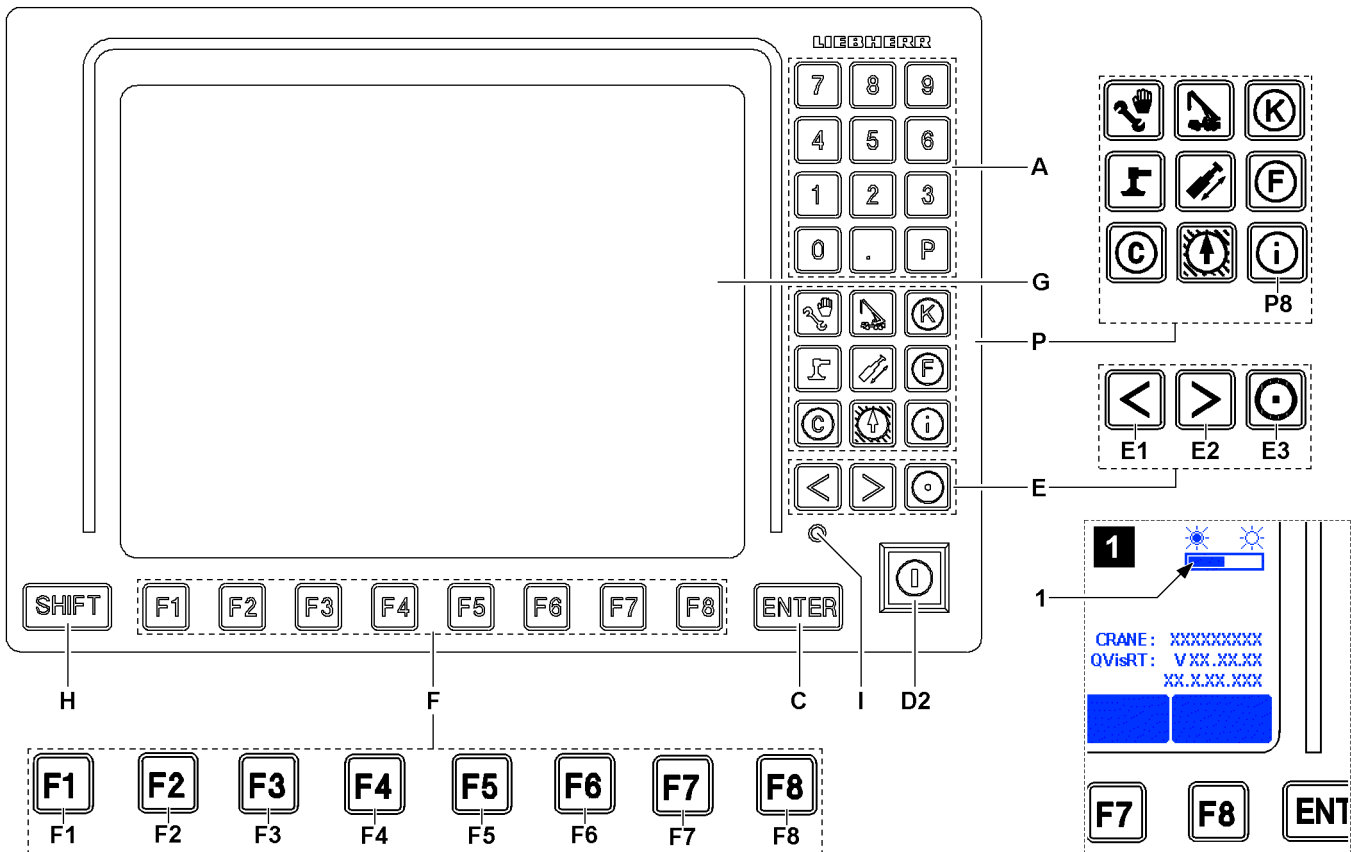


Fig.125386: Operating element on LICCON monitor 2

- A** Keypad
  - The function is program dependent
- P** Program keys
  - Only the *BSE test system* program key **P8** with function
- P8** BSE test system
  - Call up the *BSE test system* program
  - **Note:** Description of the BSE test system, see the Diagnostics manual.
- C** ENTER key
  - Confirmation of changes in the running program
- D2** Key button
  - Change over winch 1 and winch 2 parallel operation regulation.
  - **Note:** Only active for crane types with winch 1 and winch 2 parallel operation  
Only active for parallel operation of winch 1 and winch 2.
- E** Special function keys
  - The functions of the special function keys are program-dependent and are further explained in the description of the individual LICCON programs.
  - **Monitor brightness adjustment:**
    - Press **E3** (hold down) and **E1**: Change night design incrementally

- Press **E3** (hold down) and **E2**: Brightness setting in several stages  
The brightness setting can be made from all available programs (for example: set up, crane operation). The current brightness setting of the LICCON monitor can be seen via the bar display **1** on the starting screen of the *BSE test system program* (illustration **1**).
  - **Note:** See also section “Operating elements on LICCON monitor 0”
- F** Function keys
- The function keys should always be viewed in conjunction with the function key icon line on the display **G**.
- G** Display
- A program-dependent operating screen appears on the display
- H** SHIFT key
- Second-level key assignments, for example Supervisory function
- I** Indicator light
- Indicator light for the monitor supply voltage

## 4 Set up program



### Note

- ▶ The monitor illustrations in this chapter are only examples.
- ▶ The numerical values in the individual icons and charts do not have to necessarily match the crane exactly.
- ▶ Numbers and letters can be replaced by place holders.
- ▶ The programmed load charts for the crane are binding.



### WARNING

Danger of accident due to deviating set up configuration!

If the actual set up configuration of the crane deviates from the entries and settings in the *Set up* program, then the overload protection is not correctly set.

An incorrectly set overload protection calculates the actual load incorrectly and transmits faulty display values.

The crane can be overloaded without being noticed and topple over. Personnel can be severely injured or killed.

- ▶ The entries and settings in the *set up* program must match the actual set up configuration of the crane.

After correct system start of the LICCON computer system, it changes automatically to the *Set up* program. The set up screen is shown in the *Set up* program.

The program can also be called up via the program key, see section “LICCON Monitor 0 operating elements”.

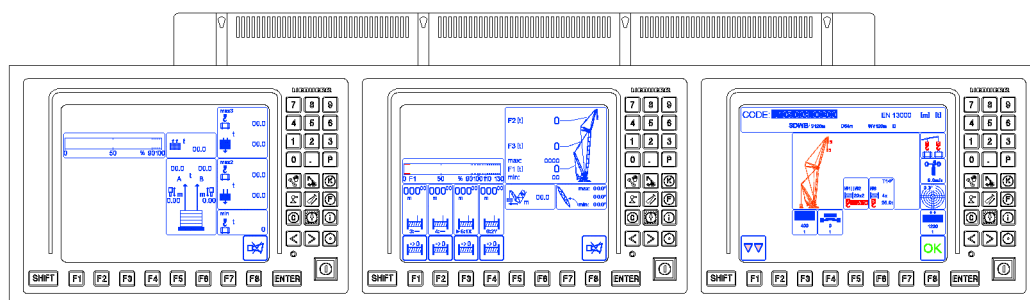


Fig. 119926: Three LICCON monitors

**Note**

- ▶ All entries and settings to be made by the crane operator in the *Set up* program can only be carried out on **LICCON monitor 0**.
- ▶ LICCON monitor 0 is located on the right of the monitor arrangement.

**Note**

Adjustment and display of set up configuration and reeving.

- ▶ Normally, after booting up the LICCON computer system, the most recently used set up configuration and the reeving used at that time will be automatically set and displayed.

The crane operator must enter and set the actual set up configuration of the crane in the *Set up* program. The LICCON computer system will then set the overload protection accordingly with these entries and settings.

## 4.1 Screen display in the *Set up* program

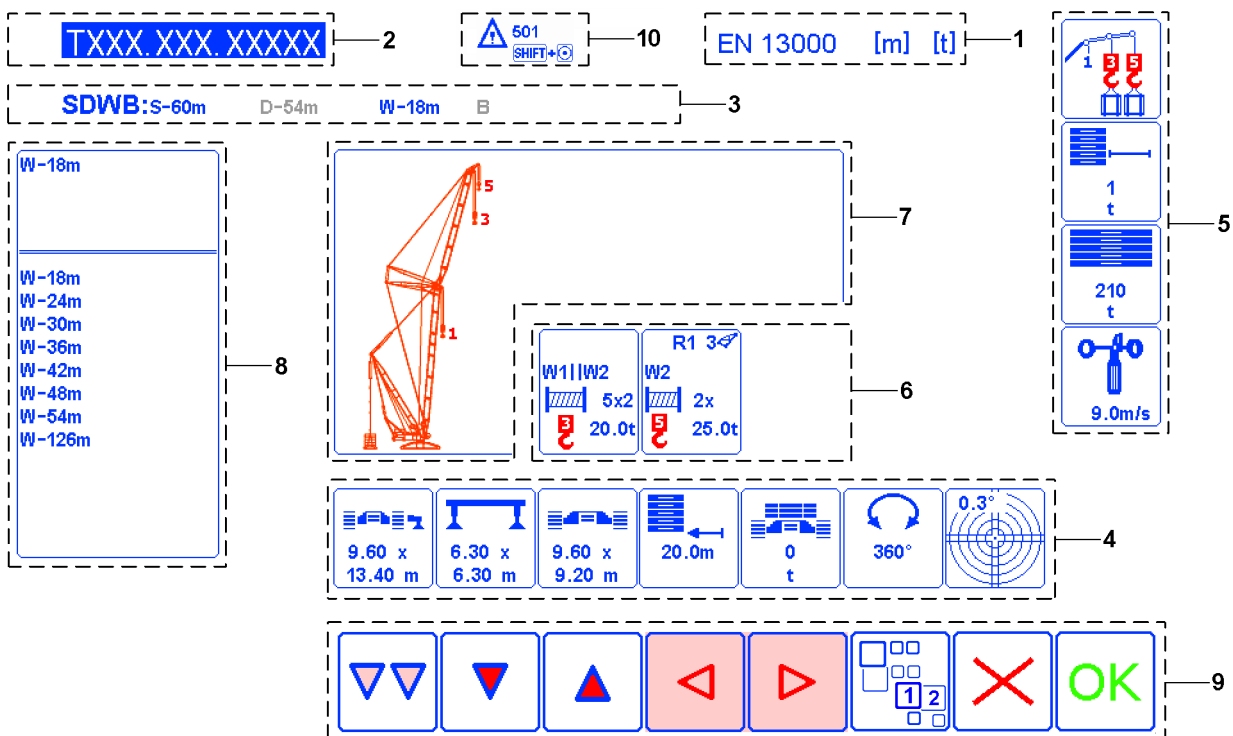


Fig.161570: Example of a screen display in the *Set up* program

The screen display in the *Set up* program consists of the following program categories:

- 1 Unit category
  - The measuring units with which the crane control works are displayed.
- 2 Chart name category
  - The set chart name (chart number) is displayed.
- 3 Operating mode category
  - The set operating mode is displayed.
- 4/5 Set up functions
  - 4 Set up completion category
    - The set values for the set up completion are displayed.
  - 5 Environmental / mechanical influence category
    - The set values for environmental influence / mechanical influence are displayed.
- 6 Lifting category
  - The set hoist winch operation is displayed.
  - The set hoist winch assignment is displayed.

- The set reeving is displayed.
- The set hook weight is displayed.

As well as program comprehensive:

- 7 Display window
  - The set operating mode is symbolized.
  - The possible hook positions are displayed.
- 8 Editing / selection window
  - Possible settings and values for editing or selecting are displayed.
- 9 *Function key icons*
  - Functions assigned to the function keys are displayed as icons.
- 10 Code for limitations and notes
  - There may be limitations and notes for the set up configuration that is set. If limitations and notes are available, they are specified by codes. The reference texts describe the corresponding codes.  
Display reference texts, see section "Reference texts".

## 4.2 Operating elements in the Set up program

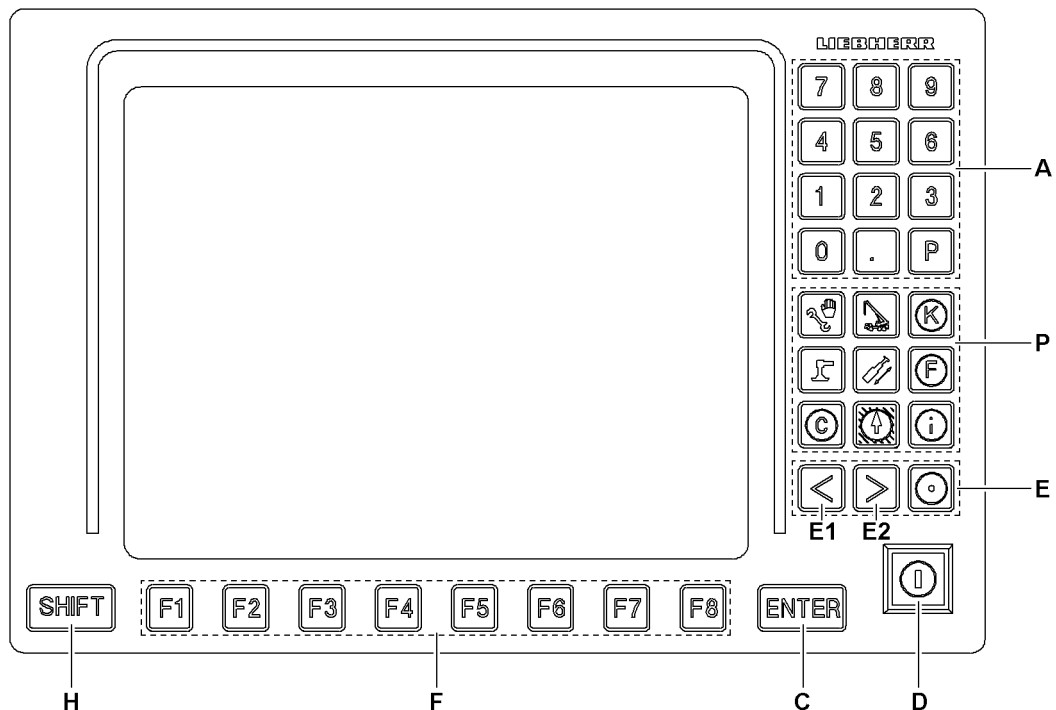


Fig.119927: Operating elements in the Set up program

- A Keypad**
  - The keys **0** to **9** on the keypad can be used to enter the respective number directly.
  - Decimal digits can be created with the key **“.”**
  - The **“P”** button has no function in the *Set up* program.
- P Program keys**
  - Selection of individual programs. The settings made in the set up program are discarded and the set up configuration that was confirmed last with the function key **F8** (OK) is used.  
A program that is currently running **cannot** be called up again using its program key.
- C ENTER key**
  - Entry confirmation for selections made or for edited values.
  - After entering the chart name (chart number), the ENTER key **C** searches the corresponding operating mode. If an error is present, a short beep sounds.

- After changing / editing within a category, the ENTER key **C** sets the new value.
- D** Set up key
- Has no function in the *Set up* program
- E** Special function keys
- The key **E1**: has the same function as function key F4 in the *Set up* program.
  - The key **E2**: has the same function as function key F5 in the *Set up* program.
  - The key **E3**: in combination with the SHIFT key **H** is used to display reference texts in the *Set up* program
- Note:** Only when a code for limitations and notes is available.
- F** Function keys
- The function key line consists of function keys **F1** to **F8** and the function key icon bar above it.
  - The function keys correspond to the various function key icons above them.
- H** SHIFT key
- In combination with the key **E3**, it is used to display reference texts in the *Set up* program
- Note:** Only when a code for limitations and notes is available.

### 4.3 Function key line in the *Set up* program

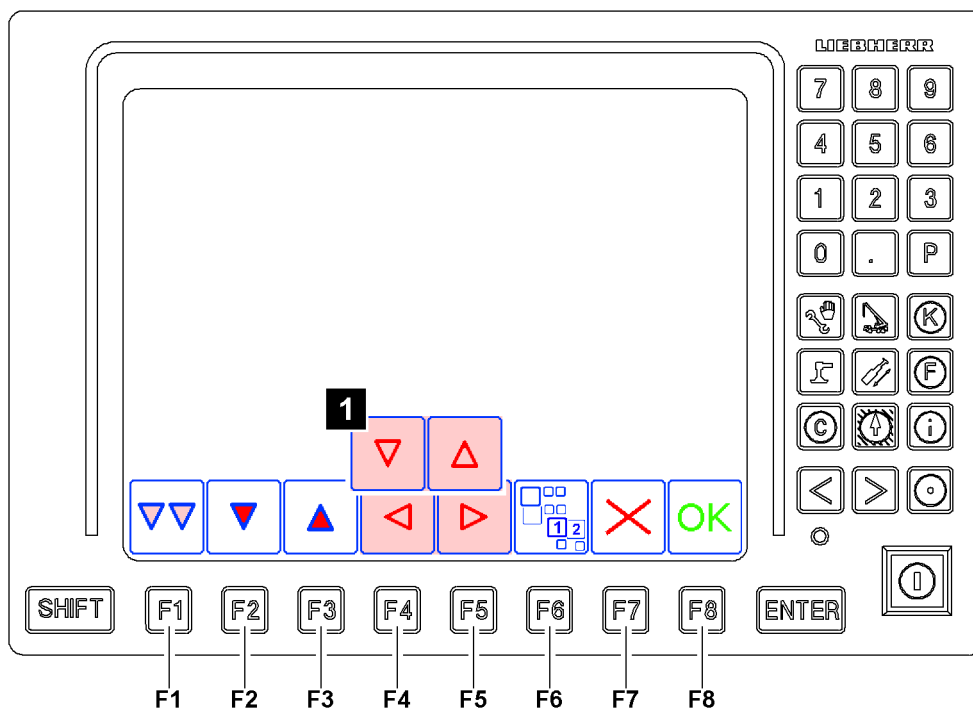


Fig.119928: Function key line in the *Set up* program

The function key line consists of function keys **F1** to **F8** and the function key icon bar above it. The function keys correspond to the various function key icons above them.



**Note**

- Not all function keys on the LICCON monitor are always active and assigned with icons. Only when a function key is presently available is the corresponding icon shown.

**F1** Function key

- Change to the next category by pressing the function key **F1**.
- **Note:** The active category is always highlighted in pink.



- F2** Function key
  - Navigation in the Editing / selection window: change downward
  - **Note:** If it is not possible to change further downward, a short beep sounds.
- F3** Function key
  - Navigation in the Editing / selection window: change upward
  - **Note:** If it is not possible to change further upward, a short beep sounds.
- F4** Function key
  - Navigation in the pink highlighted (active) program category
  - Left arrow: change within the selection to the left
  - Down arrow, Illustration 1: change within the selection downward
  - **Note:** If it is not possible to change further in that direction, a short beep sounds.
- F5** Function key
  - Navigation in the pink highlighted (active) program category
  - Right arrow: change within the selection to the left
  - Up arrow, Illustration 1: change upward within the selection
  - **Note:** If it is not possible to change further in that direction, a short beep sounds.
- F6** Function key
  - If additional levels are present, then they can be selected by pressing the function key **F6**.
- F7** Function key
  - Reset the *Set up* program to the last valid set up configuration
- F8** Function key
  - Take over the current settings as the new set up configuration.
  - **Note:** By pressing the function key **F8**, the *Set up* program is completed and the *Crane operation* program is called up.

## 4.4 Setting the set up configuration in general

Make sure that the following prerequisite is met:

- There is no load on the hook.

The set up configuration is set in the following program categories:

- Operating mode category
- Set up completion category
- Environmental / mechanical influence category
- Lifting category



### WARNING

Incorrect operation in the *Set up* program!

The *Set up program* is correctly carried out when **all** program categories are set and the actual conditions of the crane and environment are depicted.

Incorrect operation in the *Set up* program leads to an incorrectly set overload protection.

An incorrectly set overload protection calculates the actual load incorrectly and transmits faulty display values.

The crane can be overloaded without being noticed and topple over. Personnel can be severely injured or killed.

- ▶ In the *Set up* program, always set **all** program categories according to the actual configurations of the crane and the environment.
- ▶ Before taking over the settings in the *Set up* program, check all program categories.



### Note

The following sections describe by means of an example how to change from the crane basic setting to a more extensive operating mode.

All entries and settings can therefore be explained by example.

- ▶ If the required operating mode deviates, make your own entries and settings and do not skip required steps.

## 4.5 Structure of the operating mode category

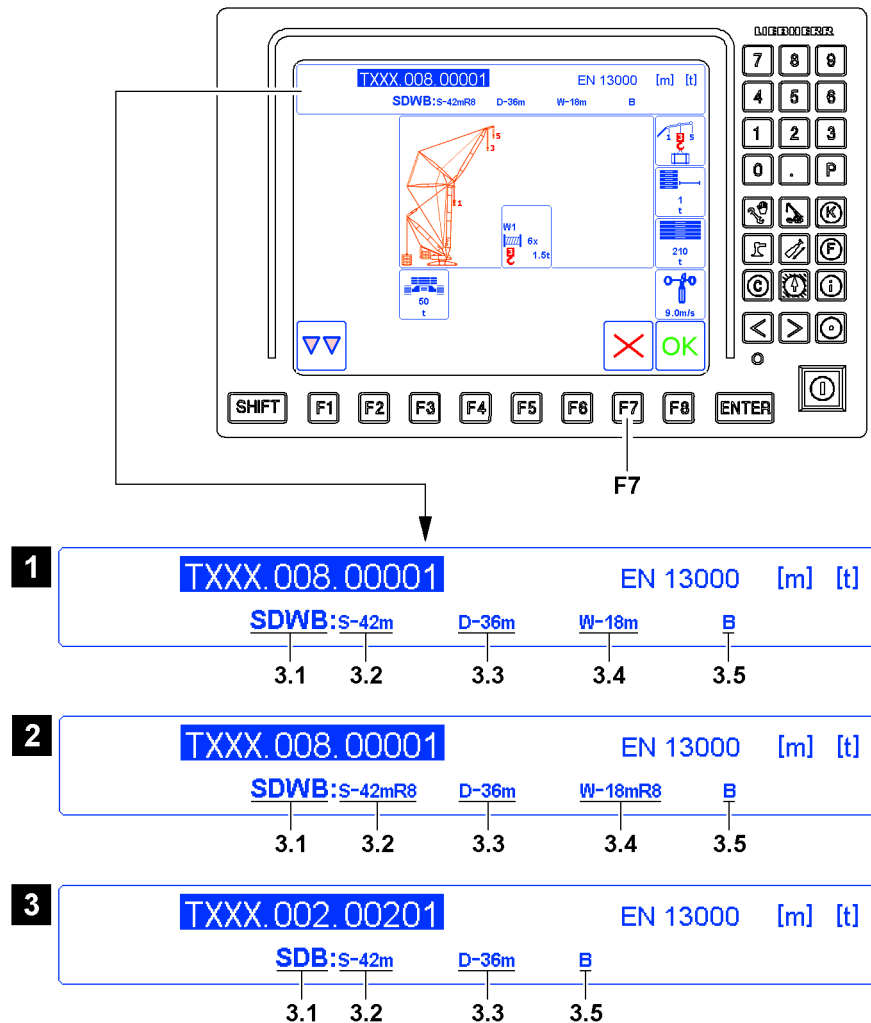


Fig.119915: Structure of the operating mode category

The components of the boom system can be combined with each other to operating modes according to certain rules.

The individual components are coded via markers.

The operating mode consists of up to five markers, see illustration 1.

The operating mode is set in the operating mode category.

Markers for operating mode in the *Set up* program:

- 3.1** Abbreviation
  - Abbreviation of the operating mode
- 3.2** Main boom
  - Type and length of the main boom
  - **Note:** On some main booms, various roller sets can be set up additionally, see illustration 2
- 3.3** Derrick boom
  - Length of the derrick boom
  - **Note:** This appears only in the corresponding operating mode.
- 3.4** Auxiliary boom / accessory
  - Type and length of the auxiliary boom / accessory
  - **Note:** On some auxiliary booms, various roller sets can be set up additionally, see illustration 2.

- **Note:** This appears only in the corresponding operating mode.
- 3.5 Derrick ballast**
- Derrick ballast version
  - **Note:** This appears only in the corresponding operating mode.



**Note**

- ▶ If a marker for an operating mode does not appear, then the following markers move up, see example illustration 3.
- ▶ If the *Abort* icon appears above a function key **F7**, then the procedure can be aborted at any time. All entries and settings made up to that point are discarded.

**The operating mode can be set two ways:**

- Setting the operating mode via chart names (chart number)
- Setting the operating mode via the function keys

**4.6 Setting the operating mode via chart name (chart number)**

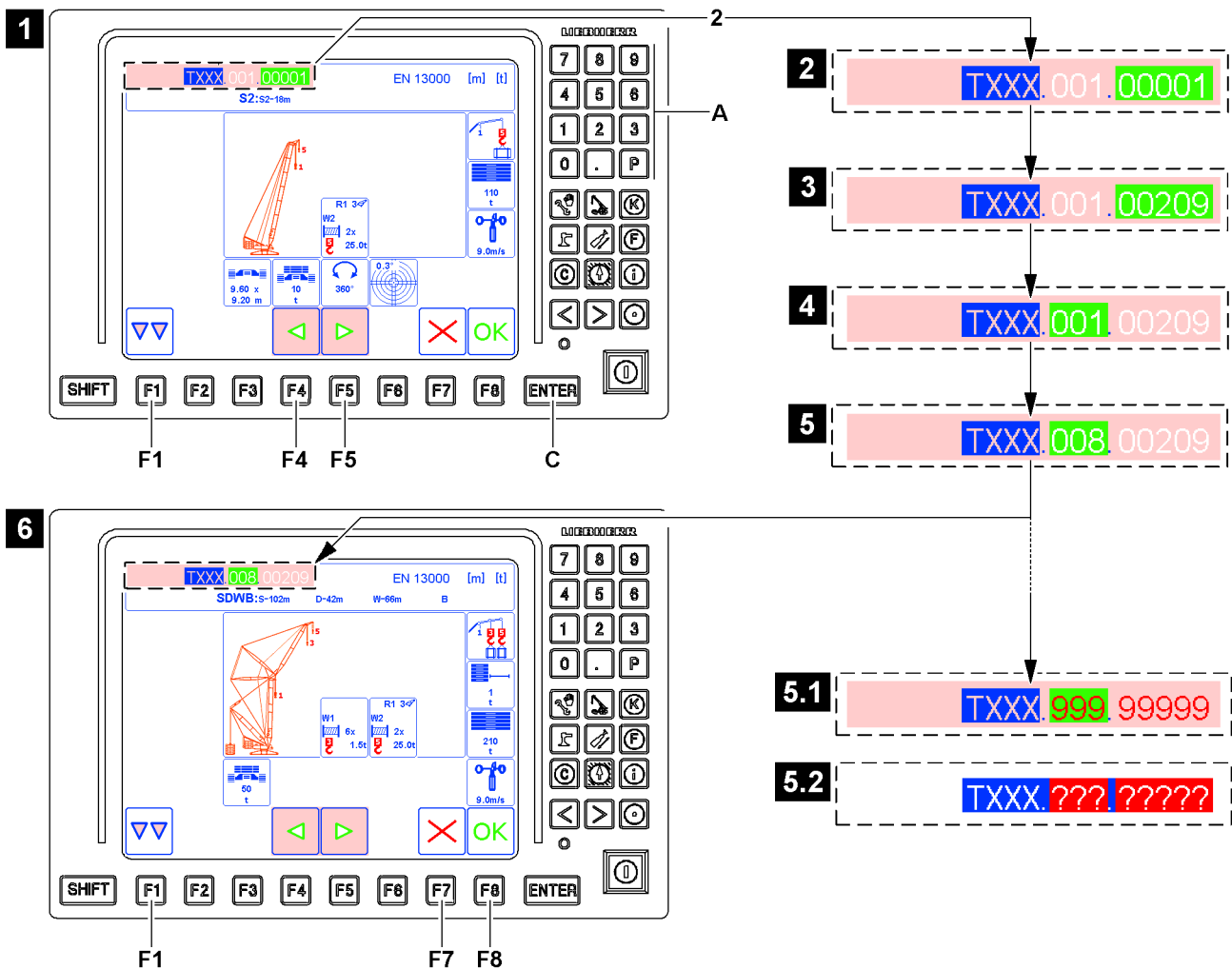


Fig.120679



**Note**

- The following section describes by example how a certain chart name (chart number) is entered.
- ▶ Always enter the required chart name (chart number).
  - ▶ If the *Abort* icon appears above a function key **F7**, then the procedure can be aborted at any time. All entries and settings made up to that point are discarded.

LWE/LR 1800-1-0-000/27200-07-02/en

Make sure that the following prerequisites are met:

- The *Set up* program is called up.
- The required chart name (chart number) is known.

▶ Press the function key **F1** until the chart name category **2** is highlighted in pink, see illustration 1.

**Result:**

- The chart name category **2** is active. The editable area of the chart name (chart number) is highlighted additionally in green.



**Note**

Navigation in the chart name category **2**

- ▶ Press the function key **F4**: The editable area changes to the left.
- ▶ Press the function key **F5**: The editable area changes to the right.

When the rear five digits of the chart name (chart number) are highlighted in green (illustration 2):

- ▶ Enter the number sequence using the keypad **A**, in example "00209".

**Result:**

- The entered number sequence is shown in the editable area of the chart name (chart number), see illustration 3.

▶ Press the function key **F4**.

**Result:**

- The editable area of the chart name (chart number) changes, see illustration 4.

When the center three digits of the chart name (chart number) are highlighted in green (illustration 4):

- ▶ Enter the number sequence using the keypad **A**, in example "008".

**Result:**

- The entered number sequence is shown in the editable area of the chart name (chart number), see illustration 5.

▶ Accept the chart name (chart number) with the ENTER key **C**.

**Result:**

- The chart name (chart number) is accepted.
- The screen display is matched, see illustration 6.

**Problem remedy**

Invalid chart name (chart number)

When trying to accept an invalid number sequence, the numbers are displayed in red (illustration 5.1) or replaced by red question marks ("?") (illustration 5.2).

- ▶ Enter and accept only a valid chart name (chart number).

## 4.7 Setting the operating mode via the function keys



**Note**

The following section describes by example how a certain operating mode is set.  
 ▶ Always set the required operating mode.

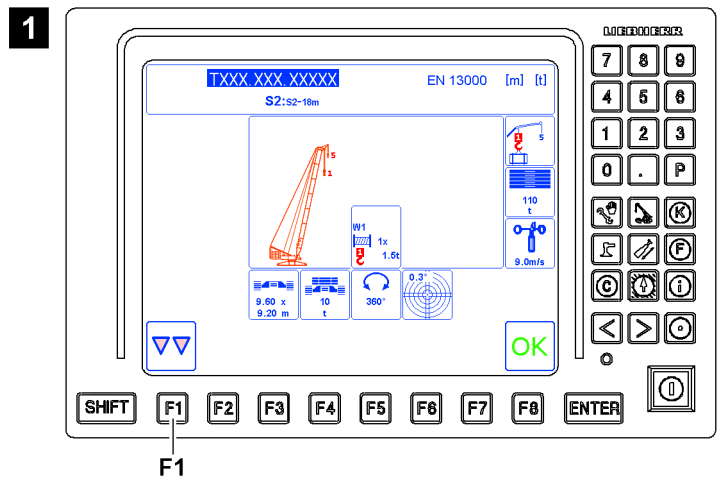


Fig. 119929

Make sure that the following prerequisite is met:

- The Set up program is called up, see illustration 1.

### 4.7.1 Selecting the operating mode category

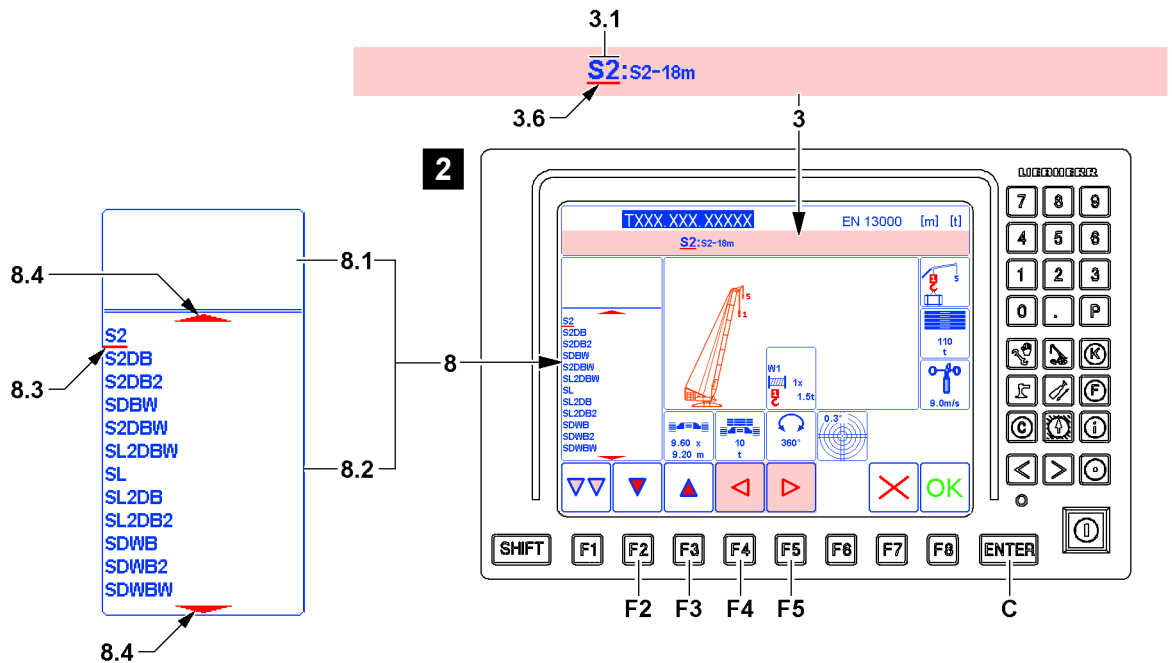


Fig. 119919

- ▶ Press the function key **F1** until the operating mode category **3** is highlighted in pink, see illustration 2.

**Result:**

- The operating mode category **3** is selected.  
 The selection bar **3.6** automatically underlines the first marker: Abbreviation **3.1**

LWE/LR 1800-1-0-000/27200-07-02/en

- The Editing / selection window **8** appears.
- The abbreviations available for selection are displayed in the lower area **8.2** of the Editing / selection window **8**.
- The icons for navigation in the individual program categories appear above function key **F2**, function key **F3**, function key **F4** and function key **F5**.

**Note**

Navigation in the operating mode category **3**

- ▶ Press the function key **F4**: The selection bar **3.6** moves to the left.
- ▶ Press the function key **F5**: The selection bar **3.6** moves to the right.

**Note**

Navigation in the Editing / selection window **8**

- ▶ Press the function key **F2**: The selection bar **8.3** changes downward by one line.
- ▶ Press the function key **F3**: The selection bar **8.3** changes upward by one line.
- ▶ If a directional triangle **8.4** appears on the upper and lower end of a window, additional selection possibilities are present in this direction.
- ▶ When the upper area **8.1** and the lower area **8.2** are assigned: Press the ENTER key **C** and switch between the upper area **8.1** and the lower area **8.2**.

## 4.7.2 Selecting the abbreviation for the boom system

Make sure that the following prerequisite is met:

- The operating mode category **3** is selected.
- ▶ Press the function key **F5** or function key **F4** until the abbreviation **3.1** is underlined with the selection bar **3.6** (in the example “S2”), see illustration **2**.

**Result:**

- The abbreviations available for selection are displayed in the lower area **8.2** of the Editing / selection window **8**.

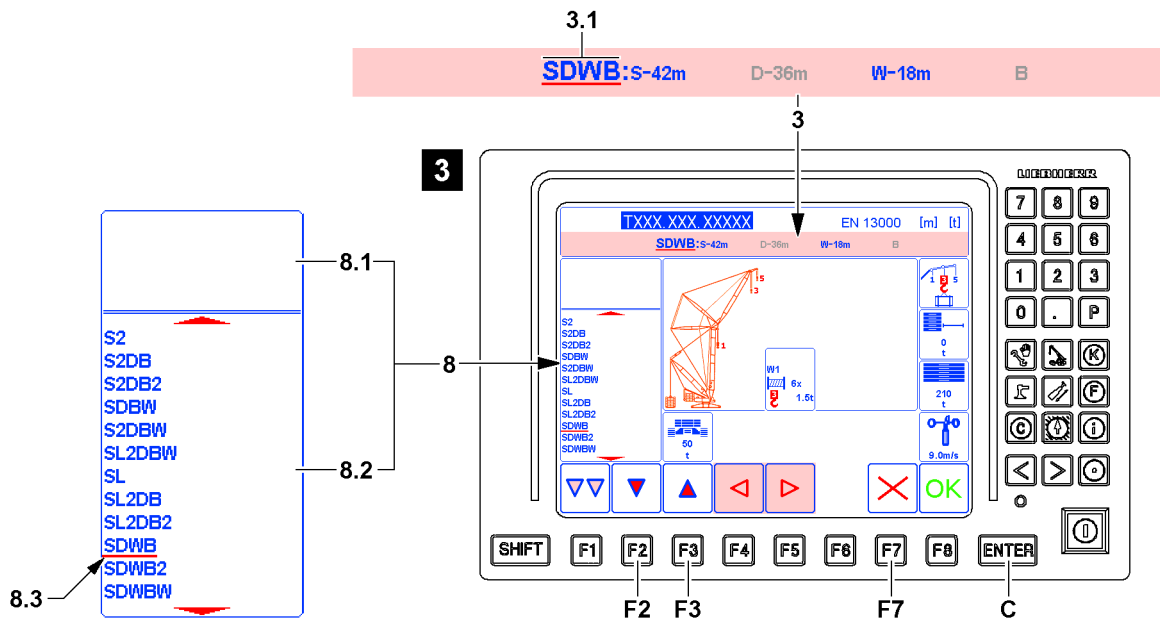


Fig. 119930

- ▶ Press the function key **F2** or function key **F3** until the required abbreviation is underlined with the selection bar **8.3**. In the example “SDWB”, see illustration **3**.

When the required abbreviation is underlined with the selection bar **8.3**:

- ▶ Press the ENTER key **C**.

**Result:**

- The abbreviation is selected (example “SDWB”).
- The newly selected abbreviation 3.1 appears in the operating mode category 3.
- The graphic display of the crane in the display window changes accordingly.

**4.7.3 Determining the main boom variation**

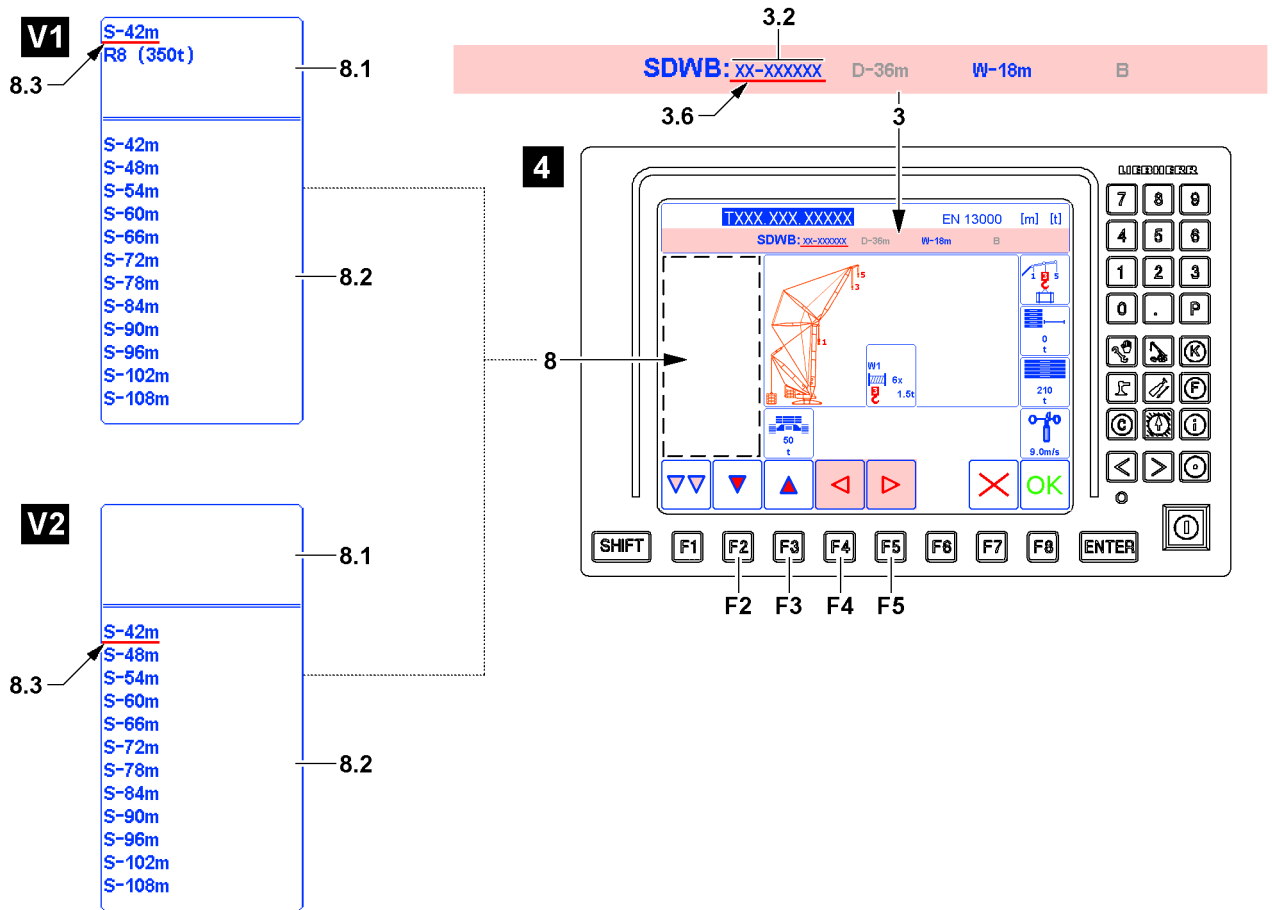


Fig.119935

At first, the main boom 3.2 must be selected in the operating mode category 3.

- ▶ Press the function key F5 or function key F4 until the main boom 3.2 is underlined with the selection bar 3.6, see illustration 4.

**Result:**

- First variation, illustration V1

**Note:** The first variation appears only when various roller sets can be assigned to the main boom in the Set up program.

- The preselection options are displayed in the upper area 8.1 of the Editing / selection window 8. The first preselection option is automatically underlined and activated with the selection bar 8.3.
- The main booms available for section are displayed in the lower area 8.2 of the Editing / selection window 8.

- Second variation, illustration V2

**Note:** The second variation appears only when no various roller sets can be assigned to the main boom in the Set up program.

- No selection option appears in the upper area 8.1 of the Editing / selection window 8.
- The main booms available for section are displayed in the lower area 8.2 of the Editing / selection window 8.

LWE/LR 1800-1-0-000/27200-07-02/en

Depending on the view of the Editing / selection window **8** you must proceed differently:

- ▶ If the first variation is shown (illustration **V1**), proceed with section “Selecting the main boom for the first variation (V1)”.
- ▶ If the second variation is shown (illustration **V2**), proceed with section “Selecting the main boom for the second variation (V2)”.

#### 4.7.4 Selecting the main boom for the first variation (V1)

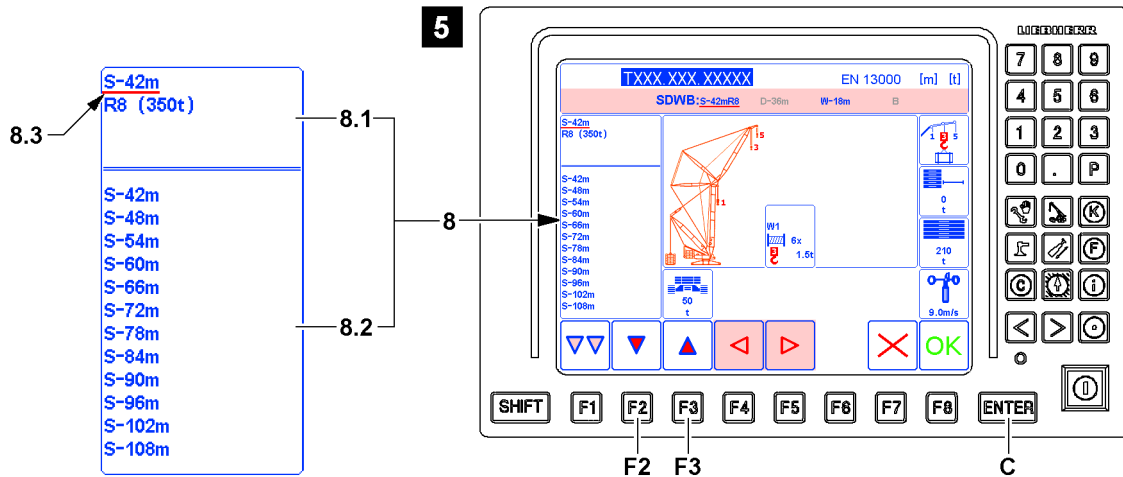


Fig.119920

- ▶ Press the function key **F2** or function key **F3** until the required preselection option in the upper area **8.1** is underlined with the selection bar **8.3** (in the example “S-42m”, see illustration 5).

When the required preselection option is underlined with the selection bar **8.3**:

- ▶ Press the ENTER key **C**.

**Result:**

- The selection bar **8.3** changes in the lower area **8.2** of the Editing / selection window **8**.

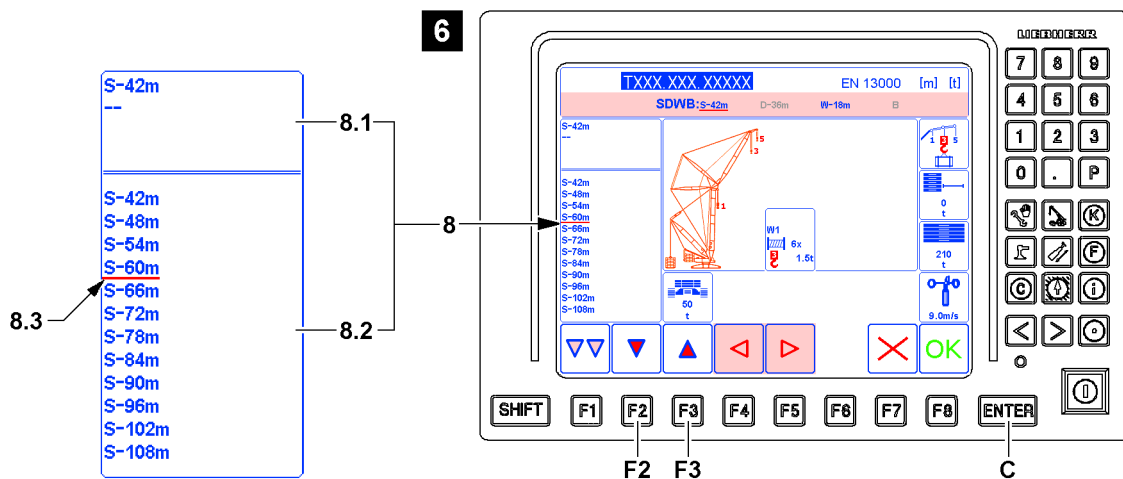


Fig.119937

- ▶ Press the function key **F2** or function key **F3** until the required main boom is underlined with the selection bar **8.3** (in the example “S-60m”, see illustration 6).

When the required main boom is underlined with the selection bar **8.3**:

- ▶ Press the ENTER key **C**.



**Result:**

- The main boom is selected (in the example "S-60m").
- The selection bar **8.3** changes in the upper area **8.1** of the Editing / selection window **8**.

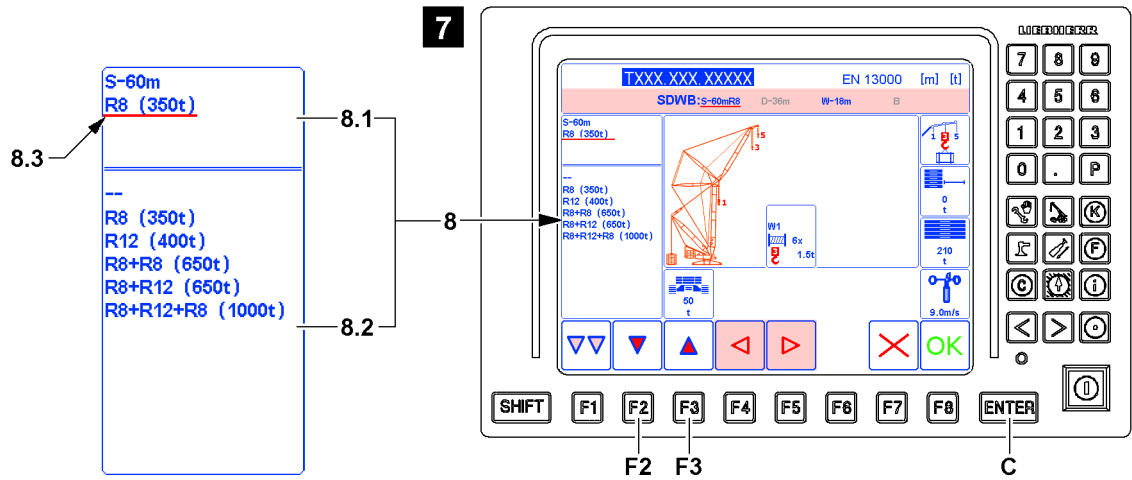


Fig.119938

- ▶ Press the function key **F2** or function key **F3** until the required preselection option in the upper area **8.1** is underlined with the selection bar **8.3** (in the example "R8 (350t)", see illustration 7).

When the required preselection option is underlined with the selection bar **8.3**:

- ▶ Press the ENTER key **C**.

**Result:**

- The selection bar **8.3** changes in the lower area **8.2** of the Editing / selection window **8**.

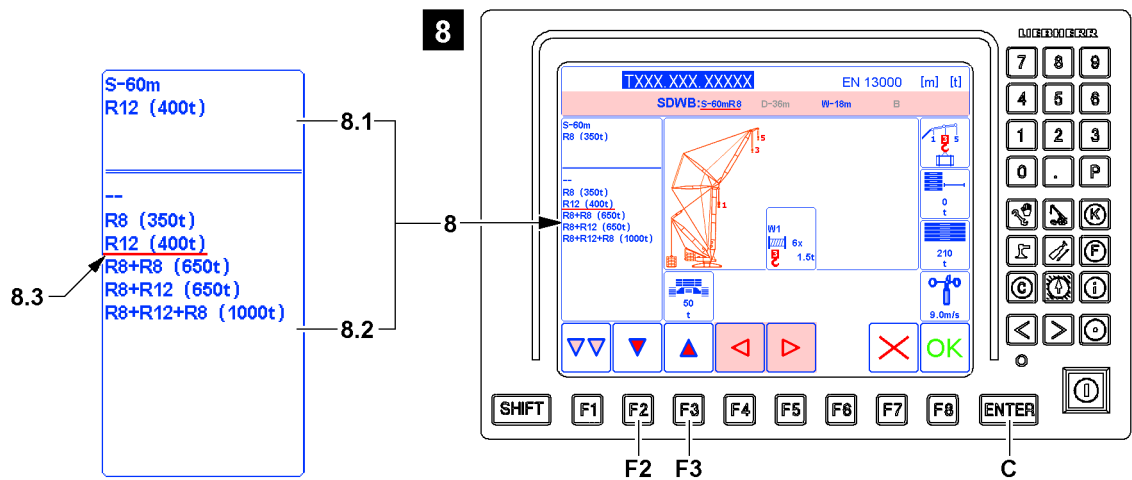


Fig.119939

- ▶ Press the function key **F2** or function key **F3** until the required roller set is underlined with the selection bar **8.3** (in the example "R12 (400t)", see illustration 8).

LWE/LR 1800-1-0-000/27200-07-02/en

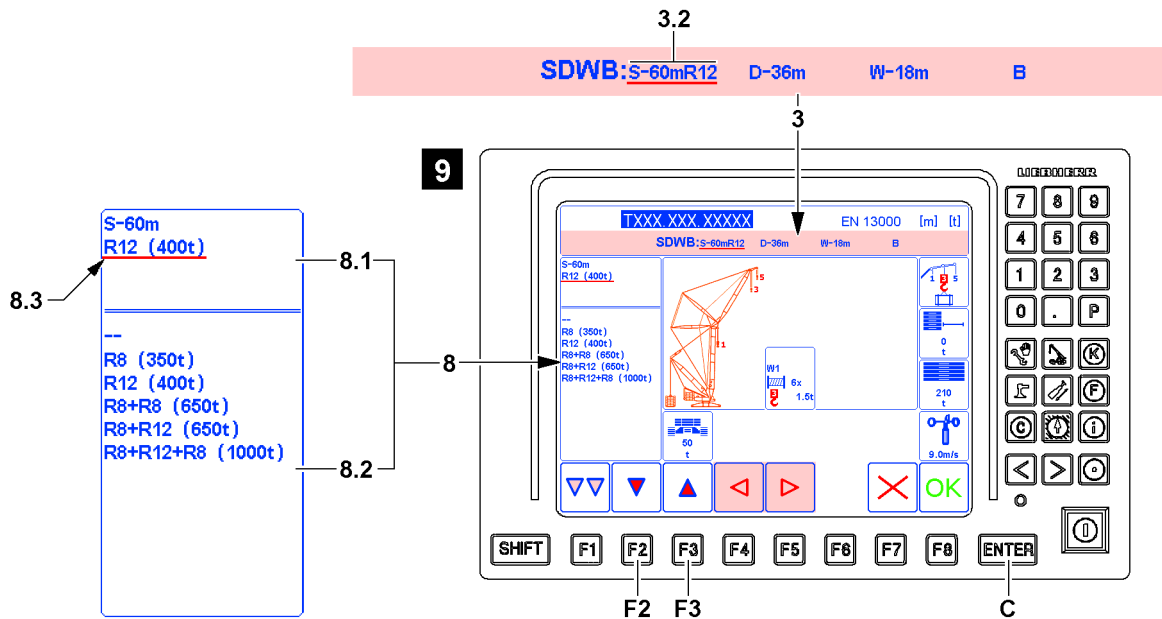


Fig.119940

When the required roller set is underlined with the selection bar 8.3:

- ▶ Press the ENTER key C.

**Result:**

- The roller set is selected (in example “R12 (400t”).
- The selection bar 8.3 changes in the upper area 8.1 of the Editing / selection window 8.
- The operating mode category 3 includes the newly selected main boom with roller set 3.2, see illustration 9.

### 4.7.5 Selecting the main boom for the second variation (V2)

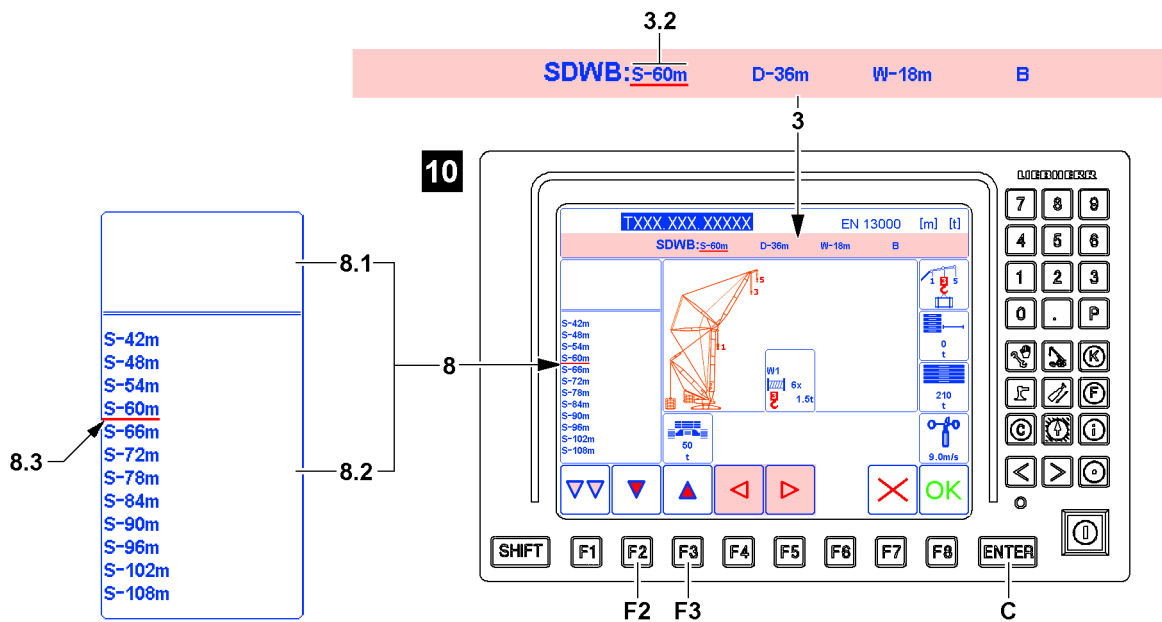


Fig.119931

- ▶ Press the function key F2 or function key F3 until the required main boom is underlined with the selection bar 8.3 (in the example “S-60m”), see illustration 10.

LWE/LR 1800-1-0-000/27200-07-02/en

When the required main boom is underlined with the selection bar **8.3**:

- ▶ Press the ENTER key **C**.

**Result:**

- The main boom is selected (in the example "S-60m").
- The newly selected main boom **3.2** appears in the operating mode category **3**.

**4.7.6 Invalid chart name**

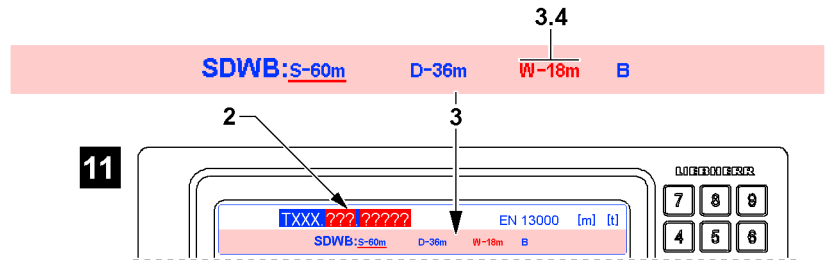


Fig.119932

- ▶ Check if the chart name **2** is displayed in blue lettering.

**Problem remedy**

After pressing the ENTER key **C**, is the chart name **2** replaced by the red highlighted question mark ("?" - see illustration **11**)?

Additional entries and settings must be made to obtain a valid set up configuration. If a valid set up configuration is prevented by a certain marker, then this marker is highlighted in red. In the example, the marker for auxiliary boom / accessory **3.4** must still be processed.

- ▶ Continue making entries and settings normally until it is the turn for the red highlighted marker.

**4.7.7 Selecting the derrick boom**

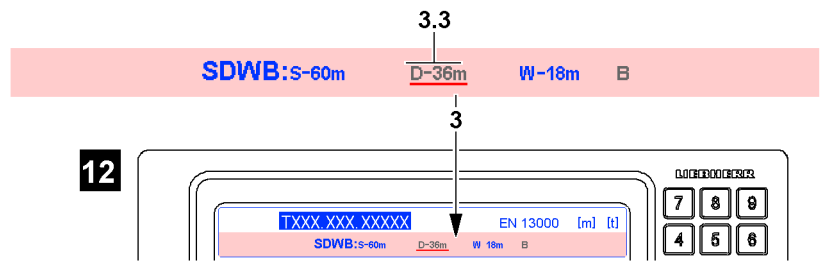


Fig.119933



**Note**

Illustration **3.3**: If the text for the derrick boom **12** appears in gray, then no additional entries and settings for this marker are possible.

- ▶ Correctly selected markers with gray lettering can be skipped.

LWE/LR 1800-1-0-000/27200-07-02/en

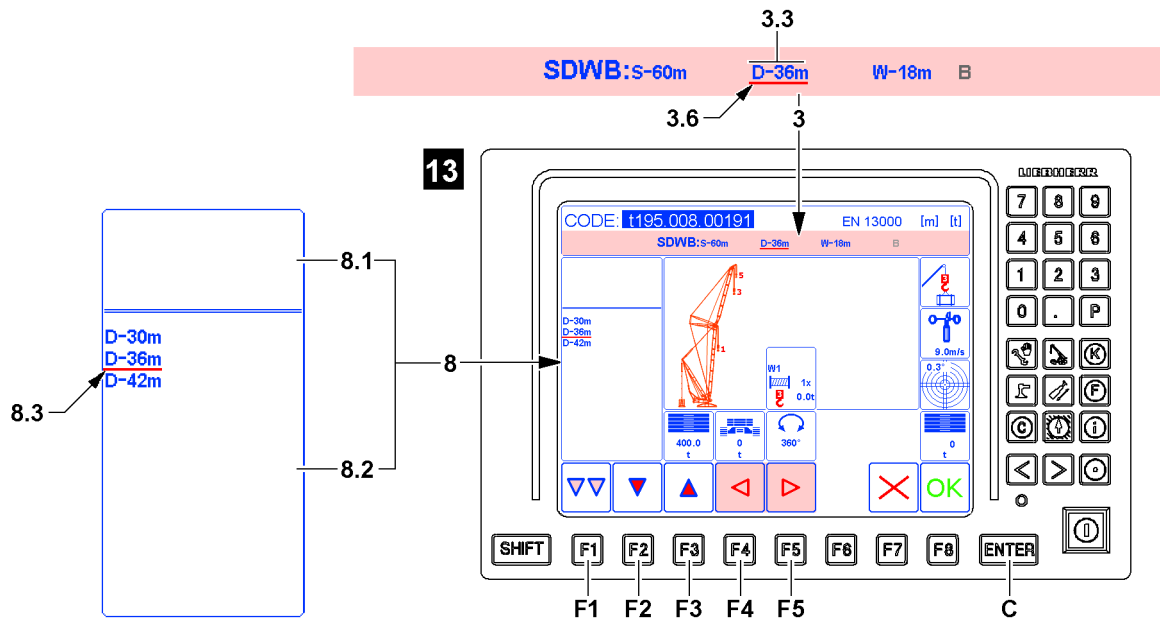


Fig.119934

**Note**

If the correct derrick boom **3.3** already appears, then the entries and settings for this marker can be skipped.

- ▶ Press the function key **F5** or function key **F4** until the next marker to be changed is underlined with the selection bar **3.6**.
- ▶ If all entries and settings in the operating mode category **3** are correct, press the function key **F1** and switch to the next category.

First, the operating mode category **3** for the derrick boom **3.3** must be selected.

- ▶ Press the function key **F5** or function key **F4** until the derrick boom **3.3** is underlined with the selection bar **3.6** (in the example "D-36m"), see illustration **13**.

**Result:**

- The derrick booms available for selection are displayed in the lower area **8.2** of the editing / selection window **8**.

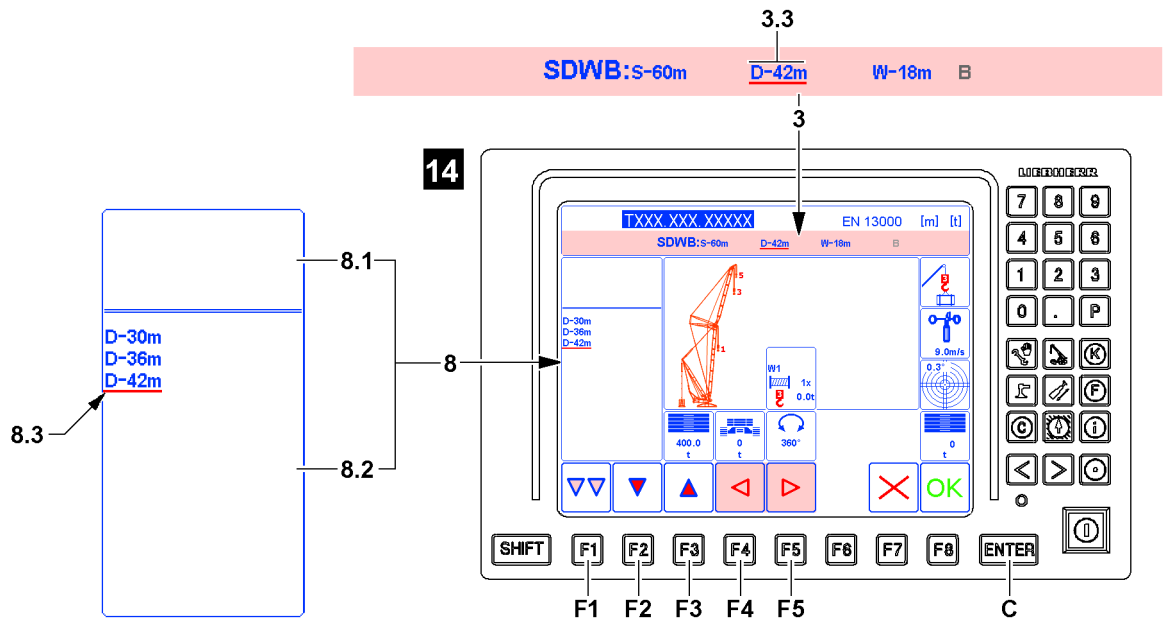


Fig.119941

- ▶ Press the function key **F2** or function key **F3** until the required derrick boom is underlined with the selection bar **8.3**. (In the example “D-42m”), see illustration **14**.

When the required derrick boom is underlined with the selection bar **8.3**:

- ▶ Press the ENTER key **C**.

**Result:**

- The derrick boom is selected (example “D-42m”).
- The newly selected derrick boom **3.3** appears in the operating mode category **3**.

**Problem remedy**

Is the required selection for a market not available in the operating mode category **3**?

The previously made entries and settings were not made correctly.

In the *Set up* program only entries and settings can be made for which load charts are available.

- ▶ Correct the previously made entries and settings.

**4.7.8 Selecting the auxiliary boom / accessory**

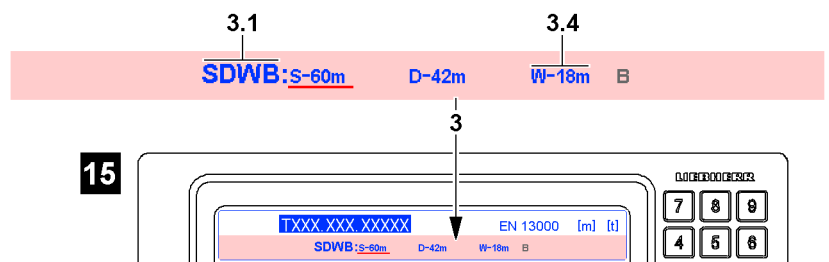


Fig.119942

The auxiliary boom / accessory **3.4** marker only appears when a corresponding abbreviation **3.1** is selected, see illustration **15**.



**Note**

If the text for the auxiliary boom / accessory **3.4** appears in gray, then no additional entries and settings for this marker are possible.

- ▶ Correctly selected markers with gray lettering can be skipped.

LWE/LR\_1800-1-0-000/27200-07-02/en

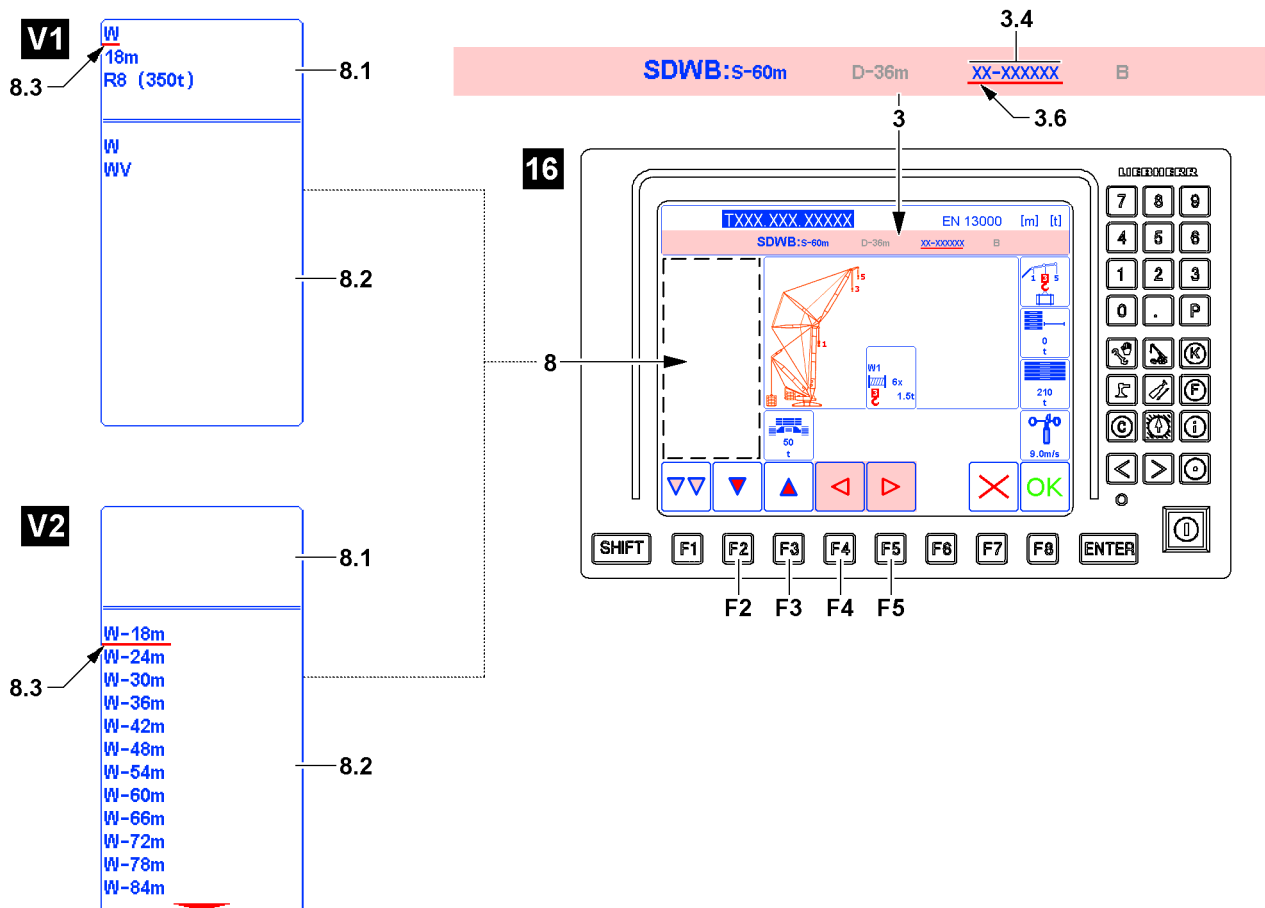


Fig.119943

**Note**

If the correct auxiliary boom / accessory 3.4 already appears, then the entries and settings for this marker can be skipped.

- ▶ Press the function key **F5** or function key **F4** until the next marker to be changed is underlined with the selection bar 3.6.
- ▶ If all entries and settings in the operating mode category 3 are correct, press the function key **F1** and switch to the next category.

### 4.7.9 Determining the auxiliary boom / accessory variation

At first, the operating mode category 3 for the auxiliary boom / accessory 3.4 must be selected.

- ▶ Press the function key **F5** or function key **F4** until the auxiliary boom / accessory 3.4 marker is underlined with the selection bar 3.6, see illustration 16.

**Result:**

- First variation, illustration **V1**

**Note:** The first variation appears solely when various operating modes and / or roller sets can be assigned to the auxiliary boom / accessory in the *Set up* program.

- The preselection options are displayed in the upper area 8.1 of the Editing / selection window 8. The first preselection option is automatically underlined and activated with the selection bar 8.3.
- The settings available for selection are displayed in the lower area 8.2 of the Editing / selection window 8

- Second variation, illustration **V2**

**Note:** The second variation appears solely when no various operating modes and roller sets can be assigned to the auxiliary boom / accessory in the *Set up* program.

- No selection option appears in the upper area 8.1 of the Editing / selection window 8.

- The settings available for selection are displayed in the lower area **8.2** of the Editing / selection window **8**

Depending on the view of the Editing / selection window **8** you must proceed differently:

- ▶ If the first variation is shown (illustration **V1**), proceed with section “Selecting the auxiliary boom / accessory for the first variation (V1)”.
- ▶ If the second variation is shown (illustration **V2**), proceed with section “Selecting the auxiliary boom / accessory for the second variation (V2)”.

### 4.7.10 Selecting the auxiliary boom / accessory for the first variation (V1)

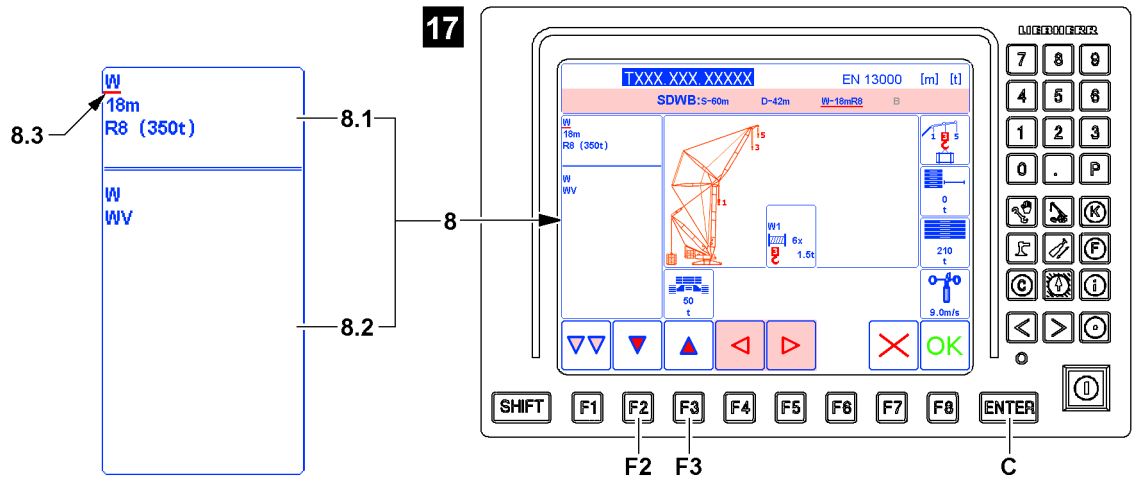


Fig.119944

- ▶ Press the function key **F2** or function key **F3** until the required preselection option in the upper area **8.1** is underlined with the selection bar **8.3** (in the example “W”), see illustration **17**.

When the required preselection option is underlined with the selection bar **8.3**:

- ▶ Press the ENTER key **C**.

**Result:**

- The selection bar **8.3** changes in the lower area **8.2** of the Editing / selection window **8**.

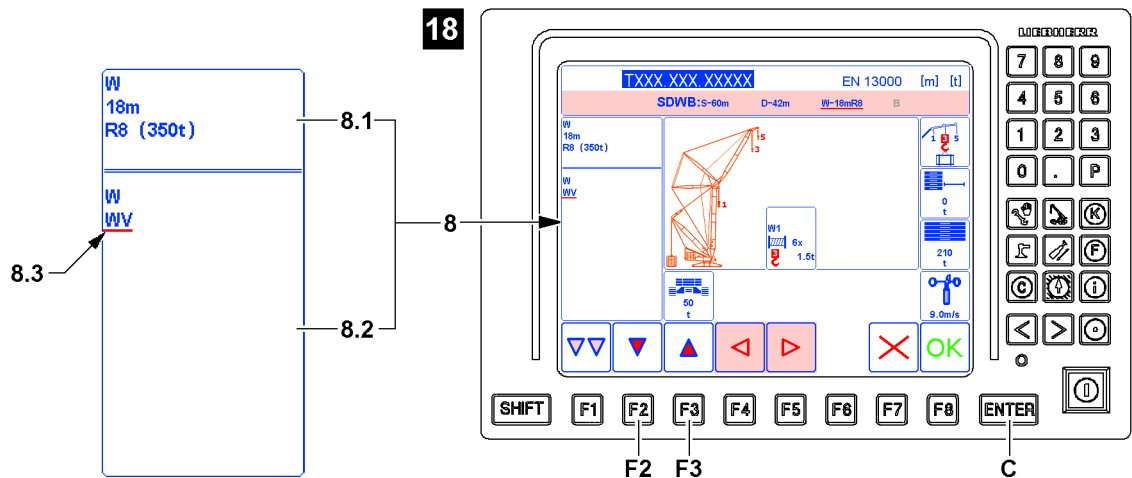


Fig.119945

- ▶ Press the function key **F2** or function key **F3** until the required setting is underlined with the selection bar **8.3** (in the example “WV”), see illustration **18**.

LWE/LR 1800-1-0-000/27200-07-02/en

When the required setting is underlined with the selection bar **8.3**:

- ▶ Press the ENTER key **C**.

**Result:**

- The setting is selected.
- The selection bar **8.3** changes in the upper area **8.1** of the Editing / selection window **8**.

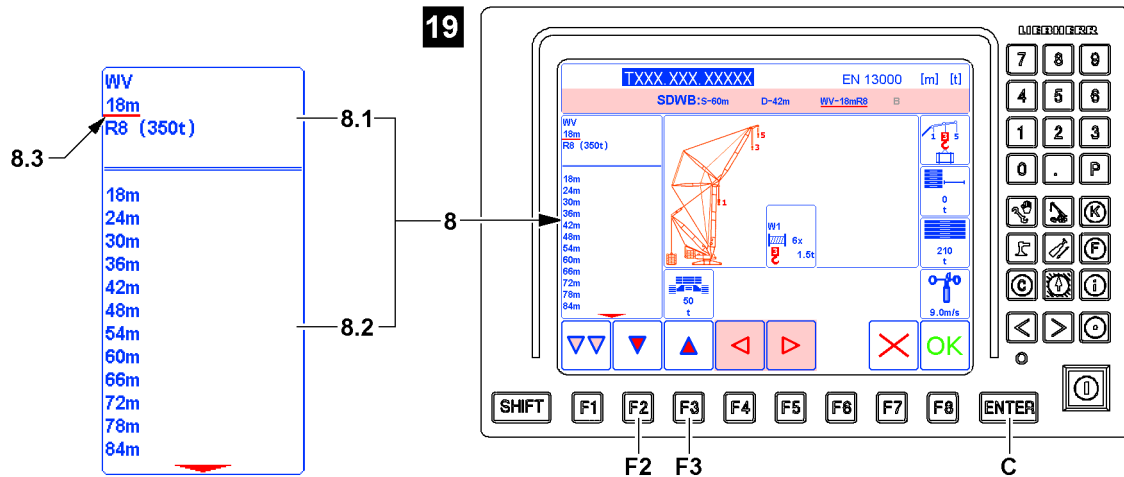


Fig.119946

- ▶ Press the function key **F2** or function key **F3** until the required preselection option in the upper area **8.1** is underlined with the selection bar **8.3** (in the example “18m”), see illustration **19**.

When the required preselection option is underlined with the selection bar **8.3**:

- ▶ Press the ENTER key **C**.

**Result:**

- The selection bar **8.3** changes in the lower area **8.2** of the Editing / selection window **8**.

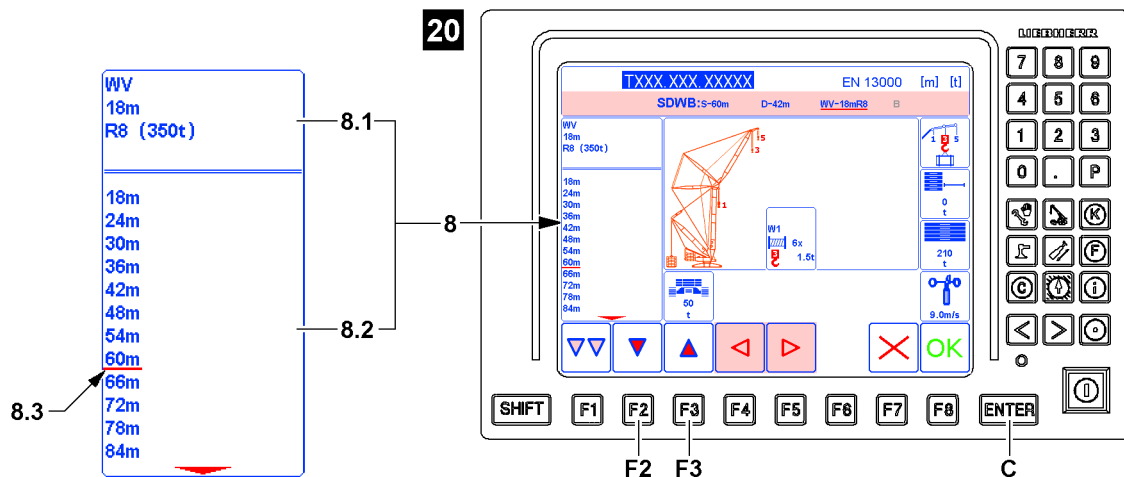


Fig.120576

- ▶ Press the function key **F2** or function key **F3** until the required setting is underlined with the selection bar **8.3** (in the example “60m”), see illustration **20**.

When the required roller set is underlined with the selection bar **8.3**:

- ▶ Press the ENTER key **C**.

**Result:**

- The setting is selected.



- The selection bar **8.3** changes in the upper area **8.1** of the Editing / selection window **8**.

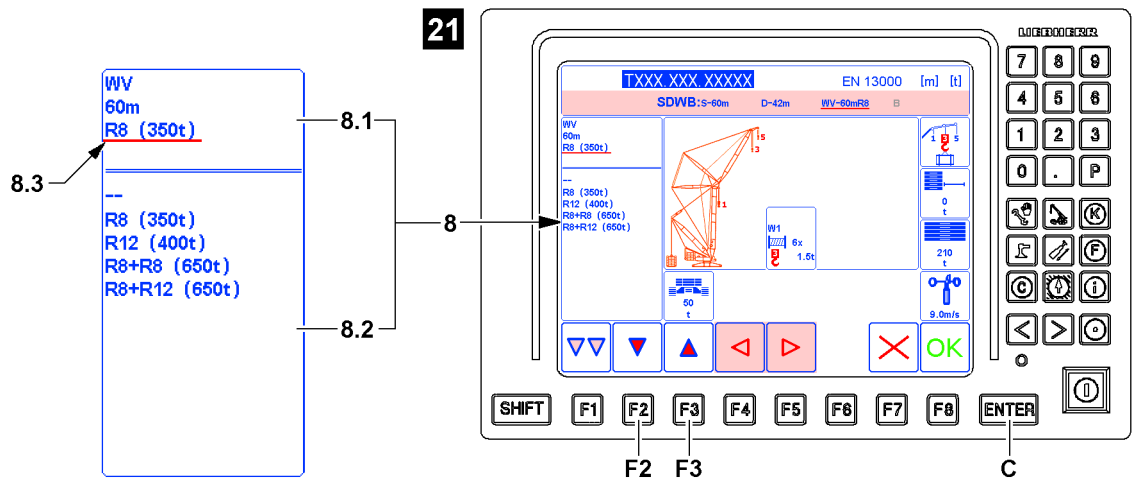


Fig.120577

- ▶ Press the function key **F2** or function key **F3** until the required preselection option in the upper area **8.1** is underlined with the selection bar **8.3** (in the example “R8 (350t)”, see illustration **21**).

When the required preselection option is underlined with the selection bar **8.3**:

- ▶ Press the ENTER key **C**.

**Result:**

- The selection bar **8.3** changes in the lower area **8.2** of the editing / selection window **8**.

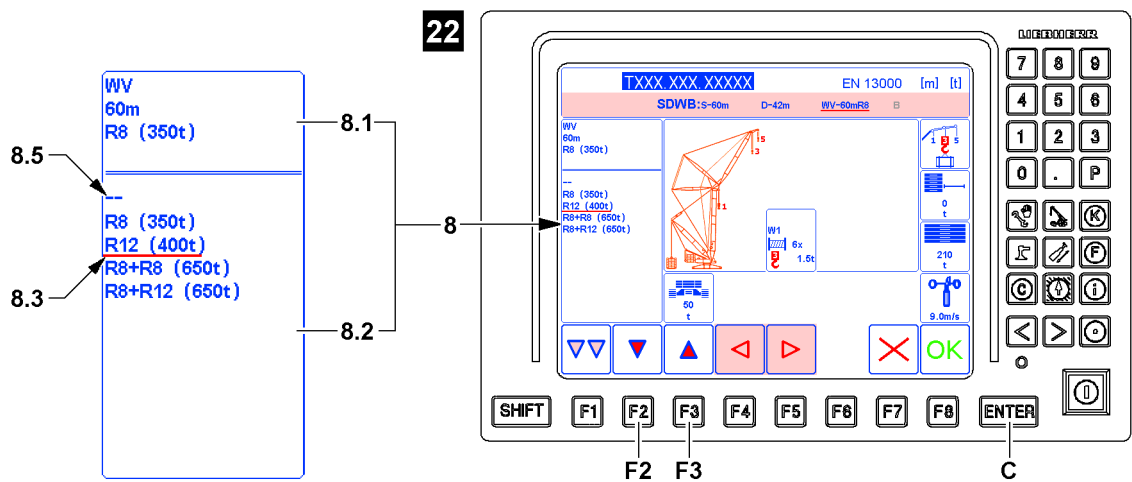


Fig.164449

- ▶ Press the function key **F2** or function key **F3** until the required setting is underlined with the selection bar **8.3** (in the example “R12 (400t)”, see illustration **22**).



**Note**

- ▶ Selection “--” **8.5** means that **no** roller set is assembled on the corresponding boom.

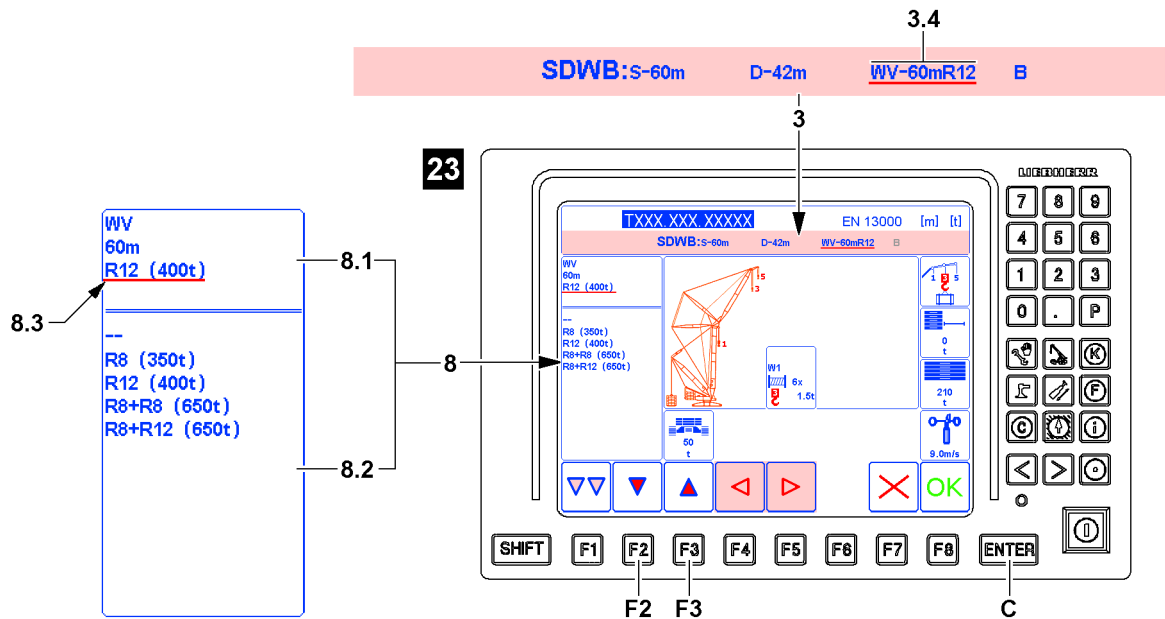


Fig.120579

When the required setting is underlined with the selection bar 8.3:

- Press the ENTER key C.

**Result:**

- The setting is selected.
- The selection bar 8.3 changes in the upper area 8.1 of the Editing / selection window 8.
- The operating mode category 3 shows the selected settings for auxiliary boom / accessory 3.4, see illustration 23.

#### 4.7.11 Selecting the auxiliary boom / accessory for the second variation (V2)

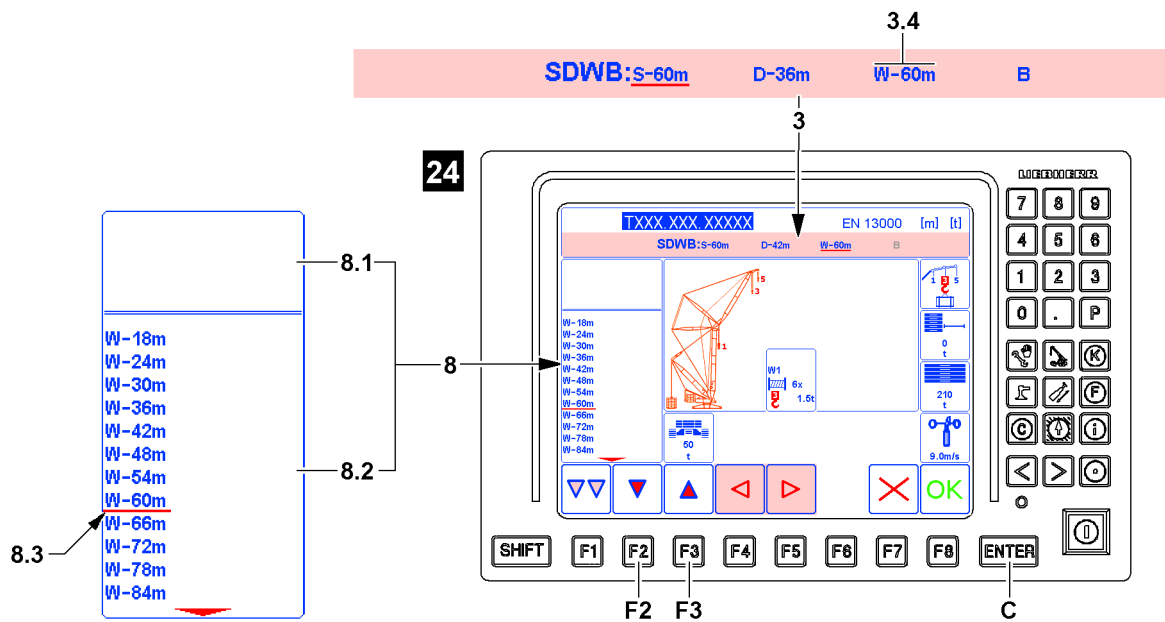


Fig.120580

- Press the function key F2 or function key F3 until the required main boom is underlined with the selection bar 8.3 (in the example “W-60m”), see illustration 24.

When the required main boom is underlined with the selection bar **8.3**:  
 ▶ Press the ENTER key **C**.

**Result:**

- The auxiliary boom / accessory is selected (in example “W-60m”).
- The operating mode category **3** shows the selected settings for auxiliary boom / accessory **3.4**.

**4.7.12 Selecting derrick ballast settings**

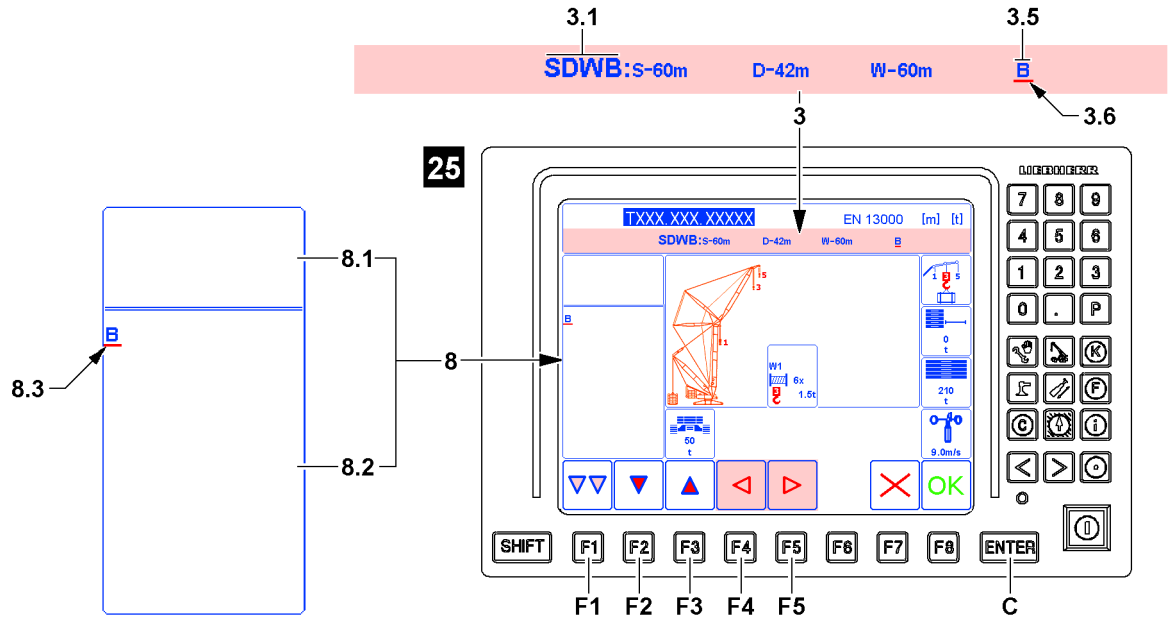


Fig.120581

The derrick ballast **3.5** marker only appears when a corresponding abbreviation **3.1** is selected.



**Note**

If the text for the derrick ballast **3.5** appears in gray, then no additional entries and settings for this marker are possible.

- ▶ Correctly selected markers with gray lettering can be skipped.



**Note**

If the correct derrick ballast **3.5** already appears, then the entries and settings for this marker can be skipped.

- ▶ Press the function key **F5** or function key **F4** until the next marker to be changed is underlined with the selection bar **3.6**.
- ▶ If all entries and settings in the operating mode category **3** are correct, press the function key **F1** and switch to the next category.



**Note**

Whether a suspended ballast or a ballast trailer or the operating mode with removed ballast pallet is used as a derrick ballast **3.5** depends on the selected abbreviation **3.1**.

- ▶ To change between suspended ballast, ballast trailer or the operating mode with removed ballast pallet, see section: “Selecting the abbreviation for the boom system”.
- ▶ Settings regarding the derrick ballast weight are made via the set up functions, see section “Setting the set up functions”.

At first, the operating mode category **3** for the derrick ballast **3.5** must be selected.

- ▶ Press the function key **F5** or function key **F4** until the derrick ballast **3.5** is underlined with the selection bar **3.6** (in the example “B”), see illustration **25**.

LWE/LR 1800-1-0-000/27200-07-02/en

**Result:**

- The lower area **8.2** of the Editing / selection window **8** displays the abbreviations for derrick ballast settings available for selection.

When another derrick ballast setting is available for selection:

- ▶ Press the function key **F2** or function key **F3** until the required derrick ballast setting is underlined with the selection bar **8.3**.

When the required derrick ballast setting is underlined with the selection bar **8.3**:

- ▶ Press the ENTER key **C**.

**Result:**

- The derrick ballast setting is selected.
- The newly selected derrick ballast **3.5** appears in the operating mode category **3**.

**Problem remedy**

Are the required selection for the entries and settings of a marker not available in the operating mode category **3**?

The previously made entries and settings were not made correctly.

In the *Set up* program only entries and settings can be made for which load charts are available.

- ▶ Correct the previously made entries and settings.

**4.7.13 Accepting the entries and settings of the operating mode category**

Make sure that the following prerequisites are met:

- All selected entries and settings in the operating mode category **3** are correct and complete.
- ▶ Press the function key **F1**.

**Result:**

- The entries and settings of the operating mode category are completed.
- The set up completion category is automatically called up.

**Problem remedy**

After pressing the function key **F1**, was it determined that one or several markers are not correct?

By pressing the function key **F1**, the individual program categories can be switched through one after the other. The first program category is called up after the last one.

- ▶ Press the function key **F1** until the operating mode category **3** is called up again. Then all entries and settings can be changed.

## 4.8 Setting the set up functions

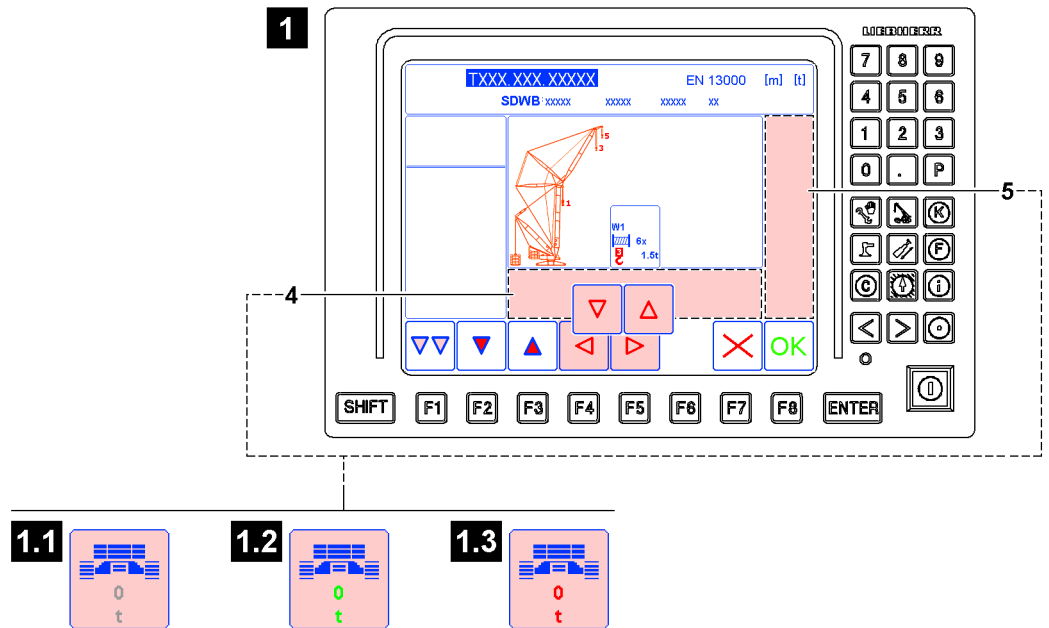


Fig.121745

The set up functions include the set up supplementary category 4 and the environmental influence / mechanical influence category 5, see illustration 1.

The individual set up functions are described as features.

- The set up supplement category 4 includes the lower area of the screen display.
- The environmental / mechanical influence category 5 includes the right area of the screen display.

Depending on the respective load chart, the individual set up functions are assigned to the respective program category.



**Note**

Values in gray letters

Sample illustration 1.1: If the text of the value for the entries and settings appears in gray in one or several of the icons, then no additional entries and settings for this marker are presently possible. All entries and settings are specified by the operating mode category.

- ▶ Correctly selected markers with gray lettering can be skipped.



**Note**

Values in green letters

Sample illustration 1.2: If the text of the value for the entries and settings appears in green in one or several of the icons, then additional entries and settings for this marker are possible.

- ▶ Correctly selected markers with green lettering can be skipped.



**Note**

Values in red letters





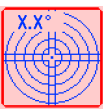

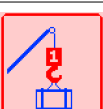
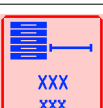
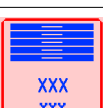
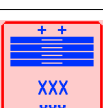
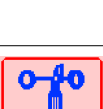
Exemplary illustration 1.3: If the text of the value for the entries and settings appears in red in one or more of the icons, then additional entries and settings for this feature within the chart filter are required.

- ▶ A release for the set up configuration only occurs when none of the values for the entries and settings appear in red.

**Note**

The scope of the markers depends on the crane type and crane configuration.

- Not all crane types have all listed monitoring functions.

Overview of markers of the set up supplement category and the environmental / mechanical influence category	
	<p>Set up function <i>Crane chassis</i></p> <p>Adjustment option for the crane chassis (on crawler travel gear, auxiliary support or assembly support)</p> <p><b>Note:</b> Adjustment option does not appear for all operating modes.</p>
	<p>Set up function <i>Derrick ballast radius</i></p> <p>Adjustment option for the derrick ballast radius</p> <p><b>Note:</b> Adjustment option does not appear for all operating modes.</p>
	<p>Set up function <i>Central ballast</i></p> <p>Adjustment option for the central ballast</p> <p><b>Note:</b> Adjustment option does not appear for all operating modes.</p>
	<p>Set up function <i>Slewing range</i></p> <p>Adjustment option for the crane superstructure slewing range</p> <p><b>Note:</b> Adjustment option does not appear for all operating modes.</p>
	<p>Set up function <i>Incline range</i></p> <p>Adjustment option for the load chart incline range</p> <p><b>Note:</b> Adjustment option does not appear for all operating modes.</p>
	<p><i>Project chart</i> set up function</p> <p>Adjustment option with an available project chart</p> <p><b>Note:</b> Adjustment option does not appear for all crane types and operating modes.</p>
	<p><i>Load position</i> set up function</p> <p>Adjustment option for the position of the load on the boom system</p> <p><b>Note:</b> Adjustment option does not appear for all operating modes.</p>
	<p>Set up function <i>Weight derrick ballast</i></p> <p>Adjustment option for the weight of the derrick ballast on the derrick boom</p> <p><b>Note:</b> Adjustment option does not appear for all operating modes.</p>
	<p>Set up function <i>Counterweight</i></p> <p>Adjustment option for the weight of the counterweight on the crane superstructure</p> <p><b>Note:</b> Adjustment option does not appear for all operating modes.</p>
	<p>Set up function <i>Counterweight on the turntable extension</i></p> <p>Adjustment option for the weight of the counterweight on the turntable extension (crane superstructure)</p> <p><b>Note:</b> Adjustment option does not appear for all operating modes.</p>
	<p>Set up function <i>Wind speed</i></p> <p>Adjustment option for the maximum permissible wind speed of the load chart</p> <p><b>Note:</b> Adjustment option does not appear for all operating modes.</p>

### 4.8.1 Selecting the program category

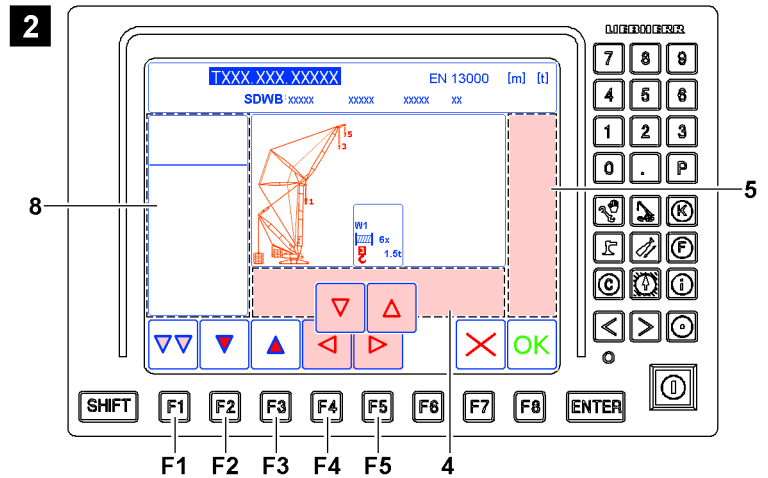


Fig.121746

#### Selecting the set up completion category

- ▶ Press the function key **F1** until the set up completion category **4** is highlighted in pink.

#### Result:

- The set up completion category **4** is selected. A red selection frame surrounds the first marker.
- The Editing / selection window **8** appears.
- The icons for navigation in the individual program categories appear above function key **F2**, function key **F3**, function key **F4** and function key **F5**.



#### Note

Navigation in the set up completion category **4**

- ▶ Press the function key **F4**: The red selection frame moves by one icon to the left.
- ▶ Press the function key **F5**: The red selection frame moves by one icon to the right.
- ▶ If the red selection frame is moved in one direction past the edge of the set up completion category **4** then it enters again from the other direction.



#### Note

Navigation in the Editing / selection window **8**

- ▶ Press the function key **F2**: The selection bar changes downward by one line.
- ▶ Press the function key **F3**: The selection bar changes upward by one line.

#### Selecting the environmental / mechanical influence category

- ▶ Press the function key **F1** until the environmental / mechanical influence category **5** is highlighted in pink.

#### Result:

- The environmental / mechanical influence category **5** is selected. The red selection frame surrounds the first marker.
- The Editing / selection window **8** appears.
- The icons for navigation in the individual program categories appear above function key **F2**, function key **F3**, function key **F4** and function key **F5**.

**Note**

Navigation in the environmental / mechanical influence category **5**

- ▶ Press the function key **F4**: The red selection frame moves down by one icon.
- ▶ Press the function key **F5**: The red selection frame moves up by one icon.
- ▶ If the red selection frame is moved in one direction past the edge of the environmental / mechanical influence category **5** then it enters again from the other direction.

**Note**

Navigation in the Editing / selection window **8**

- ▶ Press the function key **F2**: The selection bar changes downward by one line.
- ▶ Press the function key **F3**: The selection bar changes upward by one line.

## 4.8.2 Setting the crane chassis

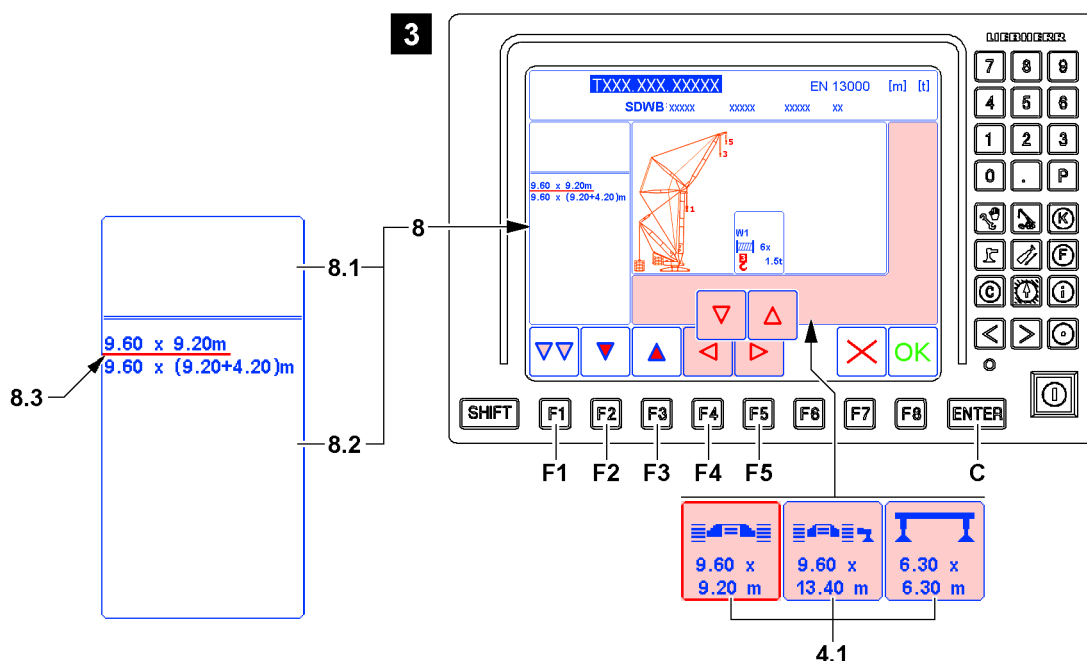


Fig.121747

**Note**

If the correct set up configuration crane chassis **4.1** already appears, then the entries and settings for this marker can be skipped.




- ▶ Press the function key **F5** or the function key **F4** and select the next marker to be changed.

**Note**

The following section describes by example how a certain set up configuration for the crane chassis is set.

- ▶ Always set the required set up configuration for the crane chassis.



<b>Crane chassis set up configuration icons</b>	
	Crane on crawler travel gear <sup>1)</sup>
	Crane on crawler travel gear with auxiliary support installed on one side <sup>1)</sup>
	Crane on assembly support <sup>1)</sup>

1) Only for certain crane types and / or operating modes.

When the respective program category is not yet highlighted in pink:

- ▶ Press the function key **F1** until the respective program category is highlighted in pink.

When the *crane chassis set up configuration* icon **4.1** is not yet bordered in red:

- ▶ Press the function key **F5** or the function key **F4** until the *Set up configuration crane chassis* icon **4.1** is bordered in red.

**Result:**

- The settings available for selection are displayed in the lower area **8.2** of the Editing / selection window **8**, see example illustration **3**.
- ▶ Press the function key **F2** or function key **F3** until the required setting is underlined with the selection bar **8.3** (in the example “9.60 x 9.20m”).

When the required main boom is underlined with the selection bar **8.3**:

- ▶ Press the ENTER key **C**.

**Result:**

- The set up configuration for the crane chassis is selected, the respective icon for the set up configuration crane chassis **4.1** (in the example Crane on crawler travel gear “9.60 x 9.20m”) appears.

### 4.8.3 Setting the derrick ballast radius

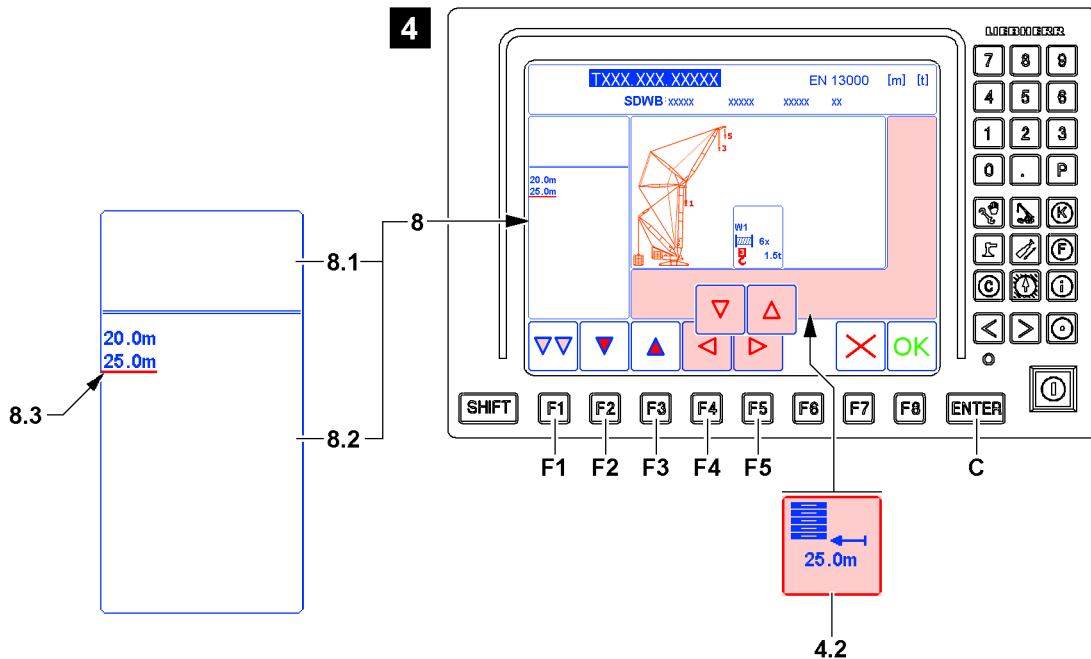


Fig.121756



#### Note

- ▶ The *setting the derrick ballast radius* marker appears only for certain derrick ballast versions.



#### Note

If the correct derrick ballast radius **4.2** already appears, then the entries and settings for this marker can be skipped.

- ▶ Press the function key **F5** or the function key **F4** and select the next marker to be changed.



#### Note

The following section describes by example how a certain derrick ballast radius is set.

- ▶ Always set the required derrick ballast radius.

When the respective program category is not yet highlighted in pink:

- ▶ Press the function key **F1** until the respective program category is highlighted in pink.

When the *Derrick ballast radius* icon **4.2** is not yet bordered in red:

- ▶ Press the function key **F5** or the function key **F4** until the *Derrick ballast radius* icon **4.2** is bordered in red.

#### Result:

- The settings available for selection are displayed in the lower area **8.2** of the Editing / selection window **8**, see example illustration **4**.

- ▶ Press the function key **F2** or function key **F3** until the required setting is underlined with the selection bar **8.3** (in the example “25.0m”).

When the required derrick ballast radius is underlined with the selection bar **8.3**:

- ▶ Press the ENTER key **C**.

#### Result:

- The derrick ballast radius is selected, the respective *Derrick ballast radius* icon **4.2** (in the example “25.0m”) appears.

## 4.8.4 Setting the central ballast

Depending on the crane type and load chart there are two possibilities to set the central ballast:

- Specified settings distances: The central ballast must be selected from a list, see section “Setting the central ballast: Specified settings distances”.
- Stepless settings distances: The central ballast must be entered within a specified range, see section “Setting the central ballast: Stepless settings distances”.

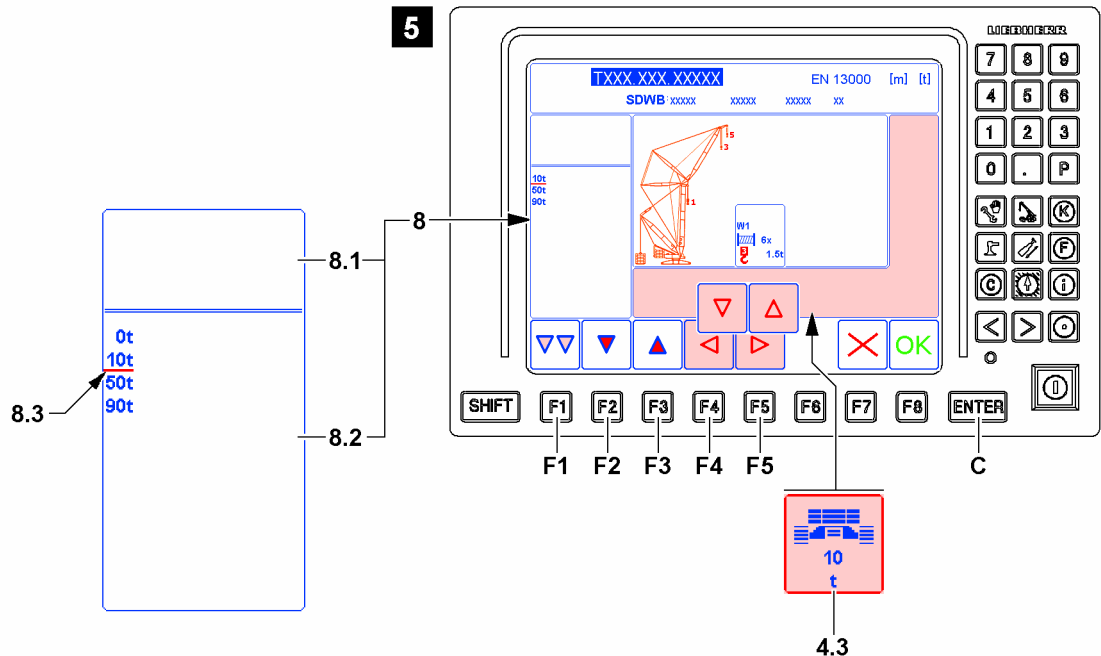


Fig.128075



### Note

If the correct central ballast **4.3** already appears, then the entries and settings for this marker can be skipped.

- ▶ Press the function key **F5** or the function key **F4** and select the next marker to be changed.



### Note

The following section describes by example how a certain central ballast is set.

- ▶ Always set the required central ballast.

### Setting the central ballast: Specified settings distances

When the respective program category is not yet highlighted in pink:

- ▶ Press the function key **F1** until the respective program category is highlighted in pink.

When the *central ballast radius* icon **4.3** is not yet bordered in red:

- ▶ Press the function key **F5** or the function key **F4** until the *Central ballast* icon **4.3** is bordered in red.

### Result:

- The settings available for selection are displayed in the lower area **8.2** of the Editing / selection window **8**, see example illustration **5**.

- ▶ Press the function key **F2** or function key **F3** until the required setting is underlined with the selection bar **8.3**, (in the example “10t”).

When the required central ballast is underlined with the selection bar **8.3**:

- ▶ Press the ENTER key **C**.

**Result:**

- The central ballast is selected, the respective *Central ballast* icon **4.3** (in the example “10t”) appears.

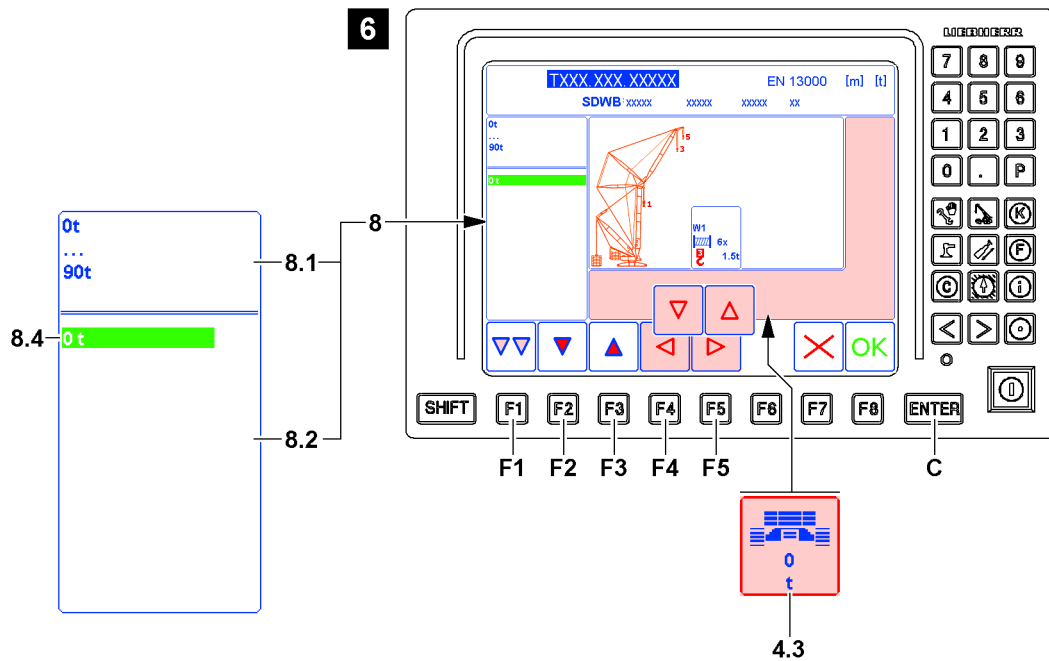
**Setting the central ballast: Stepless settings distances**

Fig.121758

When the respective program category is not yet highlighted in pink:

- ▶ Press the function key **F1** until the respective program category is highlighted in pink.

When the *central ballast radius* icon **4.3** is not yet bordered in red:

- ▶ Press the function key **F5** or the function key **F4** until the *Central ballast* icon **4.3** is bordered in red.

**Result:**

- Illustration **6**:

- The permissible range of the central ballast is displayed in the upper area **8.1** of the Editing / selection window **8**.
- A green field **8.4** with the currently selected central ballast appears in the lower area **8.2** of the Editing / selection window **8**.

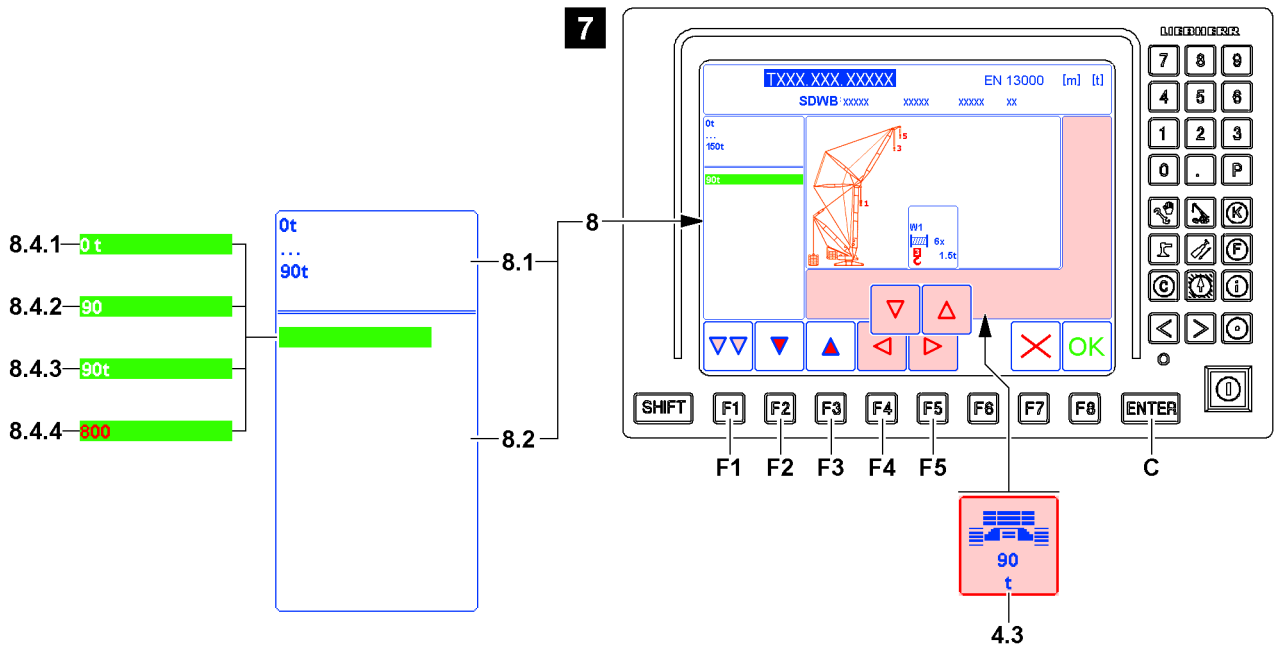


Fig.121744

Illustration 7: The entry is made without the weight unit.

- ▶ Enter the required number sequence using the keypad **A**, in the example “90”.

**Result:**

- The original value **8.4.1** (in the example “0t”) disappears.
- The entered value **8.4.2** (in the example “90”) appears.

- ▶ Press the ENTER key **C**.

**Result:**

- The new value **8.4.3** is taken over and displayed in the *Central ballast* icon **4.3**.

**Problem remedy**

Invalid input value

When trying to accept an invalid input value **8.4.4**, the numbers are shown in red.

Enter only permissible values according to the specifications from the upper area **8.1** of the Editing / selection window **8**.

- ▶ Enter the permissible value via the keypad **A**.

## 4.8.5 Setting the slewing range

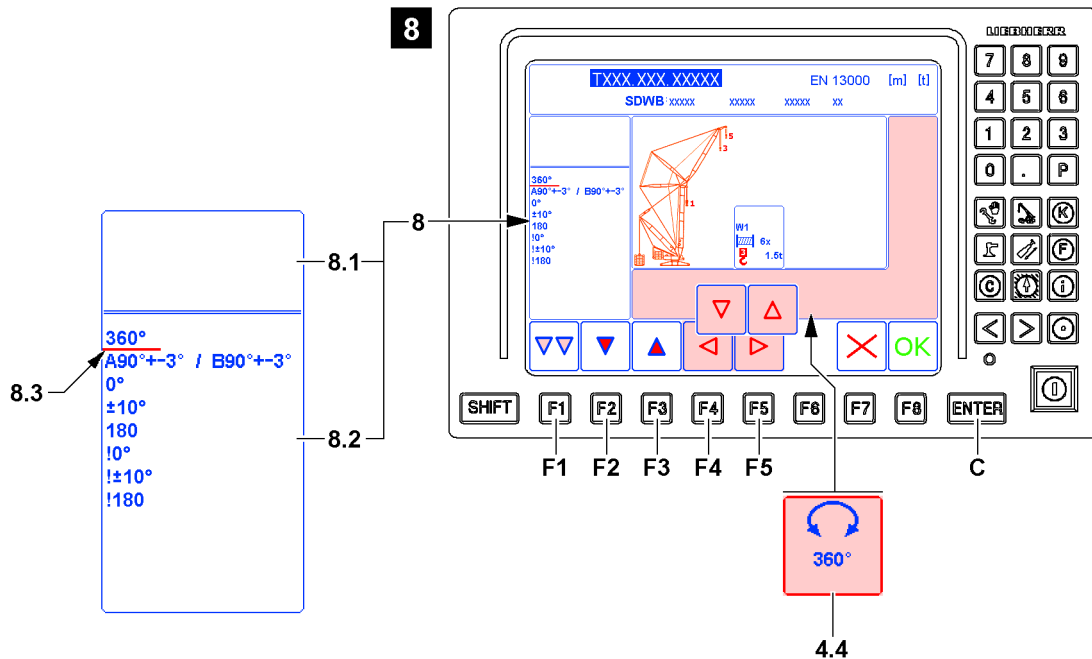


Fig.121759

The turning range **4.4** marker only appears when an alternative setting is possible.



### Note

If the correct slewing range **4.4** already appears, then the entries and settings for this marker can be skipped.

- ▶ Press the function key **F5** or the function key **F4** and select the next marker to be changed.



### Note

The following section describes by example how a certain turning range is selected.

- ▶ Always select the required slewing range.

When the respective program category is not yet highlighted in pink:

- ▶ Press the function key **F1** until the respective program category is highlighted in pink.

When the *Slewing range* icon **4.4** is not yet bordered in red:

- ▶ Press the function key **F5** or the function key **F4** until the *Slewing range* icon **4.4** is bordered in red.

### Result:

- The settings available for selection are displayed in the lower area **8.2** of the Editing / selection window **8**, see the sample list illustration **8**.

When another setting for the slewing range is to be set:

- ▶ Press the function key **F2** or function key **F3** until the required setting is underlined with the selection bar **8.3**, in the example “360°”.

When the required slewing range setting is underlined with the selection bar **8.3**:

- ▶ Press the ENTER key **C**.

### Result:

- The new value is taken over and displayed in the *Slewing range* icon **4.4**.

## 4.8.6 Setting the incline range



### WARNING

Impermissible incline exceeded!

When no incline range is shown, then  $\pm 0.3^\circ$  applies as the largest permissible incline.

- ▶ Never exceed the permissible incline.

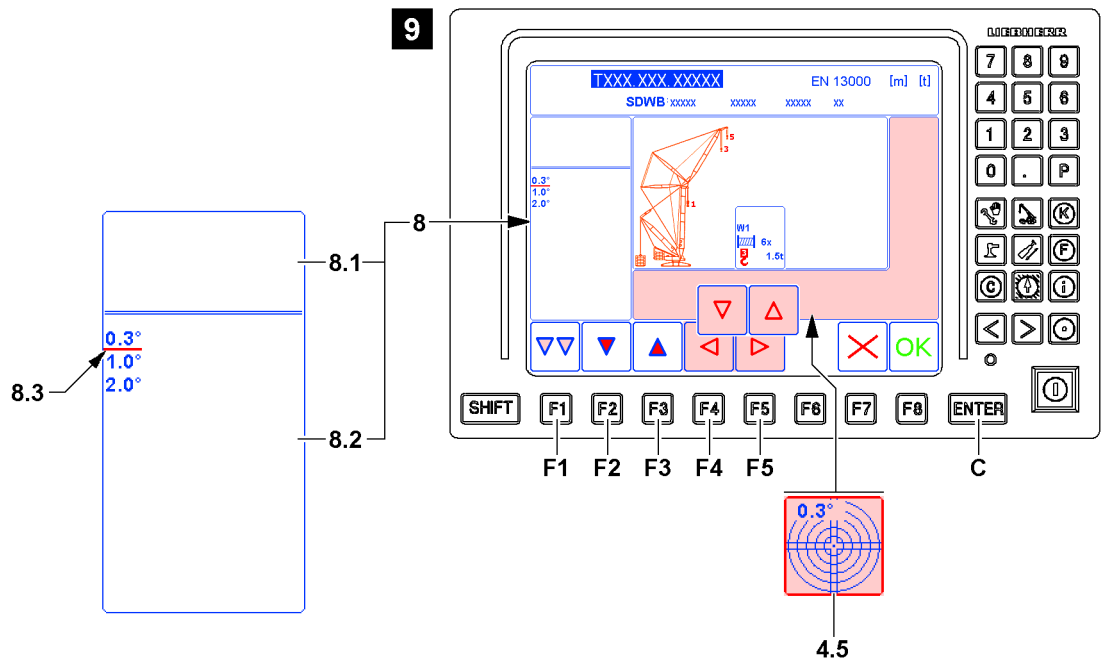


Fig.121760

The incline range cannot be set in all operating modes. If the incline range is not adjustable, then the icon *Incline range* 4.5 is not shown in some operating modes.

There are two possibilities to set the incline range depending on the crane type and load chart:

- Specified settings distances: The incline range must be selected from a list, see section “Setting the incline range: Specified settings distances”.
- Stepless settings distances: The incline range must be entered within a specified range, see section “Setting the incline range: Stepless settings distances”.



### Note

If the correct incline range 4.5 already appears, then the entries and settings for this marker can be skipped.

- ▶ Press the function key **F5** or the function key **F4** and select the next marker to be changed.



### Note

The following section describes by example how a certain incline range is set.

- ▶ Always set the required incline range.

### Setting the incline range: Specified settings distances

When the respective program category is not yet highlighted in pink:

- ▶ Press the function key **F1** until the respective program category is highlighted in pink.

When the *Incline range* icon 4.5 is not yet bordered in red:

- ▶ Press the function key **F5** or the function key **F4** until the *Incline range* icon 4.5 is bordered in red.

**Result:**

- The settings available for selection are displayed in the lower area **8.2** of the Editing / selection window **8**, see example illustration **9**.

- ▶ Press the function key **F2** or function key **F3** until the required setting is underlined with the selection bar **8.3**, (in the example “0.3°”).

When the required incline range is underlined with the selection bar **8.3**:

- ▶ Press the ENTER key **C**.

**Result:**

- The incline range is selected, the respective *Incline range* icon **4.5** (in the example “0.3°”) appears.

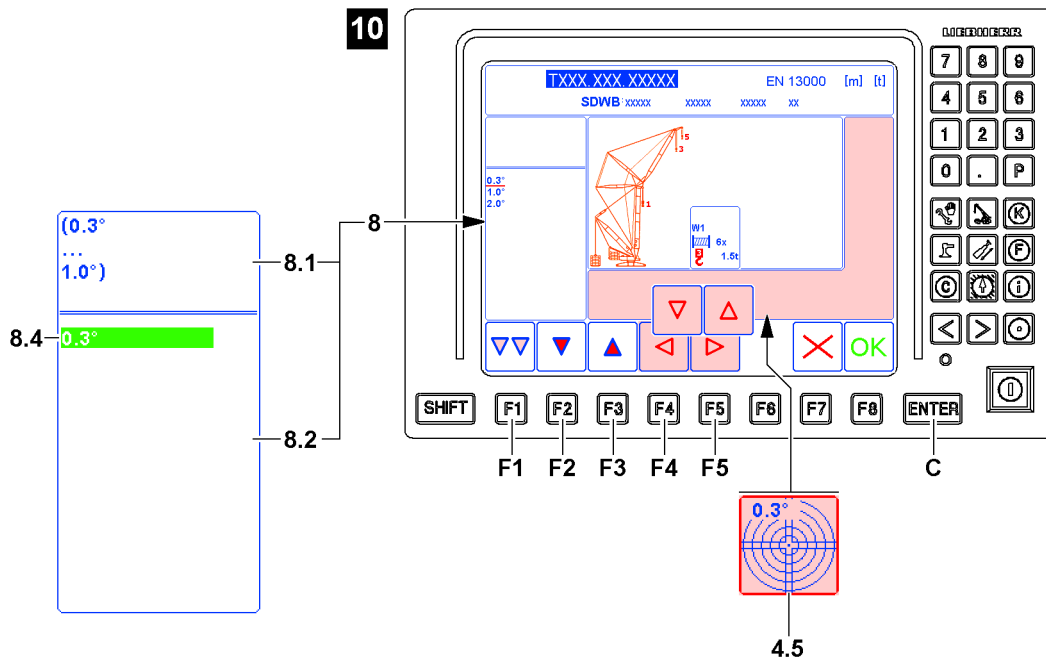
**Setting the incline range: Stepless settings distances**

Fig.121761

When the respective program category is not yet highlighted in pink:

- ▶ Press the function key **F1** until the respective program category is highlighted in pink.

When the *Incline range* icon **4.5** is not yet bordered in red:

- ▶ Press the function key **F4** or the function key **F5** until the *Incline range* icon **4.5** is bordered in red.

**Result:**

Illustration **10**:

- The permissible incline range is displayed in the upper area **8.1** of the Editing / selection window **8**.
- A green field **8.4** with the currently selected incline range appears in the lower area **8.2** of the Editing / selection window **8**.



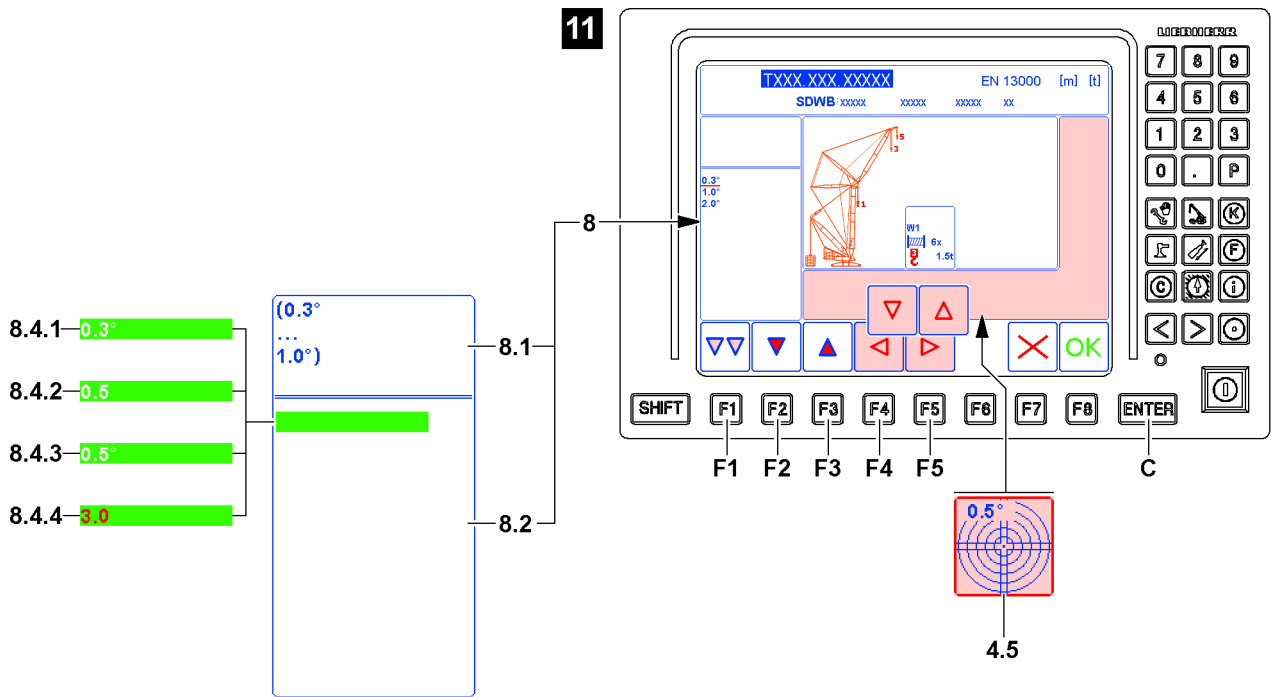


Fig.121762

Illustration 11, the entry is made without the measuring unit.

- ▶ Enter the required number sequence using the keypad **A**, in the example “0.5”.

**Result:**

- The original value **8.4.1** (in the example “0.3°”) disappears.
- The entered value **8.4.2** (in the example “0.5”) appears.

- ▶ Press the ENTER key **C**.

**Result:**

- The new value **8.4.3** (in example “0.5°”) is taken over and shown in the *Incline range* icon **4.5**.

**Problem remedy**

Invalid input value

When trying to accept an invalid input value **8.4.4**, the numbers are shown in red.

Enter only values according to the specifications from the upper area **8.1** of the Editing / selection window **8**.

- ▶ Enter the permissible value via the keypad **A**.

## 4.8.7 Setting the project chart

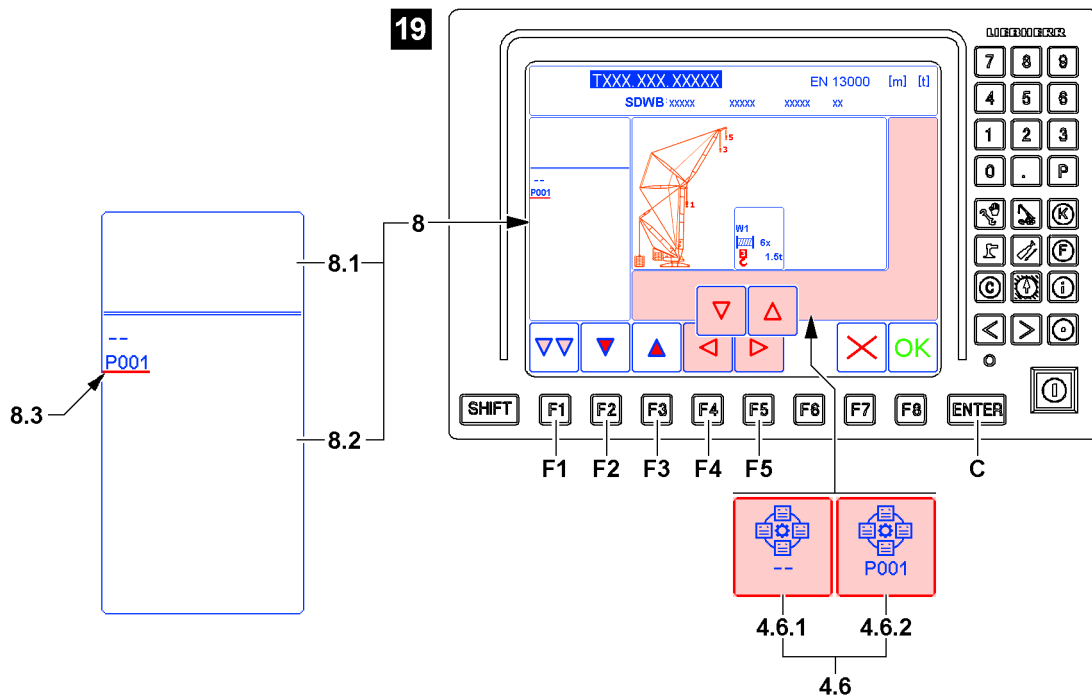


Fig.161656: Setting the project chart



### Note

- ▶ There are project charts only for certain crane types and certain operating modes.

Project charts are load charts for special projects. A project chart results from a set up configuration that was created only for a special project.

If an operating mode is selected for which there is a project chart:

- The *project chart 4.6* marker appears.

*Project chart* marker **4.6**:

- **4.6.1** No project chart set.  
It appears when a general set up configuration is set.
- **4.6.2** Project chart set.  
It appears when a set up configuration for a project chart is set.  
The number of the corresponding project is displayed in the icon (in the example “P001”).

For certain set up conditions, a selection appears in the lower area **8.2** of the editing / selection window **8**. If this is the case, the correct project chart must be set.



### Note

If the correct project chart **4.6** already appears, then the entries and settings for this marker can be skipped.

- ▶ Press the function key **F5** or the function key **F4** and select the next marker to be changed.



### Note

The following section describes by example how a certain project chart is set.

- ▶ Always set the required project chart.

When the respective program category is not yet highlighted in pink:

- ▶ Press the function key **F1** until the respective program category is highlighted in pink.

When the *Project chart* icon **4.6** is not yet bordered in red:

- ▶ Press the function key **F5** or the function key **F4** until the *Project chart* icon **4.6** is bordered in red.

**Result:**

- The settings available for selection are displayed in the lower area **8.2** of the Editing / selection window **8**, see the sample list illustration **19**.

When another setting for the project chart should be set:

- ▶ Press the function key **F2** or function key **F3** until the required setting is underlined with the selection bar **8.3** (in the example “P001”).

When the required project chart setting is underlined with the selection bar **8.3**:

- ▶ Press the ENTER key **C**.

**Result:**

- The new load project chart setting is taken over and displayed in the *project chart* icon **4.6**.

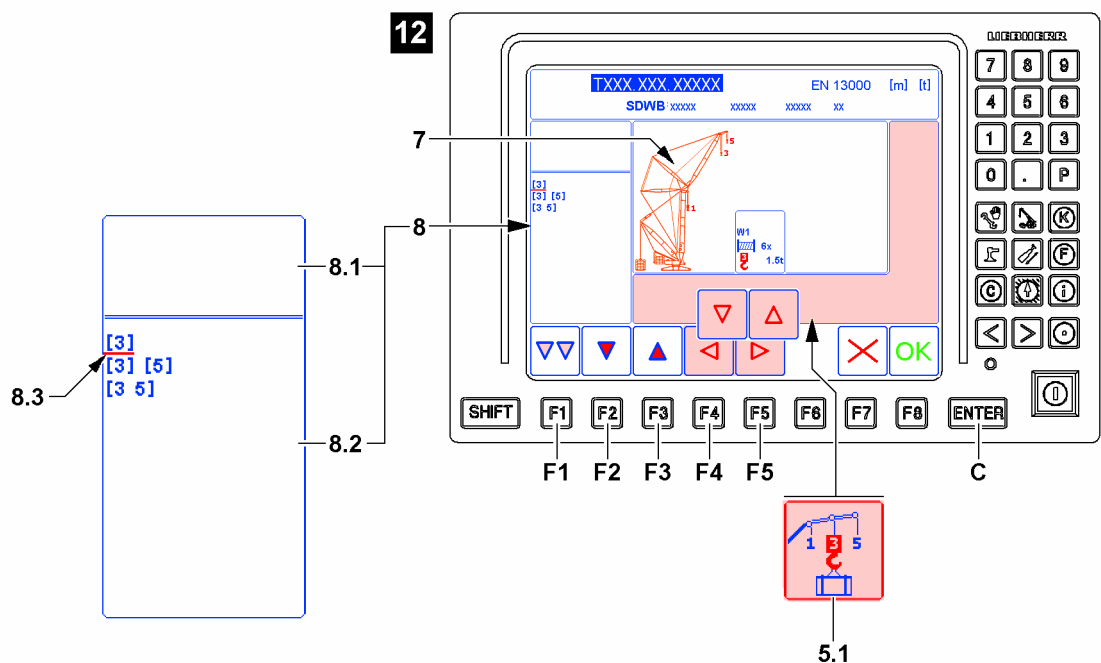
**4.8.8 Setting the load position**

Fig.128082

**Note**

If the correct load position **5.1** already appears, then the settings for this marker can be skipped.

- ▶ Press the function key **F5** or the function key **F4** and select the next marker to be changed.

**Note**

The following section describes by example how a certain load position is selected.

- ▶ Always select the required load position.

When the respective program category is not yet highlighted in pink:

- ▶ Press the function key **F1** until the respective program category is highlighted in pink.

When the *Load position* icon **5.1** is not yet bordered in red:

- ▶ Press the function key **F4** or the function key **F5** until the *Load position* icon **5.1** is bordered in red.

**Result:**

Illustration **12**:

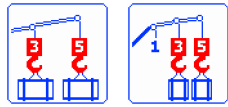
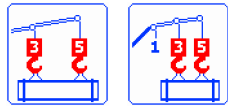
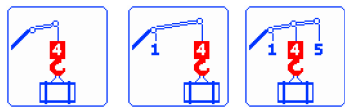
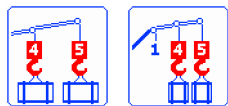
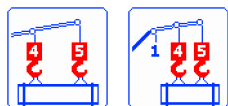
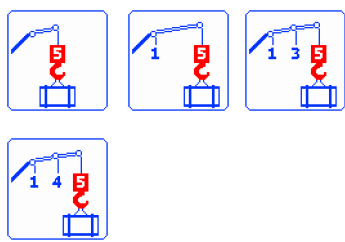
- The *load position* icon **5.1** is bordered in red and activated.
- The possible load positions are displayed in the lower area **8.2** of the Editing / selection window **8**.

**Note**

Possible load positions

- ▶ The possible load positions are visualized in the display window 7.
- ▶ The possible load positions depend on the selected operating mode.

Possible load positions	
Sign / possible icons	Description
[1]	<p>Single hook operation: Hook 1 is reeved on load position 1. A load is fastened on hook 1.</p>
[1] [3]	<p>Two hook operation: Hook 1 is reeved on load position 1. Hook 3 is reeved on load position 3. First load is fastened on hook 1. A second load is fastened on hook 3.</p>
[1] [4]	<p>Two hook operation: Hook 1 is reeved on load position 1. Hook 4 is reeved on load position 4. First load is fastened on hook 1. A second load is fastened on hook 4.</p>
[1] [4] [5]	<p>Two hook operation with boom nose: Hook 1 is reeved in on load position 1. Hook 4 is reeved in on load position 4. Hook 5 is reeved in on load position 5 (boom nose). First load is fastened on hook 1. A second load is fastened on hook 4. The third load is fastened on hook 5.</p>
[1] [4 5]	<p>Two hook operation with boom nose: Hook 1 is reeved in on load position 1. Hook 4 is reeved in on load position 4. Hook 5 is reeved in on load position 5 (boom nose). First load is fastened on hook 1. A combined second load is fastened on hook 4 and hook 5.</p>
[1] [5]	<p>Two hook operation: Hook 1 is reeved on load position 1. Hook 5 is reeved on load position 5. First load is fastened on hook 1. A second load is fastened on hook 5.</p>
[1 3]	<p>Two hook operation: Hook 1 is reeved on load position 1. Hook 3 is reeved on load position 3. A combined load is fastened on hook 1 and hook 3.</p>
[1 4]	<p>Two hook operation: Hook 1 is reeved on load position 1. Hook 4 is reeved on load position 4. A combined load is fastened on hook 1 and hook 4.</p>
[1 5]	<p>Two hook operation: Hook 1 is reeved on load position 1. Hook 5 is reeved on load position 5. A combined load is fastened on hook 1 and hook 5.</p>
[3]	<p>Single hook operation: Hook 3 is reeved on load position 3. A load is fastened on hook 3.</p>

Possible load positions		
Sign / possible icons	Description	
[3] [5]		Two hook operation: Hook 3 is reeved on load position 3. Hook 5 is reeved on load position 5. First load is fastened on hook 3. A second load is fastened on hook 5.
[3 5]		Two hook operation: Hook 3 is reeved on load position 3. Hook 5 is reeved on load position 5. A combined load is fastened on hook 3 and hook 5.
[4]		Single hook operation: Hook 4 is reeved on load position 4. A load is fastened on hook 4.
[4] [5]		Two hook operation: Hook 4 is reeved on load position 4. Hook 5 is reeved on load position 5. First load is fastened on hook 4. A second load is fastened on hook 5.
[4 5]		Two hook operation: Hook 4 is reeved on load position 4. Hook 5 is reeved on load position 5. A combined load is fastened on hook 4 and hook 5.
[5]		Single hook operation: Hook 5 is reeved on load position 5. A load is fastened on hook 5.

- ▶ Press the function key **F2** or function key **F3** until the required load position is underlined with the selection bar **8.3**. For example “[3]”.

When the required load position is underlined with the selection bar **8.3**:

- ▶ Press the ENTER key **C**.

**Result:**

- The load position is selected (example “[3]”).
- The load position is accepted and shown in the *Load position icon 5.1*.

## 4.8.9 Setting the derrick ballast weight

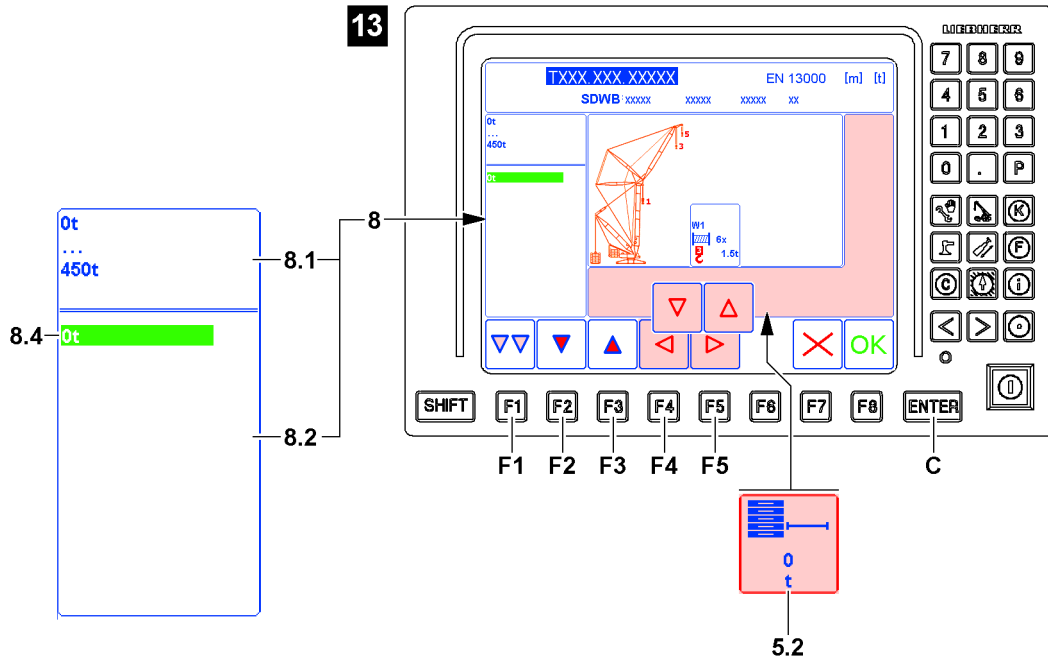


Fig.121764

The derrick ballast weight **5.2** marker only appears when an operating mode with derrick ballast is selected.



### Note

If the correct derrick ballast weight **5.2** already appears, then the entries and settings for this marker can be skipped.

- ▶ Press the function key **F5** or the function key **F4** and select the next marker to be changed.



### Note

The following section describes by example how a certain derrick ballast weight is entered.

- ▶ Always enter the required derrick ballast weight.

When the respective program category is not yet highlighted in pink:

- ▶ Press the function key **F1** until the respective program category is highlighted in pink.

When the *Derrick ballast weight* icon **5.2** is not yet bordered in red:

- ▶ Press the function key **F5** or the function key **F4** until the *Derrick ballast weight* icon **5.2** is bordered in red, see illustration **13**.

### Result:

- The possible range of the derrick ballast weight is displayed in the upper area **8.1** of the Editing / selection window **8**.
- A green field **8.4** with the currently selected derrick ballast weight appears in the lower area **8.2** of the Editing / selection window **8**.

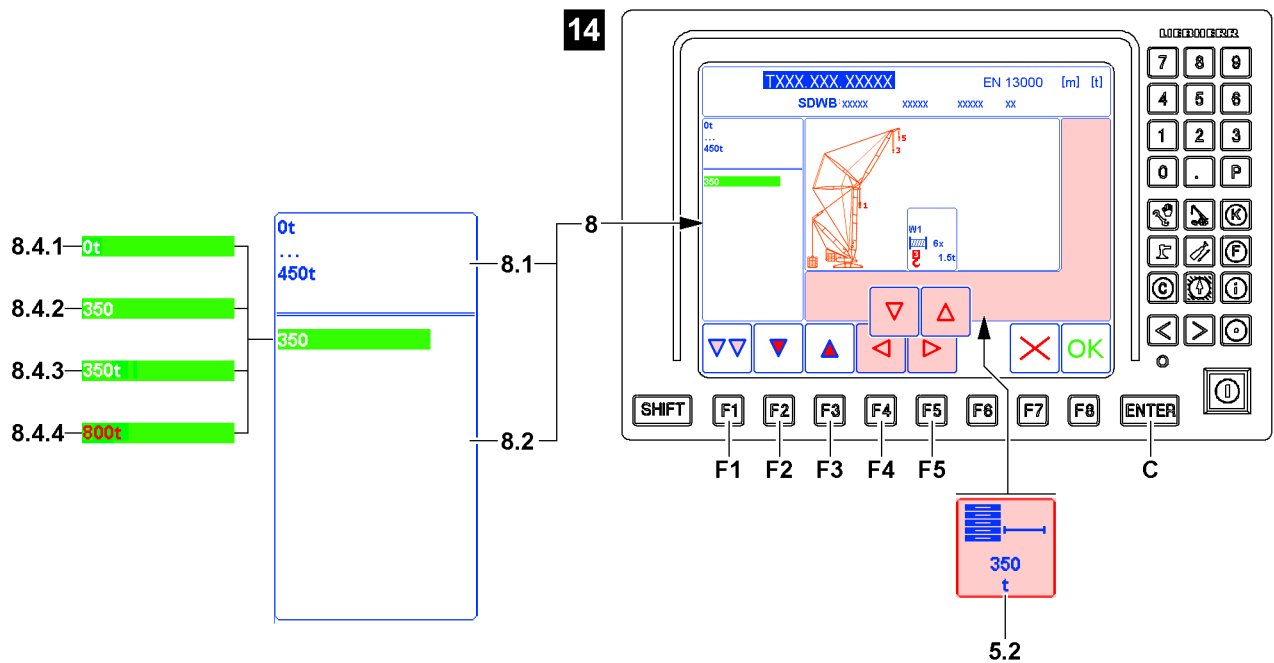


Fig.121765

Illustration 14, the entry is made without the measuring unit:

- ▶ Enter the required number sequence using the keypad **A**, in the example “350”.

**Result:**

- The original value **8.4.1** (in the example “0”) disappears.
- The entered value **8.4.2** (in the example “350”) appears.

- ▶ Press the ENTER key **C**.

**Result:**

- The new value **8.4.3** (in example “350t”) is taken over and shown in the *Derrick ballast weight* icon **5.2**.

**Problem remedy**

Invalid input value

When trying to accept an invalid input value **8.4.4**, the numbers are shown in red.

Enter only values according to the specifications from the upper area **8.1** of the Editing / selection window **8**.

- ▶ Enter the permissible value via the keypad **A**.

#### 4.8.10 Setting the counterweight

Depending on the crane type and load chart there are two possibilities to set the counterweight:

- Specified settings distances: The counterweight must be selected from a list, see section “Setting the counterweight: Specified settings distances”.
- Stepless settings distances: The counterweight must be entered within a specified range, see section “Setting the counterweight: Stepless settings distances”.

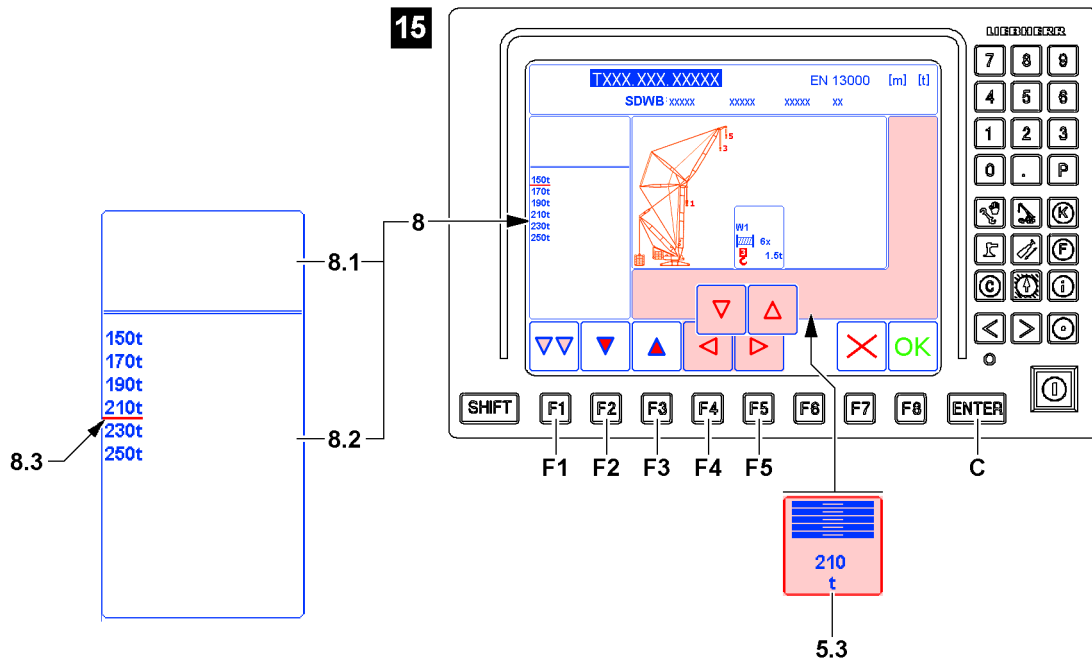


Fig.121766

**Note**

If the correct counterweight **5.3** already appears, then the entries and settings for this marker can be skipped.

- ▶ Press the function key **F5** or the function key **F4** and select the next marker to be changed.

**Note**

The following section describes by example how a certain counterweight is set.

- ▶ Always set the required counterweight.

**Setting the counterweight: Specified settings distances**

When the respective program category is not yet highlighted in pink:

- ▶ Press the function key **F1** until the respective program category is highlighted in pink.

When the *counterweight weight* icon **5.3** is not yet bordered in red:

- ▶ Press the function key **F5** or the function key **F4** until the *Counterweight* icon **5.3** is bordered in red.

**Result:**

- The settings available for selection are displayed in the lower area **8.2** of the Editing / selection window **8**, see example illustration **15**.

- ▶ Press the function key **F2** or function key **F3** until the required setting is underlined with the selection bar **8.3**, (in the example “210t”).

When the required counterweight is underlined with the selection bar **8.3**:

- ▶ Press the ENTER key **C**.

**Result:**

- The counterweight is selected, the respective *Counterweight* icon **5.3** (in the example “210t”) appears.



### Setting the counterweight: Stepless settings distances

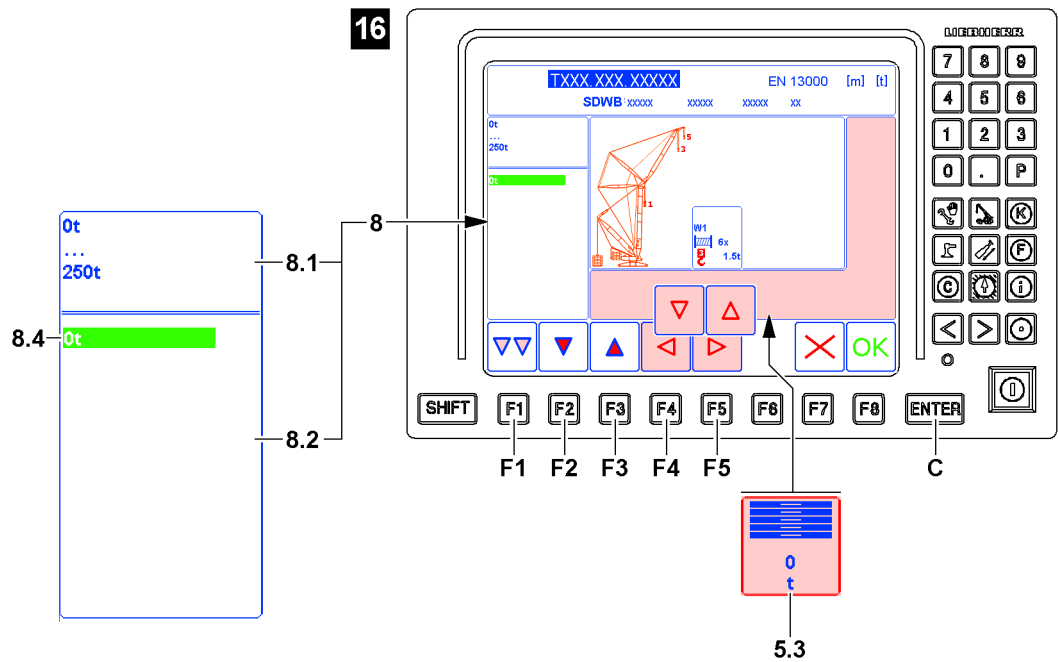


Fig.121767

When the respective program category is not yet highlighted in pink:

- ▶ Press the function key **F1** until the respective program category is highlighted in pink.

When the *counterweight weight* icon **5.3** is not yet bordered in red:

- ▶ Press the function key **F5** or the function key **F4** until the *Counterweight* icon **5.3** is bordered in red.

#### Result:

– Illustration **16**:

- In the upper area **8.1** of the Editing / selection window **8** the permissible range of the counterweight is displayed.
- A green field **8.4** with the currently selected counterweight appears in the lower area **8.2** of the Editing / selection window **8**.

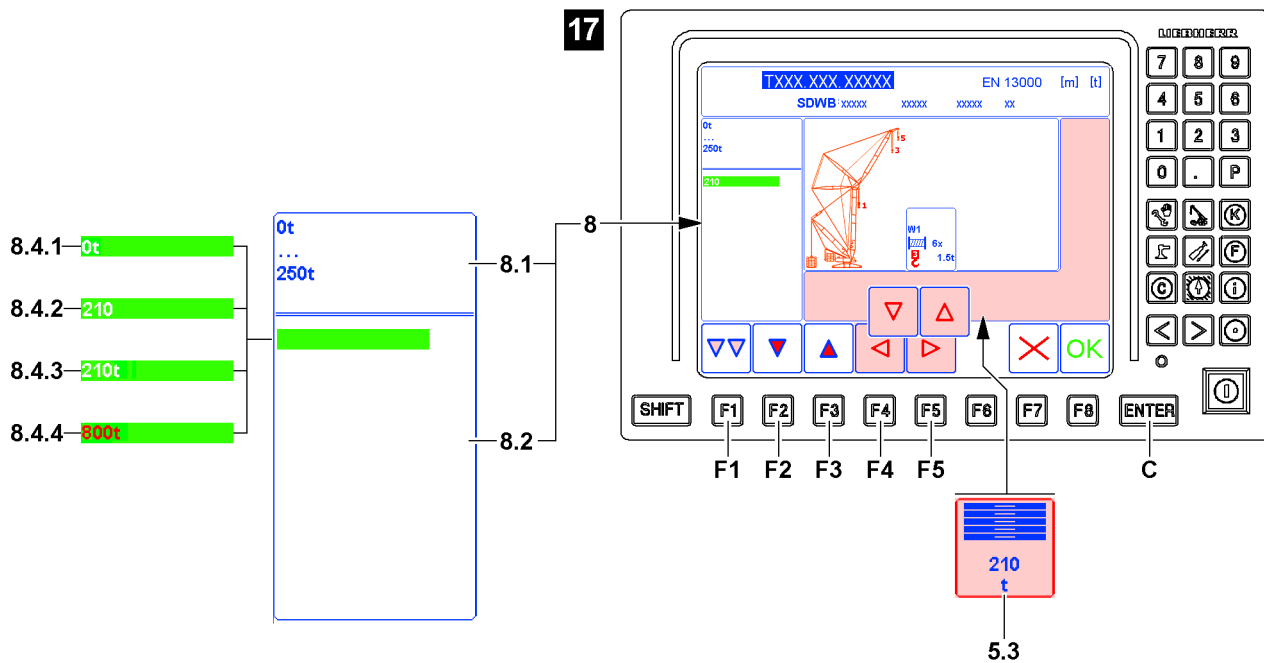


Fig.121768

Illustration 17: The entry is made without the weight unit.

- ▶ Enter the required number sequence using the keypad **A**, in the example “210”.

**Result:**

- The original value **8.4.1** (in the example “0t”) disappears.
- The entered value **8.4.2** (in the example “210”) appears.

- ▶ Press the ENTER key **C**.

**Result:**

- The new value **8.4.3** is taken over and displayed in the *Counterweight* icon **5.3**.

**Problem remedy**

Invalid input value

When trying to accept an invalid input value **8.4.4**, the numbers are shown in red.

Enter only permissible values according to the specifications from the upper area **8.1** of the Editing / selection window **8**.

- ▶ Enter the permissible value via the keypad **A**.

### 4.8.11 Setting the wind speed

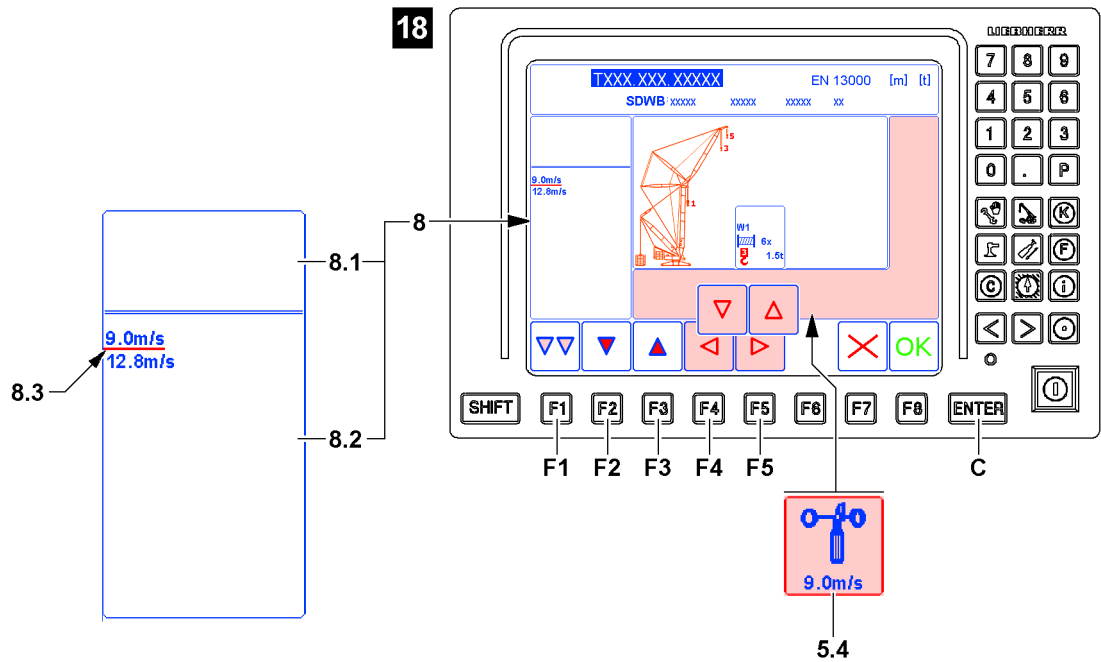


Fig.121769



#### Note

If the correct maximum wind speed **5.4** already appears, then the settings for this marker can be skipped.

- ▶ Press the function key **F5** or the function key **F4** and select the next marker to be changed.



#### Note

The following section describes by example how a certain wind speed is set.

- ▶ Always set the required wind speed.

When the respective program category is not yet highlighted in pink:

- ▶ Press the function key **F1** until the respective program category is highlighted in pink.

When the *wind speed weight* icon **5.4** is not yet bordered in red:

- ▶ Press the function key **F4** or the function key **F5** until the *Wind speed* icon **5.4** is bordered in red, see illustration **18**.

#### Result:

- The possible maximum wind speeds are displayed in the lower area **8.2** of the Editing / selection window **8**.

- ▶ Press the function key **F2** or function key **F3** until the required wind speed is underlined with the selection bar **8.3**. In the example “9.0m/s”.

When the required wind speed is underlined with the selection bar **8.3**:

- ▶ Press the ENTER key **C**.

#### Result:

- The maximum wind speed is selected (example “9.0m/s”).
- The maximum wind speed is accepted and shown in the *Wind speed* icon **5.4**.

### 4.8.12 Accepting the entries and settings

Make sure that the following prerequisites are met:

- All entries and settings in the currently called up program category are correct and complete.

► Press the function key **F1**.

**Result:**

- Entries and settings are completed.
- The next category is automatically called up.

#### Problem remedy

After pressing the function key **F1**, was it determined that one or several markers are not correct?

By pressing the function key **F1**, the individual program categories can be switched through one after the other. The first program category is called up after the last one.

- Press the function key **F1** until the respective program category is called up again. Then all entries and settings can be changed.

## 4.9 Lifting category

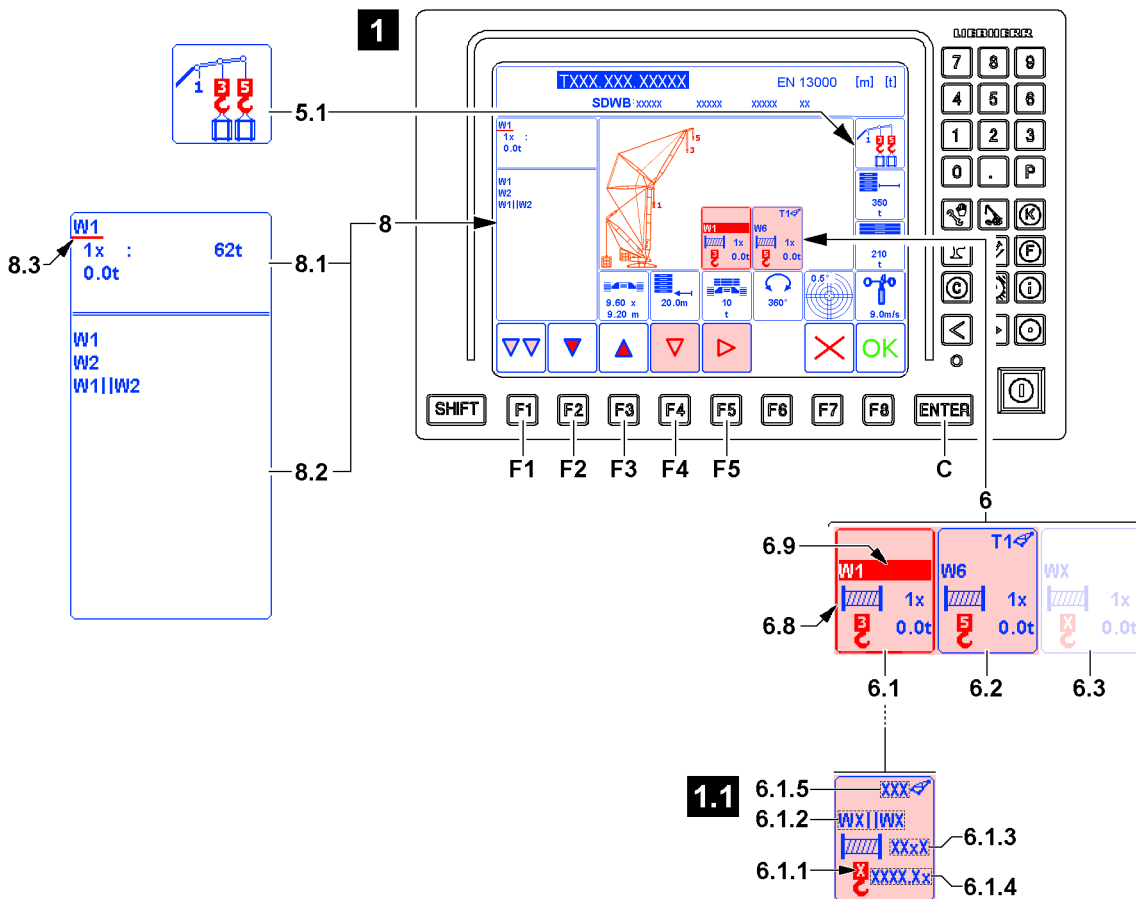


Fig.120603

The lifting category **6** includes, depending on the number of selected load positions, one to three display windows, see illustration **1**.

The display windows are always dependent on the settings for the *Load position* icon **5.1**.

- 6.1** Display window
  - The display window for the first load position
- 6.2** Display window
  - The display window for the second load position

LWE/LR 1800-1-0-000/27200-07-02/en

- **Note:** Appears only when a second load position was selected.
- 6.3** Display window
- Display window for the third load position
  - **Note:** Appears only when a third load position was selected.

Markers in the display window of the respective load position, see illustration 1.1:

- 6.1.1** Load position
- Selected load position
- 6.1.2** Hoist winch
- Assigned hoist winch, in parallel operation\* both assigned hoist winches are shown.
  - Note:** Only active for crane types with winch 1 and winch 2 parallel operation
- 6.1.3** Reeving
- Reeving of an assigned hoist winch
- 6.1.4** Hook block weight
- Weight of reeved hook block
- 6.1.5** Fixed accessory
- Type / kind of fixed accessory
  - **Note:** Appears only when a fixed accessory (load position 5) was selected.

#### 4.9.1 Selecting the lifting category



##### Note

If the correct hoist winch, reeving and accessory, if applicable, are already assigned to a load position, then the settings for this marker can be skipped.

- ▶ Press function key **F2** or function key **F3** until the display window for the next load position is activated.
- ▶ If no other settings are required: Change to the following section "Taking over the entries and settings from the lift category".

- 
- ▶ Press the function key **F1** until the lifting category **6** is highlighted in pink, see illustration 1.

##### Result:

- The lifting category **6** is selected.  
The red selection frame **6.8** surrounds the first display window **6.1**.  
The first marker in the first display window **6.1** is set to active.  
The active marker is always highlighted with a red surface **6.9**.
- The Editing / selection window **8** appears.
- The preselection options are displayed in the upper area **8.1** of the Editing / selection window **8**.  
The first preselection option is automatically underlined and activated with the selection bar **8.3**.
- The lower area **8.2** of the Editing / selection window **8** displays the respective selection possibilities.
- The icons for navigation in the individual program categories appear above function key **F2**, function key **F3**, function key **F4** and function key **F5**.



##### Note

Navigation in the lifting category **6**

Applies only when several display windows are shown.

- ▶ Press the function key **F4**: The red selection frame **6.8** moves by one icon to the left.
- ▶ Press the function key **F5**: The red selection frame **6.8** moves by one icon to the right.
- ▶ If the red selection frame **6.8** is moved in one direction past the edge of the lifting category **6** then it enters again from the other direction.

**Note**

Navigation in the Editing / selection window **8**

- ▶ Press the function key **F2**: The selection bar **8.3** changes downward by one line.
- ▶ Press the function key **F3**: The selection bar **8.3** changes upward by one line.
- ▶ When the upper area **8.1** and the lower area **8.2** are assigned: Press the ENTER key **C** and switch between the upper area **8.1** and the lower area **8.2**.

## 4.9.2 Assigning the hoist winch (normal operation of hoist winch)

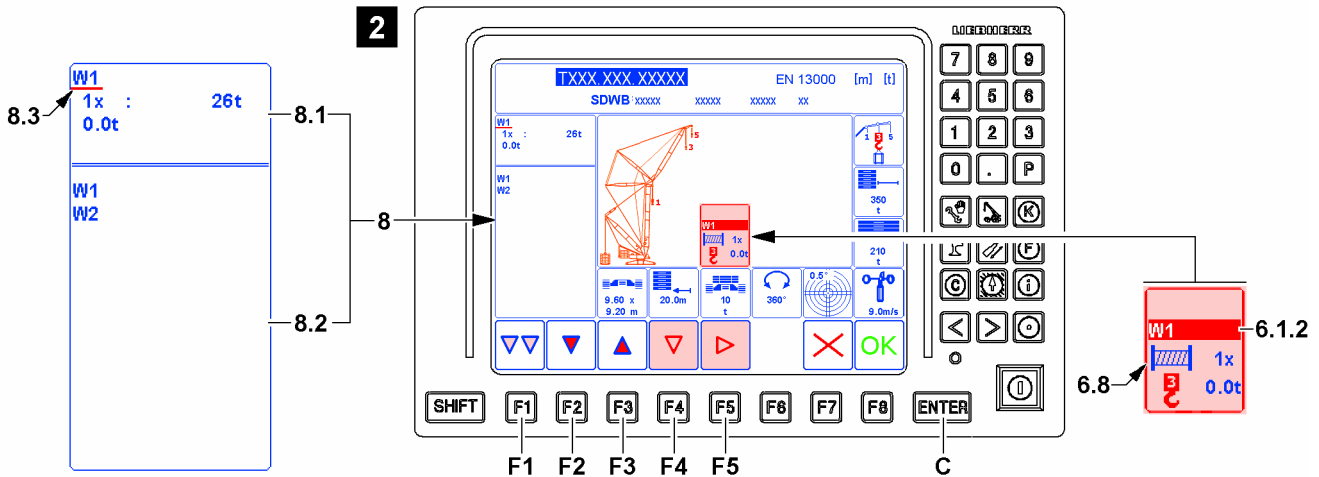


Fig.128076

**Note**

The following section describes by example how **one** certain hoist winch is assigned to a certain load position (normal operation of hoist winch).

- ▶ Always assign the hoist winch to the required load position.

**Note**

Assigning abbreviations for the hoist winches

- ▶ W1: Abbreviation for winch 1.
- ▶ W2: Abbreviation for winch 2\*.
- ▶ W6: Abbreviation for winch 6\*.

Make sure that the following prerequisite is met:

- All entries and settings in the previous program category are correct and complete.

When the desired display window is not marked with the red selection frame **6.8**:

- ▶ Press the function key **F5** or function key **F4** until the red selection frame **6.8** marks the desired display window (in example “load position 3”), see illustration **2**.

**Result:**

- The preselection options are displayed in the upper area **8.1** of the Editing / selection window **8**. The first preselection option is automatically underlined and activated with the selection bar **8.3**.
- The lower area **8.2** of the Editing / selection window **8** displays the respective selection possibilities.

- ▶ Press the function key **F2** or function key **F3** until the hoist winch selection in the upper area **8.1** is underlined with the selection bar **8.3**. (In the example “W1”).

**Result:**

- The display for the assigned hoist winch **6.1.2** is highlighted in red in the active display window.

When the hoist winch selection is underlined with the selection bar **8.3**:

▶ Press the ENTER key **C**.

**Result:**

- The selection bar **8.3** changes in the lower area **8.2** of the Editing / selection window **8**.

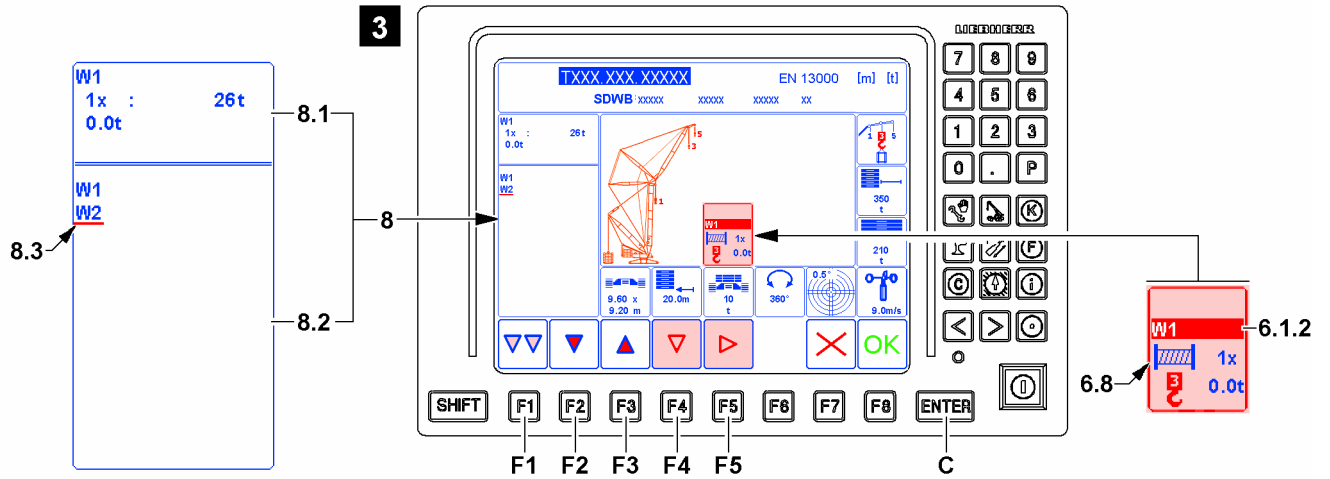


Fig.128077

▶ Press the function key **F2** or function key **F3** until the required selection in the lower area **8.2** is underlined with the selection bar **8.3**, see illustration **3**.

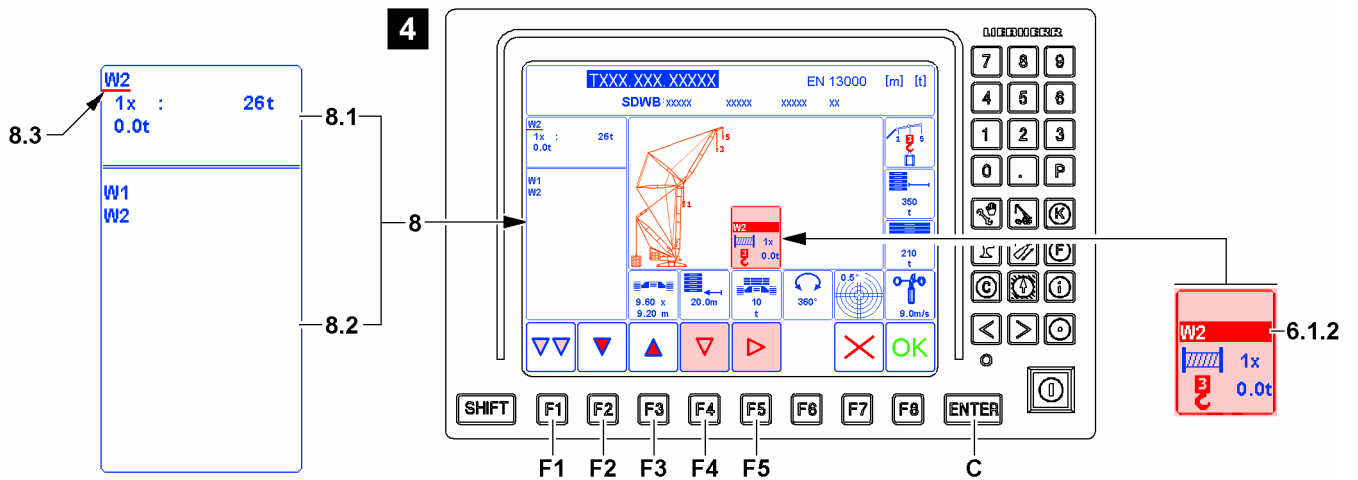


Fig.128078

When the required preselection option is underlined with the selection bar **8.3**:

▶ Press the ENTER key **C**.

**Result:**

- The preselection possibility is defined.
- The new setting appears in the icon for load position 3 as the assigned hoist winch **6.1.2**, see illustration **4**.
- The selection bar **8.3** changes again in the upper area **8.1** of the Editing / selection window **8**.

LWE/LR 1800-1-0-000/27200-07-02/en

### 4.9.3 Assigning the hoist winch (parallel operation of hoist winches)

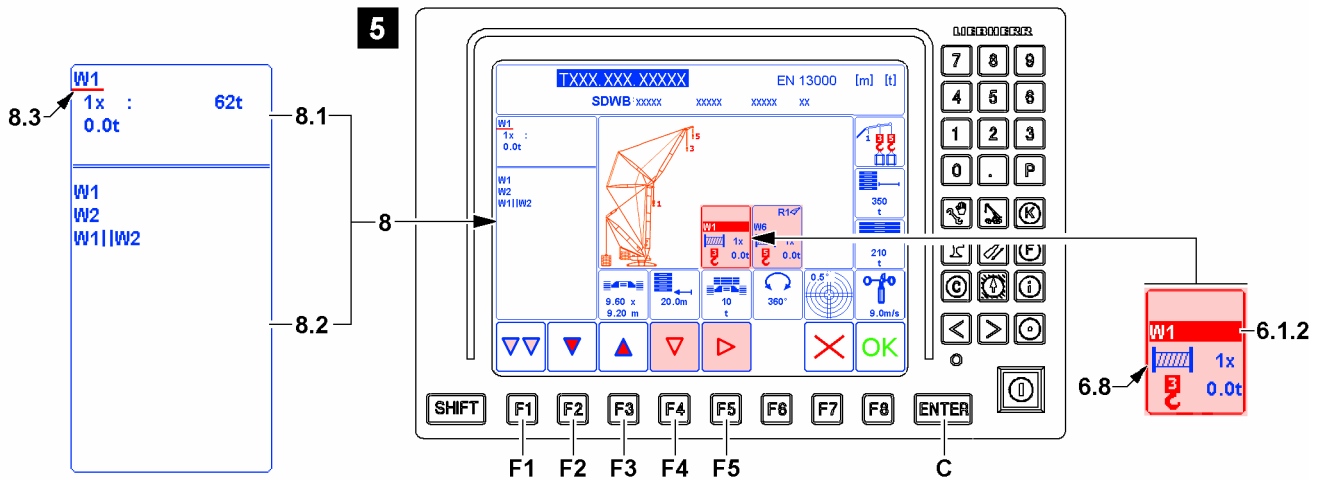


Fig.128079



#### Note

Only active for crane types with winch 1 and winch 2 parallel operation

The following section describes as an example how **two** hoist winches are assigned to a certain load position (parallel operation of hoist winches).

- ▶ Always assign the hoist winches to the required load position.



#### Note

Assigning abbreviations for the hoist winches

- ▶ W1: Abbreviation for winch 1.
- ▶ W2: Abbreviation for winch 2\*.
- ▶ W6: Abbreviation for winch 6\*.

Make sure that the following prerequisite is met:

- All entries and settings in the previous program category are correct and complete.

When the desired display window is not marked with the red selection frame 6.8:

- ▶ Press the function key **F5** or function key **F4** until the red selection frame 6.8 marks the desired display window (in example “load position 3”), see illustration 5.

#### Result:

- The preselection options are displayed in the upper area 8.1 of the Editing / selection window 8. The first preselection option is automatically underlined and activated with the selection bar 8.3.
- The lower area 8.2 of the Editing / selection window 8 displays the respective selection possibilities.

- ▶ Press the function key **F2** or function key **F3** until the hoist winch selection in the upper area 8.1 is underlined with the selection bar 8.3. (In the example “W1”).

#### Result:

- The display for the assigned hoist winch 6.1.2 is highlighted in red in the active display window.

When the hoist winch selection is underlined with the selection bar 8.3:

- ▶ Press the ENTER key **C**.

#### Result:

- The selection bar 8.3 changes in the lower area 8.2 of the Editing / selection window 8.



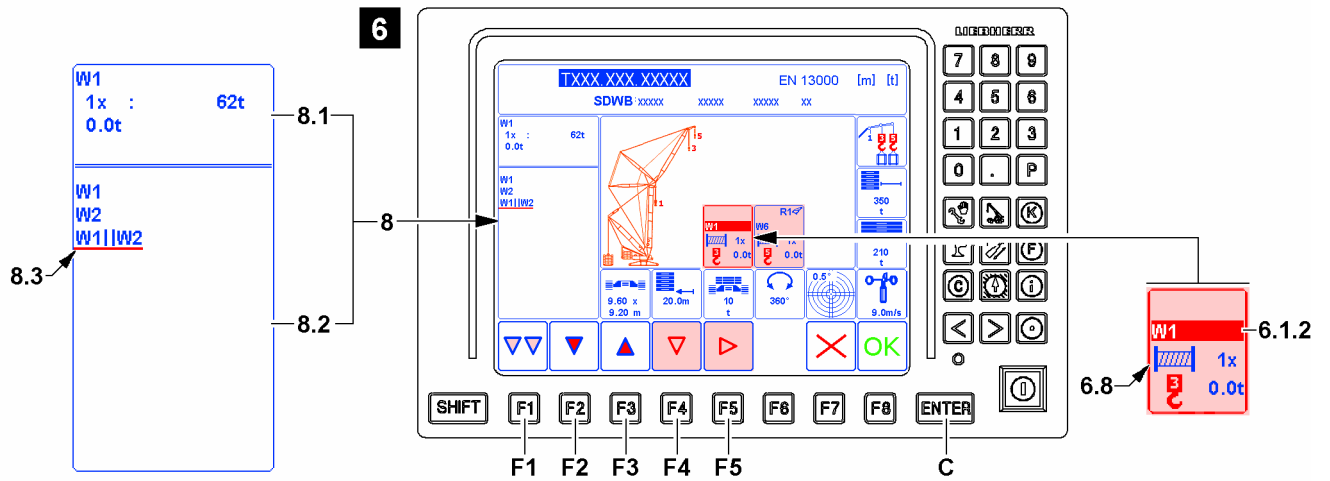


Fig.128080

- ▶ Press the function key **F2** or function key **F3** until the required selection in the upper area 8.2 is underlined with the selection bar 8.3. (For example “Parallel operation WI and WII”), see illustration 6.

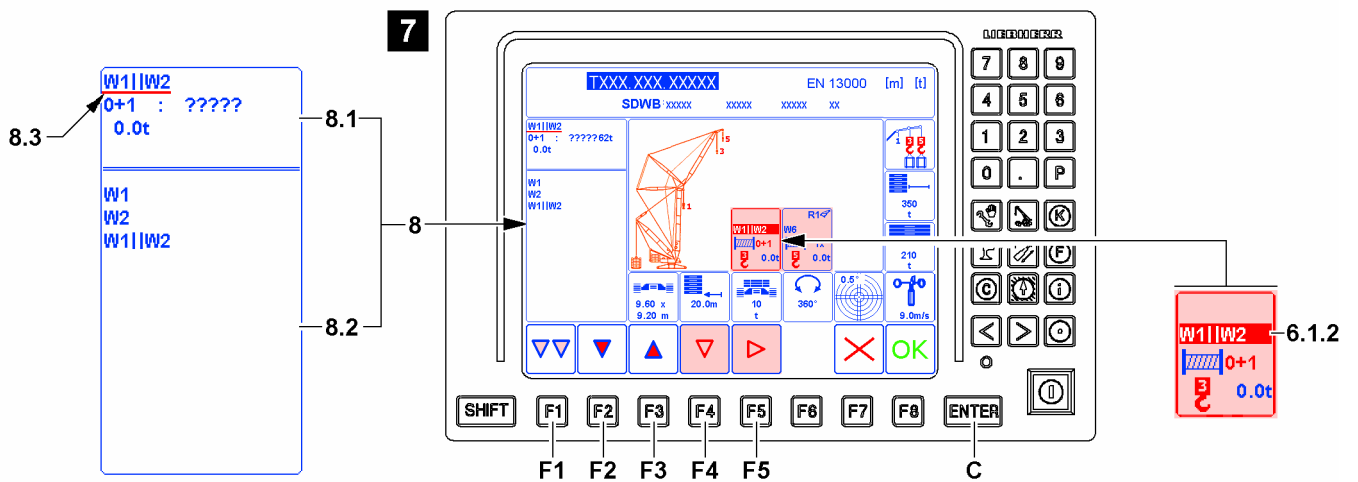


Fig.128081

When the required preselection option is underlined with the selection bar 8.3:

- ▶ Press the ENTER key **C**.

**Result:**

- The preselection possibility is defined (In example “Parallel operation WI and WII”).
- The new setting appears in the icon for load position 3 as the assigned hoist winch 6.1.2, see illustration 7.
- The selection bar 8.3 changes again in the upper area 8.1 of the Editing / selection window 8.

#### 4.9.4 Assigning the reeving (normal operation of hoist winch)

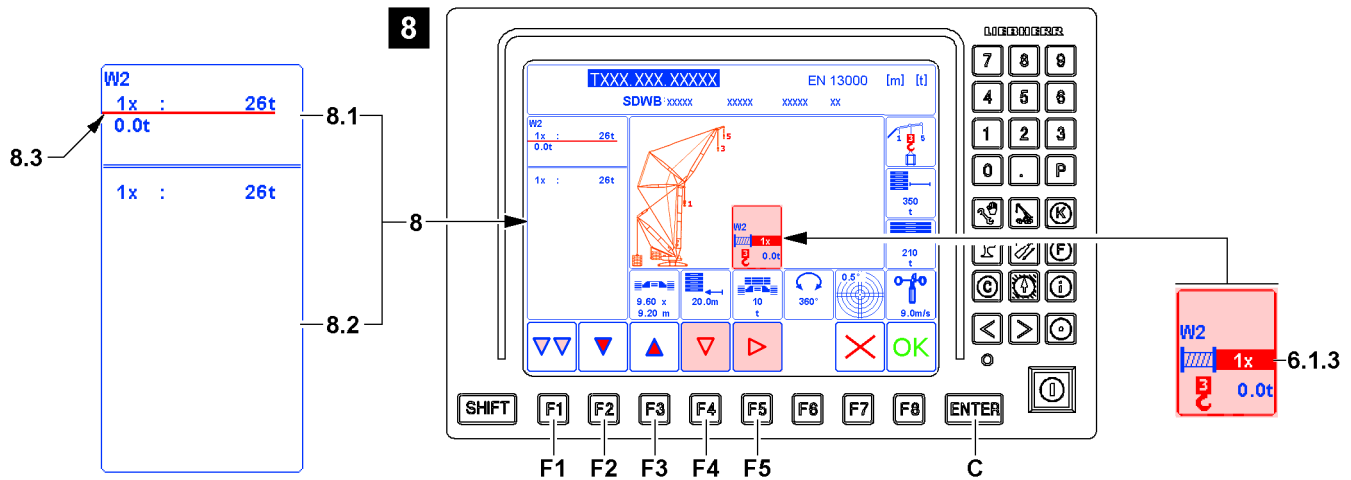


Fig.128083



#### Note

The following section describes by example how a certain reeving for normal operation of hoist winch is assigned.

- ▶ Always assign the required reeving.



#### Note

If the correct reeving 6.1.3 already appears, then the settings for this marker can be skipped.

Change to the next marker (if present):

- ▶ Press the function key **F2** or function key **F3** until the next marker to be changed is underlined with the selection bar 8.3.

Change to the next display window (if present):

- ▶ Press the function key **F5** or the function key **F4** and select the next display window.

End the *Set up* program (when all entries and settings are made):

- ▶ When all entries and settings in the lifting category 6 are correct, see section "Taking over entries and settings from the set up program".

- The preselection options are displayed in the upper area 8.1 of the Editing / selection window 8. The first preselection option is automatically underlined and activated with the selection bar 8.3.
- The lower area 8.2 of the Editing / selection window 8 displays the respective selection possibilities.



#### Note

The following section describes by means of an example how a certain reeving is entered.

- ▶ Always enter the required reeving.

- ▶ Press the function key **F2** or function key **F3** until the reeving in the upper area 8.1 is underlined with the selection bar 8.3. (For example "1x : 12.6t"), see illustration 8.

#### Result:

- The display for the reeving 6.1.3 is highlighted in red in the active display window.

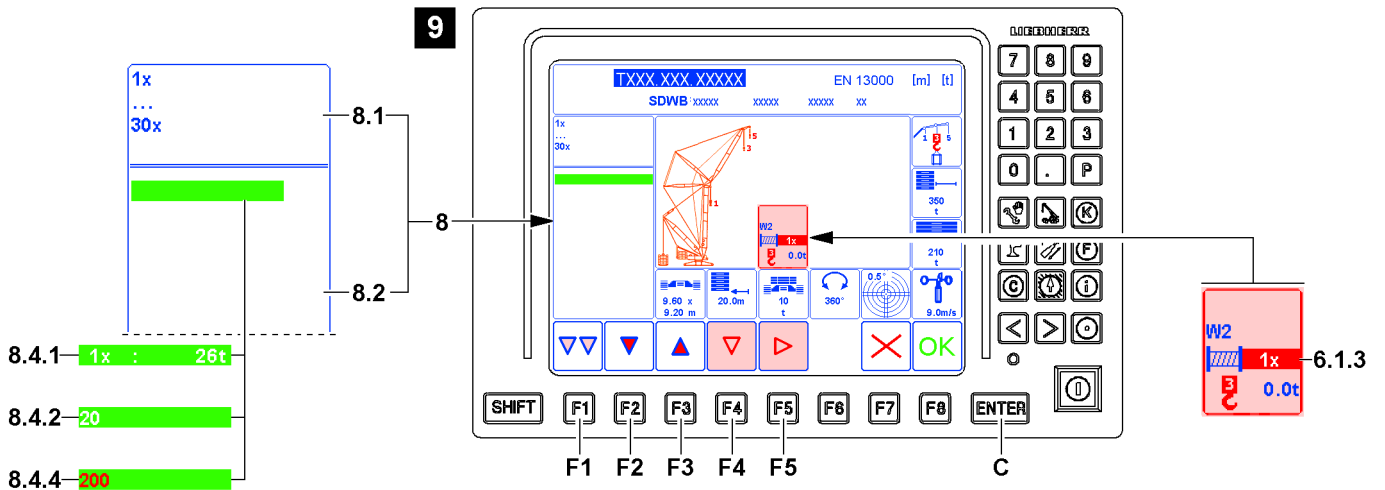


Fig.128084

When the reeving is underlined with the selection bar 8.3:

- ▶ Press the ENTER key C.

**Result:**

- The permissible reeving values are displayed in the upper area 8.1 of the Editing / selection window 8, see illustration 9.
- A green input field with the reeving value from the upper area 8.1 appears in the lower area 8.2 of the Editing / selection window 8.

- ▶ Enter the required number sequence using the keypad A, in the example “20”.

**Result:**

- The original value 8.4.1 (in example “1x : 12.6t”) disappears.
- The new value 8.4.2 (in the example “20”) appears.

**Problem remedy**

Invalid input value

When trying to accept an invalid input value 8.4.4, the numbers are shown in red.

Enter only values according to the specifications from the upper area 8.1 of the Editing / selection window 8.

- ▶ Enter the permissible value via the keypad A.

LWE/LR-1800-1-0-000/27200-07-02/en

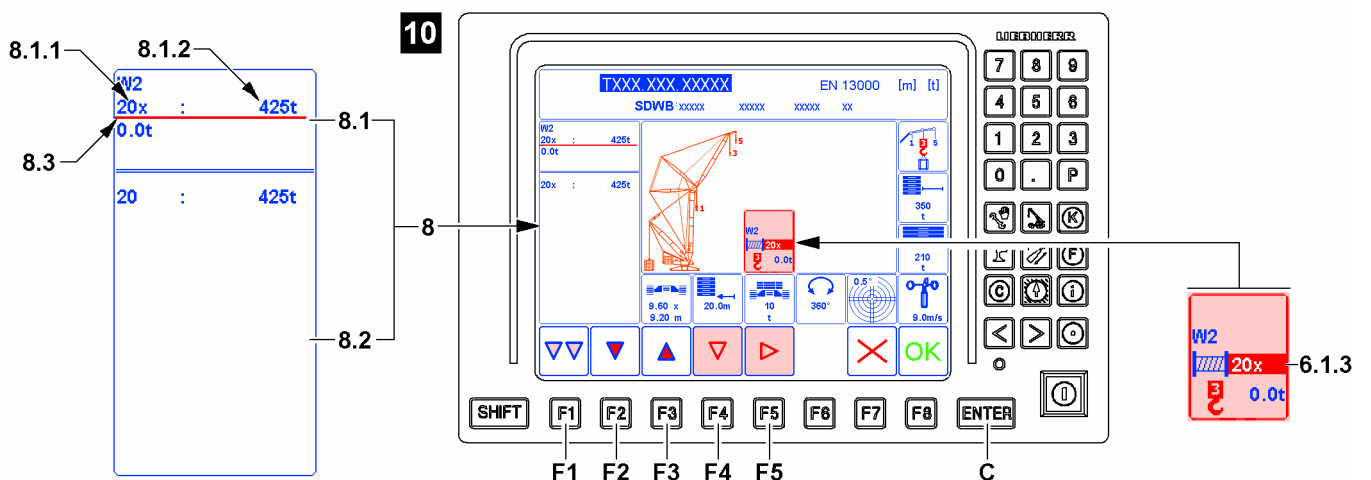


Fig.128085

- ▶ Press the ENTER key C.

**Result:**

- The new value is taken over, see illustration 10.
- The new value for the reeving **6.1.3** appears in the display window.
- The upper area **8.1** displays the entered reeving **8.1.1**. In addition, the maximum load **8.1.2** that could be lifted with this reeving under ideal conditions appears.

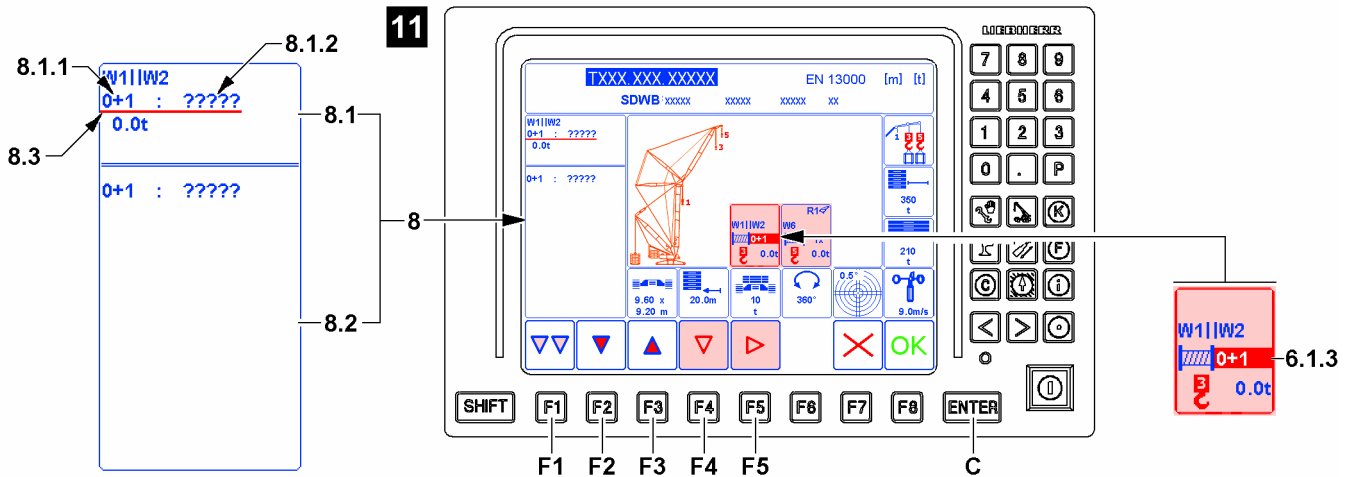
**4.9.5 Assigning the reeving (parallel operation of hoist winch)**

Fig.128086

**Note**

Only active for crane types with winch 1 and winch 2 parallel operation

The following section describes as an example how a certain reeving for parallel operation of hoist winch is assigned.

- ▶ Always assign the required reeving.

**Note**

Illustration 11: If question marks (“?”) appear behind the reeving number **8.1.1**, then no valid reeving has been entered.

If the icon **OK** turns off above the function key **F8**, then an invalid selection is active.

- ▶ A valid reeving must now be entered.

**Note****Effect of single / parallel operation of hoist winches for the reeving line**

Changes for values for the reeving **8.1.1** and the maximum load **8.1.2**:

The current reeving are added together when changing from the parallel operation of hoist winches to single operation of one hoist winch.

When changing from single operation of one hoist winch to parallel operation of two hoist winches, the current reeving **8.1.1** is divided.

If the number cannot be divided, question marks (“?”) or the value “0.0” appear instead of a maximum load **8.1.2**, see illustration 11.

- ▶ A valid reeving must be entered.
- ▶ For the subsequent procedure, see the following section “Assigning reeving”.

- The preselection options are displayed in the upper area **8.1** of the Editing / selection window **8**. The first preselection option is automatically underlined and activated with the selection bar **8.3**.
- The lower area **8.2** of the editing / selection window **8** displays the respective selection possibilities.

**Note**

The following section describes by means of an example how a certain reeving is entered.

► Always enter the required reeving.

► Press the function key **F2** or function key **F3** until the reeving in the upper area **8.1** is underlined with the selection bar **8.3**. (For example “0+1 : ?????”).

**Result:**

– The display for the reeving **6.1.3** is highlighted in red in the active display window.

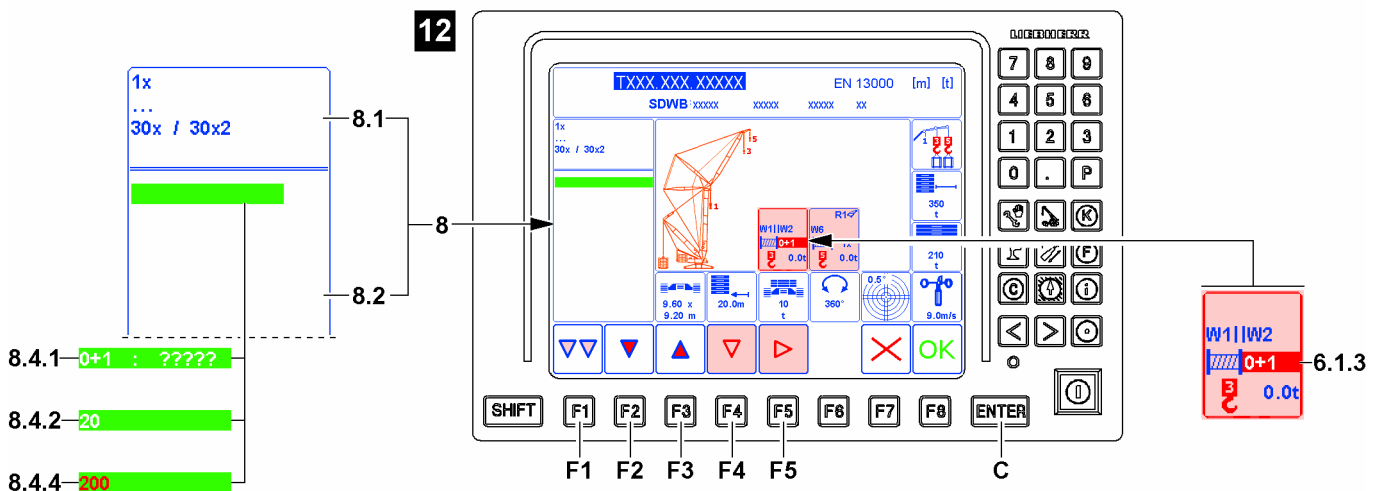


Fig.128087

When the reeving is underlined with the selection bar **8.3**:

► Press the ENTER key **C**.

**Result:**

- The permissible reeving is displayed in the upper area **8.1** of the Editing / selection window **8**, see illustration **12**.
- A green input field with the reeving value from the upper area **8.1** appears in the lower area **8.2** of the Editing / selection window **8**.

**Note**

► Always only one value must be entered for the reeving. In parallel operation\*, the abbreviation “x2” is automatically added to the value and the value is assigned to both hoist winches.

► Enter the required number sequence using the keypad **A**, in the example “20”.

**Result:**

- The original value **8.4.1** (in the example “0+1 : ?????”) disappears.
- The new value **8.4.2** (in the example “20”) appears.

**Problem remedy**

Invalid input value

When trying to accept an invalid input value **8.4.4**, the numbers are shown in red.

Enter only values according to the specifications from the upper area **8.1** of the Editing / selection window **8**.

► Enter the permissible value via the keypad **A**.

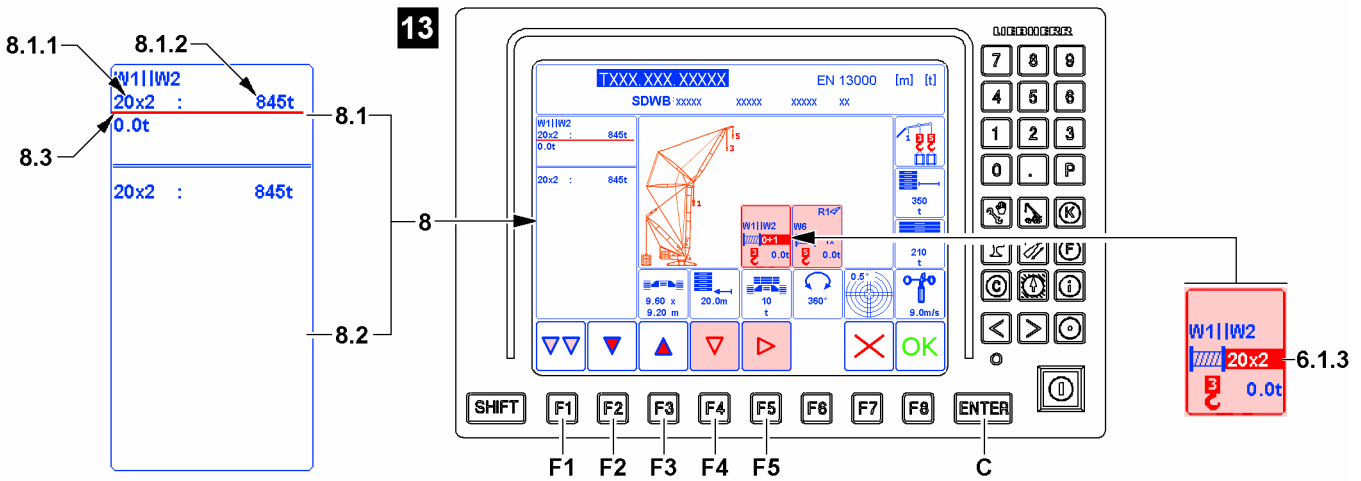


Fig.128088

► Press the ENTER key C.

**Result:**

- The new value is accepted and changed for parallel operation if necessary, see illustration 13.
- The new value for the reeving 6.1.3 appears in the display window.
- The upper area 8.1 displays the entered reeving 8.1.1. In addition, the maximum load 8.1.2 that could be lifted with this reeving under ideal conditions appears.

### 4.9.6 Entering the hook block weight

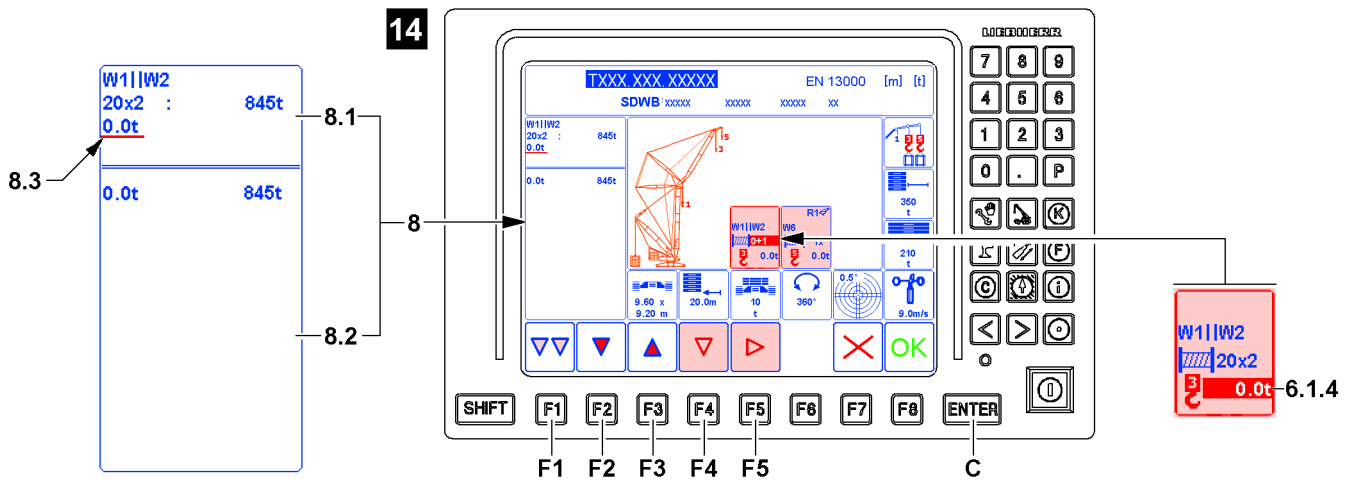


Fig.128089



**Note**

If the correct hook block weight **6.1.4** already appears, then the settings for this marker can be skipped.

Change to the next marker (if present):

- ▶ Press the function key **F2** or function key **F3** until the next marker to be changed is underlined with the selection bar **8.3**.

Change to the next display window (if present):

- ▶ Press the function key **F5** or the function key **F4** and select the next display window.

End the *Set up* program (when all entries and settings are made):

- ▶ When all entries and settings in the lifting category **6** are correct, see section “Taking over entries and settings from the set up program”.

- The preselection options are displayed in the upper area **8.1** of the Editing / selection window **8**. The first preselection option is automatically underlined and activated with the selection bar **8.3**.
- The lower area **8.2** of the Editing / selection window **8** displays the respective selection possibilities.



**Note**

The following section describes by example how a certain hook block weight is entered.

- ▶ Always enter the required hook block weight.

- ▶ Press the function key **F2** or function key **F3** until the hook block weight in the upper area **8.1** is underlined with the selection bar **8.3**. (In the example “0.0t”).

**Result:**

- The display for the hook block weight **6.1.4** is highlighted in red in the active display window.

When the hook block weight is underlined with the selection bar **8.3**, see illustration **14**:

- ▶ Press the ENTER key **C**.

**Result:**

- The permissible hook block weight is displayed in the upper area **8.1** of the Editing / selection window **8**.
- A green input field with the hook block weight from the upper area **8.1** appears in the lower area **8.2** of the Editing / selection window **8**.

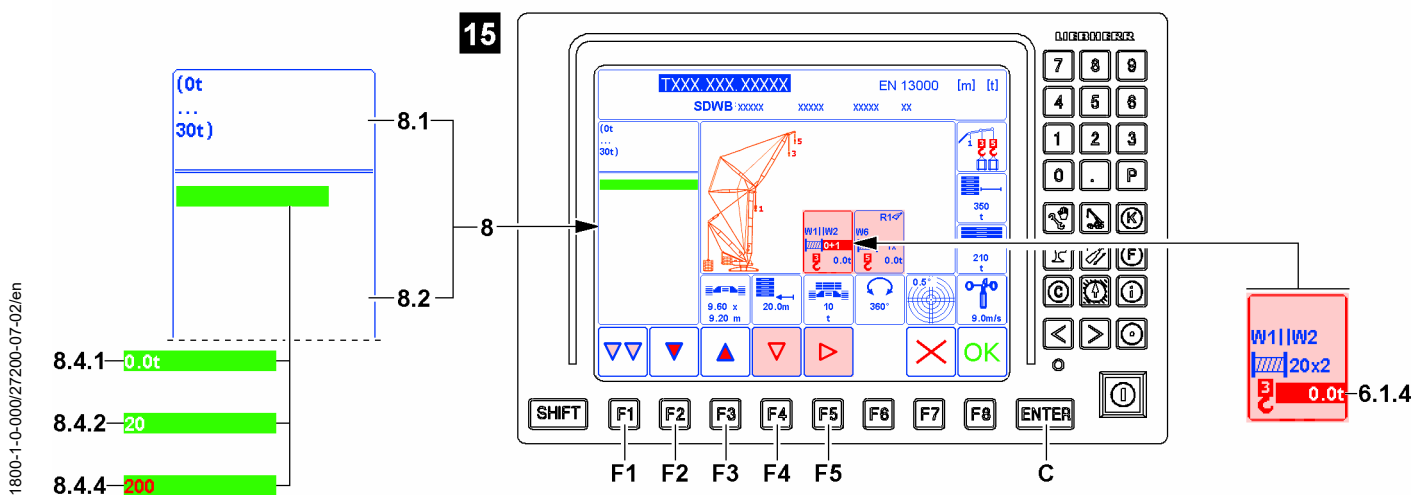


Fig.128090

The entry is made without the measuring unit:

- ▶ Enter the required number sequence using the keypad **A**, in the example “20”.

LWE/LR 1800-1-0-000/27200-07-02/en

**Result:**

**Illustration 15:**

- The original value **8.4.1** (in the example "0t") disappears.
- The new value **8.4.2** (in the example "20") appears.

**Problem remedy**

Invalid input value

When trying to accept an invalid input value **8.4.4**, the numbers are shown in red.

Enter only values according to the specifications from the upper area **8.1** of the Editing / selection window **8**.

- ▶ Enter the permissible value via the keypad **A**.

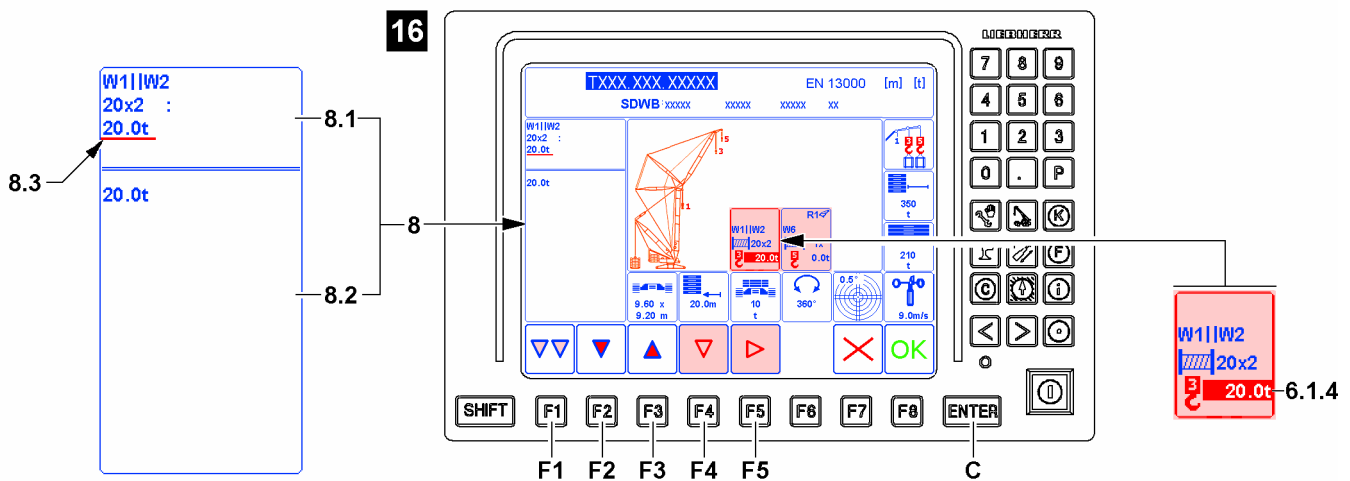


Fig. 128091

- ▶ Press the ENTER key **C**.

**Result:**

- The new value is taken over, see illustration **16**.
- The new value for the hook block weight **6.1.4** appears in the display window.
- The new value for the hook block weight appears in the upper area **8.1**.

**4.9.7 Assigning the fixed accessory**

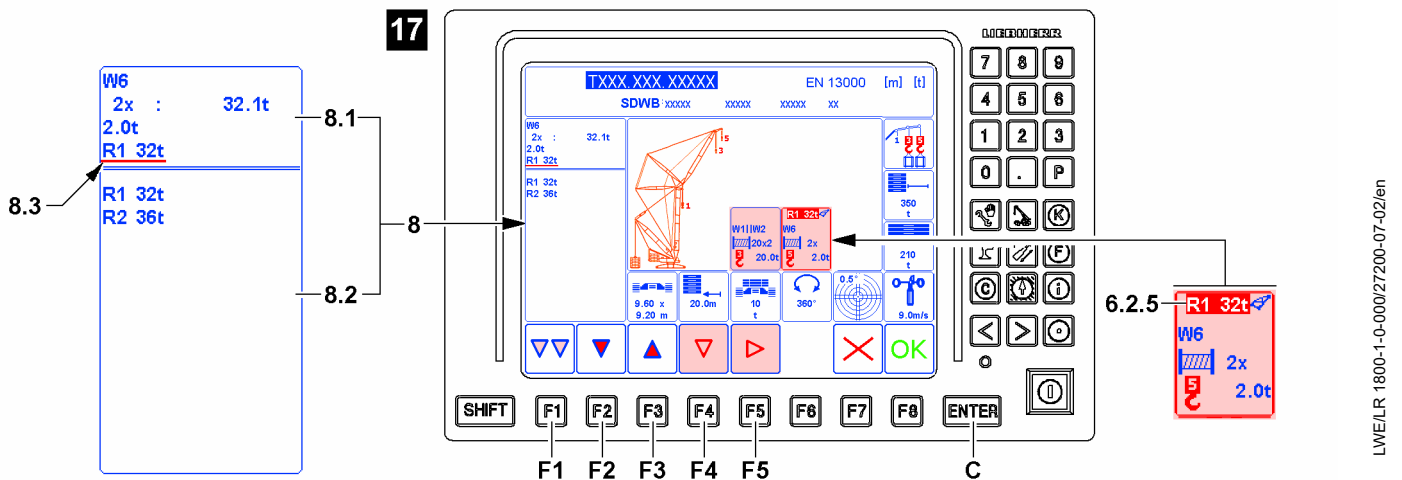


Fig. 128092

The marker for the fixed accessory **6.2.5** only appears when a corresponding load position is selected.



**Note**

If the correct maximum fixed accessory **6.2.5** already appears, then the settings for this marker can be skipped.

Change to another marker (if necessary):

- ▶ Press the function key **F2** or function key **F3** until the next marker to be changed is underlined with the selection bar **8.3**.

Change to the next display window (if present):

- ▶ Press the function key **F5** or the function key **F4** and select the next display window.

End the *Set up* program (when all entries and settings are made):

- ▶ When all entries and settings in the lifting category **6** are correct, see section "Taking over entries and settings from the set up program".

- The preselection options are displayed in the upper area **8.1** of the Editing / selection window **8**. The first preselection option is automatically underlined and activated with the selection bar **8.3**.
- The lower area **8.2** of the Editing / selection window **8** displays the respective selection possibilities.

**Note**

Abbreviations for fixed accessories

Only the fixed accessory is listed for which a load chart is available.

For example, the following can appear corresponding to the load chart name (chart number):

- ▶ R1: Abbreviation for boom nose 1. (Appears only when a valid load chart for boom nose 1 is available).
- ▶ R2: Abbreviation for boom nose 2. (Appears only when a valid load chart for boom nose 2 is available).

Make sure that the following prerequisite is met:

- The desired display window is marked with the red selection frame **6.8**.

When the desired display window is not marked with the red selection frame **6.8**:

- ▶ Press the function key **F5** or function key **F4** until the red selection frame **6.8** marks the desired display window (in example "load position 5"), see illustration **17**.
- ▶ Press the function key **F2** or function key **F3** until the fixed accessory in the upper area **8.1** is underlined with the selection bar **8.3**. (In the example "R1 32t").

**Result:**

- The display for the fixed accessory **6.2.5** is highlighted in red in the active display window.

When the fixed accessory is underlined with the selection bar **8.3**:

- ▶ Press the ENTER key **C**.

**Result:**

- The selection bar **8.3** changes in the lower area **8.2** of the Editing / selection window **8**.

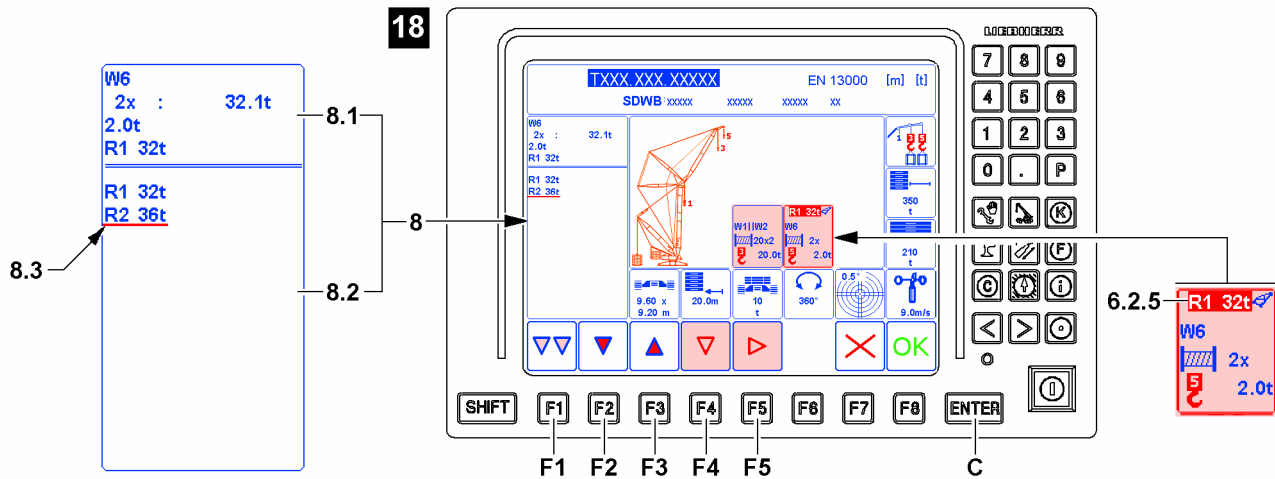


Fig.128093

- Press the function key **F2** or function key **F3** until the required selection in the upper area **8.2** is underlined with the selection bar **8.3**. (In the example “R2 36t”, see illustration 18).

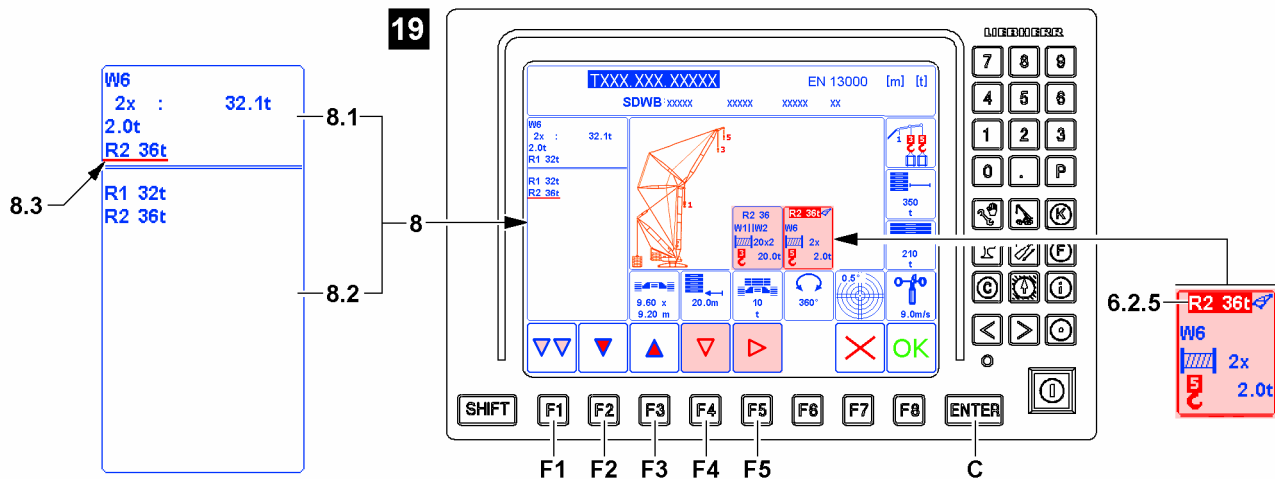


Fig.128094

- Press the ENTER key **C**.

**Result:**

- The selection is defined (example “R 2 36t”).
- The selected setting appears as the fixed accessory **6.2.5** in the icon for load position 5, see illustration 19.
- The selection bar **8.3** changes again in the upper area **8.1** of the Editing / selection window **8**.

### 4.9.8 Taking over the entries and settings of the lifting category

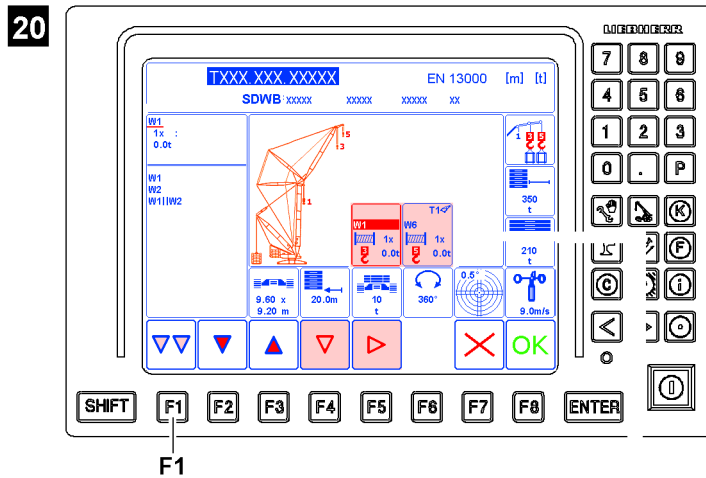


Fig.128096

Make sure that the following prerequisites are met:

- All selected entries and settings in the lifting category are correct and complete.
- ▶ Change to the following section “Taking over the entries and settings from the set up program”.

#### Problem remedy

Was it determined that one or more markers are not correct?

By pressing the function key **F1**, the individual program categories can be switched through one after the other. The first program category is called up after the last one.

- ▶ Press the function key **F1** until the lifting category is called up again. Then all entries and settings can be changed, see illustration 20.

### 4.10 Taking over the entries and settings from the Set up program

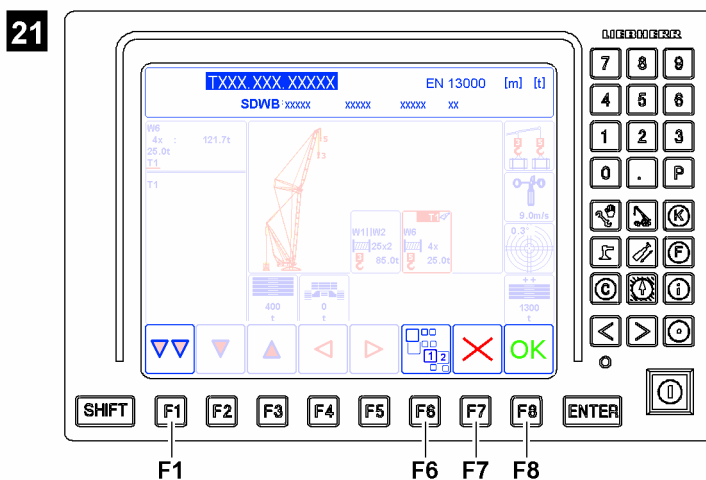


Fig.128095

LWE/LR 1800-1-0-000/27200-07-02/en

**WARNING**

Danger of accident due to deviating set up configuration!

If the actual set up configuration of the crane deviates from the entries and settings in the *Set up* program, then the overload protection is not correctly set.

An incorrectly set overload protection calculates the actual load incorrectly and transmits faulty display values.

The crane can be overloaded without being noticed and topple over. Personnel can be severely injured or killed.

- ▶ The entries and settings in the *set up* program must match the actual set up configuration of the crane.

Make sure that the following prerequisite is met:

- There is no load on the hook.

- ▶ Check all entries and settings on the screen to ensure they are correct.

If the icon for additional levels appears above the function key **F6** (see illustration 21), then they must be checked also.

When the icon for additional levels appears:

- ▶ Press the function key **F6** and check all entries and settings on the screen to ensure they are correct.

When all entries and settings have been checked to ensure that they are correct:

- ▶ Press the function key **F8** (below the *OK* icon) and take over the entries and settings from the *Set up* program.

**Result:**

- The *Set up* program is ended.
- Entries and settings from the *Set up* program have been taken over on the crane operating screen.
- The crane operating screen is called up.

**Problem remedy**

Was it determined that one or more markers are not correct?

By pressing the function key **F1**, the individual program categories can be switched through one after the other. The first program category is called up after the last one.

- ▶ Press the function key **F1** until the category to be changed is called up. Then all entries and settings can be changed.

**Note**

Caution Program abort.

- ▶ By pressing the function key **F7**, the process is aborted and the last valid entries and settings from the *Set up* program are called up.

## 4.11 Reference texts

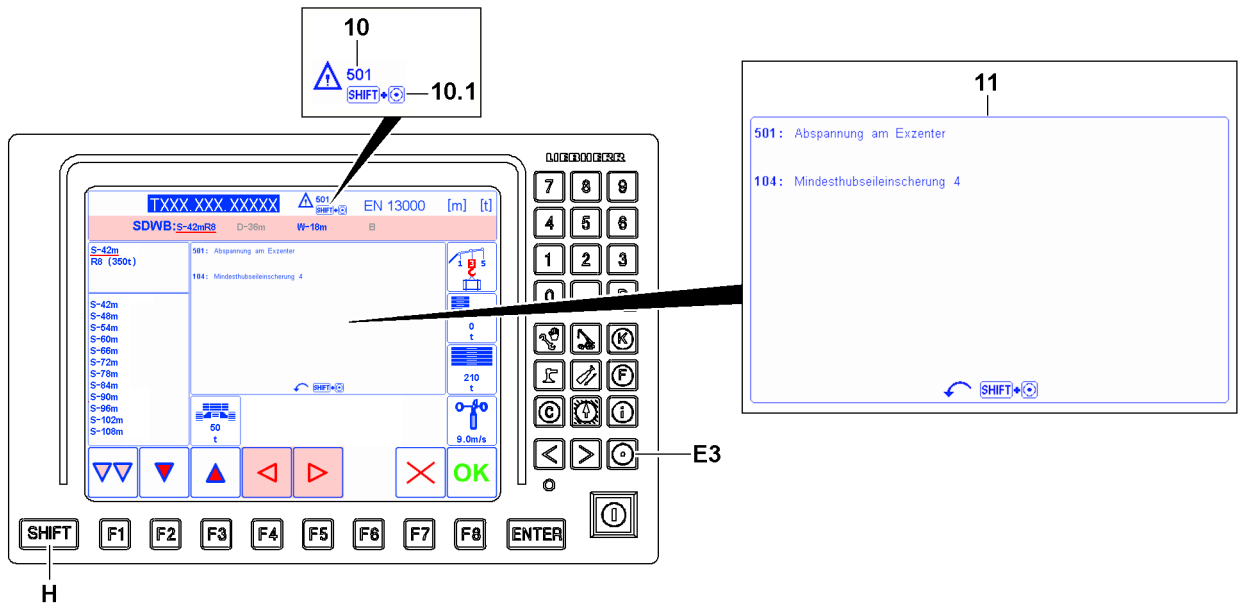


Fig.161571: Displaying the reference texts



### WARNING

Disregard of limitations and notes!  
 Toppling crane, failure of crane structures.  
 Death or severe injuries, high property damage.  
 ► Adhere to the limitations and notes.

There may be limitations and notes for the set up configuration that is set. If limitations and notes are available, they are specified by codes **10**. The reference texts **11** describe the corresponding codes **10**. Reference texts can be displayed and hidden with the key combination **10.1**.

The limitations and notes in the *Set up* program are identical to the limitations and notes in the load charts.

When at last one Code **10** is specified:

- Hold down the Shift key **H** and subsequently press the key **E3**.

#### Result:

- The reference texts **11** are displayed.

When reference texts **11** are displayed:

- Hold down the Shift key **H** and subsequently press the key **E3**.

#### Result:

- The reference texts **11** are hidden.

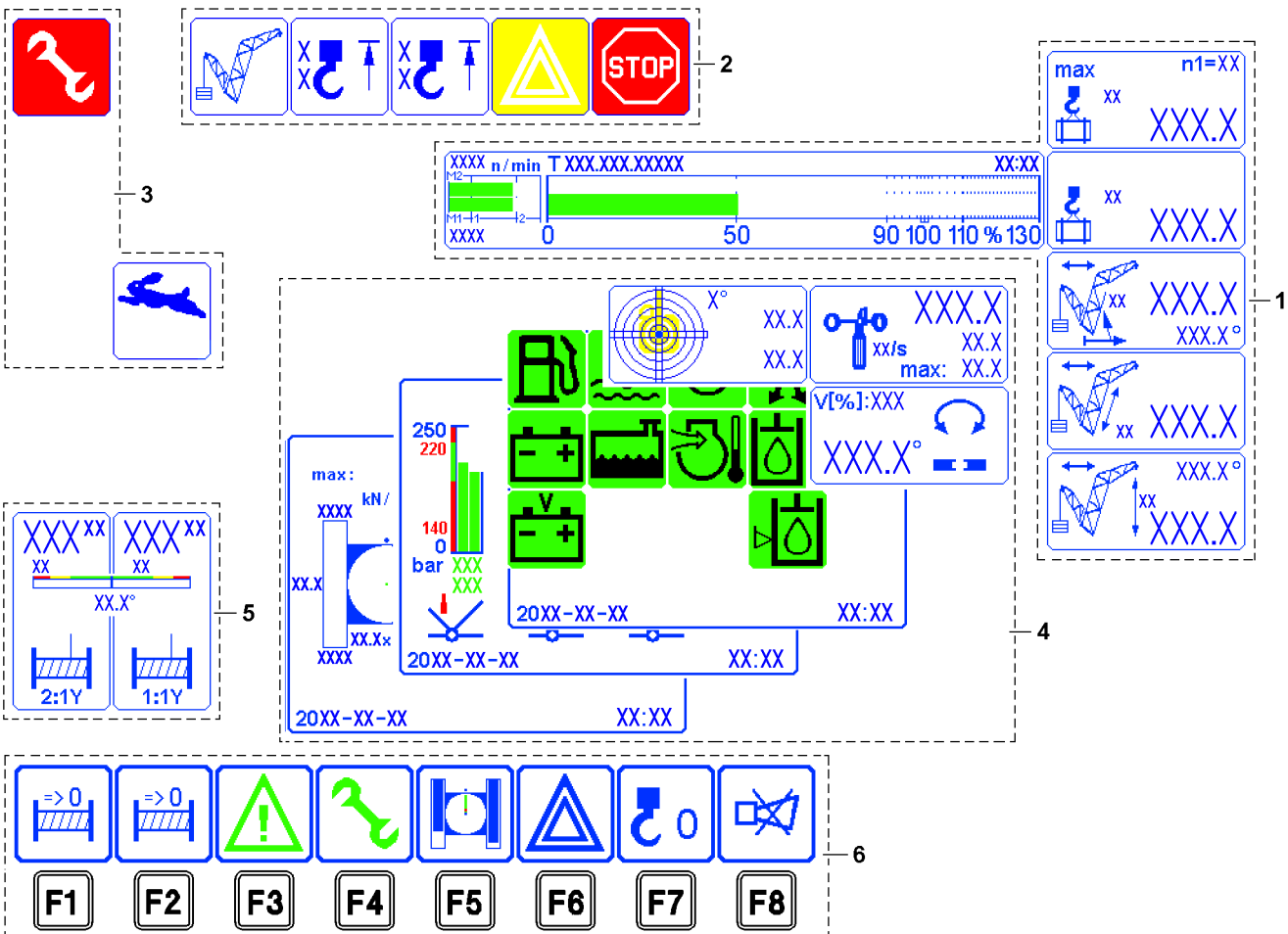
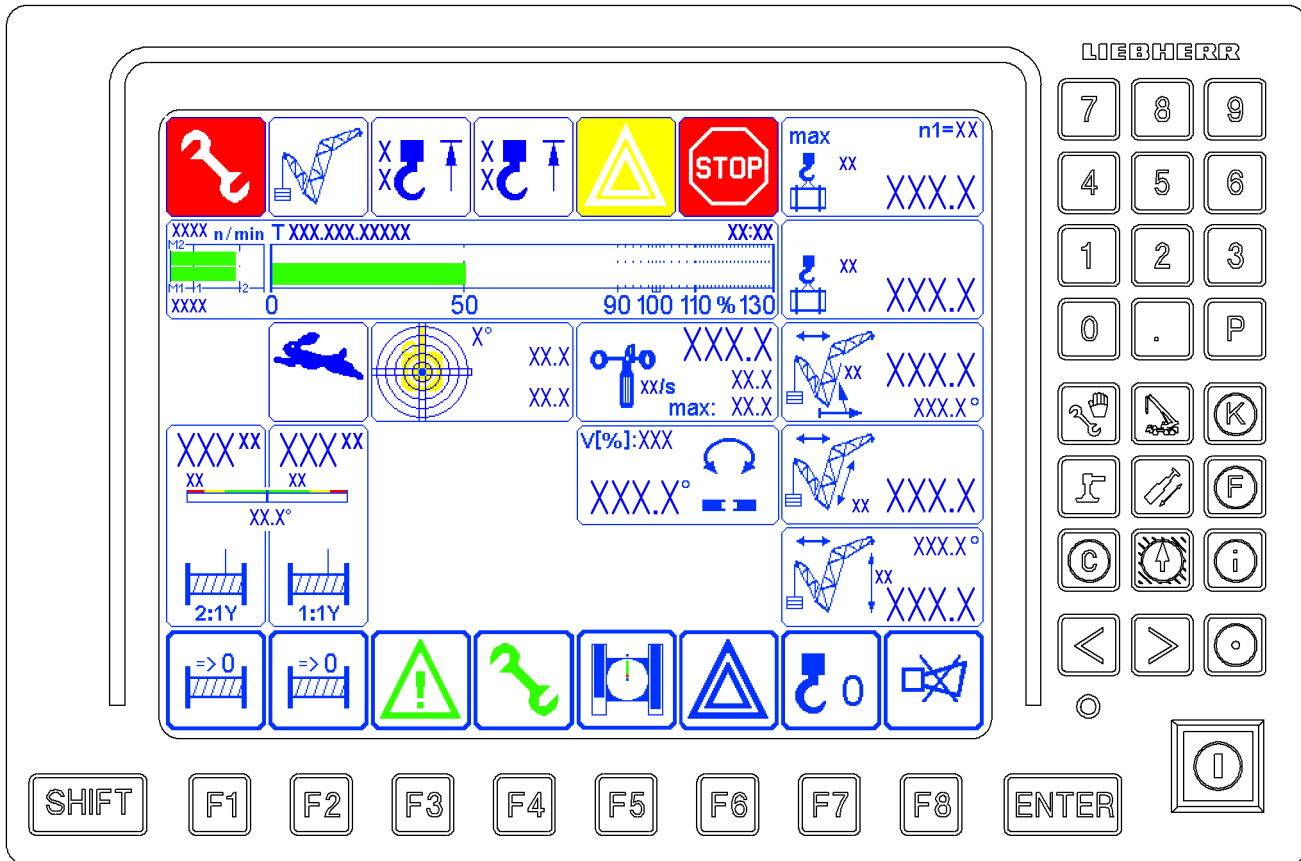


Fig.164492

LWE/LR 1800-1-0-000/27200-07-02/en

## 5 The *Crane operation* program on LICCON monitor 0

The *Crane operation* program assists the crane operator by displaying the data relevant for crane operation clearly on three LICCON monitors. An acoustic signal accompanies all critical displays. Depending on the equipment, a range of other icons may also be turned on as additional displays, either as required by the crane operator, or automatically in case of a problem.

It also alerts the crane operator to imminent overload conditions. In the event of overload and many error conditions, which could be hazardous during crane operation, the system shuts off.

LICCON monitor 0 is divided into six areas in the *Crane operation* program:

- 1 Crane geometry and load information
- 2 Alarm functions
- 3 LICCON Monitor 0 special functions
- 4 Monitoring field
  - Monitoring functions during crane operation
  - Monitoring of relapse cylinders
  - Monitoring the surface pressure and center of gravity
  - Monitored auxiliary functions
- 5 Winch display
  - Winch 1 and winch 2
- 6 Function key line
  - The function keys always refer to the icons shown directly above them
  - **Note:** If no icon is shown on the line directly above the function key, then no function is assigned in the program to the function key.



---

### Note

- ▶ The monitor illustrations in this chapter are only examples.
  - ▶ The numerical values in the individual icons and charts do not have to necessarily match the crane exactly.
  - ▶ The configuration of the LICCON monitor with icons is only descriptive.
  - ▶ An identical icon display will **not** appear during crane operation.
-

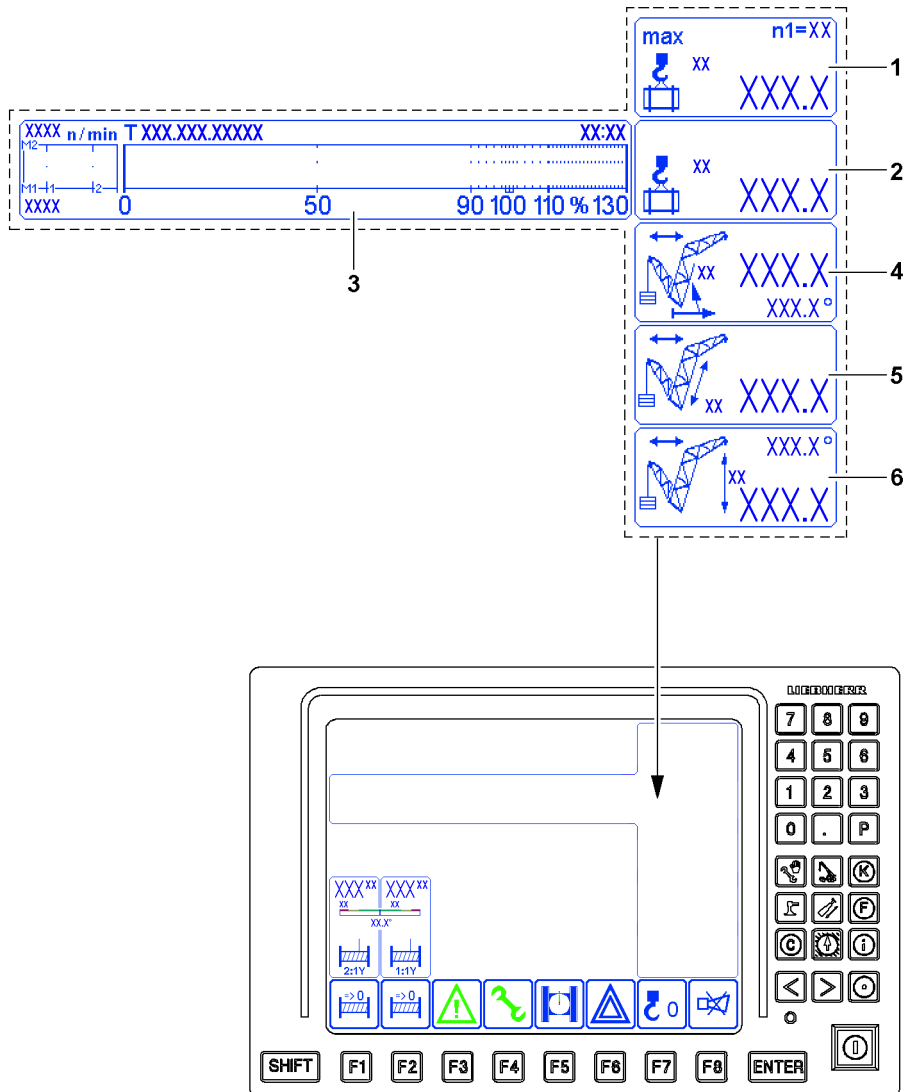


Fig.161659



## 5.1 Crane geometry and load information

Display on LICCON monitor 0



---

**Note**

- ▶ The crane illustrations in this section are only examples and are generalized.
  - ▶ They may differ from the crane type and equipment.
- 

The information regarding crane geometry and load involves six icons:

- 1 Maximum load
- 2 Actual load
- 3 Utilization bar diagram
- 4 Boom radius
- 5 Boom length
- 6 Pulley head height



---

**Note**

- ▶ A question mark (?) is shown instead of values when no load chart value can be accessed. Example: The crane is not in the range of the load chart.
  - ▶ A question mark (?) is shown instead of values if the value cannot be calculated / determined. Example: A sensor error can be present - pay attention to the error messages.
-

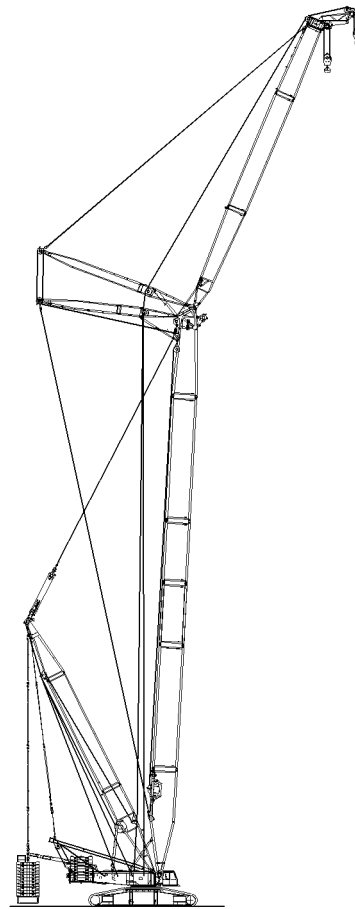
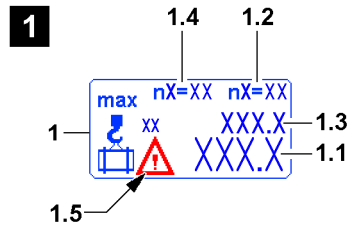
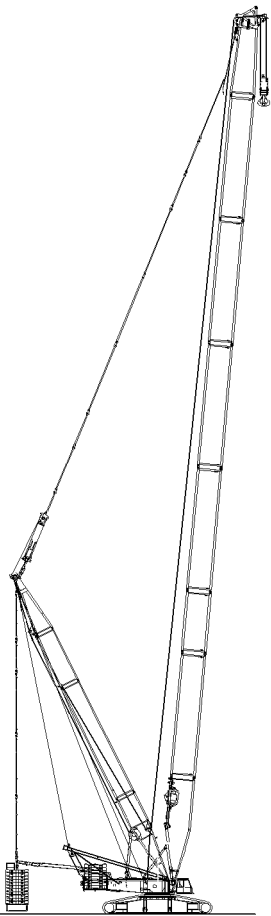
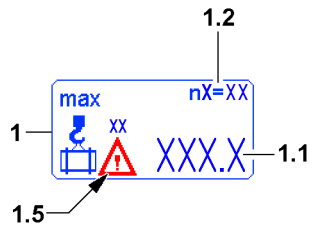


Fig.121770

LWE/LR 1800-1-0-000/27200-07-02/en

### 5.1.1 Maximum load

According to the set up configuration, the following changes:

- The illustration of the icon
- The position of values in the icon, see sample illustration 1.

#### 1 Maximum load icon

- In [t] or [lb]

#### 1.1 Maximum load

- Maximum load in the **first** load position
- In [t] or [lb]

#### 1.2 Reeving

- Reeving in the **first** load position
- Load position (n1 to n5) and assigned reeving number (settings from the *Set up* program)
  - n1= Load position 1
  - n2= Load position 2
  - n3= Load position 3
  - n4= Load position 4
  - n5= Load position 5

#### 1.3 Maximum load

- **Note:** Appears only when a second load position is selected (settings from the *Set up* program).
- Maximum load in the **second** load position
- In [t] or [lb]

#### 1.4 Reeving

- Reeving on the **second** load position
- Load position (n1 to n5) and assigned reeving number (settings from the *Set up* program)
  - n1= Load position 1
  - n2= Load position 2
  - n3= Load position 3
  - n4= Load position 4
  - n5= Load position 5

#### 1.5 Warning icon\*

- **Note:** Appears solely for certain crane types.
- Appears possibly when:
  - The permissible wind speed is exceeded
  - The permissible crane incline is exceeded



#### Note

- ▶ The *Maximum load* (also *Maximum load according to the load chart and the reeving*) is the load, which the crane can lift in its current operating condition with the maximum utilized ballast / counterweight.

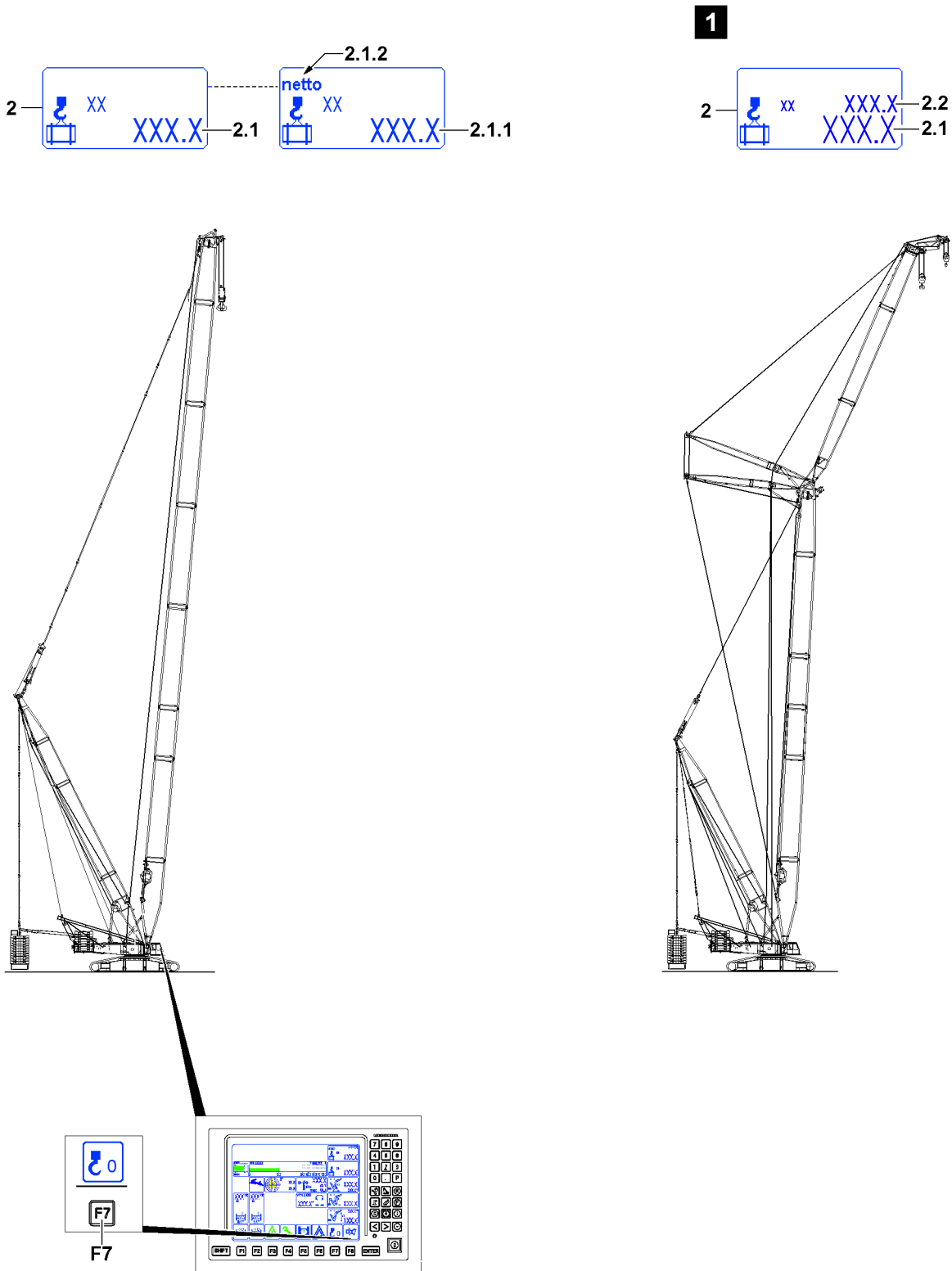


Fig.123759

LWE/LR 1800-1-0-000/27200-07-02/en

## 5.1.2 Actual load (current load) / net load

According to the set up configuration, the following changes:

- The illustration of the icon
- The position and number of values in the icon, see sample illustration 1.

### 2 Actual load / net load icon

- With text for the measuring unit [t] or [lb]

### 2.1 Actual load display

- *Actual load* display = load (in [t] or [lb]) that is currently suspended on the **first** load position.
- Display of the calculated total load including the weights of the load carrying, load taking on and / or fastening equipment.

#### 2.1.1 Net load display

- *Net load* display = the *Actual load* display 2.1 can be changed at any time to *Net load* display 2.1.1 (tared) by pressing the function key **F7**.
- After pressing the function key **F7** the display value is set to zero and the word *net* 2.1.2 is shown.
- As long as the net load is set, the icon above the function key **F7** is shown in red.
- If taring is cancelled, the word *net* 2.1.2 disappears from the icon and the gross load value is displayed.

The change to net load is cancelled by the following actions:

- By pressing the function key **F7** again.
- By telescoping the boom more than three LE (LE= 1 decimeter or 1/10 ft).
- Luffing more than  $\pm 4^\circ$ .
- **Note:** This makes it possible to eliminate the weights of the load handling, load taking on and / or fastening equipment in the display value. The maximum load is not increased / adjusted.



### WARNING

Incorrectly determined weight of the load!

Due to operating errors or tolerances, deviations can occur for the displayed values in the *Actual load / net load* icon 2.

- ▶ The *Actual load / Net load* display is not a calibrated weighing device.
- ▶ Always observe the actual weight of the load in connection with the load charts and the set up configuration of the crane.



### Note

- ▶ The *Actual load* display 2.2 for the **second** load position appears only for certain crane types with special load charts for two load positions.

### 2.2 Actual load display

- **Note:** Appears only when a second load position is selected (settings from the *Set up* program).
- *Actual load* display = load (in [t] or [lb]) that is currently suspended on the **second** load position.
- Display of the calculated total load including the weights of the load carrying, load taking on and / or fastening equipment.

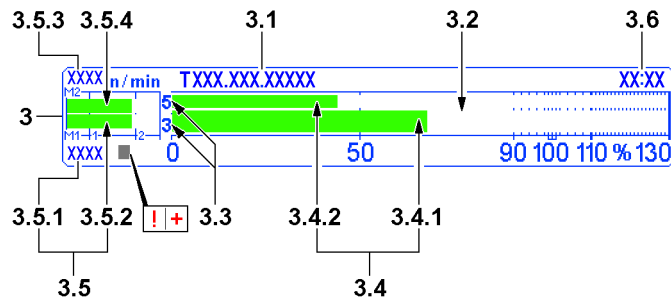


Fig.161657

### 5.1.3 Utilization bar diagram

- 3 Bar diagram of utilization icon
  - In percent
- 3.1 Chart names
  - Note to the set chart name (chart number) with associated operating mode
- 3.2 Utilization scale
  - Marking from a utilization of 90 %<sup>1)</sup>: **Advance warning**
  - Marking at a utilization of 100 %<sup>1)</sup>: **STOP shut-off**
  - **Note:** 1) Factory settings, observe section “Setting the limit values for the load torque limiter for advance warning and shut-off”.
- 3.3 Load position
  - The load position assigned to the respective utilization bar
- 3.4 Utilization bar
  - Current utilization of the crane
  - It appears in blue, green, yellow and red, depending on the situation
  - Utilization bar 3.4 blue / green: Utilization in the permissible range
  - Utilization bar 3.4 yellow: Advance warning! Utilization just before impermissible range
  - Utilization bar 3.4 red: Warning! Utilization in the impermissible range
  - For two load positions:
    - 3.4.1 Utilization bar for the **first** load position
    - 3.4.2 Utilization bar for the **second** load position



**Note**

► The set up configuration of the crane can only be changed when the utilization bar 3.4 is blue.

Utilization of the crane	
Current utilization of the crane	$= \frac{\text{Actual load}}{\text{Maximum load}}$

- 3.5 Engine rpm
  - In revolutions per minute
  - The engine rpm is always shown numerically and graphically
  - If the icon “+” appears on the rpm display, the engine rpm is locked
  - If the “!” symbol appears on the rpm display, the engine rpm is limited
    - The engine rpm can be limited in ECO mode, see section “ECO mode”
  - **Note:** Only for certain crane types.
  - **NOTICE!** If the display is in red, an error is present.
  - **Note:** Question marks (“?”) appear if there is an error in the rpm recording. Then the system switches to an engine rpm specified by the control for the output regulation of the drives. The specified engine rpm is displayed blinking. An error message is output.
  - 3.5.1 numeric display
  - 3.5.2 graphic display, in the form of a bar diagram
  - Only for crane types with two engines:
    - 3.5.3 numeric display for engine 2
    - 3.5.4 graphic display for engine 2, in the form of a bar diagram
- 3.6 Time

LWE/LR 1800-1-0-000/27200-07-02/en

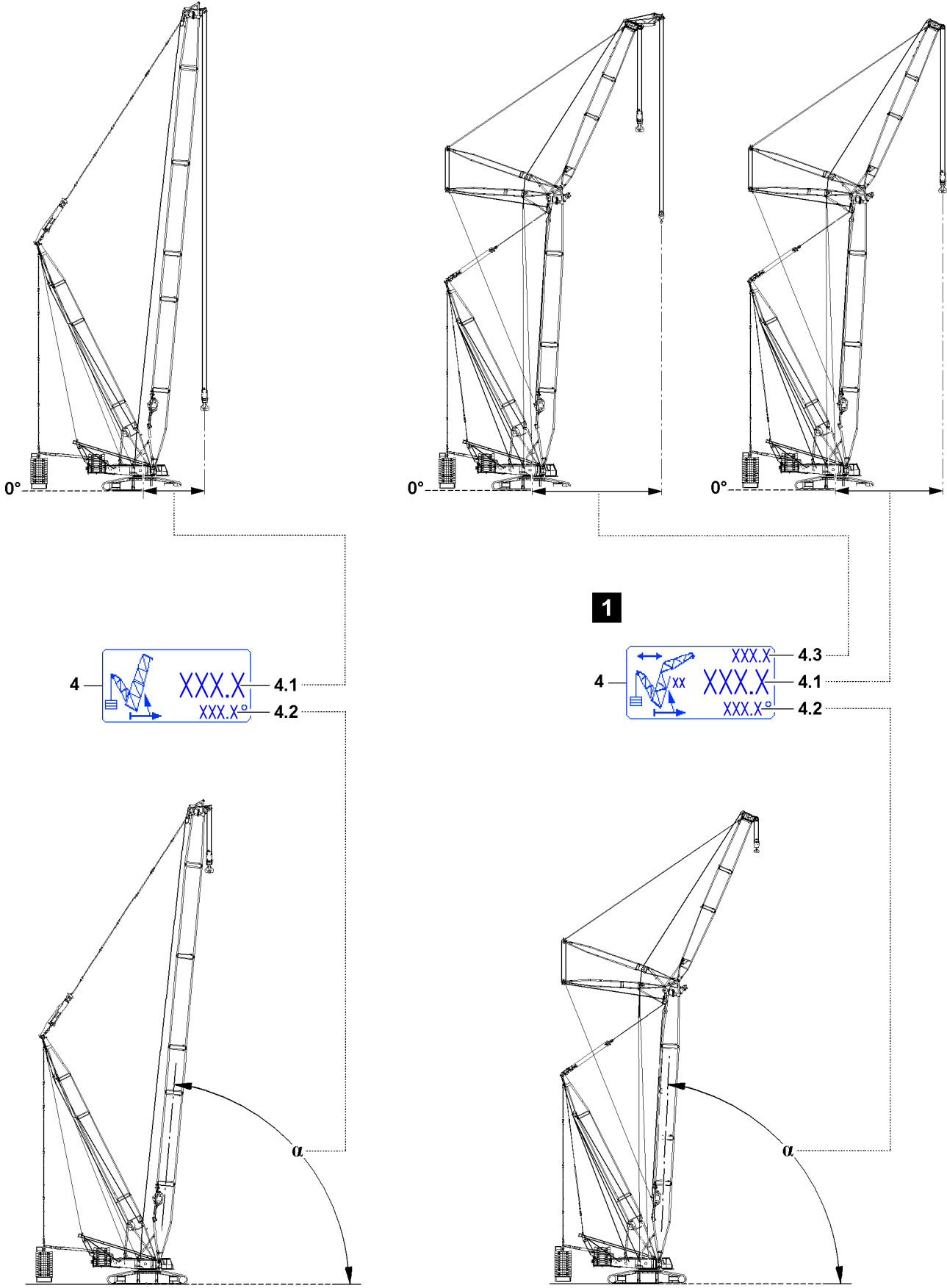


Fig.114264

LWE/LR 1800-1-0-000/27200-07-02/en



## 5.1.4 Boom radius

According to the set up configuration, the following changes:

- The illustration of the icon
- The position and number of values in the icon, see sample illustration 1.

### 4 Boom radius icon

#### 4.1 Boom radius

- **First** load position boom radius
- In [m] or [ft]

Denotes the horizontal distance of the load hook from the rotation axis of the crane superstructure. This also takes the boom flexation due to its own weight and the suspended weight of the load into account.

#### 4.2 Main boom angle

- In [°]
- The angle of the main boom (angle  $\alpha$ ) to the horizontal is displayed

#### 4.3 Boom radius

- **Note:** Appears only when a **second** load position is selected (settings from the *Set up* program).
- **Second** load position boom radius
- In [m] or [ft]

Denotes the horizontal distance of the load hook from the rotation axis of the crane superstructure. This also takes the boom flexation due to its own weight and the suspended weight of the load into account.

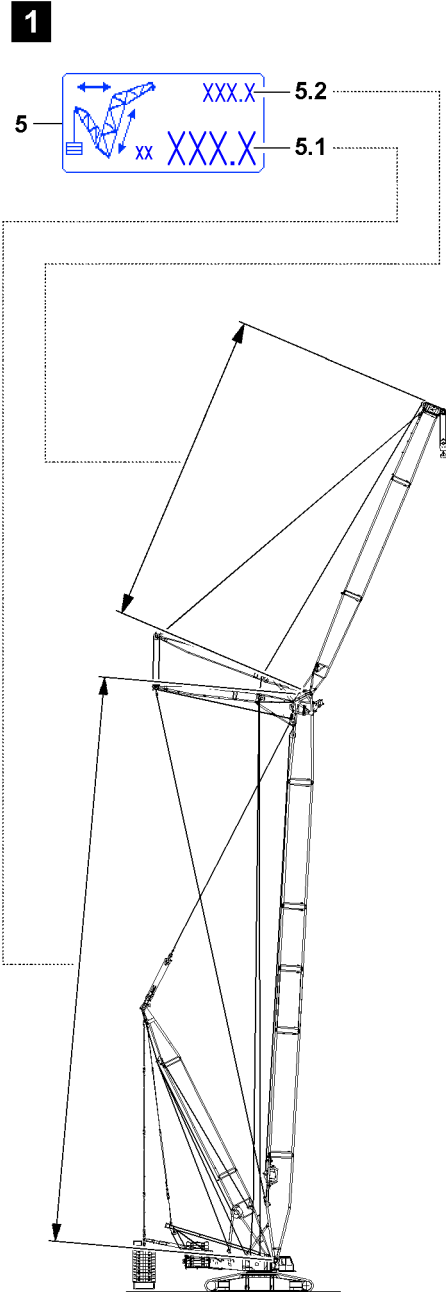
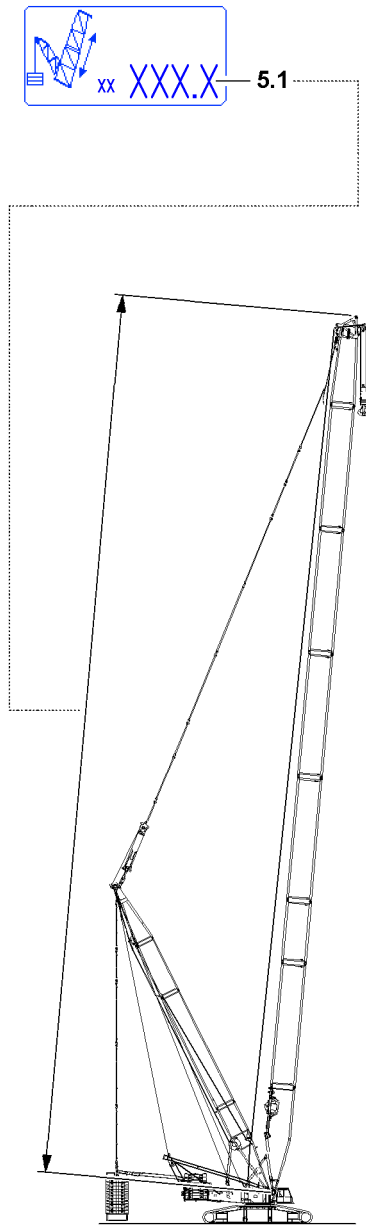


Fig.114265

LWE/LR 1800-1-0-000/27200-07-02/en

## 5.1.5 Boom length

According to the set up configuration, the following changes:

- The illustration of the icon
- The position of values in the icon, see sample illustration 1.

### 5 Boom length icon

#### 5.1 Main boom length

- In [m] or [ft]

#### 5.2 Length of auxiliary boom / accessory

- In [m] or [ft]

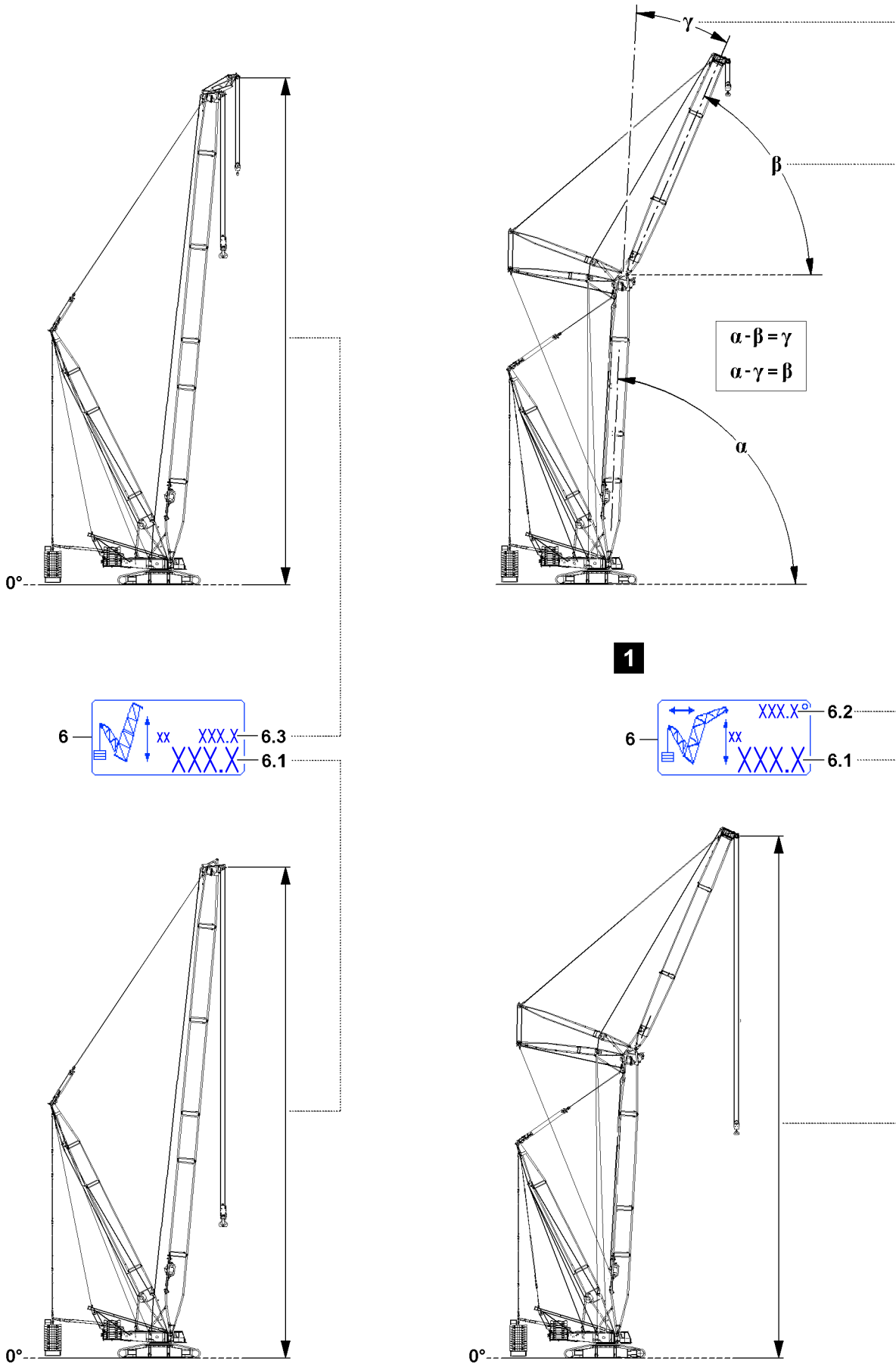


Fig.114266

LWE/LR 1800-1-0-000/27200-07-02/en

## 5.1.6 Pulley head height



### Note

- ▶ Main boom angle  $\alpha$ : The angle of the main boom to the horizontal
- ▶ Auxiliary boom / accessory angle  $\beta$ : The angle of the auxiliary boom / accessory to the horizontal.
- ▶ Auxiliary boom / accessory relative angle  $\gamma$ : The angle of the auxiliary boom / accessory is determined relative to the main boom.

According to the set up configuration, the following changes:

- The illustration of the icon
- The position of values in the icon, see sample illustration 1.

### 6 Pulley head height icon

#### 6.1 Pulley head height

- **First** load position pulley head height
- In [m] or [ft]
- Marks the vertical distance from the placement surface of the crane to the selected pulley head axle.

#### 6.2 Auxiliary boom / accessory angle

- In [°]



### Note

- ▶ Depending on the set up configuration and the load chart, a differentiation is made between an absolute angle display or a relative angle display.

#### $\beta$ Auxiliary boom / accessory absolute angle

- The angle of the auxiliary boom / accessory to the horizontal in [°]
- Display absolute angle: For operating modes with load chart for a fixed defined main boom angle.

or

#### $\gamma$ Auxiliary boom / accessory relative angle

- Angle between the main boom and the auxiliary boom / accessory in [°]
- Display relative angle: For operating modes with load chart for a fixed defined angle auxiliary boom / accessory.

#### 6.3 Pulley head height

- **Note:** Appears only when a second load position is selected (settings from the *Set up* program).
- **Second** load position pulley head height
- In [m] or [ft]
- Marks the vertical distance from the placement surface of the crane to the selected pulley head axle.

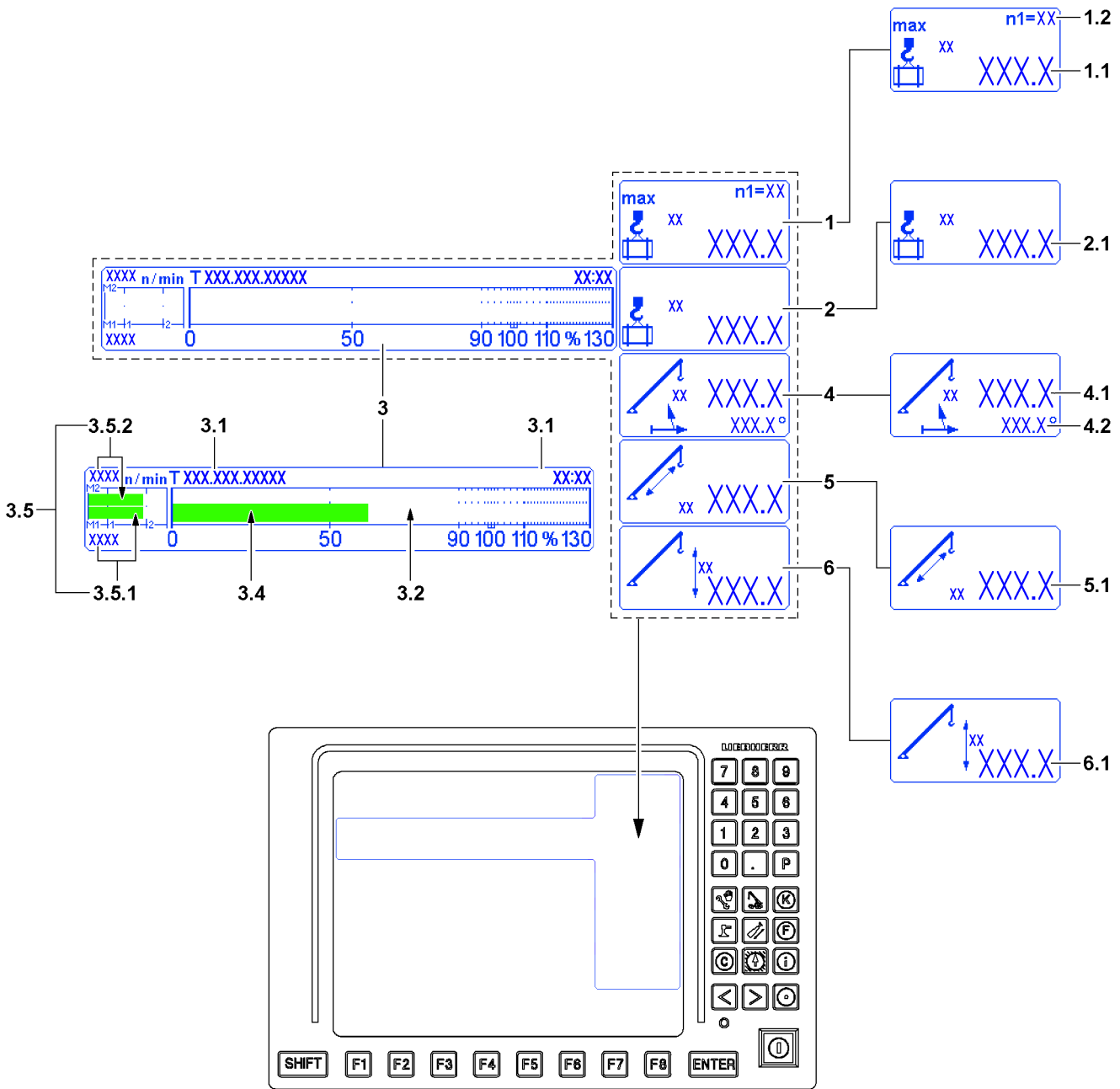


Fig.164493

## 5.2 Information about crane geometry and load in the SA-operating mode

Display on LICCON monitor 0



### Note

► Only for crane types with SA-operating mode.

The information about crane geometry and load in the SA-operating mode is comprised of six icons:

- 1 Maximum load
  - Maximum load **1.1** in the SA-operating mode  
In [t] or [lb]
  - **1.2** Reeving place holder
- 2 Actual load
  - *Actual load* display **2.1** in the SA-operating mode  
In [t] or [lb]
- 3 Utilization bar diagram
  - **3.1** Chart names
    - Note to the set chart name (chart number) with associated operating mode
    - **Note:** Depending on the crane type either in the left or right upper area of the utilization bar diagram **3**.
  - **3.2** Utilization scale
    - Marking from a utilization of 90 %: Advance warning
    - Marking at a utilization of 100 %: STOP shut-off
  - **3.4** Utilization bar
    - Current utilization of the crane in the SA-operating mode
    - It appears in blue, green, yellow and red, depending on the situation
    - Utilization bar **3.4** blue / green: Utilization in the permissible range
    - Utilization bar **3.4** yellow: **Advance warning!** Utilization just before impermissible range
    - Utilization bar **3.4** red: **Warning!** Utilization in the impermissible range
  - **3.5** Engine rpm
    - In revolutions per minute
    - The engine rpm is always shown numerically and graphically
    - When the rpm is locked, a "+" is shown behind the rpm value.
    - **NOTICE!** If the display is red, an error is present.
    - **Note:** Question marks (?) appear if there is an error in the rpm recording. Then the nominal speed for the diesel engine is set for the output regulation of the drives. The set nominal speed is shown blinking. An error message is output.
    - Only for crane types with two engines:
      - 3.5.1** First engine (Engine 1)
      - 3.5.2** Second engine (Engine 2)

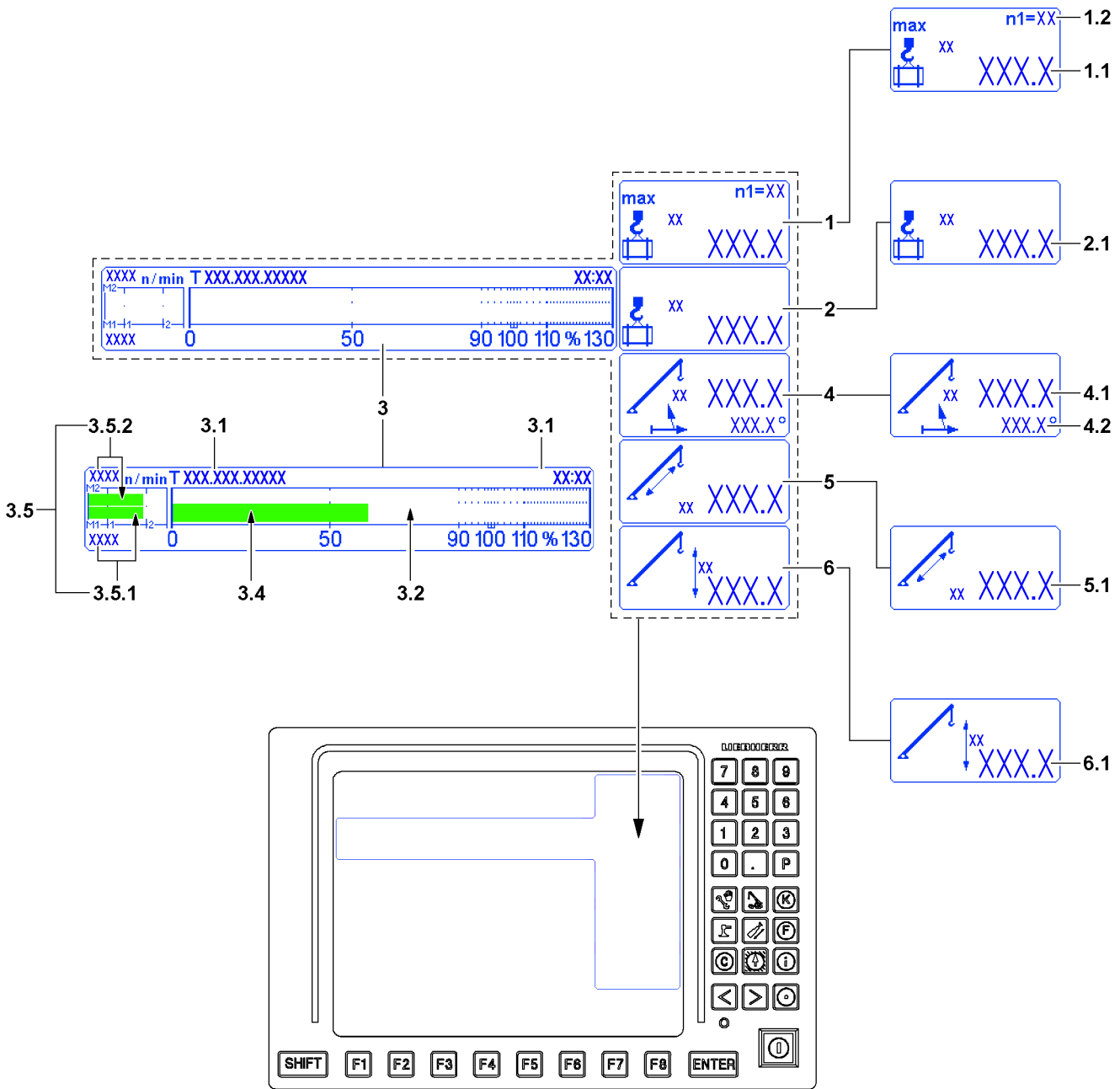


Fig.164493



**4 Boom radius**

- Boom radius **4.1** of SA-frame in reference to the slewing ring center  
In [m] or [ft]
- Angle **4.2** of the SA-frame

**5 Length**

- Length **5.1** of the SA-frame between the pin point on the turntable and the pin point of the SA-assembly cylinder  
In [m] or [ft]

**6 Height**

- Height **6.1** of the center of the pin point of the SA-assembly cylinder above the placement location of the crane  
In [m] or [ft]

**WARNING**

*Actual load* display tolerances!

Due to tolerances, deviations can occur for the displayed values in the *Actual load* icon **2**.

The *Actual load* display is not a calibrated weighing device.

- ▶ Always observe the actual weight of the load in connection with the load charts and the set up configuration of the crane.

**Note**

- ▶ A question mark (?) is shown instead of values when no load chart value can be accessed. Example: The crane is not in the range of the load chart.
- ▶ A question mark (?) is shown instead of values if the value cannot be calculated / determined. Example: A sensor error can be present - pay attention to the error messages.

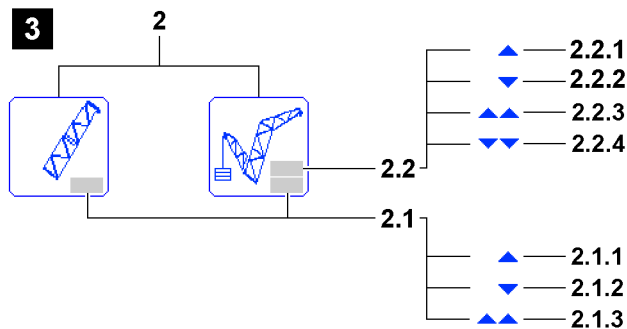
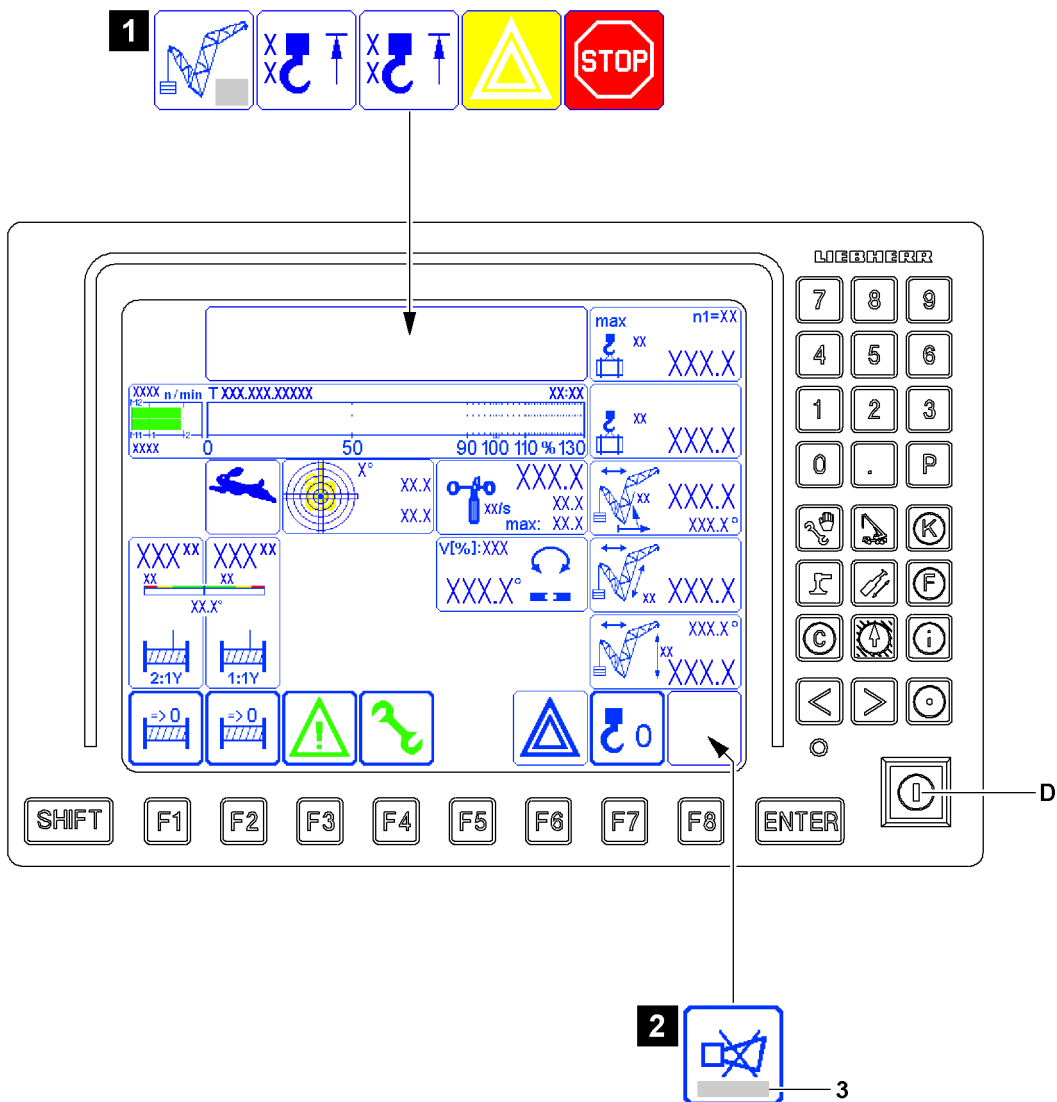


Fig.164494

## 5.3 Alarm functions

---

### NOTICE

Triggered alarm function!

If an alarm function is triggered (for example an advance warning occurrence or shut off of crane movement), the cause must be determined.

- ▶ Always pay attention to triggered alarm functions.
  - ▶ Alarm function can flash over the monitor.
- 

The limit ranges of the crane movements are monitored. When the limit ranges are reached, the crane operator is warned by the alarm functions.

The alarm functions are shown on the LICCON monitor:

- Displayed visually with icons, see illustration 1.
- Indicated acoustically by a *horn* warning sound, see illustration 2.

In case of a failure of the relevant sensors / limit switches, special error messages **3** are added.

### 5.3.1 Boom limitation

See illustration 3

#### Main boom limitation signs

---



#### Note

- ▶ The *Boom limitation* icon **2** can change in different operating modes, but it is shown always in the same position on the LICCON monitor.
  - ▶ The field *on the bottom* **2.1** refers to the main boom.
  - ▶ The field *on the top* **2.2** refers to the auxiliary boom / accessory.
-

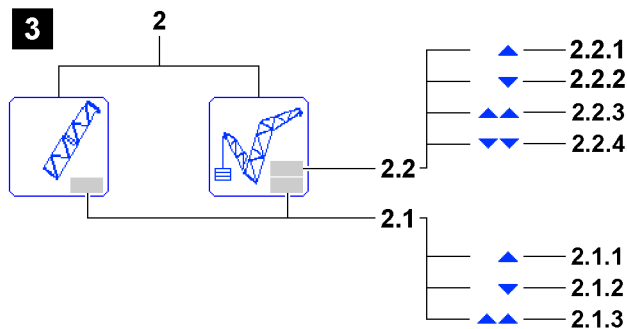
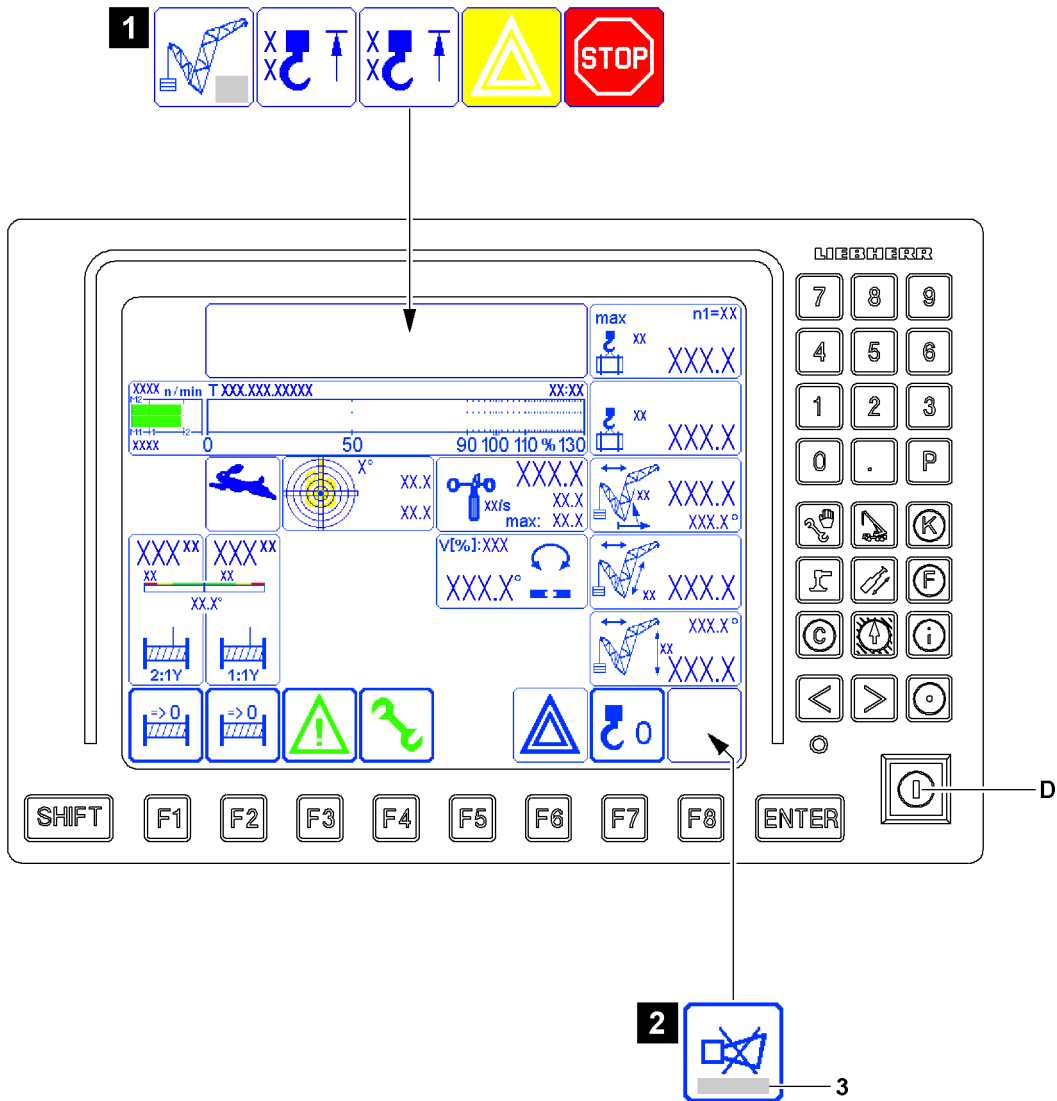




Fig.164494

**2.1 Main boom boom limitation icon**

- The luffing range of the main boom is limited both upward and downward.
- This icon appears if an end position determined by the load chart is reached when luffing the boom or when luffing the boom is disabled by a proximity switch.

Position	Icon	Description
2.1.1		The <i>Luffing up the main boom</i> shut-off takes place when running against the upper load chart limit  <b>or</b> The <i>Luff main boom up</i> shut-off takes place due to utilization greater than <b>95 %</b> and falling load capacity when luffing up the main boom <sup>1)</sup> .  <b>Note:</b> Luffing down the main boom is still possible.
2.1.2		The <i>Luffing down the main boom</i> shut-off is triggered by running against the lower load chart limit.  <b>Note:</b> Luffing up the main boom is still possible.

1) Only for certain crane types and boom systems.




**WARNING**

Alarm function deactivated!

When the set up key **D** is actuated, there is no shut-off of crane movement via position **2.1.1** and position **2.1.2**.

► Observe the Crane operating instructions, chapter 4.20.

Position	Icon	Description
2.1.3		The <i>Luffing up the main boom</i> shut-off is triggered by running against the block limit switch of the main boom relapse cylinders on the left / right (boom steep)  <b>or</b> Due to an error in one block limit switch of the main boom relapse cylinders.  <b>Note:</b> Luffing down the main boom is still possible.

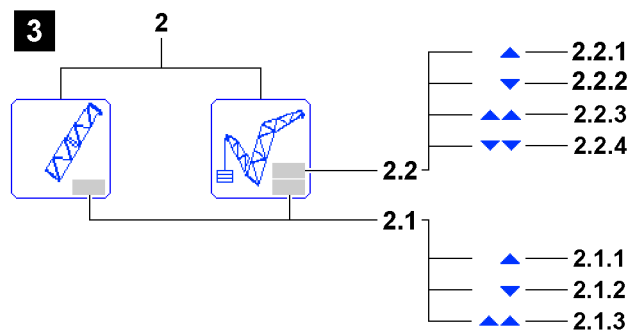
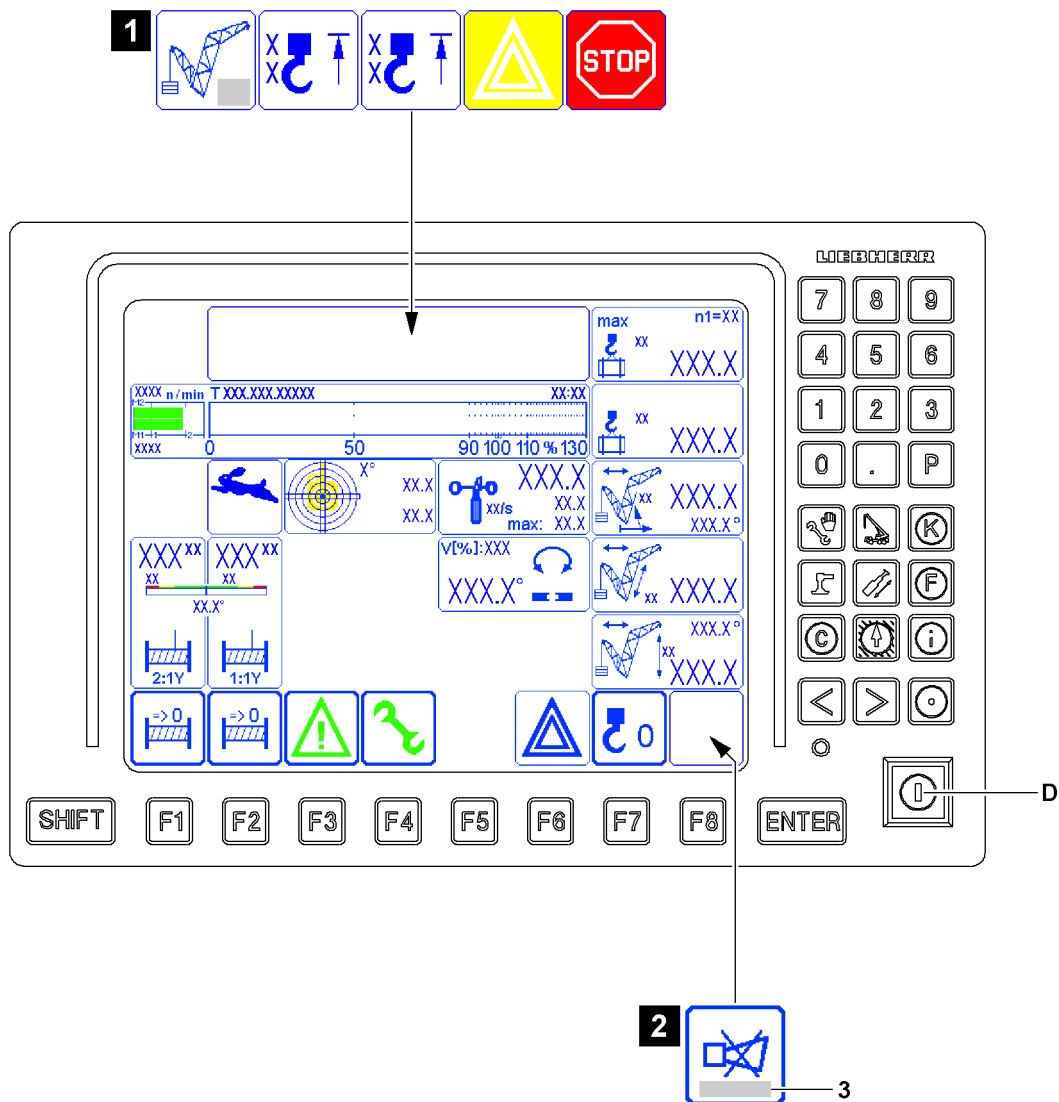


Fig.164494

## Auxiliary boom / accessory limitation sign



### Note

- ▶ The *Boom limitation* icon **2** can change in different operating modes, but it is shown always in the same position on the LICCON monitor.
- ▶ The field *on the bottom* **2.1** refers to the main boom limit signs.
- ▶ The field *on top* **2.2** refers to the auxiliary boom / accessory limit signs.

### 2.2 Auxiliary boom / accessory boom limitation icon

- The luffing range of the auxiliary boom / accessory is limited both upward and downward.
- This icon appears if an end position determined by the load chart is reached when luffing the auxiliary boom / accessory or when luffing is disabled by a limit switch.

Position	Icon	Description
2.2.1		The <i>Luffing up the auxiliary boom / accessory</i> shut-off takes place by reaching the upper load chart limit. <b>Note:</b> Luffing the auxiliary boom / accessories down remains possible.
2.2.2		The <i>Luffing down the auxiliary boom / accessory</i> shut-off is triggered by running against the lower load chart limit. <b>Note:</b> Luffing up the auxiliary boom / accessories remains possible.



### WARNING

Alarm function deactivated!

When the set up key **D** is actuated, there is no shut-off of crane movement via position **2.2.1** and position **2.2.2**.

- ▶ Observe the Crane operating instructions, chapter 4.20.

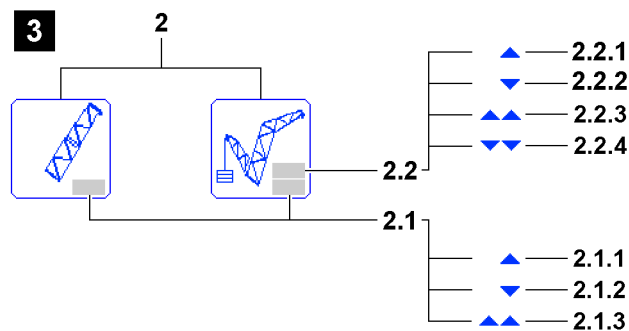
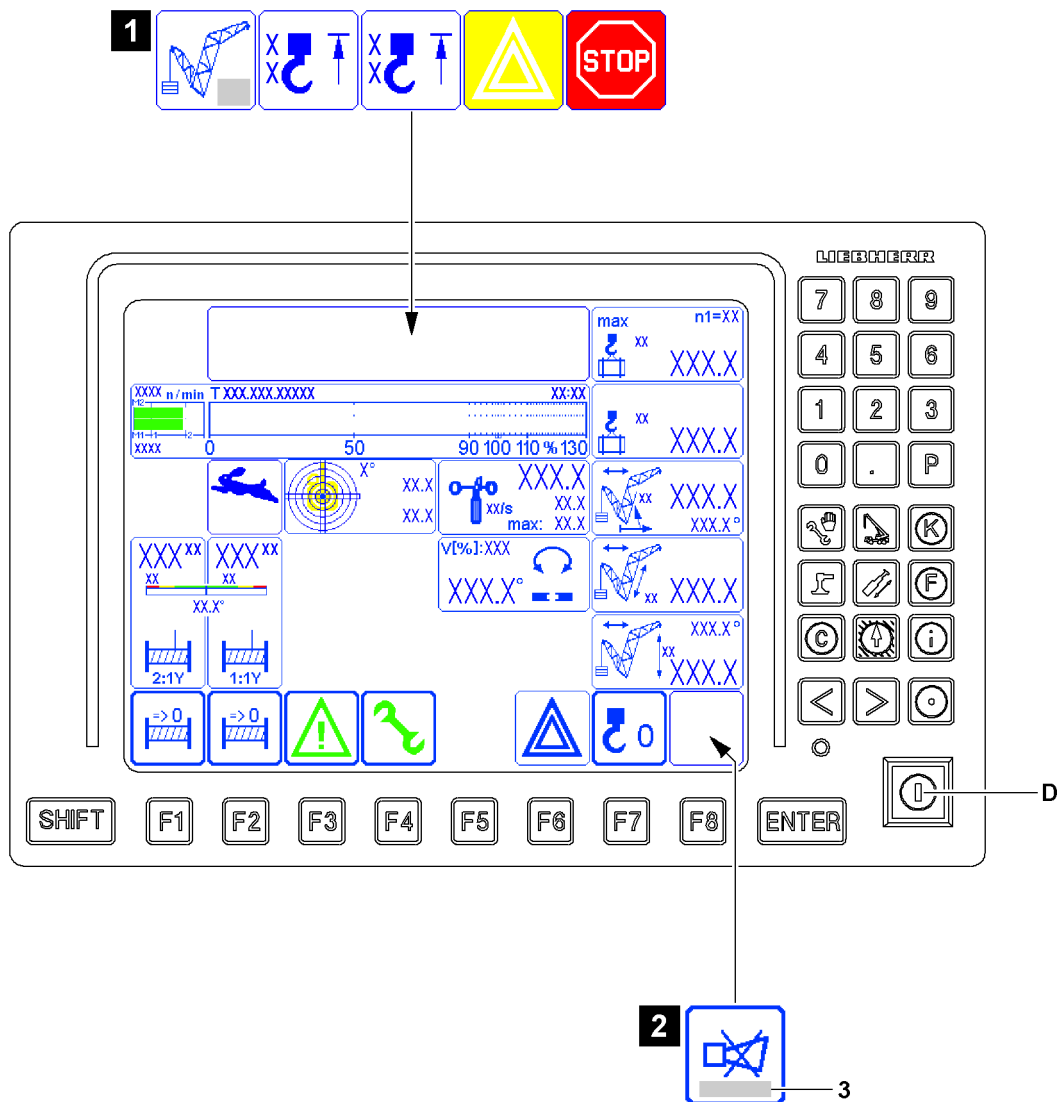




Fig.164494

LWE/LR 1800-1-0-000/27200-07-02/en



Position	Icon	Description
2.2.3		<p>The <i>Luffing up the auxiliary boom / accessory</i> shut-off is triggered by running against a block limit switch of the auxiliary boom / accessory relapse cylinders</p> <p><b>or</b></p> <p>the relapse flap</p> <p><b>or</b></p> <p>an error on one limit switch occurs.</p> <p><b>Note:</b> Luffing the auxiliary boom / accessories down remains possible.</p>
2.2.4		<p>The <i>Luffing down the auxiliary boom / accessory</i> shut-off is triggered by running against a block limit switch (on auxiliary boom / accessory lower left / right)</p> <p><b>or</b></p> <p>an error occurs on one of these limit switches.</p> <p><b>Note:</b> Luffing up the auxiliary boom / accessories remains possible.</p>

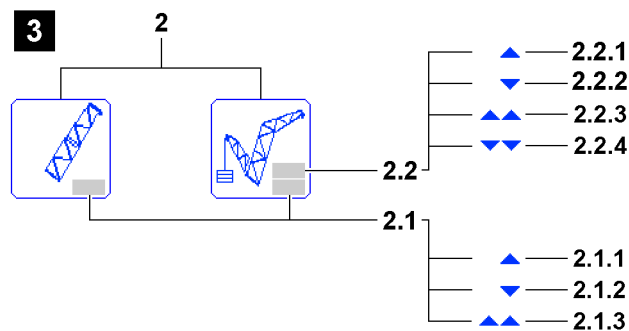
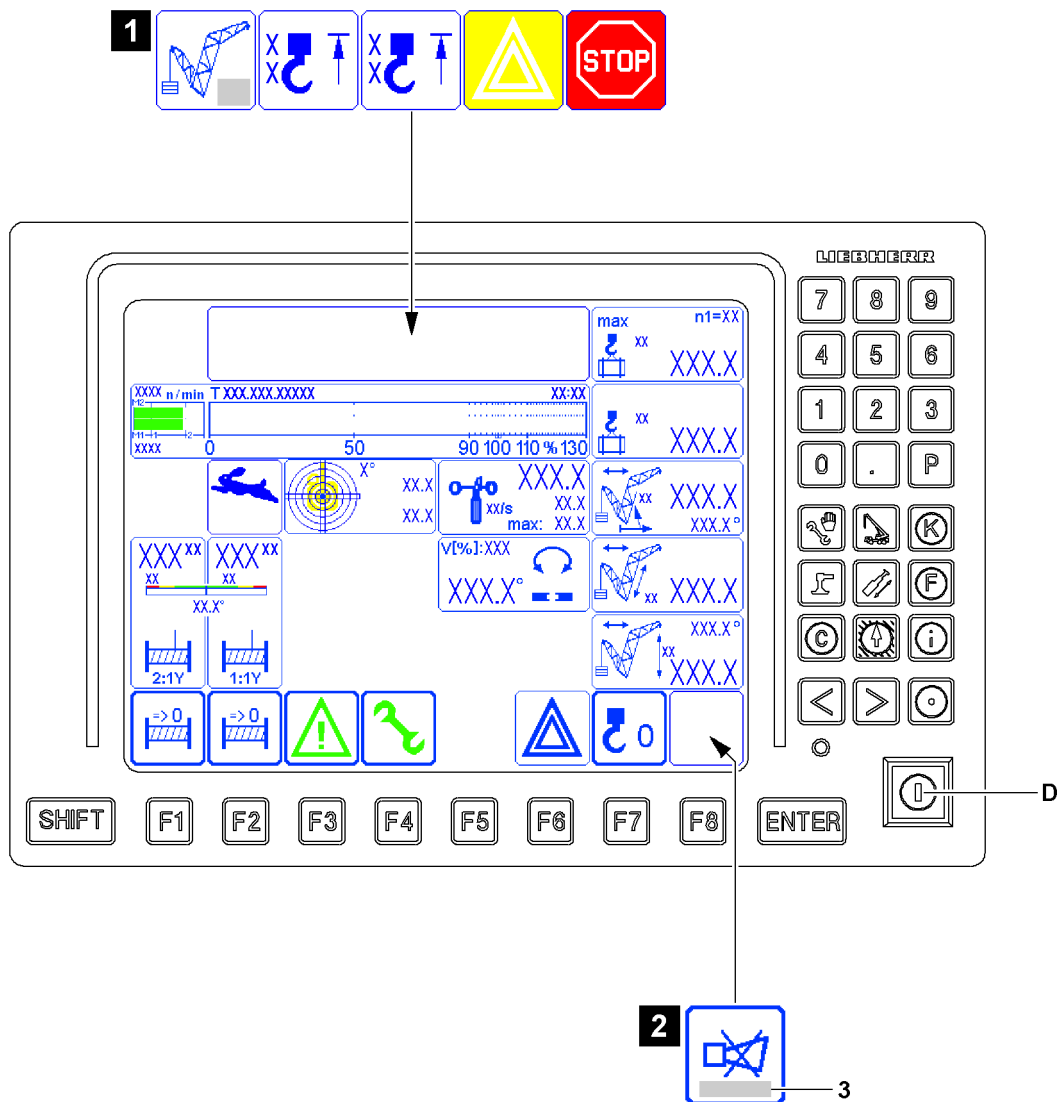


Fig.164494

LWE/LR 1800-1-0-000/27200-07-02/en

### 5.3.2 Failure of sensor / limit switch

**NOTICE**

Failure of sensor / limit switch!

Depending on the classification of the sensor / limit switch, the crane can continue to be operated with limitation or is shut off by the control.

An error message is issued in the *Horn* icon 3, see illustration 2.

The error message shows defective sensors / limit switches, see the Diagnostics manual.

- ▶ The error must be remedied immediately.
- ▶ Crane movements after a failure of a sensor / limit switch must be carried out anticipatorily and with extreme caution.

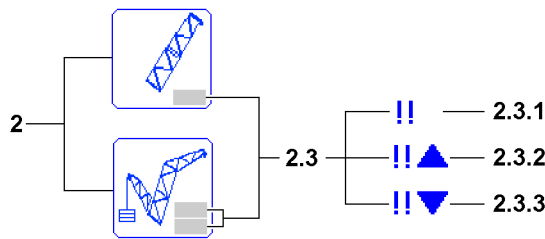


Fig.114275

Position	Icon	Description
2.3.1	!!	At least one associated sensor / limit switch is defective / missing on the auxiliary boom / accessory. If an alarm function occurs at the same time, then the icon can be shown differently, see position 2.3.1, position 2.3.2 or position 2.3.3.
2.3.2	!!▲	
2.3.3	!!▼	



**Note**

- ▶ Not every failure of a sensor / limit switch on the boom is shown in the *Boom limitation* icon 2. Observe the error message in the *Horn* icon 3.
- ▶ Depending on the classification of the sensor / limit switch, the respective crane movement is shut off in case of a failure and **cannot be bypassed**.
- ▶ When deflecting the master switch, an operating error message is issued in the *Horn* icon 3. The operating error message shows defective sensors / limit switches.
- ▶ If the error cannot be remedied by yourself, contact Liebherr Service.

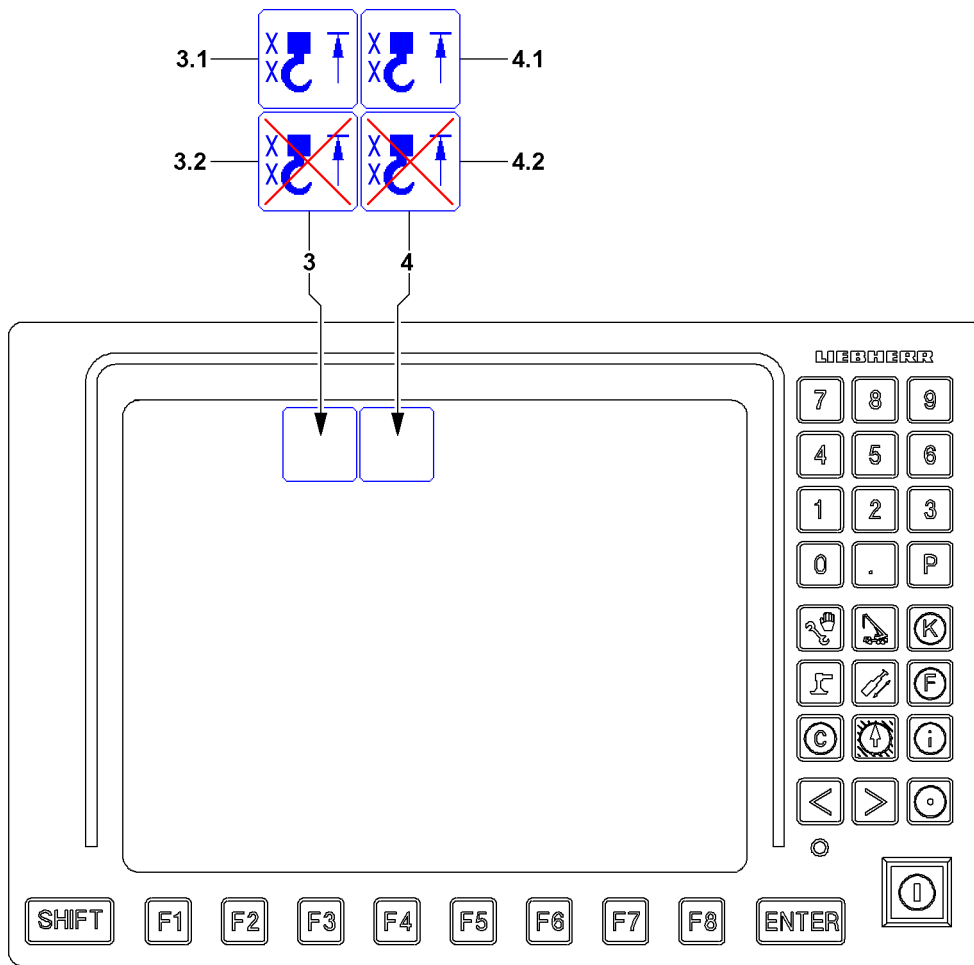


Fig.114276

### 5.3.3 Hoist limit switch

In order to prevent the crane from being operated without a hoist limit switch (HES), the presence of the hoist limit switch is continuously monitored by the crane control. If a hoist limit switch required for a particular operating mode is not plugged in, therefore not active on the LSB bus system, the corresponding crane movements are stopped and an operating error message is also issued.

The identification of the triggered hoist limit switch (for example HES1 for hoist limit switch 1) appears in the respective icon.



#### WARNING

Hoist limit switch not functioning!

- ▶ Before crane operation, check the hoist limit switches for function and correct assembly.

#### 3 Hoist top icon

Hoist limit switch for the first load position

##### 3.1 Hoist top triggered icon

- The *Hoist top triggered icon* appears when:
  - The hook block is pulled against the hoist limit switch weight.
  - The hoist limit switch weight is not attached freely (for example on placed down boom).
  - The hoist limit switch is not recognized by the crane control, even though it is required for the operating mode.
  - The hoist limit switch has an internal error.
- **Note:** Spool up hoist winches is turned off. Additional crane movements can be turned off.

##### 3.2 Hoist top bypassed icon

- The *hoist top bypassed icon* appears if the hoist limit switch is bypassed, see section "Special functions LICCON monitor 0".

#### 4 Hoist top icon

Hoist limit switch for the second load position

##### 4.1 Hoist top triggered icon

- The *Hoist top triggered icon* appears when:
  - The hook block is pulled against the hoist limit switch weight.
  - The hoist limit switch weight is not attached freely (for example on placed down boom).
  - The hoist limit switch is not recognized by the crane control, even though it is required for the operating mode.
  - The hoist limit switch has an internal error.
- **Note:** Spool up hoist winches is turned off. Additional crane movements can be turned off.

##### 4.2 Hoist top bypassed icon

- The *hoist top bypassed icon* appears if the hoist limit switch is bypassed, see section "Special functions LICCON monitor 0".

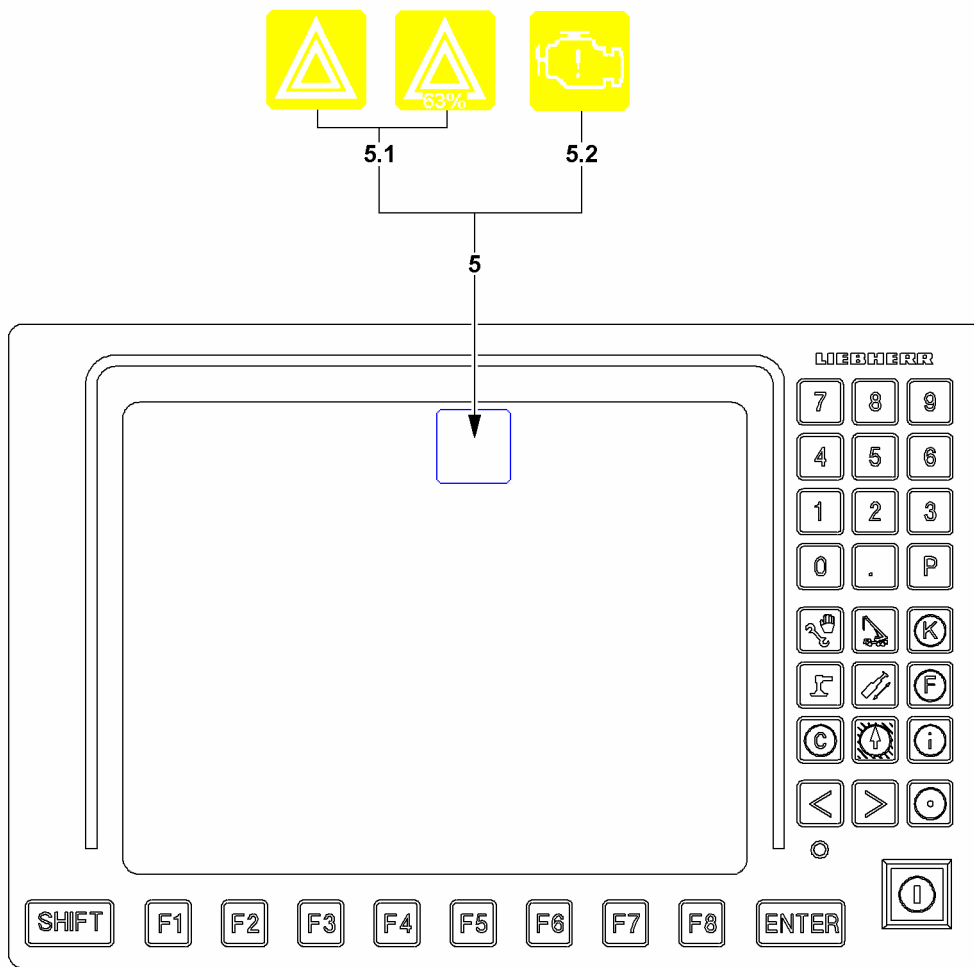


Fig.148617

LWE/LR 1800-1-0-000/27200-07-02/en

## 5.3.4 Occurrence of an advance warning

### 5 Advance warning icons

#### 5.1 Utilization advance warning icon

- The current utilization of the crane results from the *actual load* value and the *maximum load* value.
- The *Utilization advance warning* icon appears if:
  - The current utilization of the crane exceeds the limit programmed for the advance warning (standard value 90 percent)
  - or**
  - The current utilization of the crane exceeds the limit set for the advance warning (example value 63 percent).

#### 5.2 Engine monitoring advance warning icon

- The *Engine monitoring advance warning* icon appears if:
  - An advance warning for one or more monitoring functions in the engine monitoring occurs.
  - or**
  - A load reduction is triggered by the exhaust aftertreatment (only for engines with an SCR system for exhaust aftertreatment).
- **NOTICE!** If the engine monitoring advance warning **5.2** appears, the monitoring functions must be checked.



### WARNING

Non-observance of advance warnings!

If advance warnings are not observed, then this can result in a sudden shut-off of the crane movement.

A sudden shut off of the crane movement can result in high stress and strain for crane and load. High strain for the crane and load can cause accidents.

- ▶ Operate the crane in such a way that there is no shut off of crane movements by the crane control.
- ▶ Pay attention to advance warnings and approach a possible shut off of crane movements extremely cautiously.

### NOTICE

Shut off engine monitoring!

Outside of the *crane operation* program, the engine monitoring is turned off.

When the engine monitoring is turned off, problems and warning occurrences are not recognized.

This could result in crane failure.

- ▶ If work is not carried out in the *Crane operation* program, then turn the crane engine off and operate the LICCON computer system in stand-by mode, see section "Power-Save mode and Stand-by mode on the LICCON computer system".
- ▶ If work has to be carried out for a longer period outside of the *Crane operation* program, with the crane engine running, then switch regularly to the engine monitoring screen.

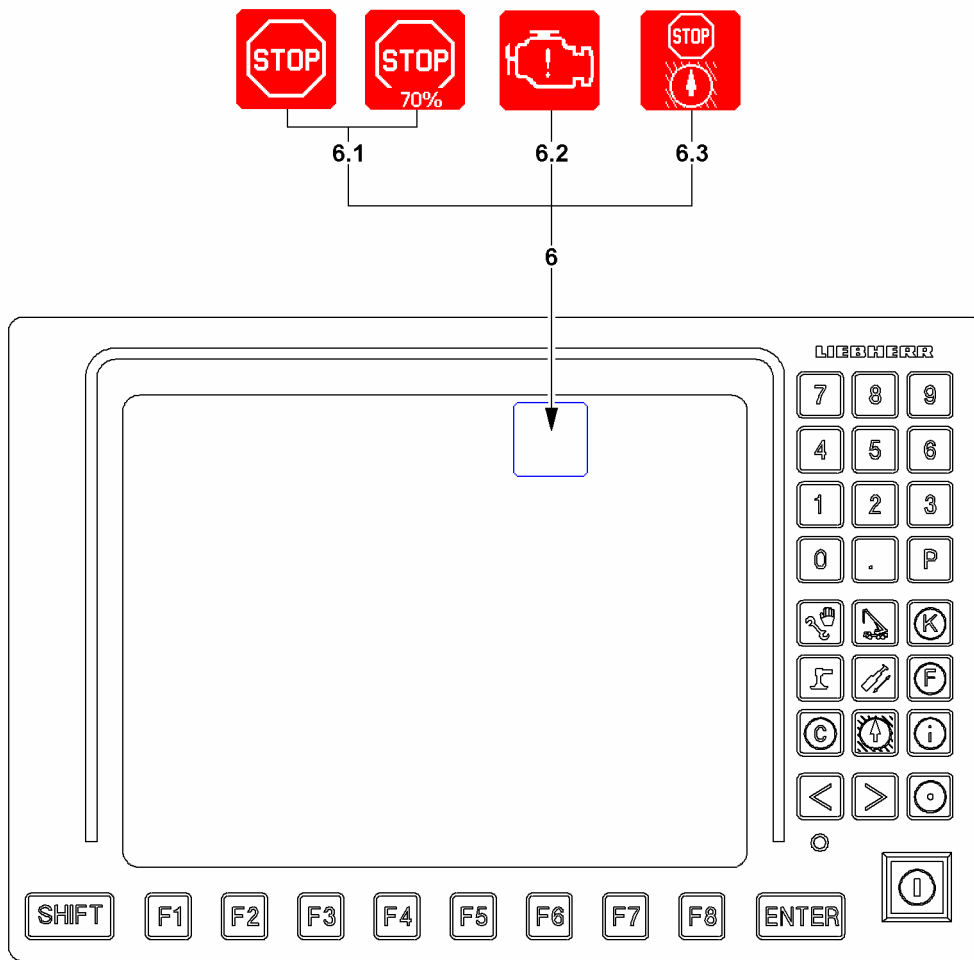


Fig.148618

LWE/LR 1800-1-0-000/27200-07-02/en



## 5.3.5 Shutting off the crane movement

### 6 STOP icons

#### 6.1 LMB-STOP icon

- The *LMB-STOP* icon appears when the crane movement is turned off via the overload protection

Possible causes:

- **Utilization of the crane:**
  - The *LMB-STOP* icon appears when the current utilization of the crane exceeds the programmed limit for the overload protection (Standard 100 percent).
  - or**
  - The *LMB-STOP* icon appears when the current utilization of the crane exceeds the limit set for the overload protection (example value 70 percent).
- **Sensor error:** The *LMB-STOP* icon appears when a sensor which is required to monitor the load chart has an error (*LMB-STOP* is triggered).
- **No load chart:** The *LMB-STOP* icon appears if no load chart is available (*LMB-STOP* is triggered).



#### WARNING

Crane movements with active *LMB-STOP*!

With active *LMB-STOP* **6.1**, not all crane movements are necessarily turned off. Under certain circumstances, load moment decreasing crane movements are possible.

- ▶ Always determine the exact cause for the *LMB-STOP* **6.1**.
- ▶ Carry out any crane movements that are still possible with extreme caution.

#### 6.2 Engine STOP icon

- The *Engine-STOP* icon appears if:
  - A STOP event takes place in engine monitoring.
  - or**
  - A load reduction is triggered by the exhaust aftertreatment (only for engines with an SCR system for exhaust aftertreatment).

#### 6.3 Working range limitation STOP icon

- Appears if a STOP event takes place in the working range limitation
- **Note:** Appears only on crane types with Working range limitation\*



#### WARNING

Shut off of the crane movement!

A sudden shut off of the crane movement can result in high stress and strain for crane and load. High strain for the crane and load can cause accidents.

- ▶ Operate the crane in such a way if possible that there is no shut off of crane movements by the crane control.
- ▶ Monitor the display instruments constantly.
- ▶ If not otherwise possible, approach a possible shut off of crane movements with extreme caution.

#### NOTICE

Shut off engine monitoring!

Outside of the *crane operation* program, the engine monitoring is turned off.

When the engine monitoring is turned off, problems and warning occurrences are not recognized.

This could result in crane failure.

- ▶ If work is not carried out in the *Crane operation* program, then turn the crane engine off and operate the LICCON computer system in stand-by mode, see section "Power-Save mode and Stand-by mode on the LICCON computer system".
- ▶ If work has to be carried out for a longer period outside of the *Crane operation* program, with the crane engine running, then switch regularly to the engine monitoring screen.

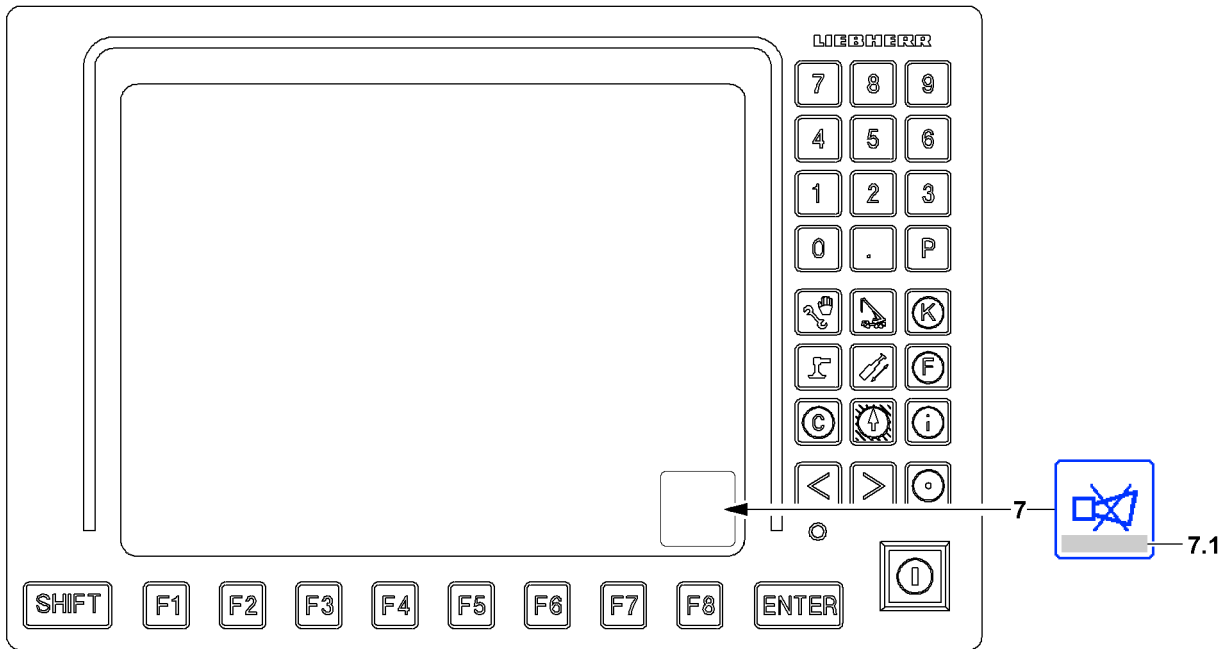


Fig.114279

LWE/LR 1800-1-0-000/27200-07-02/en

### 5.3.6 Acoustic warning on LICCON monitor 0

Acoustic warnings on LICCON monitor 0 are indicated by the *horn* warning sound.

The *horn* warning sound is divided into two categories:

- The *horn* is a beeping sound that lasts approximately 0.5 seconds and that is repeated every second.
- A *short horn* is a beeping sound of a duration of approximately 0.1 seconds, which is repeated in a second cycle.

#### 7 Horn icon

- When the *Horn* icon **7** is shown on the LICCON monitor, any acoustic signals that occur can be shut off by LICCON monitor 0 by pressing the function key **F8**.
- If an error message is shown in the *Horn* icon **7** in the field **7.1**, then it can be used to determine the present error. Pressing the function key **F8** twice automatically switches to the error determination screen of the BSE test system. The error is displayed there in documentary form.

#### Horn warning sound

- Sounds in addition to the visual display of an error message in the field **7.1** in case of operational errors are found that lead to a shut-off of a crane movement.  
Operational errors are, for example:
  - Overload
  - Boom outside of the angle / boom radius range of the load chart
- In case of application errors with error number (LICCON Error Code LEC). For example sensor errors, which occur due to insufficient sensor signals or a defective sensor.  
Monitored sensors are, for example:
  - Length sensor
  - Angle sensor
  - Pressure sensor
  - Pull test brackets (force test boxes)
  - Inductive sensors
  - Hoist limit switch
  - Wind sensor
  - Battery voltage

#### Short horn warning sound

Sounds in addition to the visual display of error messages that do not have an error number and do not lead directly to crane movement shut-off by the LICCON overload protection

Monitored error messages are, for example:

- Maximum permissible wind speed exceeded (only with an activated wind sensor\*)
- Crane utilization value for advance warning (90 %) has been reached

#### Acoustic warning priority

- The *Horn* warning around has higher priority than the *Short horn* warning sound, i.e. *Horn* takes preference over *Short horn*.
- Both the *Horn* warning sound as well as the *Short horn* warning sound become active again after shut down if a new error occurs.

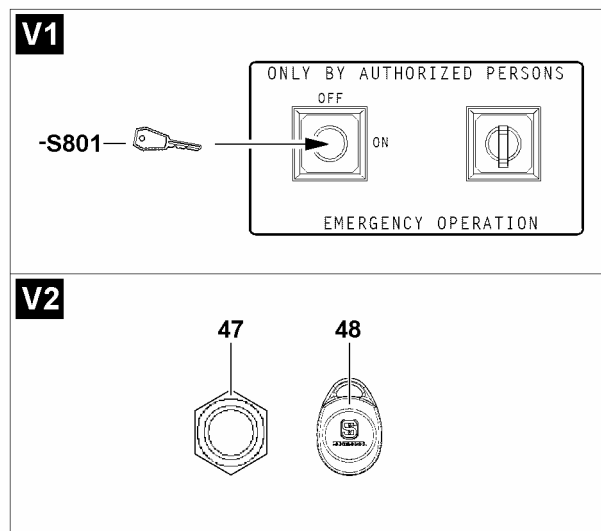
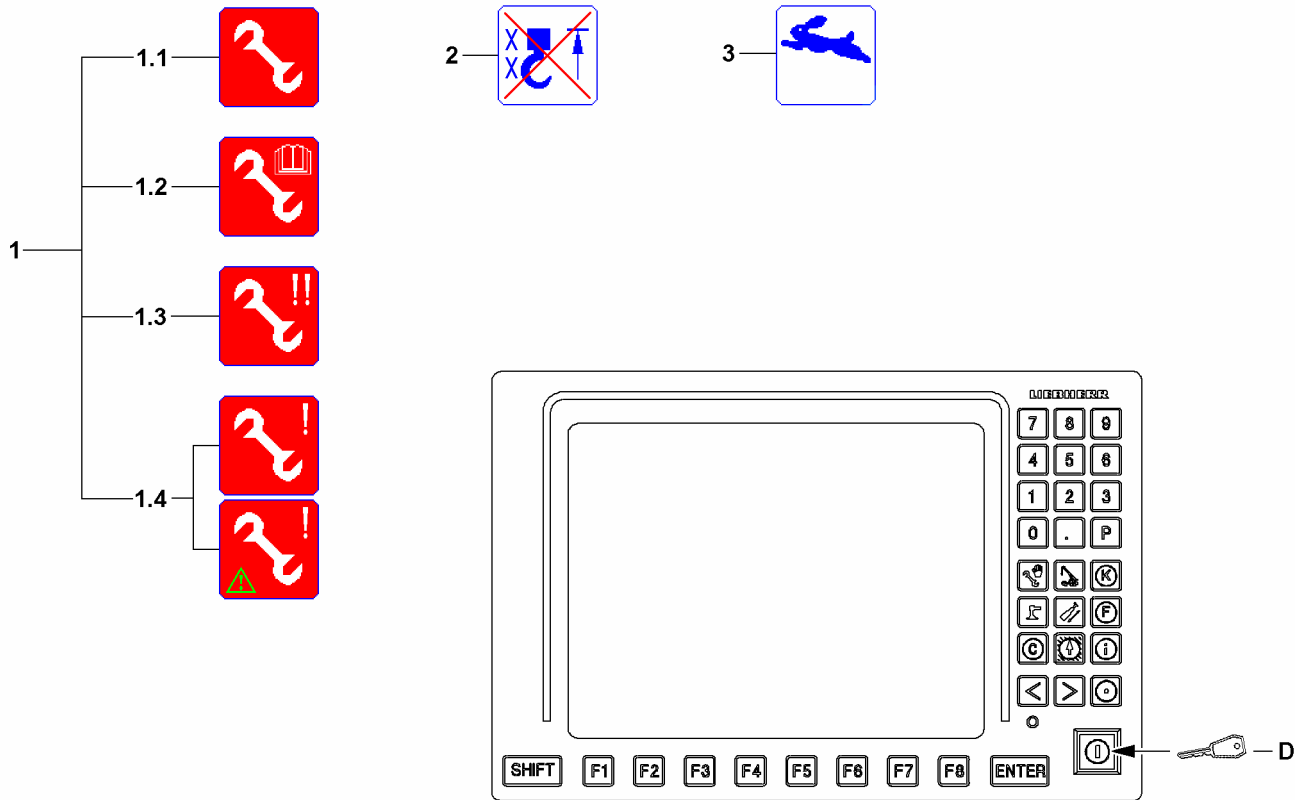


Fig.153664

## 5.4 LICCON Monitor 0 special functions



### Note

Additional special functions

- ▶ Observe section "Special function LICCON monitor 2".



### WARNING

Danger of accident due to the *Exceedance of shut-off limits of the LICCON overload protection* function!

If the shut off limits of the LICCON overload protection are exceeded, there is no additional protection against crane overload.

Due to erroneous operation or deliberate misuse, the crane could collapse, the boom can break off or the crane can topple over.

Personnel can be severely injured or killed.

- ▶ The *Exceedance of shut-off limits of the LICCON overload protection* function is only permissible in emergencies and for assembly purposes.
- ▶ The set up key **D** may only be actuated by persons who are aware of the effects of their acts regarding the function *Exceedance of shut off limits of the LICCON overload protection*.
- ▶ The *Exceedance of shut-off limits of the LICCON overload protection* function requires the presence of an authorized person and must be performed with utmost caution.
- ▶ Crane operation with the *Exceedance of shut-off limits of the LICCON overload protection* function activated is prohibited.

Before pressing the set up key **D** make sure that:

- Operation and specifications to use the set up key **D** from the Crane operating instructions, chapter 4.20 and 7.15 are known to the crane operator and have been understood.



### Note

- ▶ The various *Assembly operation* icons **1** are shown in the same position in the LICCON monitor, depending on the operating mode, illustration **2**.

### 5.4.1 Exceeding the shut off limits of the LICCON overload protection

#### 1.1 Assembly icon

- The *Assembly* icon **1.1** appears when a special case for operation of the LICCON overload protection was activated, for example the shut-off limits of the LICCON overload protection were bypassed by the set up key **D**.



### Note

- ▶ The *Assembly* icon **1.1** appears on LICCON monitor 2, when the difference monitoring of the derrick ballast guying is bypassed, see the Crane operating instructions, chapter 5.35 / 5.36.

### 5.4.2 No load chart is available

#### 1.2 Assembly - no load chart icon

- The *Assembly - no load chart* icon **1.2** appears when the shut off limits of the LICCON overload protection are bypassed via the set up key **D** and no load chart is available.
- The crane may only be operated according to the specifications of the respective chapter in the Crane operating instructions and / or the erection / take-down charts.
- **Note:** By pressing the set up key **D**, all erection / take-down procedures can be carried out within the erection / take-down charts, for which no load charts are available.

### 5.4.3 Emergency operation LICCON overload protection (according to EN 13000:2010)



#### WARNING

Increased danger of accident during emergency operation of the LICCON overload protection! In emergency operation, the crane movements are no longer monitored by the LICCON overload protection.

- ▶ The emergency operation may only be activated by persons who are aware of the consequences of their actions.
- ▶ A shut-off by the LICCON overload protection may not be circumvented by the emergency operation.
- ▶ If normal crane operation is possible, then the emergency operation may not be activated.
- ▶ All crane movements must be carried out with extreme caution and anticipatorily.

#### 1.3 Emergency operation activated icon

- The *Emergency operation activated* icon **1.3** appears:
  - When the emergency operation of the LICCON overload protection is activated via the key button **S801** or by actuating the transponder **48** on the sensor **47**.



#### Note

Activating emergency operation

- ▶ If emergency operation of the LICCON overload protection is activated via the key button **S801** or by actuation of the transponder **48** on a sensor **47** depends on the crane type. For the location, see the Crane operating instructions, chapter 4.01.

### 5.4.4 Additional emergency operating modes



#### WARNING

Improper crane operation!

If one of the *additional emergency operating modes* icon **1.4** appears, then there is a high danger of accident due to erroneous operation of the crane.

Safety equipment could be deactivated.

Personnel can be killed or injured.

This could result in property damage.

- ▶ Deactivate the *additional emergency operating modes* **1.4** icon again or contact Liebherr Service and coordinate further procedure.

#### 1.4 Additional emergency operating modes icon

- The *additional emergency operating modes* icon **1.4** appears if additional emergency operating modes were activated.

### 5.4.5 Bypassing the difference force monitoring of derrick ballast guying



#### WARNING

Overload of crane!

Erroneous operation when bypassing the difference force monitoring for the derrick ballast guying.

- ▶ Observe the Crane operating instructions, chapter 5.35 / 5.36.

- D** The shut-off *Difference force monitoring derrick ballast guying* is bypassed by the set up key **D**. Observe the Crane operating instructions, chapter 5.35 / 5.36.

### 5.4.6 Bypassing the hoist limit switch

#### 2 Hoist top bypassed icon

- The *Hoist top bypassed* icon **2** appears when the shut-off *Hoist top* is bypassed using the set up key **D**.

**Note:** The *Crane operation* program is locked, meaning that no other program can be turned on via the program keys.

### 5.4.7 Rapid gear



**Note**

- ▶ **Crane operation without rapid gear:** The speeds of the individual crane movements are independent of each other. There is no interference of the movement speeds.
- ▶ **Crane operation with rapid gear:** If the rapid gear is activated, the individual crane movements can reach the highest possible movement speed. As a result, it can happen that during several simultaneous crane movements individual speed movements are slowed down.

Add the rapid gear only when:

- If the highest possible movement speed is to be made possible for individual crane movements **and**
- Interference between the movement speeds does not create a problem.

**3 Rapid gear icon**

- The *Rapid gear icon 3* appears if the rapid gear is enabled for one or more crane movements.

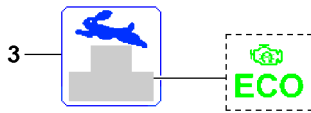


Fig.166559: Additional ECO mode\* display in the rapid gear icon

Only on crane types with ECO mode\*:

For a description of the ECO mode, see chapter 5.72

### 5.5 Crane operation monitoring functions

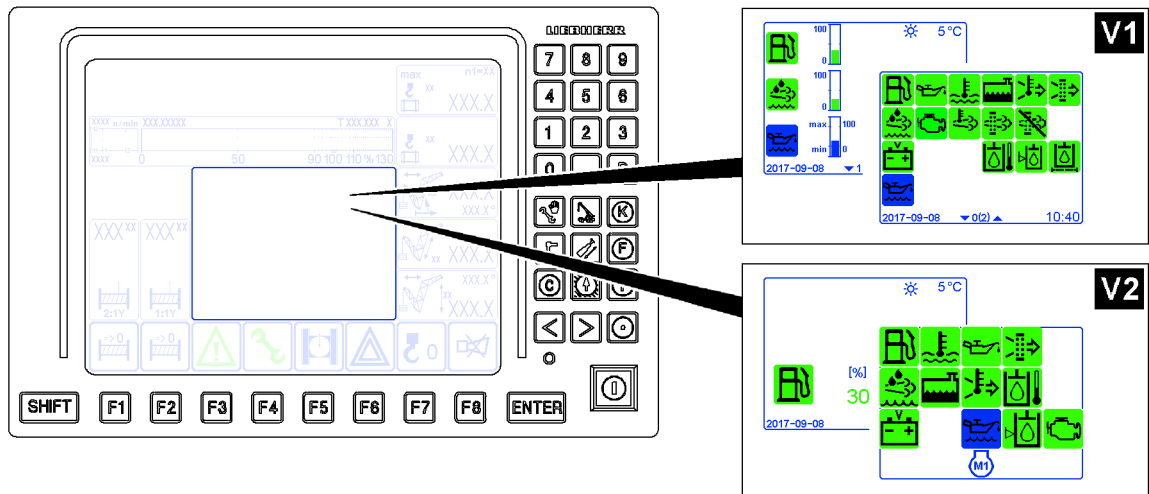


Fig.153670: Variants of the crane operation monitoring functions

Depending on the crane configuration, there are two variants of the crane operation monitoring functions during crane operation:

- Crane operation monitoring functions variant **V1**
- Crane operation monitoring functions variant **V2**



**Note**

The variants differ in their display and operation.

- ▶ Based on the display, such as the fuel gauge, the suitable variant can be assigned to the crane.

LWE/LR\_1800-1-0-000/27200-07-02/en

### 5.5.1 Crane operation monitoring functions variant 1

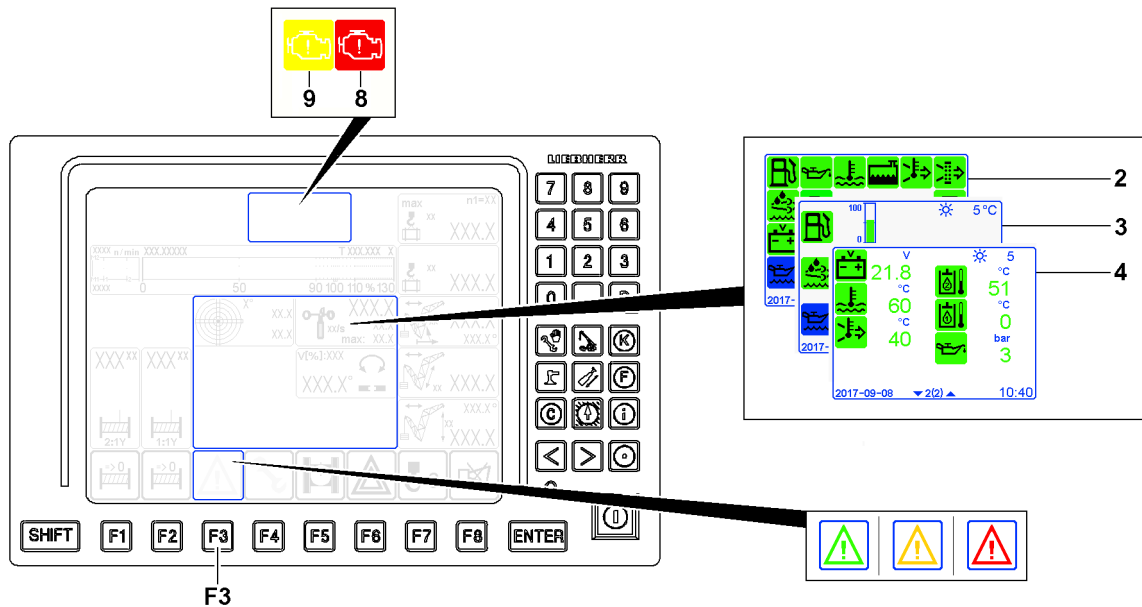


Fig.164491: Crane operation monitoring functions

The crane operation monitoring functions include the following displays:

- 2 Monitoring function icons
- 3 Fill level individual control displays
- 4 Actual value displays individual control displays

The monitoring functions are always active and can be displayed in the monitoring field, if necessary. The crane operator is automatically alerted in case of a warning occurrence by the color of the icon over the function key **F3**.

Meaning of the color of the warning icon over the function key **F3**:

- Green warning icon: All monitoring functions are ok.
- Warning icon yellow: Advance warning for one or several monitoring functions.
- Warning icon red: Warning for one or several monitoring functions.



#### WARNING

Non-observance of alarm functions!

If alarm functions are not observed, then it can result in a sudden shut off of the crane movement. A sudden shut off of the crane movement can result in high stress and strain for crane and load. High strain for the crane and load can cause accidents.

- ▶ If the *engine monitoring advance warning 9* icon appears, the monitoring functions must be checked.
- ▶ If the *engine stop 8* icon appears, crane operation must be stopped, the engine must be turned off and the problems must be resolved.

#### NOTICE

Danger of severe crane engine damage!

If the monitoring functions report a problem and / or warning occurrence, then you must react immediately and remedy the problem.

- ▶ React to problems and / or warning occurrences immediately and remedy the problem.
- ▶ If necessary, stop crane operation and turn the crane engine off.



**NOTICE**

Shut off engine monitoring!

Outside of the crane operation program, the monitoring functions are turned off.

When the engine monitoring is turned off, problems and warning occurrences are not recognized.

This could result in crane failure.

- ▶ If work is not carried out in the Crane operation program, then turn the crane engine off and operate the LICCON computer system in stand-by mode, see section “Power-Save mode and Stand-by mode on the LICCON computer system”.
- ▶ If work has to be carried out for a longer period outside of the crane operation program, with the crane engine running, then switch continuously to the engine monitoring screen and check the display values.
- ▶ Register changes in the display values mindfully and proceed anticipatorily, for example, refuel in time.

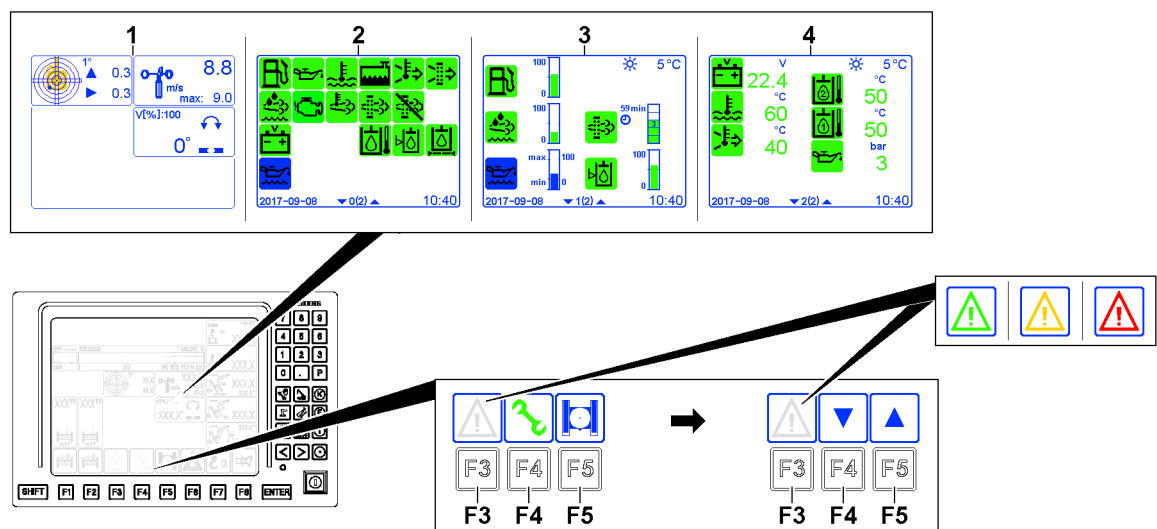
**Order of the displays in the crane operation monitoring functions**

Fig.152779: Displays in the crane operation monitoring functions

The order of the displays in the crane operation monitoring functions is specified by the LICCON computer system according to the current situation.

- Pressing the function key **F3**, hides the monitored auxiliary functions **1**, the crane operation monitoring functions are displayed. The function assignments of the function keys **F4-F5** change.
- By pressing the function key **F4** and function key **F5**, it is possible to switch between the following displays:
  - **2** Monitoring function icons
  - **3** Fill level individual control displays
  - **4** Actual value displays individual control displays
- By pressing the function key **F3** again, the crane operation monitoring functions are hidden again. The monitored auxiliary functions **1** are displayed again.

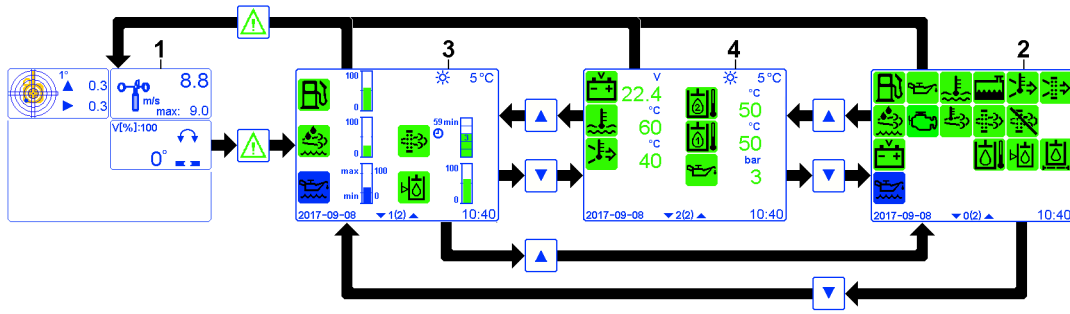


Fig.157717: Example for the order of the displays, when the warning icon over function key F3 is green

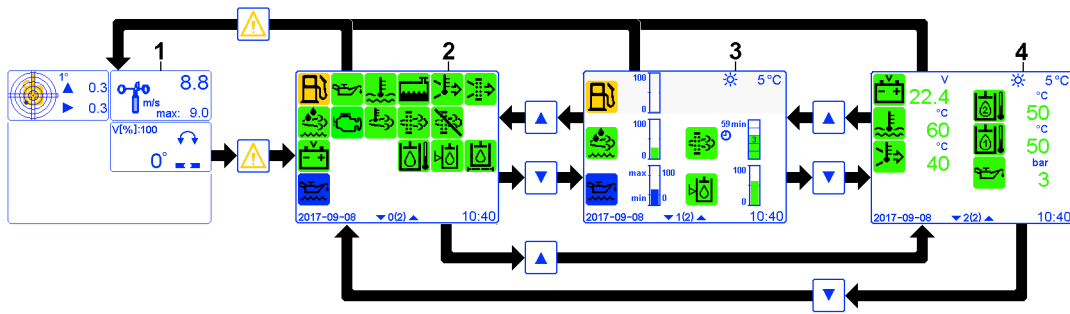


Fig.157719: Example for the order of the displays, when the warning icon over function key F3 is yellow

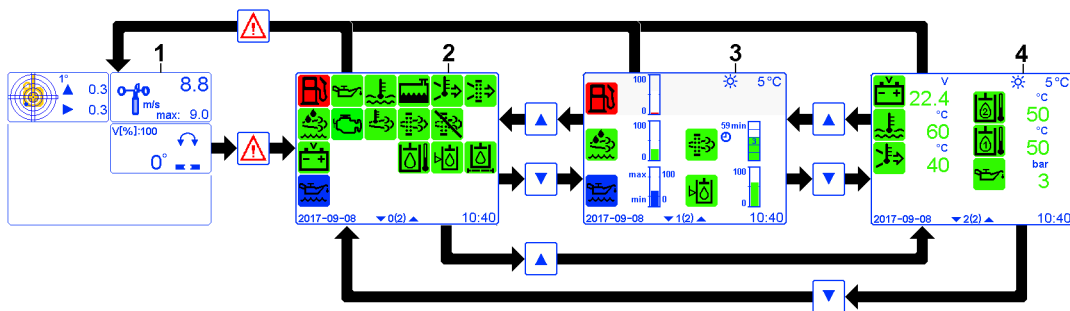


Fig.157718: Example for the order of the displays, when the warning icon over function key F3 is red

► Press the function keys in the corresponding order.

### Calling up / masking the crane operation monitoring functions

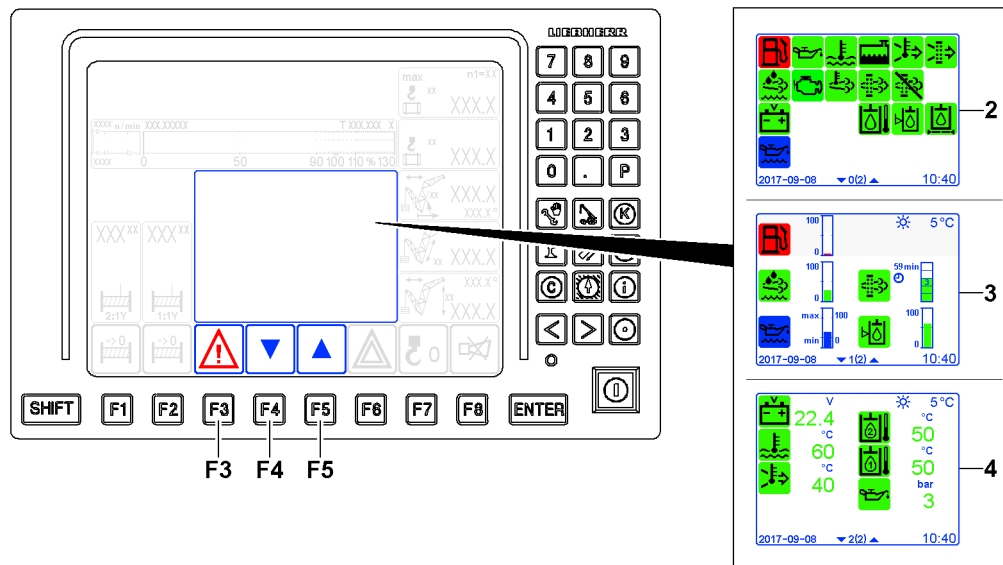


Fig.152783: Example for the fuel reserve low / depleted warning event

If a warning event occurs on one or on several monitoring functions, then this is indicated by the color of the warning icon over the function key **F3**. The warning icon is displayed statically and via the color of the monitoring function that triggered the warning event.

Example for the low / depleted fuel reserve warning event:

- The icon above the function key **F3** is red.
- In the monitoring functions icon **2**, the *fuel reserve* icon appears in red
- In the *fill level* individual control displays **3**, the *fuel reserve* icon appears in red and the assigned bar graph shows an empty fill level.
- The *actual value displays* individual control displays **4** do not provide any further information regarding this warning event.

To call up / hide the crane operation monitoring functions:

- ▶ Press the function keys in the corresponding order, see section “Order of the displays in the crane operation monitoring functions”

#### Result:

- By pressing the function key **F4** and function key **F5**, it is possible to switch between the displays.
- By pressing the function key **F3** again, the crane operation monitoring functions can be immediately masked again.
- For a description of the monitoring function icons **2**, see the following section “Overview of icons for monitoring functions”.
- Description of the *fill level* individual control displays **3**, see the following section “Overview of the individual control displays”.
- Description of the *actual value displays* individual control displays **4**, see the following section “Overview of individual control displays”.

Overview of icons for monitoring functions

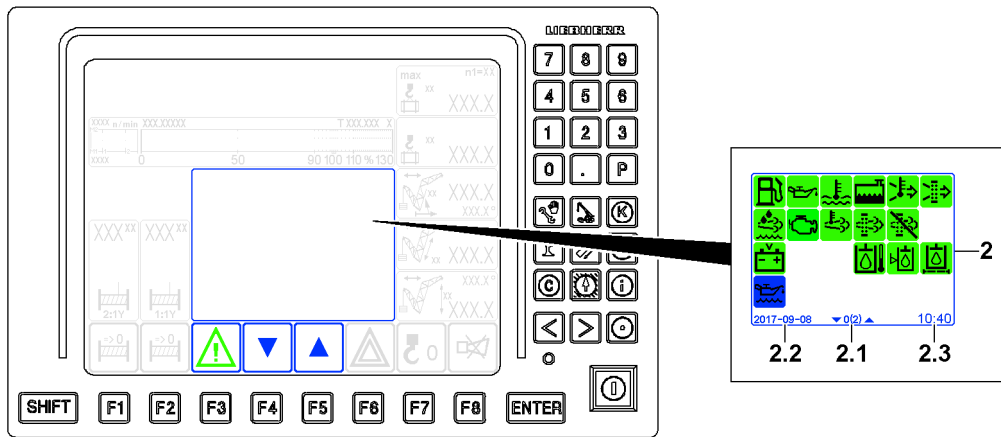



Fig.153661: Monitoring function icons


- 2 Monitoring function icons
  - The following appears in addition to the monitoring function icons:
    - 2.1 Page counter
    - 2.2 Date
    - 2.3 Time




**Note**


The scope of the monitoring function icons 2 depends on the crane type and crane configuration.  
 ▶ Not all crane types have all listed monitoring functions.


	<b>Fuel reserve</b>
Green:	Fuel reserve sufficient
Yellow:	Fuel reserve is short
Red:	Fuel reserve low / depleted / system error <b>NOTICE!</b> Add fuel immediately / Immediately bring the crane to a standstill, turn the crane engine off and remedy the problem. Pay attention to the error message.


	<b>Engine oil pressure</b>
Green:	Engine oil pressure OK (engine on)
Red:	Engine oil pressure too low (engine on) / system error <b>NOTICE!</b> Immediately bring the crane to a standstill, turn the engine off and remedy the problem. Pay attention to the error message.


LWE/LR 1800-1-0-000/27200-07-02/en

 <b>Coolant temperature</b>	
Green:	Coolant temperature OK
Red:	Coolant temperature too high / system error <b>NOTICE!</b> Immediately bring the crane to a standstill, turn the engine off and remedy the problem. Pay attention to the error message.

 <b>Coolant level</b>	
Green:	Coolant level OK
Red:	Coolant level too low / system error <b>NOTICE!</b> Immediately bring the crane to a standstill, turn the engine off and remedy the problem. Pay attention to the error message.

 <b>Charge air temperature</b>	
Green:	Charge air temperature OK
Red:	Charge air temperature too high / system error <b>NOTICE!</b> Immediately bring the crane to a standstill, turn the engine off and remedy the problem. Pay attention to the error message.

 <b>Engine air filter</b>	
Green:	Air intake opening / air filter OK (engine on)
Yellow	Air intake opening / air filter dirty (engine on) / system error <b>NOTICE!</b> Immediately bring the crane to a standstill, turn the engine off and remedy the problem. Pay attention to the error message.

 <b>Urea tank / exhaust aftertreatment <sup>1)</sup></b>	
Green:	Urea reserve sufficient
Yellow:	The urea reserve is low or erroneous function of exhaust aftertreatment <sup>2)</sup> <b>Advance warning!</b> Add urea or remedy the malfunction of the exhaust aftertreatment. Pay attention to the error message.
Red:	Urea level too low / depleted or erroneous function of exhaust aftertreatment system <sup>2)</sup> / system error <b>NOTICE!</b> Add urea or remedy the erroneous function of the exhaust aftertreatment / immediately bring the crane to a standstill, turn the engine off and remedy the problem. Pay attention to the error message.

1) Applies only for engines with the SCR system.

2) Under some circumstances a power reduction or start block of the engine is triggered. The type and scope of a power reduction or start block of the engine depends on the respectively valid national / regional regulations and the vehicle configuration.




### WARNING

Triggers power reduction or start block of the engine!

If the urea level is too low or if there is a malfunction in the exhaust aftertreatment, then a power reduction or starting block of the engine can be triggered.


The crane operation and travel operation can be limited or disabled.

- ▶ Replenish the Urea level in time.
- ▶ Remedy the faulty function of the exhaust aftertreatment immediately.
- ▶ Observe any valid national / regional regulations and the vehicle configuration.


 <b>Exhaust aftertreatment <sup>1)</sup></b>	
Green:	Exhaust aftertreatment OK
Yellow / red:	Urea level too low / depleted or erroneous function of exhaust aftertreatment system <sup>2)</sup> / system error <b>NOTICE!</b> Add urea or remedy the malfunction of the exhaust aftertreatment. Under some circumstances a power reduction or start block of the engine <sup>2)</sup> is triggered, pay attention to the error message.

1) Applies only for engines with the SCR system.


2) Under some circumstances a power reduction or start block of the engine is triggered. The type and scope of a power reduction or start block of the engine depends on the respectively valid national / regional regulations and the vehicle configuration.

 <b>Exhaust gas temperature <sup>4)</sup></b>	
Green:	Normal exhaust gas temperature
Yellow	High exhaust gas temperature, diesel particle filter regeneration is carried out <b>Note:</b> Engine noise may change slightly during regeneration. After generation is complete, the icon turns green again.


4) Only for engines with a diesel particle filter (DPF).


 <b>Diesel particle filter<sup>4)</sup></b>	
Green:	Diesel particle filter <sup>4)</sup> OK
Yellow	Diesel particle filter <sup>4)</sup> reports an advance warning <b>Note:</b> Call up the individual control displays and check the load condition of the diesel particle filter <sup>4)</sup> . Pay attention to the error message.
Red:	Diesel particle filter <sup>4)</sup> reports a warning / problem <b>NOTICE!</b> Call up the individual control displays and check the load condition of the diesel particle filter <sup>4)</sup> . Remedy the problem. Pay attention to the error message.


4) Only for engines with a diesel particle filter (DPF).

 <b>Disabling diesel particle filter regeneration<sup>4)</sup></b>	
Green:	Automatic regeneration of the diesel particle filter is not disabled
Yellow	Automatic regeneration of the diesel particle filter is disabled <b>NOTICE!</b> If automatic regeneration of the diesel particle filter is disabled for too long, damage can occur to the crane engine and the exhaust gas system.

4) Only for engines with a diesel particle filter (DPF).


 <b>Battery voltage</b>	
Green:	Battery voltage OK
Red:	Overtoltage or undervoltage in on-board power supply / system error <b>NOTICE!</b> Immediately bring the crane to a standstill, turn the engine off and remedy the problem. Pay attention to the error message.

 <b>Hydraulic oil temperature</b>	
Green:	Hydraulic oil temperature OK
Red:	Hydraulic oil temperature too high / system error <b>NOTICE!</b> Immediately bring the crane to a standstill, turn the engine off and remedy the problem. Pay attention to the error message.


 <b>Hydraulic oil level<sup>3)</sup></b>	
Green:	Hydraulic oil level OK
Yellow / red:	Hydraulic oil level too low / error / system error <b>NOTICE!</b> Immediately bring the crane to a standstill, turn the engine off and remedy the problem. Pay attention to the error message.


3) Only for certain crane types.

LWE/LR 1800-1-0-000/27200-07-02/en

 <b>Hydraulic oil filter</b>	
Green:	Leak oil filter, return filter <sup>3)</sup> and charge pressure filter <sup>3)</sup> OK (engine on)
Red:	Leak oil filter, return filter <sup>3)</sup> and / or charge pressure filter <sup>3)</sup> dirty (engine on) / system error <b>NOTICE!</b> Immediately bring the crane to a standstill, turn the engine off and remedy the problem. Pay attention to the error message.

3) Only for certain crane types.

 <b>Engine oil level</b>	
Blue	The engine oil level can not be checked here on the display, call up the individual indicator light.

 <b>Charge control display (alternator)<sup>5)</sup></b>	
Green:	Charge control OK (engine on)
Red:	Charge control has a problem (engine on) / system error <b>NOTICE!</b> Immediately bring the crane to a standstill, turn the engine off and remedy the problem. Pay attention to the error message.

5) Alternatively, the charge control display is located on the BKE, see the Crane operating instructions, chapter 4.01.

### Overview of the individual control displays

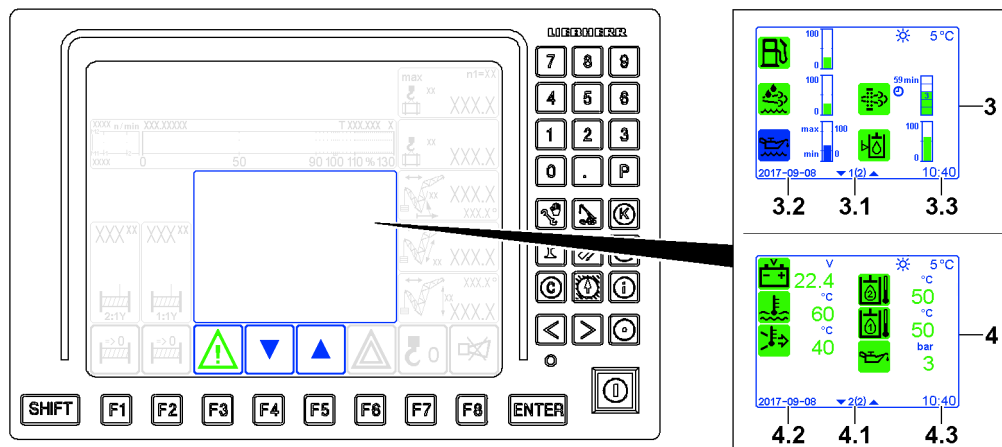


Fig.153662: Overview of the individual control displays

- **3 Fill level individual control displays**
  - The following also appears:
    - **3.1** Page counter
    - **3.2** Date
    - **3.3** Time
- **4 Actual value displays individual control displays**
  - The following also appears:
    - **4.1** Page counter



- 4.2 Date
- 4.3 Time



### Note

- ▶ Detailed individual control displays can be displayed for some monitoring functions.
- ▶ The display values in the depicted individual indicator displays are examples.
- ▶ Some displays appear only for certain crane types.

### Fuel reserve individual control display

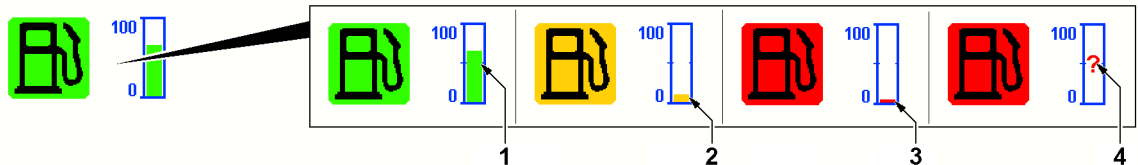


Fig.148374: Fuel reserve, bar graph

- Icon and bar **1** green: Fuel reserve sufficient
- Icon and bar **2** yellow: Fuel reserve is short
- Icon and bar **3** red: Fuel reserve low / depleted
- Icon and question mark **4** red: System error, the fill level cannot be determined

**NOTICE!** Add fuel immediately before it is depleted / Immediately bring the crane to a standstill, turn the crane engine off and remedy the problem. Pay attention to the error message.

The exact fill level can be read based on the scale of the bar chart:

- Scale value 100: The tank is completely full
- Scale value 0: The tank is completely empty

### Urea tank individual control displays

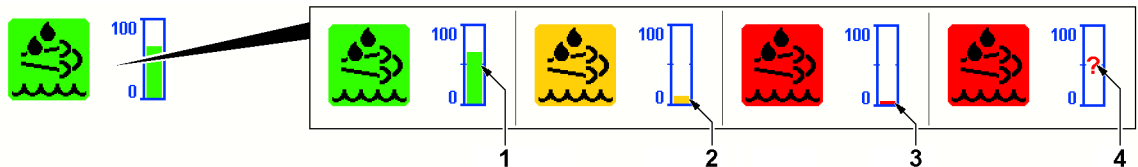


Fig.148376: Urea reserve, bar graph

- Icon and bar **1** green: Urea reserve sufficient
- Icon and bar **2** yellow: Urea reserve is short
- Icon and bar **3** red: Urea reserve low / depleted
- Icon and question mark **4** red: System error, the fill level cannot be determined, erroneous function of the exhaust aftertreatment

**NOTICE!** Add urea immediately before it is depleted / Immediately bring the crane to a standstill, turn the crane engine off and remedy the problem. Pay attention to the error message.

The exact fill level can be read based on the scale of the bar chart:

- Scale value 100: The tank is completely full
- Scale value 0: The tank is completely empty

## Engine oil level individual control display

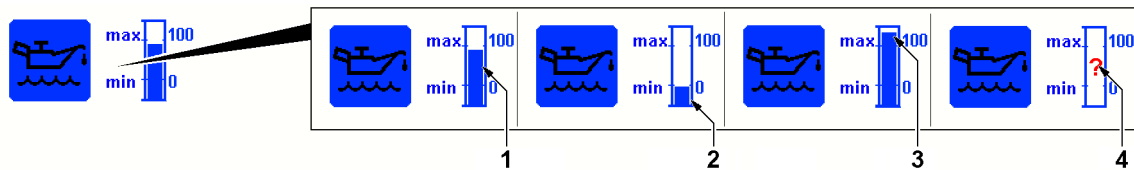


Fig.148378: Engine oil level, bar graph

- Icon and bar **1** blue, bar height between 0 and 100: Normal engine oil level
  - Icon and bar **2** blue, bar height below 0: Engine oil underfilled
  - Icon and bar **3** blue, bar height above 100: Engine oil overfilled
  - Icon blue and question mark **4** red: faulty measurement value, fill level cannot be determined
- Note:** When the engine is running an erroneous test value appears, to check the engine oil level align the crane horizontally and turn the engine off.

**NOTICE!** Do not start the engine if the engine oil is underfilled or overfilled. Remedy the problem and observe the error message.

The exact fill level can be read based on the scale of the bar chart:

- Scale value 100: Engine oil fill level upper limit
- Scale value 0: Engine oil fill level lower limit

## Diesel particle filter individual control display

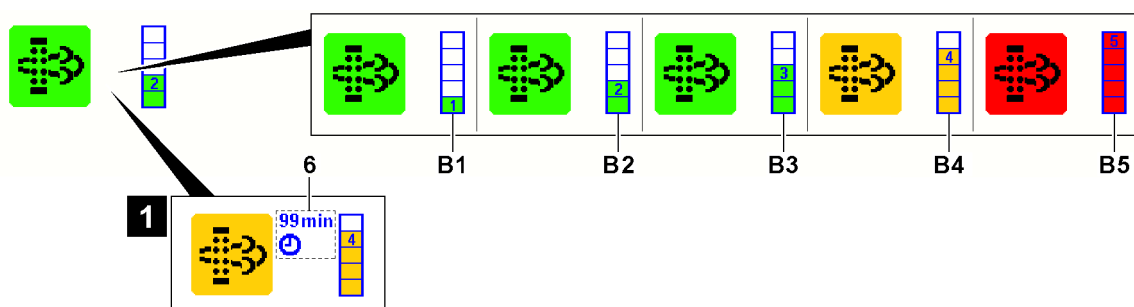


Fig.152687: Diesel particle filter load condition, bar graph

- **B1** Load condition 1 (green)
  - Load condition OK, diesel particle filter minimally loaded
- **B2** Load condition 2 (green)
  - Load condition OK, diesel particle filter slightly loaded
- **B3** Load condition 3 (green)
  - Load condition OK, diesel particle filter half loaded
- **B4** Load condition 4 (yellow)
  - Load condition increased, diesel particle filter strongly loaded
- **B5** Load condition 5 (red)
  - Load condition critical, diesel particle filter with maximum load
- **6** Regeneration time
  - This appears only when regeneration at a standstill of the diesel particle filter has started, see illustration **1**
  - The remaining time (regeneration time) of regeneration at a standstill of the diesel particle filter is displayed continuously.
  - **Note:** Start regeneration at a standstill of the diesel particle filter, see the Crane operating instructions, chapter 4.03.

If load condition 4 **B4** appears, Liebherr-Werk Ehingen GmbH recommends carrying out regeneration at a standstill as soon as possible (during the work day).

If load condition 5 **B5** appears and regeneration at a standstill is no longer possible:

- Stop engine operation.
- Contact Customer Service at Liebherr-Werk Ehingen GmbH.



### Note

Load condition 5 **B5**

- ▶ The engine torque is reduced to protect the engine against damage.

Hydraulic oil level individual control display

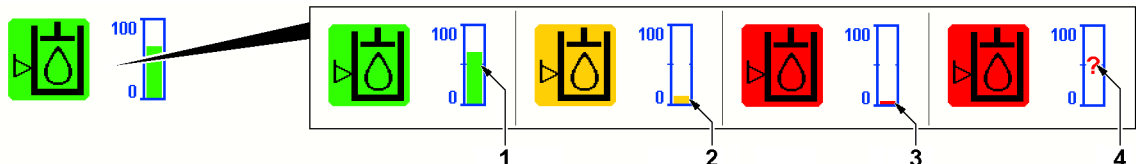


Fig.152689: Hydraulic oil level, bar graph

- Icon and bar **1** green: Hydraulic oil level OK
- Icon and bar **2** yellow: Hydraulic oil level low
- Icon and bar **3** red: Hydraulic oil level too low
- Icon and question mark **4** red: System error, the hydraulic oil level cannot be determined

**NOTICE!** Stop crane operation if the hydraulic oil level is too low. Remedy the problem and observe the error message.

The exact fill level can be read based on the scale of the bar chart:

- Scale value 100: The tank is completely full
- Scale value 0: The tank is completely empty

Battery voltage individual control display



Fig.148382: Battery voltage icon, display value and unit of measure

Icon and display value

- Green: Battery voltage OK
- Red: Overvoltage or undervoltage in on-board power supply / system error

**NOTICE!** Immediately bring the crane to a standstill, turn the crane engine off and remedy the problem. Pay attention to the error message.

Coolant temperature individual control display



Fig.148383: Coolant temperature icon, display value and unit of measure

Icon and display value

- Green: Coolant temperature OK
- Red: Charge air temperature too high / system error

**NOTICE!** Immediately bring the crane to a standstill, turn the crane engine off and remedy the problem. Pay attention to the error message.

## Charge air temperature individual control display



*Fig.148384: Charge air temperature icon, display value and measuring unit*

## Icon and display value

- Green: Charge air temperature OK
  - Red: Charge air temperature too high / system error
- NOTICE!** Immediately bring the crane to a standstill, turn the crane engine off and remedy the problem. Pay attention to the error message.

## Hydraulic circuit 1 hydraulic oil temperature individual control display



*Fig.148386: Hydraulic oil temperature, hydraulic circuit 1 icon, display value and unit of measure*

## Icon and display value

- Green: Hydraulic temperature in hydraulic circuit 1 OK
  - Red: Hydraulic temperature in hydraulic circuit 1 too high
- NOTICE!** Immediately bring the crane to a standstill, turn the crane engine off and remedy the problem. Pay attention to the error message.

## Hydraulic circuit 2 hydraulic oil temperature individual control display



*Fig.148387: Hydraulic oil temperature, hydraulic circuit 2 icon, display value and unit of measure*

## Icon and display value

- Green: Hydraulic temperature in hydraulic circuit 2 OK
  - Red: Hydraulic temperature in hydraulic circuit 2 too high
- NOTICE!** Immediately bring the crane to a standstill, turn the crane engine off and remedy the problem. Pay attention to the error message.

## Engine oil pressure individual control display



*Fig.148388: Engine oil pressure, display value and unit of measure*

## Icon and display value

- Green: Engine oil pressure OK
  - Red: Engine oil pressure too low
- NOTICE!** Immediately bring the crane to a standstill, turn the crane engine off and remedy the problem. Pay attention to the error message.

Empty page!

LWE/LR 1800-1-0-000/27200-07-02/en

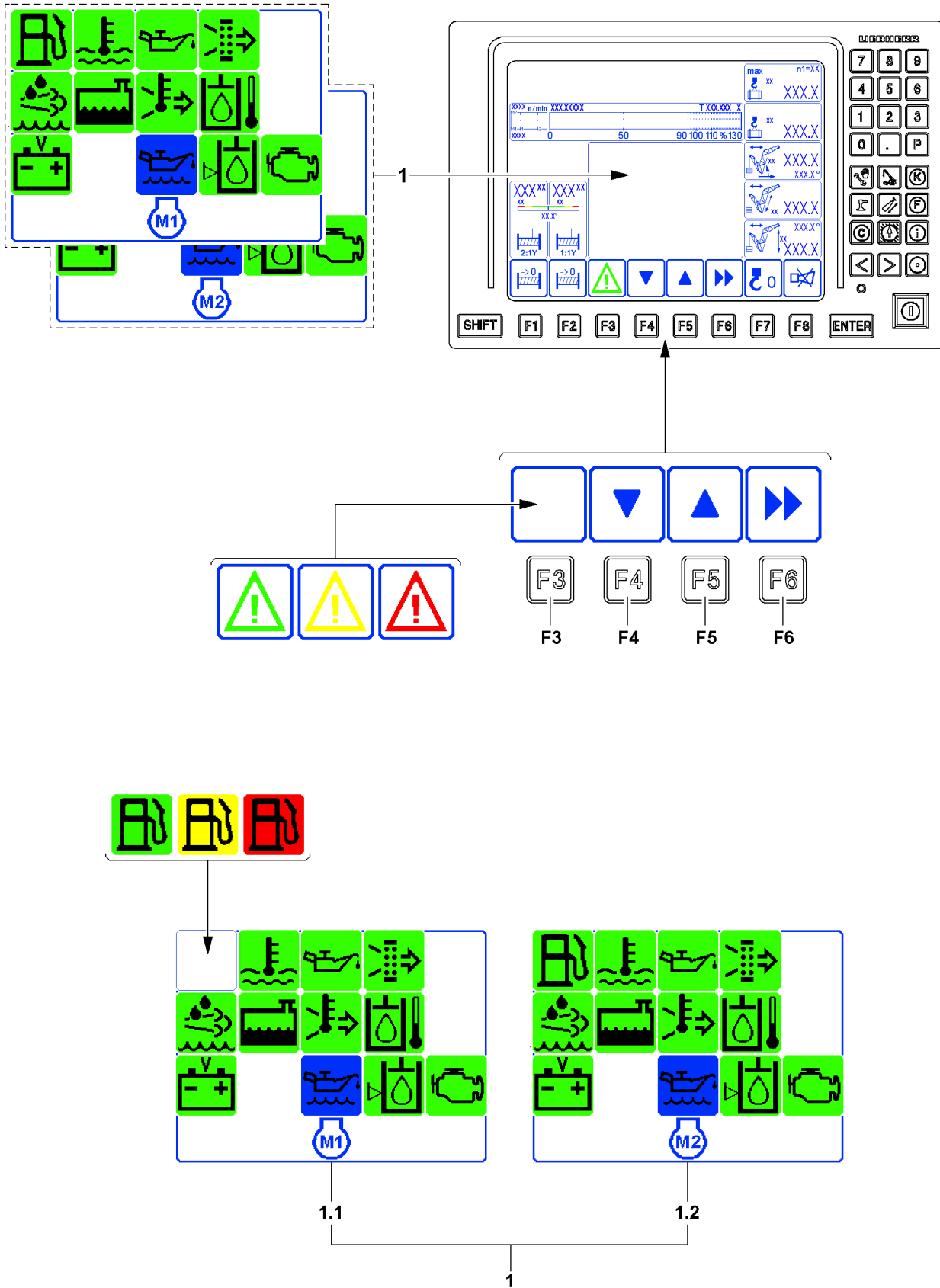


Fig.121774

## 5.5.2 Monitoring functions during crane operation variant 2

The monitoring functions **1** are always active and can be displayed in the monitoring field, if necessary. The crane operator is automatically alerted in case of a warning occurrence by the color of the icon over the function key **F3**.

The monitoring field has its fixed position on the LICCON monitor and can be hidden or assigned with other functions.

By pressing the function key **F3**, the monitoring functions **1** are displayed in the monitoring field.

---

### NOTICE

There is a danger of severe damage to the engine if warnings are ignored!

If other programs are used for extended periods of time, for example the *Set up* program or *Test system* program, it is essential to switch to the crane operation screen in order to ensure that no events have occurred, which could lead to damage or destruction of the engine.

- ▶ Switch continuously to the crane operation screen and check the displays.
- 

### NOTICE

Danger of severe engine damage!

If the engine monitoring reports a problem and / or warning occurrence, then you must react immediately and remedy the problem.

- ▶ React to problems and / or warning occurrences immediately and remedy the problem.
  - ▶ If necessary, stop crane operation and turn the engine off.
- 

### NOTICE

Shut off engine monitoring!

Outside of the *crane operation* program, the monitoring functions are turned off.

When the engine monitoring is turned off, problems and warning occurrences are not recognized.

This could result in crane failure.

- ▶ If work is not carried out in the *Crane operation* program, then turn the crane engine off and operate the LICCON computer system in stand-by mode, see section "LICCON computer system in stand-by mode".
  - ▶ If work has to be carried out for a longer period outside of the *crane operation* program, with the crane engine running, then switch continuously to the engine monitoring screen and check the display values.
  - ▶ Register changes in the display values mindfully and proceed anticipatorily, for example, refuel in time.
- 

Warning icon color key above the function key **F3**

- Green warning icon: All monitoring functions are ok.
- Warning icon yellow: Advance warning for one or several monitoring functions.
- Warning icon red: Warning for one or several monitoring functions.

Monitoring functions **1**:

- Engine M1 monitoring functions **1.1**
- Engine M2 monitoring functions **1.2**

**Note:** Appears exclusively for crane types with two crane engines.

### Calling up the monitoring functions

If a warning event occurs in one or more monitoring functions in the monitoring field, this is indicated by the color change of the warning icon over the function key **F3**. The warning icon is displayed statically and via the color of the monitoring function that triggered the warning event.

- ▶ Press the function key **F3** until the desired monitoring functions **1** page is called up.

**Result:**

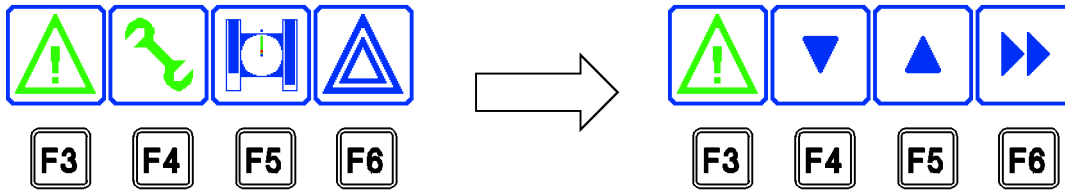


Fig.114282

- The assignment of the function key **F4**, function key **F5** and function key **F6** changes.
- The monitoring functions **1** are displayed in the monitoring field on the LICCON monitor.

For the colors for the icons of the monitoring function **1**, see the following section “Overview of icons for monitoring functions”:

- Green: Monitored function ok
- Yellow: Advance warning for the monitored function
- Red: Warning for the monitored function

Call up the individual control displays one after the other:

- ▶ Press the function key **F4** or function key **F5**.

**Result:**


- The individual control displays appear, see the following section “Overview of the individual control displays”


Mask the monitoring functions **1**:

- ▶ Press the function key **F6**.

**Overview of icons for monitoring functions**

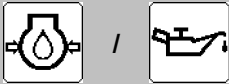
In the monitoring field **1** appear the following monitoring functions:


	<b>Fuel reserve</b>
Green:	Fuel reserve <b>more</b> or equal to 5 %
Yellow:	Fuel reserve approx. 3 % - 4 %
Red:	Fuel reserve <b>less than</b> 3 % <b>NOTICE!</b> Immediately bring the crane to a standstill, turn the engine off and remedy the problem. Pay attention to the error message.


	<b>Coolant temperature</b>
Green:	Coolant temperature OK
Red:	Coolant temperature <b>too high</b> <b>NOTICE!</b> Immediately bring the crane to a standstill, turn the engine off and remedy the problem. Pay attention to the error message.

LWE/LR 1800-1-0-000/27200-07-02/en




		<b>Engine oil pressure</b>
Green:		Engine oil pressure OK (engine on)
Red:		Engine oil pressure too low (engine on) <b>NOTICE!</b> Immediately bring the crane to a standstill, turn the engine off and remedy the problem. Pay attention to the error message.


		<b>Engine air filter</b>
Green:		Air filter OK (engine on)
Yellow		Air filter dirty (engine on) <b>NOTICE!</b> Immediately bring the crane to a standstill, turn the engine off and remedy the problem. Pay attention to the error message.

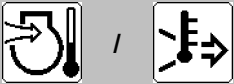
		<b>Charge control display<sup>1)</sup></b>
Green:		Alternator OK (engine on)
Red:		Alternator does not charge (engine on) <b>NOTICE!</b> Immediately bring the crane to a standstill, turn the engine off and remedy the problem. Pay attention to the error message.


1) Only for certain crane types.

		<b>Urea tank / exhaust aftertreatment <sup>1)</sup></b>
Green:		Urea available
Yellow / red:		Urea level too low or erroneous function of exhaust aftertreatment system <b>NOTICE!</b> Add urea or remedy the malfunction of the exhaust aftertreatment. Under some circumstances a power reduction or start block of the engine <sup>1</sup> is triggered, pay attention to the error message.


1) Only for certain crane types.


		<b>Coolant level</b>
Green:		Coolant level OK
Red:		Insufficient coolant <b>NOTICE!</b> Immediately bring the crane to a standstill, turn the engine off and remedy the problem. Pay attention to the error message.

		Charge air temperature
Green:		Charge air temperature OK
Red:		Charge air temperature too high <b>NOTICE!</b> Immediately bring the crane to a standstill, turn the engine off and remedy the problem. Pay attention to the error message.


		Hydraulic oil temperature <sup>1)</sup>
Green:		Hydraulic oil temperature OK
Red:		Hydraulic oil temperature too high <b>NOTICE!</b> Immediately bring the crane to a standstill, turn the engine off and remedy the problem. Pay attention to the error message.

1) Only for certain crane types.


		Battery voltage
Green:		Battery voltage OK
Red:		On-board power supply over / undervoltage <b>NOTICE!</b> Immediately bring the crane to a standstill, turn the engine off and remedy the problem. Pay attention to the error message.

		Engine oil level <sup>1)</sup>
Green:		Engine oil level OK
Blue		The engine oil level can not be checked here on the display, call up the individual indicator light.
Red:		Engine oil level not OK <b>NOTICE!</b> Immediately bring the crane to a standstill, turn the engine off and remedy the problem. Call up individual indicator lights and adjust the engine oil according to the display - pay attention to error message.

1) Only for certain crane types.

		Hydraulic oil level <sup>1)</sup>
Green:		Hydraulic oil level OK
Yellow / red:		Hydraulic oil level too low <b>NOTICE!</b> Immediately bring the crane to a standstill, turn the engine off and remedy the problem. Pay attention to the error message.

1) Only for certain crane types.

	<b>Exhaust aftertreatment<sup>1)</sup></b>
Green:	Exhaust aftertreatment OK
Yellow / red:	Erroneous function, exhaust aftertreatment or urea level too low <b>NOTICE!</b> Add urea or remedy the malfunction of the exhaust aftertreatment. Under some circumstances a power reduction or start block of the engine <sup>1</sup> is triggered, pay attention to the error message.

1) Only for certain crane types.

**Overview of the individual control displays**



**Note**

► For some monitoring functions in the monitoring field, the display values can be shown by switching through using the function key **F4** or function key **F5**. The illustrated individual control displays are only examples.

*Fuel reserve individual control display*

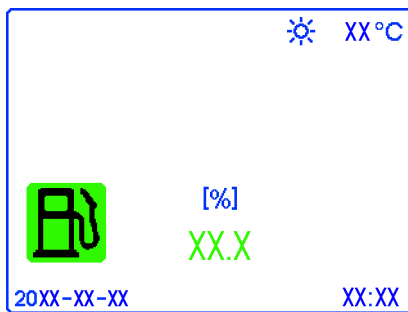


Fig.114283: Fuel reserve

*Individual control display Coolant temperature Single motor / Double motor*

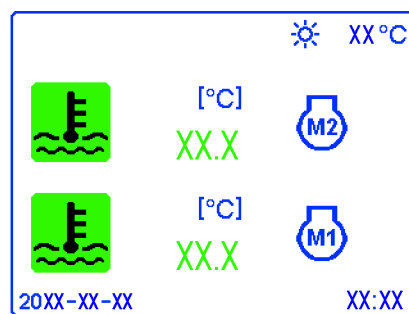
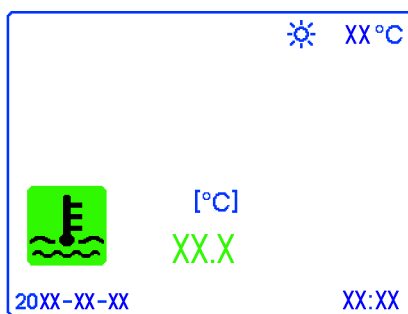


Fig.121781: Single engine / double engine coolant temperature

LWE/LR 1800-1-0-000/27200-07-02/en

Engine oil pressure individual control display

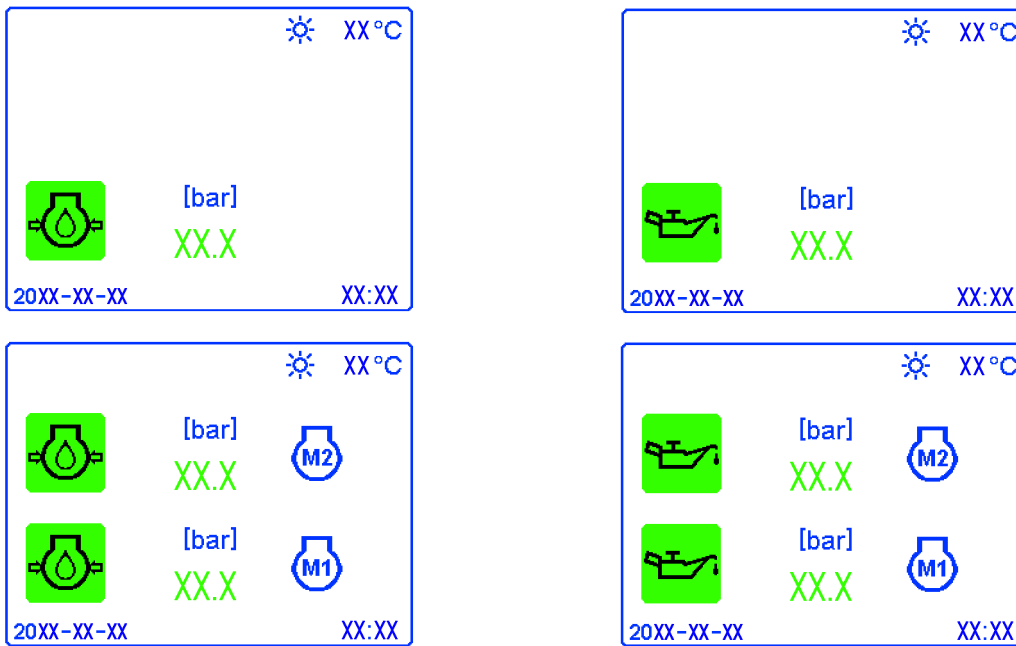


Fig.121782: Single engine / double engine engine oil pressure (both icon variations)

Individual control display Urea reserve

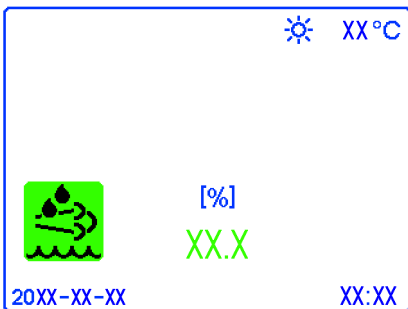


Fig.121788: Urea reserve (only for certain crane types)

Charge air temperature individual control display

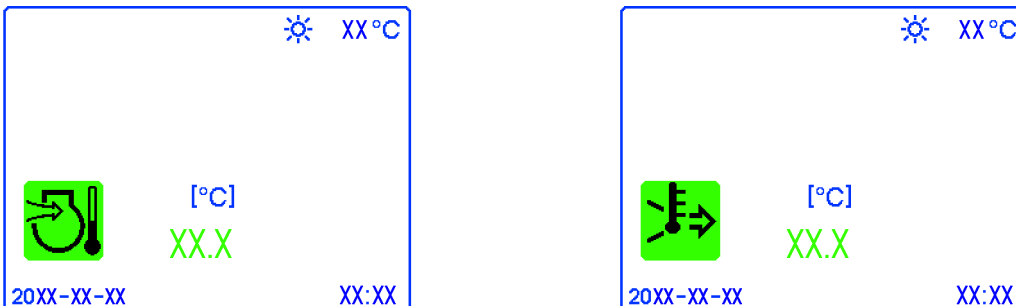


Fig.121784: Charge air temperature (both icon variations)

LWE/LR 1800-1-0-000/27200-07-02/en

Individual control display *Hydraulic oil temperature*

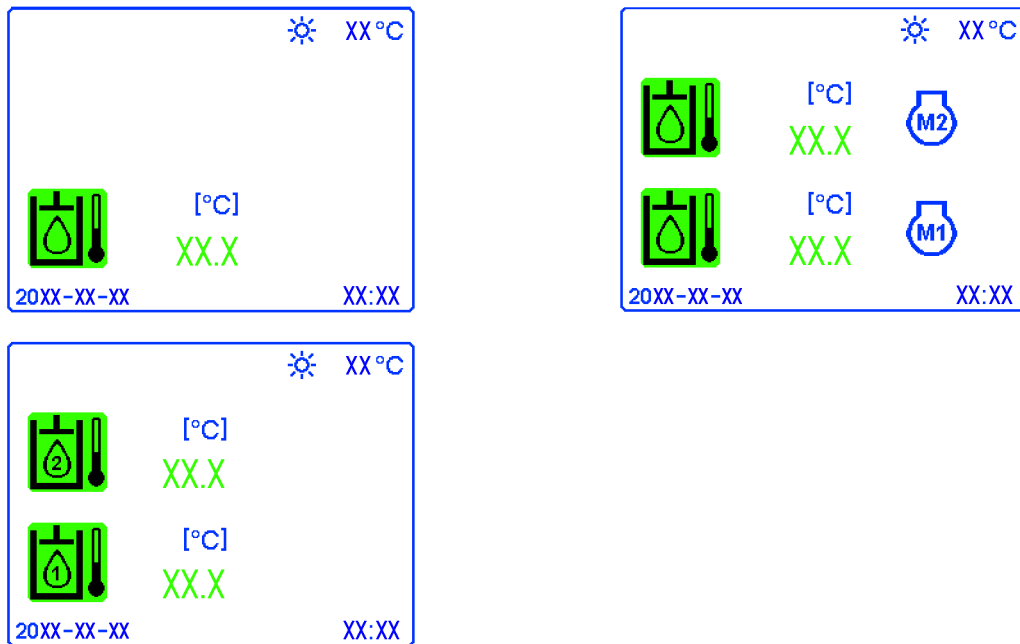


Fig.121787: Single engine / double engine hydraulic oil temperature (only for certain crane types)

Battery voltage individual control display

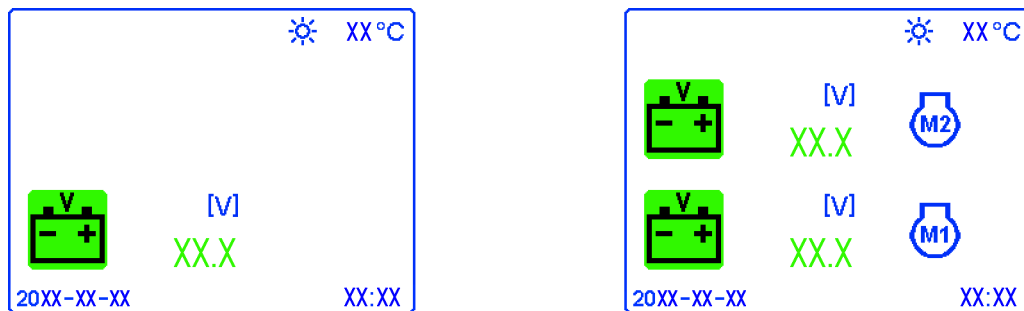


Fig.121785: Single engine / double engine battery voltage

Engine oil level individual control display



**Note**

- ▶ When the engine is running an erroneous test value appears, to check the engine oil level align the crane horizontally and turn the engine off.

## Engine oil level Number value

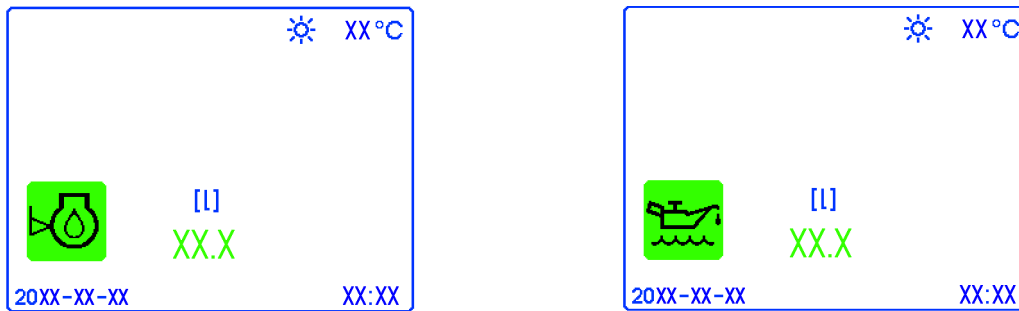


Fig.121786: Engine oil level number value over / under fill (both variations of the icons, only for certain crane types)

## Engine oil level Bar diagram

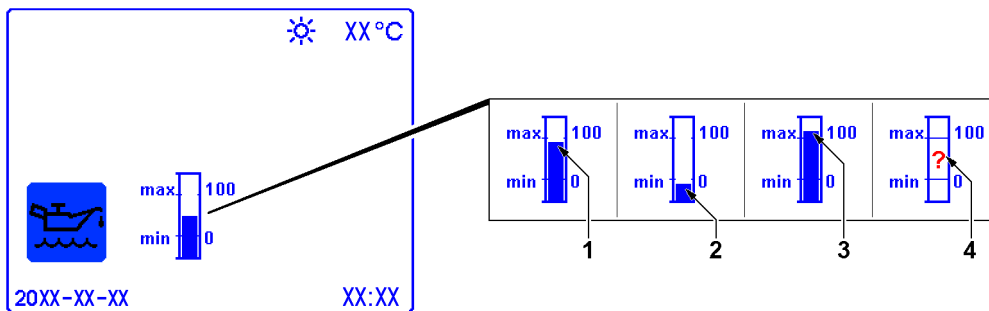


Fig.123757: Engine oil level, bar diagram fill level (only for certain crane types)

- At a normal level, the bar 1 reaches a display between 0 and 100.
- If underfilled, the bar 2 reaches a display under 0.
- If overfilled, the bar 3 reaches a display above 100.
- In case of an incorrect measurement value, the question mark (?) 4 appears

## Hydraulic oil level individual control display

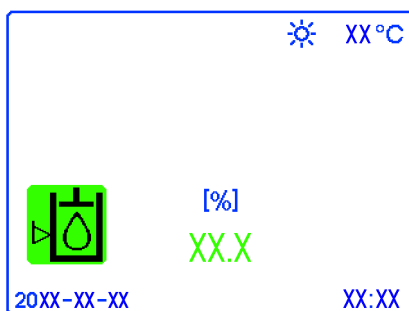










Fig.121790: Hydraulic oil level (only for certain crane types)

### Overview of function key assignment

Function key	Function / description
 	<p>By pressing the function key <b>F3</b> once, the monitoring functions of engine M1 are displayed. By pressing the function key <b>F3</b> twice, the monitoring functions of engine M2 are displayed.</p> <p>Green icon: All monitoring functions are ok.            Icon yellow: Advance warning for one or several monitoring functions.            Icon red: Warning for one or several monitoring functions.</p> <p><b>NOTICE!</b>: Always pay attention to advance warnings and act accordingly.</p>

Function key	Function / description
 	<p>By pressing the function key <b>F4</b>, the individual control displays are called up one after the other in sequence from the beginning.</p>

Function key	Function / description
 	<p>By pressing the function key <b>F5</b>, the individual control displays are called up one after the other in sequence from behind.</p>

Function key	Function / description
 	<p>Change back by one selection level by pressing the function key <b>F6</b>.</p>

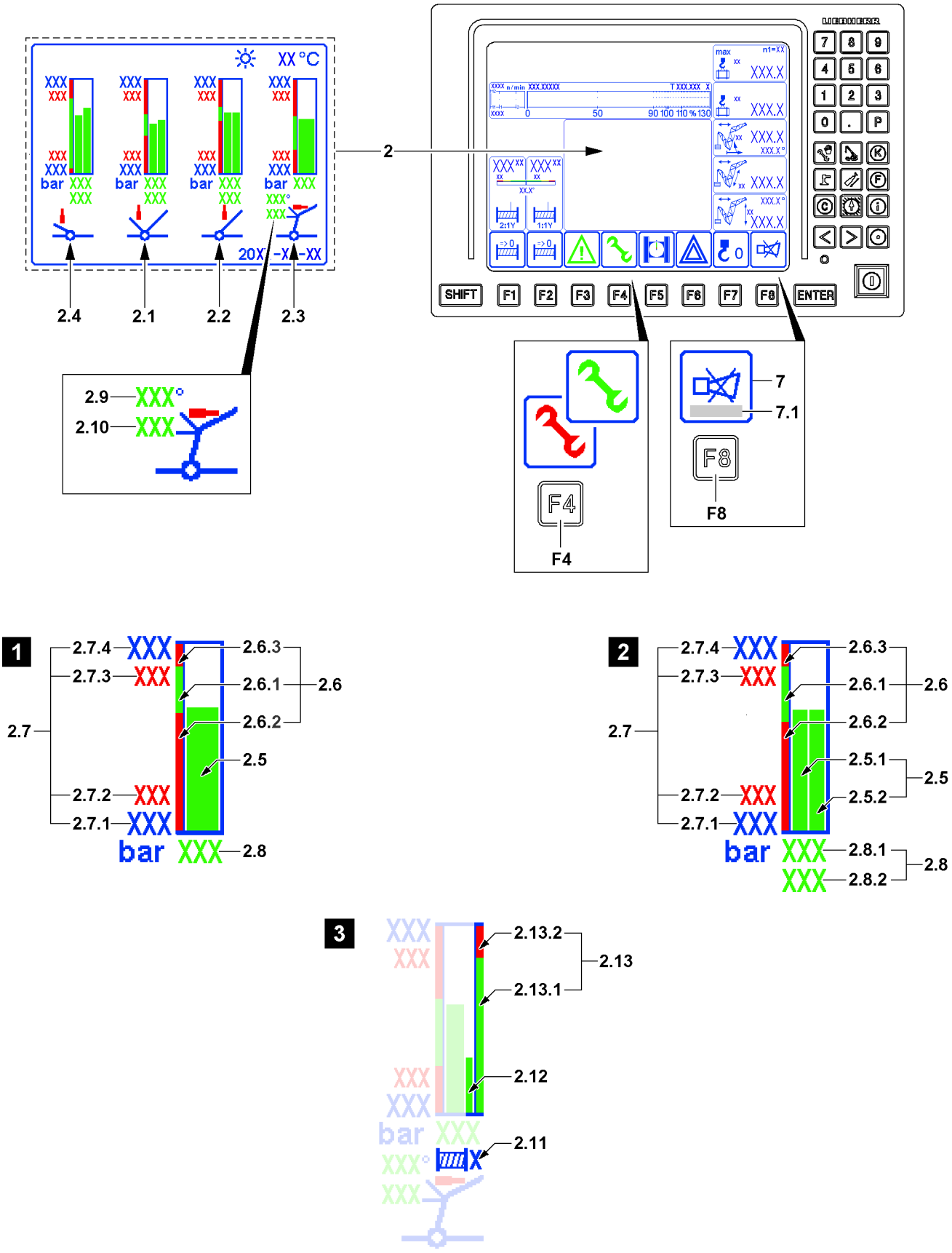


Fig.125388



## 5.6 Relapse cylinder / erection cylinder monitoring

The monitoring of the relapse cylinders **2** is always active and can be displayed in the monitoring field, if necessary. The crane operator is automatically alerted in case of a warning occurrence by the color of the icon over the function key **F4**.

The monitoring field has its fixed position on the LICCON monitor and can be hidden or assigned with other functions.

By pressing the function key **F4**, the relapse cylinder monitoring **2** is displayed in the monitoring field.



### WARNING

Pressure in impermissible range!

- ▶ Make sure that the pressure displays are always in the permissible range.
- ▶ Counteract an impermissible pressure immediately.



### WARNING

Shut off monitoring of relapse cylinders!

- ▶ Outside of the *Crane operation* program, the monitoring of the relapse cylinders is turned off!
- ▶ When the monitoring of the relapse cylinders is turned off, warning events are not recognized!

Color key of warning icon above function key **F4**

- Green warning icon: Monitoring of relapse cylinders is ok.
- Warning icon red: Warning for one or several relapse cylinders.

- If a warning occurs, an error message **7.1** is issued in the *Horn* icon **7** for some errors. The error message **7.1** includes an acoustic signal through the LICCON monitor and an error description.
- Press the function key **F8** once: The acoustic signal is turned off.  
Press the function key **F8** twice: The error description for the error message **7.1** that occurred last is called up.

#### 2 Display field

- Depending on the set up configuration and crane type, up to four pressure displays appear.
- The individual pressure displays always refer to the relapse cylinder / erection cylinder, which are highlighted in the icon directly underneath.

#### 2.1 Derrick relapse cylinder

#### 2.2 Main boom relapse cylinder

#### 2.3 Auxiliary boom / accessory relapse cylinder

#### 2.4 Erection cylinder SA-frame

- **Note:** Only present for certain crane types



### Note

- ▶ **Illustration 1:** Example of display of individual relapse cylinders
- ▶ **Illustration 2:** Example of display of double relapse cylinders
- ▶ **Illustration 3:** Example supplementary Winch pressure display\* during erection procedures (only for certain crane types)

#### 2.5 Actual pressure bar graph

- Actual pressure on relapse cylinder bar graph
- For double relapse cylinders:
  - 2.5.1** Bar graph of first relapse cylinder
  - 2.5.2** Bar graph of second relapse cylinder
- **Note:** When the actual pressure is in the permissible range, the actual pressure bar graph **2.5** is shown in green.  
**Warning!** When the actual pressure is in the impermissible range, the actual pressure bar graph **2.5** is shown in red. Immediately counteract the high pressure.

#### 2.6 Pressure display scale

- **2.6.1** Ideal pressure range

- **2.6.2** Minimum pressure range fallen below  
**Note:** Appears only if a minimum pressure is monitored.
- **2.6.3** Highest pressure range exceeded
- 2.7** Pressure display values
  - **2.7.1** Lowest display value
  - **2.7.2** Minimum pressure value  
**Note:** Appears only if a minimum pressure is monitored.
  - **2.7.3** Highest pressure value
  - **2.7.4** Highest display value
- 2.8** Relapse cylinder pressure
  - Relapse cylinder pressure actual value
  - For double relapse cylinders:
    - 2.8.1** Pressure of the first relapse cylinders
    - 2.8.2** Pressure of the second relapse cylinders
- 2.9** WA-frame 1 angle
- 2.10** WA-frame 2 angle

### Winch pressure display\* during erection procedures (only for certain crane types)

See illustration 3

The wind pressure is displayed when the following prerequisites are met:

- The main boom is luffed to below 10 degrees.
- The luffing jib is set up.
- Parallel operation\* is not preselected.

---

#### NOTICE

Incorrect pressure display!

Components can be damaged.

The winch pressure is only displayed when winch 1 or winch 2 is spooled.

- ▶ When winch 1 or winch 2 is spooled up: Always observe the winch pressure.
- 

The winch pressure is only displayed when winch 1 or winch 2 is spooled. Winch 1 or winch 2 is **not** spooled, the supply pressure appears.

- 2.11** Displayed winch
  - Displays the winch for which the winch pressure is shown.
  - **Note:** The winch moved last is always shown (winch 1 or winch 2).
- 2.12** Winch pressure bar graph
  - Bar graph for winch pressure of the displayed winch **2.11**
  - **Note:** When the actual pressure is in the permissible range, the winch pressure bar graph **2.12** is shown in green.  
**Warning!** When the actual pressure is in the impermissible range, the winch pressure bar graph **2.12** is shown in red. Immediately counteract the high pressure.
- 2.13** Pressure display scale
  - **2.13.1** Ideal pressure range
  - **2.13.2** Highest pressure range exceeded



#### Note

Additional display values on the *Relapse cylinder monitoring display 2*

- ▶ The date and ambient temperature are also displayed.
-

Empty page!

LWE/LR 1800-1-0-000/27200-07-02/en

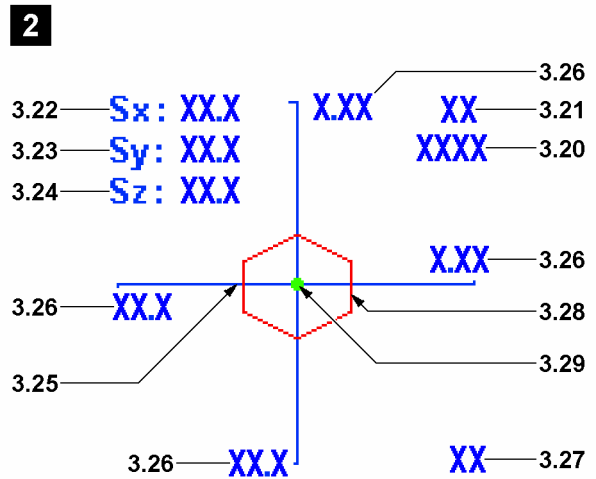
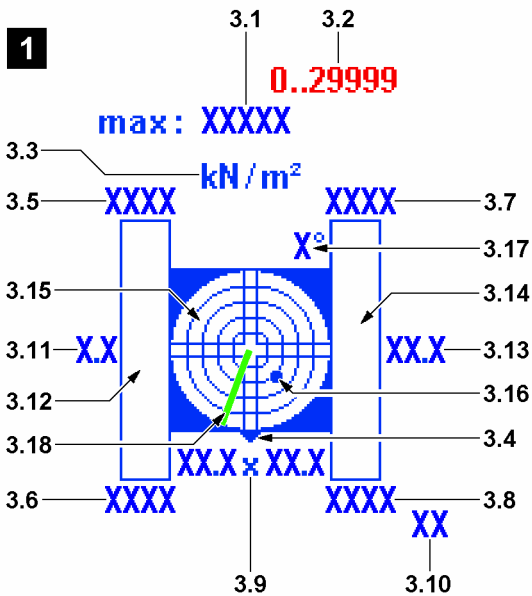
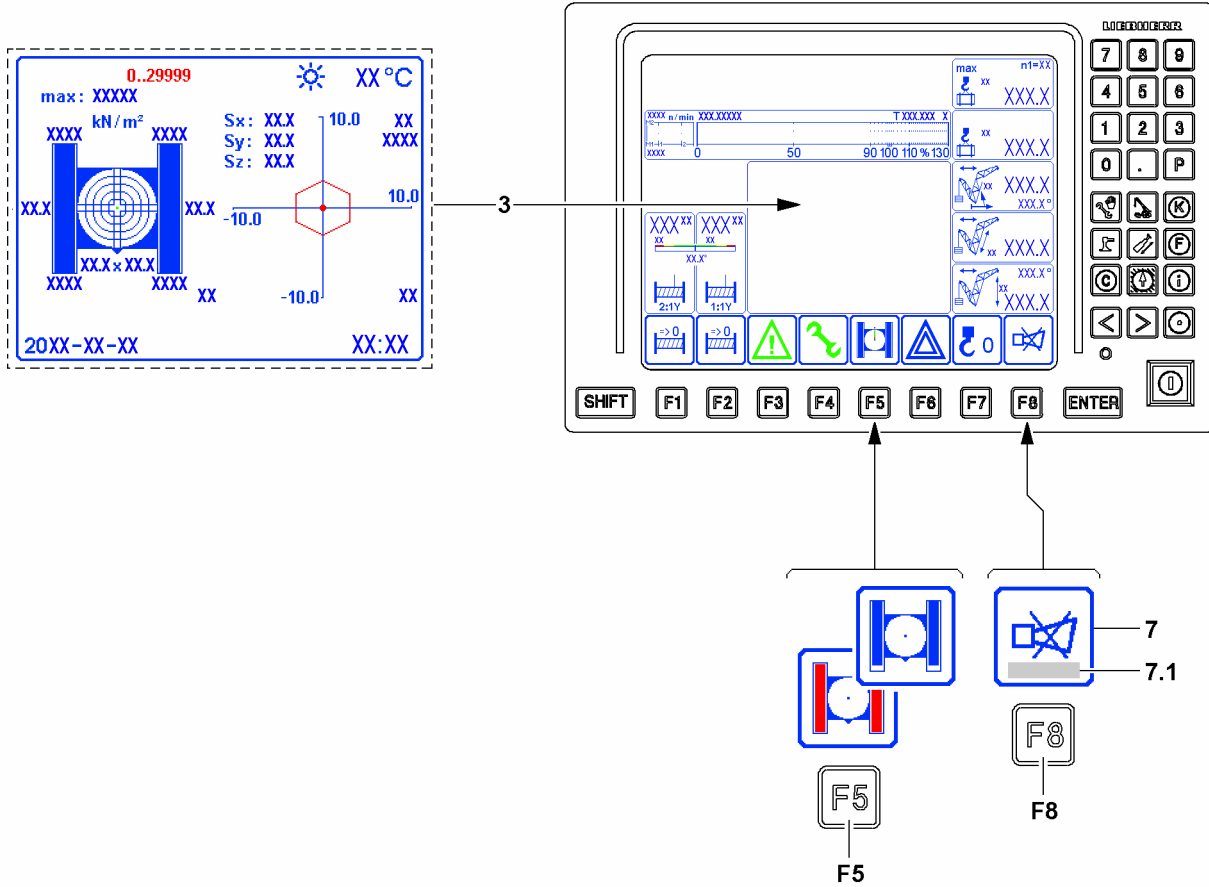


Fig.144107

## 5.7 Monitoring the surface pressure and center of gravity



### WARNING

The crane can topple over!

When the programmed limit values are reached in the monitoring of surface pressure and center of gravity, there is no automatic shut-off of crane movements.

The displayed values are calculated and are informative. Calculated values are below the tolerances and unpredictable influences, for example crane control, surrounding and environmental influences. Due to the resulting tolerance field of the values, the monitoring of surface pressure and center of gravity may not be used to determine the limit values of the crane.

If this is disregarded, then the crane can topple over.

Personnel can be severely injured or killed.

- ▶ Do not use the displayed values to determine the limit values of the crane and to utilize the crane to its tipping limit or until it sinks in.
- ▶ Make sure that all values are within the programmed limit values.



### WARNING

Increased surface pressure!

The calculation of the values for the display of the surface pressure in the LICCON monitor are based on ideal assumptions.

- ▶ Side deformations of the boom system due to wind, inclined position and elastic resilience of the steel structure are not taken into account but they can lead to an increase of the surface pressure.



### WARNING

Shifting of the center of gravity!

The calculation of the values for the display of the center of gravity in the LICCON monitor are based on ideal assumptions.

- ▶ Side deformations of the boom system due to wind, inclined position and elastic resilience of the steel structure are not taken into account but they can lead to a shifting of the center of gravity.

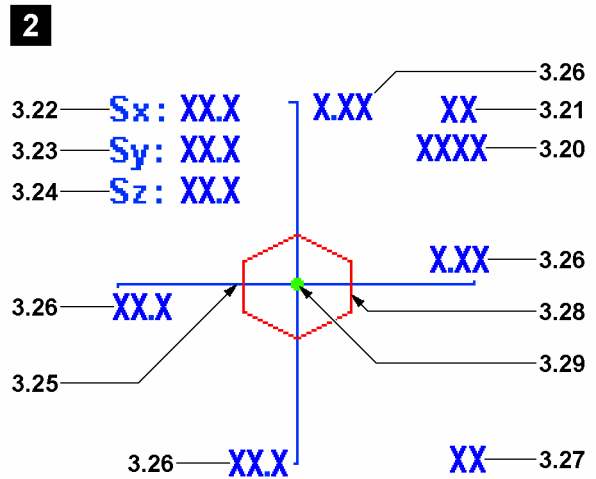
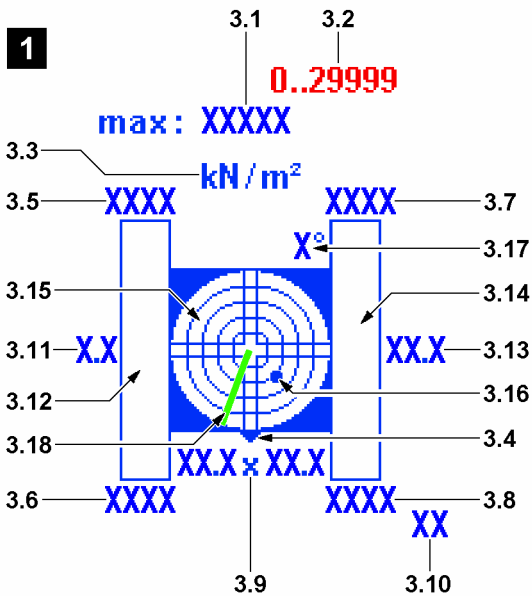
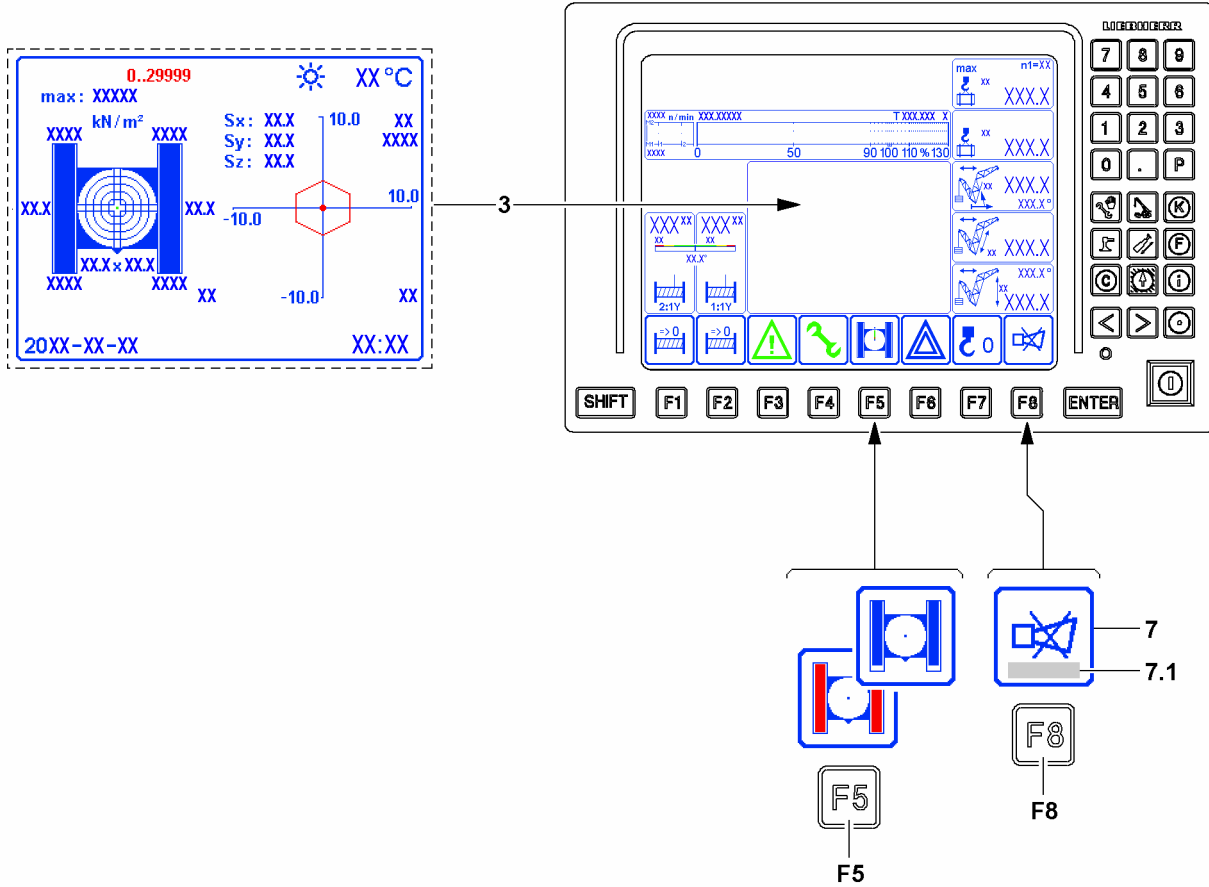


Fig.144107

The monitoring of surface pressure and center of gravity **3** is always active and can be displayed in the monitoring field, if necessary. The crane operator is automatically alerted in case of a warning occurrence by the color of the icon over the function key **F5**.

The monitoring field has its fixed position on the LICCON monitor and can be hidden or assigned with other functions.

By pressing the function key **F5**, the surface pressure and center of gravity monitoring **3** is displayed in the monitoring field.



#### Note

Turned off monitoring of surface pressure and center of gravity.

- ▶ Outside of the *Crane operation* program, the monitoring of surface pressure and center of gravity is turned off.
- ▶ When the monitoring of surface pressure and center of gravity is turned off, warning events are not recognized.

Color key of warning icon above function key **F5**:

- Blue warning icon: Monitoring the surface pressure and center of gravity is ok.
- Crawler carrier in warning icon red: Warning for monitoring of surface pressure and center of gravity.

#### Error messages:

- If a warning occurs, an error message **7.1** is issued in the *Horn* icon **7** for some errors. The error message **7.1** includes an acoustic signal through the LICCON monitor and an error description.
- Press the function key **F8** once: The acoustic signal is turned off.
- Press the function key **F8** twice: The error description for the error message **7.1** that occurred last is called up.



#### Note

- ▶ **Illustration 1:** Surface pressure display
- ▶ **Illustration 2:** *Center of gravity* display

#### 3 Monitoring of surface pressure and center of gravity display

- The values are calculated depending on the set up configuration of the crane and the load.

#### Surface pressure display, illustration 1:

- 3.1 Permissible surface pressure
  - The value is entered by the crane operator via the keypad.
- 3.2 Input area
  - Input area for the permissible surface pressure **3.1**.
- 3.3 Measuring unit for surface pressure
  - Measuring unit for the pressure data in the display surface pressure (illustration **1**).
- 3.4 Direction specification
  - The triangle symbolizes where the front of the crawler travel gear is in the illustration.
  - **Note:** The front on the crawler travel gear is always on the side where the chain tensioning devices for the crawler carriers are located. The position of the turntable has no influence on this. The position of the turntable can be derived from the boom direction **3.18**.
- 3.5 Surface pressure
  - Calculated actual value of surface pressure on the crawler travel gear, left rear.
- 3.6 Surface pressure
  - Calculated actual value of surface pressure on the crawler travel gear, left front.
- 3.7 Surface pressure
  - Calculated actual value of surface pressure on the crawler travel gear, right rear.
- 3.8 Surface pressure
  - Calculated actual value of surface pressure on the crawler travel gear, right front.

- 3.9** Travel gear base
  - Base dimensions of the crawler travel gear.
- 3.10** Length data measuring unit
  - Measuring unit for the measuring data in the display surface pressure (illustration 1).
- 3.11** Placement surface
  - Calculated placement surface of crawler carrier right as value.
- 3.12** Placement surface
  - Calculated placement surface of crawler carrier right as graphic.
- 3.13** Placement surface
  - Calculated placement surface of crawler carrier left as value.
- 3.14** Placement surface
  - Calculated placement surface of crawler carrier left as graphic.
- 3.15** Incline indicator
  - The graphic display is in the form of a spirit level, with a moving dot **3.16** representing the air bubble.
  - **Note:** Incline display with number values, see section “Monitored auxiliary functions”.
- 3.16** Dot
  - The center of the dot **3.16** shows the incline.
- 3.17** Display resolution
  - This value indicates the resolution of the graphic display of the incline indicator. This displayed value corresponds with the outermost ring of the spirit level. The resolution is matched automatically to the inclination.
- 3.18** Boom direction
  - Current boom direction in reference to the displayed icon.
  - The boom direction corresponds to the viewing direction *to the front* from the crane cab.



#### Note

Example for the incline indicator **3.15**:

- ▶ **Example:** The dot **3.16** lies on the second ring from the inside in the lower right quadrant. The display resolution **3.17** is  $1^\circ$ . Therefore an inclination of  $0.4^\circ$  is displayed. The highest point on the placement surface of the crawler travel gear is on the front left side. Therefore, the crane is inclined back to the right  $0.4^\circ$  from the point of view of the crawler travel gear.



#### WARNING

The crane can topple over!

If the permissible incline of the crane is exceeded, the crane can topple over.

- ▶ Do not exceed the permissible incline from the load chart.
- ▶ Do not exceed the permissible incline for driving the crane, see Crane operating instructions, chapter 4.10.

**Center of gravity display, illustration 2:**

- 3.20** Weight data
  - Calculated total weight of the crane including load.
- 3.21** Weight unit
  - Weight unit for the weight data **3.20** in the display center of gravity (illustration 2).
- 3.22** Center of gravity position
  - Calculated center of gravity position in direction Sx
- 3.23** Center of gravity position
  - Calculated center of gravity position in direction Sy
- 3.24** Center of gravity position
  - Calculated center of gravity position in direction Sz



**3.25** Axis of coordinates

- The axis of coordinates **3.25** is aligned according to the direction of the display surface pressure (illustration 1) centered to the slewing ring on the placement surface of the crane.

**3.26** Scale value

- Scale value on the axis of coordinates **3.25**

**3.27** Measuring unit

- Measuring unit in the display center of gravity (illustration 2)

**3.28** Core area

- Calculated core area of the crane according to the set up configuration, load and ground conditions.
- **Note:** The core area is an important reference point for the center of gravity of the crane.

**3.29** Center of gravity Sx/Sy

- Calculated center of gravity displayed graphically in direction Sx/Sy
- **Note:** The position is in direct relation to the center of gravity position **3.22** and center of gravity position **3.23** values

**Note**

Additional display values on the *Monitoring of surface pressure and center of gravity* display 3

- ▶ Date, time and ambient temperature are also displayed.

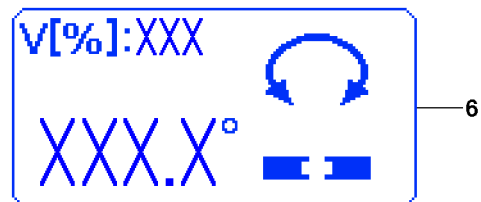
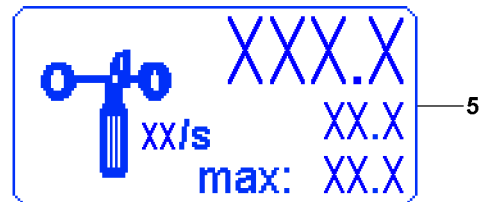
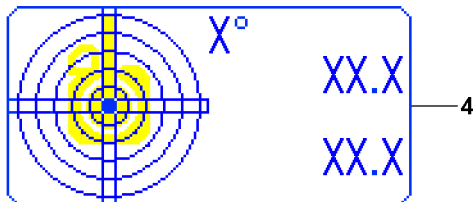
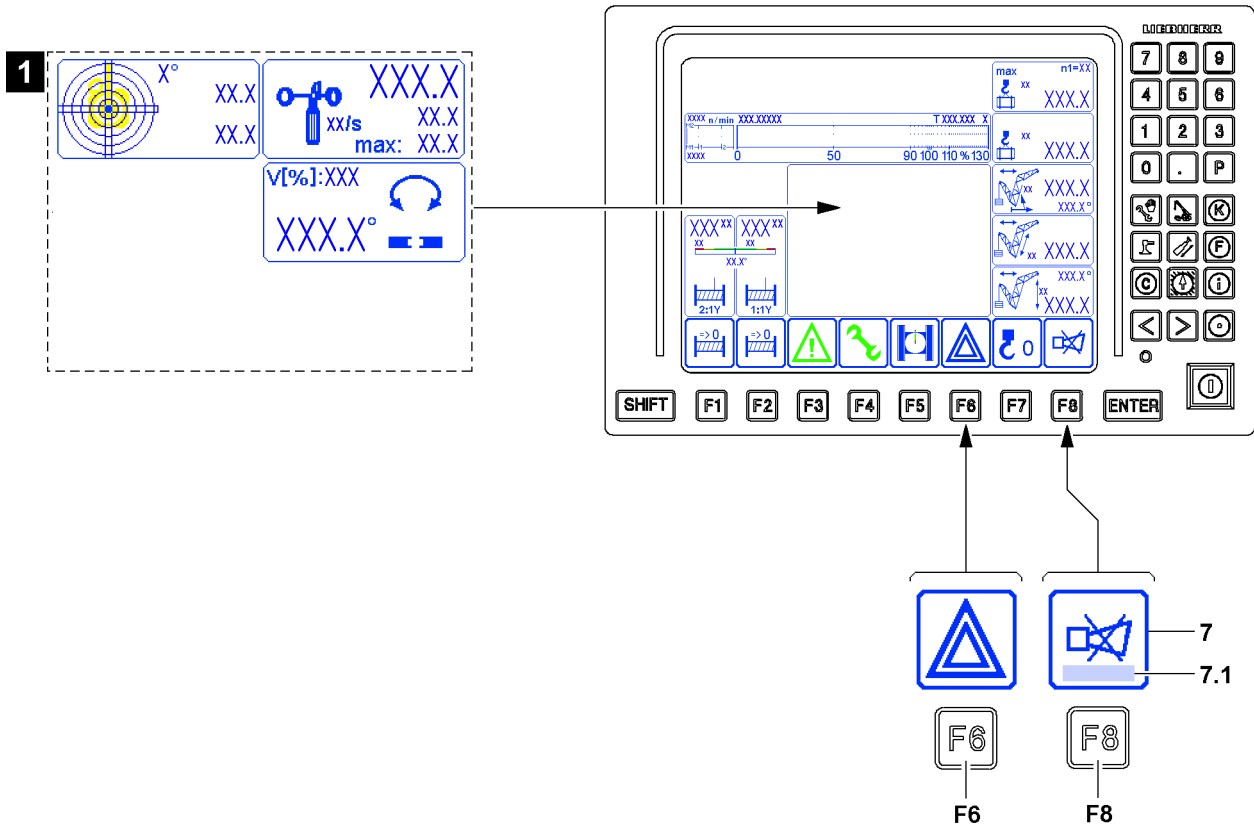


Fig.116013

LWE/LR 1800-1-0-000/27200-07-02/en

## 5.8 Monitored auxiliary functions

The monitored auxiliary functions (illustration 1) are always active and can be displayed in the monitoring field, if necessary.

The monitoring field has its fixed position on the LICCON monitor and can be hidden or assigned with other functions.

By pressing the function key **F6**, the monitored auxiliary functions are displayed / masked in the monitoring field.



### Note

Shut off *Monitored auxiliary functions*

- ▶ Outside of the *Crane operation* program, the monitored auxiliary functions are turned off.
- ▶ When the monitored auxiliary functions are turned off, warning events are not recognized.

The appearance of the icon over function key **F6** changes according to the condition:

Icon with filled in frame = auxiliary functions icons turned off

Icon with frame not filled in = auxiliary functions icons turned on

**Note:** If a monitored limit has been exceeded, a warning is issued the corresponding icon is displayed, even if the monitoring icons have been hidden.

### Error messages:

- If a warning occurs, an error message **7.1** is issued in the *Horn* icon **7** for some errors. The error message **7.1** includes an acoustic signal through the LICCON monitor and an error description.
- Press the function key **F8** once: The acoustic signal is turned off.
- Press the function key **F8** twice: The error description for the error message **7.1** that occurred last is called up.

### Auxiliary functions:

- 4** Crane incline
- 5** Wind speed
- 6** Slewing range

### 5.8.1 Display of auxiliary functions

The display changes depending if the monitored auxiliary functions are turned on or off via the function key **F6**.

#### Monitored auxiliary functions turned off:

- No error:  
Icons are not shown.
- Error in one function:  
Icon with error message is shown.

#### Monitored auxiliary functions turned on:

- Icons are displayed permanently

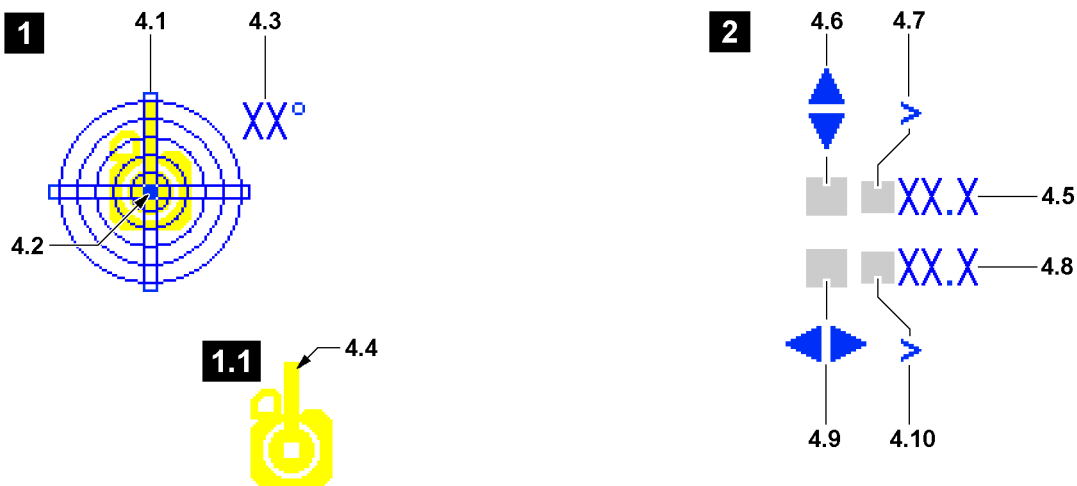
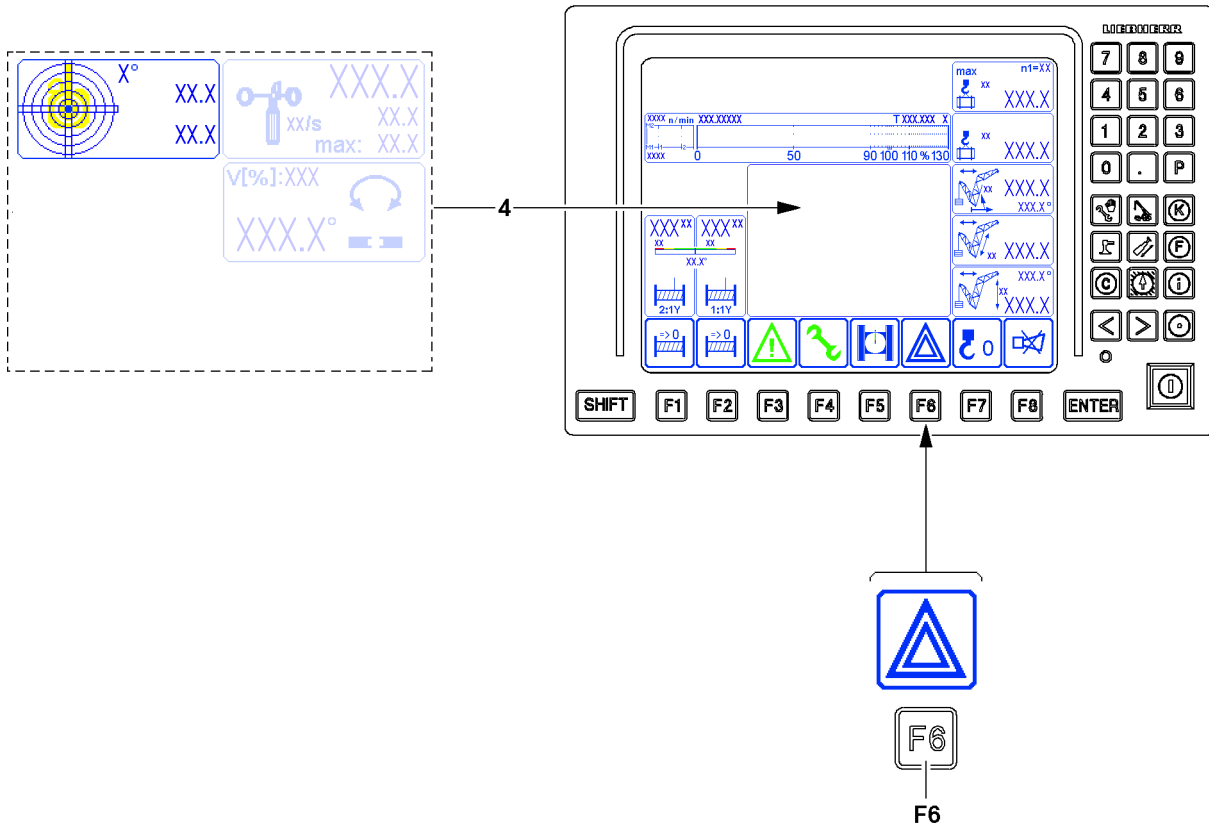


Fig.114292

## 5.8.2 Crane incline



### WARNING

The crane can topple over!

If the permissible incline of the crane is exceeded, the crane can topple over.

The *larger than* icon shows that the crane is inclined further than can be shown.

The exact incline can then not be read.

- ▶ Do not exceed the permissible incline from the load chart.
- ▶ Do not exceed the permissible incline for driving the crane, see Crane operating instructions, chapter 4.10.

#### 4 Incline icon

- Display of the incline of the crane to the horizontal in the longitudinal and lateral direction. The display is graphic as well as numeric.
- The display is divided in a graphic section (illustration 1) and a numeric section (illustration 2).
- The direction specification refers to the direction of the crane superstructure (view from the cab).

#### Graphical section(illustration 1):

##### 4.1 Graphic display

- The graphic display is in the form of a spirit level, with a moving dot 4.2 representing the air bubble.

##### 4.2 Dot

- The center of the dot 4.2 shows the incline value.

##### 4.3 Display resolution

- This value indicates the resolution of the graphic display. The resolution is matched automatically to the inclination.

##### 4.4 Boom direction

- In the graphic view 4.1, the overhead view of the imitated crane superstructure is highlighted, see illustration 1.1. The main boom direction 4.4 is symbolized by a wide yellow line and is provided for orientation in the display.

#### Numeric section (illustration 2):

##### 4.5 Longitudinal direction

- Incline of crane in the longitudinal direction in [°].

##### 4.6 Direction arrow

- The direction arrow shows the direction of the incline

##### 4.7 Display range exceeded

- If the *greater than* icon appears, then the display range is exceeded.
- **Note:** The crane is inclined further than can be shown.

##### 4.8 Lateral direction

- Incline of crane in lateral direction in [°]

##### 4.9 Direction arrow

- The direction arrow shows the direction of the incline

##### 4.10 Display range exceeded

- If the *greater than* icon appears, then the display range is exceeded
- **Note:** The crane is inclined further than can be shown.



### Note

Orientation of the crane in the *Incline* icon 4.

- ▶ Observe the main boom direction 4.4.

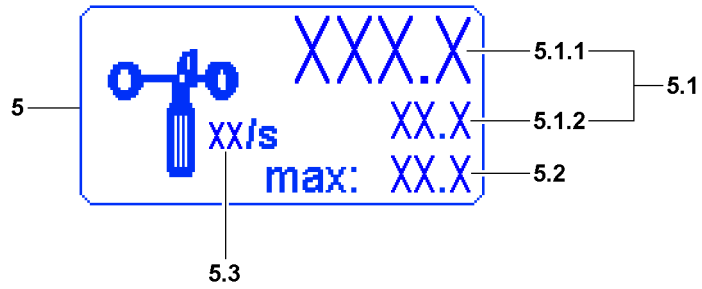
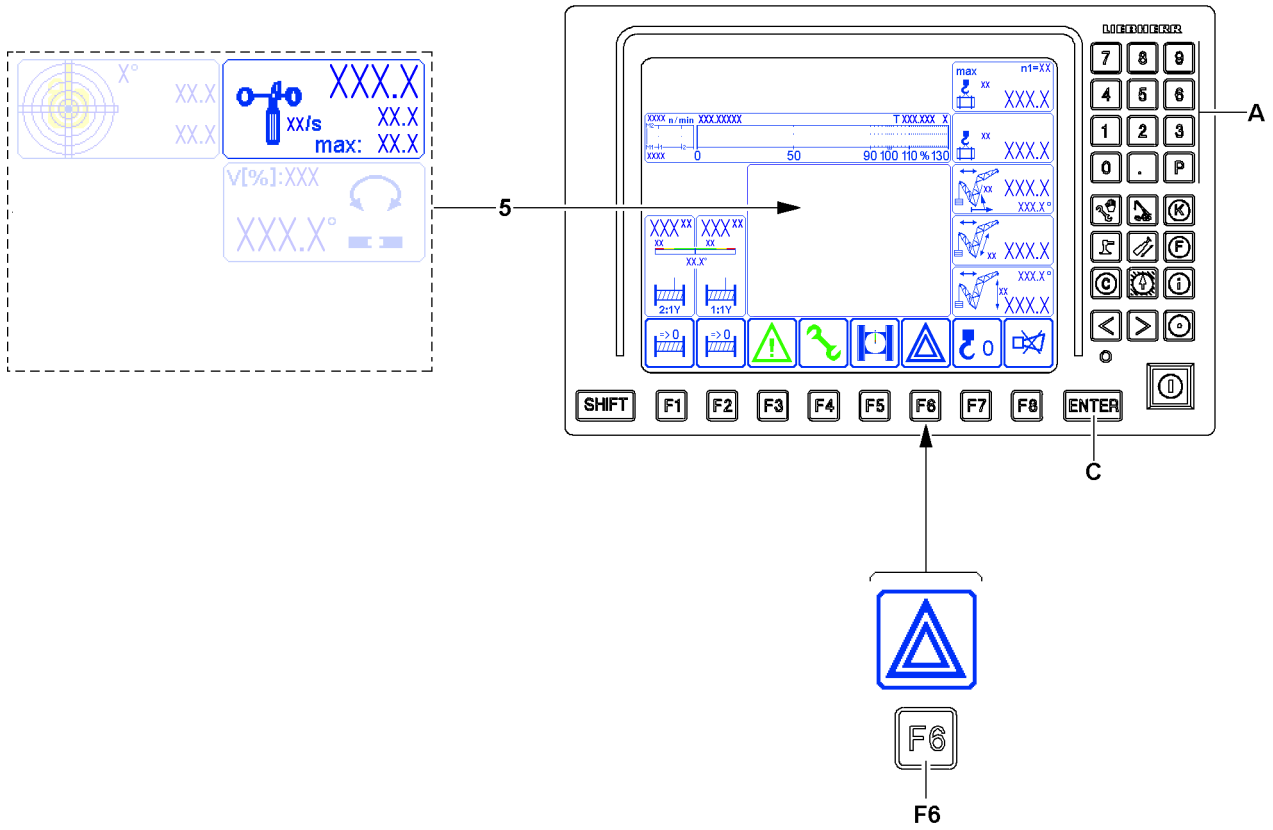


Fig.121798

### 5.8.3 Wind speed



#### WARNING

Wind speed too high!

If the maximum permissible wind speed is exceeded with an erected boom system, there is a danger of accident.

Dangerous situations can arise, such as oscillating load or shaking crane.

The crane can topple over, personnel can be severely injured or killed.

- ▶ **The crane movements will not be shut-off.**
- ▶ The boom system must be taken down in time before exceeding the maximum permissible wind speed of the crane.
- ▶ The danger notes, see Crane operating instructions, chapter 2.04 must be strictly observed and adhered to.

#### 5 Wind speed icon

##### 5.1 Current wind speed

- **Note:** If a wind sensor is connected, then the wind speed appears at **5.1.1** If two wind sensors are connected (Example: crane operation with an auxiliary boom / accessory), then a second wind speed is displayed at **5.1.2**
- **5.1.1** current wind speed WG1
- **5.1.2** current wind speed WG2



#### WARNING

Crane operation without the wind speed display value!

If a question mark (?) appears on the current wind speed **5.1** display instead of number values, then a wind sensor which must be present is missing or there is an error in the wind sensor.

- ▶ Before starting to work with the crane, make sure that all wind sensors that must be present are present and functioning.
- ▶ Remedy the error immediately.
- ▶ If an error cannot be remedied, then it must be ensured that the wind speed is monitored in another manner.

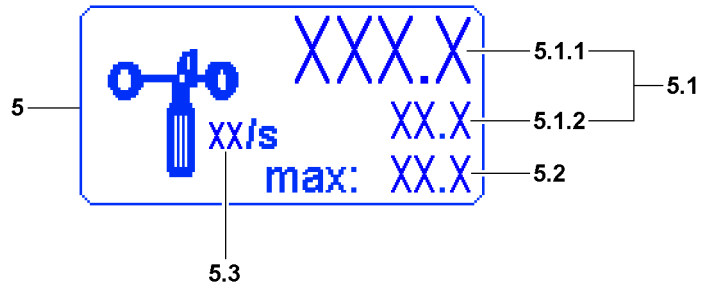
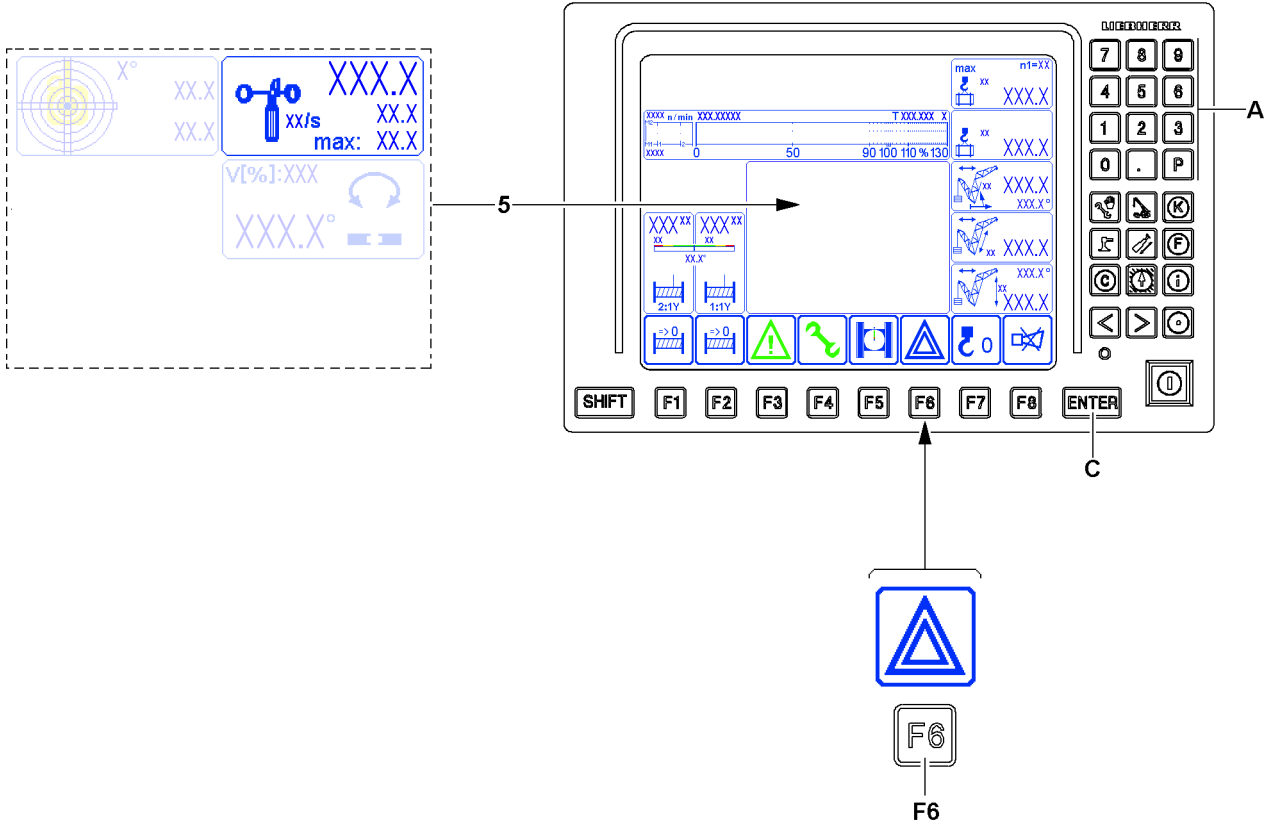


Fig.121798



**Note**

- ▶ If several wind sensors are connected, the installation location of the wind sensor determines the corresponding display in the *Wind speed* icon **5**.
- ▶ The priority depends on the installation location of the wind sensor, from the outside (auxiliary boom / accessory) to the inside (main boom). The wind speed for the outside wind sensor is shown independently from the inside wind sensor.

**5.2 Maximum permissible wind speed**

- The value depends on the operating mode and the set up configuration.
- If the current wind speed value exceeds the displayed maximum value, the maximum value starts to blink and the *Short horn* warning sound sounds.

**Note**

- ▶ If access to a load chart is not possible, then the maximum value starts to blink and the *Short horn* warning sound sounds.

**5.3 Measuring unit**

- [m/s] or [ft/s]

**Reducing the maximum permissible wind speed\*****Note**

- ▶ This function is not available for all crane types.

The value for the maximum permissible wind speed **5.2** can possibly be reduced.

Ensure that the following prerequisite is met:

- The *Wind speed* icon **5** is shown.

**Reduce the wind speed:**

1. Press the ENTER key **C**.
2. As soon as the value for the maximum permissible wind speed **5.2** is highlighted in blue, enter the new value via the keypad **A**.
3. Press the ENTER key **C** again. The changed value for the maximum permissible wind speed **5.2** is shown in red.

**Cancel reduce the wind speed:**

1. Press the ENTER key **C**.
2. As soon as the value for the maximum permissible wind speed **5.2** is highlighted in blue, enter 0 (zero) as the new value via the keypad **A**.
3. Press the ENTER key **C** again. The original value from the load chart is taken over again.

**Note**

- ▶ If you try to enter a value for the maximum permissible wind speed **5.2** which is too high, then the highest possible value is taken over.

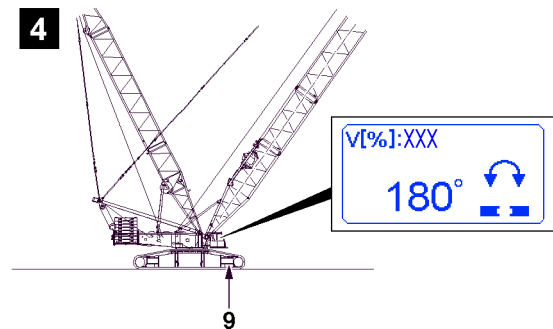
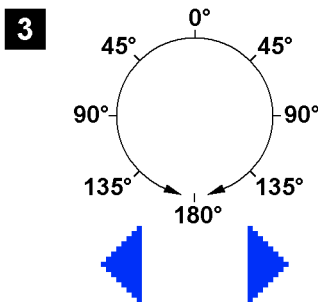
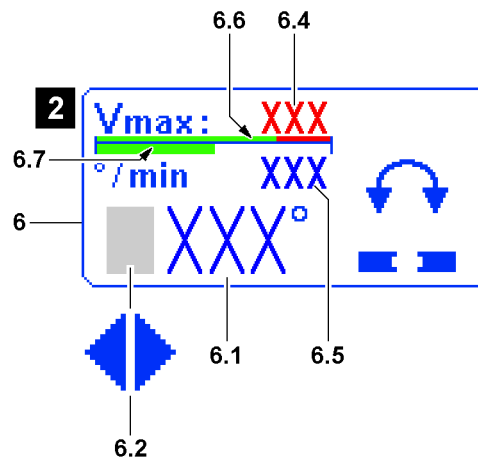
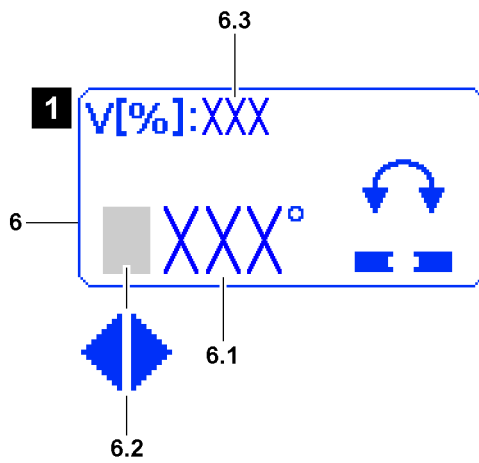
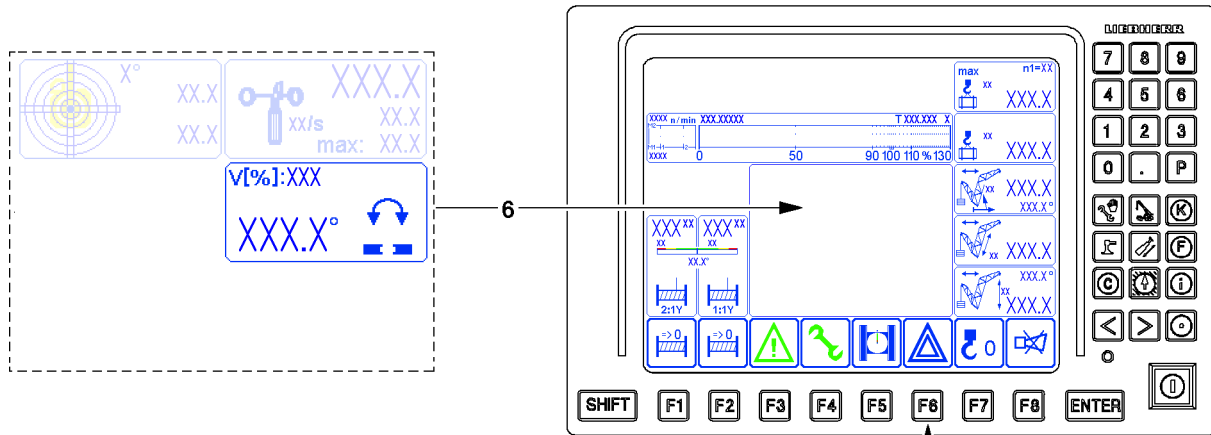


Fig.144105

LWE/LR 1800-1-0-000/27200-07-02/en

## 5.8.4 Slewing range

### 6 Slewing range icon

- Depending on the crane type, either the illustration 1 or illustration 2 icon appears.



#### WARNING

Danger of accident in case of excessive slewing speed!

Danger of toppling or collapsing crane.

Death, severe bodily injuries, property damage.

- ▶ Observe the slewing speed according to the specifications in the load chart manual.

#### 6.1 Slewing angle

- Slewing angle of the crane superstructure in relation to the working direction *to the rear* (0°)
- The number value can increase on both sides to the maximum value of 180°, see illustration 3
- **Note:** At display value 180°, the crane superstructure is exactly in the forward position, see illustration 4. The front of the crawler travel gear is where the chain tensioning devices 9 are located.

#### 6.2 Direction of rotation

- The direction arrow in front of the value indicates the direction of rotation of the crane superstructure.
- The direction arrow is in relation to the working direction *to the rear* (0°), see illustration 3
- Left arrow: The crane superstructure is turned to the left.
- Right arrow: The crane superstructure is turned to the right.
- **Note:** If the crane superstructure is positioned exactly to the front (display value 180°) or to the rear (display value 0°) there is no direction arrow.

#### 6.3 Slewing speed

- Only for crane types with the illustration 1 icon
  - Maximum slewing speed in [%]
  - Identifies the set maximum slewing speed of the slewing gear with a fully deflected master switch, relating to the maximum attainable slewing speed of the slewing gear at a preselected speed of 100 %.
- This value can be infinitely preselected, see section “master switch / pedal sensor speed reduction”..

#### 6.4 Permissible slewing speed

- Only for crane types with the illustration 2 icon
- Number value for the permissible slewing speed in degrees per minute [°/min]. The permissible slewing speed is calculated depending on the current crane utilization and displayed.
- **Note:**  
The permissible slewing speed is reduced depending on the load down until the permissible value indicated in the load chart manual is reached. The crane driver is responsible for making sure this value is never exceeded. The slewing speed is not reduced automatically with the help of the crane control.

#### 6.5 Current slewing speed

- Only for crane types with the illustration 2 icon
- Number value for the current slewing speed in degrees per minute [°/min]
- Blue number value: Slewing speed in the permissible range
- Red number value (blinking): Slewing speed above the permissible range

#### 6.6 Slewing speed scale

- Only for crane types with the illustration 2 icon
- Green range: Slewing speed in the permissible range
- Red range: Slewing speed above the permissible range

#### 6.7 Slewing speed bar diagram

- Only for crane types with the illustration 2 icon
- Green bar: Slewing speed in the permissible range

- Red bar: Slewing speed above the permissible range

Empty page!

LWE/LR 1800-1-0-000/27200-07-02/en

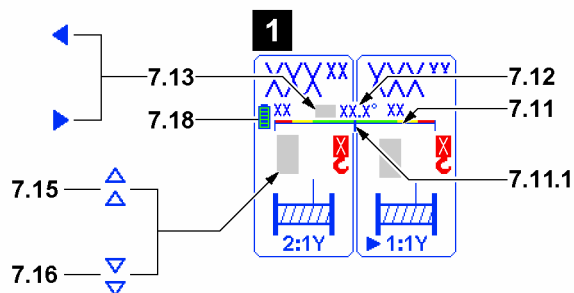
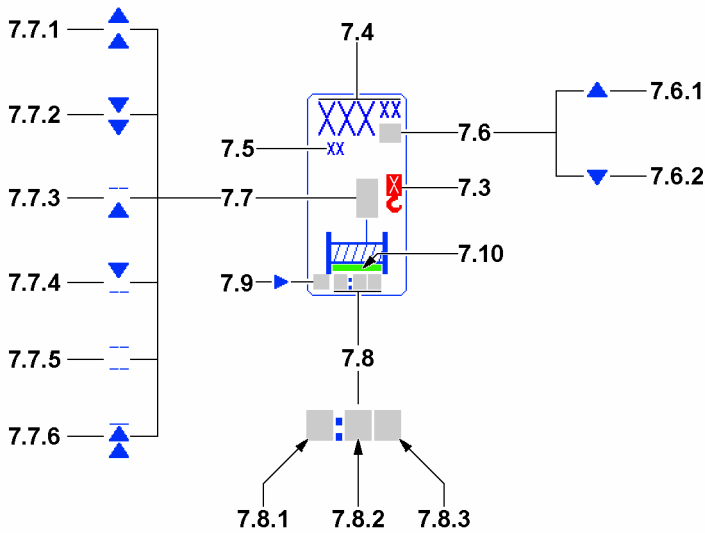
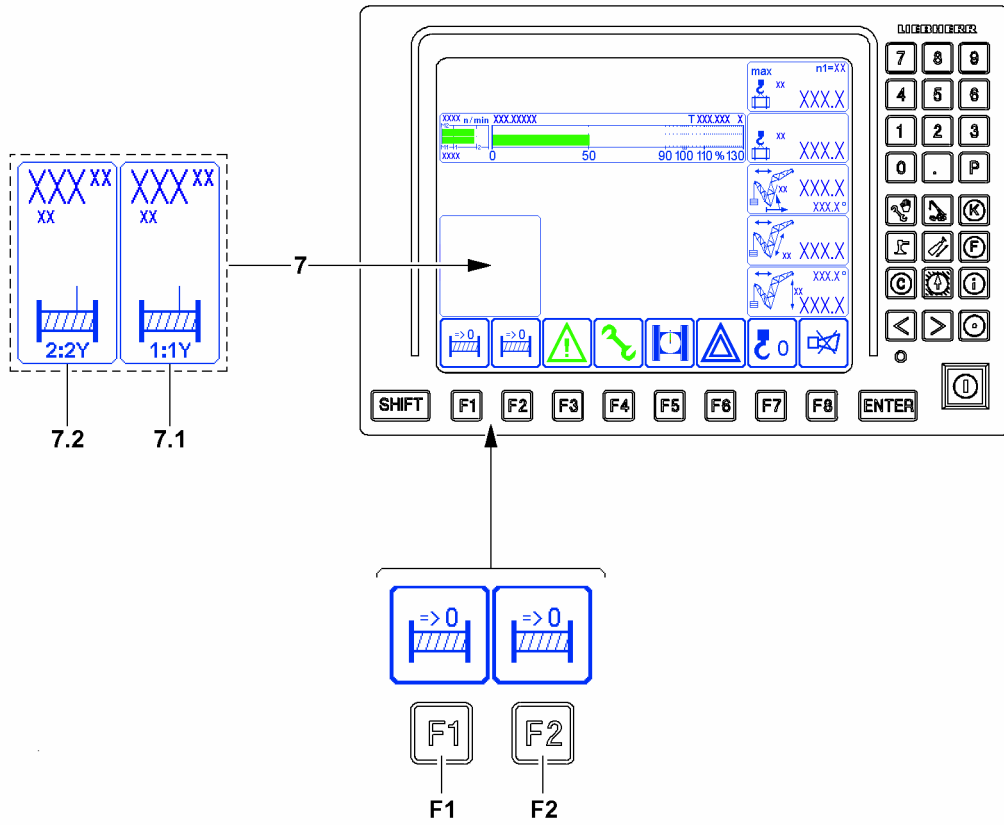


Fig.153663

LWE/LR 1800-1-0-000/27200-07-02/en

## 5.9 LICCON Monitor 0 winch display

The winch displays 7 have a fixed position on the LICCON monitor.

The current position of each winch can be set as the zero point:

- Hoist winch: The completed hook path is calculated with the reeving set in the *Set up* program. A prerequisite for a correct display is that the value entered matches the entered reeving and the actual number of rope strands between the boom head and the hook block.
- Control winch: Rope length of winch spooled out / up
  - F1** Function key
    - The *reset winch display* icon appears above the function key **F1**. Pressing the button sets the display of the rope measurement to zero. Path measurement applies from here.
  - F2** Function key
    - The *reset winch display* icon appears above the function key **F2**. Pressing the button sets the display of the rope measurement to zero. Path measurement applies from here.
- 7** Winch display
  - 7.1** *Winch 1* icon
    - Icon for winch 1 (WI)
  - 7.2** *Winch 2* icon
    - Icon for winch 2 (WII)



### Note

- ▶ The displays for winch 1 and winch 2 are identical and are explained for one icon element.

### 7.3 Load position

- Load position to which the winch is assigned.

### 7.4 Completed path

- In [m] or [ft], see Measuring unit **7.5**  
From a zero point to be determined
- The positions before the decimal point are displayed with a maximum of three large digits. The digits after the decimal point are displayed in small digits. Setting to zero point, see also section “The function key line of LICCON monitor 0”).
- The following applies as hoist winch:
  - For single operation (normal operation) with the reeving set in the *Set up* program: completed hook path.
  - For parallel operation\* with the set total reeving made in the *set up* program: distance completed by the hook block.
  - A prerequisite for a correct display is that the reeving value entered corresponds to the actual number of rope strands between the boom head and the hook block.

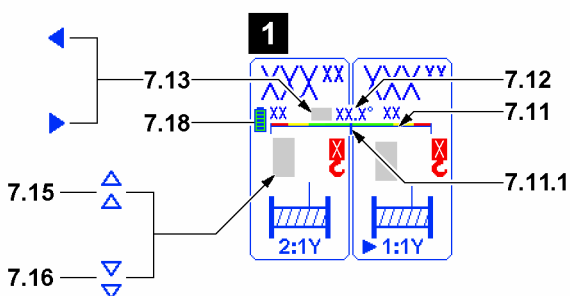
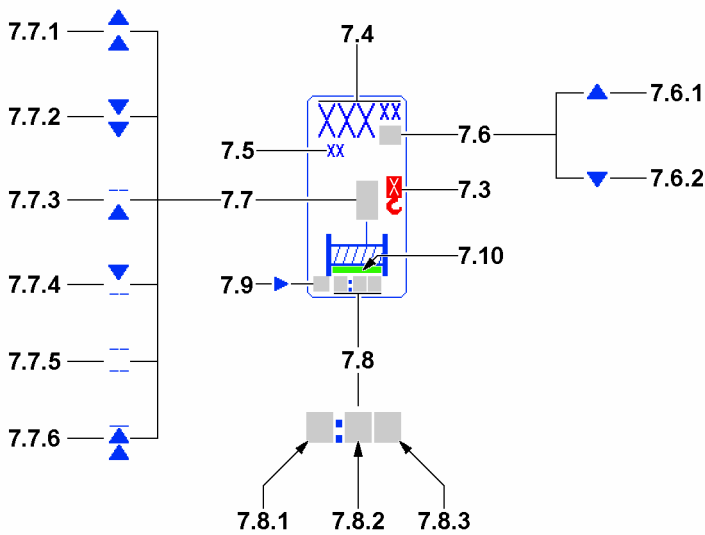
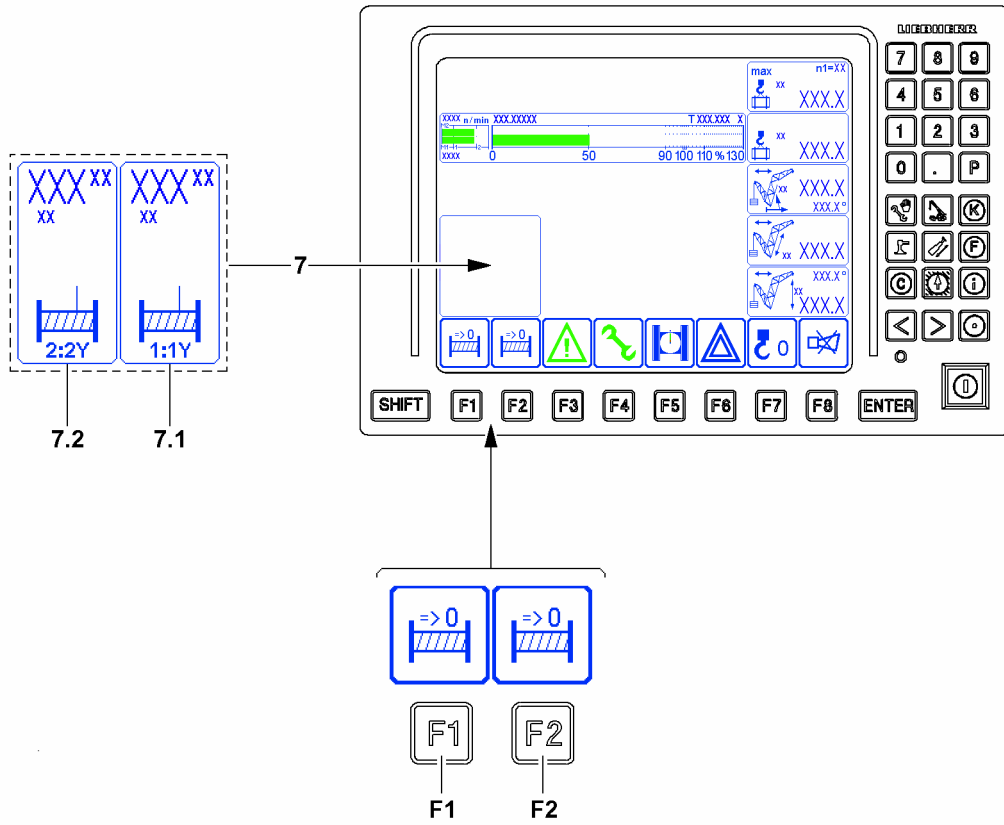


Fig.153663

LWE/LR 1800-1-0-000/27200-07-02/en



**Note**

Display area of winch displays.

- ▶ The completed path **7.4** display has only three positions before the decimal point, any positions before that are cut off. The crane operator must evaluate for himself if, for example 200 m of rope are spooled up on a winch or 1200 m. **The display in both cases would be identical with 200 m.**

For use as a hoist winch:

- ▶ The hook path calculation only works accurately if the load is suspended freely and is not luffed during the lifting procedure. Flexation and rope expansion are not taken into account.
- ▶ The length display (hook path display) is only correct when the winch is calibrated.

**7.5** Measuring unit

- Measuring unit of the hook path display: [m] or [ft]

**7.6** Direction of hook movement

- The arrows on the length value show the direction of the hook movement in relation to the zero point
- *Up* arrow **7.6.1**: Hook moves upward from the zero point
- *Down* arrow **7.6.2**: Hook moves downward from the zero point

**7.7** Winch status display

- There are five winch condition icons, all blinking
- **Note**: If a winch status icon does not appear, the activated winch is inactive and is neither spooled up nor spooled out.

**7.7.1** Spool out

- The winch is spooled out

**7.7.2** Spool up

- The winch is spooled up

**7.7.3** Spooled out

- Additional spooling out of the winch is blocked

**7.7.4** Spooled up

- Additional spooling up of the winch is blocked

**7.7.5** Winch deactivated

- The winch is deactivated or unplugged
- **Note**: The winch cannot be controlled.

**7.7.6** Winch turned off in emergency

- Spooling out of the winch is blocked
- **Note**: Pay attention to the error message

**7.8** Master switch assignment

- **7.8.1** First digit
  - First digit: Winch number, every winch icon is permanently assigned to a winch
- **7.8.2** Second digit
  - Master switch number, according to the assigned master switch
  - ? : No master switch assigned
- **7.8.3** Letter
  - Actuation direction of the master switch, see illustration
  - ? : No actuation direction assigned

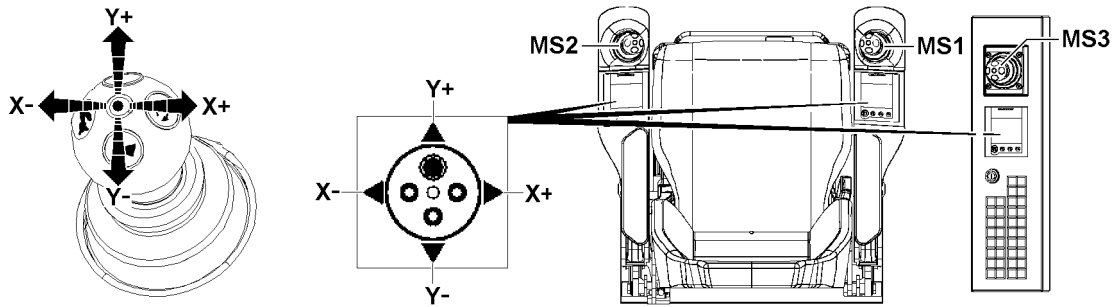


Fig.164495: Master switch actuation directions

**MS1** Master switch 1

**MS2** Master switch 2

**MS3** Master switch 3

**X+** To the right

**X-** To the left

**Y+** To the front

**Y-** To the rear

#### 7.9 Vibration sensor

- If the vibration sensor for a winch is activated on the master switch, then an arrow appears in this winch icon for the activated vibration sensor.
- **Note:** The vibration sensor is activated at the first actuated crane function.

#### 7.10 Winch speed

- **Note:** Only for certain crane types.
- If the maximum winch speed is reduced, a bar in the respective length appears on the bottom in the winch icon. Example: Half the length corresponds to a 50 % reduction of the maximum winch speed, see the example in illustration 1.1.



#### Note

On crane types with parallel operation\* of hoist winches:

- For a detailed description of parallel operation\* of winch 1 and winch 2, see the Crane operating instructions, chapter 4.05.

#### Winch 1 and winch 2 parallel operation, illustration 1:

##### 7.11 Incline indicator

- Graphic display of incline of hook block during parallel operation with winch 1 and winch 2

##### 7.11.1 Display bar

- Appears as soon as the hook block is inclined
- The display bar 7.11.1 appears in green, yellow and red, depending on the situation
- Green display bar 7.11.1: Incline in the permissible range
- Display bar 7.11.1 yellow: **Advance warning!** Incline just before impermissible range
- Display bar 7.11.1 red: **Warning!** Incline in an impermissible range

##### 7.12 Incline value

- Incline value of hook block in parallel operation with winch 1 and winch 2.  
The incline value appears in degrees [°].

##### 7.13 Incline direction

- Incline direction of hook block in parallel operation with winch 1 and winch 2.

##### 7.15 Spool winch out

- If the *Spool winch out* icon 7.15 appears in the winch display: Spool the winch out to align the hook block

##### 7.16 Spool winch up

- If the *Spool winch up* icon 7.16 appears in the winch display: Spool the winch up to align the hook block

##### 7.18 Hook block incline sensor battery

- The icon displays the charge level of the hook block incline sensor battery during parallel operation.
  - Green icon, five bars are displayed: Battery full
  - As the charge level decreases, the number of bars decreases.

- Red icon, no bars are displayed: Battery discharged, the battery must be replaced.
- For a description of the hook block incline sensor, see chapter 5.19.10

**Note:** Only available for certain crane types with a corresponding hook block incline sensor.



### WARNING

Hook block inclined!

If the hook block gets so far into a sloped position that the red range (example illustration 1.1) is reached in the incline display, then there is a danger of accident.

- ▶ Always correct the position of the hook block in time.
- ▶ Always keep the incline of the hook block within the green range.

### Maintenance displays, illustration 1.2:

#### 7.14 *Winch overheated* icon

- If the *Winch overheated* icon 7.14 appears, the temperature in the respective winch is too high.

**Note:** Only for certain crane types with temperature sensors in the winches.

#### 7.17 *Insufficient oil* icon

- If the *Insufficient oil* icon 7.17 appears permanently after correct completion of the *Winch gear* oil level measurement, the oil level in the respective winch is too low.

**Note:** Only for certain crane types.



### WARNING

Overheated winch!

If a winch is operated further, even though the *Winch overheated* icon 7.14 appears, the winch can be severely damaged.

The winch can fail and accidents can occur.

- ▶ Let the overheated winch cool off.



### WARNING

Insufficient oil in the winch!

If a winch is operated further, even though the *Insufficient oil* icon 7.17 appears, the winch can be severely damaged.

The winch can fail and accidents can occur.

- ▶ Remedy the insufficient oil immediately.

## 5.10 Setting the limit values for the load torque limiter for advance warning and shut-off

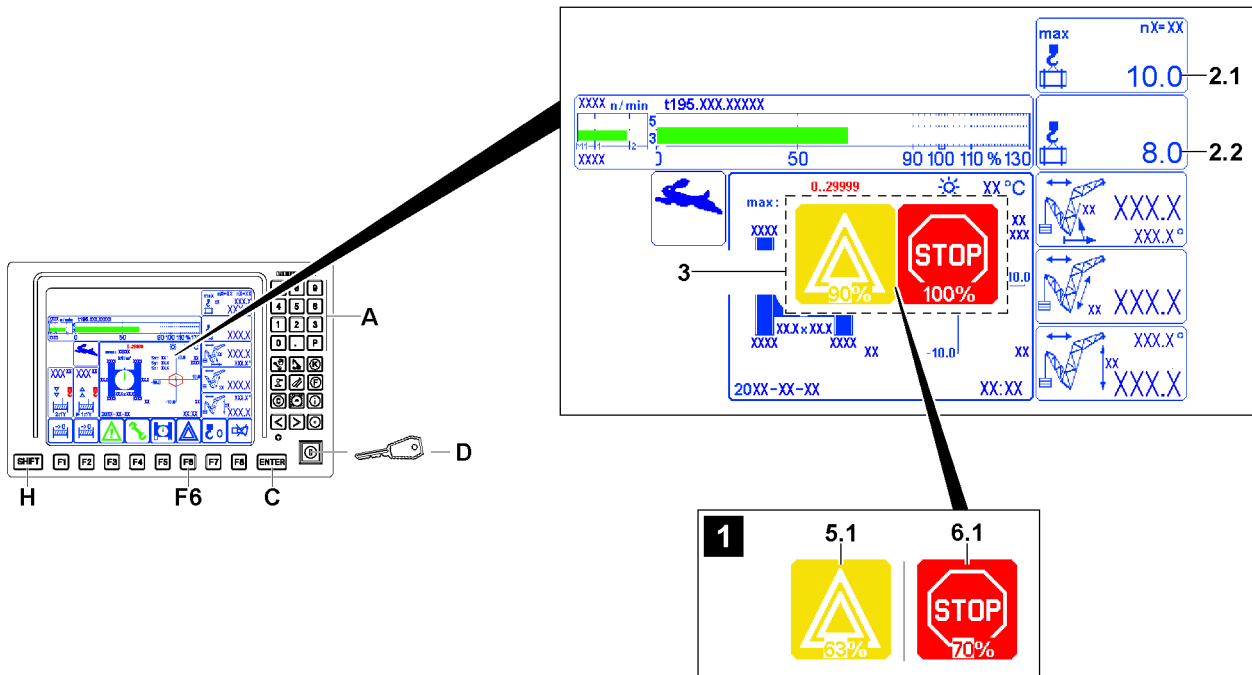


Fig.152777: Setting the limit values for the load torque limiter for advance warning and shut-off

The crane driver can reduce the factory set limit values of the load torque limiter for advance warning and shut-off.

Factory settings:

- The limit value<sup>advance warning</sup> is 90 %
- The limit value<sup>shut-off</sup> is 100 %

If the limit values for the load torque limiter for advance warning and shut-off are reduced:

- The displayed maximum load **2.1** cannot be lifted without exceeding the shut-off limits of the LICCON overload protection.
- Crane movements are shut off earlier by the crane control.



### WARNING

Crane possibilities additionally limited!

If the limit value<sup>shut-off</sup> is reduced, the crane possibilities are additionally reduced.

The maximum load **2.1** can only be lifted by exceeding the shut-off limits of the LICCON overload protection.

The maximum boom radius of the crane can be reduced.

For crane operation on a variable support, the slewing range can be significantly limited.

- ▶ Select the limit value<sup>shut-off</sup> such that crane operation is possible without exceeding the shut off limits of the LICCON overload protection.
- ▶ Before exceeding the shut-off limits of the LICCON overload protection, it is recommended to reset the factory set limit value<sup>shut-off</sup>.
- ▶ When transferring the crane to another crane operator: Inform the next crane operator about the changed limit values for the load torque limiter for advance warning and shut-off.



### Note

- ▶ In order to not limit crane performance, it is advisable to only reduce the limit value<sup>advance warning</sup>.

**Note**

Crane control EN13000:2010 active

Exceeding the shut off limits of the LICCON overload protection.

- ▶ By pressing the set up key **D** the limit value<sup>shut-off</sup> can be exceeded only 1/10.
- ▶ Example: If the limit value<sup>shut-off</sup> is set to 70 %, the set up key **D** can be used to exceed crane utilization to maximum 77 %.
- ▶ In order to bypass the limit value<sup>shut-off</sup> beyond that, the emergency operation LICCON overload protection must be activated.

**Note**

Crane control EN13000:2010 not active

Exceeding the shut off limits of the LICCON overload protection.

- ▶ By pressing the set up key **D** the limit value<sup>shut-off</sup> is bypassed.

Ensure that the following prerequisite is met:

- The <sup>shut-off</sup> limit value is selected such that crane operation is possible without exceeding the shut-off limits of the LICCON overload protection.

### 5.10.1 Displaying the set limit values

- ▶ Press the SHIFT key **H** and the function key **F6** at the same time.

**Result:**

- The settings window **3** opens.
- The limit value<sup>advance warning</sup> can be read in the *advance warning* setting icon **5.1**.
- The limit value<sup>shut-off</sup> can be read in the *STOP* settings icon **6.1**.

Close the settings window **3**:

- ▶ Press the SHIFT key **H** and the function key **F6** at the same time.  
**or**  
Wait ten seconds.

### 5.10.2 Setting the limit value

**Note**

If you try to set a limit value that is too high, the highest possible value is taken over.

If you try to set a limit value that is too low, the lowest possible value is taken over.

The difference between the limit values is at least 1/10 of the limit value<sup>shut-off</sup>.

- ▶ Select the limit value<sup>advance warning</sup> between 18 and 90.
- ▶ Select the limit value<sup>shut-off</sup> between 20 and 100.

- ▶ Press the SHIFT key **H** and the function key **F6** at the same time.

**Result:**

- The settings window **3** opens.
- The limit value<sup>advance warning</sup> is highlighted in white in the *advance warning* settings icon **5.1** and can be set, see illustration **1**.

**Note**

- ▶ It is possible to switch between the adjustable limit values by pressing the Enter key **C**.

Set a new<sup>advance warning</sup> limit value:

- ▶ Enter the required limit value<sup>advance warning</sup> (for example 63) using the keys (0 to 9) on the numerical keypad **A**.

**Result:**

- The new limit value<sup>advance warning</sup> is displayed in the *advance warning* setting icon **5.1**.

**Problem remedy**

Is the set limit value<sup>advance warning</sup> always rejected?

The difference between the limit values must be at least 1/10 of the limit value<sup>shut-off</sup>. If the limit value<sup>advance warning</sup> is increased, the limit value<sup>shut-off</sup> must be correspondingly high.

► First increase the limit value<sup>shut-off</sup>.

► Press the Enter key **C** until the limit value<sup>shut-off</sup> is highlighted in white in the *STOP* setting icon **6.1**, see illustration 1.

Set a new limit value<sup>shut-off</sup>.

► Enter the required limit value<sup>shut-off</sup> (for example 70) using the keys (0 to 9) on the numerical keypad **A**.

**Result:**

– The new limit value<sup>shut-off</sup> is displayed in the *STOP* setting icon **6.1**.

End the settings:

► Press the SHIFT key **H** and the function key **F6** at the same time.

or

Wait ten seconds.

**Result:**

– The settings window **3** closes.

– The limit values are set.

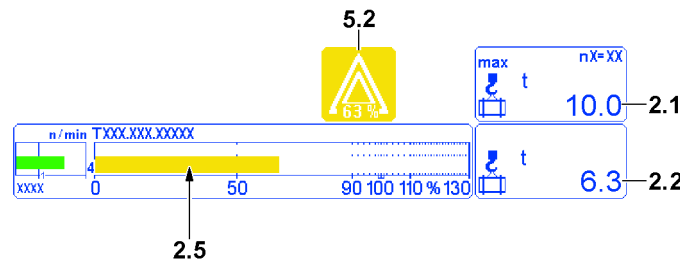
**Example 1: Occurrence of an advance warning with reduced limit value<sup>advance warning</sup>**

Fig.147878: Limit value<sup>advance warning</sup> set to 63 %, crane utilization 63 %

- The actual load value **2.2** reaches 63 % of the maximum load value **2.1**
- The utilization bar **2.5** turns yellow
- The advance warning icon **5.2** appears with the set limit value<sup>advance warning</sup> (in the example, 63 %)

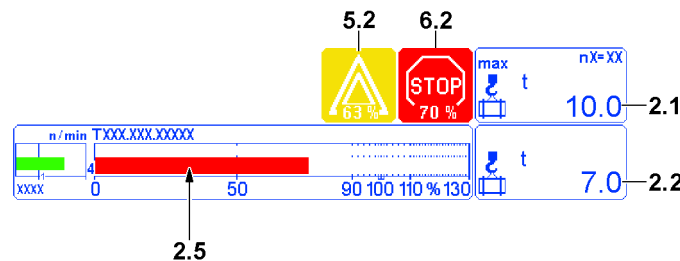
**Example 2: Occurrence of a shut-off with reduced limit value<sup>shut-off</sup>**

Fig.147879: Limit value<sup>shut-off</sup> set to 70 %, crane utilization 70 %

- The actual load value **2.2** reaches 70 % of the maximum load value **2.1**
- The utilization bar **2.5** turns red
- The advance warning icon **5.2** appears with the set limit value<sup>advance warning</sup> (in the example, 63 %)
- The STOP icon **6.2** appears with the set limit value<sup>shut-off</sup> (in the example, 70 %)
- Load moment increasing crane movements are shut off

- ▶ When transferring the crane to another crane operator: Inform the next crane operator about the changed limit values for the load torque limiter for advance warning and shut-off.

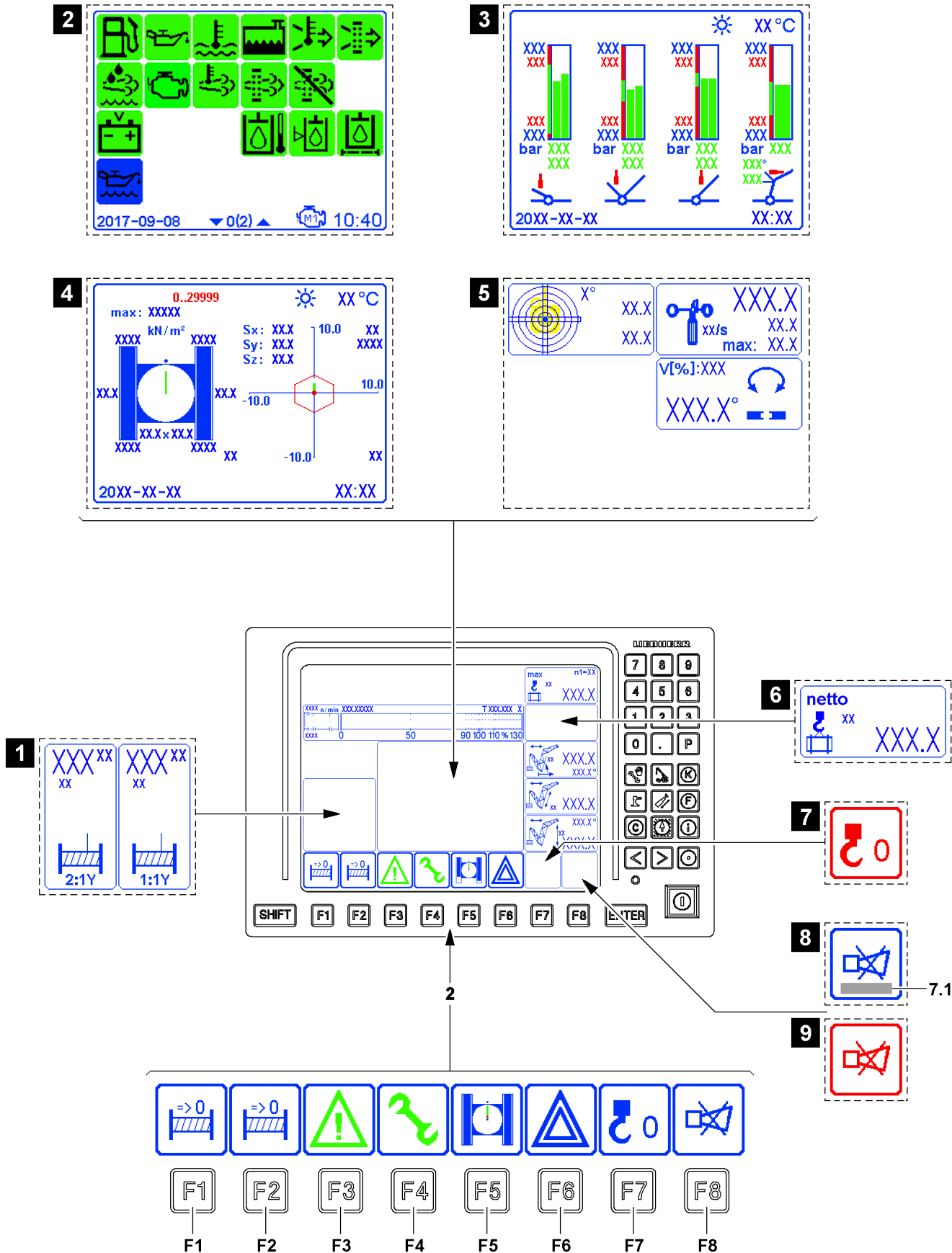


Fig.161665

LWE/LR 1800-1-0-000/27200-07-02/en



## 5.11 The function key line of LICCON monitor 0

The function key line consists of function keys **F1** to **F8** and the function key icon bar above it. The function keys correspond to the various function key icons above them.

The function key icons always show the functions which are activated by pressing the button.

The function is called up after pressing a button. In addition, the icon above it can change its display, its meaning or its text.

Not all function keys must have assigned icons. This depends on the respective program selection.

### F1 Function key

- Determine the zero point for the Winch 2\* *completed path* display, see illustration 1.
- The *reset winch display* icon appears above the function key **F1**. Pressing the button sets the *Completed path* display to zero. Path measurement applies from here.

### F2 Function key

- Determine the zero point for the Winch 1 *completed path* display, see illustration 1.
- The *reset winch display* icon appears above the function key **F2**. Pressing the button sets the *Completed path* display to zero. Path measurement applies from here.
- **Note:** When winch 1 and winch 2 work in parallel operation, then the *completed path* displays for winch 1 and winch 2 can only be set together to zero with the function key **F1**.

Then the function key **F2** has no function.

### F3 Function key

- Display or hide crane operation monitoring functions (illustration 2)  
See also section "Crane operation monitoring functions".

### F4 Function key

- Display or hide relapse cylinder / erection cylinder monitoring (illustration 3).  
See also section "Relapse cylinder / erection cylinder monitoring".

### F5 Function key

- Display or hide surface pressure and center of gravity monitoring (illustration 4).  
See also section "Surface pressure and center of gravity monitoring".

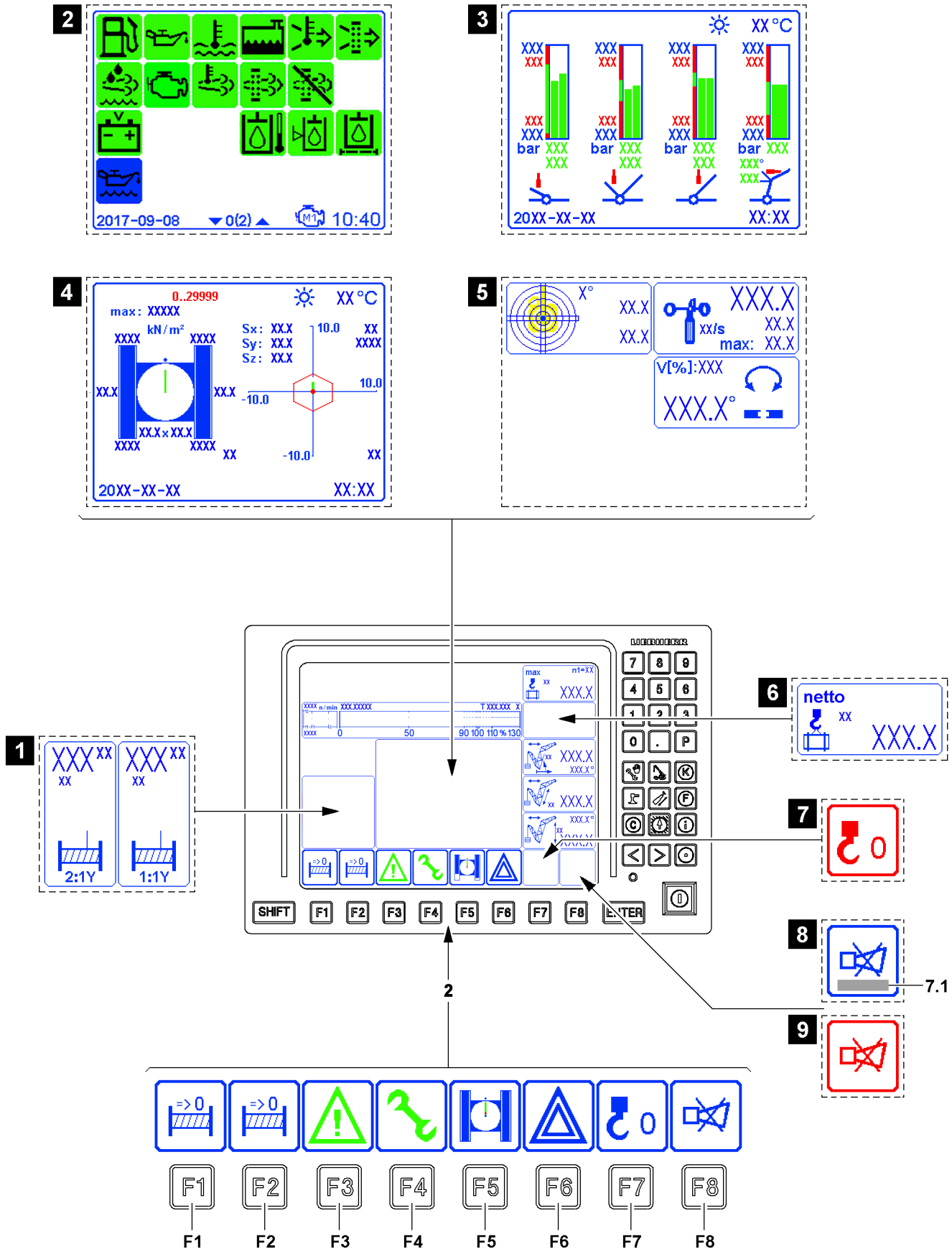


Fig.161665

**F6** Function key

- Display or hide monitored auxiliary functions (illustration 5)  
See also section "Monitored auxiliary functions"

**Note**

- ▶ The monitoring of all auxiliary functions is always active, even if the monitoring icons are hidden.
- ▶ When a monitored limit is exceeded, then an acoustic warning is issued by the LICCON monitor and the respective icon is shown continuously.

**F7** Function key

- Taring: When the function key **F7** is pressed, the *Actual load* display is set to zero. At the same time, the word *net* appears in the display, see illustration 6.  
If the taring is cancelled again, then the word *net* disappears from the display and the gross load value is displayed.
- Taring is cancelled by one of the following two actions:
  1. By pressing the function key **F7** again.
  2. Luffing more than  $\pm 4^\circ$ .

**Note**

By taring it is possible, for example, to eliminate weights of carrying equipment, load handling equipment or fastening equipment.

- ▶ Therefore the calculated weight of the load to be lifted (net load) can be displayed.
- ▶ As long as taring is active, the function key icon is shown in red, see illustration 7.

**F8** Function key

- Shut-off of acoustic warning and possibly calling up of error message **7.1** (illustration 8).  
Press the function key **F8** once: The acoustic signal is turned off.  
Press the function key **F8** twice: The error description for the error message **7.1** that occurred last is called up.
- **Note:** A new error turns the acoustic warning on again.

**WARNING**

Malfunctions in the crane control!

A special program is available for LIEBHERR crane acceptance in the LICCON computer system. This program is blocked after completion of crane acceptance.

If the function key icon displays red permanently and without a visible reason (illustration 9), then the special program is activated.

- ▶ Contact Liebherr Customer Service immediately.
- ▶ In order to prevent error functions, access to the special program is only permitted for trained Liebherr personnel.

## 5.12 Other operating elements

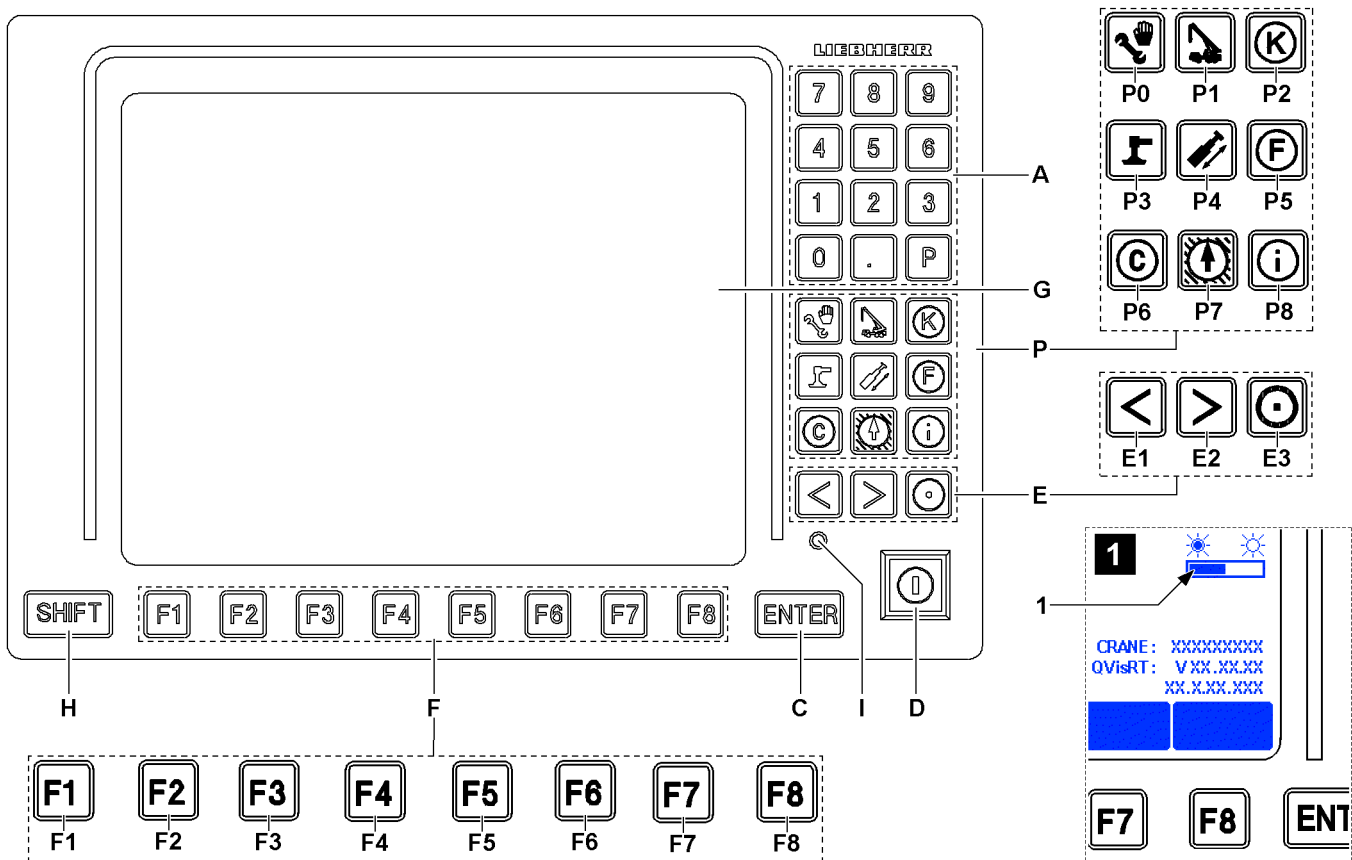


Fig.120677

The following functions are assigned to the other operating elements of the display and operating unit of the LICCON computer system in the *Crane operation* program.

- A Keypad**
  - Keys “0” to “9”, “P” and “.” (illustration 1) have no function in the *Crane operation* program.
- P Program keys**
  - The program keys are used to select individual programs. The program specific peculiarities must be observed, see the respective sections of the programs in this chapter.
  - **Note:** The program currently running **cannot** be called up again using its program key. The programs can only be called up with the program key when no functions are activated via the set up key **D** at the same time.
- C ENTER key**
  - No function in *crane operation* program
- D Set up key**
  - Zero position (not actuated):  
Normal operation.
  - Touching:  
Function *Exceedance of shut-off limits of the LICCON overload protection* released.
  - **Exceeding the shut off limits of the LICCON overload protection**  
If the shut-off limits of the LICCON overload protection are exceeded, the LICCON overload protection shuts the crane movements off.  
These shut offs can be exceeded by the set up key **D** in the *right touching* position. To do so, chapter 4.20 in the *Crane operating instructions* must be observed.

**Note**

Carry out the erection / take-down procedures.

- ▶ By pressing the set up key **D**, all erection / take-down procedures can be carried out within the erection / take-down charts, for which no load charts are available.

- **Bypass of hoist limit switch**

The hoist limit switch turns the crane movement off when:

- The hook block is pulled against the hoist limit switch weight.
- The hoist limit switch weight is not attached freely (for example on placed down boom).
- The hoist limit switch has an internal error.

This shut-off can be bypassed by the set up key **D** in the *right touching* position. To do so, chapter 4.20 in the Crane operating instructions must be observed.

- E** Special function keys

- Monitor brightness adjustment (see section “Operating elements of the LICCON monitors”)

**Note**

- ▶ Additional functions of the special function keys **E** are program-dependent and are further explained in the description of the individual LICCON programs.

- F** Function keys

- The function key line consists of function keys **F1** to **F8** and the function key icon bar above it.

The function keys correspond to the various function key icons above them.

- H** SHIFT key

- Second level key assignments

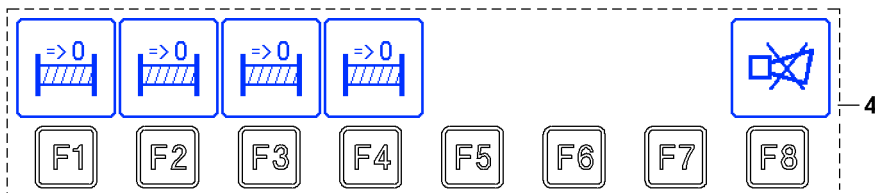
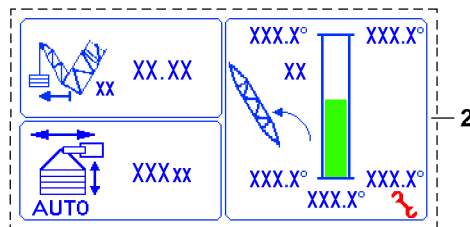
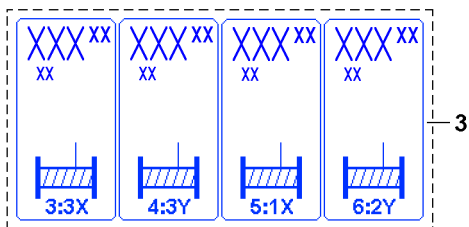
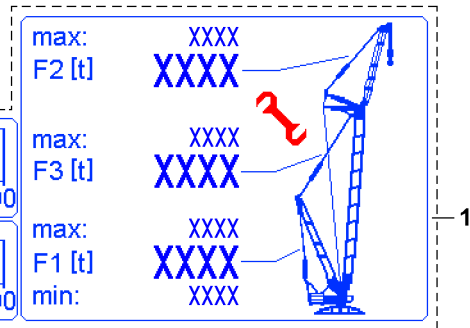
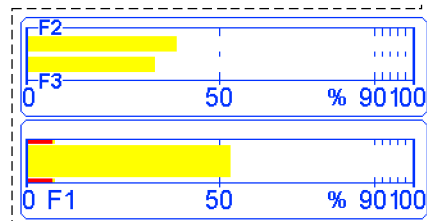
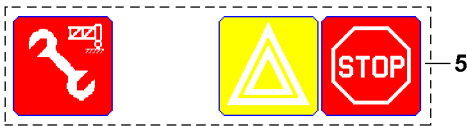
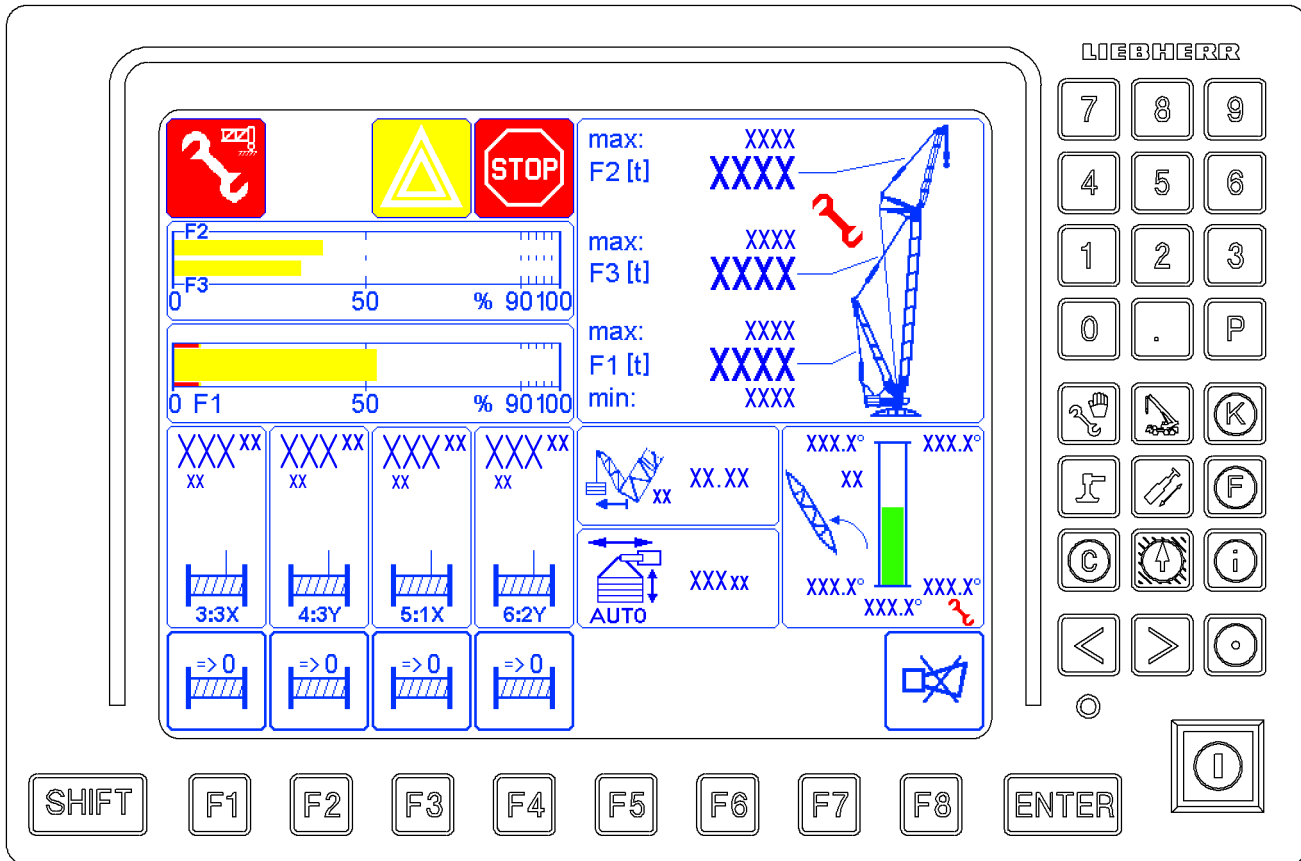


Fig.125381

LWE/LR 1800-1-0-000/27200-07-02/en

## 6 The *Crane operation* program on LICCON monitor 1

The *Crane operation* LICCON program assists the crane operator by displaying the data relevant for crane operation clearly on three LICCON monitors. An acoustic signal accompanies all critical displays.

LICCON monitor 1 is divided into four areas in the *Crane operation* program:

- 1 F-load display
  - F1-load display
  - F2-load display
    - Note:** Appears only for the corresponding boom system
  - F3-load display
    - Note:** Appears only for the corresponding boom system
- 2 Derrick boom geometry
  - Boom radius and angle of the derrick boom
    - Note:** Appears only for the corresponding boom system
- 3 Winch display
  - Winch 3 to winch 6
- 4 Function key line
  - The function keys always refer to the icons shown directly above them
  - **Note:** If no icon is shown on the line directly above the function key, then no function is assigned in the program to the function key. See for example function key F5 to function key F7.
- 5 Alarm functions
  - Alarm functions of LICCON monitor 1



### Note

- ▶ The monitor illustrations in this chapter are only examples.
  - ▶ The numerical values in the individual icons and charts do not have to necessarily match the crane exactly.
  - ▶ The configuration of the LICCON monitor with icons is only descriptive.
  - ▶ An identical icon display will **not** appear during crane operation.
- 



### Note

- ▶ The suspended ballast and the ballast trailer\* are generally referred to as the **derrick ballast**.
-

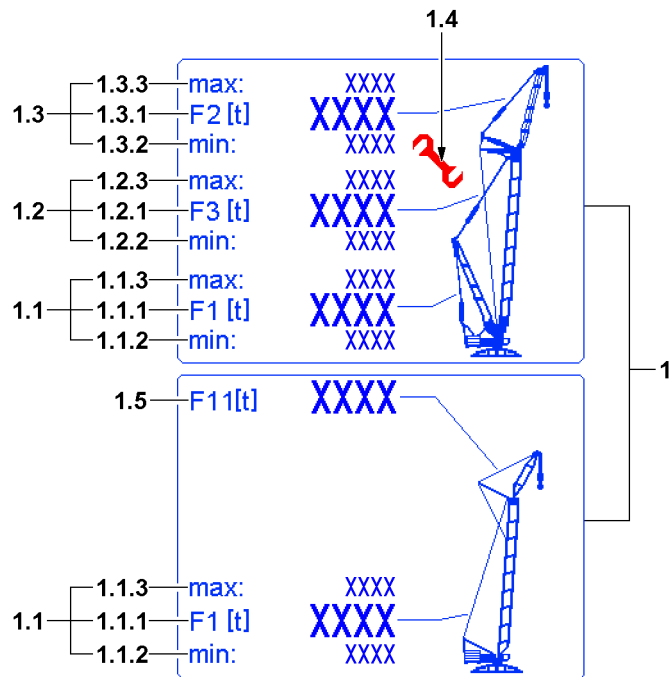
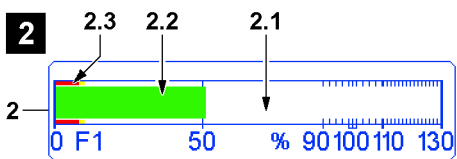
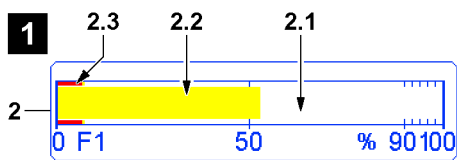
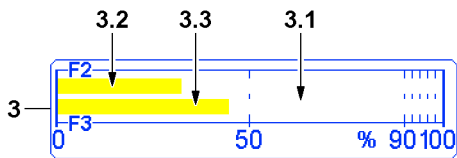
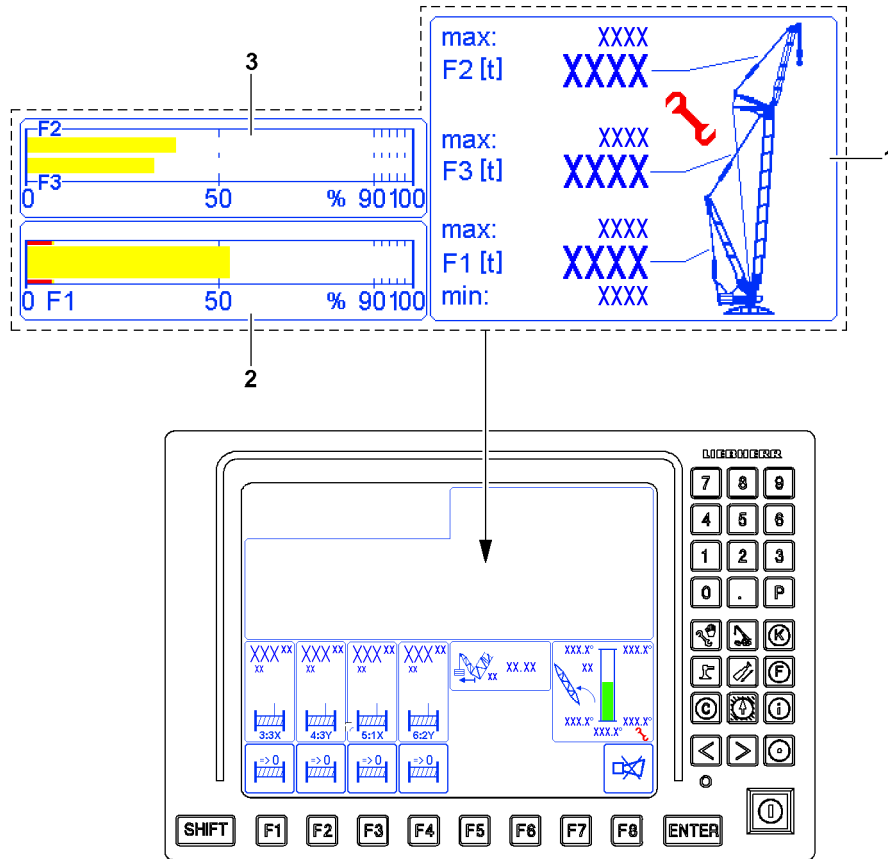


Fig.122454

LWE/LR 1800-1-0-000/27200-07-02/en



## 6.1 F-load display

From the ratio of the operating force  $F_{\text{actual}}$  to the permissible maximum force  $F_{\text{max}}$  results the respective F-utilization.

The F-load display includes various display modes:

- Numeric displays
- Bar diagrams, when a ratio of operating force  $F_{\text{actual}}$  to the permissible maximum force  $F_{\text{max}}$  is shown.



### WARNING

Damage, overload and toppling of the crane!

If the permissible values of the F-load display are exceeded / fallen below, then the crane can be damaged or overloaded and topple over.

As long as the set up boom system is not completely assembled and not all sensors, which are required for this operating mode are electrically connected, no maximum forces and minimum forces are displayed in the F-load display.

In these cases it must be determined with the assembly drawing which maximum forces are permissible on the F-load display.

These maximum forces must be monitored by the crane operator and may not be exceeded during assembly / removal of the crane.

- ▶ The crane operator must ensure that the permissible values of the F-load display are not exceeded / fallen below.
- ▶ Observe and adhere to the maximum forces for the F-load display from the assembly drawings.



### Note

The values of the F-load display depend on the set up configuration of the crane and the crane geometry.

The values of the F-load display change continuously when the crane is moved.

- ▶ Monitor the F-load display continuously.

### 6.1.1 Numeric F-load display

#### 1 Numeric displays

- Type and scope of numeric displays depends on the set up configuration and the operating situation.

#### 1.1 F1-display

##### 1.1.1 F1-actual value ( $F1_{\text{actual}}$ )

- F1-force actual value

##### 1.1.2 F1-minimum ( $F1_{\text{min}}$ )

- F1-force minimum value

**Note:** Appears only outside a load chart, at activated assembly operation or in special situations.

##### 1.1.3 F1-maximum ( $F1_{\text{max}}$ )

- F1-force maximum value

**Note:** Appears only outside a load chart, at activated assembly operation or in special situations.

#### 1.2 F3-display

- **Note:** Appears only for the corresponding boom system

##### 1.2.1 F3-actual value ( $F3_{\text{actual}}$ )

- F3-force actual value

##### 1.2.2 F3-minimum ( $F3_{\text{min}}$ )

- F3-force minimum value

**Note:** Appears only outside a load chart, at activated assembly operation or in special situations.

##### 1.2.3 F3-maximum ( $F3_{\text{max}}$ )

- F3-force maximum value

**Note:** Appears only outside a load chart, at activated assembly operation or in special situations.

### 1.3 F2-display

- **Note:** Appears only for the corresponding boom system

#### 1.3.1 F2-actual value ( $F2_{\text{actual}}$ )

- F2-force actual value

#### 1.3.2 F2-minimum ( $F2_{\text{min}}$ )

- F2-force minimum value

**Note:** Appears only outside a load chart, at activated assembly operation or in special situations.

#### 1.3.3 F2-maximum ( $F2_{\text{max}}$ )

- F2-force maximum value

**Note:** Appears only outside a load chart at activated assembly operation

### 1.4 Assembly icon

- Appears when assembly operation is activated

### 1.5 F11-display

- F11-force actual value
- **Note:** Appears only for the corresponding boom system

Empty page!

LWE/LR 1800-1-0-000/27200-07-02/en

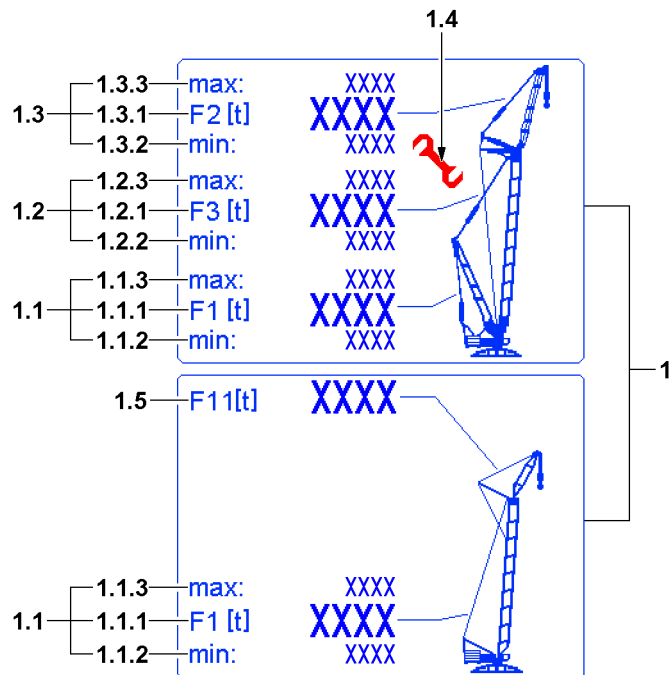
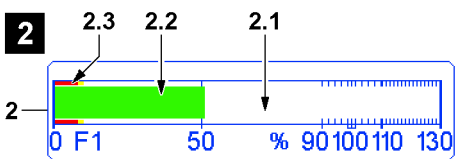
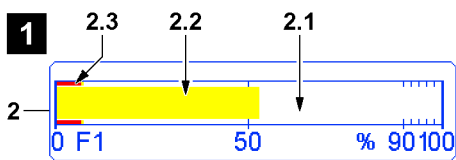
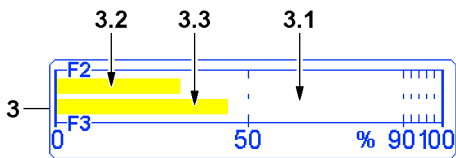
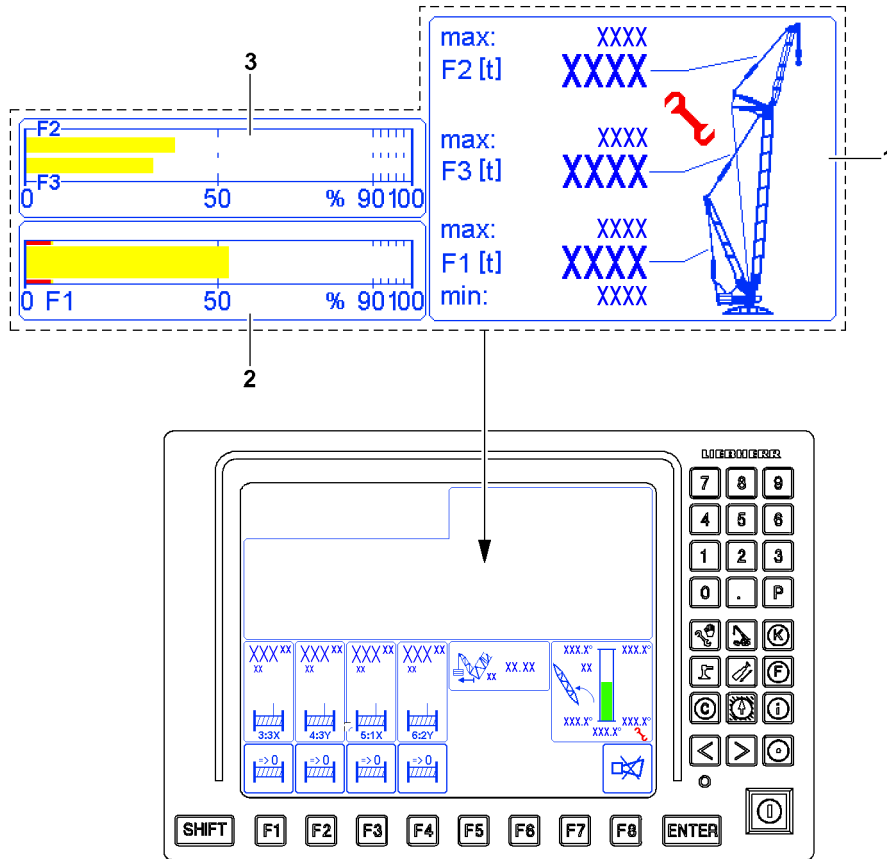


Fig.122454

LWE/LR 1800-1-0-000/27200-07-02/en

## 6.1.2 F1-display bar

Pull test brackets Test point 1A and 1B (F1 force) are in the A-frame guying

- F1-display bar in assembly operation: Scale from 0 % to 100 % (outside a load chart), see illustration 1
- F1-display bar in crane operation: Scale from 0 % to 130 % (within a load chart), see illustration 2

### 2 Display bar

- Display bar for graphic illustration of F1-force

#### 2.1 Display scale

- Crane operation: Scale from 0 % to 130 % (within a load chart)
- Assembly operation: Scale from 0 % to 100 % (outside a load chart)

#### 2.2 F1-bar

- Graphic illustration of the F1-actual value ( $F1_{\text{actual}}$ )
- Appears in green, yellow and red, depending on the situation
- F1-bar **2.2** green:  $F1_{\text{actual}}$  present in the permissible range and load chart
- F1-bar **2.2** yellow: **Advance warning!**  $F1_{\text{actual}}$  shortly before the impermissible range
- **Note:** During assembly operation, the F1-bar **2.2** is also shown in yellow within the permissible range.
- F1-bar **2.2** red: **Warning!**  $F1_{\text{actual}}$  in the impermissible range

#### 2.3 F1-minimum

- Graphic illustration of range  $F1_{\text{min}}$   
 Yellow range:  $F1_{\text{min-advance warning}}$  - advance warning for F1-minimum  
 Red range:  $F1_{\text{min-Stop}}$  - Warning / stop for F1-minimum

## 6.1.3 F2/F3-display bar

Pull test brackets test point 2A and 2B (F2 force) are in the N/W-guying

Pull test brackets test point 3A and 3B (F3 force) are in the guying derrick boom / main boom on the main boom head



### Note

- ▶ The F2/F3-display bar appears only in certain situations, for example with activated assembly operation and corresponding boom system.

### 3 Display bar

- Display bar for graphic illustration of F2/F3-force

#### 3.1 Display scale

- Scale from 0 % to 100 %

#### 3.2 F2-bar

- Graphic illustration of the F2-actual value ( $F2_{\text{actual}}$ )
- Appears in yellow and red, depending on the situation
- F2-bar **3.2** yellow: Assembly operation -  $F2_{\text{actual}}$  in the permissible range
- F2-bar **3.2** red: **Warning!**  $F2_{\text{actual}}$  in the impermissible range

#### 3.3 F3-bar

- Graphic illustration of F3-actual value
- Appears in yellow and red, depending on the situation
- F3-bar **3.3** yellow: Assembly operation -  $F3_{\text{actual}}$  in the permissible range
- F3-bar **3.3** red: **Warning!**  $F3_{\text{actual}}$  in the impermissible range

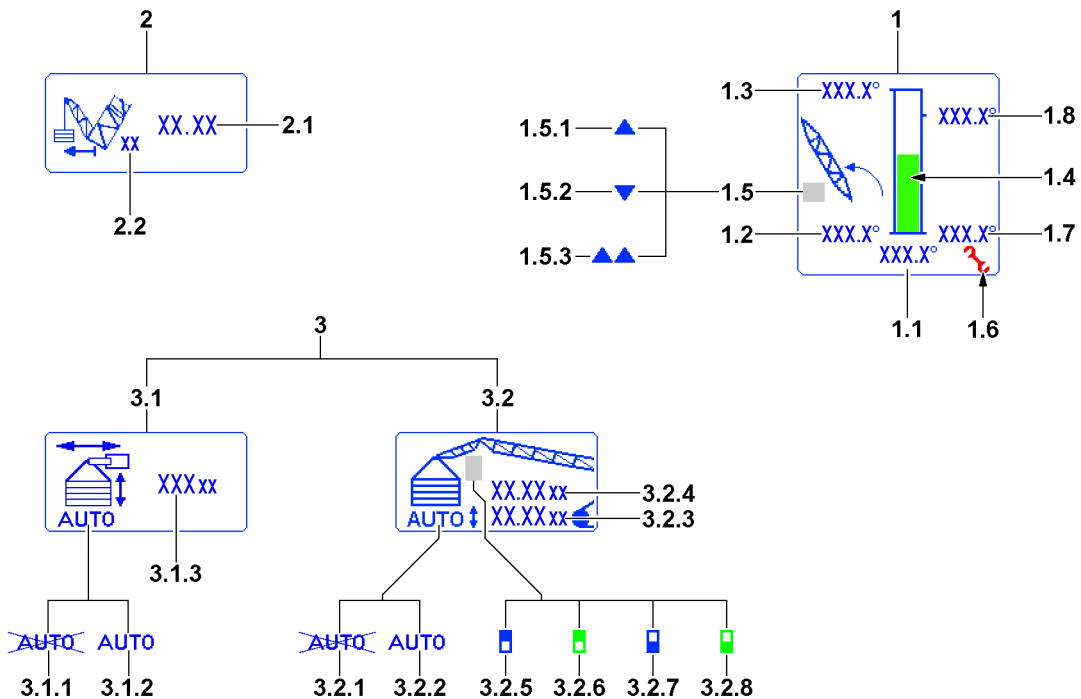
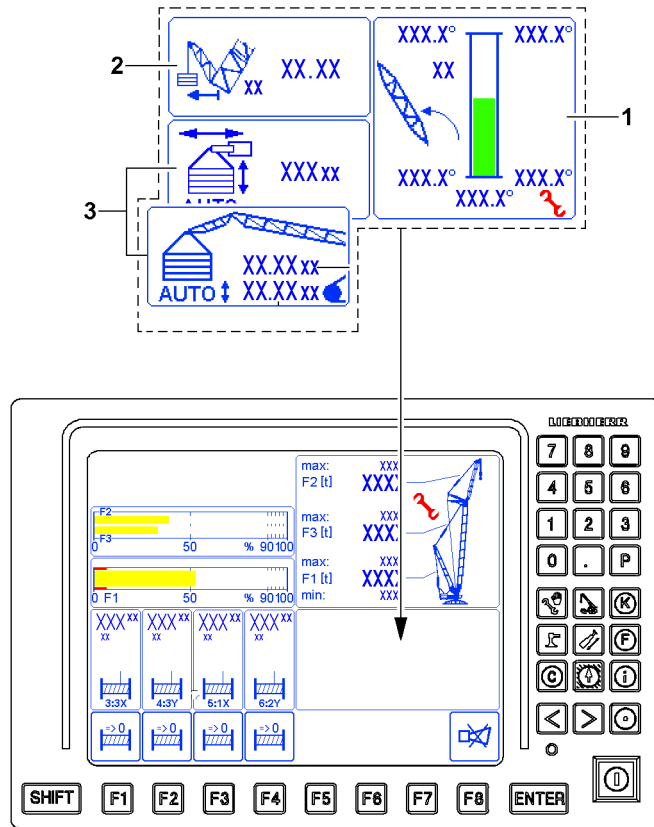


Fig.156203

LWE/LR 1800-1-0-000/27200-07-02/en

## 6.2 Derrick boom angle indicator

- 1 Derrick angle
  - 1.1 Actual angle
    - Current actual angle of the derrick boom
    - Actual angle **1.1** red: **Warning!** Derrick boom angle in the impermissible range
  - 1.2 Minimum angle
    - Minimum angle of the Derrick boom to the front (to the horizontal)
  - 1.3 Maximum angle
    - Maximum angle of the Derrick boom to the front (to the horizontal)
  - 1.4 Bar graph
    - Graphic illustration of the derrick angle as a bar graph in relation to the minimum / maximum value.
    - It appears in green and red, depending on the situation
    - Column **1.4** green: Derrick boom angle in the permissible range
    - Column **1.4** red: **Warning!** Derrick boom angle in the impermissible range
  - 1.5 Derrick alarm function
    - **1.5.1** Up arrow: Derrick boom maximum angle exceeded
    - **1.5.2** Down arrow: Derrick boom minimum angle fallen below
    - **1.5.3** Double up arrow: Derrick boom relapse press in the block position
  - 1.6 *Assembly* icon
    - The *assembly* icon **1.6** appears when a defined angle range for the derrick boom for erection and take-down of the boom system is specified.
  - 1.7 Assembly minimum angle
    - Assembly: Minimum angle of the Derrick boom to the front (to the horizontal)
  - 1.8 Maximum angle Assembly
    - Assembly: Maximum angle of the Derrick boom to the front (to the horizontal)

## 6.3 Derrick ballast boom radius display

- 2 *Derrick ballast* boom radius
  - 2.1 Boom radius value
    - Current boom radius value of the derrick ballast
    - Measured from the center of the slewing ring to the center of the derrick ballast
  - 2.2 Measuring unit
    - Measuring unit of boom radius value

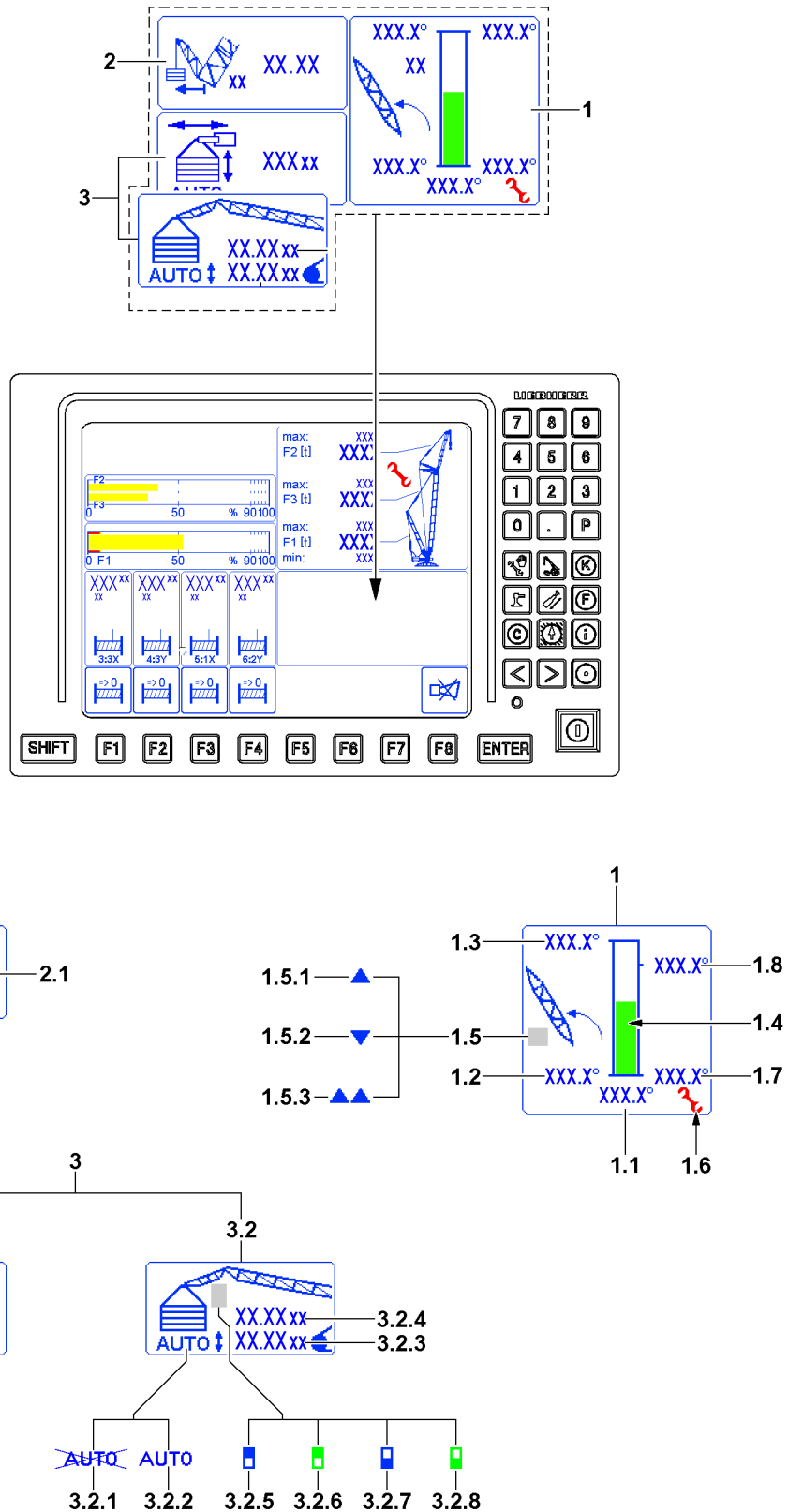


Fig.156203



## 6.4 Ballast automatic\*

The appearance of the ballast automatic icon **3** depends on the respective crane set up configuration:

- 3.1 Ballast trailer ballast automatic icon**
  - For set up configurations with a ballast trailer
- 3.2 Suspended ballast ballast automatic icon**
  - For set up configurations with an adjustable suspended ballast guide

### 6.4.1 Ballast trailer ballast automatic

When turning on the *ballast trailer ballast automatic* (see the Crane operating instructions, chapter 4.01 and chapter 5.35...), a saved value (current F1-force and / or ballast trailer incline) is set.

As soon as the ballast trailer guide is adjusted, the ballast automatic controls the pull cylinder to regulate that the actual value is maintained with respect to the saved value (situation dependent F1-force or ballast trailer incline).

- 3.1 Ballast trailer ballast automatic icon**
  - 3.1.1** Ballast automatic turned off
  - 3.1.2** Ballast automatic turned on
  - 3.1.3** Saved value
    - Depending on the situation:
      - Saved F1-force
      - or**
      - Ballast trailer incline

### 6.4.2 Suspended ballast ballast automatic



#### Note

- ▶ Only for set up configurations with an adjustable suspended ballast guide.

After turning on the *suspended ballast ballast automatic* (see the Crane operating instructions, chapter 4.01 and chapter 5.36...), a saved value (calculated current height difference of the suspended ballast with respect to the crane placement surface) is set.

*Suspended ballast guide adjustment ballast automatic:* As soon as the suspended ballast guide is adjusted, the ballast automatic controls the activated pull cylinder to regulate that the actual value is maintained with respect to the saved value.

*Suspended ballast derrick adjustment ballast automatic:* As soon as the derrick boom is adjusted, the ballast automatic controls the activated pull cylinder to regulate that the actual value is maintained with respect to the saved value.

- 3.2 Suspended ballast ballast automatic icon**
  - 3.2.1** Ballast automatic turned off
  - 3.2.2** Ballast automatic turned on
  - 3.2.3** Actual value
    - Calculated current height difference of the suspended ballast with respect to the crane placement surface
  - 3.2.4** Saved value
    - Calculated height difference of the suspended ballast with respect to the crane placement surface when turned on

**WARNING**

Collision between the suspended ballast and the ground!

The actual value **3.2.3** is below the tolerance in the calculation: The calculation is based on idealized assumptions. For example, level and homogenous ground, rigid crane structure, no consideration of exterior influences and tolerances of the components.

- ▶ The actual value **3.2.3** and the saved value **3.2.4** may not be used to ensure the distance between the suspended ballast and the ground.

## 6.5 Suspended ballast guide “V-frame” pinning mechanism

For crane types with two hydraulic cylinders (large / small) For retracting and extending the derrick ballast guide, the status of the pin in the pinning mechanism is also displayed. Regardless if the ballast automatic\* is turned on or not.

**Note**

- ▶ Operating elements for controlling the pinning mechanism can be found on the instrument panel of the crane cab, see chapter 4.01.
- ▶ The pinning mechanism can only be operated if both hydraulic cylinders (large / small) of the V-frame are fully retracted.
- ▶ The two hydraulic cylinders (large / small) are controlled via the *Extending / retracting the derrick ballast guide* function, see chapter 4.05 and chapter 6.08.
- ▶ If the pin is inserted in the pinning mechanism, only the large hydraulic cylinder can be controlled.
- ▶ If the pin in the pinning mechanism is unpinned, only the small hydraulic cylinder can be controlled.

### 3.2.5 Pin inserted icon / blue

- Pin displayed in blue: The pin is inserted and not ready to be unpinned

### 3.2.6 Pin inserted icon / green

- Pin displayed in green: The pin is inserted and ready to be unpinned

### 3.2.7 Pin released icon / blue

- Pin displayed in blue: The pin is unpinned and not ready to be inserted

### 3.2.8 Pin unpinned icon / green

- Pin displayed in green: The pin is unpinned and ready to be pinned

**Note**

- ▶ The pin displayed blinks when it is not completely inserted / unpinned. For example, when controlling the pinning mechanism or when the pin is not in an end position.

Empty page!

LWE/LR 1800-1-0-000/27200-07-02/en

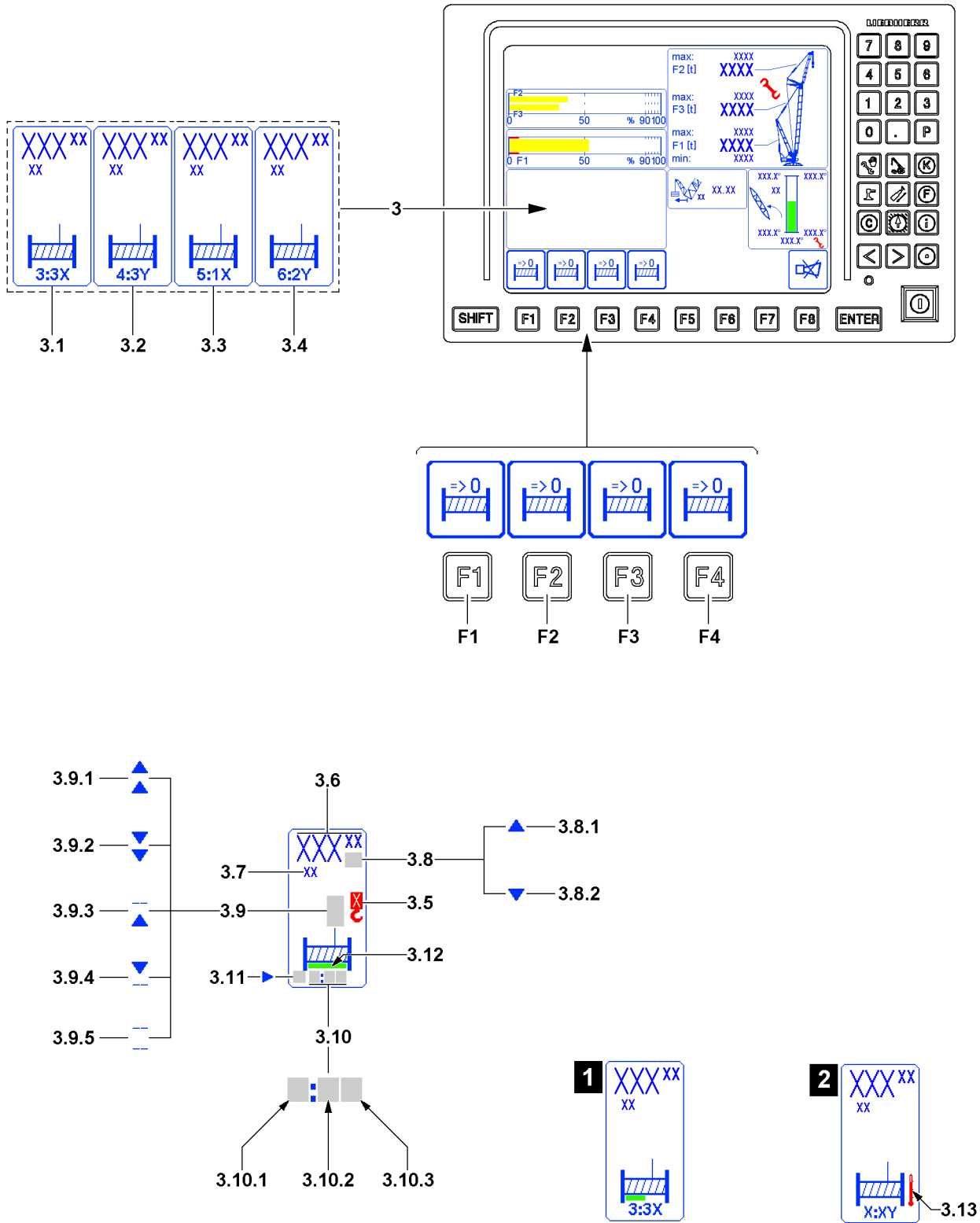


Fig.115251

## 6.6 LICCON Monitor 1 winch display

The winch displays **3** have a fixed position on the LICCON monitor.

There are two values that can be displayed depending on the use of the winch:

- Using the winch as a hoist winch: The completed hook path is displayed.
  - The completed hook path is calculated with the reeving set in the *Set up* program. A prerequisite for a correct display is that the value entered matches the entered reeving and the actual number of rope strands between the boom head and the hook block.
- Using the winch as a control winch: The spooled out / up rope length of the winch is displayed.

The current position of each winch can be set as zero point.

### F1 Function key

- The *reset winch display* icon appears above the function key **F1**. Pressing the button sets the *Completed path* display to zero. Path measurement applies from here.

### F2 Function key

- The *reset winch display* icon appears above the function key **F2**. Pressing the button sets the *Completed path* display to zero. Path measurement applies from here.

### F3 Function key

- The *reset winch display* icon appears above the function key **F3**. Pressing the button sets the *Completed path* display to zero. Path measurement applies from here.

### F4 Function key

- The *reset winch display* icon appears above the function key **F4**. Pressing the button sets the *Completed path* display to zero. Path measurement applies from here.

### 3 Winch display

#### 3.1 Winch 3 icon

- Icon for winch 3 (WIII)

#### 3.2 Winch 4 icon

- Icon for winch 4 (WIV)

#### 3.3 Winch 5 icon

- Icon for winch 5 (WV)

#### 3.4 Winch 6 icon

- Icon for winch 6 (WVI)



### Note

- ▶ The displays for winch 3 to winch 6 are identical and are explained based on one icon element.

### 3.5 Load position

- Load position to which the winch is assigned.
- **Note:** Appears only when using it as hoist winch.

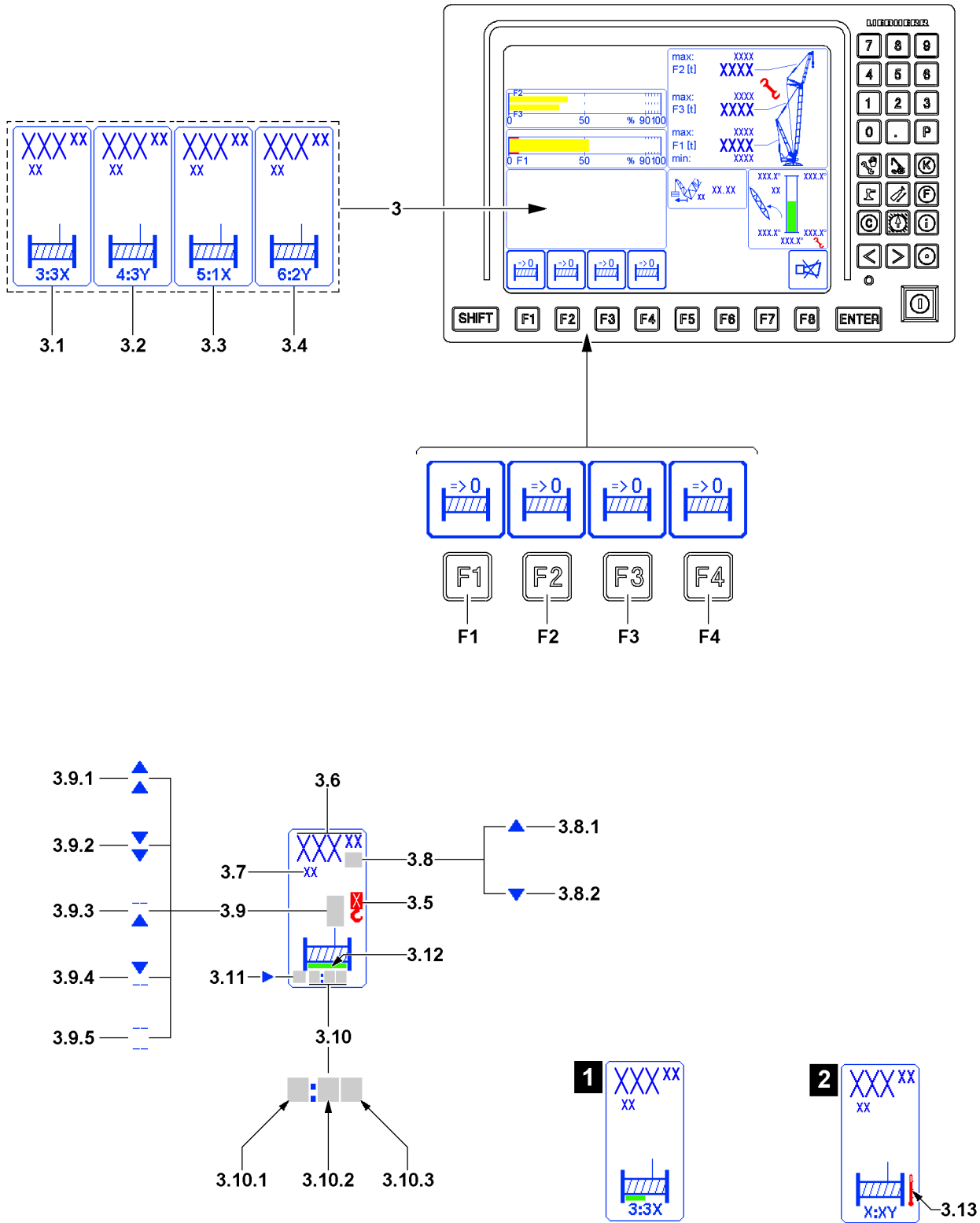


Fig.115251

**3.6 Completed path**

- Completed hook path from a selectable zero point.
- or**
- Spooled out / spooled up rope length from a selectable zero point
- The positions before the decimal point are displayed with a maximum of three large digits. The digits after the decimal point are displayed in small digits. Setting to zero point, see also section “Function key line of LICCON monitor 1”).
- A prerequisite for a correct display is that the value entered matches the entered reeving and the actual number of rope strands between the boom head and the hook block.

**3.7 Measuring unit**

- Measuring unit of the *completed path* display in [m] or [ft]

**Note**

Display area of winch displays.

- ▶ The completed path **3.6** display has only three positions before the decimal point, any positions before that are cut off. The crane operator must evaluate for himself if, for example 200 m of rope are spooled up on a winch or 1200 m. **The display in both cases would be identical with 200 m.**

For use as a hoist winch:

- ▶ The hook path calculation only works accurately if the load is suspended freely and is not luffed during the lifting procedure. Flexation and rope expansion are not taken into account.
- ▶ The *completed path* display is only correct when the winch is calibrated.

**3.8 Direction of hook movement**

- The arrows on the length value show the direction of the hook movement in relation to the zero point
- Up arrow **3.8.1**: Hook moves upward from the zero point
- Down arrow **3.8.2**: Hook moves downward from the zero point

**3.9 Winch status display**

- There are five winch condition icons, all blinking
- **Note:** If a winch status icon does not appear, the activated winch is inactive and is neither spooled up nor spooled out.

**3.9.1 Spool out**

- The winch is spooled out

**3.9.2 Spool up**

- The winch is spooled up

**3.9.3 Spooled out**

- Additional spooling out of the winch is blocked

**3.9.4 Spooled up**

- Additional spooling up of the winch is blocked

**3.9.5 Winch deactivated**

- The winch is deactivated or unplugged
- **Note:** The winch cannot be controlled.

**3.10 Master switch assignment**

- **3.10.1 First digit**
  - First digit: Winch number, every winch icon is permanently assigned to a winch
- **3.10.2 Second digit**
  - Master switch number, according to the assigned master switch
  - ? : No master switch assigned
- **3.10.3 Letter**
  - Actuation direction of the master switch, see illustration
  - ? : No actuation direction assigned

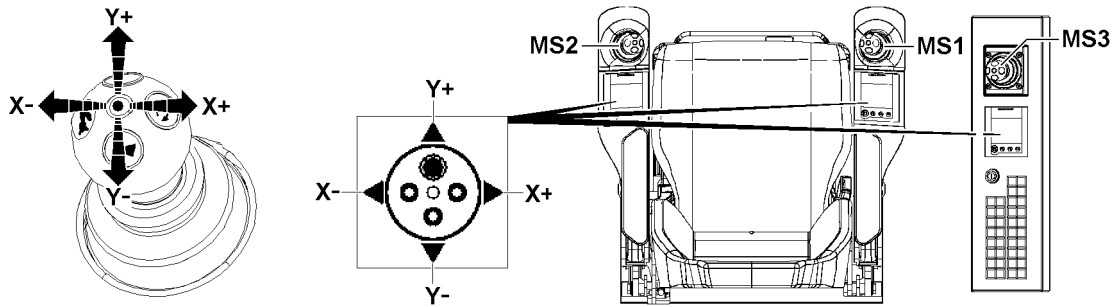


Fig.164495: Master switch actuation directions

**MS1** Master switch 1

**MS2** Master switch 2

**MS3** Master switch 3

**X+** To the right

**X-** To the left

**Y+** To the front

**Y-** To the rear

### 3.11 Vibration sensor

- If the vibration sensor for a winch is activated on the master switch, then an arrow appears in this winch icon for the activated vibration sensor.
- **Note:** The vibration sensor is activated at the first actuated crane function.

### 3.12 Winch speed

- If the maximum winch speed is reduced, a bar in the respective length appears on the bottom in the winch icon. Example: Half the length corresponds to a 50 % reduction of the maximum winch speed, see the example in illustration 1.

## Maintenance displays, illustration 2:

### 3.13 Winch overheated icon

- If the *Winch overheated* icon 3.13 appears, the temperature in the respective winch is too high.

**Note:** Only for certain crane types with temperature sensors in the winches.



## WARNING

Overheated winch!

If a winch is operated further, even though the *Overheated* icon 3.13 appears, the winch can be severely damaged.

The winch can fail and accidents can occur.

- ▶ Let the overheated winch cool off.



Empty page!

LWE/LR 1800-1-0-000/27200-07-02/en

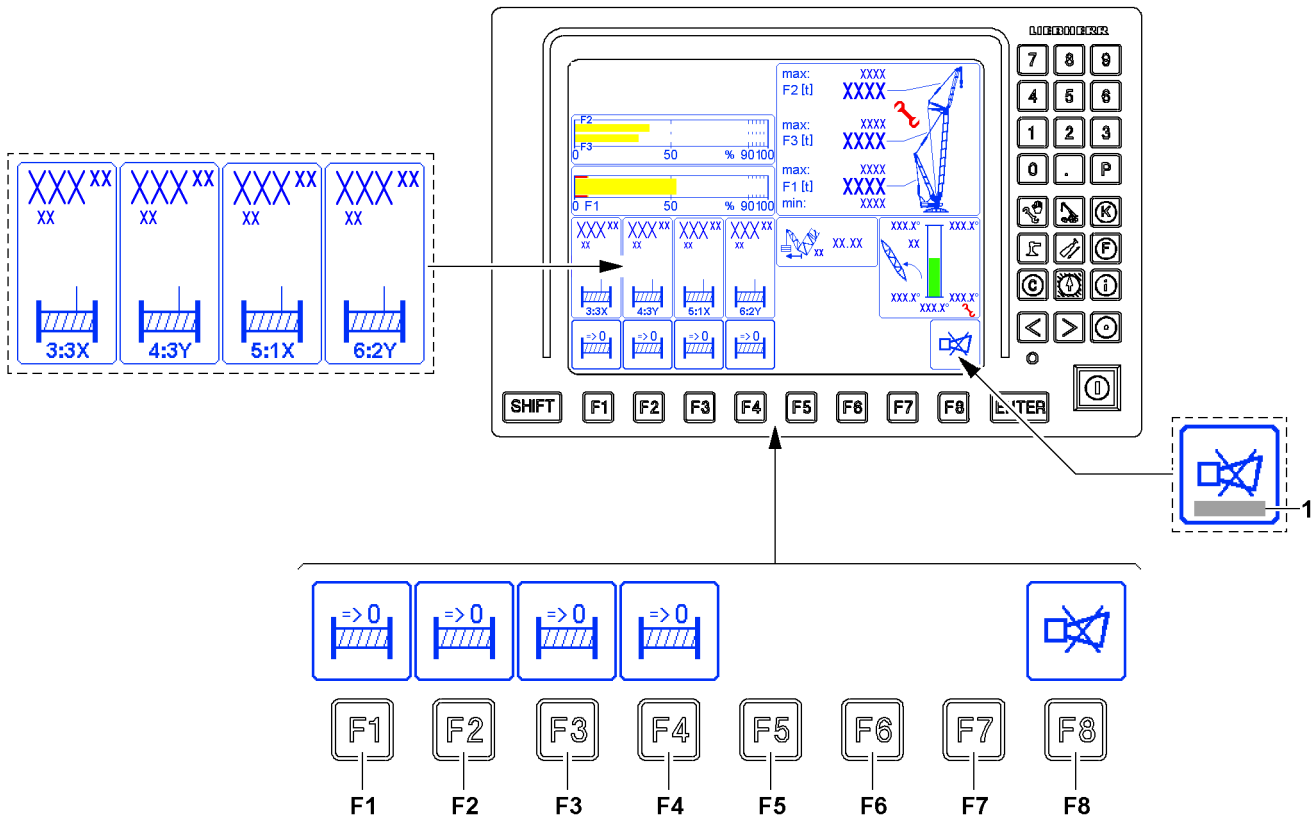


Fig.115252

## 6.7 The function key line of LICCON monitor 1

The function key line consists of function keys **F1** to **F8** and the function key icon bar above it. The function keys correspond to the various function key icons above them.

The function key icons always show the functions which are activated by pressing the button.

The function is called up after pressing a button. In addition, the icon above it can change its display, its meaning or its text.

Not all function keys must have assigned icons. This depends on the respective program selection.

### F1 Function key

- Determine the zero point for the Winch 3\* *completed path* display.
- The *reset winch display* icon appears above the function key **F1**. Pressing the button sets the *Completed path* display to zero. Path measurement applies from here.

### F2 Function key

- Determine the zero point for the Winch 4\* *completed path* display.
- The *reset winch display* icon appears above the function key **F2**. Pressing the button sets the *Completed path* display to zero. Path measurement applies from here.

### F3 Function key

- Determine the zero point for the Winch 5\* *completed path* display.
- The *reset winch display* icon appears above the function key **F3**. Pressing the button sets the *Completed path* display to zero. Path measurement applies from here.

### F4 Function key

- Determine the zero point for the Winch 6\* *completed path* display.
- The *reset winch display* icon appears above the function key **F4**. Pressing the button sets the *Completed path* display to zero. Path measurement applies from here.

### F5 Function key

- No function

### F6 Function key

- No function

### F7 Function key

- No function

### F8 Function key

- Shut-off of acoustic warning and possibly calling up of error messages **1**.  
Press the function key **F8** once: The acoustic signal is turned off.  
Press the function key **F8** twice: The error description for the error message **1** that occurred last is called up.
- **Note:** A new error turns the acoustic warning on again.

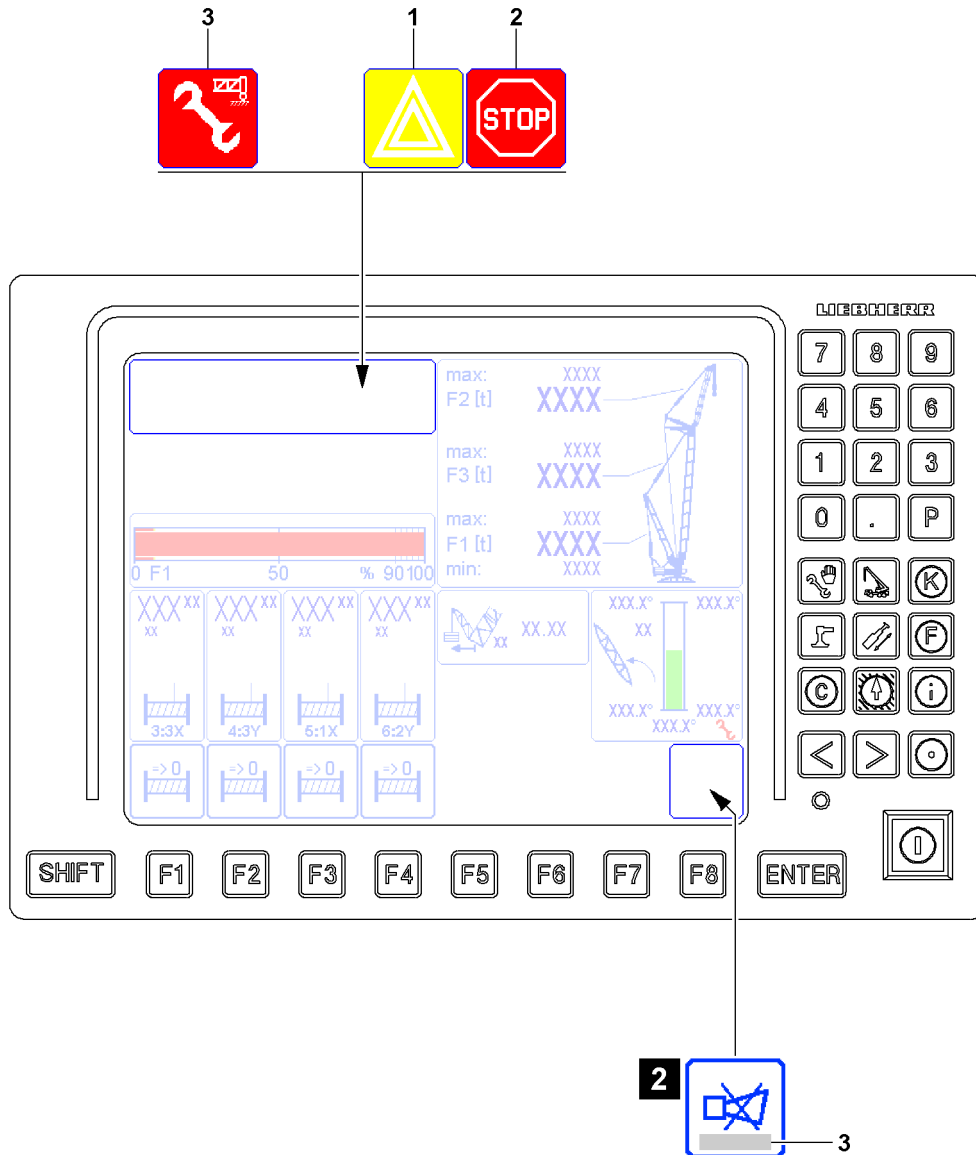


Fig.125389

## 6.8 Alarm functions of LICCON monitor 1



### WARNING

Shut off of the crane movement!

If advance warnings are not observed, then this can result in a sudden shut-off of the crane movement.

A sudden shut off of the crane movement can result in high stress and strain for crane and load. High strain for the crane and load can cause accidents.

- ▶ Operate the crane in such a way if possible that there is no shut off of crane movements by the crane control.
- ▶ Monitor the display instruments constantly.
- ▶ If not otherwise possible, approach a possible shut off of crane movements with extreme caution.



### Note

LMB-STOP shut off delay

- ▶ An LMB-STOP with shut off delay always remains for a certain period of time. Possible fluctuating movements of the crane can be thereby minimized.

### 6.8.1 Occurrence of an advance warning

#### 1 Advance warning icon

- If an advance warning occurs, for example:  $F1_{\text{actual}}$  less than  $F1_{\text{min-warning value}}$
- $F1_{\text{min-warning value}}$  is prioritized to  $F1_{\text{min}}$  as advance warning value.
- **Example:**  $F1_{\text{min}}$  plus advance warning extra (approx. 15 t) results in  $F1_{\text{min-warning value}}$ .

### 6.8.2 Shutting off the crane movement

#### 2 LMB-STOP icon

- The *LMB-STOP* icon **2** appears if a shut off limit is exceeded.  
Example:  $F1_{\text{actual}}$  less than  $F1_{\text{min}}$
- **Note:** Individual crane movements are shut off. Pay attention to error messages **3** and display values.

### 6.8.3 Boom on the ground function

#### 3 Ausleger am Boden icon

- The *Boom on the ground* icon **3** appears when the *Boom on ground function* is activated.
- **Note:** *Boom on ground* function operating elements, see the Crane operating instructions, chapter 4.01.

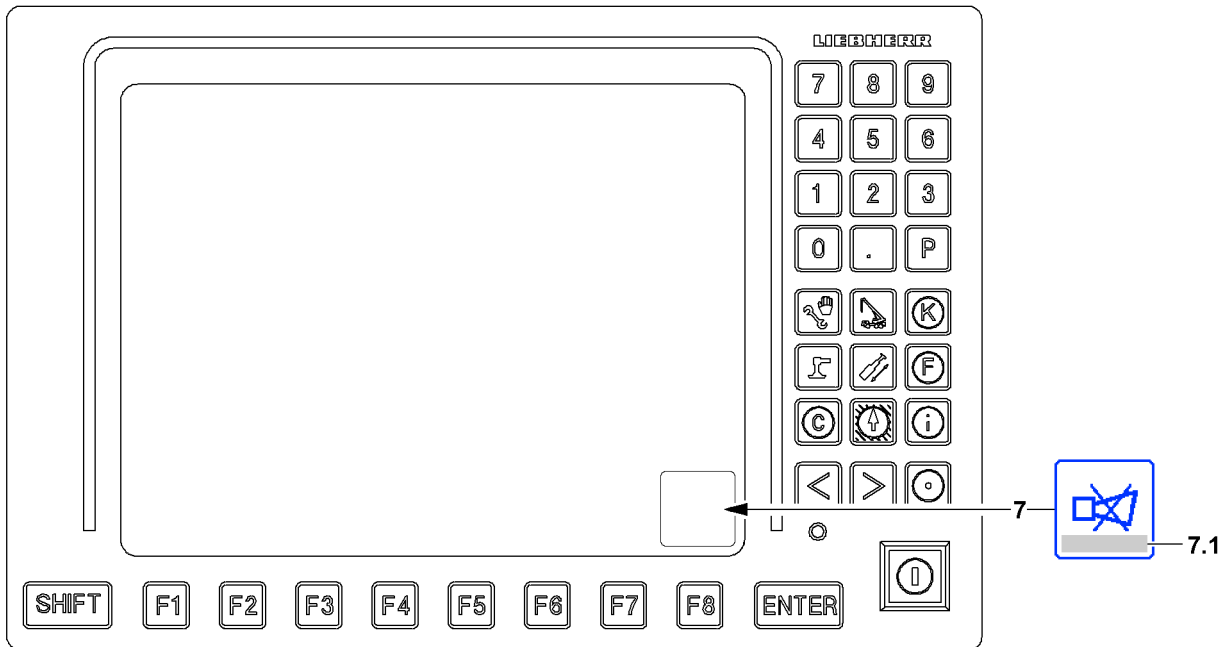


Fig.114279

LWE/LR 1800-1-0-000/27200-07-02/en

## 6.9 Acoustic warning on LICCON monitor 1

Acoustic warnings on LICCON monitor 1 are indicated by the *horn* warning sound.

The *horn* warning sound is divided into two categories:

- The *horn* is a beeping sound that lasts approximately 0.5 seconds and that is repeated every second.
- A *short horn* is a beeping sound of a duration of approximately 0.1 seconds, which is repeated in a second cycle.

### 7 Horn icon

- When the *Horn* icon **7** is shown on the LICCON monitor, any acoustic signals that occur can be shut off by LICCON monitor 1 by pressing the function key **F8**.
- If an error message is shown in the *Horn* icon **7** in the field **7.1**, then it can be used to determine the present error. Pressing the function key **F8** twice automatically switches to the error determination screen of the BSE test system. The error is displayed there in documentary form.

### 6.9.1 Horn warning sound

- Sounds in addition to the visual display of an error message in the field **7.1** in case of operational errors are found that lead to a shut-off of a crane movement.  
Operational errors are, for example:
  - Exceeding of limit values in the F-load display
  - Exceeding of limit values in the geometry Derrick boom
- In case of application errors with error number (LICCON Error Code LEC)

### 6.9.2 Short horn warning sound

Sounds in addition to the visual display of error messages that do not have an error number and do not lead directly to crane movement shut-off by the LICCON overload protection

Monitored error messages are, for example:

- Advance warning by approaching the limit values in the F-load display

### 6.9.3 Acoustic warning priority

- The *Horn* warning around has higher priority than the *Short horn* warning sound, i.e. *Horn* takes preference over *Short horn*.
- Both the *Horn* warning sound as well as the *Short horn* warning sound become active again after shut down if a new error occurs.

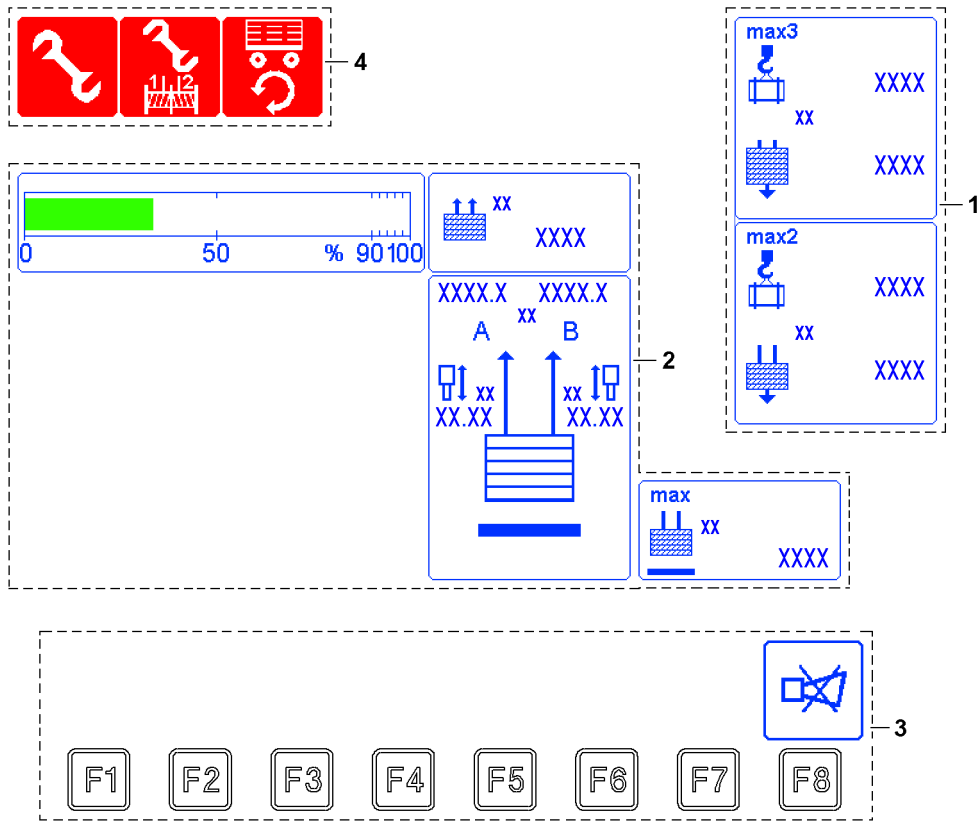
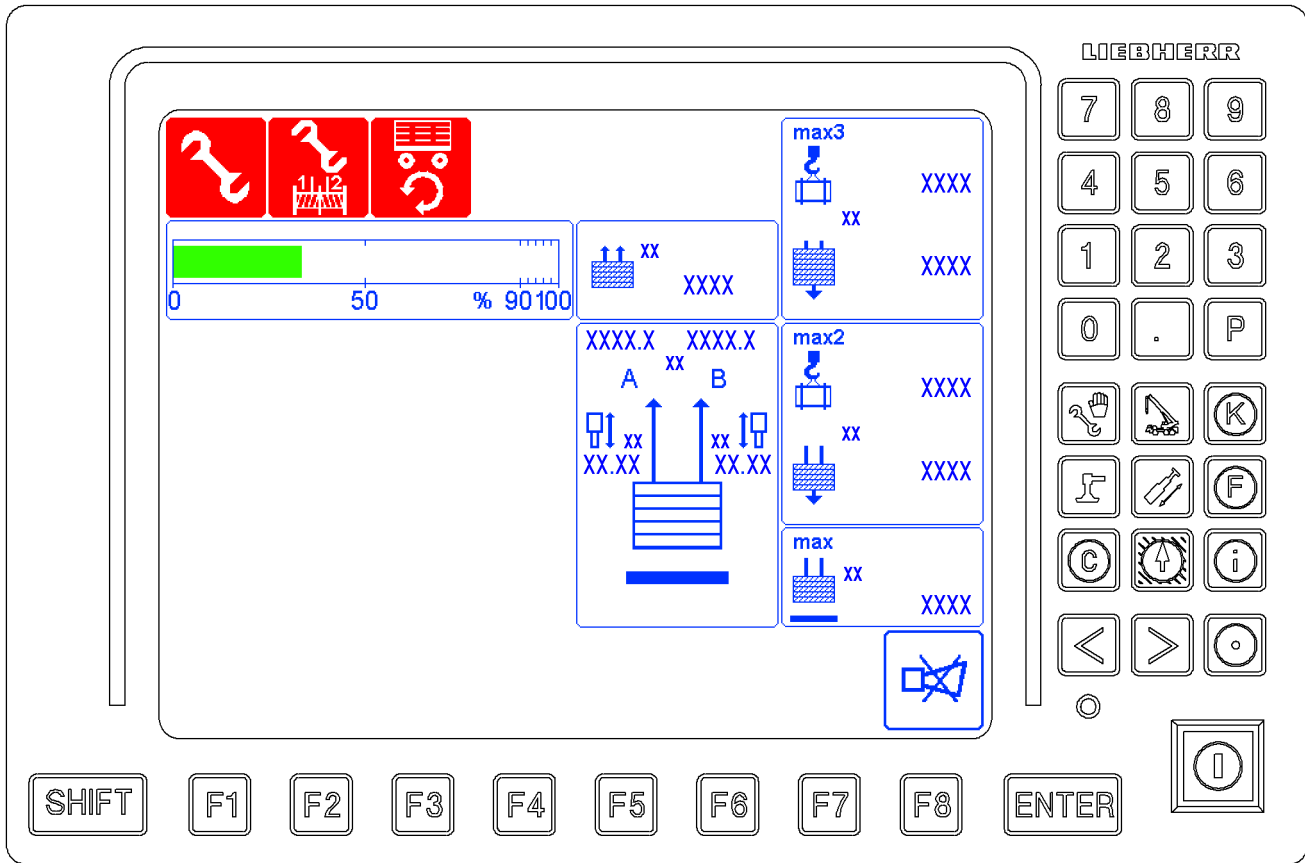


Fig.146944

LWE/LR 1800-1-0-000/27200-07-02/en



## 7 The *Crane operation* program on LICCON monitor 2

The *Crane operation* LICCON program assists the crane operator by displaying the data relevant for crane operation clearly on three LICCON monitors. An acoustic signal accompanies all critical displays. Depending on the equipment, a range of other icons may also be turned on as additional displays, either as required by the crane operator, or automatically in case of a problem.

It also alerts the crane operator to imminent overload conditions. In the event of overload and many error conditions, which could be hazardous during crane operation, the system shuts off.



### Note

- ▶ The suspended ballast and the ballast trailer\* are generally referred to as the **derrick ballast**.
- ▶ The fixed compensation weight that is installed on the turntable is generally referred to as the **counterweight**.

The LICCON monitor 2 is divided into three areas in the *Crane operation* program:

- 1 Load max
  - Maximum load depending on the derrick ballast
- 2 Derrick ballast
  - Derrick ballast weight
  - Derrick guying forces
  - Utilization of the derrick ballast
  - Maximum liftable derrick ballast for the current crane condition, without falling below  $F1_{min}$  when lifting
- 3 Function key line
  - The function keys always refer to the icons shown directly above them
  - **Note:** If no icon is shown on the line directly above the function key, then no function is assigned in the program to the function key.
- 4 LICCON Monitor 2 special functions



### Note

- ▶ The monitor illustrations in this chapter are only examples.
- ▶ The numerical values in the individual icons and charts do not have to necessarily match the crane exactly.
- ▶ The configuration of the LICCON monitor with icons is only descriptive.
- ▶ An identical icon display will **not** appear during crane operation.

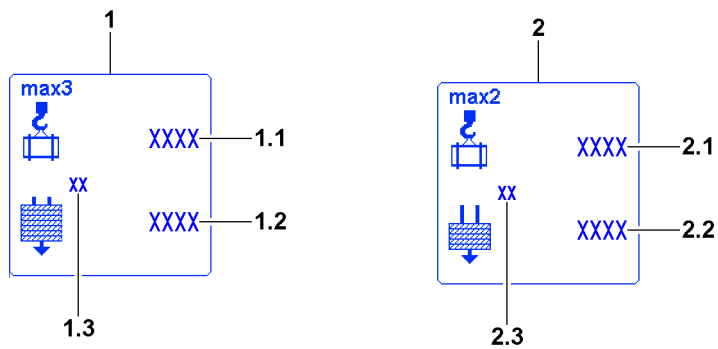
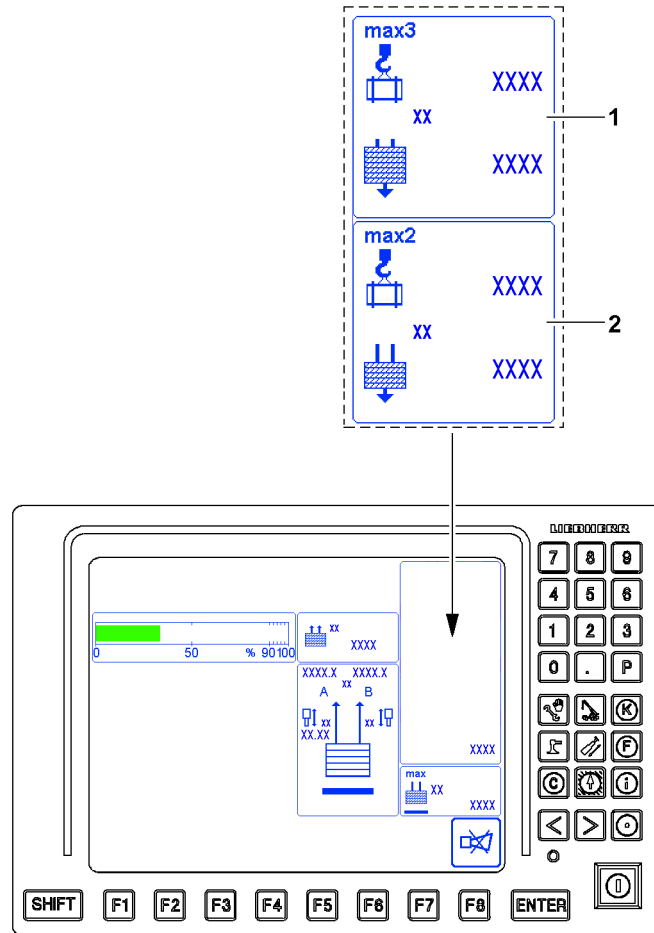


Fig.146945

## 7.1 Load max

The information regarding crane geometry and load involves two icons:

**1** Load max3

**Note:** This is hidden as soon as two hook operation is set in the *set up* program.

**2** Load max2

**Note:** This is hidden as soon as two hook operation is set in the *set up* program.



**Note**

- ▶ Question marks (?) are shown instead of values if the value cannot be calculated / determined.  
Example: A sensor error can be present - pay attention to the error messages.

### 7.1.1 Load max3

The *load max3* icon **1** shows the maximum load with maximum derrick ballast within the framework of the load chart.

The *load max3* icon **1** is hidden as soon as two hook operation is set in the *set up* program.

**1** *Load max3* icon

**1.1** Possible load<sub>max3</sub>

- Is the load that the crane could currently lift if the maximum derrick ballast were placed according to the load chart.
- In [t] or [lb]

**1.2** Maximum derrick ballast

- Maximum derrick ballast according to the load chart

**1.3** Measuring unit

- Measuring unit for the display values in the *Load max3* icon **1**: [t] or [lbs]

### 7.1.2 Load max2

The *load max2* icon **2** displays the highest possible load in the current operating status (**current derrick ballast** fully utilized).

The *load max2* icon **2** is hidden as soon as two hook operation is set in the *set up* program.

**2** *Load max2* icon

**2.1** Possible load<sub>max2</sub>

- This is the maximum load that the crane can lift in the current operating status. For that, the placed derrick ballast must be fully utilized (Derrick ballast lifted off the ground).
- In [t] or [lb]

**2.2** Placed derrick ballast

- Currently placed derrick ballast

**2.3** Measuring unit

- Measuring unit for the display values in the *Load max2* icon **2**: [t] or [lbs]

## 7.2 Derrick ballast



**Note**

- ▶ A question mark (?) is shown instead of values if the value cannot be calculated / determined.  
Example: A sensor error can be present - pay attention to the error messages.

The force components / load of the guying derrick ballast is recorded on guying A and guying B of the derrick ballast.

Test points guying A are:

- Test point 4A = pressure sensor ring surface left F4A
- Test point 5A = pressure sensor piston surface left F5A

Test points guying B are:

- Test point 4B = pressure sensor ring surface right F4B
- Test point 5B = pressure sensor piston surface right F5B

### 7.2.1 Derrick ballast utilization display

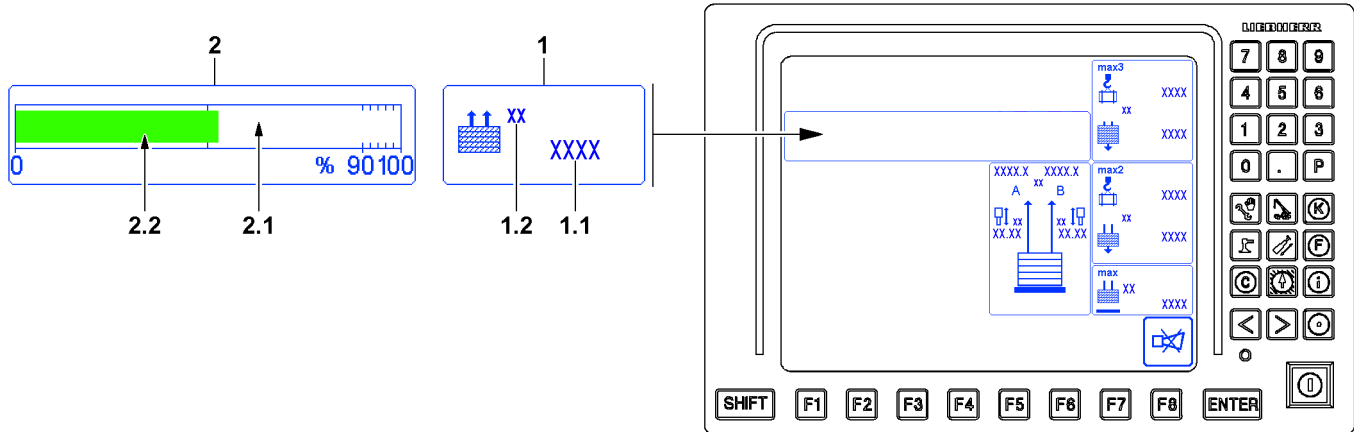


Fig.146946

In the icon *Pulled derrick ballast 1* the currently pulled derrick ballast is shown. The value results from the vertical force components / load on guying A and guying B of the derrick ballast.

- 1** *Pulled derrick ballast* icon
  - 1.1** *Pulled derrick ballast*
    - Currently pulled derrick ballast
    - Sum of forces / load from guying A and guying B
  - 1.2** *Measuring unit*
    - Measuring unit for the display values in the *Pulled derrick ballast* icon 1: [t] or [lbs]

The *Derrick ballast utilization bar* icon 2 depicts the ratio of the pulled derrick ballast ( $BA_{\text{pulled}}$ ) to the placed derrick ballast ( $BA_{\text{placed}}$ ) as a percentage.

- 2** *Derrick ballast utilization bar* icon
  - Display bar for graphic display of derrick ballast utilization
- 2.1** *Display scale*
  - Scale from 0 % to 100 %
- 2.2** *Pulled derrick ballast*
  - Graphic illustration of pulled derrick ballast
  - If the derrick ballast is completely pulled, the derrick ballast lifts off the ground

## 7.2.2 Suspended ballast\*

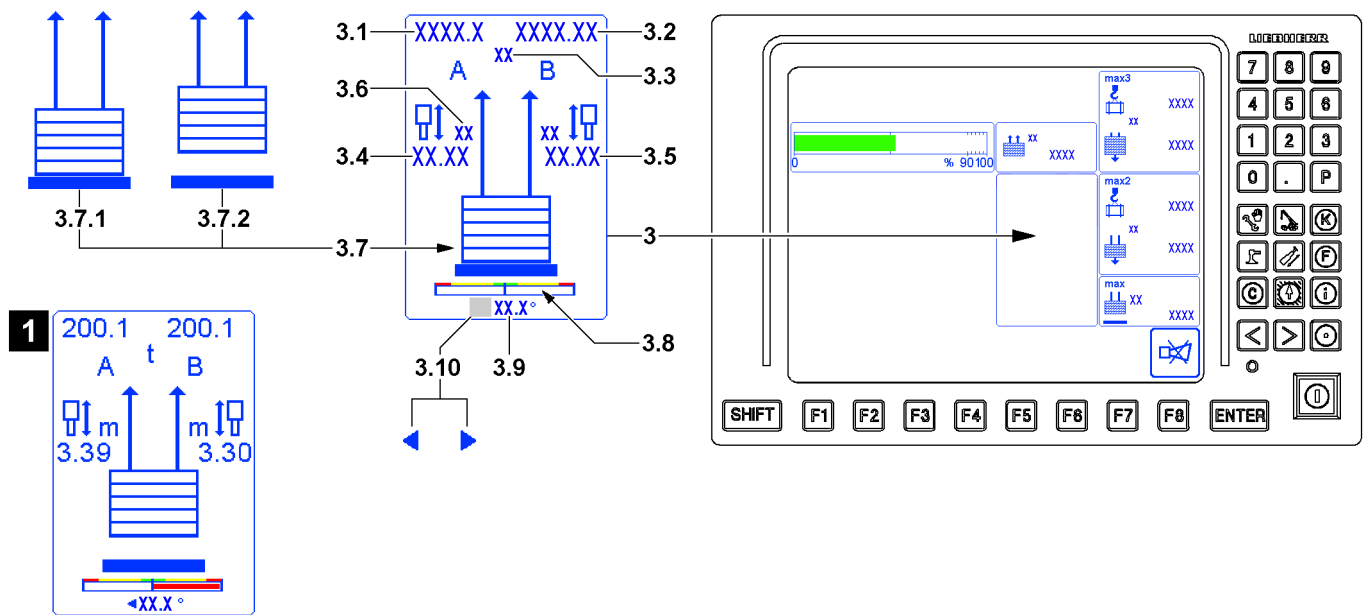


Fig. 146947

If the crane is set up with suspended ballast\*, then the displays in the *Guying derrick ballast* icon 3 are automatically adapted by the LICCON computer system.



### WARNING

Derrick ballast on unsuitable ground!

If the derrick ballast gets so far into a sloped position in lateral direction that the red range (example illustration 1) is reached in the incline display, then there is a danger of accident.

If the derrick ballast sinks too far into the ground, then there is a danger of accident.

- ▶ Always correct the position of the derrick ballast in time. Hold the extension length A and extension length B even.
- ▶ The derrick ballast may only be set down if the ground is sufficiently load bearing and even.

### 3 Derrick ballast guying icon

#### 3.1 Guying A

- Current force / load on guying A

#### 3.2 Guying B

- Current force / load on guying B

#### 3.3 Measuring unit

- Measuring unit for display values guying A and guying B: [t] or [lbs]

#### 3.4 Extension length A

- Current extension length of pull cylinder of guying A

#### 3.5 Extension length B

- Current extension length of pull cylinder of guying B

#### 3.6 Measuring unit

- Measuring unit for extension length of pull cylinders of guying A and guying B: [m] or [ft]

#### 3.7 Ground contact

- Display for ground contact of the derrick ballast
- 3.7.1 Derrick ballast has ground contact
- 3.7.2 Derrick ballast lifted

#### 3.8 Incline indicator

- Graphic display of the derrick ballast incline in the lateral direction
- **Note:** Not for the suspended ballast for the *Ballast Constant* version

### 3.9 Incline value

- Incline value of the derrick ballast in the lateral direction  
The incline value appears in degrees [°].



#### Note

- ▶ The incline direction **3.10** appears only when the derrick ballast is inclined in the lateral direction.

### 3.10 Incline direction

- Incline direction of the derrick ballast in the lateral direction
- Appears only when the derrick ballast is inclined in the lateral direction

## 7.2.3 Ballast trailer\*

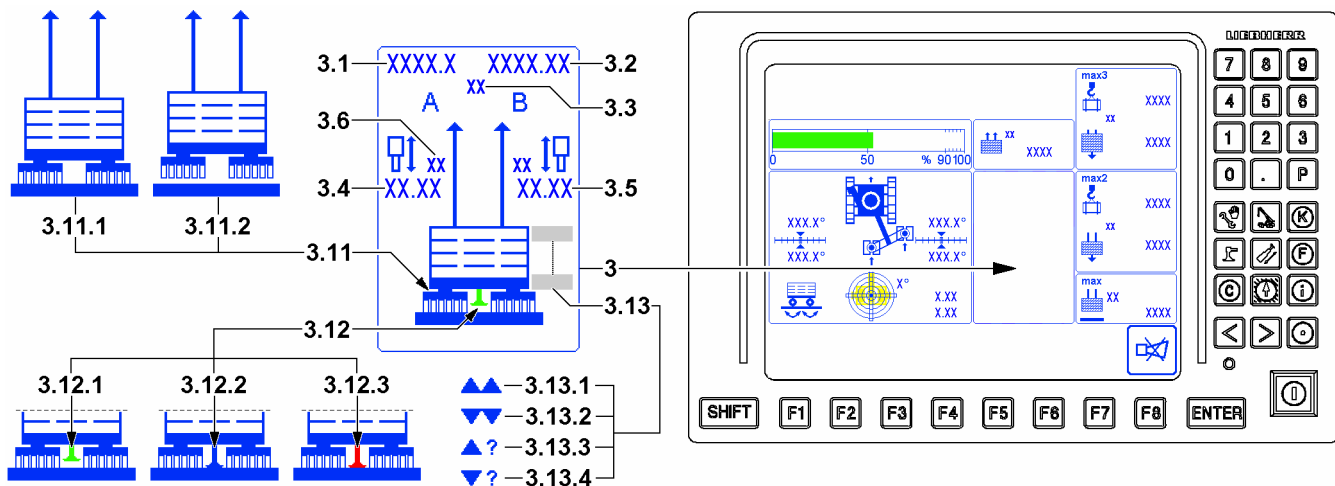


Fig.146961

If the crane is set up with a ballast trailer\*, then the displays in the *Guying derrick ballast* icon **3** are automatically adapted by the LICCON computer system.



#### WARNING

Ballast trailer on unsuitable ground!

If the ballast trailer gets too far into an incline position, then there is a danger of accident.

If the ballast trailer sinks too far into the ground, then there is a danger of accident.

- ▶ Always correct the position of the ballast trailer in time. Hold the extension length A and extension length B even.
- ▶ The ballast trailer may only be set down if the ground is sufficiently load bearing and even.

#### 3 Derrick ballast guying icon

##### 3.1 Guying A

- Current force / load on guying A

##### 3.2 Guying B

- Current force / load on guying B

##### 3.3 Measuring unit

- Measuring unit for display values guying A and guying B: [t] or [lbs]

##### 3.4 Extension length A

- Current extension length of pull cylinder of guying A

##### 3.5 Extension length B

- Current extension length of pull cylinder of guying B

##### 3.6 Measuring unit

- Measuring unit for extension length of pull cylinders of guying A and guying B: [m] or [ft]

##### 3.11 Ground contact

- Display for ground contact of ballast trailer

- 3.11.1 Ballast trailer has contact with the ground
- 3.11.2 Ballast trailer lifted
- 3.12 Ballast trailer support
  - Display for the status of the support ballast trailer
  - 3.12.1 Support retracted, ballast trailer not supported
  - 3.12.2 Support extended, ballast trailer is supported
  - 3.12.3 Support not in nominal position

**Notice!** Support not completely retracted and selection travel gear, slewing gear or sliding cylinder selected



**Note**

Ballast trailer limit signs 3.13

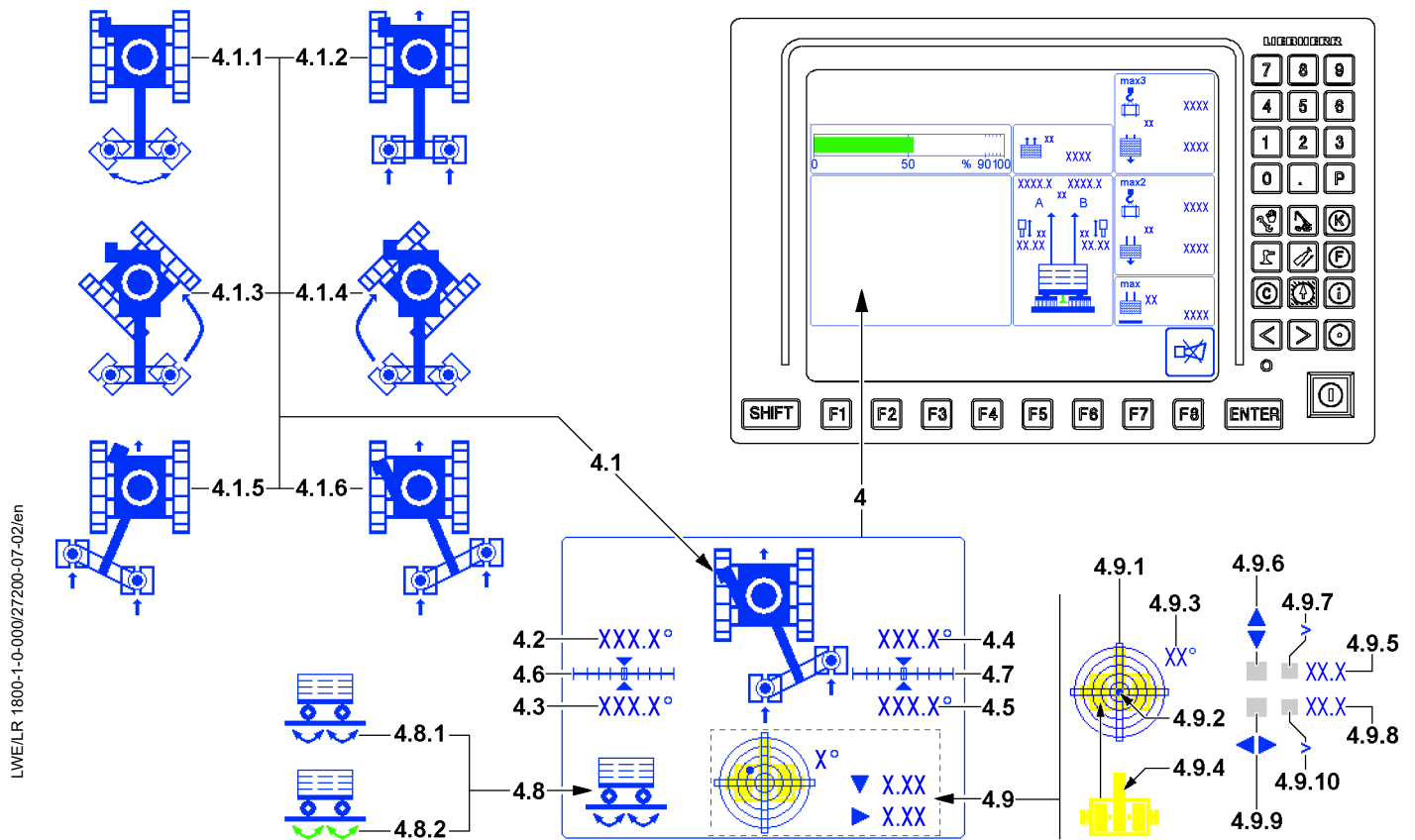
► The permissible level difference between the placement surface of the crane and the ballast trailer is limited both upward and downward. In order to avoid causing mechanical damage to the crane or the ballast trailer, the upper and lower limit values are monitored. If a limit value is exceeded, the corresponding limit sign appears. The movements on the crane, or on the ballast trailer, are turned off.

3.13 Ballast trailer limit signs

- 3.13.1 Upper end position limit value exceeded (ballast trailer too far above the crane placement surface)
- 3.13.2 Lower end position limit value exceeded (ballast trailer too far below the crane placement surface)
- 3.13.3 Upper end position monitoring defective
- 3.13.4 Lower end position monitoring defective

**Notice!** There is no shut-off when reaching the upper end position. Remedy the error immediately.

**Notice!** There is no shut-off when reaching the lower end position. Remedy the error immediately.



LWE/LR 1800-1-0-000/27200-07-02/en

Fig.146962

#### 4 *Ballast trailer icon*

##### 4.1 Steering operating modes

- Display for a set steering operating mode
- **4.1.1** Ballast trailer circular travel
- **4.1.2** Ballast trailer towing
- **4.1.3** Ballast trailer corrective steering (crane drives left)
- **4.1.4** Ballast trailer corrective steering (crane drives right)
- **4.1.5** Ballast trailer parallel travel (ballast trailer offset left)
- **4.1.6** Ballast trailer parallel travel (ballast trailer offset right)

##### 4.2 Left nominal angle

- Nominal angle for the left wheel set

##### 4.3 Actual angle left

- Actual angle for the left wheel set
- If the left nominal angle **4.2** is not reached:
  - The left actual angle **4.3** is shown in red
  - In the left graphic display **4.6** the *actual value* position arrow is not the same as the *nominal value* arrow

##### 4.4 Right nominal angle

- Nominal angle for the right wheel set

##### 4.5 Actual angle right

- Actual angle for the right wheel set
- If the right nominal angle **4.2** is not reached:
  - The right actual angle **4.5** is shown in red
  - In the right graphic display **4.7** the *actual value* position arrow is not the same as the *nominal value* arrow

##### 4.6 Left graphic display

- Actual angle and nominal angle graphic display for the left wheel set

##### 4.7 Graphic display right

- Actual angle and nominal angle graphic display for the right wheel set

##### 4.7 Drive status

- Status display for the ballast trailer drive
- **4.8.1** Drive turned on (not active)
- **4.8.2** Drive turned on and active

##### 4.9 *Ballast trailer incline* display

- Display of the incline of the ballast trailer to the horizontal in longitudinal and lateral direction.
- The display is divided in a graphic section and a numeric section.
- The direction specification refers to the overhead view of the ballast trailer on the graphic display.

#### Graphic part:

##### 4.9.1 Graphic display

- The graphic display is in the form of a spirit level, with a moving dot **4.2** representing the air bubble.

##### 4.9.2 Dot

- The center of the dot **4.9.2** shows the incline value.

##### 4.9.3 Display resolution

- This value indicates the resolution of the graphic display. The resolution is matched automatically to the inclination.

##### 4.9.4 Ballast trailer guide position

- An overhead view of the ballast trailer is highlighted in the graphic illustration **4.9.1**. The displayed position of the ballast trailer guide **4.9.4** serves as orientation on the display.

#### Numeric part:

##### 4.9.5 Longitudinal direction

- Incline of crane in the longitudinal direction in [°].



- 4.9.6** Direction arrow
- The direction arrow shows the direction of the incline
- 4.9.7** Display range exceeded
- If the *greater than* icon appears, then the display range is exceeded
  - **Note:** The crane is inclined further than can be shown.
- 4.9.8** Lateral direction
- Incline of crane in lateral direction in [°]
- 4.9.9** Direction arrow
- The direction arrow shows the direction of the incline
- 4.9.10** Display range exceeded
- If the *greater than* icon appears, then the display range is exceeded
  - **Note:** The crane is inclined further than can be shown.



### Note

Orientation of the crane on the *ballast trailer incline* display **4.9**.

- ▶ Pay attention to the position of the ballast trailer guide **4.9.4**.

## 7.2.4 Ballast trailer: Bypassing the end position limit value (only crane type LR 1500)

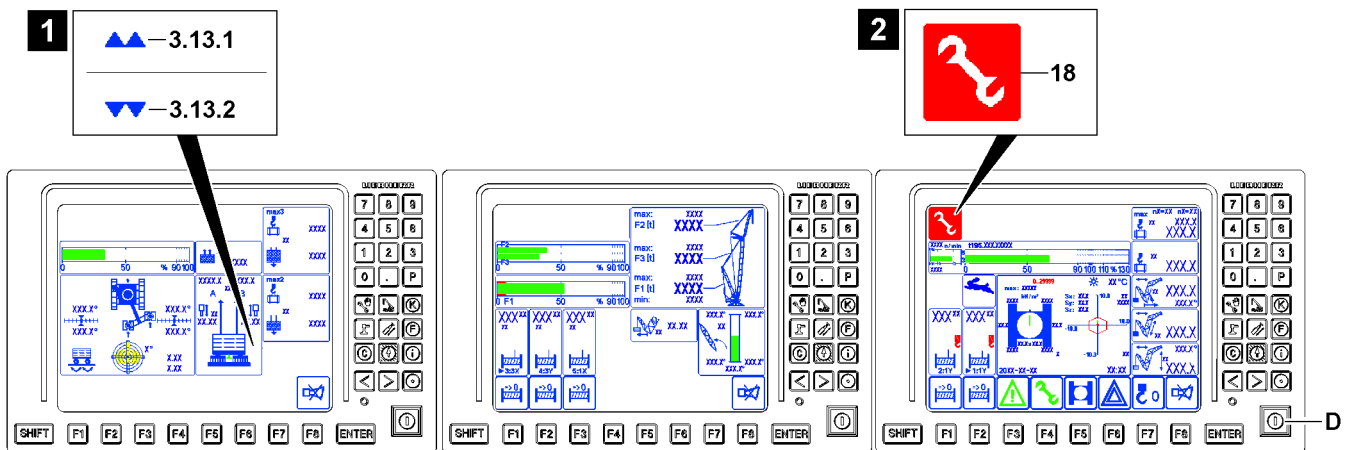


Fig.152776: Example: Bypassing the end position limit value

If the ballast trailer is too far above / below the crane placement surface, a shut-off occurs. The limit values can be slightly exceeded in emergency situations or for assembly purposes with special handling. This should make it possible to establish a condition without a shut-off.



### WARNING

Danger of accident due to the *Exceedance of shut-off limits of the LICCON overload protection* function!

The *Exceedance of shut off limits of the LICCON overload protection* function is activated by pressing the set up key **D**.

Due to erroneous operation or deliberate misuse, the crane could collapse, the boom can break off or the crane can topple over.

Personnel can be severely injured or killed.

- ▶ The *Exceedance of shut-off limits of the LICCON overload protection* function is only permissible in emergencies and for assembly purposes.
- ▶ The set up key **D** may only be actuated by persons who are aware of the effects of their acts regarding the function *Exceedance of shut off limits of the LICCON overload protection*.
- ▶ The *Exceedance of shut off limits of the LICCON overload protection* function requires the presence of an authorized person and must be performed with utmost caution.
- ▶ Crane operation with the *Exceedance of shut-off limits of the LICCON overload protection* function activated is prohibited.

- After a shut-off of crane movements, see illustration 1:
  - The *upper end position* limit value **3.13.1** icon or *lower end position* limit value **3.13.2** icon appears.
  - The limit value can be slightly exceeded by pressing the set up key **D**. The assembly icon **18** appears after pressing the set up key **D**.
  - Create a condition without shut-off.
  - As soon as the limit value is no longer exceeded, the *Exceeding the shut-off limits of the LICCON overload protection* function is reset.
- If a condition without shut-off cannot be created:
  - Adjust the crane movements that led to the shut-off (illustration 1).
  - Suitable measures must be used to reduce the level difference between the placement surface of the crane and the ballast trailer.

## 7.2.5 Maximum liftable derrick ballast

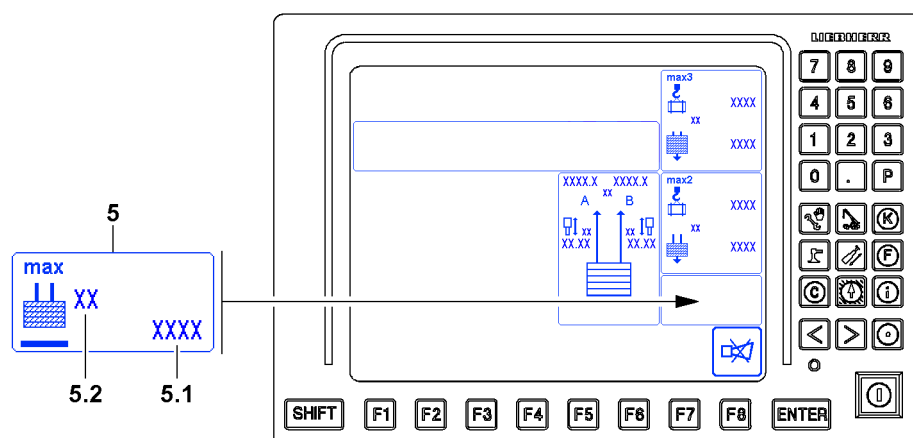


Fig.146950

The *maximum liftable derrick ballast* icon **5** displays the derrick ballast that, with reference to the current crane condition, can be lifted off the ground with the pull cylinder or off the suspended ballast palette in case of the VarioTray without falling below the  $F1_{min}$  force.

### 5 Maximum liftable derrick ballast icon

#### 5.1 Maximum liftable derrick ballast

- Maximum derrick ballast

#### 5.2 Measuring unit

- Measuring unit for display values in the *Maximum liftable derrick ballast* icon **5**: [t] or [lb]

## 7.3 LICCON Monitor 2 special functions

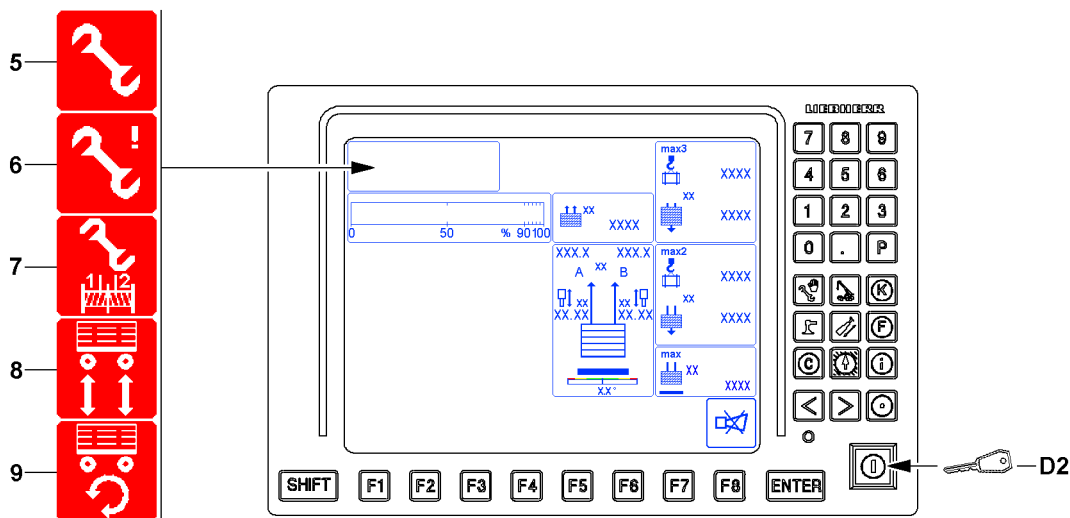


Fig.146951

### 7.3.1 Derrick ballast guying difference force monitoring shut-off

#### 5 Assembly icon

- The Assembly icon 5 appears when the difference force monitoring derrick ballast guying shut-off is bypassed. The shut-off is bypassed using the key button (set up key) of LICCON monitor 0 (right monitor), see section “Special functions LICCON monitor 0”.



#### Note

Derrick ballast guying difference force monitoring shut-off

- Observe the Crane operating instructions, chapter 5.35 / 5.36.

### 7.3.2 Winch 1 and winch 2 parallel operation regulation



#### Note

- Only on crane types with parallel operation of hoist winches\*



#### Note

Different radio incline sensors

Differentiate radio incline sensor type 1 and type 2 from each other.

The utilized radio incline sensors can be easily identified based on the winch display.

- Radio incline sensor type 1 (Hirschmann) does not have a display for the battery state of charge on the winch display on LICCON monitor 0.
- Radio incline sensor type 2 (Steute) has a display for the state of charge on the winch display on LICCON monitor 0.
- For a description of the winch display, see section “LICCON Monitor 0 winch display”.

#### Radio incline sensor type 1

The parallel operation of winch 1 and winch 2 is regulated from a pulley head height of more than 20 m over the test pulleys. If a problem occurs, switch over to a regulation via the winch speed sensors.

**WARNING**

Impermissible change over of *winch 1 and winch 2 parallel operation* regulation!

- ▶ Changing the *winch 1 and winch 2 parallel operation* regulation is only permissible if - due to contamination, icing or failure of the path measurement system of the test pulleys - a correct path measurement of the hoist ropes of winch 1 and winch 2 is not possible.
- ▶ Changing the *parallel operation winch 1 and winch 2* regulation is only permissible if it is not possible to immediately clean or de-ice the test pulleys or repair the path measurement system.
- ▶ As long as the *winch 1 and winch 2 parallel operation* regulation is changed over, the crane driver must align the position of the hook block manually in general.

**Radio incline sensor type 2**

The parallel operation of winch 1 and winch 2 is regulated based on the incline value of the hook block. Automatic regulation can be deactivated, for example for assembly tasks. If winch 1 and winch 2 are then adjusted, they spool at the adjusted rope speeds.

**Changing over winch 1 and winch 2 parallel operation regulation****Note**

- ▶ With radio incline sensor type 1 and a pulley head height below 20 m the function is deactivated, since the system is already regulated via the winch speed sensors.

**D2** Key button

- Change over winch 1 and winch 2 parallel operation regulation.
- **Note:** After switching the regulation, winch 1 and winch 2 must be adjusted, see chapter 4.05.  
The function is turned off by pressing the key button **D2** again.  
The function is also turned off if the engine or the ignition is turned off.

**7** *Parallel operation regulation switched over* icon

- The *Parallel operation regulation switched over* icon **7** appears when the winch 1 and winch 2 parallel operation regulation is switched over.
- **Note:** After turning the function off, the icon turns off.

**7.3.3 Ballast trailer emergency operation****6** *Assembly* icon

- The *Assembly* icon **6** appears when the emergency operation ballast trailer is activated, see the Crane operating instructions, chapter 5.35.

**8** *Drive clear emergency operation* icon

- The *Drive clear emergency operation* icon **8** appears when:
  - Ballast trailer emergency operation is activated
  - *Drive clear emergency operation* is activated

**9** *Turn clear emergency operation* icon

- The *Turn clear emergency operation* icon **9** appears when:
  - Ballast trailer emergency operation is activated
  - *Emergency operation turn clear* is engaged

Empty page!

LWE/LR 1800-1-0-000/27200-07-02/en

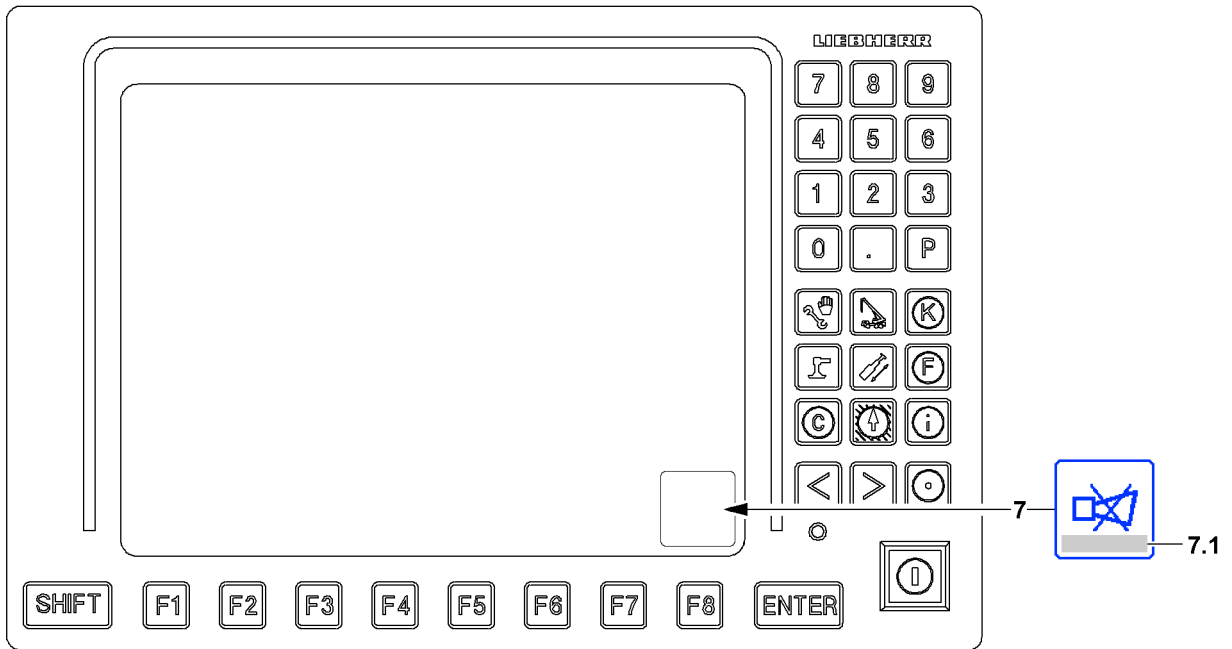


Fig.114279

## 7.4 Acoustic warning on LICCON monitor 2

Acoustic warnings on LICCON monitor 2 are indicated by the *horn* warning sound.

The *horn* warning sound is divided into two categories:

- The *horn* is a beeping sound that lasts approximately 0.5 seconds and that is repeated every second.
- A *short horn* is a beeping sound of a duration of approximately 0.1 seconds, which is repeated in a second cycle.

### 7 Horn icon

- When the *horn* icon **7** is shown on the LICCON monitor, any acoustic signals that occur can be shut off by LICCON monitor 2 by pressing the function key **F8**.
- If an error message is shown in the *Horn* icon **7** in the field **7.1**, then it can be used to determine the present error. Pressing the function key **F8** twice automatically switches to the error determination screen of the BSE test system. The error is displayed there in documentary form.

### 7.4.1 Horn warning sound

1. Sounds in addition to the visual display of an error message in the field **7.1** in case of operational errors are found that lead to a shut-off of a crane movement.

Operational errors are, for example:

- Difference between *Force / load on guying A* and *Force / load on guying B* is too large

2. In case of application errors with error number (LICCON Error Code LEC)

### 7.4.2 Short horn warning sound

Sounds in addition to the visual display of error messages that do not have an error number and do not lead directly to crane movement shut-off by the LICCON overload protection

Monitored error messages are, for example:

- Advance warning by approaching the limit values in the F-load display

### 7.4.3 Acoustic warning priority

- The *Horn* warning around has higher priority than the *Short horn* warning sound, i.e. *Horn* takes preference over *Short horn*.
- Both the *Horn* warning sound as well as the *Short horn* warning sound become active again after shut down if a new error occurs.

## 8 Curve illustration program

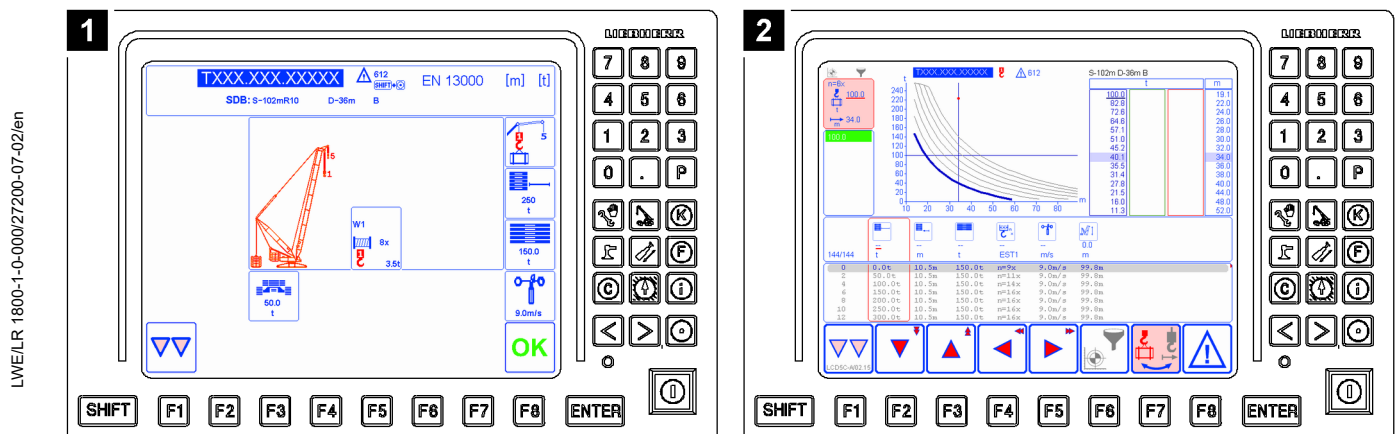


Fig.164420: Exemplary illustration of displays in the Curve illustration program

LWE/LR 1800-1-0-000/27200-07-02/en

In the *Curve illustration* program, the load charts appear on the LICCON monitor as curves and as numerical values, see illustration 2.

The curve illustration of the load charts is based on:

- The load charts
- The entries and settings in the *Set up* program, see illustration 1
- The entries and settings in the *Curve illustration* program, see illustration 2

The following can be carried out in the *Curve illustration* program:

- Curve illustration and numeric illustration of load charts
- Filtering of load columns
- Filtering of a set load case
- Comparison of different load columns

For a description of the *Curve illustration* program, see the LICCON job planner operating instructions / load chart illustration.



Empty page!

LWE/LR 1800-1-0-000/27200-07-02/en

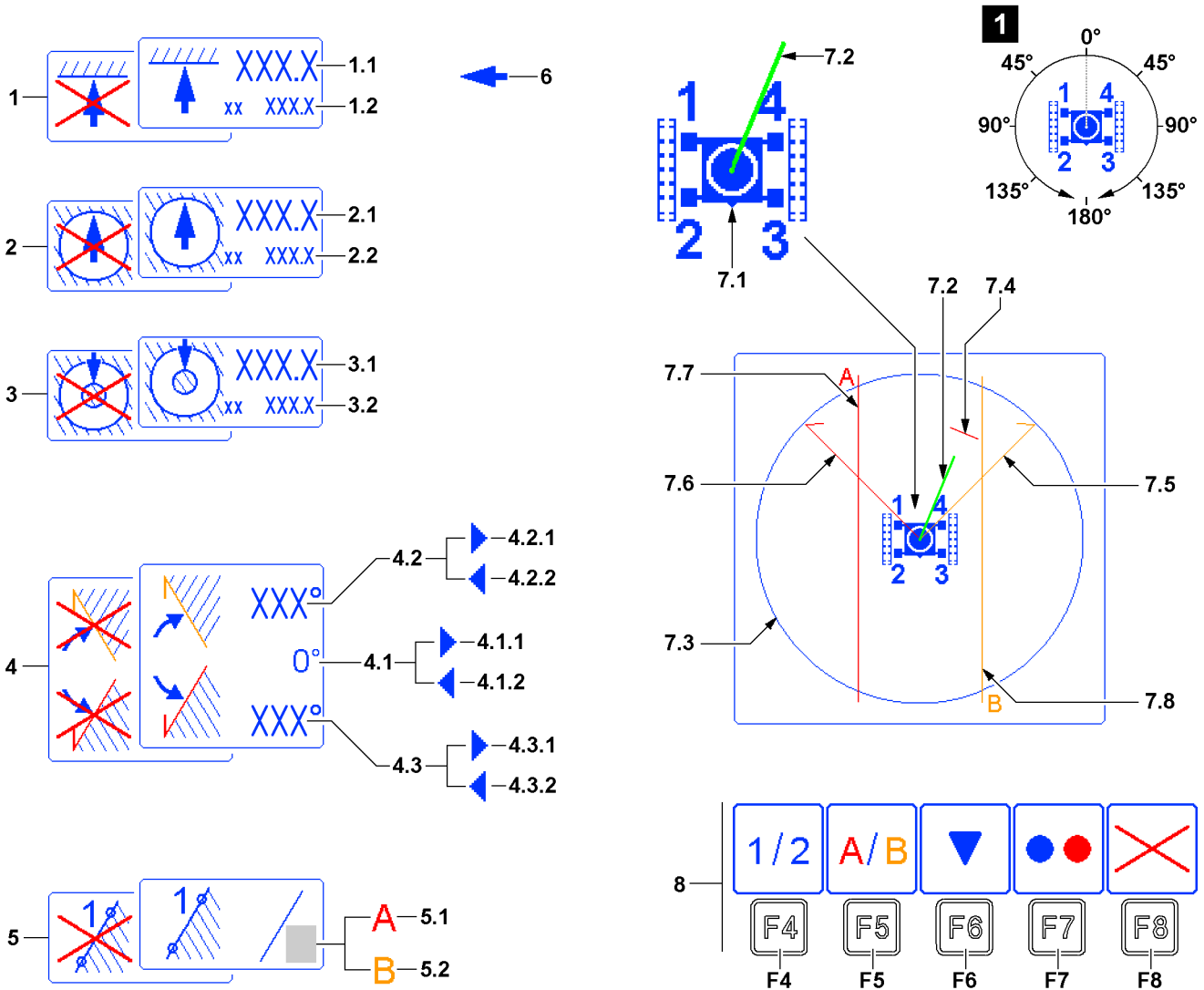
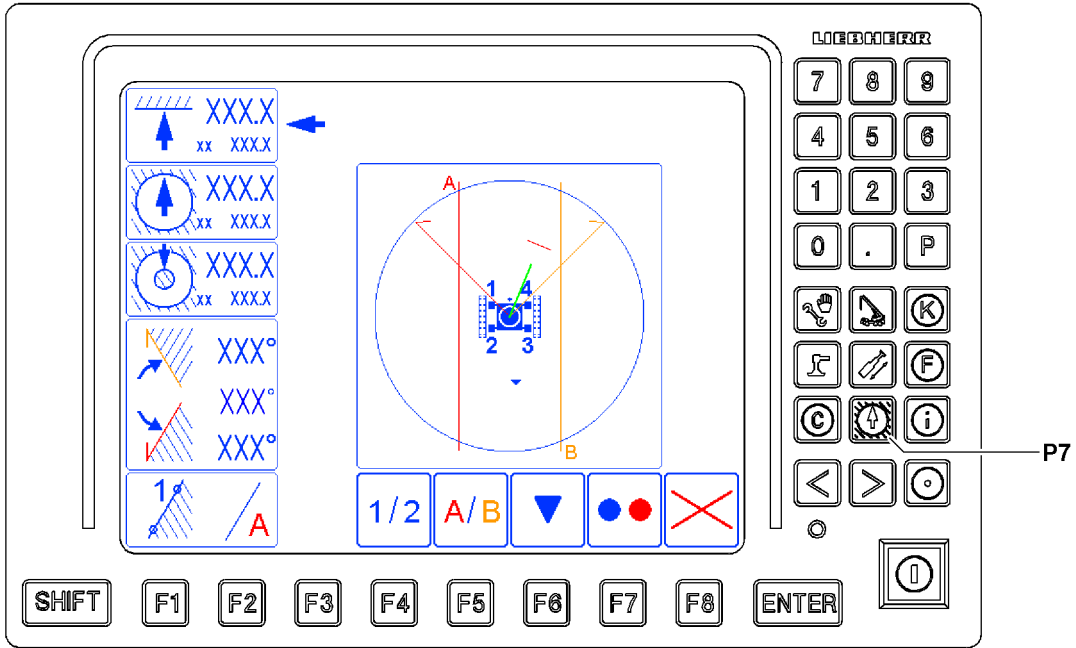


Fig.116057

LWE/LR 1800-1-0-000/27200-07-02/en

## 9 Working range limitation program

For a detailed description of the *Working range limitation* program, see the separate Operating instructions for the Working range limitation.

### 9.1 Starting the program

- ▶ Press the program key P7.

### 9.2 Operating interface



#### Note

- ▶ The limit function icons are shown crossed out if they are inactive.

- 1 Pulley head height
  - Limitation of pulley head height
  - Limits the height of the load pulley to a predetermined dimension
- 1.1 Limit value
  - The limitation is made by reaching the limit value of the pulley head height
- 1.2 Actual value
  - Current pulley head height
- 2 Working radius<sub>max</sub>
  - Limitation of the maximum working radius (maximum boom radius)
  - Limits the working radius of the load hook to a predetermined upper limit
- 2.1 Limit value
  - The limitation is made by reaching the limit value for the maximum working radius
- 2.2 Actual value
  - Current working radius
- 3 Working radius<sub>min</sub>
  - Limitation of the minimum working radius (minimum boom radius)
  - Limits the working radius of the load hook to a predetermined lower limit
- 3.1 Limit value
  - The limitation is made by reaching the limit value for the minimum working radius
- 3.2 Actual value
  - Current working radius

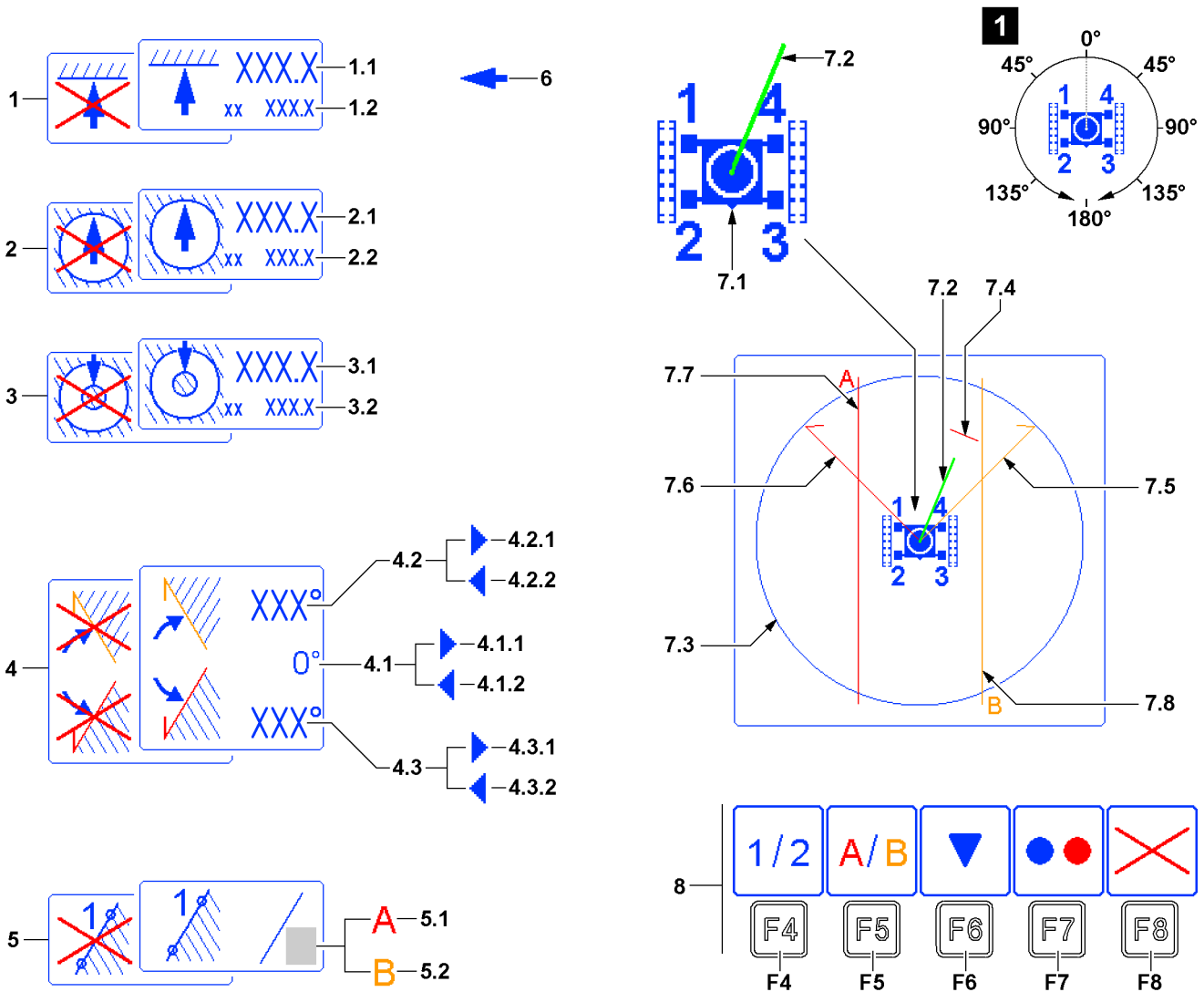
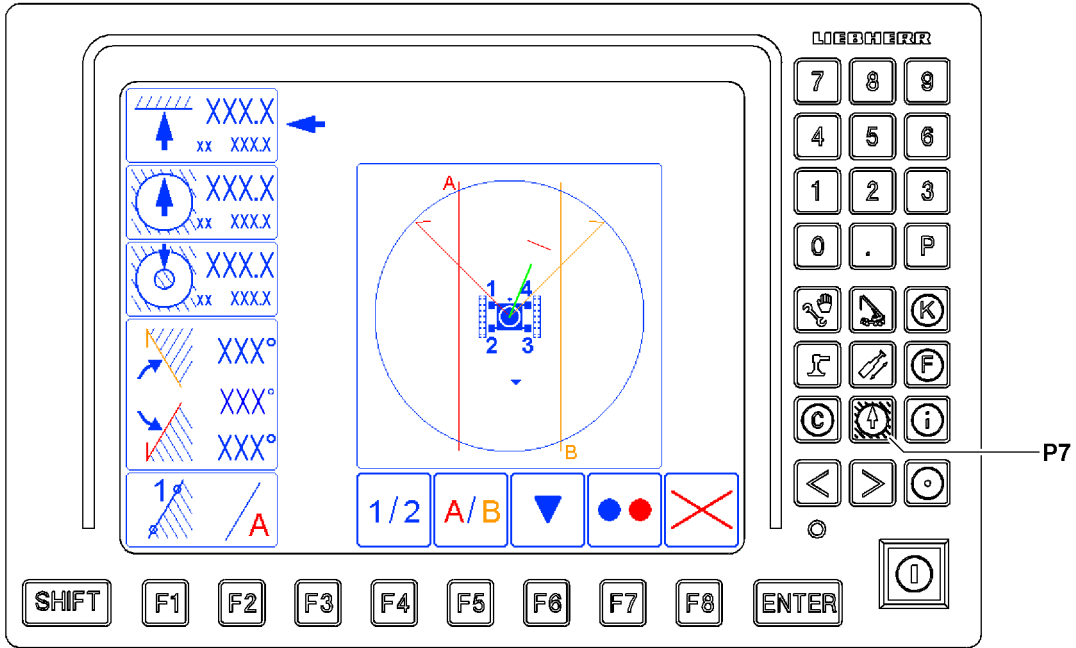


Fig.116057

LWE/LR 1800-1-0-000/27200-07-02/en

- 4 Turning limitation
  - Limitation of the slewing range
  - Limits the slewing range of the crane superstructure to a predetermined angle range.
  - Each consists of one right limit angle **4.2** and one left limit angle **4.3**.
- 4.1 Slewing angle
  - Current slewing angle of the crane superstructure
  - Main working direction of the crane = slewing angle 0°  
Slewing angle 0° is displayed when the crane superstructure is oriented exactly to the rear.
  - The slewing angle increases on both sides up to 180° when the crane superstructure is turned. When turning past 180°, the side is changed on the Scaling display, see illustration 1.
  - Right arrow **4.1.1**: *Crane superstructure turned to the right range*
  - Left arrow **4.1.2**: *Crane superstructure turned to the left range*
- 4.2 Right limit angle
  - The limitation is made by reaching this right limit angle
  - Right arrow **4.2.1**: The limit angle is in the *Crane superstructure turned to the right range*
  - Left arrow **4.2.2** The limit angle is in the *Crane superstructure turned to the left range*
- 4.3 Left limit angle
  - The limitation is made by reaching this left limit angle
  - Right arrow **4.3.1**: The limit angle is in the *Crane superstructure turned to the right range*
  - Left arrow **4.3.2** The limit angle is in the *Crane superstructure turned to the left range*
- 5 Edge limitation
  - Limitation of freely selectable edges (limitations)
  - Consists of up to two edges („edge A **5.1**“ and „edge B **5.2**“), which do not have to run through the center of the slewing ring.




---

**Note**

- ▶ Due to the edge limitation it is possible to determine the working range limits, which allow turning 360° compared to the slewing angle limitation. If necessary, the boom radius must be shorted for turning.
-

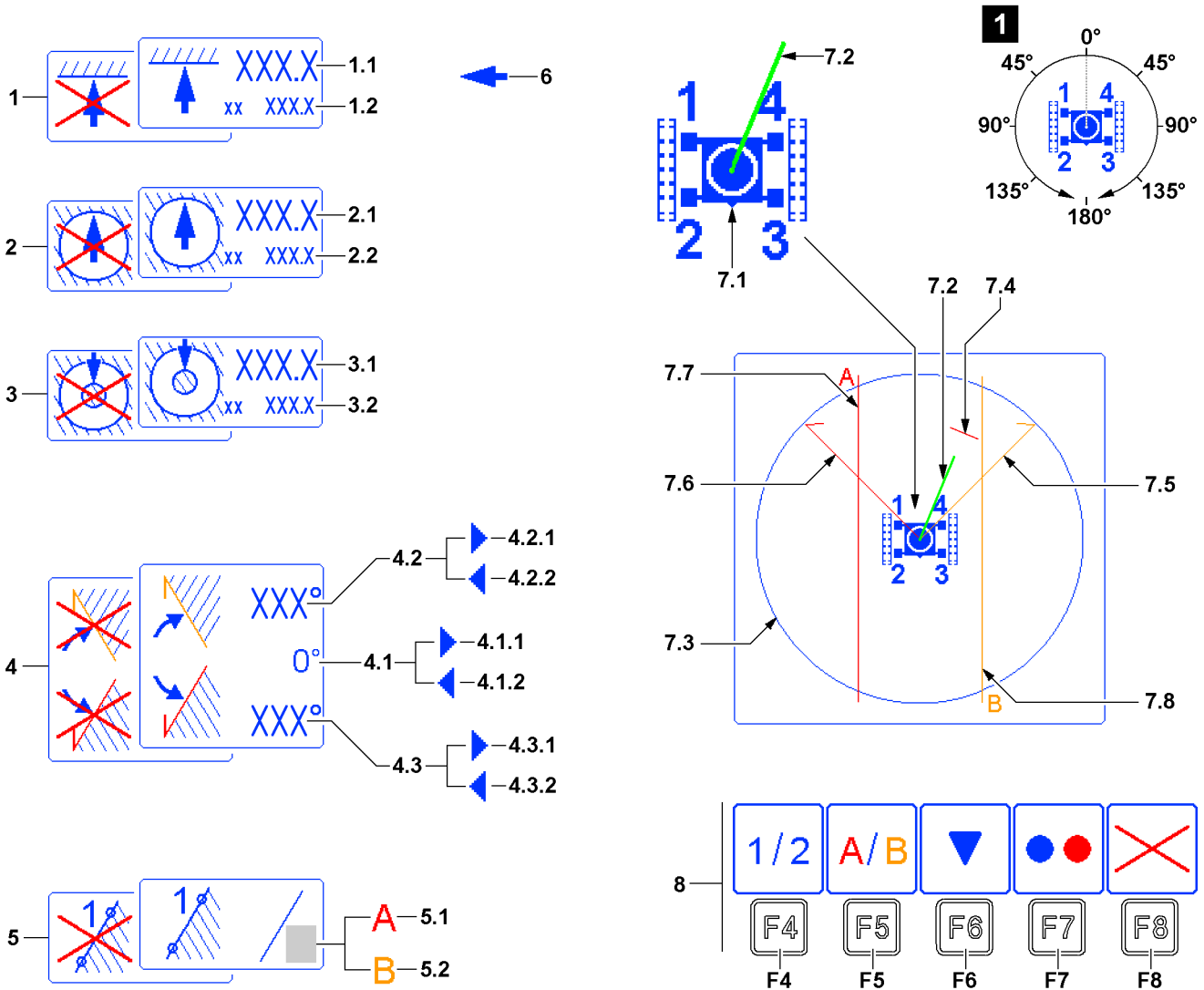
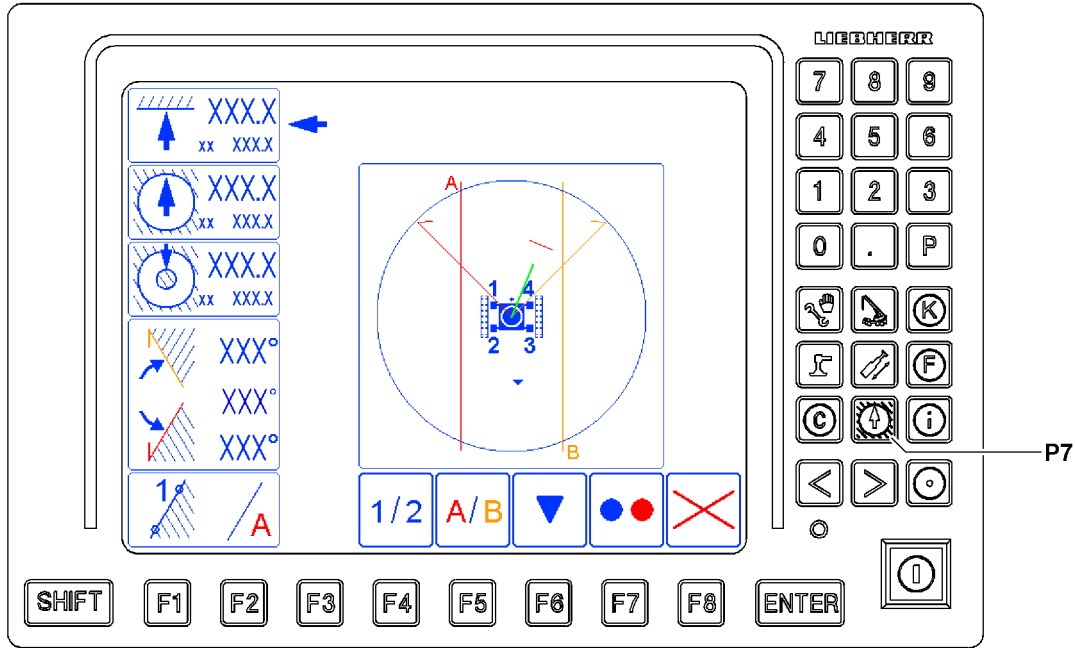


Fig.116057

LWE/LR 1800-1-0-000/27200-07-02/en

- 6** Function selector
  - To select the limitation functions (Position **1** to **5**)
- 7** Graphic display
  - Graphic display of programmed working range limits viewed from above. The crawler travel gear is shown in the center.
  - The triangle **7.1** shows where the front is on the crawler travel gear.
  - The green bar **7.2** shows the current direction and boom radius of the main boom. The longer the green bar, the larger the boom radius of the crane.
- 7.3** Crane working radius
  - Graphic illustration of the maximum working radius (maximum boom radius) of the crane under ideal conditions.
  - **Note:** The setting cannot be changed in the program.
- 7.4** Working radius<sub>max</sub>
  - Graphic illustration of the maximum working radius (maximum boom radius).
  - Based on the limit value **2.1** from the *Working radius<sub>max</sub>* icon **2**
  - **Note:** If the green bar **7.2** crosses the red line of the working radius<sub>max</sub> **7.4**, a shut-off occurs.
- 7.5** Right limit angle
  - Graphic illustration of the right limit angle.
  - Based on the limit angle right **4.2** from the *Turning limit* icon **4**
  - **Note:** If the green bar **7.2** and the orange line of the right limit angle **7.5** are superimposed, a shut-off occurs.
- 7.6** Left limit angle
  - Graphic illustration of the left limit angle.
  - Based on the left limit angle **4.3** from the *Turning limit* icon **4**
  - **Note:** If the green bar **7.2** and the red line of the left limit angle **7.6** are superimposed, a shut-off occurs.
- 7.7** Edge A
  - Graphic illustration of edge A
  - Based on edge A **5.1** from the *Edge limitation* icon **5**
  - **Note:** If the green bar **7.2** crosses the red line of edge A **7.7**, a shut-off occurs.
- 7.8** Edge B
  - Graphic illustration of edge B
  - Based on edge B **5.2** from the *Edge limitation* icon **5**
  - **Note:** If the green bar **7.2** crosses the orange line of edge B **7.8**, a shut-off occurs.

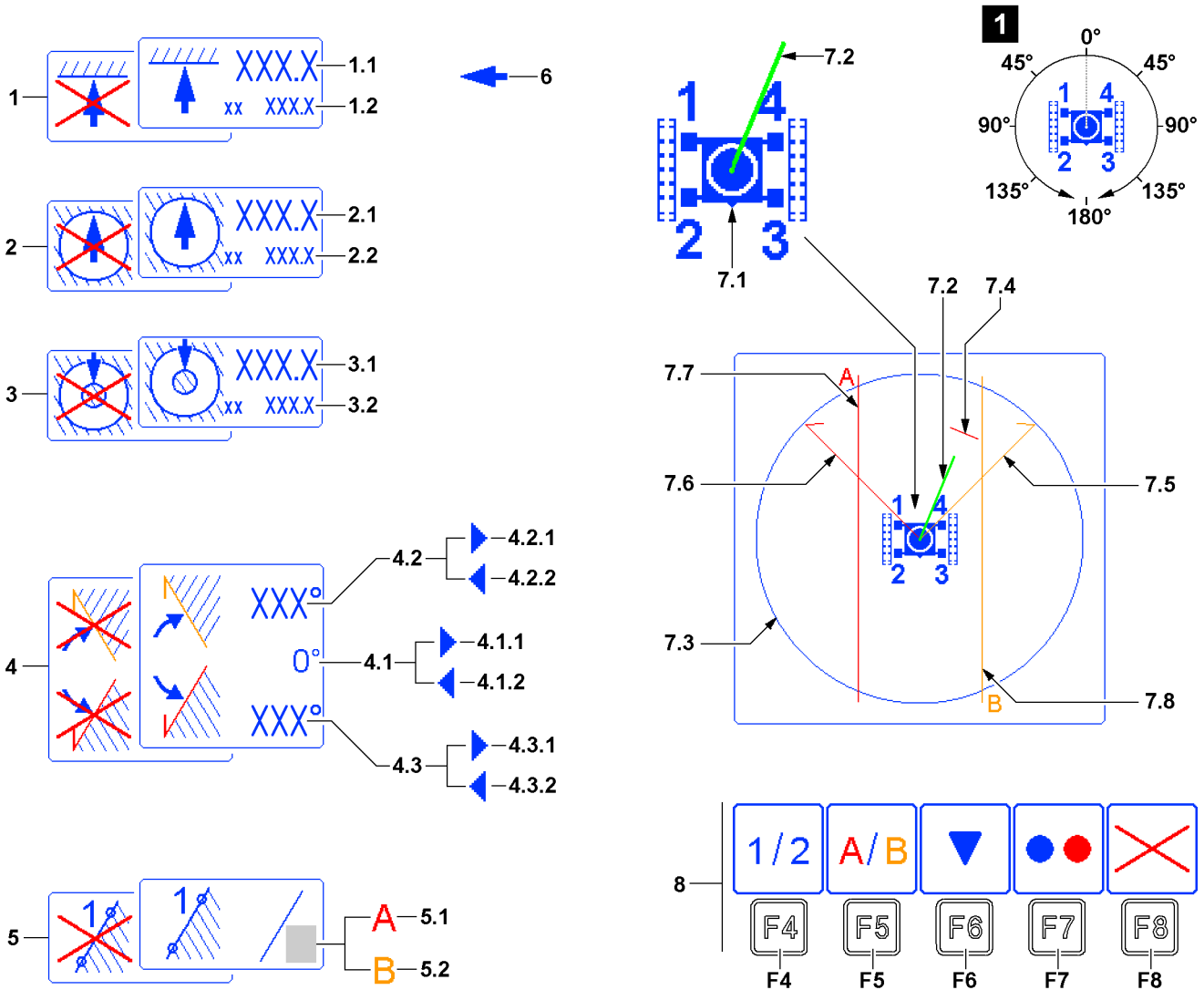
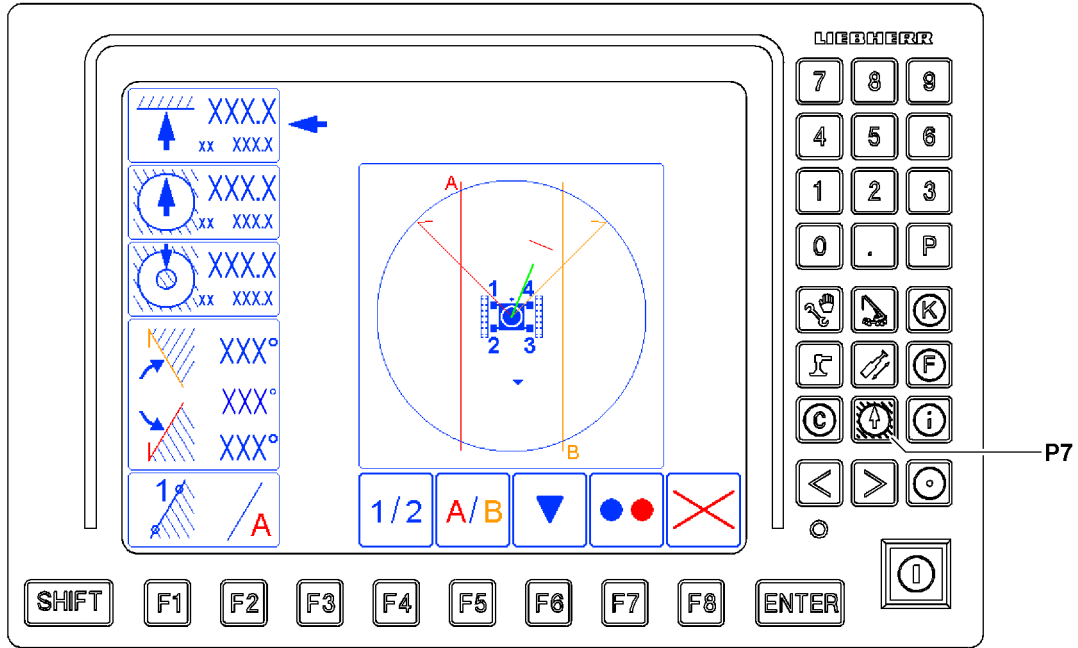


Fig.116057

LWE/LR 1800-1-0-000/27200-07-02/en



### 9.2.1 Function key line in the *Working range limitation* program

**F4** Function key

- Selection of point 1 or 2 of selected edge A (red) or B (black)

**F5** Function key

- Selection of edge A (red) or B (black) that is being programmed

**F6** Function key

- The function selector is moved down by one limit function

**F7** Function key

- ON / OFF

The limitation function selected with the function selector **6** changes its status. If previously active, it will now be inactive when the function key **F7** is pressed, and vice versa. An inactive limit function is identified by a crossed out icon. If the function selector **6** shows a turning limit to the left or the right, then both limits will always be switched.

**Note:** For the edge limit **5**, only the preselected edge will be switched. The edge that is not displayed can be active or inactive at the same time.



**Note**

- ▶ Limit functions can only be added via the function key **F7** when the boom is in the respective permissible range.

**F8** Function key

- All limit functions become inactive

### 9.3 Occurrence of a shut-off in the working range limitation

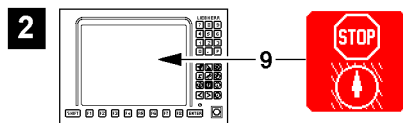


Fig.115262

If the programmed working range limitation is actuated, then this status is shown in the crane operating screen by a STOP icon **9**, see illustration **2**.

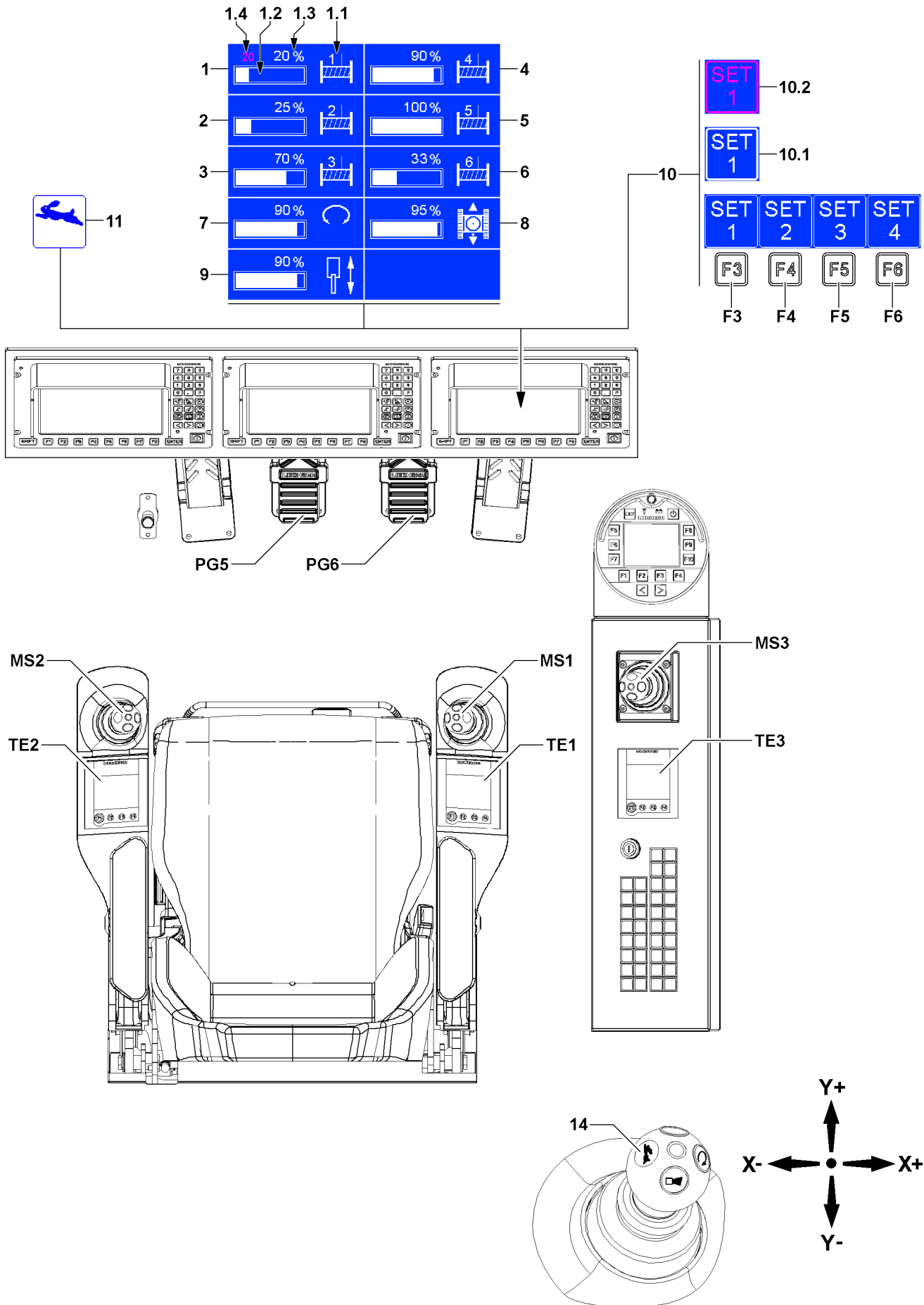


Fig.164496

LWE/LR 1800-1-0-000/27200-07-02/en

## 10 Master switch / pedal sensor speed reduction

The speed reduction of master switches / pedal sensor is made in the settings window. The speeds of the displayed crane movements / crane functions can be limited steplessly to the desired value.

This reduces the maximum speed of the crane function to the value set in the settings window.



### WARNING

Deactivated master switch speed reduction!

When the rapid gear **11** is engaged, the speed reductions of the master switches can be ineffective. Too high a crane speed can cause accidents.

- ▶ Turn the rapid gear **11** off when a speed reduction of the master switches is necessary.



### WARNING

Danger of accident!

- ▶ Make the preselection of the slewing speed according to the specifications in the load chart manual.
- ▶ The following applies: The longer the boom and / or the greater the load, the lower the set maximum slewing speed must be.
- ▶ **Never** deflect the master switch for the slewing gear to the stop with a long boom and / or great load.

### 10.1 Operating elements with master switch / pedal sensor speed reduction

**MS1** Master switch 1

**TE1** Touch display 1

**MS2** Master switch 2

**TE2** Touch display 2

**MS3** Master switch 3

**TE3** Touch display 3

**PG5** Pedal sensor 5

**PG6** Pedal sensor 6

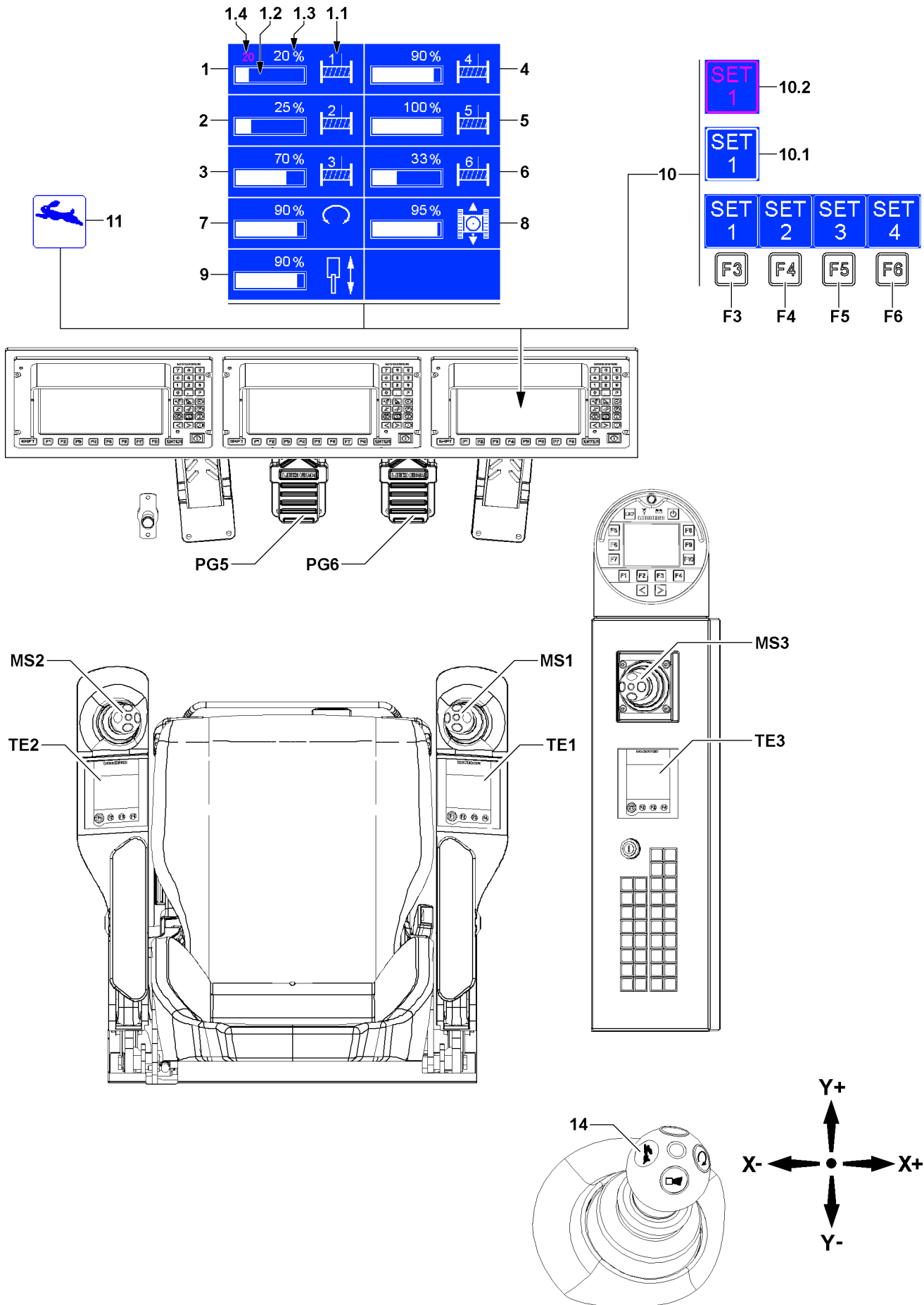


Fig.164496

## 10.2 Operating interface in the settings window for master switch / pedal sensor speed reduction



### Note

- ▶ The structure of the individual settings windows is always the same. The assembly is explained based on the settings window for winch 1 and the SET1 fast setting.

- 1 Winch 1 settings window
  - **Note:** Appears only when the winch is active
- 1.1 *Assignment* icon
  - Icon of the assigned crane movement / crane function
  - The icon corresponds to the illustration on the respective TE-display
- 1.2 Bar diagram
  - Graphic display of the current speed reduction
- 1.3 Display value
  - Numeric display of the current speed reduction in [%]
- 1.4 Saved value
  - Previous saved value of the current speed reduction in [%]
  - **Note:** Appears only when setting the fast settings\*.
- 2 Winch 2 settings window
  - **Note:** Appears only when the winch is active
- 3 Winch 3 settings window
  - **Note:** Appears only when the winch is active
- 4 Winch 4 settings window
  - **Note:** Appears only when the winch is active
- 5 Winch 5 settings window
  - **Note:** Appears only when the winch is active
- 6 Winch 6 settings window
  - **Note:** Appears only when the winch is active
- 7 Slewing gear settings window
- 8 Crawler settings window
- 9 Assembly cylinder settings window
  - **Note:** Appears only when the assembly cylinder is active
- 10 Fast setting
  - Four freely programmable fast settings are possible
- 10.1 Fast setting selected
  - The bold frame marks the currently selected fast setting
- 10.2 Changeable fast setting
  - The red highlighting marks the changeable fast setting

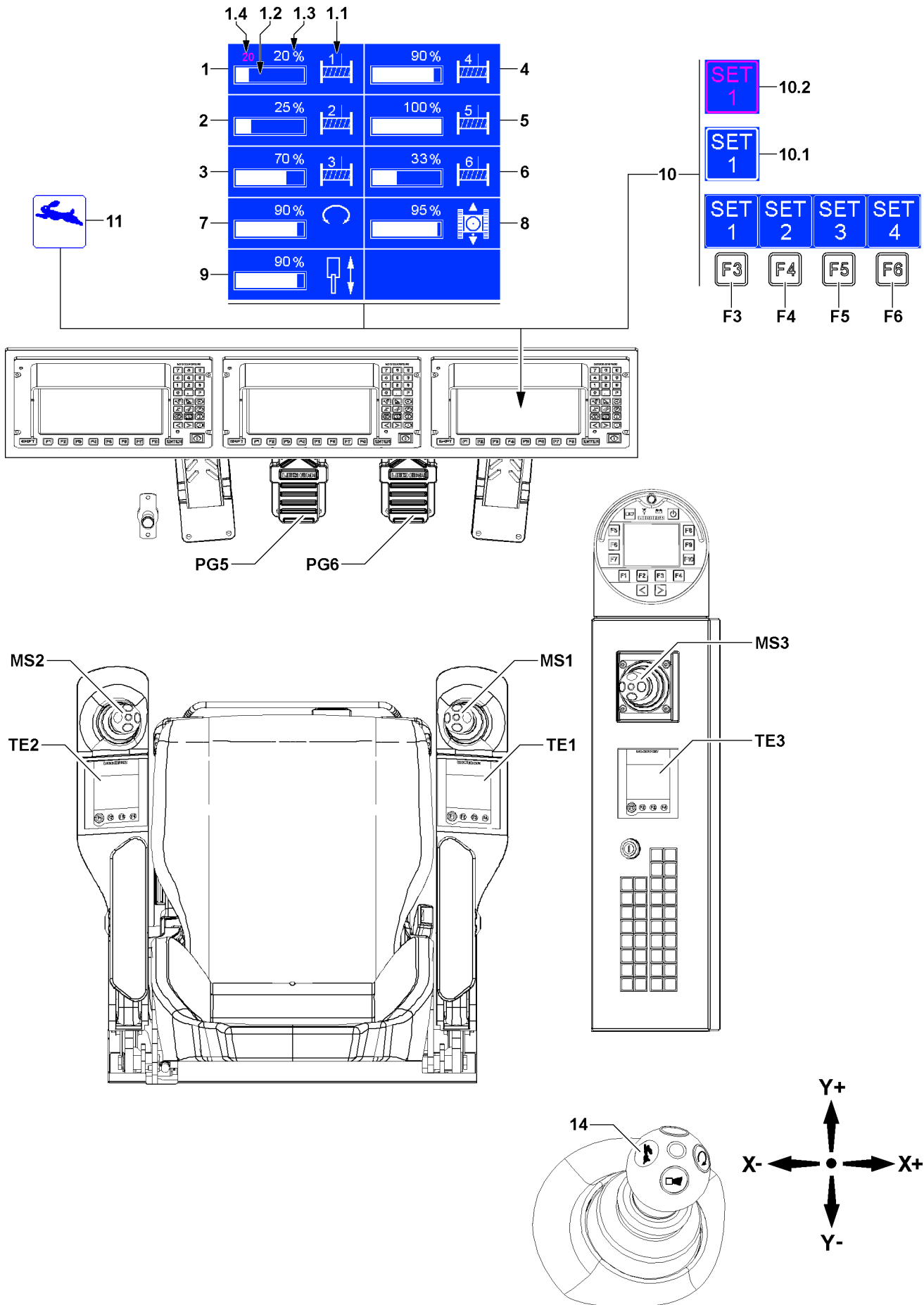


Fig.164496

## 10.3 Editing the speed reduction

**Note**

Only the settings for the displayed crane movements / crane functions can be carried out.

- ▶ If necessary, activate required crane movements / crane functions before calling up the settings windows.

### 10.3.1 Displaying the settings window

- ▶ Press the rapid gear **14** button on a master switch at least two seconds.

**Result:**

- The settings window for the master switch / pedal sensor speed reduction is shown for ten seconds.

**Note**

The settings window is automatically hidden after ten seconds if during that time there is no access to the speed reduction of a crane function.

- ▶ Continue in time with the next steps.

### 10.3.2 Operating the fast settings

Four different fast settings for the master switch / pedal sensor speed reduction can be saved and called up by pressing a button.

**Operating elements:**

- **F3** Function key
  - Select / operate fast setting 1 (SET1)
- **F4** Function key
  - Select / operate fast setting 2 (SET2)
- **F5** Function key
  - Select / operate fast setting 3 (SET3)
- **F6** Function key
  - Select / operate fast setting 4 (SET4)

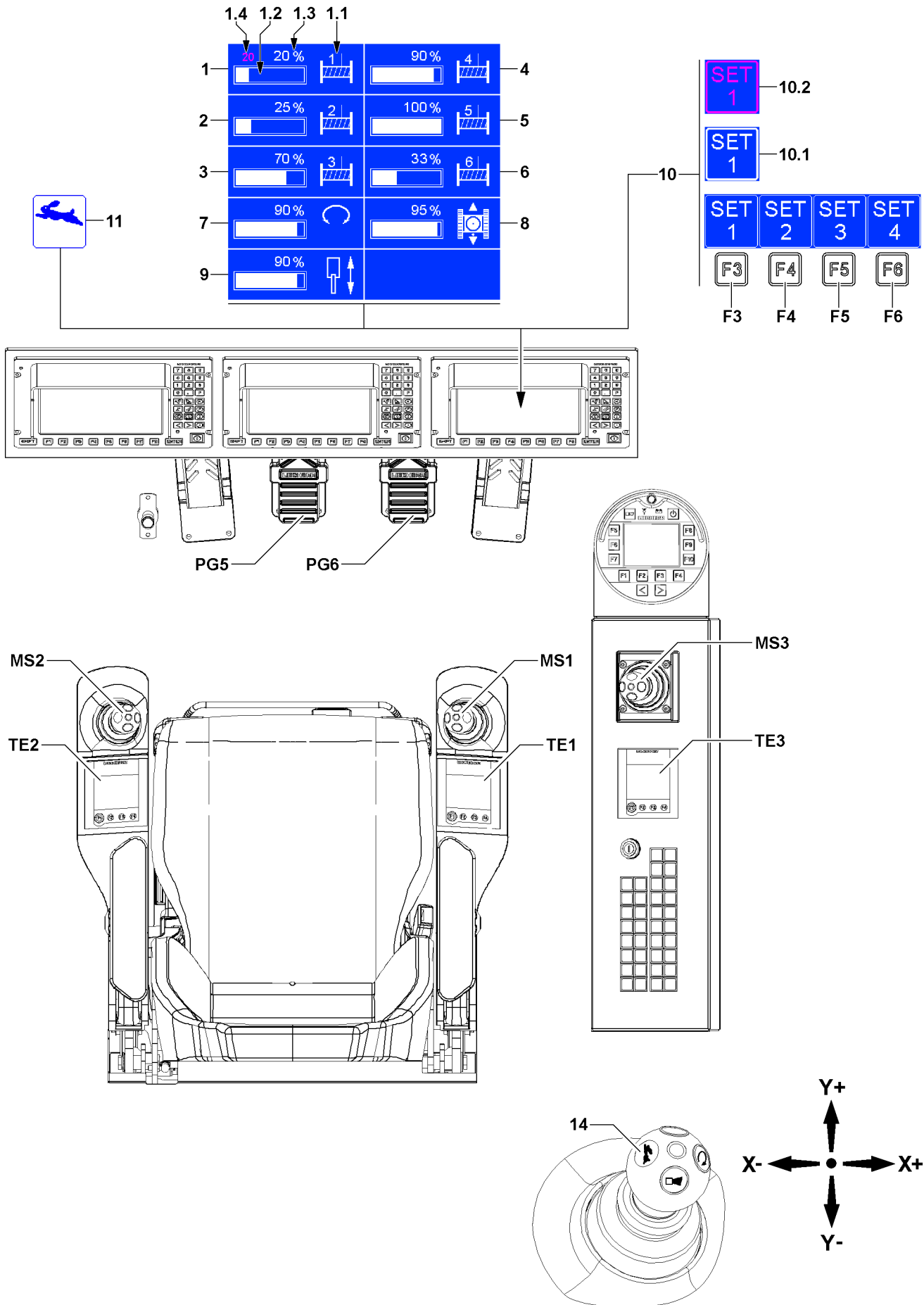


Fig.164496

LWE/LR 1800-1-0-000/27200-07-02/en



**Selecting the fast setting**

Select fast setting 1 (SET1):

- ▶ Press the function key **F3**.

**Result:**

- Fast setting 1 (SET1) is selected.
- The frame around the *SET1* icon is shown in bold, see the example fast setting selected **10.1**.

Select fast setting 2 (SET2):

- ▶ Press the function key **F4**.

**Result:**

- Fast setting 2 (SET2) is selected.
- The frame around the *SET2* icon is shown in bold.

Select fast setting 3 (SET3):

- ▶ Press the function key **F5**.

**Result:**

- Fast setting 3 (SET3) is selected.
- The frame around the *SET3* icon is shown in bold.

Select fast setting 4 (SET4):

- ▶ Press the function key **F6**.

**Result:**

- Fast setting 4 (SET4) is selected.
- The frame around the *SET4* icon is shown in bold.

**Changing and saving settings**

The speed reduction is always set via the master switch / pedal sensor that controls the crane movement.

**Note**

- ▶ If the master switch / pedal sensor is deflected lightly, the value is slowly increased / reduced.
- ▶ If the master switch / pedal sensor is deflected strongly, the value is quickly increased / reduced.

As an example, a new setting for the *spool winch 1* crane movement is saved in fast setting 1 (SET1). The crane movement is carried out via the master switch **MS1**.

The procedure is identical for all crane functions.

**Note**

- ▶ The change that is made applies only for the selected fast setting, in the example fast setting 1 (SET1). Each of the four fast settings must be set and saved separately.

If the frame around the *SET1* icon is not yet shown in bold:

- ▶ Press the function key **F3**.

**Result:**

- Fast setting selected **10.1** appears.

Reduce the speed reduction value:

- ▶ Move the master switch **MS1** in direction Y- (to the rear).

**Result:**

- Changeable fast setting **10.2** appears.
- The previous saved value **1.4** is displayed in red.

- The bar in the bar diagram **1.2** becomes shorter.
- The display value **1.3** is reduced.

Increase the speed reduction value:

- ▶ Move the master switch **MS1** in direction Y+ (to the front).

**Result:**

- Changeable fast setting **10.2** appears.
- The previous saved value **1.4** is displayed in red.
- The bar in the bar diagram **1.2** becomes longer.
- The display value **1.3** is increased.



**Note**

- ▶ All settings can be changed one after the other as desired.
- 

When the desired setting is reached:

- ▶ Press the function key **F3**.

**Result:**

- Fast setting selected **10.1** appears.
- All current settings are saved as fast setting 1 (SET1).
- The previous saved values **1.4** are hidden

### 10.3.3 Hiding the settings window



**Note**

- ▶ If the settings window is hidden, the last changes are discarded as long as changeable fast setting **10.2** is displayed.
- 

- ▶ Press the rapid gear **14** button on a master switch at least two seconds.  
**or**  
Wait ten seconds without further steps.

**Result:**

- The settings window for the speed reduction of the master switch / pedal sensor is hidden.

## 11 Checking the gear oil fill level of the winches

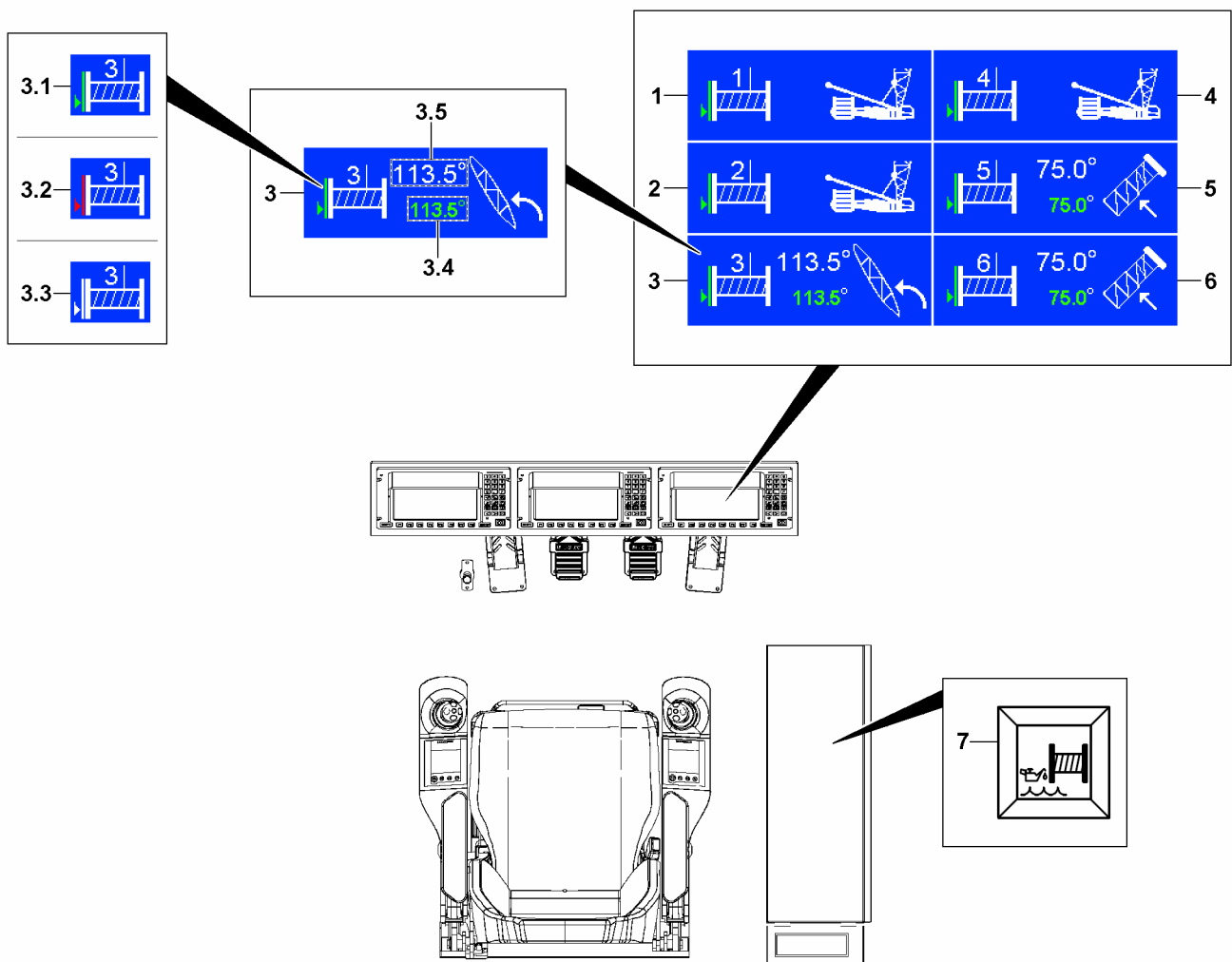


Fig.155124: Checking the gear oil fill level of the winches

The gear oil fill level of the winches can be shown for testing purposes.

Depending on the installation position of the winches, additional steps may be necessary for a correct check.

The individual winches must be aligned by setting specific boom angles.



### Note

Only winches that are connected and operational are displayed.

- ▶ If necessary, connect the operational winch before testing.



### WARNING

Insufficient gear oil in the winch!

If a winch is operated, even though the gear oil fill level is too low, the winch can be severely damaged.

The winch can fail and accidents can occur.

- ▶ Determine the cause for the insufficient gear oil and remedy it.
- ▶ Bring the gear oil fill level to the normal level.

## 11.1 Operating interface for the *Gear oil fill level* display



### Note

- ▶ The structure of the individual displays is always the same and is described based on the display of winch (WIII).
- ▶ For winches that must be aligned for testing, a nominal angle and an actual angle for the relevant boom is also displayed.

- 1 *Winch (WI)* display
  - **Note:** Only appears if *winch(WI)* is connected and operational.
- 2 *Winch (WII)* display
  - **Note:** Only appears if *winch(WII)* is connected and operational.
- 3 *Winch (WIII)* display
  - **Note:** Only appears if *winch(WIII)* is connected and operational.
  - **3.1 Fill level *ok***
    - The gear oil fill level for the winch is ok
  - **3.2 Fill level *too low***
    - The gear oil fill level for the winch is too low, gear oil must be added before start up
  - **3.3 *No measurement* display**
    - Actual angle **3.5** deviating from nominal angle **3.4**
  - **3.4 Nominal angle**
    - Nominal angle **3.4** (measurement window) for the relevant boom
  - **3.5 Actual angle**
    - Actual angle **3.5** for the relevant boom
    - Appears blinking red if deviation from the nominal angle **3.4** (measurement window) is too great



### Note

Deviating angle indicators between the *gear oil fill level* display and the operating screen. A directly assigned actual angle is always taken into consideration for the *gear oil fill level* display. It always provides the exact position of the respective winch. The angles shown on the operating screen take the flexation of the boom system into account and can therefore deviate.

- ▶ The boom angle can be adjusted when the *gear oil filling level* display is shown.

- 4 *Winch (WIV)* display
  - **Note:** Only appears if *winch(WIV)* is connected and operational.
- 5 *Winch (WV)* display
  - **Note:** Only appears if *winch(WV)* is connected and operational.
- 6 *Winch (WVI)* display
  - **Note:** Only appears if *winch(WVI)* is connected and operational.

## 11.2 Carrying out the test procedure

Make sure that the following prerequisites are met:

- The crane is operational
- The winch has been at a standstill for at least 15 minutes
- The maximum deviation from the horizontal position of the crane is  $\pm 0.3^\circ$  ( $\pm 0.5\%$ ).



### WARNING

Incorrect testing!

If the maximum deviation from the horizontal position of the crane is too great, the test result is distorted.

A too low gear oil fill level will not be detected.

If a winch is operated further, even though the gear oil fill level is too low, the winch can be severely damaged.

The winch can fail and accidents can occur.

- ▶ Align the crane horizontally.

### 11.2.1 Show / hide settings window

- ▶ Press the Gear oil fill level **7** button on the instrument panel.

**Result:**

- The *Gear oil fill level* display is shown.

- ▶ Press the Gear oil fill level **7** button on the instrument panel again.

**Result:**

- The *Gear oil fill level* display is hidden.

### 11.2.2 Procedure

- ▶ Check all displayed fill levels.

Using the example of the *Winch (WIII) 3* display, the individual steps are explained.

If Fill level *ok 3.1* is displayed:

- ▶ No additional steps necessary.

If Fill level *too low 3.2* is displayed:

- ▶ The gear oil fill level is too low, gear oil must be added before start up.



**Note**

- ▶ For maintenance of the winches, see chapter 7.05.
- 

If *No measurement* display **3.3** is shown, the boom angle must adjusted on the relevant boom for testing:

- ▶ To the extent permitted in the current set up configuration, set the actual angle **3.5** according to the nominal angle **3.4**.

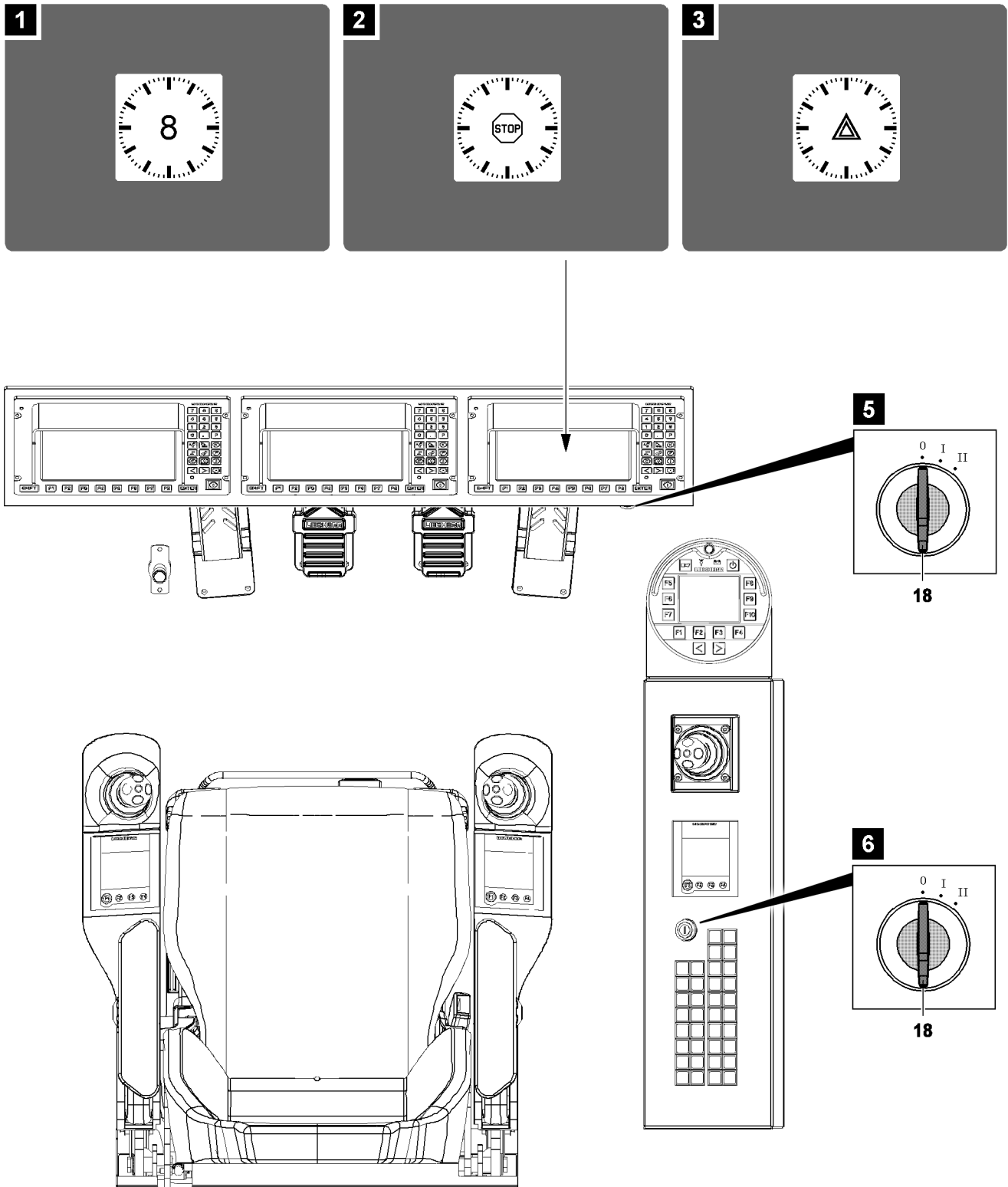


Fig.164497

LWE/LR 1800-1-0-000/27200-07-02/en

## 12 Power Save mode and Stand-by mode in the LICCON computer system



### Note

- ▶ Depending on the crane type, the ignition switch **18** is located either below LICCON Monitor 0, illustration **5** or on the instrument panel, illustration **6**.

### 12.1 Power Save mode

If the crane engine is turned off to position 0 (ignition **OFF**) - by turning the ignition switch **18** - the LICCON computer system changes to the Power-Save mode.

Power Save mode enables the crane operator - within approx. eight seconds after turning off the ignition - either to change to Stand-by mode or to start the crane engine again without having to restart the LICCON computer system.

If no program key is actuated within eight seconds, then the LICCON computer system turns off completely.



### Note

- ▶ No crane movements are possible in Power Save mode.

#### Turn the crane engine off

- ▶ Turn the ignition switch **18** to position 0 (ignition **OFF**).

#### Result:

- The crane engine is turned off.
- **Power Save mode** is active.
- The clock with a Power-Save run time (approx. eight seconds) appears, illustration **1**.



### Note

- ▶ After eight seconds have elapsed, a clock appears briefly with an integrated STOP icon, which displays the complete turning off of the LICCON computer system.

- The clock with integrated STOP icon appears for a few seconds, illustration **2**.
- All processes on the LICCON computer system are stopped.
- The LICCON computer system turns off completely.

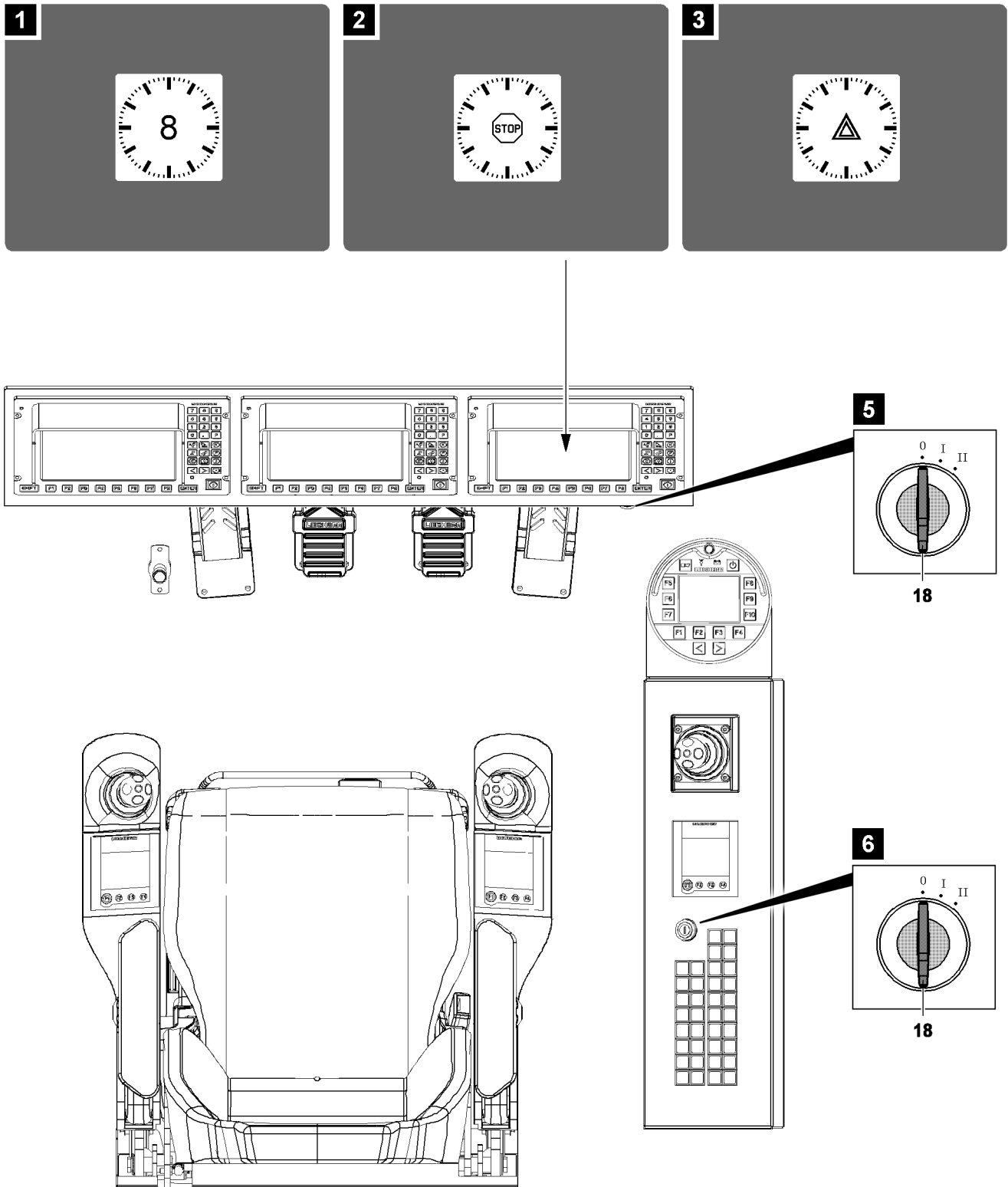


Fig.164497

LWE/LR 1800-1-0-000/27200-07-02/en



**Press any key in Power-save mode once****Note**

▶ Pressing a key in Power-Save mode once shortens the Power-Save alarm time to five seconds.

▶ Press any key.

**Result:**

– The Power-Save alarm time is shortened to five seconds.

**Press any key twice in Power-save mode**

▶ Press any key twice in succession.

**Result:**

- The Power Save alarm time is set to zero.
- The clock with integrated STOP icon appears for a few seconds, illustration 2.
- All processes on the LICCON computer system are stopped.
- The LICCON computer system turns off completely.

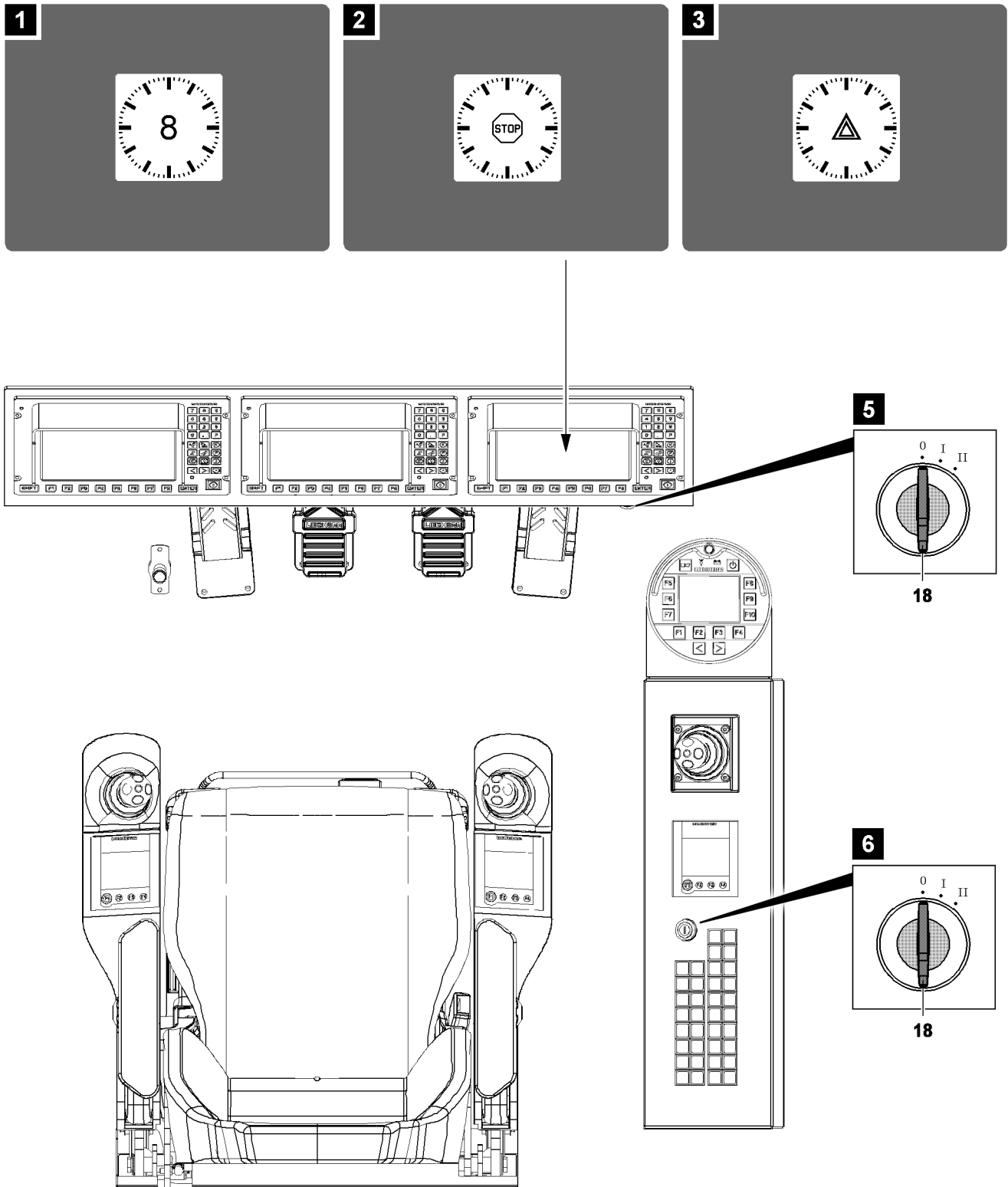


Fig.164497

LWE/LR 1800-1-0-000/27200-07-02/en

## 12.2 Stand-by mode

After pressing the Engine STOP key - the crane engine is turned off - LICCON monitor continues to display the operating interface of the most recently active application program for an additional 10 minutes, illustration 3.

Stand-by mode is reached after 10 minutes have elapsed. The Stand-by mode is displayed by the Stand-by clock + warning icon on the LICCON monitor and by a repeated short acoustic signal (*short horn*) with longer intervals.



### Note

- ▶ In Stand-by mode, no crane movements are possible.

There are two ways of achieving Stand-by mode with the LICCON computer system.

### Turn the crane engine off

Turning the engine off with the engine STOP key:

- ▶ Press the engine STOP key.
- ▶ Leave the ignition key **18** in position "1".

### Result:

- The crane engine is turned off.
- The ten minute period is over.
- ▶ Within the ten minute time frame, press **any key**.

### Result:

- The ten minute time period is reset and starts again.
- ▶ Do **not** press any key during the ten minute period.

### Result:

- After the period is over, **stand-by mode** is reached.
- The display area on the LICCON monitor turns black.
- The stand-by clock with a warning icon is displayed, illustration 3.
- A repeating acoustic signal from the LICCON monitor sounds every half minute.



### Note

- ▶ Stand-by mode does not lead to the automatic shut-off of the LICCON computer system.

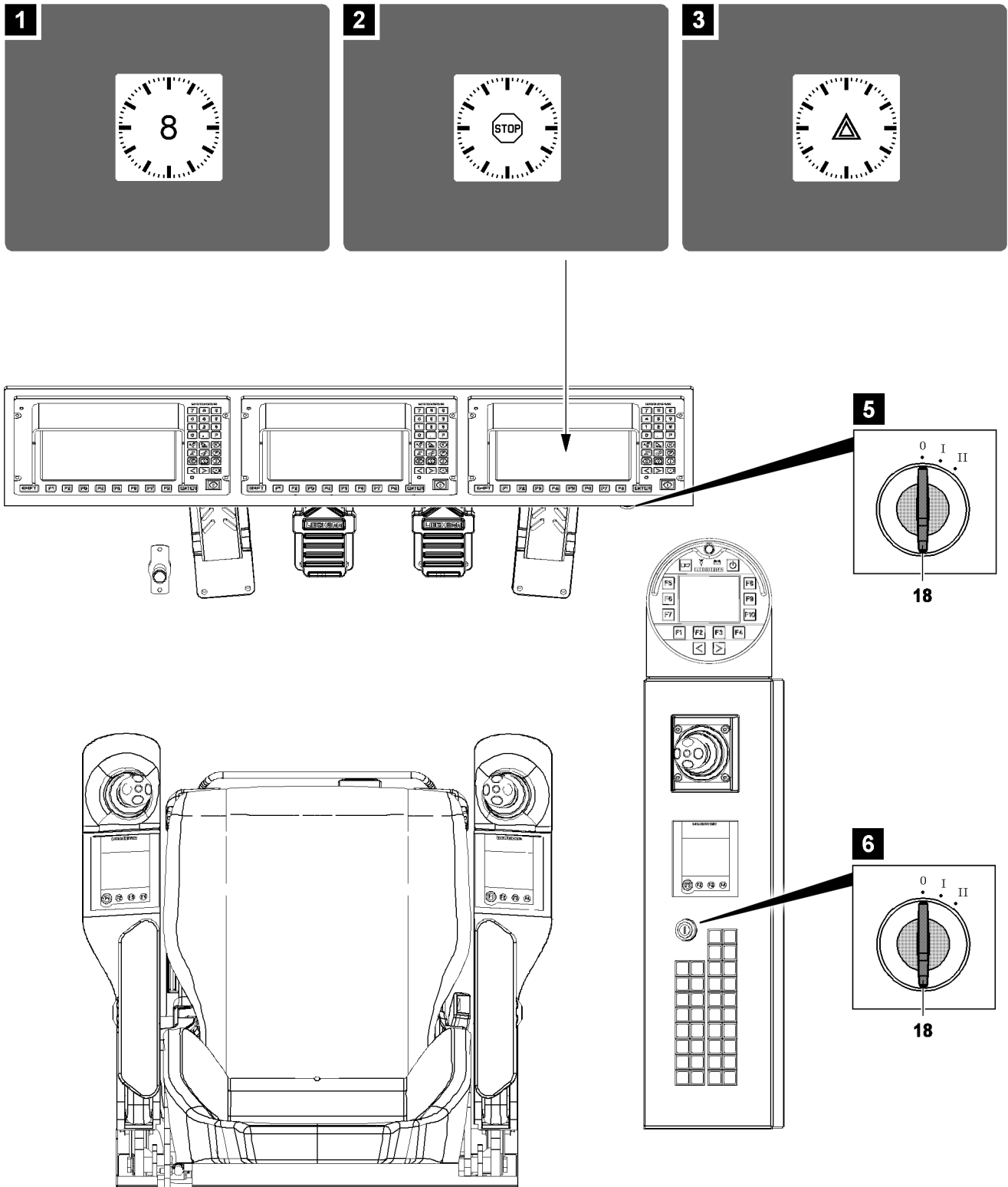


Fig.164497

LWE/LR 1800-1-0-000/27200-07-02/en

**Turn the LICCON computer system off from the Stand-by mode**

- ▶ Turn the ignition switch to position 0.

**Result:**

- Power-Save mode becomes active.

**Note**

- ▶ See section "Power-Save mode".
-

---

Empty page!

LWE/LR 1800-1-0-000/27200-07-02/en

## 4.03 Start up and shut down of crane

1	Safety	2
2	Crane start-up at low temperatures	2
3	Assembling the central ballast and assembly support	3
4	Assembling the turntable	3
5	Placing the extension ladder on the crane cab	3
6	Bringing the crane cab into the operating position	5
7	Bringing the cab platform into the operating position	6
8	Checking before start up	9
9	Diesel particle filter (DPF)*	20
10	<i>Exhaust system cleaning procedure</i>	25
11	Crane driver's seat	26
12	Control platform	31
13	Crane cab	33
14	Electrical external power supply	39
15	Jump starting the diesel engine	41
16	Preheating the hydraulic oil with Hydraulic oil preheating*	42
17	Starting the LICCON computer system (before engine start)	45
18	Starting and turning off the engine	46
19	Starting the LICCON computer system parallel to the engine	50
20	Bringing the crane cab into the transport position	50

# 1 Safety

Before crane start-up, observe the safety instructions:

- Information regarding personal protective equipment. See chapter 2.04.
- Information regarding fall protection equipment. See chapter 2.06.
- Information regarding accesses to the crane. See chapter 2.07.
- Information regarding accessible surfaces. See chapter 2.07.
- Information regarding the use of ladders. See chapter 2.04.10.



## WARNING

Danger of falling!

During assembly / disassembly, inspection and maintenance work, assembly personnel must be secured with appropriate aids to prevent them from falling.

Death, severe bodily injuries, property damage.

- ▶ All work at a height, when there is a danger of falling, must be carried out with suitable aids.
- ▶ If aids are not available and work cannot be carried out from the ground, then assembly personnel must secure themselves with the supplied fall arrest system to prevent falling, see the Crane operating instructions, chapter 2.04.
- ▶ If fall protection equipment is available, then it must be used, see the Crane operating instructions, chapter 2.06.
- ▶ When lifting, lowering, swinging crane parts in and out, no persons may remain in the danger zone.
- ▶ If railings are present on the components, then they must be brought into the corresponding position and secured for assembly / disassembly work.
- ▶ Only step on the aids, ladders and catwalks with clean shoes.
- ▶ Keep aids, ladders and catwalks free of heavy dirt, snow and ice.
- ▶ During all assembly and disassembly work, maintenance work and inspections, travel or crane operation is prohibited.
- ▶ Remaining on a suspended load is prohibited.
- ▶ Stepping or walking on crane components and lattice sections with an incline of more than 20° is prohibited.
- ▶ For all assembly work, the crane operator of the main crane must be in voice contact with the crane operator / crane operators of the auxiliary crane / auxiliary cranes.
- ▶ For the assembly / disassembly tasks, the crane operator may only initiate crane movements when the responsible guide has explicitly released the movement.



## WARNING

Danger of impact / crushing!

When lifting / lowering and positioning crane components, there is an increased danger of impact / crushing.

Death, severe bodily injuries, property damage.

- ▶ Make sure that personnel cannot be caught by components.
- ▶ When working in a danger zone: Use aids to protect limbs.



## WARNING

Danger of falling!

During assembly and disassembly of crane components, personnel must be secured with appropriate aids to prevent them from falling.

Death, severe bodily injuries, property damage.

- ▶ Use personal protective equipment.

## 2 Crane start-up at low temperatures



### Note

- ▶ Before crane start-up in particular, observe and adhere to chapter 2.08.



### 3 Assembling the central ballast and assembly support



#### Note

- ▶ Assemble the central ballast, see chapter 3.03.
- ▶ Assemble the assembly support, see chapter 3.09.
- ▶ Assemble the chassis steps and catwalks, see chapter 2.06.

### 4 Assembling the turntable



#### Note

- ▶ Assemble the turntable, see chapter 3.02.
- ▶ Assemble the catwalks on the turntable, see chapter 2.06.
- ▶ Assemble the railing on the turntable, see chapter 2.06.

### 5 Placing the extension ladder on the crane cab



#### Note

- ▶ The transport unit crawler center section / turntable can be additionally equipped with the SA-frame.
- ▶ For the weights and dimensions of the transport unit, see chapter 1.03.



#### Note

- ▶ The extension ladder **4** is located in the transport position to the side on the steel structure of the crawler carrier.

Make sure that the following prerequisites are met:

- The crawler center section / turntable is lying properly on the substructure.
- The central ballast is assembled.
- The assembly support is assembled.
- The ground is level and horizontal for crane assembly.
- The ground is sufficiently load bearing to safely absorb the weight of the transport unit above the assembly support.

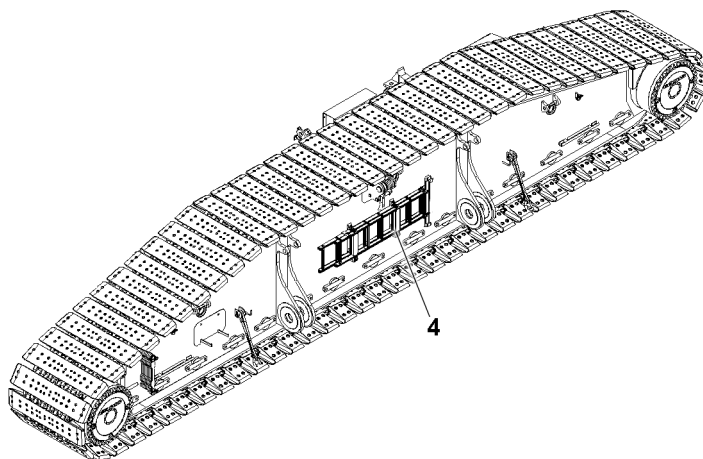


Fig.154387: Transport position of the extension ladder **4** on the crawler carrier

- ▶ Take the extension ladder **4** on the crawler carrier from the transport position, see chapter 2.07.

- ▶ Extend the extension ladder 4 to the maximum length and secure it properly.

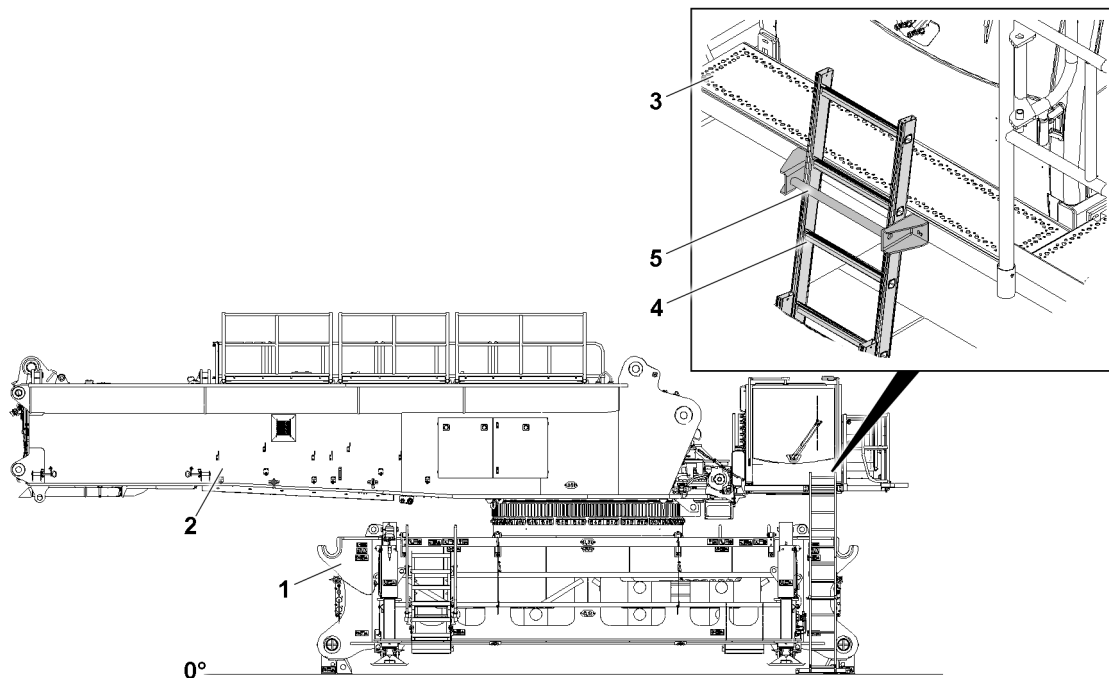


Fig.154388: Placing the extension ladder 4 on the crane cab

- ▶ Position the extension ladder 4 on the crane cab 3 behind the fastening 5.



#### WARNING

Danger of falling!  
Death, severe bodily injuries, property damage.

- ▶ Make sure that the crane driver and / or the crane operating / assembly personnel is sufficiently secured against falling when working aloft.
  - ▶ Only access the extension ladder and climb up to the crane cab after all required safety precautions have been observed.
- 
- ▶ Access the crane cab catwalk using the extension ladder 4.

## 6 Bringing the crane cab into the operating position

### 6.1 Releasing the tension belt from the crane cab

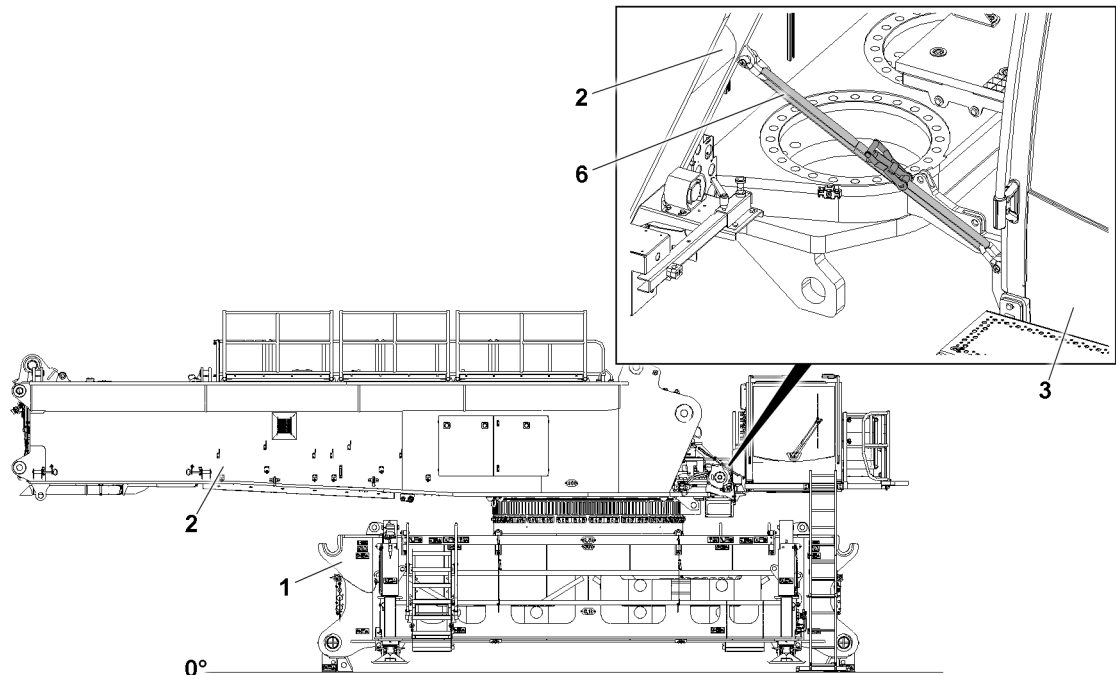


Fig.154389: Releasing the tension belt from the crane cab

Make sure that the following prerequisites are met:

- The extension ladder 4 is laying properly against the crane cab.
- The catwalks and railing on the turntable 2 are in the operating position.

► Release and remove the tension belt 6 between the crane cab 3 and the turntable 2.

**Result:**

- The crane cab 3 is released.

### 6.2 Swinging the crane cab into the operating position

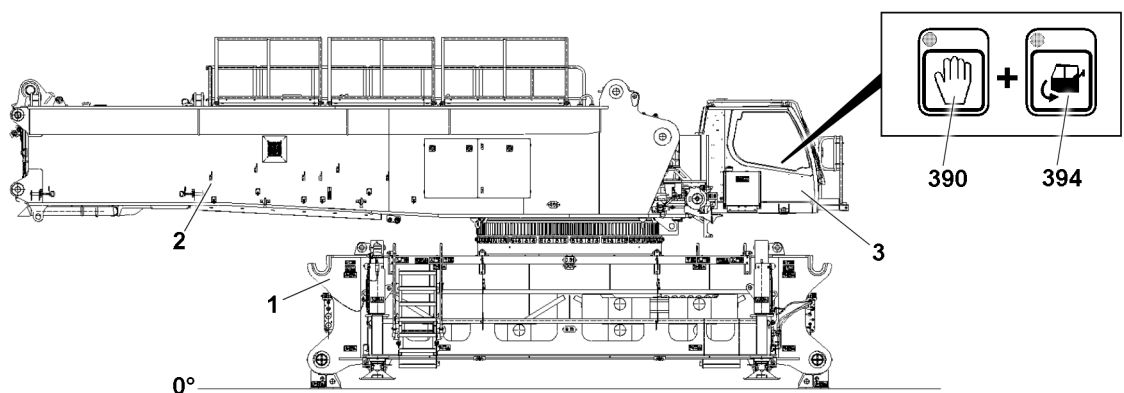


Fig.154390: Swinging the crane cab into the operating position

Make sure that the following prerequisites are met:

- The tension belt 6 is removed.
- The cab platform is in the transport position.

**NOTICE**

Leaning extension ladder!

If the extension ladder is leaned against the crane cab when swinging out the crane cab **3**, the crane cab and extension ladder can be damaged.

Property damage.

- ▶ Make sure that the extension ladder is removed before swinging out the crane cab.

- ▶ Remove the extension ladder.

**WARNING**

Swinging crane cab!

Death, severe bodily injuries, property damage.

- ▶ Make sure that there are no persons within the danger zone when swinging out the crane cab **3**.

**Note**

- ▶ The crane operator cab can also be swung in the BTT into the operating position, see chapter 5.31 or 6.08.

- ▶ Start the engine, see section "Starting the engine".
- ▶ Swing the crane cab **3** out: Press the button **390** and button **394**.
- ▶ Swing out the crane cab **3** completely.

When the crane cab **3** has reached the operating position:

- ▶ Release the button **390** and button **394**.

## 7 Bringing the cab platform into the operating position

### 7.1 Assembling the step in the operating position

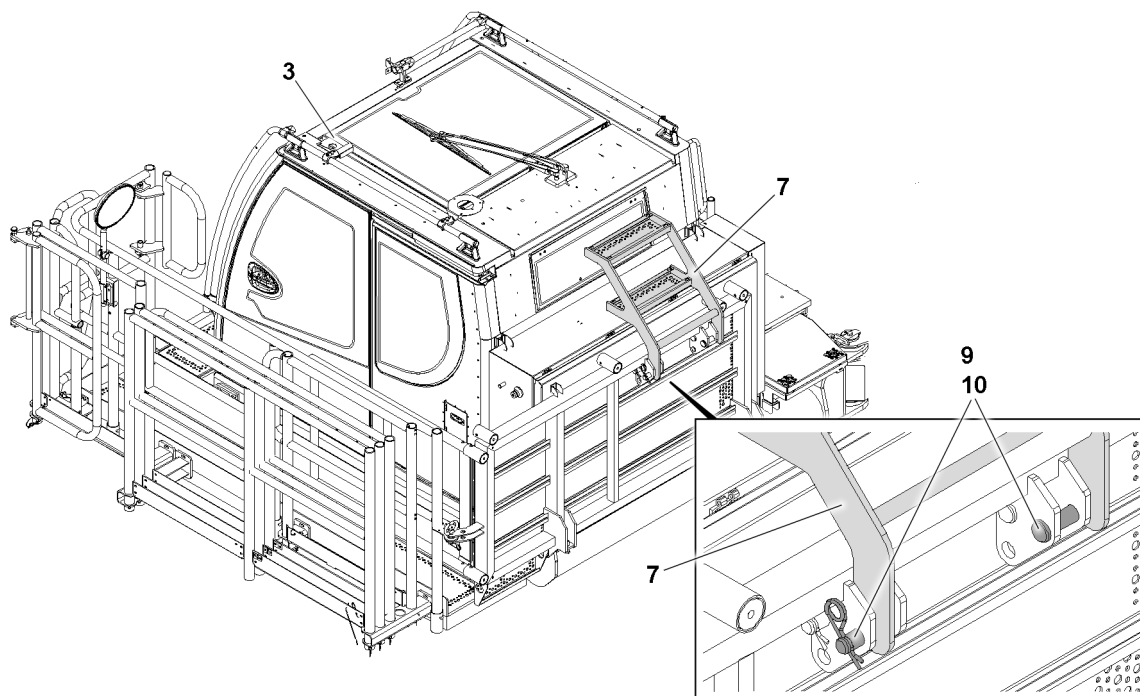


Fig.154391: Assembling the step in the operating position

Make sure that the following prerequisite is met:

- The crane cab **3** is in the operating position.

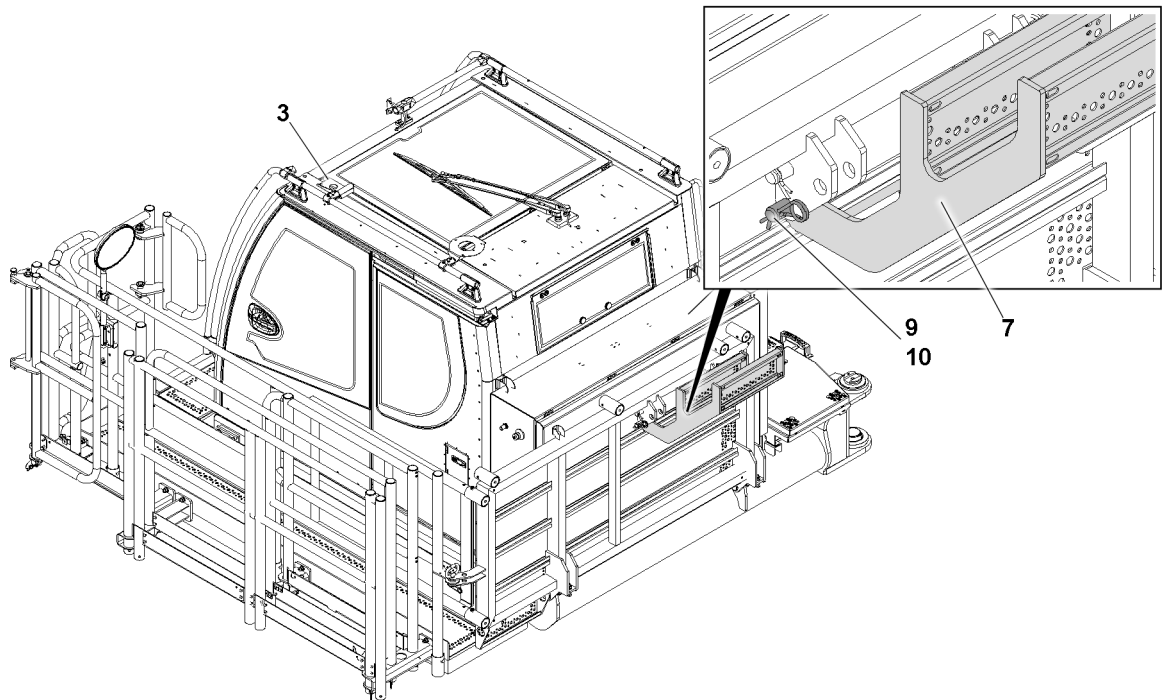
**WARNING**

Danger of crushing!

When swinging the step 7, limbs can be crushed.

Death, severe bodily injuries, property damage.

- ▶ Swing the step 7 slowly and carefully into the operating position.
- 
- ▶ Unpin the step 7 in the transport position: Remove the retaining elements 10 and completely unpin the pins 9.



*Fig.154392: Securing the step in the operating position*

- ▶ Swing the step 7 backward into the operating position.

When the step 7 is in the operating position:

- ▶ Insert the pin 9 in the operating position on both sides.
- ▶ Secure the pin 9: Attach the retaining elements 10.

## 7.2 Assembling the cab platform

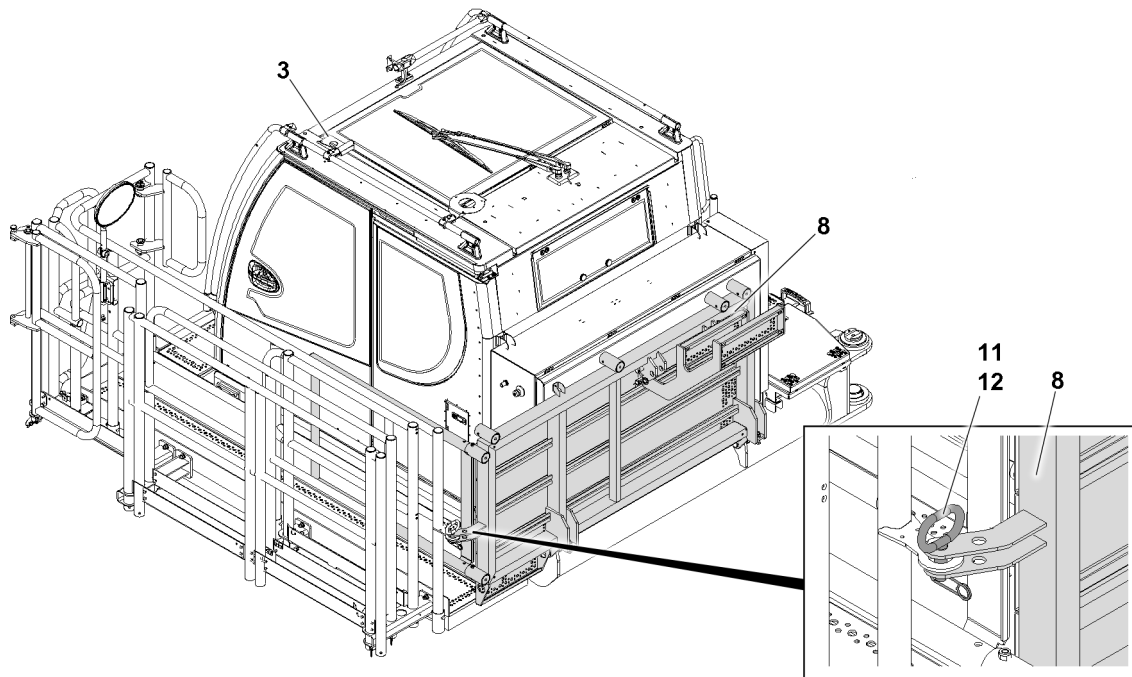


Fig.154393: Releasing the cab platform

Make sure that the following prerequisite is met:

- The step 7 is properly pinned and secured in operating position.



### WARNING

Folding down of the platform!  
Death, severe bodily injuries, property damage.

- ▶ Fold the cab platform **8** carefully by hand.
- ▶ Make sure that there is no one under the cab platform **88** during the folding procedure.

During assembly, the cab platform **8** is folded down with the installed lateral railing.

- ▶ Unpin the cab platform **8** in the transport position: Remove the retaining element **12** and unpin the plug **11**.

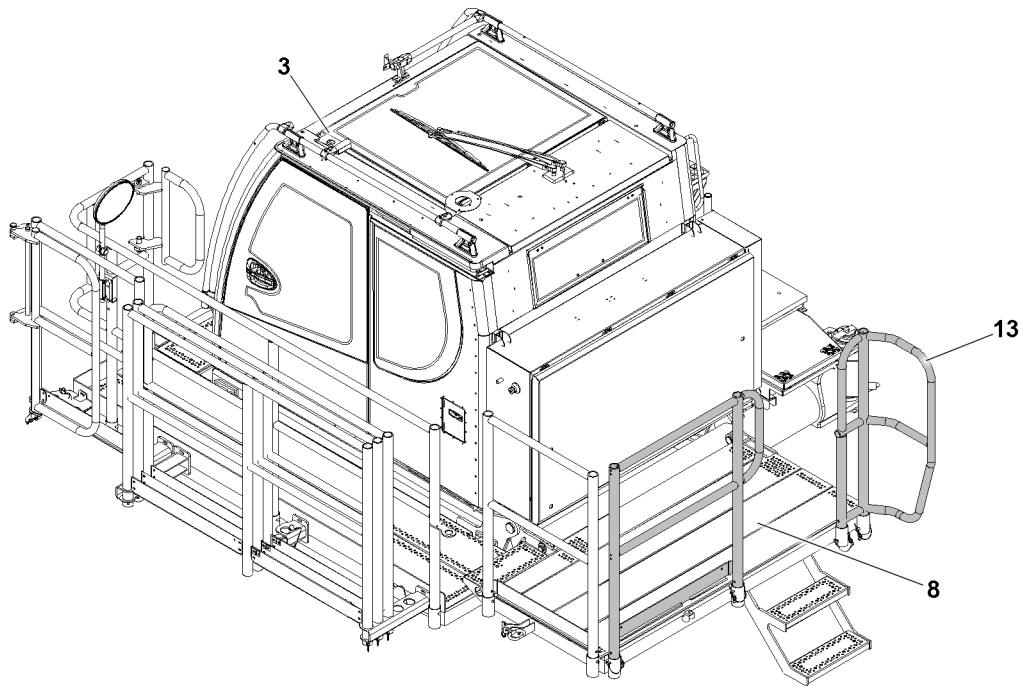


Fig.154394: Folding down the cab platform

- ▶ Swing the cab platform **8** downward into the operating position.
- ▶ Pin the plug **11** again.
- ▶ Secure the plug **11**: Attach the retaining element **12**.

### 7.3 Assembling the railing



#### Note

- ▶ Assemble the railing **13** on the cab platform **8**, see chapter 2.06.

## 8 Checking before start up

Various checks must be performed every time before crane start up.

If an item is low or lacking during an inspection, then it must be refilled or brought to normal status before crane start-up.

If the inspection shows a very dirty filter, then it must be replaced before crane start-up.



#### WARNING

Operating safety of the crane!

Defects on components, missing quantities or dirty filters affect the operating safety of the crane.

- ▶ If a defect on a component is found during the check, the defect must be remedied before crane start-up.
- ▶ If an item is low or lacking during an inspection, then it must be refilled or brought to normal status before crane start-up.
- ▶ If the inspection shows a very dirty filter, then it must be replaced before crane start-up.

**WARNING**

Heated crane components!

When the engine is running, crane components can heat up significantly. This applies especially to exhaust system, the engine, the coolant circuit and the respective gears in the crane chassis and in the crane superstructure.

Touching heated crane components can cause severe injuries.

- ▶ Carry out the checks before starting the crane, when the crane components are cold.
- ▶ Let already heated components cool off before checking.
- ▶ Proceed with special caution near heated crane components.

**WARNING**

Emergency devices not operational!

If emergency devices, such as the EMERGENCY STOP switch, ladders etc. are not accessible or operational, then they cannot be used in case of an emergency.

Death, severe bodily injuries, property damage.

- ▶ Check emergency devices before start up for accessibility or operational readiness.
- ▶ Open or remove anti-theft devices, such as locks on the emergency devices.

**Note**

- ▶ The illustrations, icons and monitor illustrations in this chapter are only examples.
- ▶ The numerical values in the individual icons and charts do not have to necessarily match the crane exactly.
- ▶ Numbers and letters can be replaced by place holders.
- ▶ The display and assignment of the icons can deviate, depending on the set up configuration, operating status and configuration of the crane.
- ▶ In addition, many of the illustrations show the maximum configuration of the LICCON monitor with icons.
- ▶ In crane operation, an identical display will **not** appear on the LICCON monitor.

**Note**

- ▶ For fill quantities, service items and lubricants, see Service fill and chapter 7.06 and chapter 7.07.

Make sure that the following prerequisites are met:

- The ignition switches are in position “I”.
- The engine is off.
- The engine is at ambient temperature.
- The LICCON computer system is in “stand-by mode”.

## 8.1 Checking the general condition of the crane

**WARNING**

Danger of accident due to falling parts!

Loose parts, such as pins, retaining elements or ice, which are on the boom or crane superstructure can fall down during crane operation and hit personnel.

Death, severe bodily injuries, property damage.

- ▶ Before starting crane operation, make sure that there are no loose parts on the boom and crane superstructure.
- ▶ Check the crane for visible damage before starting crane operation.
- ▶ Carry out a function test of available safety equipment.
- ▶ Make sure that the crane is standing on level, load bearing ground.
- ▶ Make sure that the crane is properly supported and horizontally aligned.
- ▶ Make sure that the gear ring of the slewing ring connection is clean and greased.
- ▶ Make sure that the air supply to the oil and water cooler is clear.
- ▶ Make sure that side covers are closed and locked.
- ▶ Make sure that no persons or objects are in the danger zone of the crane.



- ▶ Make sure that the cable, hose and rope drum as well as the limit switches are free of snow, frost and ice.
- ▶ Make sure that there are no loose parts on the boom and the crane superstructure.

## 8.2 Performing a visual inspection



### WARNING

Avoidable low quantities / problems can cause critical situations unnecessarily.

- ▶ Carry out visual inspections thoroughly, conscientiously and completely.

Make sure that the following prerequisites are met:

- The engine is off.
- The engine is at ambient temperature.

### 8.2.1 Checking the engine oil level

#### Crane types with an electronic engine oil level display



#### Note

Crane types with an electronic engine oil level display

- ▶ Check the engine oil level, see section “Calling up and checking the monitoring functions of the LICCON computer system”.

#### Crane types without an electronic engine oil level display

For a detailed description of checking the engine oil level, see chapter 7.05.

For detailed description of the crane engine, see the Operating instructions of the engine manufacturer.

- ▶ Check the oil level on the dipstick.

### 8.2.2 Checking the winch oil level

For a detailed description of checking the oil level, see chapter 4.02.

- ▶ Check the oil level on the winches.

### 8.2.3 Checking the hydraulic tank

For detailed description of checking the filters on the hydraulic tank, see chapter 7.05.

#### Checking the oil level in the hydraulic tank

- ▶ Check the oil level in the hydraulic tank on the sight gauge.

#### Checking the filter for the hydraulic tank

- ▶ Check the hydraulic tank filter.

### 8.2.4 Checking the coolant level



### WARNING

Danger of injury due to scalding of the skin!

- ▶ Check the coolant level only when the engine is cold.
- ▶ Never open the cap on the coolant reservoir as long as the engine is warm. The cooling system is under pressure.
- ▶ To protect face, hands and arms from hot steam of hot coolant, cover the cap with a large rag when opening.

The coolant expansion tanks must be filled up to the overflow on the filler neck.

- ▶ Check the coolant level on the engine.

If the coolant level is too low:

- ▶ Add coolant, see chapter 7.05.

## 8.2.5 Checking the central lubrication systems

### NOTICE

Damage to crane components!

Missing or insufficient lubrication can cause damage on the crane components.

Expensive and extensive repairs can result.

- ▶ Make sure that the grease containers for the central lubrication system always show a sufficient fill level.
- ▶ Replace missing lubricant.

The grease container must be filled at all times with sufficient lubricant.

- ▶ Check the grease container.

If the fill level on the grease container is too low:

- ▶ Add lubricant, see chapter 7.04 and chapter 7.05.

## 8.2.6 Checking the window cleaning fluid

### NOTICE

Frozen window cleaning fluid!

If the window cleaning fluid is not frost resistant, then the window washer system can freeze during the cold time of the year.

Failure of the window washer system is the result.

The window washer system can be damaged.

- ▶ Change the window cleaning fluid in time to a frost resistant type.

Before the start of the cold season:

- ▶ Empty the container for the window cleaning fluid and refill it with a commercially available, frost resistant window cleaning fluid.

## 8.3 Calling up and checking the monitoring functions of the LICCON computer system

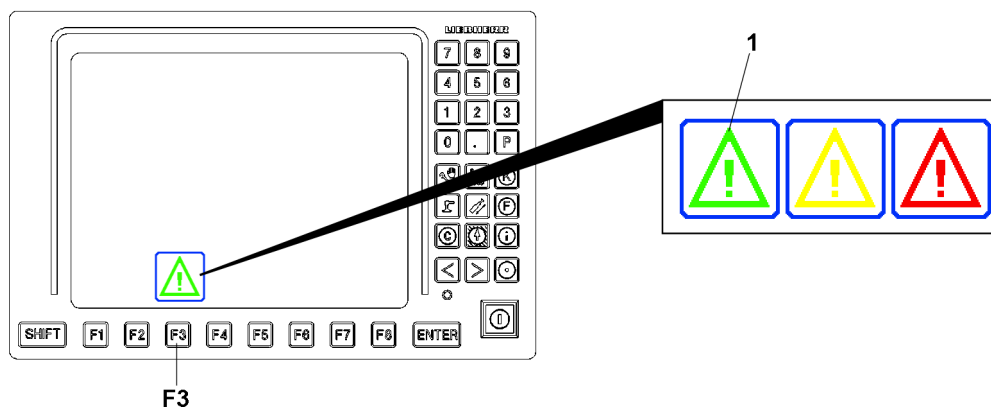


Fig.147668: Monitoring function warning icon

The monitoring functions are described in detail in chapter 4.02.

The selected crane components and operating conditions are monitored in the crane operation program. The warning icon **1** above the function key **F3** is displayed in green when all monitoring functions are ok. If a control value reached a limit range, or if there is a malfunction or warning, the warning icon **1** above the function key **F3** is displayed in yellow or red.

#### NOTICE

The warning icon **1** is displayed in yellow or red - malfunction / warning!

Damage to components.

- ▶ End crane movement.
- ▶ Turn the engine off.
- ▶ Remedy the cause of the error.
- ▶ Observe and adhere to the instructions in chapter 4.02.

The monitoring functions do not replace the visual inspections:

- Levels close to being too low can be recognized during visual inspections.
- Imminent problems can be recognized better through visual inspections.

The monitoring functions react in general only when a missing amount / problem is present. Avoidable missing amounts / problems impede crane operation and cause unnecessary delays and / or downtime.

Make sure that the following prerequisites are met:

- The ignition switch in the crane cab is in the position "I".
- The engine is off.
- The engine is at ambient temperature.
- The LICCON computer system is in "stand-by mode".
- The LICCON computer system is in the "Crane operation" program.



#### Note

- ▶ For a detailed description of the displays on the LICCON monitor, see chapter 4.02.
- ▶ For a detailed description of the safety equipment, see chapter 4.04.

### 8.3.1 Checking the fuel level



#### WARNING

Danger of fire and explosion!

- ▶ Turn the engine independent heater\* off approx. 3 minutes before refueling the fuel tank.
- ▶ Before refueling the fuel tank, turn the engine off.



#### Note

If the fuel tank has run dry, then the fuel system must be bled!

- ▶ Refuel in time.

Make sure that the following prerequisite is met:

- The LICCON computer system is booted up and in the "Crane operation" program.

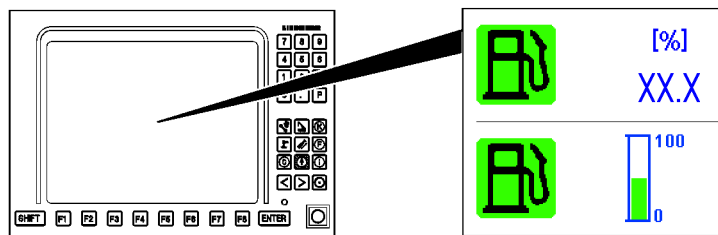


Fig.147669: Fuel reserve display - both variations

Depending on the crane type, the fuel reserve is displayed as a percentage value or a bar graph.

- ▶ Call up the monitoring functions, see chapter 4.02.

- ▶ Check the fuel reserve.

### 8.3.2 Checking the urea reserve



#### Note

- ▶ Valid only for engines that are equipped with an exhaust aftertreatment with SCR system.



#### WARNING

Power reduction or starting block of the engine!  
Insufficient urea reserve can trigger a power reduction or starting block of the engine.  
Crane and / or travel operation can be limited.

- ▶ Add Urea in time.

Make sure that the following prerequisite is met:

- The LICCON computer system is booted up and in the “Crane operation” program.

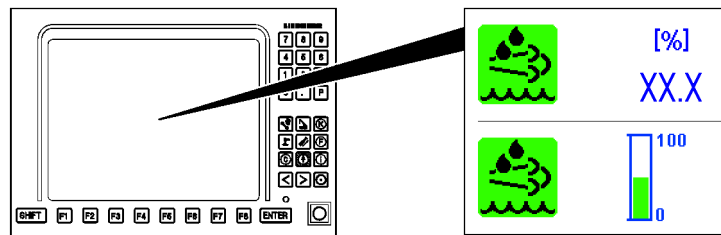


Fig.147670: Urea reserve display - both variations

Depending on the crane type, the urea reserve is displayed as a percentage value or a bar graph.

- ▶ Call up the monitoring functions, see chapter 4.02.
- ▶ Check the urea reserve.

### 8.3.3 Checking the diesel particle filter load condition (DPF)

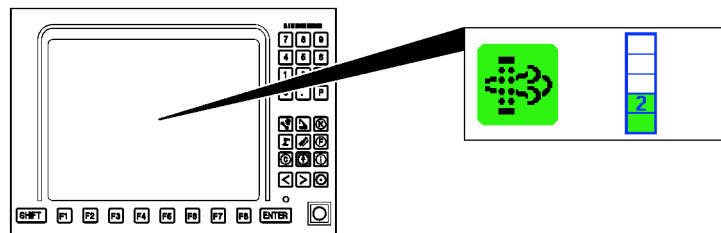


Fig.152660: Diesel particle filter load condition, example for load condition 2 (green)



#### Note

- ▶ Applies only for engines with a diesel particle filter (DPF).

Make sure that the following prerequisite is met:

- The LICCON computer system is booted up and in the “Crane operation” program.

The load condition of the diesel particle filter is displayed as a bar graph.

Explanation of the bar graph:

- Load condition 1 (green): Load condition OK, diesel particle filter minimally loaded
- Load condition 2 (green): Load condition OK, diesel particle filter slightly loaded
- Load condition 3 (green): Load condition OK, diesel particle filter half loaded
- Load condition 4 (yellow): Load condition increased, diesel particle filter strongly loaded
- **Note:** Prompt need for action required regarding the load condition of the diesel particle filter.
- Load condition 5 (red): Load condition critical, diesel particle filter with maximum load
- **Note:** Immediate need for action required regarding the load condition of the diesel particle filter.

- ▶ Call up the monitoring functions, see chapter 4.02.

Before starting the engine:

- ▶ Check the diesel particle filter load condition.

### 8.3.4 Checking the engine oil level

Make sure that the following prerequisite is met:

- The LICCON computer system is booted up and in the “Crane operation” program.

#### Engine oil level display, variation 1

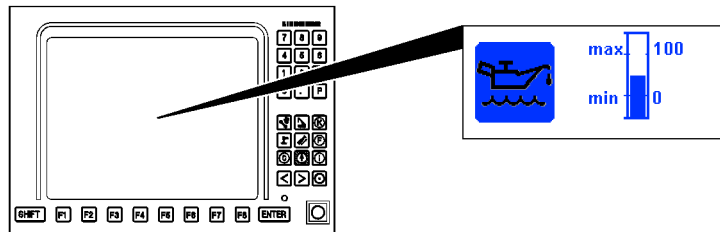


Fig.147671: Engine oil level display, example for engine oil level between min and max

The engine oil level is displayed as a bar graph.

Explanation of the bar graph:

- Under *min*: Engine oil level too low
- Between *min* and *max*: Engine oil level OK
- Over *max*: Engine oil level overfilled



#### Note

- ▶ The engine oil level can only be displayed when the engine is turned off.

- ▶ Call up the monitoring functions, see chapter 4.02.

Before starting the engine:

- ▶ Check the engine oil level.
- ▶ Adjust the engine oil, if necessary.

#### Engine oil level display, variation 2

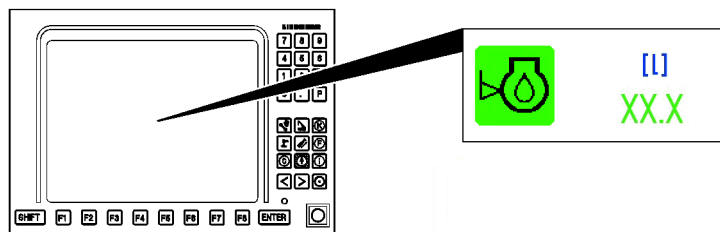


Fig.153666: Engine oil level in liters

On the LICCON monitor, the engine oil level is indicated in liters.

- ▶ Call up the screen display monitoring functions in the LICCON computer system and check the engine oil level.

The engine oil level can be read on the analog display:

- If “0.0” is shown on the analog display, then the engine oil level is ok.
- If “-1.0” is shown on the analog display, then 1 liter of engine oil must be drained.
- If “+1.5” is shown on the analog display, then 1.5 liter of engine oil must be added.

- ▶ Adjust the engine oil, if necessary.

### 8.3.5 Checking the hydraulic oil level

Make sure that the following prerequisite is met:

- The LICCON computer system is booted up and in the “Crane operation” program.

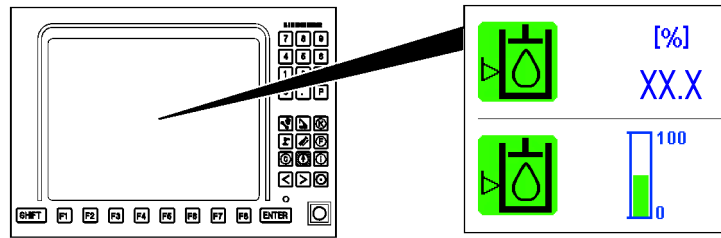


Fig.153667: Hydraulic oil level as a percentage

Depending on the crane type, the hydraulic oil level is displayed as a percentage value or a bar graph.

- ▶ Call up the monitoring functions, see chapter 4.02.
- ▶ Check the hydraulic oil level.

### 8.3.6 Checking the battery voltage

When the crane has been “out of operation” for a longer period of time and users, such as the airplane warning light are turned on, the batteries can discharge significantly.

At low ambient temperatures, there is a greater power requirement opposed by reduced battery power.

- The battery voltage must be checked at regular intervals and the batteries must be recharged, if necessary.
- At low ambient temperatures, pay attention that the batteries are well charged.

#### Checking the battery voltage on LICCON monitor

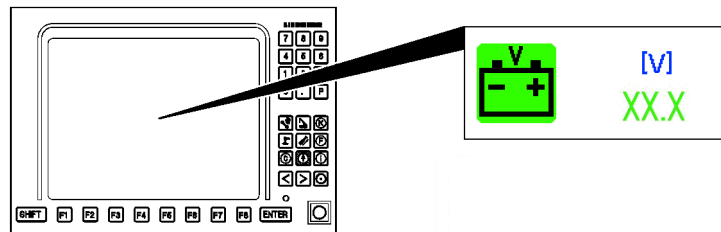


Fig.153668: Battery voltage

The battery voltage is shown in Volt on the LICCON monitor.

For a detailed description see chapter 4.02.

- ▶ Call up the screen display monitoring functions in the LICCON computer system and check the battery voltage.
- or**

Check the battery voltage on the batteries:

See chapter 7.05.

#### Checking the battery voltage on the batteries



#### Note

- ▶ See chapter 7.05.

### 8.3.7 Checking the center of gravity display on the LICCON monitor



**WARNING**

Shifting of the center of gravity!

The calculation of the values for the display of the center of gravity in the LICCON monitor are based on ideal assumptions.

- ▶ Side deformations of the boom system due to wind, incline position and elastic resilience of the steel structure are not taken into account but they can lead to a shifting of the center of gravity.

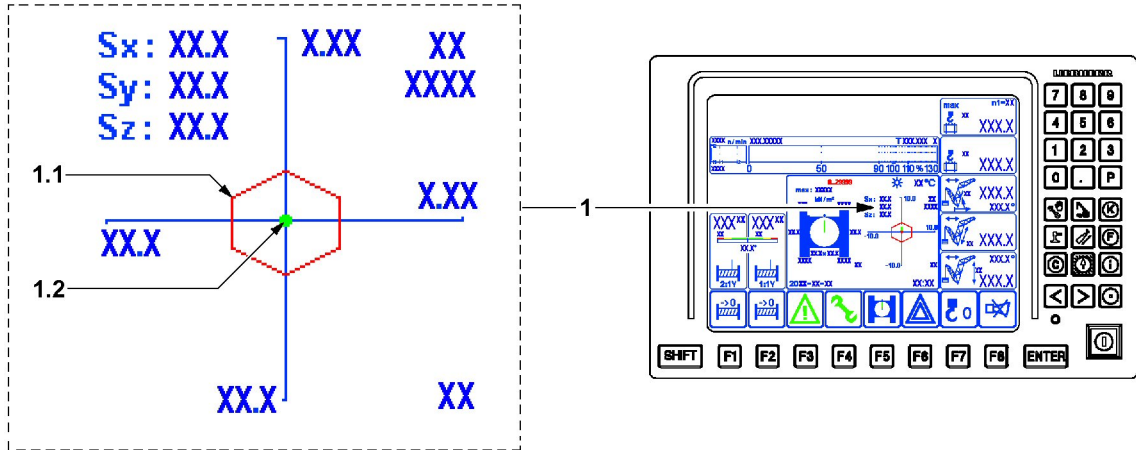


Fig.115325

Center of gravity display	
Position	Name
1.1	Core area
1.2	Center of gravity



**WARNING**

Center of gravity of the crane is outside the core area!

If the center of gravity 1.2 of the crane is outside the core area 1.1, then the crane can topple over. Death, severe bodily injuries, property damage.

- ▶ The center of gravity 1.2 must always be within the core area 1.1.



**Note**

- ▶ If the center of gravity 1.2 of the crane is within the core area 1.1, then the center of gravity 1.2 is shown in green.
- ▶ If the center of gravity 1.2 of the crane is outside the core area 1.1, then the center of gravity 1.2 is shown in red.

### 8.3.8 Checking the display for the surface pressure in the LICCON monitor



**WARNING**

Increased surface pressure!

The calculation of the values for the display of the surface pressure in the LICCON monitor are based on ideal assumptions.

- ▶ Side deformations of the boom system due to wind, incline position and elastic resilience of the steel structure are not taken into account but they can lead to an increase of the surface pressure.

LWE/LR 1800-1-0-000/27200-07-02/en

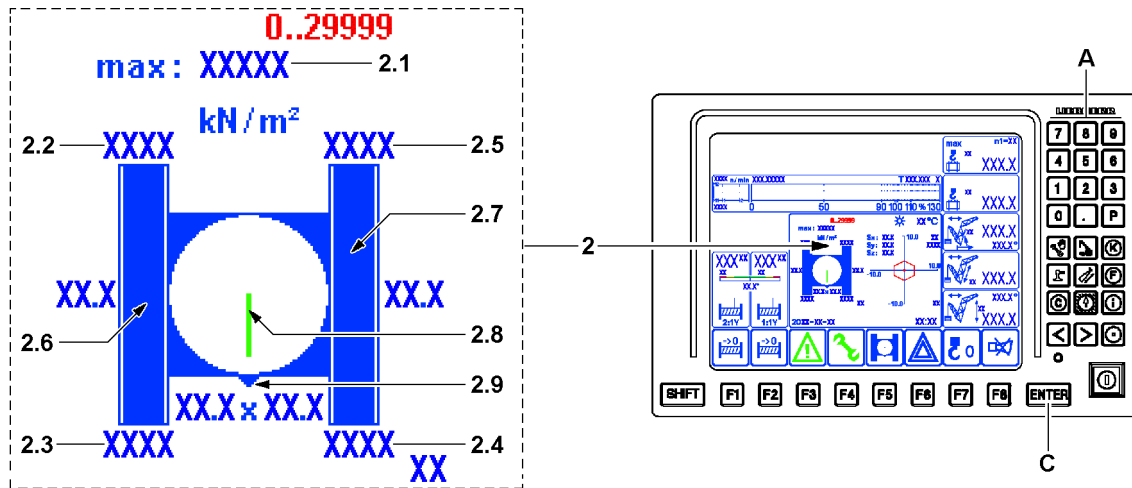


Fig.115326

Surface pressure display	
Position	Name
2.1	Maximum surface pressure
2.2	Right rear surface pressure
2.3	Front right surface pressure
2.4	Front left surface pressure
2.5	Rear left surface pressure
2.6	Right crawler carrier support
2.7	Left crawler carrier support
2.8	Boom position <sup>1)</sup>
2.9	"Front side of crawler travel gear" <sup>2)</sup> marker

1) The boom position corresponds to the "viewing direction to the front" from the crane cab.

2) The side where the chain tension device for the crawler carrier is located is always at the front on the crawler travel gear.



### WARNING

Surface pressure too high!

If the maximum surface pressure **2.1** is exceeded, the crane can topple over.

Death, severe bodily injuries, property damage.

- ▶ Do not exceed the maximum value for the surface pressure.



### Note

- ▶ The support of the crawler carrier is shown graphically.
- ▶ If the resulting surface pressure can be distributed so that the maximum surface pressure is not exceeded **and** the resulting forces can be transferred safely into the ground, then the stability of the crane is ensured.

The following specifications and instructions must be observed:

- The highest possible surface pressure, which may be obtained on the travel route must be entered as the maximum surface pressure **2.1**.

### Entering / changing the maximum permissible surface pressure

Make sure that the following prerequisite is met:

- The "Crane operation" program is called up.
- The maximum permissible surface pressure of the ground is known.



- ▶ Press the enter key **C**.

**Result:**

- The value for the maximum surface pressure **2.1** can be changed.
- ▶ Enter the value for the maximum permissible surface pressure via the keypad **A**.
- ▶ Press the enter key **C**.

**Result:**

- The new value for the maximum surface pressure **2.1** appears.
- ▶ Check the value for the maximum permissible surface pressure.

### 8.3.9 Checking the display for the incline in the LICCON monitor

Display of the incline of the crane to the horizontal in longitudinal and lateral direction. The display is graphic as well as numeric.

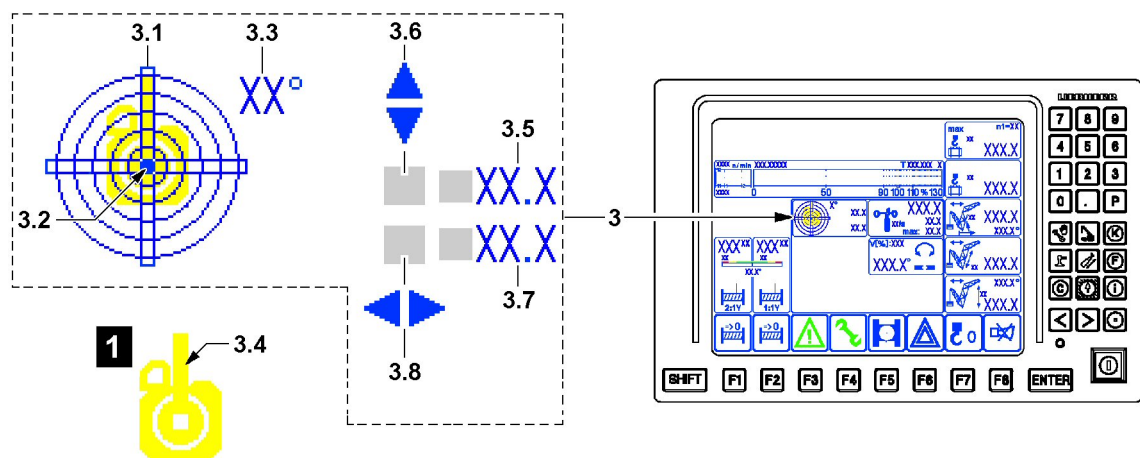


Fig.115327

Surface pressure display	
Position	Name
3.1	Sight gauge
3.2	Bubble
3.3	Display resolution
3.4	Boom position <sup>3)</sup>
3.5	Incline in the longitudinal direction
3.6	Incline direction
3.7	Incline in the lateral direction
3.8	Incline direction

3) The boom position in the sight gauge **3.1** is highlighted as orientation aid, see detail **1**. The boom position corresponds to the "viewing direction to the front" from the crane cab in relation to the spirit level **3.1**.



**WARNING**

The crane can topple over!  
 If the permissible inclines are exceeded, the crane can topple over.  
 Death, severe bodily injuries, property damage.

- ▶ Make sure that the permissible inclines are never exceeded.

## 9 Diesel particle filter (DPF)\*



### Note

- Applies only for engines with a diesel particle filter (DPF).

### 9.1 Calling up the diesel particle filter load condition

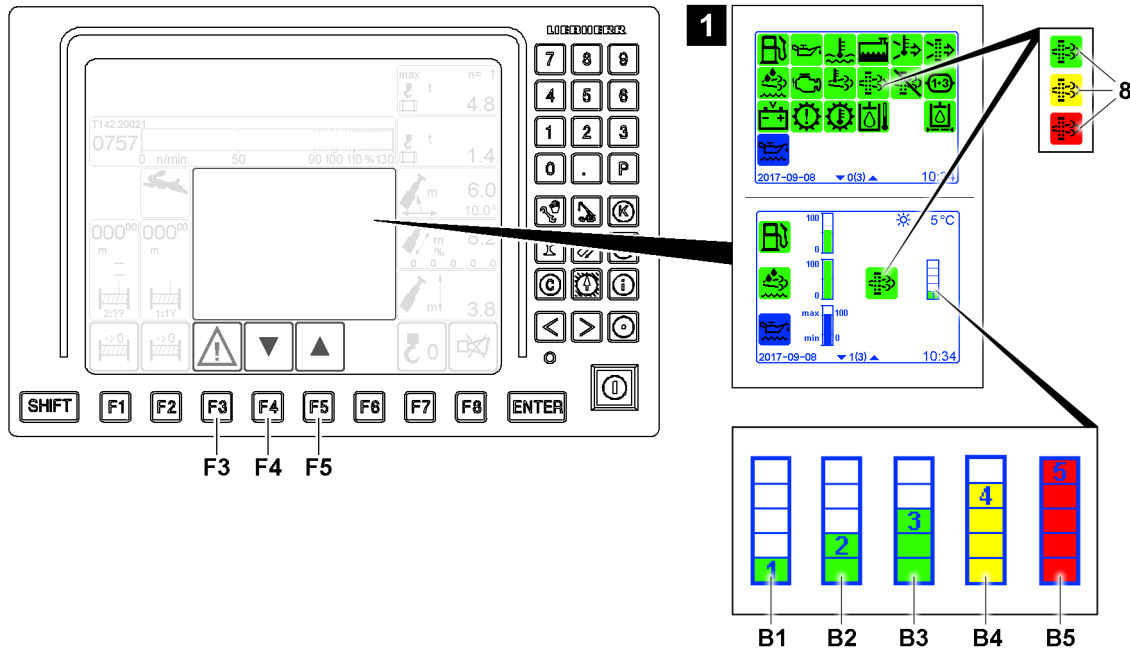


Fig.152140: Calling up the diesel particle filter load condition

Make sure that the following prerequisites are met:

- The ignition is turned on.
- The *Crane operation* program is active.

- Press the function key **F3**.

### Result:

- The monitoring functions / individual control displays are displayed on the LICCON monitor, see illustration 1.



### Note

- By pressing the function key **F4** / function key **F5**, it is possible to switch between the monitoring functions / individual control displays.

There are five load conditions for the diesel particle filter.

Read the load condition on the LICCON monitor:

- Load condition 1 **B1** (green): Load condition OK, diesel particle filter minimally loaded
- Load condition 2 **B2** (green): Load condition OK, diesel particle filter slightly loaded
- Load condition 3 **B3** (green): Load condition OK, diesel particle filter half loaded
- Load condition 4 **B4** (yellow): Load condition increased, diesel particle filter strongly loaded
- Load condition 5 **B5** (red): Load condition critical, diesel particle filter with maximum load

If the icon **8** appears / blinks yellow or red:

- Check the diesel particle filter load condition
- Observe the error messages and have it evaluated in the BSE test system

If the load condition 4 **B4** icon appears, Liebherr-Werk Ehingen GmbH recommends carrying out regeneration at a standstill as soon as possible (during the work day).

If the load condition 5 **B5** icon appears and regeneration at a standstill is no longer possible:

- ▶ Stop engine operation.
- ▶ Contact Customer Service at Liebherr-Werk Ehingen GmbH.



### Note

Load condition 5 **B5**

- ▶ The engine torque is reduced to protect the engine against damage.

## 9.2 Automatic regeneration of the diesel particle filter



### WARNING

Regeneration of the diesel particle filter\* in an environment with a fire hazard!  
High exhaust gas temperature. Danger of fire.

- ▶ In an environment with a fire hazard, disable or stop automatic regeneration.

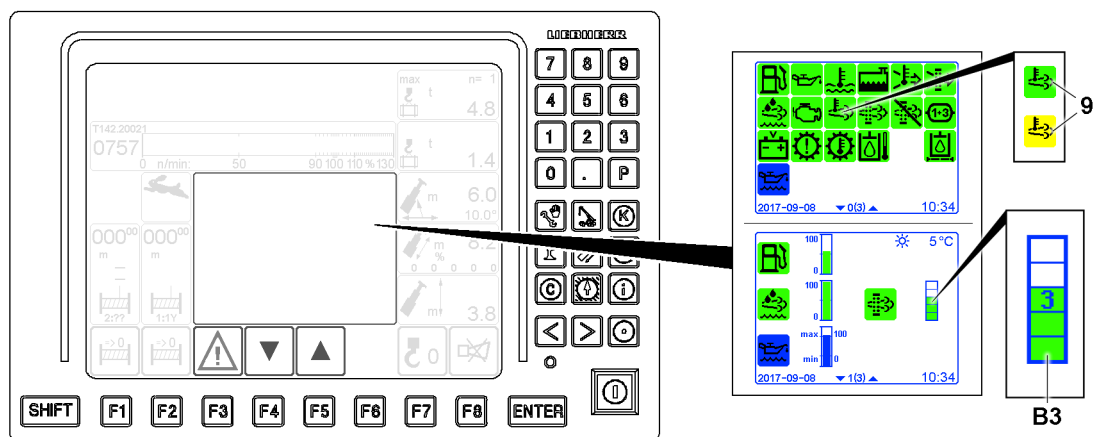


Fig. 152143: Possible displays during automatic regeneration of the diesel particle filter

From load condition 3 **B3**, automatic regeneration is carried out automatically during engine operation. This means no limitations for crane operation. Engine noise may change slightly during automatic regeneration.

Automatic Regeneration is triggered only when the ambient conditions (load profile) of the engine permit regeneration. The engine must be operated continuously for at least one hour to complete automatic regeneration.

While the diesel particle filter is being regenerated, the icon **9** in the crane operation monitoring functions turns yellow. When generation is complete, the icon **9** turns green.

## 9.3 Disabling automatic regeneration of the diesel particle filter

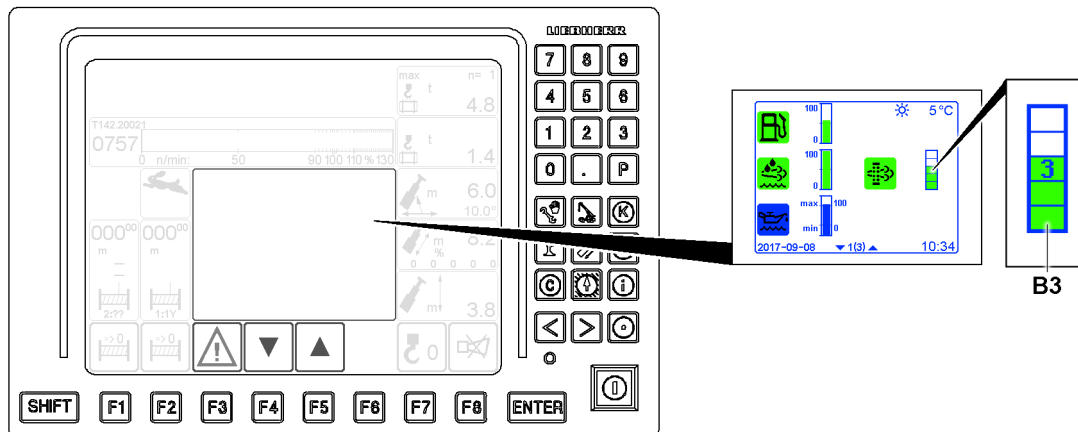


Fig.151823: Displays for load condition 3

From load condition 3 **B3**, automatic regeneration is carried out automatically during engine operation.

If needed, automatic regeneration can be:

- disabled as a precaution,
- interrupted and disabled while it is being carried out

Make sure that the following prerequisites are met:

- The crane is at a standstill.
- The monitoring functions are displayed on the LICCON monitor.

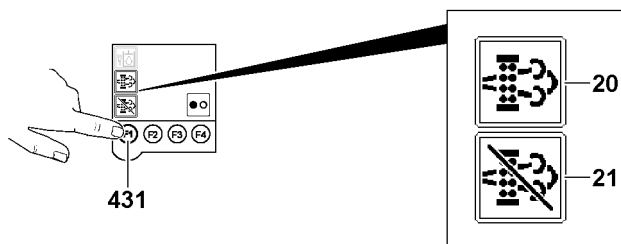


Fig.151820: Icons for controlling diesel particle filter regeneration on TE2

- ▶ Press the F1 key **431** on the left touch display (TE2) until the *Diesel particle filter regeneration at a standstill* **20** icon and *Disable diesel particle filter regeneration* icon **21** are displayed, see illustration.

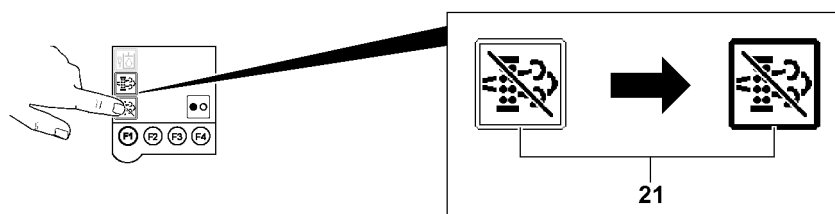


Fig.151821: Selecting disabling regeneration of the diesel particle filter

- ▶ Tap the *disable diesel particle filter regeneration* icon **21** to select it.

**Result:**

- The frame of the Symbol *disable diesel particle filter regeneration* icon **21** is displayed in bold.
- Disabling regeneration of the diesel particle filter is selected.

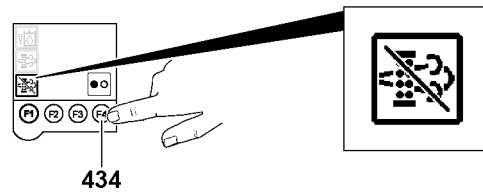


Fig.154109: Disabling automatic regeneration of the diesel particle filter

- ▶ Press the F4 key 434.

**Result:**

- Automatic regeneration of the diesel particle filter is disabled.

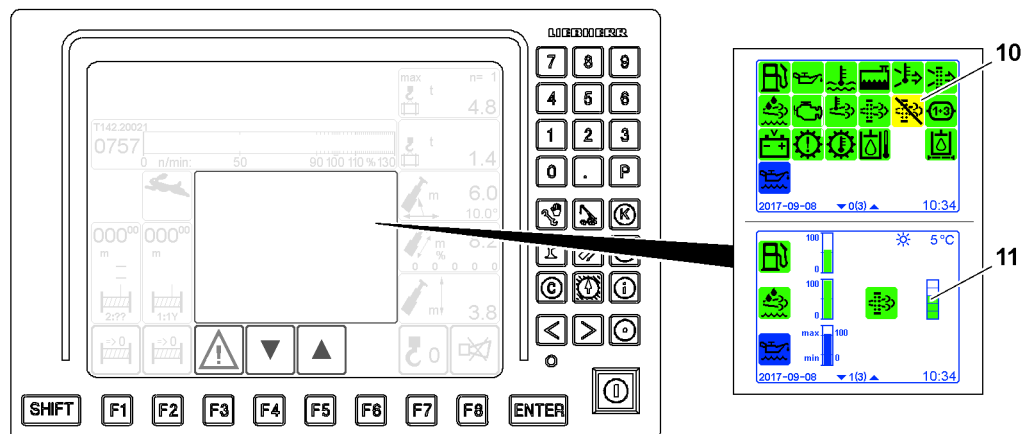


Fig.151824: Displays during disabling automatic regeneration of the diesel particle filter

As long as the automatic regeneration of the diesel particle filter is disabled, the *disable diesel particle filter regeneration* icon 10 appears yellow.

If automatic regeneration of the diesel particle filter is disabled:

- ▶ Monitor the *load condition* display 11. As soon as the load condition is increased (yellow), Liebherr-Werk Ehingen GmbH recommends carrying out a regeneration at a standstill as soon as possible (during the work day).

## 9.4 Regenerating at a standstill of the diesel particle filter



**WARNING**

Regeneration of the diesel particle filter\* in an environment with a fire hazard!  
High exhaust gas temperature. Danger of fire.

- ▶ In an environment with a fire hazard, do not carry out regeneration at a standstill of the diesel particle filter.

**NOTICE**

Turn off the engine during regeneration at a standstill!  
Interrupting the regeneration at a standstill by turning off the engine destroys the diesel particle filter (DPF).

- ▶ Do **not** interrupt regeneration at a standstill by turning off the engine.



**Note**

High temperatures at the exhaust outlet

- ▶ Only if necessary: Carry out regeneration at a standstill.

Regeneration at a standstill of the diesel particle filter must be initiated on touch display 2. Regeneration at a standstill can be carried out at the earliest from load condition 2 and at the latest by load con-

dition 4. In addition, no crane movement or travel movement may be started. The engine rpm may not be increased (idle).



#### Note

- ▶ Do **not** carry out any crane operation or travel operation during regeneration at a standstill!

Make sure that the following prerequisites are met:

- The crane is at a standstill, no master switch or pedal sensor has been actuated.
- The BTT is in the charging cradle.
- The engine rpm is not increased, the engine is idling.
- The load condition of the diesel particle filter is displayed on the LICCON monitor.
- At least load condition 2 is reached.

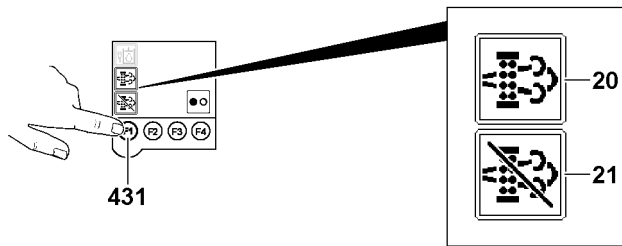


Fig.151820: Icons for controlling diesel particle filter regeneration on TE2

- ▶ Press the F1 key **431** on the left touch display (TE2) until the *Diesel particle filter regeneration at a standstill* **20** icon and *Disable diesel particle filter regeneration* icon **21** are displayed, see illustration.

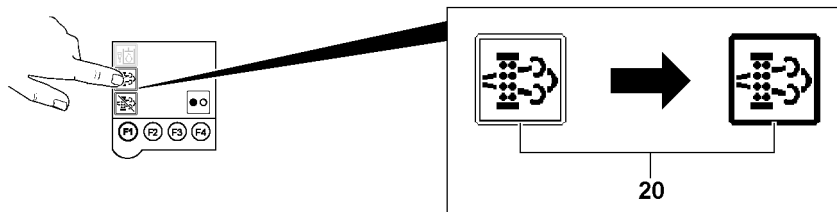


Fig.151822: Selecting regeneration at a standstill of the diesel particle filter

- ▶ Tap the *diesel particle filter regeneration at a standstill* icon **20** to select it.

#### Result:

- The frame of the Symbol *diesel particle filter regeneration at a standstill* icon **20** is displayed in bold.
- Regeneration at a standstill of the diesel particle filter is selected.

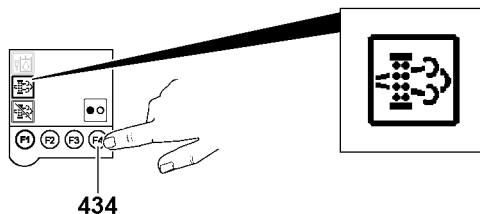


Fig.151826: Activating regeneration at a standstill of the diesel particle filter

- ▶ Press the F4 key **434**.

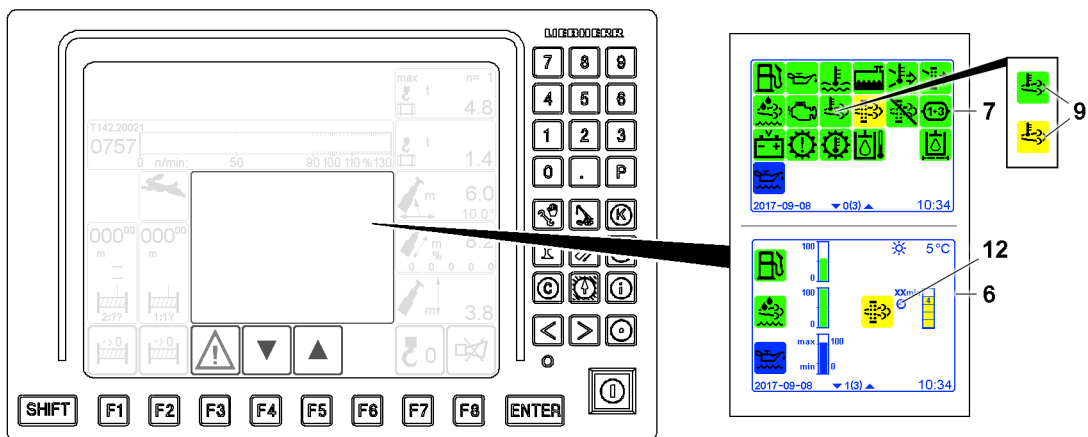
**Result:**

Fig.152142: Example of carrying out the regeneration at a standstill of the diesel particle filter with load condition 4

- Regeneration at a standstill of the diesel particle filter has started.
  - The crane operation monitoring functions 7 icon 9 turns yellow.
  - The remaining regeneration time 12 is displayed on the individual control displays 6.
- ▶ Wait until the regeneration time 12 has elapsed.

**Result:**

- The icon 9 turns green.
- After successful regeneration, a permissible load condition is reached.

## 10 Exhaust system cleaning procedure

The automatic cleaning procedure for the *exhaust system* prevents damaging the exhaust system.

Prior to the *exhaust system* cleaning procedure, the engine rpm is increased for 10 to 20 minutes by the crane control. A message 1 is displayed.

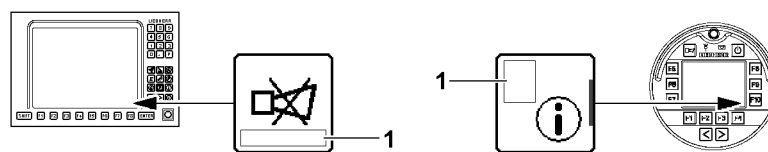


Fig.154108: Note regarding the message 1 in the display field

If the engine is turned off during the cleaning procedure, the cleaning procedure restarts the next time the engine is started.

**NOTICE**

*Exhaust system* cleaning procedure active!  
Hot exhaust system. Property damage.

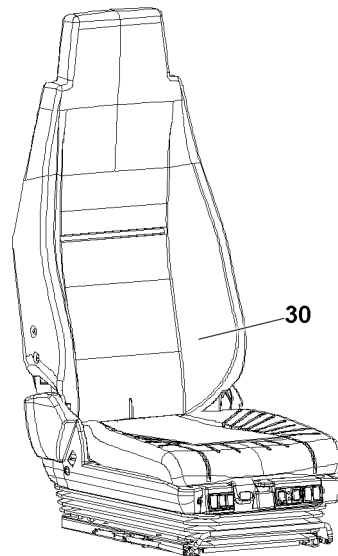
If the *exhaust system* cleaning procedure active message is displayed:

- ▶ Do **not** turn the engine off.

If the *exhaust system* cleaning procedure active message disappears:

- ▶ The engine can be turned off.

## 11 Crane driver's seat



*Fig.147578: Adjusting the crane driver's seat*

The crane driver's seat **30** can be adjusted to suit any body size.

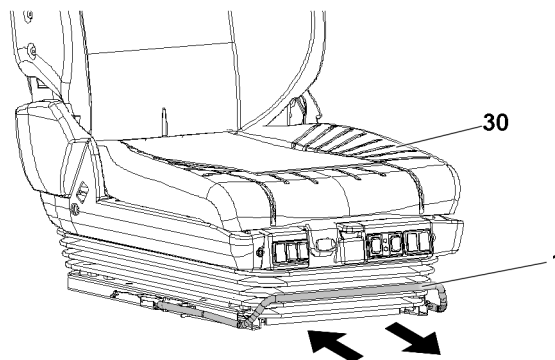


### **WARNING**

Sudden backward movement of the crane driver's seat when the crane cab is tilted!  
Danger of crushing.

- ▶ Adjust the seat position only when the crane cab is in the horizontal position.

### 11.1 Horizontal adjustment



*Fig.147579: Adjusting the crane driver's seat horizontally*

- ▶ Pull the lever **1** up.
- ▶ Push the crane driver's seat **30** forward / backward.
- ▶ Engage the lever **1**.

#### **Result:**

- The crane driver's seat **30** is horizontally adjusted.



## 11.2 Backrest adjustment

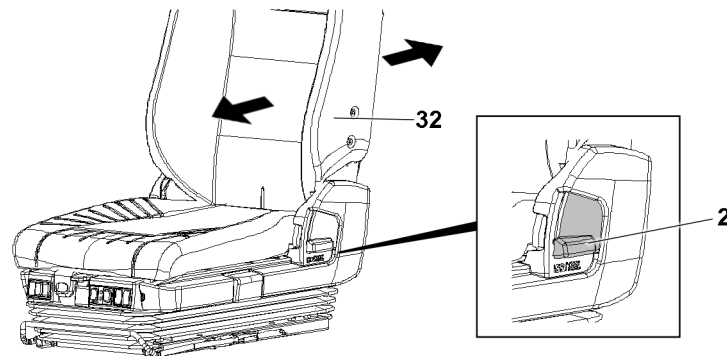


Fig.147580: Adjusting the backrest

- ▶ Pull the lever 2 up completely.
- ▶ Bring the backrest 32 into the desired position using body weight.
- ▶ Engage the lever 2.

**Result:**

- The desired backrest position is adjusted.

## 11.3 Integrated pneumatic system (IPS)

The “Integrated pneumatic system” (IPS) makes it possible to optimally adapt the backrest contour to the body.

### 11.3.1 “Lower” lumbar area support

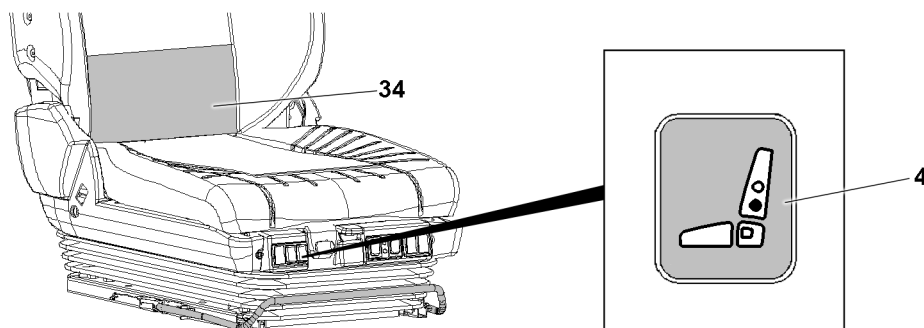


Fig.147581: Lower lumbar area support

- ▶ Press the button 4.

**Result:**

- The air chamber 34 for the “lower lumbar area support” is inflated.

- ▶ Press the button 4.

**Result:**

- The air chamber 34 for the “lower lumbar area support” is deflated.

### 11.3.2 “Upper” lumbar area support

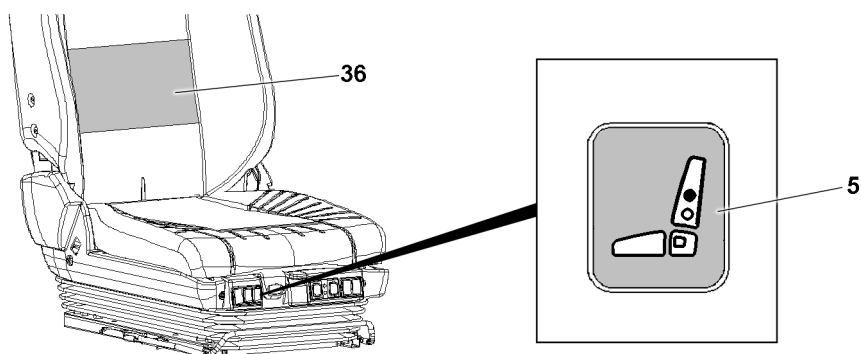


Fig.147582: Upper lumbar area support

- ▶ Press the button **5** forward.

**Result:**

- The air chamber **36** for the “upper lumbar area support” is inflated.

- ▶ Press the button **5** backward.

**Result:**

- The air chamber **36** for the “upper lumbar area support” is deflated.

### 11.4 Incline adjustment

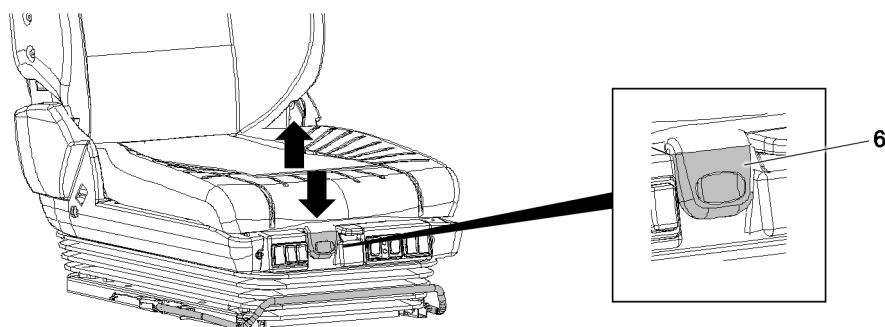


Fig.147583: Incline adjustment

- ▶ Pull the lever **6** up.
- ▶ Adjust the seat incline by inflating or releasing the front of the seat cushion.
- ▶ Engage the lever **6**.

**Result:**

- The incline adjustment has been set.

## 11.5 Seat cushion adjustment

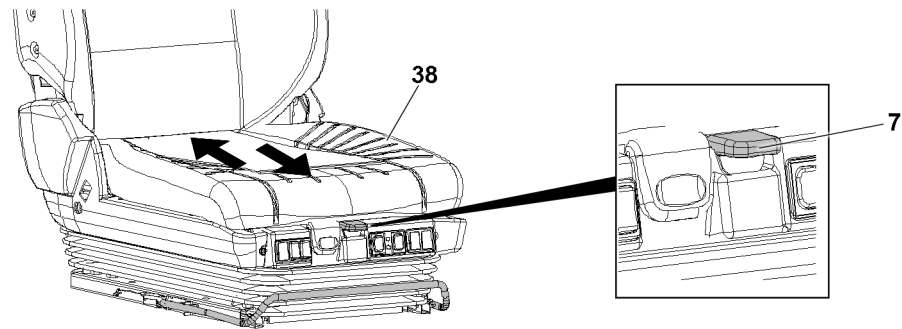


Fig.147584: Adjusting the seat cushion

- ▶ Pull the lever 7 up.
- ▶ Push the seat cushion 38 forward / backward.
- ▶ Engage the lever 7.

**Result:**

- The seat cushion 38 is adjusted.

## 11.6 Height adjustment

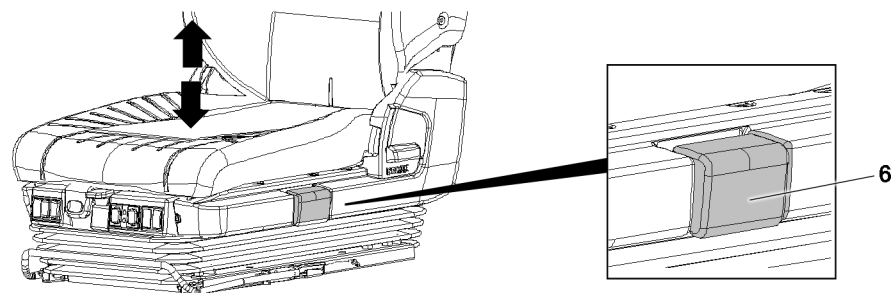


Fig.147585: Adjusting the seat height

---

**NOTICE**

Crane driver's seat adjusted too low!  
No seat suspension is available.

- ▶ Before starting to work: Adjust the crane driver's seat so that there is headroom and the pedals can be pressed down fully.

- 
- ▶ Adjust the seat height: Pull or press the handle 6.
  - ▶ Release the handle 6.

**Result:**

- The desired seat height is adjusted.

## 11.7 Heater / climate control

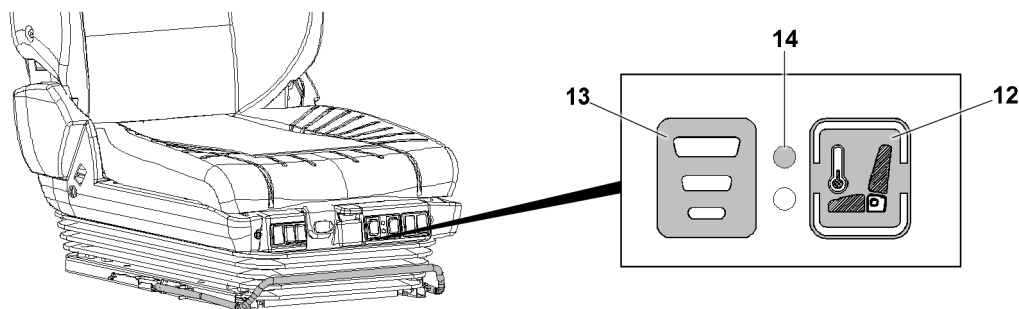


Fig.147586: Heater / climate control

### NOTICE

Anomalous use of the heater / climate control!  
Overheating, damage to the seat.

- ▶ Do **not** dry wet clothing.
- ▶ Do **not** place objects such as, for example, clothing, cushions or bags on the seat.
- ▶ Do **not** use seat covers on the seat.
- ▶ If the seat is not occupied, use of the heater / climate control is prohibited.



### WARNING

Continuous operation of the climate control!  
Undercooling.

- ▶ Avoid the continuous operation of the climate control.

### 11.7.1 Heater / climate control

The button **12** has three switch positions.

Switch position neutral (center position): No function, switch position "OFF".

Switch position up: Heater turned on.

Switch position down: Fan on.

- ▶ Button **12** in the "OFF" switch position.

#### Result:

- The heater / climate control is turned off.

- ▶ Push the button **12** upward.

#### Result:

- Heater turned on.

- ▶ Press the button **12** downward.

#### Result:

- Fan on.

### 11.7.2 Heater / fan stages

The button **13** has three switch stages. The switch levels can be selected from low to high.

- ▶ Select the switch stage: Press the button **13**.

#### Result:

- The heater / fan stage is set.

### 11.7.3 Heater / climate control indicator light

If the red indicator light **14** blinks, a problem is displayed.

- ▶ The red indicator light **14** blinks: Switch the button **12** to the neutral switch position (center position).

**Result:**

- The heater / climate control is turned off.
- ▶ Remedy the problem.

## 12 Control platform

### 12.1 Folding the console

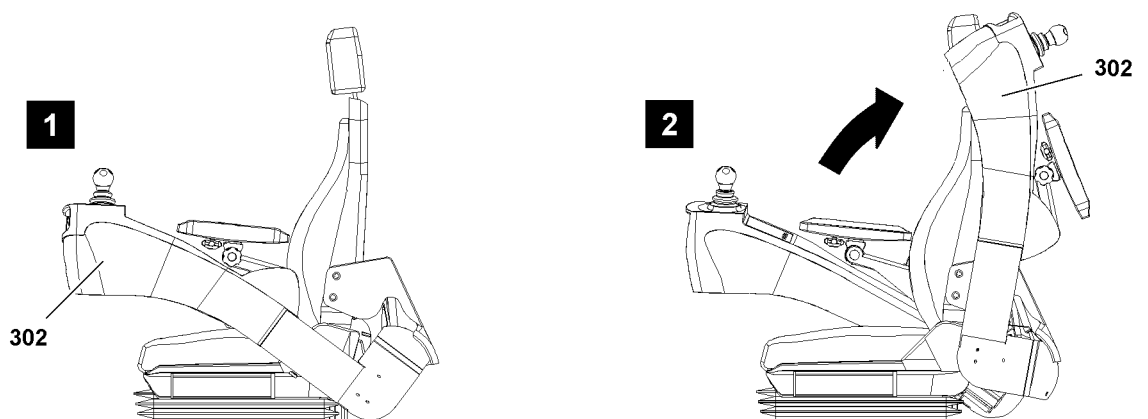


Fig.122071: Folding the console

The console **302** can be folded up or down.

- Operating position: The console **302** is folded down, illustration **1**.
- Entry / exit position: The console **302** is folded up, illustration **2**.

**WARNING**

Sudden folding down of the console!  
Danger of crushing, property damage.

After entering and exiting:

- ▶ Fold down the console **302** each time after entering and exiting.
- ▶ Do not allow the console **302** to fall down.

Before entering and exiting:

- ▶ Fold the console **302** up.

## 12.2 Adjusting the consoles

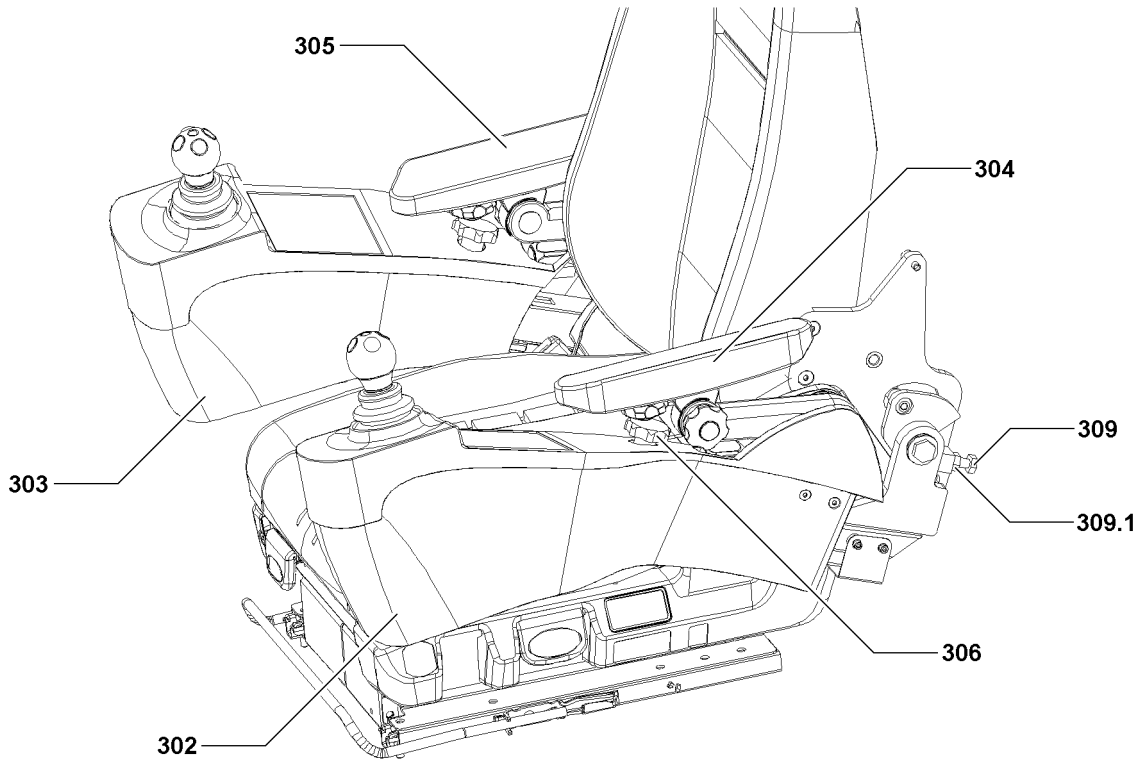


Fig.122072: Adjusting the consoles

The consoles can be adjusted individually to the respective body size of the crane driver.

The consoles can be adjusted to suit the crane driver as described for the left console **302**. The adjustment of the right console **303** functions the same way.

### 12.2.1 Adjusting the incline

- ▶ Bring the console **302** to the operating position.
- ▶ Release the nut **309.1**.
- ▶ Turn the stop screw **309** until the console **302** is set to the desired inclination.
- ▶ Secure the stop screw **309** with the nut **309.1**.

**Result:**

- The console inclination is adjusted.

### 12.2.2 Adjusting the console horizontally



**Note**

- ▶ The star handle screw **306** functionally a combination of a clamping screw and a detent pin.

- ▶ Fold the armrest **304** up.
- ▶ Turn the star handle screw **306** and unclamp the console **302**.
- ▶ Tighten the star handle screw **306**.

**Result:**

- The console **302** is unlocked.
- ▶ Adjust the console **302** by moving it horizontally.

When the console **302** is in the desired position:

- ▶ Release and engage the star handle screw **306**.

- ▶ Turn the star handle screw **306** and clamp the console.

**Result:**

- The console **302** is horizontally adjusted.
- ▶ Fold the armrest **304** down.

## 12.3 Armrests

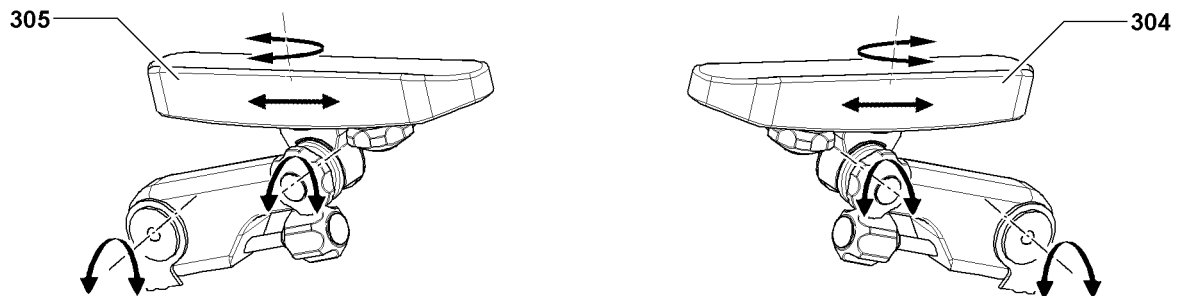


Fig.122073: Armrests

By releasing the adjustment screws, the armrests can be adjusted individually. To operate the master switches comfortably, set the armrests to the size of the crane driver.

- ▶ Release the adjustment screws.
- ▶ Adjust the left armrest **304** and right armrest **305**.
- ▶ Close the adjustment screws.

## 13 Crane cab

### 13.1 Turning on the heater and climate control system

The crane cab can be heated or ventilated depending on the desired temperature, see chapter 6.02.

### 13.2 Tilting the crane cab

To give the crane driver a better field of vision, the crane cab can be tilted upwards.

When the crane cab is tilted up, the catwalk around the cab is also inclined.

The incline of the crane cab can be adjusted via the function keys on the operating and control unit (BKE).

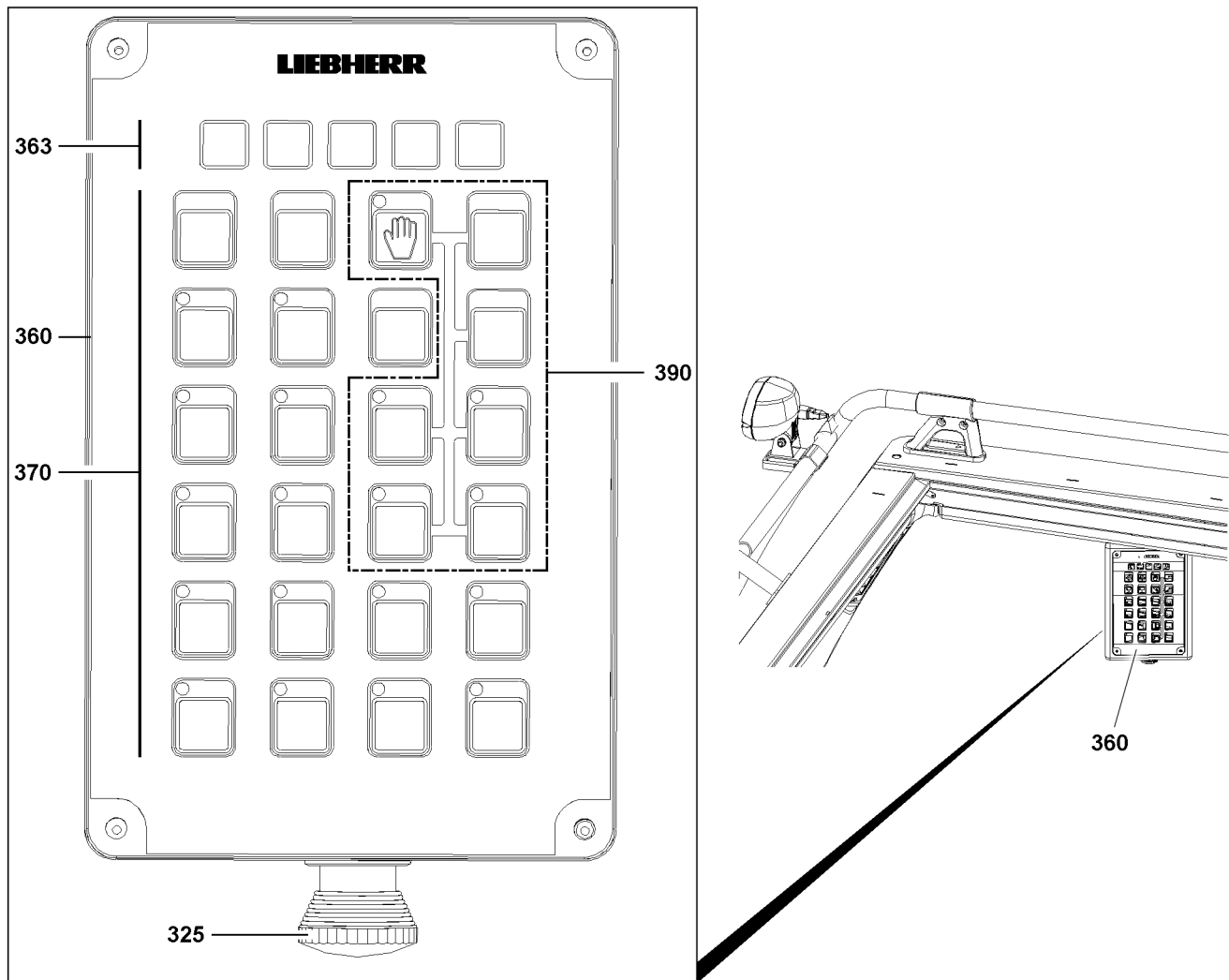


Fig.128957: Operating and control unit (BKE) in the crane cab



### WARNING

Danger of accident!

When the crane cab is tilted or tilting, personnel who move freely in the cab can fall.

When the crane cab is tilted or tilting, the door of the crane cab can start to move suddenly when opening it.

Death, severe bodily injuries, property damage.

- ▶ Tilt the crane cab only when properly seated in the seat.
- ▶ Before getting up from the seat, set the crane cab into horizontal position.
- ▶ After completion of working with the crane, return the crane cab to horizontal position.

When the cab door must be opened with tilted crane cab:

- ▶ Grasp the cab door handle safely and carefully open the cab door.



### WARNING

Inclined catwalk!

If persons are on a tilted or tilting catwalk, they can fall.

Death, severe bodily injuries, property damage.

- ▶ It is prohibited for anyone to remain under the catwalk when tilting the crane cab.
- ▶ It is prohibited for anyone to remain on a tilted catwalk.
- ▶ Before stepping on the catwalk, set it to horizontal position.

After completion of working with the crane, return the crane cab to horizontal position.



Make sure that the following prerequisite is met:

- There are no persons in the incline range of the crane cab and the catwalk.

### 13.2.1 Tilting the cab upward

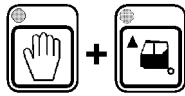


Fig.117719

- ▶ Activate the enable button **390** and then press the operating button **391**.

**Result:**

- The cab swings upward.

### 13.2.2 Moving the cab to the horizontal position



Fig.117720

- ▶ Activate the enable button **390** and then press the operating button **392**.

**Result:**

- The cab swings downward.

## 13.3 Window wiper / window washer system

### 13.3.1 Operating the window wipers

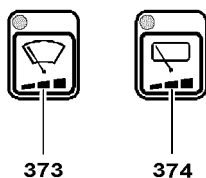


Fig.118205

The window wipers on the front and roof window can be operated via the function buttons on the operating and control unit (BKE), see illustration. Each window has a button assigned to it.

#### Turning the window wiper on

There are four different wipe stages.

Pressing the button **373** or the button **374** (less than 0.5 seconds) reduces the wiper speed incrementally:

1. Continuous operation
2. Short interval
3. Long interval
4. Wiper off

- When the wipe stage “Wiper off” is reached, an acoustical signal sounds on the BKE.

To activate the window wiper on the front window:

- ▶ Press the button **373** until the desired wipe stage is reached.
- or**

To activate the window wiper on the roof window:

Press the button **374** until the desired wipe stage is reached.

#### Turning the window wiper off

- ▶ Press the button **373** or the button **374** for at least one second.
- or**
- ▶ Press the button **373** or button **374** until an acoustical signal sounds on the BKE (0.5 seconds).

### 13.3.2 Operating the window washer system

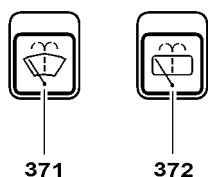


Fig.118214

The window washer system on the front and roof window can be operated using the function buttons on the operating and control unit. Each window has a button assigned to it.

The wiper motor and the water pump run as long as the button **371** or button **372** is pressed down.

After pressing the button **371** or the button **372**, three additional wipe movements are carried out before the wiper arms return to their original position.

To activate the window washer system for the front window:

- ▶ Press the button **371**.
- or**

To activate the window washer system for the roof window:

Press the button **372**.

### 13.3.3 Filling the window washer system

For the location of the reservoir for the window cleaning fluid, see chapter 4.01.

---

#### NOTICE

Frozen window cleaning fluid!

If the window cleaning fluid is not frost resistant, then the window washer system can freeze during the cold time of the year.

Failure of the window washer system is the result.

The window washer system can be damaged.

- ▶ Change the window cleaning fluid in time to a frost resistant type.
- 

Before the start of the cold season:

- ▶ Fill the reservoir with a frost resistant window cleaning fluid.

## 13.4 Checking the horn



### WARNING

Warning effect of horn!

If the horn is used outside of danger situations, then it can lose its warning effect.

If the horn loses its warning effect, then severe injuries can occur as a result.

Death, severe bodily injuries, property damage.

If the horn is to be checked:

- ▶ Notify all personnel in the vicinity that the horn is being checked for function.

When the horn test is completed:

- ▶ Notify all personnel in the vicinity that the testing of the horn has been completed.
- ▶ Do not use the horn unnecessarily.

Make sure that the following prerequisite is met:

- Any personnel in the vicinity has been notified that the horn is being checked for function.

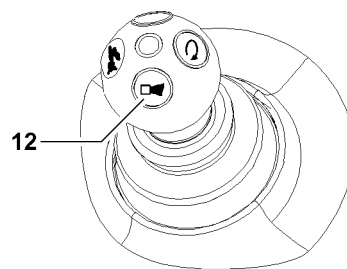


Fig.115322: Horn button

Before starting to work, check that the horn is functioning:

- ▶ Press the button **12** on any desired master switch.

### Result:

- The horn sounds.

### Problem remedy

The horn does not sound?

The horn is defective or is malfunctioning.

- ▶ Repair the horn before starting crane operation.

After successful testing of the horn:

- ▶ Notify any personnel in the vicinity that the testing of the horn has been completed.

## 13.5 Opening / closing cab doors and cab windows

Unsecured or unlocked cab doors or cab windows can move suddenly if, for example:

- The crane is driven / braked.
- The crane cab is inclined.



### WARNING

Danger of accident!

Unsecured or unlocked cab doors or cab windows which move suddenly can cause accidents.

If the crane is driven with open window or open cab door, the crane cab can be damaged.

Death, severe bodily injuries, property damage.

- ▶ Secure or lock cab doors or cab windows to prevent them from moving suddenly.

**WARNING**

Danger of crushing!

When closing the cab door and cab windows, hands and / or other limbs can be crushed.

- ▶ When closing the cab door and cab windows, make sure that no limbs are injured.

Open the cab door:

- ▶ Unlock and open the cab door.

Close the cab door:

- ▶ Pull the cab door closed and lock.

Open the cab window:

- ▶ Unlock and open the cab window.

Close the cab window:

- ▶ Pull the cab window closed and lock.

## 13.6 Opening / closing the roof window

### 13.6.1 Opening the roof window

**WARNING**

Hands can get trapped!

- ▶ Watch your hands when closing the roof window.

A pair of nitrogen gas cylinders support the lifting movement of the roof window.

- ▶ Open the window lock.
  - ▶ To open from inside, press on the roof window.
- or**

If you only want to partly open the roof window:

Adjust the window in the desired position with the provided perforated belt.

### 13.6.2 Closing the roof window

**WARNING**

Hands can get trapped!

- ▶ Watch your hands when closing the roof window.

- ▶ To close the roof window, pull the window down on the locking handle.

When the roof window is closed:

- ▶ Close the window lock.

## 14 Electrical external power supply

### 14.1 External power supply via an external power source

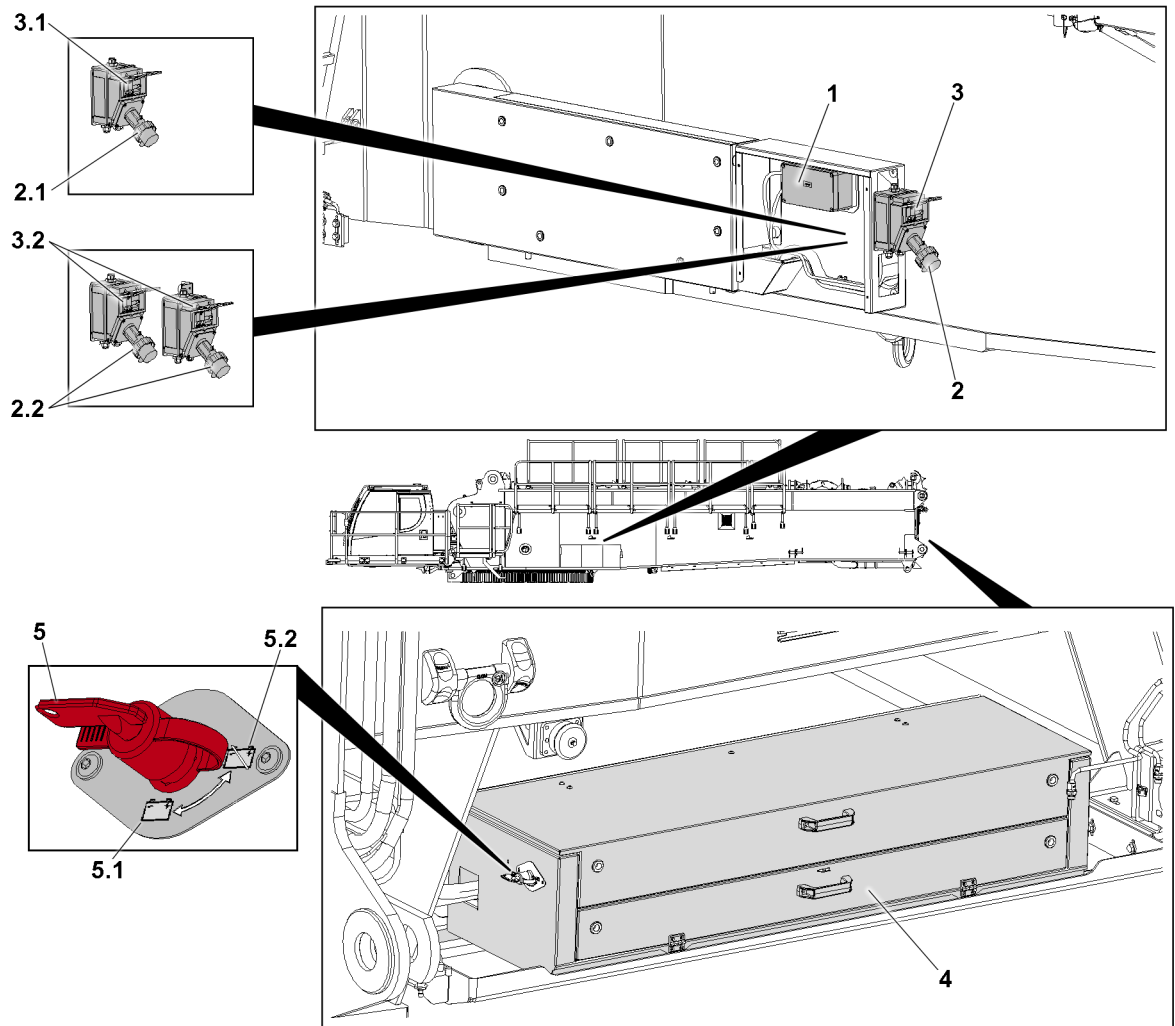


Fig.158799: External power supply via an external power source

- |     |                                       |     |                                 |
|-----|---------------------------------------|-----|---------------------------------|
| 1   | Battery charger                       | 3.2 | Circuit breaker for (2 x 110 V) |
| 2   | CEE sockets for external power supply | 4   | Battery system                  |
| 2.1 | CEE socket (230 V)                    | 5   | Battery disconnect switch       |
| 2.2 | CEE sockets (2 x 110 V)               | 5.1 | Connected position              |
| 3   | Circuit breaker                       | 5.2 | Disconnected position           |
| 3.1 | Circuit breaker for (230 V)           |     |                                 |

The battery disconnect switch **5** has the following positions:

- Connected position **5.1**: The battery electric circuit is **connected**
- Disconnected position **5.2**: The battery electric circuit is **disconnected**

Make sure that the following prerequisites are met:

- The battery disconnect switch **5** is in the **connected** position **5.1**.
- The circuit breakers **3** are in the **active** position.



#### Note

- ▶ The battery charger **1** automatically controls the feed based on the voltage of the batteries to be charged.

**Note**

- ▶ Depending on the country configuration of the crane, 230 V or 2 x 110 V is used for the external power supply.

- ▶ Remove the cover caps from the external power supply socket.
- ▶ Connect the line CEE plug connection with the power source (230 V / 110 V).
- ▶ Insert the line CEE plug connection into the socket (230 V) **2.1** or in the sockets (2 x 110 V) **2.2**.

**Result:**

- The external power supply via an external power source is established.

**Note**

- ▶ While the external power supply is connected, the batteries are automatically charged by the battery charger **1**.

## 14.2 External power supply via the aggregate\*

Only for crane types with a Hatz-aggregate\* on the turntable, see also Chapter 5.72.

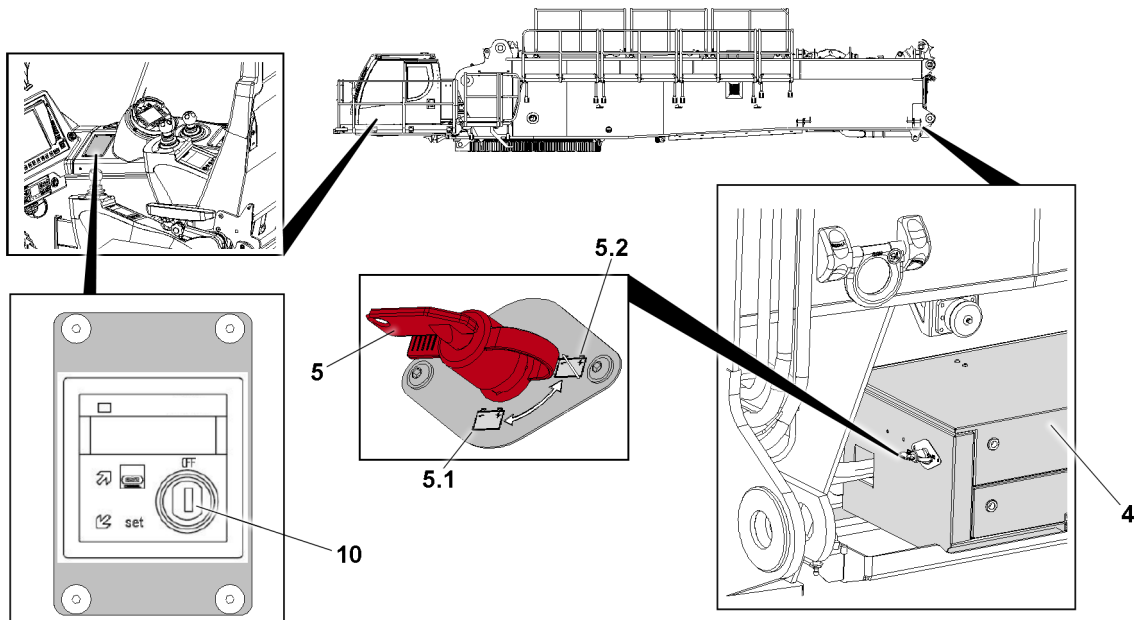


Fig.158797: External power supply via the aggregate (24 V)

- |                                    |   |
|------------------------------------|---|
| <b>4</b> Battery system            | <b>5.2</b> Disconnected position        |
| <b>5</b> Battery disconnect switch | <b>10</b> Aggregate operating elements* |
| <b>5.1</b> Connected position      |   |

The battery disconnect switch **5** has the following positions:

- Connected position **5.1**: The battery electric circuit is **connected**
- Disconnected position **5.2**: The battery electric circuit is **disconnected**

Make sure that the following prerequisites are met:

- The battery disconnect switch **5** is in the **connected** position **5.1**.
- ▶ Start the aggregate in the crane cab via the aggregate operating elements **10** using the ignition key.

**Result:**

- The external power supply via the aggregate (24 V)\* is established.

**Note**

- ▶ While the external power supply is connected, the batteries are automatically charged by the aggregate (24 V)\*.

## 15 Jump starting the diesel engine

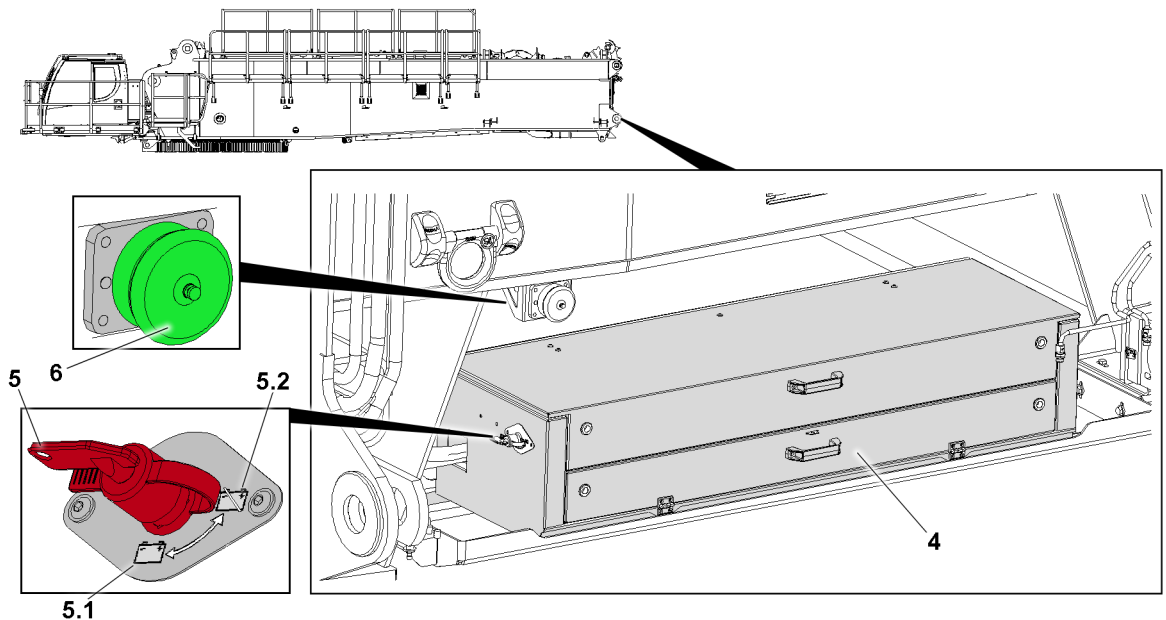


Fig.158798: Battery system with socket for jump start

- |                                    |                                     |
|------------------------------------|-------------------------------------|
| <b>4</b> Battery system            | <b>5.2</b> Disconnected position    |
| <b>5</b> Battery disconnect switch | <b>6</b> NATO socket for jump start |
| <b>5.1</b> Connected position      |                                     |

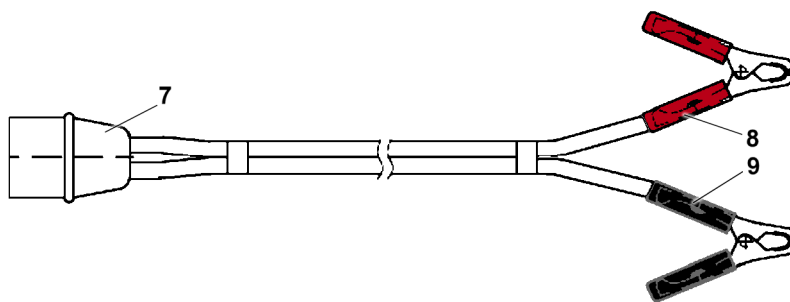


Fig.158796: Jumper cable 2P/ 24 V

- |  |  |
|--|--|
| <b>7</b> NATO connector                  | <b>9</b> Plastic terminal clamp, black (-) |
| <b>8</b> Plastic terminal clamp, red (+) |  |

The battery disconnect switch **5** has the following positions:

- Connected position **5.1**: The battery electric circuit is **connected**
- Disconnected position **5.2**: The battery electric circuit is **disconnected**

Make sure that the following prerequisites are met:

- The battery disconnect switch **5** is in the **connected** position **5.1**.
- The power source has a voltage of **24 V**.

**Note**

If jump starting using a motorized auxiliary vehicle:

- ▶ Make sure that the auxiliary engine is turned on while jump starting.
- 
- ▶ Remove the covering cap from the jump starting socket **6**.
  - ▶ Insert the NATO connector **7** into the jump starting socket **6**.
  - ▶ Connect the jumper cable with the **red** plastic terminal clamp **8** to the positive terminal of the auxiliary battery.
  - ▶ Connect the jumper cable with the **black** plastic terminal clamp **9** to the negative terminal of the auxiliary battery.
  - ▶ Start the crane diesel engine.

**Note**

- ▶ The batteries are charged via the crane generator while the diesel engine is running.

If the diesel engine is running independently:

- ▶ Disconnect the jumper cable with the **black** plastic terminal clamp **9** from the negative terminal of the auxiliary battery.
- ▶ Disconnect the jumper cable with the **red** plastic terminal clamp **8** from the positive terminal of the auxiliary battery.
- ▶ Remove the NATO connector **7** from the jump starting socket **6**.
- ▶ Fasten the covering cap on the jump starting socket **6**.

## 16 Preheating the hydraulic oil with Hydraulic oil preheating\*

The hydraulic oil can be preheated with the Hydraulic oil preheating\*.

**NOTICE**

Damage of hydraulic crane components!

If the required measures are not carried out for use of the crane at low temperatures, then the crane or crane components can be damaged.

Extensive repairs and / or downtime can result.

- ▶ Engage the Hydraulic oil preheating\*.
- ▶ Warm up the crane components according to chapter 2.08.

**Note**

- ▶ Always preheat the hydraulic oil at low ambient temperatures.
- ▶ From a hydraulic oil temperature above 25 °C , do not turn the Hydraulic oil preheating\* on.
- ▶ The current hydraulic oil temperature can be called up via the individual control display on the LIC-CON monitor.

### 16.1 Turning hydraulic oil preheating\* on

Make sure that the following prerequisite is met:

- The engine is running.

**Note**

When the Hydraulic oil preheating\* is turned on, various crane movements are turned off.

- ▶ If necessary, turn the Hydraulic oil preheating\* off.



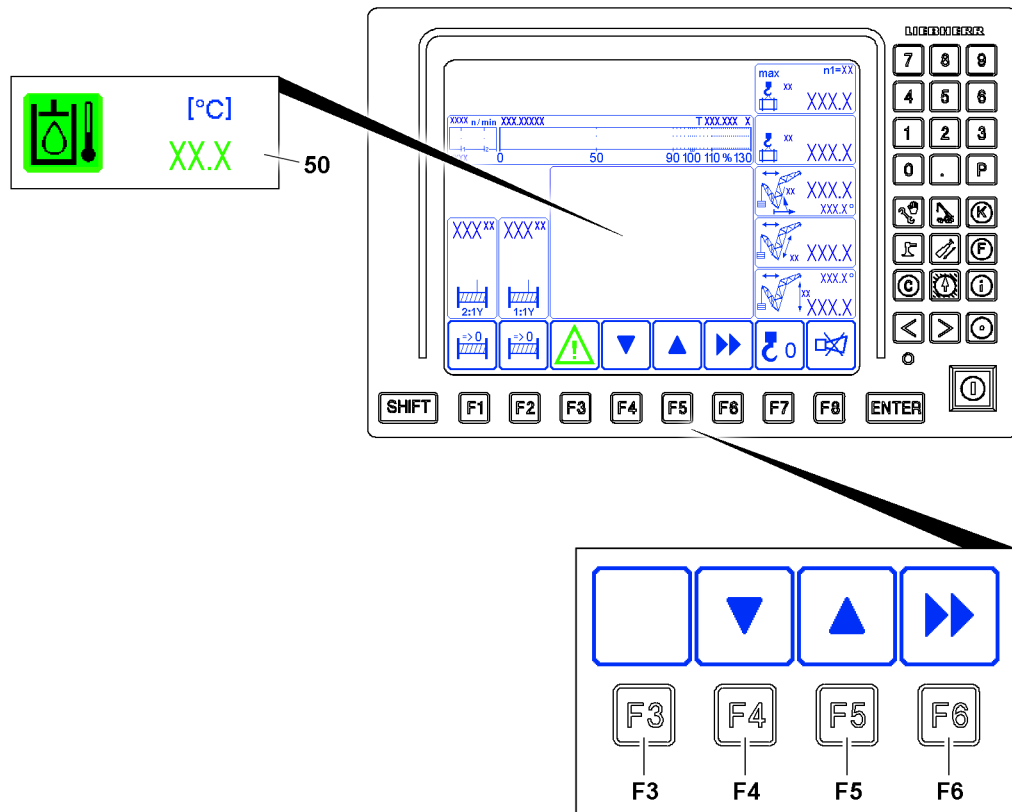


Fig.153669: Activating the monitoring field hydraulic oil preheating with its monitoring functions on the LICCON monitor

- ▶ In the “Crane operation” program, press the function key **F3**.

**Result:**

- The monitoring field with monitoring functions is displayed on the LICCON monitor.
- ▶ Press the function key **F4** until the individual control display for the hydraulic oil temperature is shown on the LICCON monitor.

**Result:**

- The current hydraulic oil temperature can be read.

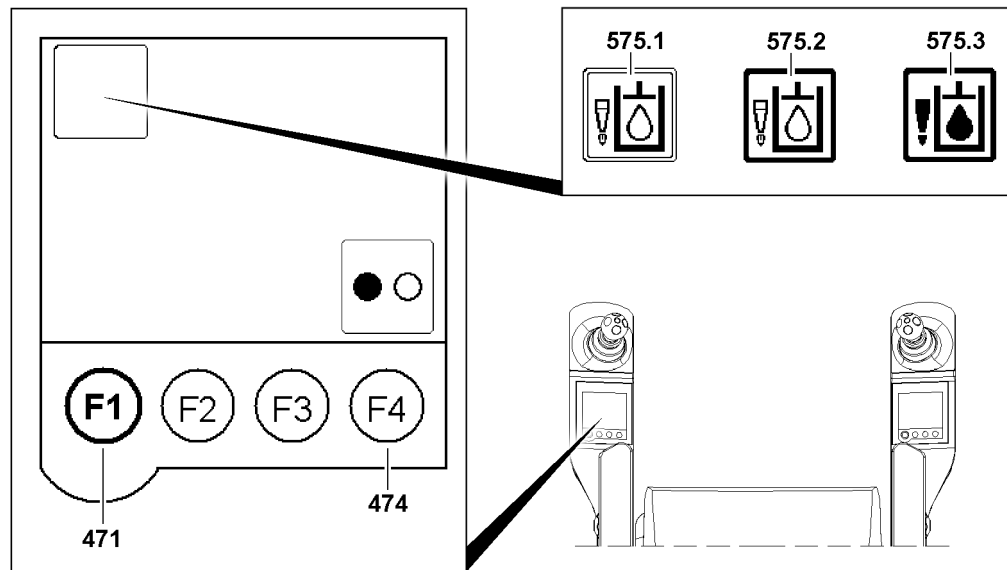


Fig.128959: Selecting the Hydraulic oil preheating function on TE2

- ▶ Press the F1 key **471** on the left touch display until the “Hydraulic oil preheating” menu appears.

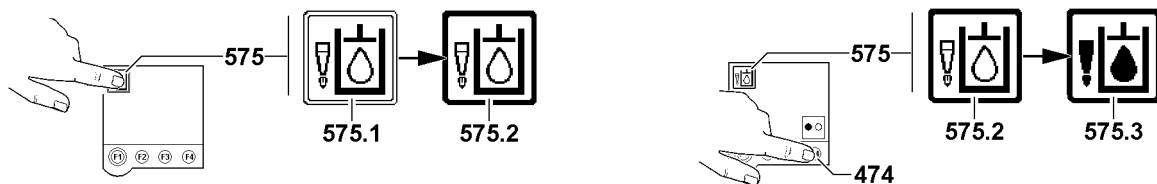


Fig.115320: Selecting the function Hydraulic oil preheating

- ▶ Select the function “Hydraulic oil preheating” **575** by touching the icon **575.1** on the display.

**Result:**

- Icon **575.1** changed to icon **575.2** (icon bordered in black).

- ▶ Press the F4 key **474**.

**Result:**

- The icon **575.2** changes to icon **575.3** (icon filled out).
- The hydraulic oil preheating is turned on.

When the hydraulic oil temperature in the individual control display **50** has reached the operating temperature:

- ▶ Press the F4 key **474**.

**Result:**

- Hydraulic oil preheating is turned off.
- The icon **575.2** appears (icon not filled out).

- ▶ Press the function key **F3**.  
or  
Press the function key **F6** twice.

**Result:**

- The monitoring field with monitoring functions is not displayed.

## 17 Starting the LICCON computer system (before engine start)

There are two operating modes for the LICCON computer system:

- LICCON computer system in “stand-by mode” (crane engine turned off).
- The LICCON computer system in normal mode (crane engine turned on).

### 17.1 System start of the LICCON computer system

After the ignition is turned on, the LICCON computer system boots up and carries out a self-test, see chapter 4.02.

Make sure that the following prerequisite is met:

- Do not operate any operating elements during the system start of the LICCON computer system.



#### Note

During the boot up phase, if an operating element is actuated (for example the master switch is moved from the zero position), the system start may be aborted as a result.

- ▶ After an abort at system start: Turn the engine and ignition off and then start again.

- ▶ Wait for the boot up phase.

#### Result:

- The set up screen appears on the LICCON monitor.
- Normally the previously selected set up configuration is displayed.
- ▶ Check the set up configuration.

#### Problem remedy

The LICCON monitor does not show the required set up configuration?

- ▶ Set the required set up configuration, see section “Changing the set up configuration”.

#### Problem remedy

Does an error message appear on the LICCON monitor?

- ▶ Turn the engine and ignition off and then start again.

When an error message appears again:

- ▶ Contact Liebherr Customer Service.

### 17.2 Taking over the set up configuration that was previously set

Make sure that the following prerequisite is met:

- The entries and settings in the “Set up” program match the actual set up configuration of the crane.

When the entries and settings in the Set up program are correct:

- ▶ Press the function key **F8**.

#### Result:

- The entries and settings are taken over and the “Set up” program is ended. The crane operation program is called up and the crane operating screen is shown.

### 17.3 Changing the set up configuration

The entries and settings for the set up configuration can be changed in the Set up program.

- ▶ Call up the set up program and make the entries and settings for the set up configuration.



#### Note

- ▶ For detailed description of the entries and settings in the Set up program, see chapter 4.02.

When the entries and settings in the Set up program are correct:

- ▶ Press the function key **F8**.

**Result:**

- The entries and settings are taken over and the “Set up” program is ended. The crane operation program is called up and the crane operating screen is shown.

## 17.4 Setting the speed reduction master switch

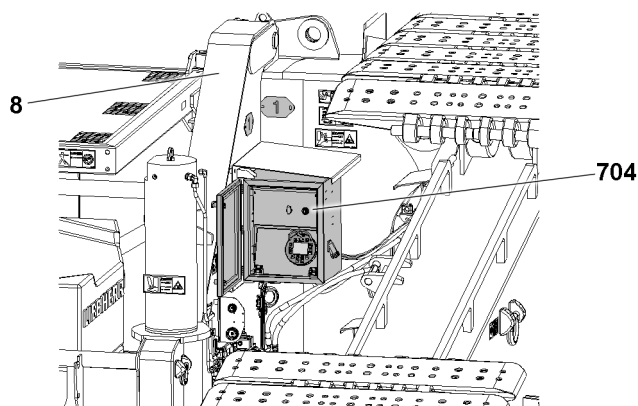


**Note**

- ▶ For detailed description to set the speed reduction master switch, see chapter 4.02.

## 18 Starting and turning off the engine

Operate the engine according to the manufacturer's specifications, see the separate operating instructions of the engine manufacturer.



*Fig.160410: Starting the engine*

Observe the additional ignition switch **704** on the crawler travel gear:

- If the crawler travel gear and turntable are electrically connected, both ignition switches must be turned on in order to turn on the ignition. To turn off the ignition, turning off one ignition switch is sufficient (series connection).
- The ignition switch **704** is located on the central ballast-bracket **8** with the sign “1”.

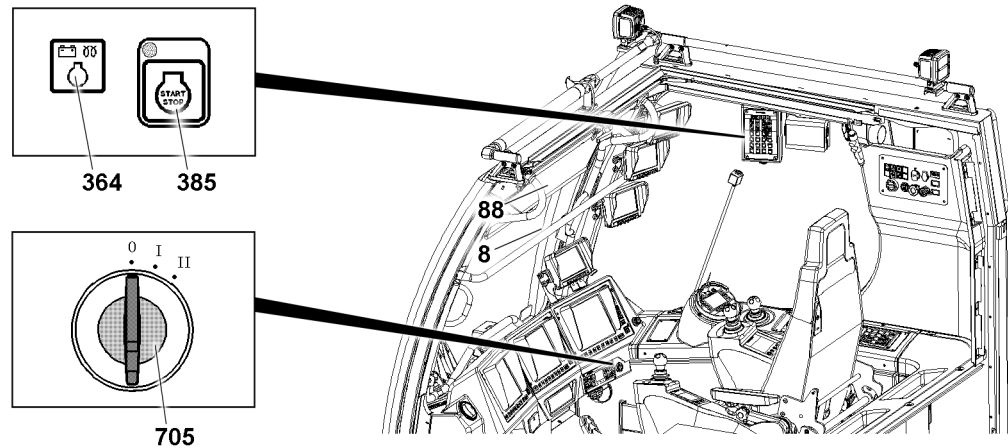


Fig.154398: Starting the engine



#### Note

- ▶ As long as the indicator light **364** lights up yellow, engine preheating is active.

Make sure that the following prerequisites are met:

- The ignition switch **705** is in position “I”.
- In the LICCON computer system, the Crane operation program is called up and the crane operation screen is shown.
- Indicator light **364** blinks yellow (1 Hz).

#### NOTICE

Danger of property damage!

- ▶ Start the engine only when the indicator light **364** blinks yellow.
- ▶ Do not press down on the gas pedal during starting.
- ▶ Do not actuate the starter motor too long and pause in between starting attempts, see Operating instructions from the engine manufacturer.
- ▶ Let the engine warm up before subjecting the engine to a full load, see operating instructions from the engine manufacturer.

## 18.1 Starting the engine

When the indicator light **364** blinks yellow (1 Hz), the engine is ready to start.

- ▶ Press the “Engine START / STOP” operating button **385**.

#### Result:

- The engine starts.
- ▶ Check the instruments after starting the engine.

## 18.2 Checking the operating and control instruments after start

- LICCON monitor: If a control value has reached a limit value, then the monitoring functions are automatically called up in the Crane operation program and the error or problem are pointed out.
- Operating and control unit (BKE): If an error or a problem occurs, then the error or the problem are pointed out.



#### Note

- ▶ For a detailed description of the operating and control instruments, see chapter 4.01.

## 18.2.1 Checking the monitoring functions on the LICCON monitor

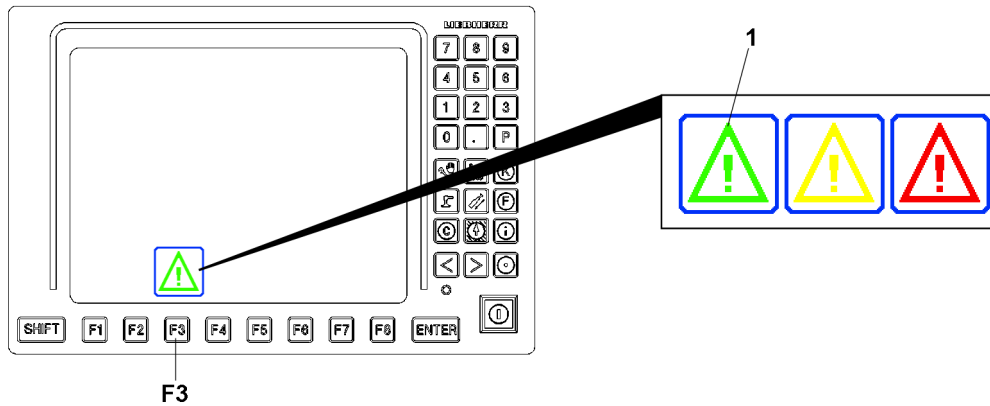


Fig.147668: Monitoring function warning icon

The monitoring functions are described in detail in chapter 4.02.

The crane components and operating conditions are monitored in the LICCON computer system. The warning icon **1** above the function key **F3** is displayed in green when all monitoring functions are ok. If a control value reached a limit range, or if there is a malfunction or warning, the warning icon **1** above the function key **F3** is displayed in yellow or red

### NOTICE

The warning icon **1** is displayed in yellow or red - malfunction / warning!  
Damage to components.

- ▶ End crane movement.
- ▶ Turn the engine off.
- ▶ Remedy the cause of the error.
- ▶ Observe and adhere to the instructions in chapter 4.02.



### Note

- ▶ The monitoring functions react in general only when an error or problem is present. Avoidable missing amounts / problems impede crane operation and cause unnecessary delays and / or down-time.

- ▶ Check the warning icon of the function key **F3**.

When the warning icon for the function key **F3** is shown in "yellow" or "red" and the monitoring functions are not automatically shown:

- ▶ Press the function key **F3** and evaluate the monitoring functions, see chapter 4.02.

## 18.3 Turning the engine off

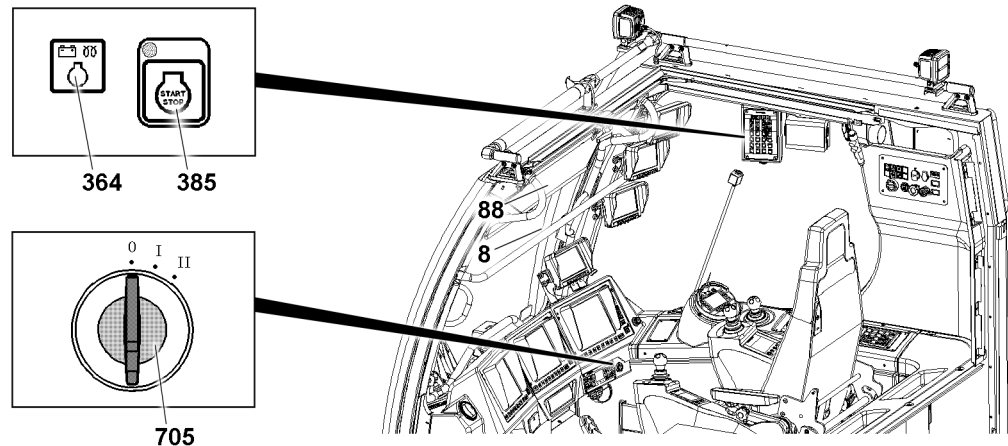


Fig.154398: Turning the engine off

### NOTICE

Increased engine wear!

If the engine is suddenly turned off after operation with full engine load or in case of increased coolant temperature (above 95 °C), then this can lead to increased wear over time.

- ▶ Before turning the engine off, let the engine run for approximately three to five minutes at idling speed without a load.



### Note

LICCON computer system in "stand-by mode"

- ▶ If the engine is turned off, the LICCON computer system can continue to be operated in "Stand-by mode", see chapter 4.02.

### 18.3.1 Turning the engine off

To turn the engine off use the operating and control unit (BKE).

When the engine is running:

- ▶ Press the "Engine START / STOP" operating button **385**.

#### Result:

- The engine turns off.
- ▶ Release the operating button **385**.

### 18.3.2 Turning the engine off in the event of danger

### NOTICE

Improper use of the EMERGENCY STOP switch!

Repeated improper use of the EMERGENCY STOP switch can cause increased wear on the crane.

- ▶ Use of the EMERGENCY STOP switch for normal operation is not permitted.
- ▶ Use the EMERGENCY STOP switch only in emergency situations.

If an emergency situation occurs:

- ▶ Actuate the EMERGENCY STOP switch.

#### Result:

- The crane is turned off.

After pressing an EMERGENCY STOP switch it is possible that the LICCON computer system must be reset.

Reset the LICCON computer system after an EMERGENCY STOP:

- ▶ Release the actuated EMERGENCY STOP switch.
- ▶ Turn the key switch **705** momentarily to position "0" and then again to position "I".

## 19 Starting the LICCON computer system parallel to the engine



### Note

If the engine was started with the ignition switch **705** without having started the LICCON computer system first, then the LICCON computer system starts parallel to the engine start.

- ▶ Start the LICCON computer system first, see section "Starting the LICCON computer system (before engine start)"

## 20 Bringing the crane cab into the transport position

Make sure that the following prerequisites are met:

- The counterweight has been properly disassembled.
- The counterweight brackets have been properly disassembled.
- The crawler carriers are disassembled on the crawler travel gear.
- The SA-frame has been properly disassembled on the turntable.
- The central ballast is properly disassembled.
- The turntable is properly aligned with the crawler center section.
- The crawler center section is properly supported and horizontally aligned.
- The catwalks and railing on the turntable are in the operating position.



## 20.1 Removing the railings on the cab platform

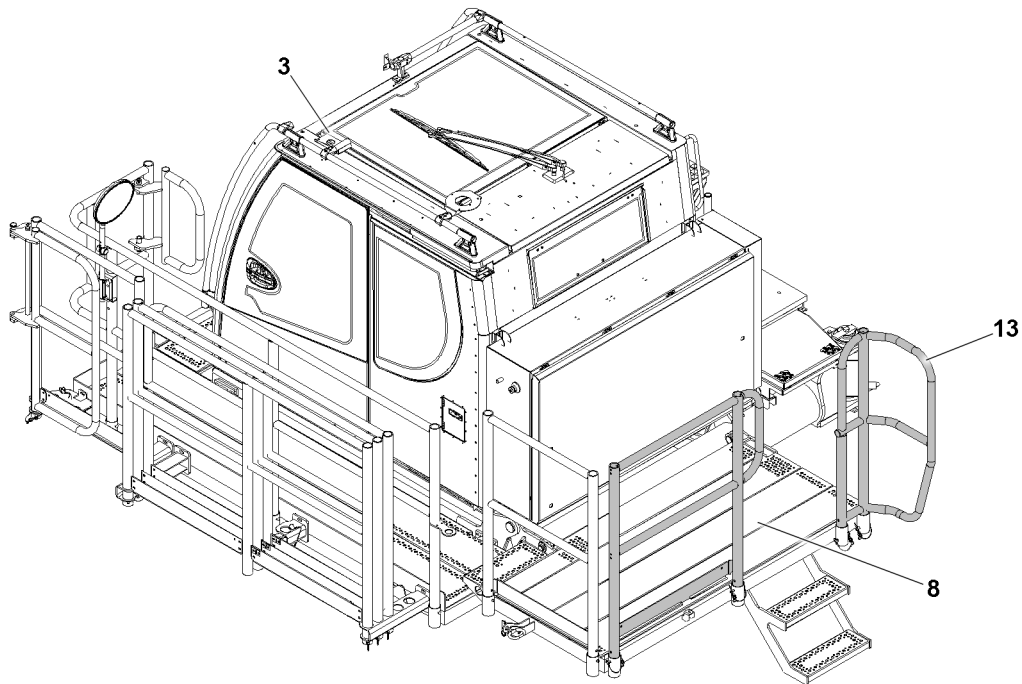


Fig.154394: Folding down the cab platform



### Note

► Disassemble the railings **13** on the cab platform **8**, see chapter 2.06.

## 20.2 Bringing the cab platform into the transport position

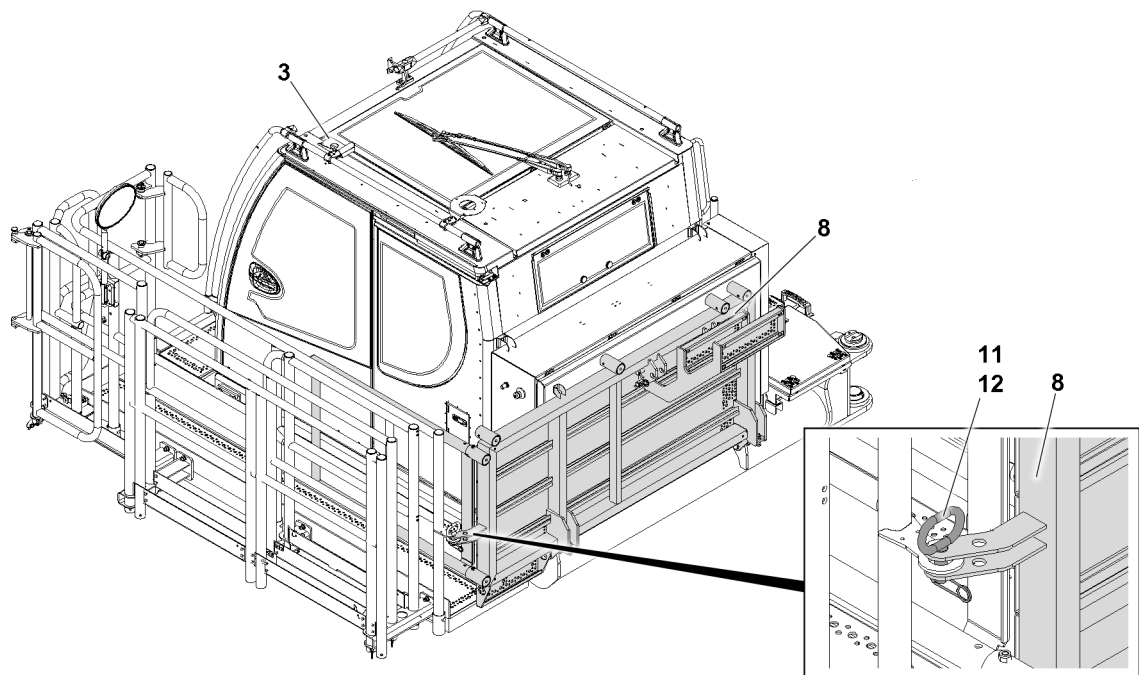


Fig.154393: Bringing the cab platform into the transport position

Make sure that the following prerequisites are met:

- The railings on the cab platform are removed.
- The step is properly pinned and secured in operating position.



### WARNING

Danger of crushing!

When swinging the cab platform **8**, limbs can be crushed.

Death, severe bodily injuries, property damage.

- ▶ Swing the cab platform **8** slowly and carefully into the transport position.

- ▶ Remove the retaining element **12** and unpin the plug **11** in the transport position.
- ▶ Fold the cab platform **8** up into the transport position.

When the cab platform **8** is in the transport position:

- ▶ Secure the cab platform **8** with plug **11**.
- ▶ Secure the plug **11**: Attach the retaining element **12**.

## 20.3 Swinging the step into the transport position

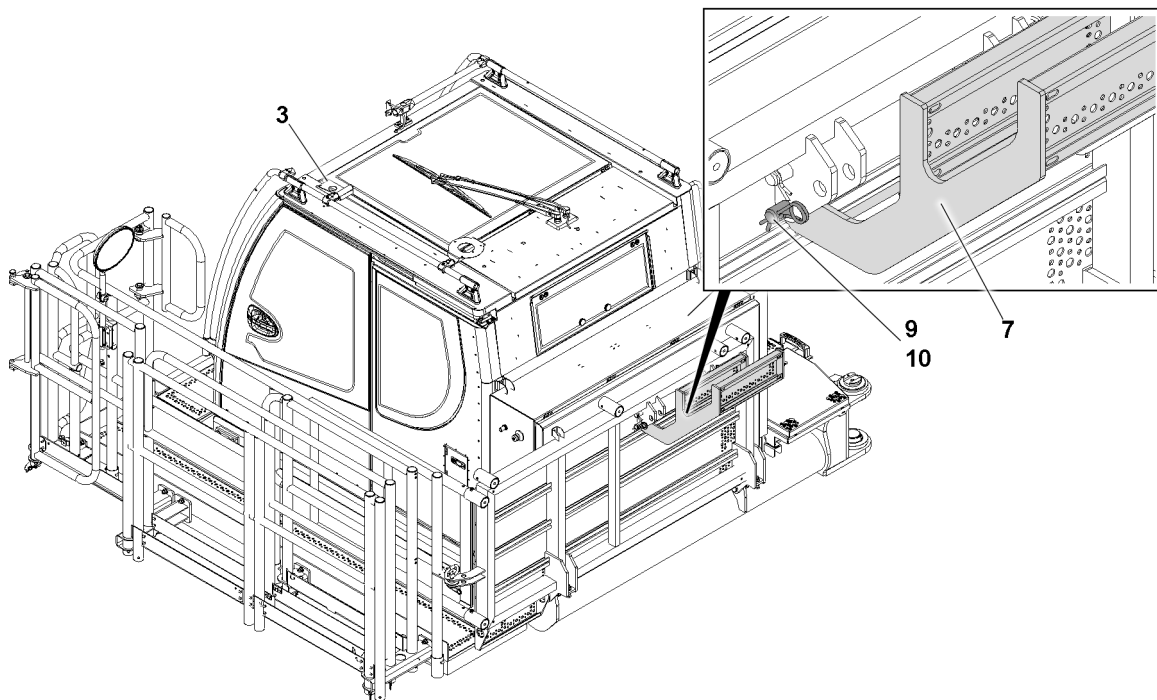


Fig.154392: Assembling the step in the transport position



### WARNING

Danger of crushing!

When swinging the step **7**, limbs can be crushed.

Death, severe bodily injuries, property damage.

- ▶ Swing the step **7** slowly and carefully into the transport position.

- ▶ Unpin the step **7** in the operating position: Remove the retaining elements **10** and completely unpin the pins **9**.

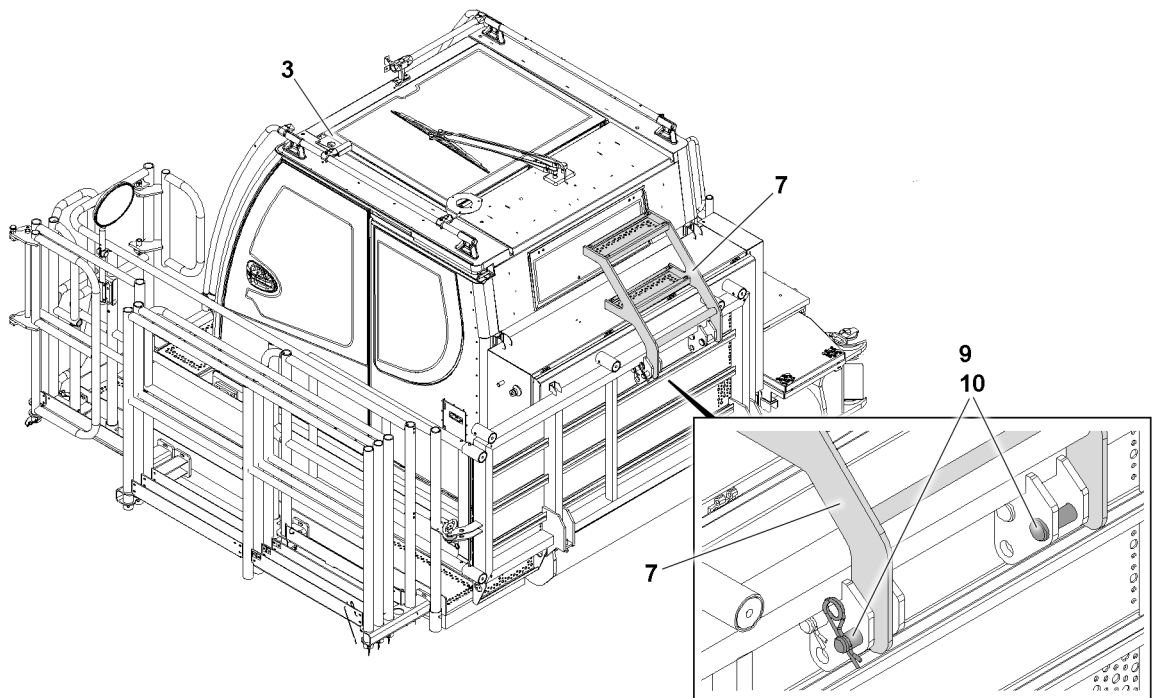


Fig.154391: Securing the step in the transport position

- ▶ Swing the step 7 up into the transport position.

When the step 7 is in the transport position:

- ▶ Insert the pin 9 in the operating position on both sides.
- ▶ Secure the pin 9: Attach the retaining elements 10.

## 20.4 Bringing the crane cab into the transport position

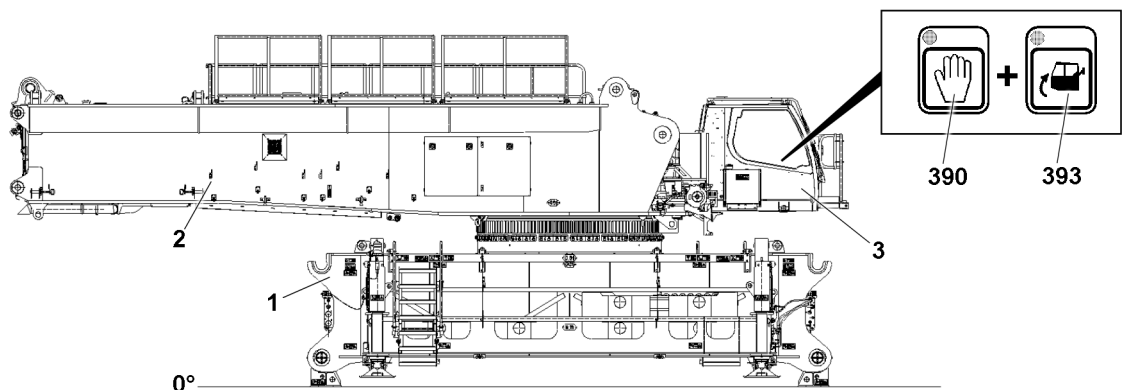


Fig.154399: Bringing the crane cab into the transport position

Make sure that the following prerequisites are met:

- The step is in the transport position.
- The cab platform is in the transport position.



### Note

- ▶ The crane operator cab can also be swung in the BTT into the operating position, see chapter 5.31 or 6.08.

- ▶ Start the engine, see section “Starting the engine”.

When the motor is running:

- ▶ Swing the crane cab in: Press the button 390 and button 393.

When the crane cab has reached the transport position:

- ▶ Release the button **390** and button **393**.

## 20.5 Placing the extension ladder on the crane cab

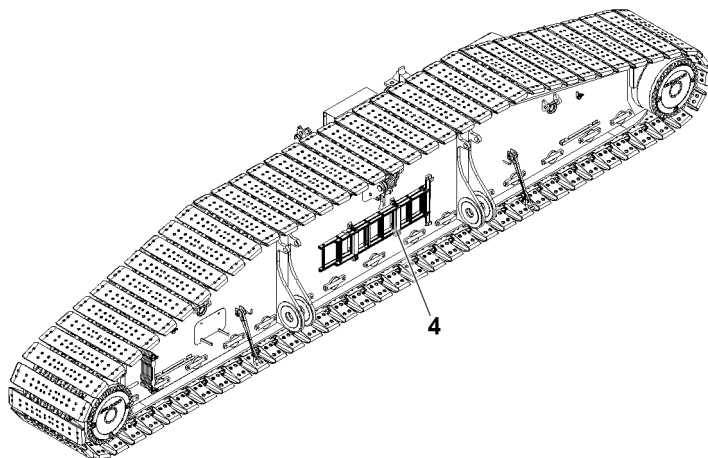


Fig. 154387: Transport position of the extension ladder **4** on the crawler carrier

The extension ladder **4** is located in the transport position to the side on the steel structure of the crawler carrier.

- ▶ Take the extension ladder **4** on the crawler carrier from the transport position, see chapter 2.07.
- ▶ Extend the extension ladder **4** to the maximum length and secure it properly.

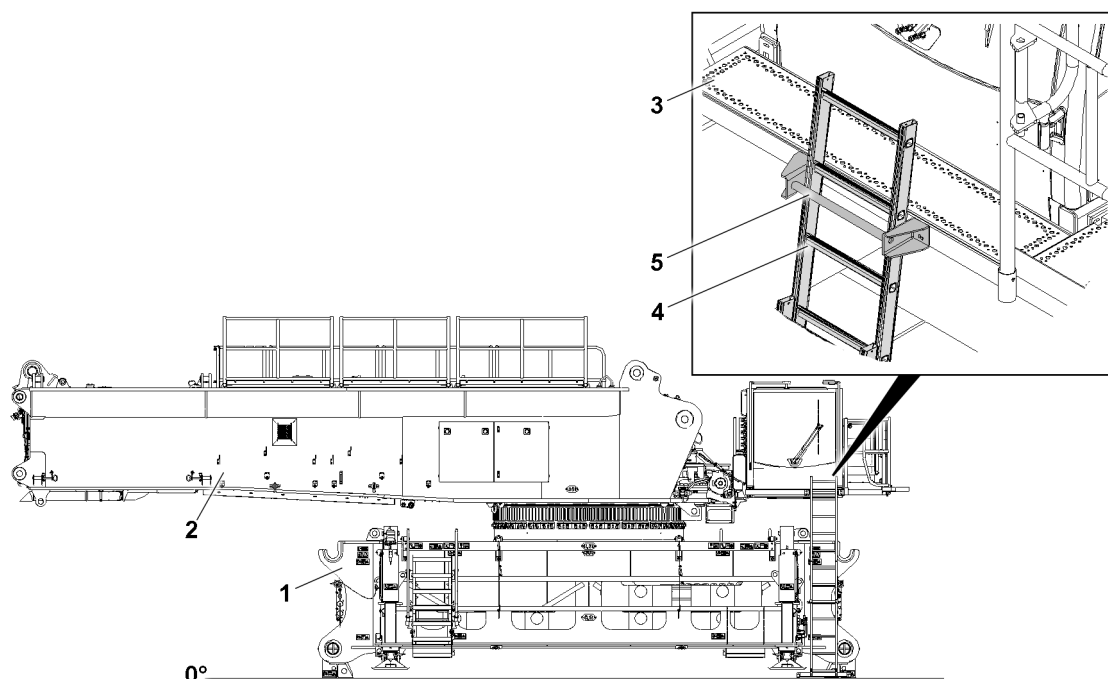


Fig. 154388: Placing the extension ladder **4** on the crane cab

- ▶ Position the extension ladder **4** on the crane cab **3** behind the fastening **5**.

**WARNING**

Danger of falling!

Death, severe bodily injuries, property damage.

- ▶ Make sure that the crane driver and / or the crane operating / assembly personnel is sufficiently secured against falling when working aloft.
- ▶ Only access the extension ladder and climb up to the crane cab after all required safety precautions have been observed.

- ▶ Leave the crane cab catwalk using the extension ladder 4.

## 20.6 Securing the crane cab with the tension belt in transport position

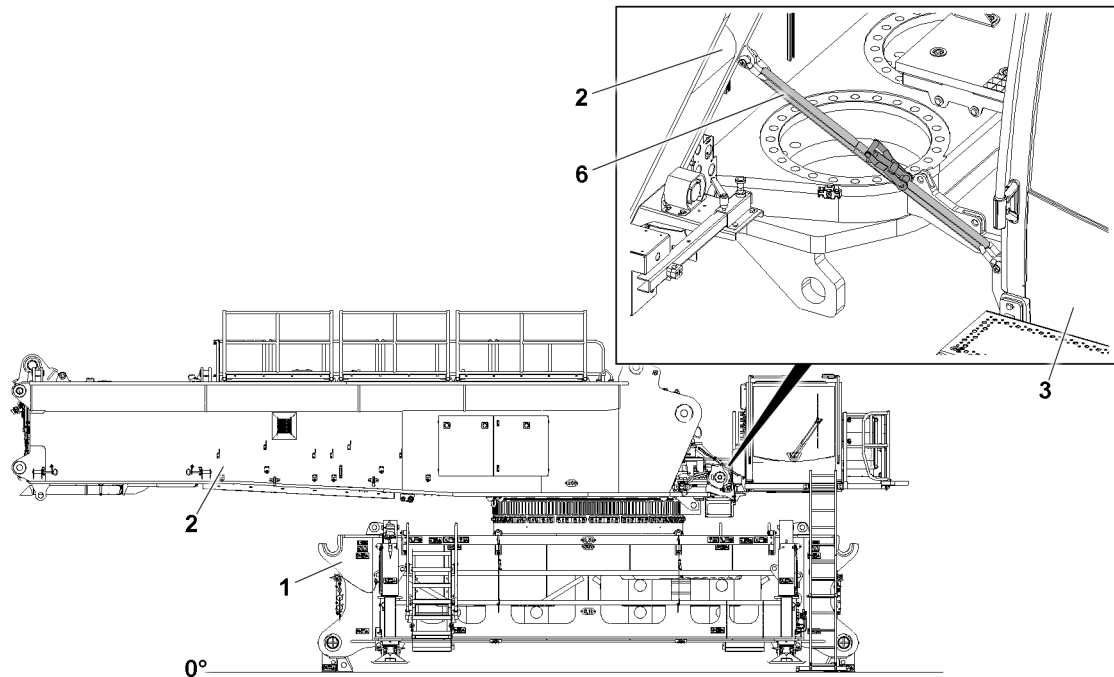


Fig.154389: Securing the crane cab with the tension belt in transport position

- ▶ Guide the tension belt 6 through the shackle on the crane cab 3 and on the turntable 2.
- ▶ Rig the crane cab 3 on the turntable 2 with the tension belt 6.

**Result:**

- The crane cab 3 is secured in transport position.
- ▶ Remove the ladder.

---

Empty page!

LWE/LR 1800-1-0-000/27200-07-02/en

## 4.04 Safety equipment

1	General	3
2	Crane geometry quick test	3
3	Overload protection quick test	3
4	LICCON computer system	3
5	Safety equipment on the crane	9

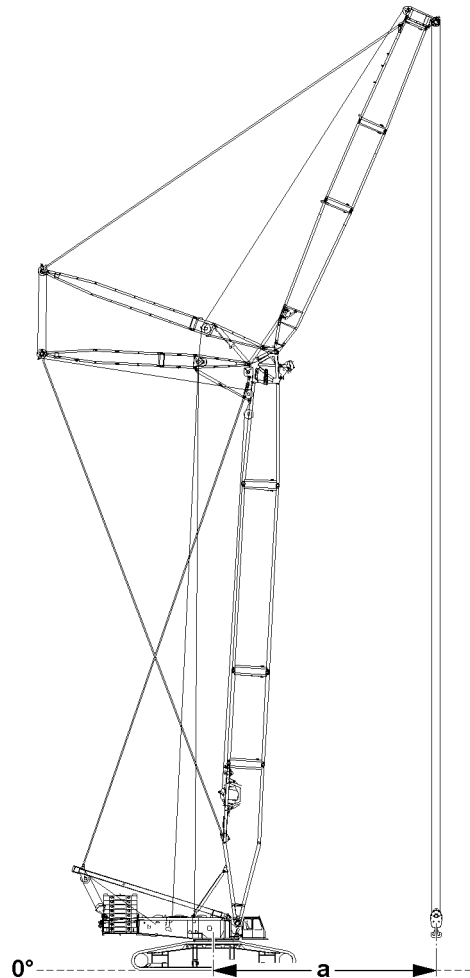
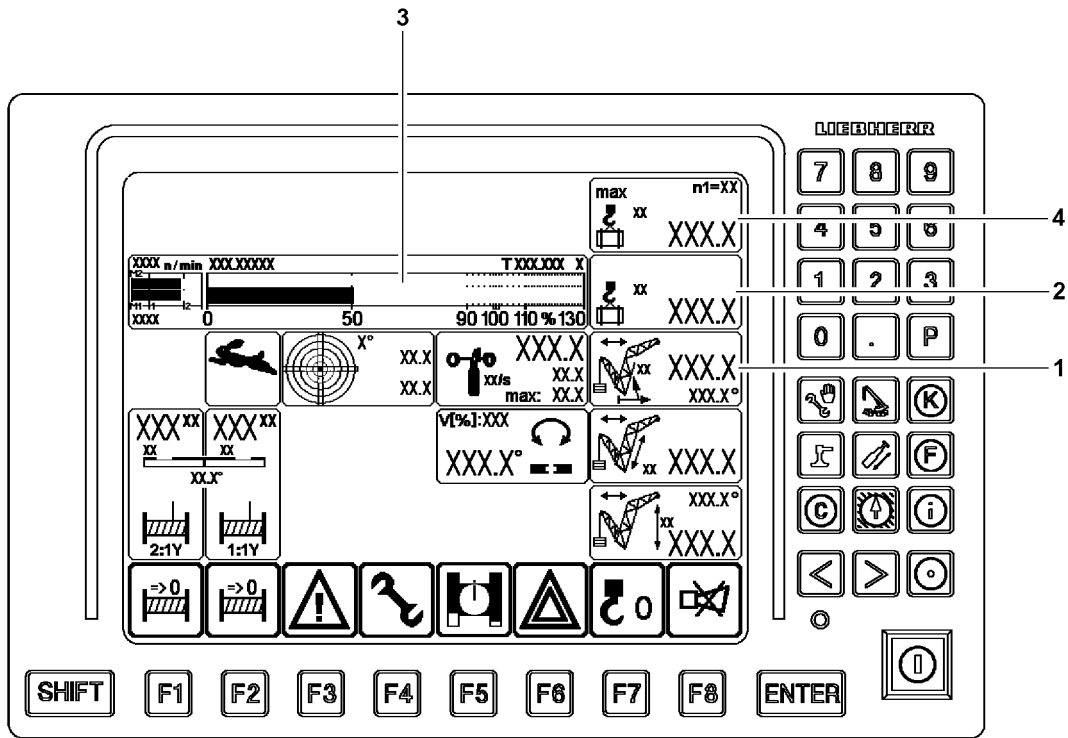


Fig.115293

LWE/LR 1800-1-0-000/27200-07-02/en



# 1 General

The crane operator is obligated before every crane operation to ensure that the warning and safety equipment are functioning.



## WARNING

Danger of accident due to defective warning and safety equipment!

If the crane is operated with defective warning and safety equipment, then there is a danger of accident!

Personnel can be killed or seriously injured!

This can result in property damage!

- ▶ Make sure that all warning and safety equipment is functioning.
- ▶ Make sure that the overload protection is functioning.

## 2 Crane geometry quick test

Make sure that the following prerequisites are met:

- The crane is horizontally aligned.
- The set up configuration has been entered correctly in the LICCON computer system.
- There is no load on the hook.

Measure the horizontal distance of the load hook from the rotation axis of the crane superstructure on the ground:

- The boom radius **1** display value must match the measured value **a**.

## 3 Overload protection quick test

Fasten a known weight, for example a counterweight plate. Then lift the counterweight plate completely and then set it down.

Make sure that the following prerequisite is met:

- The crane is horizontally aligned.

The respective displayed values must be plausible:

- **2** Actual load display
- Utilization bar **3**: Ratio of the actual load display **2** value to the maximum load value **4**
- Example:
  - The actual load display **2** is 100 t.
  - The maximum load value **4** is 200 t.
  - The Utilization bar **3** shows 50 %.

## 4 LICCON computer system

The LICCON computer system is a system for controlling and monitoring mobile cranes. In addition to the LICCON overload protection (Load torque limiter = LMB), there are a number of application programs that can be used for controlling and monitoring the crane movements. For a detailed description see the Crane operating instructions, chapter 4.02 and chapter 4.20.

### 4.1 LICCON overload protection

The LICCON overload protection is programmed to **shut off** the crane movements if the permissible load momentum is exceeded (LMB-STOP).

The LICCON overload protection may not be used as an operational shut-off device for crane movements of any kind.

An overload protection cannot detect all occurring conditions by itself. Careful and diligent crane operation by the crane operator is important.

The basis for the calculation of the utilization of the crane is:

- The current data and values recorded by the crane control.
- The set up configuration entered by the crane operator.

Direct influence is taken, among others:

- Failure of a test device (for example: pull test brackets, angle sensors, pressure sensor).
- A set up configuration incorrectly or deviating entered by the crane operator.
- Environmental influences not considered (such as wind influence, ground with insufficient load bearing capability).
- Assembly and operating errors.



### WARNING

Danger of accident due to assembly and operating errors!

Due to assembly and operating errors it is possible that the overload protection is not effective or shut-off is delayed!

A set up configuration that deviates from the load chart cannot be detected by the overload protection!

Environmental influences that are not considered cannot be detected by the overload protection!

Dangerous situations and accidents can result!

Personnel can be killed or seriously injured!

This can result in property damage!

- ▶ Always assemble and operate the crane carefully!



### WARNING

Operational utilization of the overload protection!

If the LICCON overload protection is utilized as an operational shut-off device for crane movements, then there is a danger of accident!

For example, crane movements can be shut off abruptly or uncontrolled!

The behavior of the load and crane cannot be predicted in such a case!

Personnel can be killed or seriously injured!

This can result in property damage!

- ▶ Do not use the LICCON overload protection as an operational shut-off device for crane movements!



### WARNING

Lifting of unknown loads!

The presence of the overload protection does not relieve the crane operator of his obligation for care and attention!

The crane may not be operated only according to the displays of the LICCON overload protection!

Lifting of loads with an unknown weight and unknown properties can lead to accidents!

Personnel can be killed or seriously injured!

This can result in property damage!

- ▶ Before lifting a load, its weight and properties must be known to the crane operator!
- ▶ The crane operator must check with the load chart if the crane is able to carry out the work safely!

The LICCON computer system detects various values, which result in optical and acoustical warnings if exceeded:

Within the crane operator's cab:

- Acoustic warning "Horn / short horn" on the LICCON monitor
- Optical warning "Blinking value / display" on the LICCON monitor

Outside the crane operator's cab:

- Acoustic warning via the horn on the turntable
- Optical warning via the warning light on the turntable

All warnings, even those that do not lead to an immediate shut-off must be noted by the crane operator and personnel within the danger zone.

The overload protection can **not** detect (examples of cases):

- The hooking of the load or the load handling equipment
- Excessive retarding forces
- Loads falling onto the rope
- Angular pull
- Driving the crane on ground that is excessively sloped
- Collapsing ground

#### 4.1.1 Failure of the overload protection



##### **WARNING**

Crane operation without overload protection!

If the LICCON overload protection is no longer functioning properly because of one or more errors, then there is a danger of accident if crane operation is continued!

Due to operation of the crane with failed LICCON overload protection, the crane can be overloaded and collapse!

Personnel can be killed or seriously injured!

This can result in property damage!

- ▶ Crane operation without overload protection is prohibited!
- ▶ Take the boom system down if necessary according to the specification in the crane documentation!
- ▶ Do not restart crane operation again until the overload protection is functioning again!

A failed overload protection:

- Must be repaired before the crane can be operated again.
- May only be bypassed in emergency cases or emergency situations.

## 4.2 Bypassing the overload protection

The overload protection can be bypassed in case of:

- Failure of the overload protection.
- In an emergency situation (according to EN 13000:2010).

#### 4.2.1 Bypassing the overload protection: Failure of the overload protection



##### **Note**

- ▶ Does **not** apply for cranes with configuration according to EN 13000:2010!

To bring the crane into a safe condition after failure of a component required for the overload protection, it may be necessary to bypass the overload protection.



##### **WARNING**

Bypassed overload protection!

If the overload protection is bypassed, crane movements are no longer monitored!

The crane can be overloaded and collapse!

Personnel can be killed or seriously injured!

This could result in property damage!

- ▶ Then carry out only crane movements in the range of a valid load chart!
- ▶ Take the boom system down if necessary according to the specification in the crane documentation!

### 4.2.2 Overload protection bypass: Failure of overload protection (according to EN 13000:2010)



#### Note

- ▶ Applies **only** to cranes with configuration according to EN 13000:2010!

To bring the crane into a safe condition after failure of a component required for the overload protection, it may be necessary to bypass the overload protection.

With the specification that:

- The bypass is automatically reset at engine stop.
- The bypass is automatically reset after no later than 30 minutes.
- The bypass of the overload protection limits the working speed to no more than maximum 15 %.



#### WARNING

Bypassed overload protection!

If the overload protection is bypassed, crane movements are no longer monitored!

The crane can be overloaded and collapse!

Personnel can be killed or seriously injured!

This could result in property damage!

- ▶ Then carry out only crane movements in the range of a valid load chart!
- ▶ Take the boom system down if necessary according to the specification in the crane documentation!

### 4.2.3 Overload protection bypass: Emergency situation (according to EN 13000:2010)

In an emergency situation, it may be necessary to bypass the overload protection.

With the specification that:

- The bypass is automatically reset at engine stop.
- The bypass is automatically reset after no later than 30 minutes.
- The bypass of the overload protection limits the working speed to no more than maximum 15 %.



#### DANGER

Overload of the crane!

After a bypass of the overload protection, the crane movements are no longer shut off in case of a danger of overload of the crane!

An overload of the crane can result in severe damage or collapse!

Personnel can be killed or seriously injured!

This can result in property damage!

- ▶ Do not subject the crane to such a load that it collapses!
- ▶ Clear and secure the danger zone of the crane!

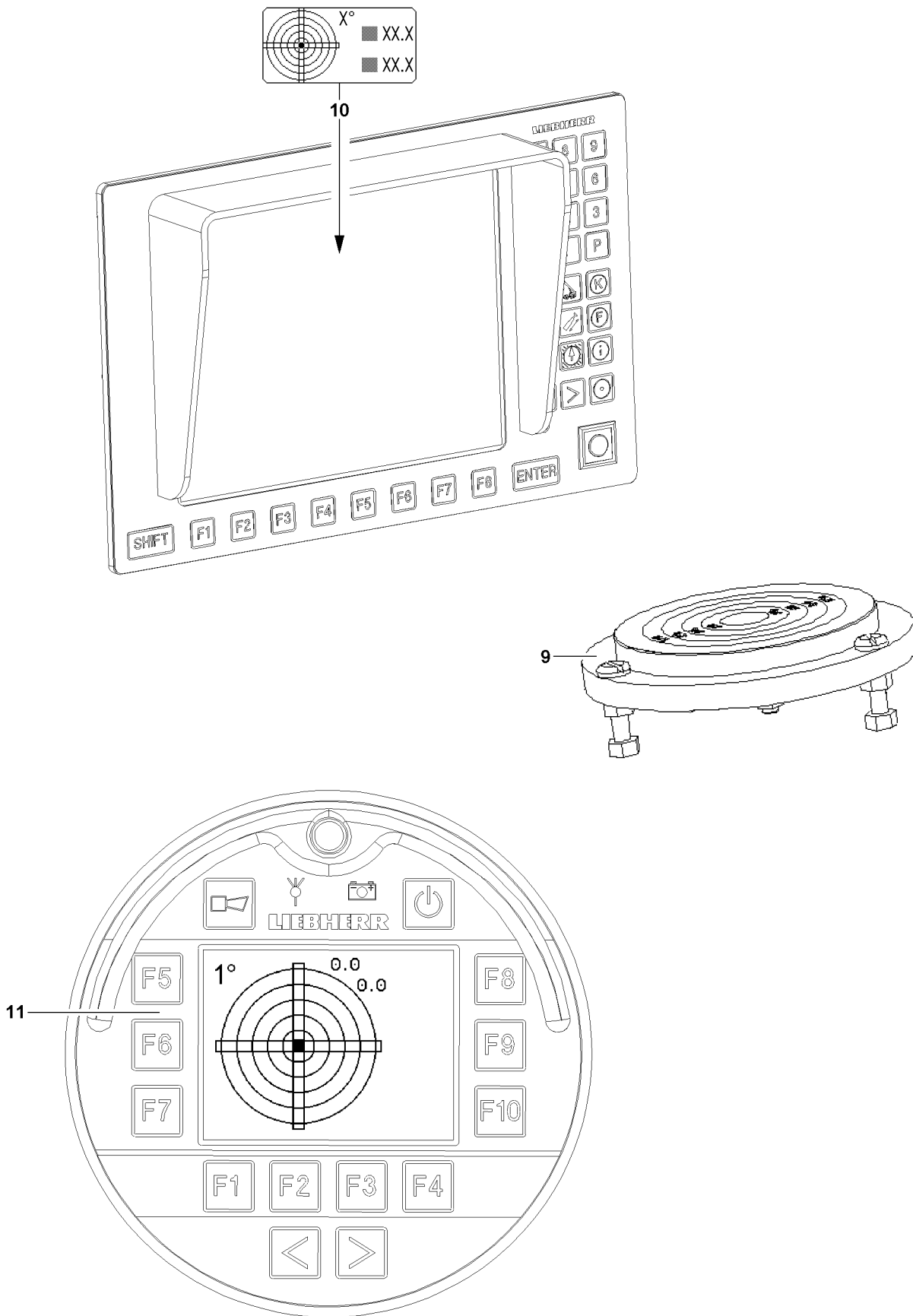


#### Note

- ▶ Location of the bypass device, see the Crane operating instructions, chapter 4.01 and chapter 4.02.

Empty page!

LWE/LR 1800-1-0-000/27200-07-02/en



LWE/LR 1800-1-0-000/27200-07-02/en

Fig.115294

## 5 Safety equipment on the crane

### 5.1 Leveling instruments

To ensure the working safety of the crane, the crane must be aligned on level ground with sufficient load bearing capacity according to the load chart.

The current values are continuously shown in the Incline icon **10**, see the Crane operating instructions, chapter 4.02.

The incline is shown manually in the sight gauge **9** on the crawler travel gear.



#### WARNING

The crane can topple over!

If the leveling instruments are defective or incorrectly adjusted, there is a danger that the crane is not aligned according to the load chart!

A crane that is not aligned according to the load chart can topple over!

Personnel can be killed or seriously injured!

This can result in property damage!

- ▶ Make sure to align the crane according to the load chart!

#### 5.1.1 Leveling instruments on the LICCON monitor

The incline of the crane is shown in the Incline icon **10** graphically as well as numerically, see the Crane operating instructions, chapter 4.02.

#### 5.1.2 Leveling instruments on the BTT operating element



#### Note

- ▶ This applies only for cranes with BTT operating element

The incline of the crane is shown in the Incline display menu **11** graphically as well as numerically, see the Crane operating instructions, chapter 3.05 and 5.31.

#### 5.1.3 Leveling instrument quick test



#### Note

The horizontal alignment of the crane can be checked with a spirit level on the top of the slewing ring, for example.

- ▶ The alignment of the top of the slewing ring is the determining factor for the incline display.

Make sure that the following prerequisites are met:

- The crane is horizontally aligned.
- There is no load on the hook.

For a horizontally aligned crane:

- The sight gauge **9** on the crawler travel gear must display 0°.
- 0° must always be shown in the incline icon **10**.

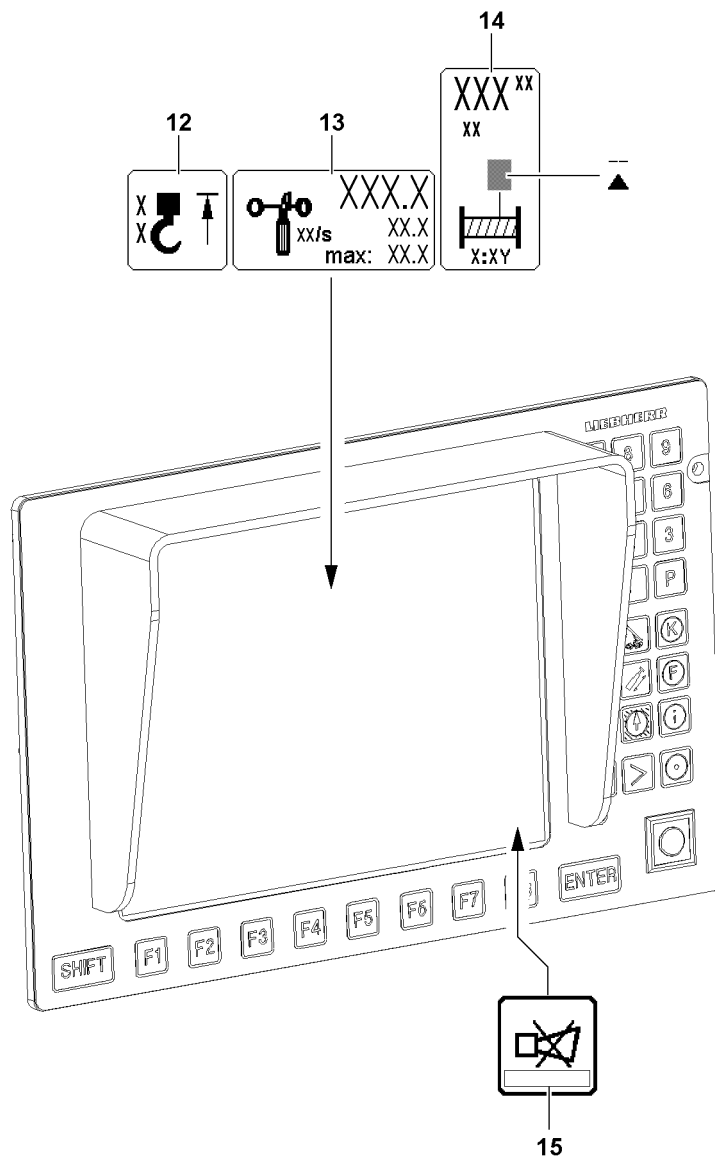


Fig.115295

LWE/LR 1800-1-0-000/27200-07-02/en



## 5.2 Acoustic and optical warning devices



### Note

- ▶ Overview of acoustic and optical warnings, see the Crane operating instructions, chapter 4.20.
- 
- The acoustic and optical warning devices must be functioning and operational.
  - Take care of any possible detriments in function, such as snow on the warning lights.

## 5.3 “Hoist top” hoist limit switch

The hoist limit switch is intended to prevent the hook block from running against the boom head.

Before every use of the crane, hoist limit switch functionality must be checked by moving the switch weight with the hook block.

For assembly purposes and in emergency cases, the hoist limit switch can be bypassed, see the Crane operating instructions, chapter 4.20.



### WARNING

Falling load and property damage!

If the hoist limit switch is defective, there is danger that the hook block or the load hook is pulled against the pulley head!

Falling load and property damage can result!

Personnel can be severely injured or killed!

- ▶ Crane operation without or with a defective hoist limit switch is prohibited!
- ▶ Repair or replace a defective hoist limit switch!

The hoist limit switch must actuate when the hoist limit switch weight is lifted by the load hook / hook block:

- When the hoist limit switch is actuated, the “Hoist top” icon **12** appears on the operating screen. The “Spool winch up” crane movement as well as other crane movements which have an influence on the hoist rope are shut off.

### 5.3.1 Hoist limit switch quick test

When the hoist limit switch weight is lifted:

- The “Hoist top” icon **12** must appear on the operating screen.
- The actuated crane movement must be shut off.

## 5.4 Error messages by the LICCON computer system

Two types are differentiated (all crane types except LR1400/2):

- Operating error
  - Displayed in field **15** by error number / LEC: B.....
- System error in the LICCON computer system
  - Displayed in field **15** by error number / LEC: E.....

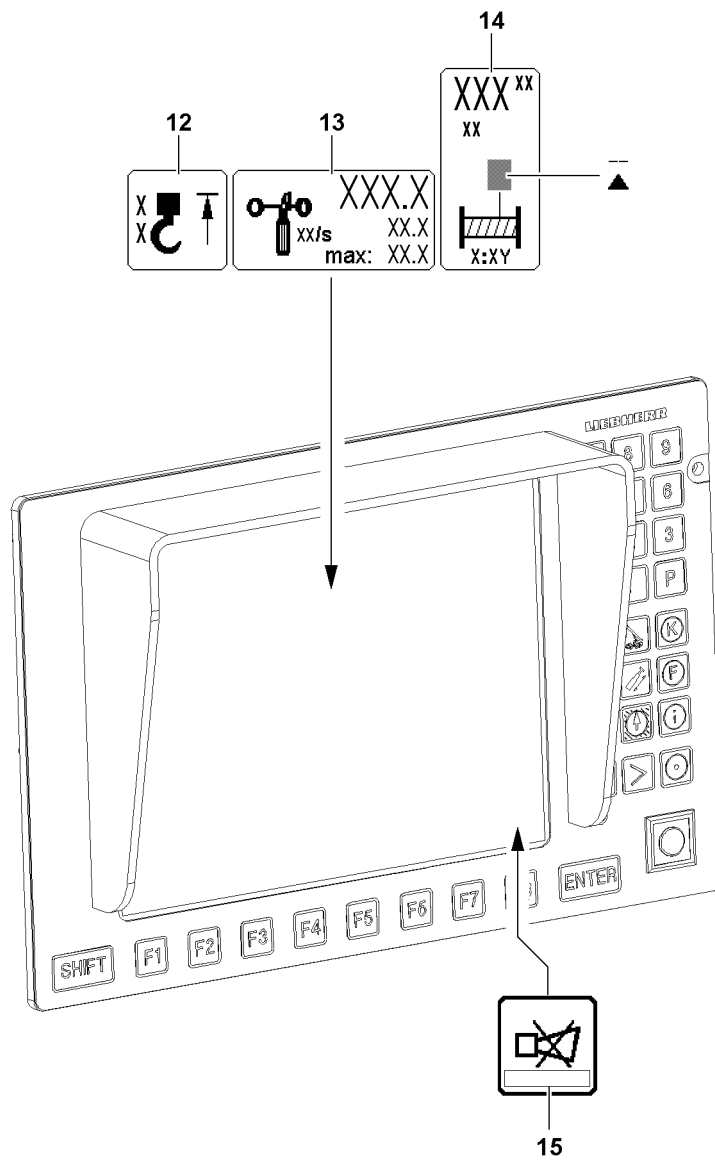


Fig.115295

LWE/LR 1800-1-0-000/27200-07-02/en

## 5.5 Wind speed sensor

The wind warning by the wind speed sensor appears on the operating screen of the LICCON computer system.



### WARNING

The crane can topple over!

If the crane is operated with a defective wind speed sensor, then there is the danger that excessively high wind speeds are not recognized!

The crane can topple over!

Personnel can be killed or seriously injured!

This can result in property damage!

- ▶ Crane operation with a defective wind speed sensor is prohibited!
- ▶ Repair / replace a defective wind speed sensor!

If there is wind, then the wind speed sensor must report its speed:

- If the actual wind speed value exceeds the displayed maximum value, the value in the “Wind speed” icon **13** starts to blink and the “Short horn” acoustic alarm sounds on the LICCON monitor. But there is **no shut-off** of crane movements.



### Note

- ▶ To set the wind speed, see the Crane operating instructions, chapter 4.02.

### 5.5.1 Wind speed sensor quick test

When blowing in the cups:

- The wind speed sensor must start to move.
- An actual value must be displayed in the “Wind speed” icon **13**.

## 5.6 Winch spooled out limit switch

The limit switches for the winches are adjusted at the factory. If used properly, the winches will not need readjustment.



### Note

Minimum rope coils in the shut-off point!

For the winches, a minimum of three rope coils are set for each drum.

- ▶ The shut-off must occur **before** reaching the third minimum rope coil.



### WARNING

The load can fall off!

If the “Winch spooled out” limit switch does not turn off **before** three minimum rope coils are reached, then there is the danger, when it is spooled out further, that the rope mounting locks rip out and the load falls down!

Falling load can cause the crane to sway and / or topple over!

Personnel can be severely injured or killed!

This can result in property damage!

- ▶ Crane operation with an incorrectly or non-adjusted winch is strictly prohibited!
- ▶ If the winch falls below the three minimum rope coils per winch, have it readjusted by **Liebherr Customer Service!**

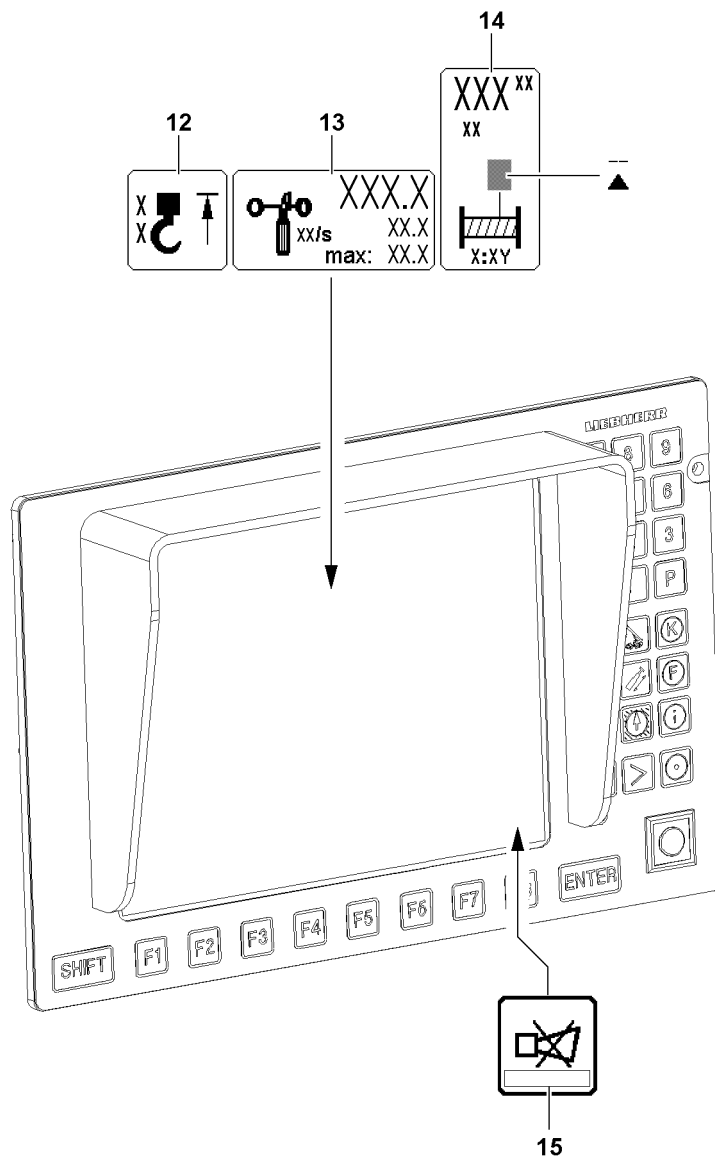


Fig.115295

LWE/LR 1800-1-0-000/27200-07-02/en

**WARNING**

The load can fall off!

If the rope is not spooled up or out properly, then the adjustment of the “Winch spooled out” limit switch is altered!

If the adjustment of the “Winch spooled out” limit switch has been altered, then there is the danger of the minimum rope coils being fallen below!

The load can fall down!

Falling load can cause the crane to sway and / or topple over!

Personnel can be severely injured or killed!

This can result in property damage!

- ▶ **Never** pull the end of rope underneath the winch by spooling up the rope winch!
- ▶ **Never** pull the rope from the “stationary” winch!
- ▶ If you suspect that the “Winch spooled out” limit switch is not adjusted correctly: Check the shut-off without a load on the hook!

The “Winch spooled out” limit switch must shut off when the minimum rope coils for the winch are reached:

- When the minimum rope coil for the winch is reached, then the “Winch spooled out” display appears in the winch icon **14**, see illustration. The “Spool winch out” crane movement is shut off.

### 5.6.1 Winch limit switch quick test

When the minimum rope coil is reached:

- The “Winch spooled out” display must appear in the winch icon **14**.
- The “Spool winch out” crane movement must be shut off.

## 5.7 Servo oil pressure monitoring in the winches

- If no servo oil pressure is present when the master switch is actuated, a corresponding error message appears in field **15**.

## 5.8 Pressure monitoring in the relapse cylinders

Pressure sensors are installed in the hydraulic cylinders. The pressure measured with the pressure sensor is shown on the LICCON monitor, see the Crane operating instructions, chapter 4.02.

**WARNING**

Danger of accident due to the crane toppling over or destruction of the crane!

If the pressure drops, the relapse cylinder can no longer stabilize the boom!

The crane can topple over or be destroyed!

Personnel can be severely injured or killed!

- ▶ During crane operation: Constantly monitor the pressure in the relapse cylinders!

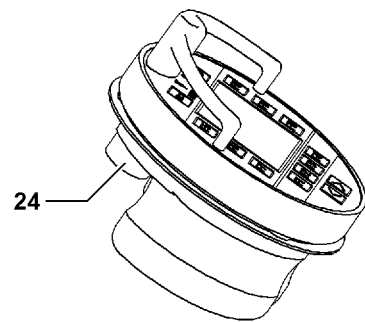
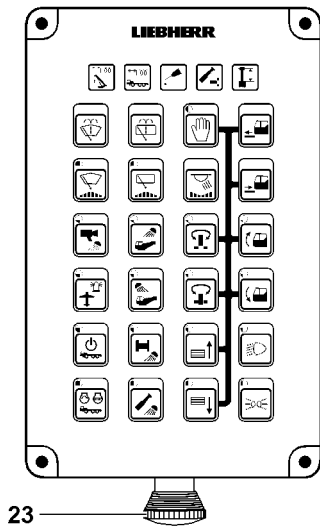
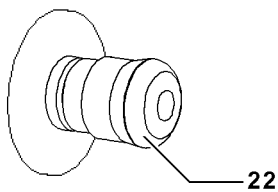
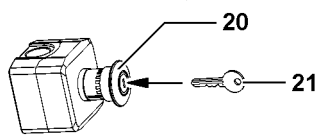
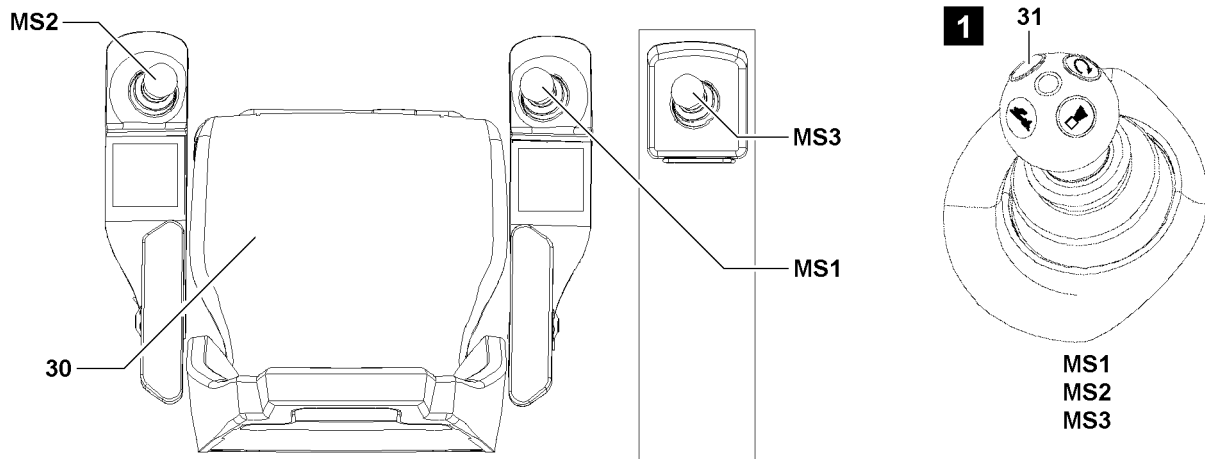


Fig.115296

LWE/LR 1800-1-0-000/27200-07-02/en

## 5.9 EMERGENCY STOP switch / EMERGENCY OFF switch

If an EMERGENCY STOP switch / EMERGENCY OFF switch is actuated, then the crane movement can be stopped with it.



### WARNING

Defective EMERGENCY STOP switch / EMERGENCY OFF switch!

If the crane is operated with a defective EMERGENCY STOP switch / EMERGENCY OFF switch, then the crane movement cannot be stopped by actuating the EMERGENCY STOP switch!

This could result in accidents!

Personnel can be killed or seriously injured!

This can result in property damage!

- ▶ Crane operation with a defective EMERGENCY STOP switch / EMERGENCY OFF switch is prohibited!
- ▶ Repair or replace a defective EMERGENCY STOP switch / EMERGENCY OFF switch!

### NOTICE

Operational actuation of the EMERGENCY STOP switch / EMERGENCY OFF switch

Actuation of the EMERGENCY STOP switch / EMERGENCY OFF switch causes the crane movement to stop abruptly!

Abruptly stopping the crane movement can cause the load to swing!

Swinging loads can cause accidents!

- ▶ Do not use the EMERGENCY STOP switch / EMERGENCY OFF switch operationally!
- ▶ Use the EMERGENCY STOP switch / EMERGENCY OFF switch only in emergency situations!

The EMERGENCY OFF switch is available in various versions, depending on the crane type:

- After actuating a version switch\* **20**, the release is only obtained by an authorized person with a key **21** and then by briefly turning the ignition “Off - On”.
- After actuation of the version switch\* **22**, the release is obtained by turning and unlocking the knob and then turning the ignition “Off - On” briefly.
- After actuation of the version switch\* **23**, the release is obtained by turning and unlocking the knob and then turning the ignition “Off - On” briefly.
- After actuation of the version switch\* **24**, the release is obtained by turning and unlocking the knob and then turning the ignition “Off - On” briefly.



### Note

- ▶ Which EMERGENCY OFF switch is on the crane depends on the crane type.
- ▶ The switch **24** on the BTT is only activated when working with the BTT.

### 5.9.1 EMERGENCY OFF switch quick test

After actuation of the EMERGENCY STOP switch / EMERGENCY OFF switch:

- The crane movements must be stopped.
- No crane movements must be possible until the release was issued by turning and unlocking the knob and then turning the ignition “Off - On” momentarily.

## 5.10 Control release

The control release can be made via the following switches:

- **30** Seat contact button
- Button **31** on master switch **MS1**, **MS2** and **MS3**

The seat contact button **30** shuts down the crane control as soon as the crane operator gets up from the seat.

This prevents unintended crane movements by accidentally touching the master switch, for example when getting in or out of the cab.

Each one of the buttons **31** on master switch **MS1**, **MS2** und **MS3** bypasses the seat contact button **30** if needed, for example when it is necessary to work while standing up.

## 5.11 Hydraulic safety valves

A differentiation is made between three types:

- Pressure limiting valves
  - Prevent pipe and hose bursts due to excessive pressure.
- Shut off valves
  - Control and secure the working cylinders.
- Check valves
  - Control and secure the flow direction.



### Note

- ▶ See separate hydraulic diagram.

## 5.12 Gravity-actuated relapse retainer



### Note

- ▶ Only for cranes with a luffing accessory.

The gravity actuated relapse retainer (oscillation guard / flap / relapse support) prevent the luffing accessory from tipping to the rear in the “steepest position”.



### WARNING

The crane can topple over!

If the gravity actuated relapse retainer (oscillation guard / flap / relapse support) is hard to move, then it will no longer function!

Shut-off and limit functions can be disabled!

The crane can be overloaded and topple over!

Personnel can be killed or seriously injured!

This can result in property damage!

- ▶ Before erecting the crane, check the relapse retainer for easy movement!
- ▶ Crane operation with a hard to move relapse retainer is prohibited!

## 5.13 Angle sensor



### Note

- ▶ See the separate wiring diagram.

## 5.14 Test brackets (force test boxes)



### Note

- ▶ See the separate wiring diagram.

## 5.15 Boom system limit switch



### WARNING

Danger of toppling or destroying the crane!

If the crane movement is stopped by the block limit switches, then the load forces cannot be absorbed and calculated by the control!

The crane can be overloaded and topple over!

Personnel can be hit and killed or seriously injured!

This can result in property damage!

- ▶ Do **not** use the hoist limit switch as an operational shut off device!
- ▶ Do not actuate the block limit switches!



LWE/LR 1800-1-0-000/27200-07-02/en

---

Empty page!

LWE/LR 1800-1-0-000/27200-07-02/en

## 4.05 Crane operation

1	Description	2
2	Safety instructions	2
3	Prerequisites for crane operation	4
4	Master switch assignment	5
5	Locking / releasing the winch	6
6	Master switch functions	10
7	Changing the speed of the crane movement via the engine rpm	22
8	Spooling the hoist winches up / out (load lifting / load lowering)	24
9	Hoist winch in parallel operation	28
10	Luffing the boom system up / down	40
11	Turning the crane superstructure	44
12	Controlling the ballast functions (pull cylinder / derrick ballast guide / ballast automatic)	49
13	Assembly operating mode SA	61
14	Operating the ballast trailer support cylinders	63
15	Spooling the assembly winch up / out	65

# 1 Description

With the crane various crane movements can be carried out using the master switch in the crane cab. Through these crane movements, the load can be taken up, positioned and taken down precisely.



## Note

Alternative control options are available.

Individual functions can be controlled alternatively with other operating elements.

- ▶ Instrument panel operating elements, see chapter 4.01.
- ▶ BTT operating elements, see chapter 5.31.
- ▶ Radio remote control operating elements, see chapter 6.08.
- ▶ The control panels and operating buttons are described separately in the corresponding chapter.

The following crane movements are possible with the master switch:

- Spooling the hoist winch up / out
- Hoist winch in parallel operation
- Luffing the boom system up / down
  - Luffing the main boom up / down
  - Luffing the derrick boom up / down
  - Luffing the luffing lattice jib up / down
- Turning the crane superstructure
  - Slewing gear parking brake
  - Slewing gear brake pedal and slewing gear freewheeling
  - Turning the crane superstructure to the right / left
- Controlling the ballast functions (pull cylinder / derrick ballast guide / ballast automatic)
  - Calling up the master switch assignment for ballast functions
  - Retracting / extending the pull cylinder (lifting / lowering the derrick ballast)
  - Extending / retracting the derrick ballast guide (increasing / decreasing the derrick ballast boom radius)
  - Turning the ballast automatic on / off
- Assembly operating mode SA
  - Luffing the SA-frame up / down
  - Extending / retracting the assembly cylinder
- Operating the ballast trailer support cylinders
  - Calling up the master switch assignment for ballast functions
  - Extending / retracting the ballast trailer support cylinders
- Spooling the assembly winch up / out

The crane movements are described in the following sections.

## 2 Safety instructions



### WARNING

Operating condition on crane is **not safe!**

Crane can topple over, death, severe property damage in crane.

Only when the crane is in a safe operating condition:

- ▶ Start crane operation.

Solely when all safety equipment is functioning:

- ▶ Start crane operation.

The safety equipment is described in detail in chapter 2.04.

Additional notes and danger notes for crane operation are described in chapter 2.04 and chapter 4.08.

**Note**

- ▶ Observe and adhere to the specifications in chapter 2.04 and chapter 4.08.

**WARNING**

Personnel in the danger zone!  
Crushing danger, death, severe bodily injuries.

- ▶ Monitor the danger zone.
- ▶ If persons are in the danger zone: Sound the warning signal (horn).
- ▶ Make sure that there are **no** persons in the danger zone.
- ▶ Block off the slewing range if necessary.

**WARNING**

Obstacle in working range!  
Property damage on crane and on obstacle.

- ▶ Monitor the working range.
- ▶ Make sure that there are **no** obstacles within the working area of the crane and the crane components.

**WARNING**

Danger of accident!  
Death, severe bodily injuries, property damage.

- ▶ The crane driver must evaluate constantly if the data shown on the operating screen can even be correct. He may not rely blindly on the LICCON system but must think for himself and must recognize a possible error or overload conditions.

**WARNING**

Improper crane operation!  
If ballast automatic is turned on, the crane controls the pull cylinder automatically.

- ▶ When ballast automatic is turned on, keep in mind that the crane controls the pull cylinder automatically.

**WARNING**

Error on the LICCON monitor display!  
Death, severe bodily injury, property damage.

- ▶ Monitor the displays in LICCON monitor.
- ▶ Monitor the utilization conditions and forces.
- ▶ Observe and adhere to the instructions in chapter 4.02.

**NOTICE**

Collision of the hook block with the boom head!  
The crane movements have a direct effect on the hoist rope.

- ▶ Equalize the boom movements by spooling the hoist winch.

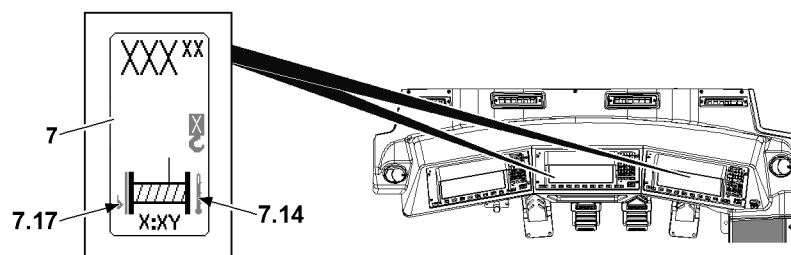


Fig.155159: The winch overheated icon 7.14 and low oil icon 7.17

**WARNING**

Overheated winch!

If a winch is operated further even though the *winch overheated* icon 7.14 or the *low oil* icon 7.17 appears, the winch can be severely damaged.

The winch can fail and accidents can occur.

- ▶ Let the overheated winch cool off.
- ▶ Immediately add oil to the winch.

**Note**

- ▶ The selected crane movements can be controlled alternatively with the BTT or the radio remote control\*.
- ▶ Observe chapter 5.31 and the radio remote control operating instructions.

**Note**

- ▶ For a detailed description of the operating elements in the crane cab, see chapter 4.01.
- ▶ For a detailed description of the displays on the LICCON monitors, see chapter 4.02.

### 3 Prerequisites for crane operation

Make sure that the following prerequisites are met:

- The ground is able to support the weight of the crane, the load and the load handling equipment.
- The crane is horizontally aligned, the permissible incline according to the load chart is adhered to.
- The counterweight / ballast is installed and secured according to the data in the load chart.
- The hook block is correctly reeved in according to the reeving plan.
- The diesel engine is running.
- Crawler operation is turned off.
- The set up configuration has been entered correctly in the LICCON computer system.
- All displays are within a permissible range.
- All safety equipment has been set according to the data in the load chart.
- The winches are correctly assigned to the respective load positions, see chapter 4.02.
- The crane is properly put into operation, see chapter 4.03.
- There are no persons or objects in the danger zone.
- There are no persons or objects in the working area.

## 4 Master switch assignment

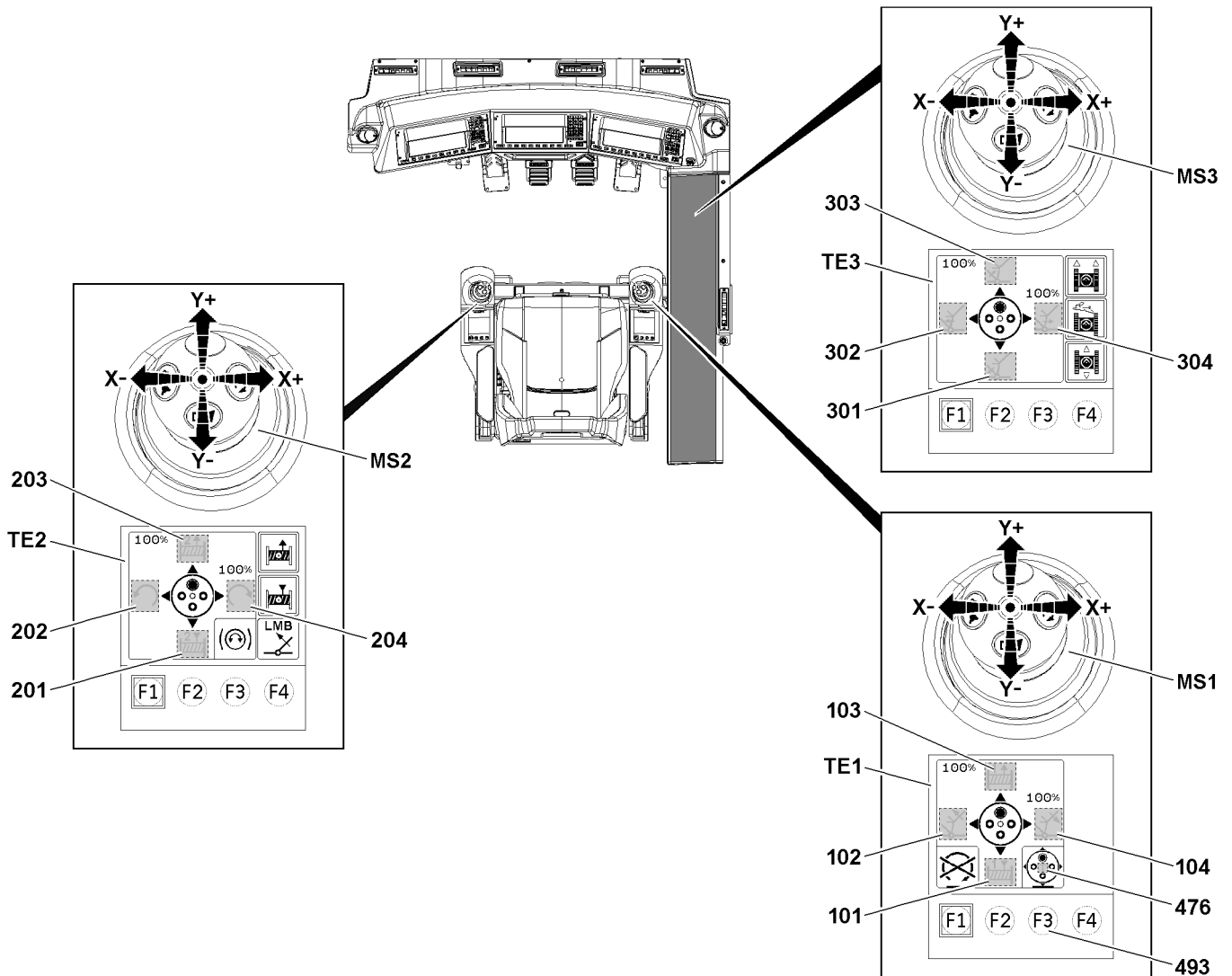


Fig.155128: Master switch assignment

The master switch assignment is the determining factor for the function assignment of the master switch. One or more master switch assignments are possible depending on the set up configuration. Each master switch assignment has its own abbreviation **476** that is displayed on the touch display **TE1**. For example, "T" as the abbreviation **476** for master switch assignment T.

- The touch display **TE1** shows the function assignments for the master switch **MS1**.
  - The field **101** shows the function assignment for direction **Y-** (to the rear)
  - The field **102** shows the function assignment for direction **X-** (to the left)
  - The field **103** shows the function assignment for direction **Y+** (to the front)
  - The field **104** shows the function assignment for direction **X+** (to the right)
- The touch display **TE2** shows the function assignments for the master switch **MS2**.
  - The field **201** shows the function assignment for direction **Y-** (to the rear)
  - The field **202** shows the function assignment for direction **X-** (to the left)
  - The field **203** shows the function assignment for direction **Y+** (to the front)
  - The field **204** shows the function assignment for direction **X+** (to the right)
- The touch display **TE3** shows the function assignments for the master switch **MS3**.
  - The field **301** shows the function assignment for direction **Y-** (to the rear)
  - The field **302** shows the function assignment for direction **X-** (to the left)

- The field **303** shows the function assignment for direction **Y+** (to the front)
- The field **304** shows the function assignment for direction **X+** (to the right)

## 4.1 Changing the master switch assignment

Make sure that the following prerequisites are met:

- Multiple master switch assignments are possible.
- All master switches are in the neutral position.

► Press the F3 key **493** until the necessary master switch assignment is displayed.



### Note

► For a detailed description of the icons on the touch display, see chapter 4.01.

## 5 Locking / releasing the winch

Each winch can be locked or released.

### NOTICE

Locking or releasing the winch during a crane movement!  
Possible malfunction of the crane control.

Only when no crane movement is performed:

► Block or release the winches.

Make sure that the following prerequisites are met:

- The master switches are in the neutral position.
- No crane movement is carried out.

### 5.1 Locking / releasing the hoist winch

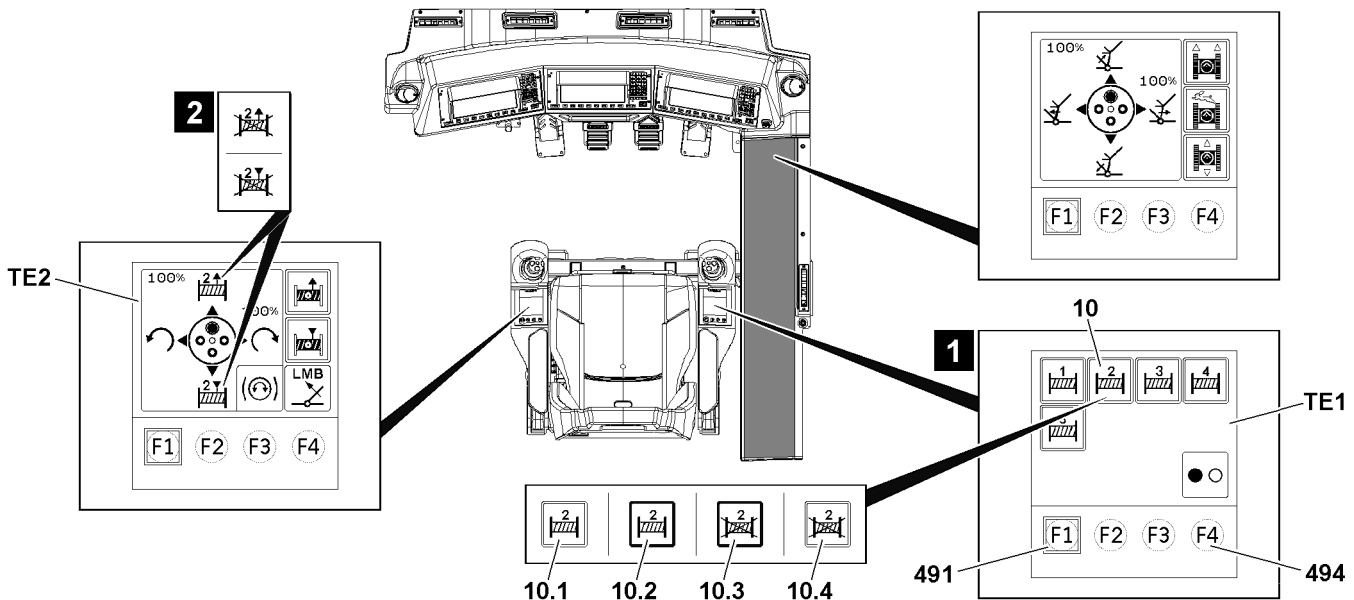


Fig.155132: Locking / releasing the hoist winch

Locking / releasing a hoist winch is explained based on the example of winch 2. There are the same variants of the icon for all other winches.

The icon *lock / release* winch 2 **10** appears in the following variants:

- **10.1** Winch 2 released / deselected icon



- **10.2** *Winch 2 released / selected* icon
- **10.3** *Winch 2 locked / selected* icon
- **10.4** *Winch 2 locked / deselected* icon

### 5.1.1 Locking the hoist winch

Make sure that the following prerequisite is met:

- Winch 2 is released.
- ▶ Press the F1 key **491** on the touch display **TE1** until the *Winch locking / releasing* menu appears, see illustration 1.

**Result:**

- The *winch 2 released / deselected* icon **10.1** is displayed.
- ▶ Touch the *Winch 2 released / deselected* icon **10.1** with a finger tip.

**Result:**

- The *Winch 2 released / deselected* icon **10.1** turns off.
- The *winch 2 released / selected* icon **10.2** is displayed.

- ▶ Press the F4 key **494**.

**Result:**

- The *Winch 2 released / selected* icon **10.2** disappears.
- The *winch 2 locked / selected* icon **10.3** is displayed.
- The touch display **TE2** shows the icons of *winch 2* crossed out, see illustration 2.
- Winch 2 is blocked.
- ▶ Close the *winch lock / release* menu: Press the F1-key **491** on the touch display **TE1** until the normal master switch assignment is displayed again.

### 5.1.2 Releasing the hoist winch

Make sure that the following prerequisite is met:

- Winch 2 is blocked.
- ▶ Press the F1 key **491** on the touch display **TE1** until the *Winch locking / releasing* menu appears, see illustration 1.

**Result:**

- The *winch 2 locked / deselected* **10.4** icon is displayed.
- ▶ Touch the *Winch 2 locked / deselected* **10.4** icon with a finger tip.

**Result:**

- The *Winch 2 locked / deselected* **10.4** icon turns off.
- The *winch 2 locked / selected* icon **10.3** is displayed.

- ▶ Press the F4 key **494**.

**Result:**

- The *Winch 2 locked / selected* icon **10.3** disappears.
- The *winch 2 released / selected* icon **10.2** is displayed.
- The touch display **TE2** shows the icons of *winch 2* no longer crossed out.
- Winch 2 is released.
- ▶ Close the *winch lock / release* menu: Press the F1-key **491** on the touch display **TE1** until the normal master switch assignment is displayed again.

## 5.2 Locking / releasing the control winch

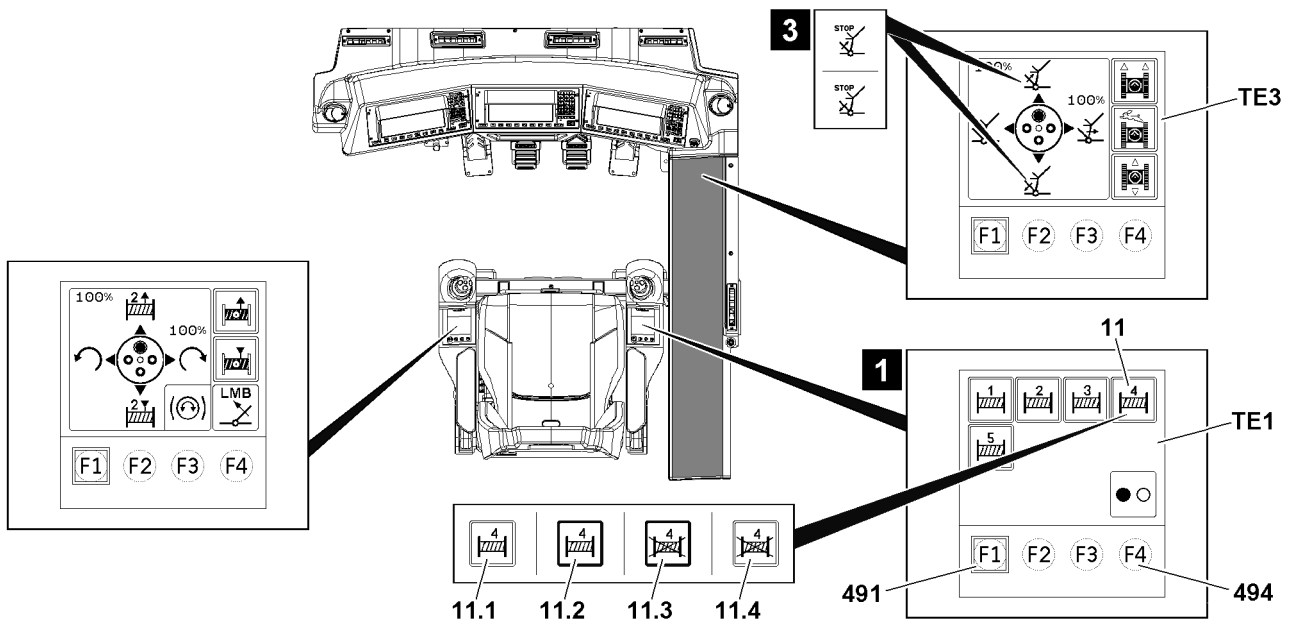


Fig.155133: Locking / releasing the control winch

Locking / releasing a control winch is explained based on the example of winch 4 in an operating mode with the luffing jib and derrick boom. There are the same variants of the icon for all other winches.

The icon *lock / release* winch 4 11 appears in the following variants:

- 11.1 Winch 4 released / deselected icon
- 11.2 Winch 4 released / selected icon
- 11.3 Winch 4 locked / selected icon
- 11.4 Winch 4 locked / deselected icon

### 5.2.1 Locking the control winch

Make sure that the following prerequisite is met:

- Winch 4 is released.

- ▶ Press the F1 key 491 on the touch display TE1 until the *Winch locking / releasing* menu appears, see illustration 1.

**Result:**

- The *winch 4 released / deselected* icon 11.1 is displayed.
- ▶ Touch the *Winch 4 released / deselected* icon 11.1 with a finger tip.

**Result:**

- The *Winch 4 released / deselected* icon 11.1 turns off.
- The *winch 4 released / selected* icon 11.2 is displayed.

- ▶ Press the F4 key 494.

**Result:**

- The *Winch 4 released / selected* icon 11.2 disappears.
- The *winch 4 locked / selected* icon 11.3 is displayed.
- The touch display TE3 shows the icons for the adjustment of the derrick boom with the text *STOP*, see illustration 3.
- Winch 4 is locked, therefore the adjustment of the derrick boom is not possible.

- ▶ Close the *winch lock / release* menu: Press the F1-key **491** on the touch display **TE1** until the normal master switch assignment is displayed again.

## 5.2.2 Releasing the control winch

Make sure that the following prerequisite is met:

- Winch 4 is blocked.

- ▶ Press the F1 key **491** on the touch display **TE1** until the *Winch locking / releasing* menu appears, see illustration 1.

### Result:

- The winch 4 locked / deselected **11.4** icon is displayed.
- ▶ Touch the Winch 4 locked / deselected **11.4** icon with a finger tip.

### Result:

- The Winch 4 locked / deselected **11.4** icon turns off.
- The *winch 4 locked / selected* icon **11.3** is displayed.

- ▶ Press the F4 key **494**.

### Result:

- The *Winch 4 locked / selected* icon **11.3** disappears.
- The *winch 4 released / selected* icon **11.2** is displayed.
- The touch display **TE2** no longer shows the icons for the adjustment of the derrick boom with the text *STOP*, see illustration.
- Winch 4 is released, therefore the adjustment of the derrick boom is again possible.
- ▶ Close the *winch lock / release* menu: Press the F1-key **491** on the touch display **TE1** until the normal master switch assignment is displayed again.

## 6 Master switch functions



### WARNING

Danger of fatal injury!

Death, severe bodily injuries, property damage.

- ▶ It is prohibited for personnel to remain in the danger zone.
- ▶ Make sure that there are no obstacles within the working area of the crane.
- ▶ Give a short warning signal (horn) before starting a crane movement.
- ▶ Observe the danger notes for crane operation, see chapter 5.01.



### Note

Change of master switch assignment!

The assignment of the master switches to the respective units on the crane can change, depending on the set up configuration and winch application.

- ▶ Check the master switch assignment before actuating the master switch on the TE.



### Note

- ▶ In order to protect the crane and reduce the danger of accidents always use the master switch slowly and sensitively.

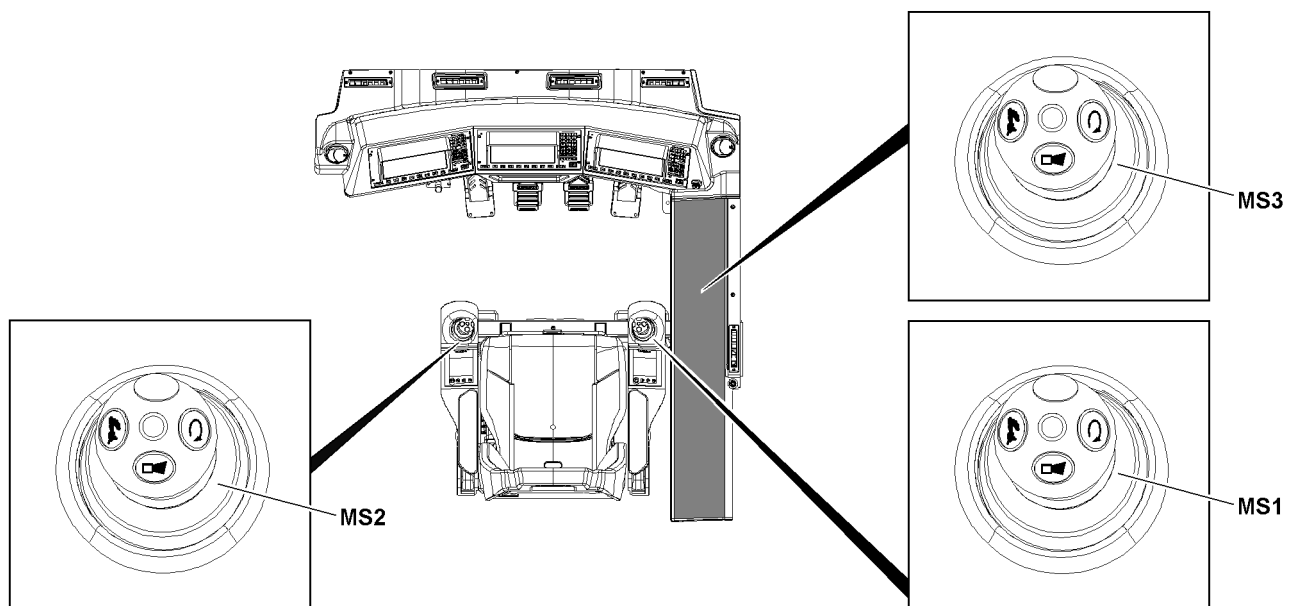


Fig.155134: Master switches in the crane cab

Master switch **MS1**, master switch **MS2** and master switch **MS3** each have four buttons and a vibration sensor. The same buttons always control the same functions.

The following functions can be regulated with the buttons:

- Giving a warning signal
- Engine rpm lock
- Rapid gear (Power Plus)
- Seat contact button
- Vibration sensor
- Speed reduction master switch / pedal sensor

## 6.1 Giving a warning signal

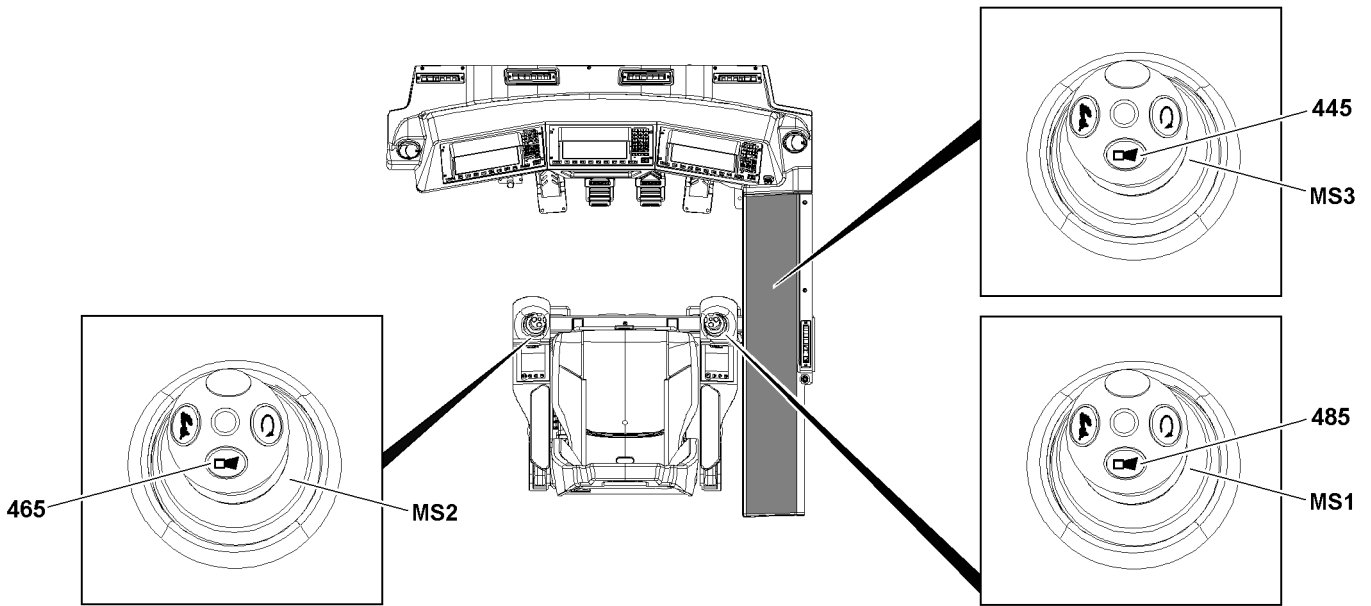


Fig.155130: Giving a warning signal



### WARNING

Crane movement without warning signal!

Without warning signals, personnel within the danger zone of the crane can be surprised by a crane movement.

Death, severe bodily injuries, property damage.

► Before initiating a crane movement, give a warning signal (horn).

- Press the button **485** on the master switch **MS1**.
- or
- Press the button **465** on the master switch **MS2**.
- or
- Press the button **445** on the master switch **MS3**.

### Result:

- Warning signal sounds.

## 6.2 Engine rpm lock

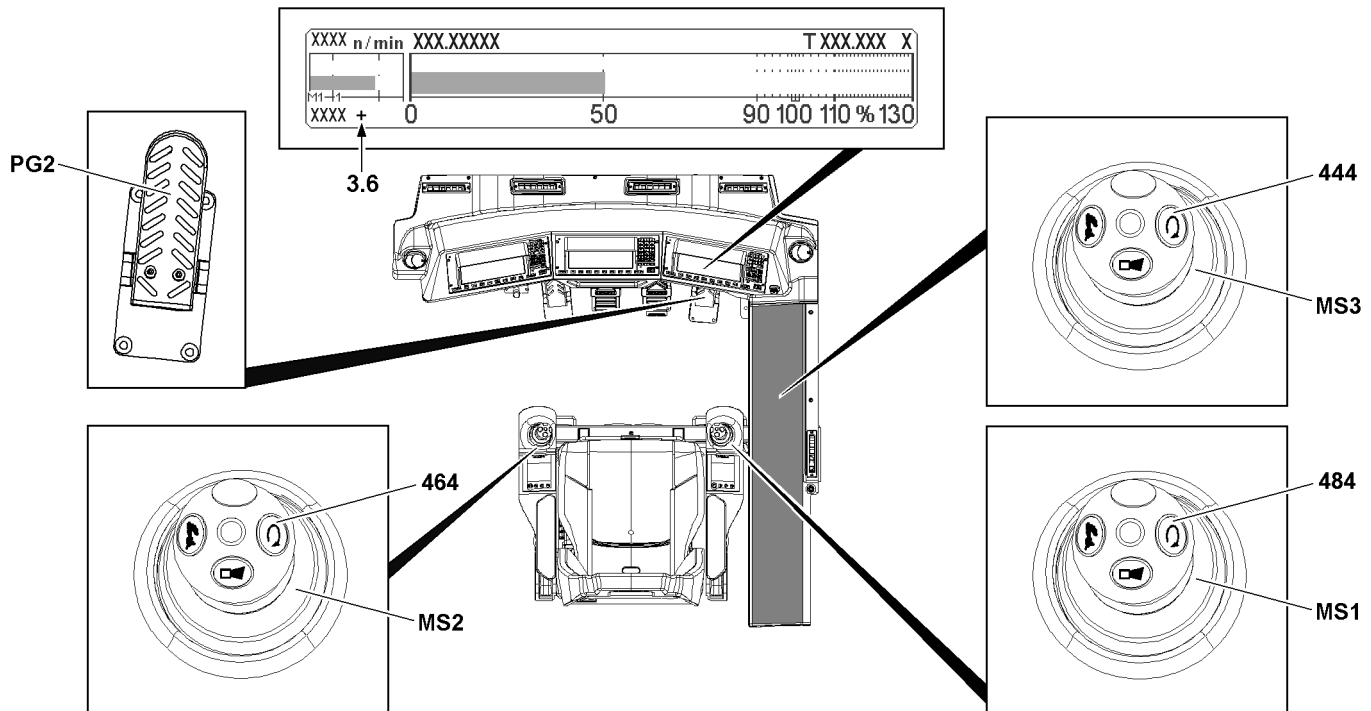


Fig.155135: Engine rpm lock

### 6.2.1 Setting the engine rpm lock

Locking the engine rpm relieves the crane operator if he needs to work for an extended period with constant rpm. The engine regulation can be locked in any position.

- ▶ Press the pedal **PG2** for the engine regulation down until the desired rpm is reached.
- ▶ Press the button **484** on the master switch **MS1**.
  - or
  - Press the button **464** on the master switch **MS2**.
  - or
  - Press the button **444** on the master switch **MS3**.

#### Result:

- The engine rpm lock is set.
- The *engine rpm locked* icon **3.6** appears on the LICCON monitor.



#### Note

- ▶ The locked engine rpm can be overridden by pressing the pedal **PG2**. If the button **484**, the button **464** or the button **444** is pressed during the override, the current rpm will be used.

### 6.2.2 Releasing the engine rpm lock

Make sure that the following prerequisite is met:

- The pedal **PG2** is not actuated.

When the engine rpm is locked:

- ▶ Press the button **484** on the master switch **MS1**.
- or
- Press the button **464** on the master switch **MS2**.
- or
- Press the button **444** on the master switch **MS3**.
- or
- Tap the pedal **PG2** briefly.

**Result:**

- The engine rpm lock is released.
- The *engine rpm locked* icon **3.6** disappears on the LICCON monitor.

### 6.3 Rapid gear (Power Plus)

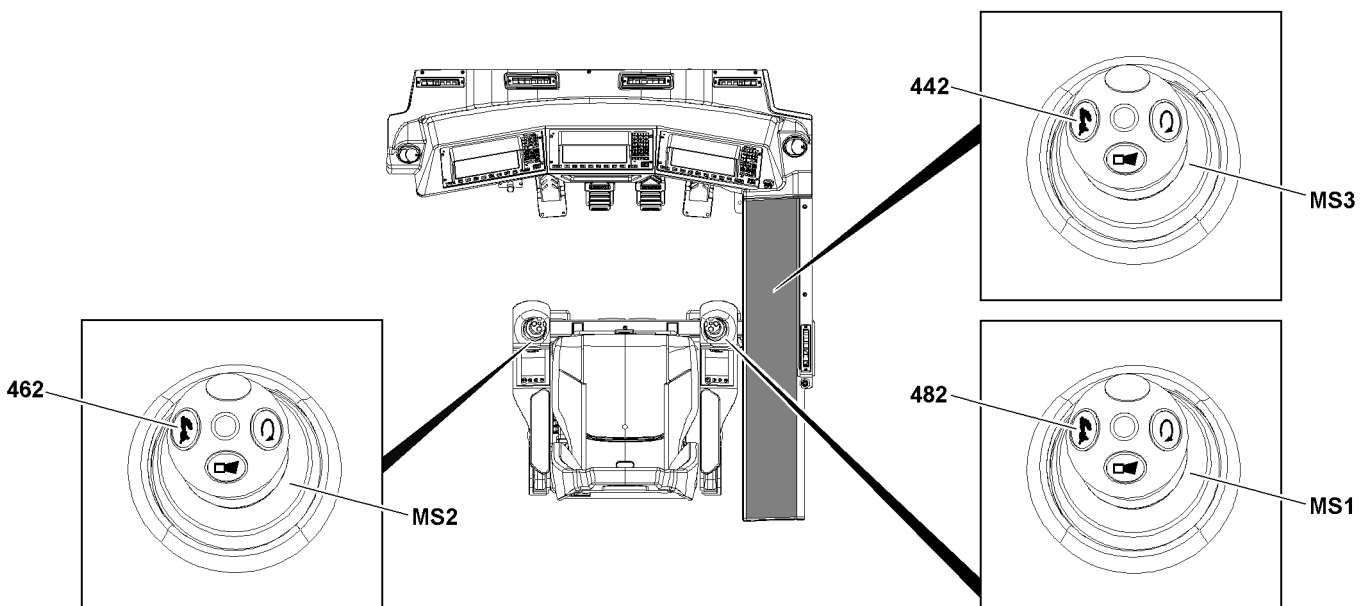


Fig.155129: Rapid gear (Power Plus)

When the rapid gear is engaged, the maximum speed of the selected crane movements is increased.

Double function on the button **482**, button **462** and button **442**:

- When briefly pressing (less than a second) one of the buttons, the rapid gear is turned on / off.
- By pressing one of the buttons for longer (more than two seconds) the settings window for *Speed reduction master switch / pedal sensor* turned on / off, see section “Speed reduction master switch / pedal sensor”.



#### WARNING

Danger of accident in case of a single to triple reeving!  
Death, severe bodily injuries, property damage.

- ▶ Do **NOT** turn the rapid gear on if the crane is loaded to more than 50 % of its maximum permitted load bearing capacity for the respective boom radius.

**Note**

Special features of the rapid gear (Power Plus)

- ▶ The effectiveness of the rapid gear function depends on the setting for the speed reduction master switch. If a smaller value is set for the speed reduction, then the rapid gear function is low.
- ▶ When the rapid gear is engaged and various crane movements are actuated at the same time, then there may be loss of speed for some crane movements.
- ▶ If the total power requirement of all actuated crane movements is greater than the available power, then the crane movement that requires the most power is reduced.
- ▶ If another crane movement is added or taken back to one or more actuated crane movements then this has an influence on the other movements. For that reason we recommend in situations in which an interference of the individual crane movements is troublesome, not to activate the rapid gear or to turn it off.

### 6.3.1 Activating the rapid gear

- ▶ Press the button **482** on the master switch **MS1**.  
or  
Press the button **462** on the master switch **MS2**.  
or  
Press the button **442** on the master switch **MS3**.

**Result:**

- The rapid gear is switched on.
- The icon **3** appears on the LICCON monitor.

### 6.3.2 Turning the rapid gear off

When the rapid gear is engaged:

- ▶ Press the button **482** on the master switch **MS1**.  
or  
Press the button **462** on the master switch **MS2**.  
or  
Press the button **442** on the master switch **MS3**.

**Result:**

- The rapid gear is turned off.
- The icon **3** turns off on the LICCON monitor.



## 6.4 Seat contact button

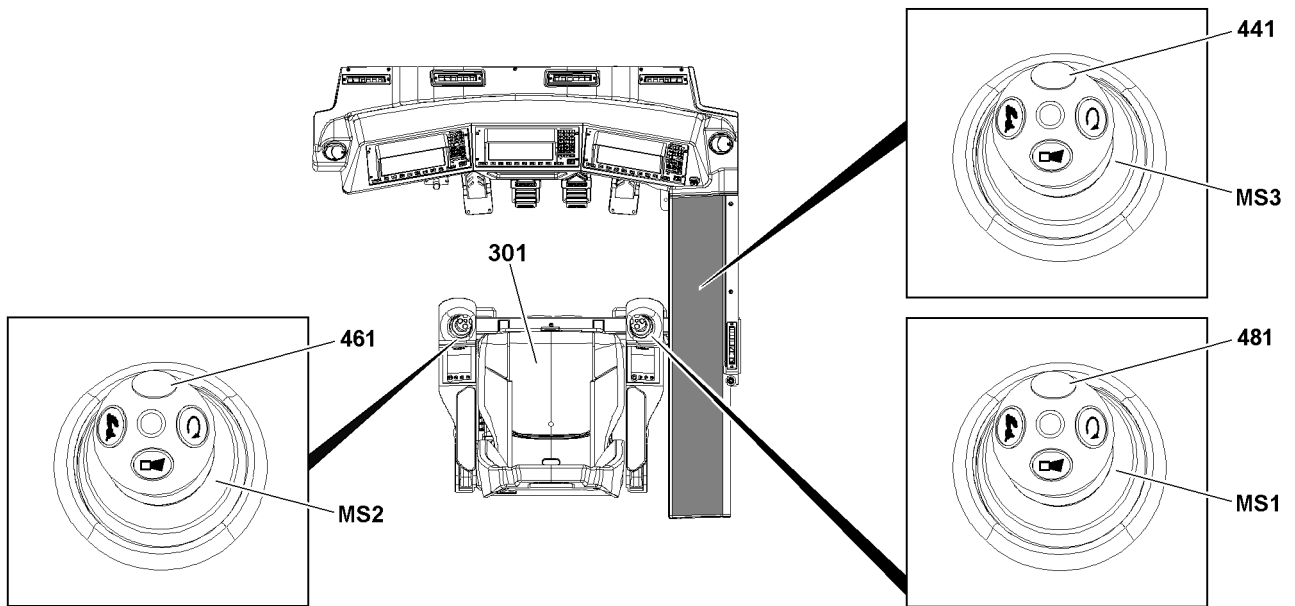


Fig.155126: Actuating / bypassing the seat contact button

### 6.4.1 Actuating the seat contact button

To release a crane movement, the seat contact button **301** must be pressed. As soon as the crane driver sits down on the crane seat, the seat contact button **301** is actuated.

To actuate the seat contact button **301**:

- ▶ Sit on the driver's seat.

**Result:**

- Crane movements can be controlled.

### 6.4.2 Bypassing the seat contact button

If the crane driver must work while standing, the seat contact button **301** must be bypassed.

Multiple function on the button **481**, button **461** and button **441**:

- If a button is continuously pressed when the seat contact button **301** is not actuated, the seat contact button is bypassed.
- If a button is briefly pressed (less than two seconds) when the seat contact button **301** is actuated, the vibration sensor is turned on / off, see section "Vibration sensor".
- If the button **481** or button **461** is continuously pressed when the seat contact button **301** is pressed, separate operation is possible in parallel operation, see section "Hoist winches in parallel operation".

Make sure that the following prerequisite is met:

- The seat contact button **301** is **not** actuated.
- ▶ Press and hold the button **481** on the master switch **MS1**.  
or  
Press and hold the button **461** on the master switch **MS2**.  
or  
Press and hold the button **441** on the master switch **MS3**.

**Result:**

- The seat contact button **301** is bypassed.
- Crane movements can be controlled.

**Note**

- ▶ The seat contact button **301** is only bypassed as long as the button **481**, button **461** or button **441** is pressed.
- ▶ When sitting on the driver's seat, as long as the button **481**, button **461** or button **441** is pressed, the setting of the vibration sensor is possibly changed, see section "Vibration sensor".

## 6.5 Vibration sensor

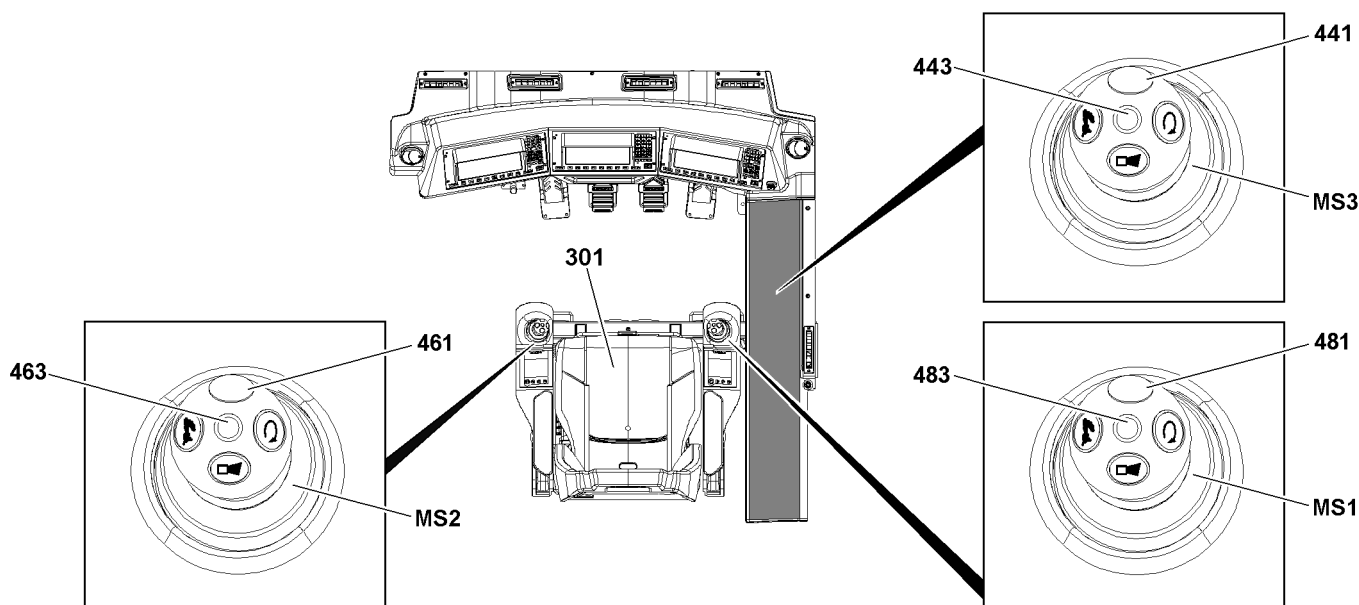


Fig.155137: Vibration sensor

When the vibration sensor is turned on, a crane movement can also be detected via the vibration of the concerned master switch. A plunger moves within the master switch and creates vibrations.

- The master switch **MS1** has a vibration sensor **483**.
- The master switch **MS2** has a vibration sensor **463**.
- The master switch **MS3** has a vibration sensor **443**.

Multiple function on the button **481**, button **461** and button **441**:

- If a button is briefly pressed (less than two seconds) when the seat contact button **301** is actuated, the vibration sensor is turned on / off.
- If a button is continuously pressed when the seat contact button **301** is not actuated, the seat contact button is bypassed, see section "Seat contact button".
- If the button **481** or button **461** is continuously pressed when the seat contact button **301** is pressed, separate operation is possible in parallel operation, see section "Hoist winches in parallel operation".

### 6.5.1 Turning on and activating the vibration sensor

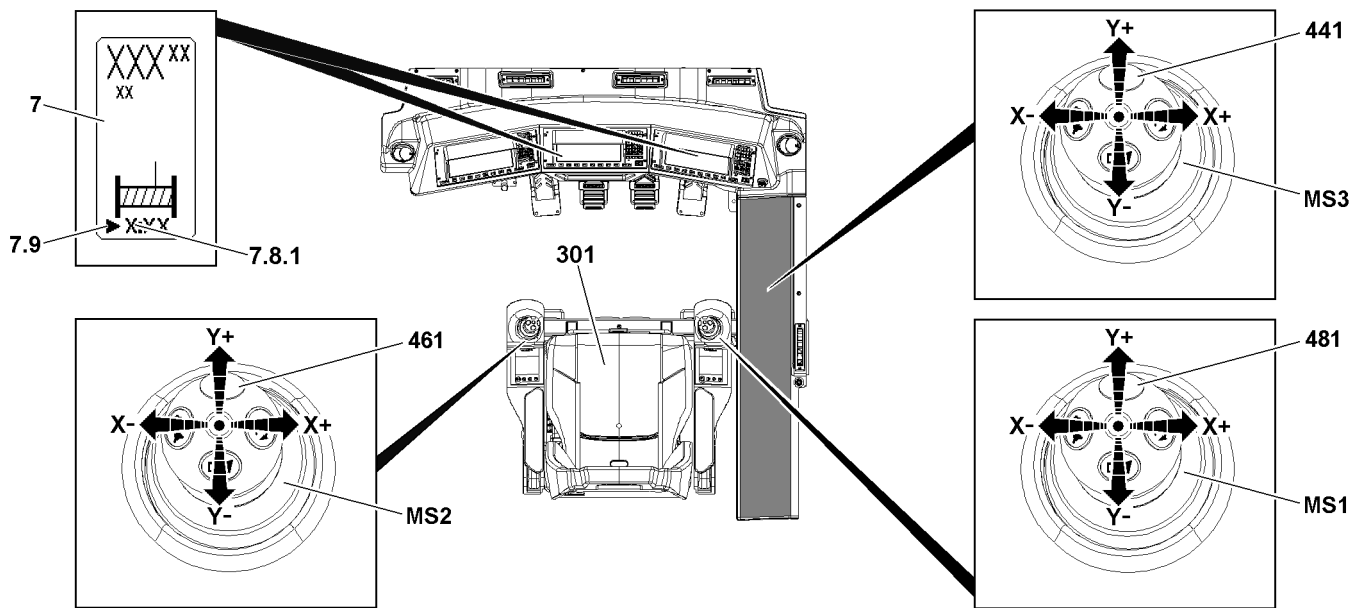


Fig.155136: Turning on and activating the vibration sensor

When the vibration sensor is turned on, a crane movement can also be detected via the vibration of the concerned master switch.

- The vibration sensor can only be activated for one deflection axis per master switch.
- To activate the vibration sensor for the other deflection axis, the master switch must be set briefly to the zero position. It is now possible to activate the other deflection axis.

Make sure that the following prerequisite is met:

- The seat contact button **301** is actuated.



#### Note

- ▶ The vibration sensor can only be activated if the seat contact button **301** is pressed.
- ▶ The vibration sensor must be turned on and activated separately for each master switch.

When the vibration sensor for the master switch **MS1** is turned off:

- ▶ Briefly actuate the button **481** (less than two seconds).

#### Result:

- The vibration sensor on the master switch **MS1** is turned on.
- As soon as the master switch **MS1** is moved from the zero position in direction **Y+** or direction **Y-**, the vibration sensor is activated in the Y-direction.
- As soon as the master switch **MS1** is moved from the zero position in direction **X+** or direction **X-**, the vibration sensor is activated in the X-direction.

When the vibration sensor for the master switch **MS2** is turned off:

- ▶ Briefly actuate the button **461** (less than two seconds).

#### Result:

- The vibration sensor on the master switch **MS2** is turned on.
- As soon as the master switch **MS2** is moved from the zero position in direction **Y+** or direction **Y-**, the vibration sensor is activated in the Y-direction.
- As soon as the master switch **MS2** is moved from the zero position in direction **X+** or direction **X-**, the vibration sensor is activated in the X-direction.

When the vibration sensor for the master switch **MS3** is turned off:

- ▶ Briefly actuate the button **441** (less than two seconds).

**Result:**

- The vibration sensor on the master switch **MS3** is turned on.
- As soon as the master switch **MS3** is moved from the zero position in direction **Y+** or direction **Y-**, the vibration sensor is activated in the Y-direction.
- As soon as the master switch **MS3** is moved from the zero position in direction **X+** or direction **X-**, the vibration sensor is activated in the X-direction.

**Note**

For the winches, identification takes place regarding the vibration sensor.

- ▶ The assignment of the winch displays **7** takes place via the winch numbers **7.8.1**. For winch 1, there is the number 1, for winch 2 there is the number 2, etc.
- ▶ As soon as the vibration sensor for a master switch is turned on, the relative winch display **7** shows the icon **7.9**. This signals at this moment for which winches the turned on vibration sensor can report a crane movement.
- ▶ As soon as the vibration sensor for a direction of deflection is activated, the icon **7.9** for the winch that was not considered. If the master switch is no longer deflected, the icon **7.9** appears again.

### 6.5.2 Turning the vibration sensor off

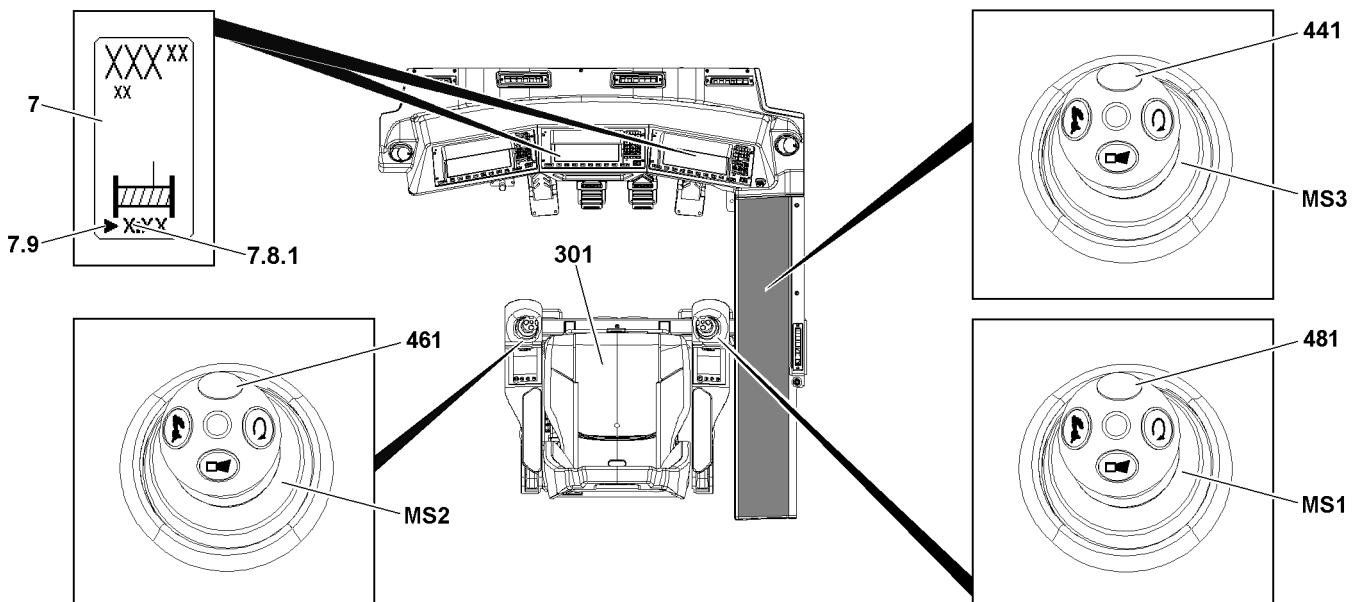


Fig.155139: Turning the vibration sensor off

Make sure that the following prerequisite is met:

- The seat contact button **301** is actuated.

**Note**

- ▶ The vibration sensor can only be turned off if the seat contact button **301** is pressed.
- ▶ The vibration sensor must be turned off separately for each master switch.
- ▶ The vibration sensor can also be turned off during the deflection movement.

When the vibration sensor for the master switch **MS1** is turned on:

- ▶ Briefly actuate the button **481** (less than two seconds).

**Result:**

- The vibration sensor is deactivated and turned off.

When the vibration sensor for the master switch **MS2** is turned on:

- ▶ Briefly actuate the button **461** (less than two seconds).

**Result:**

- The vibration sensor is deactivated and turned off.

When the vibration sensor for the master switch **MS3** is turned on:

- ▶ Briefly actuate the button **441** (less than two seconds).

**Result:**

- The vibration sensor is deactivated and turned off.

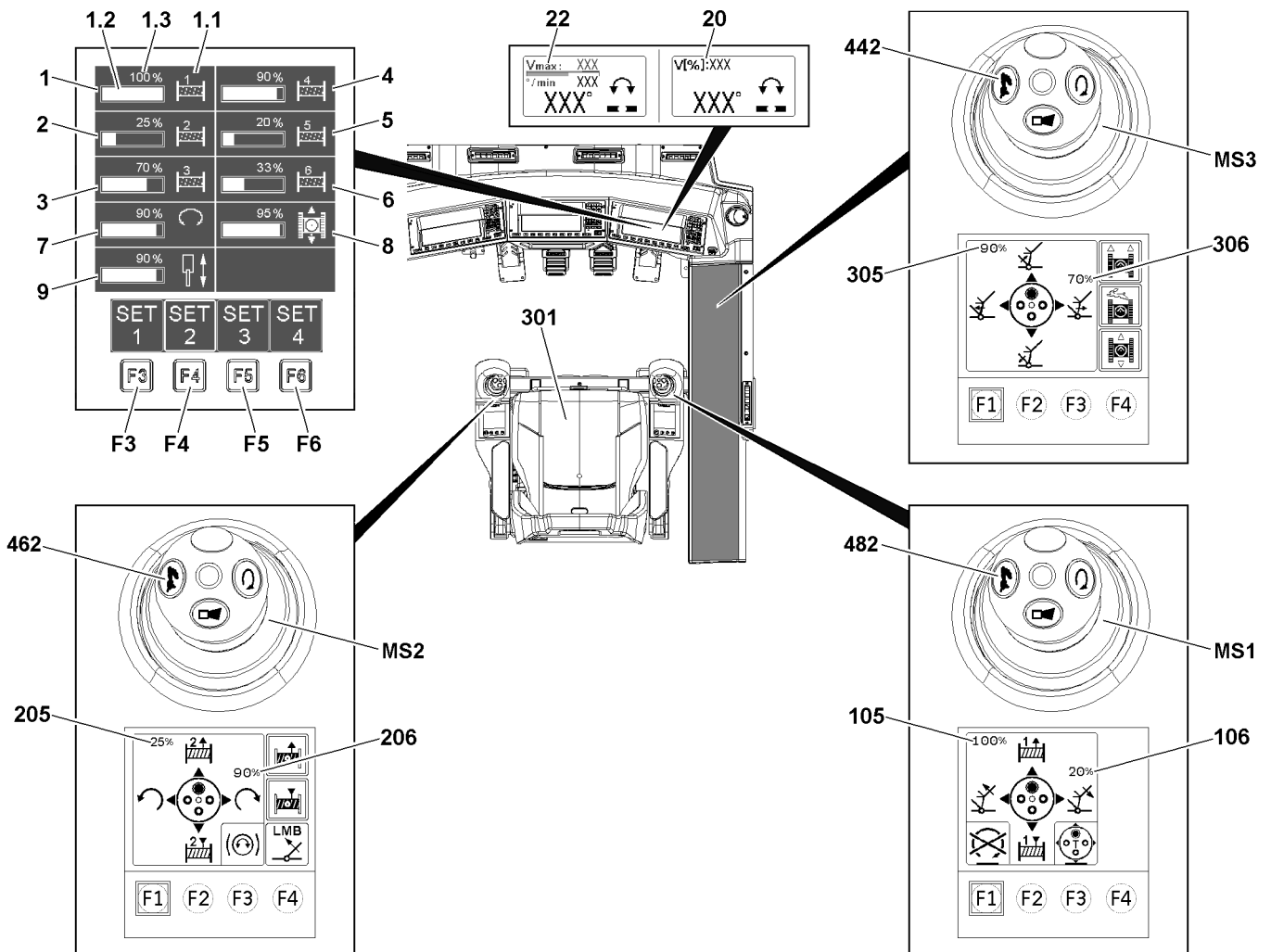


**Note**

For the winches, identification takes place regarding the vibration sensor.

- ▶ The assignment of the winch displays **7** takes place via the winch numbers **7.8.1**. For winch 1, there is the number 1, for winch 2 there is the number 2, etc.
- ▶ As soon as the vibration sensor for a master switch is turned off, the relative winch display **7** no longer shows the icon **7.9**.

### 6.6 Speed reduction master switch / pedal sensor



*Fig.155138: Speed reduction master switch / pedal sensor*

The maximum obtainable speed of the crane movement when the master switch has maximum deflection can be reduced in the settings window “Speed reduction master switch / pedal sensor”.

Four different fast settings for the speed reduction master switch / pedal sensor can be called up by pressing a button.

LWE/LR 1800-1-0-000/27200-07-02/en

**Note**

Select other setting values within the fast settings.

- ▶ Setting the speed reduction master switch / pedal sensor, see chapter 4.02.

Double function on the button **482**, button **462** and button **442**:

- By pressing one of the buttons for longer (more than two seconds) the settings window for *Speed reduction master switch / pedal sensor* turned on / off, see section Speed reduction master switch / pedal sensor.
- When briefly pressing (less than a second) one of the buttons, the rapid gear is turned on / off, see section “fast gear (Power Plus)”.

### 6.6.1 Displaying the setting value in the settings window

**Note**

▶ Only settings windows for active crane movements / crane functions appear.

▶ The structure of the individual settings windows is the same and is described based on the Winch 1 settings window **1**.

- **1** Winch 1 settings window
  - Settings window with an icon, bar diagram and setting value
  - **Note:** In the case of parallel operation of winch 1 and winch 2, the setting also takes place in Winch 1 settings window **1**.
- **1.1** *Assignment* icon
  - Icon of assigned crane movement / crane function
  - The icon corresponds to the illustration in the respective TE- display
- **1.2** Bar diagram
  - Graphic illustration of the current speed reduction
- **1.3** Set value
  - Numeric display of the current speed reduction in [%]
- **2** Winch 2 settings window
  - Settings window with an icon, bar diagram and setting value
  - **Note:** In the case of parallel operation of winch 1 and winch 2, the setting takes place in Winch 1 settings window **1**.
- **3** Winch 3 settings window
  - Settings window with an icon, bar diagram and setting value
- **4** Winch 4 settings window
  - Settings window with an icon, bar diagram and setting value
- **5** Winch 5 settings window
  - Settings window with an icon, bar diagram and setting value
- **6** Winch 6 settings window
  - Settings window with an icon, bar diagram and setting value
- **7** Slewing gear settings window
  - Settings window with an icon, bar diagram and setting value
- **8** Crawler settings window
  - Settings window with an icon, bar diagram and setting value
- **9** Assembly cylinder settings window
  - Settings window with an icon, bar diagram and setting value

### 6.6.2 Displaying the setting values on the touch displays

- **106** Set value
  - Speed reduction for master switch **MS1** in the X-direction (to the right / to the left)
- **105** Set value

- Speed reduction for master switch **MS1** in the Y-direction (to the front / to the rear)
- **206** Set value
- Speed reduction for master switch **MS2** in the X-direction (to the right / to the left)
- **205** Set value
- Speed reduction for master switch **MS2** in the Y-direction (to the front / to the rear)
- **306** Set value
- Speed reduction for master switch **MS3** in the X-direction (to the right / to the left)
- **305** Set value
- Speed reduction for master switch **MS3** in the Y-direction (to the front / to the rear)

### 6.6.3 Displaying the setting value on the operating screen



#### Note

- ▶ Depending on the crane configuration, either the slewing gear setting value **20** or slewing speed **22** appears.
- ▶ The slewing gear settings window is displayed on the touch display of the master switch, which controls the *Turning the crane superstructure* crane movement. See section "Display of the setting values on the touch displays".

- **20** Slewing gear setting value
  - Speed reduction for the *turning the crane superstructure* crane movement.
- **22** Slewing speed display
  - Display for the permissible slewing speed and the current slewing speed.
  - **Note:** No information can be derived from the slewing gear setting value. The obtainable current slewing speed depends on the setting selected in the slewing gear settings window **7**.

### 6.6.4 Showing the *Speed reduction master switch* setting window

- ▶ Press the button **482** on the master switch **MS1** for at least two seconds.
- or
- ▶ Press the button **462** on the master switch **MS2** for at least two seconds.
- or
- ▶ Press the button **442** on the master switch **MS3** for at least two seconds.

#### Result:

- The *Speed reduction master switch / pedal sensor* settings window is shown.



#### Note

- ▶ The settings window disappears again after ten seconds without additional tasks.

### 6.6.5 Selecting the fast setting

Select fast setting 1 (SET1):

- ▶ Press the function key **F3**.

#### Result:

- Fast setting 1 (SET1) is selected.
- The frame around the *SET1* icon is shown in bold.

Select fast setting 2 (SET2):

- ▶ Press the function key **F4**.

#### Result:

- Fast setting 2 (SET2) is selected.
- The frame around the *SET2* icon is shown in bold.

Select fast setting 3 (SET3):

- ▶ Press the function key **F5**.

**Result:**

- Fast setting 3 (SET3) is selected.
- The frame around the *SET3* icon is shown in bold.

Select fast setting 4 (SET4):

- ▶ Press the function key **F6**.

**Result:**

- Fast setting 4 (SET4) is selected.
- The frame around the *SET4* icon is shown in bold.

### 6.6.6 Hiding the *Speed reduction master switch* setting window

When the settings window is displayed:

- ▶ Press the button **482** on the master switch **MS1** for at least two seconds.  
**or**
- Press the button **462** on the master switch **MS2** for at least two seconds.  
**or**
- Press the button **442** on the master switch **MS3** for at least two seconds.  
**or**
- Wait ten seconds without further action.

**Result:**

- The *Speed reduction master switch / pedal sensor* settings window is hidden.

## 7 Changing the speed of the crane movement via the engine rpm

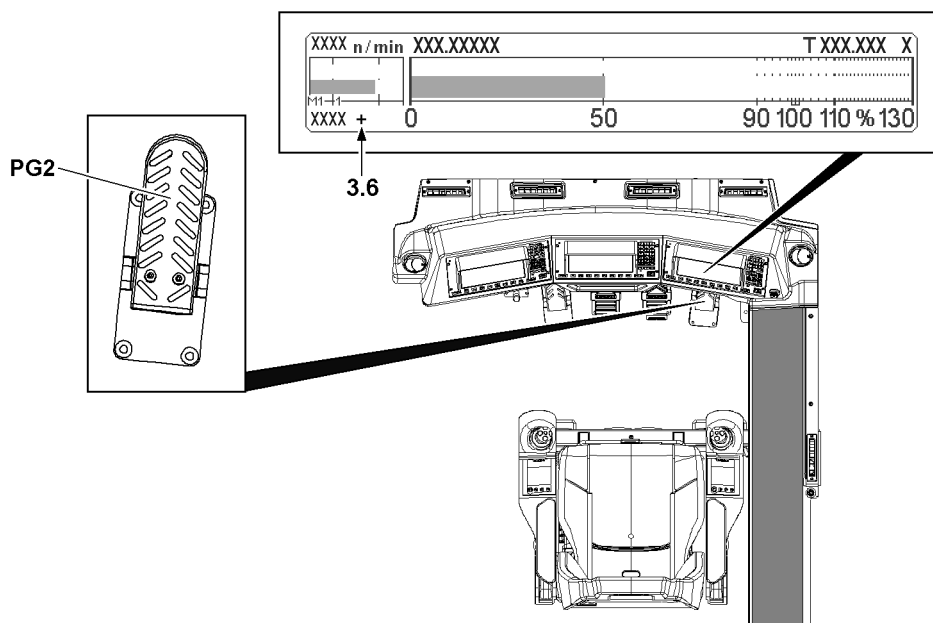


Fig.155141: Changing the engine rpm

In addition to the master switch deflection and the use of the rapid gear, other factors influence the speed of the crane movements.



The following have an influence on the possible speed, for example:

- The number of simultaneous crane movements
- Load and set up configuration of the crane
- Temperature of the hydraulic oil and the work environment

Through the targeted control of the engine rpm, the crane operator can additionally change the speed of the crane movement.

The crane control supports the crane operator through the automatic control of the idle engine rpm. Without crane movements, the idle engine rpm is reduced to a minimum. To carry out the crane movements, the idle engine rpm is increased to a performance-based minimum speed.



---

**Note**

Locked engine rpm

If the *Engine rpm locked* icon **3.6** appears, the crane control is limited in the control of the idle engine rpm.

Also if the *Engine rpm locked* icon **3.6** appears: The locked engine rpm can be increased by pressing the pedal **PG2**.

- ▶ For a detailed description, see section “Engine rpm lock”.
- 

When a possibly high speed of the crane movement is important:

- ▶ Press the pedal **PG2** and increase the engine rpm.

When a high speed of the crane movement is not important:

- ▶ Do not press the pedal **PG2** and do not lock an increased engine rpm.

## 8 Spooling the hoist winches up / out (load lifting / load lowering)

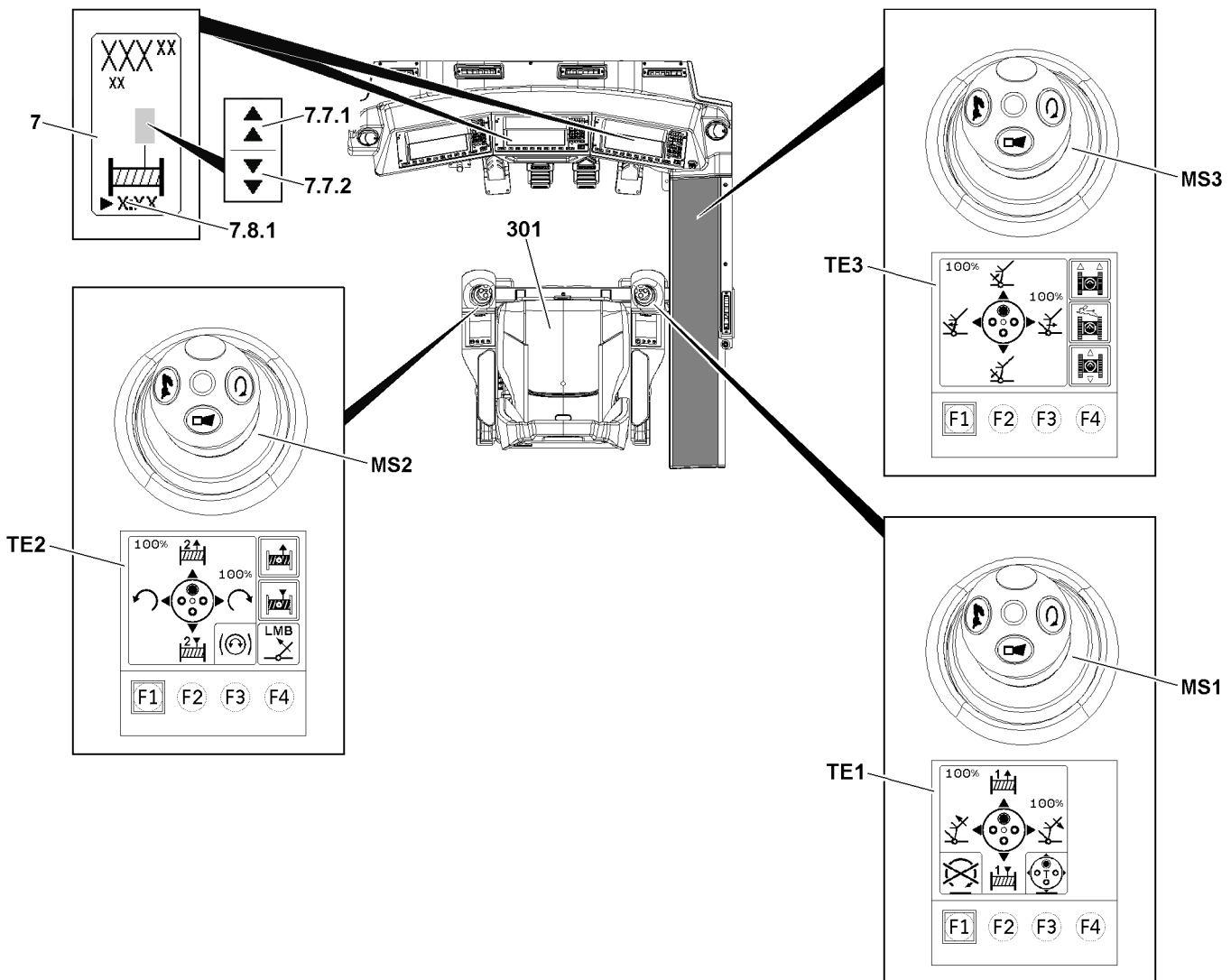


Fig.155142: Function assignment of the master switch, example master switch assignment T



### Note

The assignment of the master switches can change, depending on the set up configuration and winch application.

- Switch the master switch assignment, see section “master switch assignment”.



### Note

- The maximum obtainable speed of the crane movement can be reduced in the settings window “Speed reduction master switch / pedal sensor”. Observe the section “Speed reduction master switch / pedal sensor”.
- If the rapid gear is engaged, ensure that a higher crane movement speed is reached with the same master switch deflection. Observe the section “rapid gear (Power Plus)”.
- If the engine rpm is increased, ensure that a higher crane movement speed is reached with the same master switch deflection. Observe the section “Changing the speed of the crane movement via the engine rpm”.

This section applies only to winches that are used as hoist winches:

- Winch 1 as a hoist winch

- Winch 2 as a hoist winch
- Winch 5 as a hoist winch
- Winch 6 as a hoist winch

The determining factor for controlling the *Spooling the hoist winches up / out* crane movement is always the displayed function assignment on the touch display, see section “Master switch assignment”.

- The touch display **TE1** shows the function assignments for the master switch **MS1**.
- The touch display **TE2** shows the function assignments for the master switch **MS2**.
- The touch display **TE3** shows the function assignments for the master switch **MS3**.

Each winch has a separate winch display **7**. The assignment of the winch displays **7** takes place via the winch numbers **7.8.1**. For winch 1, there is the number 1, for winch 2 there is the number 2, etc.

The winch display **7** shows the icon **7.7.1** and icon **7.7.2** when the winch turns. This makes all spooling up and out operations identifiable.

It is only possible to control crane movements from the crane cab when the seat contact button **301** is pressed or bypassed. Bypass the seat contact button, see section “Seat contact button”.

Make sure that the following prerequisites are met:

- The corresponding function assignment *Spooling the hoist winch up / out* is displayed on the touch display of the master switch.
- The master switches are in the neutral position.
- The crane is at a standstill.
- The hoist winch to operate is released, see section “Locking / releasing the winch”.

## 8.1 Spooling winch 1 up / out

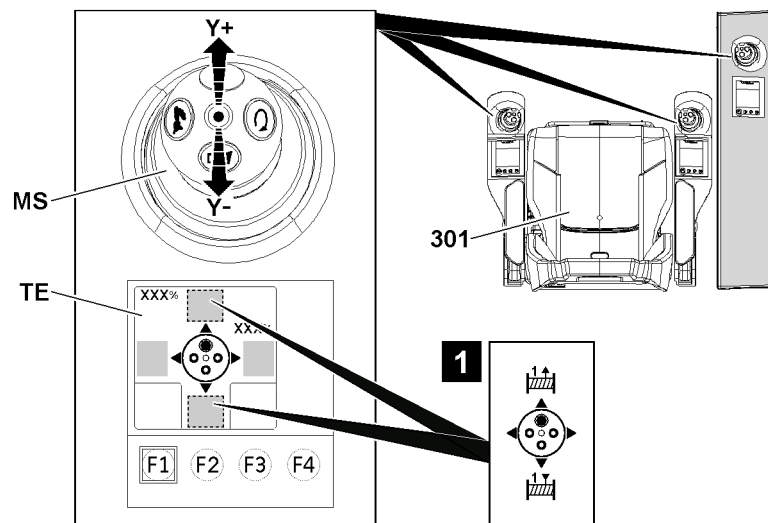


Fig.155145: Spooling winch 1 up / out

Make sure that the following prerequisites are met:

- The touch display **TE** of the concerned master switch shows the function assignment *spool winch 1 up / out*.
- The seat contact button **301** is pressed or bypassed.

### 8.1.1 Spooling winch up 1

The master switch **MS** function assignment is according to the illustration 1:

- ▶ Move the master switch **MS** in direction **Y-**.

**Result:**

- Winch 1 spools up, a fastened load is lifted.

### 8.1.2 Spooling out winch 1

The master switch **MS** function assignment is according to the illustration 1:

- Move the master switch **MS** in direction **Y+**.

**Result:**

- Winch 1 spools out, a fastened load is lowered.

## 8.2 Spooling winch 2 up / out

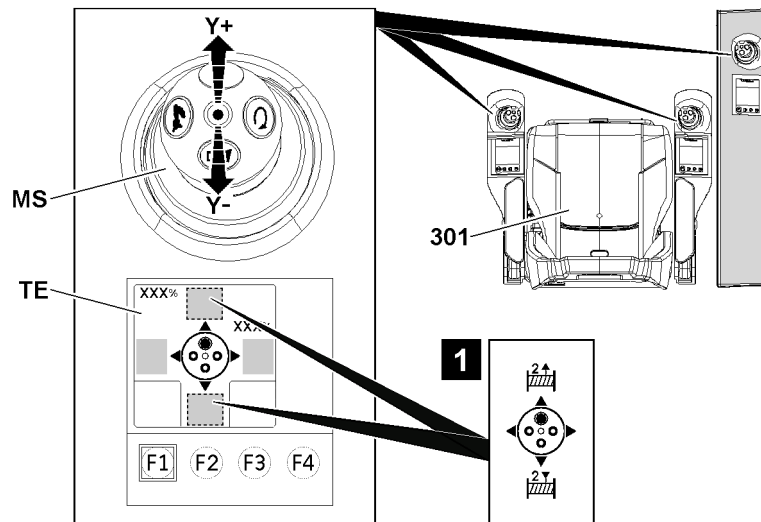


Fig.155146: Spooling winch 2 up / out

Make sure that the following prerequisites are met:

- The touch display **TE** of the concerned master switch shows the function assignment *spool winch 2 up / out*.
- The seat contact button **301** is pressed or bypassed.

### 8.2.1 Spooling winch up 2

The master switch **MS** function assignment is according to the illustration 1:

- Move the master switch **MS** in direction **Y-**.

**Result:**

- Winch 2 spools up, a fastened load is lifted.

### 8.2.2 Spooling out winch 2

The master switch **MS** function assignment is according to the illustration 1:

- Move the master switch **MS** in direction **Y+**.

**Result:**

- Winch 2 spools out, a fastened load is lowered.

## 8.3 Spooling winch 5 up / out

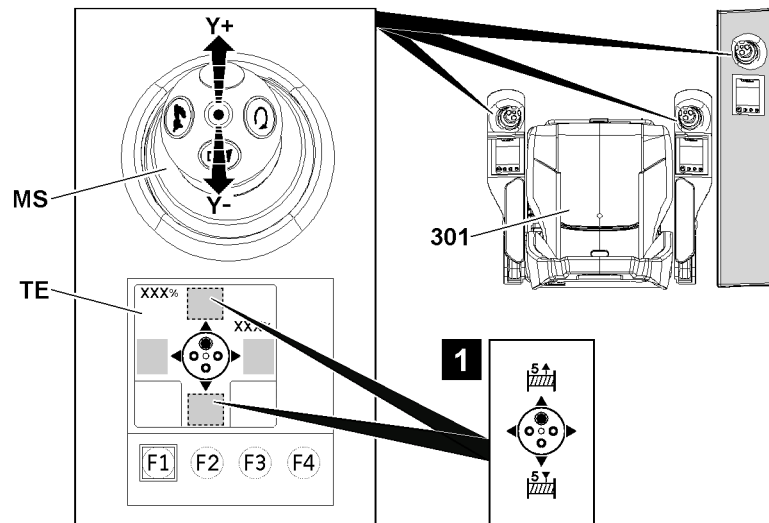


Fig.155147: Spooling winch 5 up / out



### Note

Winch 5 is normally a control winch.

- ▶ Only for crane types for which winch 5 is a hoist winch.

Make sure that the following prerequisites are met:

- The touch display **TE** of the concerned master switch shows the function assignment *spool winch 5 up / out*.
- The seat contact button **301** is pressed or bypassed.

### 8.3.1 Spooling winch up 5

The master switch **MS** function assignment is according to the illustration 1:

- ▶ Move the master switch **MS** in direction **Y-**.

#### Result:

- Winch 5 spools up, a fastened load is lifted.

### 8.3.2 Spooling out winch 5

The master switch **MS** function assignment is according to the illustration 1:

- ▶ Move the master switch **MS** in direction **Y+**.

#### Result:

- Winch 5 spools out, a fastened load is lowered.

## 8.4 Spooling winch 6 up / out

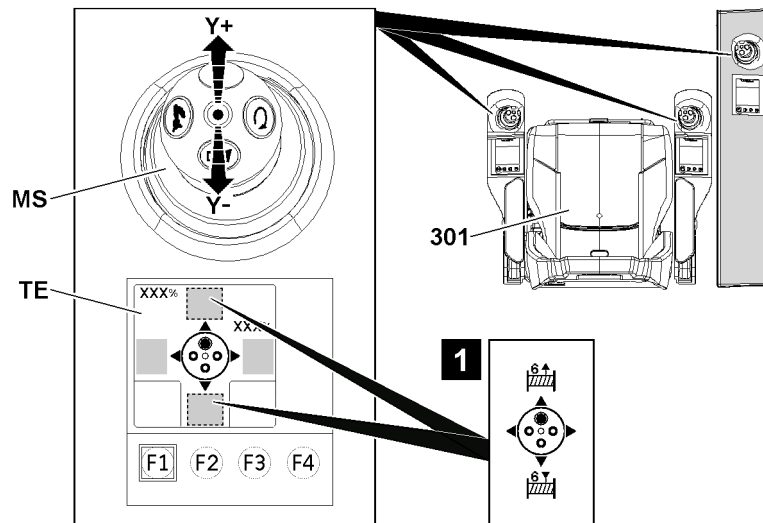


Fig.155148: Spooling winch 6 up / out

Make sure that the following prerequisites are met:

- The touch display **TE** of the concerned master switch shows the function assignment *spool winch 6 up / out*.
- The seat contact button **301** is pressed or bypassed.

### 8.4.1 Spooling winch up 6

The master switch **MS** function assignment is according to the illustration 1:

- ▶ Move the master switch **MS** in direction **Y-**.

**Result:**

- Winch 6 spools up, a fastened load is lifted.

### 8.4.2 Spooling out winch 6

The master switch **MS** function assignment is according to the illustration 1:

- ▶ Move the master switch **MS** in direction **Y+**.

**Result:**

- Winch 6 spools out, a fastened load is lowered.

## 9 Hoist winch in parallel operation

For parallel operation, winch 1 and winch 2 are used.

In parallel operation, winch 1 and winch 2 are actuated simultaneously with the master switch.



### WARNING

Danger of accident!

Death, severe bodily injuries, property damage.

- ▶ The number of the reeving of the hoist ropes for every winch in parallel operation must be identical.
- ▶ Make sure to unpin the transport pins on the roller blocks before the horizontal alignment and before crane operation.
- ▶ Make sure that the danger zone of the hook blocks is free of any personnel.

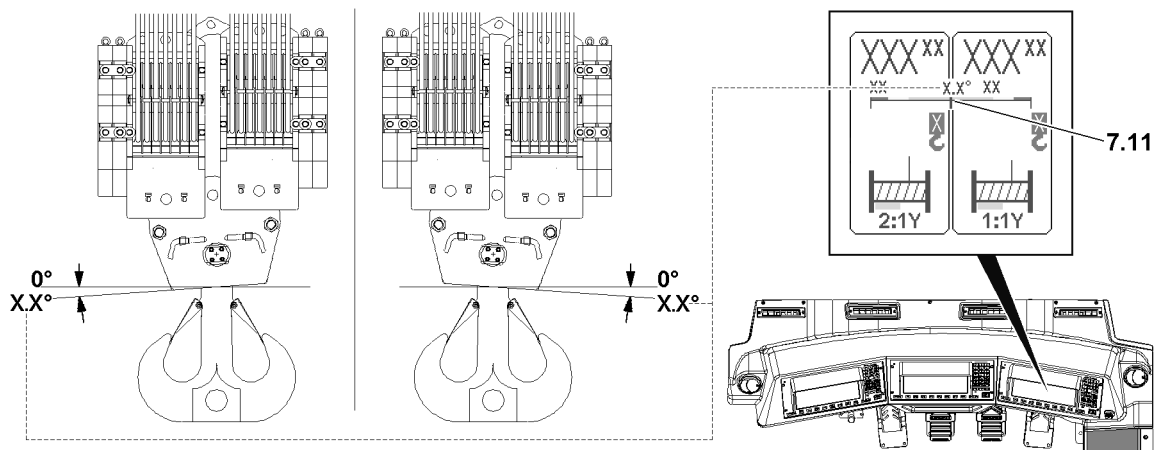


Fig.155149: Checking the radio incline sensor



### WARNING

Incorrectly installed radio incline sensor!  
Death, severe bodily injuries, property damage.

- ▶ After installation, check the function of the radio incline sensor on the hook block.
- ▶ Before starting crane operation, put the freely suspended hook block for winch individual operation with low rope speed on each side within the green area and check the plausibility of the incline indicator 7.11.



### WARNING

The incline indicator reacts laterally reversed!

If the incline indicator reacts laterally reversed, there is a danger of accident when spooling the hoist winch up and out.

- ▶ The winches must be reeved in according to the reeving plan on the correct roller blocks.
- ▶ The radio incline sensor must be installed correctly.



### Note

- ▶ The radio incline sensor must be installed on the hook block such that it is turned toward the crane cab.

Make sure that the following prerequisites are met:

- In the set up program, winch 1 and winch 2 are set as hoist winches in parallel operation.
- All rope pulleys, change over pulleys and test pulleys on the boom system are free of contamination, snow, frost and ice.
- The roller blocks of the hook block are installed together, see chapter 5.19 or the separate hook block operating instructions.
- The roller blocks of the hook block are reeved according to the load charts.
- The roller blocks of the hook block are properly reeved according to the reeving plan, see separate reeving plan.
- The minimum reeving according to the reeving plan may not be fallen below.
- The total reeving has been entered on the LICCON monitor.
- The number of the reeving of the hoist ropes for every winch must be identical and even.

## 9.1 Setting up parallel operation

Setting up parallel operation includes:

- Adapting to the wind speed
  - In the case of rope reeving greater than 2 x 20-way, adjustments must be made to the wind speed.
- Manually aligning the winch / hook block for individual operation

- For assembly operations, reeving in of the hoist rope or manual alignment of the hook block, individual operation of the winches may be necessary.
- Change over the *winch 1 and winch 2 parallel operation* regulation.
- It is necessary in certain situations to switch the regulation.
- Adjust winch 1 and winch 2
- To be able to spool winch 1 and winch 2 in parallel with In parallel operation with an adjusted rope speed

### 9.1.1 Adapting to the wind speed



#### WARNING

Winch speed / rope speed too high!

- ▶ In the case or rope reeving greater than 2 x 20-way, do not increase the winch speed / rope speed above 70 % of the maximum speed.

In the case or rope reeving greater than 2 x 20-way, reduce the wind speed to must be reduced to a maximum of 70%.

- ▶ Make the corresponding setting in the speed reduction master switch / pedal sensor settings window, see section “Speed reduction master switch / pedal sensor”.

### 9.1.2 Manually aligning the winch / hook block for individual operation

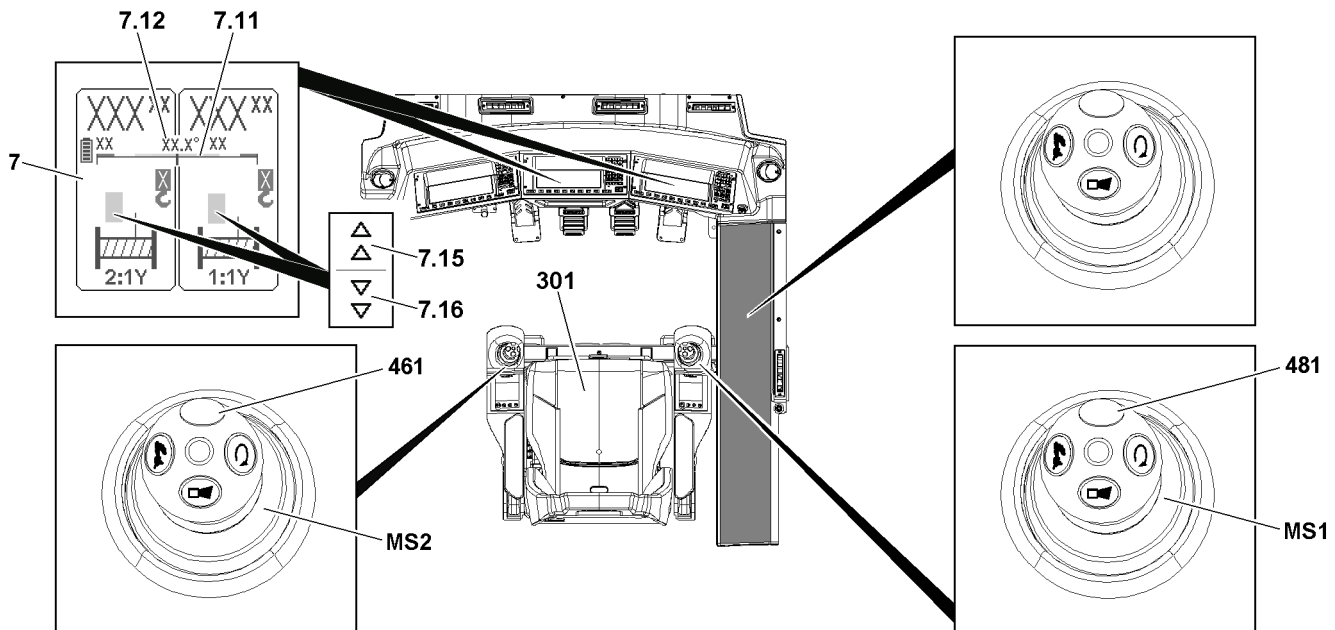


Fig.155151: Incline indicator for the hook block

The hook can be inclined in individual operation with winch 1 or winch 2. If the incline position of the hook block is excessive, a block position and / or shut-off takes place. In the case of a block position or an active shut-off, it is only possible to reduce the inclination position.



#### WARNING

Danger of accident!

In the case of low reeving or a high winch speed / rope speed, it is possible for the hook block to move with force to the block position.

- ▶ Never move the hook block to the block.
- ▶ Keep the incline indicator **7.11** for the hook block within the green range.
- ▶ Spool the hoist winches up and out with a reasonable winch speed / rope speed.



**WARNING**

Hook block inclined!

If the incline indicator **7.11** leaves the green area, the hook block must be realigned.

- ▶ Align the hook block horizontally (lateral incline 0°).

In certain situations, it may be necessary to intervene in parallel operation:

- Manually align the hook block
  - Spool winch 1 and winch 2 out or up until the hook block is aligned horizontally.
  - **Note:** To make it easier to manually align the hook block, there are supporting icons on the winch display **7**.
  - The incline indicator **7.11** graphically shows the lateral inclination of the hook block
  - The incline value **7.12** shows the lateral incline of the hook block as a number value
  - If the icon **7.15** appears on the winch display, spool out the corresponding winch to reduce the lateral incline of the hook block.
  - If the icon **7.16** appears on the winch display, spool up the corresponding winch to reduce the lateral incline of the hook block.
- Individually control winch 1 and winch 2

**Note**

If parallel operation is set in the set up program, the winch individual operation deviates from the normal procedure.

- ▶ Winch 1 can only be controlled in individual operation if the master switch **MS1**, seat contact button **301** and button **481** are actuated at the same time.
- ▶ Winch 2 can only be controlled in individual operation if the master switch **MS2**, seat contact button **301** and button **461** are actuated at the same time.

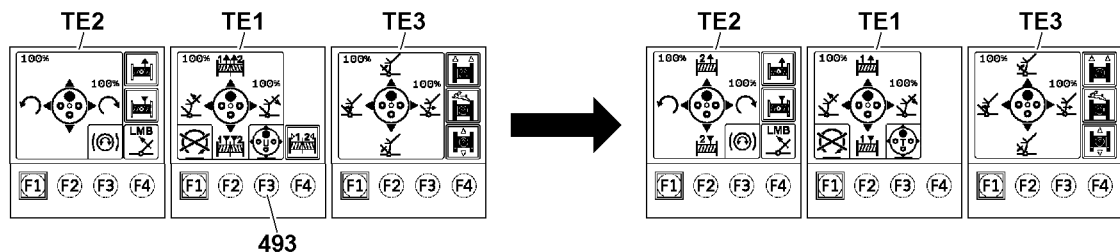
**Setting individual operation for winch 1 and winch 2**

Fig.155152: Setting individual operation for winch 1 and winch 2

- ▶ Press the F3 key **493** on the touch display **TE1** until the master switch assignment for individual operation of winch 1 and winch 2 is displayed.

**Result:**

- The touch display **TE1** shows in the Y direction the spool winch 1 up / out function assignment
- The touch display **TE2** shows in the Y direction the spool winch 2 up / out function assignment.

### Individual operation for winch 1

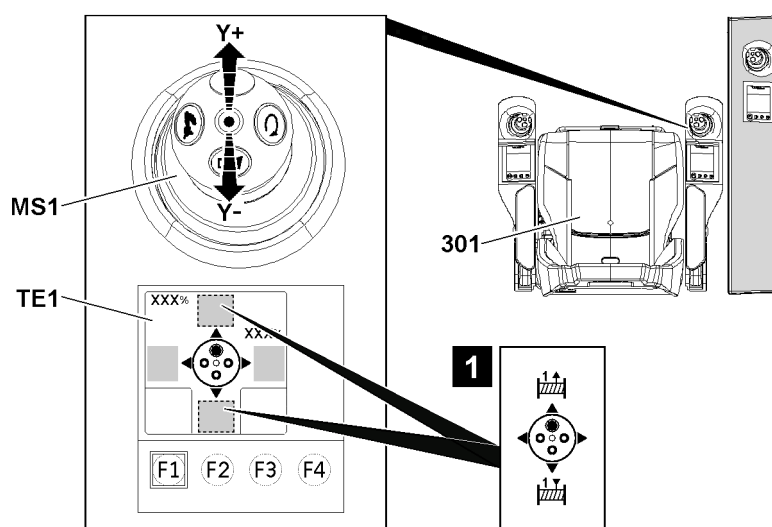


Fig.155154: Individual operation for winch 1

Make sure that the following prerequisite is met:

- The seat contact button **301** is actuated.

- ▶ Spool out winch 1: Press the button **481** while moving the master switch **MS1** in direction **Y+**.
- ▶ Spool up winch 1: Press the button **481** while moving the master switch **MS1** in direction **Y-**.

### Individual operation for winch 2

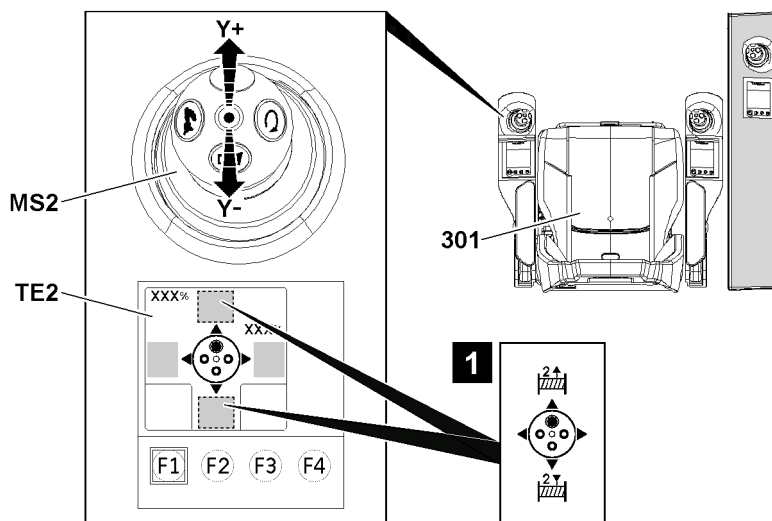


Fig.155155: Individual operation for winch 2

Make sure that the following prerequisite is met:

- The seat contact button **301** is actuated.

- ▶ Spool out winch 2: Press the button **461** while moving the master switch **MS2** in direction **Y+**.
- ▶ Spool up winch 2: Press the button **461** while moving the master switch **MS2** in direction **Y-**.

**Stopping individual operation for winch 1 and winch 2**

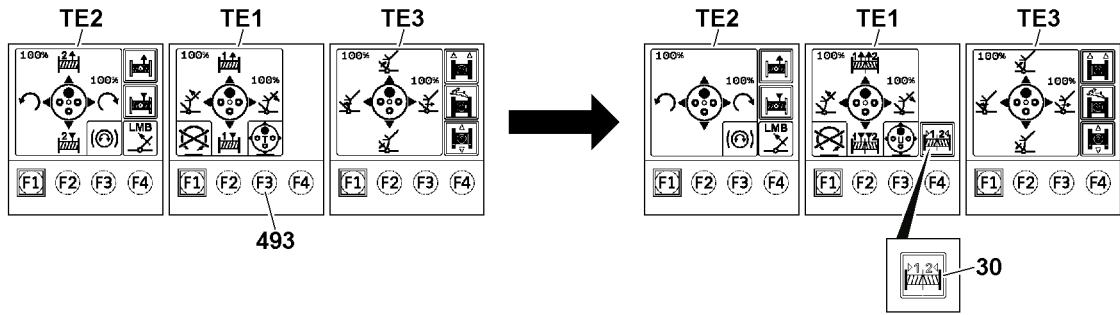


Fig.155153: Stopping individual operation for winch 1 and winch 2

- ▶ Press the F3 key **493** until the master switch assignment for the parallel operation of winch 1 and winch 2 is displayed.

**Result:**

- The touch display **TE1** shows in the Y direction the function assignment spool winch 1 and winch 2 up / out in parallel operation.

**NOTICE**

Incorrectly controlled parallel operation.

- ▶ If the *winch adjustment* icon **30** appears on the touch display **TE1**, the winches must be adjusted for parallel operation.

If the *winch adjustment* icon **30** appears on the touch display **TE1**:

- ▶ Adjust winch 1 and winch 2 with respect to each other, observe section “Adjusting winch 1 and winch 2”.

**9.1.3 Changing over the winch 1 and winch 2 parallel operation regulation**

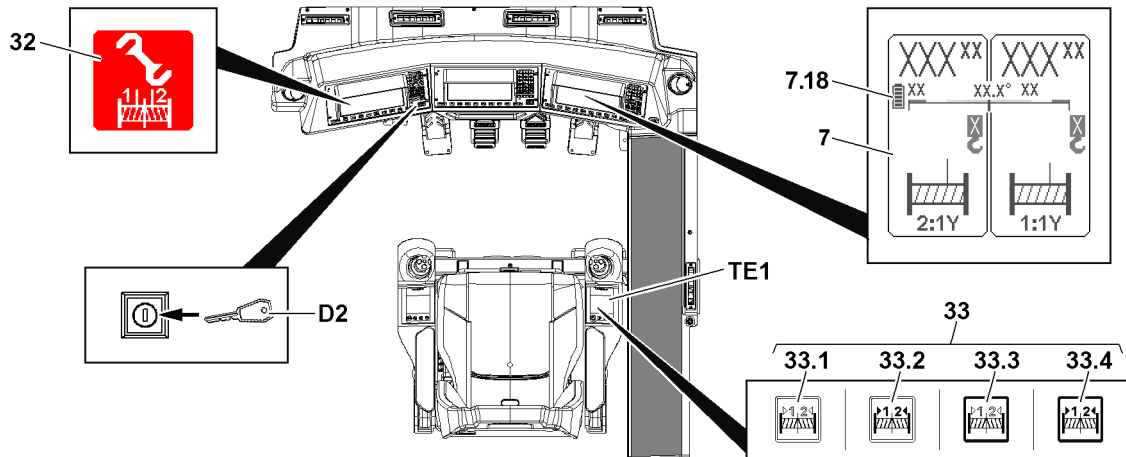


Fig.155156: Changing over the winch 1 and winch 2 parallel operation regulation

**Specifications according to the utilized radio incline sensor**

Depending on the incline sensor used, there is a difference in handling.

LWE/LR 1800-1-0-000/27200-07-02/en

**Note**

Differentiate radio incline sensor type 1 and type 2 from each other.

The utilized radio incline sensors can be easily identified based on the winch display.

- ▶ Radio incline sensor type 1 (Hirschmann) does not have a display for the battery state of charge on the winch display 7.
- ▶ Radio incline sensor type 2 (Steute) has a display for the state of charge, the *Hook block incline sensor battery 7.18* icon appears on the winch display 7.

---

**Specifications for radio incline sensor type 1**

- The parallel operation of winch 1 and winch 2 is regulated from a pulley head height of more than 20 m via the test pulleys. If a problem occurs, switch over to a regulation via the winch speed sensors. After switching the regulation, winch 1 and winch 2 must be adjusted.
- Pulley head height of greater than 20 m , regulated via the test pulleys: The *parallel operation regulation switched over* icon **32** does not appear.
- Pulley head height of greater than 20 m , regulated via the winch speed sensor: The *Parallel operation regulation switched over* icon **32** appears.
- Pulley head height of less than 20 m , regulated via the winch speed sensor: The *parallel operation regulation switched over* icon **32** does not appear.

**WARNING**

Impermissible change over of *winch 1 and winch 2 parallel operation* regulation!

- ▶ Changing the *winch 1 and winch 2 parallel operation* regulation is only permissible if - due to contamination, icing or failure of the test pulleys - a correct path measurement of the hoist ropes of winch 1 and winch 2 is not possible.
- ▶ Changing the *winch 1 and winch 2 parallel operation* regulation is only permissible if it is not possible to immediately clean, de-ice or repair the test pulleys.
- ▶ If the *parallel operation regulation switched over* icon **32** appears, the crane driver must align the position of the hook block manually in general.

---

**Specifications for radio incline sensor type 2**

The parallel operation of winch 1 and winch 2 is regulated based on the lateral incline of the hook block. Automatic regulation controls the rope speeds of winch 1 and winch 2 based on the measured incline value. Automatic regulation can be deactivated, for example for assembly tasks. If winch 1 and winch 2 are then adjusted, they spool at the adjusted rope speeds without considering the lateral incline of the hook block.

- Crane operation with a freely suspended hook, the following applies: Activate automatic regulation. Deactivate automatic regulation only in the case of a malfunction.
- Outside of crane operation with a freely suspended hook, the following applies: Only activate automatic regulation after the hook block has lifted up off the ground.
- Automatic regulation deactivated: The *Parallel operation regulation switched over* icon **32** appears.
- Automatic regulation activated: The *parallel operation regulation switched over* icon **32** does not appear.

**WARNING**

Impermissible change over of *winch 1 and winch 2 parallel operation* regulation!

- ▶ Changing the *winch 1 and winch 2 parallel operation* regulation is only permissible if the hook block is not hanging free.
- ▶ Changing the *winch 1 and winch 2 parallel operation* regulation is only permissible if a malfunction of automatic regulation is detected.
- ▶ If the *parallel operation regulation switched over* icon **32** appears, the crane driver must align the position of the hook block manually in general.

## Switching over parallel operation regulation



### Note

#### Deactivated function

With radio incline sensor type 1 and a pulley head height below 20 m, it is no longer possible to switch to parallel operation regulation as under these conditions, the change takes place automatically.

- ▶ In the case of automatic switching to parallel operation regulation, the *Parallel operation regulation switched over* icon **32** does not appear.

Make sure that the following prerequisites are met:

- The crane engine is running.
- Winch 1 and winch 2 are controlled in parallel operation with one master switch.
- For radio incline sensor type 1 also: The pulley head height is above 20 m.

- ▶ Press the key button **D2**.

### Result:

- The *Parallel operation regulation switched over* icon **32** appears.

## 9.1.4 Adjusting winch 1 and winch 2

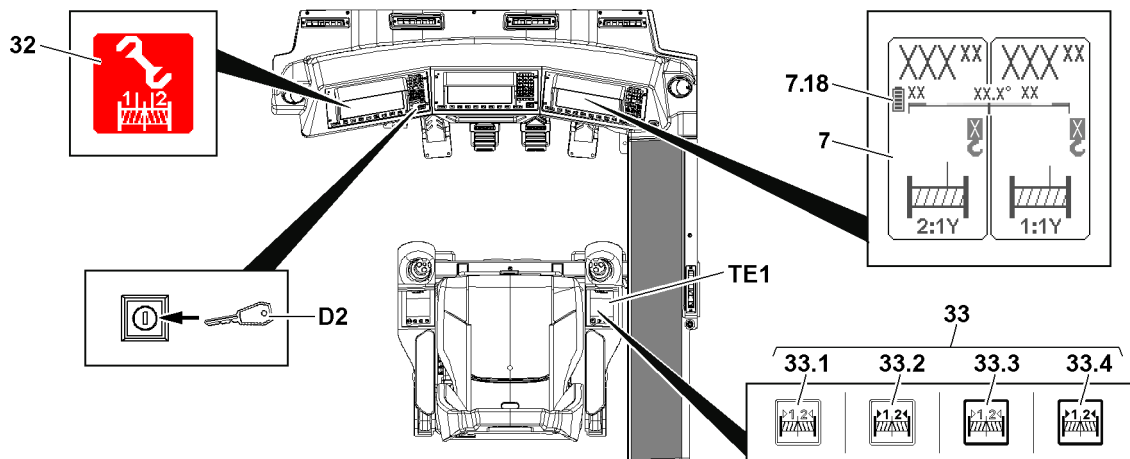


Fig.155156: Adjusting winch 1 and winch 2

- In the case of radio incline sensor type 1, the winches must be adjusted in general. After adjustment, spool winch 1 and winch 2 at the adjusted rope speeds.
- In the case of radio incline sensor type 2, the winches must only be adjusted if the *winch adjustment* icon **33** appears. This is the case if automatic regulation was deactivated using the key button **D2** and the *parallel operation regulation switched over* icon **32** appears. If winch 1 and winch 2 are then adjusted, they spool at the adjusted rope speeds.

If master switch assignment with parallel operation is set and winch adjustment is possible, the *winch adjustment* icon **33** appears on the touch display **TE1**.

The *winch adjustment* icon **33** represents various conditions:

- **33.1 Deselected / not adjusted** icon
  - Appears when adjustment has not yet been carried out.
- **33.2 Deselected / adjusted** icon
  - Appears when the adjustment has already been carried out.
  - **Note:** Adjustment can be repeated at any time.
- **33.3 Selected / not adjusted** icon
- **33.4 Selected / adjusted** icon

**Note**

Differentiate radio incline sensor type 1 and type 2 from each other.

The utilized radio incline sensors can be easily identified based on the winch display.

- ▶ Radio incline sensor type 1 (Hirschmann) does not have a display for the battery state of charge on the winch display 7.
- ▶ Radio incline sensor type 2 (Steute) has a display for the state of charge, the *Hook block incline sensor battery 7.18* icon appears on the winch display 7.

**Note**

- ▶ For the master switch assignment with parallel operation of winch 1 and winch 2 both winches can **NOT** be spooled up or out individually.
- ▶ In parallel operation, the winch display 7 changes. For description of winch displays on the LIC-CON monitors, see chapter 4.02.

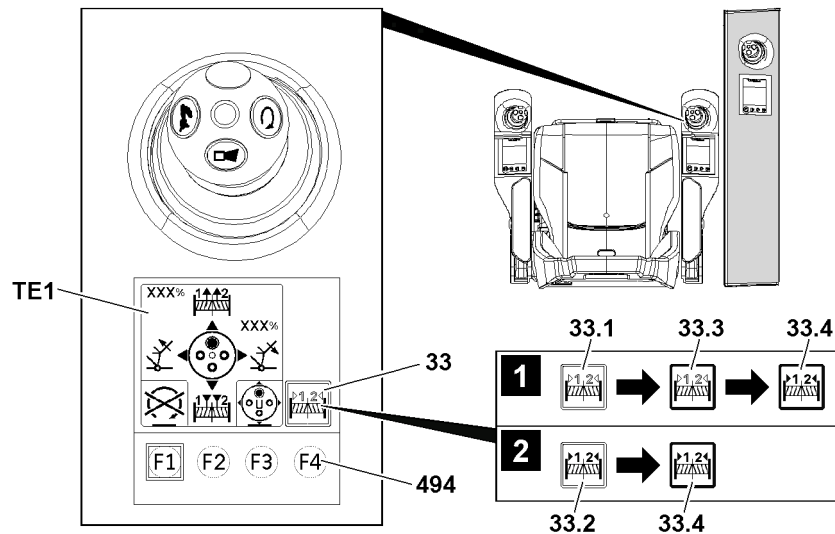


Fig.155157: Adjusting winch 1 and winch 2

**Note**

- ▶ If the hook block is lifted off the ground but not horizontally aligned, the hook block must be aligned before being adjusted, see section “Manually aligning the winch / hook block for individual operation”.

Make sure that the following prerequisites are met:

- With a freely suspended hook block: The hook block is horizontally aligned, the visual inspection has been performed.
- A master switch assignment with winch 1 and winch 2 parallel operation is set on the touch display TE1.
- The *winch adjustment* icon 33 is shown on the touch display TE1.

**Adjusting winch 1 and winch 2 for the first time**

- ▶ Preselect winch adjustment by touching the *deselected / not adjusted* icon 33.1 with a fingertip, see illustration 1.

**Result:**

- The *deselected / not adjusted* icon 33.1 disappears.
- The *selected / not adjusted* icon 33.3 appears.

- ▶ Press the F4 key 494 on the touch display TE1.

**Result:**

- The *selected / not adjusted* icon 33.3 disappears.

- The *selected / adjusted* icon **33.4** appears.
- Winch 1 and winch 2 are adjusted.

### Readjusting winch 1 and winch 2



#### Note

It may be necessary to readjust the winches.

- ▶ If the position of the hook block was changed after adjusting the winches in individual operation.
- ▶ If the rope speeds of winch 1 and winch 2 deviate from each other.

- ▶ Preselect winch adjustment by touching the *deselected / adjusted* icon **33.2** with a fingertip, see illustration **2**.

#### Result:

- The *deselected / adjusted* icon **33.2** disappears.
- The *selected / adjusted* icon **33.4** appears.
- ▶ Press the F4 key **494** on the touch display **TE1**.

#### Result:

- The *selected / adjusted* icon **33.4** still appears.
- Winch 1 and winch 2 are readjusted.

## 9.2 Winch 1 and winch 2 in parallel operation



### WARNING

Incline position of the hook block!

If the balance bar on the roller blocks is inclined, then the load on the individual roller blocks is significantly increased. The boom, hook block or ropes can be overloaded.

Death, severe bodily injuries, property damage.

- ▶ Make sure that the number of reevings on winch 1 and winch 2 is identical and even.
- ▶ Unpin the transport pin on the roller blocks before crane operation.
- ▶ Make sure that the balance bar is always aligned horizontally on the roller blocks. Visual inspection hook block.
- ▶ Always correct the position of the hook block in time.

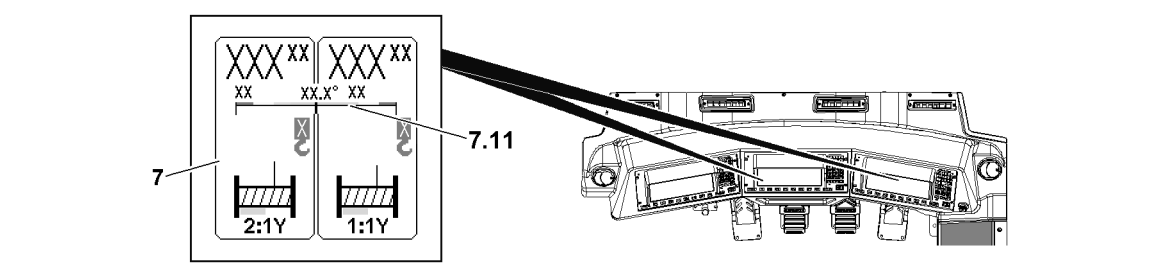


Fig.155160: Incline indicator for the hook block

**WARNING**

Hook block inclined!

If the hook block gets so far into an incline position that the red range is reached on the incline display, then there is a danger of accident.

Death, severe bodily injuries, property damage.

- ▶ The incline of the hook block is displayed in the winch display **7** on the LICCON monitor.
- ▶ When the incline display **7.11** of the hook block is in the red range, then there is a danger of accidents.
- ▶ Make sure that the incline display **7.11** of the hook block is always in the green range.

If the incline indicator **7.11** has left the green area:

- ▶ Align the hook block horizontally, see section “Manually aligning the winch / hook block for individual operation”.

**Note**

- ▶ The incline sensor is an assistance system. The crane driver must make sure that the hook block is horizontally aligned (lateral incline 0°).

### 9.2.1 Additional specifications for radio incline sensor type 1

- The parallel operation of winch 1 and winch 2 is regulated from a pulley head height of more than 20 m over the test pulleys.
- This function only functions correctly if the test pulleys are ready for use.

**WARNING**

Hook block inclined!

Due to dirty or iced-up test pulleys it is possible that the rope length of winch 1 and winch 2 is incorrectly measured.

This incorrect measurement causes the hook block to move into an impermissible incline position and the winches are not automatically stopped.

Death, severe bodily injuries, property damage.

- ▶ Make sure that the test pulleys on the boom end section are free of dirt, snow, frost and ice.

In the case of any incline position:

- ▶ Align the hook block, see section “Manually aligning the winch / hook block for individual operation”.

In the case of a repeated incline position:

- ▶ Switch to parallel operation regulation, see section “switching over winch 1 and winch 2 parallel operation regulation”.

### 9.2.2 Additional specifications for radio incline sensor type 2

- The parallel operation of winch 1 and winch 2 is regulated based on the incline value of the hook block.
- This function only functions correctly if the hook block is freely suspended.

**NOTICE**

Automatic regulation for parallel operation malfunction!

If the hook block is not freely suspended, for example to carry it along when erecting the boom, automatic regulation for parallel operation does not function correctly.

- ▶ If the hook block is not freely suspended, deactivate automatic regulation for parallel operation. Observe the section “Changing over winch 1 and winch 2 parallel operation regulation”.



## 9.2.3 Spooling winch 1 and winch 2 up and out in parallel operation

### NOTICE

Basket formation on the rope of winch 2 during parallel operation!

In the case of continuous use of the **same / similar** boom system in parallel operation, there is an increased danger of basket formation on the rope of winch 2.

When a longer use with the **same** boom system is carried out:

- ▶ Increased check of the hoist rope when there are signs that basket formation is starting.

When continuous use with a **similar**<sup>1)</sup> boom system is carried out:

- ▶ Increased check of the hoist rope when there are signs that basket formation is starting.

When signs regarding the start of basket formation occur:

- ▶ Contact Liebherr Customer Service.

1) Boom systems with small differences in total lengths or with a comparable rope run

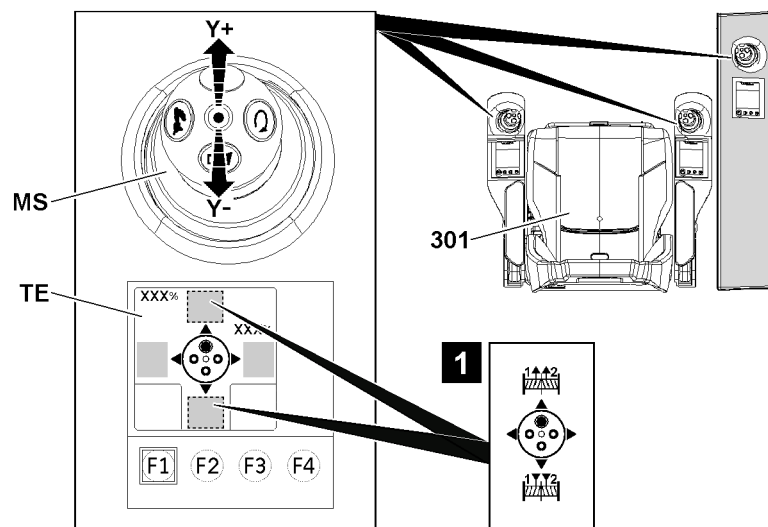


Fig.155158: Spooling winch 1 and winch 2 up / out in parallel operation

Make sure that the following prerequisites are met:

- Parallel operation is set, see section “Setting up parallel operation”.
- The touch display **TE** of the concerned master switch shows the function assignment *pool winch 1 and winch 2 up / out in parallel operation*.
- The seat contact button **301** is pressed or bypassed.
- In the case of continuous use of the **same / similar** boom system, the ropes of winch 1 and winch 2 are subjected to increased inspection.



### Note

Does the hook block incline during operation?

- ▶ Observe the section “Setting up parallel operation”.

### Spooling winch 1 and winch 2 up in parallel operation

The master switch **MS** function assignment is according to the illustration 1:

- ▶ Move the master switch **MS** in direction **Y-**.

### Result:

- Winch 1 and winch 2 spool up in parallel, a fastened load is lifted.

### Spooling out winch 1 and winch 2 in parallel operation

The master switch **MS** function assignment is according to the illustration 1:

- ▶ Move the master switch **MS** in direction **Y+**.

**Result:**

- Winch 1 and winch 2 spool out in parallel, a fastened load is lowered.

## 10 Luffing the boom system up / down

---

**WARNING**

Impermissible luffing up of the boom!

If the LICCON overload protection turns off while trying to lift the load with the hoist winch, then a subsequent luffing movement can cause the crane to topple over or damage it.

Death, severe bodily injuries, property damage.

- ▶ Do **NOT** luff up the boom to lift a load off the ground.
- 

Luffing the boom system up / down, see the corresponding sections:

- Luffing the main boom up / down.
  - Luffing the derrick boom up / down.
  - Luffing the luffing lattice jib up / down.
- 

**Note**

The assignment of the master switches can change, depending on the set up configuration and winch application.

- ▶ Switch the master switch assignment, see section “master switch assignment”.
- 

**Note**

- ▶ The maximum obtainable speed of the crane movement can be reduced in the settings window “Speed reduction master switch / pedal sensor”. Observe the section “Speed reduction master switch / pedal sensor”.
  - ▶ If the rapid gear is engaged, ensure that a higher crane movement speed is reached with the same master switch deflection. Observe the section “rapid gear (Power Plus)”.
  - ▶ If the engine rpm is increased, ensure that a higher crane movement speed is reached with the same master switch deflection. Observe the section “Changing the speed of the crane movement via the engine rpm”.
-

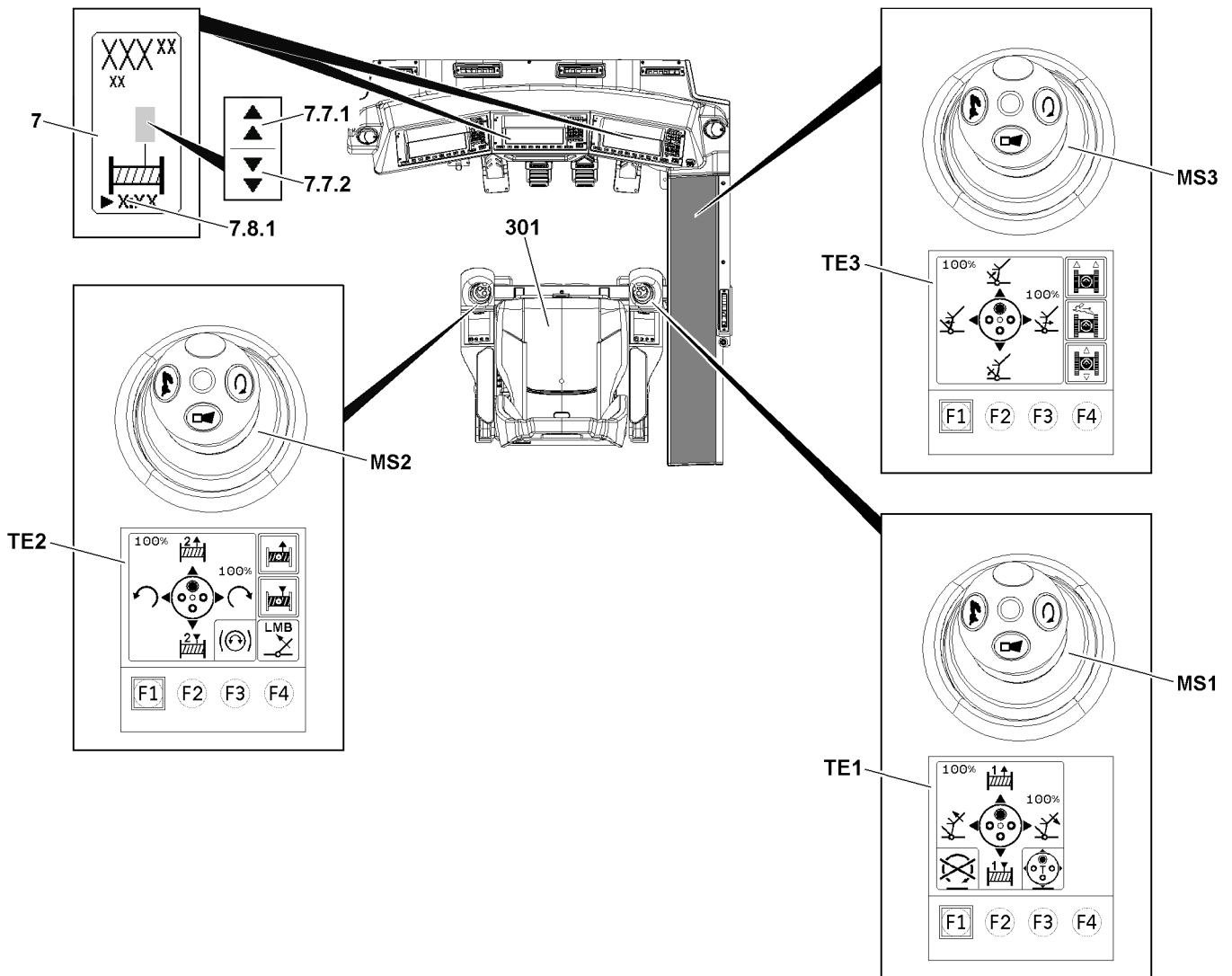


Fig.155142: Function assignment of the master switch, example master switch assignment T

The determining factor for controlling the *luffing the boom system up / down* crane movement is always the displayed function assignment on the touch display, see section “Master switch assignment”.

- The touch display **TE1** shows the function assignments for the master switch **MS1**.
- The touch display **TE2** shows the function assignments for the master switch **MS2**.
- The touch display **TE3** shows the function assignments for the master switch **MS3**.

Each winch has a separate winch display **7**. The assignment of the winch displays **7** takes place via the winch numbers **7.8.1**. For winch 1, there is the number 1, for winch 2 there is the number 2, etc.

The winch display **7** shows the icon **7.7.1** and icon **7.7.2** when the winch turns. This makes all spooling up and out operations identifiable.

Make sure that the following prerequisites are met:

- The corresponding function assignment *Luffing the boom system up / down* is displayed on the touch display of the master switch.
- The master switches are in the neutral position.
- The crane is at a standstill.
- The control winch to operate is released, see section “Locking / releasing the winch”.

## 10.1 Luffing the main boom up / down

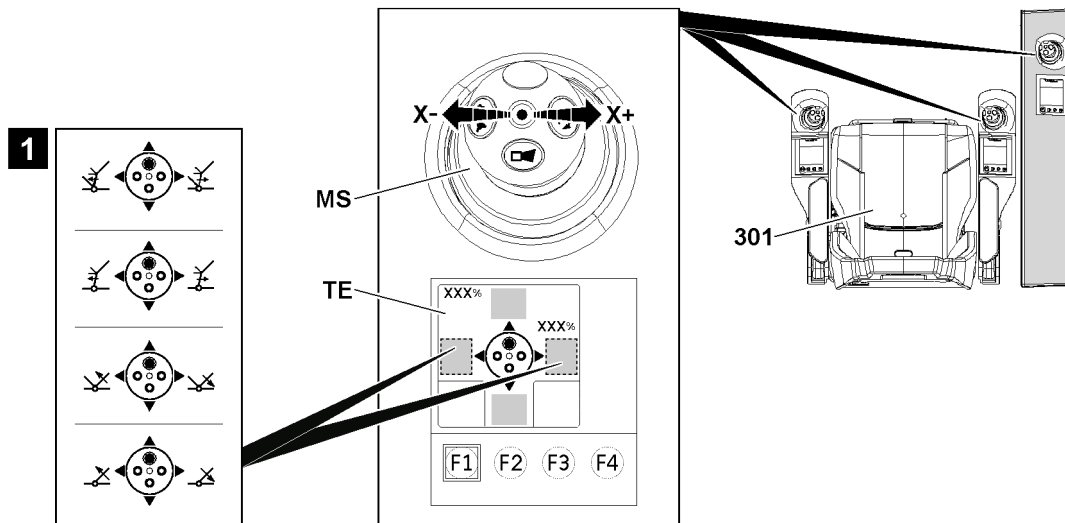


Fig.155161: Luffing the main boom up / down

Make sure that the following prerequisites are met:

- The touch display **TE** of the concerned master switch shows the function assignment *Luffing the main boom up / down*.
- The seat contact button **301** is pressed or bypassed.

### 10.1.1 Luffing the main boom up

The master switch **MS** function assignment is according to the illustration 1:

- ▶ Move the master switch **MS** in direction **X-**.

**Result:**

- The main boom is luffed up.

### 10.1.2 Luffing the main boom down

The master switch **MS** function assignment is according to the illustration 1:

- ▶ Move the master switch **MS** in direction **X+**.

**Result:**

- The main boom is luffed down.

## 10.2 Luffing the derrick boom up / down

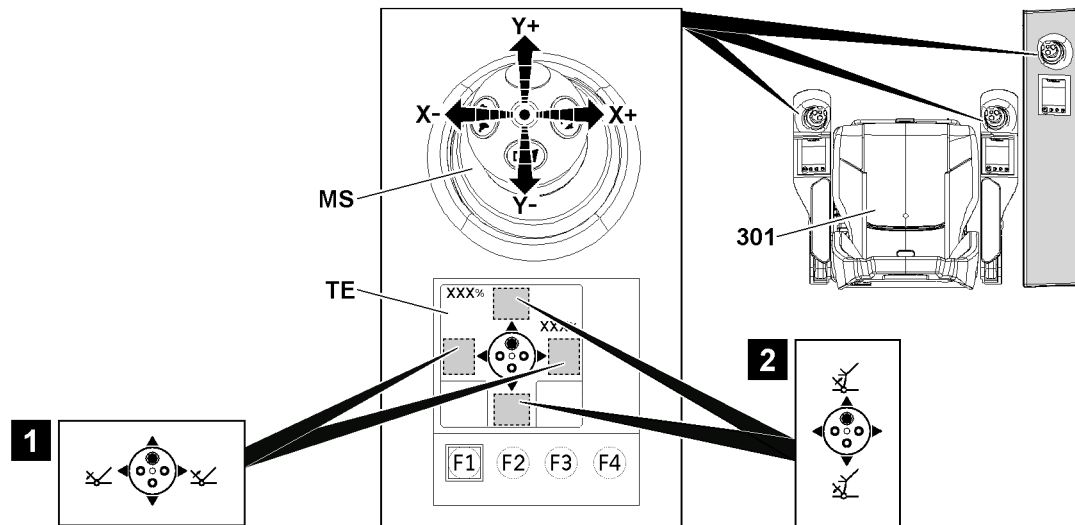


Fig.155162: Luffing the derrick boom up / down

Make sure that the following prerequisites are met:

- The touch display **TE** of the concerned master switch shows the function assignment *Luffing the derrick boom up / down*.
- The seat contact button **301** is pressed or bypassed.



### Note

- ▶ The function assignment *Luffing the derrick boom up / down* appears either according to illustration 1 or according to illustration 2.

### 10.2.1 Luffing the derrick boom up

The master switch **MS** function assignment is according to the illustration 1:

- ▶ Move the master switch **MS** in direction **X-**.

#### Result:

- The derrick boom is luffed up.

The master switch **MS** function assignment is according to the illustration 2:

- ▶ Move the master switch **MS** in direction **Y-**.

#### Result:

- The derrick boom is luffed up.

### 10.2.2 Luffing the derrick boom down

The master switch **MS** function assignment is according to the illustration 1:

- ▶ Move the master switch **MS** in direction **X+**.

#### Result:

- The derrick boom is luffed down.

The master switch **MS** function assignment is according to the illustration 2:

- ▶ Move the master switch **MS** in direction **Y+**.

#### Result:

- The derrick boom is luffed down.

## 10.3 Luffing the luffing lattice jib up / down

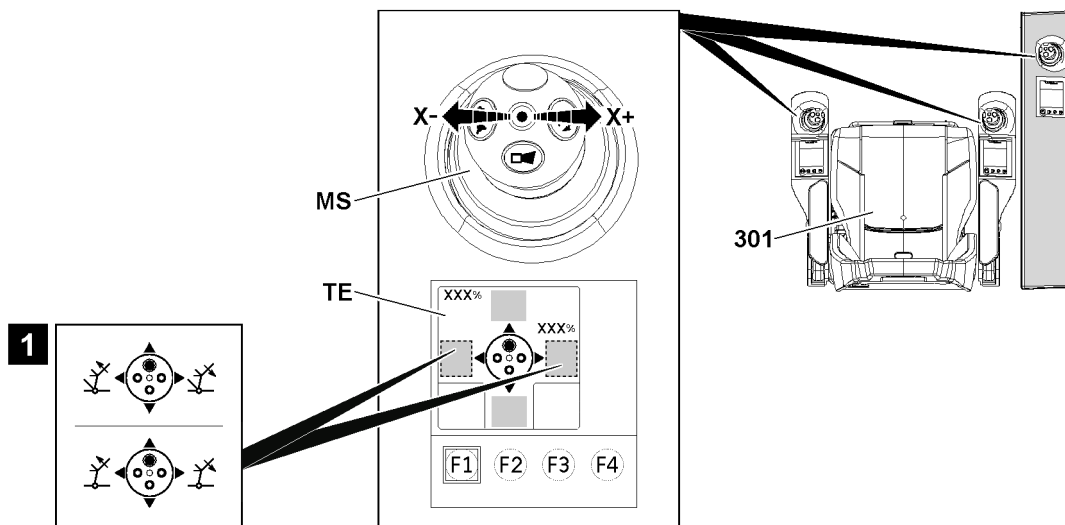


Fig.155163: Luffing the luffing lattice jib up / down

Make sure that the following prerequisites are met:

- The touch display **TE** of the concerned master switch shows the function assignment *Luffing the luffing lattice jib up / down*.
- The seat contact button **301** is pressed or bypassed.

### 10.3.1 Luffing the luffing lattice jib up

The master switch **MS** function assignment is according to the illustration 1:

- ▶ Move the master switch **MS** in direction **X-**.

**Result:**

- The luffing lattice jib is luffed up.

### 10.3.2 Luffing the luffing lattice jib down

The master switch **MS** function assignment is according to the illustration 1:

- ▶ Move the master switch **MS** in direction **X+**.

**Result:**

- The luffing lattice jib is luffed down.

## 11 Turning the crane superstructure



### WARNING

Uncontrolled turning of the crane superstructure!

As long as the parking brake of the slewing gear is released, the slewing gear can turn in an uncontrolled manner due to wind, incline position or angular pull.

Death, severe bodily injuries, property damage.

- ▶ Close the parking brake of the slewing gear if there is danger of the uncontrolled turning of the crane superstructure.

**Note**

- ▶ The maximum obtainable speed of the crane movement can be reduced in the settings window “Speed reduction master switch / pedal sensor”. Observe the section “Speed reduction master switch / pedal sensor”.
- ▶ If the rapid gear is engaged, ensure that a higher crane movement speed is reached with the same master switch deflection. Observe the section “rapid gear (Power Plus)”.
- ▶ If the engine rpm is increased, ensure that a higher crane movement speed is reached with the same master switch deflection. Observe the section “Changing the speed of the crane movement via the engine rpm”.

## 11.1 Slewing gear parking brake

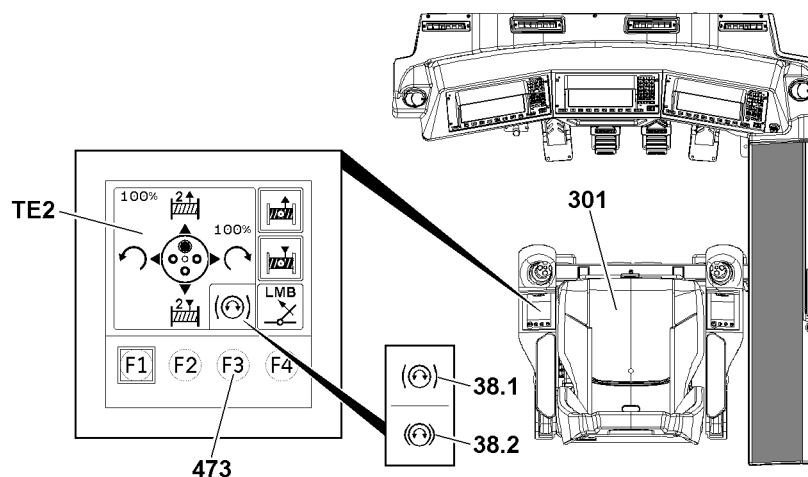


Fig.155164: Opening and closing the slewing gear parking brake

The parking brake of the slewing gear can be operated with the F3-key **473** on the touch display **TE2**.

- If the icon **38.1** appears, the *release the parking brake* target state is set
  - In the case of the *release the parking brake* target state, it remains released regardless of whether the slewing gear is actuated or not by deflecting the master switch. This is to prevent a sudden stop.
- If the icon **38.2** appears, the *apply the parking brake* target state is set
  - In the case of the *apply the parking brake* target state, it is automatically applied as soon as the slewing gear is actuated by deflecting the master switch. The parking brake is applied automatically after it is released as soon as the slewing gear is no longer actuated by deflecting the master switch (master switch zero position).

The parking brake is automatically applied if:

- The crane operator gets up from the crane operator's seat (seat contact button **301** no longer actuated) and the seat contact button is not bypassed at the same time.
- The Diesel engine is turned off.

The parking brake can **NOT** be released if:

- The working range limitation is active.
- A load chart with a limited slewing range is selected.

### 11.1.1 Releasing the parking brake

Make sure that the following prerequisites are met:

- The *apply the parking brake* target state is set, the icon **38.2** is displayed.
  - The seat contact button **301** is pressed or bypassed.
  - The diesel engine is running.
- ▶ Press the F3 key **473**.

**Result:**

- The *release the parking brake* target state is set.
- The Icon **38.2** turns off and the icon **38.1** appears.

**11.1.2 Applying the parking brake**

Make sure that the following prerequisites are met:

- The *release the parking brake* target state is set, the icon **38.1** is displayed.
- The seat contact button **301** is pressed or bypassed.
- The diesel engine is running.

- ▶ Press the F3 key **473**.
- or
- Turn the Diesel engine off.
- or
- The seat contact button **301** is not pressed or bypassed.

**Result:**

- The *apply the parking brake* target state is set.
- The Icon **38.1** turns off and the icon **38.2** appears.

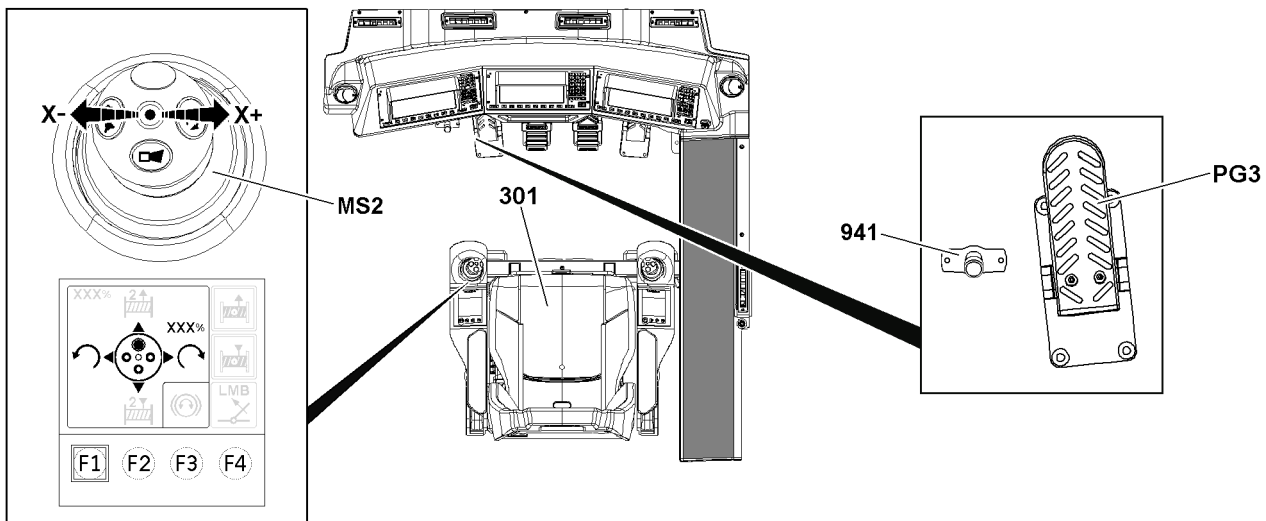
**11.2 Slewing gear brake pedal and slewing gear freewheeling**

Fig.155165: Operating the slewing gear brake pedal and slewing gear brake freewheeling

**NOTICE**

Damage to the slewing gear and roller ring connection!

The slewing gear brake cannot brake the full turning momentum. Failure to comply with the following instructions could damage the slewing gear or roller ring connection.

- ▶ Only use the pedal **PG3** at minimum slewing speeds. The master switch **MS2** must be almost in the neutral position when pressing down on the pedal.
- ▶ Do **not** abruptly brake the crane slewing movement by simultaneously moving the master switch **MS2** to the zero position and pressing down on the pedal **PG3**.

Use the pedal **PG3** to actuate the slewing gear brake only in the following cases:

- Starting the slewing movement of the crane superstructure with a strong side wind
- Stopping the slewing movement of the crane superstructure with a strong side wind

Slewing gear freewheeling does not function while simultaneously controlling the slewing movement of the crane superstructure.



**Note**

Uncontrolled turning of the crane superstructure.

- ▶ Apply the slewing gear parking brake with a strong side wind.

### 11.2.1 Starting the slewing movement of the crane superstructure with a strong side wind

When turning against the wind with a strong side wind and with a long boom system, the crane superstructure will turn to the opposite direction due to leaks in the hydraulic motor.

This can be avoided as follows:

- ▶ Actuate the pedal **PG3** and deflect the master switch **MS2** to the desired turning direction.
- ▶ Slowly release the pedal **PG3** until the crane superstructure turns in the desired turning direction.

### 11.2.2 Stopping the slewing movement of the crane superstructure with a strong side wind

- ▶ Return the master switch **MS2** almost to the zero position to decelerate the crane to the minimum slewing speed.
- ▶ Press down on the pedal **PG3** carefully, until the crane has come to a standstill in the desired position.

### 11.2.3 Switching the slewing gear to freewheeling

In order to position the boom over the load more easily, the slewing gear can be switched to freewheeling.

Make sure that the following prerequisites are met:

- The seat contact button **301** is pressed or bypassed.
- The diesel engine is running.
- The master switch **MS2** is **not** deflected.

**Note**

The activation of freewheeling and the simultaneous actuation of the slewing movement are mutually exclusive.

- ▶ When the master switch **MS2** is deflected, the slewing gear cannot be switched to freewheeling via the foot button **941**.
- ▶ When pressing the foot button **941**, the slewing movement can **not** be carried out by deflecting the master switch **MS2**.

The slewing gear **cannot** be switched to freewheeling if:

- A load chart with a limited slewing range is selected.
- The working range limitation is active.

- ▶ Press the foot button **941**.

**Result:**

- The slewing gear is switched to freewheeling.

## 11.3 Turning the crane superstructure to the right / left

**WARNING**

Persons or obstacles within the danger zone!  
Death, severe bodily injuries, property damage.

- ▶ It is prohibited for personnel to remain in the danger zone.
- ▶ Make sure that there are no obstacles within the working area of the crane.
- ▶ Give a short warning signal (horn) before starting a crane movement.
- ▶ When turning with a load: Initiate and brake a turning movement extremely sensitively.

**WARNING****Oscillating loads!**

If the suitable slewing speed is exceeded, there is the danger that the loads will start to swing. The crane can be damaged or topple over.

Death, severe bodily injuries, property damage.

- ▶ Turning with a load: Initiate and brake a turning movement extremely sensitively.
- ▶ Longer boom and larger load: Operate the crane with a lower slewing speed.
- ▶ Observe and adhere to the values in the load chart manual.

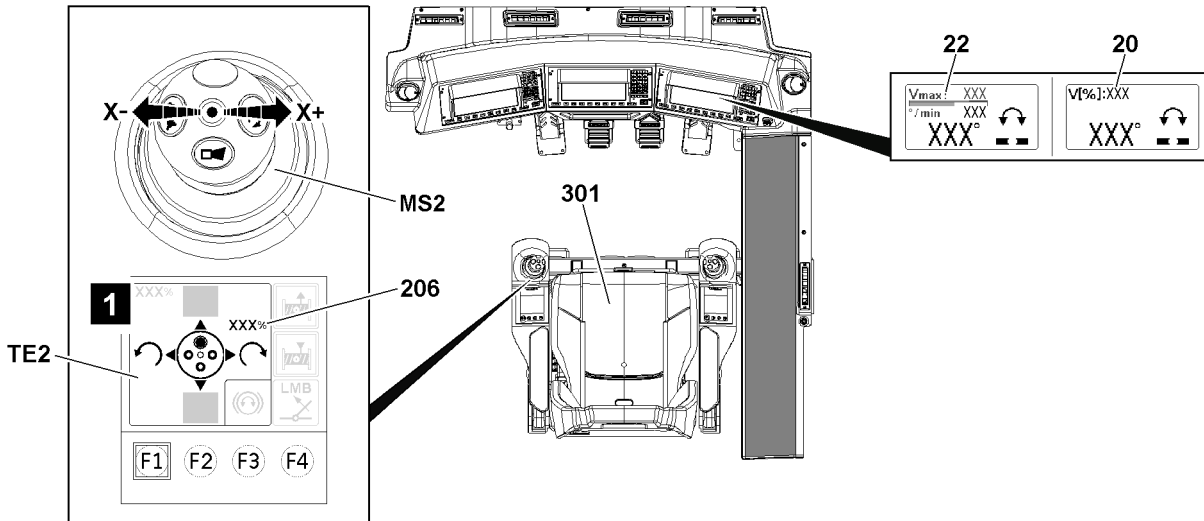


Fig.155166: Turning the crane superstructure to the right / left

The set speed reduction for the *turning the crane superstructure* crane movement is displayed as a setting value **206** on the touch display **TE2**. This setting value **206** is also the maximum slewing speed.

Depending on the crane configuration, either the slewing gear setting value **20** or slewing speed **22** appears:

- **20** Slewing gear setting value
  - Speed reduction for the *turning the crane superstructure* crane movement.
- **22** Slewing speed display
  - Display for the permissible slewing speed and the current slewing speed.
  - For a detailed description of the rotational speed display **22**, see chapter 4.02.
  - **Note:** No information can be derived from the slewing gear setting value. The reachable current slewing speed corresponds to the setting value **206**.

The slewing gear can be operated with the parking brake **released** or **applied**, see section “Slewing gear parking brake”.

Make sure that the following prerequisites are met:

- The maximum permissible slewing speed is set in the settings window, see section “Speed reduction master switch / pedal sensor”.
- The touch display **TE2** for the master switch **MS2** shows the *Turning the crane superstructure to the right / left* function assignment.
- The seat contact button **301** is pressed or bypassed.

### 11.3.1 Preselecting the slewing speed



#### WARNING

Slewing speed too high for actual operating conditions!  
Toppling crane, failure of crane structure.  
Death, severe bodily injuries, property damage.

- ▶ Adhere to the permissible slewing speed in the load charts.
- ▶ When selecting the slewing speed, take the actual operating conditions also into account.
- ▶ Select the slewing speed depending on the actual operating conditions.

The load chart manual lists the maximum slewing speeds in  $^{\circ}/\text{min}$  for **ideal conditions**, see the load chart manual.

The maximum reachable slewing speed can be reduced in the settings window, see section “Speed reduction master switch / pedal sensor”.

Basic rule: With a longer boom and a larger load, you have to turn with a slower speed.

### 11.3.2 Turning the crane superstructure to the right

The master switch **MS2** function assignment is according to the illustration 1:

- ▶ Move the master switch **MS2** in direction **X+**.

#### Result:

- The crane superstructure turns to the right.

### 11.3.3 Turning the crane superstructure to the left

The master switch **MS2** function assignment is according to the illustration 1:

- ▶ Move the master switch **MS** in direction **X-**.

#### Result:

- The crane superstructure turns to the left.

## 12 Controlling the ballast functions (pull cylinder / derrick ballast guide / ballast automatic)

To control the pull cylinder or the derrick ballast guide, the master switch assignment for ballast functions must be called up.

The ballast automatic can also be activated.

### 12.1 Calling up the master switch assignment for ballast functions

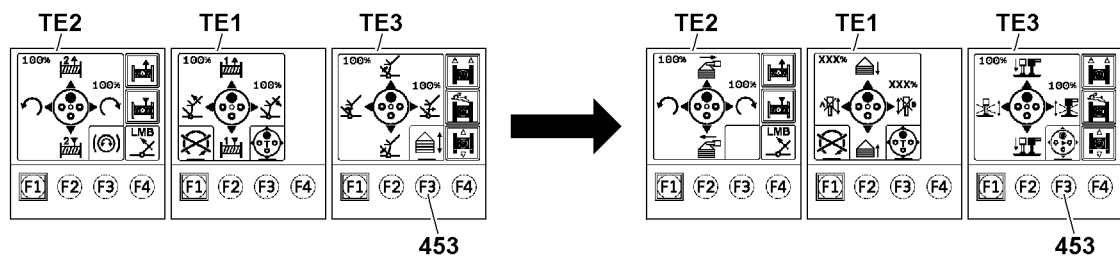


Fig.155182: Calling up the master switch assignment for ballast functions

Make sure that the following prerequisite is met:

- An operating mode with derrick ballast is set up.

- ▶ Press the F3 key **453** on the touch display **TE3**.

**Result:**

- The master switch assignment for the ballast functions is called up.
- **Note:** The master switch assignment for the ballast trailer support cylinder appears only when an operating mode with a ballast trailer is set up.

## 12.2 Retracting / extending the pull cylinder (lifting / lowering the derrick ballast)

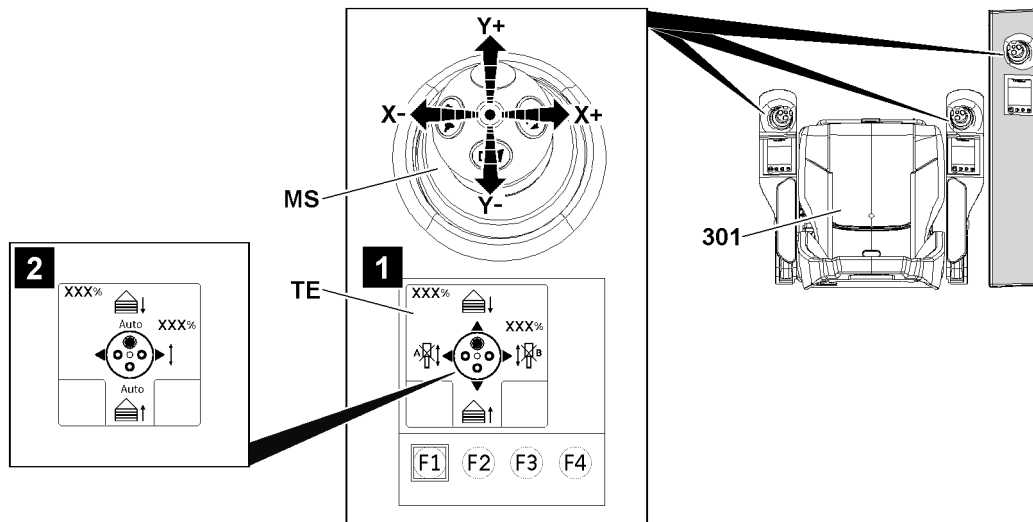


Fig.155167: Retracting / extending the pull cylinder (lifting / lowering the derrick ballast)

Make sure that the following prerequisites are met:

- The seat contact button **301** is pressed or bypassed.
- The master switch assignment for the ballast functions is called up.



**Note**

Automatic program turned on, see the function assignment illustration **2**

If an automatic program for ballast automatic is turned on, pull cylinder control (lifting / lowering the derrick ballast) takes place automatically.

- ▶ Turn off the automatic program to permit control via the master switch **MS**.

- ▶ Move the master switch **MS** in direction **Y+** (forward).

**Result:**

- Pull cylinder A and pull cylinder B extend together.
- A freely suspended derrick ballast is lowered.
- When the derrick ballast is set down, a part of the pulled derrick ballast is reduced.

- ▶ Move the master switch **MS** in direction **Y-** (to the rear).

**Result:**

- Pull cylinder A and pull cylinder B retract together.
- A freely suspended derrick ballast is lifted.
- When the derrick ballast is set down, a part of the pulled derrick ballast is increased.

- ▶ Move the master switch **MS** in direction **X+Y+** (combined to the front right).

**Result:**

- Pull cylinder A extends and pull cylinder B is locked.
- A freely suspended derrick ballast is lowered to the left.
- When the derrick ballast is set down, a part of the left pulled derrick ballast (guying A) is reduced.

- ▶ Move the master switch **MS** in direction **X-Y+** (combined to the front left).

**Result:**

- Pull cylinder B extends and pull cylinder A is locked.
- A freely suspended derrick ballast is lowered to the right.
- When the derrick ballast is set down, a part of the right pulled derrick ballast (guying B) is reduced.

- ▶ Move the master switch **MS** in direction **X+Y-** (combined to the rear right).

**Result:**

- Pull cylinder A retracts and pull cylinder B is locked.
- A freely suspended derrick ballast is lifted to the left.
- When the derrick ballast is set down, a part of the left pulled derrick ballast (guying A) is increased.

- ▶ Move the master switch **MS** in direction **X-Y-** (combined to the rear left).

**Result:**

- Pull cylinder B retracts and pull cylinder A is locked.
- A freely suspended derrick ballast is lifted to the right.
- When the derrick ballast is set down, a part of the right pulled derrick ballast (guying A) is increased.

## 12.3 Extending / retracting the derrick ballast guide (increasing / decreasing the derrick ballast boom radius)

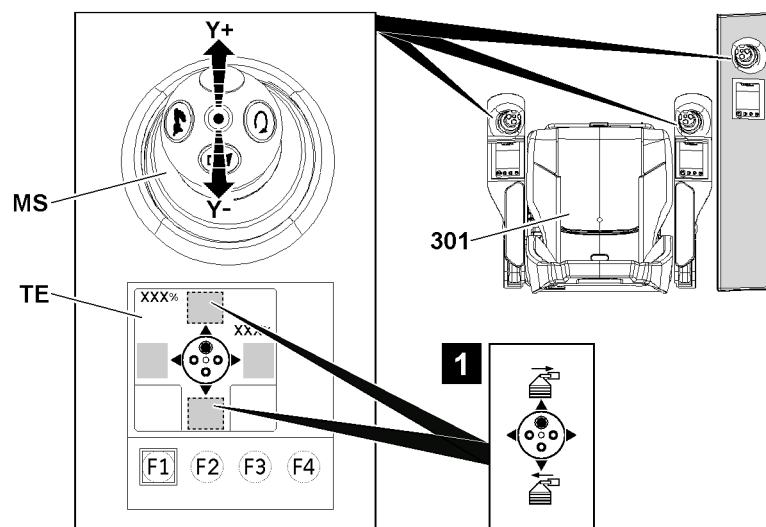


Fig.155168: Extending / retracting the derrick ballast guide

Make sure that the following prerequisites are met:

- The seat contact button **301** is pressed or bypassed.
- The master switch assignment for the ballast functions is called up.



**Note**

Observe for the suspended ballast guide “V-frame”.

- ▶ In the case of crane types with two hydraulic cylinders (large / small), for retracting and extending the derrick ballast guide, section “Suspended ballast guide “V-frame” pinning mechanism” must be observed for exceeding / falling below a derrick ballast boom radius of 16 m.

### 12.3.1 Extending the derrick ballast guide

The master switch **MS** function assignment is according to the illustration **1**:

- ▶ Move the master switch **MS** in direction **Y-**.

**Result:**

- The derrick ballast guide extends.

**12.3.2 Retracting the derrick ballast guide**

The master switch **MS** function assignment is according to the illustration 1:

- ▶ Move the master switch **MS** in direction **Y+**.

**Result:**

- The derrick ballast guide retracts.

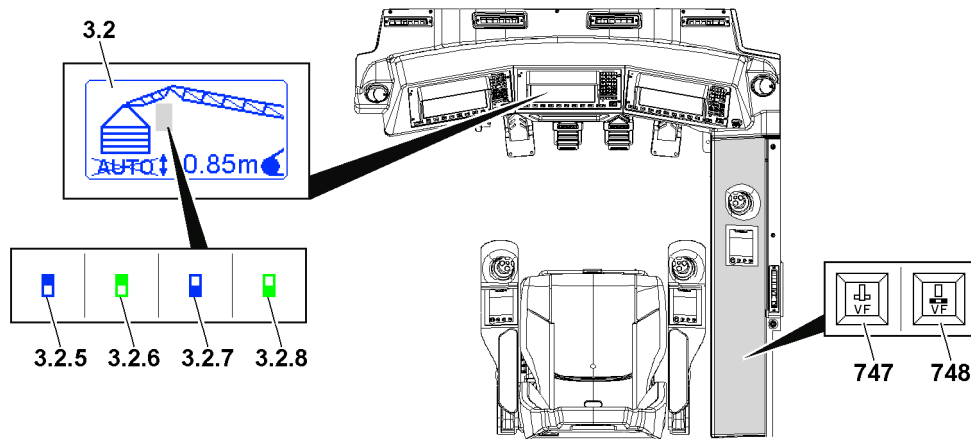
**12.3.3 Suspended ballast guide “V-frame” pinning mechanism**

Fig.156204: Operating and visualizing the suspended ballast guide “V-frame” pinning mechanism

**Note**

- ▶ Only for crane types with two hydraulic cylinders (large / small), for retracting and extending the derrick ballast guide.
- ▶ The status of the pinning mechanism is displayed in the *suspended ballast automatic* icon **3.2**. Regardless if the ballast automatic\* is turned on or not.

In the case of crane types with two hydraulic cylinders (large / small), for retracting and extending the derrick ballast guide, the status of the pinning mechanism is also queried.

- The pinning mechanism can only be operated if both hydraulic cylinders (large / small) of the V-frame are fully retracted.
- The hydraulic cylinders are controlled via the *Extending / retracting the derrick ballast guide* function.
- If the pin in the pinning mechanism is inserted, only the large hydraulic cylinder can be controlled.
  - The large hydraulic cylinder adjusts the derrick ballast guide in an area from 16 m and above.
- If the pin in the pinning mechanism is unpinning, only the small hydraulic cylinder can be controlled.
  - The small hydraulic cylinder adjusts the derrick ballast guide in an area up to 16 m and below.

Pinning mechanism status:

- The pin displayed in the *suspended ballast automatic* icon **3.2** blinks when it is not completely inserted / unpinning. For example, when controlling the pinning mechanism or when the pin is not in the end position.
- **3.2.5 Pin inserted icon / blue**
  - Pin displayed in blue: The pin is inserted and not ready to be unpinning
- **3.2.6 Pin inserted icon / green**
  - Pin displayed in green: The pin is inserted and ready to be unpinning
- **3.2.7 Pin released icon / blue**

- Pin displayed in blue: The pin is unpinned and not ready to be inserted
- **3.2.8 Pin unpinned icon / green**
- Pin displayed in green: The pin is unpinned and ready to be pinned

### Inserting the pins

Make sure that the following prerequisites are met:

- Both hydraulic cylinders (large / small) of the V-frame are completely retracted.
- The *Pin unpinned icon / green 3.2.8* is displayed on the LICCON monitor.
- ▶ Press the *pin the V-frame operating button 747* and hold it down for the duration of the pinning procedure.

#### Result:

- The operating button and the displayed pin will flash for the duration of the pinning procedure.
- As soon as the pinning procedure is completed, the *Pin inserted icon / green 3.2.6* appears.

### Unpinning the pin

Make sure that the following prerequisites are met:

- Both hydraulic cylinders (large / small) of the V-frame are fully retracted.
- The *Pin pinned icon / green 3.2.6* is displayed on the LICCON monitor.
- ▶ Press the *unpin the V-frame operating button 748* and hold it down for the duration of the unpinning procedure.

#### Result:

- The operating button and the displayed pin will flash for the duration of the unpinning procedure.
- As soon as the unpinning procedure is completed, the *Pin unpinned icon / green 3.2.8* appears.

## 12.4 Turning the ballast automatic on / off

There are two variations for the ballast automatic, depending on the crane type

- Variation 1: Ballast automatic with selection menu
  - The ballast automatic is turned on and off in the selection menu
- Variation 2: Ballast automatic *in the master switch assignment*
  - The ballast automatic is turned on and off within the master switch assignment

The ballast automatic controls the pull cylinder in consideration of a situation-related saved value.



### WARNING

Improper crane operation!

The saved value for controlling the ballast automatic is set when turning on the ballast automatic.

- ▶ Only turn on the ballast automatic when the conditions are such that nothing is opposing the control of the pull cylinder.
- ▶ Automatic control across the hoisting range of the pull cylinder does not take place.
- ▶ Automatic control is based on the calculated crane geometry. External influences, such as obstacles, cannot be detected by the automatic control.

Possibly saved values are:

- F1-force
- Ballast trailer incline
- Height difference of the derrick ballast with respect to the crane placement surface

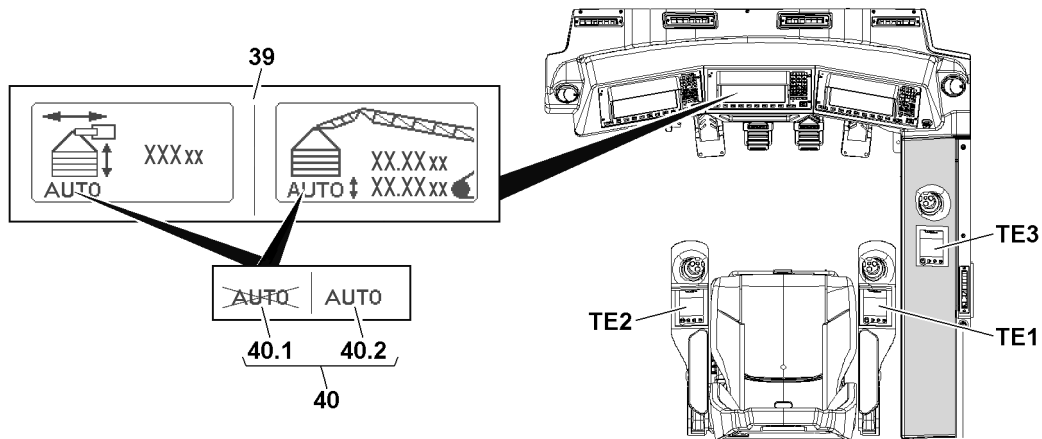


Fig.155172: Operating and visualizing the ballast automatic

The operation and visualization of the ballast automatic takes place on the touch display **TE1**, touch display **TE2**, touch display **TE3** and ballast automatic icon **39**.

The ballast automatic icon **39** appears on the crane operating screen on the center LICCON monitor.

The illustration of the ballast automatic icon **39** on the crane operating screen depends on the configuration and set up configuration.

The status is shown in the ballast automatic icon **39** as text **40**.

If the automatic off text **40.1** appears, the ballast automatic is turned off.

If the automatic on text **40.2** appears, the ballast automatic is turned on.



#### WARNING

Improper crane operation!

If the automatic on text **40.2** appears, the ballast automatic is turned on. The crane controls the pull cylinder in an automated manner.

- ▶ When ballast automatic is turned on, keep in mind that the crane controls the pull cylinder automatically.



### 12.4.1 Variation 1: Ballast automatic with selection menu

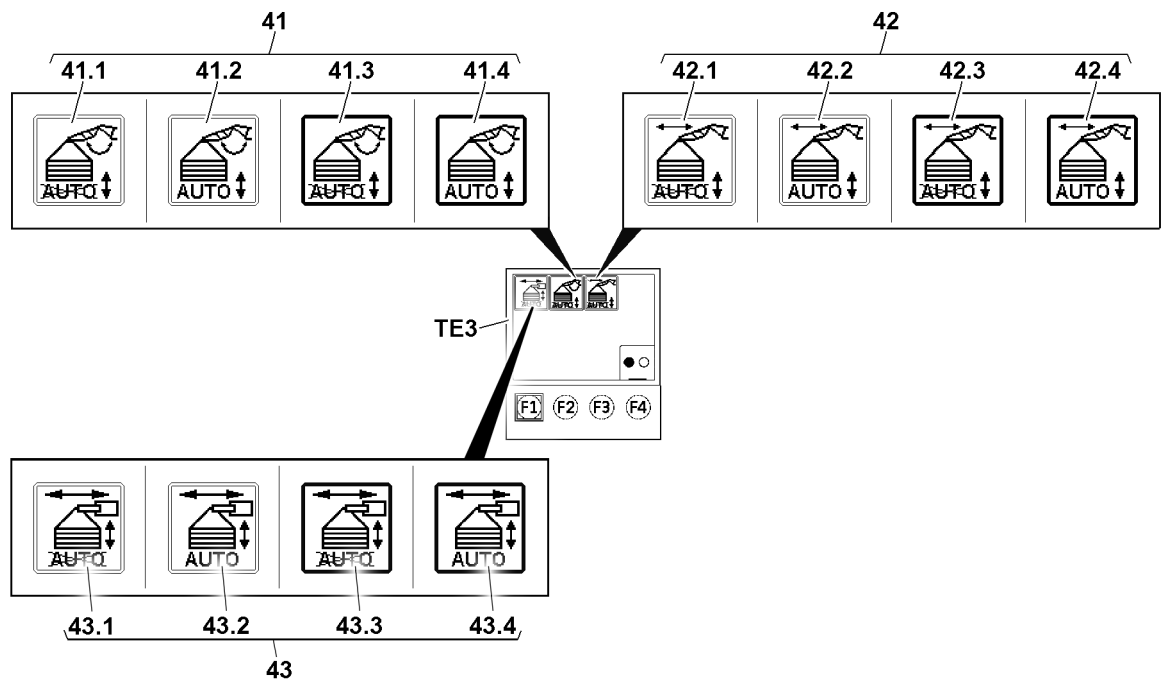


Fig.159624: Status displays of variation 1 of the ballast automatic

Individual selections can be made with the ballast automatic with selection menu. The automatic programs control the ballast automatic.

The status is displayed on a touch display **TE3** when the selection menu is called up.

- With the *derrick adjustment* ballast automatic, the *derrick adjustment* icon **41** appears with the following variations:
  - **41.1** *Derrick adjustment deselected / turned off* icon
  - **41.2** *Derrick adjustment deselected / turned on* icon
  - **41.3** *Derrick adjustment selected / turned off* icon
  - **41.4** *Derrick adjustment selected / turned on* icon
- With the *guide adjustment* ballast automatic, the *guide adjustment* icon **42** appears with the following variations:
  - **42.1** *Guide adjustment deselected / turned off* icon
  - **42.2** *Guide adjustment deselected / turned on* icon
  - **42.3** *Guide adjustment selected / turned off* icon
  - **42.4** *Guide adjustment selected / turned on* icon
- With the *ballast trailer* ballast automatic, the *ballast trailer* icon **43** appears with the following variations:
  - **43.1** *Ballast trailer deselected / turned off* icon
  - **43.2** *Ballast trailer deselected / turned on* icon
  - **43.3** *Ballast trailer selected / turned off* icon
  - **43.4** *Ballast trailer selected / turned on* icon

### Calling up the selection menu

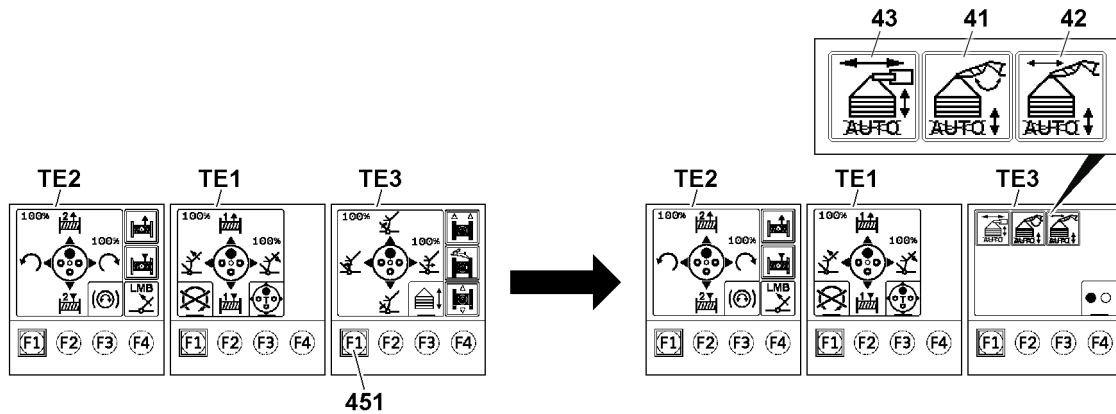


Fig.159625: Calling up the selection menu

- Press the F1-key **451** on the touch display **TE3** until the selection menu is displayed.

#### Result:

- The selection menu for the ballast automatic is called up.
- The *derrick adjustment* icon **41** and *guide adjustment* icon **42** and *ballast trailer* icon **43** appear on the touch display **TE3**.
- The touch display **TE1** and touch display **TE2** do not change their displays.

### Turning the automatic programs on

The following automatic programs can be turned on individually or together:

- *Derrick adjustment* ballast automatic
- *Guide adjustment* ballast automatic

The following automatic program can only be turned on individually:

- *Ballast trailer* ballast automatic

Turning on the *derrick adjustment* ballast automatic

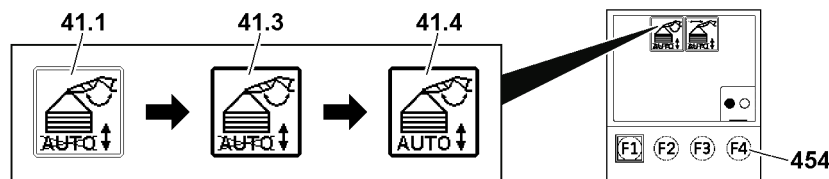


Fig.155175: Turning on the derrick adjustment ballast automatic

- Select the *Derrick adjustment deselected / turned off* icon **41.1** by touching it briefly with a finger tip (less than one second).

#### Result:

- The *derrick adjustment* ballast automatic is selected.
- The *derrick adjustment selected / turned off* icon **41.3** is displayed.

- Press the function key **454**.

#### Result:

- The *derrick adjustment* ballast automatic is turned on.
- The *derrick adjustment selected / turned on* icon **41.4** is displayed.
- The pull cylinders are automatically controlled by the luffing movement of the derrick boom.

Turning on the *guide adjustment ballast automatic*

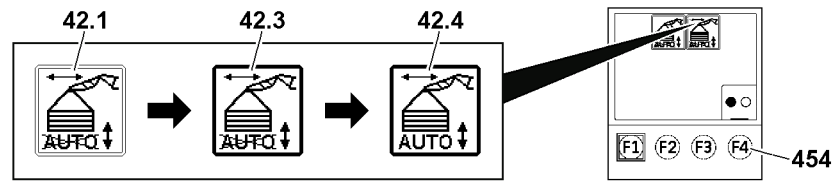


Fig.155176: Turning on the *guide adjustment ballast automatic*

- ▶ Select the *guide adjustment deselected / turned off* icon **42.1** by touching it briefly with a finger tip (less than one second).

**Result:**

- The *guide adjustment ballast automatic* is selected.
- The *guide adjustment selected / turned off* icon **42.3** is displayed.

- ▶ Press the function key **454**.

**Result:**

- The *guide adjustment ballast automatic* is turned on.
- The *guide adjustment selected / turned on* icon **42.4** is displayed.
- The pull cylinders are automatically controlled by the adjustment of the derrick ballast guide.

Turning on *ballast trailer ballast automatic*

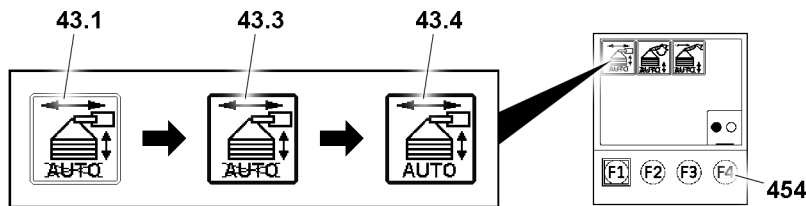


Fig.159621: Turning on *ballast trailer ballast automatic*

- ▶ Select the *ballast trailer deselected / turned off* icon **43.1** by touching it briefly with a finger tip (less than one second).

**Result:**

- The *ballast trailer ballast automatic* is selected.
- The *Ballast trailer selected / turned off* icon **43.3** is displayed.

- ▶ Press the function key **454**.

**Result:**

- The *Ballast trailer ballast automatic* is turned on.
- The *Ballast trailer selected / turned on* icon **43.4** is displayed.
- The pull cylinders are automatically controlled by adjusting the ballast trailer guide and by the luffing movement of the derrick boom.

Closing the selection menu

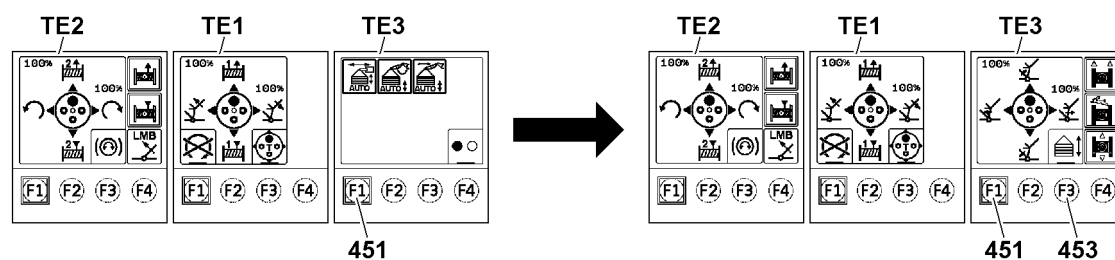


Fig.159626: Closing the selection menu

- ▶ Press the F1 key **451** on the touch display **TE3**.

**Result:**

- The selection menu for the ballast automatic is closed.



**Note**

- ▶ Press the F3-key **453** on the touch display **TE3** to call up the master switch assignment for ballast functions, see section “Calling up the master switch assignment for ballast functions”.
- ▶ Press the F1-key **451** on the Touch display **TE3** to call up the selection menu again.

**Turning the automatic programs off**

The following automatic programs can be turned off individually or together:

- *Derrick adjustment* ballast automatic
- *Guide adjustment* ballast automatic

The following automatic program can only be turned off individually:

- *Ballast trailer* ballast automatic

Turning off the *derrick adjustment* ballast automatic

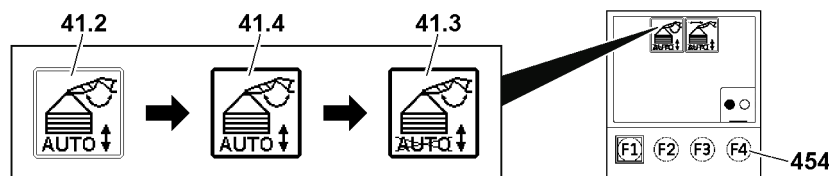


Fig.155177: Turning off the derrick adjustment ballast automatic

- ▶ Select the *Derrick adjustment deselected / turned on* icon **41.2** by touching it briefly with a finger tip (less than one second).

**Result:**

- The *derrick adjustment* ballast automatic is selected.
- The *derrick adjustment selected / turned on* icon **41.4** is displayed.

- ▶ Press the function key **454**.

**Result:**

- The *derrick adjustment* ballast automatic is turned off.
- The *derrick adjustment selected / turned off* icon **41.3** is displayed.
- The pull cylinders are no longer automatically controlled by the luffing movement of the derrick boom.

Turning off the *guide adjustment* ballast automatic

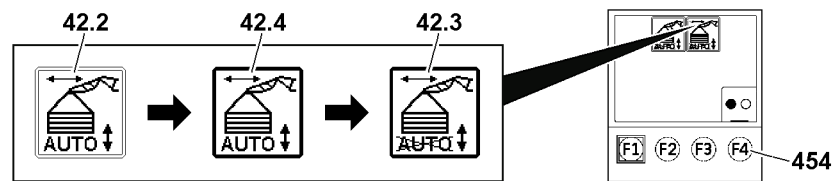


Fig.155178: Turning off the *guide adjustment* ballast automatic

- ▶ Select the *guide adjustment deselected / turned on* icon **42.2** by touching it briefly with a finger tip (less than one second).

**Result:**

- The *guide adjustment* ballast automatic is selected.
- The *guide adjustment selected / turned on* icon **42.4** is displayed.

- ▶ Press the function key **454**.

**Result:**

- The *guide adjustment* ballast automatic is turned off.
- The *guide adjustment selected / turned off* icon **42.3** is displayed.
- The pull cylinders are no longer automatically controlled by the adjustment of the derrick ballast guide.

Turning the *ballast trailer* ballast automatic off

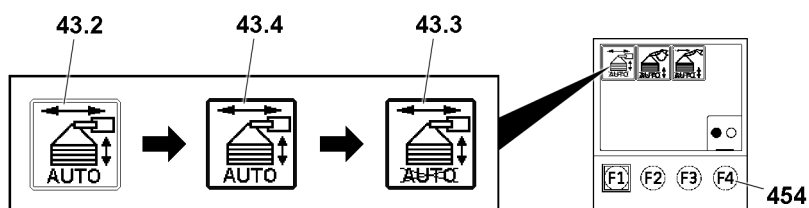


Fig.159622: Turning the *ballast trailer* ballast automatic off

- ▶ Select the *ballast trailer deselected / turned on* icon **43.2** by touching it briefly with a finger tip (less than one second).

**Result:**

- The *ballast trailer* ballast automatic is selected.
- The *ballast trailer selected / turned on* icon **43.4** is displayed.

- ▶ Press the function key **454**.

**Result:**

- The *ballast trailer* ballast automatic is turned off.
- The *derrick adjustment selected / turned off* icon **43.3** is displayed.
- The pull cylinders are no longer automatically controlled by the adjustment of the ballast trailer guide.

Closing the selection menu

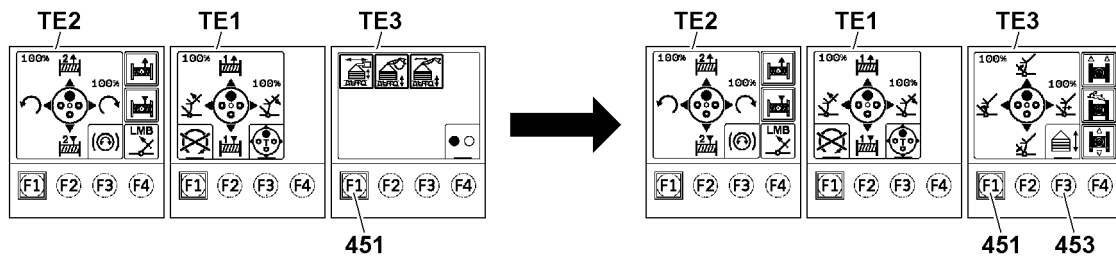


Fig.159627: Closing the selection menu

- ▶ Press the F1 key **451** on the touch display **TE3**.

**Result:**

- The selection menu for the ballast automatic is closed.



**Note**

- ▶ Press the F3-key **453** on the touch display **TE3** to call up the master switch assignment for ballast functions, see section “Calling up the master switch assignment for ballast functions”.
- ▶ Press the F1-key **451** on the Touch display **TE3** to call up the selection menu again.

## 12.4.2 Variation 2: Ballast automatic in the master switch assignment

Variation 2 of the ballast automatic is turned on and off directly in the master switch assignment for ballast functions.

Make sure that the following prerequisite is met:

- The master switch assignment for the ballast functions is called up.

**Turning on the ballast automatic in the master switch assignment**

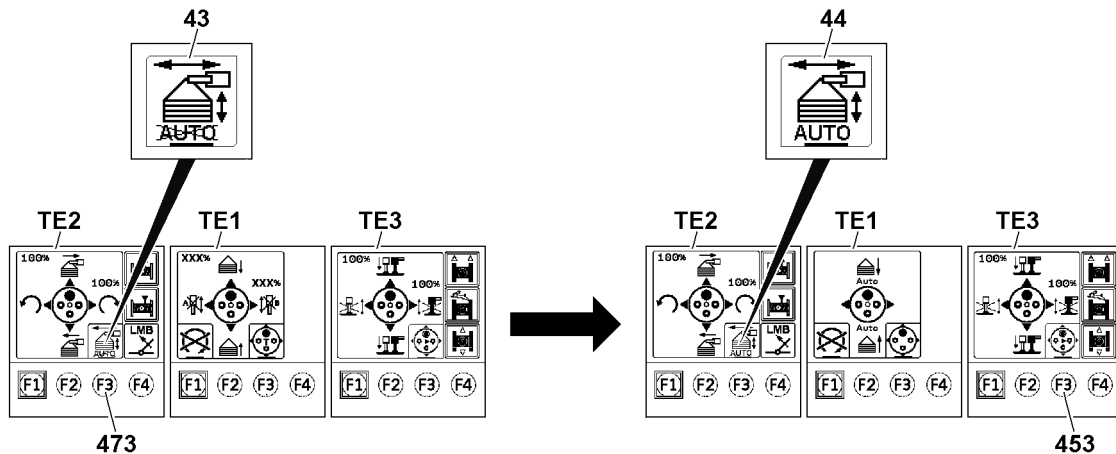


Fig.155187: Turning on the ballast automatic in the master switch assignment

- ▶ Press the F3 key **473** on the touch display **TE2**.

**Result:**

- The *ballast automatic off* icon **43** disappears, the *ballast automatic on* icon **44** appears.
- The ballast automatic is turned on.
- The pull cylinders are automatically controlled by the luffing movement of the derrick boom.
- The pull cylinders are automatically controlled by the adjustment of the derrick ballast guide.

**Note**

- ▶ Press the F3-key **453** on the touch display **TE3** to hide the master switch assignment for ballast functions again.

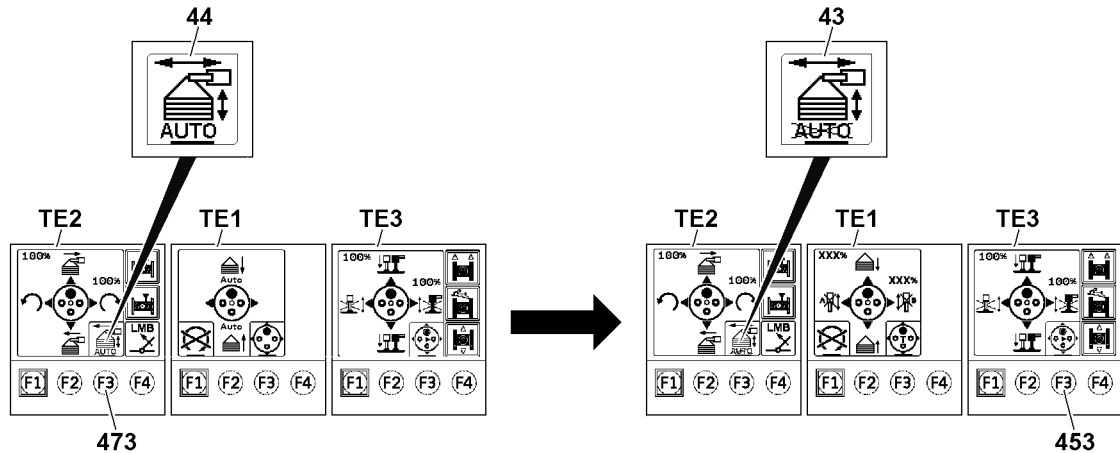
**Turning off the ballast automatic in the master switch assignment**

Fig.155188: Turning off the ballast automatic in the master switch assignment

- ▶ Press the F3 key **473** on the touch display **TE2**.

**Result:**

- The *ballast automatic on* icon **44** disappears, the *ballast automatic off* icon **43** appears.
- The ballast automatic is turned off.
- The pull cylinders are no longer automatically controlled by the luffing movement of the derrick boom.
- The pull cylinders are no longer automatically controlled by the adjustment of the derrick ballast guide.

**Note**

- ▶ Press the F3-key **453** on the touch display **TE3** to hide the master switch assignment for ballast functions again.

## 13 Assembly operating mode SA

**Note**

- ▶ If the crane is operated in the SA operating mode, the SA-frame acts as a boom.
- ▶ If the crane is operated in the SA operating mode, assembly cylinder acts as a hoist device.

**Note**

- ▶ The maximum obtainable speed of the crane movement can be reduced in the settings window "Speed reduction master switch / pedal sensor". Observe the section "Speed reduction master switch / pedal sensor".
- ▶ If the rapid gear is engaged, ensure that a higher crane movement speed is reached with the same master switch deflection. Observe the section "rapid gear (Power Plus)".
- ▶ If the engine rpm is increased, ensure that a higher crane movement speed is reached with the same master switch deflection. Observe the section "Changing the speed of the crane movement via the engine rpm".

## 13.1 Luffing the SA-frame up / down

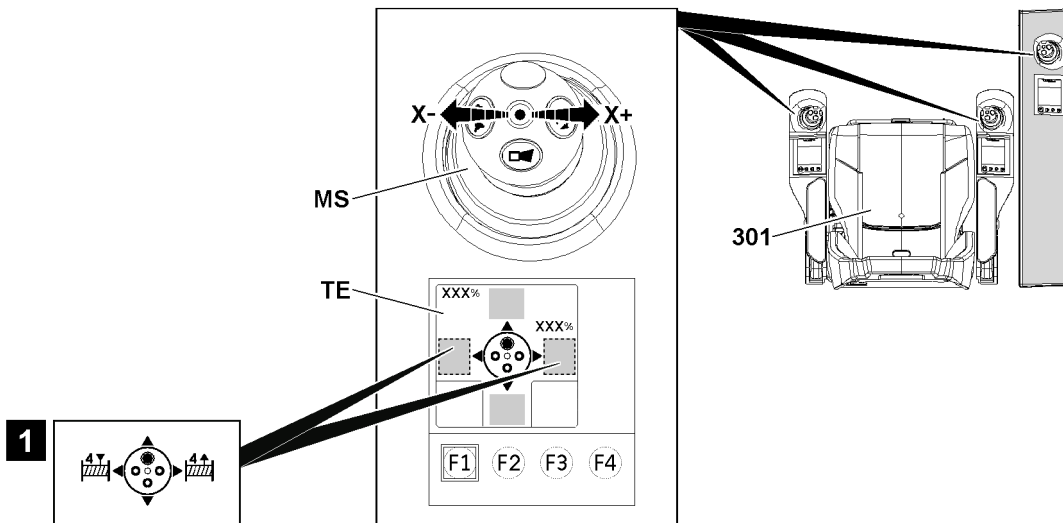


Fig.155169: Luffing the SA-frame up / down

Make sure that the following prerequisites are met:

- The SA assembly operating mode is set up, see chapter 4.02.
- The SA-frame is erected to approx. 80°, see chapter 5.02.
- The touch display **TE** of the concerned master switch shows the function assignment *Luffing the SA-frame up / down*.
- The seat contact button **301** is pressed or bypassed.

### 13.1.1 Luffing the SA-frame up

The master switch **MS** function assignment is according to the illustration 1:

- ▶ Move the master switch **MS** in direction **X-**.

**Result:**

- The SA-frame is luffed up.

### 13.1.2 Luffing the SA-frame down

The master switch **MS** function assignment is according to the illustration 1:

- ▶ Move the master switch **MS** in direction **X+**.

**Result:**

- The SA-frame is luffed down.



## 13.2 Extending / retracting the assembly cylinder

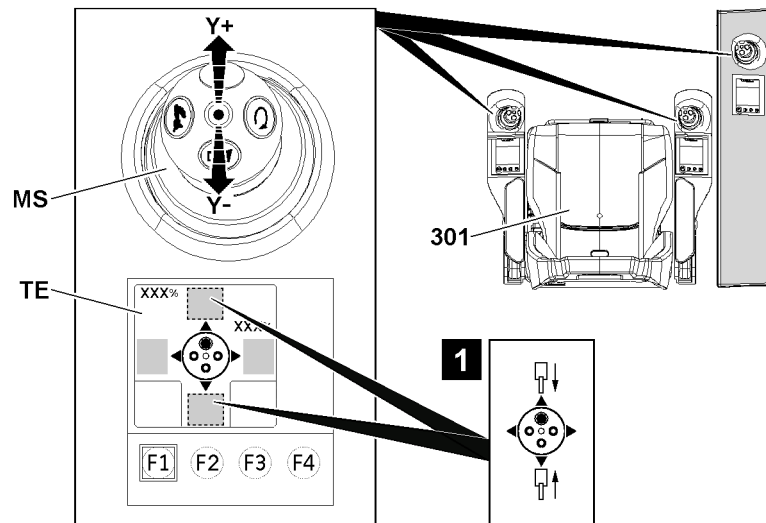


Fig.155170: Extending / retracting the assembly cylinder

Make sure that the following prerequisites are met:

- The SA assembly operating mode is set up, see chapter 4.02.
- The touch display **TE** of the concerned master switch shows the *Extending / retracting the assembly cylinder* function assignment.
- The seat contact button **301** is pressed or bypassed.

### 13.2.1 Extending the assembly cylinder

The master switch **MS** function assignment is according to the illustration 1:

- ▶ Move the master switch **MS** in direction **Y+**.

**Result:**

- The assembly cylinder extends, a fastened load is lowered.

### 13.2.2 Retracting the assembly cylinder

The master switch **MS** function assignment is according to the illustration 1:

- ▶ Move the master switch **MS** in direction **Y-**.

**Result:**

- The assembly cylinder retracts, a fastened load is lifted.

## 14 Operating the ballast trailer support cylinders

To be able to operate the ballast trailer support cylinders with the master switch, the master switch assignment for ballast functions must be called up.

## 14.1 Calling up the master switch assignment for ballast functions

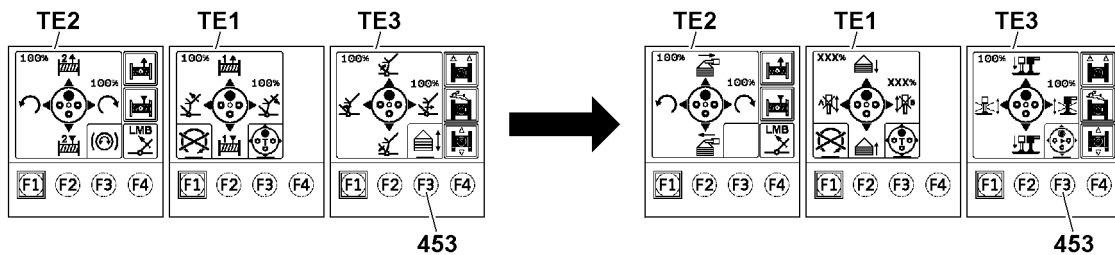


Fig.155182: Calling up the master switch assignment for ballast functions

Make sure that the following prerequisite is met:

- An operating mode with ballast trailer is set up.
- ▶ Press the F3 key **453** on the touch display **TE3**.

**Result:**

- The master switch assignment for the ballast functions is called up.



### Note

- ▶ Press the F3-key **453** on the touch display **TE3** to hide the master switch assignment for ballast functions again.

## 14.2 Extending / retracting the ballast trailer support cylinders

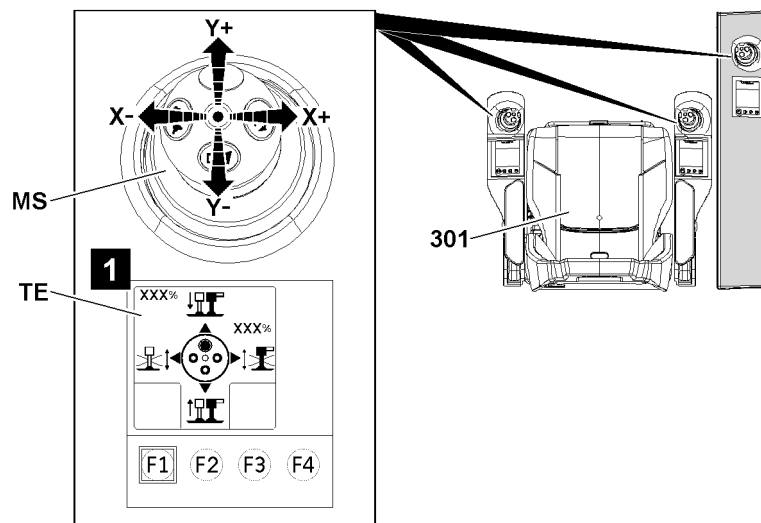


Fig.155171: Extending / retracting the ballast trailer support cylinders



### Note

- ▶ For a detailed description of the ballast trailer, see chapter 5.35 and chapter 5.35.10.

Make sure that the following prerequisites are met:

- An operating mode with ballast trailer is set up, see chapter 4.02.
- The master switch assignment for the ballast functions is called up.
- The touch display **TE** of the concerned master switch shows the function assignment for extending / retracting the ballast trailer support cylinders, see illustration 1.
- The seat contact button **301** is pressed or bypassed.
- ▶ Move the master switch **MS** in direction **Y+** (forward).

**Result:**

- The *front* support cylinder and the *rear* support cylinder extend together.
- ▶ Move the master switch **MS** in direction **Y-** (to the rear).

**Result:**

- The *front* support cylinder and *rear* support cylinder retract together.
- ▶ Move the master switch **MS** in direction **X+Y+** (combined to the front right).

**Result:**

- The *rear* support cylinder extends, the *front* support cylinder is locked.
- ▶ Move the master switch **MS** in direction **X-Y+** (combined to the front left).

**Result:**

- The *front* support cylinder extends, the *rear* support cylinder is locked.
- ▶ Move the master switch **MS** in direction **X+Y-** (combined to the rear right).

**Result:**

- The *rear* support cylinder retracts, the *front* support cylinder is locked.
- ▶ Move the master switch **MS** in direction **X-Y-** (combined to the rear left).

**Result:**

- The *front* support cylinder retracts, the *rear* support cylinder is locked.

## 15 Spooling the assembly winch up / out

**WARNING**

Overload of the assembly winch!

When the assembly winch is used for improper uses, for example for hoisting work, then the assembly winch can be overloaded and fail.

Death, severe bodily injuries, property damage.

- ▶ Only use the assembly winch for approved uses.

The assembly winch is installed on the turntable front side.

This section describes how the assembly winch is operated from the crane cab with the touch display.

- Spool the variable assembly winch out / up:
  - The assembly winch is spooled up / out as long as the function key is actuated.
- Spool the assembly winch up constantly:
  - The assembly which is spooled up / out constantly with constant tension after pressing the function key.

**Note**

- ▶ Operate the assembly winch with the radio remote control, see the radio remote control operating instructions.

## 15.1 Spooling the assembly winch out / up

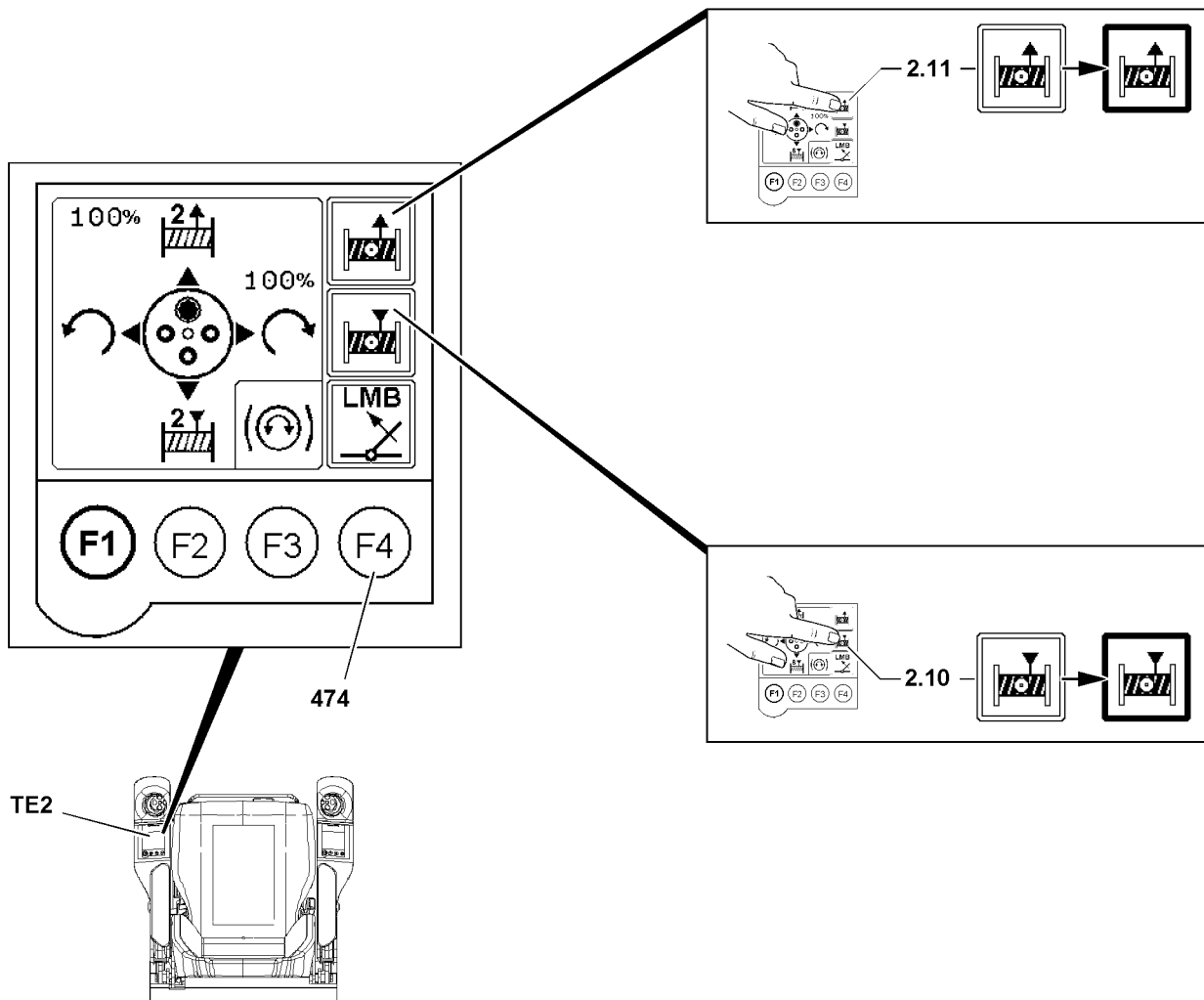


Fig.151390: Spooling the assembly winch out / up

Make sure that the following prerequisites are met:

- The “Spool the assembly winch out” and “Spool the assembly winch up” functions are only used for reeving work.
- The touch functions for the assembly winch are shown on the touch display **TE2**, see illustration.

### 15.1.1 Spooling the assembly winch out

- ▶ Select the icon **2.11** by touching it briefly with a finger tip (less than one second).

**Result:**

- The icon **2.11** is bordered in black.

The assembly winch is spooled out as long as the F4 key **474** is actuated.

- ▶ Press the F4 key **474**.

**Result:**

- The winch in the icon **2.11** blinks as long as the F4-key **474** is actuated.

**Deselect the *spool out the assembly winch* function.**

- ▶ Select other functions on the touch display **TE2**.

**or**

Deselect the icon **2.11** by touching it briefly with a finger tip (less than one second).

**Result:**

- The icon **2.11** is no longer bordered in black.
- The *spool out the assembly winch* function is deselected.

**15.1.2 Spool up the assembly winch**

- ▶ Select the icon **2.10** by touching it briefly with a finger tip (less than one second).

**Result:**

- The icon **2.10** is bordered in black.

The assembly winch is spooled up as long as the function key **474** is actuated.

- ▶ Press the function key **474**.

**Result:**

- The winch in the icon **2.10** blinks as long as the function key **474** is actuated.

**Deselect the *spool out the assembly winch* function.**

- ▶ Select other functions on the touch display **TE2**.

**or**

Deselect the icon **2.10** by touching it briefly with a finger tip (less than one second).

**Result:**

- The icon **2.10** is no longer bordered in black.
- The *spool up the assembly winch* function is deselected.

## 15.2 Spooling the assembly winch up constantly

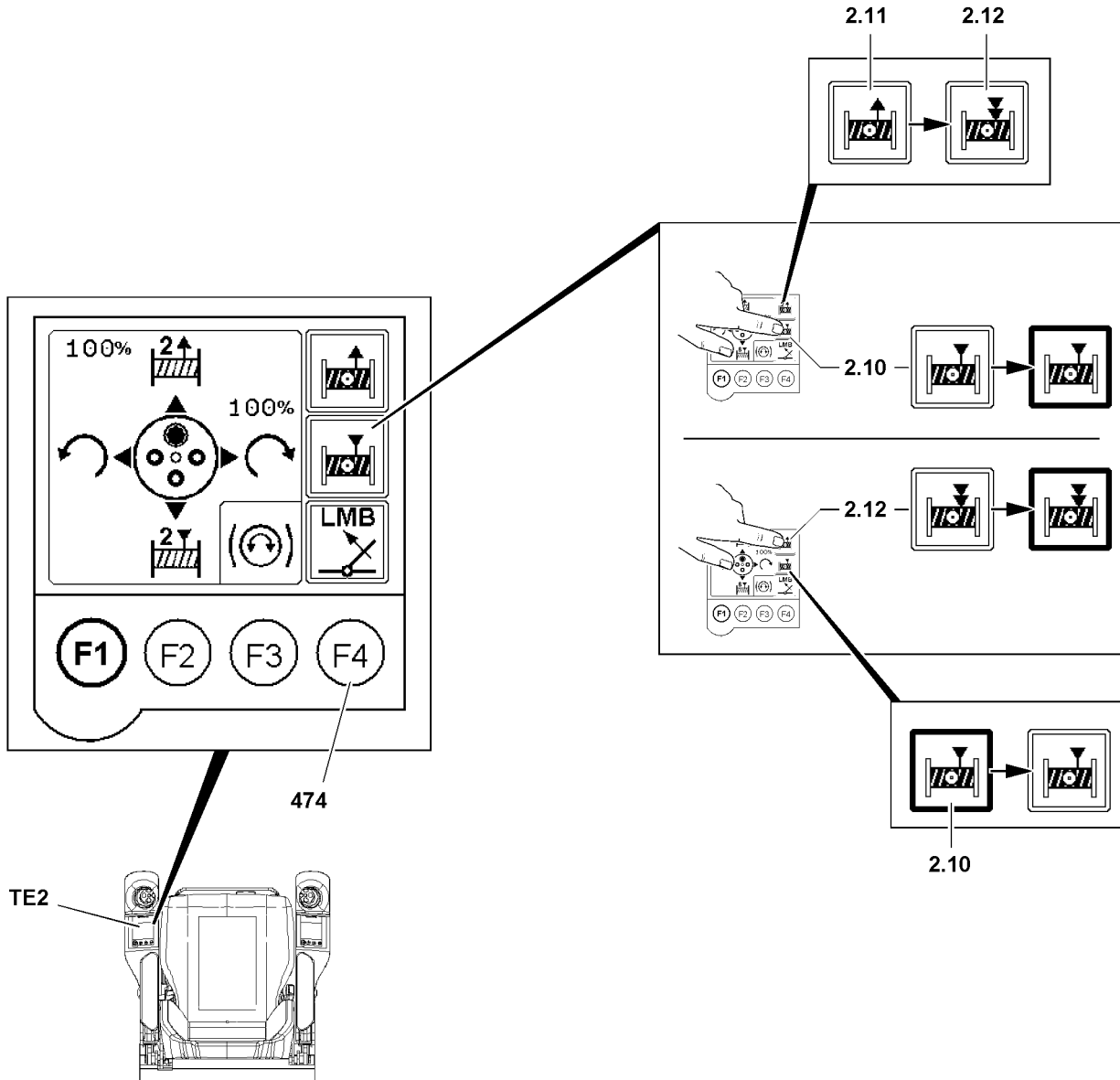


Fig.151391: Spooling the assembly winch up constantly



### WARNING

Overload of the assembly winch!

If the “Spool up the assembly winch constantly” function is used for improper uses, for example for reeving procedures, the assembly winch can be overloaded and fail.

Death, severe bodily injuries, property damage.

- ▶ Do not use the “Spool up the assembly winch constantly” function for reeving procedures
- ▶ For reeving procedures, only use the “Spool the assembly winch out / up” function.

Make sure that the following prerequisites are met:

- The “Spool up the assembly winch constantly” function is only used for erection or take-down procedures in operating modes with a luffing jib in order to keep hoist ropes under constant tension, as long as the hook block cannot be reeved in.
- The touch functions for the assembly winch are shown on the touch display **TE2**, see illustration.
- ▶ Select the icon **2.10** by touching it longer with a finger tip (two seconds).

**Result:**

- The icon **2.10** is bordered in black.
- Instead of the icon **2.11**, the icon **2.12** is shown.
- ▶ Select the icon **2.12** by touching it briefly with a finger tip (less than one second).

**Result:**

- The icon **2.12** is bordered in black.
- The icon **2.10** is no longer bordered in black.
- ▶ Press the function key **474** for at least one second.

**Result:**

- The assembly winch is spooled up constantly / kept under constant tension.
- The winch in the icon **2.12** blinks.

**Stop the constant spooling up of the assembly winch**

- ▶ Deselect the icon **2.12** by touching it briefly with a finger tip (less than one second).

**Result:**

- The assembly winch is no longer spooled up.
- The icon **2.12** is no longer bordered in black.

or

- ▶ Press the function key **474**.

**Result:**

- The assembly winch is no longer spooled up.
- The icon **2.12** remains bordered in black.

or

- ▶ Select other functions on the touch display **TE2**.

**Result:**

- The assembly winch is no longer spooled up.
- The icon **2.12** is no longer bordered in black.

---

Empty page!

LWE/LR 1800-1-0-000/27200-07-02/en



## 4.06 Rope reeving

1	Wire ropes and rope end connections	2
2	Reeving in the hoist rope	5
3	Reeving in / reeving out the hook block, rope end connection in the standard version	8
4	Reeving in / reeving out the hook block, rope end connection with L-shaped rope lock	11
5	Attaching and removing the load hook*	15
6	Two-part hoist limit switch weight	18
7	One-part hoist limit switch weight	21
8	Assembling / disassembling the wedge lock	23
9	Rope reeving	35

# 1 Wire ropes and rope end connections

## 1.1 Wire ropes

Check if a **rotating resistant** or a **non-rotating** rope is required for the application. The selected type of rope then requires the corresponding rope end connections, see the Crane operating instructions, chapter 8.04.



### Note

- ▶ The correct choice and use of the wire rope and the rope end connections are a decisive precondition for proper and accident-free crane operation.



### DANGER

Incorrect rope type!

Danger of severe injuries to personnel and property damage.

- ▶ **Never** use rotation-resistant ropes with a rotating rope end connection.
- ▶ **Never** install a twist compensator / swivel.

## 1.2 Rope end connections

Rope end connections are grouped into:

- Rope lock (standard version), with locking clamp or locking cast sleeve
- L-shaped rope lock, with locking clamp or locking cast sleeve
- Wedge lock, on the rope end
  - Without locking clamp / locking cast sleeve



### Note

- ▶ A locking clamp is pressed on the rope.
- ▶ A locking cast sleeve is cast with the rope.
- ▶ A wedge lock is wedged with the rope.



### WARNING

The load can be ripped off!

If the rope end connection is installed incorrectly, the rope can rip off.

Death, severe bodily injuries, property damage.

- ▶ Only use the provided fastening points.
- ▶ Use the respective rope end connection only at the correspondingly implemented fastening points.

### 1.2.1 Rope lock (standard version)

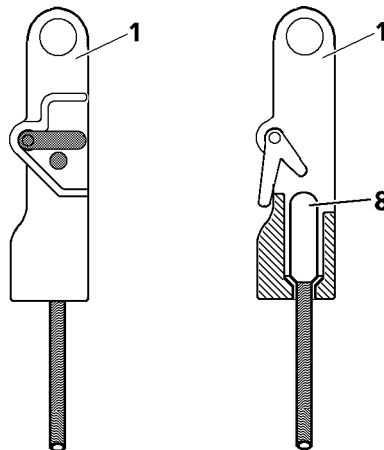


Fig.144019: Rope lock (standard version) with locking clamp / locking cast sleeve

The rope end connection consists of:

- Rope lock (standard version) **1** with locking clamp / locking cast sleeve **8**  
Only use them on the conventional fastening points for rope end connections.

### 1.2.2 L-shaped rope lock



#### WARNING

The load can be ripped off!  
Death, severe bodily injuries, property damage.

- ▶ The rope end connection with L-shaped rope lock is only permitted for use on appropriately designed fastening points.
- ▶ Make sure that the rope end connection with L-shaped rope lock is only used on appropriately designed fastening points.

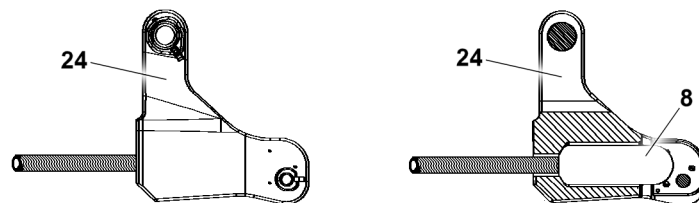


Fig.158793: L-shaped rope lock, with locking clamp / locking cast sleeve

The rope end connection consists of:

- L-shaped rope lock, **24** with locking clamp / locking cast sleeve **8**  
Only use on the appropriately designed fastening points for rope end connection with L-shaped rope lock.



#### Note

##### Fastening points for rope end connection with L-shaped rope lock

- ▶ Fastening points that are designed accordingly have a guide surface for the L-shaped rope lock.
- ▶ If the rope lock is touching the guide surface, the rope does not bend with a load.

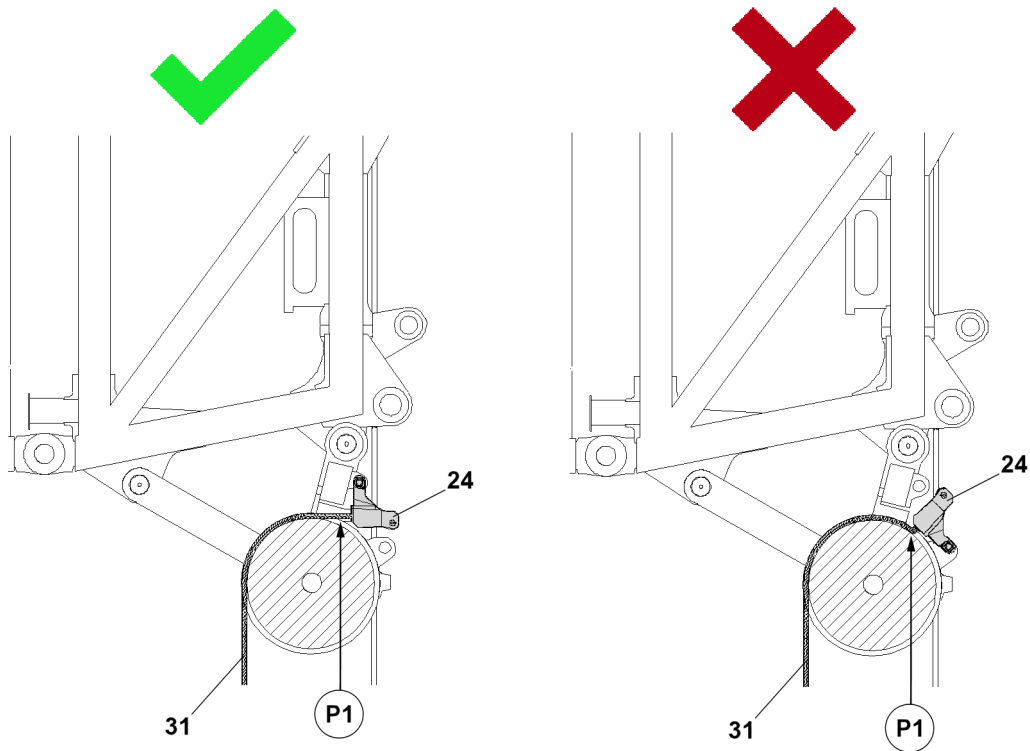


Fig.158794: Example for the correct / wrong use of the rope end connection with an L-shaped rope lock 24

Make sure that the L-shaped rope lock 24 is used in the correct pin point.

- The pin point must be selected according to the reeving plan.
- The pin point is designed as a fastening point for rope end connections with L-shaped rope lock.
- By using the correct pin point, the bending of the hoist rope 31 in point P1 prevented.

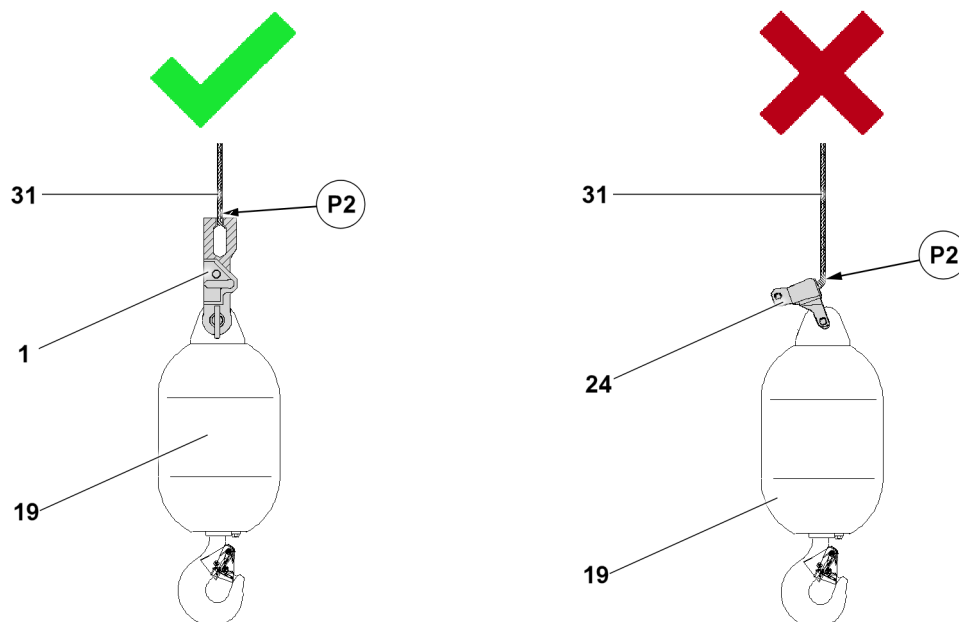


Fig.158795: Example for the correct / wrong use of the rope end connections

Make sure that the L-shaped rope lock 24 is used on the correct component:

- The L-shaped rope lock 24 may only be pinned in an appropriately designed fastening point.
- By using the correct rope end connection on the load hook 19, in the provided example for the rope lock (standard version) 1, a bending of the hoist rope 31 in point P2 is prevented.

### 1.2.3 Wedge lock

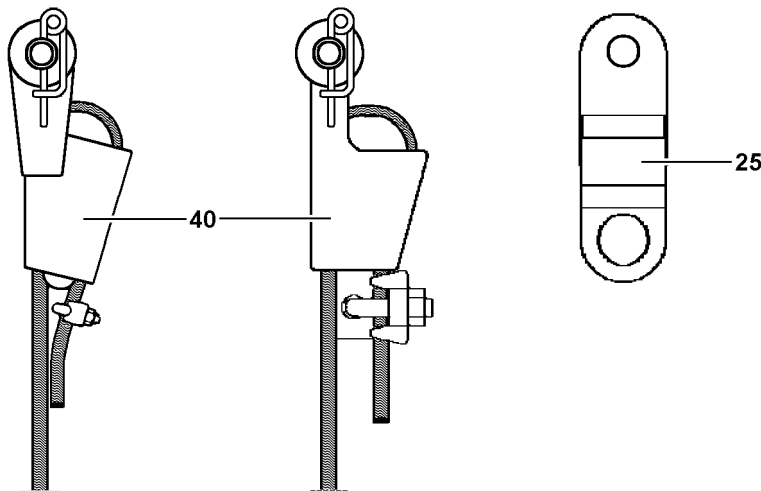


Fig.160486: Wedge locks installed on the rope (rope without locking clamp / locking cast sleeve), adapter\* separate

The rope end connection consists of:

- Wedge lock **40**, installed without locking clamp / locking cast sleeve on the rope  
Only use them on the conventional fastening points for rope end connections.  
**Note:** Exemplary illustration for possible construction forms.
- Adapter wedge lock **25**, when the pin bore of the wedge lock does not have the required diameter.



#### Note

- ▶ Observe the section “Assembling / disassembling the wedge lock”.

## 2 Reeving in the hoist rope



#### WARNING

Slipping during assembly work!  
Danger of falling.

Death, severe injury, property damage.

- ▶ The boom system may only be accessed if assembly personnel is protected with suitable safety measures to prevent them from falling.
- ▶ If safety ropes are present on the boom system, then assembly personnel must connect an approved fall arrest system to the retaining ropes of the boom system on the left and right with both snap hooks and secure themselves to prevent them from falling.
- ▶ Without appropriate safety measures it is **strictly** prohibited to step on the boom system.
- ▶ If railings are present for the crane, then they must be brought into the corresponding position and secured for assembly / disassembly.
- ▶ Carry out all assembly work from a safe location.
- ▶ Observe the assembly guidelines in the Crane operating instructions, chapter 5.01.



#### WARNING

Danger of accident due to a running rope!

People can be caught due to a turning rope pulley and / or a running rope.

Death, severe bodily injuries, property damage.

- ▶ Adhere to the safety distance from ropes and turning rope pulleys.
- ▶ Do not remain in the danger zone.

**WARNING**

Danger of accident due to uneven spooling during reeving in / reeving out!  
The rope can catch components and personnel.  
Death, severe bodily injuries, property damage.

- ▶ Spool the winches synchronously.
- ▶ Observe the rope run.
- ▶ Do not remain in the danger zone.

Make sure that the following prerequisites are met:

- The ground is level and of sufficient load bearing capacity.
- **Only for cranes with crane support:** The crane is properly supported.
- The crane is horizontally aligned.
- The slewing gear brake is applied.
- The boom end section is just above the ground.

## 2.1 Reeving in the hoist rope with the assembly winch

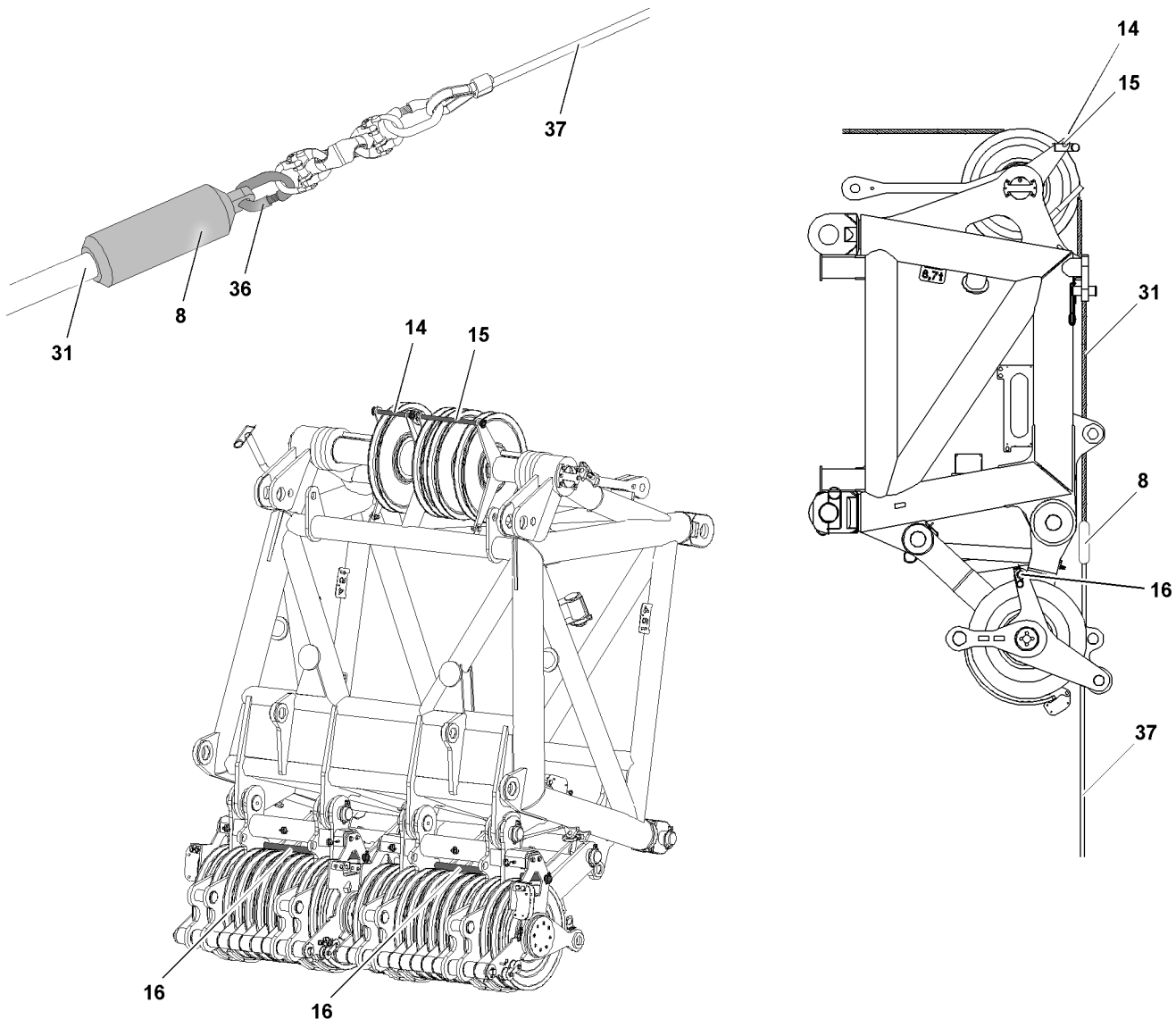


Fig.158792: Reeving in with assembly winch

- ▶ Wear an approved fall arrest system and protective equipment, see the Crane operating instructions, chapter 2.04.

- ▶ Bring the fall protection equipment on the crane superstructure and on the lattice boom in operating position and secure, see Crane operating instructions, chapter 2.06.
- ▶ Properly hang the fall arrest system on the intended safety ropes and / or fastening points.
- ▶ Switch the assembly winch to freewheeling.
- ▶ Remove the rope retaining pin **14**, rope retaining pin **15** and rope retaining pin **16**.
- ▶ Connect the auxiliary rope **37** with the auxiliary reeving rope (hemp rope).
- ▶ Reeve in the auxiliary rope **37** in the reverse direction between the hook block and the pulley head.
- ▶ Bring the auxiliary rope **37** with the auxiliary reeving rope (hemp rope) upward over the back pulley, which is to be reeved in according to the reeving plan.
- ▶ Pull the auxiliary rope **37** to the rear to the hoist winch.
- ▶ Release the auxiliary reeving rope (hemp rope) from the auxiliary rope **37**.

When the auxiliary rope **37** is on the hoist winch:

- ▶ Connect the auxiliary rope **37** with the hoist rope **31**: Open the connecting link **36**, connect it with the eyehook of the locking clamp / locking cast sleeve **8** and close the connecting link **36**.
- ▶ Turn freewheeling off on the assembly winch.

---

#### NOTICE

Hoist rope tension too low!  
Slack rope formation.

- ▶ Do not permit any slack rope formation on the hoist winch and the assembly winch.

- 
- ▶ Reeve the hoist rope **31** in: Spool the hoist rope **31** out from the hoist winch and simultaneously spool up the auxiliary rope **37** on the assembly winch.

When the hoist rope **31** is reeved in:

- ▶ Release the auxiliary rope **37** from the hoist rope **31**.
- ▶ Spool the auxiliary rope **37** up on the assembly winch.
- ▶ Pin and secure the rope retaining pin **14**, rope retaining pin **15** and rope retaining pin **16**.
- ▶ Connect the hoist rope **31** properly to the rope lock, see the following sections.

When the hoist rope **31** is properly connected to the rope lock:

- ▶ Attach the hoist limit switch weight, see the following sections.



#### Note

Parallel operation of winch 1 and winch 2!

- ▶ Repeat the above described reeving procedure with the second hoist rope.
  - ▶ Observe the reeving plan.
-

### 3 Reeving in / reeving out the hook block, rope end connection in the standard version

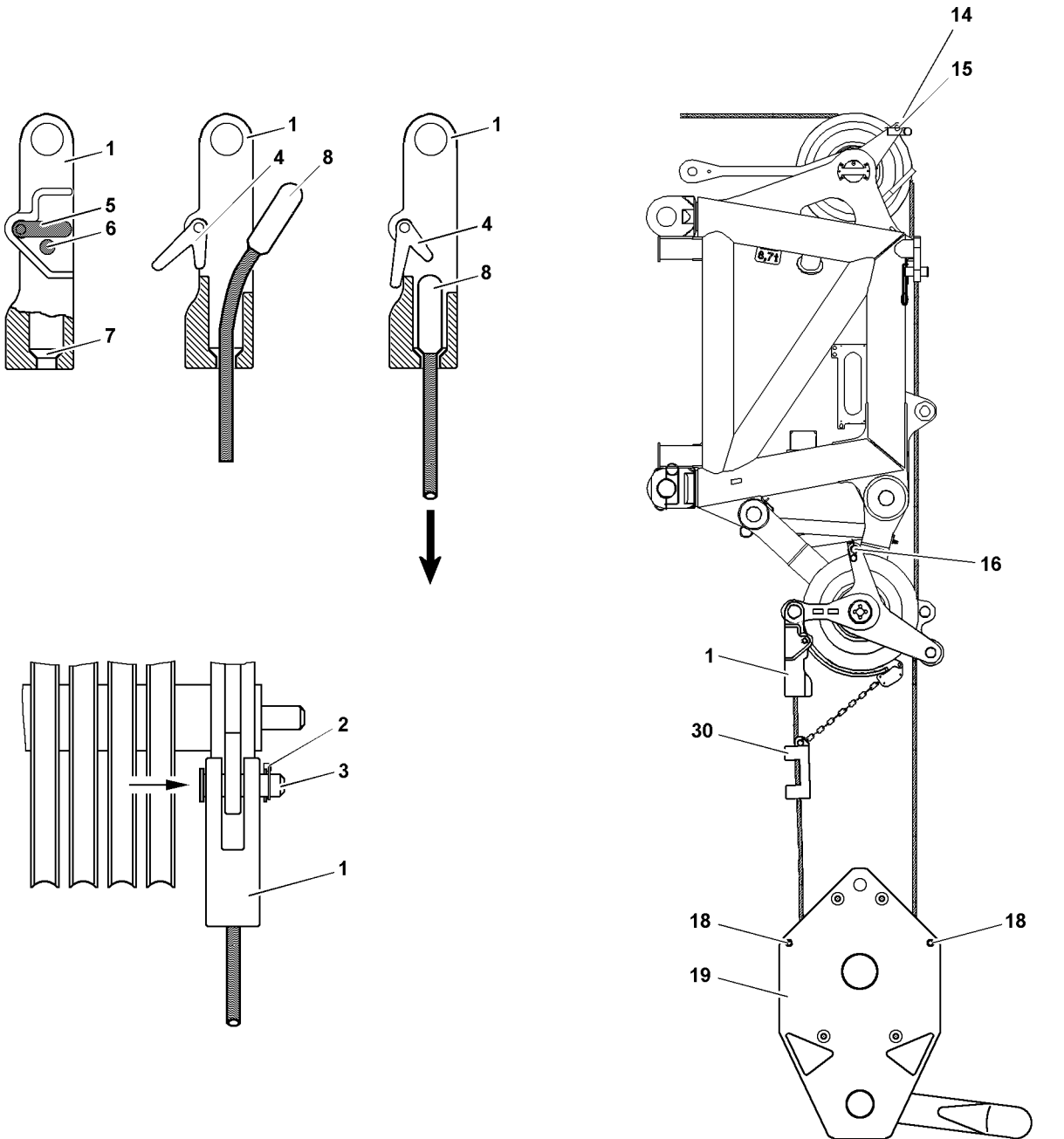


Fig.144024: Detailed view of reeving the hook block in

LWE/LR 1800-1-0-000/27200-07-02/en



## 3.1 Reeving the hook block in



### WARNING

Toppling of the hook block!

If the retaining pins are **not** pinned in the roller block / roller blocks of the hook block before putting the hook block down, then the roller blocks / hook block can topple over when reeving out the hoist rope. Death, severe injury, property damage.

- ▶ Insert the retaining pins, see the Crane operating instructions, chapter 5.19 or the separate operating instructions of the hook block.

### 3.1.1 Preparing the hook block

Make sure that the following prerequisites are met:

- The crane is horizontally aligned.
- The slewing gear brake is applied.
- The hook block is set down on the ground properly.
- The boom is luffed down to the point where the pulley head is above the hook block.
- An assistant is present to guide the hoist rope.



### WARNING

Danger of accident due to side wind!

If the slewing gear brake is released after reeving in / reeving out the hook block / load hook, then the crane can turn uncontrolled in strong side wind.

The crane can collide with near-by structures or objects.

Death, severe injury, property damage.

- ▶ Make sure that the current wind speed does not exceed the values from the wind speed chart when releasing the slewing gear brake.

### NOTICE

Hook block incorrectly reeved in!

Damage to the hoist rope.

- ▶ Carry out the reeving of the hoist rope according to the reeving plan.
- ▶ Select the rope fixed point on the hook block is in such a way that the last strand runs parallel to the remaining rope strands, as much as possible.
- ▶ Set the required hook block under the boom head.
- ▶ On the hook block **19**, remove the spring retainers **18** for both rope retaining pins and pull them both out.



### WARNING

Slipping during assembly work!

Danger of falling.

Death, severe injury, property damage.

- ▶ The boom system may only be accessed if assembly personnel is protected with suitable safety measures to prevent them from falling.
- ▶ If safety ropes are present on the boom system, then assembly personnel must connect an approved fall arrest system to the retaining ropes of the boom system on the left and right with both snap hooks and secure themselves to prevent them from falling.
- ▶ Without appropriate safety measures it is **strictly** prohibited to step on the boom system.
- ▶ If railings are present for the crane, then they must be brought into the corresponding position and secured for assembly / disassembly.
- ▶ Carry out all assembly work from a safe location.
- ▶ Observe the assembly guidelines in the Crane operating instructions, chapter 5.01.

- ▶ Reeve in the hook block.
- ▶ Insert the rope retaining pins again and secure with spring retainers.

### 3.1.2 Connecting the hoist rope to the rope lock

#### NOTICE

The hoist rope is incorrectly installed!

Damage to the hoist rope.

- ▶ Always insert the pin **3** from the “inside to the outside” and secure from the outside.
- 
- ▶ The rope lock **1** must be reeved either on the pulley head or on the hook block and secured with locking pins **2**, depending on reeving.
  - ▶ On the rope lock **1**, push in the safety pin **6**.
  - ▶ Swing the lever **5** “down” and hold it in this position.

#### Result:

- The locking pawl **4** is swung “downward”.
- ▶ Attach the rope end with the locking clamp / locking cast sleeve **8** in the rope lock **1** and pull “down” firmly (in direction of arrow), until the locking clamp / locking cast sleeve **8** is touching in the cone **7**.



#### WARNING

Locking clamp / locking cast sleeve incorrectly installed!

Danger of accident.

Death, severe injuries, property damage.

- ▶ The locking clamp / locking cast sleeve **8** must touch on the cone **7** after connecting it to the rope lock **1** and must be secured by the locking pawl **4**.

- ▶ Release the lever **5**.

#### Result:

- The lever **5** returns to the initial position and is locked by the safety pin **6**.
- ▶ Check the rope retainer. Visual inspection.

## 3.2 Reeving the hook block out



#### WARNING

Toppling of the hook block!

If the retaining pins are **not** pinned in the roller block / roller blocks of the hook block before putting the hook block down, then the roller blocks / hook block can topple over when reeving out the hoist rope.

Death, severe injury, property damage.

- ▶ Insert the retaining pins, see the Crane operating instructions, chapter 5.19 or the separate operating instructions of the hook block.

Make sure that the following prerequisites are met:

- The ground is level and of sufficient load bearing capacity.
- **Only for cranes with crane support:** The crane is properly supported.
- The crane is horizontally aligned.
- The slewing gear brake is applied.
- The boom end section is just above the ground.



#### WARNING

Danger of accident due to side wind!

If the slewing gear brake is released after reeving in / reeving out the hook block / load hook, then the crane can turn uncontrolled in strong side wind.

The crane can collide with near-by structures or objects.

Personnel can be severely injured or killed.

- ▶ Make sure that the current wind speed does not exceed the values from the wind speed chart when releasing the slewing gear brake.

### 3.2.1 Lowering the hook block



#### WARNING

Crushing of hands!

When reeving out the hook block, it can topple over.  
Death, severe injury, property damage.

- ▶ Use the handles in the safe area of the hook block.
- ▶ Make sure the hook block is safely positioned.

- ▶ Lower the hook block and place it on the ground.
- ▶ Remove the hoist limit switch weight.

### 3.2.2 Detaching the hoist rope

- ▶ On the rope lock **1**, push in the safety pin **6**.
- ▶ Swing the lever **5** "down" and hold it in this position.

#### Result:

- The locking pawl **4** is swung downward.
- The locking clamp / locking cast sleeve **8** is released.
- ▶ Push the hoist rope up and detach the locking clamp / locking cast sleeve **8**.
- ▶ Release and unpin the rope retaining pin on the hook block.
- ▶ Reeve out the hoist rope from the hook block and the pulley head.
- ▶ Insert the rope retaining pins again and secure with spring retainers.

## 4 Reeving in / reeving out the hook block, rope end connection with L-shaped rope lock

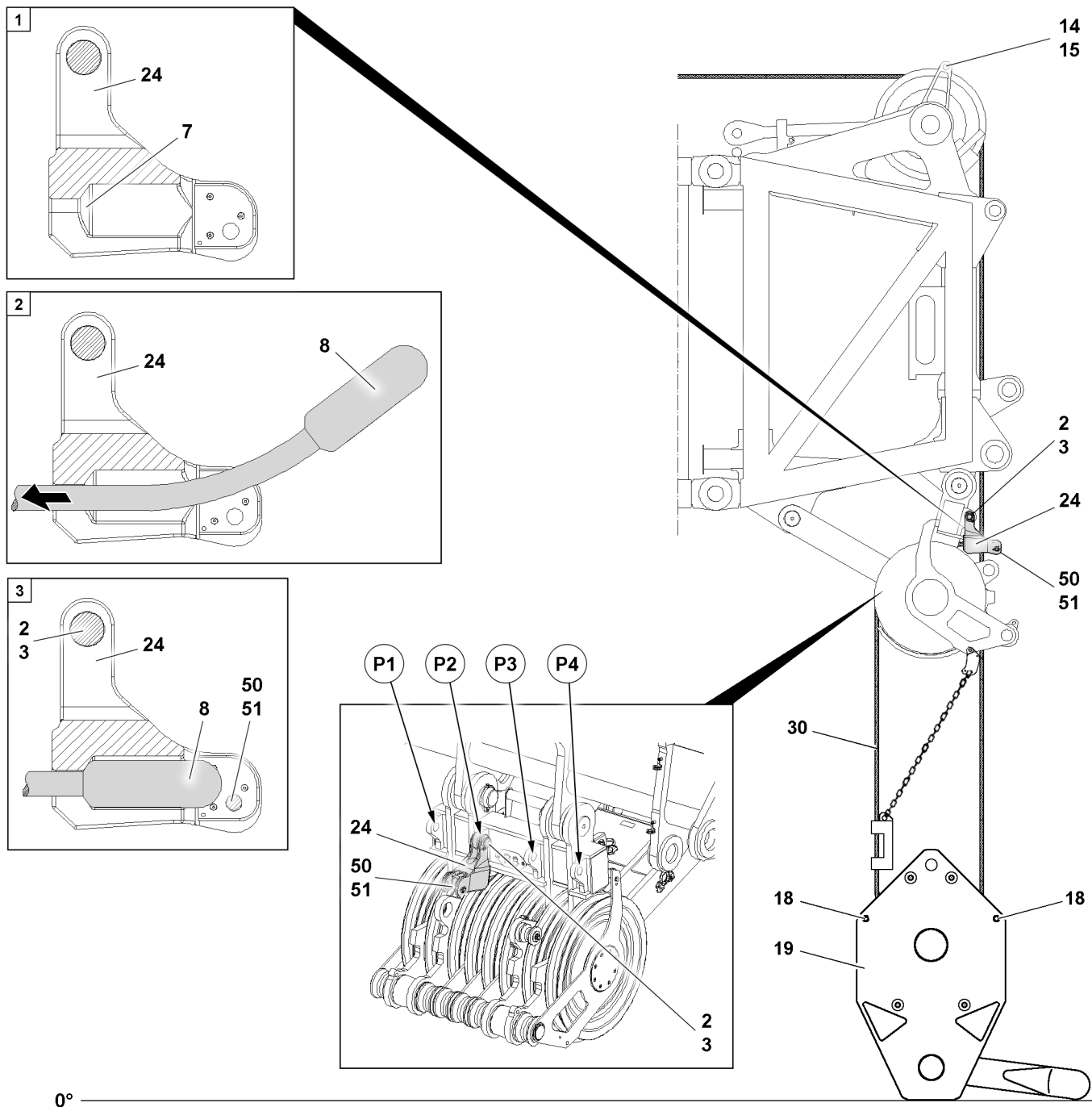


#### WARNING

The load can be ripped off!

Death, severe bodily injuries, property damage.

- ▶ The rope end connection with L-shaped rope lock is only permitted for use on appropriately designed fastening points.
- ▶ Make sure that the rope end connection with L-shaped rope lock is only used on appropriately designed fastening points.
- ▶ Do not combine an L-shaped rope lock with other components.



0°

Fig.144022: Detailed view of the hook block reeving, rope end connection with L-shaped rope lock

The rope end connection with L-shaped rope lock **24** must be installed in one of the appropriately designed fastening points (e.g. pin point **P1** to pin point **P4**) on the roller set / sets.

## 4.1 Reeving the hook block in



### WARNING

Toppling of the hook block!

If the retaining pins are **not** pinned in the roller block / roller blocks of the hook block before putting the hook block down, then the roller blocks / hook block can topple over when reeving out the hoist rope. Death, severe injury, property damage.

- ▶ Insert the retaining pins, see the Crane operating instructions, chapter 5.19 or the separate operating instructions of the hook block.

### 4.1.1 Preparing the hook block

Make sure that the following prerequisites are met:

- The crane is horizontally aligned.
- The slewing gear brake is applied.
- The hook block is set down on the ground properly.
- The boom is luffed down to the point where the pulley head is above the hook block.
- An assistant is present to guide the hoist rope.



#### WARNING

Danger of accident due to side wind!

If the slewing gear brake is released after reeving in / reeving out the hook block / load hook, then the crane can turn uncontrolled in strong side wind.

Death, severe injury, property damage.

The crane can collide with near-by structures or objects.

- ▶ Make sure that the current wind speed does not exceed the values from the wind speed chart when releasing the slewing gear brake.

#### NOTICE

Hook block incorrectly reeved in!

Damage to the hoist rope.

- ▶ Carry out the reeving of the hoist rope according to the reeving plan.

If there are no specifications for the rope fixed point on the hook block in the reeving plan:

- ▶ Select the rope fixed point on the hook block is in such a way that the last strand runs parallel to the remaining rope strands, as much as possible.

- ▶ Set the required hook block under the boom head.
- ▶ On the hook block **19**, remove the spring retainers **18** for both rope retaining pins and pull them both out.



#### WARNING

Slipping during assembly work!

Danger of falling.

Death, severe injury, property damage.

- ▶ The boom system may only be accessed if assembly personnel is protected with suitable safety measures to prevent them from falling.
  - ▶ If safety ropes are present on the boom system, then assembly personnel must connect an approved fall arrest system to the retaining ropes of the boom system on the left and right with both snap hooks and secure themselves to prevent them from falling.
  - ▶ Without appropriate safety measures it is **strictly** prohibited to step on the boom system.
  - ▶ If railings are present for the crane, then they must be brought into the corresponding position and secured for assembly / disassembly.
  - ▶ Carry out all assembly work from a safe location.
  - ▶ Observe the assembly guidelines in the Crane operating instructions, chapter 5.01.
- ▶ Reeve in the hook block.
  - ▶ Insert the rope retaining pins again and secure with spring retainers.

### 4.1.2 Connecting the hoist rope to the rope lock

#### NOTICE

The hoist rope is incorrectly installed!

Damage to the hoist rope.

- ▶ Always insert the pin **50** from the “inside to the outside” and secure from the outside.
- ▶ Pin the rope lock **24** only to the roller set / roller sets and secure with a locking pin **2**.
- ▶ On the rope lock **24**, release and unpin the retaining pin **50**.

- ▶ Attach the rope end with the locking clamp / locking cast sleeve **8** in the rope lock **24** and pull in the direction of arrow, until the locking clamp / locking cast sleeve **8** is touching in the cone **7**.

**WARNING**

Locking clamp / locking cast sleeve incorrectly installed!  
Danger of accident.

Death, severe injuries, property damage.

- ▶ The locking clamp / locking cast sleeve **8**, after being connected to the rope lock **24**, must touch the cones **7** and be secured by the retaining pin **50**.
- ▶ Insert the retaining pin **50** and secure properly with the retaining element **51**.
- ▶ Check the rope retainer. Visual inspection.

## 4.2 Reeving the hook block out

**WARNING**

Toppling of the hook block!

If the retaining pins are **not** pinned in the roller block / roller blocks of the hook block before putting the hook block down, then the roller blocks / hook block can topple over when reeving out the hoist rope.  
Death, severe injury, property damage.

- ▶ Insert the retaining pins, see the Crane operating instructions, chapter 5.19 or the separate operating instructions of the hook block.

Make sure that the following prerequisites are met:

- The ground is level and of sufficient load bearing capacity.
- **Only for cranes with crane support:** The crane is properly supported.
- The crane is horizontally aligned.
- The slewing gear brake is applied.
- The boom end section is just above the ground.

**WARNING**

Danger of accident due to side wind!

If the slewing gear brake is released after reeving in / reeving out the hook block / load hook, then the crane can turn uncontrolled in strong side wind.

Personnel can be severely injured or killed.

The crane can collide with near-by structures or objects.

- ▶ Make sure that the current wind speed does not exceed the values from the wind speed chart when releasing the slewing gear brake.

### 4.2.1 Lowering the hook block

**WARNING**

Crushing of hands!

When reeving out the hook block, it can topple over.

Death, severe injury, property damage.

- ▶ Use the handles in the safe area of the hook block.
- ▶ Make sure the hook block is safely positioned.
- ▶ Lower the hook block and place it on the ground.
- ▶ Remove the hoist limit switch weight.

### 4.2.2 Detaching the hoist rope

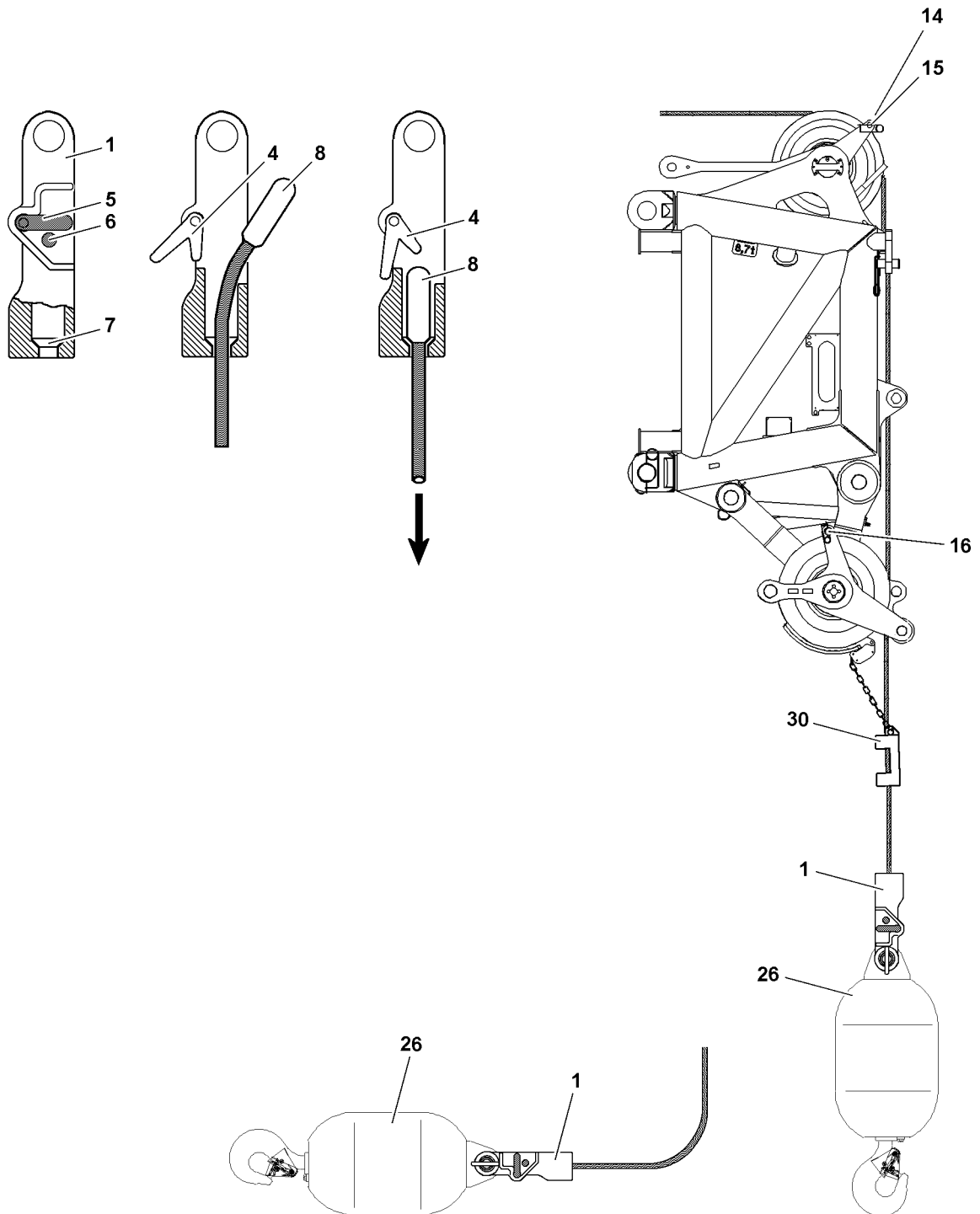
- ▶ On the rope lock **24**, release and unpin the retaining pin **50**.

**Result:**

- The locking clamp / locking cast sleeve **8** is released.

- ▶ Push the hoist rope forward and detach the locking clamp / locking cast sleeve 8.
- ▶ Release and unpin the rope retaining pin on the hook block.
- ▶ Reeve out the hoist rope from the hook block and the pulley head.
- ▶ Insert the rope retaining pins again and secure with spring retainers.

## 5 Attaching and removing the load hook\*



LWE/LR 1800-1-0-000/27200-07-02/en

Fig.121854: Load hook fastening

## 5.1 Fastening the load hook\*

### 5.1.1 Assembling the load hook\*

- ▶ Place the load hook under the pulley head of the boom.
- ▶ Release and unpin the rope retaining pins on the back pulley and on the pulley head.



#### WARNING

Slipping during assembly work!  
Danger of falling.

Death, severe injury, property damage.

- ▶ The boom system may only be accessed if assembly personnel is protected with suitable safety measures to prevent them from falling.
- ▶ If safety ropes are present on the boom system, then assembly personnel must connect an approved fall arrest system to the retaining ropes of the boom system on the left and right with both snap hooks and secure themselves to prevent them from falling.
- ▶ Without appropriate safety measures it is **strictly** prohibited to step on the boom system.
- ▶ If railings are present for the crane, then they must be brought into the corresponding position and secured for assembly / disassembly.
- ▶ Carry out all assembly work from a safe location.
- ▶ Observe the assembly guidelines in the Crane operating instructions, chapter 5.01.

- ▶ Place the hoist rope over the back pulley on the boom head.
- ▶ Insert the rope retaining pins again and secure with spring retainers.
- ▶ Pin the rope lock **1** in the load hook **26** and secure with spring retainers.

### 5.1.2 Connecting the hoist rope

Make sure that the following prerequisites are met:

- The crane is horizontally aligned.
- The slewing gear brake is applied.
- The hook block is set down on the ground properly.
- The boom is luffed down to the point where the pulley head is above the hook block.
- An assistant is present to guide the hoist rope.



#### WARNING

Danger of accident due to side wind!

If the slewing gear brake is released after reeving in / reeving out the hook block / load hook, then the crane can turn uncontrolled in strong side wind.

Personnel can be severely injured or killed.

The crane can collide with near-by structures or objects.

- ▶ Make sure that the current wind speed does not exceed the values from the wind speed chart when releasing the slewing gear brake.
- ▶ On the rope lock **1**, push in the safety pin **6**.
- ▶ Swing the lever **5** “down” and hold it in this position.

#### Result:

- The locking pawl **4** is swung “downward”.
- ▶ Attach the rope end with the locking clamp / locking cast sleeve **8** in the rope lock and pull “down” firmly (in direction of arrow), until the locking clamp / locking cast sleeve **8** is touching in the cone **7**.



#### WARNING

Locking clamp / locking cast sleeve incorrectly secured!

Damage to the locking clamp / locking cast sleeve.

Death, severe injuries, property damage

- ▶ The locking clamp / locking cast sleeve **8** must touch on the cone **7** after connecting it to the rope lock **1** and must be secured by the locking pawl **4**.



- ▶ Release the lever **5**.

**Result:**

- The lever **5** returns to the initial position and is locked by the safety pin **6**.

## 5.2 Removing the load hook\*

Make sure that the following prerequisites are met:

- The ground is level and of sufficient load bearing capacity.
- **Only for cranes with crane support:** The crane is properly supported.
- The crane is horizontally aligned.
- The slewing gear brake is applied.
- The load hook is prepared for assembly.
- An assistant is present to guide the hoist rope.

### 5.2.1 Lowering the load hook



**WARNING**

Crushing of hands!

When reeving out the hook block, it can topple over.

Death, severe injury, property damage.

- ▶ Use the handles in the safe area of the hook block.
  - ▶ Make sure the hook block is safely positioned.
- 
- ▶ Take the load hook **26** down on the ground.
  - ▶ Remove the hoist limit switch weight.

### 5.2.2 Detaching the hoist rope



**WARNING**

Danger of accident due to side wind!

If the slewing gear brake is released after reeving in / reeving out the hook block / load hook, then the crane can turn uncontrolled in strong side wind.

Death, severe injury, property damage.

The crane can collide with near-by structures or objects.

- ▶ Make sure that the current wind speed does not exceed the values from the wind speed chart when releasing the slewing gear brake.
- 
- ▶ On the rope lock **1**, push in the safety pin **6**.
  - ▶ Swing the lever **5** “down” and hold it in this position.

**Result:**

- The locking pawl **4** is swung “downward”.
  - The locking clamp / locking cast sleeve **8** is released.
- ▶ Push the hoist rope in the direction of the load hook and detach the locking clamp / locking cast sleeve **8**.
  - ▶ Remove the rope retaining pins on the pulley head and on the back pulley.
  - ▶ Lift the hoist rope from the rope pulleys.
  - ▶ Insert the rope retaining pins again and secure with spring retainers.

## 6 Two-part hoist limit switch weight

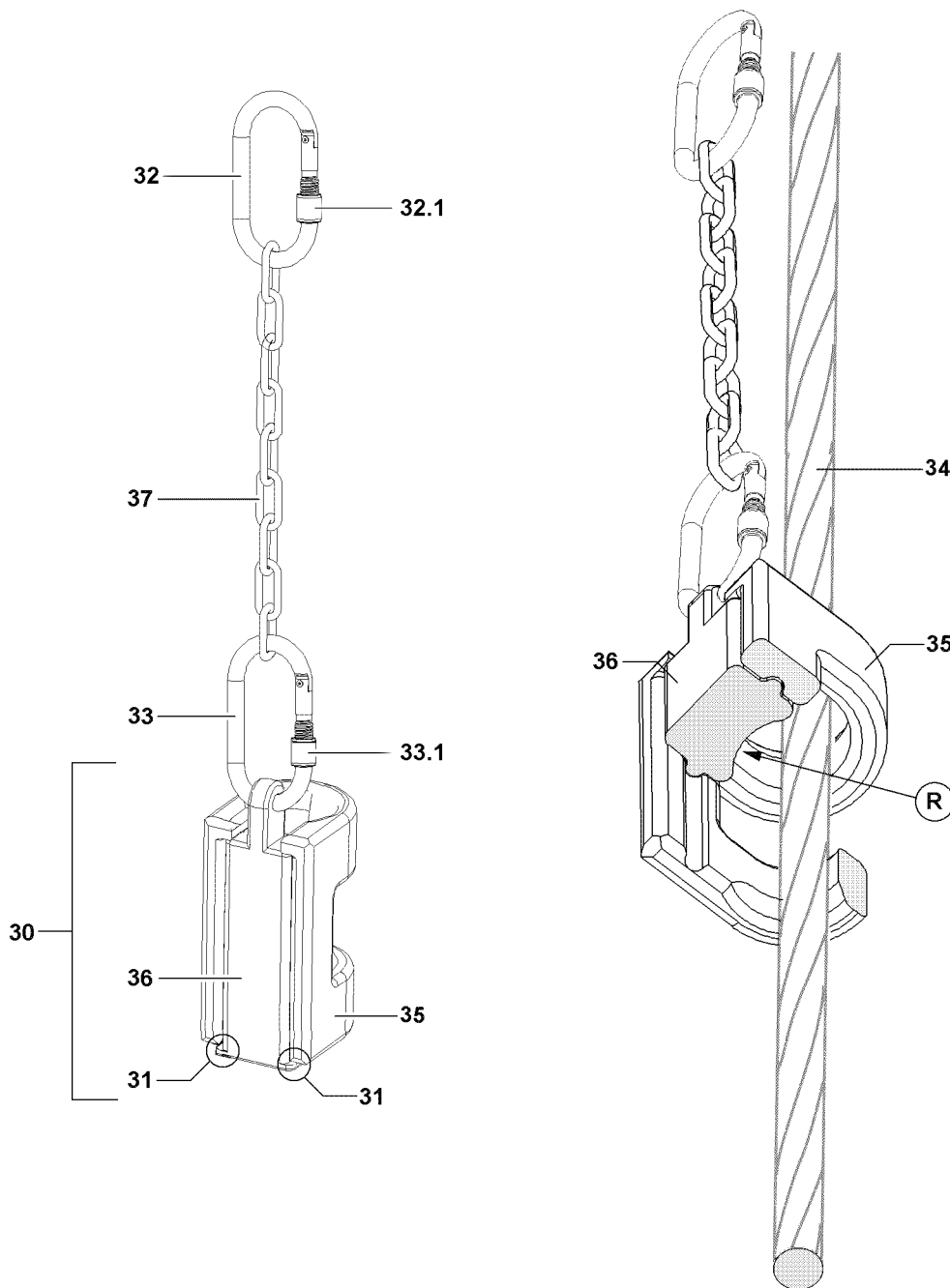


Fig.156691: Detailed view of the hoist limit switch weight

The hoist limit switch weight is connected to the hoist limit switch. By connecting the hoist limit switch weight **30** to the hoist limit switch, the *Spool winch up* crane movement is released. As soon as the hoist limit switch weight **30** is lifted, the hoist limit switch switches off the *Spool winch up* crane movement.

The following parts are required:

- **30** Hoist limit switch weight
- **32** Upper carabiner
- **33** Lower carabiner
- **37** Chain

The hoist limit switch weight **30** consists of two parts, which are pushed into each other:

- The weight **35**

- The carrier section **36**

**WARNING**

Incorrect parts installed!

The crane movement is **not** switched off or is switched off too late.

Death, severe bodily injuries, property damage.

- ▶ Do **not** replace the hoist limit switch weight **30**, carabiner and chain **37** with other parts.

The chain **37** must be attached with its full length during crane operation and may not be shortened.

**WARNING**

Chain **37** shortened!

The crane movement is **not** switched off or is switched off too late.

Death, severe bodily injuries, property damage.

- ▶ Do **not** shorten the chain **37**.

## 6.1 Attaching the hoist limit switch weight

**WARNING**

Hoist limit switch weight is incorrectly installed!

The hoist limit switch weight can fall down. Death, severe injuries.

- ▶ When detaching or attaching the hoist limit switch weight **30** make sure that the weight **35** and the carrier section **36** do not fall down.
- ▶ Make sure that the curvature **R** of the carrier section **36** points to the hoist rope **34**.
- ▶ Make sure that the noses **31** of the carrier section **36** is placed on the weight **35**.

**WARNING**

Knurled nut installed closing upward!

The carabiner could loosen up itself by itself. The hoist limit switch weight **30** can fall down.

Death or severe bodily injuries.

- ▶ **Assemble the knurled nut closing downward.**

- ▶ Connect the chain **37** to the upper carabiner **32** on the hoist limit switch.

- ▶ Secure the upper carabiner **32** with the knurled nut **32.1**.

The attachment of the hoist limit switch weight **30** depends on the position of the rope fixed point.

**Rope fixed point on the pulley head:**

- In the event of multiple hoist rope reeving, the hoist limit switch weight **30** must always be laid around the “stationary rope strand”, in other words around the rope strand that leads directly to the cable lock.

**Rope fixed point on the hook block:**

- The hoist limit switch weight **30** is laid around the outer strand that has the least angular pull, i.e. the one with the smallest angle between the connected hoist limit switch weight and the hoist rope.
  - ▶ Release and unscrew the knurled nut **33.1** from the lower carabiner **33**.
  - ▶ Push the weight **35** with one hand on the hoist rope **34** and hold.
  - ▶ With the other hand, guide the carrier section **36** behind the hoist rope **34** and under the weight **35**. The curvature **R** of the carrier section **36** must point to the hoist rope **34**.
  - ▶ Push the weight **35** on the carrier section **36**.
  - ▶ Fit the hoist limit switch weight **30** with the carrier section **36** in the lower carabiner **33**.
  - ▶ Secure the lower carabiner **33** with the knurled nut **33.1**.

## 6.2 Removing the hoist limit switch weight

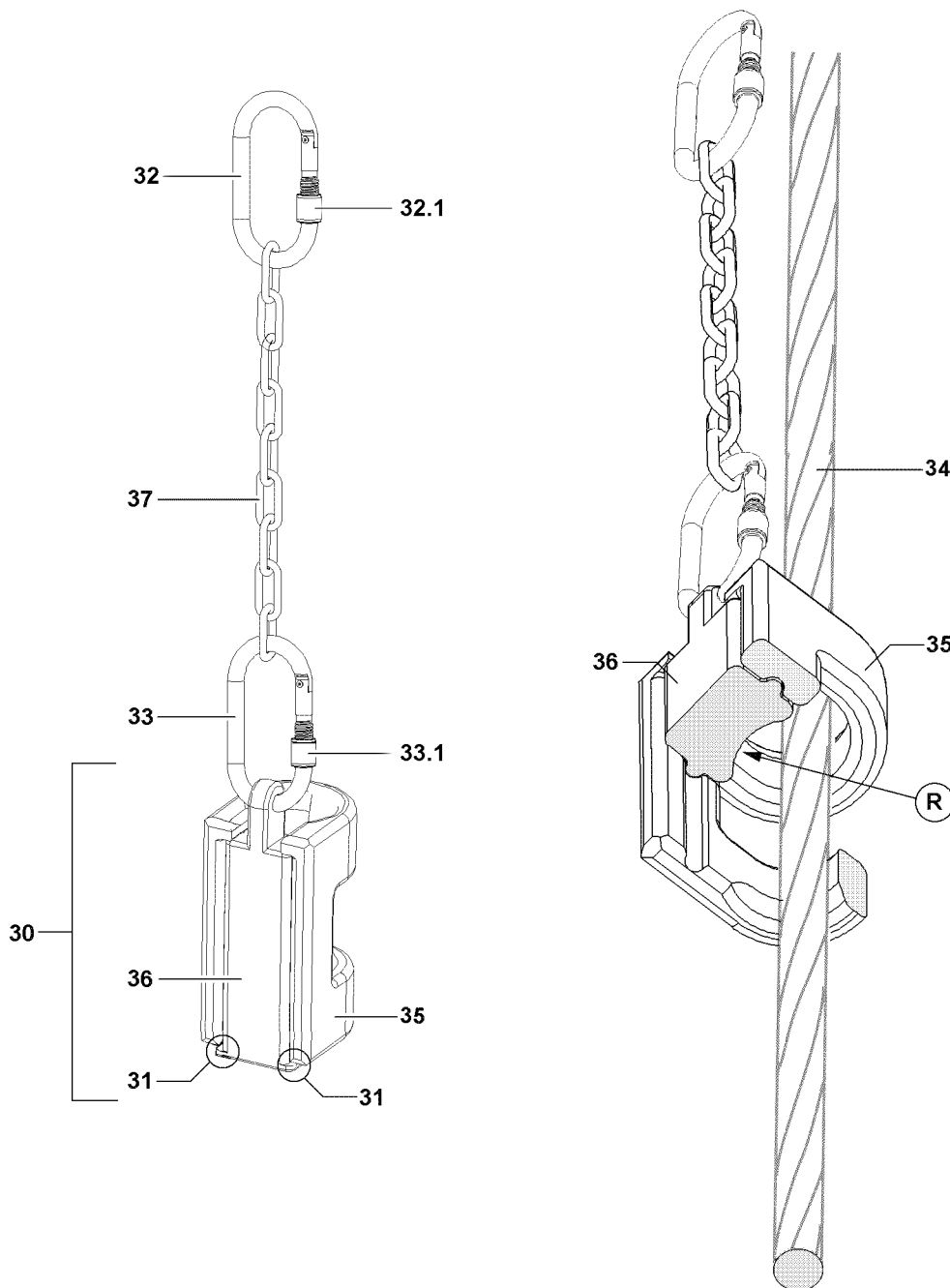


Fig.156691: Detailed view of the hoist limit switch weight



### WARNING

Hoist limit switch weight is incorrectly installed!  
The hoist limit switch weight can fall down. Death, severe injuries.

- ▶ When detaching or attaching the hoist limit switch weight **30** make sure that the weight **35** and the carrier section **36** do not fall down.
  - ▶ It is prohibited to remain in the danger zone.
- 
- ▶ Release and unscrew the knurled nut **33.1** on the lower carabiner **33**.
  - ▶ Detach the hoist limit switch weight **30** from the lower carabiner **33**.
  - ▶ Hold the weight **35** with one hand and with the other hand, push the carrier section **36** out of the weight **35**.

- ▶ Remove the chain **37** with the upper carabiner **32** on the hoist limit switch.
- ▶ Store the weight **35**, carrier section **36** and chain **37** with the carabiner safely.

## 7 One-part hoist limit switch weight

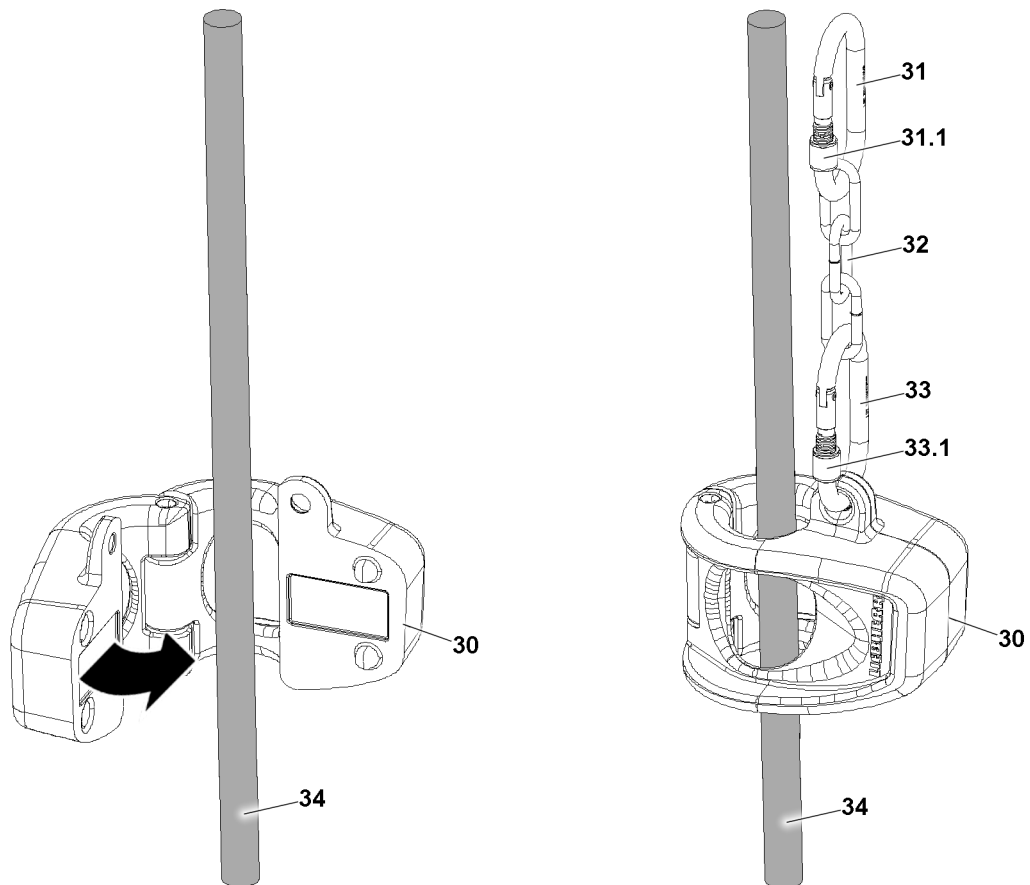


Fig.127727: Hoist limit switch weight

The hoist limit switch weight is connected to the hoist limit switch. By connecting the hoist limit switch weight **30** to the hoist limit switch, the crane movement *Spool winch up* is released. As soon as the hoist limit switch weight **30** is lifted, the hoist limit switch switches off the *Spool winch up* crane movement.

The following parts are required:

- **30** Hoist limit switch weight
- **31** Upper carabiner
- **32** Chain
- **33** Lower carabiner



### WARNING

Incorrect parts installed!

The crane movement is **not** switched off or is switched off too late.

Death, severe bodily injuries, property damage.

- ▶ Do **not** replace the hoist limit switch weight **30**, carabiner and chain **32** with other parts.

The chain **32** must be attached with its full length during crane operation and may not be shortened.

**WARNING**

Chain **32** shortened!

The crane movement is **not** switched off or is switched off too late.  
Death, severe bodily injuries, property damage.

- ▶ Do **not** shorten the chain **32**.

## 7.1 Attaching the hoist limit switch weight

**WARNING**

Hoist limit switch weight is incorrectly installed!

The hoist limit switch weight can fall down.  
Death or severe bodily injuries.

- ▶ Makes sure that the hoist limit switch weight **30**, carabiner and chain **32** do not scrape against the hoist rope **34** after assembly.
- ▶ Do **not** let the hoist limit switch weight **30** fall down.

**WARNING**

Knurled nut installed closing upward!

The carabiner could loosen up itself by itself. The hoist limit switch weight **30** can fall down.  
Death or severe bodily injuries.

- ▶ **Assemble the knurled nut closing downward.**

- ▶ Connect the chain **32** to the upper carabiner **31** on the hoist limit switch.
- ▶ Secure the upper carabiner **31** with the knurled nut **31.1**.

The attachment of the hoist limit switch weight **30** depends on the position of the rope fixed point.

**Rope fixed point on the pulley head:**

- In the event of multiple hoist rope reeving, the hoist limit switch weight **30** must always be laid around the “stationary rope strand”, in other words around the rope strand that leads directly to the cable lock.

**Rope fixed point on the hook block:**

- The hoist limit switch weight **30** is laid around the outer strand that has the least angular pull, i.e. the one with the smallest angle between the connected hoist limit switch weight **30** and the hoist rope **34**.
- ▶ Place the hoist limit switch weight **30** around the hoist rope **34**.
- ▶ Close the hoist limit switch weight **30**.
- ▶ Connect the chain **32** to the lower carabiner **33** on the hoist limit switch weight **30**.
- ▶ Secure the lower carabiner **33** with the knurled nut **33.1**.

**Result:**

- The hoist limit switch weight **30** is assembled and secured.

## 7.2 Removing the hoist limit switch weight

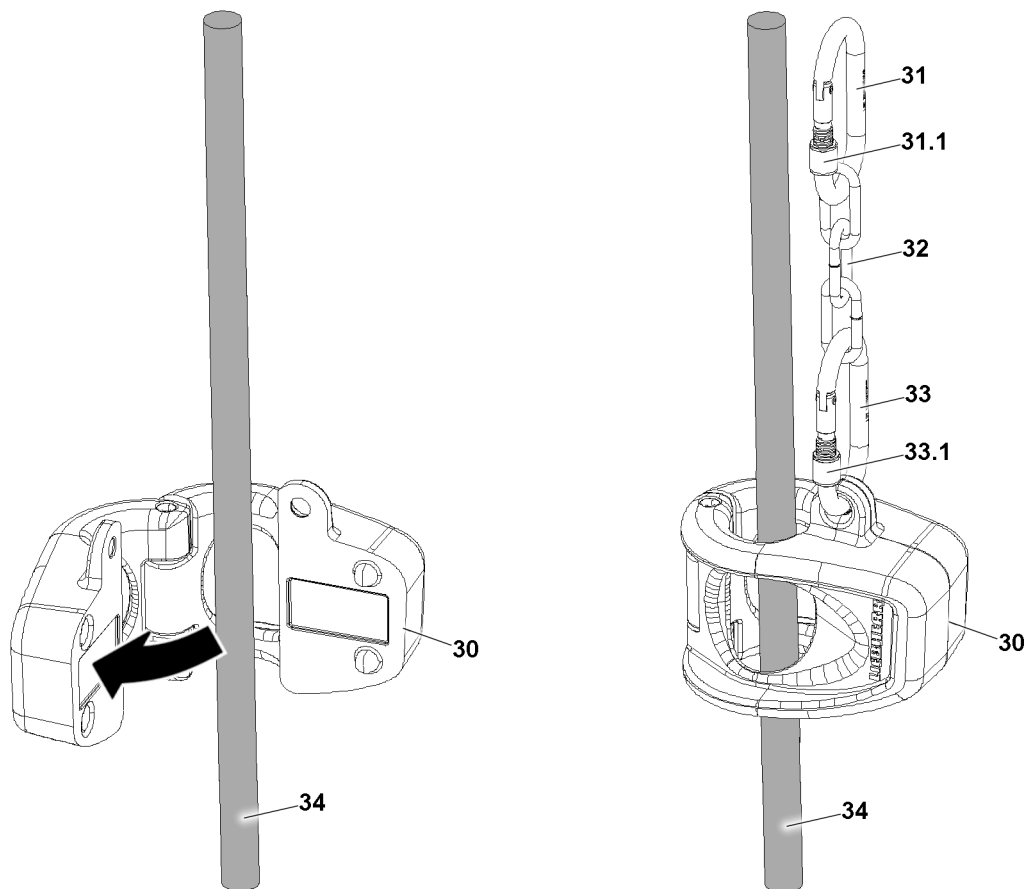


Fig.127728: Removing the hoist limit switch weight



### WARNING

Hoist limit switch weight **not** secured during disassembly!  
The hoist limit switch weight can fall down.

▶ Do **not** let the hoist limit switch weight **30** fall down during disassembly.

- ▶ Release and unscrew the knurled nut **33.1** on the lower carabiner **33**.
- ▶ Hold the hoist limit switch weight **30** with one hand and with the other hand, disconnect the lower carabiner **33** on the hoist limit switch weight **30**.
- ▶ Remove the chain **32** with the upper carabiner **31** on the hoist limit switch.
- ▶ Store the hoist limit switch weight **30**, chain **32** with the carabiner **31** and carabiner **33** safely.

## 8 Assembling / disassembling the wedge lock

Liebherr-Werk Ehingen GmbH does not have any safety concerns regarding the use of a wedge lock as a replacement for the lock. The wedge lock must be released by Liebherr-Werk Ehingen GmbH for use on the corresponding rope type. However, when using a wedge lock in connection with rotation-resistant hoist ropes, they do not have some of the positive characteristics of the lock, which can lead to a reduced service life of the rope. If a wedge lock is disassembled and then assembled again on the rope, the previously clamped part of the rope must first be cut off.

The utilized wedge lock can only be installed and assembled by authorized and trained personnel.

Make sure that the following prerequisites are met:

- The wedge lock is released for the rope diameter and rope type.
- The lock clamp / locking case sleeve has been properly disconnected.

## 8.1 Safety



### DANGER

The rope is not suitable for the wedge lock!

If an unsuitable rope is used with a wedge lock as an end connection, the end connection will fail and lead to breakage.

- ▶ Do not provide unsuitable ropes, such as fiber ropes, plastic coated ropes or spiral ropes, with a wedge lock as an end connection.
- ▶ Only provide suitable wire ropes with a wedge lock as an end connection.
- ▶ The wedge lock must be released by Liebherr-Werk Ehingen GmbH for use on the corresponding rope type.
- ▶ The wire rope diameter must match the wedge lock.
- ▶ In case of lack of clarity, contact Liebherr Service.



### WARNING

Faulty assembly / disassembly of a wedge lock!

- ▶ The utilized wedge lock can only be installed, assembled and disassembled by authorized and trained personnel.
- ▶ Wear protective clothing.
- ▶ In case of lack of clarity, contact Liebherr Service.



### WARNING

Wrong components on the wedge lock!

If the housing and wedge do not match, a correct end connection with the wedge lock is not possible. Incorrect components on the wedge lock can lead to the failure of the end connection and to breakage.

- ▶ Only use housing with an appropriate wedge.
- ▶ Keep all components of the wedge lock so that they can't be mixed up.
- ▶ If there are uncertainties regarding the composition of the wedge lock, the wedge lock may not be used.
- ▶ Only use the wedge lock with unchanged original components.



### WARNING

Damaged wedge lock!

The use of a damaged wedge lock can lead to the failure of the end connection and to breakage.

- ▶ Check all components for damage prior to assembly.
- ▶ A wedge lock with damaged components may not be installed or used.
- ▶ Do not use a wedge lock with an illegible manufacturer's mark or nominal size.



### WARNING

Reuse of a jammed area!

If a rope is used a second time in the same position with a wedge lock, the end connection will fail and lead to breakage.

If a rope in a previously jammed area is provided with a locking clamp or locking cast sleeve, the end connection can fail and lead to breakage.

- ▶ Do not use the previously jammed area of the rope again and cut it off completely.



**WARNING**

Unsuitable position for attaching a wedge lock!

If a wedge lock is installed in an unsuitable position of the rope, the end connection can fail and lead to breakage.

- ▶ Pressure marks in the clamping area on the rope and wedge lock can lead to the failure of the wedge lock.
- ▶ The wedge lock may not be clamped on an annealing separated area or a trimming of the rope.
- ▶ The surface of the clamping area on the rope and wedge lock must be free of dirt and rust.
- ▶ The clamping area may not have rope breakage.

**WARNING**

The wedge lock releases!

If there is a collision on the side of the dead rope side while using the wedge lock, the wedge lock can release.

- ▶ Secure the wedge lock against collisions.
- ▶ Do not let the dead rope end stick out such that it rises or can get caught. Secure the dead rope end with a soft tie with tape or a soft binding wire.
- ▶ Stop the spool up movements of the winch before the wedge runs against the hoist limit switch weight.

**WARNING**

The rope end turns up!

If the rope end turns up, the rope can slide through the wedge lock. The end connection can fail and lead to breakage.

- ▶ Secure the rope end against untwisting and jumping up, for example injecting, welding or soldering.
- ▶ Comply with the specified length of the dead rope end.

**NOTICE**

The rope jumps up when shortening!

If the rope is not secured against jumping up when shortened, the rope can be damaged and become unusable.

- ▶ Secure the rope against jumping up and untwisting before shortening.

**Note**

Rope too short.

In the case of fixed rope lengths, pay attention to further usability after shortening.

- ▶ Each use of a wedge lock makes a section of the rope unusable.
- ▶ Do not replace missing wedge locks / locking case sleeves too often with a wedge lock.
- ▶ Contact Liebherr Customer Service for a proper rope repair with a locking cast sleeve.

**Note**

Minimum tensile strength of the rope decreased.

The minimum tensile strength of the rope is reduced 80 % by an end connection with a wedge lock.

- ▶ This reduction is permitted on an otherwise intact rope if the wedge lock is used correctly.

## 8.2 Nominal dimensions when assembling the wedge lock

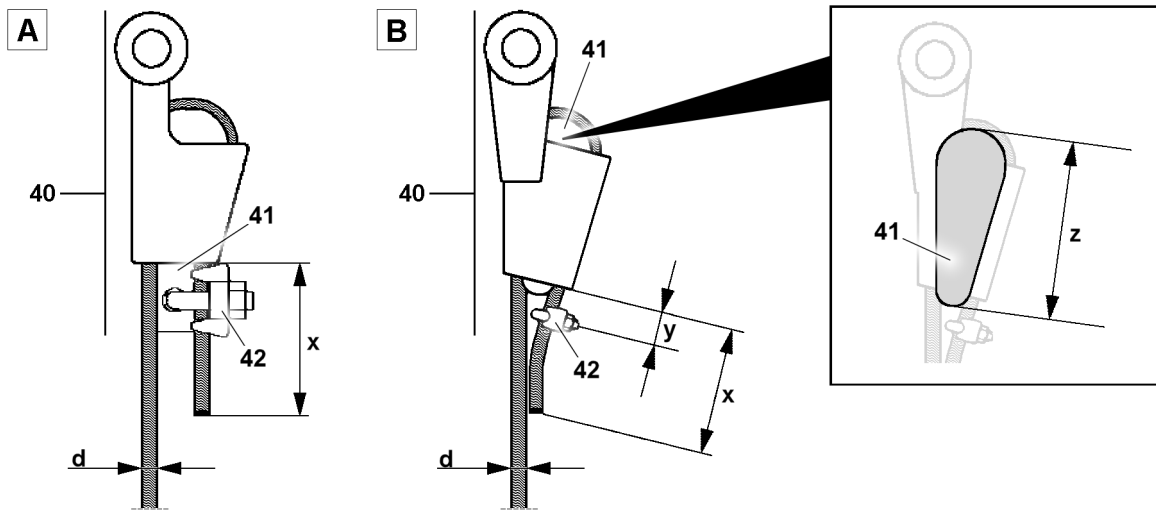


Fig.160488: Exemplary presentation of wedge locks

40	Wedge lock	x	Dead rope end length
41	Wedge	y	Distance
42	Clamp	z	Wedge length
d	Rope diameter		

- Variation **A**, Wedge lock **40** with bore for a Clamp **42** in the wedge **41**
- Variation **B**, wedge lock **40** without a bore for a clamp **42** in the wedge **41**

► Provide the long dead rope end **x** with the twentyfold rope diameter **d**. With a small rope diameter **d** not less than 150 mm.

For wedge locks **without** a bore for a clamp **42** in the wedge **41** (see variation **B**) additionally:

► Distance **y** from the rope clamp to the housing with the double rope diameter **d**. When doing so, do not exceed 75% of the wedge length **z**.



### WARNING

Nominal dimensions when assembling the wedge lock not complied with!  
The end connection can fail and lead to breakage.

► Comply with the specified length **x**.

With a wedge lock **40** **without** a bore for a clamp **42** additionally:

► Observe the specified distance **y**.

► Mark the dead rope end length **x** and distance **y** on the rope.

## 8.3 General notes for assembly

Observe the differences in the exemplary illustrations:

- Wedge lock **with** a bore for a clamp
- Wedge lock **without** a bore for a clamp

### 8.3.1 Wedge lock with a bore for a clamp

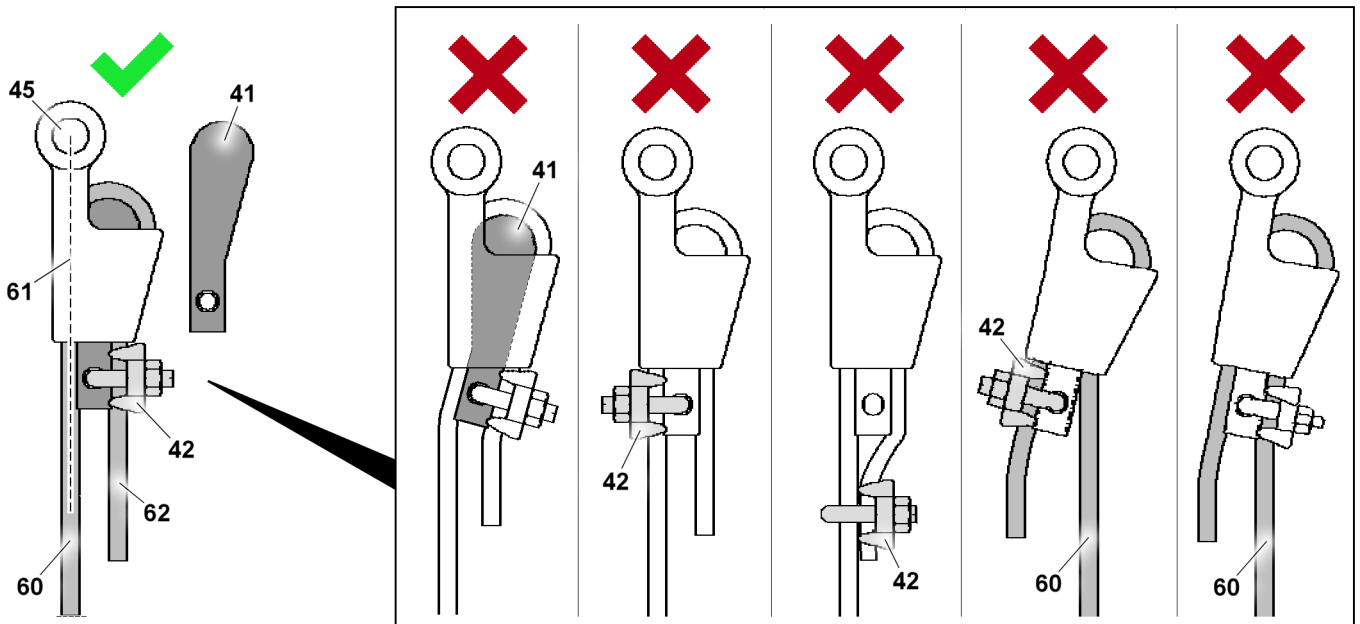


Fig.160493: Exemplary illustration with a correctly and incorrectly assembled wedge lock **with** a bore for a clamp

- 41 Wedge
- 42 Clamp
- 45 Pin bore
- 60 Rope strand, load bearing
- 61 Pull axle
- 62 Dead rope end

- Assemble the wedge **41** in the correct position. Position the wide side with a radius in the direction of the pin bore **45**. Position the long straight side toward the pull axle **61**.
- Assemble the clamp **42** in the correct position with the correct tightening torque. Screw the clamp on via the dead rope end **62** through the wedge bore.
- Run the load bearing rope strand **60** in the pull axle **61** of the wedge lock. The long axis of the load bearing rope strand **60** is perpendicular to the long axis of the pin bore **45**.

Diameter Rope	Nominal size Clamp size	Tightening torque Clamp <sup>1)</sup>
9 mm to 10 mm	3/8	61 Nm
11 mm to 13 mm	1/2	88 Nm
14 mm to 16 mm	5/8	129 Nm
18 mm to 19 mm	3/4	176 Nm
20 mm to 22 mm	7/8	305 Nm
24 mm to 26 mm	1	305 Nm
28 mm	1 1/8	305 Nm

1) Threads and support surfaces are clean, dry and free of lubricants.

#### Control bore auxiliary function\*



#### Note

- ▶ Only for wedge locks with control bore auxiliary function\*.

LWE/LR 1800-1-0-000/27200-07-02/en

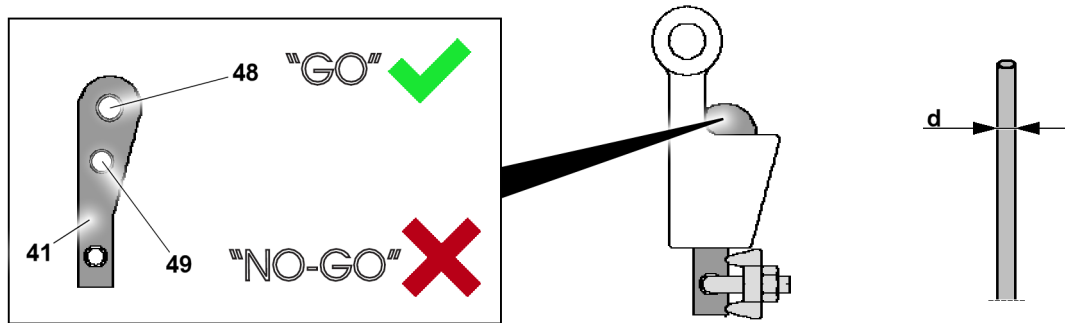


Fig.160497: Wedge lock with control bore auxiliary function\*.

41	Wedge	49	Bore "NO-GO"
48	Bore "GO"	d	Rope diameter

The wedge and rope diameter  $d$  match when all of the following criteria are met:

- The rope diameter  $d$  passes through the bore "GO" 48.
- The rope diameter  $d$  does **not** pass through the bore "NO-GO" 49.

### 8.3.2 Wedge lock without a bore for a clamp

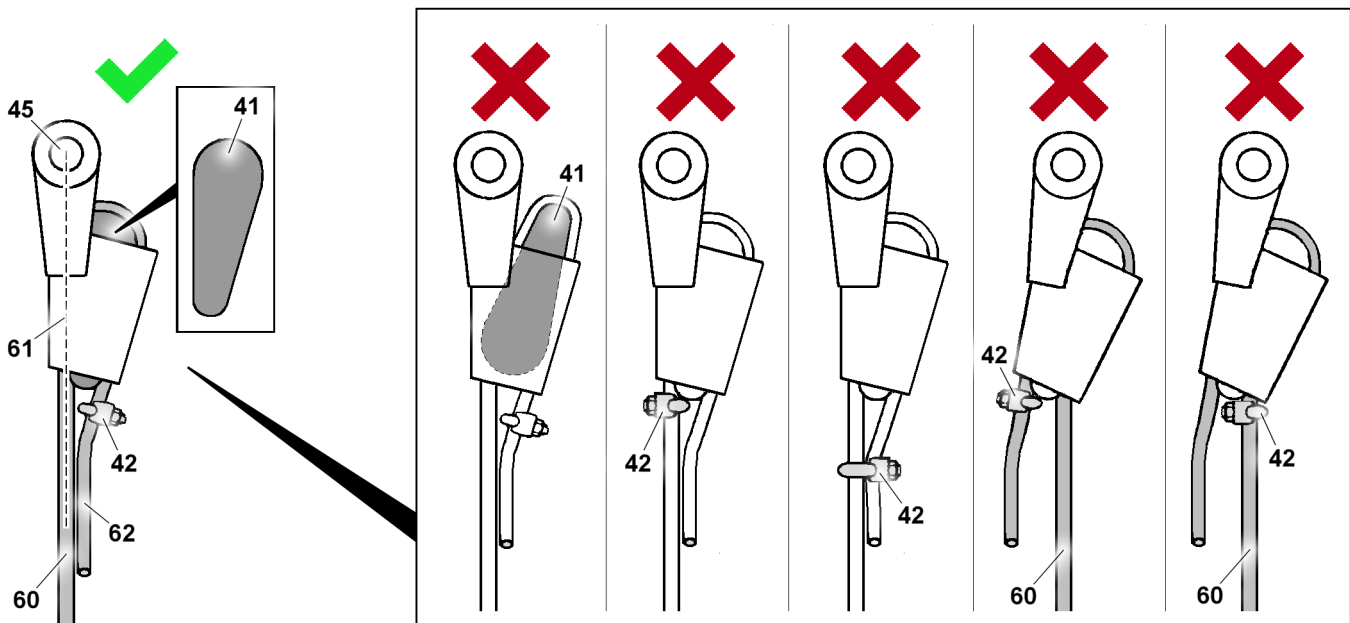


Fig.160492: Exemplary illustration with a correctly and incorrectly assembled wedge lock **without** a bore for a clamp

41	Wedge	45	Pin bore	61	Pull axle
42	Clamp	60	Rope strand, load bearing	62	Dead rope end

- Assemble the wedge 41 in the correct position. The wide side with a radius must point in the direction of the pin bore 45.
- Assemble the clamp 42 in the correct position with the correct tightening torque. Screw on with the correct distance over the dead rope end 62.
- Run the load bearing rope strand 60 in the pull axle 61 of the wedge lock. The long axis of the load bearing rope is perpendicular to the long axis of the pin bore 45.

Nominal size Wedge lock / wedge	Nominal size Clamp	Tightening torque Clamp <sup>1)</sup>
8/7	8	6 Nm
8/8	8	6 Nm
10/9	10	9 Nm
10/10	10	9 Nm
13/11	12	20 Nm
13/12	12	20 Nm
13/13	14	33 Nm
17/13	14	33 Nm
17/15	16	49 Nm
17/17	16	49 Nm
19/16	16	49 Nm
19/18	19	68 Nm
23/19	19	68 Nm
23/21	22	107 Nm
26/23	26	147 Nm
26/25	26	147 Nm
29/27	30	212 Nm
33/30	30	212 Nm
33/32	34	296 Nm

1) Threads and support surfaces are lubricated, rust-free and clean.

## 8.4 Assembling the wedge lock

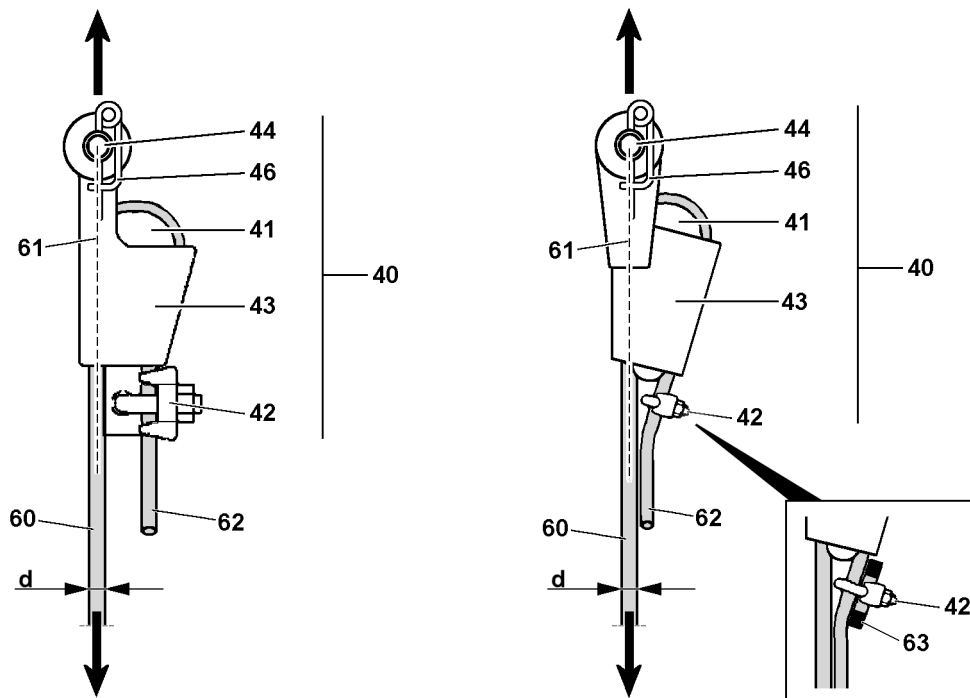


Fig.160494: Exemplary presentation, assembling the wedge lock

<b>40</b> Wedge lock	<b>60</b> Rope strand, load bearing
<b>41</b> Wedge	<b>61</b> Pull axle
<b>42</b> Clamp	<b>62</b> Dead rope end
<b>43</b> Housing	<b>63</b> Rope section
<b>44</b> Pin	<b>d</b> Rope diameter
<b>46</b> Retaining element	



### WARNING

Incorrect handling of the wedge lock!

An incorrectly or incompletely assembled wedge lock **40** can lead to an inadvertent releasing of the end connection.

An incorrectly used wedge lock **40** can lead to failure and an inadvertent releasing of the end connection.

The crane can lose stability! Persons in the danger zone are greatly endangered.

Hook blocks, load or components can fall down. Death, severe injuries, property damage.

- ▶ Use only a wedge lock **40** approved by Liebherr-Werk Ehingen GmbH.
- ▶ The wedge lock **40** must match the rope diameter.
- ▶ Do not use a wedge lock **40** with an operation temperature of below  $-40\text{ }^{\circ}\text{C}$ .
- ▶ Assemble the wedge lock **40** correctly.
- ▶ Place the rope with the wedge **41** into the housing **43** in such a way that the load bearing rope strand **60** runs in the pull axle **61** of the wedge lock **40**.
- ▶ Install the wedge **41** in the correct position.
- ▶ The clamp **42** must secure the dead rope end **62** from being pulled through.
- ▶ The clamp **42** must be tightened with the correct tightening torque.
- ▶ The clamp **42** may not be assembled on a trimming or an annealing separated area of the dead rope end **62**.
- ▶ The clamp **42** may not be assembled over both strands or on the load bearing rope strand **60**.
- ▶ The support surfaces of the clamp **42** must be rust-free and clean.
- ▶ When assembling the dead rope end **62**, secure it from jumping out of the housing **43**.
- ▶ Wear protective clothing.
- ▶ It is prohibited for personnel to remain in the danger zone.

- ▶ Select the matching wedge lock **40** for the rope diameter **d**.
- ▶ Observe the nominal dimensions when assembling the wedge lock.
- ▶ Insert the rope with the wedge **41** in the housing **43**. Observe the dead rope end length **62**

**Note**

- ▶ If applicable, insert the rope and wedge deeper into the housing by striking them carefully with a rubber hammer.

Assemble the clamp **42** depending on the wedge lock **40** version:

- ▶ Assemble the clamp **42** through the bore in the wedge **41** on the dead rope end **62**.
- or
- ▶ Assemble the clamp **42** with the specified distance from the housing **43** on the dead rope end **62**.

**Note**

- ▶ If the thread length of the clamp **42** is not sufficient, place a short, intact rope section **63** with tied ends parallel to the dead rope end **62** and assemble them together.
- ▶ The tightening torque for the clamp **42** depends on the nominal size.

**NOTICE**

Rope damage!

If the pin **44** has been assembled incorrectly, the rope may rub against the pin **44** or on the retaining element **46**.

- ▶ Always insert the pin **44** from the “inside to the outside” and secure from the outside with a retaining element **46**.

When the pin point of the wedge lock **40** matches the fixed point:

- ▶ Pin and secure the wedge lock **40** in the fixed point depending on the reeving plan.

When the pin point of the wedge lock **40** does not match the fixed point:

- ▶ Use the supplied adapter, see the following section “Assembling / disassembling the adapter on the wedge lock”.

## 8.5 Additional work

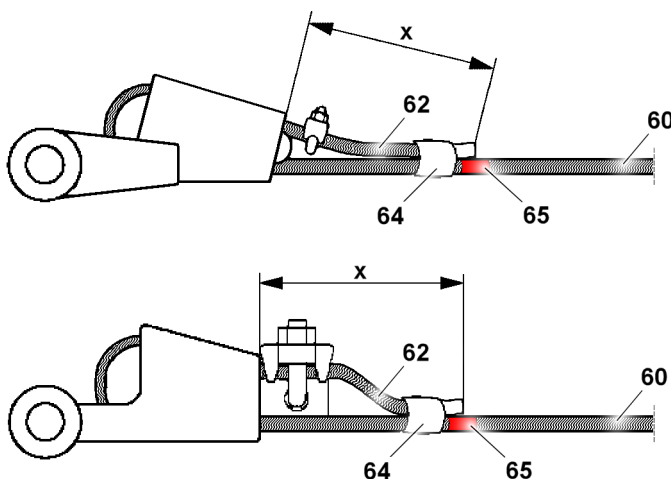


Fig.163420: Additional work: Applying the tie and marking

<b>60</b> Rope strand, load bearing	<b>65</b> Color marking
<b>62</b> Dead rope end	<b>x</b> Dead rope end length
<b>64</b> Tie	

- ▶ Also secure the dead rope end **62** with a soft tie **64** with tape or a soft binding wire.

- ▶ Permanently and clearly mark the dead rope end length **x**. Apply the color marking **65** on the load bearing rope strand **60** at the same height, see illustration.

**Note**

Use a well-visible signal color for the color marking **65**.

- ▶ The color marking **65** can be used to continuously identify the dead rope end length **x**.

## 8.6 Assembling / disassembling the adapter on the wedge lock

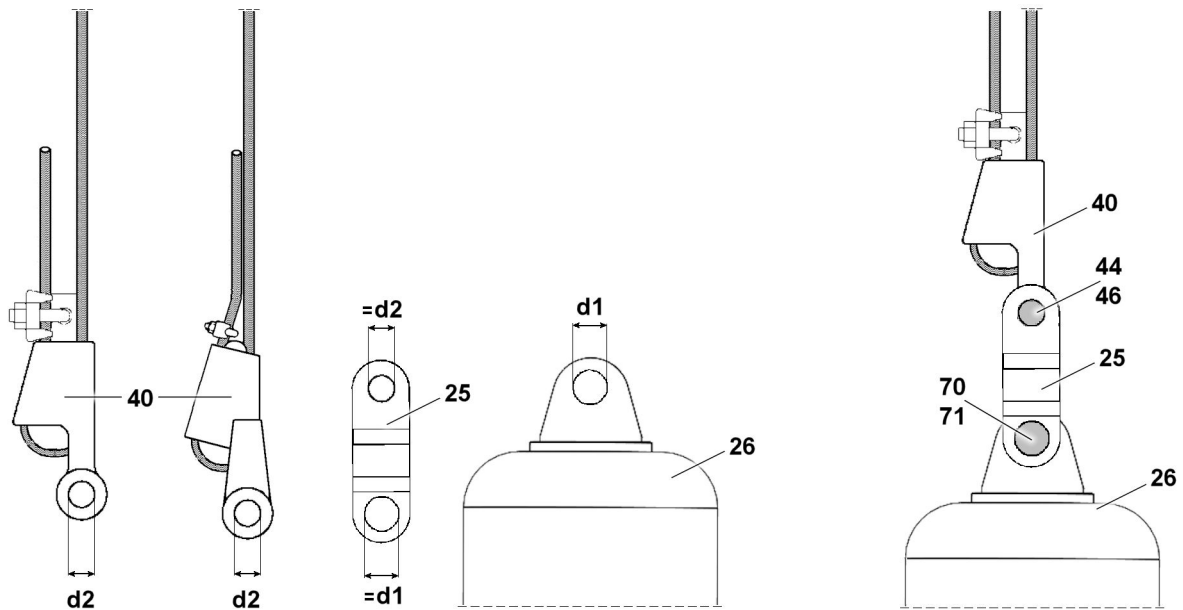


Fig.161444: Wedge lock with adapter, load hook example

<b>25</b>	Adapter	<b>71</b>	Retaining element (rope lock)
<b>26</b>	Load hook (example)	<b>d1</b>	Fixed point diameter (example)
<b>40</b>	Wedge lock	<b>d2</b>	Wedge lock diameter
<b>44</b>	Pin	<b>=d1</b>	Fixed point side diameter
<b>46</b>	Retaining element	<b>=d2</b>	Wedge lock side diameter
<b>70</b>	Pin (rope lock)		

**Note**

The fixed point for the wedge lock can be on the pulley head, hook block or load hook.

- ▶ In the shown example, the fixed point is on the load hook **26**.

If the assembled wedge lock **40** matches the rope diameter, but the wedge lock diameter **d2** does not match the fixed point diameter **d1**, the adapter **25** must be used. The pin **70** and retaining element **71** of the unutilized rope lock is needed for the adapter.

**WARNING**

Impermissible use of the adapter **25**!

If the adapter **25** is used with a rope lock, the end connection can fail and lead to breakage.

An L-shaped rope lock cannot be replaced by a wedge lock **40**. Also not with the aid of an adapter **25**. Death, severe bodily injuries, property damage.

- ▶ Use the adapter **25** only with a wedge lock **40**.

If a wedge lock **40** is needed as a replacement for an L-shaped rope lock:

- ▶ Increase / reduce the reeving by one rope strand to the extent necessary. In this way, a rope end point can be used that does not require an L-shaped rope lock.



### 8.6.1 Assembling the adapter on the wedge lock

Make sure that the following prerequisites are met:

- The rope is assembled properly on the wedge lock **40**.

If the wedge lock diameter **d2** does not match the fixed point diameter **d1**:

- ▶ Pin and secure the adapter **25** with the fixed point side diameter **=d1** to the hook block / load hook **26** or fixed point pin. To do so, use the pin **70** and retaining element **71** of the unutilized rope lock.
- ▶ Pin and secure the adapter **25** with the wedge lock side diameter **=d2** to the wedge lock **40**. To do so, use the pin **44** and retaining element **46** of the wedge lock.

**Result:**

- Wedge lock **40** pinned and secured via the adapter **25** with the fixed point.

### 8.6.2 Disassembling the adapter on the wedge lock



#### Note

If a retaining split that cannot be reused was used, it must be disposed of after a single assembly and disassembly.

- ▶ Replace the retaining splint with a reusable retaining element.

Make sure that the following prerequisites are met:

- The rope is not tensioned

Disassemble the adapter **25**:

- ▶ Unpin the adapter **25** from the hook block / load hook **26** or the fixed point. Feed the pin **70** and retaining element **71** again in the unused rope lock.
- ▶ Unpin the adapter **25** from the wedge lock **40**. Feed the pin **44** and retaining element **46** again in the wedge lock **40**.

**Result:**

- The adapter **25** is disassembled.

## 8.7 Using a wedge lock



#### WARNING

The end connection can loosen up inadvertently!

An incorrectly or incompletely assembled wedge lock can lead to an inadvertent releasing of the end connection.

- ▶ It is prohibited for personnel to remain in the danger zone.
- ▶ Supervise from a safe position when loading.

Make sure that the following prerequisites are met:

- The rope is assembled properly on the wedge lock.
- The rope is not tensioned
- The wedge lock is pinned in a permissible fixed point.
- ▶ Load the wedge lock under supervision with 10% of the minimum tensile strength of the rope.
- ▶ Wait for a two-minute setting time.
- ▶ Make sure after the setting time that there is no relative movement between the wedge and the rope.

**WARNING**

Wedge lock used incorrectly!

An incorrectly used wedge lock can lead to an inadvertent releasing of the end connection.

- ▶ Falling loads, shock loads and exceeding the permissible load bearing capacity are prohibited.
- ▶ Continuously check the components. In the case of damage, do not continue their use and replace them immediately.
- ▶ Side loads and angular pull are prohibited.
- ▶ Make sure the rope, wedge and pinning are positioned correctly.
- ▶ Check the positioning and tightening torque of the clamp at regular intervals.
- ▶ If tensile strength is lost, check that the wedge is positioned securely.

- ▶ Check all wedge lock components at regular intervals for high loads and loss of tensile strength. At least once a month.

## 8.8 Disassembling the wedge lock

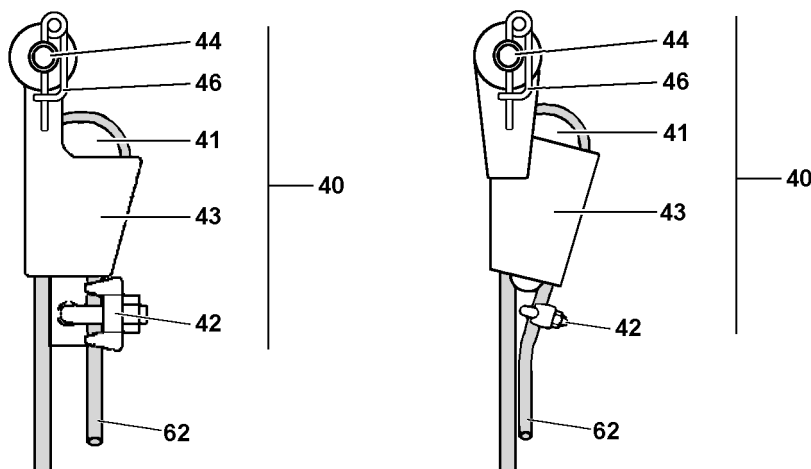


Fig.160491: Exemplary presentation of wedge locks

<b>40</b> Wedge lock	<b>44</b> Pin
<b>41</b> Wedge	<b>46</b> Retaining element
<b>42</b> Clamp	<b>62</b> Dead rope end
<b>43</b> Housing	

**WARNING**

The wedge lock is incorrectly disassembled!

- ▶ Wear protective clothing.
  - ▶ Disassemble the wedge lock **40** correctly. Check for wear and damage. In the case of damage, do not continue their use and replace them immediately.
  - ▶ When disassembling the dead rope end **62**, secure it from lashing out.
  - ▶ Do not use the previously jammed area of the rope again and cut it off completely.
- 
- ▶ Unpin the wedge lock **40** in the fixed point.

**Note**

If a retaining split that cannot be reused was used to secure the pin **44**, it must be disposed of after a single assembly and disassembly.

- ▶ Replace the retaining splint with a matching reusable retaining element **46**.

**Note**

- ▶ Store all parts of the wedge lock **40** together so they cannot be mixed up.
- ▶ Disassemble the clamp **42**. Pull the rope with the clamp **41** out of the housing **43**.

## 8.9 Disposal

**Note**

The wedge lock can be disposed of as normal steel scrap.  
▶ Observe the national guidelines.

## 9 Rope reeving

**Note**

▶ See separate reeving plans.

---

Empty page!

LWE/LR 1800-1-0-000/27200-07-02/en

## 4.07 Counterweight

1	Safety	2
2	Component overview	3
3	Fastening points	3
4	Permissible ballast assemblies	5
5	Ballast conditions	6
6	Climbing up / down the counterweight bracket	7
7	Assembling the counterweight brackets	8
8	Placing the ballast plates	10
9	Securing the counterweight	14
10	Releasing the counterweight	16
11	Removing the ballast plates	19
12	Disassembling the counterweight brackets	22

# 1 Safety

Observe the safety instructions before assembly and disassembly:

- Information regarding work on the crane. See chapter 2.04.
- Information regarding personal protective equipment. See chapter 2.04.
- Information regarding fall protection equipment. See chapter 2.06.
- Information regarding accesses to the crane. See chapter 2.07.
- Information regarding accessible surfaces. See chapter 2.07.



## WARNING

Danger of falling!

During assembly / disassembly, inspection and maintenance work, assembly personnel must be secured with appropriate aids to prevent them from falling.

Death, severe bodily injuries, property damage.

- ▶ All work at a height, when there is a danger of falling, must be carried out with suitable aids.
- ▶ If aids are not available and work cannot be carried out from the ground, then assembly personnel must secure themselves with the supplied fall arrest system to prevent falling, see chapter 2.04.
- ▶ If fall protection equipment is available, then it must be used, see chapter 2.06.
- ▶ When lifting, lowering, swinging crane parts in and out, no persons may remain in the danger zone.
- ▶ If railings are present on the components, then they must be brought into the corresponding position and secured for assembly / disassembly work.
- ▶ Only step on the aids, ladders and catwalks with clean shoes.
- ▶ Keep aids, ladders and catwalks free of heavy dirt, snow and ice.
- ▶ During all assembly and disassembly work, maintenance work and inspections, travel or crane operation is prohibited.
- ▶ Remaining on a suspended load is prohibited.
- ▶ Stepping or walking on crane components and lattice sections with an incline of more than 20° is prohibited.
- ▶ For all assembly work, the crane operator of the main crane must be in voice contact with the crane operator / crane operators of the auxiliary crane / auxiliary cranes.
- ▶ For the assembly / disassembly tasks, the crane operator may only initiate crane movements when the responsible guide has explicitly released the movement.



## WARNING

Danger of impact / crushing!

When assembling / disassembling crane components with the auxiliary crane, crane components can start to swing back and forth.

When lifting / lowering and positioning crane components, there is an increased danger of impact / crushing.

Death, severe bodily injuries, property damage.

- ▶ Make sure that personnel cannot be caught by components.
- ▶ When working in a danger zone: Use aids to protect limbs.
- ▶ Guide components with suitable aids to minimize oscillation.



## DANGER

The component can fall down!

If the corresponding component is disengaged from the auxiliary crane before the corresponding component is pinned, then the corresponding component can fall down.

Death, severe bodily injuries, property damage.

- ▶ Do not disconnect the auxiliary crane until the respective component is pinned and secured.

**WARNING**

Danger of falling!

During assembly and disassembly of crane components, personnel must be secured with appropriate aids to prevent them from falling.

Death, severe bodily injuries, property damage.

- ▶ Use personal protective equipment.

## 2 Component overview

**Note**

- ▶ Dimensions and weights, see chapter 1.03.
- ▶ The components are marked with their own weight.
- ▶ Description of the turntable extension, see chapter 4.07.10.

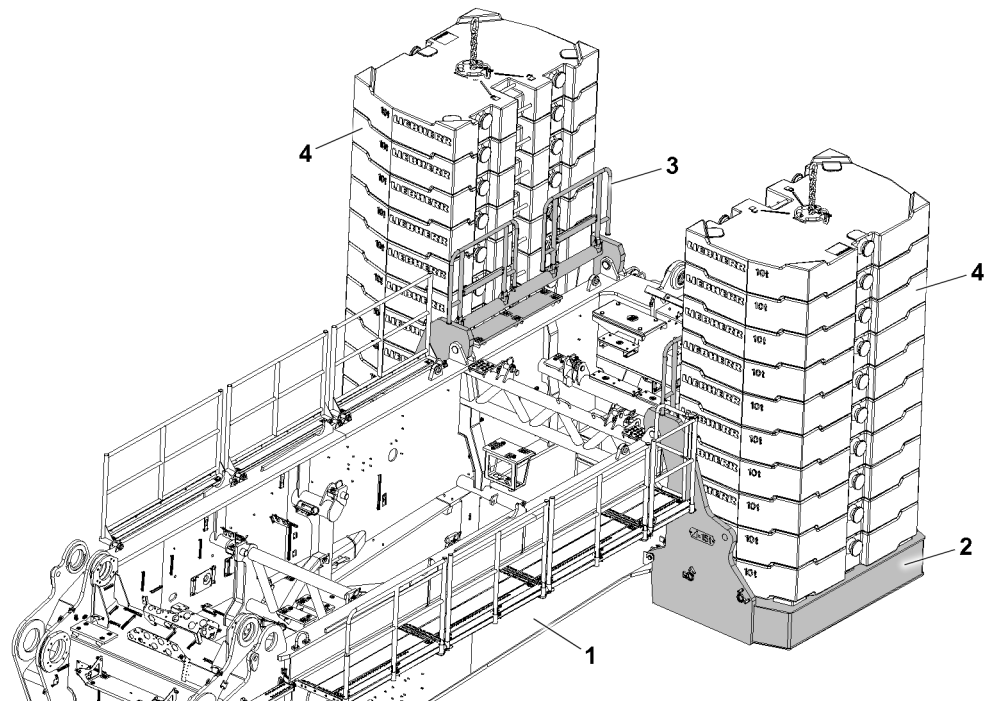


Fig.154324: Counterweight component overview

- |   |                       |   |               |
|---|-----------------------|---|---------------|
| 1 | Turntable             | 3 | Railing       |
| 2 | Counterweight bracket | 4 | Ballast plate |

## 3 Fastening points

**WARNING**

Components incorrectly fastened!

Death, severe bodily injuries, property damage.

- ▶ Fasten the components only in the intended fastening points on both sides.

**WARNING**

Fastening equipment can be ripped off!  
Death, severe bodily injuries, property damage.

- ▶ Make sure that the fastening equipment for lifting a counterweight bracket has a sufficient load carrying capacity and the required minimum length of 4 m.
- ▶ Make sure that the auxiliary crane(s) have a sufficient load carrying capacity.
- ▶ Dimensions and weights, see chapter 1.03.
- ▶ Make sure that there are no persons in the danger zone.

**WARNING**

Overload of fastening points!

If the fastening points are overloaded, they can rip off and the component can fall down.  
Death, severe bodily injuries, property damage.

- ▶ Make sure that the fastening points are not overloaded.
- ▶ Observe the maximum permissible suspended loads.
- ▶ Use at least a 25 t shackle, see illustration.

**NOTICE**

Tipping of the counterweight bracket!

Death, severe bodily injuries, property damage.

- ▶ When lifting the counterweight bracket, it tips about 6° to the rear, see illustration.

**Note**

- ▶ Pay attention to the labels in the fastening points on the counterweight brackets.

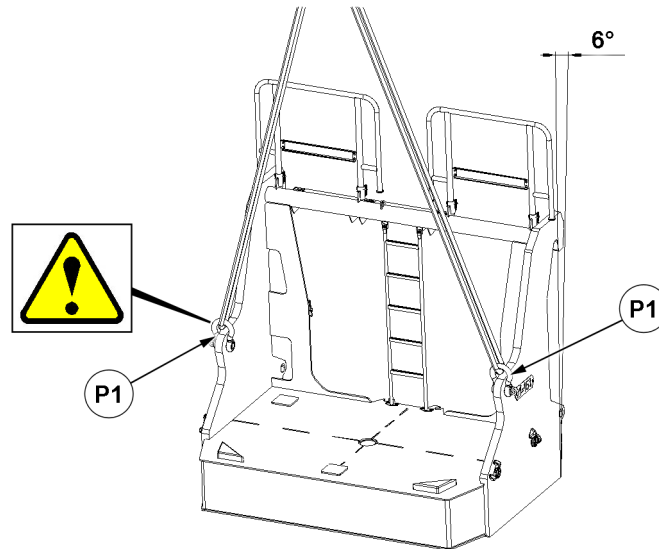


Fig.154325: Counterweight bracket fastening points

Fastening points	
P1	Counterweight bracket



## 4 Permissible ballast assemblies

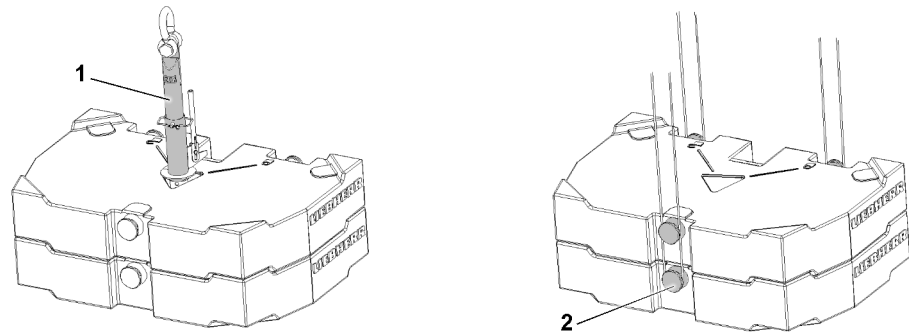


Fig.162195: Permissible ballast assemblies

1 (Twistlock) receptacle stud

2 Bitt



### WARNING

Overload of the receptacle stud and ballast plates!

If more than the permissible number of ballast plates are lifted with the receptacle stud 1, the receptacle stud 1 and the ballast plates will be overloaded and damaged.

If more than the permissible number of ballast plates are fastened with the bitt 2 and lifted, the bitt 2 will be overloaded and damaged.

The ballast plates can fall down.

Death, severe bodily injuries, property damage.

- ▶ Never fasten and lift more than the maximum permissible number of ballast plates per stroke.
- ▶ Observe the following chart “Permissible ballast assemblies”.

Individual weight Ballast plate	Maximum number of same ballast plates per stroke over	
	(Twistlock) receptacle stud	Bitt
5.0 t	2	1
7.5 t	2	2
10.0 t	2	2

Permissible ballast assemblies

## 5 Ballast conditions

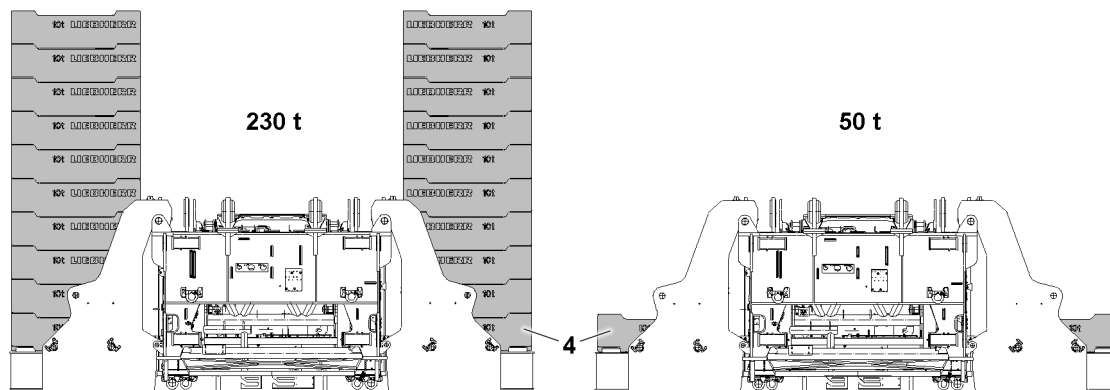


Fig.166536: Ballast conditions, example of counterweight 230 t and 50 t



### WARNING

Incorrect crane ballasting!

Death, severe bodily injuries, property damage!

- ▶ Make sure that the assembly conditions in chapter 3.06 are observed.
- ▶ Make sure that the central ballast, counterweight and if applicable the derrick ballast are installed according to the erection / take-down charts and the load charts.



### Note

- ▶ Ballast plates with 5 t , 7.5 t and 10 t can be combined.
- ▶ Examples of ballast conditions (counterweight combinations) when using ballast plates with 10 t are shown below.
- ▶ Observe the procedure when ballasting, see section “Placing the ballast plates” and “Removing the ballast plates”.

Counterweight <sup>1)</sup>	Composition	Individual weight	Quantity
50 t	Counterweight brackets	15 t	No. 2
	Ballast plates	10 t	No. 2

#### Ballast condition (counterweight combination) 50 t

1) Set up configuration in the Set up program

Counterweight <sup>1)</sup>	Composition	Individual weight	Quantity
230 t	Counterweight brackets	15 t	No. 2
	Ballast plates	10 t	No. 20

#### Ballast condition (counterweight combination) 230 t

1) Set up configuration in the Set up program

## 6 Climbing up / down the counterweight bracket

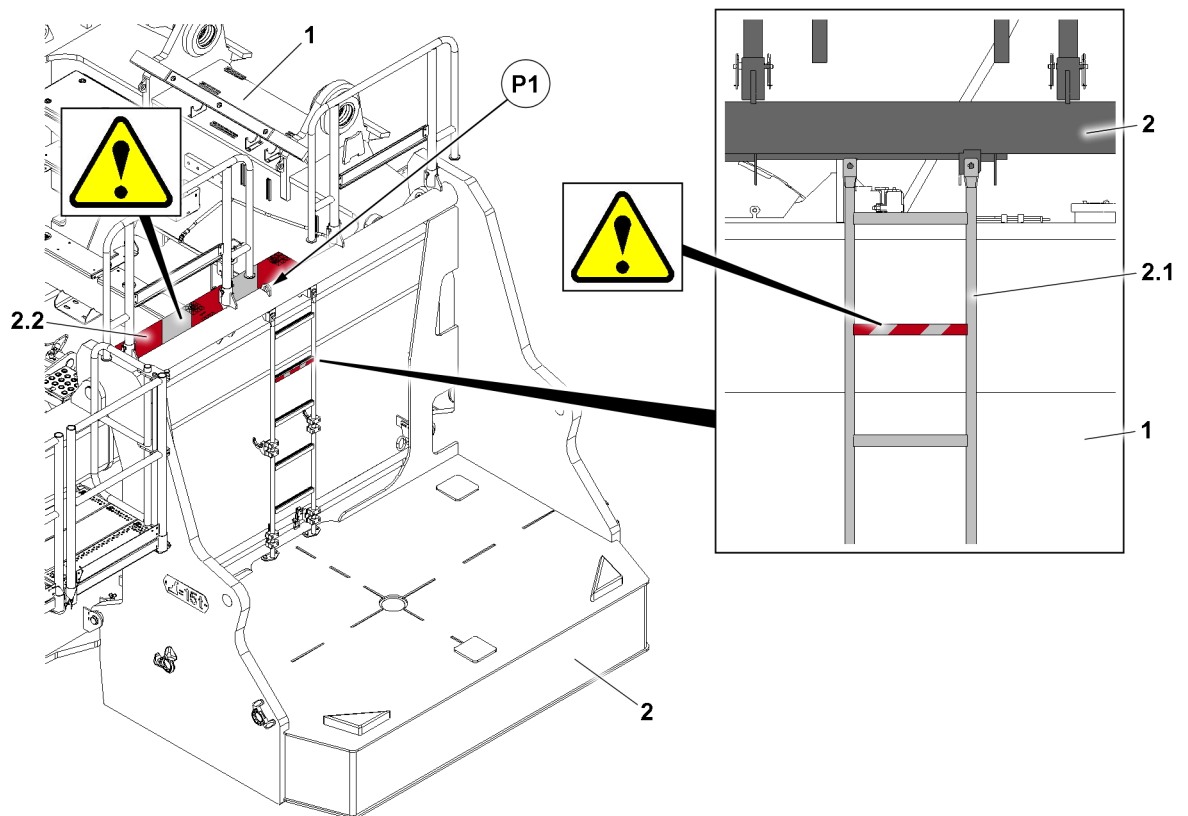


Fig.166513: Danger of falling from the counterweight bracket

- |   |                        |     |                  |
|---|------------------------|-----|------------------|
| 1 | Turntable              | 2.1 | Ladder           |
| 2 | Counterweight brackets | 2.2 | Walking surfaces |

To pin the counterweight brackets **2** on the turntable **1**, assembly personnel must climb down from the upper belt of the turntable using the ladder **2.1** on the counterweight brackets **2**. After pinning the counterweight brackets **2**, they must climb up again using the ladder **2.1** on the upper belt of the turntable.



### WARNING

Assembly personnel not secured!  
Assembly personnel can fall down.  
Death, severe bodily injuries.

- ▶ Connect assembly personnel with the fall arrest system in the hook points **P1** and secure them to prevent them from falling.



### WARNING

Danger of falling due to small step depth!  
During assembly work on the counterweight bracket, personnel can fall down.  
Death, severe bodily injuries.

- ▶ Use personal protective equipment.
- ▶ Climb on the ladder **2.1** and the counterweight bracket **2**, see chapter 2.07.
- ▶ Walk on the walking surface **2.2** with a small step depth on the counterweight bracket **2**, see chapter 2.07.

## 7 Assembling the counterweight brackets

Make sure that the following prerequisite is met:

- The crane is horizontally aligned.
- A shackle of at least 25 t is provided for lifting the counterweight bracket.
- To lift the counterweight brackets, fastening equipment with a minimum length of 4 m (fastening point to the load hook) and sufficient load carrying capacity is provided.
- There are no ballast plates on the counterweight brackets.

### 7.1 Bringing the railing on the counterweight brackets into the operating position



#### Note

- ▶ The assembly / disassembly of the railings is described in chapter 2.06.



#### WARNING

Danger of falling for assembly personnel!  
Death, severe bodily injuries, property damage.

- ▶ Assemble / disassemble the railings only according to the description in chapter 2.06.

### 7.2 Assembling the counterweight brackets on the turntable

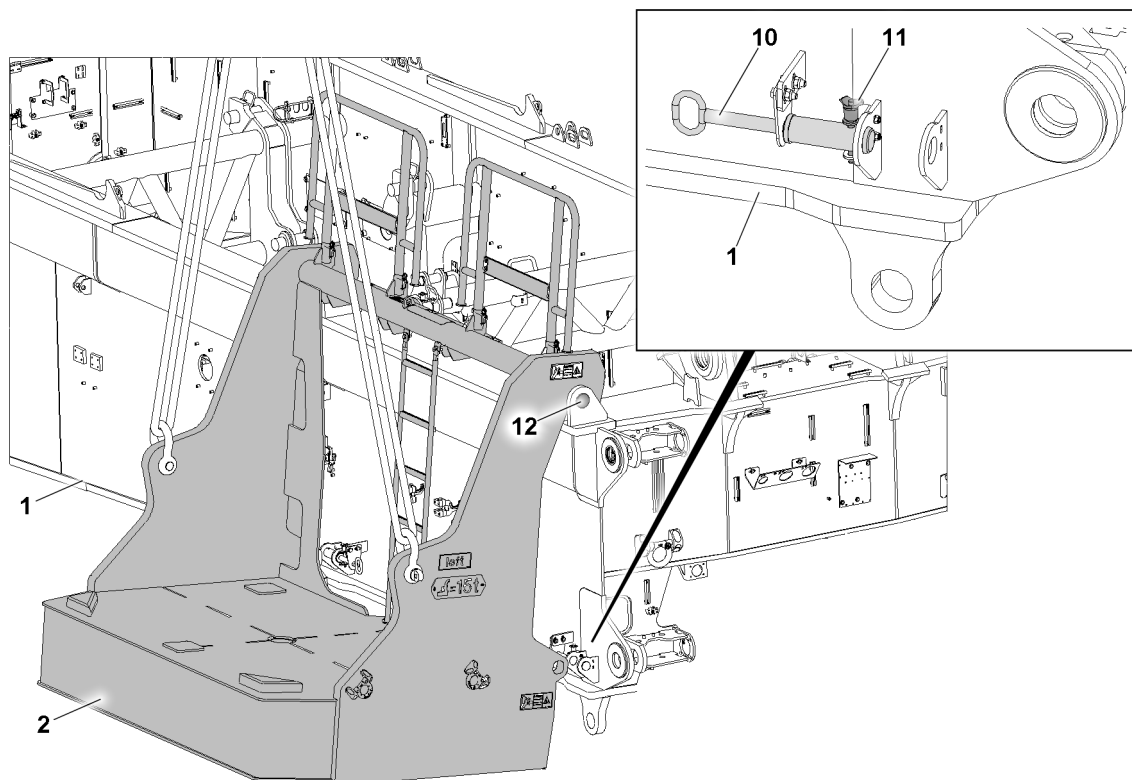


Fig.154330: Assembling the counterweight bracket

- |    |                        |    |                  |
|----|------------------------|----|------------------|
| 1  | Turntable              | 11 | Ball locking pin |
| 2  | Counterweight brackets | 12 | Hook pin         |
| 10 | Pin                    |    |                  |

**Note**

- ▶ The assembly / disassembly of the counterweight brackets **2** is described as an example.
- ▶ Remove the ball locking pin **11** from all four pin points on the turntable **1**.
- ▶ Completely unpin the pin **10** on the turntable **1** on both sides.
- ▶ Secure the pin **10** with the ball locking pin **11** in the assembly position.
- ▶ Fasten the counterweight bracket **2** properly to the auxiliary crane, see section "Fastening points".

**WARNING**

Tipping of the counterweight bracket!

Death, severe bodily injuries, property damage.

- ▶ Make sure that the fastening equipment is properly fastened to the counterweight bracket **2**.
- ▶ Make sure that there are no persons within the danger zone when lifting the counterweight bracket **2**.
- ▶ When lifting the counterweight bracket, it tips about 6° to the rear.
- ▶ Swing the counterweight bracket **2** in with the auxiliary crane to the hook pins **12** on the turntable **1**.
- ▶ Connect the counterweight bracket **2** with the hangers on the side hook pins **12** to the turntable **1**.
- ▶ Lower the counterweight bracket **2** completely on the hook pins **12**.

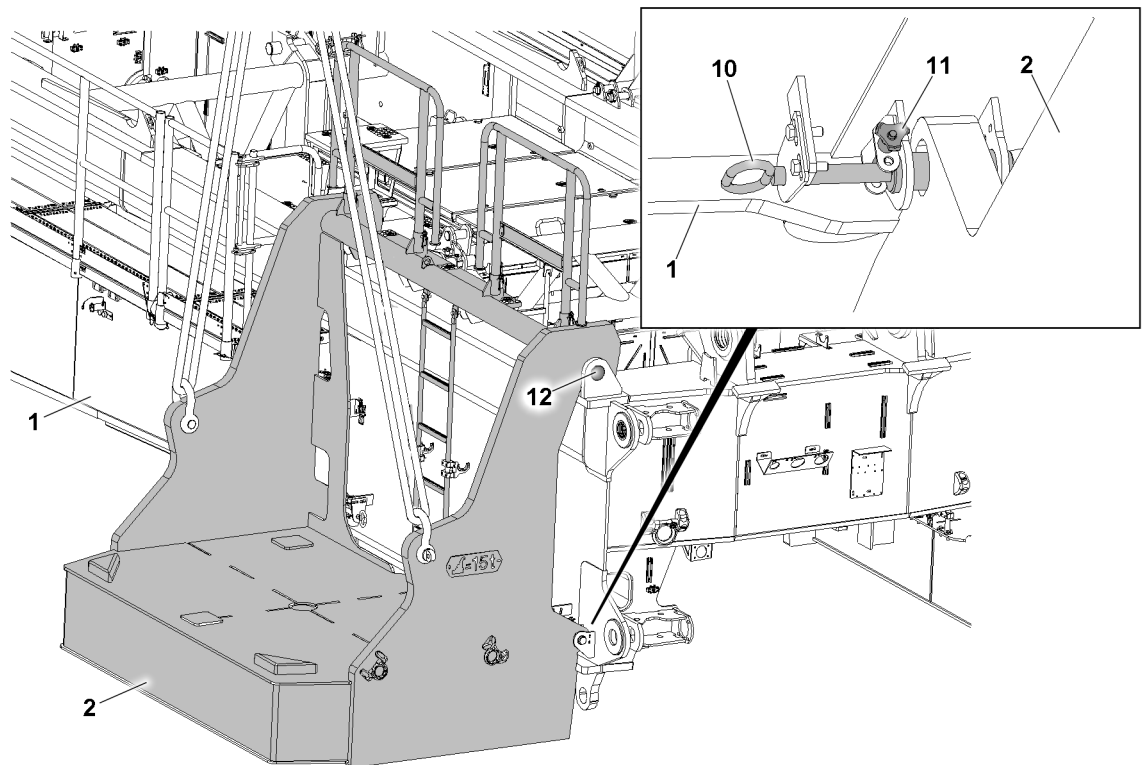


Fig.166538: Securing the counterweight bracket on the turntable

- |                                |                            |
|--------------------------------|----------------------------|
| <b>1</b> Turntable             | <b>11</b> Ball locking pin |
| <b>2</b> Counterweight bracket | <b>12</b> Hook pin         |
| <b>10</b> Pin                  |                            |

When the counterweight bracket **2** is properly connected to the hook pins **12**:

- ▶ Insert the pin **10** on both sides and secure with the ball locking pin **11**.

**Result:**

- The counterweight bracket **2** is pinned with the turntable **1**.
- ▶ Make sure that the pins **10** are secured with ball locking pins **11**.
- ▶ Release the fastening equipment on the counterweight bracket **2**.

**Note**

- ▶ The procedure for assembly of the second counterweight bracket **2** is identical to the procedure for the first counterweight bracket.
- ▶ Properly assemble the second counterweight bracket **2**.

## 8 Placing the ballast plates

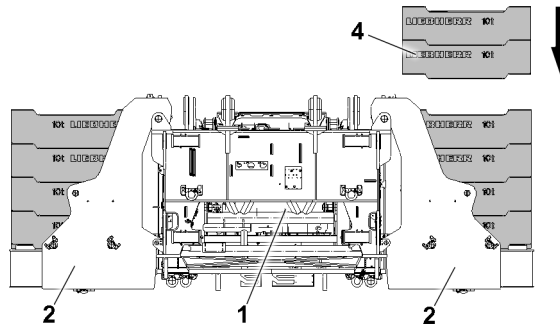


Fig.154332: Placing the ballast plates

- |   |                       |   |                |
|---|-----------------------|---|----------------|
| 1 | Turntable             | 4 | Ballast plates |
| 2 | Counterweight bracket |   |                |

**WARNING**

Incorrect crane ballasting!

If the placed counterweight deviates from the specifications depending on the situation, then the crane can be damaged or topple over.

Death, severe bodily injuries, property damage.

- ▶ Both counterweight stacks must be symmetrical to each other after ballasting.
- ▶ For the maximum permissible counterweight, depending on the assembly conditions, see chapter 3.06.
- ▶ Ensure the correct counterweight according to the specifications in the erection / take-down charts as well as the load chart.

**Note**

The required / permissible counterweight can be different depending on the situation.

- ▶ In the case of individual assembly steps, another counterweight may be necessary, for example when erecting / taking down the boom system.

**WARNING**

Risk of ballast plate breakage!

If the highest values are exceeded when stacking the ballast plates **4**, ballast plates **4** can be damaged or the stack can tip over.

Death, severe bodily injuries, property damage.

- ▶ When stacking the ballast plates, make sure that no more than 25 t is stacked on a 5 t ballast plate.
- ▶ When stacking the ballast plates, make sure that no more than 25 t is stacked on a 7.5 t ballast plate.

**WARNING**

The crane can topple over!

When ballasting the crane up / down, a weight difference of more than 20 t between the left and right turntable side can cause the crane to topple over.

Death, severe bodily injuries, property damage.

- ▶ A weight difference between the left and right turntable side of more than 20 t is prohibited.
- ▶ Alternately take down maximum 20 t of counterweight assemblies on the counterweight stacks, alternately symmetrically on the left and right.

**WARNING**

Use of damaged ballast plates!

Damaged ballast plates can break and become instable.

Death, severe bodily injuries, property damage.

- ▶ Do not use damaged ballast plates **4** and replace them immediately.

**WARNING**

Lateral offset is too large!

Death, severe bodily injuries, property damage.

If the maximum permissible offset is exceeded, ballast plates or the ballast stack can slip and fall down.

- ▶ Observe the maximum permissible lateral offset of 50 mm on the stacks.
- ▶ Make sure that the lateral offset of a ballast stack does not exceed the maximum permissible 50 mm.

**WARNING**

Danger of falling!

When working on the counterweight stack:

- ▶ Connect assembly personnel with the fall arrest system to the upper set down ballast plate and secure them to prevent them from falling, see chapter 2.06.
- ▶ The fall arrest system may not be connected to a moving ballast plate.

## 8.1 Placing the ballast plates, fastening system: "Twistlock"

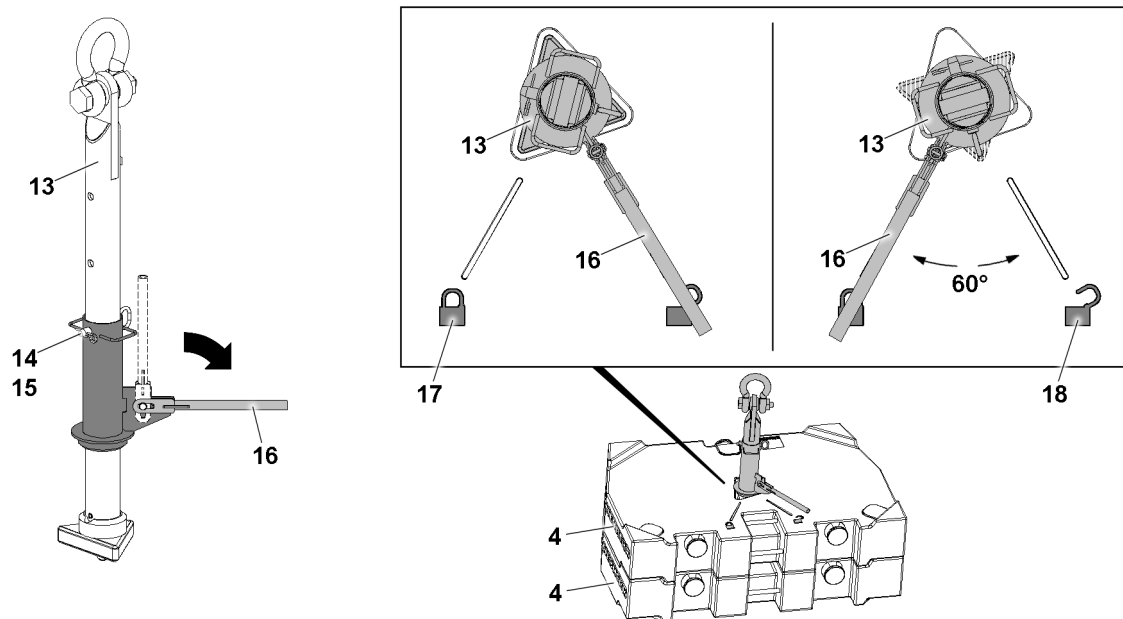


Fig.154333: Placing the ballast plates 4, fastening system: "Twistlock"

4	Ballast plates	16	Lever
13	Receptacle stud	17	"Locked" icon
14	Pin	18	"Unlocked" icon
15	Spring retainer		

- ▶ Check if the ballast plates 4 are damaged.

If a ballast plate 4 is damaged:

- ▶ Replace the ballast plate 4.



### WARNING

Too many ballast plates lifted at the same time!

If too many ballast plates 4 are lifted at the same time with the receptacle stud 13, the receptacle stud 13 will be overloaded and damaged.

The ballast plates can fall down.

Death, severe bodily injuries, property damage.

- ▶ Never fasten and lift more than the maximum permissible number of ballast plates per stroke.
- ▶ Observe section "Permissible ballast assemblies".



### WARNING

Receptacle stud used incorrectly!

If the receptacle stud 13 is not correctly set and locked, the ballast plates 4 can fall over.

Death, severe bodily injuries, property damage.

- ▶ Make sure that the receptacle stud 13 is set correctly.
- ▶ Make sure that the receptacle stud 13 for lifting the ballast plates 4 is locked correctly.

Use the receptacle stud 13 to stack the ballast plates.

Before the receptacle stud 13 is guided into the ballast plates 4, it must be ensured that the insertion depth is set correctly. The insertion length of the receptacle stud 13 can be adjusted with the pin 14.

If the insertion length of the receptacle stud 13 is to be adjusted:

- ▶ Remove the spring retainer 15 and unpin the pin 14.
- ▶ Set the correct insertion depth by moving the sleeve.
- ▶ Insert the pin 14 and secure with the spring retainer 15.
- ▶ Fasten the receptacle stud 13 to the auxiliary crane and guide it into the ballast plates 4.



- ▶ Pull the lever **16** up and fold it down.
- ▶ Swing the lever **16** 60° until the lever **16** points to the “locked” icon **17**.

**Result:**

- By lifting, the receptacle stud **13** is locked in this position with the ballast plate **4**.
- ▶ Lift the ballast plates **4**.

**WARNING**

Imprecise positioning of the ballast plates!  
Death, severe bodily injuries, property damage.  
The ballast plates **4** can fall down.

- ▶ Make sure that the ballast plates **4** are correctly centered when setting down.
- ▶ Take the ballast plates **4** down precisely onto the centering devices on the counterweight bracket, or onto another ballast plate **4**.

When the ballast plates are taken down:

- ▶ Swing the lever **16** 60° until the lever **16** points to the “unlocked” icon **18**.

**Result:**

- The receptacle stud **13** is unlocked.
- ▶ Carefully pull out the receptacle stud **13**.

## 8.2 Placing the ballast plates, fastening points: Bitt

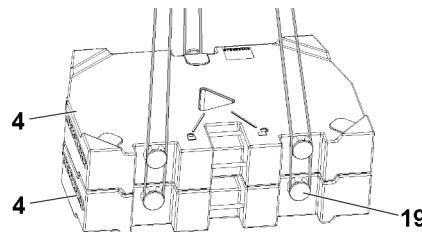


Fig.154334: Placing the ballast plates, fastening points: Bitt

**4** Ballast plates

**19** Bitt

- ▶ Check if the ballast plates **4** are damaged.

If a ballast plate **4** is damaged:

- ▶ Replace the ballast plate **4** immediately.

**WARNING**

Falling ballast plates!

If too many ballast plates **4** are lifted at the same time, the bitt **19** is overloaded.  
Ballast plates **4** can loosen up and fall down.

Death, severe bodily injuries, property damage.

- ▶ Never fasten and lift more than the maximum permissible number of ballast plates per stroke.
- ▶ Observe section “Permissible ballast assemblies”.

**WARNING**

Incorrect handling of the fastening equipment!

If fastening equipment cannot be fastened correctly and if it is not secured sufficiently to prevent it from loosening up, loads can fall down.

Death, severe bodily injuries, property damage.

- ▶ Make sure that the fastening equipment is correctly attached to the bits **19** and secured to prevent it from loosening up.

- ▶ Fasten the ballast plates **4** individually or as an assembly to the auxiliary crane.
- ▶ Lift the ballast plates **4**.

**WARNING**

Imprecise positioning of the ballast plates!  
Death, severe bodily injuries, property damage.  
The ballast plates **4** can fall down.

- ▶ Make sure that the ballast plates **4** are correctly centered when setting down.
- 
- ▶ Take the ballast plates **4** down onto the centering devices of the counterweight bracket, or another ballast plate.

When the ballast plates **4** are taken down:

- ▶ Remove the fastening equipment on the bits **19**.

## 9 Securing the counterweight

**WARNING**

Danger of falling!

- ▶ Connect assembly personnel with the fall arrest system to the upper ballast plate and secure them to prevent them from falling, see chapter 2.06.

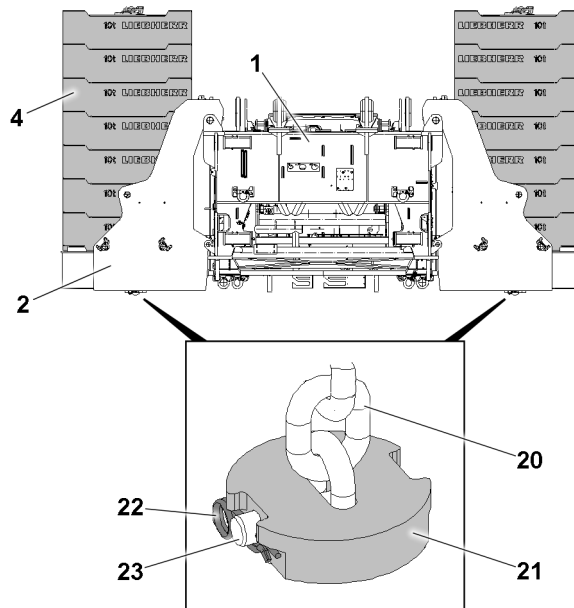


Fig.154335: Pinning the retaining chain at the bottom with the retaining plate

- |           |                       |           |                   |
|-----------|-----------------------|-----------|-------------------|
| <b>1</b>  | Turntable             | <b>21</b> | Retaining plate   |
| <b>2</b>  | Counterweight bracket | <b>22</b> | Retaining element |
| <b>4</b>  | Ballast plates        | <b>23</b> | Pin               |
| <b>20</b> | Retaining chain       |           |                   |

**WARNING**

Counterweight not secured!

If the counterweight is not properly secured, it can fall down from the counterweight brackets.  
Death, severe bodily injuries, property damage.

- ▶ Secure the counterweight after the ballasting procedure.
- 
- ▶ Fasten the retaining chain **20** with the large chain link to the auxiliary crane.

- ▶ Insert the other end of the retaining chain **20** from the top through the central opening in the counterweight stack.
- ▶ Lower the retaining chain **20** until it emerges on the underside of the counterweight bracket **2** with a sufficient length.

On the lowest chain link:

- ▶ Pin the retaining chain **20** with the retaining plate **21**: Insert the pin **23** and secure with the retaining element **22**.
- ▶ Pull the retaining chain **20** upward with the auxiliary crane and tension it slightly.

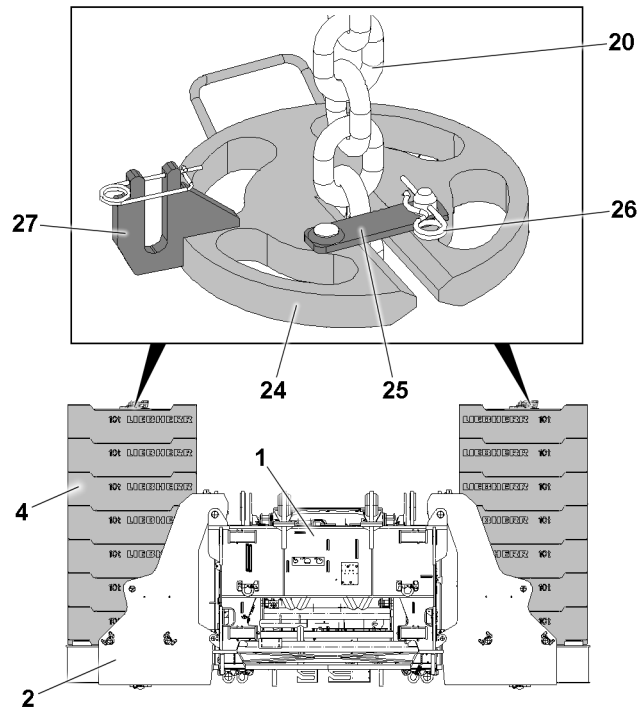


Fig.154336: Securing the retaining chain at the top with the retaining plate

- |                                |                             |
|--------------------------------|-----------------------------|
| <b>1</b> Turntable             | <b>24</b> Retaining plate   |
| <b>2</b> Counterweight bracket | <b>25</b> Retaining plate   |
| <b>4</b> Ballast plates        | <b>26</b> Retaining element |
| <b>20</b> Retaining chain      | <b>27</b> Fork              |

On the first chain link that protrudes from the upper ballast plate **4**:

- ▶ Push over the retaining plates **24**:
- ▶ Secure the retaining plate **24** with the retaining plate **25**.
- ▶ Secure the retaining plate **25** with the retaining element **26**.

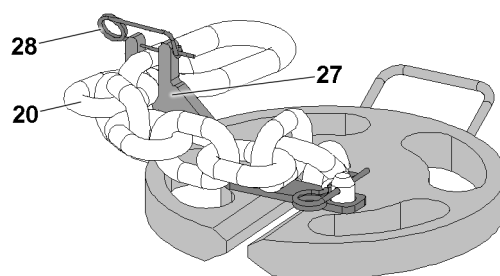


Fig.154337: Securing the chain overhang

20 Retaining chain

28 Retaining element

27 Fork



### WARNING

Danger of accident due to chain overhang!

On a partial ballast, the chain overhang can fall down on the side of the counterweight stack!

Death, severe bodily injuries, property damage.

- ▶ In case of a chain overhang, connect the retaining chain **20** to the fork **27** and secure with the retaining element **28** to prevent it from falling down.

Select the chain link to connect that results in the shortest possible chain overhang.

- ▶ Connect the retaining chain **20** to the fork **27** and secure it with the retaining element **28** to prevent it from falling down.

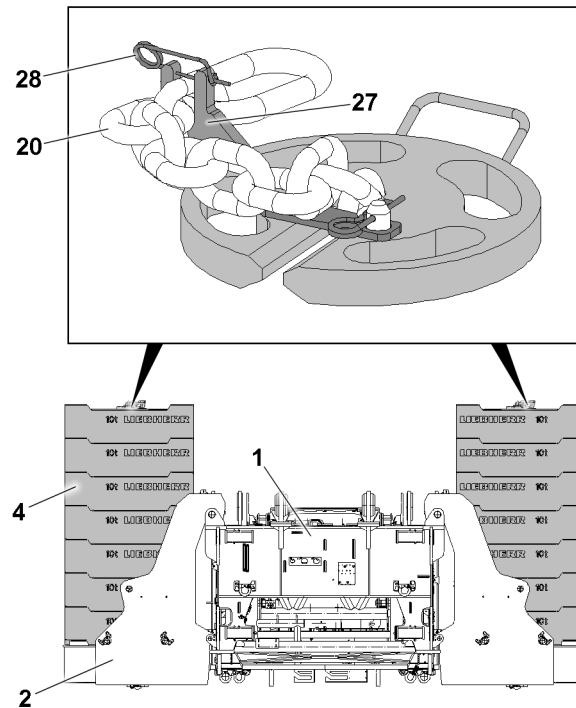
## 10 Releasing the counterweight



### WARNING

Danger of falling!

- ▶ Connect assembly personnel with the fall arrest system to the upper ballast plate and secure them to prevent them from falling, see chapter 2.06.



*Fig.154338: Releasing the chain overhang*

- |          |                       |           |                   |
|----------|-----------------------|-----------|-------------------|
| <b>1</b> | Turntable             | <b>20</b> | Retaining chain   |
| <b>2</b> | Counterweight bracket | <b>27</b> | Fork              |
| <b>4</b> | Ballast plates        | <b>28</b> | Retaining element |

Make sure that the following prerequisite is met:

- The crane is horizontally aligned.

At the top on the counterweight stack:.

- ▶ Fasten the retaining chain **20** with the large chain link to the auxiliary crane.
- ▶ Remove the retaining element **28**.
- ▶ Lift the retaining chain **20** out of the fork **27**.

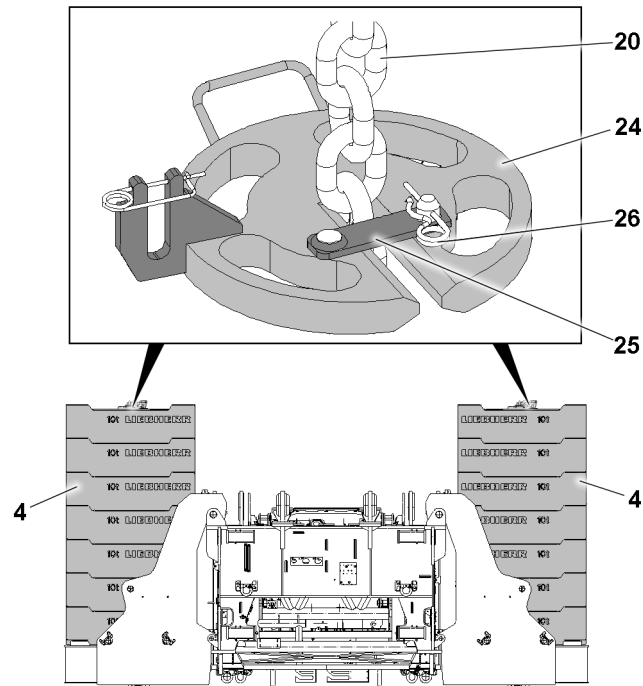


Fig. 166535: Releasing the retaining chain at the top

- |    |                 |    |                   |
|----|-----------------|----|-------------------|
| 4  | Ballast plates  | 25 | Retaining plate   |
| 20 | Retaining chain | 26 | Retaining element |
| 24 | Retaining plate |    |                   |

- ▶ Tighten the retaining chain **20** with the auxiliary crane slightly.
- ▶ Remove the retaining element **26**.
- ▶ Remove the retaining plate **25**.
- ▶ Remove the retaining plate **24**.

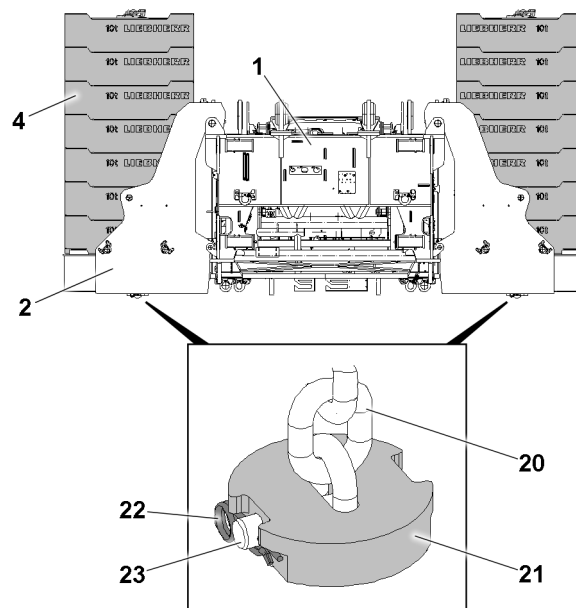


Fig. 154335: Removing the retaining plates at the bottom

- |    |                 |    |                   |
|----|-----------------|----|-------------------|
| 1  | Turntable       | 21 | Retaining plate   |
| 4  | Ballast plates  | 22 | Retaining element |
| 20 | Retaining chain | 23 | Pin               |

- ▶ Lower the retaining chain **20** with the auxiliary crane through the counterweight stack.
- ▶ Remove the retaining plate **21**: Remove the retaining element **22** and unpin the pin **23**.

**Result:**

- The retaining plate **21** is loose.
- ▶ Pull the retaining chain **20** with the auxiliary crane upward from the counterweight assembly.
- ▶ Take the retaining chain **20** down onto a suitable base or on the ground.

## 11 Removing the ballast plates

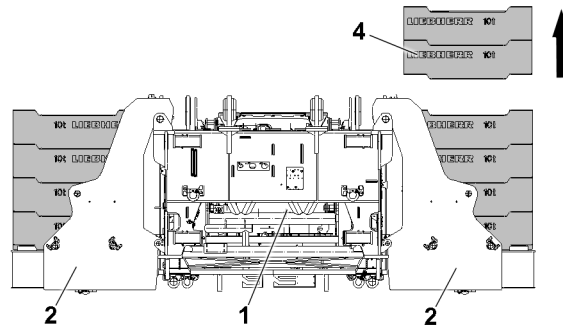


Fig.154340: Removing the ballast plates

- |   |                       |   |                |
|---|-----------------------|---|----------------|
| 1 | Turntable             | 4 | Ballast plates |
| 2 | Counterweight bracket |   |                |

**Note**

- ▶ The ballast plates **4** are marked with their own weights.

**WARNING**

Risk of ballast plate breakage!

If the highest values are exceeded when stacking the ballast plates **4**, ballast plates **4** can be damaged or the stack can tip over.

Death, severe bodily injuries, property damage.

- ▶ When stacking the ballast plates, make sure that no more than 25 t is stacked on a 5 t ballast plate.
- ▶ When stacking the ballast plates, make sure that no more than 25 t is stacked on a 7.5 t ballast plate.

**WARNING**

The crane can topple over!

When ballasting the crane up / down, a weight difference of more than 20 t between the left and right turntable side can cause the crane to topple over.

Death, severe bodily injuries, property damage.

- ▶ A weight difference between the left and right turntable side of more than 20 t is prohibited.
- ▶ Alternately take down maximum 20 t of counterweight assemblies on the counterweight stacks, alternately symmetrically on the left and right.

**WARNING**

Use of damaged ballast plates!

Damaged ballast plates can break and become instable.

Death, severe bodily injuries, property damage.

- ▶ Do not use damaged ballast plates **4** and replace them immediately.

**WARNING**

Lateral offset of more than 50 mm !

Death, severe bodily injuries, property damage.

If the maximum permissible offset is exceeded, ballast plates or the ballast stack can slip and fall down.

- ▶ Observe the maximum permissible lateral offset of 50 mm on the stacks.
- ▶ Make sure that the lateral offset of a ballast stack does not exceed the maximum permissible 50 mm.

**WARNING**

Danger of falling!

When working on the counterweight stack:

- ▶ Connect assembly personnel with the fall arrest system to the upper remaining ballast plate and secure them to prevent them from falling, see chapter 2.06.
- ▶ The fall arrest system may not be connected to a moving ballast plate.

## 11.1 Removing the ballast plates, fastening system: "Twistlock"

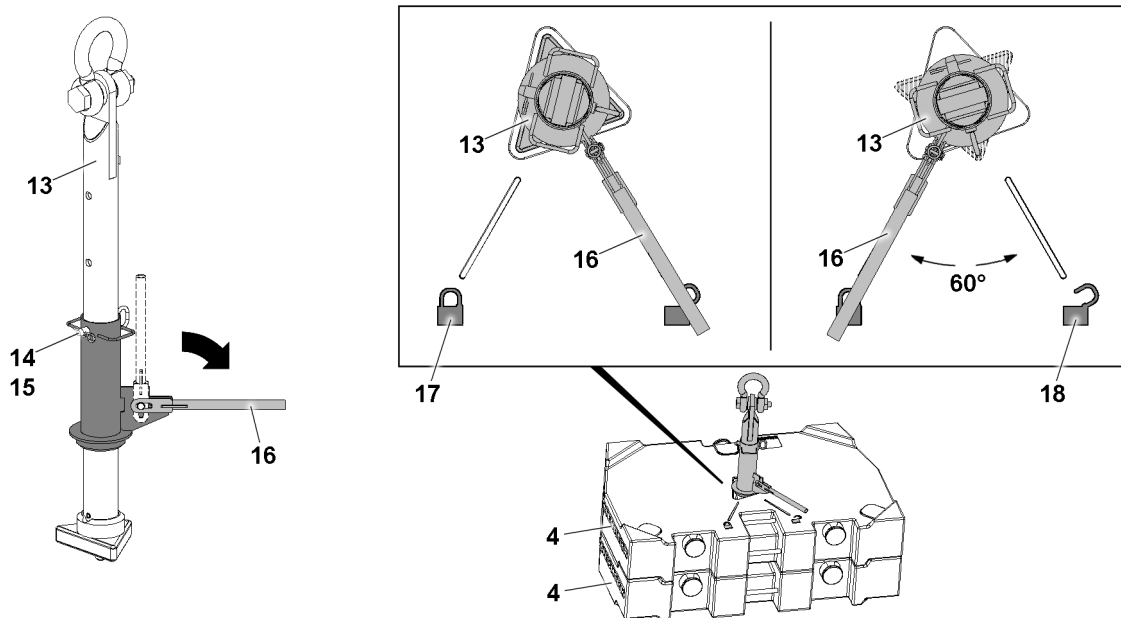


Fig.154333: Removing the ballast plates 4, fastening system: "Twistlock"

4	Ballast plates	16	Lever
13	Receptacle stud	17	"Locked" icon
14	Pin	18	"Unlocked" icon
15	Spring retainer		

**WARNING**

Too many ballast plates lifted at the same time!

If too many ballast plates 4 are lifted at the same time with the receptacle stud 13, the receptacle stud 13 will be overloaded and damaged.

The ballast plates can fall down.

Death, severe bodily injuries, property damage.

- ▶ Never fasten and lift more than the maximum permissible number of ballast plates per stroke.
- ▶ Observe section "Permissible ballast assemblies".



**WARNING**

Receptacle stud used incorrectly!

If the receptacle stud **13** is not correctly set and locked, the ballast plates **4** can fall over. Death, severe bodily injuries, property damage.

- ▶ Make sure that the receptacle stud **13** is set correctly.
- ▶ Make sure that the receptacle stud **13** for lifting the ballast plates **4** is locked correctly.

To remove the ballast plates, **4** use the receptacle stud **13**.

Before the receptacle stud **13** is guided into the ballast plates **4**, it must be ensured that the insertion depth is set correctly. The insertion length of the receptacle stud **13** can be adjusted with the pin **14**.

If the insertion length of the receptacle stud **13** is to be adjusted:

- ▶ Remove the spring retainer **15** and unpin the pin **14**.
- ▶ Set the correct insertion depth by moving the sleeve.
- ▶ Insert the pin **14** and secure with the spring retainer **15**.
- ▶ Fasten the receptacle stud **13** to the auxiliary crane and guide it into the ballast plate **4**.
- ▶ Pull the lever **16** up and fold it down.
- ▶ Swing the lever **16** 60° until the lever **16** points to the “locked” icon **17**.

**Result:**

- By lifting, the receptacle stud **13** is locked in this position with the ballast plate **4**.
- ▶ Lift the ballast plates **4** with the receptacle stud **13**.
- ▶ Take the ballast plates **4** down in a suitable location.

When the ballast plates are taken down:

- ▶ Swing the lever **16** 60° until the lever **16** points to the “unlocked” icon **18**.

**Result:**

- The receptacle stud **13** is unlocked.
- ▶ Carefully pull out the receptacle stud **13**.

## 11.2 Removing the ballast plates, fastening points: Bitt

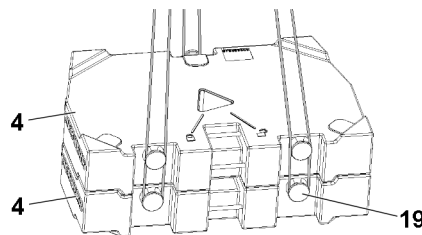


Fig.154334: Removing the ballast plates, “bitt” fastening points

**4** Ballast plates

**19** Bitt

**WARNING**

Falling ballast plates!

If too many ballast plates **4** are lifted at the same time, the bitt **19** is overloaded. Ballast plates **4** can loosen up and fall down.

Death, severe bodily injuries, property damage.

- ▶ Never fasten and lift more than the maximum permissible number of ballast plates per stroke.
- ▶ Observe section “Permissible ballast assemblies”.

**WARNING**

Incorrect handling of the fastening equipment!

If fastening equipment cannot be fastened correctly and if it is not secured sufficiently to prevent it from loosening up, loads can fall down.

Death, severe bodily injuries, property damage.

- ▶ Make sure that the fastening equipment is correctly attached to the bits **19** and that it is secured sufficiently to prevent it from loosening up.

- ▶ Fasten the ballast plates **4** individually or as an assembly to the auxiliary crane.

- ▶ Lift the ballast plates **4**.

- ▶ Take the ballast plates **4** down in a suitable location.

When the ballast plates **4** are taken down:

- ▶ Remove the fastening equipment on the bits **19**.

## 12 Disassembling the counterweight brackets

Make sure that the following prerequisite is met:

- A shackle of at least 25 t is provided for lifting the counterweight bracket.
- To lift the counterweight brackets, fastening equipment with a minimum length of 4 m (fastening point to the load hook) and sufficient load carrying capacity is provided.
- There are no ballast plates on the counterweight brackets.

### 12.1 Disassembling the counterweight brackets on the turntable

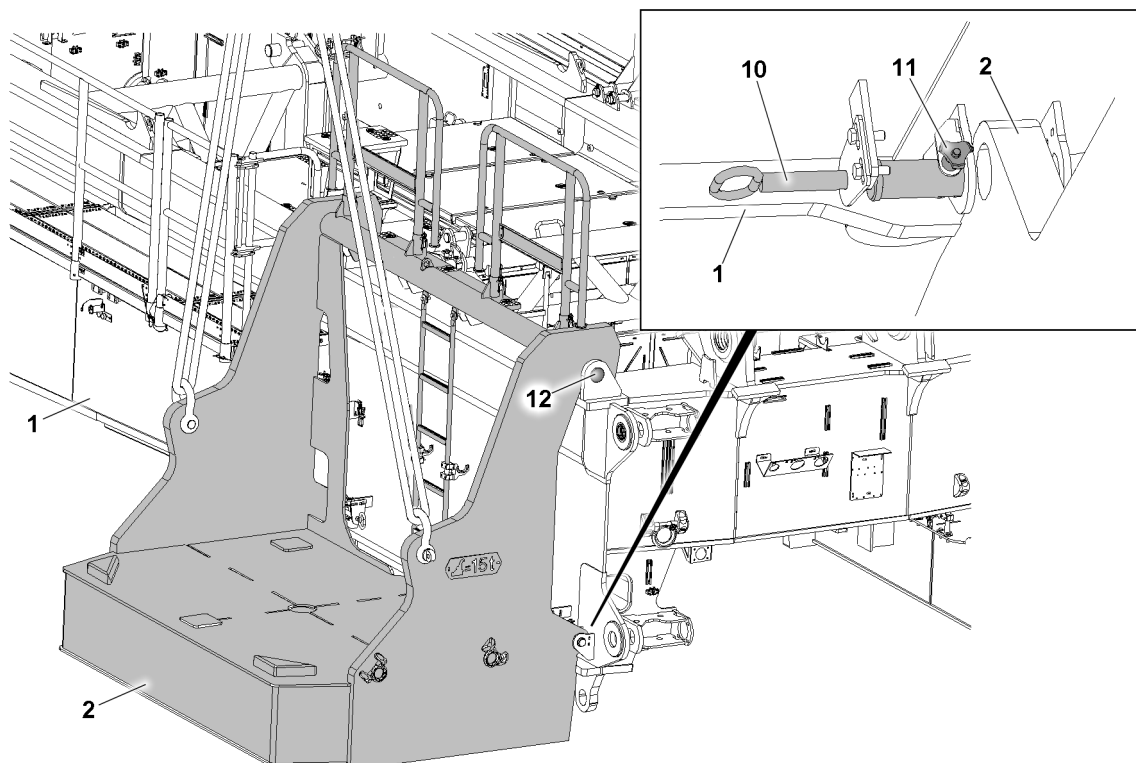


Fig.166537: Releasing the counterweight bracket on the turntable

- |          |                        |           |                  |
|----------|------------------------|-----------|------------------|
| <b>1</b> | Turntable              | <b>10</b> | Pin              |
| <b>2</b> | Counterweight brackets | <b>11</b> | Ball locking pin |

**Note**

- ▶ The assembly / disassembly of the counterweight brackets **2** is explained based on one counterweight bracket **2** as an example.

Make sure that the following prerequisite is met:

- The railings on the counterweight brackets **2** are in the operating position.
- ▶ Fasten the counterweight bracket **2** to the auxiliary crane, see section “Fastening points”.

**WARNING**

Tipping of the counterweight bracket!

Death, severe bodily injuries, property damage.

- ▶ Make sure that the fastening equipment is properly fastened to the counterweight bracket **2**.
- ▶ Make sure that there are no persons within the danger zone when lifting the counterweight bracket **2**.
- ▶ When lifting the counterweight bracket, it tips about 6° to the rear.

When the fastening equipment is tensioned properly on the counterweight bracket **2**:

- ▶ Release the pin **10**: Remove the ball locking pin **11**.
- ▶ Unpin the pin **10** on both sides.

When the pins **10** are completely unpinned on both sides:

- ▶ Lift the counterweight bracket **2** with the auxiliary crane and swing it out.
- ▶ Set the counterweight bracket **2** on a load bearing substructure or on a flatbed trailer.

When the counterweight bracket **2** is properly set on the substructure or the flatbed trailer:

- ▶ Remove the fastening equipment and the auxiliary crane.

When the counterweight bracket **2** is properly disassembled:

- ▶ Insert the pin **10** again and secure it with the ball locking pin **11**.

**Note**

- ▶ The procedure for disassembly of the second counterweight bracket **2** is identical to the procedure for the first counterweight bracket.

- ▶ Properly disassemble the second counterweight bracket **2**.

## 12.2 Bringing the railing on the counterweight brackets into the transport position

**Note**

- ▶ The assembly / disassembly of the railings is described in chapter 2.06.

**WARNING**

Danger of falling for assembly personnel!

- ▶ Assemble / disassemble the railings only according to the description in chapter 2.06.

---

Empty page!

LWE/LR 1800-1-0-000/27200-07-02/en

## 4.08 Working with a load

1	Safety instructions	3
2	Checks before starting to work with the crane	4
3	Telescoping crane movement	5
4	Taking on a load	7
5	Load weighing and load display	13
6	Crane operation	18
7	Ram work or pulling sheet piles	19
8	Crane rope pretension	20

*Fig.195219*

LWE/LR 1800-1-0-000/27200-07-02/en

# 1 Safety instructions

In addition, observe the general technical safety instructions in chapter 2.04.

In steep boom positions for which no loads are specified in the load charts, there is a danger of tipping to the rear to the counterweight side.

The danger of tipping to the rear exists especially in case of:

- Crane operation on tires
- Supported, with retracted sliding beams
- Reduced support base



## WARNING

Crane operation in steep boom positions for which no loads are specified in the load charts! The crane can tip to the rear and fatally injure personnel.

- ▶ Comply with the boom radius specified in the load chart.
- ▶ Crane operation outside the permissible set up configurations, boom radii and slewing ranges according to the load chart is prohibited.



## WARNING

Incorrect reeving number set up!

If the reeving number on the pulley head is less than the reeving number set on the LICCON computer system, it can result in an overload of the hoist rope.

The hoist rope can rip. The load can fall down and fatally injure personnel.

- ▶ Comply with the reeving numbers specified in the load chart for maximum loads.
- ▶ Make sure that the reeving on the pulley head and the reeving set on the LICCON computer system match.

The minimum rope coils must remain on the rope winches. The number of minimum rope coils depends on if the rope winch is equipped with a cam limit switch or a winch speed sensor.



## WARNING

Minimum rope coils fallen below!

The rope will be ripped out. The load falls down.

Personnel can be killed.

- ▶ Make sure that the minimum rope coils remain on the rope winch.
- ▶ Observe and comply with the number of the minimum rope coils in chapter 5.01.



## WARNING

Lift the load by luffing up!

The crane can topple over and fatally injure personnel.

- ▶ Lift the load with the hoist gear.

Always comply with the maximum loads specified in the load chart.

The weight of the hook block according the load chart must be taken into account. Subtract the weight of the hook block from the load chart value. The minimum hook block weight must be determined according to the reeving number and the data in the load charts.

For the stroke, use the hook block which is suited best for the existing set up configuration in connection with the load chart.

Initiate all crane movements carefully. Also brake the crane movements carefully. That way you can avoid a swinging or pendulum motion in the suspended load.

## 2 Checks before starting to work with the crane

Before starting work with the crane, the crane operator must carry out a further inspection to satisfy himself about the crane's operational safety:

- Check that the crane is properly supported and level.
- Check that the set up configuration set in the control matches the actual set up configuration.
- Check that all values in the load chart that apply to the current equipment configuration have been entered and met.
- Ensure that there are no people or objects within the danger zone of the crane.



### WARNING

Persons in the slewing range!  
Crushing danger, death, severe bodily injuries.

- ▶ Monitor the slewing range.
- ▶ Make sure that there are **no** persons within the slewing range.
- ▶ Block off the slewing range if necessary.



### WARNING

Obstacle in the slewing range!  
Property damage on crane and on obstacle.

- ▶ Make sure that there are **no** obstacles within the turning range of the crane and the crane components.

### 2.1 Visual check for damage



### WARNING

Danger of accident!

If the crane is operated despite existing defects, personnel can be severely injured or killed.

- ▶ In the event of deficiencies which threaten operational safety, stop crane operation immediately.

The following deficiencies threaten the crane's operational safety:

- Damage to load-bearing parts of the crane design, such as booms, supports etc.
- Failure of the hoist gear brake and consequent slipping of the load
- Functional failures in the crane control system
- Functional defects in the indicator and warning lights
- Damage to the hoist ropes
- Safety defects in the safety equipment
- Leaks on safety relevant components of the crane hydraulic

Inform the appropriate supervisor about the deficiencies on the crane and also inform your relief when crane operators are changed.

### 2.2 Operating with telescopic boom and auxiliary boom

When operating with a telescopic boom and auxiliary boom in the 0° position and with a steep luffed up telescopic boom, the hook blocks can collide with the telescopic boom or the auxiliary boom.



**NOTICE**

Operation with the telescopic boom and auxiliary boom in the 0° position and steep luffed up telescopic boom!

The hook block can collide with the telescopic boom or auxiliary boom.

- ▶ Make sure that the hook block is always at a sufficient distance from the crane structure.

Before collision of the hook block with the telescopic boom or the auxiliary boom:

- ▶ Stop spooling up the winch or end luffing up the boom.

With a hydraulic auxiliary boom:

- ▶ Increase the freedom of movement of the hook block with respect to the auxiliary boom by luffing down the auxiliary boom.

### 2.3 Telescopic boom distortion because of sunshine on one side

A temperature difference occurs between the side facing the sun and the side facing away from the sun for cranes with telescopic booms. This causes telescopic boom side distortion, which can reduce the load bearing capacity of the telescopic boom.

For example, a temperature difference between the two boom sides of 30 °C and a boom length of 60 m results in a length difference caused by the temperature difference between the two sides of the telescopic boom of approximately 22 mm. With narrow boom parts, this causes the profiles to bend sideways.

If the maximum load is being utilized during operation with a telescopic boom extension such as a fixed lattice jib, luffing lattice jib or folding jib, then it must be ensured through a visual inspection before picking up the load that the boom is not showing signs of side deformation due to one-sided sun exposure.

**WARNING**

Danger of accident due to component overload!

If the telescopic boom has become distorted because of one-sided sunlight, this can cause component overload and therefore accidents.

- ▶ Turn the crane so that both sides of the boom are heated up equally, eliminating side deformation due to temperature difference.

## 3 Telescoping crane movement

If the telescopic boom is telescoped with the jib boom or telescopic boom extension, before the telescoping procedure, ensure that:

- The crane is properly supported and horizontally aligned.
- The telescopic boom is evenly warmed up by solar radiation.
- There is no strong side wind.

**WARNING**

Damage to the telescopic boom or the hoist rope!

If these 3 factors are not adhered to, damage of the telescopic boom or the hoist rope can occur and lead to accidents.

- ▶ Support the crane properly and align it horizontally.
- ▶ Keep both sides of the boom at about the same temperature.
- ▶ Telescope only to the permissible wind speed according to the load chart.
- ▶ If the actual wind speed is higher than the permissible wind speed noted on the load chart, telescoping is prohibited.

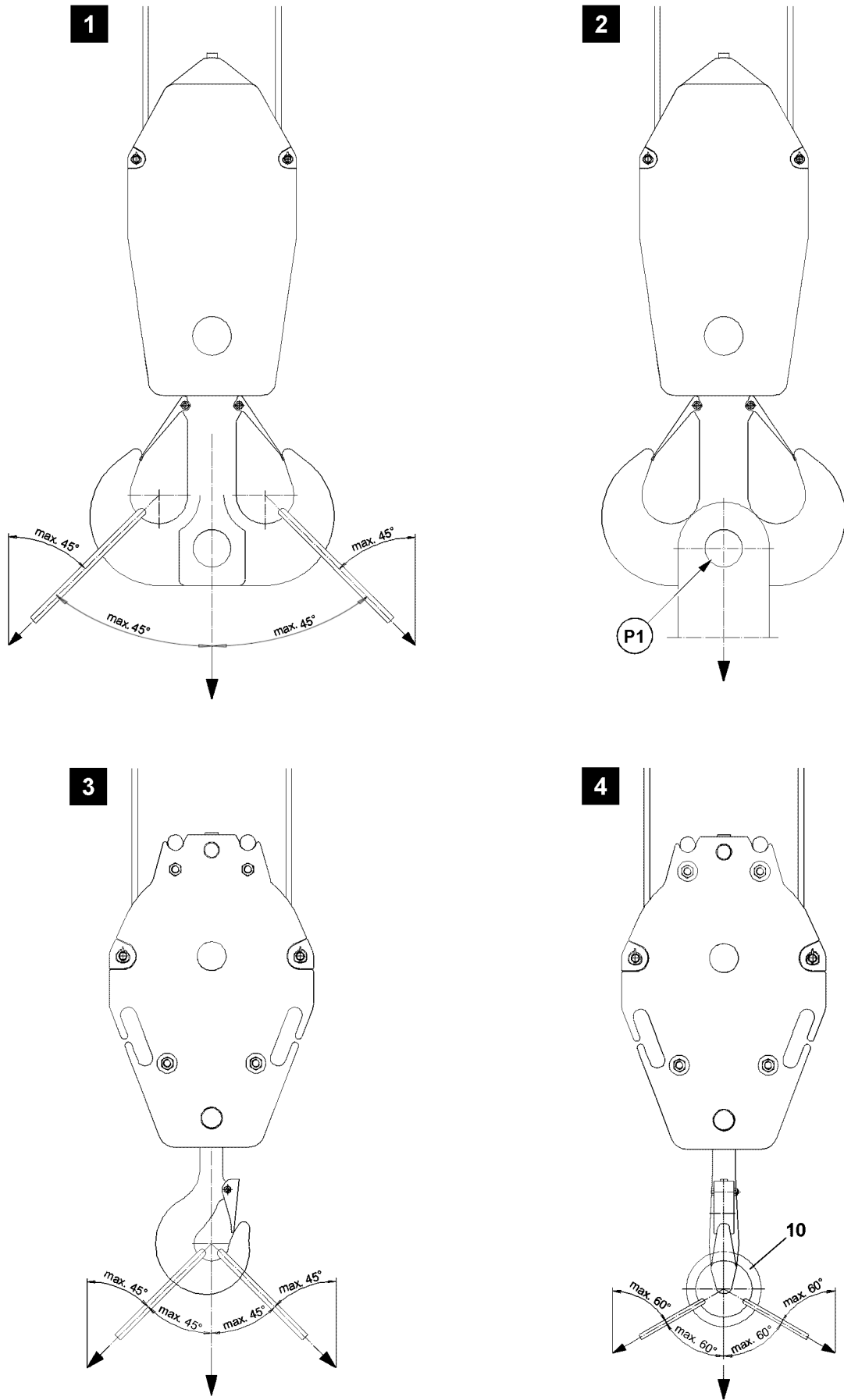


Fig.145147

LWE/LR 1800-1-0-000/27200-07-02/en

## 4 Taking on a load

The crane must always be operated in such a way that its load-bearing parts are not destroyed or damaged and its stability is ensured.

Make sure that the following prerequisites are met:

- The crane is supported and horizontally aligned.
- The LICCON overload protection has been set according to the load chart and the set up configuration.
- The LICCON overload protection is active.
- In the case of cranes with central ballast: The central ballast is installed according to the load chart.
- The counterweight is installed according to the load chart.
- In the case of cranes with derrick ballast: The derrick ballast is installed according to the load chart.
- The hook block or the load hook is correctly reeved.

### 4.1 Fastening the load



#### WARNING

Load can be ripped off!

If impermissible fastening and / or load handling equipment is used when taking on a load on the centric bore on the double hook at point **P1** (illustration **2**), then the double hook as well as the hook block can be damaged.

The load can rip off and fall down.

Personnel can be severely injured or killed.

- ▶ Lift the load via the centric bore on the double hook (point **P1**): For the technical requirements and the technical design of the fastening and / or load handling equipment contact the hook block manufacturer.



#### WARNING

The crane can topple over!

If the following conditions are not met, the crane can topple over.

Personnel can be severely injured or killed.

This could result in significant property damage.

- ▶ Pay attention to the own weight of the load handling equipment.
- ▶ Pay attention to the load bearing capacity of the load handling equipment.
- ▶ The maximum permissible incline of the strands fastened on the single or double hook in the hook jaws is 45°. See illustration **1** and illustration **3**.

If necessary for the single hook:

- ▶ Use fastening equipment with a suspension link **10**. The maximum permissible incline in this case is 60°. See illustration **4**.
- ▶ Load a single and double hook symmetrically. A maximum deviation of  $\pm 3^\circ$  from the direction of the center of gravity is permissible.

If necessary:

- ▶ Use cross beam or two cranes for taking on the load.

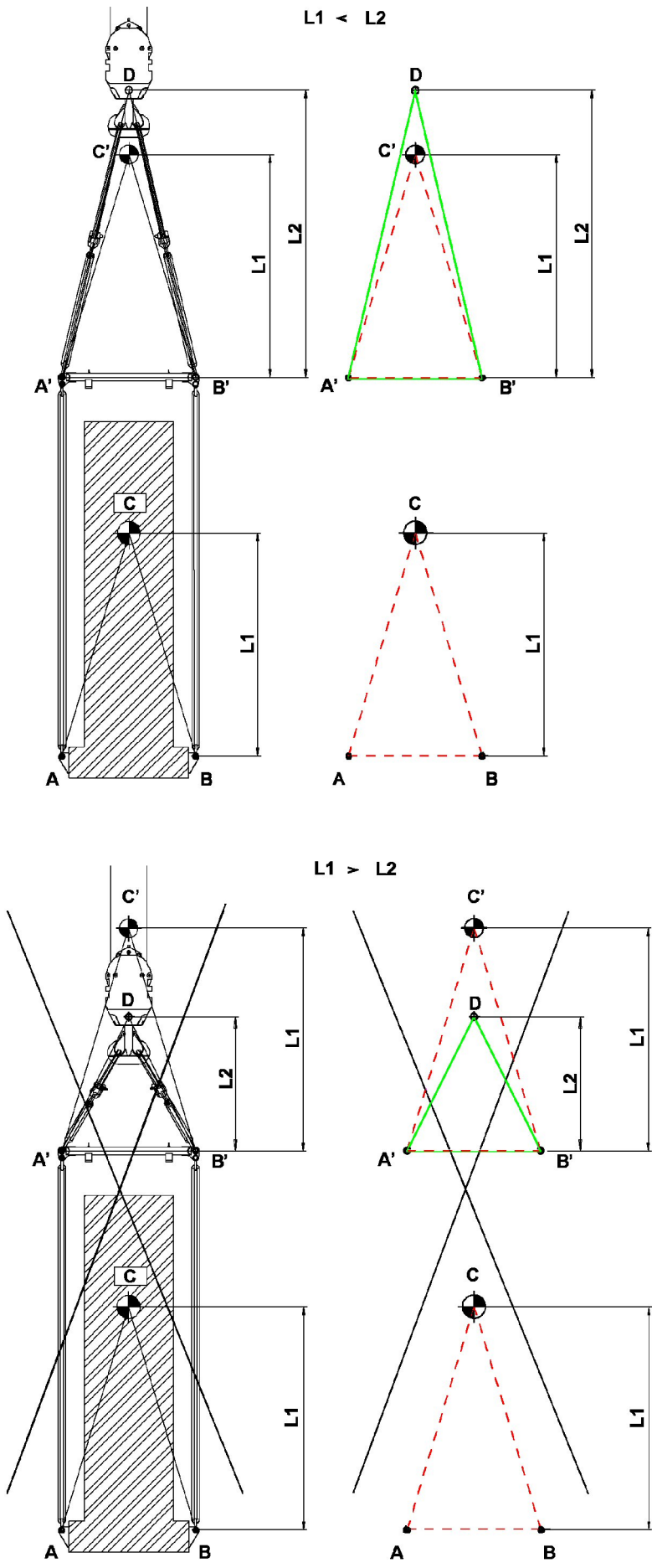


Fig.116274

LWE/LR 1800-1-0-000/27200-07-02/en

## 4.2 Taking on a load with cross beam

Cross beam are load handling equipment between crane hook and load.

The distance of the center of gravity **L1** is the vertical dimension from the fastening point of the load to the center of gravity of the load.

The cross beam height **L2** is the vertical dimension from the point of rotation of the crane hook to the next lower linkage point of the cross bar.



### WARNING

Tipping of load to the side!

If fastening ropes are used which are too short, so that the load center of gravity is above the fastening point, then there is a danger of the load tipping to the side.

Personnel can be severely injured or killed.

- ▶ The load center of gravity must be below the crane hook.
- ▶ The distance of the center of gravity **L1** must be smaller than the cross beam height **L2** ( $L1 < L2$ ).
- ▶ The triangle **A'B'C'** must be within the triangle **A'B'D**.

## 4.3 Transporting the hook block

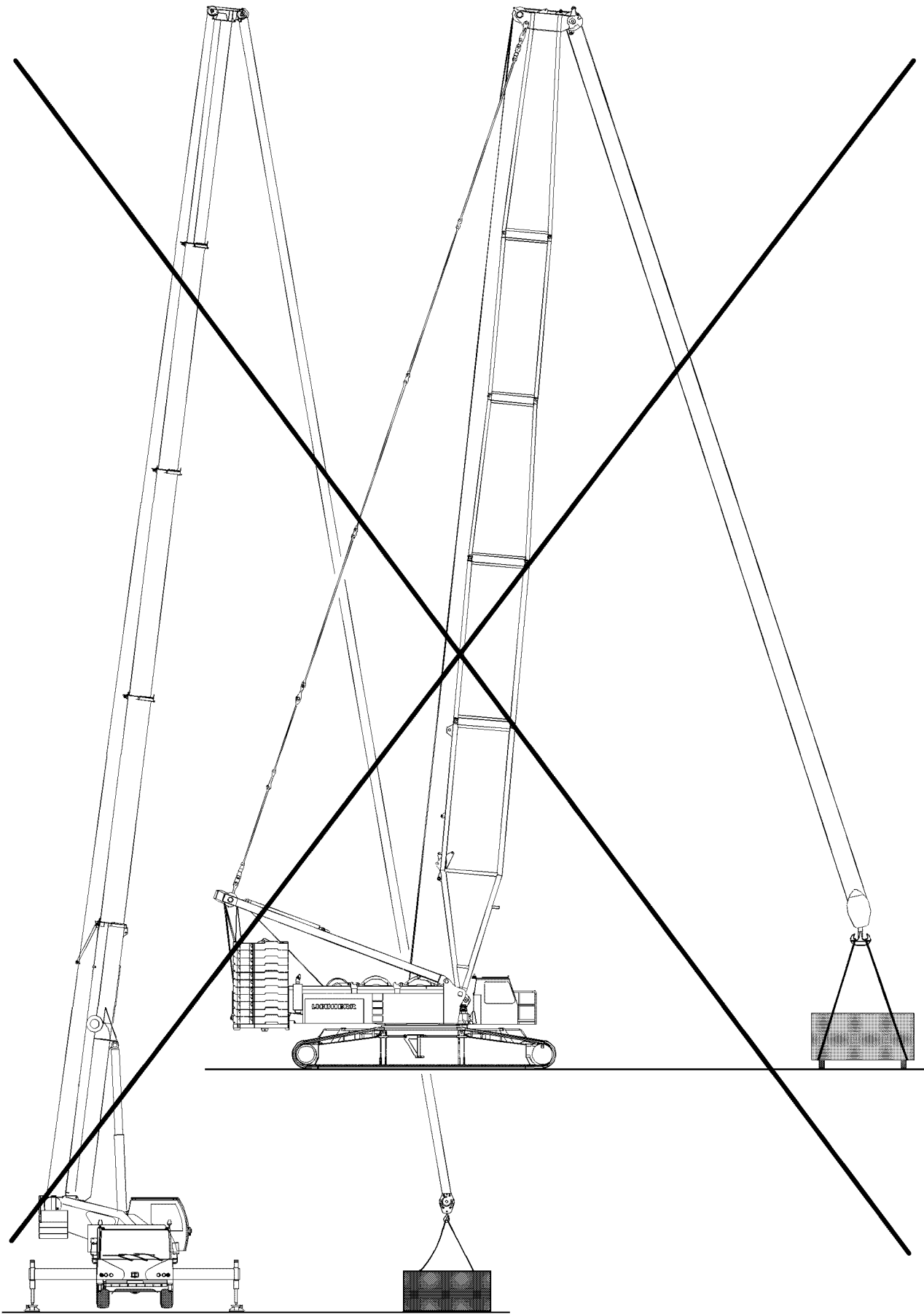


### WARNING

Danger of accident!

If a hook block is fastened incorrectly for transport, personnel can be injured.

- ▶ Fasten the hook block for transport on the fixed point in the center.
- ▶ Fastening the complete hook block on the auxiliary weights is prohibited.
- ▶ When setting down, secure the hook block against falling over.
- ▶ Prevent the load hook from rolling away.



LWE/LR 1800-1-0-000/27200-07-02/en

Fig.102716

## 4.4 Lifting the load



### WARNING

Danger of crushing for people in the load zone!

If personnel is located between the load to be lifted and a possible interfering edge (such as a wall of a building or similar) when the load is lifted, personnel can be severely injured or killed.

- ▶ Before lifting the load it must be ensured that there are no persons within the danger zone.
- ▶ It is prohibited to remain in the danger zone.
- ▶ It is prohibited for anyone to be under the load. Maintain a safe distance.
- ▶ Swinging the load is prohibited.
- ▶ Exercise extreme caution when lifting a load.



### WARNING

The crane can topple over!

If an attempt to lift a load over the hoist gear causes the LICCON overload protection to turn off, then the load may not be lifted by luffing up the boom. This causes overload or toppling the crane. Personnel can be severely injured or killed.

- ▶ Do not lift the load by luffing up the boom off the ground.



### Note

When using the assembly winch\*, observe the following:

- ▶ Use the assembly winch\* only for assembly and not for lifting loads.
- ▶ Lifting of loads with the auxiliary winch is prohibited.

If the fastening rope is manually attached by an assistant to the load to be lifted:

- Make sure that the assistant's hands are not crushed by the tightened ropes between the load and the fastening rope.
- Make sure that the assistant's body parts (hands, legs etc.) are not crushed by a swaying movement of the load during lifting.

## 4.5 Angular pull



### WARNING

The crane can topple over!

Angular pulling can destroy the crane or cause it to topple over.

Personnel can be severely injured or killed.

- ▶ Fasten (hang) the hook block always vertically over the center of gravity of the load to be lifted.
- ▶ Do not use the slewing gear to pull and set up loads.
- ▶ When lifting, compensate for boom deflection.
- ▶ Angular pull is prohibited.

The crane is designed only to lift loads vertically. During angular pulling, regardless of whether this is done in the same direction as the boom or laterally, horizontal forces are generated from the load in addition to the vertical forces, for which the boom is not designed.

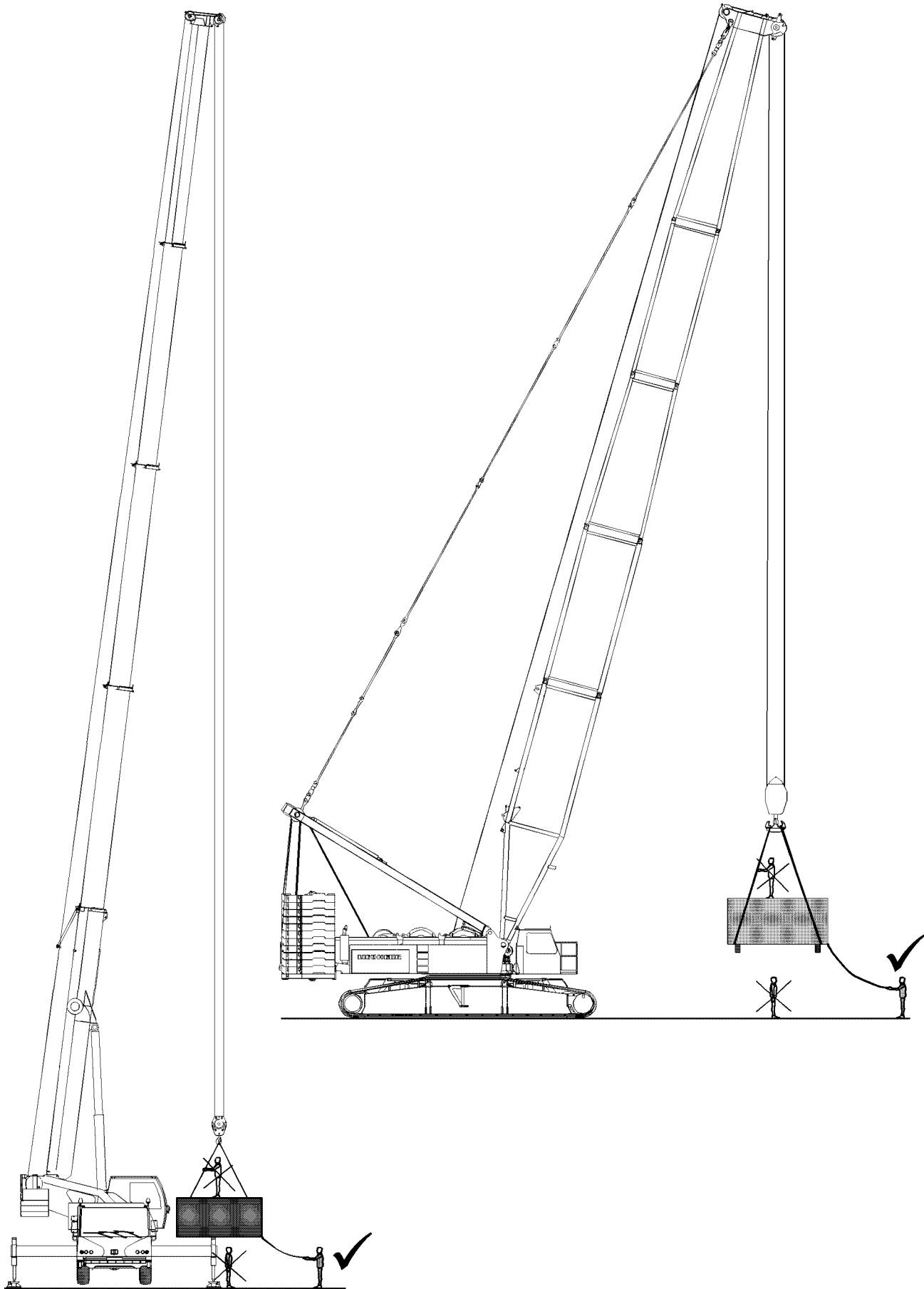


Fig.102717

LWE/LR 1800-1-0-000/27200-07-02/en



## 4.6 Breaking away fixed loads



### WARNING

The crane can topple over!

Ripping stuck loads free can destroy the crane or cause it to topple over.

Personnel can be severely injured or killed.

► Ripping stuck loads free is prohibited.

## 5 Load weighing and load display

Load weighing and load display are described based on the example of a crane with a telescopic boom. The situation is the same for a crane with a telescopic boom and lattice mast boom.

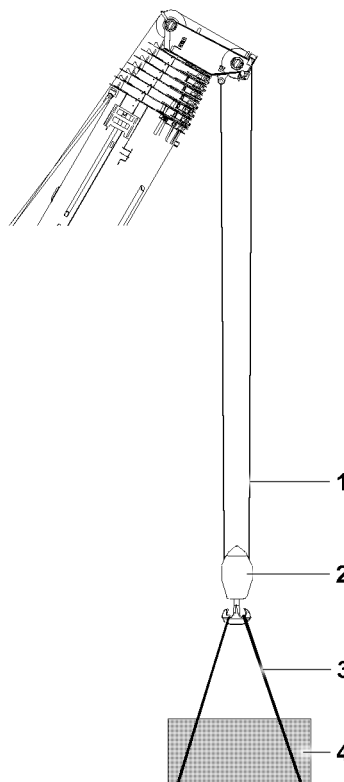


Fig.157473

- |   |                  |   |                           |
|---|------------------|---|---------------------------|
| 1 | Hoist rope       | 3 | Fastening equipment 0.5 t |
| 2 | Hook block 1.5 t | 4 | Actual load capacity 48 t |

The loads indicated in the load chart take the weight of the hoist rope into account at nominal reeving.

The weight of the hook block and the weights of the fastening equipment must be subtracted from the load indicated in the load chart and are displayed as a load

Calculation of the actual load capacity of the crane	Load
Maximum permissible load according to the load chart	50 t
Hook block weight	- 1.5 t
Fastening equipment weight	- 0.5 t
Actual load capacity	= 48 t

LWE/LR 1800-1-0-000/27200-07-02/en

The weight of the actual load capacity (the component being lifted) may be not exceed **48 t** in this example.

## 5.1 Load weighing

Make sure that the following prerequisites are met:

- The angle sensors are functioning.
- The incline sensors are functioning.
- The turn sensor in the turntable is functioning.
- The pressure sensors are functioning.
- The length sensors are functioning.
- The pull sensors are functioning.



---

### WARNING

The sensor is defective.  
Load display and load weighing are not exact.  
An error message is displayed.  
► Stop crane operation. Replace the sensor.

---

### 5.1.1 Possible weighing errors

Exact sensor signals are required for precise load weighing.

Since all sensor values are always within a certain tolerance, a weighing error can occur.

The weighing error is increasingly larger if:

- The reeving is small.
- The boom, on which the load is suspended, is short.
- The boom, on which the load is suspended, is steep.



---

### WARNING

Weighing error!  
The crane can be overloaded.  
► Plan and carry out the crane operation very carefully.

---

### 5.1.2 Adjusting the reeving

The number of reevings must be correctly set on the LICCON overload protection. If the reevings are higher than what is considered in the load chart, either the max load for LICCON 2 cranes are reduced or the actual load for LICCON 1 cranes is increased for the crane.

## 5.2 Actual load display

### 5.2.1 Hoist rope length

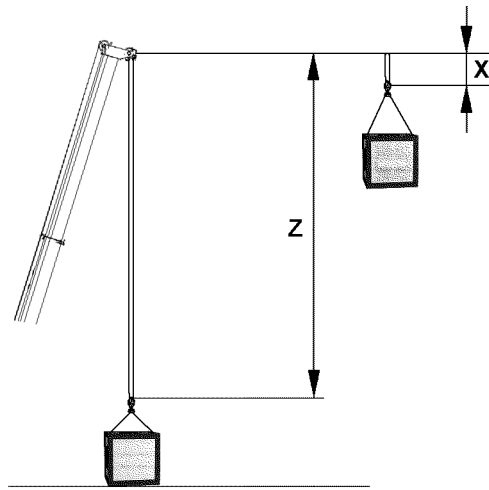


Fig.157474

**Z** Hoist rope length

**X** Hoist rope length

For the calculation of the displayed actual load, the hoist rope weight of the hoist rope length **Z** is deducted from the total load.

In that case, the number of the reevings set on the LICCON overload protection are taken into account, but no more than the nominal reeving.

If the load is raised far above the ground, (hoist rope length **X**), then the actual load display is smaller by the hoist rope weight of the load to the ground.

## 5.2.2 Lifting the load

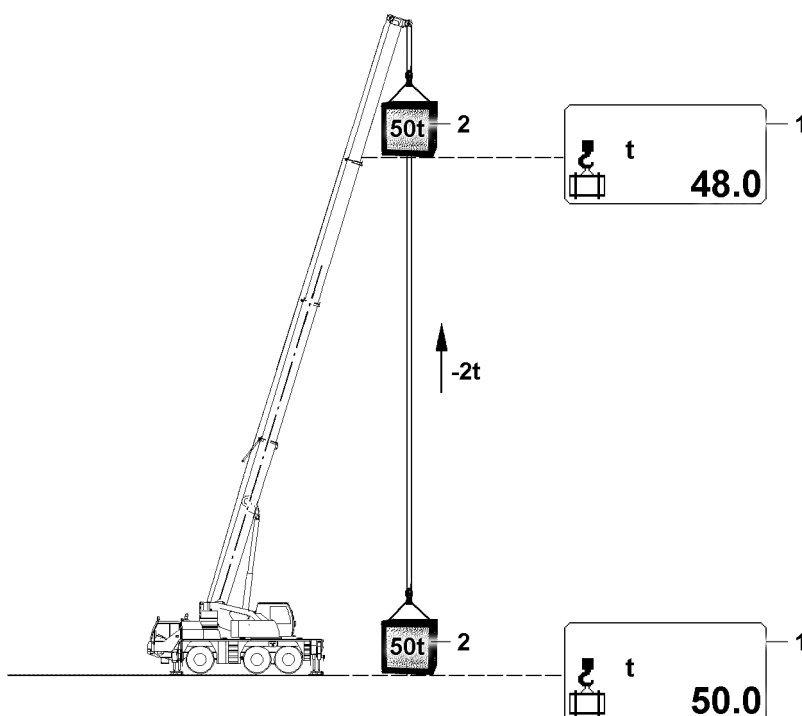


Fig.157503: Lifting the load

1 Actual load display    2 Load

The load consists of:

- Hook block
- Fastening equipment
- Actual load capacity (the component that is lifted)

When the load is lifted above the crane level, then the hoist rope to the ground is deducted on the actual load display **1**, therefore the load **2** seems increasing lighter when lifting than it did on the ground.

Therefore, a somewhat larger load can be lifted at great heights than on the ground, without triggering the LMB overload shut off.

### 5.2.3 Lowering the load

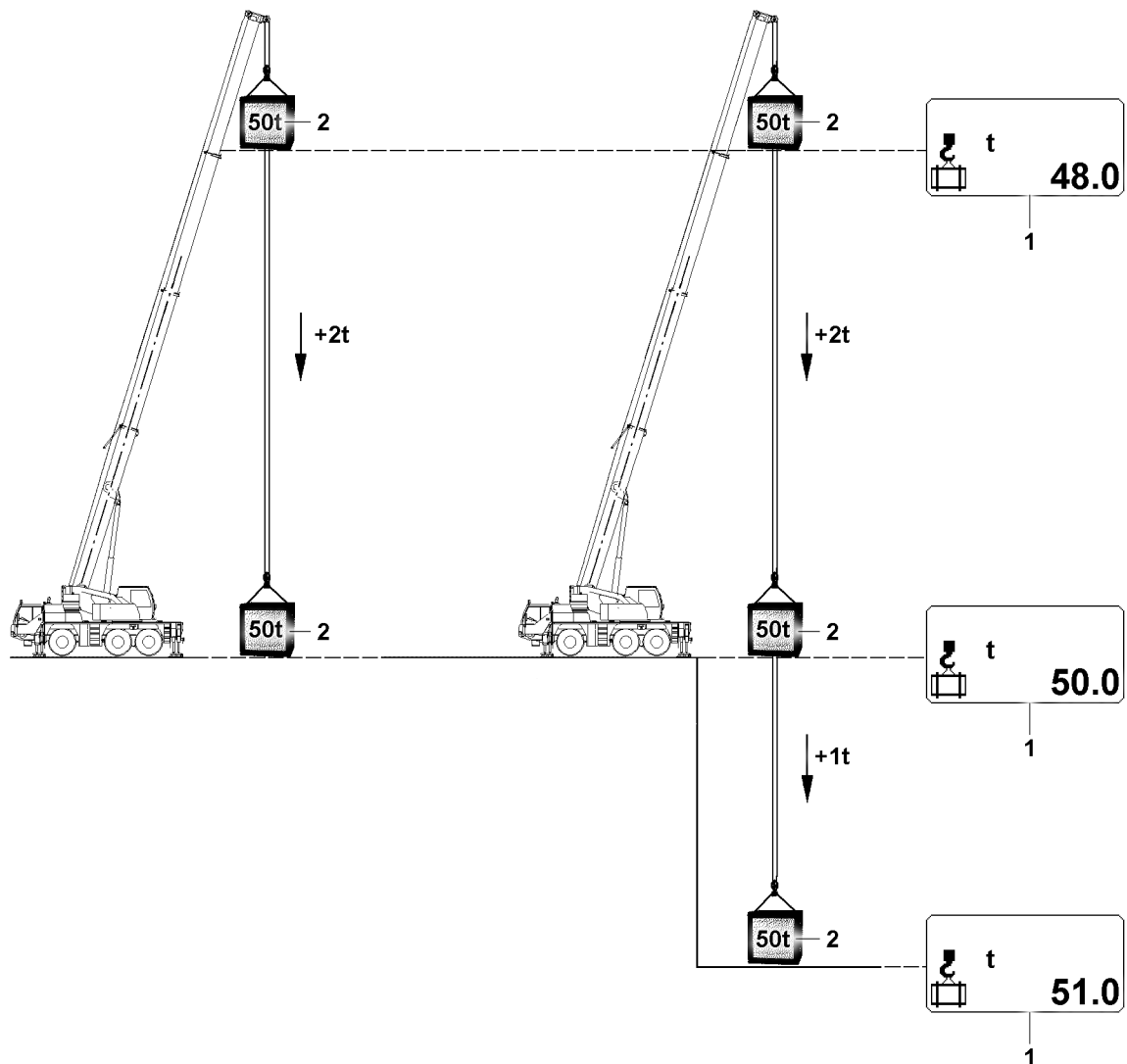


Fig.157502: Lowering the load

1 Actual load display

2 Load

The load consists of:

- Hook block
- Fastening equipment
- Actual load capacity (the component that is lifted)

When a load **2** with 100 percent utilization is picked up and then lowered, the weight of the hoist rope is calculated as the load and displayed. The utilization is then higher than 100%.



#### DANGER

When the load is lowered, the higher percentage of the hoist rope weight is **not** observed! The crane is overloaded. Death, property damage

When a load **2** is lowered:

- ▶ When taking on a load, do **not** utilize the crane 100%.
- ▶ During job planning, add the higher percentage of the hoist rope weight to the load **2**.

When lowering the load **2**, make sure that the actual load display **1** is correct and the crane overload is also displayed in the utilization bar, but the lowering movement is not shut off. In the case of an LMB overload, all crane movements are shut off, which would increase the danger of overload, however

load **2** lowering remains possible because the control assumes that the overload takes place due to lifting the load **2**.

However, the crane can also be overloaded by lowering the load **2**, especially in case of high reevings with a large hoist rope weight on the pulley head. The crane driver must observe this, so that he can relieve the crane by careful lifting again in this special case, even though the lifting and not the lowering of the load **2** is automatically shut off.

## 6 Crane operation

The maximum load capacity of the crane is not just limited by the stability, but in many cases a load-bearing component breaks when the crane is overloaded **before** the crane topples over. Components that are susceptible to buckling, such as the telescopic boom, may fail suddenly **without showing signs of distortion beforehand** if the crane is overloaded.



### WARNING

Danger of accidents for cranes with luffing cylinders!

When the luffing cylinder is in the block position, the overload protection is not functioning.

- ▶ Crane operation at block position of luffing cylinders is prohibited.

### 6.1 General



### WARNING

Load rip-off!

If the load accidentally detaches from the crane, there is a danger of fatal injury for personnel present in danger zone.

The falling load and flying debris can catch personnel.

In the event of a load rip-off, the boom system may shoot backwards, shake the crane severely or cause it to topple.

- ▶ Make sure that there is no personnel in the danger zone of the load and the crane.

A suspended load must always be kept under control. A fundamental requirement for this is the safe and delicate control of the crane's functions.



### WARNING

Danger of accident due to swaying loads!

A swaying load can damage the crane and cause it to topple.

- ▶ All crane movements must be executed slowly and delicately.
- ▶ Initiate all crane movements slowly.
- ▶ Apply the brakes slowly in all crane movements.
- ▶ Crane operation with swaying load is prohibited.

### NOTICE

Damage of rope pulleys!

- ▶ Place down hook blocks, booms, folding jibs, jib booms and boom noses in such a way that the rope pulleys do not lie on the ground and are damaged.

### 6.2 Guiding the load

The use of guide ropes is recommended to help the crane operator manage the load more precisely and to prevent the load from swaying. This will prevent undesirable movements of the load and consequent damage.

## 6.3 Danger of crushing



### WARNING

Danger of fatal injury!

Extreme caution is needed when lowering a load. Danger of fatal injury exists for personnel in the immediate area of the load being lowered.

Personnel can be severely injured or killed.

- ▶ Standing under a suspended loads is strictly prohibited.
- ▶ Observe the danger of tipping when setting down the load. For example, small support surfaces or unsuitable ground.

## 6.4 Danger of falling



### WARNING

Danger of fatal injury!

If persons are on the suspended load, then they can fall down and be severely injured or killed.

- ▶ Remaining on a suspended load is strictly prohibited.
- ▶ Remaining on or within crane components (for example: during assembly of boom sections, lattice sections) which are moved during lifting, lowering, turning or closing procedures is strictly prohibited.

## 6.5 Working in the vicinity of overhead electrical lines

If there are electricity transmission lines in the immediate vicinity of the building site, then the electrical transmission lines must be turned off by qualified electricians. If this is not possible, the danger area must be covered over or cordoned off.



### WARNING

Danger of current transfer!

If overhead electrical lines are not shut off nor covered nor blocked off, then there is an increased danger of accident due to current transfer.

- ▶ For rated voltages up to 500 kV AC: Adhere to a safety distance of 8 m.

If the crane becomes electrified despite having taken all necessary precautions, proceed as follows:

- ▶ Remain calm.
- ▶ Do not leave the crane cab.
- ▶ Warn people outside: Stay in place and do not touch the crane.
- ▶ Move the crane away from the danger zone.

## 7 Ram work or pulling sheet piles

The cranes from Liebherr Werk Ehingen GmbH have been designed to lift loads. When working with a free-riding vibrating unit for ramming and pulling operations, vibrations may be transmitted to the load bearing steel structure even if a vibration damper is used. This vibration can cause premature fatigue of the material and therefore cracks in the supporting steel structure. Furthermore, the components can loosen and fall down due to the vibrations. This work should only be performed on the mobile crane in exceptional situations or when the use of machines built specially for this work is not possible.

Before performing this work, a risk assessment must be carried out that concerns the particular risks when driving and pulling the sheet piles and handling them.

Following higher loads on the crane, shorter inspection intervals for the mobile crane and the hook block must be defined by an authorized inspector. Before and after performing the work on the free-riding jogging unit, the crane, hook block and fastening equipment as well as the vibrating unit must be inspected for damage.

The free-riding vibrating unit must be equipped with vibration dampers. Rigid connections for this equipment to the crane are prohibited!

The following vibrating unit and vibration damper combinations are permissible:

- Free-riding vibrating unit with integrated vibration dampers.
- Free-riding jogging unit combined with a vibration damper designed for this equipment.

Specifications for working with the free-riding vibrator:

- Slack rope and angular pull on the hoist rope are prohibited.
- The vibrator may only be switched on if the vibrator is connected correctly with the ramming element and the ramming element is lying flush on the ground or is partially in the ground.
- Starting or stopping the vibrating unit must take place with an eccentric moment of zero (no vibrator vibration), in order to avoid peak vibration amplitudes and resonances due to the possibility of running through the natural frequency band of the vibrator. Only after reaching the nominal speed and the operating pressure of the unit may the eccentric moment be set to the desired value or amplitude.

---

#### NOTICE

**No** vibration dampers used!

The boom or the crane can be damaged.

- ▶ Use piling equipment and pulling equipment with vibration dampers.
  - ▶ The ramming equipment and pulling equipment may **not** pass on vibrations to the boom.
- 

When pulling sheet piles, the maximum permissible pull force must be limited to 50% of the load chart value for the corresponding crane boom radius. The utilization of the hook block load may not exceed 50%.



#### Note

- ▶ When pulling sheet piles, **only** work in main boom operation or telescopic boom operation.
  - ▶ Do **not** use operating modes with a derrick, auxiliary boom or boom extensions.
- 

#### NOTICE

Maximum permissible pull force exceeded when pulling sheet piles!

The boom or the crane can be damaged.

- ▶ Limit the maximum permissible pull force to 50% of the load chart value for the corresponding crane boom radius.
  - ▶ Additionally check the pull force by measuring it.
  - ▶ Do not limit the maximum pull force of the crane **exclusively** by means of the overload protection.
- 

#### NOTICE

Hook block load utilization exceeded when pulling sheet piles!

The hook blocks or the crane can be damaged.

- ▶ Limit the utilization of the hook block load to maximum 50%.
- 

Liebherr Werk Ehingen GmbH shall not be held liable for damage caused to the machine, to the used ramming and pulling equipment, on the piling element or in the surroundings (for example adjacent buildings) due to the installation and use of the free-riding vibrator.

## 8 Crane rope pretension

Damage that can occur with multi layer spooling:

- Abrasion
- Broken wires and loop formation
- Flattenings, deformations



**NOTICE**

Crane rope pretension too low!

Loosely coiled rope layers.

Rope damage. Reduced service life of the crane rope.

Cutting of the crane rope into the lower rope layers. The load can not be lowered any further.

- ▶ To maximize the service life of the crane rope, carry out the measures in the following sections.

**Note**

- ▶ Liebherr recommends to shorten crane ropes with damage in the cross over area of the coils, in order to lengthen the service life. Shortening the crane rope, see Crane operating instructions, chapter 7.05.50.

## 8.1 Working with a high rope pull

If multiple lifts are performed with a high rope pull, loosen the lower rope layers that are rarely or never spooled out.

**NOTICE**

Loosely spooled out rope layers!

Rope damage.

Upper rope layers with a high rope pull deform the lower rope layers in the cross over area of the crane rope.

Spooling deformed rope sections over rope pulleys reduces the service life of the crane rope.

- ▶ Place a shorter crane rope.

When the lower rope layers are **not** used during repeat work:

- ▶ Increase the pretension of the lower rope layers: Spool out the entire rope length and then spool back up with the highest rope pull possible. See section "Increasing the hoist rope pretension".

### 8.1.1 Placing a shorter crane rope

**Note**

- ▶ Liebherr recommends using the entire rope length.

Unused rope sections cause the loosening of the lower rope layers.

When only a part of the crane rope length is used for a longer period of time:

- ▶ Place a shorter crane rope.

### 8.1.2 Reducing rope unwinding

**Telescopic boom**

When telescoping out less, then the smallest amount of fixed coiled up crane rope is spooled out.

- ▶ Telescope out as little as possible.

**Picking up the fastening equipment**

If the fastening equipment with a flat boom system must be picked up, then the smallest possible amount of crane rope is spooled up loose.

- ▶ Establish a flat boom system: Telescope out or luff up the boom.
- ▶ Pick up the fastening equipment.

### 8.1.3 Restoring hoist rope pretension

#### Brief description

If a multi-pulley hook block is reeved, then the entire hoist rope length can be spooled out from the rope drum.

- ▶ Spool the hoist rope out until three safety coils.
- ▶ Create 10 % maximum strand pull: Attach the load.

While the hoist rope is spooled up:

- Hold the load just off the ground.
- In the permissible range of the load chart of the relevant set up configuration: Increase the load radius by luffing down.
- ▶ Spool the hoist rope up.

#### Description using the example LR 1600-2, SL3F

This section explains the procedure with the help of the set up configuration for LR 1600-2 with boom system SL3F.

The crane-specific parameters ensure that rope is spooled out until four rope coils and as many rope coils with pretension as possible can be spooled up.

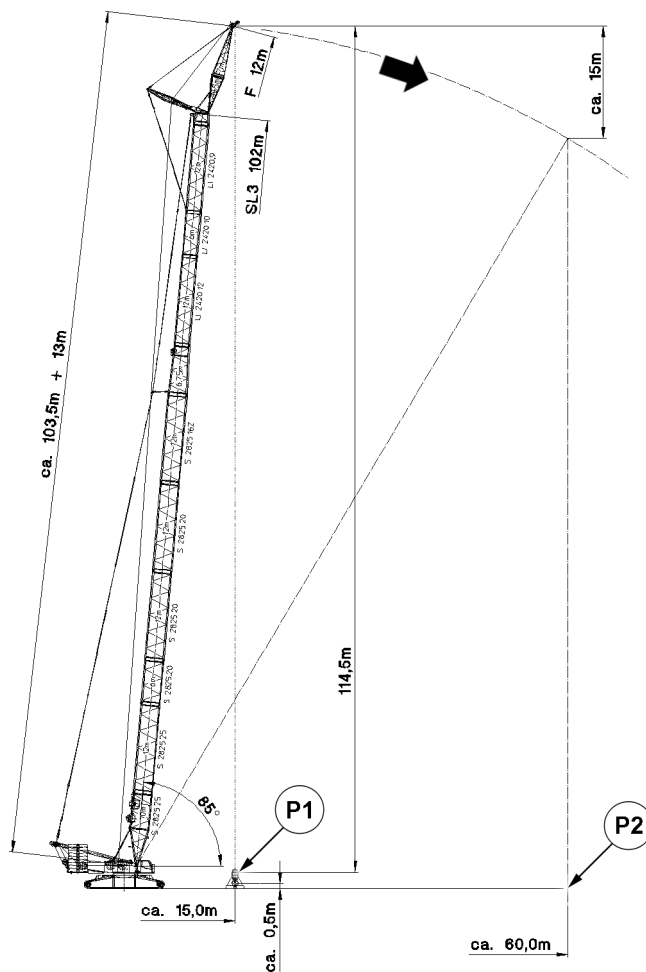


Fig.127131: LR 1600-2, SL3F: Spooling up hoist rope with pretension

Boom radius	Load	10 % of maximum strand pull
60 m	14.4 t	1.8 t

*Load example: LR 1600-2, SL3 102, F12, according to the load chart*

Hoist rope for this example:

- Hoist rope with a length of 1050 m

Hook block for this example:

- Hook block 200 DM, 5-pulley, reeved 8 times
- The weight of the hook block with ten auxiliary weights is 7.0 t

Make sure that the following prerequisites are met when hanging the load:

- Load is hung as short as possible.
- For a boom radius of 15.0 m, the hoist rope can be spooled out on the winch until four coils.

To reach sufficient rope pull, another load must be hung in addition to the hook block.

The additional load of 7.4 t is calculated from the difference between the load 14.4 t and the weight of the hook block 7.0 t.

- ▶ Fasten the load with 7.4 t.
- ▶ Until the load is 0.5 m above the ground: Lift the load.
- ▶ Set the boom system to boom radius 15.0 m.
- ▶ Spool the hoist rope out.

**Result:**

- In position **P1** there are 9 m of hoist rope (four coils) on the hoist winch:

Spooled out rope section	Length
8-way reeving, distance of ground to the F-jib with boom radius 15 m	8 x 114.5 m = 916.0 m
Winch to FA-frame	103.5 m
F-head	13.0 m
Rope pulleys	7.5 m
Total of spooled out hoist rope	1040.0 m

*Rope lengths in position P1*

While the hoist rope is spooled up:

- Hold the load just off the ground.
- In the permissible range of the load chart of the relevant set up configuration: Increase the load radius by luffing down.
- ▶ Until a boom radius of 60.0 m is reached: Spool up the hoist rope and luff down the boom at the same time.
- ▶ Set down the load.

**Result:**

- The pretension of the first and second position of the rope coils is restored.
- In position **P2** there are 130 m of hoist rope (23 coils) on the hoist winch:

Spooled up rope section	Length
Four coils initial situation	9 m
8-way reeving, F-jib height difference with boom radius 60 m	8 x 15 m = 120 m
Total of spooled up hoist rope	130 m

*Rope lengths in position P2*

- ▶ Make sure that the hoist rope on the winch remains pretensioned: Reeve out the hook block and reeve in with slower reeving. See Reeving plan.

## 8.2 Picking up and lowering overhead loads

The load is picked up overhead in the following application examples:

- Repowering wind power plants
- Disassembly of slewing tower cranes

---

### NOTICE

Load picked up overhead with loosely coiled rope layers!

The rope pull increases when the load is picked up. The rope coils in the lower rope layers move laterally and are compressed. The hoist rope can cut into the lower rope layers.

- ▶ Spool up the hoist rope without a load only with rope pretension.
- 

### NOTICE

Load lowered with cut in rope layers!

The hoist rope is pulled jerkily from the lower rope layers. Vibrations are introduced into the crane system.

Cut in hoist rope clamped between the lower rope layers. The load can **not** be lowered any further.

- ▶ To prevent the cutting in of the hoist rope, carry out the measures in the following sections.
- 

### 8.2.1 Increasing the reeving number

---

#### NOTICE

Higher reeving number than indicated on the load chart!

Slack rope formation.

The crane load drops due to additional weight from the rope strands and hook block.

If a higher reeving number is not considered in the set up configuration, the load display on the LIC-CON monitor no longer corresponds.

- ▶ Redetermine the hook block weight according to the load chart manual and adjust if necessary.
  - ▶ Check if the crane load is sufficient for higher reeving.
  - ▶ After telescoping out, check if the hook block can still reach the desired position for putting down the load.
- 

A higher reeving number reduces the rope pull. A lower rope pull prevents the cutting in of the hoist rope in the lower rope layers.

- ▶ Select the highest reeving number possible for the hoist rope.

### 8.2.2 Increasing the hook block weight

---

#### NOTICE

Lift the hook block without a load!

The hoist rope is spooled up with a low rope pull. The rope layers are spooled up loose on the rope pulley.

- ▶ Increase the rope pull: Increase the hook block weight.
- 

A higher hook block weight increases the rope pull.

- ▶ Increase the hook block weight.

If the crane load is sufficient:

- ▶ Attach an auxiliary weight between the load and hook block.

### 8.2.3 Pretensioning the hoist rope with pretensioning ballast with two hook operation

The pretensioning ballast is **not** included in the Liebherr delivery scope.

---

**NOTICE**

Lift the hook block without a load!

The hoist rope is spooled up with a low rope pull. The rope layers are spooled up loose on the rope drum.

- ▶ Pretension the hoist rope with pretensioning ballast with two hook operation.
- 

Make sure that the following prerequisites are met:

- The crane is equipped for two hook operation.
- The pretensioning ballast is present.

Properties of the pretensioning ballast:

- Developed by Liebherr.
- The weight is 4 t.
- Special tow coupling

- ▶ Fasten the pretensioning ballast on the main hook and on the auxiliary hook.

The pretensioning ballast is lifted with the main hook, the auxiliary hook is carried along without a load.

- ▶ Lift the pretensioning ballast.

When the main hook has reached the required height:

- ▶ Stop the main hook.

After the load is completely transferred to the auxiliary hook, the main hook fastening ropes release automatically.

- ▶ Lift the auxiliary hook until the pretensioning ballast hangs completely on the auxiliary hook.

When the main hook fastening ropes have released:

- ▶ Lower the pretensioning ballast with the auxiliary hook and place it on the ground.

**Result:**

- The full load is present on the main hook.

---

Empty page!

LWE/LR 1800-1-0-000/27200-07-02/en

## 4.10 Driving from the crane cab

1	Prerequisites for driving the crane (crawler operation)	2
2	Displays on the LICCON monitor	6
3	Preparing for driving the crane	10
4	Driving the crane: Load chart available	13
5	Driving the crane: No load chart is available	14
6	Driving the crane: Ballast trailer installed	18
7	Driving the crawler crane	20

# 1 Prerequisites for driving the crane (crawler operation)

For driving the crane (crawler operation) the conditions of the travel route are the deciding factor.

- For **ground inclinations within the area of a valid load chart Driving with load** is possible at a slow speed. The ground must be sufficiently level and capable of supporting the load. The supplements to the load charts for driving the crane must be observed.
- For **ground inclinations outside the area of a valid load chart Driving without load** is possible at a slow speed up to certain inclination ranges. The ground must be sufficiently level and capable of supporting the load.

Driving the crane: Load chart available

- Valid and regular load chart available
- With load on the hook
- Without load on the hook

Driving the crane: No load chart is available

- Only without load on the hook
- Only without derrick ballast
- With specifications and limitations for the set up configuration of the crane



## WARNING

The crane can topple over!

If the permissible inclinations of the crane are exceeded, the crane can topple over.

Death, severe bodily injuries, property damage.

- ▶ Do not exceed the permissible inclinations of the crane.
- ▶ Do not exceed the permissible surface pressures for the travel route.



## WARNING

The crane can topple over!

If the following specifications, instructions and prerequisites are not observed, then the crane can topple over or be overloaded.

Death, severe bodily injuries, property damage.

- ▶ The crane operator is responsible for adhering to all specifications, instructions and prerequisites in the crane documentation.
- ▶ The crane operator may not drive the crane if not all specifications, instructions and prerequisites in the crane documentation can be adhered to.
- ▶ The crane operator is responsible for the correct and complete data entry into the LICCON computer system and into the LICCON job planner, if applicable.
- ▶ All acceleration and delay maneuvers must be initiated with extreme caution and at the lowest possible speed.
- ▶ Depending on the situation, additional observers, who are acoustically or visually in contact with the crane operator (for example by radio or sight), may have to support the crane operator with shared responsibility.



## WARNING

Combined crane movements at crawler operation!

- ▶ In crawler operation, do not carry out any additional crane movements.
- ▶ Carry out additional crane movements when the crane is at a standstill, if possible.

Make sure that the following prerequisites are met:

- No personnel or objects are within the danger zone.
- The crane is in an operational condition.
- The crane is in a set up configuration permitted for travel operation.
- The installed ballast (central ballast, counterweight and derrick ballast) is locked and secured.
- There are no loose objects on the crane.
- The assembly brackets of the crawler carrier are folded down.



## 1.1 Travel route



### WARNING

The crane can topple over!

If the following specifications, instructions and prerequisites are not observed, then the crane can topple over or be overloaded.

Death, severe bodily injuries, property damage.

- ▶ The transfer from the horizontal to an uphill slope and from an uphill slope to the horizontal must be made evenly, i.e.: There may be no edges that can cause the crane to topple over. Any inclination changes must be made continuously.
- ▶ If the travel route cannot safely absorb the surface pressure, then measures must be taken to be able to safely transfer the forces to the ground.
- ▶ If measures were taken to transfer the forces to the ground, then they must be checked by an expert before starting to drive for proper execution and sufficient supportability.
- ▶ An insufficient ground condition can cause accidents, for example the crane can slide away to the side and as a result get into an impermissible incline position.

Make sure that the following prerequisites are met:

- Before starting to drive, the travel route was determined.
- Before starting to drive, the condition of the ground has been checked.
- The entire travel route can safely absorb the surface pressure.
- All inclinations occurring on the travel route can be driven safely by the crane.
- The entire travel route is free of obstacles.
- The friction coefficient between crawler travel gear and ground is sufficiently large to absorb the occurring drive forces or to exclude that the crane slips away in an incline position.
- Possible environmental influences for driving the crane (among others precipitation and wind) were taken into account for the travel route.
- The travel route was selected and prepared in such a way that the boom system can be taken down at any time.
- Select the travel route in such a way that no steering movements are required, if possible.
- With a load on the hook: Setting down the load is possible at any time.
- The entire travel route is secured as a danger zone.
- The travel route has been selected in such a way that it is possible to maintain a sufficient distance from local facilities (power lines, etc.).

For ground outside the range of a valid load chart, the following applies additionally:

- Before starting to drive, the travel route was checked in connection with the actual set up configuration of the crane on the LICCON job planner.
- Before starting to drive, the optimum positions for the boom system were determined to obtain as even a surface pressure as possible - the LICCON job planner can be used for this purpose.



### Note

- ▶ For a detailed description of the LICCON job planner on the crane, see the operating instructions LICCON job planner.
- ▶ For a detailed description of the LICCON job planner computer program, see the separate description.

### 1.1.1 Optimizing measures for the travel route

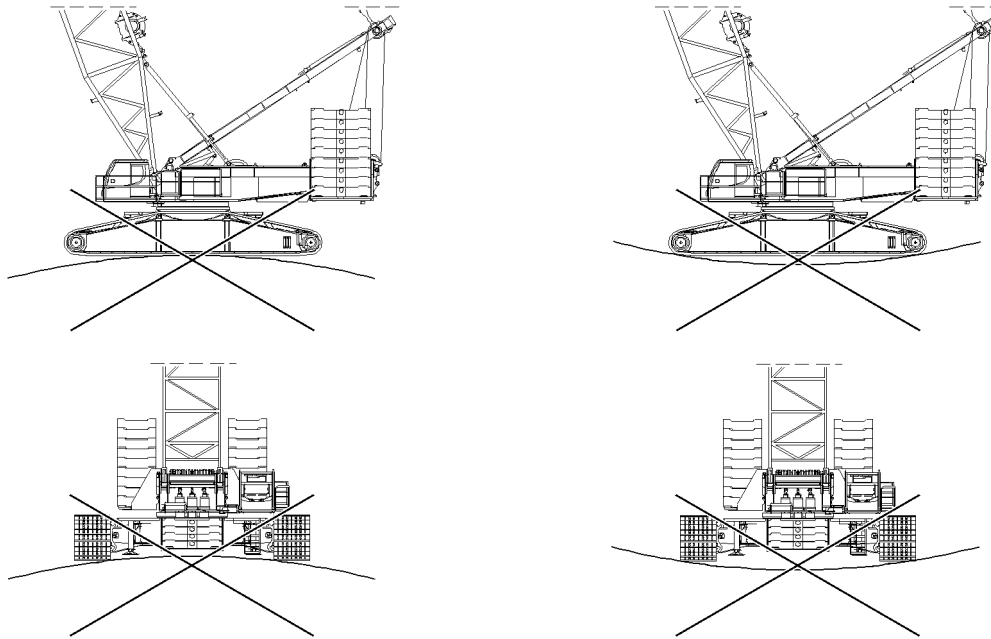


Fig.119598: Depressions, crests, track grooves and other uneven areas of the travel route cause localized pressure on the crawler travel gear

#### NOTICE

Damage to the crawler travel gear!

Continuous localized pressure on the crawler travel gear causes increased wear. Continuous increased wear can cause damage to the crawler travel gear.

- ▶ Set up the travel routes in such a way that the crawler travel gear is not subjected to continuous localized pressure.
- ▶ For extended travel operation shorten the maintenance intervals.

Through the following configuration features of the travel route, wear on the crawler travel gear can be minimized:

- Shapings of the travel route (such as depressions, crests, track grooves) have been eliminated via suitable measures.
- Lay out the travel route in such a way that no steering movements are required, if possible.

## 1.2 Calculation of required length of transfers on uphill / downhill slopes

The required length  $L$  for transfers results from the existing uphill angle  $\alpha$  and the length of the crawlers  $LC$ .

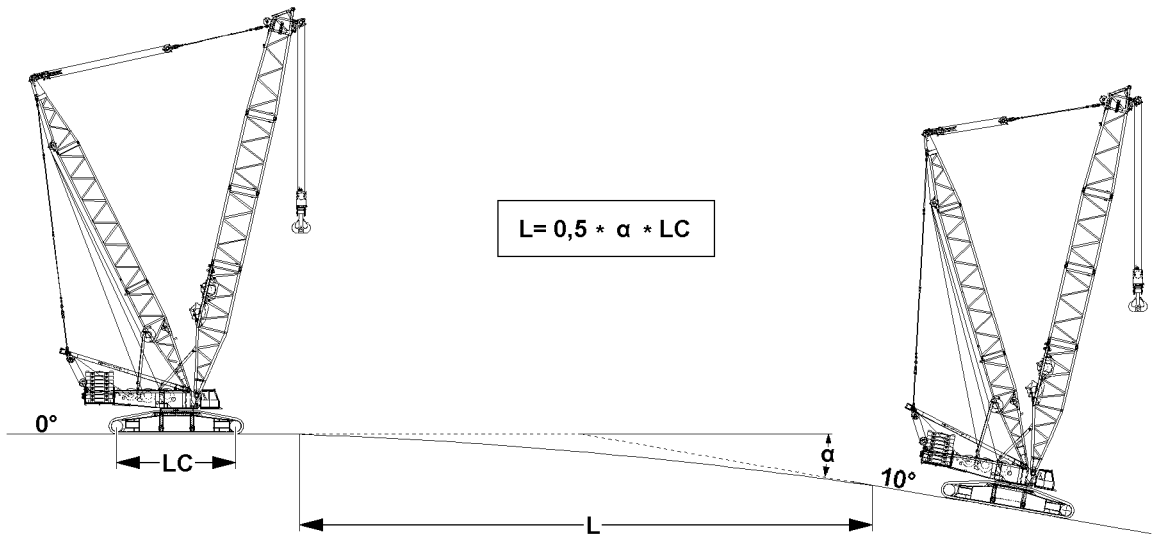


Fig.119612: Visualization: Length of transfers on uphill / downhill slopes

Abbreviation	Description
L	Required length of transfers
α	Angle rising / falling inclines in degrees
LC	Length of crawlers between drive wheels / steering wheels

### 1.2.1 Calculation example

Given:

α = 10°

LC = 17.3 m (only use the actual crane value!)

Wanted:

L = ?

Calculation formula						
L	=	0.5	*	α	*	LC
L	=	0.5	*	10	*	17.3 m
L	=	86.5 m				

LWE/LR 1800-1-0-000/27200-07-02/en

## 1.3 Travel gear / hydraulic motors / track rollers

### NOTICE

Damage to the travel gear, hydraulic motors and track rollers!

On longer travel routes and / or when driving uphill / downhill, the travel gears, hydraulic motors and / or track rollers can be overheated and damaged.

- ▶ Make sure that the travel gears - before driving the crane - have the maximum fill level.
- ▶ With suitable measuring devices make sure that the maximum permissible temperature of the travel gears, hydraulic motors and / or track rollers in travel operation over longer distances is below 90 °C. For a short time (**maximum** 10 minutes), the temperature may increase to a value between 90 °C and 100 °C.
- ▶ As soon as the maximum permissible temperature in one position is exceeded, take a break from driving for cooling down.
- ▶ The crane operator is responsible for any damage to travel gears, hydraulic motors and / or track rollers.

When the maximum permissible temperature range on a travel gear and / or hydraulic motor is reached:

- ▶ Take a break until the temperature on travel gear(s), hydraulic motor(s) and / or track rollers had dropped considerably.

Maximum permissible temperature range on travel gear(s) / hydraulic motor(s)		
	to 90 °C	between 90 °C and 100 °C
Duration of exposure	continuous	not longer than 10 minutes

When the temperature of all travel gears / hydraulic motors has dropped below 90 °C:

- ▶ Travel operation is permissible again.

## 2 Displays on the LICCON monitor



### WARNING

Danger of accident due to deviating set up configuration!

If the actual set up configuration of the crane deviates from the entries and settings in the Set up program, then the overload protection is not correctly set.

An incorrectly set overload protection calculates the actual load incorrectly and transmits faulty display values.

The crane can be overloaded without noticing it and topple over or collapse as a result.

Death, severe bodily injuries, property damage.

- ▶ The entries and settings in the set up program must match the actual set up configuration of the crane.



### WARNING

Incorrect display values!

If the display values do not increase correspondingly when lifting known weights, an erroneous display value may be present.

If the crane is operated with erroneous display values, then the crane can be overloaded.

This could result in serious accidents.

- ▶ When lifting the hook block off the ground check if the display value for the actual load increases correspondingly.
- ▶ When lifting the derrick ballast off the ground check if the display value for the pulled derrick ballast  $BA_{\text{pulled}}$  increases correspondingly.
- ▶ When lifting the load off the ground check if the display value for the actual load increases correspondingly.

Make sure that the following prerequisites are met:

- The actual set up configuration of the crane matches the entries and settings in the set up configuration.
- The assignment of the crane to the displays on the LICCON monitor is clear.
- All displays function perfectly.



**Note**

- ▶ For a detailed description of the displays on the LICCON monitor, see chapter 4.02.
- ▶ For a detailed description of the safety equipment, see chapter 4.04.

## 2.1 Center of gravity display on the LICCON monitor



**WARNING**

Shifting of the center of gravity!

The calculation of the values for the display of the center of gravity in the LICCON monitor are based on ideal assumptions.

- ▶ Side deformations of the boom system due to wind, inclined position and elastic resilience of the steel structure are not taken into account but they can lead to a shifting of the center of gravity.

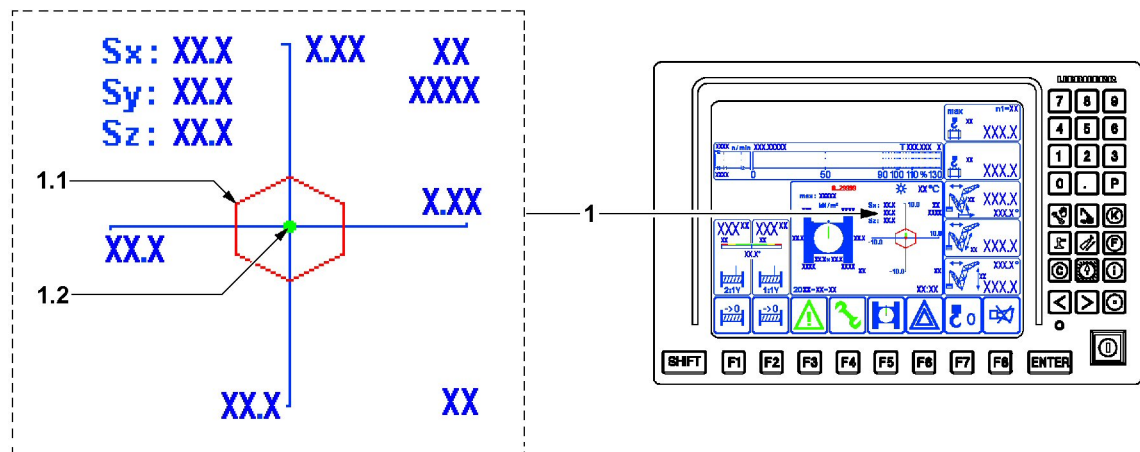


Fig.115325: Center of gravity display

Center of gravity 1 display	
Position	Name
1.1	Core area
1.2	Center of gravity



**WARNING**

Center of gravity of the crane is outside the core area!

If the center of gravity 1.2 of the crane is outside the core area 1.1, then the crane can topple over. Death, severe bodily injuries, property damage.

- ▶ To drive the crane, the center of gravity 1.2 must always be within the core area 1.1.
- ▶ If the center of gravity 1.2 is outside of the core area 1.1, then it is prohibited to drive the crane.

The following specifications and instructions must be observed:

- By luffing the boom system up and down, the position of the center of gravity 1.2 must be corrected in such a way that the overall center of gravity remains within the core area 1.1.

LWE/LR-1800-1-0-000/27200-07-02/en

## 2.2 Surface pressure display on the LICCON monitor



### WARNING

Increased surface pressure!

The calculation of the values for the display of the surface pressure in the LICCON monitor are based on ideal assumptions.

- ▶ Side deformations of the boom system due to wind, inclined position and elastic resilience of the steel structure are not taken into account but they can lead to an increase of the surface pressure.

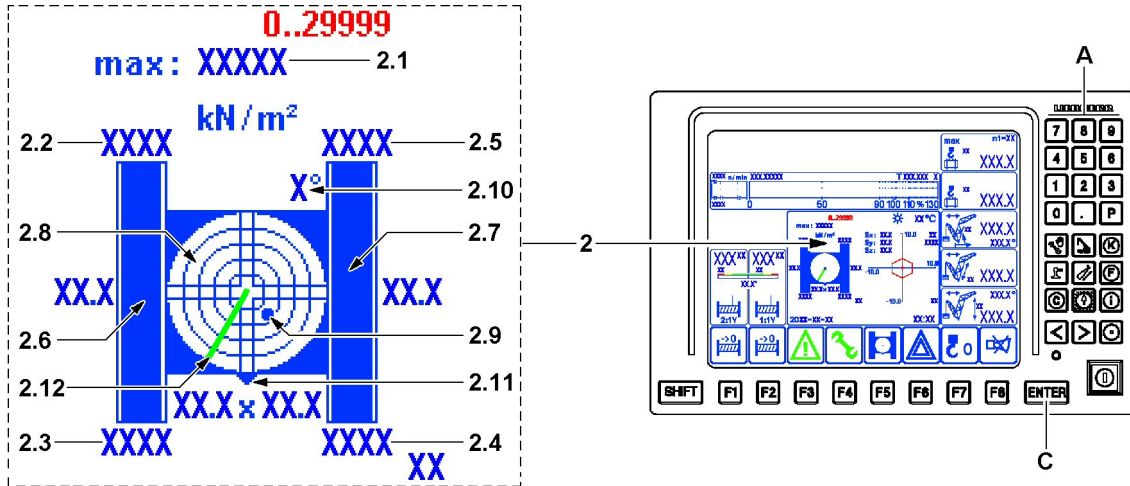


Fig.119613: Surface pressure display

Surface pressure 2 display	
Position	Name
2.1	Maximum surface pressure
2.2	Surface pressure right rear
2.3	Surface pressure right front
2.4	Surface pressure left front
2.5	Surface pressure left rear
2.6	Right crawler placement surface
2.7	Left crawler placement surface
2.8	Incline indicator <sup>1)</sup>
2.9	Point <sup>1)</sup>
2.10	Display resolution <sup>2)</sup>
2.11	Marker "Front side of crawler carrier" <sup>3)</sup>
2.12	Boom direction <sup>4)</sup>

1) The graphic display is in the form of a spirit level with a moving dot **2.9** representing the air bubble.

2) This value describes the resolution of the graphic view. The resolution is matched automatically to the inclination.

3) The front on the crawler travel gear is always on the side where the chain tension devices for the crawler carriers are located.

4) Current boom direction in reference to the displayed icon.

**WARNING**

Surface pressure too high!

If the maximum surface pressure is exceeded, the crane can topple over.

Death, severe bodily injuries, property damage.

- ▶ Do not exceed the maximum surface pressure.
- ▶ The value entered in the LICCON computer system for the maximum surface pressure **2.1** must match the actual conditions of the travel route.

**WARNING**

The crane can topple over!

If the permissible incline of the crane is exceeded, the crane can topple over.

- ▶ Do not exceed the permissible incline from the load chart.
- ▶ Do not exceed the permissible inclination for driving the crane, see the following sections.

**Note**

- ▶ The placement surface of the crawler carriers is graphically shown on the surface pressure display.
- ▶ If the resulting surface pressure can be distributed so that the maximum surface pressure of the travel route is not exceeded **and** the resulting forces can be transferred safely into the ground, then the stability of the crane is ensured.
- ▶ Incline indicator **2.8** with number values, see section "Display of incline in LICCON monitor".

The following specifications and instructions must be observed:

- The maximum surface pressure that may be reached must be entered as the maximum surface pressure **2.1**.
- By luffing the boom system up and down, the resulting surface pressure must be distributed in such a way that the maximum surface pressure of the travel route is not exceeded.
- The inclinations that are reached on the travel route are known and are taken into account.
- As soon as the crane shows the tendency that the permissible inclination could be exceeded, the load must be set down. If necessary, driving the crane must be interrupted.

### 2.2.1 Entering the maximum permissible surface pressure

Make sure that the following prerequisites are met:

- The Crane operation program is called up.
- The maximum permissible surface pressure of the travel route is known.

- ▶ Press the enter key **C**.

**Result:**

- The value for the maximum surface pressure **2.1** can be changed.
- ▶ Enter the value for the maximum permissible surface pressure via the keypad **A**.
- ▶ Press the enter key **C**.

**Result:**

- The new value for the maximum surface pressure **2.1** appears.
- ▶ Check the value for the maximum permissible surface pressure.

### 2.3 Display for the inclination on the LICCON monitor

The display of the inclination is additionally shown for the monitored auxiliary functions.

Display of the inclination of the crane to the horizontal in the longitudinal and lateral direction. The display is graphic as well as numeric.

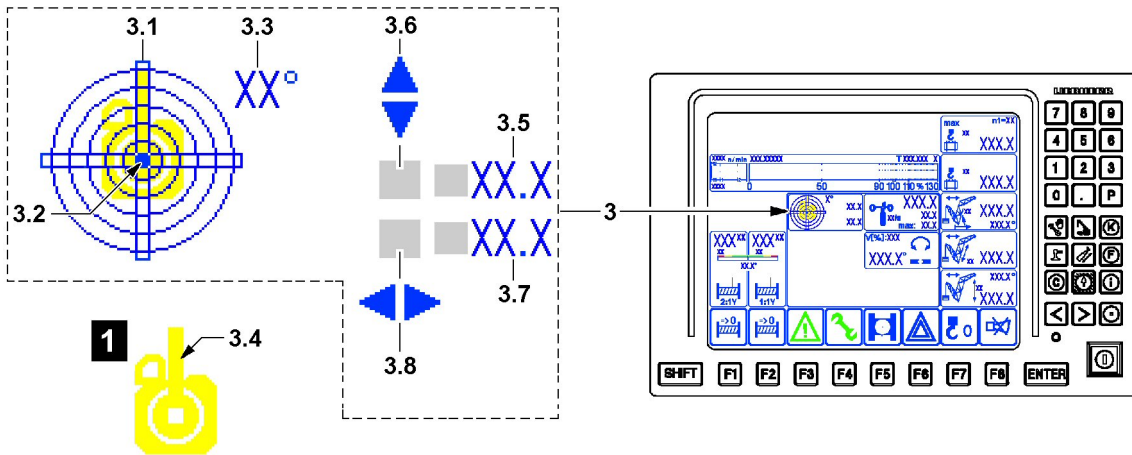


Fig.115327: Incline display

Incline 3 display	
Position	Name
3.1	Sight gauge
3.2	Bubble
3.3	Display resolution
3.4	Boom position <sup>3)</sup>
3.5	Incline in longitudinal direction
3.6	Incline direction
3.7	Incline in lateral direction
3.8	Incline direction

3) The boom position in the spirit level 3.1 is highlighted as orientation aid, see detail 1. The boom position corresponds to the "viewing direction to the front" from the crane cab in relation to the spirit level 3.1.



**WARNING**

The crane can topple over!

If the permissible incline of the crane is exceeded, the crane can topple over.

- ▶ Do not exceed the permissible incline from the load chart.
- ▶ Do not exceed the permissible inclination for driving the crane, see the following sections.

The following specifications and instructions must be observed:

- The inclinations that are reached on the travel route are known and are taken into account.
- As soon as the crane shows the tendency that the permissible inclination could be exceeded, the load on the hook and / or the suspended ballast must be set down.

## 3 Preparing for driving the crane

### 3.1 Distribution of the surface pressure

While driving, pay attention in all driving conditions to the ratio of the surface pressure between the front and the rear sides of both crawlers.

In the following examples it is assumed that the crawler travel gear and the turntable are oriented to the front.



Distribution of the surface pressure	
Position	Name
1	Center of gravity
2	Surface pressure on the front
3	Surface pressure on the rear
4	Boom position <sup>1)</sup>
5	Marker "Front side of crawler carrier" <sup>2)</sup>
6	Crawler carrier chain tension device
7	Main boom angle display
8	Core area
$\alpha$	Main boom angle

1) The boom position corresponds to the "viewing direction to the front" from the crane cab.

2) The front on the crawler travel gear is always on the side where the chain tension device for the crawler carriers is located.

Before driving the crane is it required to position the boom in such a way that a suitable distribution of surface pressure for driving is obtained.

### 3.1.1 Examples for the distribution of surface pressure

#### Surface pressure: Center of gravity in the middle

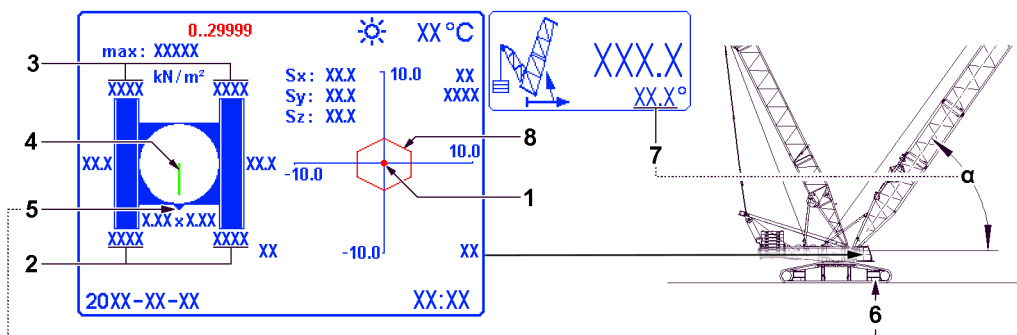


Fig.153785: Center of gravity 1 in the middle

- The surface pressure in the front 2 is the same as the surface pressure in the rear 3.

#### Surface pressure: Center of gravity in the rear

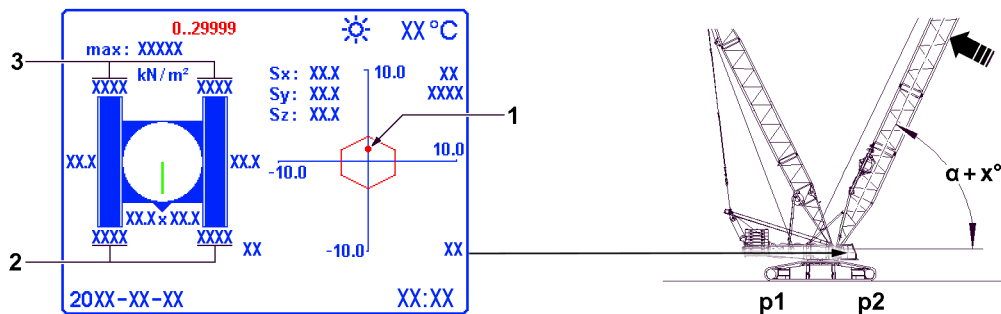


Fig.153786: Center of gravity 1 in the rear

- The main boom was luffed up.
- The surface pressure on the rear 3 is higher.

LWE/LR 1800-1-0-000/27200-07-02/en

**Surface pressure: Center of gravity in the front**

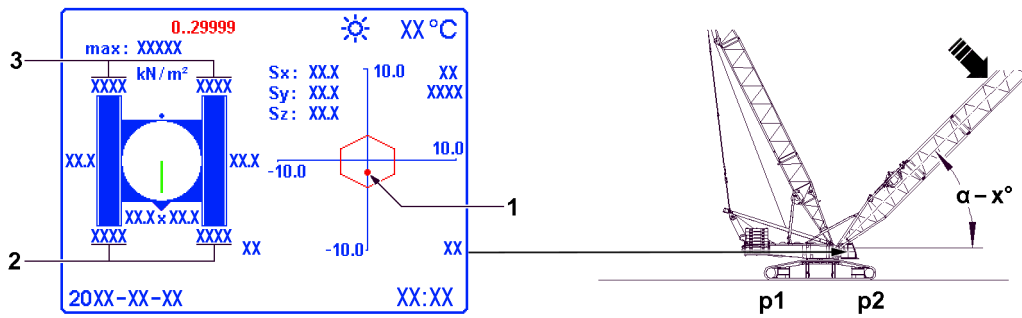


Fig.153787: Center of gravity 1 in the front

- The main boom was luffed down.
- The surface pressure on the front 2 is higher.

**3.2 Suitable distribution of the surface pressure**

If the distribution of the surface pressure is even (surface pressure on the front 2 and surface pressure on the rear 3 have approx. the same value), then steering is difficult or not possible at all.

For the suitable distribution of the surface pressure, the following applies:

- p1 = Surface pressure on the side of both crawlers with less load.
- p2 = Surface pressure on the side of both crawlers with more load.
- The center of gravity 1 must always be within the core area 8.

Distribution of surface pressure p1 to p2				
p1	/	p2	=	should be greater than 0.3

In case of unfavorable distribution of surface pressure it is required to position the boom system in such a way that a suitable distribution of the surface pressure is reached for driving.

- ▶ The turntable should be turned while at a standstill: The boom system should be luffed in such a way that the crawlers are subjected to a load as evenly as possible.
- ▶ Driving uphill: The boom system should be luffed in such a way that the side of the two crawlers that has less load is in the rear.
- ▶ Driving downhill: The boom system should be luffed in such a way that the side of the two crawlers that has less load is in the front.



**Note**

- ▶ The side with the higher surface pressure should be within the field of vision of the crane operator or the auxiliary personnel. This will ensure that it will be recognized early on that the crawler carriers sink in and respective countermeasures can be initiated.

**3.3 Steering ability**



**Note**

High load on the crane!

When driving the crane, steering movements cause a high load on the crane travel gear.

- ▶ If possible, forego steering movements with a load on the hook and / or derrick ballast.
- ▶ Select the travel route in such a way that no steering movements are required, if possible.
- ▶ If not otherwise possible, before initiating a steering movement, set down the load and / or derrick ballast.

The steering ability depends on the following factors:

- Friction conditions under the chains.

- Evenness of the ground:
  - Steering is not possible if the crawler travel gear is only making contact with the ground in the front and rear.
- Load bearing capacity of the ground:
  - If the crawler travel gear sinks into the ground, then the steering ability is significantly restricted.
- Position of the total center of gravity:
  - If the total center of gravity - taking the suspended load into account - is in the center of the crane, then steering is hard or not possible at all.

Steering ability can be improved by:

- Placing metal sheeting, sand, gravel, water underneath.
- Taking the load bearing capacity of the ground and the position of the center of gravity into account: Changing the center of gravity.

## 4 Driving the crane: Load chart available



### WARNING

The crane can topple over!

If the following conditions are not observed, the crane can topple over.

Death, severe bodily injuries, property damage.

- ▶ The ground must be sufficiently level and within the range of the permissible inclination.
- ▶ The ground must be able to safely absorb the maximum occurring surface pressures.



### WARNING

The crane can topple over!

If the permissible inclinations of the load charts are exceeded when driving the crane, then the crane can topple over or be overloaded.

If the permissible wind speeds of the load charts are exceeded when driving, then the crane can topple over or be overloaded.

Death, severe bodily injuries, property damage.

- ▶ If the inclinations are too large then driving the crane is prohibited.
- ▶ If the wind speeds are too high then driving the crane is prohibited.

Make sure that the following prerequisites are met:

- The permissible inclinations from the load charts are adhered to.
- The maximum permissible wind speeds from the load charts are adhered to.
- The maximum permissible travel speed is adhered to.
- Driving in curves: slewing gear freewheeling is actuated.

Permissible inclinations	
Overall inclination	Load charts for inclination $\pm 0.3^\circ$
Overall inclination <sup>1)</sup>	Load charts for inclination $\pm 1.0^\circ$

1) Only certain boom systems

Permissible wind speeds	
Wind speeds	See load charts

Driving with a load is possible under the conditions of the regular load chart:

- The permissible inclinations from the load charts apply for driving.
- Take the maximum permissible wind speeds from the load charts.
- Take the maximum permissible driving speed from the following sections.

## 4.1 Driving with a load on the hook and / or derrick ballast



### WARNING

The crane can topple over!

If the load on the hook or the suspended ballast collides with the crane, the ground or obstacles when driving, then the crane can be damaged and topple over.

Death, severe bodily injuries, property damage.

- ▶ Make sure that the load on the hook or the suspended ballast does not collide with anything when driving.



### WARNING

Danger of accident!

If the suspended load or the suspended derrick ballast starts to swing, then the crane operator can lose control over the crane.

If the following prerequisites are not observed, the crane can topple over.

This could result in serious accidents.

- ▶ Do not exceed the maximum permissible driving speed.
- ▶ Avoid jerky driving movements.
- ▶ The attached load and suspended derrick ballast must be secured to prevent it from swinging. If oscillating movements should occur, set the load / derrick ballast as fast as possible down on the ground. Hereby pay attention to the limit values of the load moment display and the F-load display.
- ▶ Driving and steering the crawler at the same time with a suspended load and / or installed derrick ballast is prohibited.

Make sure that the following prerequisites are met:

- The permissible inclinations from the load charts are adhered to.
- Without derrick ballast: the travel speed may **not** exceed 0.1 m/s **or** 6 m/min **or** 0.36 km/h.
- With derrick ballast: the travel speed may **not** exceed 0.05 m/s **or** 3 m/min **or** 0.18 km/h.
- Crawler operation rapid gear may not be engaged.
- The attached load hangs freely.
- The attached load must be secured to prevent it from swinging back and forth, if necessary.
- Hold the attached load as close to the ground as possible.
- Hold the attached load with the smallest boom radius as possible.
- Derrick ballast: the suspended ballast hangs freely.
- Derrick ballast: the suspended ballast is lifted off the ground maximum 250 mm.
- Derrick ballast: the derrick ballast must also be secured to prevent it from swinging back and forth.

## 4.2 Driving without a load on the hook and without derrick ballast

Make sure that the following prerequisites are met:

- Driving the crane takes place according to the inclinations from the load charts.
- Take the maximum permissible wind speeds from the load charts.
- The travel speed may not exceed 0.4 m/s **or** 24 m/min **or** 1.44 km/h.
- The hook block is secured to prevent it from swinging back and forth.

## 5 Driving the crane: No load chart is available



### WARNING

The crane can topple over!

If the following note is not observed, the crane can topple over.

Death, severe bodily injuries, property damage.

- ▶ Driving uphill must always be anticipatory, with utmost caution and at the slowest speed.
- ▶ Drive on the start of uphill and downhill slopes (for example ramps) at a right angle.
- ▶ It is prohibited to let the crane tip over an edge.

**WARNING**

The crane can topple over!

If the crane is driven outside the load chart with a load or with the derrick ballast, accidents can occur. The crane can topple over or be overloaded.

Death, severe bodily injuries, property damage.

- ▶ Driving the crane with a load outside the load chart is prohibited.
- ▶ Driving the crane with derrick ballast outside the load chart is prohibited.

Make sure that the following prerequisites are met:

- There is no load on the hook.
- No derrick ballast is installed.
- The crane engine oil level is at the maximum fill level.
- The oil level in the hydraulic oil tank must be lowered by extending the cylinders so that overflow is not possible.
- The contents of the fuel tank must be reduced so that overflow is not possible, even with the largest crane inclination.
- The travel speed may **not** exceed 0.1 m/s **or** 6 m/min **or** 0.36 km/h.
- Driving in curves: slewing gear freewheeling is actuated.
- The maximum permissible wind speed of 9 m/s is adhered to.
- The permissible lateral incline when driving without a load is adhered to.
- The permissible longitudinal inclination when driving without a load is adhered to.

Permissible lateral inclination when driving without a load and without derrick ballast		
Overall length of the main boom	Maximum permissible lateral inclination	For longitudinal inclination
Shorter than / equal to 96 m	± 3°	± 0.3°
97 m to 150 m	± 2°	± 0.3°

Permissible longitudinal inclination when driving without a load and without derrick ballast		
Overall length of the main boom	Maximum permissible longitudinal inclination	For lateral inclination
To 150 m	± 10°	± 0.3°

## 5.1 Driving uphill / downhill

**WARNING**

The crane can topple over!

If the following notes are not observed, the crane can topple over.

Death, severe bodily injuries, property damage.

- ▶ The deciding factor for driving on inclines is the exact knowledge of the operational conditions at the job site.
- ▶ Specifications, instructions and prerequisites in this chapter must be adhered to.
- ▶ Driving uphill / downhill must always be anticipatory, with utmost caution and at the slowest speed.

**WARNING**

The crane can topple over!

If the crane is driven uphill / downhill with a load or derrick ballast, the crane can topple over.

If the angle of the boom system is not matched to the incline when driving the crane on inclines, then the crane can topple over.

Death, severe bodily injuries, property damage.

- ▶ Match the angle of the boom system to the incline.
- ▶ Driving uphill with a load and / or derrick ballast is prohibited.

**WARNING**

The crane can topple over!

If the turntable is not parallel to the crawler travel gear when driving the crane on uphill or downhill inclines, then the crawler crane can topple over or be overloaded.

- ▶ For ground inclinations of more than  $0.3^\circ$ , make sure that the turntable is aligned parallel to the crawler travel gear in the  $0^\circ$  or  $180^\circ$  position before driving the crawler crane!

**WARNING**

The crane can topple over!

On ground inclinations of more than  $\pm 0.3^\circ$  the travel direction may not be changed.

- ▶ On ground inclinations of more than  $\pm 0.3^\circ$  plan the travel route in such a way that a travel direction change is not necessary.

**WARNING**

The crane can topple over!

A longitudinal inclination of more than  $\pm 0.3^\circ$  and a lateral inclination of more than  $\pm 0.3^\circ$  may not be combined.

- ▶ For a longitudinal inclination of more than  $\pm 0.3^\circ$  a maximum lateral inclination of  $\pm 0.3^\circ$  always applies. For a lateral inclination of more than  $\pm 0.3^\circ$  a maximum longitudinal inclination of  $\pm 0.3^\circ$  always applies.

Make sure that the following prerequisites are met:

- The turntable is aligned parallel to the crawler travel gear,  $0^\circ$  or  $180^\circ$  position.
- Uphill / downhill slopes with more than  $\pm 0.3^\circ$  can be driven without travel direction change.
- The maximum side inclination of  $\pm 0.3^\circ$  is adhered to.

There are two different possibilities for driving crawler cranes on uphill / downhill slopes:

- By adjusting the angle of the boom system.
- Without adjusting the angle of the boom system.

### 5.1.1 Maximum climbing ability

The maximum climbing ability of the crawler crane is limited by the following criteria:

- The location of the center of gravity for the complete crawler crane.
- The friction coefficient between the road and track pads.
- The transition between the horizontal and the uphill incline.
- The maximum permissible uphill incline of  $10^\circ$  up to a boom length of 150 m.

### 5.1.2 Driving uphill / downhill by changing the angle of the boom system

The following specifications and instructions must be observed:

- On level ground, set the optimum angle of the boom system regarding the center of gravity and the surface pressure.
- Uphill / downhill slopes: As soon as the value of the displays for the center of gravity and the surface pressure become more unfavorable, match the boom angle in the permissible range.

**WARNING**

The crane can topple over!

If the limit values for the center of gravity and the surface pressure are exceeded, then the crane can topple over or be overloaded.

- ▶ Driving without display values for the center of gravity and the surface pressure is only permissible when the center of gravity and the surface pressure are otherwise monitored and ensured.

**Note**

Driving without display values for center of gravity and surface pressure!

- ▶ On level ground, set the optimum angle of the boom system regarding the center of gravity and the surface pressure.
- ▶ When driving into an uphill incline, during the transition between the horizontal into the incline, the original angle of the boom system must be changed continuously in such a way that the same angle ratio always remains between the boom system and the horizontal. This angle must be retained in the uphill incline.
- ▶ When driving out from an uphill incline, at the transition from incline to the horizontal, change the angle of the boom system continuously so that the same angle ratio is always retained.
- ▶ As a rule, the center of gravity and the surface pressure of the crane must be taken into account.

**Positive longitudinal inclination****Note**

- ▶ When driving on positive longitudinal inclinations (uphill), the main boom must usually be luffed down.

Status	Transition	Boom angle
Driving horizontally	after uphill incline	match
Driving on the uphill incline		
Driving on the uphill incline	after horizontal	match
Driving horizontally		

**Negative longitudinal inclination****Note**

- ▶ When driving on negative longitudinal inclinations (downhill), the main boom must usually be luffed up.

Status	Transition	Boom angle
Driving horizontally	after downhill slope	match
Driving downhill		
Driving downhill	after horizontal	match
Driving horizontally		

**5.1.3 Prerequisites for driving uphill / downhill without changing the angle of the boom system**

The following specifications and instructions must be observed:

- Make sure that with the selected position of the boom system, the center of gravity and the surface pressure are within the permissible range.

**WARNING**

The crane can topple over!

If the limit values for the center of gravity and the surface pressure are exceeded, then the crane can topple over or be overloaded.

Death, severe bodily injuries, property damage.

- ▶ Before driving onto uphill and downhill slopes, check the change of the center of gravity and the surface pressure and ensure that it is permissible.
- ▶ Before driving the crane, determine if the crane may drive on the intended route without changing the boom system.
- ▶ If the intended uphill / downhill slope cannot be driven without changing the angle of the boom system, then the boom angle must be changed to be able to drive on the uphill / downhill slope.

## 5.2 Driving on side inclinations

**WARNING**

The crane can topple over!

With inclinations of more than  $\pm 0.3^\circ$  the travel direction may not be changed.

- ▶ With inclinations of more than  $\pm 0.3^\circ$  plan the travel route in such a way that a travel direction change is not necessary.

**WARNING**

The crane can topple over!

A longitudinal inclination of more than  $\pm 0.3^\circ$  and a lateral inclination of more than  $\pm 0.3^\circ$  may not be combined.

- ▶ For a longitudinal inclination of more than  $\pm 0.3^\circ$  a maximum lateral inclination of  $\pm 0.3^\circ$  always applies. For a lateral inclination of more than  $\pm 0.3^\circ$  a maximum longitudinal inclination of  $\pm 0.3^\circ$  always applies.

Make sure that the following prerequisites are met:

- The turntable is aligned parallel to the crawler travel gear ( $0^\circ$  or  $180^\circ$  position).
- Side inclinations with more than  $\pm 0.3^\circ$  can be driven without travel direction change.
- The maximum longitudinal inclination of  $\pm 0.3^\circ$  is adhered to.

## 6 Driving the crane: Ballast trailer installed

**WARNING**

The crane can topple over if the level of the road differs!

Due to impermissible level differences between the ballast trailer roadway and the crane placement level, the entire crane system can be pulled back suddenly.

The relapse cylinders can run out to the block position. The relapse cylinders and the boom system can be damaged.

Depending on the distortion of the turntable and the load of the tires on the ballast trailer, a shut-off of crane movements may be activated with a retracted ballast trailer guide due to an excessive inclination of the ballast trailer (depending on the crane type and time of crane delivery), see chapter 4.02. Death, severe bodily injuries, property damage.

- ▶ Do not exceed or fall below the permissible level difference between the ballast trailer road and the crane placement level.
- ▶ The travel path of the crane or the circular path of the ballast trailer must be level and of sufficient load bearing capacity.
- ▶ The permissible level difference of the ballast trailer travel path and crane travel path for "towing" and "parallel driving", may be maximum 250 mm when the ballast trailer guide is extended.
- ▶ The permissible level difference of the ballast trailer path and the crane travel path in relation to the crane travel path for circular driving may be no more than maximum 250 mm with the ballast trailer guide extended - based on a constant uphill incline or constant downhill incline on a  $90^\circ$  turning range.



**WARNING**

Danger of fatal injury if the permissible travel speed is exceeded!

If the permissible travel speed is exceeded, the tires can be damaged.

Death, severe bodily injuries, property damage.

As a result, significant property damage can occur on the crane and on the ballast trailer.

- ▶ The travel speed of the ballast trailer for turning and driving with more than 80 % of the maximum ballast may be no more than 0.05 m/s or 0.18 km/h.

**NOTICE**

Damage to the ballast trailer, ballast trailer guide and / or the turntable!

If the ballast trailer inclination is too large or the level difference of the standing levels between the crane and ballast trailer are too large, this can cause damage to the ballast trailer, the ballast trailer guide and / or the turntable.

- ▶ Keep the ballast trailer inclination as small as possible.
- ▶ Do not exceed the maximum permissible level difference of the standing levels of 250 kg between the crane and the ballast trailer.

**NOTICE**

Danger of damage to the crane and the ballast trailer!

Due to steering movements on the crawler track during parallel travel, the crane and the ballast trailer can be significantly damaged.

- ▶ During parallel travel, steering the crawler travel gear is prohibited.
- ▶ For parallel travel, the side tire distortion on the wheel sets must be observed by an instructed person over the entire travel route of the crane. If the tires distort by more than 100 mm, then the position of the wheel sets must be corrected.

**WARNING**

Danger of accident when driving the crane with ballast trailer!

When driving the crane - this also applies for "circular travel" - and the ballast trailer is raised due to ground unevenness, the force on test point 1 (F1-load display) increases immediately and the crane will be overloaded.

If the ballast trailer sinks while driving due to ground unevenness, the force on test point 1 (F1-load display) drops and the ballast trailer lifts off the ground, or the entire boom system is pulled backward. The crane can topple over.

Death, severe bodily injuries, property damage.

- ▶ The crane operator must constantly observe the displays on the LICCON monitor while driving the crawler crane.
- ▶ The crane operator must act anticipatorily. Already when an advance warning on test point 1 (F1-load display) occurs, the crane operator must act accordingly: By actuating the pull cylinders of the derrick ballast, correct the load / force on test point 1 (F1-load display) until it is in a permissible operating range. The permissible extension lengths of the pull cylinders must be observed.

Make sure that the following prerequisite is met:

- All specifications and notes in chapters 2.15 and 5.35 are observed and adhered to.

In principle the following must be observed:

- If the derrick ballast is raised due to external influences, then this leads to a relief of the guying between the derrick head and the derrick ballast (force on test point 4/5 drops). This leads to an increased load on the guying between the derrick head and the A-frame (force on test point 1 increases).
- If the derrick ballast loses contact with the ground due to external influences, then this leads to a higher load of the guying between the derrick head and the derrick ballast (force on test point 4/5 increases). This leads to a relief of the guying between the derrick head and the A-frame (force on test point 1 drops).

## 7 Driving the crawler crane



### WARNING

Danger of accident in inclined position!

When the slewing gear brake is released, the crane superstructure can turn uncontrolled to the side. As a result the crane can topple over.

Death, severe bodily injuries, property damage.

- ▶ In an inclined position, crane operation or crawler operation with opened slewing gear is prohibited.
- ▶ In an inclined position, the slewing gear brake must be applied.



### WARNING

The crane can topple over!

If the permissible incline of the crane is exceeded, the crane can topple over.

In impermissible inclines, the LICCON computer system does **not** turn the travel operation off.

The crane driver carries the sole responsibility for possible risks or dangers when working with impermissible inclines.

- ▶ Do not exceed the permissible incline from the load chart.
- ▶ Do not exceed the permissible incline for driving the crane.
- ▶ While driving the crane, monitor the displays for center of gravity, surface pressure and inclination on the LICCON monitor constantly.



### WARNING

The crane can topple over!

If the crane is driving too fast, then the crane can topple over.

This applies especially if the crane is driven too fast with a load and / or derrick ballast.

Death, severe bodily injuries, property damage.

- ▶ Observe the permissible highest speeds for driving the crawler crane.
- ▶ For the travel speed, take the actual operating conditions also into account.
- ▶ The data for permissible highest speeds for driving the crawler crane is based on ideal conditions. When the conditions are not ideal, then the travel speed of the crane must be reduced accordingly.
- ▶ Driving with a load and / or derrick ballast in rapid gear is prohibited.
- ▶ Driving and steering the crawler at the same time with suspended load and / or installed derrick ballast is prohibited.



### WARNING

Personnel in the danger zone!

People who remain in the danger zone are exposed to considerable danger.

Death, severe bodily injuries, property damage.

- ▶ An additional observer in radio contact with the crane operator must ensure that there are no persons or objects within the danger zone of the crane.
- ▶ The observer may not remain in the danger zone of the crane.

### 7.1 Surface pressures and force distribution when driving the crane

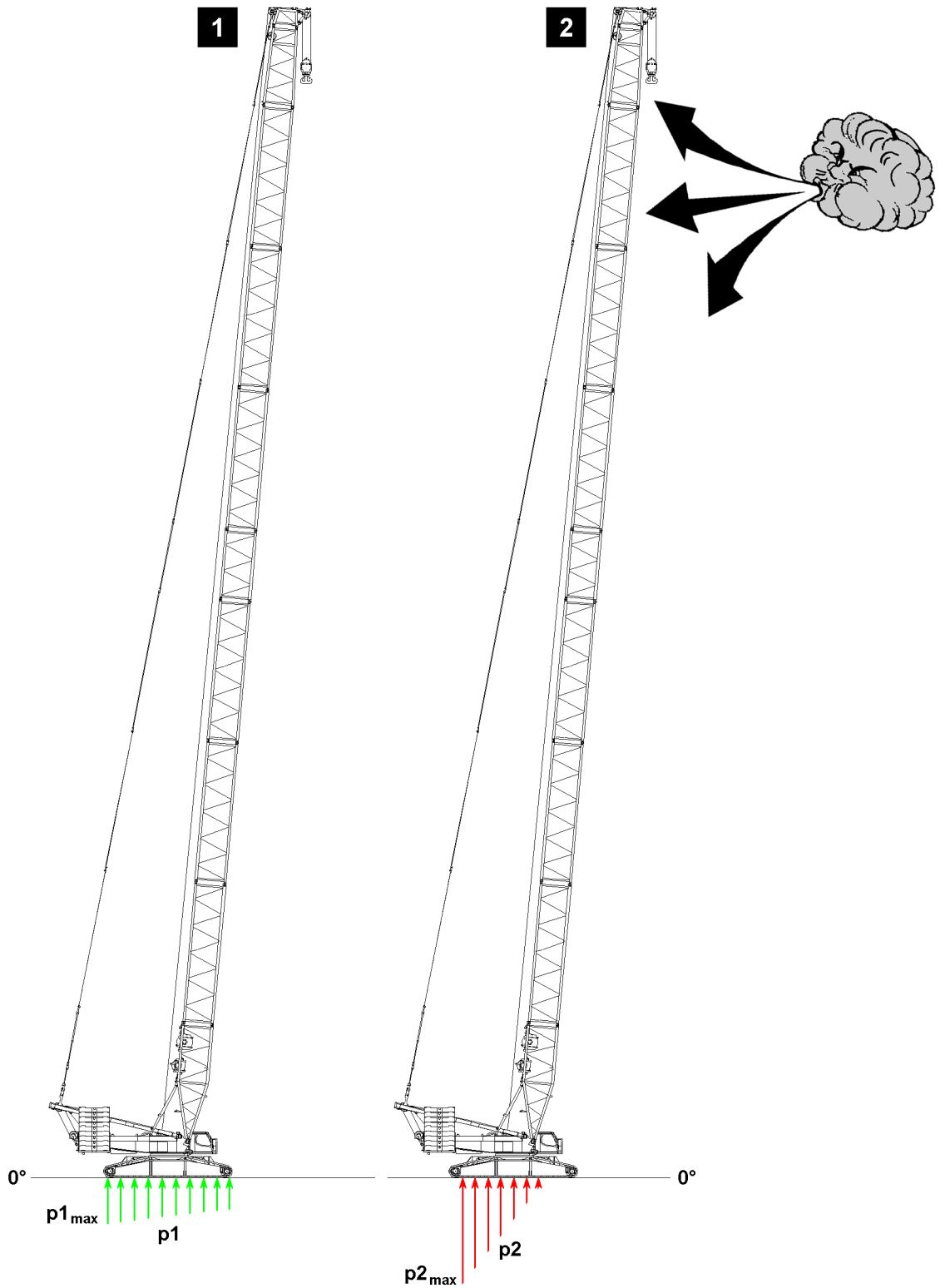


Fig. 153644:  $p2_{max}$  greater than  $p1_{max}$

LWE/LR 1800-1-0-000/27200-07-02/en

**WARNING**

The crane can topple over!

When driving crawler cranes, surface pressures can significantly increase or change due to different factors.

This can cause the crane to topple over.

Death, severe bodily injuries, property damage.

- ▶ Make sure that the ground has a sufficient load bearing capacity in the entire working range and / or over the entire travel route, to be able to safely absorb even increased surfaces pressures of the crane.
- ▶ Make sure that the center of gravity is always within the core area, see section “Prerequisites for crawler operation” and LICCON job planner.

### 7.1.1 Surface pressures in case of wind load on the boom

**WARNING**

The crane can topple over!

When driving the crane with long boom lengths and / or when driving with large sized loads and / or at high wind speeds, the surface pressures can increase significantly.

This can cause the crane to topple over.

Death, severe bodily injuries, property damage.

- ▶ Make sure that the entire travel route of the crane is sufficiently load bearing to be able to absorb even increase surface pressures - for example if “wind is coming front the front on the boom”.
- ▶ Change of surface pressures on the crawler travel gear under wind load, see the adjacent graphic.

**Illustration 1:**

- Surface pressures **p1** on the crawler travel gear without wind load.

**Illustration 2:**

- Surface pressures **p2** on the crawler travel gear in case of wind load from the front.

### 7.1.2 Force distribution when driving on pressure distributor plates

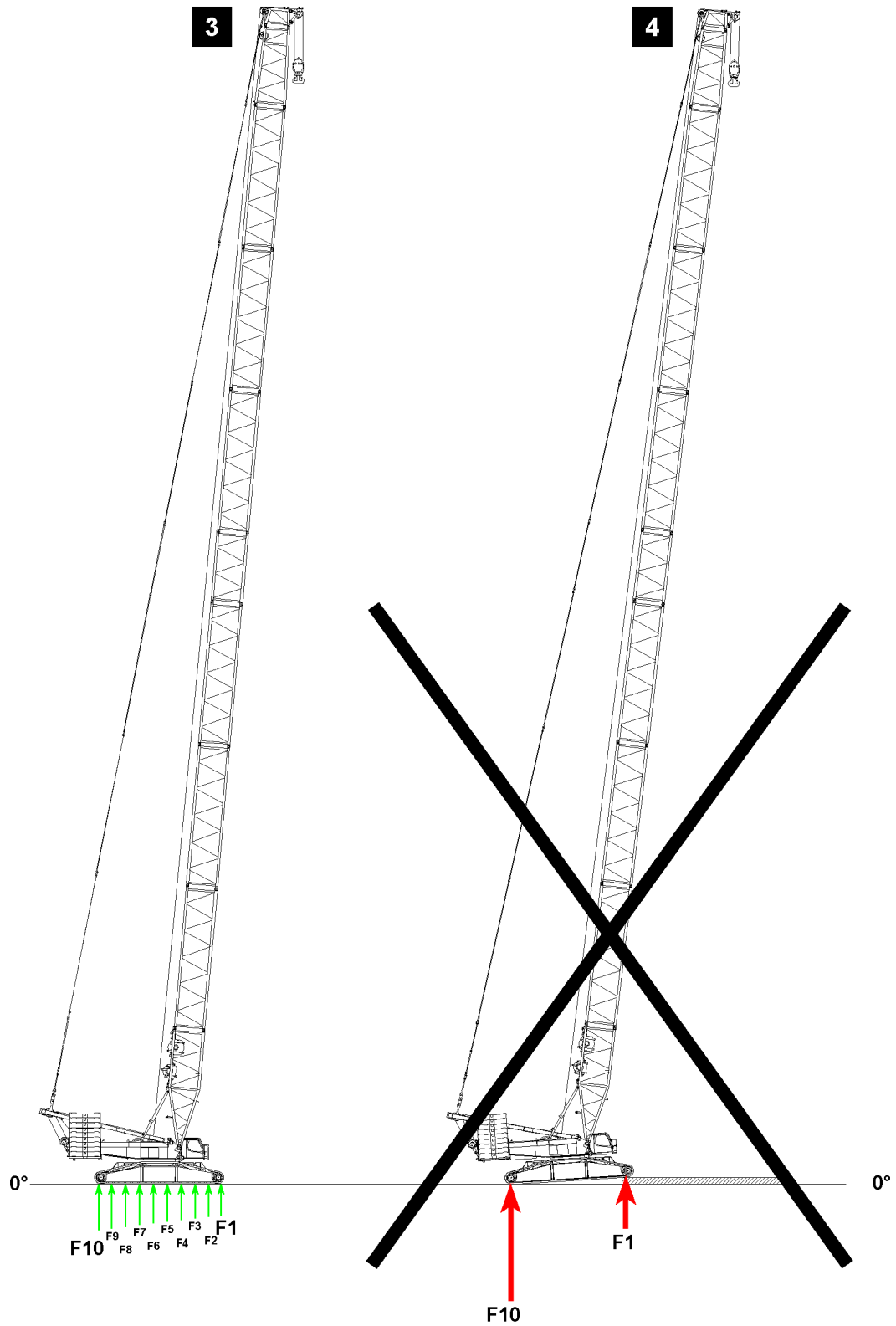


Fig. 153645: Force distribution during normal operation // driving on pressure distributor plates

LWE/LR 1800-1-0-000/27200-07-02/en

**WARNING**

The crane can topple over!

When driving the crane on pressure distributor plates, a movement of forces occurs due to the reduction of the ground contact surfaces on the crawler travel gear. The forces concentrate at force **F1** and force **F10**, see illustration 4.

This can cause the crane to topple over.

Death, severe bodily injuries, property damage.

- ▶ Make sure, before driving the crane on pressure distributor plates, that a load bearing transfer (height equalization) was established, see section "Calculation of required length of transfers".
- ▶ Driving the crane on pressure distributor plates without transfer (height equalization) is prohibited.

**Illustration 3:**

- Force distribution on crawler travel gear of the crane (normal operation)
  - Without wind influence

**Illustration 4:**

- Not permissible

Make sure that the following prerequisites are met:

- The crane is ready to drive.
- The crane engine is running.
- The set up configuration of the crane has been entered correctly in the LICCON computer system.
- The displays for inclination, surface pressure and center of gravity are shown.
- There are no persons or objects in the danger zone.

## 7.2 Operating elements for the crawler operation

### 7.2.1 Pedal carrier

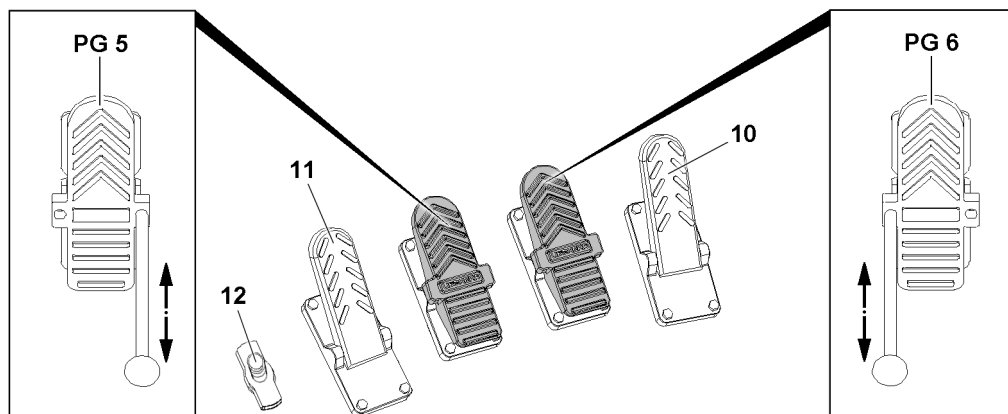
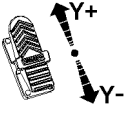
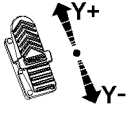


Fig.153791: Pedal carrier

- **10** Pedal for engine regulation
- **11** Slewing gear brake pedal
- **12** Foot button for freewheeling slewing gear
  - **Note:** The foot button for freewheeling slewing gear **12** is only available on certain crane types.
- **PG5** Foot rocker (pedal sensor 5)
- **PG6** Foot rocker (pedal sensor 6)

Crawler operating mode	Pedal carrier	
	 Foot rocker <b>PG5</b>	 Foot rocker <b>PG6</b>
<b>Normal travel</b>	Left crawler forward / backward: <b>PG5</b> direction <b>Y+ / Y-</b>	Right crawler forward / backward: <b>PG6</b> direction <b>Y+ / Y-</b>
<b>Parallel travel</b>	Steer both crawlers <sup>1)</sup> : <b>PG5</b> direction <b>Y+ / Y-</b>	Forward / backward both crawlers: <b>PG6</b> direction <b>Y+ / Y-</b>

1) Only for crane types with steering function with parallel travel engaged.

### Engine regulation

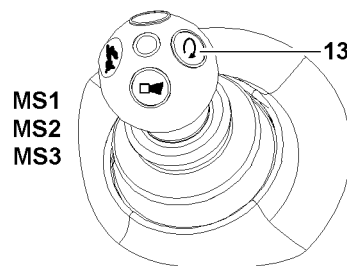


Fig.153792: Master switch (MS1, MS2, MS3)

The rpm of the crane engine is controlled with the engine regulation pedal **10**. For crawler operation, a certain rpm can be locked in, see chapter 4.05.

- ▶ Lock the current rpm of the crane engine: Press the button **13** on master switch **MS1** or master switch **MS2**.

#### Result:

- A “+” appears on the LICCON monitor behind the rpm display.
- The current rpm of the crane engine is locked.
- The rpm can be increased further via the engine regulation pedal **10**.

- ▶ Release the rpm lock: Press the button **13** on master switch **MS1** or master switch **MS2** again.

#### Result:

- The “+” behind the rpm display turns off.

### 7.2.2 Slewing gear brake on touch display 2 (TE2)

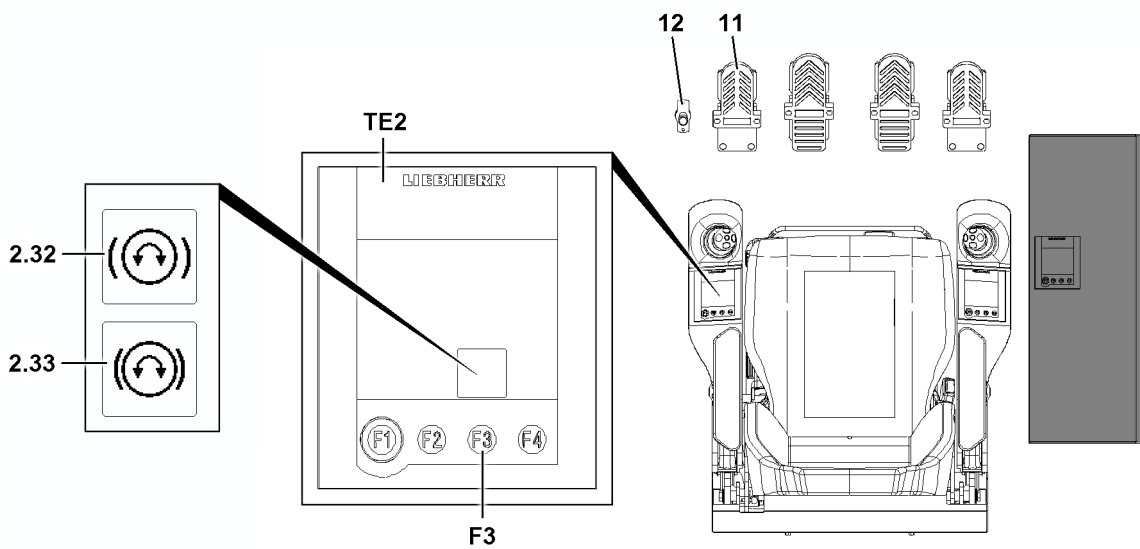


Fig.153793: Slewing gear brake in TE2

Slewing gear brake operating elements:

- 11 Slewing gear brake pedal
- 12 Foot button for freewheeling slewing gear
- Key F3: Slewing gear brake in TE2 (parking brake)

► Regulate the slewing gear brake steplessly: Press down the slewing gear brake pedal 11.

**Result:**

- The slewing gear brake is regulated according to the pedal position: The further the pedal is pressed down, the stronger the slewing gear brake brakes.

► Switch on slewing gear freewheeling: Actuate the foot button for freewheeling the slewing gear 12.

**Result:**

- Freewheeling the slewing gear is engaged as long as the foot button for freewheeling the slewing gear 12 is pressed down.

Touch display 2 TE2		
Position	Icon	Description of the function
2.32		Nominal status slewing gear brake released, icon remains even when the slewing gear brake is applied with the slewing gear brake pedal 11.
2.33		Nominal status slewing gear applied, icon remains even when the slewing gear brake is automatically released by the control.

► Apply the slewing gear brake (parking brake): Press the button F3 on touch display 2 TE2.

**Result:**

- The “Slewing gear brake applied” icon appears.

► Release the slewing gear brake (parking brake): Press the button F3 on touch display 2 TE2 again.

**Result:**

- The “slewing gear brake released” icon appears.

LWE/LR 1800-1-0-000/27200-07-02/en



### 7.2.3 Crawler operating mode icons on touch display 3 (TE3)

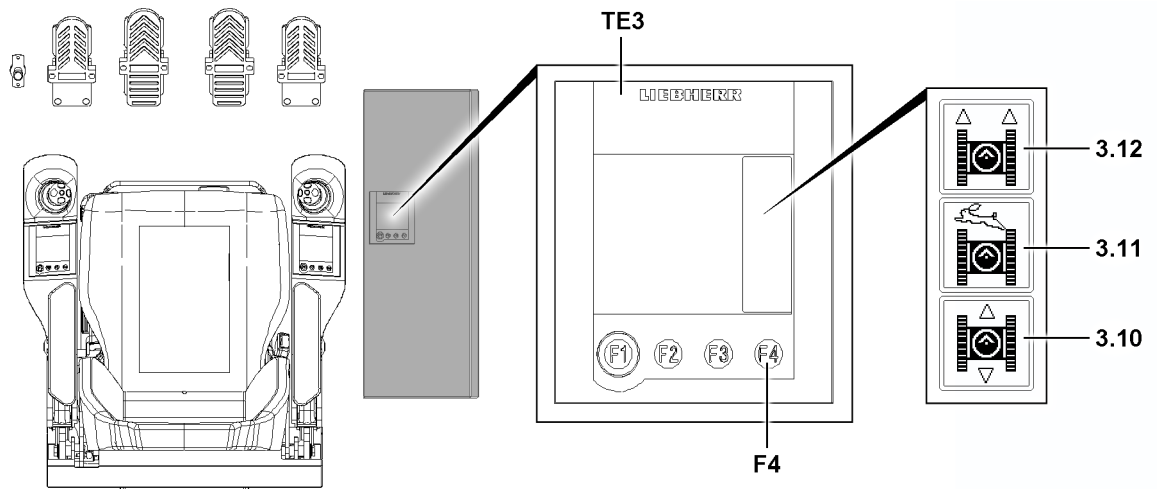





Fig.153794: Crawler operation modes in TE3

Touch display 3 TE3		
Position	Icon	Description of the function
3.10		Normal travel crawler operation turned off
		Normal travel crawler operation preselected
		Normal travel crawler operation engaged, icon blinks
3.11		Rapid gear crawler operation turned off
		Rapid gear crawler operation preselected
		Rapid gear crawler operation engaged, icon blinks

LWE/LR 1800-1-0-000/27200-07-02/en

Touch display 3 TE3		
Position	Icon	Description of the function
3.12		Parallel travel crawler operation turned off
		Parallel travel crawler operation preselected
		Parallel travel crawler operation engaged, icon blinks

### 7.3 Assignment of the crane superstructure to the travel direction

The travel direction of the crane is continuously assigned to the position of the crane superstructure.

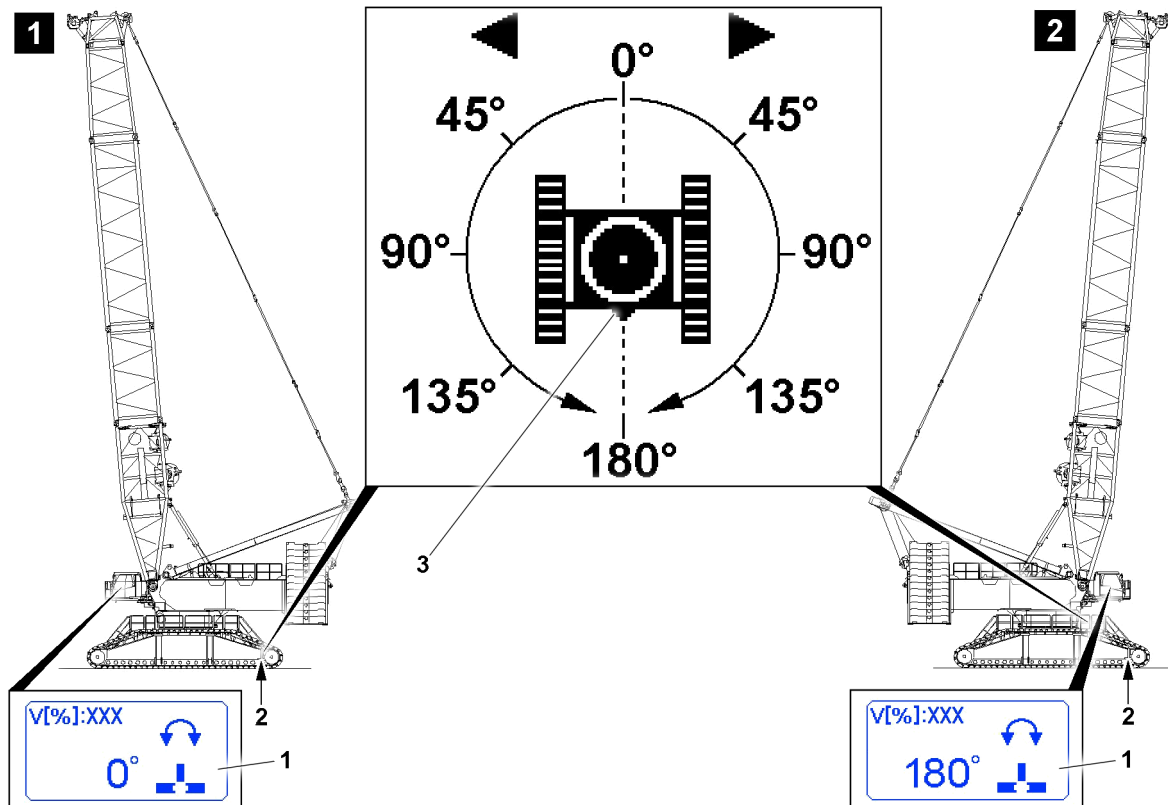


Fig.153795: Assignment of the crane superstructure to the travel direction

The position of the crane superstructure with respect to the crawler travel gear can be read with one glance on the slewing range icon 1:

- With display value 0° in the slewing range icon 1 the crane superstructure is exactly in position “to the rear”, see illustration 1.
- With display value 180° in the slewing range icon 1 the crane superstructure is exactly in position “to the front”, see illustration 2.

**Note:** The front on the crawler travel gear is always on the side where the chain tension device 2 for the crawler carriers is located. In the LICCON view of the crawler travel gear, the front side is marked by a directional triangle 3.

- With display value 0° in the slewing range icon **1** the crane superstructure is exactly in position “to the rear”.
- The apex for the assignment of the crane superstructure is at display value 90° in the slewing range icon **1**. At display values from 0° to 90° the crane superstructure is positioned “to the rear”. At display values from 90° to 180° the crane superstructure is positioned “to the front”.
- If the crane superstructure is swung over / under the display value 90° in the slewing range icon **1**, then the running direction of the crawler carriers changes to actuation direction of the foot rockers. The change happens only when the foot rockers are in position 0 (not actuated).
- If the crane superstructure is swung while driving over / under the display value 90° in the slewing range icon **1**, then the running direction of the crawler carriers and therefore the travel direction remains until the respective foot rocker is “returned” to the zero position. The new assignment of the travel direction becomes only active after the foot rockers are next time in position 0 (not actuated).



### WARNING

Change of travel direction after turning the crane superstructure!

If the crane superstructure is swung while driving over / under the display value 90° in the slewing range icon **1**, then the running direction of the crawler carriers only remains until the respective foot rocker is “returned” to the zero position. If the foot rocker is actuated again in the same direction, the crane is driven in the opposite direction.

- ▶ When performing turning movements of the crane superstructure in connection with driving the crane, pay attention to the assignment of the crane superstructure to the travel direction.
- ▶ After turning the crane superstructure, check the travel route in both directions for persons and obstacles. Initiate travel movements with utmost caution.

## 7.4 Turning crawler operating modes on / off

The crawler crane can be driven with various crawler operating modes:

- Normal crawler operation:
  - Classic crawler operation, each crawler is controlled via a separate foot pedal.
- Parallel travel crawler operation:
  - The steering movement is controlled by a separate foot pedal.
  - The travel direction is controlled by a separate foot pedal.

To obtain a higher travel speed, the rapid gear can be activated.

### 7.4.1 Selecting the function on the touch display TE3

Select a function on the touch display **TE3**, in the example “Crawler parallel operation”.



Fig.119615: Selecting the function on the touch display TE3

- ▶ “Parallel travel crawler operation” example: Select parallel travel crawler operation by touching the icon **3.12** on the touch display **3 TE3**, see illustration **1**.

#### Result:

- The “parallel travel crawler operation” icon is bordered all over.
- Parallel travel crawler operation is preselected.
- ▶ Press the button **F4** on touch display **3 TE3**, see illustration **2**.

**Result:**

- The “Crawler parallel operation” icon blinks.
- Parallel operation is activated.

**7.4.2 Turn normal travel crawler operation on / off**

Normal travel crawler operation is the prerequisite to drive the crane and must generally be activated.

**Turn normal travel crawler operation on:**

- ▶ Select normal travel crawler operation by touching the icon **3.10** on the touch display **3 TE3**.

**Result:**

- The icon **3.10** is bordered all over.
- Normal travel crawler operation is preselected.

- ▶ Press the button **F4** on touch display **3 TE3**.

**Result:**

- The icon **3.10** blinks.
- Normal travel crawler operation is activated.

**Turn normal travel crawler operation off:**

- ▶ Press the button **F4** on touch display **3 TE3**.

**Result:**

- The icon **3.10** no longer blinks.
- Normal travel crawler operation is turned off.

- ▶ Deselect normal travel crawler operation by touching the icon **3.10** on the touch display **3 TE3**.

**Result:**

- The border around the icon **3.10** disappears.
- Preselection of normal travel crawler operation is cancelled.

**7.4.3 Turning parallel travel crawler operation on / off**

Make sure that the following prerequisites are met:

- Normal travel crawler operation is activated.
- The crawlers are at a standstill.

**Turn parallel travel crawler operation on:**

- ▶ Select parallel travel crawler operation by touching the icon **3.12** on the touch display **3 TE3**.

**Result:**

- The icon **3.12** is bordered all over.
- Parallel travel crawler operation is preselected.

- ▶ Press the button **F4** on touch display **3 TE3**.

**Result:**

- The icon **3.12** blinks.
- Parallel travel crawler operation is activated.

**Turn parallel travel crawler operation off:**

- ▶ Press the button **F4** on touch display **3 TE3**.

**Result:**

- The icon **3.12** no longer blinks.
- Parallel travel crawler operation is turned off.

- ▶ Deselect parallel travel crawler operation by touching the icon **3.12** on the touch display 3 **TE3**.

**Result:**

- The border around the icon **3.12** disappears.
- Preselection of parallel travel crawler operation is cancelled.

#### 7.4.4 Turning rapid gear crawler operation on / off

**WARNING**

Travel speed too high!

If the travel speed is too high, the crane can topple over.

Death, severe bodily injuries, property damage.

- ▶ Driving with a load or derrick ballast in rapid gear crawler operation is prohibited.
- ▶ Observe the permissible highest speeds for driving the crawler crane.

Make sure that the following prerequisite is met:

- Normal travel crawler operation is activated.
- or**
- Parallel travel crawler operation is activated.

**Turn rapid gear crawler operation on:**

- ▶ Select rapid gear crawler operation by touching the icon **3.11** on the touch display 3 **TE3**.

**Result:**

- The icon **3.12** is bordered all over.
- Rapid gear crawler operation is preselected.
- ▶ Press the button **F4** on touch display 3 **TE3**.

**Result:**

- The icon **3.11** blinks.
- Rapid gear crawler operation is activated.

**Turn rapid gear crawler operation off:**

- ▶ Press the button **F4** on touch display 3 **TE3**.

**Result:**

- The icon **3.11** no longer blinks.
- Rapid gear crawler operation is turned off.

- ▶ Deselect rapid gear crawler operation by touching the icon **3.12** on the touch display 3 **TE3**.

**Result:**

- The border around the icon **3.11** disappears.
- Preselection of rapid gear crawler operation is cancelled.

## 7.5 Driving the crawler crane in normal travel

**NOTICE**

Increased wear on the crawler travel gear!

When steering in small radii, high friction forces are created that lead to increased wear.

- ▶ If possible, always drive in curves with large radii.
- ▶ Avoid turning over a stationary track, if possible.
- ▶ Avoid turning on the spot, if possible.

Make sure that the following prerequisites are met:

- A travel direction change may only be done when at a standstill.
- The desired rpm of the crane engine is set.
- Normal travel crawler operation is selected, the icon **310** blinks.

**Note**

Special hand levers can be attached on the foot rockers. The hand levers are used for delicate driving maneuvers.

The hand levers are stored in a transport retainer in the crane cab.

The technical design of the hand lever **1-A** and the hand lever **1-B** is completely identical. The differentiation of the two hand levers refers only in their assignment to the corresponding foot rockers in the assembled (connected) condition.

- ▶ Use the hand levers to control the crane especially sensitively.

### 7.5.1 Driving forward

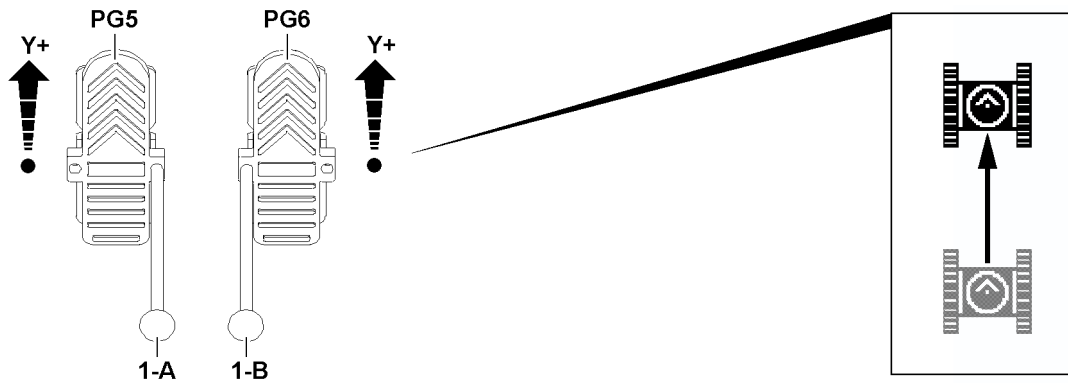


Fig.153796: Driving forward

- ▶ Deflect the left foot rocker **PG5** and the right foot rocker **PG6** synchronously to the front (direction **Y+**).

**Result:**

- The crane drives forward.

### 7.5.2 Driving in reverse

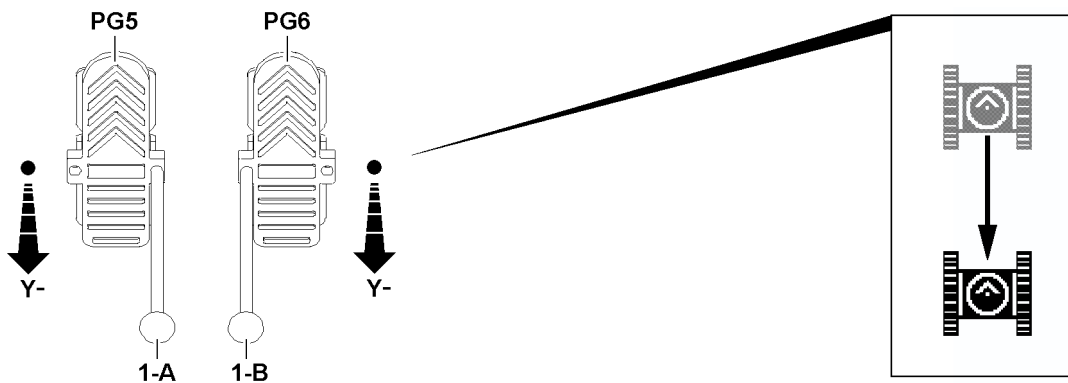


Fig.153797: Driving in reverse

- ▶ Deflect the left foot rocker **PG5** and the right foot rocker **PG6** synchronously to the rear (direction **Y-**).

**Result:**

- The crane drives backward.

### 7.5.3 Driving in curves forward to the left

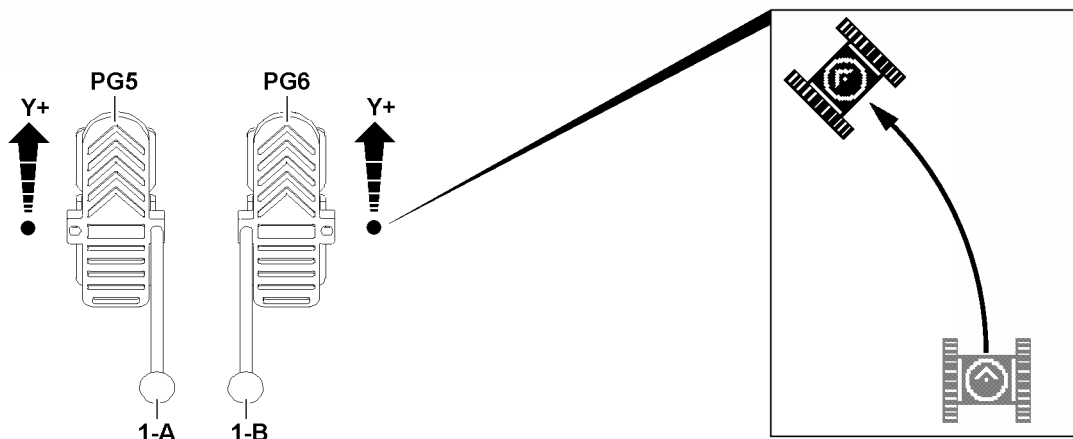


Fig.153798: Driving in curves forward to the left

- ▶ Actuate the left foot rocker **PG5** reduced to the front (direction **Y+**) and the right foot rocker **PG6** stronger to the front (direction **Y+**).

**Result:**

- The crane drives a forward curve to the left.

### 7.5.4 Driving in curves forward to the right

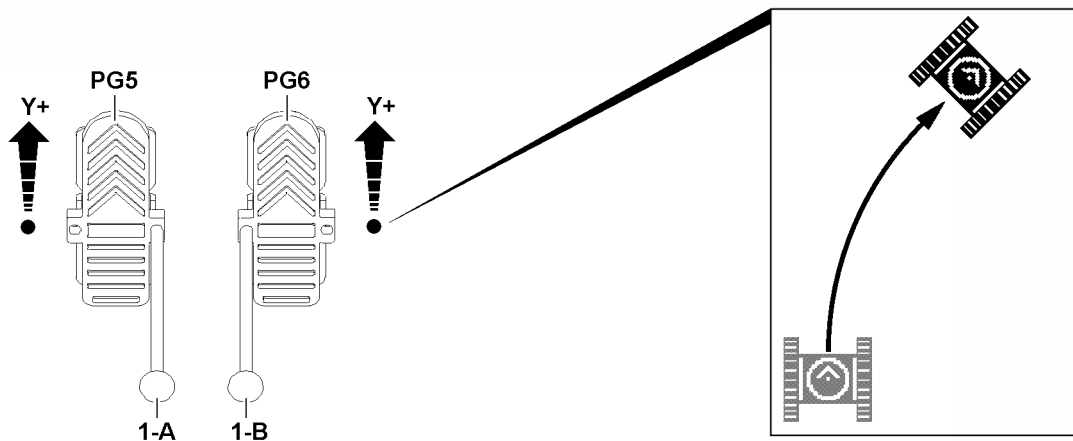


Fig.153799: Driving in curves forward to the right

- ▶ Actuate the left foot rocker **PG5** stronger to the front (direction **Y+**) and the right foot rocker **PG6** reduced to the front (direction **Y+**).

**Result:**

- The crane drives a forward curve to the right.

### 7.5.5 Driving in curves in reverse to the left

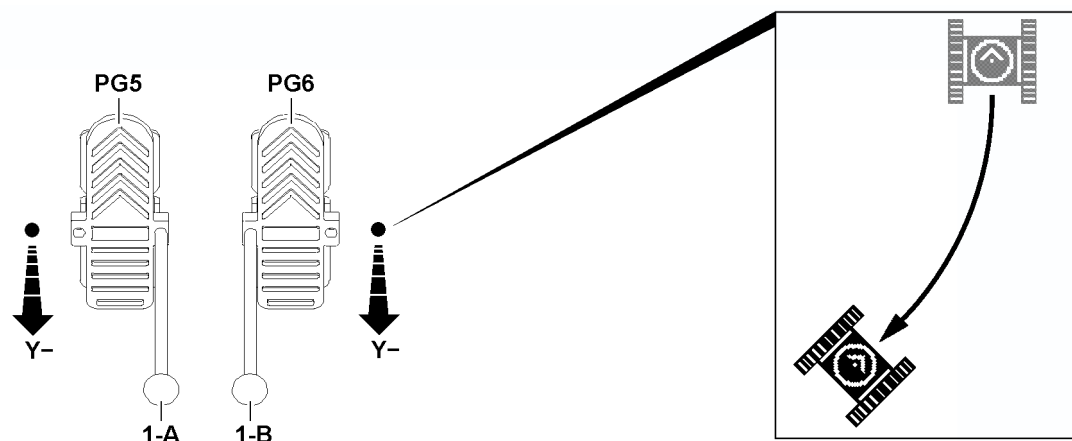


Fig.153800: Driving in curves in reverse to the left

- ▶ Actuate the left foot rocker **PG5** reduced to the rear (direction **Y-**) and the right foot rocker **PG6** stronger to the rear (direction **Y-**).

**Result:**

- The crane drives a reverse curve to the left.

### 7.5.6 Driving in curves in reverse to the right

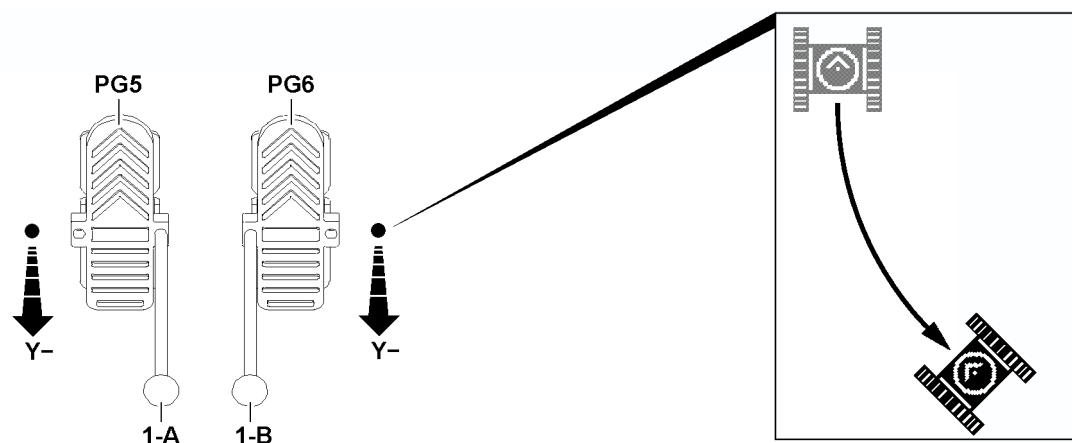


Fig.153801: Driving in curves in reverse to the right

- ▶ Actuate the left foot rocker **PG5** stronger to the rear (direction **Y-**) and the right foot rocker **PG6** reduced to the rear (direction **Y-**).

**Result:**

- The crane drives a reverse curve to the right.



### 7.5.7 Turning forward to the left

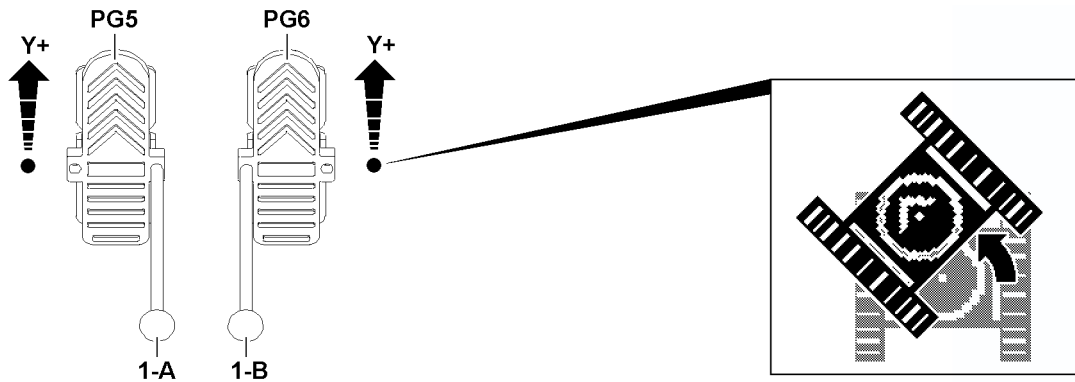


Fig.153802: Turning forward to the left

► Actuate the right foot rocker **PG6** forward (direction **Y+**).

**Result:**

- The crane is turned forward to the left.

### 7.5.8 Turning forward to the right

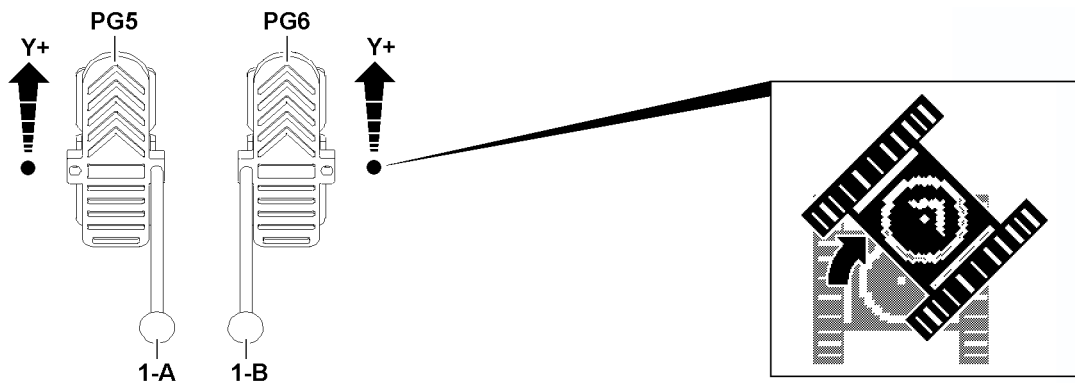


Fig.153803: Turning forward to the right

► Actuate the left foot rocker **PG5** forward (direction **Y+**).

**Result:**

- The crane is turned forward to the right.

### 7.5.9 Turning backward to the left

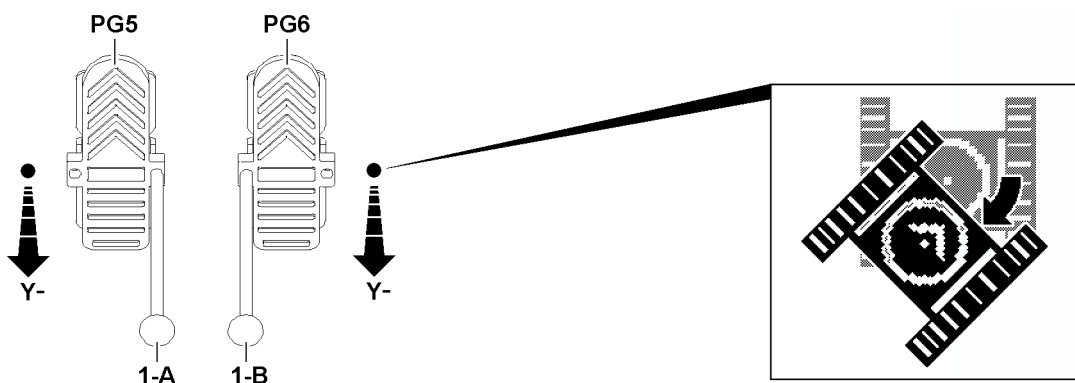


Fig.153804: Turning backward to the left

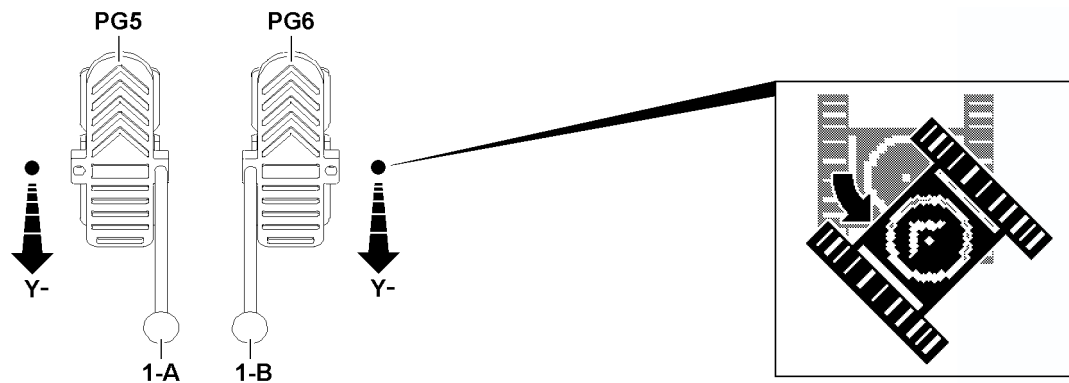
LWE/LR 1800-1-0-000/27200-07-02/en

- ▶ Actuate the right foot rocker **PG6** backward (direction **Y-**).

**Result:**

- The crane is turned backward to the left.

### 7.5.10 Turning backward to the right



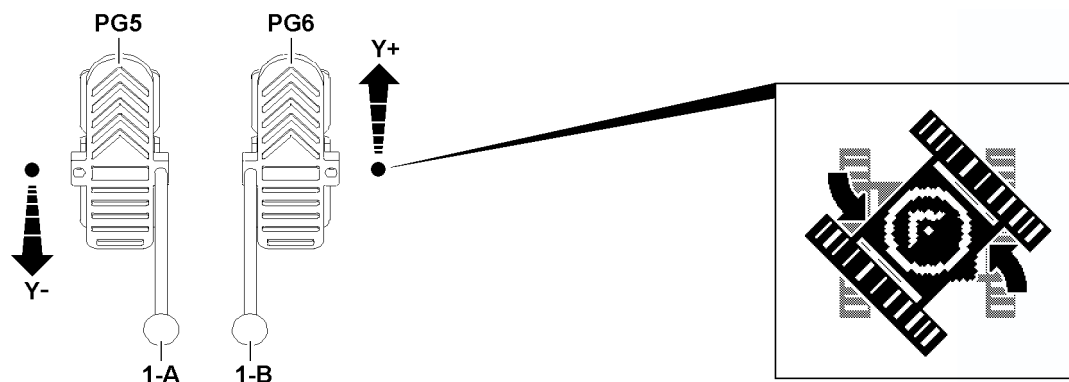
*Fig.153805: Turning backward to the right*

- ▶ Actuate the left foot rocker **PG5** backward (direction **Y-**).

**Result:**

- The crane is turned backward to the right.

### 7.5.11 Turning on the spot to the left (counterclockwise direction)



*Fig.153806: Turning on the spot to the left (counterclockwise direction)*

- ▶ Actuate the left foot rocker **PG5** to the rear (direction **Y-**) and the right foot rocker **PG6** to the front (direction **Y+**).

**Result:**

- The crane is turned to the left.

### 7.5.12 Turning on the spot to the right (clockwise)

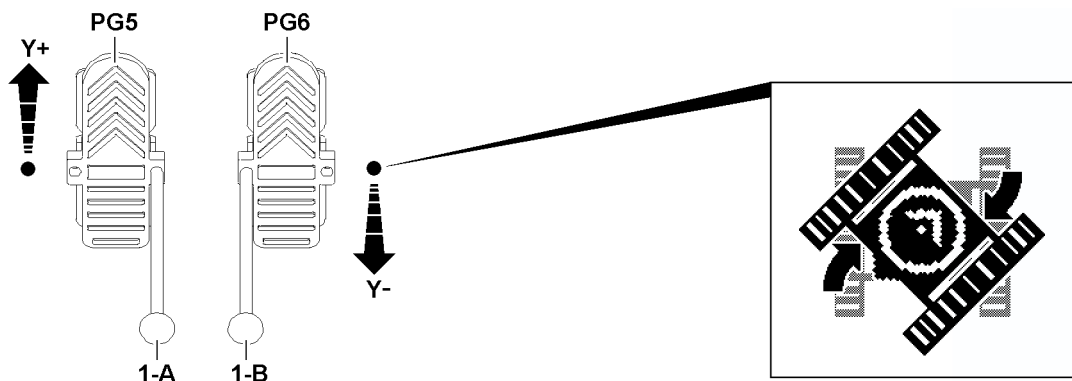


Fig.153807: Turning on the spot to the right (clockwise)

- ▶ Actuate the left foot rocker **PG5** to the front (direction **Y+**) and the right foot rocker **PG6** to the rear (direction **Y-**).

**Result:**

- The crane is turned to the right.

## 7.6 Driving the crawler crane in parallel travel

**NOTICE**

Increased wear on the crawler travel gear!

When steering in small radii, high friction forces are created that lead to increased wear.

- ▶ If possible, always drive in curves with large radii.
- ▶ Avoid turning over a stationary track, if possible.

Make sure that the following prerequisites are met:

- The desired rpm of the crane engine is set.
- Parallel travel crawler operation is selected, icon **310** and icon **312** blink.



**Note**

- ▶ Special hand levers **1-A** and hand levers **1-B** can be inserted into the foot rockers. These hand levers **1-A** and hand levers **1-B** are used for delicate driving maneuvers. The operation is identical to that for the foot rockers.
- ▶ Hand lever **1-A** and hand lever **1-B** are placed in the transport retainer on the left of the crane operator's seat.
- ▶ The technical design of the hand lever **1-A** and the hand lever **1-B** is completely identical. The differentiation of the two hand levers refers only in their assignment to the corresponding foot rockers in the assembled (connected) condition.

Turning the crawler travel gear on the spot is not possible in parallel travel.

### 7.6.1 Driving forward

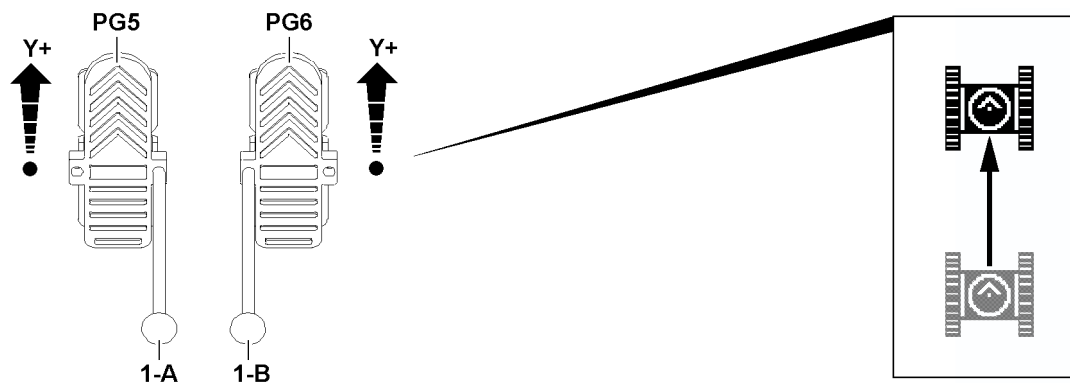


Fig.153796

- ▶ Deflect the right foot rocker **PG6** forward (direction **Y+**).

**Result:**

- The crane drives forward.



**Note**

- ▶ The further the foot rockers are actuated forward (direction **Y+**) the higher the speed.

### 7.6.2 Driving in reverse

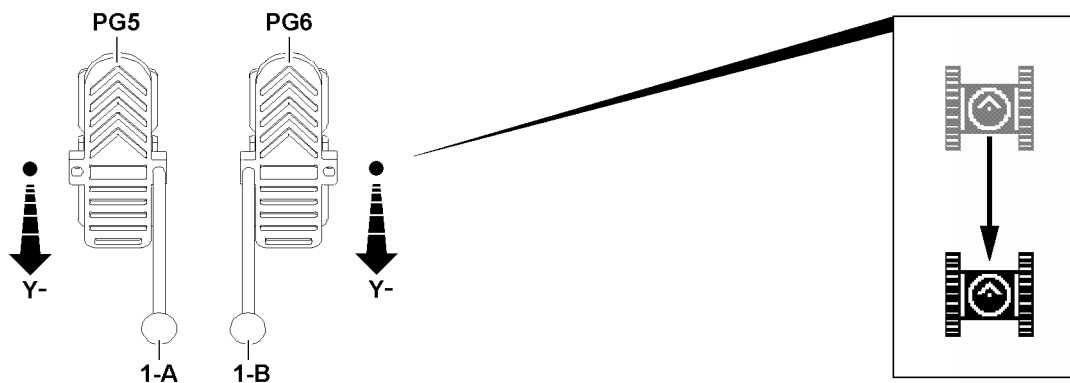


Fig.153797

- ▶ Deflect the right foot rocker **PG6** backward (direction **Y-**).

**Result:**

- The crane drives backward.



**Note**

- ▶ The further the foot rockers are actuated forward (direction **Y+**) the higher the speed.

### 7.6.3 Driving in curves forward to the left

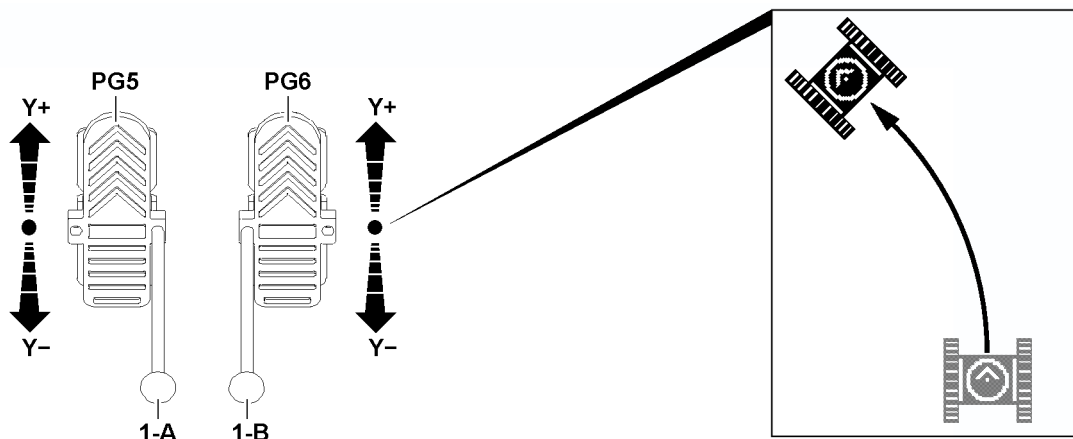


Fig.153810: Driving in curves forward to the left

- ▶ Actuate the left foot rocker **PG5** reduced to the rear (direction **Y-**) and the right foot rocker **PG6** to the front (direction **Y+**).

**Result:**

- The crane drives a forward curve to the left.



**Note**

- ▶ The further the right foot rocker **PG6** is actuated forward (direction **Y+**) the higher the speed of driving a curve.
- ▶ If the left foot rocker **PG5** is pushed fully to the rear (direction **Y-**), the left crawler stops.

### 7.6.4 Driving in curves forward to the right

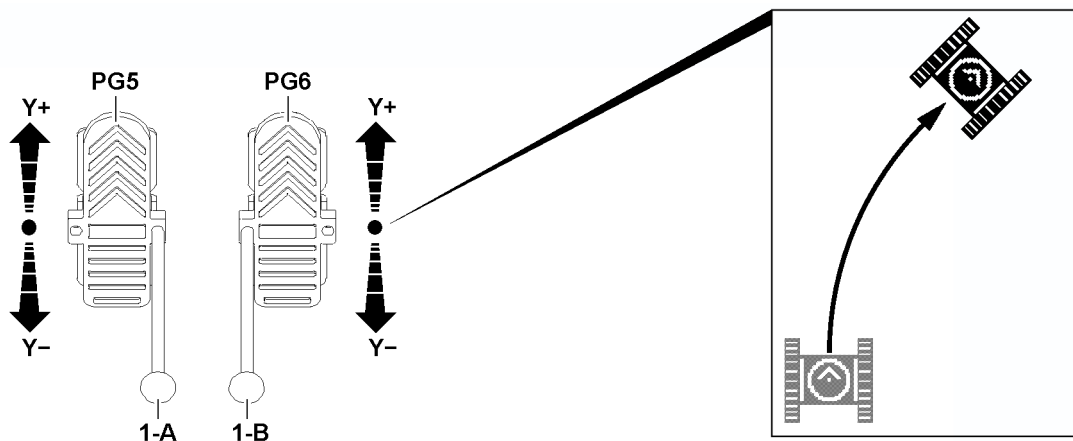


Fig.153811: Driving in curves forward to the right

- ▶ Actuate the left foot rocker **PG5** reduced to the front (direction **Y+**) and the right foot rocker **PG6** to the front (direction **Y+**).

**Result:**

- The crane drives a forward curve to the right.



**Note**

- ▶ The further the right foot rocker **PG6** is actuated forward (direction **Y+**) the higher the speed of driving a curve.
- ▶ If the left foot rocker **PG5** is pushed fully to the front (direction **Y+**), the right crawler stops.

### 7.6.5 Driving in curves in reverse to the left

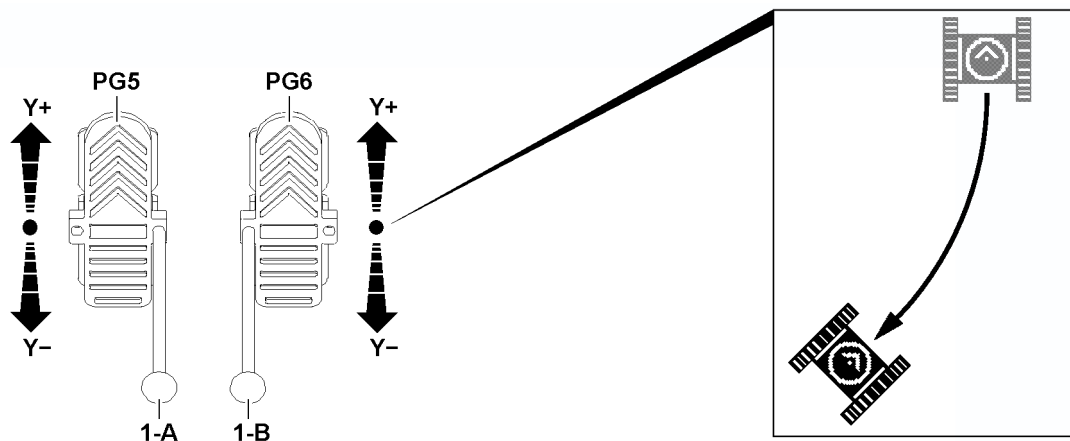


Fig.153812: Driving in curves in reverse to the left

- ▶ Actuate the left foot rocker **PG5** reduced to the rear (direction **Y-**) and the right foot rocker **PG6** to the rear (direction **Y-**).

**Result:**

- The crane drives a reverse curve to the left.



**Note**

- ▶ The further the right foot rocker **PG6** is actuated backward (direction **Y-**) the higher the speed of driving a curve.
- ▶ If the left foot rocker **PG5** is pushed fully to the rear (direction **Y-**), the left crawler stops.

### 7.6.6 Driving in curves in reverse to the right

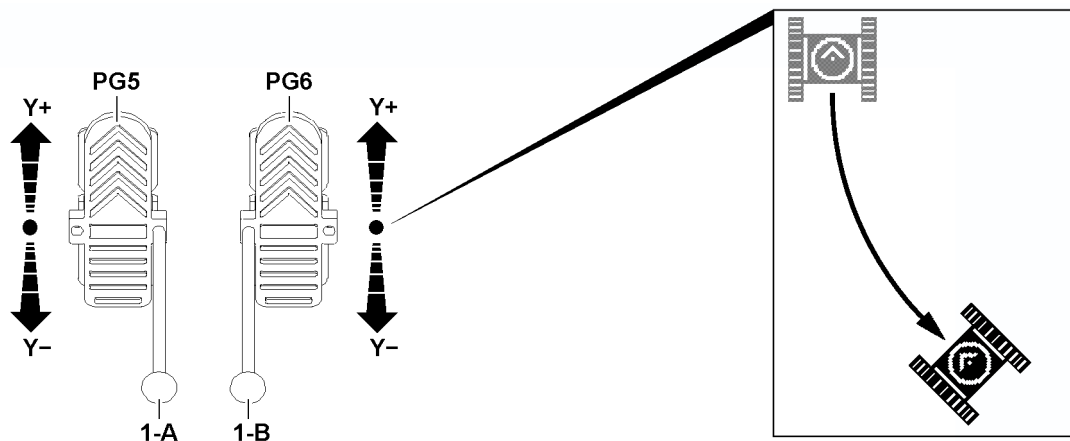


Fig.153813: Driving in curves in reverse to the right

- ▶ Actuate the left foot rocker **PG5** reduced to the front (direction **Y+**) and the right foot rocker **PG6** to the rear (direction **Y-**).

**Result:**

- The crane drives a reverse curve to the right.



**Note**

- ▶ The further the right foot rocker **PG6** is actuated backward (direction **Y-**) the higher the speed of driving a curve.
- ▶ If the left foot rocker **PG5** is pushed fully to the front (direction **Y+**), the right crawler stops.

### 7.6.7 Turning forward to the left

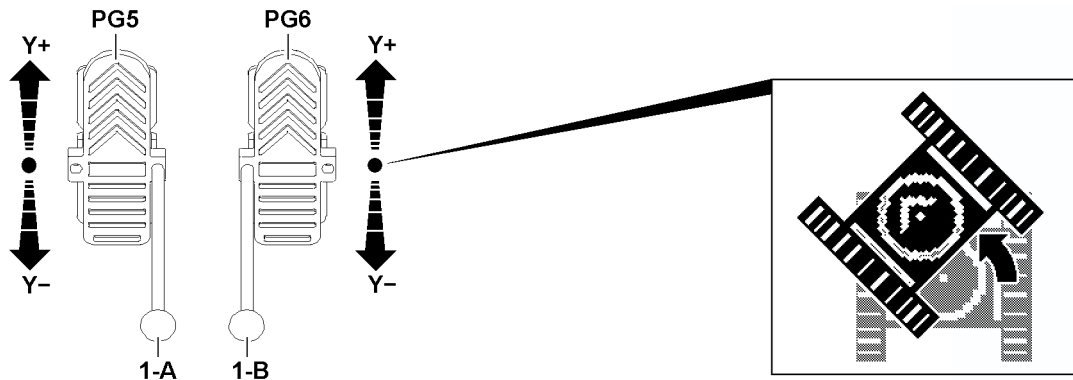


Fig.153814: Turning forward to the left

- ▶ Push through and hold the left foot rocker **PG5** fully to the rear (direction **Y-**).
- ▶ Actuate the right foot rocker **PG6** forward (direction **Y+**).

**Result:**

- The crane is turned forward to the left.



**Note**

- ▶ The further the right foot rocker **PG6** is actuated forward (direction **Y+**) the higher the speed of the turning movement.

### 7.6.8 Turning forward to the right

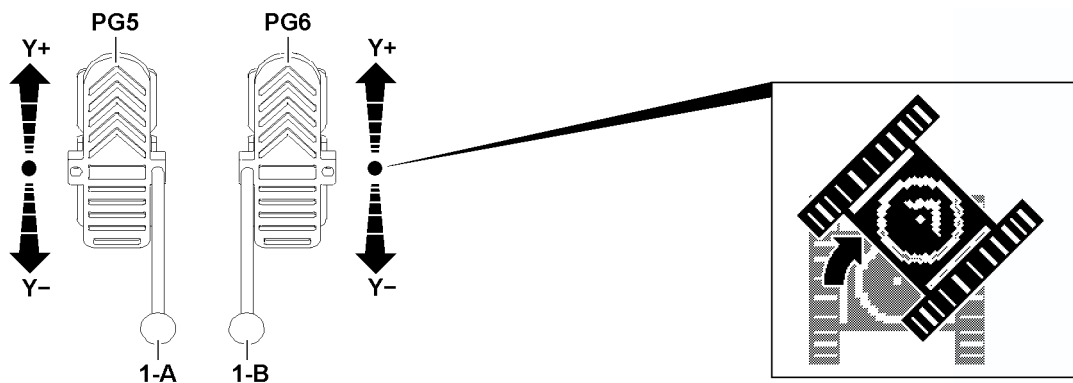


Fig.153815: Turning forward to the right

- ▶ Push through and hold the left foot rocker **PG5** fully to the front (direction **Y+**).
- ▶ Actuate the right foot rocker **PG6** forward (direction **Y+**).

**Result:**

- The crane is turned forward to the right.



**Note**

- ▶ The further the right foot rocker **PG6** is actuated forward (direction **Y+**) the higher the speed of the turning movement.

### 7.6.9 Turning backward to the left

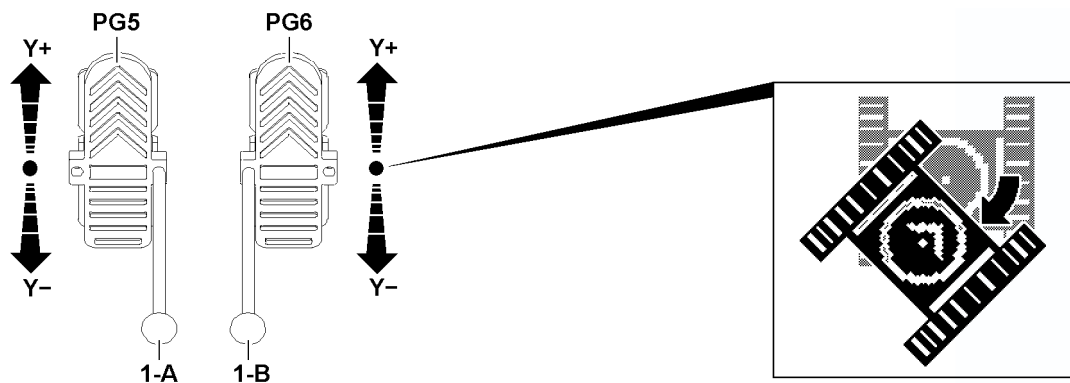


Fig.153816: Turning backward to the left

- ▶ Push through and hold the left foot rocker **PG5** fully to the rear (direction **Y-**).
- ▶ Actuate the right foot rocker **PG6** backward (direction **Y-**).

**Result:**

- The crane is turned backward to the left.



**Note**

- ▶ The further the right foot rocker **PG6** is actuated backward (direction **Y-**) the higher the speed of the turning movement.

### 7.6.10 Turning backward to the right

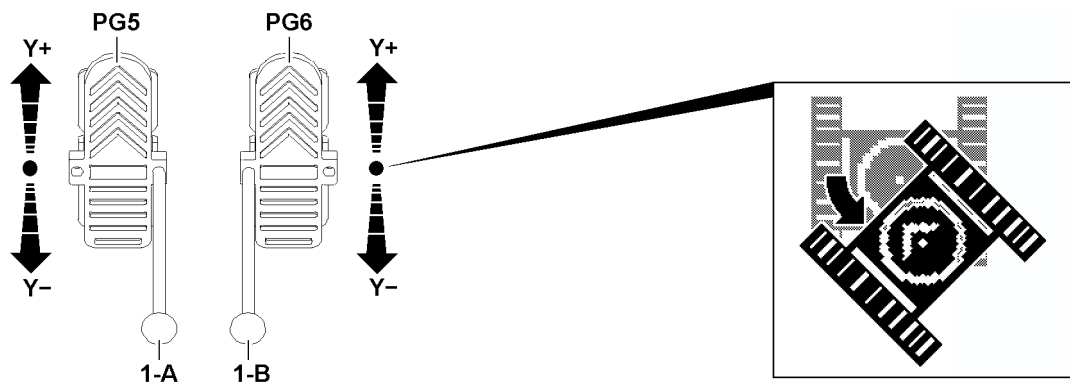


Fig.153817: Turning backward to the right

- ▶ Push through and hold the left foot rocker **PG5** fully to the front (direction **Y+**).
- ▶ Actuate the right foot rocker **PG6** backward (direction **Y-**).

**Result:**

- The crane is turned backward to the right.



**Note**

- ▶ The further the right foot rocker **PG6** is actuated backward (direction **Y-**) the higher the speed of the turning movement.



## 4.15 Reeving plans

1 Reeving plans

---

2

LWE/LR 1800-1-0-000/27200-07-02/en

# 1 Reeving plans

**Note**

- ▶ See the separate reeving plans!

## 4.20 Procedure for shut-off of crane movement

1	General	3
2	Instructions for resuming crane movement	17

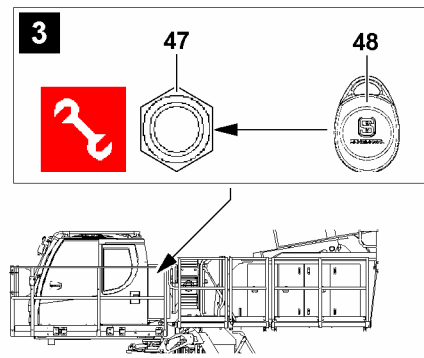
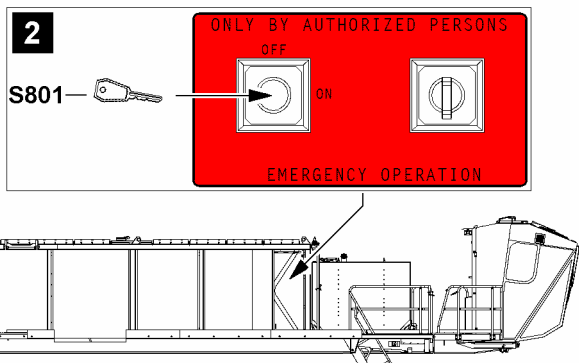
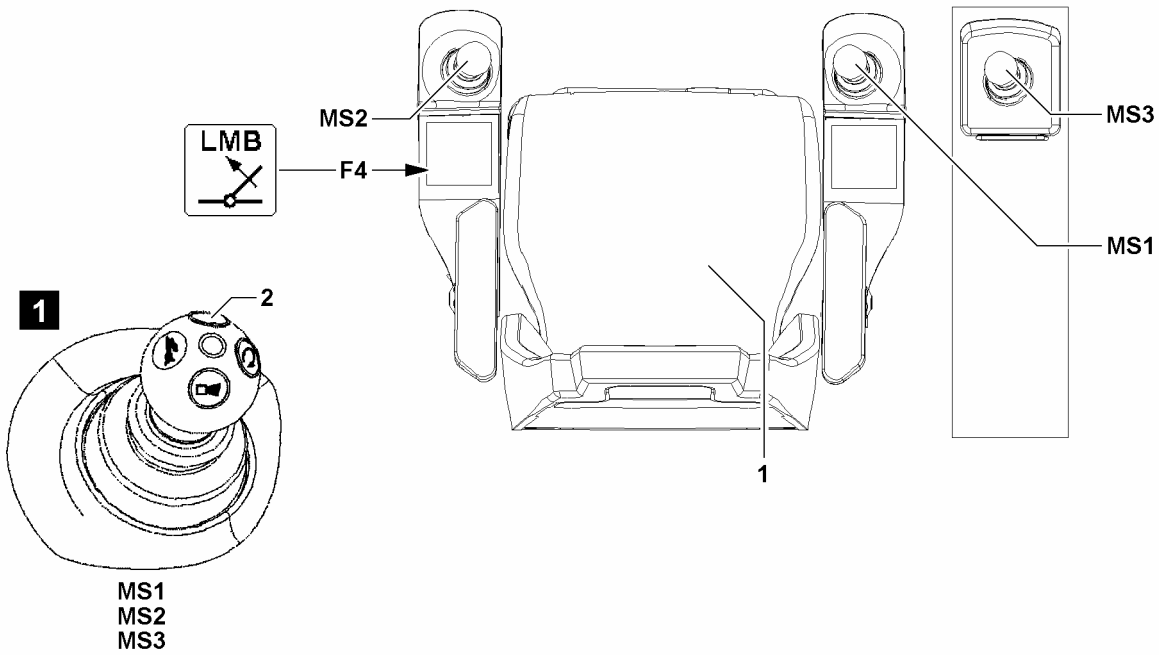
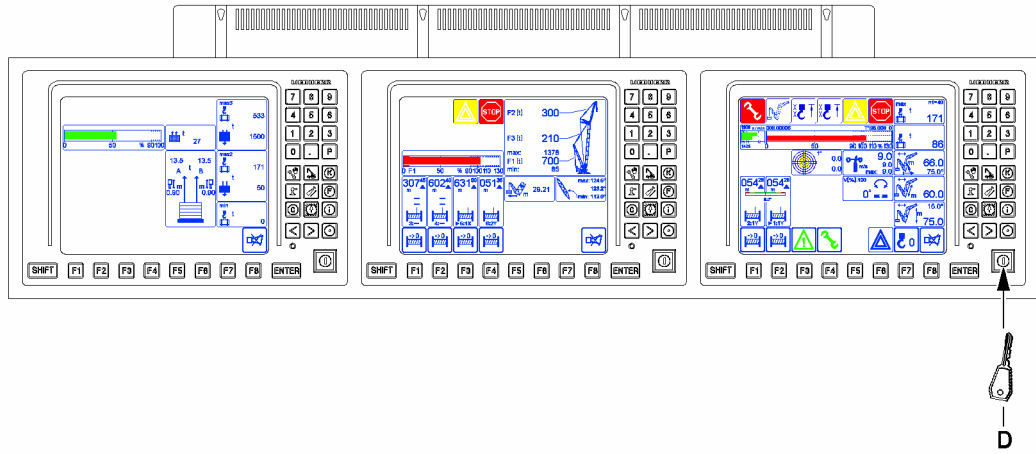


Fig.144109

LWE/LR 1800-1-0-000/27200-07-02/en

# 1 General



## WARNING

Limits of LICCON computer system!

The LICCON computer system cannot reduce the danger of accident in case of unsuitable or careless operation nor overcome physical limits.

The LICCON computer system cannot take misjudgments / erroneous operation into account.

- ▶ Safe crane operation / assembly operation and crane application is the sole responsibility of the crane operator and operating personnel.
- ▶ Always adapt crane operation / assembly operation and crane application to the operating conditions.



## Note

- ▶ The monitor illustrations in this chapter are only examples.
- ▶ The numerical values in the individual icons and charts do not have to necessarily match the crane exactly.
- ▶ Numbers and letters can be replaced by place holders.
- ▶ The display and assignment of the icons can deviate, depending on the set up configuration, operating status and configuration of the crane.
- ▶ In addition, many of the illustrations show the maximum configuration of the LICCON monitor with icons.
- ▶ In crane operation, an identical display will **not** appear on the LICCON monitor.

For monitoring the crane, three LICCON monitors are available in the instrument panel.

LICCON monitor 0

- Placed on the right in the monitor arrangement

LICCON monitor 1

- Placed in the center in the monitor arrangement

LICCON monitor 2

- Placed to the left in the monitor arrangement

If a crane movement is to be carried out with a master switch (MS1, MS2 or MS3), then at least one of the following buttons must be pressed:

- **1** Seat contact button
  - Is actuated by sitting properly on the seat.
- **2** Button
  - To bypass the seat contact button **1**, to be able to work while standing up, if necessary.
  - Each master switch (MS1, MS2 or MS3) has a button **2**, see illustration **1**



## Note

- ▶ Load hook and hook block are also generally described as hooks.

## 1.1 Operating elements for special cases during operation of the LICCON overload protection

Within the crane operator's cab, two buttons are installed as operating elements for "Special cases for operation of the LICCON overload protection":

- Button **F4** on the left control panel
- The set up key **D** on LICCON monitor 0

Depending on the crane configuration, an additional operating element can be installed outside the crane operator's cab for "Special cases during operation of the LICCON overload protection".

Depending on the crane type, either:

- Key switch **S801** in the control cabinet, see illustration **2**

or

- Sensor **47** and transponder **48** on the outside of the control cabinet, see illustration **3**

## 1.2 Special cases during operation of the LICCON overload protection

When special cases occur during operation of the LICCON overload protection, then the functionality of the LICCON overload protection is accessed.



### WARNING

Intervention of the functionality of the LICCON overload protection!

If the functionality of the LICCON overload protection is accessed by pressing the key **F4**, set up key **D**, the key switch **S801** or sensor **47** via the transponder **48**, then the LICCON overload protection is entirely deactivated, bypassed or limited.

It is possible to exceed several shut-off limits of the LICCON overload protection simultaneously or one after the other.

It is possible to carry out crane movements that are not monitored by the LICCON overload protection. Without the LICCON overload protection, no additional protection against overload of the crane via the crane control is present.

- ▶ When accessing the functionality of the LICCON overload protection, take into account that the LICCON overload protection is deactivated totally or is limited.
- ▶ Access the functionality of the LICCON overload protection exclusively according to the specifications in the crane documentation.

### Possible limitations in the crane control:

- During certain “Special cases at operation of the LICCON overload protection”, the working speed of the crane is significantly reduced.
- During certain “Special cases at operation of the LICCON overload protection”, the possibility to control the crane is limited in time.
- During certain “Special cases at operation of the LICCON overload protection”, the individual display instruments show no values.

### 1.2.1 Special operating conditions

If a special operating condition occurs, such as self-blocking of overload protection (“Deadlock”), pressing button **F4** or set up key **D** can provide a remedy.

By pressing the key **F4** you can:

- Luff in with suspended load, after the boom radius range of the load chart is left

By pressing the set up key **D**, the function “Exceeding the shut-off limits of the LICCON overload protection” is activated. This makes it possible:

- To exceed the maximum permissible load moment
- To exceed the maximum value of the F-load display in crane operation.
- To enable individual, limited crane movements after *LMB STOP* shut-off



### Note

- ▶ Depending on the crane configuration, exceeding the maximum permissible load momentum is limited to 110 %.

### 1.2.2 Assembly / disassembly procedures

By pressing the set up key **D** you can:

- Bypass the LICCON overload protection to carry out erection / take down procedures and assembly procedures.
- Bypass *hoist top* shut-off (erection / take down procedures and assembly procedures)

**Note**

- ▶ For assembly / disassembly procedures, depending on the circumstances there may not be any display values or they may be significantly reduced.
- ▶ The display of the required display values or determination of required values is ensured when proceeding correctly.

### 1.2.3 Failure of components

**WARNING**

Improper crane operation!

If the LICCON overload protection turns the crane movement off due to failure of components, then the exact cause for the shut-off must be determined.

After a failure of components, no normal operating condition can be reached. No normal crane operation is possible.

- ▶ For the procedure, see the Crane operating instructions, chapter 4.04.
- ▶ Resume normal crane operation only when the cause for the shut-off has been remedied and the crane control is fully functioning.

Depending on the crane configuration, a shut-off due to “failure of components” can be bypassed by:

- Activating the LMB-emergency operation:
  - Key switch **S801** in the control cabinet  
or
  - Sensor **47** via the transponder **48** on the rear side of the crane cab
- or
- Press the set up button **D**.

The activated function includes the following:

- Allows crane movements in case of failure of components, for example sensors which are required for monitoring by the LICCON overload protection.

### 1.2.4 Emergency situations

**WARNING**

Overload of crane!

If the LICCON overload protection is bypassed, then the LICCON overload protection is entirely deactivated.

If the LICCON overload protection is bypassed, there is no further protection against crane overload. There is no longer a load torque limiter.

If the LICCON overload protection is bypassed, the crane can be overloaded readily.

Overloading the crane can lead to accidents.

During accidents, personnel could be killed or seriously injured.

- ▶ If the LICCON overload protection is bypassed, take into account that the LICCON overload protection is entirely deactivated.
- ▶ If the LICCON overload protection is bypassed, the crane operator assumes the full responsibility for his actions.

Depending on the crane configuration, the LICCON overload protection can be bypassed as follows:

- Activating the LMB-emergency operation:
  - Key switch **S801** in the control cabinet  
or
  - Sensor **47** via the transponder **48** on the rear side of the crane cab
- or
- Press the set up button **D**.

The activated function includes the following:

- Allowing crane movements in emergency situations without monitoring by the LICCON overload protection

**Note**

- ▶ Installation location of the key switch **S801** or sensor **47**, see illustration **2** or illustration **3**. The transponder **48** (when a sensor **47** is installed) is supplied upon crane delivery and must be accessible to the respective personnel (for example the crane operator).
- ▶ For the procedure, see the Crane operating instructions, chapter 4.04.

### 1.3 Operating condition of crane

A “**normal operating condition**” can only be reached if all of the following statements apply:

- The crane is in a proper condition.
- The crane is set up according to the specifications in the crane documentation.
- The set up configuration of the crane has been entered correctly into the LICCON computer system.
- The crane is in the range of a valid load chart.
- The crane utilization is in the range of 0 % to 100 %.
- The F-load display is in the permissible range.
- All required displays in the LICCON monitors provide the correct display values.
- All required display instruments are functioning.
- The local conditions meet the specifications for crane application.

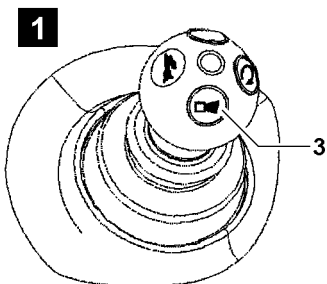
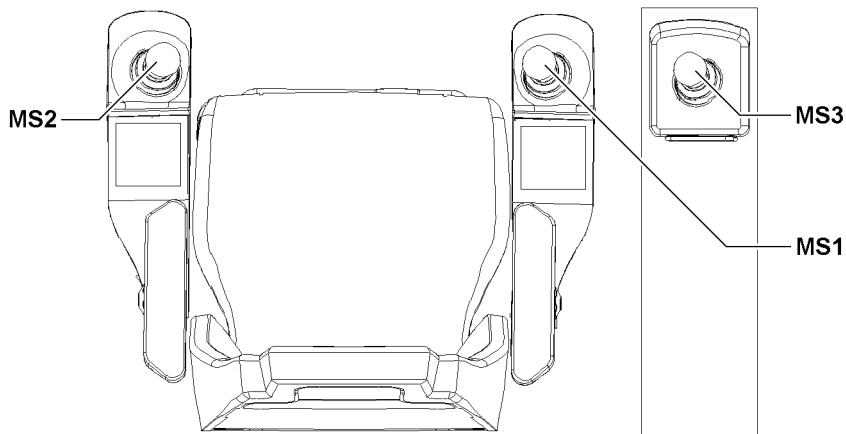
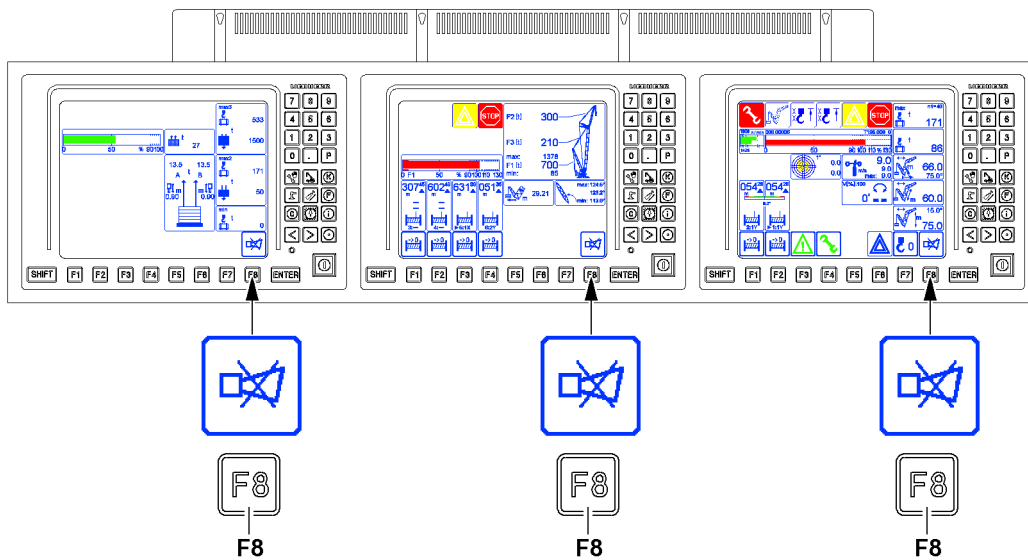
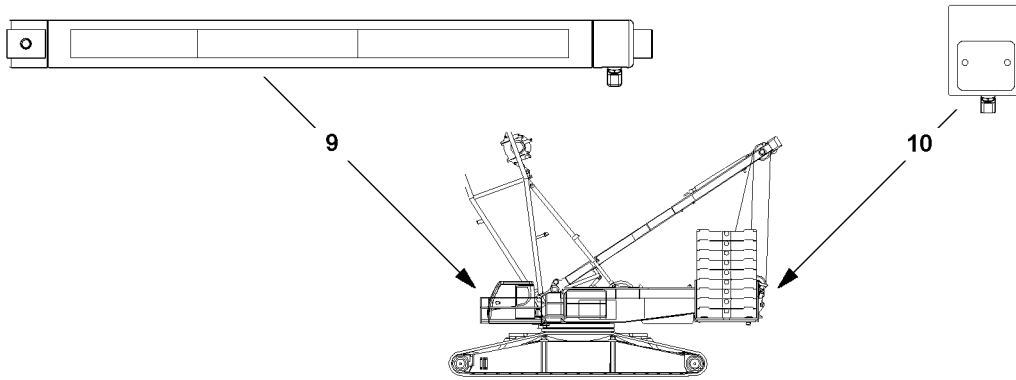
The “**operating condition is not normal**”, among others, if one or more of the following statements apply:

- The crane has defects that compromise operational safety.
- The crane is not set up according to the specifications in the crane documentation.
- The set up configuration of the crane deviates from the entries in the LICCON computer system.
- The limit values from the load charts are exceeded.
- The maximum permissible load momentum is exceeded.
- The *hoist top* shut-off is bypassed.
- The limit values from the F-load display are exceeded.
- Required displays in the LICCON monitors provide no correct display values.
- Required display instruments are not functioning.
- The functionality of the LICCON overload protection has been accessed by pressing the key **F4**, set up key **D** or key switch **S801** or sensor **47** via transponder **48**.
- When LMB emergency operation is activated.
- Crane movements are carried out without a functioning overload protection.
- Crane movements are carried out outside of the load charts.
- A special case at operation of the LICCON overload protection has occurred.



Empty page!

LWE/LR 1800-1-0-000/27200-07-02/en



MS1  
MS2  
MS3

Fig.144108

LWE/LR 1800-1-0-000/27200-07-02/en

## 1.4 Overview of acoustic / optical warnings

- The acoustic warnings are issued to the crane operator via the signal sounds of the LICCON monitors.
- The acoustic warnings are issued to the surrounding crane area via a horn on the turntable.
- The optical warnings are issued to the crane operator via warning icons on the LICCON monitors.
- The LMB warning lights (three color light **9** on the crane cab and warning light **10** on the rear of the turntable) are used to issue optical warnings to the crane surrounding area.
- The acoustic warnings within the crane operator's cab are shut off by pressing the button **F8** on the corresponding LICCON monitor.
- The acoustic warnings outside the crane operator's cab are shut off by pressing the button **3**. Each master switch (MS1, MS2 or MS3) has a button **3**, see illustration **1**

### 1.4.1 General notes regarding the acoustic / optical warnings to the surrounding crane area



#### WARNING

Disregard of acoustic or optical warnings!

If persons in the crane surrounding area are not informed about the meaning of acoustic / optical warnings of the crane, then there is a danger of accidents.

- ▶ Only persons who have been informed about how to proceed correctly according to the acoustic / optical warnings may be in the crane surrounding area.

In reference to the horn on the turntable, the following applies:

- An intermittent sound is heard: A special case in the operation of the LICCON overload protection has occurred or the overload protection has turned the crane movement off.

In reference to the three color light **9**, the following applies:

- The three color light **9** lights up green: The crane is in normal operating condition.
- The three color light **9** lights up yellow: The crane is still in normal operating condition, an advance warning for upcoming shut-off exists.
- The three color light **9** lights up red: The crane movement was turned off by the overload protection.
- The three color light **9** blinks yellow: A special case at operation of the LICCON overload protection has occurred.
- The three color light **9** blinks red: A special case at operation of the LICCON overload protection has occurred.

In reference to the warning light **10** on the rear of the turntable, the following applies:

- The warning light **10** lights up red: The crane movement was shut off.
- The warning light **10** blinks red: A special case at operation of the LICCON overload protection has occurred.

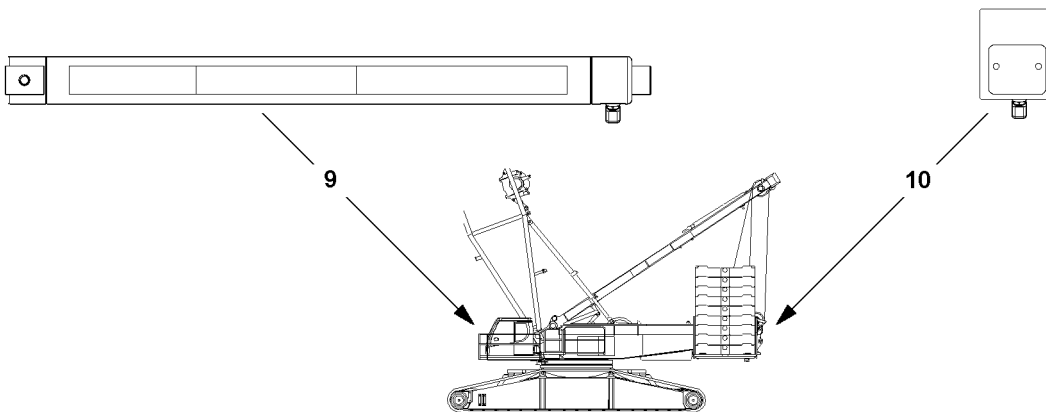
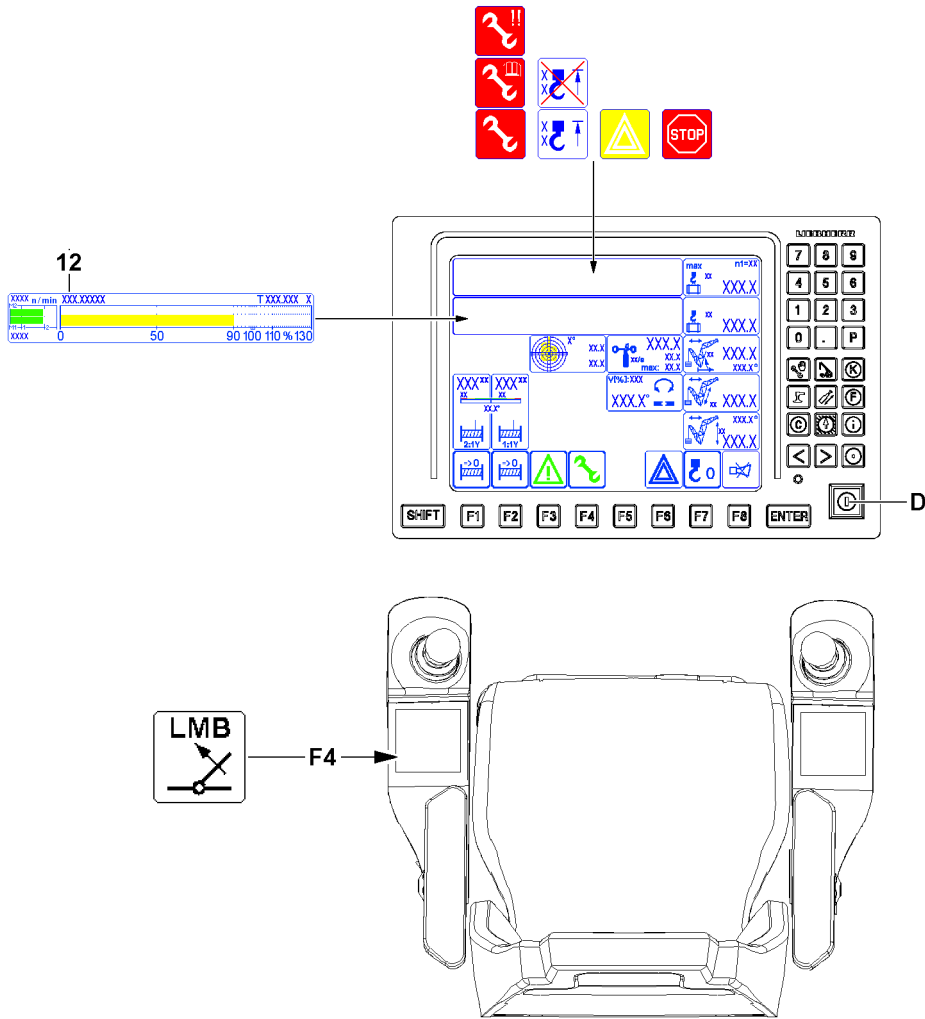


Fig.115284

LWE/LR 1800-1-0-000/27200-07-02/en

## 1.4.2 Description of acoustic / visual warnings

The occurrence of acoustic / optical warnings in crane operation is explained via sample situations. The situation numbers from the chart "Overview of possible situations" is valid for the following charts in this chapter:

- Acoustic / visual warnings on the LICCON monitor
- LMB warning lights
- Horn on the turntable



### Note

- ▶ The percentage values in the chart "Overview of possible situations" refers to the crane utilization according to the display in the bar diagram for utilization **12**.

Overview of possible situations	
Situation number	Sample description of the situation
<b>Situation 001</b>	Normal operating condition with crane utilization of 0 % to 100 %.
<b>Situation 003</b>	The crane movement was turned off due to a crane utilization above 100 % - shut-off <i>LMB-STOP</i> was triggered.
<b>Situation 004</b>	The crane movement was turned off even though the crane utilization is below 100 % - shut-off <i>LMB-STOP</i> was triggered.
<b>Situation 005</b>	The "luffing in with suspended load" crane movement is carried out at a crane utilization above 100 % via the key <b>F4</b> .
<b>Situation 006</b>	Failure of LICCON overload protection components
<b>Situation 010</b>	The shut off limits of the LICCON overload protection are deactivated / exceeded via the set up key <b>D</b> .
<b>Situation 011</b>	An actuated hoist limit switch ( <i>hoist top</i> shut-off) is bypassed via the set up key <b>D</b> .
<b>Situation 020</b>	The assembly operation was activated via the set up key <b>D</b> to erect / take down the boom. No load chart is available.

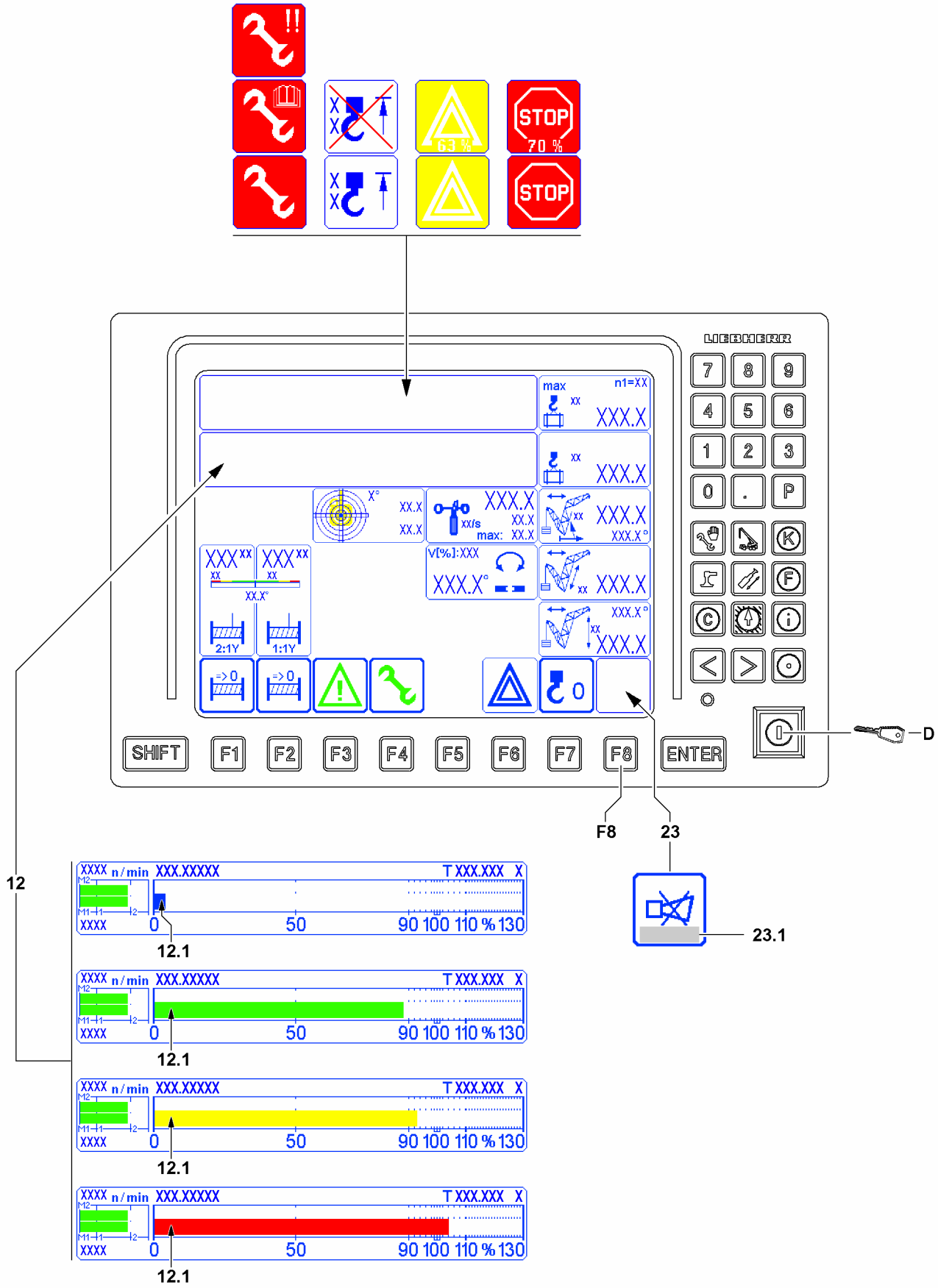


Fig.148654

LWE/LR 1800-1-0-000/27200-07-02/en

### 1.4.3 Acoustic / visual warnings within the crane operator's cab



**Note**

The percentage values refer to the crane utilization according to the display in the bar diagram for utilization **12**.

If the limit values for the load torque limiter for advance warning and shut-off are set otherwise by the crane driver, the percentage values are correspondingly lower. See the Crane operating instructions, chapter 4.02.

- ▶ Up to utilization of 20%, the utilization bar **12.1** is blue, when the actual load is simultaneously lower than 0.5 t.
- ▶ Up to utilization of 90 %, the utilization bar **12.1** is green. In the case of very low utilization, the utilization bar **12.1** is also blue.
- ▶ Above utilization of 90% to 100 %, the utilization bar **12.1** is yellow.
- ▶ Above utilization of 100 %, the utilization bar **12.1** is red.



**WARNING**

Improper crane operation!

- ▶ In relation with acoustic / optical warnings in the *Horn* icon **23**, observe the notes regarding error messages **23.1**.



**Note**

- ▶ For a more detailed description of the situations according to the situation numbers, see chart "Overview of possible situations"

Acoustic / visual warnings on the LICCON monitor							
Situation <sup>4)</sup>	Acoustic warning		Visual warning LICCON monitor				
	Horn short <sup>2)</sup>	Horn long <sup>2)</sup>	Warning signs		Special signs		
<b>Situation 001</b>	Above 90 % <sup>5)</sup>	-	Above 90 % <sup>5)</sup>	-	-	-	-
<b>Situation 003</b>	Above 90 % <sup>5)</sup>	Above 101 % <sup>5)</sup>	Above 90 % <sup>5)</sup>	Above 101 % <sup>5)</sup>	-	-	-
<b>Situation 004</b>	-	Always	-	Always	-	-	-
<b>Situation 005</b>	-	Above 101 % <sup>5)</sup>	Above 101 % <sup>5)</sup>	Above 101 % <sup>5)</sup>			
<b>Situation 006</b>				Always	Always <sup>3)</sup>		
<b>Situation 010</b>	Above 90 % <sup>5)</sup>	Above 101 % <sup>5)</sup>	Above 90 % <sup>5)</sup>	Above 101 % <sup>5)</sup>	Always	-	-
<b>Situation 011<sup>1)</sup></b>	-	Always	-	-	-	-	Always
<b>Situation 020</b>	-	Always	-	-	-	Always	-

<sup>1)</sup> Is in part superseded by other warnings.

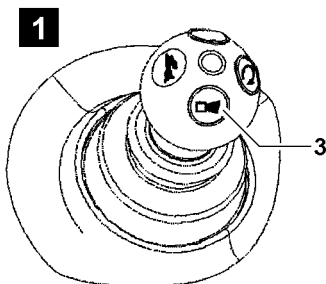
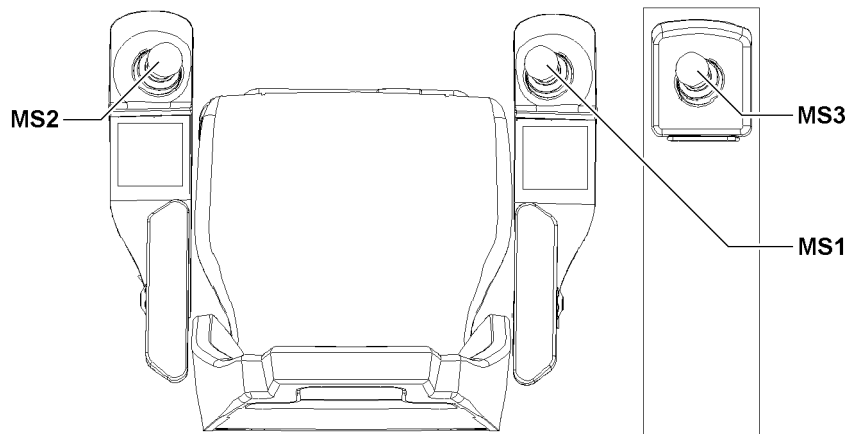
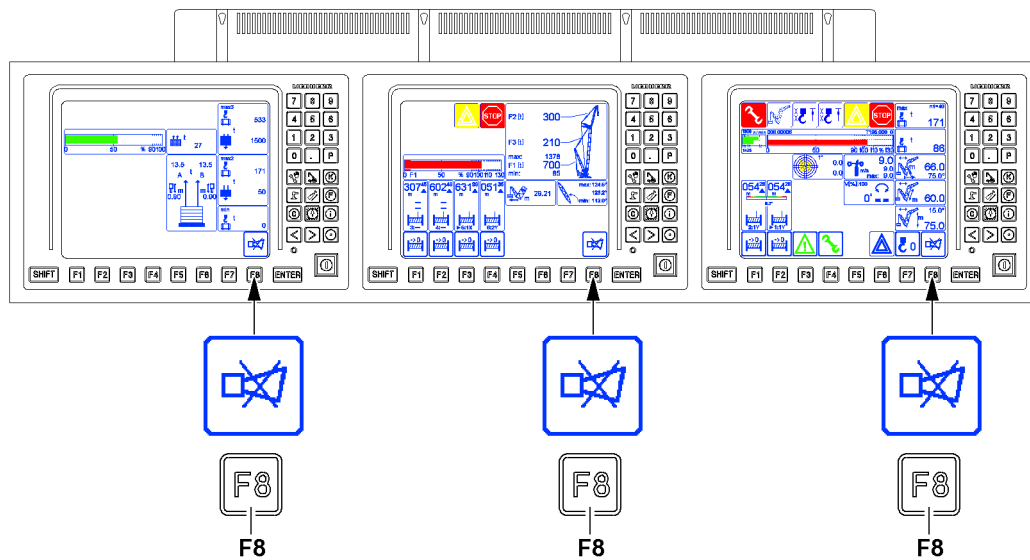
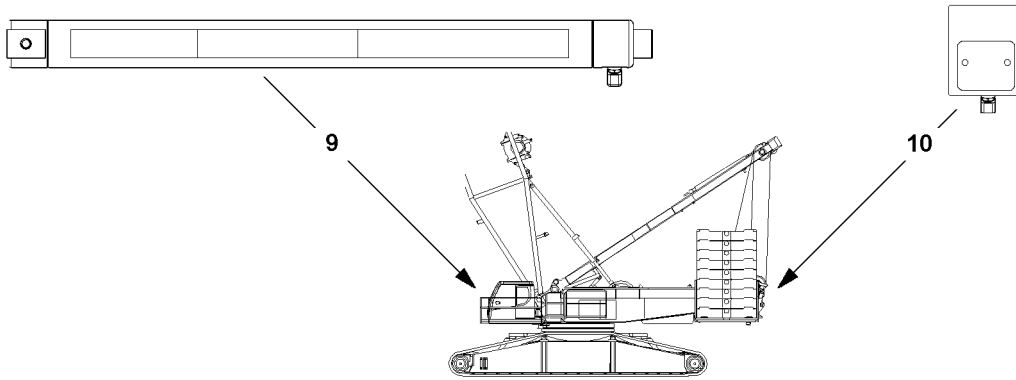
<sup>2)</sup> Can be turned off immediately on the LICCON monitor with the function key **F8**.

<sup>3)</sup> Depending on the crane configuration, a variant of this icon appears, see the Crane operating instructions, chapter 4.02.

<sup>4)</sup> Description of individual situations, see chart "Overview of possible situations".

<sup>5)</sup> If the limit values for the load torque limiter for advance warning and shut-off are set otherwise by the crane driver, this value can be lower. See the Crane operating instructions, chapter 4.02.

LWE/LR 1800-1-0-000/27200-07-02/en



MS1  
MS2  
MS3

Fig.144108

LWE/LR 1800-1-0-000/27200-07-02/en



### 1.4.4 Acoustic / visual warnings outside the crane operator's cab



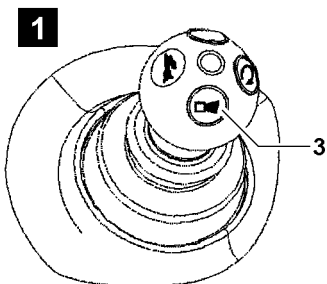
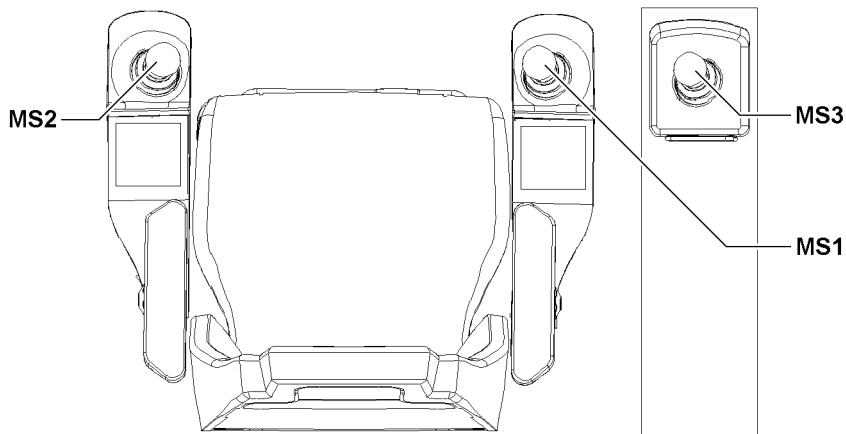
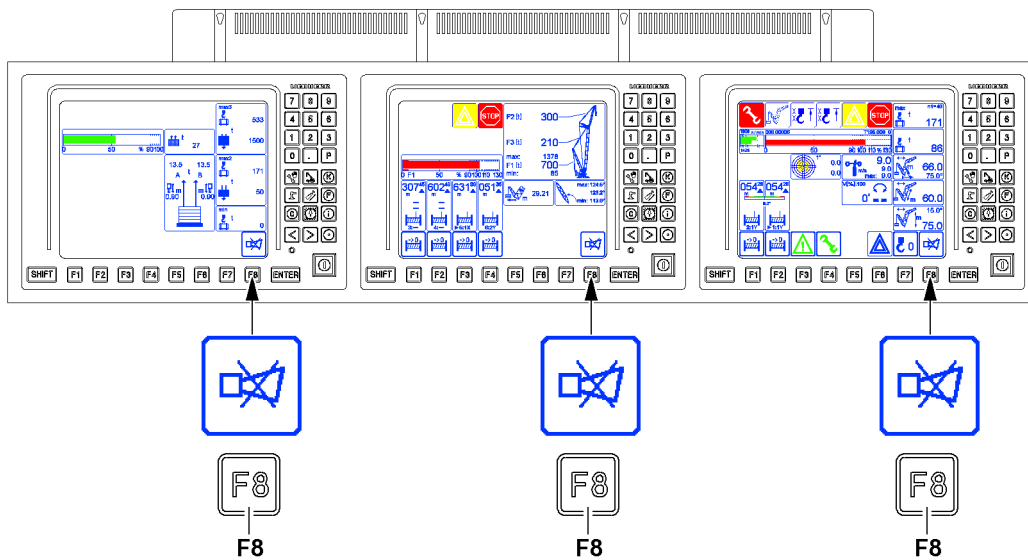
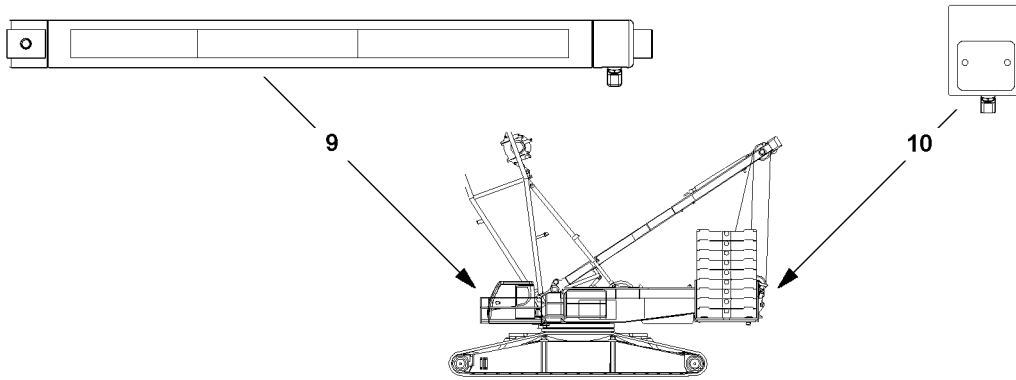
#### Note

- ▶ For description of the situations assigned to the situation numbers, see chart "Overview of possible situations"
- ▶ The percentage values refer to the crane utilization according to the display in the crane operating screen.

LMB warning lights					
Situation number	At utilization of crane	Three color light 9			Warning light 10
		Green	Yellow	Red	Red
Situation 001	0 % to 89 %	Lights up			
	90 % to 100 %		Lights up		
Situation 003	Above 101 %			Lights up	Lights up
Situation 004	Always			Lights up	Lights up
Situation 005	Above 101 %			Blinks	Blinks
Situation 006	Always			Blinks	Blinks
Situation 010 <sup>6)</sup>	0 % to 89 %	Lights up			
	90 % to 100 %		Lights up		
	101 % to 110 %		Blinks		
	Above 111 %			Lights up	Lights up
Situation 010	0 % to 89 %	Lights up			
	90 % to 100 %		Lights up		
	Above 101 %			Blinks	Blinks
Situation 011 <sup>1)</sup>	Always		Blinks		
Situation 020	No display value		Blinks		

<sup>1)</sup> Is in part superseded by other warnings

<sup>6)</sup> Cranes according to EN13000:2010



MS1  
MS2  
MS3

Fig.144108

LWE/LR 1800-1-0-000/27200-07-02/en

**Note**

- ▶ For description of the situations assigned to the situation numbers, see chart "Overview of possible situations"
- ▶ The percentage values refer to the crane utilization according to the display in the crane operating screen.

Acoustical signals on the turntable that can be shut off by actuating a button **3** (illustration **1**). The signal shut-off is effective no earlier than after five seconds.

Signal turntable		
Situation number	At utilization of crane	Signal type
<b>Situation 001</b>	0 % to 89 %	-
<b>Situation 002</b>	90 % to 100 %	-
<b>Situation 003</b>	Above 101 %	Intermittent sound, can be shut off after five seconds
<b>Situation 004</b>	Always	-
<b>Situation 005</b>	Above 101 %	Intermittent sound, can be shut off after five seconds
<b>Situation 006</b>	Always	Intermittent sound
<b>Situation 010</b>	Above 111 %	Intermittent sound, can be shut off after five seconds
<b>Situation 011<sup>1)</sup></b>	Always	Intermittent sound, can be shut off after five seconds
<b>Situation 020</b>	No display value	-

<sup>1)</sup> Is in part superseded by other warnings

## 2 Instructions for resuming crane movement

**WARNING**

Danger of accident!

If the following points are not observed, personnel can be severely injured or killed.

- ▶ The crane operator bears the sole and full responsibility for the adherence to measures to be taken in case of shut-off of crane movement.

## 2.1 Overview Load chart

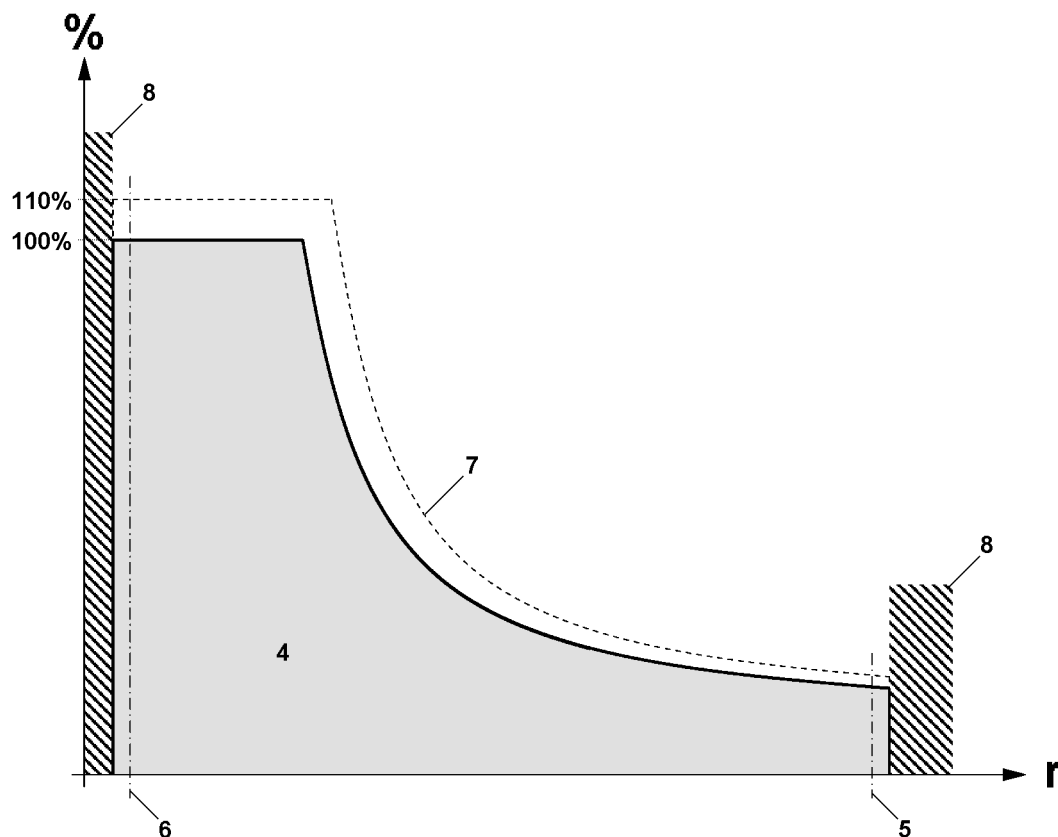


Fig.125392: Sample overview of a load chart

Axle	Description
r	Boom radius (working radius)
%	Utilization of the crane in percentages

Position	Description
4	Range "Load chart available"
5	Lower limit angle load chart <sup>1)</sup>
6	Upper limit angle load chart <sup>2)</sup>
7	Curve utilization 110 %
8	Range "No load chart available"

<sup>1)</sup> Maximum boom radius of the boom within the load chart reached, the boom is located within the load chart in the flattest position.

<sup>2)</sup> Minimum boom radius of the boom within the load chart reached, the boom is located within the load chart in the steepest position.

## 2.2 Shut-off of crane movement

The LICCON computer system carries out the following shut-offs if a limit value is exceeded during crane operation:

- Shut-off *overload*
- Shut-off *luffing the main boom up / down*
- Shut-off *luffing the auxiliary boom / accessory up / down*

- Shut off *maximum / minimum value F-load display*
- Shut-off *spooling the winch up / out*
- Hoist top shut-off
- *Luffing the derrick boom up / down* shut-off
- Shut-off *parallel operation winch 1 and winch 2*
- Shut-off *difference force monitoring of derrick ballast guying*
- Shut-off due to error message

**Note**

- ▶ For detailed description of the individually listed icons, see Crane operating instructions, chapter 4.02.

**WARNING**

Improper crane operation!

If the LICCON overload protection turns the crane movement off, then the exact cause for the shut-off must be determined first.

- ▶ Determine the cause for the shut-off and remedy it if possible without pressing the key **F4** “Luffing in with suspended load” or the set up key **D**.
- ▶ If it is not possible to reset the crane movement causing the shut-off, see section “Procedure for special cases at operation of the LICCON overload protection”.

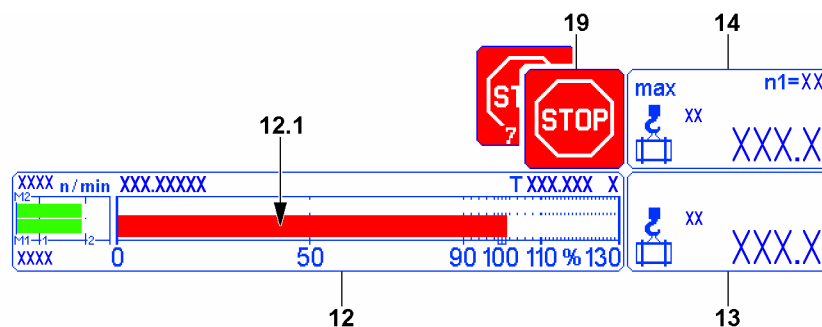
**2.2.1 Shut-off overload**

Fig.148655

In the bar diagram utilization **12** the utilization bar **12.1** exceeds the 100 % mark. The LICCON overload protection has turned off the crane movement, **LMB-STOP** icon **19** appears. The actual load **13** has exceeded the maximum load **14**.

**Note**

Limit values for the load torque limiter for advance warning and shut-off reduced

If the limit values for the load torque limiter for advance warning and shut-off are reduced by the crane operator, shut-off takes place earlier according to the set value.

- ▶ Observe the settings of the limit values for the load torque limiter for advance warning and shut-off, see the crane operating instructions, chapter 4.02.

- ▶ Wait for a short time until the crane movement has come to a complete standstill.

When the bar diagram utilization **12** shows less or equal 100 %:

- ▶ Carry out crane movements in such a way that no repeated shut-off by the LICCON overload protection occurs.

When the bar diagram utilization **12** shows more than 100 %:

- ▶ Check if there are permissible tasks, which positively influence the utilization of the crane.

When necessary and possible:

- ▶ Set down the load.

**Note**

It is possible that the following tasks can positively influence the utilization of the crane:

- ▶ Set down the load and reduce the boom radius by driving the crane.
  - ▶ Set down and reduce the load.
  - ▶ Set down the load and reconfigure the crane to obtain higher load chart values.
- 
- ▶ Carry out permissible tasks that positively influence the utilization of the crane.

**Problem remedy**

The crane operation is limited because the maximum load **14** is seemingly too low or reached too soon?

- ▶ Make sure that the load bearing capacity of the crane is sufficient for the upcoming crane application.
- ▶ Make sure that a valid set up configuration has been entered in the LICCON computer system.
- ▶ Make sure that the crane is assembled according to the specifications in the crane documentation.
- ▶ Make sure that the actual set up configuration and the entered set up status of the crane match.
- ▶ Make sure that all attachment parts and guy rods on the boom system, which are not needed, have been removed (weight).
- ▶ Make sure that the boom system is free of snow and ice (weight).
- ▶ Make sure that the environmental influences (for example wind influence) onto the crane are not too great.
- ▶ Contact Liebherr Service.

When the shut-off cannot be remedied despite the observance of all points listed here:

- ▶ Change to section "Procedure for special cases at operation of the LICCON overload protection".

## 2.2.2 Shut-off luffing the main boom up / down

**Note**

- ▶ The illustration of the icon **15** depends on the set up configuration of the crane.

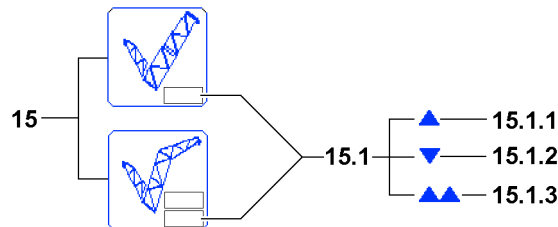


Fig.115275

In the icon **15** the arrow **15.1.1** or arrow **15.1.2** blinks and the LICCON overload protection has shut off the crane movement.

"Luffing the main boom up" (arrow **15.1.1**) or "Luffing the main boom down" (arrow **15.1.2**) was shut off because the upper / lower limit angle of the selected load chart was exceeded / fallen below.

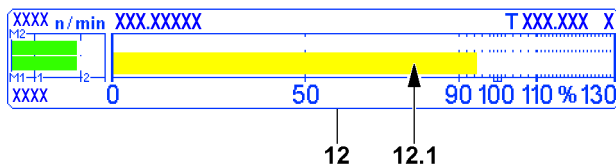


Fig.115276

**Note**

- ▶ If the utilization of the crane is more than 95 % (in bar diagram utilization **12** the utilization bar **12.1** exceeds 95 %) and the maximum load according to the load chart (falling load capacity) drops by continuing to luff up the boom, then the arrow **15.1.1** also appears and the crane movement “Luffing the main boom up” is turned off.

If the double arrow **15.1.3** appears, then:

- **either** it was luffed up to a limit switch or the limit switch has turned off the crane movement “Luffing the main boom up”
- **or** there is an error on one of the “Main boom top” limit switches

The arrow **15.1.1** appears and the crane movement “Luffing the main boom up” was turned off:

- ▶ Luff the main boom down.

**Result:**

- Crane operation is possible again.

The arrow **15.1.2** appears and the crane movement “Luffing the main boom down” was turned off:

- ▶ Luff the main boom up.

**Result:**

- Crane operation is possible again.

The double arrow **15.1.3** appears and the crane movement “Luffing the main boom up” was turned off:

- ▶ Luff the main boom down.

**Result:**

- Crane operation is possible again.

**Problem remedy**

The double arrow **15.1.3** appears continuously?

If a double arrow **15.1.3** appears without having luffed the main boom up to a limit switch, then there may be an error in the limit switches / sensors.

- ▶ Check if there is an error message from the LICCON computer system, see the Diagnostics manual.
- ▶ If yes: Remedy the error immediately.

**WARNING**

Limited warning functions!

If one of the double version limit switches / sensors is not OK and the crane is continued to be operated, then the warning functions of the LICCON overload protection are limited.

- ▶ The crane can only be operated in an emergency after failure of a double version limit switch.
- ▶ Carry out crane movements in such a way that no repeated shut-off by the LICCON overload protection occurs.

**2.2.3 Shut-off luffing the auxiliary boom / accessory up / down****Note**

- ▶ Only in operating modes with auxiliary boom / accessory
- ▶ The illustration of the icon **15** depends on the set up configuration of the crane.
- ▶ The “auxiliary boom / accessory” designation comprises all boom types that can be luffed and are installed on the main boom.

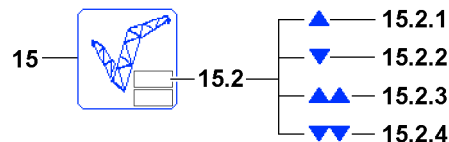


Fig.115277

The arrow **15.2.1** or arrow **15.2.2** blinks in the icon **15** (upper field) and the LICCON overload protection has shut off the crane movement.

“Luffing the equipment up” (arrow **15.2.1**) or “Luffing the equipment down” (arrow **15.2.2**) was shut off because the upper / lower limit angle of the selected load chart was exceeded or fallen below.

If the double arrow **15.2.3** appears, then:

- **either** it was luffed up to a limit switch or the limit switch has turned off the crane movement “Luffing the auxiliary boom / accessory up”
- **or** the mechanical relapse support has turned off the crane movement “Luffing the auxiliary boom / accessory up”
- **or** there is an error on one of the “Auxiliary boom / accessory top” limit switches.

If the double arrow **15.2.4** appears, then:

- **either** it was luffed down to a limit switch “Auxiliary boom / accessory bottom” and the limit switch has turned off the crane movement “Luffing the auxiliary boom / accessory up”
- **or** there is an error on one of the “Auxiliary boom / accessory bottom” limit switches

The arrow **15.2.1** appears and the crane movement “Luffing the auxiliary boom / accessory up” was turned off:

- ▶ Luff the auxiliary boom / accessory down.

**Result:**

- Crane operation is possible again.

The arrow **15.2.2** appears and the crane movement “Luffing the auxiliary boom / accessory down” was turned off:

- ▶ Luff the auxiliary boom / accessory up.

**Result:**

- Crane operation is possible again.

The double arrow **15.2.3** appears and the crane movement “Luffing the auxiliary boom / accessory up” was turned off:

- ▶ Luff the auxiliary boom / accessory down.

**Result:**

- Crane operation is possible again.

---

**Problem remedy**

The double arrow **15.2.3** appears continuously?

If a double arrow **15.2.3** appears without having luffed up to a limit switch, then there may be an error in the limit switches “Auxiliary boom / accessory top”.

- ▶ Check if there is an error message from the LICCON computer system, see the Diagnostics manual.
- ▶ If yes: Remedy the error immediately.

The double arrow **15.2.4** appears and the crane movement “Luffing the auxiliary boom / accessory down” was turned off:

- ▶ Luff the auxiliary boom / accessory up.

**Result:**

- Crane operation is possible again.



**Problem remedy**

The double arrow **15.2.4** appears continuously?

If a double arrow **15.2.4** appears without having luffed down to a limit switch, then there may be an error in the limit switches / sensors.

- ▶ Check if there is an error message from the LICCON computer system, see the Diagnostics manual.
- ▶ If yes: Remedy the error immediately.

**WARNING**

Limited warning functions!

If one of the double version limit switches / sensors is not OK and the crane is continued to be operated, then the warning functions of the LICCON overload protection are limited.

- ▶ The crane can only be operated in an emergency after failure of a double version limit switch / sensor.
- ▶ Carry out crane movements in such a way that no repeated shut-off by the LICCON overload protection occurs.

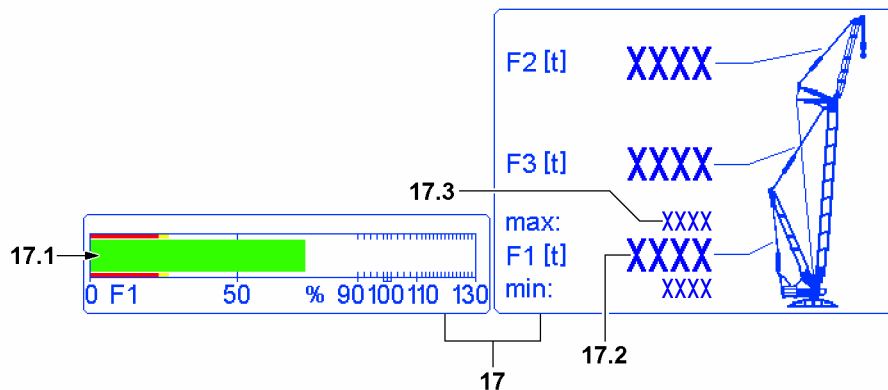
**2.2.4 Maximum / minimum value F-load display during crane operation shut-off**

Fig. 148663

The illustration of the F-load display **17** depends on the set up configuration of the crane and can vary. The values for test point 2 (force F2) and test point 3 (force F3) are possibly shown.

F-load display during crane operation:

- The force determined in test point 1 is generally described as  $F1_{\text{actual}}$  (actual value F1).
- In the icon **17** (F-load display), the force ratio for test point 1 is shown both in number values as well as an F1-bar display.
- The value  $F1_{\text{max}}$  **17.3** corresponds to the 100 % mark on the F1-bar display.
- The F1-utilization bar **17.1** shows the ratio  $F1_{\text{actual}}$  **17.2** to  $F1_{\text{max}}$  **17.3**.
- The F1-utilization bar **17.1** is green as long as the values for test point 1 (force F1) lie within the normal range for crane operation.

**Note****F-load display during assembly operation**

During erection / take down operations and assembly operations, the F-load display **17** may have an expanded display range in some cases.

- ▶ Observe the “Carrying out the erection / take down procedures” section.

### Maximum value F1 during crane operation shut-off

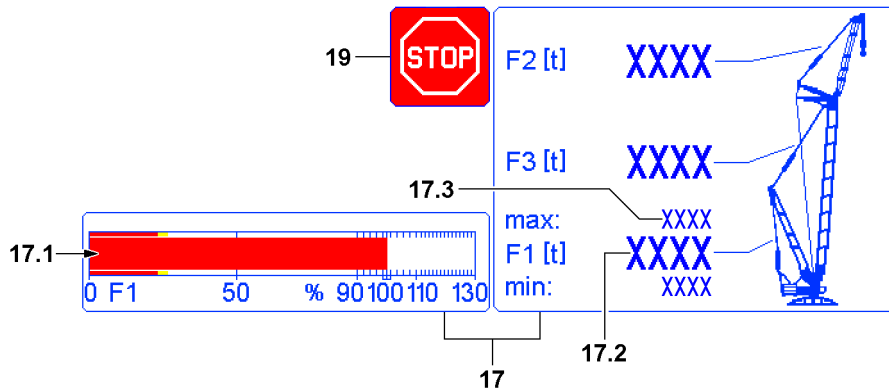


Fig.115278

On the F-load display 17, the F1-utilization bar 17.1 exceeds the 100 % mark and the LICCON overload protection has shut off the crane movement. The value  $F1_{\text{actual}}$  17.2 has exceeded the value  $F1_{\text{max}}$  17.3.

All other movements that lead to a worsening of the force ratio on the F-load display 17 are turned off.

- ▶ Reverse any crane movement that has caused the shut-off.
- or
- ▶ Alternatively initiate a crane movement that improves the force ratio in the F-load display 17.

#### Result:

- Crane operation is possible again.
- ▶ Carry out crane movements in such a way that no repeated shut-off by the LICCON overload protection occurs.

#### Problem remedy

The crane operation is limited because the value  $F1_{\text{max}}$  17.3 apparently is being reached too early?

- ▶ Make sure that a valid set up configuration has been entered in the LICCON computer system.
- ▶ Make sure that the crane is assembled according to the specifications in the crane documentation.
- ▶ Make sure that the actual set up configuration and the entered set up status of the crane match.
- ▶ Make sure that all attachment parts and guy rods on the boom system, which are not needed, have been removed (weight).
- ▶ Make sure that the boom system is free of snow and ice (weight).
- ▶ Make sure that the wind influence on the crane is not too great.

If no irregularities can be found:

- ▶ Contact Liebherr Service.

When the shut-off cannot be remedied despite the observance of all points listed here:

- ▶ Change to section "Procedure for special cases at operation of the LICCON overload protection".

### Minimum value F1 during crane operation shut-off



#### Note

- ▶ A minimum value F1 ( $F1_{\text{min}}$ ) shut-off only occurs in operating modes with derrick ballast. The status  $F1_{\text{actual}} = F1_{\text{min}}$  cannot be reached in all other operating modes.

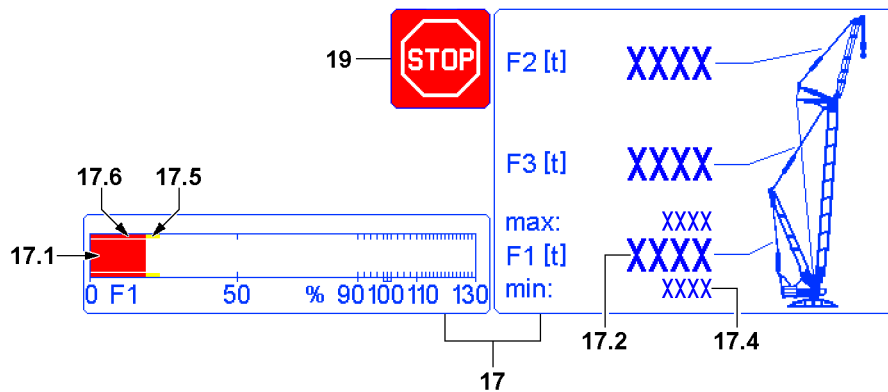


Fig. 115279

On the F-load display 17, when falling below the  $F1_{\min}$  advance warning bar 17.5, a warning of the upcoming shut-off is issued by the F1-utilization bar 17.1.

If the F1-utilization bar 17.1 falls below the  $F1_{\min}$ -STOP bar 17.6, then the LICCON overload protection shuts off the crane movement. The value  $F1_{\text{actual}}$  17.2 has fallen below the value  $F1_{\min}$  17.4.

All other movements that lead to a worsening of the force ratio on the F-load display 17 are turned off.

- ▶ Reverse any crane movement that has caused the shut-off.
- or
- Initiate an alternative crane movement that increases the force F1 (value  $F1_{\text{actual}}$  17.2).

#### Result:

- Crane operation is possible again.
- ▶ Carry out crane movements in such a way that no repeated shut-off by the LICCON overload protection occurs.

#### Problem remedy

The crane operation is limited because the value  $F1_{\min}$  17.4 apparently is being reached too early?

- ▶ Make sure that a valid set up configuration has been entered in the LICCON computer system.
- ▶ Make sure that the crane is assembled according to the assembly drawings.
- ▶ Make sure that the actual set up configuration and the entered set up status of the crane match.
- ▶ Make sure that all attachment parts and guy rods on the boom system, which are not needed, have been removed (weight).
- ▶ Make sure that the boom system is free of snow and ice (weight).
- ▶ Make sure that the wind influence on the crane is not too great.

If no irregularities can be found:

- ▶ Contact Liebherr Service.

When the shut-off cannot be remedied despite the observance of all points listed here:

- ▶ Change to section "Procedure for special cases at operation of the LICCON overload protection".

## 2.2.5 Shut-off spooling the winch up / out



#### Note

- ▶ Applies independently for winch 1 to winch 6.
- ▶ For detailed description of winch 1 to winch 6, see Crane operating instructions, chapter 4.02.

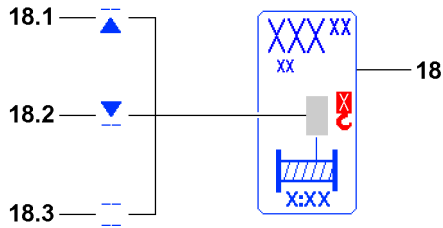


Fig.115280

In the icon **18**, the line / arrow **18.1**, arrow / line **18.2** or line / line **18.3** appears and the LICCON overload protection has shut off the crane movement.

“Spooling the winch out” (line / arrow **18.1**) or “Spooling the winch up” (arrow / line **18.2**) was shut off because the upper / lower limit value of the rope for the selected winch was exceeded or fallen below.

If the line / line **18.3** appears blinking in the icon **18**, then the concerned winch is deactivated.

The line / arrow **18.1** appears and the “Spooling the winch out” crane movement turns off:

- ▶ Spool the winch up.

**Result:**

- Crane operation is possible again.

The arrow / line **18.2** appears and the crane movement “Spooling the winch up” was turned off:

- ▶ Spool the winch out.

**Result:**

- Crane operation is possible again.

The line / line **18.3** appears and the winch is deactivated:

- ▶ Activate the winch, see Crane operating instructions, chapter 4.02.

**Result:**

- Crane operation is possible again.

## 2.2.6 Hoist top shut-off

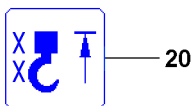


Fig.115281

The *hoist top* icon **20** appears in the LICCON monitor and the LICCON overload protection has turned off crane movement.

Spooling the hoist winch up was turned off because the hook (hook block / load hook) has touched a hoist limit switch weight during the upward movement and the concerned hoist limit switch was triggered.



**WARNING**

Property damage / falling load!

- ▶ After shut-off *spool hoist winch up (hoist top)*, for every further crane movement, the distance between the hook (hook block / load hook) and the boom head must be checked.



**Note**

- ▶ After a *hoist top* shut-off occurred, further crane movements that affect the length of the hoist rope are also shut off.

- ▶ Spool the hoist winch out.

**Result:**

- Crane operation is possible again.

**2.2.7 Luffing the derrick boom up / down shut-off****Note**

- ▶ Only in operating modes with derrick boom.

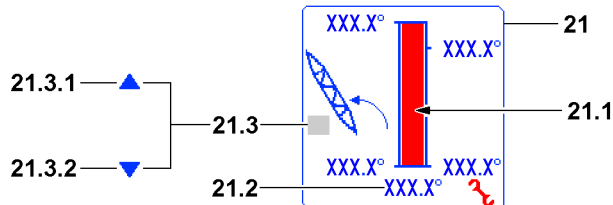


Fig. 115282

In icon **21**, the column diagram **21.1** of the derrick angle has reached the minimum / maximum value. The actual angle **21.2** has left the permissible angle range.

Arrow **21.1** or arrow **21.2** appears and the movement of the derrick boom is turned off.

“Luffing the derrick boom up” (arrow **21.1**) or “Luffing the derrick boom down” (arrow **21.2**) was shut off because the upper / lower limit angle was reached.

The arrow **21.1** appears and “Luffing the derrick boom up” was turned off:

- ▶ Luffing the derrick boom down.

**Result:**

- The shut off is nullified.

The arrow **21.2** appears and the crane movement “Luffing the derrick boom down” was turned off:

- ▶ Luff the derrick boom up.

**Result:**

- The shut off is nullified.

**Problem remedy**

The derrick boom is to be placed down?

- ▶ See Crane operating instructions, chapter 5.05.

## 2.2.8 Shut-off parallel operation winch 1 and winch 2

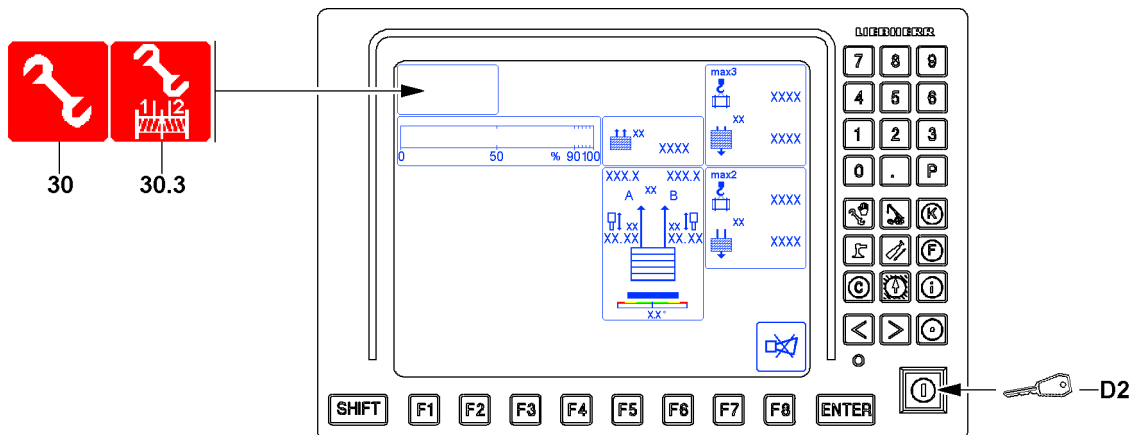


Fig.122459



### WARNING

Impermissible change over of winch 1 and winch 2 parallel operation regulation!

- ▶ Changing the winch 1 and winch 2 parallel operation regulation is only permissible if - due to contamination, icing or failure of the path measurement system of the test pulleys - a correct path measurement of the hoist ropes of winch 1 and winch 2 is not possible.
- ▶ Changing the regulation parallel operation winch 1 and winch 2 is only permissible if it is not possible to immediately clean or de-ice the test pulleys or repair the path measurement system.
- ▶ As long as the winch 1 and winch 2 parallel operation regulation is changed over, the crane driver must align the position of the hook block manually in general.

If a correct path measurement of the hoist ropes of winch 1 and winch 2 is not possible via the LIC-CON computer system, then spooling the winches is shut off and an error message is issued.

If an immediate cleaning or de-icing of the test pulleys or repair of the path measurement system is not possible:

- ▶ Reestablish parallel operation of winches, see Crane operating instructions, chapter 4.05.

Change over the regulation Parallel operation winch 1 and winch 2:

- ▶ Press the key button **D2**.

### Result:

- The regulation of the parallel operation winch 1 and winch 2 is switched over by the change over pulleys to the winch speed sensors.
- Assembly icon **30.3** and possibly assembly icon **30** appear.
- ▶ Remedy the problem as quickly as possible.
- ▶ Turn the regulation off again via the winch speed sensors: Actuate the key button **D2** again.

### Result:

- Assembly icon **30.3** and possibly assembly icon **30** turn off.



### Note

- ▶ If the engine or the ignition is turned off, the regulation is also turned off via the winch speed sensors.

### 2.2.9 Shut-off difference force monitoring of derrick ballast guying

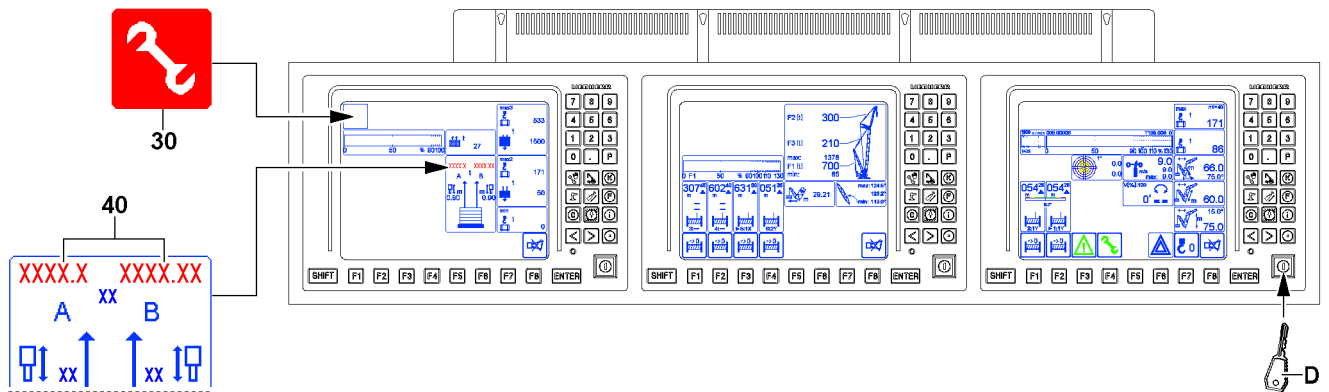


Fig.125390



**WARNING**

Danger of accident!

If the forces in the derrick ballast guyings A and B are too high, then this can lead to an overload of the crane. Components can fail and severe accidents can be the result.

- ▶ Load the derrick ballast guyings A and B evenly.

After reaching the specified limit value of the difference force threshold, the displays *guying A/B 40* blink and turn red, the function *ballast up / down* is stopped. The difference force must be lowered again.

The assembly icon **30** appears when the shut-off *difference force monitoring - derrick ballast guying* is bypassed. The shut-off is bypassed via the set up key **D** (right monitor).

Shut-off *difference force monitoring derrick ballast guying*:

- ▶ Observe the Crane operating instructions, chapter 5.35 / 5.36.

### 2.2.10 Shut-off due to error message

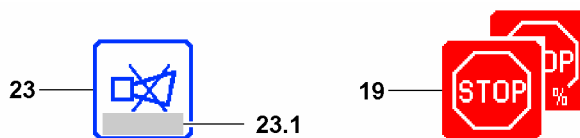


Fig.148297: Shut-off due to error message

In the icon **23** appears an error message, the icon **19** appears in the LICCON monitor and the LICCON overload protection has turned off crane movement.

- ▶ Determine the existing error with the help of the error message from the error field **23.1** in icon **23**, see Diagnostics manual.
- ▶ Rectify the error.

If the error cannot be remedied:

- ▶ Contact Liebherr Service.

**Problem remedy**

The erection of the crane, for example after assembly at a new job site or with another set up configuration, is not possible due to an error message?

- ▶ Evaluate the error message.
- ▶ Make sure that all electrical connections are established correctly.
- ▶ Check if all sensors or dummy plugs with integrated electric have been connected properly.

LWE/LR 1800-1-0-000/27200-07-02/en

**Note**

If there is a defect on an involved sensor of the load torque limiter (LMB), then the crane can no longer be operated in a normal operating condition

- ▶ Fix / replace the sensor, contact Liebherr Service if necessary.



Empty page!

LWE/LR 1800-1-0-000/27200-07-02/en

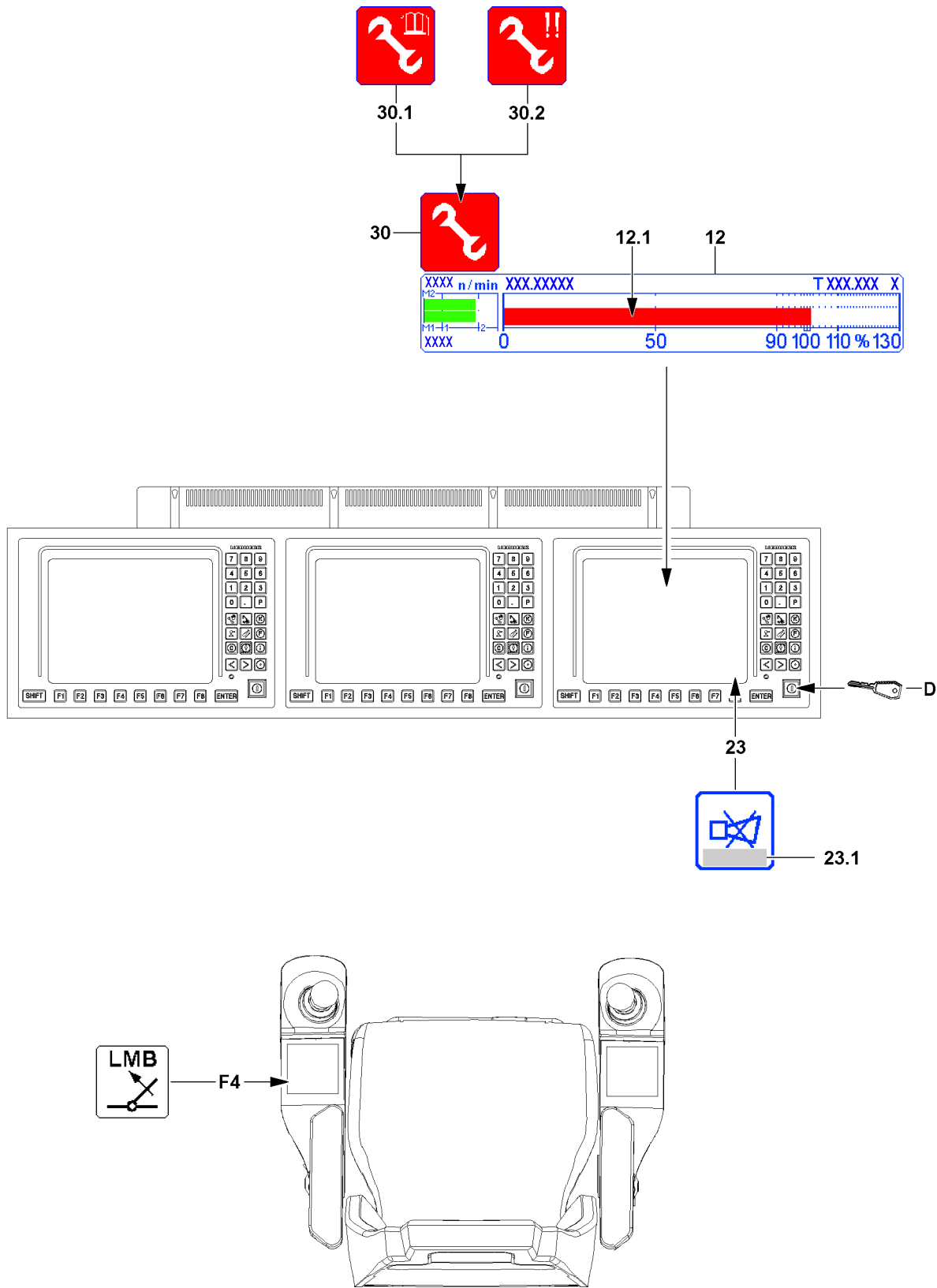


Fig.115285

LWE/LR 1800-1-0-000/27200-07-02/en

## 2.3 Procedure for special cases at operation of the LICCON overload protection

Within the crane operator's cab, the following operating elements available for Special cases at operation of the LICCON overload protection:

- Button **F4** on the left control panel
- Set up key **D** on the right LICCON monitor

By pressing button **F4** and set up key **D** the functionality of the LICCON overload protection is accessed. If the set up key **D** is actuated, the assembly icon **30** appears on LICCON monitor 0.

The assembly icon **30** appears, depending on the situation, also as:

- Assembly icon **30.1** - no load chart / assembly condition / sensor defect
- Assembly icon **30.2** - emergency operation (also with only one exclamation mark)

The *horn* icon **23** possibly displays error messages **23.1**:

- Observe and evaluate the error messages **23.1**, see also Diagnostics manual.



### WARNING

Risk of overloading and toppling of the crane!

If the functionality of the LICCON overload protection is accessed without knowing the exact cause for the shut-off, then the crane can be overloaded and topple over.

Personnel can be severely injured or killed.

- ▶ Before accessing the functionality of the LICCON overload protection, determine the exact cause for the shut-off.
- ▶ Observe and evaluate the error messages **23.1**.



### WARNING

Intervention of the functionality of the LICCON overload protection!

When accessing the functionality of the LICCON overload protection, the LICCON overload protection is deactivated totally or limited.

It is possible to exceed several shut-off limits of the LICCON overload protection simultaneously or one after the other.

It is possible to carry out crane movements that are not monitored by the LICCON overload protection. Without the LICCON overload protection, no additional protection against overload of the crane via the crane control is present.

- ▶ When accessing the functionality of the LICCON overload protection, take into account that the LICCON overload protection is deactivated totally or is limited.
- ▶ Access the functionality of the LICCON overload protection exclusively according to the specifications in the crane documentation.
- ▶ Outside of the load charts, the data in the erection / take-down charts is binding.



### WARNING

Leaving the load chart!

If the set up key **D** is actuated, it is possible that the crane leaves the range of the load charts.

Without a load chart, various display values are no longer displayed on the crane operating screen.

A load on the hook can no longer be monitored by the LICCON overload protection.

Severe accidents due to crane overload can result.

Personnel can be severely injured or killed.

- ▶ Do not leave the range of the load charts.

**WARNING**

Danger of accident due to incorrect procedure!

Due to erroneous operation or deliberate misuse, the crane could collapse, the boom can break off or the crane can topple over.

Button **F4** "Luffing in at suspended load" and set up key **D** may only be actuated when it is ensured that without their actuation no normal operating status (see section "operating status of the crane") can be reached.

- ▶ Actuate the set up key **D** only when no normal operating status can be reached with the button **F4** "Luffing in with suspended load".
- ▶ The set up key **D** may only be actuated by persons who are aware of the effects of their acts regarding the access into the functionality of the LICCON overload protection.
- ▶ Intervention of the functionality of the LICCON overload protection requires the presence of an authorized person and must be performed with utmost caution.
- ▶ Accessing the functionality of the LICCON overload protection is prohibited in normal crane operation.

**WARNING**

Expanded working / danger zone of the crane!

Due to an access the functionality of the LICCON overload protection it is possible that the working / danger zone of the crane is significantly expanded.

If these circumstances are not observed, collisions and accidents can occur.

Personnel can be severely injured or killed.

- ▶ During a special case at operation of the LICCON overload protection take an expanded working / danger zone of the crane into account and monitor it.

**WARNING**

Overload of crane!

Luffing in / pulling in of a load standing on the ground is not permissible.

When picking up a load by luffing the boom up, the crane can be overloaded.

This could result in serious accidents.

- ▶ Picking up a load by luffing up the boom is prohibited.
- ▶ Picking up a load solely via the hoist gear.

**WARNING**

Self-blockade of overload protection (Deadlock)!

After activation of the function "exceeding the shut-off limits of the LICCON overload protection", if no crane movements that lead immediately to a normal operating status (see section "operating status of the crane") are initiated, then the overload protection can be self-blocked (Deadlock).

In the case of a self-blocked overload protection, it is no longer possible to control the crane.

- ▶ After activation of the function "exceeding the shut-off limits of the LICCON overload protection" initiate crane movements that lead immediately to a normal operating condition (see section "operating condition of the crane").

**NOTICE**

Danger of mix up!

The individual functions of the set up key **D** can only be activated with this key button.

The key buttons on the other LICCON monitors are not assigned with this function.

- ▶ Do not mix up the set up key **D** with the other key buttons.
- ▶ In case of mix up: Deactivate the activated function immediately.

**Possible limitation in the crane control during certain "Special cases during operation of the LICCON overload protection":**

- During certain "Special cases for operation of the LICCON overload protection" the shut-off limits of the overload protection can be exceeded to maximum 110 % by pressing the set up key **D**
- During certain "Special cases at operation of the LICCON overload protection", the working speed of the crane is significantly reduced.

- During certain “Special cases at operation of the LICCON overload protection”, the possibility to control the crane is limited in time.
- During certain “Special cases at operation of the LICCON overload protection”, the individual display instruments show no values.



---

**Note**

Depending on the number of load positions, the display in the bar diagram utilization **12** changes.

- ▶ If an additional utilization bar appears next to the utilization bar **12.1**, then the description applies accordingly.
  - ▶ For a detailed description of the Bar diagram utilization **12**, see Crane operating instructions, chapter 4.02.
-

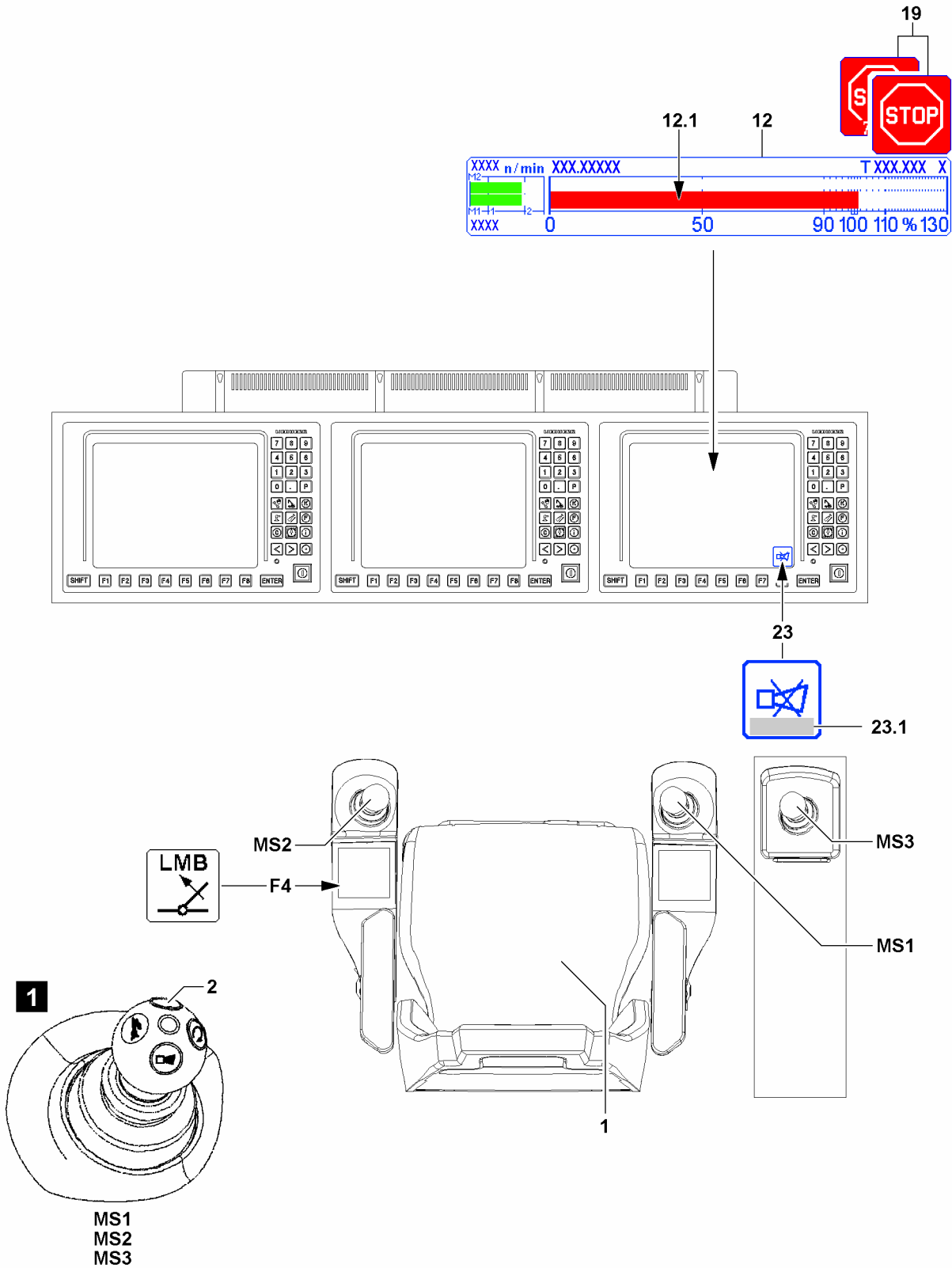


Fig.148657

LWE/LR 1800-1-0-000/27200-07-02/en

### 2.3.1 Luff in with a suspended load

If the maximum permissible load torque is exceeded, the LICCON overload protection turns off all crane movements that increase the load torque.

In the bar diagram utilization **12** (load moment display) the utilization bar **12.1** is red (shut-off limit value exceeded) and the LICCON monitor displays the icon **19**.



#### Note

Limit values for the load torque limiter for advance warning and shut-off reduced

If the limit values for the load torque limiter for advance warning and shut-off are reduced by the crane operator, shut-off takes place earlier according to the set value.

- ▶ Observe the settings of the limit values for the load torque limiter for advance warning and shut-off, see the crane operating instructions, chapter 4.02.

This shut-off limit can be exceeded by actuating the button **F4** “Luffing in with suspended load”.

Make sure that the following prerequisites are met:

- The load hangs freely.
- The load hook / hook block and boom system have no ground contact.
- Either the seat contact button **1** or one of the buttons **2** (illustration **1**) of the master switches (MS1, MS2, MS3) is actuated.



#### Note

If the load is reduced by luffing up or the values in the utilization bar diagram **12** are exceeded too much, then the “Luffing in with suspended load” button **F4** is possibly not functioning.

- ▶ Pay attention to notes regarding error messages **23.1** displayed in the *horn* icon **23**.
- ▶ For the procedure when the “Luffing in with suspended load” button **F4** is not functioning, see section “Exceedance of maximum permissible load moment”.

- ▶ Press the “luffing in with suspended load” button **F4** and hold it.

#### Result:

- The LICCON overload protection is inactive.

- ▶ Luff the load in.

#### Result:

- If the crane reaches a normal operation condition, then the icon **19** turns off, normal crane operation is possible again.

The “Luffing in with suspended load” function is deactivated:

- When the “Luffing in with suspended load” key **F4** is not longer actuated.
- When neither the seat contact button **1** nor one of the buttons **2** of the master switches (MS1, MS2, MS3) is actuated.

The “Luffing in with a suspended load” function is deactivated:

- The LICCON overload protection is active.
- ▶ Carry out crane movements in such a way that no repeated shut-off by the LICCON overload protection occurs.

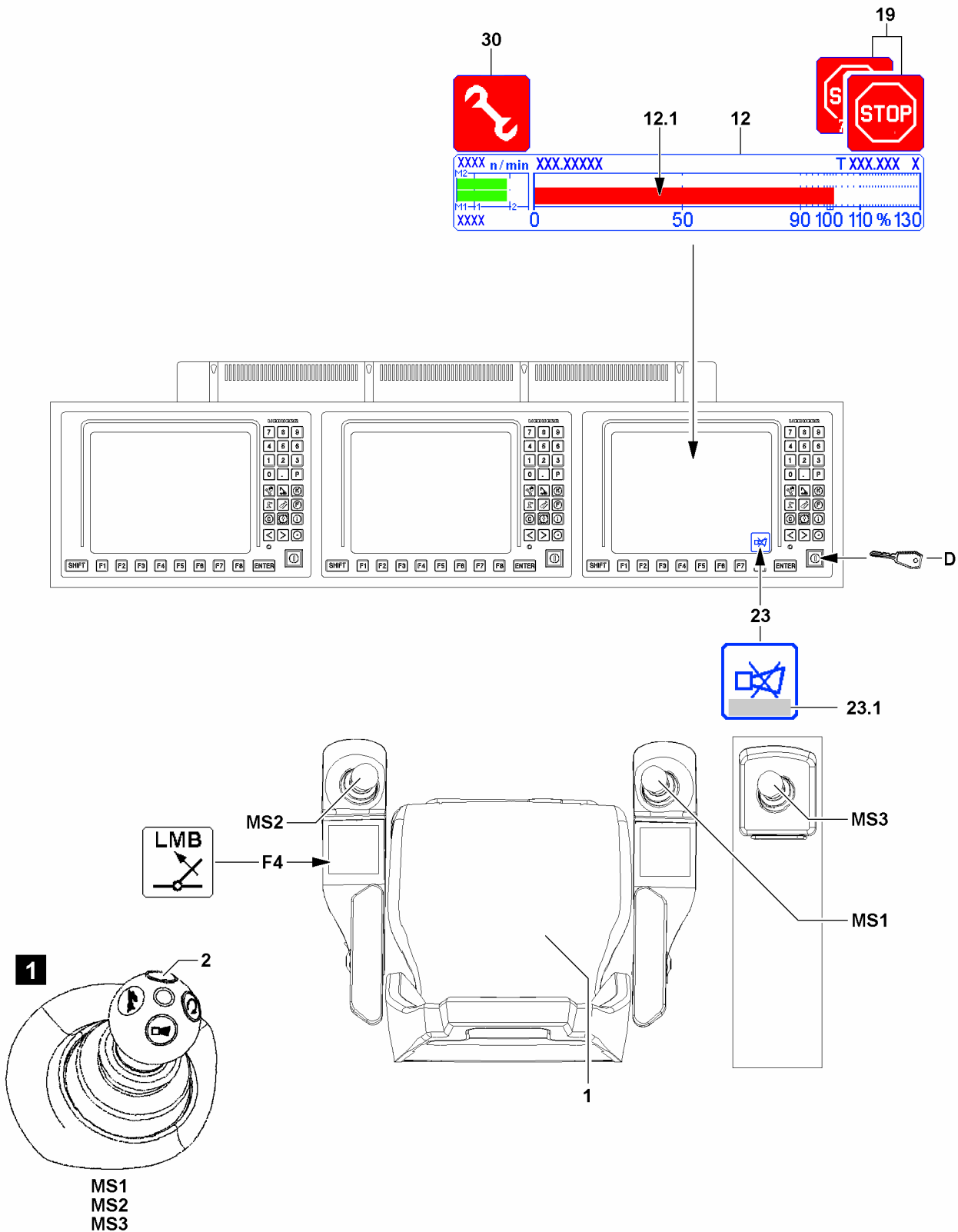


Fig.148658

LWE/LR 1800-1-0-000/27200-07-02/en



### 2.3.2 To exceed the maximum permissible load moment

If the maximum permissible load torque is exceeded, the LICCON overload protection turns off all crane movements that increase the load torque.

In the bar diagram utilization **12** (load moment display) the utilization bar **12.1** is red (shut-off limit value exceeded) and the LICCON monitor displays the icon **19**.



#### Note

Limit values for the load torque limiter for advance warning and shut-off reduced

If the limit values for the load torque limiter for advance warning and shut-off are reduced by the crane operator, shut-off takes place earlier according to the set value.

- ▶ Observe the settings of the limit values for the load torque limiter for advance warning and shut-off, see the crane operating instructions, chapter 4.02.

This limit value can be exceeded via the set up key **D** in the “right touching” position.



#### WARNING

Shut off safety equipment!

If the function “Exceedance of shut-off limits of LICCON overload protection” is activated by actuating the set up key **D** then it is possible to exceed the maximum permissible load torque.

- ▶ All notes regarding the “Special cases at operation of LICCON overload protection” must be observed.

The set up key **D** on the LICCON monitor has two positions:

- Operating position (not actuated): Crane is in normal operation.
- Position to right (touching): The function “Exceedance of shut-off limits of the LICCON overload protection” is activated, the assembly icon **30** appears in the LICCON monitor.

Make sure that the following prerequisites are met:

- With the button **F4** “Luffing in with suspended load” no normal operating condition (utilization below 100 % and no active shut-off) can be reached.
- All master switches (MS1, MS2, MS3) are in the zero position (not deflected).
- Either the seat contact button **1** or one of the buttons **2** (illustration **1**) of the master switches (MS1, MS2, MS3) is actuated.
- The crane is in the range of a load chart.



#### Note

If the values in the bar diagram utilization **12** are exceeded too far, then the functionality of the set up key **D** may be disabled.

- ▶ Pay attention to notes regarding error messages **23.1** displayed in the *horn* icon **23**.

- ▶ Turn the set up key **D** to the right (touching).

#### Result:

- The LICCON overload protection is inactive.
- The assembly icon **30** appears on the LICCON monitor.

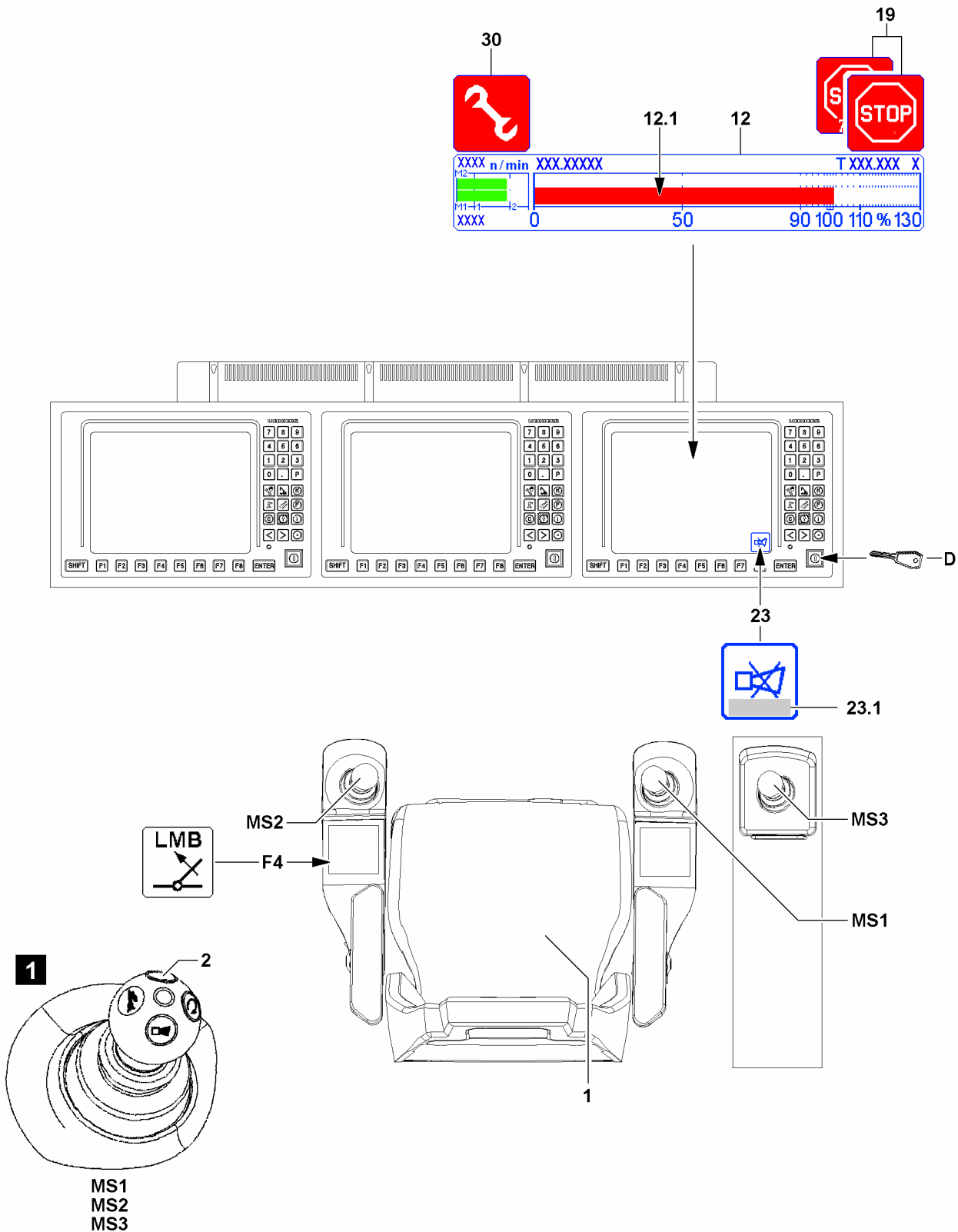


Fig.148658

LWE/LR 1800-1-0-000/27200-07-02/en

- ▶ Initiate crane movements which lead immediately to a normal operating condition (see section “operating condition of the crane”).

**Result:**

- If the crane reaches a normal operating condition, the function “Exceeding the shut-off limits of the LICCON overload protection” turns off - the assembly icon **30** turns off.

The “Exceedance of shut-off limits of LICCON overload protection” function turns off immediately also:

- If the set up key **D** is actuated again.
- If all master switches (MS1, MS2, MS3) are in the zero position for 10 seconds.
- When neither the seat contact button **1** nor one of the buttons **2** of the master switches (MS1, MS2, MS3) is actuated.
- When a *hoist top* shut-off occurs.

**Note**

- ▶ The function “Exceedance of shut-off limits of the LICCON overload protection” is only turned off when the assembly icon **30** in the LICCON monitor turns off.
- ▶ If the function “Exceedance of shut-off limits of the LICCON overload protection” does not turn off after pressing the set up key **D** once, then press the set up key **D** again until the assembly icon **30** in the LICCON monitor turns off.

The “Exceedance of shut-off limits of the LICCON overload protection” function has / was shut off:

- The assembly icon **30** in the LICCON monitor turns off.
- The working speed is possibly reduced until all master switches (MS1, MS2, MS3) are in the zero position at the same time.
- ▶ Make sure that the assembly icon **30** no longer appears on the LICCON monitor.
- ▶ Carry out crane movements in such a way that no repeated shut-off by the LICCON overload protection occurs.

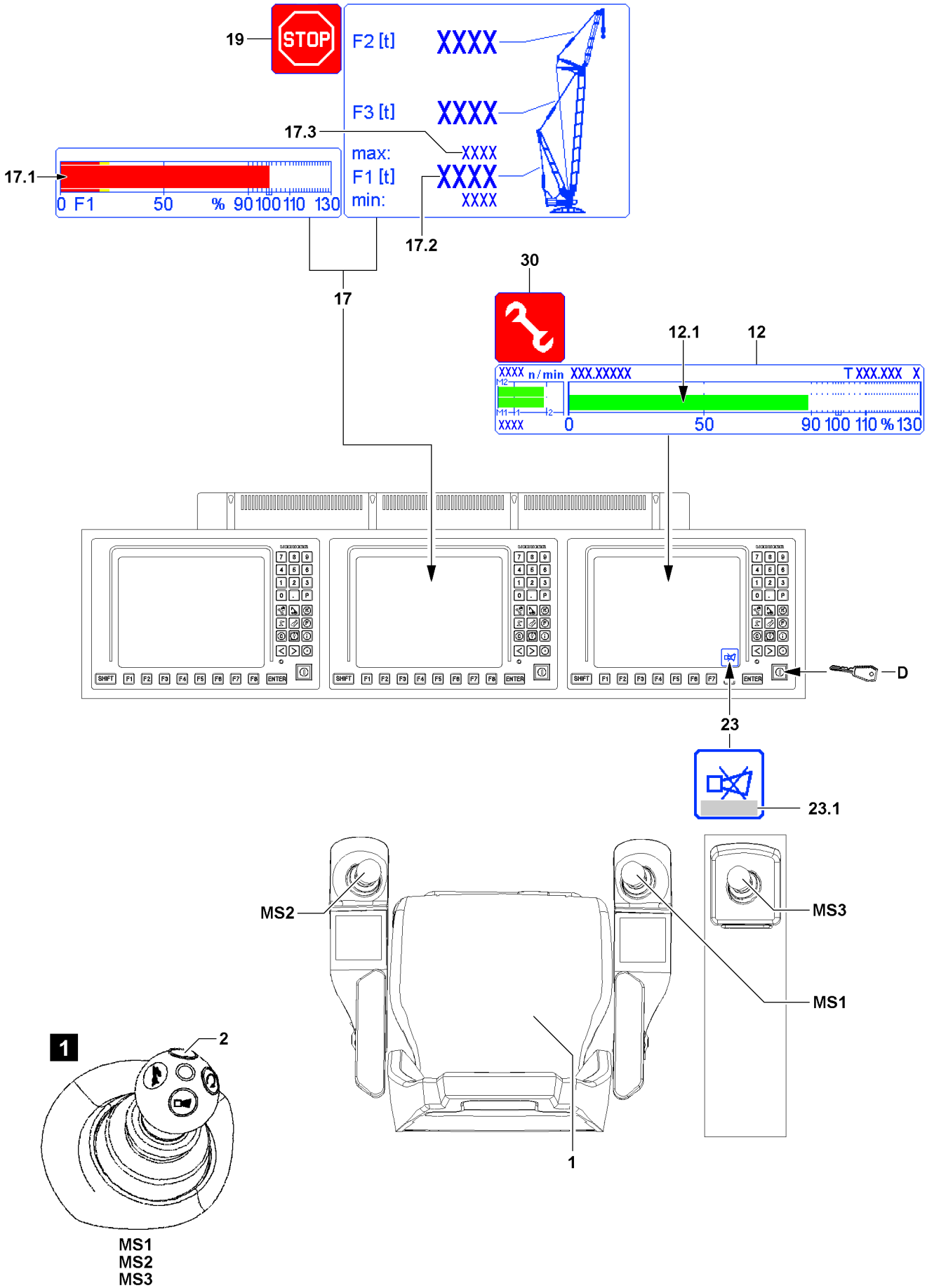


Fig.115288

LWE/LR 1800-1-0-000/27200-07-02/en

### 2.3.3 Exceeding the maximum value of the F-load display in crane operation

The illustration of the F-load display **17** depends on the set up configuration of the crane and can vary. The values for test point 2 (force F2) and test point 3 (force F3) are possibly shown.



#### WARNING

Shut off safety equipment!

If the maximum value of the F-load display **17** is exceeded by pressing the set up key **D**, then the “Exceedance of shut-off limits of the LICCON overload protection” function is automatically activated. Thus there is no shut-off if the maximum permissible load moment is exceeded.

- ▶ All notes regarding the “Special cases at operation of LICCON overload protection” must be observed.
- ▶ The utilization bar **12.1** of the bar diagram utilization **12** must be observed.
- ▶ The F1-utilization bar **17.1** of the F-load display **17** must be observed.



#### Note

- ▶ The force determined in test point 1 is generally described as  $F1_{actual}$  (actual value F1).
- ▶ On the F-load display **17**, the force ratio in test point 1 is shown as number values as well as a bar display (called F1-bar display).
- ▶ The value  $F1_{max}$  **17.3** corresponds to 100 % utilization on the F1-bar display.
- ▶ The F1-utilization bar **17.1** shows the ratio  $F1_{actual}$  **17.2** to  $F1_{max}$  **17.3**.



#### Note

- ▶ See also section “Minimum values or maximum values of F-load display reached”.

On the F1-load display **17**, the F1-utilization bar **17.1** exceeds the 100 % mark and the LICCON overload protection has shut off the crane movement. The value  $F1_{actual}$  **17.2** has exceeded the value  $F1_{max}$  **17.3**.

All other movements that lead to a worsening of the force ratio on the F-load display **17** are turned off.

The LICCON monitor with the derrick operating screen displays the icon **19**.



#### Note

If the values in the F-load display **17** or in the utilization bar diagram **12** are outside the permissible range, then the functionality of the set up key **D** may be disabled.

- ▶ Pay attention to notes regarding error messages **23.1** displayed in the *horn* icon **23**.

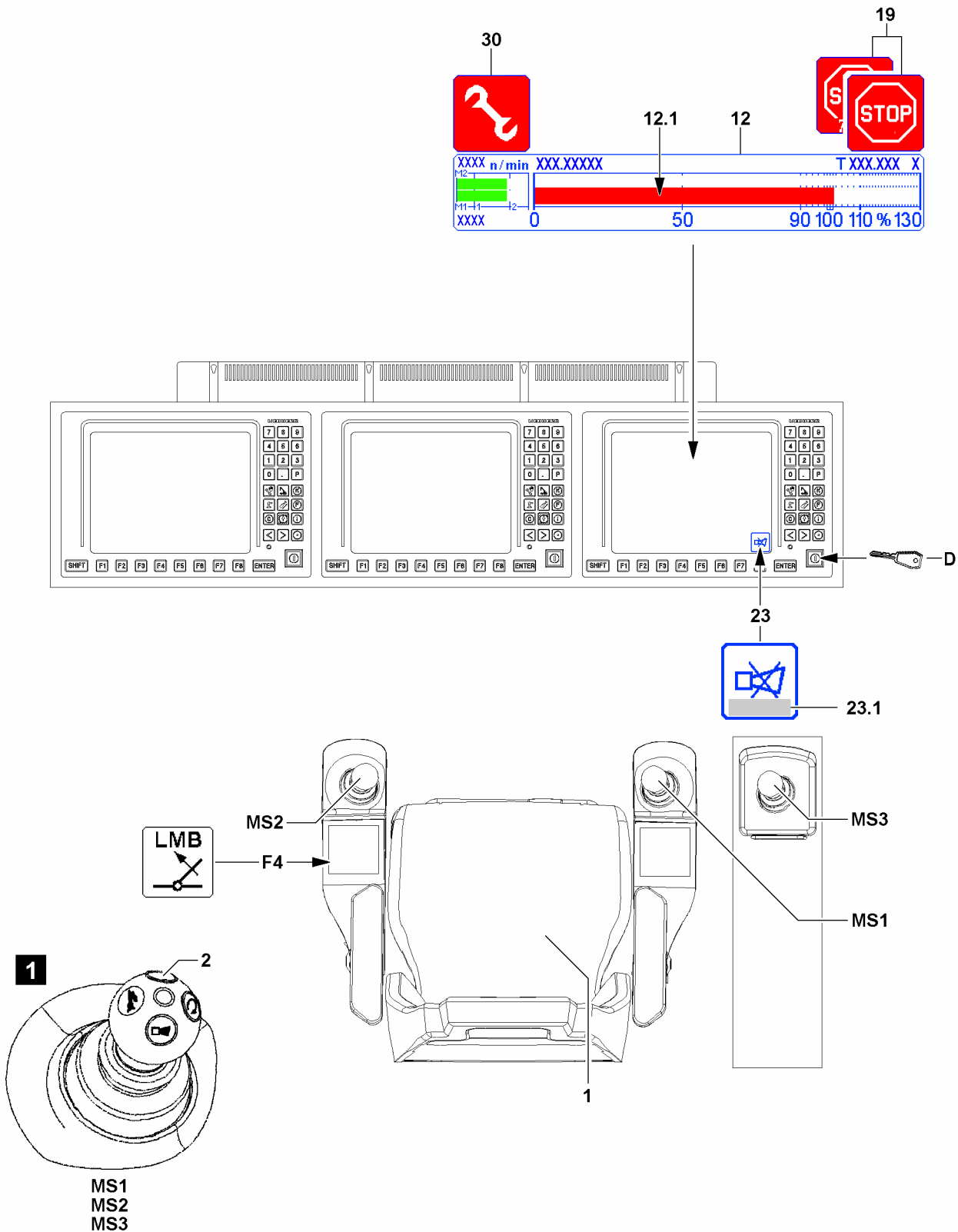


Fig.148658

LWE/LR 1800-1-0-000/27200-07-02/en

Make sure that the following prerequisites are met:

- All master switches (MS1, MS2, MS3) are in the zero position (not deflected).
- Either the seat contact button **1** or one of the buttons **2** (illustration **1**) of the master switches (MS1, MS2, MS3) is actuated.
- The crane is in the range of a load chart.
- ▶ Turn the set up key **D** to the right (touching).

**Result:**

- The function “Exceedance of shut-off limits of the LICCON overload protection” is activated. As a result the maximum value of the F-load display can be exceeded.
- The assembly icon **30** appears.
- $F_{1_{\max}}$  **17.3** can be exceeded.
- ▶ Initiate crane movements which lead immediately to a normal operating condition (see section “operating condition of the crane”).

**Result:**

- If the crane reaches a normal operating condition, the function “Exceeding the shut-off limits of the LICCON overload protection” turns off - the assembly icon **30** turns off.

The “Exceedance of shut-off limits of LICCON overload protection” function turns off immediately also:

- If the set up key **D** is actuated again.
- If all master switches (MS1, MS2, MS3) are in the zero position for 10 seconds (with load chart available).
- When neither the seat contact button **1** nor one of the buttons **2** of the master switches (MS1, MS2, MS3) is actuated.
- When a *hoist top* shut-off occurs.



**Note**

- ▶ The function “Exceedance of shut-off limits of the LICCON overload protection” is only turned off when the assembly icon **30** in the LICCON monitor turns off.
- ▶ If the function “Exceedance of shut-off limits of the LICCON overload protection” does not turn off after pressing the set up key **D** once, then press the set up key **D** again until the assembly icon **30** in the LICCON monitor turns off.

The “Exceedance of shut-off limits of the LICCON overload protection” function has / was shut off:

- The assembly icon **30** in the LICCON monitor turns off.
- The working speed is possibly reduced until all master switches (MS1, MS2, MS3) are in the zero position at the same time.
- ▶ Make sure that the assembly icon **30** no longer appears on the LICCON monitor.
- ▶ Carry out crane movements in such a way that no repeated shut-off by the LICCON overload protection occurs.

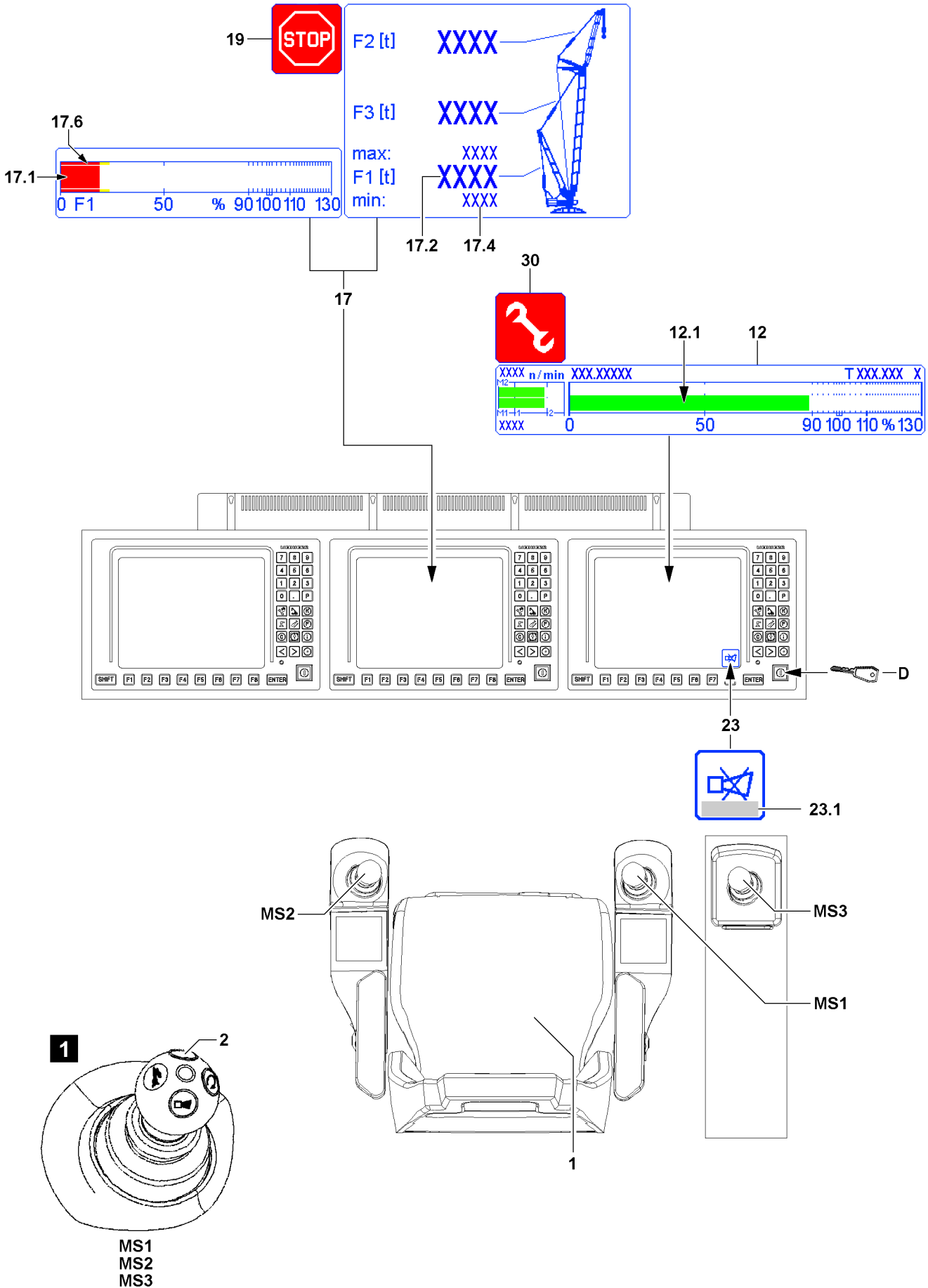


Fig.115307

LWE/LR 1800-1-0-000/27200-07-02/en



### 2.3.4 Falling below the minimum value of the F-load display in crane operation

The illustration of the F-load display **17** depends on the set up configuration of the crane and can vary. The values for test point 2 (force F2) and test point 3 (force F3) are possibly shown.



#### WARNING

Shut off safety equipment!

By pressing the set up key **D** if the minimum value of the F-load display is fallen below, then the “Exceedance of shut-off limits of the LICCON overload protection” function is automatically activated. Thus there is no shut-off if the maximum permissible load moment is exceeded.

- ▶ All notes regarding the “Special cases at operation of LICCON overload protection” must be observed.
- ▶ The utilization bar **12.1** of the bar diagram utilization **12** must be observed.
- ▶ The F1-utilization bar **17.1** of the F-load display **17** must be observed.



#### Note

- ▶ The force determined in test point 1 is generally described as  $F1_{\text{actual}}$  (actual value F1).
- ▶ On the F1-load display **17**, the force ratio is shown as number values as well as a bar display (called F1-bar display).
- ▶ The value  $F1_{\text{max}}$  **17.3** corresponds to 100 % on the F1-bar display.
- ▶ The F1-utilization bar **17.1** shows the ratio  $F1_{\text{actual}}$  **17.2** to  $F1_{\text{max}}$  **17.3**.



#### Note

- ▶ See also section “Minimum values or maximum values of F-load display reached”.

On the F1-load display **17**, the F1-utilization bar **17.1** undershoots the  $F1_{\text{min}}$  STOP bar **17.6** and the LICCON overload protection has switched off the crane movement. The value  $F1_{\text{actual}}$  **17.2** has fallen below the value  $F1_{\text{min}}$  **17.4**.

All other movements that lead to a worsening of the force ratio on the F-load display **17** are turned off.

The LICCON monitor with the derrick operating screen displays the icon **19**.



#### Note

If the values in the F-load display **17** or in the utilization bar diagram **12** are outside the permissible range, then the functionality of the set up key **D** may be disabled.

- ▶ Pay attention to notes regarding error messages **23.1** displayed in the *horn* icon **23**.

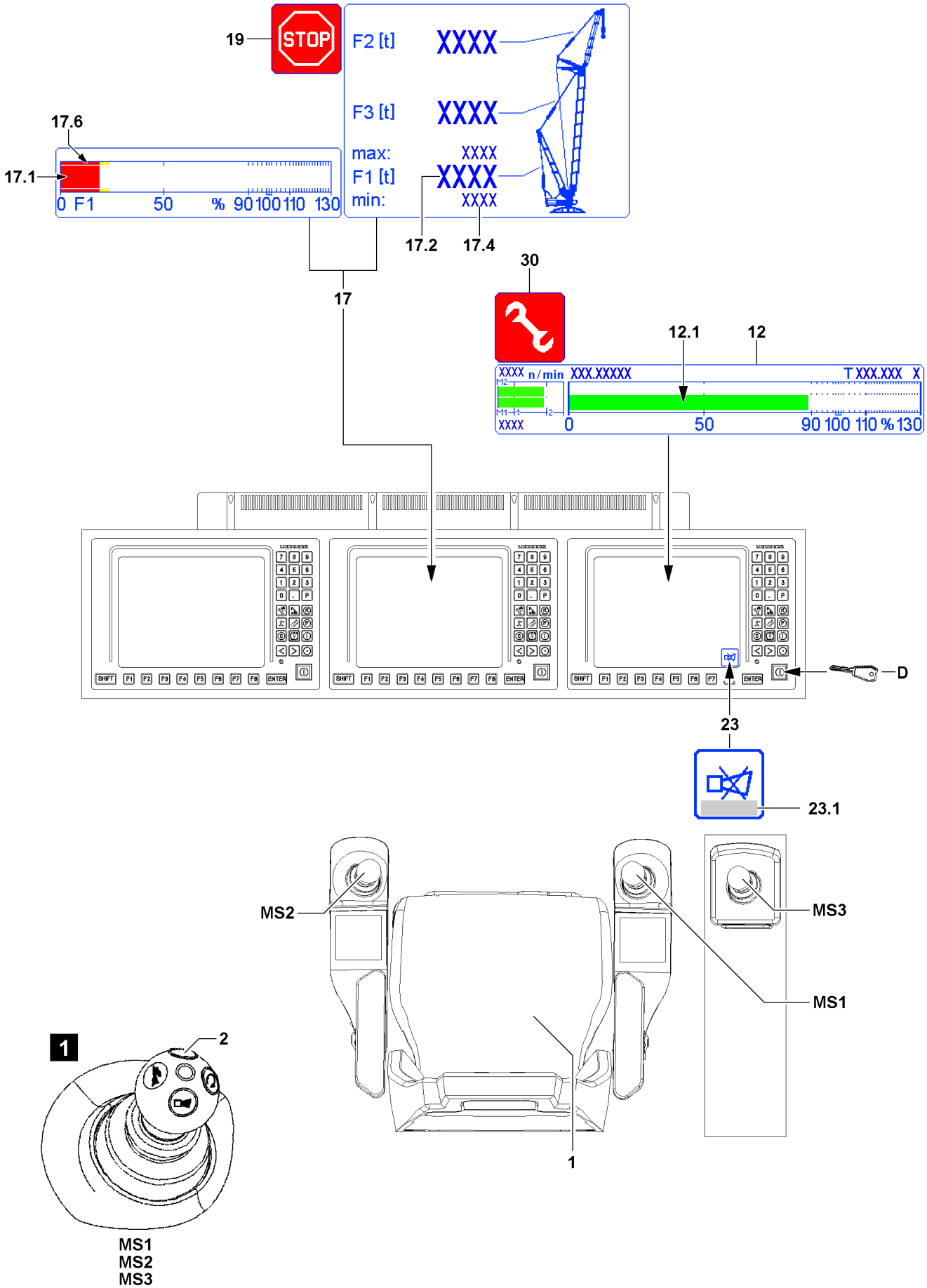


Fig.115307

LWE/LR 1800-1-0-000/27200-07-02/en

Make sure that the following prerequisites are met:

- All master switches (MS1, MS2, MS3) are in the zero position (not deflected).
- Either the seat contact button **1** or one of the buttons **2** (illustration **1**) of the master switches (MS1, MS2, MS3) is actuated.
- The crane is in the range of a load chart.
- ▶ Turn the set up key **D** to the right (touching).

**Result:**

- The function “Exceedance of shut-off limits of the LICCON overload protection” is activated. As a result the minimum value of the F-load display can be fallen below.
- The assembly icon **30** appears.
- $F_{1_{\min}}$  **17.4** can be fallen below.
- ▶ Initiate crane movements which lead immediately to a normal operating condition (see section “operating condition of the crane”).

**Result:**

- If the crane reaches a normal operating condition, the function “Exceeding the shut-off limits of the LICCON overload protection” turns off - the assembly icon **30** turns off.

The “Exceedance of shut-off limits of LICCON overload protection” function turns off immediately also:

- If the set up key **D** is actuated again.
- If all master switches (MS1, MS2, MS3) are in the zero position for 10 seconds (with load chart available).
- When neither the seat contact button **1** nor one of the buttons **2** of the master switches (MS1, MS2, MS3) is actuated.
- When a *hoist top* shut-off occurs.

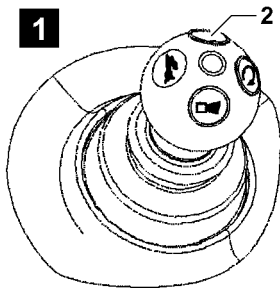
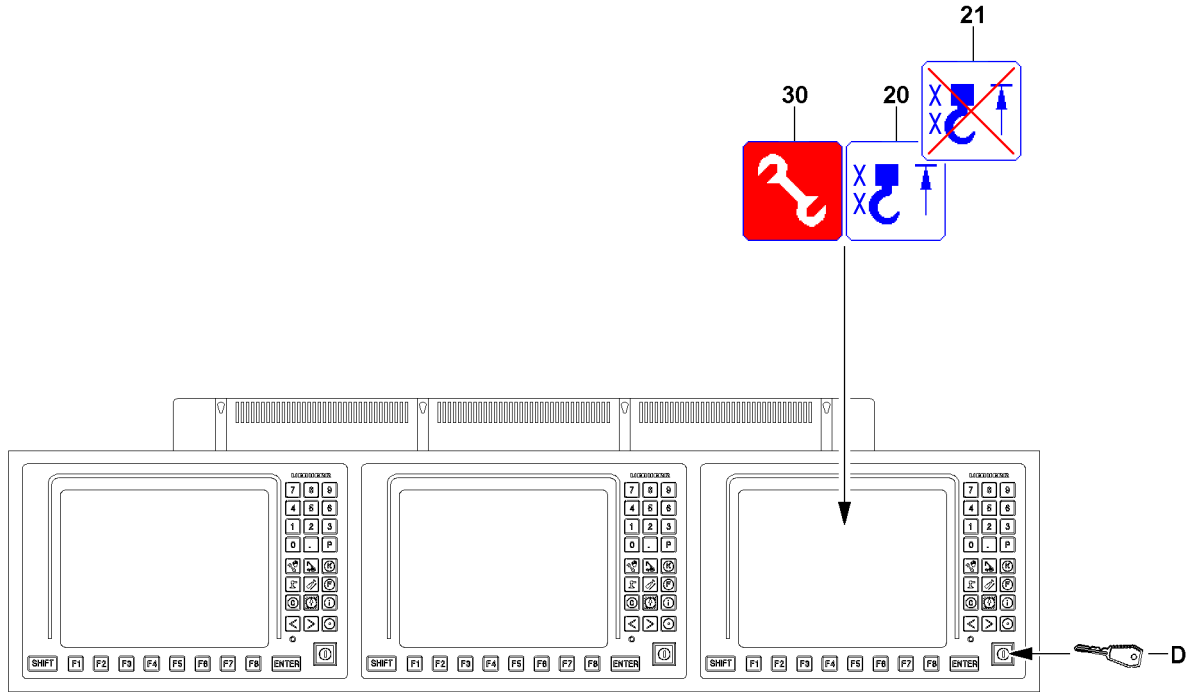


**Note**

- ▶ The function “Exceedance of shut-off limits of the LICCON overload protection” is only turned off when the assembly icon **30** in the LICCON monitor turns off.
- ▶ If the function “Exceedance of shut-off limits of the LICCON overload protection” does not turn off after pressing the set up key **D** once, then press the set up key **D** again until the assembly icon **30** in the LICCON monitor turns off.

The “Exceedance of shut-off limits of the LICCON overload protection” function has / was shut off:

- The assembly icon **30** in the LICCON monitor turns off.
- The working speed is possibly reduced until all master switches (MS1, MS2, MS3) are in the zero position at the same time.
- ▶ Make sure that the assembly icon **30** no longer appears on the LICCON monitor.
- ▶ Carry out crane movements in such a way that no repeated shut-off by the LICCON overload protection occurs.



MS1  
MS2  
MS3

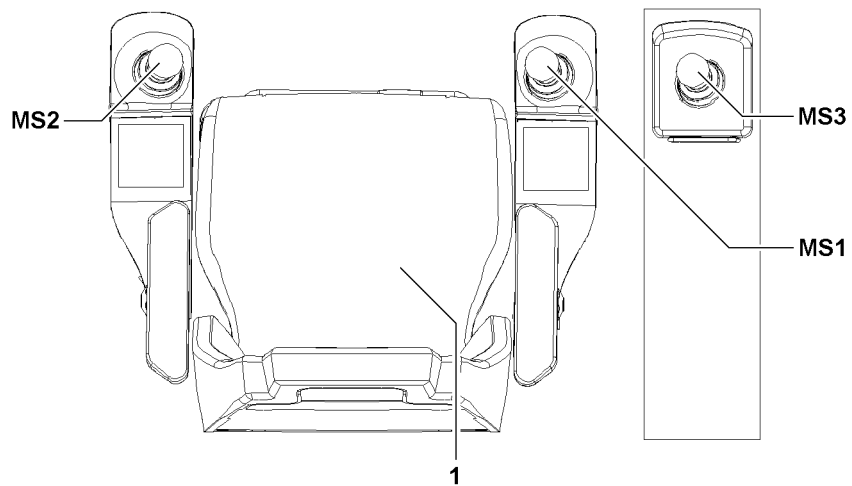


Fig.115289

LWE/LR 1800-1-0-000/27200-07-02/en

## 2.4 Bypassing the *hoist top* shut-off



### WARNING

Improper use of the function “Bypass of hoist top shut-off”!

- ▶ The function “Bypass of hoist top shut-off” may never be used to increase the lifting height during crane operation.



### WARNING

Property damage and falling load!

If the function “Bypass of hoist top shut-off” is activated, there is the danger that the hook (hook block / load hook) is pulled against the pulley head.

This danger exists especially when the hoist winch is continued to be spooled up and for crane movements which have an influence on the hoist rope, for example luffing the boom, the auxiliary boom / accessory or the derrick boom.

Property damage and falling load can result.

Personnel can be severely injured or killed.

- ▶ The function “Bypass of hoist top shut-off” may only be carried out by an authorized person, along with a guide. The guide must be in direct contact with the crane operator and must continually monitor the distance between the hook block / load hook and the boom head.
- ▶ Carry out all crane movements with utmost caution.



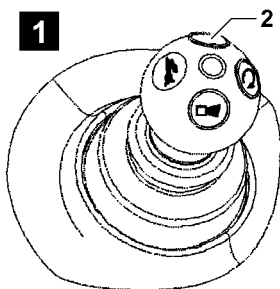
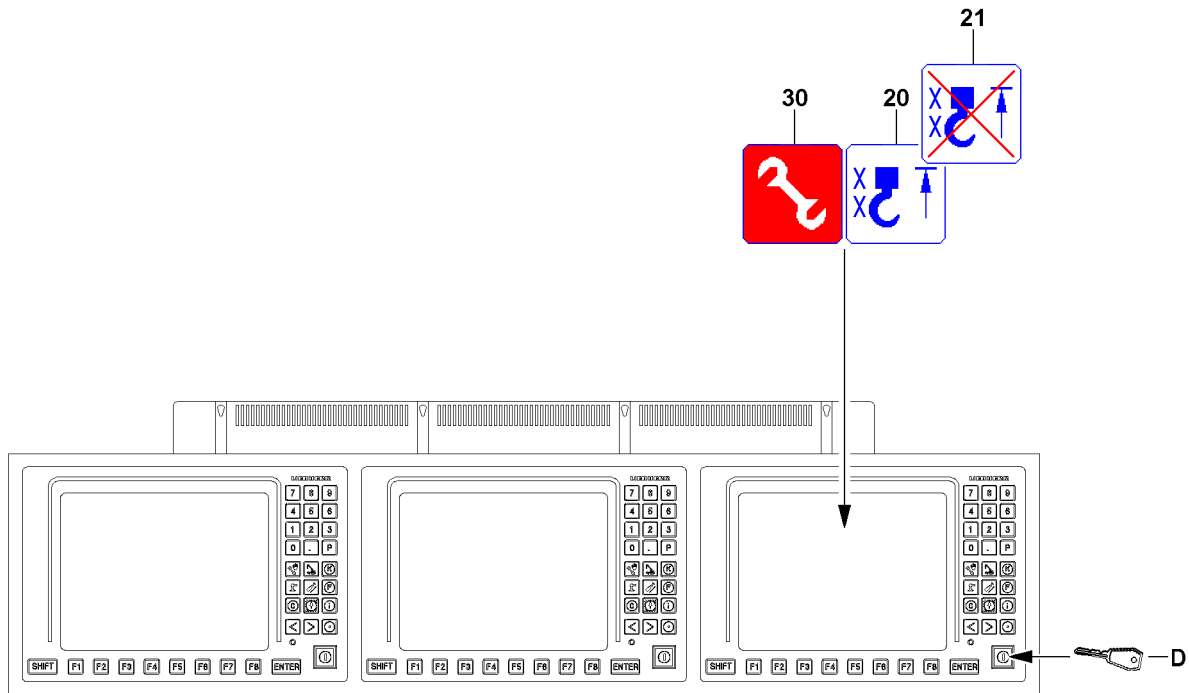
### Note

- ▶ A bypass of the *hoist top* shut-off is only possible when the shut-off has already occurred due to a triggered hoist limit switch.
- ▶ With the actuated set up key **D** (the assembly icon **30** appears on the LICCON monitor) if a hoist limit switch is triggered, then there is a new shut-off of crane movements.
- ▶ For assembly purposes or in emergency cases, if the activation of the function “Bypass of hoist top shut-off” **and** activation of the function “Exceedance of shut-off limits of the LICCON overload protection” is necessary, then the set up key **D** must be actuated until the icon **21** and assembly icon **30** appear.

Spooling the hoist winch up was turned off because the hook (hook block / load hook) has touched a hoist limit switch weight during the upward movement and the concerned hoist limit switch was triggered.

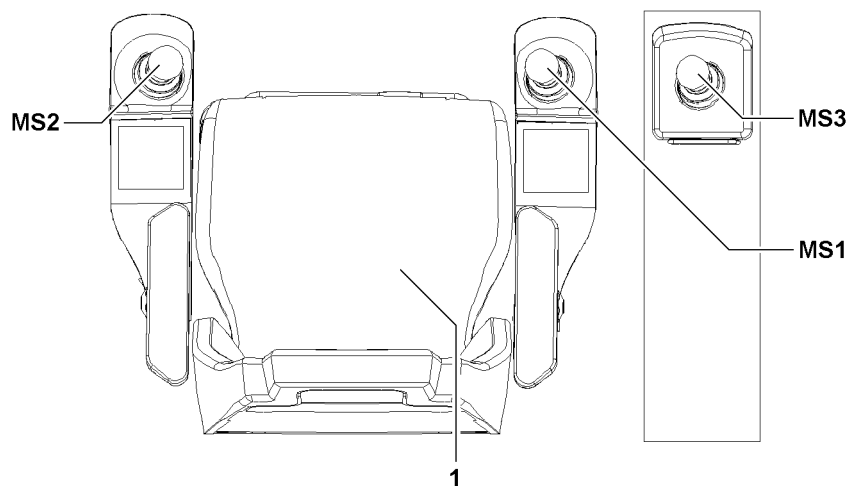
Make sure that the following prerequisites are met:

- A *hoist top* shut-off has occurred, the *hoist top* icon **20** appears in the LICCON monitor.
- Either the seat contact button **1** or one of the buttons **2** (illustration **1**) of the master switches (MS1, MS2, MS3) is actuated.
- All master switches (MS1, MS2, MS3) are in the zero position (not deflected).



MS1  
MS2  
MS3

Fig.115289



LWE/LR 1800-1-0-000/27200-07-02/en

- To bypass the *hoist top* shut-off, a combined actuation of the set up key **D** and at least one master switch is required.
- ▶ Turn the set up key **D** to the right (touching).

**Result:**

- The assembly icon **30** (assembly operation) appears on the LICCON monitor.
- The *hoist top* icon **20** on the LICCON monitor changes to the icon **21**.

Within 10 seconds, if the master switch to lift the hoist gear is deflected, the hoist limit switches are bypassed. The bypass of the *hoist top* shut-off remains active only as long as the master switch is deflected.

- ▶ Carry out a crane movement with utmost caution and by taking the safety guidelines into account.

The function "Bypass of the hoist top shut-off" turns off:

- If the set up key **D** is actuated again.
- When no master switch (MS1, MS2, MS3) was deflected for 10 seconds.
- When neither the seat contact button **1** nor one of the buttons **2** of the master switches (MS1, MS2, MS3) is actuated.
- If there is no longer a shut-off of a hoist limit switch.

The function "Bypass of the hoist top shut-off" has / was turned off:

- The assembly icon **30** (assembly operation) in the LICCON monitor turns off.
- The icon **21** on the LICCON monitor turns off.
- ▶ Make sure that the assembly icon or the assembly icon **30** (assembly operation) as well as the icon **21** no longer appear on the LICCON monitor.
- ▶ Carry out the crane movements in such a way that no repeated *hoist top* shut-off occurs.

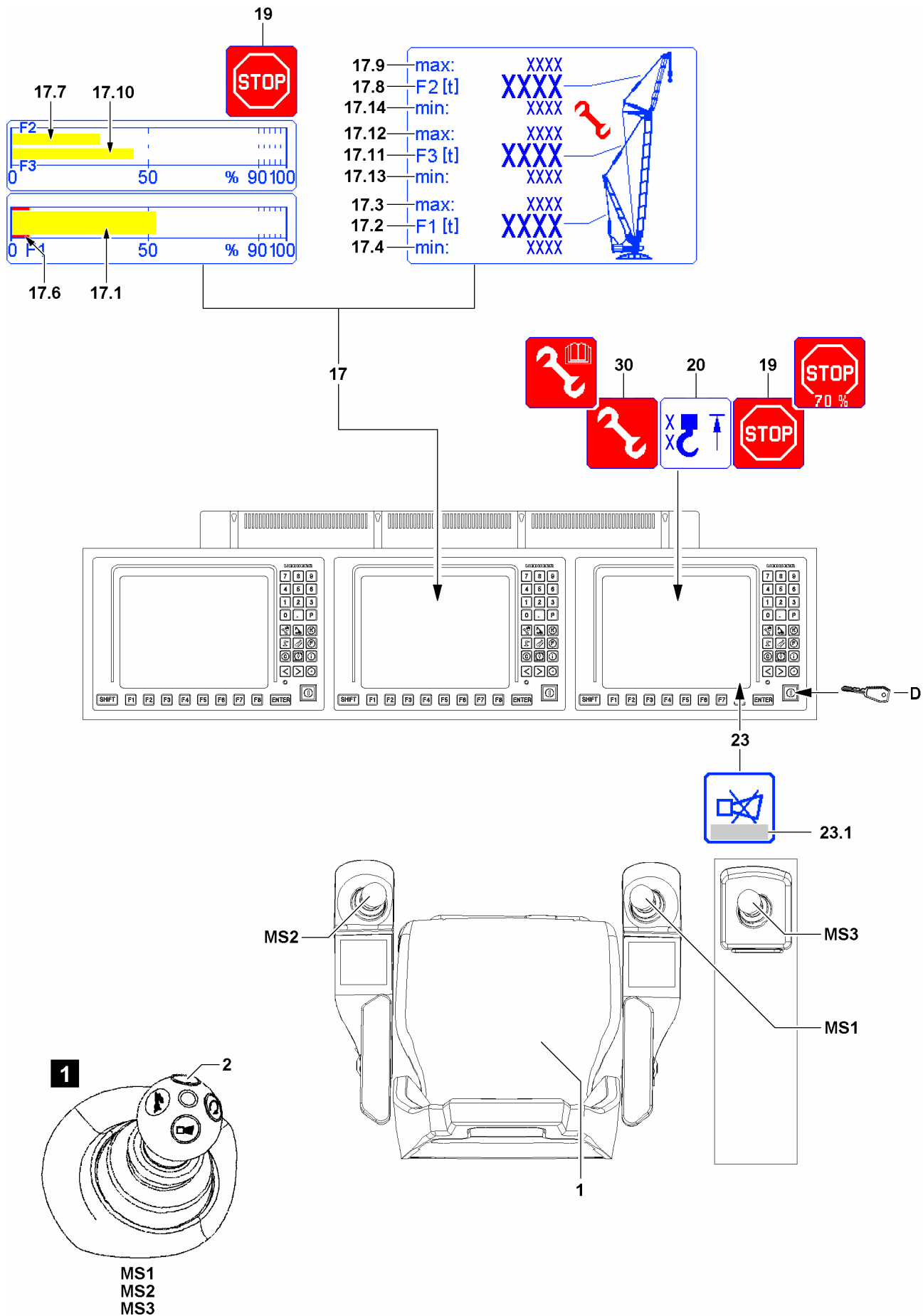


Fig.148659

LWE/LR 1800-1-0-000/27200-07-02/en



## 2.5 Carrying out the erection / take down procedures

To carry out the erection / take down procedures and assembly procedures, the LICCON overload protection can be bypassed by the set up key **D**.



### Note

- ▶ If the crane is in the “No load chart available” range, then there is a shut-off of the crane control by the LICCON overload protection. The icon **19** appears on the LICCON monitor.
- ▶ By pressing the set up key **D** all erection / take down procedures and assembly procedures can be carried out according to the specifications in the crane documentation.



### WARNING

Danger of accident during erection / take down procedures!

If the specifications of the crane documentation are not observed, the crane can collapse, the boom can break off or the crane can topple over.

Personnel can be severely injured or killed.

- ▶ Make sure to adhere to all specifications in the crane documentation.
- ▶ Make sure to observe the data in the crane documentation (for example erection / take-down charts and assembly instructions).
- ▶ Press the set up key **D** only when the set up configuration has been entered correctly in the LICCON computer system and matches the actual situation.



### WARNING

Damage, overload and toppling of the crane!

If the permissible values of the F-load display **17** are exceeded / fallen below, then the crane can be damaged or overloaded and topple over.

As long as the set up boom system is not completely assembled and not all sensors, which are required for this operating mode are electrically connected, no maximum forces and minimum forces are displayed in the F-load display **17**.

In these cases it must be determined with the assembly drawing which maximum forces are permissible on the F-load display **17**.

These maximum forces must be monitored by the crane operator and may not be exceeded during assembly / removal of the crane.

- ▶ The crane operator must ensure that the permissible values of the F-load display **17** are not exceeded / fallen below.
- ▶ Observe and adhere to the maximum forces for the F-load display **17** from the assembly drawings.

Display area of F-load display **17**:

– F1-load display  
The force determined in test point 1 is generally described as  $F1_{actual}$ .

– F2-load display  
The force determined in test point 2 is generally described as  $F2_{actual}$ .

**Note:** Appears only for the corresponding boom system.

The F2-utilization bar **17.7** only appears during assembly operation (no load chart available and set up key **D** actuated).

– F3-load display  
The force determined in test point 3 is generally described as  $F3_{actual}$ .

**Note:** Appears only for the corresponding boom system.

The F3-utilization bar **17.10** only appears during assembly operation (no load chart available and set up key **D** actuated).

**Note**

On the F-load display **17**, the force ratio is shown as number values as well as a bar display (called F-bar display).

The permissible maximum value corresponds to 100 % in the bar display.

- ▶ The F1-utilization bar **17.1** shows the ratio  $F1_{\text{actual}}$  **17.2** to  $F1_{\text{max}}$  **17.3**.
- ▶ The value  $F1_{\text{min}}$  **17.4** corresponds to the  $F1_{\text{min}}$ -STOP-bar **17.6**.
- ▶ The F2-utilization bar **17.7** shows the ratio  $F2_{\text{actual}}$  **17.8** to  $F2_{\text{max}}$  **17.9**.
- ▶ The F3-utilization bar **17.10** shows the ratio  $F3_{\text{actual}}$  **17.11** to  $F3_{\text{max}}$  **17.12**.
- ▶ The value  $F3_{\text{min}}$  **17.13** appears solely in special situations, for example during the erection of the derrick boom. The value  $F2_{\text{min}}$  **17.14** appears solely for certain crane types in special situations. If no minimum values  $F_{\text{min}}$  appear, then the data in the crane documentation (for example erection / take-down charts and assembly instructions) must be observed.
- ▶ When leaving the “load chart available” range, the appearance of the assembly icon **30** changes.

Empty page!

LWE/LR 1800-1-0-000/27200-07-02/en

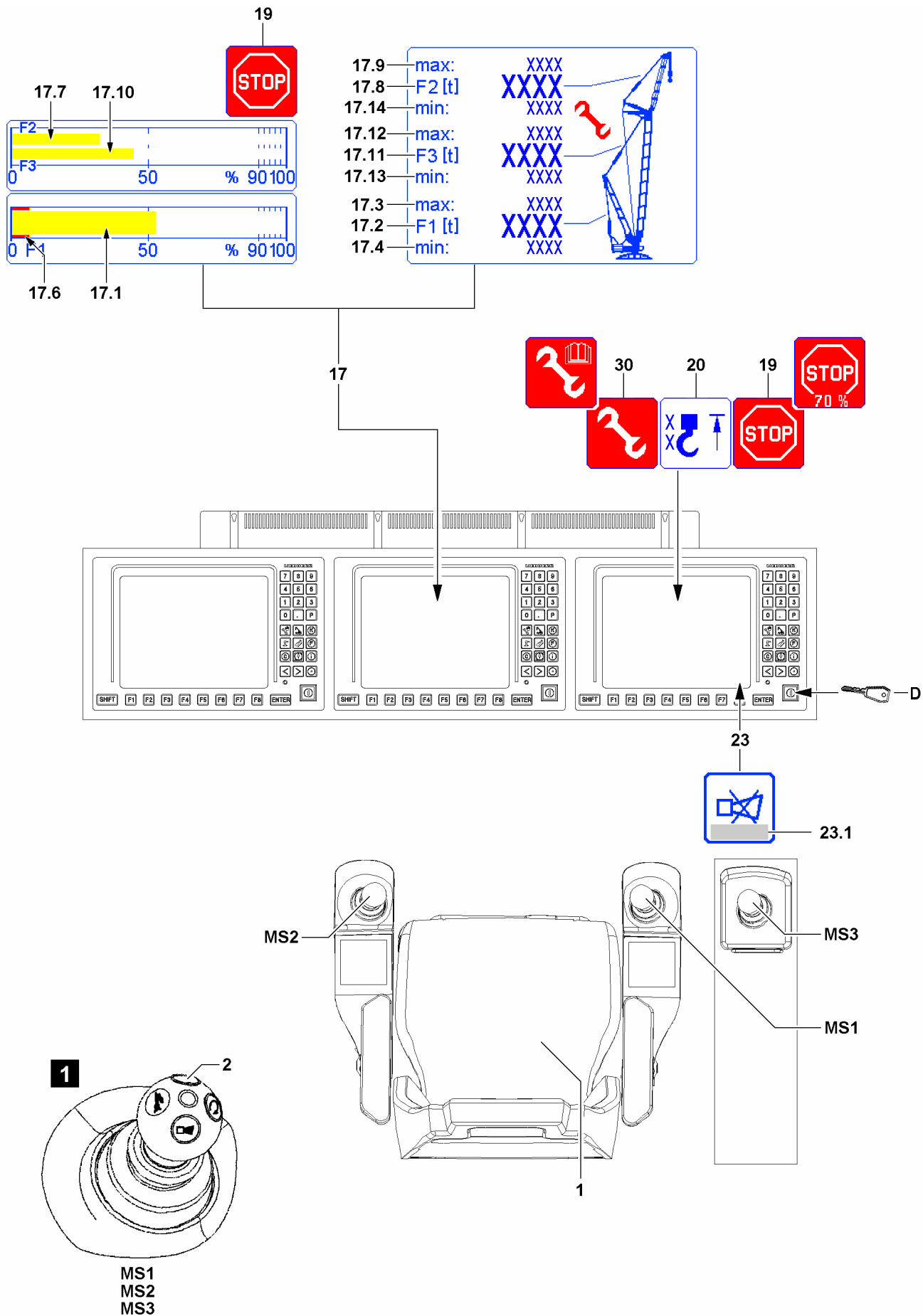


Fig.148659

LWE/LR 1800-1-0-000/27200-07-02/en

## 2.5.1 Carrying out erection procedures

Make sure that the following prerequisites are met:

- The set up configuration corresponds to the specifications in the crane documentation.
- The set up configuration has been entered correctly in the LICCON computer system.
- All master switches (MS1, MS2, MS3) are in the zero position (not deflected).
- Either the seat contact button **1** or one of the buttons **2** (illustration **1**) of the master switches (MS1, MS2, MS3) is actuated.



### Note

- ▶ Depending on the situation, the *hoist top* shut-off (icon **20** appears) must be bypassed at the same time.

- ▶ Turn the set up key **D** to the right (touching).

### Result:

- The assembly icon **30** appears.
- The erection procedure can be carried out.

### Problem remedy

The functionality of the set up key **D** is disabled by the crane control?

- ▶ Pay attention to notes regarding error messages **23.1** displayed in the *horn* icon **23**.
- ▶ Check the electrical connections.
- ▶ Check if all sensors or dummy plugs with integrated electric have been connected properly.

- ▶ Luff the boom according to the specifications of the crane documentation.
- ▶ Monitor the F-load display **17**, all values must be within the minimum values and the maximum values.

### Problem remedy

The erection / take down procedure cannot be carried out due to exceeding of the minimum or maximum values?

- ▶ See section “Minimum values or maximum values of F-load display reached”.

The “Bypass of the LICCON overload protection” via the set up key **D** turns off:

- If the set up key **D** is actuated again.
- When an range with existing load chart is reached (erection procedure).
- If all master switches (MS1, MS2, MS3) are in the zero position for 10 seconds (with “Load chart available”).
- When neither the seat contact button **1** nor one of the buttons **2** of the master switches (MS1, MS2, MS3) is actuated.

The “Exceedance of shut-off limits of the LICCON overload protection” function has / was shut off:

- The assembly icon **30** in the LICCON monitor turns off.
- ▶ After completion of the erection / take down procedures, make sure that the assembly icon **30** no longer appears in the LICCON monitor.

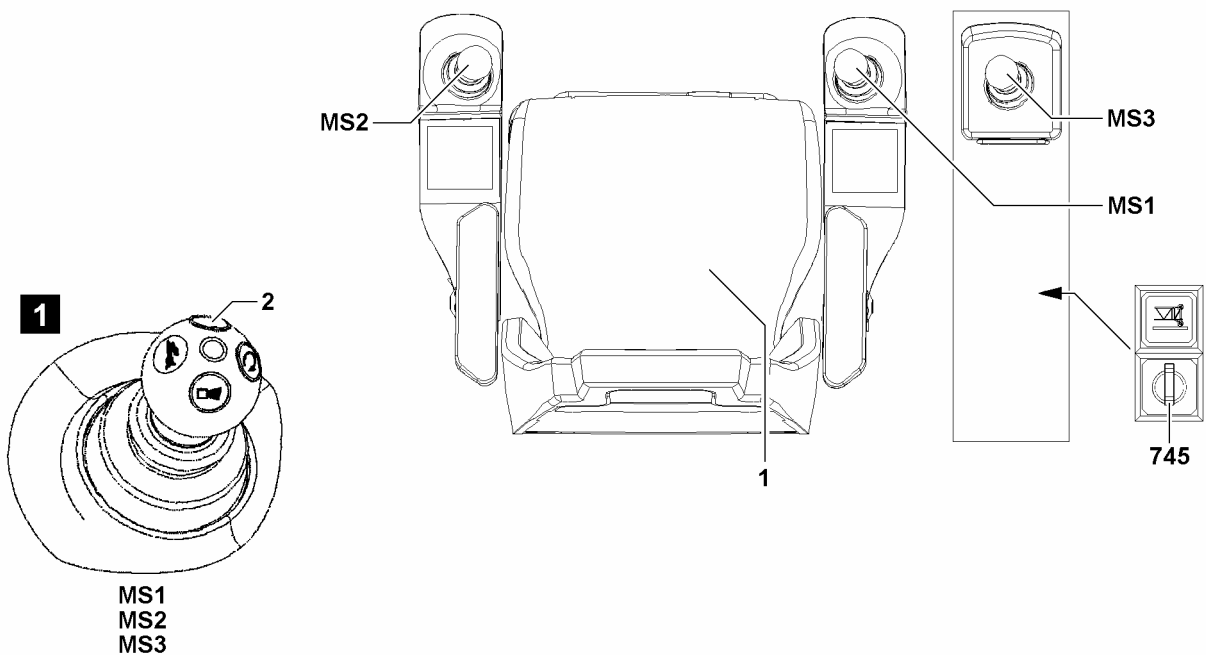
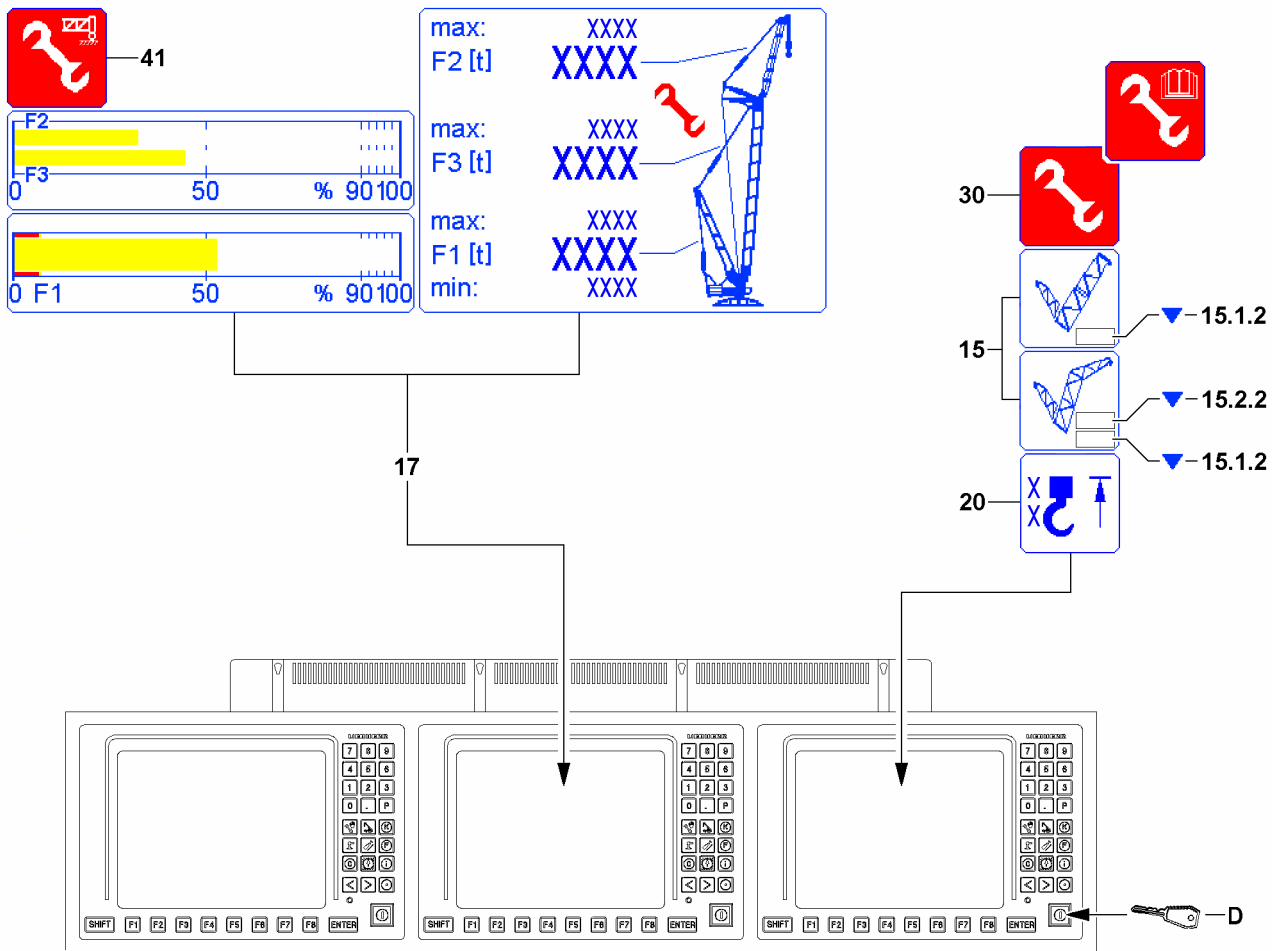


Fig.153665

LWE/LR 1800-1-0-000/27200-07-02/en

## 2.5.2 Carrying out take down procedures



### WARNING

Danger of accidents when taking the boom system down!

When the shut-off *luffing the main boom / auxiliary boom / accessory down* is bypassed, then the LICCON overload protection as a whole is deactivated, bypassed or limited.

The main boom and / or auxiliary boom / accessory can be luffed from the range of the load chart.

In case of deviations from the specifications of the crane documentation, severe accidents can be the result.

Personnel can be severely injured or killed.

- ▶ Always proceed according to the specifications of the crane documentation.
- ▶ Carry out all crane movements with utmost caution.

Make sure that the following prerequisites are met:

- With installed main boom / auxiliary boom / accessory: In the icon **15** the arrow **15.1.2** or arrow **15.2.2** appears and the LICCON overload protection has shut off the crane movement.
- Either the seat contact button **1** or one of the buttons **2** (illustration **1**) of the master switches (MS1, MS2, MS3) is actuated.
- All master switches (MS1, MS2, MS3) are in the zero position (not deflected).
- There is no load on the hook (hook block / load hook).
- If necessary, the hook (hook block / load hook) is placed on the ground.
- The set up configuration corresponds to the specifications in the crane documentation.
- The set up configuration has been entered correctly in the LICCON computer system.



### Note

- ▶ When leaving the “load chart available” range, the limit values and utilization displays for value F2 and value F3 will possibly appear.
- ▶ When leaving the “load chart available” range, the display of the assembly icon **30** changes.

- ▶ Turn the set up key **D** to the right (touching).

### Result:

- The assembly icon **30** appears on the LICCON monitor.
- The take down procedure can be carried out.
- ▶ Luff the boom according to the specifications of the crane documentation.
- ▶ Monitor the F-load display **17**, all values must be within the minimum values and the maximum values.

### Problem remedy

The erection / take down procedure cannot be carried out due to exceeding of the minimum or maximum values?

- ▶ See section “Minimum values or maximum values of F-load display reached”.

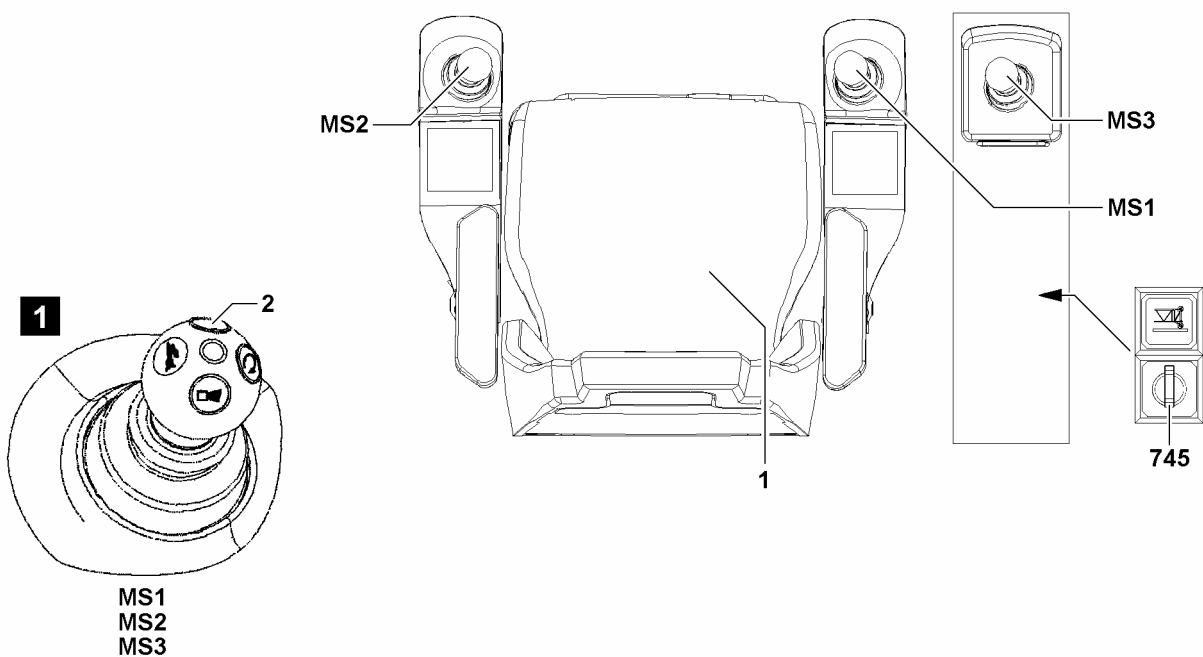
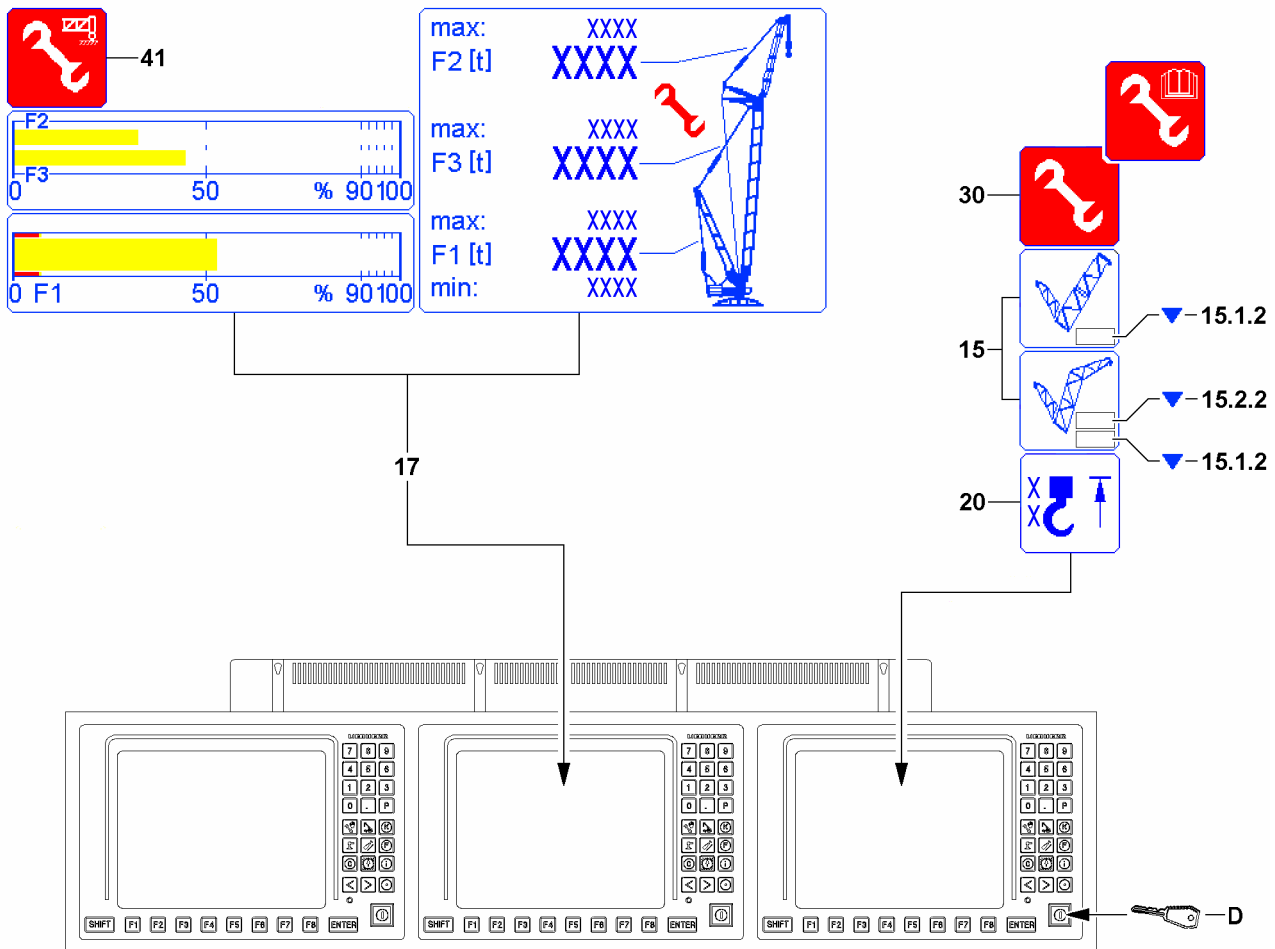


Fig.153665

LWE/LR 1800-1-0-000/27200-07-02/en



**Note**

- ▶ Depending on the situation, the *hoist top* shut-off (icon **20** appears) must be bypassed at the same time.

The “Bypass of the LICCON overload protection” via the set up key **D** turns off:

- If the set up key **D** is actuated again.
- When neither the seat contact button **1** nor one of the buttons **2** of the master switches (MS1, MS2, MS3) is actuated.
- When an area with an existing load chart is reached.

The bypass of the LICCON overload protection is / was turned off:

- The assembly icon **30** in the LICCON monitor turns off.
- ▶ Make sure that the assembly icon **30** no longer appears on the LICCON monitor.

### 2.5.3 Carrying out the assembly procedures

**WARNING**

Danger of accident during assembly procedures!

In case of deviations from the specifications of the crane documentation for the assembly procedures, severe accidents can be the result.

Personnel can be severely injured or killed.

- ▶ Always proceed according to the specifications of the crane documentation.
- ▶ **If you cannot proceed according to the crane documentation, contact Liebherr Service before carrying out any subsequent steps and agree on the procedure.**

Make sure that the following prerequisites are met:

- The set up configuration corresponds to the specifications in the crane documentation.
- The set up configuration has been entered correctly in the LICCON computer system.
- ▶ Actuate the set up key **D** only according to the corresponding specifications in the crane documentation.

### 2.5.4 Key button *Boom on the ground*

With the aid of the *Boom on the ground* key button **745**, a shut-off can be bypassed in the lowest angle range of the boom, when:

- The boom is in contact with the ground.
- At least 12.5 % of the boom weight is taken up by the ground contact.

Make sure that the following prerequisites are met:

- The set up configuration corresponds to the specifications in the crane documentation.
- The set up configuration has been entered correctly in the LICCON computer system.
- ▶ Actuate the *Boom on the ground* key button **745** and erect / take-down the boom.

**Result:**

- Icon **41** appears as long as the shut-off is bypassed.

**Note**

- ▶ The *Boom on the ground* key button **745** is on the instrument panel, see the Crane operating instructions, chapter 4.01.

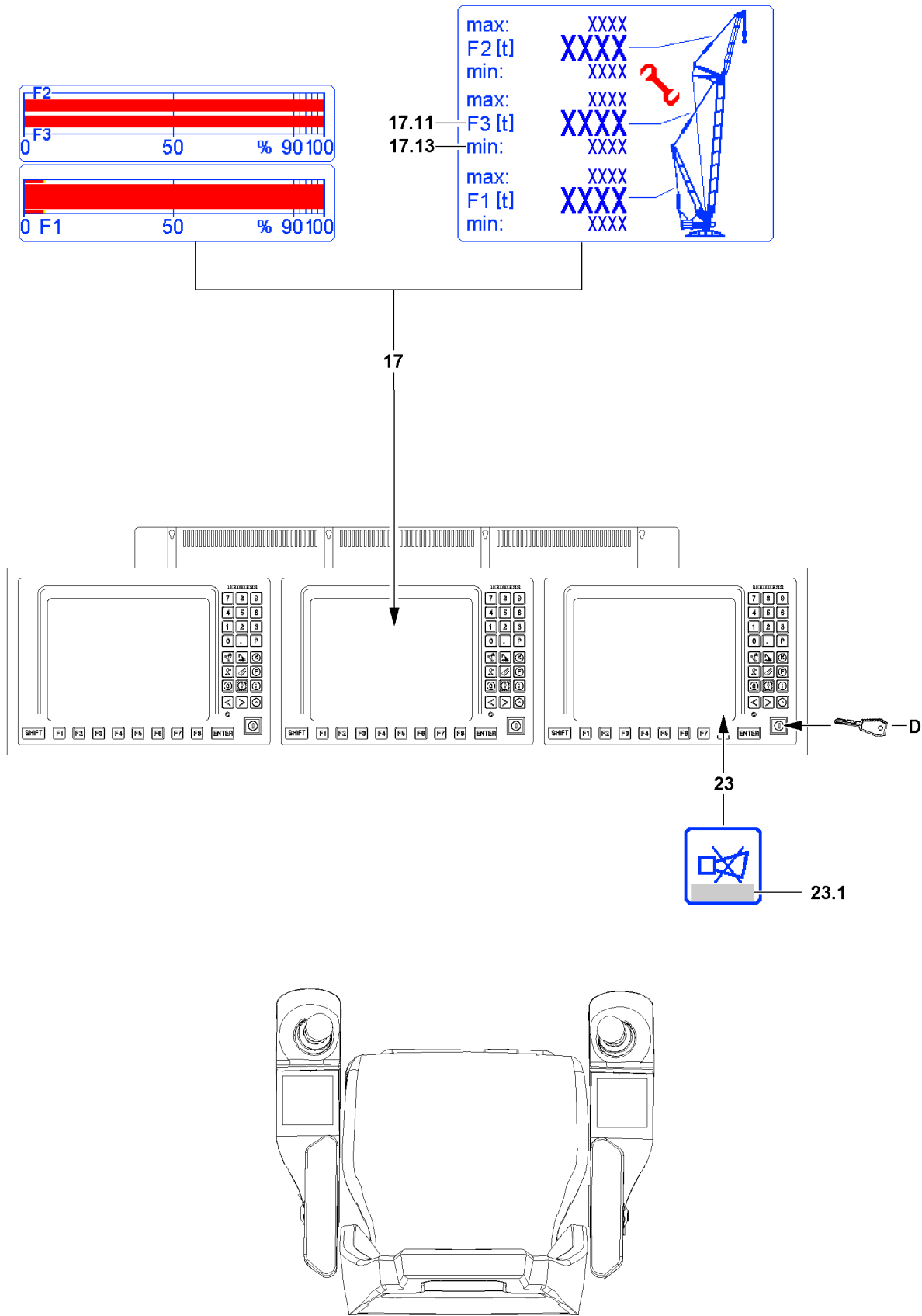


Fig.122458

## 2.6 Minimum values or maximum values of F-load display reached



### Note

- ▶ The display and assignment of the F-load display **17** can deviate depending on the set up configuration, operating condition and configuration of the crane, see Crane operating instructions, chapter 4.02.

In the F-load display **17** the minimum and maximum values were reached.

Make sure that the following prerequisites are met:

- The crane is assembled according to the specifications in the crane documentation.
- A valid set up configuration has been entered in the LICCON computer system (Set up program).
- The actual set up configuration has been entered in the LICCON computer system (Set up program).
- The hook block or the load hook is correctly installed and reeved in.
- All attachment parts and guy rods on the boom system, which are not needed, have been removed (weight).
- The boom system is free of snow and ice (weight).
- The wind influence on the crane is not too great.
- The local conditions (terrain incline) are in the permissible range.
- The notes regarding error messages **23.1** appearing in the *horn* icon **23** were observed.

### 2.6.1 Improvement of force ratio in the guying of the boom system

- ▶ Check if a crane movement was initiated, which leads to an improvement of the force ratio in the F-load display **17**.



### Note

In the permissible framework of specifications of the crane documentation, a positive influence of the force ratio in the F-load display **17** can be reached by:

- ▶ Changing the pulled derrick ballast.
- ▶ Changing the derrick ballast radius (luffing the derrick boom up / down).
- ▶ Erecting the main boom: Carrying the hook (hook block / load hook) along.
- ▶ Erection of the main boom with installed luffing jib: Spool the control winch for the luffing jib out to shift the weight of the guy rods more favorably.
- ▶ In difficult local conditions (terrain incline): Support the placed down boom system to obtain more favorable angle conditions.
- ▶ In difficult local conditions (terrain incline): Support the placed down boom system to reduce flexation.

### 2.6.2 Minimum value F3-load display during erection of the derrick boom fallen below

If the guying between the derrick boom and the main boom is not sufficiently tensioned, then it is possible that the value  $F3_{\min}$  **17.13** is fallen below. The value  $F3_{\min}$  **17.13** appears possibly only during the erection procedure of the derrick boom in the steep boom position.



### Note

- ▶ Through the targeted spooling up / out of winch 3 during the erection procedure, the guying between the derrick boom and the main boom can be slightly pretensioned depending on the circumstances and the value  $F3_{\text{actual}}$  **17.11** can be increased / maintained.

- ▶ Pretension the guying slightly between the derrick boom and the main boom so that the value  $F3_{\min}$  **17.13** is not fallen below. A collision of the luffing pulley block / guy rods with the crane (for example during the erection procedure of the derrick boom) may not occur.

When  $F3_{\min}$  **17.13** was fallen below and the movements winch 3 and winch 4 are fully or partially shut-off:

- ▶ Press the set up key **D** again when the assembly operation is activated.

**Result:**

- The value for  $F3_{\min}$  **17.13** is reduced slightly once.
- ▶ Spool winch 3 up to increase the value  $F3_{\text{actual}}$  **17.11**.

---

**Problem remedy**

The value for  $F3_{\min}$  **17.13** is fallen below again:

It is not possible to reduce the value for  $F3_{\min}$  **17.13** again.

- ▶ By spooling out winch 4 the derrick boom can be moved forward until the  $F3_{\min}$  **17.13** is masked again and winch 3 can be spooled up / out again.
-

---

## 5 Equipment

LWE/LR 1800-1-0-000/27200-07-02/en

---

LWE/LR 1800-1-0-000/27200-07-02/en

## 5.01 Technical safety instructions for assembly and disassembly

1	Equipment	2
2	Rope pulleys	2
3	Ropes	2
4	Fiber guy ropes	4
5	Control measures before crane operation	9
6	Relapse cylinders	11
7	Pneumatic springs	11
8	Manual rope winches	12
9	Weights	12
10	Guy rods	13
11	Auxiliary guying	14
12	Bypassing the overload protection	14
13	Bypassing the hoist top shut-off	16
14	Pin connections	17
15	Retaining elements	22
16	Assembling / disassembling	31
17	Erecting / taking-down	93
18	Walking on a boom component	97

# 1 Equipment

## 1.1 Checking the steel structures

All components part of the crane's delivery scope must be checked regularly together with the crane.

If equipment or components are assembled that are part of the delivery scope of another crane: Prior to first time use, check load bearing crane structures, especially steel structures, see chapter 8.01.

## 1.2 Checking the labeling



### WARNING

Labeling **not** legible or **not** present!

Components, especially guy rods, can be mixed up.

Death, severe bodily injuries, property damage.

- ▶ Do **not** continue to use the components, especially the guy rods.

## 2 Rope pulleys



### WARNING

Danger of accident due to rotating rope pulleys!

Arms and legs can be caught and crushed or severed between the rope pulleys due to rotating rope pulleys.

- ▶ It is prohibited to touch the rope pulleys during operation.
- ▶ Adhere to the safety distance to the rotating rope pulleys.

## 3 Ropes



### WARNING

Danger of accident due to a running rope!

People can be caught by running rope.

Death, severe bodily injuries, property damage.

- ▶ Adhere to the safety distance to the running ropes.
- ▶ It is prohibited for anyone to remain in the danger zone.



### WARNING

Danger of accident!

- ▶ The ropes must be checked by an expert before assembly and checks must be performed at regular intervals in order to detect possible damage or wear and tear at an early stage. See chapter 8.04.

The ropes must be taken down immediately if any of the following damage is detected:

- Breakage of a strand
- Wire breaks
- Broken wire nests
- Reduction in the rope diameter by 10 % or more of the nominal size
- Rope deformations

### 3.1 Placing the hoist rope or the control rope

In order to guarantee safety and operating characteristics, only original Liebherr spare parts or parts approved by Liebherr may be used.



**NOTICE**

Damage to the hoist rope or the control rope!

If a hoist rope or control rope is placed with worn rope pulleys, damage can occur.

- ▶ Before placing a rope, check the rope pulleys. See chapter 8.01.
- ▶ Replace worn or damaged rope pulleys.

## 3.2 Minimum rope coils

**NOTICE**

If the following notes are not observed, the cam limit switch / winch speed sensor must be readjusted!

- ▶ When the hoist rope is spooled up, the end of the hoist rope must remain in front of the winch and may not be pulled over the winch.
- ▶ Never pull the hoist rope end under the winch by spooling the winch up.
- ▶ Pull the hoist rope never off from the "stationary" winch.
- ▶ The winch speed sensor must also be readjusted, if it is determined during operation or when changing the hoist rope that the winch does not shut off when the minimum rope coils are reached.

### 3.2.1 Cranes with cam limit switch

The cam limit switch is adjusted at the factory that it turns off before the minimum rope coils are reached (three hoist rope coils on the winch).

**WARNING**

Danger of accident due to falling load!

If the following instructions are not observed, the hoist rope end attachment may be torn out, causing the load to topple.

- ▶ If a new hoist rope is used, the cam limit switch must be reset.
- ▶ The cam limit switch must be adjusted so that it turns off when only 3 hoist rope coils remain on the winch.

### 3.2.2 Cranes with winch speed sensor

The winch speed sensor is adjusted at the factory that it turns off before the minimum rope coils are reached (four hoist rope coils on the winch). If used properly, the winch turn sensor will not need readjustment.

**WARNING**

Danger of accident due to falling load!

If the following instructions are not observed, the hoist rope end attachment may be torn out, causing the load to topple.

- ▶ If a new hoist rope is placed, the winch speed sensor must be checked.
- ▶ The winch speed sensor must be set to turn off when only 4 hoist rope coils remain on the winch.

## 4 Fiber guy ropes



### WARNING

Impermissible assembly of fiber guy ropes!

The fiber guy ropes can rip.

Death, severe bodily injuries, property damage.

- ▶ Do **not** assemble fiber guy ropes that are rigidly frozen or covered with ice.
- ▶ Do **not** use buckled, knotted or twisted fiber guy ropes.
- ▶ Do **not** assemble damaged fiber guy ropes.
- ▶ Make sure that the identification of the fiber guy rope on the rod plan and the identification on the individual fiber guy ropes are identical. See section "Identifying the fiber guy rope".
- ▶ Make sure that the operating temperature of the fiber guy ropes of -40 °C to +60 °C is **not** fallen below or exceeded.
- ▶ Check the fiber guy ropes for damage prior to assembly, after disassembly and after exceptional events, see chapter 8.16.
- ▶ Comply with the maintenance intervals, see chapter 7.03.50.
- ▶ Observe the notes regarding the proper transport and storage of the fiber guy ropes, see chapter 2.04.
- ▶ Observe the instructions for the fiber guy ropes, see section "Instructions for proper handling".
- ▶ Only fasten the fiber guy ropes in the permissible range with belt loops, see section "Fastening the fiber guy ropes".



### WARNING

Temperatures below 0 °C: Fiber guy ropes that are rigidly frozen or covered with ice!

Buckling of the fiber guy ropes. The fiber guy ropes can rip.

Death, severe bodily injuries, property damage.

- ▶ Before assembling and disassembling the fiber guy ropes, check if the fiber guy ropes are rigidly frozen or covered with ice. See section "Rigidly frozen fiber guy ropes".
- ▶ While erecting and taking down the boom system, check if the fiber guy ropes are rigidly frozen or covered with ice. See section "Rigidly frozen fiber guy ropes".
- ▶ Do **not** bend, knot or twist rigidly frozen fiber guy ropes.
- ▶ Do **not** erect or take down boom systems with fiber guy ropes that are rigidly frozen or covered with ice (for example auxiliary guying, guying for the F-jib).
- ▶ Observe the instructions for the fiber guy ropes, see section "Instructions for proper handling".
- ▶ After disassembly: Check the rigidly frozen fiber guy ropes for damage, see chapter 8.16.
- ▶ Observe the notes regarding the proper transport and storage of the fiber guy ropes, see chapter 2.04.

Comply with the intended use and non-intended use of the fiber guy ropes:

- Only use fiber guy ropes as guy rope.
- Do **not** use fiber guy ropes for typical rope tasks, for example for lifting, fastening to hooks, as an auxiliary rope, diverting over rope pulley.

## 4.1 Identifying the fiber guy rope

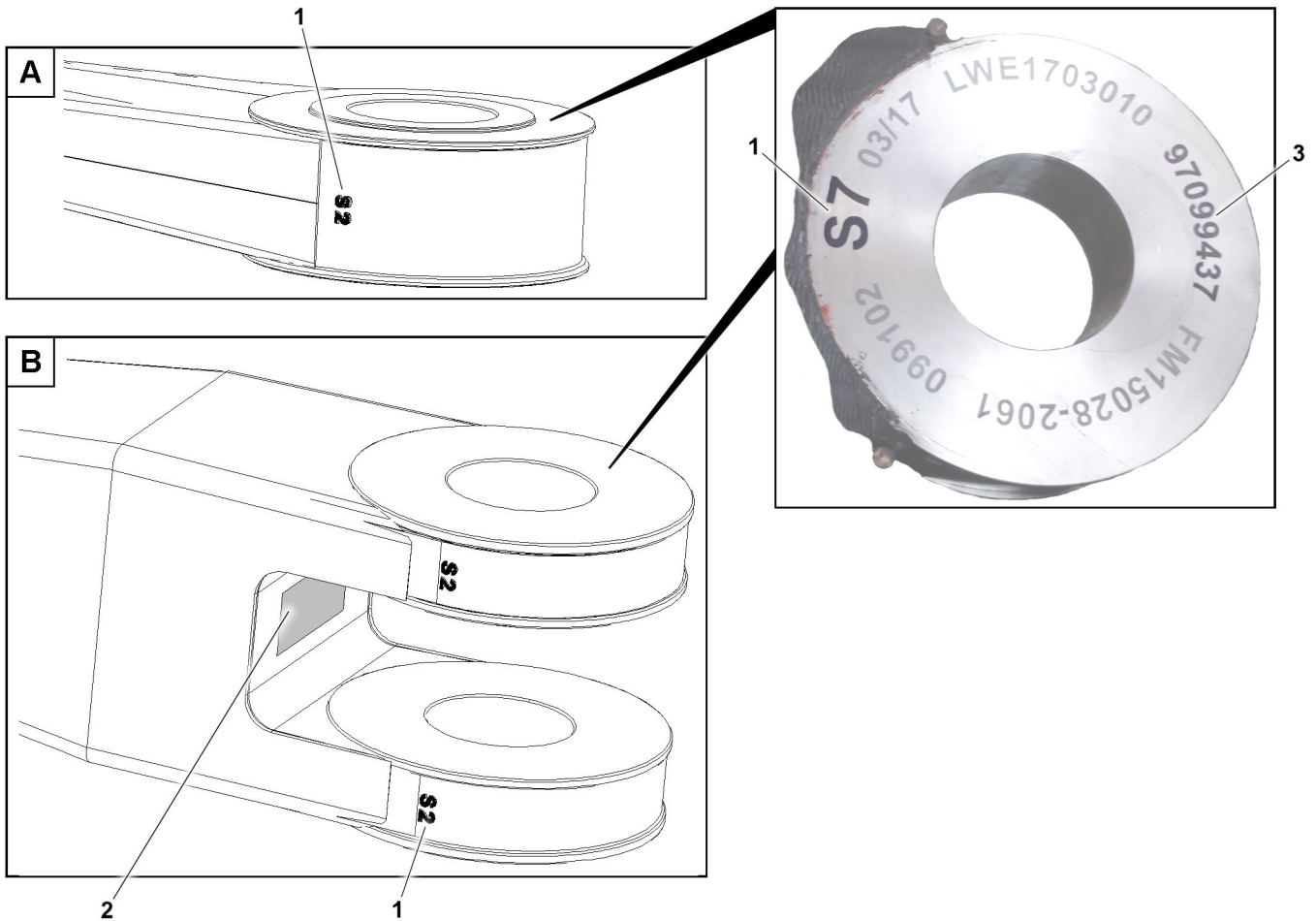


Fig.160911: Fiber guy rope, identification

- |                      |                              |                         |
|----------------------|------------------------------|-------------------------|
| <b>1</b> Rope number | <b>2</b> Component group no. | <b>3</b> Article number |
|----------------------|------------------------------|-------------------------|

Follow the instructions below for the correct identification of the fiber guy ropes:

- Make sure that rope number **1** on the rope thimble corresponds to the rope number on the rod plan.
- Make sure that article number **3** on the rope thimble corresponds to the article number on the rod plan.
- If there is an article number **3** and a component group no. **2** on the rope thimble: Make sure that component group no. **2** on the rope thimble corresponds to the component group no. on the rod plan.

## 4.2 Rigidly frozen fiber guy ropes

Feature of rigidly frozen fiber guy ropes:

- This occurs at temperatures below 0 °C.
- The water contained in the rope is frozen.
- The fiber guy rope can be covered with ice.
- The fiber guy rope can no longer be wound up or spooled out.
- Its bending behavior is considerably limited when erecting and taking down the boom system.

Detect rigidly frozen fiber guy ropes when erecting and taking down the boom system:

- Test period: During the erection or take down of take-down of the boom system, when the fiber guy ropes transition from the tensioned to the relieved condition.  
Or: When the fiber guy ropes transition from the relieved to the tensioned condition.
- Check acoustically (listening) if the noise is generated by cracking or breaking ice.

- Check visually if the fiber guy rope is starting to form a buckle.
- If noise is generated or a buckle is forming: The fiber guy rope is rigidly frozen.

Instructions for the erection and take-down of the boom system when the fiber guy ropes are rigidly frozen or covered with ice:

- End erection or take-down.
- Warm up and dry fiber guy ropes at temperatures below 50 °C. Contact Customer Service at Liebherr-Werk Ehingen GmbH.

### 4.3 Instructions for proper handling

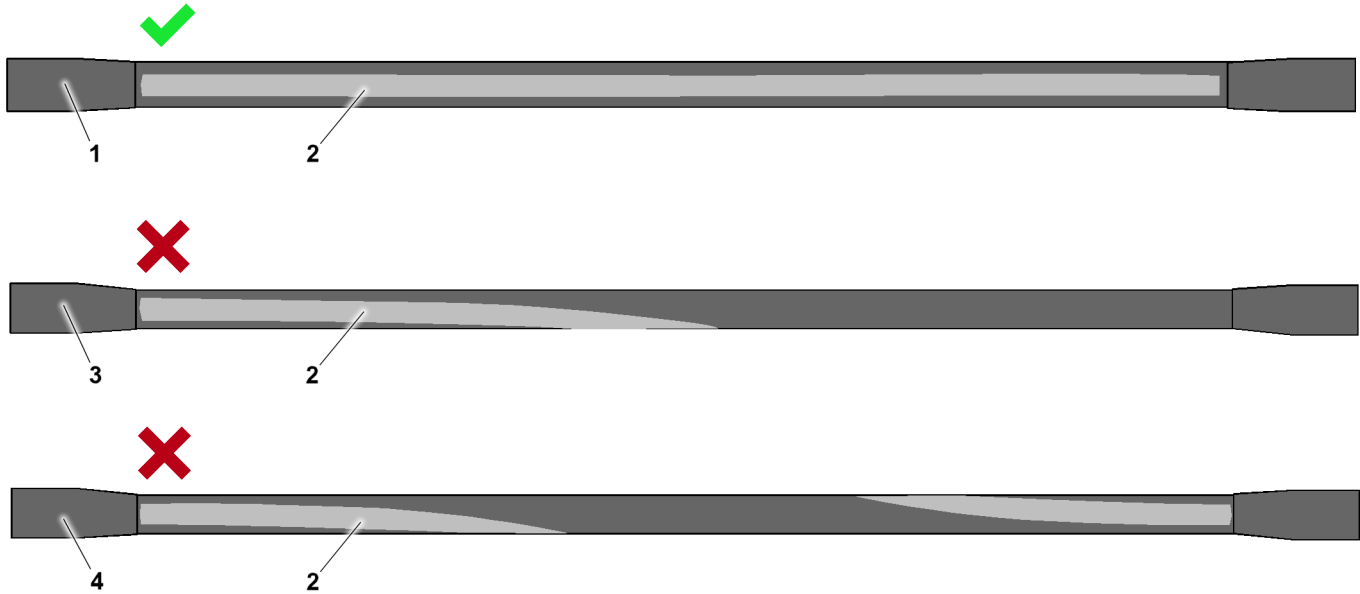
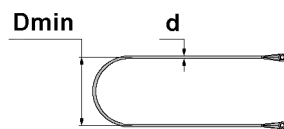


Fig.160904: Fiber guy rope, twisting marking for permissible alignment of the rope

- |   |                         |   |                             |
|---|-------------------------|---|-----------------------------|
| 1 | Straight fiber guy rope | 3 | Fiber guy rope twisted 180° |
| 2 | Twisting marking        | 4 | Fiber guy rope twisted 360° |



$$D_{min} = 20 \times d$$

Fig.160908: Fiber guy rope: Calculation of minimum permissible bending diameter

Formula element	Meaning
Dmin	Minimum permissible bending diameter
d	Rope diameter

Minimum permissible bending diameter: Definition of the formula elements

Comply with the instructions for the assembly and disassembly of the fiber guy ropes:

- If the fiber guy ropes that are rigidly frozen or covered with ice: Prior to assembly, warm up and dry fiber guy ropes at temperatures below 50 °C.
- Perform a visual inspection: Abrasion, cuts, kinks, knots, deformations, heat damage.
- Perform a visual inspection: Damage to the sheath layers and the rope end connections, gap formation between the rope thimble and the rope sheath.
- Do **not** bend, knot, twist or sever the fiber guy ropes.

- Never fall below the minimum permissible bending diameter **D<sub>min</sub>** of **20** x rope diameter **d**.
- Check the alignment of the rope end connections with respect to each other: Align the twist marking **2** straight along the entire rope length.
- Do **not** drag the fiber guy ropes over the ground, rough surfaces or sharp edges.
- Do **not** let the fiber guy ropes fall down.
- Do **not** crush the fiber guy ropes.
- Do **not** remove the crushed fiber guy ropes out of the clamping point.
- Do **not** pull the fiber guy ropes with force to the pin point.
- Pin the fiber guy ropes only with permissible and lubricated pins.
- Only fasten the fiber guy ropes in the permissible range with belt loops, see section “Fastening the fiber guy ropes”.

**Note**

Recommendation:

- ▶ Liebherr-Werk Ehingen GmbH recommends drying wet fiber guy ropes in the air at approx. 20 °C prior to erection.

#### 4.4 Fastening the fiber guy ropes

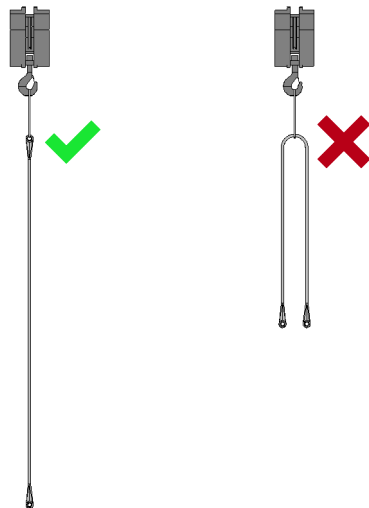


Fig.160907: Fastening the fiber guy ropes

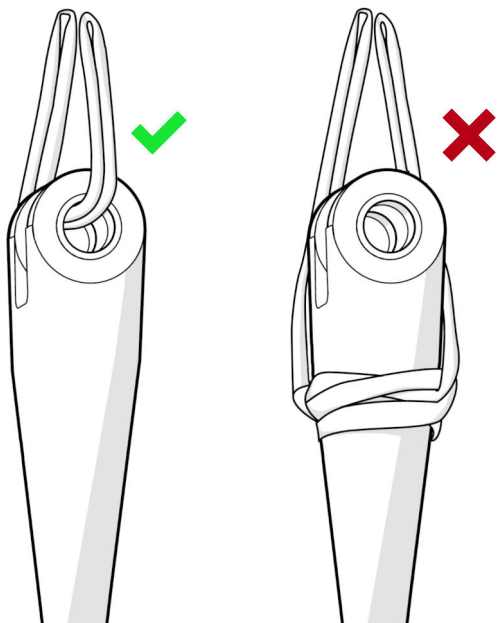


Fig.160905: Fasten the fiber guy rope: Rope end connection without ribs

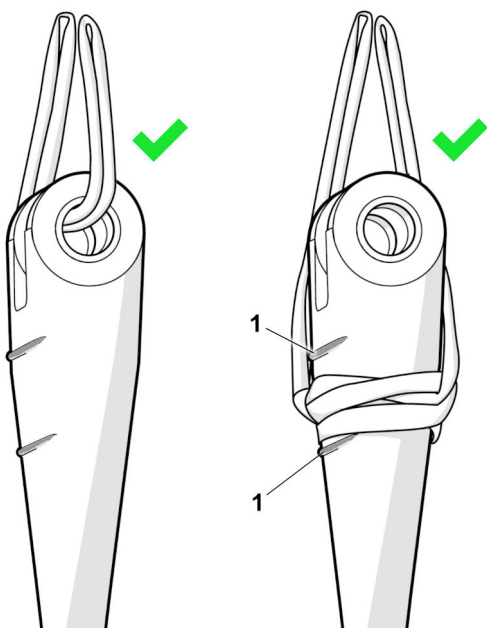


Fig.160906: Fasten the fiber guy rope: Rope end connection with ribs

1 Rib

## 5 Control measures before crane operation



### WARNING

The crane can topple over!

If the following control measures and the crane-specific additional controls are not carried out before crane operation or if they are not carried out sufficiently, then accidents can occur.

The crane can topple over, be overloaded or damaged.

Loose parts, aids or ice can fall down from the boom or the crane superstructure.

Death, severe bodily injuries, property damage.

- ▶ Crane operation with safety equipment that is **not** functioning correctly is strictly prohibited.
- ▶ Start crane operation only after all safety equipment have been checked and are functioning correctly.
- ▶ Start crane operation only if the overload protection has been set according to the data in the load chart.
- ▶ Start crane operation only if the crane is properly supported and horizontally aligned.
- ▶ Only start crane operation after making sure that there are not loose parts on the boom, crane superstructure or crane chassis.
- ▶ Only start crane operation after making sure that there is no snow, frost or ice on the boom.
- ▶ Only start crane operation after making sure that all specifications, crane conditions and / or properties that are checked and required during the extensive control measures and additional controls have also been completely fulfilled.



### WARNING

Interruption of crane operation!

If the following specifications for interruption of crane operation are not observed, accidents can occur.

- ▶ If the crane operator leaves the crane cab even if for just a short time, the crane must be secured to prevent unauthorized access.
- ▶ Before starting to work again with the crane, the crane operator is obligated to check the operating mode settings and to reset them, if necessary.



Fig.113437: Monitoring indicators

Make sure that the following prerequisites are met:

- The overload protection is not bypassed.
- No assembly operation is activated.

### 5.1 General controls before crane operation

- Make sure that no visible damage is present on the crane.
- Make sure that there are no loose parts on the boom, crane chassis and crane superstructure.
- Make sure that all hoist and control ropes are free of snow, frost and ice.
- Make sure that the boom system is free of snow, frost and ice.
- Make sure that exposed rope pulleys are free of snow, frost and ice.
- Make sure that the cable / rope drums as well as the limit switches are free of snow and ice.
- Make sure that the cylinders are free of ice.
- Make sure that the gear ring of the slewing ring connection is clean and greased.
- Make sure that the air supply to the oil and water cooler is clear.
- Make sure that steps, ladders and platforms are in the correct position for crane operation.
- Make sure that all tool boxes, compartments, coverings, covers and cabinet doors are closed.
- Make sure that no persons or objects are in the danger zone of the crane.
- Make sure that the crane is standing on level, load bearing ground.
- Make sure that the crane is sufficiently supported depending on the load case and the ground conditions.

- Make sure that there is a sufficient safety distance to excavations and slopes.
- Make sure that no obstacles are within the working range of the crane, which obstruct the required crane movements.
- Make sure that the crane has sufficient distance to live power lines.
- Make sure that the LICCON overload protection is set according to the data in the load chart.
- Make sure that the overload protection is set according to the actual set up configuration of the crane.
- Make sure that the electrical connections, the connector plug, the pull relief, the cables and the protective insulation function. Replace missing or defective parts.
- Make sure that the cable routings on the electrical connections are seated tightly. If necessary, tighten loose screw connections.
- Make sure that the existing safety equipment is functioning.
- Make sure that the overload protection is functioning.
- Make sure that the hoist limit switches are functioning.
- Make sure that the limit switch boom “steepest position” is functioning.
- Make sure that the wind speed sensor moves easily and is functioning.

## 5.2 Additional controls for cranes with crane support

- Make sure that the folding / sliding beams are secured with pins to prevent them from sliding.
- Make sure that the support plates are secured in the operating position.
- Make sure that the crane is properly supported.
- Make sure that the crane is horizontally aligned.
- Make sure that the axle suspension is blocked (mobile crane).
- Make sure that the tires have no contact to the ground (mobile crane).
- Make sure that the track chains are secured to prevent them from sagging (crawler crane).

## 5.3 Additional controls for cranes on tires on the front and supported on the rear

- Make sure that the rear folding / sliding beams are secured with pins to prevent them from sliding.
- Make sure that the rear support plates are secured in the operating position.
- Make sure that the crane is properly supported on the rear.
- Make sure that the axle pressure compensation is correctly switched.
- Make sure that the axle suspension is blocked.
- Make sure that the tires of the rear axle group have no contact with the ground.
- Make sure that a sufficient tire pressure is present in the tires.
- Make sure that the ground for the front axle group is sufficiently level and has a sufficient load bearing capacity.

## 5.4 Additional controls for cranes supported on the front and on tires on the rear

- Make sure that the front folding / sliding beams are secured with pins to prevent them from sliding.
- Make sure that the front support plates are secured in the operating position.
- Make sure that the crane is properly supported on the front.
- Make sure that the axle pressure compensation is correctly switched.
- Make sure that the axle suspension is blocked.
- Make sure that the tires of the front axle group have no contact with the ground.
- Make sure that a sufficient tire pressure is present in the tires.
- Make sure that the ground for the rear axle group is sufficiently level and has a sufficient load bearing capacity.

## 5.5 Additional controls for freestanding crane operation (on tires)

- Make sure that all prerequisites for freestanding crane operation are met.
- Make sure that sufficient tire pressure is in all tires for crane operation on tires.



- Make sure that the ground is sufficiently level for crane operation on tires and has a sufficient load bearing capacity.

## 5.6 Additional controls for cranes with a derrick boom

- Make sure that the shut-off via the limit switch - derrick is functioning.
- Make sure that the entire slewing range of the suspended ballast / ballast trailer is free of personnel and obstacles.

## 5.7 Additional controls for cranes with luffing auxiliary boom / accessories

- Make sure that the shut-off via the luffing auxiliary boom / accessories “steepest position” limit switch is functioning.
- Make sure that the shut-off via the luffing auxiliary boom / accessories “lowest position” limit switch is functioning.
- Make sure that the shut-off via the limit switch flap in the “steepest position” position is functioning.
- Make sure that the pendulum of the mechanical relapse retainer moves easily over the entire slewing range and is functioning.

## 5.8 Additional controls for certain crawler cranes

For existing crawler assembly key button:

- Make sure that the crawler assembly key button is turned off.

# 6 Relapse cylinders

## 6.1 Block position of the relapse cylinders when setting down the load

---

### NOTICE

Damage to the boom or the relapse cylinders!

If the block position of the relapse cylinders is triggered by the boom or the derrick with attached, freely suspended load, then there is a danger of damaging the boom or the relapse cylinders when setting the load on the ground. By setting down the load, the crane is relieved, and this movement causes the boom system to move to the rear.

There is no shut-off of the hoist gear lowering function.

- ▶ Actuate the opposite direction of movement which caused the block position and eliminate the block position.
- 

# 7 Pneumatic springs

Pneumatic springs are installed on various crane components to simplify the assembly of these components.

**WARNING**

Danger of crushing!

Defective pneumatic springs no longer provide the supporting properties on the movable components. Components can fall down.

Death, severe bodily injuries, property damage.

- ▶ Always check pneumatic springs for damage before actuating the corresponding components.
- ▶ Do not use components with defective pneumatic springs. Replace defective pneumatic springs immediately.
- ▶ Make sure that no persons or objects are in the movement range of the moving components which is supported by the pneumatic spring.
- ▶ It is strictly prohibited to remain or place any objects in the movement or other danger zone of the moving crane components which are supported by the pneumatic spring.

## 8 Manual rope winches

Manual rope winches are installed on various components to simplify the assembly or disassembly of these components.

**WARNING**

Danger of crushing!

Defective manual rope winches no longer provide the supporting action on the movable components. Components can fall down.

Death, severe bodily injuries, property damage.

- ▶ Always check manual rope winches for external and functional damage before actuating the respective components.
- ▶ Check the rope of the manual rope winch for damage.
- ▶ At least two rope coils must always remain on the rope drum.
- ▶ Do not use components with defective manual rope winches. Replace defective manual rope winches.
- ▶ It is strictly prohibited for personnel or objects to remain within the movement range of the components, which are supported by the manual rope winch.
- ▶ It is prohibited for personnel or objects to remain within the danger zone of the moving components.

## 9 Weights

**Note**

- ▶ The weight of each component is specified in the chapter 1.03 or the respective chapter in the Crane operating instructions or is stated on the tag attached to the corresponding component.
- ▶ If components are pushed into one another (for example the boom intermediate sections) or folded together (for example the folding jib), then the total weight is given by the sum of the individual components.

**NOTICE**

False estimation of weights

- ▶ Contact Customer Service at **Liebherr-Werk Ehingen GmbH** if the weight of the respective component is not stated on the tag or in the Crane operating instructions.
- ▶ Use an auxiliary crane with sufficient load carrying capacity including a reasonable reserve.

## 10 Guy rods



### WARNING

The boom can break off!

The arrangement of the guy rods for the boom or boom systems is stipulated in the rod plan. If the arrangement of the guy rods is not observed according to the rod plan, the crane can collapse, the boom can break off or the crane can topple over.

Death, severe bodily injuries, property damage.

- ▶ Always carry out the arrangement of the guy rods according to the rod plan.
- ▶ If an auxiliary guying is required for a certain boom length, then it must always be installed according to the rod plan on the position defined in the rod plan.



### WARNING

Unutilized guy rods on boom!

If guy rods are on the lattice sections which are not used for operation, then there is a danger of accident.

Unused guy rods can loosen up and fall down.

Death, severe bodily injuries, property damage.

The load chart is invalid.

The load display of the LICCON computer system shows an incorrect value.

The weight of the boom is too heavy for erection.

- ▶ Disassemble and remove the guy rods that are not needed on the transport retainers before erecting the boom.



### Note

- ▶ Inspection and maintenance of the guy rods, see chapter 8.15.
- ▶ In reference to the guy rods, observe section "Erection / take-down".

## 10.1 Guy rods for telescopic cranes with luffing lattice jib

### 10.1.1 Long guy rods

This section applies only to cranes with a telescopic boom and luffing lattice jib.

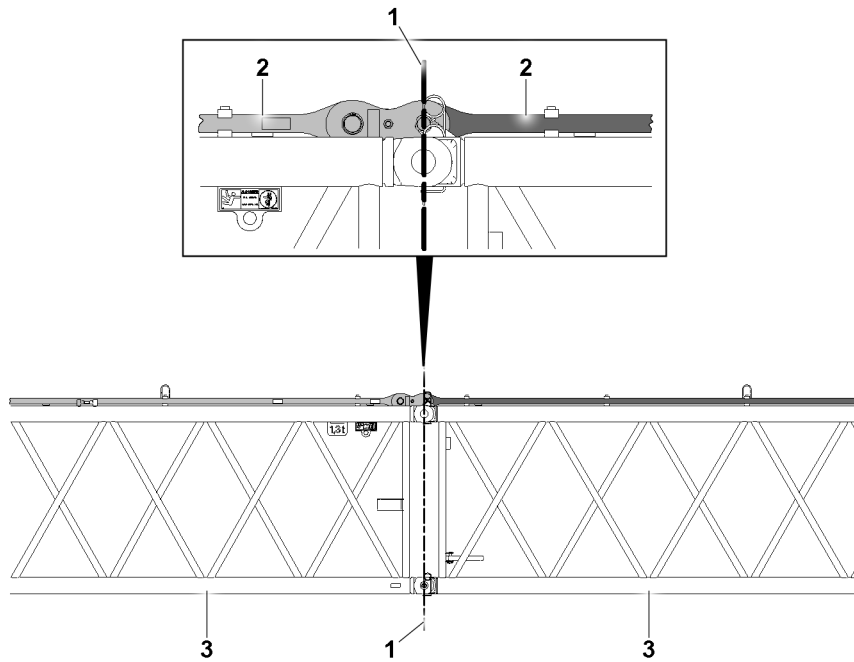


Fig.152299: Lattice section pin level

- |           |          |                 |
|-----------|----------|-----------------|
| 1         | 2        | 3               |
| Pin level | Guy rods | Lattice section |

If guy rods 2 are assembled, then close the guy rods 2 on the pin level 1 of the lattice sections 3. In this way it can be determined if the correct guy rods 2 are assembled.

To completely check the guying, the requirements of the **rod plan**, the **assembly drawings** and the **operating instructions** must be observed.

## 11 Auxiliary guying

The auxiliary guying is of significant importance for safe crane operation.

The auxiliary guying is a deciding factor in relieving the boom, or the boom system during erection and take-down as well as during crane operation.



### **WARNING**

The crane can topple over!

If the auxiliary guying is not installed or not installed on the position specified in the rod plan, then the crane can collapse, the boom can break off or the crane can topple over.

- If an auxiliary guying is specified in the rod plan for the required boom length, then it must be installed on the respective position.
- Make sure that the auxiliary guying is always completely installed and that all pins are properly pinned and secured.

## 12 Bypassing the overload protection



Fig.113438: Bypassing the overload protection

- Illustration 1: LICCON monitor (only certain crane types)
- Illustration 2: indicator light “assembly” on the crane cab instrument panel (only certain crane types)

The overload protection is considered bypassed for:

- All types of assembly operations.
- All types of exceeded shut off limits of the overload protection.
- All types of emergency operation.
- All types of crane operation with deactivated or defective sensors and limit switches.
- All types of deviation from specified set up configuration of the crane.



### DANGER

Increased danger of accident due to bypass of the overload protection!

Proper and destined use of the crane is ensured due to the construction of the overload protection system and observance of the information in the Crane operating instructions. All **sensibly foreseeable erroneous operations** of the crane have been taken into consideration.

Impermissible crane operation with bypassed overload protection – with the aim of increasing the maximum load bearing capacity of the crane above the rated value in the load chart or of extending the designated working range of the crane – does not constitute a **reasonably foreseeable erroneous operation**, rather **deliberate improper use with high danger of accident**.

The possible risks and consequences of such improper use are detailed in the Crane operating instructions.

Such deliberate improper use can neither be prevented by means of the structural version nor by means of information in the Crane operating instructions.

- ▶ Bypass the overload protection only according to the Crane operating instructions.
- ▶ Exceed the shut off limits of the overload protection only according to the Crane operating instructions.
- ▶ Any other use of the crane with bypassed overload protection than that described in the Crane operating instructions is prohibited.

If the maximum permissible load moment is exceeded, the overload protection turns all load moment increasing crane movements off.

This shut-off can be bypassed or exceeded various ways, for example:

- Exceeding the shut off limits (utilization more than 100 % or leaving the load chart).
- Activating an assembly operation.
- Activating an emergency operation.

The displays of the LICCON overload protection remain functioning when all associated sensors and limit switches are active and a load chart is available.



### WARNING

Increased danger of accident due to bypass of the overload protection!

If the overload protection is bypassed, there is no longer any protection against crane overload.

In the event of improper use, the crane could collapse, the boom can break off or the crane can topple over.

Death, severe bodily injuries, property damage.

This can result in significant property damage.

- ▶ It is only permitted to bypass the overload protection for assembly or in emergencies.
- ▶ The bypass of the overload protection may only be carried out by persons who are aware of the effects of their acts.
- ▶ Bypassing the overload protection requires the presence of a person authorized by the crane operator and must be performed with utmost caution.
- ▶ Crane operation is strictly prohibited when the overload protection is bypassed.

## 12.1 Bypassing the LICCON overload protection



### Note

- ▶ This applies only for cranes with LICCON overload protection.

Depending on the crane version, one or more operating elements are available to bypass the overload protection:

- Button in the control panel.
- Key button on the LICCON monitor.
- Key button / key switch on the instrument panel.
- Key button / key switch in the control cabinet.
- Sensor for the transponder in the crane cab / control cabinet / engine house.




---

**Note**

- ▶ For the location and function of the operating elements, see chapter 4.01 and chapter 4.02.
- 

- ▶ Actuate the respective operating element.

**Result:**

- The LICCON overload protection is bypassed / inactive.
- The “Assembly” icon appears on the LICCON monitor.
- Depending on the circumstances, acoustic and / or optical warning signals (blinkers, flashing beacons, horns and bells) sound.

If the LICCON overload protection is to be reactivated:

- ▶ No longer actuate the respective operating element or reset.

**Result:**

- The LICCON overload protection is active.
- The “Assembly” icon no longer appears on the LICCON monitor.
- The acoustic and / or optical warning signals which were triggered by the bypass are turned off again.

## 12.2 Bypassing the PAT overload protection




---

**Note**

- ▶ Applies only for cranes with PAT overload protection.
- 

- ▶ Actuate the bypass key button and turn the PAT overload protection off.

**Result:**

- The PAT overload protection is bypassed / inactive.
- ▶ Actuate the bypass key button and turn the PAT overload protection on.

**Result:**

- The PAT overload protection is active.

## 13 Bypassing the hoist top shut-off




---

**Note**

- ▶ Applies only for cranes with hoist limit switch.
- 

If the hook block touches the hoist limit switch weight during the upward movement, the hoist limit switch reacts. The “Spool up winches”, “Luff boom down” and “Telescope the telescopic boom out” crane movements are turned off. The shut-off can be bypassed.

**WARNING**

Danger of accident due to bypass of hoist top shut-off!

When bypassing the hoist top shut-off, there is a danger that the hook block may be pulled against the pulley head when continuing to lift or luffing down the boom. This may damage the pulleys and cause the loads to fall.

- ▶ The bypass of the hoist top shut-off in crane operation with a load may only be carried out by a person authorized by the crane operator with the aid of a "Guide". The guide must be in direct contact with the crane operator and must continually monitor the distance between the hook block and the boom head.
- ▶ Carry out all crane movements with maximum caution and minimum speed.

## 14 Pin connections

**WARNING**

Pin connections **not** lubricated!

If pins or pin connections are not properly greased or lubricated before assembly, then they can corrode.

The pins can be stuck in the pin bores and be damaged.

During the unpinning procedure, the pins can suddenly release.

Death, severe bodily injuries, property damage.

- ▶ Make sure that all pins, which are not supplied with grease via the central lubrication system are sufficiently greased before assembly.
- ▶ Make sure that all lube points, which are equipped with a grease fitting, are properly greased at assembly and according to the respective interval specification.
- ▶ Never insert or unpin pins by force.

**WARNING**

Pin **not** secured to prevent it from loosening up by itself!

The pin connection could loosen up suddenly.

Death, severe bodily injuries, property damage.

- ▶ Secure all pins with retaining elements against loosening up by itself.

**WARNING**

Distorted pin!

Angular pull or excessive or low hoisting force of the auxiliary crane may result in distortion of the pins. Distorted parts can suddenly fly off when the pins are unpinned.

Death, severe bodily injuries, property damage.

- ▶ When the pins are unpinned, the lifting force of the auxiliary crane must be adapted to the weight of the components being lifted.
- ▶ Do **not** unpin difficult to remove pins by force.
- ▶ Remedy the cause of the tension.

## 14.1 Inserting and unpinning the collar pins

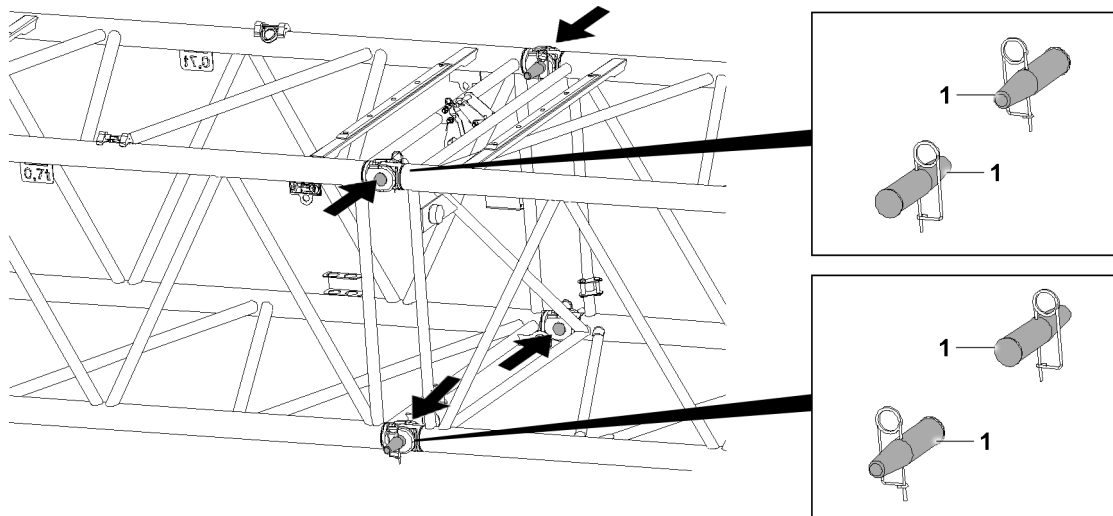


Fig.143114: Inserting the collar pins



### WARNING

The collar pin is incorrectly pinned!  
Death, severe bodily injuries, property damage.

- ▶ Insert or unpin both pins on the same horizontal level, i.e. **left and right**.
- ▶ Pin the upper collar pin **1** from the **outside to the inside** and unpin from the **inside to the outside**.
- ▶ Insert the lower collar pin **1** from the **inside to the outside** and unpin from the **outside to the inside**.

## 14.2 Inserting and unpinning the double cone pins horizontally

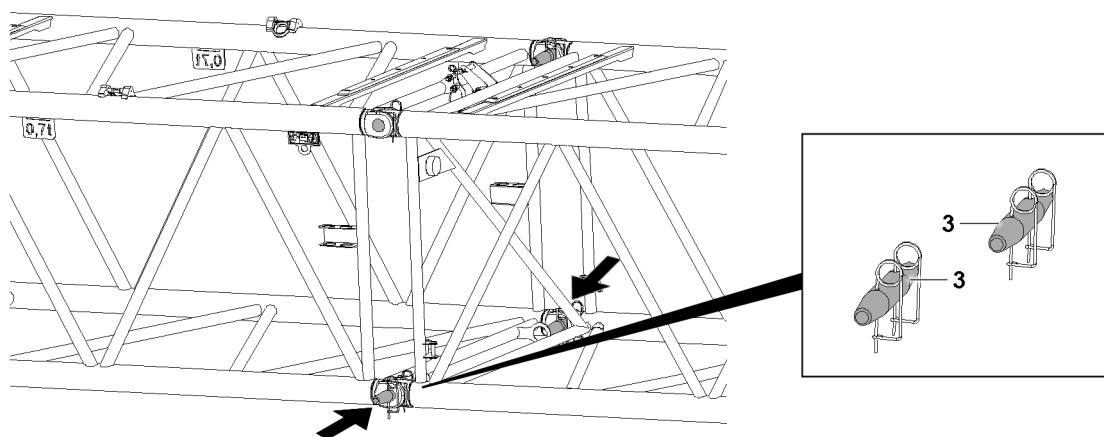


Fig.143115: Inserting the double cone pins horizontally



### WARNING

Double cone pins incorrectly pinned!  
Death, severe bodily injuries, property damage.

- ▶ Insert or unpin both pins on the same horizontal level, i.e. **left and right**.
- ▶ Insert and unpin the horizontally installable double cone pin **3** from the **outside to the inside**.



### 14.3 Inserting and unpinning the double cone pins vertically

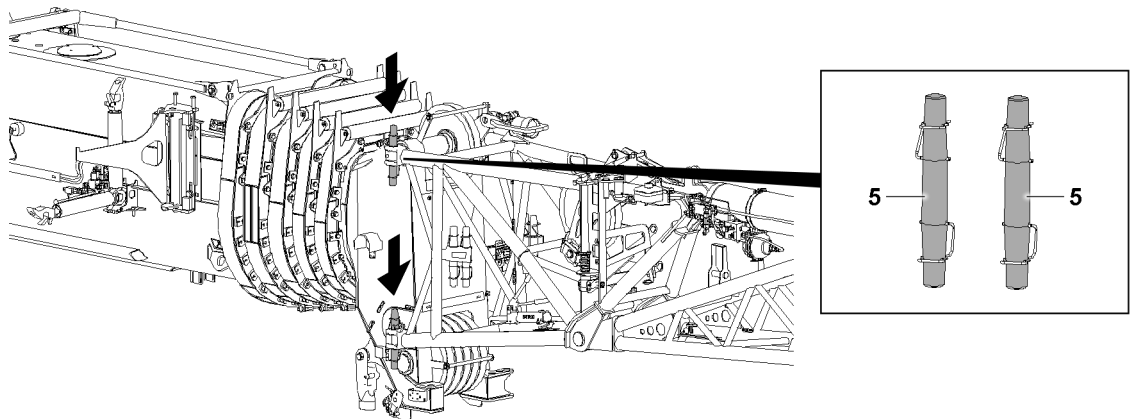


Fig.143116: Assembling the double cone pins vertically



#### WARNING

Double cone pins incorrectly pinned!  
Death, severe bodily injuries, property damage.

- ▶ Pin and unpin the vertically installable double cone pins **5** from the **top to the bottom**.

### 14.4 Impact protection

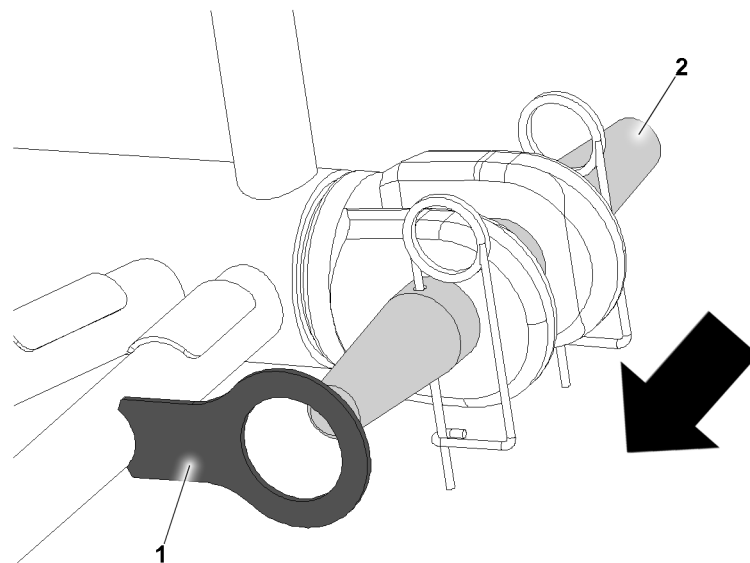


Fig.148194: Lattice section impact protection

Impact protection **1** is installed on certain lattice sections. The impact protection **1** should prevent the pins from being unpinned from the **inside to the outside**.

If impact protection **1** is installed:

- ▶ Only use double cone pins **2**.
- ▶ Only pin and unpin the double cone pins **2** from the **outside to the inside**.

## 14.5 Positioning the connecting forks for pinning

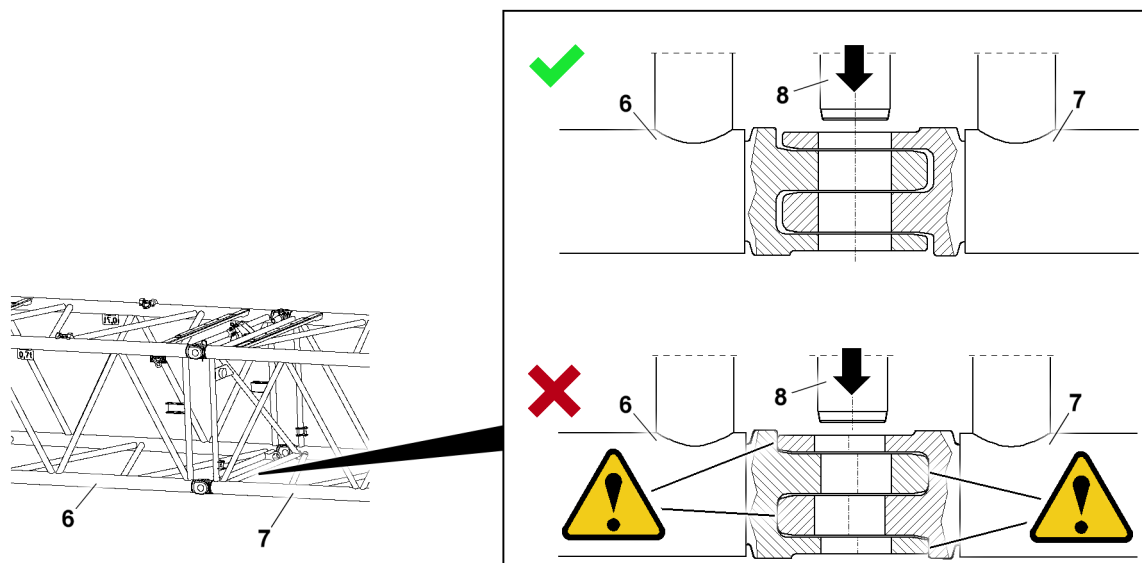


Fig.160395: Positioning the connecting forks for pinning



### WARNING

The boom can break off!

If the connecting forks of the lattice section are seriously damaged, they can break under a high load. The connecting fork, lattice section and boom can break off.

Death, severe bodily injuries, property damage.

- ▶ Do not load or push the connecting forks into each other on the block.



### Note

In the example, the pins **8** should be inserted from the inside to the outside.

On some lattice sections, they must be inserted from the outside to the inside!

- ▶ Observe the correct direction when pinning.
- ▶ Bring the lattice section **6** together with the lattice section **7** so that the bores align.



### Note

▶ When the bores align, document the necessary force for disassembly.

- ▶ Insert and secure the pin **8** in the right direction.

## 14.6 Lattice section with walking surfaces and stepping surfaces

This section is valid solely for the telescopic boom cranes.

Certain lattice sections have walking surfaces and stepping surfaces. Observe chapter 2.07 or the respective assembly chapter.

When the lattice sections have walking surfaces and stepping surfaces, the upper pin must be unpinning by assembly personnel on the lattice section. Not by assembly personnel on the ladder.

The procedure is described based on an example. Example of unpinning the N-assembly unit from the telescopic boom extension with eccentric.

Make sure that the following prerequisites are met:

- Person **1** is located on the telescopic boom extension with eccentric.
- Person **2** is located on the ladder.
- The F-assembly unit is unpinning.



Fig.159590: Unpinning the N-assembly unit

- ▶ Person 1 unpins the pin and at the same time Person 2 picks up the pin.

## 14.7 Pin transport position

The illustration in this section is an example. The transport position can be in another position depending on the lattice section.

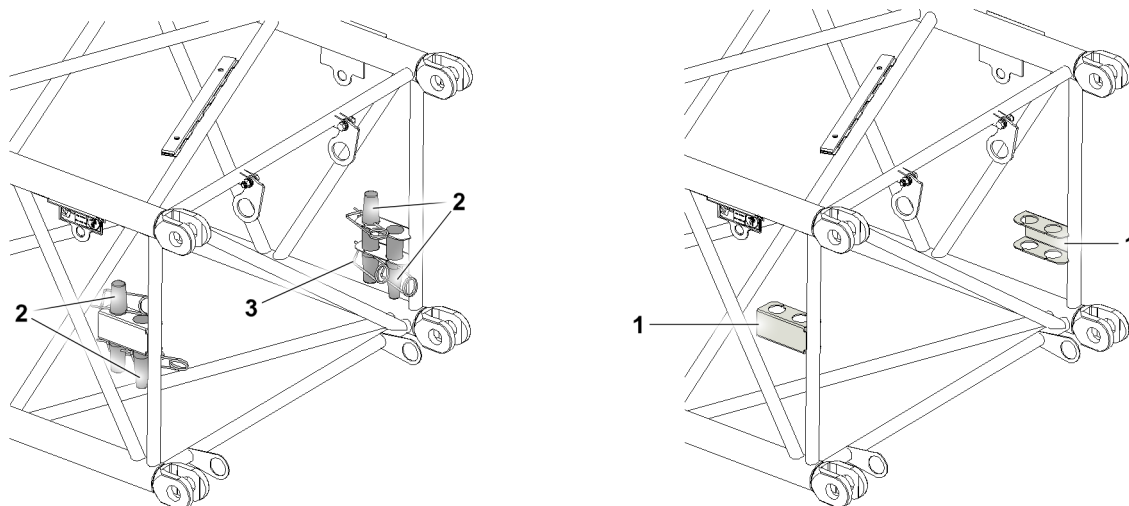


Fig.163330: Pin transport position

The retainer 1 is attached to the lattice sections. The pins 2 are inserted in the retainer 1 in the transport position and secured with retaining elements 3.

Before the lattice section is assembled:

- ▶ Make sure that the pins 2 are inserted in the retainer 1.

During disassembly of the lattice section:

- ▶ After the pin 2 is removed from the lattice section: Insert the pin 2 in the retainer 1.

## 15 Retaining elements

### 15.1 Checking the retaining elements

Retaining elements are used to secure the pins. Due to mechanical damage / distortion, the function of the retaining elements can be compromised. In addition, the spring force of the retaining elements can be reduced significantly. Do **not** re-use retaining elements if there is insufficient spring force. The pin retainer must be secured with a correctly **functioning** retaining element.



#### WARNING

Mechanical damage or deformation of the retaining elements!

The retaining elements can fail.

The pin can unpin by itself.

Death, severe bodily injury, property damage.

- ▶ Use exclusively functioning retaining elements in a proper condition.
- ▶ Replace defective retaining elements.

### 15.2 Overview of the retaining elements

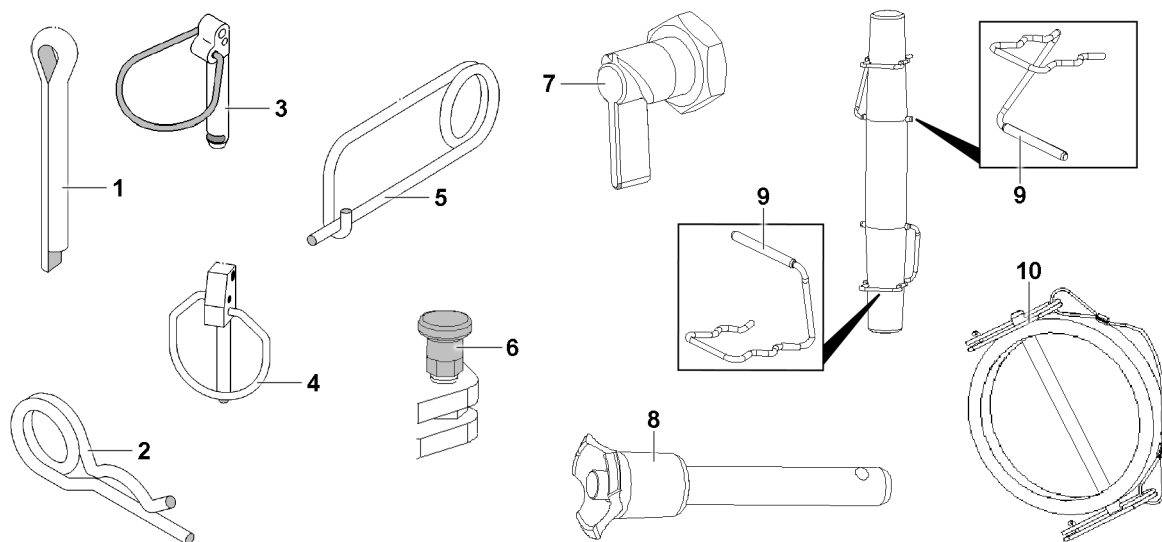


Fig.163492: Retaining elements

- |   |                    |    |   |
|---|--------------------|----|---|
| 1 | Split pin          | 6  | Detent pin                                      |
| 2 | Cotter pin         | 7  | Latch   |
| 3 | Safety locking pin | 8  | Ball locking pin                                |
| 4 | Locking pin        | 9  | Retaining clip                                  |
| 5 | Spring retainer    | 10 | Retaining pin with the ring and spring retainer |

## 15.3 Split pin

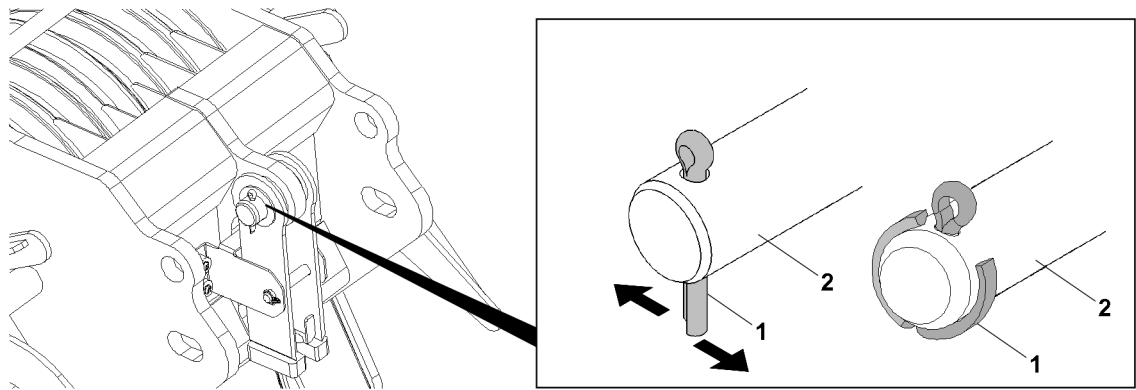


Fig.143105: Split pin

1 Split pin

2 Pin



### WARNING

Multiple use of a split pin 1!  
The split pin 1 can break.

- ▶ Assemble the split pin 1 only once.
- ▶ Use a correctly sized split pin 1.

- ▶ Secure the pin 2: Insert the split pin 1.
- ▶ Bend the end of the split pin 1 toward the outside.

### Problem remedy

Is the split pin 1 defective?

- ▶ Replace the split pin 1.

## 15.4 Cotter pin

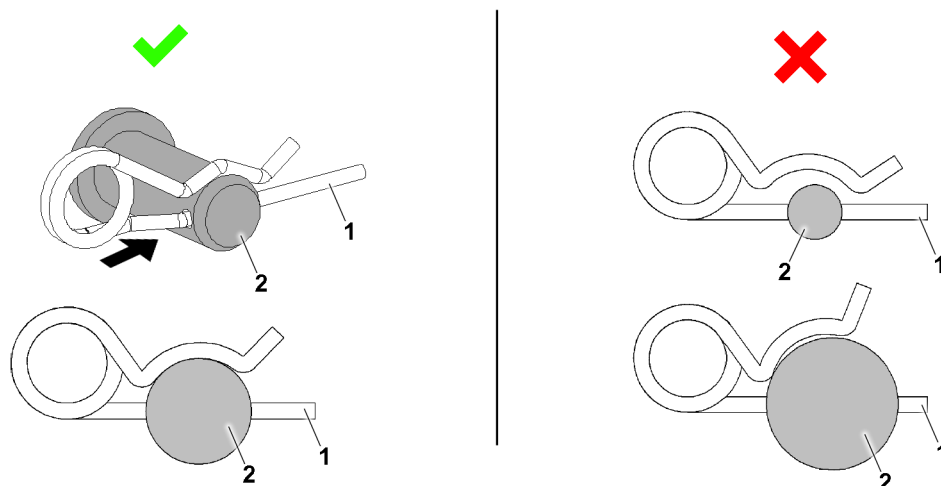


Fig.163494: Cotter pin, correct and incorrect dimensions

1 Cotter pin

2 Pin

**WARNING**

Improper dimensions of the cotter pin 1!

The cotter pin 1 can loosen up by itself.

- ▶ Use a correctly sized cotter pin 1.
- 
- ▶ Secure the pin 2: Insert the cotter pin 1.

**Problem remedy**

Is the spring tension too low?

The cotter pin 1 is defective.

- ▶ Replace the cotter pin 1.

## 15.5 Safety locking pin

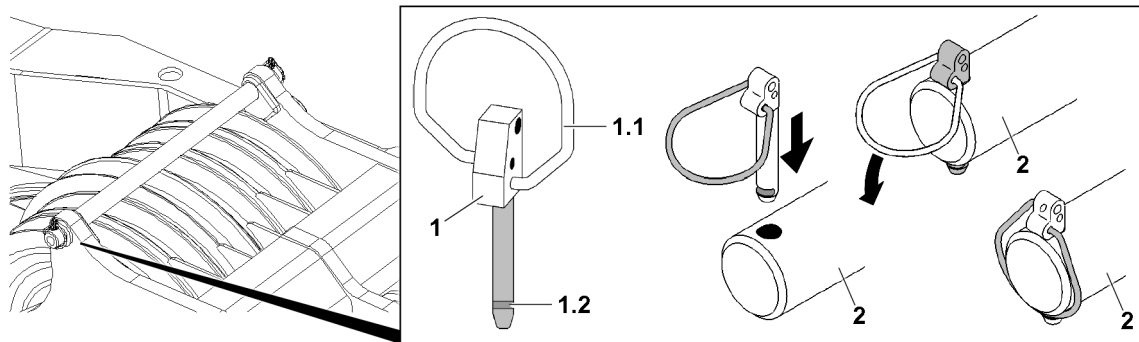


Fig.143103: Safety locking pin

1 Safety locking pin

1.2 Groove

1.1 Spring clip

2 Pin

Increased effort is necessary for opening the safety locking pin 1.

**WARNING**

Spring clip 1.1 **not** engaged!

The safety locking pin 1 can loosen up by itself.

- ▶ Engage the spring clip 1.1 completely in the groove 1.2.
- 
- ▶ Secure the pin 2: Insert the safety locking pin 1.
  - ▶ Close the spring clip 1.1 and engage it completely in the groove 1.2.

**Problem remedy**

Does the spring clip 1.1 **not** engage completely?

The spring clip 1.1 tension is too low.

- ▶ Replace the safety locking pin 1.

## 15.6 Locking pin

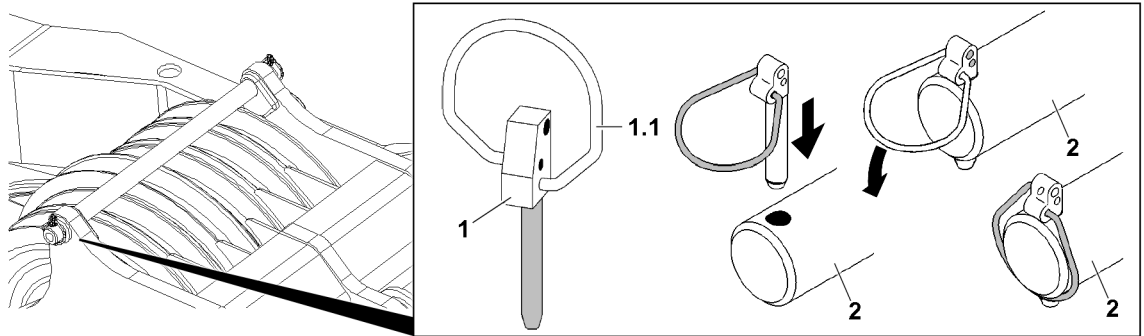


Fig.143104: Locking pin

1 Safety locking pin  
1.1 Spring clip

2 Pin



### WARNING

The locking pin **1** is **not** completely closed!  
The locking pin **1** can loosen up by itself.

- ▶ Close the spring clip **1.1** completely.
- ▶ Secure the pin **2**: Insert the locking pin **1**.
- ▶ Close the spring clip **1.1** completely.

### Problem remedy

Does the spring clip **1.1** not close completely?  
The spring clip **1.1** tension is too low.

- ▶ Replace the locking pin **1**.

## 15.7 Spring retainer

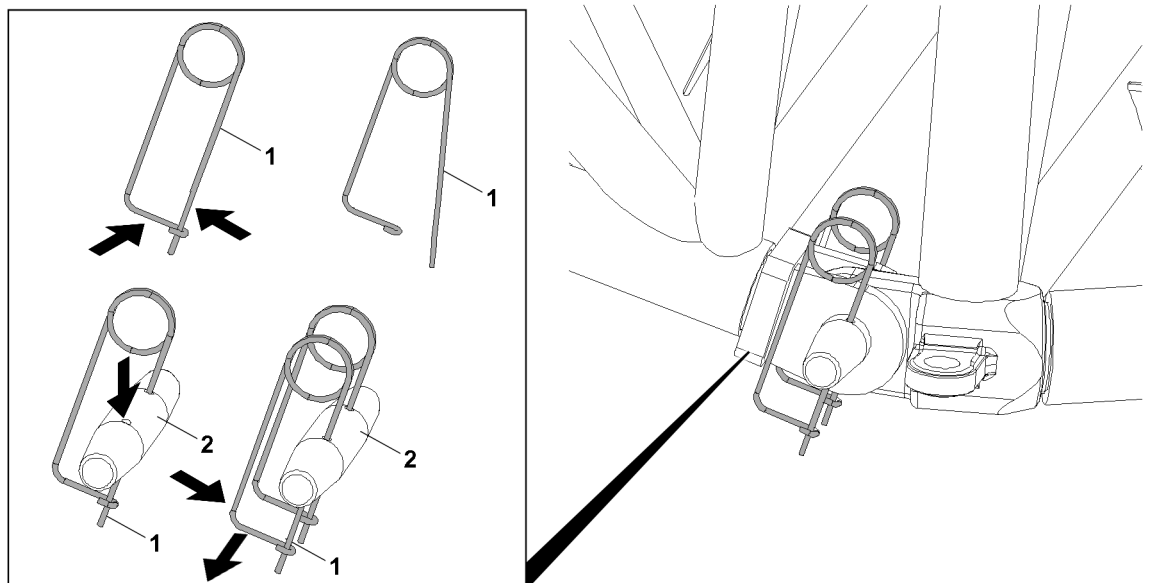


Fig.143108: Spring retainer

1 Spring retainer

**WARNING**

The spring retainer **1** is **not** closed!  
The spring retainer **1** can loosen up by itself.

- ▶ Close the spring retainer **1**.
- 
- ▶ Secure the pin **2**: Insert the spring retainer **1**.
  - ▶ Close the spring retainer **1**.

**Problem remedy**

Is the spring tension too low?  
The spring retainer **1** is defective.

- ▶ Replace the spring retainer **1**.

## 15.8 Detent pin

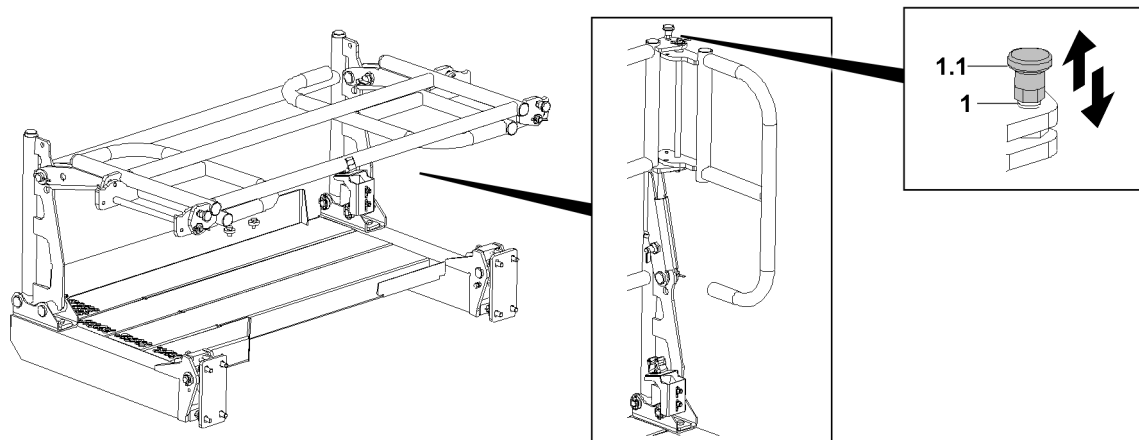


Fig.143110: Detent pin

**1** Detent pin

**1.1** Handle

**WARNING**

The handle **1.1** is **not** locked!  
The detent pin **1** can loosen up by itself.

- ▶ Lock the detent pin **1**.
- 
- ▶ Pull the handle **1.1**.

**Result:**

- The detent pin **1** is unlocked.
- ▶ Insert the detent pin **1**: Release the handle **1.1**.

**Result:**

- The detent pin **1** is pinned.

**Problem remedy**

Can the handle **1.1** not be pulled?  
The detent pin **1** is defective.

- ▶ Replace the detent pin **1**.



## 15.9 Latch

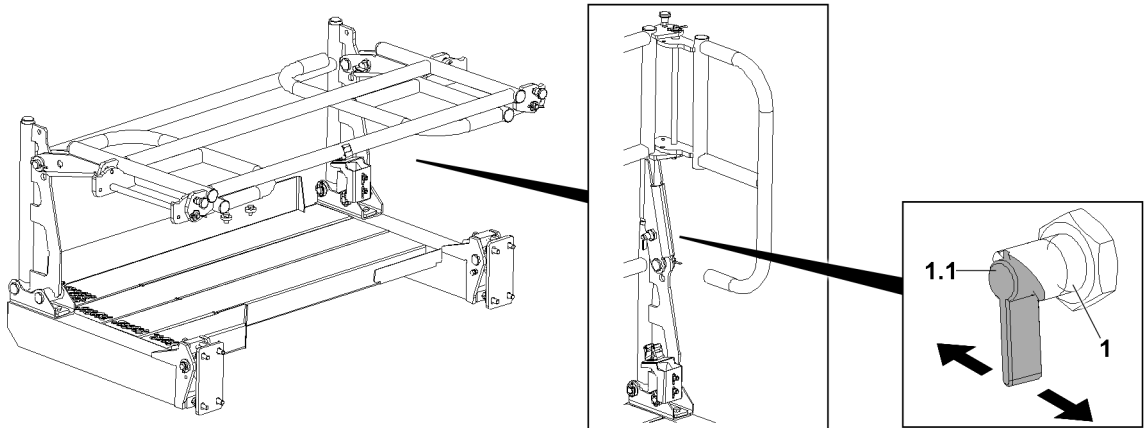


Fig.143111: Latch

1 Latch

1.1 Lever



### WARNING

The latch **1** is **not** locked!  
The latch **1** can loosen up by itself.  
▶ Lock the latch **1**.

▶ Operate the lever **1.1**.

### Result:

- The latch **1** is unlocked.
- ▶ Pin the latch **1**: Release the lever **1.1** and swing the railing until the latch is pinned.

### Problem remedy

Can the lever **1.1** not be actuated?  
The latch **1** is defective.  
▶ Replace the latch **1**.

## 15.10 Ball locking pin

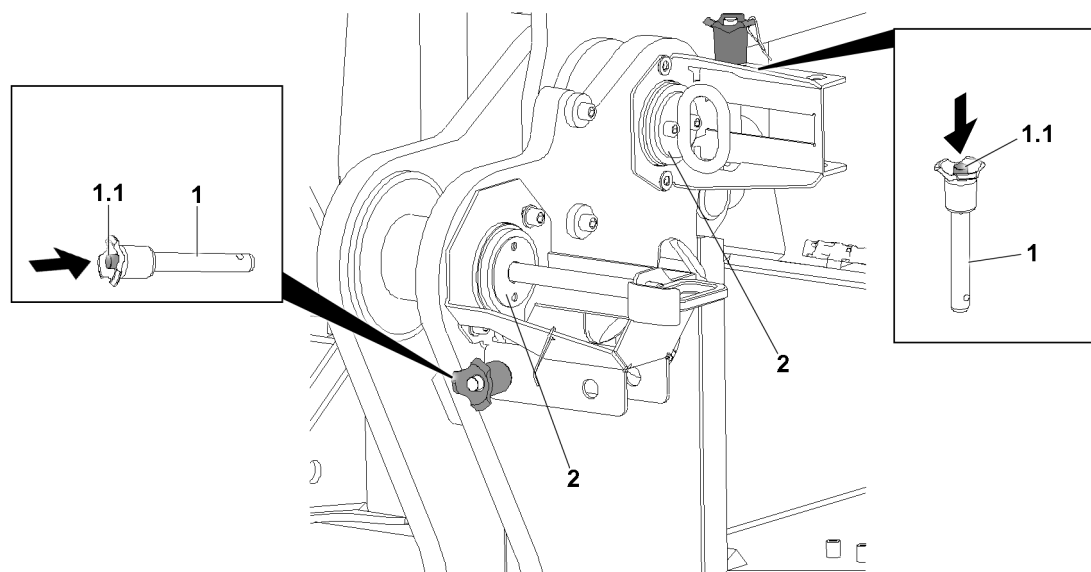


Fig.143109: Ball locking pin

- 1 Ball locking pin  
 1.1 Press button  
 2 Pin



### WARNING

The ball locking pin **1** is **not** locked!  
 The ball locking pin **1** can loosen up by itself.

- ▶ Lock the ball locking pin **1**.
- ▶ Secure the pin **2**: Actuate the press button **1.1**.

### Result:

- The ball locking pin **1** is unlocked.
- ▶ Insert the ball locking pin **1** and release the press button **1.1**.

### Result:

- The ball locking pin **1** is pinned and secured.

### Problem remedy

Can the press button **1.1** not be actuated?

The ball locking pin **1** is defective.

- ▶ Replace the ball locking pin **1**.

## 15.11 Retaining clips

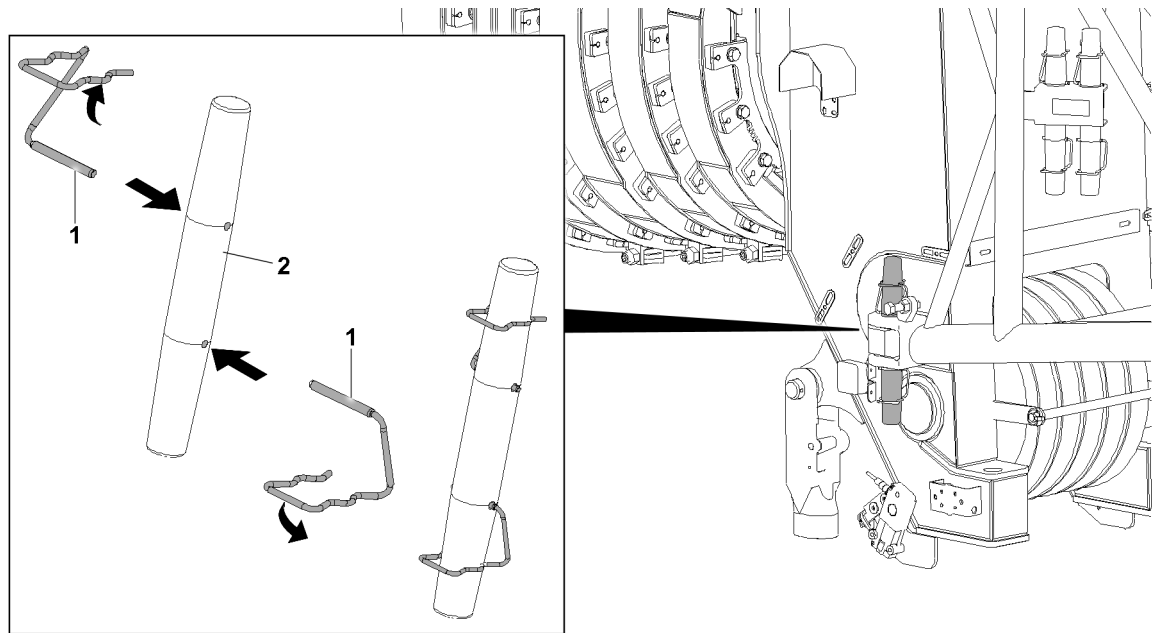


Fig.143107: Retaining clips 1

1 Retaining clip

2 Pin



### WARNING

Incorrect retaining element!  
Shearing off of the retaining elements.

- ▶ To secure the folding jib pinning: Use retaining clips 1.
- ▶ The use of other retaining elements is **prohibited**.



### WARNING

Retaining clip **not** engaged!  
The retaining clip 1 can loosen up by itself.

- ▶ Engage the retaining clip 1.
- ▶ Secure the pin 2: Insert the retaining clip 1.
- ▶ Engage the retaining clip 1.

### Problem remedy

Is the retaining clip 1 defective?  
The spring force of the retaining clip 1 is too low.

- ▶ Replace the retaining clip 1.

## 15.12 Retaining pin with the ring and spring retainer

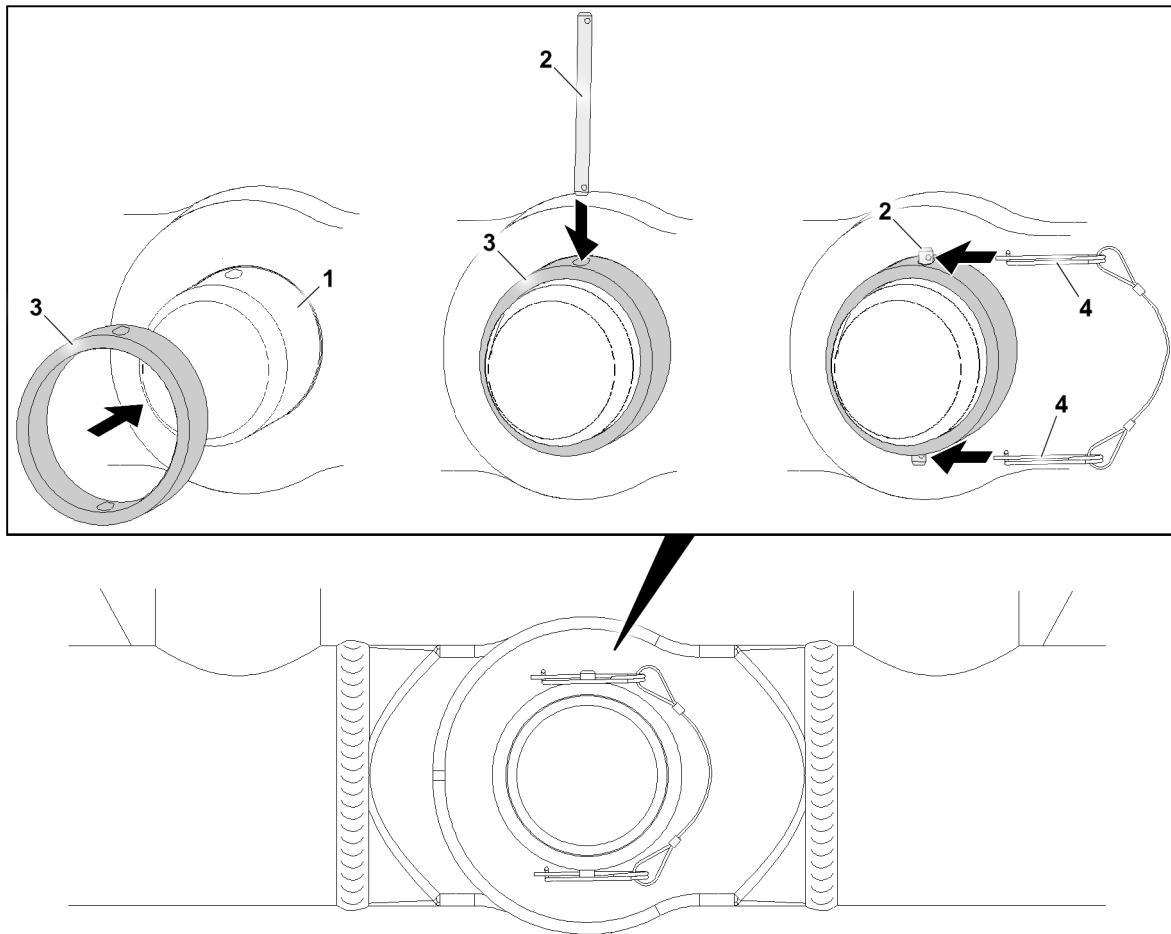


Fig.163493: Using the retaining pin with ring and spring retainer

- |   |               |   |                  |
|---|---------------|---|------------------|
| 1 | Pin           | 3 | Ring             |
| 2 | Retaining pin | 4 | Spring retainers |



### WARNING

Incorrect retaining element!  
Shearing off of the retaining elements. Failure of the retaining elements.

If specified by the factory for securing the pin 1:

- ▶ Use the retaining pin 2 with the corresponding ring 3 and spring retainers 4.
- ▶ The use of other retaining elements is **prohibited**.

To sure the pin 1:

- ▶ Push the ring 3 over the pin 1. Pay attention to the alignment of the bores.
- ▶ Insert the retaining pin 2 through the bores in the ring 3 and pin 1.
- ▶ Secure the retaining pin 2 on both sides with spring retainers 4.

### Problem remedy

Is the retaining pin 2 bent / cracked?

The retaining pin 2 is defective.

- ▶ Replace the retaining pin 2.

### Problem remedy

Is the spring tension too low?

The spring retainer 4 is defective.

- ▶ Replace the spring retainer 4.

## 16 Assembling / disassembling



### WARNING

Danger of fatal injury due to incorrect assembly or disassembly!

The assembly / disassembly of lattice sections and / or components may never be performed by untrained personnel.

An erroneous assembly / disassembly of lattice sections and / or components can cause damage on load carrying crane structures.

Crane components can fail due to improper assembly / disassembly.

Death, severe bodily injuries, property damage.

- ▶ Make sure that the assembly / disassembly of lattice sections and / or components is carried out only by authorized and trained expert personnel.
- ▶ Make sure that the fastening equipment on lattice sections and / or components is always fastened properly.
- ▶ Make sure that lattice sections and / or components are always properly pinned and secured at assembly.
- ▶ For assembly / disassembly of individual components, also observe the chapters relating to those components.
- ▶ The boom combinations must be assembled according to the separately supplied rod plans.
- ▶ All components which must be transported separately must be transported with suitable auxiliary cranes and fastening equipment near ground level.



### WARNING

Failure of auxiliary winch!

- ▶ Only use the auxiliary winch (assembly or reeving winch) for assembly and not to lift loads.
- ▶ Lifting of loads with the auxiliary winch is prohibited.



### WARNING

Danger of impact / crushing!

When assembling / disassembling crane components with the auxiliary crane, crane components can start to swing back and forth.

When lifting / lowering and positioning crane components, there is an increased danger of impact / crushing.

Death, severe bodily injuries, property damage.

- ▶ Make sure that personnel cannot be caught by components.
- ▶ Make sure that the crane is horizontally aligned.
- ▶ When working in a danger zone: Use aids to protect limbs.
- ▶ Guide components with suitable aids to minimize oscillation.
- ▶ During assembly / disassembly no one may be in the dangerous area around or underneath the suspended components before the load has been secured.

Part of the category "Aids for working at a height" are, for example:

- Lifting platforms
- Scaffolding
- Auxiliary cranes
- Ladders

**WARNING**

Danger of falling!

During assembly / disassembly, inspection and maintenance work, assembly personnel must be secured with appropriate aids to prevent them from falling.

Death, severe bodily injuries, property damage.

- ▶ All work at a height, when there is a danger of falling, must be carried out with suitable aids.
- ▶ If aids are not available and work cannot be carried out from the ground, then assembly personnel must secure themselves with the supplied fall arrest system to prevent falling, see chapter 2.04.
- ▶ If fall protection equipment is available, then it must be used, see chapter 2.06.
- ▶ When lifting, lowering, swinging crane parts in and out, no persons may remain in the danger zone.
- ▶ When closing or opening boom systems during boom assembly or boom disassembly, no persons may remain on the boom system or in the danger zone.
- ▶ If railings are present on the components, then they must be brought into the corresponding position and secured for assembly / disassembly work.
- ▶ Only step on the aids, ladders and catwalks with clean shoes.
- ▶ Keep aids, ladders and catwalks free of heavy dirt, snow, frost and ice.
- ▶ During all assembly and disassembly work, maintenance work and inspections, travel or crane operation is prohibited.
- ▶ Remaining on a suspended load is prohibited.
- ▶ Stepping and walking on crane components and lattice sections with an incline of more than 20° is prohibited.
- ▶ For all assembly work, the crane driver of the main crane must be in voice contact with the crane driver / crane drivers of the auxiliary crane / auxiliary cranes.
- ▶ For all assembly work, the crane driver of the main crane must be in voice contact with the assembly personnel.
- ▶ For assembly tasks, the crane driver may only initiate crane movements when the responsible guide has explicitly released the movement.

**DANGER**

The component can fall down!

If the corresponding component is disengaged from the auxiliary crane before the corresponding component is pinned, then the corresponding component can fall down.

Death, severe bodily injuries, property damage.

- ▶ Do not detach the auxiliary crane and the fastening equipment until the respective component is pinned and secured.

**WARNING**

The component can fall down!

If the corresponding component is unpinned without being secured by an auxiliary crane, the corresponding component can fall down.

Death, severe bodily injuries, property damage.

- ▶ Do not unpin the component until it is secured by an auxiliary crane.

**WARNING**

Falling components and tools!

Whenever working at a height, for example on the crane or on an aerial platform, components or tools can fall down.

Death, severe bodily injuries, property damage.

- ▶ Make sure that the danger zone under the work area is blocked off and marked and that no personnel is located within it.

## 16.1 Assembly drawings



### WARNING

Use of assembly drawings!

Due to sole use of assembly drawings, dangerous situations can arise up to toppling of the crane. Death, severe bodily injuries, property damage.

- ▶ Assembly drawings should only be considered to be **additional** and **supplementary** information.
- ▶ The respective chapters in the crane operating instructions are decisive for the assembly and disassembly of crane structures, lattice sections or crane components.
- ▶ The detailed information and danger notes in the respective chapters must be observed.

## 16.2 Specifications for the set up configuration for cranes with lattice mast with LICCON overload protection

If exact specifications for the settings of the LICCON overload protection are not available, the following rules apply.

### If the crane is erected:

- The LICCON overload protection must be set in accordance with the future set up configuration of the operational crane.
- The future set up configuration of the operational crane corresponds to the specifications in the load chart according to which the crane is operated.
- Take the intermediate operating mode into account. For example, when the SA-operating mode has its own load chart.

### If the crane is dismantled:

- The LICCON overload protection must remain set in accordance with the last set up configuration of the operational crane.
- The last set up configuration of the operational crane corresponds to the specifications in the load chart according to which the crane is operated.
- Take the intermediate operating mode into account. For example, when the SA-operating mode has its own load chart.

### If the crane is changed to another set up configuration:

- The LICCON overload protection must remain set in accordance with the last set up configuration of the operational crane until all crane components to be disassembled have been removed. As soon as crane components are installed again, the LICCON overload protection must be set in accordance with the future set up configuration of the operational crane.



### Note

- ▶ The settings for the LICCON overload protection are entered in the Set up program, see chapter 4.02.

## 16.3 Guiding crane structures, lattice sections or crane components



### WARNING

Danger due to oscillating load!

During the assembly of crane structures, lattice sections or crane components with the auxiliary crane, they can start to swing back and forth.

Death, severe bodily injuries, property damage.

- ▶ To guide and position crane structures, lattice sections or crane components always use a guide rope.
- ▶ Make sure that there are no persons or obstacles within the danger zone.
- ▶ Make sure that the guide rope is long enough.

## 16.4 Fastening the lattice sections



### WARNING

Fastening equipment incorrectly attached to the fastening point!

If the fastening equipment incorrectly is attached to the fastening point, the lattice sections can loosen up and fall down.

Death, severe bodily injuries, property damage.

- ▶ Correctly attach suitable fastening equipment to the fastening point.

### 16.4.1 Eyehook fastening point

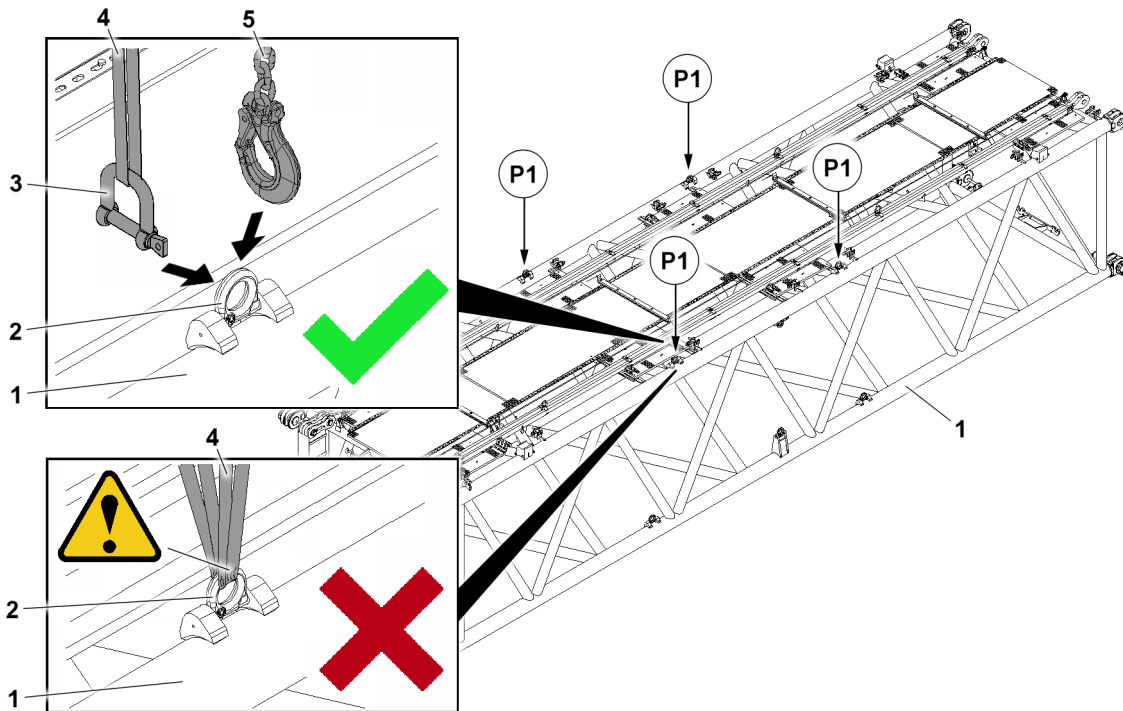


Fig.159190: Correct and incorrect fastening of an eyehook 2

P1	Fastening points	3	Shackle fastening equipment
1	Lattice section	4	Belt loop fastening equipment
2	Eyehook	5	Chain hanger fastening equipment

Make sure that the following prerequisites are met:

- The fastening equipment has been selected correctly for the load case.
- The fastening equipment is in a perfect condition.



### WARNING

Fastening equipment incorrectly attached to the fastening point!

If the fastening equipment 4 is incorrectly attached to the fastening point, the lattice sections can loosen up and fall down.

The belt loop fastening equipment 4 can be crushed and rip.

Death, severe bodily injuries, property damage.

- ▶ Only attach the belt loop fastening equipment 4 with shackle fastening equipment 3 together to the eyehook 2.

When the fastening points **P1** on the lattice section **1** correspond to the illustrated eyehooks **2**:

- ▶ Only fasten the belt loop fastening equipment 4 with shackle fastening equipment 3 to the eyehook 2.

or

Fasten the chain hanger fastening equipment 5 to the eyehook 2.



### 16.4.2 Bitt fastening point

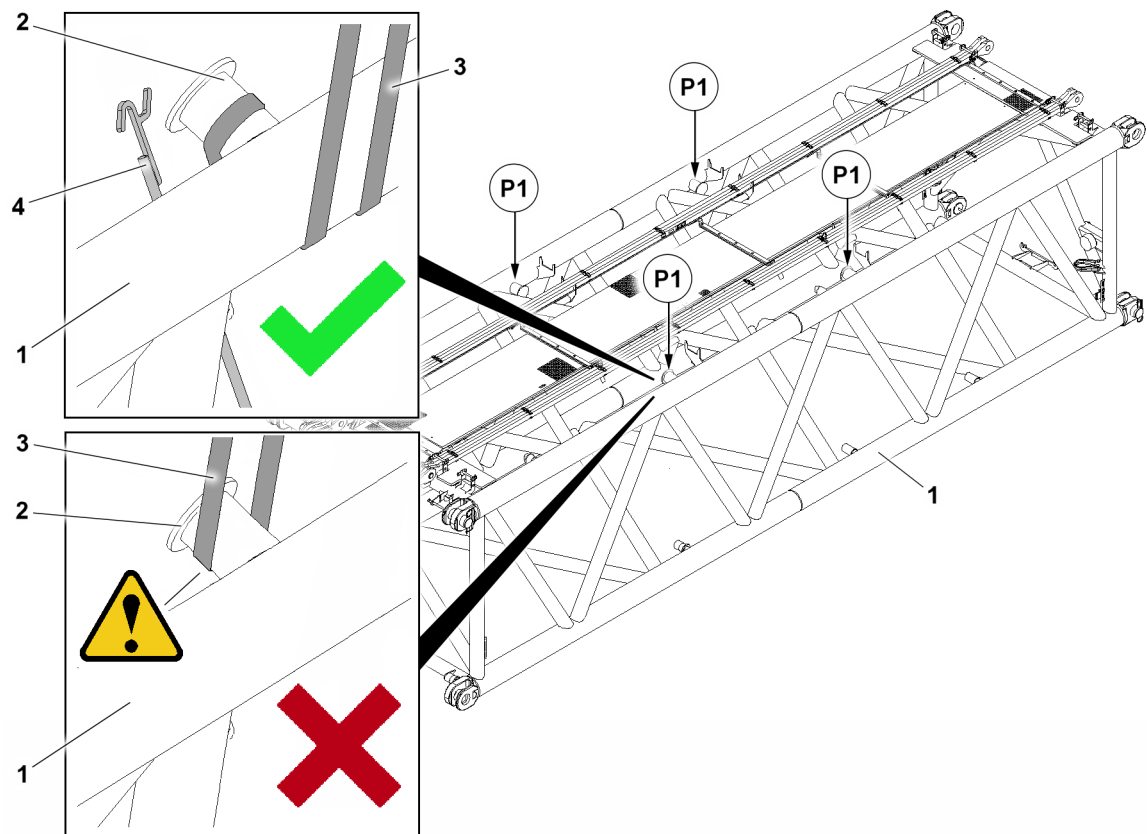


Fig.159189: Correct and incorrect fastening of a bitt 2

P1	Fastening points	3	Belt loop fastening equipment
1	Lattice section	4	Auxiliary rod
2	Bitt		

Make sure that the following prerequisites are met:

- The fastening equipment has been selected correctly for the load case.
- The fastening equipment is in a perfect condition.



#### WARNING

Fastening equipment incorrectly attached to the fastening point!

If the belt loop fastening equipment 3 is incorrectly attached to the bitt 2, the lattice sections can loosen up and fall down.

The belt loop fastening equipment 3 can slide down.

Death, severe bodily injuries, property damage.

- ▶ Fasten the belt loop fastening equipment 3 only by wrapping it on the corner pipe of the lattice section 1 on the bitt 2.

Use an auxiliary rod 4 to attach the belt loop fastening equipment 3 safely from the ground.

When the fastening points P1 on the lattice section 1 correspond to the illustrated bitts 2:

- ▶ Fasten the belt loop fastening equipment 3 by wrapping it on the corner pipe of the lattice section 1 on the bitt 2.

### 16.4.3 Fastening the lattice sections

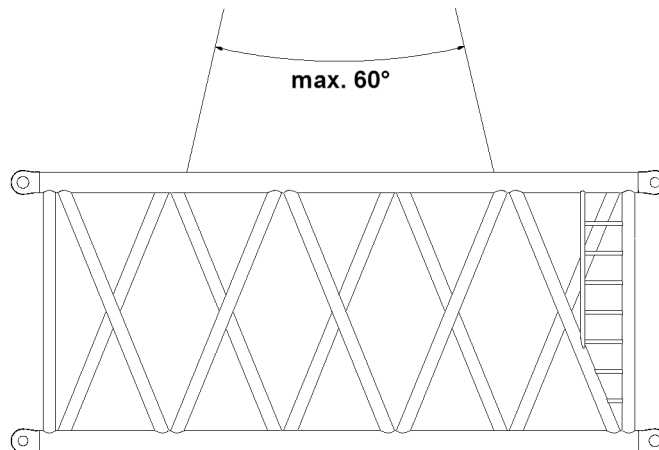


Fig. 164543: Fastening equipment, spreading angle maximum 60°

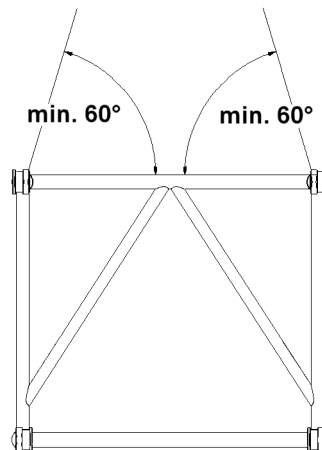


Fig. 164544: Fastening equipment, incline angle minimum 60°

Make sure that the following prerequisites are met:

- The fastening equipment has been selected correctly for the load case.
- The fastening equipment is in a perfect condition.



#### WARNING

Incorrect length of the fastening equipment!

The fastening points can be overloaded. The lattice sections can fall down.

- ▶ When fastening, observe a **maximum** spread angle of 60°.
- ▶ When fastening, observe a **minimum** incline angle of 60°.
- ▶ Select fastening equipment with a suitable length.

## 16.5 Fastening of guy rods

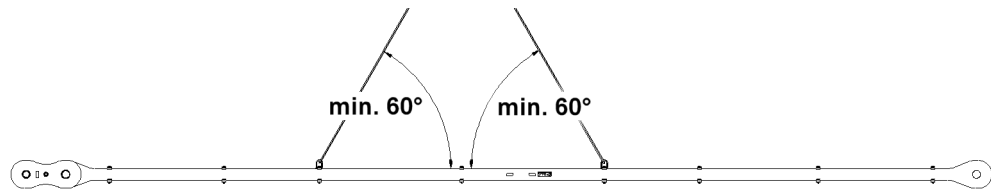


Fig.164542: Fastening equipment, incline angle minimum 60°

Make sure that the following prerequisites are met:

- The fastening equipment has been selected correctly for the load case.
- The fastening equipment is in a perfect condition.



### WARNING

Incorrect length of the fastening equipment!

The fastening points can be overloaded. Guy rods can fall down.

- ▶ When fastening, observe a **minimum** incline angle of 60°.
- ▶ Select fastening equipment with a suitable length.

## 16.6 Assembling / disassembling the electrical lines



### WARNING

The crane can topple over!

If mechanical crane components, which have electrical connections are not immediately electrically connected after assembly then the limit switches and / or electrical sensors are not functioning.

Safety relevant shut offs are not recognized by the LICCON computer system.

Any errors or safety relevant messages which might occur are not shown on the LICCON computer system.

Death, severe bodily injuries, property damage.

- ▶ Make sure that the electrical connections are made immediately after installation of the respective crane components on the crane.
- ▶ Make sure that the procedure to make the electrical connections to the boom end sections in the respective assembly and set up chapters are observed.

### NOTICE

Damage to the electrical connections!

If the following measures are not adhered to, the electrical connections can be damaged.

- ▶ Do not plug in the plug connection or unplug them under tension.
- ▶ Do not pinch or crush electrical connections.

When pulling the cable out:

- ▶ Hold the plug and not the cable. Do not pull on the cable to release the plug connection.
- ▶ Relieve the electrical connections in operating condition.
- ▶ In case of defective or faulty electrical lines, contact Customer Service at Liebherr-Werk Ehingen GmbH.



### WARNING

Malfunction if dummy plugs are not installed!

If the dummy plugs are not fit on the non-required electrical connections, then malfunctions or functional limitations can occur on the crane.

- ▶ Make sure that all non-required electrical connections, which have a dummy plug, are closed off with dummy plugs.
- ▶ Observe the wiring diagram.

**NOTICE**

Property damage due to dirt and / or corrosion!

The plug connections are only protected when plugged in. If the plug connections are not plugged in, then the contact surfaces can corrode.

This could result in malfunctions.

- ▶ Always plug or screw the plug connections together properly.
- ▶ Keep plug connections clean and dry. Clean contact surfaces provide the best signal transfer.
- ▶ Close off the plug connections that are not used with dust caps.

- ▶ Establish the electrical connections to the installed crane components properly.
- ▶ As a rule, close off on-required electrical connections (for example of accessories which are not installed) with the respective dummy plugs.
- ▶ Properly close off electrical connections, which have no dummy plugs, with the corresponding protective dust or cover caps.

If a pull relief for the cable drum is present:

- ▶ Connect the pull relief in the fixed point and relieve the plug connection from the pull strain.

After installing the plug connections:

- ▶ Check all plug connections for proper connection.

If a plug connection is not properly connected:

- ▶ Plug or screw the plug connection together properly.

After removing the plug connections:

- ▶ Protect the electrical connections with protective dust or cover caps or place them in intended storage retainers.
- ▶ After unplugging the electrical plug connections, install the dummy plugs, see Electrical wiring diagram.

If locking brackets are present:

- ▶ Close the locking bracket.

## 16.7 Assembling / disassembling of hydraulic lines

When connecting and releasing hydraulic lines with quick couplings, make sure that the coupling procedure is carried out correctly.

**WARNING**

Danger of accident due to loss of pressure or leakage!

Incorrectly coupled or self-loosening quick couplings (particularly return lines) can result in serious accidents due to component failure.

Death, severe bodily injuries, property damage.

- ▶ Check the quick couplings after assembly for correct connection.
- ▶ Make sure that the sleeve and plug are bolted with the knurled nut after assembly.

**WARNING**

Pressure in the hydraulic lines!

If the pressure supply is not interrupted before releasing the hydraulic lines, the hydraulic oil can escape with high pressure.

Death, severe bodily injuries, property damage.

- ▶ Release the pressure in the hydraulic system before releasing. Interrupt the pressure supply and wait a short time.
- ▶ Release the pressure in the hydraulic system before connecting or disconnecting: Turn the engine off and wait for a short time.
- ▶ Connect the coupling components (sleeve and connector) and screw them together with the knurled nut.
- ▶ Tighten the hydraulic coupling by hand. Turn the knurled nut until it reaches a tangible, fixed stop position.

## 16.8 Bypassing at crawler assembly / disassembly



### Note

- ▶ Applies only for cranes with crawler assembly key button.



### WARNING

High danger of accident in case of actuated crawler assembly key button!

If the crawler assembly key button is actuated, the overload protection is bypassed. No shut-off at overload will occur in assembly operation nor in crane operation.

In the event of misuse, the crane can topple over.

Death, severe bodily injuries, property damage.

- ▶ The crawler assembly key button may only be actuated for assembly tasks.
- ▶ All other usage of the crawler assembly key button other than as described in the operating instructions is prohibited.
- ▶ Crane operation with the crawler assembly key button enabled is strictly prohibited.

### 16.8.1 Activating the bypass at crawler assembly and crawler disassembly

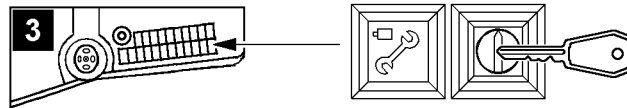


Fig.113441: Activating the bypass

- Illustration 3: Crawler assembly key button and *Crawler assembly* indicator light with *Crawler assembly off* touch function

- ▶ Actuate the crawler assembly key button.

#### Result:

- The LICCON overload protection is inactive.
- The indicator light *Crawler assembly* lights up.

### 16.8.2 Deactivating the bypass at crawler assembly and crawler disassembly

Make sure that the following prerequisites are met:

- The LICCON overload protection is bypassed / inactive and the “Bypass at assembly and disassembly” is activated.
- The *crawler assembly* indicator light illuminates.

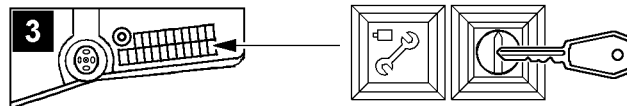


Fig.113441: Deactivating the bypass

If the bypass at crawler assembly is to be turned off:

- ▶ Turn the crawler assembly off by pressing the off button *Crawler assembly off*.

#### Result:

- The indicator light in the button *Crawler assembly* turns off.

## 16.9 Bypassing at assembly / disassembly

Depending on the crane version, the “Bypass at assembly and disassembly” is activated by:

- The set up button (key button) on the LICCON monitor.
- The assembly key button in the instrument panel.

**Note**

- ▶ This applies only for cranes with LICCON overload protection.
- ▶ The *Assembly* indicator light is only present on the instrument panel for certain crane types.

**WARNING**

High danger of accident at crane operation with activated “Bypass at assembly and disassembly”! With the “Bypass at assembly and disassembly” activated, the overload protection and, if applicable, also the hoist limit switches are bypassed.

In the event of improper use, the crane could collapse, the boom can break off or the crane can topple over.

Death, severe bodily injuries, property damage.

- ▶ The activation of the “Bypass at assembly and disassembly” is only permissible for assembly and disassembly purposes.
- ▶ All other usage of the “Bypass at assembly and disassembly” other than as described in the operating instructions is prohibited.
- ▶ The “Bypass at assembly and disassembly” may only be activated by persons who are aware of the consequences of a bypass.
- ▶ Crane operation with activated “Bypass at assembly and disassembly” is strictly prohibited.
- ▶ The “Bypass at assembly and disassembly” must be deactivated immediately after assembly and disassembly work.
- ▶ The crane operator or a person authorized by him must make sure that no misuse of the bypass device is possible (remove the key and store it safely, if necessary).

### 16.9.1 Activating the bypass at assembly and disassembly



Fig.113438: Activating the bypass at assembly and disassembly

- Illustration 1: LICCON monitor (only certain crane types)
- Illustration 2: indicator light “assembly” on the crane cab instrument panel (only certain crane types)
- ▶ Actuate the respective operating element.

**Result:**

- The LICCON overload protection is bypassed / inactive and the “Bypass at assembly and disassembly” is activated.
- The “Assembly” icon appears on the LICCON monitor and / or the “Assembly” indicator light on the instrument panel lights up.
- Depending on the circumstances, acoustic and / or optical warning signals (blinkers, flashing beacons, horns and bells) sound.

### 16.9.2 Bypassing at assembly and disassembly



Fig.113437: Bypassing at assembly and disassembly

- ▶ No longer actuate the respective operating element or reset.

**Result:**

- The LICCON overload protection is active and the “Bypass at assembly and disassembly” is deactivated.

- The “Assembly” icon turns off on the LICCON monitor and / or the “Assembly” indicator light on the instrument panel no longer lights up.
- The acoustic and / or optical warning signals which were triggered by the bypass are turned off again.

## 16.10 Actuation of winches and / or crane movements during assembly / disassembly



### Note

- ▶ The winches and / or crane movements can be controlled from the crane cab or, depending on the crane set up configuration, with the BTT or the radio remote control\*.
- ▶ From the crane cab: Observe chapter 4.05.
- ▶ With the BTT or the radio remote control\* (only properly equipped crane types): Observe chapter 5.31 and chapter 6.08.



### WARNING

Uncoordinated procedure for assembly tasks!  
Death, severe bodily injuries, property damage.

- ▶ Before starting the assembly tasks, define the course of action and agree on all steps with all involved personnel.
- ▶ Monitor all steps and continuously check the course of action.
- ▶ In the case of unforeseen events, stop the course of action and agree on the new situation with all involved personnel.
- ▶ Make sure that winches and / or crane movements are only controlled by people who are aware of the effects on the crane and / or boom system as well as the connected dangers.
- ▶ Make sure that no persons, objects or obstacles are in the danger zone of the crane.
- ▶ Prewarn persons within the surrounding area of the crane, for example via a horn signal.
- ▶ Perform all winch and / or crane movements anticipatorily and at a low speed.

## 16.11 Assembling / disassembling the counterweight

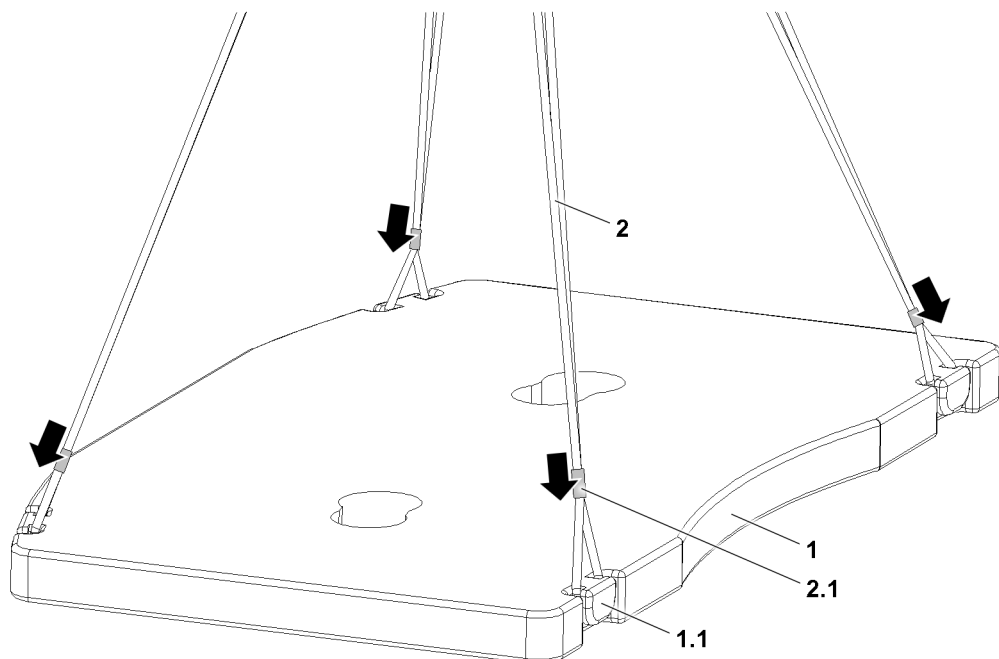


Fig.152587: Grommets and cable laid fastening rope

### 16.11.1 Grommets and cable laid fastening rope

Use the supplied fastening ropes **2** only for set up work on the crane.

The fastening ropes **2** are marked with the maximum load bearing capacity.



#### WARNING

Fastening ropes used incorrectly!

The fastening ropes can fail. The load can fall down.

- ▶ Do **not** exceed the load bearing capacity or the fastening ropes **2** when lifting the counterweight.
- ▶ **Never** fasten the fastening ropes **2** to the red marked impact points.
- ▶ **Never** cross or twist the fastening ropes **2**.

Depending on the structural form of the counterweight **1**, use two, three or four fastening ropes **2**.

- ▶ Lay the fastening rope **2** around the bits **1.1** of the counterweight **1** to be lifted.
- ▶ Until the fastening ropes **2** are positioned firmly on the fastening points: Push the mobile ferrules **2.1** in the direction of the fastening point of the counterweight **1**.

### 16.12 Assembling / disassembling the booms



#### WARNING

The crane can topple over!

Angular pull can overload the crane.

Overload can cause destruction of the crane or cause it to topple over.

Death, severe bodily injuries, property damage.

- ▶ The hook block must always be attached (hooked) vertically over the center of gravity of the load to be lifted.
- ▶ Angular pull is prohibited.

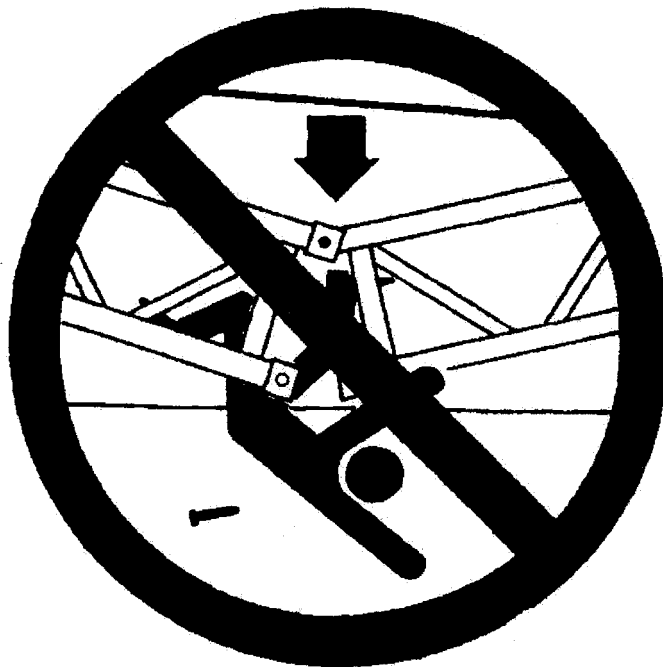


Fig.113444: Danger of accident during assembly / disassembly



**WARNING**

Danger of accident during assembly / disassembly of booms!

When you disassemble unsecured or unsupported booms, they can fall down.

Death, severe bodily injuries, property damage.

- ▶ Never unpin the pins under unsecured or unsupported booms.
- ▶ Never unpin the connector pins on unsecured or unsupported booms.
- ▶ Do not stand under the booms or within the complete danger zone during the pinning and unpinning procedure of the booms.
- ▶ Secure the pins in the bearing points and in the receptacles.
- ▶ The railing must be horizontal during the assembly and disassembly of the booms.
- ▶ Do not lean the ladder against the component being disassembled.

Make sure that the following prerequisites are met for the closing assembly:

- If parts of the equipment (for example lattice sections) are not in contact with the ground during assembly / disassembly, then they must be supported with suitable, stable materials.
- Take down the parts of the equipment with rope pulleys in such a way that the rope pulleys are not damaged.
- During disassembly make sure that the auxiliary crane can lift the load vertically.
- Have an auxiliary crane with sufficient load bearing capacity available to be able to hold the load at the corresponding radius.

## 16.13 Fastening positions for assembly / disassembly of the lattice jib

**WARNING**

Danger of fatal accidents due falling components!

The maximum permissible tensile load on the fastening eye is engraved on the fastening eye.

The maximum permissible fastening load of the respective components can differ to the maximum permissible tensile load of the fastening eye.

Components can be damaged at overload and fall down during lifting.

- ▶ Observe the maximum permissible fastening load according to the operating instructions and the tags on the components.
- ▶ Fasten the lattice jib only according to the following descriptions.
- ▶ Do not overload the components.

### 16.13.1 Closing the end section

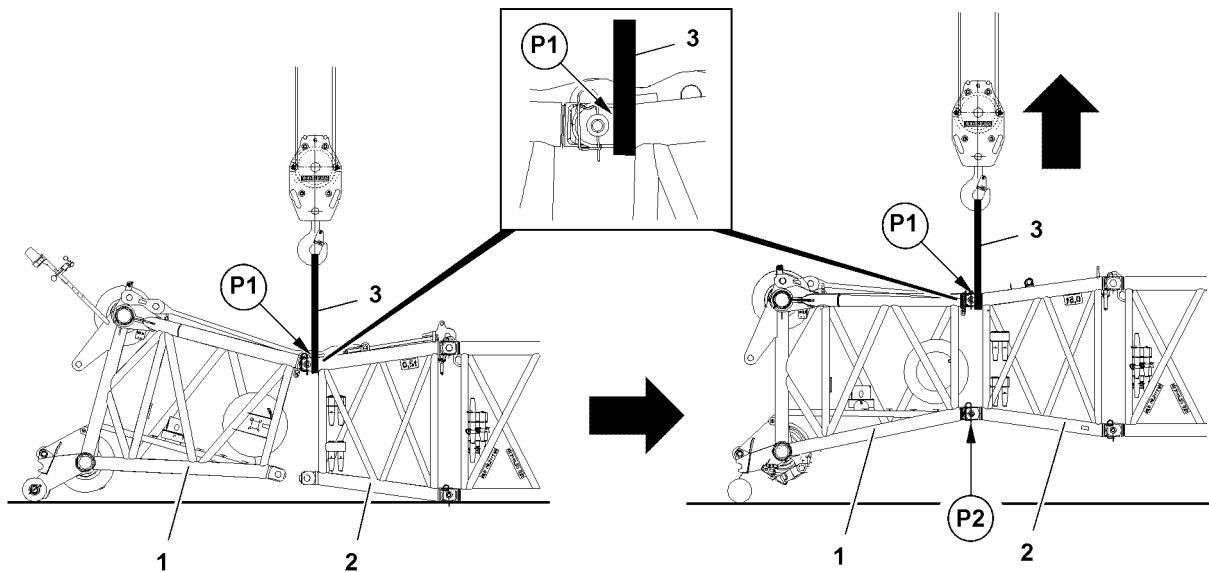


Fig.117840: Closing the end section

Observe the following for closing the end section:

- Use textile type fastening equipment **3**.
- Loop the textile type fastening equipment **3** on the left and right around on the pin points.

Before fastening:

- ▶ Check the position of the spring retainers and correct, if necessary.
- ▶ Fasten the textile type fastening equipment **3** on the upper pin points **P1** between the end section **1** and the pinned component **2**.
- ▶ Lift the lattice jib until the lower pin points **P2** align between the end section **1** and the component **2**.
- ▶ Pin the end section **1** and component **2** on the lower pin points **P2** on the left and right.

After pinning:

- ▶ Remove the textile type fastening equipment **3**.

### 16.13.2 Taking the lattice jib down into the roller cart



#### Note

- ▶ The following illustrations are examples and may not match your crane exactly.

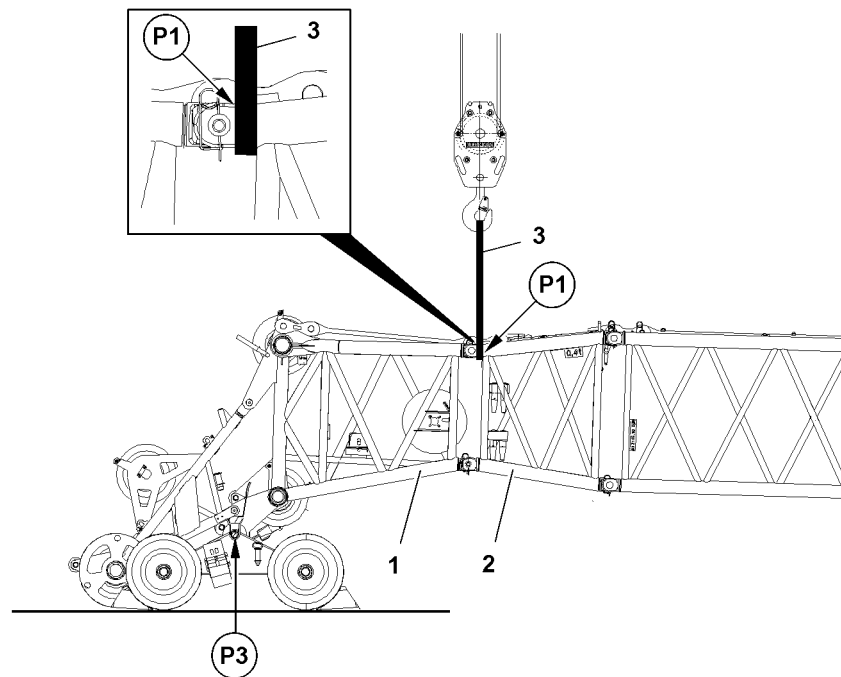


Fig.117842: Taking the lattice jib down into the roller cart (telescopic crane with lattice jib)

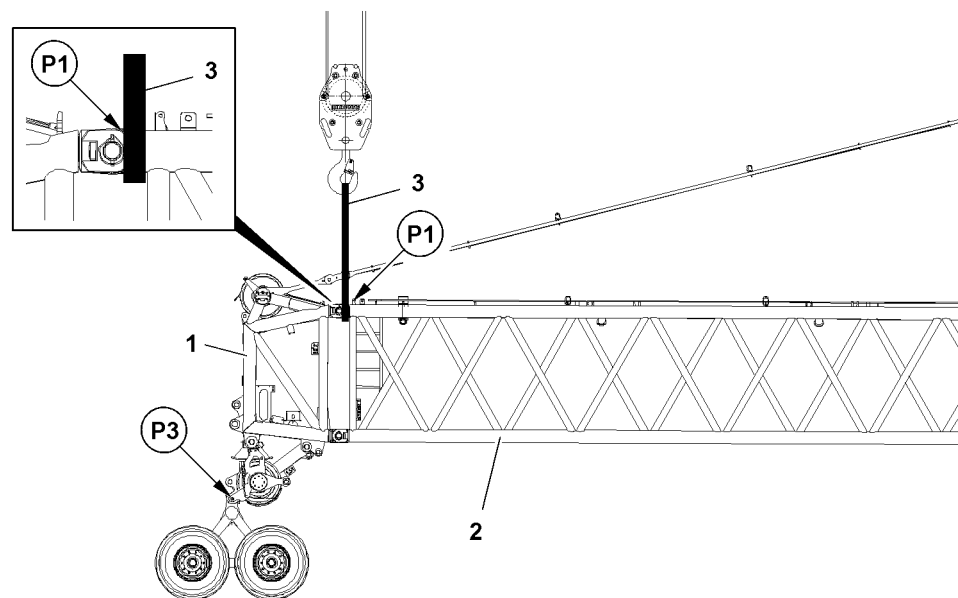


Fig.121550: Taking the lattice jib down into the roller cart (crane with lattice mast)

When taking it down into the roller cart, observe the following:

- The end section 1 is completely assembled.
- Use textile type fastening equipment 3.
- Loop the textile type fastening equipment 3 on the left and right around on the pin points.

Before fastening:

- ▶ Check the position of the spring retainers and correct, if necessary.
- ▶ Fasten the textile type fastening equipment 3 on the upper pin points P1 between the end section 1 and the pinned component 2.
- ▶ Lift the lattice jib and take it down into the roller cart 4.
- ▶ Pin the end section 1 with the roller cart 4 on the pin points P3 on the left and right.
- ▶ Remove the textile type fastening equipment 3.

**Note**

- ▶ The disassembly and removal of the roller cart 4 is must be carried out accordingly.

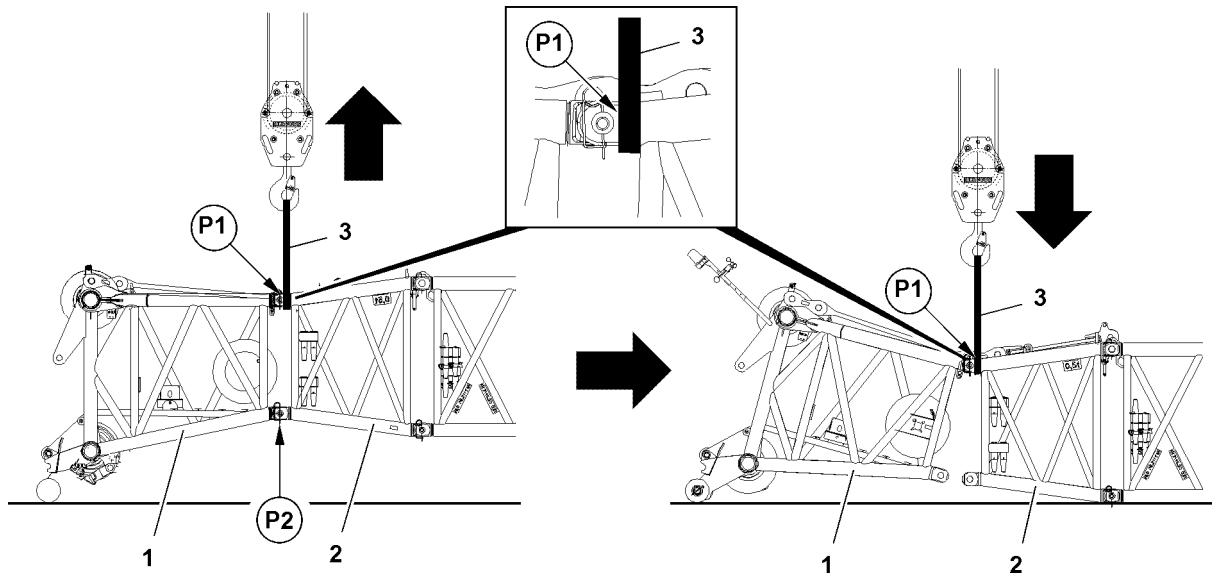
**16.13.3 Opening the end section**

Fig.117841: Opening the end section

For opening the end section, observe the following:

- The roller cart is disassembled and removed.
- Use textile type fastening equipment 3.
- Loop the textile type fastening equipment 3 on the left and right around on the pin points.

Before fastening:

- ▶ Check the position of the spring retainers and correct, if necessary.
- ▶ Fasten the textile type fastening equipment 3 on the upper pin points P1 between the end section 1 and the pinned component 2.
- ▶ Lift the lattice jib and relieve the pins on the lower pin points P2.
- ▶ Unpin the end section 1 and the component 2 on the lower pin points P2 on the left and right.
- ▶ Take the lattice jib down onto the ground.
- ▶ Remove the textile type fastening equipment 3.

### 16.13.4 Holding the luffing lattice jib

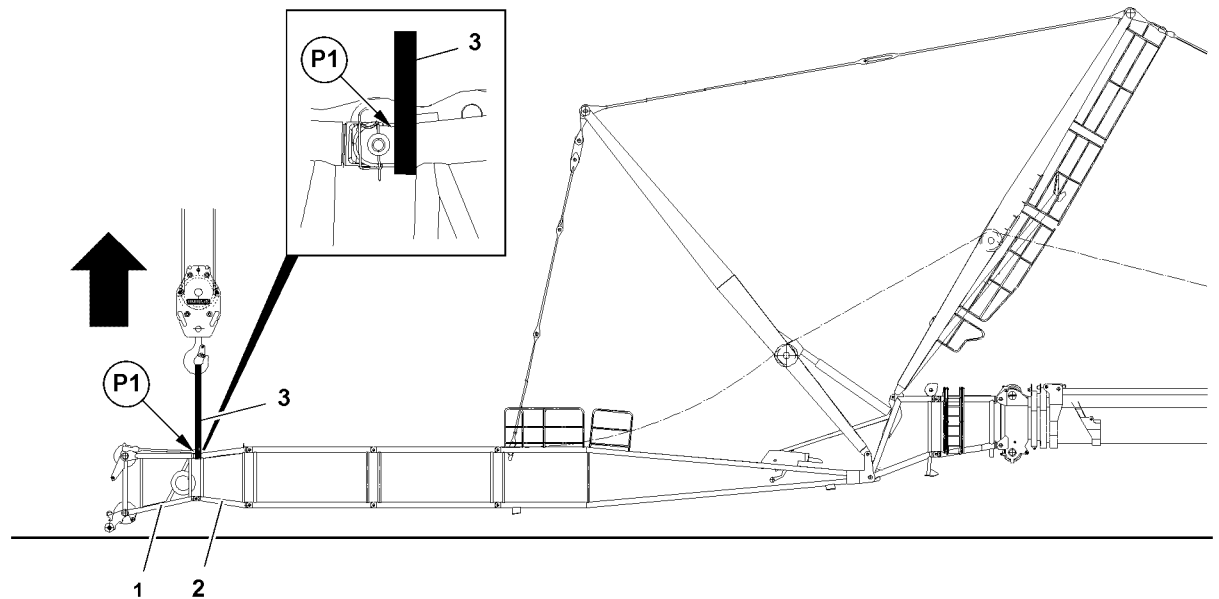


Fig.117843: Holding the luffing lattice jib

To be able to install or remove the guy rods and "flying assembly", the luffing lattice jib must be held on the upper pin points **P1**.

When holding the luffing lattice jib, observe the following:

- The lattice jib has been completely assembled.
- Use textile type fastening equipment **3**.
- Loop the textile type fastening equipment **3** on the left and right around on the pin points.

Before fastening:

- ▶ Check the position of the spring retainers and correct, if necessary.
- ▶ Fasten the textile type fastening equipment **3** on the upper pin points **P1** between the end section **1** and the pinned component **2**.
- ▶ Lift the lattice jib and assemble the guy rods.

When the guy rods are assembled:

- ▶ Remove the textile type fastening equipment **3**.



#### Note

- ▶ The disassembly of the guy rods must be carried out accordingly.

### 16.13.5 Assembling the fixed lattice jib on the TF-adapter



#### WARNING

Mortal danger if the lattice jib tilts over!

Due to unfavorable center of gravity, only certain lattice jib lengths can be installed / removed as an assembled lattice jib.

If a lattice jib length cannot be installed / removed as an assembled lattice jib, then they must be installed / removed individually in flying mode.

- ▶ Check if the respective lattice jib length can be installed / removed as an assembled lattice jib. See charts in chapter 5.01.10.

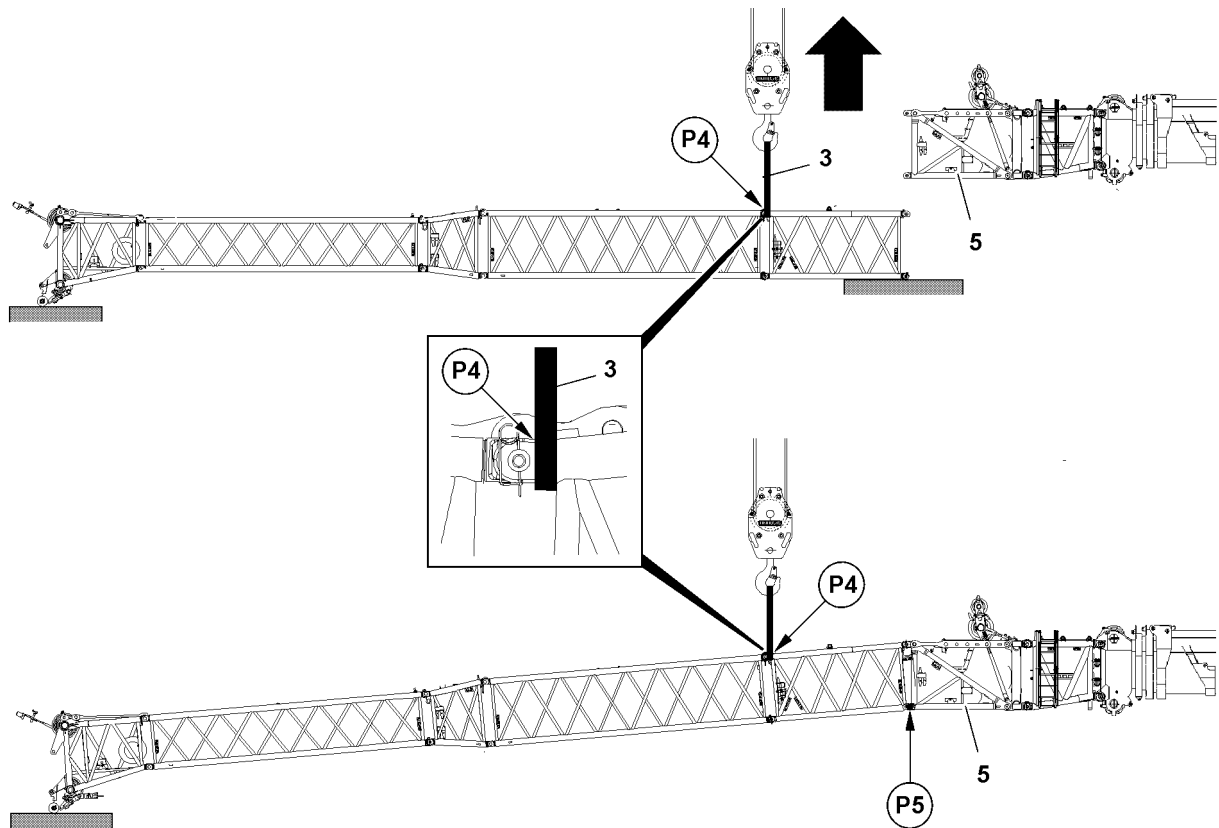


Fig.117844: Assembling the lattice jib on the TF-adapter

Observe the following when assembling the TF-adapter:

- The lattice jib is assembled.
- The TF-adapter **5** is assembled.
- Use textile type fastening equipment **3**.
- Loop the textile type fastening equipment **3** on the left and right around on the pin points.

Before fastening:

- ▶ Check the position of the spring retainers and correct, if necessary.

Fasten between the lattice sections, which are installed directly on the TF-adapter.

- ▶ Fasten the textile type fastening equipment **3** to the upper pin points **P4**.
- ▶ Lift the lattice jib and fit it in the lower pin point **P5** on the TF-adapter **5**.
- ▶ Pin the lattice jib in the lower pin point **P5** with the TF-adapter **5**.

After pinning:

- ▶ Remove the textile type fastening equipment **3**.



### WARNING

Mortal danger if the lattice jib tilts over!

- ▶ Make sure to always observe the permissible lattice jib length at disassembly.
- ▶ Disassemble accordingly.

### 16.13.6 Closing the fixed lattice jib

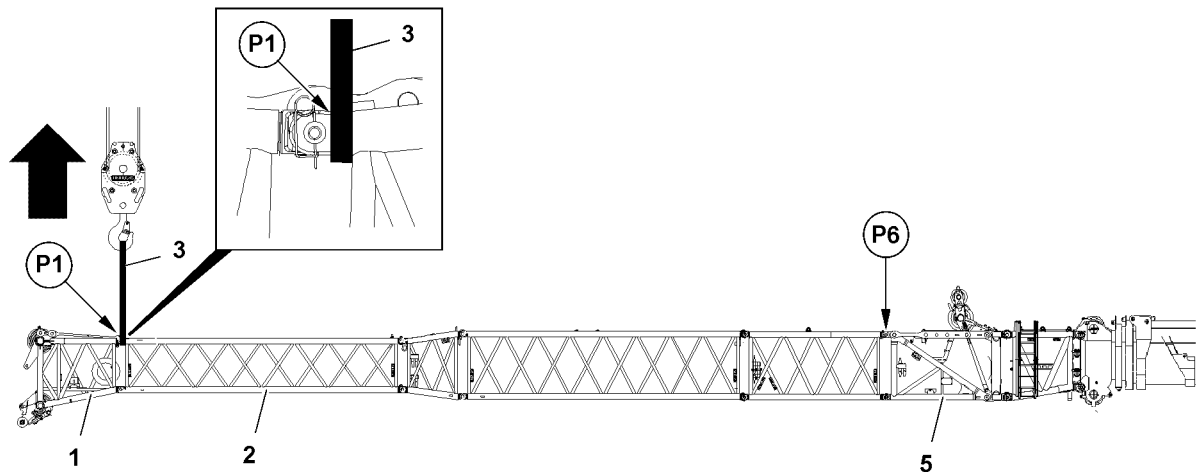


Fig.117850: Closing the lattice jib

Observe the following when assembling the TF-adapter:

- The lattice jib is pinned in the lower pin points of the TF-adapter **5**.
- Use textile type fastening equipment **3**.
- Loop the textile type fastening equipment **3** on the left and right around on the pin points.

Before fastening:

- ▶ Check the position of the spring retainers and correct, if necessary.
- ▶ Fasten the textile type fastening equipment **3** on the upper pin points **P1** between the end section **1** and the pinned component **2**.
- ▶ Lift the lattice jib and fit it in the upper pin point **P6** on the TF-adapter **5**.
- ▶ Pin the lattice jib in the upper pin point **P6** with the TF-adapter **5**.

After pinning:

- ▶ Remove the textile type fastening equipment **3**.



#### Note

- ▶ Disassemble accordingly.

### 16.13.7 Angle adjustment on the fixed lattice jib with mechanical adjustment

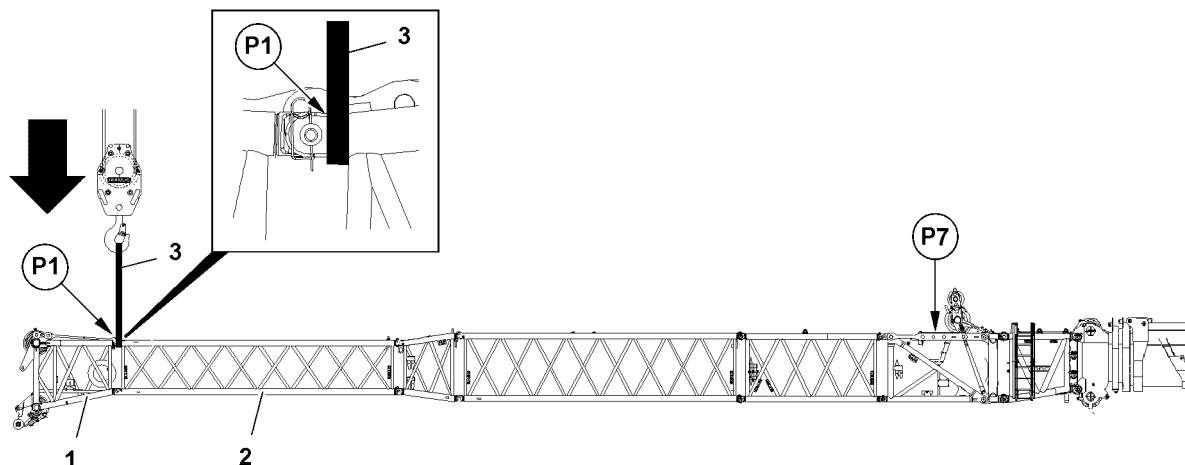


Fig.117851: Angle adjustment on the fixed lattice jib

For the angle adjustment on the fixed lattice jib, observe the following:

- The lattice jib has been completely assembled.
- Use textile type fastening equipment 3.
- Loop the textile type fastening equipment 3 on the left and right around on the pin points.

Before fastening:

- ▶ Check the position of the spring retainers and correct, if necessary.
- ▶ Fasten the textile type fastening equipment 3 on the upper pin points P1 between the end section 1 and the pinned component 2.
- ▶ Lift the lattice jib and relieve the pins on the angle adjustment P7.
- ▶ Unpin the angle adjustment P7, see chapter 5.03.
- ▶ Set and pin a new angle on the angle adjustment P7, see chapter 5.03.
- ▶ Lower the lattice jib.

After lowering:

- ▶ Remove the textile type fastening equipment 3.

### 16.13.8 Loading the preassembled lattice jib

For loading the lattice jib, observe the following:

- The lattice jib has been preassembled.
- Use textile type fastening equipment.
- Loop the textile type fastening equipment on the left and right around on the pin points.

Before fastening:

- ▶ Check the position of the spring retainers and correct, if necessary.
- ▶ Fasten the preassembled lattice jib according to the fastening points, chapter 5.03.

## 16.14 Assembling / disassembling the lattice sections on telescopic cranes with a luffing lattice jib

### 16.14.1 Guy rod transport retainer during assembly

The illustrations in this section are an example and may not exactly match each lattice section.

A description is provided by means of an example of the moment at which the guy rod transport retainers may be unpinned.

If the sequence is not observed, the guy rods can fall from the lattice sections and kill personnel and cause serious injuries and property damage.



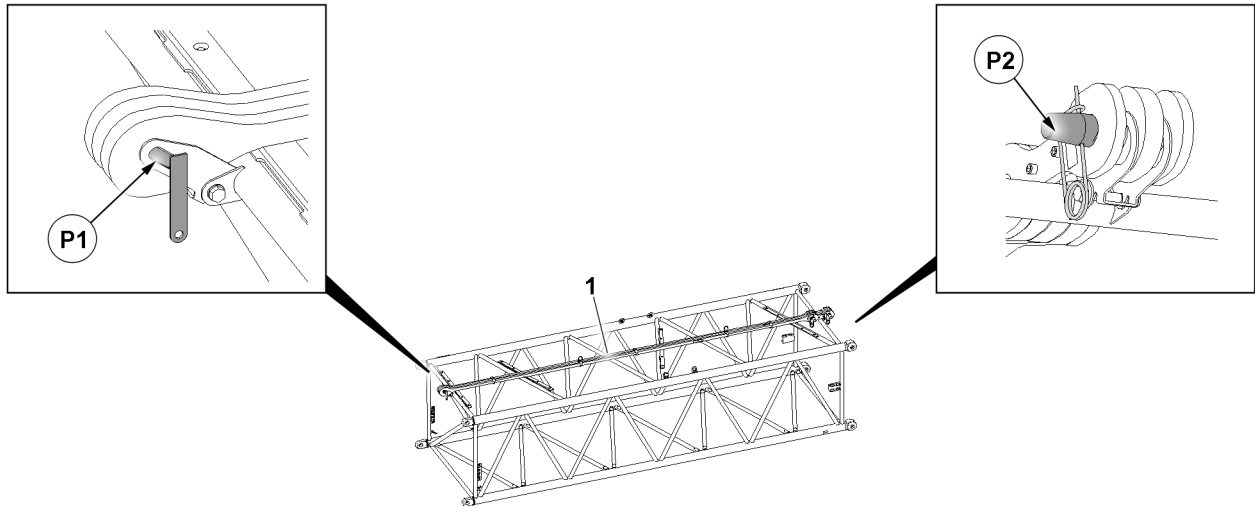


Fig.159460: Guy rod transport retainer

Before a lattice section is fastened:

- ▶ Make sure that the guy rod **1** is secured on both sides in position **P1** and position **P2**.

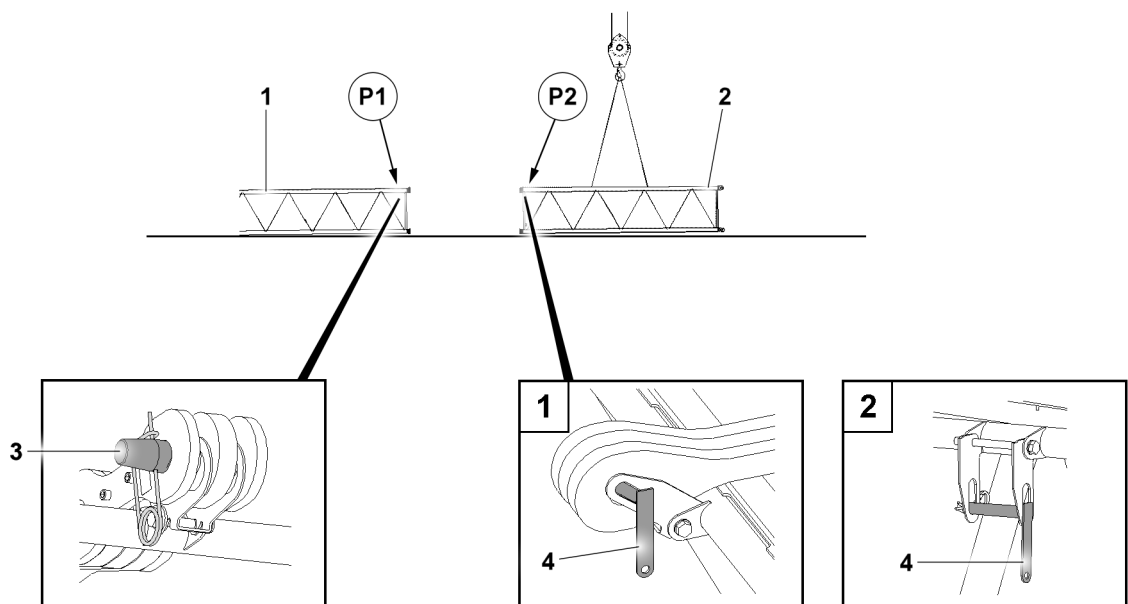


Fig.159592: Disassembling the guy rod transport retainer

Make sure that the following prerequisites are met:

- The lattice section **1** is pinned with the crane.
- The lattice section **2** is taken approx. 2 m from the lattice section **1** onto the ground.

- ▶ In position **P1**: Unpin the pin **3**.

When the lattice section **2** is taken approx. 2 m from the lattice section **1** onto the ground:

- ▶ In position **P2**: Unpin the pins **4** and insert it into the transport position and secure.

**Result:**

- The lattice section **1** guy rod transport retainer is uninned on the side of the lattice section **2**.
- The lattice section **2** guy rod transport retainer is uninned on the side of the lattice section **1**.

**WARNING**

Guy rods on the lattice section **not completely** secured against falling down!  
Death, severe bodily injuries, property damage.

If the lattice section is moved:

- ▶ Carry out the movements slowly and carefully.
- ▶ Comply with the safety distance from the lattice section and guy rods.

- ▶ Position the lattice section **2** in the pin position.

**Further procedure**

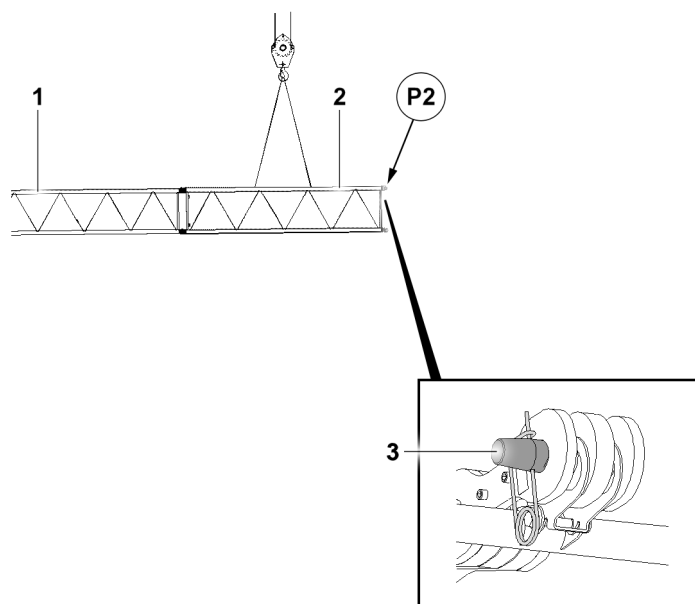
Pin the lattice sections.

**16.14.2 Guy rod transport retainer during disassembly**

The illustrations in this section are an example and may not exactly match each lattice section.

A description is provided by means of an example of the moment at which the guy rod transport retainers must be pinned.

If the sequence is not observed, the guy rods can fall from the lattice sections and kill personnel and cause serious injuries and property damage.



*Fig.159591: Assembling the guy rod transport retainer*

Make sure that the following prerequisites are met:

- The lattice section **1** is pinned with the crane.
- The lattice section **2** is pinned with the lattice section **1**.
- ▶ Secure the guy rod in the transport position in position **P2**: Insert and secure the pin **3**.

**Result:**

- The lattice section **2** guy rod is secured on one side in the transport position.

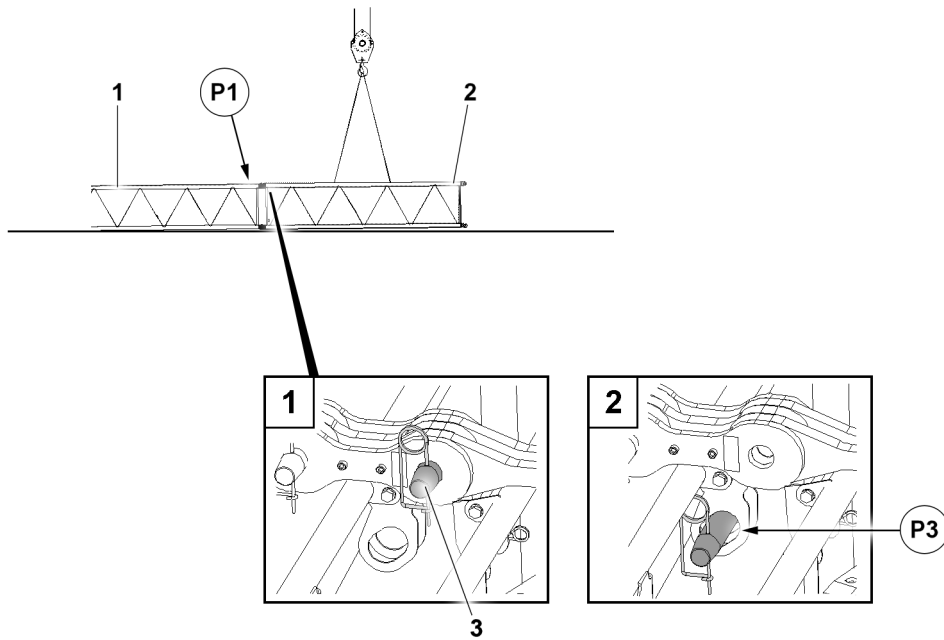


Fig. 159587: Disassembling the guy rod transport retainer

- ▶ Unpin the lattice section 2 guy rod from the lattice section 1 guy rod: Release and unpin the pin 3.
- ▶ In position P3: Insert and secure the pin 3.
- ▶ Unpin the lattice section 2 from the lattice section 1.



#### WARNING

Guy rods on the lattice section **not completely** secured against falling down!  
Death, severe bodily injuries, property damage.

If the lattice section is moved:

- ▶ Carry out the movements slowly and carefully.
- ▶ Comply with the safety distance from the lattice section and guy rods.

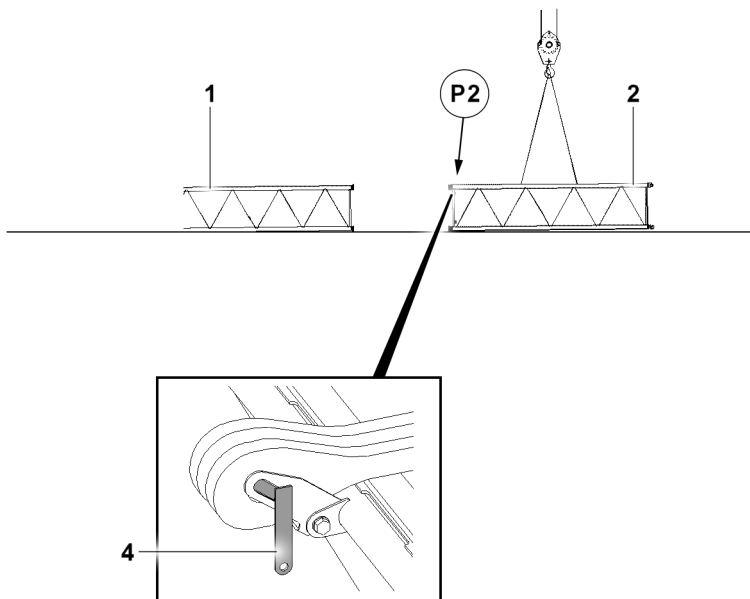


Fig. 159588: Assembling the guy rod transport retainer

- ▶ Move the lattice section 2 approx. 2 m away from the lattice section 1.
- ▶ Take the lattice section 2 down onto the ground.

- ▶ Secure the lattice section 2 guy rod in the transport position in position **P2**: Insert and secure the pin 4.

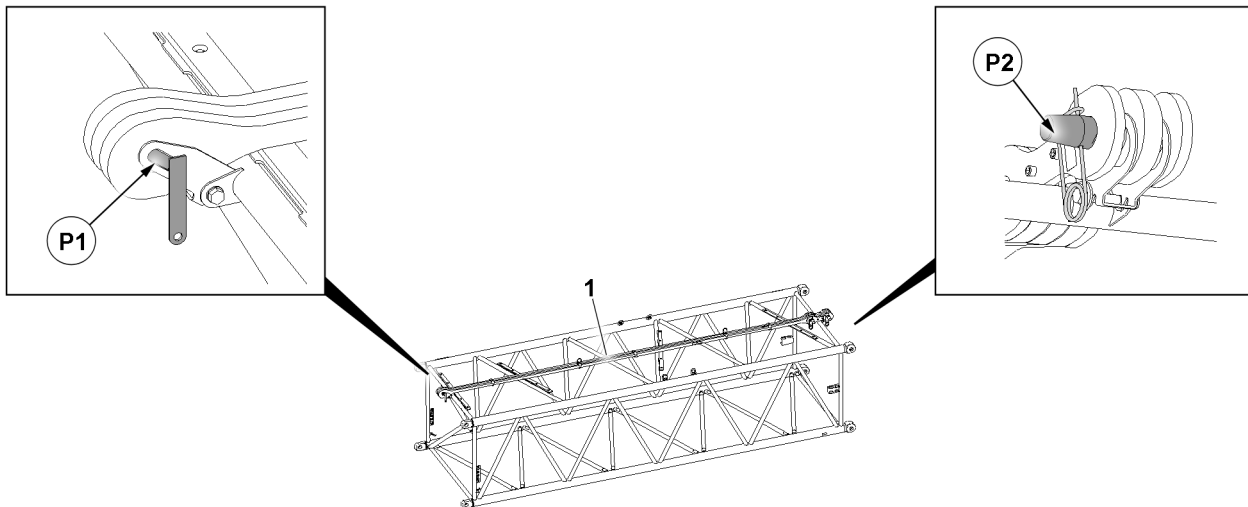


Fig.159460: Guy rod transport retainer

- ▶ Make sure that the guy rod 1 is secured on both sides in position **P1** and position **P2**.

**Result:**

- The lattice section 2 guy rod is secured on both sides in the transport position.

Empty page!

LWE/LR 1800-1-0-000/27200-07-02/en

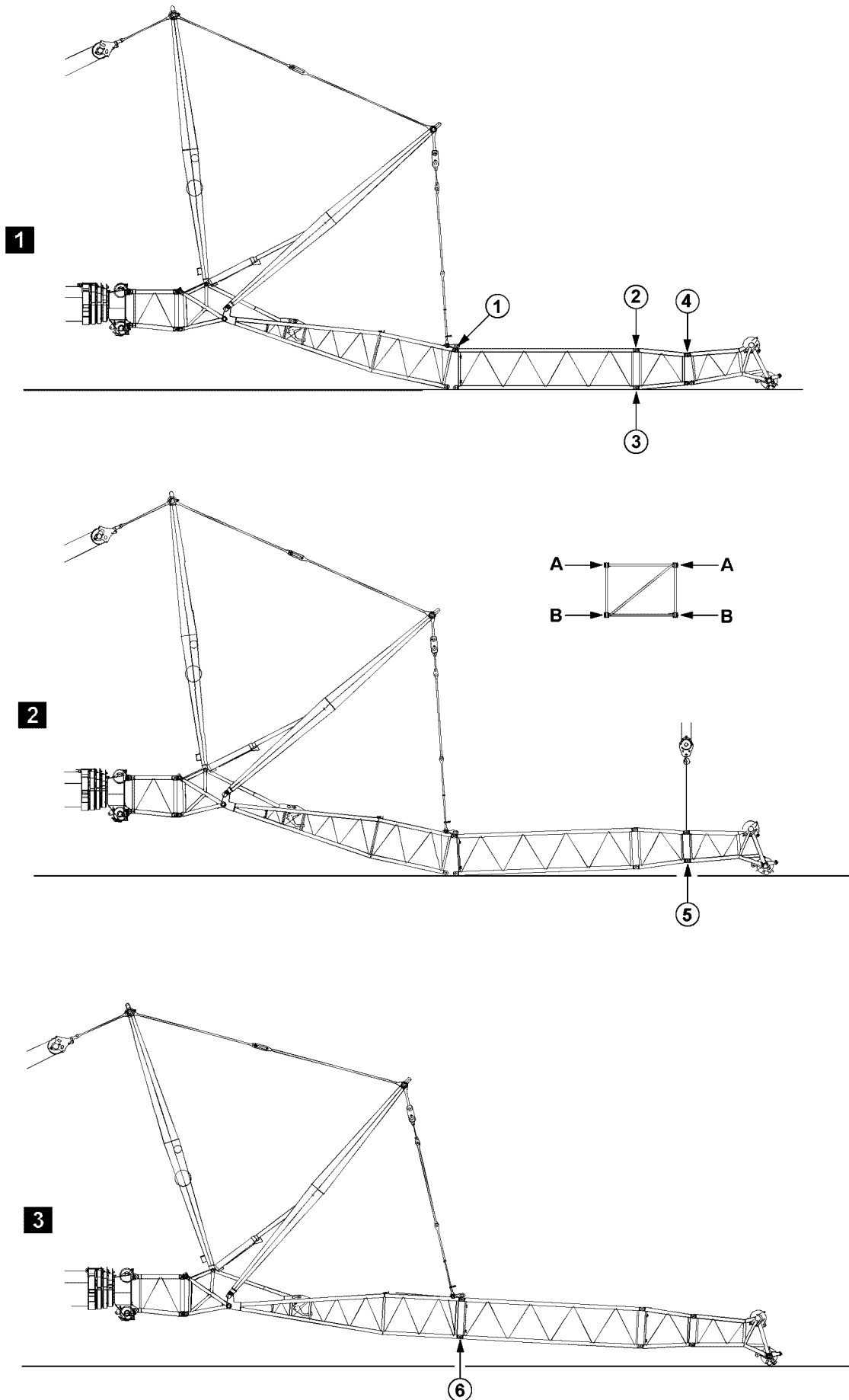


Fig.197718: Example of cranes with a telescopic boom

LWE/LR 1800-1-0-000/27200-07-02/en

### 16.14.3 Assembling the lattice sections on a luffing lattice jib

The illustrations serve as examples. The illustrations may differ depending on the crane.



---

**WARNING**

Danger of fatal injury when assembling auxiliary booms!

If the pins are not pinned in the given sequence, then lattice sections may suddenly fold down or fall down.

Death, severe bodily injuries, property damage.

▶ Pins must be pinned in the order specified.

---

- ▶ Pin and secure pins on both sides (level **A**) in point **1**, illustration **1**.
- ▶ Pin and secure pins on both sides (level **A**) in point **2**, illustration **1**.
- ▶ Pin and secure pins on both sides (level **B**) in point **3**, illustration **1**.
- ▶ Pin and secure pins on both sides (level **A**) in point **4**, illustration **1**.
- ▶ Close the end section with the auxiliary crane, illustration **2**.
- ▶ Pin and secure pins on both sides (level **B**) in point **5**, illustration **2**.
- ▶ Lift the lattice sections, illustration **3**.
- ▶ Pin and secure pins on both sides (level **B**) in point **6**, illustration **3**.

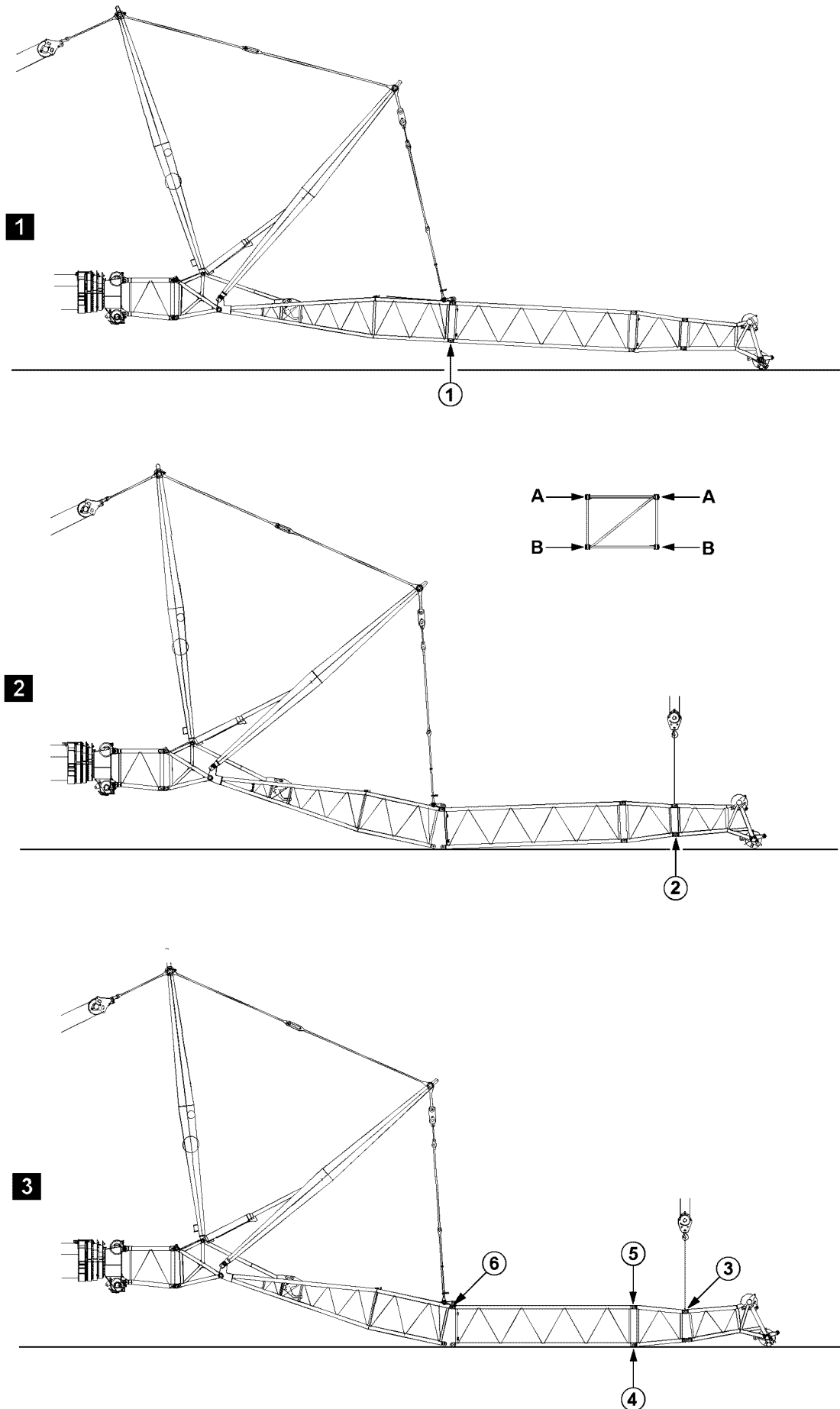


Fig.197719: Example of cranes with a telescopic boom

LWE/LR 1800-1-0-000/27200-07-02/en



### 16.14.4 Disassembling the lattice sections on a luffing lattice jib

The illustrations serve as examples. The illustrations may differ depending on the crane.



---

#### WARNING

Danger of fatal injury when disassembling auxiliary booms!

If the pins are not unpinned in the given sequence, then lattice sections may suddenly fold down or fall down.

Death, severe bodily injuries, property damage.

▶ Pins must be unpinned in the specified order.

---

- ▶ Luff the boom down until the end section touches the ground slightly, illustration 1.
- ▶ Guy the boom with NA-frame I, illustration 1.
- ▶ Release and unpin the pins on both sides (level **B**) in point 1, illustration 1.
- ▶ Open the boom with the NA-frame I and take the boom down completely, illustration 2.
- ▶ Lift the end section with the auxiliary crane, illustration 2.
- ▶ Release and unpin the pins on both sides (level **B**) in point 2, illustration 2.
- ▶ Release and unpin the pins on both sides (level **A**) in point 3, illustration 3.
- ▶ Release and unpin the pins on both sides (level **B**) in point 4, illustration 3.
- ▶ Release and unpin the pins on both sides (level **A**) in point 5, illustration 3.
- ▶ Release and unpin the pins on both sides (level **A**) in point 6, illustration 3.

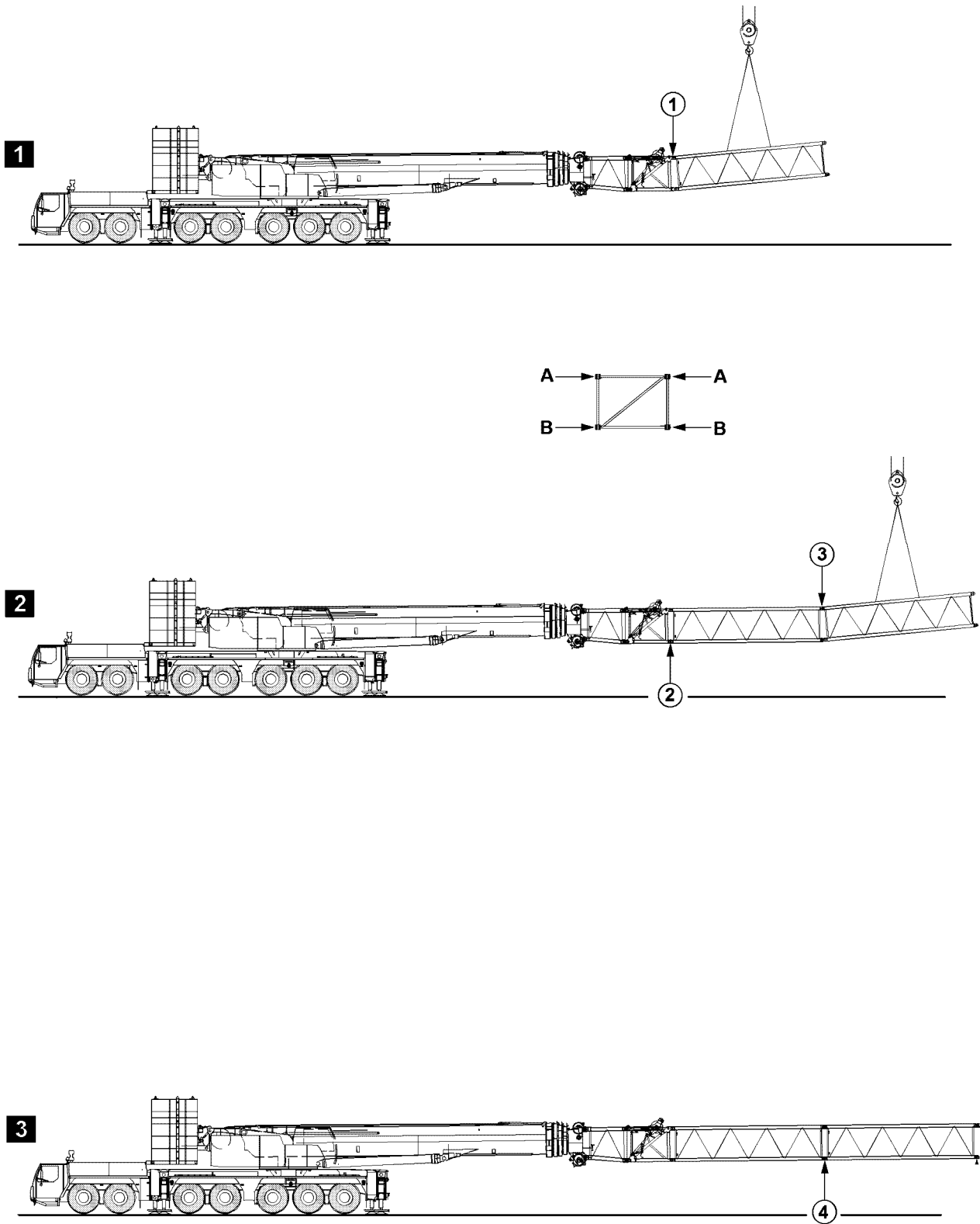


Fig.197705: Example of cranes with a telescopic boom

## 16.15 Assembling / disassembling the lattice sections on telescopic cranes with an auxiliary boom, with an auxiliary crane

### 16.15.1 Assembling the lattice sections on an auxiliary boom with an auxiliary crane

The illustrations serve as examples. The illustrations may differ depending on the crane.



---

#### WARNING

Danger of fatal injury when assembling auxiliary booms!

If the pins are not pinned in the given sequence, then lattice sections may suddenly fold down or fall down.

Death, severe bodily injuries, property damage.

▶ Pins must be pinned in the order specified.

- 
- ▶ Pin and secure pins on both sides (level **A**) in point **1**, illustration **1**.
  - ▶ Pin and secure pins on both sides (level **B**) in point **2**, illustration **2**.
  - ▶ Pin and secure pins on both sides (level **A**) in point **3**, illustration **2**.
  - ▶ Pin and secure pins on both sides (level **B**) in point **4**, illustration **3**.

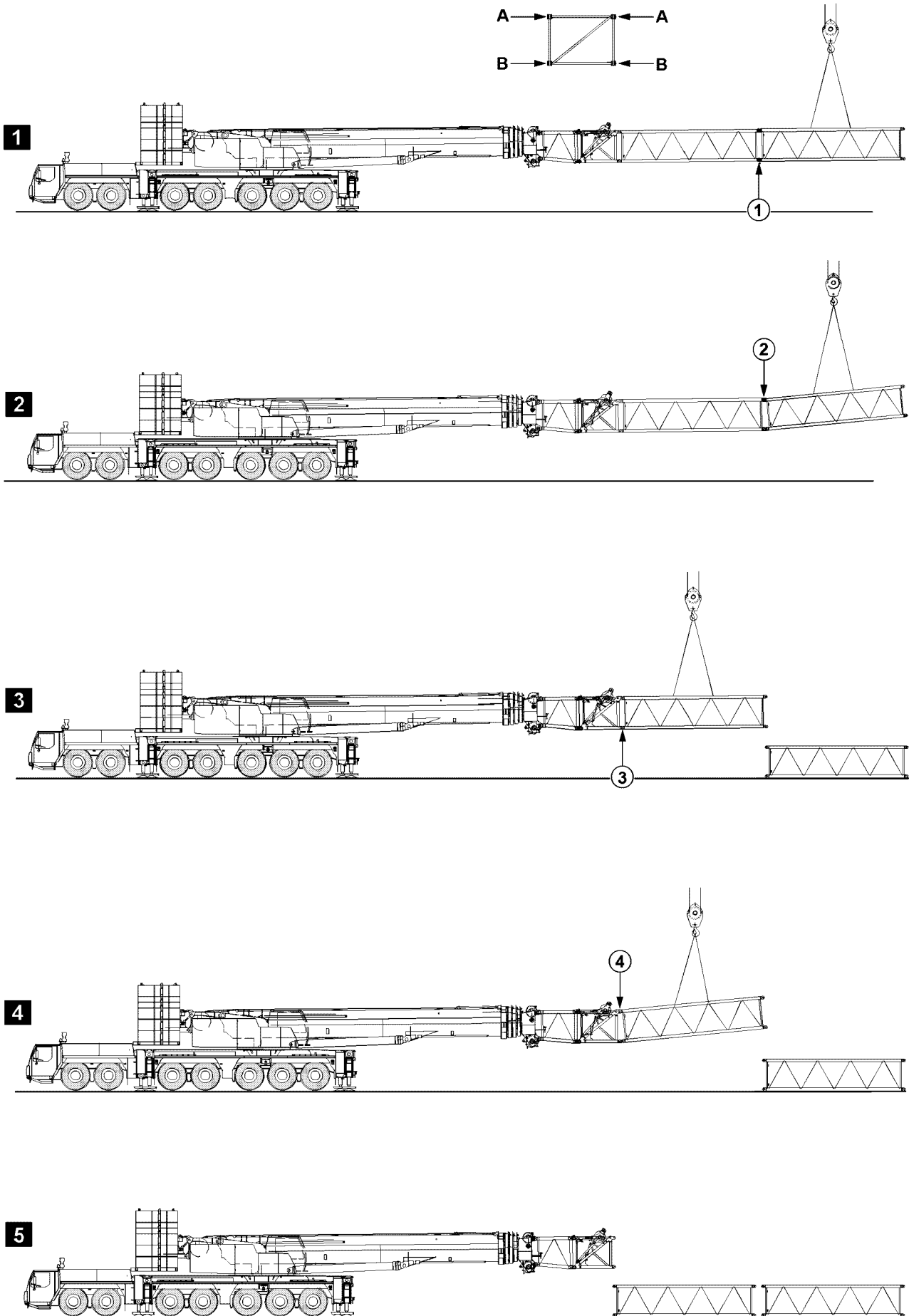


Fig.105510: Example of cranes with a telescopic boom

LWE/LR 1800-1-0-000/27200-07-02/en

## 16.15.2 Disassembling the lattice sections on an auxiliary boom with an auxiliary crane

The illustrations serve as examples. The illustrations may differ depending on the crane.



---

### WARNING

Danger of fatal injury when disassembling auxiliary booms!

If the pins are not unpinned in the given sequence, then lattice sections may suddenly fold down or fall down.

Death, severe bodily injuries, property damage.

▶ Pins must be unpinned in the specified order.

- 
- ▶ Release and unpin the pins on both sides (level **B**) in point **1**, illustration **1**.
  - ▶ Release and unpin the pins on both sides (level **A**) in point **2**, illustration **2**.
  - ▶ Release and unpin the pins on both sides (level **B**) in point **3**, illustration **3**.
  - ▶ Release and unpin the pins on both sides (level **A**) in point **4**, illustration **4**.

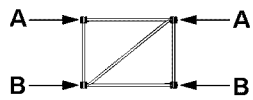
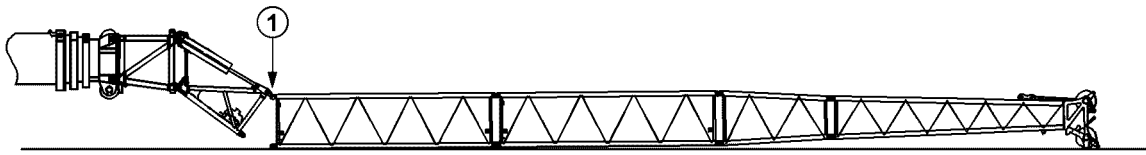
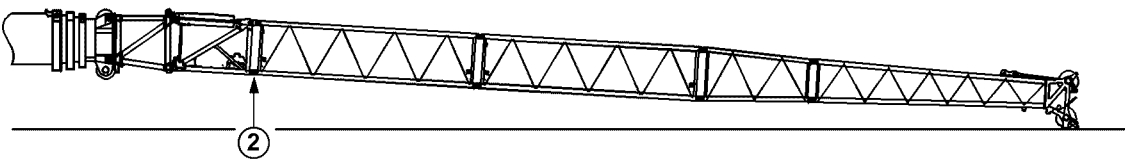
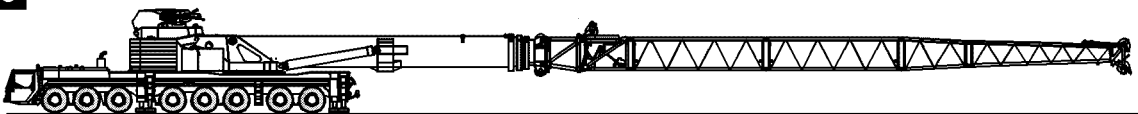
**1****2****3**

Fig.197712: Example of cranes with a telescopic boom

## 16.16 Assembling / disassembling the lattice sections on telescopic cranes with an auxiliary boom, without an auxiliary crane

### 16.16.1 Assembling the lattice sections on an auxiliary boom without an auxiliary crane

The illustrations serve as examples. The illustrations may differ depending on the crane.



---

#### WARNING

Danger of fatal injury when assembling auxiliary booms!

If the pins are not pinned in the given sequence, then lattice sections may suddenly fold down or fall down.

Death, severe bodily injuries, property damage.

- ▶ Pins must be pinned in the order specified.

---

For cranes with hydraulic angle adjustment and self-supporting auxiliary boom, the assembly / disassembly of additional lattice sections may be performed using the crane itself.

In order to do so, proceed as follows.

- ▶ Assemble the lattice sections to the required length.
- ▶ Pin and secure pins on both sides (level **A**) in point **1**, illustration **1**.
- ▶ Close the auxiliary boom until the pins can be pinned in point **2**, illustration **2**.
- ▶ Pin and secure pins on both sides (level **B**) in point **2**, illustration **2**.

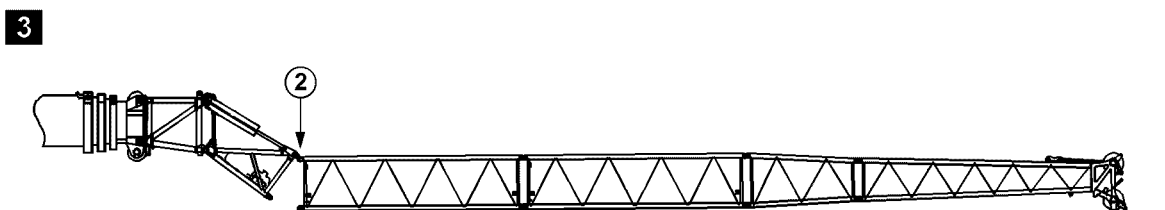
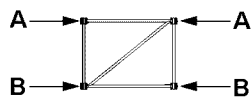
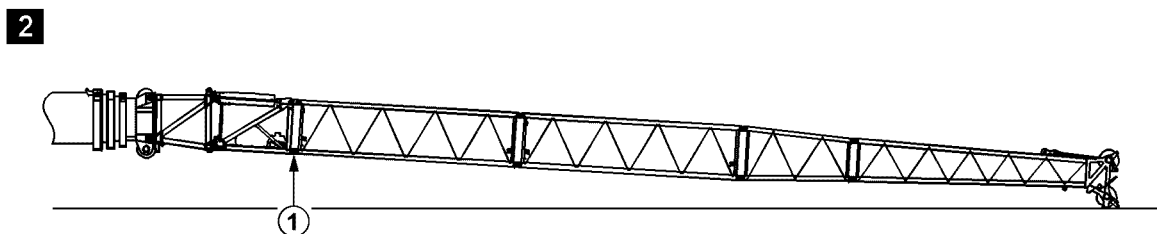
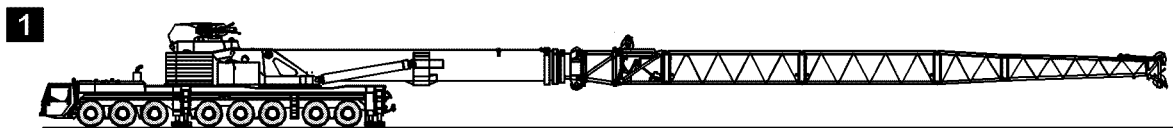


Fig.197713: Example of cranes with a telescopic boom



## 16.16.2 Disassembling the lattice sections on an auxiliary boom without an auxiliary crane

The illustrations serve as examples. The illustrations may differ depending on the crane.



### WARNING

Danger of fatal injury when disassembling auxiliary booms!

If the pins are not unpinned in the given sequence, then lattice sections may suddenly fold down or fall down.

Death, severe bodily injuries, property damage.

- ▶ Pins must be unpinned in the specified order.

For cranes with hydraulic angle adjustment and self-supporting auxiliary boom, the assembly / disassembly of additional lattice sections may be performed using the crane itself.

In order to do so, proceed as follows.

### NOTICE

Damage to the hydraulic cylinders on the TF-adapter!

- ▶ As soon as the lattice jib is placed, stop the luff down movement.
- ▶ It is prohibited to set down the fixed lattice jib "roughly".

- ▶ Luff the main boom down until the end section touches the ground slightly, illustration 2.

If it is not possible to luff down that far:

- ▶ Adjust the TF-adapter until the end section touches the ground slightly, illustration 2.
- ▶ Release and unpin the pins on both sides (level **B**) in point 1, illustration 2.

### NOTICE

Damage to the hydraulic cylinders on the TF-adapter.

- ▶ As soon as the lattice jib is placed, stop the opening movement.

- ▶ Open the auxiliary boom until the lattice sections to be removed are lying on the ground completely, illustration 3.
- ▶ Release and unpin the pins on both sides (level **A**) in point 2, illustration 3.
- ▶ Completely remove the auxiliary boom.

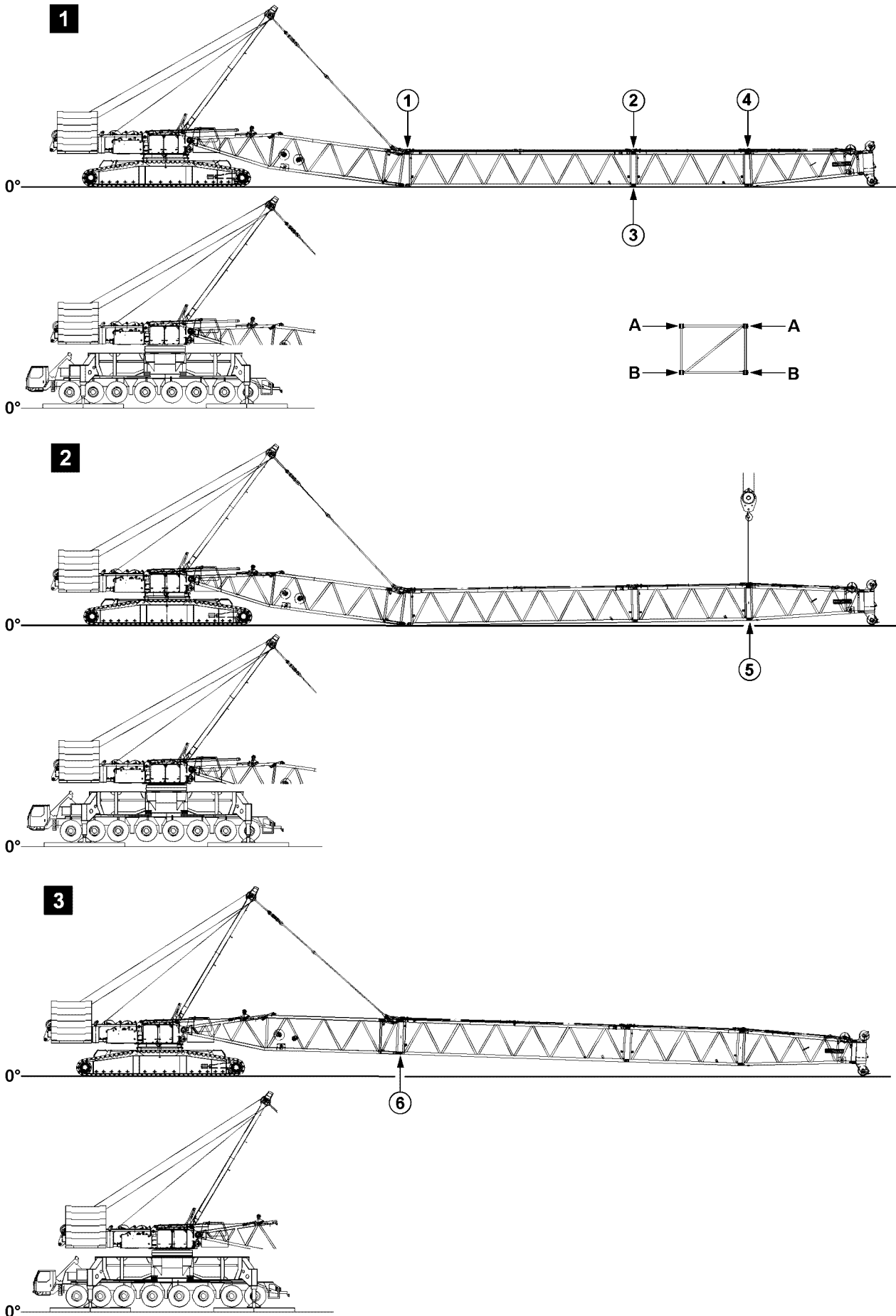


Fig.121633: Example of cranes with a lattice mast boom

LWE/LR 1800-1-0-000/27200-07-02/en

## 16.17 Assembling / disassembling of lattice sections for lattice mast cranes

### 16.17.1 Assembling lattice sections

The illustrations serve as examples. The illustrations may differ depending on the crane.



---

#### WARNING

Danger of fatal injury when assembling booms!

If the pins are not pinned in the given sequence, then lattice sections may suddenly fold down or fall down.

Death, severe bodily injuries, property damage.

▶ Pins must be pinned in the order specified.

---

- ▶ Pin and secure pins on both sides (level **A**) in point **1**, illustration **1**.
- ▶ Pin and secure pins on both sides (level **A**) in point **2**, illustration **1**.
- ▶ Pin and secure pins on both sides (level **B**) in point **3**, illustration **1**.
- ▶ Pin and secure pins on both sides (level **A**) in point **4**, illustration **1**.
- ▶ Lift the end section with the auxiliary crane, illustration **2**.
- ▶ Pin and secure pins on both sides (level **B**) in point **5**, illustration **2**.
- ▶ Close the boom system with the SA-frame, illustration **3**.
- ▶ Pin and secure pins on both sides (level **B**) in point **6**, illustration **3**.

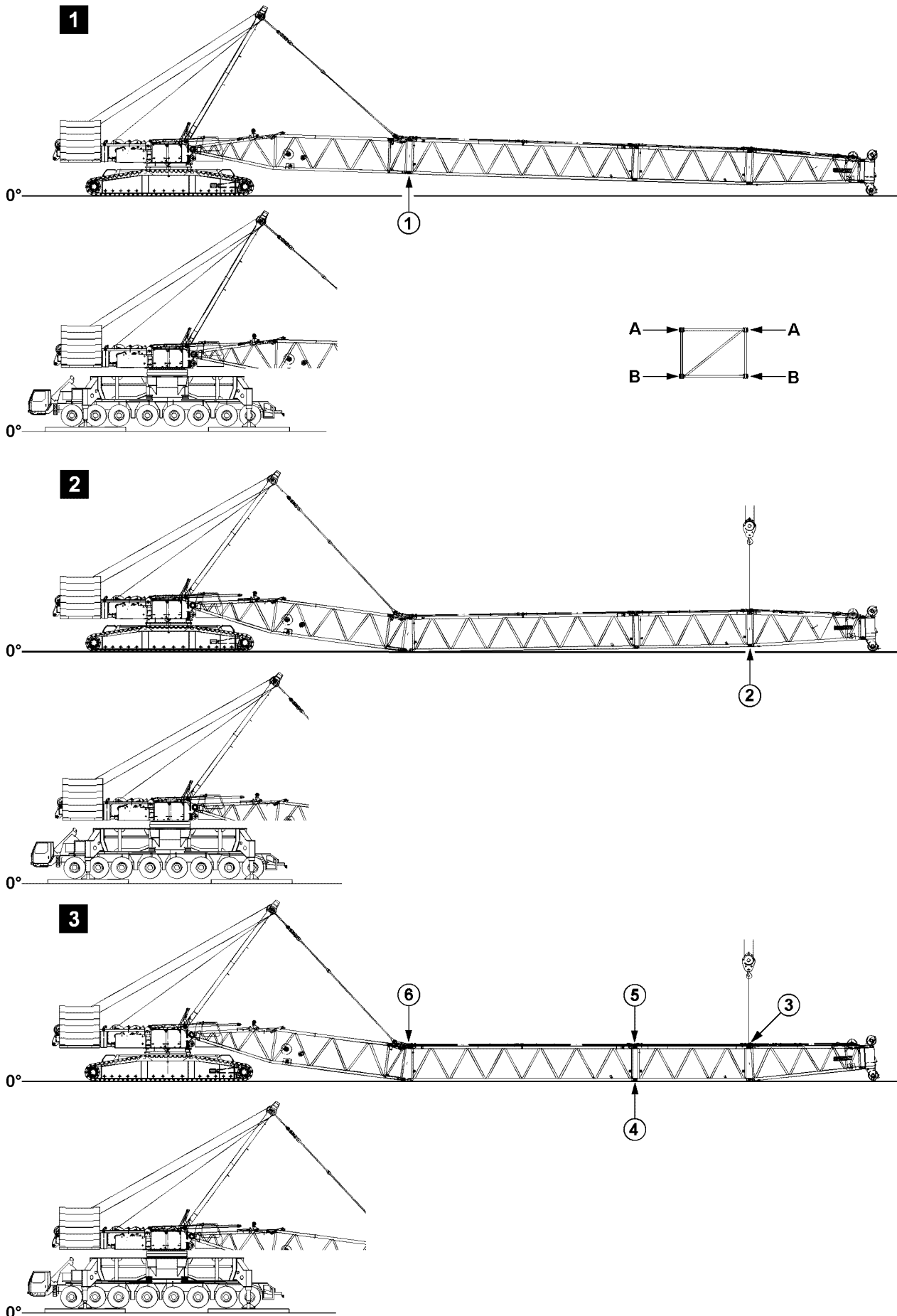


Fig.121634: Example of cranes with a lattice mast boom

LWE/LR 1800-1-0-000/27200-07-02/en

## 16.17.2 Disassembling lattice sections

The illustrations serve as examples. The illustrations may differ depending on the crane.



### WARNING

Danger of fatal injury when disassembling booms!

If the pins are not unpinned in the given sequence, then lattice sections may suddenly fold down or fall down.

Death, severe bodily injuries, property damage.

- ▶ Make sure that the SA-frame guying is tensioned before the pins are unpinned in point **1**, see illustration **1**.
  - ▶ Pins must be unpinned in the specified order.
- 
- ▶ Luff the boom down until the end section touches the ground slightly, illustration **1**.
  - ▶ Guy the boom with SA-frame, illustration **1**.
  - ▶ Release and unpin the pins on both sides (level **B**) in point **1**, illustration **1**.
  - ▶ Open the boom system with the SA-frame, illustration **2**.
  - ▶ Take the lattice sections down completely, illustration **2**.
  - ▶ Lift the end section with the auxiliary crane, illustration **2**.
  - ▶ Release and unpin the pins on both sides (level **B**) in point **2**, illustration **2**.
  - ▶ Release and unpin the pins on both sides (level **A**) in point **3**, illustration **3**.
  - ▶ Release and unpin the pins on both sides (level **B**) in point **4**, illustration **3**.
  - ▶ Release and unpin the pins on both sides (level **A**) in point **5**, illustration **3**.
  - ▶ Release and unpin the pins on both sides (level **A**) in point **6**, illustration **3**.

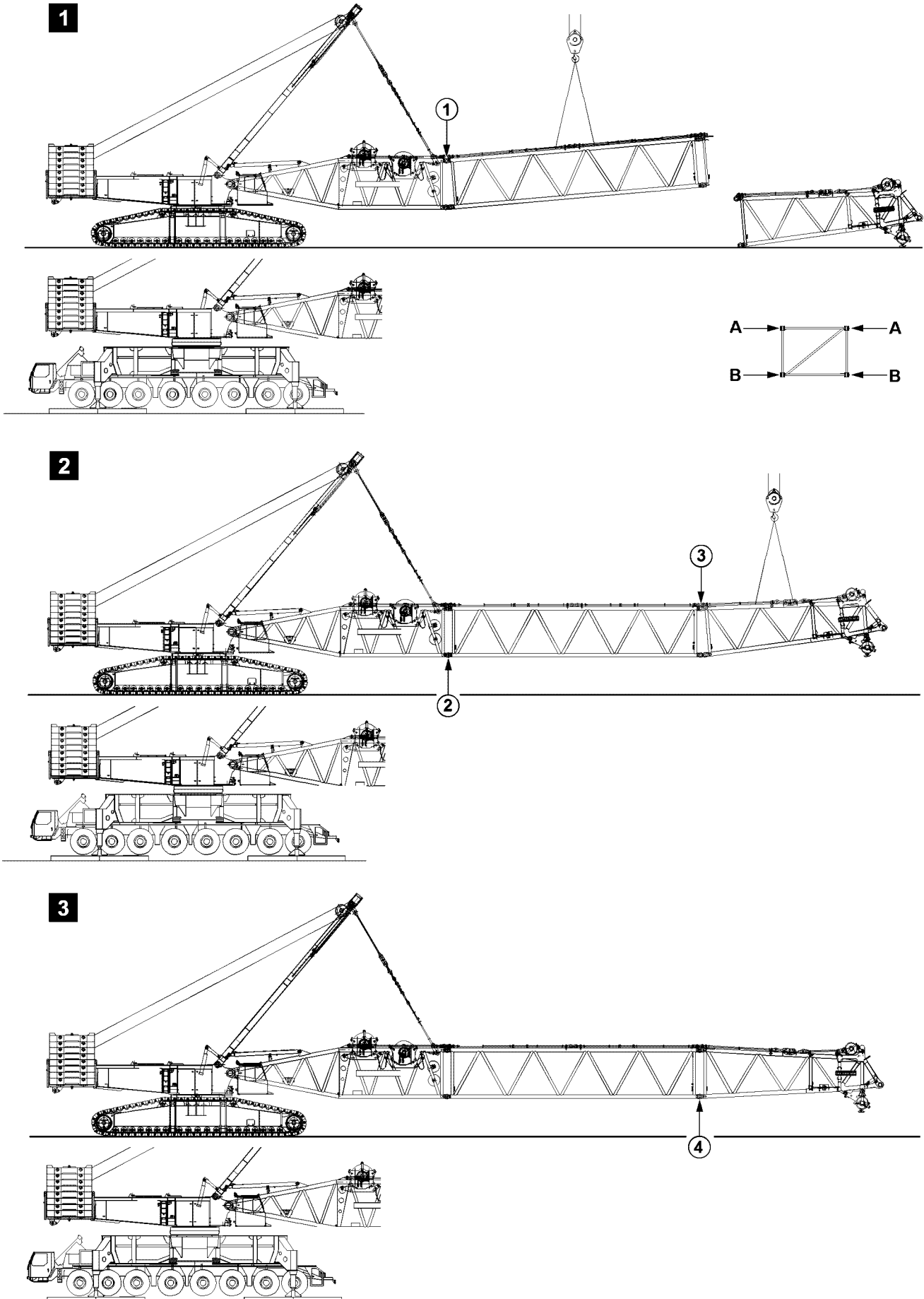


Fig.198182: Example of cranes with a lattice mast boom

LWE/LR 1800-1-0-000/27200-07-02/en

## 16.18 Flying assembly / disassembly of lattice sections

### 16.18.1 Flying assembly of lattice sections

The illustrations serve as examples. The illustrations may differ depending on the crane.



---

#### **WARNING**

Danger of fatal injury when assembling booms!

If the pins are not pinned in the given sequence, then lattice sections may suddenly fold down or fall down.

Death, severe bodily injuries, property damage.

▶ Pins must be pinned in the order specified.

---

- ▶ Pin and secure pins on both sides (level **A**) in point **1**, illustration **1**.
- ▶ Pin and secure pins on both sides (level **B**) in point **2**, illustration **2**.
- ▶ Pin and secure pins on both sides (level **A**) in point **3**, illustration **2**.
- ▶ Pin and secure pins on both sides (level **B**) in point **4**, illustration **3**.

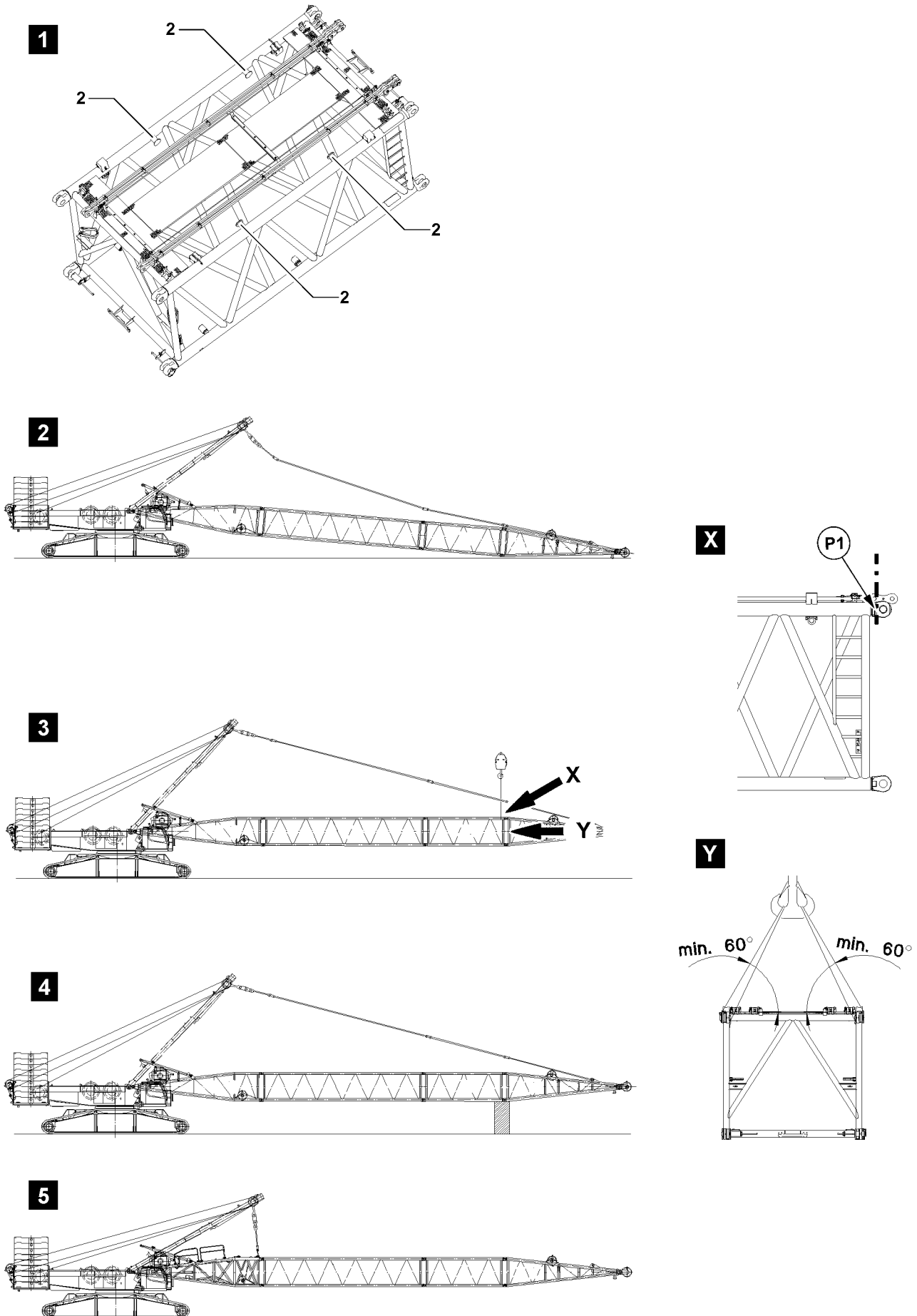


Fig.111448: Guying the pivot section with the SA-frame

LWE/LR 1800-1-0-000/27200-07-02/en



## 16.18.2 Flying disassembly of lattice sections

The illustrations serve as examples. The illustrations may differ depending on the crane.

The flying disassembly of lattice sections can be used on:

- Derrick boom
- Main boom

Make sure that the following prerequisite is met:

- Before guying the pivot section, secure the boom properly to prevent it from falling down.

### Guying the pivot section in flying mode with the SA-frame

There are three ways to change the guy point for flying disassembly:

- Take down the boom on the ground.
  - Secure the boom with the auxiliary crane.
  - Support the boom.
- ▶ Take down the boom on the ground, see illustration 2.  
or



#### WARNING

Lattice section incorrectly attached!

If the fastening equipment is attached on the bits **2** when securing the boom, then the bits will be overloaded. The lattice section will be damaged.

The boom can fall down.

Death, severe bodily injuries, property damage.

If an auxiliary crane is used to secure the boom for flying disassembly:

- ▶ Do **not** fasten the lattice section to the bits **2**, see illustration 1.
- ▶ Attach the fastening equipment in the area of point **P1** on both sides on the lattice section, see detail **X**.
- ▶ Make sure that the long fastening equipment is used, so that the angle between the cross-section of the lattice section and guyed fastening equipment is at least 60°, see detail **Y**.

Secure the boom with the auxiliary crane, see illustration 3.

or



#### WARNING

Falling boom!

If the boom is not properly and securely supported from below, then the boom can fall down.

- ▶ Support the boom properly and safely with suitable material.

Support the boom, see illustration 4.

#### Result:

- The guy rods can be disassembled.
- ▶ Take down, secure and disassemble the guy rods.
- ▶ Pin and secure the guy rods SA-frame on the pivot section.
- ▶ Tighten the SA-frame guy rods until the boom is in a horizontal position.

#### Result:

- Pivot section is guyed in flying mode with the SA-frame, see illustration 5.
- The lattice sections can be disassembled in flying mode.

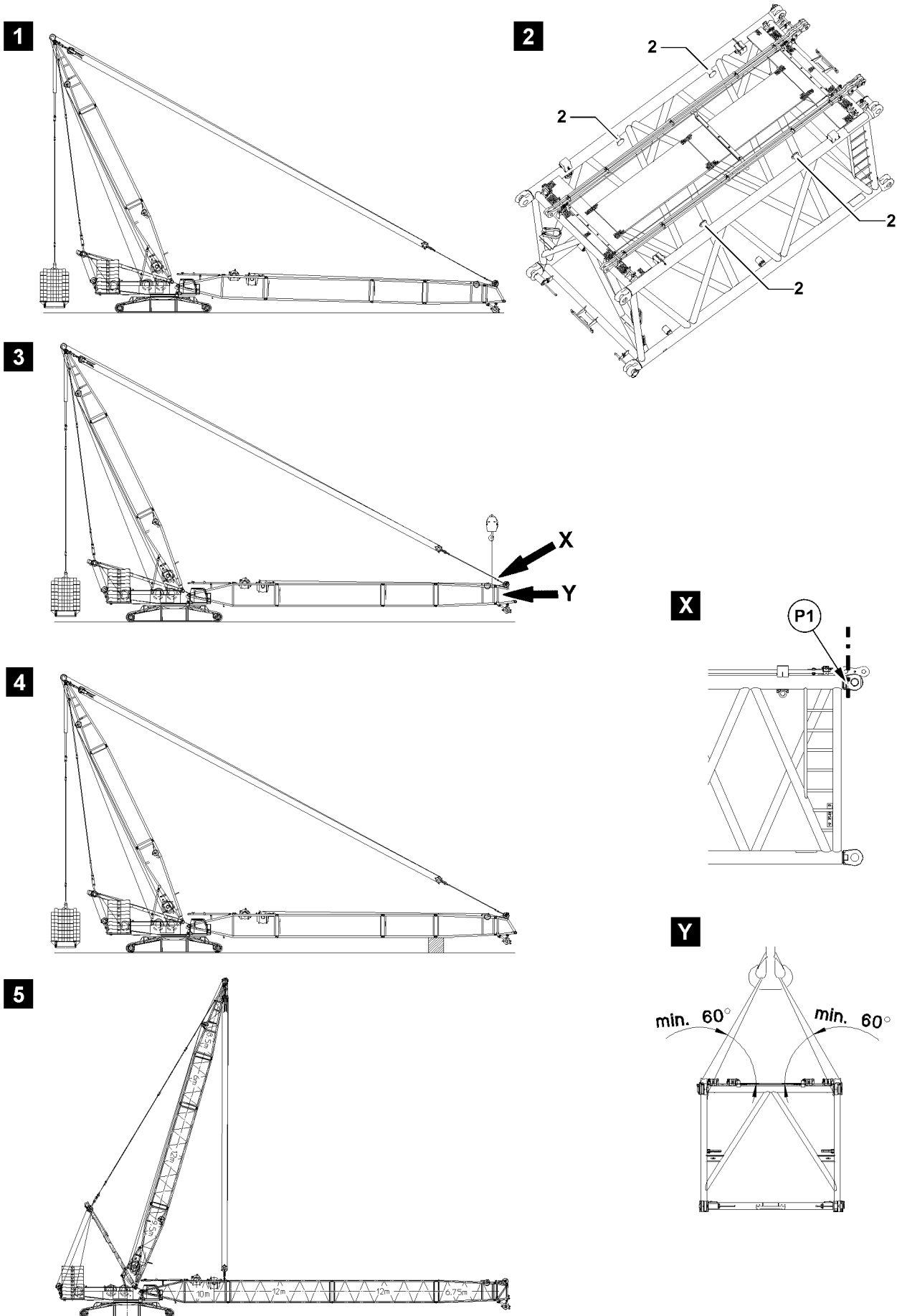


Fig.111449: Guying the pivot section with the derrick boom

LWE/LR 1800-1-0-000/27200-07-02/en

### Guying the pivot section in flying mode with the derrick boom

There are three ways to change the guy point for flying disassembly:

- Take down the boom on the ground.
  - Secure the boom with the auxiliary crane.
  - Support the boom.
- ▶ Take down the boom on the ground, see illustration 1.  
or



#### WARNING

Lattice section incorrectly attached!

If the fastening equipment is attached on the bits **2** when securing the boom, then the bits will be overloaded. The lattice section will be damaged.

The boom can fall down.

Death, severe bodily injuries, property damage.

If the auxiliary crane is used to secure the boom for flying disassembly:

- ▶ Do **not** fasten the lattice section to the bits **2**, see illustration 2.
- ▶ Attach the fastening equipment in the area of point **P1** on both sides on the lattice section, see detail **X**.
- ▶ Make sure that the long fastening equipment is used, so that the angle between the cross-section of the lattice section and guyed fastening equipment is at least 60°, see detail **Y**.

Secure the boom with the auxiliary crane, see illustration 3.

or



#### WARNING

Falling boom!

If the boom is not properly supported from below, then the boom can fall down.

- ▶ Support the boom properly and safely with suitable material.

Support the boom, see illustration 4.

#### Result:

- The guy rods can be disassembled.
- ▶ Take down, secure and disassemble the guy rods.
- ▶ Pin and secure the luffing pulley block on the pivot section.
- ▶ Tighten the control rope until the boom is in a horizontal position.

#### Result:

- Pivot section is guyed in flying mode with the derrick boom, see illustration 5.
- The lattice sections can be disassembled in flying mode.

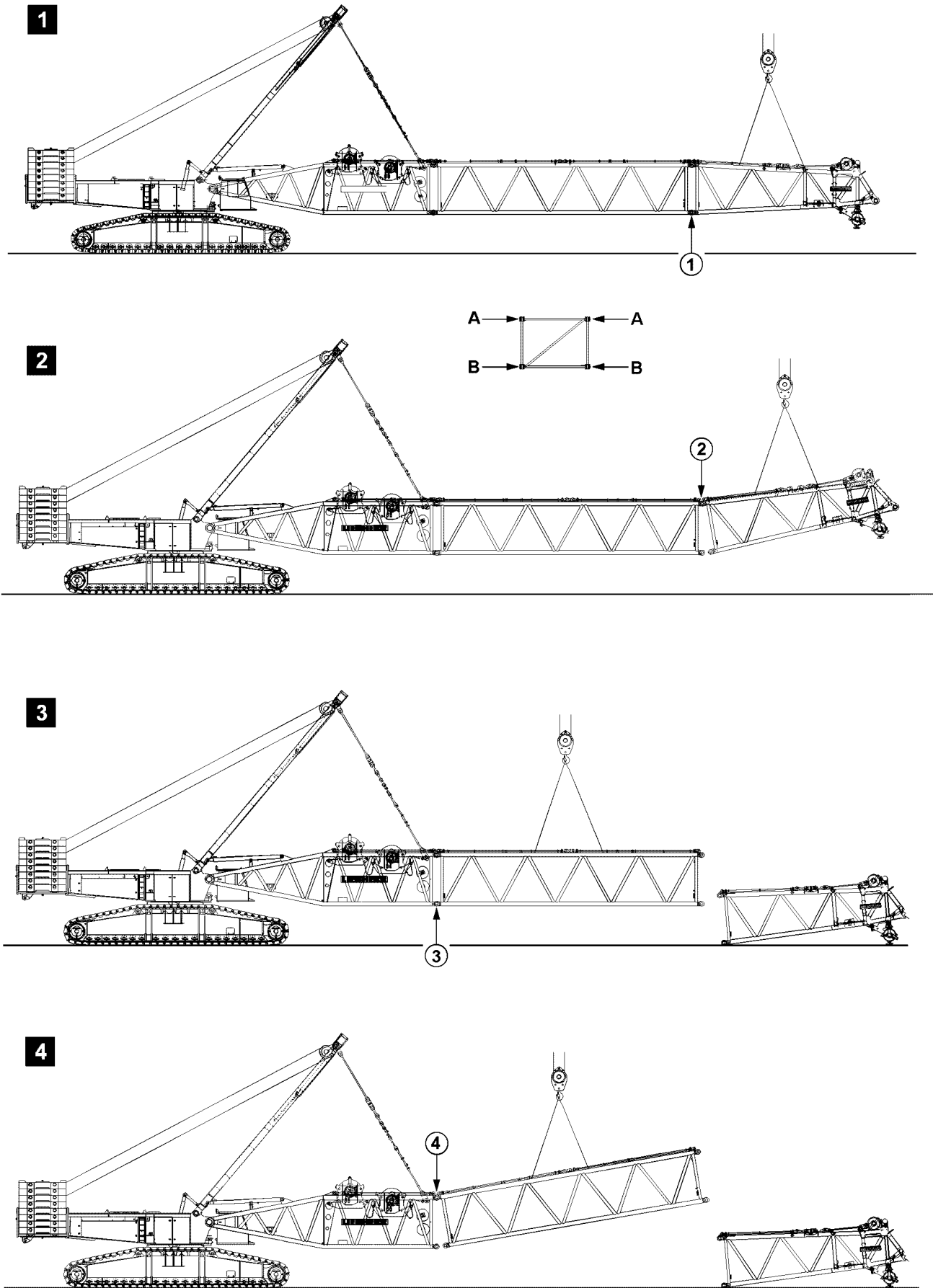


Fig.105511: Example of cranes with a lattice mast boom

LWE/LR 1800-1-0-000/27200-07-02/en

## Unpinning the lattice components



### WARNING

Danger of fatal injury when disassembling booms!

If the pins are not unpinned in the given sequence, then lattice sections may suddenly fold down or fall down.

Death, severe bodily injuries, property damage.

▶ Pins must be unpinned in the specified order.

- ▶ Release and unpin the pins on both sides (level **B**) in point **1**, illustration 1.
- ▶ Release and unpin the pins on both sides (level **A**) in point **2**, illustration 2.
- ▶ Release and unpin the pins on both sides (level **B**) in point **3**, illustration 3.
- ▶ Release and unpin the pins on both sides (level **A**) in point **4**, illustration 4.

## 16.19 Supporting long lattice mast booms for erection and take-down



### Note

- ▶ The illustrations of the crane and lattice mast boom are simplified and are examples and may not match your crane exactly.
- ▶ When working on uneven ground, additional or other substructures may be necessary.

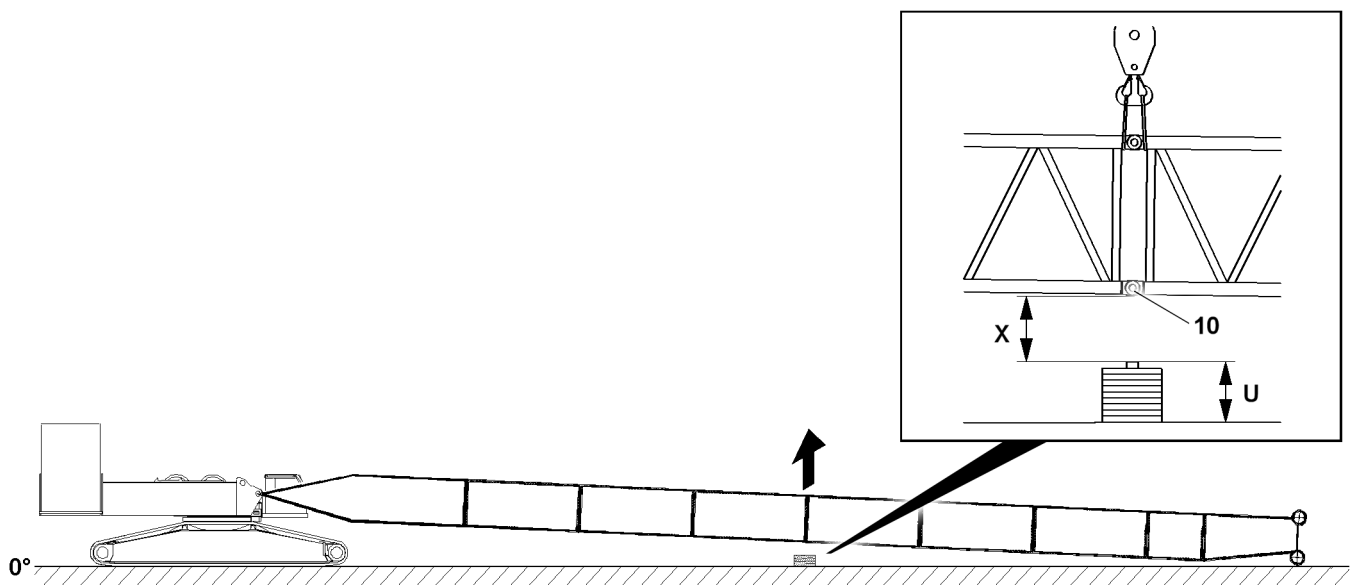


Fig.160362: Example of supporting a long boom system



### Note

- ▶ The height **U** of the substructure or dimension **X** is noted in the respective boom assembly chapter, see for example, chapter 5.38 or chapter 5.39.
- ▶ If the height **U** or dimension **X** is not available in the chapter, see the separately supplied drawing "Support assembly drawing" or the assembly drawing for the concerned boom system.

### 16.19.1 Supporting lattice mast booms for erection

Support the boom system properly for the closing procedure.

If the lower pins **10** can be inserted during closing:

- ▶ Select the height **U** of the substructure such that the maximum distance according to the dimension **X** is not exceeded.

### 16.19.2 Supporting lattice mast booms for take-down

For the take-down procedure, the boom system must be supported the same way as for erection.

If the boom system is to be taken down in the same place where it was erected:

- ▶ Take the boom system down in the same place with the same substructure.
- or

If the boom system is to be taken down in another permissible place:

Establish the same conditions for the substructure according to the dimension **X**.

## 16.20 Assembling / disassembling boom systems for supporting on ascending terrain (assembly / disassembly diagram)



### Note

- ▶ The following assembly steps are simplified and are examples and may not match your crane exactly.



### WARNING

Danger of fatal injury when assembling / disassembling booms!

If the pins are not pinned / unpinned in the specified sequence, then lattice sections may suddenly fold down or fall down.

Death, severe bodily injuries, property damage.

- ▶ Insert / unpin the pins in the specified sequence, see section "Assembly of lattice sections".
- ▶ Observe all safety technical notes in section "Assembly / disassembly".
- ▶ Make sure that there are no persons in the danger zone.



### WARNING

Horizontal movement of the boom!

- ▶ Make sure that there are no persons in the danger zone.

### 16.20.1 Assembling the boom systems on ascending terrain

Make sure that the following prerequisites are met:

- An auxiliary crane with sufficient load bearing capacity is available.

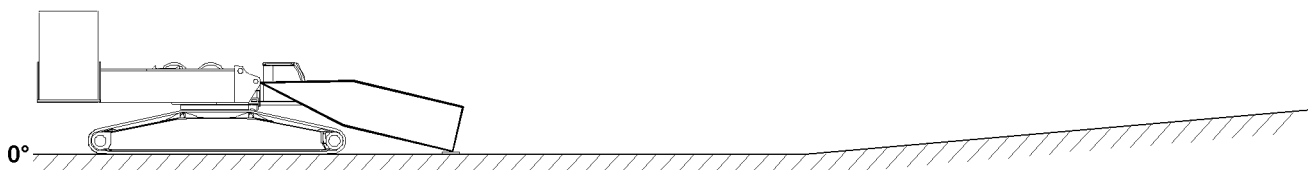


Fig.121635: Boom - pivot section installed on the turntable and taken down on the ground

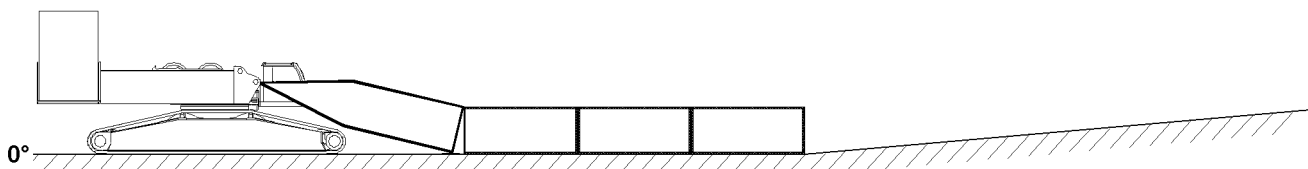


Fig.121636: Boom - intermediate sections installed on the boom - pivot section and taken down on the ground

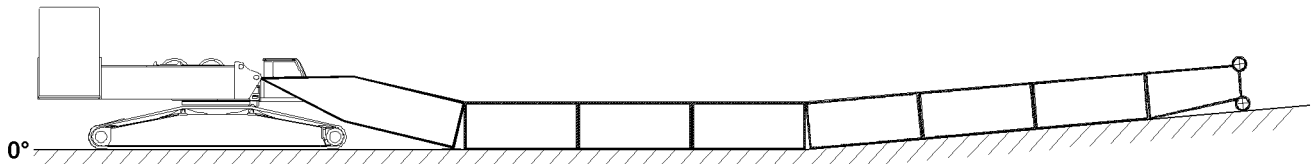


Fig.121637: Boom - intermediate sections installed and taken down on ascending terrain

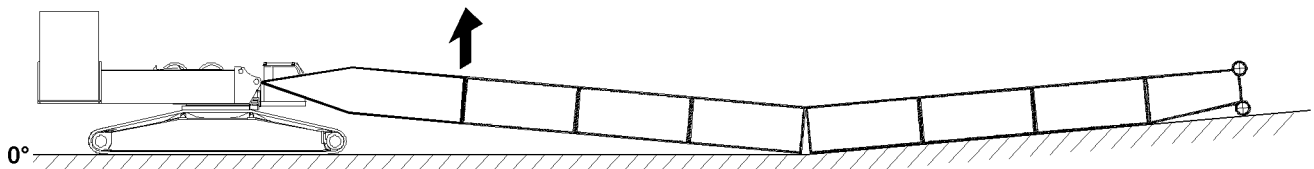


Fig.121638: Lifting and close the boom system in the area of the boom - pivot section

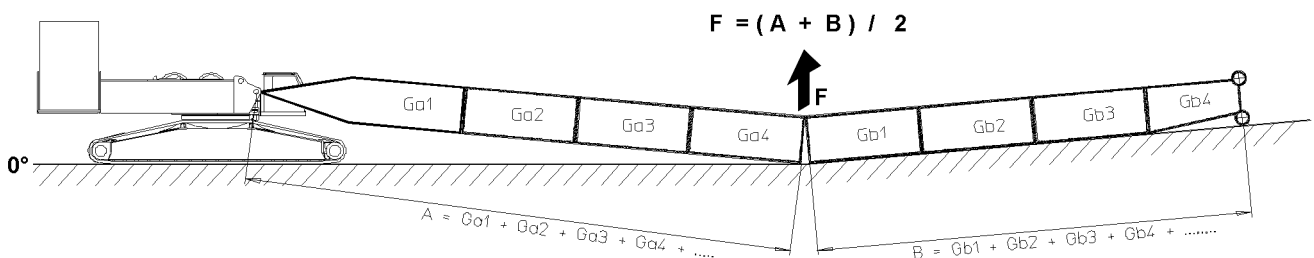


Fig.145512: Calculation of force for the closing procedure of the boom system



**Note**

- ▶ The abbreviations Ga1, Ga2, ... and Gb1, Gb2, are for the weights of the individual lattice sections.
- ▶ The weights of the lattice sections are noted on the welded-on weight tags on the lattice sections.

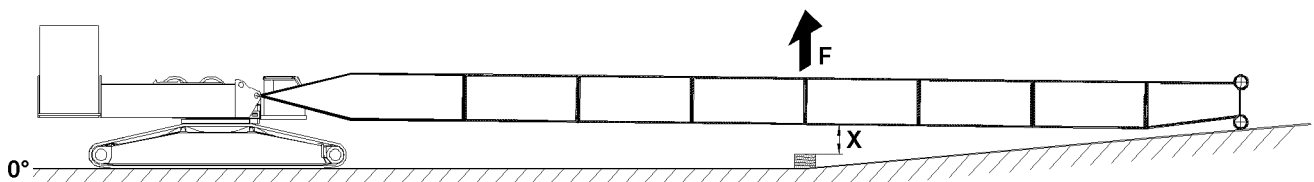


Fig.121639: Lifting and closing the boom system // Supporting the boom system



**Note**

- ▶ The height of the substructure or the dimension X is noted in the respective boom assembly chapter, see chapter 5.38 or chapter 5.39.
  - ▶ If the dimension X is not available in chapter 5.38 or chapter 5.39, see the separately supplied drawing "Support assembly drawing" or the assembly drawing for the corresponding operating mode.
- ▶ Support the boom system properly after the closing procedure.

## 16.20.2 Disassembling boom systems on ascending terrain

Make sure that the following prerequisites are met:

- An auxiliary crane with sufficient load bearing capacity is available.

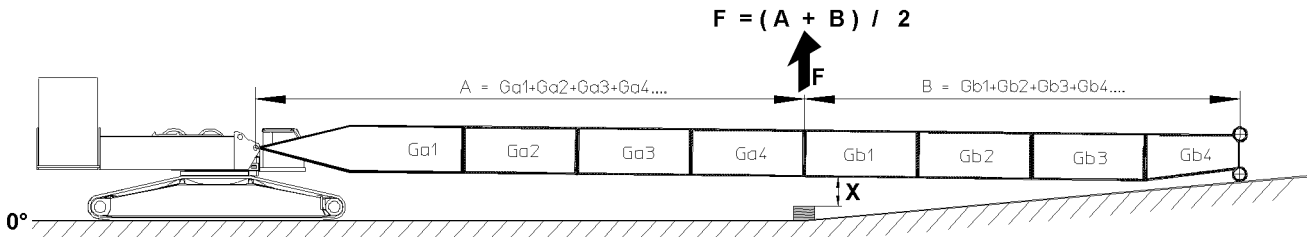


Fig.145513: Calculation of the force for opening the boom system // Lifting the boom system // Removing the substructure // Opening the boom system



**Note**

- ▶ The abbreviations Ga1, Ga2, ... and Gb1, Gb2, are for the weights of the individual lattice sections.
- ▶ The weights of the lattice sections are noted on the welded-on weight tags on the lattice sections.

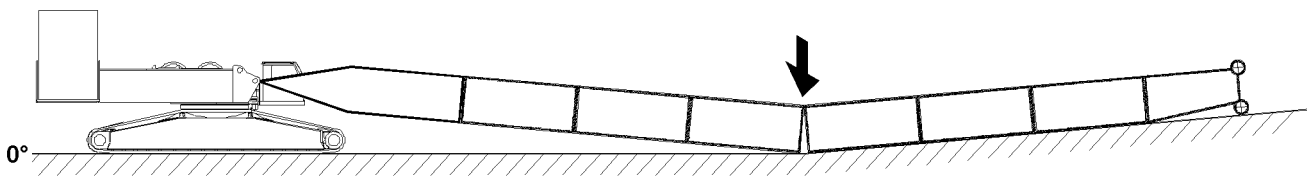


Fig.121657: Taking the boom system down

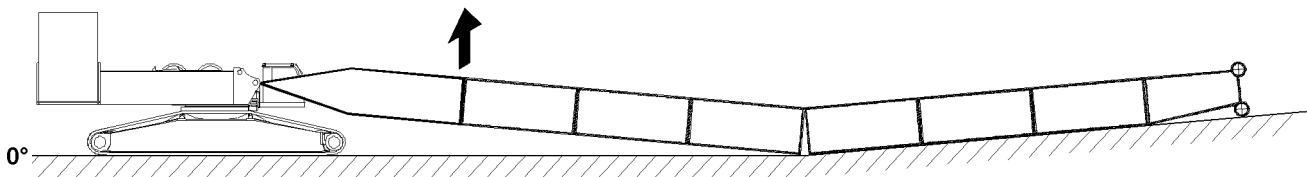


Fig.121652: Lifting and opening the boom system

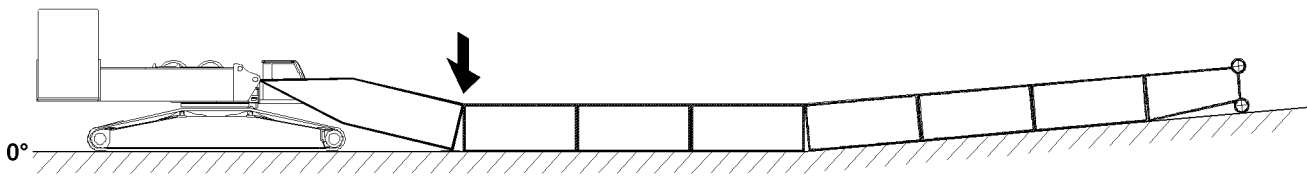


Fig.121653: Taking the boom system down

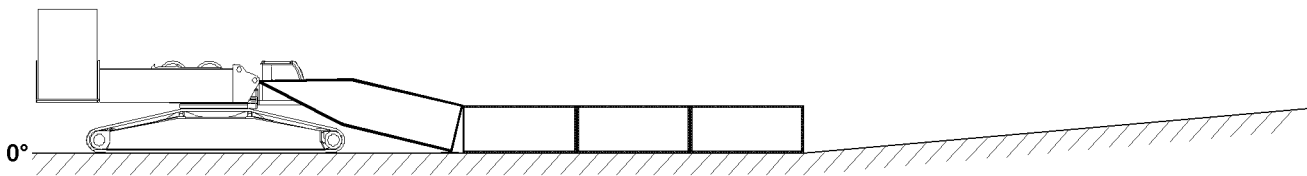


Fig.121636: Disassembling and removing the boom - intermediate sections with the end section

LWE/LR 1800-1-0-000/27200-07-02/en



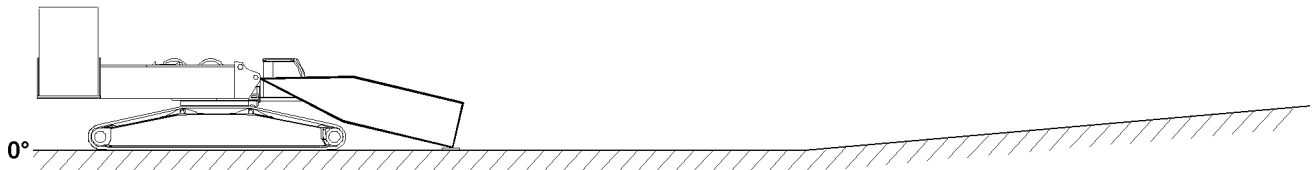


Fig.121635: Disassembling and removing the boom - intermediate sections to the boom - pivot section

- ▶ Disassemble and remove the boom - pivot section.

## 16.21 Assembling / disassembling of boom systems for supporting on descending terrain (assembly / disassembly diagram)

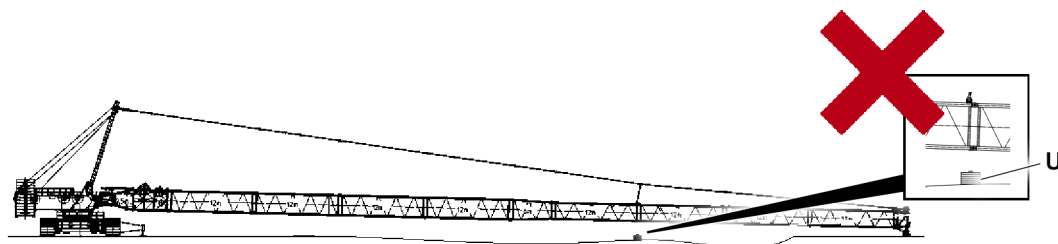


Fig.163434: Example of a boom with a substructure due to the boom length



### WARNING

Impermissible boom length!

If boom systems must be supported due to their length, there is the risk of breakage during assembly / disassembly on descending terrain.

- ▶ Observe the specifications regarding the substructure **U** in the assembly chapters and assembly drawings.
- ▶ Boom lengths, for which a substructure **U** is required must **not** be assembled / disassembled according to the assembly / disassembly diagram in the following sections.



### Note

- ▶ The following assembly steps are simplified and are examples and may not match your crane exactly.



### WARNING

Danger of fatal injury when assembling / disassembling booms!

If the pins are not pinned / unpinned in the specified sequence, then lattice sections may suddenly fold down or fall down.

Death, severe bodily injuries, property damage.

- ▶ Insert / unpin the pins in the specified sequence, see section "Assembly of lattice sections".
- ▶ Observe all safety technical notes in section "Assembly / disassembly".
- ▶ Make sure that there are no persons in the danger zone.

### 16.21.1 Assembling the boom systems on descending terrain

Make sure that the following prerequisites are met:

- The lattice sections are properly assembled.
- An auxiliary crane with sufficient load bearing capacity is available.

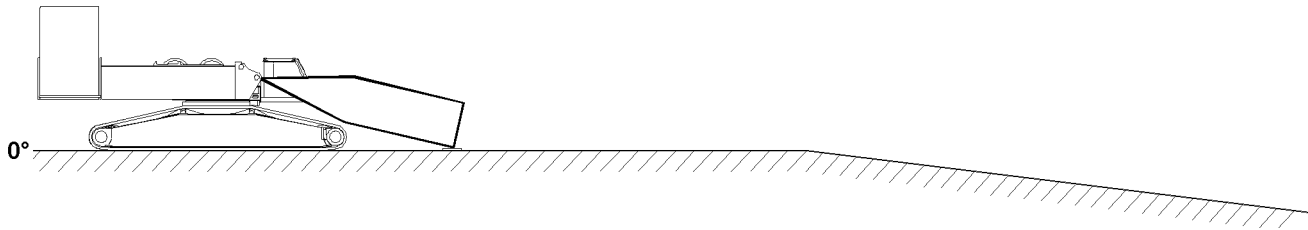


Fig.121640: Boom - pivot section installed on the turntable and taken down on the ground

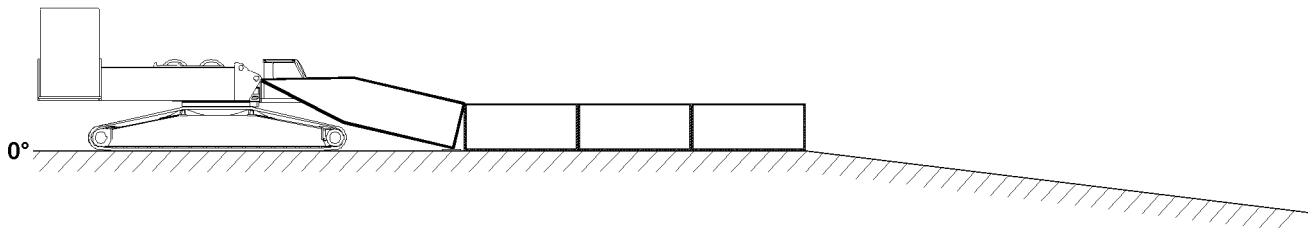


Fig.121641: Boom - intermediate sections installed on the boom - pivot section and taken down on the ground

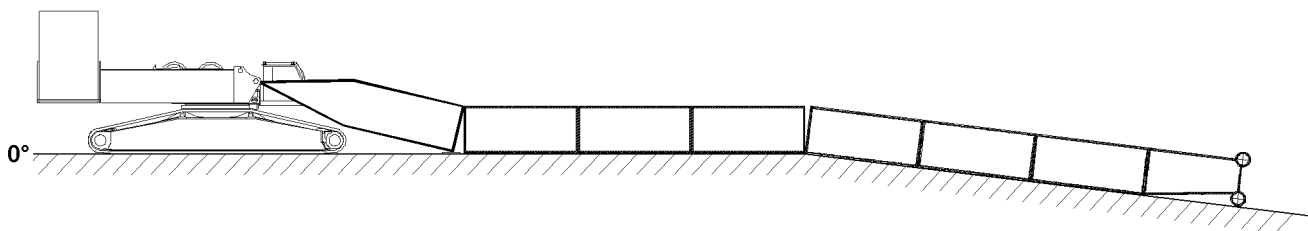


Fig.121642: Boom - intermediate sections installed and taken down on descending terrain

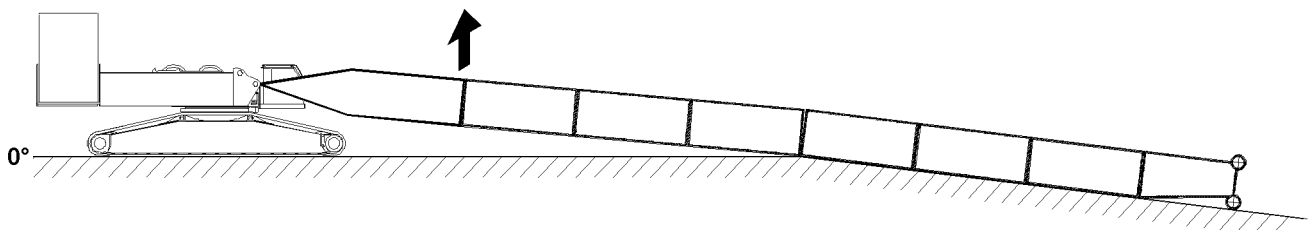


Fig.121643: Lifting and close the boom system in the area of the boom - pivot section

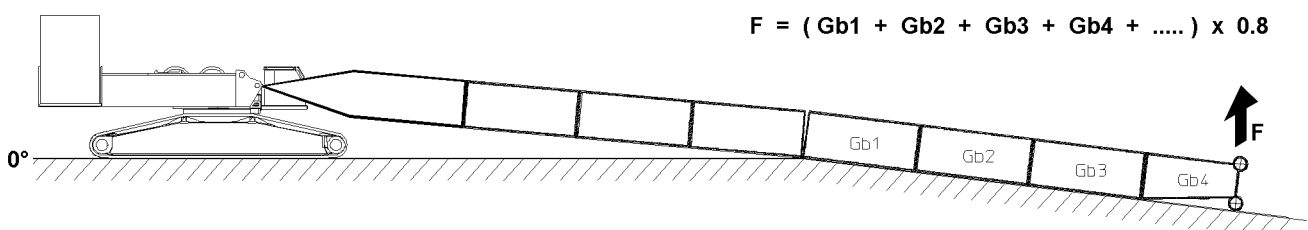


Fig.145514: Calculation of force for the closing procedure of the boom system



#### Note

- ▶ The abbreviations Gb1, Gb2, ... are for the weights of the individual lattice sections.
- ▶ The weights of the lattice sections are noted on the welded-on weight tags on the lattice sections.

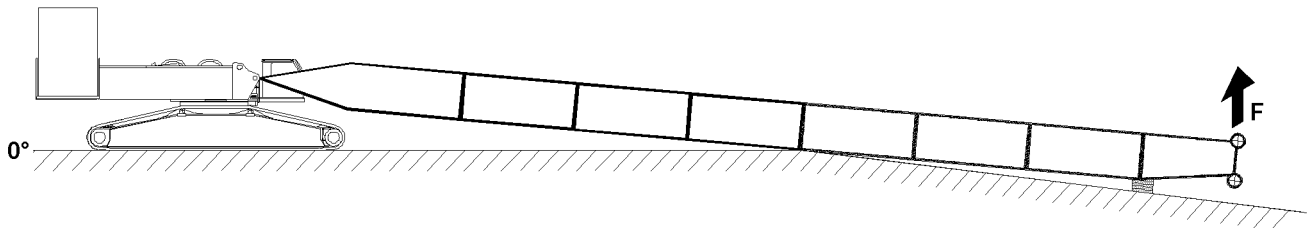


Fig.121644: Lifting and closing the boom system // Supporting the boom system



**Note**

- ▶ The height of the substructure in the area of the boom end section depends on the lay of the terrain and the resulting incline of the boom system.
- ▶ Support the boom system properly after the closing procedure.

**16.21.2 Disassembling boom systems on descending terrain**

Make sure that the following prerequisite is met:

- An auxiliary crane with sufficient load bearing capacity is available.

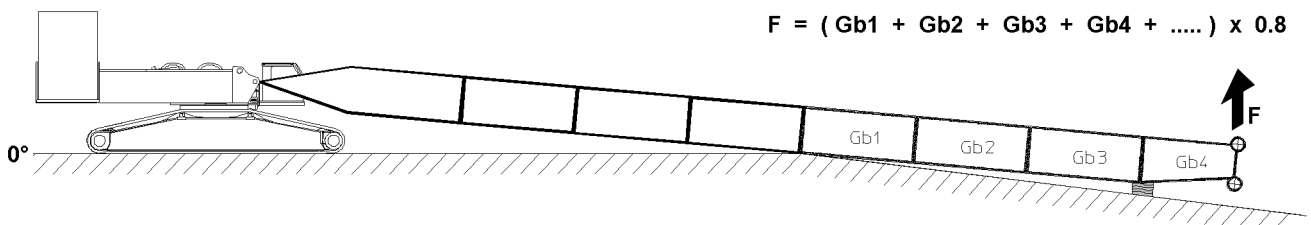


Fig.145515: Calculation of the force for opening the boom system // Lifting the boom system // Removing the substructure // Opening the boom system



**Note**

- ▶ The abbreviations Gb1, Gb2, ... are for the weights of the individual lattice sections.
- ▶ The weights of the lattice sections are noted on the welded-on weight tags on the lattice sections.

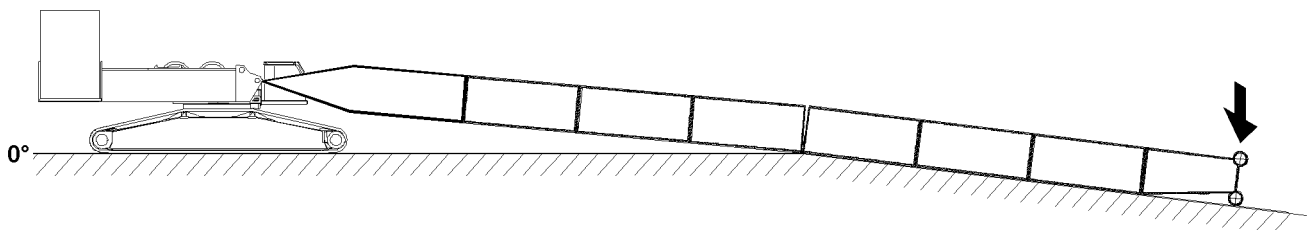


Fig.121658: Taking the boom system down

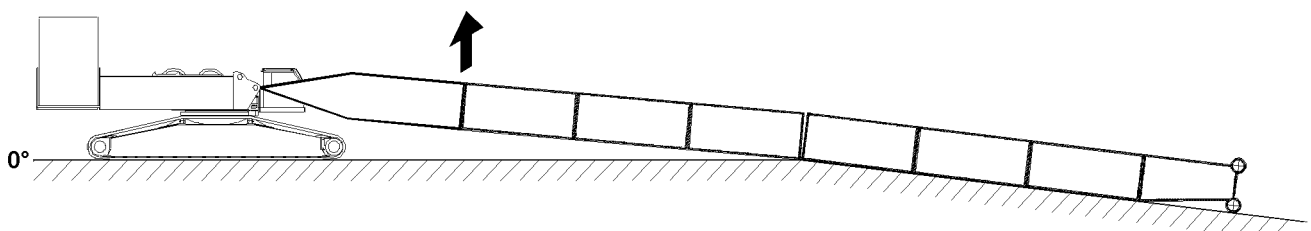


Fig.121655: Lifting and opening the boom system

LWE/LR 1800-1-0-000/27200-07-02/en

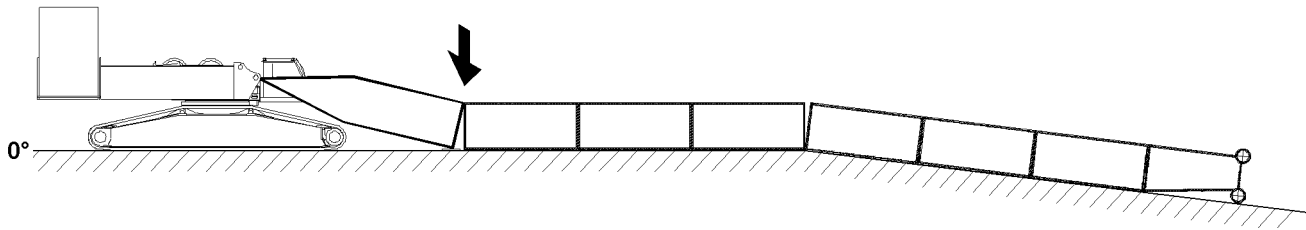


Fig.121656: Taking the boom system down

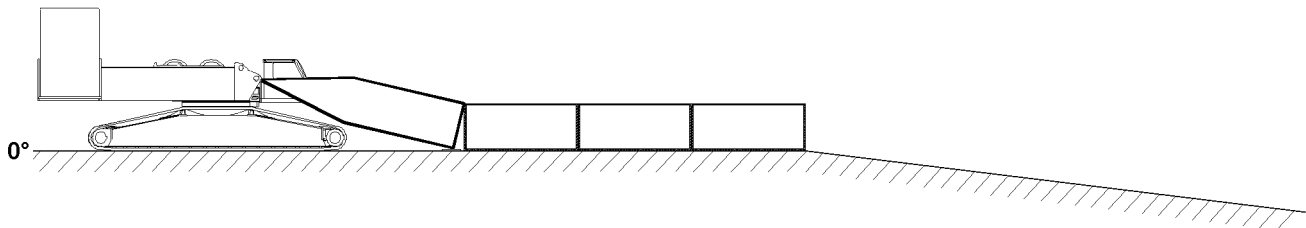


Fig.121641: Disassembling and removing the boom - intermediate sections with the end section

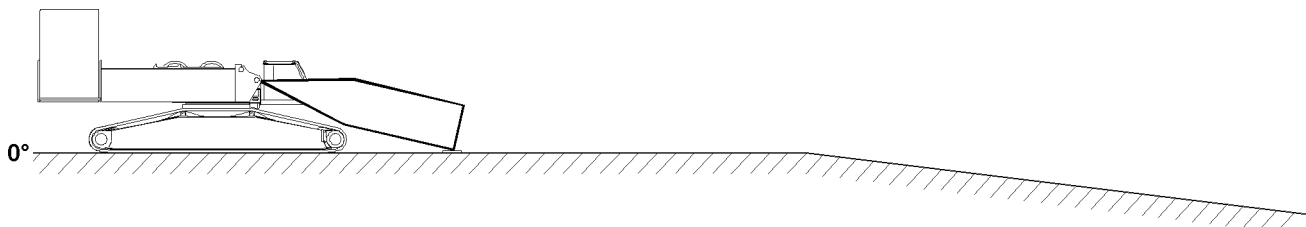


Fig.121640: Disassembling and removing the boom - intermediate sections to the boom - pivot section

- ▶ Disassemble and remove the boom - pivot section.

## 16.22 Closing the boom system - opening the boom system (via the SA-frame)



### Note

- ▶ This section is described as an example.
- ▶ The illustrations in this section are shown as an example.

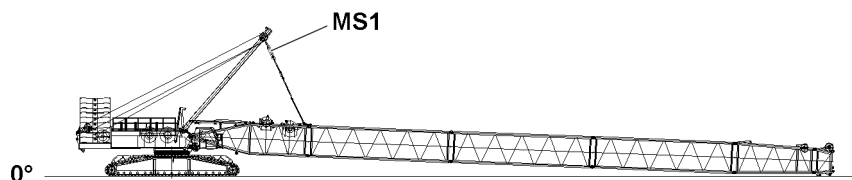


Fig.161332: Test point 1 closing the boom system - opening the boom system



### DANGER

Overload of the crane!  
Death, severe bodily injuries, property damage.

- ▶ The closing and opening of different boom systems with the SA-frame is only permissible up to certain maximum boom lengths.
- ▶ Make sure that there are no persons on the boom system as well as in the danger zone during the opening and closing procedure.

**Note**

The actual forces in test point 1 **MS1** - which are used during the closing and opening procedure of the boom system - are displayed on the LICCON monitor. The force determined in test point 1 is generally designated as  $F1_{actual}$ .

When specifications are available for the force in test point 1 **MS1** on the assembly drawing:

- ▶ Observe the specifications for the force in test point 1 **MS1**.

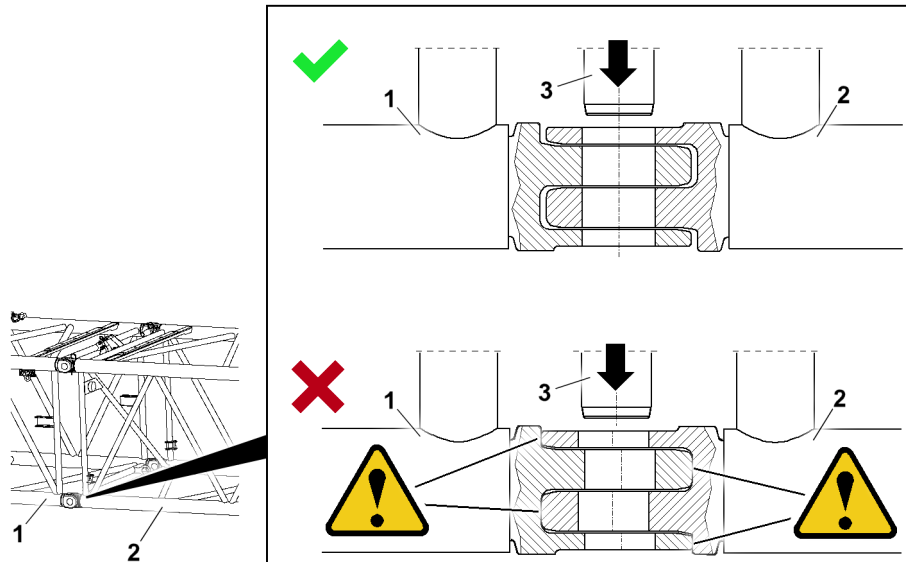


Fig.161335: Alignment of the lattice sections and overloaded pin bores

- 1 Lattice section 1
- 2 Lattice section 2

- 3 Connector pin

**DANGER**

Overload of the crane!

If when opening and closing too much force is applied in test point 1, the boom system can be overloaded.

Death, severe bodily injuries, property damage.

- ▶ Spool winch 4 up to the maximum when closing the boom system such that the pin bores of the lattice sections align. Take note of the force in test point 1. The noted value is decisive for opening.
- ▶ Do not load or push the connecting forks into each other on the block.
- ▶ When opening, use the noted force from the closing procedure as an orientation.
- ▶ The end section may **not** lift off the ground during the boom system closing and opening procedure, it must lie on the ground.
- ▶ The maximum permissible  $F1$ -total force ( $F1_{max}$ ) on the LICCON monitor may not be used as a limit value, as it protects another condition (the completely assembled boom).
- ▶ A maximum force in test point 1 specified in the assembly drawing cannot always be approached. At times, the closing procedure can be carried out with significantly lower forces, for example with light, short booms.

**Note**

- ▶ Counterweight and central ballast, see the Erection chart depending on the boom length.

### 16.22.1 Closing the boom system (via the SA-frame)

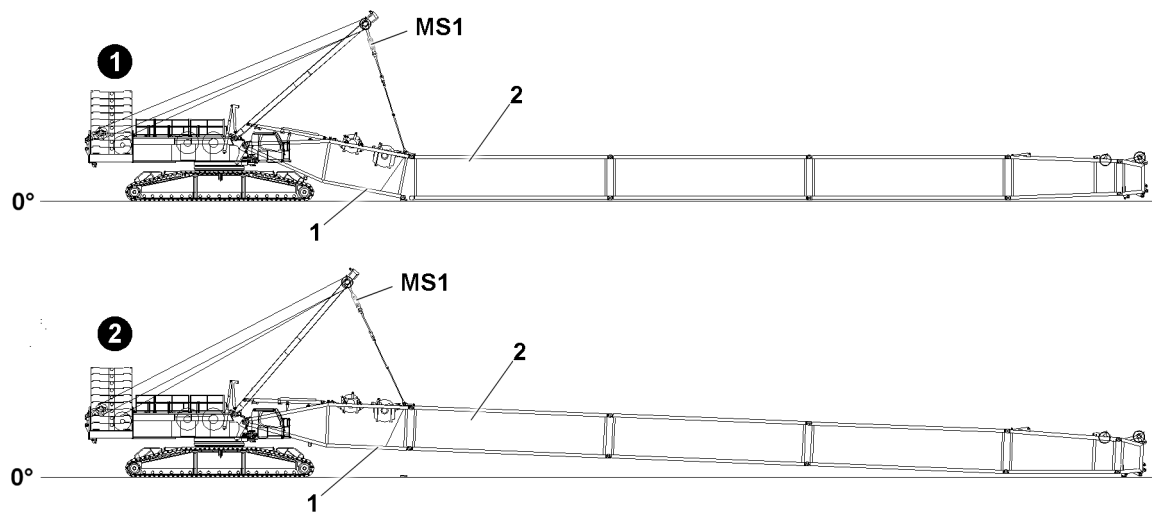


Fig.161384: Example: Boom system with closing

1 Pivot section

2 Intermediate section

Make sure that the following prerequisites are met:

- Counterweight and central ballast positioned according to the assembly drawing.



#### Note

Noted actual force in test point 1 **MS1** for later disassembly.

- ▶ When unpinning in the same location with the same ACTUAL force in test point 1 **MS1**, pull to release the connector pin.

- ▶ Spool winch 4 up such that the pin bores of the pivot section 1 and the intermediate section 2 align.

When the pin bores align:

- ▶ Take note of the actual force in test point 1 **MS1** displayed on the LICCON monitor.
- ▶ Insert the connector pin on both sides and secure.
- ▶ Spool winch 4 out such that the boom system is relieved.

#### Result:

- Boom system closed.

### 16.22.2 Opening the boom system (without derrick boom)

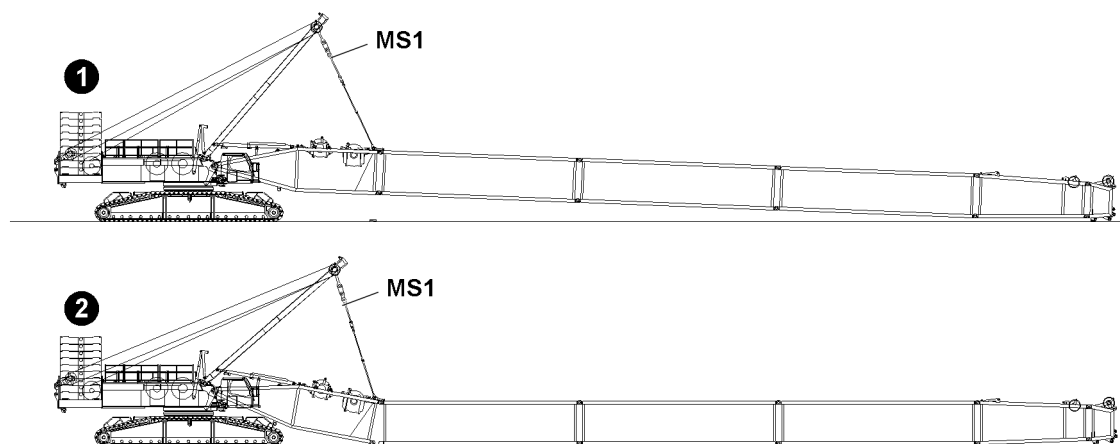


Fig.161385: Example: Opening the boom system

**Note**

- ▶ Use the noted actual force in test point 1 **MS1** to pretension the boom system.
- ▶ Spool winch 4 up until the noted actual force is reached in test point 1 **MS1**.
- ▶ Release and unpin the connector pins on both sides.

**NOTICE**

Danger of property damage!

When lowering the opened boom system incorrectly, crane components can be damaged.

- ▶ Observe the specifications regarding railings and substructure.
- ▶ Spool winch 4 out and lower the boom system properly.

**Result:**

- Boom system opened and taken down.

## 16.23 Closing the boom system - opening the boom system (via the derrick boom)

**Note**

- ▶ This section is described as an example.
- ▶ The illustrations in this section are shown as an example.

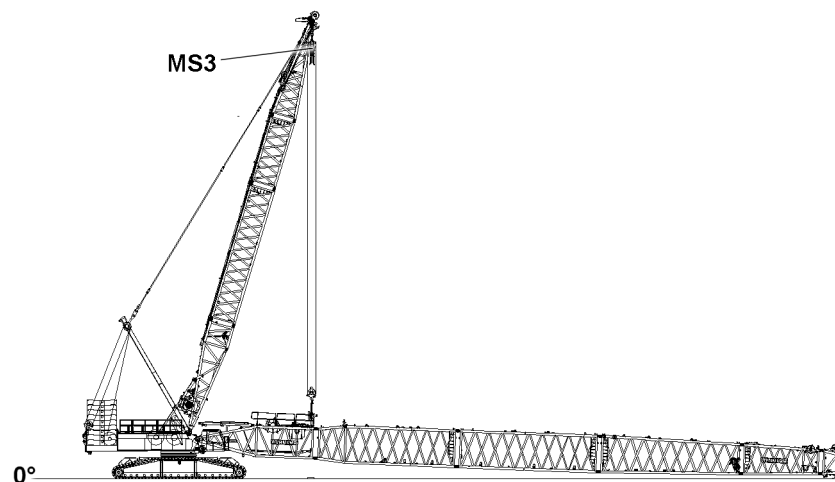


Fig.161378: Test point 3 closing the boom system - opening the boom system

**DANGER**

Overload of the crane!

Death, severe bodily injuries, property damage.

- ▶ The closing and opening of different boom systems with the derrick boom is only permissible up to certain maximum boom lengths.
- ▶ Make sure that there are no persons on the boom system as well as in the danger zone during the opening and closing procedure.

**Note**

The actual forces in test point 3 **MS3** - which are used during the closing and opening procedure of the boom system - are displayed on the LICCON monitor. The force determined in test point 3 is generally designated as  $F3^{actual}$ .

When specifications are available for the force in test point 3 **MS3** on the assembly drawing:

- ▶ Observe the specifications for the force in test point 3 **MS3**.

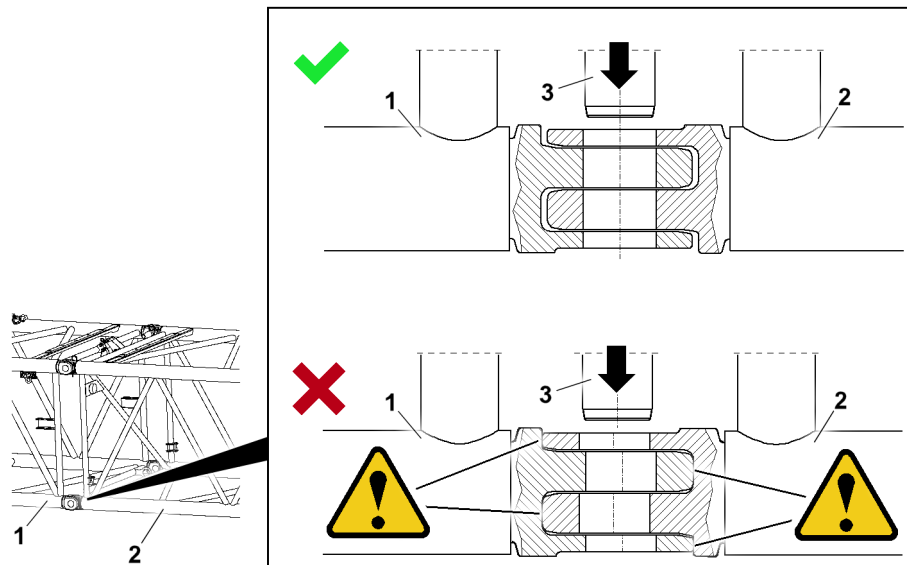


Fig.161335: Alignment of the lattice sections and overloaded pin bores

1 Lattice section 1  
2 Lattice section 2

3 Connector pin



### DANGER

Overload of the crane!

If when opening and closing too much force is applied in test point 3, the boom system can be overloaded.

Death, severe bodily injuries, property damage.

- ▶ Spool winch 3 up to the maximum when closing the boom system such that the pin bores of the lattice sections align. Take note of the force in test point 3. The noted value is decisive for opening.
- ▶ Do not load or push the connecting forks into each other on the block.
- ▶ When opening, use the noted force from the closing procedure as an orientation.
- ▶ The end section may **not** lift off the ground during the boom system closing and opening procedure, it must be lie on the ground.
- ▶ The maximum permissible F3-total force ( $F_{3_{max}}$ ) on the LICCON monitor may not be used as a limit value, as it protects another condition (the completely assembled boom).
- ▶ The maximum permissible F3-total force ( $F_{3_{max}}$ ) on the LICCON monitor cannot always be approached. At times, the closing procedure can be carried out with significantly lower forces, for example with light, short booms.



### 16.23.1 Closing the boom system (via the derrick boom)

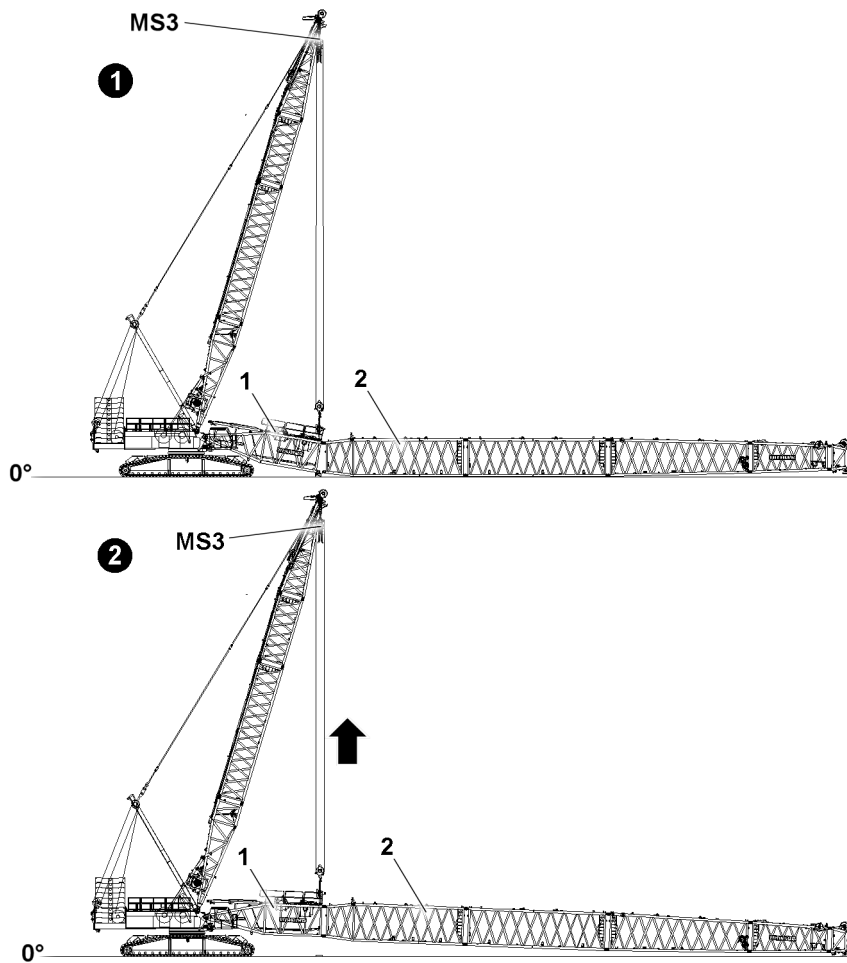


Fig.161383: Example: Closing the boom system

1 Pivot section

2 Intermediate section

Make sure that the following prerequisites are met:

- Counterweight and central ballast positioned according to the assembly drawing.



#### Note

When the pin bores align:

- ▶ When unpinning with the same ACTUAL force in test point 3 **MS3**, pull to release the connector pin.
- ▶ Spool winch 3 up to the maximum until the pin bores of the intermediate section 2 and the pivot section 1 align.

When the pin bores align:

- ▶ Take note of the actual force in test point 3 **MS3** displayed on the LICCON monitor.
- ▶ Insert the connector pin on both sides and secure.
- ▶ Spool winch 3 out such until the boom system is relieved.

#### Result:

- Boom system closed.

### 16.23.2 Opening the boom system (without derrick boom)

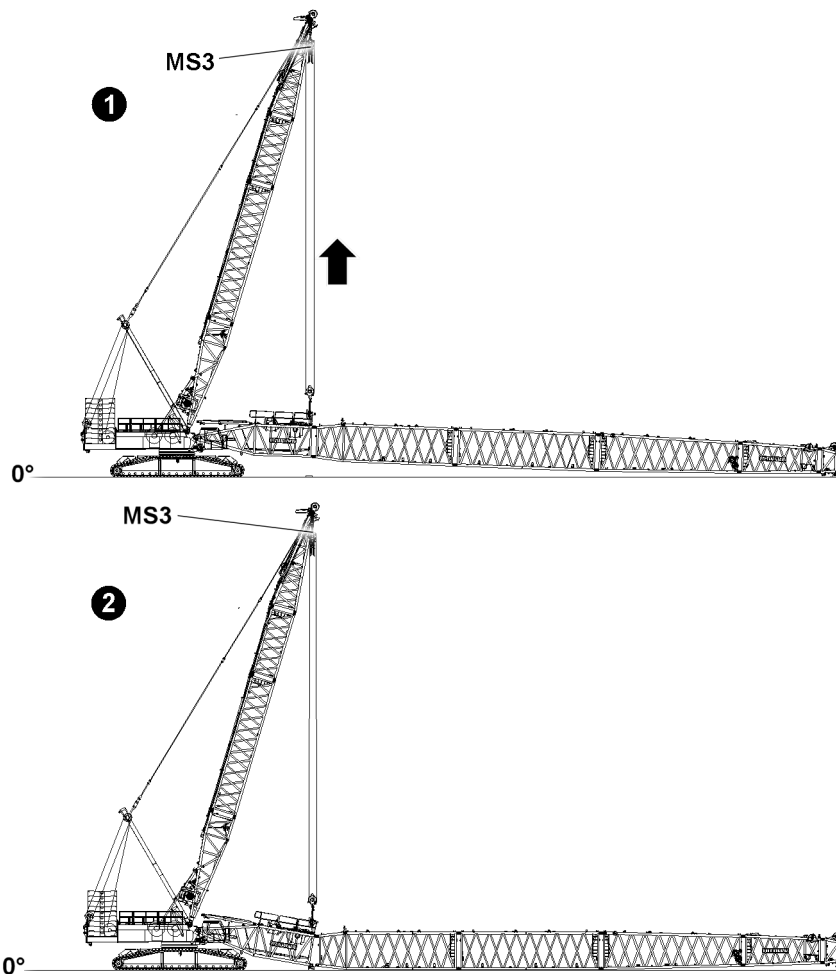


Fig.161382: Example: Opening the boom system



#### Note

- ▶ Use the noted actual force in test point 3 **MS3** to pretension the boom system.
- ▶ Spool winch 4 up until the noted actual force is reached in test point 3 **MS3**.
- ▶ Release and unpin the connector pins on both sides.

#### NOTICE

Danger of property damage!

When lowering the opened boom system incorrectly, crane components can be damaged.

- ▶ Observe the specifications regarding railings and substructure.
- ▶ Spool winch 3 out and lower the boom system properly.

#### Result:

- Boom system opened.

## 17 Erecting / taking-down



### WARNING

The crane can topple over!

Due to an unforeseen occurrence, for example: Sudden strong wind or storm can lead to dangerous operating situations, up to toppling the crane.

Death, severe bodily injuries, property damage.

- ▶ The boom must be able to be taken down at any time with its current equipment, observe the erection and take-down charts. Observe the job planner.
- ▶ The counterweights and / or ballasts required for this must always be in direct vicinity of the crane.
- ▶ The crane operator must ensure that the required counterweight and / or the required ballast is carried along when driving the crane with the equipment in place and that the boom can be placed down at any time.



### WARNING

Danger of fatal injury!

- ▶ Incorrectly installed or non-functioning limit switches as well as falling parts (pins, cotter pins, ice etc.) can cause accidents.

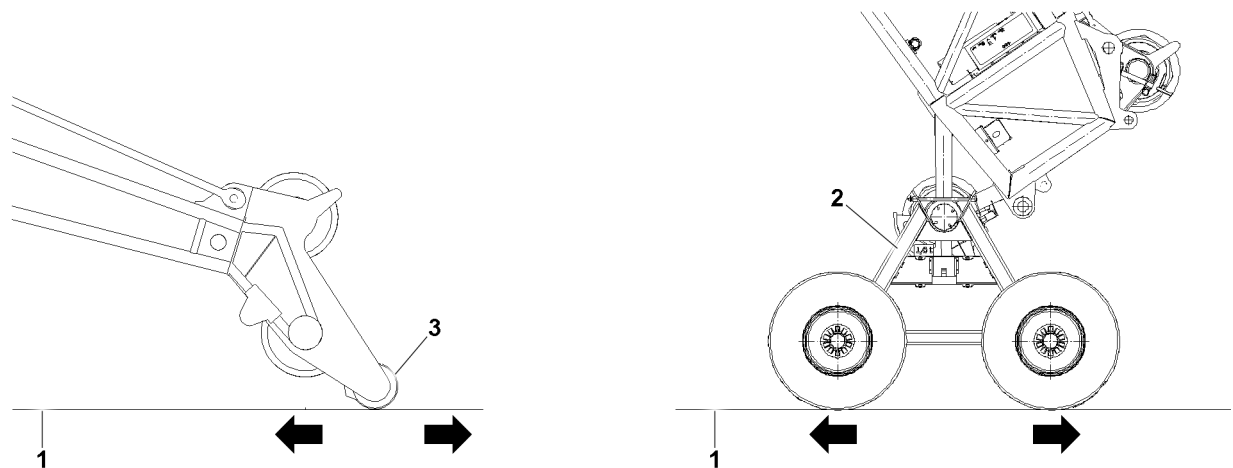


Fig.152357: Roller cart road or lattice head track roller

- |      |             |                           |
|------|-------------|---------------------------|
| 1    | 2           | 3                         |
| Road | Roller cart | Lattice head track roller |

When erecting or taking down with the aid of a roller cart **2** or a lattice head track roller **3**, make sure that the following prerequisites are met:

- The road **1** is level.
- The road **1** has a sufficient load bearing capacity.
- The road **1** is free of obstacles.
- The road **1** is free of persons.

## 17.1 Erecting / taking down with mobile cranes

Make sure that the following prerequisites are met:

- The crane is properly supported.
  - The crane is horizontally aligned.
  - The counterweight has been installed on the turntable according to the load chart or the erection / take down charts.
  - In the case of cranes with derrick ballast: The derrick ballast (suspended ballast or ballast trailer ballast) is installed according to the load chart or the erection / take down charts.
  - For cranes with a telescopic boom: The telescopic boom is telescoped in all the way.
  - The boom has been installed according to the load chart and the Crane operating instructions.
  - The hoist rope has been correctly placed in the rope pulleys and prevented from jumping out with the rope retaining pins.
  - All limit switches have been correctly assembled and are fully operational.
  - All pin connections are secured.
  - No persons in the danger zone.
  - No loose parts on the boom or the auxiliary boom.
  - The exposed rope pulleys are free of snow and ice.
  - The boom and its components (limit switches, cable drums, airplane warning light, wind speed sensor etc.) must be kept free of ice and snow.
- ▶ Check if all prerequisites have been met.

The roller cart may not be lifted off the ground.

Before the N-head lifts up:

- ▶ Unpin the roller cart on the N-head.

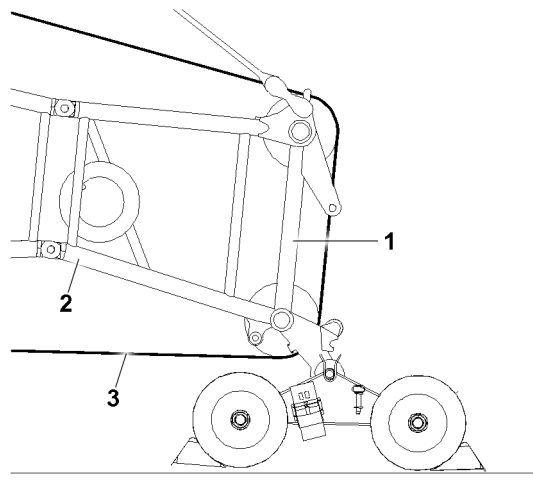


Fig.152358: Securing the hoist rope to the head of the lattice jib

When the luffing lattice jib is erected or taken down **angled**, then the hoist rope must be secured **prior to reeving in** or **after reeving out** the hook block.

Before the hook block is reeved in or after the hook block is reeved out, it is possible that the hoist rope is pulled out of the head of the lattice jib. Therefore the hoist rope must be secured by a hemp rope.



### WARNING

Hoist rope not secured!

The hoist rope can run back in the direction of the hoist winch after reeving out or reeving in the hook block.

- ▶ Secure the hoist rope with the hemp rope.
- ▶ Fasten the hemp rope with Prusik knots to the hoist rope **3**.

- ▶ Fasten both ends of the hemp rope on the corner bar pipe **2** of the head **1** of the lattice jib with tie knots.

## 17.2 Erecting / taking down with crawler cranes

Make sure that the following prerequisites are met:

- Comply with the maximum permissible incline of the crane specified in the load chart manual.
  - For cranes with a support: The crane is properly supported.
  - For cranes with a support: The crane is horizontally aligned.
  - The counterweight is installed on the turntable according to the load chart.
  - The central ballast is installed according to the load chart.
  - The counterweight is installed according to the load chart or the erection / take down charts.
  - In the case of cranes with derrick ballast: The derrick ballast (suspended ballast or ballast trailer ballast) is installed according to the load chart or the erection / take down charts.
  - For cranes with a telescopic boom: The telescopic boom is telescoped in all the way.
  - The boom has been installed according to the load chart and the Crane operating instructions.
  - The hoist rope has been correctly placed in the rope pulleys and prevented from jumping out with the rope retaining pins.
  - All limit switches have been correctly assembled and are fully operational.
  - All pin connections are secured.
  - No persons in the danger zone.
  - No loose parts on the boom or the auxiliary boom.
  - The exposed rope pulleys are free of snow and ice.
  - The boom and its components (limit switches, cable drums, airplane warning light, wind speed sensor etc.) must be kept free of ice and snow.
- ▶ Check if all prerequisites have been met.

## 17.3 Rigging the guy rods on lattice booms on placed down boom system



### WARNING

Danger of fatal injury due to damaged guy rods!

If the boom system is placed on the ground or a load bearing substructure in strong wind or longer downtime, the guy rods can be damaged due to wind influence on the boom guying. This wind influenced oscillations can lead to fatigue on the guy rods.

As a result, the guy rods could break or rip off under load - for example when erecting the boom system or in crane operation. The boom system can therefore fall uncontrolled forward onto the ground. Death, severe bodily injuries, property damage.

- ▶ Make sure that the guy rods are taken down completely on the lattice sections and relieved when the boom systems are taken down on the ground.
- ▶ Make sure that freely suspended guy rods are rigged on the lattice boom.
- ▶ Make sure that the upper pulley block is rigged on the lattice boom in Derrick operating modes.
- ▶ Make sure, that the guying on the luffing lattice jib is removed on lattice mast cranes.
- ▶ Make sure that the guy rods are inspected before resuming crane operation and that no damage or cracks are present.
- ▶ Make sure that the maintenance intervals of the guy rods are adhered to.



### Note

- ▶ In case of strong wind or longer downtimes of the crane, the boom system must be placed on the ground or on a load bearing substructure.
- ▶ The guying must be relieved and the guy rods must be placed on the transport receptacles.
- ▶ The following illustrations are examples and may not match your crane exactly.

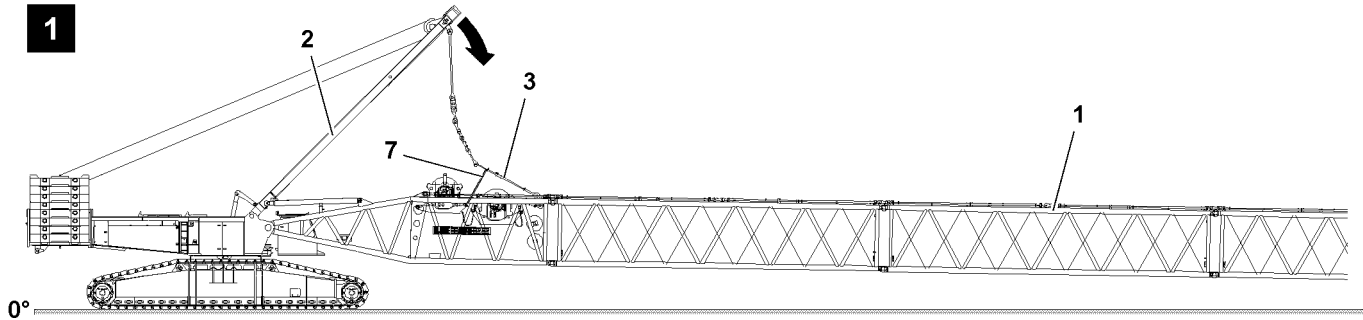


Fig.120722: Guying taken down in transport receptacle and SA-frame guying relieved

- ▶ Take the guy rods down on the lattice sections 1: Luff the SA-frame 2 down to the front until the guying is taken down completely in the transport receptacles on the lattice sections and the SA-frame guying 3 is relieved, see illustration 1.
- ▶ To minimize side oscillation of the SA-frame guying 3 due to wind influence: Rig the SA-frame guying 3 with suitable rigging straps / ropes 7 against the boom, see illustration 1.

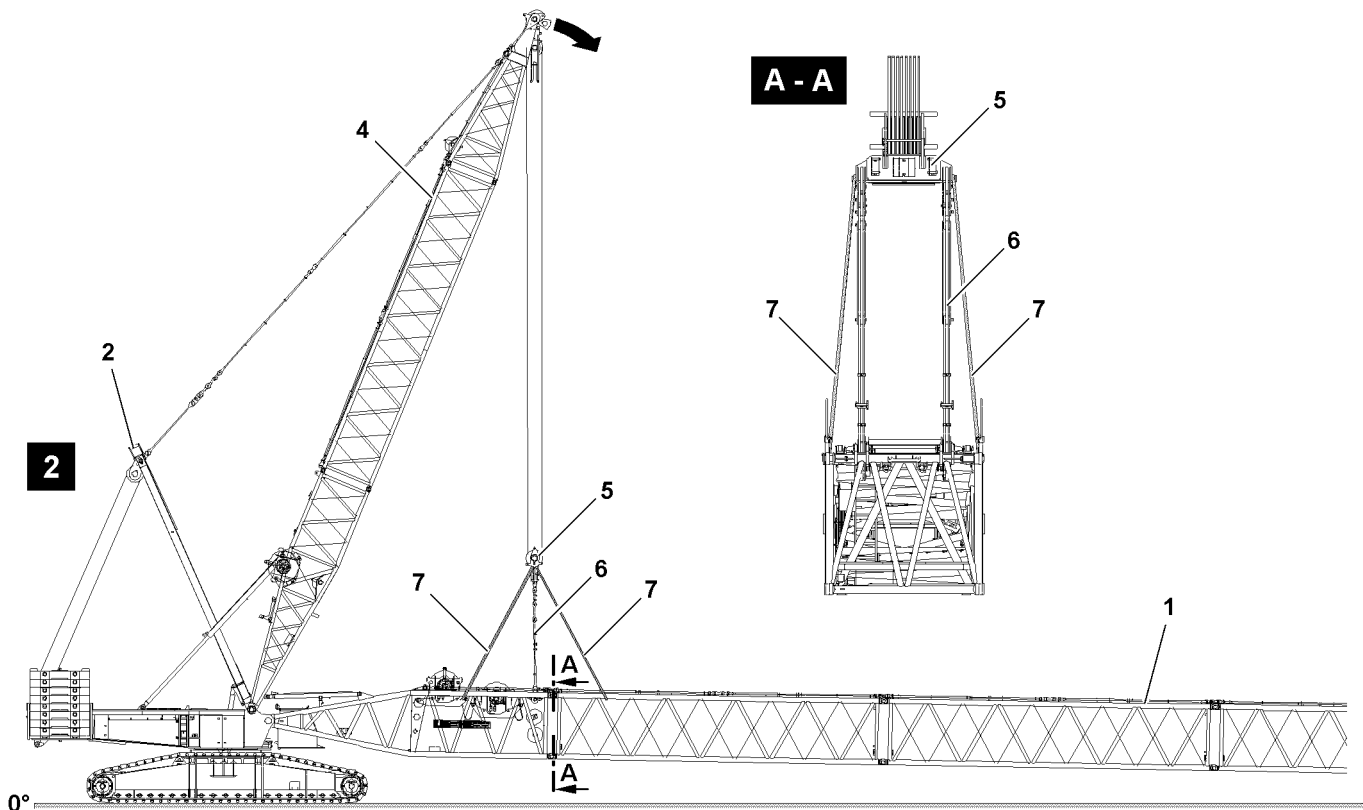


Fig.120771: Guying taken down in the transport receptacle and upper pulley block rigged against the boom

- ▶ Take the boom system down and - if present - release the derrick guying to the derrick ballast.
- ▶ Take the guy rods down on the lattice sections 1: Luff the D-boom 4 down to the front until the main boom guying is taken down completely in the transport receptacles on the lattice sections and the upper pulley block 5 is positioned over the S-pivot section, see illustration 2.
- ▶ To minimize side oscillation of the upper pulley block 5 due to wind influence: Rig the upper pulley block 5 with suitable rigging straps / ropes 7 against the boom, see illustration 2.

**For cranes with lattice mast and with luffing lattice jib the following applies:**

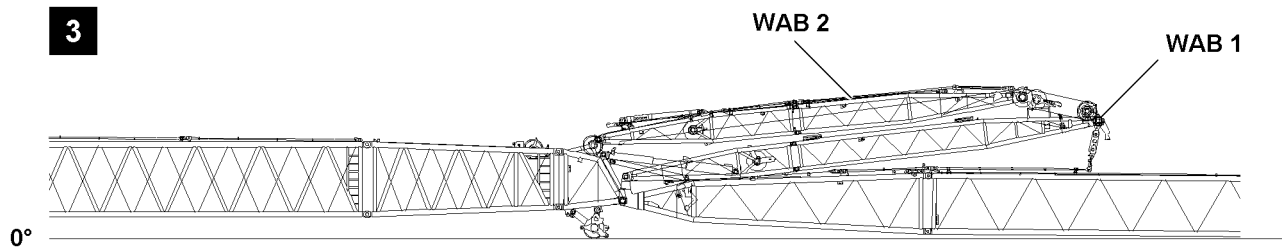


Fig.120821: Guying in the transport receptacle(s) and WA-frames taken down to the front (example crane with lattice mast)



#### WARNING

Danger of accident when removing the W-guying!

When taking down and removing the guying dangerous situations can arise.

- ▶ Make sure that the danger notes in the respective chapter of the Crane operating instructions are observed.
- ▶ Disassemble the guy rods on the luffing lattice jib and take them down into the transport receptacles.
- ▶ Take the WA-frames (WA-frame 1 **WAB 1** and WA-frame 2 **WAB 2**) down to the front.

**For telescopic cranes with luffing lattice jib the following applies:**

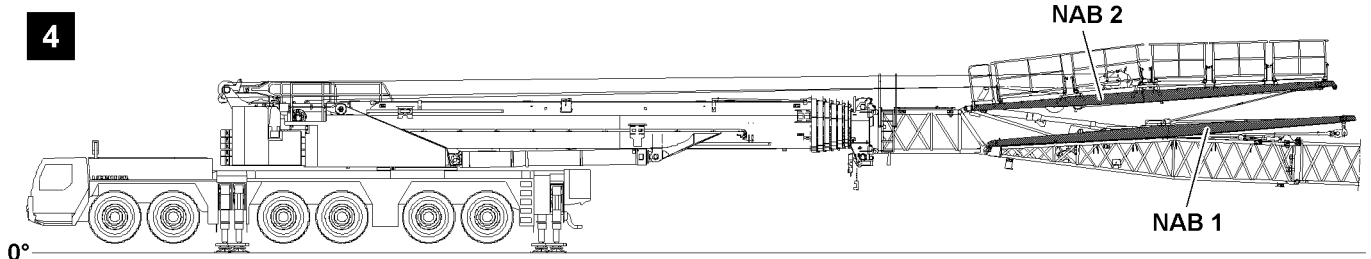


Fig.121261: Guying in the transport receptacle(s) and NA-frames taken down to the front (example telescopic crane)



#### WARNING

Danger of accident when taking the NA-frames down!

When taking the guy rods as well as the NA-frames down dangerous situations can arise.

- ▶ Make sure that the danger notes in the respective chapter of the Crane operating instructions are observed.
- ▶ Spool the jib control winch out and take the NA-frames down to the front so that the guy rods are relieved.

## 18 Walking on a boom component



#### WARNING

Falling from the boom component!

Death, severe bodily injuries.

- ▶ Before working on a boom component, personnel must wear an approved fall arrest system and protective equipment.

**WARNING**

Falling from the boom component!

Operating personnel falling from a boom component due to tripping on objects.

Death, severe bodily injuries.

- ▶ Make sure that there are no objects on the boom component when walking on it.

**WARNING**

Overload of the grating!

Operating personnel falling from the boom component grating if the grating is overloaded due to an impermissible number of personnel.

The grating for the boom components is permitted for the weight of only two people.

Death, severe bodily injuries.

- ▶ Make sure that only the permissible number of personnel can walk on the grating at the same time.

**WARNING**

Impermissible work position for the hydraulic aggregate!

If a hydraulic aggregate is placed on boom components or crane components for assembly purposes, this can cause accident situations.

Operating personnel can fall down from the grating of the boom component if the grating is overloaded by the hydraulic aggregate positioned on it.

The grating for the boom components is permitted for the weight of only two people.

Death, severe bodily injuries, property damage.

- ▶ Make sure that a hydraulic aggregate is never placed on boom components or crane components.
- ▶ The hydraulic aggregate may only be operated on the ground.



## 5.02 SA-frame

1	Safety	2
2	Function and actuation	3
3	Performing the function checks	4
4	Erecting the SA-frame	5
5	Taking the SA-frame down	9

# 1 Safety

Before accessing the crane, observe the safety instructions.

- General safety information: See chapter 2.04.
- Information regarding personal protective equipment: See chapter 2.04.
- Information regarding the use of ladders: See chapter 2.04.10.
- Information regarding available hook points: See chapter 2.06.



## WARNING

Slippery surfaces, lack of stability!

Death, severe bodily injuries, property damage.

- ▶ Keep ladders, walking surfaces, stairs and stepping surfaces free of objects and obstacles.
- ▶ Only step on ladders, stairs, walking surfaces and stepping surfaces with sufficiently clear height.
- ▶ Only step on ladders, stairs, walking surfaces and stepping surfaces with clean shoes.
- ▶ Keep ladders, stairs, walking surfaces and stepping surfaces free of heavy dirt, snow and ice.
- ▶ Stepping on ladders, stairs, walking surfaces and stepping surfaces by persons, including tools and equipment, weighing more than 150 kg is prohibited.
- ▶ Do **not** step on damaged ladders, stairs, walking surfaces and stepping surfaces and replace them immediately.
- ▶ Do **not** trip over attachment parts.
- ▶ Personnel must wear an approved fall arrest system and protective equipment before performing any work on the crane superstructure.

When fall protection equipment is **not** in the assembly / disassembly position or personnel is on **non**-walking surfaces and stepping surfaces:

- ▶ Personnel must hook themselves to the hook points and safety ropes with an approved fall arrest system to prevent falling.

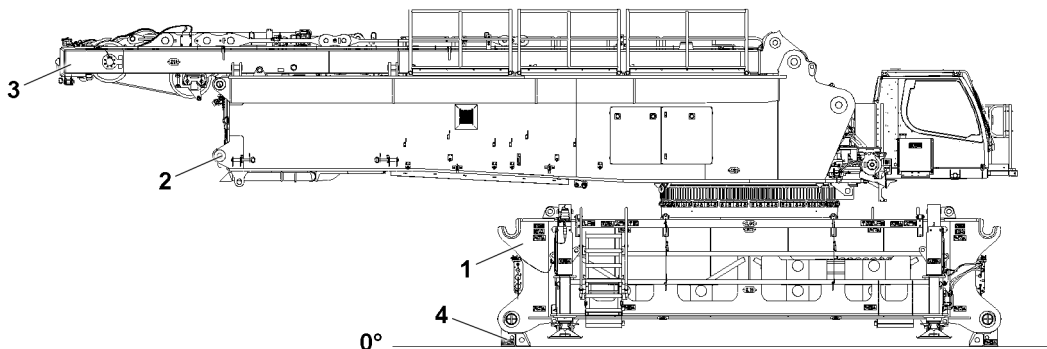


Fig.155751: The crane is lying with the crawler center section 1 on the substructure 4



## DANGER

The crane can topple over!

When the crawler center section 1 lies on the substructure 4 and the crane turntable 2 is turned, the crane can fall over.

Death, severe bodily injuries, property damage.

- ▶ Turning the turntable 2 is **prohibited**.

## 2 Function and actuation

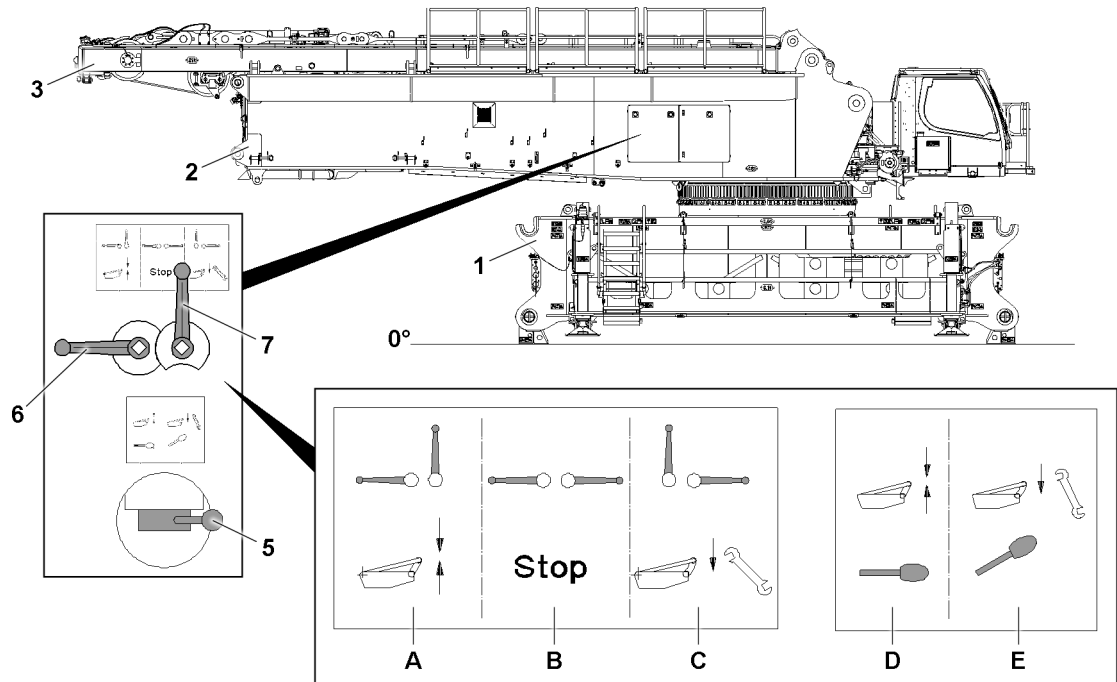


Fig.155752: Crane with SA-frame 3 and ball valves for operation



**Note**

- ▶ The SA-frame is used in assembly operation to install the crawler travel gear, see chapter 3.01.
- ▶ In addition, the SA-frame is used during assembly operation for closing the boom systems and for guying the boom during the flying assembly of lattice sections, see chapter 5.05 and chapter 5.38.

Switch positions of ball valves (ball valve 6 / ball valve 7)		
Switch position	Function	Use
A	Erecting the SA-frame	Assembly and crane operation
B	SA-frame stop, cylinder stop	Block erection cylinder
C	Lower the SA-frame	Lower the SA-frame into transport position

Switch position Hand lever 5		
Switch position	Function	Use
D <sup>1)</sup>	Erecting the SA-frame	Assembly, crane operation
E <sup>2)</sup>	Lower the SA-frame	Lower the SA-frame into transport position

1) Hand lever 5 is in zero / basic position (not actuated).  
 2) Ball valve 6 and ball valve 7 are in switch position C.

LWE/LR 1800-1-0-000/27200-07-02/en

### 3 Performing the function checks



#### WARNING

Malfunctioning safety equipment!

Death, severe bodily injuries, property damage.

- ▶ Crane operation with non-functioning safety equipment is **prohibited**.
- ▶ Start crane operation only after all safety equipment have been checked and are functioning correctly.



#### Note

- ▶ The function of the individual limit switches must be checked before erection of the boom system.
- ▶ The function of the limit switch initiators must be checked in the test system, see the Diagnostics manual.



#### Note

- ▶ If a function check on the limit switches or on the safety equipment does not lead to the desired shut offs, then the plug connections on the connector boxes or the components itself must be checked.
- ▶ If no visible connection errors or component defects can be found, contact Liebherr Service.

Make sure that the following prerequisites are met:

- All electrical connections have been made.
- The crane engine is running.
- The corresponding operating mode is set on the LICCON monitor.

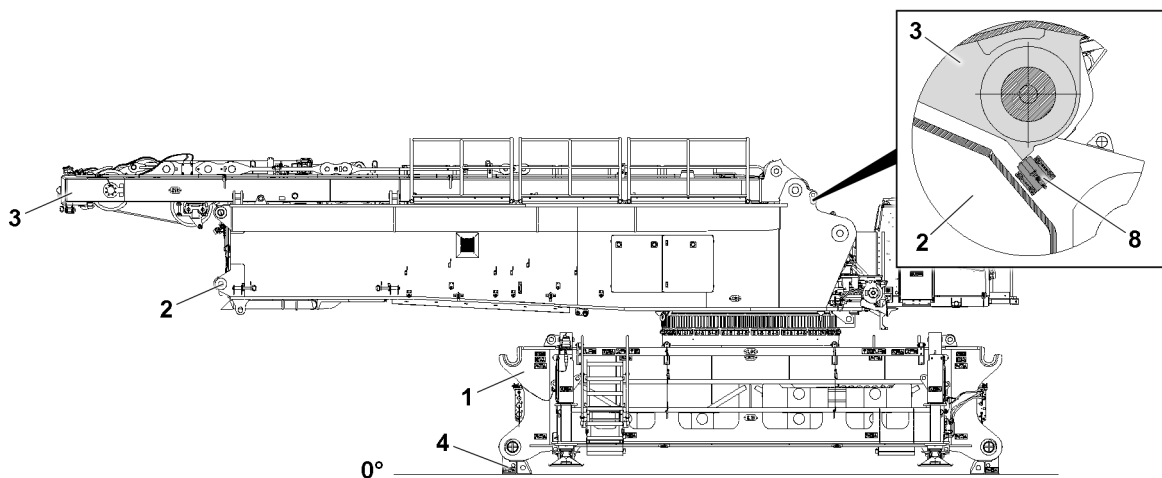


Fig.155753: Function check of the limit switch 8, SA-frame 3 on the bottom left and right



#### Note

- ▶ The limit switch functions have to be checked individually on both sides before erection of the SA-frame 3.
- ▶ Cover limit switches 8 individually with a metal plate.

#### Result:

- The spool out function of winch 4 turns off.

## 4 Erecting the SA-frame

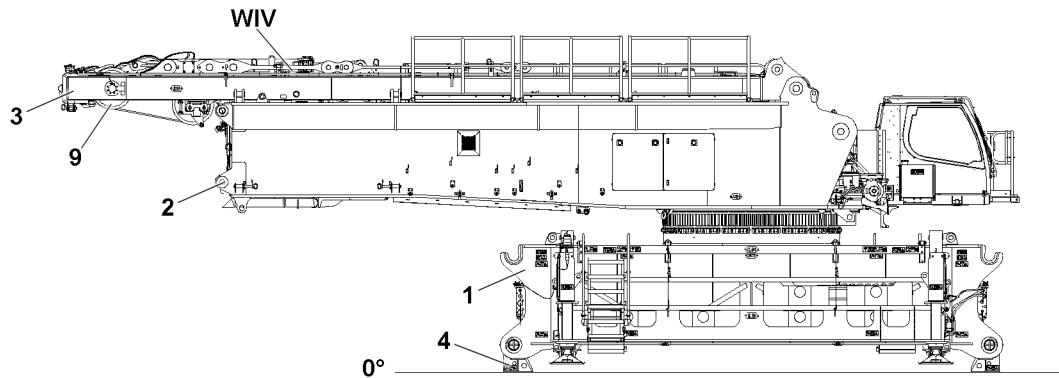


Fig.155754: SA-frame in the transport position

Make sure that the following prerequisites are met:

- The crawler center section is lying on the substructures **4**.

**or:**

The crawler travel gear is properly installed.

- The SA-frame **3** is in the transport position.
- There is no counterweight on the turntable.
- Winch **4** is reeved on the roller set **9** of the SA-frame **3**.
- The engine is running.
- The shut off limits of the LICCON overload protection are exceeded, see the Crane operating instructions, chapter 4.02.
- The SA-operating mode has been set and confirmed on the LICCON computer system.

### 4.1 Exceeding the shut off limits of the LICCON overload protection for assembly operation

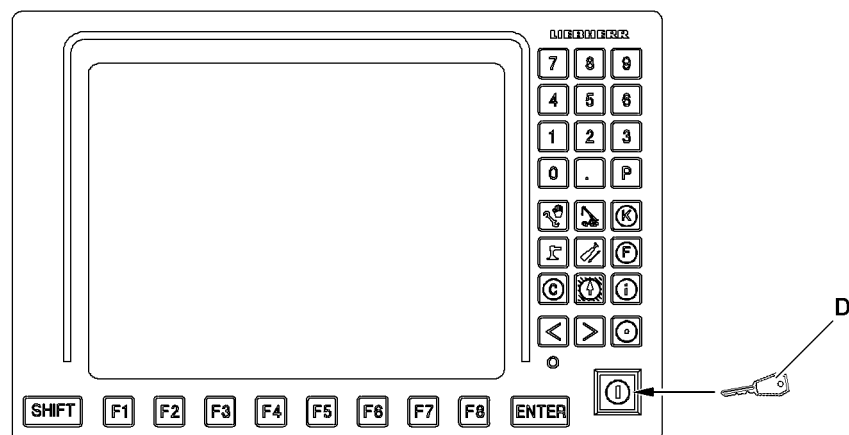


Fig.119109: LICCON monitor with assembly icon

**WARNING**

Danger of accident due to the “Exceedance of shut-off limits of the LICCON overload protection” function!

If the shut off limits of the LICCON overload protection are exceeded, there is no additional protection against crane overload.

Due to erroneous operation or deliberate misuse, the crane could collapse, the boom system can break off or the crane can topple over.

Death, severe bodily injuries, property damage.

- ▶ The function “Exceedance of shut off limits of the LICCON overload protection” is only permissible in emergencies and for assembly purposes.
- ▶ The function “Exceeding the shut off limits of the LICCON overload protection” may only be actuated by persons who know the effects of their actions regarding the function “Exceeding the shut off limits of the LICCON overload protection”.
- ▶ The “Exceedance of shut off limits of the LICCON overload protection” function requires the presence of an authorized person and must be performed with utmost caution.
- ▶ Crane operation with the “Exceedance of shut-off limits of the LICCON overload protection” function activated is prohibited.

- ▶ Exceeding the shut off limits of the LICCON overload protection: Engage assembly operation.

**Result:**

- The shut off limits of the LICCON overload protection are exceeded.
- The assembly icon appears on the LICCON monitor.

**Note**

- ▶ See Crane operating instructions, chapter 4.02 and chapter 4.20.

## 4.2 Erection procedure

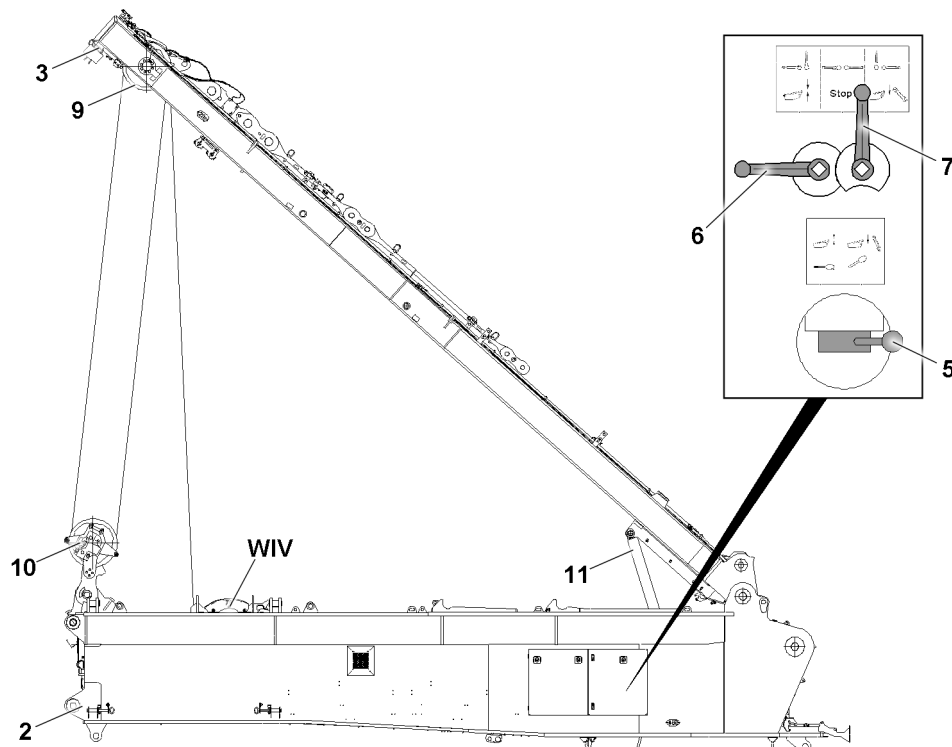


Fig.155755: Erection procedure

**NOTICE**

Danger of slack rope formation!

If winch 4 is spooled out too quickly during the erection procedure of the SA-frame **3**, slack rope can form.

- ▶ The intake rope of winch 4 must be tensioned during the entire erection procedure.
- ▶ The spool out speed of winch 4 must be matched to the erection speed of the erection cylinder **11**.

**WARNING**

Independent lowering of the SA-frame!

Due to incorrect ball valve positions during the erection procedure, the SA-frame **3** can lower backward by itself.

Death, severe bodily injuries, property damage.

- ▶ The ball valve **6** and ball valve **7** must be in position **A** during assembly and crane operation, see section "SA-frame operation".
- ▶ The ball valve position **C** "lower" and ball valve position **B** "stop" are only permissible when lowering the SA-frame onto the turntable (transport position), see section "SA-frame operation".

- ▶ Set the ball valve **6** and ball valve **7** in position **A**, see section "SA-frame operation".

**Result:**

- The SA-frame **3** is pushed upward by the erection cylinders **11** until the ropes are tensioned between the pulley support **10** and the roller set **9**.

**NOTICE**

Damage to ropes!

- ▶ Inspect the rope pulleys visually.
- ▶ The ropes must be laying correctly in the corresponding rope pulleys.

**Note**

- ▶ Functions of master switch MS1, see the Crane operating instructions, chapter 4.05.

- ▶ Move master switch MS1 in direction X+.

**Result:**

- Winch 4 spools out and the SA-frame **3** is erected forward by the erection cylinders **11**.
- The "???" turn off and the SA-operating mode is shown.

- ▶ Move master switch MS1 in direction X+.

**Result:**

- The SA-frame is lowered to the front and is now in the operating range of the SA-operating mode.

**WARNING**

The crane can topple over!

If the shut off limits of the LICCON overload protection are exceeded, there is no additional protection against overload.

Due to erroneous operation or deliberate misuse, the crane could collapse, the SA-frame can collapse or the crane can topple over.

Death, severe bodily injuries, property damage.

- ▶ When the operating range is reached, turn off / deactivate the function "Exceedance of the LICCON overload protection" immediately.

- ▶ Turn off / deactivate the function "Exceedance of the LICCON overload protection" immediately.

**Result:**

- The LICCON overload protection is active.

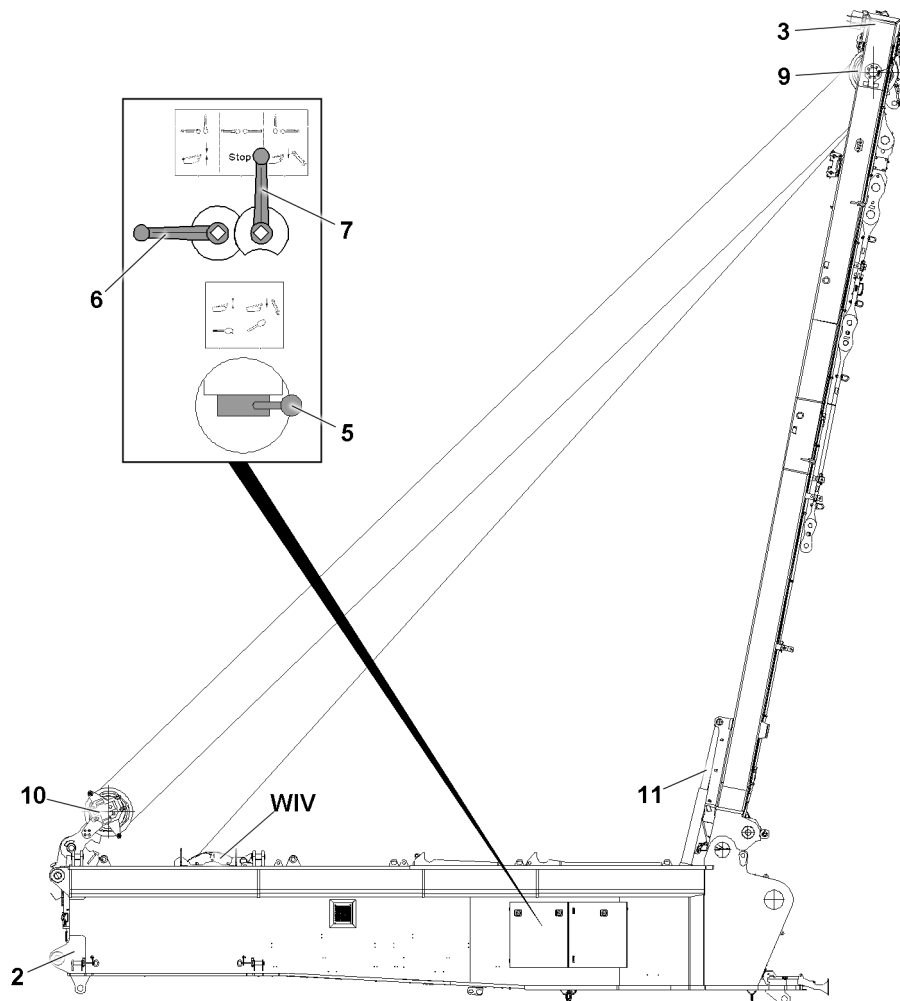


Fig.155756: Erecting the SA-frame



#### Note

- ▶ Due to the own weight of the SA-frame **3** and by spooling out winch **4** simultaneously, the SA-frame is lowered to the front.
- ▶ When the SA-frame leaves the operating range, an error message appears on the LICCON monitor and LMB stop is initiated.
- ▶ “Spooling out” winch **4** is turned off.
- ▶ “Luffing down” the SA-frame is blocked.
- ▶ “Luffing up” the SA-frame is only possible when the shut off limits of the LICCON overload protection are exceeded.
- ▶ If the minimum or maximum pressure is reached in the erection cylinders, winch **4** turns off. An error is shown.



#### WARNING

Danger of accident!

The ball valve **6** and ball valve **7** must be in position **A** during assembly and crane operation, see section “SA-frame operation”.

The ball valve position **C** and the ball valve position **B** are only permissible when lowering the SA-frame onto the turntable (transport position), see section “SA-frame operation”.

- ▶ After assembly, secure the ball valves.



**WARNING**

The crane can topple over!

Dangerous situations can result due to unauthorized access to the ball valves.

The crane can topple over.

Death, severe bodily injuries, property damage.

- ▶ Make sure that the ball valves are always protected against unauthorized access.

- ▶ Lock the turntable cover and keep the key in a safe place.

**Result:**

- The ball valves are secured against unauthorized access.

## 5 Taking the SA-frame down

### 5.1 Take down procedure

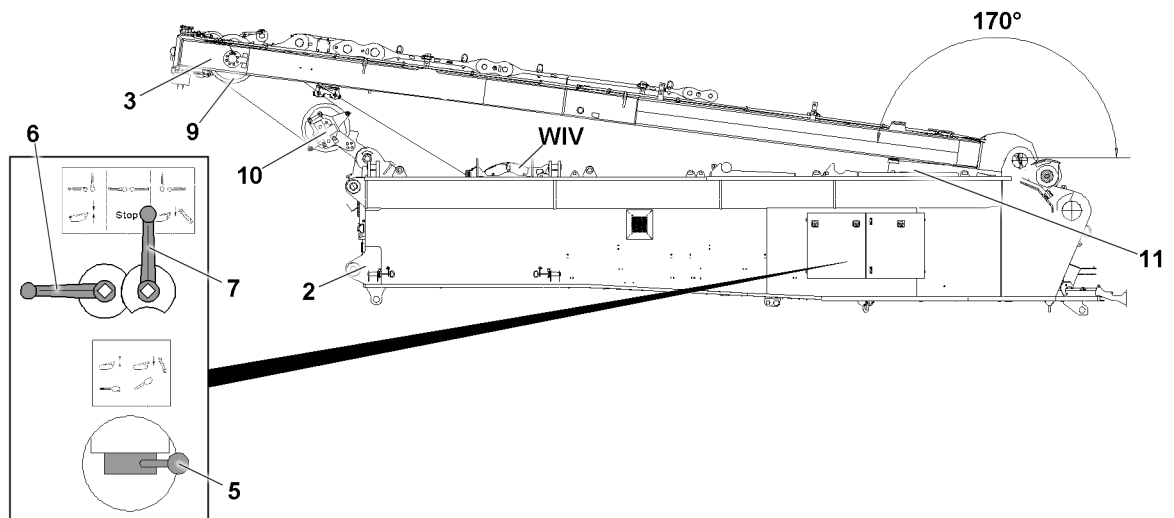


Fig.155757: Taking the SA-frame down

Make sure that the following prerequisites are met:

- The SA-operating mode has been set and confirmed on the LICCON computer system.
- The ball valve **6** and ball valve **7** are in position **A**, see section “SA-frame operation”.
- The SA-frame **3** is in the operating range.

**Note**

- ▶ Functions of master switch MS1, see the Crane operating instructions, chapter 4.05.

- ▶ Move master switch MS1 in direction X-.

**Result:**

- Winch 4 spools up.
- The SA-frame **3** is pulled back against the pressure in the erection cylinders.

**Note**

- ▶ When the SA-frame leaves the operating range when luffing up, an **error message** and **LMB STOP** is shown on the LICCON monitor.
- ▶ Spooling up of winch 4 is turned off.

**WARNING**

Danger of accident when exceeding the LICCON overload protection!

If the shut off limits of the LICCON overload protection are exceeded, there is no additional protection against overload.

Due to erroneous operation or deliberate misuse, the crane could collapse, the SA-frame can collapse or the crane can topple over.

Death, severe bodily injuries, property damage.

- ▶ The function “Exceedance of the LICCON overload protection” may only be activated or used in emergencies and for assembly purposes.
- ▶ The function “Exceedance of the LICCON overload protection” may only be activated or used by an authorized person who knows the effects of the bypass exactly.
- ▶ The “Exceedance of the LICCON overload protection” may only be carried out “anticipatorily” and with utmost caution.
- ▶ The “Exceedance of the LICCON overload protection” is only permissible if the set up configuration of the crane has been entered correctly into the LICCON computer system and has been confirmed.

- ▶ Exceeding the LICCON overload protection, see Crane operating instructions, chapter 4.02.

**Result:**

- No further protection against overload of the crane is present.
- The assembly icon appears on the LICCON monitor, see Crane operating instructions, chapter 4.02.

**WARNING**

Danger of fatal injury due to the SA-frame!

Death, severe bodily injuries, property damage.

- ▶ Make sure that no persons or objects are within the danger zone.

**WARNING**

Independent lowering of the SA-frame!

Due to an incorrect ball valve position, the SA-frame can lower backward by itself.

Death, severe bodily injuries, property damage.

It can result in slack rope build up and to destruction of crane components.

- ▶ The ball valve **6** and ball valve **7** must be in position **A** during assembly and crane operation, see section “SA-frame operation”.
- ▶ The ball valve position **C** and ball valve position **B** are only permissible when lowering the SA-frame onto the turntable (transport position), see section “SA-frame operation”.

**Note**

- ▶ Functions of master switch MS1, see the Crane operating instructions, chapter 4.05.

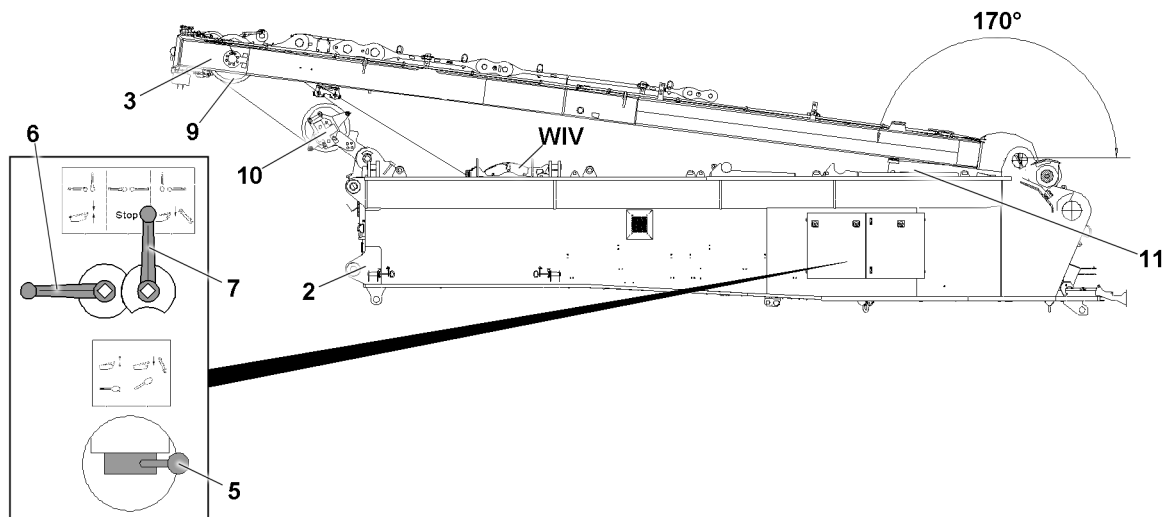


Fig.155757: Taking the SA-frame down

When the LICCON overload protection is exceeded:

- ▶ Move master switch MS1 in direction X-

**Result:**

- Due to the own weight of the SA-frame 3 and by spooling up winch 4 simultaneously, the SA-frame is lowered to the rear against the pressure in the erection cylinders 11.



**Note**

- ▶ Spooling up of winch 4 is shut off from an angle of the SA-frame 3 of approx. 170°.

**NOTICE**

Damage to the crane!

The ball valve position **B** and the ball valve position **C** are only permissible when lowering the SA-frame from 170° onto the turntable (transport position), see section "SA-frame operation".

- ▶ If this is not observed, parts of the crane will be destroyed.

**NOTICE**

SA-frame damage!

At a forward incline of the crane, the SA-frame or the rope pulleys can be damaged before the shut off is reached.

- ▶ Make sure that the SA-frame and the rope pulley are not moved together too far.
- ▶ Always use a guide when taking the SA-frame down.

When the SA-frame has reached an angle of approx. 170° and winch 4 is turned off:

- ▶ Turn off / deactivate the function "Exceedance of the LICCON overload protection".

**Result:**

- The LICCON overload protection is active.
- Winch 4 can be actuated again.

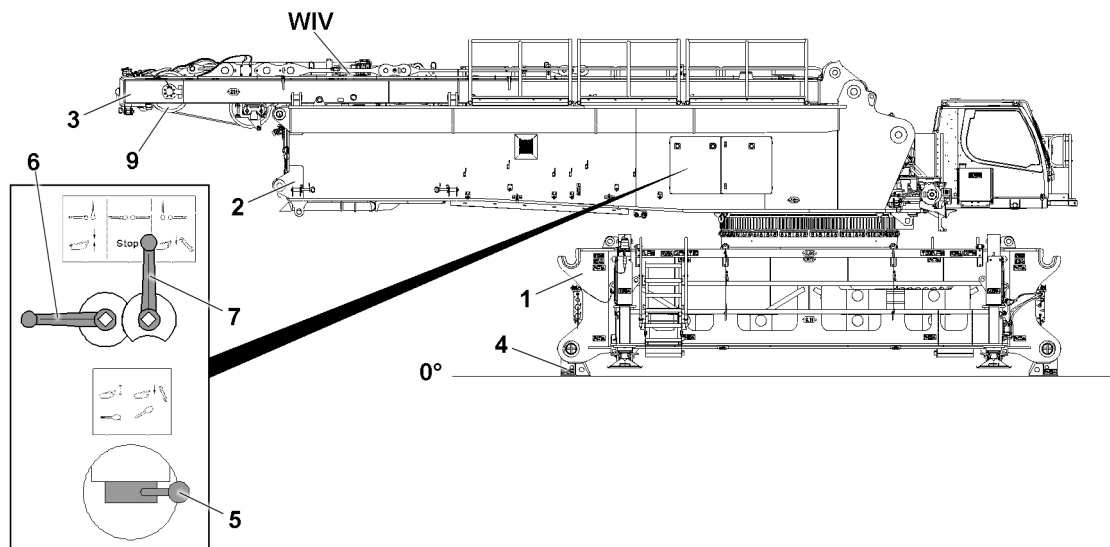


Fig.155758: Taking the SA-frame down onto the turntable

- ▶ Lower the SA-frame **3** onto the turntable **2**: Move the hand lever **5** to position **E**, see section “SA-frame operation”.

**Result:**

- The erection cylinders retract.
- The SA-frame **3** lowers.

When the SA-frame **3** is lowered completely on the turntable:

- ▶ Return the hand lever **5** to the zero position **D** and set the ball valve **6** and ball valve **7** to position **B** and secure, see section “SA-frame operation”.



**WARNING**

The crane can topple over!

Dangerous situations can result due to unauthorized access to the ball valves.

The crane can topple over.

Death, severe bodily injuries, property damage.

- ▶ Make sure that the ball valves are always protected against unauthorized access.

- ▶ Lock the turntable cover and keep the key in a safe place.

**Result:**

- The ball valves are secured against unauthorized access.

## 5.03 Boom systems

1	Boom components	2
2	Arrangement of intermediate sections and guy rods on the booms / boom systems	2
3	Wire rope auxiliary guying	5
4	Fiber guy rope auxiliary guying	15

# 1 Boom components



## Note

- ▶ For boom components including associated system dimensions, lengths and component weights refer to chapter 1.03.

# 2 Arrangement of intermediate sections and guy rods on the booms / boom systems



## Note

- ▶ The following description is an example and may not exactly match your crane.
- ▶ Lengths, weights and system dimensions of the intermediate sections are examples and may differ from the data on your crane.
- ▶ For exact crane data, and for the arrangement of intermediate sections and guy rods, refer to the respective rod plan.
- ▶ For dimensions and weights of crane components, see chapter 1.03 as well as the weight signs on the corresponding components.



## WARNING

The boom can break off!

The arrangement of the intermediate sections on booms or boom systems are based on extensive static calculations.

If the arrangement of the intermediate sections is not observed according to the rod plan, the crane can collapse, the boom can break off or the crane can topple over.

If the arrangement of the guy rods is not observed according to the rod plan, the crane can collapse, the boom can break off or the crane can topple over.

Death, severe bodily injuries, property damage.

- ▶ Only arrange the intermediate sections according to the rod plan.
- ▶ Only arrange the guy rods according to the rod plan.

If auxiliary guying is required for a certain boom length:

- ▶ Only assemble the auxiliary guying according to the rod plan in the position defined in the rod plan.

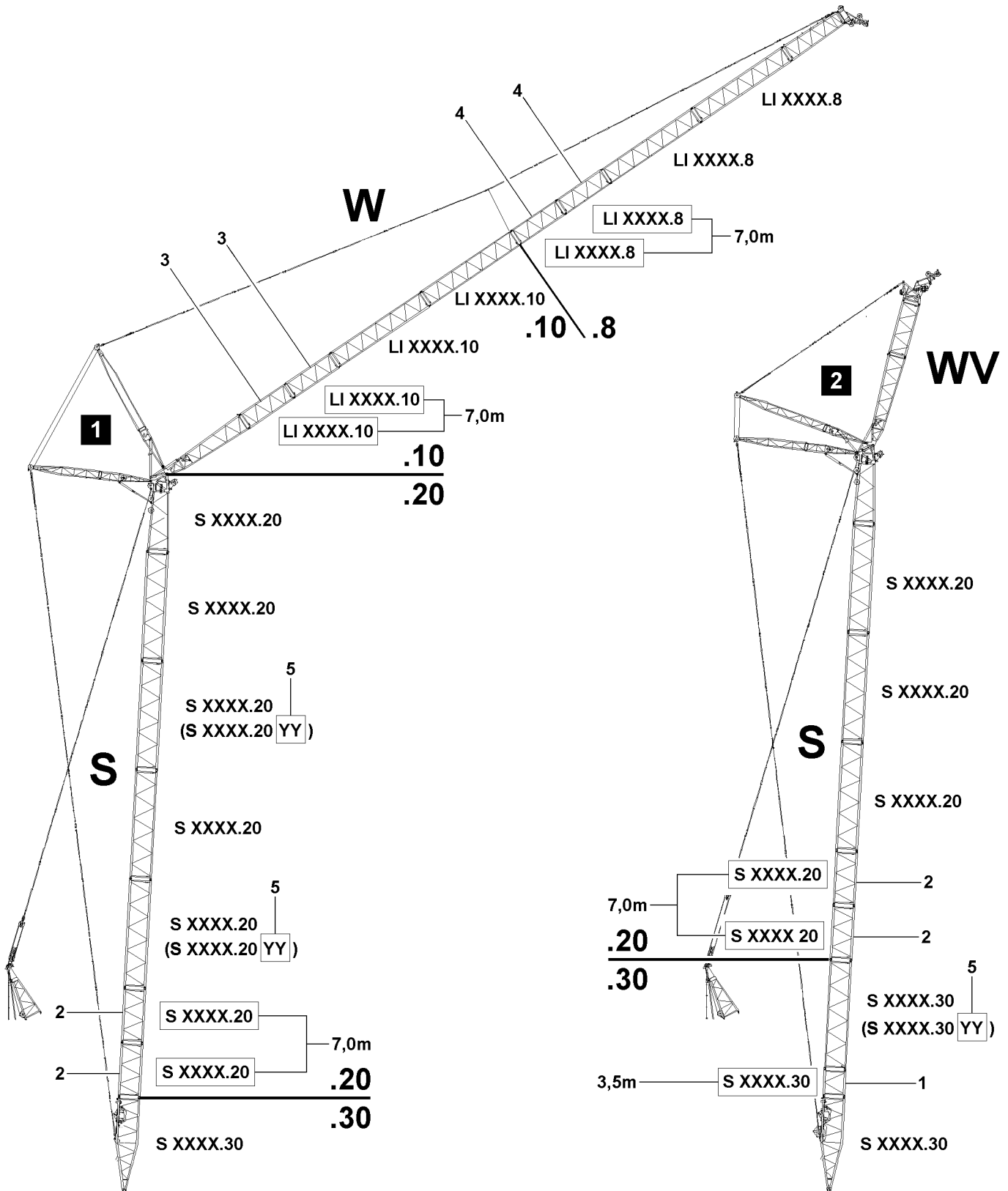


Fig.151885: Arrangement of intermediate sections and the guy rods

LWE/LR 1800-1-0-000/27200-07-02/en

System dimensions and assignment				
Position	System		Heavy	Light
1	S XXXX	.30	X	
2	S XXXX	.20		X
3	LI XXXX	.10	X	
4	LI XXXX	.8		X
5	S XXXX	.40 YY	X	

#### General specifications for the configuration of booms or boom systems:

- With the same system dimension, two short intermediate sections with a length of 3.0 m (3.5 m) are heavier than one single intermediate section with a length of 6.0 m (7.0 m).
- With the same system dimension, two short intermediate sections with a length of 6.0 m (7.0 m) are heavier than one single intermediate section with a length of 12.0 m (14.0 m).
- With the same system dimension, two short intermediate sections with a length of 3.0 m (3.5 m) can be replaced by one single intermediate section with a length of 6.0 m (7.0 m).
- With the same system dimension, two short intermediate sections with a length of 6.0 m (7.0 m) can be replaced by one single intermediate section with a length of 12.0 m (14.0 m).
- For intermediate sections with the same system dimension but different lengths, always install the short intermediate sections on the bottom in the boom, due to their weight, in direction of the slewing ring connection, see illustration 1 and illustration 2.
- The heavier one intermediate section is, the higher is the value of the last two numbers on the system dimension plate.
- Pay attention to the last two numbers following the letter combinations (YY 5) on the system dimension plate and observe them.

## 2.1 Arrangement of the intermediate sections



### WARNING

Danger of accidents due to incorrectly assembled intermediate sections!  
Death, severe bodily injuries, property damage.

- ▶ Any arrangement of the intermediate sections other than what is specified in the operating instructions or the rod plans is prohibited.
- ▶ There is the danger that intermediate sections can be mixed up, as they are differently sized and do **not** differ externally.
- ▶ The intermediate sections differ externally only by the welded on plates (.8, .10, .12, .16, .20, .25, .30, .40 YY).
- ▶ When assembling the boom, it must be ensured that the intermediate sections are only arranged and installed according to their description as indicated on the rod plan.
- ▶ Observe and adhere to the additional letter combinations (YY) 5 on the system dimension plate of the intermediate sections during assembly of the intermediate sections.



### WARNING

Arrangement of the intermediate sections!

If the arrangement of the intermediate sections is not carried out according to the rod plan, then the boom can be overloaded, bend and break off.

Death, severe bodily injuries, property damage.

- ▶ For intermediate sections with the same system dimension but with a different length, the shorter intermediate sections must always be installed on the bottom in the boom, in direction of the slewing ring connection, unless another installation position is specified in the rod plan.
- ▶ Adhere to the specifications in the rod plan in any case.



## 2.2 Arrangement of the guy rods



### WARNING

Danger of accident due to incorrectly assembled guy rods!  
Death, severe bodily injuries, property damage.

- ▶ Any arrangement of the guy rods other than what is specified in the operating instructions or the rod plans is prohibited.
- ▶ During assembly of the boom / boom system, only arrange and install the guy rods according to their description in the rod plan.



### WARNING

Arrangement of the guy rods!

If the arrangement of the guy rods is not carried out according to the rod plan, then the boom can be overloaded, bend and break off.

Death, severe bodily injuries, property damage.

- ▶ Adhere to the specifications in the rod plan in any case.

## 3 Wire rope auxiliary guying

The following auxiliary guying variations are assembled:

- The auxiliary guying consists of the fiber guy ropes, see section “Fiber guy rope auxiliary guying”.
- Auxiliary guying is comprised of wire ropes, see section “Auxiliary guying wire ropes”.



### Note

- ▶ The following descriptions and illustrations are examples and may not match your crane exactly.
- ▶ For exact crane data refer to the respective rod plan.
- ▶ In the case of questions: Contact Customer Service at Liebherr-Werk Ehingen GmbH.

The auxiliary guying, in regards to safe crane operation - especially for long boom systems - is of vital importance.

The auxiliary guying is a deciding factor in relieving the boom, or the boom system during erection and take-down as well as during crane operation.

Guy ropes with different lengths are used in the different auxiliary guying.

The assembly of the auxiliary guying between the boom guying and the boom system is implemented using different brackets, cross brackets and connector brackets.



### Note

- ▶ The boom lengths, for which an auxiliary guying is required in addition to a boom guying, can be seen in the rod plan.

Depending on the crane type and boom length:

- ▶ Assembly of the auxiliary guying: Remove the standard lugs and install the tension lugs **12**.

**WARNING**

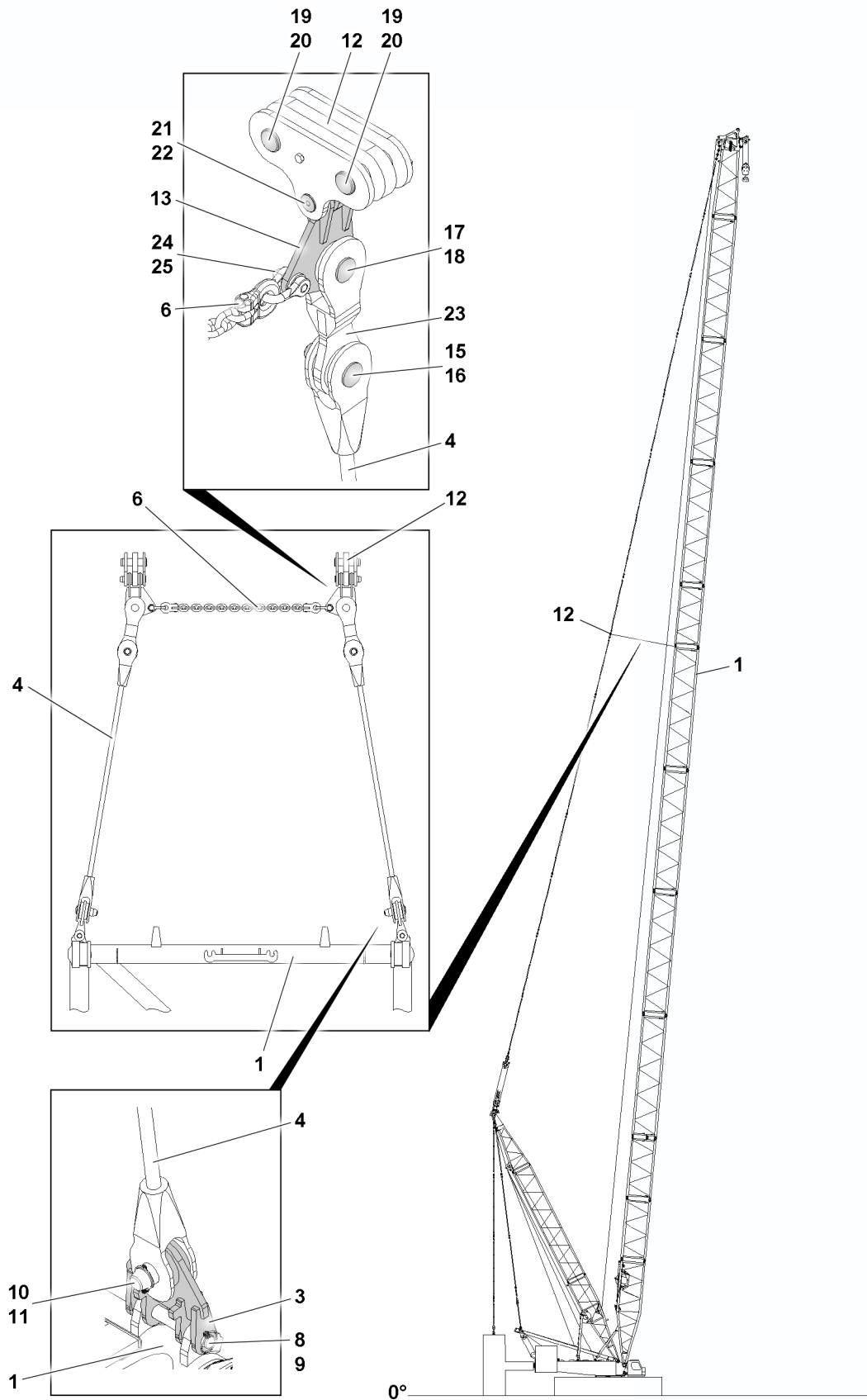
The crane can topple over!

If the auxiliary guying is not installed or not installed on the position specified in the rod plan, then the crane can collapse, the boom can break off or the crane can topple over.

Death, severe bodily injuries, property damage.

- ▶ Only assemble the auxiliary guying in the position specified in the rod plan.
- ▶ Make sure that the auxiliary guying is always completely installed and that all pins are properly pinned and secured.
- ▶ Assemble the auxiliary guying together with the boom guying when the boom / boom system is lying on the ground.
- ▶ **or:**
- ▶ Assemble the auxiliary guying together with the boom guying when the boom / boom system is lying on a load bearing substructure.
- ▶ **or:**
- ▶ Assemble the auxiliary guying together with the boom guying when the boom / boom system is held securely by the auxiliary crane.

### 3.1 Assembling the auxiliary guying on the main boom variation A



LWE/LR 1800-1-0-000/27200-07-02/en

Fig.153507: "Long" auxiliary guying on the main boom

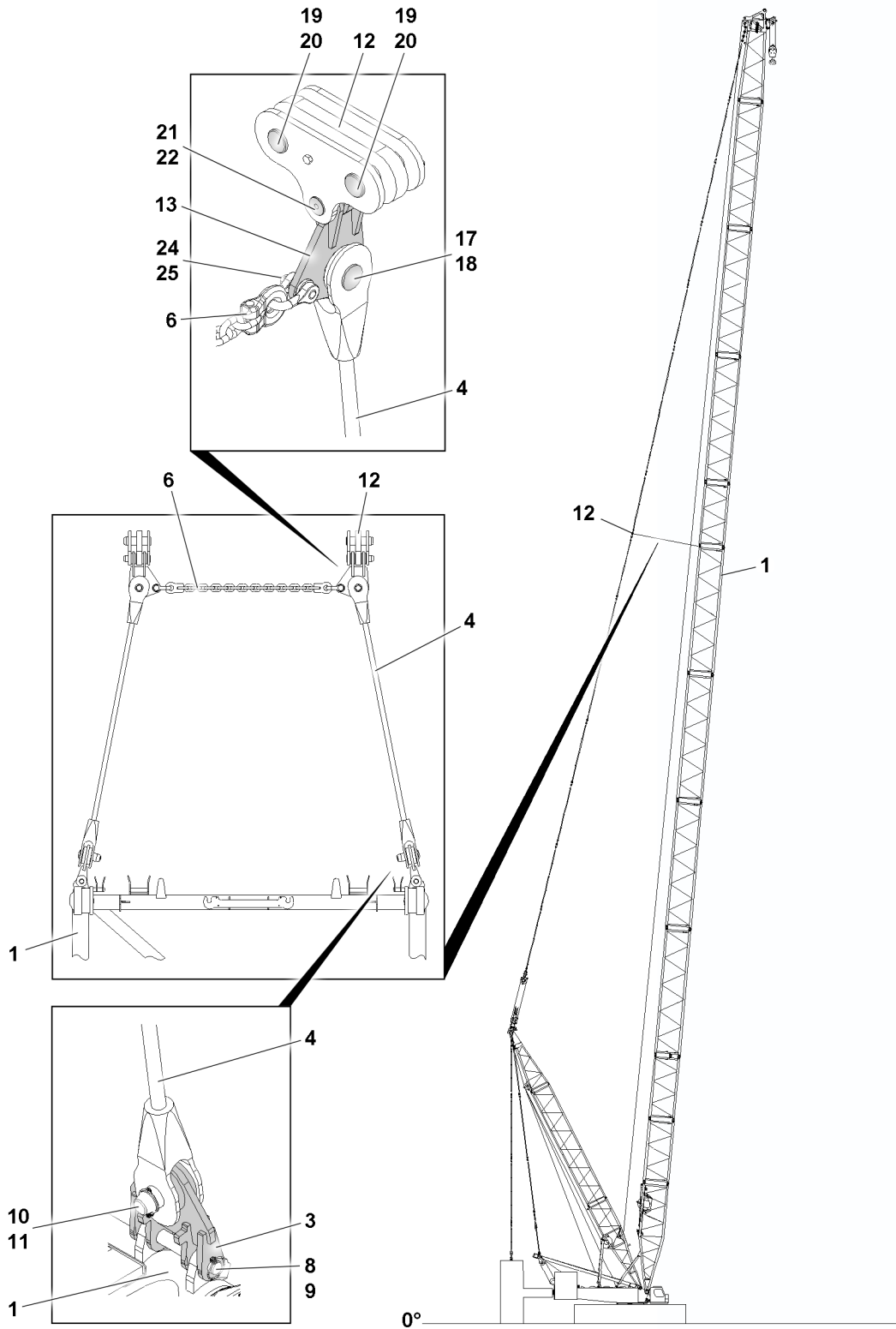


Fig.153603: "Short" auxiliary guying on the main boom

- |    |                                    |    |                   |    |                   |
|----|------------------------------------|----|-------------------|----|-------------------|
| 1  | Intermediate section <sup>1)</sup> | 11 | Retaining element | 19 | Pin               |
| 3  | Connector bracket                  | 12 | Tension lug       | 20 | Retaining element |
| 4  | Guy rope <sup>2)</sup>             | 13 | Cross bracket     | 21 | Pin               |
| 6  | Chain                              | 15 | Pin               | 22 | Retaining element |
| 8  | Pin                                | 16 | Retaining element | 23 | Bracket           |
| 9  | Retaining element                  | 17 | Pin               | 24 | Shackle           |
| 10 | Pin                                | 18 | Retaining element | 25 | Screw pin         |

<sup>1)</sup> for the exact designation of the intermediate section: see the rod plan

LWE/LR 1800-1-0-000/27200-07-02/en

<sup>2)</sup> for the exact designation of the guy rope: see the rod plan

The tension lugs **12** must be installed in the boom guying instead of standard lugs. The auxiliary guying is installed on the tension lugs **12**.

Make sure that the following prerequisites are met:

- The standard brackets are have been disassembled in the boom guying.
  - The tension lugs **12** are installed properly on both sides in the boom guying instead of standard lugs.
  - The tension lugs **12** are pinned together properly with pins **19** in the boom guying and secured with a retaining element **20**.
  - The connector bracket **3** is pinned on both sides to the intermediate section **1** with pins **8** and secured with a retaining element **9**.
- ▶ Pin the cross bracket **13** on the tension lug **12**: Insert the pin **21** and secure properly with the retaining element **22**.

**In the case of a longer auxiliary guying:**

- ▶ Pin the bracket **23** on the cross bracket **13** with a pin **17** and secure properly with the retaining element **18**.
- ▶ Install the guy rope **4**: Pin the guy rope **4** to the bracket **23** with a pin **15** and secure with the retaining element **16**.
- or**

**In the case of a shorter auxiliary guying:**

Install the guy rope **4**: Pin the guy rope **4** on the cross bracket **13** with a pin **17** and secure properly with the retaining element **18**.

If the guy rope **4** is properly pinned and secured on both sides to the bracket **23** or on both sides to the cross bracket **13**:

- ▶ Pin the guy rope **4** to the connector bracket **3** with a pin **10** and secure with the retaining element **11**.

Install the chain **6** between the cross brackets **13**:

- ▶ Properly install the chain **6** to the left and right on the cross brackets **13** with a shackle **24** and screw pin **25**.



**WARNING**

The crane can topple over!

If the chain **6** is not assembled in connection with the auxiliary guying, then the boom guying can be damaged, the boom can break off and the crane can topple over.

Death, severe bodily injuries, property damage.

- ▶ Only assemble the auxiliary guying in the position specified in the rod plan.
- ▶ If a chain **6** is specified in the rod plan, then it must always be installed in connection with the auxiliary guying, otherwise the guy rods will be pulled apart.

- ▶ Recheck the proper and complete assembly of the auxiliary guying before erecting the boom / boom system.

### 3.2 Assembling the auxiliary guying on the main boom variation B

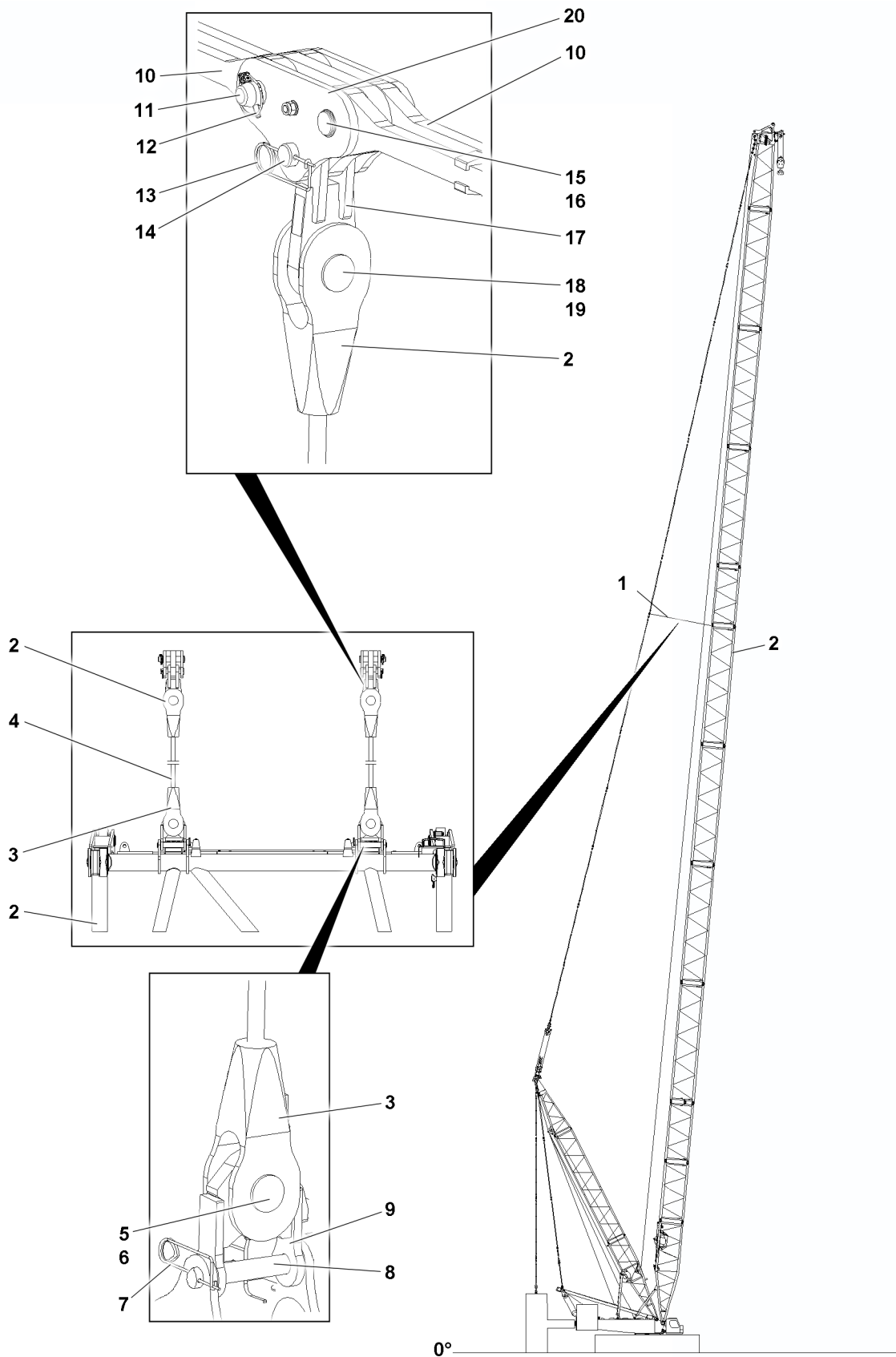


Fig.161359: Auxiliary guying on the main boom variation B

LWE/LR 1800-1-0-000/27200-07-02/en

<b>1</b>	Auxiliary guying	<b>8</b>	Pin	<b>15</b>	Pin
<b>2</b>	Intermediate section <sup>1)</sup>	<b>9</b>	Connector bracket	<b>16</b>	Retaining element
<b>3</b>	Lower connecting element	<b>10</b>	Guy rods	<b>17</b>	Cross bracket
<b>4</b>	Guy rope <sup>2)</sup>	<b>11</b>	Pin	<b>18</b>	Pin
<b>5</b>	Pin	<b>12</b>	Retaining element	<b>19</b>	Retaining element
<b>6</b>	Retaining element	<b>13</b>	Retaining element on both sides	<b>20</b>	Tension lug
<b>7</b>	Retaining element	<b>14</b>	Pin		

<sup>1)</sup> for the exact designation of the intermediate section: see the rod plan

<sup>2)</sup> for the exact designation of the guy rope: see the rod plan

The tension lugs **20** must be installed in the boom guying instead of standard lugs. The auxiliary guying is installed on the tension lugs **12**.

Make sure that the following prerequisites are met:

- The standard brackets are have been disassembled in the boom guying.
- The tension lugs **20** are installed properly on both sides in the boom guying instead of standard lugs.
- The tension lugs **20** are pinned with the pin **11** and with the pin **15** in the boom guying and secured with the retaining element **12** and retaining element **16**.
- The connector bracket **9** is pinned on both sides to the intermediate section<sup>1)</sup> **2** with pins **8** and secured with a retaining element **7**.
- ▶ Install the guy rope<sup>2)</sup> **4**: Pin the guy rope<sup>2)</sup> **4** on the cross bracket **17** with a pin **14** and secure properly with the retaining element **13**.

If the guy rope<sup>2)</sup> **4** is properly pinned and secured on both sides to the cross bracket **17**:

- ▶ Pin the guy rope<sup>2)</sup> **4** to the connector bracket **9** with a pin **5** and secure with the retaining element **6**.

#### Result:

- The auxiliary guying is assembled.



#### WARNING

The crane can topple over!

If the chain **6** is not assembled in connection with the auxiliary guying, then the boom guying can be damaged, the boom can break off and the crane can topple over.

Death, severe bodily injuries, property damage.

- ▶ Only assemble the auxiliary guying in the position specified in the rod plan.
- ▶ Recheck the proper and complete assembly of the auxiliary guying before erecting the boom / boom system.

### 3.3 Assembling the auxiliary guying on the W-boom

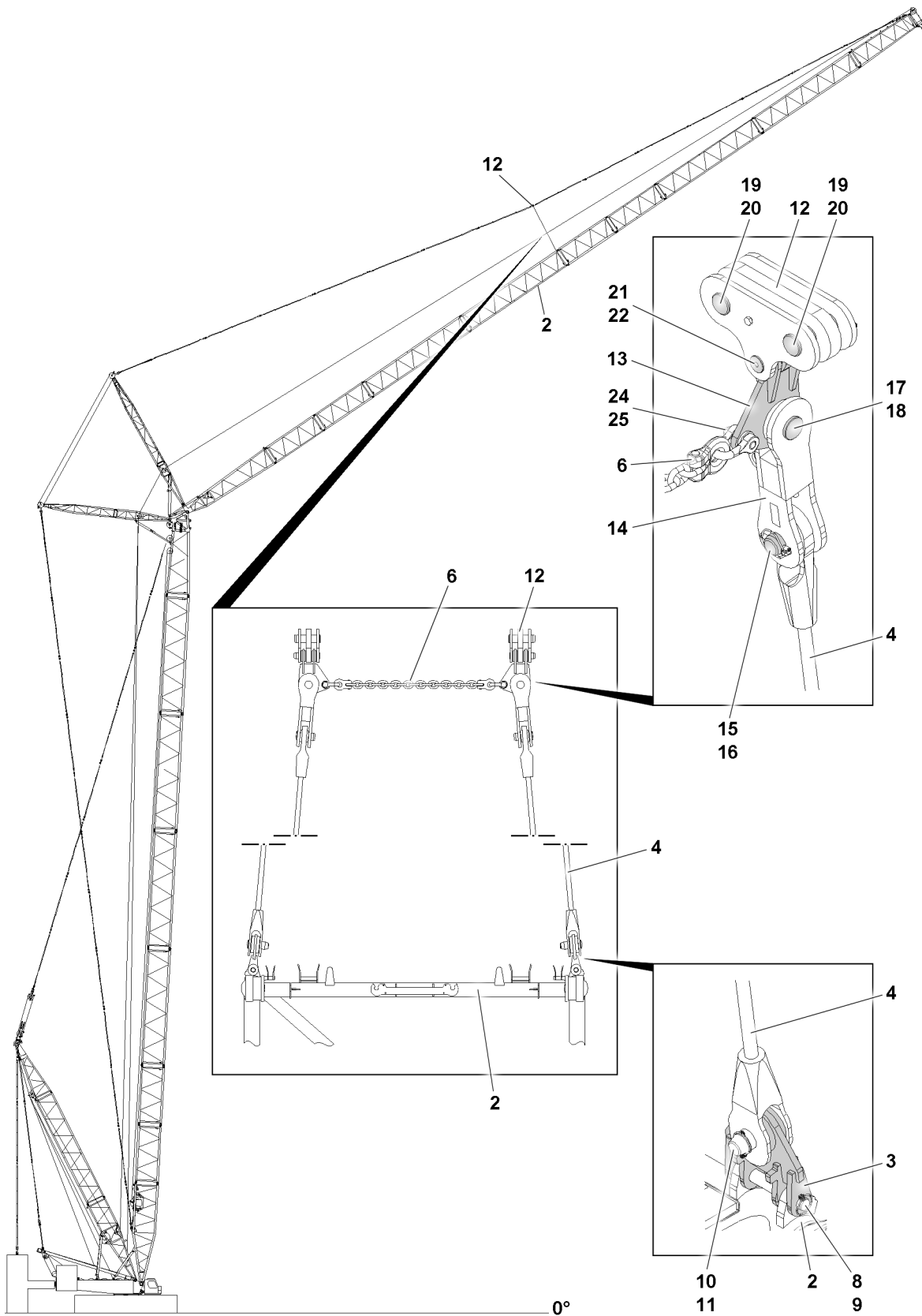


Fig.153508: Auxiliary guying on the W-boom

2 Intermediate section <sup>1)</sup>

11 Retaining element

18 Retaining element

For continuation of legend for illustrations, see next page

LWE/LR 1800-1-0-000/27200-07-02/en



<b>3</b>	Connector bracket	<b>12</b>	Tension lug	<b>19</b>	Pin
<b>4</b>	Guy rope <sup>2)</sup>	<b>13</b>	Cross bracket	<b>20</b>	Retaining element
<b>6</b>	Chain	<b>14</b>	Cross bracket	<b>21</b>	Pin
<b>8</b>	Pin	<b>15</b>	Pin	<b>22</b>	Retaining element
<b>9</b>	Retaining element	<b>16</b>	Retaining element	<b>24</b>	Shackle
<b>10</b>	Pin	<b>17</b>	Pin	<b>25</b>	Screw pin

<sup>1)</sup> for the exact designation of the intermediate section: see the rod plan

<sup>2)</sup> for the exact designation of the guy rope: see the rod plan

The tension lugs **12** must be installed in the boom guying instead of standard lugs. The auxiliary guying is installed on the tension lugs **12**.

Make sure that the following prerequisites are met:

- The standard brackets are have been disassembled in the boom guying.
- The tension lugs **12** are installed properly on both sides in the boom guying instead of standard lugs.
- The tension lugs **12** are pinned together properly with pins **19** in the boom guying and secured with a retaining element **20**.
- The connector bracket **3** is pinned on both sides to the intermediate section **2** with pins **8** and secured with a retaining element **9**.
- ▶ Pin the cross bracket **13** on the tension lug **12**: Insert the pin **21** and secure properly with the retaining element **22**.
- ▶ Pin the cross bracket **14** on the cross bracket **13** with a pin **17** and secure properly with the retaining element **18**.
- ▶ Install the guy rope **4**: Pin the guy rope **4** on the cross bracket **14** with a pin **15** and secure with the retaining element **16**.

If the guy rope **4** is properly pinned and secured on both sides to the cross bracket **14**:

- ▶ Pin the guy rope **4** to the connector bracket **3** with a pin **10** and secure with the retaining element **11**.

Install the chain **6** between the cross brackets **13**:

- ▶ Properly install the chain **6** to the left and right on the cross bracket **13** with a shackle **24** and screw pin **25**.



#### WARNING

The crane can topple over!

If the chain **6** is not assembled in connection with the auxiliary guying, then the boom guying can be damaged, the boom can break off and the crane can topple over.

Death, severe bodily injuries, property damage.

- ▶ Only assemble the auxiliary guying in the position specified in the rod plan.
  - ▶ If a chain **6** is specified in the rod plan, then it must always be installed in connection with the auxiliary guying, otherwise the guy rods will be pulled apart.
- 
- ▶ Recheck the proper and complete assembly of the auxiliary guying before erecting the boom / boom system.

*Fig.195219*

LWE/LR 1800-1-0-000/27200-07-02/en

## 4 Fiber guy rope auxiliary guying

The following auxiliary guying variations are assembled:

- The auxiliary guying consists of the fiber guy ropes, see section “Fiber guy rope auxiliary guying”.
- Auxiliary guying is comprised of wire ropes, see section “Auxiliary guying wire ropes”.



### Note

- ▶ The auxiliary guying made of fiber guy ropes are not available for all crane types.
- ▶ The following descriptions and illustrations are examples and may not match your crane exactly.
- ▶ For exact crane data refer to the respective rod plan.
- ▶ In the case of questions: Contact Customer Service at Liebherr-Werk Ehingen GmbH.



### WARNING

Impermissible assembly of fiber guy ropes!

The fiber guy ropes can rip.

Death, severe bodily injuries, property damage.

- ▶ Do **not** assemble fiber guy ropes that are rigidly frozen or covered with ice.
- ▶ Do **not** use buckled, knotted or twisted fiber guy ropes.
- ▶ Do **not** assemble damaged fiber guy ropes.
- ▶ Make sure that the identification of the fiber guy rope on the rod plan and the identification on the individual fiber guy ropes are identical. Identify the fiber guy rope, see chapter 5.01.
- ▶ Make sure that the operating temperature of the fiber guy ropes of  $-40\text{ °C}$  to  $+60\text{ °C}$  is **not** fallen below or exceeded.
- ▶ Check the fiber guy ropes for damage prior to assembly, after disassembly and after exceptional events, see chapter 8.16.
- ▶ Comply with the maintenance intervals, see chapter 7.03.50.
- ▶ Observe the notes regarding the proper transport and storage of the fiber guy ropes, see chapter 2.04.
- ▶ Comply with the instructions for the assembly and disassembly of the fiber guy ropes, see chapter 5.01.
- ▶ Only fasten the fiber guy ropes in the permissible range with belt loops, see chapter 5.01.



### WARNING

Temperatures below  $0\text{ °C}$ : Fiber guy ropes that are rigidly frozen or covered with ice!

Buckling of the fiber guy ropes. The fiber guy ropes can rip.

Death, severe bodily injuries, property damage.

- ▶ Before assembling and disassembling the fiber guy ropes, check if the fiber guy ropes are rigidly frozen or covered with ice.
- ▶ Before erecting and taking down the boom system, check if the fiber guy ropes are rigidly frozen or covered with ice.
- ▶ Do **not** bend, knot or twist rigidly frozen fiber guy ropes.
- ▶ Do **not** erect or take down boom systems with fiber guy ropes that are rigidly frozen or covered with ice (for example auxiliary guying, guying for the F-jib).
- ▶ Comply with the instructions for rigidly frozen fiber guy ropes, see chapter 5.01.
- ▶ Observe the instructions for the proper handling of fiber guy ropes, see chapter 5.01.
- ▶ After disassembly: Check the rigidly frozen fiber guy ropes for damage, see chapter 8.16.
- ▶ Observe the notes regarding the proper transport and storage of the fiber guy ropes, see chapter 2.04.

The auxiliary guying, in regards to safe crane operation - especially for long boom systems - is of vital importance.

The auxiliary guying is a deciding factor in relieving the boom, or the boom system during erection and take-down as well as during crane operation.

Guy ropes with different lengths are used in the different auxiliary guyings.

The installation of the auxiliary guying between the boom guying and the boom system is implemented using different brackets, cross brackets or connector brackets.

**Note**

- ▶ The boom lengths, for which an auxiliary guying is required in addition to a boom guying, can be seen in the rod plan.

Depending on the crane type and boom length:

- ▶ Assembly of the auxiliary guying: Remove the standard lugs and install the tension lugs **12**.

**WARNING**

The crane can topple over!

If the auxiliary guying is not installed or not installed on the position specified in the rod plan, then the crane can collapse, the boom can break off or the crane can topple over.

Death, severe bodily injuries, property damage.

- ▶ Only assemble the auxiliary guying in the position specified in the rod plan.
- ▶ Make sure that the auxiliary guying is always completely installed and that all pins are properly pinned and secured.
- ▶ Assemble the auxiliary guying together with the boom guying when the boom / boom system is lying on the ground.
- ▶ **or:**
- ▶ Assemble the auxiliary guying together with the boom guying when the boom / boom system is lying on a load bearing substructure.
- ▶ **or:**
- ▶ Assemble the auxiliary guying together with the boom guying when the boom / boom system is held securely by the auxiliary crane.

### 4.1 Assembling the auxiliary guying on the main boom

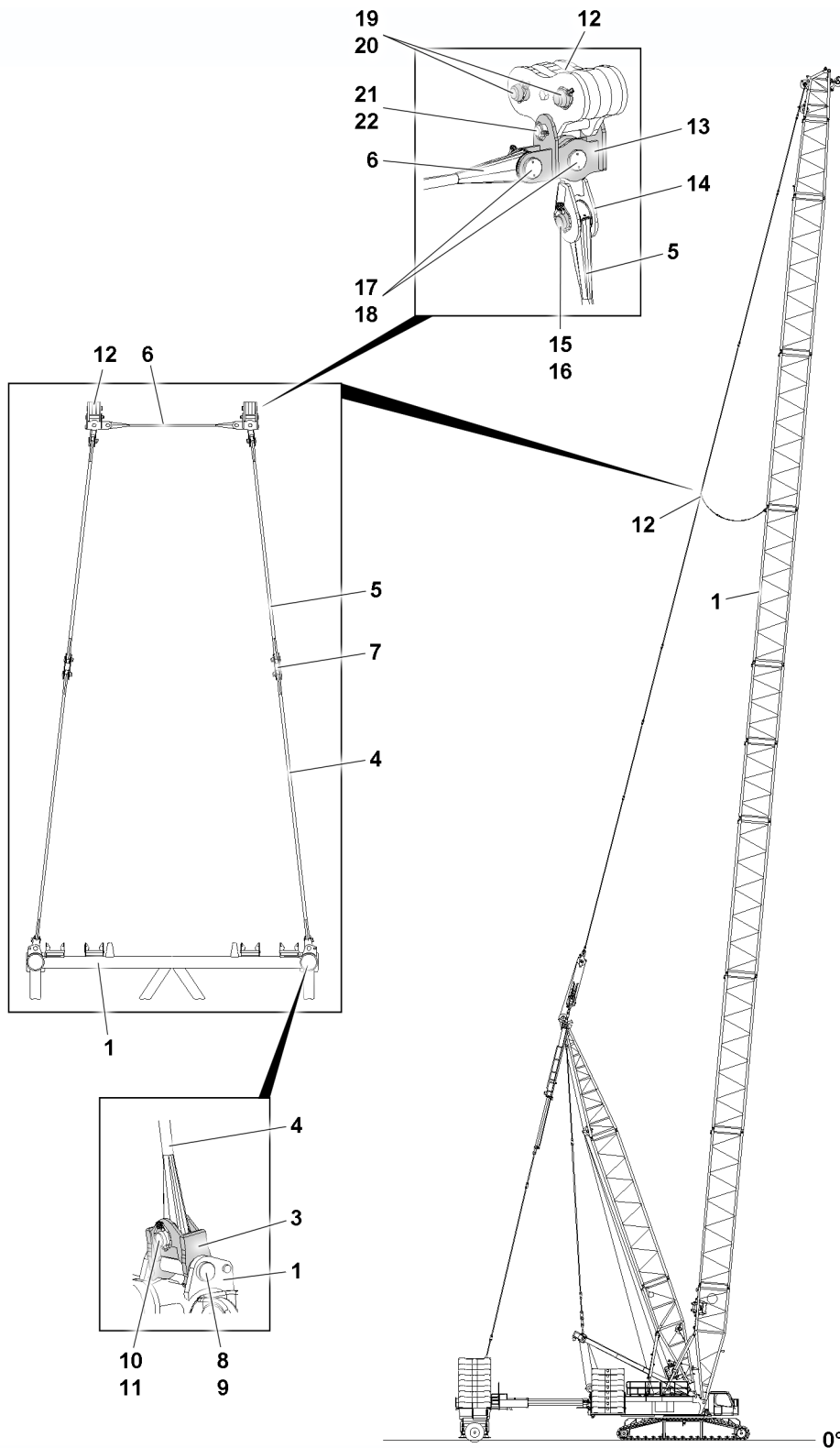


Fig.153504: Auxiliary guying on the main boom

- |   |                             |                             |
|---|-----------------------------|-----------------------------|
| <b>1</b> Intermediate section <sup>1)</sup> | <b>9</b> Retaining element  | <b>16</b> Retaining element |
| <b>3</b> Connector bracket                  | <b>10</b> Pin               | <b>17</b> Pin               |
| <b>4</b> Fiber guy rope <sup>2)</sup>       | <b>11</b> Retaining element | <b>18</b> Retaining element |
| <b>5</b> Fiber guy rope <sup>2)</sup>       | <b>12</b> Tension lug       | <b>19</b> Pin               |

For continuation of legend for illustrations, see next page

LWE/LR 1800-1-0-000/27200-07-02/en

<b>6</b>	Fiber guy rope <sup>2)</sup>	<b>13</b>	Cross bracket	<b>20</b>	Retaining element
<b>7</b>	Connector bracket	<b>14</b>	Cross bracket	<b>21</b>	Pin
<b>8</b>	Pin	<b>15</b>	Pin	<b>22</b>	Retaining element

<sup>1)</sup> for the exact designation of the intermediate section: See the rod plan

<sup>2)</sup> for the exact designation of the fiber guy rope: See the rod plan

The tension lugs **12** must be installed in the boom guying instead of standard lugs. The auxiliary guying is installed on the tension lugs **12**.

Make sure that the following prerequisites are met:

- The standard brackets are have been disassembled in the boom guying.
- The tension lugs **12** are installed properly on both sides in the boom guying instead of standard lugs.
- The tension lugs **12** are pinned together properly with pins **19** in the boom guying and secured with a retaining element **20**.
- The connector bracket **3** is pinned on both sides to the intermediate section **1** with pins **9** and secured with a retaining element **8**.
- ▶ Pin the cross bracket **13** on the tension lug **12**: Insert the pin **21** and secure properly with the retaining element **22**.
- ▶ Pin the cross bracket **14** on the cross bracket **13** with a pin **17** and secure properly with the retaining element **18**.
- ▶ Install the guy rope **5**: Pin the guy rope **5** on the cross bracket **14** with a pin **15** and secure with the retaining element **16**.

If the guy rope **5** is properly pinned and secured on both sides to the cross bracket **14**:

- ▶ Properly pin and secure the guy rope **4** with the connector bracket **7** to the guy rope **5**.
- ▶ Pin the guy rope **4** to the connector bracket **3** with a pin **10** and secure with the retaining element **11**.

Install the guy rope **6** between the cross brackets **13**:

- ▶ Pin the guy rope **6** to the left and right on the cross bracket **13** with a pin **17** and secure properly with the retaining element **18**.



### WARNING

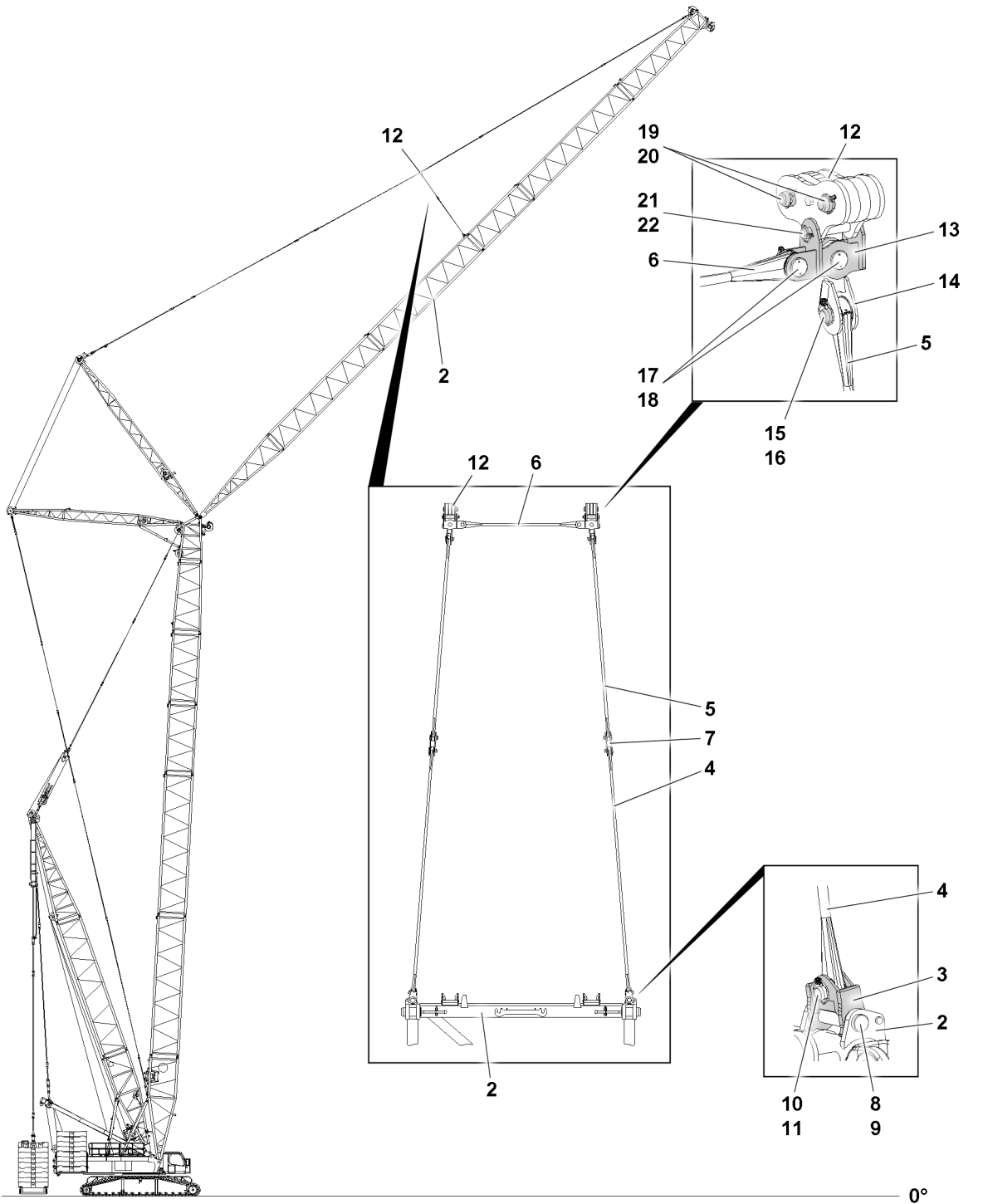
The crane can topple over!

If the guy rope **6** is not installed in connection with the auxiliary guying, then the boom guying can be damaged, the boom can break off and the crane can topple over.

Death, severe bodily injuries, property damage.

- ▶ Only assemble the auxiliary guying in the position specified in the rod plan.
  - ▶ If a guy rope **6** is specified in the rod plan, then it must always be installed in connection with the auxiliary guying, otherwise the guy rods will be pulled apart.
- 
- ▶ Recheck the proper and complete assembly of the auxiliary guying before erecting the boom / boom system.

### 4.2 Assembling the auxiliary guying on the W-boom



LWE/LR 1800-1-0-000/27200-07-02/en

Fig.153505: Auxiliary guying on the W- boom

- |   |                             |                             |
|---|-----------------------------|-----------------------------|
| <b>2</b> Intermediate section <sup>1)</sup> | <b>9</b> Retaining element  | <b>16</b> Retaining element |
| <b>3</b> Connector bracket                  | <b>10</b> Pin               | <b>17</b> Pin               |
| <b>4</b> Fiber guy rope <sup>2)</sup>       | <b>11</b> Retaining element | <b>18</b> Retaining element |
| <b>5</b> Fiber guy rope <sup>2)</sup>       | <b>12</b> Tension lug       | <b>19</b> Pin               |
| <b>6</b> Fiber guy rope <sup>2)</sup>       | <b>13</b> Cross bracket     | <b>20</b> Retaining element |
| <b>7</b> Connector bracket                  | <b>14</b> Cross bracket     | <b>21</b> Pin               |
| <b>8</b> Pin                                | <b>15</b> Pin               | <b>22</b> Retaining element |

<sup>1)</sup> for the exact designation of the intermediate section: See the rod plan

<sup>2)</sup> for the exact designation of the fiber guy rope: See the rod plan

The tension lugs **12** must be installed in the boom guying instead of standard lugs. The auxiliary guying is installed on the tension lugs **12**.

Make sure that the following prerequisites are met:

- The standard brackets are have been disassembled in the boom guying.
- The tension lugs **12** are installed properly on both sides in the boom guying instead of standard lugs.
- The tension lugs **12** are pinned together properly with pins **19** in the boom guying and secured with a retaining element **20**.
- The connector bracket **3** is pinned on both sides to the intermediate section **1** with pins **9** and secured with a retaining element **8**.
- ▶ Pin the cross bracket **13** on the tension lug **12**: Insert the pin **21** and secure properly with the retaining element **22**.
- ▶ Pin the cross bracket **14** on the cross bracket **13** with a pin **17** and secure properly with the retaining element **18**.
- ▶ Install the guy rope **5**: Pin the guy rope **5** on the cross bracket **14** with a pin **15** and secure with the retaining element **16**.

If the guy rope **5** is properly pinned and secured on both sides to the cross bracket **14**:

- ▶ Properly pin and secure the guy rope **4** with the connector bracket **7** to the guy rope **5**.
- ▶ Pin the guy rope **4** to the connector bracket **3** with a pin **10** and secure with the retaining element **11**.

Install the guy rope **6** between the cross brackets **13**:

- ▶ Pin the guy rope **6** to the left and right on the cross bracket **13** with a pin **17** and secure properly with the retaining element **18**.



#### WARNING

The crane can topple over!

If the guy rope **6** is not installed in connection with the auxiliary guying, then the boom guying can be damaged, the boom can break off and the crane can topple over.

Death, severe bodily injuries, property damage.

- ▶ Only assemble the auxiliary guying in the position specified in the rod plan.
  - ▶ If a guy rope **6** is specified in the rod plan, then it must always be installed in connection with the auxiliary guying, otherwise the guy rods will be pulled apart.
- 
- ▶ Recheck the proper and complete assembly of the auxiliary guying before erecting the boom / boom system.



## 5.05 Derrick boom

1	Component overview	2
2	Fastening points for derrick components	2
3	D-boom assembly on the crane	7
4	D-boom assembly on the ground	34
5	Flying D-boom assembly	37
6	Erecting the D-boom	43
7	D-boom disassembly on the crane	53
8	D-boom disassembly on the ground	80
9	Flying D-boom disassembly	82

# 1 Component overview



## Note

- ▶ The assembly sections are marked with their own weight.



## Note

- ▶ Dimensions and weights, see chapter 1.03.

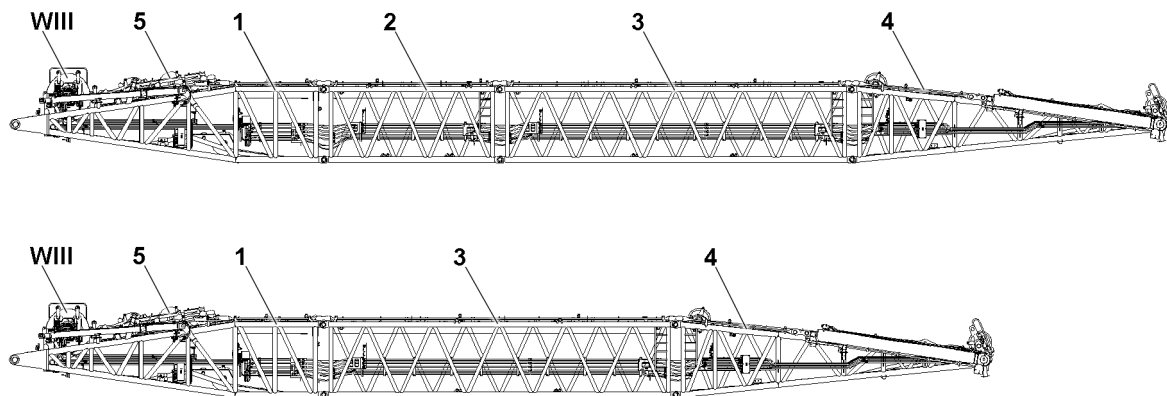


Fig.153368: Example, D-boom combination

- |   |                                     |      |                        |
|---|-------------------------------------|------|------------------------|
| 1 | D-pivot section                     | 4    | D-end section          |
| 2 | D-intermediate section 2524.20 6 m  | 5    | S-luffing pulley block |
| 3 | D-intermediate section 2524.16 12 m | WIII | Winch 3                |

## 2 Fastening points for derrick components



### WARNING

Component incorrectly fastened!

Death, severe bodily injuries, property damage.

- ▶ Fasten the components only in the intended fastening points on both sides.
- ▶ Fastening of components and description of fastening points, see chapter 5.01.

### 2.1 D-pivot section fastening points

There are two variations of the D-pivot section:

- D-pivot section with removable winch 3
- D-pivot section with fixed installed winch 3

### 2.1.1 D-pivot section with removable winch 3

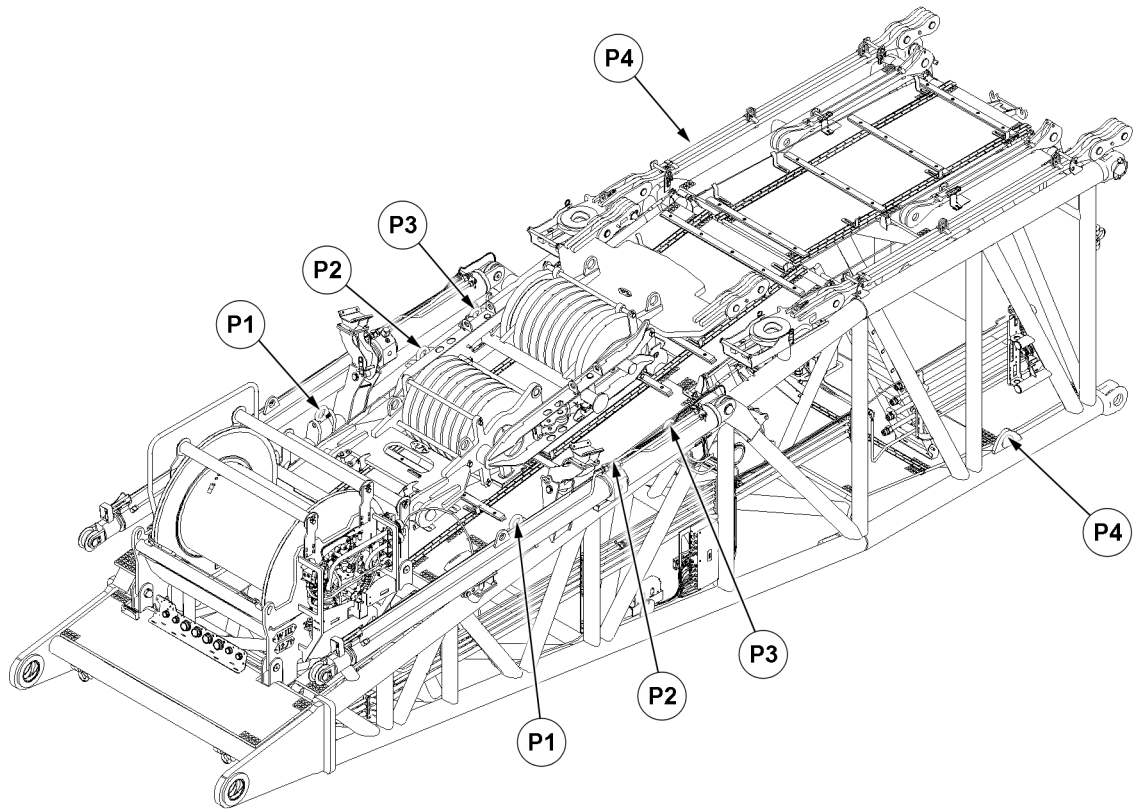


Fig.159646: D-pivot section fastening points (variation with removable winch 3)

Fastening points	
P1 and P2	D-pivot section with winch 3
P3	D-pivot section without winch 3 installed
P4	D-boom completely assembled

LWE/LR 1800-1-0-000/27200-07-02/en

### 2.1.2 D-pivot section with fixed installed winch 3

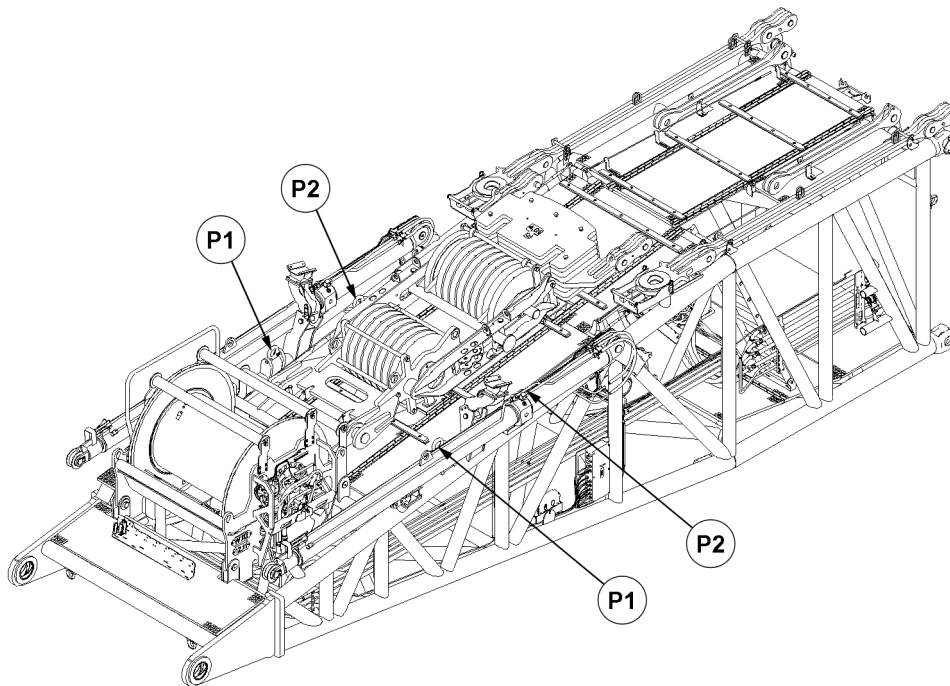


Fig.153369: D-pivot section fastening points (variation with fixed installed winch 3)

Fastening points	
P1 and P2	D-pivot section

### 2.2 D-intermediate section 2524.20 6 m fastening points

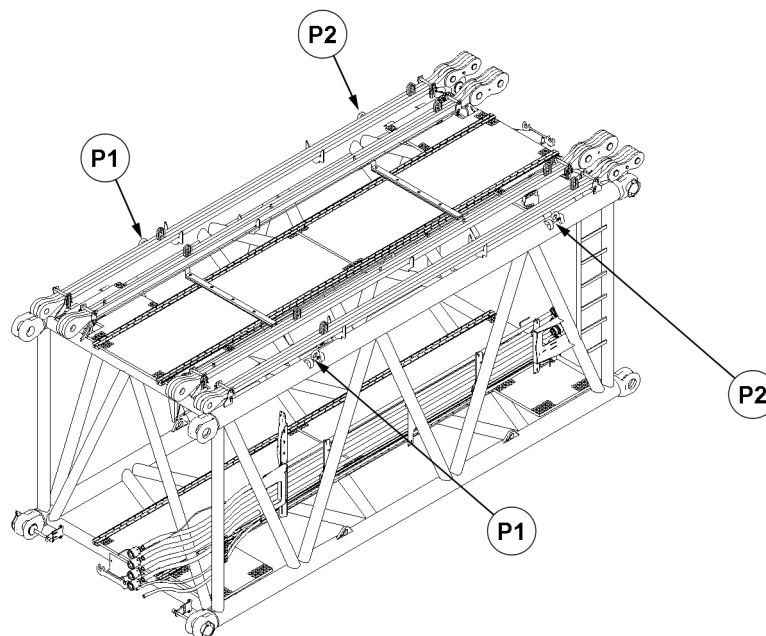


Fig.153370: D-intermediate section 2524.20 6 m fastening points

LWE/LR 1800-1-0-000/27200-07-02/en

Fastening points	
P1 and P2	D-intermediate section 2524.20 6 m

### 2.3 D-intermediate section 2524.16 12 m fastening points

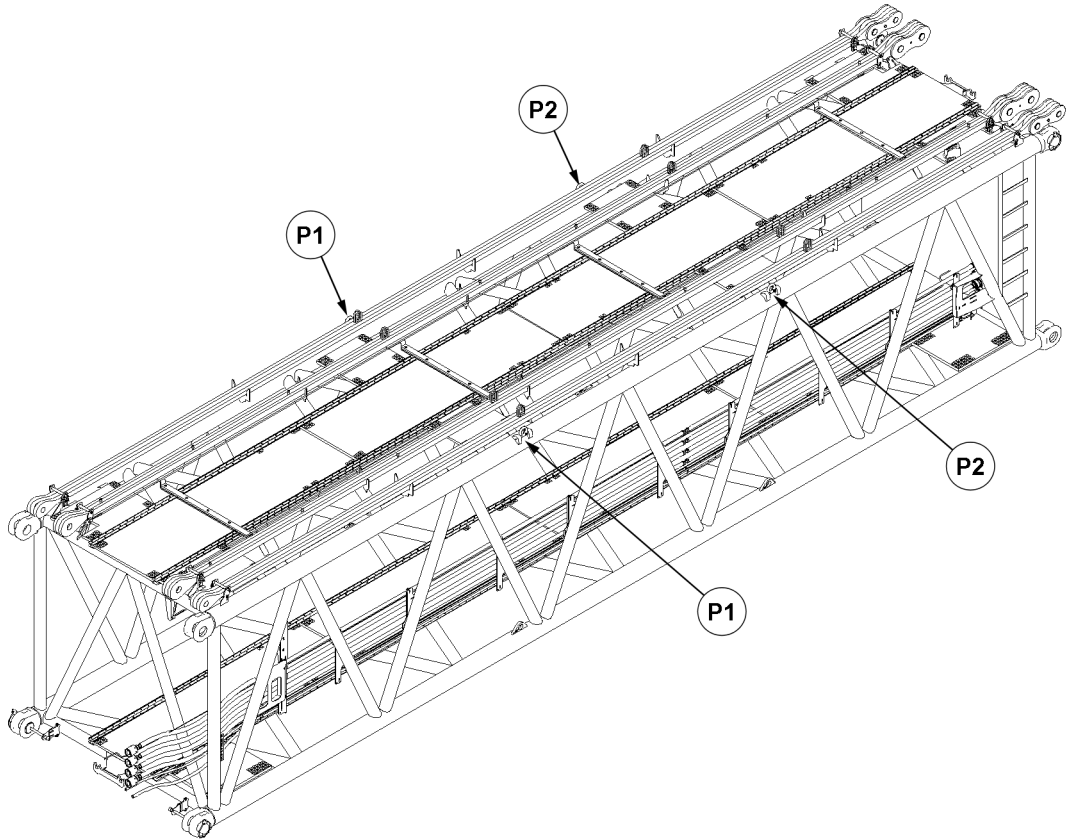


Fig.153371: D-intermediate section 2524.16 12 m fastening points

Fastening points	
P1 and P2	D-intermediate section 2524.16 12 m

LWE/LR 1800-1-0-000/27200-07-02/en

## 2.4 D-end section fastening points

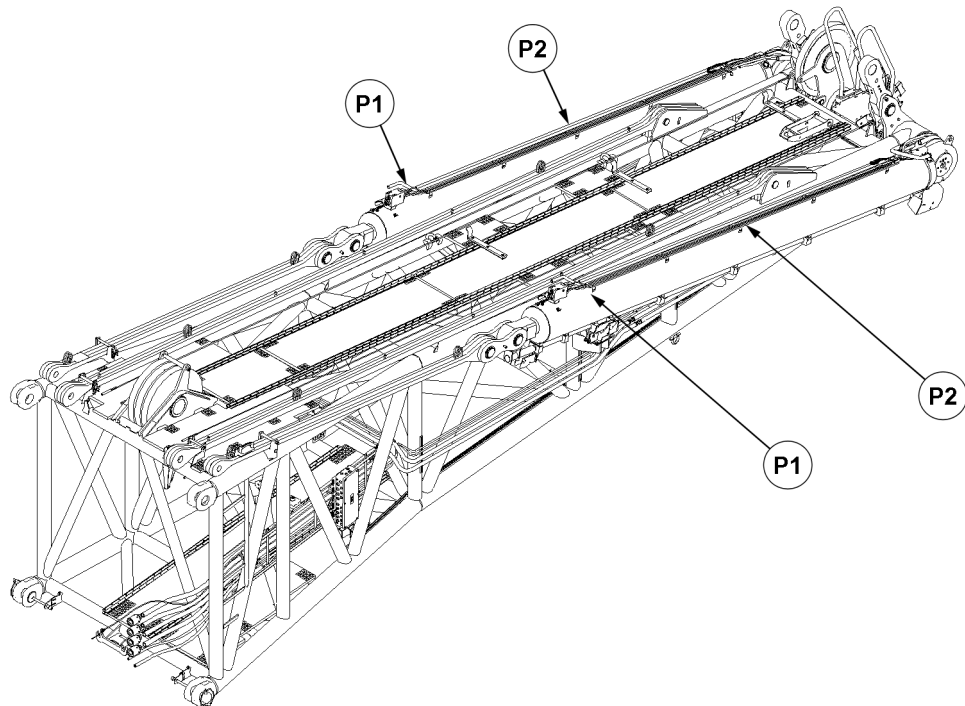


Fig.153372: D-end section fastening points

Fastening points	
P1 and P2	D-end section

## 2.5 S-luffing pulley block fastening points

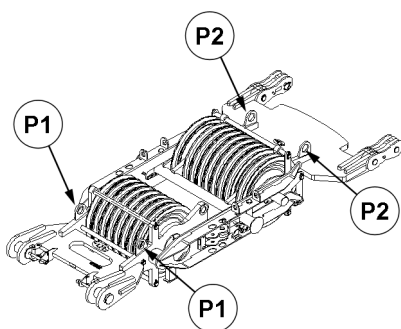


Fig.159687: S-luffing pulley block fastening points

Fastening points	
P1 and P2	S-luffing pulley block

## 2.6 S-luffing pulley block auxiliary weight fastening points

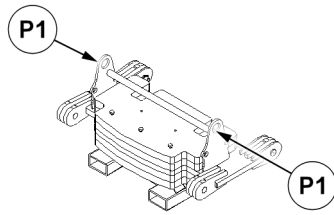


Fig.159684: S-luffing pulley block auxiliary weight fastening points

Fastening points	
P1	Auxiliary weight

## 3 D-boom assembly on the crane



### WARNING

Danger of falling!

During assembly / disassembly, inspection and maintenance work, assembly personnel must be secured with appropriate aids to prevent them from falling.

If this is not observed, assembly personnel could fall and be killed or seriously injured.

- ▶ All work at a height, when there is a danger of falling, must be carried out with suitable aids.
- ▶ If aids are not available and work cannot be carried out from the ground, then assembly personnel must secure themselves with the supplied fall arrest system to prevent falling, see chapter 2.04.
- ▶ If fall protection equipment is available, then it must be used, see chapter 2.06.
- ▶ When lifting, lowering, swinging crane parts in and out, no persons may remain in the danger zone.
- ▶ If railings are present on the components, then they must be brought into the corresponding position and secured for assembly / disassembly work.
- ▶ Only step on the aids, ladders and catwalks with clean shoes.
- ▶ Keep aids, ladders and catwalks free of heavy dirt, snow and ice.
- ▶ During all assembly and disassembly work, maintenance work and inspections, travel or crane operation is prohibited.
- ▶ Remaining on a suspended load is prohibited.
- ▶ Stepping or walking on crane components and lattice sections, which have an incline of more than 20° is prohibited.
- ▶ For all assembly work, the crane operator of the main crane must be in voice contact with the crane operator / crane operators of the auxiliary crane / auxiliary cranes.
- ▶ For assembly / disassembly tasks, the crane operator may only initiate crane movements when the responsible guide has explicitly released the movement.



### WARNING

Danger of impact / crushing!

When assembling / disassembling crane components with the auxiliary crane, crane components can start to swing back and forth.

When lifting / lowering and positioning crane components, there is an increased danger of impact / crushing.

Death, severe bodily injuries, property damage.

- ▶ Make sure that personnel cannot be caught by components.
- ▶ When working in danger zones: Use aids to protect limbs.
- ▶ Guide components with suitable aids to minimize oscillation.

**DANGER**

The components can fall down!

If the corresponding component is disengaged from the auxiliary crane before the corresponding component is pinned, then the corresponding component can fall down.

Death, severe bodily injuries, property damage.

- ▶ Do not detach the auxiliary crane until the respective component is pinned and secured.

**WARNING**

The lattice sections can fall down!

If the lattice sections are not pinned and secured correctly, then they can fall down.

Death, severe bodily injuries, property damage.

- ▶ Insert or unpin both pins on the same horizontal level, i.e. **left and right**.
- ▶ Do not stand under the lattice sections or within the entire danger zone during the pinning and unpinning procedure of the boom.
- ▶ Safely secure the pins in the storage locations as well as in the receptacles.
- ▶ It is prohibited to lean the ladder against the component being disassembled.

**WARNING**

The crane can topple over!

If the specifications listed below are **not** observed, the crane can collapse, the main boom can break off or the crane can topple over.

Death, severe bodily injuries, property damage.

- ▶ For the combination of the boom lattice sections, observe and adhere to the Rod plan and chapter 5.03.
- ▶ During assembly / disassembly operations, observe and adhere to the instructions in chapter 5.01.

**WARNING**

Danger of fatal injury due to falling components!

The pins can loosen up by themselves at the pin connections and cause components to fall down.

Death, severe bodily injuries, property damage.

- ▶ All pins must be secured after assembly with the intended retaining elements. Check visually.

**NOTICE**

Damage to the derrick boom and SA-frame!

If the SA-frame is pulled by winch 4 (intake gear) to the rear in direction of the turntable, then the derrick-boom and the SA-frame can be severely damaged.

Expensive and extensive repairs can result.

- ▶ As long as the guying between the SA-frame and the assembled D-pivot section or between the SA-frame and the assembled D-boom is **not** assembled and guyed, do not pull the SA-frame to the rear in the direction of the turntable.

**NOTICE**

Damage to the D-boom and SA-frame!

If the SA-frame is pulled back in the direction of the turntable during assembly / disassembly of the D-pivot section on the SA-frame, this can cause considerable damage to the SA-frame and the D-pivot section.

- ▶ Make sure that the SA-frame is at an angle of less than 90° during assembly of the D-pivot section.

**Note**

- ▶ For the combination of the boom lattice sections, observe and adhere to the Rod plan and chapter 5.03.



Make sure that the following prerequisites are met:

- The crane is horizontally aligned.
- An auxiliary crane is available.
- An assembly scaffolding / work platform is available.
- The counterweight has been installed on the turntable according to the load chart.
- The LICCON overload protection has been set according to the data in the load chart.
- The LICCON overload protection settings have been compared with the actual set up configuration.
- No main boom is assembled on the turntable.
- The assembly cylinder on the SA-frame is pinned and secured in the transport position.

### 3.1 Turning the turntable into the assembly position



#### DANGER

The crane can topple over!

If the following conditions are not met before turning the turntable - **without** installed D-boom, the crane can topple over.

Death, severe bodily injuries, property damage.

- ▶ Observe the specifications in the erection and take-down charts.
- ▶ Observe the assembly conditions for operation on crawlers, see chapter 3.06.

- ▶ Turn the turntable in the lengthwise direction of the crawler travel gear.

### 3.2 Exceeding the shut-off limits of the LICCON overload protection for assembly operation



#### WARNING

Danger of accident due to the “Exceedance of shut-off limits of the LICCON overload protection” function.

If the shut-off limits of the LICCON overload protection are exceeded, there is no additional protection against crane overload.

Due to erroneous operation or deliberate misuse, the crane could collapse, the boom can break off or the crane can topple over.

Death, severe bodily injuries, property damage.

- ▶ The function “Exceedance of shut off limits of the LICCON overload protection” is only permissible in emergencies and for assembly purposes.
- ▶ The function “Exceeding the shut off limits of the LICCON overload protection” may only be actuated by persons who know the effects of their actions regarding the function “Exceeding the shut off limits of the LICCON overload protection”.
- ▶ The “Exceedance of shut off limits of the LICCON overload protection” function requires the presence of an authorized person and must be performed with utmost caution.
- ▶ Crane operation with the “Exceedance of shut off limits of the LICCON overload protection” function activated is prohibited.

- ▶ Exceeding the shut off limits of the LICCON overload protection: Activate assembly operation.

#### Result:

- The shut off limits of the LICCON overload protection are exceeded.
- The assembly icon appears on the LICCON monitor.



#### Note

- ▶ See chapter 4.02 and chapter 4.20.

## 3.3 Assembling the D-boom in sections

### 3.3.1 Erecting the D-relapse cylinder



#### WARNING

Danger of falling!

If the D-relapse cylinder is brought to the operating position when the D-pivot section is already installed on the SA-frame, assembly personnel can fall down.

Death, severe bodily injuries, property damage.

- ▶ Make sure that the D-pivot section is located on the ground when the D-relapse cylinder is brought to the assembly position on both sides.

Make sure that the following prerequisite is met:

- The D-pivot section is set down on the ground properly.

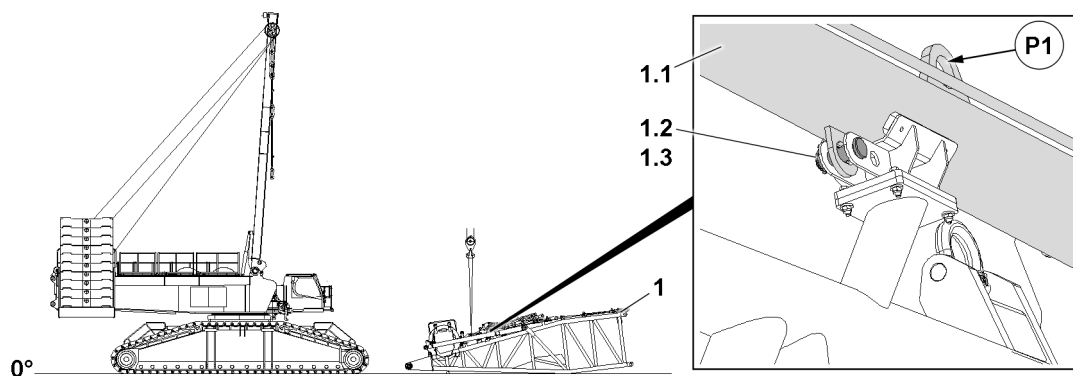


Fig.153374: Preparing the D-pivot section for assembly

- ▶ Fasten the D-relapse cylinder **1.1** to the auxiliary crane in point **P1**.
- ▶ Remove the retaining element **1.3** and unpin the pin **1.2** from the transport position.

#### Result:

- The D-relapse cylinder **1.1** is released.
- ▶ Insert the adjacent pin **1.2** in the park position and secure with the retaining element **1.3**.

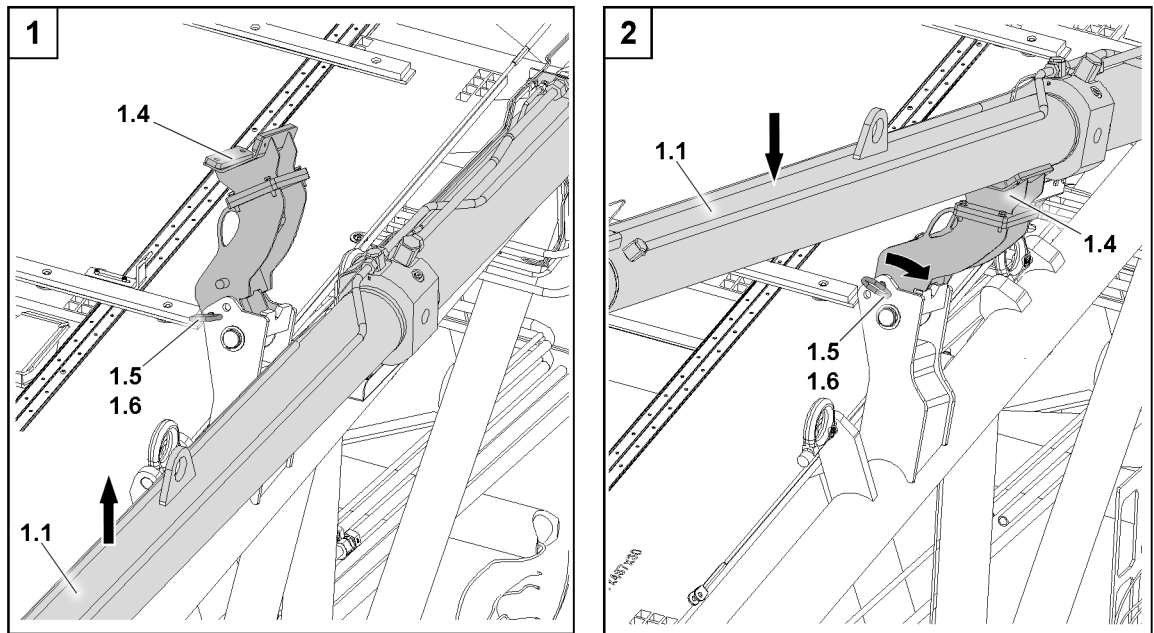


Fig.153375: Bringing the D-relapse cylinder into the assembly position

- ▶ Lift the D-relapse cylinder **1.1** with the auxiliary crane.
- ▶ Remove the retaining element **1.6** and unpin the grip pin **1.5** from the transport position.

**Result:**

- The support **1.4** is released.



**WARNING**

Danger of crushed limbs!

When swinging the support **1.4**, fingers and hands can be crushed.

- ▶ Do not reach with your hands into the danger zone.
- ▶ Swing the support **1.4** up to the stop.
- ▶ Insert the grip pin **1.5** in the operating position and secure with the retaining element **1.6**.

**Result:**

- The support **1.4** is secured in the operating position.



**WARNING**

Danger of crushed limbs!

When taking the D-relapse cylinder **1.1** down, fingers and hands can be crushed.

- ▶ Do not reach with your hands into the danger zone.
- ▶ Take the D-relapse cylinder **1.1** down with the auxiliary crane on the support **1.4**.
- ▶ Remove the fastening equipment.



**Note**

- ▶ The procedure for handling the second D-relapse cylinder is identical to the procedure for the first D-relapse cylinder.
- ▶ Bring the second D-relapse cylinder **1.1** into the operating position.

### 3.3.2 Variation with removable winch 3: Preparing the S-luffing pulley block for assembly

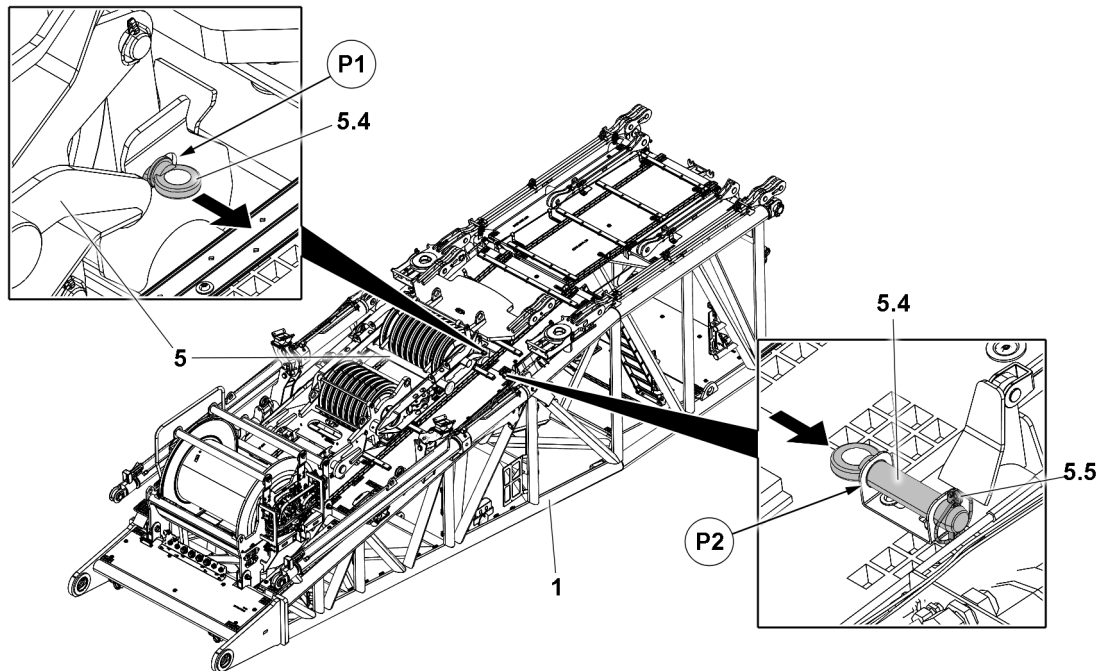


Fig.159655: Preparing the S-luffing pulley block for assembly (variation with removable winch 3)

Make sure that the following prerequisite is met:

- The D-pivot section is set down properly on the ground.
- ▶ Remove the transport retainer from the S-luffing pulley block 1 on the pin point P1: Remove two safety locking pins 5.5 and two pins 5.4.
- ▶ Insert the transport retainer into the D-pivot section 1 in park position: Insert the pin 5.4 in point P2 and secure with the safety locking pin 5.5.

### 3.3.3 Pinning the D-pivot section on the SA-frame

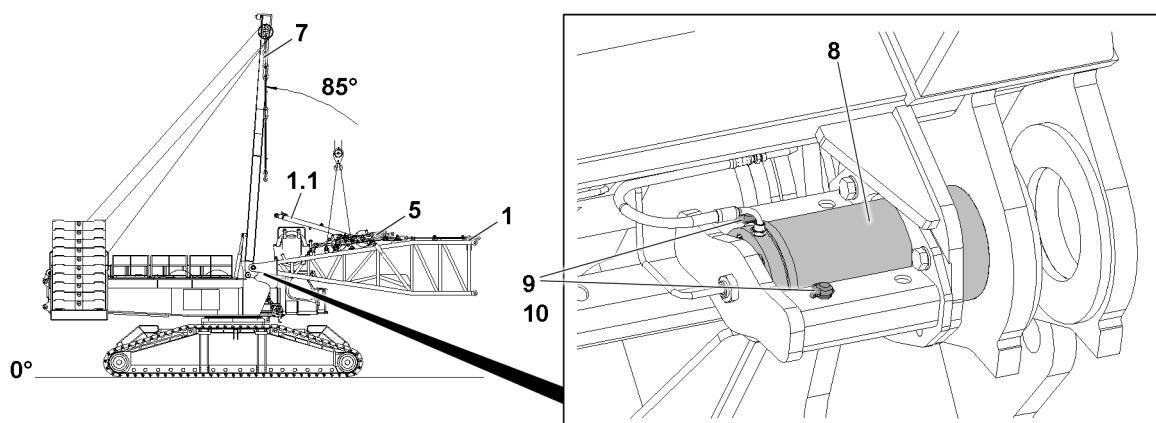


Fig.153376: Positioning the D-pivot section on the SA-frame // Connector pin unpinned

**DANGER**

Danger of fatal injury due to falling components!

If the pin connections are not visually inspected, the pins can loosen up by themselves and cause components to fall down.

Death, severe bodily injuries, property damage.

- ▶ All pins must be secured after assembly with the intended retaining elements. Check visually.
- ▶ The guy rods must be inspected regularly, see chapter 8.15.

Make sure that the following prerequisites are met:

- The SA-frame **7** is approx. at 85°.
- The connector pins **8** on the SA-frame are fully unpinned.
- The connector pins **8** are secured with retaining pins **9**.
- The connector pins between the turntable and the S-pivot section are fully unpinned.
- Winch 3 is assembled on the D-pivot section.
- The S-luffing pulley block **5** is in the transport receptacle on the D-pivot section **1**.
- The D-relapse cylinders **1.1** are in the operating position.
- The central ballast is installed according to the load chart.
- The counterweight is installed according to the load chart.
- The crane engine is running.

**Note**

- ▶ Fastening points, see section “Fastening points for derrick components”.

**WARNING**

Danger of tipping!

If winch 3 and / or the S-luffing pulley block **5** is not located on the D-pivot section when placing the D-pivot section on the ground, the D-pivot section **1** can tip over.

Death, severe bodily injuries, property damage.

- ▶ Support the D-pivot section **1**.

**NOTICE**

Damage to the D-pivot section and SA-frame!

If the SA-frame is in an impermissible angle setting (greater than 85°) during assembly of the D-pivot section, the D-pivot section and the SA-frame could be damaged when lowered to the ground.

- ▶ Make sure that the SA-frame is at a maximum angle of 85° during assembly of the D-pivot section.
- ▶ Fasten the D-pivot section **1** to the auxiliary crane and swing it in to the pin location on the SA-frame **7**.

**WARNING**

Falling D-pivot section!

Due to non-secured or insufficiently secured connector pins, the D-pivot section can fall down.

Death, severe bodily injuries, property damage.

- ▶ The connector pins **8** must be secured after the pinning procedure to the SA-frame **7** with the retaining pins **9**.

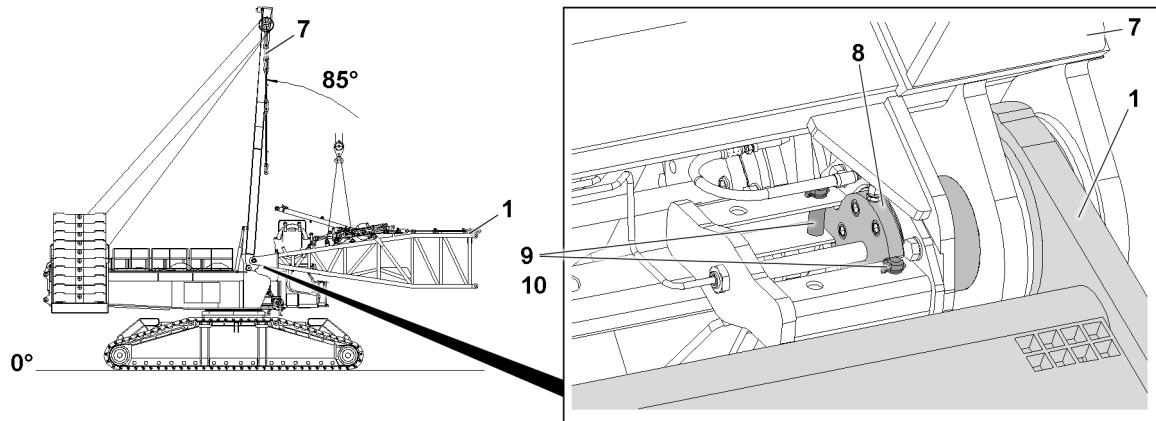


Fig.153377: D-pivot section pinned on the SA-frame

When the pin bores between the SA-frame and the D-pivot section align:

- ▶ Insert the connector pin **8** on both sides: Actuate the BTT.

When the connector pins **8** are completely pinned on both sides:

- ▶ Secure the connector pins **8** with retaining pins **9** on both sides.
- ▶ Insert the retaining pin **9** and secure with the retaining element **10**.

#### NOTICE

Damage to the D-pivot section!

Property damage can occur to the D-pivot section **1** if taking the assembled D-pivot section down onto the ground.

- ▶ Make sure that the D-pivot section **1** is not taken down below the alignment level.
- ▶ When taking the D-pivot section **1** down, always use a sufficiently load bearing and large enough substructure **11**.
- ▶ When taking down the D-pivot section **1**, make sure that the connector pins between the turntable and the S-pivot section are completely unpinned.

#### NOTICE

Damage to the crane components!

The crane components can be damaged by moving the SA-frame during assembly of the D-pivot section.

- ▶ Make sure the SA-frame is not luffed up or down during the assembly of the D-pivot section and after lowering the D-pivot section.

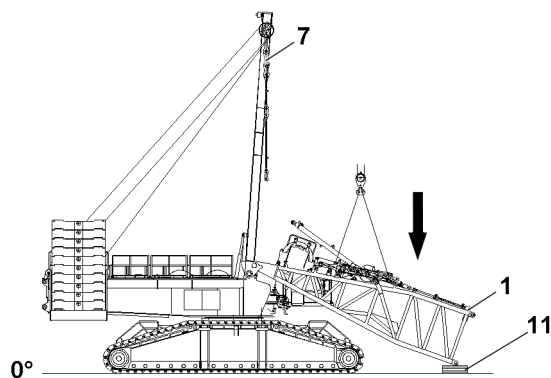


Fig.153378: Taking the D-pivot section down onto the substructure

- ▶ Build up the substructure **11** to at least 350 mm.
- ▶ Take the D-pivot section **1** down carefully with the auxiliary crane onto the substructure **11**.

- ▶ Remove the auxiliary crane.

### 3.3.4 Establishing the hydraulic connections to the D-pivot section

The hydraulic connections are established with quick couplings.

---

#### NOTICE

Danger of property damage!

If the hydraulic lines are not connected with the turntable before lowering the SA-frame to the front, then they can be crushed when lowering the SA-frame.

- ▶ Make sure, before lowering the SA-frame to the front, that the hydraulic lines are connected with the turntable.
- 

When connecting hydraulic lines with quick couplings, make sure that the coupling procedure is carried out correctly.

---



#### WARNING

Pressure in the hydraulic lines!

If the pressure supply is not interrupted before connecting / releasing the hydraulic lines, the hydraulic oil can escape with high pressure.

Death, severe bodily injuries, property damage.

- ▶ Release the pressure in the hydraulic system before connecting / disconnecting: Interrupt the pressure supply and wait for a short time.
- 



#### WARNING

Loss of pressure or leakage!

Incorrectly coupled or self-loosening quick couplings (particularly return lines) can result in serious accidents due to component failure.

- ▶ Check that the quick couplings have been properly connected before using the crane.
  - ▶ Connect the coupling components (sleeve and connector) and screw together with the knurled nut.
  - ▶ Tighten the hydraulic coupling by hand. Turn the knurled nut until it reaches a tangible, fixed stop position.
  - ▶ Establish the hydraulic connections, see the Hydraulic diagram.
- 

### 3.3.5 Establishing the electrical connections to the D-pivot section

---

#### NOTICE

Damage to the electrical connections!

If the electrical connection between the terminal box and the D-pivot section and the cable drum in the D-pivot section is established before the boom end section is assembled and electrically connected, then the electric connection can be damaged.

- ▶ Make sure that the electric connection between the terminal box in the D-pivot section and the cable drum in the D-pivot section is only established **after** assembly and the connection of the electric wiring for the boom end section.
- 



#### Note

- ▶ To establish the electrical connections on the D-pivot section: Use the electric wiring diagram.
- 

Make sure that the following prerequisite is met:

- The D-pivot section is completely assembled and placed on the substructure.
- ▶ Establish the electrical connections.
- ▶ Make sure that all electrical connections to the D-pivot section have been established.

**WARNING**

Malfunction if dummy plugs are not installed!

If the dummy plugs on the non-required electrical connections are not installed, then malfunctions or functional limitations can occur on the crane.

- ▶ Make sure that all non-required electrical connections, which have a dummy plug, are closed off with dummy plugs.
  - ▶ Pay attention to the Electrical wiring diagram.
- 
- ▶ As a rule, close off on-required electrical connections (for example for accessories which cannot be installed) with the respective dummy plugs.

**NOTICE**

Property damage due to dirt and / or corrosion!

If unnecessary electrical connections are not closed off with the respective protective caps, then dirt and / or corrosion can damage the electrical connections.

This could result in malfunctions.

- ▶ Make sure that all non-required electrical connections are always closed off properly.
  - ▶ Pay attention to the Electrical wiring diagram.
- 
- ▶ Close electrical connections, which have no dummy plugs, off properly with the corresponding protective caps.

### 3.3.6 Variation with removable winch 3: Taking the S-luffing pulley block down onto the ground

Make sure that the following prerequisites are met:

- The S-luffing pulley block transport locks are removed.

**Note**

- ▶ Fastening points, see section “Fastening points for derrick components”.

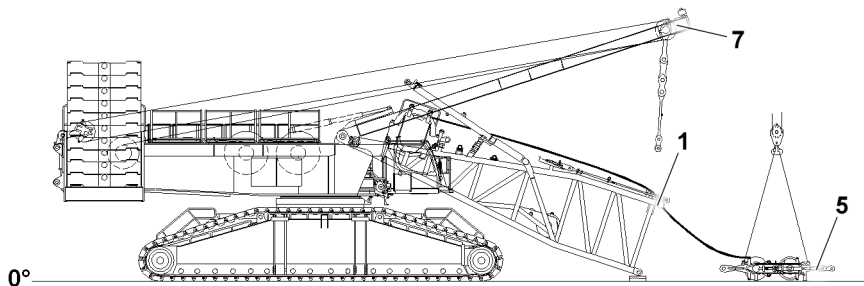


Fig.159658: Taking the S-luffing pulley block down onto the ground

**NOTICE**

Rope damage!

- ▶ When spooling winch 3 **WIII** out, make sure that no slack rope forms.
- 
- ▶ Fasten the S-luffing pulley block **5** to the auxiliary crane.
  - ▶ Pull the S-luffing pulley block **5** with the auxiliary crane while spooling winch 3 **WIII** out, in front of the D-pivot section **1**. Make sure that the control rope runs between the flying assembly guying.
  - ▶ Take the S-luffing pulley block **5** down with the auxiliary crane to the side in front of the D-pivot section **1**.
  - ▶ Remove the auxiliary crane.



### 3.3.7 Variation with fixed installed winch 3: Taking the S-luffing pulley block down onto the ground

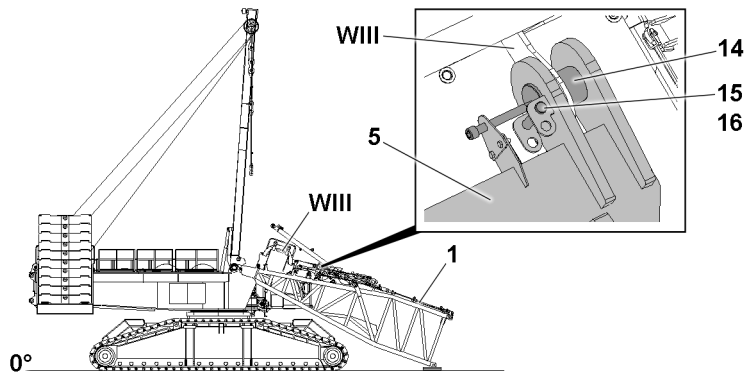


Fig.159659: Unpinning the S-luffing pulley block (variation with fixed installed winch 3)



#### WARNING

Slipping S-luffing pulley block!

By unpinning the S-luffing pulley block **5** on winch **3 WIII**, the S-luffing pulley block can start to slip. Death, severe bodily injuries, property damage.

- ▶ The S-luffing pulley block **5** must be secured by an auxiliary crane before unpinning it on winch **3 WIII**.
- ▶ After unpinning and before lifting the S-luffing pulley block **5** leave the danger zone.



#### Note

- ▶ Fastening points, see section "Fastening points for derrick components".
- ▶ Fasten the S-luffing pulley block **5** to the auxiliary crane.
- ▶ Remove the retaining element **16** on both sides and unpin the retaining pin **15** on both sides.
- ▶ Unpin the S-luffing pulley block **5** on winch **3 WIII**: Unpin the pin **14** on both sides.

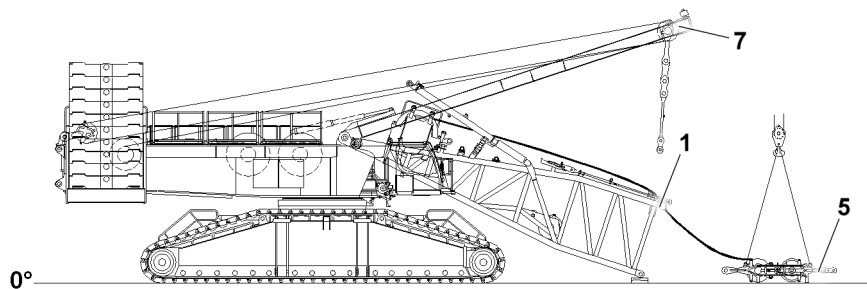


Fig.159658: Taking the S-luffing pulley block down onto the ground

#### NOTICE

Rope damage!

- ▶ When spooling winch **3 WIII** out, make sure that no slack rope forms.
- ▶ Pull the S-luffing pulley block **5** with the auxiliary crane while spooling winch **3 WIII** out, in front of the D-pivot section **4**. Make sure that the control rope runs between the flying assembly guying.
- ▶ Take the S-luffing pulley block **5** down with the auxiliary crane to the side in front of the D-pivot section **4**.
- ▶ Remove the auxiliary crane.

### 3.3.8 Lowering the SA-frame to the front and assembling the flying assembly guying

Make sure that the following prerequisites are met:

- The auxiliary crane is removed.
- The hydraulic connections to the D-pivot section are established.
- The transport retainers for the guy rods on the SA-frame are released.
- The D-pivot section is supported.

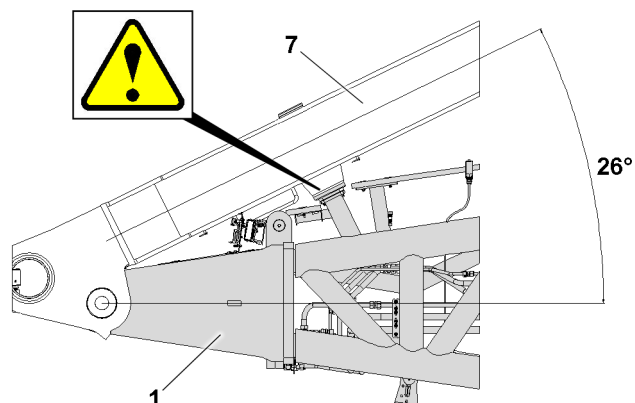


Fig.153394: SA-frame 7 on the D-pivot section 1 stop

---

#### NOTICE

Danger of slack rope formation!

From an angle of 26° between the SA-frame 7 and the D-pivot section 1, the SA-frame 7 touches at the stop of the D-pivot section 1.

The block position is not monitored by the control. When spooling winch 4 out further, slack rope may form.

- Make sure that winch 4 is no longer actuated when the block position is reached.
-

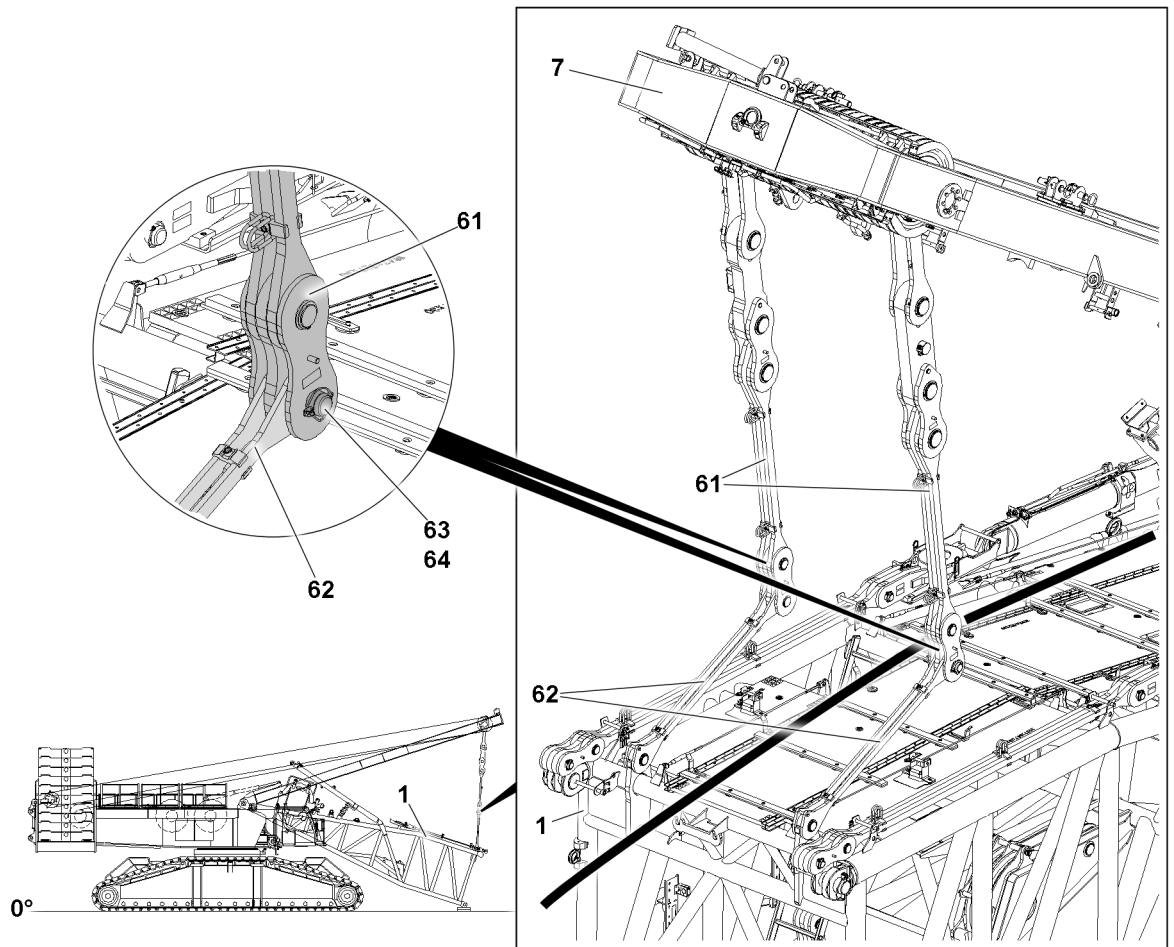


Fig.159657: Pinning the flying assembly guying



### WARNING

Moving SA-frame while staying in the danger zone!  
Death, severe bodily injury, property damage.

- ▶ Leave the danger zone between the SA-frame and D-pivot section.
- ▶ Observation of SA-frame lowering by the guide.



### Note

- ▶ For assembly of the D-boom, the guy rods **61** of the SA-frame **7** must be pinned with the flying assembly guy rods **62** on the D-pivot section **1** so that the D-boom can be lifted over the SA-frame **7** and assembled.

- ▶ Lower the SA-frame **7** until the flying assembly guying can be assembled.
- ▶ Assemble the flying assembly guying between the SA-frame **7** and the D-pivot section **1**.
- ▶ Release the flying assembly guy rods **62** from the transport retainers.
- ▶ Lift the flying assembly guy rods **62** and align them with the guy rods **61** of the SA-frame **7**.

When the pin bores align:

- ▶ Insert the pin **63** and secure it with the retaining element **64**.

When the guying for the flying assembly between the SA-frame **7** and the D-pivot section **1** is properly assembled and secured:

- ▶ Lift the SA-frame **7** until the flying assembly guying is tensioned.

### 3.3.9 Assembling the D-lattice sections

Make sure that the following prerequisites are met:

- The D-pivot section is pinned and secured on the SA-frame.
- The D-pivot section is taken down on the substructure.
- The S-luffing pulley block is positioned to the side in front of the D-pivot section.



#### Note

- ▶ Always support the D-lattice sections sufficiently for easier assembly.
- ▶ Pin and unpin the D-lattice sections with the pin pulling device, see chapter 5.30.



#### Note

- ▶ Fastening points, see section “Fastening points for derrick components”.

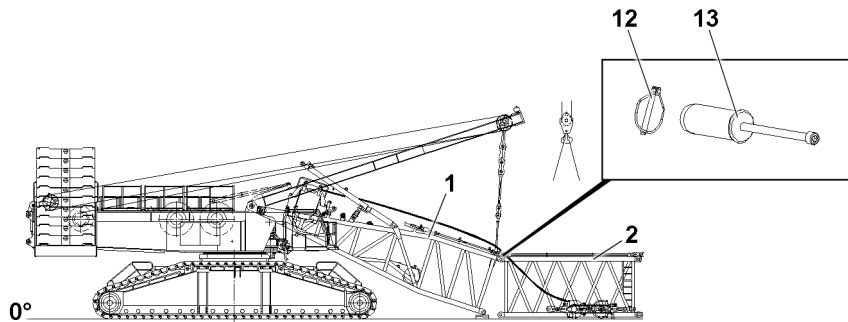


Fig. 159660: Assembling the D-lattice sections

Pin the D-intermediate section 2 to the D-pivot section 1 on top.

- ▶ Connect the D-intermediate section 2 to the auxiliary crane and align with the D-pivot section 1.

When the pin bores on the D-pivot section 1 align with those on the D-intermediate section 3:

- ▶ Insert the pin 13 on both sides on top and secure with the retaining element 12.

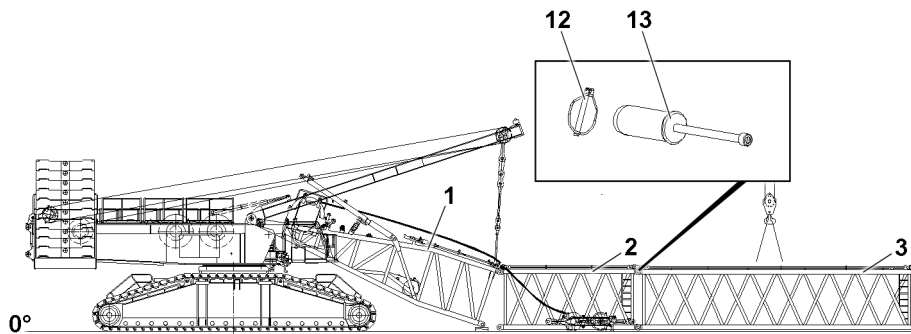


Fig. 159661: Assembling the D-lattice sections

Pin the D-intermediate section 3 to the D-intermediate section 2 on the top and bottom.

- ▶ Connect the D-intermediate section 3 to the auxiliary crane and align with the D-intermediate section 2.

When the pin bores on the D-intermediate section 3 align with those on the D-intermediate section 2:

- ▶ Insert the pin 13 on both sides on top and bottom and secure with the retaining element 12.

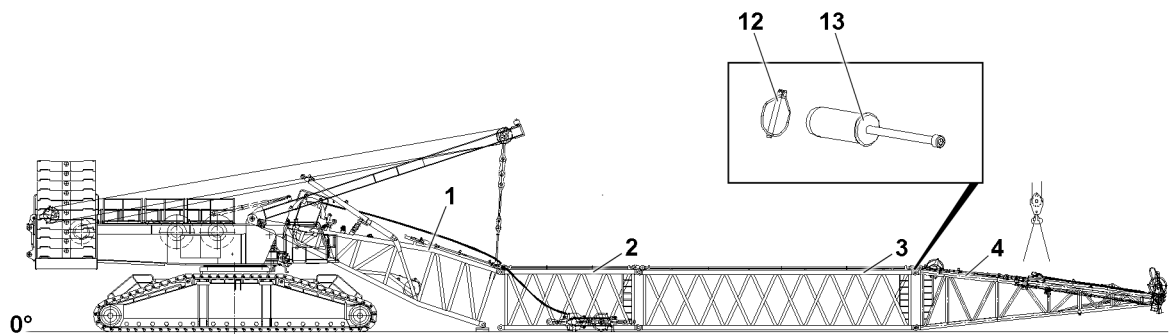


Fig. 159662: Assembling the D-lattice sections

Pin the D-end section 4 to the D-intermediate section 3 on the top and bottom.

- ▶ Connect the D-end section 4 to the auxiliary crane and align with the D-intermediate section 3.

When the pin bores on the D-intermediate section 3 align with those on the D-end section 4:

- ▶ Insert the pin 13 on both sides on top and bottom and secure with the retaining element 12.

### 3.3.10 Pulling the S-luffing pulley block to the D-end section and taking it down on the ground

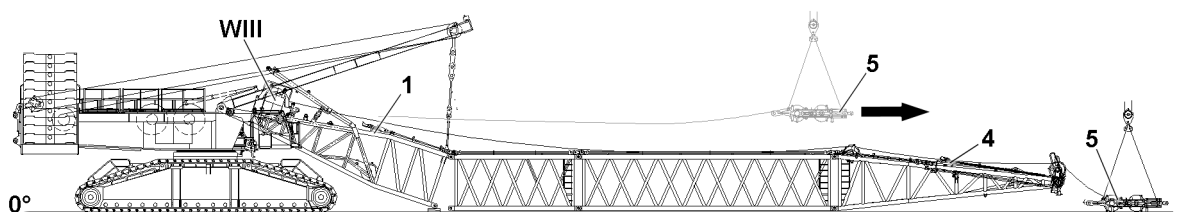


Fig. 159663: Pulling the S-luffing pulley block to the D-end section



#### Note

- ▶ Fastening points, see section "Fastening points for derrick components".
- ▶ Fasten the S-luffing pulley block 5 to the auxiliary crane.

#### NOTICE

Rope damage!

- ▶ When spooling winch 3 **WIII** out, make sure that no slack rope forms.
- ▶ Pull the S-luffing pulley block 5 with the auxiliary crane to the D-end section 4 while spooling out winch 3 **WIII** at the same time.
- ▶ Take the S-luffing pulley block 5 down with the auxiliary crane in front of D-end section 4.
- ▶ Reeve in the control rope of winch 3 and secure it to the rope pulley of the end section, see the Reeving plan and Chapter 4.06.
- ▶ Reeve in the control rope of winch 3 on the S-luffing pulley block and secure it to the rope fixed point, see the Reeving plan and Chapter 4.06.
- ▶ Remove the auxiliary crane.

### 3.3.11 Releasing the upper pulley block on the lower pulley block

Make sure that the following prerequisites are met:

- The S-luffing pulley block **5** is lying on the ground or on a substructure with sufficient load-bearing capacity.
- The auxiliary crane is removed.

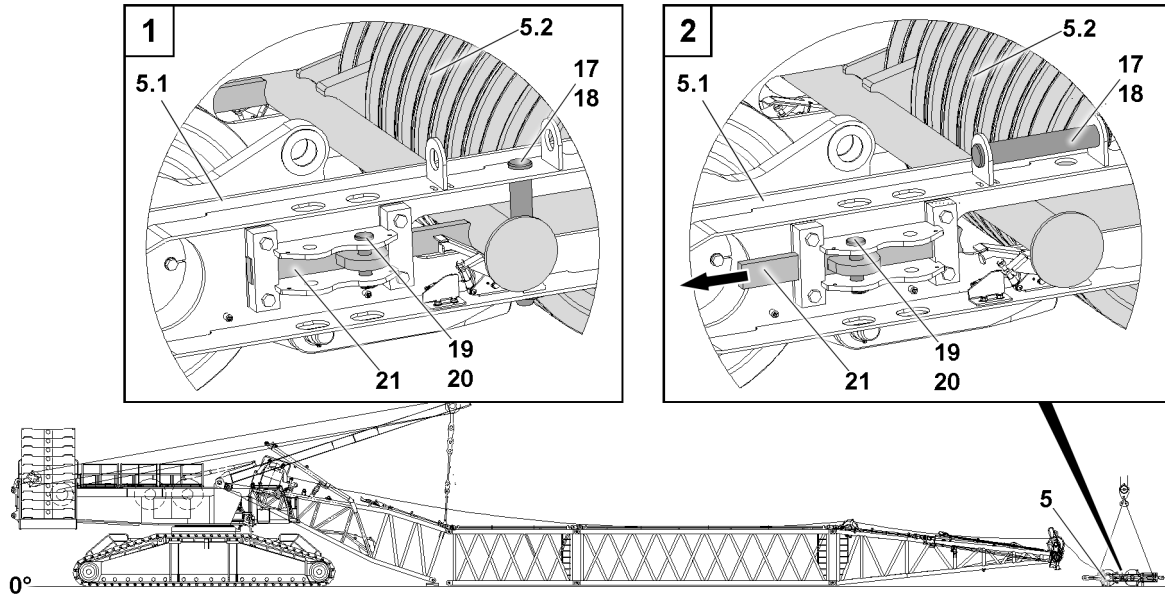


Fig.159692: Releasing the upper pulley block **5.2** on the lower pulley block **5.1**

- ▶ Remove the retaining element **20** on both sides and unpin the pin **19** from the transport position.
- ▶ Move the latch **21** to the stop.
- ▶ Insert the pin **19** in the operating position and secure with the retaining element **20**.
- ▶ Remove the retaining element **18** on both sides and unpin the pin **17** from the transport position.

#### Result:

- The transport retainer between the upper pulley block **5.2** and the lower pulley block **5.1** is removed.

When the upper pulley block **5.2** and lower pulley block **5.1** are released:

- ▶ Insert the pin **17** on both sides in the park position and secure with the retaining element **18**.

### 3.3.12 “Closing” the D-boom

Make sure that the following prerequisites are met:

- The D-lattice sections are pinned and secured.
- The SA-frame guy rods and the guy rods for flying assembly are properly pinned and secured.



#### WARNING

Danger of accident!

- ▶ The maximum permissible total force in test point 1 **MS 1** may not exceed 125 t.
- ▶ Take note of the force used in test point 1 **MS 1** during the closing procedure of the D-boom and keep it ready for opening the D-boom.
- ▶ Make sure that the D-end section lies maximum 500 mm below the alignment level.

#### NOTICE

Further erection of the D-pivot section!

Property damage to the D-intermediate section and D-pivot section.

- ▶ Erect the D-pivot section until the pin bores on the D-pivot section and on the D-intermediate section align.

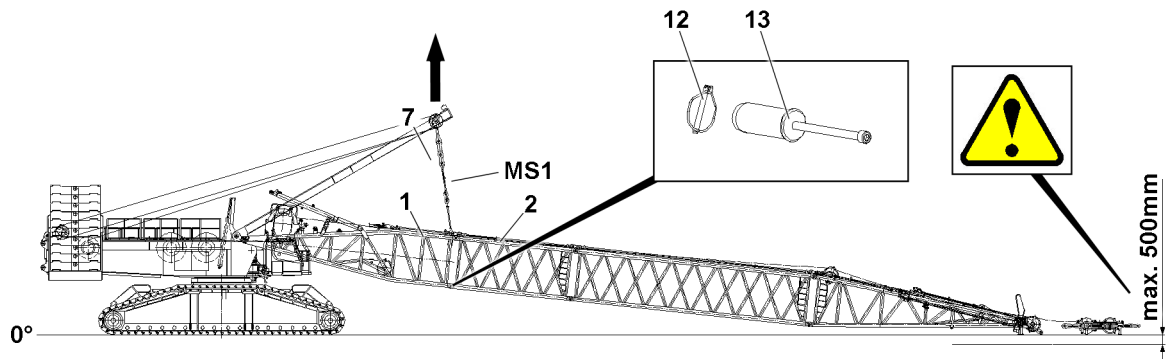


Fig.159693: D-boom closed

Erect the SA-frame 7 until the pin bores on the D-pivot section 1 and on the D-intermediate section 2 align on the “bottom”:

- ▶ Insert the pin 13 on both sides on the bottom and secure with the retaining element 12.

### 3.3.13 Bringing the ladder into the operating position

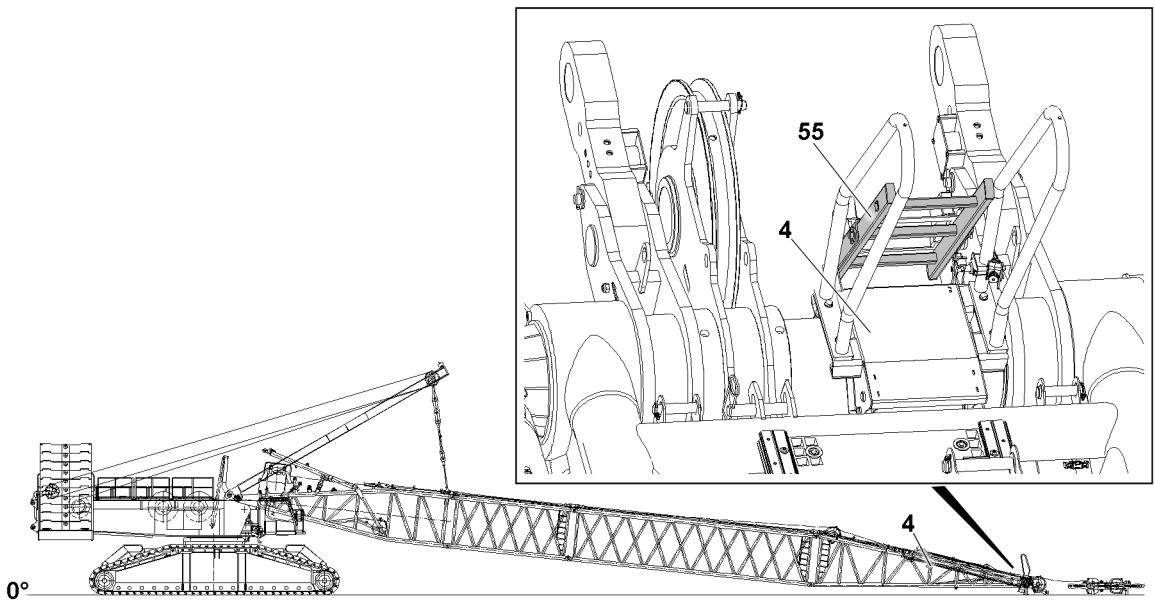


Fig.159694: Bringing the ladder into the operating position



**Note**

- ▶ Bring the ladder 55 into the operating position, see chapter 2.06.

### 3.3.14 Bringing the pull test brackets into the operating position

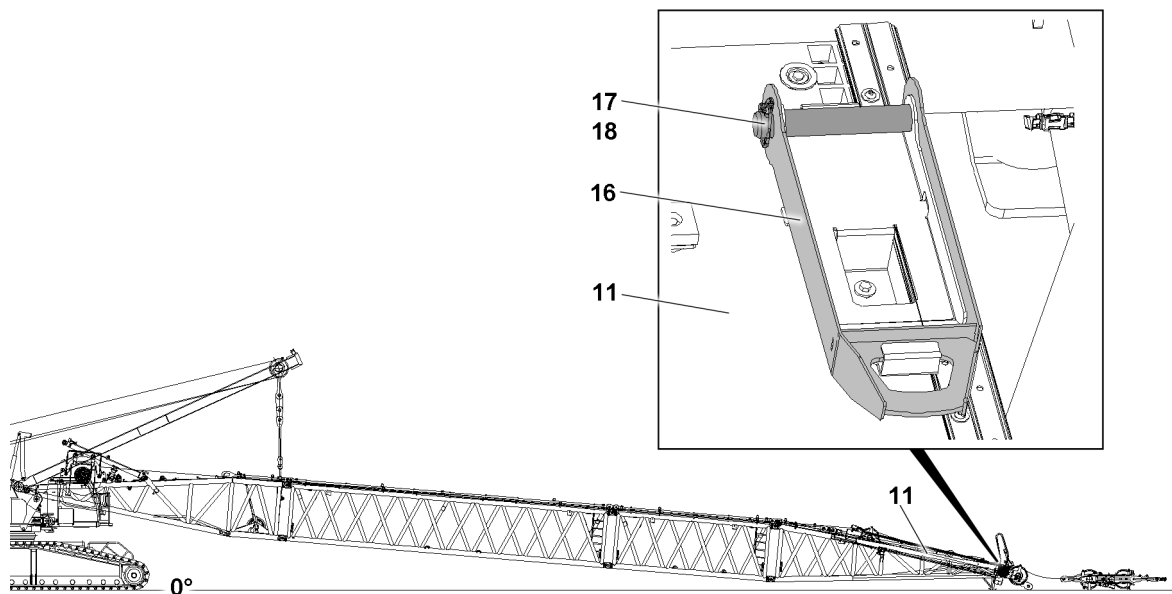


Fig.159695: Releasing the lashing lug

- ▶ Remove the retaining element **27** and unpin the pin **26**.
- ▶ Remove the lashing lug **25** from the transport retainer.

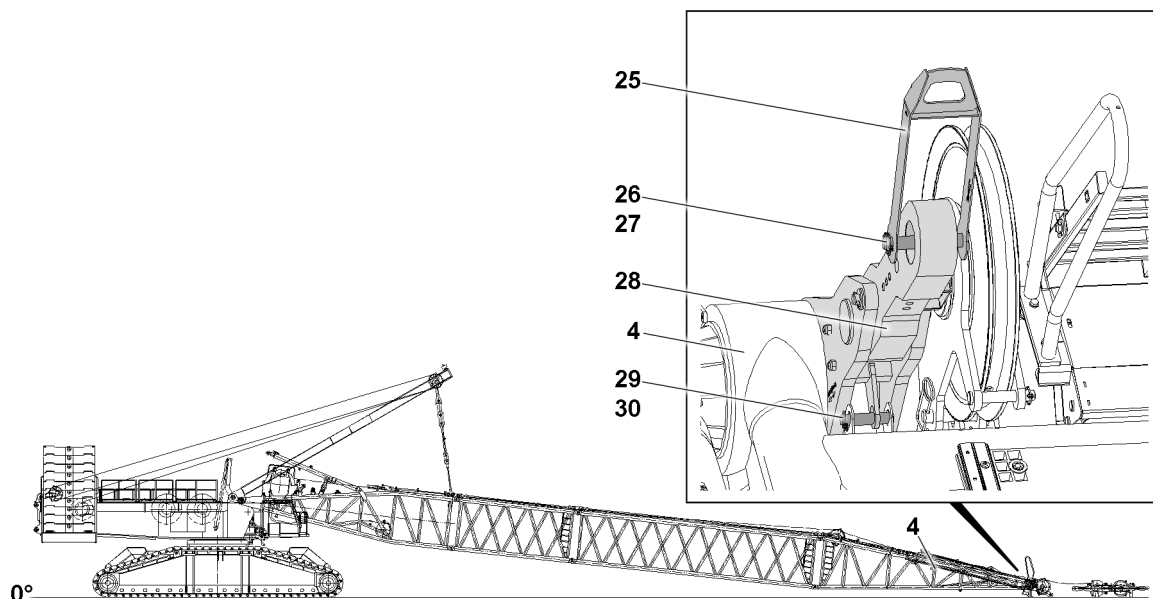


Fig.159696: Releasing the pull test bracket

#### NOTICE

Danger of property damage!

- ▶ Fasten the pull test bracket **28** to the auxiliary crane only when using the lashing lug **25**.
- ▶ Connect the lashing lug **25** with the pull test bracket **28**: Insert the pin **26** and secure it with the retaining element **27**.
- ▶ Fasten the lashing lug **25** to the auxiliary crane.



**WARNING**

The pull test bracket can cause danger of fatal injury!

If the pull test brackets are not secured with an auxiliary crane during the swinging procedure, they can swing forward due to their weight.

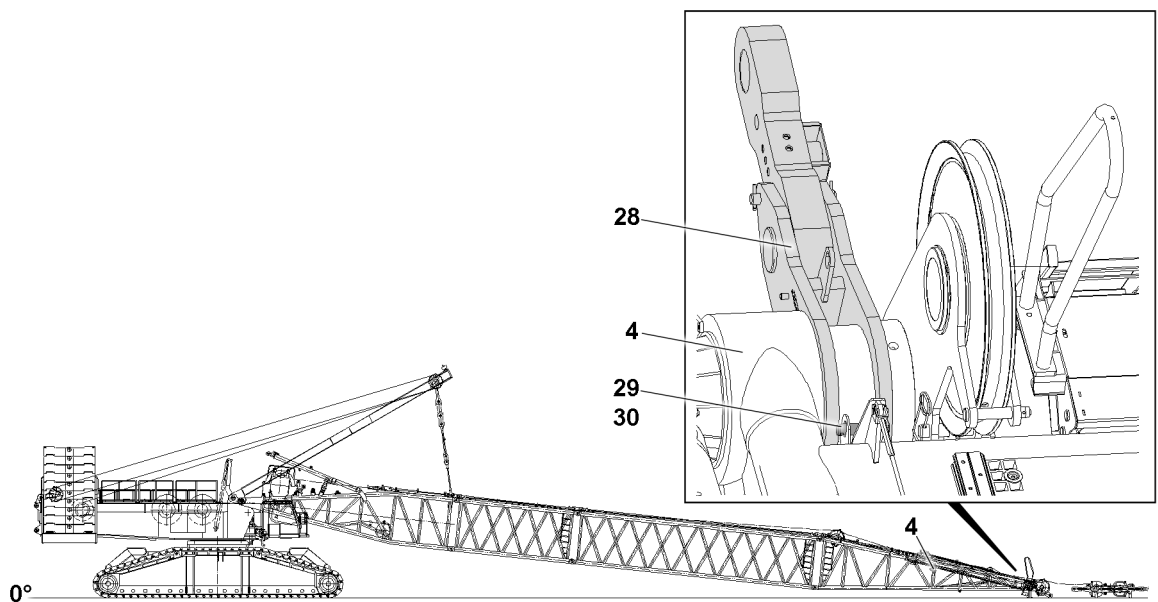
Death, severe bodily injuries, property damage.

- ▶ Swing the pull test bracket **28** into operating position only with the aid of an auxiliary crane.
- ▶ Swinging the pull test bracket **28** without an auxiliary crane is **prohibited**.

- ▶ Tighten the fastening equipment carefully with the auxiliary crane.

Bring the first pull test bracket **28** into the operating position.

- ▶ Remove the retaining element **30** from the transport retainer and unpin the retaining pin **29**.
- ▶ Swing the pull test bracket **28** forward with the auxiliary crane.



*Fig.159697: Bringing the pull test bracket into the operating position*

When the pull test bracket **28** is swung forward completely:

- ▶ Remove the auxiliary crane.
- ▶ Remove the lashing lug **25** from the pull test bracket **28**.
- ▶ Insert the retaining pin **29** back into the transport position and secure with the retaining element **30**.
- ▶ Bring the second pull test bracket into the operating position.

After both pull test brackets are in the operating position:

- ▶ Fasten the lashing lug **25** in the transport position.

### 3.3.15 Bringing the pulley retainer into the operating position

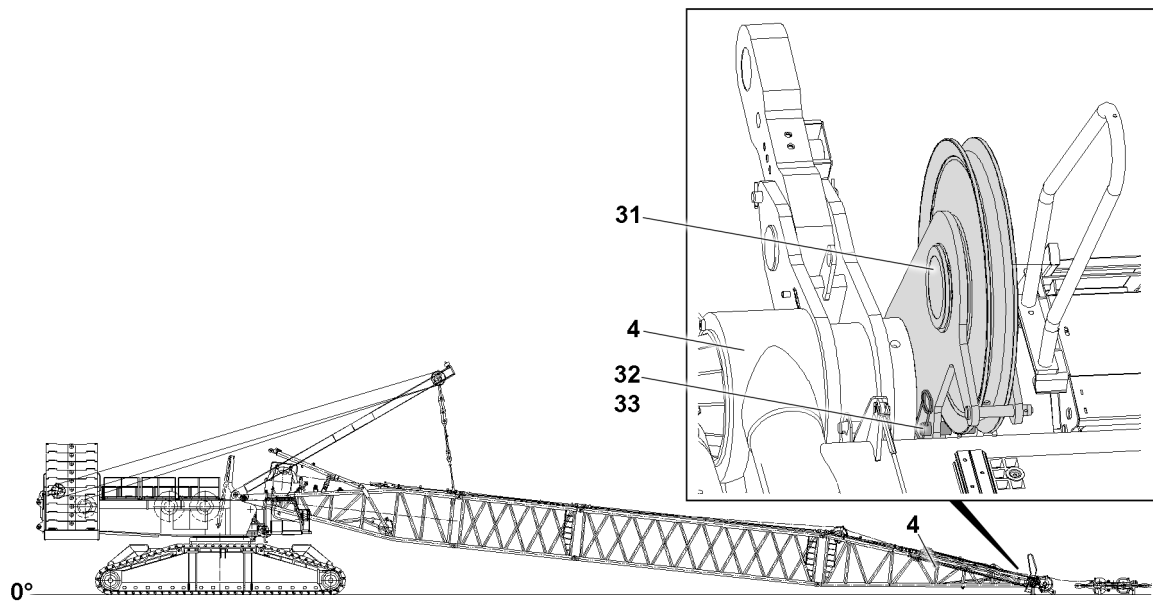


Fig.159698: Releasing the pulley retainer



#### WARNING

Danger of fatal injury due to the pulley retainer!

If the pulley retainer is not secured with an auxiliary crane during the swinging procedure, then it can swing forward due to its weight.

Death, severe bodily injuries, property damage.

- ▶ Swing the pulley retainer **31** into operating position only with the aid of an auxiliary crane.
- ▶ Swinging the pulley retainer without an auxiliary crane is **prohibited**.

- ▶ Fasten the pulley retainer **31** to the auxiliary crane.

When the pulley retainer **31** is properly fastened to the auxiliary crane:

- ▶ Tension the fastening equipment carefully.
- ▶ Remove the retaining element **33** from the transport retainer and unpin the retaining pin **32**.

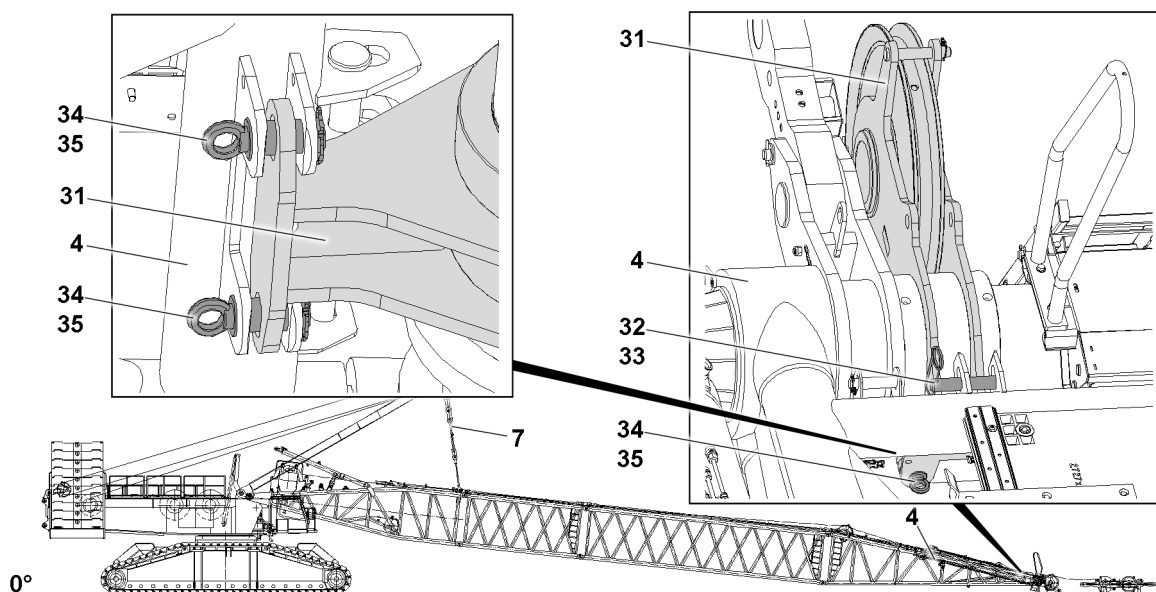


Fig.159699: Bringing the pulley retainer into the operating position

- ▶ Remove the retaining element **35** and unpin the grip pin **34**.
- ▶ Swing the pulley retainer **31** forward with the auxiliary crane.

When the pulley retainer **31** is in the operating position:

- ▶ Insert the grip pin **34** in the operating position of the pulley retainer **31** twice and secure with the retaining element **35**.
- ▶ Remove the auxiliary crane.
- ▶ Insert the retaining pin **32** back into the transport position and secure with the retaining element **33**.

### 3.3.16 Establishing the hydraulic connections on the D-boom

The hydraulic connections are established with quick couplings.

Make sure that the following prerequisites are met:

- The D-lattice sections are pinned and secured.
- The D-boom system is closed.
- All connector pins on the D-boom system are properly pinned and secured.

When connecting hydraulic lines with quick couplings, make sure that the coupling procedure is carried out correctly.



#### WARNING

Pressure in the hydraulic lines!

If the pressure supply is not interrupted before connecting / releasing the hydraulic lines, the hydraulic oil can escape with high pressure.

Death, severe bodily injuries, property damage.

- ▶ Release the pressure in the hydraulic system before connecting / disconnecting: Interrupt the pressure supply and wait for a short time.



#### WARNING

Loss of pressure or leakage!

Incorrectly coupled or self-loosening quick couplings (particularly return lines) can result in serious accidents due to component failure.

- ▶ Check that the quick couplings have been properly connected before using the crane.
- ▶ Connect the coupling components (sleeve and connector) and screw together with the knurled nut.
- ▶ Tighten the hydraulic coupling by hand. Turn the knurled nut until it reaches a tangible, fixed stop position.
- ▶ Establish the hydraulic connections, see the Hydraulic diagram.

### 3.3.17 Establishing the electrical connections on the D-boom



#### Note

- ▶ To establish the electrical connections on the D-boom: Use the electric wiring diagram.

- ▶ Establish the electrical connections.
- ▶ Make sure that all electrical connections on the D-boom have been established.



#### WARNING

Malfunction if dummy plugs are not installed!

If the dummy plugs on the non-required electrical connections are not installed, then malfunctions or functional limitations can occur on the crane.

- ▶ Make sure that all non-required electrical connections, which have a dummy plug, are closed off with dummy plugs.
- ▶ Pay attention to the Electrical wiring diagram.
- ▶ As a rule, close off on-required electrical connections (for example for accessories which cannot be installed) with the respective dummy plugs.

**NOTICE**

Property damage due to dirt and / or corrosion!

If unnecessary electrical connections are not closed off with the respective protective caps, then dirt and / or corrosion can damage the electrical connections.

This could result in malfunctions.

- ▶ Make sure that all non-required electrical connections are always closed off properly.
- ▶ Pay attention to the Electrical wiring diagram.

- ▶ Close electrical connections, which have no dummy plugs, off properly with the corresponding protective caps.

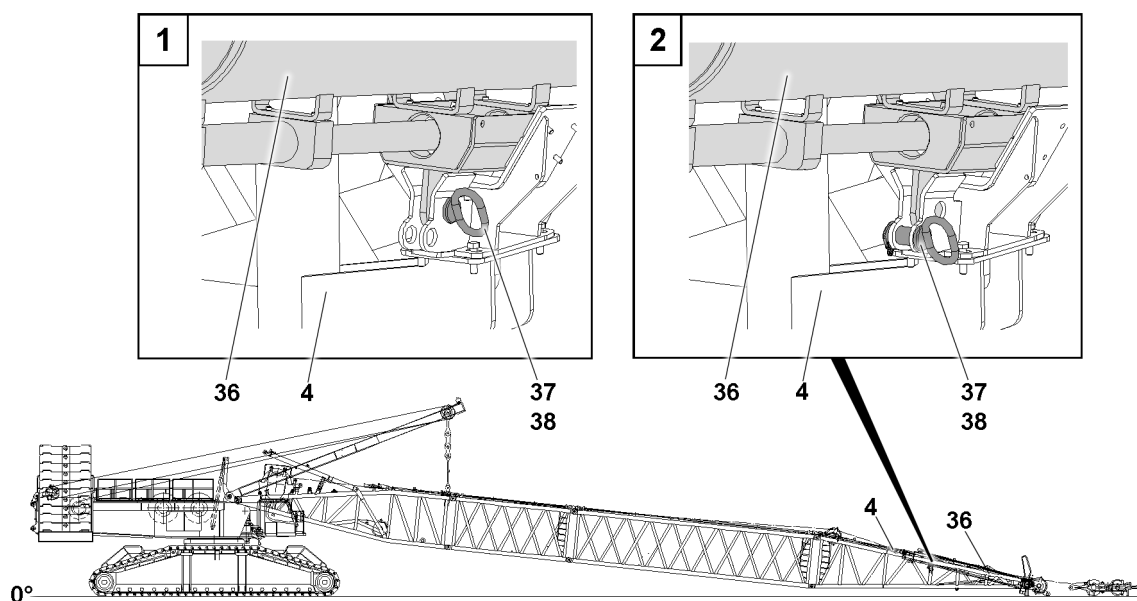
**3.3.18 Releasing the pull cylinder**

Fig.159700: Releasing the pull cylinder in the transport position

- ▶ Remove the retaining element **38** on both sides.
- ▶ Unpin the grip pin **37** and insert it close fitting in the park position and secure with the retaining element **38**.

**Result:**

- The pull cylinders **36** are released.

### 3.3.19 Extending the pull cylinder and pinning with the guy rods

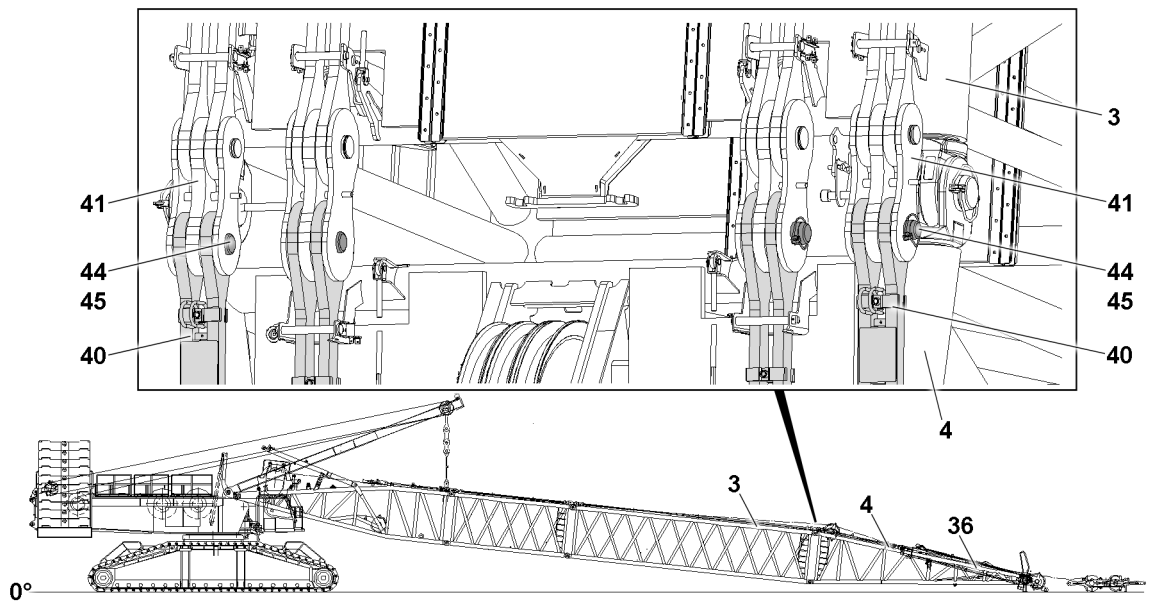


Fig.160981: Connecting the guy rods with the guy rods pinned on the pull cylinder



#### Note

- ▶ To be able to pin the guy rods **41** with the guy rods **40** on the pull cylinders **36**, the guy rods **40** on the pull cylinder **36** must be extended approx. 150 mm.
- ▶ Do **not** disconnect the guy rods **40** from the pull cylinder **36**.

- ▶ Release the pin **44** on both sides on the guy rods **41** and unpin.
- ▶ Extend the guy rods **40** on the pull cylinder **36** on both sides approx. 150 mm.

When the pin bores between the guy rod **40** and the guy rod **41** align:

- ▶ Insert the pin **44** on both sides and properly secure with the retaining element **45**.

### 3.3.20 Assembling the D-guy rods



#### WARNING

Failure to perform inspection and maintenance on the guy rods!

If the regular inspection and maintenance of the guy rods is not carried out or is carried out only in irregular intervals, then severe accidents can occur due to existing and unrecognized damage to the guy rods.

Death, severe bodily injuries, property damage.

- ▶ The guy rods must be checked before every assembly, see chapter 8.15.



#### Note

- ▶ The L-guy rods must be assembled and secured according to the separately supplied assembly drawings.
- ▶ The numbering on the guy rods must be identical to the numbering in the rod plan.
- ▶ The D-guy rods are taken down and secured for transport on the D-lattice sections. Before assembly, the transport retainers must be released.
- ▶ Release the transport retainers of the guy rods.

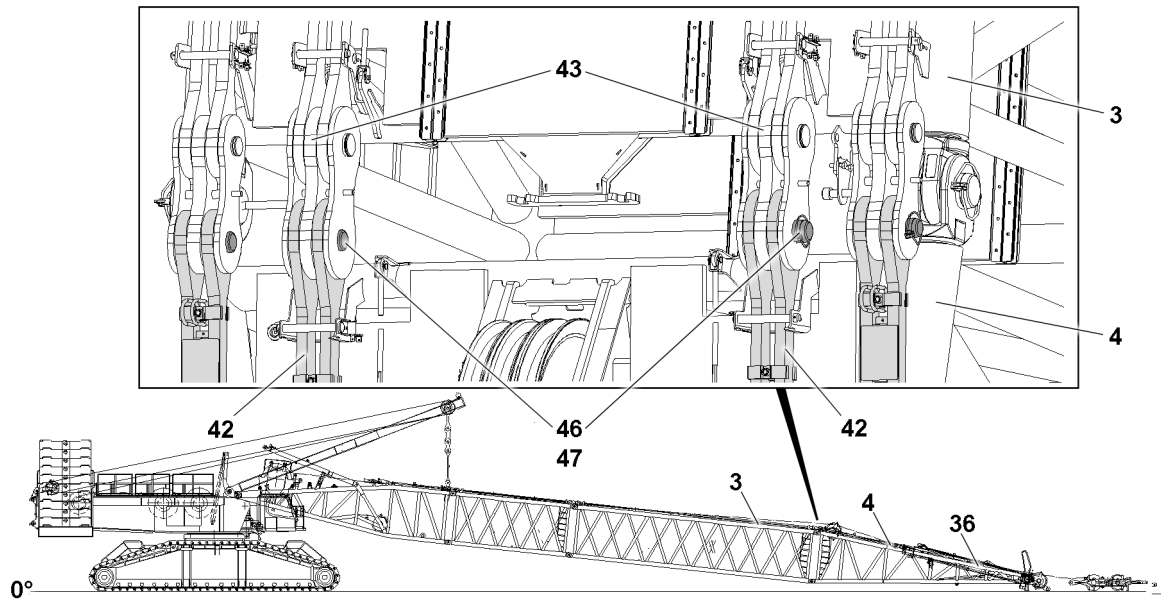


Fig.160982: Pinning the guy rods



### DANGER

Danger of accident!

- The pins **46** of the D-guy rods may only be pinned from the “inside” to the “outside”.

Pin the guy rods **43** of the D-intermediate section **3** with the guy rods **42** on the D-end section **4**.

- Insert the pin **46** and secure it with the retaining element **47**.

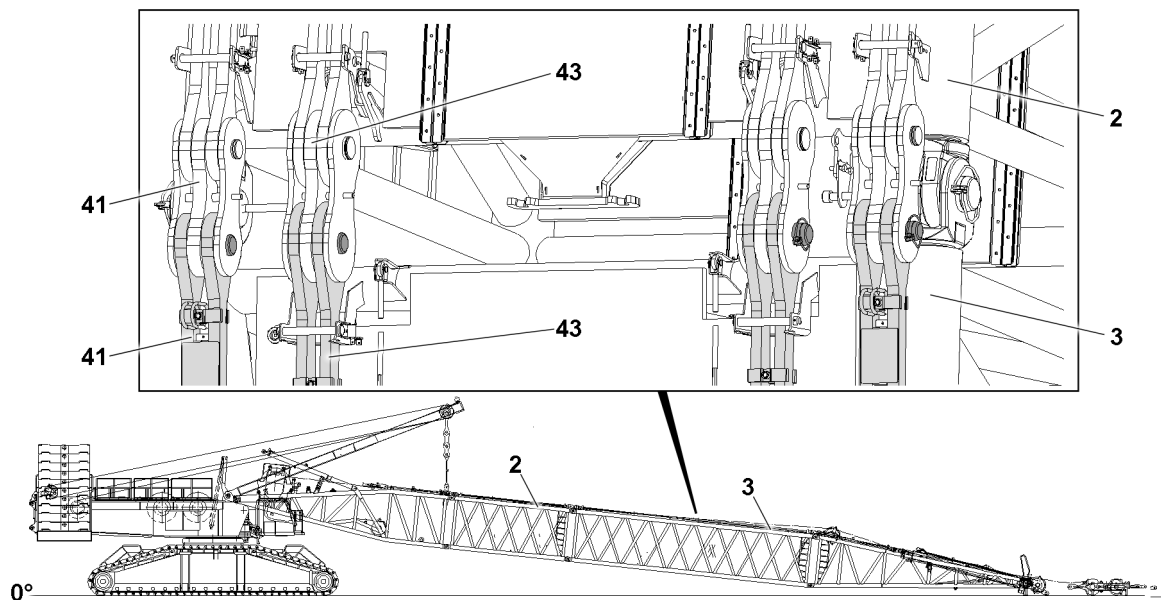


Fig.159665: Pinning the guy rods



### Note

- The procedure for assembling the guy rods **41**, **43** between the D-intermediate section **2** and the D-intermediate section **3** is identical to the procedure described above.

- Pin the guy rods **41**, **43** of the D-intermediate section **2** with the guy rods **41**, **43** of the D-intermediate section **3**.

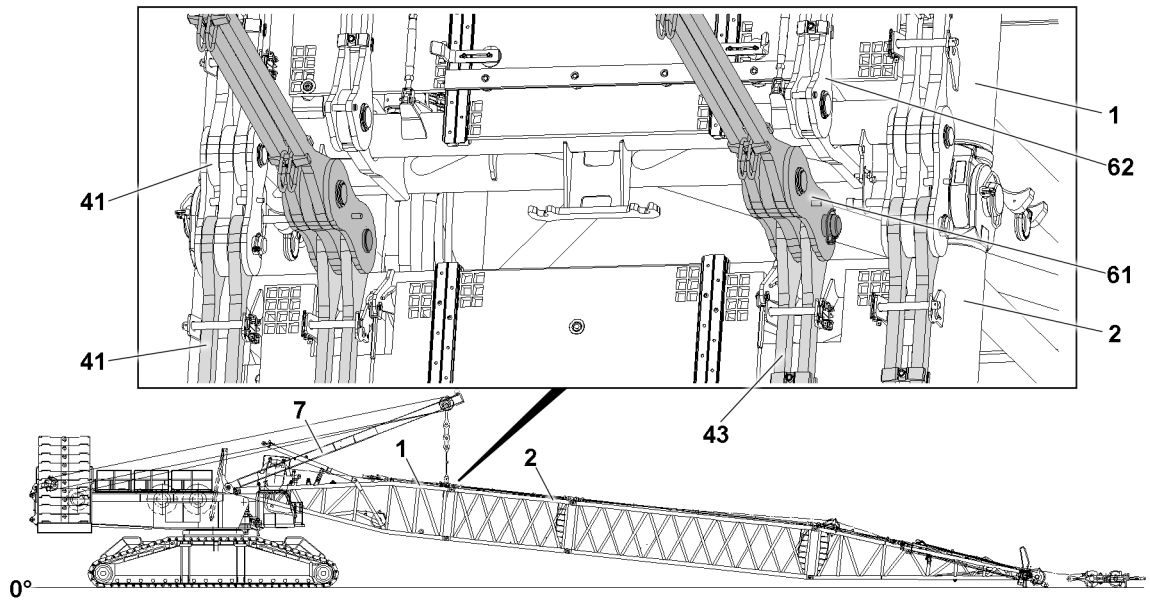


Fig.159664: Pinning the guy rods

- ▶ Lower the SA-frame 7 until the guy rods 43 can be pinned.
- ▶ Unpin the guy rods 61 from the flying assembly guying 62.
- ▶ Secure the flying assembly guying 62 in park position.
- ▶ Pin the guy rods 43 of the D-intermediate section 2 with the guy rods 61 of the SA-frame 7.



#### Note

- ▶ The procedure for assembling the guy rods 41 between the D-intermediate section 2 and the D-pivot section 1 is identical to the procedure described above.
- ▶ Pin the guy rods 41 of the D-intermediate section 2 with the guy rods of the D-pivot section 1.

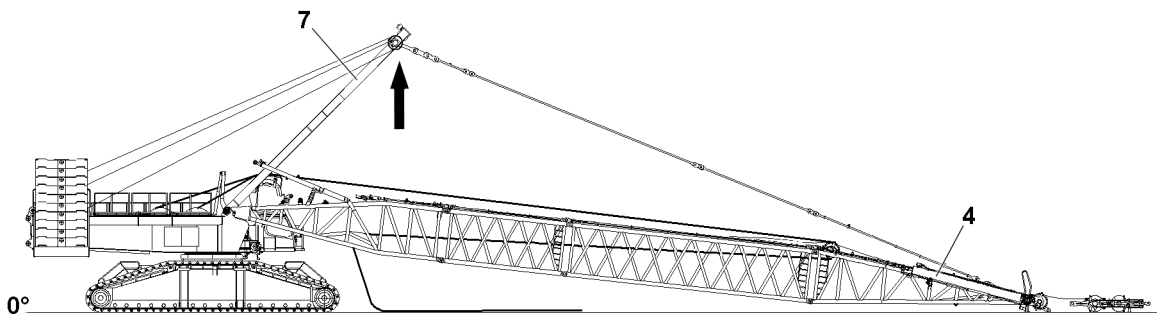


Fig.160985: Erecting the SA-frame and tensioning the D-guying

When all guy rods are pinned and secured with each other:

- ▶ Actuate winch 4 until the guy rods are tensioned between the SA-frame 7 and the D-end section 4.

### 3.3.21 Pinning the pull brackets with the guy rods of the D-pivot section

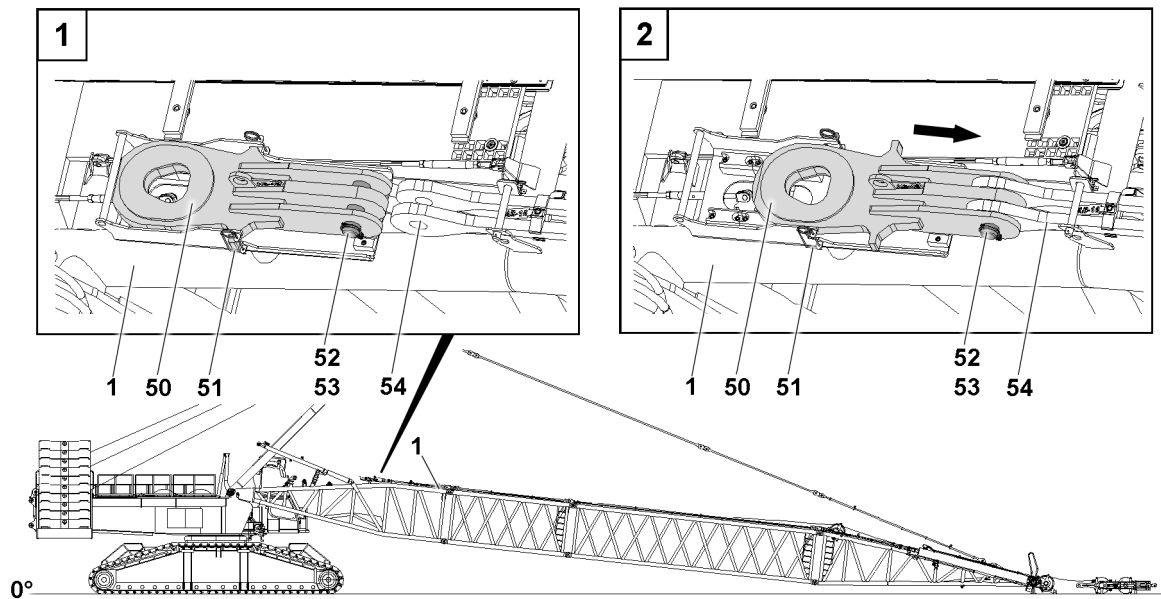


Fig.160983: Pull bracket, park position



#### Note

► This section does **not** apply to “suspended ballast BV” and “ballast trailer” ballast variations. Leave the pull brackets in the park position

- Remove the retaining element **53** and unpin the pin **52**.
- Fasten the pull bracket **50** to the auxiliary crane.
- Remove the retaining element **51** on both sides.
- Swing the pull bracket **50** with the auxiliary crane to the guy rods **54** of the D-pivot section **1**.

Pin the pull bracket **50** with the guy rods **54** of the D-pivot section **1**.

- Insert the pin **52** and secure it with the retaining element **53**.

### 3.3.22 Reeving the hoist rope in on the D-boom

Make sure that the following prerequisite is met:

- The rope guard on the rope pulley **S1** and rope pulley **S2** is pulled.

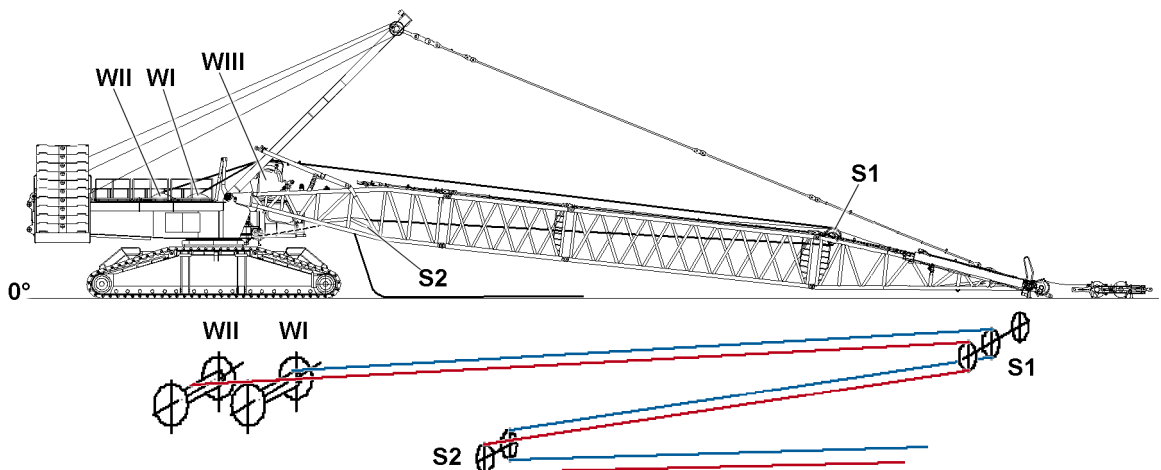


Fig.160984: Hoist rope reeving(s) on the D-boom



**DANGER**

Falling hoist ropes!

If the following conditions are not met before erecting the D-boom, the hoist rope can fall down due to its own weight.

Death, severe bodily injuries, property damage.

- ▶ Enough hoist rope must be guided over the rope pulleys so that the hoist rope is **not** pulled back and falls down when erecting the D-boom.

**NOTICE**

Incorrect reeving!

When reeving in the hoist rope in the incorrect rope pulley, the hoist rope and the crane could be damaged.

- ▶ Observe the reeving plan.

**Note**

- ▶ Hoist rope reeving: See chapter 4.06.

**Note**

- ▶ Reeving in the hoist rope of winch 1 **WI** and winch 2 **WII** on the D-boom is identical and is described using the example of the hoist rope of winch 1 **WI**.
- ▶ The number of reeved in hoist ropes (winch 1 **WI** and / or winch 2 **WII**) depends on the planned crane operation, the load to be lifted and on single or parallel operation.
- ▶ Observe the reeving plans.

- ▶ Spool the assembly winch auxiliary rope out slowly and evenly and opposite to the hoist rope run from winch 1 **WI** betweenrope pulley **S2**, rope pulley **S1** and reeve the protective rollers of winch 3 **WIII** in on the D-boom.

When the auxiliary rope is located directly in front of winch 1 **WI**:

- ▶ Properly connect the auxiliary rope with the hoist rope of winch 1 **WI**.

**Note**

- ▶ The spooling up of the assembly winch and the spooling out of the hoist winch must be done synchronously.

When the auxiliary rope is properly connected with the hoist rope of winch 1 **WI**:

- ▶ Spool the assembly winch **50** up slowly and carefully and simultaneously spool winch 1 **WI** out.

**NOTICE**

Danger of property damage!

If the assembly winch is not stopped in time when reeving the hoist rope in, the hoist rope can be pulled into the assembly winch and damage it.

- ▶ Make sure that the assembly winch is stopped in time before the hoist rope is pulled into the assembly winch.

When the hoist rope is pulled out over the rope pulley **S1** in the direction of the turntable:

- ▶ Stop the assembly winch and winch 1 **WI**.
- ▶ Disconnect the auxiliary rope and hoist rope from winch 1 **WI**.
- ▶ Pull the hoist rope winch 1 **WI**, while simultaneously spooling out winch 1 **WI**, a few meters toward the D-end section.
- ▶ Stop winch 1 **WI** and take the hoist rope down onto the ground.

When the hoist rope of winch 1 **WI** is properly reeved into the D-boom:

- ▶ Properly pin and secure the rope retaining pins on the change over pulleys.

If a second hoist rope is required, for example for parallel operation:

- ▶ Reeve in the hoist rope of winch 2 **WII** according to the procedure used for winch 1 into the D-boom.

When the hoist rope of winch 1 **WI** and winch 2 **WII** is properly reeved in on the D-boom and pulled with sufficient rope reserve to the D-end section:

- ▶ Close the rope guard on the rope pulley **S1** and rope pulley **S2** and secure.

## 4 D-boom assembly on the ground



### Note

- ▶ For D-boom assembly “on the ground”, the D-pivot section, D-intermediate sections and D-end section can be pinned and secured as a preassembled unit with the auxiliary crane directly on the SA-frame.



### WARNING

Danger of accident!

Death, severe bodily injuries, property damage.

- ▶ Assembly of the D-boom “on the ground” is only described as an example, for the detailed assembly process, see section “Assembling the D-boom in sections”.
- ▶ Observe the danger notes in section “Assembling the D-boom in sections”.

Make sure that the following prerequisites are met:

- The crane is horizontally aligned.
- The central ballast has been installed on the turntable according to the load chart.
- The counterweight has been installed on the turntable according to the load chart.
- The LICCON overload protection has been set according to the data in the load chart.
- The LICCON overload protection settings have been compared with the actual set up configuration.

### 4.1 Preassembling the D-boom on the ground



### WARNING

Danger due to lattice sections!

Death, severe bodily injuries, property damage.

- ▶ Make sure that the D-pivot section is properly supported.
- ▶ Make sure that the D-boom sections are properly pinned and secured.



Fig.153410: Placing the pivot section on the ground

- ▶ Take the D-pivot section **1** down on the ground with the auxiliary crane.

When the D-pivot section is placed on the ground and properly supported with the substructure **U**:

- ▶ Remove the auxiliary crane.
- ▶ Set up the D-relapse cylinder, see section “Setting up the D-relapse cylinder”.

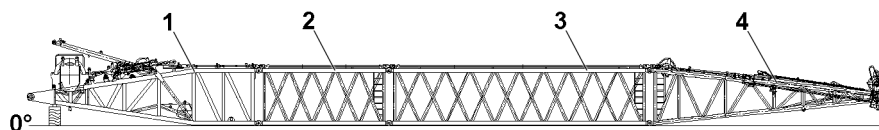


Fig.160986: Preassembling the D-boom on the ground

- ▶ Pin and properly secure the D-pivot section **1**, D-intermediate section **2**, D-intermediate section **3** and D-end section **4** with each other on the ground, see section “Assembling the D-boom in sections”.

## 4.2 Assembling the D-boom on the SA-frame

Make sure that the following prerequisites are met:

- The travel route of the crane is level and horizontal.
- The ground in the area of the travel route is able to safely take on the weight of the crane.
- There are no persons and / or obstacles along the travel route.
- The D-release cylinders are in the operating position.



### WARNING

Driving crane!

Death, severe bodily injuries, property damage.

- ▶ Make sure that there are no persons or obstacles in the danger zone when pulling the crane into the D-boom.

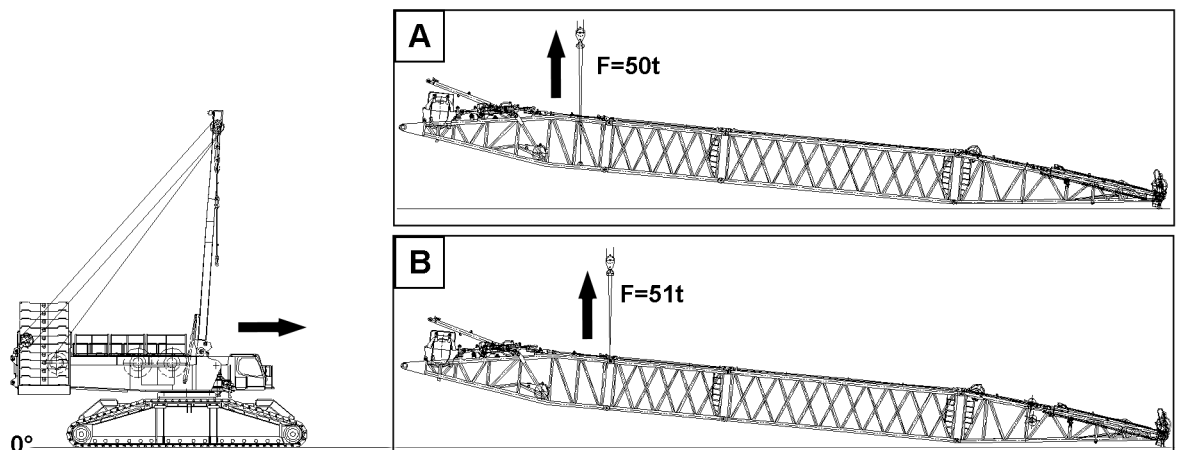


Fig. 159666: Lifting the D-boom with the auxiliary crane and driving the crane to the boom

The following suspended loads arise when lifting the D-boom with an auxiliary crane:

- D-boom with lashing lugs and boom lengths 33 m or 39 m:  $F = 50 \text{ t}$
- D-boom without lashing lugs and boom lengths 33 m or 39 m:  $F = 51 \text{ t}$

- ▶ Fasten the D-boom via the lashing lugs to the auxiliary crane (variation A).

or

Fasten the D-boom with slings over corner bars to the fork connections on the auxiliary crane (variation B).

- ▶ Lift the D-boom with the auxiliary crane.
- ▶ Retract the crane carefully to the pin location.

or

Lift the D-boom with two auxiliary cranes and swing it carefully to the crane.

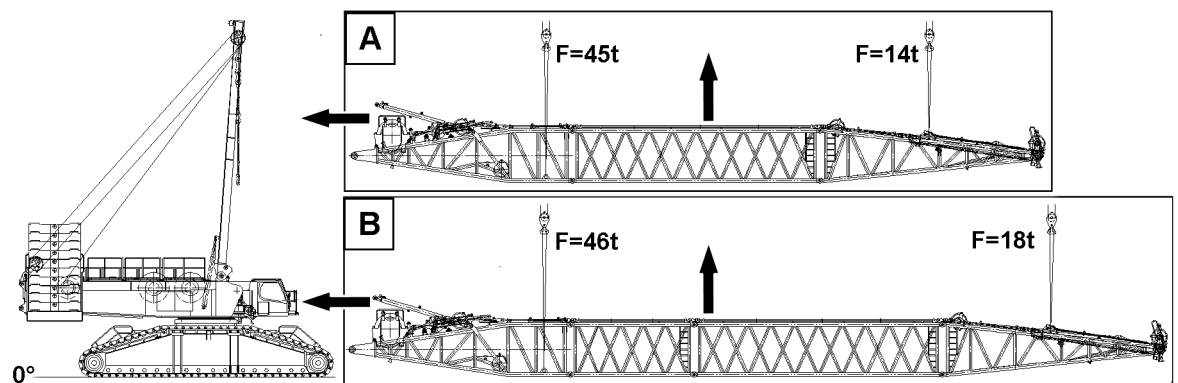


Fig. 159667: Lifting the D-boom with two auxiliary cranes and swinging it to the crane (variation with lashing lugs)

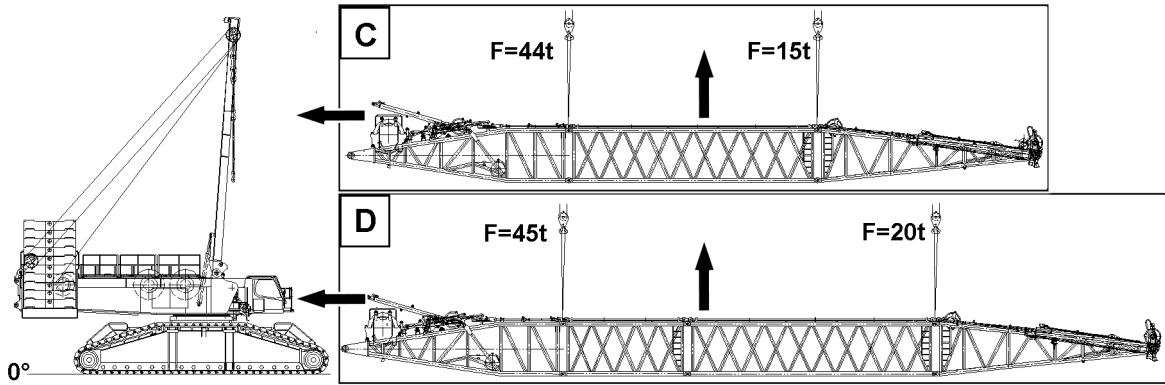


Fig.159668: Lifting the D-boom with two auxiliary cranes and swinging it to the crane (variation without lashing lugs)

The following suspended loads arise when lifting the D-boom with two auxiliary cranes:

- D-boom with lashing lugs and boom lengths 33 m:  $F = 45 \text{ t} + F = 14 \text{ t}$  (variation A)
- D-boom with lashing lugs and boom lengths 39 m:  $F = 46 \text{ t} + F = 18 \text{ t}$  (variation B)
- D-boom without lashing lugs and boom lengths 33 m:  $F = 44 \text{ t} + F = 15 \text{ t}$  (variation C)
- D-boom without lashing lugs and boom lengths 39 m:  $F = 45 \text{ t} + F = 20 \text{ t}$  (variation C)

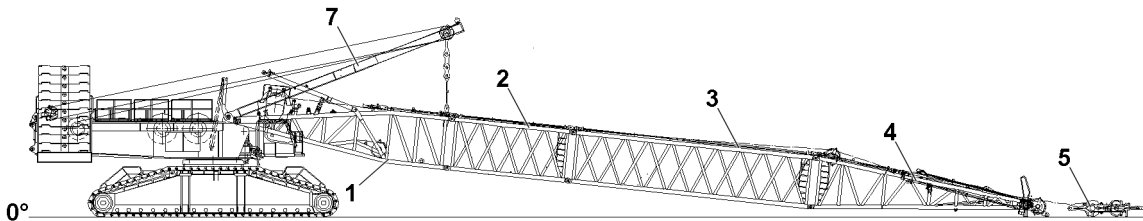


Fig.160987: Pinning the D-boom on the SA-frame

When the pin bores between the SA-frame 7 and the D-pivot section 1 align:

- ▶ Insert the pin and secure with retaining element, see section “Pinning the D-pivot section on the SA-frame”.

When the D-boom is properly pinned and secured on the SA-frame 7:

- ▶ Lower the D-boom to the ground and remove the auxiliary crane or auxiliary cranes.

#### NOTICE

Danger of property damage!  
Damage to the hydraulic lines.

- ▶ Make sure that the hydraulic connections from the turntable to the D-pivot section 1 are established before the SA-frame 7 is lowered to the front.
- ▶ Establish the electrical connections from the turntable to the D-pivot section 1 properly.
- ▶ Establish the hydraulic connections from the turntable to the D-pivot section 1 properly.

### 4.3 Completing the D-boom assembly

Make sure that the following prerequisites are met:

- The D-boom is properly pinned and secured on the SA-frame 7.
- The electrical connections to the D-pivot section 1 are properly established.
- The hydraulic connections to the D-pivot section 1 are properly established.
- ▶ Unpin the S-luffing pulley block 5 on the D-pivot section 1 and take it down with the auxiliary crane in front of the D-end section 4, see section “Pulling the S-luffing pulley block to the D-end section and taking it down on the ground”.
- ▶ Bring the pull test brackets into the operating position, see section “Bringing the pull test brackets into the operating position”.

- ▶ Bring the pulley retainer into the operating position, see section “Bringing the pulley retainer into the operating position”.
- ▶ Pin the pull brackets with the guy rods of the C-pivot section, see “Pinning the pull brackets with the guy rods of the D-pivot section”.
- ▶ Lower the SA-frame **7** to the front and assemble the D-guying, see section “Assembling the D-guy rods”.
- ▶ Properly reeve in the hoist rope on the D-boom, see section “Reeving the hoist rope on the D-boom” and chapter 4.06.
- ▶ Pin the S-luffing pulley block **5** to the pull test brackets of the D-end section **4**.
- ▶ Change the S-luffing pulley block **5** to the operating position.
- ▶ Reeve in the control rope of winch **3** and secure it to the rope pulley of the end section, see the Reeving plan and Chapter 4.06.
- ▶ Reeve in the control rope of winch **3** on the S-luffing pulley block **5** and secure it to the rope fixed point, see the Reeving plan and Chapter 4.06.
- ▶ Check the safety equipment, see section “Checking the function of the safety equipment”.
- ▶ Properly establish the electrical connections on the D-boom.
- ▶ Properly establish the hydraulic connections on the D-boom.

## 5 Flying D-boom assembly



### Note

- ▶ For the “flying” assembly of the D-boom, the D-intermediate section can be pinned and secured with an auxiliary crane on the D-pivot section and subsequently the D-end section on the D-intermediate section.



### WARNING

- Standing below the lattice sections!  
Death, severe bodily injuries, property damage.
- ▶ Standing below the lattice sections is prohibited.



### WARNING

- Danger of accident!  
Death, severe bodily injuries, property damage.
- ▶ Do not exceed the maximum permissible total force on test point MS1 of 125 t.
  - ▶ The “flying” D-boom assembly is only described as an example, for the detailed assembly process, see section “Assembling the D-boom in sections”.
  - ▶ Observe the danger notes in section “Assembling the D-boom in sections”.

Make sure that the following prerequisites are met:

- The crane is horizontally aligned.
- The central ballast has been installed on the turntable according to the load chart, at least 10 t.
- The counterweight has been installed on the turntable according to the load chart, at least 130 t.
- The LICCON overload protection has been set according to the data in the load chart.
- The LICCON overload protection settings have been compared with the actual set up configuration.

## 5.1 Assembling the D-pivot section on the SA-frame

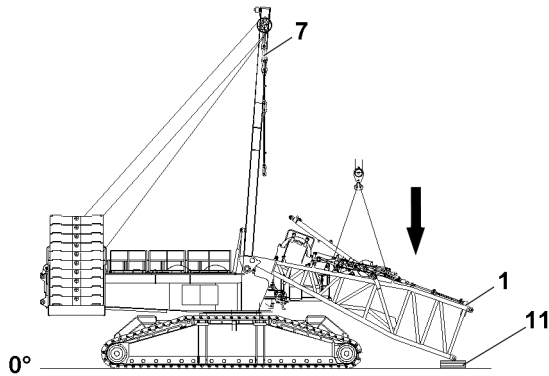


Fig.153378: Assembling the D-pivot section on the SA-frame

- ▶ Fasten the D-pivot section 1 to the auxiliary crane.
- ▶ Swing the D-pivot section 1 in with the auxiliary crane to the SA-frame 7.

When the pin bores between the SA-frame 7 and the D-pivot section align:

- ▶ Properly pin and secure the D-pivot section 1 on the SA-frame 7, see section “Pinning the D-pivot section on the SA-frame”.
- ▶ Take the D-pivot section 1 down with the auxiliary crane on the substructure 11 (at least 350 mm).
- ▶ Remove the auxiliary crane on the D-pivot section 1.
- ▶ Establish the electrical connections from the turntable to the D-pivot section 1 properly.

### NOTICE

Danger of property damage!  
Damage to the hydraulic lines.

- ▶ Make sure that the hydraulic connections from the turntable to the D-pivot section 1 are established before the SA-frame 7 is lowered to the front.
- ▶ Establish the hydraulic connections from the turntable to the D-pivot section 1 properly.

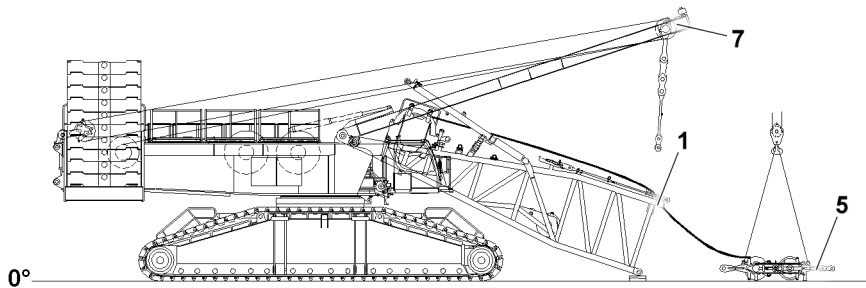
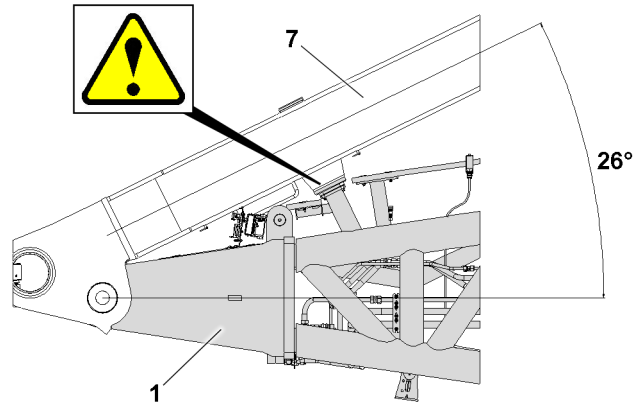


Fig.159658: Taking the S-luffing pulley block down onto the ground

- ▶ Use the auxiliary crane to take the S-luffing pulley block 5 down to the side of the D-pivot section 4 while simultaneously spooling winch 3 **WIII** out. Make sure that the control rope runs between the flying assembly guying, see section “Taking the S-luffing pulley block down onto the ground”.
- ▶ Remove the auxiliary crane.



*Fig.153394: SA-frame 7 on the D-pivot section 1 stop*

---

**NOTICE**

Danger of slack rope formation!

From an angle of 26° between the SA-frame 7 and the D-pivot section 1, the SA-frame 7 touches at the stop of the D-pivot section 1.

The block position is not monitored by the control. When spooling winch 4 out further, slack rope may form.

- ▶ Make sure that winch 4 is no longer actuated when the block position is reached.
- 

When the D-pivot section 1 is properly pinned and secured on the SA-frame 7:

- ▶ Lower the SA-frame 7 to the front in direction of the D-pivot section 1.

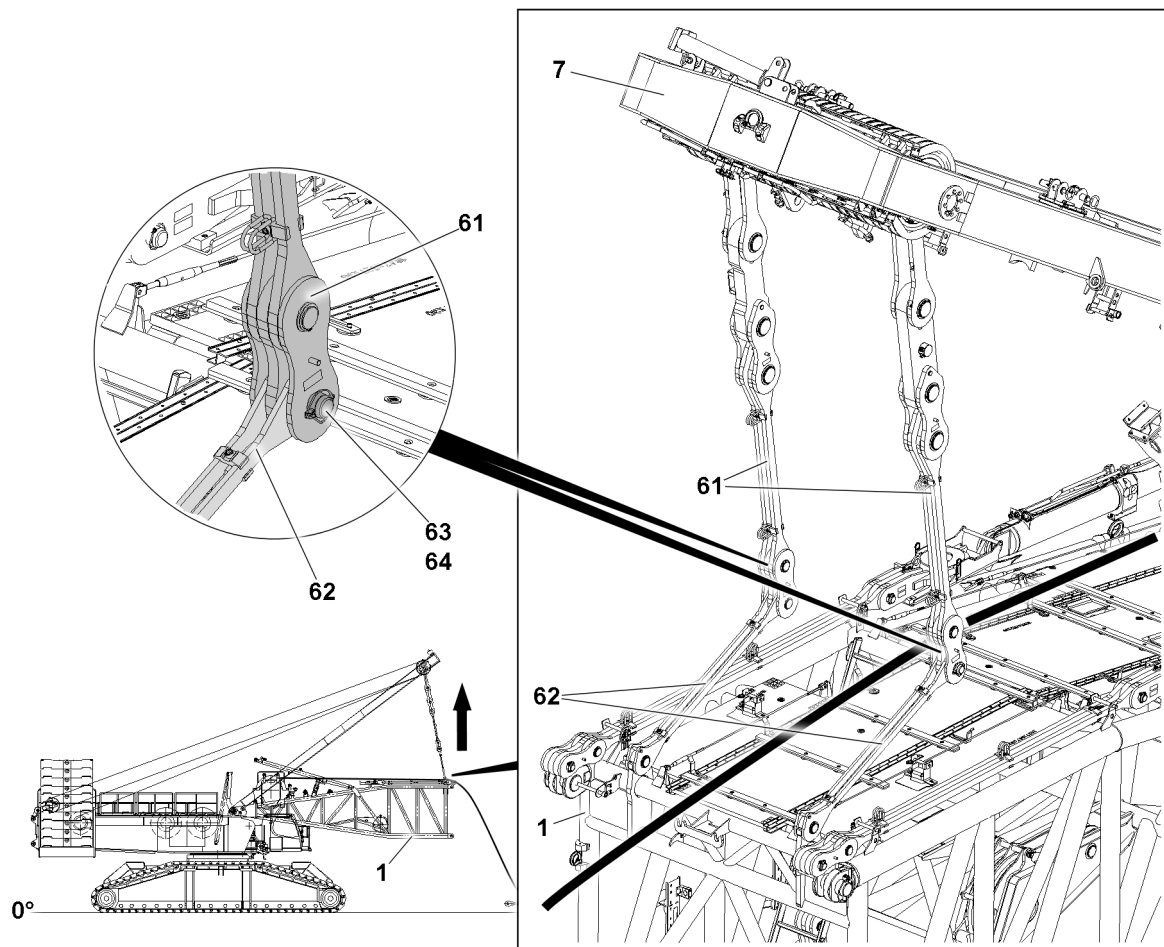


Fig.159669: Assembling the flying assembly guying



#### Note

- ▶ For assembly of the D-boom, the guy rods **61** of the SA-frame **7** must be pinned with the flying assembly guy rods **62** on the D-pivot section **1** so that the D-pivot section **1** can be lifted and held above the SA-frame **7**.
- ▶ Assemble the flying assembly guying between the SA-frame **7** and the D-pivot section **1**.
- ▶ Release the flying assembly guy rods **62** from the transport retainers.
- ▶ Lift the flying assembly guy rods **62** and align them with the guy rods **61** of the SA-frame **7**.

When the pin bores align:

- ▶ Insert the pin **63** and secure it with the retaining element **64**.

#### NOTICE

Retightening of the luffing pulley block due to insufficient control rope length!

Property damage.

- ▶ Make sure that before lifting the SA-frame that enough winch 3 control rope is spooled out so that the luffing pulley block will not be tightened.

When the guying for the flying assembly between the SA-frame **7** and the D-pivot section **1** is properly assembled and secured:

- ▶ Lift the SA-frame **7** until the D-pivot section **1** hangs horizontally on the SA-frame **7**.



## 5.2 Assembling the D-intermediate section on the D-pivot section

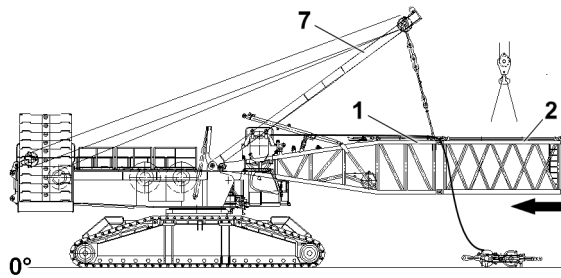


Fig. 159670: Assembling the D-intermediate section on the D-pivot section

- ▶ Fasten the D-intermediate section **2** to the auxiliary crane.
- ▶ Swing the D-intermediate section **2** in to the pin points on the D-pivot section **1**.

When the pin bores between the D-pivot section **1** and the D-intermediate section **2** align:

- ▶ Insert the pins on both sides on the top and bottom and secure with the retaining element, see section "Assembling the D-boom in sections".

When the D-intermediate section is properly pinned and secured on the D-pivot section:

- ▶ Remove the auxiliary crane.

## 5.3 Assembling the D-intermediate section on the D-intermediate section

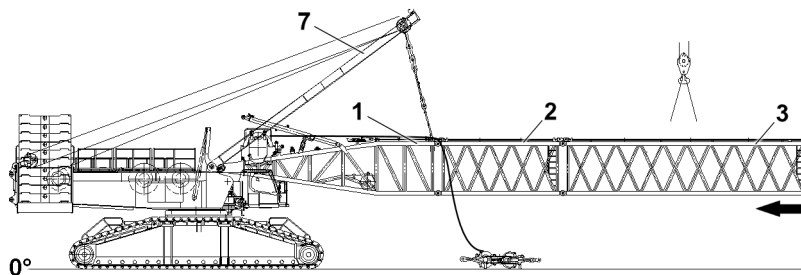


Fig. 159671: Assembling the D-intermediate section on the D-intermediate section

- ▶ Fasten the D-intermediate section **3** to the auxiliary crane.
- ▶ Swing the D-intermediate section **3** in to the pin points on the D-intermediate section **2**.

When the pin bores between the D-intermediate section **2** and the D-intermediate section **3** align:

- ▶ Insert the pins on both sides on the top and bottom and secure with the retaining element, see section "Assembling the D-boom in sections".

When the D-intermediate section is properly pinned and secured on the D-intermediate section:

- ▶ Remove the auxiliary crane.

## 5.4 Assembling the D-end section on the D-intermediate section

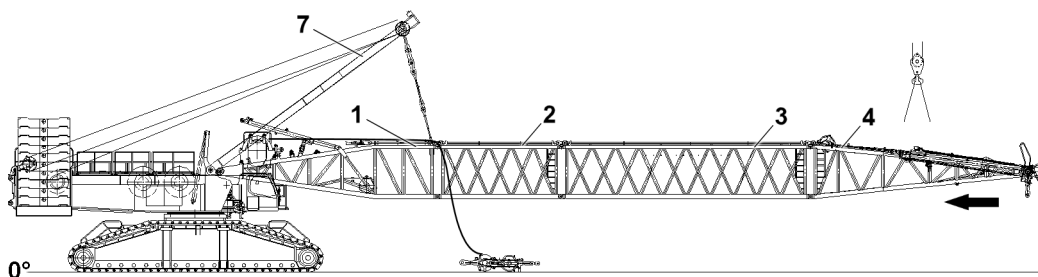


Fig. 159672: Assembling the D-end section on the D-intermediate section

- ▶ Fasten the D-end section 4 to the auxiliary crane.
- ▶ Swing the D-end section 4 in to the pin points on the D-intermediate section 3.

When the pin bores between the D-intermediate section 3 and the D-end section 4 align:

- ▶ Insert the pins on both sides on the top and bottom and secure with the retaining element, see section "Assembling the D-boom in sections".

When the D-end section is properly pinned and secured on the D-intermediate section:

- ▶ Remove the auxiliary crane.

## 5.5 Taking the S-luffing pulley block down in front of D-end section

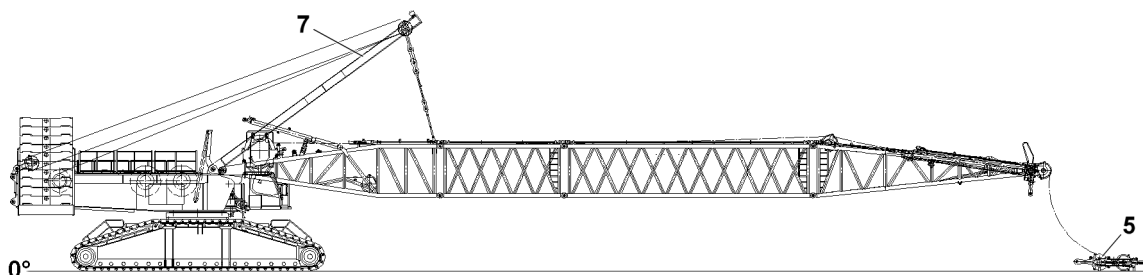


Fig. 159673: Taking the S-luffing pulley block down in front of D-end section

- ▶ Take the S-luffing pulley block 5 down with the auxiliary crane in front of the D-end section 4, see section "Pulling the S-luffing pulley block to the D-end section and taking it down on the ground".

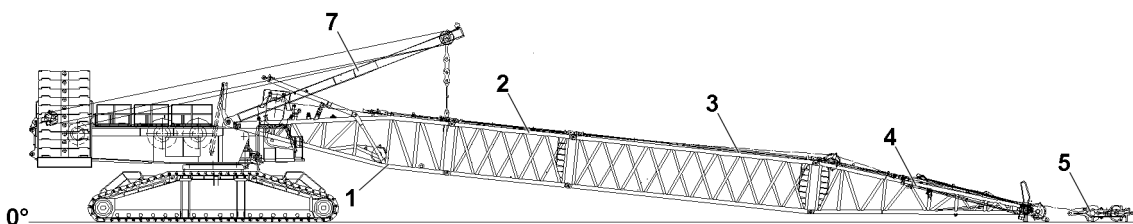


Fig. 160987: Pinning the D-boom on the SA-frame

- ▶ Take the D-boom down on the ground or on the substructure.

## 5.6 Completing the D-boom assembly

Make sure that the following prerequisite is met:

- The D-boom is properly pinned and secured to the D-pivot section 1.
- The electrical connections to the D-pivot section 1 are properly established.
- The hydraulic connections to the D-pivot section 1 are properly established.
- ▶ Disassemble the flying assembly guying between the SA-frame 7 and the D-pivot section 1.

- ▶ Lower the SA-frame **7** to the front and assemble the D-guying, see section “Assembling the D-guy rods”.
- ▶ Properly reeve the hoist rope on the D-boom, see section “Reeving the hoist rope on the D-boom”.
- ▶ Pin the S-luffing pulley block **5** to the pull test brackets of the D-end section **4**.
- ▶ Change the S-luffing pulley block **5** to the operating position.
- ▶ Reeve in the control rope of winch **3** and secure it to the rope pulley of the end section, see the Reeving plan and Chapter 4.06.
- ▶ Reeve in the control rope of winch **3** on the S-luffing pulley block **5** and secure it to the rope fixed point, see the Reeving plan and Chapter 4.06.
- ▶ Check the safety equipment, see section “Checking the function of the safety equipment”.
- ▶ Properly establish the electrical connections on the D-boom.
- ▶ Properly establish the hydraulic connections on the D-boom.

## 6 Erecting the D-boom



### DANGER

The crane can topple over!

- ▶ It is not permitted to turn the crane during the erection procedure.
- ▶ Observe the specifications in the erection and take-down charts.



### WARNING

The crane can topple over!

If the following conditions are not met before erecting the D-boom, the crane can topple over. Death, severe bodily injuries, property damage.

- ▶ Observe the technical safety instructions, see chapter 5.01.
- ▶ Extend the D-relapse cylinder before erection.
- ▶ Do not allow slack rope to build up on the control winch (winch 3).
- ▶ The ball valve cabinet must be locked. Always pull the key and hand it to an authorized person.



### WARNING

Falling hoist rope!

If the hoist rope before the erection procedure is not properly secured onto the corresponding length on the D-boom, it can fall down backward on the basis of its own weight.

Death, severe bodily injuries, property damage.

- ▶ Reeve in the hoist rope before the erection procedure with sufficient length on the D-boom.
- ▶ The hoist rope must be constantly monitored during erection.
- ▶ Do not step into the danger zone.

Make sure that the following prerequisites are met:

- The crane is horizontally aligned.
- All electrical connections on the D-boom have been established.
- All limit switches are functioning.
- The central ballast is installed according to the load chart.
- The counterweight has been installed on the turntable according to the load chart.
- All pin connections are secured.
- The relapse cylinders are in the assembly / operating position.
- The hoist rope / hoist ropes have been inserted correctly in the rope pulleys and are prevented from jumping out by the rope retaining pins.
- The LICCON overload protection has been set according to the data in the load chart.
- The LICCON overload protection settings have been compared with the actual set up configuration.
- Assembly operation is activated.
- The assembly icon is visible on the LICCON monitor.
- No personnel is present in the danger zone.

## 6.1 Extending the D-relapse cylinder



### WARNING

Danger of fatal injury due to the D-boom!

If the D-relapse cylinders are not extended before erecting the D-boom, then the D-boom can fall backward.

Death, severe bodily injuries, property damage.

- ▶ The D-relapse cylinders must be extended before erection of the D-boom.
- ▶ The ball valve must be secured during crane operation to prevent unintended actuation.

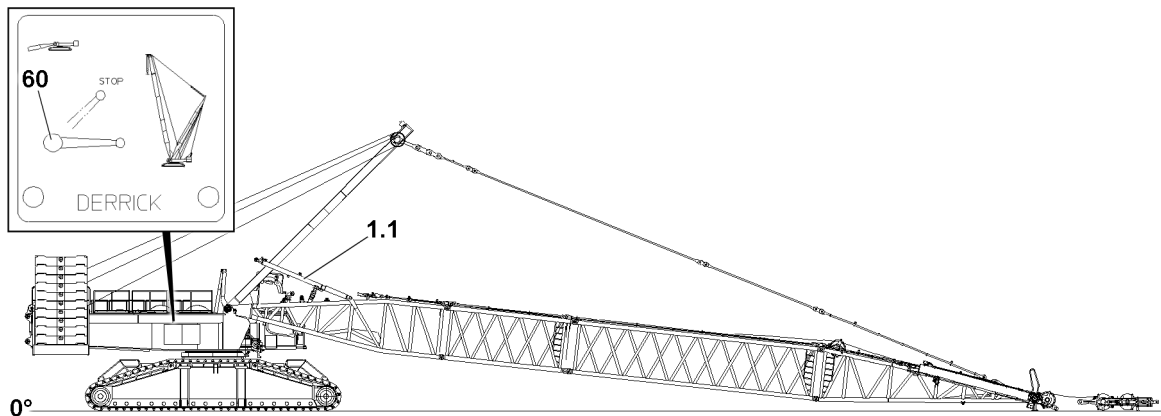


Fig.160988: Extending the piston rod on the D-relapse cylinder 1.1

The piston rod on the D-relapse cylinder must be extended by actuating the ball valve 60.

Ball valve positions	
Horizontal	Crane operation, extend the piston rod
Vertical	Assembly, retract the piston rod
45°	STOP (the piston rod cannot be retracted / extended)

Make sure that the following prerequisite is met:

- All hydraulic connections have been established.
- ▶ Move the ball valve 60 to the horizontal position.

### Result:

- The piston rods of the D-relapse cylinders 1.1 extend.



### Note

- ▶ The ball valve 60 is secured by closing the cabinet door and removing the key.
- ▶ Close the cabinet door and pull out the key.
- ▶ Hand the key to an authorized person.

## 6.2 Erection procedure

Make sure that the following prerequisites are met:

- The D-relapse cylinders are fully extended before erection.
- The D-guying is properly assembled and secured.
- The control rope of winch 3 is properly inserted and secured on the rope pulleys of the D-end section, see the Reeving plan.
- The control rope of winch 3 is properly reeved on the S-luffing pulley block and secured properly on the rope fixed point, see the Reeving plan.
- The S-luffing pulley block is lying on the ground with sufficient “rope reserve”.
- The connector pins between the upper pulley block and the lower pulley block are unpinned, see section “Releasing the upper pulley block on the lower pulley block”.

### 6.2.1 Lifting the D-boom off the ground

Make sure that the following prerequisites are met:

- Sufficient control rope (winch 3) is spooled out.
- The pull test brackets are folded to the front in the operating position.

---

#### NOTICE

Damage to the control rope and the S-luffing pulley block!

When lifting the D-boom, the control rope or the S-luffing pulley block can be damaged.

- ▶ When lifting the D-boom, carefully spool out winch 3 so that the S-luffing pulley block remains on the ground and the control rope is not tensioned.
  - ▶ Check the rope run on the D-end section, carry out a visual inspection.
  - ▶ Make sure that no slack rope on winch 3 forms when lifting the D-boom.
- 



#### DANGER

The crane can topple over!

- ▶ It is prohibited to turn the crane superstructure during the erection procedure.
  - ▶ Do not allow slack rope to build up on the control winch (winch 3).
  - ▶ Make sure that the S-luffing pulley block remains on the ground during the erection of the D-boom.
  - ▶ Lift the D-boom off the ground carefully and at a slow speed, erect it maximum to the horizontal.
- 
- ▶ Lift the D-boom off the ground carefully and at a slow speed.

### 6.2.2 Pinning the S-luffing pulley block on the pull test brackets



#### Note

- ▶ The following illustrations are shown in part without the control rope (winch 3).
  - ▶ The following illustrations are examples and may not match your crane exactly.
-

Make sure that the following prerequisites are met:

- The pull test brackets are in the operating position.
- The D-boom has been lifted off the ground.
- The pins **57** are unpinned on both sides.
- The transport retainer on the S-luffing pulley block is removed.

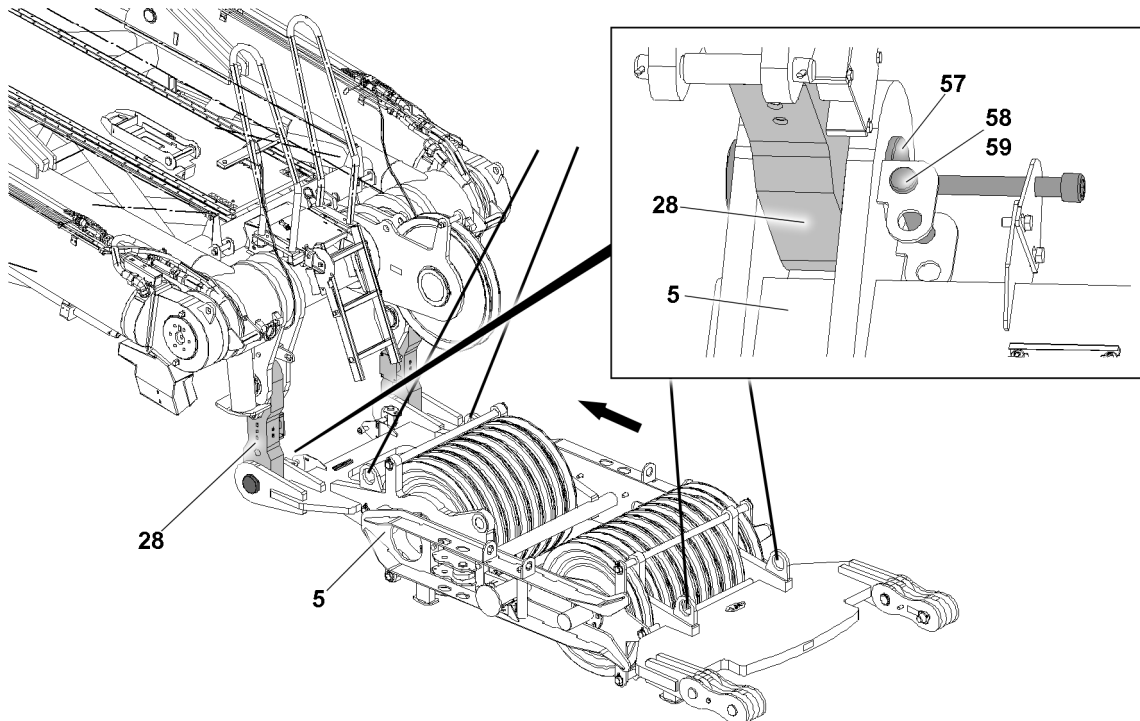


Fig.159685: Pinning the S-luffing pulley block on the pull test brackets

Pin the S-luffing pulley block **5** on the D-end section **4** with the pull test brackets **28**.

- ▶ Fasten the S-luffing pulley block **5** properly to the auxiliary crane.

#### NOTICE

Tensioning of the control rope!

When swinging the S-luffing pulley block **5** on the D-end section **4** the control rope can tension. Damage to the control rope.

- ▶ When swinging the S-luffing pulley block **5** in to the D-end section **4**, observe the control rope.
- ▶ Slowly and carefully spool winch **3** out during the swinging procedure.
- ▶ Do not allow slack rope to build up on the control winch (winch **3**).

When the S-luffing pulley block **5** is properly fastened to the auxiliary crane:

- ▶ Lift the S-luffing pulley block **5** with the auxiliary crane and swing it in to the pull test brackets **28** on the D-end section **4**.
- ▶ Align the S-luffing pulley block **5** on the pull test brackets **28** until the pin bores align.
- ▶ Insert the pin **57** completely on both sides.

When the pins **57** are fully inserted on both sides:

- ▶ Insert the retaining pins **58** on both sides and secure with the retaining element **59**.

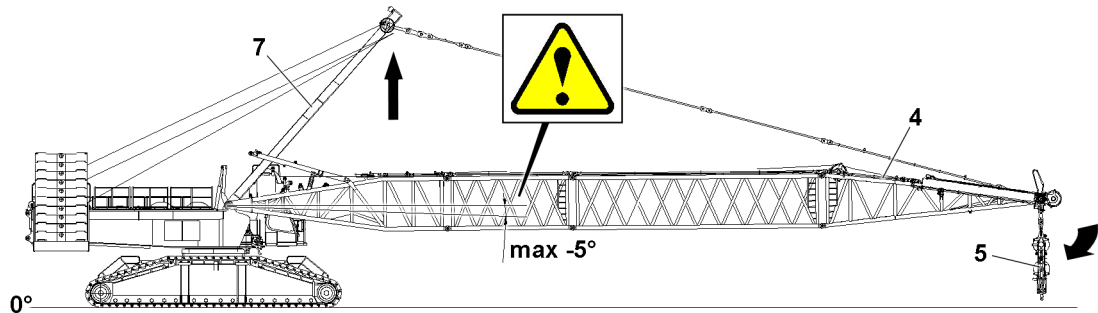


Fig.160989: Luffing the D-boom up and lowering the S-luffing pulley block



### WARNING

The crane can topple over!

Death, severe bodily injuries, property damage.

- ▶ When assembling the S-luffing pulley block **5**, the D-boom may hang down a maximum of 5°.

### NOTICE

Damage to the luffing pulley block!

If the S-luffing pulley block **5** lowers to the ground after assembly on the pull test brackets with the auxiliary crane, the S-luffing pulley block **5** will be damaged when further lifting the D-boom.

- ▶ Make sure that the D-boom, before lowering the S-luffing pulley block **5**, is luffed up enough so that the S-luffing pulley block **5** can be lowered down with the auxiliary crane without coming into contact with the ground.
- ▶ Make sure that after lowering, the S-luffing pulley block **5** hangs freely on the pull test brackets.

When the pins are properly secured on both sides:

- ▶ Lower the S-luffing pulley block **5** carefully with the auxiliary crane until the S-luffing pulley block **5** hangs vertically.

## 6.2.3 Reeving the control rope in on the S-luffing pulley block

When the control rope is not yet reeved into the S-luffing pulley block, at this point reeve the control rope in to the S-luffing pulley block.

Make sure that the following prerequisites are met:

- The S-luffing pulley block is hanging vertically on the pull test brackets.
- The D-boom has been lifted off the ground.
- The auxiliary rope is properly reeved into the S-luffing pulley block according to the reeving plan.

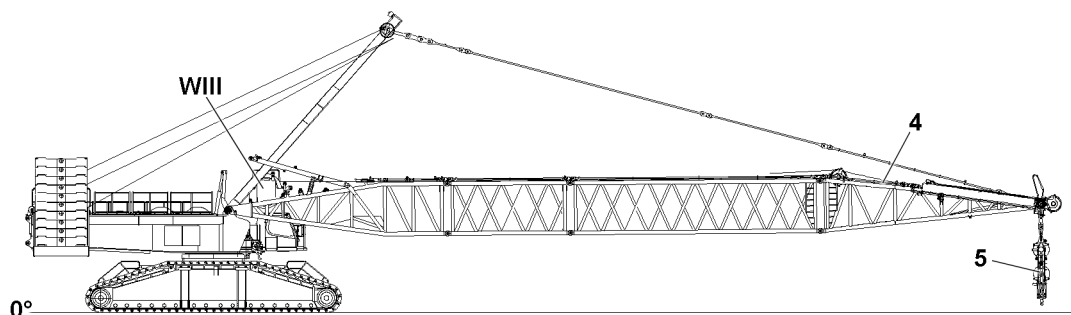


Fig.159677: Luffing the D-boom up and lowering the S-luffing pulley block

### NOTICE

Rope damage!

- ▶ When spooling winch 3 **WIII** out, make sure that no slack rope forms.

- ▶ Spool the winch 3 **WIII** control rope out and pull it to the D-end section **4**.
- ▶ Reeve in the control rope of winch 3 and secure it to the rope pulley of the end section, see the Reeing plan and Chapter 4.06.
- ▶ Connect the winch 3 control rope with the S-luffing pulley block auxiliary rope.
- ▶ While spooling winch 3 **WIII** out, simultaneously reeve the control rope in to the S-luffing pulley block to the rope fixed point, see the Reeing plan and chapter 4.06.
- ▶ Remove the auxiliary rope from the control rope.
- ▶ Securing the control rope to the rope fixed point

## 6.2.4 Pinning the auxiliary weight to the S-luffing pulley block



### Note

- ▶ The following illustrations are shown in part without the control rope (winch 3).
- ▶ The following illustrations are examples and may not match your crane exactly.

Make sure that the following prerequisites are met:

- The D-boom has been lifted off the ground.
- The S-luffing pulley block is hanging vertically on the pull test brackets.
- The pins **66** are unpinning on both sides.

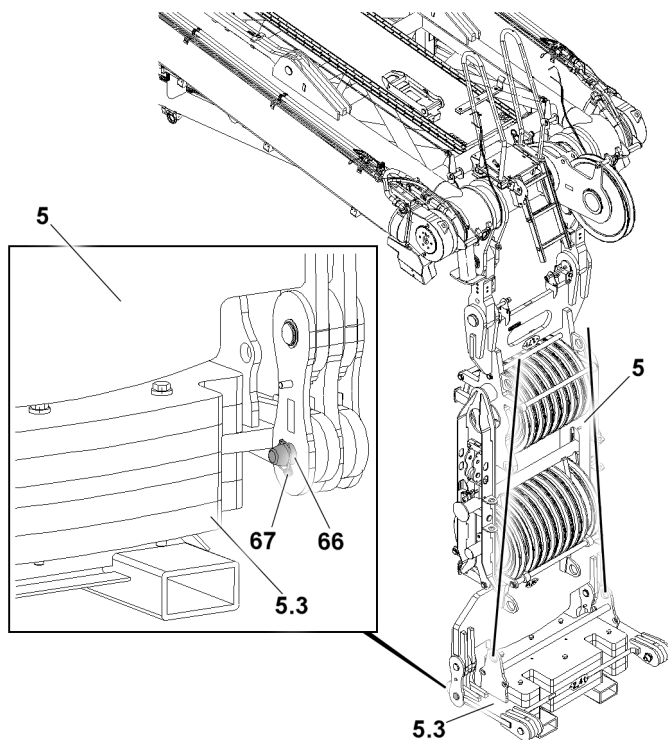


Fig.159675: Pinning the auxiliary weight to the S-luffing pulley block

- ▶ Fasten the auxiliary weight **5.3** properly to the auxiliary crane.

When the auxiliary weight **5.3** is properly fastened to the auxiliary crane:

- ▶ Lift the auxiliary weight **5.3** with the auxiliary crane and swing it in to the S-luffing pulley block **5**.
- ▶ Align the auxiliary weight **5.3** with the S-luffing pulley block **5** until the pin bores align.
- ▶ Insert the pin **66** on both sides completely and secure with the safety locking pin **67**.



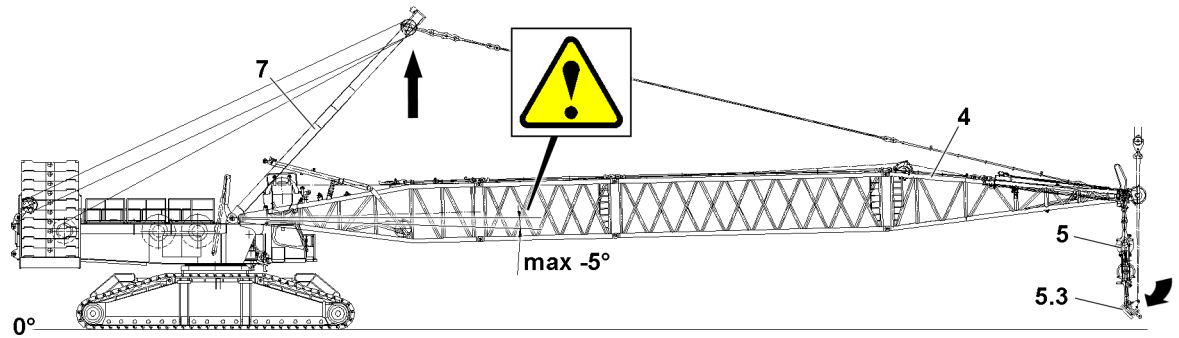


Fig.159676: Luffing the D-boom up and lowering the S-luffing pulley block



### WARNING

The crane can topple over!

Death, severe bodily injuries, property damage.

- ▶ When assembling the auxiliary weight **5.3**, the D-boom may hang down a maximum of 5°.

### NOTICE

Damage to the auxiliary weight!

If the auxiliary weight **5.3** lowers to the ground after assembly on the S-luffing pulley block **5** with the auxiliary crane, the auxiliary weight **5.3** can be damaged when further lifting the D-boom.

- ▶ Make sure that the D-boom, before lowering the auxiliary weight **5.3**, is luffed up enough so that the auxiliary weight **5.3** can be lowered down with the auxiliary crane without coming into contact with the ground.
- ▶ Make sure that after the auxiliary weight **5.3** is lowered, it hangs freely on the S-luffing pulley block **5**.

When the pins are properly secured on both sides:

- ▶ Lower the auxiliary weight **5.3** carefully with the auxiliary crane until the auxiliary weight **5.3** hangs vertically.

## 6.2.5 Establishing the electrical connections to the S-luffing pulley block



### Note

- ▶ To establish the electrical connections on the S-luffing pulley block: Use the electric wiring diagram.
- ▶ Establish the electrical connections.

## 6.2.6 Checking the function of the safety equipment



### WARNING

Malfunctioning safety equipment!

If the function of the safety equipment is defective.

Death, severe bodily injuries, property damage.

- ▶ Crane operation with non-functioning safety equipment is **prohibited**.



### Note

- ▶ The function of the individual limit switches must be checked before erection.
- ▶ The function of the limit switch initiators must be checked in the test system, see the "Diagnostics manual".

**Note**

- ▶ If a function check on the limit switches or on the safety equipment does not lead to the desired shut-offs, then the plug connections on the connector boxes or the components itself must be checked.
- ▶ If no visible connection errors or component defects can be found, contact **LIEBHERR** Customer Service.

Make sure that the following prerequisites are met:

- All electrical connections have been established.
- The crane engine is running.
- The corresponding operating mode is set on the LICCON monitor.

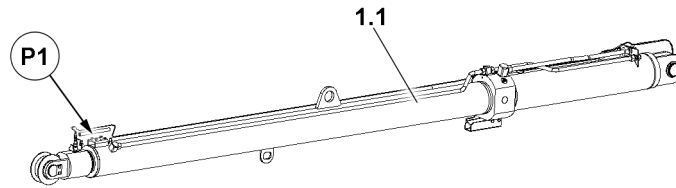
**D-boom, relapse cylinder limit switch**

Fig.153407: Limit switch initiators on the D-relapse cylinders

**Note**

- ▶ The limit switch functions have to be checked individually before erection.
- ▶ Cover the limit switch initiators in point **P1** individually with a metal plate, see chapter 8.12.

**Result:**

- Winch 4 turns off in upward movement.
- The “D-boom angle” icon appears on the LICCON monitor 1, see chapter 4.02.

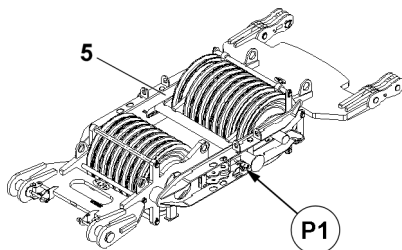
**Limit switch on the S-luffing pulley block**

Fig.159688: Limit switch initiators on the S-luffing pulley block

**Note**

- ▶ The limit switch functions have to be checked individually before erection.
- ▶ Cover the limit switch initiators in point **P1** individually with a metal plate.

**Result:**

- The spool up function of winch 3 turns off.

### Limit switch pull cylinder on the D-end section

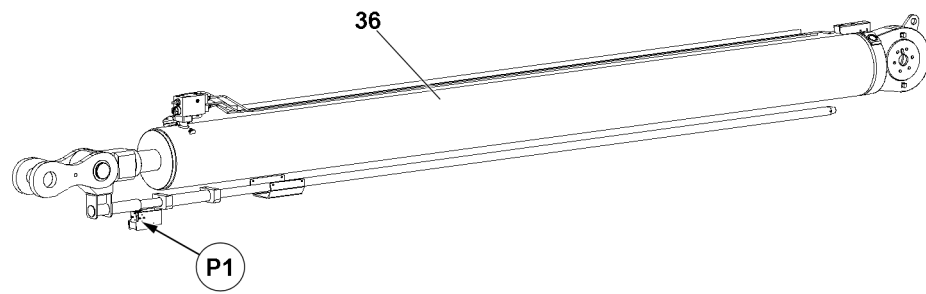


Fig.153406: Limit switch initiators on the pull cylinders



#### Note

- ▶ The limit switch functions have to be checked individually before erection.
- ▶ Cover the limit switch initiators in point **P1** individually with a metal plate.

#### Result:

- The retraction of the pull cylinder is completed.

### 6.2.7 Erecting the D-boom to 85°

The erection of the D-boom to approx. 85° is required in order to make space in the assembly area of the S-pivot section and permit the assembly of the S-pivot section without a problem.



#### WARNING

The crane can topple over!

Death, severe bodily injuries, property damage.

- ▶ It is prohibited to turn the crane superstructure during the erection procedure.
- ▶ Make sure during the erection procedure of the D-boom that the D-relapse cylinder engages in the stop rail of the D-relapse retainer.
- ▶ Make sure that no slack rope forms on winch 3.



#### Note

- ▶ Winch 3 is turned off completely from a D-boom angle of 78°. It is no longer possible to lift / lower the upper pulley block.

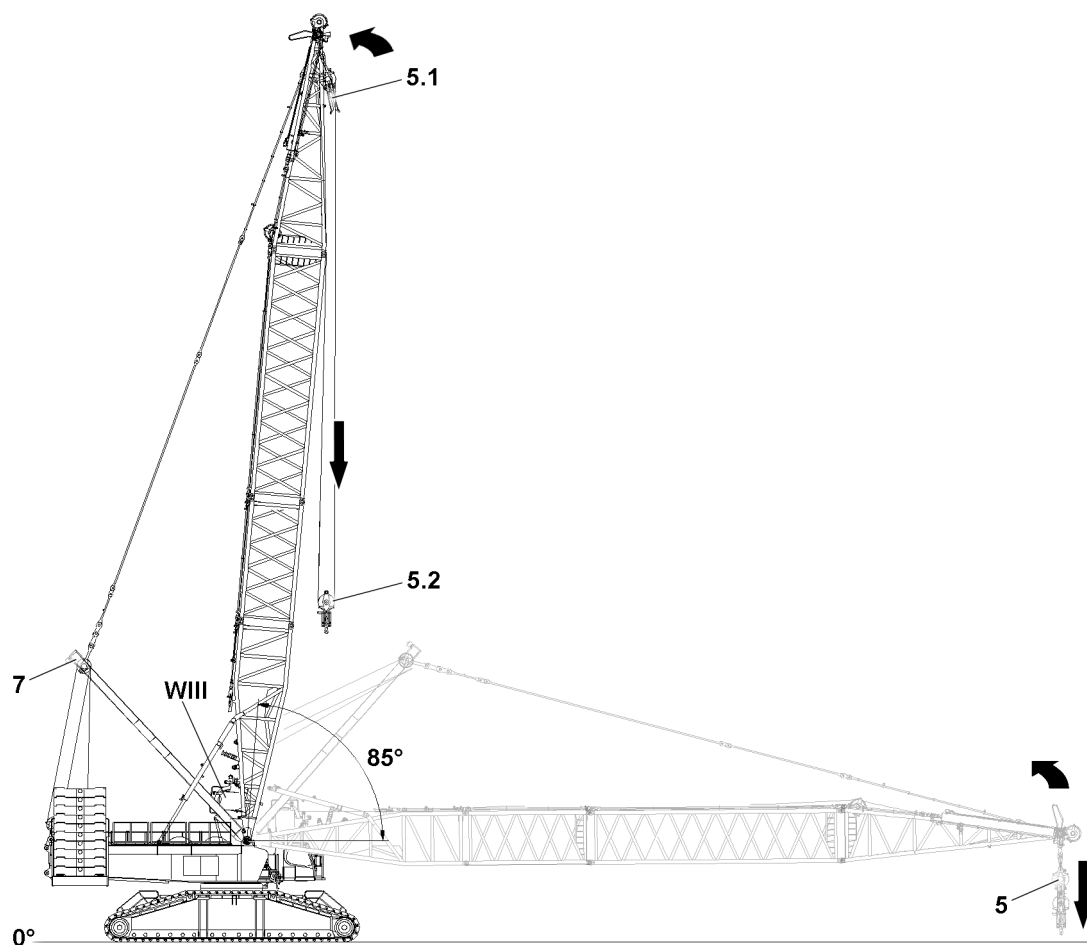


Fig.160990: Erecting the D-boom

#### NOTICE

Danger of property damage!

- ▶ Make sure that the upper pulley block **5.2** is lowered during the erection procedure of the D-boom.
- ▶ Make sure that the upper pulley block **5.2** is located at the height of the D-pivot section (see illustration), before the D-boom reaches the boom angle setting of  $76^\circ$ .

When luffing up the D-boom, lower the upper pulley block **5.2** continuously.

- ▶ Actuate winch 4 and erect the D-boom to an angle range of maximum  $85^\circ$ .

#### Result:

- The upper pulley block **5.2** is located at the height of the D-pivot section, see illustration

## 7 D-boom disassembly on the crane



### WARNING

Danger of falling!

During assembly / disassembly, inspection and maintenance work, assembly personnel must be secured with appropriate aids to prevent them from falling.

If this is not observed, assembly personnel could fall and be killed or seriously injured.

- ▶ All work at a height, when there is a danger of falling, must be carried out with suitable aids.
- ▶ If aids are not available and work cannot be carried out from the ground, then assembly personnel must secure themselves with the supplied fall arrest system to prevent falling, see chapter 2.04.
- ▶ If fall protection equipment is available, then it must be used, see chapter 2.06.
- ▶ When lifting, lowering, swinging crane parts in and out, no persons may remain in the danger zone.
- ▶ If railings are present on the components, then they must be brought into the corresponding position and secured for assembly / disassembly work.
- ▶ Only step on the aids, ladders and catwalks with clean shoes.
- ▶ Keep aids, ladders and catwalks free of heavy dirt, snow and ice.
- ▶ During all assembly and disassembly work, maintenance work and inspections, travel or crane operation is prohibited.
- ▶ Remaining on a suspended load is prohibited.
- ▶ Stepping or walking on crane components and lattice sections, which have an incline of more than 20° is prohibited.
- ▶ For all assembly work, the crane operator of the main crane must be in voice contact with the crane operator / crane operators of the auxiliary crane / auxiliary cranes.
- ▶ For assembly / disassembly tasks, the crane operator may only initiate crane movements when the responsible guide has explicitly released the movement.



### WARNING

Danger of impact / crushing!

When assembling / disassembling crane components with the auxiliary crane, crane components can start to swing back and forth.

When lifting / lowering and positioning crane components, there is an increased danger of impact / crushing.

Death, severe bodily injuries, property damage.

- ▶ Make sure that personnel cannot be caught by components.
- ▶ When working in danger zones: Use aids to protect limbs.
- ▶ Guide components with suitable aids to minimize oscillation.



### DANGER

The components can fall down!

If the corresponding component is disengaged from the auxiliary crane before the corresponding component is pinned, then the corresponding component can fall down.

Death, severe bodily injuries, property damage.

- ▶ Do not detach the auxiliary crane until the respective component is pinned and secured.



### WARNING

The lattice sections can fall down!

If the lattice sections are not pinned and secured correctly, then they can fall down.

Death, severe bodily injuries, property damage.

- ▶ Insert or unpin both pins on the same horizontal level, i.e. **left and right**.
- ▶ Do not stand under the lattice sections or within the entire danger zone during the pinning and unpinning procedure of the boom.
- ▶ Safely secure the pins in the storage locations as well as in the receptacles.
- ▶ It is prohibited to lean the ladder against the component being disassembled.

---

**NOTICE**

Damage to the D-boom and SA-frame!

If the SA-frame is pulled by winch 4 (intake gear) to the rear in direction of the turntable, then the D-boom and the SA-frame can be severely damaged.

Expensive and extensive repairs can result.

- ▶ As long as the guying between the SA-frame and the assembled D-pivot section or between the SA-frame and the assembled D-boom is **not** assembled and gayed, do not pull the SA-frame to the rear in the direction of the turntable.

---

**NOTICE**

Damage to the D-boom and SA-frame!

If the SA-frame is pulled back in the direction of the turntable during assembly / disassembly of the D-pivot section on the SA-frame, this can cause considerable damage to the SA-frame and the D-pivot section.

- ▶ Make sure that the SA-frame is at an angle of less than 90° during assembly of the D-pivot section.

---

Make sure that the following prerequisites are met:

- The crane is horizontally aligned.
- An auxiliary crane is available.
- An assembly scaffolding / work platform is available.
- The central ballast is installed according to the load chart.
- The counterweight has been installed on the turntable according to the load chart.
- The LICCON overload protection has been set according to the data in the load chart.
- The LICCON overload protection settings have been compared with the actual set up configuration.
- The main boom is disassembled.

## 7.1 Turning the turntable into the disassembly position

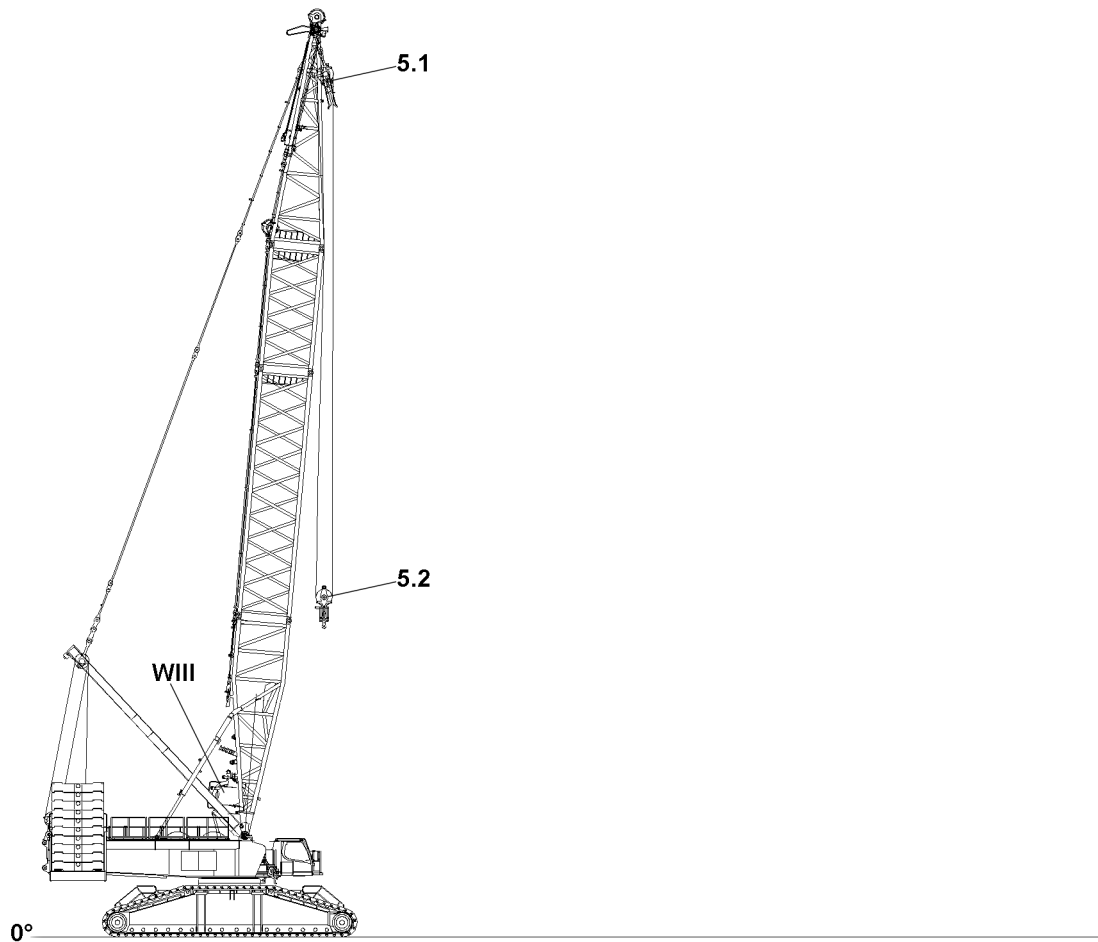


Fig.153419: D-boom



### DANGER

The crane can topple over!  
Death, severe bodily injuries, property damage.

- ▶ After disassembly of the D-boom, observe the assembly conditions for operation on crawlers, see chapter 3.06.
- ▶ Turn the turntable in the lengthwise direction of the crawler travel gear.

## 7.2 Exceeding the shut-off limits of the LICCON overload protection for assembly operation



### WARNING

Danger of accident due to the “Exceedance of shut-off limits of the LICCON overload protection” function!

If the shut off limits of the LICCON overload protection are exceeded, there is no additional protection against crane overload.

Due to erroneous operation or deliberate misuse, the crane could collapse, the boom can break off or the crane can topple over.

Death, severe bodily injuries, property damage.

- ▶ The function “Exceedance of shut off limits of the LICCON overload protection” is only permissible in emergencies and for assembly purposes.
- ▶ The function “Exceeding the shut off limits of the LICCON overload protection” may only be actuated by persons who know the effects of their actions regarding the function “Exceeding the shut off limits of the LICCON overload protection”.
- ▶ The “Exceedance of shut off limits of the LICCON overload protection” function requires the presence of an authorized person and must be performed with utmost caution.
- ▶ Crane operation with the “Exceedance of shut off limits of the LICCON overload protection” function activated is prohibited.

- ▶ Exceeding the shut off limits of the LICCON overload protection: Activate assembly operation.

### Result:

- The shut-off limits of the LICCON overload protection are exceeded.
- The assembly icon appears on the LICCON monitor.



### Note

- ▶ See chapter 4.02 and chapter 4.20.

## 7.3 Disassembling the D-boom in sections



### WARNING

Falling boom!

If the D-boom is not properly supported before disassembly or held with an auxiliary crane, then the D-boom can fall down when it is unpinned.

Death, severe bodily injuries, property damage.

- ▶ Before supporting the D-boom, the ground condition must be checked regarding load bearing capacity and level.

If the ground condition is not classified as sufficient:

- ▶ Support the D-boom properly and safely with suitable material.



### 7.3.1 Disassembling the auxiliary weight and the S-luffing pulley block

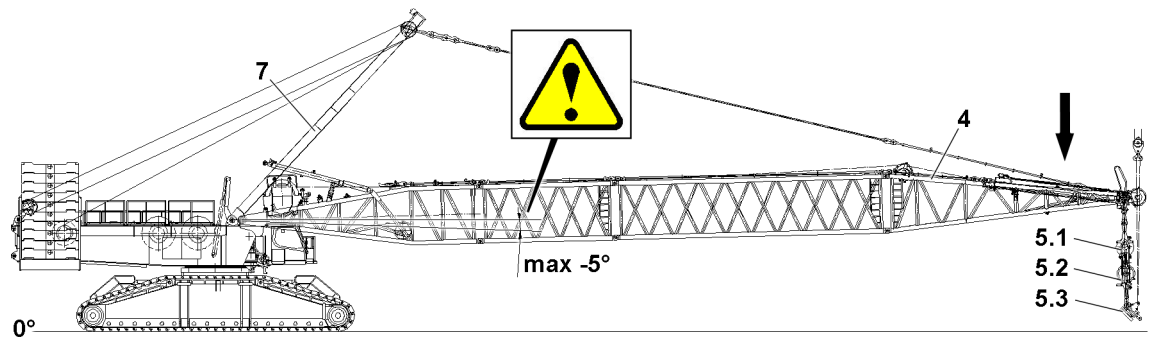


Fig.159678: Luffing the D-boom down



#### WARNING

The crane can topple over!  
Death, severe bodily injuries, property damage.

- ▶ When disassembling the auxiliary weight **5.3** and the S-luffing pulley block **5**, the D-boom may hang down a maximum of 5°.

#### NOTICE

Damage to the S-luffing pulley block!

If the D-boom is lowered too quickly to the “front”, significant damage can be caused to the S-luffing pulley block and the D-end section.

- ▶ Lower the D-boom forward carefully and at a slow speed.
- ▶ Make sure that the auxiliary weight **5.3** or the upper pulley block **5.2** does not run on the ground when lowering the D-boom.
- ▶ Make sure that the upper pulley block **5.2** does not collide uncontrolled with the lower pulley block **5.1** when spooling up winch 3.



#### CAUTION

Retracting the upper pulley block into the lower pulley block.

Crushing of limbs.

- ▶ When retracting the upper pulley block into the lower pulley block do not reach between them.
- ▶ Lower the D-boom to the front to the horizontal and spool winch 3 up at the same time.

When the upper pulley block **5.2** approaches the lower pulley block **5.1**:

- ▶ Align the upper pulley block **5.2** with the bracket of the lower pulley block **5.1**.

When the upper pulley block is aligned:

- ▶ Retract the upper pulley block **5.2** by spooling winch 3 up in the bracket to the limit switches.

#### Result:

- “Lift” winch 3 (pull the S-luffing pulley block together) turns off.
- “Lower” winch 4 (luff the D-boom down) turns off.



#### Note

Make it possible to lower the D-boom:

- ▶ Drive the upper pulley block **5.2** out of the limit switch position by spooling winch 3 out.
- ▶ Before pinning the S-luffing pulley block **5**, retract the upper pulley block **5.2** by spooling winch 3 back up to the limit switches.
- ▶ Pin the S-luffing pulley block **5** for transport, see section “Pinning the upper pulley block with the lower pulley block”.

### 7.3.2 Pinning the upper pulley block with the lower pulley block

Make sure that the following prerequisites are met:

- The S-luffing pulley block hangs in the reeved condition on the D-end section.
- The pin 17 is in the park position.

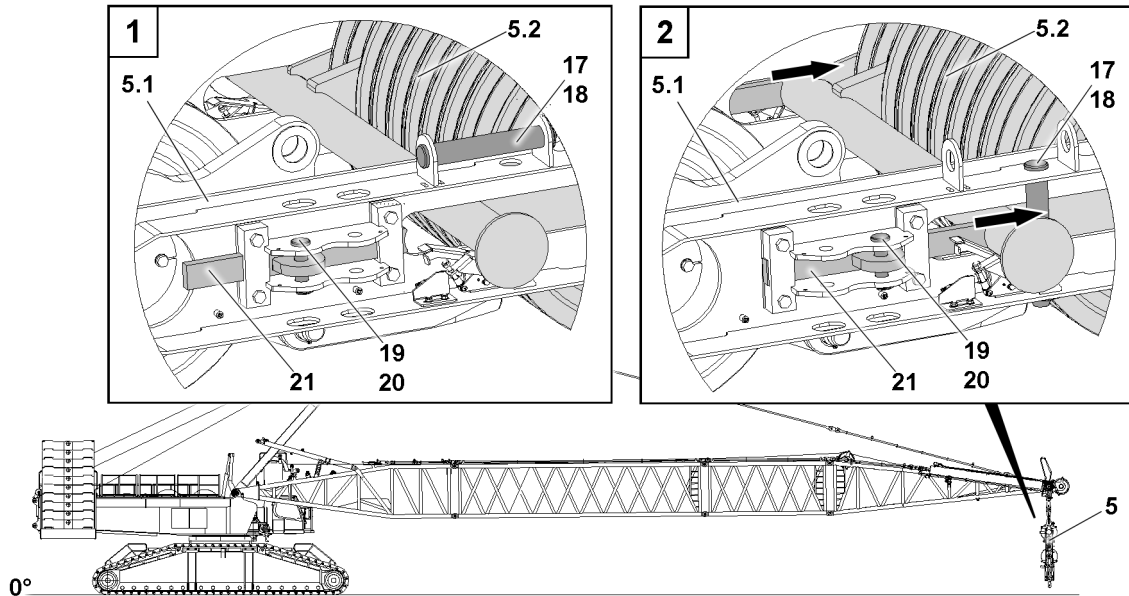


Fig.153421: Pinning the upper pulley block with the lower pulley block for transport

The upper pulley block 5.2 must be pinned with the lower pulley block 5.1 before the complete S-luffing pulley block can be taken down in the transport receptacle on the D-pivot section.

- ▶ Remove the retaining element 20 and unpin the pin 19 on both sides.
- ▶ Move the latch 21 to the stop.
- ▶ Insert the pin 19 in the transport position on both sides and secure with the retaining element 20.
- ▶ Unpin the pins 17 in the park position on both sides: Release the retaining element 18 and unpin the pins 17.
- ▶ Insert the pin 17 in the transport position on both sides on the bracket of the lower pulley block 5.1 and secure with the retaining element 18.

#### Result:

- The upper pulley block 5.2 is connected with the lower pulley block 5.1 and now forms the S-luffing pulley block 5 “transport unit”.

#### Problem remedy

Is it not possible to insert the pin 17 in the transport position?

- ▶ Fasten the upper pulley block 5.2 on both sides to the auxiliary crane and lift carefully to the stop on the latch 21.
- ▶ Insert the pin 17 in the transport position on both sides on the bracket of the lower pulley block 5.1 and secure with the retaining element 18.

### 7.3.3 Disconnecting the electrical connections to the S-luffing pulley block

Make sure that the following prerequisites are met:

- The D-boom is in the “horizontal” position.
- The upper pulley block is secured on both sides to the lower pulley block.



#### Note

- ▶ Disconnect the electrical connections, use the Electric wiring diagram.

- ▶ Disconnect the electrical connections from the S-luffing pulley block to the terminal box on the D-end section.

When the electrical connections from the S-luffing pulley block to the terminal box are disconnected:

- ▶ Close the electrical connections off properly with dummy plugs, protective caps or caps.

### 7.3.4 Reeving the hoist ropes out

#### NOTICE

Overspooled winch!

If the hoist rope is pulled under the winch when spooling up, then the adjustment of the winch speed sensor can change.

A new adjustment by **Liebherr Customer Service** is required.

- ▶ Stop the winch in time, with sufficient rope reserve.
- ▶ Do not overspool the winch.

- ▶ Reeve the hoist ropes out: Spool the winch 1 and winch 2 hoist rope up.

### 7.3.5 Unpinning the auxiliary weight and taking it down on the ground

Make sure that the following prerequisites are met:

- The S-luffing pulley block is secured in the transport position.
- An auxiliary crane is on hand.

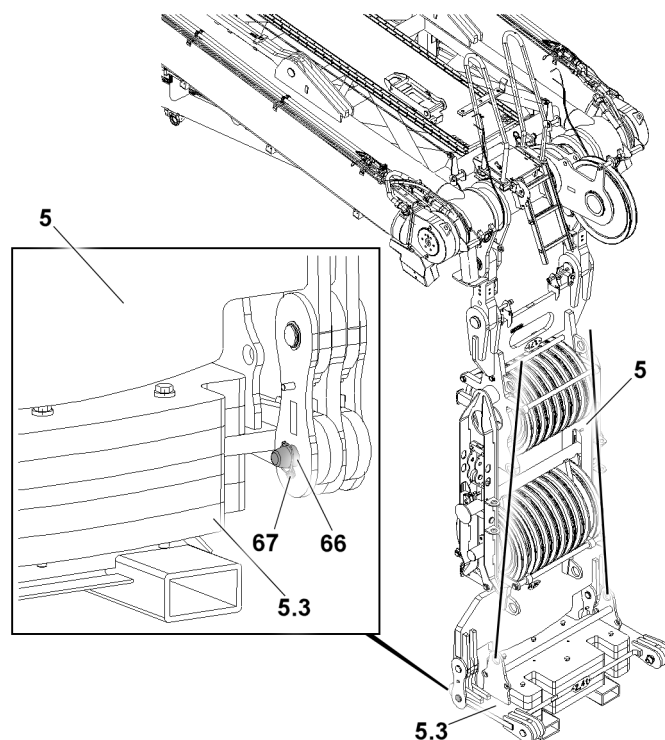


Fig.159675: Unpinning the auxiliary weight and taking it down on the ground

- ▶ Fasten the auxiliary weight **5.3** properly to the auxiliary crane.
- ▶ Lift the auxiliary weight **5.3** with the auxiliary crane to the horizontal.

Disassemble the auxiliary weight **5.3** on the S-luffing pulley block **5** and take it down on the ground at a sufficient distance.

When the auxiliary weight **5.3** hangs horizontally on the auxiliary crane:

- ▶ Remove the safety retaining pin **67** and unpin the pin **66** on both sides.
- ▶ Unpin the pin **57** on both sides.

**Result:**

- The auxiliary weight **5.3** is unpinned.

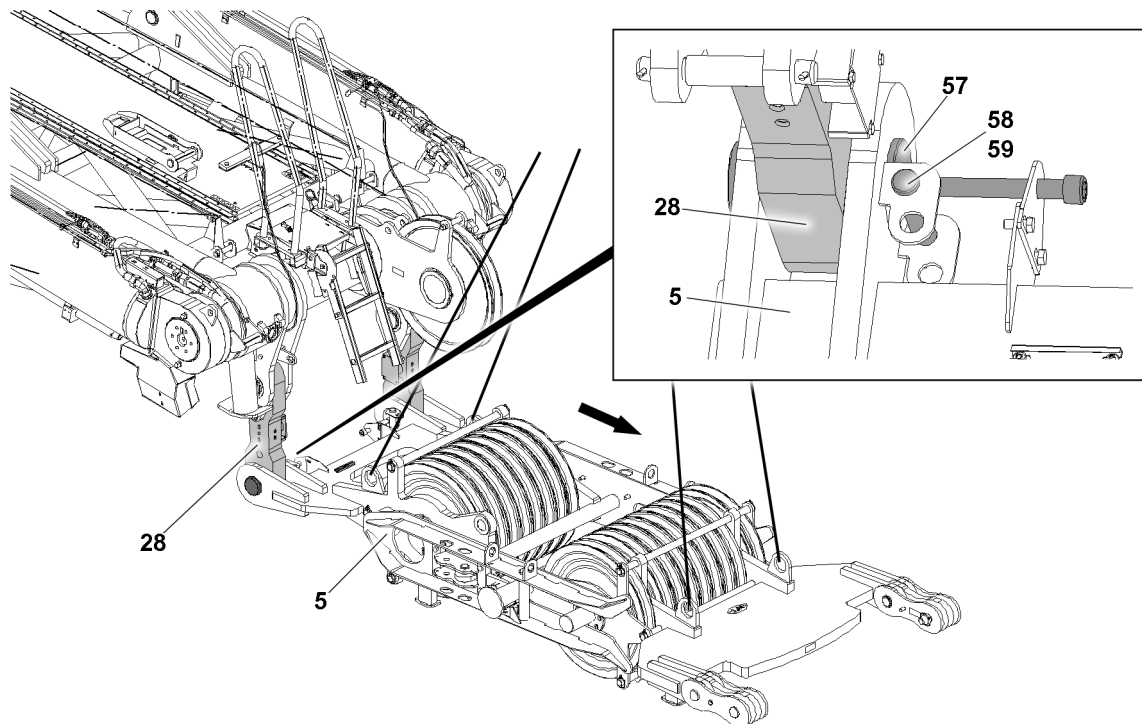
When the auxiliary weight **5.3** is unpinned on both sides:

- ▶ Swing the auxiliary weight **5.3** out with the auxiliary crane.
- ▶ Take the auxiliary weight **5.3** down on the ground with the auxiliary crane.
- ▶ Remove the auxiliary crane.

### 7.3.6 Unpinning the S-luffing pulley block and taking it down on the ground

Make sure that the following prerequisites are met:

- The electrical connections to the S-luffing pulley block are disconnected.
- The dummy plugs are properly assembled.
- An auxiliary crane is on hand.



*Fig.159686: Unpinning the S-luffing pulley block on the pull test brackets and taking it down on the ground*

- ▶ Fasten the S-luffing pulley block **5** properly to the auxiliary crane.
- ▶ Lift the S-luffing pulley block **5** with the auxiliary crane to the horizontal.

Disassemble the S-luffing pulley block **5** on the pull test brackets **28** and take it down on the ground at a sufficient distance.

When the S-luffing pulley block **5** hangs horizontally on the auxiliary crane:

- ▶ Remove the retaining element **59** and unpin the pin **58** on both sides.
- ▶ Unpin the pin **57** on both sides.

**Result:**

- The S-luffing pulley block **5** is unpinned.

**NOTICE**

Danger of slack rope formation!

- ▶ Make sure that no slack rope on winch 3 forms when swinging the S-luffing pulley block out.

When the S-luffing pulley block **5** is unpinned on both sides:

- ▶ Swing the S-luffing pulley block **5** out with the auxiliary crane and spool winch 3 out at the same time.
- ▶ Take the S-luffing pulley block **5** down on the ground with the auxiliary crane.
- ▶ Remove the auxiliary crane.

### 7.3.7 Bringing the pulley retainer on the D-end section into the transport position

Make sure that the following prerequisite is met:

- The S-luffing pulley block is disassembled on the D-end section and taken down on the ground.

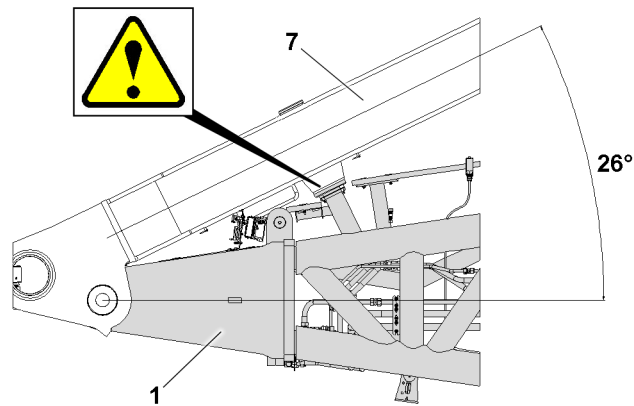


Fig.153394: SA-frame 7 on the D-pivot section 1 stop

#### NOTICE

Danger of slack rope formation!

From an angle of 26° between the SA-frame 7 and the D-pivot section 1, the SA-frame 7 touches at the stop of the D-pivot section 1.

The block position is not monitored by the control. When spooling winch 4 out further, slack rope may form.

- ▶ Make sure that winch 4 is no longer actuated when the block position is reached.

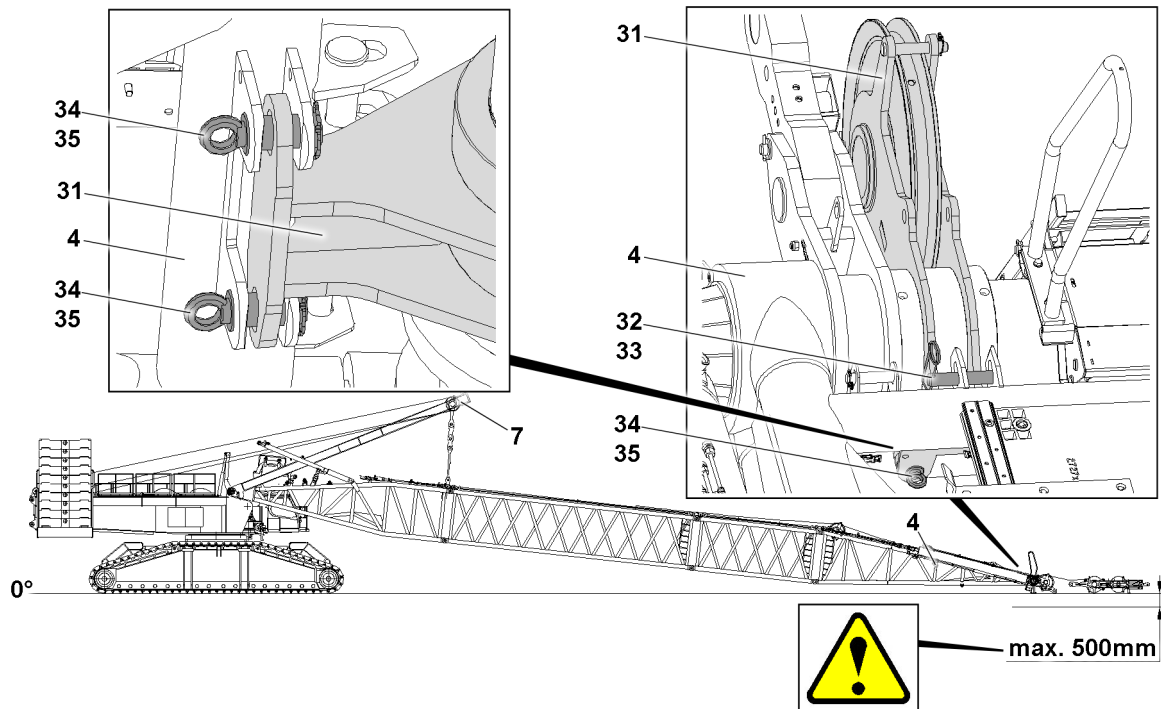


Fig.153389: Releasing the pulley retainer on the D-end section



#### WARNING

Danger of accident!

Death, severe bodily injuries, property damage.

- ▶ Make sure that the D-end section lies maximum 500 mm below the alignment level.

- ▶ Take the D-boom down carefully and at a low speed onto the substructure or the ground.
- ▶ Take the D-guy rods down completely between the SA-frame 7 and the D-end section 4 into the transport retainers of the D-lattice sections: Lower the SA-frame 7 to the front.

When the D-guy rods are in the transport retainers of the lattice sections:

- ▶ Pin and secure the D-guy rods in the transport retainers.
- ▶ Unpin the pulley retainer 31 in the operating position: Remove the retaining element 35 and unpin the grip pin 34 on both sides.
- ▶ Unpin the retaining pin 32 in the transport position of the pulley retainer 31: Remove the retaining element 33 and unpin the retaining pin 32.

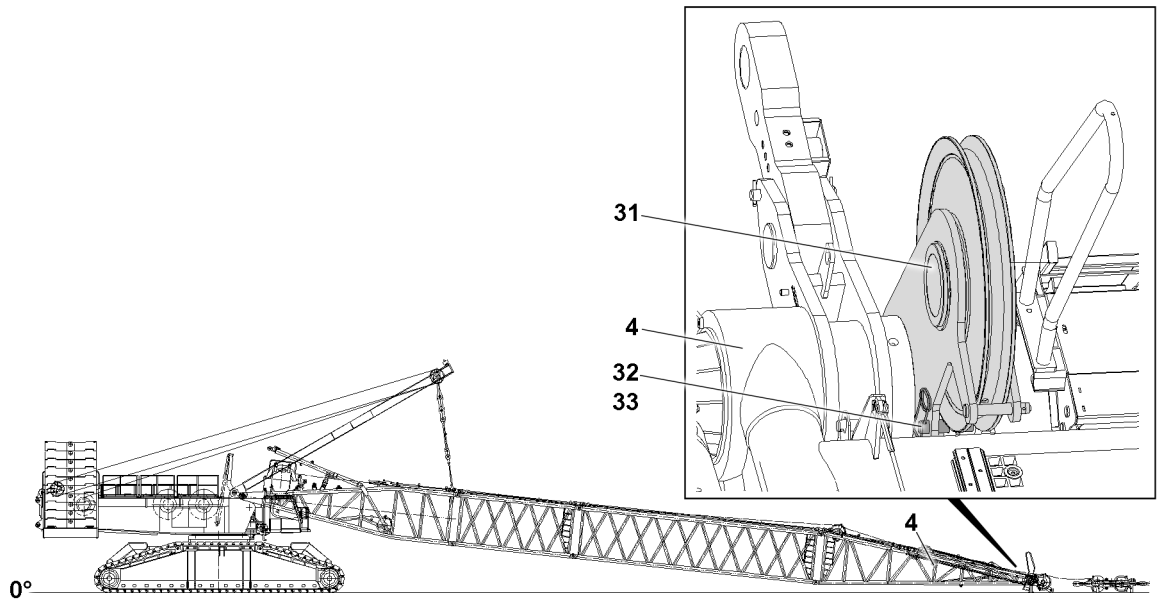


Fig.159698: Bringing the pulley retainer into the transport position



#### WARNING

Danger of fatal injury due to the pulley retainer!

If the pulley retainer **31** is not secured with an auxiliary crane during the swinging procedure, then it can swing forward due to its weight.

Death, severe bodily injuries, property damage.

- ▶ Swing the pulley retainer **31** into the transport position only with the aid of an auxiliary crane.
- ▶ Swinging the pulley retainer **31** without an auxiliary crane is **prohibited**.

- ▶ Fasten the pulley retainer **31** to the auxiliary crane.
- ▶ Swing the pulley retainer **31** upward with the auxiliary crane into the transport position.

When the pulley retainer **31** is in the transport position:

- ▶ Insert the retaining pin **32** and secure it with the retaining element **33**.

When the pulley retainer **31** is pinned and secured in the transport position:

- ▶ Remove the auxiliary crane.
- ▶ Insert the grip pin **34** again and secure it with the retaining element **35**.

### 7.3.8 Bringing the pull test brackets into the transport position

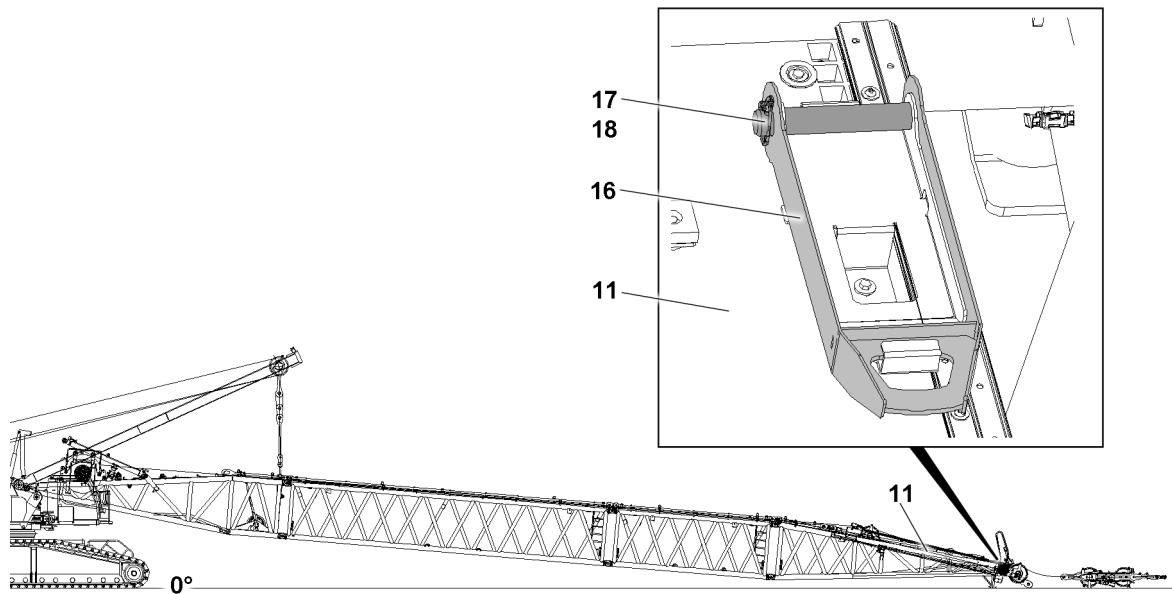


Fig.159695: Assembling the lashing lugs on the pull test bracket

- ▶ Remove the retaining element **27** and unpin the pin **26**.
- ▶ Remove the lashing lug **25** from the transport retainer.

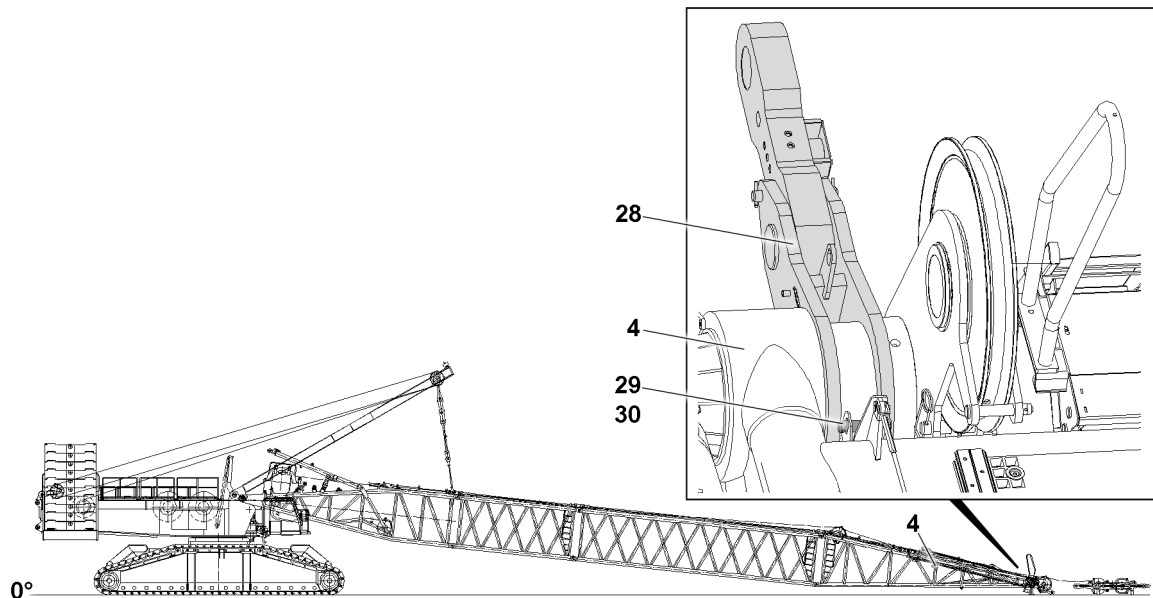


Fig.159697: Pull test bracket

- ▶ Remove the retaining element **30** and unpin the retaining pin **29** from the transport position.



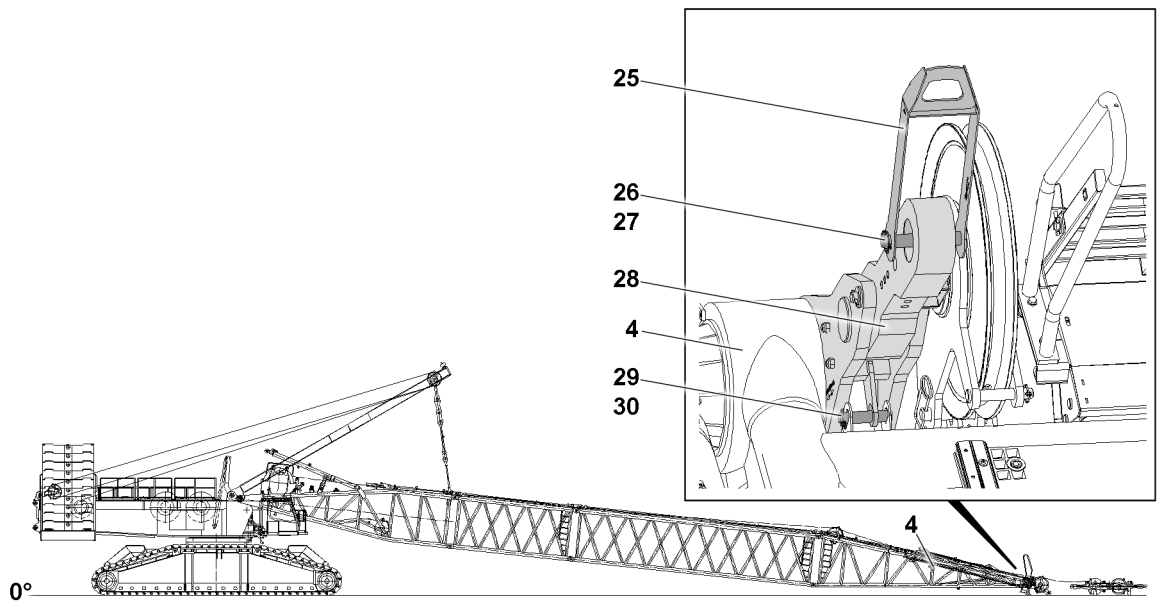


Fig.159696: Releasing the pull test brackets

#### NOTICE

Danger of property damage!

- ▶ Fasten the pull test bracket **28** to the auxiliary crane only when using the lashing lug **25**.
- ▶ Connect the lashing lug **25** with the pull test bracket **28**: Insert the pin **26** and secure it with the retaining element **27**.
- ▶ Fasten the lashing lug **25** to the auxiliary crane.



#### WARNING

The pull test bracket can cause danger of fatal injury!

If the pull test brackets are not secured with an auxiliary crane during the swinging procedure, they can swing forward due to their weight.

Death, severe bodily injuries, property damage.

- ▶ Swing the pull test bracket **28** into the transport position only with the aid of an auxiliary crane.
- ▶ Swinging the pull test bracket **28** without an auxiliary crane is **prohibited**.

- ▶ Tighten the fastening equipment carefully with the auxiliary crane.

Bring the first pull test bracket **28** into the transport position.

- ▶ Swing the pull test bracket **28** up with the auxiliary crane.
- ▶ Insert the retaining pin **29** and secure with the retaining element **30**.

When the pull test bracket **28** is secured to the transport retainer:

- ▶ Remove the auxiliary crane.
- ▶ Remove the lashing lug **25** from the pull test bracket **28**.
- ▶ Bring the second pull test bracket into the operating position.

After both pull test brackets are in the operating position:

- ▶ Fasten the lashing lug **25** in the transport position.

### 7.3.9 Disassembling the D-guy rods

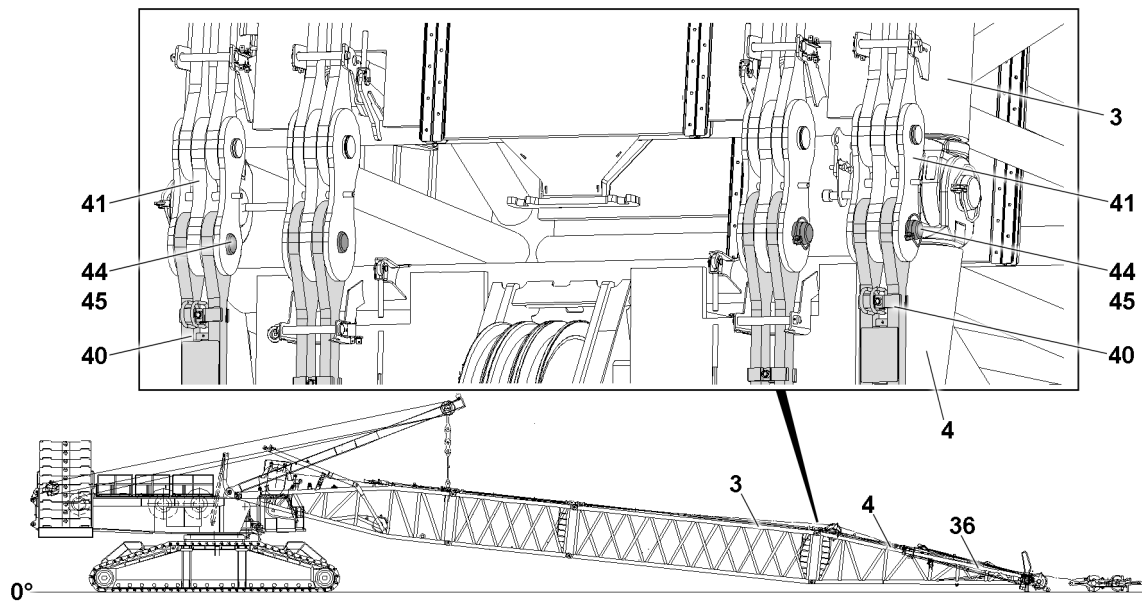


Fig.160981: Unpinning the guy rods

Make sure that the following prerequisite is met:

- The D-boom is lying completely on the ground.
- The guy rods are pinned and secured in the transport retainers.



#### Note

- ▶ Do **not** unpin the guy rods **40** on the pull cylinder **36**.
- ▶ Unpin the guy rods **40** of the pull cylinder **36** and the guy rods **41** of the D-intermediate section **2**: Remove the retaining element **45** and unpin the pin **44**.

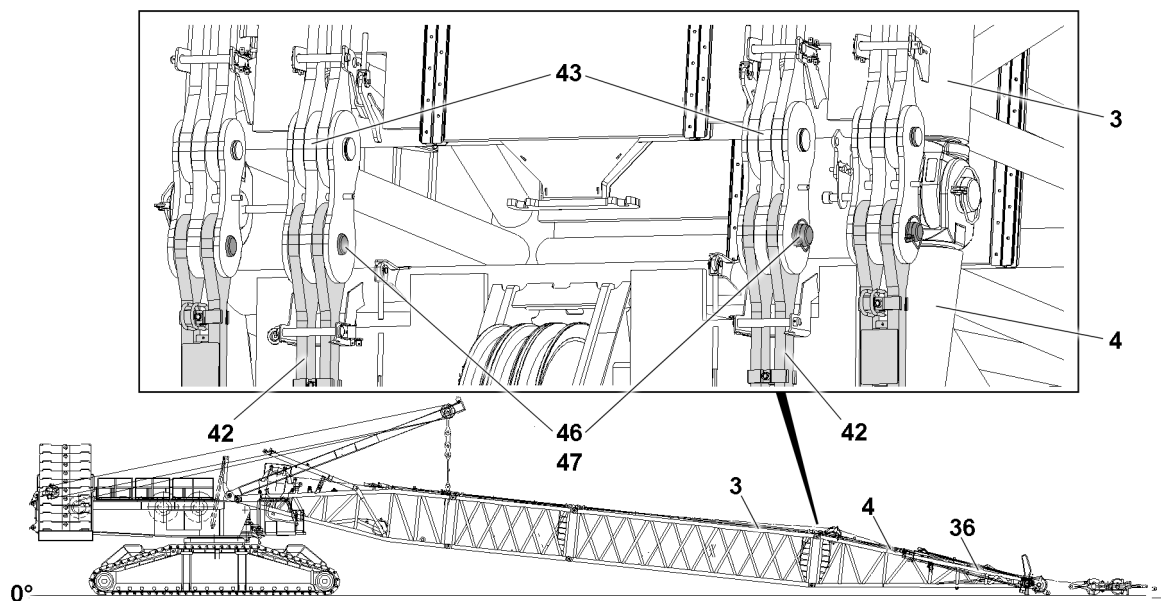


Fig.160982: Unpinning the guy rods

- ▶ Unpin the D-guy rods **42** of the D-pivot section **4** and unpin the D-guy rods **43** of the D-intermediate section **2**: Remove the retaining element **47** and unpin the pin **46**.

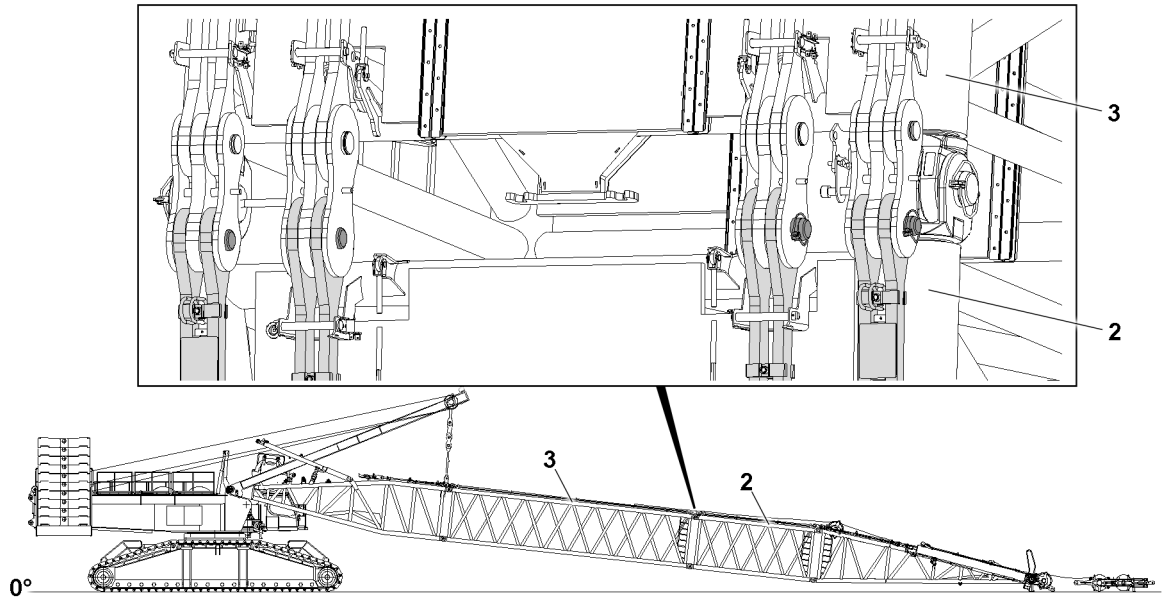


Fig.153393: Unpinning the guy rods



**Note**

- ▶ The procedure for disassembling the guy rods between the D-intermediate section 2 and the D-intermediate section 3 is identical to the procedure described above.
- ▶ Unpin the guy rods of the D-intermediate section 2 from the guy rods of the D-intermediate section 3.

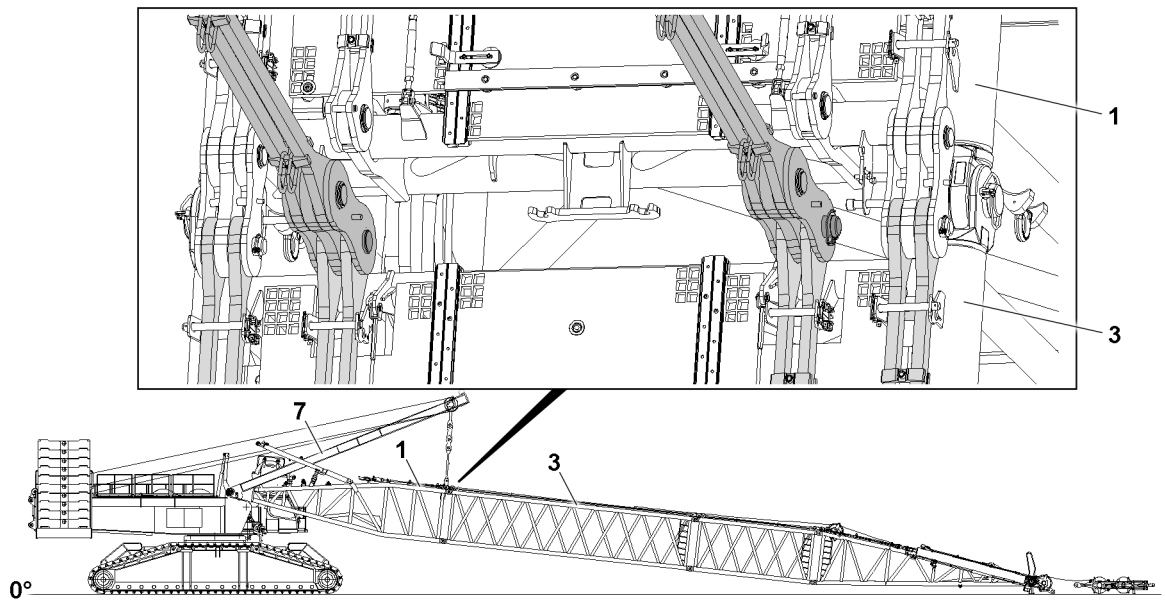


Fig.153397: Unpinning the guy rods



**Note**

- ▶ The procedure for disassembling the guy rods between the D-pivot section 1 and the D-intermediate section 3 is identical to the procedure described above.

LWE/LR 1800-1-0-000/27200-07-02/en

**WARNING**

Swinging components!

The guy rods of the SA-frame can start to swing due to their own weight when unpinning.  
Death, severe bodily injuries.

- ▶ Make sure that there are no persons in the danger zone during the entire unpinning procedure.
- 
- ▶ Unpin the guy rods of the SA-frame **7** from the guy rods of the D-intermediate section **3**.
  - ▶ Unpin the guy rods of the D-pivot section **1** from the guy rods of the D-intermediate section **3**.

### 7.3.10 Unpinning the pull brackets from the guy rods of the D-pivot section

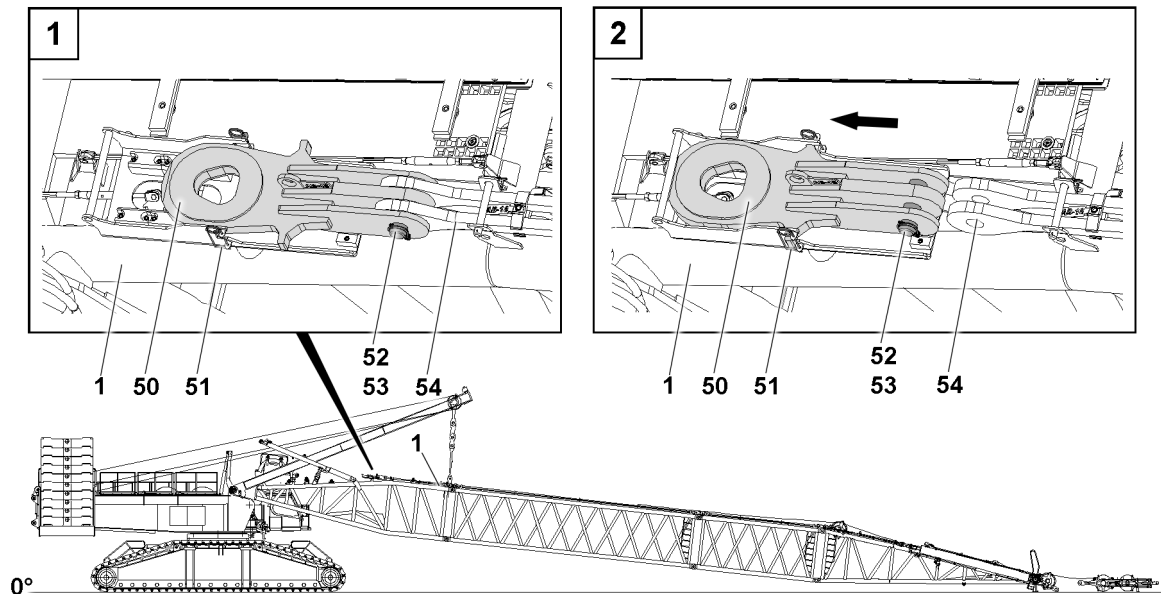


Fig.153424: Pull bracket transport position

- ▶ Fasten the pull bracket **50** to the auxiliary crane.
- ▶ Remove the retaining element **53** and unpin the pin **52**.
- ▶ Remove the retaining element **51** on both sides.
- ▶ Swing the pull bracket **50** with the auxiliary crane from the guy rods **54** of the D-pivot section **1**.

Secure the pull bracket **50** in the transport position.

- ▶ Fix the retaining element **51** on both sides.

### 7.3.11 Retracting the pull cylinder

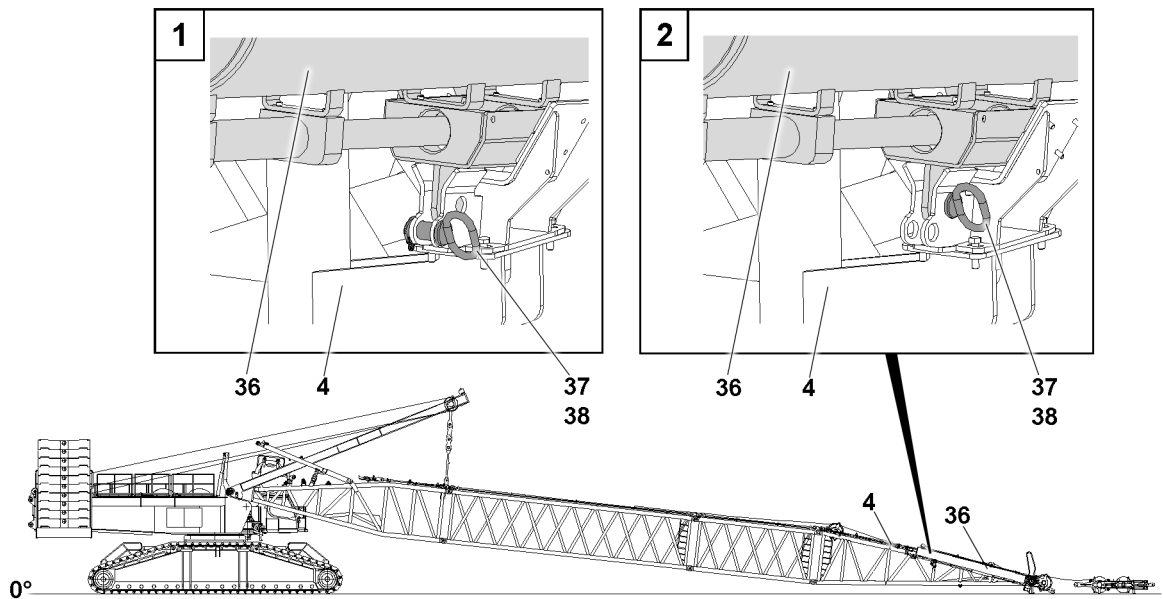


Fig.153426: Retracting the pull cylinder

Make sure that the following prerequisite is met:

- The guy rods are taken down, unpinned and secured.
- ▶ Retract the pull cylinder **36** on both sides completely.

### 7.3.12 Securing the pull cylinder

Make sure that the following prerequisites are met:

- The pull cylinders are fully retracted.
- ▶ Remove the retaining element **38** and unpin the grip pin **37** from the park position.
- ▶ Insert the grip pin **37** in the transport position and secure with the retaining element **38**.

**Result:**

- The pull cylinder **36** is secured in the transport position.

### 7.3.13 Disconnecting the hydraulic connections on the D-boom

The hydraulic connections are established with quick couplings.

When disconnecting hydraulic lines with quick couplings, make sure that the coupling procedure is carried out correctly.



#### **WARNING**

Pressure in the hydraulic lines!

If the pressure supply is not interrupted before connecting / releasing the hydraulic lines, the hydraulic oil can escape with high pressure.

Death, severe bodily injuries, property damage.

- ▶ Release the pressure in the hydraulic system before connecting / disconnecting: Interrupt the pressure supply and wait for a short time.
- ▶ Release the hydraulic coupling by hand.
- ▶ Disconnect the hydraulic connections, see the Hydraulic diagram.
- ▶ Protect the hydraulic connections from contamination with caps.

### 7.3.14 Disconnecting the electrical connections on the D-boom

- ▶ Disconnect the electrical connections, see the wiring diagram.
- ▶ Close the electrical connections off properly with dummy plugs or protective caps.

### 7.3.15 Bringing the ladder into the transport position

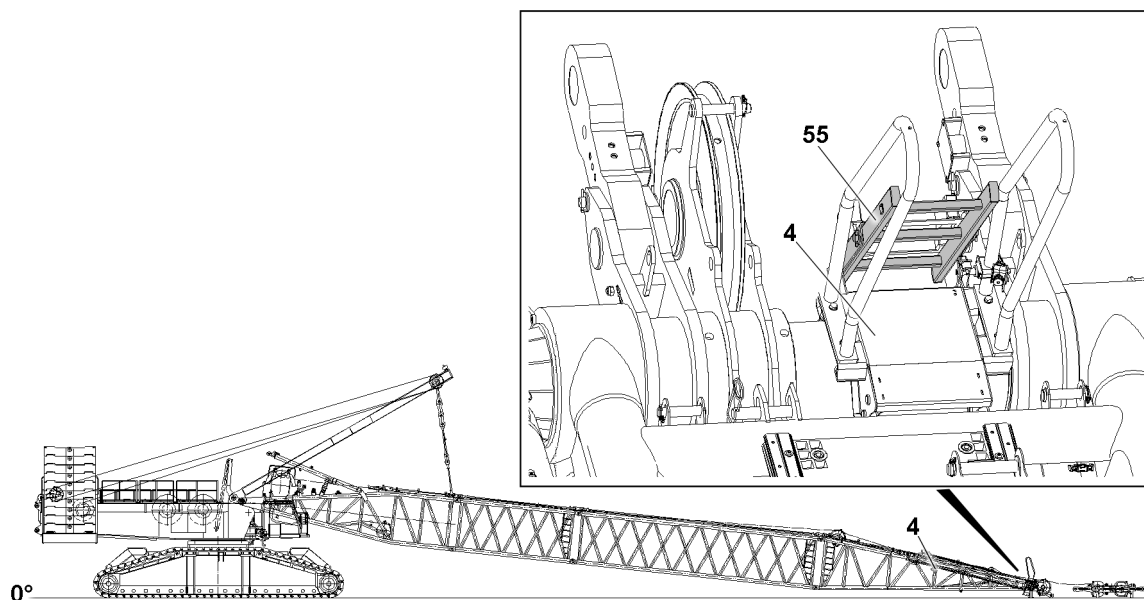


Fig.159694: Bringing the ladder into the transport position



#### Note

- ▶ Bring the ladder **55** into the transport position, see chapter 2.06.

### 7.3.16 “Opening” the D-boom and taking it down

Make sure that the following prerequisite is met:

- The boom guying between the guy rods of the SA-frame and the guy rods of the D-intermediate section is unpinned.

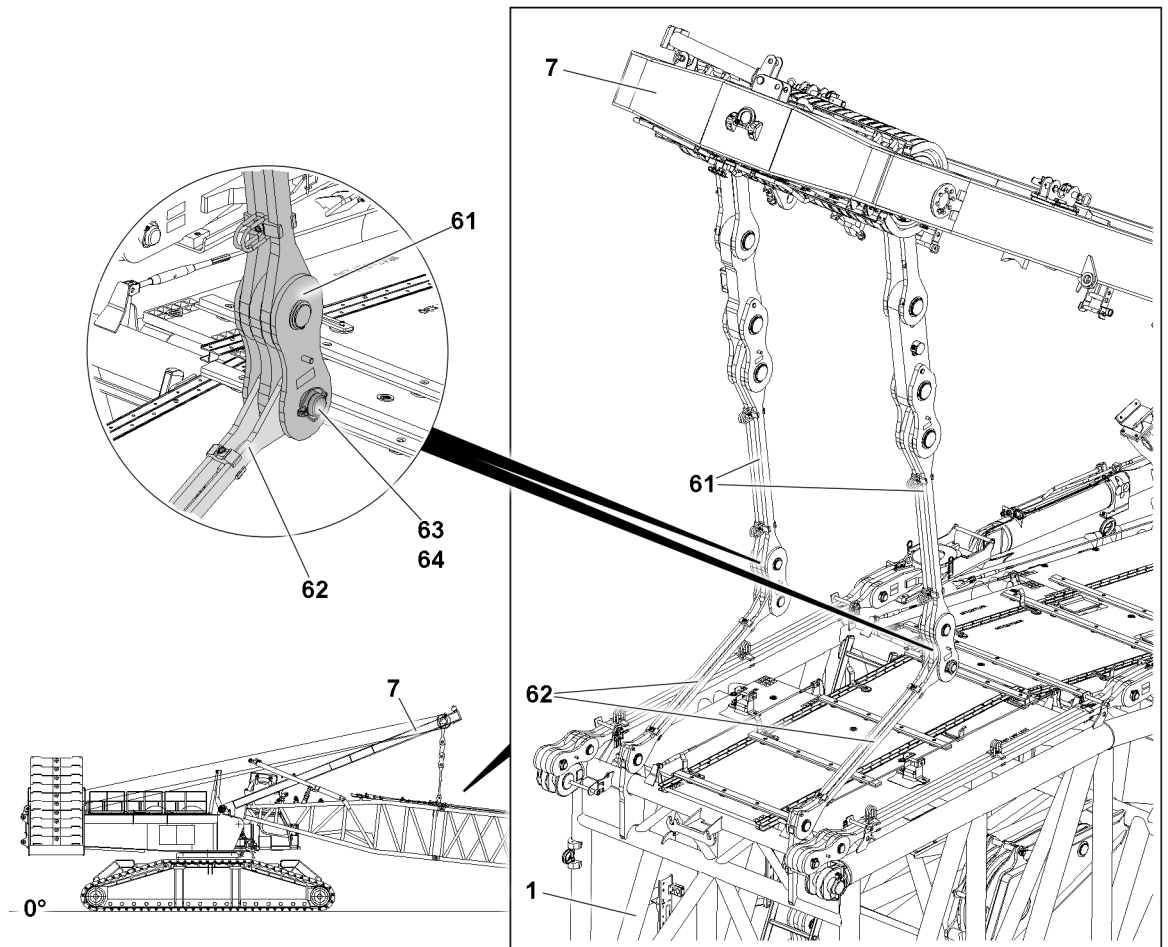


Fig.153437: Opening the D-boom



#### Note

- ▶ For assembly of the D-boom, the guy rods **61** of the SA-frame **7** must be pinned with the flying assembly guy rods **62** on the D-pivot section **1** so that the D-boom can be lowered over the SA-frame **7** and disassembled.

- ▶ Assemble the flying assembly guying between the SA-frame **7** and the D-pivot section **1**.
- ▶ Release the flying assembly guy rods **62** from the transport retainers.
- ▶ Lift the flying assembly guy rods **62** and align them with the guy rods **61** of the SA-frame **7**.

When the pin bores align:

- ▶ Insert the pin **63** and secure it with the retaining element **64**.

When the guying for the flying assembly between the SA-frame **7** and the D-pivot section **1** is properly assembled and secured:

- ▶ Luff the SA-frame **7** up until the guying between the SA-frame and the D-pivot section is tensioned and the total force of the closing procedure is reached.

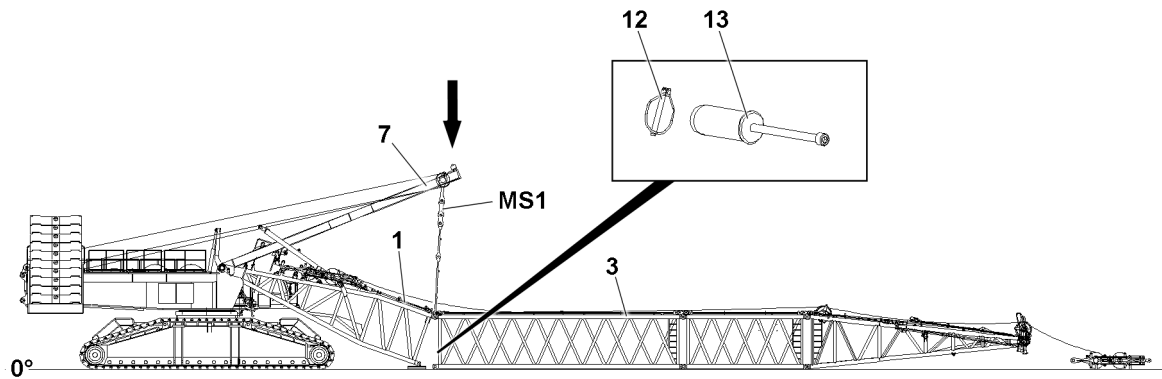


Fig.153438: Opening the D-boom

**WARNING**

The boom can suddenly fold down!

When unpinning the D-boom on the D-pivot section, the D-boom can fall down. Death, severe bodily injuries, property damage.

- ▶ Make sure that the total force in test point 1 **MS1** does not exceed 125 t.
- ▶ Luff the SA-frame **7** up so far until the total force in test point 1 **MS1** displays the value used for the closing procedure of the D-boom.
- ▶ It is prohibited for anyone to remain under the D-boom during the unpinning procedure.
- ▶ Make sure that the D-boom is safely held by the guying.

- ▶ Unpin the D-pivot section **1** and the D-intermediate section **3** at the bottom: Release the retaining element **12** on both sides at the bottom and unpin the pin **13**.

When the pins **13** are unpinned on both sides:

- ▶ Luff the SA-frame **7** down and take the D-boom down on the substructure with a height of at least 350 mm.
- ▶ Luff the SA-frame **7** down until the guying to the D-pivot section **1** is relieved.
- ▶ Unpin the D-guying: Release and unpin the pin.
- ▶ Take the flying assembly guy rods **62** down on the D-pivot section **1** and secure.
- ▶ Luff the SA-frame **7** up to approx. 85°.

### 7.3.17 Retracting the D-relapse cylinder

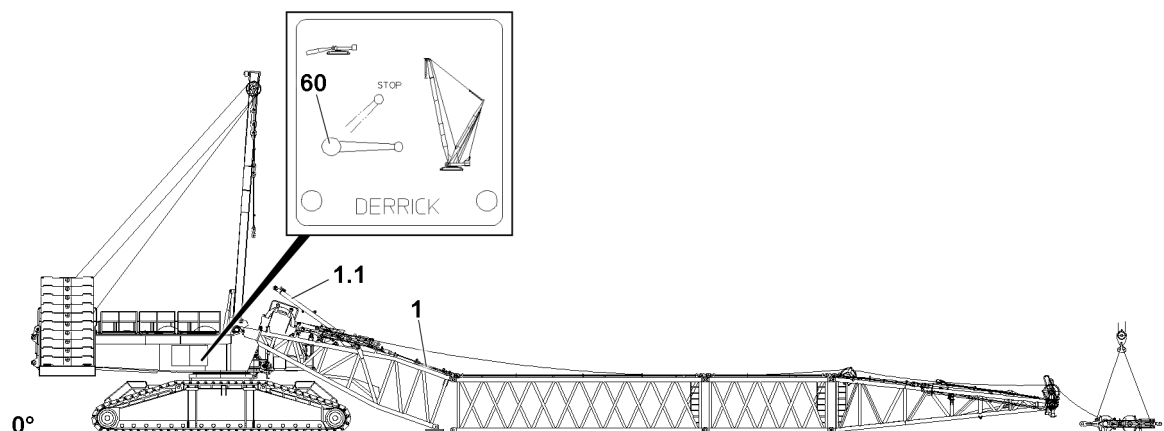


Fig.153427: Retracting the piston rod on the D-relapse cylinder



**WARNING**

Danger of fatal injury due to the D-boom!

Death, severe bodily injuries, property damage.

- ▶ The ball valve **60** must be secured during crane operation to prevent unintended actuation.

The piston rod on the D-relapse cylinder **1.1** must be retracted by actuating the ball valve **60**.

Ball valve positions	
Horizontal	Crane operation, extend the piston rod
Vertical	Assembly, retract the piston rod
45°	STOP (the piston rod cannot be retracted / extended)

Make sure that the following prerequisite is met:

- All hydraulic connections have been established.

- ▶ Move the ball valve **60** into the vertical position.

**Result:**

- The piston rods of the D-relapse cylinders **1.1** retract.

**Note**

- ▶ The ball valve **60** is secured by closing the cabinet door and removing the key.

- ▶ Close the cabinet door and pull out the key.

- ▶ Hand the key to an authorized person.

### 7.3.18 Variation with removable winch 3: Taking the S-luffing pulley block down into the transport receptacle on the D-pivot section

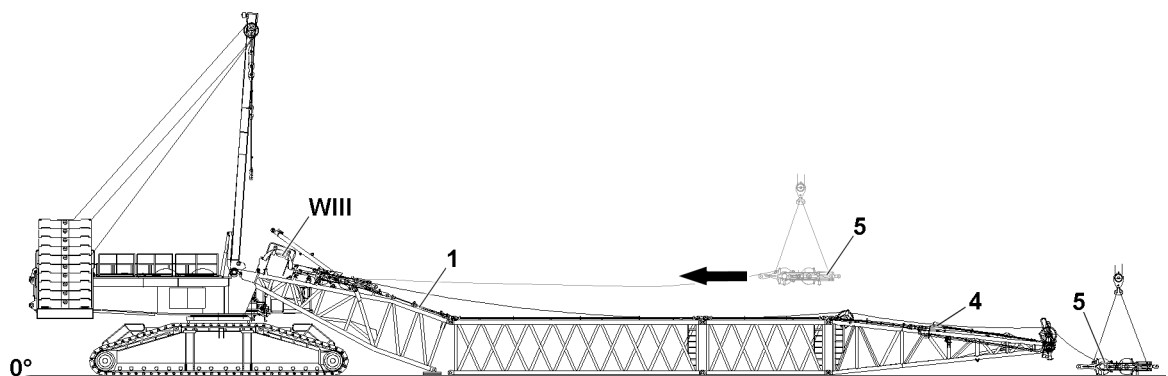


Fig.159689: Taking the S-luffing pulley block down (variation with removable winch 3)

Make sure that the following prerequisites are met:

- The lower and the upper pulley blocks are pinned as an S-luffing pulley block **5** “transport unit”.
- The rope retaining pins on the D-end section are released and unpinned.
- The guy rods are taken down in the transport retainers and secured.
- The SA-frame is luffed up to approx. 85°.
- The D-boom is lying fully on the ground (on the substructure).
- The electrical connections are separated.
- The electrical connections are closed off with dummy plugs, protective caps or caps.

- ▶ Fasten the S-luffing pulley block **5** to the auxiliary crane, see section “Fastening points for derrick components”.
- ▶ Tension the fastening equipment between the S-luffing pulley block and the hook block of the auxiliary crane.

**NOTICE**

Slack rope formation!

- ▶ Always keep the control rope of winch 3 slightly tensioned.
- ▶ Pull the S-luffing pulley block **5** with the auxiliary crane to the D-pivot section **1** while spooling winch 3 up at the same time.
- ▶ Place the S-luffing pulley block **5** in the transport receptacle on the D-pivot section.

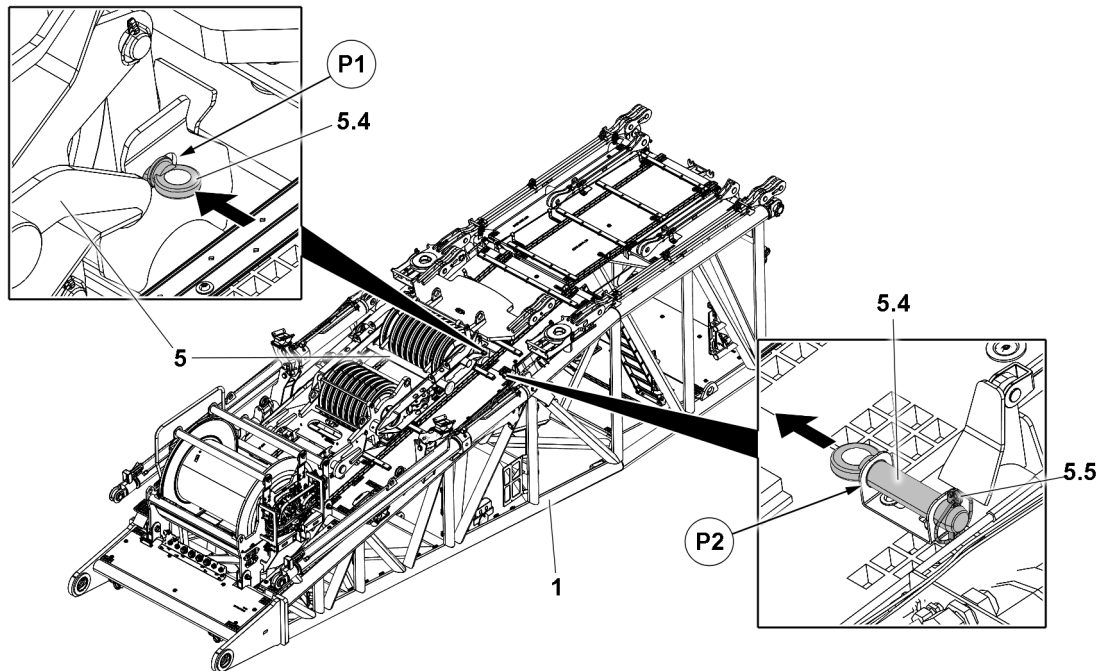


Fig.159690: Place the S-luffing pulley block in the transport receptacle on the D-pivot section and secure it.

Pin and secure the S-luffing pulley block **5** on the D-pivot section **1**.

- ▶ Remove the transport retainer of the D-pivot section **1** in the pin point **P2** from the park position: Remove two safety locking pins **5.5** and two pins **5.4**.
- ▶ Insert the transport retainer in the S-luffing pulley block **5**: Insert the pin **5.4** in the pin point **P1** and secure with the safety locking pin **5.5**.

### 7.3.19 Variation with fixed installed winch 3: Taking the S-luffing pulley block down into the transport receptacle on the D-pivot section

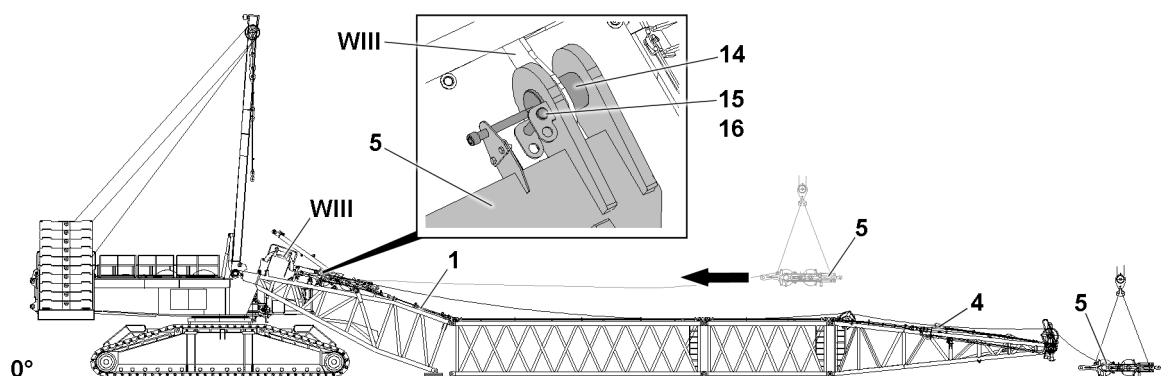


Fig.153428: Taking the S-luffing pulley block (variation with fixed installed winch 3)

Make sure that the following prerequisites are met:

- The lower and the upper pulley blocks are pinned as an S-luffing pulley block **5** “transport unit”.
- The rope retaining pins on the D-end section are released and unpinned.
- The guy rods are taken down in the transport retainers and secured.
- The SA-frame is luffed up to approx. 85°.
- The D-boom is lying fully on the ground (on the substructure).
- The pins **14** are unpinned.
- The electrical connections are separated.
- The electrical connections are closed off with dummy plugs, protective caps or caps.
- ▶ Fasten the S-luffing pulley block **5** to the auxiliary crane, see section “Fastening points for derrick components”.
- ▶ Tension the fastening equipment between the S-luffing pulley block and the hook block of the auxiliary crane.

#### NOTICE

Slack rope formation!

- ▶ Always keep the control rope of winch 3 slightly tensioned.
- ▶ Pull the S-luffing pulley block **5** with the auxiliary crane to the D-pivot section **1** while spooling winch 3 up at the same time.
- ▶ Place the S-luffing pulley block **5** in the transport receptacle on the D-pivot section.
- ▶ Pin and secure the S-luffing pulley block **5** on the D-pivot section **1** with winch 3 **WIII**: Insert the pin **14** and secure it with the retaining pin **15** and retaining element **16**.

### 7.3.20 Disassembling the D-lattice sections

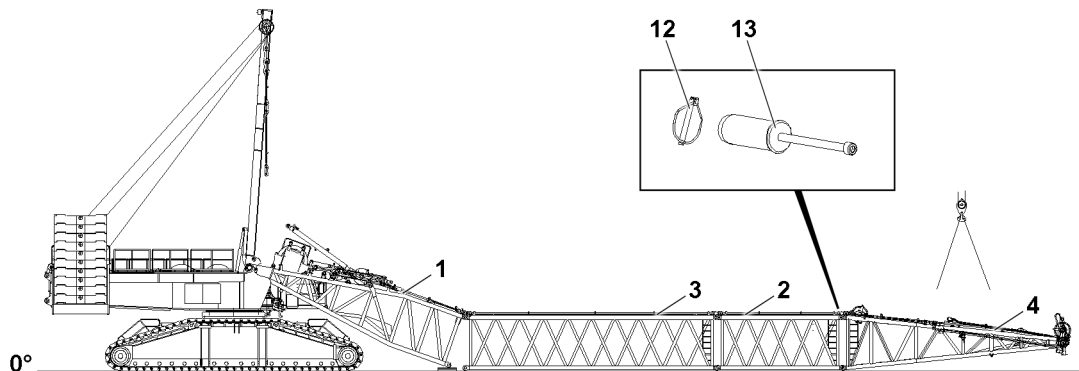


Fig.153381: Disassembling the D-lattice sections



#### WARNING

Tipping lattice sections!

When the lattice sections are unpinned, they can tip over, depending on the ground or the substructure.

Death, severe bodily injuries, property damage.

- ▶ The lattice sections must be safely held by the auxiliary crane before unpinning them.
- ▶ The fastening equipment must be tensioned before unpinning.



#### Note

- ▶ Always support the D-lattice sections sufficiently for easier disassembly.
- ▶ Pin and unpin the D-lattice sections with the pin pulling device, see chapter 5.30.



#### Note

- ▶ Fastening points, see section “Fastening points for derrick components”.

Make sure that the following prerequisite is met:

- The S-luffing pulley block is pinned and secured to the D-pivot section on winch 3.
- ▶ Fasten the D-end section 4 to the auxiliary crane.

When the D-end section 4 is held safely by the auxiliary crane:

- ▶ Release and unpin the pin 13 on both sides on the top and bottom.
- ▶ Remove the D-end section 4 with the auxiliary crane.

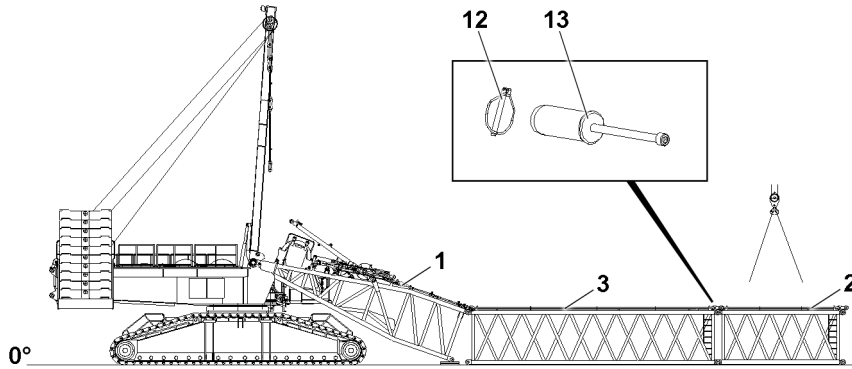


Fig. 153380: Disassembling the D-lattice sections

- ▶ Fasten the D-intermediate section 2 to the auxiliary crane.

When the D-intermediate section 2 is held safely by the auxiliary crane:

- ▶ Release and unpin the pin 13 on both sides on the top and bottom.
- ▶ Remove the D-intermediate section 2 with the auxiliary crane.

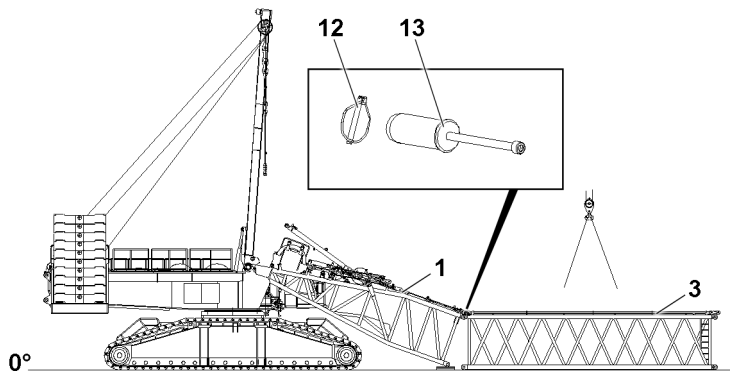


Fig. 153379: Disassembling the D-lattice sections

- ▶ Fasten the D-intermediate section 3 to the auxiliary crane.

When the D-intermediate section 3 is held safely by the auxiliary crane:

- ▶ Release and unpin the pin 13 on both sides on top.
- ▶ Remove the D-intermediate section 2 with the auxiliary crane.

### 7.3.21 Disconnecting the hydraulic connections to the D-pivot section

The hydraulic connections are established with quick couplings.

When disconnecting hydraulic lines with quick couplings, make sure that the coupling procedure is carried out correctly.

**WARNING**

Pressure in the hydraulic lines!

If the pressure supply is not interrupted before connecting / releasing the hydraulic lines, the hydraulic oil can escape with high pressure.

Death, severe bodily injuries, property damage.

- ▶ Release the pressure in the hydraulic system before connecting / disconnecting: Interrupt the pressure supply and wait for a short time.
- 
- ▶ Release the hydraulic coupling by hand.
  - ▶ Disconnect the hydraulic connections, see the Hydraulic diagram.
  - ▶ Protect the hydraulic connections from contamination with caps.

### 7.3.2 Disconnecting the electrical connections to the D-pivot section

- ▶ Disconnect the electrical connections, see the wiring diagram.
- ▶ Close the electrical connections off properly with dummy plugs or protective caps.

### 7.3.23 Unpinning the D-pivot section on the SA-frame

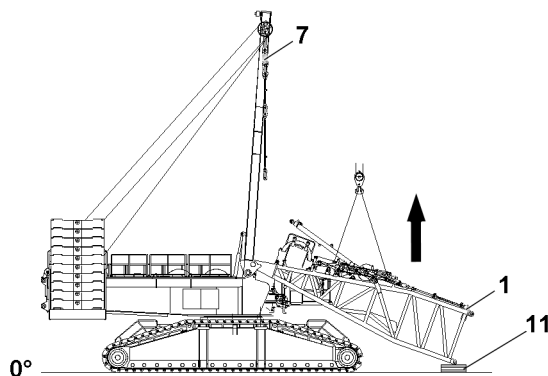


Fig.153429: Lifting the D-pivot section to the horizontal

Make sure that the following prerequisites are met:

- The D-lattice sections are disassembled.
  - The crane engine is running.
- ▶ Fasten the D-pivot section 1 to the auxiliary crane.
  - ▶ Lift the D-pivot section 1 with the auxiliary crane off the ground.

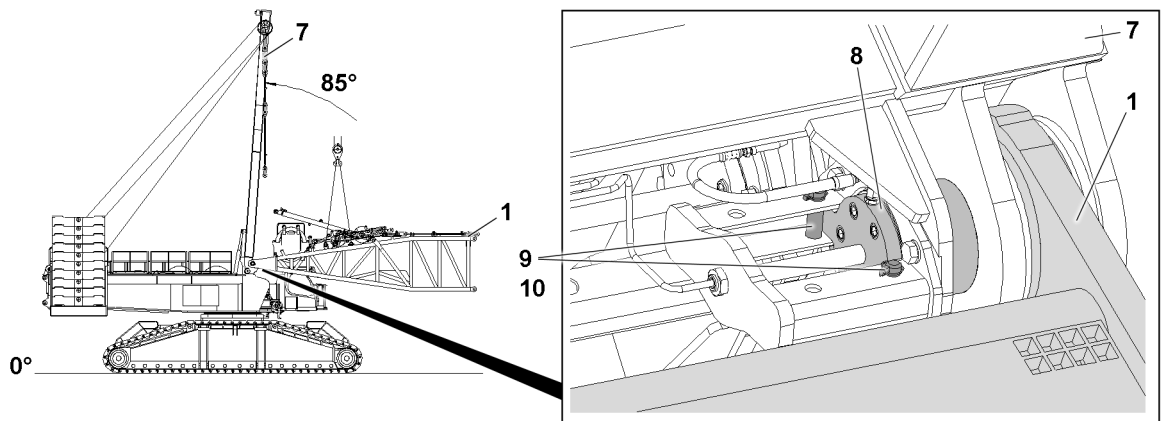


Fig.153377: Unpinning the D-pivot section on the SA-frame

**WARNING**

The crane can topple over!  
Death, severe bodily injuries, property damage.

- ▶ Make sure that the specifications are complied with in the assembly conditions, see chapter 3.06.

- ▶ Lift the D-pivot section **1** with the auxiliary crane to the horizontal.

When the D-pivot section **1** hangs horizontally on the auxiliary crane:

- ▶ Release the connector pin **8**: Remove the retaining element **10** and unpin the retaining pin **9**.

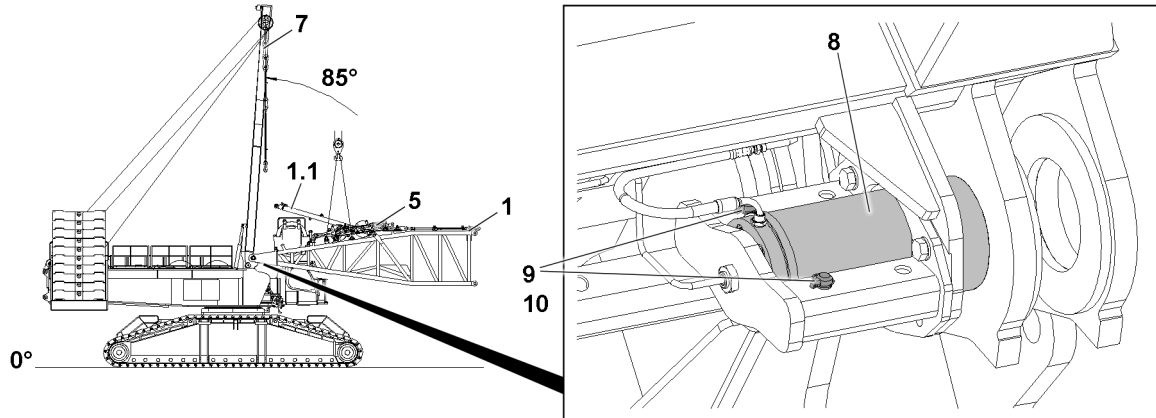


Fig.153376: Unpinning the D-pivot section on the SA-frame

- ▶ Unpin the connector pin **8** on both sides.

**WARNING**

Danger of tipping!

If the D-pivot section **1** is taken down on the ground, then it must be supported accordingly.  
If the D-pivot section **1** is not properly supported, then it can tip forward.

Death, severe bodily injuries, property damage.

- ▶ Support the D-pivot section **1** properly.

- ▶ Swing the D-pivot section **1** out with the auxiliary crane on the SA-frame **7** and take it down on the ground.

### 7.3.24 Taking down and securing the D-relapse cylinder in the transport position

**WARNING**

Danger of falling!

If the D-relapse cylinder is brought to the transport position when the D-pivot section is still installed on the SA-frame, assembly personnel can fall down.

Death, severe bodily injuries, property damage.

- ▶ Make sure that the D-pivot section is located on the ground when the D-relapse cylinder is brought to the assembly position on both sides.

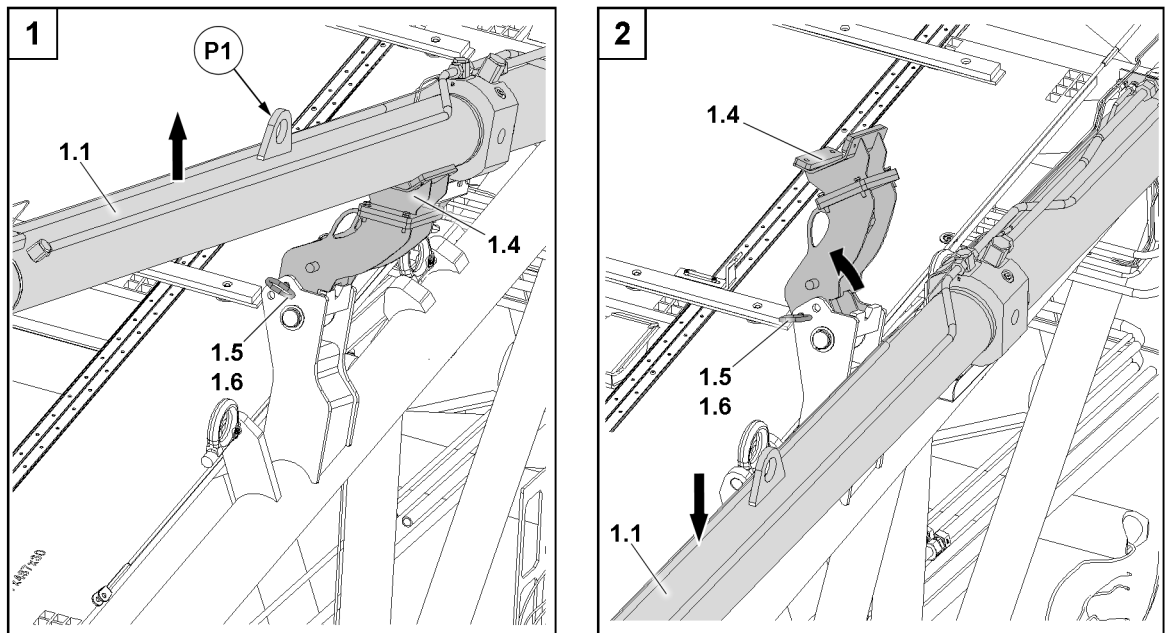


Fig.153430: Taking the D-relapse cylinder down in the transport position

Make sure that the following prerequisite is met:

- The D-pivot section is set down on the ground properly.
- ▶ Fasten the D-relapse cylinder 1.1 in point P1 to the auxiliary crane.
- ▶ Lift the D-relapse cylinder 1.1 out with the auxiliary crane on the support 1.4.

When the D-relapse cylinder 1.1 is safely held by the auxiliary crane:

- ▶ Remove the retaining element 1.6 and unpin the grip pin 1.5.



#### WARNING

Danger of crushed limbs!

When swinging the support 1.4, fingers and hands can be crushed.

- ▶ Do not reach with your hands into the danger zone.

- ▶ Swing the support 1.4 into the transport position.

When the support 1.4 is in the transport position:

- ▶ Insert the grip pin 1.5 in the transport position and secure with the retaining element 1.6.

#### Result:

- The support 1.4 is secured in the transport position.



#### WARNING

Danger of crushed limbs!

When taking the D-relapse cylinder 1.1 down, fingers and hands can be crushed.

- ▶ Do not reach with your hands into the danger zone.

- ▶ Take the D-relapse cylinder 1.1 down with the auxiliary crane in the transport position.

- ▶ Remove the fastening equipment.

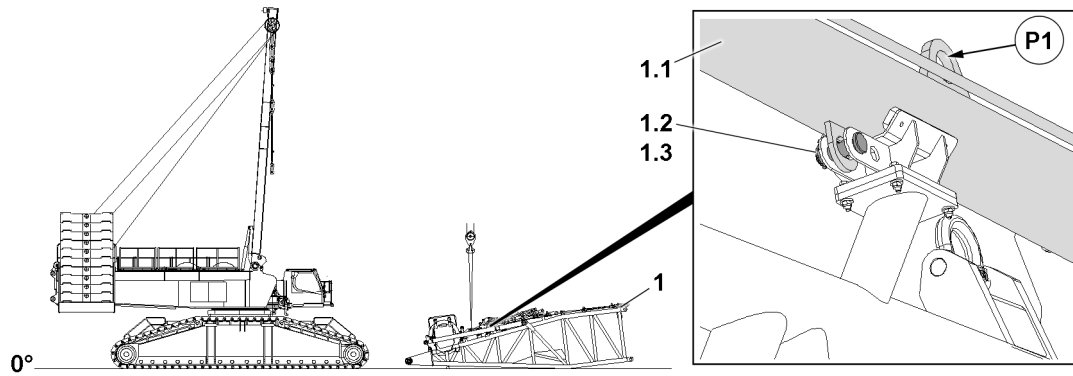


Fig.153374: Securing the D-relapse cylinder in the transport position

- ▶ Unpin the pin 1.2 from the park position P1.
- ▶ Insert the pin 1.2 in the transport position and secure with the retaining element 1.3.

**Result:**

- The D-relapse cylinder 1.1 is secured in the transport position.



**Note**

- ▶ The procedure for taking down the second D-relapse cylinder 1.1 is identical to the procedure for the first D-relapse cylinder.
- ▶ Take down and secure the second D-relapse cylinder in the transport position.

## 8 D-boom disassembly on the ground

### 8.1 Disassembling the D-boom on the ground



**Note**

- ▶ For disassembly “on the ground” the D-pivot section, D-intermediate section and D-end section can be unpinned and removed as a preassembled unit directly on the crane with the auxiliary crane.



**WARNING**

Danger of accident!

If the following conditions are not observed, personnel can be severely injured or killed.

- ▶ Disassembly of the D-boom “on the ground” is only described as an example, for the detailed disassembly process, see section “Disassembling the D-boom in sections”.



**WARNING**

Driving crane!

Death, severe bodily injuries, property damage.

- ▶ Make sure that there are no persons or obstacles in the danger zone when pulling the crane into the D-boom.

Make sure that the following prerequisites are met:

- The crane is horizontally aligned correctly.
- The central ballast is installed according to the load chart.
- The counterweight has been installed on the turntable according to the load chart.
- The assembly conditions are adhered to, see chapter 3.06.
- The LICCON overload protection has been set according to the data in the load chart.
- The LICCON overload protection settings have been compared with the actual set up configuration.
- The relapse cylinders and pull cylinders are retracted.
- The hoist ropes are reeved out.



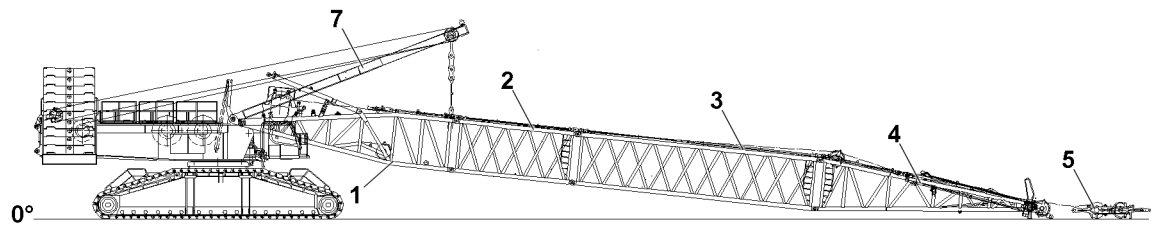


Fig.160987: Unpinning the D-boom of the guying of the SA-frame

- ▶ Pull the S-luffing pulley block **5** with the auxiliary crane to the D-pivot section **1** while spooling winch **3** up at the same time.
- ▶ Set down the S-luffing pulley block **5** in the transport receptacle on the D-pivot section **1** and secure, see section "Disassembling the D-boom in sections".
- ▶ Erect the SA-frame **7** to approx. 85°.
- ▶ Disconnect the hydraulic and electrical connections.

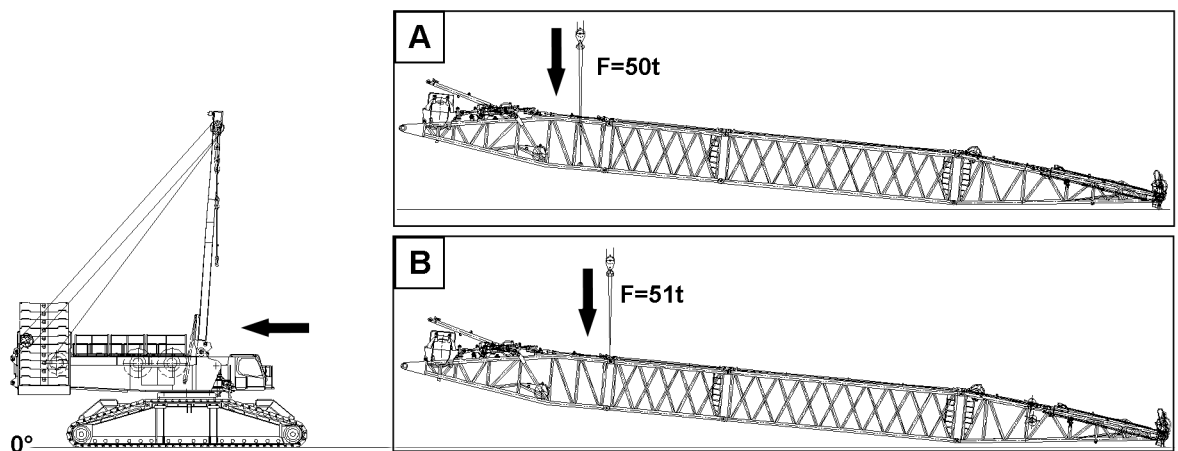


Fig.159680: Fastening the D-boom with the auxiliary crane // Extending the crawler crane

The following suspended loads arise when lifting the D-boom with an auxiliary crane:

- D-boom with lashing lugs and boom lengths 33 m or 39 m:  $F = 50 \text{ t}$
- D-boom without lashing lugs and boom lengths 33 m or 39 m:  $F = 51 \text{ t}$

- ▶ Fasten the D-boom via the lashing lugs to the auxiliary crane (variation A).  
**or**  
Fasten the D-boom with slings over corner bars to the fork connections on the auxiliary crane (variation B).
- ▶ Unpin the D-boom: Unpin the pin on the SA-frame, see section "Disassembling the D-boom in sections."

When the D-boom is unpinned:

- ▶ Carefully drive the crane away from the D-boom.  
**or**  
Lift the D-boom with two auxiliary cranes.

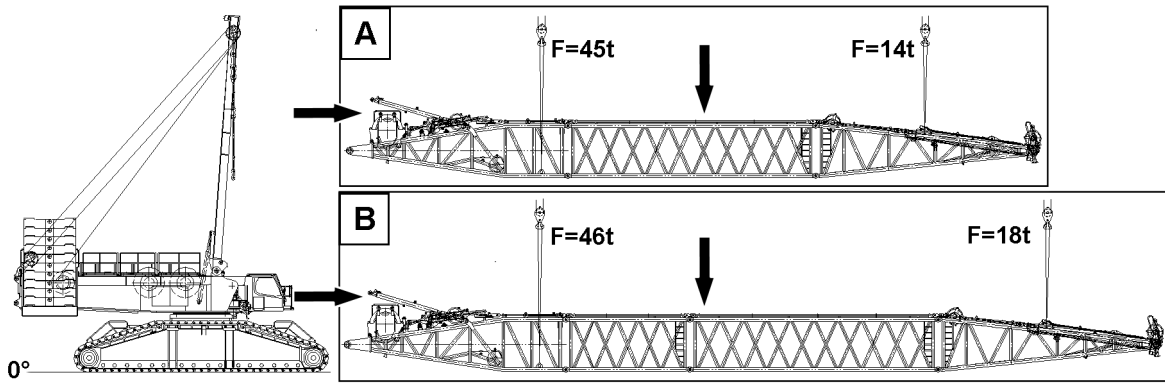


Fig. 159681: Lifting the D-boom with two auxiliary cranes (variation with lashing lugs)

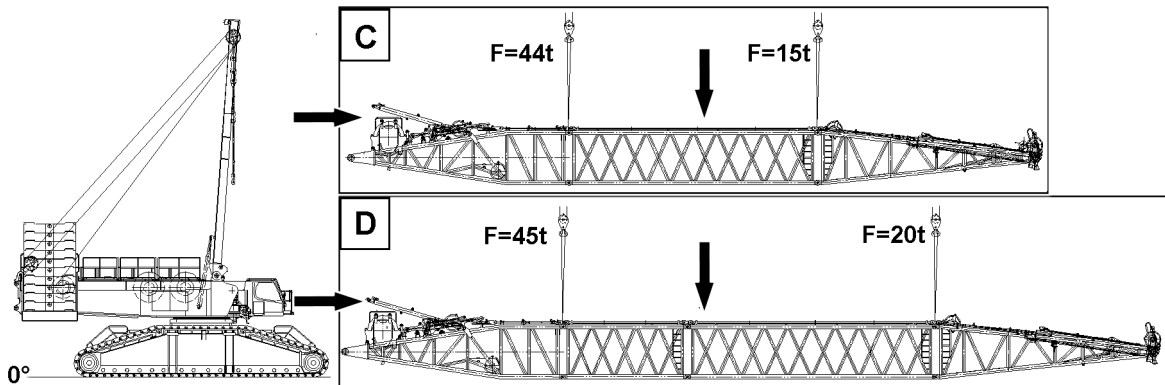


Fig. 159682: Lifting the D-boom with two auxiliary cranes (variation without lashing lugs)

The following suspended loads arise when lifting the D-boom with two auxiliary cranes:

- D-boom with lashing lugs and boom lengths 33 m:  $F = 45 \text{ t} + F = 14 \text{ t}$  (variation A)
- D-boom with lashing lugs and boom lengths 39 m:  $F = 46 \text{ t} + F = 18 \text{ t}$  (variation B)
- D-boom without lashing lugs and boom lengths 33 m:  $F = 44 \text{ t} + F = 15 \text{ t}$  (variation C)
- D-boom without lashing lugs and boom lengths 39 m:  $F = 45 \text{ t} + F = 20 \text{ t}$  (variation C)

- ▶ Fasten the D-boom to two auxiliary cranes.
- ▶ Unpin the D-boom: Unpin the pin on the SA-frame, see section “Disassembling the D-boom in sections.”

When the D-boom is unpinned:

- ▶ Swing the D-boom with two auxiliary cranes.

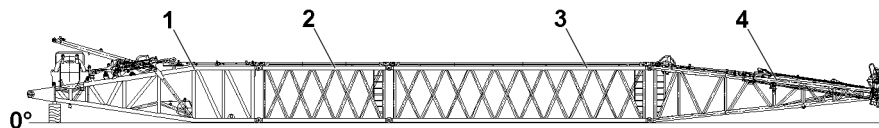


Fig. 160986: Taking the D-boom down on the ground

- ▶ Take the D-boom down on the ground with the auxiliary crane or auxiliary cranes.
- ▶ Disassemble the D-lattice sections, see section “Disassembling the D-boom in sections”.

## 9 Flying D-boom disassembly



### Note

- ▶ For the “flying” disassembly of the D-boom, the D-end section can be unpinned and removed with an auxiliary crane on the D-intermediate section and subsequently the D-intermediate section on the D-pivot section can be unpinned and removed.

**WARNING**

Danger of accident!

Death, severe bodily injuries, property damage.

- ▶ Do not exceed the maximum permissible total force on test point MS1 of 125 t.
- ▶ The “flying” disassembly of the D-boom is only described as an example, for the detailed disassembly process, see section “Disassembling the D-boom in sections”.

Make sure that the following prerequisites are met:

- The crane is horizontally aligned.
- The central ballast has been installed on the turntable according to the load chart, at least 10 t.
- The counterweight has been installed on the turntable according to the load chart, at least 130 t.
- The assembly conditions are adhered to, see chapter 3.06.
- The LICCON overload protection has been set according to the data in the load chart.
- The LICCON overload protection settings have been compared with the actual set up configuration.
- The hydraulic and electrical connections on the D-boom are disconnected.
- The D-relapse cylinders and pull cylinders are retracted.
- The hoist ropes are reeved out.

## 9.1 Assembling the flying assembly guying

- ▶ Pull the S-luffing pulley block **5** with the auxiliary crane to the D-pivot section **1** while spooling winch 3 up at the same time.
- ▶ Set down the S-luffing pulley block **5** in the transport receptacle on the D-pivot section **1** and secure, see section “Disassembling the D-boom in sections”.
- ▶ Lower the SA-frame to the front.

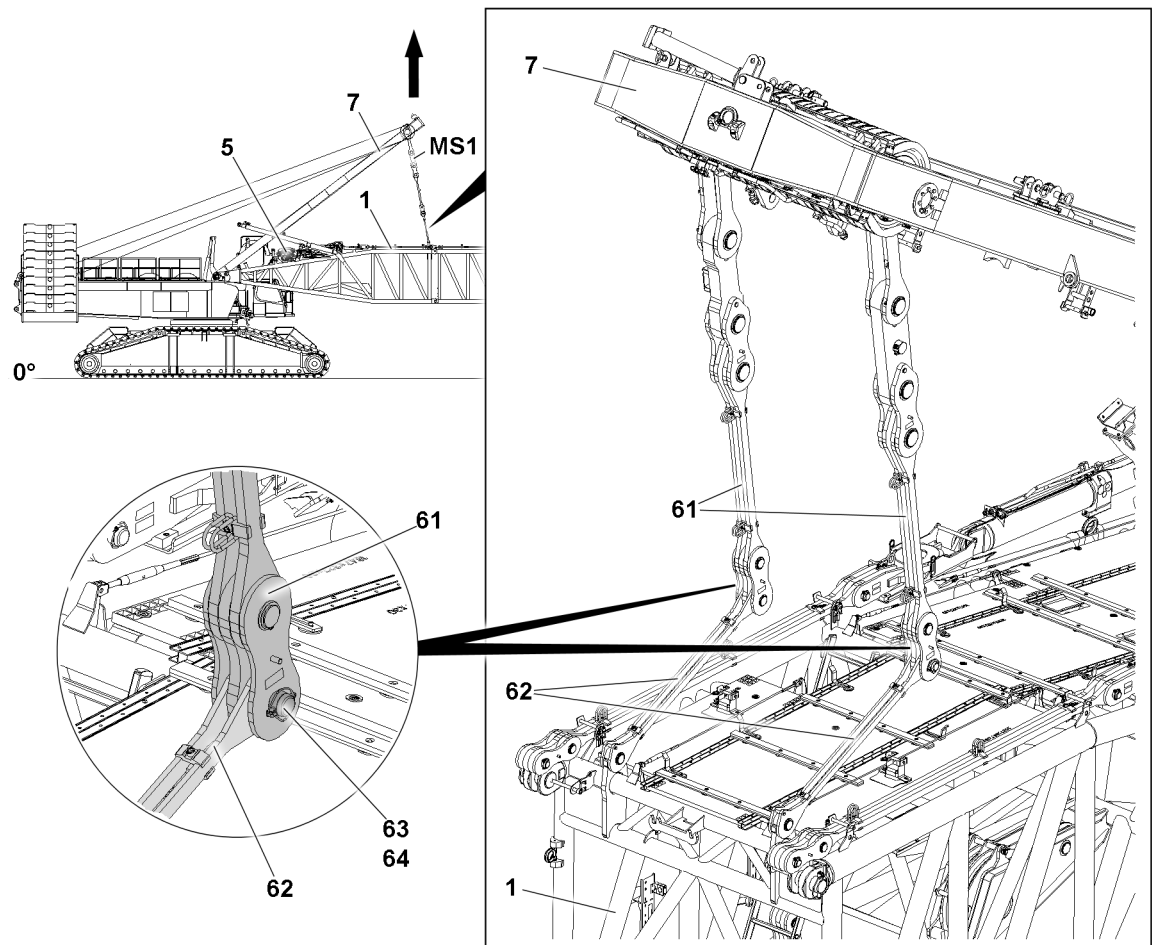


Fig.153433: Assembling the flying assembly guying

- ▶ Release the flying assembly guy rods **62** from the transport retainers.
- ▶ Lift the flying assembly guy rods **62** and align them with the guy rods **61** of the SA-frame **7**.

When the pin bores align:

- ▶ Insert the pin **63** and secure it with the retaining element **64**.



### WARNING

Danger of accident!

Death, severe bodily injuries, property damage.

- ▶ Make sure that the total force in test point **1 MS1** does not exceed 125 t.
- ▶ It is prohibited for anyone to be under the D-boom.
- ▶ Make sure that the D-boom is safely held by the guying.

When the guying for the flying assembly between the SA-frame **7** and the D-pivot section **1** is properly assembled and secured:

- ▶ Lift the SA-frame **7** until the D-boom hangs horizontally on the SA-frame **7**.

## 9.2 Disassembling the D-end section on the D-intermediate section

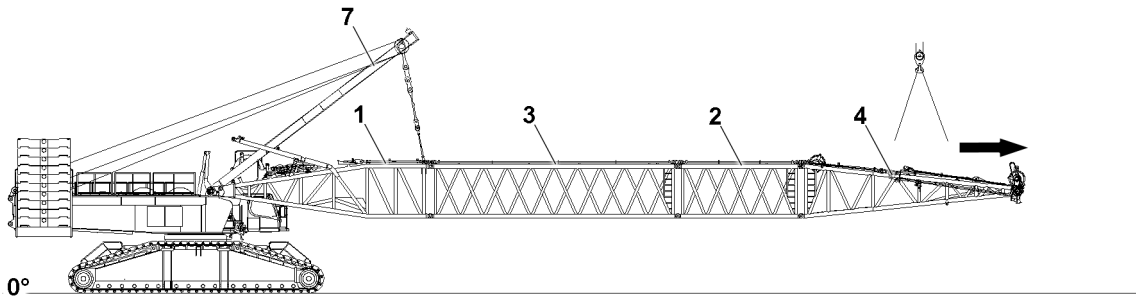


Fig.153434: Disassembling the D-end section on the D-intermediate section

- ▶ Fasten the D-end section **4** to the auxiliary crane.
- ▶ Unpin the D-end section **4** on the D-intermediate section **2** on both sides at the top and bottom and remove, see section “Disassembling the D-boom in sections”.

## 9.3 Disassembling the D-intermediate section on the D-intermediate section

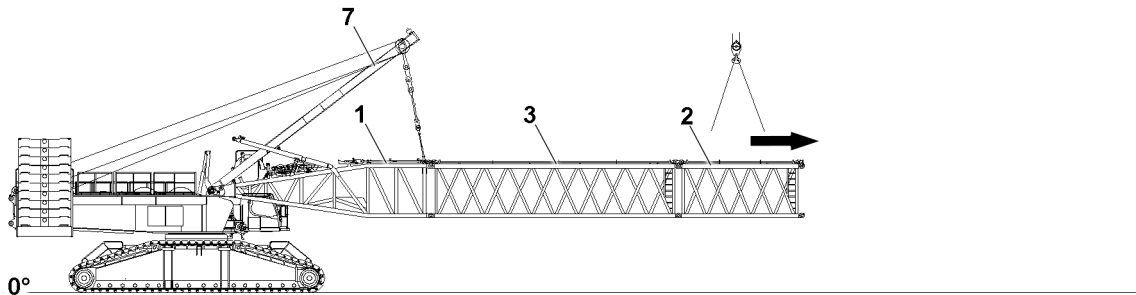


Fig.153435: Disassembling the D-intermediate section on the D-intermediate section

- ▶ Fasten the D-intermediate section **2** to the auxiliary crane.

- ▶ Unpin the D-intermediate section 2 on the D-intermediate section 3 on both sides at the top and bottom and remove, see section “Disassembling the D-boom in sections”.

## 9.4 Disassembling the D-intermediate section on the D-pivot section

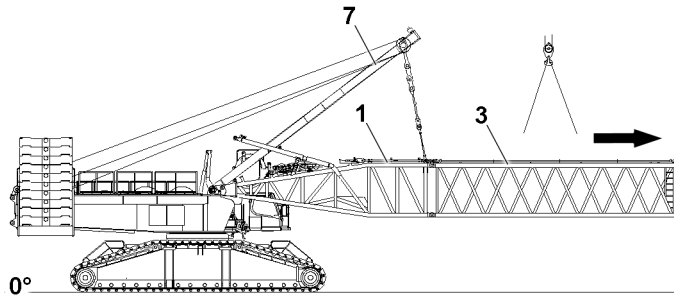


Fig.153436: Disassembling the D-intermediate section on the D-pivot section

- ▶ Fasten the D-intermediate section 3 to the auxiliary crane.
- ▶ Unpin the D-intermediate section 3 on the D-pivot section 1 on both sides at the top and bottom and remove, see section “Disassembling the D-boom in sections”.

## 9.5 Disassembling the D-pivot section on the SA-frame

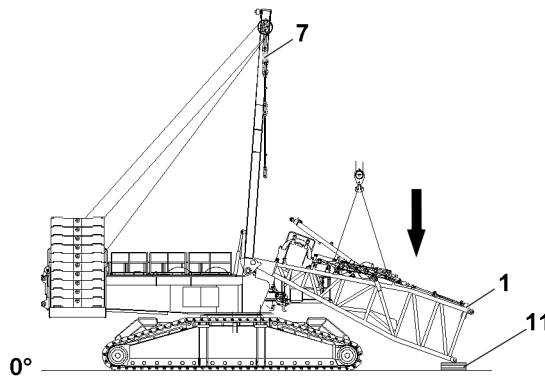


Fig.153378: Disassembling the D-pivot section on the SA-frame

- ▶ Take the D-pivot section 1 down onto the substructure 11 with a minimum height of 350 mm.
- ▶ Luff the SA-frame 7 down until the D-guying to the D-pivot section 1 is relieved.
- ▶ Unpin the flying assembly guying.
- ▶ Luff the SA-frame 7 up to approx. 85°.
- ▶ Fasten the D-pivot section 1 to the auxiliary crane.
- ▶ Lift the D-pivot section 1 with the auxiliary crane to the horizontal.
- ▶ Unpin the D-pivot section 1 on the SA-frame 7 and remove, see section “Disassembling the D-boom in sections”.

---

Empty page!

LWE/LR 1800-1-0-000/27200-07-02/en

## 5.07 Luffing jib - W-system

1	Safety	2
2	Component overview	4
3	Fastening points	4
4	Assembling	11
5	Information about erecting / taking down the boom system with the luffing jib	54
6	Erecting the boom system with luffing jib	60
7	Crane operation	68
8	Taking the boom system down with the luffing jib	69
9	Disassembling	79

# 1 Safety

Observe the safety instructions before assembly and disassembly:

- Information regarding personal protective equipment. See chapter 2.04.
- Information regarding fall protection equipment. See chapter 2.06.
- Information regarding accesses to the crane. See chapter 2.07.
- Information regarding accessible surfaces. See chapter 2.07.



## WARNING

Danger of falling!

During assembly / disassembly, inspection and maintenance work, assembly personnel must be secured with appropriate aids to prevent them from falling.

Death, severe bodily injuries, property damage.

- ▶ All work at a height, when there is a danger of falling, must be carried out with suitable aids.
- ▶ If aids are not available and work cannot be carried out from the ground, then assembly personnel must secure themselves with the supplied fall arrest system to prevent falling, see the Crane operating instructions, chapter 2.04.
- ▶ If fall protection equipment is available, then it must be used, see the Crane operating instructions, chapter 2.06.
- ▶ When lifting, lowering, swinging crane parts in and out, no persons may remain in the danger zone.
- ▶ If railings are present on the components, then they must be brought into the corresponding position and secured for assembly / disassembly work.
- ▶ Only step on the aids, ladders and catwalks with clean shoes.
- ▶ Keep aids, ladders and catwalks free of heavy dirt, snow and ice.
- ▶ During all assembly and disassembly work, maintenance work and inspections, travel or crane operation is prohibited.
- ▶ Remaining on a suspended load is prohibited.
- ▶ Stepping or walking on crane components and lattice sections with an incline of more than 20° is prohibited.
- ▶ For all assembly work, the crane operator of the main crane must be in voice contact with the crane operator / crane operators of the auxiliary crane / auxiliary cranes.
- ▶ For the assembly / disassembly tasks, the crane operator may only initiate crane movements when the responsible guide has explicitly released the movement.



## WARNING

Danger of impact / crushing!

When assembling / disassembling crane components with the auxiliary crane, crane components can start to swing back and forth.

When lifting / lowering and positioning crane components, there is an increased danger of impact / crushing.

Death, severe bodily injuries, property damage.

- ▶ Make sure that personnel cannot be caught by components.
- ▶ When working in a danger zone: Use aids to protect limbs.
- ▶ Guide components with suitable aids to minimize oscillation.



## DANGER

The component can fall down!

If the corresponding component is disengaged from the auxiliary crane before the corresponding component is pinned, then the corresponding component can fall down.

Death, severe bodily injuries, property damage.

- ▶ Do not disconnect the auxiliary crane until the respective component is pinned and secured.



**WARNING**

Danger of falling!

During assembly and disassembly of crane components, personnel must be secured with appropriate aids to prevent them from falling.

Death, severe bodily injuries, property damage.

- ▶ Use personal protective equipment.

**WARNING**

Falling of the boom lattice sections!

If the boom lattice sections are not pinned and secured correctly, then they can fall down.

Death, severe bodily injuries, property damage.

- ▶ Insert or unpin both pins on the same horizontal level, i.e. **left and right**.
- ▶ Standing under the boom lattice sections or within the entire danger zone during the main boom pinning and unpinning procedure is prohibited.
- ▶ Safely secure the pins in the storage locations as well as in the receptacles.
- ▶ It is prohibited to lean the ladder against the component to be disassembled.

**WARNING**

Danger of accident due to unintended actuation of the master switch!

During assembly and disassembly of the boom system with the radio remote control, the unintended actuation of the master switch, (the "turning" function in particular), can lead to the uncontrolled movement of the boom system and therefore dangerous situations for personnel.

Death, severe bodily injuries, property damage.

- ▶ During assembly and disassembly of the boom system with the radio remote control: Observe and adhere to the specifications in chapter 5.31 and chapter 6.08.

**WARNING**

The crane can topple over!

If the specifications listed below are **not** observed, the crane can collapse, the boom can break off or the crane can topple over.

Death, severe bodily injuries, property damage.

- ▶ Observe and adhere to the specifications in chapter 5.01 and chapter 5.03.
- ▶ Secure all pins after assembly with the intended retaining elements.
- ▶ Assemble and secure the guy rods, see the Rod plan. Make sure that the numbering in the rod plan is identical to the numbering on the guy rods.

**WARNING**

Danger of accident!

If no guide is present during assembly work who has voice connection to the crane operator as well as to the drivers of the auxiliary units, then there is a great danger of accident.

Crane movements that are carried out without the approval of the guide can cause accidents.

Death, severe bodily injuries, property damage.

- ▶ For all assembly work, observe the instructions of the guide.
- ▶ Make sure that the danger zone can be seen completely by the crane operator and / or the guide.

**WARNING**

Neglectful inspection and maintenance of guy rods!

Death, severe bodily injuries, property damage.

- ▶ Inspect the guy rods before every assembly, see chapter 8.15.
- ▶ Adhere to the inspection intervals and maintenance intervals.

**WARNING**

Unutilized guy rods on boom!

If guy rods are on the lattice sections which are not required for crane operation, then there is a danger of accident.

Death, severe bodily injuries, property damage.

- ▶ Remove guy rods that are **not** required from the lattice sections, see chapter 5.01.

## 2 Component overview

**Note**

- ▶ Boom components (boom-lattice sections) such as W-assembly unit, L-end section as well as dimensions and weights, see chapter 1.03.
- ▶ Combination of the various boom systems, see the Rod plan and chapter 5.03.

## 3 Fastening points

**WARNING**

Fastening equipment can be ripped off!

Death, severe bodily injuries, property damage.

- ▶ Make sure that the fastening equipment has a sufficient load carrying capacity and the required minimum length.
- ▶ Make sure that the auxiliary crane(s) have a sufficient load carrying capacity.
- ▶ Pay attention and adhere to the labels on the fastening points on the boom lattice sections and crane components.
- ▶ Make sure that there are no persons in the danger zone.

**WARNING**

Components incorrectly fastened!

Death, severe bodily injuries, property damage.

- ▶ Fasten the components only in the intended fastening points on both sides.

**WARNING**

Overload of fastening points!

If the fastening points are overloaded, they can rip off and the component can fall down.

Death, severe bodily injuries, property damage.

- ▶ Make sure that the fastening points are not overloaded.
- ▶ Observe the maximum permissible suspended loads.

**Note**

- ▶ The H, S and L-intermediate sections are available in various system dimensions.
- ▶ The distance between the fastening points can vary, depending on the respective H, S or L-intermediate section.
- ▶ The boom lattice section must be fastened on both sides to the fastening points.

### 3.1 WA-frame 1 pivot section and WA-frame 2 pivot section unit fastening points

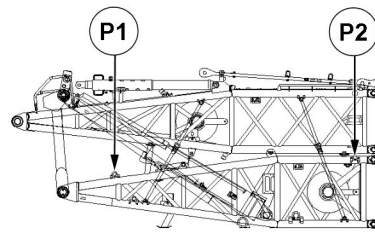


Fig.155783: WA-frame 1 pivot section and WA-frame 2 pivot section unit fastening points

Fastening points	
P1 + P2	WA-frame 1 pivot section and WA-frame 2 pivot section unit

### 3.2 WA-frame 1 intermediate section 4 m and WA-frame 2 intermediate section 4 m unit fastening points

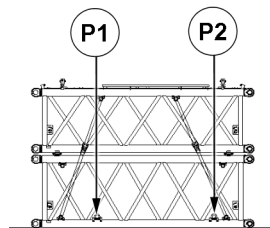


Fig.155784: WA-frame 1 intermediate section 4 m and WA-frame 2 intermediate section 4 m unit fastening points

Fastening points	
P1 + P2	WA-frame 1 intermediate section 4 m and WA-frame 2 intermediate section 4 m unit

### 3.3 WA-frame 1 end section and WA-frame 2 end section unit fastening points

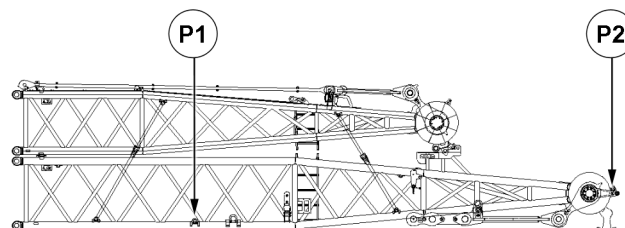


Fig.155785: WA-frame 1 end section and WA-frame 2 end section unit fastening points

LWE/LR 1800-1-0-000/27200-07-02/en

Fastening points	
P1 + P2	WA-frame 1 end section and WA-frame 2 end section unit

### 3.4 WA-frame 1 pivot section with WA-frame 1 intermediate section 4 m and WA-frame 2 pivot section with WA-frame 2 intermediate section 4 m unit fastening points

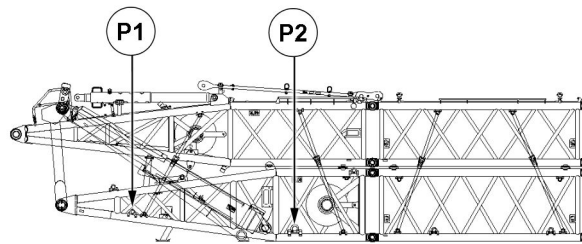


Fig.155786: WA-frame 1 pivot section with WA-frame 1 intermediate section 4 m and WA-frame 2 pivot section with WA-frame 2 intermediate section 4 m unit fastening points

Fastening points	
P1 + P2	WA-frame 1 pivot section with WA-frame 1 intermediate section 4 m and WA-frame 2 pivot section with WA-frame 2 intermediate section 4 m unit

### 3.5 WA-frame 1 pivot section with WA-frame 1 end section and WA-frame 2 pivot section with WA-frame 2 end section unit fastening points

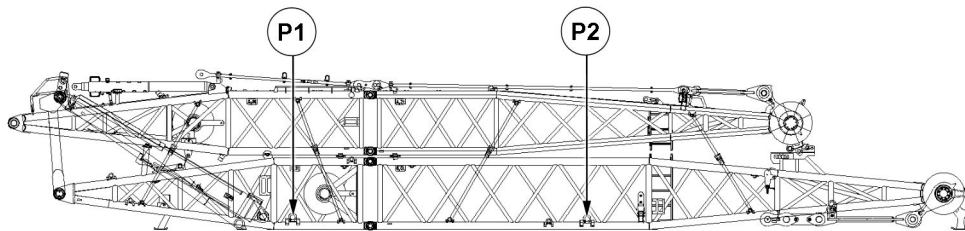


Fig.155787: WA-frame 1 pivot section with WA-frame 1 end section and WA-frame 2 pivot section with WA-frame 2 end section unit fastening points

Fastening points	
P1 + P2	WA-frame 1 pivot section with WA-frame 1 end section and WA-frame 2 pivot section with WA-frame 2 end section unit

### 3.6 WA-frame 1 pivot section with WA-frame 1 intermediate section 4 m WA-frame 1 end section and WA-frame 2 pivot section with WA-frame 2 intermediate section 4 m , WA-frame 2 end section unit fastening points

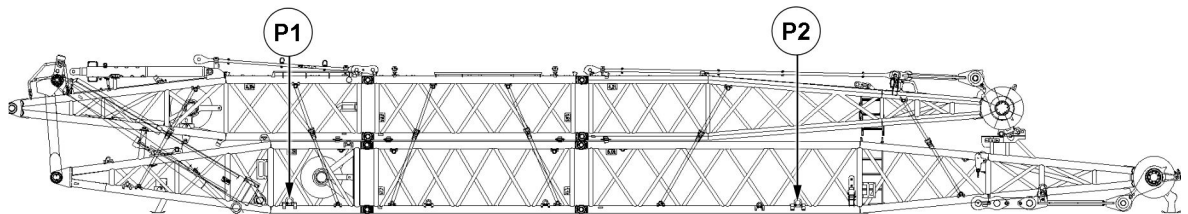


Fig.155781: WA-frame 1 pivot section with WA-frame 1 intermediate section 4 m WA-frame 1 end section and WA-frame 2 pivot section with WA-frame 2 intermediate section 4 m , WA-frame 2 end section unit fastening points

Fastening points	
P1 + P2	WA-frame 1 pivot section with WA-frame 1 intermediate section 4 m WA-frame 1 end section and WA-frame 2 pivot section with WA-frame 2 intermediate section 4 m WA-frame 2 end section unit

### 3.7 W-pivot section 8 m fastening points

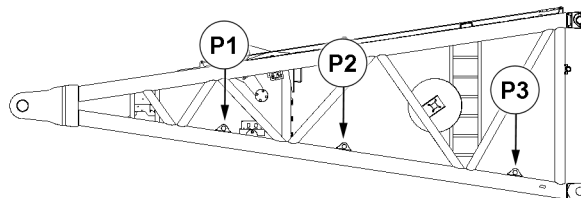


Fig.155782: W-pivot section 8 m fastening points

Fastening points	
P1 + P2	W-pivot section 8 m
P2 + P3	W-pivot section 8 m and SL-reducer 6 m <sup>1)</sup>
P3	W-pivot section 8 m and S-intermediate section 12 m <sup>1)</sup>

<sup>1)</sup> see the sign on the W-pivot section

LWE/LR 1800-1-0-000/27200-07-02/en

### 3.8 S-intermediate section 6 m fastening points

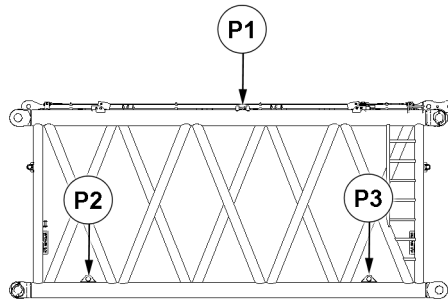


Fig.154347: S-intermediate section 6 m fastening points

Fastening points	
P1 or P2 + P3	S-intermediate section 6 m

### 3.9 S-intermediate section 12 m fastening points

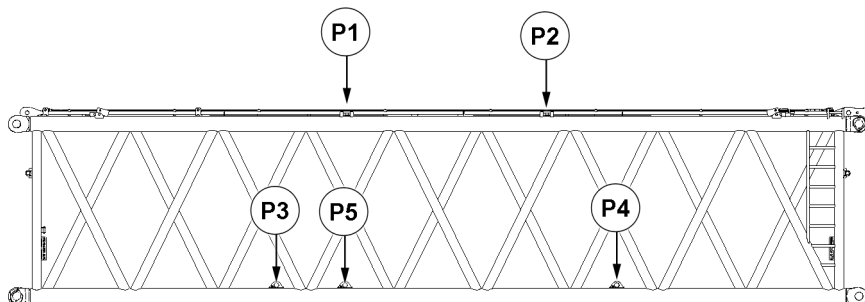


Fig.154346: S-intermediate section 12 m fastening points

Fastening points	
P1 + P2 or P3 + P4	S-intermediate section 12 m
P5	W-pivot section 8 m and S-intermediate section 12 m <sup>1)</sup>

1) see the sign on the W-pivot section

### 3.10 SL-reducer 6 m fastening points

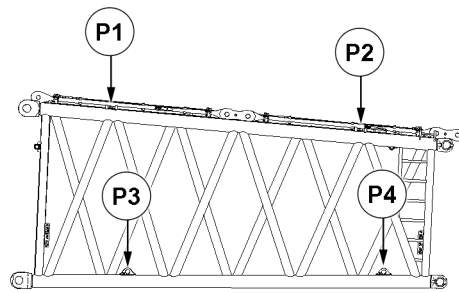


Fig.154348: SL-reducer 6 m fastening points

Fastening points	
P1 + P2 or P3 + P4	SL-reducer 6 m

### 3.11 L-intermediate section 6 m fastening points

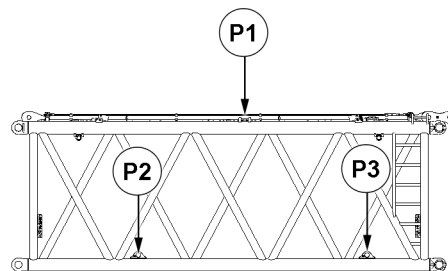


Fig.154350: L-intermediate section 6 m fastening points

Fastening points	
P1 or P2 + P3	L-intermediate section 6 m

LWE/LR 1800-1-0-000/27200-07-02/en

### 3.12 L-intermediate section 12 m fastening points

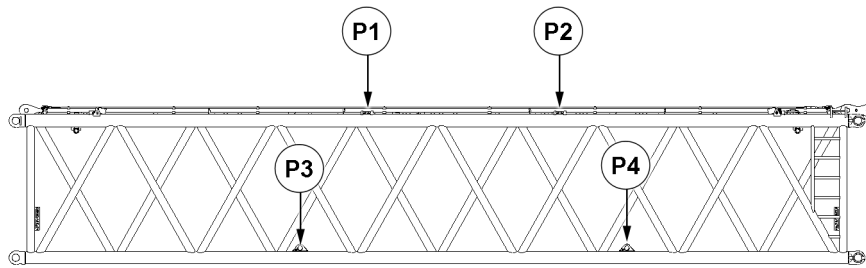


Fig.154349: L-intermediate section 12 m fastening points

Fastening points	
P1 + P2 or P3 + P4	L-intermediate section 12 m

### 3.13 L-end section fastening points

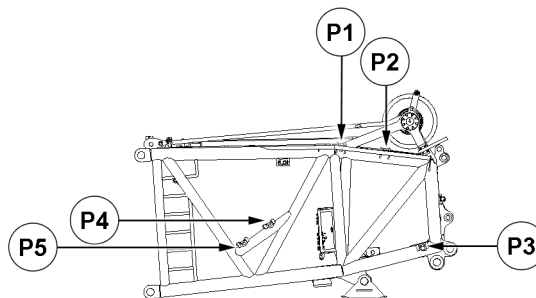


Fig.154351: L-end section fastening points

Fastening points	
P1	L-end section without roller set (fastening equipment > 4.5 m)
P2	L-end section with roller set (fastening equipment > 4.5 m)
P5 + P3	L-end section without roller set (fastening equipment > 6 m)
P4 + P3	L-end section with roller set (fastening equipment > 6 m)



### 3.14 S-end section fastening points

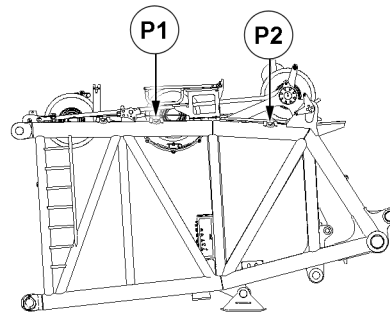


Fig.154352: S-end section fastening points

Fastening points	
P1 + P2	S-end section

## 4 Assembling

Make sure that the following prerequisites are met:

- The crane is placed on ground with a sufficient load bearing capacity.
- The crane is horizontally aligned.
- The main boom is completely assembled and aligned horizontally.
- The central ballast has been installed on the crawler travel gear according to the load chart or the erection and take-down charts.
- The counterweight has been installed on the turntable and taken down on the suspended ballast / ballast trailer according to the load chart or the erection and take-down charts.
- The LICCON overload protection has been set according to the data in the load charts and / or the erection and take-down charts.
- The LICCON overload protection settings have been checked for completeness and correctness.
- All electrical connections on the main boom are established.
- All limit switches have been checked for their mechanical function.
- An auxiliary crane with sufficient load bearing capacity is available.
- An assembly scaffolding or a work platform is available.
- All catwalks and standing space accessed during assembly must be free of snow, ice and heavy dirt.

## 4.1 Assembling the wind sensor

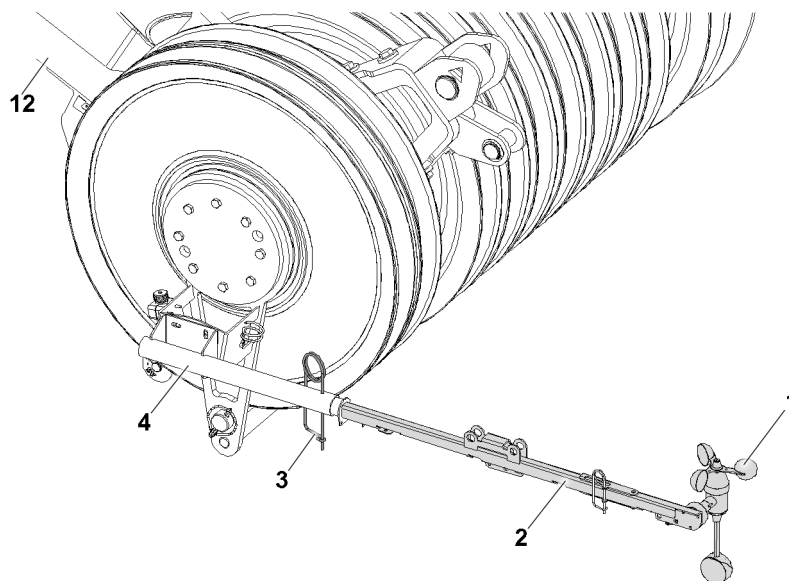


Fig.155788: Wind sensor, WA-frame 2

The wind sensor 1 is assembled on the end section 12 of WA-frame 2.

- ▶ Insert the retainer 2 in the pipe 4.
- ▶ Secure the retainer 2 with the retaining element 3.

## 4.2 Placing NA-frame 2 on assembly supports

### NOTICE

Rigging belts **not** removed!

Rigging belts pulling off. Property damage.

- ▶ Remove the rigging belts before continuing with assembly.

Make sure that the following prerequisites are met:

- The assembly unit is assembled, WA-frame 1 and WA-frame 2 are assembled to the necessary lengths.
- All rigging belts from WA-frame 1 to WA-frame 2 are removed.

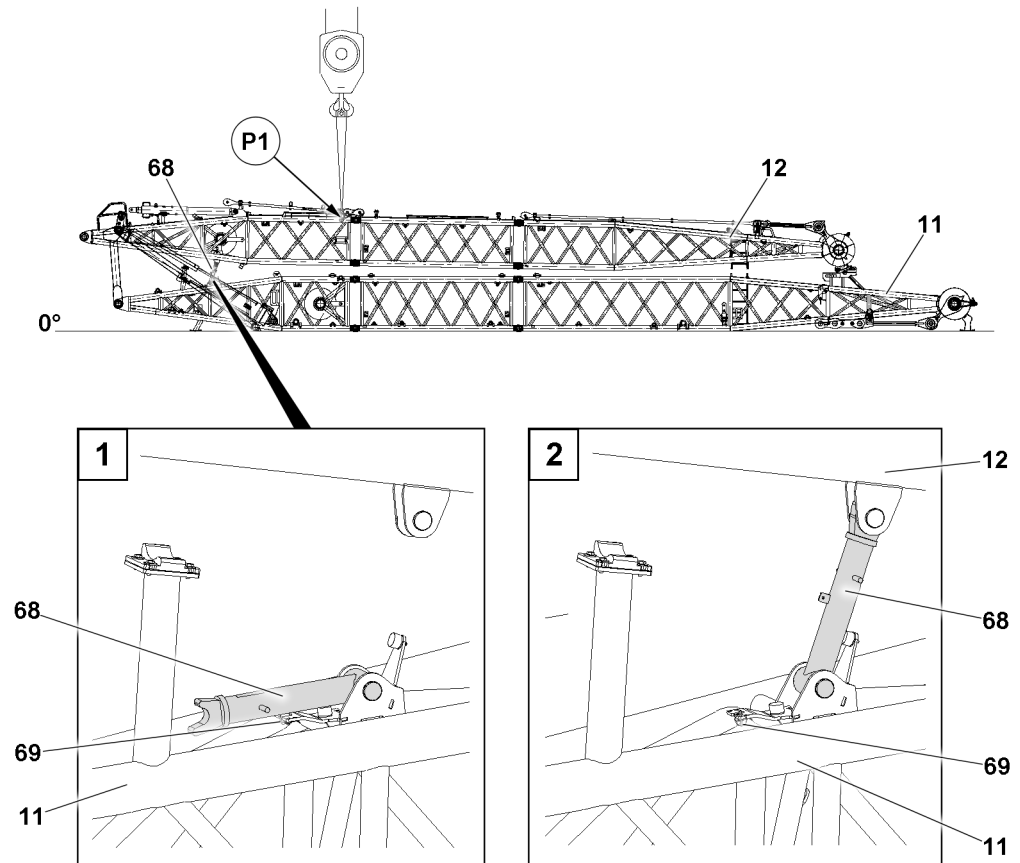


Fig.166591: Placing NA-frame 2 on assembly supports

- ▶ Fasten WA-frame 2 **12** to the auxiliary crane in point **P1**.
- ▶ Lift WA-frame 2 **12** off of WA-frame 1 **11** until the assembly supports **68** are free.
- ▶ Release the assembly supports **68**: Remove the retaining elements **69**.
- ▶ Fold the assembly supports **68** up.
- ▶ Release WA-frame 2 **12** from the assembly supports **68** and from the auxiliary crane.

### 4.3 Pinning WA-frame 1 on the S-end section

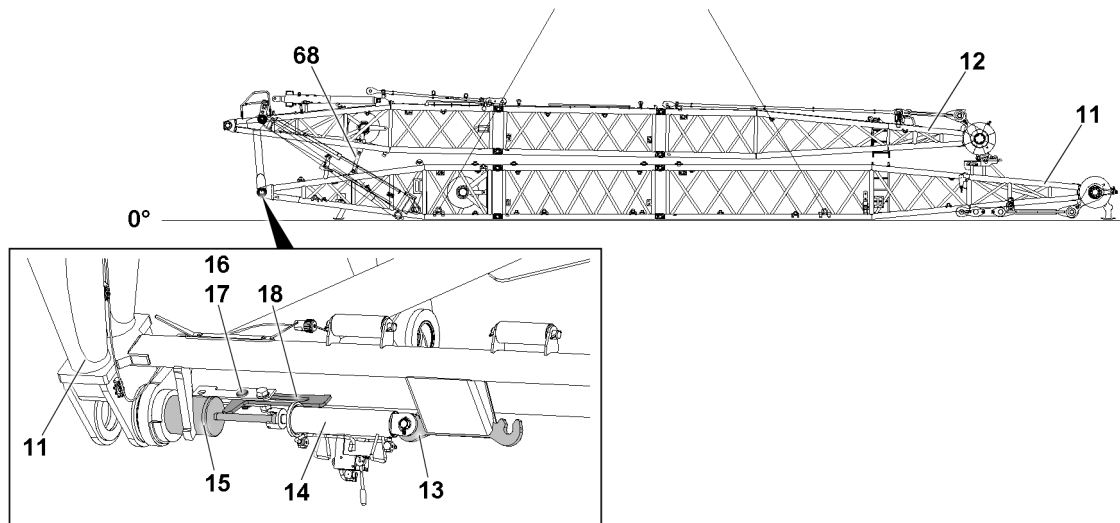


Fig.166583: WA-frame 1, connector pin

Make sure that the following prerequisites are met:

- WA-frame 2 **12** is placed on assembly supports **68**.
- An auxiliary crane is available.
- The assembly unit is correctly fastened to the auxiliary crane, see section "Fastening points".
- The pin pulling cylinder is connected to the hydraulic system.



#### Note

- For information concerning working with the pin pulling device, see chapter 5.30.

Unpin the connector pin **15** on WA-frame 1.

- Release the connector pin **15**: Remove the retaining element **17** and unpin the pin **16**.
- Slide the retaining plate **18** into the assembly position.
- Secure the retaining plate **18**: Insert the pin **16**.
- Secure the pin **16**: Attach the retaining element **17**.
- Unpin the connector pin **15**: Insert the pin pulling cylinder **14** in the pin pulling device **13** and fit it on the screw of the connector pin **15**.
- Unpin the connector pin **15** completely on both sides.

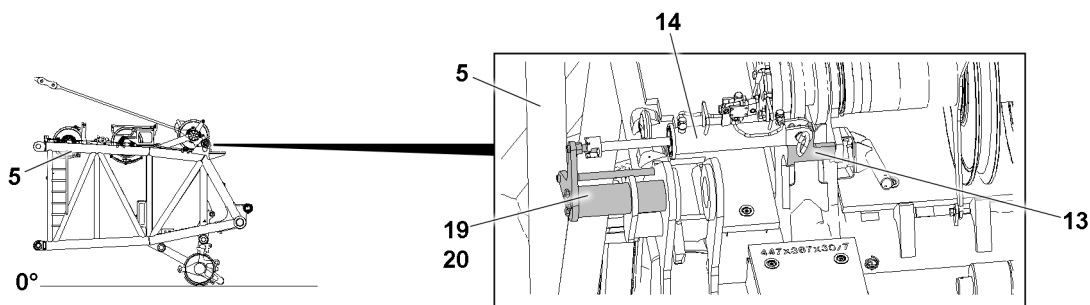


Fig.155793: S-end section, connector pin

Unpin the connector pin **19** on the S-end section.

- Release the connector pin **19**: Remove the retaining element **20**.
- Unpin the connector pin **19**: Insert the pin pulling cylinder **14** in the pin pulling device **13** and fit it on the screw of the connector pin **19**.
- Unpin the connector pin **19** completely on both sides.

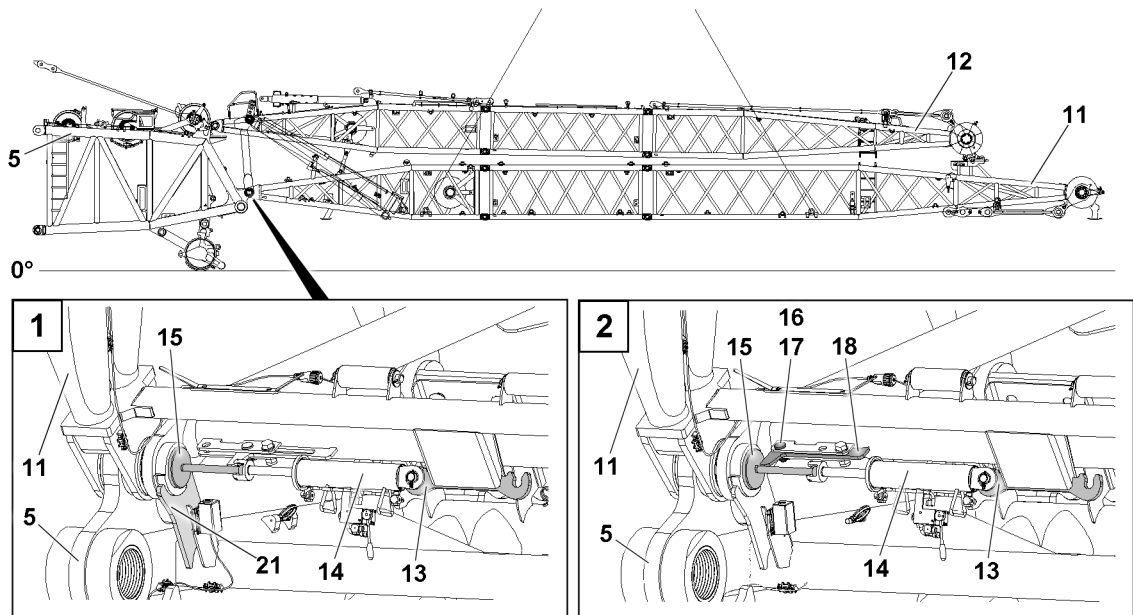


Fig.155791: WA-frame 1, pinning procedure



#### Note

- ▶ The pinning procedure is described based on the example of one pin position.



#### WARNING

Persons in the danger zone while lifting the load or during the pinning procedure!  
Danger of crushing.

Death, severe bodily injuries, property damage.

- ▶ Make sure, when swinging the W-assembly unit into the pin points, that no persons are in the danger zone.
- ▶ Swinging the load is prohibited.
- ▶ Make sure that no personnel is within the danger zone when operating the pin pulling device.
- ▶ Operate the pin pulling device with utmost caution on the pin pulling aggregate.

- ▶ Fasten the W-assembly unit to the auxiliary crane, see section "Fastening points".
- ▶ Swing the W-assembly unit in with the auxiliary crane to the pin points.
- ▶ Insert the W-assembly unit or the WA-frame 1 11 in the centerings 21 on the S-end section 5.

Prerequisite for the pin position: The pin pulling cylinder 14 is inserted in the pin pulling device 13 and fixed on the screw of the connector pin 15.

- ▶ Pin WA-frame 1 11 on the S-end section 5: Insert the connector pin 15 with the pin pulling cylinder 14.
- ▶ Remove the retaining element 17 and unpin the pin 16.
- ▶ Slide the retaining plate 18 into the operating position.
- ▶ Secure the retaining plate 18: Insert the pin 16.
- ▶ Secure the pin 16: Attach the retaining element 17.

#### Result:

- The connector pin 15 is secured by the retaining plate 18.
- ▶ Repeat the pinning procedure in the second pin position.
- ▶ Take the W-assembly unit down on the ground with the auxiliary crane.
- ▶ Remove the fastening equipment.

## 4.4 Separating the WA-frames

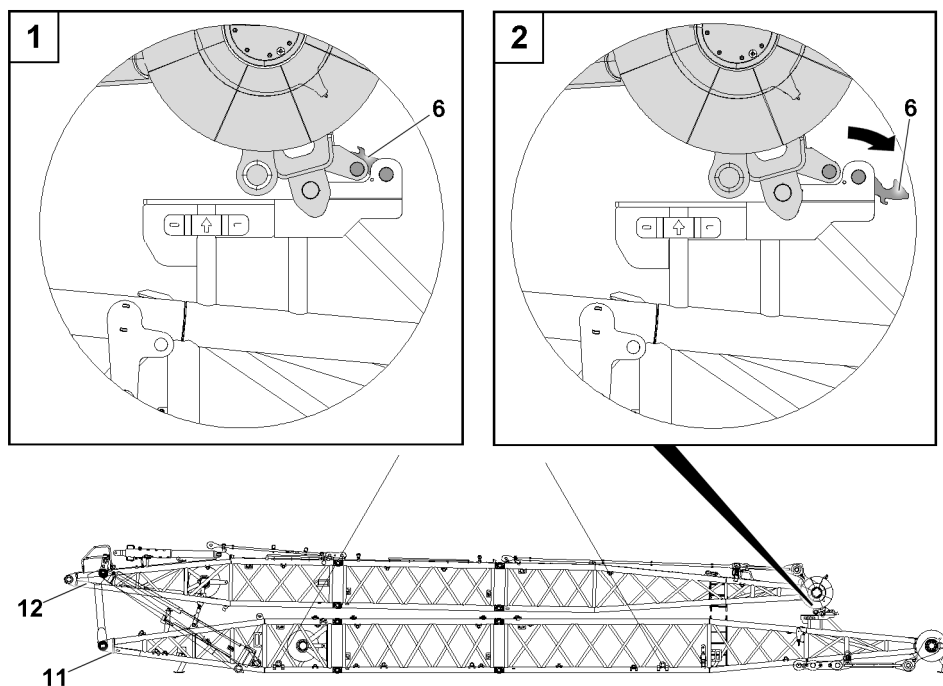


Fig.155789: W-assembly unit, WA-frames transport retainer

### NOTICE

The plate **6** is in the wrong position!  
Damage to crane components.

- ▶ Make sure that both plates **6** are folded down before assembling W-frame **2 12**.
- ▶ Fold the plate **6** down on both sides of the W-assembly unit.

## 4.5 Pinning WA-frame 2 on the S-end section

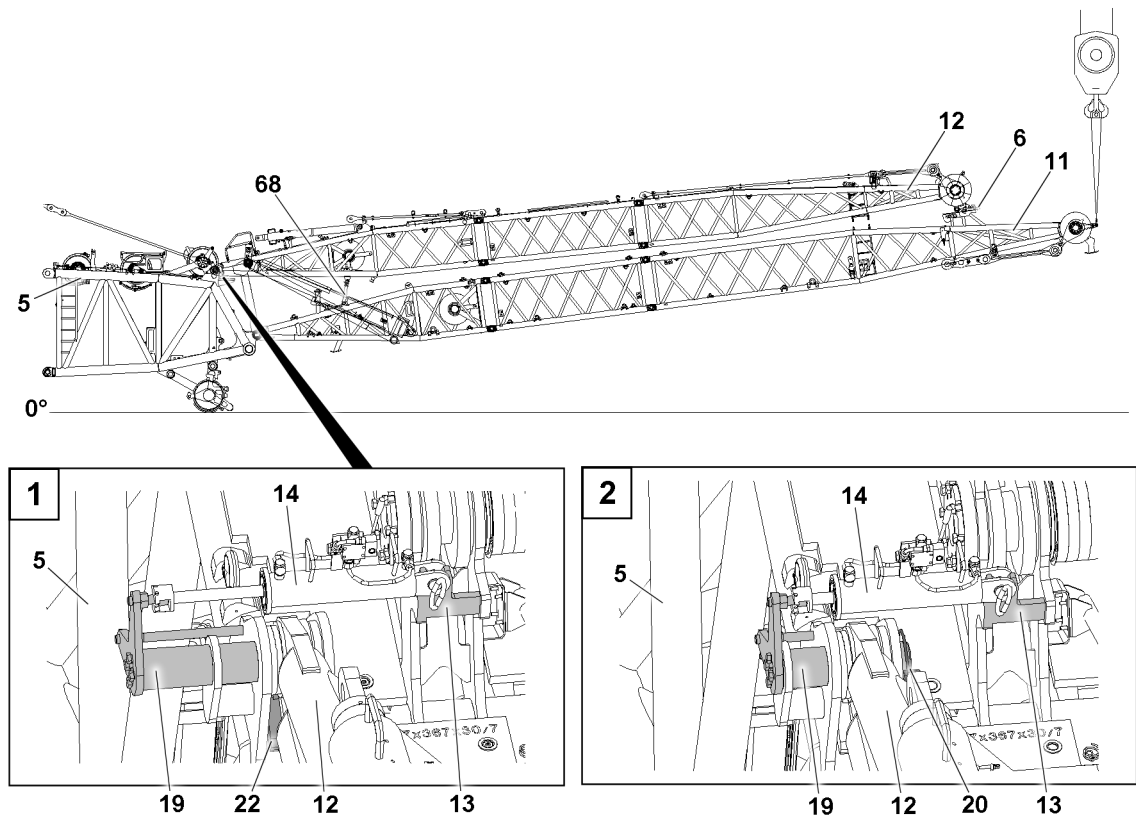


Fig.166584: WA-frame 2, pin position on the S-end section

Make sure that the following prerequisites are met:

- The rigging belts are removed.
- The WA-frames are separated, both plates **6** are folded down.
- WA-frame 2 **12** is on the assembly supports **68**.



### Note

- ▶ The pinning procedure is described based on the example of one position.

- ▶ Fasten the W-assembly unit to the auxiliary crane, see illustration.
- ▶ Lift the W-assembly unit.
- ▶ Insert the W-assembly unit or the WA-frame 2 **12** in the centerings **22** on the S-end section **5**.

Prerequisite for the pin position: The pin pulling cylinder **14** is inserted in the pin pulling device **13** and fixed on the screw of the connector pin **19**.

- ▶ Pin WA-frame 2 **12** on the S-end section **5**: Insert the connector pin **19** with the pin pulling cylinder **14**.
- ▶ Secure the connector pin **19**: Attach the retaining element **20**.
- ▶ Repeat the pinning procedure in the second pin position.

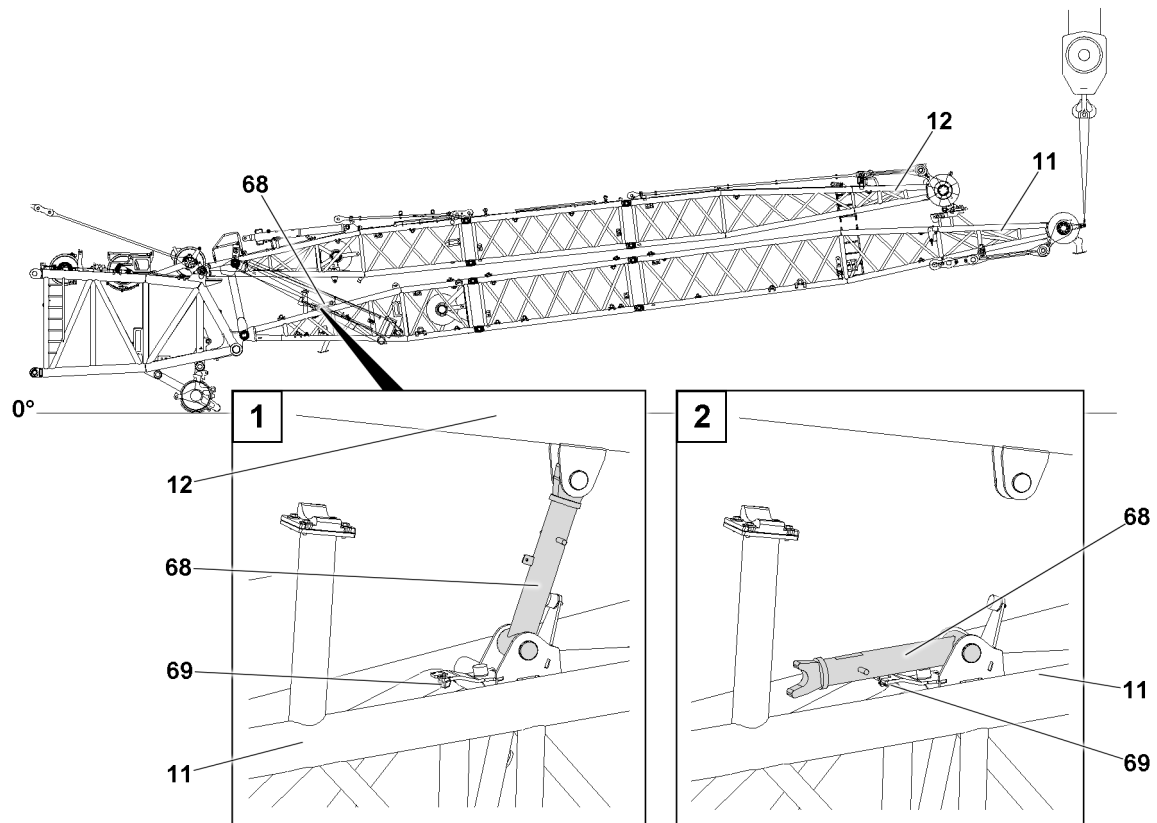


Fig.166585: Swinging the assembly supports into the park position

WA-frame 1 11 and WA-frame 2 12 are so far away from each other that the assembly supports 68 are free.

- ▶ Swing the assembly supports 68 into the park position.
- ▶ Secure the assembly supports 68: Attach the retaining elements 69.

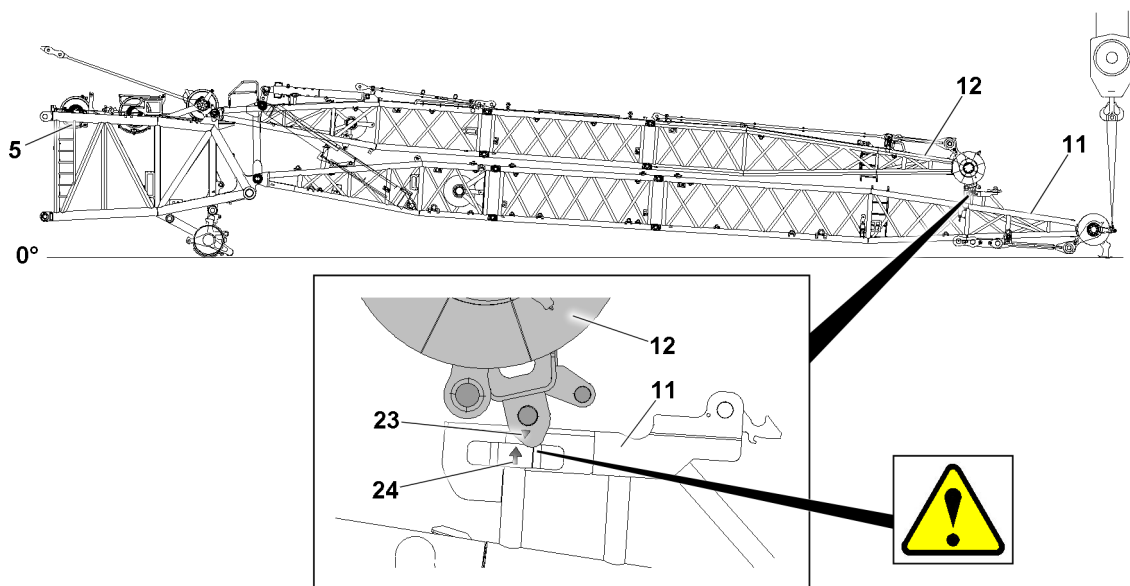


Fig.155794: Marking on WA-frame 1



**WARNING**

Collision between WA-frame 2 and the relapse cylinder!

If when taking down the W-assembly unit, the triangle **23** from WA-frame 2 **12** crosses the arrow **24** on WA-frame 1 **11**, this can lead to a collision between WA-frame 2 and the relapse cylinder.

This can result in significant property damage.

- ▶ Make sure when taking down the W-assembly unit, that the triangle **23** from WA-frame 2 **12** does not cross the arrow **24** on WA-frame 1 **11**.
  - ▶ Support the W-assembly unit.
- 
- ▶ Take the W-assembly unit down on the ground with the auxiliary crane.
  - ▶ Remove the fastening equipment.

## 4.6 Lowering the relapse support

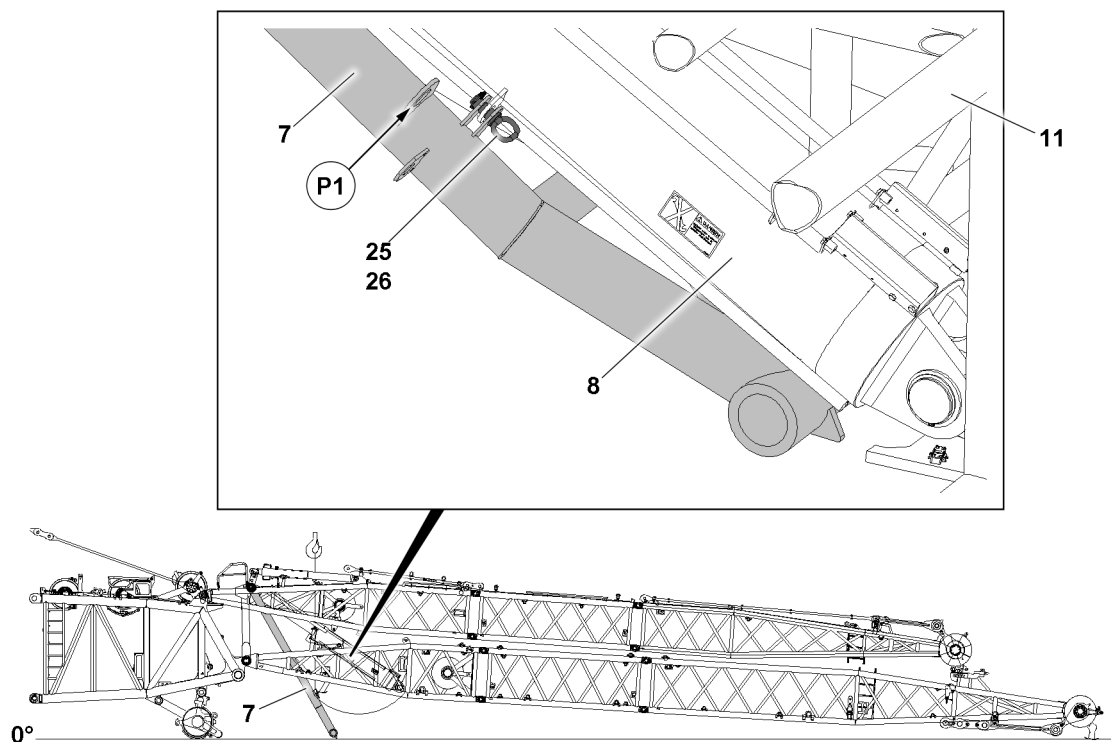


Fig.155795: Relapse support

- ▶ Fasten the relapse support **7** to the auxiliary crane in point **P1**.
- ▶ Release the relapse support **7**: Remove the retaining element **26** and unpin the socket pin **25**.
- ▶ Carefully lower the relapse support **7** to the ground with the auxiliary crane.
- ▶ Insert the socket pin **25** again in the relapse support **7** and secure with the retaining element **26**.

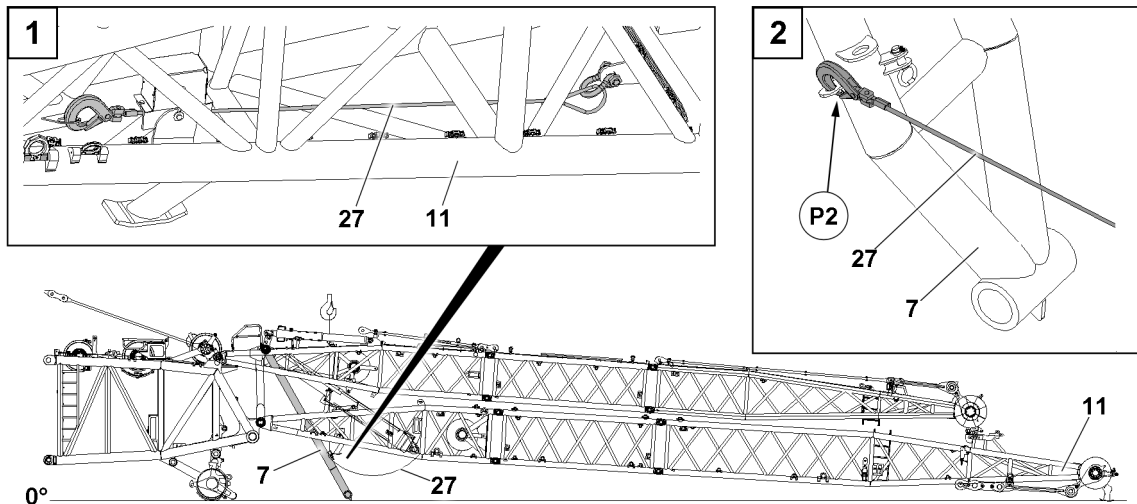


Fig.155796: Rope

- ▶ Release the rope 27 on WA-frame 1 11 from the park position: Open the hook.
- ▶ Attach the rope 27 in point P2 to the relapse support 7.

## 4.7 Establishing the electrical connections between the S-end section and the WA-frames

### NOTICE

Missing electrical connection!  
Damage to crane components.

- ▶ Before erecting the WA-frames: Establish the electrical connection between the S-end section and the WA-frames.



### Note

- ▶ To establish the electrical connections to the terminal boxes on the WA-frame: Observe the wiring diagram.

Make sure that the following prerequisite is met:

- WA-frame 1 is pinned with the S-end section.
- WA-frame 2 is pinned with the S-end section.



### WARNING

Malfunction if dummy plugs are **not** assembled!

If the dummy plugs are not fit on the non-required electrical connections, then malfunctions or functional limitations can occur on the crane.

- ▶ Make sure that all non-required electrical connections, which have a dummy plug are closed off with dummy plugs.
- ▶ Observe the wiring diagram.
- ▶ As a rule, close off non-required electrical connections (for example for accessories that are not assembled) with the respective dummy plugs.

### NOTICE

Property damage due to dirt and / or corrosion!

If unnecessary electrical connections are not closed off with the respective protective caps, then dirt and / or corrosion can damage the electrical connections.

This could result in malfunctions.

- ▶ Make sure that all non-required electrical connections are always closed off properly.
- ▶ Observe the wiring diagram.

- ▶ Close electrical connections that do not have dummy plugs properly with the corresponding protective caps or caps.
- ▶ Establish the electrical connections between the S-end section and WA-frame 1.
- ▶ Establish the electrical connections between the S-end section and WA-frame 2.
- ▶ Make sure that all electrical connections are established.
- ▶ Check the electrical connections.

## 4.8 Checking the function of the safety equipment

Make sure that the following prerequisites are met:

- All electrical connections are established.
- The appropriate operating mode is set.

### 4.8.1 Wind speed sensor

- ▶ Check the movement and the function of the wind speed sensor.

### 4.8.2 Relapse cylinder

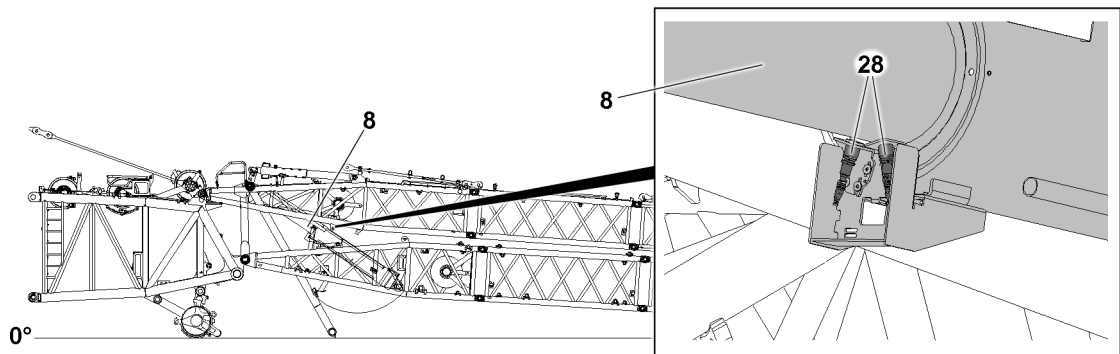


Fig.155797: Checking the function of the relapse cylinder limit switches

Make sure that the following prerequisites are met:

- The electrical connection to the relapse cylinder limit switches is established.

#### NOTICE

Damage to the relapse cylinder **8**!

Before erecting WA-frame 1, the electrical connection for the limit switches of the relapse cylinder **8** must be established. If this is **not** the case, WA-frame 1 can be pulled back over the mechanical stop of the relapse cylinder **8**, which may damage the relapse cylinder **8**.

- ▶ Establish the electrical connection for the relapse cylinder **8** limit switches.
- 
- ▶ Make sure that the electrical connection for the limit switches of the relapse cylinder **8** is established.
  - ▶ Check the relapse cylinders for leaks (visual inspection).
  - ▶ Cover the limit switch initiators **28** of the relapse cylinder **8** individually with a metal plate.

#### Result:

- The icon appears on the LICCON monitor.
- The **spool up function** of the W-control winch turns off.

## 4.9 Releasing the brackets on WA-frame 1

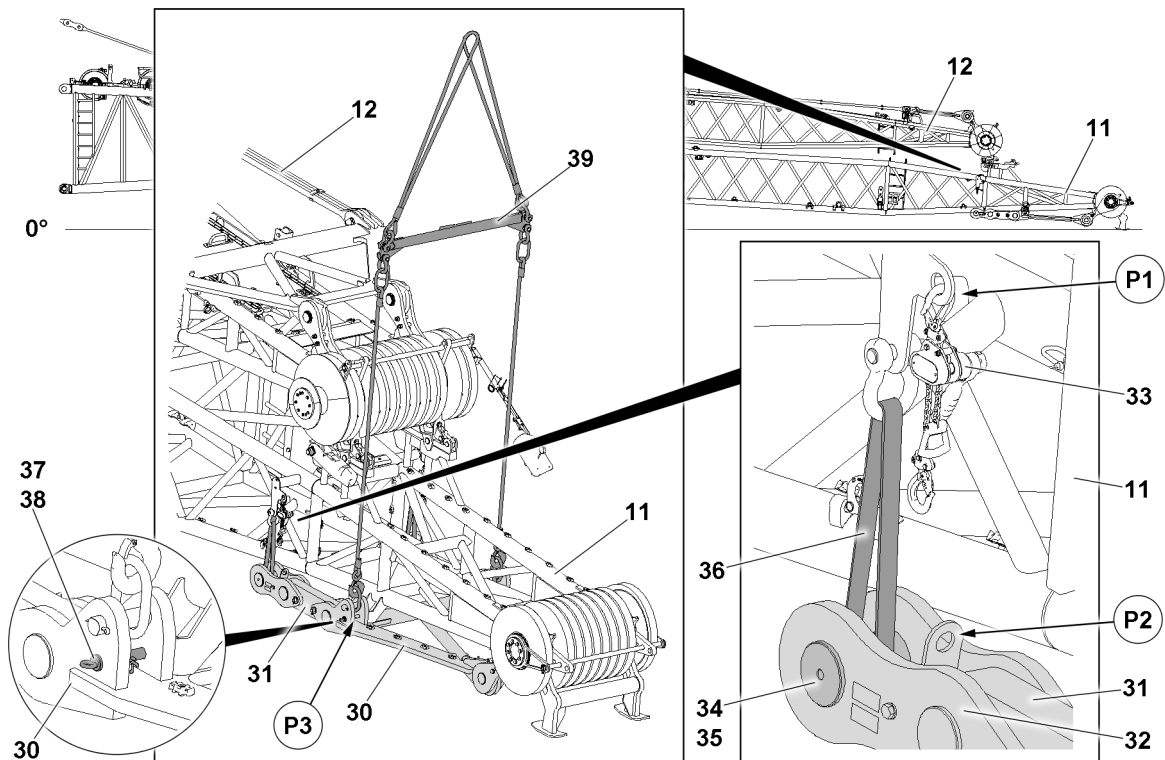


Fig.155798: WA-frame 1, releasing the brackets, ratchet hoist



### Note

- ▶ This procedure is described for one side.

- ▶ Connect the ratchet hoist **33** to the lug in point **1** and to the lug in point **P2**.



### WARNING

The ratchet hoist **33** is **not** tensioned!  
Danger of crushing. The pull bracket **32** falls down.

- ▶ Tension the ratchet hoist **33** before the pull bracket **32** is released.
- ▶ Tension the ratchet hoist **33** until the pin **34** can be unpinned.
- ▶ Release the pull bracket **32**: Remove the retaining element **35** and unpin the pin **34**.
- ▶ Remove the ring loop **36**.
- ▶ Insert the pin **34** again.
- ▶ Secure the pin **34**: Attach the retaining element **35**.
- ▶ Use the ratchet hoist **33** to lower the pull bracket **32** and pull test bracket **31**.
- ▶ Repeat the procedure for the other side of WA-frame 1.
- ▶ Remove the ratchet hoist **33**.

## 4.10 Releasing the cross beam on WA-frame 1

### NOTICE

Use of the auxiliary cross beam **39**!

Do not use the auxiliary cross beam **39** to lift the W-frames.

- ▶ Make sure that the auxiliary cross beam **39** is only used for lowering the cross beam **30**.

- ▶ Fasten the auxiliary cross beam **39** to the cross beam **30** in point **P3**.
- ▶ Release the auxiliary cross beam **39** on both sides: Remove the retaining element **38** and unpin the pin **37**.

- ▶ Take the cross beam **30** down onto the ground with the auxiliary cross beam **39**.
- ▶ Insert the pin **37** again.
- ▶ Secure the pin **37**: Attach the retaining element **38**.
- ▶ Remove the auxiliary cross beam **39**.

## 4.11 Reeving the ropes in



### WARNING

Running ropes!

Danger of crushing.

- ▶ Adhere to the safety distance to the running ropes.
- ▶ Radio contact is available between crane operator and assembly personnel.

### NOTICE

Slack rope formation!

Due to slack rope formation, the hoist rope and the W-control rope can be damaged.

This can result in significant property damage.

- ▶ When spooling the hoist rope or the W-control rope up or out, do not allow slack rope formation.
- ▶ When spooling up or out, hold the hoist rope and the W-control rope taut.

Differentiation between the ropes:

- The auxiliary rope is the assembly winch rope.
- The forerunner rope is a rope that is used to draw in a hoist rope or a control rope.

Make sure that the following prerequisites are met:

- The WA-frames are completely assembled.
- The cross beam of WA-frame 1 it released.
- The transport retainers of the guy rods of WA-frame 1 are completely released.

### 4.11.1 Swinging the change over pulley into the operating position

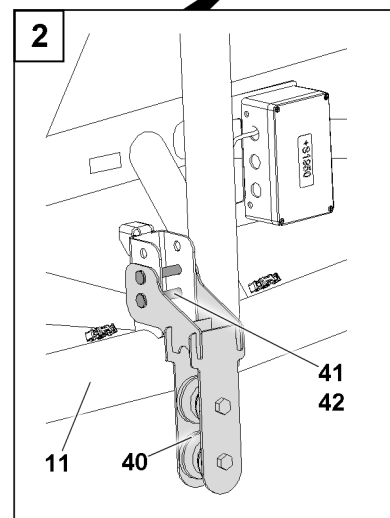
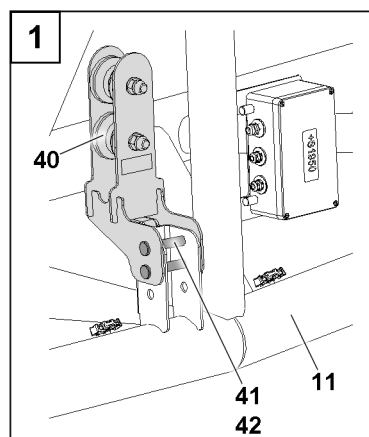
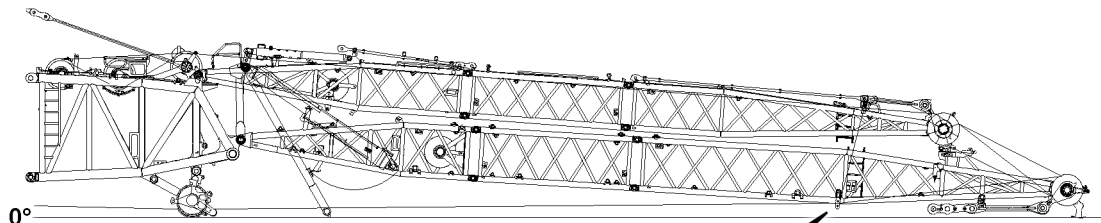


Fig.155799: Change over pulley

The change over pulley **40** must be pinned on WA-frame **11** in the operating position.

- ▶ Remove the retaining element **42** and unpin the pin **41**.
- ▶ Swing the change over pulley **40** into the operating position.
- ▶ Secure the change over pulley **40**: Insert the pin **41**.
- ▶ Secure the pin **41**: Attach the retaining element **42**.

#### 4.11.2 Swinging the assembly pulley into the operating position

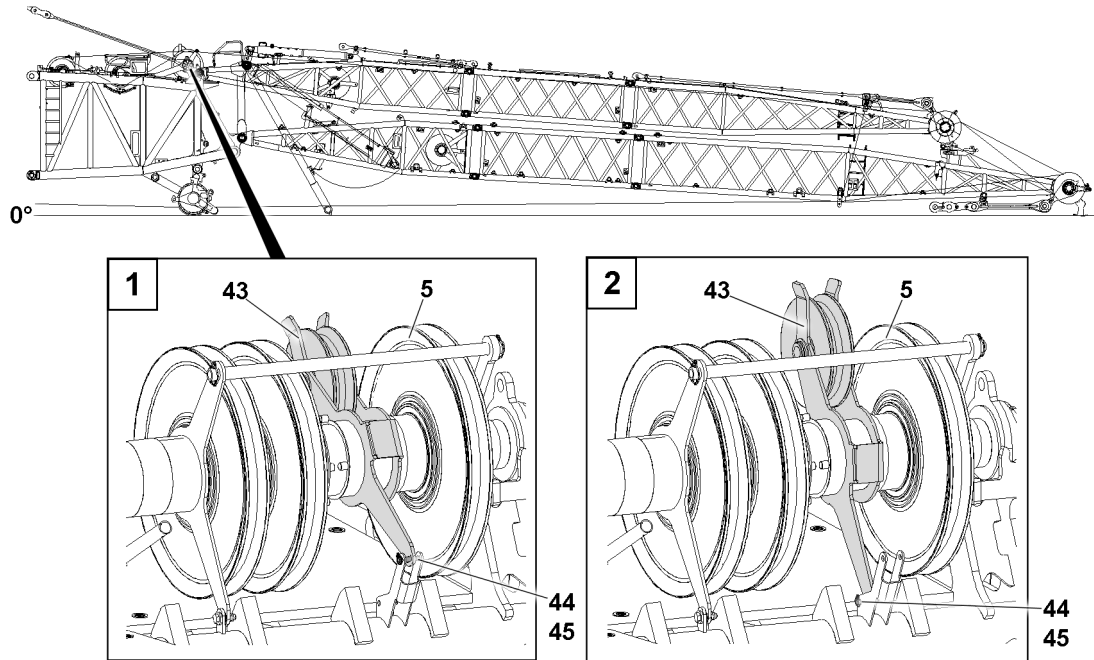


Fig.155800: Assembly pulley

The assembly pulley **43** must be pinned to the S-end section **5** in the operating position.

- ▶ Remove the retaining element **45** and unpin the pin **44**.
- ▶ Swing the assembly pulley **43** into the operating position.
- ▶ Secure the assembly pulley **43**: Insert the pin **44**.
- ▶ Secure the pin **44**: Attach the retaining element **45**.

#### 4.11.3 Removing the rope retainer

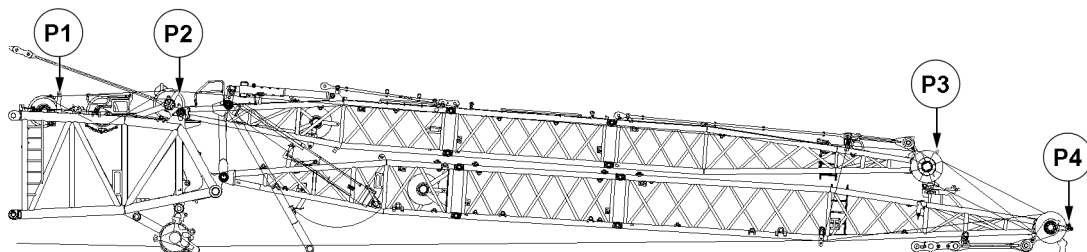


Fig.155801: Rope retainer

- ▶ Remove the rope retainer in the rope pulleys in point **P1**, point **P2**, point **P3** and point **P4**: Remove the retaining elements and rods.

#### 4.11.4 Pulling the hoist rope to the S-end section

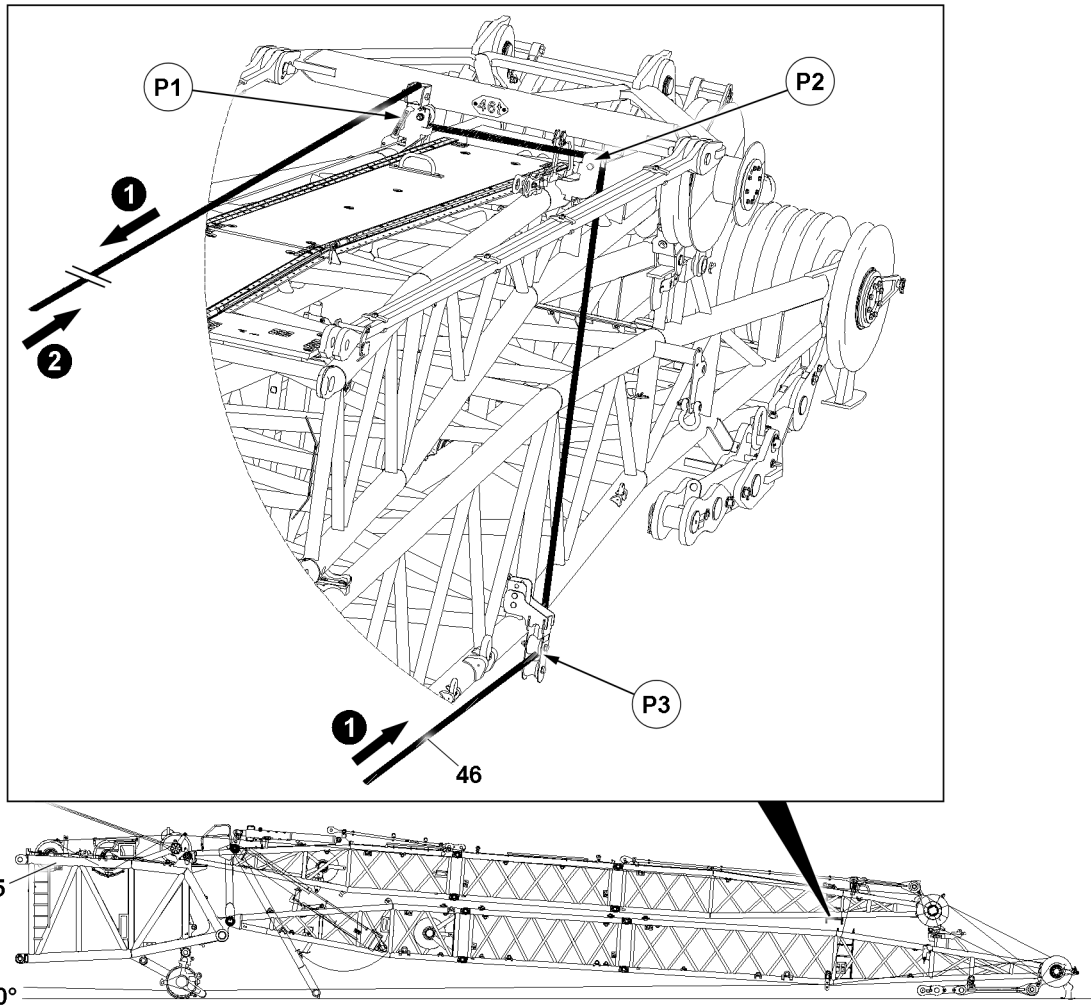


Fig.155802: Hoist rope on the S-end section

The line **46** shows the course for pulling the hoist rope in.

- ▶ Guide the auxiliary rope over the change over pulley in point **P3**, point **P2** and point **P1**.
- ▶ Pull the auxiliary rope over the main boom to winch 1 and assemble on the hoist rope.

The hoist rope is used in a further step to erect WA-frame 2.

- ▶ Spool the auxiliary rope up on the assembly winch and spool the hoist rope out at the same time.
- ▶ Pull the hoist rope to the S-end section **5**.
- ▶ Disassemble the auxiliary rope on the hoist rope. Take the hoist rope down on the S-end section.

### 4.11.5 Pulling the W-control rope to the WA-frames

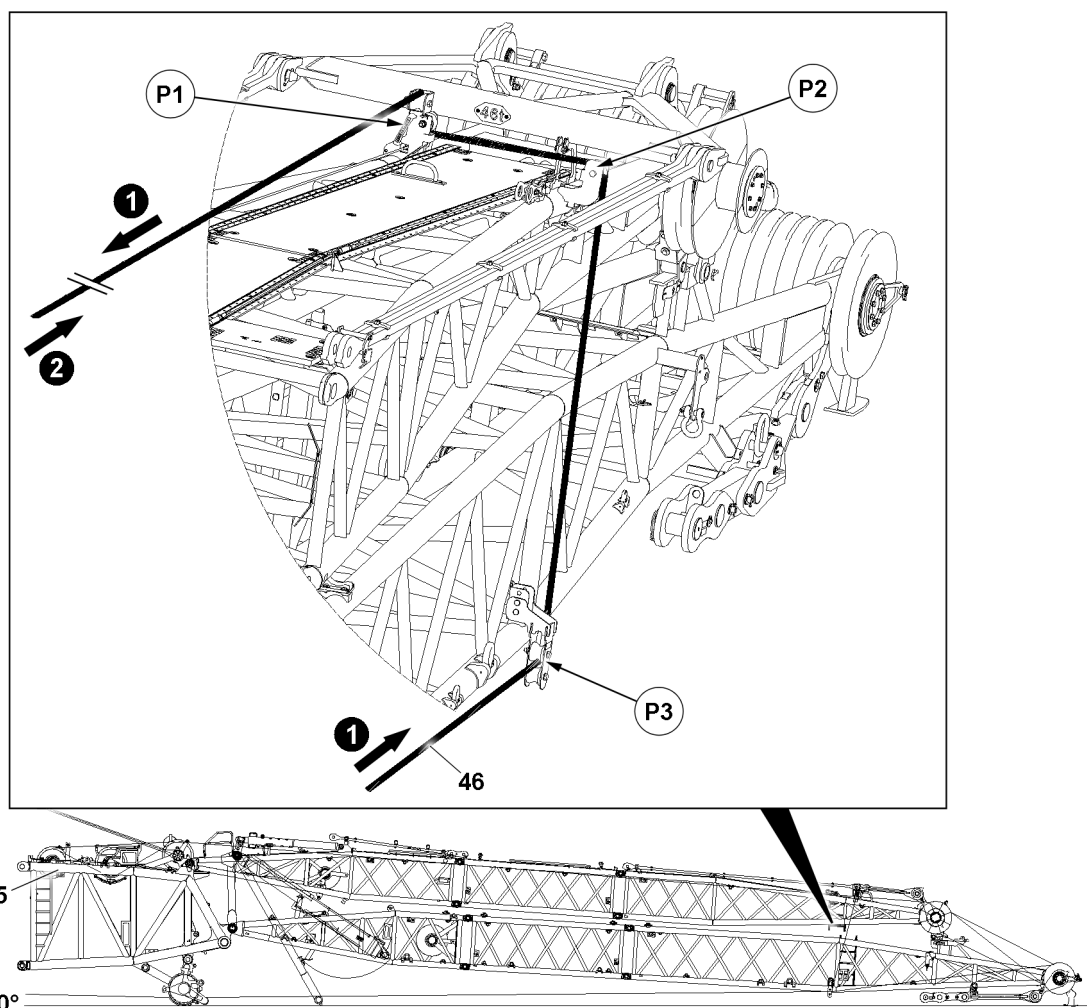


Fig.155802: W-control rope on the S-end section

The line **46** shows the course for pulling the W-control rope in.

- ▶ Guide the auxiliary rope over the change over pulley in point **P3**, point **P2** and point **P1**.
- ▶ Pull the auxiliary rope over the main boom to winch **5** and assemble on the W-control rope.

Reeving the W-control rope, see the Reeving plan.

- ▶ Spool the auxiliary rope up on the assembly winch and spool the W-control rope out at the same time.
- ▶ Pull the W-control rope to the WA-frames.
- ▶ Remove the auxiliary rope from the W-control rope.



### 4.11.6 Pulling in the W-control rope on the WA-frames

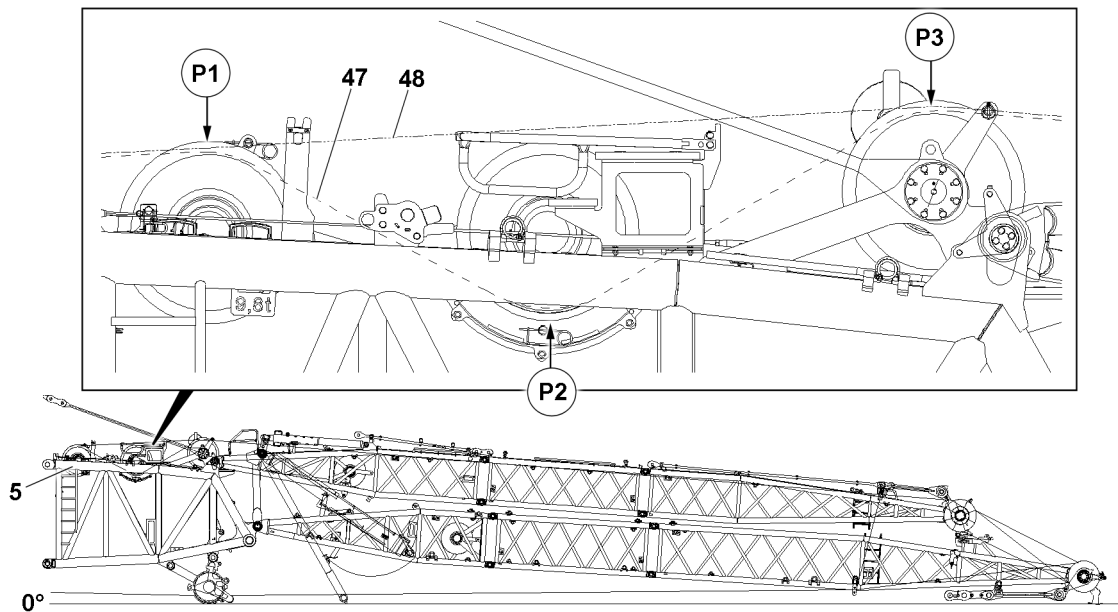


Fig.155803: Rope run on the S-end section



#### Note

- ▶ Guide the W-control rope **47** through below the rope pulley in point **P2**.
- ▶ Guide the hoist rope **48** over the rope pulley in point **P2**.

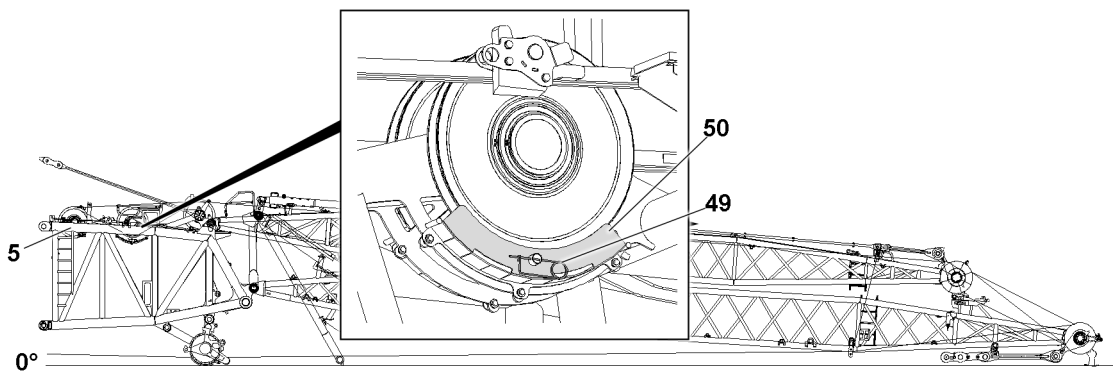


Fig.155804: Rope pulley on the S-end section

- ▶ Release the plate **50**: Remove the retaining element **49**.
- ▶ Remove the plate **50**.
- ▶ Guide the W-control rope **47** through below the rope pulley.
- ▶ Reassemble the plate **50**.
- ▶ Secure the plate **50**: Attach the retaining element **49**.

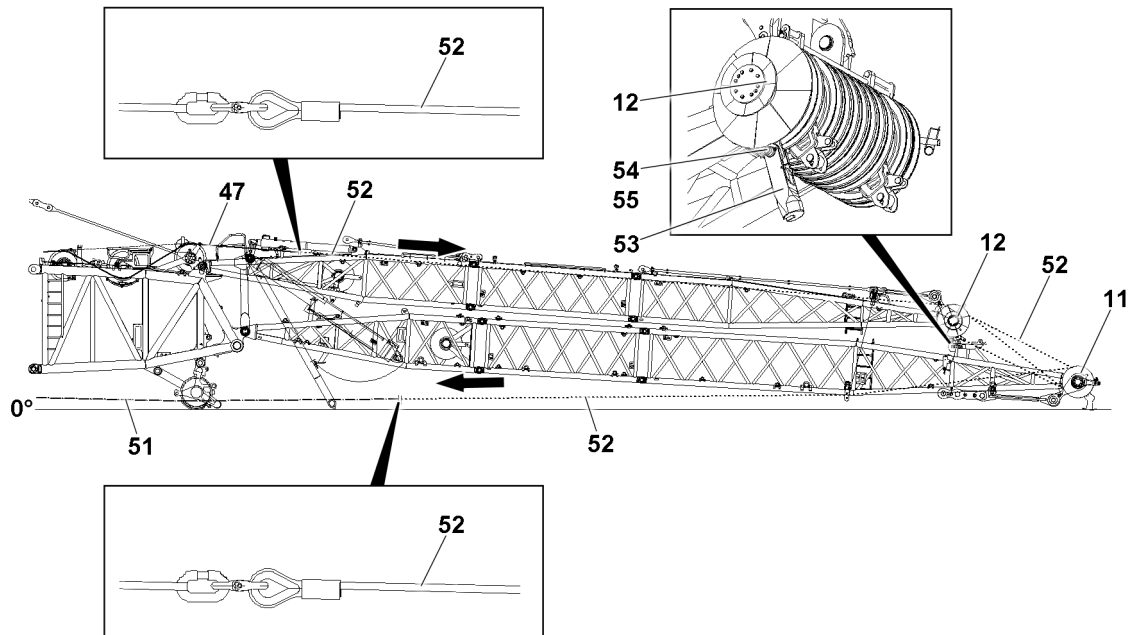


Fig.155805: WA-frames: W-control rope, forerunner rope, auxiliary rope, lock

- ▶ Fasten the forerunner rope **52** to the W-control rope **47**.
- ▶ Pull the auxiliary rope **51** to the forerunner rope **52**.
- ▶ Fasten the forerunner rope **52** to the auxiliary rope **51**.
- ▶ Pull the W-control rope **47** in until the W-control rope **47** can be inserted in the lock **53**: Spool the assembly winch up and simultaneously spool winch 5 out at the same speed.

If the lock **53** is **not** assembled:

- ▶ Pin the lock **53**: Insert the pin **54**.
- ▶ Secure the pin **54**: Attach the retaining element **55**.
- ▶ Disconnect the forerunner rope **52** from the W-control rope **47** and the auxiliary rope **51**.
- ▶ Coil up and store the forerunner rope **52**.
- ▶ Spool the auxiliary rope **51** up.
- ▶ Insert the W-control rope **47** in the lock **53** and secure.

#### 4.11.7 Assembling the rope retainer

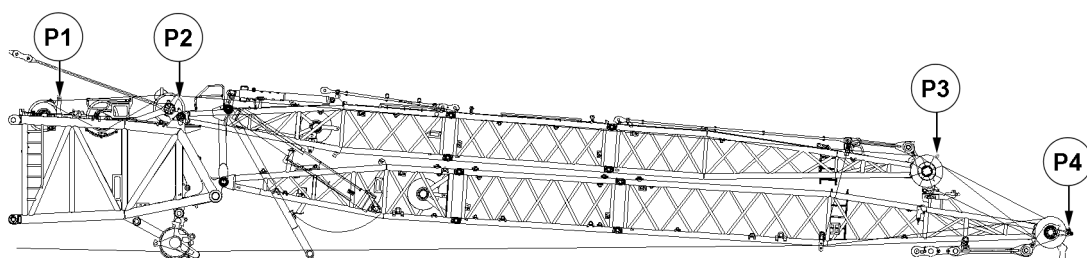


Fig.155801: Rope retainer

- ▶ Assemble the rope retainer in the rope pulleys in point **P1**, point **P2**, point **P3** and point **P4**: Attach the rods and retaining elements.

### 4.11.8 Pinning the change over pulley in the park position

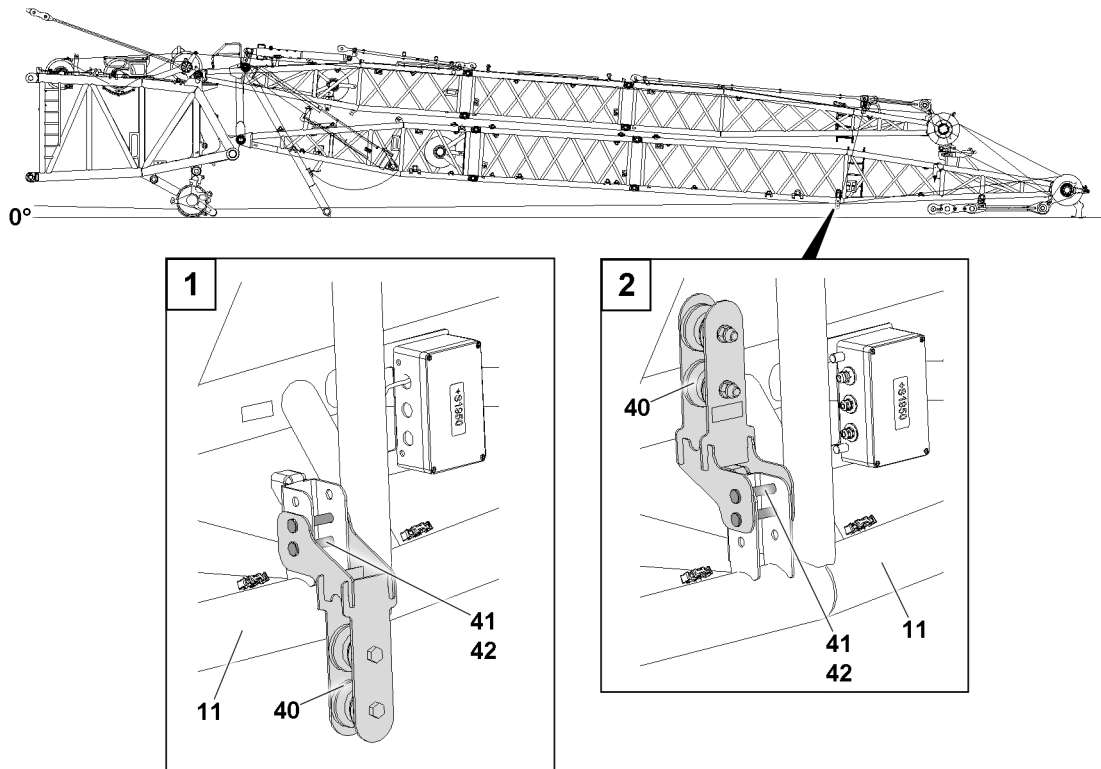


Fig.155806: Change over pulley

The change over pulley 40 is pinned to WA-frame 11 in the park position.

- ▶ Remove the retaining element 42 and unpin the pin 41.
- ▶ Swing the change over pulley 40 into the park position.
- ▶ Secure the change over pulley 40: Insert the pin 41.
- ▶ Secure the pin 41: Attach the retaining element 42.

### 4.12 Pinning the guy rods on the lattice sections

Lengths of the necessary guy rods, see the Rod plan.

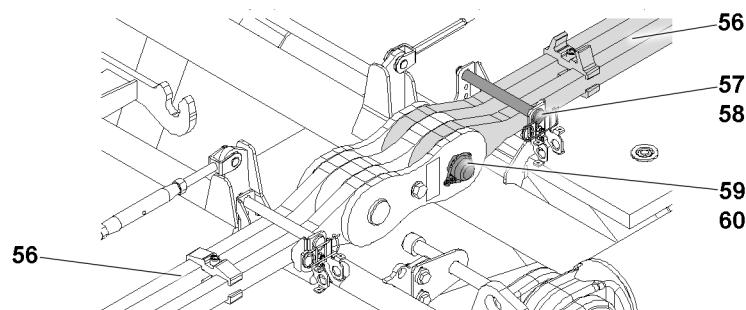


Fig.155807: Guy rods on the lattice sections

- ▶ Release the guy rods 56 on the lattice sections: Remove the retaining elements 58 and unpin the pin 57.
- ▶ Insert the pin 57 in the park positions in the retainers.
- ▶ Secure the pin 57 in the park positions: Attach the retaining elements 58.
- ▶ Make sure that all guy rods have been released.

**NOTICE**

Impermissibly inserted pins!

If the pins of the guy rods are **not** pinned from the “inside” to the “outside”, the hoist rope can scrape on the pins and be damaged.

▶ Always insert the guy rod pins from the “inside” to the “outside”, see the Rod plan.

- ▶ Pin the guy rods **56** on the lattice sections with each other: Insert the pin **59**.
- ▶ Secure the pin **59**: Attach the retaining elements **60**.
- ▶ Make sure that all guy rods are pinned and secured with each other.

### 4.13 Preparing for erection of WA-frame 2

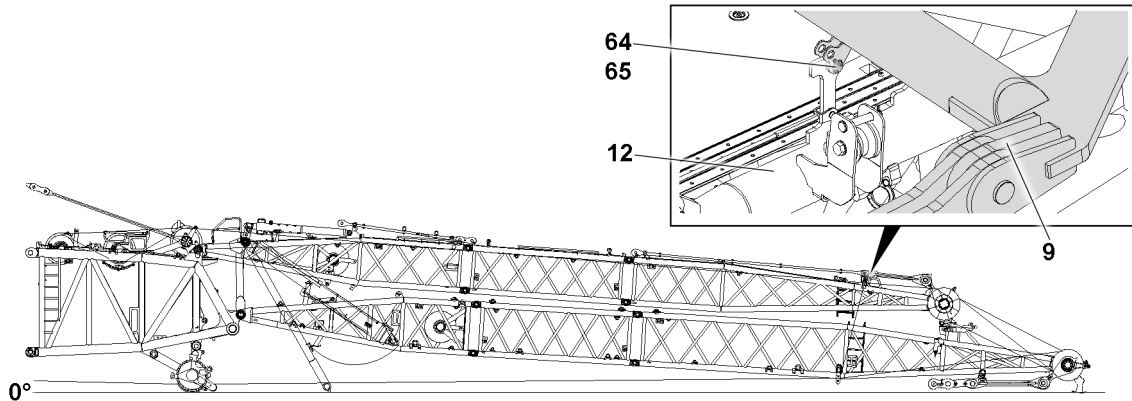


Fig.155809: Releasing the cross beam

Preparations for erection: Release the cross beam.

- ▶ Remove the transport retainers on both sides on the cross beam **9**: Remove the retaining elements **65** and unpin the pin **64**.
- ▶ Insert the pin **64** in the park positions in the retainers.
- ▶ Secure the pin **64**: Attach the retaining elements **65**.

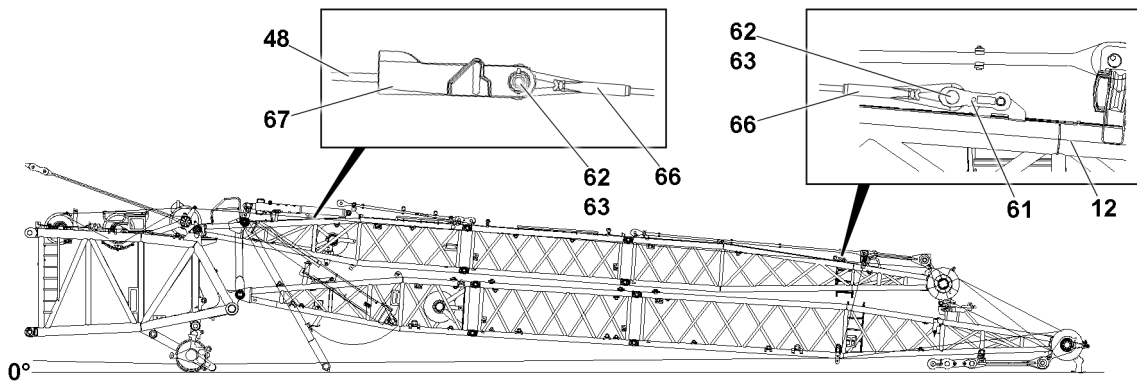


Fig.155808: Assembling the erection rope

Preparations for erection: Assemble the erection rope.

Pin the erection rope **66** to the bracket **61**.

- ▶ Insert the pin **62**.
- ▶ Secure the pin **62**: Attach the retaining element **63**.

**NOTICE**

Impermissible hoist rope run with short main boom lengths!

The hoist rope collides with the luffing pulley block.

- ▶ With short main boom lengths: Direct the hoist rope outside the luffing pulley block.

To erect WA-frame 2, the hoist rope **48** of hoist winch 1 or hoist winch 2 must be used.

**WARNING**

Operation of the incorrect hoist winch!

To protect against a mix up:

- ▶ When operating the hoist winch to erect WA-frame 2, the unused hoist winches must be blocked.
- ▶ Block unutilized hoist winches, see chapter 4.05.

If the lock **67** is **not** fastened to the erection rope **66**:

- ▶ Connect and secure the hoist rope **48** to the lock **67**.
- ▶ Pin the erection rope **66** to the lock **67**.

## 4.14 Erecting WA-frame 2

**WARNING**

**Unsynchronized** spooling of the hoist winch and the control winch!

Overload of the crane.

- ▶ When erecting the WA-frame, spool the hoist winch and the control winch synchronously with each other.
- ▶ Have the spooling procedure visually monitored by a guide.

**WARNING**

Defective relapse cylinder!

Release of WA-frame 2, when WA-frame 1 is in the steep position.

Damaged relapse cylinder, if in the block position.

- ▶ Check the relapse cylinder before erecting the WA-frames.
- ▶ Connect the electrical connection to the limit switches of the relapse cylinder and check.

**WARNING**

Slack rope formation of the hoist rope or the W-control rope!

Uncontrolled oscillation of WA-frame 1 or WA-frame 2.

- ▶ Tension the hoist rope and the W-control rope evenly during take-down.

When WA-frame 2 moves, the relapse cylinder must have always built up pressure.

### 4.14.1 Erecting WA-frame 2 to the pin position

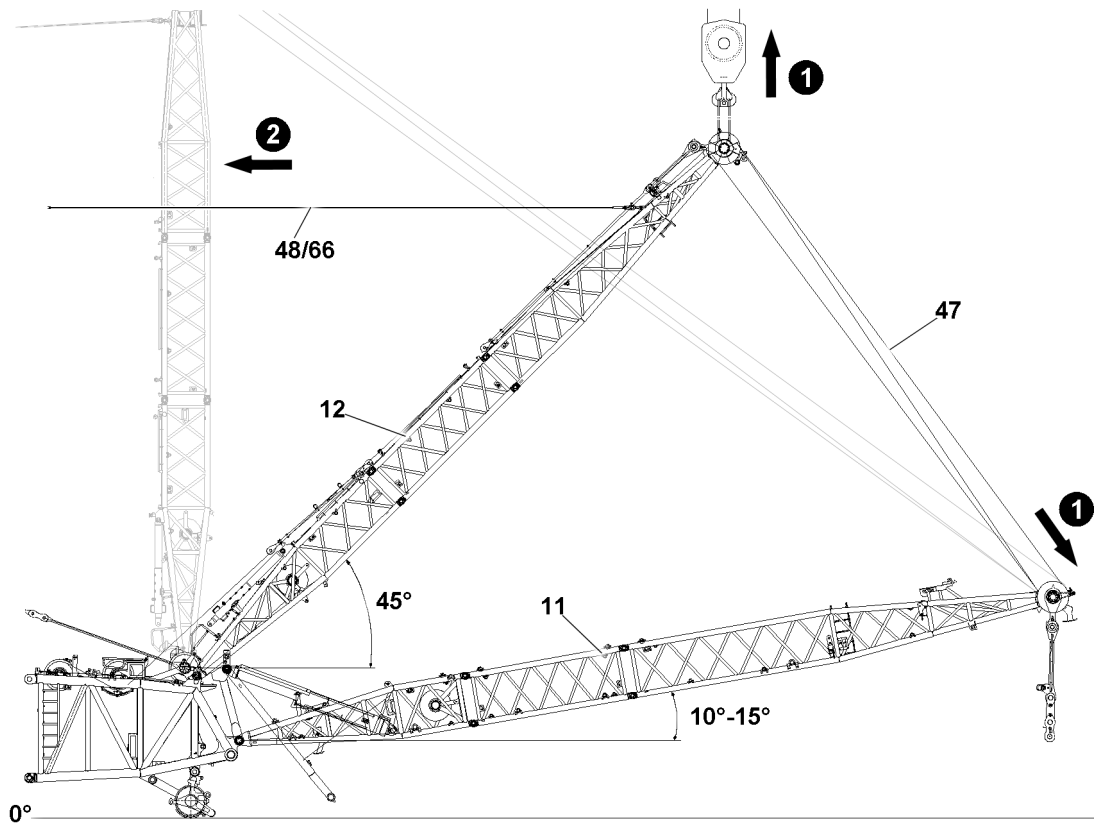


Fig.166586: WA-frame 2, erecting with the auxiliary crane

Make sure that the following prerequisites are met:

- A suitable auxiliary crane and suitable fastening equipment are available.
- The relapse cylinder is checked and free of defects.
- The relapse support is assembled with the assembly rope on WA-frame 1.

► Fasten the auxiliary crane with the fastening equipment to the bitt.



#### Note

► Erect WA-frame 2 **12** with the auxiliary crane, required load bearing capacity approx. 22 t.



#### WARNING

Load change to the hoist rope in position WA-frame 2 **12** smaller than 45°!

The hoist rope can be overloaded.

Death, severe bodily injuries, property damage.

► Erect WA-frame 2 **12** with the auxiliary crane to at least the 45° position.

Carry out the following actions at the same time until WA-frame 2 is erected in the 45° position:

- Erect WA-frame 2 **12** with the auxiliary crane.
- Hold WA-frame 1 **11** such that the angle to the level is 10° to 15°, such that the W-control rope **47** is spooled out.
- Guide the hoist rope **48** loosely.
- Erect WA-frame 2 **12** briefly.
- Erect WA-frame 2 **12** to the 45° position.

---

**NOTICE**

Damage to the hoist winch!

If WA-frame 2 **12** is pulled too soon with the hoist rope **48**, the hoist rope **48** can be overloaded.

If the actual pressure is too high when erecting WA-frame 2 **12**, the hoist winch or the hoist rope **48** can be damaged.

- ▶ Erect WA-frame 2 **12** with the hoist winch from at least the "45 °" position.
  - ▶ When erecting WA-frame 2 **12**, observe the winch pressure display of the hoist winch.
  - ▶ Winch pressure display of the hoist winch, see chapter 4.02.
- 

Carry out the following actions at the same time until WA-frame 2 is erected in the 90° position:

- Erect WA-frame 2 **12** with the hoist rope **48**.
- Observe the winch pressure display for the hoist winch, see chapter 4.02.
- Hold WA-frame 1 **11** such that the angle to the level is 10° to 15°, such that the W-control rope **47** is spooled out.
- Guide the auxiliary crane loosely.
- ▶ Erect WA-frame 2 **12** further with the hoist rope **48** to the 90° position.

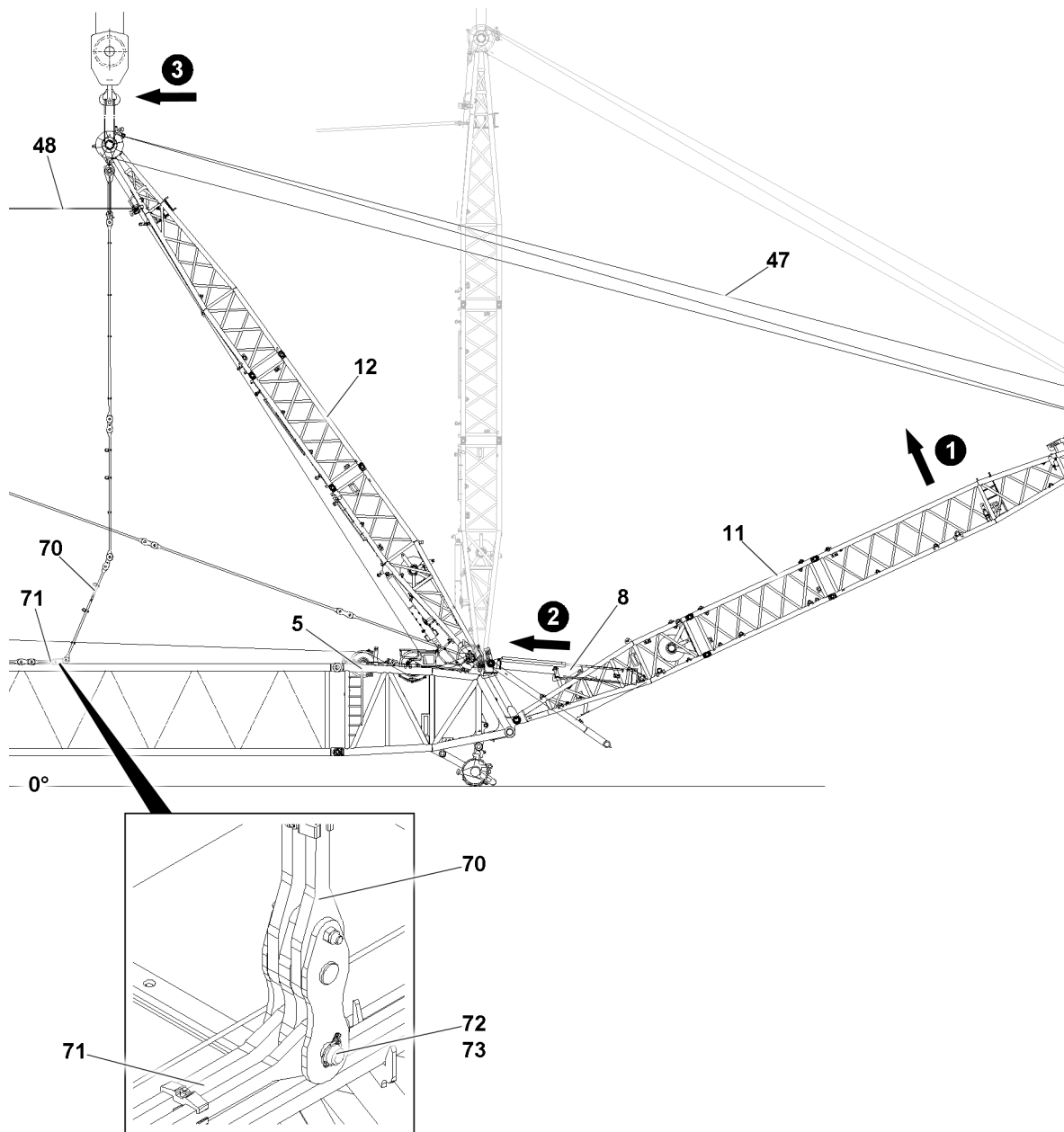


Fig.155811: WA-frame 2, erecting with the hoist rope



### WARNING

Impermissible WA-frame 1-position!

Release of WA-frame 2 12, if WA-frame 1 11 does **not** press against the relapse cylinder 8.

- ▶ While WA-frame 2 12 is being erected, pull WA-frame 1 11 against the relapse cylinder 8.
- ▶ Check the cylinder pressure of the relapse cylinder on the LICCON monitor pressure display.

Carry out the following actions at the same time until WA-frame 1 11 is lifted far enough that the relapse cylinder 8 lies on the S-end section 5:

- Check the cylinder pressure of the relapse cylinder on the LICCON monitor pressure display.
- Spool the W-control rope 47 up.
- ▶ Lift WA-frame 1 11 until the relapse cylinder 8 lies on the S-end section 5.



**WARNING**

Movement of WA-frame 2!

Crushing of limbs.

Damage to components if WA-frame 2 **12** is pulled back too far.

- ▶ Adhere to the safety distance from the moving components.
- ▶ Have the movements visually monitored by a guide.

Carry out the following actions at the same time until WA-frame 2 **12** is erected far enough that the guy rods can be pinned:

- Erect WA-frame 2 **12** with the hoist rope **48**.
- Spool the W-control rope **47** out.
- Observe the winch pressure display for the hoist winch, see chapter 4.02.
- Check the cylinder pressure of the relapse cylinder on the LICCON monitor pressure display.
- Let WA-frame 1 **11** be lifted until the relapse cylinder **8** builds up pressure.
- Make sure that the W-control rope **47** is tensioned.
- Guide the auxiliary crane loosely.

The guy rods must be pinned with each other on both sides of the S-lattice section and pinned and secured to the S-pivot section.

- ▶ Erect WA-frame 2 **12** until the guy rods **70** can be pinned with the guy rods **71**.

**Result:**

- From an angle of 90°, the guy rods **70** release from the receptacles on WA-frame 2 **12**.
- ▶ Relieve the auxiliary crane and disconnect the fastening equipment.
- ▶ Remove the auxiliary crane.

### 4.14.2 Pinning the WA-frame 2 guy rods

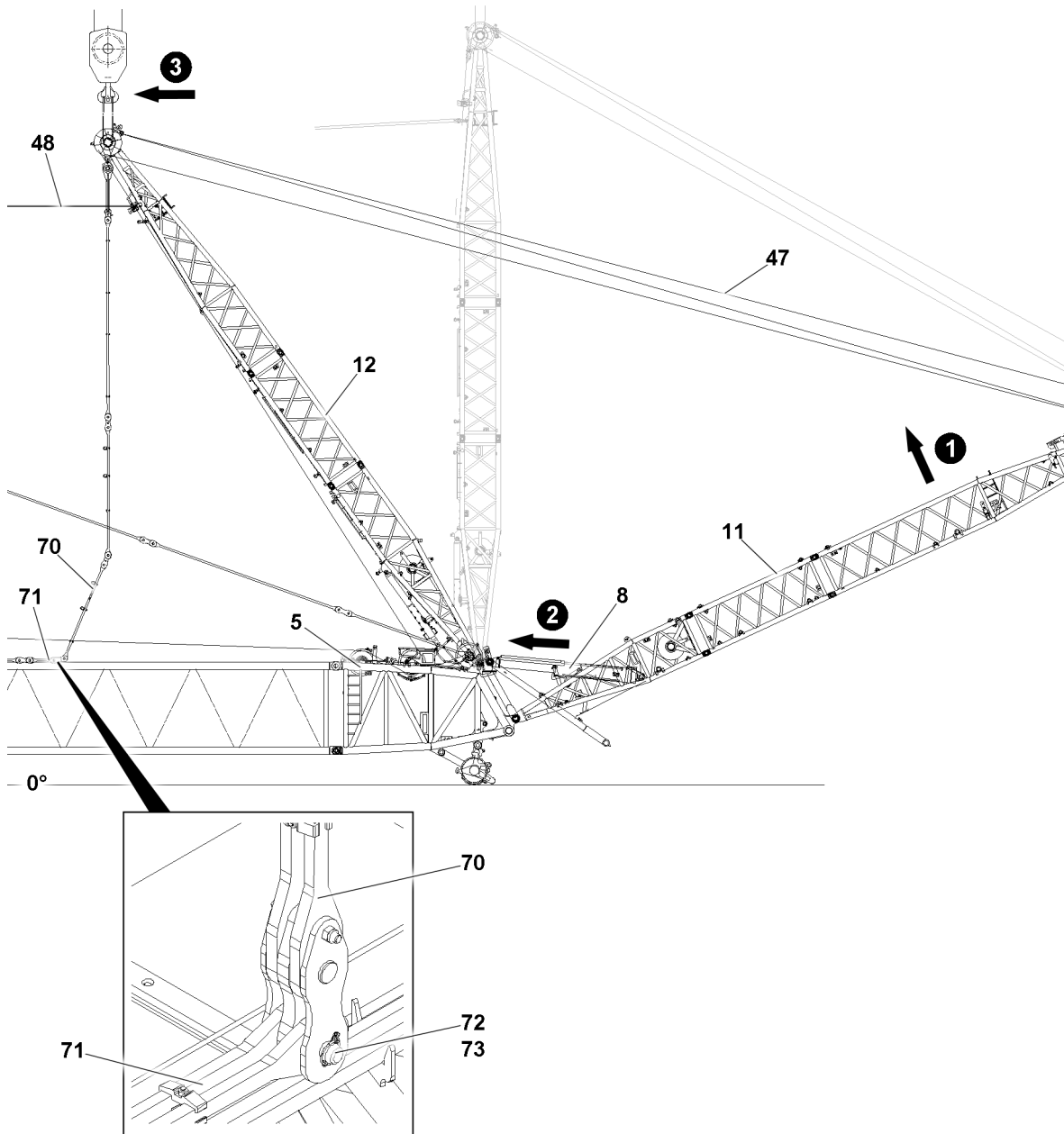


Fig.155811: Pinning the guy rods

Length of the necessary guy rods, see the Rod plan.



#### WARNING

Impermissible length of the guy rods **71**!  
Damage or falling of crane components.

- ▶ Make sure that the necessary length of the guy rods from the rod plan coincides with the assembled length of the guy rods **71**.



#### WARNING

Oscillation of the lifted guy rod!  
Death, severe bodily injuries.

- ▶ Adhere to the safety distance to the lifted guy rods.

**NOTICE**

Impermissibly inserted pins!

If the pins of the guy rods are **not** pinned from the “inside” to the “outside”, the hoist rope can scrape on the pins and be damaged.

▶ Always insert the guy rod pins from the “inside” to the “outside”, see the Rod plan.

- ▶ On both sides of the S-lattice section: Pin the guy rods **70** on the guy rods **71**.
- ▶ Insert the pin **72**.
- ▶ Secure the pin **72**: Attach the retaining element **73**.

#### 4.14.3 Pinning the W-relapse supports

**WARNING**

Movement of WA-frame 2!

Crushing of limbs.

Damage to components if WA-frame 2 is pulled back too far.

- ▶ Adhere to the safety distance from the moving components.
- ▶ Have the movements visually monitored by a guide.

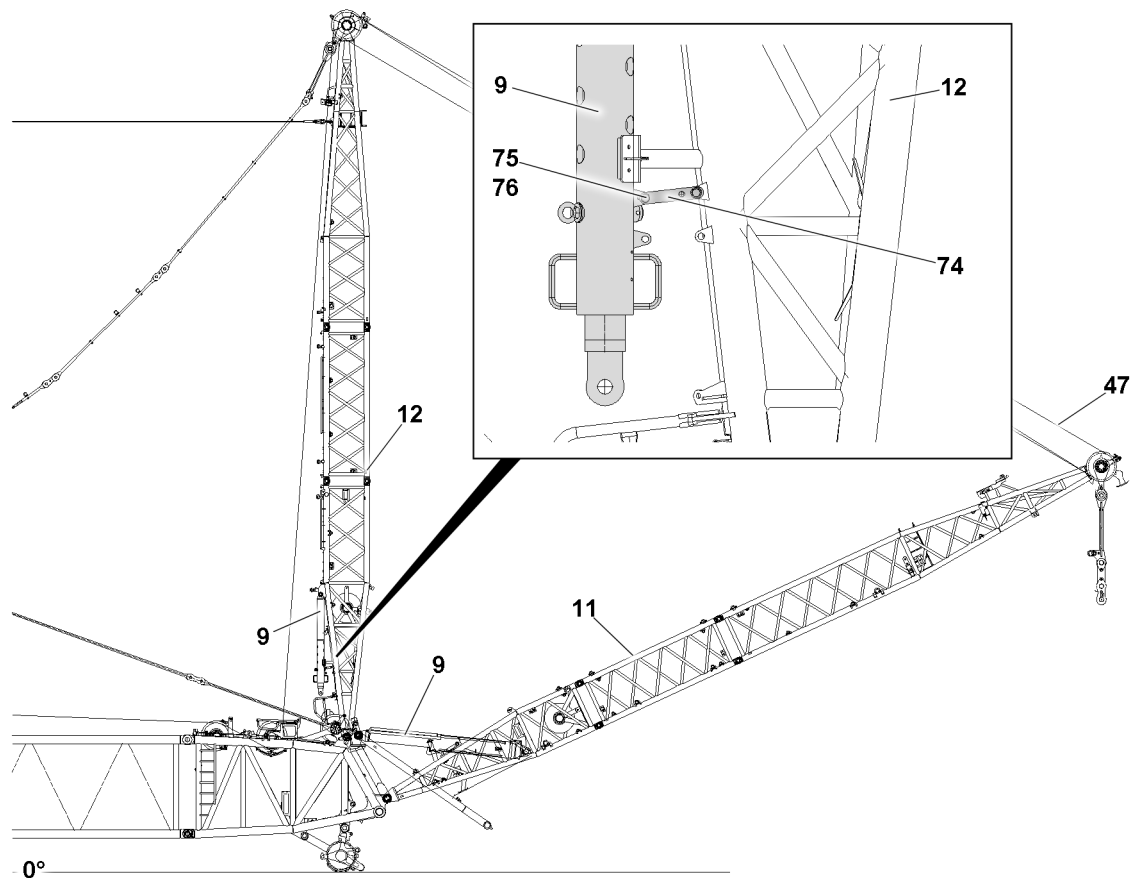


Fig.155812: WA-frame 2, W-relapse supports secured

**WARNING**

Impermissible WA-frame 1-position!

Release of WA-frame 2 **12**, if WA-frame 1 **11** does **not** press against the relapse cylinder **8**.

Danger of crushing.

- ▶ Adhere to the safety distance from the WA-frames.
- ▶ While WA-frame 2 **12** is being erected, pull WA-frame 1 **11** against the relapse cylinder **8**.
- ▶ Check the cylinder pressure of the relapse cylinder on the LICCON monitor pressure display.

**WARNING**

Swinging W-relapse support!

If WA-frame 2 **12** is pulled back too far, the W-relapse support **9** can swing back when releasing due to its weight.

Death, severe bodily injuries.

- ▶ Make sure that WA-frame 2 **12** is in a vertical position.
  - ▶ Assembly personnel must be to the side of the assembly unit.
- 
- ▶ Place WA-frame 2 **12** in a vertical position, keep WA-frame 1 **11** in position.

This procedure is described based on the example of one W-relapse support.

The W-relapse support **9** is pinned and secured with the retainer **74**.

- ▶ Release the W-relapse support **9**: Remove the retaining element **76** and unpin the pin **75**.
- ▶ Swing the retainer **74**.
- ▶ Pin the pins **75** again on the retainer **74**.
- ▶ Secure the pin **75**: Attach the retaining element **76**.
- ▶ Repeat the procedure for the second W-relapse support.

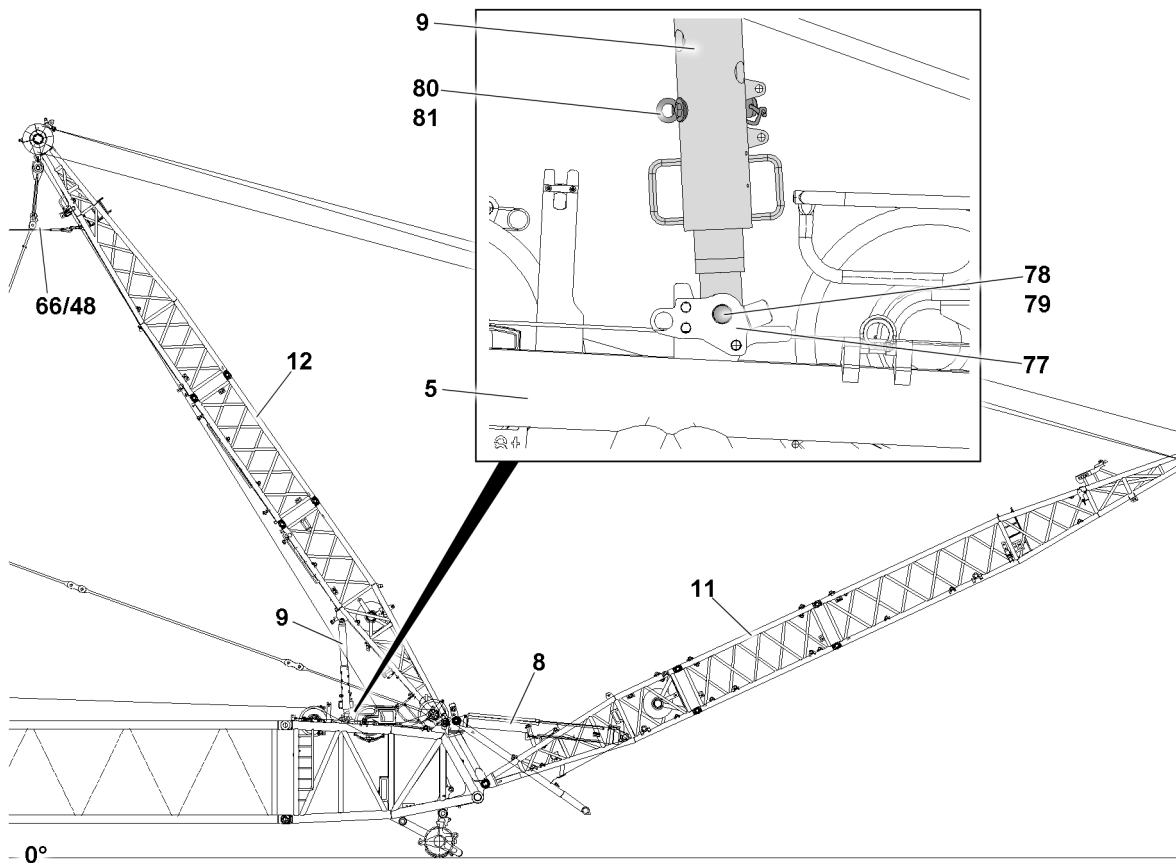


Fig.155813: WA-frame 2, W-relapse supports pinned on the S-end section

- ▶ Lugs **77** on the S-end section **5**: Remove the retaining element **79** and unpin the pin **78**.

**WARNING**

WA-frame 2 pulled back too far and W-relapse support secured!

If the W-relapse support is unpinned in this position, the W-relapse support will oscillate in the direction of the S-end section and can damage components.

- ▶ Release the W-relapse support **9** before WA-frame 2 **12** is pulled back.
- 
- ▶ Pull WA-frame 2 **12** back while keeping WA-frame 1 **11** in position.
  - ▶ Pull WA-frame 2 **12** back until the pin bores of the W-relapse supports **9** and brackets **77** align.

- ▶ Pin the W-relapse supports **9** to the brackets **77**: Insert the pin **78**.
- ▶ Secure the pin **78**: Attach the retaining elements **79**.
- ▶ Release the lock of the W-relapse supports **9**: Remove the retaining elements **81** and unpin the socket pin **80**.

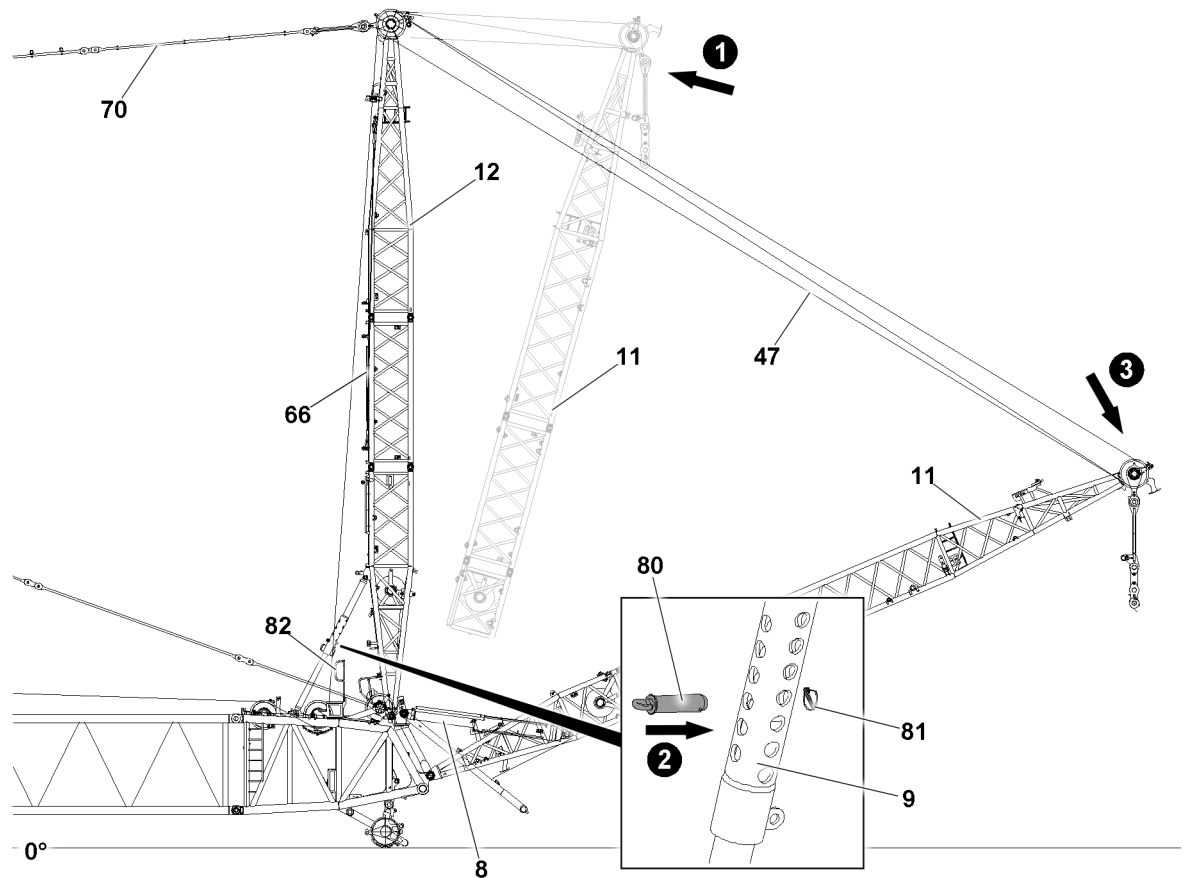


Fig.155814: WA-frame 2, pinning the W-relapse supports

- ▶ Until the guy rods **70** tension: Spool the hoist rope **48** out and simultaneously spool the W-control rope **47** up.



#### WARNING

Oscillating erection rope **66**!  
Danger of crushing.

- ▶ Adhere to the safety distance from the erection rope **66**.

- ▶ Spool the hoist rope **48** out further until the erection rope **66** hangs vertically on WA-frame 2 **12**.
- ▶ Remove the hoist rope **48** from the lock.
- ▶ Remove the lock from the erection rope **66**, see section "Preparing for erection of WA-frame 2".

A work platform is required for securing the erection rope to WA-frame 2 **12**.

- ▶ Secure the erection rope **66** on WA-frame 2 **12**.
- ▶ Erect WA-frame 1 **11** until the relapse cylinders **8** turn off: Spool the W-control rope **47** up.



#### Note

- ▶ Set up the railing **82**, see chapter 2.06.

**NOTICE**

Incorrect pin bore selection!  
Crane components can be damaged.

- ▶ Pin the W-relapse support **9** in the maximum possible length.
  - ▶ Insert the socket pin **80** in the W-relapse supports **9** where the pin bores align.
- 
- ▶ Pin the W-relapse support **9**: Insert the socket pin **80**.
  - ▶ Secure the socket pin **80**: Attach the retaining element **81**.
  - ▶ Lower WA-frame 1 **11**: Spool the W-control rope **47** out.

#### 4.14.4 Pinning the guy rods from the intermediate section

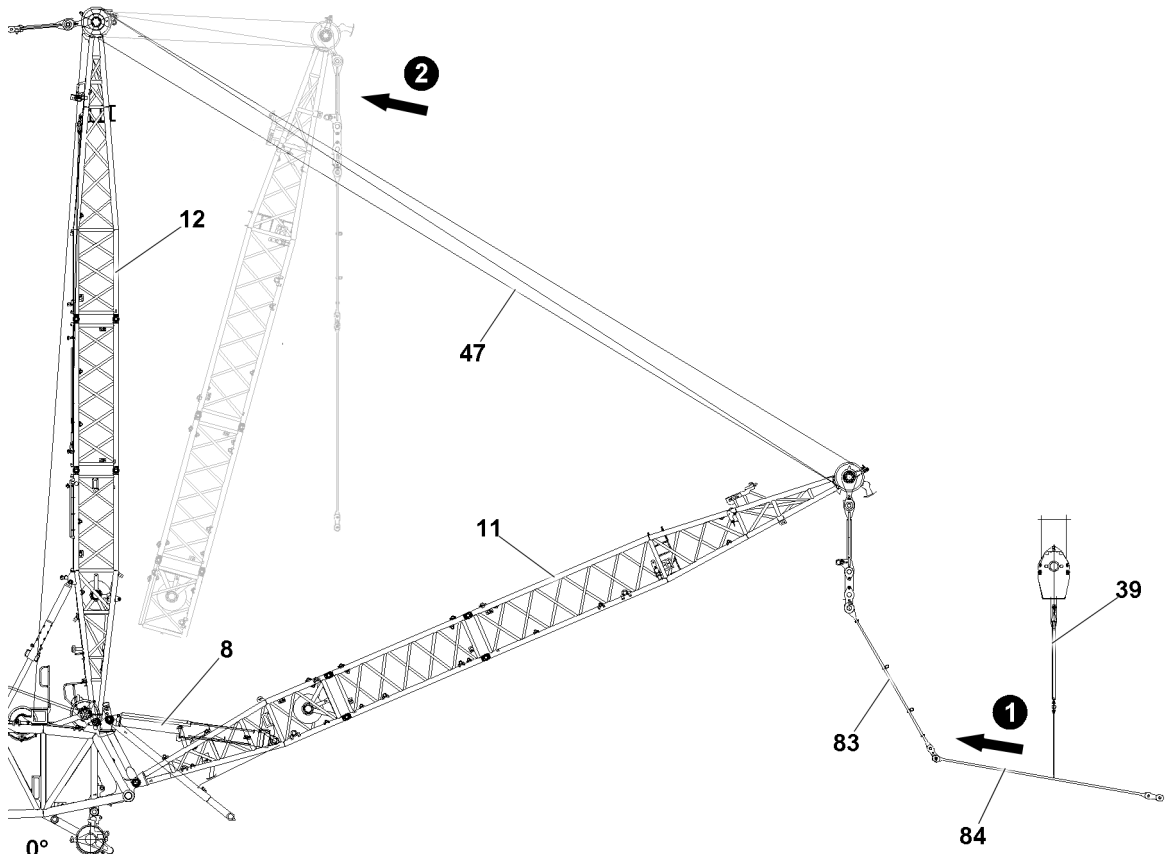


Fig.155815: Pinning the guy rods

Length of the necessary guy rods, see the Rod plan.

Install WA-frame 1 **11** guy rods **83** and the first guy rods **84** from the following intermediate section or SL-reducer.

**Note**

- ▶ Use the cross beam **39** to hold up the guy rods.
- 
- ▶ Pin the guy rods **83** with the guy rods **84**, see section "Pinning the guy rods on the lattice sections".
  - ▶ Erect WA-frame 1 **11** until the relapse cylinders **8** turn off: Spool the W-control rope **47** up.

## 4.15 Assembling the W-lattice jib



### WARNING

Impermissible W-boom assembly!

The crane can topple over. Death, severe bodily injuries, property damage.

- ▶ Take the combination of the various boom systems from the Rod plan and adhere to it.
- ▶ Observe the data in chapter 5.01 and chapter 5.03.
- ▶ Make sure that all pin connections are secured after assembly.

### 4.15.1 Preassembling the W-pivot section and lattice section



### WARNING

Impermissible procedure when closing the lattice sections!

Crushing of limbs if the lattice section tips over.

- ▶ Observe the various procedures when assembling the lattice sections.



### WARNING

**Unstable** position of the preassembled lattice units!

Danger of crushing due to tipping of the preassembled lattice unit.

- ▶ Observe the stable position of the respective lattice unit.

### NOTICE

The W-pivot section is assembled individually on the S-end section!

Collision and damage to components.

- ▶ Assemble the W-pivot section as a preassembled unit with the S-intermediate section or the SL-reducer on the S-end section.

Closing the lattice sections depends on the type of lattice section on which the W-pivot section is assembled:

- S-intermediate section 12 m
- SL-reducer 6 m

#### Assembling S-intermediate section 12 m

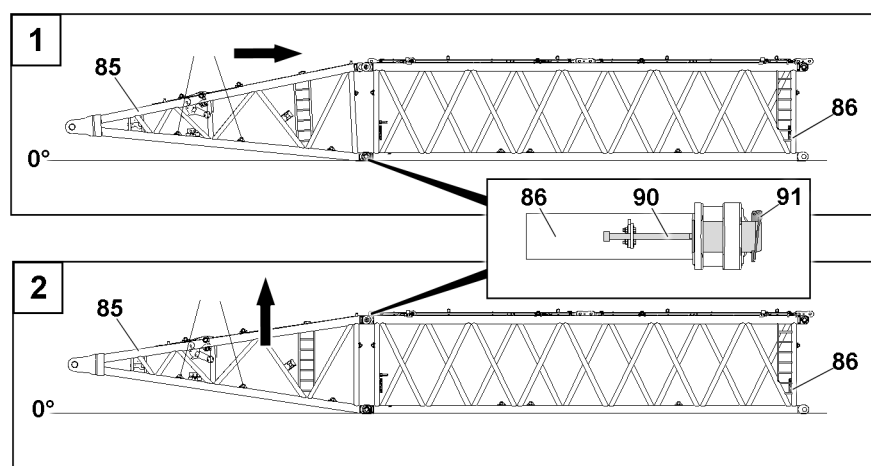


Fig.155816: Assembling the W-pivot section, 12 m S-intermediate section

The WA-pivot section **85** is pinned with the pin pulling cylinder, see chapter 5.30.

- ▶ Fasten the W-pivot section **85** to the auxiliary crane and lift.
- ▶ Position the W-pivot section **85** on the S-intermediate section **86** such that the pin bores align at the “bottom”.

- ▶ Insert the pin **90** on both sides.
- ▶ Secure the pin **90**: Attach the retaining elements **91**.
- ▶ Lift the SL-reducer **87** until the pin bores align at the “top”.
- ▶ Insert the pin **90** on both sides.
- ▶ Secure the pin **90**: Attach the retaining elements **91**.

#### Assembling the SL-reducer 6 m

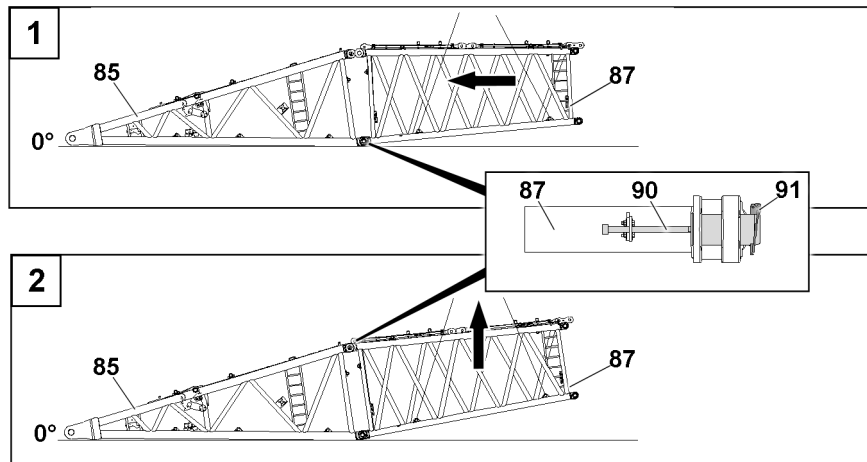


Fig.155817: Assembling the W-pivot section, 6 m SL-reducer

The SL-reducer **87** is pinned with the pin pulling cylinder, see chapter 5.30.

- ▶ Fasten the SL-reducer **87** to the auxiliary crane and lift.
- ▶ Position the SL-reducer **87** on the W-pivot section **85** such that the pin bores align at the “bottom”.
- ▶ Insert the pin **90** on both sides.
- ▶ Secure the pin **90**: Attach the retaining elements **91**.
- ▶ Lift the SL-reducer **87** until the pin bores align at the “top”.
- ▶ Insert the pin **90** on both sides.
- ▶ Secure the pin **90**: Attach the retaining elements **91**.

#### 4.15.2 Assembling the preassembled boom unit on the S-end section

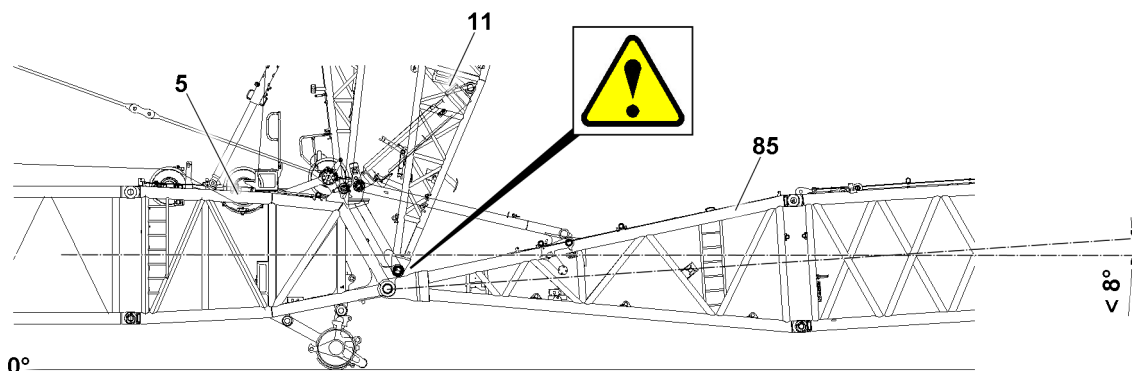


Fig.155819: Minimum permissible angle between the S-end section and W-pivot section



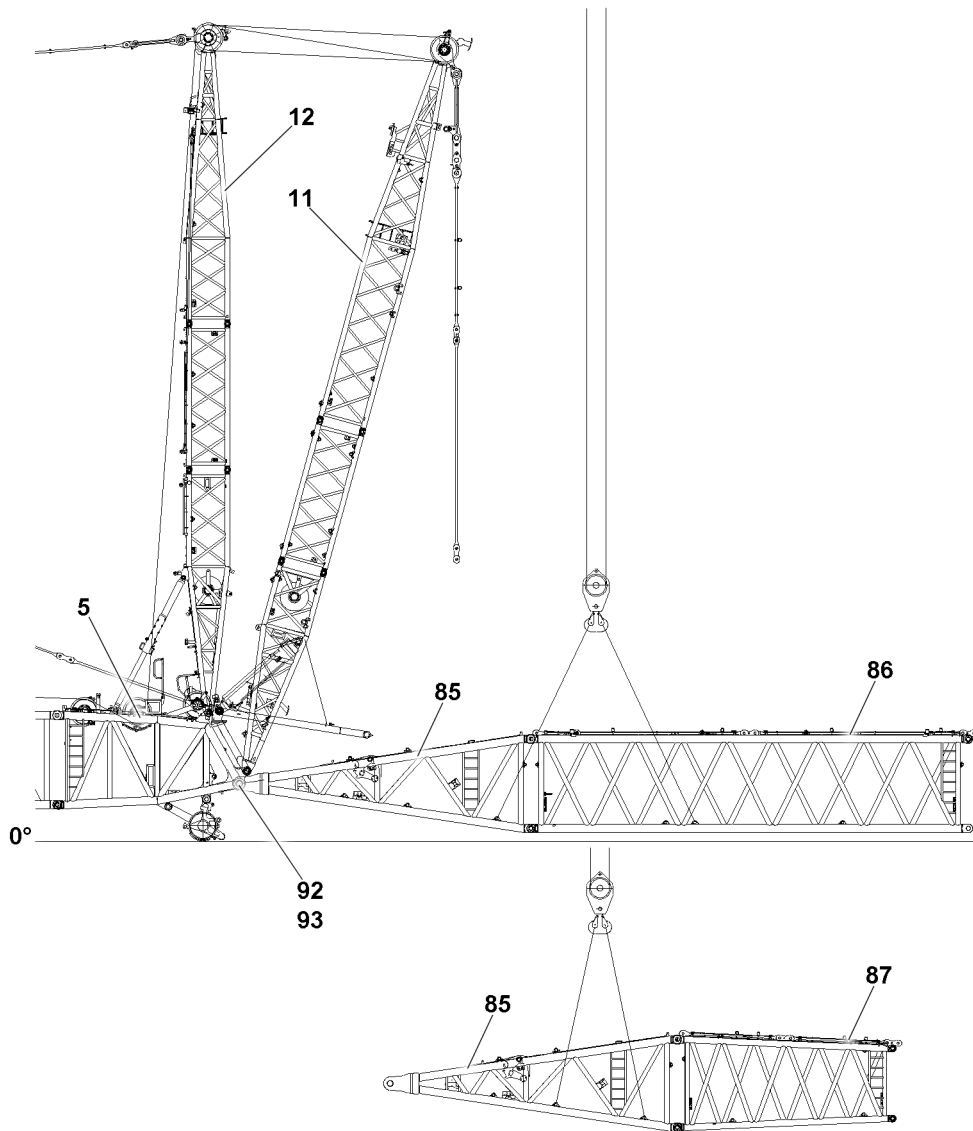
**NOTICE**

Minimum permissible angle between the S-end section **5** and the W-pivot section **85** **not** observed!  
Collision and damage to components.

- ▶ Observe the negative angle between the S-end section **5** and the W-pivot section **85** of less than  $8^\circ$ .

Reduce the angle if necessary:

- ▶ Lift the main boom.



*Fig.155818: Pinning the preassembled lattice unit on the S-end section*

Make sure that the following prerequisite is met:

- The connector pins **92** are completely unpinned.

**NOTICE**

WA-frame **1 11** **not** in the steepest position!  
Collision between the auxiliary crane and WA-frame **1**.  
Property damage.

- ▶ Before assembling the preassembled lattice unit, move WA-frame **1 11** to the steepest position.
- ▶ Erect WA-frame **1 11** to the steepest position.

The fastening points for the preassembled lattice unit are shown on signs on the W-pivot section **85**, or see section "Fastening points".

The illustration shows an example of a preassembled lattice unit consisting of the W-pivot section **85** and S-intermediate section 12 m **86**.

- ▶ Fasten the preassembled lattice unit to the auxiliary crane.
- ▶ Position the preassembled lattice unit with the auxiliary crane on the S-end section **5** until the pin bores align.
- ▶ Pin the W-pivot section **85** on the S-end section **5**, see the following procedure.

The pin procedure is described based on the example of one connector pin.

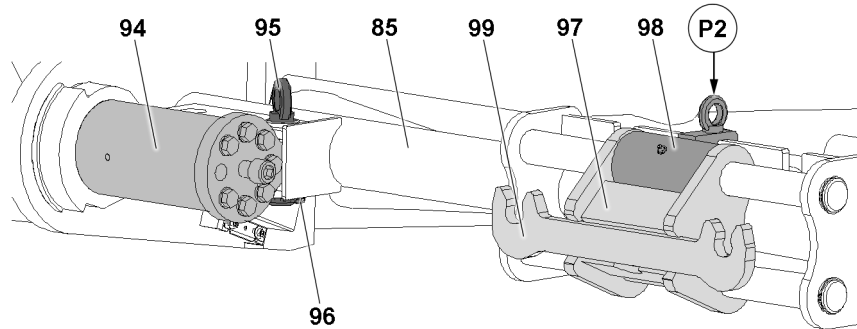


Fig.155821: Pinning the W-pivot section, first step

The connector pins **94** are pinned in three steps. In order to pin the connector pins **94** completely, the brackets **97** must be shifted.

- ▶ Release the connector pin **94**: Remove the retaining element **96** and unpin the retaining pin **95**.
- ▶ Make sure that the flap **98** is engaged in position **P2**.
- ▶ Insert the pin pulling cylinder in the pin pulling device **99** and fit it on the screw of the connector pin **94**.
- ▶ Until the pin pulling cylinder is completely extended: Actuate the pin pulling cylinder.
- ▶ Remove the pin pulling cylinder.

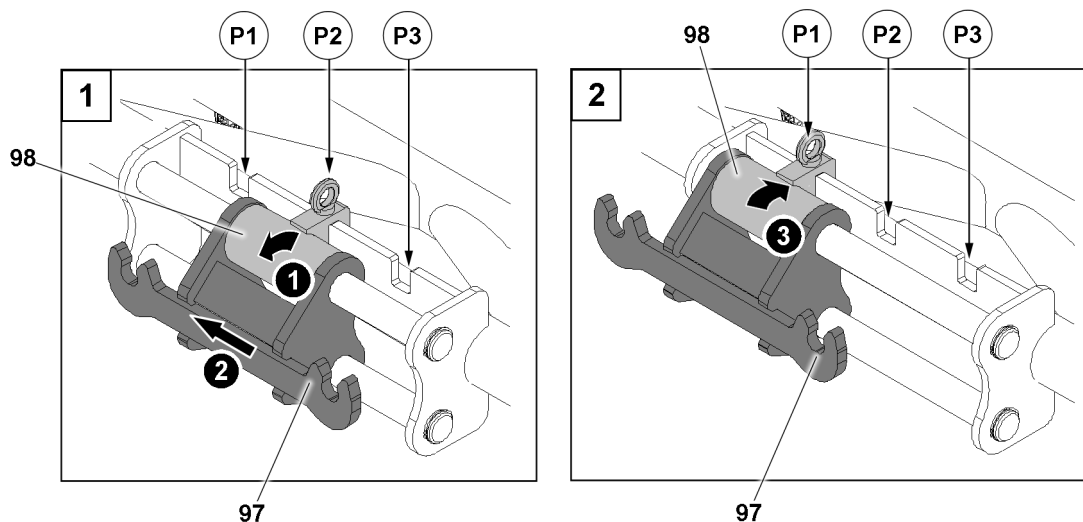
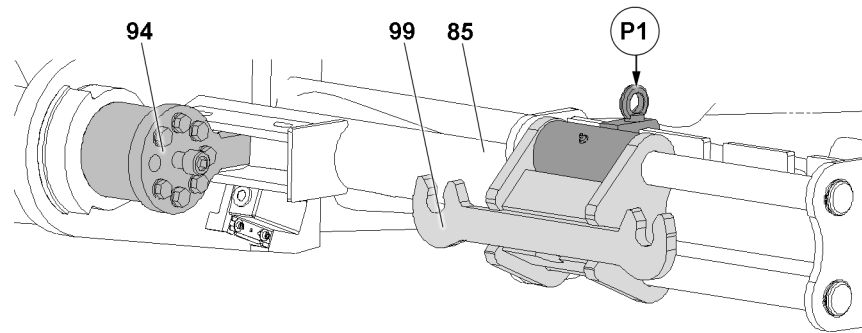


Fig.155824: Pinning the W-pivot section, second step

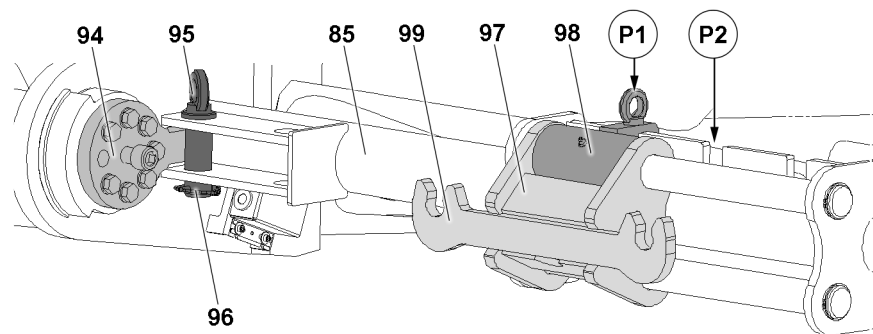
The flap **98** can be engaged in position **P1**, position **P2** and position **P3**.

- ▶ Lift the flap **98**.
- ▶ Move the bracket **97**.
- ▶ Snap the flap **98** into position **P1**.



*Fig.155822: Pinning the W-pivot section, third step*

- ▶ Insert the pin pulling cylinder in the pin pulling device **99** and fit it on the screw of the connector pin **94**.
- ▶ Until the connector pin **94** is completely pinned: Actuate the pin pulling cylinder.



*Fig.155823: Pinning the W-pivot section, connector pin pinned and secured*

When the connector pin **94** is completely pinned:

- ▶ Secure the connector pin **94**: Insert the retaining pin **95**.
- ▶ Secure the retaining pin **95**: Attach the retaining element **96**.
- ▶ Move the bracket **97** again and snap it into position **P2**.
- ▶ Repeat the pinning procedure in the second pin position.

### 4.15.3 Assembling the lattice sections

This section refers to the SL-reducer and the L-end section as an example.

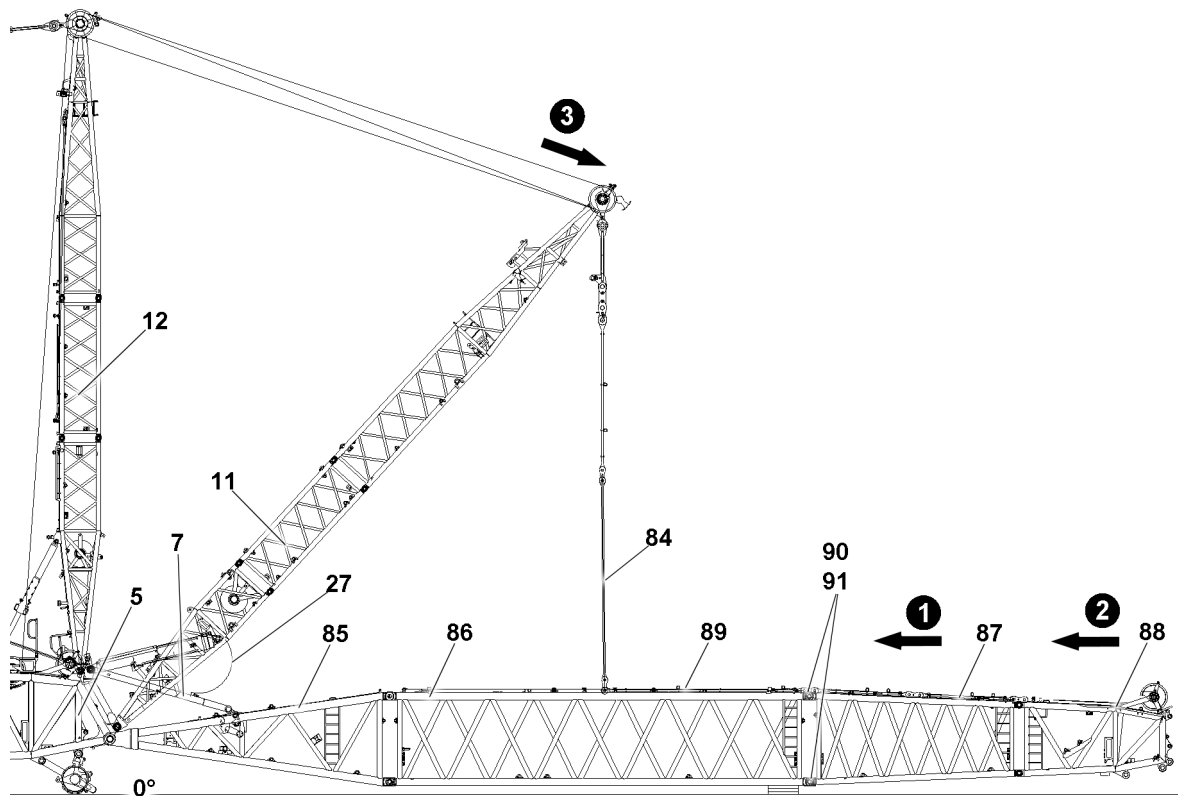


Fig.155820: Assembling the lattice sections

Make sure that the following prerequisites are met:

- The connector pins on the SL-reducer - in direction of the expansion of the boom system - are completely unpinned.
- The preassembled lattice unit is lying properly on the ground or on the substructure.

The lattice sections are pinned with the pin pulling cylinder, see chapter 5.30.

- ▶ Fasten the SL-reducer **87** to the auxiliary crane and position on the preassembled lattice unit until the pin bores align.

When the pin bores on the lattice sections align at the “top”:

- ▶ Insert the connector pin **90** at the “top” on both sides with the pin pulling cylinder to the stop.
- ▶ Secure both connector pins **90**: Attach the retaining element **91**.

When the connector pins **90** at the “top” are fully pinned to the stop and secured on both sides:

- ▶ Insert the connector pin **90** at the “bottom” with the pin pulling cylinder to the stop.
- ▶ Secure both connector pins **90**: Attach the retaining element **91**.
- ▶ Remove the auxiliary crane.
- ▶ Continue with W-boom assembly to the required system length, assemble the L-end section **88**.
- ▶ Disconnect the retaining rope **27** from the relapse support **7**.
- ▶ Fasten the retaining rope **27** to WA-frame **11** in the park position, see section “Lowering the relapse support”.
- ▶ Lower WA-frame **11** with adjustment until the guy rods **84** can be pinned with the guy rods **89**.

#### 4.15.4 Pinning the guy rods on the lattice sections

##### NOTICE

Impermissibly inserted pins!

If the pins of the guy rods are **not** pinned from the “inside” to the “outside”, the hoist rope can scrape on the pins and be damaged.

- ▶ Always insert the guy rod pins from the “inside” to the “outside”, see the Rod plan.

**WARNING**

Oscillating guy rods!  
Danger of crushing. Danger of falling.

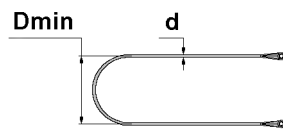
- ▶ Maintain the safety distance.
  - ▶ Keep the guy rods from oscillating.
- 
- ▶ Pin the guy rods **84** with the guy rods **89**, see section "Pinning the guy rods on the lattice sections".
  - ▶ Pin the guy rods **89** on the lattice sections with each other, see section "Pinning the guy rods on the lattice sections".
  - ▶ Make sure that all guy rods are pinned and secured with each other.

#### 4.15.5 Assembling the auxiliary guying

This section is valid solely only for the W-lattice jibs with the auxiliary guying.

An auxiliary guying must be assembled depending on the boom system, see the rod plan.

Fiber guy ropes are used for the auxiliary guying. Comply with the following regulations.



$$D_{min} = 20 \times d$$

Fig.160908: Fiber guy rope: Calculation of minimum permissible bending diameter

Formula element	Meaning
Dmin	Minimum permissible bending diameter
d	Rope diameter

Minimum permissible bending diameter: Definition of the formula elements

**WARNING**

Impermissible assembly of fiber guy ropes!

The fiber guy ropes can rip.

Death, severe bodily injuries, property damage.

- ▶ Before assembling the fiber guy ropes, check if the fiber guy ropes are rigidly frozen or covered with ice. See chapter 5.01.
- ▶ Do **not** assemble fiber guy ropes that are rigidly frozen or covered with ice.
- ▶ Do **not** use buckled, knotted or twisted fiber guy ropes.
- ▶ Never fall below the minimum permissible bending diameter **Dmin** of **20 x** rope diameter **d**.
- ▶ Do **not** assemble damaged fiber guy ropes.
- ▶ Make sure that the identification of the fiber guy rope on the rod plan and the identification on the individual fiber guy ropes are identical. Identify the fiber guy rope, see chapter 5.01.
- ▶ Make sure that the operating temperature of the fiber guy ropes of -40 °C to +60 °C is **not** fallen below or exceeded.
- ▶ Check the fiber guy ropes for damage prior to assembly, after disassembly and after exceptional events, see chapter 8.16.
- ▶ Comply with the maintenance intervals, see chapter 7.03.50.
- ▶ Replace damaged fiber guy ropes.
- ▶ Observe the notes regarding the proper transport and storage of the fiber guy ropes, see chapter 2.04.
- ▶ Observe the instructions for the proper handling of fiber guy ropes, see chapter 5.01.
- ▶ Only fasten the fiber guy ropes in the permissible range with belt loops, see chapter 5.01.

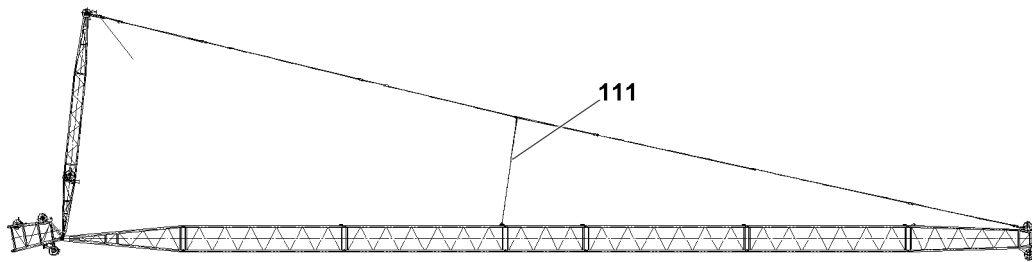


Fig.155827: Auxiliary guying, illustration shown as an example



#### Note

- ▶ Auxiliary guying **111** is not required for every system. Refer to the rod plans if auxiliary guying **111** is required.
  - ▶ Assembly of the auxiliary guying **111**, see the rod plan. The numbering in the rod plans must be identical to the numbering on the guy rods.
  - ▶ Auxiliary guying **111** assembly procedure, see chapter 5.01 and chapter 5.03.
- 
- ▶ Lift WA-frame 1 until the auxiliary guying **111** can be assembled.
  - ▶ Assemble the auxiliary guying.
  - ▶ Make sure that the auxiliary guying is properly pinned and secured.

#### 4.15.6 Assembling the airplane warning light and wind sensor on the L-end section

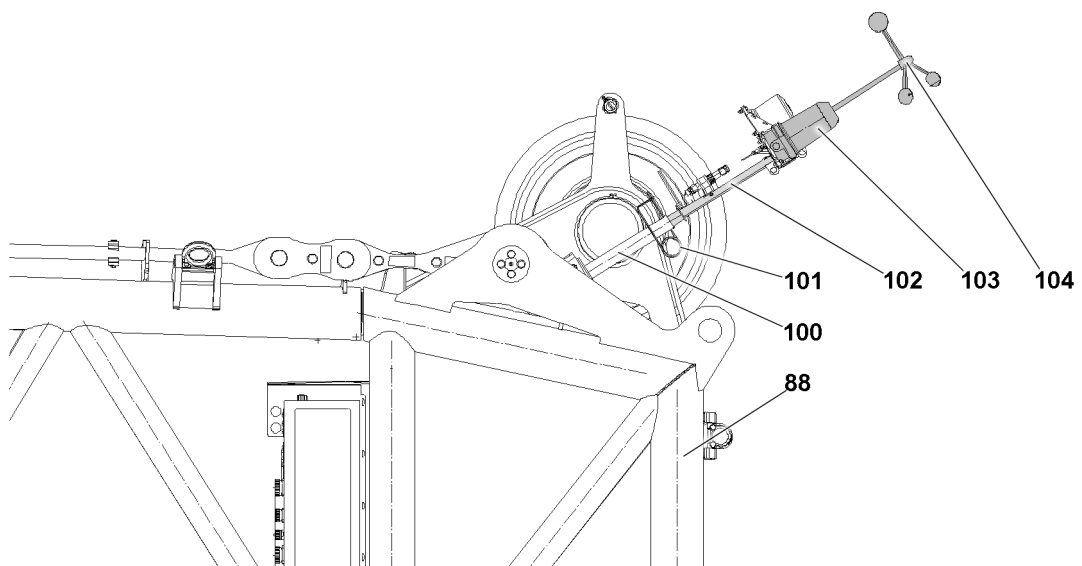


Fig.155825: Airplane warning light and wind sensor, L-end section

The wind sensor **104** and airplane warning light **103** are assembled on the L-end section **88**.

- ▶ Insert the retainer **102** in the pipe **100**.
- ▶ Secure the retainer **102**: Attach the retaining element **101**.

### 4.15.7 Establishing the electrical connections between the S-end section and the W-boom

Make sure that the following prerequisites are met:

- The W-boom is properly assembled on the ground and secured.
- The electrical connections to the S-end section have been established.
- The hoist limit switches are properly installed and secured on the pulley head / pulley heads.

---

#### NOTICE

Damage to the electrical connections!

If the electrical connection from the terminal box on the W-pivot section to the cable drum on the W-pivot section is established first before the connection from the cable drum to the terminal box on the L-end section, then the electrical connection will be damaged when spooling out the cable drum.

- ▶ Establish first the electrical connection from the cable drum on the W-pivot section to the terminal box on the L-end section and then the electrical connection from the terminal box on the W-pivot section to the cable drum.
- 



#### Note

- ▶ To establish the electrical connections on the end section of the W-boom: Observe the wiring diagram.
- 

- ▶ Establish the electrical connections.
  - ▶ Make sure that all electrical connections on the W-boom are established.
- 



#### WARNING

Malfunction if dummy plugs are **not** assembled!

If the dummy plugs are not fit on the non-required electrical connections, then malfunctions or functional limitations can occur on the crane.

- ▶ Make sure that all non-required electrical connections, which have a dummy plug are closed off with dummy plugs.
  - ▶ Observe the wiring diagram.
- 
- ▶ As a rule, close off non-required electrical connections (for example for accessories that are not assembled) with the respective dummy plugs.
- 

#### NOTICE

Property damage due to dirt and / or corrosion!

If unnecessary electrical connections are not closed off with the respective protective caps, then dirt and / or corrosion can damage the electrical connections.

This could result in malfunctions.

- ▶ Make sure that all non-required electrical connections are always closed off properly.
  - ▶ Observe the wiring diagram.
- 
- ▶ Properly close off the electrical connections without dummy plugs with the corresponding protective caps.
- 

### 4.15.8 Checking the function of the safety equipment

Make sure that the following prerequisites are met:

- All electrical connections are established.
- The appropriate operating mode is set.

#### Wind speed sensor

- ▶ Check the movement and the function of the wind speed sensor.

#### Airplane warning light

- ▶ Turn the airplane warning light on and visually check the function.

## Oscillation guard

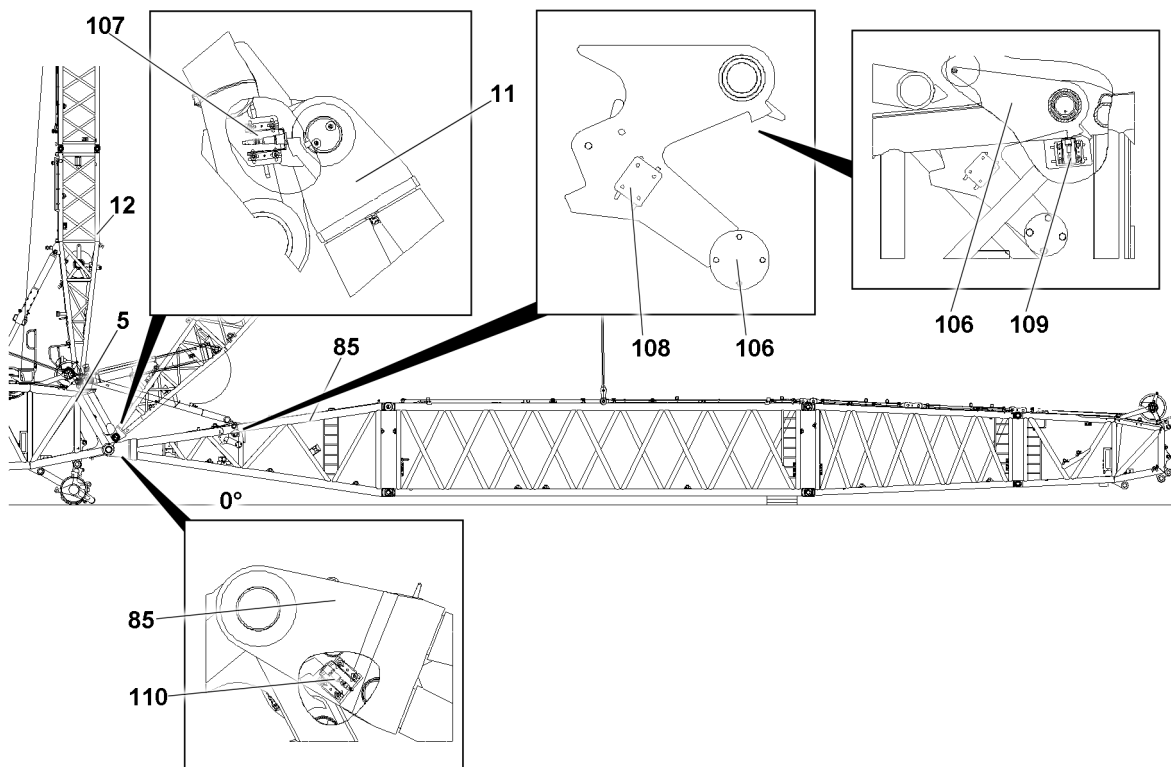


Fig.155826: Oscillation guard, limit switch



### DANGER

Danger of tipping over if the oscillation guard is hard to move!  
The mechanical relapse retainer no longer functions if the oscillation guard **106** moves with difficulty. The W-lattice jib can tip backwards uncontrolled and cause the crane to topple over.

- ▶ Crane operation with hard to move oscillation guard **106** is prohibited.
- ▶ Check the oscillation guard **106** for easy movement.

### Limit switch, general



### WARNING

The crane control does **not** turn off in a timely manner!  
▶ The limit switch functions have to be checked individually before erection.



### Note

- ▶ The limit switch initiators are checked manually as follows.
- ▶ Check the limit switch initiators, see chapter 8.12.

### Limit switch on the S-end section, "WA-Frame 1 bottom" position

- ▶ Cover the left and right "WA-frame 1 bottom" limit switch initiators **107** individually with a metal plate.

### Result:

- The icon appears on the LICCON monitor.
- The **spool out function** of the W-control winch turns off.



### Limit switch on the W-pivot section

“Luffing jib bottom” limit switch

- ▶ Cover the left and right “luffing jib bottom” limit switch initiators **110** individually with a metal plate.

**Result:**

- The icon appears on the LICCON monitor.
- The **spool out function** of the W-control winch turns off.

“Right flap” limit switch, mechanical relapse support in the flap

- ▶ Cover the left and right “flap right” limit switch initiators **108** individually with a metal plate.

**Result:**

- The icon appears on the LICCON monitor.
- The **spool up function** of the W-control winch turns off.

“Flap in position” limit switch

- ▶ Cover the left and right “flap in position” limit switch initiators **109** individually with a metal plate.

**Result:**

- An error message appears on the LICCON monitor.
- The **spool up function** of the W-control winch turns off.

### Hoist limit switch

When replacing or changing the hoist limit switch (HES), the HES must have the correct bus address and the correct software version in order to be recognized again by the bus system (LSB).

- ▶ Actuate the hoist limit switch manually.

**Result:**

- The icon appears on the LICCON monitor.
- The **spool up** of the hoist winch turns off.

## 4.16 Assembling the roller cart on the L-end section

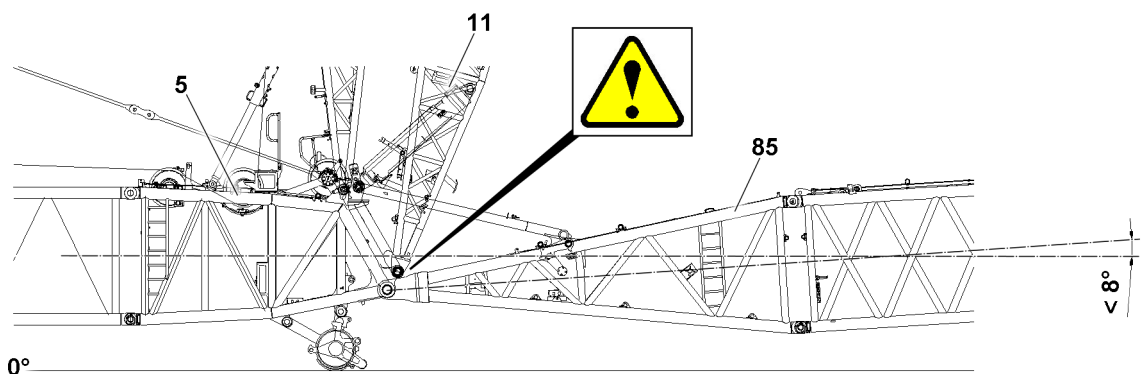


Fig.155819: Minimum permissible angle between the S-end section and W-pivot section

**NOTICE**

Minimum permissible angle between the S-end section **5** and the W-pivot section **85** **not** observed!  
Collision and damage to components.

- ▶ Observe the negative angle between the S-end section **5** and the W-pivot section **85** of less than  $8^\circ$ .

Reduce the angle if necessary:

- ▶ Lift the main boom.

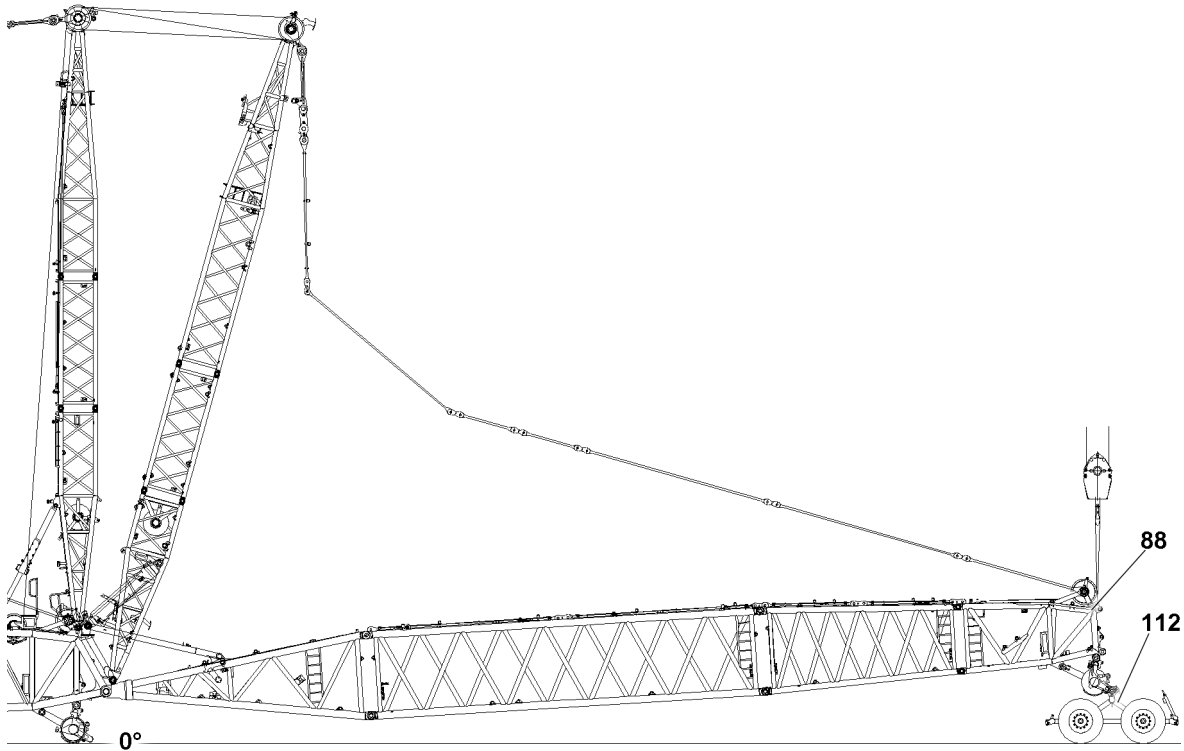


Fig.155828: Roller cart on the luffing jib head

**Note**

- ▶ Lift the W-boom with the auxiliary crane, required load bearing capacity approx. 27.5 t.

- ▶ Lift the W-boom with the auxiliary crane until the roller cart **112** can be pushed under.

Assembling of the roller cart, see chapter 5.61.

- ▶ Push the roller cart **112** under the luffing jib head **88** and assemble.

## 4.17 Pulling the hoist rope in

**WARNING**

Running ropes!  
Danger of crushing.

- ▶ Adhere to the safety distance to the running ropes.
- ▶ Radio contact is available between crane operator and assembly personnel.

**NOTICE**

Impermissible reeving!  
Damage to the crane. Breakage of the rope.

- ▶ Reeve in the ropes according to the reeving plan.

**NOTICE**

Slack rope formation!

Due to slack rope formation, the hoist rope and the W-control rope can be damaged.

Property damage.

- ▶ When spooling the hoist rope or the W-control rope up or out, do not allow slack rope formation.
- ▶ When spooling up or out, hold the hoist rope and the W-control rope taut.

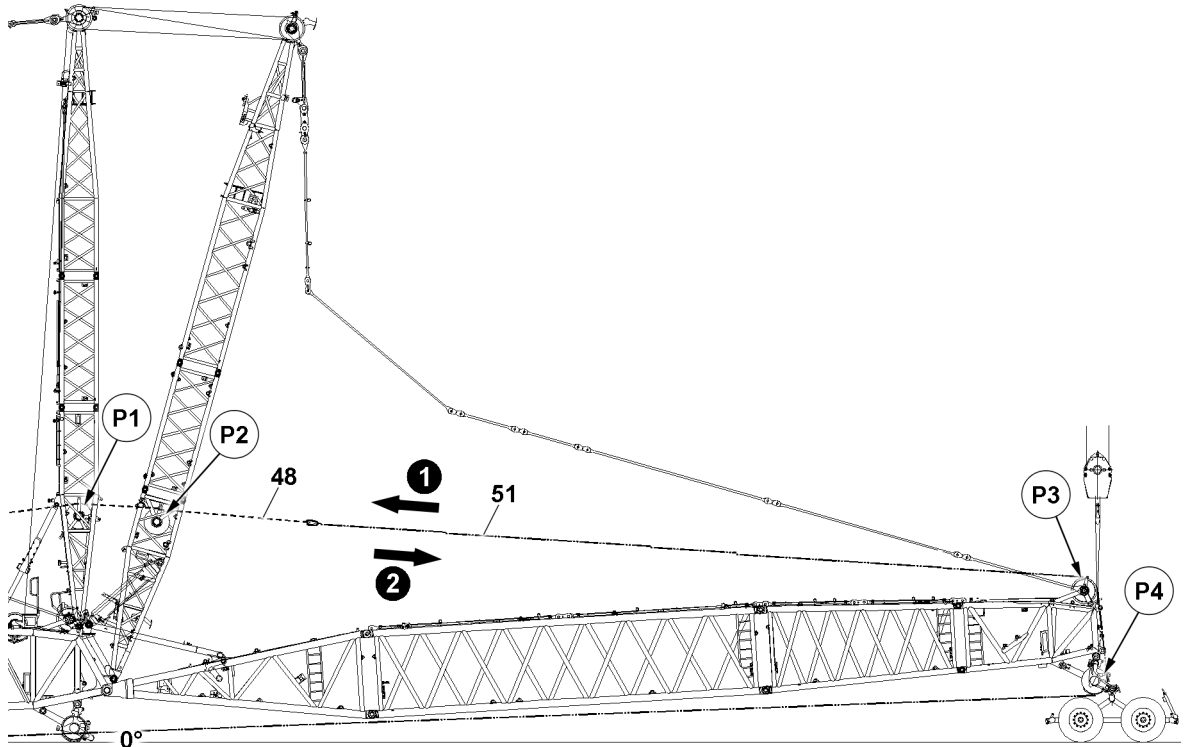


Fig.155829: Pulling the hoist rope in

On every WA-frame, a pulley is available for the hoist rope of winch 1 and winch 2. Rope reeving, see the reeving plan.

- ▶ Remove the rope retainer in the rope pulleys in point **P3** and point **P4**: Remove the rope retaining elements and rods.

This procedure is described based on the example of one hoist rope.

The line shows the course for the auxiliary rope **51** and the hoist rope **48**.

A work platform is required for pulling in the auxiliary rope on the WA-frames.

- ▶ Spool the auxiliary rope **51** out and pull it over the pulleys in point **P4**, point **P3**, point **P2** and point **P1**.
- ▶ Fasten the auxiliary rope **51** to the hoist rope **48**.
- ▶ Pull the hoist rope **48** to the rope pulley in point **P3**: Spool the auxiliary rope **51** up and spool the hoist rope **48** out at the same time.
- ▶ Spool the hoist rope **48** out to the ground.
- ▶ Disconnect the auxiliary rope **51** from the hoist rope **48**.
- ▶ Spool the auxiliary rope **51** up.

If two hoist ropes are reeved:

- ▶ Repeat the procedure for the second hoist rope.
- ▶ Assemble the rope retainer in the rope pulleys in point **P3** and point **P4**: Attach the rope retaining elements and rods.

## 5 Information about erecting / taking down the boom system with the luffing jib

### 5.1 Boom system position during erection / take-down

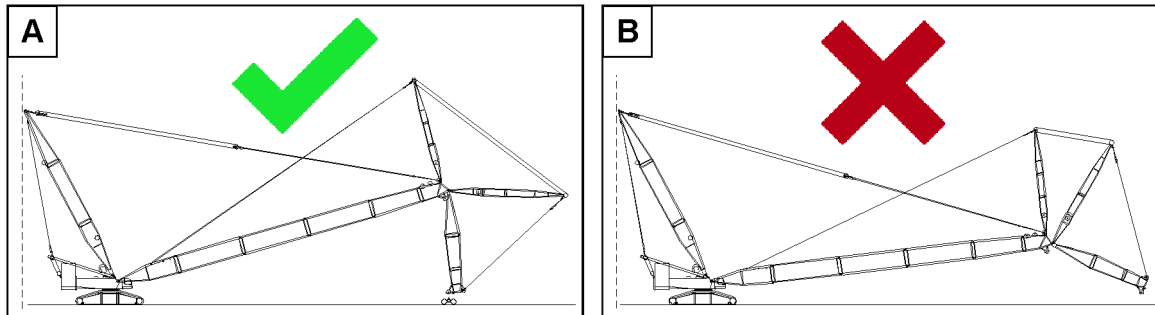


Fig.163401: Example of erecting / taking down the boom system angled or stretched

#### Variation A

- Example for erecting / taking down the boom system with the luffing jib “angled” in a normal case. For lifting / positioning, the luffing jib is in the most vertical position possible. In addition, the luffing jib is guided on the roller cart.
- **Note:** This chapter describes how angled erection / take-down takes place.

#### Variation B

- Example for erecting / taking down the boom system with the luffing jib “stretched” in a special case. For lifting / positioning, the luffing jib is in a relatively horizontal position.
- **Note:** This chapter does **not** describe how stretched erection / take-down takes place. **Only** specifically released boom systems may be used to erect or take down boom systems stretched.



#### WARNING

The crane can topple over!

If attempting to impermissibly erect or take down a boom system stretched, the crane can be overloaded and topple over.

Death, severe bodily injuries, property damage.

- ▶ Observe the erection and take-down charts.
- ▶ Only erect or take-down the boom systems stretched if explicitly released to do so.
- ▶ In case of doubt, erect or take-down the boom system angled.

### 5.2 Use of the mechanical auxiliary support



#### Note

- ▶ Mechanical auxiliary support, see chapter 3.04.

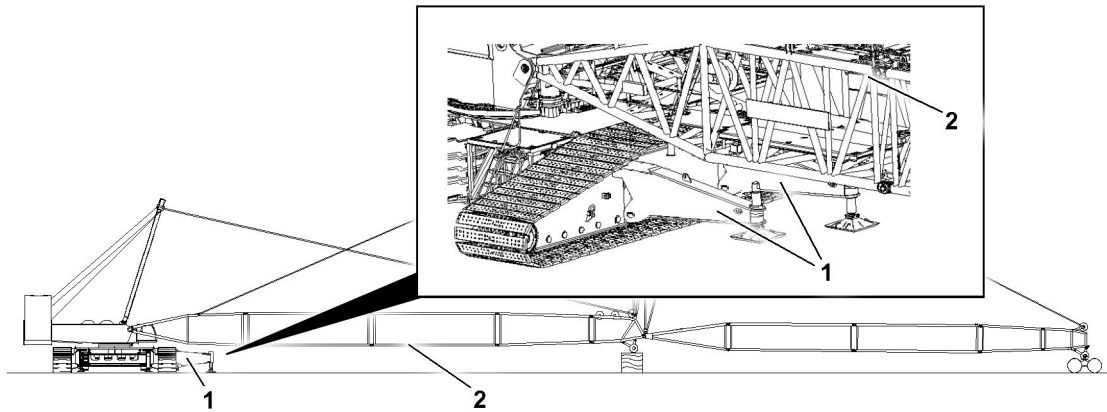


Fig.163404: Example for use of the mechanical auxiliary support

For certain boom systems, the mechanical auxiliary support **1** must be installed for erection and take-down.

The main boom **2** with the luffing jib must be erected or taken down exactly in the direction of the mechanical auxiliary support **1**, see illustration.



#### WARNING

Mechanical auxiliary support not used or used incorrectly!

If the mechanical auxiliary support is not used correctly even if the specification is provided, the permissible forces during erection / take-down of the boom system will be exceeded.

If the boom system is erected or taken down in the wrong direction, the mechanical auxiliary support has no effect.

The crane can topple over.

Death, severe bodily injuries, property damage.

- ▶ Observe the specifications on the use of the mechanical auxiliary support.
- ▶ Erect and take down the main boom **2** with the luffing jib in the direction of the mechanical auxiliary support **1**.

### 5.3 Determining the steepest main boom operating position

If a specific position is not specified for the set up boom system for erection / take-down, the steepest operating position of the main boom must be known.



#### WARNING

The main boom is in the wrong position!

If the main boom is in the wrong position, the crane can be overloaded during erection / take-down and topple over.

Death, severe bodily injuries, property damage.

- ▶ Before erection / take-down of the boom system, determine the correct position of the boom system.

If there are no explicit specifications regarding the position of the boom system:

- ▶ Determine the steepest operating position of the main boom and approach it at the specified moment.

If there are explicit specifications regarding the position of the boom system, for example in the erection and take-down charts:

- ▶ Approach the positions of the boom system at the specified moment.

Make sure that the following prerequisites are met:

- The set up configuration of the crane and the selected / set load chart match.
- The additional specifications of the erection and take-down charts are observed.
- The additional specifications of the crane documentation including the assembly drawings / assembly plans are observed.

Four different options are described below.

The four options are:

- Curve illustration of the load charts (crane)
- Load chart manual document
- LICCON job planner (PC)
- Curve illustration of the load charts (PC)

### 5.3.1 Curve illustration of the load charts (crane)

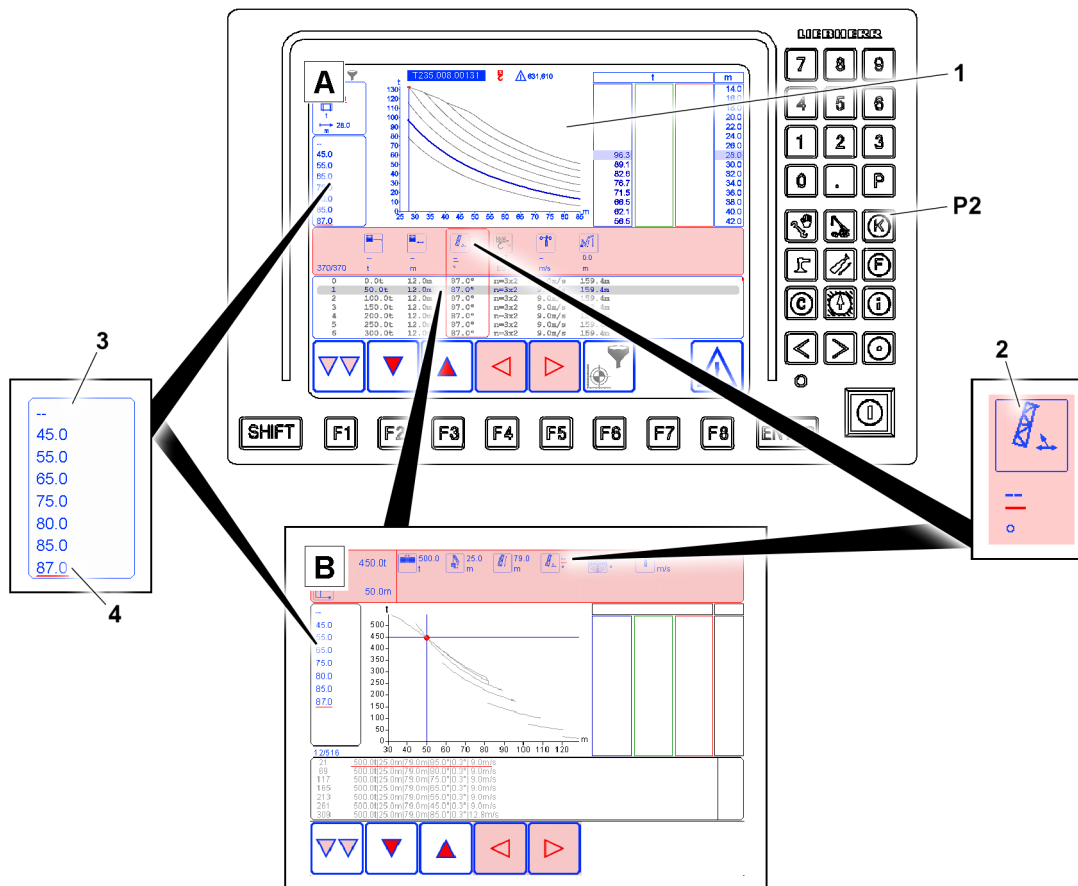


Fig.160418: Example for the curve illustration of load charts on the crane (LICCON monitor)

#### 1 Curve illustration

- Curve illustration of load charts
- **Note:** The curve illustration is called up via a program key **P2** on the right LICCON monitor.
- **Note:** The view of the curve illustration can vary, see variation **A** and variation **B**

#### 2 Main boom angle icon

- Designates the column with the list of the main boom angles
- **Note:** As soon as the main boom angle icon **2** is selected, all main boom angles of the set load chart are displayed in increasing order in the Editing / selection window **3**.

#### 3 Editing / selection window

- If the main boom angle icon **2** is selected, all main boom angles of the set load charts are displayed in increasing order here.

#### 4 Main boom angle

- The largest main boom angle **4** generates the steepest operating position of the main boom. The largest main boom angle is located in the lowest position in the editing / selection window **3**. In the example shown, the 87° main boom angle is underlined.

- ▶ Call up the curve illustration **1** for the set up configuration of the crane.
- ▶ Select the main boom angle icon **2**.
- ▶ Scroll to the very bottom of the editing / selection window **3** to display the largest main boom angle **4** of the set load chart.

**Result:**

- The largest main boom angle **4** corresponds to the steepest operating position of the main boom.
- Unless the specifications state otherwise, use the steepest determined operating position of the main boom for the erection / take-down of the boom system.

**5.3.2 Load chart manual document**

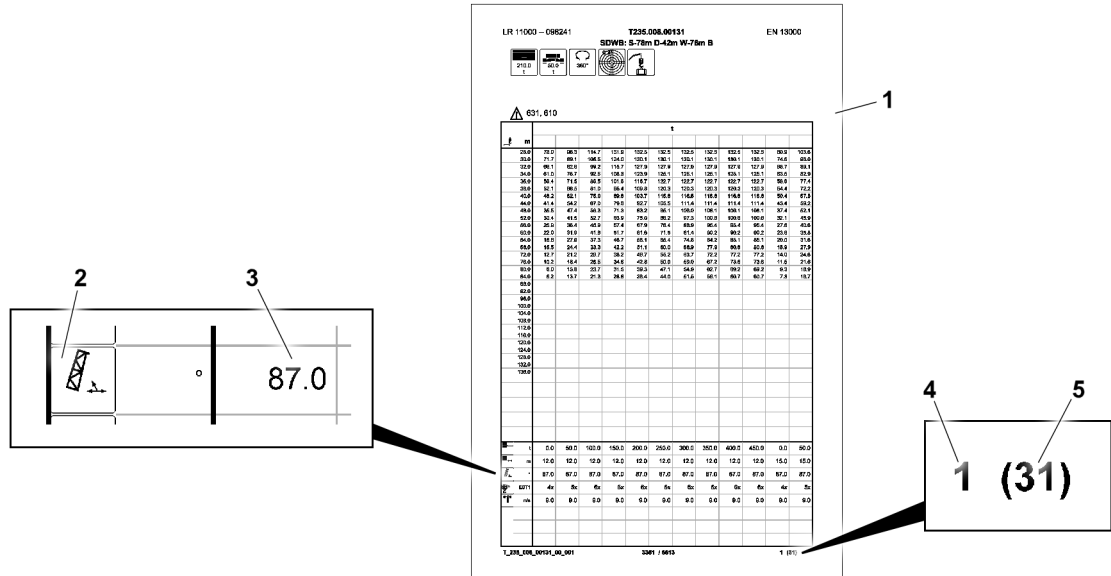


Fig.160411: Example for a load chart in the load chart manual document

**1** Load chart

**2** Main boom angle icon

- Designates the line with the list of the main boom angles

**3** Angle value

- The largest angle value **3** generates the steepest operating position of the main boom. In the example shown, the main boom angle is 87°.

**Note:** The steepest operating position of the main boom corresponds to the largest angle value **3** in the line. Observe all pages of the respective load chart **1**.

**4** Page number

- If the load chart is comprised of multiple pages, they are numbered. The page number of the currently displayed page is indicated here.

- **Note:** The example shown shows page 1 of 31 pages.

**5** Page number

- Total number of load chart pages.
- **Note:** To determine the steepest permissible operating position of the main boom, observe all pages of the respective load chart.

- ▶ Select the load chart for the crane set up configuration.
- ▶ Determine the highest angle value **3** on all pages of the load chart in the line of the main boom angle icon **2**.

LWE/LR 1800-1-0-000/27200-07-02/en

**Result:**

- The largest angle value **3** corresponds to the steepest operating position of the main boom.
- Unless the specifications state otherwise, use the steepest determined operating position of the main boom for the erection / take-down of the boom system.

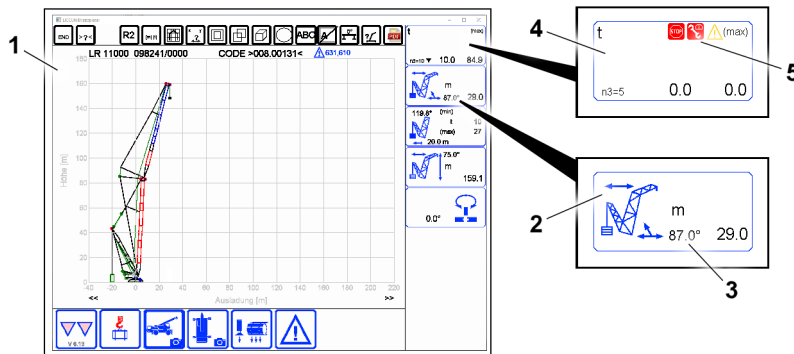
**5.3.3 LICCON job planner (PC)**

Fig.160416: Example of the LICCON job planner in the Computer (PC)

**1** LICCON job planner program

**2** Boom radius icon

- Boom radius and main boom angle display

**3** Main boom angle

- The largest main boom angle **3** generates the steepest operating position of the main boom. In the example shown, the main boom angle is 87°.
- **Note:** If the LMB function (load momentum limiter) is turned off in the LICCON job planner, the main boom positions that are too steep can be simulated. Simulate the steepest operating position of the main boom in the LICCON job planner with active LMB function (load momentum limiter).

**4** Load icon

- Reeving, maximum load and actual load display.

**5** Warning icons

- If a warning event occurs, a warning icon appears. Multiple warning icons can appear at the same time.
- **Note:** Warning icons can also appear in other icons, for example in the case of incorrect ballasting of derrick ballast.

**Note**

To ensure a valid simulation of the steepest operating position of the main boom, make sure that the corresponding LICCON job planner fulfills all the conditions of the load chart.

- ▶ A valid maximum load appears in the load icon **4**.
- ▶ A warning icon **5** does not appear.

▶ Set the set up configuration of the crane in the LICCON job planner.

▶ Determine the steepest operating position of the main boom in the load chart through a simulation with the LICCON job planner.

**Result:**

- The largest main boom angle **3** that can be simulated corresponds to the steepest operating position of the main boom.
- Unless the specifications state otherwise, use the steepest determined operating position of the main boom for the erection / take-down of the boom system.



### 5.3.4 Curve illustration of load charts (PC)

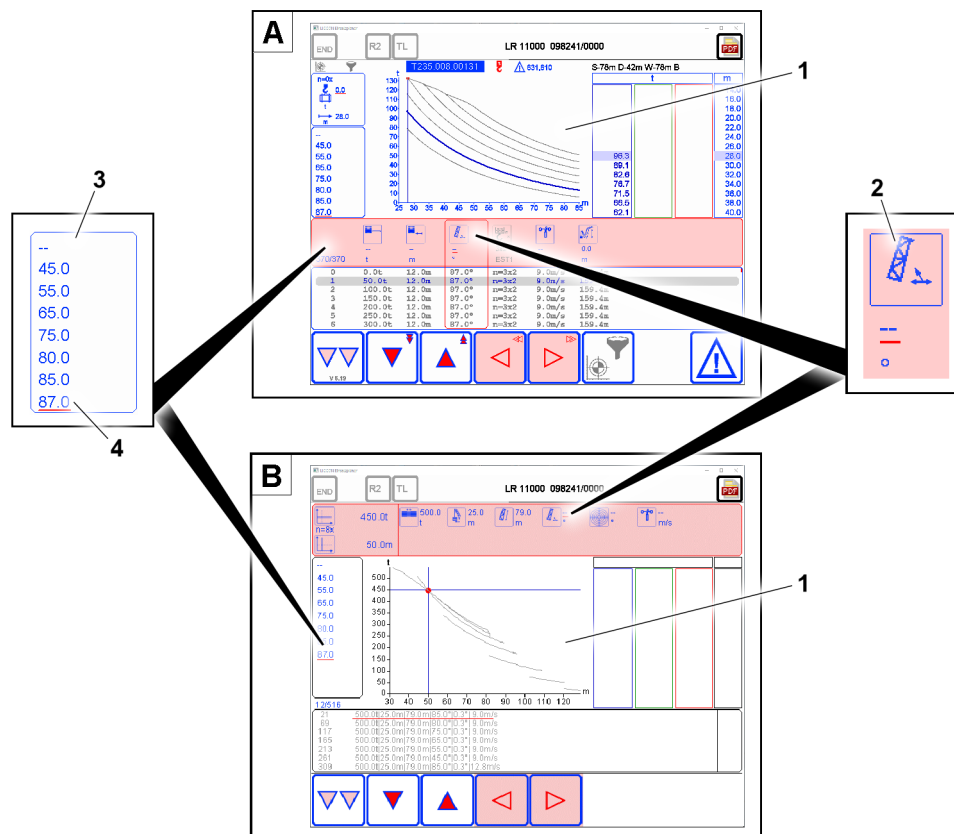


Fig.160456: Example for the curve illustration of load charts on the crane (PC)

#### 1 Curve illustration

- Curve illustration of load charts
- **Note:** The view of the curve illustration can vary, see variation **A** and variation **B**

#### 2 Main boom angle icon

- List of the main boom angles
- **Note:** As soon as the main boom angle icon **2** is selected, all main boom angles of the set load chart are displayed in increasing order in the Editing / selection window **3**.

#### 3 Editing / selection window

- If the main boom angle icon **2** is selected, all main boom angles of the set load charts are displayed in increasing order here.

#### 4 Main boom angle

- The largest main boom angle **4** generates the steepest operating position of the main boom. The largest main boom angle is located in the lowest position in the editing / selection window **3**. In the example shown, the 87° main boom angle is underlined.
- **Note:** Scroll to the very bottom of the editing / selection window **3** to display the largest main boom angle **4** of the set load chart.

- ▶ Set the set up configuration of the crane in the LICCON job planner.
- ▶ Call up the curve illustration **1**.
- ▶ Select the main boom angle icon **2**.
- ▶ Scroll to the very bottom of the editing / selection window **3** to display the largest main boom angle **4** of the set load chart.

#### Result:

- The largest main boom angle **4** corresponds to the steepest operating position of the main boom.

- Unless the specifications state otherwise, use the steepest determined operating position of the main boom for the erection / take-down of the boom system.

## 6 Erecting the boom system with luffing jib

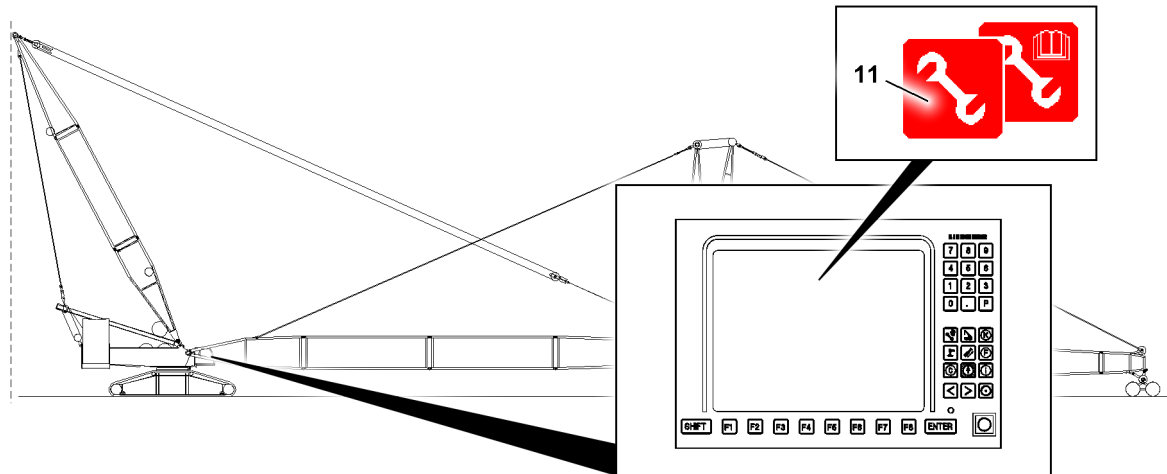


Fig.160419: Assembly operation activated, variations of the assembly icon on the LICCON monitor



### Note

The *assembly icon 11* has a small area for additional signs to the top right.

- ▶ A symbolized manual can appear there during erection / take-down procedures.
- ▶ For a detailed description of the variations of the *assembly icon 11*, see chapter 4.02.



### WARNING

Erection and take down charts not observed!

The specifications regarding the erection procedure are implemented, the erection / take-down charts are observed.

If the specifications in the erection and take-down charts are not observed, the crane can topple over during erection or take-down of the boom system.

Death, severe bodily injuries, property damage.

- ▶ The set up configuration of the crane must correspond to the erection and take-down charts.
- ▶ The ground slope must correspond to the erection and take-down charts.
- ▶ The wind speed must correspond to the erection and take-down charts.



### WARNING

Impermissible assembly procedures during assembly operation!

If assembly operation is activated, the *assembly icon 11* appears. The LICCON overload protection is bypassed in order to carry out the specified erection / take-down procedures and assembly procedures.

In the case of deviations from the specified sequences, misuse of the function or due to impermissible assembly procedures, the crane can be overloaded and topple over.

Death, severe bodily injuries, property damage.

- ▶ Assembly operation may only be activated by persons who know and can estimate the effects.
- ▶ Activate the assembly operation only when the correct set up configuration was entered in the LICCON computer system.
- ▶ Comply with the specifications, observe the erection / take-down charts.
- ▶ Normal crane operation with activated assembly operation is prohibited, the *assembly icon 11* may not appear.

**WARNING**

The boom system folds backward!

If the minimum hook block weight is not observed, the boom system can tip backwards in steep positions and the crane can topple over.

Death, severe bodily injuries, property damage

- ▶ Observe the minimum hook block weight.

**WARNING**

Remaining in the danger zone!

Persons located within the boom system during erection / take-down can fall down.

Persons below or directly on the boom system can be crushed or struck by the boom system during erection /take-down.

Death, severe bodily injuries, property damage.

- ▶ No one may be located on, inside, below or directly near the boom system during erection / take-down of the boom system.

**WARNING**

Turning of the crane superstructure when erecting / taking down the boom system!

If the crane superstructure is turned when erecting / taking down the boom system, the crane can be overloaded and topple over.

Death, severe bodily injuries, property damage.

- ▶ It is prohibited to turn the crane superstructure when erecting / taking down the boom system.

**WARNING**

The crane superstructure turns uncontrolled!

If the slewing gear brake is released, then the crane superstructure can turn uncontrolled in strong side wind or in an inclined position.

Death, severe bodily injuries, property damage.

- ▶ Secure the crane superstructure against turning movements when erecting / taking down the boom system.
- ▶ Operate the slewing gear and slewing gear brake anticipatorily in case of side wind or incline position.

**WARNING**

Wind speed too high!

If the maximum permissible wind speeds are disregarded, the crane can topple over.

Death, severe bodily injuries, property damage.

- ▶ Observe the specifications regarding the wind speed in the erection and take-down charts.

When there are no specifications regarding the wind speed in the erection and take-down charts:

- ▶ Comply with the specifications regarding the wind speed from the wind out of operation charts.

**WARNING**

Relapse cylinder not extended!

If the relapse cylinders of the main boom are not extended prior to erection or if the control device is damaged, then the relapse retainer of the main boom will not function.

The Main boom can tilt over to the rear.

Death, severe bodily injuries, property damage.

- ▶ Prior to erection, make sure that the relapse cylinders are completely extended.

**WARNING**

Oscillation guard not functioning!

If the oscillation guard is hard to move, damaged or not in the correct position, the luffing jib mechanical relapse retainer will not function.

The luffing jib can tilt over to the rear.

Death, severe bodily injuries, property damage.

- ▶ Prior to erection, make sure that the oscillation guard is intact and easy to move.

**WARNING**

Mechanical auxiliary support not used or used incorrectly!

If the mechanical auxiliary support is not used correctly even if the specification is provided, the permissible forces during erection / take-down of the boom system will be exceeded.

If the boom system is erected or taken down on the wrong side, the mechanical auxiliary support has no effect.

The crane can topple over.

Death, severe bodily injuries, property damage.

- ▶ Observe the specifications on the use of the mechanical auxiliary support.
- ▶ Erect and take down the main boom with the luffing jib on the correct side.

**WARNING**

Unused guy rods or objects on the boom!

If there are unused guy rods or objects on the boom that are not needed there for operation, there is danger of accident.

The guy rods or objects can release and fall down.

The boom weight is too high.

Death, severe bodily injuries, property damage.

- ▶ Prior to erection, check the boom system and remove all unused guy rods and objects.

**WARNING**

The crane is overloaded!

If the permissible forces are not observed, there is danger of accident.

The crane and boom system can be overloaded and fail, the crane can collapse or tip over.

Death, severe bodily injuries, property damage.

- ▶ Adapt the luffing jib control continuously so that the maximum forces are not exceeded.
- ▶ Monitor the displays in the LICCON computer system, observe the limit values.
- ▶ Do not allow slack rope to form on the control winches.

**WARNING**

Falling hoist rope!

If a hoist rope that is not reeved in is not pulled with the respective length over the luffing jib end section during erection / take-down of the boom system, it can fall backward due to its own weight.

Death, severe bodily injuries, property damage.

- ▶ Pull the rope end out at least 10 m over the luffing jib end section and put it down on the ground.
- ▶ Monitor the behavior of the hoist rope during erection / take-down.

Make sure that the following prerequisites are met:

- The crane has been set up according to the data in the load charts and the erection and take-down charts.
- The LICCON overload protection has been set according to the data in the load charts and erection and take-down charts.
- The LICCON overload protection settings have been checked for completeness and correctness.
- Assembly operation of the crane control is activated: The assembly icon is visible on the LICCON monitor.
- The crane is horizontally aligned.
- When there are specifications on the use of the mechanical auxiliary support: The mechanical auxiliary support is installed correctly and the boom system is erected on it.
- The boom system is in a position permissible for erection.

- The specifications regarding the erection procedure are implemented, the erection / take-down charts are observed.
- Crane ballasting (counterweight, central ballast, if necessary derrick ballast and auxiliary ballast) is carried out according to the load charts and the erection and take-down charts.
- The maximum permissible wind speeds are observed.
- The luffing jib is completely assembled.
- The roller cart is assembled on the luffing jib end section.
- The guy rods are properly assembled.
- Non-required guy rods are removed from the lattice sections.
- All pin connections are secured.
- All electrical connections are established.
- All hydraulic connections are established.
- The function checks were carried out properly.
- All limit switches and warning devices are functioning.
- The hoist rope has been correctly inserted in the rope pulleys and is prevented from jumping out with the rope retaining pins.
- The rope end of the hoist rope must be pulled out at least 10 m over the luffing jib end section.
- In the case of boom systems with a minimum hook block weight, the minimum hook block weight is observed.
- There are no loose or unnecessary parts on the boom system.
- The boom system and the safety equipment are free of snow, frost and ice.
- No personnel or obstacles are within the danger zone.
- Unless the specifications state otherwise, use the steepest operating position of the main boom for the erection / take-down of the boom system. See section “Determining the steepest main boom operating position”.

The steepest operating position of the main boom is individual for every boom system.

- For this individual angle, the place holder  $MAX^{\circ TL/AAT}$  is used in the following description.

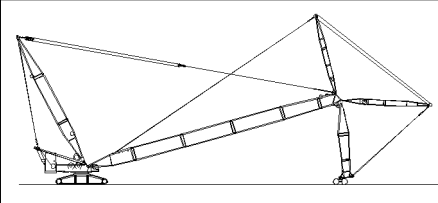
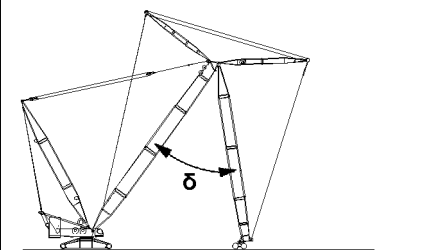
## 6.1 Information regarding the erection procedure

The set up configuration of the crane and the local conditions influence the erection procedure.

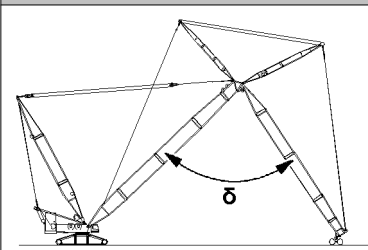
The erection procedure can be divided into two parts:

- The first part of the erection procedure is carried out until the roller cart can be removed with the steepest possible main boom.
- In the second part of the erection procedure, the boom system is lifted out of the roller cart and luffed down into the operating position.  
The entire boom weight is carried by the crane.

At the end of the first part of the erection procedure, the boom positions vary according to the set up configuration, see the examples in the following chart.

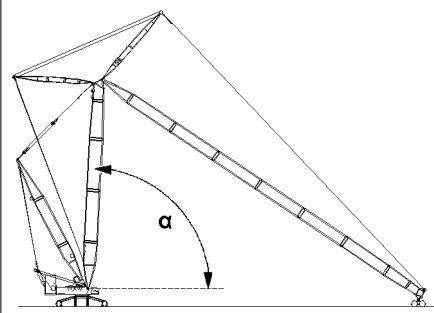
Examples for variations of the boom positions during the erection procedure depending on the set up configuration	
	<p>With an installed roller cart with ground contact, the luffing jib is almost vertical.</p> <p><b>Note:</b> This is the case, for example, when a relatively shorter luffing jib is installed on a longer main boom.</p>
	<p>With an installed roller cart with ground contact, the luffing jib has reached the “luffing jib bottom” switch position.</p> <p><b>Note:</b> Without a roller set on the main boom, the luffing jib reaches the “luffing jib bottom” switch position with an intermediate angle <math>\delta</math> of approx. <math>45^{\circ}</math>.</p>

### Examples for variations of the boom positions during the erection procedure depending on the set up configuration



With an installed roller cart with ground contact, the luffing jib has reached the “luffing jib bottom” switch position.

**Note:** With a roller set on the main boom, the luffing jib reaches the “luffing jib bottom” switch position with an intermediate angle  $\delta$  of approx.  $80^\circ$ .



With an installed roller cart with ground contact, the main boom has reached the steepest operating position (angle  $\alpha$  equal to  $\text{MAX}^\circ_{\text{TLT/AAT}}$ ).

**Note:** This is the case, for example, when a long luffing jib is installed on a short main boom.



#### WARNING

Impermissible installation of a roller set!

If a roller set is installed impermissibly on the main boom, the intermediate angle  $\delta$  is too large.

During erection or take down of the boom, the crane can topple over if the intermediate angle  $\delta$  is too large.

Death, severe bodily injuries, property damage.

► Install a roller set on the main boom only if the boom system with luffing jib is released to do so.

## 6.2 Carrying out the erection procedure

The erection procedure is carried out with activated assembly operation, the LICCON overload protection is bypassed.



#### Note

► The illustrations of the crane are an example. The illustration of the crane differs from the crane.

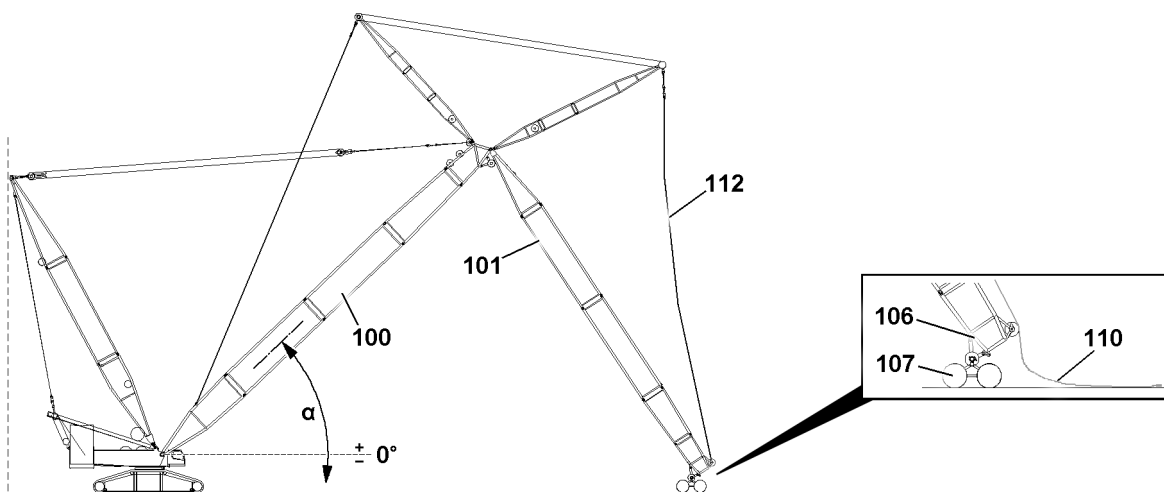


Fig.163402: Carrying out the erection procedure

The roller cart **107** must absorb the proportional weight of the boom system as long as possible during the erection procedure.

When doing so, the hoist rope **110** is guided with a length of at least 10 m over the luffing jib end section.



### WARNING

Overloading of the crane when erecting the boom system!

If the guy rods **112** are tensioned as long as the roller cart **107** must absorb the proportional weight of the boom system, the crane carries too much boom weight. The forces on the boom system become too high.

The crane can be overloaded and topple over.

Death, severe bodily injuries, property damage.

- ▶ When luffing the main boom **100** up, spool the luffing jib control rope out such that the guy rods **112** sag slightly.
- ▶ Do not permit slack rope formation on the luffing jib control rope.



### WARNING

Falling hoist rope!

Death, severe bodily injuries, property damage.

- ▶ During erection, walk along with the roller cart **107** and constantly monitor the hoist rope **110**.
- ▶ The hoist rope **110** may not lift off the ground.
- ▶ The overhang of the hoist rope **110** of 10 m beyond the luffing jib end section may not be shortened.

If auxiliary guying is assembled on the boom system. Comply with the following regulations.



### WARNING

Temperatures below 0 °C: Fiber guy ropes that are rigidly frozen or covered with ice!

Buckling of the fiber guy ropes. The fiber guy ropes can rip.

Death, severe bodily injuries, property damage.

- ▶ While erecting the boom system, check if the fiber guy ropes are rigidly frozen or covered with ice.
- ▶ Do **not** bend fiber guy ropes that are rigidly frozen or covered with ice.
- ▶ Do **not** erect boom systems with fiber guy ropes that are rigidly frozen or covered with ice (for example auxiliary guying, guying for the F-jib).
- ▶ Observe the instructions in chapter 5.01.

As long as the luffing jib end section **106** can be held on the ground with the roller cart **107**:

- ▶ Luff the main boom **100** up as steep as possible and at the same time spool the luffing jib **101** control rope out so that the guy rods **112** sag slightly.

### Result:

One of the following events occurs depending on the set up configuration:

- The luffing jib **101** is almost vertical.
- The luffing jib **101** has reached the “luffing jib bottom” switch position.
- The main boom **100** has reached its steepest operating position (angle  $\alpha$  equal to  $MAX^{\circ TL/AAT}$ ).

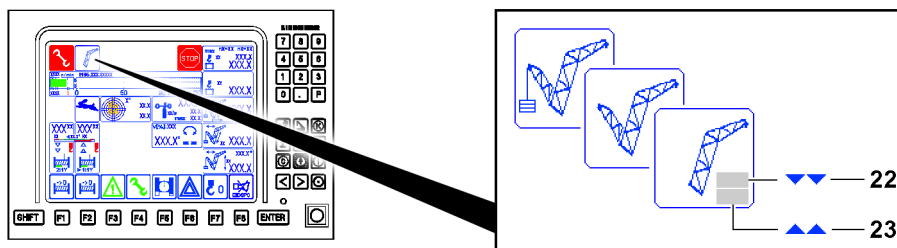


Fig.160420: The “luffing jib bottom” and “steep main boom” switch position

**Note**

When the “luffing jib bottom” switch position blocks a necessary crane movement:

- ▶ Luff the luffing jib up  $0.5^\circ$  until the icon **22** turns off.

When the “steep main boom” switch position blocks a necessary crane movement:

- ▶ Luff the main boom down  $0.5^\circ$  until the icon **23** turns off.

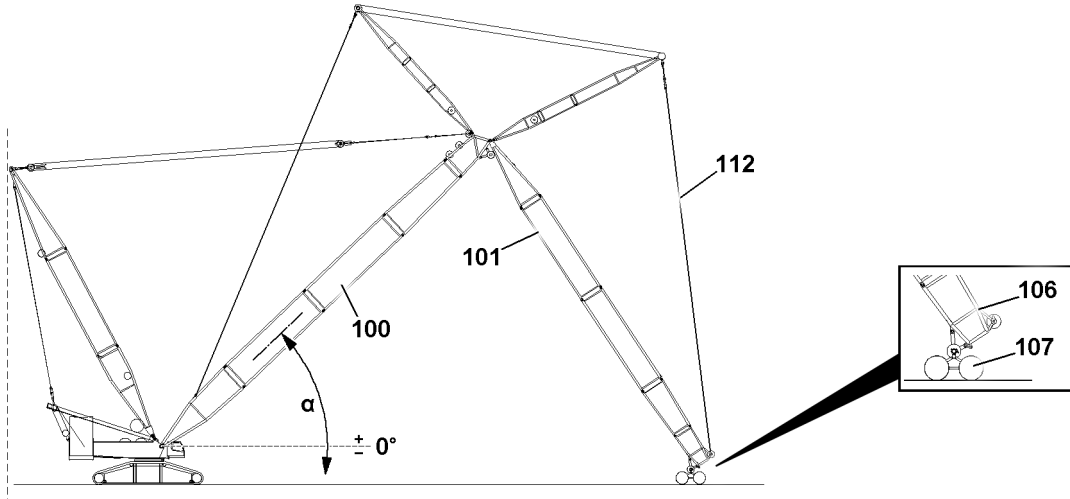


Fig.160375: Carrying out the erection procedure

- ▶ Tighten the guy rods **112**, spool the luffing jib **101** control rope up to do so.
- ▶ Release the roller cart **107** from the luffing jib end section **106**, see chapter 5.61.

**WARNING**

Main boom not in the correct position!

If the main boom **100** is not luffed up as far as possible when lifting the luffing jib **101**, the crane can be overloaded.

Death, severe bodily injuries, property damage.

- ▶ Luff the main boom **100** up as far as possible before the luffing jib **101** is lifted out of the roller cart **107**.

When the main boom **100** is not yet in the steepest operating position:

- ▶ Luff the main boom **100** up until the luffing jib end section **106** lifts up approx. 0.5 m from the roller cart **107**.

or:

If the main boom **100** is already in the steepest operating position (angle  $\alpha$  gleich  $MAX^\circ_{TLT/AAT}$ ):

- ▶ Luff the luffing jib **101** up until the luffing jib end section **106** lifts up approx. 0.5 m from the roller cart **107**.

When the luffing jib end section **106** is lifted approx. 0.5 m from the roller cart **107**:

- ▶ Remove the roller cart **107**.
- ▶ Reeve the hook block in and position the hoist limit switch weight, see chapter 4.06 and the separate reeving plans.

**WARNING**

Incorrect weight of the hook block!

If an attempt is made to use a hook block with an impermissible weight, there is danger of accident.

- ▶ Specifications for the weight of the hook block

If required in the erection and take down chart:

- ▶ Guide the hook block.



**WARNING**

Collision between the hook block and the luffing jib end section!  
Components can be damaged and fall down.

- ▶ Before luffing the luffing jib up, establish sufficient distance between the hook block and the luffing jib end section **106**.
- ▶ Position the hook block below the luffing jib end section **106** such that the hoist limit switch is not actuated when the hook block is hanging freely.

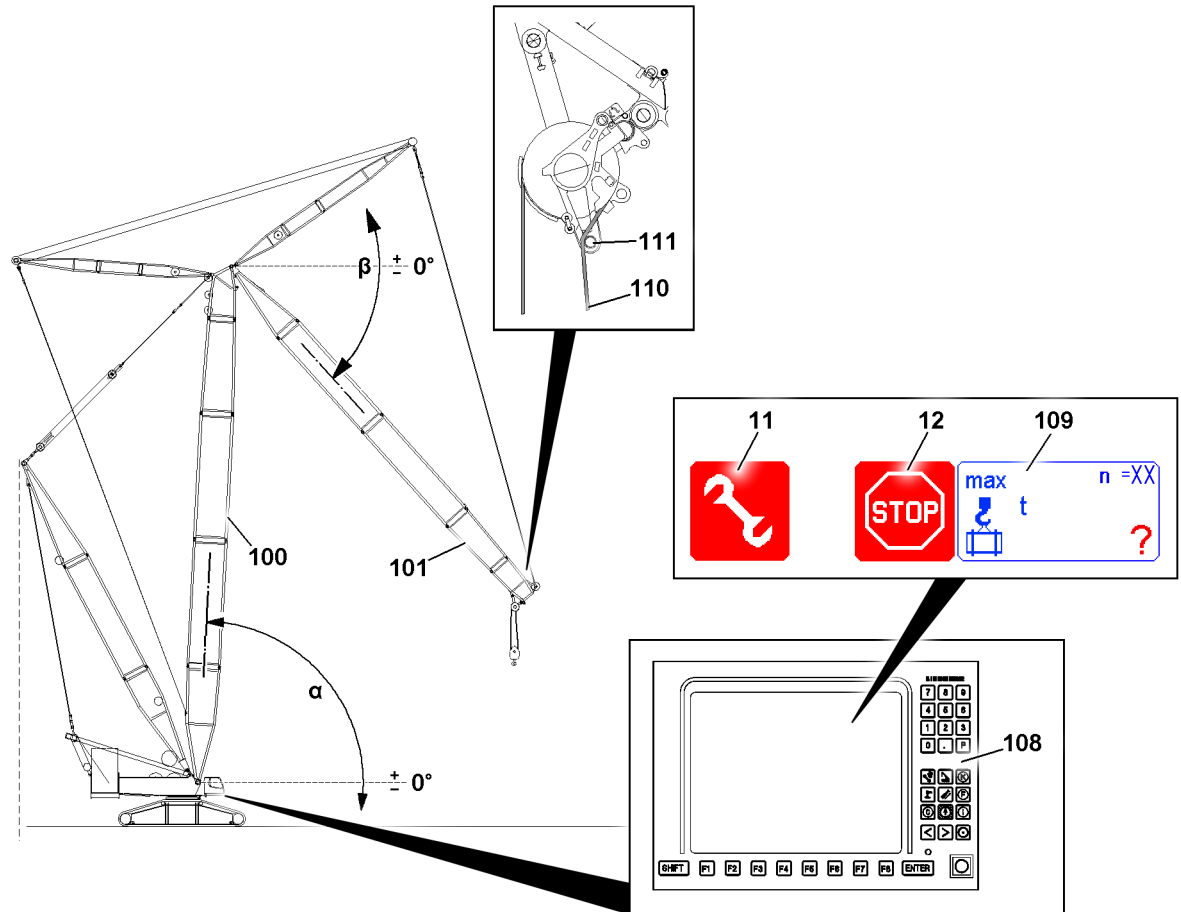


Fig.160422: Carrying out the erection procedure

**NOTICE**

Damage to the hoist rope!

If the hoist rope **110** is reeved on the hook block and redirected over the small guard rollers **111**, the hoist gear may no longer be driven as long as the hook block hangs free. Due to spooling up or spooling out, the hoist rope **110** and the guard rollers **111** can be damaged.

- ▶ Do not spool the hoist rope **110** up or out with a freely hanging hook block if the luffing jib **101** is luffed down below the horizontal (angle  $\beta$  less than  $0^\circ$ ).

When the main boom **100** is not yet in the steepest operating position (angle  $\alpha$  equal to  $MAX^\circ_{TLT/AAT}$ ):

- ▶ Luff the main boom **100** up to the steepest operating position.

**Note**

During the erection procedure, the main boom **100** must be at the steepest angle  $\alpha$  of  $MAX^\circ_{TLT/AAT}$  so that the luffing jib **101** can be luffed up securely from below in the range of a load chart. When doing so, the luffing jib **101** may initially not exceed an angle  $\beta$  of  $70^\circ$ . An angle  $\beta$  above  $70^\circ$  is usually only permissible with active monitoring by means of the load chart.

- ▶ A too large boom radius results when the main boom **100** and luffing jib **101** are too flat.
- ▶ A too small boom radius results when the main boom **100** and luffing jib **101** are too steep.

**WARNING**

The crane can tip over!

The crane can tip forward if the boom radius of the boom system is too large.

The crane can tip to the rear if the boom radius of the boom system is too small.

Death, severe bodily injuries, property damage.

- ▶ The boom radii specified in the load chart may not be exceeded or fallen below, even if there is no load on the hook.
- ▶ Assembly operation must be ended when reaching the lowest operating position of the luffing jib **101**. The *Assembly* icon **11** may no longer appear. Also turn the assembly operation off manually.

Only when the main boom **100** is in the steepest operating position (angle  $\alpha$  equal to  $MAX^{\circ TLT/AAT}$ ):

- ▶ Luff the luffing jib **101** up to its lowest operating position. When doing so, observe a permissible angle window for the angle  $\beta$  of  $0^{\circ}$  to  $70^{\circ}$ .

**Problem remedy**

Does the *Assembly* icon **11** not turn off on the LICCON monitor **108** even if the luffing jib **101** is luffed up to an angle  $\beta$  of  $70^{\circ}$ ?

Under some circumstances, the boom system is not in the angle range of the set load chart.

- ▶ Check if the set load chart specifies a target angle for the main boom **100** or the luffing jib **101**.
- ▶ If yes, approach the target angle without an unnecessary increase of the boom radius.
- ▶ When no, check all settings and displays, contact Liebherr Customer Service.

When the luffing jib **101** has reached its lowest operating position:

- ▶ Make sure that the *STOP* icon **12** on the LICCON monitor **108** has turned off.

**Result:**

- Monitoring by means of the load chart is activated.
- The *Maximum load* icon **109** displays a number instead of a question mark “?”.

Only when the *Assembly* icon **11** continues to be displayed:

- ▶ Turn assembly operation off, see chapter 4.01 / 4.02.

**Result:**

- The *Assembly* icon **11** disappears.
- Assembly operation is switched off.

**Note**

When monitoring by means of the load chart is activated:

- ▶ Adapt the additional specifications from the **erection and take-down charts** to the set load chart.
- ▶ In the case of boom systems with a minimum hook block weight, comply with the minimum hook block weight.

## 7 Crane operation

**Note**

- ▶ Observe the notes, see chapter 4.05, chapter 4.08 and chapter 5.01.

Make sure that the following prerequisites are met:

- The LICCON overload protection is active.
- The LICCON overload protection has been set according to the data in the load chart.
- The main boom is in the specified angle position according to the load chart.
- The crane structure complies with the load chart. The ballast and auxiliary equipment that was only needed for erection has been removed.



### WARNING

The crane can topple over!

Death, severe bodily injuries, property damage.

- ▶ Check the horizontal position of the crane before and during crane operation.
- ▶ If the crane operator leaves the cab, even for a short time, the operating mode setting must be checked and reset if necessary before resuming crane operation.

## 7.1 Checking the settings

- ▶ Check the function of the overload protection by running against the operating positions “on top” and “bottom”.
- ▶ Check the hoist limit switch by running against the hoist limit switch weight.
- ▶ Check the function of the limit switches on the relapse cylinders.

## 8 Taking the boom system down with the luffing jib

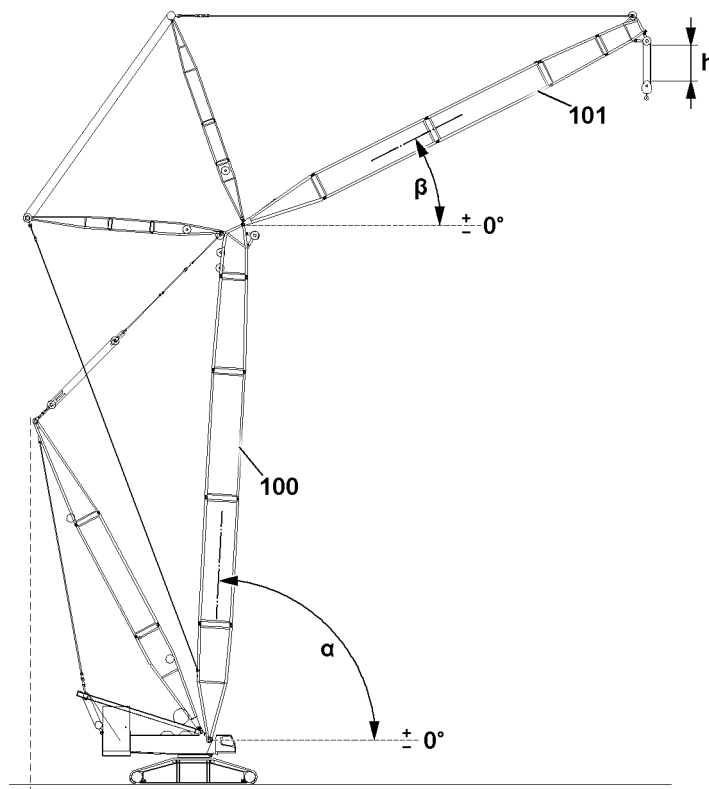


Fig.160393: Carrying out the take-down procedure

**WARNING**

Erection and take down charts not observed!

The specifications regarding the erection procedure are implemented, the erection / take-down charts are observed.

If the specifications in the erection and take-down charts are not observed, the crane can topple over during erection or take-down of the boom system.

Death, severe bodily injuries, property damage.

- ▶ The set up configuration of the crane must correspond to the erection and take-down charts.
- ▶ The ground slope must correspond to the erection and take-down charts.
- ▶ The wind speed must correspond to the erection and take-down charts.

**WARNING**

Impermissible assembly procedures during assembly operation!

If assembly operation is activated, the LICCON overload protection is bypassed. The specified erection / take-down procedures and assembly procedures can be carried out.

In the case of deviations from the specified sequences, misuse of the function or due to impermissible assembly procedures, the crane can be overloaded and topple over.

Death, severe bodily injuries, property damage.

- ▶ Assembly operation may only be activated by persons who know and can estimate the effects.
- ▶ Activate the assembly operation only when the correct set up configuration was entered in the LICCON computer system.
- ▶ Comply with the specifications, observe the erection / take-down charts.
- ▶ Normal crane operation with activated assembly operation is prohibited.

**WARNING**

The boom system folds backward!

If the minimum hook block weight is not observed, the boom system can tip backwards in steep positions and the crane can topple over.

Death, severe bodily injuries, property damage

- ▶ Observe the minimum hook block weight.

**WARNING**

Remaining in the danger zone!

Persons located within the boom system during erection / take-down can fall down.

Persons below or directly on the boom system can be crushed or struck by the boom system during erection /take-down.

Death, severe bodily injuries, property damage.

- ▶ No one may be located on, inside, below or directly near the boom system during erection / take-down of the boom system.

**WARNING**

Turning of the crane superstructure when erecting / taking down the boom system!

If the crane superstructure is turned when erecting / taking down the boom system, the crane can be overloaded and topple over.

Death, severe bodily injuries, property damage.

- ▶ It is prohibited to turn the crane superstructure when erecting / taking down the boom system.

**WARNING**

The crane superstructure turns uncontrolled!

If the slewing gear brake is released, then the crane superstructure can turn uncontrolled in strong side wind or in an inclined position.

Death, severe bodily injuries, property damage.

- ▶ Secure the crane superstructure against turning movements when erecting / taking down the boom system.
- ▶ Operate the slewing gear and slewing gear brake anticipatorily in case of side wind or incline position.

**WARNING**

Wind speed too high!

If the maximum permissible wind speeds are disregarded, the crane can topple over.  
Death, severe bodily injuries, property damage.

- ▶ Observe the specifications regarding the wind speed in the erection and take-down charts.

When there are no specifications regarding the wind speed in the erection and take-down charts:

- ▶ Comply with the specifications regarding the wind speed from the wind out of operation charts.

**WARNING**

Mechanical auxiliary support not used or used incorrectly!

If the mechanical auxiliary support is not used correctly even if the specification is provided, the permissible forces during erection / take-down of the boom system will be exceeded.

If the boom system is erected or taken down on the wrong side, the mechanical auxiliary support has no effect.

The crane can topple over.

Death, severe bodily injuries, property damage.

- ▶ Observe the specifications on the use of the mechanical auxiliary support.
- ▶ Erect and take down the main boom with the luffing jib on the correct side.

**WARNING**

The crane is overloaded!

If the permissible forces are not observed, there is danger of accident.

The crane and boom system can be overloaded and fail, the crane can collapse or tip over.

Death, severe bodily injuries, property damage.

- ▶ Adapt the luffing jib control continuously so that the maximum forces are not exceeded.
- ▶ Monitor the displays in the LICCON computer system, observe the limit values.
- ▶ Do not allow slack rope to form on the control winches.

**WARNING**

The distance between the hook block / load hook and the pulley head is too small!

If the hook block or load hook are too close to the pulley head, a collision can occur during the take-down procedure. Components can be damaged and fall down.

Death, severe bodily injuries, property damage.

- ▶ Ensure sufficient distance between the hook block / load hook and the pulley head.

Make sure that the following prerequisites are met:

- The crane has been set up according to the data in the load charts and the erection and take-down charts.
- The LICCON overload protection has been set according to the data in the load charts and erection and take-down charts.
- The LICCON overload protection settings have been checked for completeness and correctness.
- The crane is horizontally aligned.
- When there are specifications on the use of the mechanical auxiliary support: The mechanical auxiliary support is installed correctly and the boom system is erected on it.
- The terrain is suitable for taking the boom system down.
- The specifications for the take-down procedure are implemented, the erection / take-down charts are adhered to.
- Crane ballasting (counterweight, central ballast, if necessary derrick ballast and auxiliary ballast) is carried out according to the load charts and the erection and take-down charts.
- In the case of boom systems with a minimum hook block weight, the minimum hook block weight is observed.
- The main boom **100** is luffed up to its steepest operating position according to the load chart.
- The luffing jib **101** is luffed down to its lowest operating position according to the load chart.
- The hook block / load hook is positioned at a distance **h** of 5 m below the pulley head.
- A roller cart is on hand.
- The maximum permissible wind speeds are observed.
- The boom system and the safety equipment are free of snow, frost and ice.

- No personnel or obstacles are within the danger zone.
- Unless the specifications state otherwise, use the steepest operating position of the main boom for the erection / take-down of the boom system. See section “Determining the steepest main boom operating position”.

The steepest operating position of the main boom is individual for every boom system.

- For this individual angle  $\alpha$ , the place holder  $MAX^{\circ TLT/AAT}$  is used in the following description.



#### Note

- ▶ Within the load chart, the luff down of the luffing jib **101** is turned off as soon as the lowest operating position of the luffing jib **101** is reached. The lowest limit angle of the load chart is reached.
- ▶ In the lowest operating position, the luffing jib **101** always has a positive angle  $\beta$ .

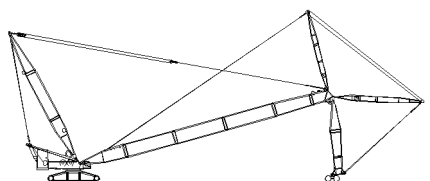
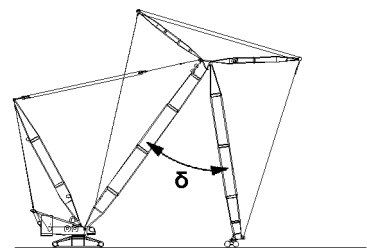
## 8.1 Information regarding the take-down procedure

The set up configuration of the crane and the local conditions influence the take-down procedure.

The take-down procedure can be divided into two parts:

- The first part of the take-down procedure is carried out until the roller cart can be removed with the steepest possible main boom.
- During the second part of the take-down procedure, the boom system is taken down completely onto the ground.

At the end of the first part of the take-down procedure, the boom positions vary according to the set up configuration, see the following charts.

Examples for variations of the boom positions during the take-down procedure depending on the set up configuration	
	<p>When the luffing jib is hanging almost vertically, the main boom is luffed down to the point where the roller cart can be installed.</p> <p><b>Note:</b> This is the case, for example, when a relatively shorter luffing jib is installed on a longer main boom.</p>
	<p>When the luffing jib is in the “luffing jib bottom” switch position, the main boom is luffed down to the point where the roller cart can be installed.</p> <p><b>Note:</b> Without a roller set on the main boom, the luffing jib reaches the “luffing jib bottom” switch position with an intermediate angle <math>\delta</math> of approx. <math>45^\circ</math>.</p>

Examples for variations of the boom positions during the take-down procedure depending on the set up configuration	
	<p>When the luffing jib is in the “luffing jib bottom” switch position, the main boom is luffed down to the point where the roller cart can be installed.</p> <p><b>Note:</b> With a roller set on the main boom, the luffing jib reaches the “luffing jib bottom” switch position with an intermediate angle <math>\delta</math> of approx. <math>80^\circ</math>.</p>
	<p>With the main boom in the steepest operating position (angle <math>\alpha</math> gleich <math>\text{MAX}^\circ_{\text{TLT/AAT}}</math>) the luffing jib is luffed down to the point where the roller cart can be installed.</p> <p><b>Note:</b> This is the case, for example, when a long luffing jib is installed on a short main boom.</p>

## 8.2 Carrying out the take-down procedure

If auxiliary guying is assembled on the boom system. Comply with the following regulations.



### WARNING

Temperatures below  $0^\circ\text{C}$ : Fiber guy ropes that are rigidly frozen or covered with ice!  
Buckling of the fiber guy ropes. The fiber guy ropes can rip.  
Death, severe bodily injuries, property damage.

- ▶ While taking down the boom system, check if the fiber guy ropes are rigidly frozen or covered with ice.
- ▶ Do **not** bend fiber guy ropes that are rigidly frozen or covered with ice.
- ▶ Do **not** take down boom systems with fiber guy ropes that are rigidly frozen or covered with ice (for example auxiliary guying, guying for the F-jib).
- ▶ Observe the instructions in chapter 5.01.

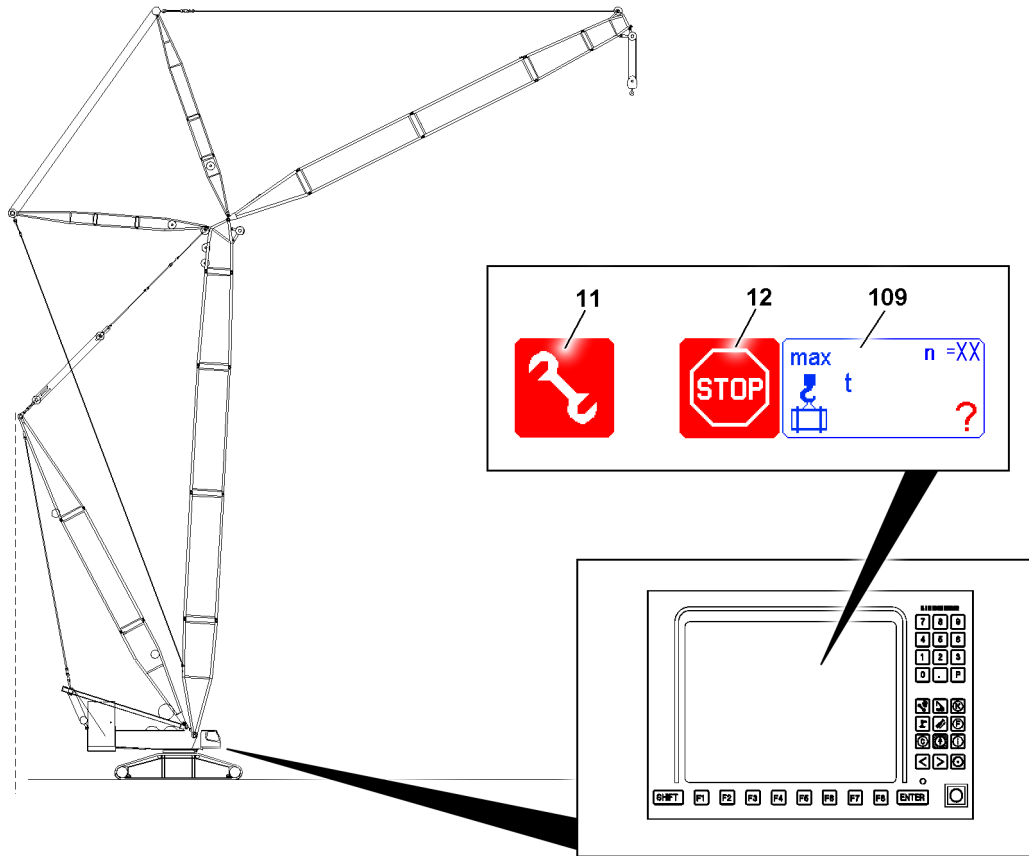


Fig.160454: Carrying out the take-down procedure



### WARNING

Impermissible assembly procedures during assembly operation!

If assembly operation is activated, the *assembly* icon **11** appears. The LICCON overload protection is bypassed in order to carry out the specified erection / take-down procedures and assembly procedures.

In the case of deviations from the specified sequences, misuse of the function or due to impermissible assembly procedures, the crane can be overloaded and topple over.

Death, severe bodily injuries, property damage.

- ▶ Assembly operation may only be activated by persons who know and can estimate the effects.
- ▶ Activate the assembly operation only when the correct set up configuration was entered in the LICCON computer system.
- ▶ Comply with the specifications, observe the erection / take-down charts.
- ▶ Normal crane operation with activated assembly operation is prohibited.

- ▶ Activate assembly operation, see chapter 4.01 / 4.02.

### Result:

- The LICCON overload protection is bypassed, the specified erection / take-down procedures and assembly procedures can be carried out.
- The *assembly* icon **11** appears on the LICCON monitor.



### Note

Limit angle of the load chart

- ▶ If the lower limit angle in the load chart is fallen below, the load value disappears in the *maximum load* icon **109** and a question mark appears.
- ▶ Alarm functions appear on the crane operating screen, the *STOP* icon **12** appears.



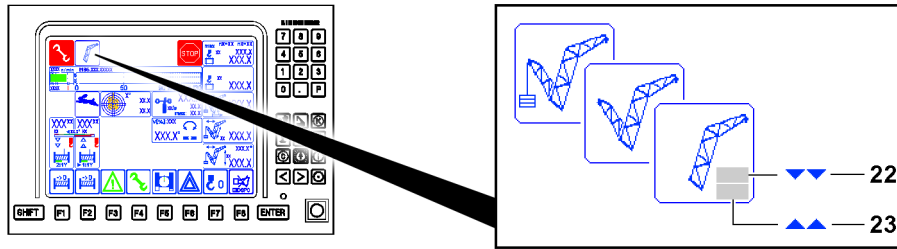


Fig.160420: The "luffing jib bottom" and "steep main boom" switch position



### Note

When the "luffing jib bottom" switch position blocks a necessary crane movement:

- ▶ Luff the luffing jib up  $0.5^\circ$  until the icon **22** turns off.

When the "steep main boom" switch position blocks a necessary crane movement:

- ▶ Luff the main boom down  $0.5^\circ$  until the icon **23** turns off.

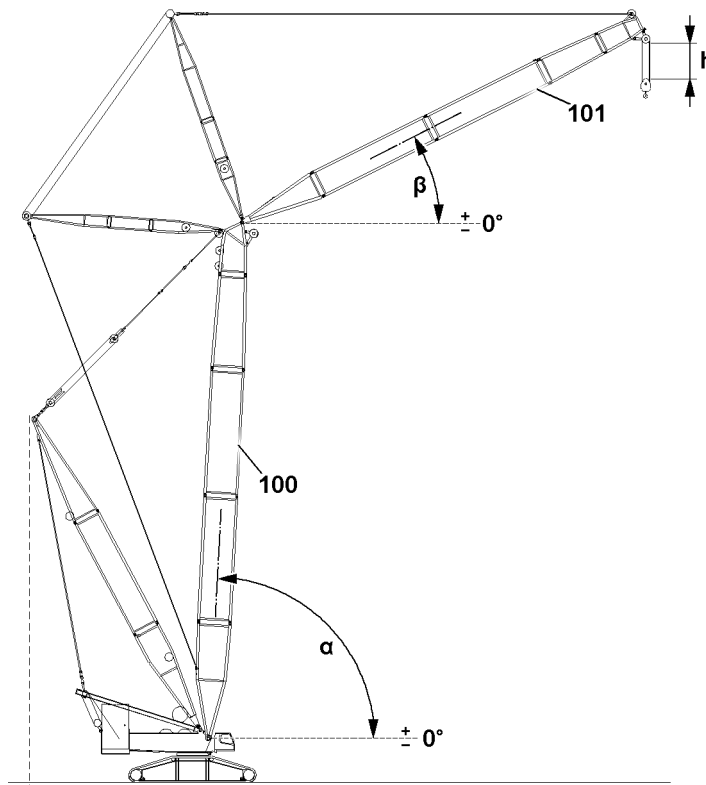


Fig.160393: Carrying out the take-down procedure



### WARNING

The main boom is in the wrong position!

If the main boom is in the wrong position, the crane can be overloaded and topple over. Death, severe bodily injuries, property damage.

- ▶ During the take-down procedure, the main boom must remain at a steep angle  $\alpha$  of  $\text{MAX}^\circ \text{TLT/AAT}$ , until the luffing jib **101** reaches the "luffing jib bottom" switch position, or the luffing jib end section can be set down in the roller cart.

**WARNING**

The distance between the hook block / load hook and the pulley head is too small!  
If the hook block or load hook are too close to the pulley head, a collision can occur during the take-down procedure. Components can be damaged and fall down.

Death, severe bodily injuries, property damage.

- ▶ Ensure sufficient distance between the hook block / load hook and the pulley head.

Only when the luffing jib **101** is not yet at an angle  $\beta \leq 70^\circ$ :

- ▶ Luff the luffing jib **101** down to an angle  $\beta$  of  $70^\circ$ . Maintain a distance  $h$  of 5 m when doing so.

Only when the main boom **100** is not yet in the steepest operating position (angle  $\alpha$  equal to  $\text{MAX}^\circ_{\text{TLT/AAT}}$ ):

- ▶ Luff the main boom **100** up to the steepest operating position, at the same time hold the luffing jib **101** in the present angle position (angle  $\beta$ ) by spooling the luffing jib control rope out.

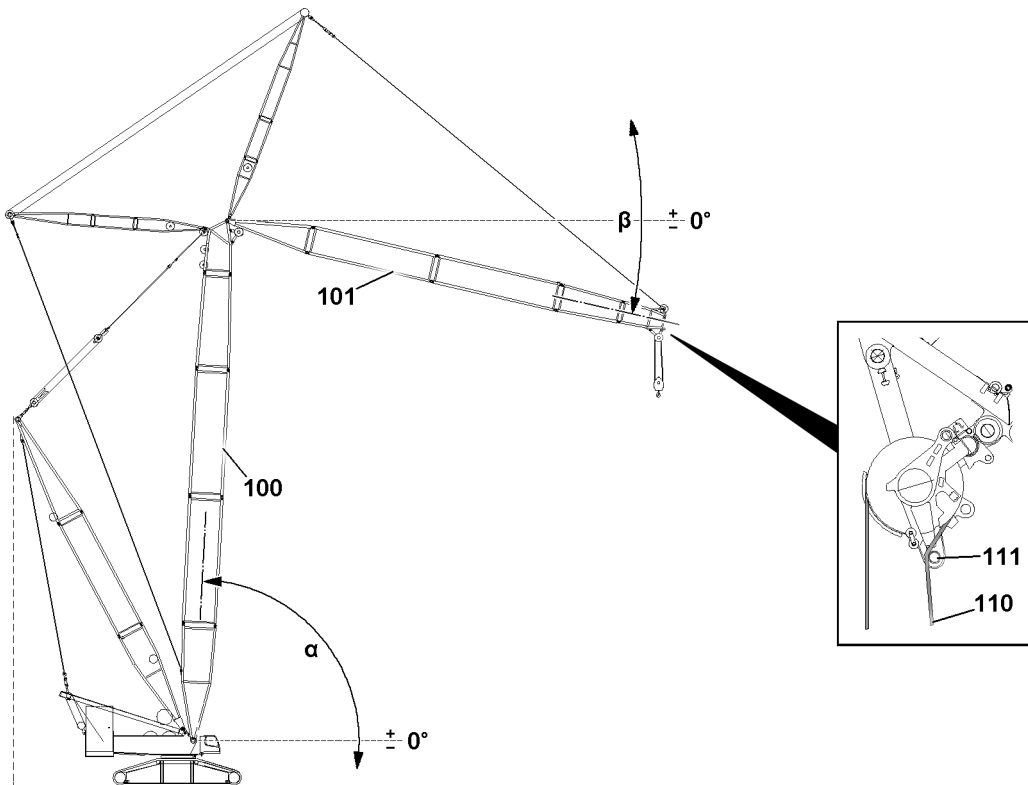


Fig.160385: Carrying out the take-down procedure

**NOTICE**

Damage to the hoist rope!

If the hoist rope **110** is reeved on the hook block and redirected over the small guard rollers **111**, the hoist gear may no longer be driven as long as the hook block hangs free. Due to spooling up or spooling out, the hoist rope **110** and the guard rollers **111** can be damaged.

- ▶ Do not spool the hoist rope **110** up or out with a freely hanging hook block if the luffing jib **101** is luffed down below the horizontal (angle  $\beta$  less than  $0^\circ$ ). Return the luffing jib **101** to the horizontal only to operate the hoist gear.

Only when the main boom **100** is in the steepest operating position (angle  $\alpha$  equal to  $\text{MAX}^\circ_{\text{TLT/AAT}}$ ):

- ▶ Luff the luffing jib **101** down until one of the following occurs.

**Result:**

- The luffing jib **101** has reached the “luffing jib bottom” switch position.
- The luffing jib **101** can be luffed down until the hook block lies on the floor and the luffing jib end section is located slightly above it.

Only when the luffing jib **101** has reached the “luffing jib bottom” switch position:

- ▶ Luff the main boom **100** down until one of the following occurs.

**Result:**

- The luffing jib **101** hangs down almost vertically (angle  $\beta$  at  $-85^\circ$ ).
- The main boom **100** can be luffed down until the hook block lies on the floor and the luffing jib end section is located slightly above it. The luffing jib **101** does not hang steeper than  $-85^\circ$ .

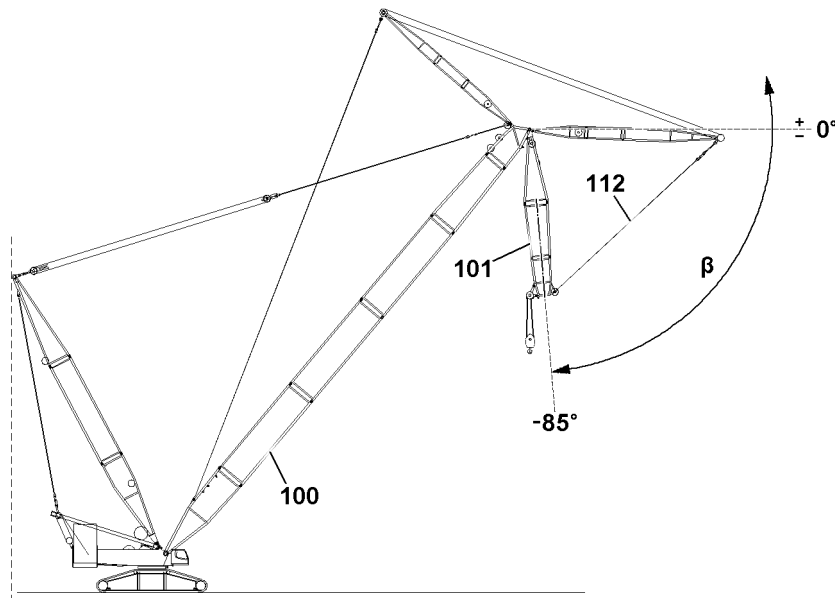


Fig.160382: Carry out the take-down procedure: The luffing jib hangs down almost vertically

Only when the luffing jib **101** hangs down almost vertically (angle  $\beta$  at  $-85^\circ$ ):

- ▶ Continue to luff the main boom **100** down and keep the luffing jib **101** at an angle  $\beta$  of  $-85^\circ$  by spooling the luffing jib control rope up until the hook block touches the ground. When doing so, do not let the guy rods **112** sag.
- ▶ Remove the hoist limit switch weight and reeve out the hook block, see chapter 4.06.



**WARNING**

Falling hoist rope!

If the hoist rope is not pulled with the respective length over the luffing jib end section after reeving the hook block out, it can fall backward due to its own weight.

Death, severe bodily injuries, property damage.

- ▶ The rope end must be pulled out at least 10 m over the luffing jib end section.
  - ▶ Monitor the behavior of the hoist rope during the take-down procedure.
  - ▶ Carry along the rope end to avoid damage.
- 
- ▶ Pull the rope end out at least 10 m over the luffing jib end section and take it down on the ground.

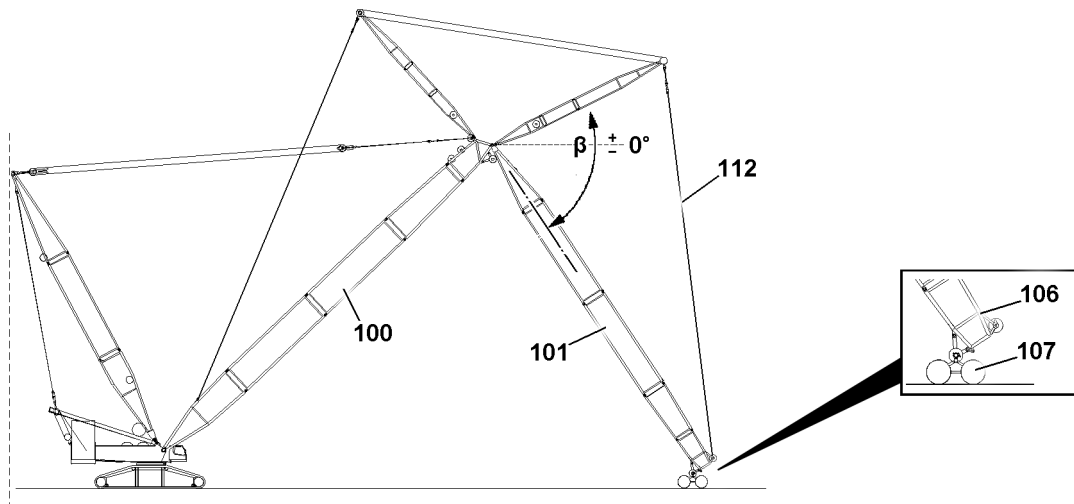


Fig.160391: Carrying out the take-down procedure

### NOTICE

Overload of the roller cart!

If a vertically positioned luffing jib **101** is lowered onto the roller cart **107**, the roller cart **107** can be overloaded and collapse.

- ▶ Lower the luffing jib **101** with angle  $\beta$  -85° or smaller on the roller cart **107**.
- ▶ Do not lower the luffing jib **101** with an angle  $\beta$  of -86° and above onto the roller cart **107**.

- ▶ Luff the main boom **100** down until the receptacles on the luffing jib end section **106** touch the receptacles of the roller cart **107**.
- ▶ Assemble the roller cart **107** on the luffing jib end section **106**, see chapter 5.61.



### WARNING

Overload of the crane or roller cart when taking the boom system down!

If the guy rods **112** are tensioned, the crane or the roller cart **107** carry too much boom weight. The forces on the boom system or the roller cart **107** become too high.

The crane or roller cart **107** can be overloaded.

Death, severe bodily injuries, property damage.

- ▶ When luffing the main boom down, spool the luffing jib control rope out such that the guy rods **112** sag slightly.
- ▶ Do not permit slack rope formation on the luffing jib control rope.

The roller cart **107** must move away from the crane in the direction of the boom:

- ▶ Continue to luff down the main boom **100** and simultaneously spool the luffing jib control rope out so that the guy rods **112** sag slightly.

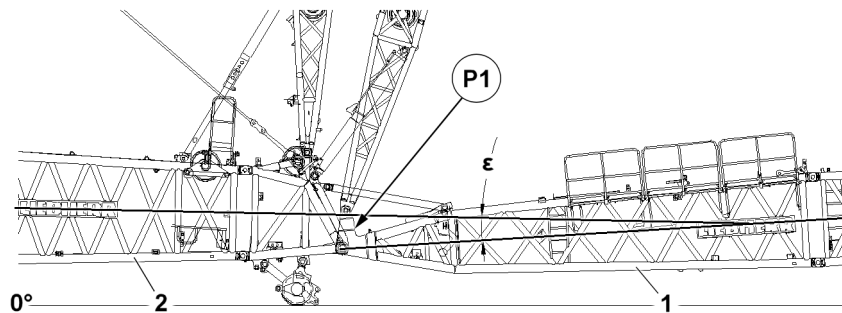


Fig.162241: Angle  $\epsilon$  between the W-connector head and the W-pivot section

1 W-pivot section

2 W-connector head

**NOTICE**

Lifting the W-pivot section **1** above an angle of 8°!

If the angle  $\epsilon$  between the W-pivot section **1** and the W-connector head **2** is greater than 8°, crane components collide in position **P1** and are damaged.

- ▶ The angle window up to 8° may not be left.

To reduce the possible angle  $\epsilon$ :

- ▶ Lift the main boom and support it if necessary.

- ▶ Luff the main boom down completely.

**WARNING**

Danger of accident!

Personnel in the danger zone can be caught.

Death, severe bodily injuries, property damage.

- ▶ Make sure that no personnel is within the danger zone.
- ▶ Secure the hoist rope with the assembly rope and pull it back slowly over the rope pulleys in the WA-frames and lower it toward the connection point of the main boom **100** and the luffing jib **101**.
- ▶ Take the hoist rope down.

## 9 Disassembling

Make sure that the following prerequisites are met:

- The content of the section “For your safety during assembly and disassembly” is known.
- The LICCON overload protection has been set according to the data in the load chart.
- The LICCON overload protection is exceeded.
- The assembly icon is visible on the LICCON monitor.
- An auxiliary crane with sufficient load bearing capacity is available.
- An assembly scaffolding or a work platform is available.
- All catwalks and standing space accessed during assembly must be free of snow, ice and heavy dirt.

### 9.1 Pulling the hoist rope over the WA-frames

**WARNING**

Running ropes!

Danger of crushing.

- ▶ Adhere to the safety distance to the running ropes.
- ▶ Radio contact is available between crane operator and assembly personnel.

**NOTICE**

Slack rope formation!

The hoist rope can be damaged. Property damage.

- ▶ When spooling the hoist rope up or out, allow **no** slack rope formation.
- ▶ Hold the hoist rope taut when spooling it up or out.

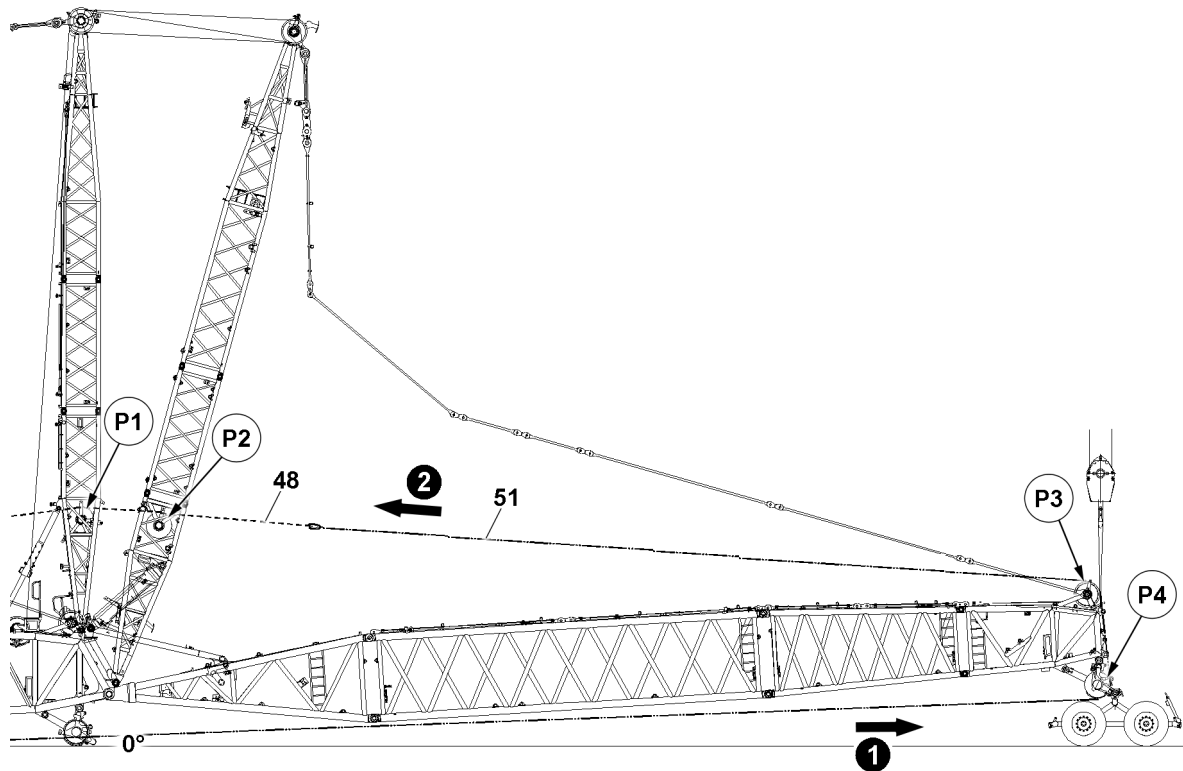


Fig.155835: Removing the hoist rope

On every WA-frame, a pulley is available for the hoist rope of winch 1 and winch 2. Rope reeving, see the reeving plan.

- ▶ Remove the rope retainer in the rope pulleys in point **P3** and point **P4**: Remove the rope retaining elements and rods.

This procedure is described based on the example of one hoist rope.

The line shows the course for the auxiliary rope **51** and the hoist rope **48**.

- ▶ Spool the auxiliary rope **51** out and pull to the roller set in point **P4**.
- ▶ Fasten the auxiliary rope **51** to the hoist rope **48**.
- ▶ Pull the hoist rope **48** to the rope pulley in point **P1**: Spool the auxiliary rope **51** out and spool the hoist rope **48** up at the same time.
- ▶ Lower the hoist rope **48** onto the main boom and disconnect it from the auxiliary rope **51**.

A work platform is required for removing the auxiliary rope on the WA-frames.

- ▶ Spool the auxiliary rope **51** up.
- ▶ Assemble the rope retainer in the rope pulleys in point **P3** and point **P4**: Attach the rope retaining elements and rods.

## 9.2 Disassembling the roller cart on the luffing jib head

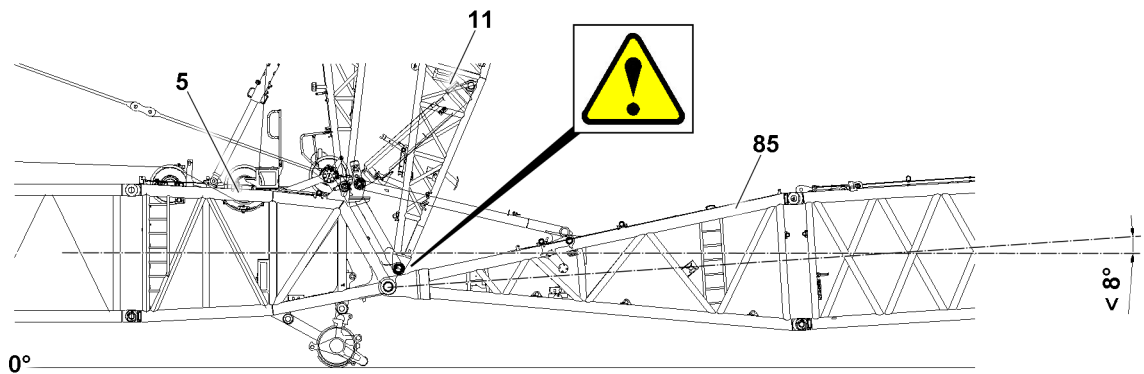


Fig.155819: Minimum permissible angle between the S-end section and W-pivot section

### NOTICE

Minimum permissible angle between the S-end section **5** and the W-pivot section **85** **not** observed! Collision and damage to components.

- ▶ Observe the negative angle between the S-end section **5** and the W-pivot section **85** of less than  $8^\circ$ .

Reduce the angle if necessary:

- ▶ Lift and support the main boom.

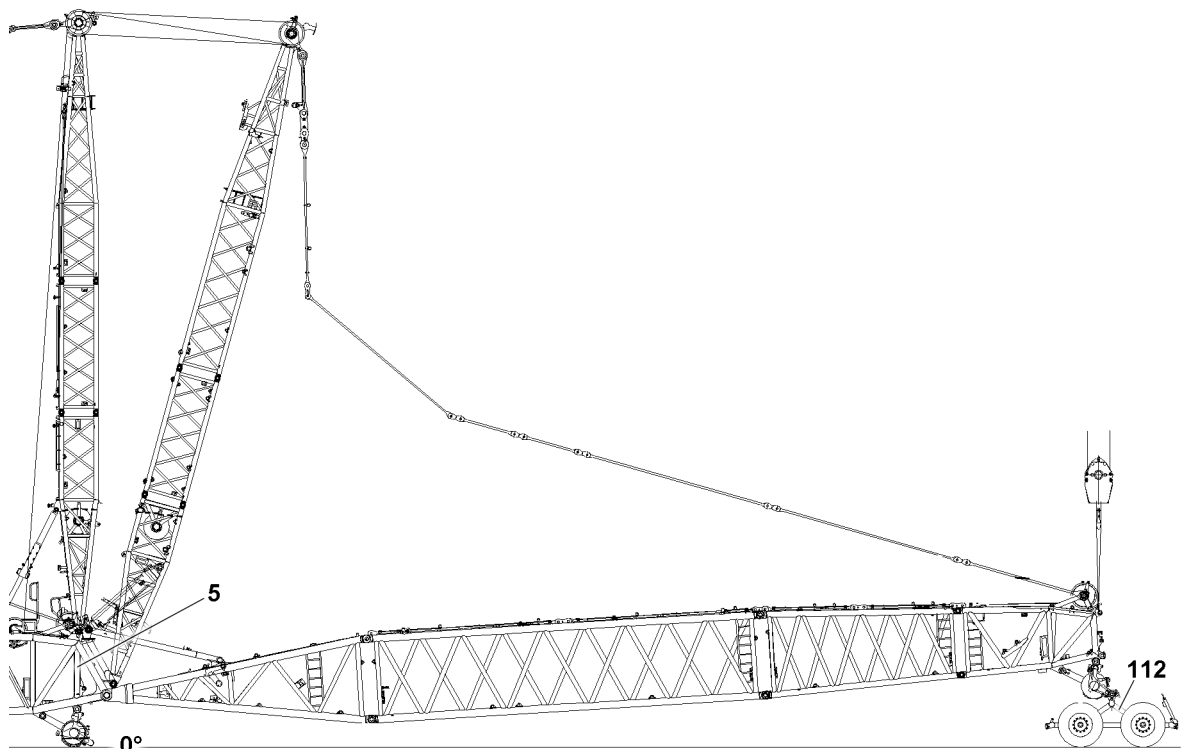


Fig.155834: Roller cart on the luffing jib head

- ▶ Lift the W-boom with the auxiliary crane until the roller cart **112** can be removed.

Roller cart disassembly, see chapter 5.61.

- ▶ Disassemble the roller cart **112**.

## 9.3 Disassembling the W-lattice jib



### WARNING

Impermissible W-boom disassembly!

Death, severe bodily injuries, property damage.

- ▶ Observe the data in chapter 5.01 and chapter 5.03.

### 9.3.1 Disconnecting the electrical connections between the S-end section and the W-boom

#### NOTICE

Damage to the cable drum or cable!

If the electrical connection between the terminal box W-pivot section and cable drum is not separated before spooling up the cable drum, the electrical connection will be damaged.

If the cable of the cable drum is not properly spooled up on the cable drum after unplugging on the L-end section, then the cable drum or the cable can be significantly damaged.

- ▶ Release the electrical connection first from the terminal box of the W-pivot section to the cable drum and then the electrical connection from the cable drum to the L-end section.
- ▶ After unplugging, spool the cable onto the cable drum.
- ▶ Disconnect the electrical connections.
- ▶ After unplugging, spool the cable onto the cable drum and secure it to prevent it from spooling out inadvertently.
- ▶ Secure the cable: Reestablish the electrical connection between the terminal box and the cable drum on the W-pivot section.

#### NOTICE

Property damage due to dirt and / or corrosion!

If unnecessary electrical connections are not closed off with the respective protective caps, then dirt and / or corrosion can damage the electrical connections.

This could result in malfunctions.

- ▶ Make sure that all non-required electrical connections are always closed off properly.
- ▶ Observe the wiring diagram.
- ▶ Properly close off the electrical connections without dummy plugs with the corresponding protective caps.
- ▶ Secure all electrical connections with protective caps to prevent any dirt infiltration.



### 9.3.2 Disassembling the airplane warning light and wind sensor on the L-end section

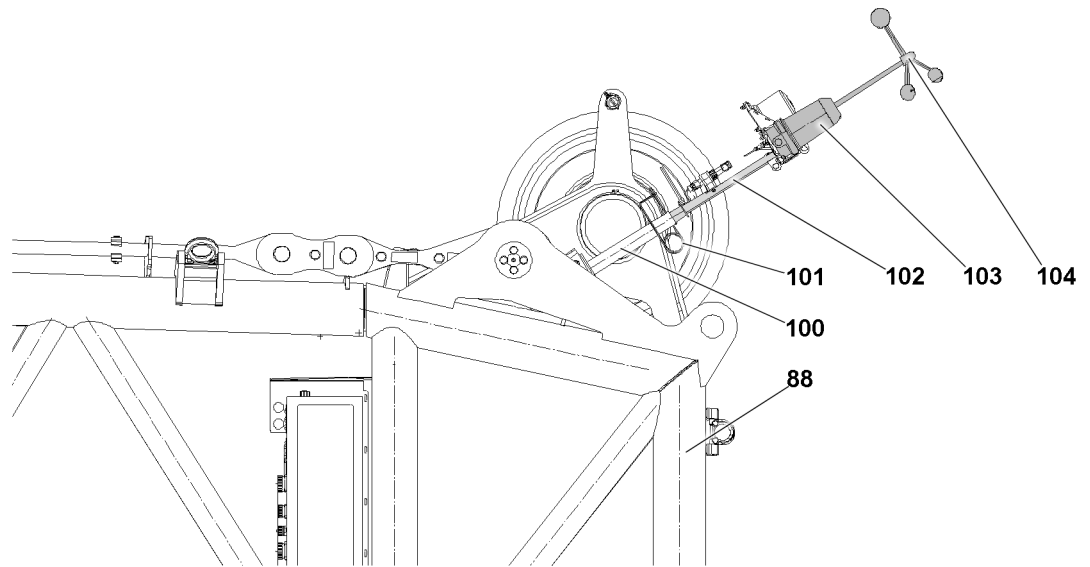
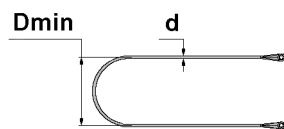


Fig.155825: Airplane warning light and wind sensor, L-end section

- ▶ Remove the retaining element **101**.
- ▶ Remove the retainer **102** with the airplane warning light **103** and wind sensor **104**.

### 9.3.3 Disassembling the auxiliary guying

This section is valid solely only for the W-lattice jibs with the assembled auxiliary guying. An auxiliary guying is assembled depending on the boom system, see the rod plan. Fiber guy ropes are used for the auxiliary guying. Comply with the following regulations.



$$D_{min} = 20 \times d$$

Fig.160908: Fiber guy rope: Calculation of minimum permissible bending diameter

Formula element	Meaning
Dmin	Minimum permissible bending diameter
d	Rope diameter

Minimum permissible bending diameter: Definition of the formula elements

LWE/LR 1800-1-0-000/27200-07-02/en

**WARNING**

Temperatures below 0 °C: Fiber guy ropes that are rigidly frozen or covered with ice!  
Buckling of the fiber guy ropes. The fiber guy ropes can rip.  
Death, severe bodily injuries, property damage.

- ▶ While taking down the WA-frame 1 system, check if the fiber guy ropes are rigidly frozen or covered with ice.
- ▶ Do **not** bend fiber guy ropes that are rigidly frozen or covered with ice.
- ▶ Do **not** take down boom systems with fiber guy ropes that are rigidly frozen or covered with ice (for example auxiliary guying, guying for the F-jib).
- ▶ Observe the instructions in chapter 5.01.

**WARNING**

Impermissible disassembly of fiber guy ropes!  
The fiber guy ropes can be damaged.

Death, severe bodily injuries, property damage.

- ▶ Before disassembling the fiber guy ropes, check if the fiber guy ropes are rigidly frozen or covered with ice. See chapter 5.01.
- ▶ Do **not** disassemble fiber guy ropes that are rigidly frozen or covered with ice.
- ▶ Do **not** bend, knot or twist the fiber guy ropes.
- ▶ Never fall below the minimum permissible bending diameter **D<sub>min</sub>** of **20** x rope diameter **d**.
- ▶ Check the fiber guy ropes for damage prior to assembly, after disassembly and after exceptional events, see chapter 8.16.
- ▶ Comply with the maintenance intervals, see chapter 7.03.50.
- ▶ Replace damaged fiber guy ropes.
- ▶ Observe the notes regarding the proper transport and storage of the fiber guy ropes, see chapter 2.04.
- ▶ Observe the instructions for the proper handling of fiber guy ropes, see chapter 5.01.
- ▶ Only fasten the fiber guy ropes in the permissible range with belt loops, see chapter 5.01.

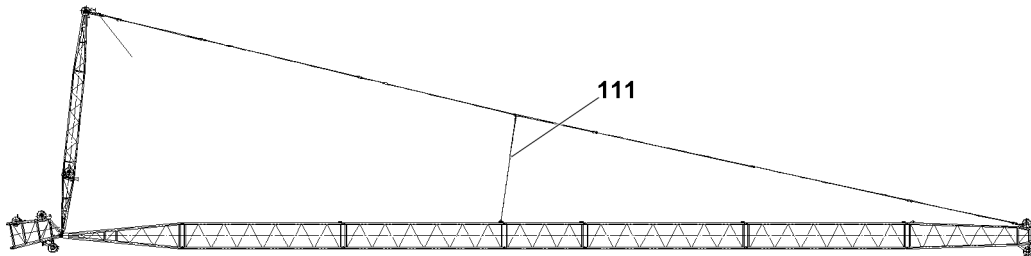


Fig.155827: Auxiliary guying

- ▶ Observe the specifications for fiber guy ropes.
- ▶ Lower WA-frame 1 until the auxiliary guying **111** can be disassembled.
- ▶ Disassemble the auxiliary guying, see chapter 5.01 and chapter 5.03.

### 9.3.4 Unpinning the guy rods on the lattice sections

- ▶ Take the guy rods down on the lattice section.

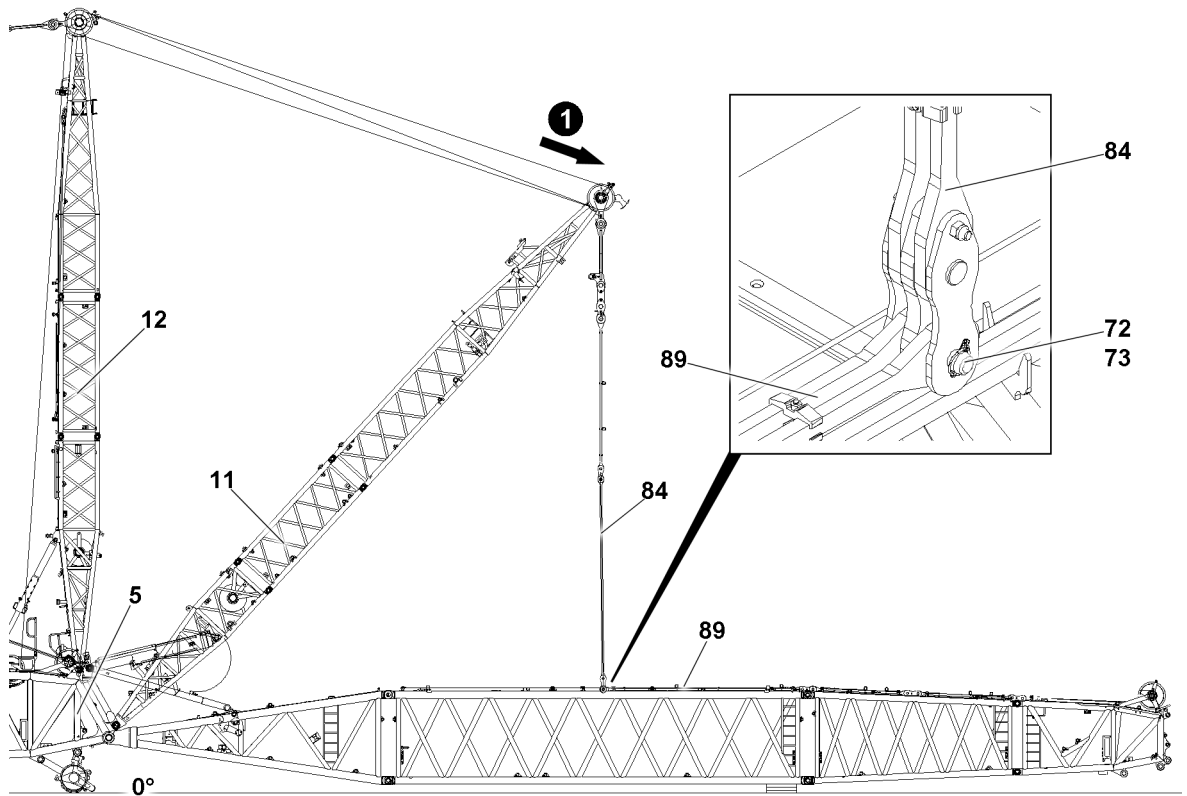


Fig.155836: Opening the guy rods



### WARNING

Oscillating guy rods!  
Danger of crushing. Danger of falling.

- ▶ Maintain the safety distance.
  - ▶ Keep the guy rods from oscillating.
- 
- ▶ Unpin the guy rods **84** on the guy rods **89** on both sides: Remove the retaining elements **73** and unpin the pin **72**.

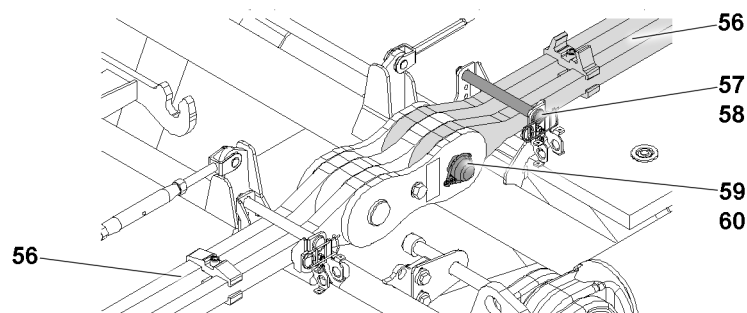


Fig.155807: Unpinning the guy rods

- ▶ Unpin the guy rods **56** on the lattice sections: Remove the retaining elements **60** and unpin the pin **59**.

The retaining elements **58** and pin **57** are in the park positions in the retainers.

- ▶ Secure the guy rods **56** on the lattice sections in the transport position: Insert the pin **57**.
- ▶ Secure the pin **57** in the transport positions: Attach the retaining elements **58**.

If present:

- ▶ Disassemble the auxiliary rods.

### 9.3.5 Securing the W-relapse support

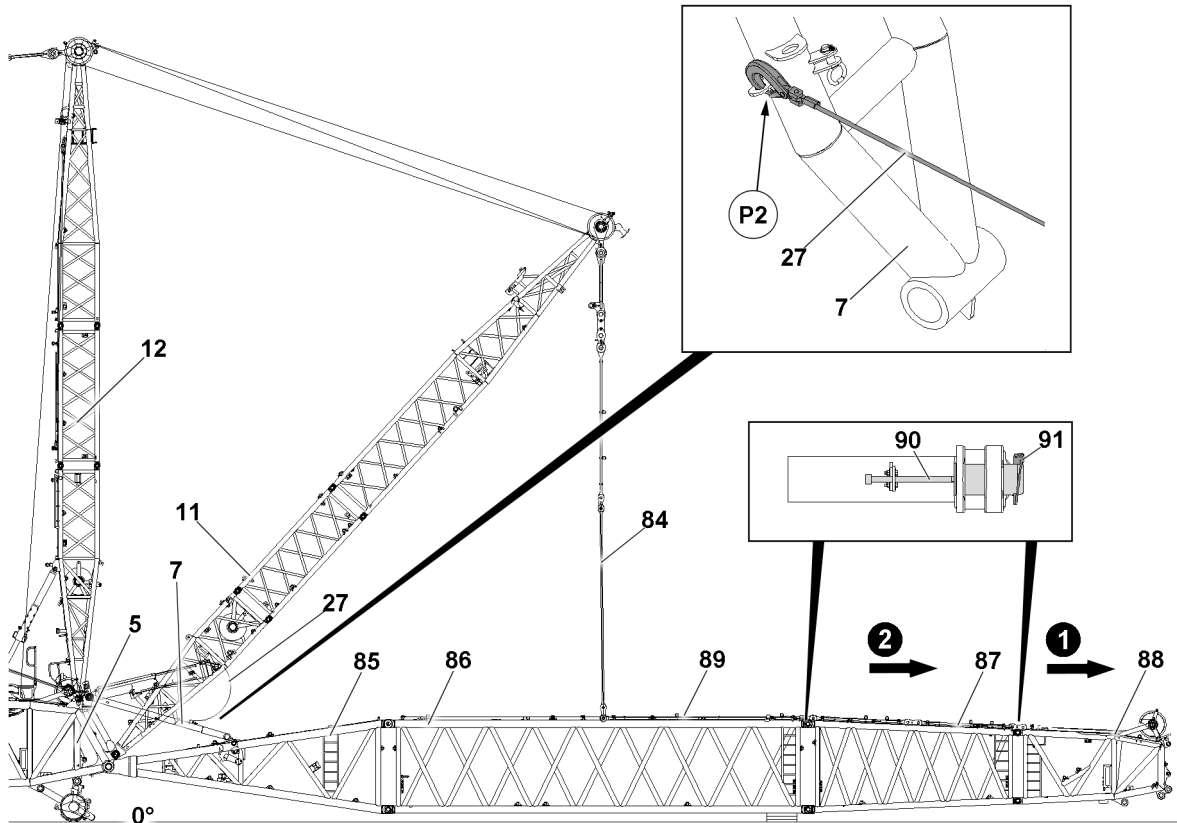


Fig.155837: Securing the W-relapse support

- ▶ Disconnect the retaining rope 27 from WA-frame 1 11.
- ▶ Connect the retaining rope 27 in point P2 to the W-relapse support 7.

**Result:**

- The W-relapse support is secured.

### 9.3.6 Disassembling the lattice sections

This section refers to the SL-reducer and the L-end section as an example.

Make sure that the following prerequisite is met:

- The guy rods are unpinned and secured on the lattice sections.

The intermediate sections are unpinned with the pin pulling cylinder, see chapter 5.30.

The disassembly of an L-end section is described as an example.

- ▶ Fasten the L-end section 88 to the auxiliary crane and lift until the fastening equipment tensions.
- ▶ Remove the retaining elements 91 on both sides at the “bottom” and unpin the connector pin 90 with the pin pulling cylinder.
- ▶ Remove the retaining elements 91 on both sides at the “top” and unpin the connector pin 90 with the pin pulling cylinder.

When the connector pins at the “top” and “bottom” are fully unpinned:

- ▶ Remove the L-end section with the auxiliary crane and take it down.
- ▶ Remove the auxiliary crane.

- ▶ For transport, insert all connector pins on the L-lattice section **88** and secure with the retaining elements.
- ▶ Up to the preassembled boom unit: Disassemble the remaining lattice sections in the same way.

### 9.3.7 Unpinning the preassembled boom unit on the S-end section

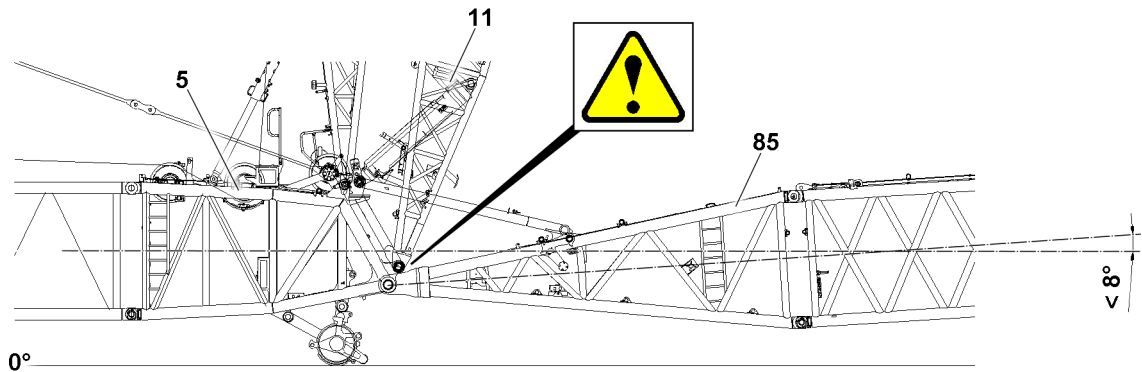


Fig.155819: Minimum permissible angle between the S-end section and W-pivot section

---

#### NOTICE

The W-pivot section is disassembled individually on the S-end section!  
Collision and damage to components.

- ▶ Disassemble the W-pivot section as a preassembled unit with the S-intermediate section or the SL-reducer on the S-end section.
- 

#### NOTICE

Minimum permissible angle between the S-end section **5** and the W-pivot section **85** **not** observed!  
Collision and damage to components.

- ▶ Observe the negative angle between the S-end section **5** and the W-pivot section **85** of less than  $8^\circ$ .
-

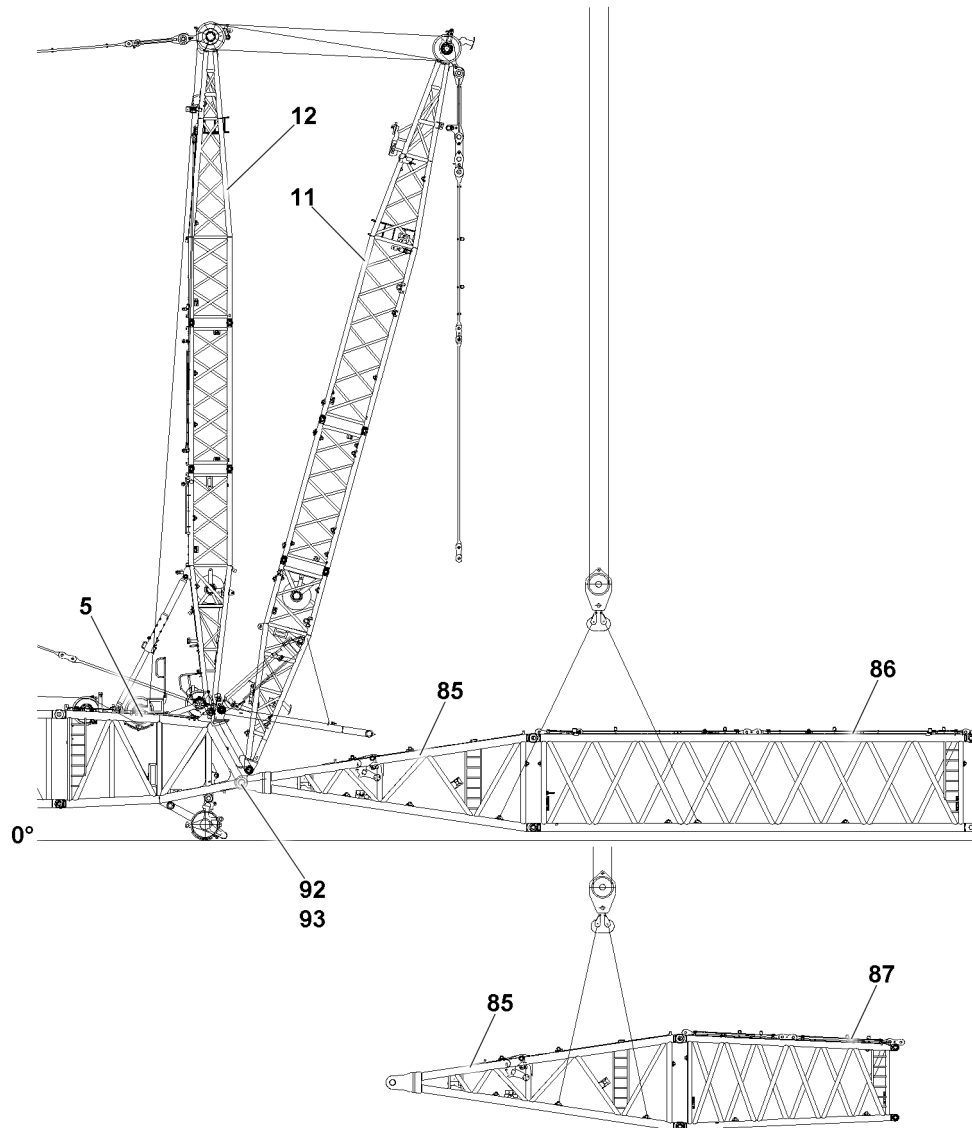


Fig.155818: Unpinning the preassembled boom unit on the S-end section

#### NOTICE

WA-frame 1 **11** **not** in the steepest position!

Collision between the auxiliary crane and WA-frame 1 **11**. Damage to components.

► Before assembling the preassembled lattice unit, erect WA-frame 1 **11** to the steepest position.

► Erect WA-frame 1 **11** to the steepest position.

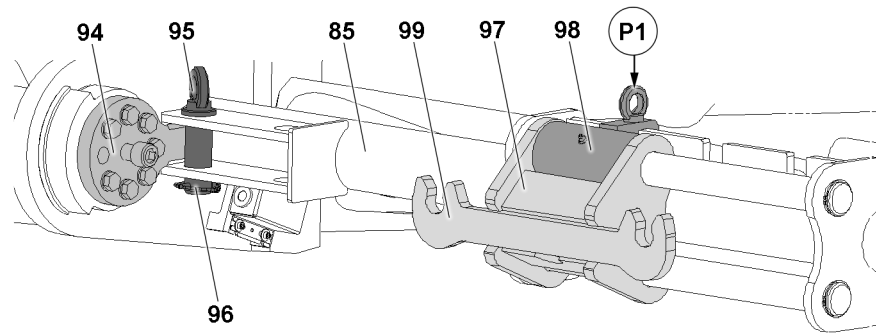
The fastening points for the preassembled lattice unit are shown on signs on the W-pivot section **85**, or see section "Fastening points".

The illustration shows an example of a preassembled lattice unit consisting of the W-pivot section **85** and S-intermediate section 12 m **86**.

► Fasten the preassembled lattice unit to the auxiliary crane and lift until the fastening equipment tensions.

► Unpin the W-pivot section **85** on the S-end section **5**, see the following procedure.

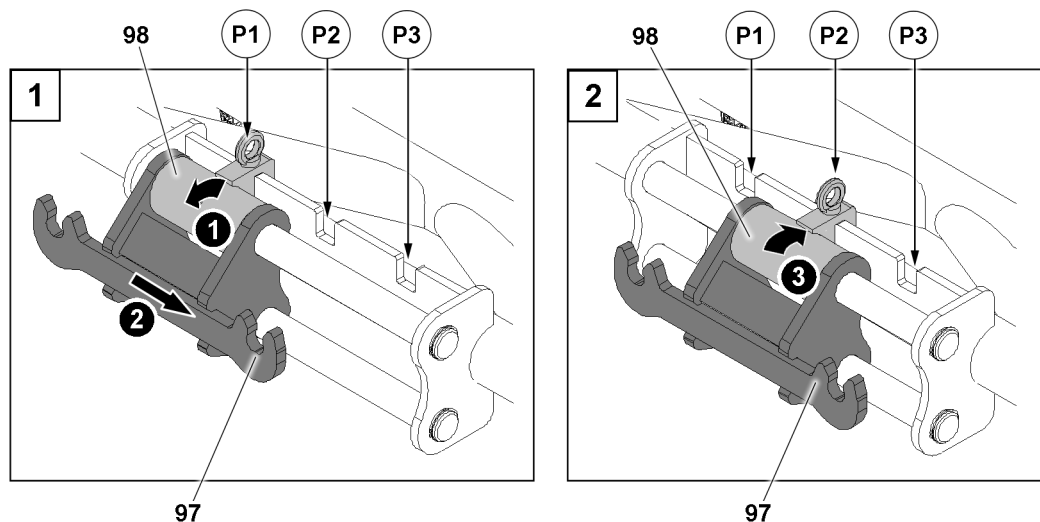
The unpinning procedure is described based on the example of one connector pin.



*Fig.155838: Unpinning the W-pivot section, first step*

The connector pins **94** are pinned in three steps. In order to pin the connector pins **94** completely, the brackets **97** must be shifted.

- ▶ Release the connector pin **94**: Remove the retaining element **96** and unpin the retaining pin **95**.
- ▶ Make sure that the flap **98** is engaged in position **P1**.
- ▶ Insert the pin pulling cylinder in the pin pulling device **99** and fit it on the screw of the connector pin **94**.
- ▶ Until the pin pulling cylinder is completely retracted: Actuate the pin pulling cylinder.
- ▶ Remove the pin pulling cylinder.



*Fig.155839: Unpinning the W-pivot section, second step*

The flap **98** can be engaged in position **P1**, position **P2** and position **P3**.

- ▶ Lift the flap **98**.
- ▶ Move the bracket **97**.
- ▶ Snap the flap **98** into position **P2**.

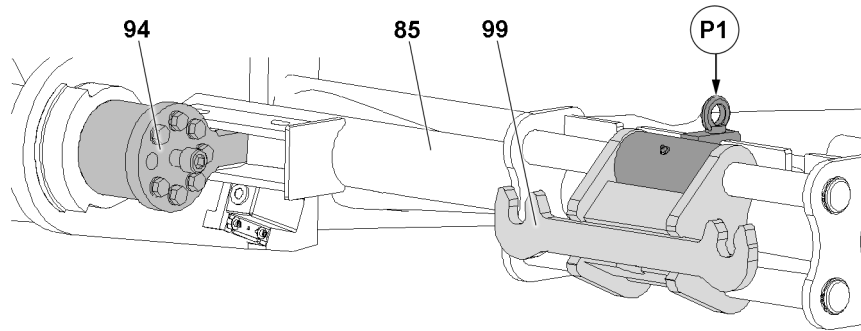


Fig.155840: Unpinning the W-pivot section, third step

- ▶ Insert the pin pulling cylinder in the pin pulling device **99** and fit it on the screw of the connector pin **94**.
- ▶ Until the connector pin **94** is completely unpinned: Actuate the pin pulling cylinder.

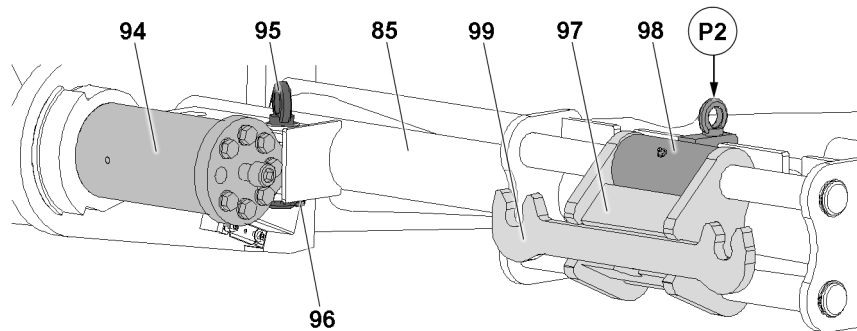


Fig.155841: Unpinning the W-pivot section, connector pin fully unpinned and secured

When the connector pin **94** is completely unpinned:

- ▶ Secure the connector pin **94**: Insert the retaining pin **95**.
- ▶ Secure the retaining pin **95**: Attach the retaining element **96**.
- ▶ Repeat the pinning procedure in the second pin position.

When the preassembled boom unit is completely unpinned:

- ▶ Swing the preassembled boom unit with the auxiliary crane and take it down.

### 9.3.8 Disassembling the preassembled boom unit



#### WARNING

Impermissible procedure when opening the lattice sections!  
Crushing of limbs if the lattice section tips over.

- ▶ Observe the various procedures when disassembling the lattice sections.



#### WARNING

**Unstable** position of the preassembled lattice units!  
Danger of crushing due to tipping of the preassembled lattice unit.

- ▶ Observe the stable position of the respective lattice unit.

Opening the lattice sections depends on the type of lattice section on which the W-pivot section is disassembled:

- S-intermediate section 12 m
- SL-reducer 6 m



Make sure that the following prerequisite is met:

- The preassembled boom unit is positioned on the ground.

### Disassembling S-intermediate section 12 m

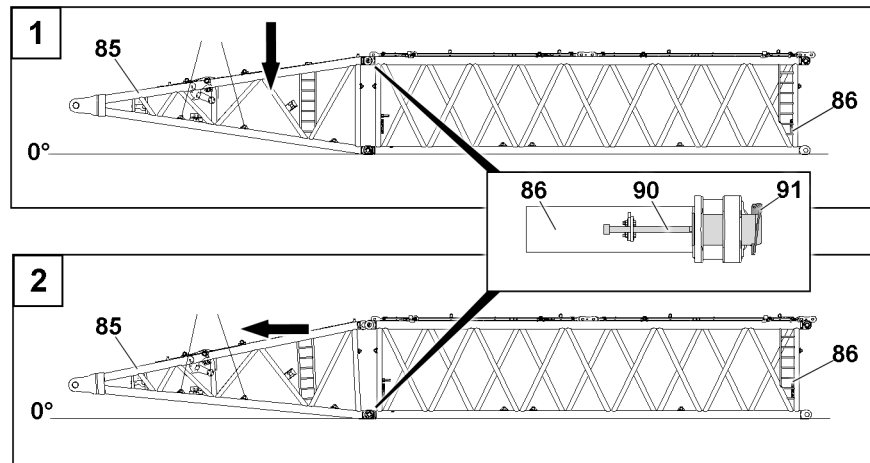


Fig.155843: Disassembling the W-pivot section, 12 m lattice section

The WA-pivot section **85** is unpinned with the pin pulling cylinder, see chapter 5.30.

- ▶ Fasten the W-pivot section **85** to the auxiliary crane and lift until the fastening equipment tensions.
- ▶ Unpin the W-pivot section **85** on both sides at the “top”: Remove the retaining elements **91** and unpin the pin **90**.
- ▶ Lower the W-pivot section **85**.
- ▶ Unpin the W-pivot section **85** on both sides at the “bottom”: Remove the retaining elements **91** and unpin the pin **90**.
- ▶ Swing the W-pivot section **85** with the auxiliary crane and take it down.
- ▶ Insert and secure the pin **90** again in the W-pivot section **85** and the S-intermediate section **86**.

### Disassembling the SL-reducer 6 m

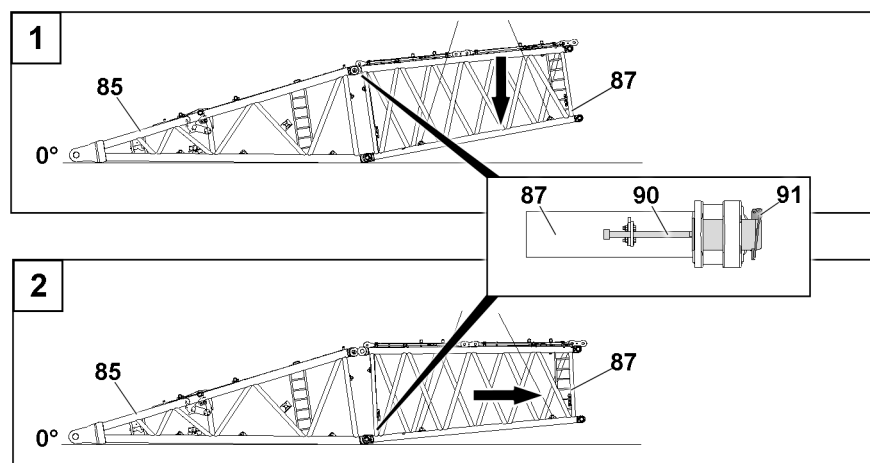


Fig.155842: Disassembling the W-pivot section, 6 m lattice section

The SL-reducer **87** is unpinned with the pin pulling cylinder, see chapter 5.30.

- ▶ Fasten the SL-reducer **87** to the auxiliary crane and lift until the fastening equipment tensions.
- ▶ Unpin the SL-reducer **87** on both sides at the “top”: Remove the retaining elements **91** and unpin the pin **90**.
- ▶ Lower the SL-reducer **87**.

- ▶ Unpin the SL-reducer **87** on both sides at the “bottom”: Remove the retaining elements **91** and unpin the pin **90**.
- ▶ Swing the SL-reducer **87** with the auxiliary crane and take it down.
- ▶ Insert and secure the pin **90** again in the W-pivot section **85** and the SL-reducer **87**.

## 9.4 Taking the WA-frames down



### WARNING

Defective relapse cylinder!

Release of WA-frame 2, when WA-frame 1 is in the steepest position.

Damaged relapse cylinder, if in the block position.

- ▶ Check the relapse cylinder before taking the WA-frames down.
- ▶ Check the electrical connection to the limit switches of the relapse cylinders.



### WARNING

**Unsynchronized** spooling of the hoist winch and the control winch!

Overload of the crane.

- ▶ When taking the WA-frame down, spool the hoist winch and the control winch synchronously with each other.
- ▶ Have the spooling procedure visually monitored by a guide.



### WARNING

Slack rope formation of the hoist rope or the W-control rope!

Uncontrolled oscillation of WA-frame 1 or WA-frame 2.

- ▶ Tension the hoist rope and the W-control rope evenly during take-down.

When WA-frame 2 moves, the relapse cylinder must have always built up pressure.

### 9.4.1 Unpinning the guy rods from the intermediate section

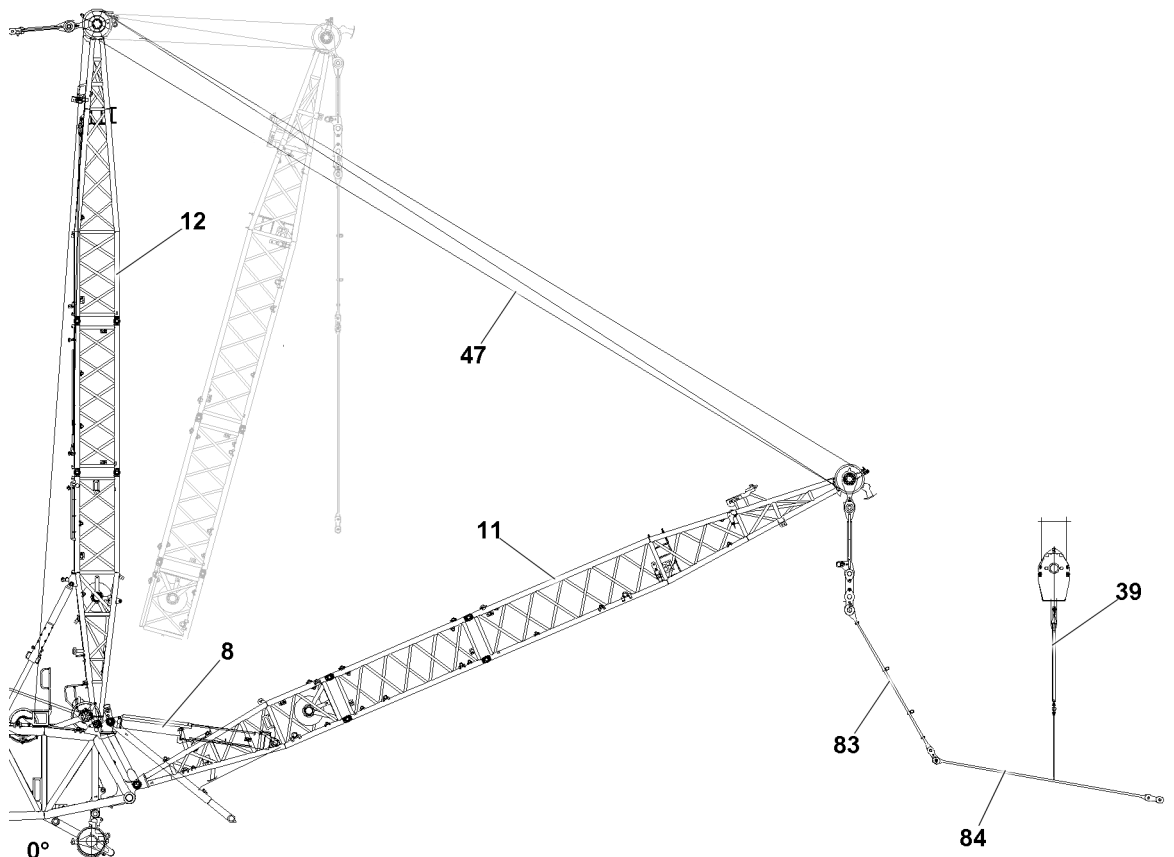


Fig.155844: Unpinning the guy rods

Length of the guy rods, see the rod plan.

Remove WA-frame 1 11 guy rods 83 and the first guy rods 84 from the following intermediate section or SL-reducer.



#### Note

- ▶ Use the cross beam 39 to hold the guy rods.
- ▶ Lower WA-frame 1 11: Spool the W-control rope 47 out.
- ▶ Unpin the guy rods 83 with the guy rods 84, see section "Unpinning the guy rods on the lattice sections".
- ▶ Erect WA-frame 1 11 until the relapse cylinders 8 turn off: Spool the W-control rope 47 up.

## 9.4.2 Connecting the erection rope with the hoist rope

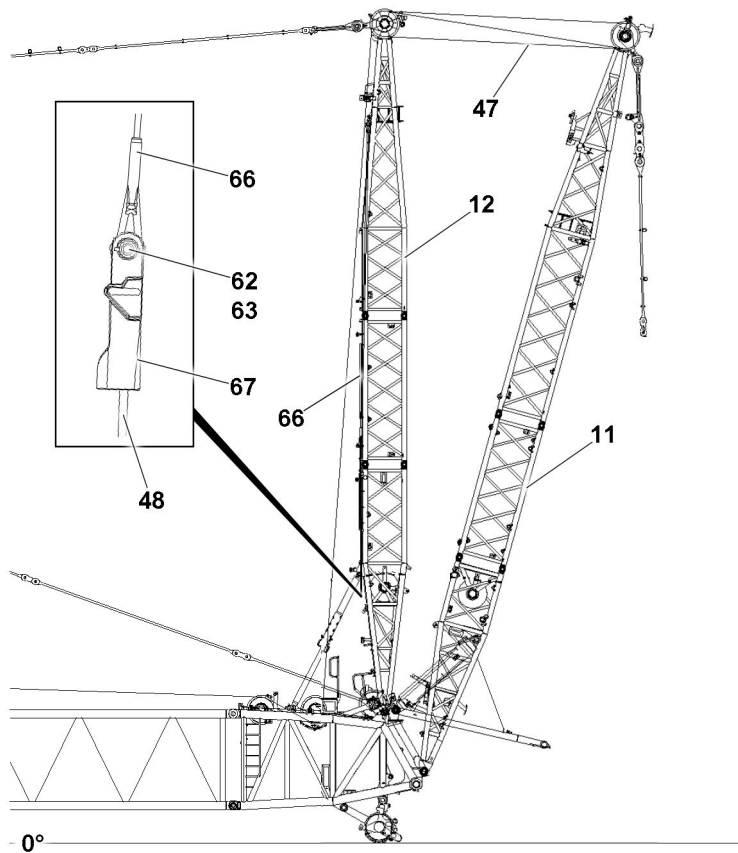


Fig.155845: WA-frame 2, releasing the erection rope

A work platform is required for releasing the erection rope from WA-frame 2 12.

- ▶ Release the erection rope 66 in the park position.

### NOTICE

Impermissible hoist rope run with short main boom lengths!  
The hoist rope collides with the luffing pulley block.

- ▶ With short main boom lengths: Direct the hoist rope outside the luffing pulley block.

To erect / take down WA-frame 2 12, the hoist rope of hoist winch 1 or hoist winch 2 must be used.



### WARNING

Operation of the incorrect hoist winch!

To protect against a mix up:

- ▶ When operating the hoist winch to erect / take down WA-frame 2 12, the unused hoist winches must be blocked.
- ▶ Block unutilized hoist winches, see chapter 4.05.
- ▶ Fasten the hoist rope 48 in the lock 67.
- ▶ Fasten the erection rope 66 to the lock 67: Insert the pin 62.
- ▶ Secure the pin 62: Attach the retaining element 63.

### 9.4.3 Unpinning the relapse support

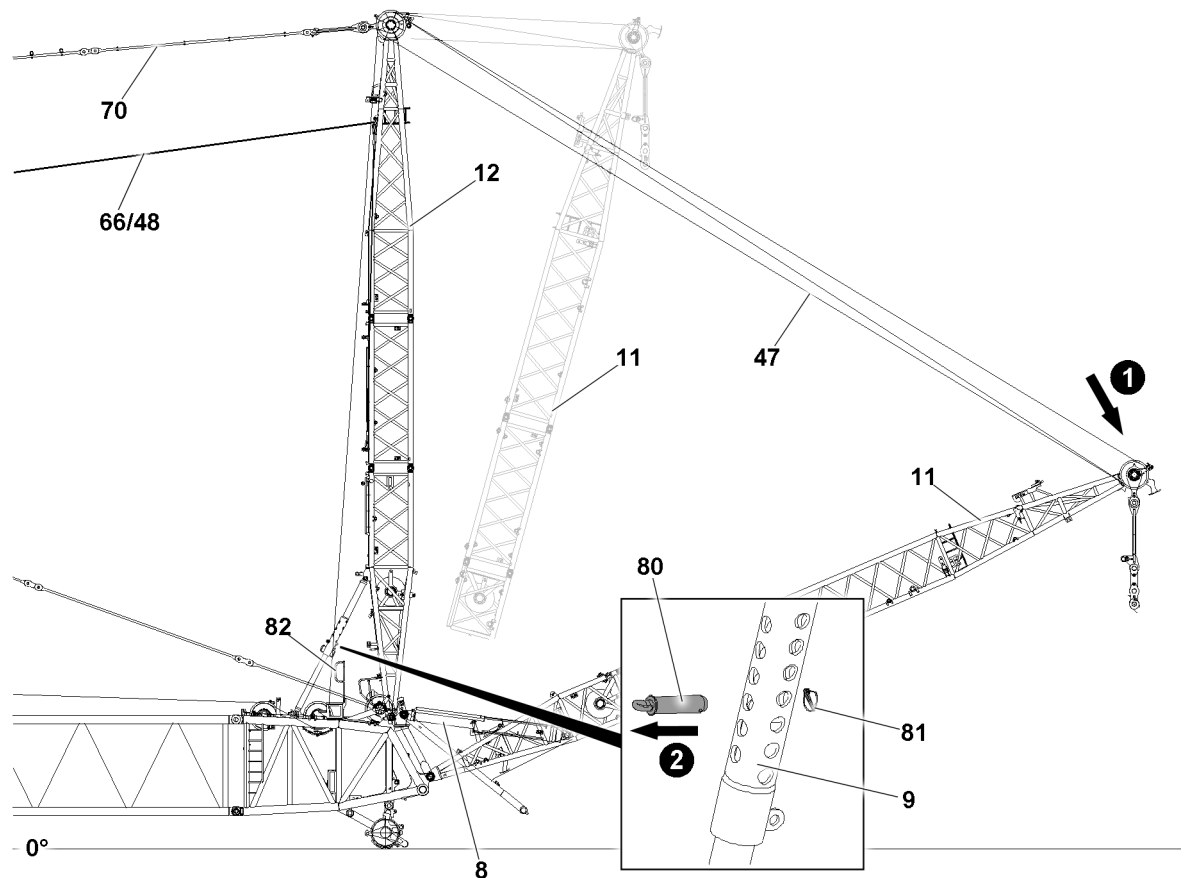


Fig.155846: WA-frame 2, releasing the relapse support locking

Make sure that the following prerequisites are met:

- The W-lattice jib is disassembled.
- WA-frame 1 11 is in the steepest position.
- The erection rope 66 is connected with the hoist rope 48.
- ▶ Spool the hoist rope 48 up until the erection rope 66 is slightly tensioned.
- ▶ Release the locking of the relapse supports 9 on both sides: Remove the retaining elements 81 and unpin the pin 80.



#### WARNING

Impermissible WA-frame 1-position!

Release of WA-frame 2 12, if WA-frame 1 11 does **not** press against the relapse cylinder 8.

- ▶ While WA-frame 2 12 is being erected, pull WA-frame 1 11 against the relapse cylinder 8.
- ▶ Check the cylinder pressure of the relapse cylinder on the LICCON monitor pressure display.

- ▶ Lower WA-frame 1 11.



#### Note

- ▶ Take the railing 82 down, see chapter 2.06.



#### WARNING

Movement of WA-frame 2 12!

Crushing of limbs.

Damage to components if WA-frame 2 12 is pulled back too far.

- ▶ Adhere to the safety distance from the moving components.
- ▶ Have the movements visually monitored by a guide.

**NOTICE**

Release supports **9** unpinned when pulling back the WA-frame **2 12**!

Damage to WA-frame **2**!

- ▶ Release the lock before WA-frame **2 12** is pulled back.

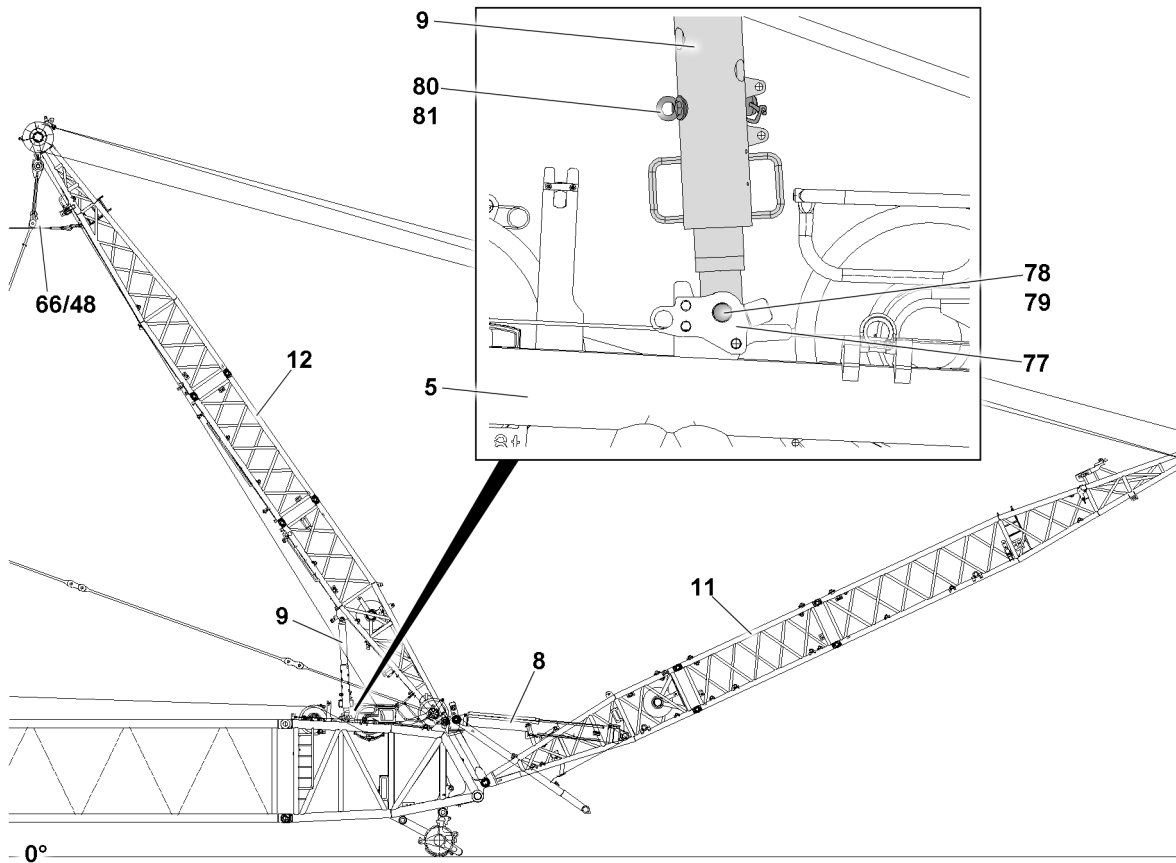


Fig.155813: WA-frame 2, relapse supports

Carry out the following actions at the same time until WA-frame **2 12** is erected far enough that the relapse supports **9** are inserted completely:

- Erect WA-frame **2 12** with the hoist rope **48**.
- Spool the W-control rope **47** out.
- Check the cylinder pressure of the relapse cylinder on the LICCON monitor pressure display.
- ▶ Pull WA-frame **2 12** back until the relapse supports **9** are fully inserted, keep WA-frame **1 11** in position.

This procedure is described based on the example of one relapse support.

- ▶ Lock the relapse supports **9**: Insert the pin **80**.
- ▶ Secure the pin **80**: Attach the retaining elements **81**.
- ▶ Unpin the relapse supports **9** from the brackets **77**: Remove the retaining elements **79** and unpin the pin **78**.
- ▶ Repeat the procedure for the second relapse support.

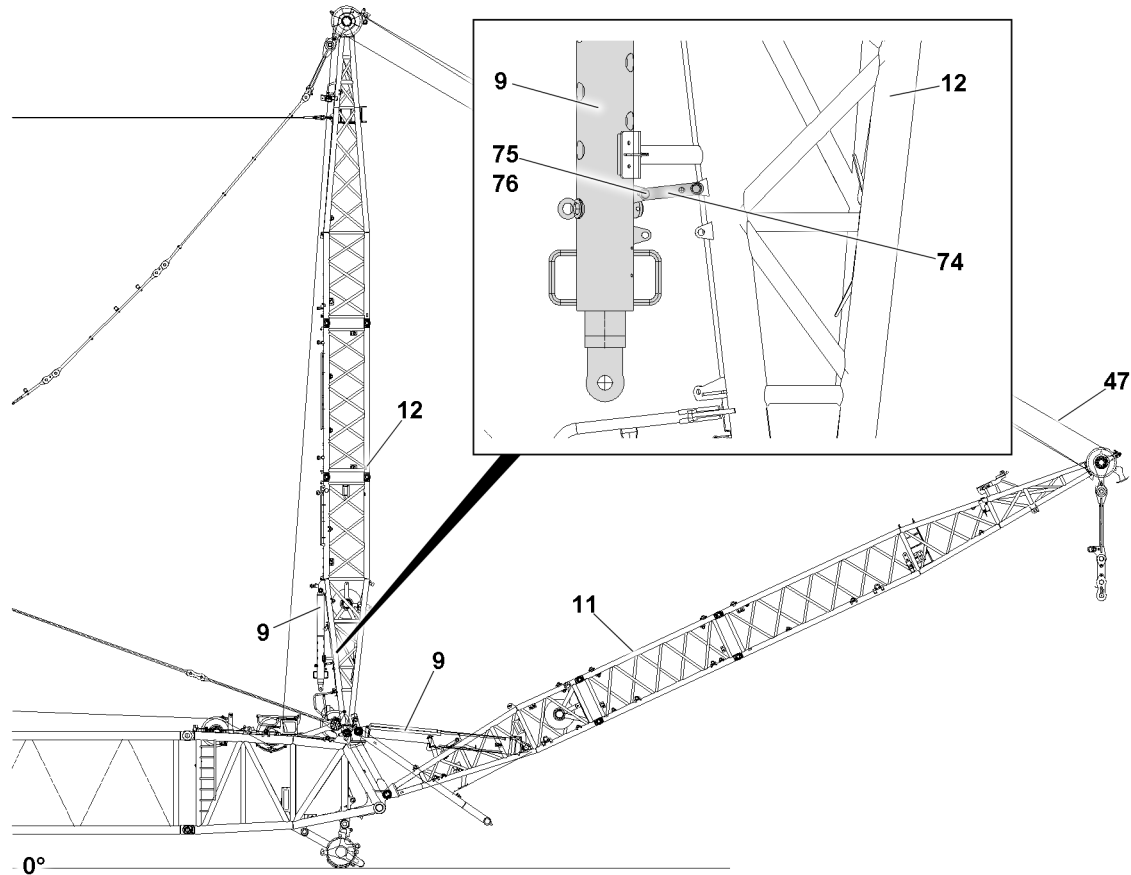


Fig.155812: WA-frame 2, securing the relapse supports in a vertical position

Carry out the following actions at the same time until WA-frame 2 12 is erected:

- Spool the W-control rope 47 up.
- Guide WA-frame 2 12 with the hoist rope 48.
- Check the cylinder pressure of the relapse cylinder on the LICCON monitor pressure display.
- ▶ Place WA-frame 2 12 in a vertical position, keep WA-frame 1 11 in position.

This procedure is described based on the example of one relapse support.

The pins 75 are pinned and secured in the retainer 74.

- ▶ Connect the relapse support 9 with the retainer 74: Insert the pin 75.
- ▶ Secure the pin 75: Attach the retaining element 76.
- ▶ Repeat the procedure for the second relapse support.

#### 9.4.4 Securing the lugs on WA-frame 1

- ▶ Connect the ratchet hoist 33 to the lug in point 1 and to the lug in point P2.
- ▶ Use the ratchet hoist 33 to swing the pull bracket 32 and pull test bracket 31.
- ▶ Attach the ring loop 36.
- ▶ Secure the pin 34: Attach the retaining element 35.
- ▶ Repeat the procedure for the other side of WA-frame 1.
- ▶ Remove the ratchet hoist 33.

### 9.4.5 Unpinning the WA-frame 2 guy rods

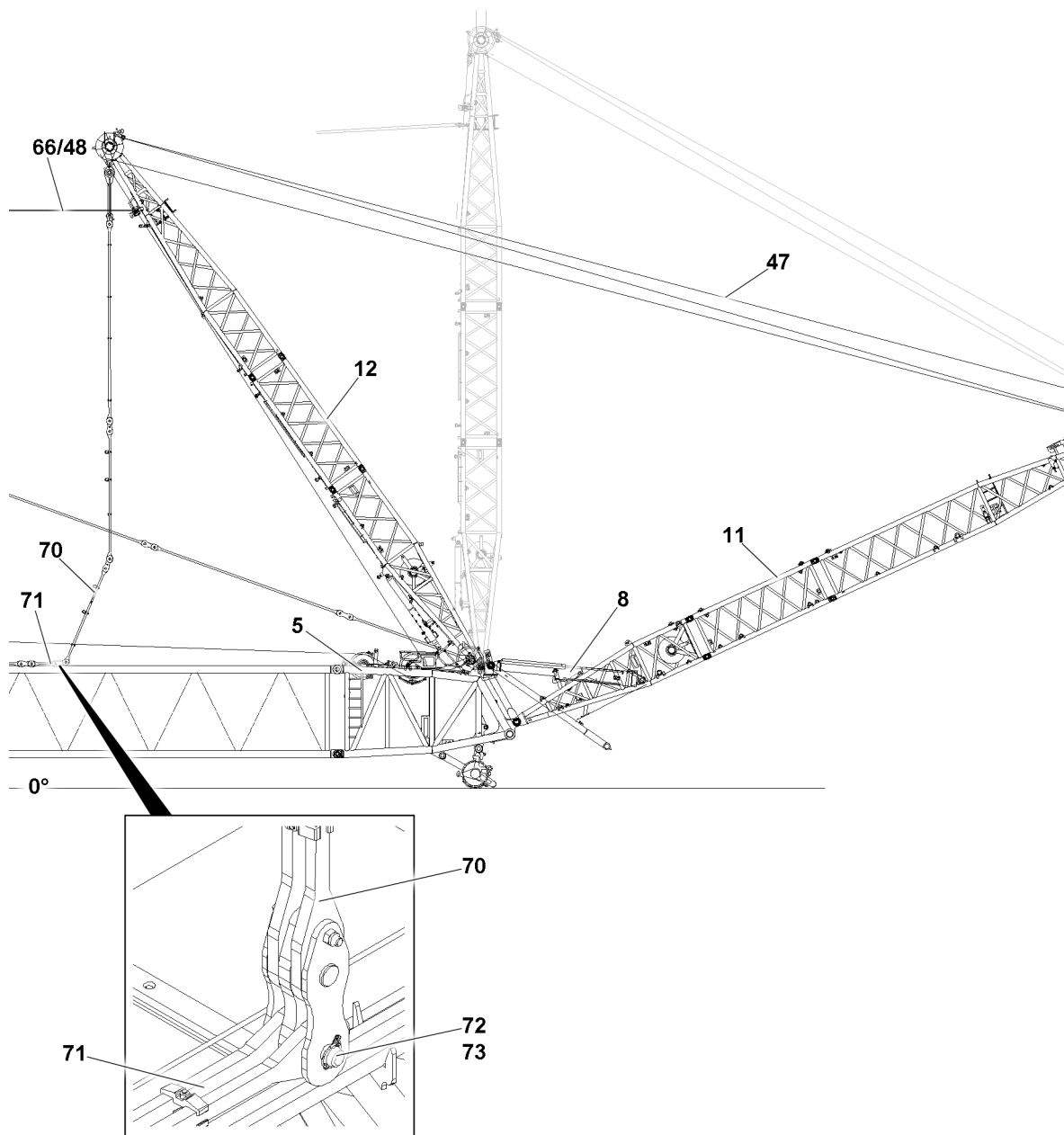


Fig.155847: Unpinning the guy rods

Carry out the following actions at the same time until WA-frame 2 **12** is erected far enough that the guy rods can be unpinned:

- Erect WA-frame 2 **12** with the hoist rope **48**.
- Spool the W-control rope **47** out.
- Check the cylinder pressure of the relapse cylinder on the LICCON monitor pressure display.



#### WARNING

Impermissible WA-frame 1-position!

Release of WA-frame 2 **12**, if WA-frame 1 **11** does **not** press against the relapse cylinder **8**.

- ▶ While WA-frame 2 **12** is being erected, pull WA-frame 1 **11** against the relapse cylinder **8**.
- ▶ Check the cylinder pressure of the relapse cylinder on the LICCON monitor pressure display.

- ▶ Pull WA-frame 2 **12** back until the guy rods **71** lie on the S-lattice sections and the guy rods **70** hang vertically, keep WA-frame 1 **11** in position.



**WARNING**

Oscillating guy rods!  
Death, severe bodily injuries.

▶ Adhere to the safety distance from the hanging guy rods.

- ▶ Unpin the guy rods **71** on the guy rods **70**: Remove the retaining elements **73** and unpin the pin **72**.
- ▶ Unpin and secure the guy rods on the S-lattice sections, see chapter 5.38.

### 9.4.6 Securing the cross beam on WA-frame 1

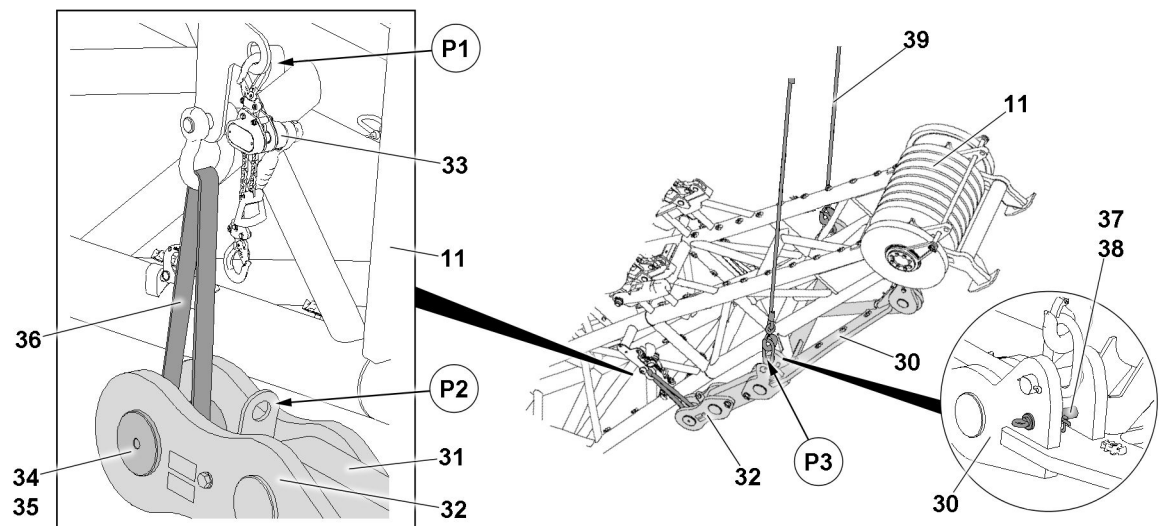


Fig.155850: Securing the cross beam

**Note**

▶ This procedure is described for one side.

**NOTICE**

Use of the auxiliary cross beam **39**!

Do not use the auxiliary cross beam **39** to lift the W-frames.

▶ Make sure that the auxiliary cross beam **39** is only used for lowering the cross beam **30**.

A work platform is required for securing the cross beam **30** to WA-frame 1 **11**.

- ▶ Fasten the auxiliary cross beam **39** to the cross beam **30**.
- ▶ Release the pin **37**: Remove the retaining element **38**.
- ▶ Unpin the pin **37**.
- ▶ Swing the cross beam **30** up with the auxiliary cross beam **39** until it can be pinned to WA-frame 1 **11** in point **P3**.
- ▶ Secure the cross beam **30** on both sides: Insert the pin **37**.
- ▶ Secure the pin **37**: Attach the retaining element **38**.
- ▶ Remove the auxiliary cross beam **39**.

### 9.4.7 Taking the WA-frames down

Make sure that the following prerequisite is met:

- A suitable auxiliary crane and suitable fastening equipment are available.

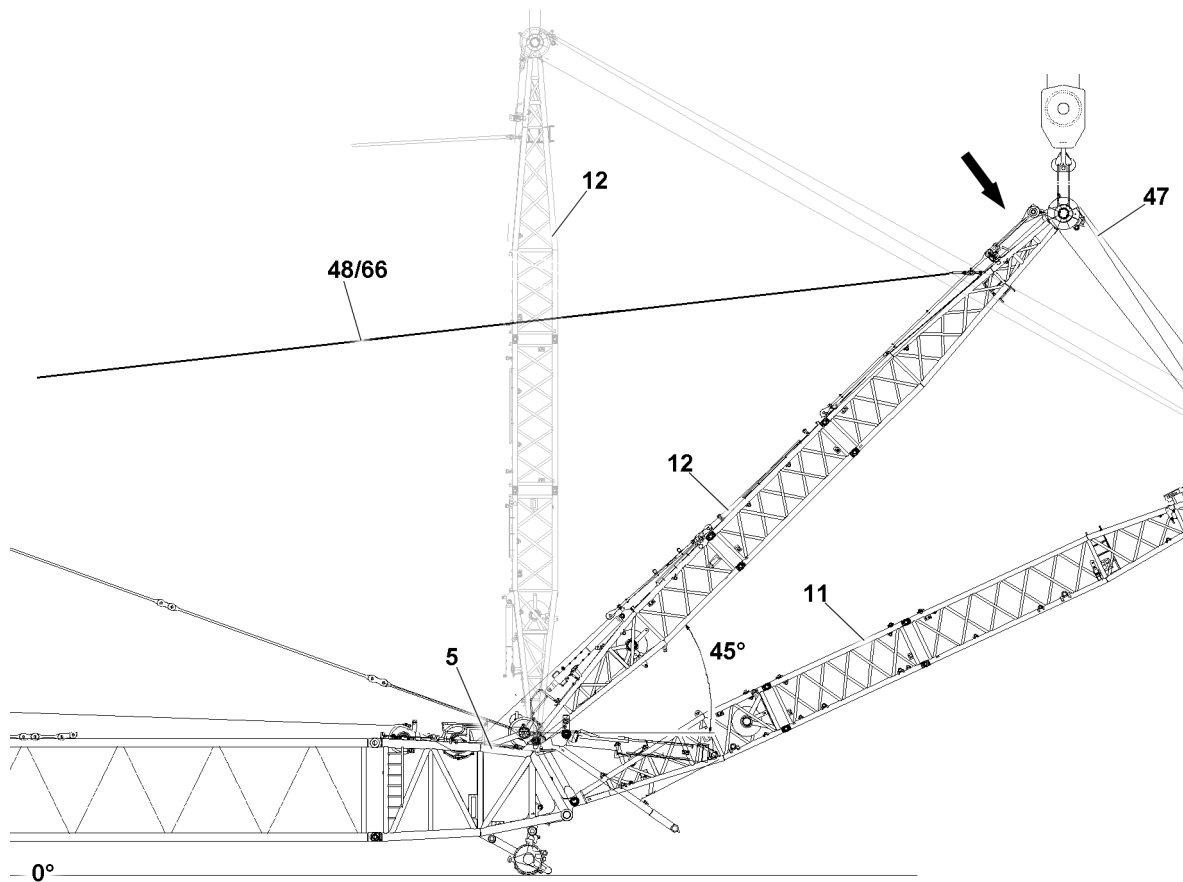


Fig.155848: Taking the WA-frames down with the auxiliary crane



#### Note

- ▶ Hold WA-frame 2 **12** with the auxiliary crane, required load bearing capacity approx. 22 t.



#### WARNING

Danger of accident!

If WA-frame 2 **12** is taken down too far with the hoist rope **48**, the hoist rope **48** can be overloaded and rip off.

If the actual pressure is too high when taking WA-frame 2 **12** down, the hoist winch or the hoist rope **48** can be damaged.

- ▶ Take WA-frame 2 **12** down maximum to the "45 °" position with the hoist rope **48**.
- ▶ When taking WA-frame 2 **12** down, observe the winch pressure display of the hoist winch.
- ▶ Winch pressure display of the hoist winch, see chapter 4.02.

When WA-frame 2 **12** is in the "45° position":

- ▶ Secure WA-frame 2 **12** with the auxiliary crane.

Carry out the following actions at the same time until WA-frame 2 **12** is erected to the 45° position:

- Take WA-frame 2 **12** down with the auxiliary crane.
- Observe the winch pressure display for the hoist winch, see chapter 4.02.
- Spool the hoist rope **48** out.
- Spool the W-control rope **47** up.
- ▶ Take WA-frame 2 **12** down to the 45° position, keep WA-frame 1 **11** in position.
- ▶ Fasten the auxiliary crane with the fastening equipment to the bitt.
- ▶ Tension WA-frame 2 **12** with the auxiliary crane until the fastening equipment tensions.
- ▶ Spool the hoist rope **48** out until the erection rope **66** lies on WA-frame 2 **12**.
- ▶ Remove the hoist rope **48** from the lock.

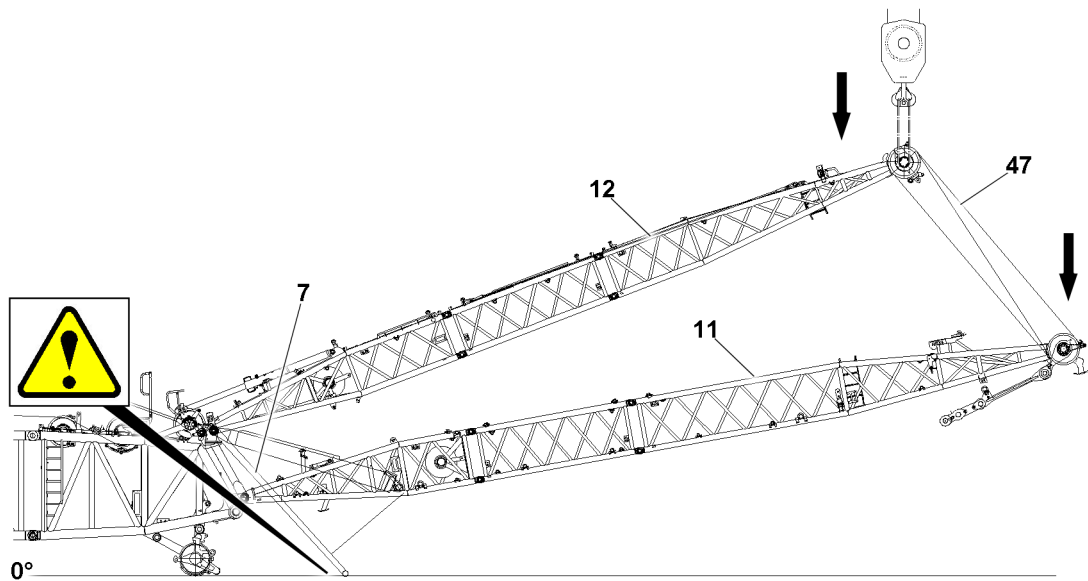


Fig.166587: Taking the WA-frames down

Carry out the following actions at the same time until WA-frame 1 **11** is located just above the ground:

- Keep the W-control rope **47** tensioned.
- Take WA-frame 2 **12** down with the auxiliary crane.
- ▶ Reduce the distance between the WA-frames alternately and take the WA-frames down further.

---

#### NOTICE

The relapse support **7** gets stuck / drags on the ground!  
Property damage.

- ▶ Protect the relapse support **7** against damage, by supporting it for example.
  - ▶ Keep WA-frame 1 **11** just above the ground.
-

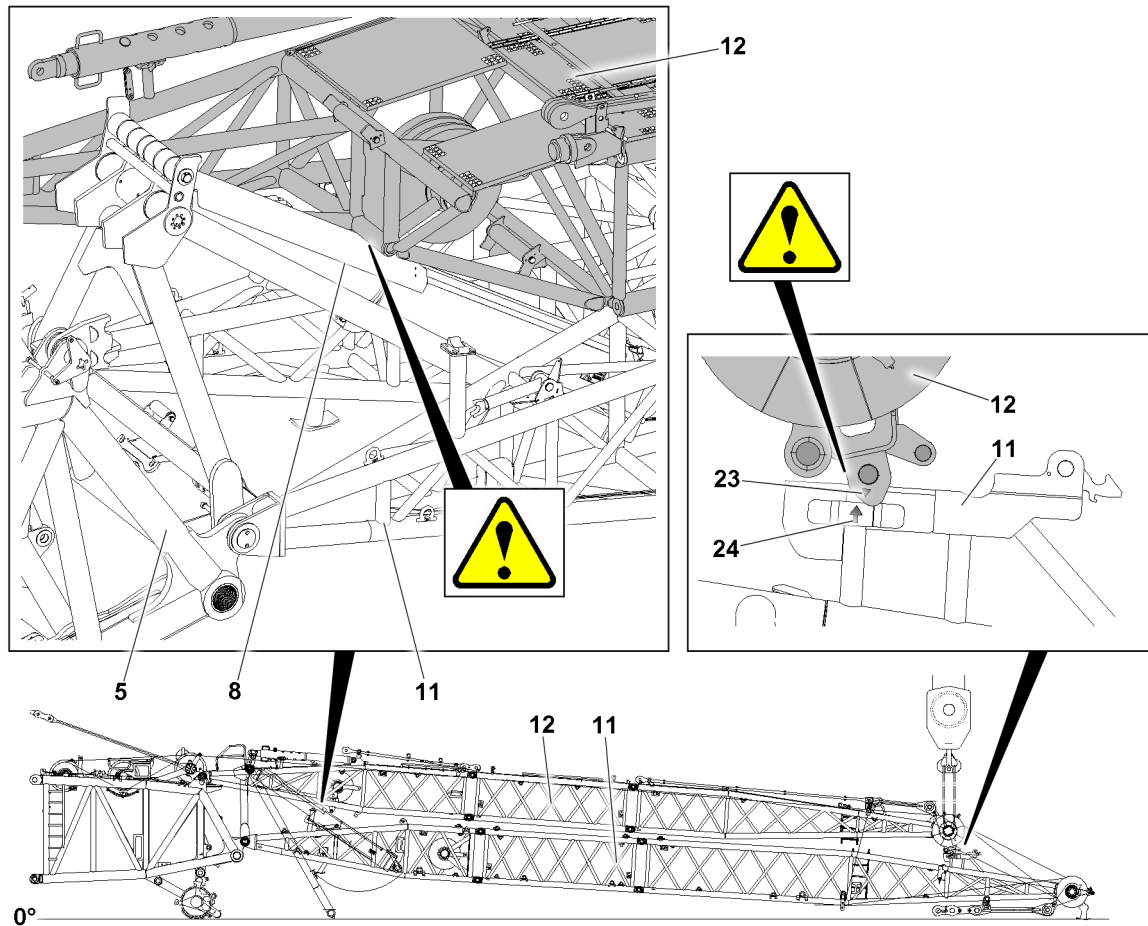


Fig.155851: Taking the WA-frames down

Carry out the following actions at the same time until WA-frame 2 **12** lies on WA-frame 1 **11**:

- Spool the W-control rope **47** up.
- Take WA-frame 2 **12** down with the auxiliary crane.

#### NOTICE

W-control rope **47** spooled up too far!

WA-frames colliding. The W-control rope **47** can **not** be reeved out any further. Property damage.

- ▶ Make sure that the WA-frame is **not** tensioned with the W-control rope **47**.

#### NOTICE

Collision between WA-frame 2 and the relapse cylinder!

If when taking down WA-frame 2 **12** the triangle **23** of WA-frame 2 **12** crosses the arrow **24** on WA-frame 1 **11**, this can lead to a collision between WA-frame 2 **12** and the relapse cylinder **8**.

This can result in significant property damage.

- ▶ Make sure when taking down W-frame 2 **12**, that the triangle **23** of WA-frame 2 **12** does not cross the arrow **24** on WA-frame 1 **11**.
- ▶ Support WA-frame 1 **11**.
- ▶ Take WA-frame 2 **12** down until WA-frame 1 **11** is lying on the ground and WA-frame 2 **12** is lying on WA-frame 1 **11**.
- ▶ Remove the fastening equipment.

## 9.5 Securing and unpinning the guy rods on the lattice sections

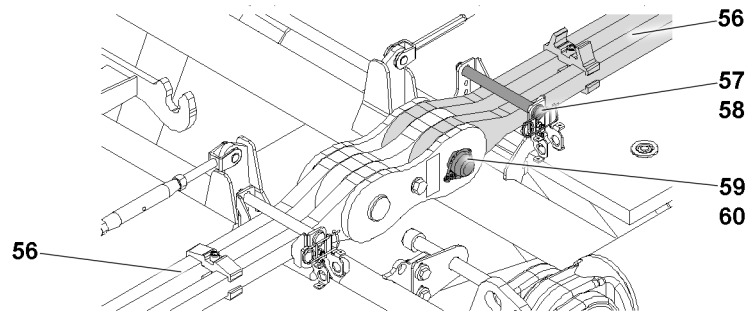


Fig.155807: Guy rods on the lattice sections

- ▶ Unpin the pin **57** from the park positions in the retainers.
- ▶ Secure the guy rods **56** on the lattice sections: Insert the pin **57**.
- ▶ Secure the pin **57**: Attach the retaining elements **58**.
- ▶ Unpin the guy rods **56** on the lattice sections from each other: Remove the retaining element **60** and unpin the pin **59**.

## 9.6 Securing the cross beam

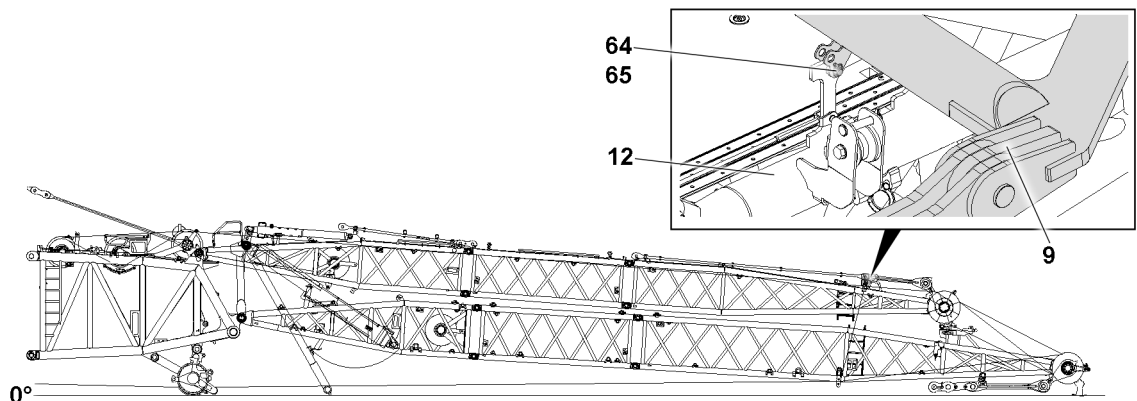


Fig.155809: Securing the cross beam

The pins **64** are in the park position in the brackets.

- ▶ Secure the cross beam **9** on both sides in the transport retainers: Insert the pin **64**.
- ▶ Secure the pin **64**: Secure the retaining elements **65**.

## 9.7 Pinning the relapse support to the relapse cylinder

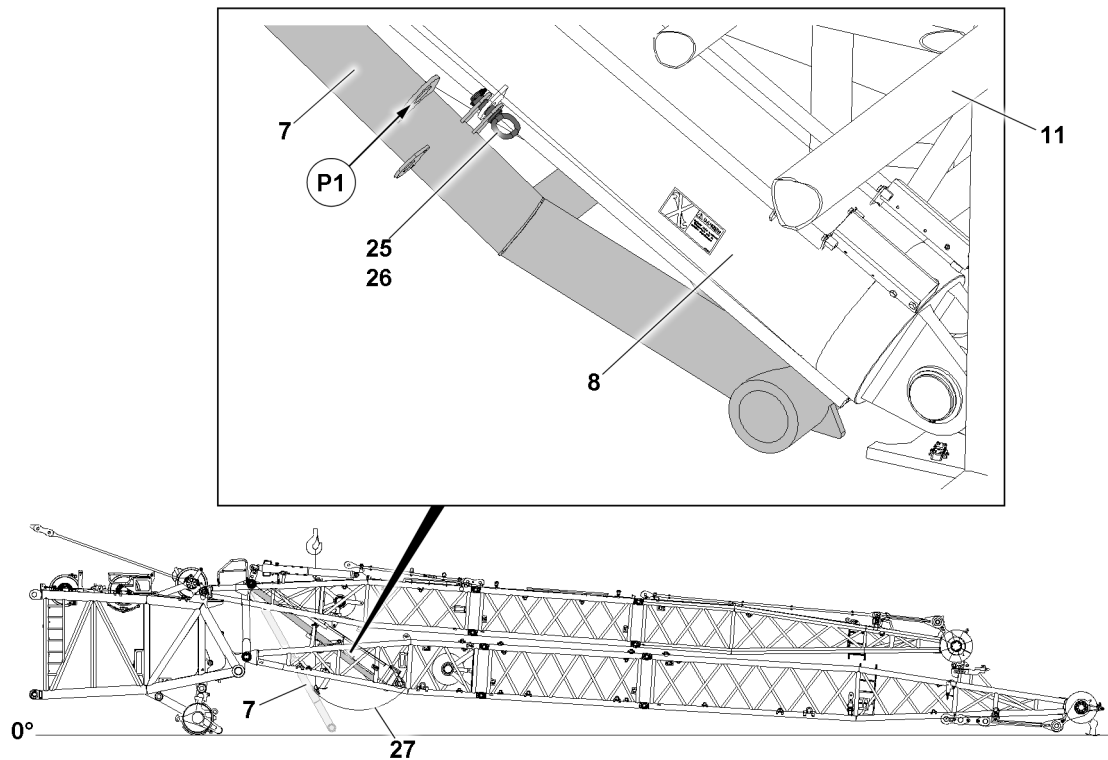


Fig.155853: Relapse support

The W-relapse support 7 is secured with the rope 27 on the lug.

- ▶ Release the rope 27 from the relapse support 7: Open the hook.
- ▶ Fasten the relapse support 7 to the auxiliary crane in point P1.
- ▶ Remove the retaining element 26 and unpin the socket pin 25.
- ▶ Swing the relapse support 7 up with the auxiliary crane until the relapse support 7 can be pinned.
- ▶ Secure the relapse support 7: Insert the socket pin 25.
- ▶ Secure the socket pin 25: Attach the retaining element 26.

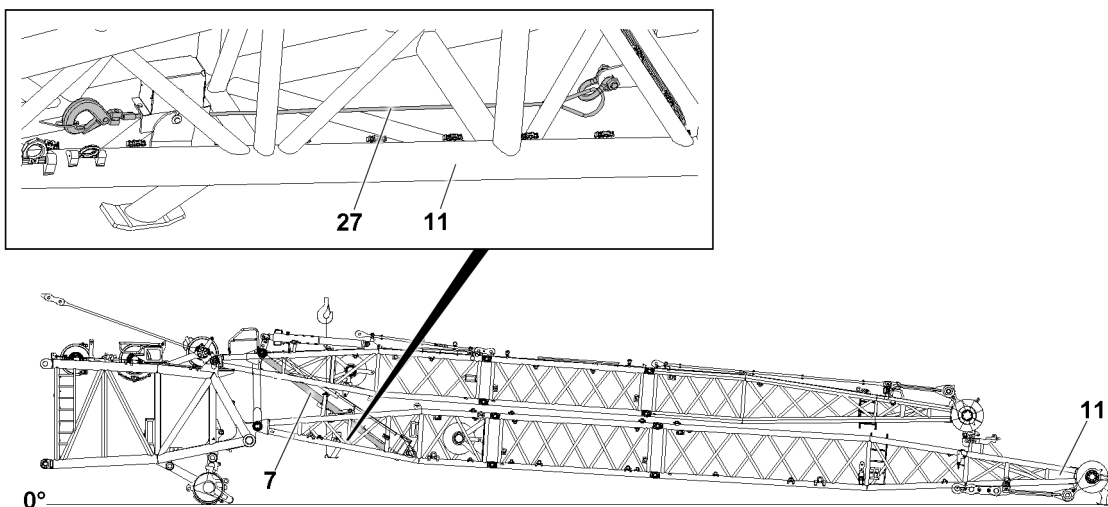


Fig.155852: Rope

- ▶ Release the rope 27 from the relapse support 7: Open the hook.

Secure the rope 27 on WA-frame 11 in the park position

- ▶ Connect the hook to WA-frame 1 11.

## 9.8 Disassembling the erection rope

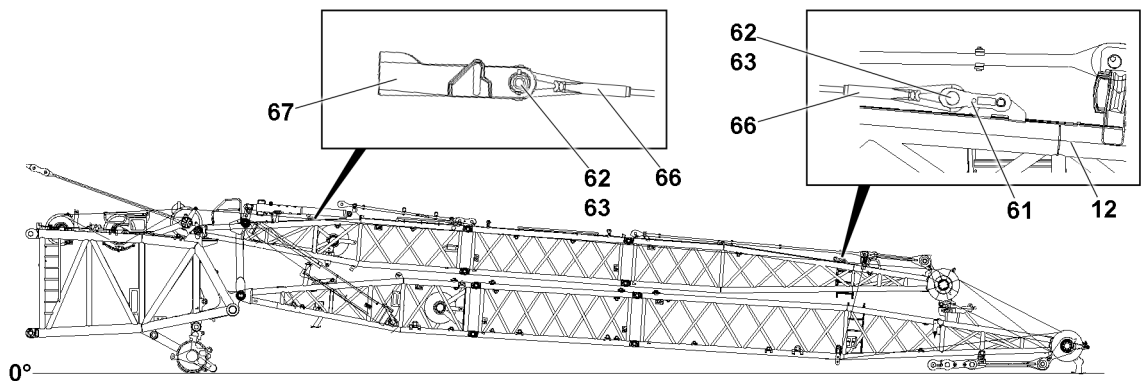


Fig.155854: Disassembling the erection rope

Remove the lock 67:

- ▶ Remove the retaining element 63 and unpin the pin 62.

Unpin the erection rope 66 from the lug 61:

- ▶ Remove the retaining element 63 and unpin the pin 62.
- ▶ Remove the erection rope 66.

## 9.9 Reeving the ropes out



### WARNING

Running ropes!  
Danger of crushing.

- ▶ Adhere to the safety distance to the running ropes.
- ▶ Radio contact is available between crane operator and assembly personnel.



### WARNING

Falling or uncontrolled moving lock clamp!

Danger of accident when spooling ropes up. Death, severe bodily injuries, property damage.

- ▶ Before spooling up: Fasten the assembly winch auxiliary rope to the W-control rope / hoist rope.
- ▶ While spooling up: Actuate the winches synchronously.

### NOTICE

Slack rope formation!

Due to slack rope formation, the hoist rope and the W-control rope can be damaged.  
This can result in significant property damage.

- ▶ When spooling the hoist rope or the W-control rope up or out, do not allow slack rope formation.
- ▶ When spooling up or out, hold the hoist rope and the W-control rope taut.

Differentiation between the ropes:

- The auxiliary rope is the assembly winch rope.
- The forerunner rope is a rope that is used to draw in a hoist rope or a control rope.

Make sure that the following prerequisite is met:

- The WA-frames are completely taken down.

### 9.9.1 Swinging the change over pulley into the operating position

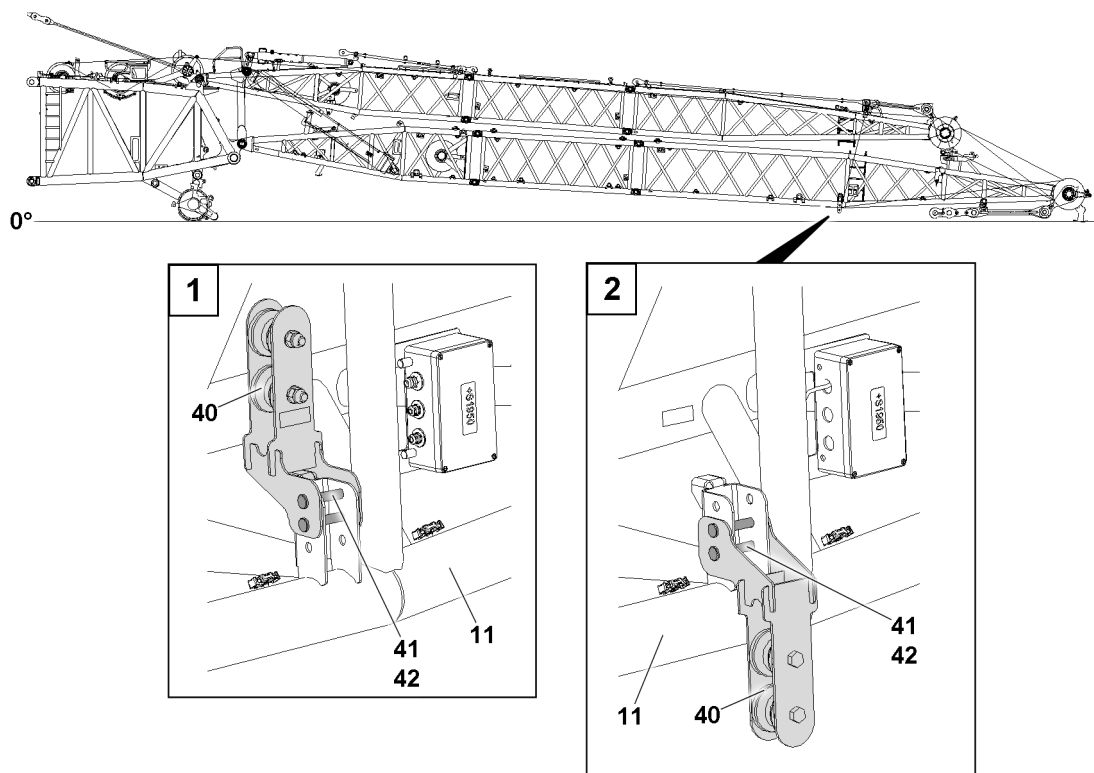


Fig.155855: Change over pulley

The change over pulley **40** must be pinned on WA-frame **11** in the operating position.

- ▶ Remove the retaining element **42** and unpin the pin **41**.
- ▶ Swing the change over pulley **40** into the operating position.
- ▶ Secure the change over pulley **40**: Insert the pin **41**.
- ▶ Secure the pin **41**: Attach the retaining element **42**.



### 9.9.2 Swinging the assembly pulley into the operating position

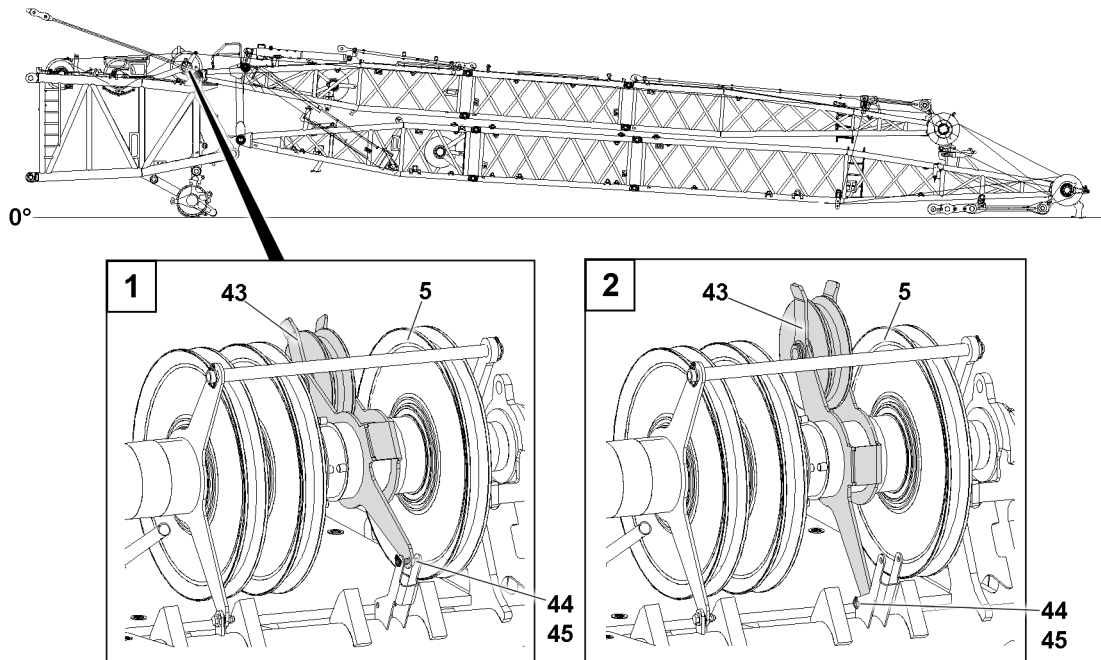


Fig.155856: Assembly pulley

The assembly pulley **43** must be pinned to the S-end section **5** in the operating position.

- ▶ Remove the retaining element **45** and unpin the pin **44**.
- ▶ Swing the assembly pulley **43** into the operating position.
- ▶ Secure the assembly pulley **43**: Insert the pin **44**.
- ▶ Secure the pin **44**: Attach the retaining element **45**.

### 9.9.3 Removing the rope retainer

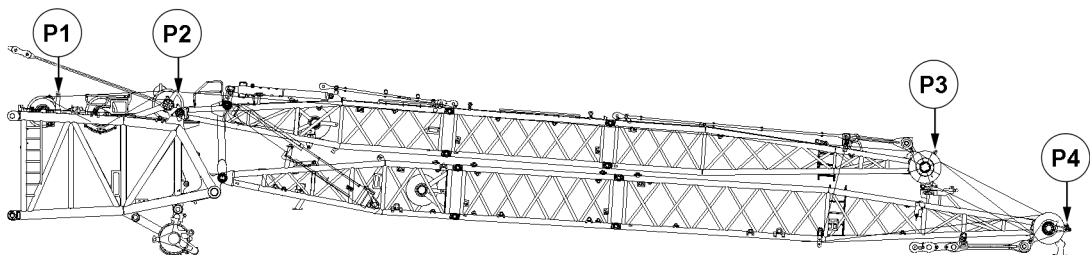


Fig.155857: Rope retainer

- ▶ Remove the rope retainer in the rope pulleys in point **P1**, point **P2**, point **P3** and point **P4**: Remove the retaining elements and rods.

### 9.9.4 Reeving the W-control rope out on the WA-frames

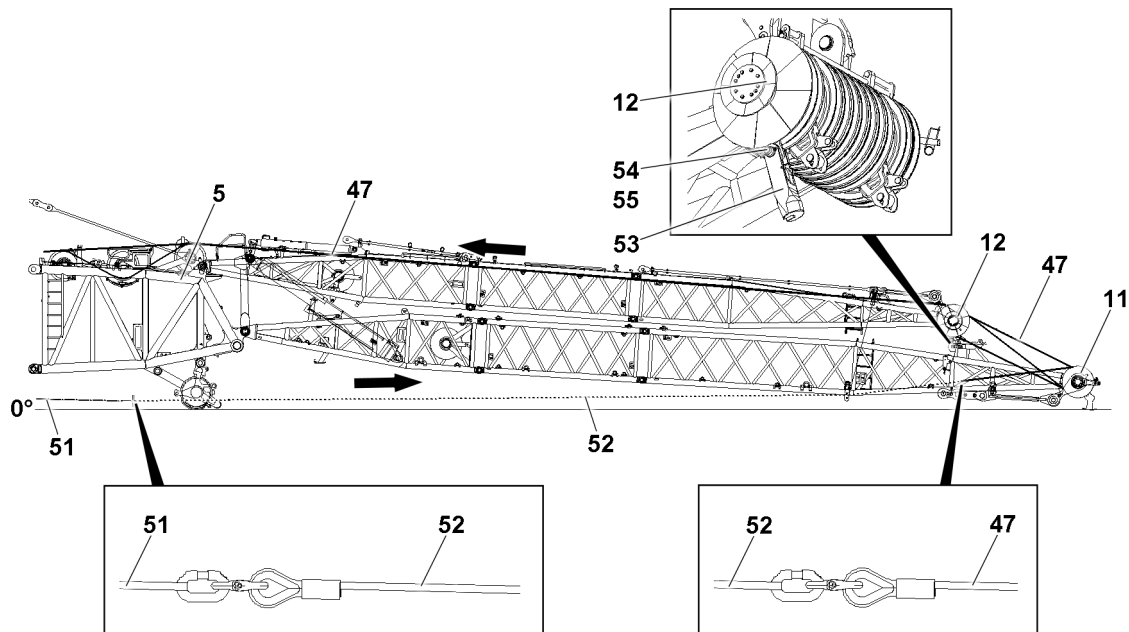


Fig.155858: Forerunner rope, W-control rope, lock

- ▶ Remove the W-control rope **47** from the lock **53**.
- ▶ Remove the lock **53**: Remove the retaining element **55** and unpin the pin **54**.

While the W-control rope is reeved out, the forerunner rope is reeved into the WA-frames at the same time.

- ▶ Pull the forerunner rope **52** to the W-control rope **47**.
- ▶ Fasten the forerunner rope **52** to the W-control rope **47**.
- ▶ Spool the auxiliary rope **51** out from the assembly winch and fasten to the forerunner rope **52**.
- ▶ Reeve the W-control rope **47** out: Spool the assembly winch out and simultaneously spool winch **5** up at the same speed until the forerunner rope **52** is located on the S-end section **5**.
- ▶ Disconnect the W-control rope **47** from the forerunner rope **52**.
- ▶ Disconnect the auxiliary rope **51** from the forerunner rope **52**.
- ▶ Secure the forerunner rope **4** to WA-frame 2.
- ▶ Spool the auxiliary rope **51** up until the auxiliary rope **51** is located on the S-end section **5**.

### 9.9.5 Spooling the W-control rope up

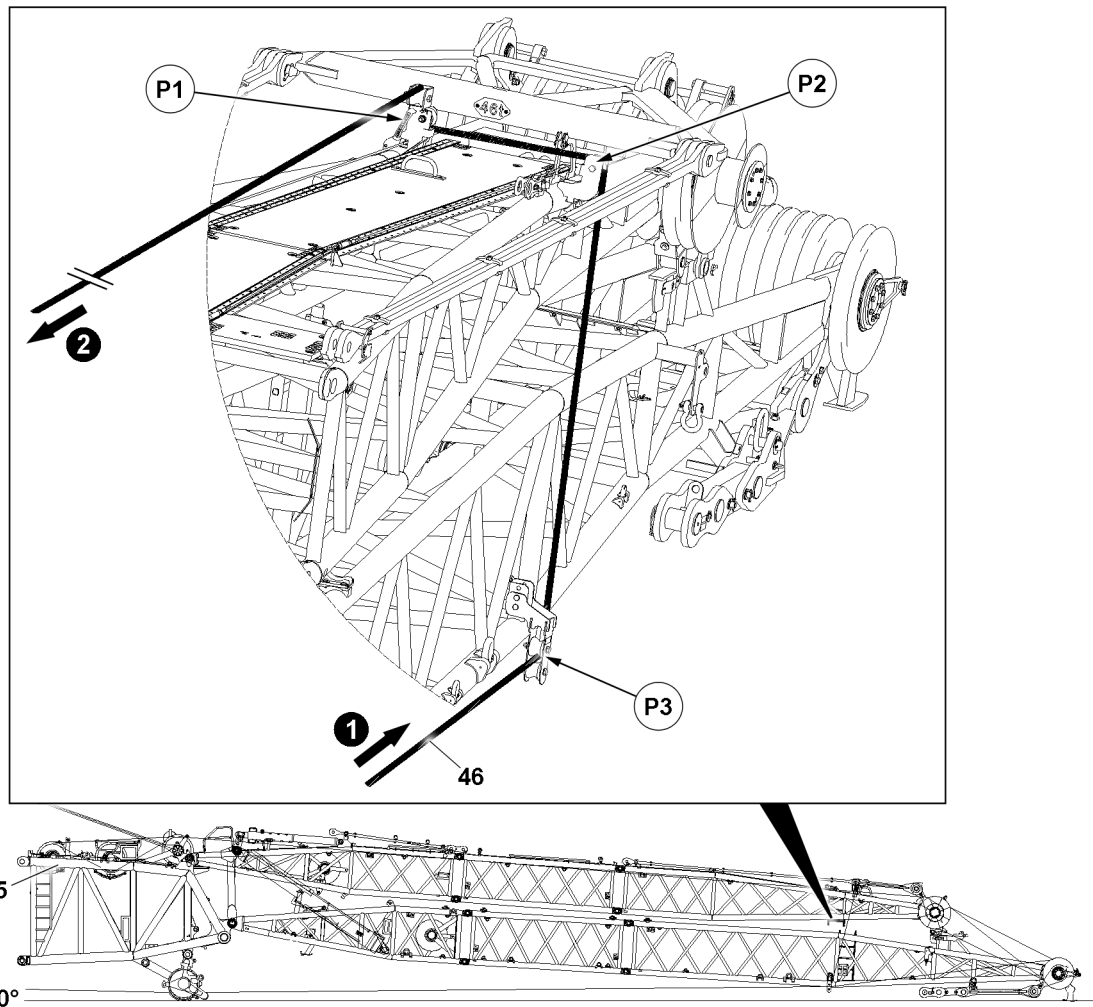


Fig.155859: Rope run

The line **46** shows the course for pulling the auxiliary rope in.

- ▶ Guide the auxiliary rope over the change over pulley in point **P3**, point **P2** and point **P1**.
- ▶ Pull the auxiliary rope over WA-frame 2 to the S-end section and assemble on the W-control rope.



#### WARNING

Falling or uncontrolled moving lock clamp!  
 Danger of accident when spooling the W-control rope up.  
 Death, severe bodily injuries, property damage.

- ▶ Before spooling up: Fasten the assembly winch auxiliary rope to the W-control rope.
- ▶ Spool the W-control rope up to winch 5 and spool the auxiliary rope out at the same time.

When the W-control rope is spooled up on winch 5:

- ▶ Remove the auxiliary rope from the W-control rope.
- ▶ Spool the auxiliary rope up until the auxiliary rope is on the S-end section.

### 9.9.6 Spooling the hoist rope up

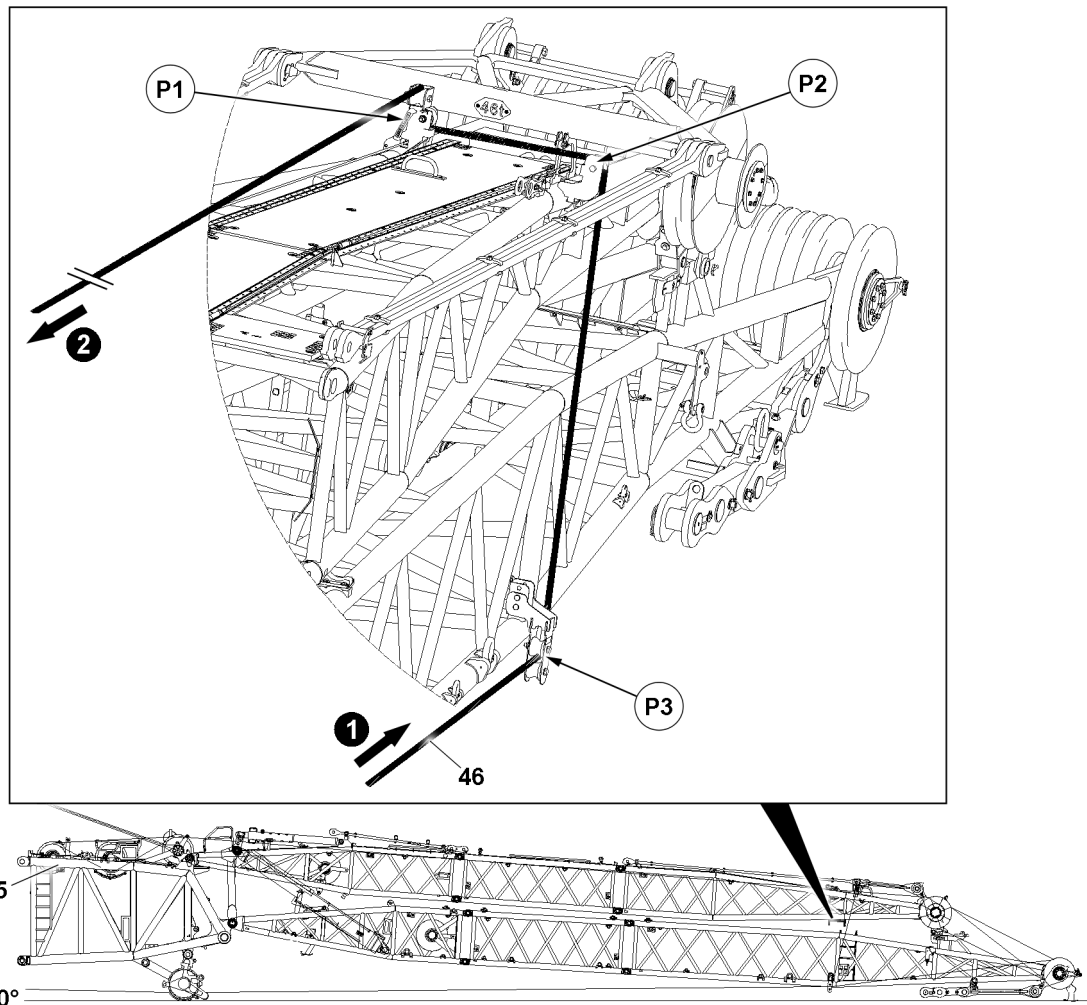


Fig.155859: Rope run

The line **46** shows the course for pulling the auxiliary rope in.

- ▶ Assemble the auxiliary rope on the hoist rope.



#### WARNING

Falling or uncontrolled moving lock clamp!

Danger of accident when spooling the hoist rope up. Death, severe bodily injuries, property damage.

- ▶ Before spooling up: Attach the assembly winch auxiliary rope to the hoist rope.
- ▶ Spool the hoist rope up maximum to the derrick pivot section.
- ▶ Do **not** spool the hoist rope up further through the derrick boom.
- ▶ Spool the hoist rope up to the hoist winch and spool the auxiliary rope out simultaneously.

When the hoist rope is spooled up on the hoist winch:

- ▶ Disassemble the auxiliary rope on the hoist rope.
- ▶ Spool the auxiliary rope up.

### 9.9.7 Assembling the rope retainer

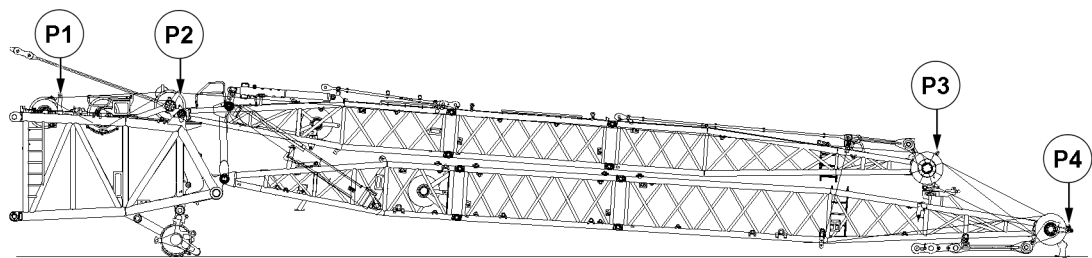


Fig.155857: Rope retainer

- ▶ Assemble the rope retainer in the rope pulleys in point **P1**, point **P2**, point **P3** and point **P4**: Attach the rods and retaining elements.

### 9.9.8 Pinning the change over pulley in the park position

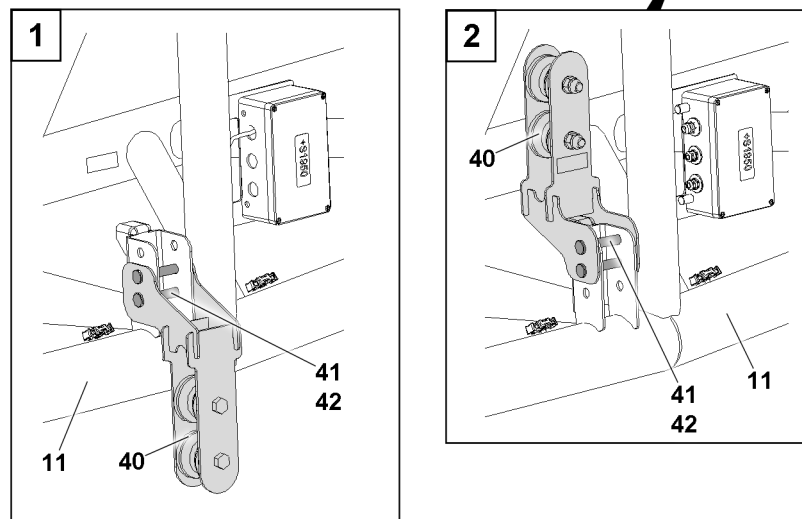
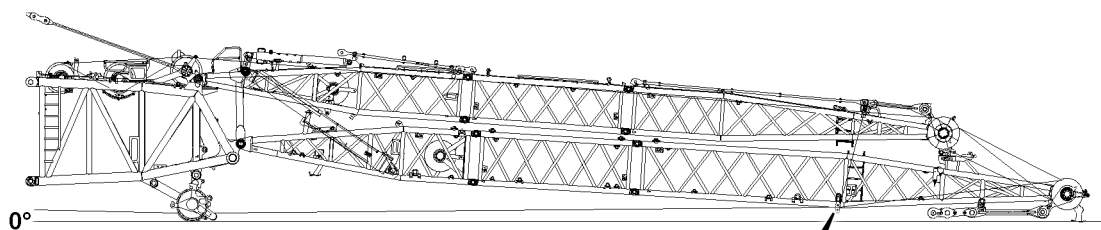


Fig.155863: Change over pulley

The change over pulley **40** is pinned to WA-frame **11** in the park position.

- ▶ Remove the retaining element **42** and unpin the pin **41**.
- ▶ Swing the change over pulley **40** into the park position.
- ▶ Secure the change over pulley **40**: Insert the pin **41**.
- ▶ Secure the pin **41**: Attach the retaining element **42**.

### 9.10 Disconnecting the electrical connections between the S-end section and the WA-frames

- ▶ Disconnect the electrical connections.

**NOTICE**

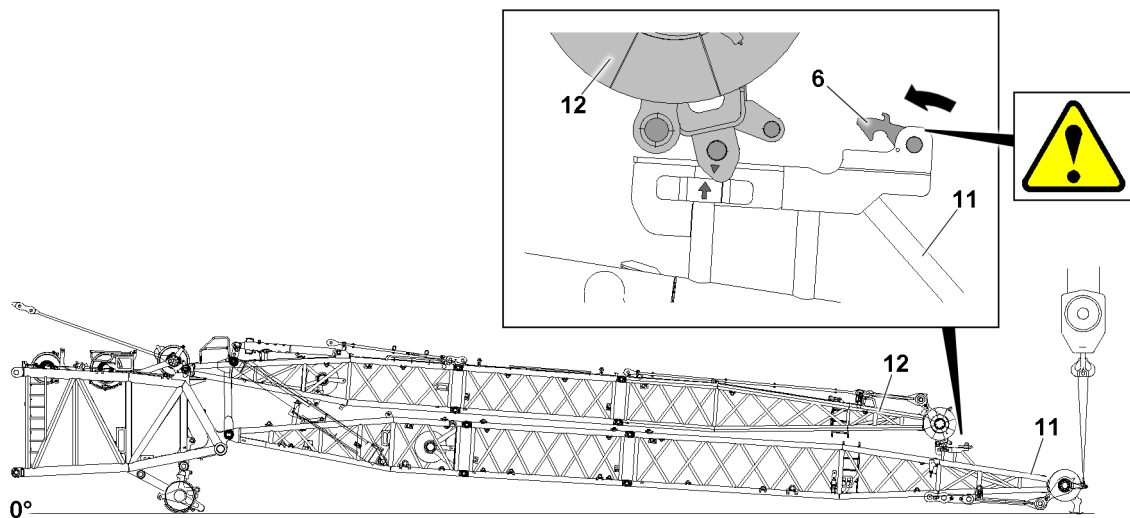
Property damage due to dirt and / or corrosion!

If unnecessary electrical connections are not closed off with the respective protective caps, then dirt and / or corrosion can damage the electrical connections.

This could result in malfunctions.

- ▶ Make sure that all non-required electrical connections are always closed off properly.
  - ▶ Observe the wiring diagram.
- 
- ▶ Properly close off the electrical connections without dummy plugs with the corresponding protective caps.
  - ▶ Secure all electrical connections with protective caps to prevent any dirt infiltration.

## 9.11 Unpinning WA-frame 2 on the S-end section



*Fig.166593: Plates 6 in the transport position*

Make sure that the following prerequisites are met:

- All electrical connections are disconnected.
- The pin pulling cylinder is connected to the hydraulic system.

Prepare the connection of WA-frame 1 **11** with WA-frame 2 **12**:

- ▶ Fold both plates **6** into the transport position.
- ▶ Fasten the W-assembly unit to the auxiliary crane, see illustration.

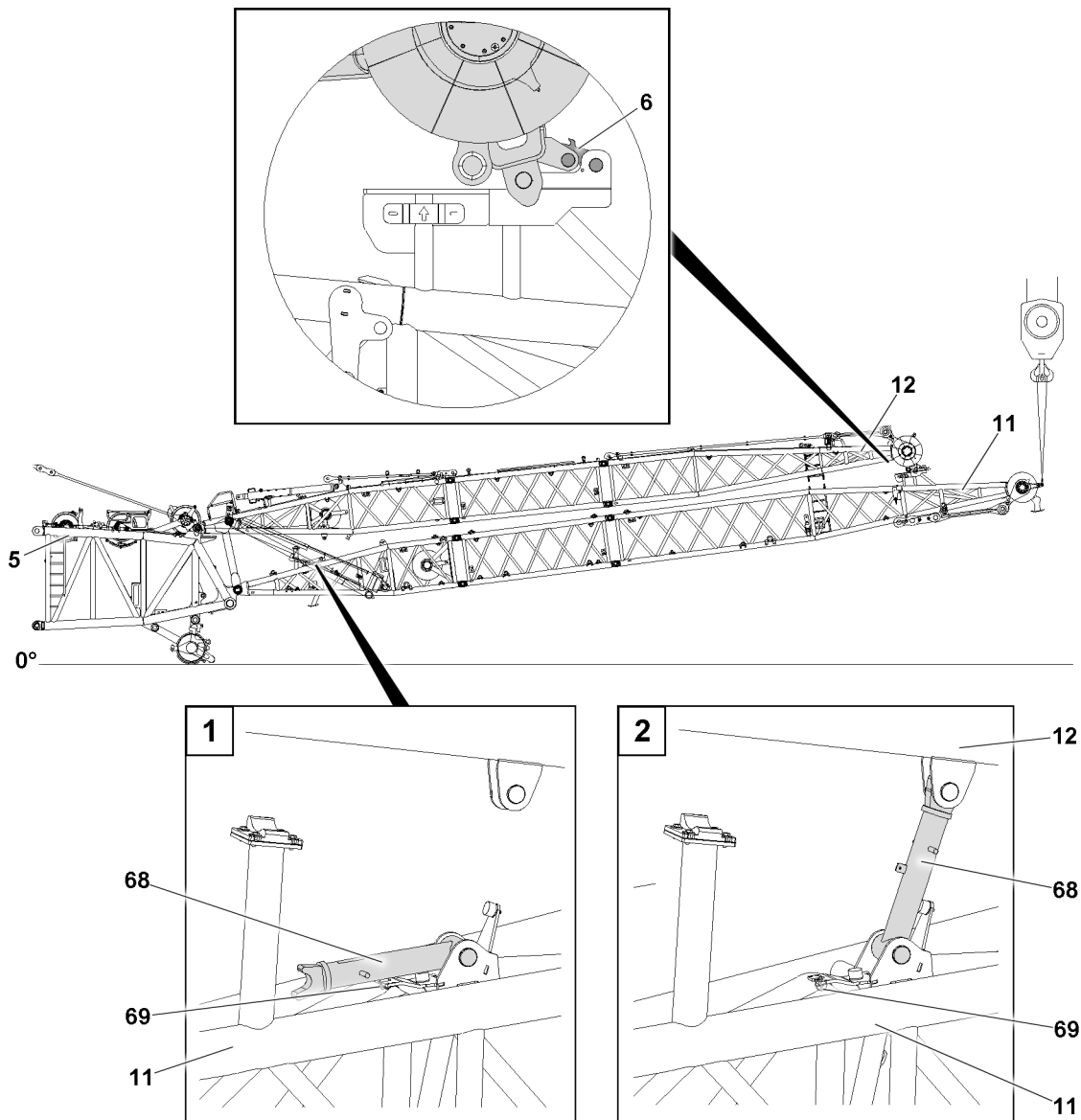


Fig.166589: Lifting the W-assembly unit



### WARNING

WA-frame 2 not secured!

WA-frame 2 **12** can slip and fall down.

▶ Make sure that WA-frame 2 **12** engages in both plates **6** of WA-frame 1 **11**.

▶ Lift the W-assembly unit until WA-frame 2 **12** engages in both plates **6** of WA-frame 1 **11**.

WA-frame 1 **11** and WA-frame 2 **12** are so far away from each other that the assembly supports **68** are free.

▶ Remove the retaining elements **69**.

▶ Fold the assembly supports **68** up.

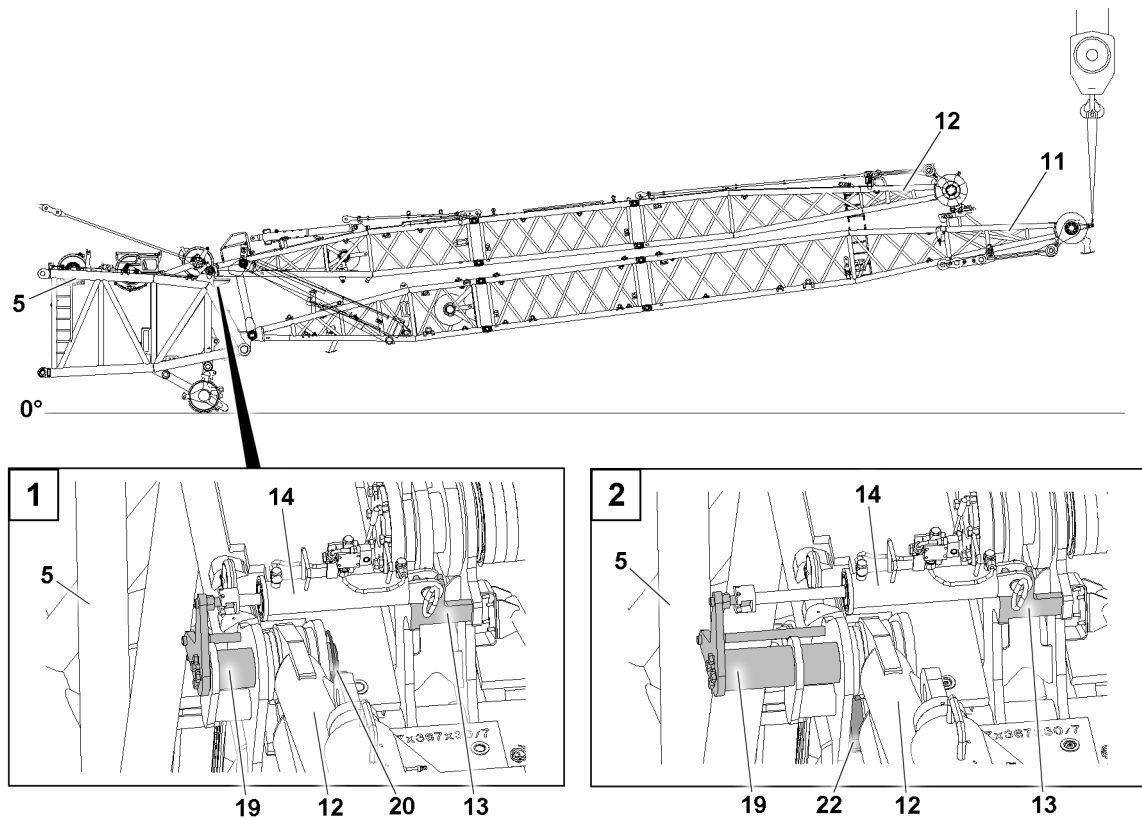


Fig.166588: Unpinning WA-frame 2



#### Note

The connector pin 19 jams.

- ▶ Due to careful lifting / lowering with the auxiliary crane, the connector pin 19 can be released.

WA-frame 2 12 is unpinned with the pin pulling device, see chapter 5.30.

The unpinning procedure is described based on the example of one position.

Prerequisite for the pin position: The pin pulling cylinder 14 is inserted in the pin pulling device 13 and fixed on the screw of the connector pin 19.

- ▶ Unpinning WA-frame 2 12 on the S-end section 5: Remove the retaining element 20 and unpin the connector pin 19 with the pin pulling cylinder.
- ▶ Repeat the unpinning procedure in the second position.

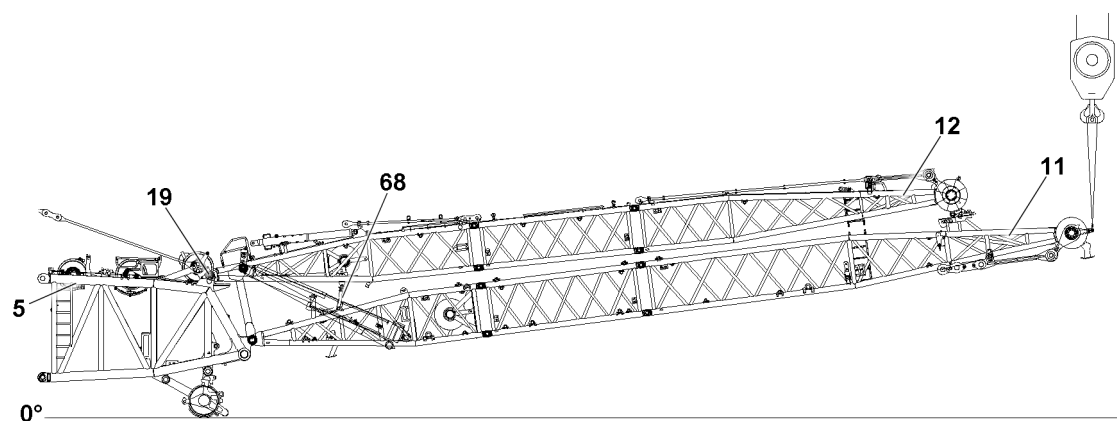


Fig.166590: Lowering the W-assembly unit down onto the ground



When WA-frame 2 **12** is unpinned on both sides and the assembly supports **68** are folded up:

- ▶ Lower the W-assembly unit down onto the ground.

**Result:**

- WA-frame 2 **12** lowers onto the assembly supports **68**.
- ▶ Remove the fastening equipment.
- ▶ Pin and secure the connector pin **19** on the S-end section **5** again.

## 9.12 Unpinning WA-frame 1 on the S-end section



**WARNING**

Persons in the danger zone while lifting the load or during the pinning procedure!

Danger of crushing.

Death, severe bodily injuries.

- ▶ Make sure, when swinging the W-pivot section into the pin points, that no persons are in the danger zone.
- ▶ Swinging the load is prohibited.
- ▶ Make sure that no personnel is within the danger zone when operating the pin pulling device.
- ▶ Operate the pin pulling device with utmost caution on the pin pulling aggregate.

Make sure that the following prerequisites are met:

- The W-assembly unit is lying on the ground.
- The pin pulling cylinder is connected to the hydraulic system.

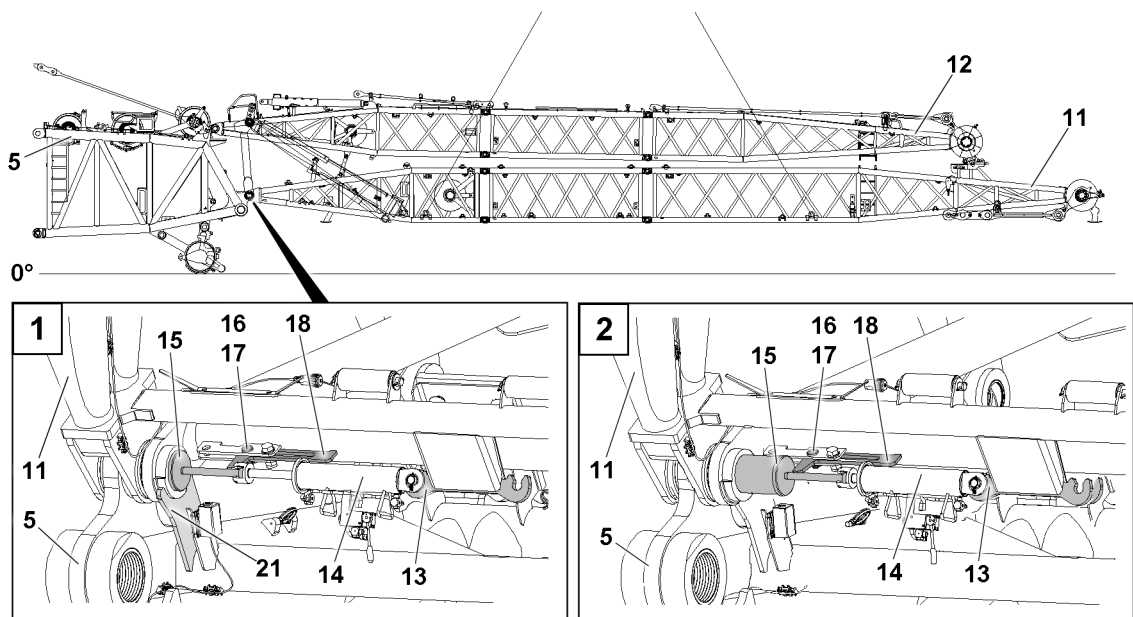


Fig.155862: WA-frame 1, unpinning position on the S-end section

WA-frame 1 **11** is unpinned with the pin pulling device, see chapter 5.30.

- ▶ Fasten the W-assembly unit to the auxiliary crane, see section “Fastening points”.

The unpinning procedure is described based on the example of one position.

Prerequisite for the pin position: The pin pulling cylinder **14** is inserted in the pin pulling device **13** and fixed on the screw of the connector pin **15**.

- ▶ Release the connector pin **15**: Remove the retaining element **17** and unpin the pin **16**.
- ▶ Slide the retaining plate **18** into the assembly position.
- ▶ Secure the retaining plate **18**: Insert the pin **16**.
- ▶ Secure the pin **16**: Attach the retaining element **17**.

- ▶ Unpin WA-frame 1 **11** on the S-end section **5**: Unpin the connector pin **15** with the pin pulling cylinder.
- ▶ Repeat the unpinning procedure in the second pin position.
- ▶ Swing the W-assembly unit out with the auxiliary crane from the S-end section and take it down.
- ▶ Pin and secure the connector pin **15** on WA-frame 1 **5** again.

### 9.13 Lifting WA-frame 2 from the assembly supports

Make sure that the following prerequisite is met:

- The assembly unit is positioned securely on even ground.

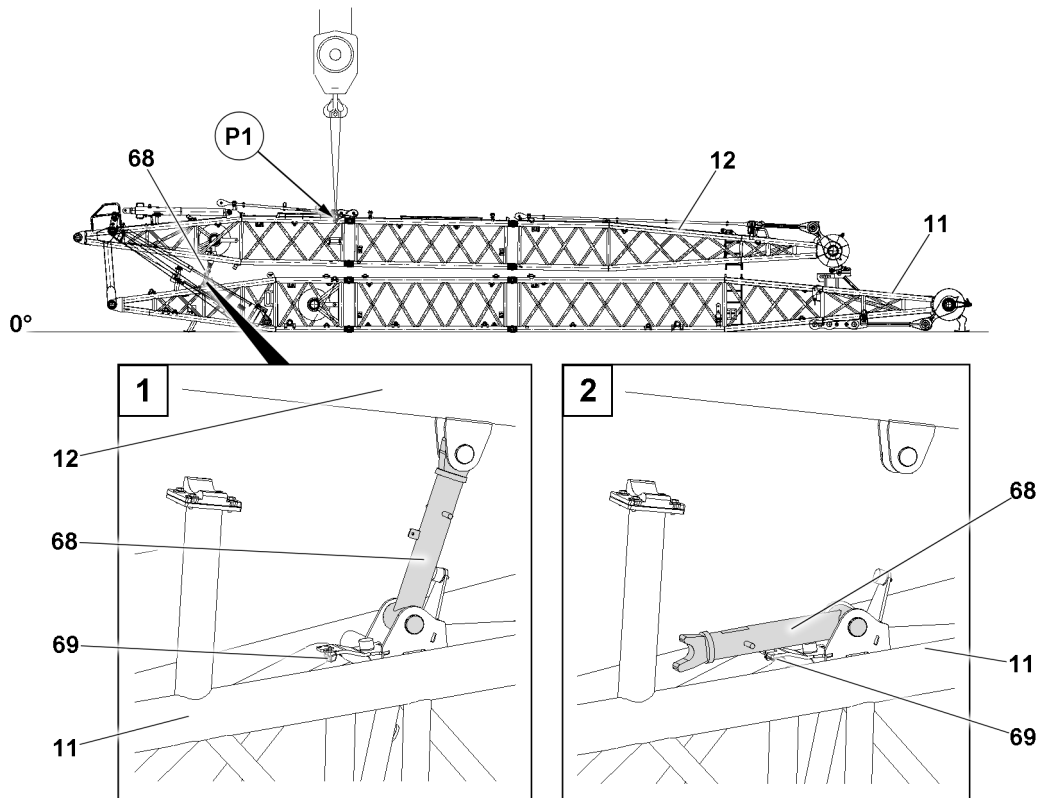


Fig.166592: Lifting WA-frame 2 from the assembly supports

- ▶ Fasten WA-frame 2 **12** to the auxiliary crane in point **P1**.
- ▶ Lift WA-frame 2 **12** from the assembly supports **68**.
- ▶ Fold the assembly supports **68** down.
- ▶ Secure the assembly supports **68**: Fasten the retaining elements **69**.
- ▶ Lower WA-frame 2 **12** onto WA-frame 1 **11**.



#### WARNING

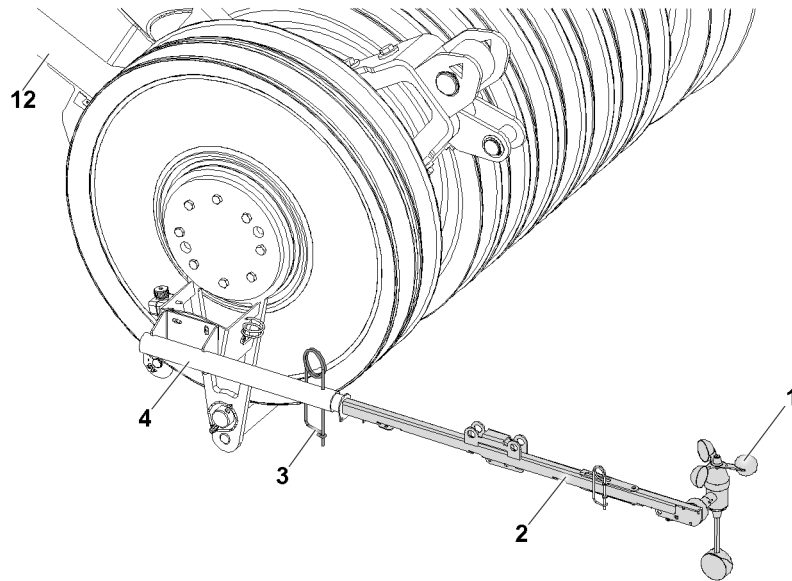
Rigging belts **not** assembled!

Danger of accident when establishing the transport units and during transport.

- ▶ Assemble the rigging belts before disconnecting the W-assembly unit in the transport units.
- ▶ Use the factory-provided rigging belts.
- ▶ Check the completeness of the rigging belts prior to transport.

- ▶ Release WA-frame 2 **12** from the auxiliary crane.
- ▶ Assemble the rigging belts according to the specifications, observe the illustrations in section "Fastening points" and in the rigging plans.

## 9.14 Disassembling the airplane warning light and wind sensor



*Fig.155788: Airplane warning light and wind sensor*

The wind sensor **1** must be disassembled on the end section of WA-frame **2**.

- ▶ Remove the retaining element **3** on the retainer **2**.
- ▶ Remove the retainer **2** from the pipe **4**.

---

Empty page!

LWE/LR 1800-1-0-000/27200-07-02/en

## 5.10 Boom nose lattice boom

1	Safety	2
2	Component overview	3
3	Fastening points for boom nose 25 t	4
4	Assembling the boom nose 25 t	6
5	Crane operation	11
6	Disassembling the 25 t boom nose	14

# 1 Safety

Observe the safety instructions before assembly and disassembly:

- Information regarding personal protective equipment. See chapter 2.04.
- Information regarding fall protection equipment. See chapter 2.06.
- Information regarding accesses to the crane. See chapter 2.07.
- Information regarding accessible surfaces. See chapter 2.07.



## WARNING

Danger of falling!

During assembly / disassembly, inspection and maintenance work, assembly personnel must be secured with appropriate aids to prevent them from falling.

Death, severe bodily injuries, property damage.

- ▶ All work at a height, when there is a danger of falling, must be carried out with suitable aids.
- ▶ If aids are not available and work cannot be carried out from the ground, then assembly personnel must secure themselves with the supplied fall arrest system to prevent falling, see chapter 2.04.
- ▶ If fall protection equipment is available, then it must be used, see chapter 2.06.
- ▶ When lifting, lowering, swinging crane parts in and out, no persons may remain in the danger zone.
- ▶ If railings are present on the components, then they must be brought into the corresponding position and secured for assembly / disassembly work.
- ▶ Only step on the aids, ladders and catwalks with clean shoes.
- ▶ Keep aids, ladders and catwalks free of heavy dirt, snow and ice.
- ▶ During all assembly and disassembly work, maintenance work and inspections, travel or crane operation is prohibited.
- ▶ Remaining on a suspended load is prohibited.
- ▶ Stepping or walking on crane components and lattice sections with an incline of more than 20° is prohibited.
- ▶ For all assembly work, the crane operator of the main crane must be in voice contact with the crane operator / crane operators of the auxiliary crane / auxiliary cranes.
- ▶ For the assembly / disassembly tasks, the crane operator may only initiate crane movements when the responsible guide has explicitly released the movement.



## WARNING

Danger of impact / crushing!

When assembling / disassembling crane components with the auxiliary crane, crane components can start to swing back and forth.

When lifting / lowering and positioning crane components, there is an increased danger of impact / crushing.

Death, severe bodily injuries, property damage.

- ▶ Make sure that personnel cannot be caught by components.
- ▶ When working in a danger zone: Use aids to protect limbs.
- ▶ Guide components with suitable aids to minimize oscillation.



## DANGER

The component can fall down!

If the corresponding component is disengaged from the auxiliary crane before the corresponding component is pinned, then the corresponding component can fall down.

Death, severe bodily injuries, property damage.

- ▶ Do not disconnect the auxiliary crane until the respective component is pinned and secured.



## WARNING

Danger of falling!

During assembly and disassembly of crane components, personnel must be secured with appropriate aids to prevent them from falling.

Death, severe bodily injuries, property damage.

- ▶ Use personal protective equipment.

**WARNING**

The boom nose can fall down!

If the boom nose is not pinned and secured correctly, then it can fall down.

Death, severe bodily injuries, property damage.

- ▶ Insert or unpin both pins on the same horizontal level, i.e. **left and right**.
- ▶ It is prohibited to stand under the boom nose or within the complete danger zone during the pinning and unpinning procedure of the boom nose.
- ▶ Safely secure the pins in the storage locations as well as in the receptacles.
- ▶ It is prohibited to lean the ladder against the component to be disassembled.

## 2 Component overview

**Note**

- ▶ The boom nose is marked with its own weight.
- ▶ Dimensions and weights, see chapter 1.03.

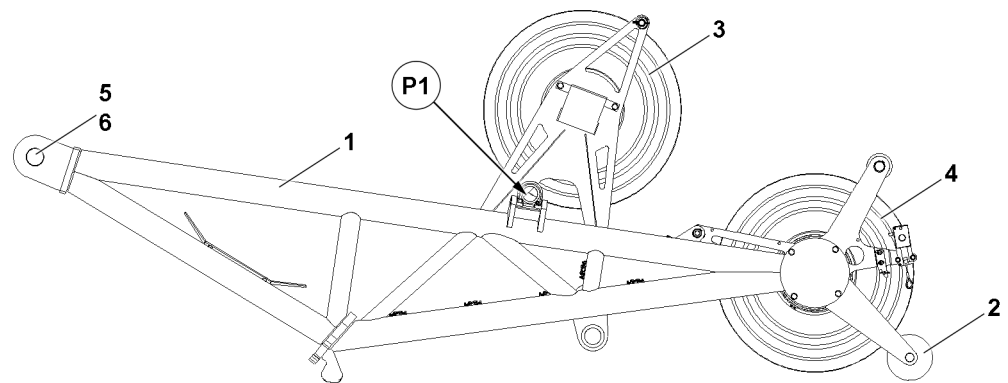


Fig.155759: Boom nose 25 t

Position	Component
1	Boom nose 25 t
2	Base roller
3	Rope pulley I
4	Rope pulley II
5	Pin
6	Retaining element

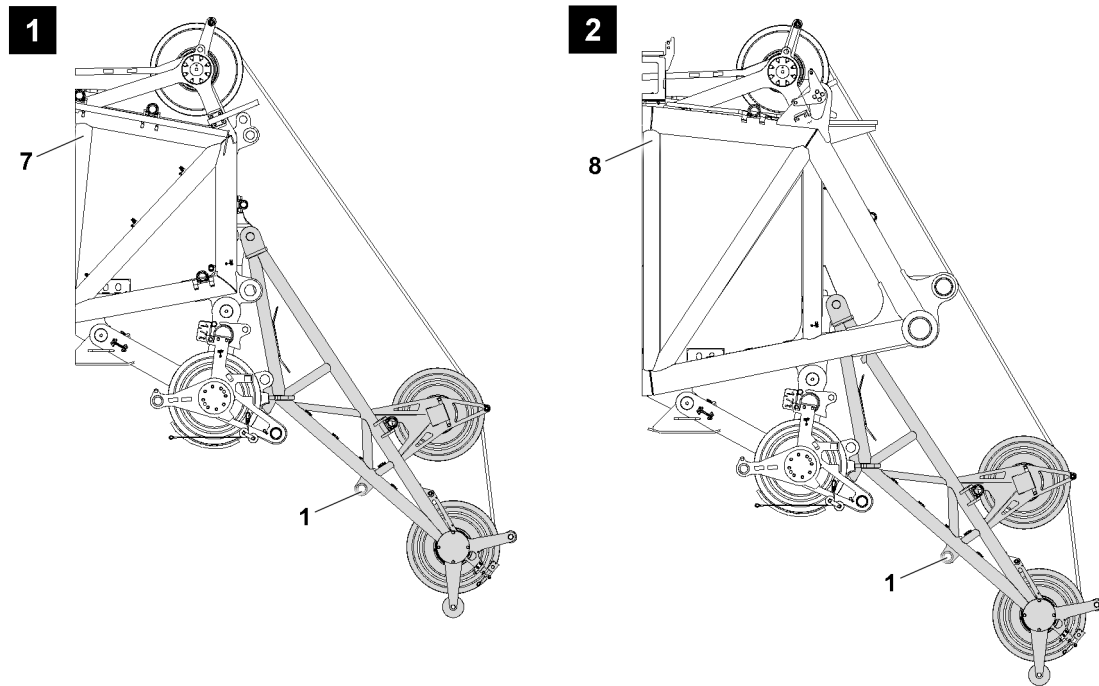


Fig.155760: Installation possibilities of the boom nose

Installation possibilities of the boom nose	
Illustration	Boom
1	Boom with L-end section 7
2	Boom with S-end section 8

### 3 Fastening points for boom nose 25 t

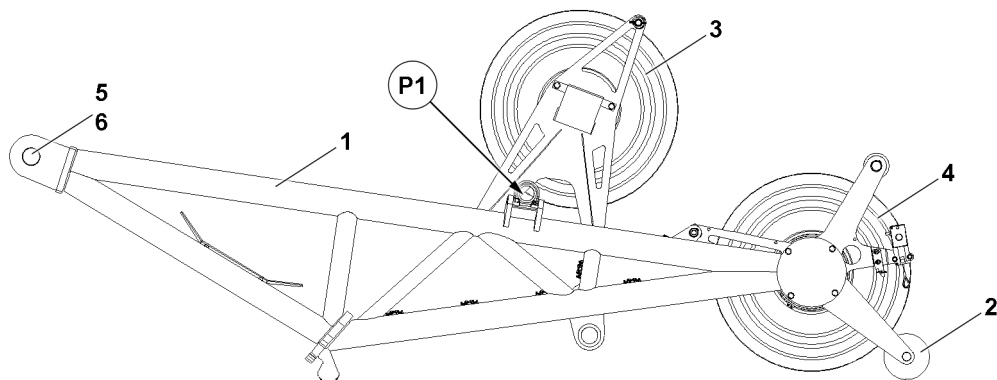


Fig.155759: Fastening points for boom nose 25 t

LWE/LR 1800-1-0-000/27200-07-02/en



**WARNING**

Fastening equipment can be ripped off!  
Death, severe bodily injuries, property damage.

- ▶ Make sure that the fastening equipment has a sufficient load carrying capacity and the required minimum length.
- ▶ Make sure that the auxiliary crane(s) have a sufficient load carrying capacity.
- ▶ Pay attention and adhere to the labels on the fastening points on the crane components.
- ▶ Make sure that there are no persons in the danger zone.

**WARNING**

Components incorrectly fastened!  
Death, severe bodily injuries, property damage.

- ▶ Fasten the components only in the intended fastening points on both sides.

**WARNING**

Overload of fastening points!  
If the fastening points are overloaded, they can rip off and the component can fall down.  
Death, severe bodily injuries, property damage.

- ▶ Make sure that the fastening points are not overloaded.
- ▶ Observe the maximum permissible suspended loads.

Fastening points	
P1	Boom nose

## 4 Assembling the boom nose 25 t

### 4.1 Assembly procedure

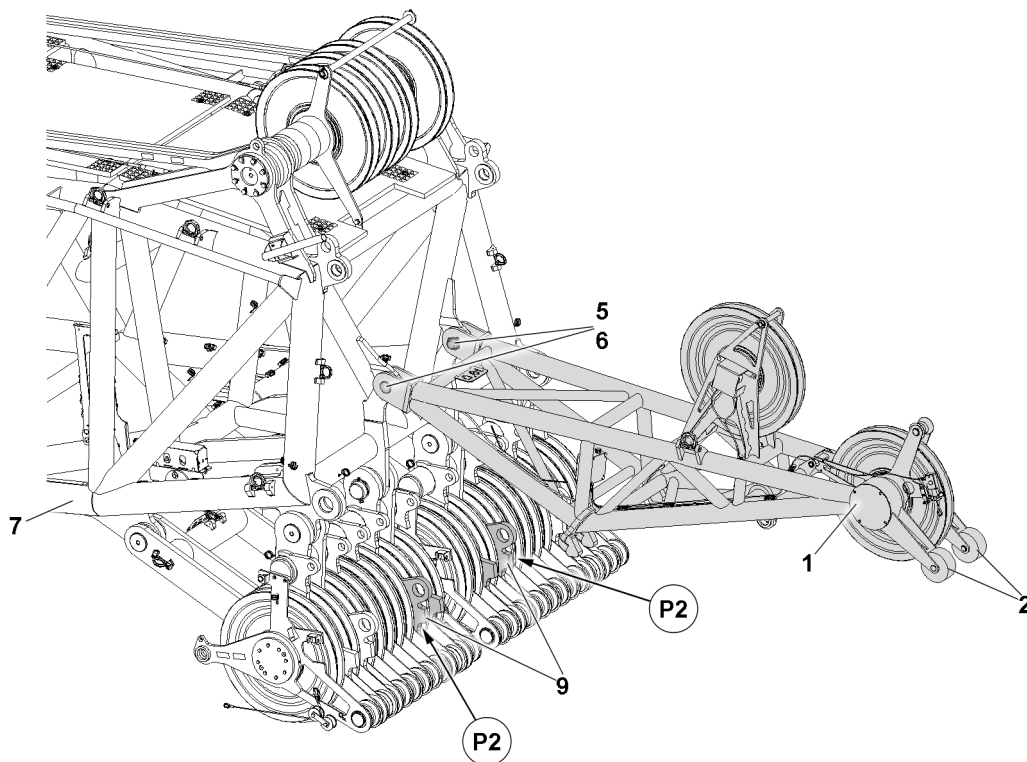


Fig.155761

Make sure that the following prerequisites are met:

- The crane is horizontally aligned.
- The boom including the respective end section is assembled.
- The boom is taken down on a load-bearing substructure.
- The counterweight is installed on the turntable according to the load chart.
- The LICCON overload protection has been set according to the data in the load chart.
- The LICCON overload protection is exceeded.
- The assembly icon is visible on the LICCON monitor.
- An auxiliary crane is available.
- The boom end section is lying on the ground.

**WARNING**

Danger of accident due to the “Exceedance of shut-off limits of the LICCON overload protection” function!

If the shut off limits of the LICCON overload protection are exceeded, there is no additional protection against crane overload.

Due to erroneous operation or deliberate misuse, the crane could collapse, the boom can break off or the crane can topple over.

Death, severe bodily injuries, property damage.

- ▶ The “Exceedance of shut-off limits of the LICCON overload protection” function is only permissible in emergencies and for assembly purposes.
- ▶ The function “Exceeding the shut off limits of the LICCON overload protection” may only be actuated by persons who know the effects of their actions regarding the function “Exceeding the shut off limits of the LICCON overload protection”.
- ▶ The “Exceedance of shut off limits of the LICCON overload protection” function requires the presence of an authorized person and must be performed with utmost caution.
- ▶ Crane operation with the “Exceedance of shut-off limits of the LICCON overload protection” function activated is prohibited.

**Note**

- ▶ For assembly of the boom nose on the end section, the assembly procedure and the process are identical for all boom variations.
- ▶ The assembly of the boom nose is described therefore as an example based on a variation with the L-end section.

- ▶ Fasten the boom nose **1** to the auxiliary crane.
- ▶ Lift the boom nose **1** with the auxiliary crane and swing it to the L-end section **7**.
- ▶ Position the boom nose **1** in the pin points.

**WARNING**

The pins can loosen up by themselves!

If the pins are not secured with the safety locking pins, the pins can release during crane operation.

This can cause the crane to topple over.

Death, severe bodily injuries, property damage.

- ▶ Make sure that all pins are properly inserted and secured.

The boom nose is pinned in two points.

- ▶ Pin the boom nose **1** with the L-end section **7** at the “**top**”: Insert the pin **5**.
- ▶ Secure the pin **5**: Attach the retaining element **6**.
- ▶ Place the boom nose **1** with the auxiliary crane on the base rollers **2** on the ground.
- ▶ Remove the auxiliary crane.

**Note**

- ▶ Reeve the hoist rope in according to the Reeving plan, see the Reeving plan.

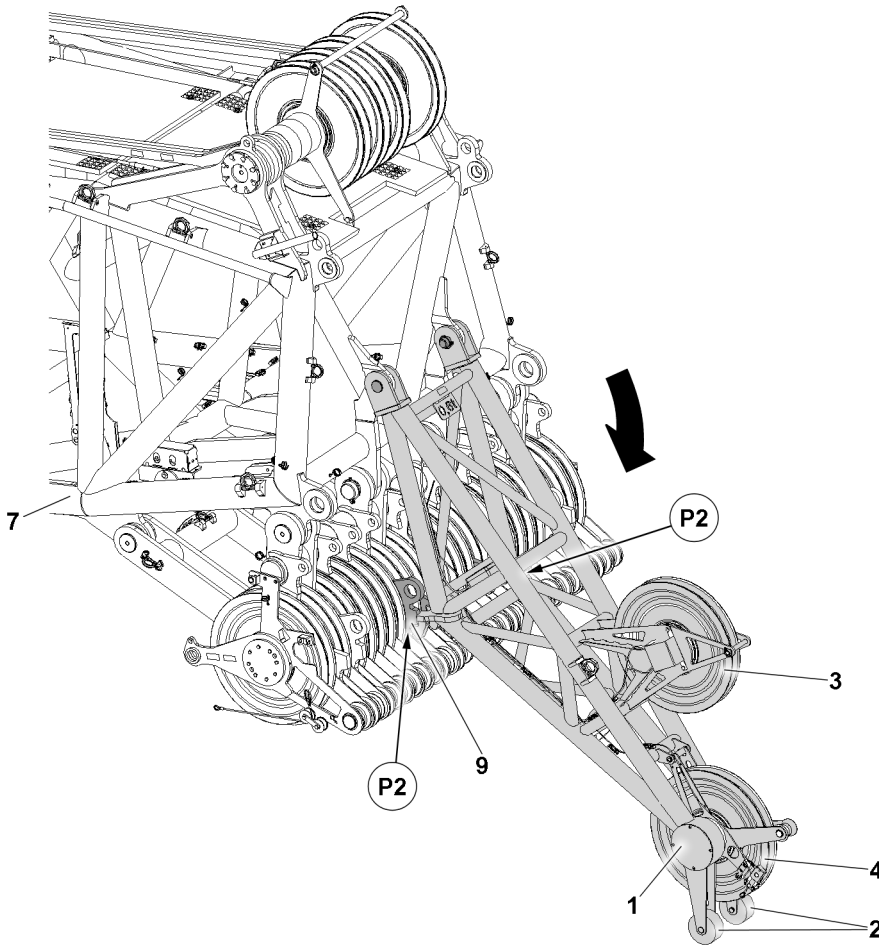


Fig.155762: Boom nose in the transport position

- ▶ Pull the hoist rope over rope pulley I 3 and rope pulley II 4.
- ▶ Luff the boom up until the boom nose 1 lies on the L-end section 7 at the “bottom” in the receptacle 9 in points P2.



#### WARNING

Falling hoist rope!

If the hoist rope is not properly secured with a corresponding length on the boom nose before the erection procedure, it can fall backward due to its own weight.

Death, severe bodily injuries, property damage.

- ▶ Reeve the hoist rope in with sufficient length on the boom nose before the erection process.
- ▶ The hoist rope must be constantly monitored during erection.
- ▶ Do not enter the danger zone.



#### WARNING

Danger of accident due to side wind!

If the slewing gear brake is released after reeving in / reeving out the hook block / load hook, then the crane can turn uncontrolled in strong side wind.

Death, severe bodily injuries, property damage.

The crane can collide with near-by structures or objects.

- ▶ Make sure that the current wind speed does not exceed the values from the wind speed chart when releasing the slewing gear brake.

- ▶ Apply the slewing gear brake before reeving in the hook block.
- ▶ Reeve in the hook block properly and attach the hoist limit switch weight.

## 4.2 Establishing the electrical connections

### NOTICE

Damage to the electrical connection on the cable drum!

If the electrical connection from the cable drum on the L-pivot section to the terminal box on the L-pivot section is established first before the connection to the terminal box on the respective end section, the electrical connection can be damaged when spooling out the cable drum.

- ▶ Establish first the electrical connection from the cable drum in the L-pivot section to the terminal box on the respective end section and then the electrical connection from the terminal box in the L-pivot section to the cable drum in the L-pivot section.



### Note

- ▶ To establish the electrical connections, see the wiring diagram.

Make sure that the following prerequisites are met:

- The boom is completely assembled.
- The airplane warning light and the wind speed sensor are assembled.
- ▶ Establish the electrical connections.
- ▶ Make sure that all electrical connections to the D-pivot section have been established.



### WARNING

Malfunction if dummy plugs are not installed!

If the dummy plugs are not fit on the non-required electrical connections, then malfunctions or functional limitations can occur on the crane.

- ▶ Make sure that all non-required electrical connections, which have a dummy plug, are closed off with dummy plugs.
- ▶ Observe the wiring diagram.
- ▶ As a rule, close off non-required electrical connections (for example for accessories that are not assembled) with the respective dummy plugs.

### NOTICE

Property damage due to dirt and / or corrosion!

If unnecessary electrical connections are not closed off with the respective protective caps, then dirt and / or corrosion can damage the electrical connections.

This could result in malfunctions.

- ▶ Make sure that all non-required electrical connections are always closed off properly.
- ▶ Observe the wiring diagram.
- ▶ Properly close off the electrical connections without dummy plugs with the corresponding protective caps.

## 4.3 Function check



### WARNING

Malfunctioning safety equipment!

If the function of the safety equipment is defective, personnel can be severely injured or killed.

- ▶ Crane operation with non-functioning safety equipment is **prohibited**.



### Note

- ▶ The function of the individual limit switches must be checked before erection.
- ▶ The function of the limit switch initiators must be checked in the test system, see the Diagnostics manual.

**Note**

- ▶ If a function check on the limit switches or on the safety equipment does not lead to the desired shut-offs, then the plug connections on the terminal boxes or the components itself must be checked.
- ▶ If no visible connection errors or component defects can be found, contact **Liebherr** Customer Service.

Make sure that the following prerequisites are met:

- All electrical connections have been established.
- The crane engine is running.
- The corresponding operating mode is set on the LICCON monitor.

**4.3.1 Checking the wind speed sensor**

- ▶ Check the movement and the function of the wind speed sensor.

**4.3.2 Checking the airplane warning light**

- ▶ Turn the airplane warning light on.
- ▶ Check the function visually.

**4.3.3 Checking the hoist limit switch on the pulley head****Note**

- ▶ When replacing or changing a hoist limit switch (HES), the corresponding hoist limit switch must have the correct bus address and the correct software version in order to be detected again by the bus system (LSB).

- ▶ Actuate the hoist limit switch manually on the pulley head.

**Result:**

- The spooling up of the hoist winch turns off.
- The “Hoist top” icon appears on the LICCON monitor 0.
- The limit switch is functioning.

**4.3.4 Checking the limit switches in general****Note**

- ▶ The limit switch functions have to be checked individually before erection.
- ▶ To check the limit switches, see corresponding chapter for the respective boom system in the Crane operating instructions.

**4.4 Erecting the boom****WARNING**

The crane can topple over!

If the following conditions are not met before erecting the boom, the crane can topple over. Death, severe bodily injuries, property damage.

- ▶ Observe and comply with the technical safety instructions, see chapter 5.01.
- ▶ Observe the specifications in the erection and take-down charts.
- ▶ Extend the relapse cylinder before erection.

Make sure that the following prerequisite is met:

- The LICCON overload protection is exceeded.

**WARNING**

The crane can topple over!

The crane can topple over if the crane is operated with the LICCON overload protection exceeded. Death, severe bodily injuries, property damage.

- ▶ The boom radii specified in the load chart may not be exceeded or fallen below, even if there is no load on the hook.

**Note**

- ▶ When the lowest operating position of the boom is reached, the set load chart of the LICCON overload protection is activated.
- ▶ The maximum load icon displays a load number in "t" instead of the display "???".

- ▶ Luff the boom up to the lowest operating position.
- ▶ When the boom has reached the lowest operating position: Make sure that the assembly icon on the LICCON monitor turns off.

**Result:**

- The LICCON overload protection is active.

## 5 Crane operation

Observe the notes in chapter 4.05, chapter 4.08 and chapter 5.01.

Make sure that the following prerequisites are met:

- The LICCON overload protection has been set according to the data in the load chart.
- The LICCON overload protection is active.
- The assembly icon on the LICCON monitor is off, see chapter 4.02.

**WARNING**

Load reduction!

During crane operation with an installed boom nose, the value in the load charts is reduced by the own weight of the boom nose.

Death, severe bodily injuries, property damage.

- ▶ Observe the load charts.

**WARNING**

The crane can topple over!

Death, severe bodily injuries, property damage.

- ▶ Check the horizontal position of the crane before and during crane operation.
- ▶ If the crane operator leaves the crane cab, even for a short time, the operating mode setting must be checked and reset, if necessary, before resuming crane operation.

### 5.1 Load and reeving during crane operation

**Note**

Load and reeving during crane operation is explained based on an exemplary reeving plan.

- ▶ Observe the specifications on the respective reeving plan.

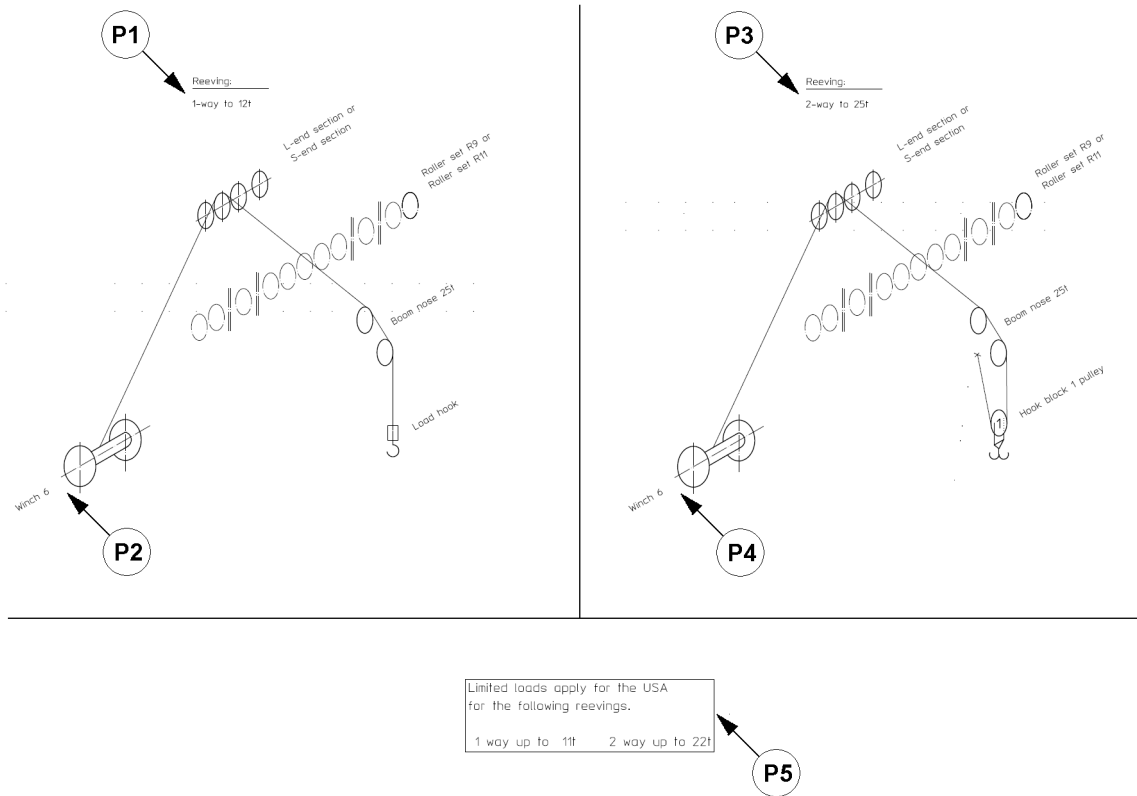


Fig.167807: Exemplary excerpt of the reeving plan for a 25t boom nose

Example with a 25t boom nose reeving plan	
Position	Specifications
<b>P1</b>	Reeving and load / strand pull In the illustrated example, a load of up to 12 t is possible with a 1-way reeving. What a necessary strand pull <sup>1)</sup> corresponds to via the specified hoist winch of 12 t .
<b>P2</b>	Specified hoist winch In the illustrated example, winch 6 (W VI) is specified.
<b>P3</b>	Reeving and load / strand pull In the illustrated example, a load of up to 25 t is possible with a 2-way reeving. What a necessary strand pull <sup>1)</sup> corresponds to via the specified hoist winch of 12.5 t.
<b>P4</b>	Specified hoist winch In the illustrated example, winch 6 is specified.
<b>P5</b>	Supplementary specifications In the illustrated example, the following limitations apply for the USA: With a 1x reeving, a load of up to 11 t. With a 2x reeving, a load of up to 22 t.

1) Without considering friction losses.

LWE/LR 1800-1-0-000/27200-07-02/en



**Note****Special releases for the reeving plan from Liebherr-Werk Ehingen**

Special releases for the reeving plan can contain for example an alternative rope run or an alternative hoist winch.

- ▶ The “reeving and load / strand pull” specifications still apply, shown in the example in position **P1** and position **P3**.
- ▶ When in this example an alternative **hoist winch with a considerably higher maximum strand pull** is used, only 12 t can still be lifted with simple reeving according to position **P1**. Regardless of the fact that due to the higher strand pull a higher load seems achievable.
- ▶ Winch 1 and winch 2 has a considerably higher maximum strand pull than winch 6.

**WARNING**

Overload of the boom nose!

In case of deviation from the “Reeving and load / strand pull” specifications, the boom nose can be overloaded.

If a winch with a higher strand pull may be used:

- ▶ Make sure that the “Reeving and load / strand pull” specifications are observed.

## 5.2 Checking the settings

- ▶ Check the function of the overload protection by running against the operating positions on top and bottom.
- ▶ Check the hoist limit switch by running against the hoist limit switch weight.
- ▶ Check the function of the force test bracket on the boom nose.

## 6 Disassembling the 25 t boom nose

### 6.1 Taking the boom down

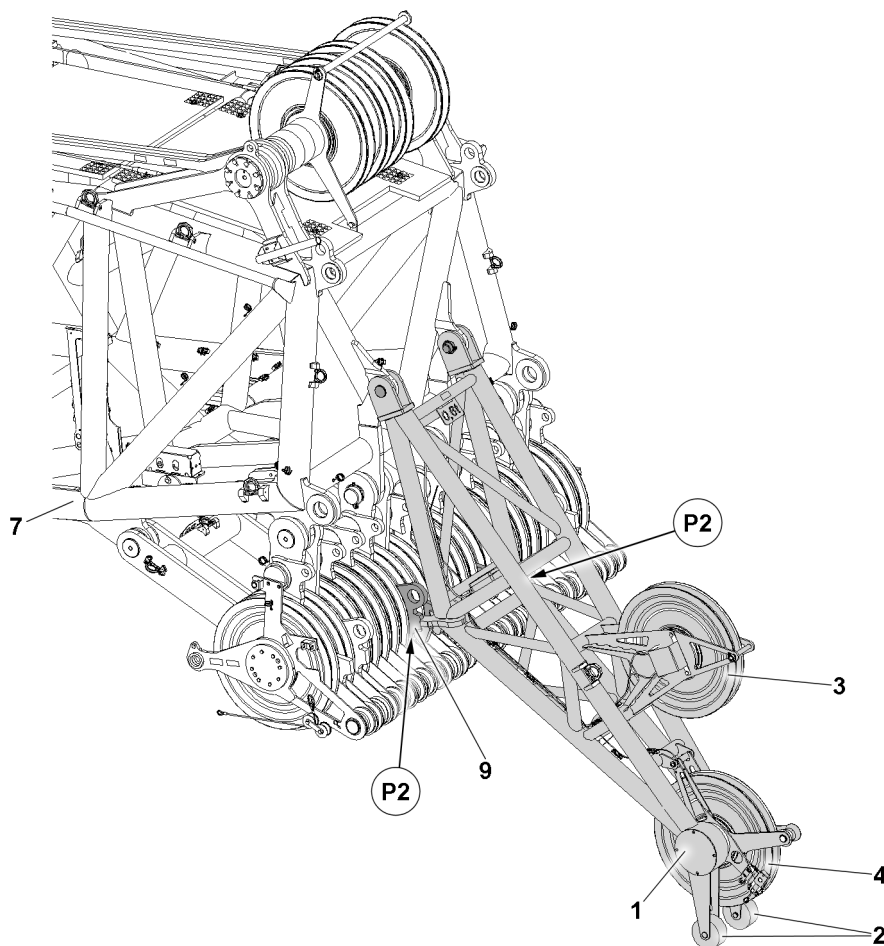


Fig.155763: Taking the boom down

Make sure that the following prerequisites are met:

- The crane is properly supported and horizontally aligned.
- An auxiliary crane is available.
- The counterweight is installed on the turntable according to the load chart.
- The LICCON overload protection has been set according to the data in the load chart.
- The LICCON overload protection settings have been compared with the actual set up configuration.

**WARNING**

Danger of accident due to the “Exceedance of shut-off limits of the LICCON overload protection” function!

If the shut off limits of the LICCON overload protection are exceeded, there is no additional protection against crane overload.

Due to erroneous operation or deliberate misuse, the crane could collapse, the boom can break off or the crane can topple over.

Death, severe bodily injuries, property damage.

- ▶ The “Exceedance of shut-off limits of the LICCON overload protection” function is only permissible in emergencies and for assembly purposes.
- ▶ The function “Exceeding the shut off limits of the LICCON overload protection” may only be actuated by persons who know the effects of their actions regarding the function “Exceeding the shut off limits of the LICCON overload protection”.
- ▶ The “Exceedance of shut off limits of the LICCON overload protection” function requires the presence of an authorized person and must be performed with utmost caution.
- ▶ Crane operation with the “Exceedance of shut-off limits of the LICCON overload protection” function activated is prohibited.

**WARNING**

The crane can topple over!

If the following conditions are not met before taking down the boom, the crane can topple over and fatally injure personnel.

Death, severe bodily injuries, property damage.

- ▶ Observe and comply with the technical safety instructions, see chapter 5.01.
- ▶ Observe the specifications in the erection and take-down charts.

**NOTICE**

Damage to the boom components!

Taking down the boom system can lead to a collision between the hook block and the pulley head.

The boom components can be severely damaged.

- ▶ Luff the boom system down at the same time and spool the hoist winch out.

**WARNING**

The crane can topple over!

If the danger notes for take-down of the boom or the boom systems in the following chapters are not observed, then the crane can topple over.

Death, severe bodily injuries, property damage.

Boom nose assembled on the end section:

- ▶ Observe and adhere to the danger notes in chapter 5.38, chapter 5.39 or chapter 5.07.

**Note**

- ▶ For disassembly of the boom nose on the end section, the assembly procedure and the process are identical for all boom variations.
- ▶ The disassembly of the boom nose is described therefore based on the example of a variation with an L-end section.

- ▶ Luff the boom down according to the instructions in the above chapters.
- ▶ At the same time, spool the hoist winch out and luff the boom down until the hook block touches the ground.
- ▶ Disassemble the hoist limit switch weight and reeve the hook block out.
- ▶ Luff the boom down until the L-end section **7** and the boom nose **1** on the base rollers **2** are lying on the ground.
- ▶ Disassemble the hoist rope.

## 6.2 Disconnecting the electrical connections

Make sure that the following prerequisite is met:

- The boom is properly taken down as specified.

### NOTICE

Damage to the electrical connections on the cable drum!

If the electrical connection from the cable drum on the L-pivot section to the terminal box on the respective end section is disconnected and spooled up first, then the electrical connection from the cable drum to the terminal box on the L-pivot section can be damaged.

- ▶ Disconnect first the electrical connection from the cable drum to the terminal box on the L-pivot section and then the electrical connection from the terminal box to the respective end section.

- ▶ Store the cable from the terminal box on the L-pivot section properly.
- ▶ Spool the cable drum up and secure it to prevent inadvertent spooling out.
- ▶ Disconnect the electrical connections, see the wiring diagram.
- ▶ Store the electrical connections properly and protect them against damage.
- ▶ Close off the electrical connections properly with dummy plugs or protective caps.

## 6.3 Disassembly procedure

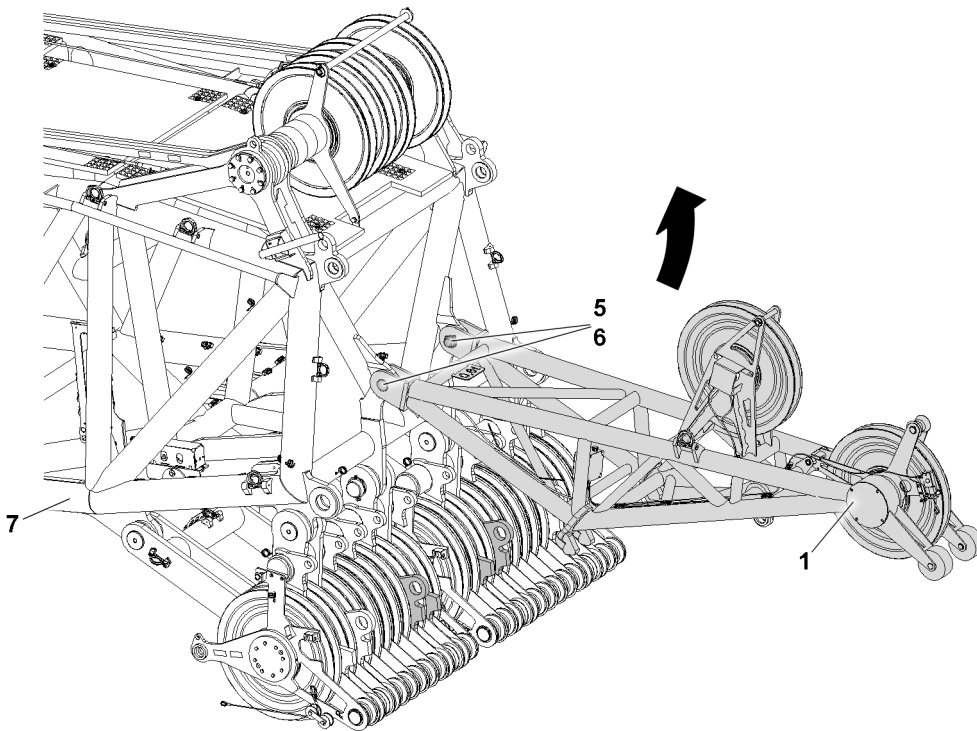


Fig.155764: Disassembling the boom nose

Make sure that the following prerequisites are met:

- The L-end section **7** and the boom nose **1** are lying on the ground.
- The electrical connections are properly disconnected.

- ▶ Fasten the boom nose **1** to the auxiliary crane.
- ▶ Swing the boom nose **1** upward with the auxiliary crane.

The boom nose is pinned in two points.

- ▶ Remove the retaining element **6** at the “top” on the L-end section **7**.
- ▶ Unpin the pin **5**.
- ▶ Remove the boom nose **1** with the auxiliary crane and take it down onto the ground.

- ▶ Remove the auxiliary crane.

---

Empty page!

LWE/LR 1800-1-0-000/27200-07-02/en

## 5.13 Fixed jib – F-system

1	Component overview	2
2	F-jib fastening points	4
3	Assembling the F-jib	7
4	Erecting the boom	41
5	Operating the crane	43
6	Taking the boom down	44
7	Disassembling the F-jib	47

# 1 Component overview



## Note

- The assembly sections are marked with their own weight.



## Note

- Dimensions and weights, see chapter 1.03.

## 1.1 F-pivot section

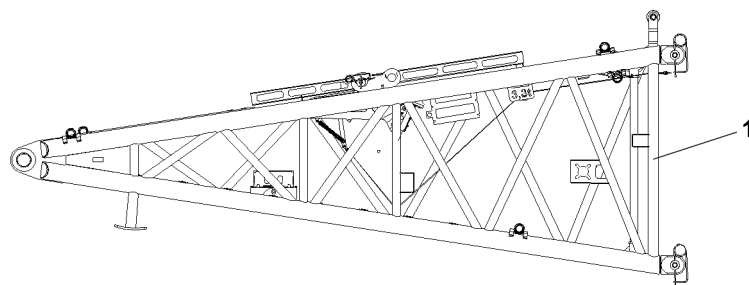


Fig.155928: F-pivot section

Position	Component
1	F-pivot section

## 1.2 F-intermediate section 3 m

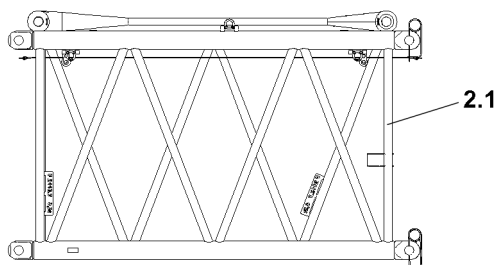


Fig.155929: F-intermediate section 3 m

Position	Component
2.1	F-intermediate section 3 m



### 1.3 F-intermediate section 6 m

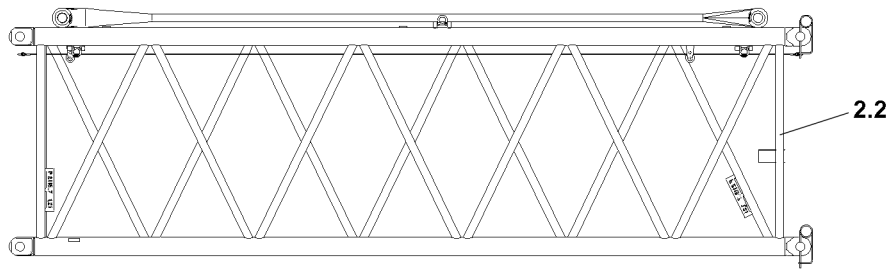


Fig.155930: F-intermediate section 6 m

Position	Component
2.2	F-intermediate section 6 m

### 1.4 F-intermediate section 12 m

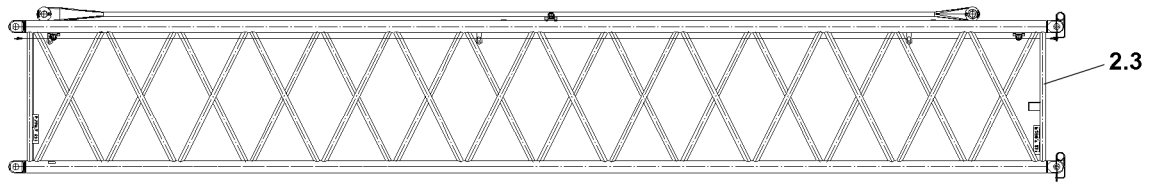


Fig.155931: F-intermediate section 12 m

Position	Component
2.3	F-intermediate section 12 m

### 1.5 F-end section

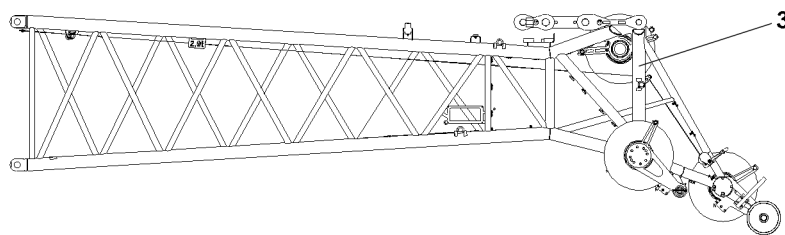


Fig.155933: F-end section

Position	Component
3	F-end section

LWE/LR 1800-1-0-000/27200-07-02/en

## 1.6 F-assembly unit

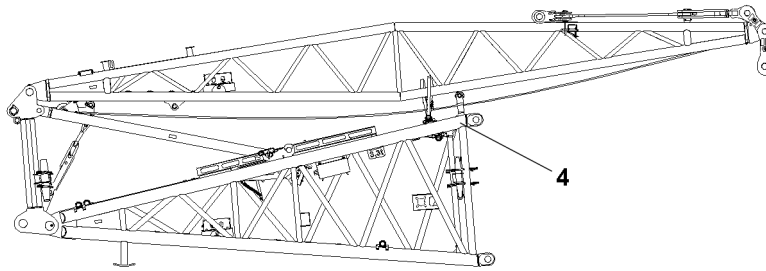


Fig.155934: F-assembly unit

Position	Component
4	F-assembly unit

## 1.7 F-assembly unit with F-end section

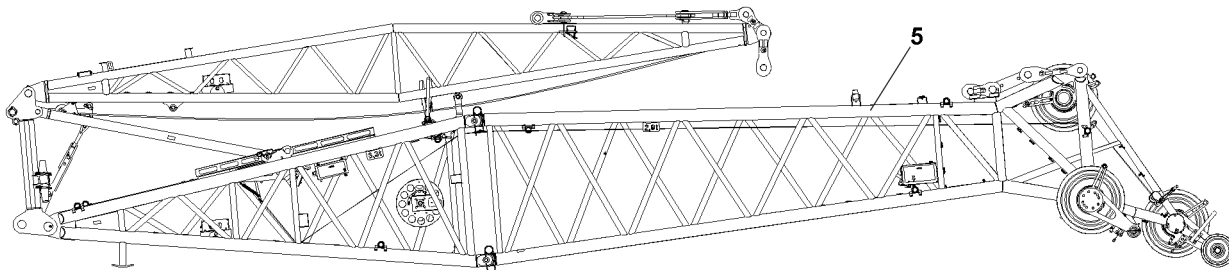


Fig.156328: F-assembly unit with F-end section

Position	Component
5	F-assembly unit with F-end section

## 2 F-jib fastening points



### WARNING

Falling lattice sections!

Death, severe bodily injuries, property damage.

- ▶ Make sure that the lattice sections are properly fastened on the respective fastening points.
- ▶ Make sure that the fastening equipment has the appropriate length and a sufficient load bearing capacity.
- ▶ Pay attention and adhere to the labels on the fastening points on the lattice sections and crane components.



### Note

- ▶ The recommended length for the fastening equipment is 6 m.

## 2.1 F-pivot section

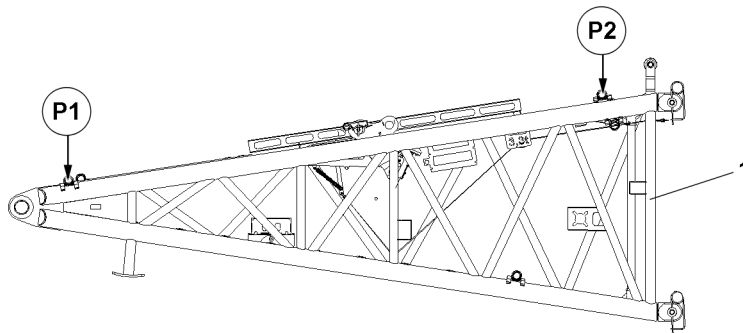


Fig.156329: F-pivot section

Fastening points	
P1 and P2	F-pivot section

## 2.2 F-intermediate section 3 m

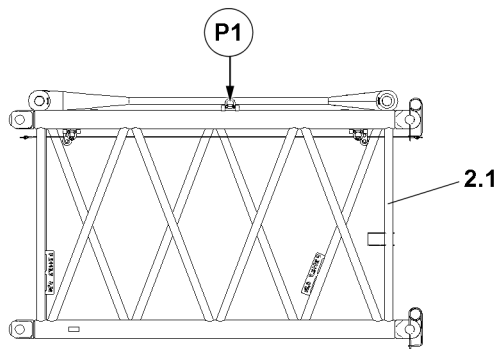


Fig.156330: F-intermediate section 3 m

Fastening points	
P1	F-intermediate section 3 m

## 2.3 F-intermediate section 6 m

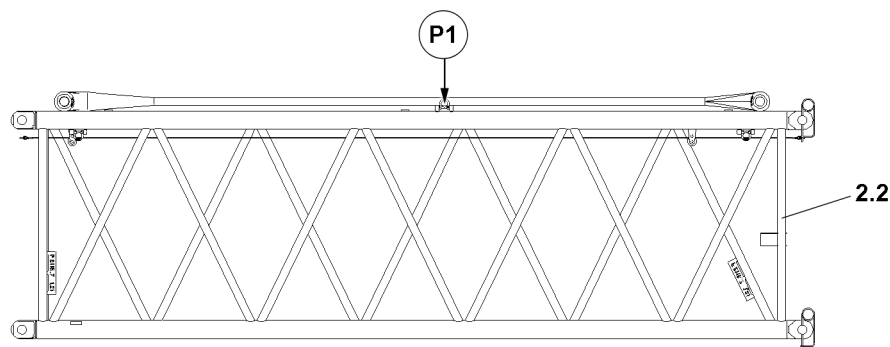


Fig.156331: F-intermediate section 6 m

LWE/LR 1800-1-0-000/27200-07-02/en

Fastening points	
P1	F-intermediate section 6 m

## 2.4 F-intermediate section 12 m

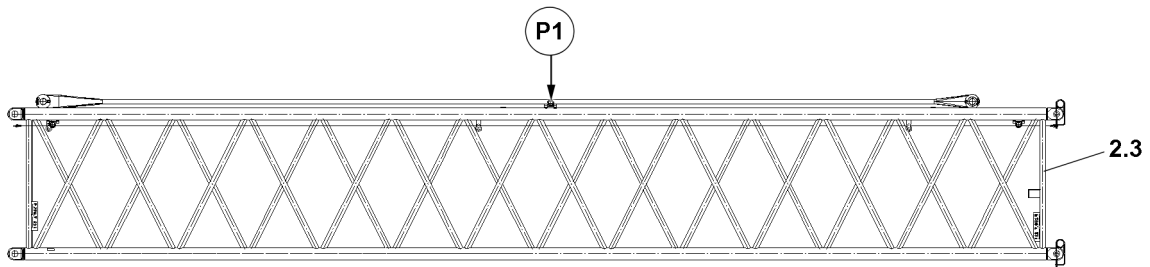


Fig.156332: F-intermediate section 12 m

Fastening points	
P1	F-intermediate section 12 m

## 2.5 F-end section

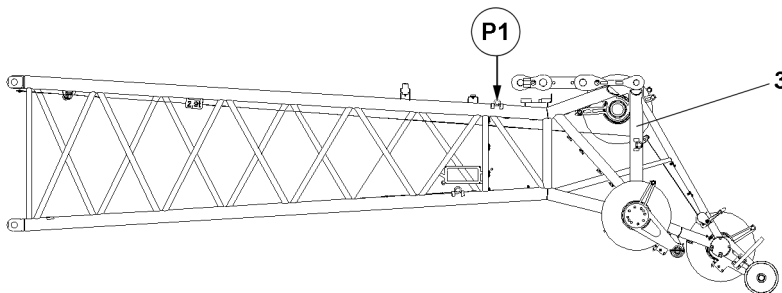


Fig.156333: F-end section

Fastening points	
P1	F-end section

## 2.6 F-assembly unit

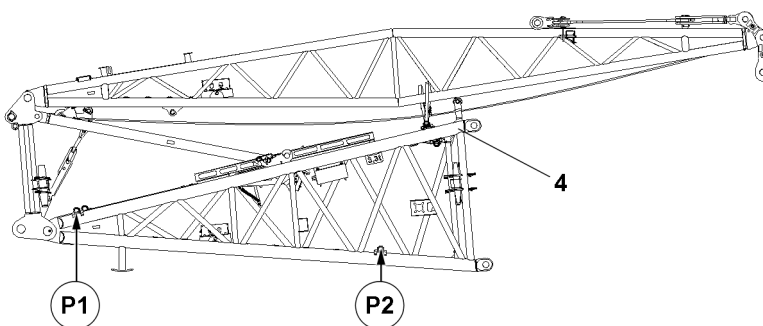


Fig.156334: F-assembly unit

LWE/LR 1800-1-0-000/27200-07-02/en

Fastening points	
P1 and P2	F-assembly unit

## 2.7 F-jib 12 m

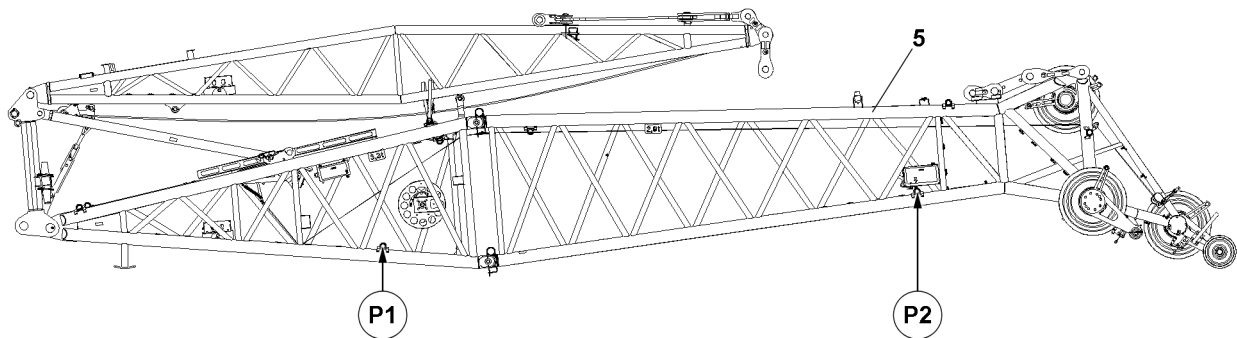


Fig.156335: F-assembly unit with F-end section

Fastening points	
P1 and P2	F-jib 12 m

## 3 Assembling the F-jib



### WARNING

Danger of falling!

During assembly / disassembly, inspection and maintenance work, assembly personnel must be secured with appropriate aids to prevent them from falling.

Death, severe bodily injuries, property damage.

- ▶ All work at a height, when there is a danger of falling, must be carried out with suitable aids.
- ▶ If aids are not available and work cannot be carried out from the ground, then assembly personnel must secure themselves with the supplied fall arrest system to prevent falling, see chapter 2.04.
- ▶ If fall protection equipment is available, then it must be used, see chapter 2.06.
- ▶ When lifting, lowering, swinging crane parts in and out, no persons may remain in the danger zone.
- ▶ When closing or opening boom systems during boom assembly or boom disassembly, no persons may remain on the boom system or in the danger zone.
- ▶ If railings are present on the components, then they must be brought into the corresponding position and secured for assembly / disassembly work.
- ▶ Only step on the aids, ladders and catwalks with clean shoes.
- ▶ Keep aids, ladders and catwalks free of heavy dirt, snow, frost and ice.
- ▶ During all assembly and disassembly work, maintenance work and inspections, travel or crane operation is prohibited.
- ▶ Remaining on a suspended load is prohibited.
- ▶ Stepping or walking on crane components and lattice sections with an incline of more than 20° is prohibited.
- ▶ For all assembly / disassembly work, the crane operator of the main crane must be in voice contact with the crane operator / crane operators of the auxiliary crane / auxiliary cranes.
- ▶ For assembly / disassembly work, the crane operator may only initiate crane movements when the responsible guide has explicitly released the movement.

**WARNING**

Working without aids!

Death, severe bodily injuries, property damage.

When assembling and disassembling crane components with the auxiliary crane, they can start to swing back and forth.

When lifting / lowering and positioning crane components, there is an increased danger of impact / crushing.

- ▶ Make sure that personnel cannot be caught by components.
- ▶ When working in a danger zone: Use aids to protect limbs.
- ▶ Guide components with suitable aids to minimize oscillation.
- ▶ Maintain the safety distance.

**DANGER**

Do not disconnect the auxiliary crane until the component is completely pinned and secured!

Death, severe bodily injuries, property damage.

If a component is disengaged from the auxiliary crane before it is pinned, then it can fall.

- ▶ Do not disconnect the auxiliary crane until the component is pinned and secured.

**WARNING**

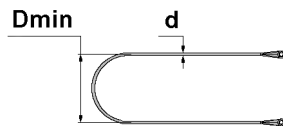
Incorrect or incomplete pinning!

Death, severe bodily injuries, property damage.

If the lattice sections are not pinned and secured correctly, then they can fall down.

- ▶ Insert or unpin both pins on the same horizontal level, i.e. **left and right**.
- ▶ Do not stand under the lattice sections or within the entire danger zone during the boom pinning and unpinning procedure.
- ▶ Safely secure the pins in the storage locations as well as in the receptacles.

Fiber guy ropes are used for the guying of the F-jib, see the rod plan. Comply with the following regulations.



$$D_{min} = 20 \times d$$

Fig.160908: Fiber guy rope: Calculation of minimum permissible bending diameter

Formula element	Meaning
Dmin	Minimum permissible bending diameter
d	Rope diameter

Minimum permissible bending diameter: Definition of the formula elements

**WARNING**

Impermissible assembly of fiber guy ropes!

The fiber guy ropes can rip.

Death, severe bodily injuries, property damage.

- ▶ Before assembling the fiber guy ropes, check if the fiber guy ropes are rigidly frozen or covered with ice. See chapter 5.01.
- ▶ Do **not** assemble fiber guy ropes that are rigidly frozen or covered with ice.
- ▶ Do **not** use buckled, knotted or twisted fiber guy ropes.
- ▶ Never fall below the minimum permissible bending diameter **D<sub>min</sub>** of **20** x rope diameter **d**.
- ▶ Do **not** assemble damaged fiber guy ropes.
- ▶ Make sure that the identification of the fiber guy rope on the rod plan and the identification on the individual fiber guy ropes are identical. Identify the fiber guy rope, see chapter 5.01.
- ▶ Make sure that the operating temperature of the fiber guy ropes of -40 °C to +60 °C is **not** fallen below or exceeded.
- ▶ Check the fiber guy ropes for damage prior to assembly, after disassembly and after exceptional events, see chapter 8.16.
- ▶ Comply with the maintenance intervals, see chapter 7.03.50.
- ▶ Replace damaged fiber guy ropes.
- ▶ Observe the notes regarding the proper transport and storage of the fiber guy ropes, see chapter 2.04.
- ▶ Observe the instructions for the proper handling of fiber guy ropes, see chapter 5.01.
- ▶ Only fasten the fiber guy ropes in the permissible range with belt loops, see chapter 5.01.

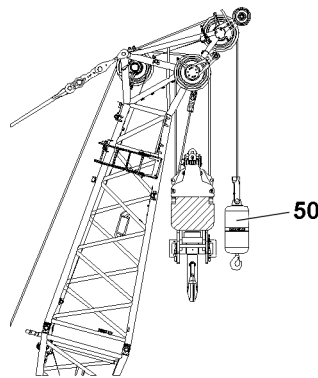


Fig.153260: Using the load hook on the boom nose

**50** Load hook

**NOTICE**

Use of an impermissible load hook!

Collision and damage to the boom nose.

- ▶ Make sure that only the load hook **50** is attached to the integrated boom nose.

**WARNING**

Suspended hook block during assembly!

Death, severe bodily injuries, property damage.

- ▶ During assembly, no hook block may be attached to the F-jib.

**Note**

- ▶ The F-jib is **not** adjustable during crane operation.
- ▶ The F-jib can be assembled with different angles to the main boom.
- ▶ Various lengths are possible.
- ▶ Observe and adhere to the rod plan.

### 3.1 Assembly prerequisites

Make sure that the following prerequisites are met:

- The incline of the base and travel route of the crawler travel gear is  $0^\circ \pm 0.3^\circ$ .
- The base and travel route have a sufficient load bearing capacity.
- The derrick boom is installed with the required length on the crane, see chapter 5.05.
- The SL-boom combination is installed with the required length on the crane and taken down on the ground or on the substructure.
- All WA-frame guy rods have been removed on the SL-boom combination.
- The suspended ballast pallet is near the crane.
- The suspended ballast pallet is aligned with the center of rotation of the crane.
- The suspended ballast is placed on the suspended ballast pallet according to the erection and take-down chart.
- The LICCON overload protection has been set according to the data in the load chart.
- The LICCON overload protection settings match the actual set up configuration of the crane.
- The LICCON overload protection is exceeded.
- The assembly icon is visible on the LICCON monitor.
- All unnecessary function keys and manual control levers are blocked on the radio remote control, see chapter 5.31 and chapter 6.08.
- An auxiliary crane is available.

### 3.2 F-jib assembly variations



#### WARNING

Maximum permissible assembly lengths exceeded!

If the maximum permissible assembly lengths are not complied with when assembling the F-jib, then dangerous situations can arise.

Death, severe bodily injuries, property damage.

- ▶ Make sure that the maximum permissible assembly lengths are adhered to.



#### WARNING

Non-compliance with the assembly descriptions!

Death, severe bodily injuries, property damage.

- ▶ The F-jib must always be assembled in accordance with the corresponding description in the respective section.
- ▶ Make sure that the danger notes in the respective assembly description are observed.

#### 3.2.1 Assembling on the main boom

The fixed jib can be assembled on the main boom on the following lattice sections:

- L-end section
- F-connector head

#### 3.2.2 Assembly variation V1

Assemble the F-jib in individual parts:

- For assembly variation V1, the F-jib is assembled out of individual lattice sections.

#### 3.2.3 Assembly variation V2

Assemble the complete F-jib (maximum length of 12 m) in flying mode:

- For assembly variation V2, the F-assembly unit is assembled in flying mode with the already assembled F-end section.

Differences from assembly variation V1:

- The relapse support is pinned during assembly with the F-pivot section.
- The F-jib 12 m can remain hanging on the main boom without the auxiliary crane.



### 3.3 F-jib assembly steps

This chapter describes the assembly of the F-jib on the F-connector head as an example.

#### 3.3.1 Validity of the assembly steps for the respective assembly variation



##### WARNING

Maximum permissible assembly lengths exceeded!  
Death, severe bodily injuries, property damage.

► Observe the maximum permissible assembly lengths.

The fixed jib can be assembled on the main boom on the following lattice sections:

- L-end section
- F-connector head

This chapter describes the assembly of the F-jib on the F-connector head as an example.

This chapter contains the assembly steps for both assembly variations:

- Assembly variation V1
- Flying assembly: Assembly variation V2

Assembly steps that apply only to one of the assembly variations are marked.

Illustrations that apply to both assembly steps provide an example of the situation for assembly variation V1.

#### 3.3.2 Assembly variation V2 flying assembly: Positioning the F-jib 12 m on the F-connector head

The assembly step applies only to assembly variation V2.

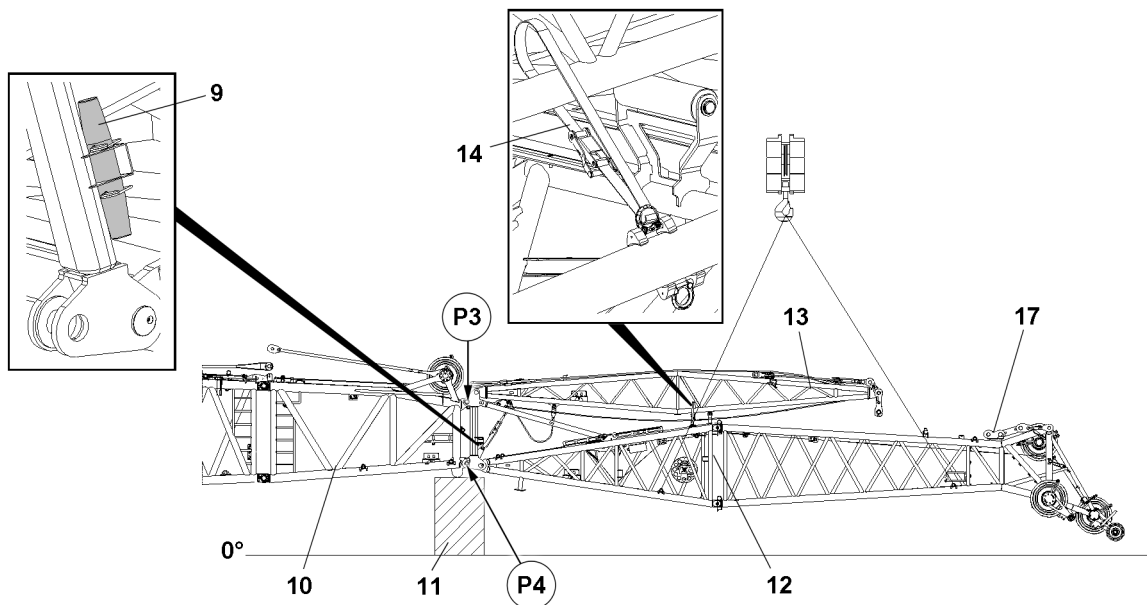


Fig.156571: Pinning the F-jib 12 m on the F-connector head

9	Pin	12	F-jib 12 m	17	F-end section
10	F-connector head	13	FA-frame		
11	Substructure	14	Rigging belt		

Make sure that the following prerequisites are met:

- The main boom is assembled.
  - The main boom is taken down on the substructure **11**.
  - The substructure **11** is sufficiently high to be able to assemble the F-jib 12 m.
  - The F-guy ropes are **not** assembled on the FA-frame **13** or on the F-end section **17**.
  - The pins in point **P3** are unpinned.
  - The pins **9** are in the transport retainer.
  - A pin pulling device is present.
  - The rigging belts **14** are removed.
- ▶ Fasten the F-jib 12 m to the auxiliary crane.
  - ▶ Lift the F-jib 12 m with the auxiliary crane and position on the F-connector head **10** so that it can be pinned in the pin locations.

### 3.3.3 Assembly variation V1: Positioning the F-assembly unit on the F-connector head

The assembly step applies only to assembly variation V1.

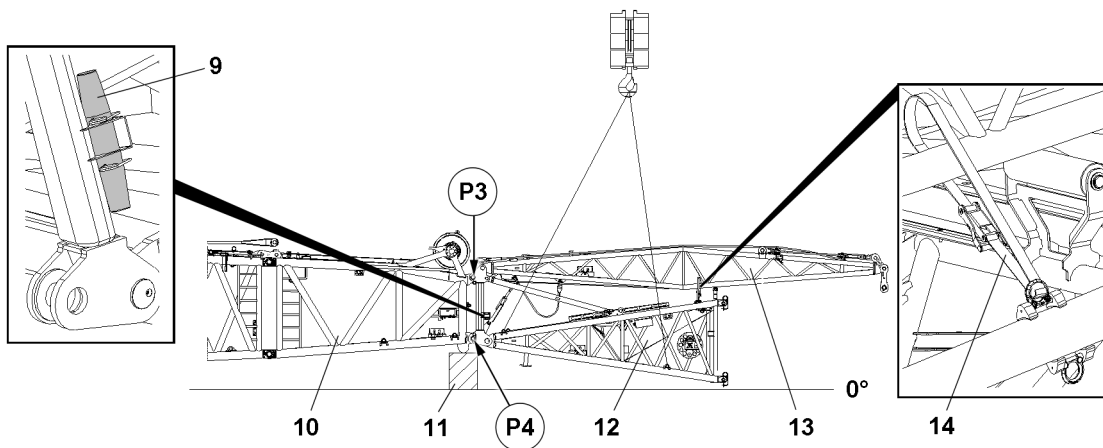


Fig.156336: Positioning the F-assembly unit on the F-connector head

<b>9</b> Pin	<b>11</b> Substructure	<b>13</b> FA-frame
<b>10</b> F-connector head	<b>12</b> F-assembly unit	<b>14</b> Rigging belt

Make sure that the following prerequisites are met:

- The main boom is assembled.
  - The main boom is taken down on the substructure **11**.
  - The substructure **11** is sufficiently high to be able to assemble the F-assembly unit.
  - The pins in point **P3** are unpinned.
  - The pins **9** are in the transport retainer.
  - A pin pulling device is present.
  - The rigging belts **14** are removed.
- ▶ Fasten the F-assembly unit to the auxiliary crane.
  - ▶ Lift the F-assembly unit with the auxiliary crane and position on the F-connector head **10** so that it can be pinned in the pin locations.

### 3.3.4 Pinning the F-assembly unit to the F-connector head

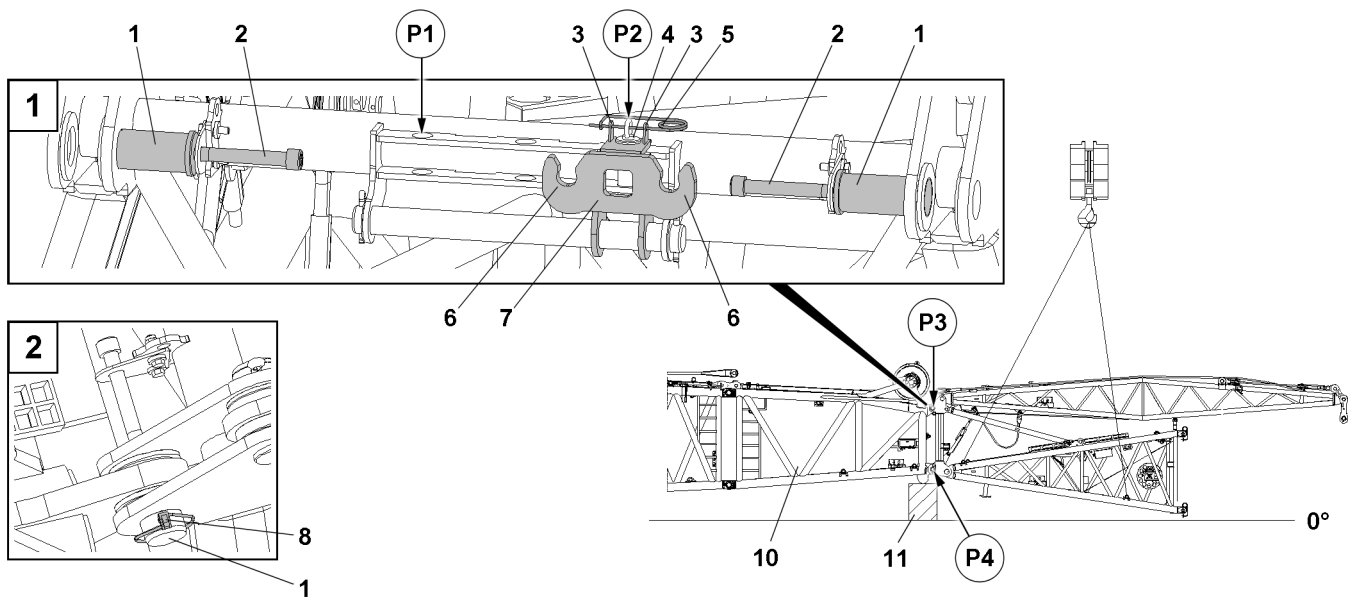


Fig.156566: Pinning the F-assembly unit to the F-connector head

1	Pin	4	Pin	7	Bracket
2	Screw	5	Retaining element	8	Retaining element
3	Brackets	6	Hook	10	F-connector head

#### Pin points:

- The F-assembly unit is pinned twice on the F-connector head **10** in point **P3**.
- The F-assembly unit is pinned twice on the F-connector head **10** in point **P4**.

The pins in point **P3** are inserted with the pin pulling device.

Ascent to the F-connector head **10** via the installed ladder or basic unit. Follow the instructions, see chapter 2.06.

To attach the pin pulling cylinder, the bracket must be positioned and pinned depending on the pin point in point **P1** or point **P2**.

- ▶ Position the bracket **7** for the first pin **1**.
- ▶ Insert the pin **4**.
- ▶ Secure the pin **4** with the retaining element **5** to both brackets **3**.
- ▶ Connect the pin pulling device to the screw **2** and the hook **6**.
- ▶ Insert the first pin **1** and secure with the retaining element **8**.
- ▶ Position, pin and secure the bracket **7** for the second pin **1**.
- ▶ Connect the pin pulling device to the screw **2** and the hook **6**.
- ▶ Insert the second pin **1** and secure with the retaining element **8**.



#### WARNING

Standing within the boom system!

Crushing / shearing of limbs-

Death, severe bodily injuries.

- ▶ While the F-assembly unit lowers: Maintain the safety distance.
- ▶ Make sure that no crane movements are performed while pinning in the area of the lower pin points.
- ▶ Maintain a safety distance: Stay away from the lattice sections during pinning.

- ▶ Lower the F-assembly unit until the pins can be pinned in point **P4**.

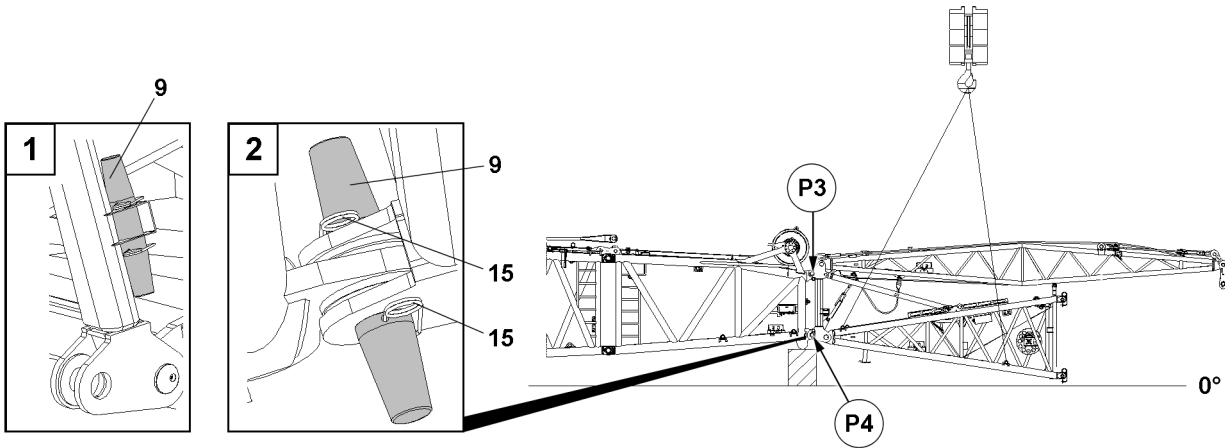


Fig.156337: Pinning the F-assembly unit to the F-connector head

9 Pin    15 Retaining element

- ▶ Remove the pin 9 from the transport receptacle.
- ▶ Insert the first pin 9 in point P4 and secure with the retaining elements 15.
- ▶ Insert the second pin 9 in point P4 and secure with the retaining elements 15.

### 3.3.5 Pinning the bracket in the middle position

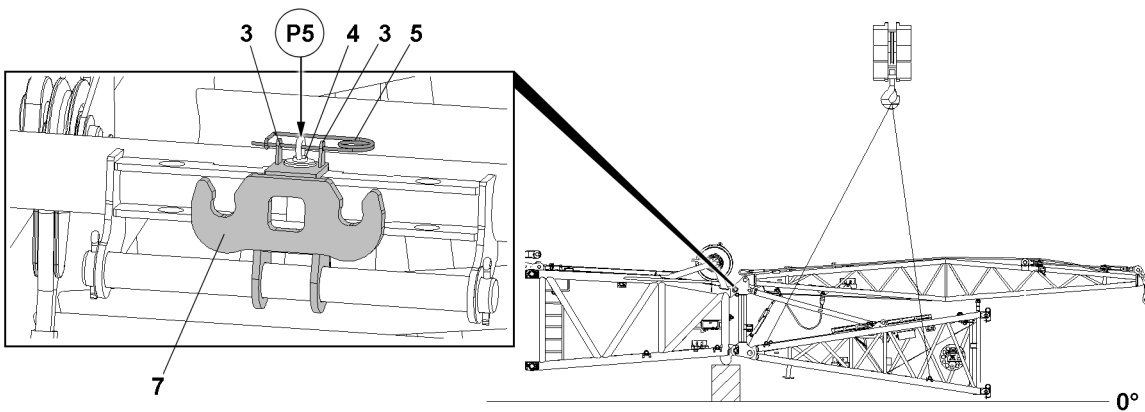


Fig.156342: Pinning the bracket in the middle position

3 Bracket    5 Retaining element  
4 Pin    7 Bracket



#### WARNING

Bracket pinned in an incorrect position!  
The rope collar clamp can remain hanging when reeving in on the bracket. Property damage.  
▶ Make sure that the bracket is in the middle position.

This section applies only in the case that the F-assembly unit is assembled on the L-head and parallel operation is used.

- ▶ Put the bracket 7 in position P5.
- ▶ Insert the pin 4.
- ▶ Secure the pin 4 with the retaining element 5 to both brackets 3.

### 3.3.6 Assembly variation V2 flying assembly: F-relapse support pinned in the transport position

The assembly step applies only to assembly variation V2.

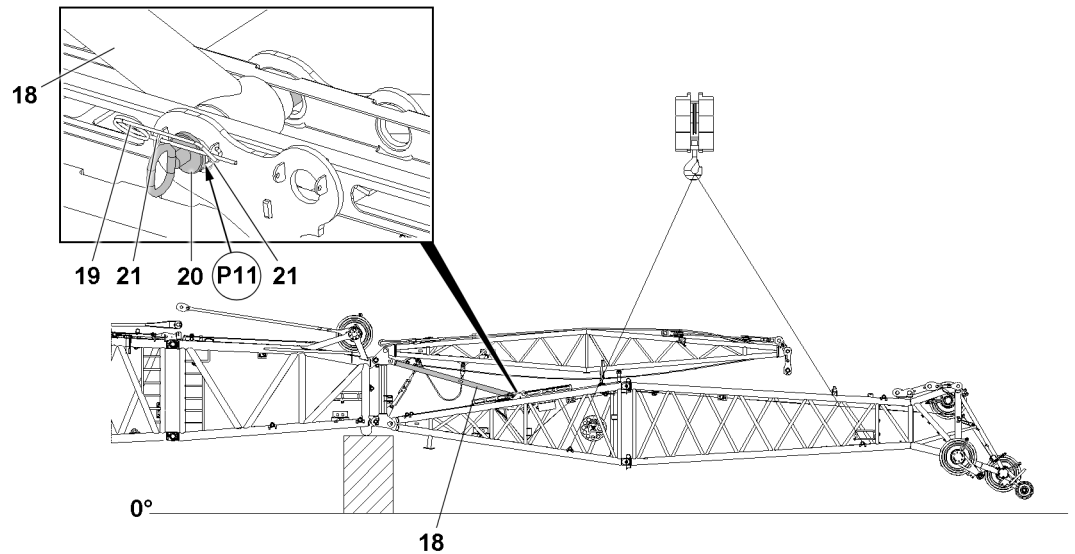


Fig.156572: Prerequisite for flying assembly: F-relapse support pinned in the transport position

<b>18</b> F-relapse support	<b>20</b> Pin
<b>19</b> Retaining element	<b>21</b> Bracket

The pin **20** must remain inserted in the transport position **P11** until the following prerequisites are fulfilled:

- The FAB-guy ropes are assembled.
- The FA-relapse retainer is closed.
- The F-guy ropes are assembled.

- ▶ Make sure that the F-relapse support **18** is pinned in the transport position **P11** with the pin **20** and secured with the retaining element **19** to the lugs **21**.

### 3.3.7 Assembly variation V1: Releasing the F-relapse support

The assembly step applies only to assembly variation V1.

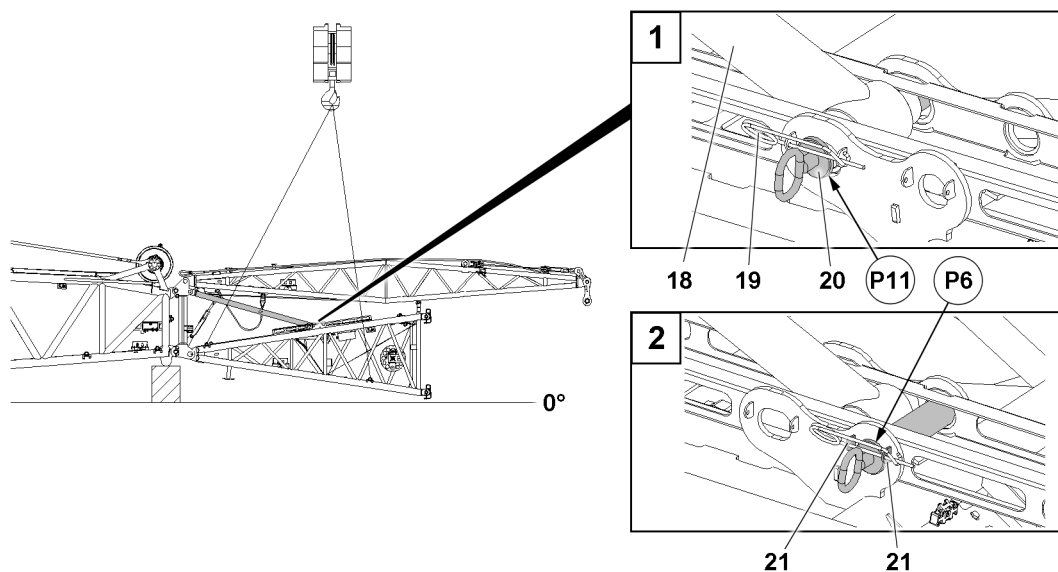


Fig.156340: Releasing the F-relapse support from the transport position

<b>18</b> F-relapse support	<b>20</b> Pin
<b>19</b> Retaining element	<b>21</b> Brackets

- ▶ Make sure that the F-relapse support **18** is relieved.

- ▶ Release the F-relapse support **18** from the transport position **P11**: Remove the retaining element **19** and unpin the pin **20**.
- ▶ Insert the pin **20** in the stop position **P6** and secure with the retaining element **19** to the brackets **21**.

### 3.3.8 Releasing the FA-frame relapse retainer

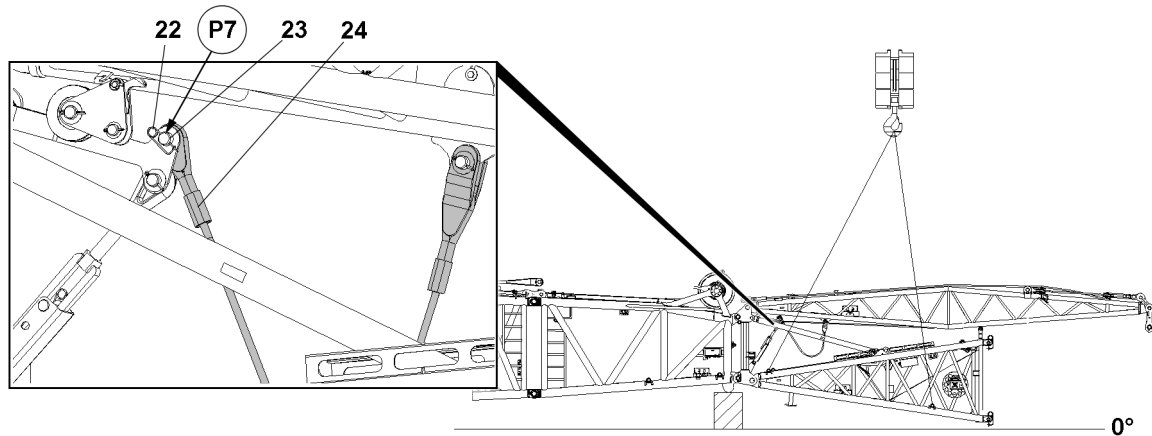


Fig.156338: Releasing the FA-frame relapse retainer

- |                             |                    |
|-----------------------------|--------------------|
| <b>22</b> Pin               | <b>24</b> Guy rope |
| <b>23</b> Retaining element |                    |



#### WARNING

Unsecured guy rope **24**!

The guy rope **24** of the FA-frame relapse retainer can fall down due to its own weight during unpinning.

Death, severe bodily injuries, property damage.

- ▶ Make sure when unpinning the FA-frame relapse retainer, that the guy rope **24** is safely held.
- ▶ Assembly personnel must be to the side of the assembly unit.

- ▶ Remove the retaining element **22**.
- ▶ Unpin the pin **23** in position **P7**.
- ▶ Take the guy rope **24** down.
- ▶ Insert the pin **23** in position **P7**.
- ▶ Secure the pin **23** with the retaining element **22**.

### 3.3.9 Assembly variation V1: Taking the F-assembly unit down on the ground

The assembly step applies only to assembly variation V1.

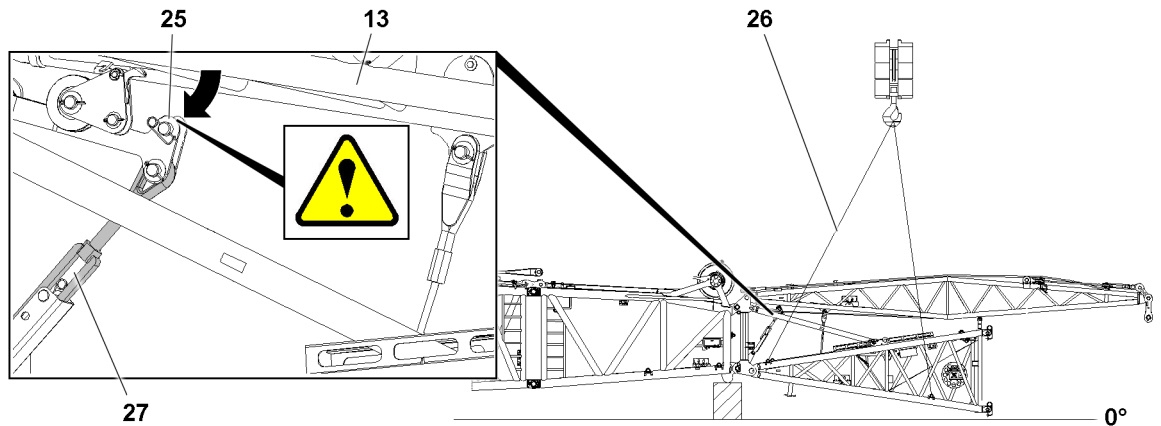


Fig. 156339: Taking the F-assembly unit down on the ground

13	FA-frame	26	Fastening equipment
25	FA-frame relapse retainer	27	Turnbuckle

Make sure that the following prerequisites are met:

- The FA-frame relapse retainer **25** is released.



#### WARNING

Lowering of the F-assembly unit!  
Crushing of limbs.

- ▶ Maintain the safety distance.

#### NOTICE

The turnbuckle **27** is twisted too far!

The FA-frame relapse retainer **25** collides with the FA-frame **13**. Damage to crane components.

- ▶ Check the length of the turnbuckle **27**. If necessary: Shorten the turnbuckle **27**.
- ▶ Visually supervise the procedure for taking the F-assembly unit down.

- ▶ Slowly lower the F-assembly unit.

When the F-assembly unit is lying on the ground:

- ▶ Remove the fastening equipment **26**.
- ▶ Remove the auxiliary crane.

### 3.3.10 Assembling the FAB-guy ropes on the rocker on the FA-frame

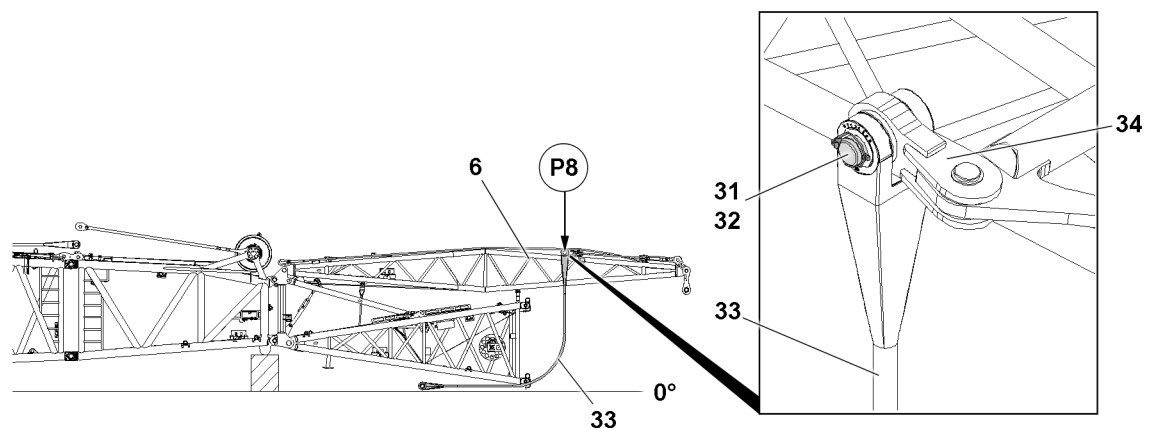


Fig. 156341: Assembling the FAB-guy rope on the rocker on the FA-frame

6	FA-frame	33	FAB-guy rope
---	----------	----	--------------

For continuation of legend for illustrations, see next page

- 31** Pin  
**32** Retaining element

- 34** Rocker



**Note**

- ▶ The assembly of the FAB-guy rope **33** is described based on the example of one side.
  - ▶ The assembly applies in the same way for both sides.
- 
- ▶ Make sure that the guy ropes are assembled according to the rod plan.
  - ▶ Position the FAB-guy rope **33** such that it can be pinned to the rocker **34** of the FA frame **6**.
  - ▶ Pin the FAB-guy rope **33** with the rocker **34**: Insert the pin **31** and secure with the retaining element **32**.

When the first FAB-guy rope **33** is properly assembled and secured:

- ▶ Pin the second FAB-guy rope **33** to the rocker **34**.
- ▶ Take down the free ends of the FAB-guy ropes **33** to the side of the boom.

### 3.3.11 Releasing the transport pinning of the rocker from the FA-frame

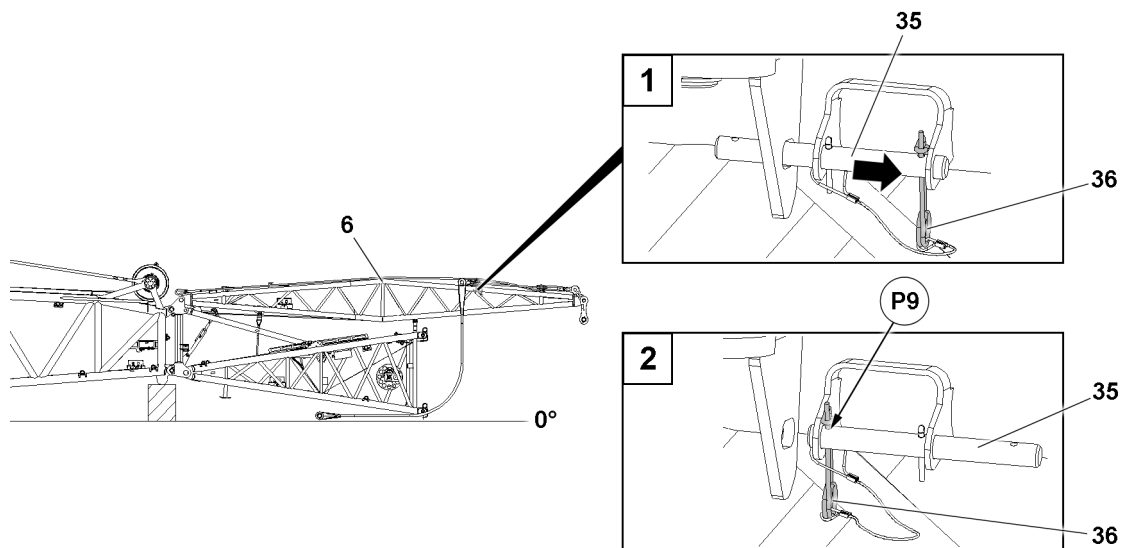


Fig.156343: Releasing the transport pinning from the FA-frame rocker

- 6** FA-frame  
**35** Pin  
**36** Retaining element

- ▶ Remove the retaining element **36**.
- ▶ Until the pin **35** can be secured in point **P9** with the retaining element **36**: Unpin the pin **35**.
- ▶ Secure the pin **35** with the retaining element **36** in position **P9**.



### 3.3.12 Assembling the guy ropes of the FAB-guying on the main boom

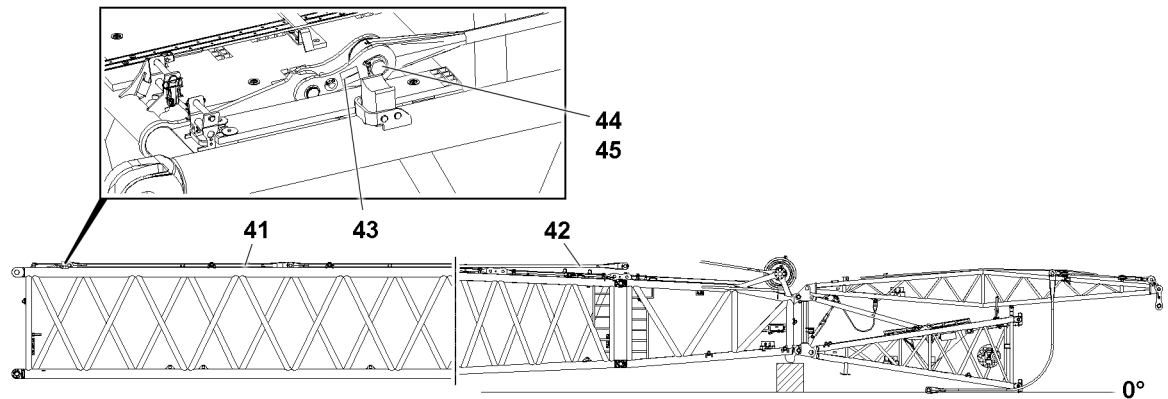


Fig.156567: Pinning the guy ropes of the FAB-guying, S-intermediate section example

41	FAB-guy rope S2*	44	Pin
42	FAB-guy rope S10	45	Retaining element
43	Bracket		

The brackets for pinning the FAB-guy ropes are located on a certain S-intermediate section and L-intermediate section, see the rod plan for the position.

- ▶ Take the FAB-guy ropes down according to the rod plan onto the main boom.



#### Note

- ▶ The assembly of the FAB-guy ropes is described based on the example of one side.
- ▶ The assembly applies in the same way for both sides.
- ▶ Pin the FAB-guy rope to the bracket **43**: Insert the pin **44**.
- ▶ Secure the pin **44** with the retaining element **45**.

If required in the rod plan:

- ▶ Pin FAB-guy rope S2\* **41** with FAB-guy rope S10 **42**.

### 3.3.13 Assembling the F-guy ropes on the FA-frame

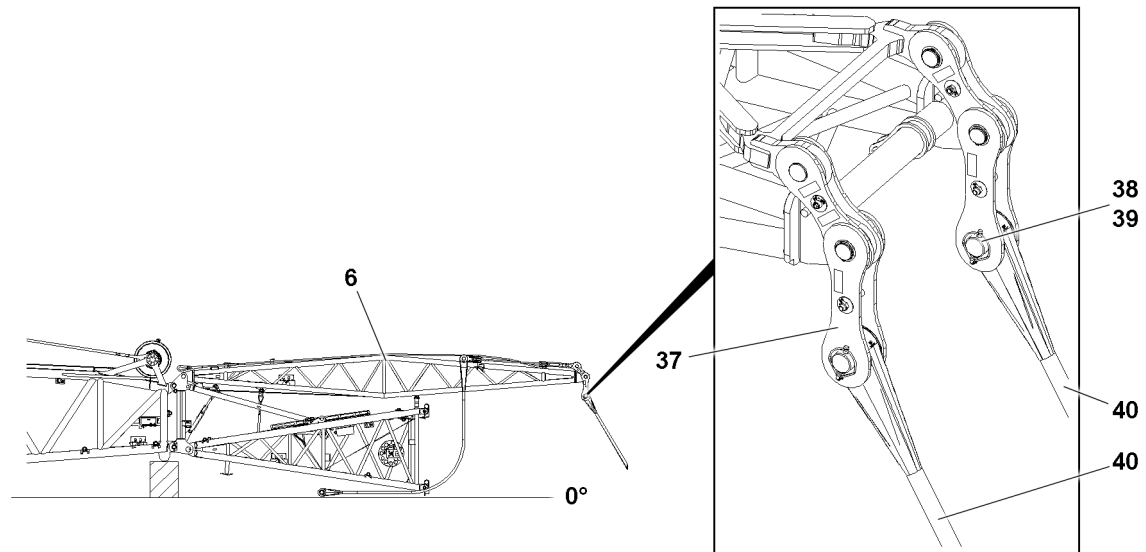


Fig.156344: F-guy ropes

<b>6</b>	FA-frame	<b>39</b>	Retaining element
<b>37</b>	Bracket	<b>40</b>	F-guy rope
<b>38</b>	Pin		



#### Note

- ▶ The assembly of the F-guy rope **40** is described based on the example of one side.
  - ▶ The assembly applies in the same way for both sides.
- 
- ▶ Make sure that the guy ropes are assembled in accordance with the rod plan.
  - ▶ Position the F-guy rope **40** such that it can be pinned to the bracket **37** of the FA frame **6**.
  - ▶ Pin the F-guy rope **40** to the bracket **37**: Insert the pin **38** and secure with the retaining element **39**.
- When the first F-guy rope **40** is assembled and secured:
- ▶ Assemble the second F-guy rope **40**.
  - ▶ Take down the free ends of the F-guy ropes **40** to the side of the boom.

### 3.3.14 Assembly variation V1: Fixing the relapse support flap in the “flap down” position

The assembly step applies only to assembly variation V1.

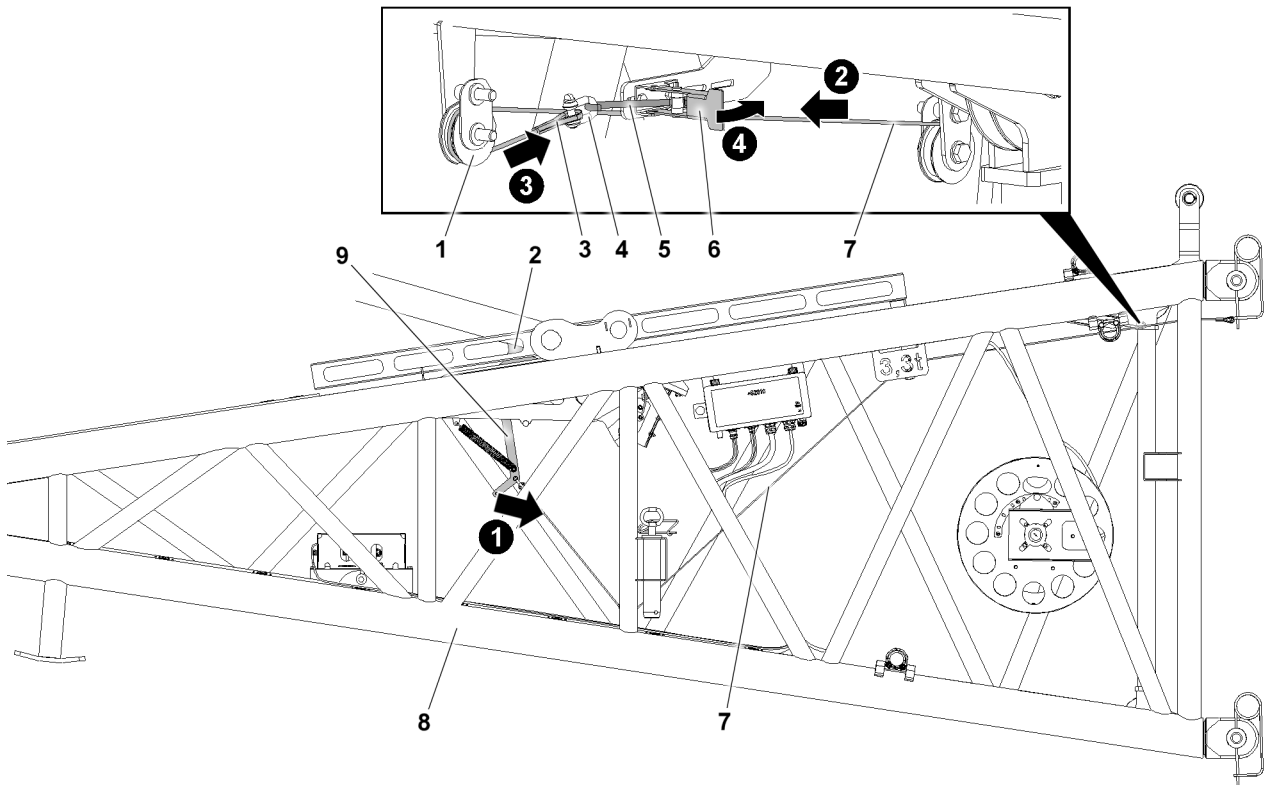


Fig.164812: Fixing the relapse support, "flap down" position

- |   |             |   |                 |   |                 |
|---|-------------|---|-----------------|---|-----------------|
| 1 | Rope pulley | 4 | Shackle         | 7 | Rope            |
| 2 | Flap        | 5 | Hook closure    | 8 | F-pivot section |
| 3 | Rope loop   | 6 | Tension element | 9 | Lever           |



#### Note

- ▶ Liebherr-Werk Ehingen GmbH recommends that two people carry out this work step.



#### WARNING

Flap **not** fixed!

Snapping up of the flap **2**. Crushing of limbs. Severe bodily injuries.

- ▶ Until the flap **2** is fixed on the hook closure **5**: Hold the flap **2**.
- ▶ Fix the flap **2** with the rope **7** to the hook closure **5**.
- ▶ Person 1: Pull the flap **2** with the lever **9** "downward" and keep it pulled.
- ▶ Person 2: Make sure that the rope **7** lies on the assigned rope pulley.
- ▶ Person 2: Connect the rope loop **3** with the shackle **4** to the hook closure **5**.
- ▶ Person 2: Tension the rope **7** with the tension element **6**.

### 3.3.15 Assembly variation V2 flying assembly: Fixing the relapse support flap in the "flap down" position

The assembly step applies only to assembly variation V2.

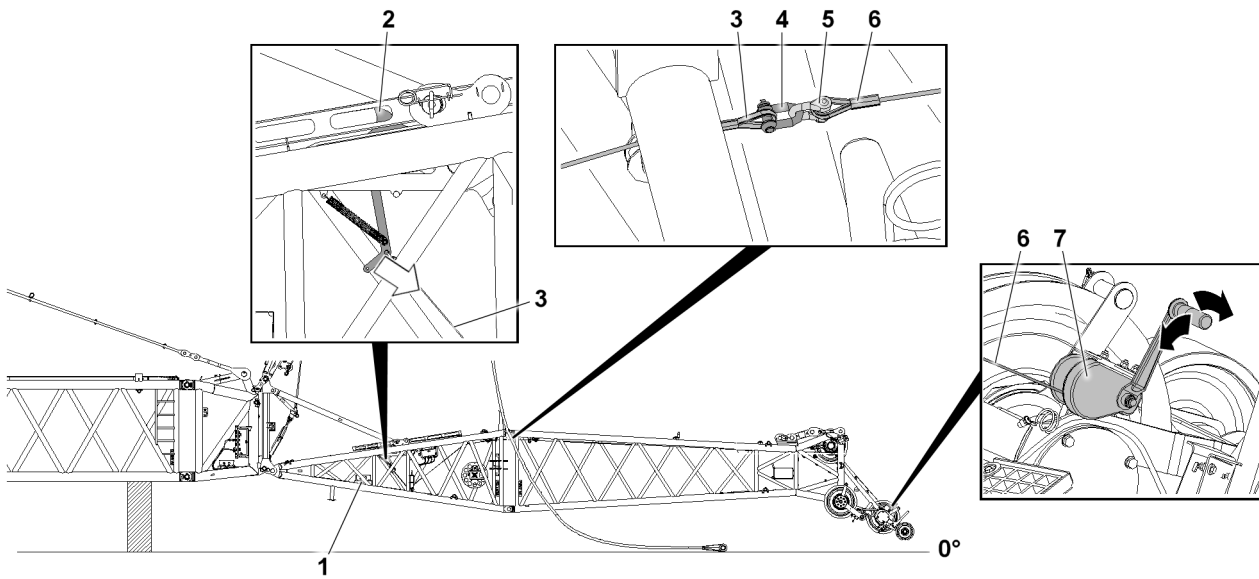


Fig.161279: Fixing the relapse support, “flap down” position, with the manual rope winch

1	F-pivot section	4	Shackle	7	Manual rope winch
2	Flap	5	Shackle		
3	Rope	6	Rope		

The flap 2 on the F-pivot section 1 is adjusted with the manual rope winch 7.

- ▶ Make sure that the rope 3 is connected with the rope 6: The shackle 4 and shackle 5 are connected together.
- ▶ To the stop: Pull the flap 2 with the aid of the manual rope winch 7 “downward”.

### 3.3.16 Unpinning the rope pulley retainer from the transport retainer

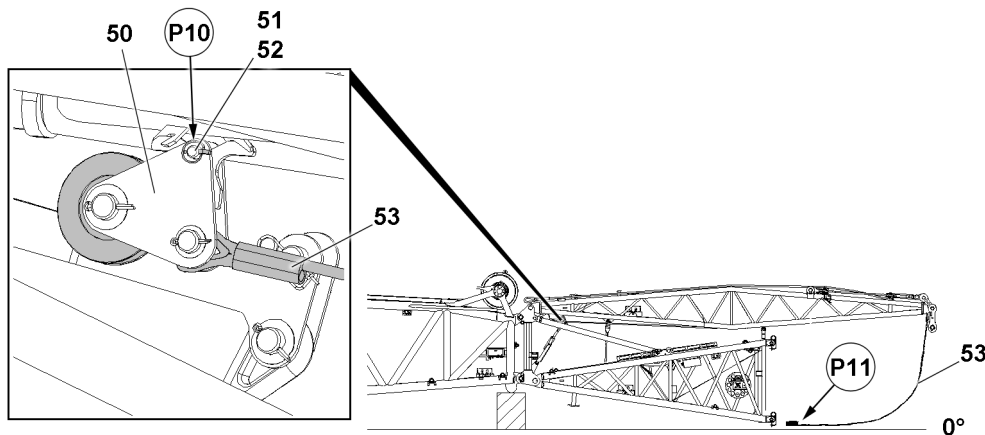


Fig.156345: Rope pulley retainer in the transport position

50	Rope pulley retainer	52	Retaining element
51	Pin	53	Fastening rope



#### CAUTION

Falling rope pulley retainer 50!  
Crushing of limbs.

- ▶ Make sure that the rope pulley retainer 50 is safely held when unpinning.
- ▶ Assembly personnel must be to the side of the assembly unit.
- ▶ Remove the retaining element 52 and unpin the pin 51.

When the rope pulley retainer **50** is released:

- ▶ Insert the pin **51** in position **P10** and secure with the retaining element **52**.
- ▶ Take down the rope pulley retainer **50** and fastening rope **53** in point **P11**.

### 3.3.17 Prerequisites for erecting the FA-frame

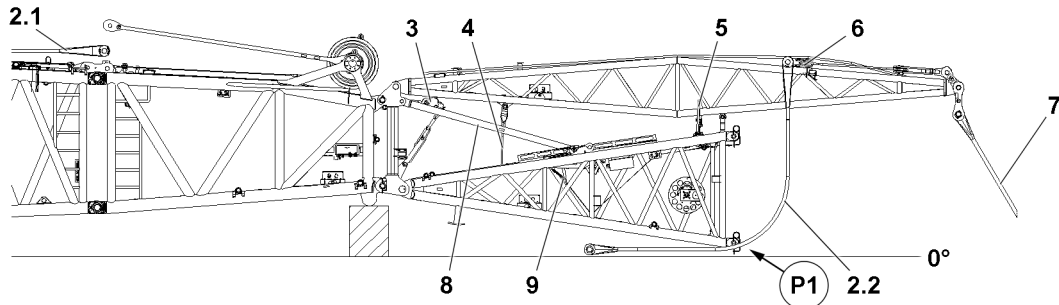


Fig.156346: Erecting the FA-frame: Prerequisites

<b>2.1</b>	FAB-guy ropes (intermediate section)	<b>6</b>	Transport pinning
<b>2.2</b>	FAB-guy ropes (FA-frame)	<b>7</b>	F-guy ropes
<b>3</b>	Rope pulley retainer	<b>8</b>	F-relapse support
<b>4</b>	FA-frame relapse retainer	<b>9</b>	Relapse support flap
<b>5</b>	Rigging belts		

#### NOTICE

The FA-frame relapse retainer is **not** separated!  
Property damage.

If the guy rope of the FA-frame relapse retainer **4** is not separated, it will be damaged during erection of the FA-frame.

- ▶ Make sure that the guy rope of the FA-frame relapse retainer **4** is separated during the erection of the FA-frame.

Make sure that the following prerequisites are met:

- The F-assembly unit is assembled.
- The rigging belts **5** are removed.
- Only for assembly variation V1: The F-relapse support **8** is pinned in the stop position.
- Only for assembly variation V2: The F-relapse support **8** is pinned in the transport position.
- The FA-frame relapse retainer **4** is separated.
- The FAB-guy ropes **2.1** are assembled according to the rod plan.
- The FAB-guy ropes **2.2** are assembled according to the rod plan.
- The F-guy ropes **7** are assembled according to the rod plan.
- The rocker transport lock **6** is unpinned.
- The relapse support flap **9** is in the “flap down” position.
- The relapse support flap **9** is fixed with the auxiliary rope.
- The rope pulley retainer **3** is in position **P1**.

### 3.3.18 Removing the fastening rope from the transport position

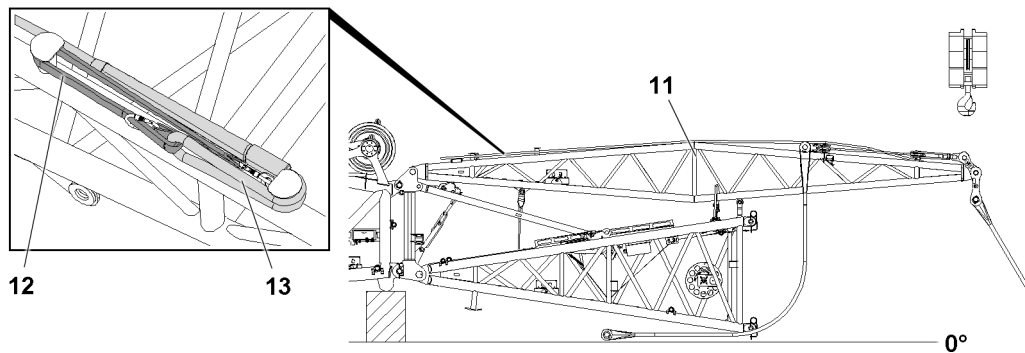


Fig.156347: Fastening rope in the transport position

- |    |             |    |                |
|----|-------------|----|----------------|
| 11 | FA-frame    | 13 | Fastening rope |
| 12 | Round sling | 14 | Snap hook      |

- ▶ Open the snap hook 14.
- ▶ Release the round sling 12 from the fastening rope 13.
- ▶ Remove the fastening rope 13 from the transport position.
- ▶ Fasten the FA-frame 11 with the fastening rope 13 to the auxiliary crane.

### 3.3.19 Erecting the FA-frame

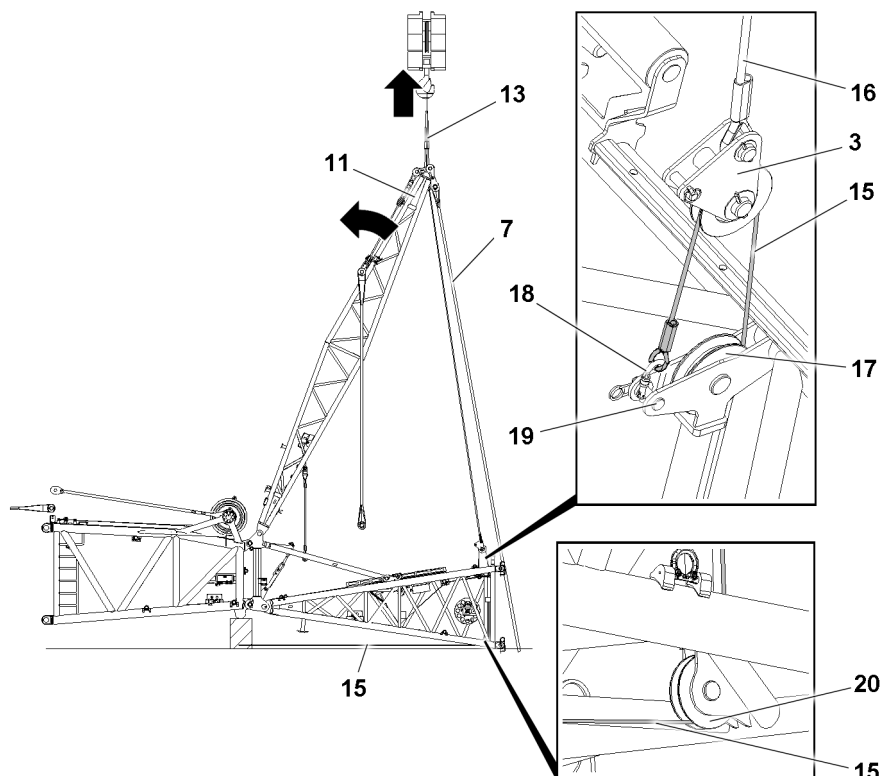


Fig.156349: Reeving the assembly winch rope in on the rope pulley retainer

- |    |                      |    |                |
|----|----------------------|----|----------------|
| 3  | Rope pulley retainer | 16 | Fastening rope |
| 7  | F-guy ropes          | 17 | Rope pulley    |
| 11 | FA-frame             | 18 | Snap hook      |
| 13 | Fastening rope       | 19 | Pin            |
| 15 | Assembly winch rope  | 20 | Rope pulley    |

- ▶ Make sure that the assembly winch rope is reeved in only on the rope pulley retainer **3**.
- ▶ Guide the assembly winch rope **15** over the rope pulley **20** and rope pulley **17** and reeve in on the rope pulley retainer **3**.
- ▶ Secure the assembly winch rope **15** with the snap hook **18** to the pin **19**.




---

### WARNING

Relaxed fastening rope **13**!

If the fastening rope **13** does **not** remain tensioned during assembly, the FA-frame **11** can swing suddenly in direction of the main boom.

Death, severe bodily injury, property damage.

- ▶ Make sure that there are no persons within the danger zone.
  - ▶ Make sure that the fastening rope **13** is tensioned during all assembly and disassembly operations.
- 

### NOTICE

F-guy rope **7** **not** guided!

Damage to components.

When the FA-frame is erected:

- ▶ Make sure that the F-guy ropes **7** are guided.
- 

### NOTICE

Swinging the FA-frame **11** in the direction of the main boom!

Property damage to the FA-frame **11**, the F-connector head (or: L-end section) **23** as well as the rope pulley retainer **3**

- ▶ Make sure that a guide supervises the swinging process of the FA-frame **11**.
  - ▶ Make sure that the guide is constantly in visual and acoustic contact with the crane operator.
  - ▶ Maintain the safety distance.
  - ▶ Make sure that the assembly winch rope **15** is spooled out during the swinging process of the FA-frame **11**.
- 

- ▶ Erect the FA-frame **11** with the auxiliary crane and spool out the assembly winch rope **15** at the same time.

### 3.3.20 Pinning the FAB-guy ropes

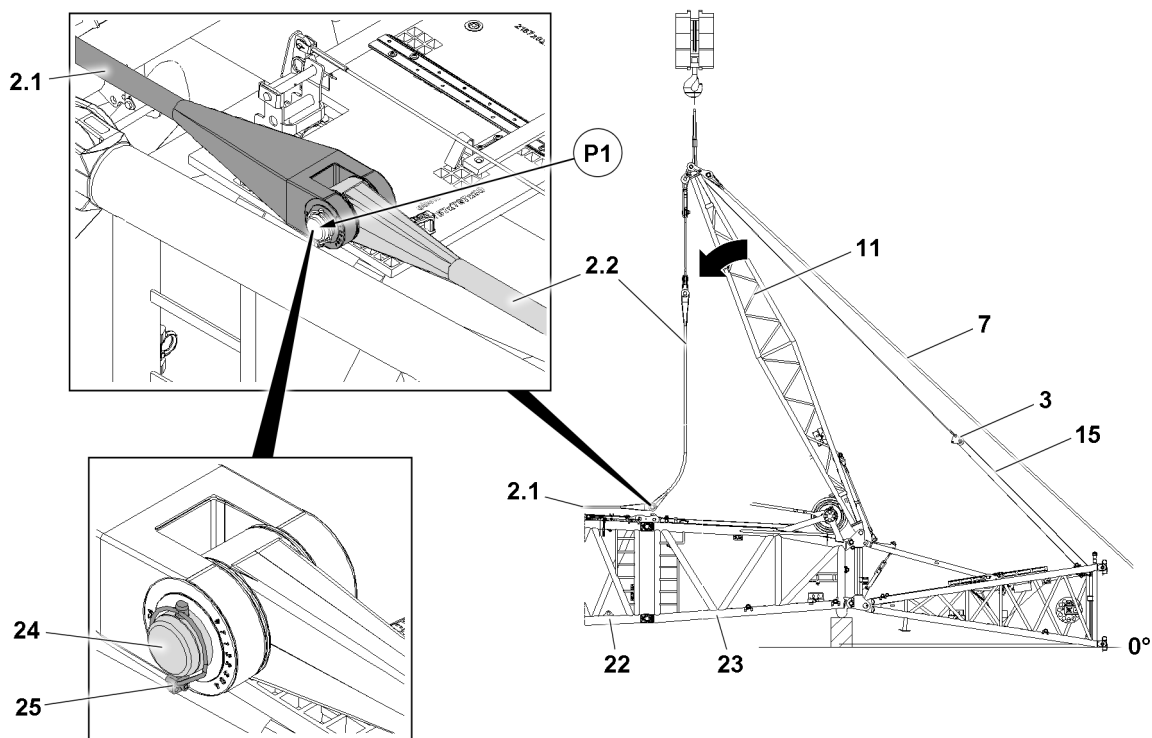


Fig. 156350: Pinning the FAB-guy ropes

2.1	FAB-guy ropes (intermediate section)	15	Assembly winch rope
2.2	FAB-guy ropes (FA-frame)	22	Intermediate section
3	Rope pulley retainer	23	F-connector head (or: L-end section)
7	F-guy ropes	24	Pin
11	FA-frame	25	Retaining element



#### WARNING

Swinging of the FA-frame **11**!  
Crushing of limbs.  
► Maintain the safety distance.

#### NOTICE

Swinging the FA-frame **11** in the direction of the main boom!  
Property damage to the FA-frame **11**, the F-connector head (or: L-end section) **23** as well as the rope pulley retainer **3**  
► Make sure that a guide supervises the swinging process of the FA-frame **11**.  
► Make sure that the guide is constantly in visual and acoustic contact with the crane operator.  
► Maintain the safety distance.  
► Make sure that the assembly winch rope **15** is spooled out during the swinging process of the FA-frame **11**.

#### NOTICE

F-guy rope **7** **not** guided!  
Damage to components.

When the FA-frame is erected:

► Make sure that the F-guy ropes **7** are guided.



- ▶ Until the FAB-guy ropes can be pinned in position **P1**: Carefully swing the FA-frame **11** with the auxiliary crane in direction of the main boom and spool out the assembly winch rope **15** at the same time.
- ▶ Make sure that the FAB-guy ropes are assembled according to the rod plan.
- ▶ Align the FAB-guy ropes **2.1** and FAB-guy ropes **2.2** such that the FAB-guy ropes can be pinned.
- ▶ Pin the FAB-guying FAB-guy rope **2.1** with the FAB-guying **2.2**: Insert the pin **24** and secure with the retaining element **25**.
- ▶ Pin the FAB-guy ropes on the opposite side the same way as described before and secure with the retaining element.

### 3.3.21 Putting the FA-frame in the operating position

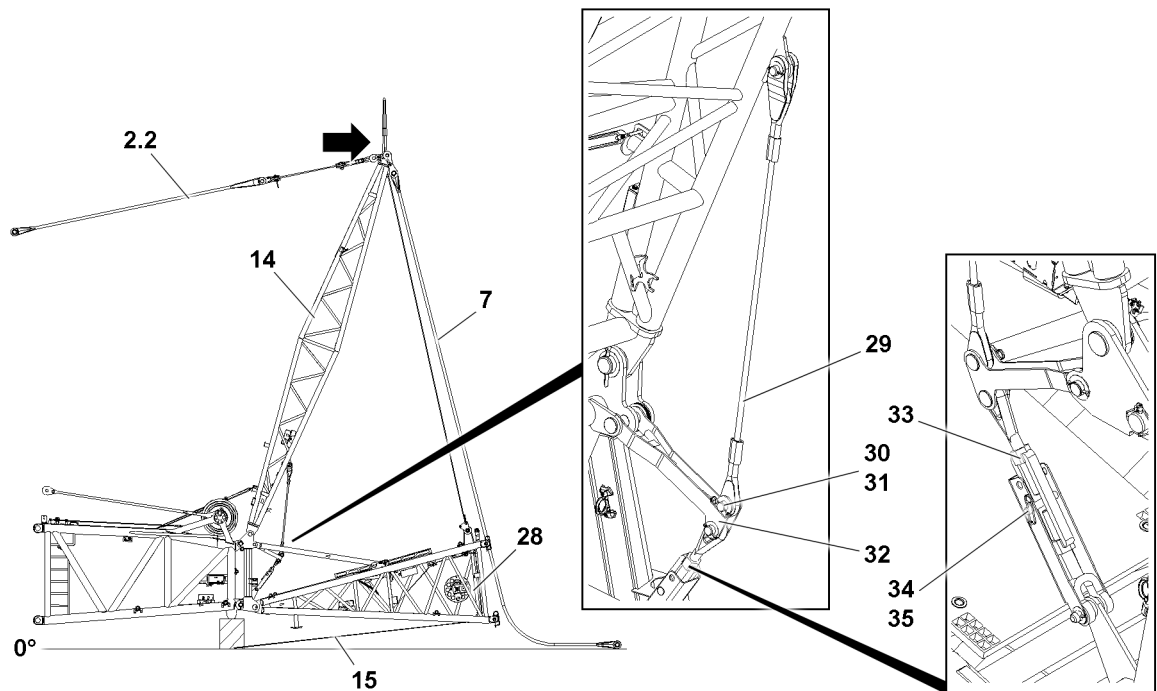


Fig.156558: Bringing the FA-frame into the operating position

2.2	FAB-guy rope	30	Pin
7	F-guy ropes	31	Retaining element
14	FA-frame	32	FA-frame relapse retainer
15	Assembly winch rope	33	Turnbuckle
28	F-pivot section	34	Pin
29	Guy rope	35	Retaining element

Make sure that the following prerequisite is met:

- The FAB-guy ropes are properly pinned and secured.

#### NOTICE

F-guy rope **7** **not** guided!  
Damage to components.

When the FA-frame is erected:

- ▶ Make sure that the F-guy ropes **7** are guided.



#### WARNING

Swinging of the FA-frame **14**!  
Crushing of limbs.

- ▶ Maintain the safety distance.

**NOTICE**

Swinging of the FA-frame **14**!

Damage to crane components.

- ▶ Make sure that a guide supervises the swinging process of the FA-frame **14**.
  - ▶ Make sure that the guide is constantly in visual and acoustic contact with the crane operator.
- 
- ▶ Until the FAB-guy ropes **2.2** are tensioned: Pull the FA-frame **14** with the assembly winch rope **15** in direction of the F-pivot section **28**.

**Result:**

- Assembly variation V1: The F-pivot section **28** moves up.
- V2 flying assembly: The F-pivot section **28** remains in a horizontal position.

For assembly of the guy rope **29**: Climb onto the grating on the F-pivot section **28**.

- ▶ Pin the guy rope **29** with the FA-frame relapse retainer **32**.
- ▶ Insert the pin **30** and secure with the retaining element **31**.

When the FA-frame relapse retainer **32** is properly pinned and secured:

- ▶ Tighten the turnbuckle **33**.
- ▶ Secure the turnbuckle **33** with the pin **34** and retaining element **35** to prevent it from twisting.

**Result:**

- The turnbuckle **33** is secured to prevent it from twisting during crane operation.
- The FA-frame **14** is fixed in the operating position.

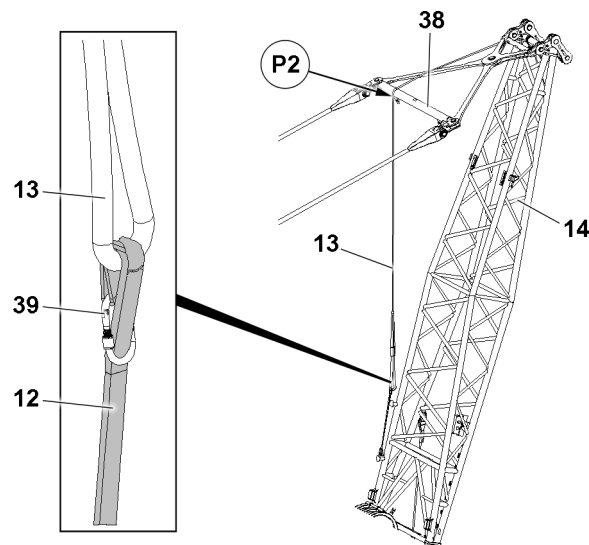
**3.3.22 Fixing the fastening rope to the FA-frame**

Fig.156568: Fixing the fastening rope to the FA-frame

<b>12</b>	Round sling	<b>38</b>	Rocker
<b>13</b>	Fastening rope	<b>39</b>	Snap hook
<b>14</b>	FA-frame		

**NOTICE**

Unsecured fastening rope **13**!

If the fastening rope **13** is **not** properly secured, then the fastening rope **30** can remain hanging on the crane components during crane operation.

The fastening rope **13** will be damaged.

- ▶ Make sure that the fastening rope **13** is secured to the FA-frame **14** before starting to work with the crane.
- 
- ▶ Put the fastening rope **13** in position **P2** over the rocker **38**.

- ▶ Until the fastening rope **13** is hanging vertically: Lower the fastening rope **13**.
- ▶ Remove the fastening rope **13** from the auxiliary crane.

**WARNING**

The fastening rope **13** is fixed in an impermissible manner!  
Damage to the fastening rope, round sling and crane components. Falling of damaged parts.

- ▶ Connect the round sling **12** as a loop to the fastening rope **13**.
  - ▶ Secure the loop with the snap hook **39** to the round sling **12**.
  - ▶ Assemble the strand from the fastening rope **13**, snap hook **39** and round sling **12** with the maximum possible length.
- 
- ▶ Fix the fastening rope **13** to the FA-frame **14**: Fasten the round sling **12** with the carabiner **39** to the fastening rope **13**.

### 3.3.23 Pinning the rope pulley retainer to the FA-frame

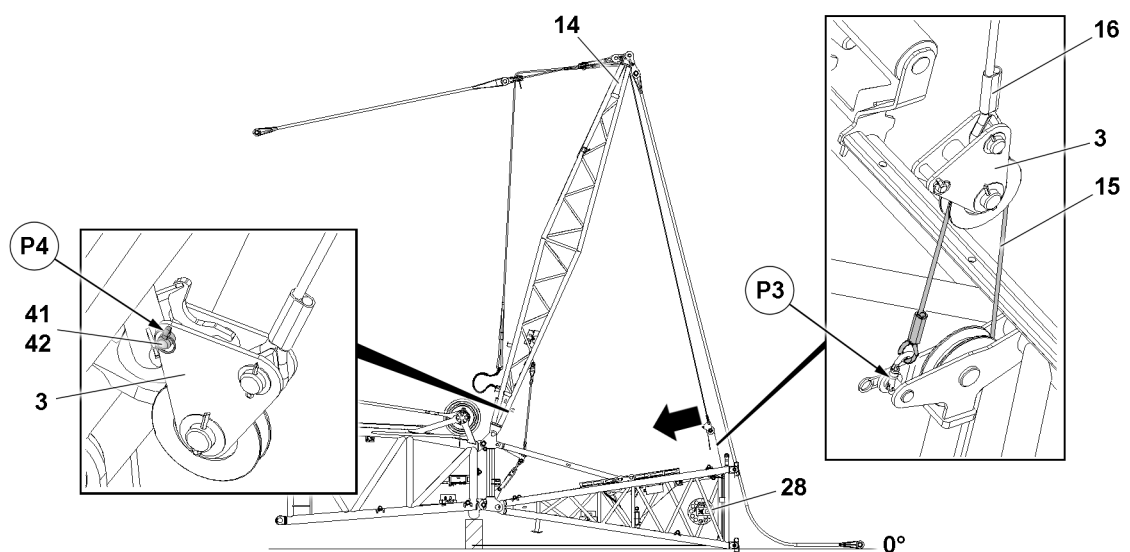


Fig.156559: Pinning the rope pulley retainer to the FA-frame

<b>3</b>	Rope pulley retainer	<b>28</b>	F-pivot section
<b>14</b>	FA-frame	<b>41</b>	Pin
<b>15</b>	Assembly winch rope	<b>42</b>	Retaining element

**WARNING**

Take the F-pivot section **28** down onto the ground!  
Crushing of limbs.

- ▶ Maintain the safety distance.
- 
- ▶ Until the F-pivot section **28** is lying on the ground: Spool the assembly winch rope **15** out.
  - ▶ Until the assembly winch rope **15** can be reeved out: Spool the assembly winch rope **15** out.
  - ▶ Release the assembly winch rope **15** in position **P3** and reeve out on the rope pulley retainer **3**.

For assembly of the rope pulley retainer **3**: Climb onto the grating on the F-connector head (or: L-end section).

- ▶ Swing the rope pulley retainer **3** to the FA-frame **14** and pin in position **P4**.
- ▶ Insert the pin **41** and secure with the retaining element **42**.

### 3.3.24 Assembly variation V2 flying assembly: Inserting the F-relapse support pin in the park position

The assembly step applies only to assembly variation V2.

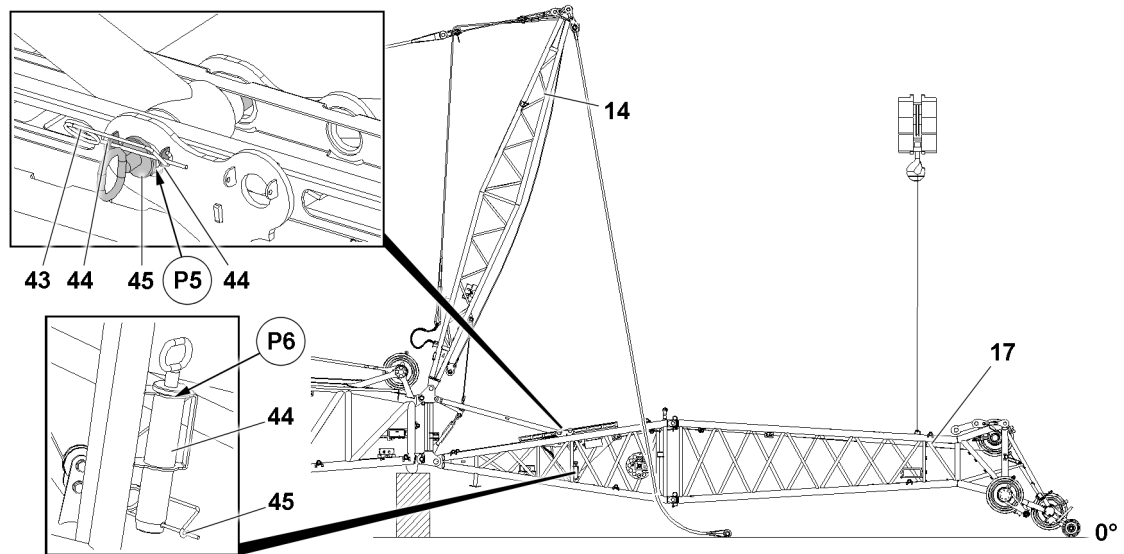


Fig.156573: Inserting the F-relapse support pin in the park position

14	FA-frame	44	Brackets
17	F-end section	45	Pin
43	Retaining element		

Make sure that the following prerequisites are met:

- The FA-frame **14** is in the operating position.
  - The FAB-guy ropes are assembled.
  - The FA-relapse retainer is closed.
  - The F-guy ropes are assembled.
- ▶ Fasten the F-end section **17** to the auxiliary crane.
  - ▶ Until the pin **45** is relieved: Lift the F-jib.
  - ▶ Release the pin **45** out of the transport position **P5**: Remove the retaining element **43** and unpin the pin **45**.
  - ▶ Insert the pin **45** in the park position **P6** and secure to the brackets **44** with the retaining element **43**.
  - ▶ Take the L-end section **17** down onto the ground.

### 3.3.25 Assembly variation V1: Inserting the F-relapse support pin in the park position

The assembly step applies only to assembly variation V1.

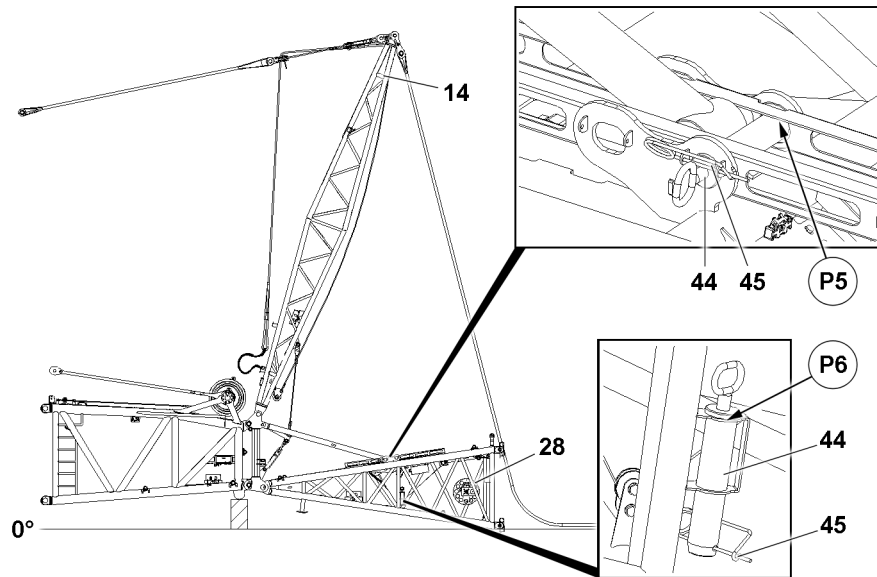


Fig. 156560: Inserting the F-relapse support pin in the park position

14	FA-frame	44	Pin
28	F-pivot section	45	Retaining element

Make sure that the following prerequisite is met:

- The FA-frame **14** is in the operating position.
- ▶ Release the pin **44** out of the fastening position **P5**: Remove the retaining element **45** and unpin the pin **44**.
- ▶ Insert the pin **44** in the park position **P6** and secure with the retaining element **45**.

### 3.3.26 Assembly variation V1: Assembling the F-jib 12 m

The assembly step applies only to assembly variation V1.

Make sure that the following prerequisites are met:

- The F-end section is available.
- ▶ Make sure that the F-lattice jib is assembled according to the rod plan.

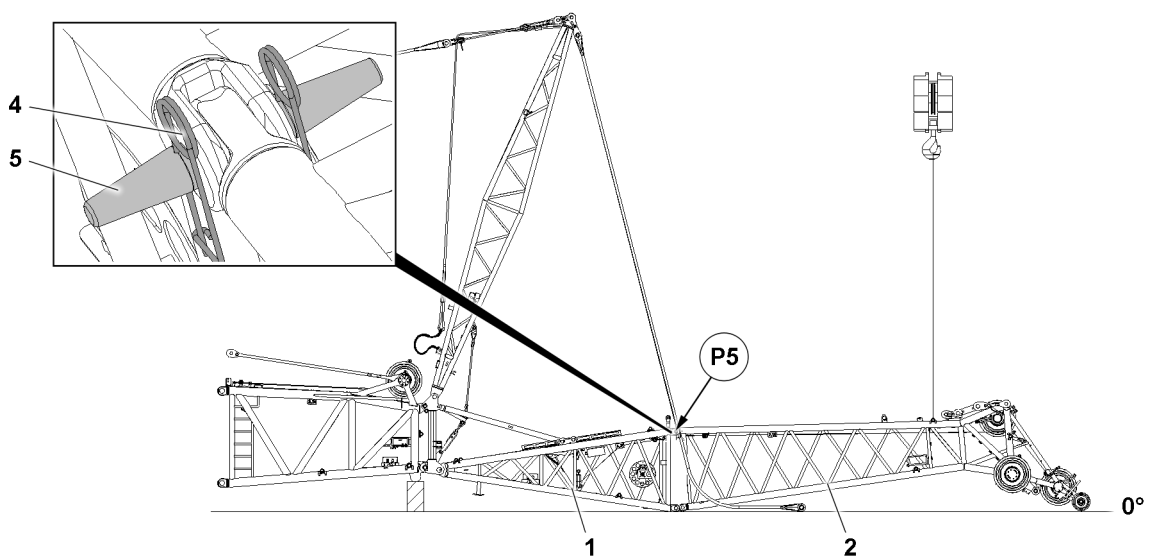


Fig. 156578: Pinning the F-end section on the F-pivot section

1	F-pivot section	4	Retaining element
2	F-end section	5	Pin

The F-end section **2** is pinned in four pin points on the F-pivot section **1**. Every pin point is present on both sides of the component on one level.

- ▶ Fasten the F-end section **2** to the auxiliary crane.
- ▶ Position the F-end section **2** on the F-pivot section **1**.
- ▶ Both sides in position **P5**: Insert the pin **5** and secure with the retaining element **4**.

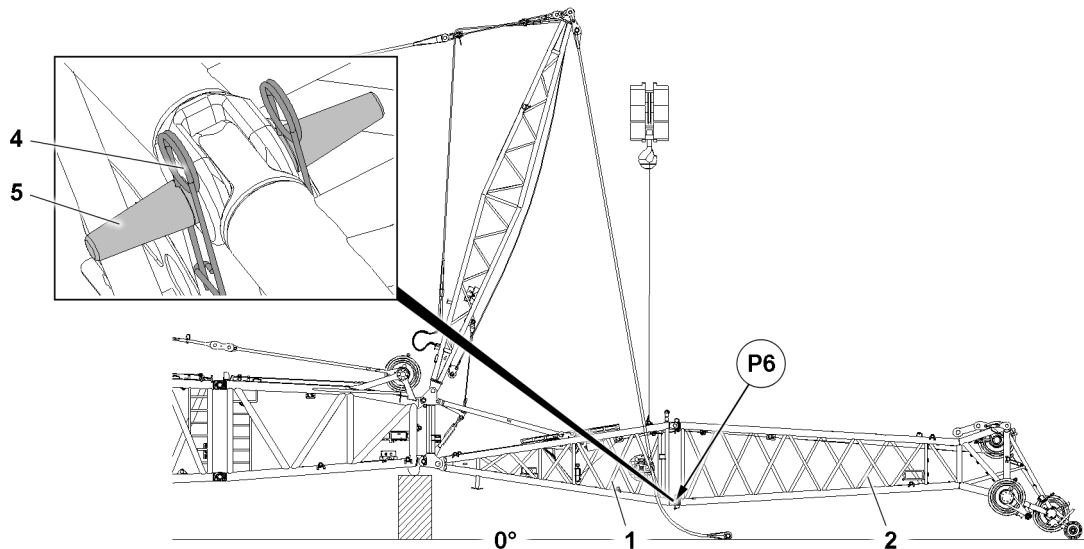


Fig.156576: Closing the F-jib 12 m

- |          |                 |          |                   |
|----------|-----------------|----------|-------------------|
| <b>1</b> | F-pivot section | <b>4</b> | Retaining element |
| <b>2</b> | F-end section   | <b>5</b> | Pin               |

- ▶ Fasten the F-pivot section **1** to the auxiliary crane.
- ▶ Close the F-jib 12 m: Lift the F-pivot section **1** carefully until the pin points align in position **P6**.
- ▶ Both sides in position **P6**: Insert the pin **5** and secure with the retaining element **4**.
- ▶ Remove the auxiliary crane.

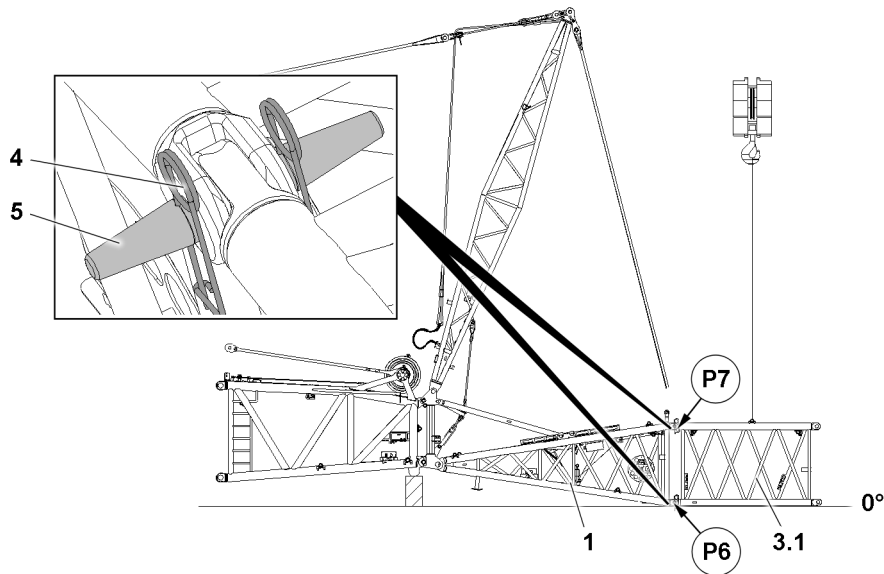
### 3.3.27 Assembly variation V1: Assembling the F-jib, larger than 12 m

The assembly step applies only to assembly variation V1.

Make sure that the following prerequisites are met:

- The required F-lattice sections are available.
- ▶ Make sure that the F-lattice jib is assembled according to the rod plan.

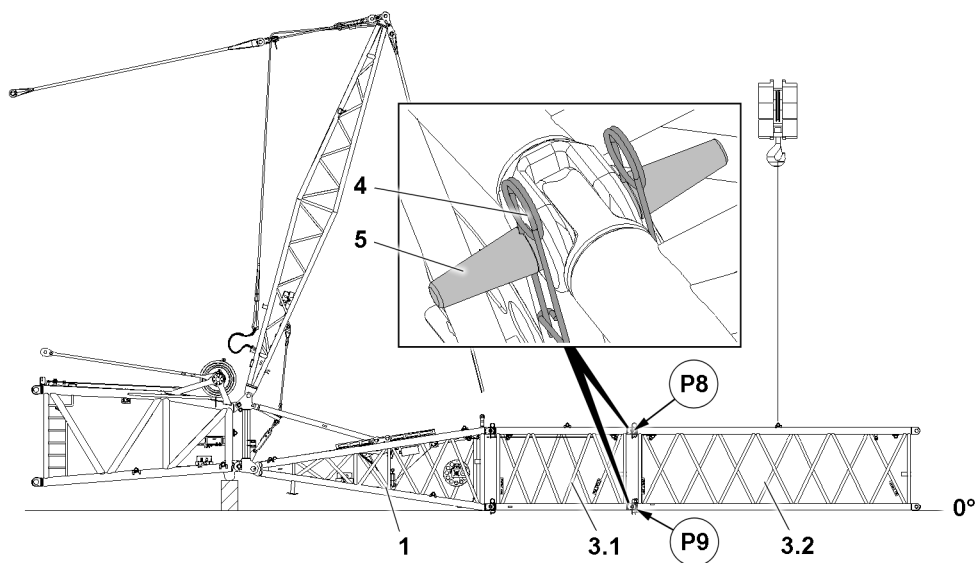
The illustrations in this section refer as an example to an F-jib with two F-intermediate sections.



*Fig.156886: Pinning the F-intermediate section on the F-pivot section*

- |     |                        |   |                   |
|-----|------------------------|---|-------------------|
| 1   | F-pivot section        | 4 | Retaining element |
| 3.1 | F-intermediate section | 5 | Pin               |

- ▶ Fasten the F-intermediate section 3.1 to the auxiliary crane.
- ▶ Position the F-intermediate section 3.1 on the F-pivot section 1.
- ▶ Both sides in position P7: Insert the pin 5 and secure with the retaining element 4.
- ▶ Both sides in position P6: Insert the pin 5 and secure with the retaining element 4.



*Fig.156878: Assembling the F-intermediate sections*

- |     |                        |   |                   |
|-----|------------------------|---|-------------------|
| 1   | F-pivot section        | 4 | Retaining element |
| 3.1 | F-intermediate section | 5 | Pin               |
| 3.2 | F-intermediate section |   |                   |

If additional intermediate sections must be assembled:

- ▶ Position the F-intermediate section 3.2 on the F-intermediate section 3.1.
- ▶ Both sides in position P8: Insert the pin 5 and secure with the retaining element 4.
- ▶ Both sides in position P9: Insert the pin 5 and secure with the retaining element 4.

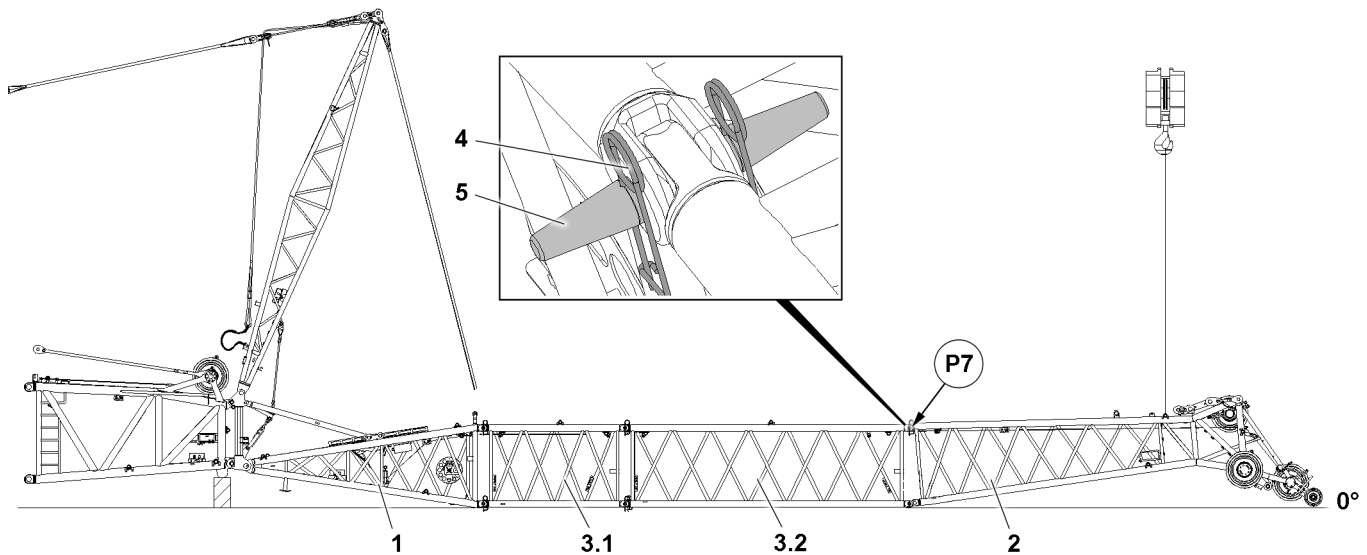


Fig.156875: Pinning the F-end section

- |   |                 |     |                        |   |                   |
|---|-----------------|-----|------------------------|---|-------------------|
| 1 | F-pivot section | 3.1 | F-intermediate section | 4 | Retaining element |
| 2 | F-end section   | 3.2 | F-intermediate section | 5 | Pin               |

- ▶ Fasten the F-end section 2 to the auxiliary crane.
- ▶ Position the F-end section 2 on the F-intermediate section 3.2.
- ▶ Both sides in position P7: Insert the pin 5 and secure with the retaining element 4.

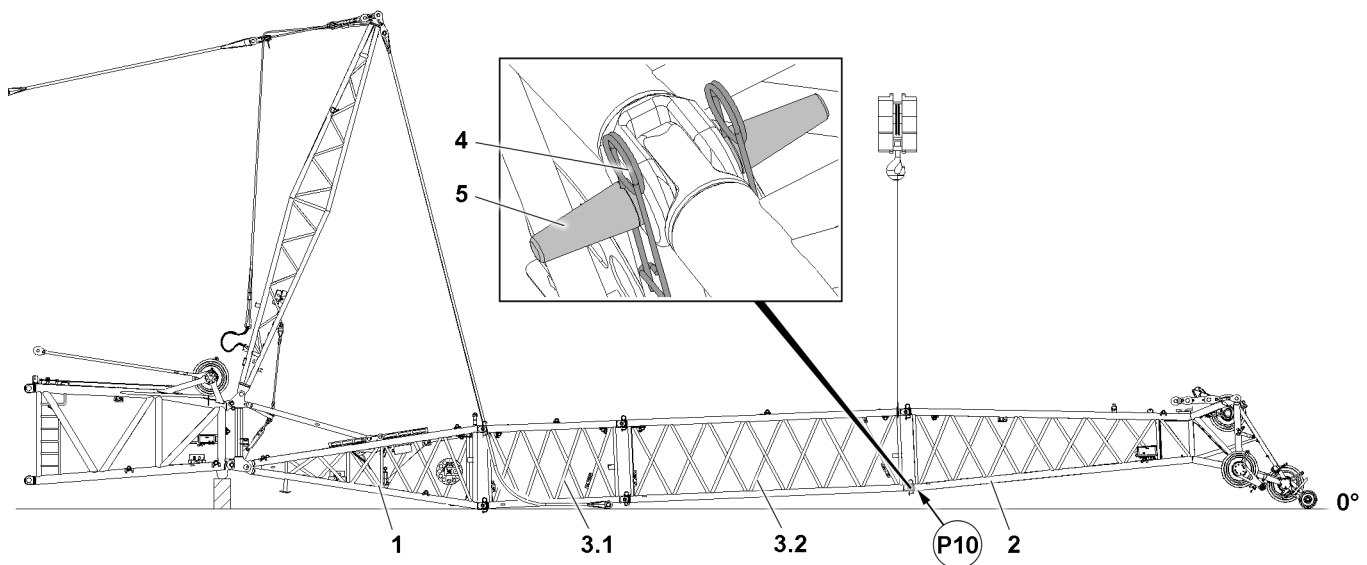


Fig.156580: Close the F-jib: Pinning the F-end section

- |   |                 |     |                        |   |                   |
|---|-----------------|-----|------------------------|---|-------------------|
| 1 | F-pivot section | 3.1 | F-intermediate section | 4 | Retaining element |
| 2 | F-end section   | 3.2 | F-intermediate section | 5 | Pin               |

- ▶ Fasten the F-intermediate section 3.2 to the auxiliary crane.
- ▶ Until the pin points align in position P10: Lift the F-intermediate section 3.2 carefully.
- ▶ Both sides in position P10: Insert the pin 5 and secure with the retaining element 4.
- ▶ Remove the auxiliary crane.



### 3.3.28 Assembling the F-guying



#### WARNING

Impermissible pull brackets and guy ropes!  
The crane can topple over. Death.

- ▶ Assemble the specific pull brackets and F-guy ropes in accordance with the rod plan.

When the F-intermediate sections are assembled:

- ▶ Assemble additional guy rods.

The F-guying combination depends on:

- F-jib assembly length
- F-jib operating angle

#### Checking the pull brackets

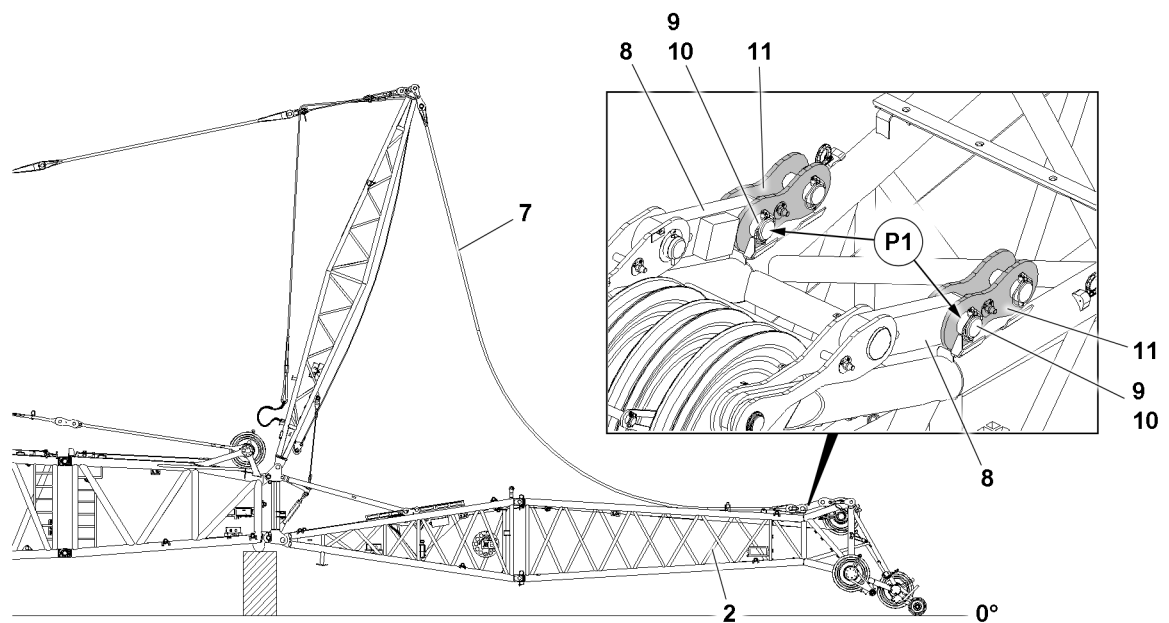


Fig.156569: F-guying: Checking the pull brackets

<b>2</b>	F-end section	<b>9</b>	Pin
<b>7</b>	F-guying	<b>10</b>	Retaining element
<b>8</b>	Pull test bracket	<b>11</b>	Pull bracket

The angle of the fixed jib is reached using different pull brackets.

- ▶ Check the pull brackets **11** assembled on the F-end section **2** with the specifications in the rod plan.

If the rod plan indicates other pull brackets:

- ▶ Unpin the pull brackets **11**: Remove the retaining element **10** and unpin the pin **9**.
- ▶ Remove the pull brackets **11**.
- ▶ Make sure that the combination of the assembled F-guying **7** matches the rod plan.
- ▶ Position the first pull bracket **11** with the auxiliary crane on the pull test bracket **8**.
- ▶ Insert the pin **9** in point **P1** and secure it with the retaining element **10**.
- ▶ Position and pin the second pull bracket **11** in the same way on the second pull test bracket **8** and secure with the retaining element **10**.

### Assembling the F-guy ropes

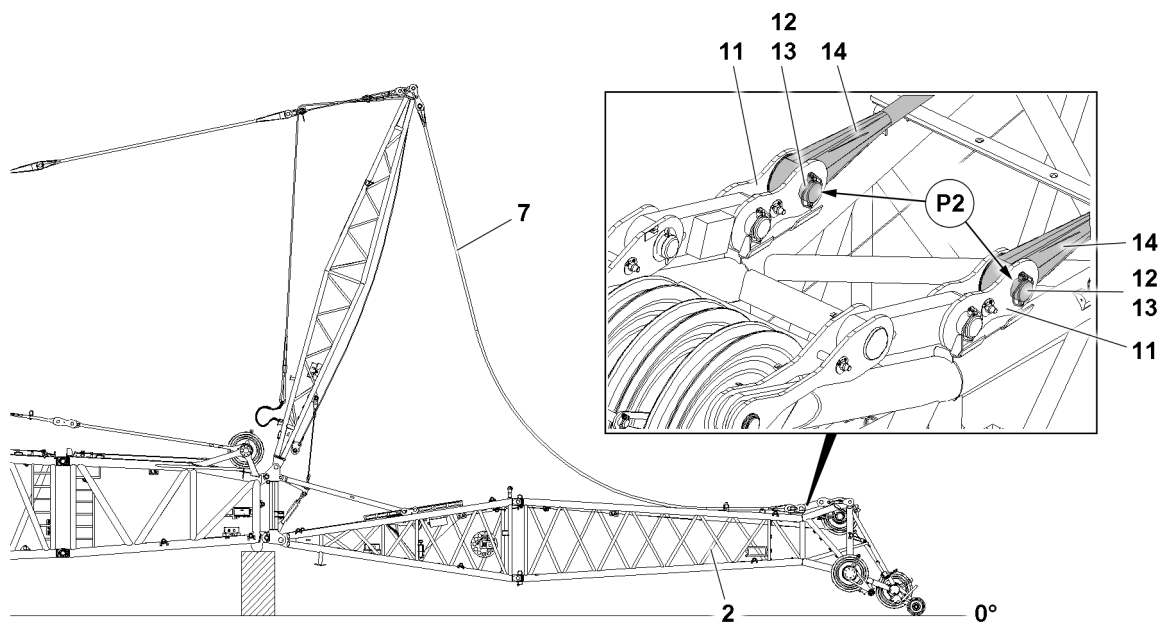


Fig.156563: Assembling the F-guy ropes

2	F-end section	12	Pin
7	F-guying	13	Retaining element
11	Pull bracket	14	F-guy rope

Make sure that the following prerequisites are met:

- The required pull brackets **11** are assembled according to the rod plan on the pull test bracket **8**.
- ▶ Make sure that the combination of the assembled F-guying **7** matches the rod plan.

Assemble the F-guy ropes **14**: Example based on the pull bracket **11**.

- ▶ Until pinning is possible: Position the F-guy rope **14** on the pull bracket **11**.
- ▶ Insert the pin **12** in point **P2** and secure it with the retaining element **13**.
- ▶ Position and pin the second F-guy rope **14** in the same way and secure with the retaining element **13**.

### 3.3.29 Assembly variation V1: Pulling the flap with the rope winch into the “flap down” position

The assembly step applies only to assembly variation V1.

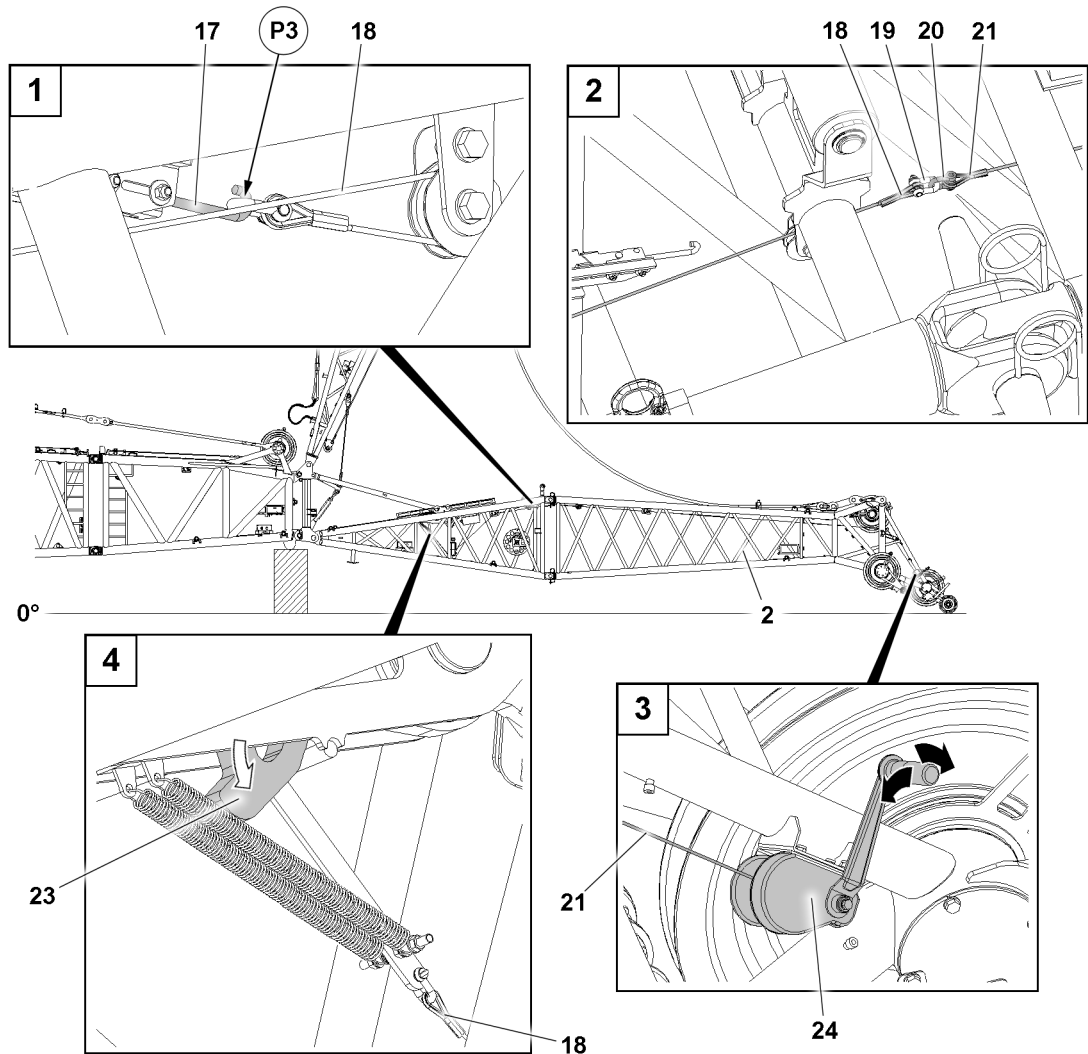


Fig.156564: Pulling and fixing the flap in the “flap down” position

2	F-end section	20	Shackle
17	Hook closure	21	Control rope
18	Control rope	23	Flap
19	Shackle	24	Manual rope winch

The control rope 18 is the flap 23 rope.

- ▶ Detach the control rope 18 from the hook closure 17 in point P3.

The control rope 21 is the manual rope winch 24 rope.

- ▶ Fasten the control rope 18 with the shackle 19 to the shackle 20 of the control rope 21.
- ▶ To the stop: Pull the flap 23 with the aid of the manual rope winch 24 “downward”.

### 3.3.30 Pulling the flap with the rope winch into the “flap up” position

Make sure that the following prerequisites are met:

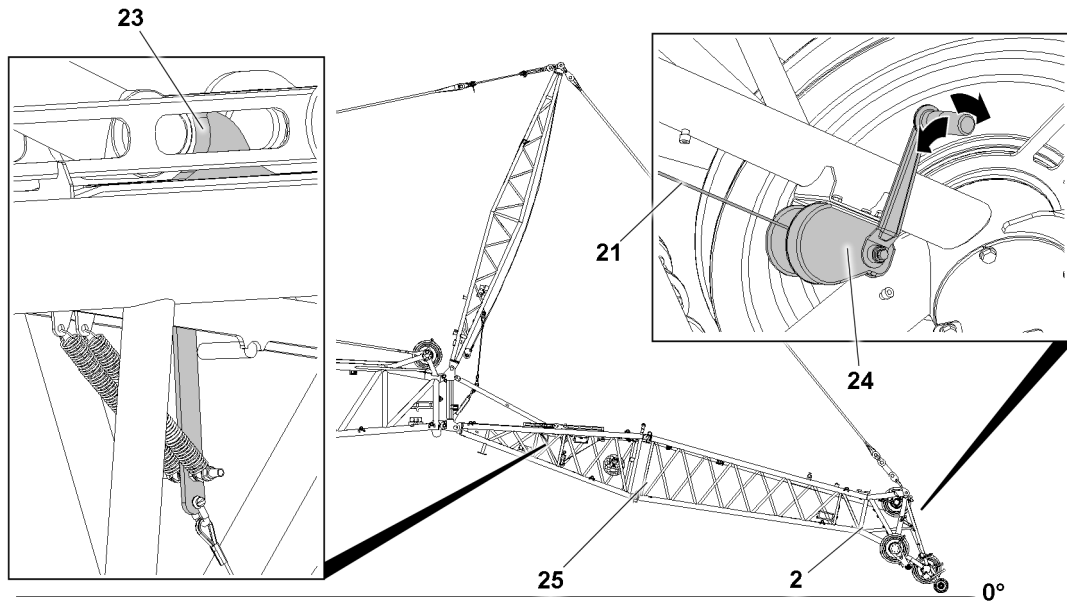


Fig.156565: Flap in the operating position

- |           |               |           |                   |
|-----------|---------------|-----------|-------------------|
| <b>2</b>  | F-end section | <b>24</b> | Manual rope winch |
| <b>21</b> | Control rope  | <b>25</b> | F-jib             |
| <b>23</b> | Flap          |           |                   |



#### WARNING

Temperatures below 0 °C: Fiber guy ropes that are rigidly frozen or covered with ice!  
Buckling of the fiber guy ropes. The fiber guy ropes can rip.  
Death, severe bodily injuries, property damage.

- ▶ While erecting the boom system, check if the fiber guy ropes are rigidly frozen or covered with ice.
- ▶ Do **not** bend fiber guy ropes that are rigidly frozen or covered with ice.
- ▶ Do **not** erect boom systems with fiber guy ropes that are rigidly frozen or covered with ice (for example auxiliary guying, guying for the F-jib).
- ▶ Observe the instructions in chapter 5.01.



#### WARNING

Impermissible flap position!

If the flap **23** is **not** in the “top” operating position, the F-jib **25** can fall down uncontrollably when erecting the boom system and during crane operation.  
Death, severe bodily injuries, property damage.

- ▶ Make sure that the flap **23** is in the “top” operating position immediately before lifting the F-end section **2** or when erecting the boom.
- 
- ▶ Until the F-end section **2** is lifted off the ground: Lift the main boom.
  - ▶ Until the flap **23** is in the “top” operating position: Spool the control rope **21** out with the manual rope winch **24**.

### 3.3.31 Positioning the adjustable end pulley

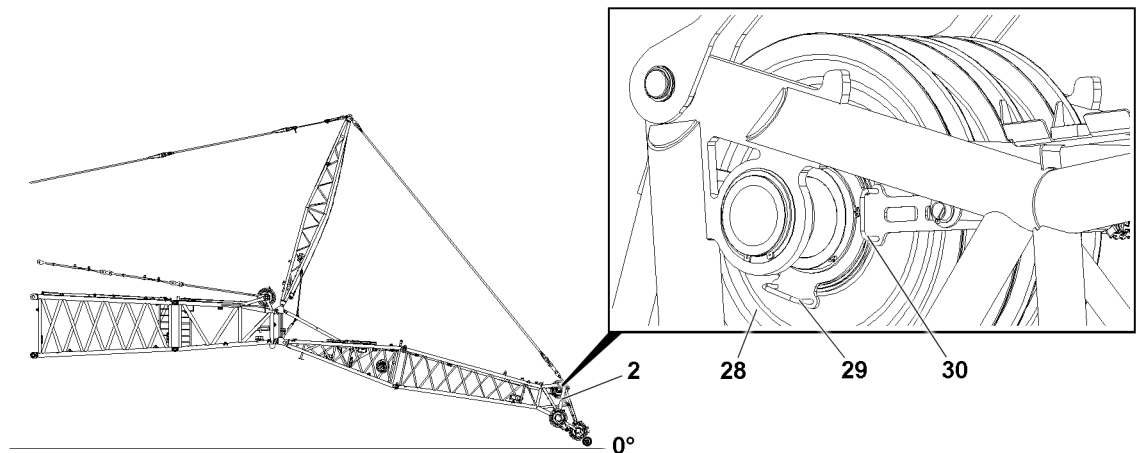


Fig.156570: F-end section, adjustable end pulley

2	F-end section	29	Handle
28	End pulley	30	Handle

The required position of the end pulley **28** depends on the reeving, see the reeving plan.

- ▶ Adjust the end pulley **28**: Move the end pulley **28** with the handle **29** and handle **30** to the required position.

### 3.3.32 Pulling the hoist rope in

Make sure that the following prerequisites are met:

- The adjustable end pulley is positioned.
- The hook block is **not** assembled.



#### WARNING

Running rope!  
Crushing of limbs.

- ▶ Maintain the safety distance.

- ▶ Pull in the assembly winch rope according to the reeving plan in the opposite direction on the F-jib and main boom.
- ▶ Remove the rope guard rods from all rope pulleys.

The assembly winch rope must be connected with the hoist rope on the turntable.

- ▶ Connect the assembly winch rope via the screw connecting link with the rope release clamp to the hoist rope.
- ▶ Until the hoist rope is pulled in on the roller set to the F-end section: Spool the hoist winch out and spool the assembly winch up at the same time.

If additional hoist ropes are pulled in:

- ▶ Pull in the hoist rope in the same way.
- ▶ Disconnect the assembly winch rope from the hoist rope and spool up carefully.
- ▶ Pin and secure the rope guard rods to all rope pulleys.

### 3.3.33 Establishing the electrical connections

Make sure that the following prerequisites are met:

- The F-jib is completely assembled.
- The airplane warning light and the wind speed sensor are assembled.

**NOTICE**

Damage to the electrical connection on the cable drum!

If the electrical connection from the cable drum on the F-pivot section to the terminal box on the L-end section or on the F-connector head is established first before the connection to the terminal box on the F-end section, the electrical connection can be damaged when spooling out the cable drum.

- ▶ Establish first the electrical connection from the cable drum on the F-pivot section to the terminal box on the F-end section and then the electrical connection from the terminal box on the F-connector head or on the L-end section to the cable drum on the F-pivot section.

**Note**

- ▶ Establish the electrical connections to the F-jib, see the wiring diagram.

- ▶ Establish the electrical connections.
- ▶ Make sure that all electrical connections on the boom are established.

### 3.3.34 Checking the function of the safety equipment

**WARNING**

Malfunctioning safety equipment!

Death, severe bodily injuries, property damage.

- ▶ Crane operation with non-functioning safety equipment is **prohibited**.

**Note**

- ▶ The function of the individual limit switches must be checked before erection of the boom system.
- ▶ The function of the limit switch initiators must be checked in the test system, see the “Diagnostics manual”.

**Note**

- ▶ If a function check on the limit switches or on the safety equipment does not lead to the desired shut-offs, then the plug connections on the connector boxes or the components itself must be checked. If no visible connection errors or component defects can be found, contact **Liebherr** Customer Service.

Make sure that the following prerequisites are met:

- All electrical connections have been established.
- The crane engine is running.
- The corresponding operating mode is set on the LICCON monitor.

#### Checking the wind speed sensor

- ▶ Check the movement and the function of the wind speed sensor.

#### Checking the airplane warning light

- ▶ Turn on the airplane warning light in the crane cab, see chapter 4.01.
- ▶ Check the function visually.

#### Relapse retainer: Checking the flap function

The limit switch functions have to be checked individually before erection.

- ▶ Cover the limit switch initiators individually with a metal plate.

**Result:**

- The movement is turned off.
- The icon appears on the LICCON monitor.
- The limit switch is functioning.

### Checking the hoist limit switch on the pulley head



#### Note

- ▶ When replacing or changing a hoist limit switch (HES), the corresponding hoist limit switch must have the correct bus address and the correct software version in order to be detected again by the bus system (LSB).
- 
- ▶ Actuate the hoist limit switch manually on the pulley head.

#### Result:

- The spooling up of the hoist winch turns off.
- The “Hoist top” icon appears on the LICCON monitor 0.
- The limit switch is functioning.

### Checking the limit switches in general



#### Note

- ▶ The limit switch functions have to be checked individually before erection.
- ▶ To check the limit switches, see corresponding chapter.

## 4 Erecting the boom



#### WARNING

The crane can topple over!

For certain boom lengths, the mechanical auxiliary supports must be assembled, see the Erection and take-down charts.

Death, severe bodily injuries, property damage.

- ▶ Observe the specifications in the erection and take-down charts.



#### WARNING

The crane can topple over!

If the following conditions are not met before erecting the boom, the crane can topple over.

Death, severe bodily injuries, property damage.

- ▶ Observe the technical safety instructions, see chapter 5.01.
- ▶ Extend the relapse cylinder before erection.
- ▶ Do not allow slack rope to form on the control winch.



#### WARNING

Falling hoist rope!

If the hoist rope before the erection procedure is not properly secured onto the end section, it can fall down backward on the basis of its own weight.

Death, severe bodily injuries, property damage.

- ▶ Secure the hoist rope properly on the end section before the erection procedure.

## 4.1 Erecting the boom

Make sure that the following prerequisites are met:

- The crane is horizontally aligned.
- All electrical connections are established.
- All limit switches are functioning.
- The central ballast is placed according to the data in the erection and take-down charts.
- The counterweight has been installed to the turntable according to the data in the erection and take-down charts.
- All pin connections are secured.
- The hoist rope has been correctly inserted in the rope pulleys and is prevented from jumping out with the rope retaining pins.
- There are no loose parts on the boom.
- The LICCON overload protection has been set according to the data in the load chart.
- The LICCON overload protection settings have been compared with the actual set up configuration.
- The LICCON overload protection is exceeded.
- The assembly icon is visible on the LICCON monitor.

### 4.1.1 Erection procedure



#### WARNING

The crane can topple over!  
Death, severe bodily injuries, property damage.

- ▶ It is prohibited to turn the crane superstructure while erecting the boom.
- ▶ The specifications in the erection and take-down charts must be observed.



#### WARNING

Temperatures below 0 °C: Fiber guy ropes that are rigidly frozen or covered with ice!  
Buckling of the fiber guy ropes. The fiber guy ropes can rip.  
Death, severe bodily injuries, property damage.

- ▶ While erecting the boom system, check if the fiber guy ropes are rigidly frozen or covered with ice.
- ▶ Do **not** bend fiber guy ropes that are rigidly frozen or covered with ice.
- ▶ Do **not** erect boom systems with fiber guy ropes that are rigidly frozen or covered with ice (for example auxiliary guying, guying for the F-jib).
- ▶ Observe the instructions in chapter 5.01.

### Reeving the hook block in

Make sure that the following prerequisites are met:

- The crane is horizontally aligned.
- The slewing gear brake is applied.



#### WARNING

Danger of accident due to side wind!

If the slewing gear brake is released after reeving in / reeving out the hook block / load hook, then the crane can turn uncontrolled in strong side wind.

Death, severe bodily injuries, property damage.

The crane can collide with near-by structures or objects.

- ▶ Make sure that the current wind speed does not exceed the values from the wind speed chart when releasing the slewing gear brake.
- ▶ Luff the boom up until the hook block can be reeved in.
- ▶ Reeve in the hook block properly, see chapter 4.06 and the separate reeving plans.
- ▶ Properly secure the hoist rope to the rope fixed point, see chapter 4.06.
- ▶ Attach the hoist limit switch weight, see chapter 4.06.



### Erecting the boom



#### **DANGER**

The crane can topple over!

Death, severe bodily injuries, property damage.

- ▶ The boom radii specified in the load chart may not be exceeded or fallen below, even if there is no load on the hook.



#### **Note**

- ▶ When the “lowest” operating position of the boom is reached, the set load chart of the LICCON overload protection is activated.
- ▶ The maximum load icon displays a load number in “t” instead of the “???” display.

- ▶ Until the “lowest” operating position is reached: Luff the boom up and spool the hoist rope out.

When the boom has reached the “lowest” operating position:

- ▶ Make sure that the assembly icon on the LICCON monitor turns off.

#### **Result:**

- The LICCON overload protection is active.

## 5 Operating the crane

### 5.1 Preparing for crane operation



#### **Note**

- ▶ Observe the notes, see chapter 4.05, chapter 4.08 and chapter 5.01.

Make sure that the following prerequisites are met:

- The LICCON overload protection is active.
- The LICCON overload protection has been set according to the data in the load chart.



#### **WARNING**

The crane can topple over!

Death, severe bodily injuries, property damage.

- ▶ Check the horizontal position of the crane before and during crane operation.
- ▶ If the crane operator leaves the crane cab, even for a short time, the operating mode setting must be checked and reset, if necessary, before resuming crane operation.

### 5.2 Checking the settings

- ▶ Check the function of the overload protection by running against the operating positions “on top” and “bottom”.
- ▶ Check the hoist limit switch by running against the hoist limit switch weight.

When the overload protection and hoist limit switch function:

- ▶ Luff the boom into the operating position.

## 6 Taking the boom down



### WARNING

The crane can topple over!

If the following conditions are not met before taking down the boom, the crane can topple over. Death, severe bodily injuries, property damage.

- ▶ Observe the technical safety instructions, see chapter 5.01.
- ▶ Observe the specifications in the erection and take-down charts.

### NOTICE

Damage to the boom components!

Taking down the boom system can lead to a collision between the hook block and the pulley head. The boom components can be severely damaged.

- ▶ Luff the boom system down at the same time and spool the hoist winch out.



### WARNING

Temperatures below 0 °C: Fiber guy ropes that are rigidly frozen or covered with ice!

Buckling of the fiber guy ropes. The fiber guy ropes can rip.

Death, severe bodily injuries, property damage.

- ▶ While taking down the boom system, check if the fiber guy ropes are rigidly frozen or covered with ice.
- ▶ Do **not** bend fiber guy ropes that are rigidly frozen or covered with ice.
- ▶ Do **not** take down boom systems with fiber guy ropes that are rigidly frozen or covered with ice (for example auxiliary guying, guying for the F-jib).
- ▶ Observe the instructions in chapter 5.01.

### 6.1 Prerequisites for taking down the boom

Make sure that the following prerequisites are met:

- The incline of the base and travel route of the crawler travel gear is  $0^\circ \pm 0.3^\circ$ .
- The base and travel route have a sufficient load bearing capacity.
- The main boom is luffed down to the “lowest” operating position.
- The LICCON overload protection has been set according to the data in the load chart.
- The LICCON overload protection is exceeded.
- The assembly icon is visible on the LICCON monitor.
- All unnecessary function keys and manual control levers are blocked on the radio remote control, see chapter 5.31 and chapter 6.08.
- An auxiliary crane is on hand.

### 6.2 Luffing the S-boom down



#### Note

- ▶ The luff down movement is turned off as soon as the “lowest” operating position is reached.
- ▶ When the “lowest” operating position of the S-boom is reached, the load display in the maximum load icon turns off and the “???” display appears instead of the load display.
- ▶ Alarm functions appear on the crane operating screen.

- ▶ Until the “lowest” operating position is reached: Luff the S-boom down.

#### Result:

- The luffing movement is turned off.
- The “STOP” icon appears on the LICCON monitor.
- The horn icon appears on the LICCON monitor.

**WARNING**

The crane can topple over!

In assembly operation the LICCON overload protection is deactivated.

In the event of deliberate improper use, the crane could collapse, the boom can break off or the crane can topple over.

Death, severe bodily injuries, property damage.

- ▶ Activate the assembly operation only when the consequences are known.
- ▶ Enter the set up configuration correctly into the LICCON computer system.
- ▶ Observe the erection / take down charts.
- ▶ Crane operation with deactivated LICCON overload protection is prohibited.
- ▶ In assembly operation only load torque reducing crane movements may be carried out until a permissible operating and load range.
- ▶ The crane operator carries complete and sole responsibility for his actions if the LICCON overload protection is deactivated.

When the boom has reached the “lowest” operating position:

- ▶ Activate assembly operation, see chapter 4.02.

**Result:**

- The LICCON overload protection is deactivated.
- The assembly icon appears on the LICCON monitor.
- ▶ At the same time, luff down the boom system and spool out the hoist winch until the hook block touches the ground.

When the hook block touches the ground:

- ▶ Properly take down / set down the hook block onto the floor or a suitable substructure.

When the hook block is properly set down:

- ▶ Disassemble the hoist limit switch weight.
- ▶ Reeve out the hook block, see chapter 4.06.
- ▶ Carefully spool the hoist rope up.
- ▶ Remove the hook block with the auxiliary crane.

### 6.3 Pulling the flap with the rope winch into the “flap down” position

Make sure that the following prerequisites are met:

- The hook block is reeved out and removed.
- The substructure for the main boom is prepared.

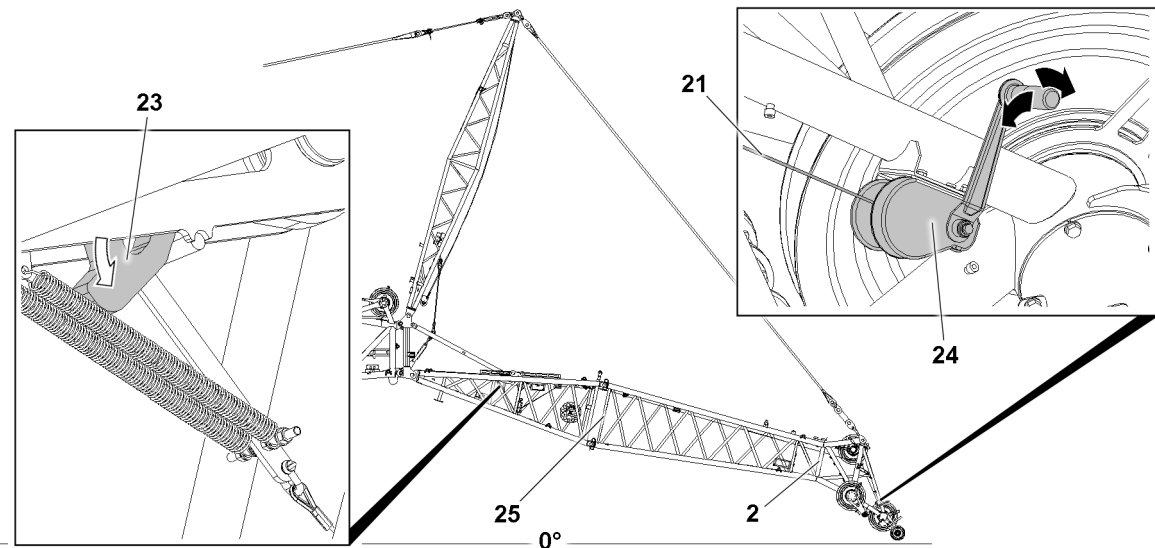


Fig.156574: Flap “down” position

- |           |               |           |                   |
|-----------|---------------|-----------|-------------------|
| <b>2</b>  | F-end section | <b>24</b> | Manual rope winch |
| <b>21</b> | Control rope  | <b>25</b> | F-jib             |
| <b>23</b> | Flap          |           |                   |

#### NOTICE

Careless take-down of the F-jib!  
Property damage!

- ▶ Make sure that the boom system is carefully luffed down at a slow speed.
  - ▶ When the F-jib comes into contact with the ground, carefully luff the boom system down further until the main boom lies on a load bearing substructure.
- 
- ▶ Until the F-end section **2** is in contact with the ground: Luff the main boom down carefully.



#### WARNING

The flap **23** is in the wrong position!  
Components are damaged when taking down the F-jib **25**.  
Death, severe bodily injuries, property damage.

- ▶ Make sure that the flap **23** is in the “down” position immediately before taking down the F-jib **25**.
- 
- ▶ Until the flap **23** is in the “down” position: Spool the control rope **21** up with the manual rope winch **24**.
  - ▶ Pull the flap **23** with the aid of the manual rope winch **24** “downward” to the stop.

During disassembly, the relapse support must be pinned in the transport position on the F-pivot section.

- ▶ Make sure that the substructure for the main boom is high enough.
- ▶ Take the main boom down onto the substructure.

## 7 Disassembling the F-jib



### WARNING

Danger of falling!

During assembly / disassembly, inspection and maintenance work, assembly personnel must be secured with appropriate aids to prevent them from falling.

Death, severe bodily injuries, property damage.

- ▶ All work at a height, when there is a danger of falling, must be carried out with suitable aids.
- ▶ If aids are not available and work cannot be carried out from the ground, then assembly personnel must secure themselves with the supplied fall arrest system to prevent falling, see chapter 2.04.
- ▶ If fall protection equipment is available, then it must be used, see chapter 2.06.
- ▶ When lifting, lowering, swinging crane parts in and out, no persons may remain in the danger zone.
- ▶ If railings are present on the components, then they must be brought into the corresponding position and secured for assembly / disassembly work.
- ▶ It is prohibited to lean the ladder against the component to be disassembled.
- ▶ Only step on the aids, ladders and catwalks with clean shoes.
- ▶ Keep aids, ladders and catwalks free of heavy dirt, snow and ice.
- ▶ During all assembly and disassembly work, maintenance work and inspections, travel or crane operation is prohibited.
- ▶ Remaining on a suspended load is prohibited.
- ▶ Stepping or walking on crane components and lattice sections with an incline of more than 20° is prohibited.
- ▶ For all assembly / disassembly work, the crane operator of the main crane must be in voice contact with the crane operator / crane operators of the auxiliary crane / auxiliary cranes.
- ▶ For assembly / disassembly work, the crane operator may only initiate crane movements when the responsible guide has explicitly released the movement.



### WARNING

Danger of impact / crushing!

When assembling / disassembling crane components with the auxiliary crane, crane components can start to swing back and forth.

When lifting / lowering and positioning crane components, there is an increased danger of impact / crushing.

Death, severe bodily injuries, property damage.

- ▶ Make sure that personnel cannot be caught by components.
- ▶ When working in a danger zone: Use aids to protect limbs.
- ▶ Guide components with suitable aids to minimize oscillation.



### WARNING

The component can fall down!

If the corresponding component is disengaged from the auxiliary crane before the corresponding component is pinned, then the corresponding component can fall down.

Death, severe bodily injuries, property damage.

- ▶ Do not disconnect the auxiliary crane until the respective component is pinned and secured.



### WARNING

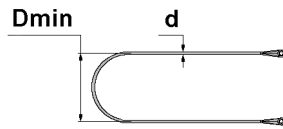
The lattice sections can fall down!

If the lattice sections are not pinned and secured correctly, then they can fall down.

Death, severe bodily injuries, property damage.

- ▶ Insert or unpin both pins on the same horizontal level, i.e. **left and right**.
- ▶ Do not stand under the lattice sections or within the entire danger zone during the boom pinning and unpinning procedure.
- ▶ Safely secure the pins in the storage locations as well as in the receptacles.
- ▶ It is prohibited to lean the ladder against the component to be disassembled.

Fiber guy ropes are used for the guying of the F-jib, see the rod plan. Comply with the following regulations.



$$D_{min} = 20 \times d$$

Fig.160908: Fiber guy rope: Calculation of minimum permissible bending diameter

Formula element	Meaning
Dmin	Minimum permissible bending diameter
d	Rope diameter

Minimum permissible bending diameter: Definition of the formula elements



### WARNING

Impermissible disassembly of fiber guy ropes!

The fiber guy ropes can be damaged.

Death, severe bodily injuries, property damage.

- ▶ Before disassembling the fiber guy ropes, check if the fiber guy ropes are rigidly frozen or covered with ice. See chapter 5.01.
- ▶ Do **not** disassemble fiber guy ropes that are rigidly frozen or covered with ice.
- ▶ Do **not** bend, knot or twist the fiber guy ropes.
- ▶ Never fall below the minimum permissible bending diameter **Dmin** of **20** x rope diameter **d**.
- ▶ Check the fiber guy ropes for damage prior to assembly, after disassembly and after exceptional events, see chapter 8.16.
- ▶ Comply with the maintenance intervals, see chapter 7.03.50.
- ▶ Replace damaged fiber guy ropes.
- ▶ Observe the notes regarding the proper transport and storage of the fiber guy ropes, see chapter 2.04.
- ▶ Observe the instructions for the proper handling of fiber guy ropes, see chapter 5.01.
- ▶ Only fasten the fiber guy ropes in the permissible range with belt loops, see chapter 5.01.

## 7.1 Disassembly prerequisites

Make sure that the following prerequisites are met:

- The boom system is properly taken down on a substructure.
- The hook block is reeved out.
- An auxiliary crane is on hand.

## 7.2 F-jib disassembly variations



### WARNING

Non-compliance with the disassembly descriptions!

Death, severe bodily injuries, property damage.

- ▶ The F-jib must always be disassembled in accordance with the corresponding description in the respective section.
- ▶ Make sure that the danger notes in the corresponding disassembly description are observed.

### 7.2.1 Disassembling on the main boom

The F-assembly unit is disassembled on one of these components on the main boom:

- L-end section

- F-connector head

### 7.2.2 Disassembly variation V1

Disassemble the F-jib in individual parts:

- For disassembly variation V1, the individual lattice sections are disassembled from the F-jib.

### 7.2.3 Disassembly variation V2

Disassemble the complete F-jib (maximum length of 12 m) in flying mode:

- For disassembly variation V2, the F-assembly unit is disassembled in flying mode with the assembled F-end section.

Differences from disassembly variation V1:

- The relapse support is pinned with the F-pivot section during disassembly.
- The F-jib 12 m can remain hanging on the main boom without the auxiliary crane.

## 7.3 F-jib disassembly steps

### 7.3.1 Validity of the disassembly steps for the respective disassembly variation

The fixed jib is disassembled from the main boom on one of the following lattice sections:

- L-end section
- F-connector head

This chapter describes the disassembly of the F-jib on the F-connector head as an example.

This chapter contains the disassembly steps for both disassembly variations:

- Disassembly variation V1
- Flying assembly: Disassembly variation V2

Illustrations that apply to both disassembly steps provide an example of the situation for disassembly variation V1.

Disassembly steps that apply only to one of the disassembly variations are marked.

### 7.3.2 Disconnecting the electrical connections

Make sure that the following prerequisite is met:

- The boom system is properly taken down.

---

#### NOTICE

Damage to the electrical connection on the cable drum!

If the electrical connection between the F-connector head or the L-end section **and** the F-pivot section is not separated before spooling up the cable drum, the electrical connection will be damaged.

If the cable of the cable drum is not properly spooled up on the cable drum after unplugging the F-end section, then the cable drum or the cable can be significantly damaged.

- ▶ Disconnect the electrical connection from the cable drum on the F-pivot section to the terminal box on the L-connector head or the L-end section first **and** then the electrical connection from the terminal box on the F-end section to the cable drum.
  - ▶ After unplugging, spool up the cable onto the cable drum.
- 
- ▶ Disconnect the electrical connections properly, see the wiring diagram.
  - ▶ After unplugging, spool up the cable onto the cable drum and secure it to prevent it from spooling out inadvertently.
  - ▶ Secure the cable: Reestablish the electrical connection between the F-connector head or the L-end section and the cable drum.
  - ▶ Close off the electrical connections properly with dummy plugs or protective caps.

### 7.3.3 Pulling back the hoist rope

Make sure that the following prerequisites are met:

- The hook block has been removed.



#### WARNING

Running rope!  
Crushing of limbs.

- ▶ Maintain the safety distance.

- ▶ Remove the rope guard rods from all rope pulleys.

The assembly winch rope must be connected with the hoist rope on the turntable.

- ▶ Connect the assembly winch rope via the screw connecting link with the rope release clamp to the hoist rope.
- ▶ Ensure freedom of movement of the rope release clamp: Keep the hoist rope tensioned with the assembly winch rope.
- ▶ Until the hoist rope is pulled to at least the main boom: Spool the hoist winch up and spool the assembly winch out at the same time.
- ▶ Disconnect the assembly winch rope from the hoist rope.

If additional hoist ropes are pulled back:

- ▶ Pull back the hoist rope in the same way.
- ▶ Pin and secure the rope guard rods to all rope pulleys.

### 7.3.4 Disassembly variation V2 flying disassembly: Pinning the F-relapse support in the transport position

The disassembly step applies only to disassembly variation V2.

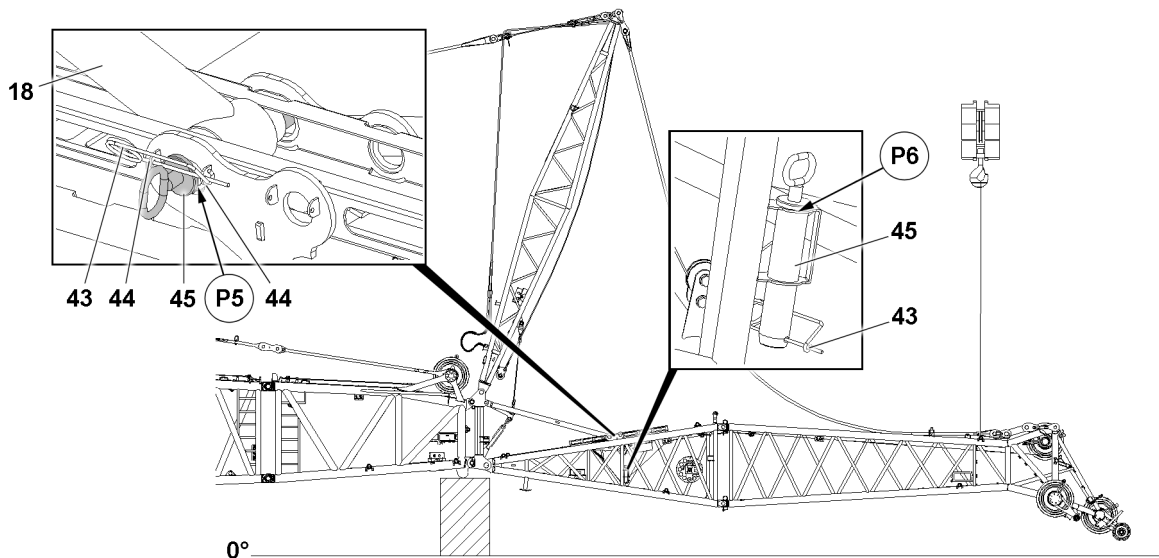


Fig. 156577: Prerequisite for flying assembly: Pinning the F-relapse support in the transport position

- |                      |             |
|----------------------|-------------|
| 18 F-relapse support | 44 Brackets |
| 43 Retaining element | 45 Pin      |

The pin 45 must remain inserted for the subsequent disassembly steps in position P5.

- ▶ Fasten the F-end section to the auxiliary crane.
- ▶ Remove the retaining element 43 and unpin the pin 45 from the park position P6.
- ▶ Until the F-relapse support 18 can be pinned in the transport position P5: Lift or lower the F-jib with the auxiliary crane.
- ▶ Insert the pin 45 in the transport position P5 and secure to the lugs 44 with the retaining element 43.



### 7.3.5 Fixing the flap with the auxiliary rope to the F-pivot section

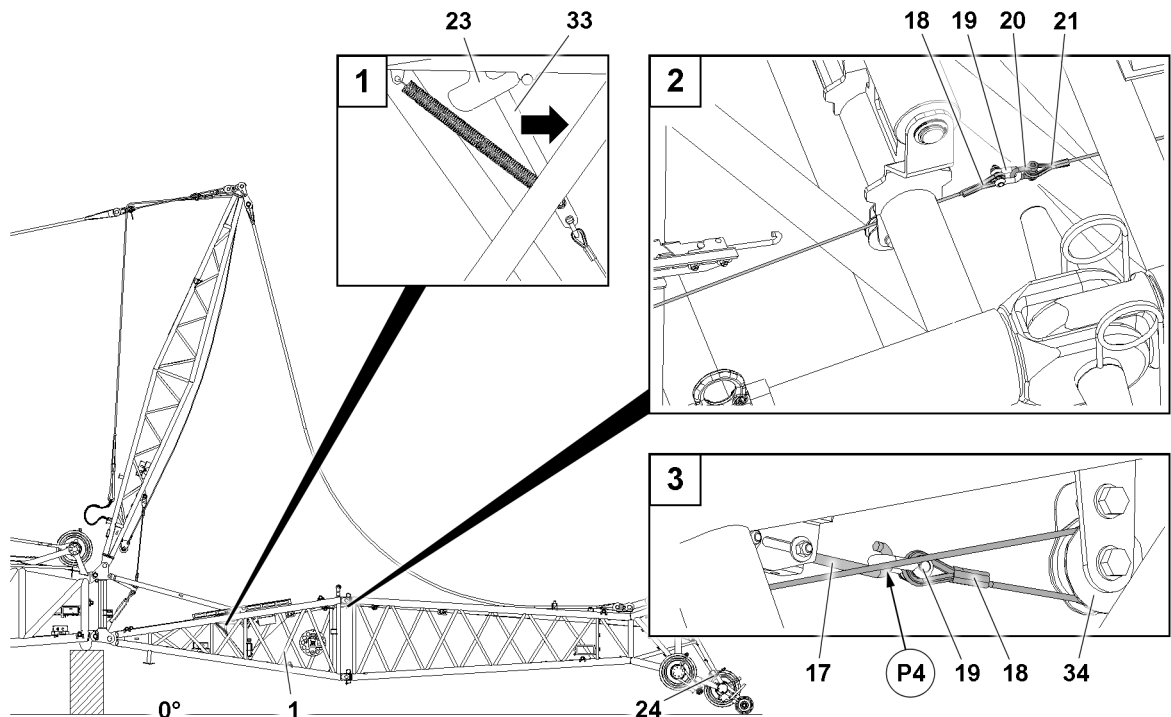


Fig.156575: Fixing the flap with the auxiliary rope to the F-pivot section

1	F-pivot section	21	Control rope
17	Hook closure	23	Flap
18	Control rope	24	Manual rope winch
19	Shackle	33	Flat steel bar
20	Shackle	34	Rope pulley



#### WARNING

The control rope **18** is tensioned!  
Severe bodily injuries.

- ▶ While the control rope **18** is unhooked: Keep the flap **23** in position.

The control rope **18** is the rope connected with the flap **23**.

The control rope **21** is the rope connected with the manual rope winch **24**.



#### Note

- ▶ Liebherr-Werk Ehingen GmbH recommends that two people carry out this work step.
- ▶ Person 1: Pull the flat steel bar **33** and keep the flap **23** in position.
- ▶ Person 2: Open the shackle **19** and detach the control rope **21** from the shackle **20**.
- ▶ Person 2: Make sure that the control rope **18** runs over the rope pulley **34**.
- ▶ Person 2: Secure the shackle **19** to the control rope **18**.
- ▶ Person 2: Attach the control rope **18** with the shackle **19** to the hook closure **17** in point **P4**.

### 7.3.6 Disassembling the F-guy ropes

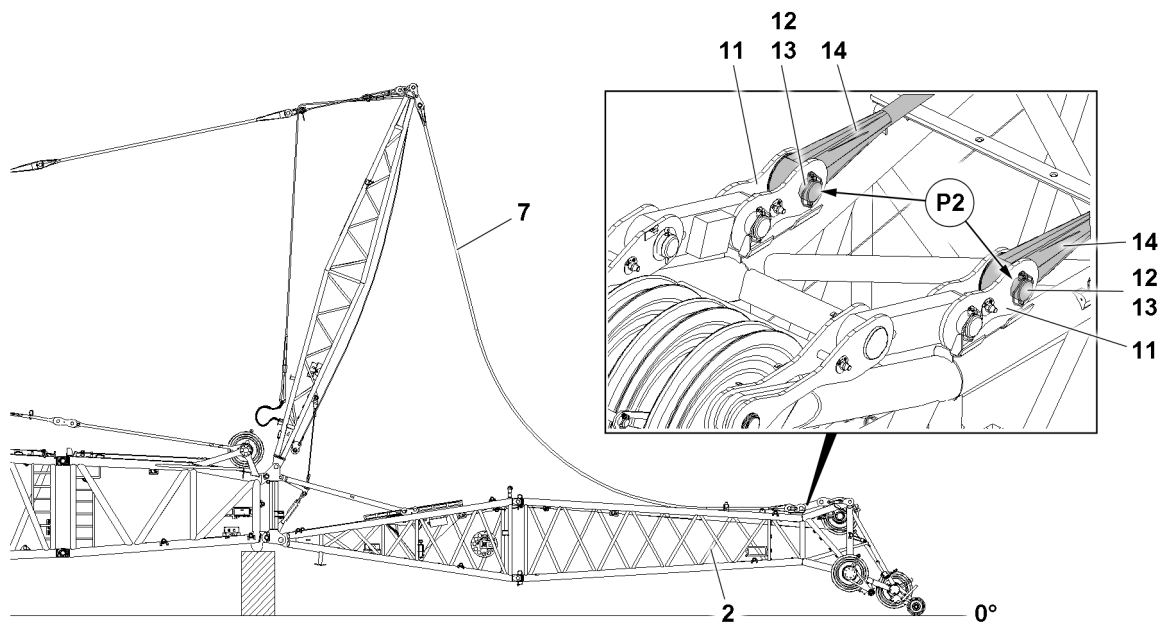


Fig.156563: Disassembling the F-guy ropes

2	F-end section	12	Pin
7	F-guying	13	Retaining element
11	Pull bracket	14	F-guy rope

Disassemble the F-guy ropes **14**: Example based on the pull bracket **11**.

Depending on the length of the F-jib, the F-guying **7** can be combined out of additional F-guy ropes.

- ▶ Remove the retaining element **13** and unpin the pin **12** in point **P2**.
- ▶ Unpin the second F-guy rope **14** in the same way.

When the F-intermediate sections are assembled:

- ▶ Disassemble the F-guy ropes of the F-intermediate sections.
- ▶ Take down the F-guy ropes assembled on the FA-frame to the side of the boom onto the ground.

### 7.3.7 Disassembly variation V1: Disassembling the F-jib 12 m

The disassembly step applies only to disassembly variation V1.

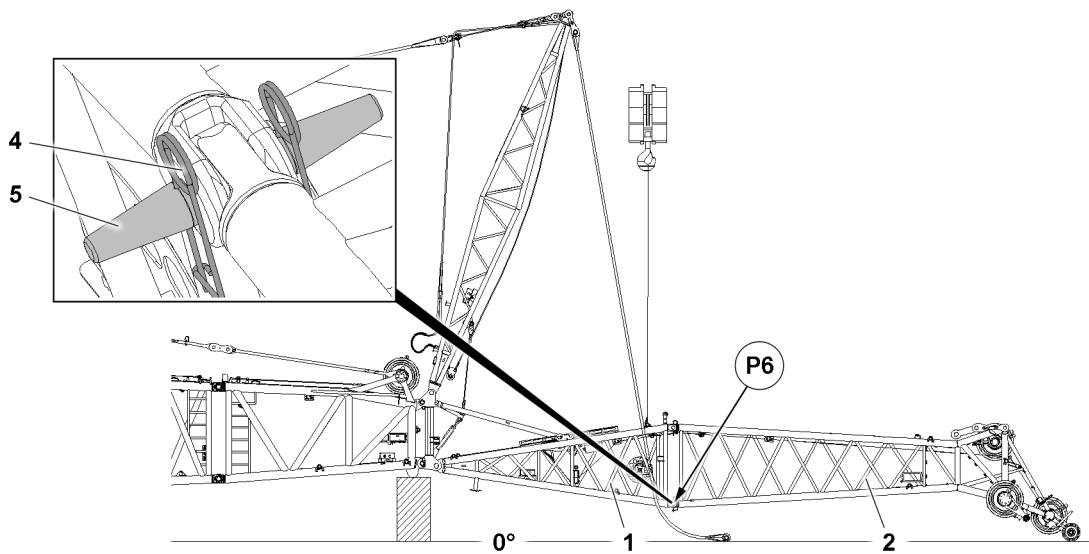


Fig.156576: Opening the F-jib 12 m

- |   |                 |   |                   |
|---|-----------------|---|-------------------|
| 1 | F-pivot section | 4 | Retaining element |
| 2 | F-end section   | 5 | Pin               |

The F-end section 2 is pinned in four pin points on the F-pivot section 1. Every pin point is present on both sides of the component on one level.



#### WARNING

Lattice sections **not** secured!

When unpinning, lattice sections can swing down.

- ▶ Make sure that the lattice sections are secured before unpinning from the auxiliary crane.
  - ▶ Tension the fastening equipment before unpinning.
  - ▶ Maintain the safety distance.
- 
- ▶ Fasten the F-pivot section 1 to the auxiliary crane and tension the fastening equipment.
  - ▶ Open the F-jib 12 m on both sides in position **P6**: Remove the retaining element 4 and unpin the pin 5.
  - ▶ Take down the F-pivot section 1 and F-end section 2 with the auxiliary crane carefully onto the sub-structure on the ground.

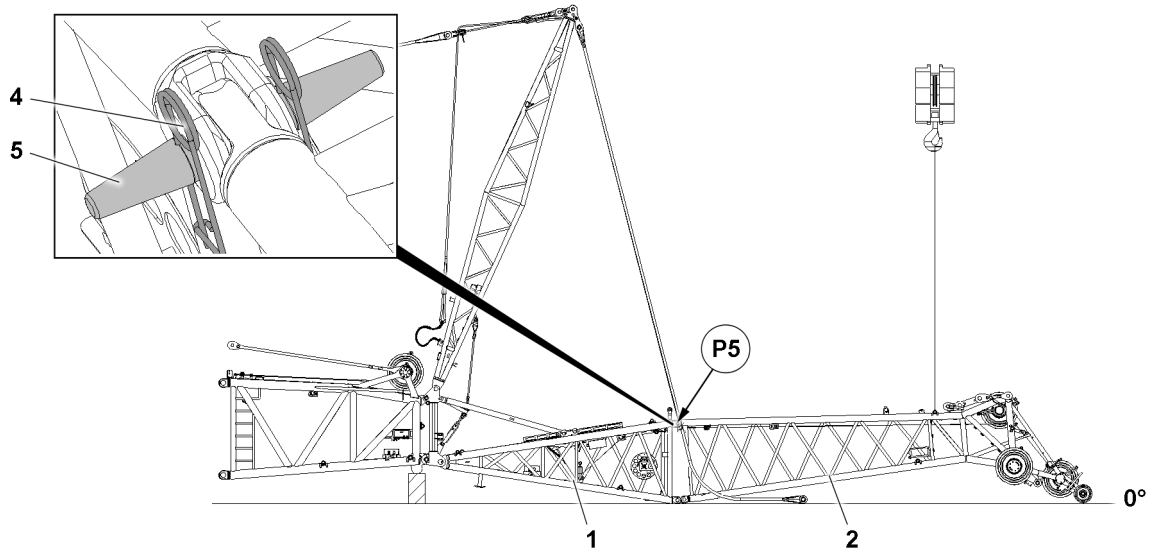


Fig.156578: Unpinning the F-end section

- |   |                 |   |                   |
|---|-----------------|---|-------------------|
| 1 | F-pivot section | 4 | Retaining element |
| 2 | F-end section   | 5 | Pin               |

- ▶ Fasten the F-end section 2 to the auxiliary crane and tension the fastening equipment.
- ▶ Both sides in position P5: Remove the retaining element 4 and unpin the pin 5.
- ▶ Remove the F-end section 2.

### 7.3.8 Disassembly variation V1: Disassembling the F-jib, larger than 12 m

The disassembly step applies only to disassembly variation V1.

The illustrations in this section refer as an example to an F-jib with two F-intermediate sections.

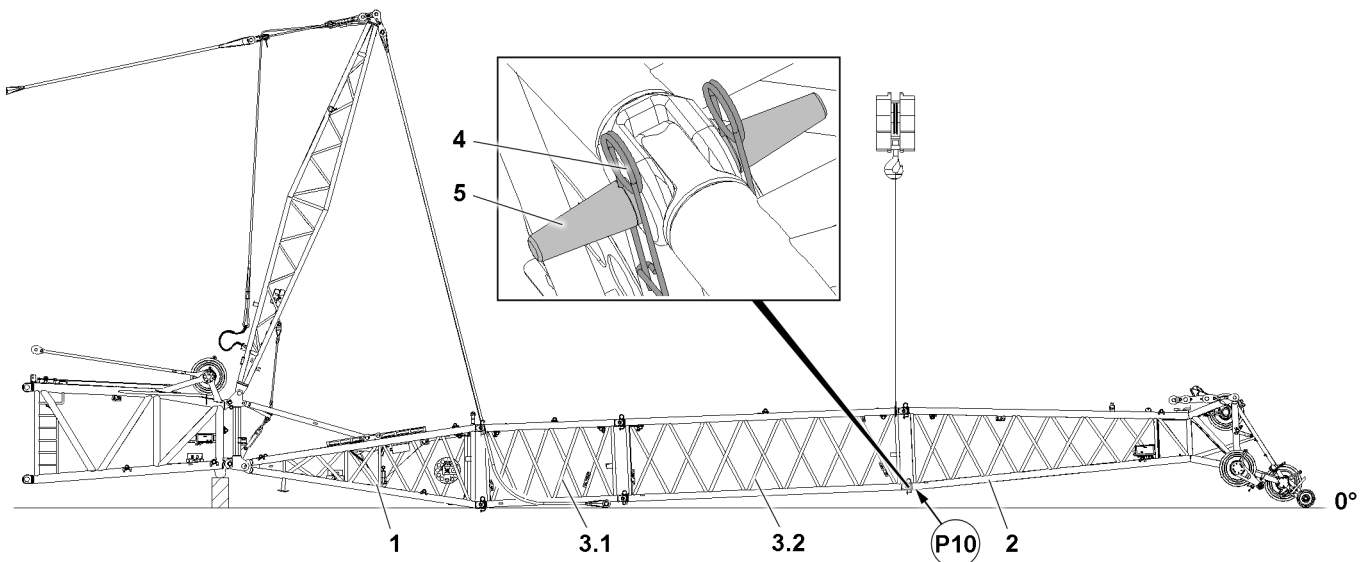


Fig.156580: Opening the F-jib: Unpinning the F-end section

- |   |                 |     |                        |   |                   |
|---|-----------------|-----|------------------------|---|-------------------|
| 1 | F-pivot section | 3.1 | F-intermediate section | 4 | Retaining element |
| 2 | F-end section   | 3.2 | F-intermediate section | 5 | Pin               |

The F-end section 2 is pinned in four pin points on the F-intermediate section 3.2. Every pin point is present on both sides of the component on one level.

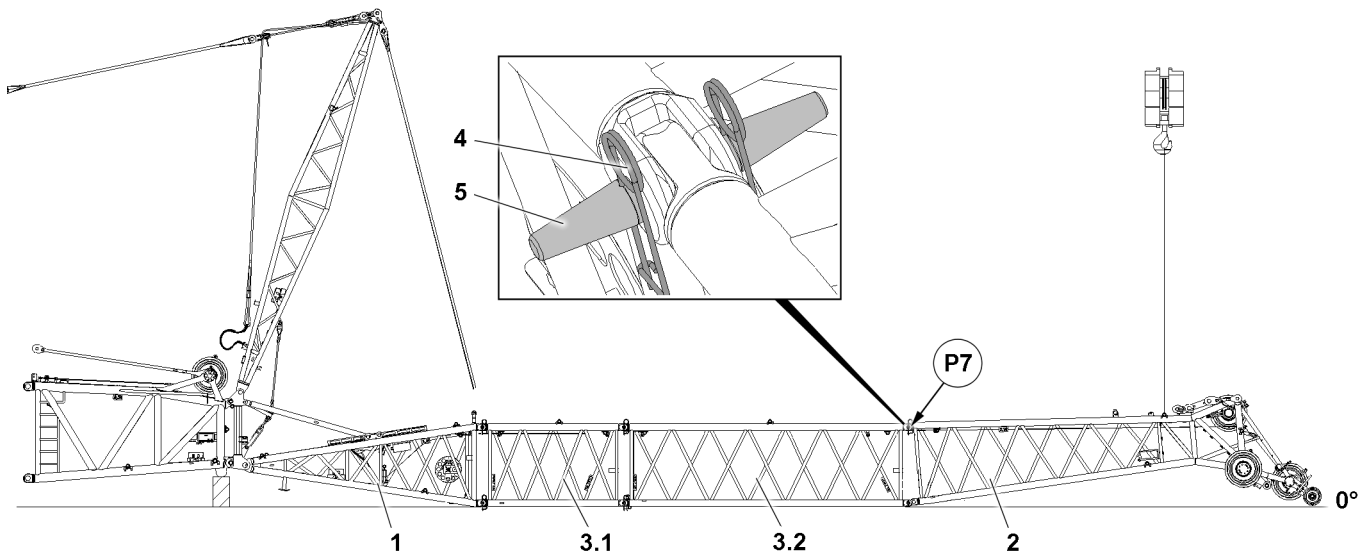
**WARNING**

Lattice sections **not** secured!

When unpinning, lattice sections can swing down.

- ▶ Make sure that the lattice sections are secured before unpinning from the auxiliary crane.
- ▶ Tension the fastening equipment before unpinning.
- ▶ Maintain the safety distance.

- ▶ Fasten the F-intermediate section **3.2** to the auxiliary crane and tension the fastening equipment.
- ▶ Both sides in position **P10**: Remove the retaining element **4** and unpin the pin **5**.
- ▶ Take down the F-intermediate section **3.2** and F-end section **2** with the auxiliary crane carefully onto the substructure on the ground.



*Fig.156875: Disassembling the F-end section*

<b>1</b>	F-pivot section	<b>3.1</b>	F-intermediate section	<b>4</b>	Retaining element
<b>2</b>	F-end section	<b>3.2</b>	F-intermediate section	<b>5</b>	Pin

- ▶ Fasten the F-end section **2** to the auxiliary crane and tension the fastening equipment.
- ▶ Both sides in position **P7**: Remove the retaining element **4** and unpin the pin **5**.
- ▶ Remove the F-end section **2** with the auxiliary crane.

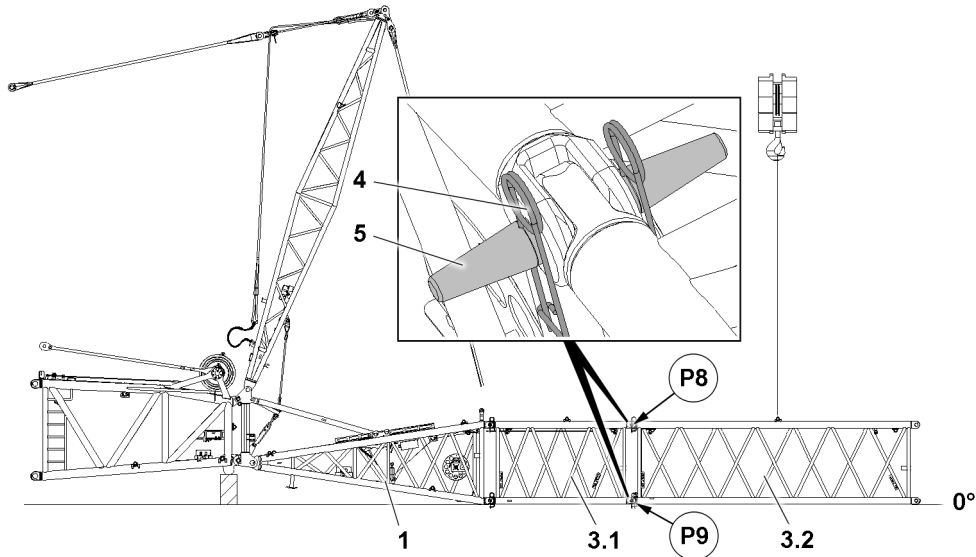


Fig.156878: Disassembling the F-intermediate sections

- |     |                        |   |                   |
|-----|------------------------|---|-------------------|
| 1   | F-pivot section        | 4 | Retaining element |
| 3.1 | F-intermediate section | 5 | Pin               |
| 3.2 | F-intermediate section |   |                   |

- ▶ Fasten the F-intermediate section 3.2 to the auxiliary crane and tension the fastening equipment.
- ▶ Both sides in position P9: Remove the retaining element 4 and unpin the pin 5.
- ▶ Both sides in position P8: Remove the retaining element 4 and unpin the pin 5.
- ▶ Remove the F-intermediate section 3.2 with the auxiliary crane.

When additional F-intermediate sections are assembled on the F-intermediate section 3.1:

- ▶ Disassemble the F-intermediate section in the same way.

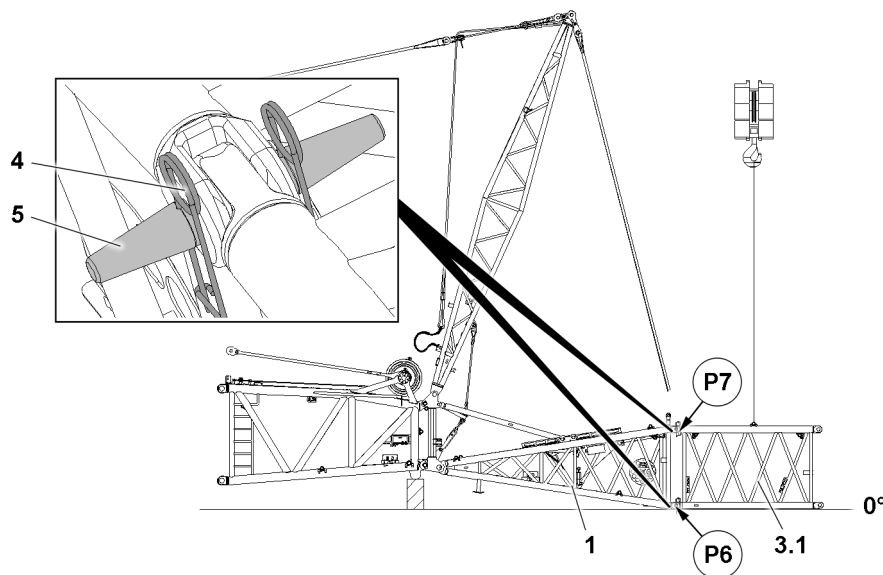


Fig.156886: Disassembling the F-intermediate section on the F-pivot section

- |     |                        |   |                   |
|-----|------------------------|---|-------------------|
| 1   | F-pivot section        | 4 | Retaining element |
| 3.1 | F-intermediate section | 5 | Pin               |

- ▶ Fasten the F-intermediate section 3.1 to the auxiliary crane.
- ▶ Lift the F-intermediate section 3.1 and support the F-pivot section 1.
- ▶ Take the F-pivot section 1 down onto the substructure and tension the fastening equipment.
- ▶ Both sides in position P6: Remove the retaining element 4 and unpin the pin 5.
- ▶ Both sides in position P7: Remove the retaining element 4 and unpin the pin 5.

- ▶ Remove the F-intermediate section 3.1 with the auxiliary crane.

### 7.3.9 Disassembly variation V1: Pinning the relapse support pin in the stop position

The disassembly step applies only to disassembly variation V1.

Make sure that the following prerequisite is met:

- The F-lattice sections are disassembled.

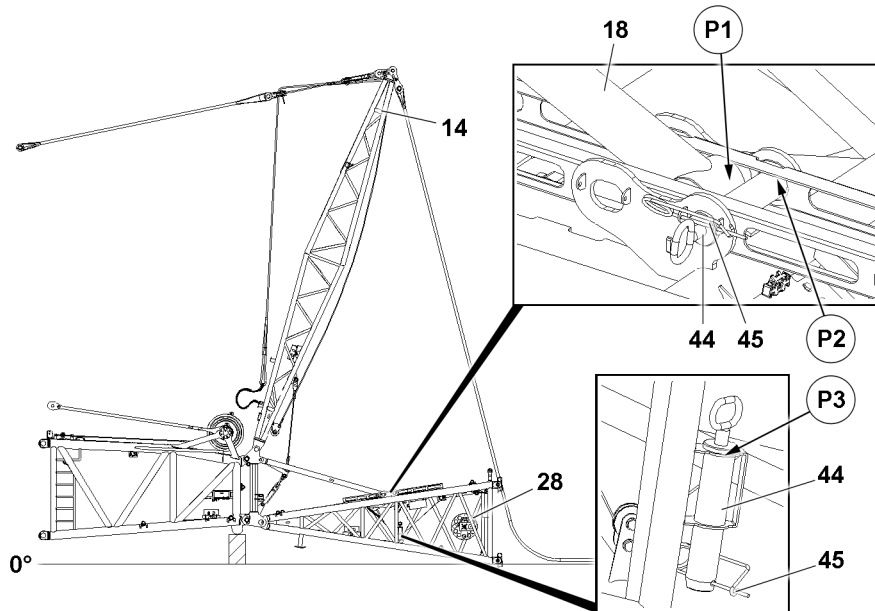


Fig.156879: Inserting the F-relapse support pin in the stop position

18	F-relapse support	44	Pin
28	F-pivot section	45	Retaining element

- ▶ Make sure that the F-relapse support 18 is located on the right side with respect to the pin 44, see position P1.
- ▶ Remove the retaining element 45 and unpin the pin 44 from the transport position P3.
- ▶ Insert the pin 44 in the stop position P2 and secure with the retaining element 45.

### 7.3.10 Releasing the fastening rope on the FA-frame

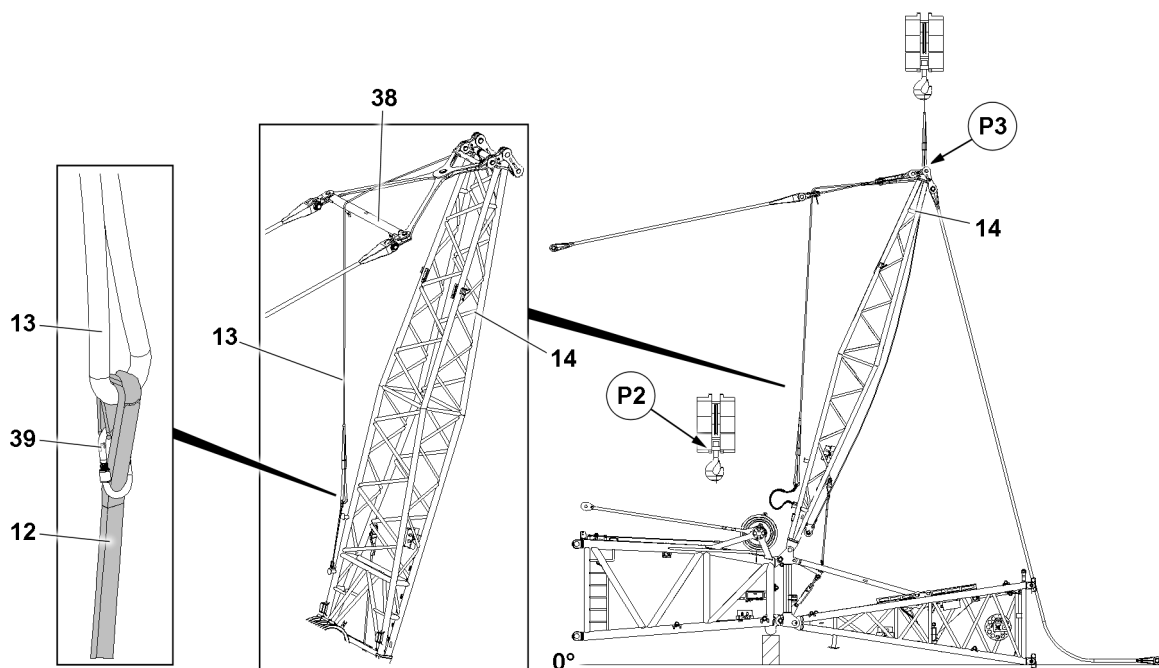


Fig.156881: Releasing the fastening rope on the FA-frame

- |                   |              |
|-------------------|--------------|
| 12 Round sling    | 38 Rocker    |
| 13 Fastening rope | 39 Snap hook |
| 14 FA-frame       |              |

- ▶ Open the snap hook **39** and remove the round sling **12** from the fastening rope **13**.
- ▶ Fasten the fastening rope **13** to the auxiliary crane, position **P2**.
- ▶ Position the auxiliary crane and fastening rope **13** vertically above the FA-frame **14**, position **P3**.



### 7.3.11 Reeving the assembly winch rope in on the rope pulley retainer

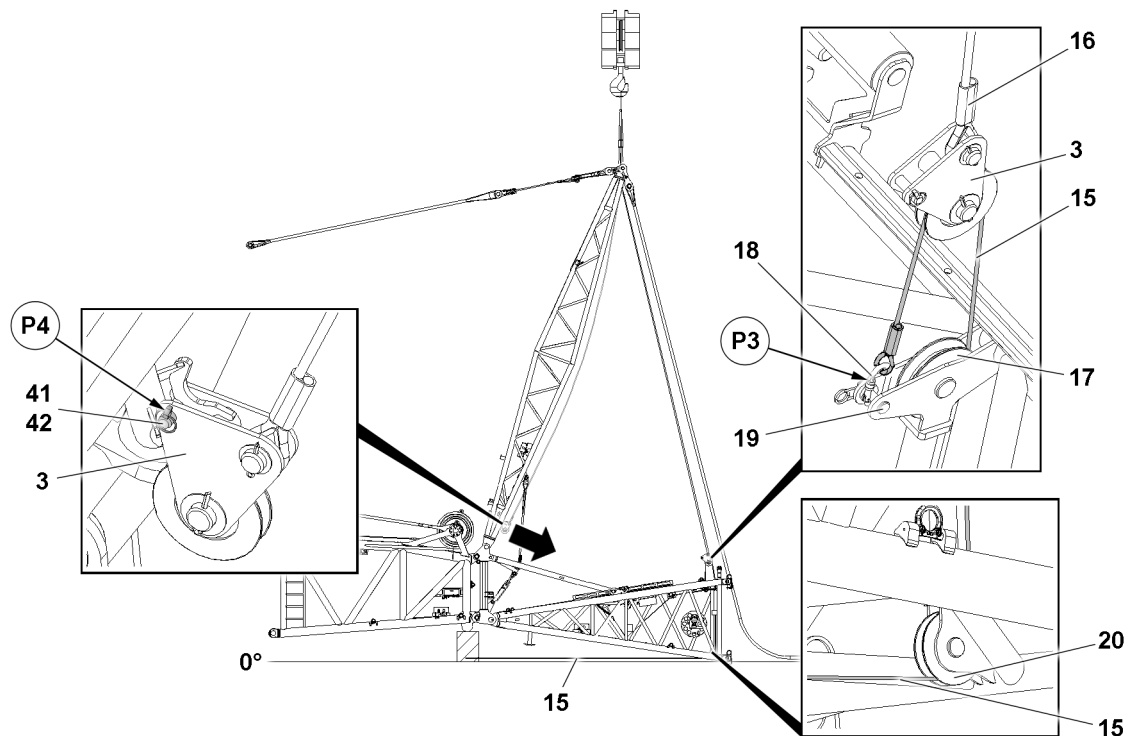


Fig.156882: Reeving the assembly winch rope in on the rope pulley retainer

<b>3</b>	Rope pulley retainer	<b>19</b>	Pin
<b>15</b>	Assembly winch rope	<b>20</b>	Rope pulley
<b>16</b>	Fastening rope	<b>41</b>	Pin
<b>17</b>	Rope pulley	<b>42</b>	Retaining element
<b>18</b>	Snap hook		

- ▶ Make sure that the assembly winch rope is reeved in only on the rope pulley retainer **3**.
- ▶ Spool the assembly winch rope **15** out and pull it over the rope pulley **20** and rope pulley **17** to position **P3**.

The rope pulley retainer **3** is unpinned on the transport retainer in position **P4**.

- ▶ Remove the retaining element **42** and unpin the pin **41**.
- ▶ Swing the rope pulley retainer **3** with the fastening rope **16** into position **P3**.
- ▶ Reeve the assembly winch rope **15** in on the rope pulley retainer **3**.
- ▶ Secure the assembly winch rope **15** with the snap hook **18** to the pin **19**.

### 7.3.12 Releasing the FA-frame relapse retainer

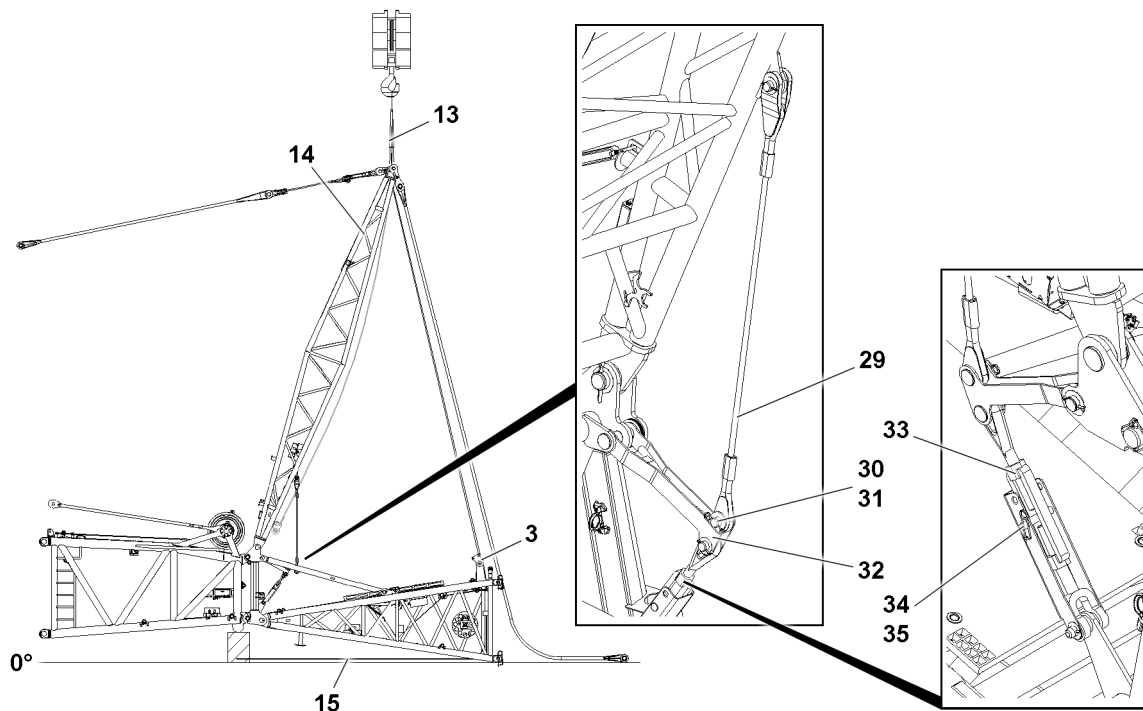


Fig.156880: Releasing the FA-frame relapse retainer

<b>3</b> Rope pulley retainer	<b>31</b> Retaining element
<b>13</b> Fastening rope	<b>32</b> FA-frame relapse retainer
<b>14</b> FA-frame	<b>33</b> Turnbuckle
<b>15</b> Assembly winch rope	<b>34</b> Pin
<b>29</b> Guy rope	<b>35</b> Retaining element
<b>30</b> Pin	

Make sure that the following prerequisites are met:

- The FA-frame **14** is secured with the fastening rope **13** to the auxiliary crane.
  - The assembly winch rope **15** is reeved in on the rope pulley retainer **3**.
  - The FA-frame **14** is secured with the assembly winch rope **15** in direction of the main boom to prevent swinging.
- ▶ Release the turnbuckle **33**: Remove the retaining element and unpin the pin.
  - ▶ Until the fastening rope can be unpinned: Lengthen the turnbuckle **33**.
  - ▶ Unpin the guy rope **29** on the FA-frame relapse retainer **32**: Remove the retaining element **31** and unpin the pin **30**.
  - ▶ Let the guy rope **29** hang in a vertical position.
  - ▶ When taking down, avoid collision with the FA-frame: Shorten the turnbuckle **33**.
  - ▶ Secure the turnbuckle **33**: Insert the pin **34** and secure it with the retaining element **35**.

### 7.3.13 Unpinning the FAB-guy ropes

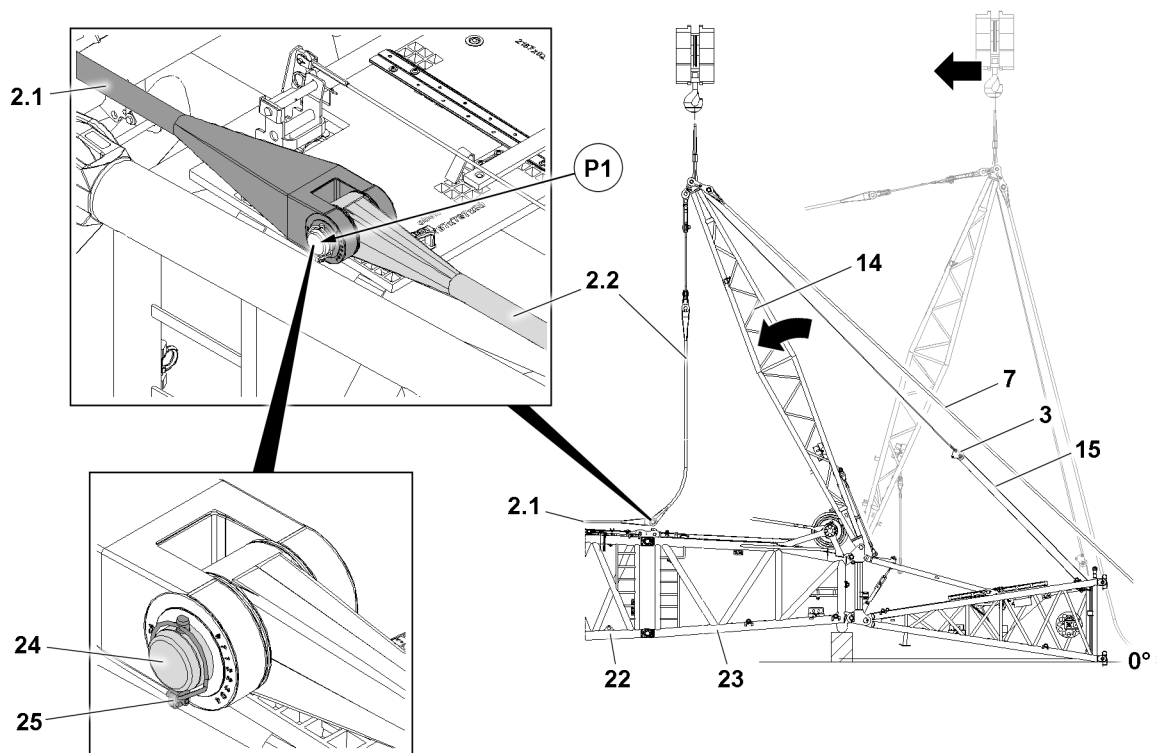


Fig.156883: Unpinning the FAB-guy ropes

- |     |                                      |    |                      |
|-----|--------------------------------------|----|----------------------|
| 2.1 | FAB-guy ropes (intermediate section) | 15 | Assembly winch rope  |
| 2.2 | FAB-guy ropes (FA-frame)             | 22 | Intermediate section |
| 3   | Rope pulley retainer                 | 23 | F-connector head     |
| 7   | F-guy ropes                          | 24 | Pin                  |
| 14  | FA-frame                             | 25 | Retaining element    |



#### WARNING

Swinging of the FA-frame **14**!  
Crushing of limbs.

- ▶ Maintain the safety distance.

#### NOTICE

Swinging the FA-frame **14** in the direction of the main boom!

Property damage to the FA-frame **14**, the F-connector head (or: L-end section) **23** as well as the rope pulley retainer **3**

- ▶ Make sure that a guide supervises the swinging process of the FA-frame **14**.
- ▶ Make sure that the guide is constantly in visual and acoustic contact with the crane operator.
- ▶ Maintain the safety distance.
- ▶ Make sure that the assembly winch rope **15** is spooled out during the swinging process of the FA-frame **14**.

#### NOTICE

F-guy rope **7** **not** guided!  
Damage to components.

When the FA-frame is swung:

- ▶ Make sure that the F-guy ropes **7** are guided.

- ▶ Until the FAB-guy ropes can be unpinning in position **P1**: Carefully swing the FA-frame **14** with the auxiliary crane in direction of the main boom and spool out the assembly winch rope **15** at the same time.
- ▶ Unpin the FAB-guy rope **2.1** on the FAB-guy rope **2.2**: Remove the retaining element **25** and unpin the pin **24**.
- ▶ Unpin the FAB-guy rope on the opposite side the same way as described before.

### 7.3.14 Pulling the FA-frame in direction of the F-pivot section

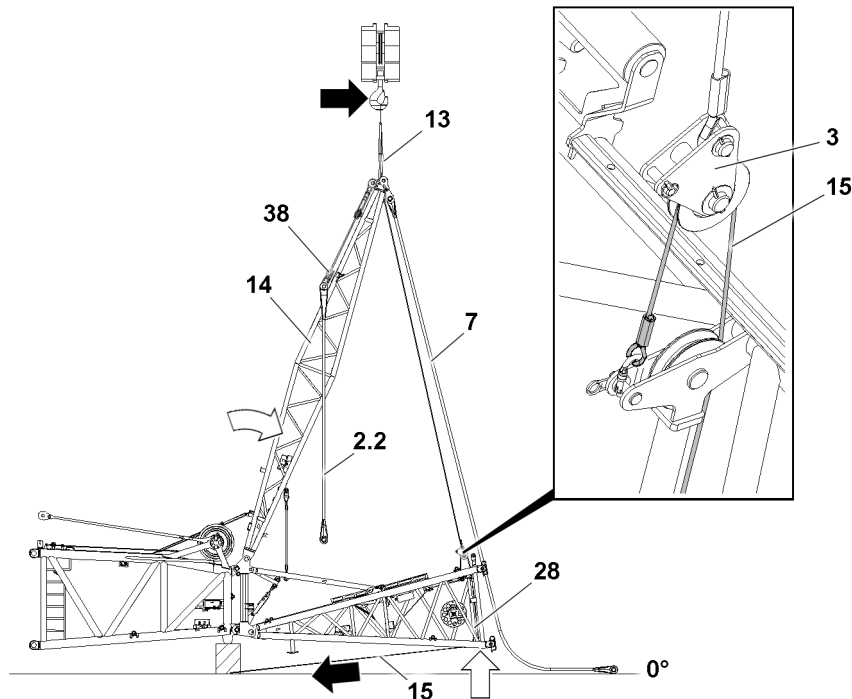


Fig.156884: Pulling the FA-frame in direction of the F-pivot section

<b>3</b> Rope pulley retainer	<b>14</b> FA-frame
<b>2.2</b> FAB-guy rope	<b>15</b> Assembly winch rope
<b>7</b> F-guy rope	<b>28</b> F-pivot section
<b>13</b> Fastening rope	<b>38</b> Rocker



#### WARNING

Swinging of the FA-frame **14**!  
Crushing of limbs.

- ▶ Maintain the safety distance.

#### NOTICE

Swinging the FA-frame **14** in direction of the F-pivot section!

Property damage to the following components: The FA-frame **14**, F-pivot section **28**, F-connector head (or: L-end section) **23**, rope pulley retainer **3**.

- ▶ Make sure that a guide supervises the swinging process of the FA-frame **14**.
- ▶ Make sure that the guide is constantly in visual and acoustic contact with the crane operator.
- ▶ Maintain the safety distance.
- ▶ Make sure that the assembly winch rope **15** is spooled up during the swinging process of the FA-frame **14**.

**WARNING**

F-guy rope **7** not guided!  
Damage to components.

When the FA-frame is swung:

- ▶ Make sure that the F-guy ropes **7** are guided.

The FA-frame **14** is pulled with the assembly winch rope **15** in direction of the F-pivot section **28**.

Until the rope pulley retainer **3** is located just above the F-pivot section **28**: Pull the FA-frame **14** in direction of the F-pivot section **28**.

- ▶ Spool assembly winch rope **15** up carefully and at the same time guide the FA-frame **14** with the auxiliary crane.

**Result:**

- With disassembly variation V1: The F-pivot section **28** lifts up from the ground.
- The rocker **38** is lying on the FA-frame.
- The FAB-guy ropes **2.2** move in the vertical position.

**WARNING**

Take the F-pivot section **28** down onto the ground!  
Crushing of limbs.

- ▶ Maintain the safety distance.

- ▶ Until the F-pivot section **28** is lying on the ground: Lower the FA-frame **14** with the auxiliary crane in direction of the F-pivot section **28**.

### 7.3.15 Reeving the assembly winch rope out

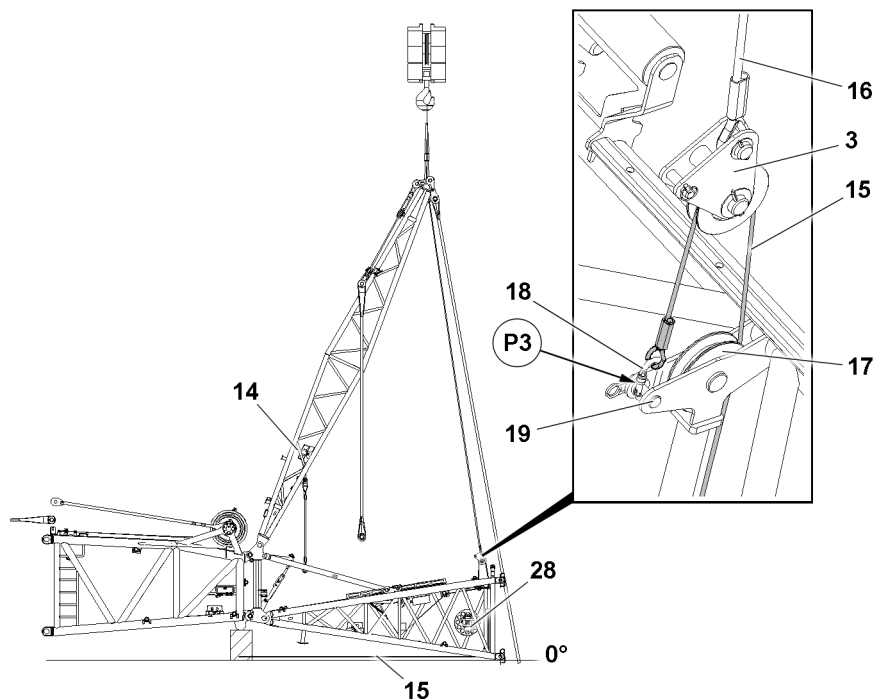


Fig.156885: Reeving the assembly winch rope out

- |                               |                           |
|-------------------------------|---------------------------|
| <b>3</b> Rope pulley retainer | <b>16</b> Fastening rope  |
| <b>14</b> FA-frame            | <b>18</b> Snap hook       |
| <b>15</b> Assembly winch rope | <b>28</b> F-pivot section |

Make sure that the following prerequisites are met:

- The F-pivot section **28** is lying on the ground.

**WARNING**

Swinging rope pulley retainer **3**!  
Death, severe bodily injury.

- ▶ Make sure that the rope pulley retainer **3** is held while the assembly winch rope **15** is reeved out.
- 
- ▶ Hold the rope pulley retainer **3**.
  - ▶ Open the snap hook **18** in position **P3**.
  - ▶ Reeve the assembly winch rope **15** out to the rope pulley retainer **3**.
  - ▶ Until the rope pulley retainer **3** and fastening rope **16** hang vertically: Guide the rope pulley retainer **3**.

### 7.3.16 Taking the FA-frame down

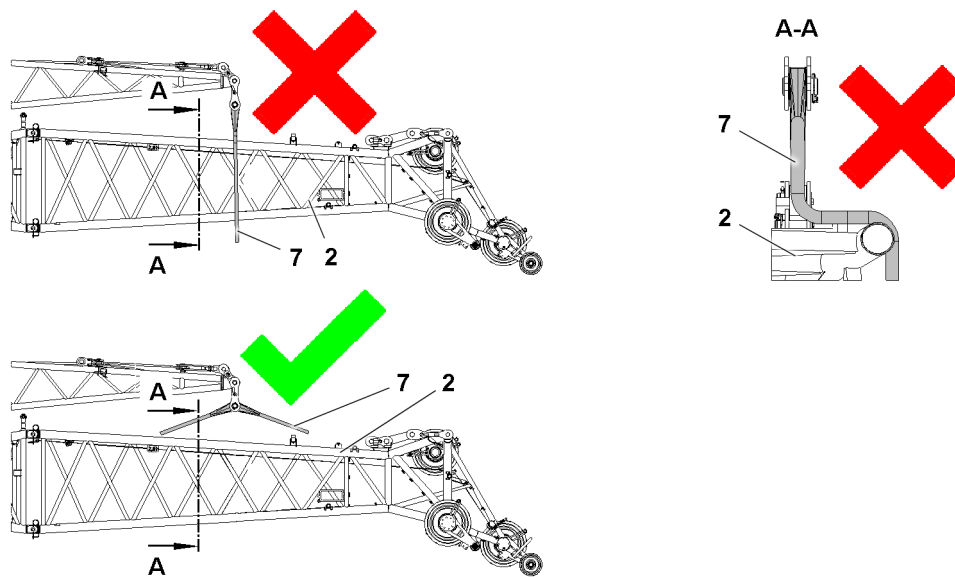


Fig.156889: Impermissible and permissible rope routing: Example with the F-guy rope and assembled F-end section

**2** F-end section

**7** F-guy rope

Make sure that the following prerequisites are met:

- With disassembly variation V2 flying disassembly: The F-guy ropes **7** are unpinned on the F-end section **2**.

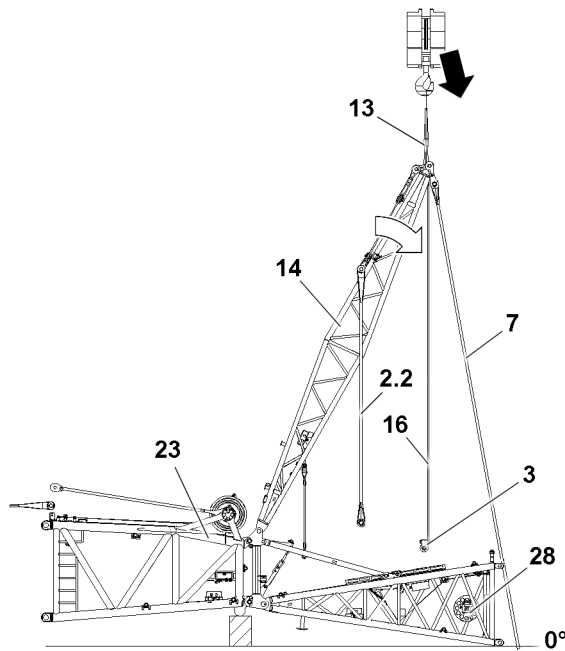


Fig.156887: Taking the FA-frame down on the F-pivot section

2.2	FAB-guy rope	14	FA-frame
3	Rope pulley retainer	16	Fastening rope
7	F-guy rope	28	F-pivot section
13	Fastening rope		



#### WARNING

Take the FA-frame **14** down on the F-pivot section **28**!  
Crushing of limbs.

- ▶ Make sure that a guide supervises the swinging process of the FA-frame **14**.
- ▶ Make sure that the guide is constantly in visual and acoustic contact with the crane operator.
- ▶ Maintain the safety distance.



#### WARNING

Relaxed fastening rope **13**!

If the fastening rope **13** does **not** remain tensioned during disassembly, the FA-frame **14** can swing suddenly in direction of the F-pivot section **28**.

Death, severe bodily injury, property damage.

- ▶ Make sure that there are no persons within the danger zone.
- ▶ Make sure that the fastening rope **13** is tensioned during all assembly and disassembly operations.



#### WARNING

The F-guy ropes **7** and FAB-guy ropes **2.2** are trapped or bent too far!  
Damage to the guy ropes.

- ▶ Make sure that the fiber guy ropes are not buckled, crushed or damaged in any other way when taking down the FA-frame.
  - ▶ Make sure that the F-guy ropes **7** and FAB-guy ropes **2.2** are guided along the side of the F-jib.
  - ▶ Make sure that minimum permissible bending diameter of **20** x rope diameter on the fiber guy ropes is never fallen below.
- 
- ▶ While the FA-frame **14** is being taken down: Make sure that the rope pulley retainer **3** and fastening rope **16** are taken down before the F-pivot section **28**.

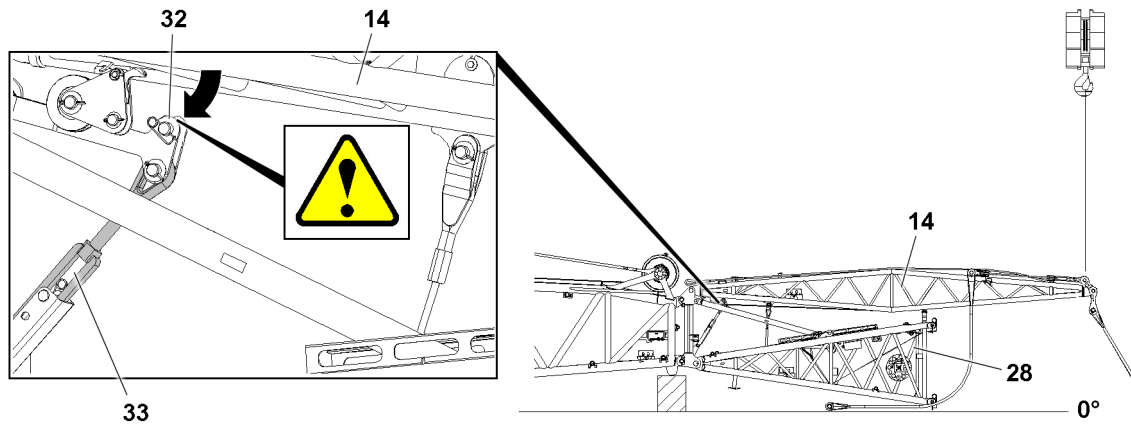


Fig.156888: Taking the FA-frame down on the F-fastening section

28	F-fastening section	32	FA-frame relapse retainer
14	FA-frame	33	Turnbuckle

#### NOTICE

The turnbuckle **33** is twisted too far!

The FA-frame relapse retainer **32** collides with the FA-frame **14**. Damage to crane components.

- ▶ Check the length of the turnbuckle **33**. If necessary: Shorten the turnbuckle **33**.
- ▶ Visually supervise the procedure for taking the F-assembly unit down.

- ▶ Take down the FA-frame **14** with the auxiliary crane on the F-fastening section **28**.

### 7.3.17 Securing the fastening rope in the transport position

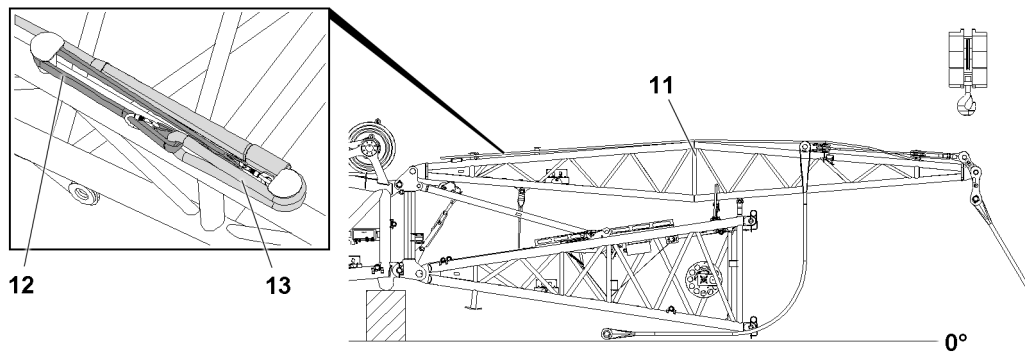


Fig.156347: Securing the fastening rope in the transport position

11	FA-frame	13	Fastening rope
12	Round sling	14	Snap hook

- ▶ Take the fastening rope **13** down and disconnect it from the auxiliary crane.
- ▶ Connect the round sling **12** as a loop to the fastening rope **13** and secure with the snap hook.
- ▶ Secure the fastening rope **13** with the round sling **12** to the FA-frame **11** retainers in the transport position.



### 7.3.18 Disassembling the guy ropes on the FA-frame

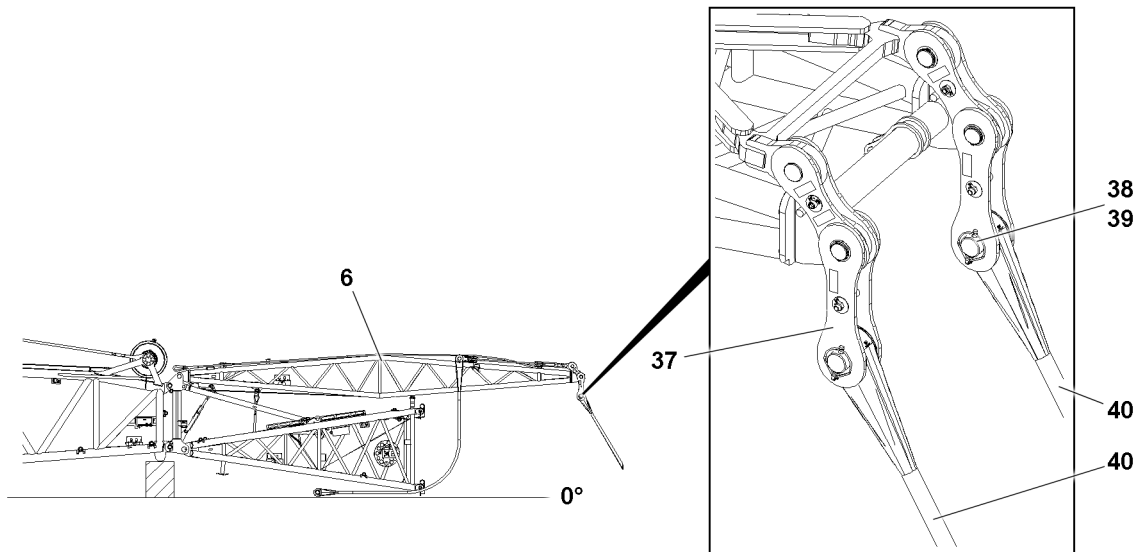


Fig.156344: Disassembling the F-guy ropes

<b>6</b>	FA-frame	<b>39</b>	Retaining element
<b>37</b>	Bracket	<b>40</b>	F-guy rope
<b>38</b>	Pin		



#### Note

- ▶ The disassembly of the F-guy rope **40** is described based on the example of one side.
- ▶ The disassembly applies in the same way for both sides.



#### CAUTION

Falling F-guy rope **40**!  
Crushing of limbs.

- ▶ Make sure that the F-guy rope **40** is safely held when unpinning.
  - ▶ Assembly personnel must be to the side of the assembly unit.
- 
- ▶ Unpin the F-guy rope **40** on the bracket **37**: Remove the retaining element **39** and unpin the pin **38**.
  - ▶ Remove the F-guy rope **40**.

When the first F-guy rope **40** is properly removed:

- ▶ Disassemble the second F-guy rope **40**.
- ▶ Check the fiber guy ropes, see chapter 8.16

### 7.3.19 Disassembling the guy ropes of the FAB-guying on the main boom

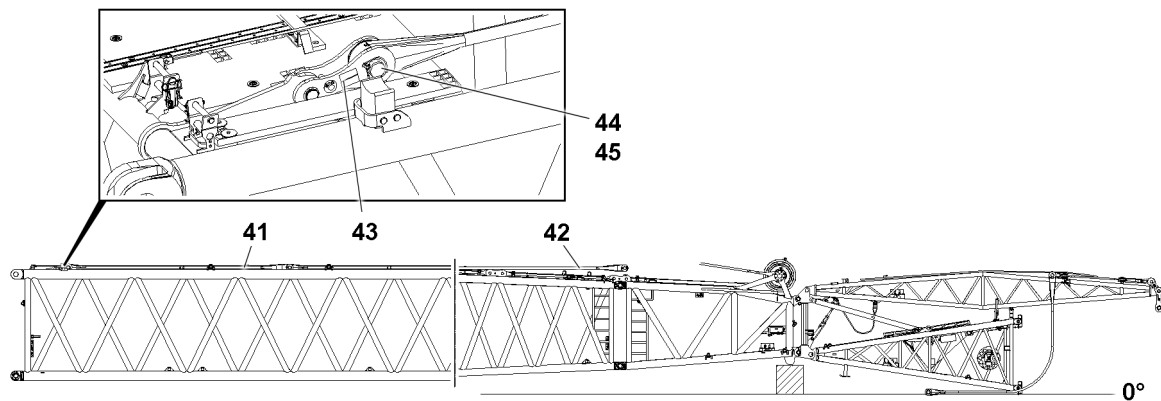


Fig.156567: Unpinning the guy ropes of the FAB-guying, S-intermediate section example

41	FAB-guy rope S10	44	Pin
42	FAB-guy rope S2*	45	Retaining element
43	Bracket		

The brackets for pinning the FAB-guy ropes are located on a certain S-intermediate section, see the rod plan for the position.



#### Note

- ▶ The disassembly of the FAB-guy ropes is described based on the example of one side.
- ▶ The disassembly applies in the same way for both sides.

- ▶ Unpin the FAB-guy rope from the bracket **43**: Remove the retaining element **45** and unpin the pin **44**.

If necessary:

- ▶ Unpin FAB-guy rope S2\* **42** from FAB-guy rope S10 **41**.
- ▶ Check the fiber guy ropes, see chapter 8.16

### 7.3.20 Securing the rocker in the transport position

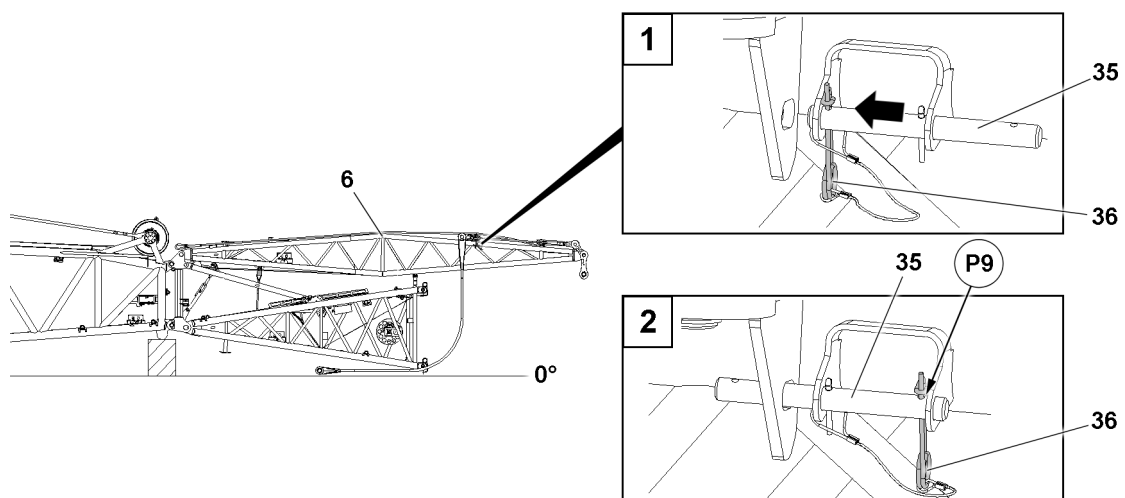


Fig.156893: Securing the rocker in the transport position

6	FA-frame	36	Retaining element
35	Pin		

For transport, the rocker must be pinned on the FA-frame **6**.

- ▶ Remove the retaining element **36**.
- ▶ Until the pin **35** can be secured in point **P9** with the retaining element **36**: Insert the pin **35**.
- ▶ Secure the pin **35** with the retaining element **36** in position **P9**.

### 7.3.21 Disassembling the FAB-guy ropes on the rocker on the FA-frame

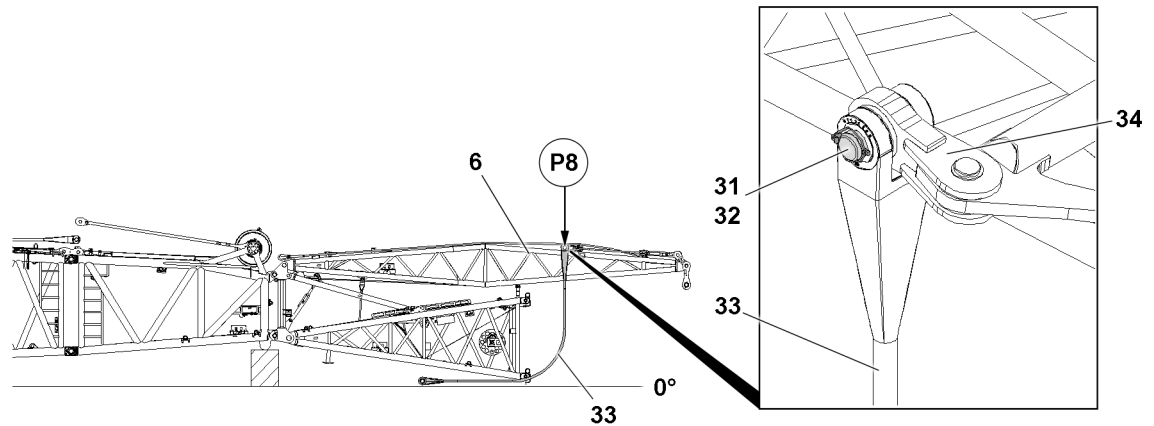


Fig.156341: Disassembling the FAB-guy rope on the rocker on the FA-frame

<b>6</b>	FA-frame	<b>33</b>	FAB-guy rope
<b>31</b>	Pin	<b>34</b>	Rocker
<b>32</b>	Retaining element		



#### Note

- ▶ The disassembly of the FAB-guy rope **33** is described based on the example of one side.
- ▶ The disassembly applies in the same way for both sides.



#### CAUTION

Falling FAB-guy rope **33**!  
Crushing of limbs.

- ▶ Make sure that the FAB-guy rope **33** is held when unpinning.
  - ▶ Assembly personnel must be to the side of the assembly unit.
- 
- ▶ Unpin the FAB-guy rope **33** from the rocker **34**: Remove the retaining element **32** and unpin the pin **31**.

When the first FAB-guy rope **33** is properly removed:

- ▶ Disassemble the second FAB-guy rope **33** from the rocker **34**.

### 7.3.2 Pinning the rope pulley retainer in the transport retainer

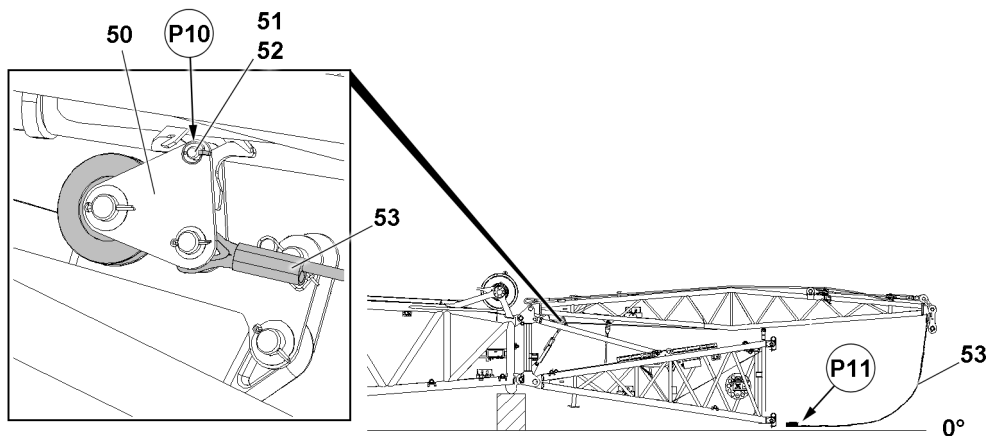


Fig.156345: Rope pulley retainer pinned in the transport position

50	Rope pulley retainer	52	Retaining element
51	Pin	53	Fastening rope



#### CAUTION

Falling rope pulley retainer **50**!  
Crushing of limbs.

- ▶ Make sure that the rope pulley retainer **50** is safely held when pinning.
- ▶ Assembly personnel must be to the side of the assembly unit.

The rope pulley retainer **50** is located with the fastening rope **53** near position **P11**.

- ▶ Position the rope pulley retainer **50** in the transport retainer.
- ▶ Pin the rope pulley retainer **50** in position **P10**: Insert the pin **51** and secure it with the retaining element **52**.

### 7.3.23 Pinning the FA-frame relapse retainer

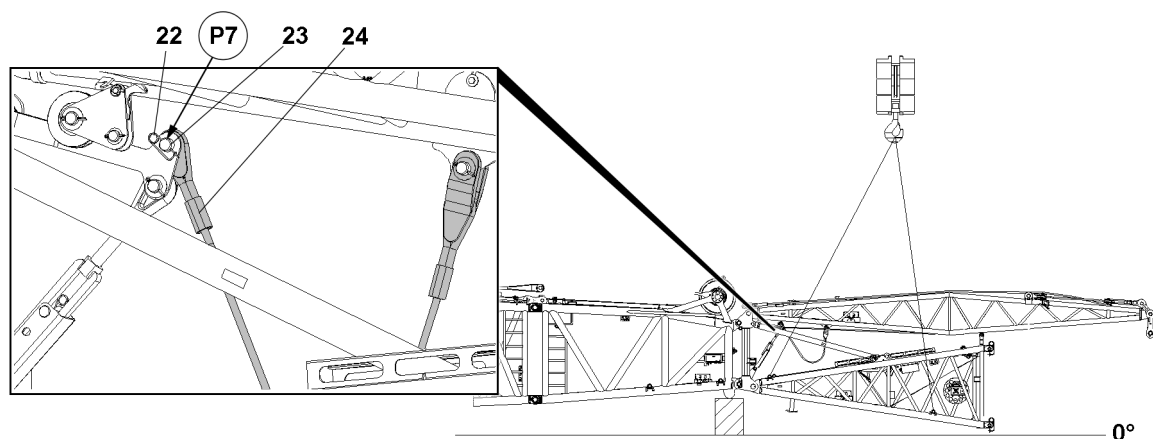


Fig.156338: Pinning the FA-frame relapse retainer

22	Retaining element	24	Guy rope
23	Pin		

**CAUTION**

Unsecured guy rope **24**!

Crushing of limbs.

- ▶ Make sure when pinning the FA-frame relapse retainer, that the guy rope **24** is safely held.
- ▶ Assembly personnel must be to the side of the assembly unit.

- ▶ Put the guy rope **24** in position **P7**.
- ▶ Insert the pin **23** in position **P7**.
- ▶ Secure the pin **23** with the retaining element **22**.
- ▶ Fasten the F-assembly unit to the auxiliary crane.

### 7.3.24 Disassembly variation V1: Pinning the F-relapse support in the transport position

The disassembly step applies only to disassembly variation V1.

Make sure that the following prerequisites are met:

- The F-assembly unit is fastened to the auxiliary crane.

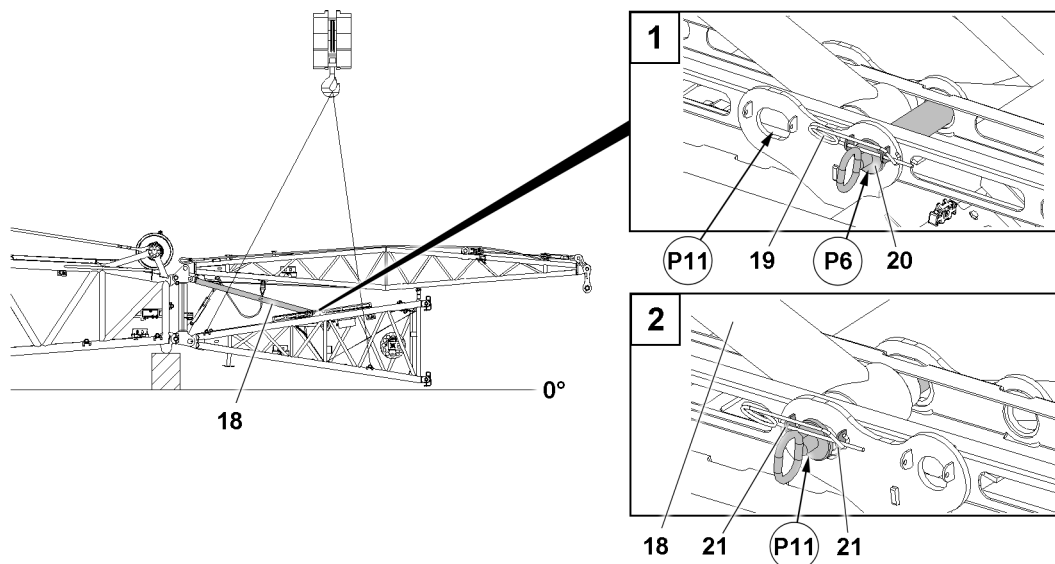


Fig.156894: Pinning the F-relapse support in the transport position

<b>18</b> F-relapse support	<b>20</b> Pin
<b>19</b> Retaining element	<b>21</b> Brackets

- ▶ Until the F-relapse support **18** can be pinned in the transport position **P11**: Lift or lower the F-assembly unit.
- ▶ Remove the pin **20** from the stop position **P6**: Remove the retaining element **19** and unpin the pin **20**.
- ▶ Pin the F-relapse support **18** in the transport position **P11**: Insert the pin **20** and secure it with the retaining element **19** to the brackets **21**.

### 7.3.25 Unpinning the F-assembly unit from the F-connector head

Make sure that the following prerequisites are met:

- The F-relapse retainer is pinned in the transport position.

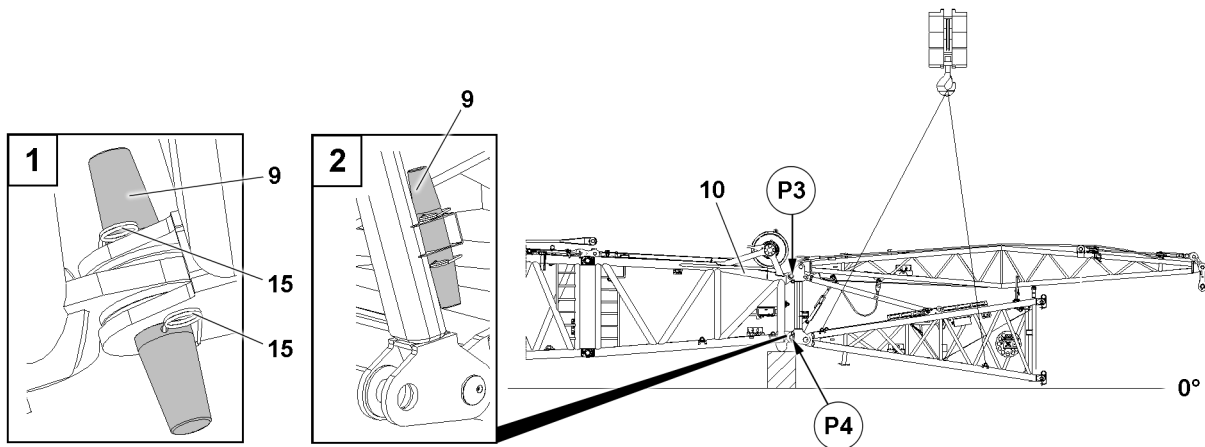


Fig.156895: Unpinning the F-assembly unit at the “bottom”

- 9 Pin
- 14 Rigging belt
- 15 Retaining element

Pin points:

- The F-assembly unit is unpinned twice from the F-connector head 10 in position P3.
- The F-assembly unit is unpinned twice from the F-connector head 10 in position P4.



**WARNING**

Standing within the boom system!  
Crushing / shearing of limbs-.  
Death, severe bodily injuries.

- ▶ Make sure that no crane movements are performed while unpinning in the area of the lower unpinning points.
  - ▶ Maintain a safety distance: Stay away from the lattice sections during unpinning.
- 
- ▶ Until the pins 9 are relieved in position P4: Lift or lower the F-assembly unit with the auxiliary crane.
  - ▶ Make sure that the pins in position P4 are relieved.
  - ▶ In position P4: Remove the retaining elements 15 and unpin the first pin 9.
  - ▶ In position P4: Remove the retaining elements 15 and unpin the second pin 9.
  - ▶ Insert the pin 9 in the transport retainer and secure with retaining elements 15.

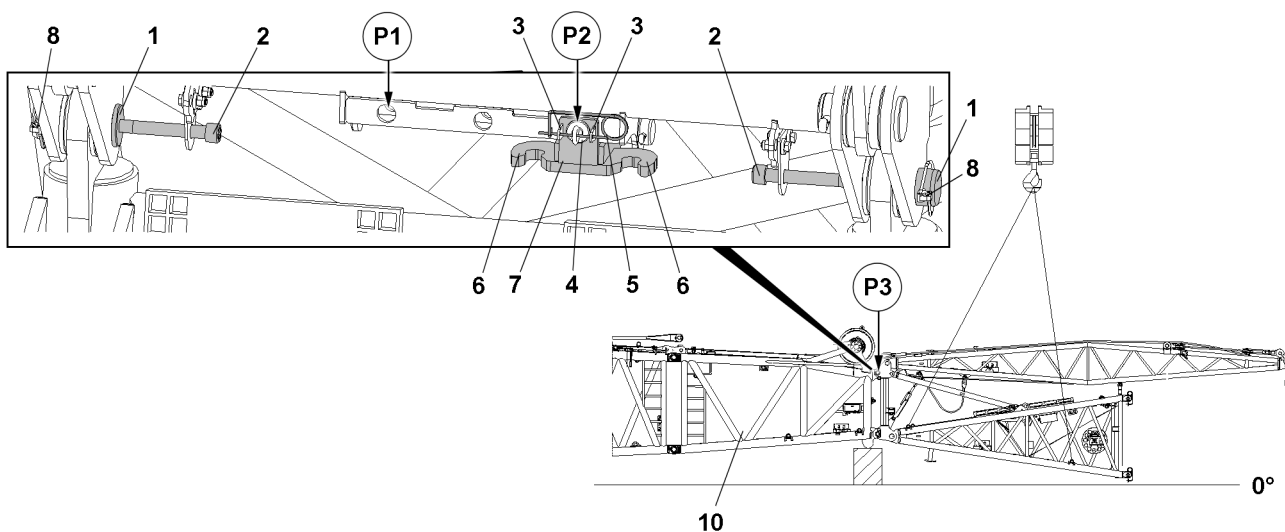


Fig.156896: Unpinning the F-assembly unit at the “top”

- 1 Pin
- 2 Screw
- 3 Brackets
- 4 Pin
- 5 Retaining element
- 6 Hook
- 7 Bracket
- 8 Retaining element
- 10 F-connector head

LWE/LR 1800-1-0-000/27200-07-02/en

The pins in position **P3** are unpinned with the pin pulling device.

Ascent to the F-connector head **10** via the installed ladder or basic unit. Follow the instructions, see chapter 2.06.

To attach the pin pulling cylinder, the bracket must be positioned and pinned depending on the unpinning point in position **P1** or position **P2**.

- ▶ Position the bracket **7** for the first pin **1**.
- ▶ Secure the pin **4** with the retaining element **5** to both brackets **3**.
- ▶ Connect the pin pulling device to the screw **2** and the hook **6**.
- ▶ First pin: Remove the retaining element **8** and unpin the pin **1**.
- ▶ Position, pin and secure the bracket **7** for the second pin **1**.
- ▶ Connect the pin pulling device to the screw **2** and the hook **6**.
- ▶ Second pin: Remove the retaining element **8** and unpin the pin **1**.
- ▶ Remove the F-assembly unit and take it down onto the ground or a substructure with sufficient load bearing capacity.

### 7.3.26 Preparing the F-assembly unit for transport

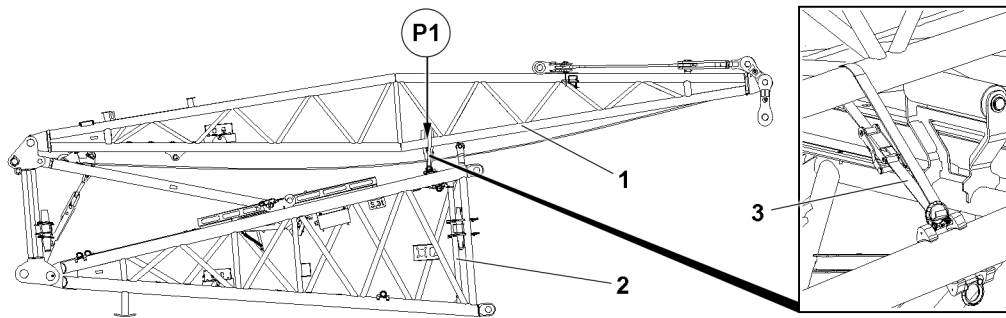


Fig.156897: Preparing the F-assembly unit for transport

- |   |                 |   |              |
|---|-----------------|---|--------------|
| 1 | FA-frame        | 3 | Rigging belt |
| 2 | F-pivot section |   |              |

- ▶ Rig the F-pivot section **2** and FA-frame **1** on both sides in position **P1** with the rigging belt **3**.

---

Empty page!

LWE/LR 1800-1-0-000/27200-07-02/en



## 5.14 Roller set

1	Roller set component overview	2
2	Fastening points for roller set	3
3	Assembling the roller set / roller sets	4
4	Disassembling the roller set / roller sets	10

# 1 Roller set component overview



## Note

- ▶ The roller set is marked with its own weight.
- ▶ Dimensions and weights, see the Crane operating instructions, chapter 1.03.

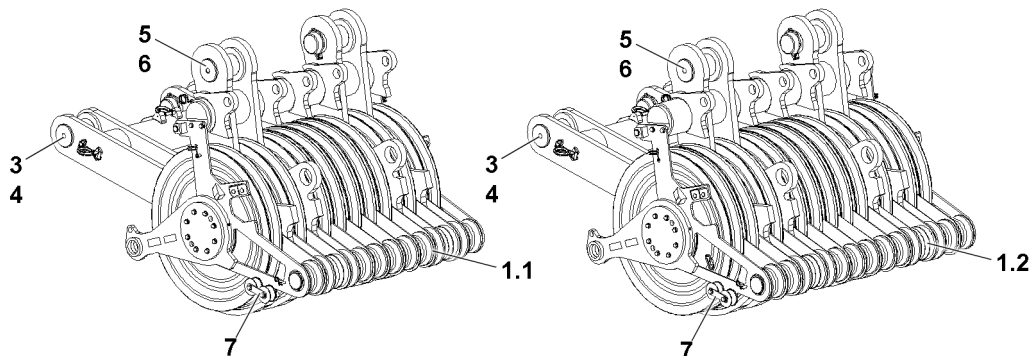


Fig.151411: Roller set component overview

Position	Component	Designation
1.1	Roller set 325 t	R9
1.2	Roller set 325 t	R11

Position	Component
3	Connector pin
4	Retaining element
5	Connector pin
6	Retaining element
7	Change over pulleys

Roller set component overview

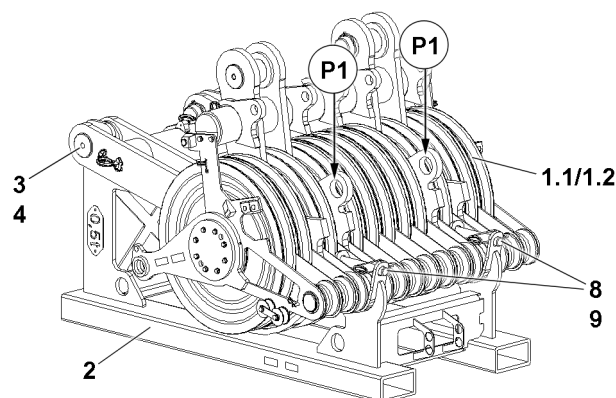


Fig.151410: Roller set with rack component overview

Position	Component
1.1/1.2	Roller set 325 t
2	Compartment
3	Connector pin
4	Retaining element
8	Retaining pin
9	Retaining element

*Roller set with rack component overview*

## 2 Fastening points for roller set



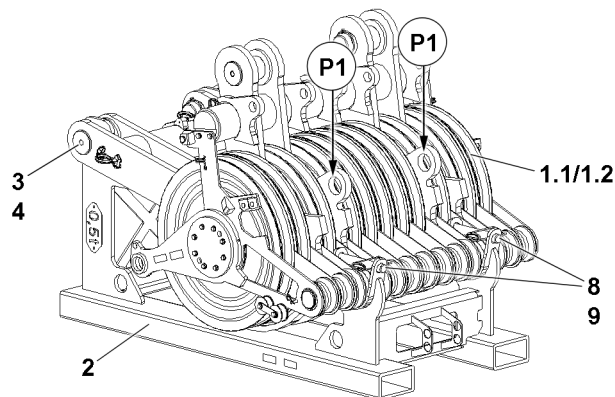
### WARNING

Component incorrectly fastened!

Life-threatening situations can arise due to improper or incorrect fastening of the corresponding components.

Death, severe bodily injuries, property damage.

- ▶ Fasten the components only on the intended fastening points on both sides.
- ▶ Fastening of components and description of fastening points, see Crane operating instructions, chapter 5.01.



*Fig.151410: Roller set fastening points*

Point	Component
P1	Roller set

*Roller set fastening points*

### 3 Assembling the roller set / roller sets



#### WARNING

Danger of falling!

During assembly / disassembly, inspection and maintenance work, personnel must be secured with appropriate aids to prevent them from falling.

Death, severe bodily injuries, property damage.

- ▶ All work at a height, when there is a danger of falling, must be carried out with suitable aids.
- ▶ If aids are not available and work cannot be carried out from the ground, then assembly personnel must secure themselves with the supplied fall arrest system to prevent falling, see the Crane operating instructions, chapter 2.04.
- ▶ If fall protection equipment is available, then it must be used, see the Crane operating instructions, chapter 2.06.
- ▶ When lifting, lowering, swinging crane parts in and out, no persons may remain in the danger zone.
- ▶ If railings are present on the components, then they must be brought into the corresponding position and secured for assembly / disassembly work.
- ▶ It is prohibited to lean the ladder against the component being disassembled.
- ▶ Only step on the aids, ladders and catwalks with clean shoes.
- ▶ Keep aids, ladders and catwalks free of heavy dirt, snow and ice.
- ▶ During all assembly and disassembly work, maintenance work and inspections, travel or crane operation is prohibited.
- ▶ Remaining on a suspended load is prohibited.
- ▶ Stepping or walking on crane components and lattice sections, which have an incline of more than 20° is prohibited.
- ▶ For all assembly work, the crane operator of the main crane must be in voice contact with the crane operator / crane operators of the auxiliary crane / auxiliary cranes.
- ▶ For assembly / disassembly tasks, the crane operator may only initiate crane movements when the responsible guide has explicitly released the movement.



#### WARNING

Danger of impact / crushing!

When installing / removing crane components with the auxiliary crane, crane components can start to swing back and forth.

When lifting / lowering and positioning crane components, there is an increased danger of impacts / crushing.

Death, severe bodily injuries, property damage.

- ▶ Make sure that personnel cannot be caught by components.
- ▶ When working in danger zones: Use aids to protect limbs.
- ▶ Guide components with suitable aids to minimize oscillation.



#### DANGER

The components can fall down!

If the corresponding component is disengaged from the auxiliary crane before the corresponding component is pinned, then the corresponding component can fall down.

Death, severe bodily injuries, property damage.

- ▶ Do not disengage the auxiliary crane until the respective component is pinned and secured.



#### WARNING

Falling roller set!

If the roller set is not pinned and secured correctly, then it can fall down.

Death, severe bodily injuries, property damage.

- ▶ Pin or unpin both pins, which are laying in one horizontal level.
- ▶ It is prohibited to stand under the roller set or within the complete danger zone during the pinning and unpinning procedure of the roller set.
- ▶ Safely secure the pins in the storage locations as well as in the receptacles.

**WARNING**

Overload of boom system!

If only one roller set is used and the roller set is assembled off center of the end section, then the boom system can be overloaded.

Death, severe bodily injuries, property damage.

- ▶ Observe the installation position of the roller set / the roller sets on the respective boom end section, see Reeving plan.

**WARNING**

The crane can topple over!

If the roller set is improperly assembled, the crane can topple over.

Death, severe bodily injuries, property damage.

- ▶ Observe the Erection and take down charts.
- ▶ Observe the load charts.
- ▶ Pay attention to the description on the roller set.

**WARNING**

Working below a suspended load!

The boom can fall down.

Death, severe bodily injuries, property damage.

- ▶ Make sure that the auxiliary crane is properly supported and horizontally aligned.
- ▶ Make sure that the utilization of the auxiliary crane is **maximum 90 %**.
- ▶ Make sure that the engine of the auxiliary crane is turned off for assembly of the roller sets.

**WARNING**

Impermissible fastening equipment!

The boom can fall down.

Death, severe bodily injuries, property damage.

- ▶ Use only inspected fastening equipment.

**WARNING**

Incorrectly assembled roller set!

The crane can fall over.

Death, severe bodily injuries, property damage.

- ▶ Make sure that the roller sets are installed in the correct positions, see the reeving plan.
- ▶ Pay attention to the description on the roller set.

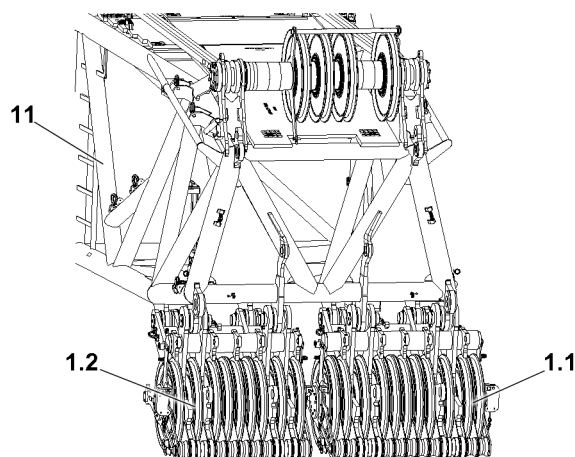


Fig.151420: Roller set

Make sure that the following prerequisites are met:

- The crane is horizontally aligned.
- The L-end section is approx. 2.00 m above the ground.
- The boom system is supported with materials with load bearing capacity.
- **or**
- The boom system is safely held by the auxiliary crane.
- An assembly scaffolding / work platform is available.
- A forklift is available.
- The feet on the L-end section are disassembled, see the Crane operating instructions, chapter 5.38.

### 3.1 Assembling the roller sets R9/R11 on the S or L end section



#### Note

- ▶ For assembly of the roller set on the main boom, the main boom can be held by its own main boom guying. Liebherr-Werk Ehingen GmbH recommends additionally securing the main boom during assembly of the roller set with an auxiliary crane with sufficient load carrying capacity or to support it with load bearing materials.



#### Note

- ▶ The assembly / disassembly of the roller sets R9 or R11 is identical and is described based on the example of roller set R11.
- ▶ The assembly / disassembly of the roller sets on the L-end section or on the S-end section is identical and is described based on the example of the L-end section.

Make sure that the following prerequisites are met:

- The connector pins are unpinned on the L-end section **11** in points **P2**.
- **or**
- The connector pins **5** on the roller set **1.1** on the rack **2** are unpinned.

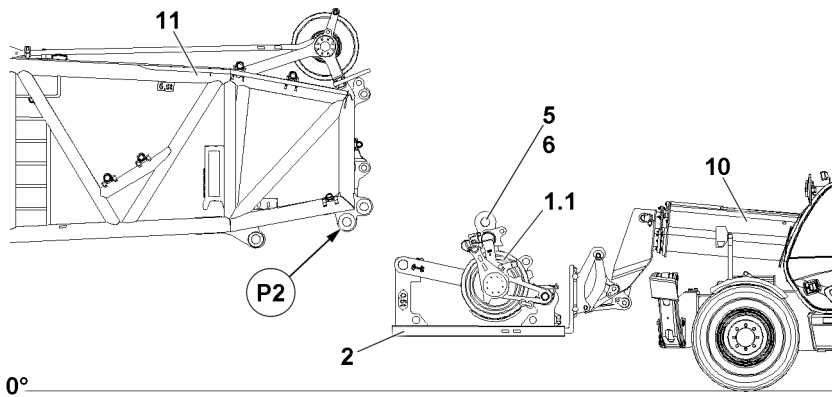


Fig.151413: Starting the roller set

- ▶ Lift the roller set **1.1** on the rack **2** with the forklift **10** and retract it to the pin points **P2**.
- ▶ Align the roller set **1.1** on the rack **2** with the forklift **10** on the pin bores at the points **P2**.

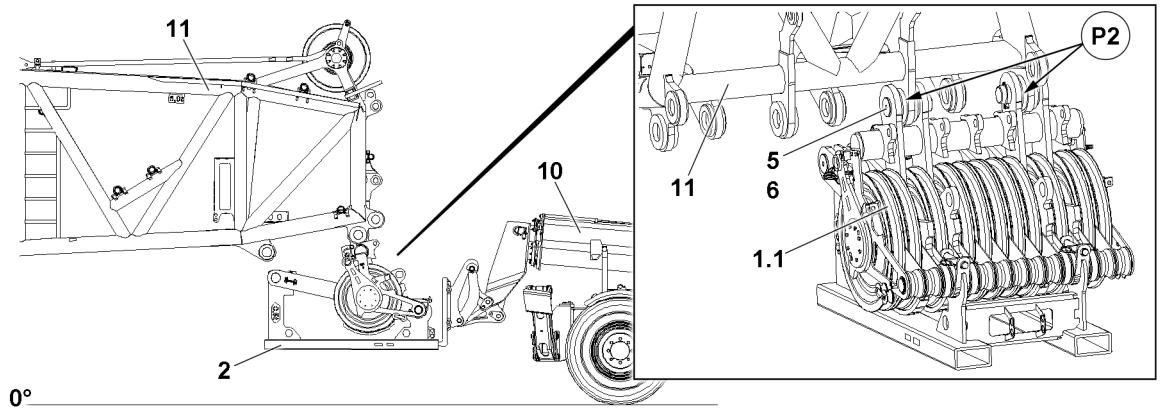


Fig.151414: Pinning the roller set

The roller set 1.1 is pinned a total of four times.

- ▶ Pin the roller set 1.1 in points P2 with the L-end section 11 twice: Insert the connector pin 5 and secure it with a retaining element 6.

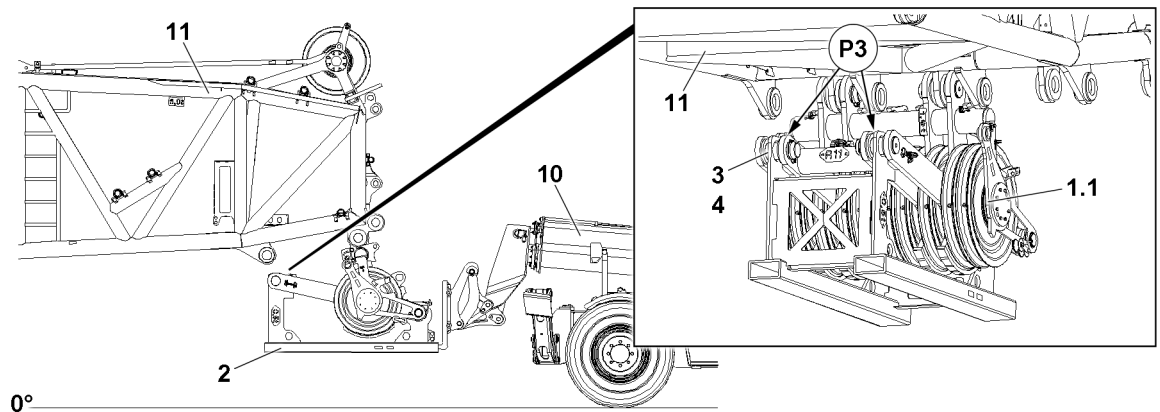


Fig.151415: Unpinning the roller set from the rack

- ▶ Unpin the roller set 1.1 in points P3 from the boom 2 twice: Remove the retaining element 4 and unpin the connector pin 3.

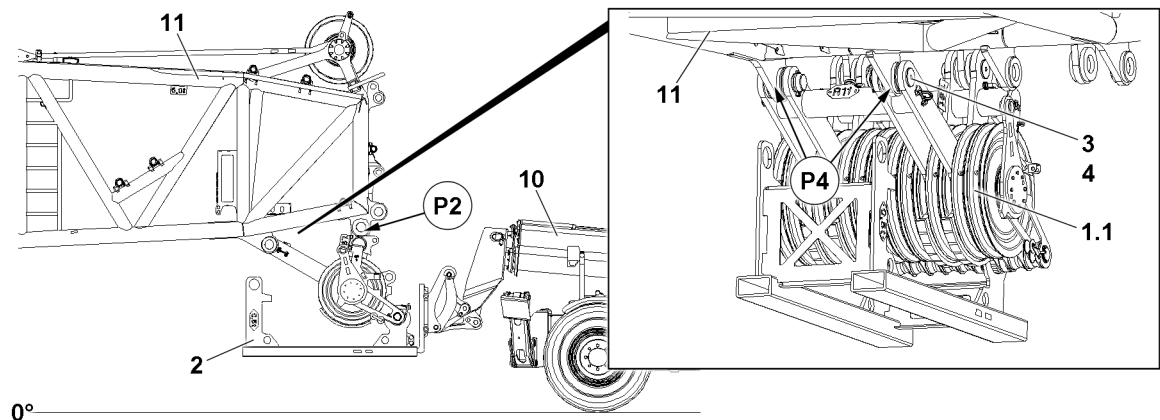


Fig.151416: Pinning the roller set

LWE/LR 1800-1-0-000/27200-07-02/en

When the roller set **1.1** is pinned and secured at points **P2**:

- ▶ Press the roller set **1.1** on the rack **2** with the forklift **10** until the roller set **1.1** can be pinned on the L-end section **11** in points **P4**.

When the pin bores align in points **P4**:

- ▶ Insert the connector pins **3** in points **P4** twice and secure with the retaining element **4**.

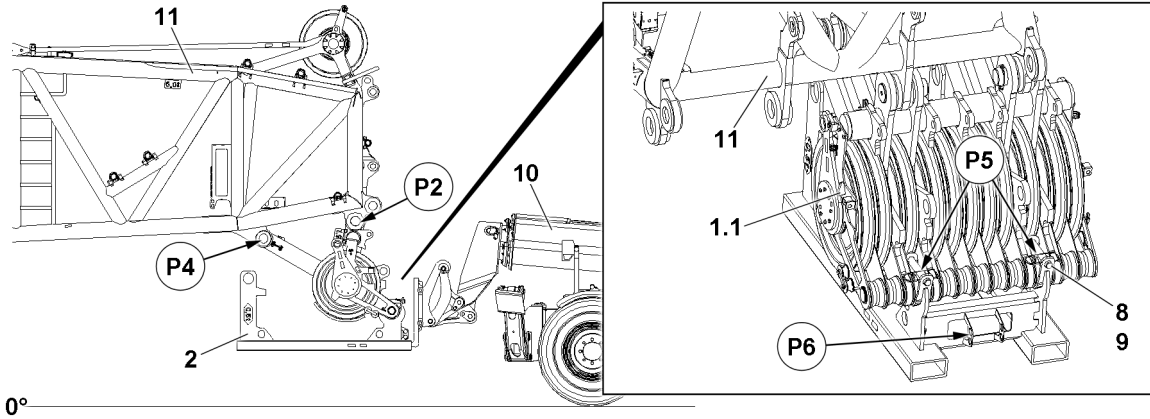


Fig.151417: Releasing the roller set from the rack

When the roller set **1.1** is pinned and secured at points **P2** and at points **P4**:

- ▶ Release the roller set **1.1** from the rack **2** in point **P5**: Remove the retaining element **9** twice and unpin the retaining pin **8**.
- ▶ Insert the retaining pin **8** in the park position on the rack **2** in point **P6** and secure with the retaining element **9**.
- ▶ Remove the rack **2** with the forklift **10**.

### 3.2 Assembling the hoist limit switch weight

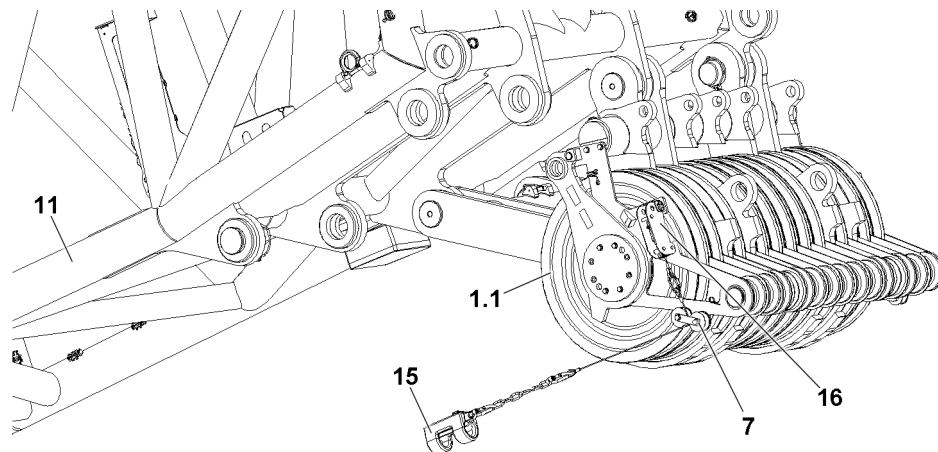


Fig.151418: Assembling the hoist limit switch weight



#### Note

- ▶ During assembly, pay attention to the correct position of the hoist limit switch **16**, see the Electric wiring diagram and the reeving plan.
- ▶ Connect the hoist limit switch weight **15** through the rope pulleys **7** with the hoist limit switch **16**.



### 3.3 Assembling the fixed point

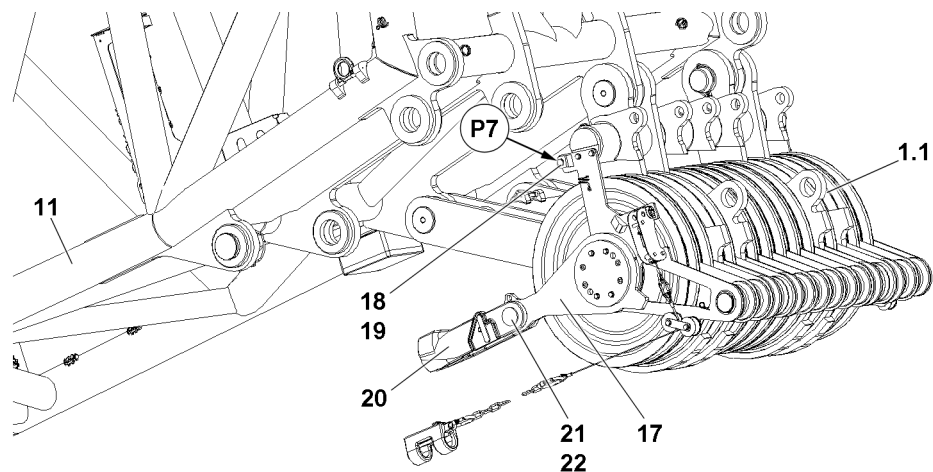


Fig.151419: Assembling the hoist limit switch weight



#### Note

- ▶ During assembly, pay attention to the correct position of the fixed point **17**, see the reeving plan.



#### WARNING

Fixed point swinging down!

The fixed point **17** can swing down by itself due to its own weight when unpinning in point **P7**.  
Death, severe bodily injuries.

Fingers and hands can be crushed.

- ▶ For safety reasons, assemble the fixed point **17** always with **two** persons!
  - ▶ When unpinning the fixed point, hold the fixed point **17**!
  - ▶ Do not reach with your hands into the danger zone!
- 
- ▶ Release the fixed point **17** in point **P7**: Remove the retaining element **19** and unpin the pin **18**.
  - ▶ Swing the fixed point **17**.
  - ▶ Assemble the rope lock **20** on the fixed point **17**: Insert the pin **21** and secure it with the retaining element **22**.

## 4 Disassembling the roller set / roller sets



### WARNING

Danger of falling!

During assembly / disassembly, inspection and maintenance work, personnel must be secured with appropriate aids to prevent them from falling.

Death, severe bodily injuries, property damage.

- ▶ All work at a height, when there is a danger of falling, must be carried out with suitable aids.
- ▶ If aids are not available and work cannot be carried out from the ground, then assembly personnel must secure themselves with the supplied fall arrest system to prevent falling, see the Crane operating instructions, chapter 2.04.
- ▶ If fall protection equipment is available, then it must be used, see the Crane operating instructions, chapter 2.06.
- ▶ When lifting, lowering, swinging crane parts in and out, no persons may remain in the danger zone.
- ▶ If railings are present on the components, then they must be brought into the corresponding position and secured for assembly / disassembly work.
- ▶ It is prohibited to lean the ladder against the component being disassembled.
- ▶ Only step on the aids, ladders and catwalks with clean shoes.
- ▶ Keep aids, ladders and catwalks free of heavy dirt, snow and ice.
- ▶ During all assembly and disassembly work, maintenance work and inspections, travel or crane operation is prohibited.
- ▶ Remaining on a suspended load is prohibited.
- ▶ Stepping or walking on crane components and lattice sections, which have an incline of more than 20° is prohibited.
- ▶ For all assembly work, the crane operator of the main crane must be in voice contact with the crane operator / crane operators of the auxiliary crane / auxiliary cranes.
- ▶ For assembly / disassembly tasks, the crane operator may only initiate crane movements when the responsible guide has explicitly released the movement.



### WARNING

Danger of impact / crushing!

When installing / removing crane components with the auxiliary crane, crane components can start to swing back and forth.

When lifting / lowering and positioning crane components, there is an increased danger of impacts / crushing.

Death, severe bodily injuries, property damage.

- ▶ Make sure that personnel cannot be caught by components.
- ▶ When working in danger zones: Use aids to protect limbs.
- ▶ Guide components with suitable aids to minimize oscillation.



### DANGER

The components can fall down!

If the corresponding component is disengaged from the auxiliary crane before the corresponding component is pinned, then the corresponding component can fall down.

Death, severe bodily injuries, property damage.

- ▶ Do not disengage the auxiliary crane until the respective component is pinned and secured.



### WARNING

The crane can topple over!

If the roller set is improperly assembled, the crane can topple over.

Death, severe bodily injuries, property damage.

- ▶ Observe the Erection and take down charts.
- ▶ Observe the load charts.
- ▶ Pay attention to the description on the roller set.

**WARNING**

Working below a suspended load!

The boom can fall down.

Death, severe bodily injuries, property damage.

- ▶ Make sure that the auxiliary crane is properly supported and horizontally aligned.
- ▶ Make sure that the utilization of the auxiliary crane is **maximum 90 %**.
- ▶ Make sure that the engine of the auxiliary crane is turned off for assembly of the roller sets.

**WARNING**

Impermissible fastening equipment!

The boom can fall down.

Death, severe bodily injuries, property damage.

- ▶ Use only inspected fastening equipment.

Make sure that the following prerequisites are met:

- The crane is horizontally aligned.
- The L-end section is approx. 2.00 m above the ground.
- The boom system is supported with materials with load bearing capacity.
- **or**
- The boom system is safely held by the auxiliary crane.
- The rope has been reeved out.
- An assembly scaffolding / work platform is available.
- A forklift is available.
- A rack is available.

## 4.1 Disassembling the fixed point

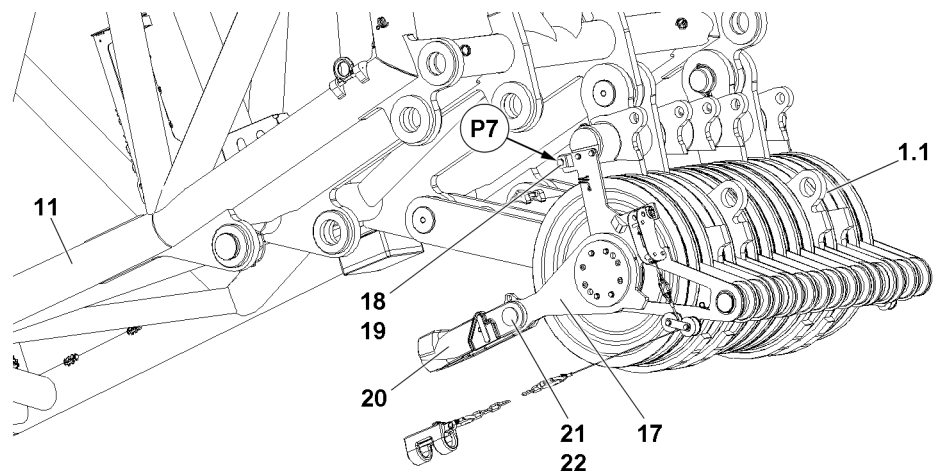


Fig.151419: Disassembling the fixed point

**WARNING**

Fixed point swinging down!

The fixed point **17** can swing down by itself due to its own weight when pinning in point **P7**.

Death, severe bodily injuries.

Fingers and hands can be crushed.

- ▶ For safety reasons, assemble the fixed point **17** always with **two** persons!
  - ▶ When pinning the fixed point, hold the fixed point **17**!
  - ▶ Do not reach with your hands into the danger zone!
- 
- ▶ Disassemble the rope lock **20** on the fixed point **17**: Remove the retaining element **22** and unpin the pin **21**.
  - ▶ Swing the fixed point **17** to point **P7**.
  - ▶ Secure the fixed point **17** in point **P7**: Insert the pin **18** and secure it with the retaining element **19**.

## 4.2 Disassembling the hoist limit switch weight

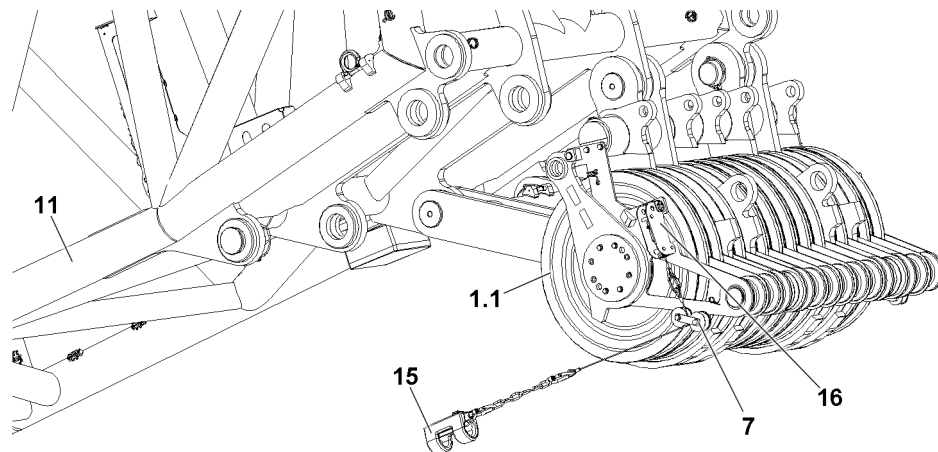


Fig.151418: Disassembling the hoist limit switch weight

- ▶ Disconnect the hoist limit switch weight **15** from the hoist limit switch **16**.

## 4.3 Disassembling the roller sets R9/R11 on the S or L end section



### Note

- ▶ For disassembly of the roller set on the main boom, the main boom can be held by its own main boom guying. Liebherr-Werk Ehingen GmbH recommends additionally securing the main boom during disassembly of the roller set with an auxiliary crane with sufficient load carrying capacity or to support it with load bearing materials.



### Note

- ▶ The assembly / disassembly of the roller sets R9 or R11 is identical and is described based on the example of roller set R11.
- ▶ The assembly / disassembly of the roller sets on the L-end section or on the S-end section is identical and is described based on the example of the L-end section.

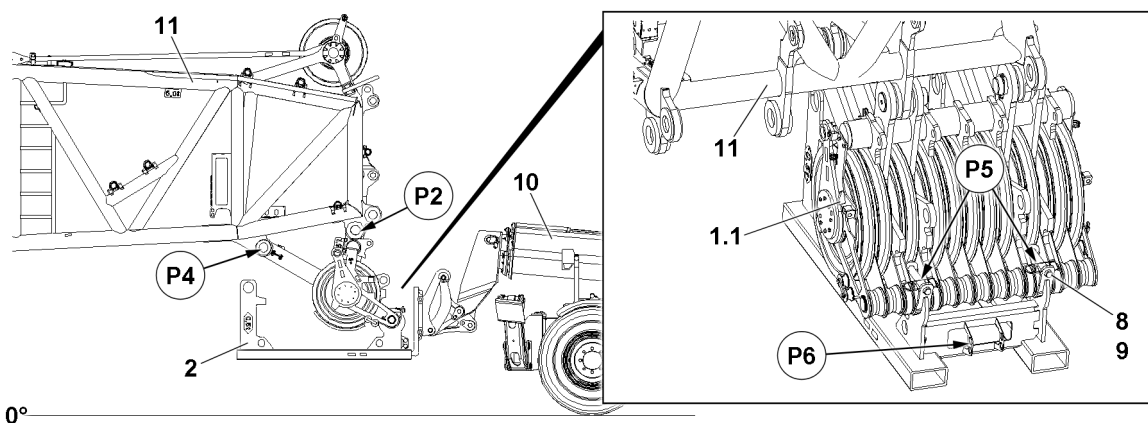


Fig.151417: Pinning the roller set with the rack

- ▶ Lift the rack **2** with the forklift **10** and retract it into the pin points **P5**.
- ▶ Align the rack **2** with the forklift **10** on the pin bores at points **P5**.
- ▶ Remove the retaining element **9** and unpin the retaining pin **8** from the parking position in point **P6**.

When the pin bores align in points **P5**:

- ▶ Insert the retaining pins **8** in points **P5** twice and secure with the retaining element **9**.

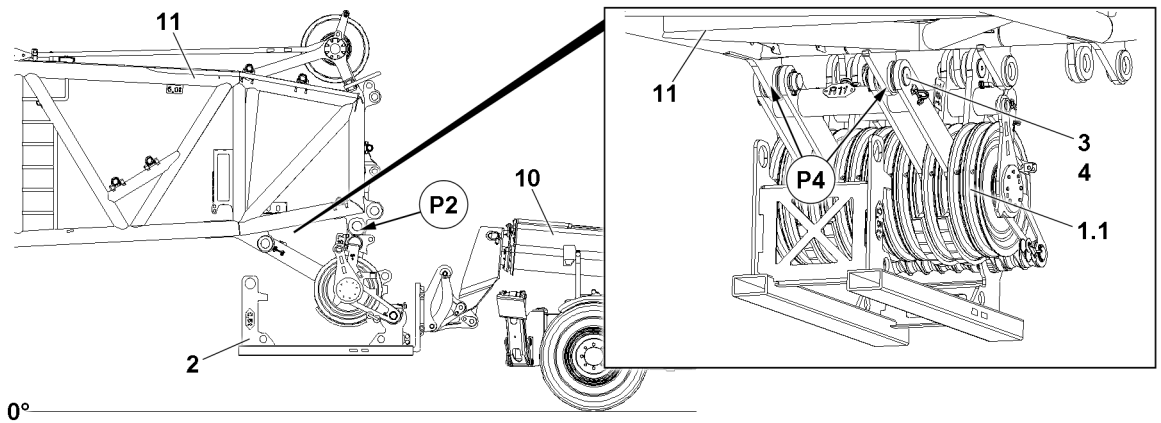


Fig. 151416: Unpinning the roller set from the L-end section

- ▶ Unpin the roller set 1.1 in points P4 from the L-end section 11 twice: Remove the retaining element 4 and unpin the connector pin 3.

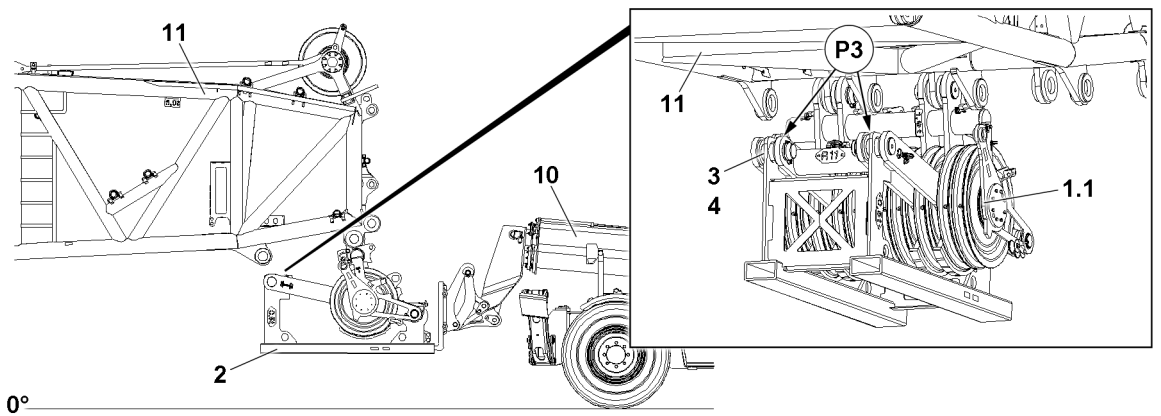


Fig. 151415: Pinning the roller set with the rack

When the roller set 1.1 is unpinned at points P4:

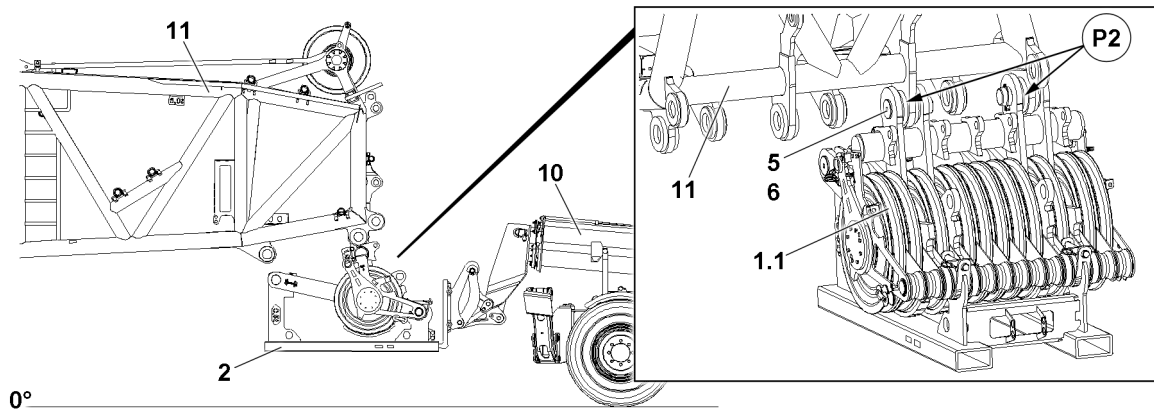
- ▶ Move back the rack 2 with the forklift 10 as far as possible until the roller set 1.1 can be pinned on the rack 2 at points P3.

When the pin bores align in points P3:

- ▶ Insert the connector pins 3 in points P3 twice and secure with the retaining element 4.

**Result:**

- The roller set 1.1 is pinned and secured with the rack 2.



*Fig.151414: Removing the roller set*

When the roller set **1.1** is pinned and secured with the rack **2** in point **P3**:

- ▶ Remove the retaining element **6** twice in points **P2** and unpin the connector pin **5**.
- ▶ Remove the roller set **1.1** on the rack **2** with the forklift **10**.
- ▶ Assemble the feet on the L-end section, see the Crane operating instructions, chapter 5.38.

## 5.15 Roller cart

1 Roller cart

2

LWE/LR 1800-1-0-000/27200-07-02/en

# 1 Roller cart

**Note**

▶ See chapter 5.61!



## 5.19 Hook blocks

1	Safety	2
2	Radio sending unit for the hook block incline indicator	2
3	Slack rope formation	3
4	Hook block or load hook fastening points for transport	4
5	Transporting the hook block or load hook with a forklift truck	5
6	Rope guard	5
7	Double hook block for single operation variation A	7
8	Double hook block for single operation variation B	11
9	Double hook block for parallel operation variation A	16
10	Double hook block for parallel operation variation B	23
11	Overview of the auxiliary weight fastening systems	31
12	Fastening system 1	34
13	Fastening system 2	36
14	Fastening system 3	38
15	Fastening system 4	40

# 1 Safety

Before using the hook block, observe the safety instructions.

- General safety information: See chapter 2.04.
- Information regarding the labeling of the load carriers: See chapter 2.05.10.
- Information regarding rope reeving: See chapter 4.06.
- Reeving plans

Differently sized hook blocks can be used for various load cases.

The load hooks and hook blocks approved for this crane type are listed in the load chart.

The hook blocks shown in this chapter are examples only and can deviate from the existing hook block.

For a detailed description of the hook block, see the separate Operating instructions from the hook block manufacturer.



## WARNING

Improper assembly!

Death, severe bodily injuries, property damage.

- ▶ Observe and adhere to the data in the erection and take-down charts.
- ▶ Observe and adhere to the data in the load charts.
- ▶ Assemble the hook block according to instruction.
- ▶ Observe and adhere to the minimum required hook block weight.

The maximum permissible own weight (WT max.) is engraved on the ballastable hook blocks.



## WARNING

Maximum permissible own weight of the hook block exceeded.

Hook block failure.

- ▶ Do **not** exceed the maximum permissible own weight (WT max.) of the hook block.



## WARNING

The hook block weight is too low!

Slack rope formation, spooling problems on the winches.

Death, severe bodily injuries, property damage.

- ▶ Avoid slack rope formation.
- ▶ Calculate the minimum required hook block weight before lifting the load.
- ▶ Select the weight of the hook block depending on the calculation.

When the hook block weight is too low:

- ▶ Select a heavier hook block or increase the hook block weight with auxiliary weights or modification kits.

## 2 Radio sending unit for the hook block incline indicator



### Note

Applies only for crane types with the hook block incline indicator.

In case of cranes with a separate description for the assembly and disassembly of the radio sending unit:

- ▶ Observe the Crane operating instructions, chapter 5.19.10.

## 3 Slack rope formation

If the hook block can no longer be lowered due to slack rope formation, then the following steps must be carried out.

### 3.1 Spooling up loose hoist rope

- ▶ Spool up loose hoist rope between the boom head and the winch carefully onto the winch.



---

**Note**

- ▶ A slight rope slack must remain between the boom head and the winch!
- 

### 3.2 Luffing the boom down

When luffing the boom down, the hoist rope length can shorten and the hook block can collide with the boom head.

---

**NOTICE**

Hoist rope too short!

Danger of collision.

- ▶ Do not pull the hook block against the boom head.
- 

- ▶ Luff the boom down carefully.

**Result:**

- The hoist rope between the boom head and the winch is tensioned.

### 3.3 Lowering the hook block

- ▶ Lower the hook block carefully with the winch.

## 4 Hook block or load hook fastening points for transport

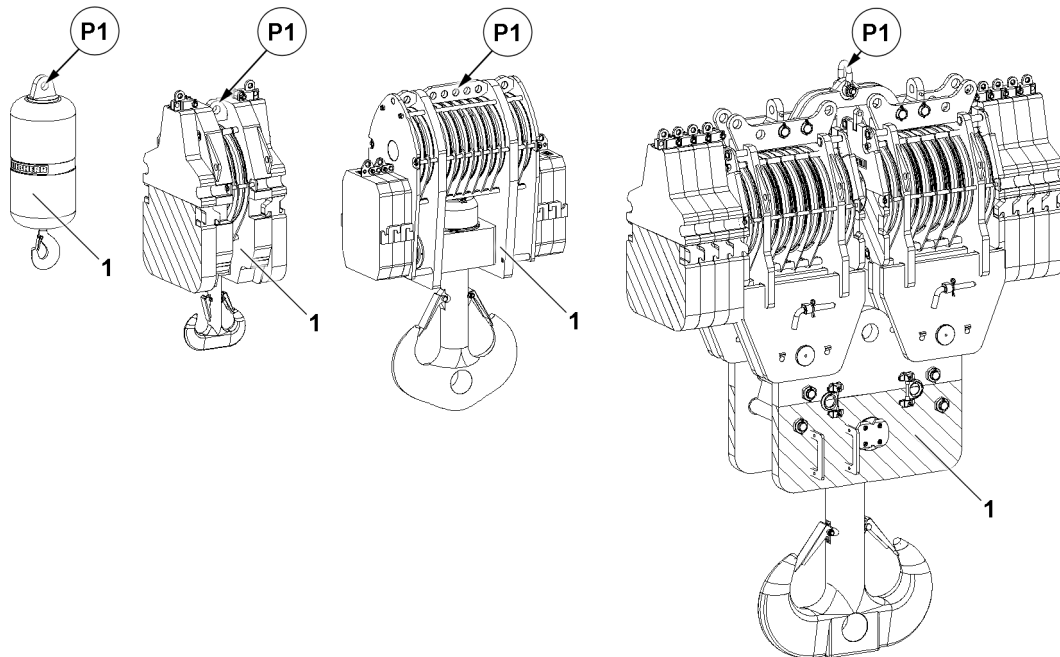


Fig.151986: Hook block or load hook fastening points



### WARNING

Hook block or load hook incorrectly fastened!  
Failure of the fastening points, the hook block or load hook **1** falls down.  
Death, severe bodily injuries, property damage.

- ▶ Fasten the hook block or load hook **1** exclusively in the center in the fastening point **P1**.
- ▶ In order to transport the double hook block, a shackle pursuant to DIN 82101 shall be provided that can carry at least the entire weight of the hook block.

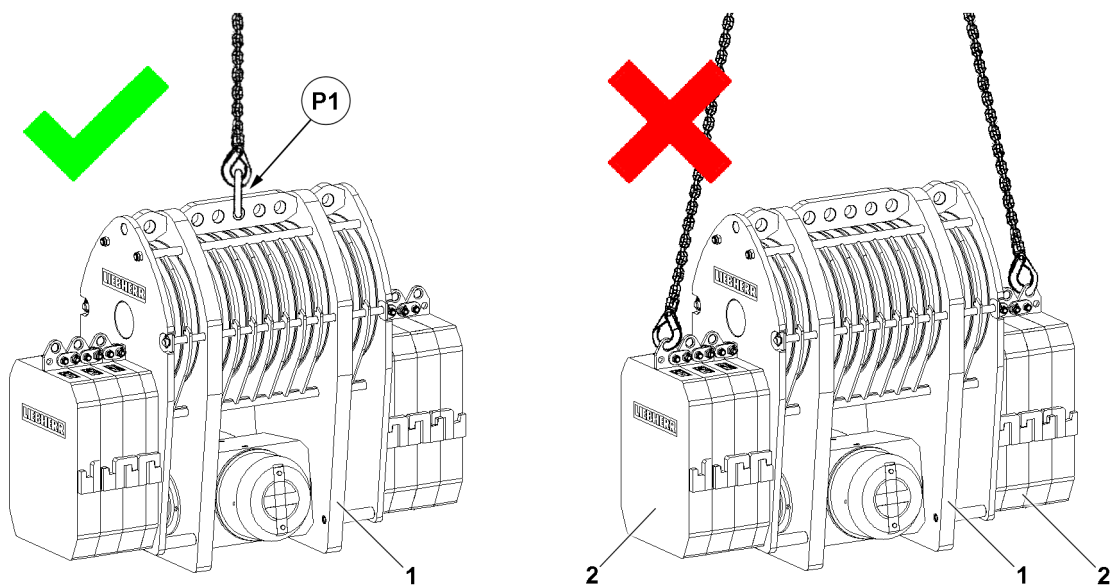


Fig.151985: Hook block fastening points

**WARNING**

Hook block incorrectly fastened!

Failure of the fastening points, the hook block **1** falls down.

Death, severe bodily injuries, property damage.

- ▶ Do **not** fasten the hook block **1** to the auxiliary weights **2**.
- ▶ Fasten the hook block **1** exclusively in the center in the fastening point **P1**.

## 5 Transporting the hook block or load hook with a forklift truck

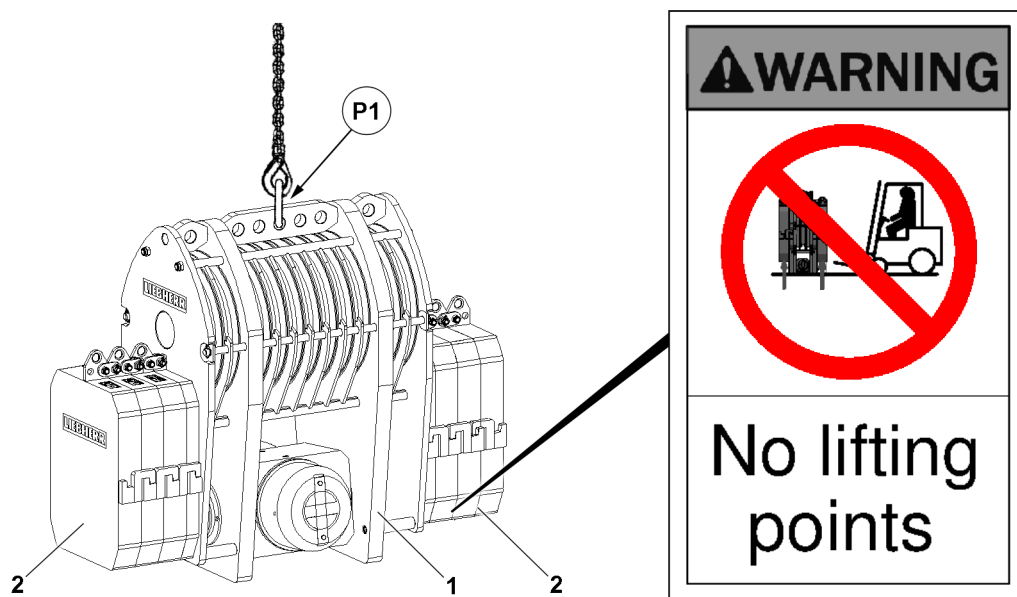


Fig.151987: Transporting the hook block or load hook

**WARNING**

Lifting the hook block on the additional weights with the forklift truck!

Failure of the additional weights, the hook block **1** falls down.

Death, severe bodily injuries, property damage.

- ▶ Do **not** lift the hook block **1** with a forklift truck on the auxiliary weights **2**.
- ▶ Take the hook block **1** or hook block components down for transport on a load bearing pallet or materials.

## 6 Rope guard

Rope guard systems are used to protect hands and guide the hoist rope.

A distinction is made between the following rope guard systems:

- Rope guard with rope guard pin
- Folding rope guard

The folding rope guard is only available as an option for certain crane types.

## 6.1 Rope guard pin

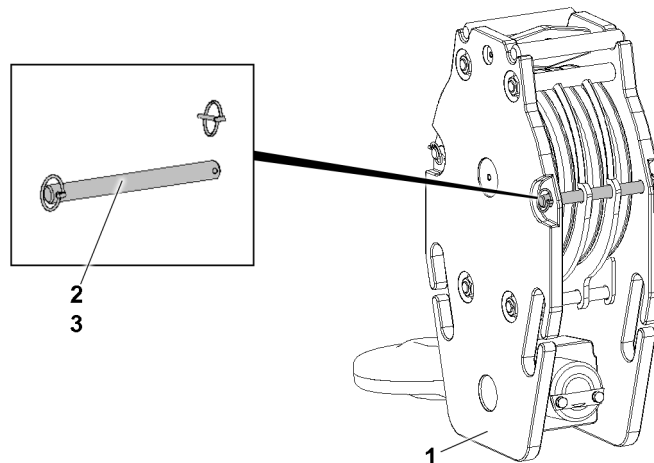


Fig.151988: Rope guard system-rope guard pins

Before assembly of the hoist rope, all rope guard pins 2 must be disassembled.

- ▶ Remove the retaining elements 3 and unpin the rope guard pin 2 on both sides.
- ▶ Reeve the hoist rope in.
- ▶ Insert the rope guard pin 2 on both sides and secure it with the retaining elements 3.

## 6.2 Folding rope guard

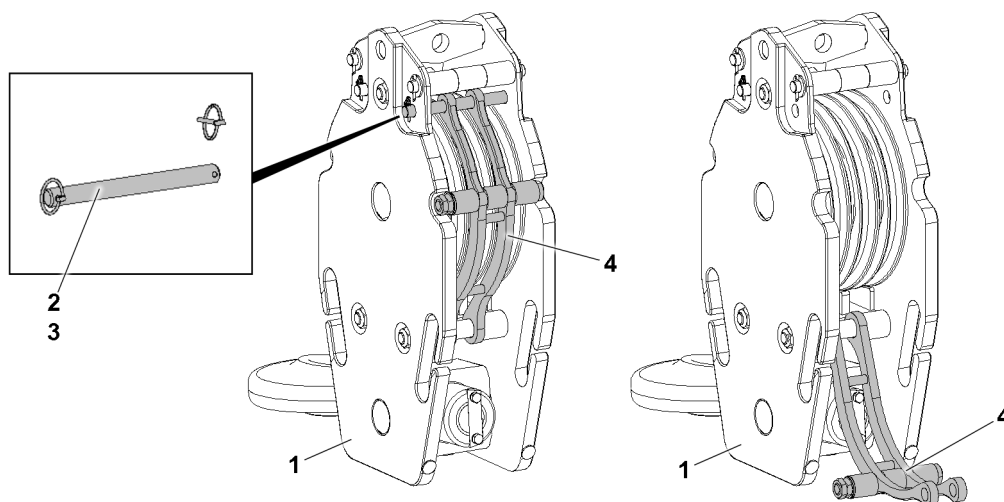


Fig.151989: Rope guard system-folding rope guard

Before assembly of the hoist rope, the folding rope guard 4 must be folded down.



### WARNING

Folding rope guard 4 not secured!  
Hands can be crushed.

- ▶ Before unpinning, secure the folding rope guard 4. Then fold it down.
- ▶ Remove the retaining element 3 and unpin the pin 2.
- ▶ Fold the folding rope guard 4 down completely.
- ▶ Reeve the hoist rope in.
- ▶ Fold the folding rope guard 4 up.

- ▶ Insert the pin **2** and secure it with the retaining element **3**.

## 7 Double hook block for single operation variation A

The assembly / disassemble is described as an example. Make sure that some of the steps must be performed on both sides.

### 7.1 Assembling the hook block

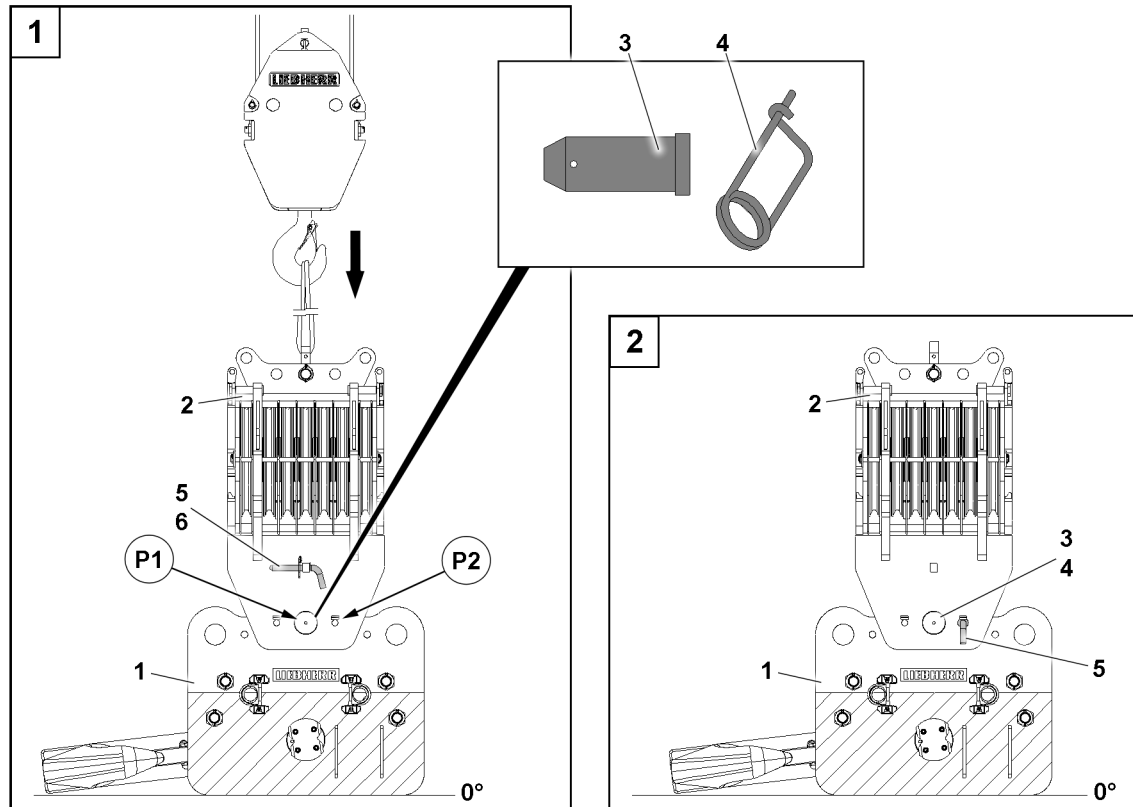


Fig.160641: Assembling the roller block on the cross beam

If the hook blocks are to be used in single operation, then the roller block **2** must be installed centered on the cross beam **1**.

#### 7.1.1 Assembling the roller block on the cross beam

Make sure that the following prerequisites are met:

- The ground is sufficiently load bearing to take on the weight of the hook block safely.
- The ground is level and horizontal.
- The cross beam **1** is taken down onto the ground.
- The pin **3** is unpinned.
- The retaining element **4** is available.

**WARNING**

Tipping of the roller block!

If the retaining pins **5** are not pinned on the cross beam during assembly of the roller block **2**, then the roller block **2** tips to the side when the auxiliary crane is removed.

Death, severe bodily injuries, property damage.

- ▶ Insert the retaining pin **5** into the bore in point **P2** on the hook block and secure.
- ▶ Make sure before removing the auxiliary crane that the roller block **2** is properly pinned and secured.

Position the roller block on the cross beam **1**:

- ▶ Fasten the roller block **2** to the auxiliary crane.
- ▶ Position the roller block **2** on the cross beam **1** and align it in point **P1**.

Insert the pin **3**:

- ▶ Insert the pin **3** in point **P1**.
- ▶ Secure the pin **3** with the retaining element **4**.

Secure the roller block **2** to prevent it from tipping over:

- ▶ Remove the retaining element **6** from the transport receptacle.
- ▶ Store the retaining element **6**.
- ▶ Unpin the retaining pin **5**.
- ▶ Insert the retaining pin **5** in point **P2**.
- ▶ Lock the retaining pin **5**.

When the roller block **2** is secured by the retaining pin **5**:

- ▶ Remove the auxiliary crane.

### 7.1.2 Assembling the auxiliary weights

**Note**

- ▶ Assemble the auxiliary weights, see section "Overview of the auxiliary weight fastening systems".

### 7.1.3 Preparing the hook block for crane operation

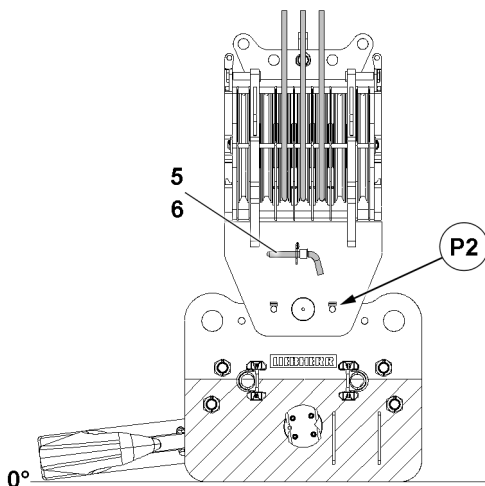


Fig.160642: Preparing the hook block for crane operation

**Note**

- ▶ The reeving in of the hook block is described in chapter 4.06 of the Crane operating instructions.
- ▶ Observe the "permissible hook block weights" in the erection and take down charts.



- ▶ Reeve the hoist rope in according to the instructions in chapter 4.06 of the Crane operating instructions and the reeving plans.

### NOTICE

Retaining pins **5** inserted when lifting the load!

If the retaining pin **5** is not unpinned in point **P2** prior to crane operation, then the retaining pin **5** may be shorn off when lifting the load.

- ▶ Unpin the retaining pin **5** from the hook block before crane operation.

When the hook block is properly reeved in and has been lifted off the ground:

- ▶ Unlock the retaining pin **5** in point **P2**.
- ▶ Unpin the retaining pin **5**.
- ▶ Insert the retaining pin **5** in the transport receptacle.
- ▶ Secure the retaining pin **5** with the retaining element **6**.

## 7.2 Disassembling the hook block

### 7.2.1 Preparing the hook block for disassembly

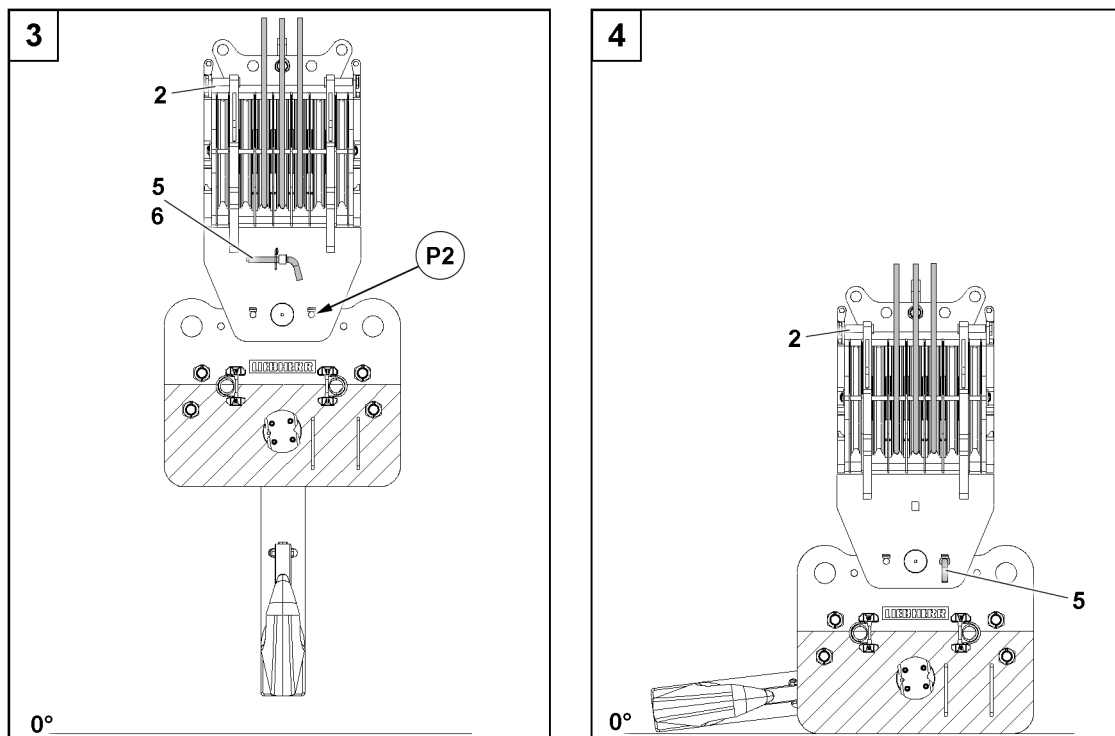


Fig.160644: Preparing the hook block for disassembly



### Note

- ▶ The reeving out of the hook block is described in chapter 4.06 of the Crane operating instructions.
- ▶ Observe the “permissible hook block weights” in the erection and take-down charts.

### NOTICE

Retaining pin **5** unpinned when setting down the hook block!

If the retaining pin **5** is not inserted before the roller block **2** is set down on the ground, it will tip over to the side.

Death, severe bodily injuries, property damage.

- ▶ Insert and secure the retaining pin **5**, before setting the hook block on the ground, in point **P2**.

Make sure that the following prerequisites are met:

- The ground is sufficiently load bearing to take on the weight of the hook block and the auxiliary weights safely.
- The ground is level and horizontal.

Secure the roller block **2** to prevent it from tipping over:

- ▶ Remove the retaining element **6** from the transport receptacle.
- ▶ Store the retaining element **6**.
- ▶ Unpin the retaining pin **5** from the transport receptacle.
- ▶ Insert the retaining pin **5** in point **P2**.
- ▶ Lock the retaining pin **5**.
- ▶ Lower the hook block completely to the ground.

When the hook block has been placed on the ground properly:

- ▶ Reeve out the hoist rope according to chapter 4.06 of the Crane operating instructions.

## 7.2.2 Disassembling the auxiliary weights



### Note

- ▶ Disassemble the auxiliary weights, see section “Overview of the auxiliary weight fastening systems”.

## 7.2.3 Disassembling the roller block on the cross beam

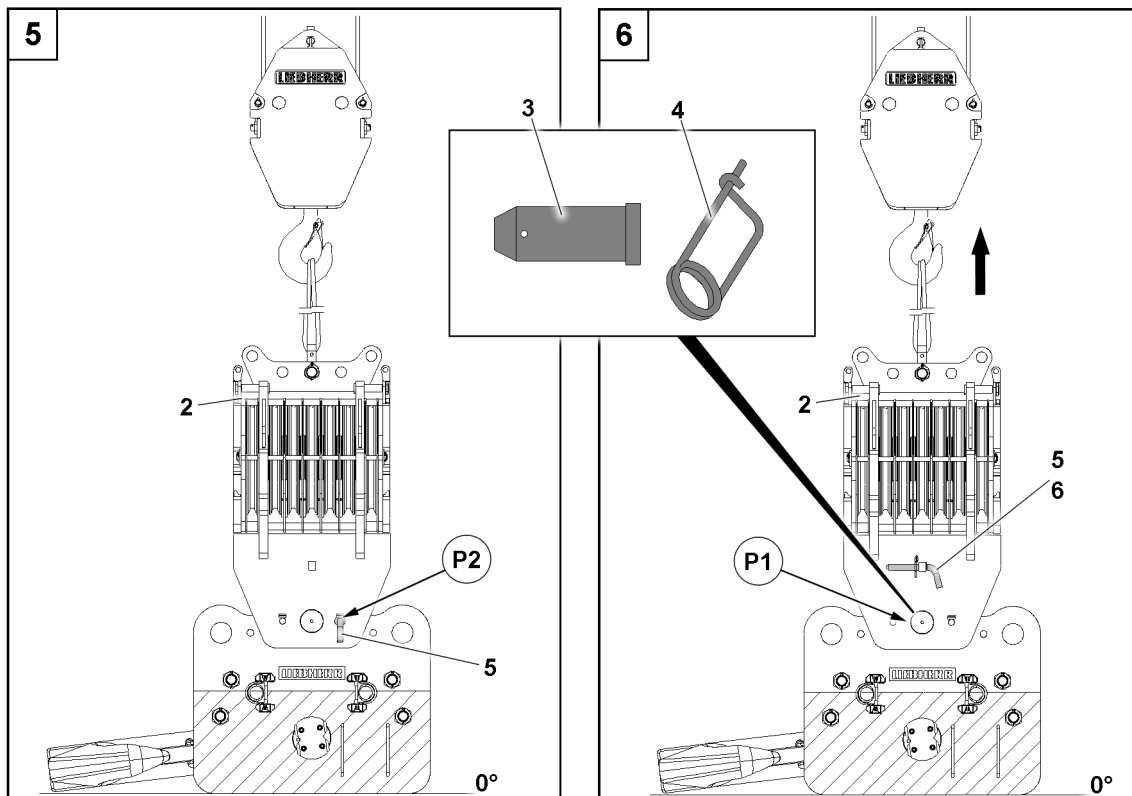


Fig.160645: Disassembling the roller block on the cross beam

Make sure that the following prerequisite is met:

- The auxiliary weights have been disassembled.
- ▶ Fasten the roller block **2** to the auxiliary crane.
- ▶ Tension the fastening equipment carefully.

When the fastening equipment on the roller block is tensioned:

- ▶ Unlock the retaining pin **5** in point **P2**.

- ▶ Unpin the retaining pin **5**.
- ▶ Insert the retaining pin **5** in the transport receptacle.
- ▶ Secure the retaining pin **5** with the retaining element **6**.

Unpin the pin **3**:

- ▶ Remove the retaining element **4** in point **P1**.
- ▶ Unpin the pin **3**.

Remove the roller block **2**:

- ▶ Swing the roller block **2** out with auxiliary crane.
- ▶ Place the roller block **2** on the ground.
- ▶ Remove the auxiliary crane.

## 8 Double hook block for single operation variation B

The assembly / disassemble is described as an example. Make sure that some of the steps must be performed on both sides.

### 8.1 Assembling the hook block

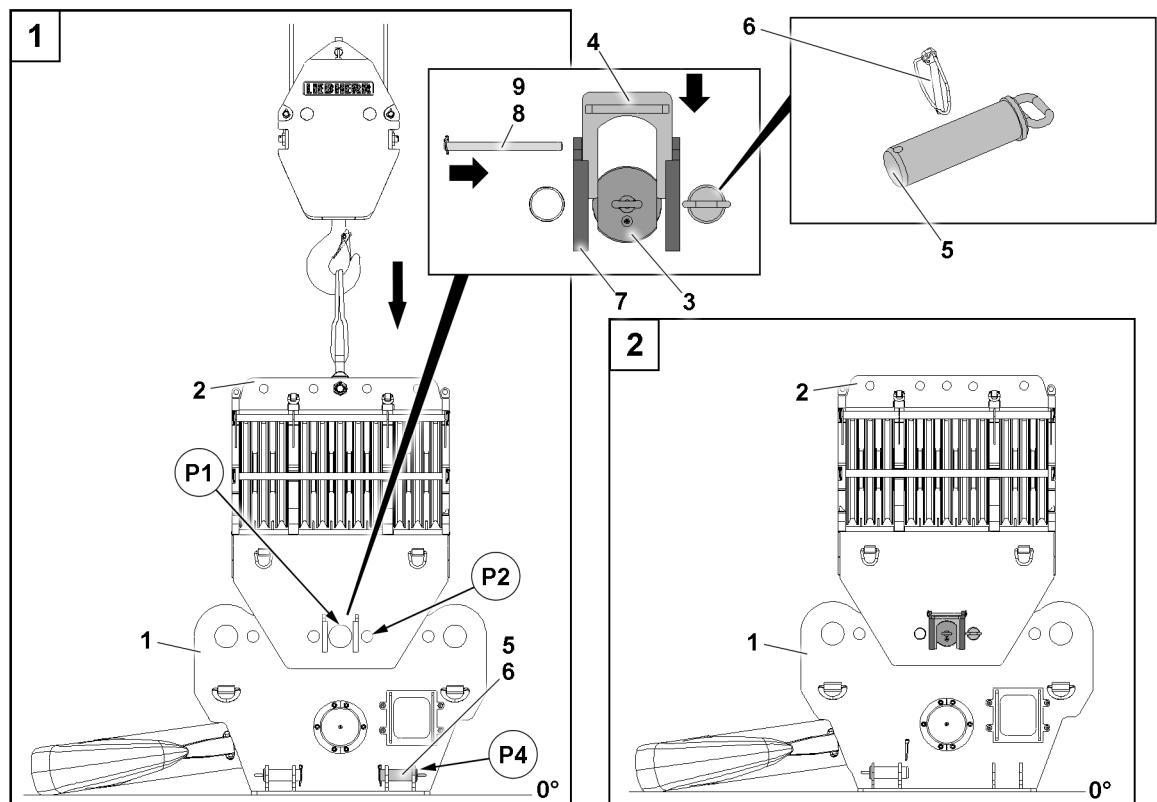


Fig.160629: Assembling the roller block on the cross beam

If the hook blocks are to be used in single operation, then the roller block **2** must be installed centered on the cross beam **1**.

### 8.1.1 Assembling the roller block on the cross beam

Make sure that the following prerequisites are met:

- The ground is sufficiently load bearing to take on the weight of the hook block safely.
- The ground is level and horizontal.
- The cross beam **1** is taken down onto the ground.
- The pin **3** is unpinned.
- The retaining plate **4** is available.
- The retaining pin **8** and the retaining elements **9** are available.



#### WARNING

Tipping of the roller block!

If the retaining pins **5** are not pinned on the cross beam during assembly of the roller block **2**, then the roller block **2** tips to the side when the auxiliary crane is removed.

Death, severe bodily injuries, property damage.

- ▶ Insert the retaining pin **5** in the bore in point **P2** on the hook block.
- ▶ Make sure before removing the auxiliary crane that the roller block **2** is properly pinned and secured.

- ▶ Fasten the roller block **2** to the auxiliary crane.
- ▶ Position the roller block **2** on the cross beam **1** and align it in point **P1**.

Insert the pin **3**:

- ▶ Insert the pin **3** in point **P1**.
- ▶ Push the retaining plate **4** in the guide rails **7** to the stop.
- ▶ Insert the retaining pin **8** in the guide rails **7**.
- ▶ Secure the retaining pins **8** with retaining elements **9** on both sides.

Secure the roller block **2** to prevent it from tipping over:

- ▶ Release the retaining pin **5** in point **P4** with the retaining element **6**.
- ▶ Unpin the retaining pin **5** from the transport receptacle in point **P4**.
- ▶ Insert the retaining pin **5** in the bore in point **P2**.
- ▶ Secure the retaining pin **5** with the retaining element **6**.

When the roller block **2** is secured by the retaining pin **5**:

- ▶ Remove the auxiliary crane.

### 8.1.2 Assembling the auxiliary weights



#### Note

- ▶ Assemble the auxiliary weights, see section "Overview of the auxiliary weight fastening systems".

### 8.1.3 Preparing the hook block for crane operation

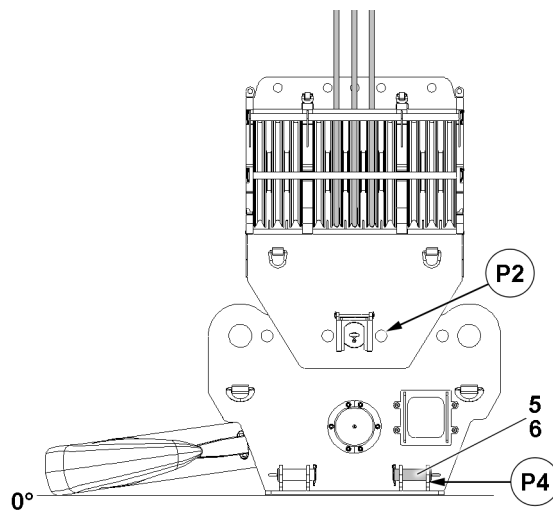


Fig.160630: Preparing the hook block for crane operation



#### Note

- ▶ The reeving in of the hook block is described in chapter 4.06 of the Crane operating instructions.
  - ▶ Observe the “permissible hook block weights” in the erection and take down charts.
- 
- ▶ Reeve the hoist rope in according to the instructions in chapter 4.06 of the Crane operating instructions and the reeving plans.

#### NOTICE

Retaining pins **5** inserted when lifting the load!

If the retaining pin **5** is not unpinned in points **P2** prior to crane operation, then the retaining pin **5** may be shorn off when lifting the load.

- ▶ Unpin the retaining pin **5** from the hook block before crane operation.

When the hook block is properly reeved in and has been lifted off the ground:

- ▶ Remove the retaining element **6** in point **P2**.
- ▶ Unpin the retaining pin **5**.
- ▶ Insert the retaining pin **5** in the transport receptacle in point **P4**.
- ▶ Secure the retaining pin **5** with the retaining element **6**.

## 8.2 Disassembling the hook block

### 8.2.1 Preparing the hook block for disassembly

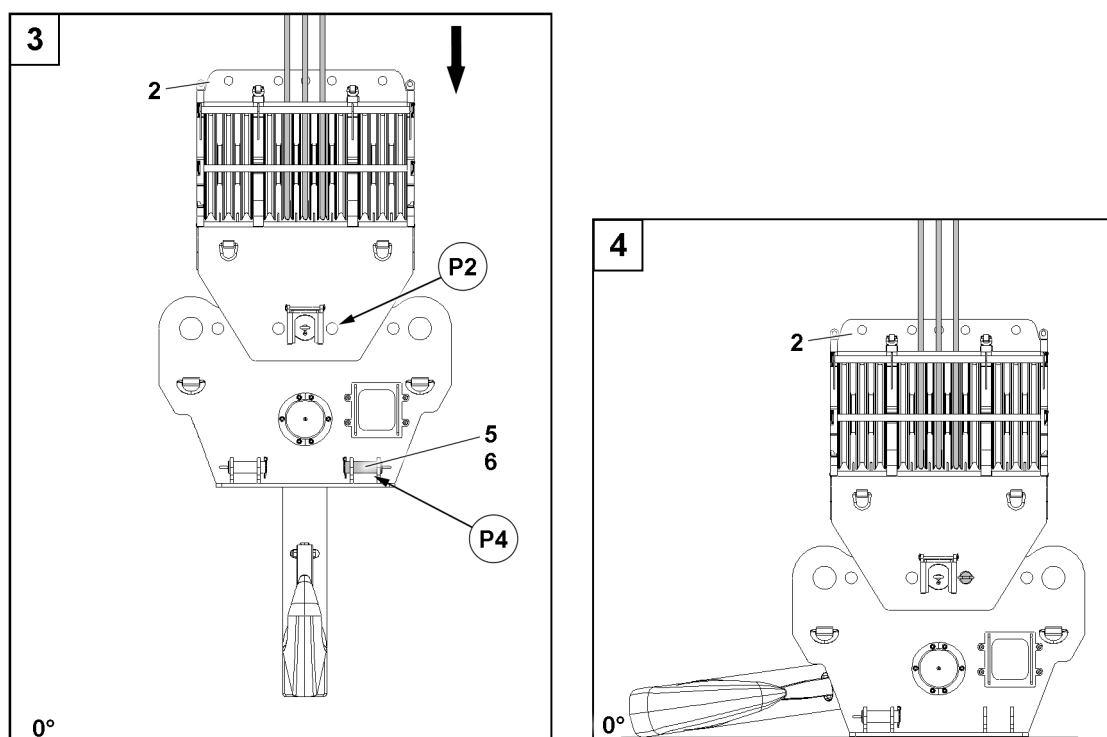


Fig.160631: Preparing the hook block for disassembly



#### Note

- ▶ The reeving out of the hook block is described in chapter 4.06 of the Crane operating instructions.
- ▶ Observe the “permissible hook block weights” in the erection and take-down charts.

#### NOTICE

Retaining pin **5** unpinned when setting down the hook block!

If the retaining pin **5** is not inserted before setting the hook block on the ground, the roller block **2** tips over to the side when it is set down.

Death, severe bodily injuries, property damage.

- ▶ Insert and secure the retaining pin **5**, before setting the hook block on the ground, in point **P2**.

Make sure that the following prerequisites are met:

- The ground is sufficiently load bearing to take on the weight of the hook block and the auxiliary weights safely.
- The ground is level and horizontal.
- ▶ Release the retaining pin **5** in point **P4** with the retaining element **6**.
- ▶ Unpin the retaining pin **5** in point **P4**.
- ▶ Insert the retaining pin **5** in point **P2**.
- ▶ Secure the retaining pin **5** in point **P2** with the retaining element **6**.

When the hook block has been placed on the ground properly:

- ▶ Reeve out the hoist rope according to chapter 4.06 of the Crane operating instructions.

## 8.2.2 Disassembling the auxiliary weights



### Note

- ▶ Disassemble the auxiliary weights, see section “Overview of the auxiliary weight fastening systems”.

## 8.2.3 Disassembling the roller block on the cross beam

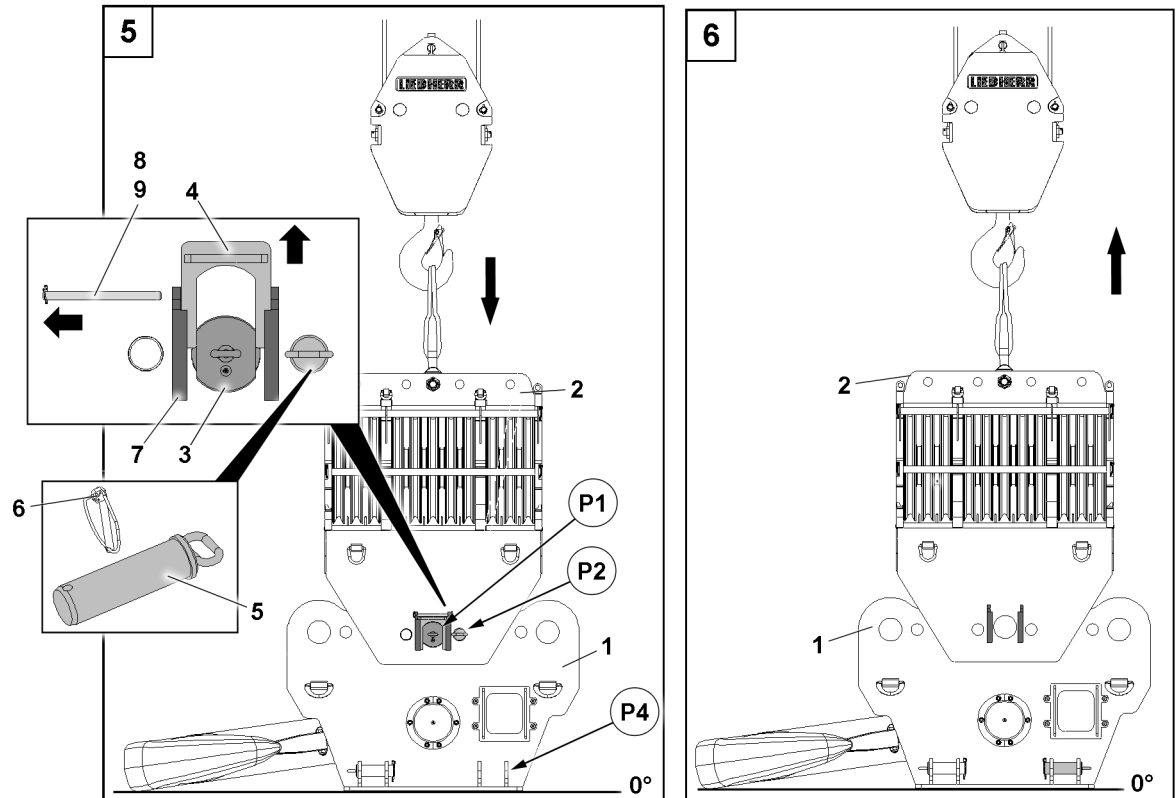


Fig.160632: Disassembling the roller block on the cross beam

Make sure that the following prerequisite is met:

- The auxiliary weights have been disassembled.

- ▶ Fasten the roller block **2** to the auxiliary crane.
- ▶ Tension the fastening equipment carefully.

When the fastening equipment on the roller block is tensioned:

- ▶ Remove the retaining element **6** in point **P2**.
- ▶ Unpin the retaining pin **5**.
- ▶ Insert the retaining pin **5** in point **P4**.
- ▶ Secure the retaining pin **5** in the transport receptacle point **P4** with the retaining element **6**.

Unpin the pin **3**:

- ▶ Remove the retaining element **9** on the retaining pin in point **P3**.
- ▶ Unpin the retaining pin **8** in the guide rails **7**.
- ▶ Push the retaining plate **4** out of the guide rails **7**.
- ▶ Unpin the pin **3**.

Remove the roller block **2**:

- ▶ Swing the roller block **2** out with auxiliary crane.
- ▶ Place the roller block **2** on the ground.
- ▶ Remove the auxiliary crane.

## 9 Double hook block for parallel operation variation A

The assembly / disassemble is described as an example. Make sure that some of the steps must be performed on both sides.

### 9.1 Assembling the hook block

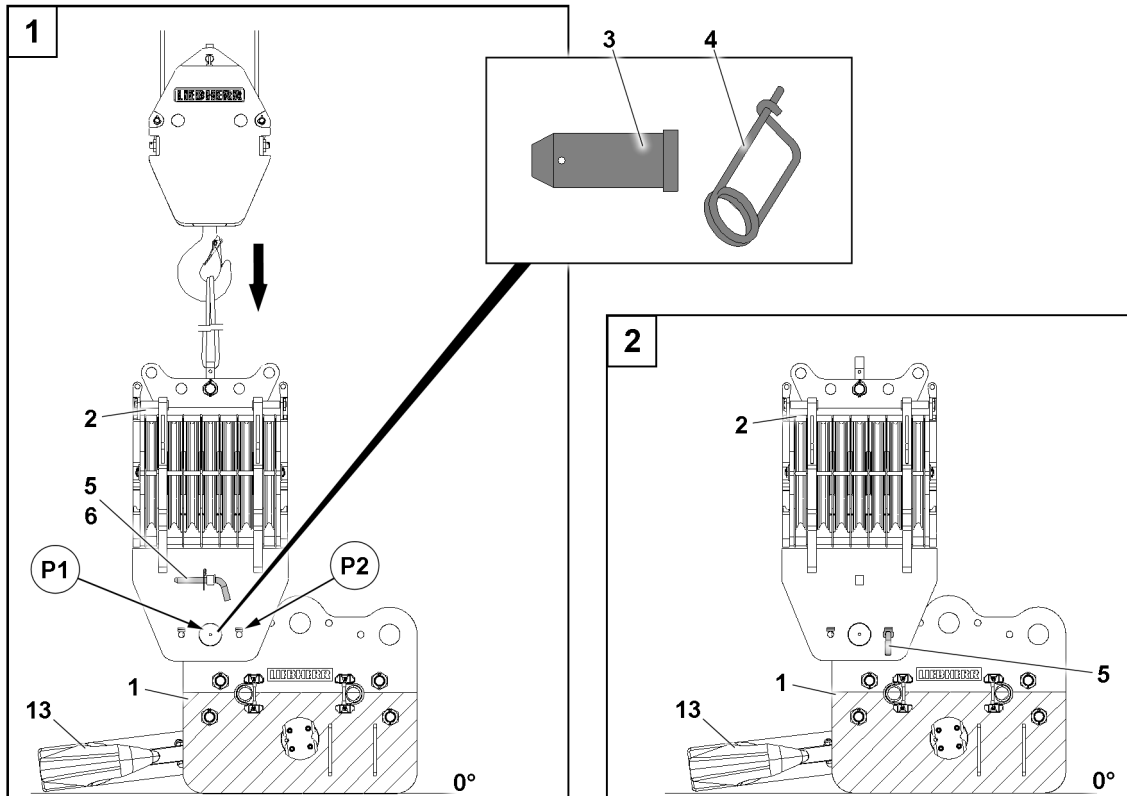


Fig.160406: Assembling a double hook block for parallel operation

If the hook blocks are to be used in parallel operation, then the roller blocks **2** must be installed on the left and right on the cross beam **1**.

#### 9.1.1 Assembling the roller blocks on the cross beam

Make sure that the following prerequisites are met:

- The ground is sufficiently load bearing to take on the weight of the hook block safely.
- The ground is level and horizontal.
- The cross beam **1** is taken down onto the ground.
- The pin **3** is unpinned.
- The retaining element **4** is available.



#### **DANGER**

Tipping of the roller blocks!

If the retaining pin **5** is not inserted in the cross beam during assembly of the roller blocks **2**, the roller blocks tip over to the side when the auxiliary crane is removed.

Death, severe bodily injuries, property damage.

- ▶ Insert the retaining pin **5** in the bore in point **P2** on the hook block.
- ▶ Make sure before removing the auxiliary crane that the roller blocks **2** are properly pinned and secured.



**Note**

- ▶ The assembly of two roller blocks **2** is identical and is described based on the example of one roller block.

Position the roller block on the cross beam:

- ▶ Fasten the roller block **2** to the auxiliary crane.

**WARNING**

Tipping of the hook block!

- ▶ Assemble the first roller block **2** on the side of the hook **13**, see illustration.

- ▶ Position the roller block **2** on the cross beam **1** and align it in point **P1**.

Insert the pin **3**:

- ▶ Insert the pin **3** in point **P1**.
- ▶ Secure the pin **3** with the retaining element **4**.

Secure the roller block **2** to prevent it from tipping over:

- ▶ Remove the retaining element **6** from the transport receptacle.
- ▶ Store the retaining element **6**.
- ▶ Unpin the retaining pin **5**.
- ▶ Insert the retaining pin **5** in the bore in point **P2**.
- ▶ Lock the retaining pin **5**.
- ▶ Remove the auxiliary crane.

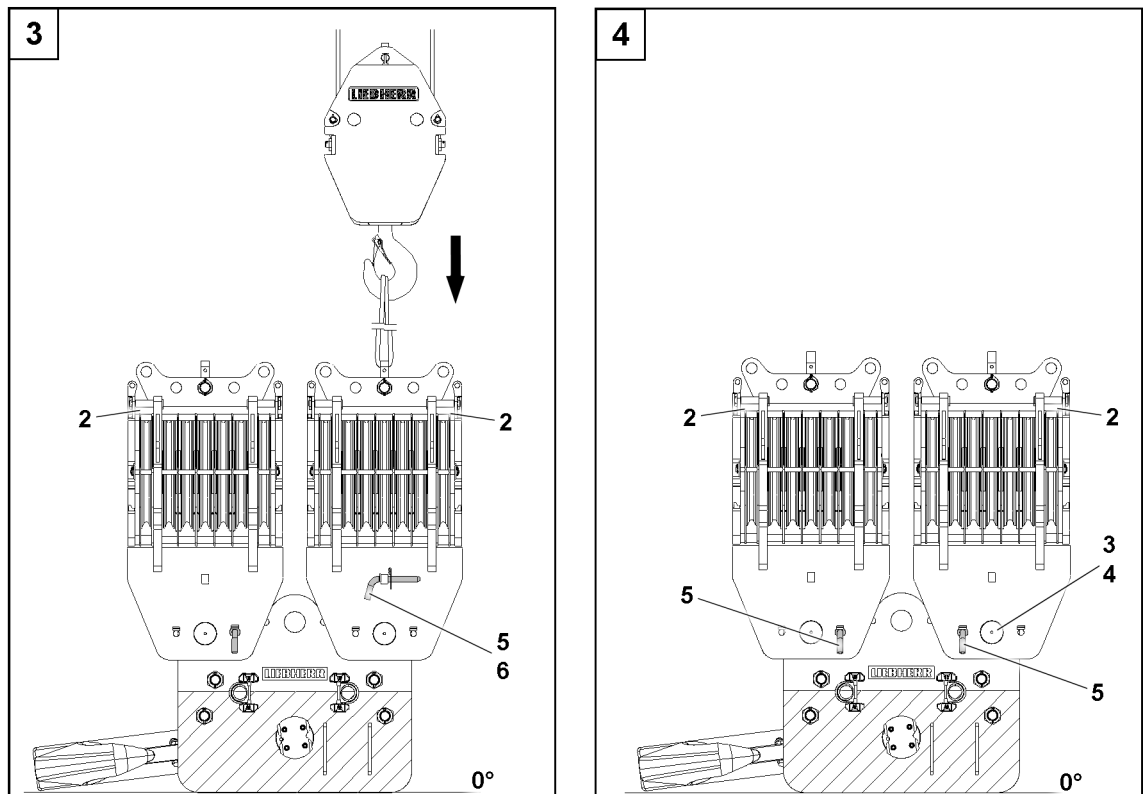


Fig.160647: Assembling the second roller block

When the roller block **2** is secured by the retaining pin **5** and retaining element **6**:

- ▶
- ▶ Fasten the second roller block **2** to the auxiliary crane.
- ▶ Assemble the second roller block **2**.
- ▶ Secure the second roller block **2**.
- ▶ Removing the auxiliary crane

### 9.1.2 Assembling the block connector

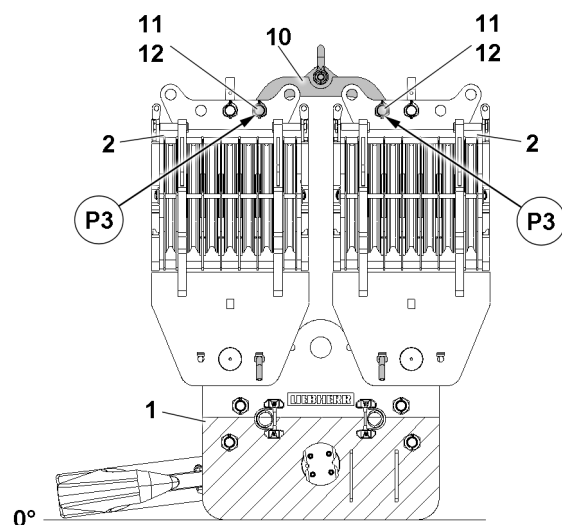


Fig.160648: Assembling the block connector

Make sure that the following prerequisite is met:

- Two roller blocks **2** are assembled and secured on the cross beam **1**.

Both roller blocks **2** are pinned with the block connector **10**:

- ▶ Fasten the block connector **10** to the auxiliary crane.
- ▶ Position the block connector **10** with auxiliary crane in the pin position.
- ▶ Insert the pin **11** on both sides on the roller blocks **2** in points **P3**.
- ▶ Secure the pin **11** with the retaining element **12**.

When the block connector **10** is pinned and secured properly:

- ▶ Remove the auxiliary crane.

### 9.1.3 Assembling the auxiliary weights



#### Note

- ▶ Disassemble the auxiliary weights, see section "Overview of the auxiliary weight fastening systems".

### 9.1.4 Preparing the hook block for crane operation

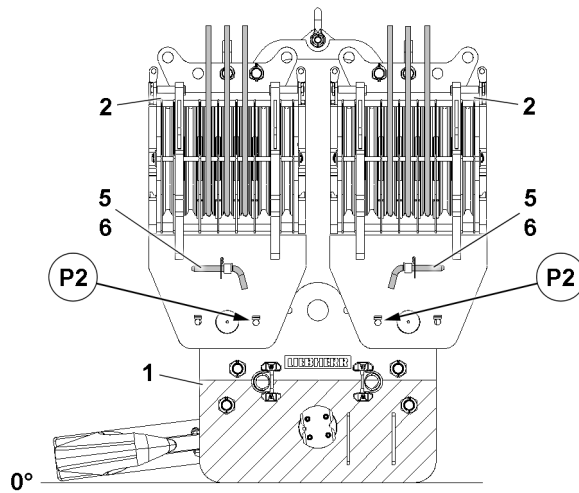


Fig. 160649: Preparing the hook block for crane operation



#### Note

- ▶ The reeving in of the hook blocks is described in chapter 4.06 of the Crane operating instructions.
  - ▶ Observe the “permissible hook block weights” in the erection and take down charts.
- 
- ▶ Reeve the hoist rope in according to the instructions in chapter 4.06 of the Crane operating instructions and the reeving plans.

#### NOTICE

Retaining pins **5** inserted when lifting the load!

If the retaining pins **5** are not unpinned in points **P2** prior to crane operation, then the retaining pins **5** may be shorn off when lifting the load.

- ▶ Unpin the retaining pin **5** from the hook block before crane operation.

When the hook block is properly reeved in and has been lifted off the ground:

- ▶ Insert the retaining pin **5** in the transport receptacle.
- ▶ Secure the retaining pin **5** with the retaining element **6**.

## 9.2 Disassembling the hook block

### 9.2.1 Preparing the hook block for disassembly

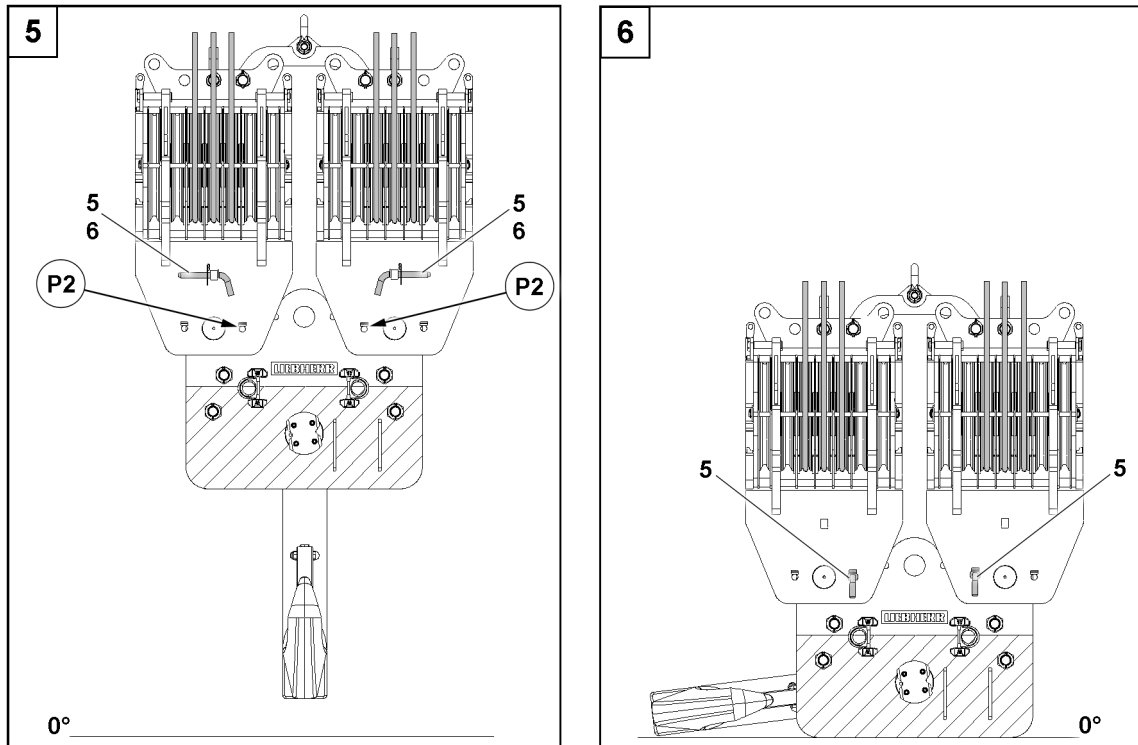


Fig.160650: Preparing the hook block for disassembly



#### Note

- ▶ The reeving out of the hook blocks is described in chapter 4.06 of the Crane operating instructions.
- ▶ Observe the “permissible hook block weights” in the erection and take-down charts.

#### NOTICE

Retaining pin **5** unpinned when setting down the hook block!

If the retaining pin **5** is not inserted before setting the hook block on the ground, then the roller blocks tip away to the side when the hoist rope is reeved out.

Death, severe bodily injuries, property damage.

- ▶ Before setting the hook block on the ground, insert and secure the retaining pins **5** on both roller blocks in point **P2**.

Make sure that the following prerequisites are met:

- The ground is sufficiently load bearing to take on the weight of the hook block and the auxiliary weights safely.
- The ground is level and horizontal.

- ▶ Remove the retaining element **6** from the transport receptacle.
- ▶ Store the retaining element **6**.
- ▶ Unpin the retaining pin **5**.
- ▶ Insert the retaining pin **5** in point **P2**.
- ▶ Lock the retaining pin **5**.
- ▶ Lower the hook block completely to the ground.

When the hook block has been placed on the ground properly:

- ▶ Reeve out the hoist rope(s) according to chapter 4.06 of the Crane operating instructions.

## 9.2.2 Disassembling the auxiliary weights



### Note

- ▶ Disassemble the auxiliary weights, see section “Overview of the auxiliary weight fastening systems”.

## 9.2.3 Disassembling the block connector

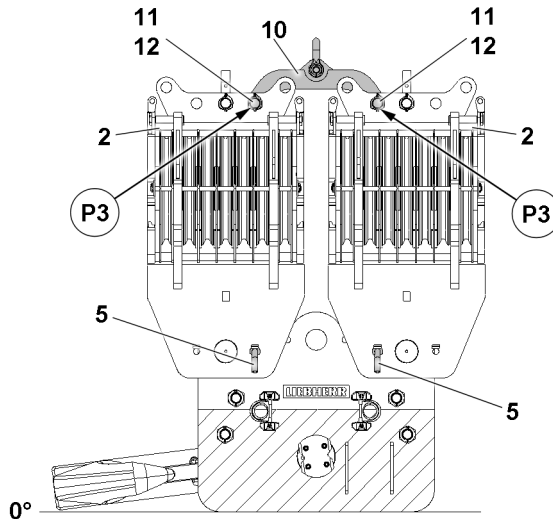


Fig.160652: Disassembling the block connector

Make sure that the following prerequisite is met:

- The retaining pins **5** are inserted and secured on both sides.
- ▶ Fasten the block connector **10** to the auxiliary crane.



### DANGER

Tipping of the roller blocks!

If the retaining pins **5**, during disassembly of the block connector **10** are not pinned on the roller blocks, then the roller blocks tip to the side when the block connector is removed. Death, severe bodily injuries, property damage.

- ▶ Make sure before removing the block connector that the roller blocks are properly pinned and secured.

Remove the block connector **10**:

- ▶ Remove the retaining elements **12** on both sides in points **P3** on the roller blocks **2**.
- ▶ Unpin the pins **11** on both sides in points **P3** on the roller blocks **2**.
- ▶ Remove the block connector **10** with the auxiliary crane.
- ▶ Take the block connector **10** down onto the ground.
- ▶ Remove the auxiliary crane.

## 9.2.4 Disassembling the roller blocks on the cross beam

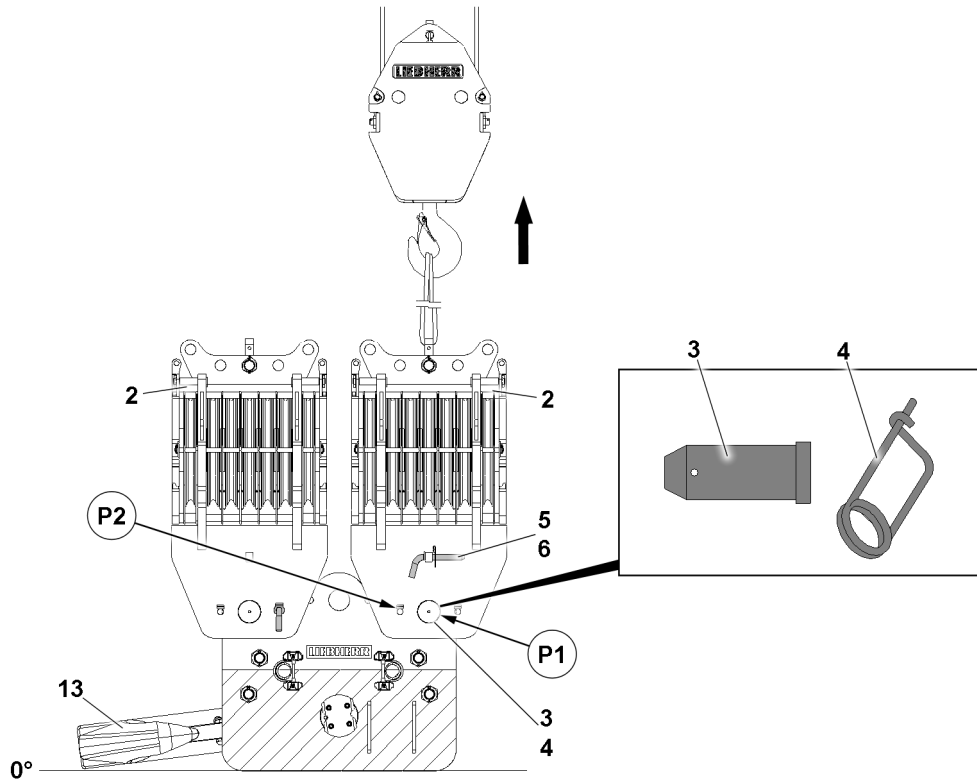


Fig.160653: Disassembling the roller block on the cross beam



### Note

- ▶ The disassembly of two roller blocks is identical and is described on the example of one roller block.

Make sure that the following prerequisites are met:

- The auxiliary weights have been disassembled.
- The block connector has been disassembled.



### WARNING

Tipping of the hook block!

- ▶ Assemble the first roller block **2** on the side without the hook **13**, see illustration.

- ▶ Fasten the roller block **2** to the auxiliary crane.
- ▶ Tension the fastening equipment carefully.

When the fastening equipment on the roller block **2** is tensioned:

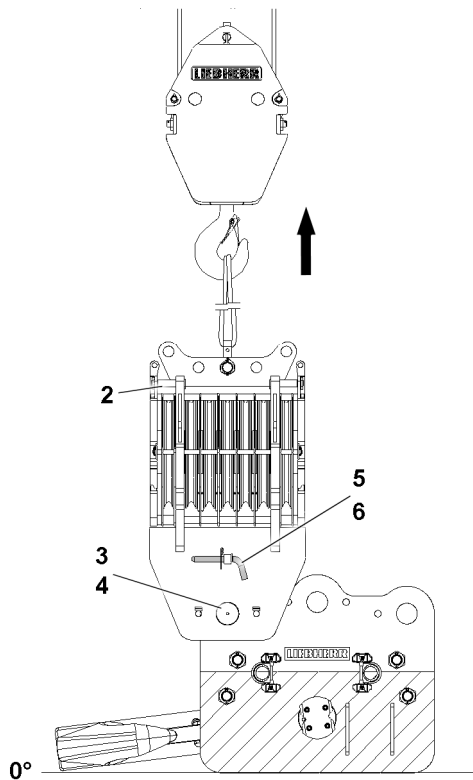
- ▶ Unlock the retaining pin **5** in point **P2**.
- ▶ Unpin the retaining pin **5**.
- ▶ Insert the retaining pin **5** in the transport receptacle.
- ▶ Secure the retaining pin **5** with the retaining element **6**.

Unpin the pin **3**:

- ▶ Remove the retaining element **4** in point **P1**.
- ▶ Unpin the pin **3**.

Remove the roller block:

- ▶ Swing the roller block **2** out with auxiliary crane.
- ▶ Take the roller block **2** down on the ground.
- ▶ Remove the auxiliary crane.



*Fig.160654: Disassembling the second roller block*

- ▶ Fasten the second roller block **2** to the auxiliary crane.
- ▶ Disassemble the second roller block **2**.
- ▶ Swing the second roller block **2** out with auxiliary crane.
- ▶ Place the second roller block **2** on the ground.
- ▶ Remove the auxiliary crane.

## 10 Double hook block for parallel operation variation B

The assembly / disassemble is described as an example. Make sure that some of the steps must be performed on both sides.

## 10.1 Assembling the hook block

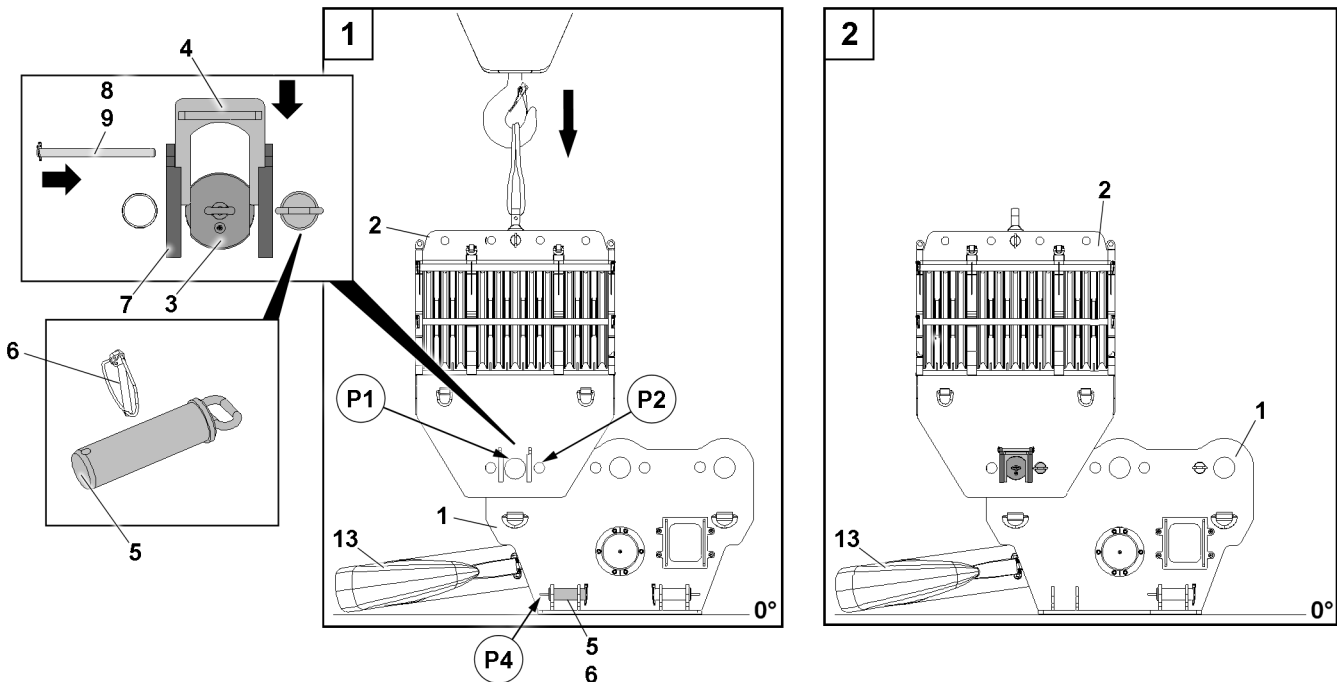


Fig. 160407: Assembling a double hook block for parallel operation

If the hook blocks are to be used in parallel operation, then the roller blocks **2** must be installed on the left and right on the cross beam **1**.

### 10.1.1 Assembling the roller blocks on the cross beam

Make sure that the following prerequisites are met:

- The ground is sufficiently load bearing to take on the weight of the hook block safely.
- The ground is level and horizontal.
- The cross beam **1** is taken down onto the ground.
- The pin **3** is unpinned.
- The retaining plate **4** is available.
- The retaining pin **8** and the retaining elements **9** are available.



#### DANGER

Tipping of the roller blocks!

If the retaining pin **5** is not inserted in the cross beam during assembly of the roller blocks **2**, the roller blocks tip over to the side when the auxiliary crane is removed.

Death, severe bodily injuries, property damage.

► Insert the retaining pin **5** in the bore in point **P2** on the hook block.

► Make sure before removing the auxiliary crane that the roller blocks **2** are properly pinned and secured.



#### Note

► The assembly of two roller blocks **2** is identical and is described based on the example of one roller block.

► Fasten the roller block **2** to the auxiliary crane.



#### WARNING

Tipping of the hook block!

► Assemble the first roller block **2** on the side of the hook **13**, see illustration.



- ▶ Position the roller block **2** on the cross beam **1** and align it with the pin bore in point **P1**.

Insert the pin **3**:

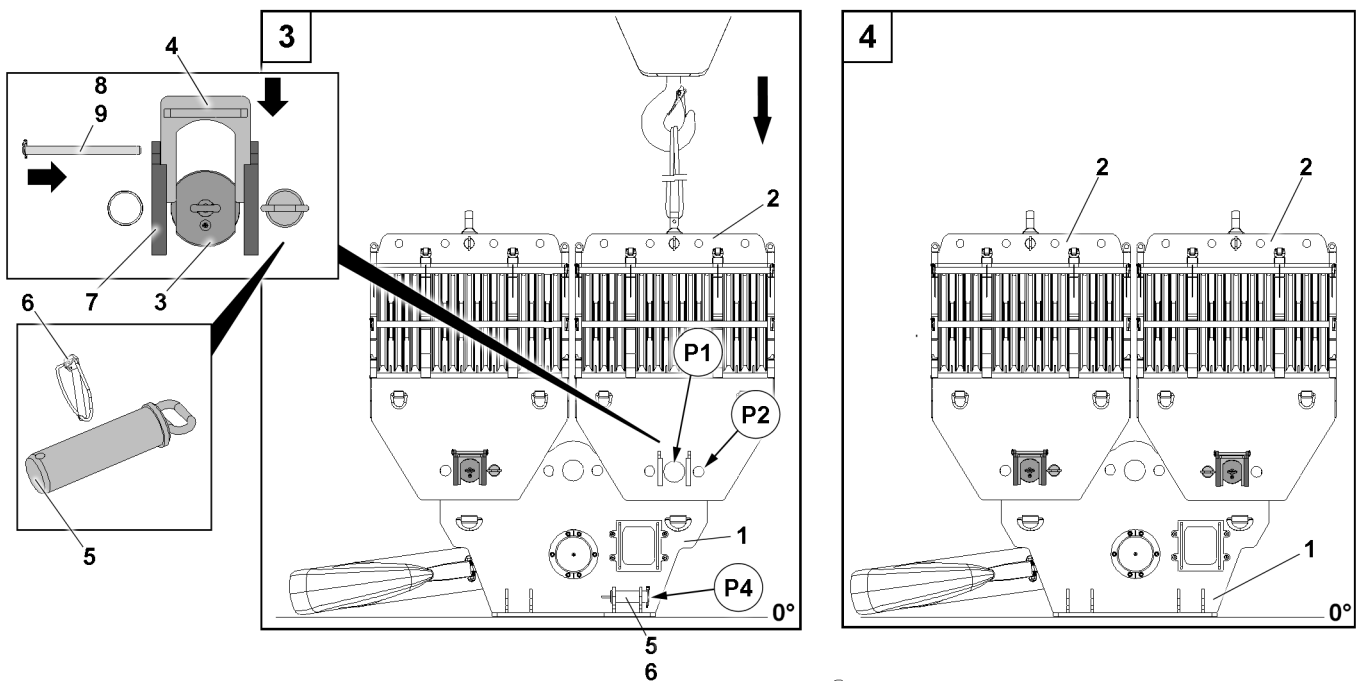
- ▶ Insert the pin **3** in point **P1**.
- ▶ Push the retaining plate **4** in the guide rails **7** to the stop.
- ▶ Insert the retaining pin **8** in the guide rails **7**.
- ▶ Secure the retaining pins **8** with retaining elements **9** on both sides.

Secure the roller block **2** to prevent it from tipping over:

- ▶ Remove the retaining element **6** in point **P4**.
- ▶ Unpin the retaining pin **5**.
- ▶ Insert the retaining pin **5** in point **P2**.
- ▶ Secure the retaining pin **5** with the retaining element **6**.

When the roller block **2** is secured by the retaining pin **5**:

- ▶ Remove the auxiliary crane.



*Fig.160634: Assembling the second roller block*

- ▶ Assemble the second roller block.
- ▶ Second roller block secured.
- ▶ Remove the auxiliary crane.

### 10.1.2 Assembling the block connector

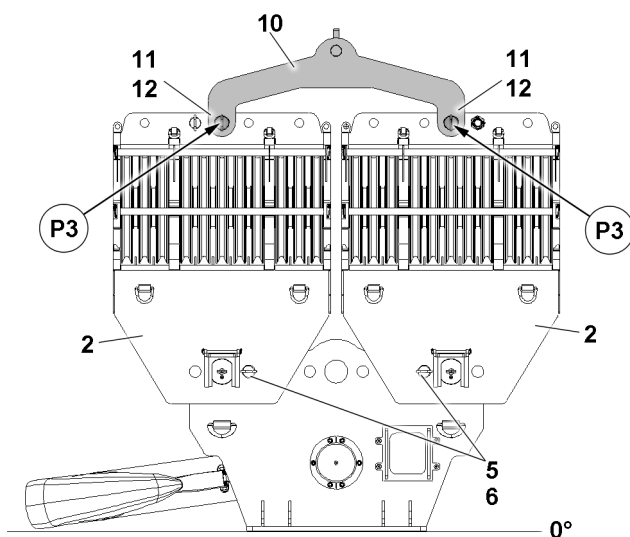


Fig. 160636: Assembling the block connector

Make sure that the following prerequisite is met:

- Two roller blocks **2** are assembled and secured on the cross beam **1**.

Both roller blocks **2** are pinned with the block connector **10**:

- ▶ Fasten the block connector **10** to the auxiliary crane.
- ▶ Position the block connector **10** with auxiliary crane in the pin position.
- ▶ Insert the pin **11** on both sides on the roller blocks **2** in points **P3** and secure it with the retaining element **12**.

When the block connector **10** is pinned and secured properly:

- ▶ Remove the auxiliary crane.

### 10.1.3 Assembling the auxiliary weights



#### Note

- ▶ Disassemble the auxiliary weights, see section “Overview of the auxiliary weight fastening systems”.

### 10.1.4 Preparing the hook block for crane operation

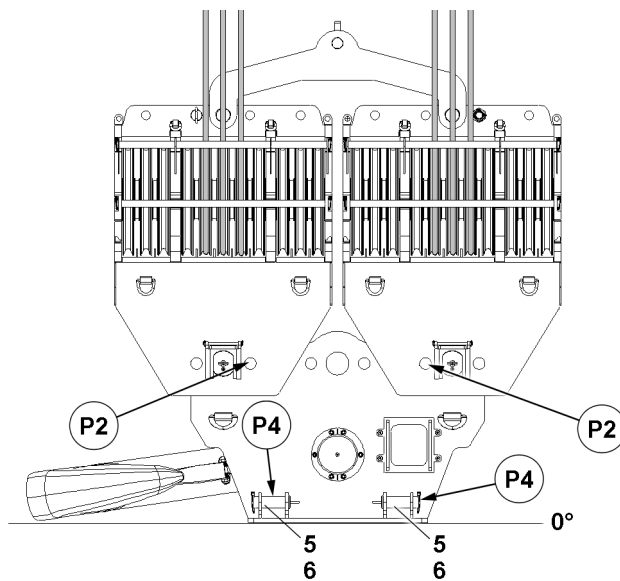


Fig.160637: Preparing the hook block for crane operation



#### Note

- ▶ The reeving in of the hook blocks is described in chapter 4.06 of the Crane operating instructions.
  - ▶ Observe the “permissible hook block weights” in the erection and take down charts.
- 
- ▶ Reeve the hoist rope in according to the instructions in chapter 4.06 of the Crane operating instructions and the reeving plans.

#### NOTICE

Retaining pins **5** inserted when lifting the load!

If the retaining pins **5** are not unpinned in points **P2** prior to crane operation, then the retaining pins **5** may be shorn off when lifting the load.

- ▶ Unpin the retaining pin **5** from the hook block before crane operation.

When the hook block is properly reeved in and has been lifted off the ground:

- ▶ Remove the retaining element **6** in point **P2**.
- ▶ Unpin the retaining pin **5**.
- ▶ Insert the retaining pin **5** in point **P4**.
- ▶ Secure the retaining pin **5** with the retaining element **6**.

## 10.2 Disassembling the hook block

### 10.2.1 Preparing the hook block for disassembly

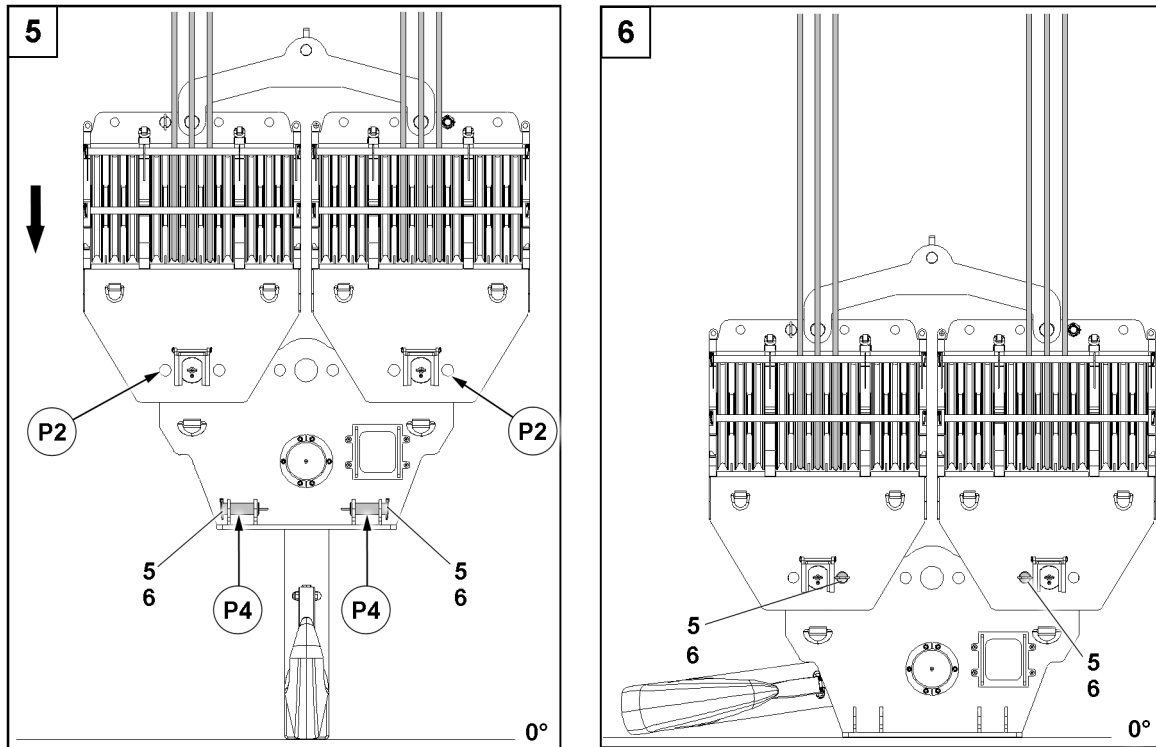


Fig.160638: Preparing the hook block for disassembly



#### Note

- ▶ The reeving out of the hook blocks is described in chapter 4.06 of the Crane operating instructions.
- ▶ Observe the “permissible hook block weights” in the erection and take-down charts.

#### NOTICE

Retaining pin **5** unpinned when setting down the hook block!

If the retaining pin **5** is not inserted before setting the hook block on the ground, then the roller blocks tip away to the side when the hoist rope is reeved out.

Death, severe bodily injuries, property damage.

- ▶ Before setting the hook block on the ground, insert and secure the retaining pins **5** on both roller blocks in point **P2**.

Make sure that the following prerequisites are met:

- The ground is sufficiently load bearing to take on the weight of the hook block and the auxiliary weights safely.
- The ground is level and horizontal.

When the hook block is properly reeved in and has been lifted off the ground:

- ▶ Remove the retaining element **6** in point **P4**.
- ▶ Unpin the retaining pin **5**.
- ▶ Insert the retaining pin **5** in point **P2**.
- ▶ Secure the retaining pin **5** with the retaining element **6**.
- ▶ Lower the hook block completely to the ground.

When the hook block has been placed on the ground properly:

- ▶ Reeve out the hoist rope(s) according to chapter 4.06 of the Crane operating instructions.

## 10.2.2 Disassembling the auxiliary weights



### Note

- ▶ Disassemble the auxiliary weights, see section “Overview of the auxiliary weight fastening systems”.

## 10.2.3 Disassembling the block connector

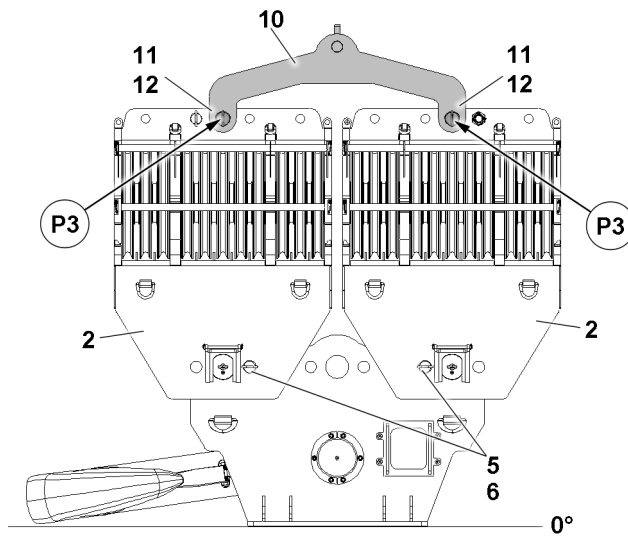


Fig.160636: Disassembling the block connector

Make sure that the following prerequisite is met:

- The retaining pins **5** are inserted and secured with retaining elements **6** on both sides.
- ▶ Fasten the block connector **10** to the auxiliary crane.



### DANGER

Tipping of the roller blocks!

If the retaining pins **5**, during disassembly of the block connector **10** are not pinned on the roller blocks, then the roller blocks tip to the side when the block connector is removed.

Death, severe bodily injuries, property damage.

- ▶ Make sure before removing the block connector that the roller blocks are properly pinned and secured.

Remove the block connector **10**:

- ▶ Remove the retaining element **12** on both sides in points **P3** on the roller blocks **2**.
- ▶ Unpin the pin **11**.
- ▶ Remove the block connector **10** with the auxiliary crane.
- ▶ Take the block connector **10** down onto the ground.
- ▶ Remove the auxiliary crane.

### 10.2.4 Disassembling the roller blocks on the cross beam

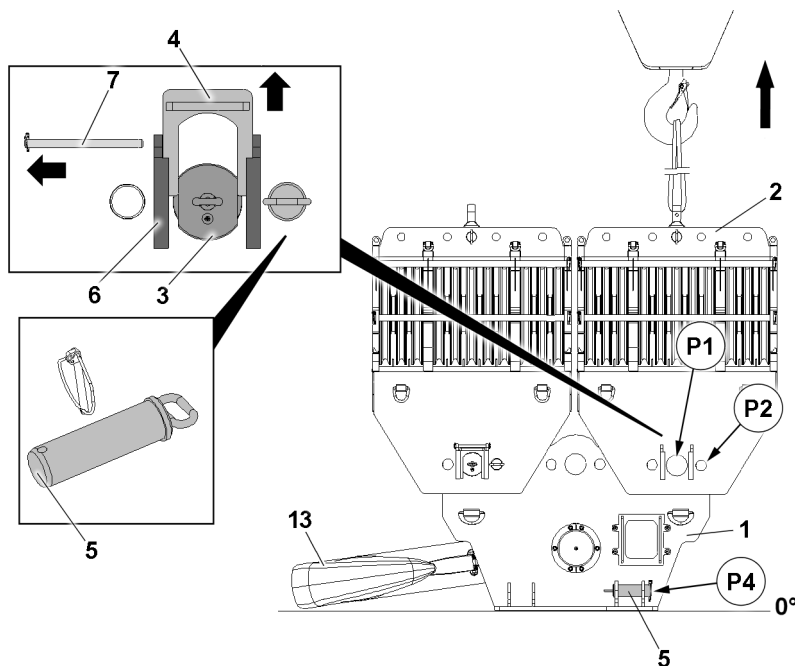


Fig.160408: Disassembling the roller block on the cross beam



#### Note

- ▶ The disassembly of two roller blocks is identical and is described on the example of one roller block.

Make sure that the following prerequisites are met:

- The auxiliary weights have been disassembled.
- The block connector has been disassembled.



#### WARNING

Tipping of the hook block!

- ▶ Assemble the first roller block **2** on the side without the hook **13**, see illustration.

- ▶ Fasten the roller block **2** to the auxiliary crane.
- ▶ Tension the fastening equipment carefully.

When the fastening equipment on the roller block is tensioned:

- ▶ Release the retaining element **5** in point **P2**.
- ▶ Unpin the retaining pin **5**.
- ▶ Insert the retaining pin **5** in point **P4**.
- ▶ Secure the retaining pin **5** with the retaining element **6**.

Unpin the pin **3**:

- ▶ Remove the retaining element **9** in point **P1**.
- ▶ Unpin the retaining pin **8** in the guide rails **7**.
- ▶ Push the retaining plate **4** out of the guide rails **7**.
- ▶ Unpin the pin **3**.

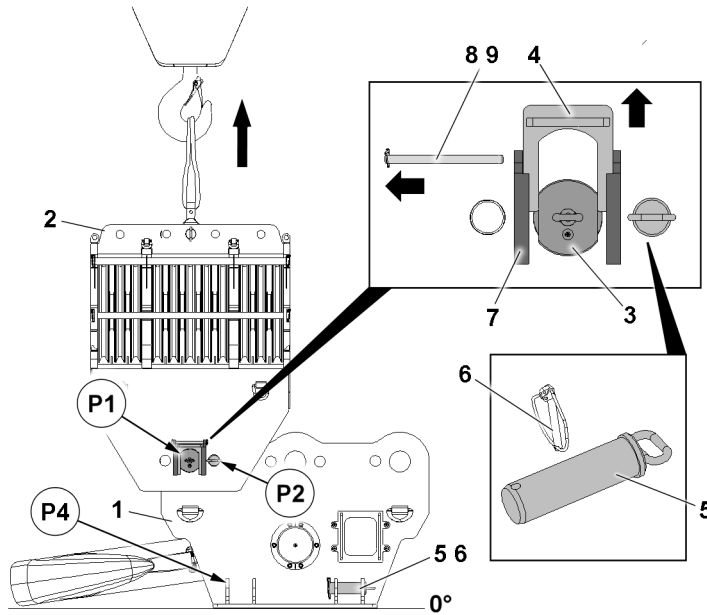


Fig.160640: Disassembling the second roller block

- ▶ Fasten the second roller block 2 to the auxiliary crane.
- ▶ Disassemble the second roller block 2.
- ▶ Swing the roller block 2 out with auxiliary crane.
- ▶ Place the roller block 2 on the ground.
- ▶ Remove the auxiliary crane.

## 11 Overview of the auxiliary weight fastening systems

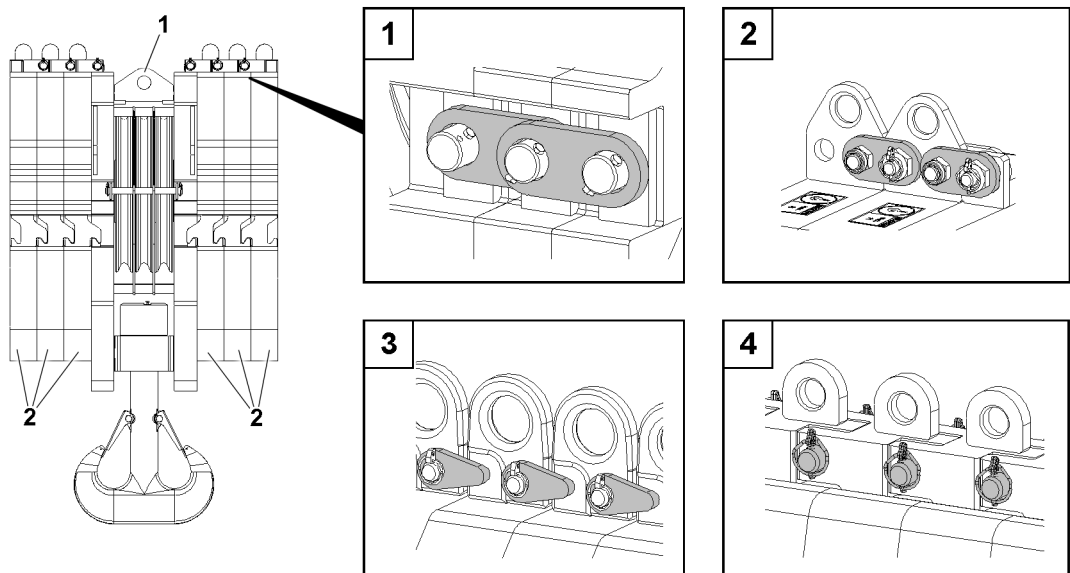


Fig.151979: Auxiliary weight fastening systems

1 Hook block

2 Auxiliary weight

If a high hook block weight is required, auxiliary weight 2 must be installed.

LWE/LR 1800-1-0-000/27200-07-02/en

**Note**

- ▶ The own weight is marked on the side on the respective auxiliary weight **2**.

**WARNING**

Tipping over of the hook block!

Death, severe bodily injuries, property damage.

- ▶ Do not exceed the maximum permissible own weight of the hook block. The maximum permissible own weight is engraved on the ballastable hook blocks. See "Engraving WT max.".

A distinction is made between the following fastening systems:

- Fastening system 1, see illustration **1**
- Fastening system 2, see illustration **2**
- Fastening system 3, see illustration **3**
- Fastening system 4, see illustration **4**

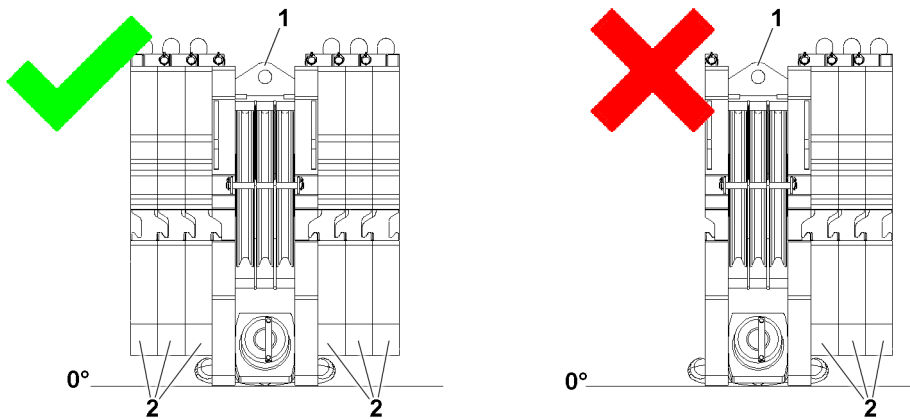


Fig.151980: Asymmetric assembly or disassembly of the auxiliary weights

**1** Hook block

**2** Auxiliary weight

**WARNING**

Tipping over of the hook block!

If the auxiliary weights **2** are installed on one side, the hook block **1** can tip over.

Death, severe bodily injuries, property damage.

- ▶ Only assemble and disassemble the auxiliary weights **2** **individually** and alternatively on the hook block **1**.
- ▶ The asymmetrical assembly and disassembly of the auxiliary weights **2** is prohibited.
- ▶ Do not exceed the maximum permissible own weight of the hook block **1**. The maximum permissible own weight is engraved on ballastable hook blocks **1**. See "Engraving WT max.".

**WARNING**

Personnel in the danger zone!

When swinging the auxiliary weights **2** in to the roller block, fingers, hands and arms can be crushed or sheered off.

Death, severe bodily injuries, property damage.

- ▶ Do not remain under suspended loads or in the danger zone.
- ▶ It is prohibited for anyone to remain between the roller block and the auxiliary weight.
- ▶ Swing the auxiliary weights in to the roller block with utmost caution and at the lowest speed possible.
- ▶ Angular pull is prohibited.



**WARNING**

Incorrect assembly of the auxiliary weights!

Death, severe bodily injuries, property damage.

- ▶ Assemble and secure the auxiliary weights **2** according to the operating instructions.
- ▶ Do not operate the crane if the auxiliary weights are **not** secured.

**WARNING**

Falling auxiliary weights!

The auxiliary weights **2** can fall down by during the assembly / disassembly of the auxiliary weights by removing the auxiliary crane.

Death, severe bodily injuries, property damage.

- ▶ Remove the auxiliary crane only when it is ensured that the auxiliary weight **2** is secured properly with the fastening equipment.

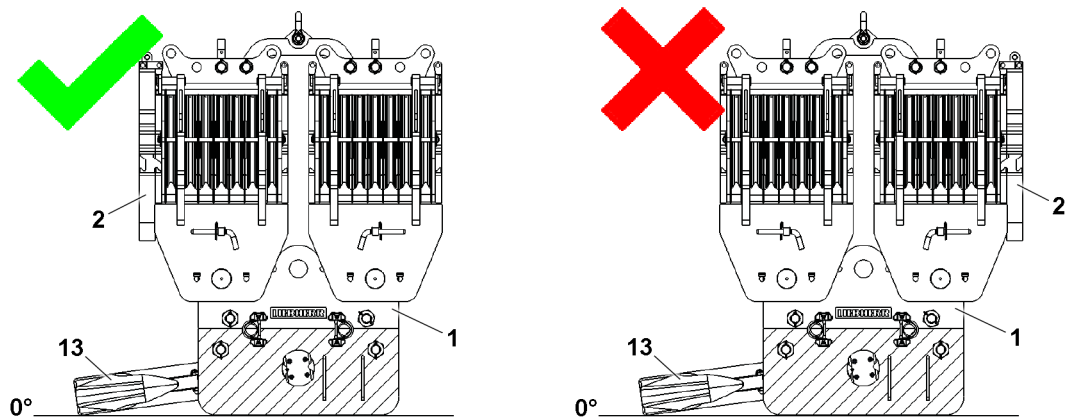


Fig.160409: Observe the location of the hook during assembly or disassembly of the auxiliary weights

- 1 Hook block
- 2 Auxiliary weight

13 Hook

**WARNING**

Impermissible weight distribution on the hook block!

If fewer auxiliary weights **2** are on the side of the hook **13**, the hook block can topple over.

Death, severe bodily injuries, property damage.

If the hook **13** swings aligned with the installation position of the auxiliary weights **2**:

- ▶ Start with the assembly of the auxiliary weights **2** on the side with the hook **13**.
- ▶ Start with the disassembly of the auxiliary weights **2** on the side without the hook **13**.
- ▶ Only assemble and disassemble the auxiliary weights **2** **individually** and alternatively on the hook block **1**.

## 12 Fastening system 1

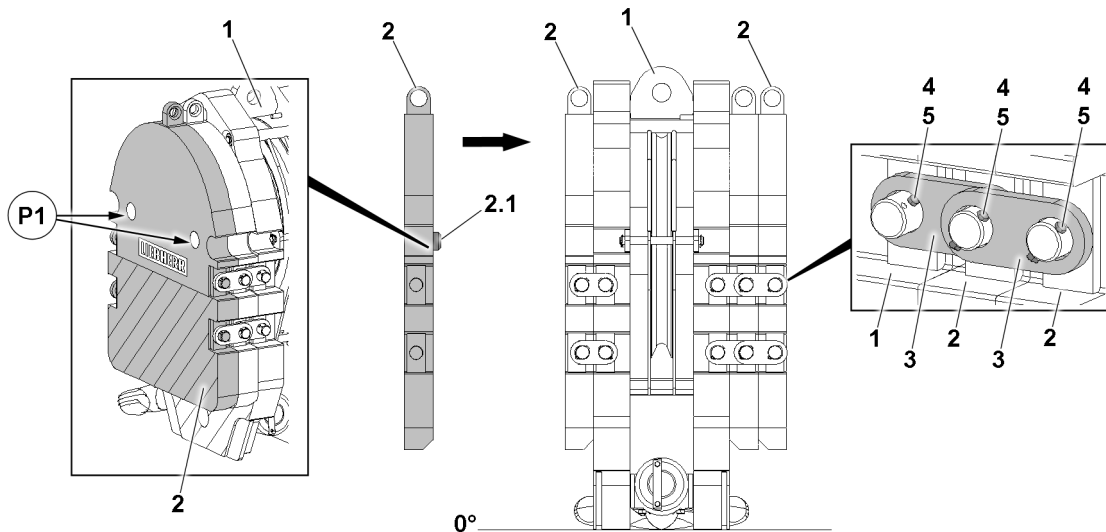


Fig.151981: Hook block, fastening system 1

### 12.1 Assembling the auxiliary weights

Make sure that the following prerequisites are met:

- The ground is of sufficient load bearing capacity.
- The ground is level and horizontal.
- The hook block is placed on the ground.

- ▶ Fasten the auxiliary weight **2** to the auxiliary crane.
- ▶ Align the auxiliary weight **2** with the hook block **1**.
- ▶ Retract the centering pin **2.1** of the auxiliary weight into the centering bores in points **P1** on the hook block **2**.



#### WARNING

Unsecured auxiliary weight is disassembled!

The auxiliary weight can topple over.

Death, severe bodily injuries, property damage.

- ▶ Never remove all mounting brackets **3** of an unsecured auxiliary weight simultaneously.
- ▶ Always install or remove the mounting brackets **3** alternately.

- ▶ Install the mounting brackets **3** on both sides and connect the hook block with the auxiliary weight **2**.
- ▶ Secure the mounting brackets **3** on both sides with screws **4** and the retaining element **5**.

When the respective auxiliary weight is properly assembled and secured:

- ▶ Remove the auxiliary crane.
- ▶ Install additional auxiliary weights as described above.

### 12.2 Preparing the hook block for crane operation



#### Note

- ▶ To reeve in the hook block, observe chapter 4.06 and the reeving plans.
  - ▶ Observe the permissible hook block weights in the erection and take-down charts.
- 
- ▶ Reeve in the hoist rope according to chapter 4.06 and the reeving plans.

## 12.3 Preparing the hook block for disassembly

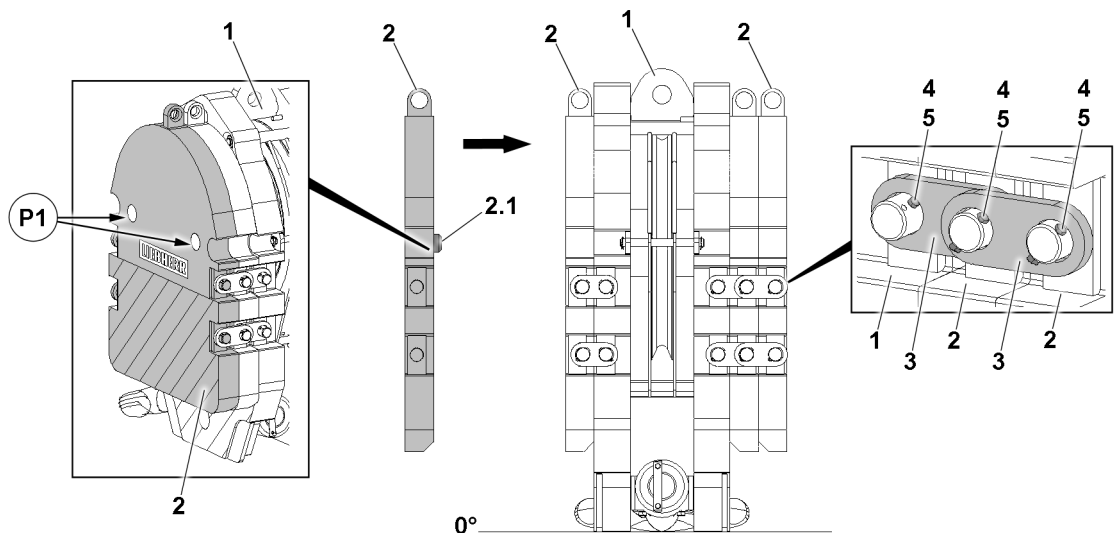


Fig.151981: Hook block, fastening system 1



### Note

- ▶ To reeve out the hook block, observe chapter 4.06 and the reeving plans.
- ▶ Observe the permissible hook block weights in the erection and take-down charts.

Make sure that the following prerequisites are met:

- The ground is of sufficient load bearing capacity.
- The ground is level and horizontal.
- The hook block is placed on the ground.

When the hook block is placed on the ground

- ▶ Reeve the hoist rope out.

## 12.4 Disassembling the auxiliary weights

- ▶ Fasten the auxiliary weight 2 to the auxiliary crane.
- ▶ Tension the fastening equipment carefully.



### WARNING

Unsecured auxiliary weight is disassembled!  
Death, severe bodily injuries.

- ▶ Never remove all mounting brackets 3 of an unsecured auxiliary weight simultaneously.
- ▶ Always install or remove the mounting brackets 3 alternately.
- ▶ Upon disassembly, only release the outermost auxiliary weight on both sides.

When the fastening equipment is tensioned on the auxiliary weight:

- ▶ Release the retaining element 5 on the mounting brackets 3 of the outermost auxiliary weight 2 and remove the screws 4.
- ▶ Remove the mounting brackets 3.

If additional mounting brackets 3 must be removed to release the outermost auxiliary weight:

- ▶ Reinstall the mounting brackets 3 of the remaining auxiliary weights again immediately.
- ▶ Lift the auxiliary weight with the auxiliary crane from the hook block.
- ▶ Take the auxiliary weight down.
- ▶ Disassemble the additional auxiliary weights as described above.

## 13 Fastening system 2

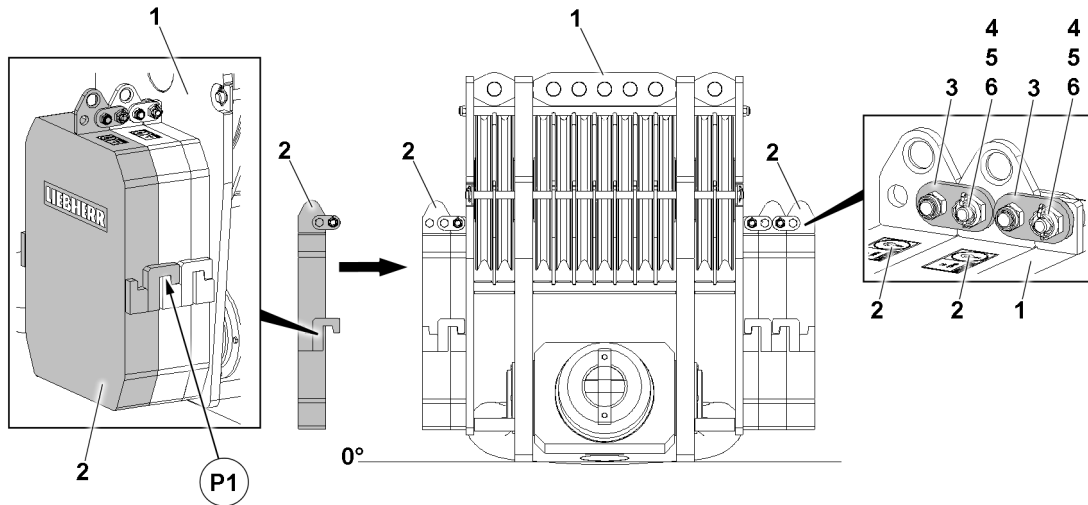


Fig.151982: Hook block, fastening system 2

### 13.1 Assembling the auxiliary weights

Make sure that the following prerequisites are met:

- The ground is of sufficient load bearing capacity.
- The ground is level and horizontal.
- The hook block is placed on the ground.

- ▶ Fasten the auxiliary weight 2 to the auxiliary crane.
- ▶ Attach the auxiliary weight 2 to the hook block 1 in position P1.



#### WARNING

Auxiliary weight not secured!  
Death, severe bodily injuries.

- ▶ Bolt and secure the mounting brackets 3 with screws 4 and nuts 5.
- ▶ Bolt the mounting brackets 3 on both sides with screws 4 and nuts 5 and secure with the retaining element 6.

When the respective auxiliary weight is properly assembled and secured:

- ▶ Remove the auxiliary crane.
- ▶ Install additional auxiliary weights as described above.

### 13.2 Preparing the hook block for crane operation



#### Note

- ▶ To reeve in the hook block, observe chapter 4.06 and the reeving plans.
- ▶ Observe the permissible hook block weights in the erection and take-down charts.
- ▶ Reeve in the hoist rope according to chapter 4.06 and the reeving plans.

### 13.3 Preparing the hook block for disassembly

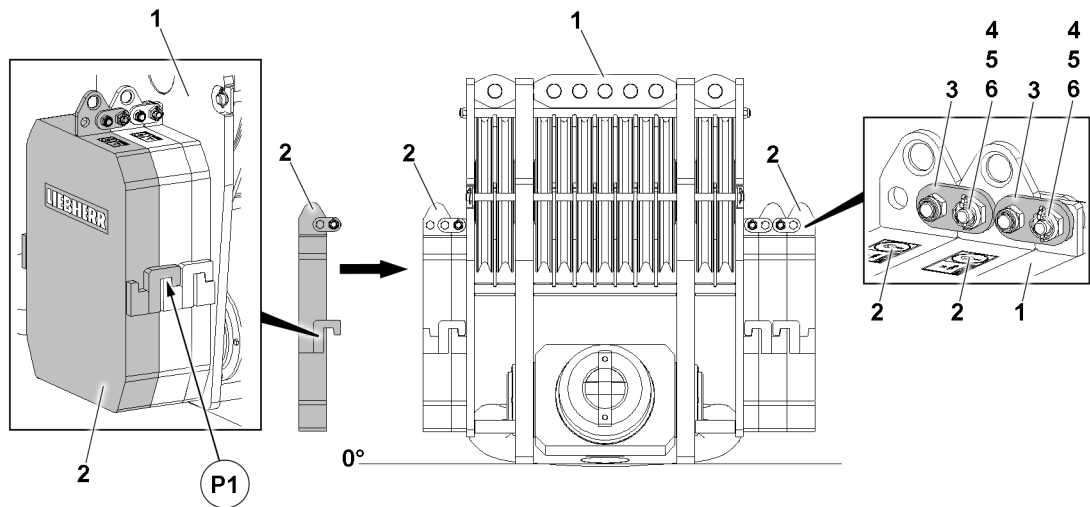


Fig.151982: Hook block, fastening system 2



#### Note

- ▶ To reeve out the hook block, observe chapter 4.06 and the reeving plans.
- ▶ Observe the permissible hook block weights in the erection and take-down charts.

Make sure that the following prerequisites are met:

- The ground is of sufficient load bearing capacity.
- The ground is level and horizontal.
- The hook block is placed on the ground.

When the hook block is placed on the ground

- ▶ Reeve the hoist rope out.

### 13.4 Disassembling the auxiliary weights

- ▶ Fasten the auxiliary weight 2 to the auxiliary crane.
- ▶ Tension the fastening equipment carefully.



#### WARNING

Disassemble the unsecured auxiliary weight!  
Death, severe bodily injuries.

- ▶ Never remove all screws 4 of the auxiliary weight simultaneously.
- ▶ Upon disassembly, only release the outermost auxiliary weight on both sides.

When the fastening equipment is tensioned on the auxiliary weight:

- ▶ Remove the retaining element 6, release the screw connections on the mounting brackets 3 of the outermost auxiliary weight 2 and remove the screws 4.
- ▶ Lift the auxiliary weight with the auxiliary crane from the hook block.
- ▶ Take the auxiliary weight down.
- ▶ Disassemble the additional auxiliary weights as described above.

## 14 Fastening system 3

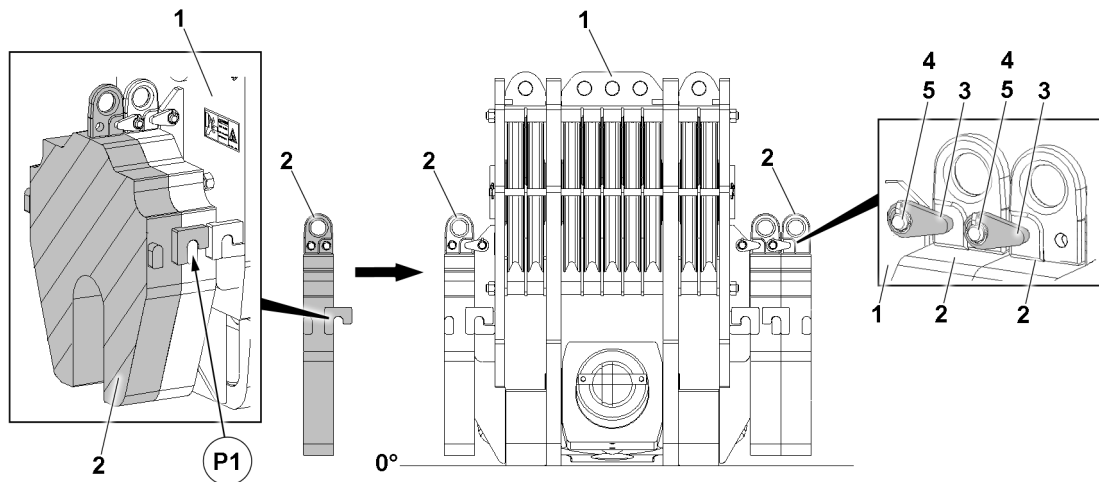


Fig.151983: Hook block, fastening system 3

### 14.1 Assembling the auxiliary weights

Make sure that the following prerequisites are met:

- The ground is of sufficient load bearing capacity.
- The ground is level and horizontal.
- The hook block is placed on the ground.

- ▶ Fasten the auxiliary weight 2 to the auxiliary crane.
- ▶ Attach the auxiliary weight 2 to the hook block 1 in position P1.



#### WARNING

Auxiliary weight not secured!  
Death, severe bodily injuries.

- ▶ Pin the mounting brackets 3 on both sides with pins 4 and secure with the retaining element 5.
- ▶ Pin the mounting brackets 3 on both sides with pins 4 and secure with the retaining element 5.

When the respective auxiliary weight is properly assembled and secured:

- ▶ Remove the auxiliary crane.
- ▶ Install additional auxiliary weights as described above.

### 14.2 Preparing the hook block for crane operation



#### Note

- ▶ To reeve in the hook block, observe chapter 4.06 and the reeving plans.
- ▶ Observe the permissible hook block weights in the erection and take-down charts.
- ▶ Reeve in the hoist rope according to chapter 4.06 and the reeving plans.

### 14.3 Preparing the hook block for disassembly

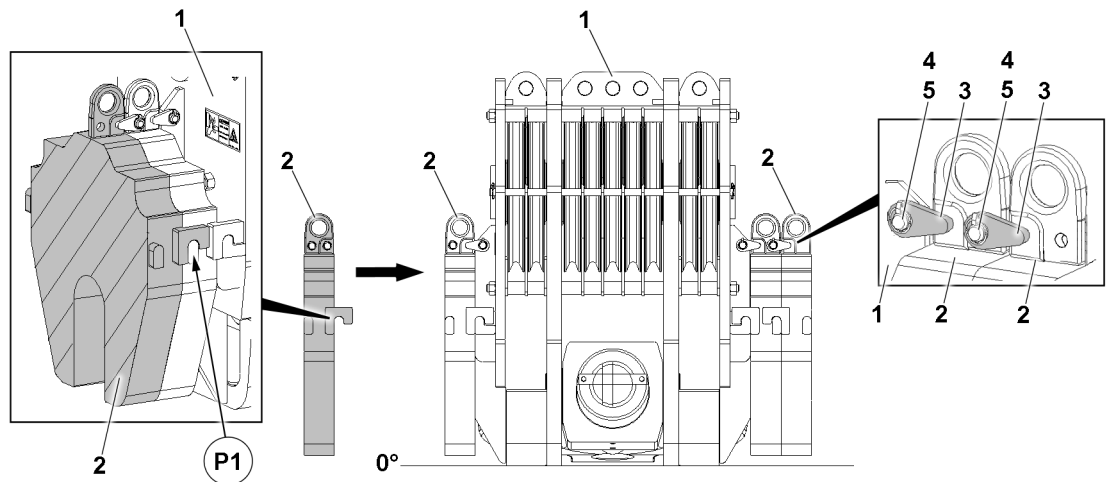


Fig.151983: Hook block, fastening system 3



#### Note

- ▶ To reeve out the hook block, observe chapter 4.06 and the reeving plans.
- ▶ Observe the permissible hook block weights in the erection and take-down charts.

Make sure that the following prerequisites are met:

- The ground is of sufficient load bearing capacity.
- The ground is level and horizontal.
- The hook block is placed on the ground.

When the hook block is placed on the ground

- ▶ Reeve the hoist rope out.

### 14.4 Disassembling the auxiliary weights

- ▶ Fasten the auxiliary weight 2 to the auxiliary crane.
- ▶ Tension the fastening equipment carefully.



#### WARNING

Disassemble the unsecured auxiliary weight!  
Death, severe bodily injuries.

- ▶ Never remove all pins 4 of the auxiliary weight simultaneously.
- ▶ Upon disassembly, only release the outermost auxiliary weight on both sides.

When the fastening equipment is tensioned on the auxiliary weight:

- ▶ Remove the retaining element 5, release the pin connections on the mounting brackets 3 of the outermost auxiliary weight 2 and remove the pins 4.
- ▶ Lift the auxiliary weight with the auxiliary crane from the hook block.
- ▶ Take the auxiliary weight down.
- ▶ Disassemble the additional auxiliary weights as described above.

## 15 Fastening system 4

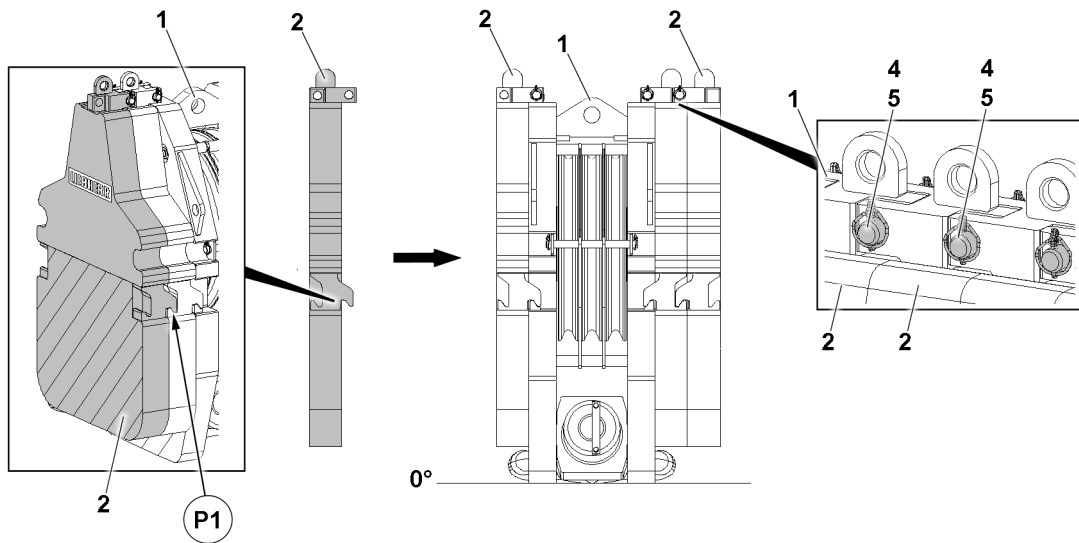


Fig.151984: Hook block, fastening system 4

### 15.1 Assembling the auxiliary weights

Make sure that the following prerequisites are met:

- The ground is of sufficient load bearing capacity.
  - The ground is level and horizontal.
  - The hook block is placed on the ground.
- ▶ Fasten the auxiliary weight 2 to the auxiliary crane.
  - ▶ Attach the auxiliary weight 2 to the hook block 1 in position P1.



#### WARNING

Auxiliary weight not secured!  
Death, severe bodily injuries.

- ▶ Secure the auxiliary weight 2: Insert the pin 4 and secure it with the retaining element 5.
- ▶ Secure the auxiliary weight 2: Insert the pin 4 and secure it with the retaining element 5.

When the respective auxiliary weight is properly assembled and secured:

- ▶ Remove the auxiliary crane.
- ▶ Install additional auxiliary weights as described above.

### 15.2 Preparing the hook block for crane operation



#### Note

- ▶ To reeve in the hook block, observe chapter 4.06 and the reeving plans.
- ▶ Observe the permissible hook block weights in the erection and take-down charts.
- ▶ Reeve in the hoist rope according to chapter 4.06 and the reeving plans.



### 15.3 Preparing the hook block for disassembly

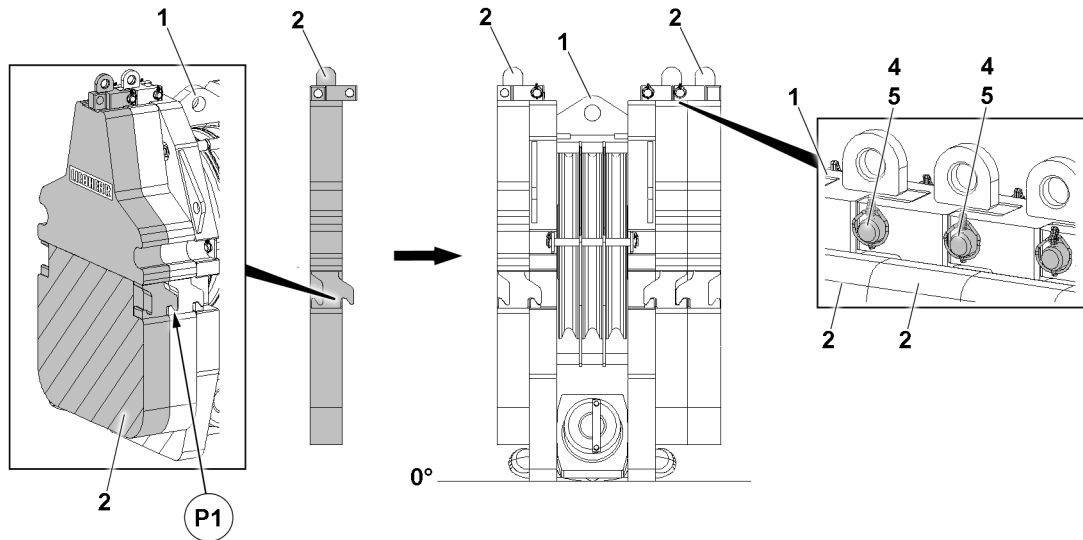


Fig.151984: Hook block, fastening system 4



#### Note

- ▶ To reeve out the hook block, observe chapter 4.06 and the reeving plans.
- ▶ Observe the permissible hook block weights in the erection and take-down charts.

Make sure that the following prerequisites are met:

- The ground is of sufficient load bearing capacity.
- The ground is level and horizontal.
- The hook block is placed on the ground.

When the hook block is placed on the ground

- ▶ Reeve the hoist rope out.

### 15.4 Disassembling the auxiliary weights

- ▶ Fasten the auxiliary weight 2 to the auxiliary crane.
- ▶ Tension the fastening equipment carefully.



#### WARNING

Disassemble the unsecured auxiliary weight!  
Death, severe bodily injuries.

- ▶ Never remove all pins 4 of the auxiliary weight simultaneously.
- ▶ Upon disassembly, only release the outermost auxiliary weight.

When the fastening equipment is tensioned on the auxiliary weight:

- ▶ Remove the retaining element 5, release the pin connections of the outermost auxiliary weight 2 and remove the pins 4.
- ▶ Lift the auxiliary weight with the auxiliary crane from the hook block.
- ▶ Take the auxiliary weight down.
- ▶ Disassemble the additional auxiliary weights as described above.

---

Empty page!

LWE/LR 1800-1-0-000/27200-07-02/en

## 5.19.10 Hook block incline sensors

1	General	2
2	Assembling the radio receiving unit	2
3	Assembling the radio sender unit on the hook block	5
4	Batteries in the radio sender unit	9
5	Radio sender unit and radio receiving unit park position	11

# 1 General

A radio sender unit and a radio receiving unit belong to the hook block incline sensor. The radio sender unit is located on the hook block. The radio receiving unit is located on the boom and forwards the signal via cable to the crane control.

Every radio sender unit is assigned fixed to a radio receiving unit. If the equipment or individual parts of the equipment must be replaced, the radio sender unit and the radio receiving unit must be left together.

## 2 Assembling the radio receiving unit

The radio receiving unit is installed on the boom (for example, on the end section or pivot section).



### Note

- ▶ The assembly of the radio receiving unit is described in this chapter as an example and may not apply exactly to your crane.
- ▶ The representation of the various mounting positions of the radio receiver are examples and may not apply exactly to your crane.
- ▶ Depending on the crane type and / or equipment, the assembly plate of the radio receiving unit may be constructed with a different design, see variation 1 and variation 2.



### Note

- ▶ When using the radio receiving unit, the radio sender unit batteries must be sufficiently charged.



### Note

- ▶ The LICCON computer system monitors in parallel operation the incline / incline position of the hook block, see the Crane operating instructions chapter 4.02 and chapter 4.05.



### WARNING

Load ripping off!

If the hook block gets into an impermissible incline / incline position in parallel operation of winch 1 and winch 2 (11I2), then the hook block can be overloaded.

Death, severe bodily injuries, property damage.

- ▶ Make sure that the radio receiving unit is properly installed.
- ▶ Make sure that the incline display in the LICCON computer system is constantly monitored during crane operation, see the Crane operating instructions, chapter 4.02.

## 2.1 Assembly plate Variation 1: Assembling / disassembling the radio receiving unit

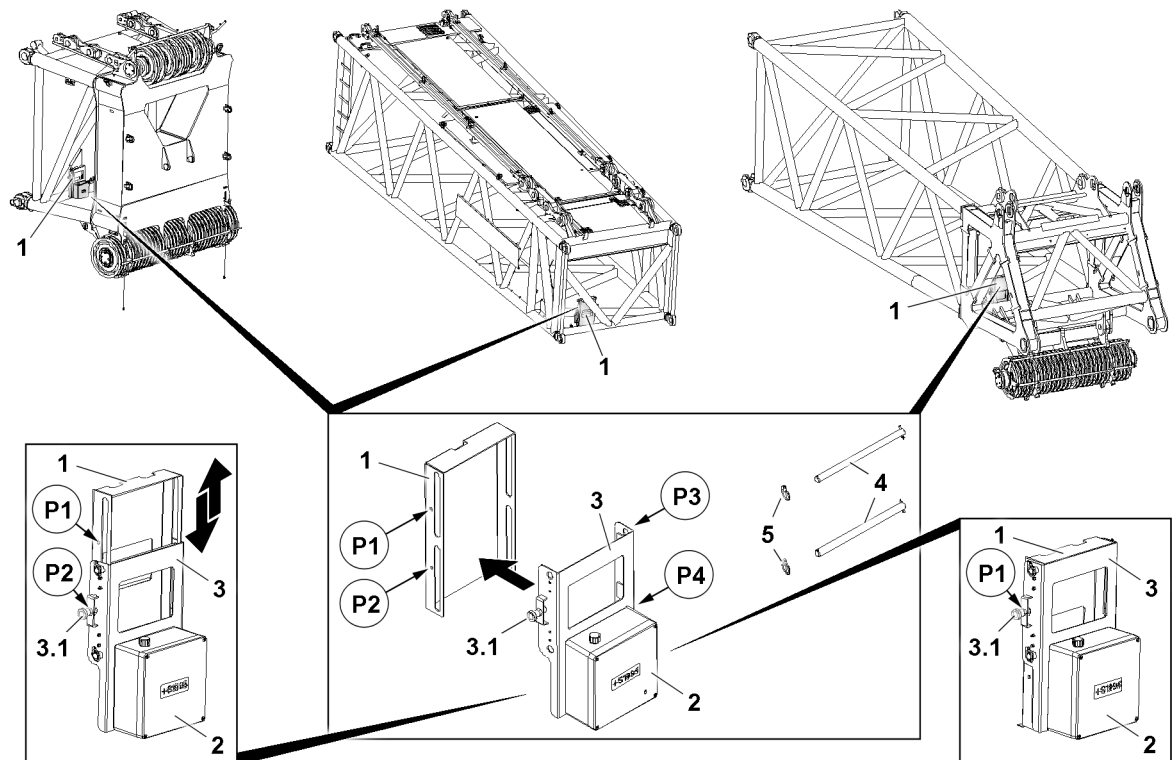


Fig.128140: Assembly plate Variation 1: Assembling the radio receiving unit, examples for the installation positions

Point **P1** = transport position lock

Point **P2** = operating position lock

The radio receiving unit **2** is screwed firmly with the assembly plate **3**.

The assembled assembly plate **3** can be moved and locked twice.

### 2.1.1 Assembling the radio receiving unit

- ▶ Pull the detent pin **3.1** on the assembly plate **3** and position and hold the radio receiving unit **2** with the assembly plate **3** on the support **1**.

When the assembly plate **3** is properly set on the support **1**:

- ▶ Release the detent pin **3.1** and make sure that the detent pin **3.1** is properly locked in point **P1**.
- ▶ Properly insert the pins **4** in the points (point **P3** and point **P4**) and secure with the retaining element **5**.

**Result:**

- The radio receiving unit **2** is properly pinned and secured on the support **1**.
- The radio receiving unit **2** is properly locked in the transport position in point **P1**.

When the radio receiving unit **2** is properly pinned and locked:

- ▶ Connect the radio receiving unit **2** electrically, see the Electric wiring diagram.

**NOTICE**

Damage to the radio receiving unit **2**!

- ▶ Make sure that the radio receiving unit **2**, when handling the respective boom head / lattice section, is always in the transport position.
- ▶ Make sure that the radio receiving unit **2**, when taking down the respective boom head / lattice section on the ground, is always in the transport position.
- ▶ Observe the section "Bringing the radio receiving unit to the transport position from the operating position".

- ▶ Protect the radio receiving unit **2** from damage.

### 2.1.2 Bringing the radio receiving unit to the operating position from the transport position

**WARNING**

Interruption of radio connection!

If the radio receiving unit **2** is left in the transport position during crane operation, the radio connection can break off.

- ▶ Make sure that the radio receiving unit **2** is in the operating position during crane operation.

The radio receiving unit **2** must be brought to the operating position before erecting the boom system and locked in point **P2**.

- ▶ Hold the radio receiving unit **2**, pull the detent pin **3.1** and slowly lower the radio receiving unit **2** in the operating position until the detent pin **3.1** engages in point **P2**.

**Result:**

- The radio receiving unit **2** is in the operating position.

### 2.1.3 Bringing the radio receiving unit to the transport position from the operating position

The radio receiving unit **2** must be brought to the transport position before disassembling the boom system and locked in point **P1**.

- ▶ Hold the radio receiving unit **2**, pull the detent pin **3.1** and slowly push the radio receiving unit **2** up to the transport position until the detent pin **3.1** engages in point **P1**.

**Result:**

- The radio receiving unit **2** is in the transport position.

### 2.1.4 Disassembling the radio receiving unit

- ▶ Disconnect the electrical connection between the terminal box and the radio receiver **2**.
- ▶ Properly store the electrical connection.

When the electrical connection is properly disconnected:

- ▶ Remove the retaining elements **5** on the pins **4**.
- ▶ Hold the radio receiving unit **2** and unpin the pin **4**.
- ▶ Pull the detent pin **3.1** lift the radio receiving unit **2** with the assembly plate **3** from the support **1**.
- ▶ Insert the pin **4** in the assembly plate **3** and secure properly with the retaining elements **5**.

## 2.2 Assembly plate Variation 2: Assembling the radio receiving unit

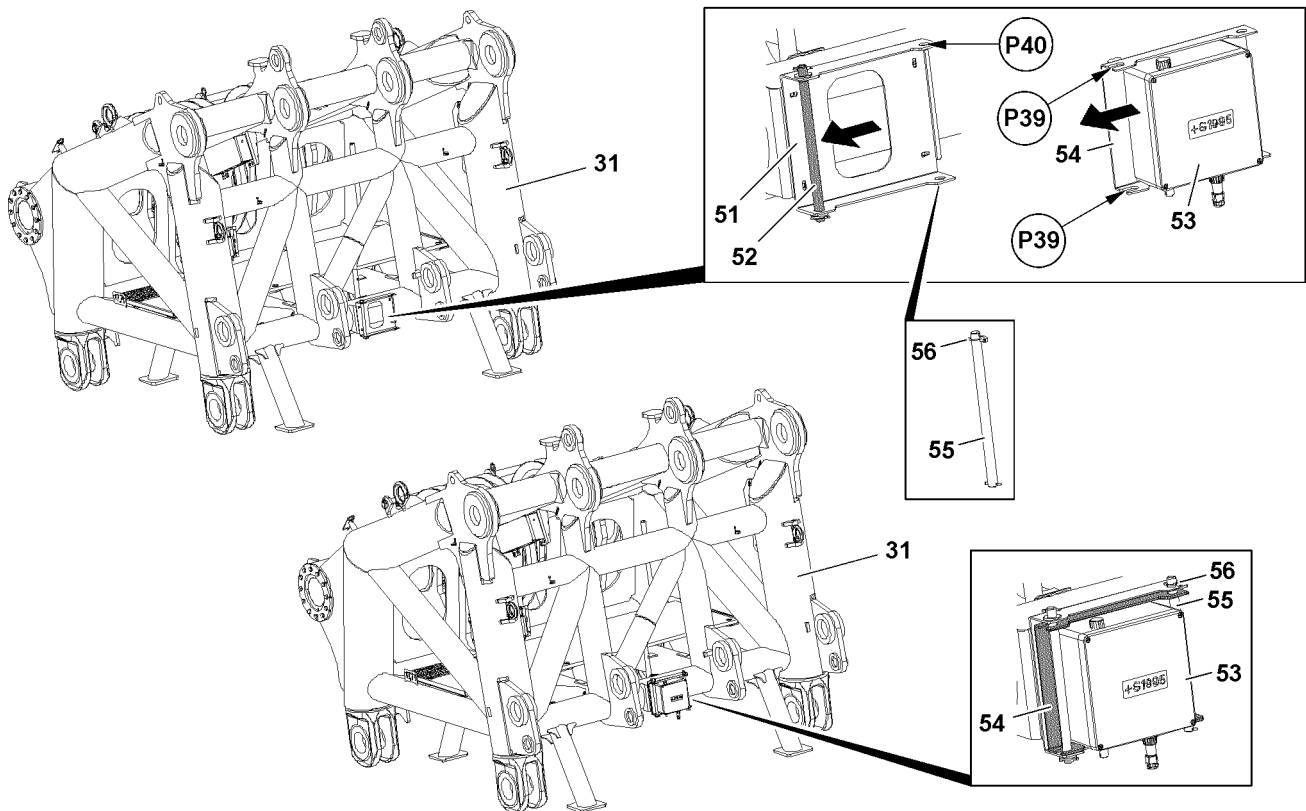


Fig.120089: Assembly plate Variation 2: Assembling the 53 radio receiving unit, examples for the installation position

The radio receiving unit 53 is screwed on the assembly plate 54.

- ▶ Move the assembly plate 54 of the radio receiving unit 53 with the fork connections at point P39 on the axle 52 of the retainer 51.

When the assembly plate 54 of the radio receiving unit 53 is properly in the retainer 51:

- ▶ Insert the pin 55 in point P40 and secure properly with the locking pin 56.
- ▶ Connect the radio receiving unit 53 electrically, see the Electric wiring diagram.

### NOTICE

Damage to the radio receiving unit 53!

- ▶ Make sure that the radio receiving unit 53 is not damaged when handling the respective boom head / lattice section.
  - ▶ Make sure that the radio receiving unit 53, when taking down the respective boom head / lattice section on the ground, is not damaged.
- 
- ▶ Protect the radio receiving unit 53 from damage.

## 3 Assembling the radio sender unit on the hook block

So that the inclination of the hook block can be recorded in parallel operation by the crane control, the radio sender unit must be properly assembled on the hook block.

**Note**

- ▶ The assembly of the radio sending unit is described in this chapter as an example and may not apply exactly to your crane.
- ▶ The representation of the various mounting positions of the hook blocks are examples and may not apply exactly to your crane.

**Note**

- ▶ The LICCON computer system monitors in parallel operation the incline / incline position of the hook block, see the Crane operating instructions chapter 4.02 and chapter 4.05.

**WARNING**

Load ripping off!

If the hook block gets into an impermissible incline / incline position in parallel operation of winch 1 and winch 2 (11I2), then the hook block can be overloaded.

Death, severe bodily injuries, property damage.

- ▶ Make sure that the radio sending unit is properly installed on the hook block.
- ▶ Make sure that the installed radio sending unit is facing the crane cab with a freely suspended hook block.
- ▶ Make sure that the incline display in the LICCON computer system is constantly monitored during crane operation, see the Crane operating instructions, chapter 4.02.



### 3.1 Assembling the radio sender unit on the hook block

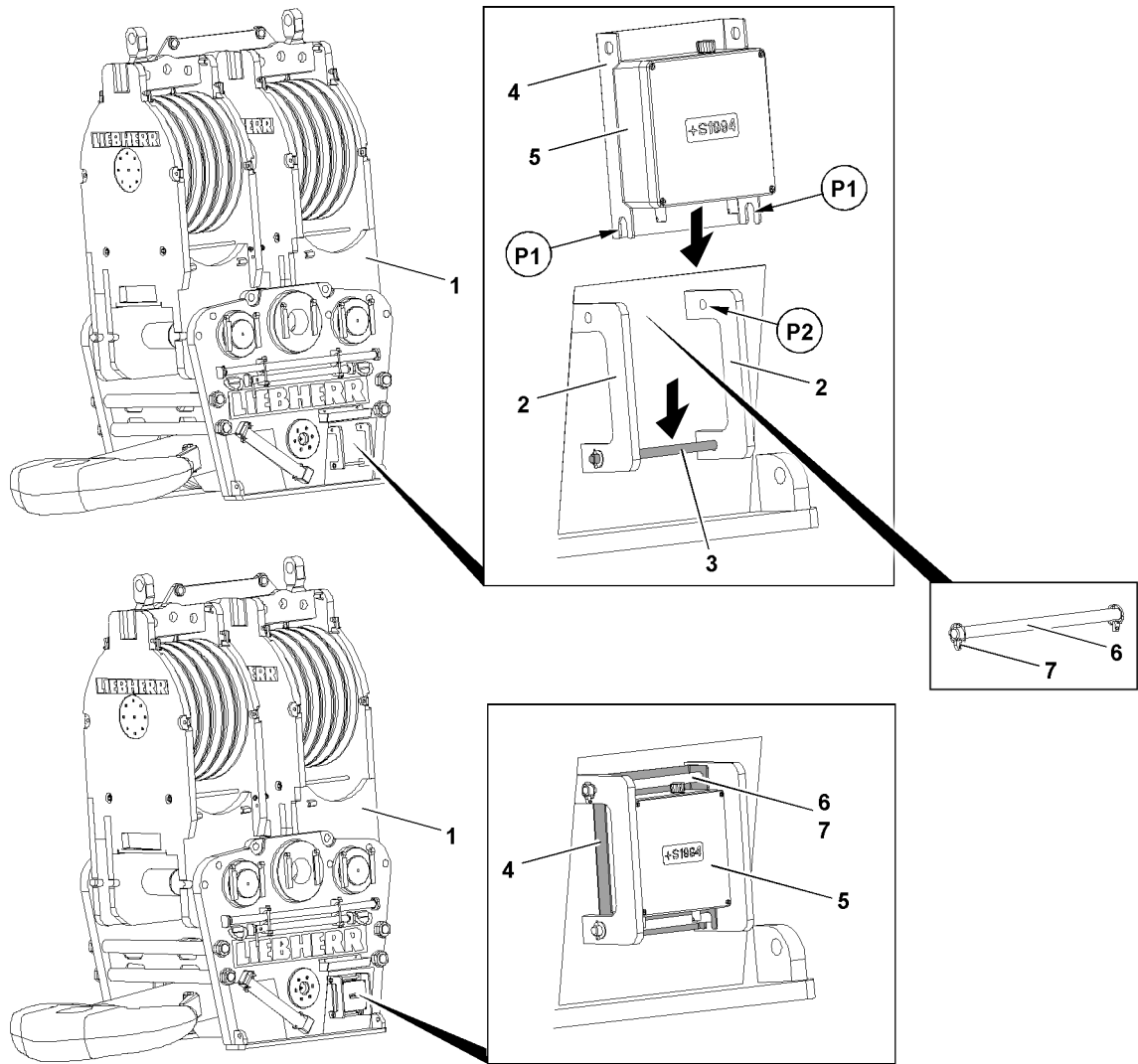


Fig.120141: Assembly of the radio sender unit 5 on the hook block

The installation of the radio sender unit 5 on the respective hook block is required to be able to ensure during parallel operation of winch 1 and winch 2 (1112) via the incline display in the respective winch icons that the hook block does not get into an impermissible incline position.

Make sure that the following prerequisites are met:

- The hook block is placed on the ground.
- The hook block has the required retainer **2** for the assembly of the radio sender unit.
- The side of the hook block on which the radio sender unit **5** is installed is facing the crane cab with a freely suspended hook block.
- The radio sender unit **5** batteries are sufficiently charged.



#### WARNING

Load ripping off!

If the hook block gets into an impermissible incline position during parallel operation of winch 1 and winch 2 (11I2), then the hook block can be overloaded.

The load can rip off and fall down.

Death, severe bodily injuries, property damage.

- ▶ Make sure that the radio sending unit **5** is properly installed on the hook block.
- ▶ Make sure that the incline display in the LICCON computer system is constantly monitored during crane operation, see the Crane operating instructions, chapter 4.02.



#### Note

- ▶ The assembly of the radio sender unit **5** on the respective hook block is described as an example.
- ▶ The example assembly of the radio sender unit **5** is identical to the assembly of the radio sender unit **5** on additional hook blocks approved for parallel operation.

The radio sender unit **5** is screwed onto the assembly plate **4**.

- ▶ Retract the assembly plate **4** of the radio sender unit **5** with the fork connections inpoint **P1** on the axle **3** of the retainer **2**.



#### WARNING

Incorrect orientation of the radio sender unit **5** with the crane.

In the case of incorrect orientation of the radio sender unit **5** with the crane, the incline indicator reacts laterally reversed.

If the incline indicator reacts laterally reversed, there is a danger of accident when spooling the hoist winch up and out.

- ▶ The side of the hook block with the installed radio sender unit **5** must face the crane cab.

When the assembly plate **4** of the radio sender unit **5** is positioned properly in the retainer **2**:

- ▶ Insert the pin **6** inpoint **P2** and secure properly with the locking pin **7**.

#### NOTICE

Damage to the radio sender unit **5**!

- ▶ Make sure that the radio sender unit **5** is not damaged when handling with the hook block.
- ▶ Protect the radio sender unit **5** from damage.

## 3.2 Disassembling the radio sender unit on the hook block

Make sure that the following prerequisite is met:

- The hook block is placed on the ground.
- ▶ Release the radio sender unit **5**: Remove the locking pin **7** and unpin the pin **6** in point **P2**.
- ▶ Lift out the radio sender unit **5** and store it properly.
- ▶ Insert the pin **6** again in point **P2** and secure properly with the locking pin **7**.
- ▶ Remove the batteries when the radio sender unit is not used for a longer period of time. Observe the section "Batteries in the radio sender unit".

## 4 Batteries in the radio sender unit

Batteries in the radio sender unit:

- check and use during assembly of the radio sender unit
- remove during disassembly of the radio sender unit
- replace if insufficiently charged



### Note

- ▶ The representation of the installation position of the radio sender unit is an example and may not apply exactly to your hook block.
- ▶ Depending on the crane type and / or equipment, the radio sender unit may have a different design, see variation 1 and variation 2.
- ▶ The batteries installed in the factory can be used as a model.

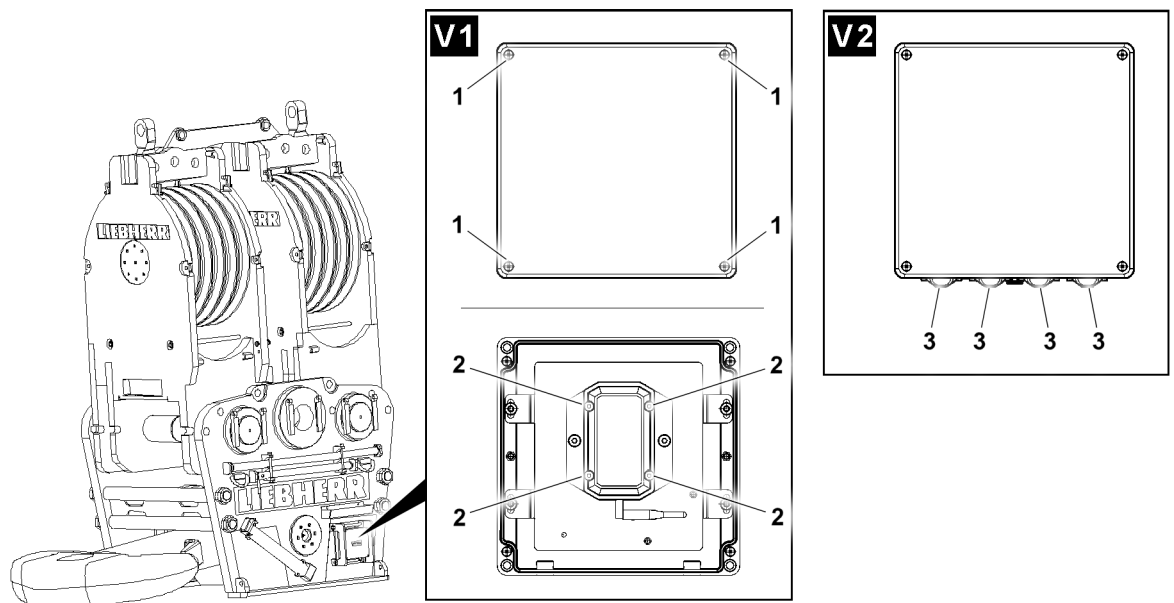


Fig.160474: Removing / replacing batteries in the radio sender unit

**V1** Radio sender unit variation 1  
**1** Screws (terminal box)  
**2** Screws (housing)

**V2** Radio sender unit variation 2  
**3** Battery compartments

### NOTICE

Destruction and failure of the radio sender unit!

If old and new batteries are used together, the batteries can run out.

The performance is limited to the weakest of all batteries in the radio sender unit.

Property damage, failure of the radio incline sensor.

- ▶ Replace all batteries at the same time. Only use new, high-quality batteries.
- ▶ Only use the same type of batteries. The type and manufacturer must be the same.
- ▶ Remove the batteries when the radio sender unit is not used for a longer period of time.
- ▶ Dispose of used batteries properly.

### NOTICE

Penetration of water in the radio sender unit!

If the radio sender unit is not closed correctly, water can enter and destroy the radio sender unit.

Property damage, failure of the radio incline sensor.

- ▶ Correctly reclose an open cover.

## 4.1 Radio sender unit variation 1:



### Note

If the wrong screws are loosened, the radio sender unit can move and supply incorrect values.  
 ▶ Only release screws **1** and screws **2**.

Radio sender unit variation 1 **V1** must be unscrewed so that the four batteries are accessible.

Suitable batteries:

- Cell size: Type C – LR14 / AM-2 / R14 / UM-2
- Voltage: Alkaline 1.5 V / Lithium 2.9...3.6 V

### 4.1.1 Open the radio sender unit:

- ▶ Release four screws **1**. Remove the terminal box cover.
- ▶ Release four screws **2**. Remove the housing cover.
- ▶ Take out the batteries.

### Result:

- The batteries can be checked, replaced or removed.

### 4.1.2 Handling the batteries:

When the battery are checked:

- ▶ If one battery is poorly charged, always replace all batteries together.

When the batteries are replaced:

- ▶ Use only suitable batteries.

When battery are removed for a long period of time:

- ▶ Store the batteries properly.

When the batteries are used:

- ▶ Insert the batteries in the right direction.

### 4.1.3 Close the radio sender unit:

- ▶ Position the housing cover. Tighten the four screws **2** crosswise.
- ▶ Check that the housing cover is positioned correctly.
- ▶ Position the terminal box cover. Tighten the four screws **1** crosswise.
- ▶ Check that the terminal box cover is positioned correctly.

## 4.2 Radio sender unit variation 2:



### Note

- ▶ With radio sender unit variation 2, the state of charge can be read on the LICCON monitor, see chapter 4.02.

Radio sender unit variation 2 **V2** has battery compartments **3** on the bottom that are accessible from the outside.

The four batteries can be replaced without tools. Alkaline primary cells with approx. 16.5 Ah shall be used preferably.

Suitable batteries:

- Cell size: Single cell type D – LR 20
- Voltage: 1.5 Volt
- Capacity: 16.5 Ah (preferably)

### 4.2.1 Battery compartments open:

- ▶ Screw off the battery compartment **3** cover.

- ▶ Take out the batteries.

**Result:**

- The batteries can be checked, replaced or removed.

#### 4.2.2 Handling the batteries:

When the battery are checked:

- ▶ If one battery is poorly charged, always replace all batteries together.

When the batteries are replaced:

- ▶ Use only suitable batteries.

When battery are removed for a long period of time:

- ▶ Store the batteries properly.

When the batteries are used:

- ▶ Insert the batteries in the right direction.

#### 4.2.3 Close the battery compartments:

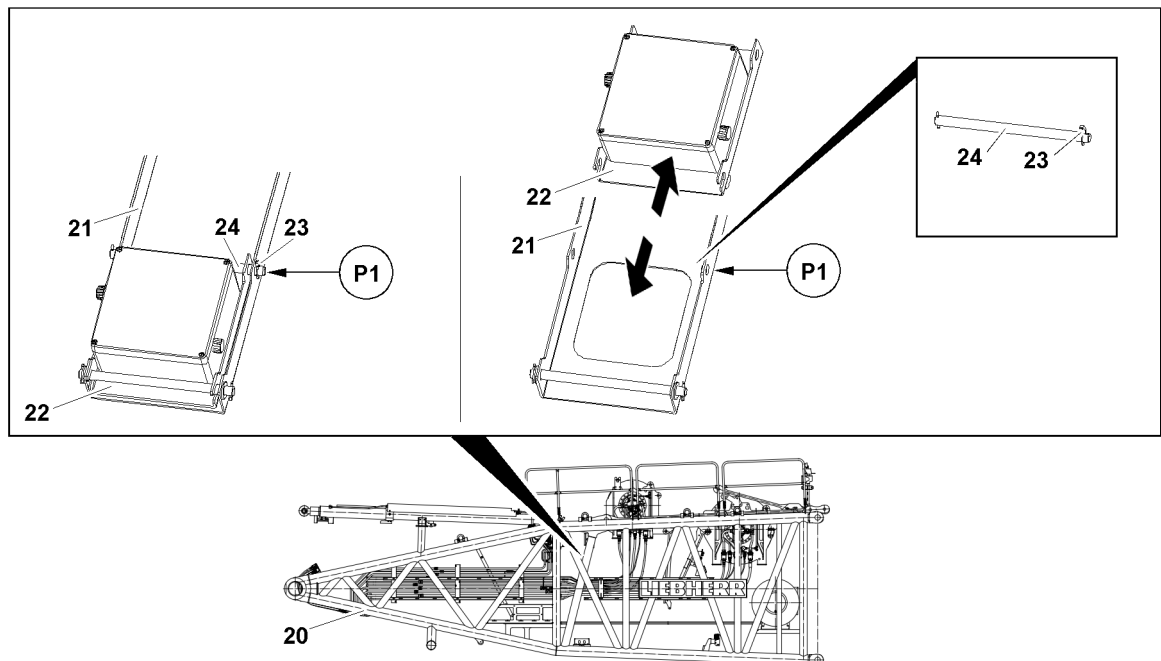
- ▶ Position the battery compartment **3** and screw closed.
- ▶ Check that the cover is positioned correctly on the battery compartment **3**.

## 5 Radio sender unit and radio receiving unit park position



**Note**

- ▶ Not available on all crane types.



*Fig.160475: Radio sender unit and radio receiving unit park position*

Usually there are two retainers **21** on the main boom pivot section **20** as park positions. The assembly plates **22** with the radio sender unit and radio receiving unit can be mounted there.

**Note**

- ▶ If there are no park positions on the main boom pivot section **20**, the radio sender unit and radio receiving unit must be stored in another manner.
- ▶ Remove the batteries when the radio sender unit is not used for a longer period of time. Observe the section "Batteries in the radio sender unit".

## 5.1 Taking the radio sender unit and radio receiving unit out of the park position

When the assembly plate **22** with the radio sender unit or the radio receiving unit is in one of the retainers **21**:

- ▶ Remove the locking pin **23** in point **P1** and unpin the pin **24**.
- ▶ Pull out the assembly plate **22** with the radio sender unit or the radio receiving unit.
- ▶ Insert the pin **24** again in point **P1** and secure with the locking pin **23**.

## 5.2 Bringing the radio sender unit and radio receiving unit into the park position

When the assembly plate **22** with the radio sender unit or the radio receiving unit should be parked in one of the retainers **21**:

- ▶ Remove the locking pin **23** in point **P1** and unpin the pin **24**.
- ▶ Push in the assembly plate **22** with the radio sender unit or the radio receiving unit.

When the bores of the retainer **21** and assembly plate **22** align in point **P1**:

- ▶ Insert the pin **24** again and secure with the locking pin **23**.

## 5.30 Pin pulling device

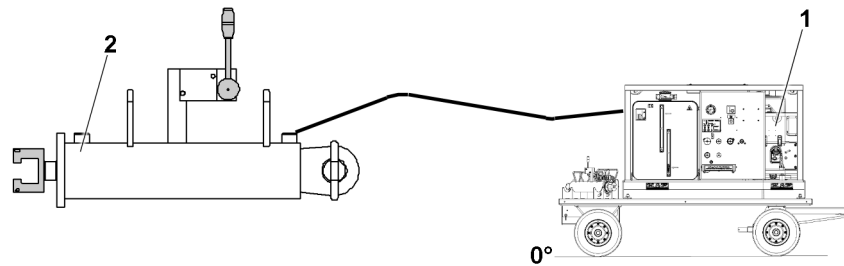
1	Product description	2
2	Component overview	2
3	Safety during assembly and disassembly	3
4	Pin pulling device (hydraulic aggregate with pin pulling cylinder)	4
5	Pin pulling device (battery-operated pin pulling cylinder)	15
6	Using the pin pulling cylinder or battery-operated pin pulling cylinder in the vertical position.	20

# 1 Product description

This chapter describes the operation of the pin pulling device.

## 2 Component overview

### 2.1 Pin pulling device (hydraulic aggregate with pin pulling cylinder)

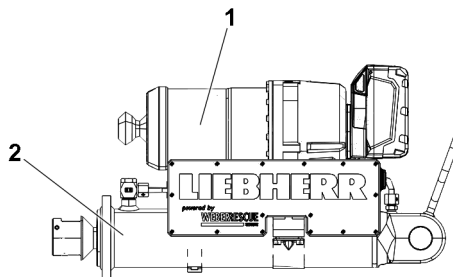


*Fig.166988: Hydraulic aggregate with pin pulling cylinder*

- 1 Hydraulic aggregate                      2 Pin pulling cylinder

The pin pulling device consists of the hydraulic aggregate and the pin pulling cylinders. The connector pins on the crawler crane and on the lattice sections are pinned and unpinned with these pin pulling cylinders. In doing so the hydraulic aggregate remains on the ground and can be positioned near the pin location, outside of the danger zone.

### 2.2 Pin pulling device (battery-operated pin pulling cylinder)



*Fig.166987: Battery-operated pin pulling cylinder*

- 1 Hydraulic aggregate                      2 Pin pulling cylinder

The battery-operated pin pulling cylinder is a specially designed hydraulic cylinder with a fully integrated rechargeable battery hydraulic aggregate. The connector pins on the crawler crane and on the lattice sections are pinned and unpinned with these battery-operated pin pulling cylinders. Due to the internal electro-hydraulic drive, they are not connected to an aggregate and therefore can be used in inaccessible areas and at great heights.



## 3 Safety during assembly and disassembly

Observe the safety instructions before assembly and disassembly:

- Information regarding personal protective equipment. See chapter 2.04.
- Information regarding the 3-point support. See chapter 2.04.10.
- Information regarding crane operation. See chapter 2.04.
- Information regarding fall protection equipment. See chapter 2.06.
- Information regarding walking surfaces and stepping surfaces. See chapter 2.07.
- Technical safety instructions for assembly and disassembly. See chapter 5.01.
- Observe the information on safety in the respective assembly chapter in section “Safety during assembly and disassembly”.

### 3.1 Assembling and disassembling



#### WARNING

Danger to operating personnel!

When pinning / unpinning the pins on the components, components can move uncontrolled. Persons and objects can be caught by moving structural parts and be dragged along.

Death, severe bodily injuries, property damage.

- ▶ It is prohibited for personnel to remain in the entire danger zone!
- ▶ Only stand on fixed components, not on the one to pin / unpin.



#### DANGER

Danger of accident!

When you disassemble unsecured or unsupported crane parts, they can fall down.

Death, severe bodily injuries, property damage.

- ▶ Never stand under unsecured or unsupported crane parts and unpin the pins.
- ▶ Never unpin the connector pins on unsecured or unsupported booms.
- ▶ Do not stand under the crane parts or within the complete danger zone during the pinning and unpinning procedure.
- ▶ Support the components and boom.
- ▶ Do not lean the ladder against the crane part being disassembled.



#### WARNING

Accidental operation of the lever, rocker switch or remote control!

Crushing of limbs if the lever, rocker switch or remote control is accidentally operated.

- ▶ Make sure that the lever, rocker switch or remote control is not accidentally operated.
- ▶ Hold the pin pulling cylinder or the battery-operated pin pulling cylinder only by the provided handles.



#### WARNING

Unsecured pin pulling cylinder!

Working with pin pulling cylinder or battery-operated pin pulling cylinder in the vertical position.

Death, severe bodily injuries, property damage.

- ▶ The instructions in section “Securing the pin pulling cylinder or the battery-operated pin pulling cylinder in the vertical position” must be observed and adhered to.

## 4 Pin pulling device (hydraulic aggregate with pin pulling cylinder)

### 4.1 Hydraulic aggregate on wheels with “emergency control” function

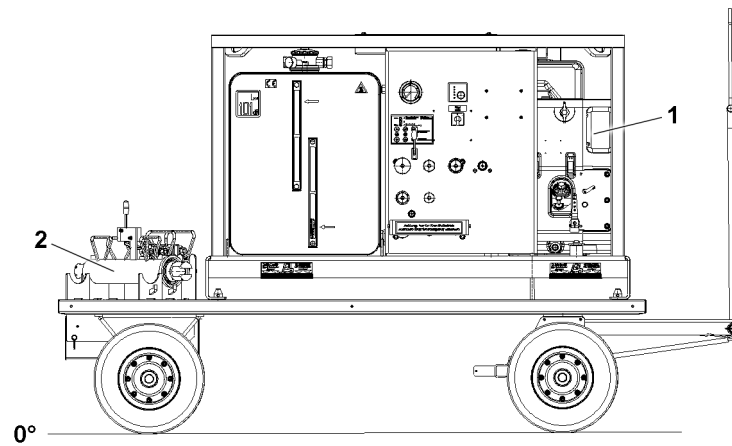


Fig.151398: Hydraulic aggregate on wheels with “emergency control” function

1 Hydraulic aggregate

2 Pin pulling cylinder

### 4.2 Hydraulic aggregate on wheels without “emergency control” function

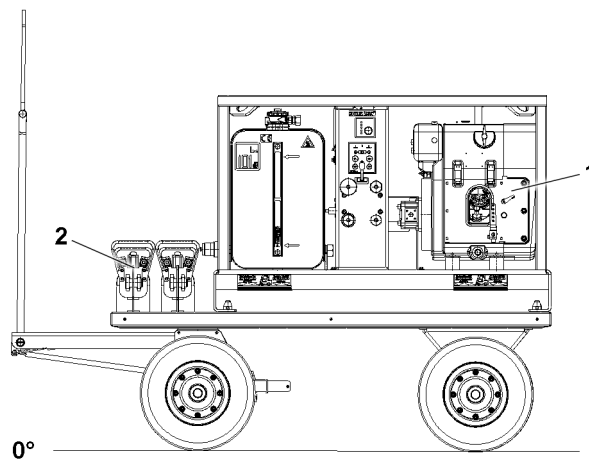
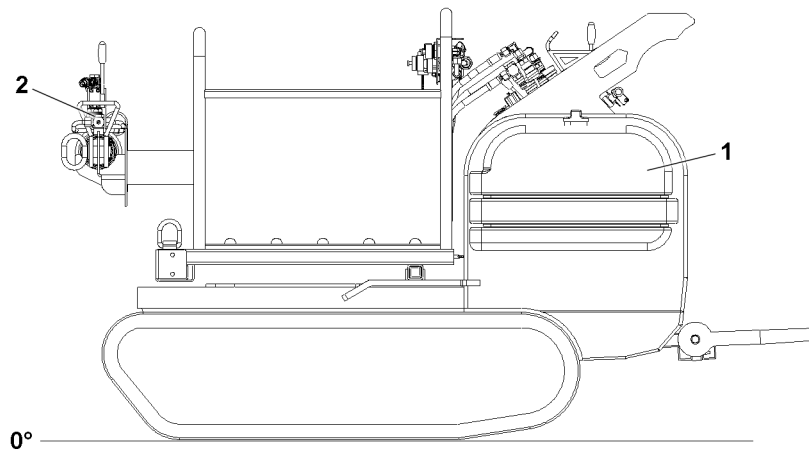


Fig.151399: Hydraulic aggregate on wheels without “emergency control” function

1 Hydraulic aggregate

2 Pin pulling cylinder

### 4.3 Hydraulic aggregate on crawlers

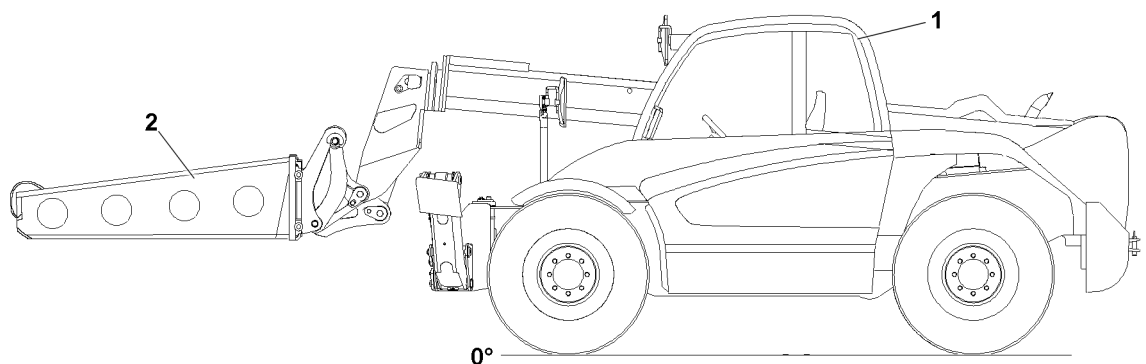


*Fig.151400: Pin pulling aggregate on crawlers*

1 Hydraulic aggregate

2 Pin pulling cylinder

### 4.4 Tele lift truck hydraulic aggregate



*Fig.157046: Tele lift truck hydraulic aggregate*

1 Tele lift truck

2 Assembly arm with pin pulling cylinder

## 4.5 Pin pulling cylinder

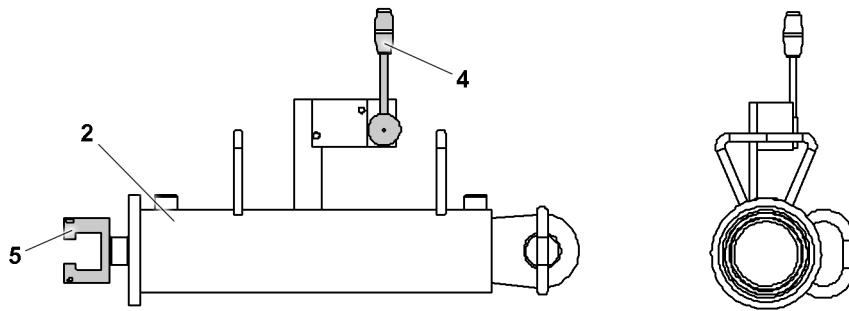


Fig.151408: Pin pulling cylinder

2 Pin pulling cylinder  
4 Lever

5 Piston rod head

## 4.6 Description of the function

### 4.6.1 Pin pulling cylinder

The pin pulling cylinder has an engaging valve that can set the movement direction of the cylinder.

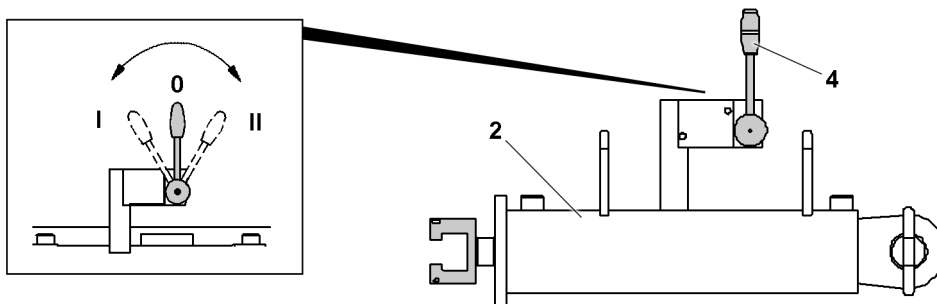


Fig.157045: Pin pulling cylinder

2 Pin pulling cylinder

4 Lever

Lever settings:

- **0 position:** Neutral position.
- **I position:** Extend the piston rod head **5**.
- **II position:** Retract the piston rod head **5**.



#### Note

- ▶ The weight of the pin pulling cylinder is approx. 25 kg.

### 4.6.2 Hydraulic aggregate

There are different structural versions of the pin pulling aggregates. In principle, there are two different categories. The hydraulic aggregates that have three setting options, “pressureless”, “low pressure” and “high pressure” and those that do not have a switch setting for pressureless circulation, and can only be operated with “low pressure” and “high pressure”. The hydraulic aggregates are depressurized by switching off the engine. The hoses for connecting the hydraulic aggregate and the pin pulling cylinder can only be connected in a depressurized condition.

**Note**

- ▶ Operate the hydraulic aggregate, see the Operating and maintenance instructions for the hydraulic aggregate.
- ▶ The illustrated hydraulic aggregate is shown as an example and may not exactly match your crane.
- ▶ Lever settings, see the Operating and maintenance instructions for the hydraulic aggregate.

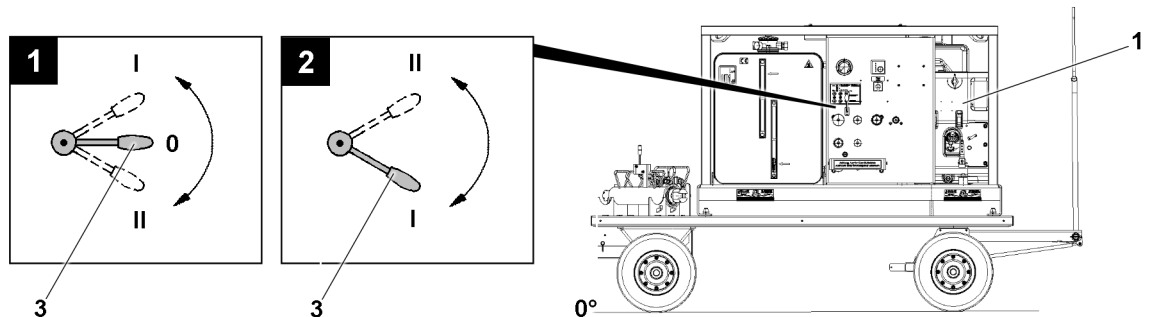


Fig.157047: Hydraulic aggregate

1 Hydraulic aggregate

3 Lever

Lever settings, see illustration 1:

- **0 position:** Neutral position
- **I position:** Low pressure: 30 Bar
- **II position:** High pressure:  $\geq 210$  bar , not engaging, spring return

Lever settings, see illustration 1:

- **0 position:** Low pressure: 30 Bar , spring centered
- **I position:** High pressure:  $\geq 210$  bar , not engaging, spring return
- **II position:** High pressure:  $\geq 210$  bar , engaging with lock, only for emergency operation

Lever settings, see illustration 2:

- **I position:** Low pressure: 30 Bar , spring centered
- **II position:** High pressure:  $\geq 210$  bar , not engaging, spring return

The **low pressure** setting serves either for positioning the pin pulling cylinder or for pinning / unpinning a “non-tensioned” pin.

A “tensioned” pin can also be pulled with the **high pressure** setting.

**Note**

- ▶ Operation with the tele lift truck: The **low pressure** and **high pressure** are set from the tele lift truck.
- ▶ Operation with the tele lift truck, see the Operating and maintenance instructions for the tele lift truck.

**WARNING**

High pressure operation!  
Death, severe bodily injuries, property damage.

- ▶ Make sure that when operating the pin pulling cylinder in high pressure operation, no one is located in the danger zone of the pin location, and in particular below or on the parts to be pinned or separated.
- ▶ It is only permitted to control the pin pulling cylinder in high pressure operation by actuating the valve on the hydraulic aggregate.

**WARNING**

Impermissible work position for the hydraulic aggregate!

If a hydraulic aggregate is placed on boom components or crane components for assembly purposes, this can cause accident situations.

Operating personnel can fall down from the grating of the boom component if the grating is overloaded by the hydraulic aggregate positioned on it.

The grating for the boom components is permitted for the weight of only two people.

Death, severe bodily injuries, property damage.

- ▶ Make sure that a hydraulic aggregate is never placed on boom components or crane components.
- ▶ The hydraulic aggregate may only be operated on the ground.

## 4.7 Hydraulic oil level, hydraulic oil, hydraulic oil pressure

**Note**

- ▶ The hydraulic oil tank is filled when starting the hydraulic aggregate.
- ▶ Check the hydraulic oil level, see Operating and maintenance instructions for the Hydraulic aggregate.

**NOTICE**

Emerging hydraulic oil!

When the hydraulic aggregate is changed and / or the operational crane hydraulic is connected, then there is a danger that the hydraulic oil is supplied during the working process into the hydraulic tank circuit and thus forwarded into the hydraulic tank of the hydraulic aggregate.

The forwarded hydraulic oil quantity exceeds the tank volume of the hydraulic aggregate. Hydraulic oil runs over and contaminates the environment.

- ▶ Make sure that the hydraulic aggregate is separated from the hydraulic circuit of the crane before hydraulic components are actuated via the crane hydraulic.
- ▶ Make sure that the work process is started and ended with the same hydraulic aggregate.
- ▶ Make sure that the same amount of hydraulic oil is in the hydraulic oil tank of the hydraulic aggregate before use and after use.

**WARNING**

Loss of pressure or leakage!

Incorrectly coupled or self-loosening quick couplings (return lines in particular) can result in serious accidents due to component failure.

Death, severe bodily injuries, property damage.

- ▶ Check that the quick couplings have been properly connected before starting work with the crane.
- ▶ Connect the coupling components (sleeve and connector) and screw them together with the knurled nut.
- ▶ Tighten the hydraulic coupling by hand. Turn the knurled nut until it reaches a tangible, fixed stop position.

**WARNING**

Pressure in the hydraulic lines!

If the pressure supply is not interrupted before connecting / releasing the hydraulic lines, the hydraulic oil can escape with high pressure.

Death, severe bodily injuries, property damage.

- ▶ Release the pressure in the hydraulic system before connecting / disconnecting: Interrupt the pressure supply and wait a short time.

## 4.8 Pinning and unpinning with the pin pulling device (hydraulic aggregate with pin pulling cylinder)



### Note

- ▶ Operate the hydraulic aggregate, see the Operating and maintenance instructions for the hydraulic aggregate.
- ▶ The illustrated hydraulic aggregate is shown as an example and may not exactly match your crane.
- ▶ Lever settings, see the Operating and maintenance instructions for the hydraulic aggregate.

### 4.8.1 Preparatory work

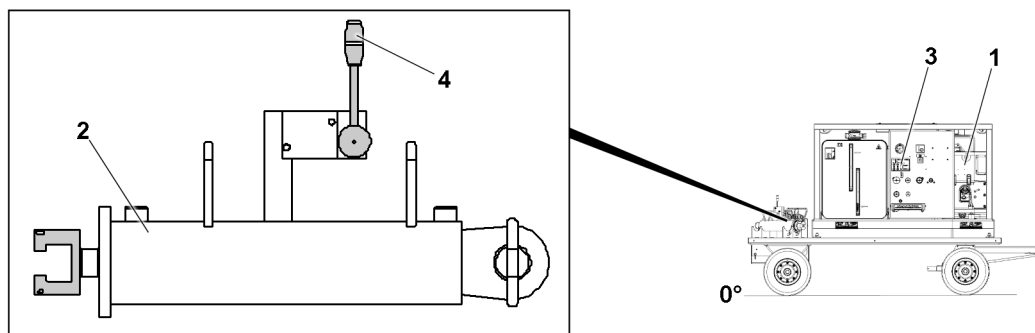


Fig.157052: Hydraulic aggregate with pin pulling cylinder

- |   |                      |   |       |
|---|----------------------|---|-------|
| 1 | Hydraulic aggregate  | 3 | Lever |
| 2 | Pin pulling cylinder | 4 | Lever |

Make sure that the following prerequisites are met:

- The pin pulling cylinder **2** is connected to the hydraulic supply.
- The hydraulic aggregate **1** is not yet started.
- The lever **3** is in the **low pressure position** or in the **0 position**.
- The lever **4** is in the **0 position**.



### WARNING

Pin pulling cylinder held manually!

Danger of falling due holding the pin pulling cylinder **2** manually.

- ▶ Use the auxiliary crane to bring the pin pulling cylinder **2** to the correct height.
- 
- ▶ Bring the pin pulling cylinder **2** to the position to be pinned.  
**or**  
Use the auxiliary crane to bring the pin pulling cylinder **2** to the correct height.

## 4.8.2 Pinning or unpinning pins, pin location variation I

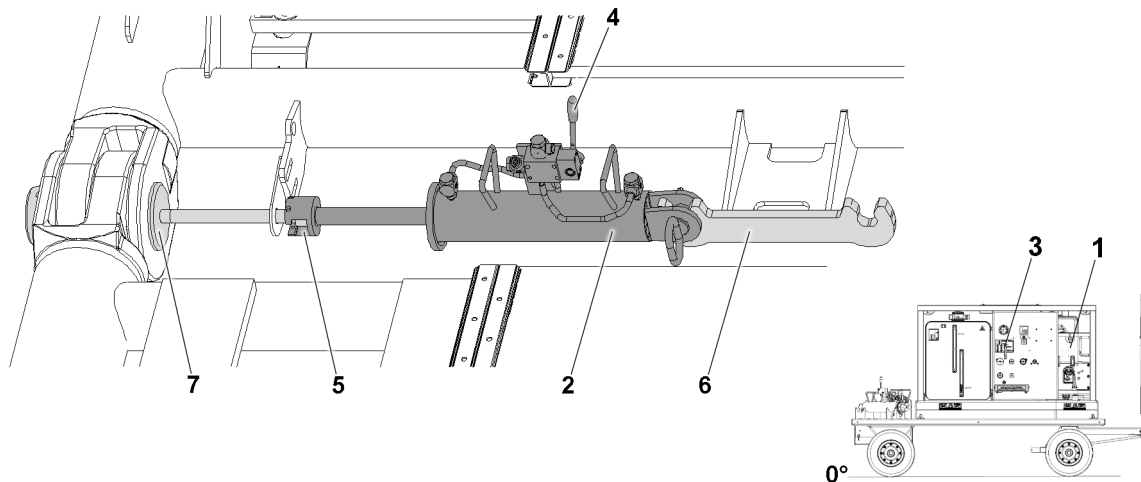


Fig.157048: Pin pulling cylinder

- |   |                      |   |                 |
|---|----------------------|---|-----------------|
| 1 | Hydraulic aggregate  | 5 | Piston rod head |
| 2 | Pin pulling cylinder | 6 | Retainer        |
| 3 | Lever                | 7 | Pin             |
| 4 | Lever                |   |                 |

### Pinning or unpinning non-tensioned pins with low pressure

- ▶ Start the hydraulic aggregate motor on the hydraulic aggregate 1.
- ▶ Set the engine rpm on the hydraulic aggregate 1.
- ▶ Set the lever 3 on the hydraulic aggregate 1 to the **low pressure position**, see section “Hydraulic aggregate”.
- ▶ Connect the pin pulling cylinder 2 to the retainer 6 on the component.

To set the pin pulling cylinder stroke, operate the lever 4:

- ▶ Connect the piston rod head 5 with the screw on the pin 7.



### WARNING

Reaching into the danger zone!

Crushing of limbs when reaching into the danger zone.

- ▶ Hold the pin pulling cylinder 2 only by the provided handles.

When the pin pulling cylinder 2 is positioned securely in the pin location:

- ▶ Operate the lever 4 on the pin pulling cylinder 2.

### Result:

- The pin is pinned or unpinned with **low pressure**.

### Pinning or unpinning tensioned pins with high pressure

The pin pulling cylinder 2 is actuated for safety reasons on the hydraulic aggregate 1!

- ▶ Start the hydraulic aggregate 1.
- ▶ Set the engine rpm on the hydraulic aggregate 1.
- ▶ Set the lever 3 on the hydraulic aggregate 1 to the **low pressure position**, see section “Hydraulic aggregate”.
- ▶ Connect the pin pulling cylinder 2 to the retainer 6 on the component.

To set the pin pulling cylinder stroke, operate the lever 4:

- ▶ Connect the piston rod head 5 with the screw on the pin 7.



**WARNING**

High pressure operation!  
Death, severe bodily injuries, property damage.

- ▶ Make sure that when operating the pin pulling cylinder in high pressure operation, no one is located in the danger zone of the pin location, and in particular below or on the parts to be pinned or separated.
- ▶ It is only permitted to control the pin pulling cylinder in high pressure operation by actuating the valve on the hydraulic aggregate.

When the pin pulling cylinder **2** is positioned securely in the pin location:

- ▶ Do not set any movement direction for the pin pulling cylinder **2**, operate the lever **4**.
- ▶ Leave the pin location.

When no one is located in the danger zone:

- ▶ Set the lever **3** on the hydraulic aggregate **1** to **high pressure**, see section "Hydraulic aggregate".

**Result:**

- The pin is pinned or unpinned with **high pressure**.

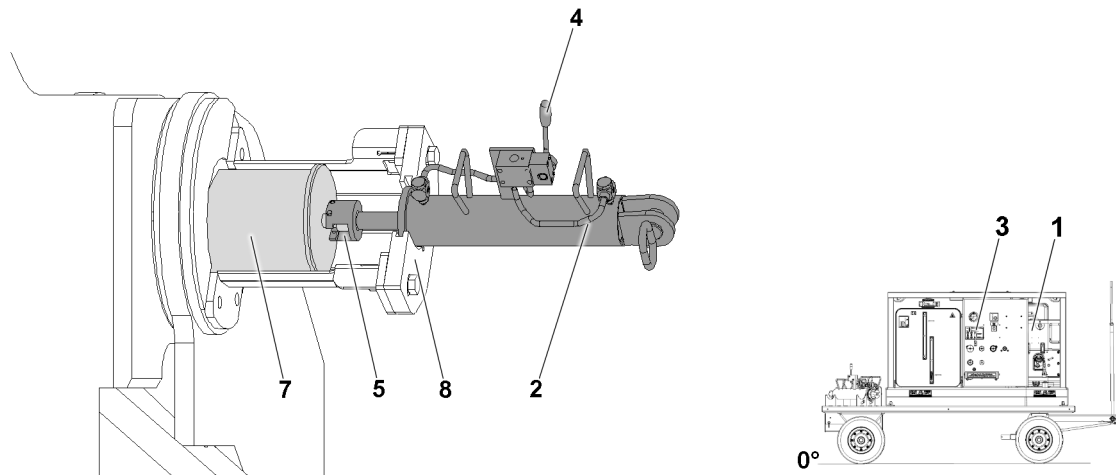
**4.8.3 Pinning or unpinning pins, pin location variation II**

Fig.157049: Pin pulling cylinder

<b>1</b>	Hydraulic aggregate	<b>5</b>	Piston rod head
<b>2</b>	Pin pulling cylinder	<b>7</b>	Pin
<b>3</b>	Lever	<b>8</b>	Retainer
<b>4</b>	Lever		

**Pinning or unpinning non-tensioned pins with low pressure**

- ▶ Start the hydraulic aggregate motor on the hydraulic aggregate **1**.
- ▶ Set the engine rpm on the hydraulic aggregate **1**.
- ▶ Set the lever **3** on the hydraulic aggregate **1** to the **low pressure position**, see section "Hydraulic aggregate".
- ▶ Place the pin pulling cylinder **2** with the collar in the retainer **8** on the component.

To set the pin pulling cylinder stroke, operate the lever **4**:

- ▶ Connect the piston rod head **5** with the screw on the pin **7**.

**WARNING**

Reaching into the danger zone!

Crushing of limbs when reaching into the danger zone.

- ▶ Hold the pin pulling cylinder **2** only by the provided handles.

When the pin pulling cylinder **2** is positioned securely in the pin location:

- ▶ Operate the lever **4** on the pin pulling cylinder **2**.

**Result:**

- The pin is pinned or unpinned with **low pressure**.

**Pinning or unpinning tensioned pins with high pressure**

The pin pulling cylinder **2** is actuated for safety reasons on the hydraulic aggregate **1**!

- ▶ Start the hydraulic aggregate **1**.
- ▶ Set the engine rpm on the hydraulic aggregate **1**.
- ▶ Set the lever **3** on the hydraulic aggregate **1** to the **low pressure position**, see section "Hydraulic aggregate".
- ▶ Place the pin pulling cylinder **2** with the collar in the retainer **8** on the component.

To set the pin pulling cylinder stroke, operate the lever **4**:

- ▶ Connect the piston rod head **5** with the screw on the pin **7**.

**WARNING**

High pressure operation!

Death, severe bodily injuries, property damage.

- ▶ Make sure that when operating the pin pulling cylinder in high pressure operation, no one is located in the danger zone of the pin location, and in particular below or on the parts to be pinned or separated.
- ▶ It is only permitted to control the pin pulling cylinder in high pressure operation by actuating the valve on the hydraulic aggregate.

When the pin pulling cylinder **2** is positioned securely in the pin location:

- ▶ Do not set any movement direction for the pin pulling cylinder **2**, operate the lever **4**.
- ▶ Leave the pin location.

When no one is located in the danger zone:

- ▶ Set the lever **3** on the hydraulic aggregate **1** to **high pressure**, see section "Hydraulic aggregate".

**Result:**

- The pin is pinned or unpinned with **high pressure**.

#### 4.8.4 Removing the pin pulling cylinder

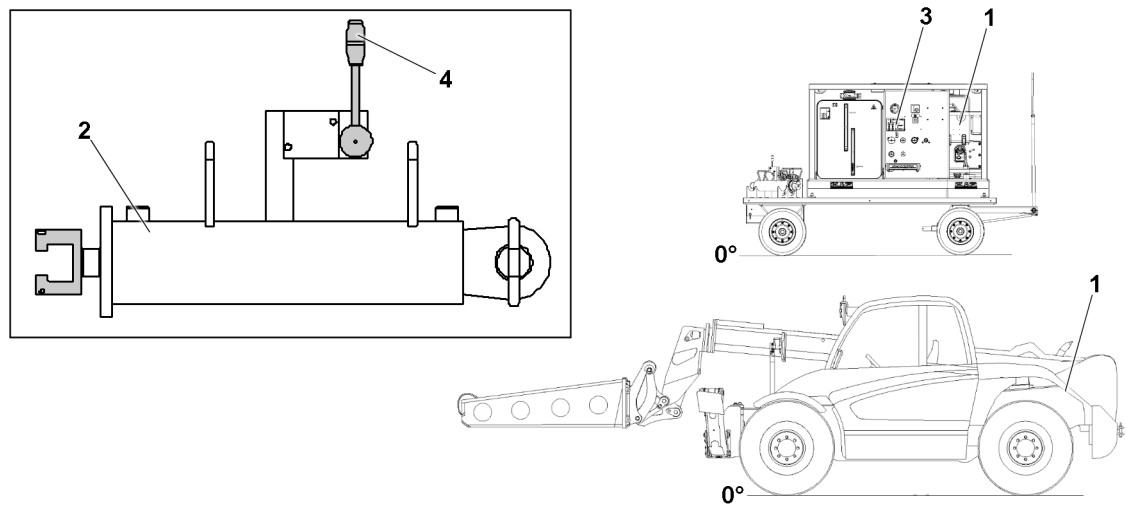


Fig.157050: Hydraulic aggregate with pin pulling cylinder

- |   |                                       |   |       |
|---|---------------------------------------|---|-------|
| 1 | Hydraulic aggregate / tele lift truck | 3 | Lever |
| 2 | Pin pulling cylinder                  | 4 | Lever |



#### Note

- ▶ Operate the hydraulic aggregate, see the Operating and maintenance instructions for the hydraulic aggregate.
- ▶ The illustrated hydraulic aggregate is shown as an example and may not exactly match your crane.
- ▶ Lever settings, see the Operating and maintenance instructions for the hydraulic aggregate.

When the pin 7 is successfully pinned or unpinned:

- ▶ Set the lever 3 on the hydraulic aggregate 1 to the **low pressure position** or the **0 position**, see section "Hydraulic aggregate".
- ▶ Depressurize the hydraulic aggregate 1: Turn the hydraulic aggregate motor off.
- ▶ Set the lever 4 on the pin pulling cylinder 2 to the **0 position**.
- ▶ Disconnect the piston rod head 5 from the screw on the pin.
- ▶ Disconnect the pin pulling cylinder 2 from the retainer 6 or retainer 8 on the component.



#### WARNING

Pin pulling cylinder held manually!

Danger of falling due holding the pin pulling cylinder 2 manually.

- ▶ Carefully lower the pin pulling cylinder 2 to the ground with the auxiliary crane.
- 
- ▶ Remove the pin pulling cylinder 2.  
**or**  
Carefully lower the pin pulling cylinder 2 to the ground with the auxiliary crane.
  - ▶ Return the pin pulling cylinder 2 to the transport retainer on the hydraulic aggregate 1.
  - ▶ Disassemble the hydraulic hoses and close the connections off with dust caps.

### 4.8.5 Operating with the tele lift truck

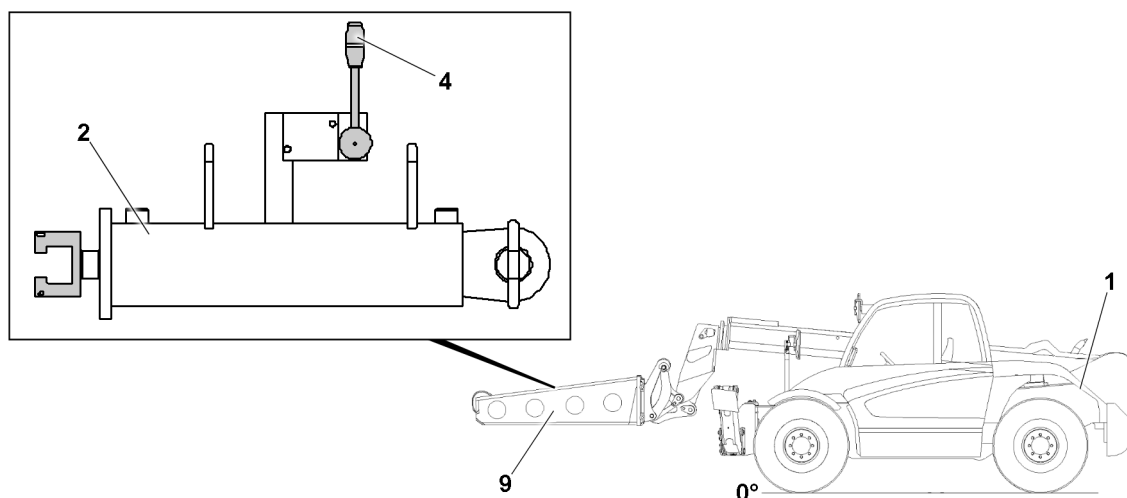


Fig.157051: Tele lift truck hydraulic aggregate

- |   |                                     |   |              |
|---|-------------------------------------|---|--------------|
| 1 | Tele lift truck hydraulic aggregate | 4 | Lever        |
| 2 | Pin pulling cylinder                | 9 | Assembly arm |



#### Note

- ▶ Operation with the tele lift truck, see the Operating and maintenance instructions for the tele lift truck.
- ▶ Inserting and unpinning the pin takes place using the same work steps described in the section "Pinning and unpinning with the pin pulling device".

The pin pulling cylinder can be pulled up or lowered via the rope winch on the assembly arm.

Operation with the tele lift truck: The **low pressure** and **high pressure** are set from the tele lift truck.

## 5 Pin pulling device (battery-operated pin pulling cylinder)

### 5.1 Battery-operated pin pulling cylinder

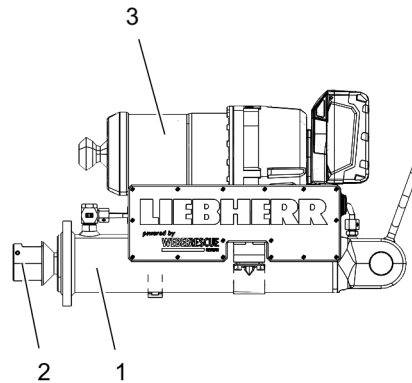


Fig.166984: Battery-operated pin pulling cylinder

- |  |   |
|--|---|
| <p>1 Pin pulling cylinder</p> <p>2 Piston rod head</p> | <p>3 Rechargeable battery hydraulic aggregate</p> |
|--|---|

### 5.2 Description of the function

#### 5.2.1 Battery-operated pin pulling cylinder

The pin pulling cylinder has a rocker switch and remote control that is used to operate the movement direction of the cylinder.

The maximum force (high pressure) is reached only by actuating the remote control. A warning tone sounds also when a certain force is exceeded.



#### Note

- ▶ The weight of the battery-operated pin pulling cylinder is approx. 15.5 kg.

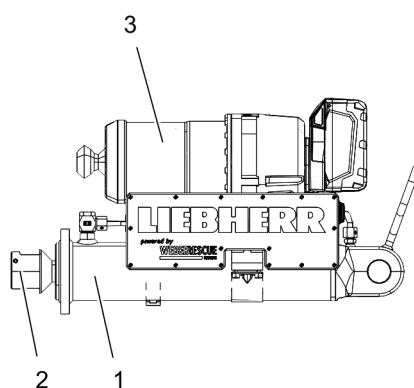


Fig.166984: Battery-operated pin pulling cylinder

- |  |                                     |
|--|-------------------------------------|
| <p><b>1</b> Pin pulling cylinder</p> <p><b>2</b> Piston rod head</p> | <p><b>3</b> Hydraulic aggregate</p> |
|--|-------------------------------------|

Rocker switch switch positions (low pressure):

- **I position:** Extend the piston rod head.
- **II position:** Retract the piston rod head.

Remote control switch positions (high pressure):

- **Button-I:** Extend the piston rod head.
- **Button-II:** Retract the piston rod head.

## 5.3 Pinning and unpinning with the pin pulling device (battery-operated pin pulling cylinder)



### Note

- ▶ Operate the battery-operated pin pulling cylinder, see the Operating and maintenance instructions for the battery-operated pin pulling cylinder.
- ▶ The illustrated battery-operated pin pulling cylinder is shown as an example and may not exactly match your crane.

### 5.3.1 Preparatory work

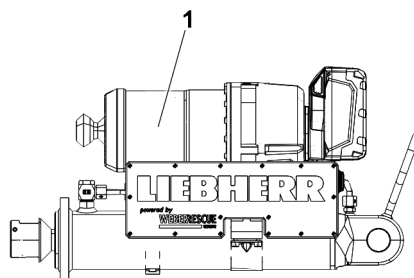


Fig.166989: Battery-operated pin pulling cylinder

- 1** Battery-operated pin pulling cylinder

**Note**

- ▶ When the battery-operated pin pulling cylinder **1** is turned on, the engine idles. The engine starts operating at a higher rpm only after the rocker switch or remote control is actuated.

**WARNING**

Pin pulling cylinder held manually!

Danger of falling due holding the battery-operated pin pulling cylinder **1** manually.

- ▶ Use the auxiliary crane to bring the battery-operated pin pulling cylinder **1** to the correct height.
- ▶ Bring the battery-operated pin pulling cylinder **1** to the position to be pinned.  
or  
Use the auxiliary crane to bring the battery-operated pin pulling cylinder **1** to the correct height.

### 5.3.2 Pinning or unpinning pins, pin location variation I

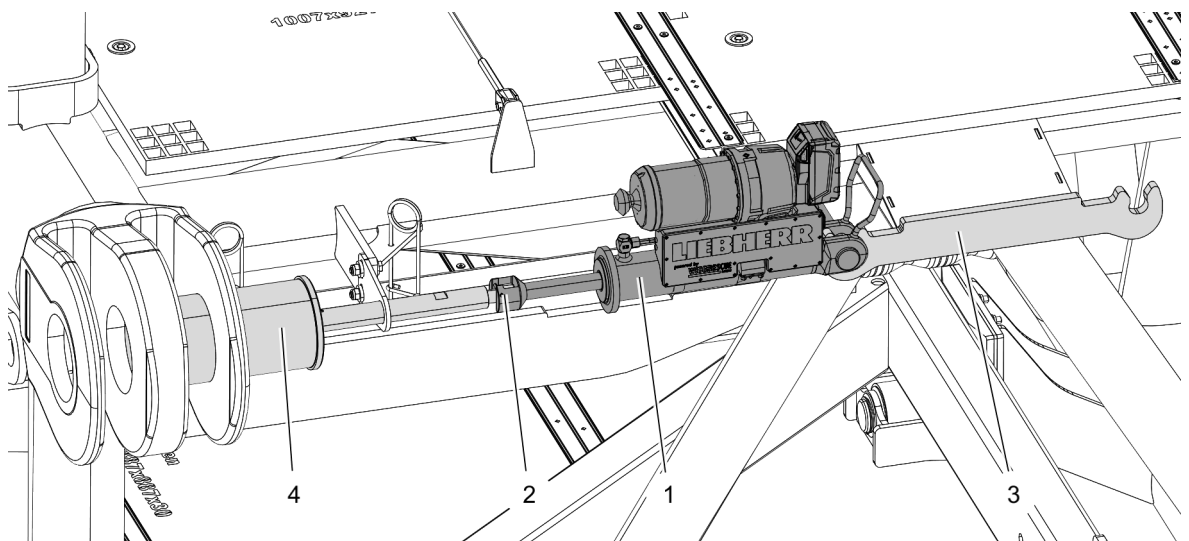


Fig.166985: Battery-operated pin pulling cylinder

- |  |                   |
|--|-------------------|
| <b>1</b> Battery-operated pin pulling cylinder | <b>3</b> Retainer |
| <b>2</b> Piston rod head                       | <b>4</b> Pin      |

#### Pinning or unpinning non-tensioned pins with low pressure

- ▶ Start the battery-operated pin pulling cylinder **1**
- ▶ Connect the battery-operated pin pulling cylinder **1** to the retainer **3** on the component.

To set the pin pulling cylinder stroke, operate the **rocker switch**:

- ▶ Connect the piston rod head **2** with the screw on the pin **4**.

**WARNING**

Reaching into the danger zone!

Crushing of limbs when reaching into the danger zone.

- ▶ Hold the battery-operated pin pulling cylinder **1** only by the provided handles.

When the battery-operated pin pulling cylinder **1** is positioned securely in the pin location:

- ▶ Actuate the **rocker switch** on the battery-operated pin pulling cylinder **1**.

**Result:**

- The pin **4** is pinned or unpinned.

#### Pinning or unpinning tensioned pins with high pressure

- ▶ Start the battery-operated pin pulling cylinder **1**
- ▶ Connect the battery-operated pin pulling cylinder **1** to the retainer **3** on the component.

To set the pin pulling cylinder stroke, operate the **rocker switch**:

- ▶ Connect the piston rod head **2** with the screw on the pin **4**.



#### WARNING

Reaching into the danger zone!

Crushing of limbs when reaching into the danger zone.

- ▶ Hold the battery-operated pin pulling cylinder **1** only by the provided handles.



#### WARNING

High pressure operation!

Death, severe bodily injuries, property damage.

- ▶ Make sure that when operating the rechargeable battery-pin pulling cylinder in high pressure operation, no one is located in the danger zone of the pin location, and in particular below or on the parts to be pinned or separated.
- ▶ It is only permitted to control the battery-operated pin pulling cylinder in high pressure operation using the remote control only outside of the hazard area.

When the battery-operated pin pulling cylinder **1** is positioned securely in the pin location:

- ▶ Leave the pin location.

When no one is located in the danger zone:

- ▶ Actuate the **remote control** for the battery-operated pin pulling cylinder **1**.

**Result:**

- The pin **4** is pinned or unpinned.

### 5.3.3 Pinning or unpinning pins, pin location variation II

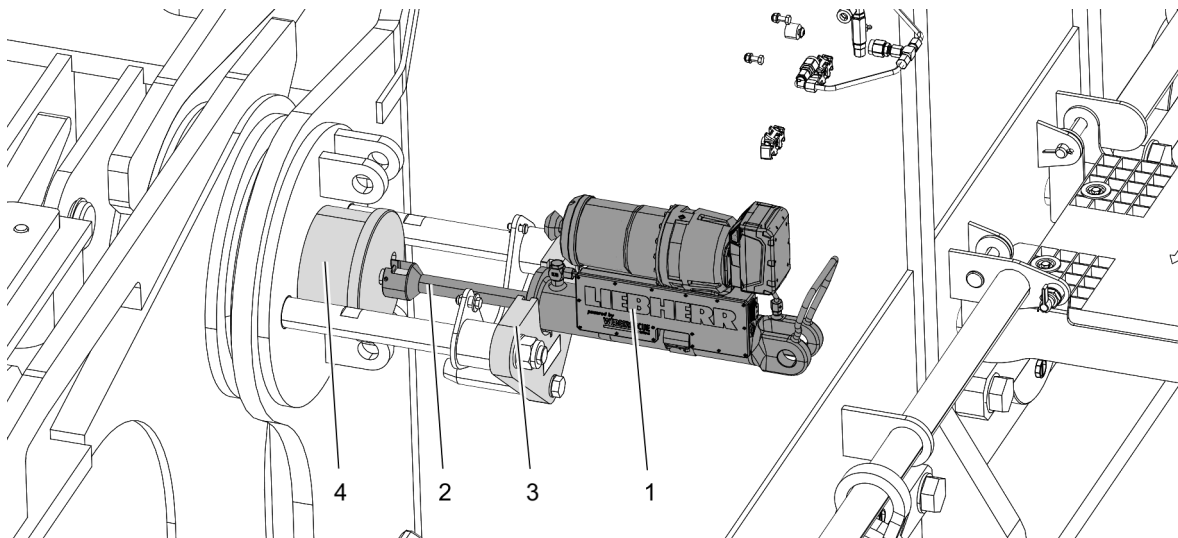


Fig.166986: Battery-operated pin pulling cylinder

- |          |                                       |          |          |
|----------|---------------------------------------|----------|----------|
| <b>1</b> | Battery-operated pin pulling cylinder | <b>3</b> | Retainer |
| <b>2</b> | Piston rod head                       | <b>4</b> | Pin      |

#### Pinning or unpinning non-tensioned pins with low pressure

- ▶ Start the battery-operated pin pulling cylinder **1**
- ▶ Place the battery-operated pin pulling cylinder **1** with the collar in the retainer **3** on the component.

To set the pin pulling cylinder stroke, operate the **rocker switch**:

- ▶ Connect the piston rod head **2** with the screw on the pin **4**.



**WARNING**

Reaching into the danger zone!  
Crushing of limbs when reaching into the danger zone.

- ▶ Hold the battery-operated pin pulling cylinder **1** only by the provided handles.

When the battery-operated pin pulling cylinder **1** is positioned securely in the pin location:

- ▶ Actuate the **rocker switch** on the battery-operated pin pulling cylinder **1**.

**Result:**

- The pin **4** is pinned or unpinned.

**Pinning or unpinning non-tensioned pins with high pressure**

- ▶ Start the battery-operated pin pulling cylinder **1**
- ▶ Place the battery-operated pin pulling cylinder **1** with the collar in the retainer **3** on the component.

To set the pin pulling cylinder stroke, operate the **rocker switch**:

- ▶ Connect the piston rod head **2** with the screw on the pin **4**.

**WARNING**

Reaching into the danger zone!  
Crushing of limbs when reaching into the danger zone.

- ▶ Hold the battery-operated pin pulling cylinder **1** only by the provided handles.

**WARNING**

High pressure operation!  
Death, severe bodily injuries, property damage.

- ▶ Make sure that when operating the rechargeable battery-pin pulling cylinder in high pressure operation, no one is located in the danger zone of the pin location, and in particular below or on the parts to be pinned or separated.
- ▶ It is only permitted to control the battery-operated pin pulling cylinder in high pressure operation using the remote control only outside of the hazard area.

When the battery-operated pin pulling cylinder **1** is positioned securely in the pin location:

- ▶ Leave the pin location.

When no one is located in the danger zone:

- ▶ Actuate the **remote control** for the battery-operated pin pulling cylinder **1**.

**Result:**

- The pin **4** is pinned or unpinned.

**5.3.4 Removing the battery-operated pin pulling cylinder****Note**

- ▶ Operate the battery-operated pin pulling cylinder, see the Operating and maintenance instructions for the battery-operated pin pulling cylinder.

When the pin is successfully pinned or unpinned:

- ▶ Turn off the battery-operated pin pulling cylinder.
- ▶ Disconnect the piston rod head from the screw on the pin.
- ▶ Disconnect the battery-operated pin pulling cylinder from the retainer on the component.

**WARNING**

Pin pulling cylinder held manually!  
Danger of falling due holding the battery-operated pin pulling cylinder manually.

- ▶ Carefully lower the battery-operated pin pulling cylinder to the ground with the auxiliary crane.

- ▶ Remove the battery-operated pin pulling cylinder.

**or**

- ▶ Carefully lower the battery-operated pin pulling cylinder to the ground with the auxiliary crane.

## 6 Using the pin pulling cylinder or battery-operated pin pulling cylinder in the vertical position.

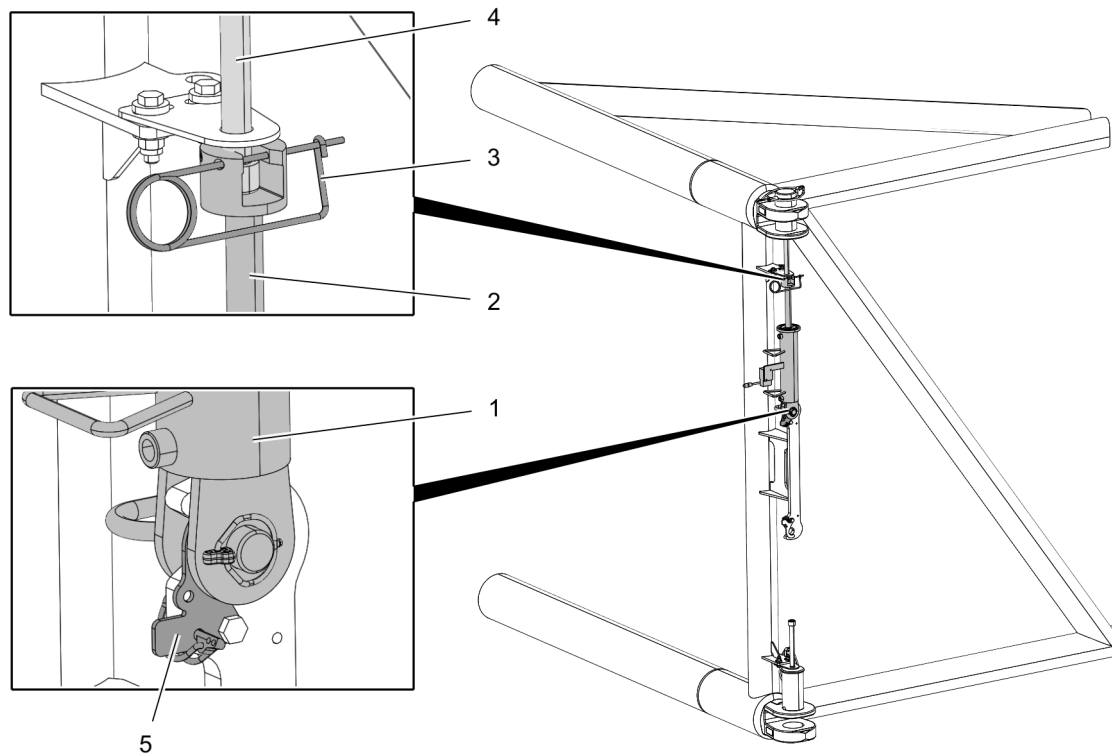


Fig.166991: Pin pulling cylinder or battery-operated pin pulling cylinder in the vertical position.

- |   |   |   |                   |
|---|---|---|-------------------|
| 1 | Pin pulling cylinder or battery-operated pin pulling cylinder | 4 | Pin               |
| 2 | Piston rod head   | 5 | Retaining element |
| 3 | Spring retainer   |   |                   |

The illustration is shown as an example and may not exactly match your crane.

The retaining element **5** is shown as an example. The structure and type of design of a retaining element **5** varies depending on the installation location.



### WARNING

Unsecured pin pulling cylinder!

When the piston rod head **2** of the pin pulling cylinder **1** is not secured by a spring retainer **3**, then the pin pulling cylinder **1** can fall down.

Death, severe bodily injuries, property damage.

- ▶ Make sure that when working with the pin pulling cylinder or the battery-operated pin pulling cylinder in the vertical position, the piston rod head **2** of the pin pulling cylinder **1** is secured by the spring retainer **3**.
- ▶ Make sure that when working with the pin pulling cylinder or the battery-operated pin pulling cylinder in the vertical position, the pin pulling cylinder **1** is secured in the retainer with the retaining element **5**.

## 5.31 BTT - Operating element

1	BTT display / operating element	2
2	Settings and status displays on the BTT	15
3	BTT start menu	16
4	Selection overview	21
5	<i>Engine operation</i> menu	22
6	<i>Assembly support</i> menu	29
7	<i>Crawler carrier assembly</i> menu	34
8	<i>Crane cab / stepladder</i> menu	39
9	<i>Assembly functions</i> menu	43
10	<i>Crane floodlight</i> menu	46
11	<i>Test system</i> menu	47
12	BTT operation	51
13	Measures in case of problems	53

# 1 BTT display / operating element

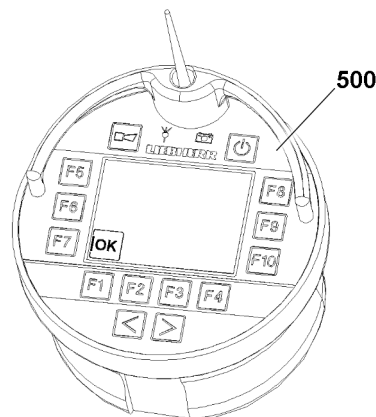


Fig.124478



## Note

- ▶ The BTT operating element is referred to as the BTT in the description.
- ▶ The base station installed fixed on the crane is referred to as BTB in the description.

The BTT is a combined display / operating element for the crane. Selected crane movements can be carried out. The data exchange is made via the BTB on the crane. The data exchange can also be made wireless as well as via a connector cable.

The BTT is operated using function keys F1 - F10 and two changeover buttons



## Note

- ▶ The illustrations or icons on the screen display of the BTT are only examples.
- ▶ They may differ from the crane.

Via the BTT **500** you can call up various menus. Various crane functions can be selected or preselected, turned on or off, or directly activated in these menus.

The operation of the BTT **500** via the function keys and changeover buttons:

- Function keys
  - The function of the function keys is menu dependent. See the respective menu section for an exact description.
- Changeover buttons
  - The function of the changeover buttons is menu dependent. See the respective menu section for an exact description.

## NOTICE

Destruction of the BTT!

- ▶ Under no circumstances clean the BTT **500** with a jet of water or a steam cleaner.

Empty page!

LWE/LR 1800-1-0-000/27200-07-02/en

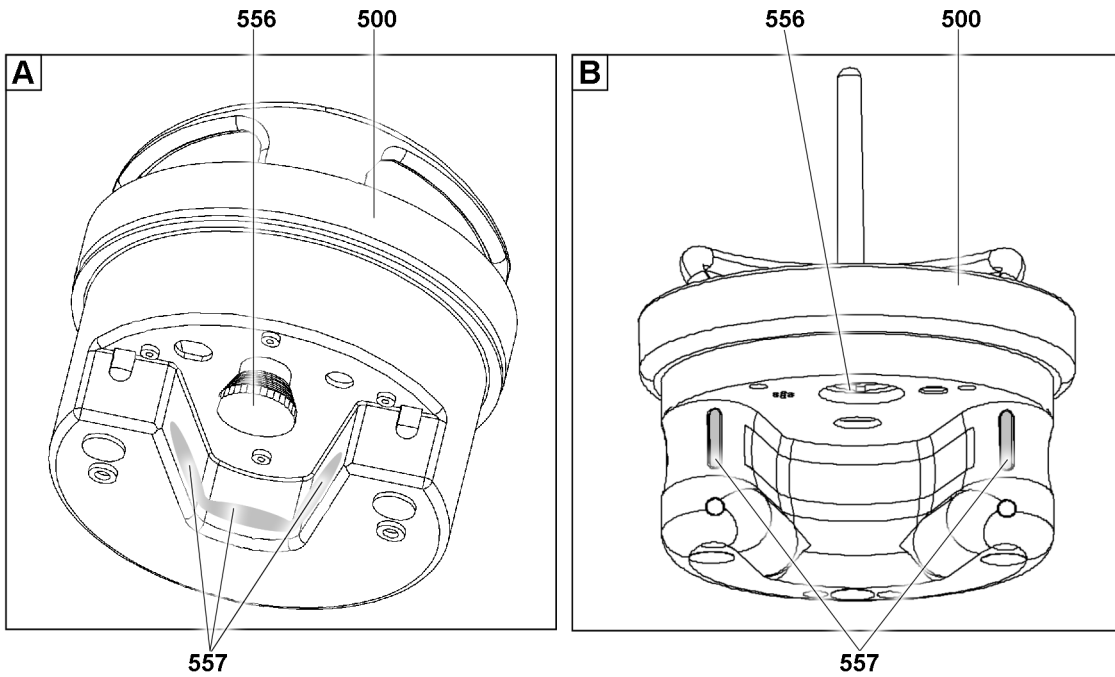
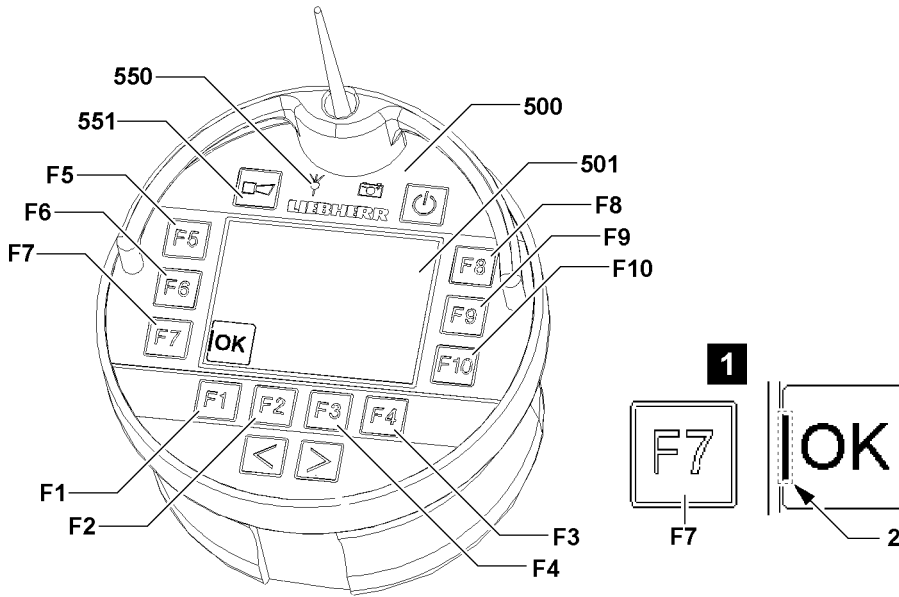


Fig.146318

- A** 2-hand keypad: On the inner surface
- B** 2-hand keypad: Button on the front side of the curvature



**Note**

► One of the described BTTs is used depending on the delivery condition of the crane.

LWE/LR 1800-1-0-000/27200-07-02/en

## 1.1 Important information about the BTT

The following important information must be observed for operation with the BTT **500**:

- The machine number on the data tag of the crane cab must match the machine number on the BTT display **501**.
- The BTT can only be turned on when the EMERGENCY STOP switch **556** on the rear of the BTT is **not** actuated.
- The rechargeable battery of the BTT is only charged if the EMERGENCY STOP switch **556** on the rear of the BTT is **not** actuated when plugging it into the charging cradle.
- When a function is selected via a function key, the corresponding icon is surrounded with a black border. In some case, additional icons are shown on the BTT display.
- The operation of the BTT must be made with two hands for safety reasons, see section “Release of button block on the BTT”.
- During crane operation via the BTT **500**, the complete crane must be in the field of visibility of the operator.
- Before any movement, which is controlled via the BTT **500**, the *horn* **551** button must be actuated.
- As soon as the reception of the radio signal deteriorates, the *transmission signal* indicator light **550** lights up orange.
- The range of the radio signal can fluctuate due to local conditions.
- If the radio contact between the BTT **500** and the BTB is interrupted or the EMERGENCY STOP switch **556** on the rear of the BTT **500** is actuated, the crane movement stops.
- Keep the BTT **500** and the charging cradle clean.
- Protect the BTT **500** from direct sun exposure.
- Protect the BTT **500** from dirt and moisture.



### Note

Function keys **F1** to **F10**

- ▶ Icons are assigned to the individual function keys. A small bar **2** marks the assigned button, see illustration 1: Example for function key **F7**.

## 1.2 Releasing the button block on the BTT

To prevent inadvertent crane operation, movements to be carried out on the BTT are secured by a button block. The 2-Hand keypad **557** can be activated by finger touch. The button block is removed.

After selecting a function, the actual movement (operation) is only released after activation of the 2-hand keypad **557**. Released icons are highlighted with the color **purple**.

If the icon is released and the respective function key is pressed, the movement is carried out.



### Note

- ▶ The actuation of the 2-hand keypad **557** is stored for 30 seconds. If no movement is actuated within these 30 seconds or if the 2-hand keypad **557** is actuated again, then the button block is activated and a signal tone sounds.

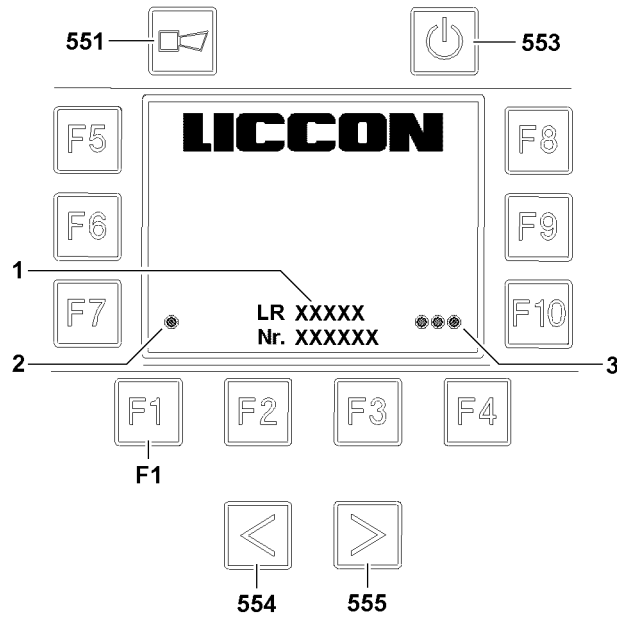


Fig.119599



## 1.3 Connecting the BTB and the BTT



### Note

- ▶ If crane type and crane number **2** do not match, a connection between BTB and BTT is not possible.

To be able to control the crane via the BTT a connection to the BTB must be established.

The connection is based on a pairing process and code comparison.

### 1.3.1 Pairing process

If the BTT is plugged into the charging cradle when the ignition is turned on, then a pairing process is carried out automatically with the BTB.

Carry out the pairing process by hand:

To do so, the turned on BTT must be plugged into the charging cradle. Various connection parameters are compared and checked for a match via an infrared interface.

When the pairing process is completed successfully, the indicator light **2** lights up green.



### Note

- ▶ If the pairing process is not successful, contact your **Liebherr customer service center** or **Liebherr-Werk Ehingen**.

### 1.3.2 Code calibration

If the BTT is plugged into the charging cradle when the ignition is turned on, the code calibration is carried out automatically.

Carry out the code calibration by hand:

One after the other, press the change over key **554**, then the change over key **555** and then the function key **F1**.

When the code calibration is completed successfully, all indicator lights **3** light up green.

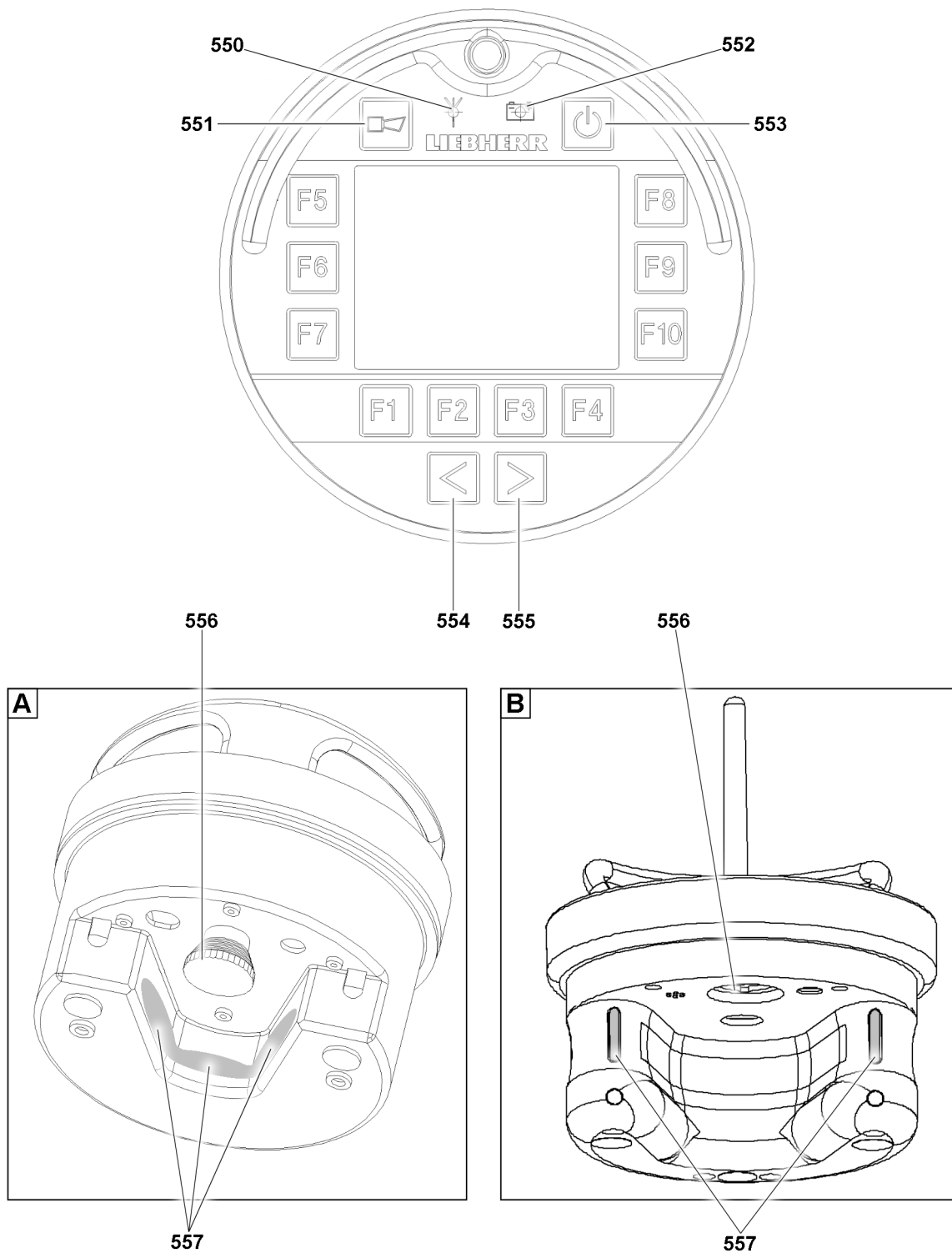


Fig.146316

**A** 2-hand keypad: On the inner surface

**B** 2-hand keypad: Button on the front side of the curvature

LWE/LR 1800-1-0-000/27200-07-02/en

## 1.4 General information regarding the BTT

- 550** *Transmission signal* indicator light
- Indicator light *green*: Transmission signal ok
  - Indicator light *yellow*: Transmission signal about to be lost
  - Indicator light *red*: Transmission signal not available
- 551** Horn *button*
- Operate the acoustic signal (horn signal)
- 552** *Rechargeable battery* indicator light
- Indicator light *green*: Rechargeable battery fully charged
  - Indicator light *yellow*: Rechargeable battery almost discharged
  - Indicator light *red*: Rechargeable battery discharged



### Note

- To recharge the rechargeable battery, the BTT **500** must be plugged into the charging cradle.

- 553** On / off button
- Turn the BTT on / off
- 554** Change over key
- Function menu / operating screen dependent
- 555** Change over key
- Function menu / operating screen dependent
- 556** EMERGENCY STOP switch
- **Note:** The EMERGENCY STOP switch **556** is on the underside of the BTT.
- 557** 2-hand keypad
- **Note:** The 2-hand keypad **557** must be actuated in order to be able to actuate a movement with the BTT.

## 1.5 Crawler travel gear operating and control instruments

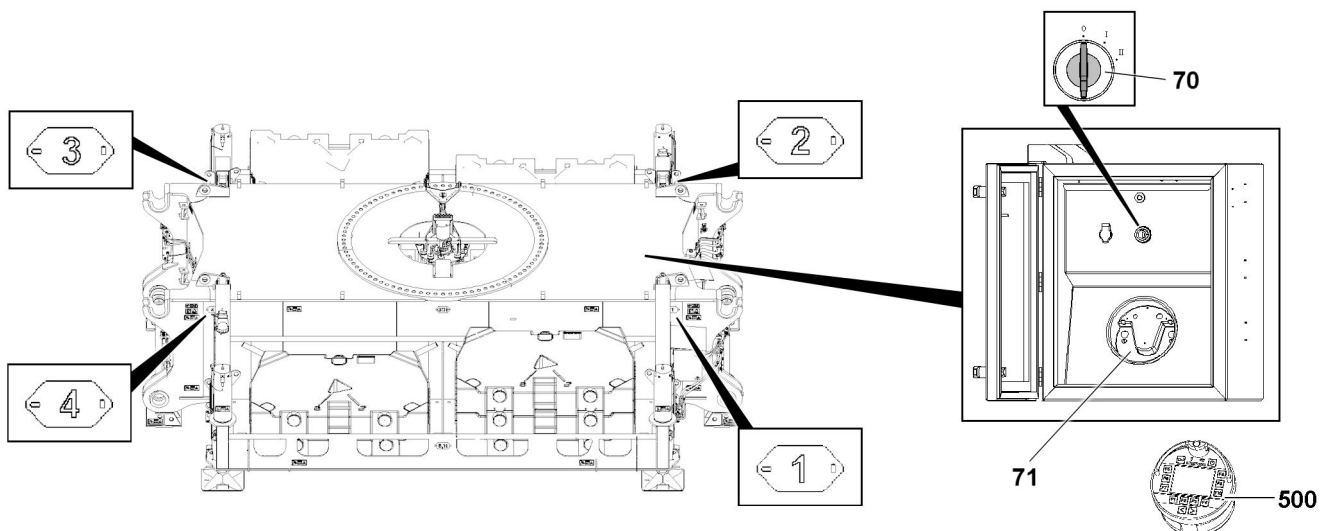


Fig.161602: Radio remote control operation: Crawler travel gear operating and control instruments

The control cabinet with the crawler travel gear operating and control instruments is located below sign 1 or between sign 3 and sign 4.

- 70** *Crawler travel gear* ignition switch
- in the control cabinet

**71 Crawler travel gear** charging cradle

- For the automatic registration of the BTT on the crawler travel gear, the BTT must be in the *crawler travel gear* charging cradle when the ignition is turned on using the *crawler travel gear* ignition switch **70**
- To recharge the rechargeable battery, the BTT **500** must be plugged into a charging cradle:
  - *Crane cab* charging cradle
  - *Crawler travel gear* charging cradle

**Note**

- For a detailed description of the operating and control instruments, see chapter 4.01.

Empty page!

LWE/LR 1800-1-0-000/27200-07-02/en

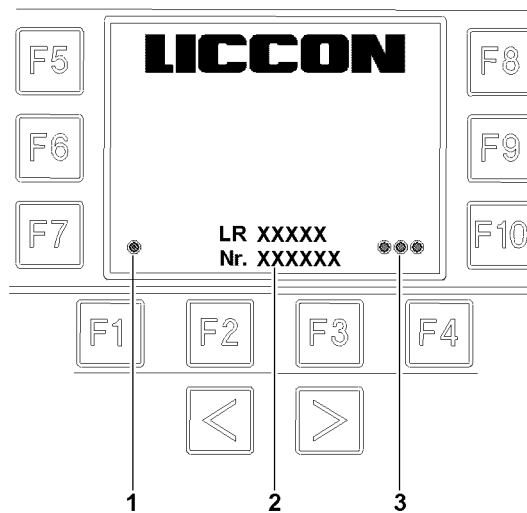
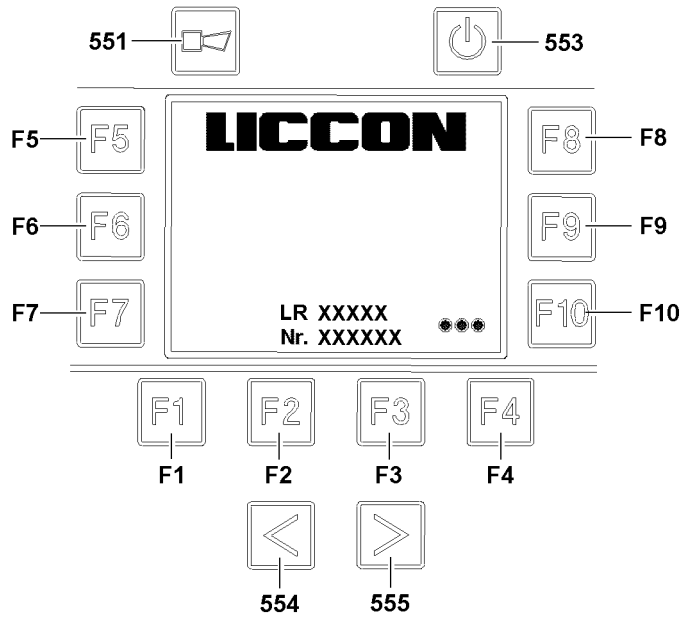


Fig.119600

LWE/LR 1800-1-0-000/27200-07-02/en

## 1.6 Start screen BTT

### 1.6.1 Icon explanation Start screen BTT

#### 1 Indicator light

Status display connection to BTT receiver

- Yellow / red: not connected
- Yellow: Transmission signal being established or disconnected
- Green / magenta: Connection prepared
- Green: Connection established
- Red: No connection between BTT and BTB

**Note:** If necessary, the pairing process must be repeated, see section "Connecting the BTB and BTT"

#### 2 Crane type and crane number

#### 3 Indicator lights

Code entry status display

- Green: Code entry OK
- Red: No code entered, code entry incorrect

#### F1- F10 Function key

- **Note:** Once the code has been successfully entered, press any function key **F1-F10** to switch back to the selection overview.

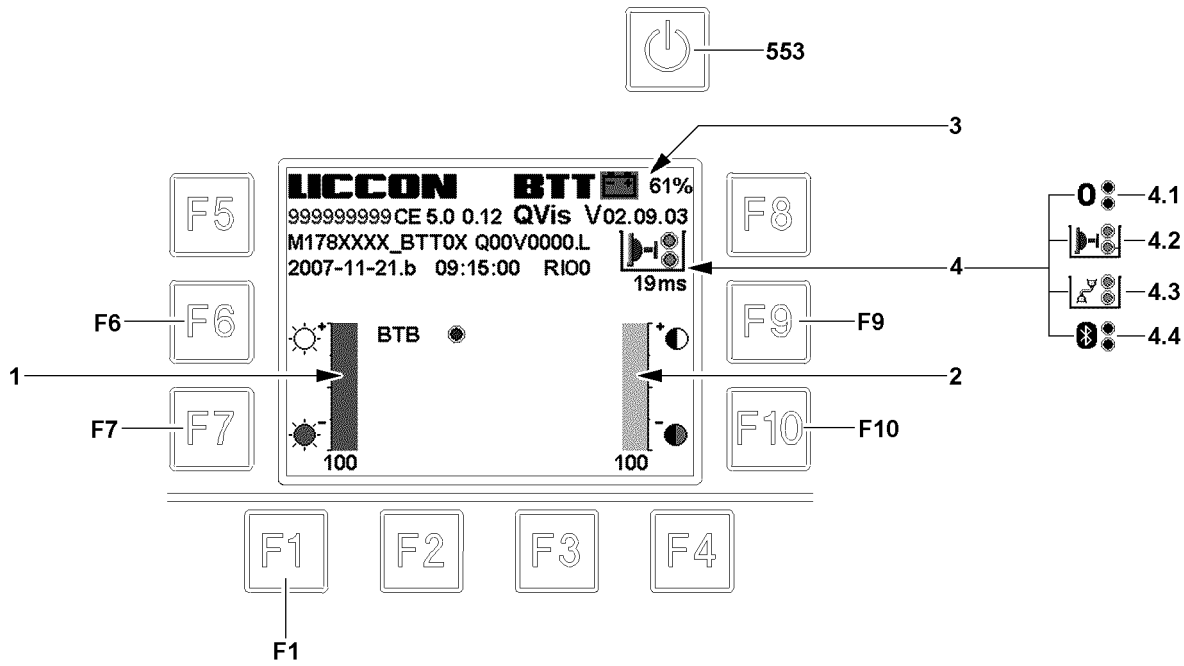


Fig.117976



## 2 Settings and status displays on the BTT

Settings can be made and status displays can be read on the BTT system screen.

### 2.1 Calling up / closing the system screen

Make sure that the following prerequisite is met:

- The start menu is displayed.
- ▶ Select the system screen: Press the On / Off button **553** momentarily until the system screen appears (max. 1 second).



#### Note

- ▶ If the On / Off button **553** is pressed too long, the BTT turns off.
- ▶ To switch back to the start menu: Press the function key **F1**.

### 2.2 Setting the brightness on the BTT display

The current setting stage for brightness can be read on the bar diagram 1.

- ▶ BTT display brighter: Press the function key **F6**.
- ▶ BTT display darker: Press the function key **F7**.

### 2.3 Setting the contrast on the BTT display



#### Note

- ▶ Only available for certain crane types.

The current setting stage for the contrast can be read on the bar diagram 2.

- ▶ BTT display more contrast: Press the function key **F9**.
- ▶ BTT display less contrast: Press the function key **F10**.

### 2.4 Determining the exact charge condition of the rechargeable battery

The exact charge condition of the rechargeable battery can be read on the charge condition display 3.

- ▶ Read the charge condition, if necessary recharge the BTT by inserting it in the charging bay.

### 2.5 Checking the connection type

The connection type can be read on the connection type display 4.

- ▶ Read the connection type.

#### Result:

- **4.1** No connection
- **4.2** Infrared
  - Note:** Appears only when the BTT is plugged into the charging cradle.
- **4.3** Cable
- **4.4** Radio

### 3 BTT start menu

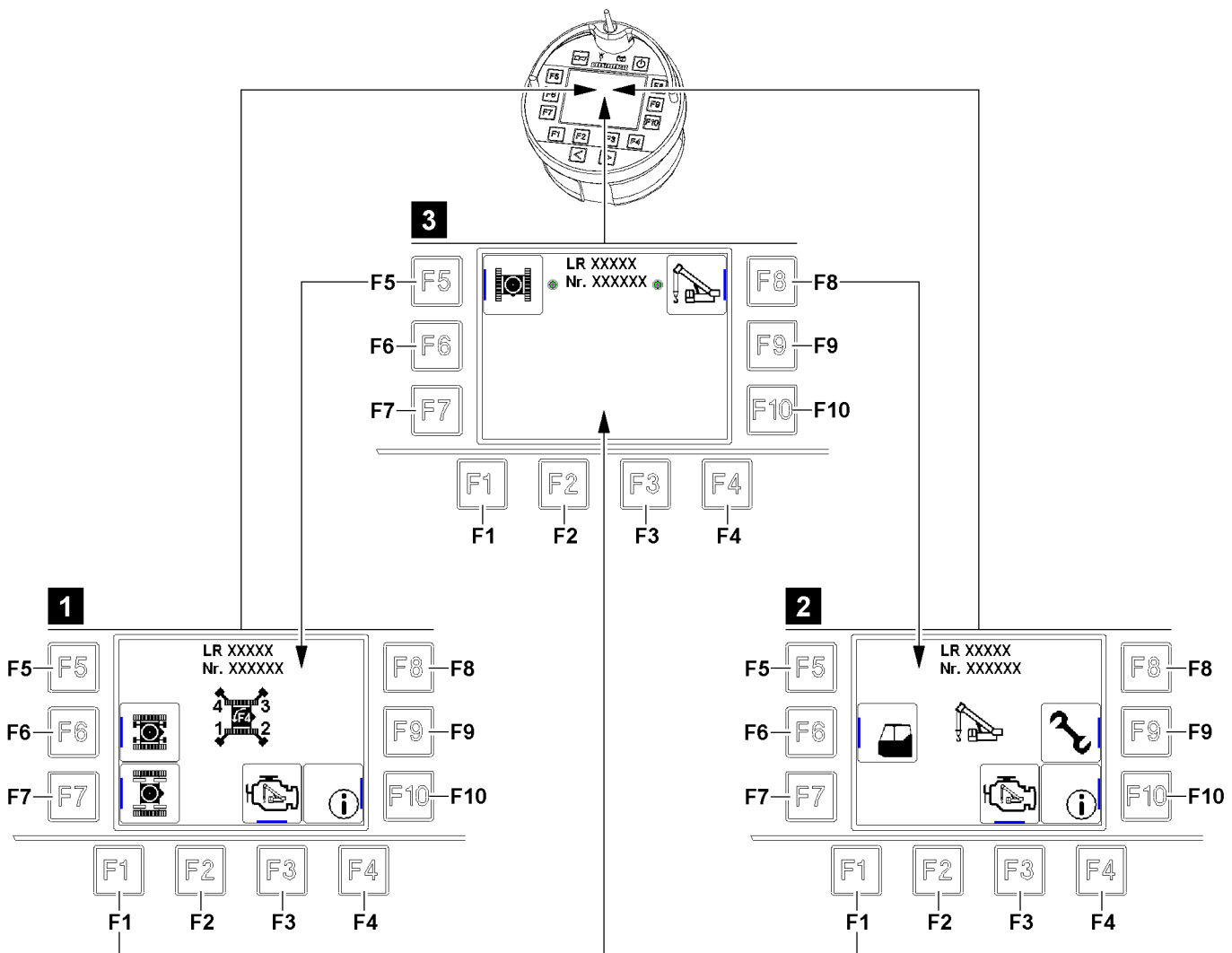


Fig.155084: BTT start menu

The crane control releases the corresponding start menus for operation as soon as the required prerequisites have been met.

The crane control takes into account:

- Structural condition of the crane
- Position of the *crawler travel gear* ignition switch
- Position of the *crane cab* ignition switch

#### Illustration 1: *Crawler travel gear* start menu

<b>F1</b>	Call up the selection overview <sup>1)</sup>
<b>F3</b>	Call up the <i>Engine operation</i> menu
<b>F4</b>	Turn the crane icon in 180° increments
<b>F6</b>	Call up the <i>Assembly support</i> menu
<b>F7</b>	Call up the <i>Crawler carrier assembly</i> menu
<b>F10</b>	Call up the <i>Test system</i> menu

1) Only available in certain situations.

Illustration 2: <i>Crane superstructure start menu</i>	
<b>F1</b>	Call up the selection overview <sup>1)</sup>
<b>F3</b>	Call up the <i>Engine operation</i> menu
<b>F6</b>	Call up the <i>Crane cab / stepladder</i> menu
<b>F9</b>	Call up the <i>Assembly functions</i> menu
<b>F10</b>	Call up the <i>Test system</i> menu

1) Only available in certain situations.

Illustration 3: <i>Selection overview</i>	
<b>F5</b>	Call up the <i>Crawler travel gear start menu</i> <sup>1)</sup>
<b>F8</b>	Call up the <i>Crane superstructure start menu</i> <sup>1)</sup>

1) Only available in certain situations.

### 3.1 Crawler travel gear start menu

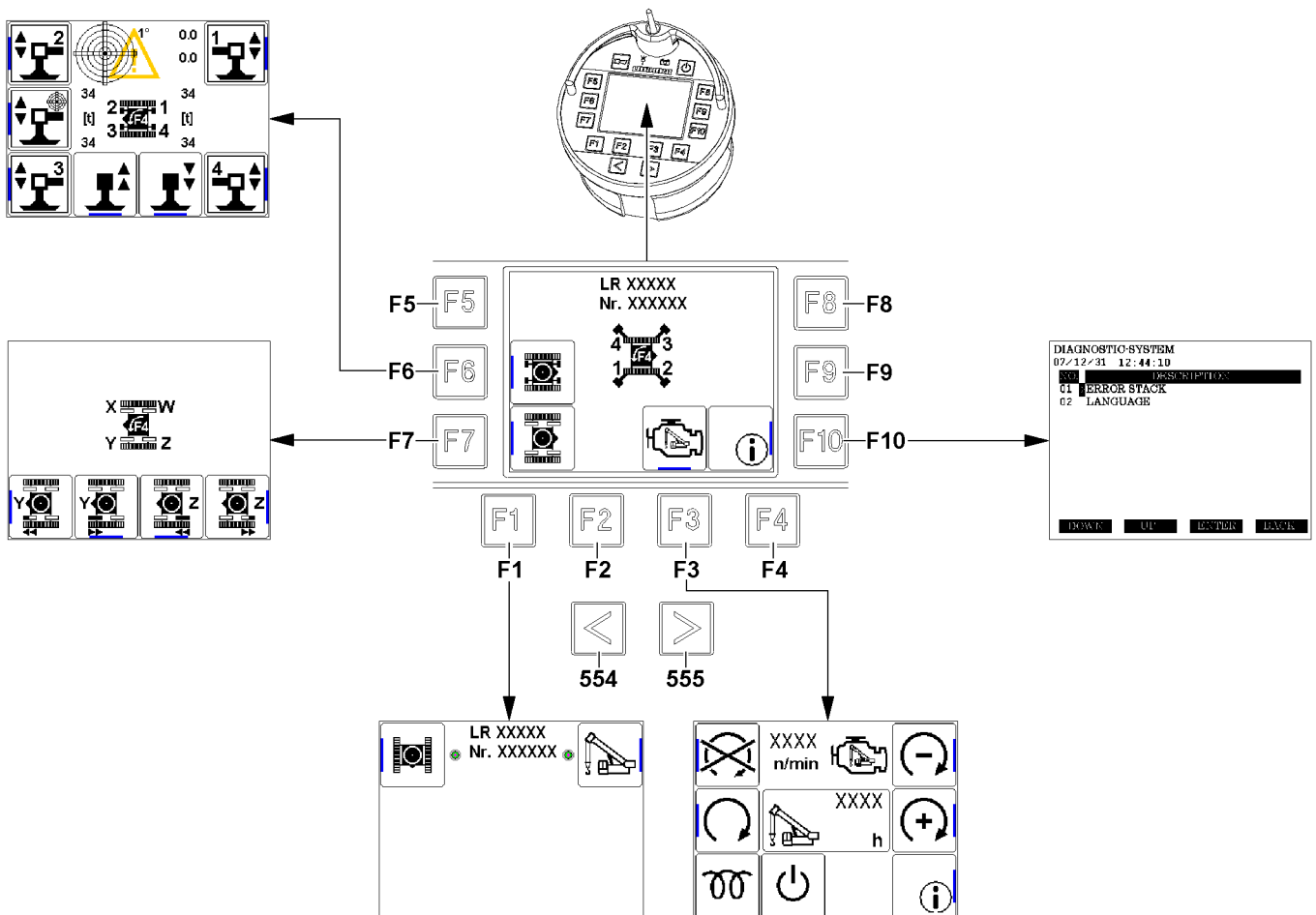


Fig.155085: Crawler travel gear start menu

LWE/LR 1800-1-0-000/27200-07-02/en

<b>F1</b>	<b>Selection overview</b>
>> <b>F5</b>	Call up the <i>Crawler travel gear</i> start menu <sup>1)</sup>
>> <b>F8</b>	Call up the <i>Crane superstructure</i> start menu <sup>1)</sup>

1) Only available in certain situations.

<b>F3</b>	<b>Engine operation menu</b>
>> <b>F1</b>	-Back to the <i>Crawler travel gear</i> start menu-
>> <b>F2</b>	Turn the ignition on / off <sup>1)</sup>
>> <b>F5</b>	Turn the engine off
>> <b>F6</b>	Turn the engine on
>> <b>F8</b>	Decrease the engine rpm
>> <b>F9</b>	Increase the engine rpm
>> <b>F10</b>	Call up the <i>Test system</i> menu
>> <b>554</b>	Call up the <i>Engine</i> monitoring functions
>> <b>555</b>	Call up the <i>Engine</i> monitoring functions

1) Only available in certain situations.

<b>F6</b>	<b>Assembly support menu</b>
>> <b>F1</b>	-Back to the <i>Crawler travel gear</i> start menu-
>> <b>F2</b>	Retract the support cylinder (when selected)
>> <b>F3</b>	Extend the support cylinder (when selected)
>> <b>F4</b>	Turn the crane icon in 180° increments
>> <b>F5</b>	Select / deselect the support cylinders according to the crane position
>> <b>F6</b>	Select / deselect automatic support
>> <b>F7</b>	Select / deselect the support cylinders according to the crane position
>> <b>F8</b>	Select / deselect the support cylinders according to the crane position
>> <b>F10</b>	Select / deselect the support cylinders according to the crane position
>> <b>554</b>	Call up the <i>Engine operation</i> menu
>> <b>555</b>	Call up the <i>Engine operation</i> menu

<b>F7</b>	<b>Crawler carrier assembly menu</b>
>> <b>F1</b>	-Back to the <i>Crawler travel gear</i> start menu-
>> <b>F2</b>	Insert the pin <b>W/Y</b>
>> <b>F3</b>	Insert the pin <b>X/Z</b>
>> <b>F4</b>	Turn the crane icon in 180° increments, select operating side <sup>2)</sup>
>> <b>F7</b>	Unpin the pin <b>W/Y</b>

F7	Crawler carrier assembly menu
>> F10	Unpin the pin X/Z
>> 554	Call up the Engine operation menu
>> 555	Call up the Engine operation menu

2) This switches between the operation of pin W+X or pin Y+Z.

F10	Test system menu
<b>Note:</b> The Test system menu can be called up at any time. If an error message for the LIC-CON computer system is present, then an error text can be viewed.	

### 3.2 Crane superstructure start menu

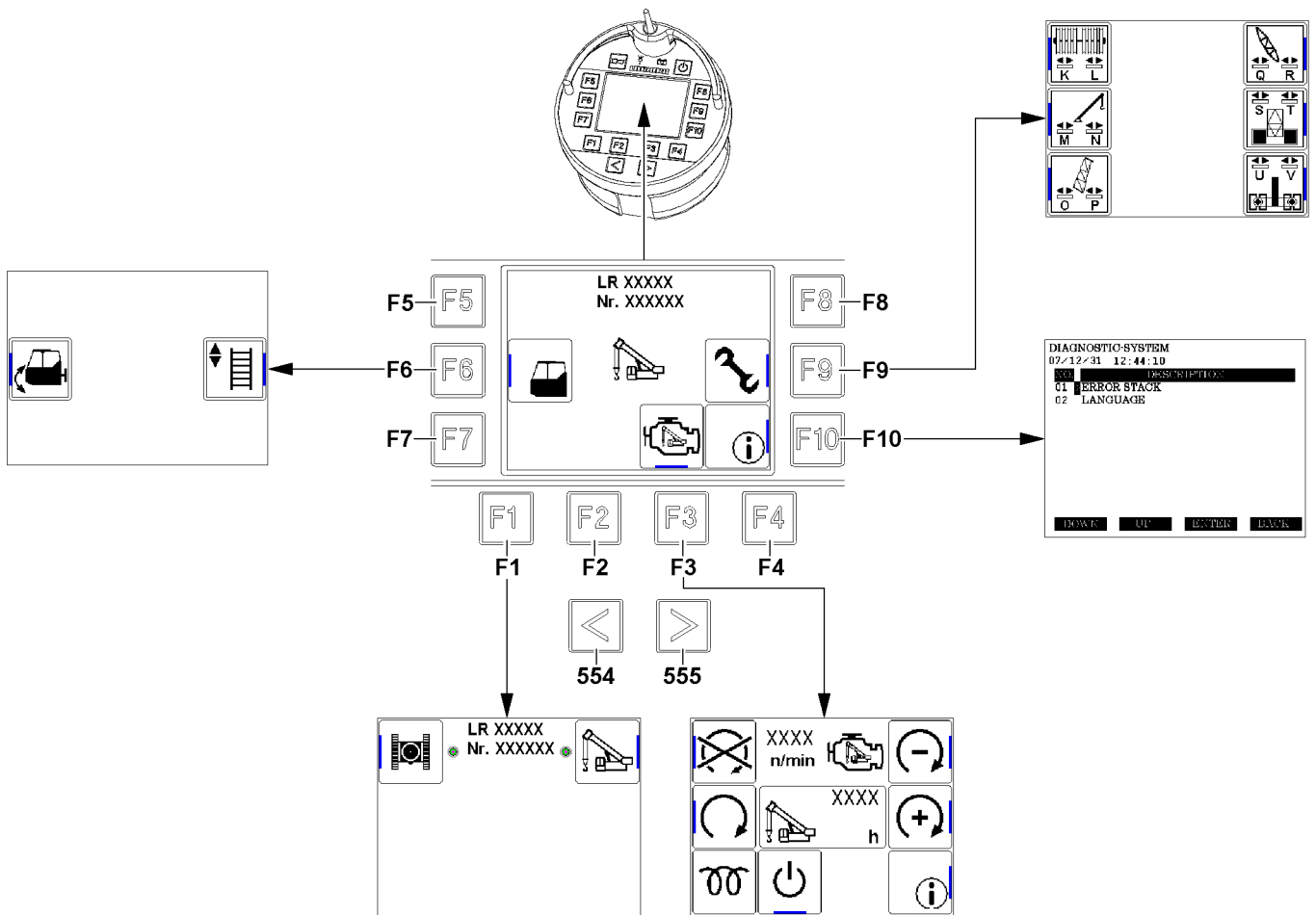


Fig.155086: Crane superstructure start menu

F1	Selection overview
>> F5	Call up the Crawler travel gear start menu <sup>1)</sup>
>> F8	Call up the Crane superstructure start menu <sup>1)</sup>

1) Only available in certain situations.

LWE/LR 1800-1-0-000/27200-07-02/en

<b>F3</b> <i>Engine operation menu</i>	
>> <b>F1</b>	-Back to the <i>Crane superstructure</i> start menu-
>> <b>F2</b>	Turn the ignition on / off <sup>1)</sup>
>> <b>F5</b>	Turn the engine off
>> <b>F6</b>	Turn the engine on
>> <b>F8</b>	Decrease the engine rpm
>> <b>F9</b>	Increase the engine rpm
>> <b>F10</b>	Call up the <i>Test system</i> menu
>> <b>554</b>	Call up the <i>Engine</i> monitoring functions
>> <b>555</b>	Call up the <i>Engine</i> monitoring functions

1) Only available in certain situations.

<b>F6</b> <i>Crane cab / stepladder menu</i>	
>> <b>F1</b>	-Back to the <i>Crane superstructure</i> start menu-
>> <b>F6</b>	Swinging the crane cab
>> <b>F9</b>	Position the stepladder <sup>3)</sup>
>> <b>554</b>	Call up the <i>Engine operation</i> menu
>> <b>555</b>	Call up the <i>Engine operation</i> menu

3) Only for crane types with corresponding equipment.

<b>F9</b> <i>Assembly functions menu</i>	
>> <b>F1</b>	-Back to the <i>Crane superstructure</i> start menu-
>> <b>F2</b>	Insert the pin (when selected)
>> <b>F3</b>	Unpin the pin (when selected)
>> <b>F5</b>	<i>Roller set</i> pinning
>> <b>F6</b>	<i>SA-frame</i> pinning
>> <b>F7</b>	<i>Main boom pivot section</i> pinning
>> <b>F8</b>	<i>Derrick boom pivot section</i> pinning <sup>3)</sup>
>> <b>F9</b>	<i>Suspended ballast guide / ballast trailer guide</i> pinning <sup>3), 7)</sup>
>> <b>F10</b>	<i>Ballast trailer guide</i> pinning <sup>3), 8)</sup>
>> <b>554</b>	Call up the <i>Crane floodlight</i> menu
>> <b>555</b>	Call up the <i>Engine operation</i> menu

3) Only for crane types with corresponding equipment.

7) *Ballast trailer guide* pinning not for crane types with a separate pinning point for the ballast trailer.

8) Only for crane types with a separate pinning point for the ballast trailer.

<b>F10</b> <i>Test system menu</i>	
<b>Note:</b> The <i>Test system</i> menu can be called up at any time. If an error message for the LIC-CON computer system is present, then an error text can be viewed.	

## 4 Selection overview

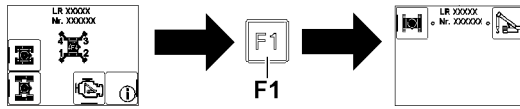


Fig.153769: Changing from the Crawler travel gear start menu to the selection overview

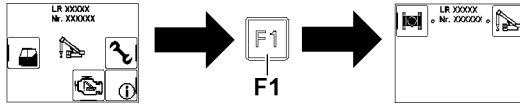


Fig.155087: Changing from the Crane superstructure start menu to the selection overview

### 4.1 Icons in the selection overview

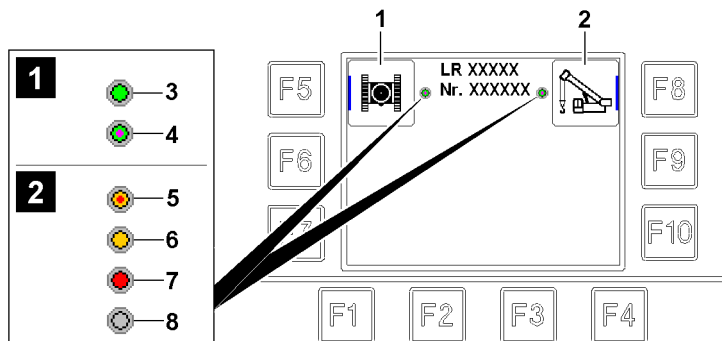


Fig.153757: Icons in the selection overview

- 1 **Crawler travel gear icon**
  - The monitoring indicator to the right of it displays the connection status between the BTT and BTB *crawler travel gear*
  - **Note:** If the monitoring indicator appears as shown in the illustration 1, the *Crawler travel gear* start menu can be operated.
- 2 **Crane superstructure icon**
  - The monitoring indicator to the left of it displays the connection status between the BTT and BTB *crane superstructure*
  - **Note:** If the monitoring indicator appears as shown in the illustration 1, the *Crane superstructure* start menu can be operated.
- 3 **Monitoring indicator green**
  - Connection established
- 4 **Monitoring indicator green / magenta dot**
  - Connection prepared
- 5 **Monitoring indicator yellow / red dot**
  - Not connected
- 6 **Monitoring indicator yellow**
  - Transmission signal being established or disconnected
- 7 **Monitoring indicator red**
  - No connection between BTT and BTB
- 8 **Monitoring indicator grey**
  - No connection between BTT and BTB

**Note**

- ▶ If the monitoring indicator appears as shown in the illustration 2, the corresponding start menu cannot be operated.
- ▶ Wait a short time (at least one minute)
- ▶ Check the structural condition of the crane. The electrical connections must be established.
- ▶ Check if the ignition switches are turned on.
- ▶ Insert the BTT in the corresponding charging cradle, and turn off the adjacent ignition switch and turn it on again.
- ▶ Wait until the BTT has booted up completely.

## 4.2 Function keys in the selection overview

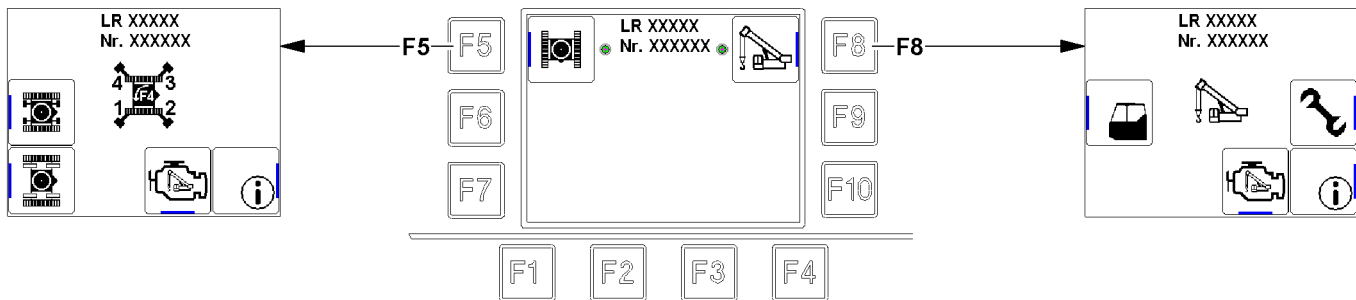


Fig.155088: Function keys in the selection overview

The crane control releases the corresponding start menus for operation as soon as the required prerequisites have been met. Check the connection status on the corresponding indicator light.

The crane control checks:

- Structural condition of the crane
- Position of the *crawler travel gear* ignition switch
- Position of the *crane cab* ignition switch

**F5** Function key

- Call up the *Crawler travel gear* start menu
- **Note:** Only available in certain situations.

**F8** Function key

- Call up the *Crane superstructure* start menu
- **Note:** Only available in certain situations.

## 5 Engine operation menu

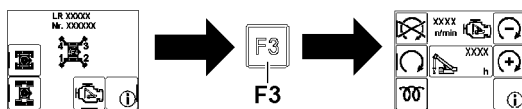


Fig.153759: Changing from the Crawler travel gear start menu to the Engine operation menu

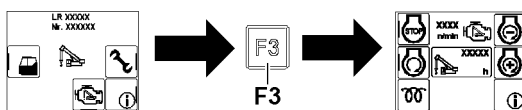


Fig.155089: Changing from the Crane superstructure start menu to the Engine operation menu



## 5.1 Icons in the *Engine operation* menu

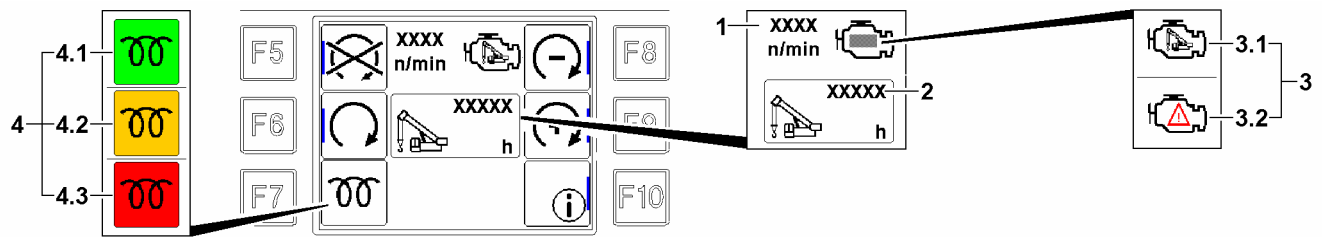


Fig.152750: Icons in the *Engine operation* menu

- 1 Engine rpm
  - Actual engine rpm
- 2 Operating hour display
  - Operating hour display for the crane
- 3 Engine monitoring
  - 3.1 Engine monitoring reports no problem
  - 3.2 Engine monitoring reports a warning event
  - NOTICE!**: Find the cause immediately and remedy it!
- 4 Monitoring indicator
  - 4.1 Monitoring indicator lights up green: Engine ready to start
  - 4.2 Monitoring indicator lights up yellow: Engine preheating is active
  - 4.3 Monitoring indicator lights up red: Engine not ready to start

## 5.2 Function keys in the *Engine operation* menu

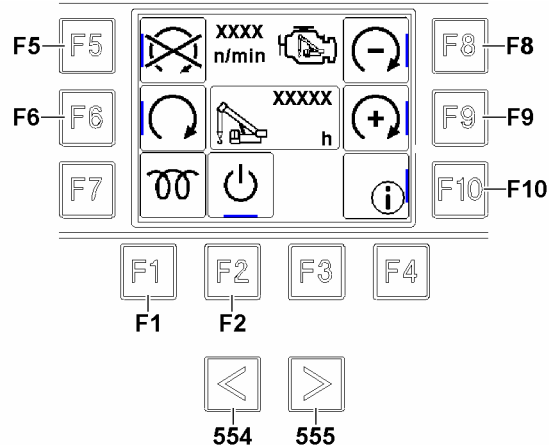


Fig.152751: Function keys in the *Engine operation* menu

- 554** Change over key
  - Call up the Engine monitoring functions
- 555** Change over key
  - Call up the Engine monitoring functions
- F1** Function key
  - Back to the start menu
  - Note:** Depends on which level from which the engine operation menu was called up
- F2** Function key
  - Turn the ignition on
  - Note:** Appears only for certain crane types in certain situations.
- F5** Function key
  - Press long: Turn the engine off

- Press momentarily (less than 0.5 seconds): Reset settings in the *Engine operation* menu
- F6** Function key
  - Turn the engine on
- F8** Function key
  - Decrease the engine rpm
  - Note:** The changed engine rpm will remain stored until the next change is made.
- F9** Function key
  - Increase the engine rpm
  - Note:** The changed engine rpm will remain stored until the next change is made.
- F10** Function key
  - Call up the *Test system* menu

### 5.3 Engine monitoring functions

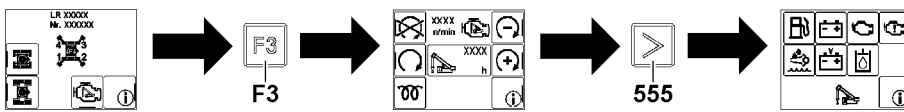


Fig.153761: Changing from the Crawler travel gear start menu to the engine monitoring functions

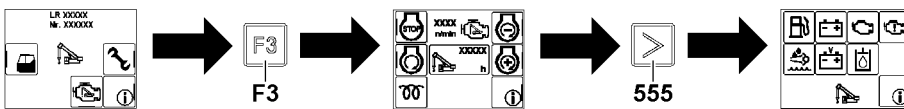


Fig.155090: Changing from the Crane superstructure start menu to the engine monitoring functions



#### WARNING

Messages / warnings for the engine monitoring functions ignored!  
 If messages / warnings for the engine monitoring functions are ignored, problems can occur.  
 If problems are not immediately rectified, the crane can fail and dangerous situations may occur.  
 Personal injury and property damage can result.

- ▶ Remedy the problem immediately.



#### WARNING

Triggers power reduction or start block of the engine!  
 If the urea level is too low or if there is a malfunction in the exhaust aftertreatment, then a power reduction or starting block of the engine can be triggered.  
 The crane operation and travel operation can be limited or disabled.

- ▶ Replenish the Urea level in time.
- ▶ Remedy the faulty function of the exhaust aftertreatment immediately.
- ▶ Observe any valid national / regional regulations and the vehicle configuration.

Messages / warnings of the engine monitoring functions can be displayed by:

- Display of warning icons  
**and / or**
- audio warnings  
**and / or**
- Automatic, situation-related switching to the engine monitoring functions

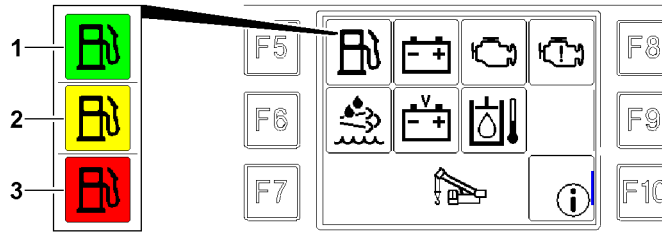


Fig.124801: Example for the colors in the icons

The colors in the icons for the monitoring functions mean:

- If a function is highlighted **green** (example icon 1), then the function is operating correctly.
- If a function is highlighted **yellow** (example icon 2), then the respective function has a problem. An advance warning is active for the *monitoring functions*.
- If a function is highlighted **red** (example icon 3), then the respective function has a problem. A warning is active for the *monitoring functions*.

### 5.3.1 Function keys in the *Engine* monitoring functions

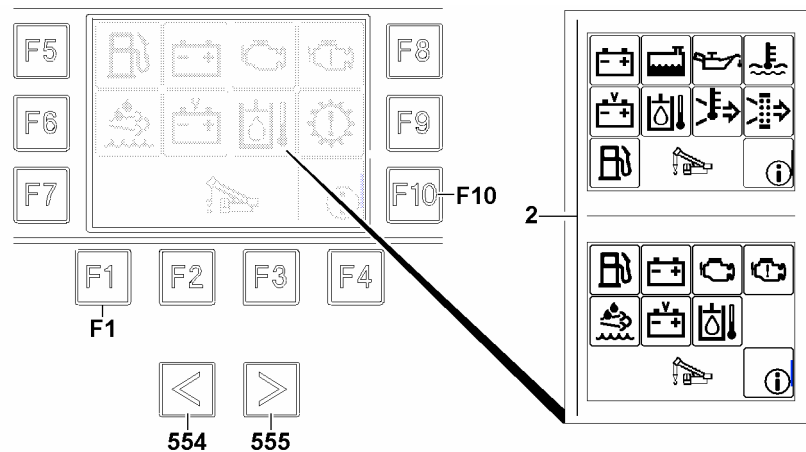


Fig.152713: Function keys in the *Engine* monitoring functions

Depending on the crane type, the depiction of the icons in the *Engine* monitoring function 2 can vary.

- 554** Change over key
  - Call up the *Engine operation* menu
- 555** Change over key
  - Call up the *Engine operation* menu
- F1** Function key
  - Back to the start menu


**Note:** Depends on which level the *Engine* monitoring functions were called up from
- F10** Function key
  - Call up the *Test system* menu


### 5.3.2 Icons in the *Engine* monitoring functions




#### Note

- The scope of the monitoring functions depends on the crane type and crane configuration.
- ▶ Not all crane types have all listed monitoring functions.


 <b>Fuel reserve</b>	
Green:	Fuel reserve is at the normal fill level, the exact display can be seen on the LICCON monitor
Yellow:	Fuel reserve is short, check the display on the LICCON monitor and add to the fuel reserve if necessary
Red:	Fuel reserve low / depleted / system error <b>NOTICE!</b> Immediately bring the crane to a standstill, turn the engine off and remedy the problem (add to the fuel reserve immediately / remedy the system error). Pay attention to the error message.


 <b>Charge control display (alternator)</b>	
Green:	Charge control OK (engine on)
Red:	Charge control has a problem (engine on) / system error <b>NOTICE!</b> Immediately bring the crane to a standstill, turn the engine off and remedy the problem. Pay attention to the error message.


 <b>Exhaust aftertreatment <sup>1)</sup></b>	
Green:	Exhaust aftertreatment OK
Yellow / red:	Malfunction Exhaust aftertreatment or Urea level too low / system error <b>NOTICE!</b> Add urea or remedy the malfunction of the exhaust aftertreatment. Under some circumstances a power reduction or start block of the engine <sup>2)</sup> is triggered, pay attention to the error message.

1) Valid only for engines equipped with an SCR system with exhaust aftertreatment.

2) The type and scope of a power reduction of the engine depends on the respectively valid national / regional regulations and the vehicle configuration. Under some circumstances, the starting procedure may be disabled (start block).


 <b>Collective warning</b>	
Green:	No warning messages present
Generally at yellow or red:	A warning is present / system error <b>NOTICE!</b> Determine the cause with the error message or in the LICCON monitor and observe the following description.
Yellow:	Air intake opening / air filter dirty <b>NOTICE!</b> Turn the engine off immediately and remedy the problem, pay attention to the error message.
Red:	Engine oil pressure too low or too high <b>NOTICE!</b> Turn the engine off immediately and remedy the problem, pay attention to the error message.


 <b>Collective warning</b>	
Red:	Engine oil level too low or too high <b>NOTICE!</b> Call up engine oil level display in the LICCON monitor and match the engine oil according to the display, see chapter 4.02. Pay attention to the error message.
Red:	Coolant level too low <b>NOTICE!</b> Turn the engine off and add coolant, see chapter 7.04 or chapter 7.05. Pay attention to the error message.
Red:	Coolant temperature too high <b>NOTICE!</b> Bring the coolant temperature into a permissible range, turn the engine off if necessary. Pay attention to the error message.
Red:	Charge air temperature too high <b>NOTICE!</b> Bring the charge air temperature into a permissible range, turn the engine off if necessary. Pay attention to the error message.

 <b>Urea tank / exhaust aftertreatment<sup>1)</sup></b>	
Green:	Urea reserve sufficient
Yellow:	The urea reserve is low or erroneous function of exhaust aftertreatment <b>Advance warning!</b> Add urea or remedy the malfunction of the exhaust aftertreatment. Pay attention to the error message.
Red:	Urea level too low or erroneous function of exhaust aftertreatment system / system error <b>NOTICE!</b> Add urea or remedy the malfunction of the exhaust aftertreatment. Under some circumstances a power reduction or start block of the engine <sup>2)</sup> is triggered, pay attention to the error message.


1) Valid only for engines equipped with an SCR system with exhaust aftertreatment.


2) The type and scope of a power reduction of the engine depends on the respectively valid national / regional regulations and the vehicle configuration. Under some circumstances, the starting procedure may be disabled (start block).


 <b>Battery voltage</b>	
Green:	Battery voltage OK
Red:	Overvoltage / undervoltage in on-board power supply / system error <b>NOTICE!</b> Immediately bring the crane to a standstill, turn the engine off and remedy the problem. Pay attention to the error message.


 <b>Hydraulic oil<sup>3)</sup></b>	
Green:	Leak oil filter, return filter <sup>3)</sup> and charge pressure filter <sup>3)</sup> OK (engine on) / hydraulic oil temperature <sup>3)</sup> OK / hydraulic oil level <sup>3)</sup> OK
Red:	Leak oil filter, return filter <sup>3)</sup> and / or charge pressure filter <sup>3)</sup> dirty (engine on) / hydraulic oil temperature <sup>3)</sup> too high / hydraulic oil level <sup>3)</sup> too low / system error  <b>NOTICE!</b> Immediately bring the crane to a standstill, turn the engine off and remedy the problem. Pay attention to the error message.


3) Only present for certain crane types.


 <b>Hydraulic oil temperature</b>	
Green:	Hydraulic oil temperature OK
Red:	Hydraulic oil temperature too high / system error  <b>NOTICE!</b> Immediately bring the crane to a standstill, turn the engine off and remedy the problem. Pay attention to the error message.


 <b>Hydraulic oil level</b>	
Green:	Hydraulic oil level OK
Red:	Hydraulic oil level too low / system error  <b>NOTICE!</b> Immediately bring the crane to a standstill, turn the engine off and remedy the problem. Pay attention to the error message.


 <b>Transmission</b>	
Green:	Transmission OK
Yellow / red:	Problem in transmission / system error  <b>NOTICE!</b> Immediately bring the crane to a standstill, turn the engine off and remedy the problem. Pay attention to the error message.


 <b>Coolant level</b>	
Green:	Coolant level OK
Red:	Insufficient coolant / system error  <b>NOTICE!</b> Immediately bring the crane to a standstill, turn the engine off and remedy the problem. Pay attention to the error message.

 <b>Engine oil pressure</b>	
Green:	Engine oil pressure OK (engine on)
Red:	Engine oil pressure too low (engine on) / system error <b>NOTICE!</b> Immediately bring the crane to a standstill, turn the engine off and remedy the problem. Pay attention to the error message.

 <b>Coolant temperature</b>	
Green:	Coolant temperature OK
Red:	Coolant temperature <b>too high</b> / system error <b>NOTICE!</b> Immediately bring the crane to a standstill, turn the engine off and remedy the problem. Pay attention to the error message.

 <b>Charge air temperature</b>	
Green:	Charge air temperature OK
Red:	Charge air temperature too high / system error <b>NOTICE!</b> Immediately bring the crane to a standstill, turn the engine off and remedy the problem. Pay attention to the error message.

 <b>Engine air filter</b>	
Green:	Air filter OK (engine on)
Yellow / red	Air filter dirty (engine on) / system error <b>NOTICE!</b> Immediately bring the crane to a standstill, turn the engine off and remedy the problem. Pay attention to the error message.

 <b>Information field</b>	
B / E:	If a <i>B (operating error)</i> or <i>E (system error)</i> appears in the information field, then at least one error message is present. Call up and evaluate the error message by pressing function key F10 on the BTT, see also Diagnostics Manual.

## 6 Assembly support menu

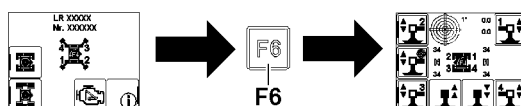


Fig.153763: Changing from the Crawler travel gear start menu to the Assembly support menu

In the *Assembly support* menu, the operator can select between manual support and automatic support.



### WARNING

Personnel in the danger zone!

Personnel can be caught and injured or killed.

- ▶ Orient the crane icon on the BTT display according to the position of the operator with respect to the crane.
- ▶ Select the location in such a way that the danger zone can be fully viewed and monitored by the operator.
- ▶ Maintain a sufficient safety distance from moving parts.

## 6.1 Icons in the *Assembly support* menu

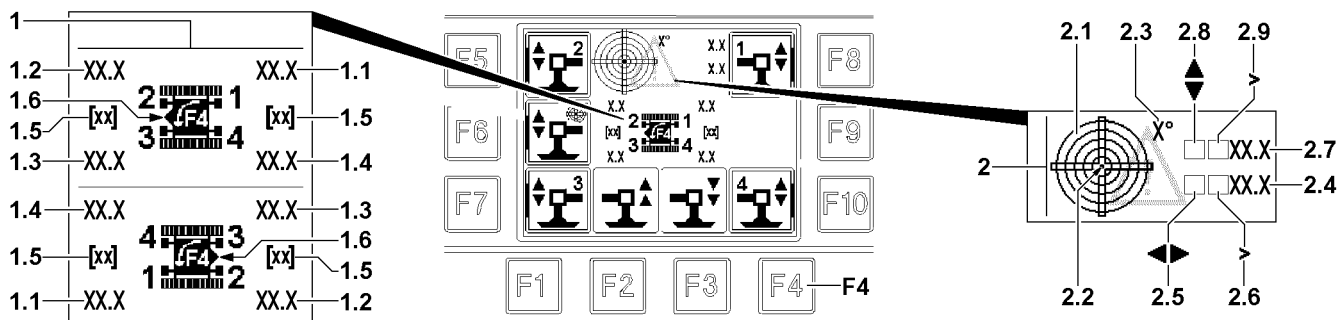


Fig.153764: Icons in the *Assembly support* menu

#### 1 Crane icon

- The numbered support cylinders are shown in the crane icon.
- Press the function key **F4** to rotate the crane icon in the display by 180°

#### 1.1 Support force value\*

- Support force value of support cylinder 1

#### 1.2 Support force value\*

- Support force value of support cylinder 2

#### 1.3 Support force value\*

- Support force value of support cylinder 3

#### 1.4 Support force value\*

- Support force value of support cylinder 4

#### 1.5 Measuring unit\*

- Measuring unit of displayed support force values

#### 1.6 Front side of crawler travel gear marker

- The *front side of crawler travel gear marker 1.6* shows the position on the display of the front side of the crawler travel gear.
- **Note:** Located on the front side of the crawler travel gear are:
  - The chain tension devices
  - Support cylinder 2 and support cylinder 3



### Note

- ▶ The support force values are not exceeded during permissible and correctly performed assembly procedures.



### WARNING

Danger of accident!

If a display value appears in red and / or flashes, the display value is in an impermissible range.

- ▶ Make sure that all displayed values are always in the permissible range.
- ▶ Only set up permissible assembly procedures.



**WARNING**

The crane can topple over!

If the *Display range exceeded* icon **2.6** appears, then the crane is inclined further than can be shown. The exact incline can then not be read.

- ▶ Do not exceed the permissible incline of the crane.

**2 Incline icon**

- Display of the incline of the crane to the horizontal in longitudinal and lateral direction. The display is graphic as well as numeric.
- The direction data refer to the orientation of the displayed crane icon

**2.1 Graphic display**

- The graphic display has the form of a sight gauge. In it is a moving dot **2.2**, which represents the air bubble

**2.2 Dot**

- The center of the dot **2.2** shows the incline value

**2.3 Display resolution**

- This value describes the resolution of the graphic display. The resolution is matched automatically to the inclination

**2.4 Longitudinal direction**

- Incline of crane in the longitudinal direction in [°].

**2.5 Direction arrow**

- The direction arrow shows the direction of the incline

**2.6 Display range exceeded**

- If the *greater than* icon appears, then the display range is exceeded.
- **Note:** The crane is inclined further than can be shown.

**2.7 Lateral direction**

- Incline of crane in lateral direction in [°]

**2.8 Direction arrow**

- The direction arrow shows the direction of the incline

**2.9 Display range exceeded**

- If the *greater than* icon appears, then the display range is exceeded
- **Note:** The crane is inclined further than can be shown.

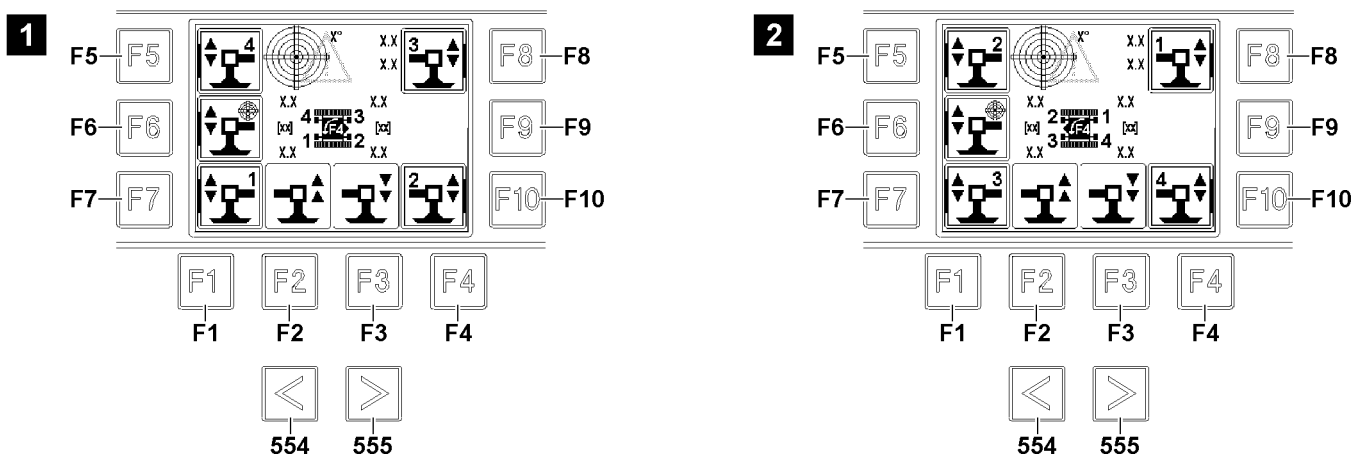
**6.2 Function keys in the *Assembly support* menu**

Fig.153765: Function keys in the *Assembly support* menu menu - possible view settings

**554** Change over key

- Call up the *Engine operation* menu

**555** Change over key

- Call up the *Engine operation* menu

- F1** Function key
  - Back to the *Crawler travel gear* start menu
- F2** Function key
  - Retract the selected support cylinder
- F3** Function key
  - Extend the selected support cylinder
- F4** Function key
  - Turn the crane icon in 180° increments
  - **Note:** This switches between the view settings illustration 1 and illustration 2
- F5** Function key
  - Select / deselect the support cylinders according to the crane position
- F6** Function key
  - Select / deselect automatic support
- F7** Function key
  - Select / deselect the support cylinders according to the crane position
- F8** Function key
  - Select / deselect the support cylinders according to the crane position
- F10** Function key
  - Select / deselect the support cylinders according to the crane position

### 6.3 Manual support

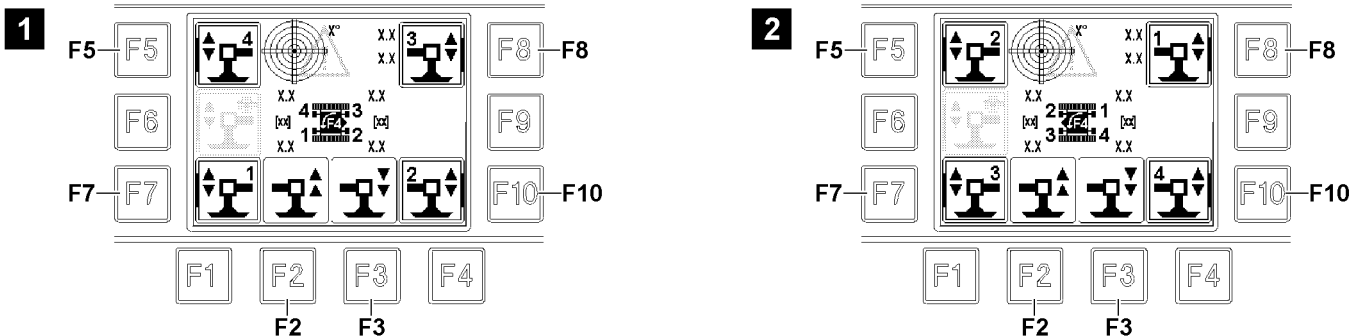


Fig.153766: Assembly support menu - manual support

The supports can be selected and controlled individually or in groups. When a support cylinder is directly selected, then the automatic support selection is cancelled.

– **Selection / deselection of the support cylinder:**

- Illustration 1: In the crane icon on the BTT display, the front side of the crawler travel gear is on the right:
  - Actuate the function key **F5** for support cylinder 4.
  - Actuate the function key **F7** for support cylinder 1.
  - Actuate the function key **F8** for support cylinder 3.
  - Actuate the function key **F10** for support cylinder 2.

**Result:** Selected support cylinders are bordered in bold. The support cylinders can be selected / deselected as desired.

The icons appear above the function key **F2** and function key **F3** appear.

- Illustration 2: In the crane icon on the BTT display, the front side of the crawler travel gear is on the left.
  - Actuate the function key **F5** for support cylinder 2.
  - Actuate the function key **F7** for support cylinder 3.
  - Actuate the function key **F8** for support cylinder 1.
  - Actuate the function key **F10** for support cylinder 4.

**Result:** Selected support cylinders are bordered in bold. The support cylinders can be selected / deselected as desired.

The icons appear above the function key **F2** and function key **F3**.

- **Control release:**
  - The control release is made by touching the 2-Hand keyboard in the rear of the BTT, see section “Release of button block on BTT”
  - After the control release is provided, the icons over the function key **F2** / function key **F3** are highlighted in purple.

**Note**

- ▶ To control the functions, a control release must be issued: The corresponding icons must be highlighted in purple.

- **Retract the selected support cylinder:**
  - Press the function key **F2**.
- **Extend the selected support cylinder:**
  - Press the function key **F3**.

## 6.4 Automatic support

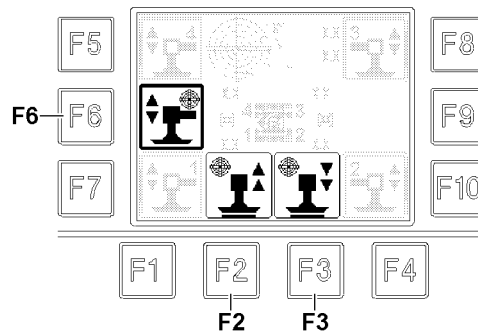


Fig.153767: Assembly support menu - automatic support

The automatic support function automatically levels the crane during the support procedure.

At selection of the automatic support, an existing individual selection of the support cylinders will be deleted.

- **Automatic support selection:**
  - Press the function key **F6**.
    - Result:** When the automatic support is selected, the icon is surrounded with a bold border. When subsequently individual support cylinders are selected / deselected, the automatic support is deselected.
    - The icons appear above the function key **F2** and function key **F3**.
- **Control release:**
  - The control release is made by touching the 2-Hand keyboard in the rear of the BTT, see section “Release of button block on BTT”
  - After the control release is provided, the icons over the function key **F2** / function key **F3** are highlighted in purple.

**Note**

- ▶ To control the functions, a control release must be issued: The corresponding icons must be highlighted in purple.

- **Levelling the crane by retracting the support cylinder:**
  - Press the function key **F2**.
- **Levelling the crane by extending the support cylinders:**
  - Press the function key **F3**.

## 7 Crawler carrier assembly menu

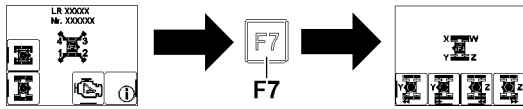


Fig.153768: Changing from the Crawler travel gear start menu to the Crawler carrier assembly menu



### WARNING

Personnel in the danger zone!

Personnel can be caught and injured or killed.

- ▶ Orient the crane icon on the BTT display according to the position of the operator with respect to the crane.
- ▶ Select the location in such a way that the danger zone can be fully viewed and monitored by the operator.
- ▶ Maintain a sufficient safety distance from moving parts.

### 7.1 Icons in the Crawler carrier assembly menu

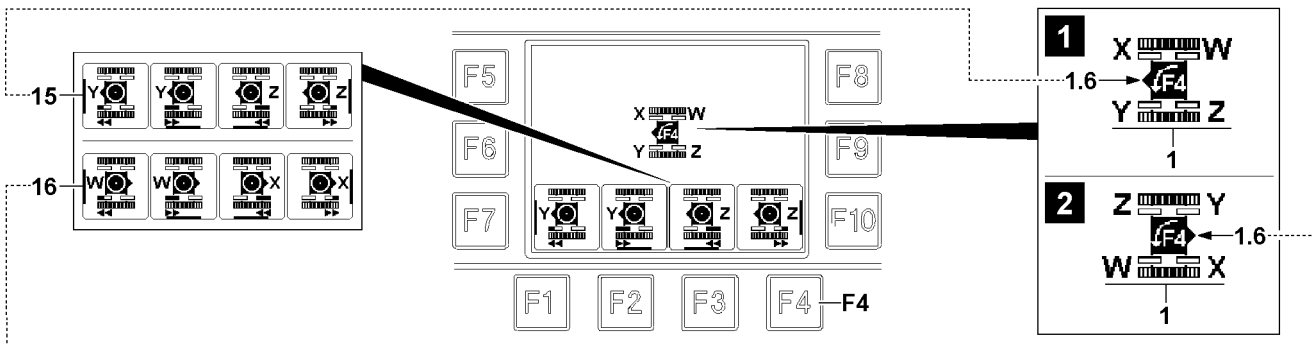


Fig.153771: Icons in the Crawler carrier assembly menu

#### 1 Crane icon

- The pin points with the assigned letters are shown in the crane icon
- Press the function key **F4** to rotate the crane icon in the display by 180°

#### 1.6 Front side of crawler travel gear marker

- The *front side of crawler travel gear marker 1.6* shows the position on the display of the front side of the crawler travel gear.
- If the *front side of crawler travel gear marker 1.6* is located on the left side (illustration 1):
  - Pin point **Y** and pin point **Z** can be operated
- If the *front side of crawler travel gear marker 1.6* is located on the right side (illustration 2):
  - Pin point **W** and pin point **X** can be operated

#### 15 Operating icons

- Pin point **Y** and pin point **Z** can be operated

#### 16 Operating icons

- Pin point **W** and pin point **X** can be operated

### 7.2 Function keys in the *Crawler carrier assembly* menu

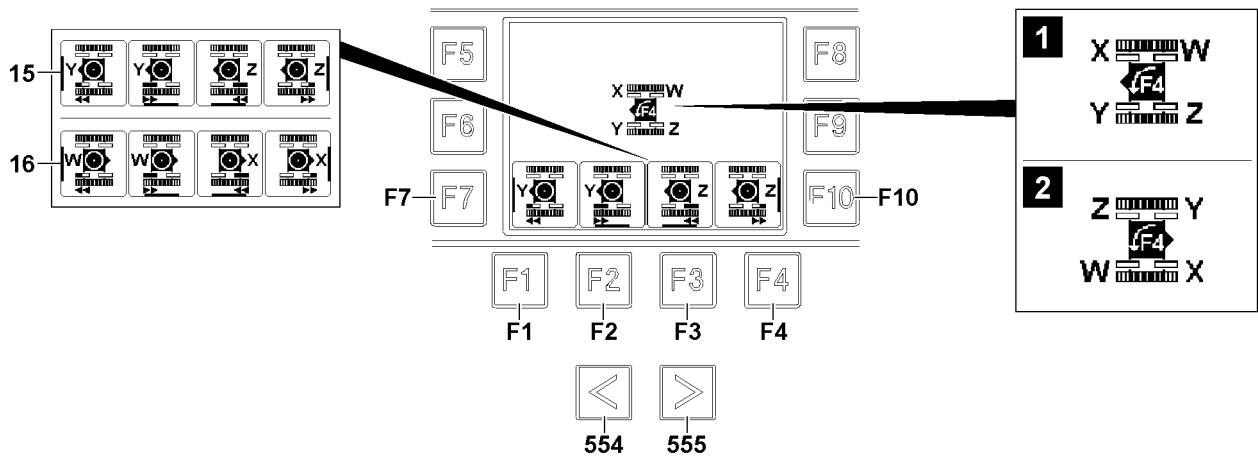


Fig.153772: Function keys in the *Crawler carrier assembly* menu - possible view settings

- 554** Change over key
  - Call up the *Engine operation* menu
- 555** Change over key
  - Call up the *Engine operation* menu
- F1** Function key
  - Back to the *Crawler travel gear* start menu
- F2** Function key
  - The operating icons **15** appear: Insert the pin **Y**
  - The operating icons **16** appear: Insert the pin **W**
- F3** Function key
  - The operating icons **15** appear: Insert the pin **Z**
  - The operating icons **16** appear: Insert the pin **X**
- F4** Function key
  - Turn the crane icon in 180° increments
  - **Note:** This switches between the view settings illustration **1** and illustration **2**
- F7** Function key
  - The operating icons **15** appear: Unpin the pin **Y**
  - The operating icons **16** appear: Unpin the pin **W**
- F10** Function key
  - The operating icons **15** appear: Unpin the pin **Z**
  - The operating icons **16** appear: Unpin the pin **X**

### 7.3 Crawler carrier assembly - pinning / unpinning the pins

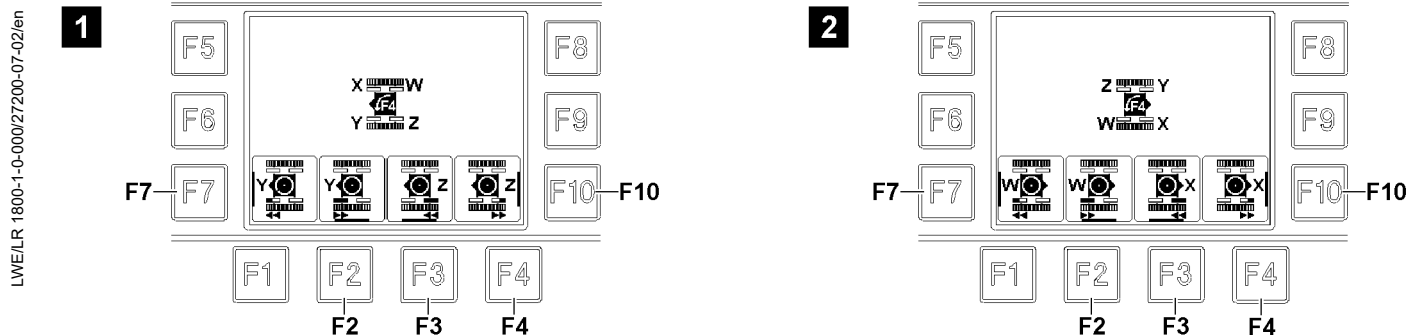


Fig.153773: *Crawler carrier assembly* menu - pinning / unpinning the pins

LWE/LR 1800-1-0-000/27200-07-02/en

- **Pin point selection:**
  - Press the function key **F4** until the view setting appears according to the illustration **1**:
    - In the crane icon on the BTT display, the front side of the crawler travel gear is on the left  
**Result:** Pin point **Y** and pin point **Z** are selected
  - Press the function key **F4** until the view setting appears according to the illustration **2**:
    - In the crane icon on the BTT display, the front side of the crawler travel gear is on the left  
**Result:** Pin point **W** and pin point **X** are selected
- **Control release:**
  - The control release is made by touching the 2-Hand keyboard in the rear of the BTT, see section “Release of button block on BTT”
  - After the control release is provided, the icons over the function key **F2** / function key **F3** and next to function key **F7** / function key **F10** are highlighted in purple.




---

**Note**

- ▶ To control the functions, a control release must be issued: The corresponding icons must be highlighted in purple.
- 

- Insert pin **Y**/pin **W**:
  - Press the function key **F2**.
- Insert pin **Z**/pin **X**:
  - Press the function key **F3**.
- Unpin pin **Y**/ pin **W**:
  - Press the function key **F7**.
- Unpin pin **Z**/ pin **X**:
  - Press the function key **F10**.

Empty page!

LWE/LR 1800-1-0-000/27200-07-02/en

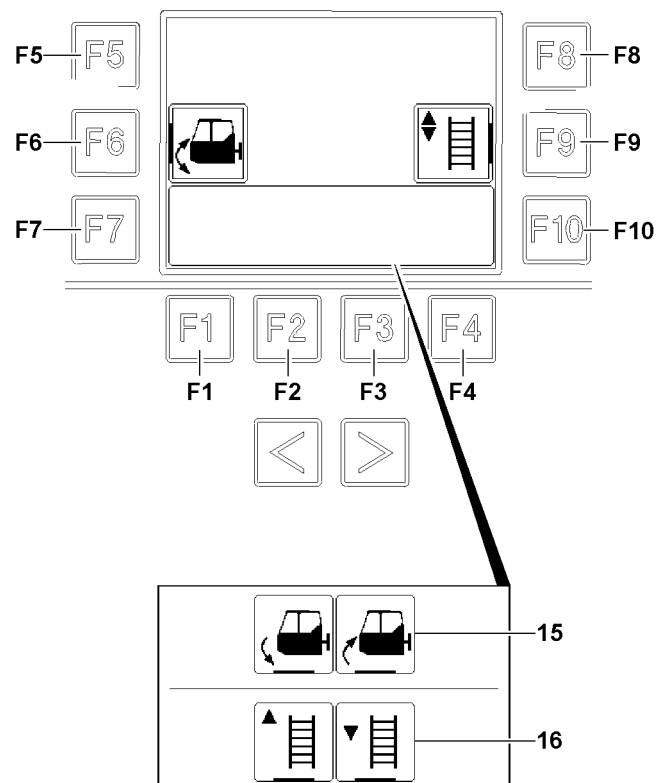


Fig.118723



## 8 Crane cab / stepladder menu

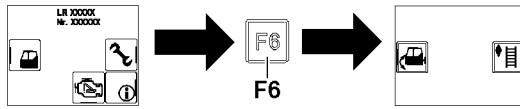


Fig.155091: Changing from Crane superstructure start menu to Crane cab / stepladder menu

### 8.1 Function keys in Crane cab / stepladder menu

- 554** Change over key
  - Call up the *Engine operation* menu
- 555** Change over key
  - Call up the *Engine operation* menu
- F1** Function key
  - Back to the *Crane superstructure* start menu
- F2** Function key
  - -No function-
- F2** Function key
  - -No function-
- F3** Function key
  - -No function-
- F5** Function key
  - -No function-
- F6** Function key
  - Selection / deselection of swinging the crane cab
  - After selection, the operating icons **15** appear additionally
- F7** Function key
  - -No function-
- F8** Function key
  - -No function-
- F9** Function key
  - Selection / deselection of positioning the stepladder
  - After selection, the operating icons **16** appear additionally
  - **Note:** Function only available for certain crane types
- F10** Function key
  - -No function-

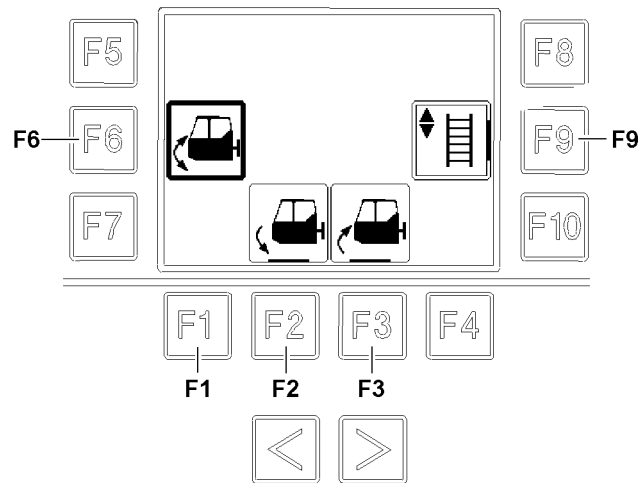


Fig.118726

LWE/LR 1800-1-0-000/27200-07-02/en

## 8.2 Swinging the crane cab

- **Selection / deselection of swinging the crane cab:**
  - Press the function key **F6**.
    - **Result:** When the selection has been made, the border on the icon to the right of function key **F6** is bold. The icons appear above the function key **F2** and function key **F3** appear.
- **Control release:**
  - The control release is made by touching the 2-Hand keyboard in the rear of the BTT, see section “Release of button block on BTT”
  - After the control release is provided, the icons over the function key **F2** and function key **F3** are highlighted in purple.



---

### Note

- ▶ To control the functions, a control release must be issued: The corresponding icons must be highlighted in purple.
- 

- **Swing the crane cab out:**
  - Press the function key **F2**.
- **Swing the crane cab in:**
  - Press the function key **F3**.
- **Leave the menu:**
  - Press the function key **F1**.

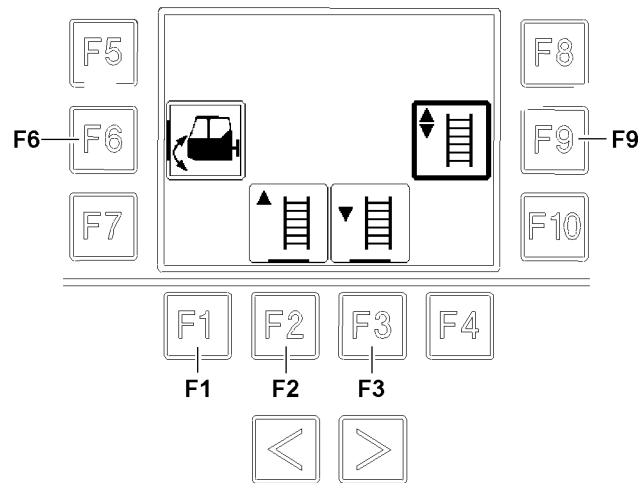


Fig.118727

LWE/LR 1800-1-0-000/27200-07-02/en

## 8.3 Positioning the stepladder



### Note

► Function only available for certain crane types.

#### – Selection / deselection of positioning the stepladder:

- Press the function key **F9**.
  - **Result:** When the selection has been made, the border on the icon to the right of function key **F9** is bold. The icons appear above the function key **F2** and function key **F3** appear.

#### – Control release:

- The control release is made by touching the 2-Hand keyboard in the rear of the BTT, see section “Release of button block on BTT”
- After the control release is provided, the icons over the function key **F2** and function key **F3** are highlighted in purple.



### Note

► To control the functions, a control release must be issued: The corresponding icons must be highlighted in purple.

#### – Stepladder up:

- Press the function key **F2**.

#### – Stepladder down:

- Press the function key **F3**.

#### – Leave the menu:

- Press the function key **F1**.

## 9 Assembly functions menu

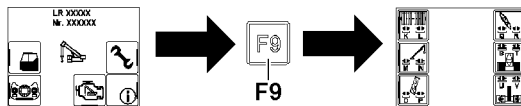


Fig.153775: Changing from the Crane superstructure start menu to the Assembly functions menu

### 9.1 Function keys in the Assembly functions menu

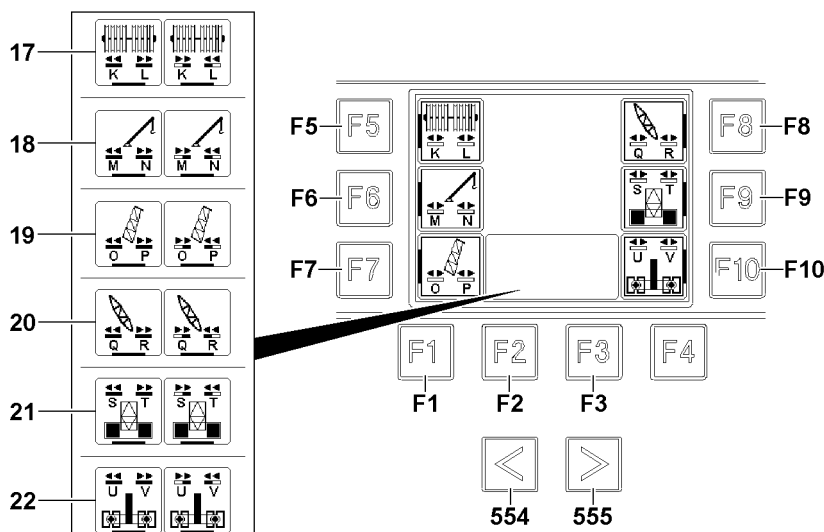


Fig.153774: Function keys in the Assembly functions menu

- 554** Change over key
- Call up the *Crane floodlight* menu
- 555** Change over key
- Call up the *Engine operation* menu
- F1** Function key
- Back to the *Crane superstructure* start menu
- F2** Function key
- The operating icons **17** appear: Insert the pin **K/L**
  - The operating icons **18** appear: Insert the pin **M/N**
  - The operating icons **19** appear: Insert the pin **O/P**
  - The operating icons **20** appear: Insert the pin **Q/R**
  - The operating icons **21** appear: Insert the pin **S/T**
  - The operating icons **22** appear: Insert the pin **U/V**
- F3** Function key
- The operating icons **17** appear: Unpin the pin **K/L**
  - The operating icons **18** appear: Unpin the pin **M/N**
  - The operating icons **19** appear: Unpin the pin **O/P**
  - The operating icons **20** appear: Unpin the pin **Q/R**
  - The operating icons **21** appear: Unpin the pin **S/T**
  - The operating icons **22** appear: Unpin the pin **U/V**
- F5** Function key
- Select / deselect roller set pinning
  - After selection, the operating icons **17** appear additionally
- F6** Function key
- Selecting / deselecting the SA-frame pinning
  - After selection, the operating icons **18** appear additionally
- F7** Function key
- Select / deselect *main boom pivot section* pinning
  - After selection, the operating icons **19** appear additionally
- F8** Function key
- Select / deselect *derrick boom pivot section* pinning
  - After selection, the operating icons **20** appear additionally
- F9** Function key
- Selecting / deselecting *suspended ballast guide / ballast trailer guide* pinning
  - After selection, the operating icons **21** appear additionally
- Note:** *Ballast trailer guide* pinning not for crane types with a separate pinning point for the ballast trailer.
- F10** Function key
- Select / deselect *ballast trailer guide* pinning
  - After selection, the operating icons **22** appear additionally
- Note:** Only for crane types with a separate pinning point for the ballast trailer.




---

**Note**

- Depending on the crane type, the *ballast trailer guide* is pinned with the function key **F9** or function key **F10**.
-

## 9.2 Assembly functions - pinning / unpinning the pins

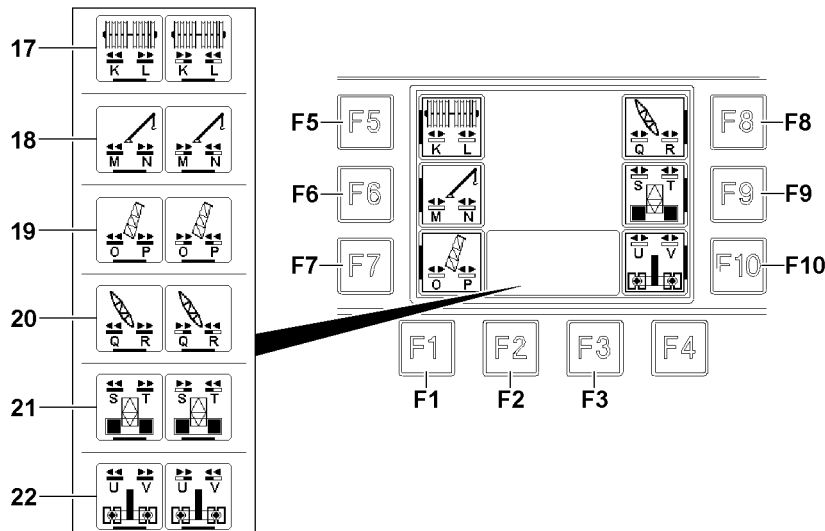


Fig.153776: Assembly functions - pinning / unpinning the pins

### – Selection / deselection of pinning / unpinning the pins

- Press the function key **F5**:
  - **Result:** Operating icons **17** appear, pin point **K** and pin point **L** are selected
- Press the function key **F6**:
  - **Result:** Operating icons **18** appear, pin point **M** and pin point **N** are selected
- Press the function key **F7**:
  - **Result:** Operating icons **19** appear, pin point **O** and pin point **P** are selected
- Press the function key **F8**:
  - **Result:** Operating icons **20** appear, pin point **Q** and pin point **R** are selected
- Press the function key **F9**:
  - **Result:** Operating icons **21** appear, pin point **S** and pin point **T** are selected
- Press the function key **F10**:
  - **Result:** Operating icons **22** appear, pin point **U** and pin point **V** are selected

### – Control release:

- The control release is made by touching the 2-Hand keyboard in the rear of the BTT, see section “Release of button block on BTT”
- After the control release is provided, the icons over the function key **F2** and function key **F3** are highlighted in purple.



### Note

- ▶ To control the functions, a control release must be issued: The corresponding icons must be highlighted in purple.

### – Insert the pin:

- Press the function key **F2**.

### – Unpin the pin:

- Press the function key **F3**.

### – Leave the menu:

- Press the function key **F1**.

## 10 Crane floodlight menu

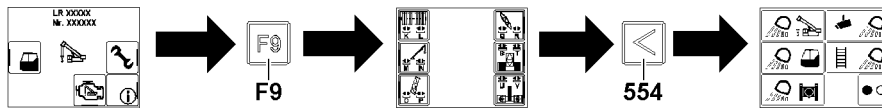


Fig.155100: Changing from the Crane superstructure start menu to the Crane floodlight menu

1) Press the change over key **554** until the *Crane floodlight* menu is displayed.



### Note

► Only with corresponding crane equipment.

In the *crane floodlight* menu, up to five different crane floodlights can be turned on / turned off individually or together.

### 10.1 Icons in the *crane floodlight* menu

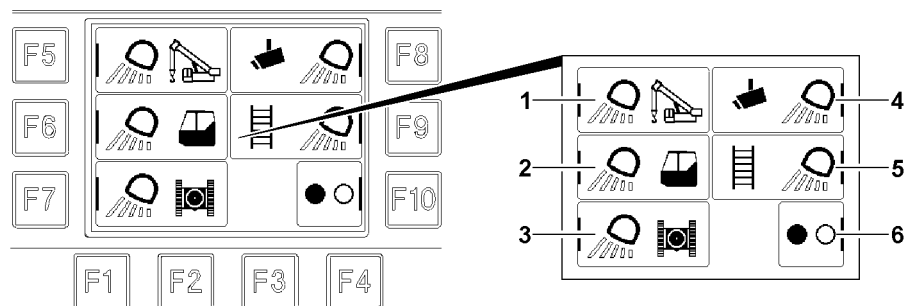


Fig.155082: Icons in the crane floodlight menu

- 1 Turntable floodlight icon
- 2 Crane cab floodlight icon
- 3 Crawler travel gear floodlight icon
- 4 Crane monitoring floodlight icon
- 5 Stepladder floodlight icon
- 6 All floodlights on / off icon

### 10.2 Function keys in the *Crane floodlight* menu

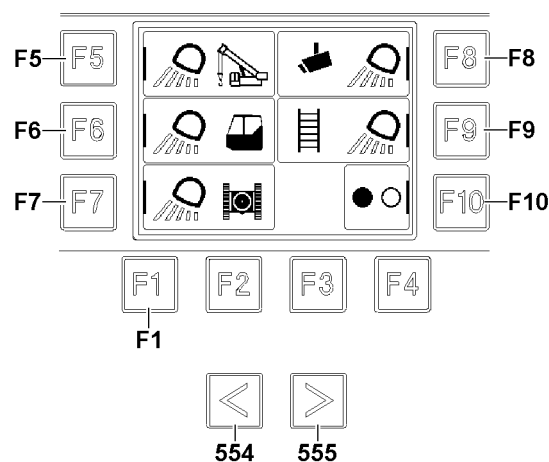


Fig.155083: Crane floodlight menu function keys



- 554** Change over key
  - Press until the subsequent menu is displayed:
    - *Engine operation* menu / *Assembly functions* menu
- 555** Change over key
  - Press until the subsequent menu is displayed:
    - *Engine operation* menu / *Assembly functions* menu
- F1** Function key
  - Back to the *Crane superstructure* start menu
    - Note:** Only when the *Crane floodlight* menu was called up via the *Assembly functions* menu.
- F5** Function key
  - Turn turntable floodlight on / off
- F6** Function key
  - Turn crane cab floodlight on / off
- F7** Function key
  - Turn crawler travel gear floodlight on / off
- F8** Function key
  - Turn camera monitoring floodlight on / off
- F9** Function key
  - Turn stepladder floodlight on / off
- F10** Function key
  - Turn all floodlights on / off

### 10.3 Turning the Floodlight\* on / off

- **Turn the floodlight on / off individually:**
  - Press the respective function key **F5-F9**.
    - Result:** The floodlight is turned on / off alternately.
- **Turn all floodlights on / off together:**
  - Press the function key **F10**.
    - Result:** All floodlights are turned on / turned off alternately together.

## 11 Test system menu

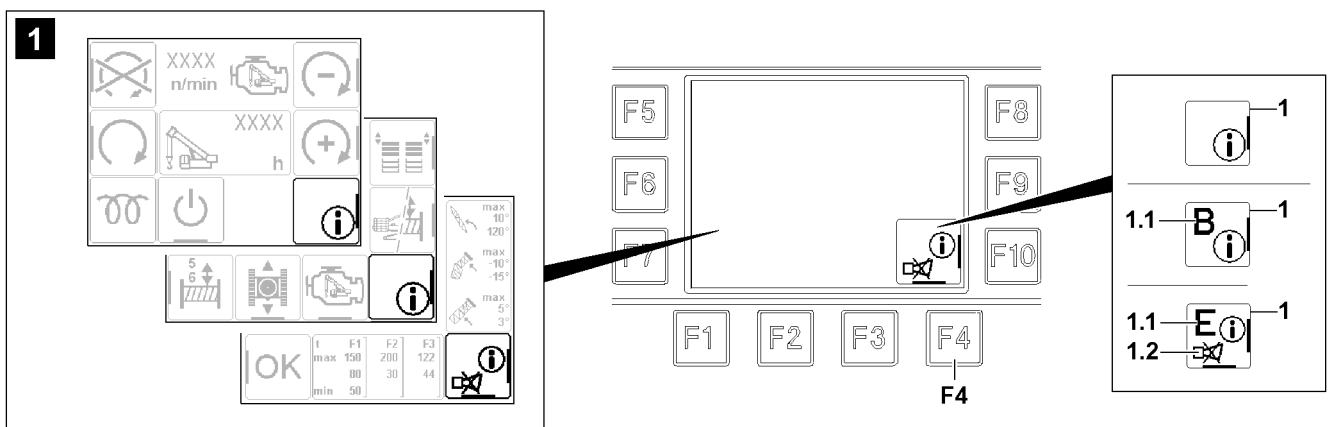


Fig.155092: Example for screen displays with test system icon

The test system is always active in the background.

The *test system* icon 1 appears in the selected screen displays, see the example in illustration 1.

In the *test system* icon 1, the following additional displays can appear:

- 1.1 *Error message* display

- An operating error (B) or system error (S) has occurred
- **1.2 Horn display**
  - *Selected acoustic warning signals* of the BTT can be shut off
  - Press the function key **F4** to turn off the disengageable *acoustic warning signal* of the BTT.
  - **Note:** Not every acoustic warning signal of the BTT can be shut off.

## 11.1 Operating interface from the *Test system* menu

If necessary, the operating interface from the *Test system* menu can be shown from all screen displays with the *Test system* icon displayed.

### 11.1.1 Show the operating interface from the *Test system* menu

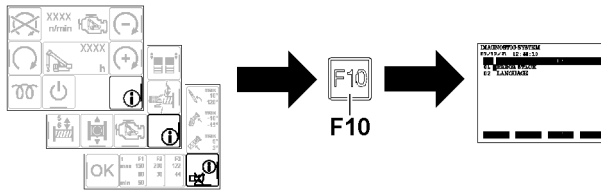


Fig.155093: Show the operating interface from the *Test system* menu

- Press the function key **F10** when the *Test system* icon is displayed.
  - The operating interface from the *Test system* menu is shown.

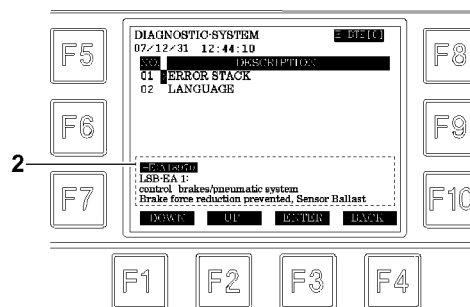


Fig.153739: Operating interface from the *Test system* menu

If an error message occurs during BTT operation, an error text **2** with an error number and description is displayed in the test system.



#### Note

- ▶ In certain situations, automatic switching to the test system takes place.



#### Note

- ▶ For a detailed description of the test system, see the Diagnostics Manual.

### 11.1.2 Hiding the *Test system* menu operating interface

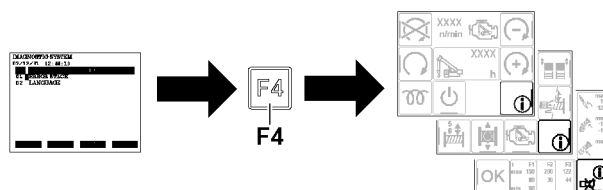
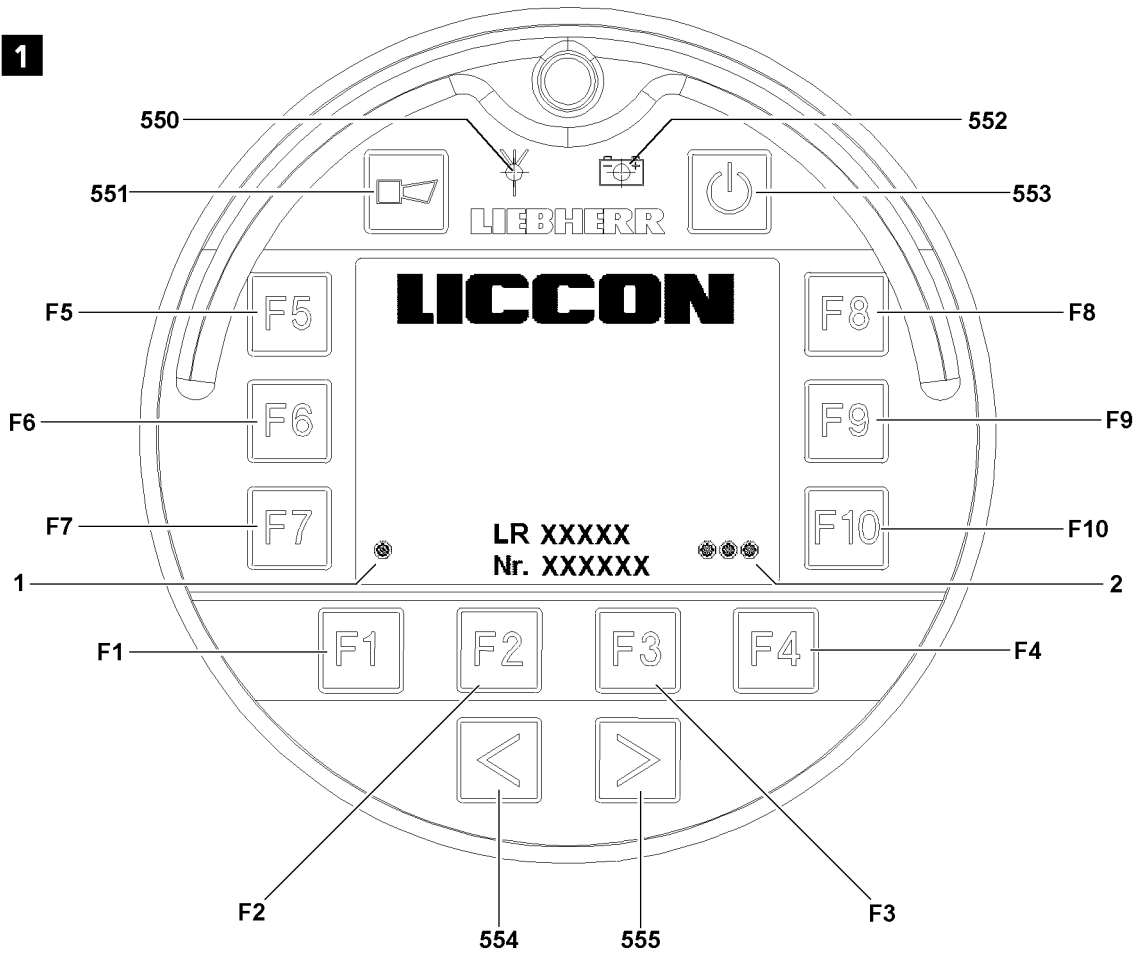


Fig.155094: Hiding the *Test system* menu operating interface

- 1) Press the function key **F4** until the *Test system* menu is hidden.

- Press the function key **F4** as often as necessary when the operating interface is displayed from the *Test system* menu.
  - The operating interface from the *Test system* menu is hidden.

1



2

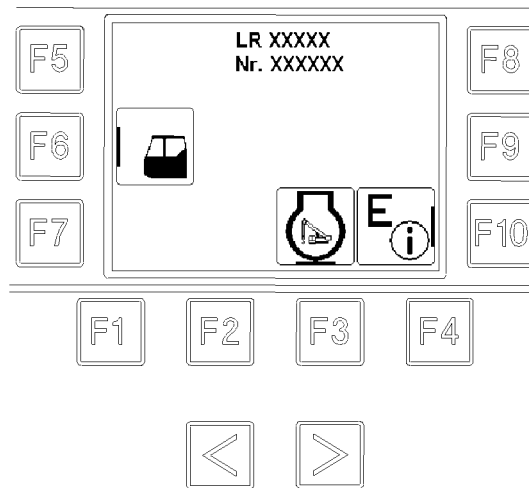


Fig.119605

LWE/LR 1800-1-0-000/27200-07-02/en

## 12 BTT operation

There are two ways to turn the BTT:

- Turning the BTT on using the ignition switch
- Turning the BTT on using the On / Off button **553**

### 12.1 Turning the BTT on using the ignition switch

Make sure that the following prerequisite is met:

- The BTT is in the charging cradle.
- ▶ Turn the ignition for the crane engine on: Actuate the ignition switch, see Crane operating instructions, chapter 4.01.

**Result:**

- The BTT turns itself on.
- After completion of the starting procedure, the *transmission signal* indicator light **550** and *rechargeable battery* indicator light **552** light up green, see illustration 1.
- The start screen is shown before the display changes to the start menu, see illustration 2.

### 12.2 Turning the BTT on using the On / Off button

Make sure that the following prerequisite is met:

- The BTT is pulled off the charging cradle
- ▶ Turn the ignition for the crane engine on: Actuate the ignition switch, see Crane operating instructions, chapter 4.01.
- ▶ Turn the BTT on: Press the On / Off button **553**.

**Result:**

- The BTT turns itself on.
- The *transmission signal* indicator light **550** and *rechargeable battery* indicator light **552** light up orange.
- The start screen is displayed, see illustration 1.
- ▶ Enter the turn on key sequence: Change over key **554**, then change over key **555** and then function key **F1**.

**Result:**

- The *transmission signal* indicator light **550** and *rechargeable battery* indicator light **552** light up green.
- The indicator light **1** and indicator light **2** light up green.
- The connection between the BTT and the receiver is established.

- ▶ Press any function key.

**Result:**

- The start menu of the BTT appears on the BTT, see illustration 2.
- ▶ Select the menu with the appropriate function key, see the relevant technical chapter.

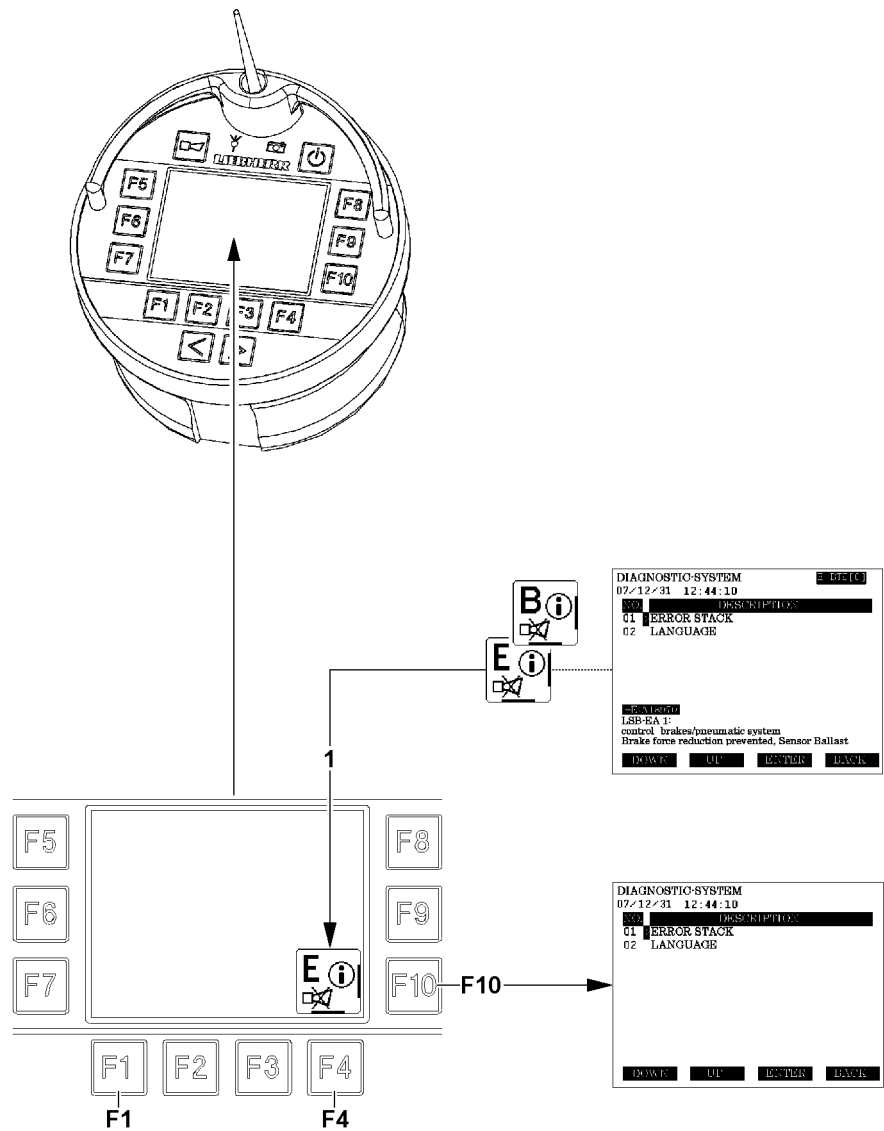


Fig.117975

## 13 Measures in case of problems

### 13.1 Did an error message occur?

If an event occurs that leads to the display of an error message, a "B" or "E" is shown in the icon 1, see illustration.




---

#### WARNING

Danger of accident!

If the displayed errors in the icon 1 are ignored, there is a danger of accident.

- ▶ Take the crane out of operation and remedy the cause of the error.
  - ▶ Do not put the crane back into operation before the cause of the error has been remedied.
- 

- ▶ Press the function key **F4**.

#### Result:

- Acoustic warning signal which can be shut off in the case of operating / system errors is turned off.
- 



#### Note

- ▶ For severe errors, the acoustic warning signal can be turned off after a waiting period (up to six seconds)!
- 

- ▶ Press the function key **F10**.

#### Result:

- The *Test system* program (error determination screen) is called up.
- 



#### Note

- ▶ To be able to find the cause of the problem, the error or errors must be read on the error determination screen / error stack of the BTT **500**, see Diagnostics manual.
- 

Close the *Test system* program (error determination screen):

- ▶ Press the function key **F1**.

#### Result:

- The *Test system* program (error determination screen) is closed.

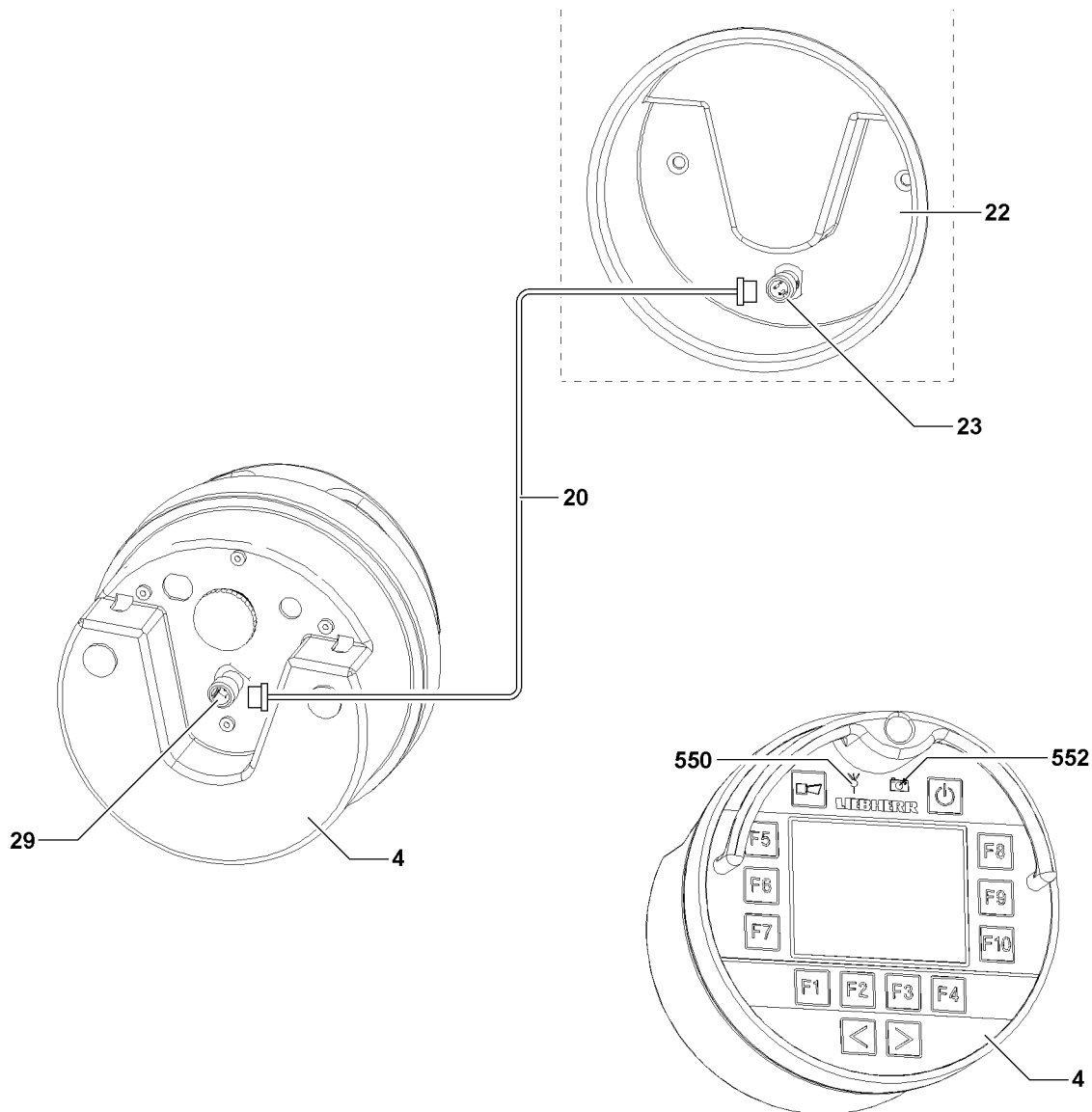


Fig.112952

## 13.2 The BTT display remains dark?



### Note

- ▶ The *rechargeable battery* indicator light **552** shows the charge condition.
- ▶ The *transmission signal* indicator light **550** shows the quality of the radio connection

When the *rechargeable battery* indicator light **552** does not light up or lights up red:

- ▶ Plug the BTT **4** into the charging cradle **22**.

When the *rechargeable battery* **552** indicator light does not light up with the BTT **4** plugged in or the BTT **4** cannot be turned on:

- ▶ Contact Liebherr Service to determine the cause of the problem and further procedure.

## 13.3 Is the radio connection faulty?

If the radio connection to the BTT **4** is faulty or interrupted (*transmission signal* indicator light **550** lights up red), then it can be bypassed with line **20**.



The radio connection to the BTT **4** can become faulty or interrupted through the following occurrences:

- By interference signals from a nearby radio tower.
- The radio module on the BTT **4** or on the BTB is defective
- The rechargeable battery in the BTT **4** is discharged.
- Due to bad selection of the placement location by the operator.

### 13.3.1 Bypassing the radio connection

Make sure that the following prerequisites are met:

- The line **20** to bypass the radio communication has been removed from the control cabinet of the crane cab.
- The BTT **4** has been removed from the charging cradle **22** and is turned on
- The caps on the plug connection **23** and the plug connection **29** have been removed.
- ▶ Screw the line **20** on the charging cradle **22** onto the plug connection **23**.
- ▶ Screw the line **20** on the BTT **4** onto the plug connection **29**.

**Result:**

- The radio communication is bypassed.



**Note**

If the BTT **4** cannot be turned on, even though the line **20** is connected to the charging cradle **22**, then the rechargeable battery may be defective.

- ▶ Contact Liebherr Service to determine the cause of the problem and further procedure.
-

---

Empty page!

LWE/LR 1800-1-0-000/27200-07-02/en

## 5.35 Derrick ballast - ballast trailer - M-BW

1	Description	2
2	Component overview	2
3	Fastening points	2
4	Radii	10
5	Stability and tipping safety	12
6	For your safety during assembly and disassembly	18
7	Prerequisites for assembly	23
8	Operating elements on the control panels	23
9	Assembling / disassembling the ballast trailer with the BTT-E	26
10	Assembling the ballast trailer	26
11	Preparing the ballast trailer for assembly on the crane	65
12	Assembling the ballast trailer on the crane	66
13	Ballasting the ballast trailer	84
14	Working with the ballast trailer	91
15	Removing ballast trailer ballast	173
16	Prerequisites for disassembly	178
17	Preparing the ballast trailer for disassembly from the crane	178
18	Disassembling the ballast trailer from the crane	179
19	Disassembling the ballast trailer	194
20	Emergency operation in case of a defective control module of the ballast trailer control	222
21	Ballast trailer maintenance intervals / maintenance instructions	229

# 1 Description



## Note

- ▶ The modular ballast trailer can be used for different types of cranes.
- ▶ Depending on the crane type, there are different adapters, which can be installed alternatively on the ballast trailer guide or on an intermediate section.
- ▶ A corresponding coding coupling is used, depending on the crane type.
- ▶ In this chapter, the illustrations used mainly represent the LR1800. The illustrations apply in the same way for additional crane types.

The pull cylinders for the ballast trailer are assembled on the D-end section and can be actuated under load.

Two wheel sets are oscillating mounted.

Ballast trailer radius: 14 m to 23 m.

The hydraulic-mechanical steering is electronically adjustable for:

- Towing, circular travel, parallel travel, manual corrective steering and manual operation

# 2 Component overview



## Note

- ▶ The assembly sections are marked with their own weight.
- ▶ The ballast trailer components, such as the ballast trailer, the ballast trailer guide and adapter plates as well as their dimensions and weights are described in chapter 1.03.

# 3 Fastening points



## WARNING

Incorrectly fastened components!

Life-threatening situations can arise due to improper or incorrect fastening of the corresponding components.

Death, severe bodily injuries, property damage.

- ▶ Fasten the components only in the intended fastening points on both sides.
- ▶ Fastening components, see chapter 5.01.

### 3.1 Transport device

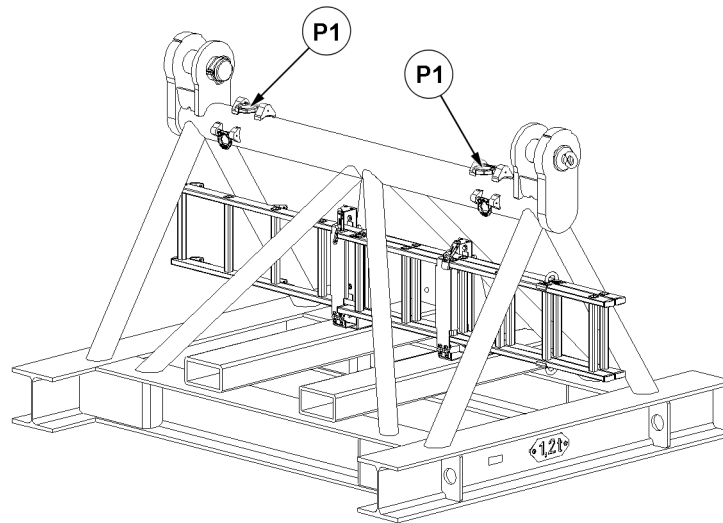


Fig.157992: Transport device fastening points

**P1** Transport device fastening points

### 3.2 Ballast trailer frame

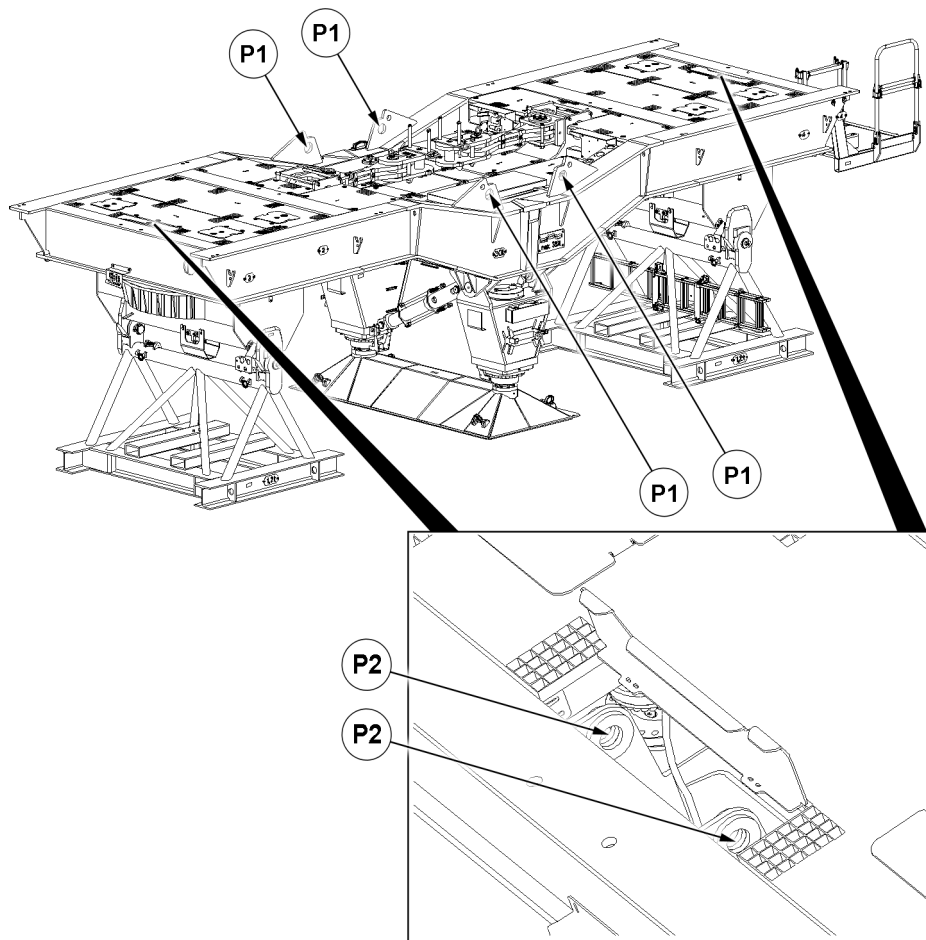


Fig.157996: Ballast trailer frame fastening points

**P1** Ballast trailer frame fastening points – single stroke

**P2** Ballast trailer frame fastening points – tandem stroke

### 3.3 Wheel set

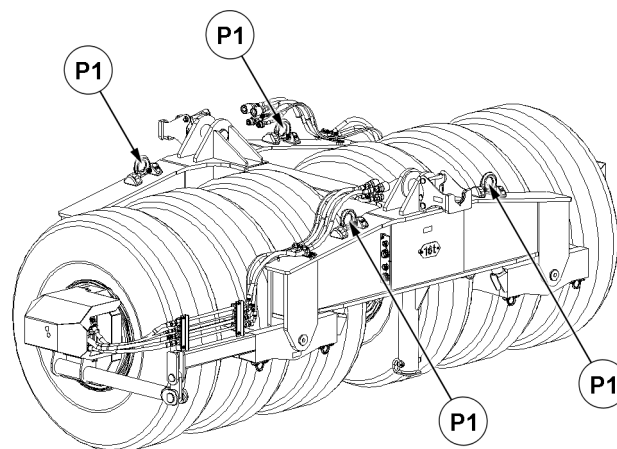


Fig.157994: Wheel set fastening points

**P1** Wheel set fastening points

### 3.4 Platform

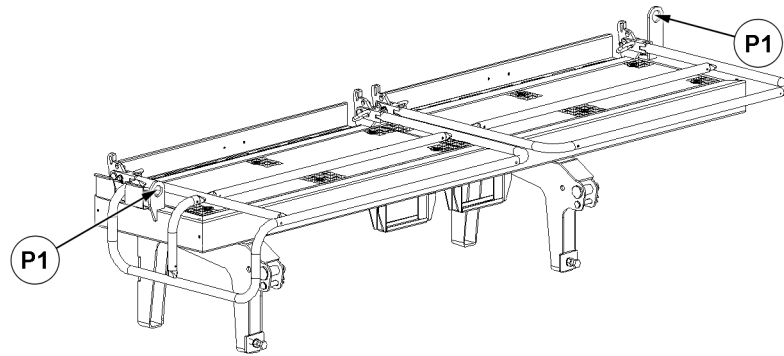


Fig.157993: Platform fastening points

P1 Platform fastening points

### 3.5 Ballast trailer

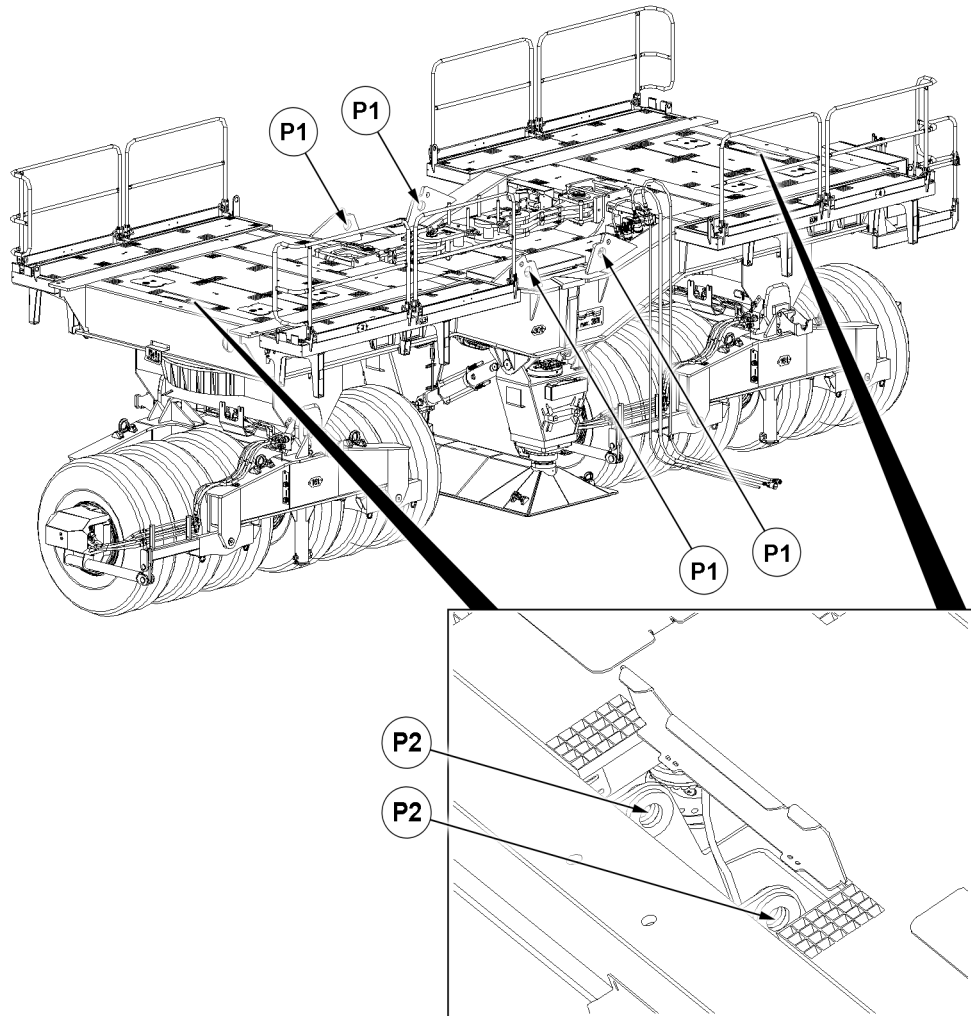


Fig.157995: Ballast trailer fastening points

P1 Ballast trailer fastening points – single stroke

P2 Ballast trailer fastening points – tandem stroke

LWE/LR 1800-1-0-000/27200-07-02/en

### 3.6 Adapter LR 1700

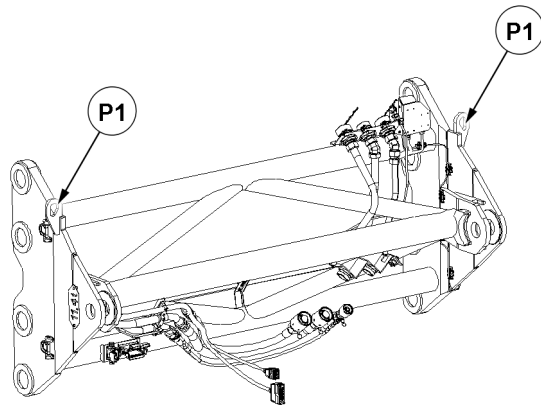


Fig.158000: Adapter fastening points

P1 Adapter fastening points

### 3.7 Adapter LR 1800

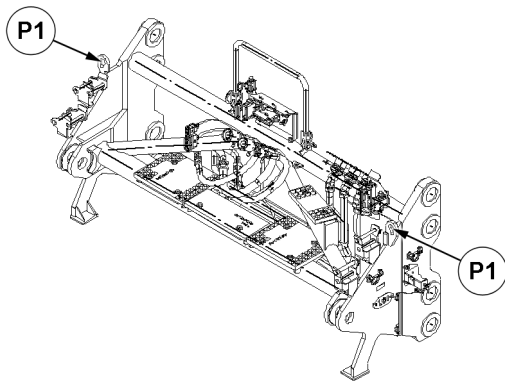


Fig.157998: Adapter fastening points

P1 Adapter fastening points



### 3.8 Adapter LR 11000

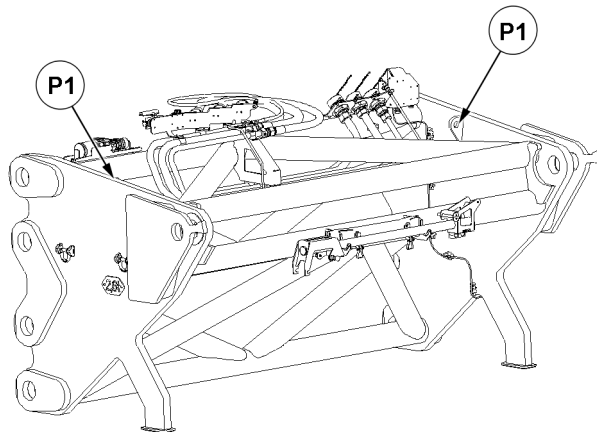


Fig.162921: Adapter fastening points

P1 Adapter fastening points

### 3.9 Intermediate section

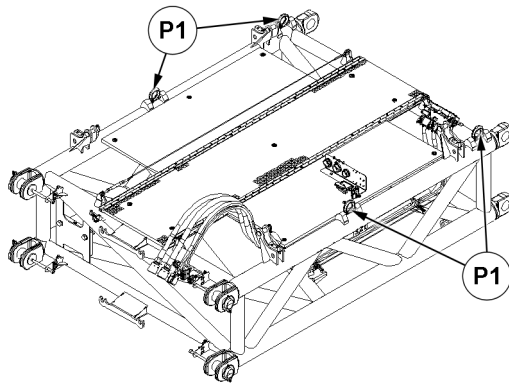


Fig.158590: Intermediate section fastening points

P1 Intermediate section fastening points

### 3.10 Ballast trailer guide without adapter



#### WARNING

Fastening equipment too short!

Death, severe bodily injuries, property damage.

If the fastening equipment is too short, they can overload the fastening points and can rip off  
The ballast trailer guide falls down.

- ▶ Use fastening equipment with a minimum length of 10 m.

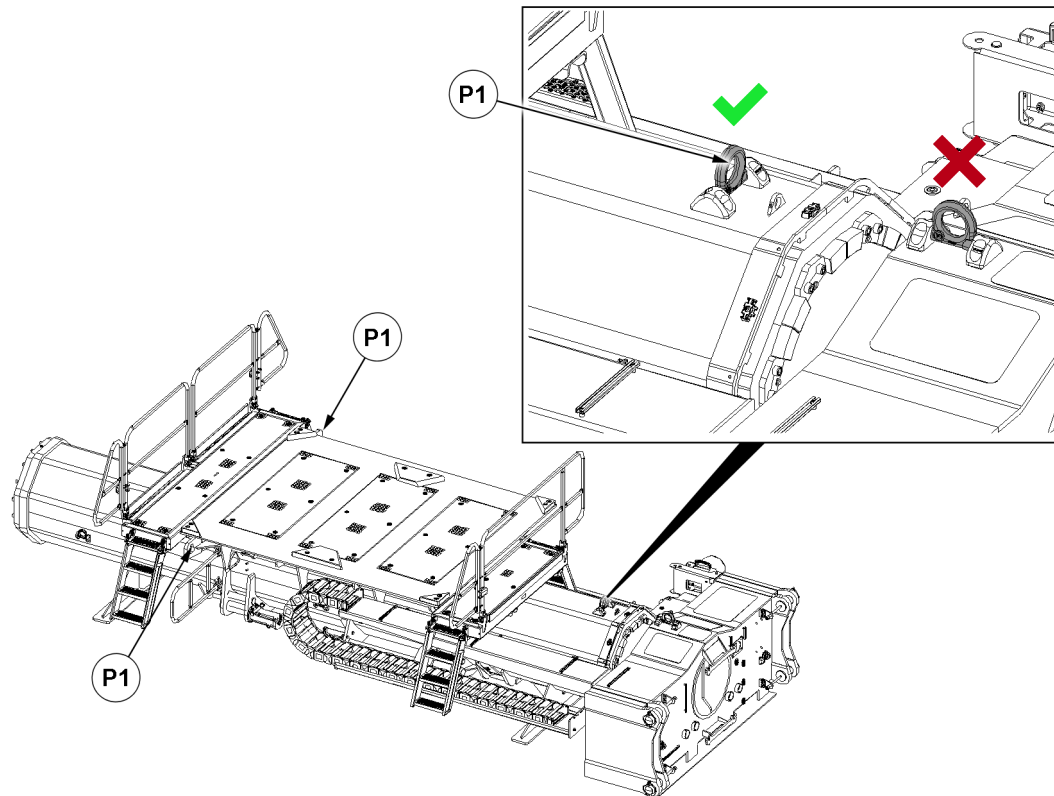


Fig.162990: Ballast trailer guide fastening points without adapter

**P1** Ballast trailer guide fastening points without adapter

### 3.11 Ballast trailer guide with adapter



#### **WARNING**

Fastening equipment too short!

Death, severe bodily injuries, property damage.

If the fastening equipment is too short, they can overload the fastening points and can rip off. The ballast trailer guide falls down.

► Use fastening equipment with a minimum length of 10 m.

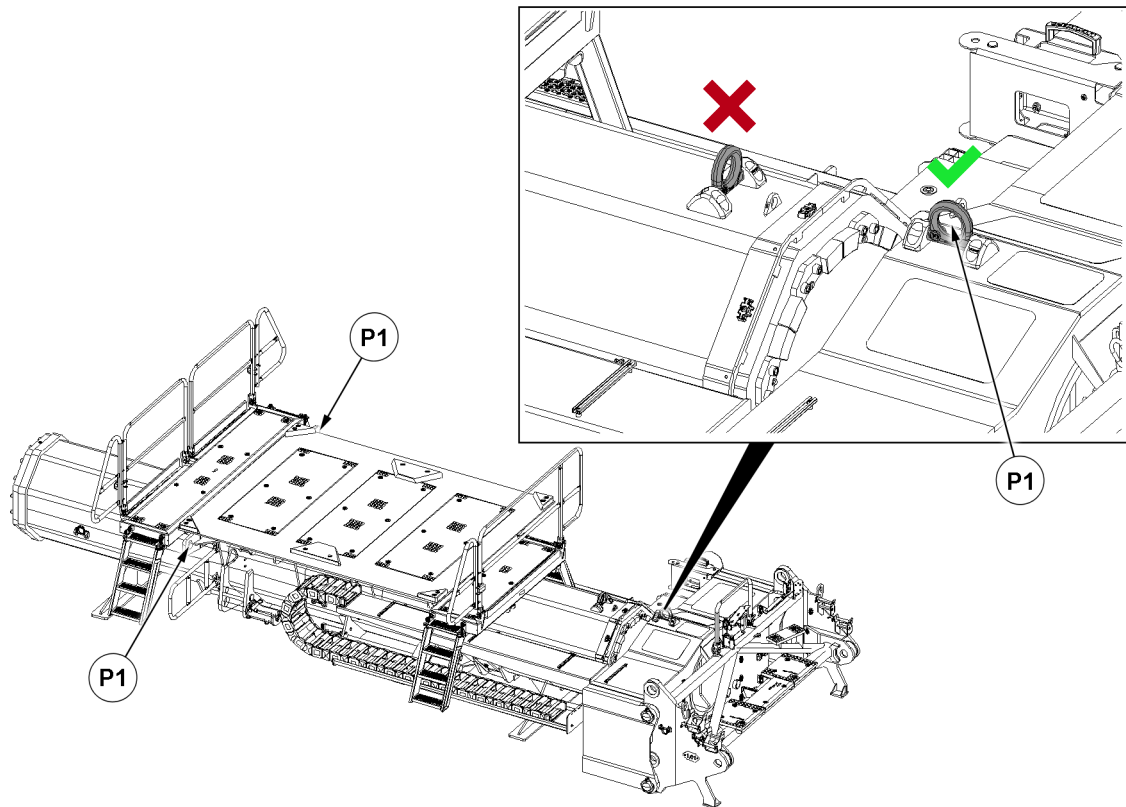


Fig.162989: Ballast trailer guide fastening points with adapter

**P1** Ballast trailer guide fastening points with adapter

### 3.12 Ballast trailer guide with intermediate section and with adapter



#### **WARNING**

Fastening equipment too short!

Death, severe bodily injuries, property damage.

If the fastening equipment is too short, they can overload the fastening points and can rip off. The ballast trailer guide falls down.

- ▶ Use fastening equipment with a minimum length of 10 m.

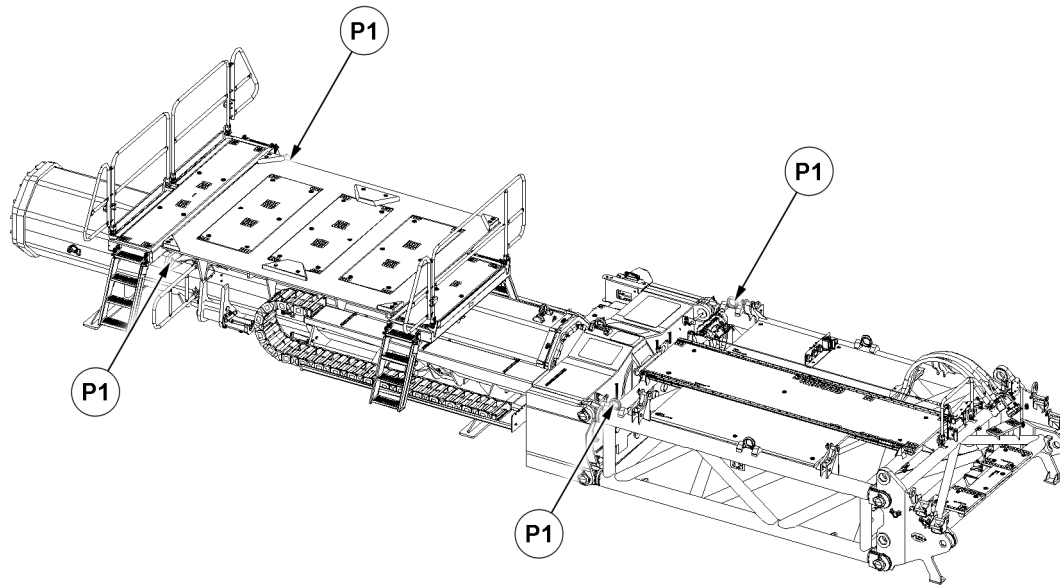


Fig.162991: Ballast trailer guide fastening points with intermediate section and with adapter

P1 Ballast trailer guide fastening points with intermediate section and adapter

## 4 Radii



### Note

- The ballast trailer radius = R1 can be changed by adjusting the telescopic guide and by installation of an intermediate section of 14 m to 23 m.

### 4.1 Ballast trailer radius 14 m - 19 m with derrick boom length of 33 m

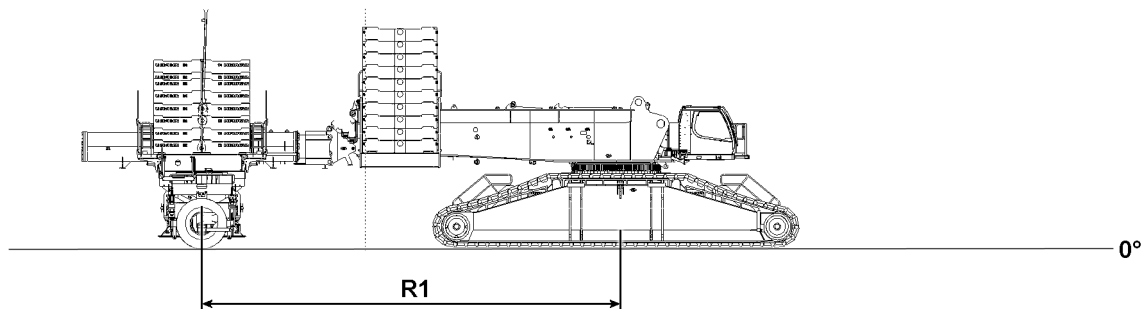


Fig.158591: Ballast trailer radius 14 m with derrick boom length of 33 m

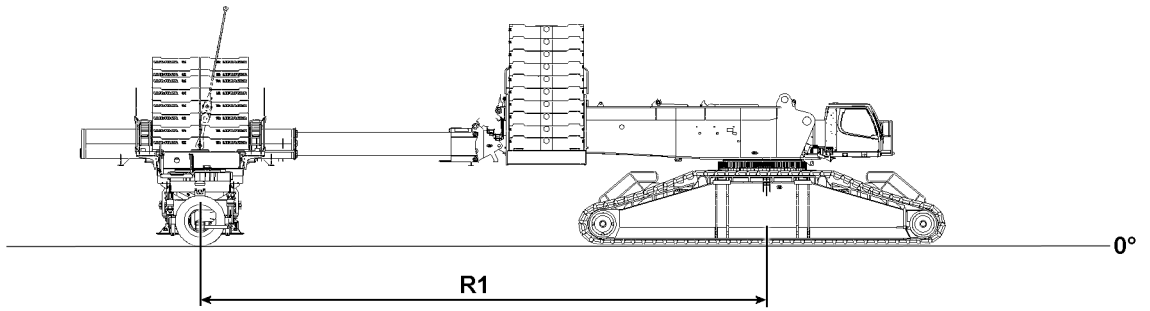


Fig.158593: Ballast trailer radius 19 m with derrick boom length of 33 m

**4.2 Ballast trailer radius 18 m - 23 m with derrick boom length of 33 m**

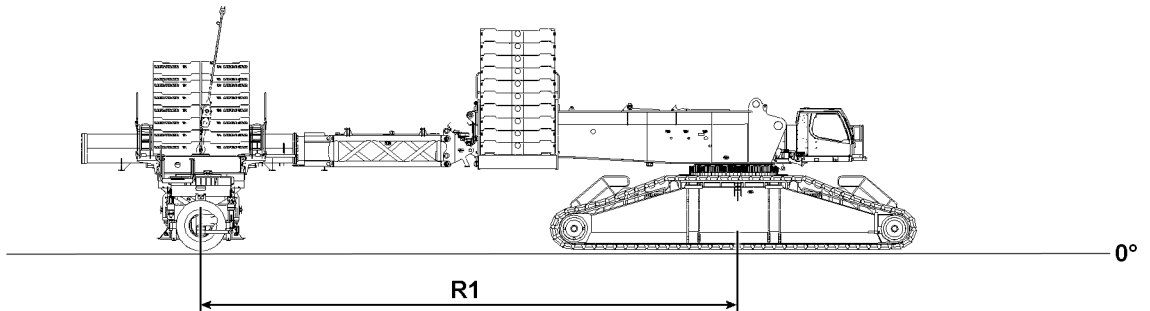


Fig.158592: Ballast trailer radius 18 m with derrick boom length of 33 m

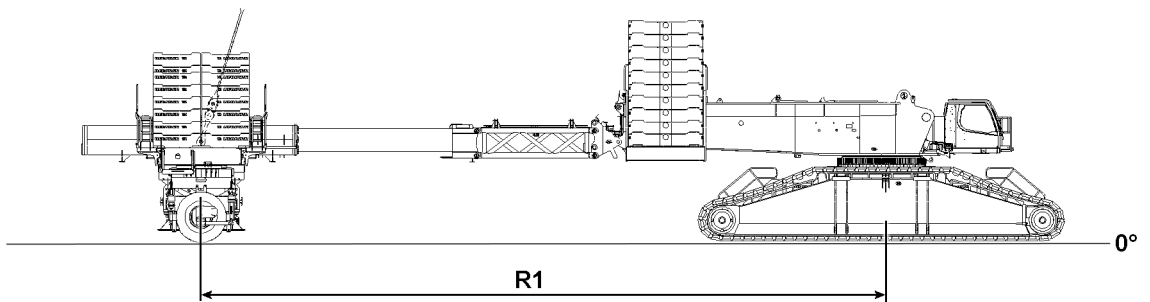


Fig.158594: Ballast trailer radius 23 m with derrick boom length of 33 m

**4.3 Ballast trailer radius 14 m - 19 m with derrick boom length of 39 m**

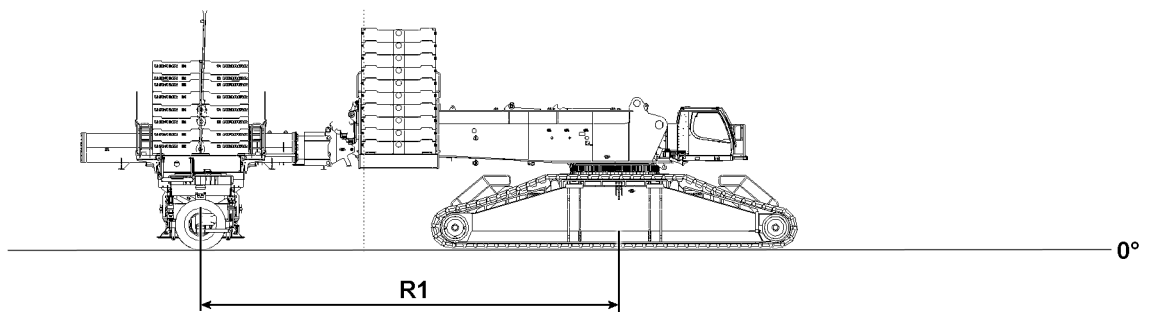


Fig.158591: Ballast trailer radius 14 m with derrick boom length of 39 m

LWE/LR 1800-1-0-000/27200-07-02/en

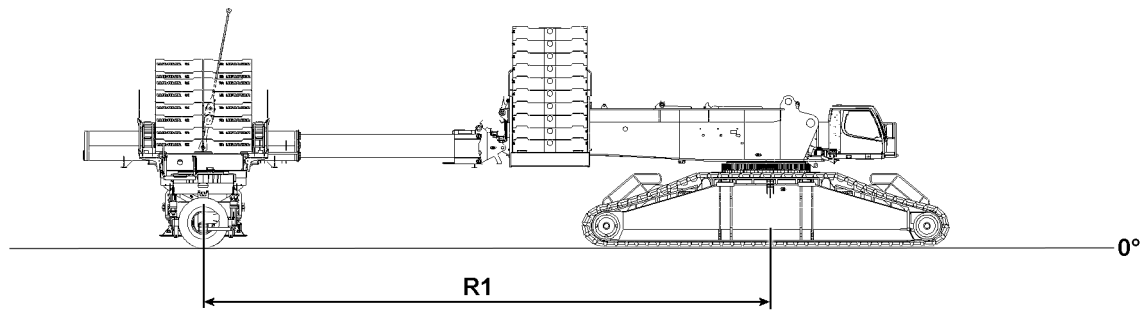


Fig.158593: Ballast trailer radius 19 m with derrick boom length of 39 m

#### 4.4 Ballast trailer radius 18 m - 23 m with derrick boom length of 39 m

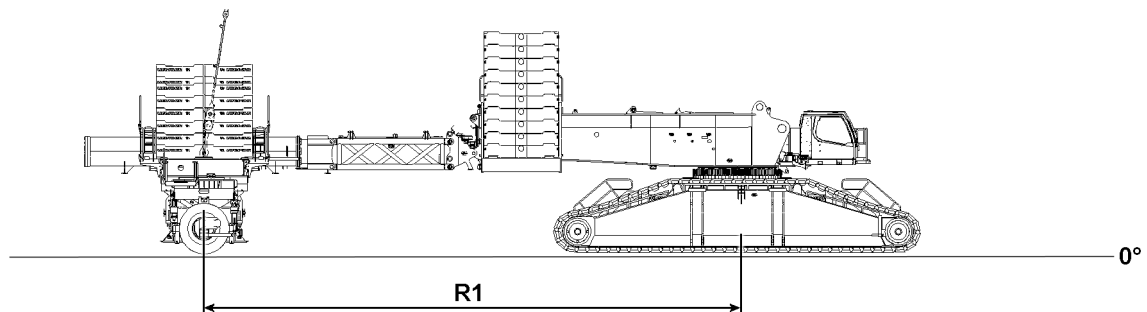


Fig.158592: Ballast trailer radius 18 m with derrick boom length of 39 m

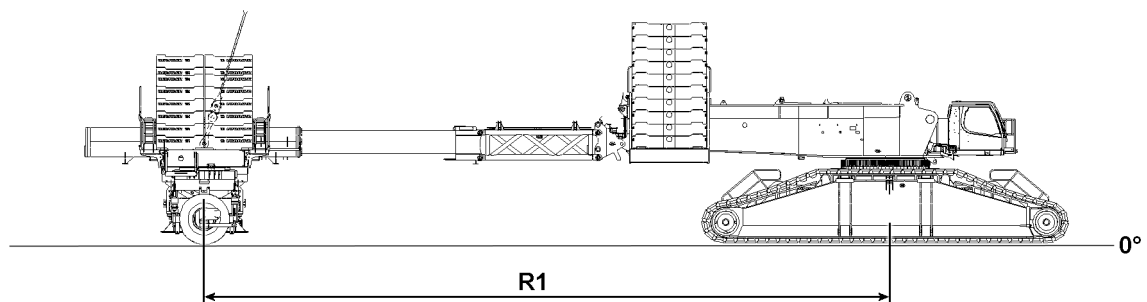


Fig.158594: Ballast trailer radius 23 m with derrick boom length of 39 m

## 5 Stability and tipping safety

### 5.1 Permissible level difference



#### WARNING

Exceedance of the permissible level difference!

If the maximum permissible values for the level difference are exceeded, then the crane can topple over.

Death, severe bodily injuries, property damage.

► Do not undershoot the permissible level difference.

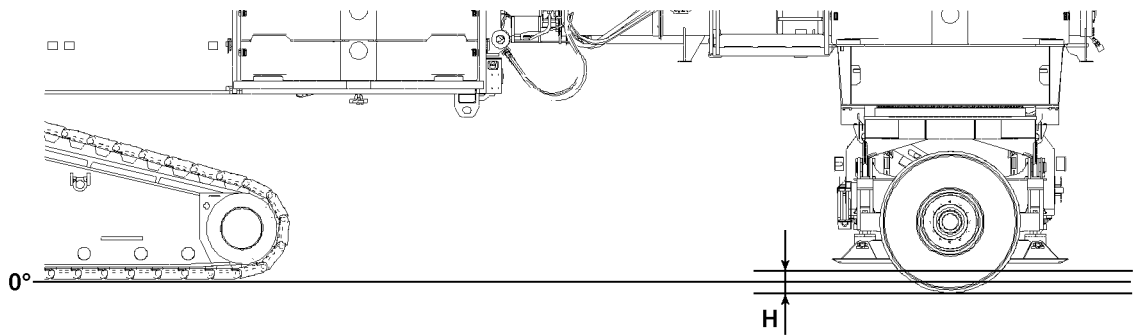


Fig.159382: Permissible level difference (illustration example)

Ballast trailer radius = R1	Level difference = H
14 m	± 150 mm
18 m / 19 m	± 300 mm
23 m	± 450 mm

Permissible level difference



**Note**

- ▶ The maximum permissible level difference corresponds to a ballast trailer inclination of ± 2° in the load direction.

## 5.2 Permissible side incline



**WARNING**

Exceeding the maximum permissible side incline!  
 If the maximum permissible side incline of the ballast trailer is exceeded, the crane can topple over.  
 Death, severe bodily injuries, property damage.

- ▶ Do not exceed the maximum permissible side incline of the ballast trailer.

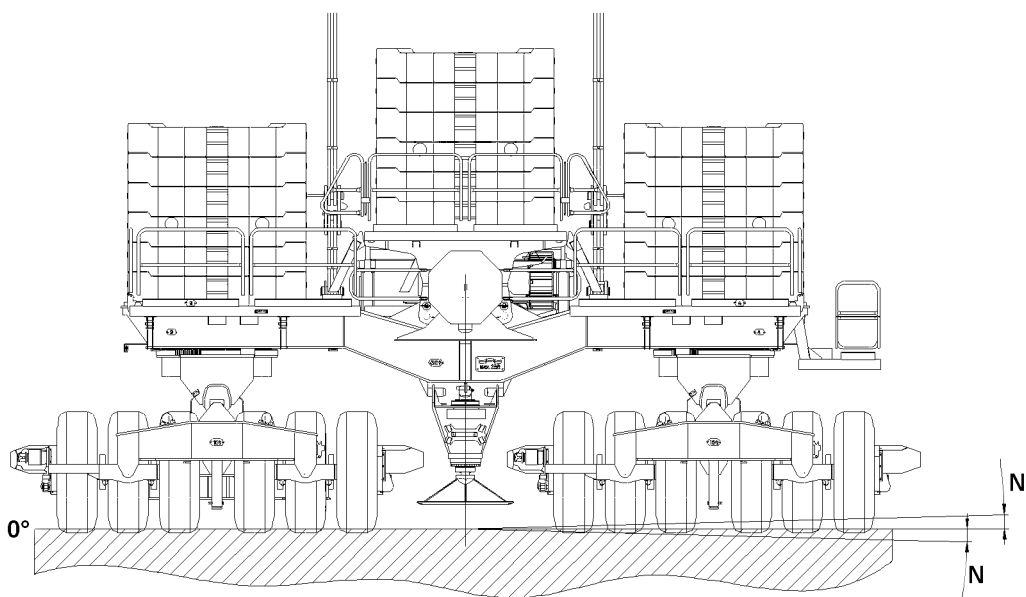


Fig.162992: Permissible side incline (illustration example)

LWE/LR 1800-1-0-000/27200-07-02/en

Ballast trailer radius = R1	Side inclination = N
14 m	$\pm 1.5^\circ$
18 m / 19 m	$\pm 1.5^\circ$
23 m	$\pm 1.5^\circ$

Permissible side incline

### 5.3 Specific ballasting for stability and tipping safety



#### WARNING

Exceedance of the permissible total weight!

If the maximum permissible weight of the ballast plates is exceeded, the ballast trailer or the crane can topple over.

Death, severe bodily injuries, property damage.

- ▶ The permissible total weight of the ballast plates may not be exceeded.



#### WARNING

Insufficient ballasting!

If insufficiently ballasted, then the ballast trailer can tip over.

Death, severe bodily injuries, property damage.

- ▶ Make sure that the turned off ballast trailer is ballasted in accordance with its assembly condition and the selected ballast trailer radius, see the following charts.
- ▶ Make sure that the ground is prepared according to the ground pressure, see the following charts.

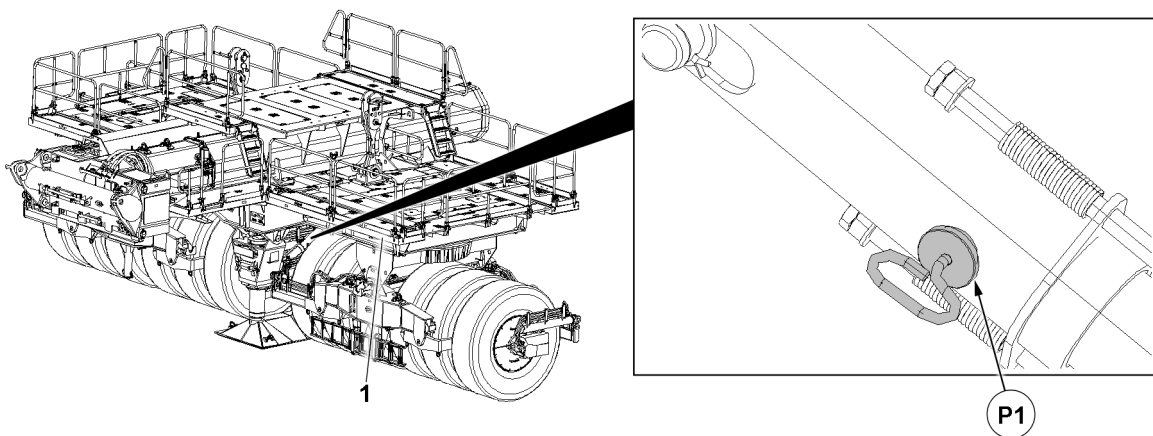


Fig.163030: Secure the ballast trailer to prevent it from tipping over.

#### 1 Ballast trailer

Make sure that the following prerequisites are met:

- The ballast trailer **1** is turned off and secured in point **P1** to prevent it from tipping over, see section: “Turn off the ballast trailer”.
- The ballast trailer is correctly ballasted, see section: “Ballast the ballast trailer”.
- The incline of the base / travel route of the ballast trailer is  $0^\circ \pm 1.5^\circ$ .
- The base / travel route of the ballast trailer is sufficiently level and capable of supporting the load.
- The permissible total weight of the ballast plates of 340 t is not exceeded.

#### 5.3.1 Ballast trailer with guide and adapter

##### Assembling the ballast trailer guide on the ballast trailer / free-standing ballast trailer

Make sure that the following prerequisites are met:

- The ballast trailer guide is telescoped in all the way.



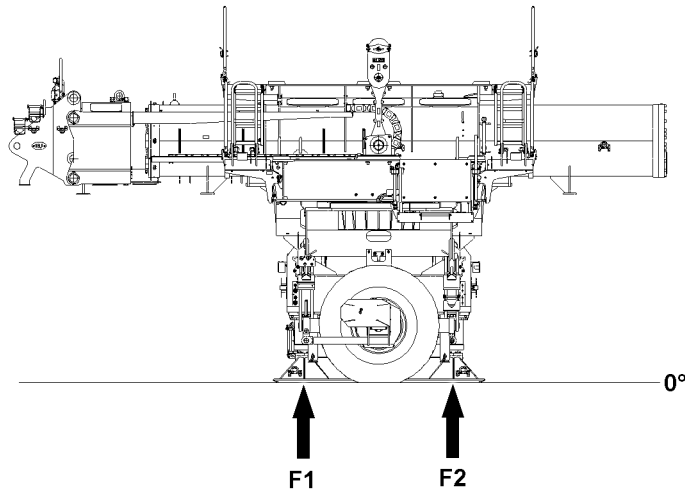


Fig.159615: Turning off the pre-installed ballast trailer with a ballast trailer radius 14 m

	Ballast trailer radius R 14 m
Ballasting (min)	0 t
Ballasting (max)	340 t
Ground pressure F1 (min)	52 t
Ground pressure F2 (min)	32 t
Ground pressure F1 (max)	222 t
Ground pressure F2 (max)	202 t

Ballasting and ground pressures for ballast trailer radius 14 m

**Assembling / disassembling on the turntable - guide telescoped in**

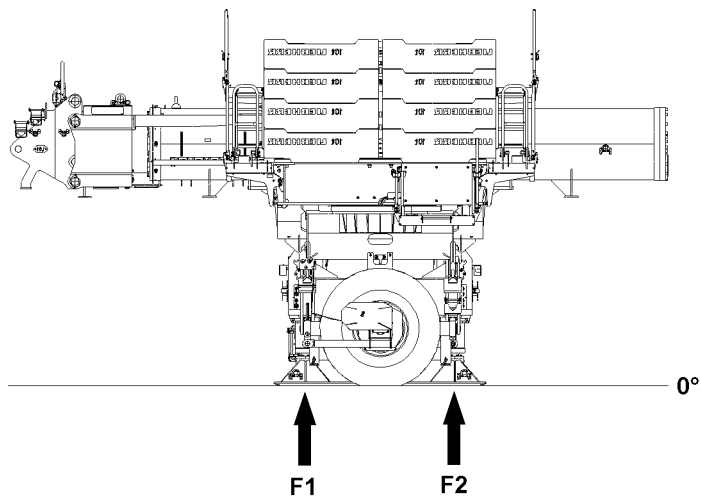


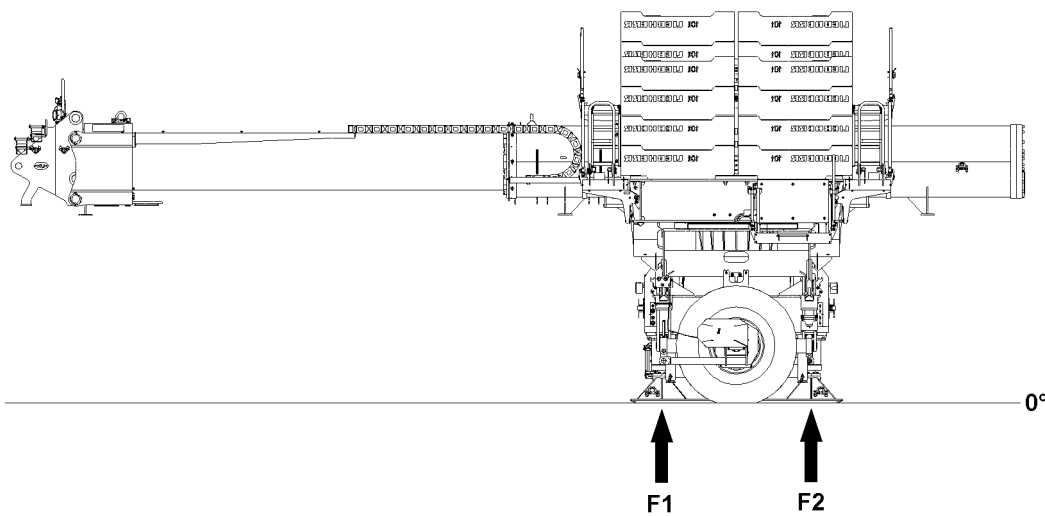
Fig.159616: Turning off the ballast trailer during assembly / disassembly and ballast trailer radius 14 m

LWE/LR 1800-1-0-000/27200-07-02/en

	<b>Ballast trailer radius R 14 m</b>
Ballasting (min)	160 t
Ballasting (max)	340 t
Ground pressure F1 (min)	132 t
Ground pressure F2 (min)	112 t
Ground pressure F1 (max)	222 t
Ground pressure F2 (max)	202 t

*Ballasting and ground pressures for ballast trailer radius 14 m*

### Assembling / disassembling on the turntable - guide telescoped out



*Fig.159617: Turning off the ballast trailer during assembly / disassembly and ballast trailer radius 19 m*

	<b>Ballast trailer radius R 19 m</b>
Ballasting (min)	220 t
Ballasting (max)	340 t
Ground pressure F1 (min)	180 t
Ground pressure F2 (min)	124 t
Ground pressure F1 (max)	240 t
Ground pressure F2 (max)	184 t

*Ballasting and ground pressures for ballast trailer radius 19 m*

## 5.3.2 Ballast trailer with guide, an intermediate section and adapter

### Assembling the ballast trailer guide on the ballast trailer / free-standing ballast trailer

Make sure that the following prerequisites are met:

- The ballast trailer guide is telescoped in all the way.

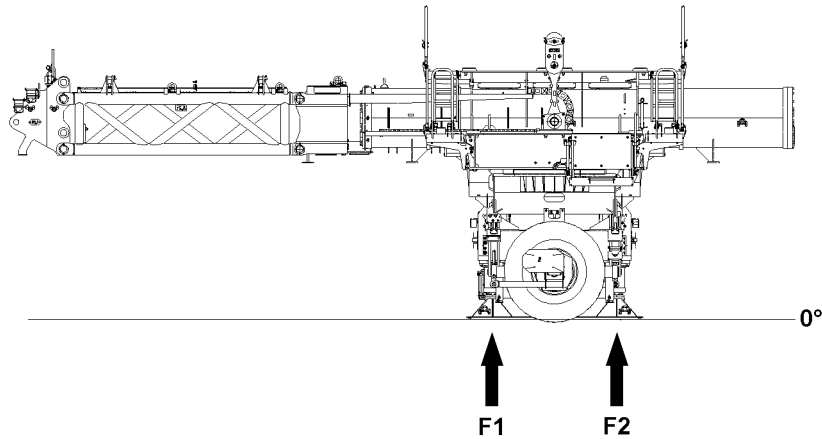


Fig.159618: Turning off the pre-installed ballast trailer with a ballast trailer radius 18 m

	Ballast trailer radius R 18 m
Ballasting (min)	0 t
Ballasting (max)	340 t
Ground pressure F1 (min)	66 t
Ground pressure F2 (min)	22 t
Ground pressure F1 (max)	236 t
Ground pressure F2 (max)	192 t

Ballasting and ground pressures for ballast trailer radius 18 m

**Assembling / disassembling on the turntable - guide telescoped in**

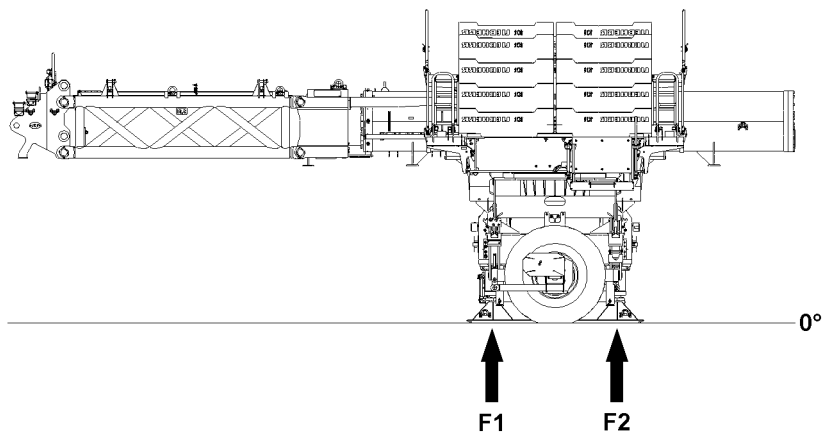


Fig.159619: Turning off the ballast trailer during assembly / disassembly and ballast trailer radius 18 m

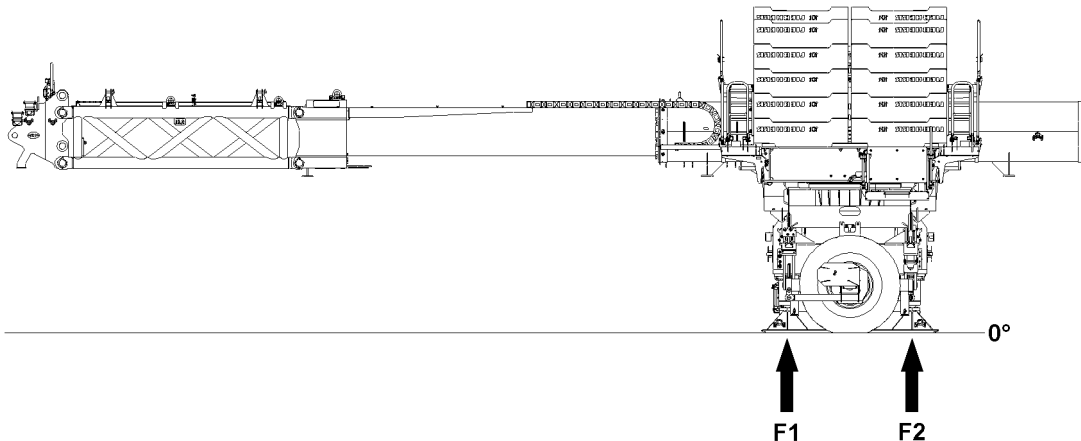
	Ballast trailer radius R 18 m
Ballasting (min)	200 t
Ballasting (max)	340 t
Ground pressure F1 (min)	166 t

LWE/LR 1800-1-0-000/27200-07-02/en

	<b>Ballast trailer radius R 18 m</b>
Ground pressure F2 (min)	122 t
Ground pressure F1 (max)	236 t
Ground pressure F2 (max)	192 t

*Ballasting and ground pressures for ballast trailer radius 18 m*

#### Assembling / disassembling on the turntable - guide telescoped out



*Fig.159620: Turning off the ballast trailer during assembly / disassembly and ballast trailer radius 23 m*



#### **WARNING**

Overload of the support!

Tipping of the ballast trailer.

Death, severe bodily injuries, property damage.

- ▶ Do not exceed the maximum ballasting according to the chart.
- ▶ If necessary, remove the ballast plates before turning off the ballast trailer.

	<b>Ballast trailer radius R 23 m</b>
Ballasting (min)	260 t
Ballasting (max)	340 t
Ground pressure F1 (min)	221 t
Ground pressure F2 (min)	127 t
Ground pressure F1 (max)	261 t
Ground pressure F2 (max)	167 t

*Ballasting and ground pressures for ballast trailer radius 23 m*

## 6 For your safety during assembly and disassembly

Observe the safety instructions before assembly and disassembly:

- Information regarding personal protective equipment. See chapter 2.04.
- Information regarding the 3-point support. See chapter 2.04.10.
- Information regarding crane operation. See chapter 2.04.

- Information regarding fall protection equipment. See chapter 2.06.
- Information regarding walking surfaces and stepping surfaces. See chapter 2.07.
- Technical safety instructions for assembly and disassembly. See chapter 5.01.

## 6.1 Assembling



### Note

Crane assembly with the auxiliary crane.

When installed components are lifted or set down with the auxiliary crane, the changed F-forces may have an effect on the boom system. The display values on the F-load displays can change and shut-offs can occur.

When installed components are lifted or set down with the auxiliary crane:

- ▶ Observe the F-load displays on the crane to be monitored.
- ▶ If necessary, correct the position of the boom system (F-forces) on the crane to be assembled.

## 6.2 Movement on the crane



### WARNING

Danger of falling!

Death, severe bodily injuries, property damage.

- ▶ If aids are not available and work cannot be carried out from the ground, then assembly personnel must secure themselves with the supplied fall arrest system to prevent falling, see chapter 2.04.
- ▶ If fall protection equipment is available, then it must be used, see chapter 2.06.
- ▶ If railings are present on the components, then they must be brought into the corresponding position and secured for assembly / disassembly work.
- ▶ Only step on the aids, ladders and catwalks with clean shoes.
- ▶ Keep aids, ladders and catwalks free of heavy dirt, snow, frost and ice.
- ▶ Stepping or walking on crane components and lattice sections with an incline of more than 20° is prohibited.
- ▶ When closing or opening boom systems during boom assembly or boom disassembly, no persons may remain on the boom system or in the danger zone.
- ▶ Remaining on a suspended load is prohibited.

## 6.3 Crane movements



### WARNING

Exceeding the permissible display values of the F-load display!

The crane can be overloaded.

This could result in serious accidents.

- ▶ Observe and adhere to the display values on the LICCON monitors.
- ▶ Observe and adhere to the specifications regarding the limit values on the assembly drawings.
- ▶ During assembly / disassembly of ballast trailers, ballast pallets or the suspended ballast guide, the F1-force is in the middle between the minimum and maximum force.



### WARNING

Danger of accident due to non-observance of the instructions of the guide!

Death, severe bodily injuries, property damage.

- ▶ For all work, observe the instructions of the guide.
- ▶ The crane operator and guide must monitor the danger zone.
- ▶ Only initiate crane movements when the responsible guide has explicitly released the movement.

**WARNING**

Danger of accident due to lack of voice contact!  
Death, severe bodily injuries, property damage.

- ▶ For all assembly / disassembly work, the crane driver of the main crane must be in voice contact with the crane driver / crane drivers of the auxiliary crane / auxiliary cranes.
- ▶ If necessary, use walkie-talkies.

**WARNING**

Crane operation and travel operation during assembly and disassembly work!  
Death, severe bodily injuries, property damage.

- ▶ During all assembly and disassembly work, travel operation and crane operation are prohibited.

## 6.4 Working at a height

**WARNING**

3-point support not adhered to!  
Personnel can fall, death, severe bodily injuries.

- ▶ Adhere to the 3-point support.
- ▶ Adhere to the prerequisites and conditions for the use of leaning ladders.

**WARNING**

Working with unsuitable aids!  
Danger of falling.

- ▶ Carry out all overhead work, where there is a danger of falling with suitable aids.
- ▶ If aids are not available and work cannot be carried out from the ground, then use the supplied fall arrest system to prevent falling, see chapter 2.04.

## 6.5 Pin connections

**DANGER**

Do not disconnect the auxiliary crane until the component is completely pinned and secured!  
Death, severe bodily injuries, property damage.

If a component is disengaged from the auxiliary crane before it is pinned, then it can fall.

- ▶ Do not disconnect the auxiliary crane until the component is pinned and secured.

**WARNING**

Unsecured pins during crane operation!  
Death, severe bodily injuries, property damage.

If the pins are not secured with the provided retaining element, the pins can release during crane operation!

The crane can topple over.

- ▶ Make sure that all pins are inserted and secured.

**WARNING**

Hands in the danger zone when pinning!  
Death, severe bodily injuries, property damage.

When pinning with the pin pulling device, the pin can release jerkily and hands can be caught.

When pinning crane components, there is a risk of crushing in the area of the pin position.

- ▶ Remove hands from the danger zone.

## 6.6 Work on the electrical connections



### WARNING

Dummy plugs are not assembled!

If unused electrical connections are not closed off with dummy plugs, then malfunctions or functional limitations can occur on the crane.

- ▶ Make sure that all unutilized electrical connections that have a dummy plug are closed off with dummy plugs.
- ▶ Observe the wiring diagram.

### NOTICE

Unprotected electrical connections!

Dirt can enter the plug and socket.

The plug and socket can corrode.

The electrical connections will be damaged and malfunction or functional limitations can be triggered.

- ▶ Close the unused electrical connections off with protective caps or caps.
- ▶ Assemble the protective caps or caps completely.
- ▶ Observe the wiring diagram.

## 6.7 Work on the hydraulic connections



### WARNING

Pressure in the hydraulic lines!

Death, severe bodily injuries, property damage.

If hydraulic lines are pressurized, then hydraulic oil can emerge with high pressure.

- ▶ Release the pressure in the hydraulic system before connecting or releasing: Interrupt the pressure supply, for example turn the engine off and wait until the hydraulic system pressure is released.



### WARNING

Quick couplings not properly connected!

Death, severe bodily injuries, property damage.

If the hydraulic system (especially the return lines) is not completely connected, the components may not function properly.

- ▶ Make sure that the quick coupling is fully coupled before starting crane operation.
- ▶ Make sure that the fastener of the quick coupling is fully connected before starting crane operation.

Prerequisites for safe hydraulic connection:

- The coupling parts (sleeve and connector) are joined together.
- The knurled nut is tightened until it reaches a tangible, fixed stop.

## 6.8 Movement of crane components



### WARNING

Oscillating or suspended load!

Death, severe bodily injuries, property damage.

When lifting / lowering and positioning crane components, there is a danger of impacts and crushing.

In the case of oscillating or suspended crane components, there is a danger of impacts and crushing.

- ▶ When lifting, lowering, swinging crane parts in and out, no persons may remain in the danger zone.
- ▶ Make sure that assembly personnel is not located in the area of the lifted load and cannot be caught by crane components.
- ▶ Make sure that there are no obstacles within the danger zone.

**WARNING**

Load not guided during movement!

Death, severe bodily injuries, property damage.

Danger of impact and crushing.

When assembling and disassembling crane components with the auxiliary crane, they can start to swing back and forth.

- ▶ Make sure that personnel cannot be caught by components.
- ▶ To guide and position crane structures, always use an aid. A guide rope, for example.
- ▶ When working in a danger zone: Use aids to protect limbs. A guide rope, for example.
- ▶ Make sure that the guide rope is long enough such that assembly personnel are outside the danger zone.

**DANGER**

Falling crane components!

If the respective crane component is disconnected from the auxiliary crane before it is pinned, then the crane component can fall down and kill personnel.

- ▶ Do not disconnect the auxiliary crane until each crane component is pinned and secured!

## 6.9 Fastening

**Note**

- ▶ The dimensions and weights of the crane components can be found in chapter 1.03.

**WARNING**

Use of incorrect fastening points!

Death, severe bodily injuries, property damage.

- ▶ Use the fastening points indicated on the crane components.
- ▶ Pay attention to the labels on the fastening points on the lattice sections and crane components.

**WARNING**

Incorrect length of the fastening equipment!

Death, severe bodily injuries, property damage.

- ▶ Use fastening equipment with a suitable length.

**WARNING**

Use of fastening equipment with unsuitable load capacity!

Death, severe bodily injuries, property damage.

- ▶ Use fastening equipment with a sufficient load carrying capacity.

## 6.10 Specific warning display for ballast trailer assembly / disassembly

**WARNING**

Assembly by unauthorized personnel

Death, severe bodily injuries, property damage.

Due to improperly carried out assembly or improper assembly conditions, the ballast trailer can tip over.

- ▶ The assembly of the ballast trailer may only be carried out by authorized personnel.



**WARNING**

Retracted support cylinder while the ballast trailer is unpinned from the turntable.

Death, severe bodily injuries, property damage.

Ballast trailer tipping danger.

The ballast trailer does not have a brake system and can start to roll in an uncontrolled manner.

When the ballast trailer is unpinned from the turntable:

- ▶ The ballast trailer must be supported with support cylinders.

**Note**

- ▶ Observe the safety instructions, see chapter 2.15.

## 7 Prerequisites for assembly

Make sure that the following prerequisites are met:

- The incline of the base / travel route of the ballast trailer is  $0^\circ \pm 1.5^\circ$ .
- The incline of the base / travel route of the crawler travel gear is  $0^\circ \pm 0.3^\circ$ .
- The base / travel route of the ballast trailer and crawler travel gear is sufficiently level and capable of supporting the load.
- The LICCON overload protection is set in accordance with the future set up configuration of the completely erected, operational crane

## 8 Operating elements on the control panels

**Note**

- ▶ The designation "R" or "L" on the wheel sets refers to the travel direction of the crane.
- ▶ "R" - Right wheel set.
- ▶ "L" - Left wheel set.

## 8.1 Control panel -A1210

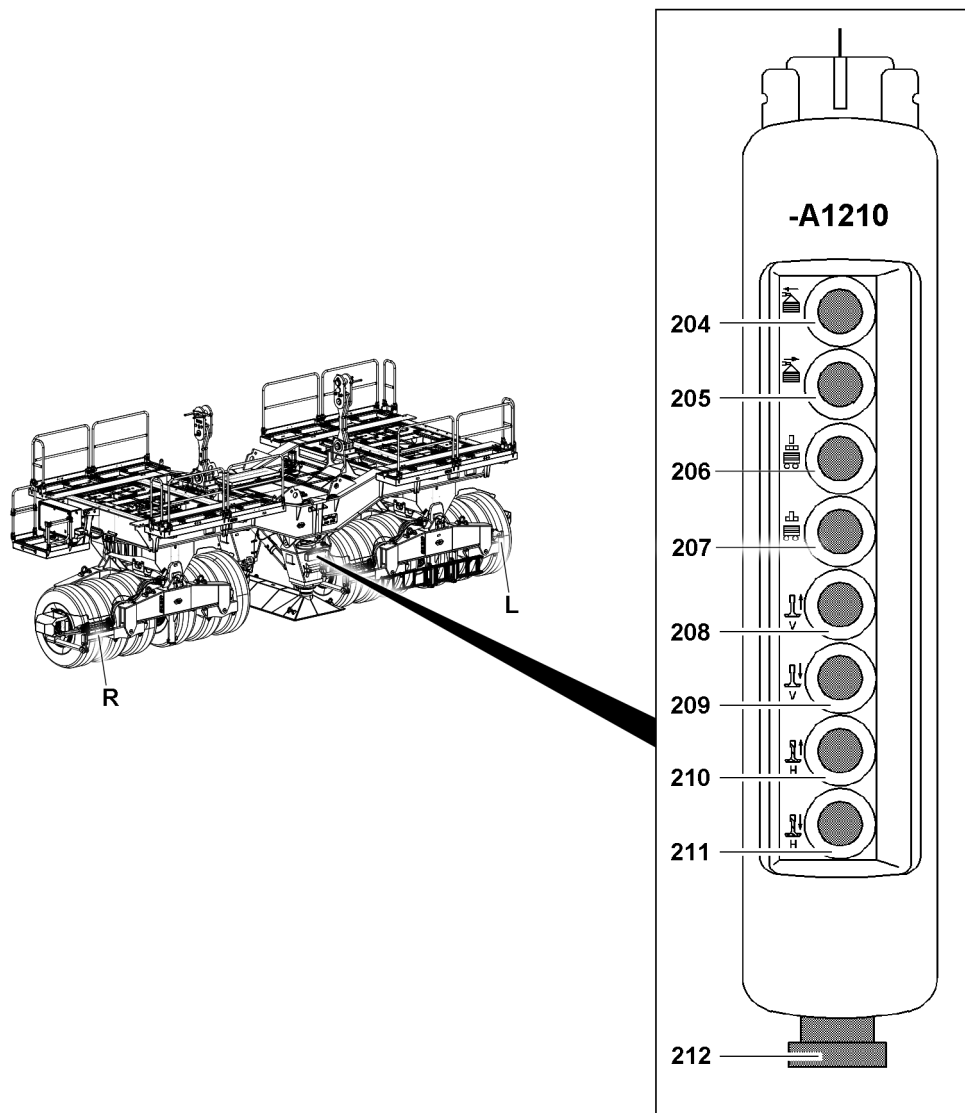


Fig.158596: Control panel -A1210

Control panel - A1210		
204	Button	• Ballast trailer, retract the guide cylinder
205	Button	• Ballast trailer, extend the guide cylinder
206	Button	• Unpin the ballast trailer on the turntable
207	Button	• Pin the ballast trailer on the turntable
208	Button	• Retract the front support cylinder
209	Button	• Extend the front support cylinder
210	Button	• Retract the rear support cylinder
211	Button	• Extend the rear support cylinder
212	Switch	• <b>EMERGENCY OFF</b>

## 8.2 Control panel -A1220

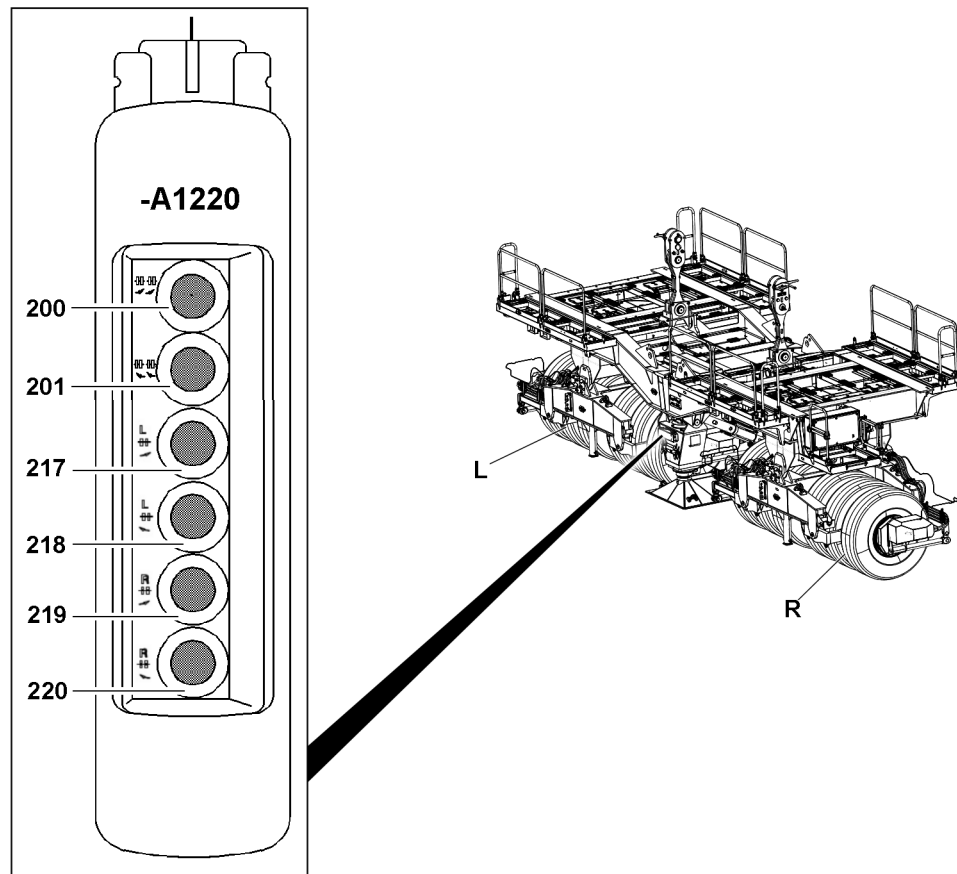


Fig.158597: Control panel -A1220

Control panel - A1220		
<b>200</b>	Button	• Corrective steering, turn wheel sets to the left
<b>201</b>	Button	• Corrective steering, turn wheel sets to the right
<b>217</b>	Button	• Turn the wheel set on the left side "L" to the right
<b>218</b>	Button	• Turn the wheel set on the left side "L" to the left • Manual operation for assembly or emergency operation
<b>219</b>	Button	• Turn the wheel set on the right side "R" to the right
<b>220</b>	Button	• Turn the wheel set on the right side "R" to the left • Manual operation for assembly or emergency operation

## 8.3 Control panel -A1230

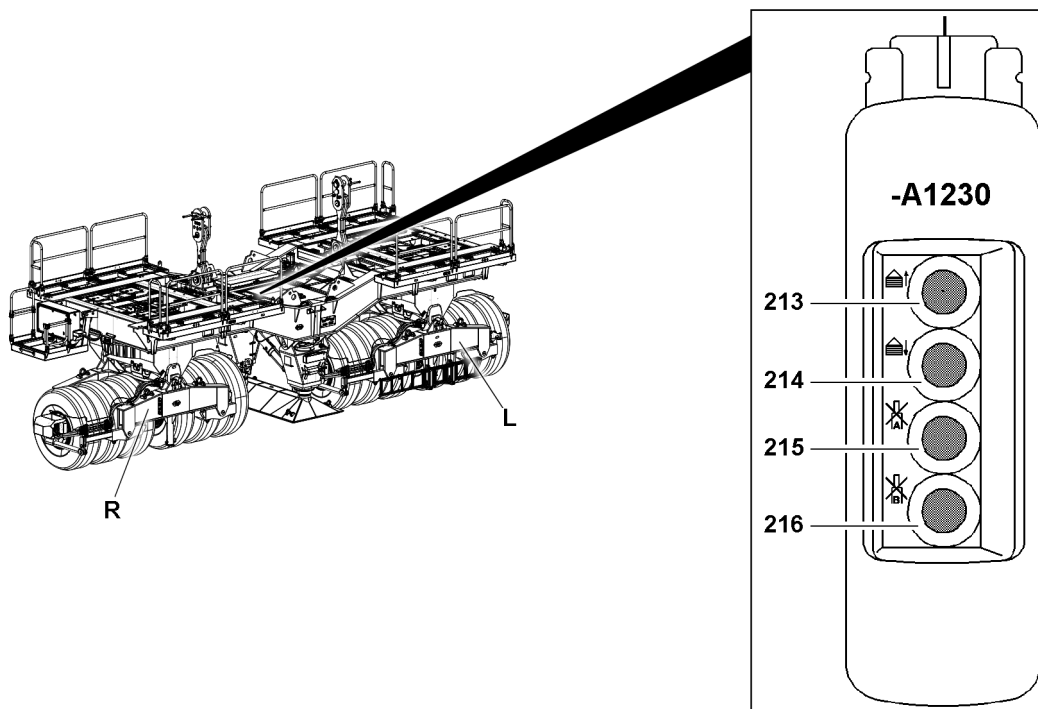


Fig.158598: Control panel -A1230

Control panel - A1230		
213	Button	• Retract both pull cylinders, lift the ballast trailer
214	Button	• Extend both pull cylinders, lower the ballast trailer
215	Button	• Stop pull cylinder A
		<b>Note:</b> The button 213 or button 214 must be pressed.
216	Button	• Stop pull cylinder B
		<b>Note:</b> The button 213 or button 214 must be pressed.

## 9 Assembling / disassembling the ballast trailer with the BTT-E



### Note

- During the assembly / disassembly of the ballast trailer, various functions can be controlled using the BTT-E (radio remote control). See the radio remote control operating instructions.

## 10 Assembling the ballast trailer

Make sure that the following prerequisites are met:

- The incline of the base / travel route of the ballast trailer is  $0^\circ \pm 1.5^\circ$ .
- The base / travel route of the ballast trailer is sufficiently level and capable of supporting the load.

## 10.1 Pre-assembling the ballast trailer

### 10.1.1 Assembling the first wheel set

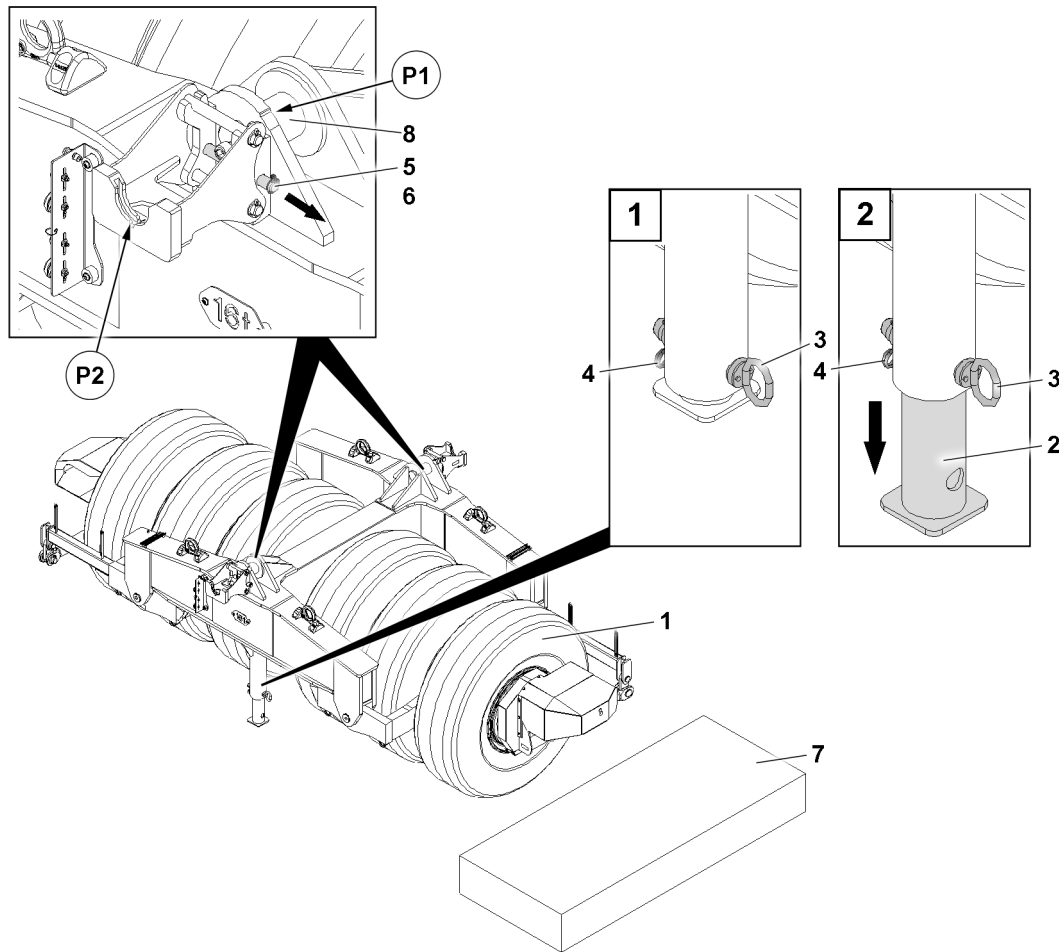


Fig.162994: Assembling the first wheel set — assembling the auxiliary supports in the operating position

- |   |                   |   |                   |
|---|-------------------|---|-------------------|
| 1 | Wheel set         | 5 | Pin               |
| 2 | Auxiliary support | 6 | Retaining element |
| 3 | Pin               | 7 | Substructure      |
| 4 | Retaining element | 8 | Pin               |

Substructure 7	
Height	330 mm
Ground pressure	30 t

Substructure dimension and ground pressure



**Note**

- ▶ The frame and wheel set **1** are pinned with each other in two pin points **P1**.
  - ▶ The pinning procedure is described based on the example of one pin point **P1**.
- 
- ▶ Fasten the first wheel set **1** to the auxiliary crane, see section “Fastening points”.

LWE/LR 1800-1-0-000/27200-07-02/en

**WARNING**

Unsecured wheel set!

Death, severe bodily injury, property damage.

If the wheel set **1** is not held by the auxiliary crane until both extendible auxiliary supports **2** are assembled, the wheel set **1** tips over.

▶ Keep the fastening equipment tensioned until both extendible auxiliary supports **2** are assembled.

▶ Place the wheel set **1** on level ground and keep the fastening equipment tensioned.

Extendible auxiliary supports **2** must be fit on both sides of the wheel set **1** in the operating position. This procedure is described for one side as an example.

▶ Remove the retaining element **4**.

▶ Unpin the pin **3**.

▶ Pull the extendible auxiliary support **2** out into the operating position.

▶ Insert the pin **3**.

▶ Secure the pin **3** with the retaining element **4**.

▶ Assemble the extendible auxiliary support **2** on the other side in the same way as described before in the operating position.

**Result:**

– The first wheel set **1** is secured to prevent it from tipping over.

▶ Remove the auxiliary crane.

▶ Remove the retaining element **6**.

▶ Unpin the pin **5**.

▶ Connect the pin pulling device in point **P2**.

▶ Unpin the pin **8**.

Position the substructure **7** such that the frame can be mounted on the wheel set **1** and the support of the frame stands on the substructure **7**. The substructure must withstand a weight of 30 t.

▶ Build up the substructure **7** approx. 330 mm.

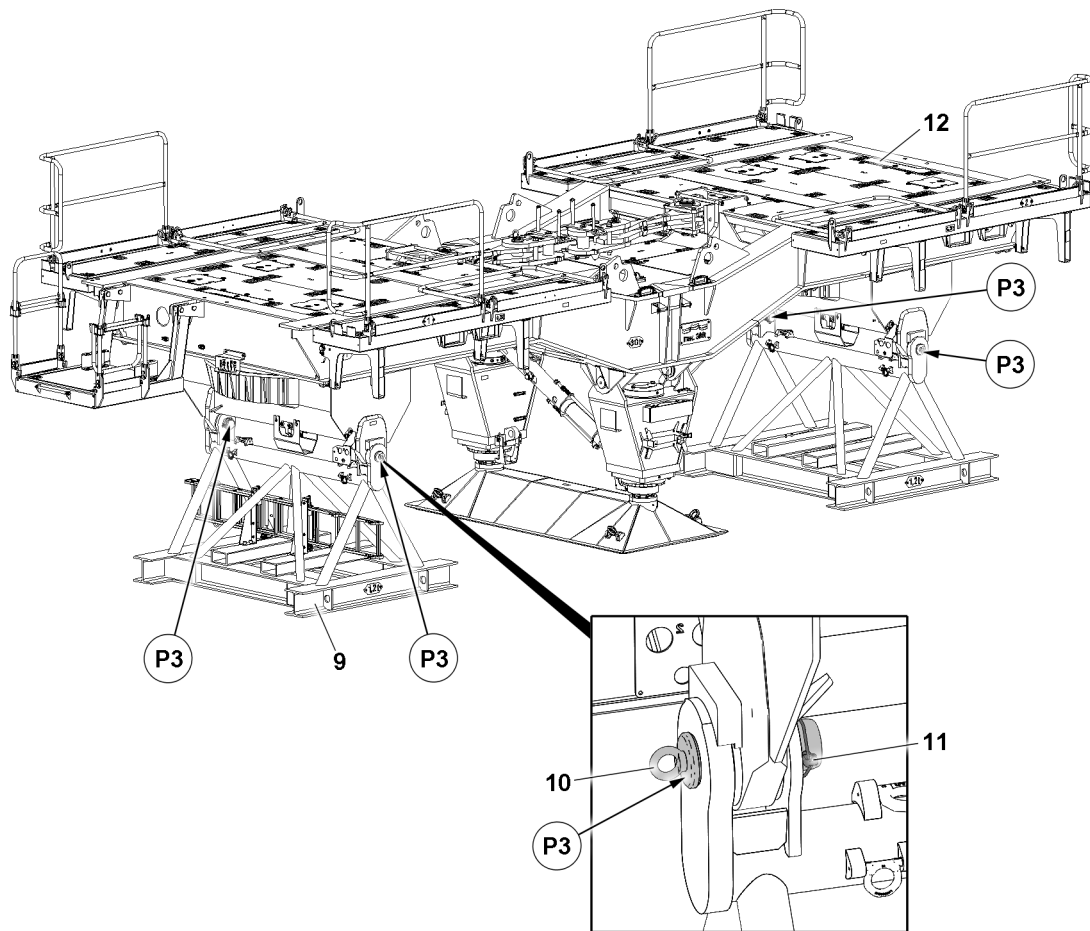


Fig.162995: Assembling the first wheel set – removing the transport device

- |    |                  |    |                   |
|----|------------------|----|-------------------|
| 9  | Transport device | 11 | Retaining element |
| 10 | Pin              | 12 | Frame             |

- ▶ Fasten the frame **12** centered to the auxiliary crane, see section “Fastening points”.
- ▶ Tension the fastening equipment until the frame is held by the auxiliary crane.

Both transport devices **9** are disassembled. This procedure is described based on the example of one side.

The pins **10** are located on both sides of the transport device in positions **P3**.

- ▶ Remove the retaining elements **11** in positions **P3**.
- ▶ Unpin the pins **10** in the positions **P3**.

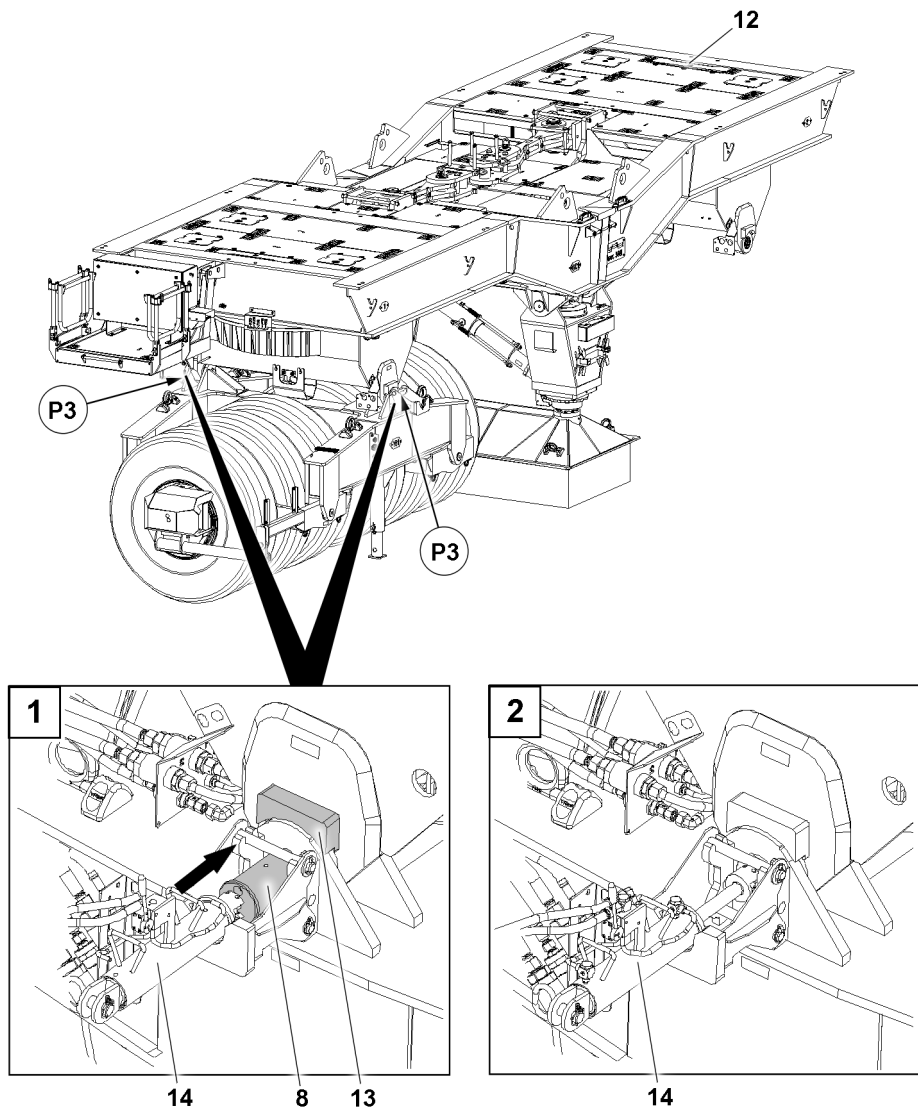


Fig.162996: Assembling the first wheel set – pinning the wheel set

- |                 |                              |
|-----------------|------------------------------|
| <b>8</b> Pin    | <b>13</b> Centering device   |
| <b>12</b> Frame | <b>14</b> Pin pulling device |

- ▶ Position the frame **12** such that the frame **12** is aligned by the centering device **13**.

The pins **8** must be inserted on both sides in positions **P3**. This pinning procedure is described based on the example of one side.

- ▶ Insert the pin **8** with the pin pulling device **14**.
- ▶ Remove the pin pulling device **14**.



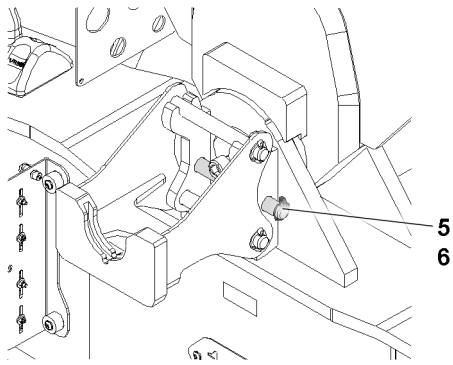


Fig.162997: Assembling the first wheel set – securing the pin

- 5** Pin
- 6** Retaining element

- ▶ Insert the pin **5**.
- ▶ Secure the pin **5** with the retaining element **6**.
- ▶ Repeat the pinning procedure on the other side in position **P3** in the same way as described above.

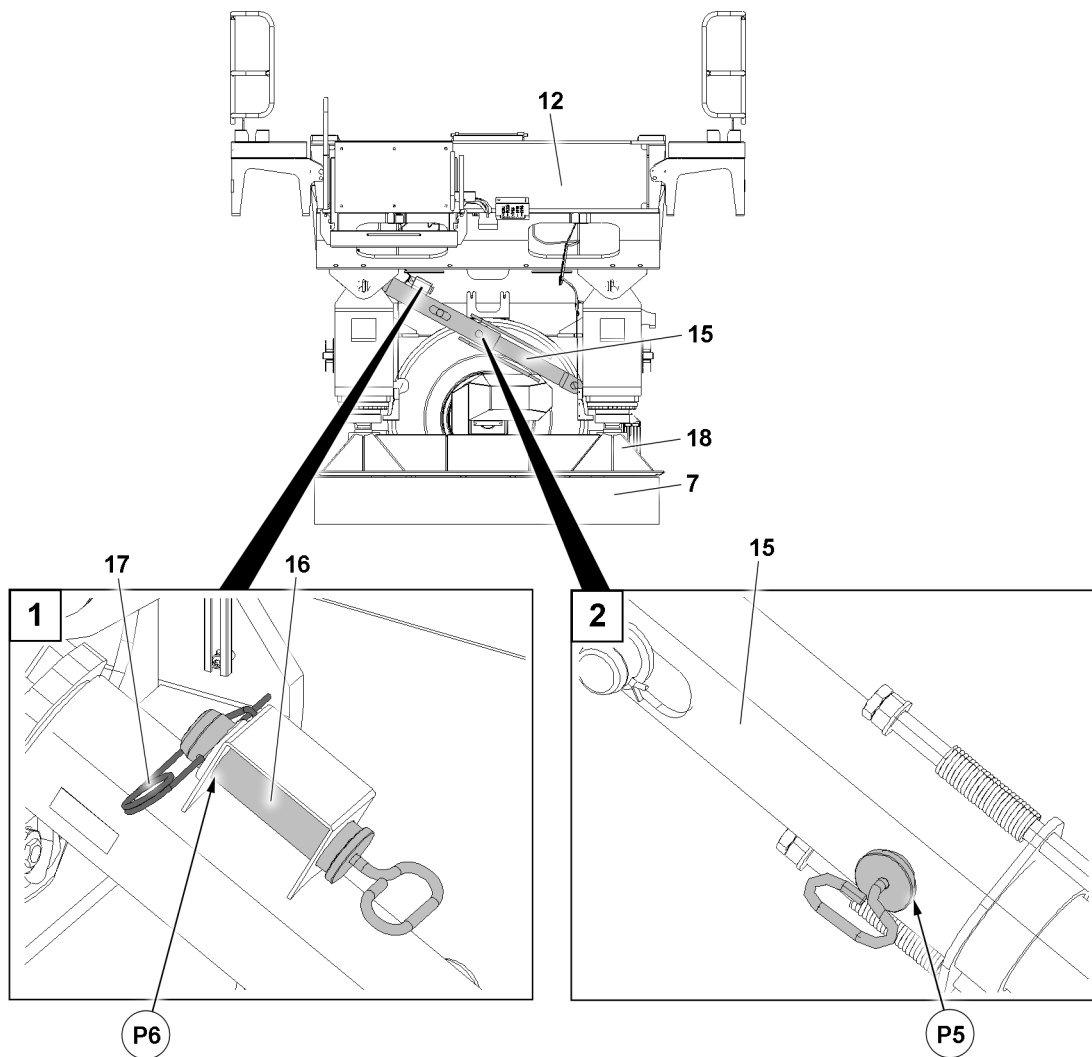


Fig.162998: Assembling the first wheel set – securing the support in the operating position

- 7** Substructure
- 12** Frame
- 15** Strut
- 16** Pin
- 17** Retaining element
- 18** Support

LWE/LR 1800-1-0-000/27200-07-02/en

**WARNING**

Unsecured strut!

Death, severe bodily injuries, property damage.

The frame **12** will topple over.

- ▶ Insert the pin **16** in the strut **15** (position **P5**) and secure with the retaining element **17** before the frame **12** is set down.

- ▶ Release the pin **16**.
- ▶ Unpin the pin **16** from the park position **P6**.
- ▶ Pin the strut **15**: Insert the pin **16** in point **P5**.
- ▶ Secure the pin **16** with the retaining element **17**.
- ▶ Set the frame **12** with the auxiliary crane on the substructure **7**.

**Result:**

- The support **18** is secured.
- The support **18** is on the substructure.
- ▶ Remove the auxiliary crane.

### 10.1.2 Assembling the second wheel set

Make sure that the following prerequisites are met:

- The first wheel set is pinned and secured with frame.
- The support is secured by pinned and secured struts.

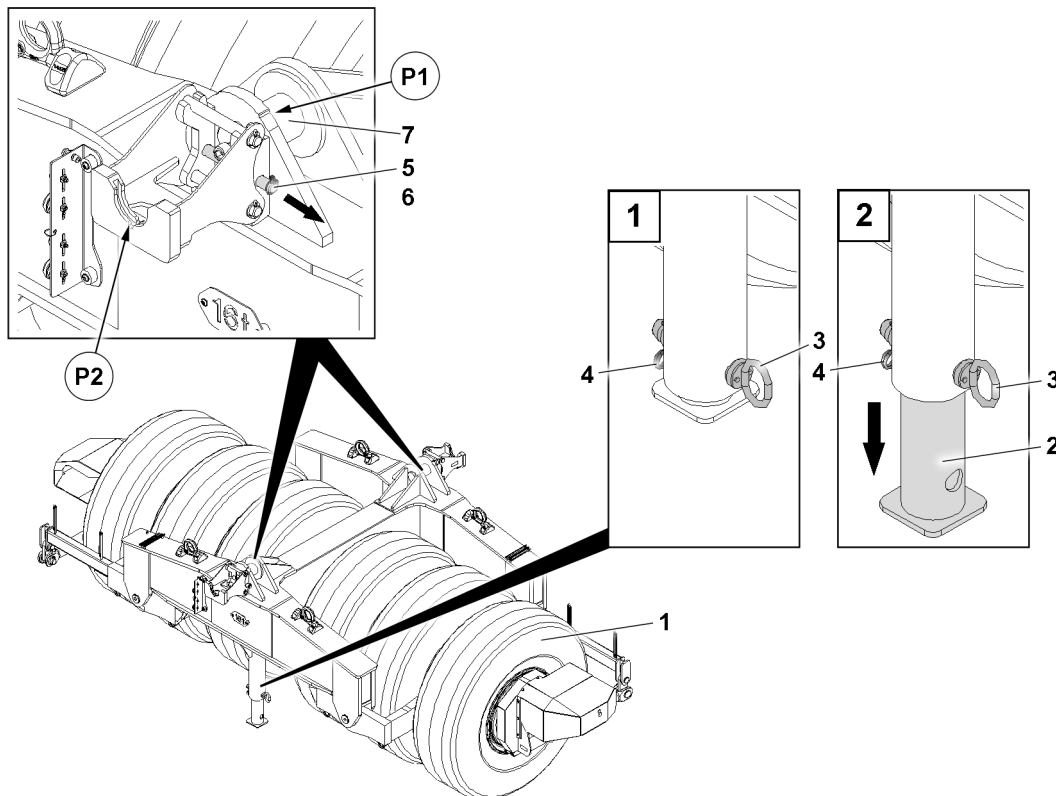


Fig.162999: Assembling the second wheel set — assembling the auxiliary supports in the operating position

1	Wheel set	5	Pin
2	Auxiliary support	6	Retaining element
3	Pin	7	Pin
4	Retaining element		

- ▶ Fasten the second wheel set **1** to the auxiliary crane, see section “Fastening points”.

**WARNING**

Unsecured wheel set!

Death, severe bodily injury, property damage.

If the wheel set **1** is not held by the auxiliary crane until both extendible auxiliary supports **2** are assembled, the wheel set **1** tips over.

▶ Keep the fastening equipment tensioned until both extendible auxiliary supports **2** are assembled.

▶ Place the wheel set **1** on level ground and keep the fastening equipment tensioned.

The extendible auxiliary supports **2** must be assembled on both sides of the wheel set **1** in the operating position. The procedure is described based on one side as an example.

▶ Remove the retaining element **4**.

▶ Unpin the pin **3**.

▶ Pull the extendible auxiliary support **2** out into the operating position.

▶ Insert the pin **3**.

▶ Secure the pin **3** with the retaining element **4**.

▶ Assemble the extendible auxiliary support **2** on the other side in the same way as described before in the operating position.

**Result:**

– The wheel set **1** is secured to prevent it from tipping over.

▶ Remove the auxiliary crane.

▶ Remove the retaining element **6**.

▶ Unpin the pin **5**.

▶ Connect the pin pulling device in point **P2**.

▶ Unpin the pin **7**.

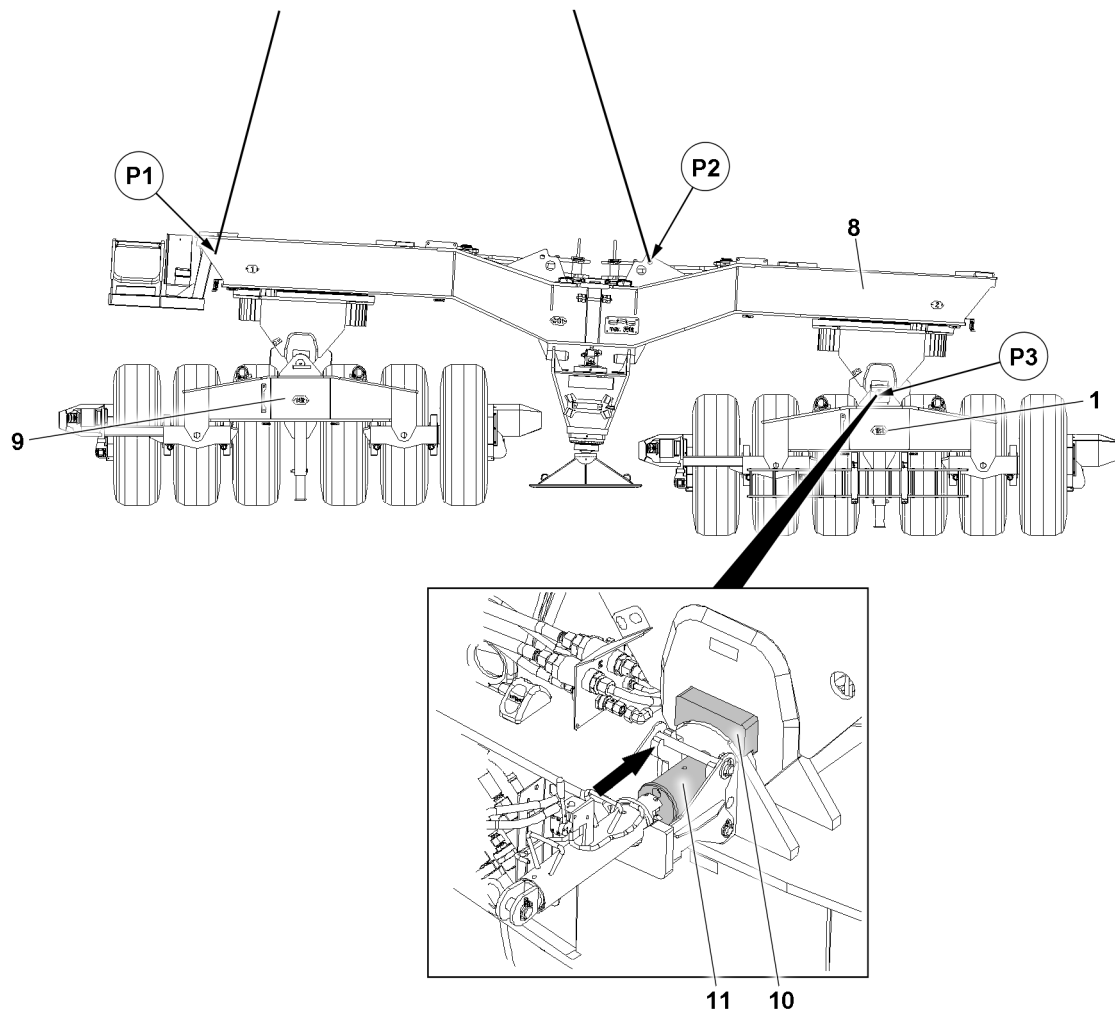


Fig.163000: Assembling the second wheel set – pinning the wheel set

- |   |           |    |                  |
|---|-----------|----|------------------|
| 1 | Wheel set | 10 | Centering device |
| 8 | Frame     | 11 | Pin              |
| 9 | Wheel set |    |                  |

When the wheel set 1 is set up and secured to prevent it from tipping over:

- ▶ Fasten the frame 8 with the first wheel set 9 to the auxiliary crane via the fastening points P1 and fastening points P2, see the section “Fastening points”.
- ▶ Position the frame 8 such that the frame 8 is aligned by the centering device 10.



#### Note

- ▶ The assembly of the second wheel set 1 on the frame 8 is identical to the assembly of the first wheel set 9.

The pins 11 must be inserted on both sides in positions P3.

This pinning procedure is described based on the example of one side.

- ▶ Pin and secure together the frame 8 and the second wheel set 1 in the same manner as described above on both sides in points P3.

### 10.1.3 Establishing the hydraulic connections

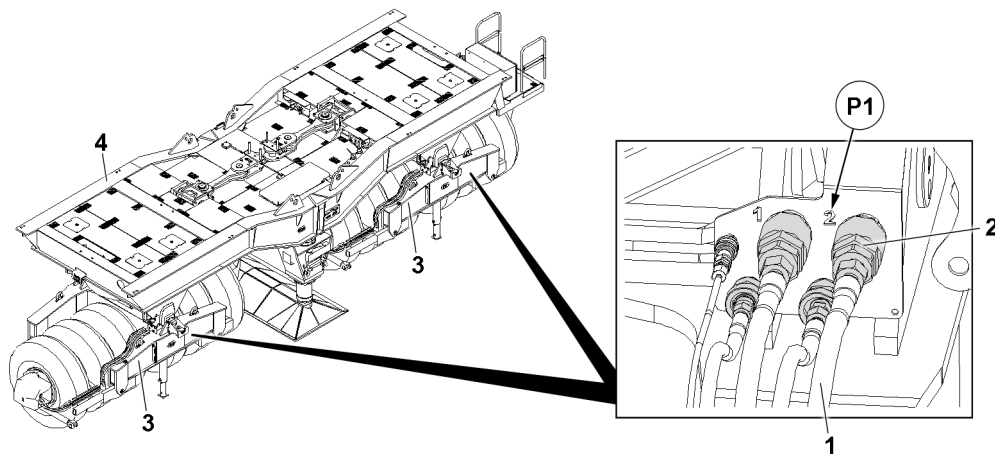


Fig.163116: Establishing the hydraulic connections

- |   |                      |   |                       |
|---|----------------------|---|-----------------------|
| 1 | Hydraulic line       | 3 | Wheel set             |
| 2 | Hydraulic connection | 4 | Ballast trailer frame |



#### Note

- ▶ The hydraulic lines **1** and assembly positions **P1** are marked with numbers.
- ▶ The markings on the hydraulic lines **1** and assembly positions **P1** must be identical.

The connection procedure is described based on one wheel set **3** as an example and applies in the same way for the second wheel set **3**.

Make sure that the following prerequisites are met:

- The pressure in the hydraulic system has been released.
- ▶ Establish the hydraulic connections **2** between the wheel set **3** and the ballast trailer frame **4**, see the hydraulic diagram.

### 10.1.4 Establishing the connection to the central lubrication system

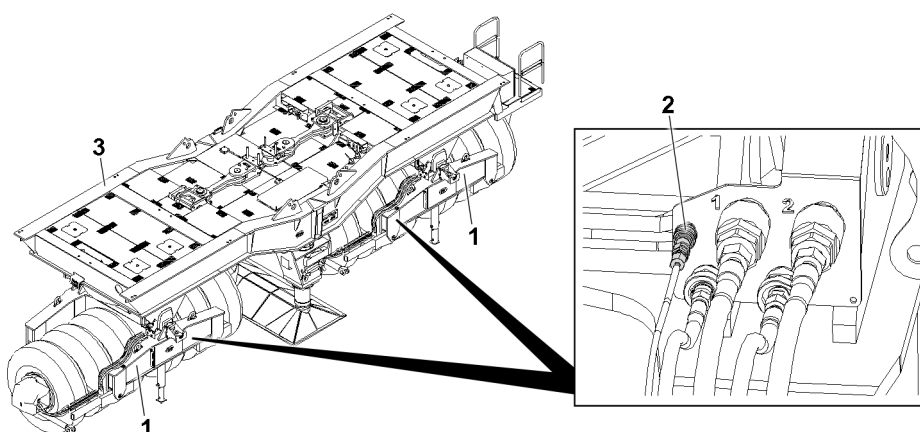


Fig.163117: Establishing the connection to the central lubrication system

- |   |                                       |   |                       |
|---|---------------------------------------|---|-----------------------|
| 1 | Wheel set                             | 3 | Ballast trailer frame |
| 2 | Central lubrication system connection |   |                       |

The connection procedure is described based on one wheel set **1** as an example and applies in the same way for the second wheel set **1**.

- ▶ Establish the connection **2** for the central lubrication system between the wheel set **1** and the ballast trailer frame **3**.

### 10.1.5 Supporting the ballast trailer

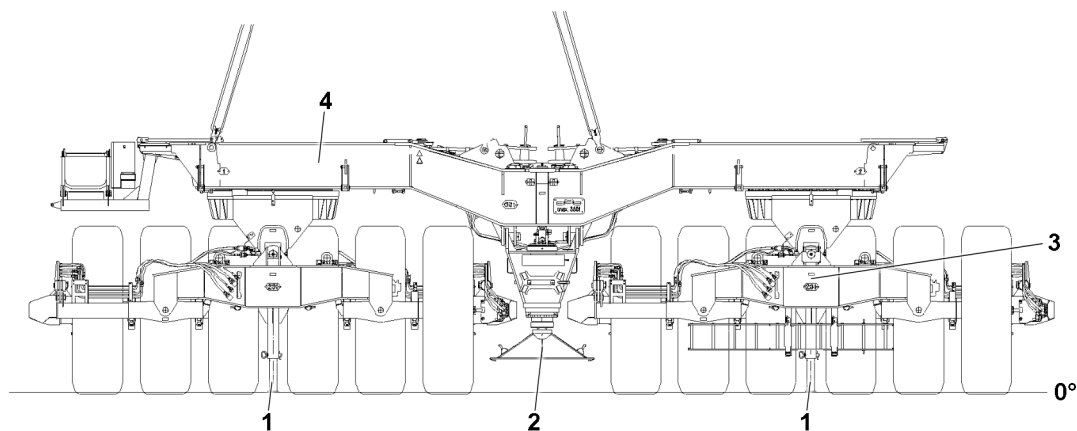


Fig.163001: Supporting the ballast trailer – Overview

- |          |                   |          |           |
|----------|-------------------|----------|-----------|
| <b>1</b> | Auxiliary support | <b>3</b> | Wheel set |
| <b>2</b> | Support           | <b>4</b> | Frame     |



#### WARNING

Overload of the auxiliary supports **1**!

The auxiliary supports **1** are not designed for the entire weight of the ballast trailer and can break. Death, severe bodily injury, property damage.

- ▶ Keep the fastening equipment tensioned until the support **2** is extended.

When the second wheel set **3** is pinned and secured with the frame **4**:

- ▶ Set the ballast trailer down such that the fastening equipment is tensioned.

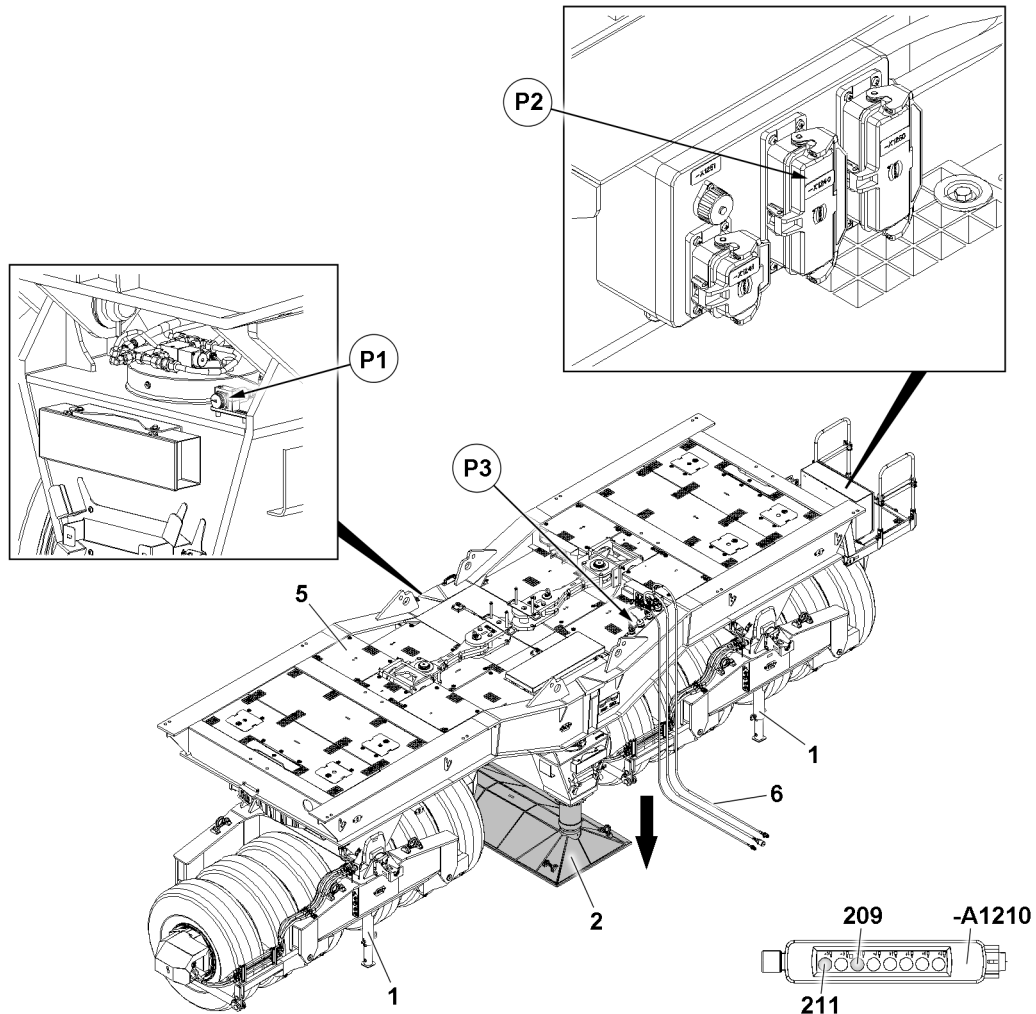


Fig.163002: Supporting the ballast trailer – Connecting the supply lines

- |   |                   |   |                 |
|---|-------------------|---|-----------------|
| 1 | Auxiliary support | 5 | Ballast trailer |
| 2 | Support           | 6 | Hydraulic line  |

- ▶ Connect the control panel **-A1210** in point **P1**, see the wiring diagram.
- ▶ Connect the voltage supply in point **P2** to the ballast trailer **5**, see the wiring diagram.

The ballast trailer **5** must be connected to an external hydraulic system, for example to the turntable or a suitable hydraulic aggregate.

- ▶ Make sure that the hydraulic system is depressurized.
- ▶ Connect the hydraulic lines **6** in point **P3** to the ballast trailer **5** and to the external hydraulic system, see the hydraulic diagram.

When the electrical and hydraulic connections have been established:

- ▶ Press the button **209** and button **211** on the control panel **-A1210**.

**Result:**

- The support **2** extends.
- ▶ Extend the support **2** until the tires are relieved.

**Result:**

- The ballast trailer **5** is secured to prevent it from tipping over.
- ▶ Retract and secure the extendible auxiliary supports **1**.
- ▶ Remove the fastening equipment.

### 10.1.6 Assembling the extension ladder on the ballast trailer

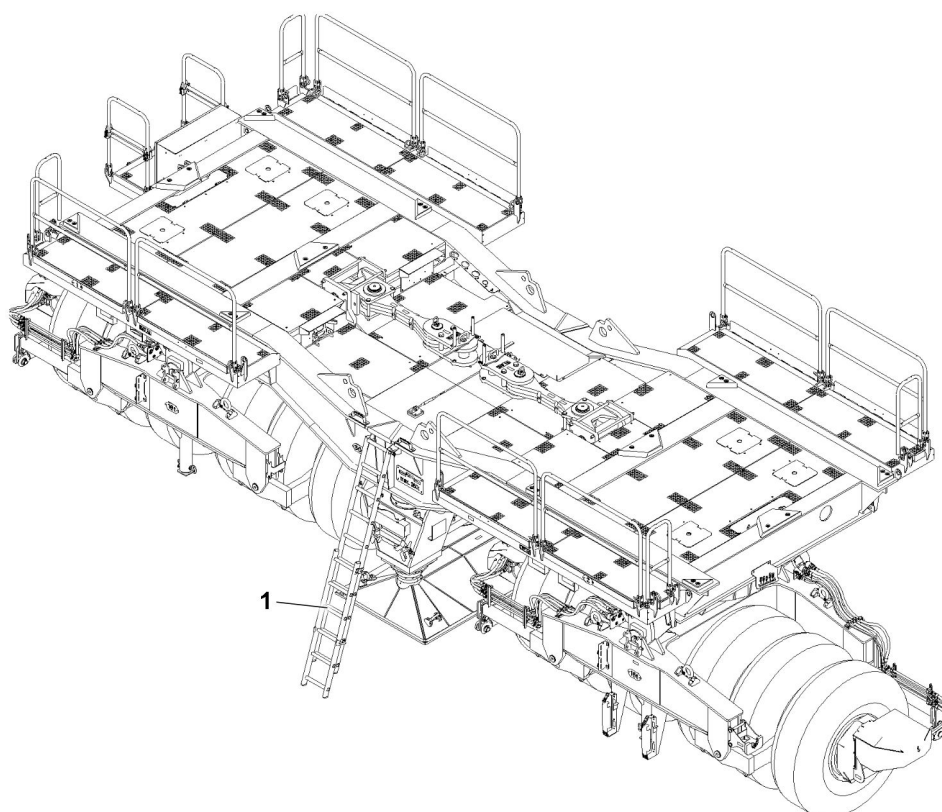


Fig.163003: Assembling the extension ladder on the ballast trailer

1 Extension ladder



#### Note

► Assembly of the extension ladder 1, see chapter 2.06.

### 10.1.7 Assembling the railing on ballast trailer and platforms



#### Note

► Railing assembly, see chapter 2.06.

### 10.1.8 Assembling the platforms

Make sure that the following prerequisites are met:

- The railings on the platforms are folded out and secured, see chapter 2.06.



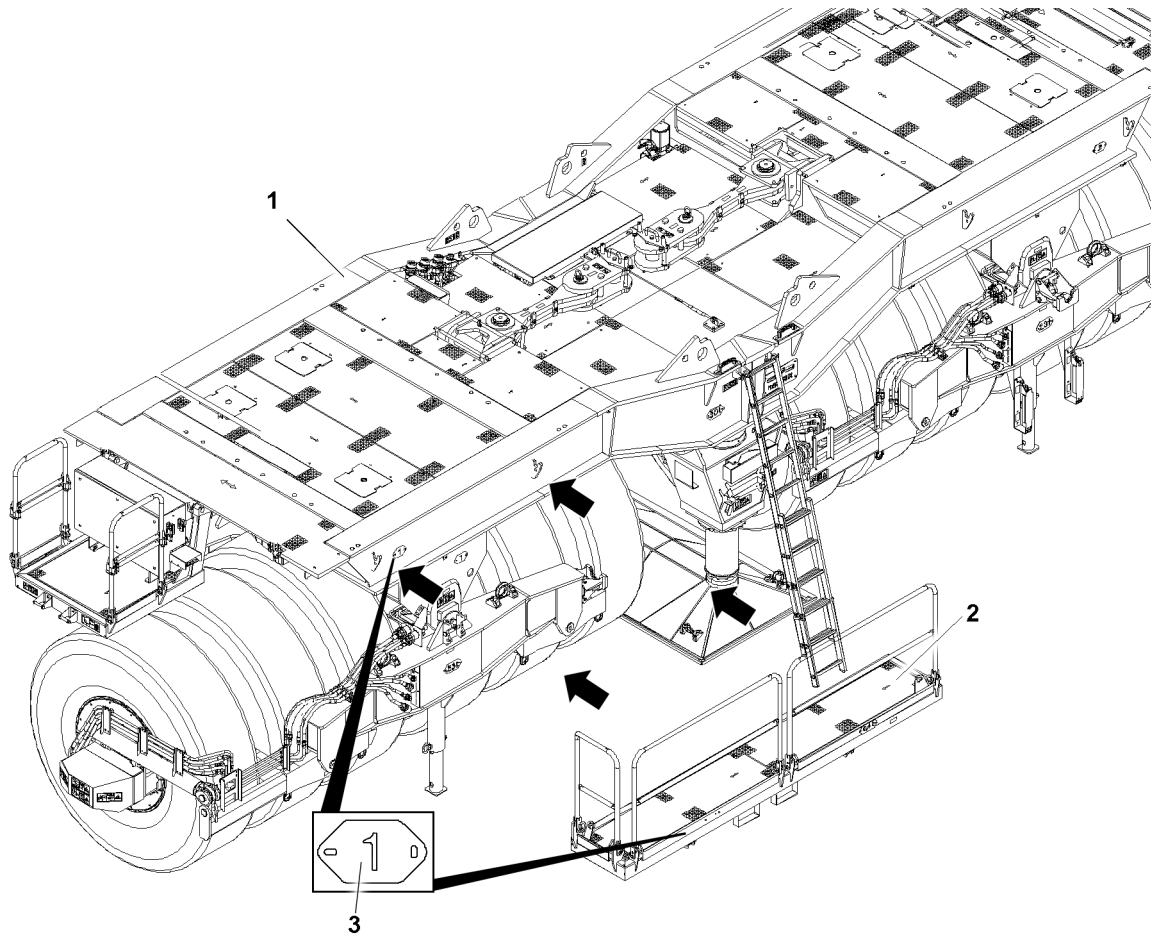


Fig.163004: Assembling the platforms – Marking

- |   |                 |   |      |
|---|-----------------|---|------|
| 1 | Ballast trailer | 3 | Sign |
| 2 | Platform        |   |      |



**Note**

- ▶ The ballast trailer 1 is equipped with four separate platforms 2.
- ▶ The positions on the ballast trailers 1 and platforms 2 are marked with signs 3.
- ▶ The markings on the ballast trailer 1 and the platform 2 must be identical.

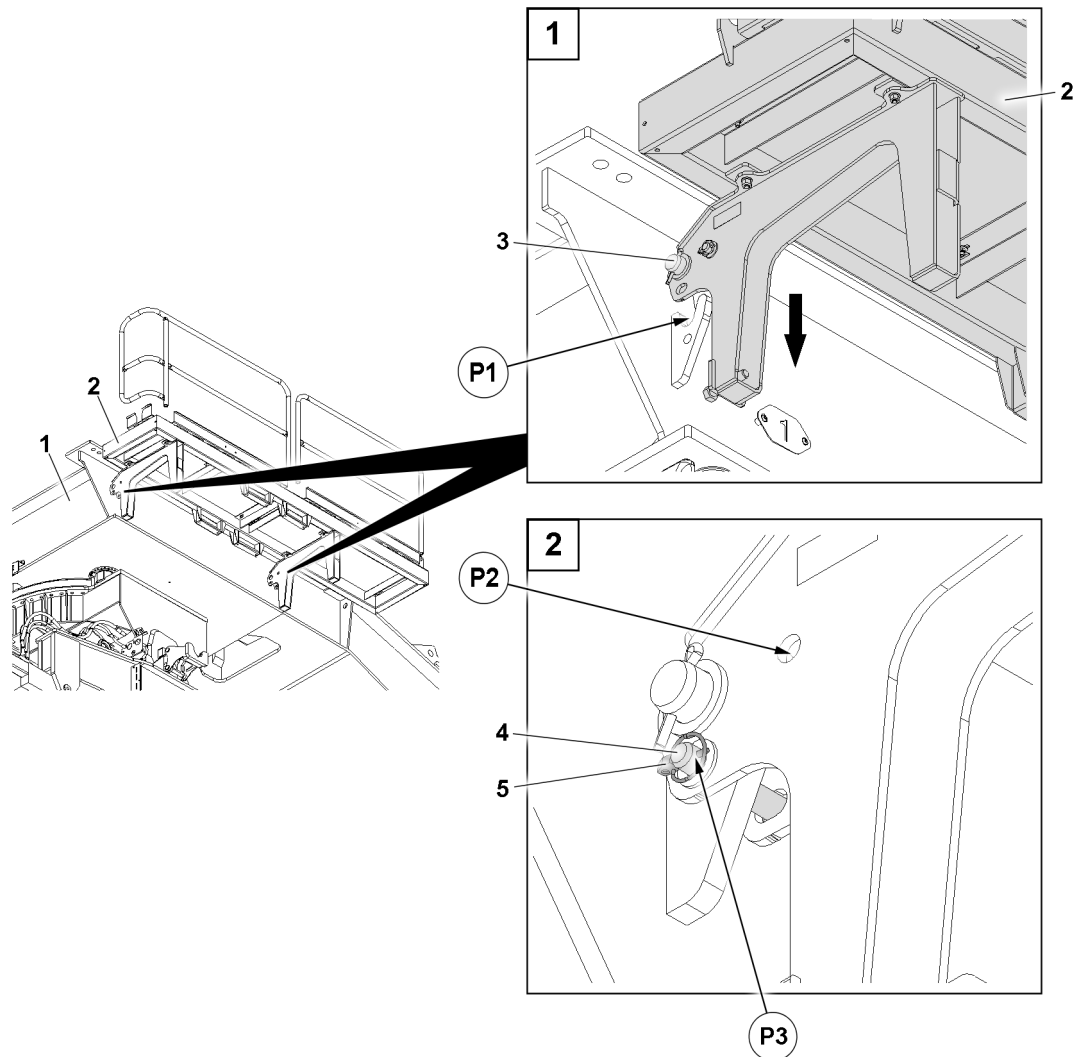


Fig.163005: Assembling the platforms – Connecting and pinning

- |   |                 |   |                   |
|---|-----------------|---|-------------------|
| 1 | Ballast trailer | 4 | Pin               |
| 2 | Platform        | 5 | Retaining element |
| 3 | Pin             |   |                   |



#### Note

- ▶ The assembly of the platforms 2 is described based on the example of one platform 2.

- ▶ Fasten the platform 2 to the auxiliary crane, see section “Fastening points”.
- ▶ Swing the platform 2 with the auxiliary crane to the points P1.
- ▶ Connect the platform 2 with pins 3 in points P1 to the ballast trailer 1.
- ▶ Release the pin 4 from the park position P2 and unpin.

The platform 2 is pinned in two points P3:

- ▶ Insert the pin 4 in point P3 and secure with the retaining element 5.
- ▶ Remove the auxiliary crane.

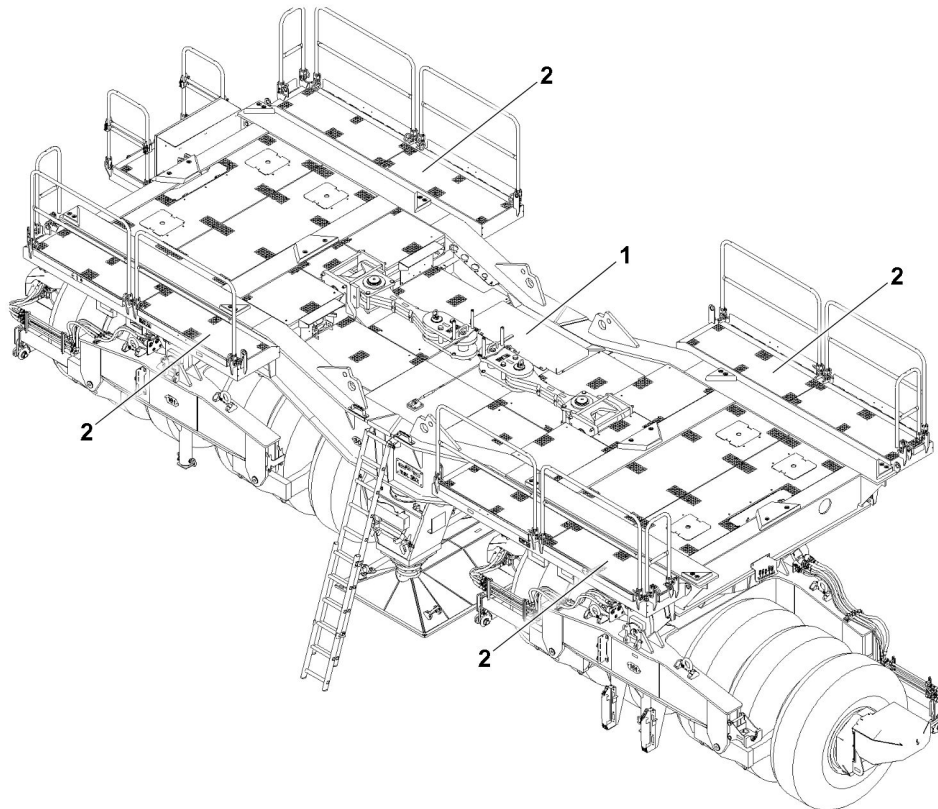


Fig.163006: Assembling the platforms

1 Ballast trailer

2 Platform

► Assemble all platforms 2 in the same way as described above on the ballast trailer 1.

### 10.1.9 Assembling the pull brackets in the assembly position

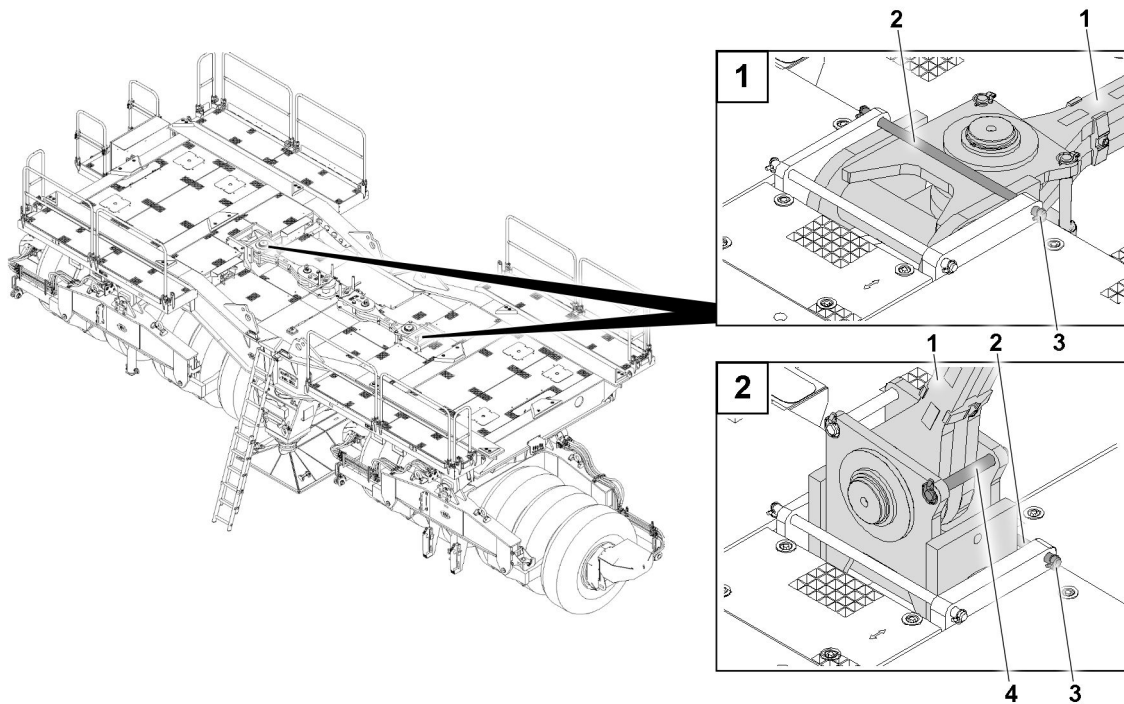


Fig.163007: Assembling the pull brackets in the assembly position

1	Pull bracket	3	Retaining element
2	Pin	4	Pin

- ▶ Release the pull bracket **1** from the transport position: Remove the retaining element **3** and unpin the pin **2**.
- ▶ Fasten the pull bracket **1** to the auxiliary crane.
- ▶ Set up the pull bracket **1** vertically with the auxiliary crane.
- ▶ Secure the pull bracket **1** in the operating position: Insert the pin **2** and secure with the retaining element **3**.



#### WARNING

Tipping of the pull bracket!

When releasing the pull bracket **1** from the auxiliary crane, the pull bracket **1** can tip over. Death, severe bodily injuries, property damage.

- ▶ Fasten the pull bracket **1** to the pin **4**.

When the pull bracket **1** leans on the pin **4**:

- ▶ Remove the auxiliary crane.
- ▶ Set up the second pull bracket **1** in the same way as described above.

### 10.1.10 Disassembling the extension ladder on the ballast trailer

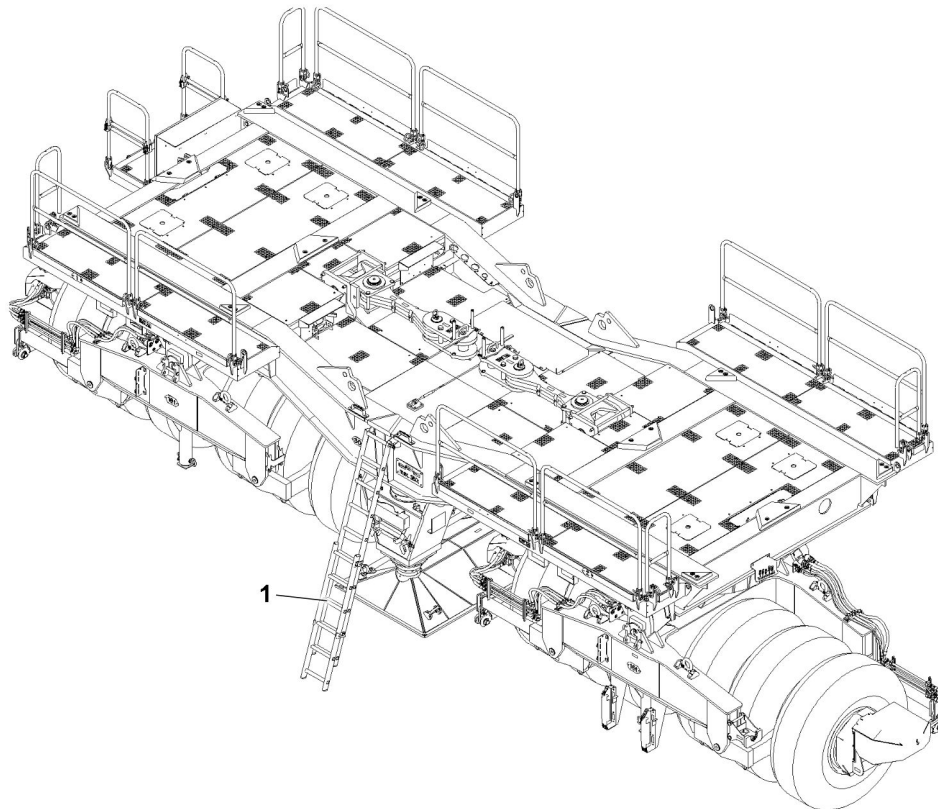


Fig.163003: Assembling the extension ladder on the ballast trailer

1 Extension ladder



**Note**

► Disassembly of the extension ladder 1, see chapter 2.06.

### 10.2 Pre-assembling the ballast trailer guide

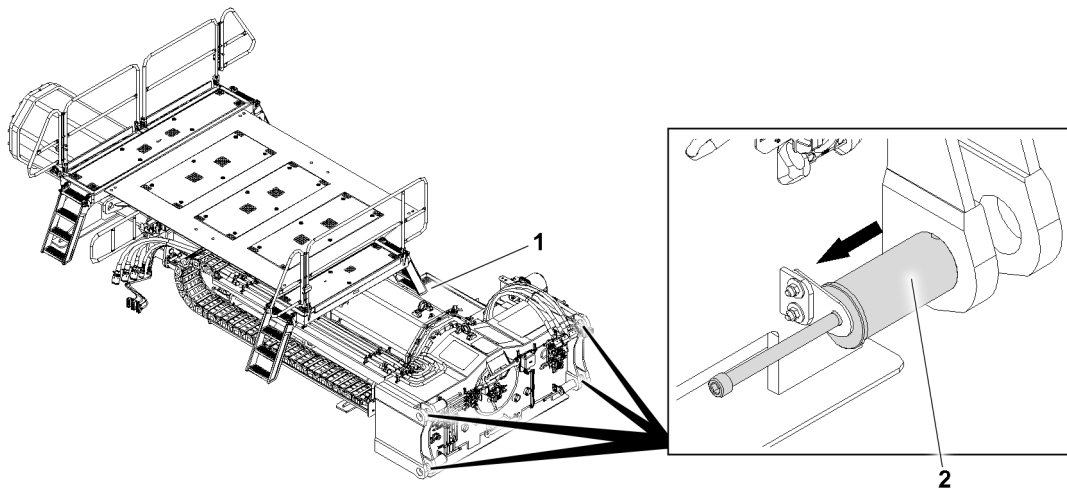


Fig.163008: Pre-assembling the ballast trailer guide – Prerequisites

1 Ballast trailer guide

2 Pin

LWE/LR 1800-1-0-000/27200-07-02/en

Make sure that the following prerequisites are met:

- The ballast trailer guide is taken down on the square timber.
- The ballast trailer guide **1** is fully retracted.
- Four pins **2** are unpinned.

### 10.2.1 Assembling the ladder and railing on the ballast trailer guide

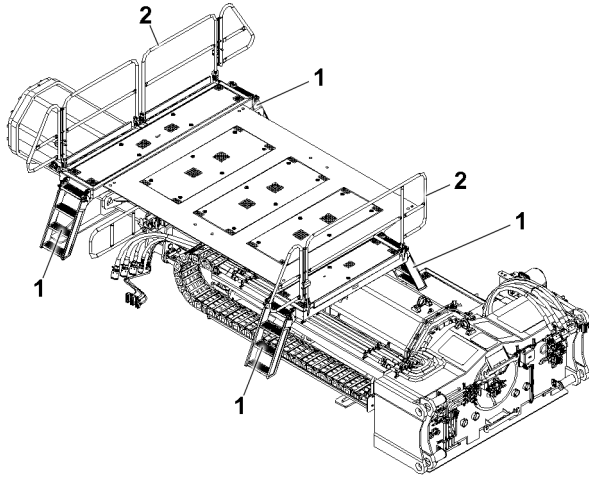


Fig.163010: Assembling the ladder and railing on the ballast trailer guide

**1** Ladder

**2** Railing



#### Note

► For the assembly of the ladders **1** and the railings **2**, see chapter 2.06.

## 10.2.2 Assembling the coding coupling

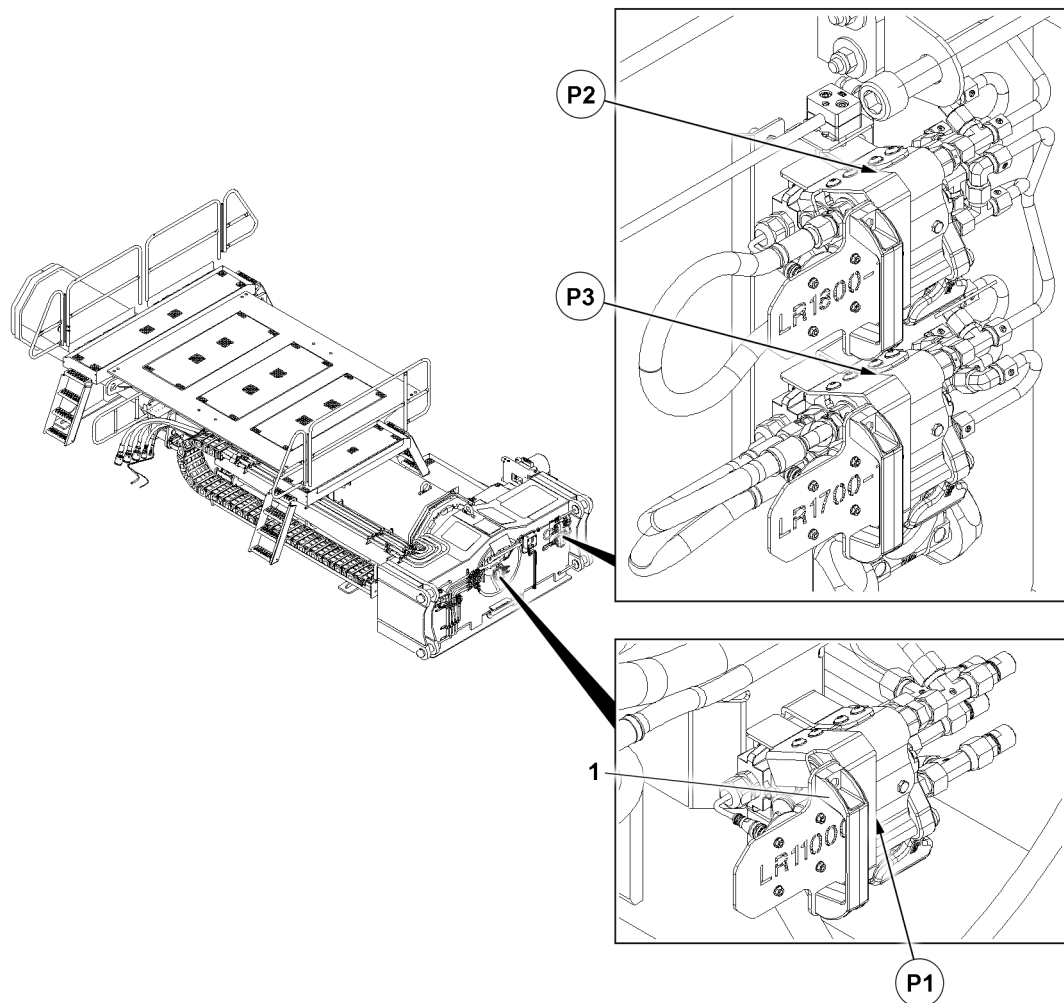


Fig.163043: Assembling the coding coupling

**P1** Operating position  
**P2** Park position

**P3** Park position  
**1** Coding coupling



### Note

- ▶ The coding couplings **1** are labelled and may only be used with the corresponding crane type.

### Checking the assembled coding coupling

- ▶ Check which coding coupling **1** is assembled in the operating position **P1**.

When the coding coupling **1** corresponds to the crane type:

- ▶ Keep the coding coupling **1** plugged in.

### Problem remedy

Does the coding coupling **1** not comply with the crane type?

- ▶ See section "Replacing the coding coupling **1**, Replace the coding coupling".

### Optional: Replacing the coding coupling

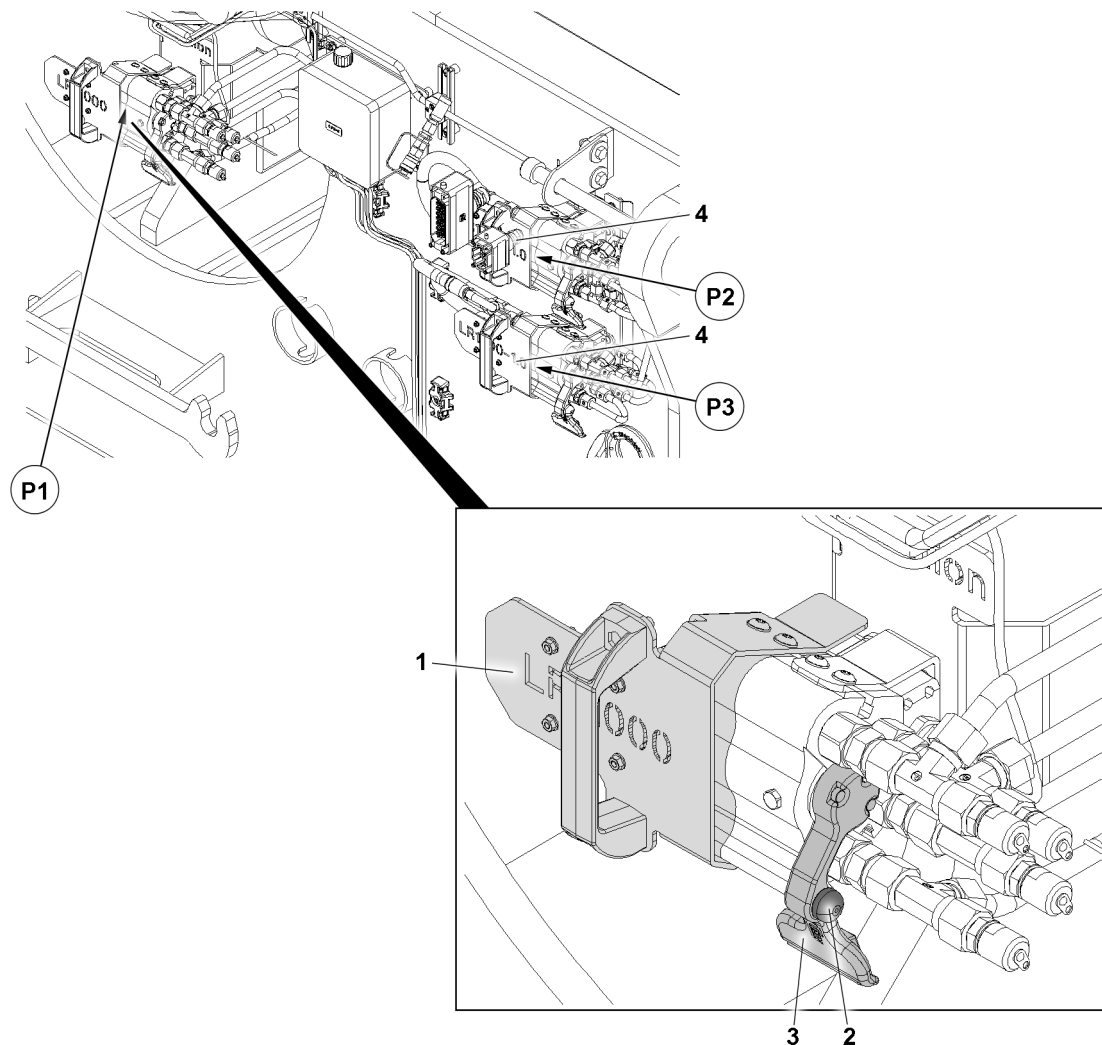


Fig.163044: Replacing the coding coupling

- |   |                   |   |                 |
|---|-------------------|---|-----------------|
| 1 | Coding coupling   | 3 | Lever           |
| 2 | Retaining element | 4 | Coding coupling |

- ▶ Pull the retaining element **2** on the coding coupling **1** to be removed.
- ▶ Open the lever **3**.
- ▶ Unplug the coding coupling **1** from the operating position **P1**.

Based on the coding coupling **4** marking, select (park position **P2** or park position: **P3**), that complies with the crane type.

- ▶ Remove the selected coding coupling **4** in the same way as described above from the park position **P2** or park position **P3**.
- ▶ Insert the coding coupling **4** to be used in the operating position **P1**.
- ▶ Insert the unrequired coding coupling **1** in the park position **P2** or park position **P3**.



### 10.2.3 Optional: Assembling the intermediate sections on the guide

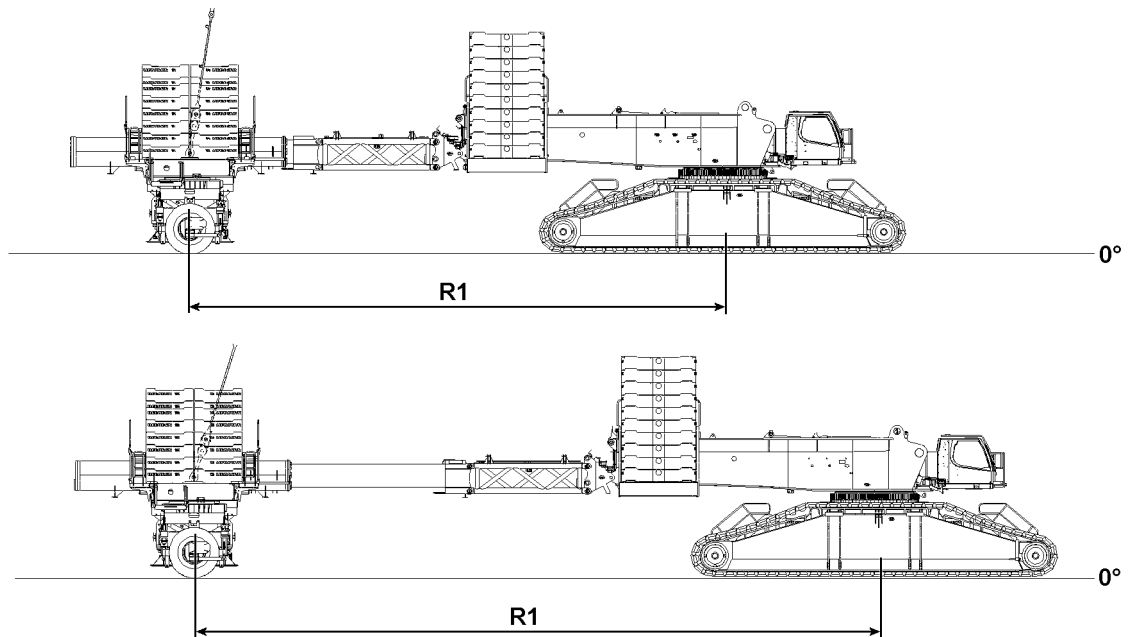


Fig.163009: Assembling the intermediate sections on the guide – Overview

Make sure that the following prerequisites are met:

- Ballast trailer radius R1 18 m - 23 m is required.

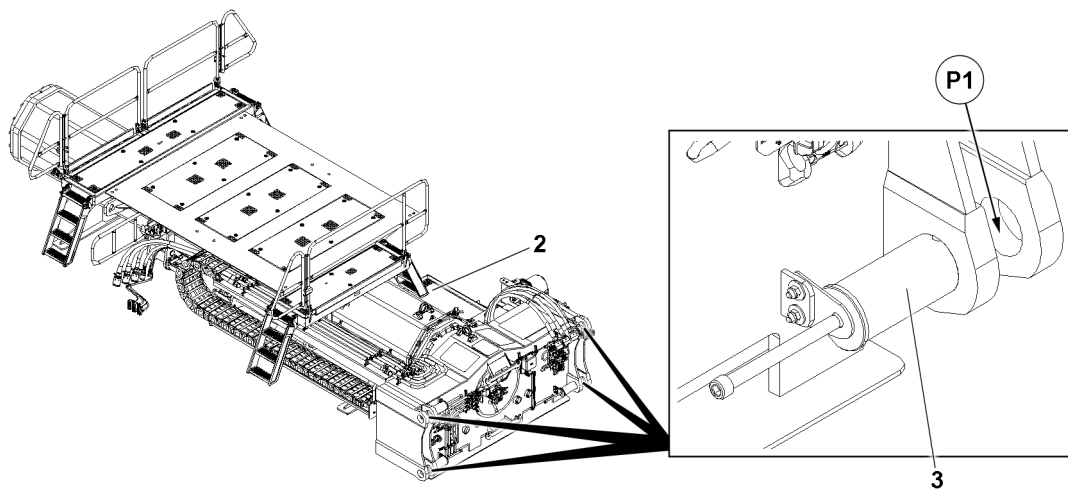


Fig.163012: Assembling the intermediate sections on the guide – Preparation

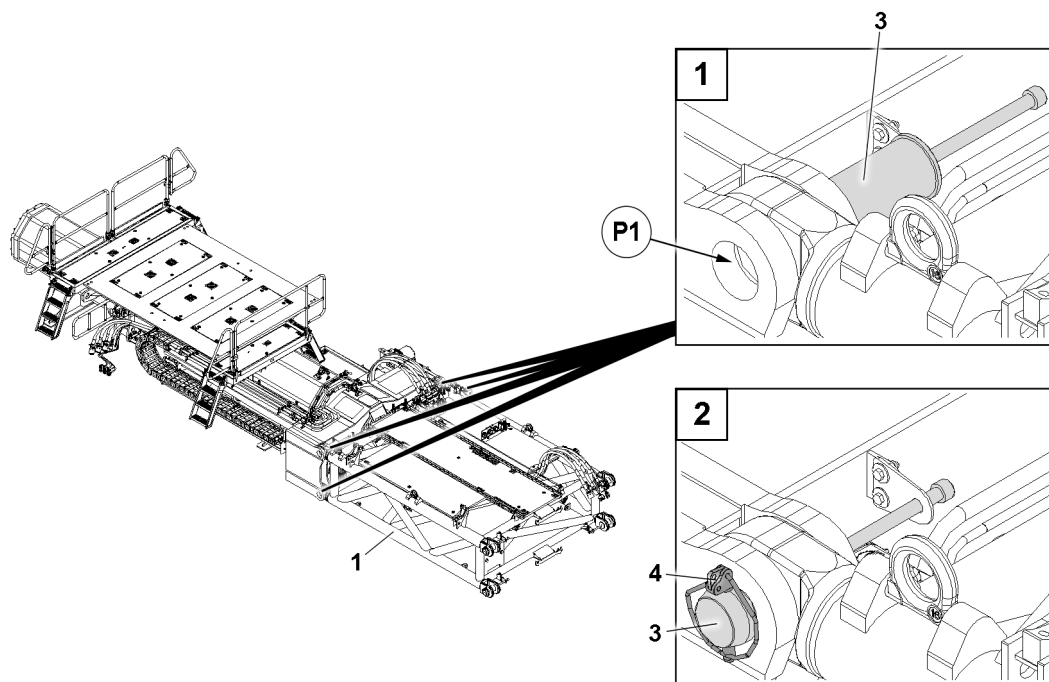
**2** Ballast trailer guide

**3** Pin

- ▶ Make sure that four pins **3** are unpinned in position **P1**.
- ▶ Fasten the intermediate section **1** to the auxiliary crane, see section Fastening points.

The intermediate section **1** is pinned four times to the ballast trailer guide **2** (positions **P1**).

A pin pulling device is used to insert the pins **3**.



*Fig.163013: Assembling the intermediate sections on the guide – Pinning procedure*

- 1 Intermediate section  
3 Pin

- 4 Retaining element

► Position the intermediate section **1** such that it is possible pin in positions **P1**.

When the pin bores align:

- Insert the pin **3**.
- Secure the pin **3** with the retaining element **4**.
- Repeat the procedure in the same way as described above for all four pins **3**.

When all four pins **3** are inserted and secured:

- Remove the auxiliary crane.

### 10.2.4 Assembling the adapter on the ballast trailer guide or intermediate section

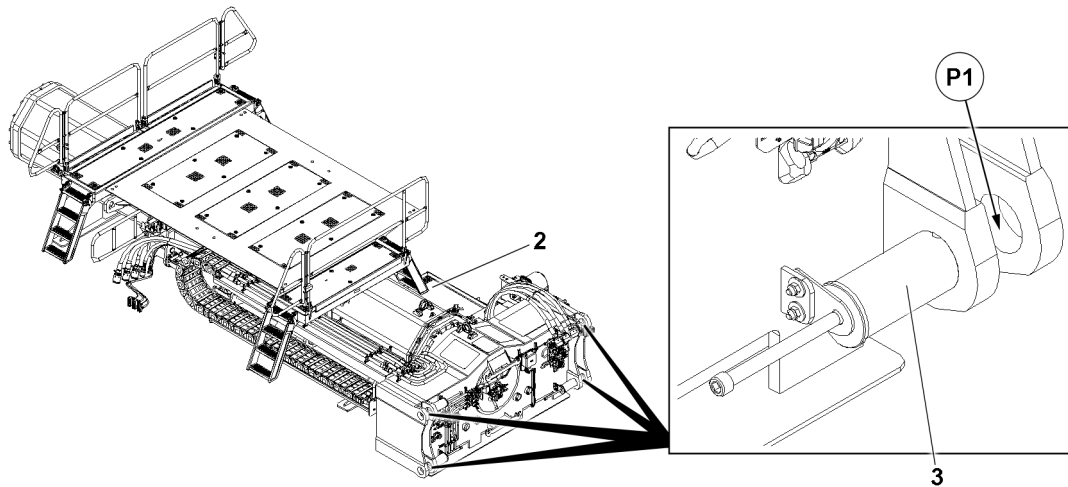


Fig. 163012: Assembling the adapter on the ballast trailer guide or intermediate section – Overview

2 Ballast trailer guide

3 Pin

Make sure that the following prerequisites are met:

- Four pins 3 are unpinned in the positions P1.

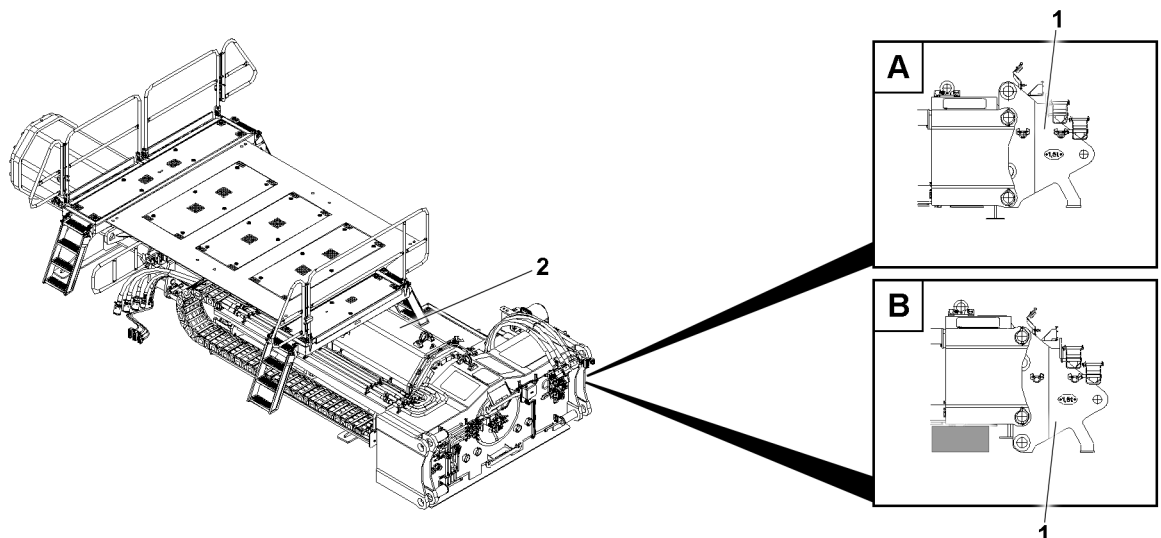


Fig. 163011: Assembling the adapter on the ballast trailer guide or intermediate section – Variants

1 Adapter

2 Ballast trailer guide

The pinning procedure for the adapter 1 on the ballast trailer 2 is identical to the pinning procedure for the adapter 1 on the intermediate section.

The pinning procedure is described based on an example and applies in the same way to the pinning procedure for an adapter 1 on an intermediate section.

Crane with Quick Connection (Variation A)

- In the case of a crane with Quick Connection (Variation A) the ballast trailer guide 2 is lying on the ground.

Crane without Quick Connection (Variation B)

- If the crane does not have the Quick-Connection (Variation B), the ballast trailer guide 2 is supported additionally about 300 mm.

For a crane with Quick Connection:

- ▶ Take the ballast trailer **2** down on the ground.  
**or**

For a crane without Quick Connection:

Support the ballast trailer guide **2** approx. 300 mm.

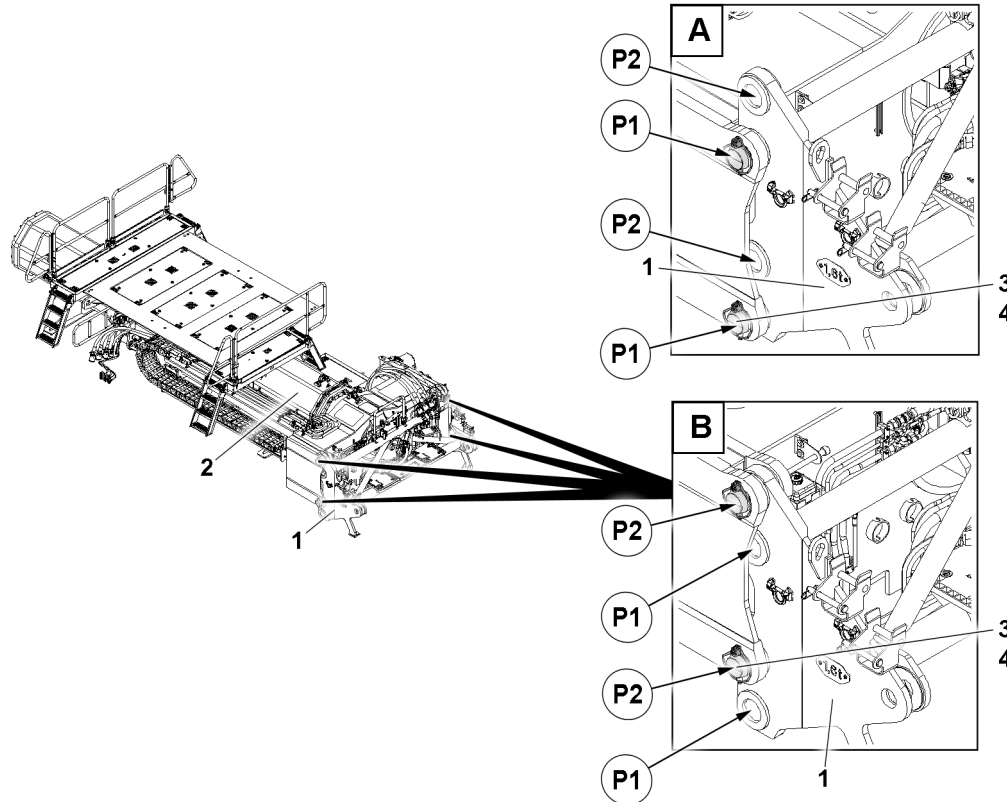


Fig.163015: Assembling the adapter on the ballast trailer guide or intermediate section – Pinning procedure

- |                         |                     |
|-------------------------|---------------------|
| 1 Adapter               | 3 Pin               |
| 2 Ballast trailer guide | 4 Retaining element |

- ▶ Fasten the adapter **1** to the auxiliary crane, see section Fastening points.

The adapter **1** is pinned four times to the ballast trailer guide **2** (positions **P1** or positions **P2**).

A pin pulling device is used to insert the pins **3**.



#### WARNING

Hands in the danger zone!

When aligning the adapter, fingers and hands can be crushed.

- ▶ Do not reach with your hands into the danger zone.

**Variation A:** For a crane with Quick Connection:

- ▶ Position the adapter **1** such that it is possible pin in the positions **P1**.  
**or**

**Variation B:** For a crane without Quick Connection:

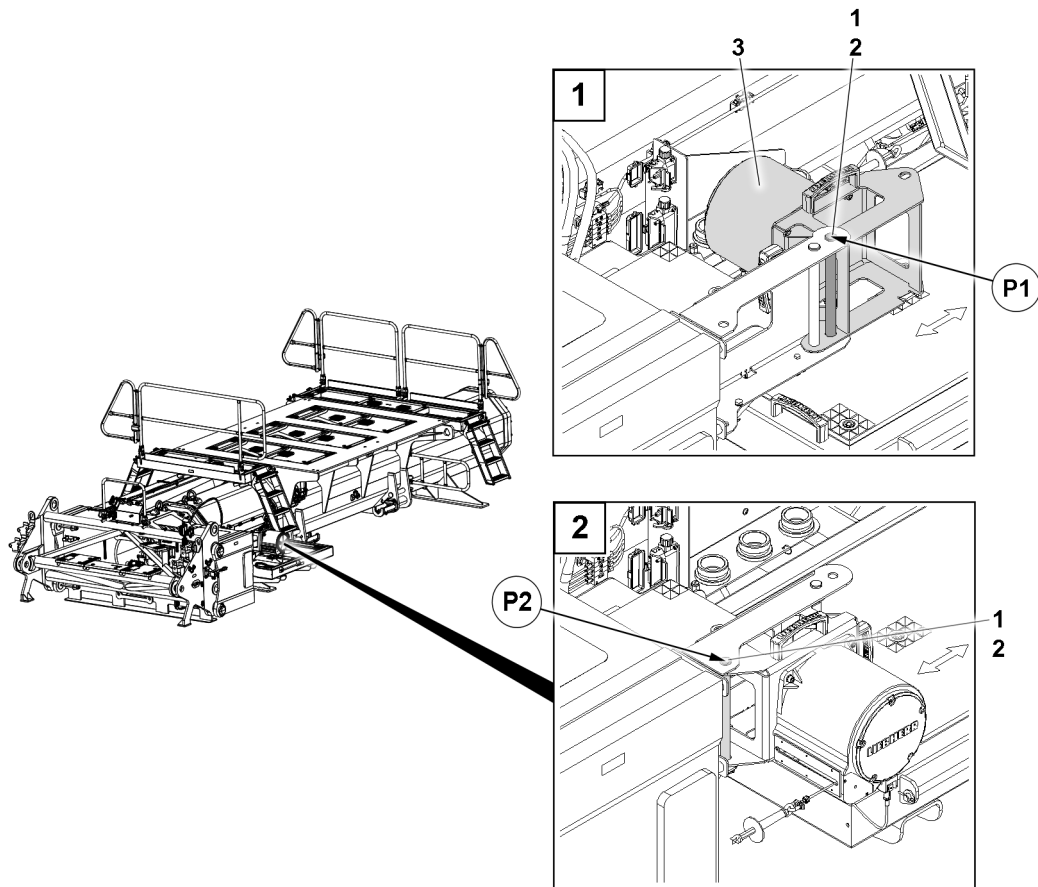
Position the adapter **1** such that it is possible pin in the positions **P2**.

When the pin bores align:

- ▶ Insert the pin **3**.
- ▶ Secure the pin **3** with the retaining element **4**.
- ▶ Repeat the procedure in the same way as described above for all four pins **3**.

- When all four pins **3** are inserted and secured:  
 ▶ Remove the auxiliary crane.

### 10.2.5 Assembling the length sensor in the operating position



*Fig.163018: Assembling the length sensor in the operating position – Swinging the length sensor into the operating position*

- |                            |                        |
|----------------------------|------------------------|
| <b>1</b> Pin               | <b>3</b> Length sensor |
| <b>2</b> Retaining element |                        |
- ▶ Release and unpin the pin **1** in position **P1**.
  - ▶ Swing the length sensor **3** into the operating position.
  - ▶ Insert the pin **1** in position **P2**.
  - ▶ Secure the pin **1** with the retaining element **2**.

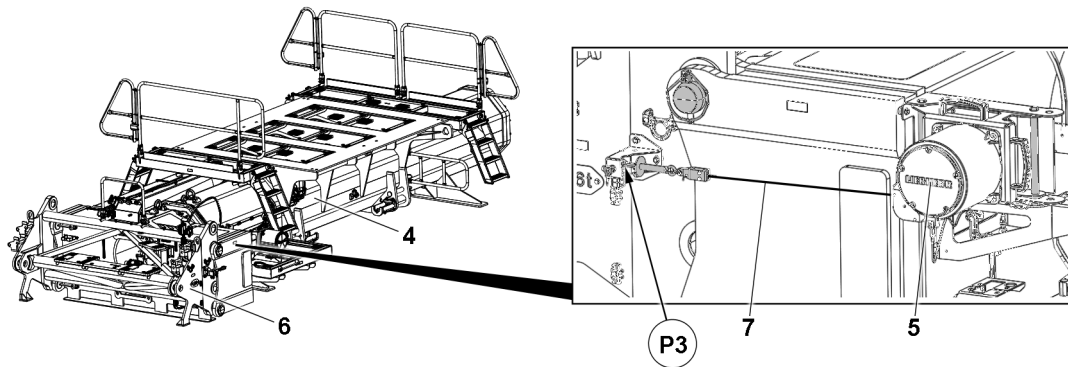


Fig.163016: Assembling the length sensor in the operating position – Assembling the length sensor line in the operating position

- |   |                       |   |         |
|---|-----------------------|---|---------|
| 4 | Ballast trailer guide | 6 | Adapter |
| 5 | Length sensor         | 7 | Line    |

When the adapter **6** is assembled on the ballast trailer guide **4**:

- ▶ Pull the line **7** of the length sensor **5** until reaching position **P3**.
- ▶ Pin and secure the line **7** of the length sensor **5** in position **P3**.

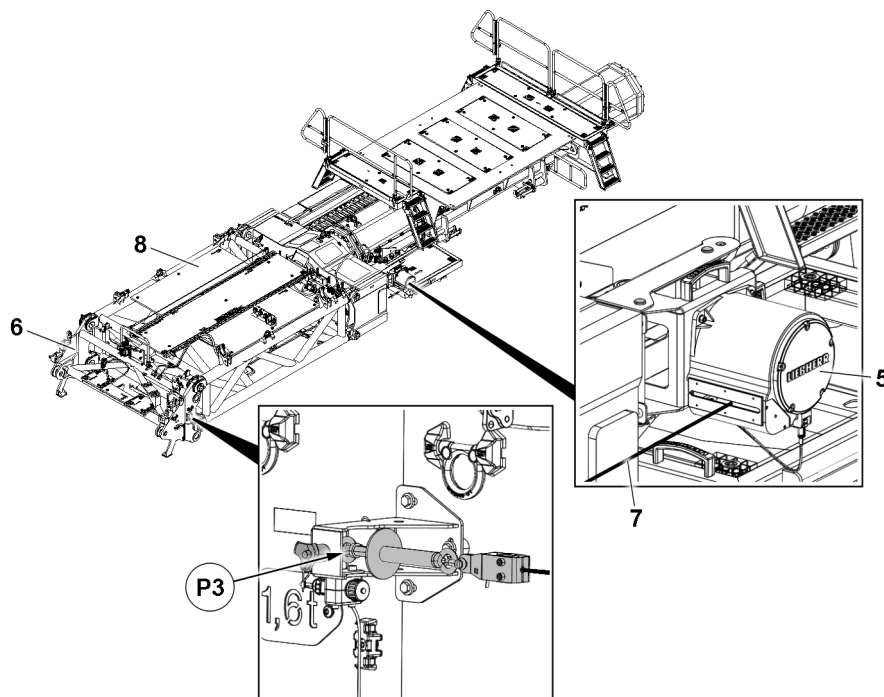


Fig.163017: Assembling the length sensor in the operating position – Assembling on the intermediate section

- |   |               |   |                      |
|---|---------------|---|----------------------|
| 5 | Length sensor | 7 | Line                 |
| 6 | Adapter       | 8 | Intermediate section |

When the adapter **6** is assembled on the intermediate section **8**:

- ▶ Pull the line **7** of the length sensor **5** until reaching position **P3**.
- ▶ Pin and secure the line **7** of the length sensor **5** in position **P3**.

## 10.2.6 Establishing the connections

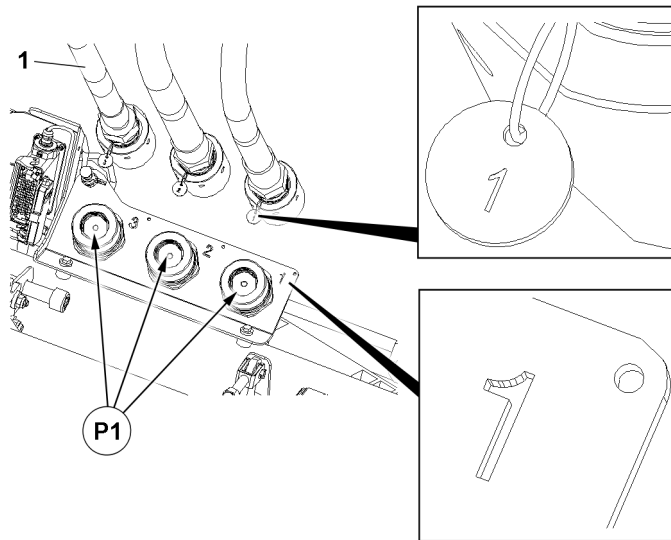


Fig.163021: Establishing the connections

1 Hydraulic line



### Note

- ▶ The hydraulic lines **1** and assembly positions **P1** are marked with numbers.
- ▶ The markings on the hydraulic lines **1** and assembly positions **P1** must be identical.

Make sure that the following prerequisites are met:

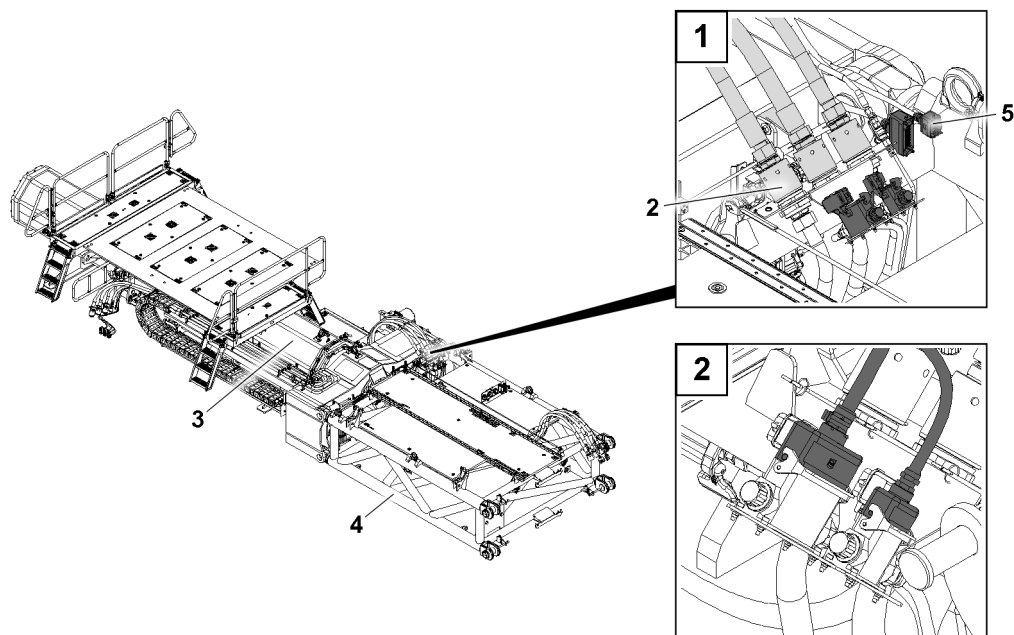
- The pressure in the hydraulic system has been released.

### Establishing the hydraulic and electrical connections between the ballast trailer guide and the intermediate section



### Note

- ▶ The section is optional.
- ▶ Some configurations do not have an intermediate section.



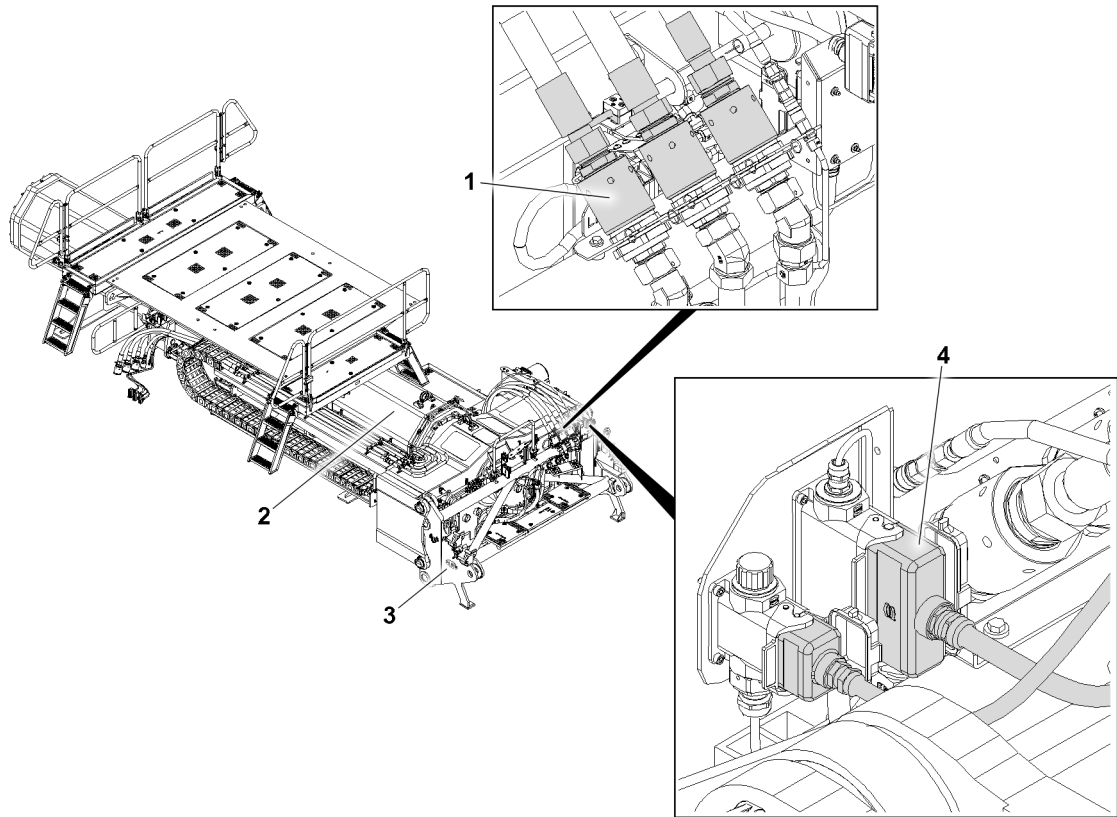
*Fig.163014: Establishing the hydraulic and electrical connections between the ballast trailer guide and the intermediate section*

- |          |                       |          |                        |
|----------|-----------------------|----------|------------------------|
| <b>2</b> | Hydraulic connection  | <b>4</b> | Intermediate section   |
| <b>3</b> | Ballast trailer guide | <b>5</b> | Electrical connections |

- ▶ Establish the hydraulic connections **2** between the ballast trailer guide **3** and the intermediate section **4**, see the hydraulic diagram.
- ▶ Establish the electrical connections **5** between the ballast trailer guide **3** and the intermediate section **4**, see the wiring diagram.



### Establishing the hydraulic and electrical connections between the ballast trailer guide and the adapter



*Fig.163019: Establishing the hydraulic and electrical connections between the ballast trailer guide and the adapter*

- |          |                       |          |                       |
|----------|-----------------------|----------|-----------------------|
| <b>1</b> | Hydraulic connection  | <b>3</b> | Adapter               |
| <b>2</b> | Ballast trailer guide | <b>4</b> | Electrical connection |

- ▶ Establish the hydraulic connections **1** between the ballast trailer guide **2** and the adapter **3**, see the hydraulic diagram.
- ▶ Establish the electrical connections **4** between the ballast trailer guide **2** and the adapter **3**, see the wiring diagram.

### Establishing the hydraulic and electrical connections between the intermediate section and the adapter

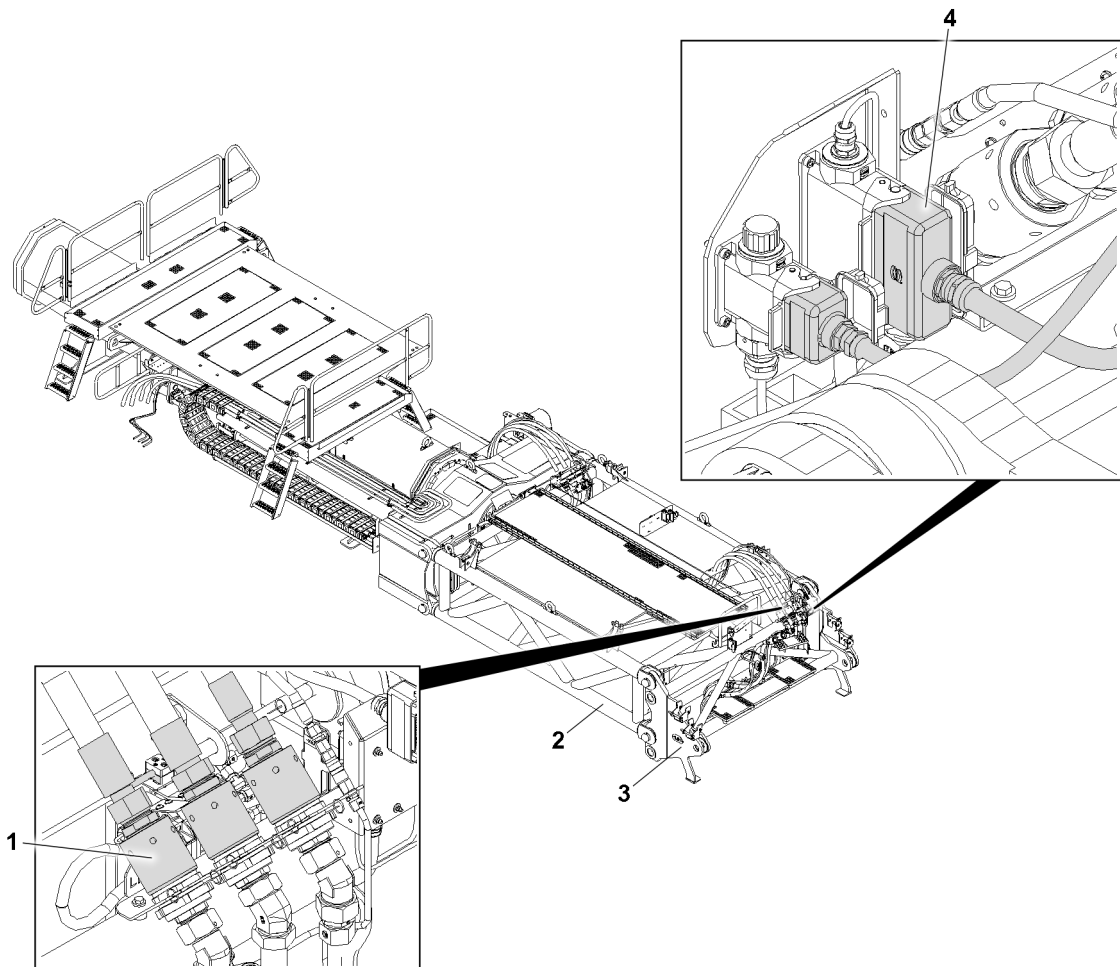


Fig.163020: Establishing the hydraulic and electrical connections between the intermediate section and the adapter

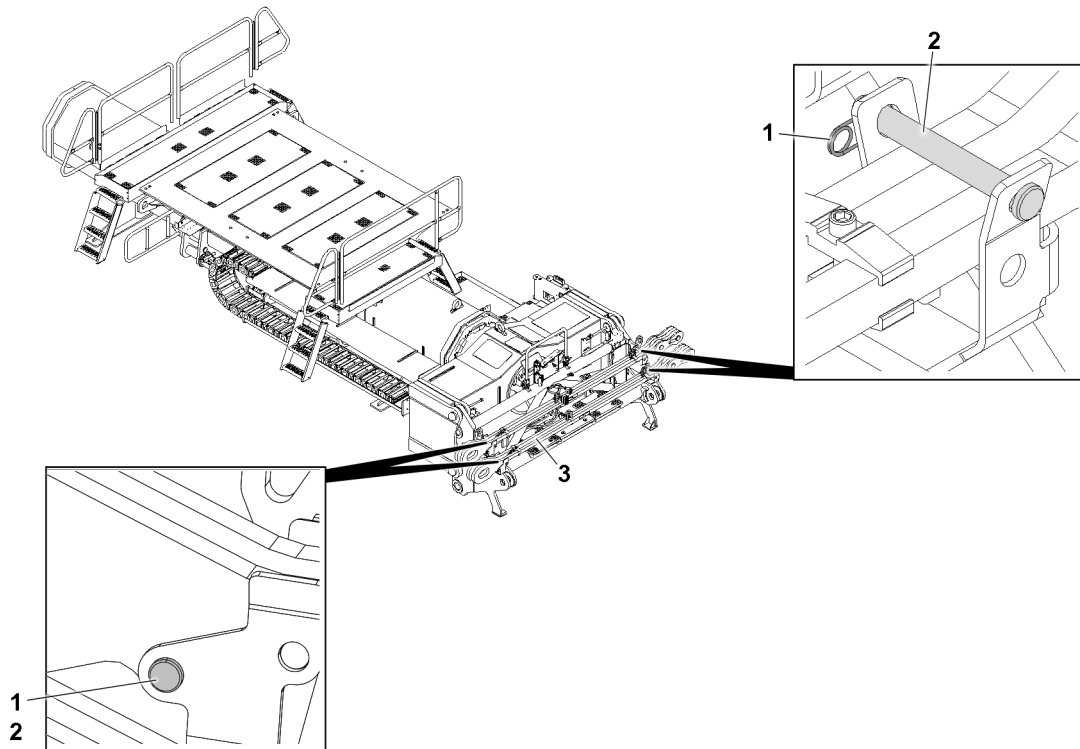
- |   |                      |   |                       |
|---|----------------------|---|-----------------------|
| 1 | Hydraulic connection | 3 | Adapter               |
| 2 | Intermediate section | 4 | Electrical connection |

- ▶ Establish the hydraulic connections 1 between the intermediate section 2 and the adapter 3, see the hydraulic diagram.
- ▶ Establish the electrical connections 4 between the intermediate section 2 and the adapter 3, see the wiring diagram.

## 10.3 Assembling the guy rods

Make sure that the following prerequisites are met:

- The derrick boom and main boom are connected together by the luffing pulley block.
- The derrick boom is moved back as far as possible.



*Fig.163035: Assembling the guy rods – Connecting the guy rods to the auxiliary crane*

- |          |                   |          |         |
|----------|-------------------|----------|---------|
| <b>1</b> | Retaining element | <b>3</b> | Guy rod |
| <b>2</b> | Retaining pin     |          |         |

- ▶ Remove the retaining elements **1** on both sides.
- ▶ Unpin the retaining pin **2** on both sides.
- ▶ Connect the guy rod **3** to the auxiliary crane.

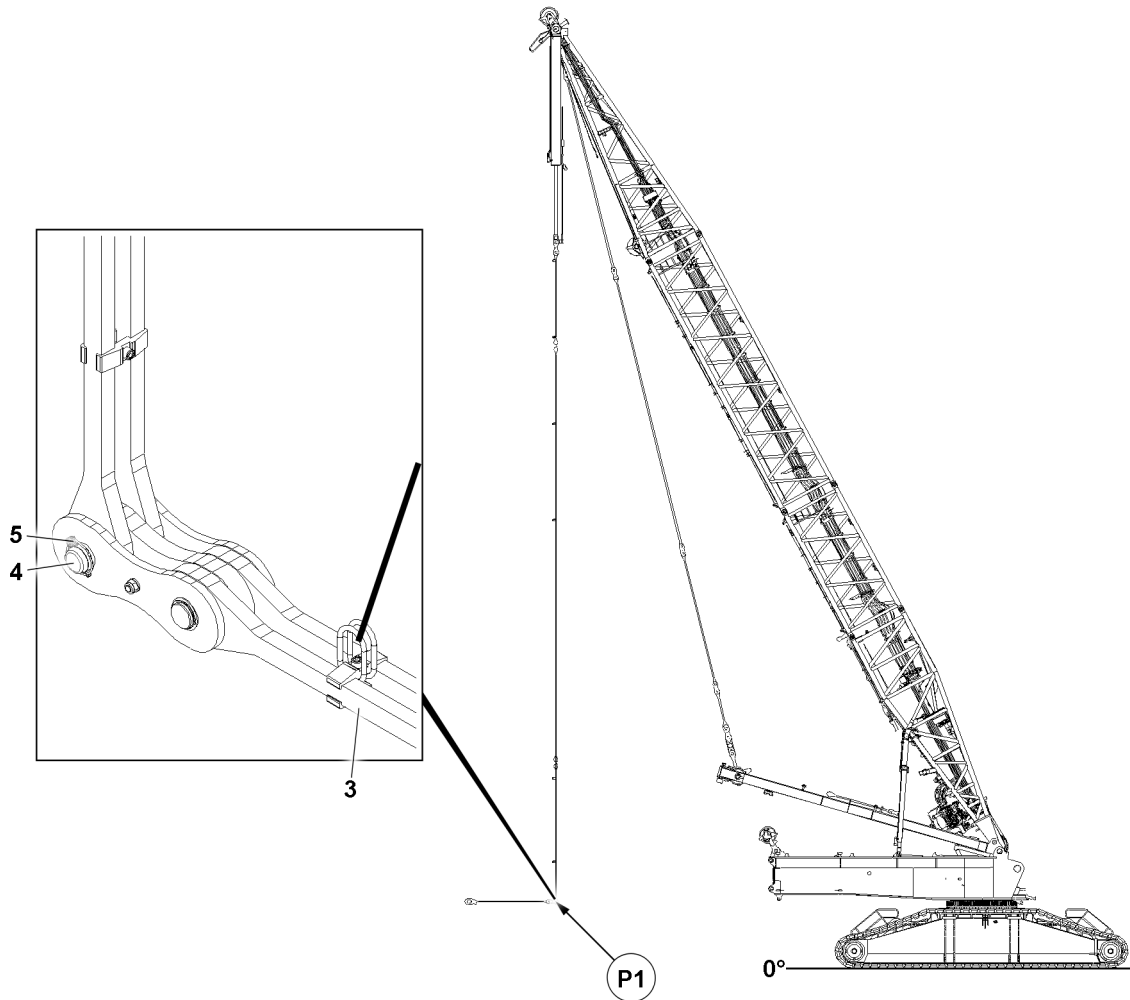


Fig.163036: Assembling the guy rods

**3** Guy rod  
**4** Pin

**5** Retaining element

- ▶ Position the guy rod **3** to permit pinning in position **P1**.
- ▶ Insert the pin **4**.
- ▶ Secure the pin **4** with the retaining element **5**.
- ▶ Lower the guy rod **3** until it is hanging vertically.
- ▶ Remove the auxiliary crane.
- ▶ Repeat the procedure in the same way as described above for the second guy rod **3**.

## 10.4 Positioning the ballast trailer

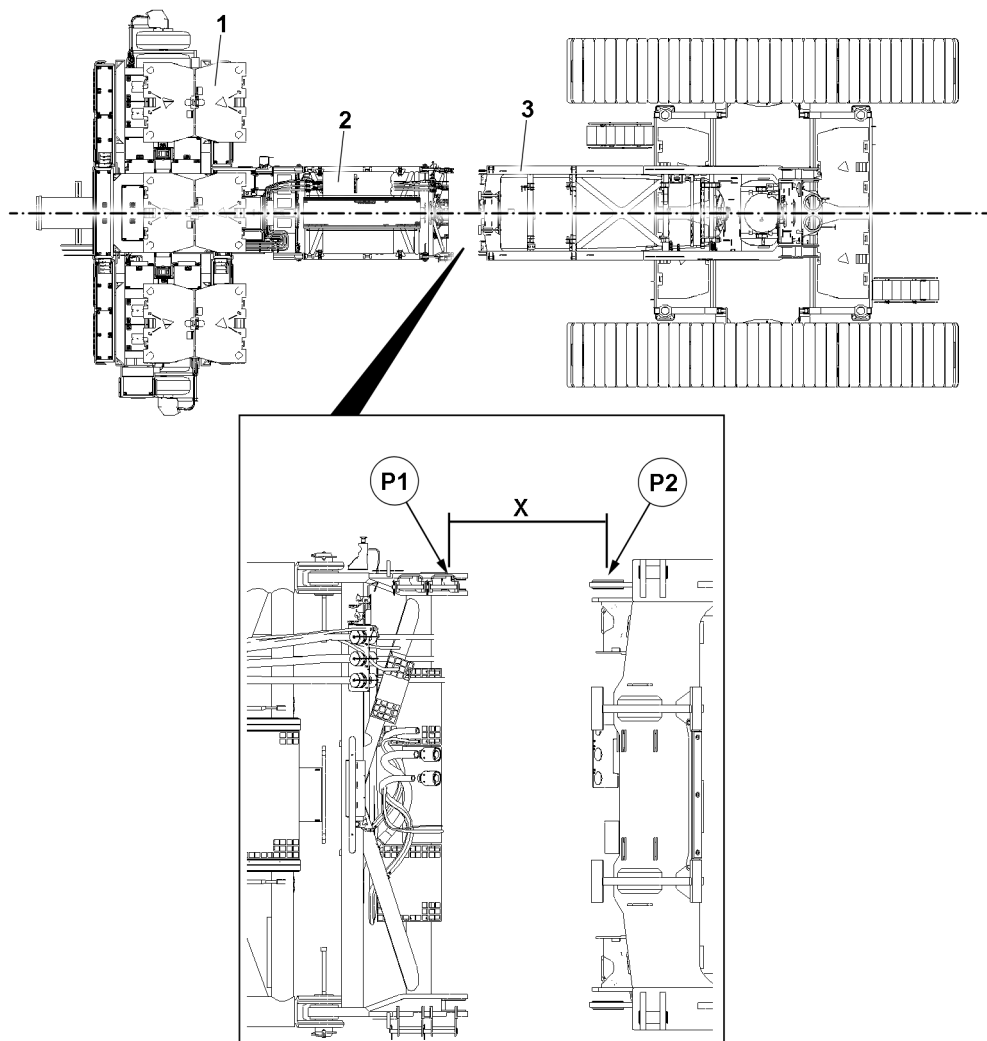


Fig.163089

Make sure that the following prerequisites are met:

- The ballast trailer guide **2** is not assembled on the ballast trailer **1**.

In order to pin the ballast trailer **1** to the turntable **3**, the ballast trailer guide **2** is telescoped out until the pin points align. As soon as the ballast trailer guide **2** is assembled, the ballast trailer **1** can no longer be positioned.

Therefore the ballast trailer **1** must now be positioned such that the ballast trailer **1** longitudinal axis and the turntable **3** longitudinal axis are aligned and there is a distance of  $X = 1\text{ m}$  between the ballast trailer guide **2** pin points (after assembly) and the turntable **3** pin points.

- ▶ Connect the ballast trailer **1** to the auxiliary crane, see section “Fastening points”.
- ▶ Position the ballast trailer **1**.

## 10.5 Assembling the ballast trailer guide on the ballast trailer

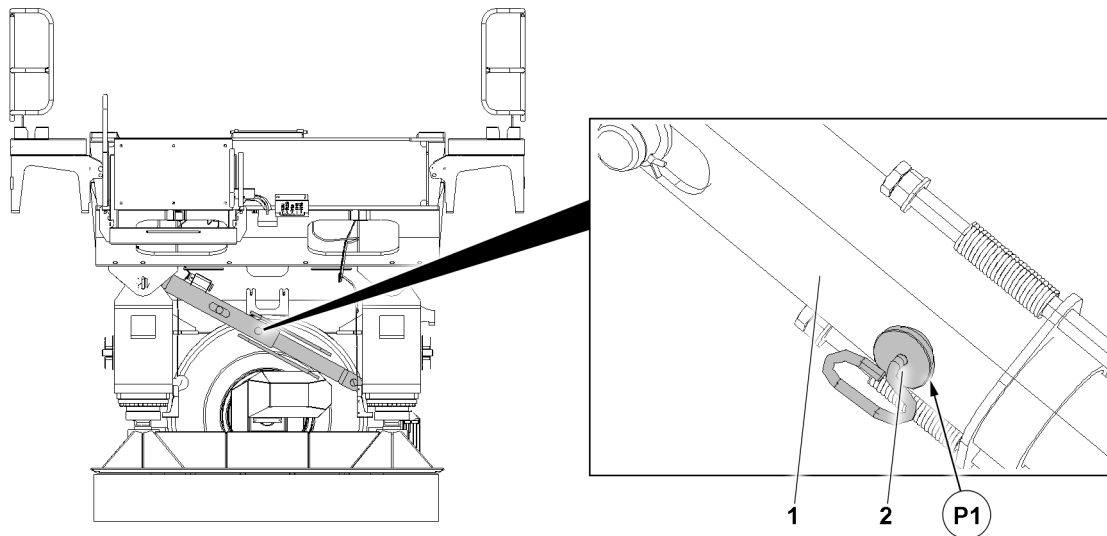


Fig.163022: Assembling the ballast trailer guide on the ballast trailer

**1** Strut

**2** Pin

Make sure that the following prerequisites are met:

- The incline of the base / travel route of the ballast trailer is  $0^\circ \pm 1.5^\circ$ .
- The base / travel route of the ballast trailer is sufficiently level and capable of supporting the load, see “Specific ballasting for stability and tipping safety”.
- The permissible level difference lies below the tolerance range, see section “Permissible level difference”.
- The strut **1** is secured in the operating position. The pin **2** is inserted in point **P1** and secured with the retaining element.
- The ballast trailer is ballasted according to its assembly condition, see section “Specific ballasting for stability and tipping safety”.
- The ballast trailer guide is telescoped in all the way.
- The ballast trailer is positioned in reference to the turntable.

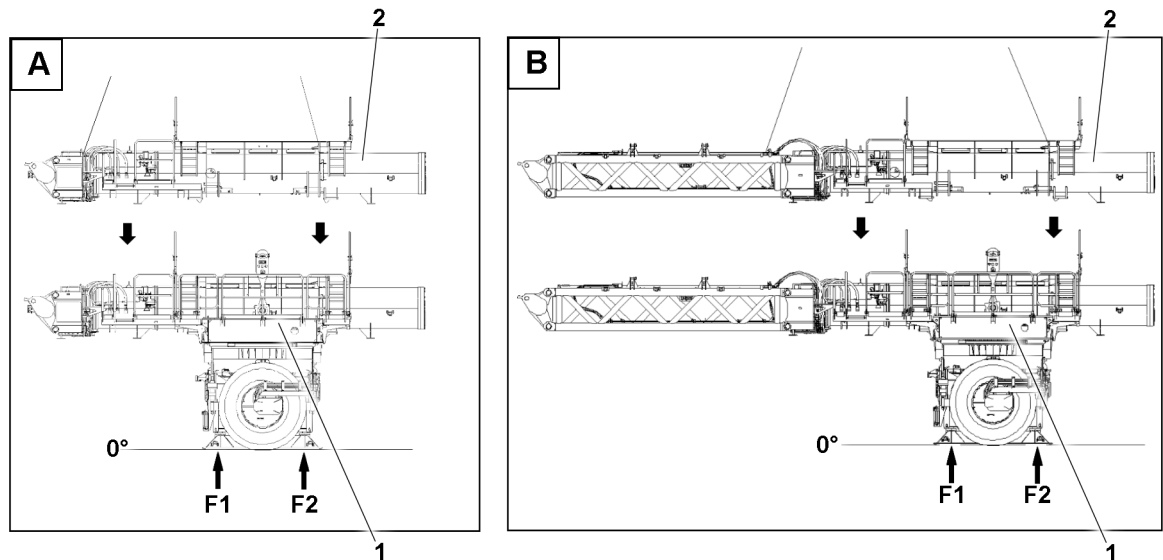


Fig.163024: Assembling the ballast trailer guide on the ballast trailer – Variations

- |  |   |
|--|---|
| <p><b>A</b> Assemble the ballast trailer guide with the adapter on the ballast trailer</p> <p><b>B</b> Assemble the ballast trailer guide with the intermediate section and adapter on the ballast trailer</p> | <p><b>1</b> Ballast trailer</p> <p><b>2</b> Ballast trailer guide</p> |
|--|---|



#### WARNING

Impermissible ballasting!

Death, severe bodily injuries, property damage.

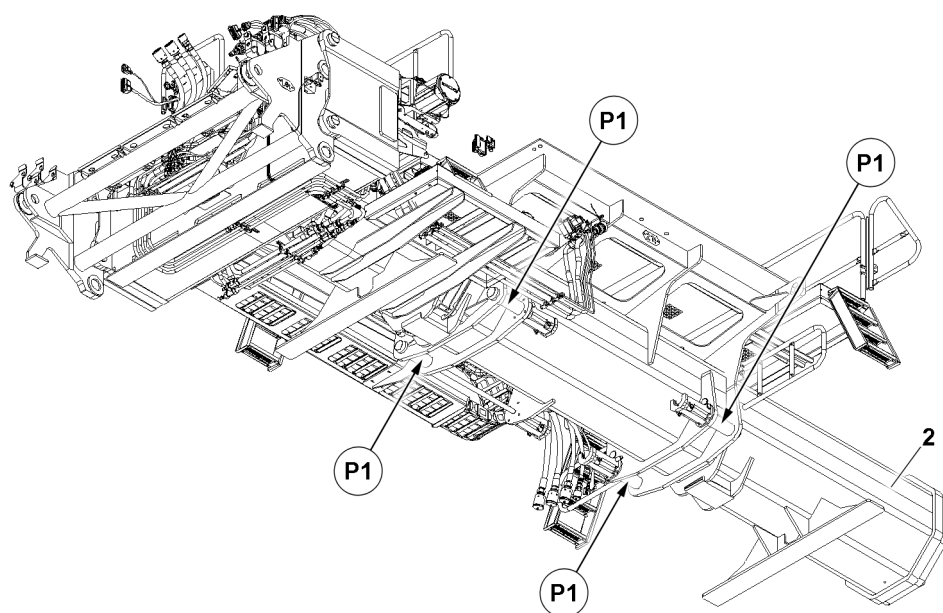
If the ballast trailer **1** is insufficiently ballasted, then the ballast trailer **1** can tip over when placing the ballast trailer guide **2**.

- ▶ Make sure when assembling the ballast trailer guide **2** that the ballast trailer **1** is ballasted according to the ballast trailer radius, see section “Specific ballasting for stability and tipping safety”.
- ▶ Make sure that the ground is prepared according to the ground pressure, see section “Specific ballasting for stability and tipping safety”.



#### Note

- ▶ The assembly of the ballast trailer guide Variation **A** is identical to the assembly of the ballast trailer guide Variation **B**.
- ▶ The assembly of the ballast trailer guide **2** is described as an example based on the variation **A** and applies in the same manner for variation **B**.



*Fig.163025: Assembling the ballast trailer guide on the ballast trailer – Pin points*

**2** Ballast trailer guide

The ballast trailer guide **2** is pinned in four points **P1** with the ballast trailer.

► Fasten the ballast trailer guide **2** to the auxiliary crane, see section “Fastening points”



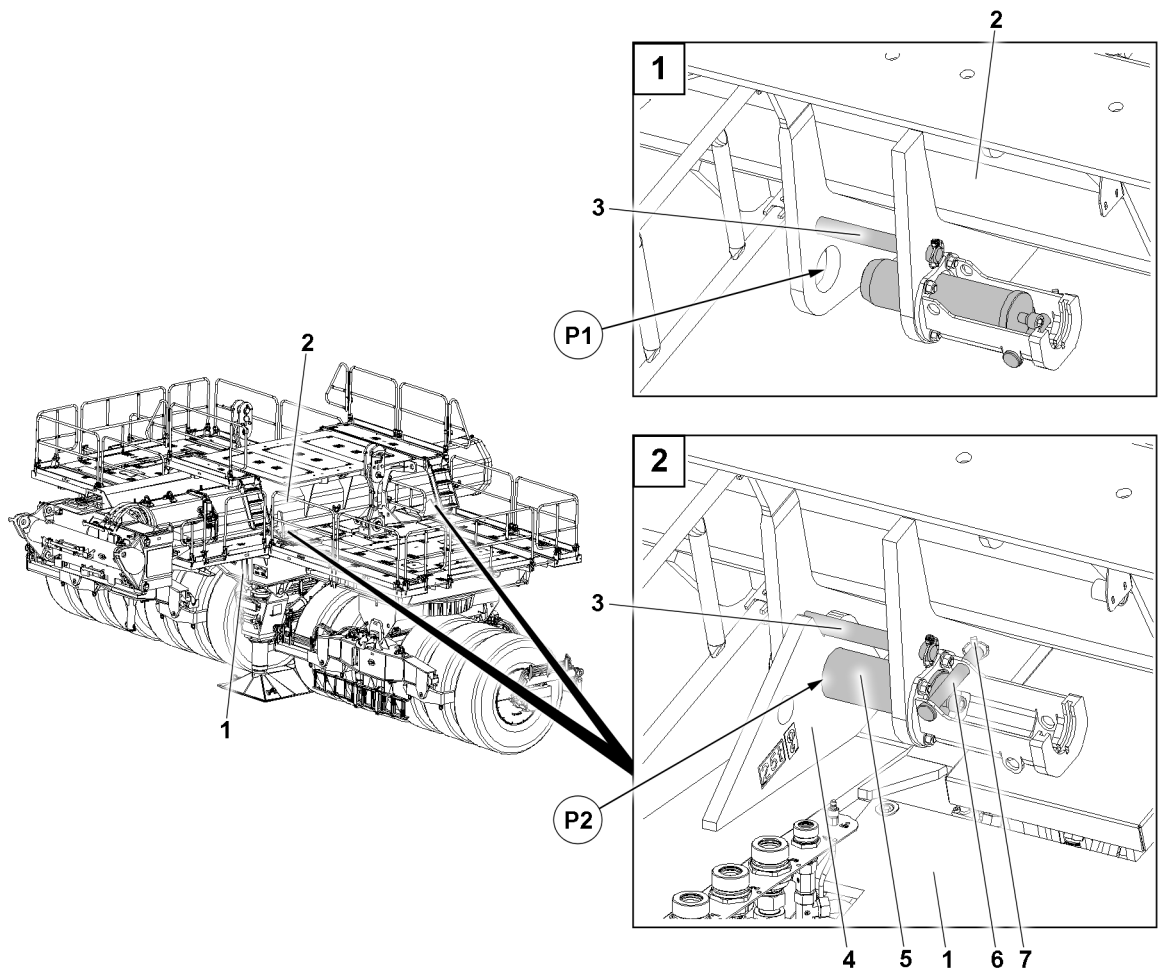


Fig.163026: Assembling the ballast trailer guide on the ballast trailer – Pinning procedure

1	Ballast trailer	5	Pin
2	Ballast trailer guide	6	Retaining pin
3	Pin	7	Retaining element
4	Receptacle		

- ▶ Position the ballast trailer guide 2 such that all pins 3 lie on the receptacle 4 of the ballast trailer 1.

When point P1 and point P2 align:

- ▶ Insert the pin 5 with the pin pulling device.
- ▶ Secure the pin 5 with the retaining pin 6.
- ▶ Secure the retaining pin 6 with the retaining element 7.
- ▶ Repeat the procedure the same way for the three additional pins 5.

When the ballast trailer guide 2 is completely pinned:

- ▶ Remove the auxiliary crane.

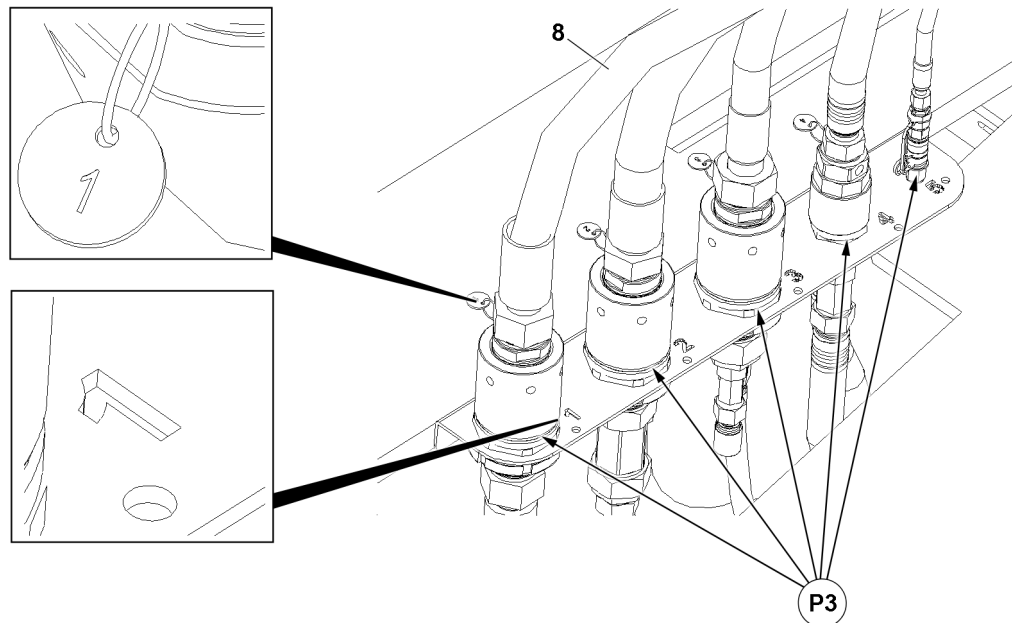


Fig.163027: Assembling the ballast trailer guide on the ballast trailer – Hydraulic line marking

8 Hydraulic lines



#### Note

- ▶ The hydraulic lines **8** and assembly positions **P3** are marked with numbers.
- ▶ The markings on the hydraulic lines **8** and assembly positions **P3** must be identical.

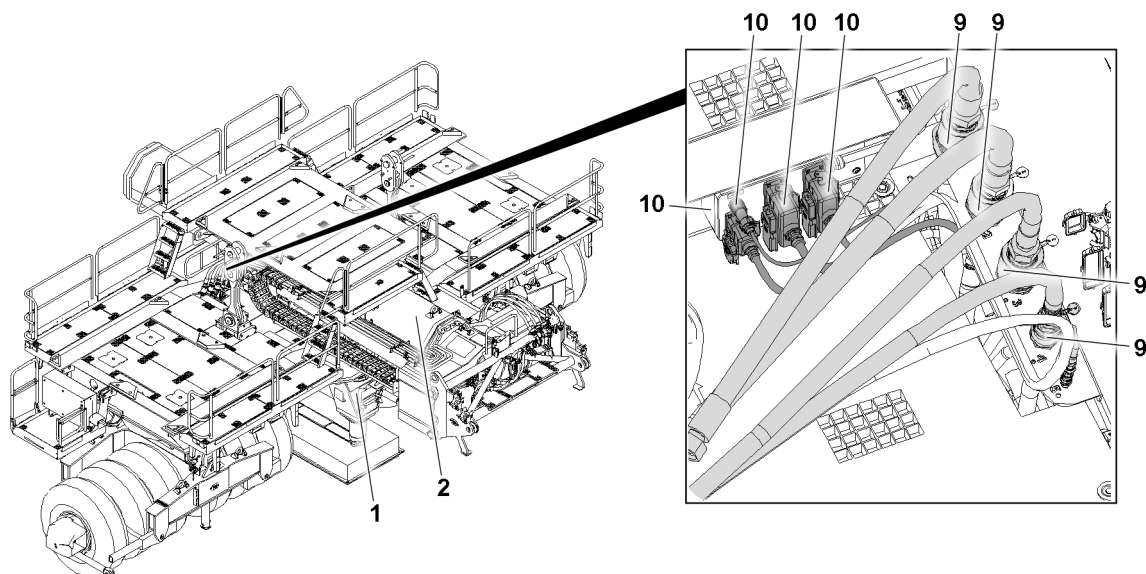


Fig.163028: Assembling the ballast trailer guide on the ballast trailer – Establishing the electrical and hydraulic connections

1 Ballast trailer	9 Hydraulic connections
2 Ballast trailer guide	10 Electrical connections

- ▶ Make sure that the hydraulic system is depressurized.
- ▶ Establish the hydraulic connections **9** between the ballast trailer guide **2** and the ballast trailer **1**, see the hydraulic diagram.
- ▶ Establish the electrical connections **10** between the ballast trailer guide **2** and the ballast trailer **1**, see the wiring diagram.

## 11 Preparing the ballast trailer for assembly on the crane

Make sure that the following prerequisites are met:

- The ballast trailer support strut is pinned.
- The ballast trailer guide is fully retracted.
- The ground absorbs the surface pressure **F1** and surface pressure **F2** of the ballast trailer, see the charts in section “Specific ballasting for stability and tipping safety”.

The specific ballasting that must lie on the ballast trailer depends on:

- The assembled components of the ballast trailer guide.
- The ballast trailer radius during assembly on the turntable.

Specific ballasting, see section “Specific ballasting for stability and tipping safety”.

- ▶ Select the specific ballasting.
- ▶ Place the specific ballasting on the ballast trailer, see section “Ballasting the ballast trailer”.

## 12 Assembling the ballast trailer on the crane

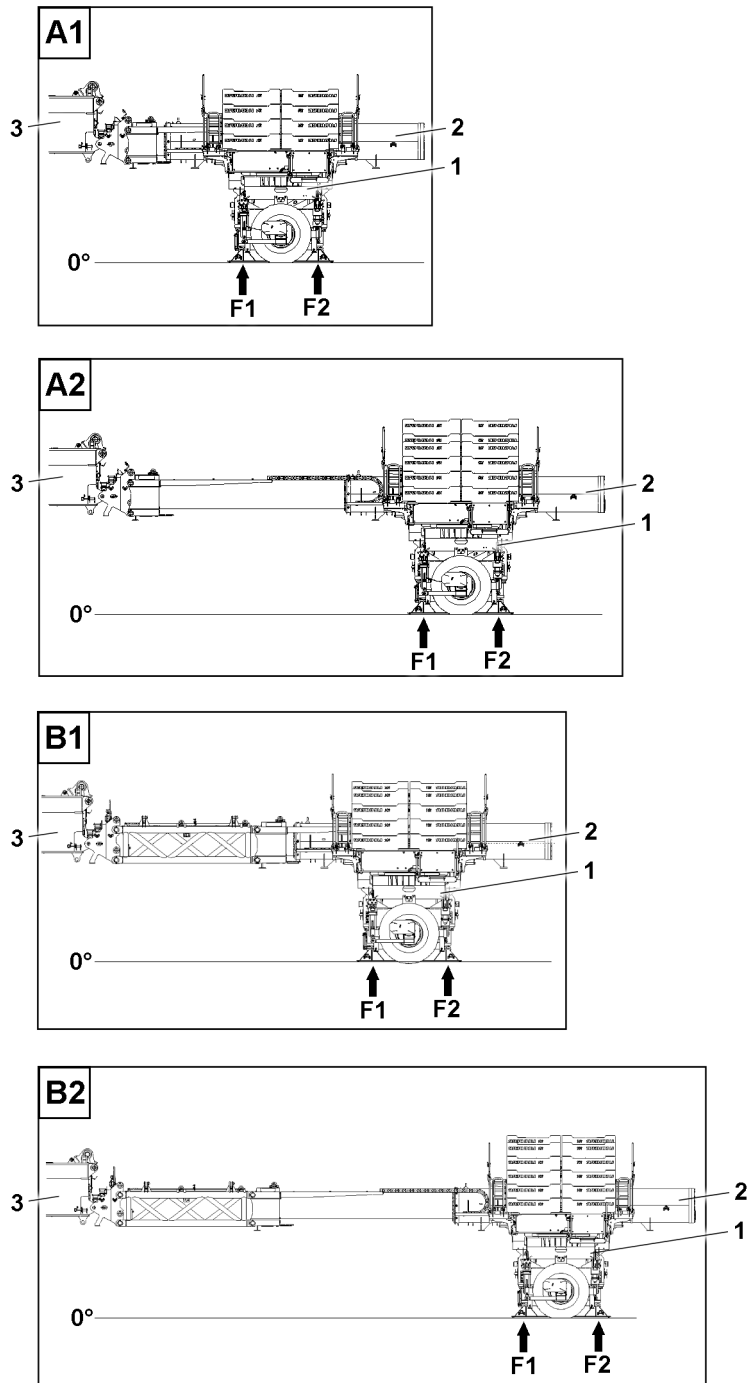


Fig.163029: Assembling the ballast trailer on the crane – Variations

- |   |                       |   |           |
|---|-----------------------|---|-----------|
| 1 | Ballast trailer       | 3 | Turntable |
| 2 | Ballast trailer guide |   |           |

**WARNING**

Impermissible ballasting!

Death, severe bodily injuries, property damage.

If the ballast trailer **1** is ballasted in an impermissible manner, the ballast trailer **1** can tip over when pinning the ballast trailer guide **2** on the turntable **3**.

Death, severe bodily injuries, property damage.

- ▶ Make sure when pinning the ballast trailer guide **2** that the ballast trailer **1** is ballasted according to the selected ballast trailer radius, see section "Specific ballasting for stability and tipping safety".
- ▶ Make sure that the ground is prepared according to the ground pressure, see section "Specific ballasting for stability and tipping safety".

**Note**

- ▶ Observe the safety instructions, see chapter 2.15.

**Note**

- ▶ The assembly of the ballast trailer on the turntable is independent of the variation.
- ▶ The assembly of the ballast trailer on the turntable is described based on the example of variation **A1** and applies in the same manner for variation **A2**, variation **B1** and variation **B2**.

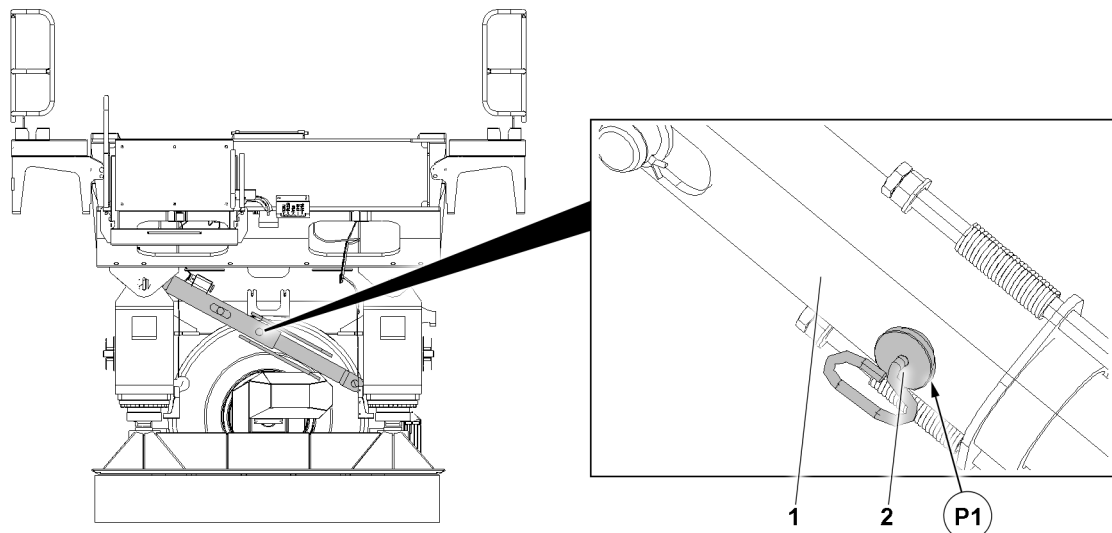


Fig.163022: Assembling the ballast trailer on the crane – Pinned support

**1** Strut

**2** Pin

Make sure that the following prerequisites are met:

- The incline of the base / travel route of the ballast trailer is  $0^\circ \pm 1.5^\circ$ .
- The base / travel route of the ballast trailer is sufficiently level and capable of supporting the load, see "Specific ballasting for stability and tipping safety".
- The permissible level difference lies below the tolerance range, see section "Permissible level difference".
- The ballast trailer is supported.
- The strut **1** is secured in the operating position. The pin **2** is inserted in point **P1** and secured with the retaining element.
- The ballast trailer is ballasted according to its assembly condition, see section "Specific ballasting for stability and tipping safety".
- The ballast trailer is completely pre-assembled.
- The ballast trailer guide is telescoped in all the way.
- The counterweight is installed on the turntable according to the load chart.

## 12.1 Assembling the extension ladder on the ballast trailer guide

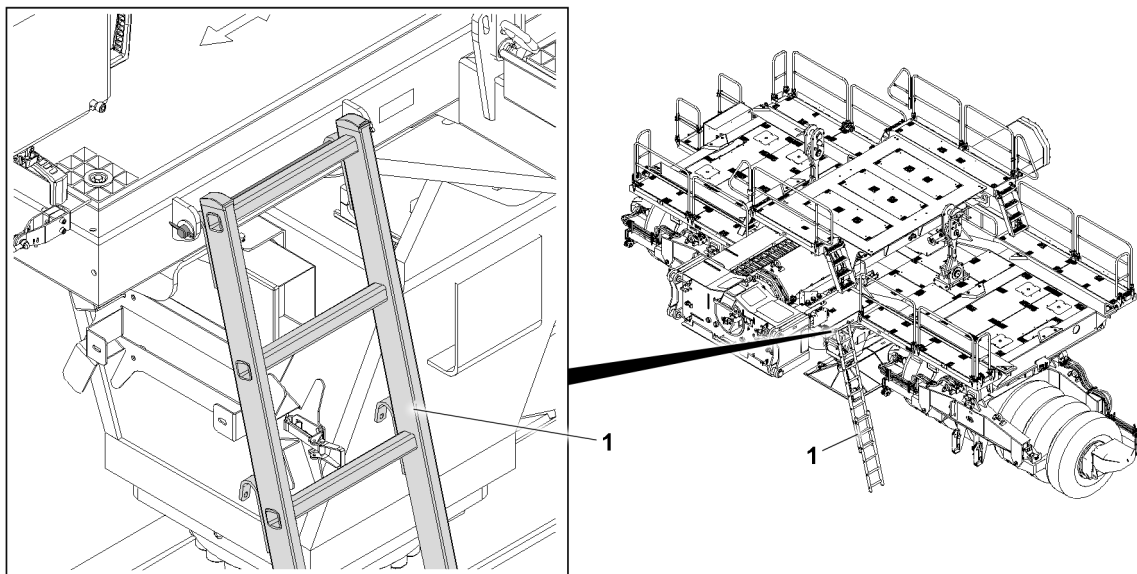


Fig.163023: Assembling the extension ladder on the ballast trailer guide

1 Extension ladder



### Note

► Assembly of the extension ladder 1, see chapter 2.06.

## 12.2 Checking the set up configuration



### Note

► If an incorrect set up configuration is set, movements necessary for assembly cannot be carried out.



### WARNING

Incorrect set up configuration set in the LICCON overload protection!

Death, severe bodily injury, property damage.

If an incorrect set up configuration is set, the necessary shut-offs may not function. The crane can be overloaded and topple over.

- Set the LICCON overload protection in accordance with the future set up configuration of the completely erected, operational crane
- Check if the LICCON overload protection is set in accordance with the future set up configuration of the completely erected, operational crane

### Problem remedy

Is the LICCON overload protection not set in accordance with the future set up configuration of the completely erected, operational crane?

- Set the LICCON overload protection in accordance with the future set up configuration of the completely erected, operational crane

## 12.3 Extending the electrical and hydraulic connections between the turntable and the ballast trailer

Depending on the local circumstances at the job location of the crane, it may be necessary when assembling / disassembling the ballast trailer to extend the electrical lines between the turntable and the ballast trailer with the extension lines.

This can ensure that after unpinning the ballast trailer guides from the turntable, they can be retracted enough so that the slewing range of the turntable is not limited by the ballast trailer guide.



### WARNING

Danger of accident due to loss of pressure or leakage!  
Death, severe bodily injuries, property damage.

- ▶ Make sure that the specifications for establishing and releasing hydraulic and electrical connections are observed.
- ▶ See section "Work on the electrical connections".
- ▶ See section "Work on the hydraulic connections".

- ▶ Assemble the electrical extension lines between the turntable and the ballast trailer.
- ▶ Assemble the hydraulic extension lines between the turntable and the ballast trailer.

## 12.4 Preparing the turntable for pinning

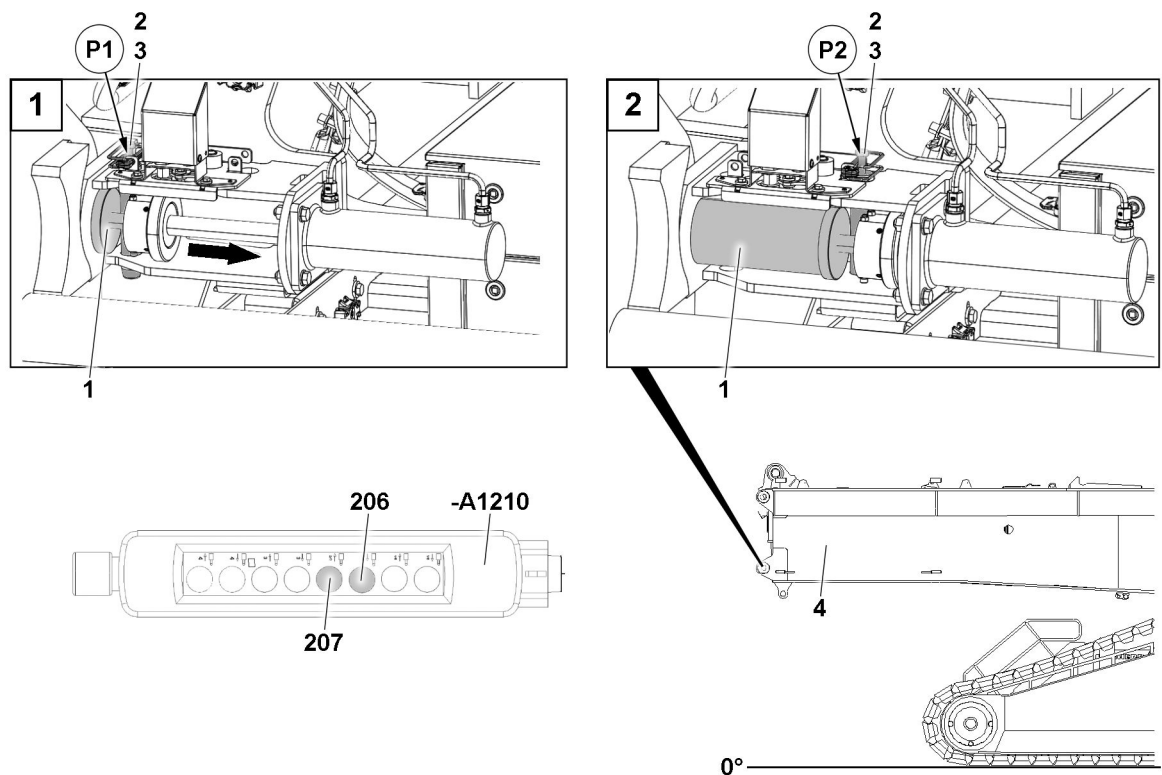


Fig.163032: Preparing the turntable for pinning

- |                      |                 |
|----------------------|-----------------|
| 1 Pin                | 3 Retaining pin |
| 2 Retaining elements | 4 Turntable     |

- ▶ Assemble the control panel **-A1210** on the turntable **4**, see the wiring diagram.

### NOTICE

Damage to the pin pulling device!

If the pins **1** are not unpinned before the pinning procedure, then the pin pulling device can be damaged.

- ▶ Make sure that the pins **1** are unpinned on both sides before pinning.

- ▶ Remove the retaining elements **2** on both sides in points **P1**.
- ▶ Unpin the retaining pin **3** on both sides in points **P1**.

When both pins **1** are released:

- ▶ Press the button **206** on the control panel **-A1210** until the pins **1** are completely unpinned.

**Result:**

- The pins **1** are unpinned.
- The ballast trailer can be pinned on the turntable **4**.
- ▶ Insert the retaining pin **3** on both sides in points **P2**.
- ▶ Insert the retaining pin **3** on both sides in points **P2** with the retaining elements **2**.

## 12.5 Pinning the ballast trailer on the turntable

**Note**

- ▶ For assembly of the ballast trailer, the electrical connection from the ballast trailer to the turntable must be established to be able to control the support cylinders, if necessary, see section “Establishing the hydraulic and electric connections between the ballast trailer and turntable”.
- ▶ The “Ballast UP / DOWN” releases are independent of whether the ballast trailer is attached, providing the conditions in the shut-off diagram are fulfilled.
- ▶ The “Ballast UP” release allows the retraction of the pull cylinder and support cylinder.
- ▶ The “Ballast DOWN” release allows the extension of the pull cylinder and support cylinder.
- ▶ This means that the support cylinder and the pull cylinder can be actuated, even if the “Ballast trailer pinned” signal is not present.

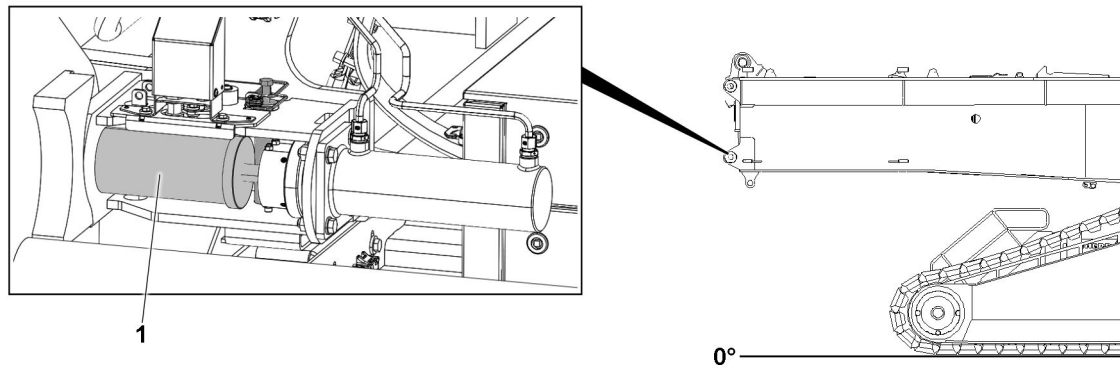


Fig.163031: Pinning the ballast trailer on the turntable – Unpinning the pin

**1 Pin**

Make sure that the following prerequisites are met:

- The pins **1** are unpinned on both sides.



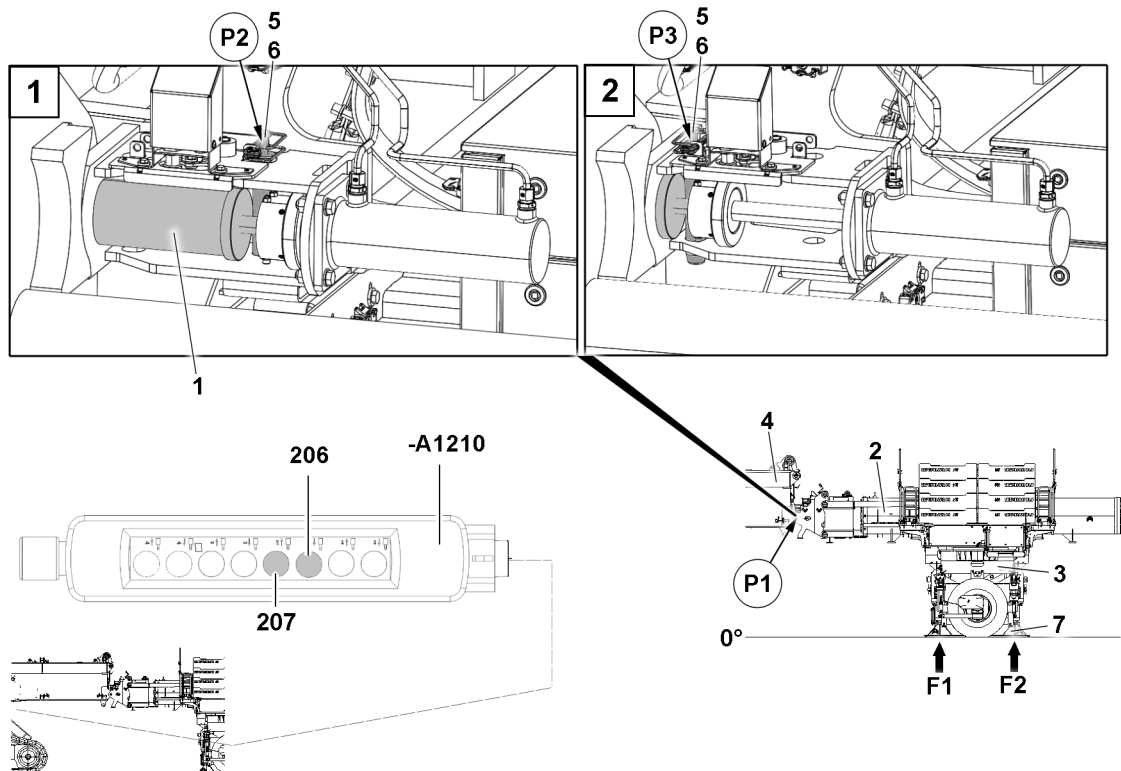


Fig.163033: Pinning the ballast trailer on the turntable – Pinning procedure

- |   |                       |   |                   |
|---|-----------------------|---|-------------------|
| 1 | Pin                   | 5 | Retaining pin     |
| 2 | Ballast trailer guide | 6 | Retaining element |
| 3 | Ballast trailer       | 7 | Support           |
| 4 | Turntable             |   |                   |

Move the crane to the ballast trailer guide such that the pin points would align when extending the ballast trailer guide

A distance must remain between the crane and the ballast trailer guide.

- ▶ Position the crane with respect to the ballast trailer guide.

#### NOTICE

No monitoring when positioning the turntable!

When positioning the turntable, the crane can be damaged.

- ▶ Have positioning monitored by a guide.

- ▶ Extend the ballast trailer guide 2 until the ballast trailer 3 and turntable 4 are positioned such that the pin bores align.
- ▶ Remove the retaining element 6 in position P2.
- ▶ Unpin the retaining pin 5 in position P2.
- ▶ Pin the ballast trailer 3 with the turntable: Press the button 207 on the control panel -A1210 until the pins 1 are completely inserted.

**Note**

- ▶ The crane control recognizes with the left and right limit switch initiators of the pin points, if the pins **1** on the turntable are fully inserted.
- ▶ If both pins **1** are fully and correctly inserted, the crane control receives the message, "Ballast trailer installed on left" and "Ballast trailer installed on right" via the limit switch initiators. Which means: The turntable can no longer be turned and the crawler cannot be moved.
- ▶ If only one pin **1** is pinned and if the crane control therefore has only one message "Ballast trailer installed" from a limit switch initiator, then the turntable can be turned anyway and the crane can be moved!
- ▶ After pinning, it must be checked again if the electrical and hydraulic connection lines are fully and correctly connected.
- ▶ The control release for the crane only occurs when the wheels sets are in one of the required positions, "Circular travel", "Towing" or "Parallel travel".

**NOTICE**

Careless positioning of the pin bores!  
The crane and ballast trailer can be severely damaged.

If one of both pins is not completely inserted:

- ▶ Position the crane with extreme caution and at the lowest possible speed so that the two pin bores align.
- ▶ Check if both pins **1** are inserted completely.

**Problem remedy**

Can the second pin **1** not be inserted?

The ballast trailer **3** and turntable **4** are not exactly aligned.

- ▶ Slightly lift or lower the ballast trailer **3** over the support **7**.
- ▶ Carefully telescope the ballast trailer guide **2** in or out.
- ▶ Carefully swing the turntable **4**.

When the second pin bore aligns between the turntable **4** and the ballast trailer guide **2**:

- ▶ Insert the second pin **1** in the same way as described above.

- ▶ Insert the retaining pin **5** in position **P3**.
- ▶ Secure the retaining pin **5** with the retaining element **6** in position **P3**.

**Result:**

- The pins **1** are inserted and secured on both sides.
- The ballast trailer **3** is pinned on the turntable.

## 12.6 Disassembling the electrical and hydraulic extension lines

**WARNING**

Danger of accident due to loss of pressure or leakage!  
Death, severe bodily injuries, property damage.

- ▶ Make sure that the specifications for establishing and releasing hydraulic and electrical connections are observed.
- ▶ See section "Work on the electrical connections".
- ▶ See section "Work on the hydraulic connections".

Make sure that the following prerequisites are met:

- The pressure in the hydraulic system has been released.
- ▶ Disassemble the electrical extension lines between the turntable and the ballast trailer, see the wiring diagram.
- ▶ Disassemble the hydraulic extension lines between the turntable and the ballast trailer, see the hydraulic diagram.

## 12.7 Establishing the hydraulic and electric connections between the ballast trailer and turntable

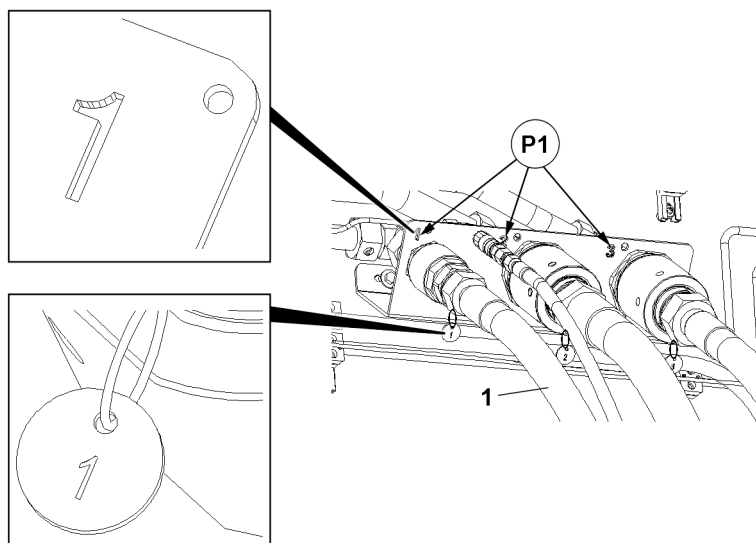


Fig.163042: Establishing the hydraulic and electric connections between the ballast trailer and turntable – Marking

1 Hydraulic line



### Note

- ▶ The hydraulic lines **1** and assembly positions **P1** are marked with numbers.
- ▶ The markings on the hydraulic lines **1** and assembly positions **P1** must be identical.

Make sure that the following prerequisites are met:

- The pressure in the hydraulic system has been released.

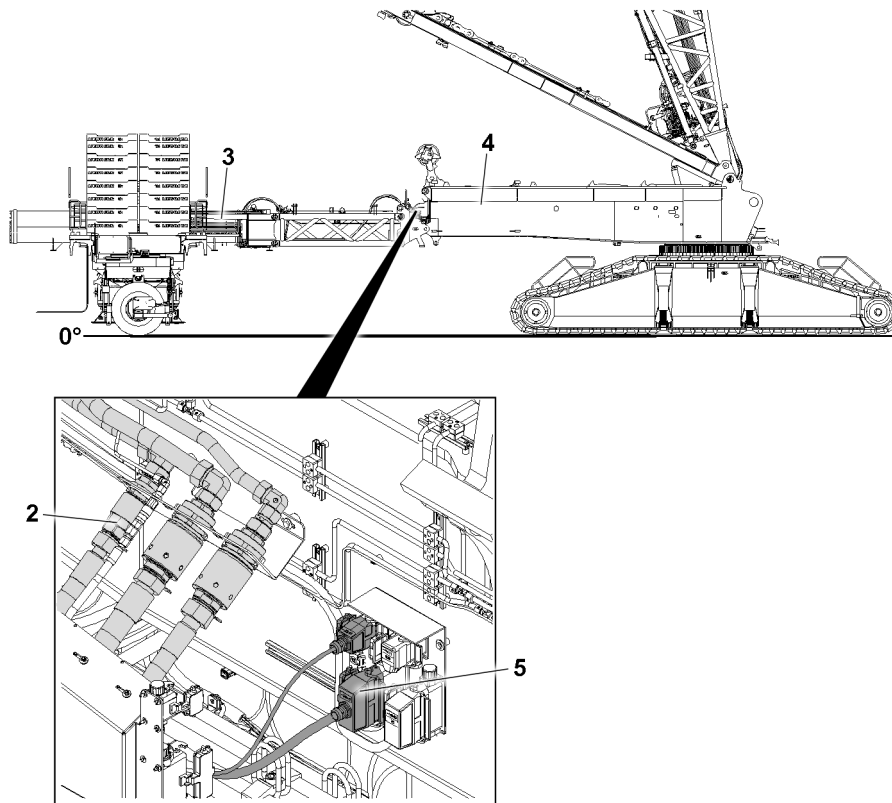


Fig.163041: Establishing the hydraulic and electric connections between the ballast trailer and turntable – Establishing the connections

- |   |                      |   |                       |
|---|----------------------|---|-----------------------|
| 2 | Hydraulic connection | 4 | Turntable             |
| 3 | Ballast trailer      | 5 | Electrical connection |

- ▶ Establish the hydraulic connections 2 between the ballast trailer 3 and the turntable 4, see the hydraulic diagram.

#### NOTICE

Switched on ignition!

If live current carrying electrical connections are disconnected or connected, then there is the danger that components can be damaged.

The crane functions can be limited.

- ▶ De-energize the electrical connections before disconnection or connection. Turn the ignition off.

- ▶ Set the ignition switch to position "0".
- ▶ Establish the electrical connections 5 between the ballast trailer 3 and the turntable 4, see the wiring diagram.

## 12.8 Triggering intermediate lubrication on the ballast trailer

#### NOTICE

Not enough fresh grease!

If intermediate lubrication is not triggered, it is possible that the components are not supplied with enough fresh grease.

Components can be damaged.

- ▶ Intermediate lubrication must be carried out twice.

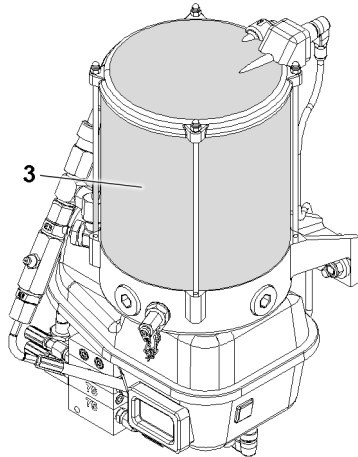


Fig.163121: Checking the grease level in the reservoir

**3** Reservoir

- ▶ Check, if the reservoir **3** for the central lubrication system on the ballast trailer is filled more than 25 percent.

---

**Problem remedy**

Is the reservoir **3** filled less than 25 percent?

- ▶ Fill the reservoir **3** completely with grease, see the service fill.
- 

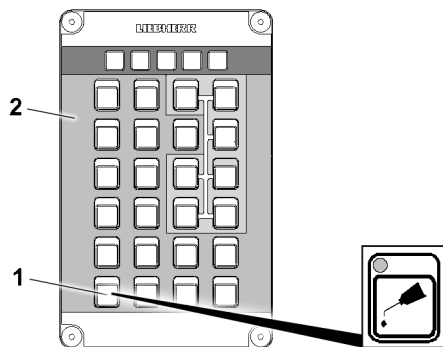


Fig.163120: Triggering intermediate lubrication on the ballast trailer

**1** Button

**2** BKE

Pressing the button **1** starts operation of the central lubrication system in the entire crane.

- ▶ Press the button **1** on the BKE **2**.
- ▶ Wait until the lubrication cycle of the intermediate lubrication is complete.
- ▶ Trigger the lubrication cycle a second time by pressing the button **1**.
- ▶ Wait until the lubrication cycle of the intermediate lubrication is complete.

## 12.9 Retracting the support cylinders

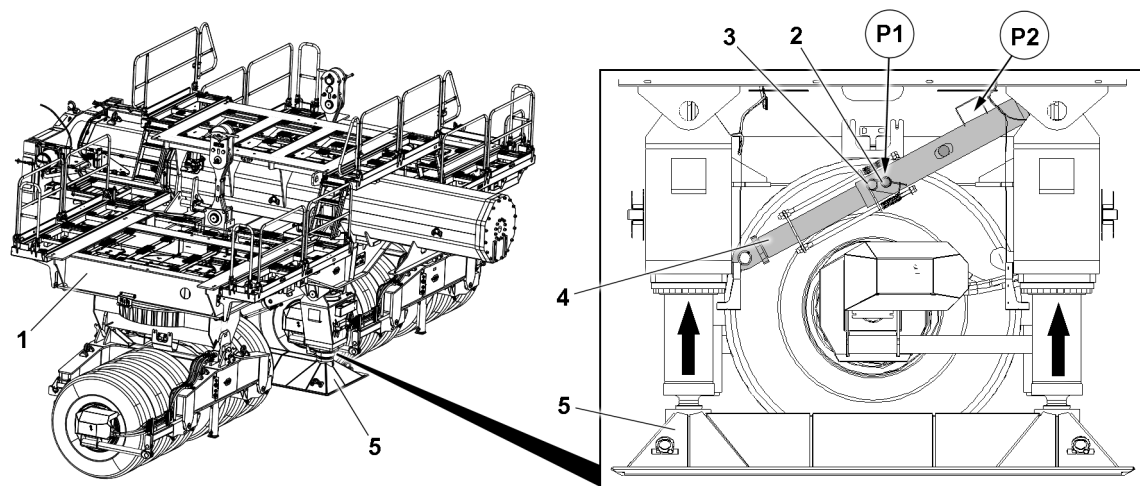


Fig.163045: Retracting the support cylinders – Overview

- |   |                   |   |                  |
|---|-------------------|---|------------------|
| 1 | Ballast trailer   | 4 | Strut            |
| 2 | Locking pin       | 5 | Support cylinder |
| 3 | Retaining element |   |                  |

### NOTICE

Supports with inserted locking pins 2!  
Property damage.

When the ballast trailer 1 is ballasted and the strut 4 is pinned in point P1:

- ▶ Supports prohibited.



### Note

- ▶ When the ballast trailer 1 is assembled and ballasted on the turntable, the locking pin 2 **must** be unpinned so that when supporting it is possible to balance the force between the strut 4 and the support cylinders 5.

Make sure that the following prerequisites are met:

- The ballast trailer 1 is pinned and secured on the turntable.
- The electrical and hydraulic connection lines are connected.

## Retracting the support cylinder 5 using the control panel -A1210

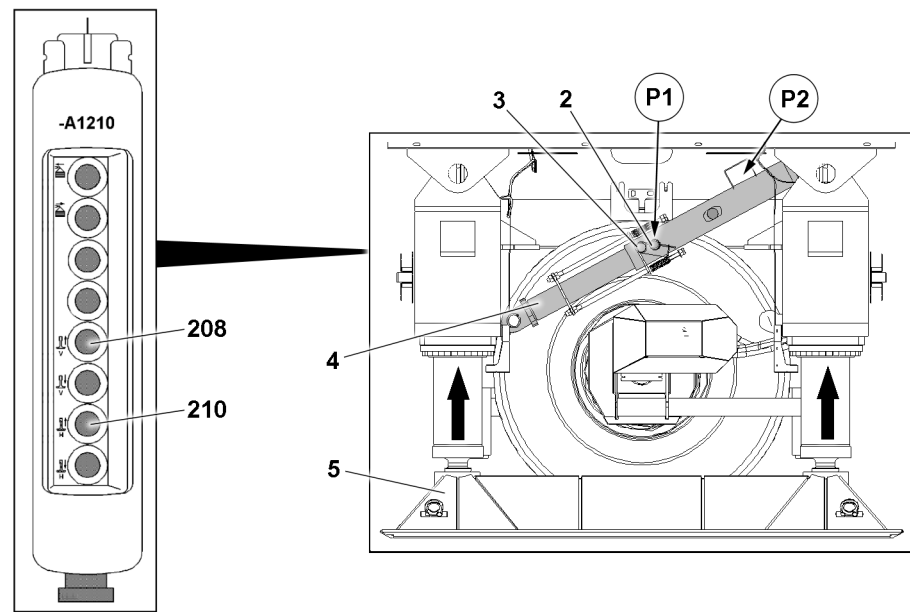


Fig.163046: Retracting the support cylinders using the control panel -A1210

- Control panel

4 Strut

**A12**

**10**

**2** Locking pin

**5** Support cylinder

**3** Retaining element

- ▶ Press the button **208** and button **210** on the control panel **-A1210** until the support cylinders **5** are relieved.

When the support cylinders **5** are relieved:

- ▶ Release the locking pin **2** in point **P1** and unpin.
- ▶ Insert the locking pin **2** in point **P2** and secure it with the retaining element **3**.
- ▶ Retract the support cylinders **5** completely.

### Retracting the support cylinder 5 using the button on the crane cab instrument panel

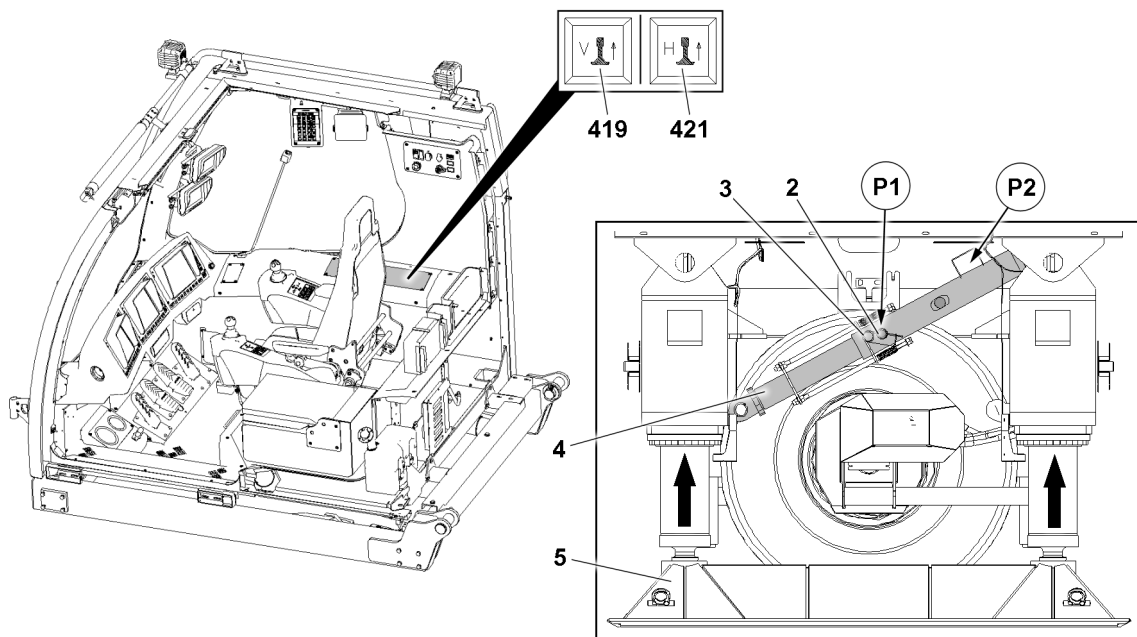


Fig.163047: Retracting the support cylinder using the button in the crane cab

<b>419</b> Button	<b>3</b> Retaining element
<b>421</b> Button	<b>4</b> Strut
<b>2</b> Locking pin	<b>5</b> Support cylinder

- ▶ Press the button **419** and button **421** in the crane cab until the support cylinders **3** are relieved.

When the support cylinders **5** are relieved:

- ▶ Release the locking pin **2** in point **P1** and unpin.
- ▶ Insert the locking pin **2** in point **P2** and secure it with the retaining element **3**.
- ▶ Retract the support cylinders **5** completely.



## Retracting the support cylinder 5 using master switch 3

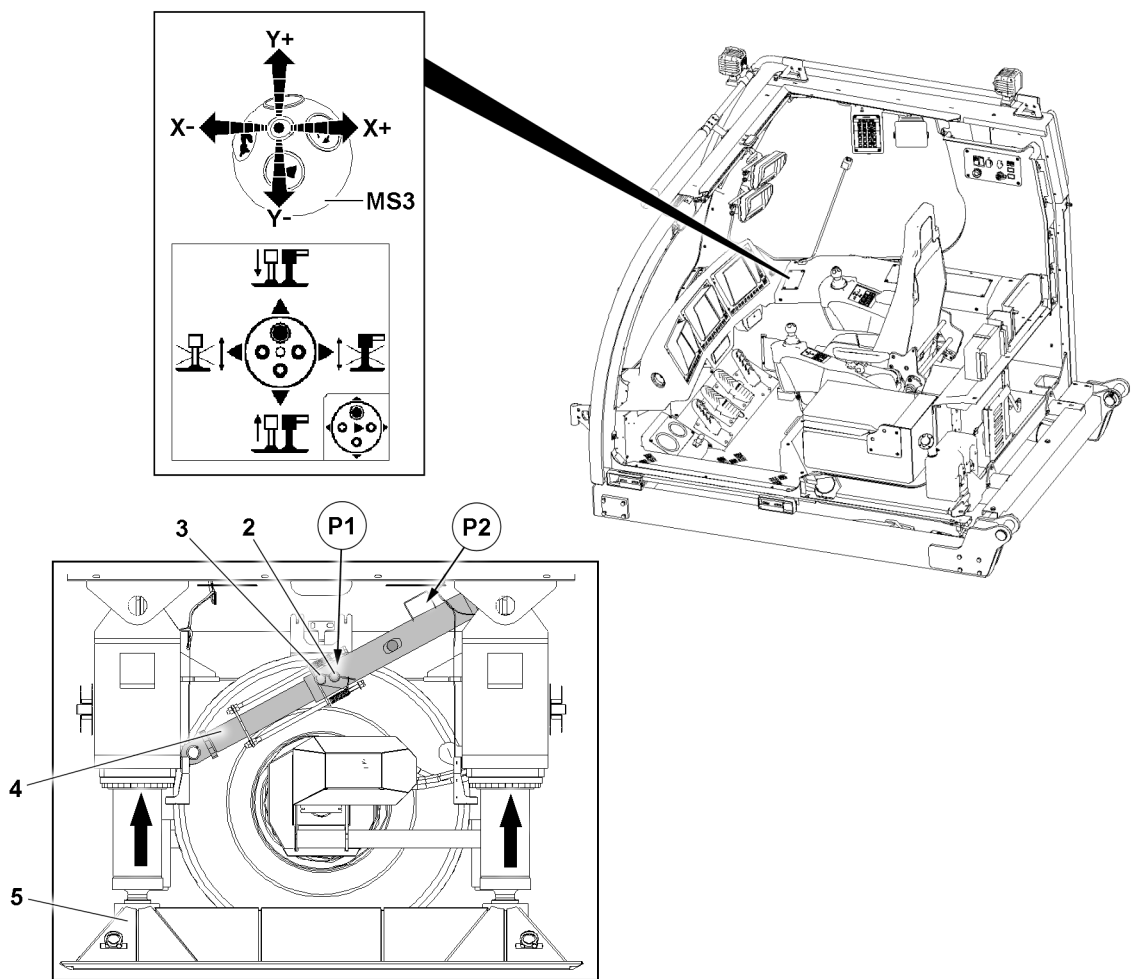


Fig.163048: Retracting the support cylinder with master switch 3

<b>MS3</b> Master switch 3	<b>4</b> Strut
<b>2</b> Locking pin	<b>5</b> Support cylinder
<b>3</b> Retaining element	

When the corresponding master switch assignment is selected:

- ▶ Actuate master switch 3 **MS3** in direction **Y-** until the support cylinders are relieved.

When the support cylinders **5** are relieved:

- ▶ Release the locking pin **2** in point **P1** and unpin.
- ▶ Insert the locking pin **2** in point **P2** and secure it with the retaining element **3**.
- ▶ Retract the support cylinders **5** completely.

**Result:**

- A visual display appears on LICCON monitor LM2.

## 12.10 Assembling the ballast trailer guying on the ballast trailer

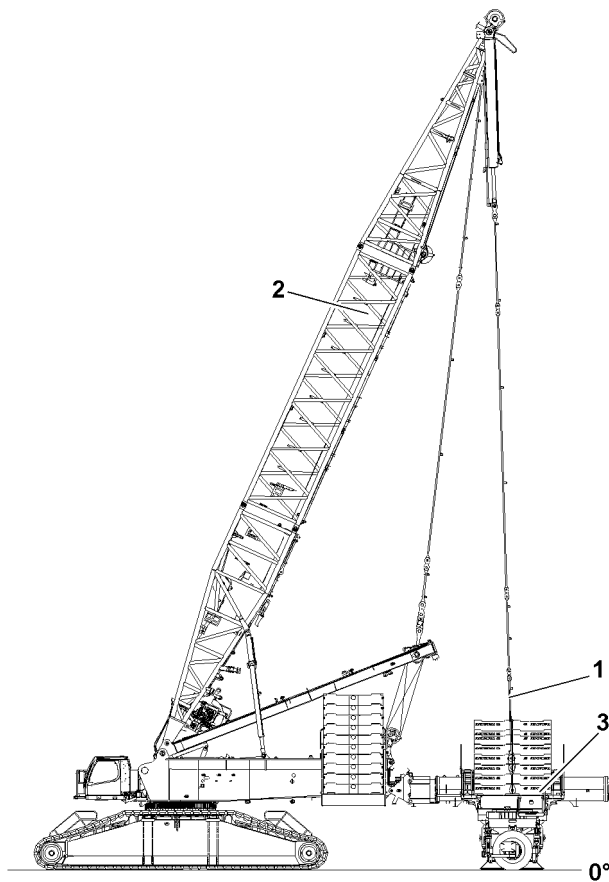


Fig.163034: Assembling the ballast trailer guying on the ballast trailer – Overview

- |   |              |   |                 |
|---|--------------|---|-----------------|
| 1 | Guy rod      | 3 | Ballast trailer |
| 2 | Derrick boom |   |                 |



### Note

- ▶ The guy rods **1** of the ballast trailer **2** must be assembled and secured according to the data in the Rod plan.
- ▶ The numbering on the rod plan and the numbering of the guy rods **1** must be identical.



### Note

- ▶ Adjust the derrick boom **2** and ballast trailer **3** to the same radius if possible.
- ▶ The derrick boom can be moved maximum to the electrical switch position. If the ballast trailer radius is larger, the guy rods **1** must be pulled with the auxiliary crane to the pin point.

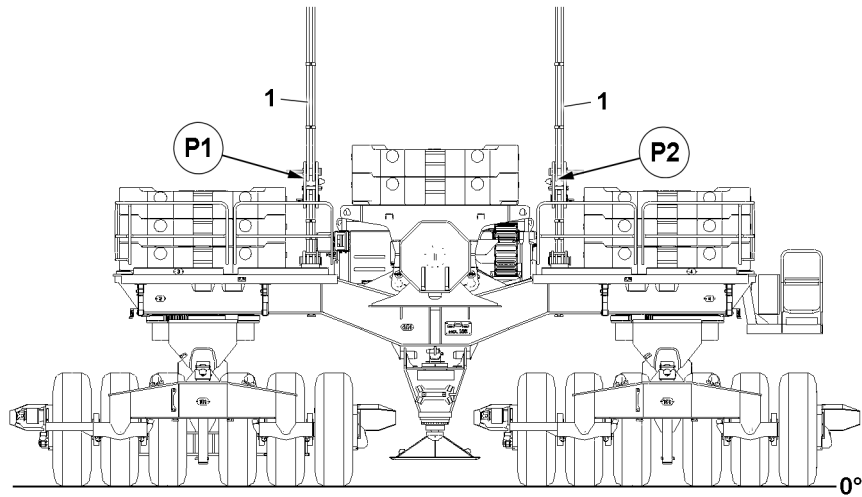


Fig.163038: Assembling the ballast trailer guying on the ballast trailer – Pin points

1 Guy rod



**Note**

- ▶ The connection of the guy rods **1** is described based on the example of the guy rods **1** in position **P1** and applies in the same manner for the guy rods **1** in position **P2**.

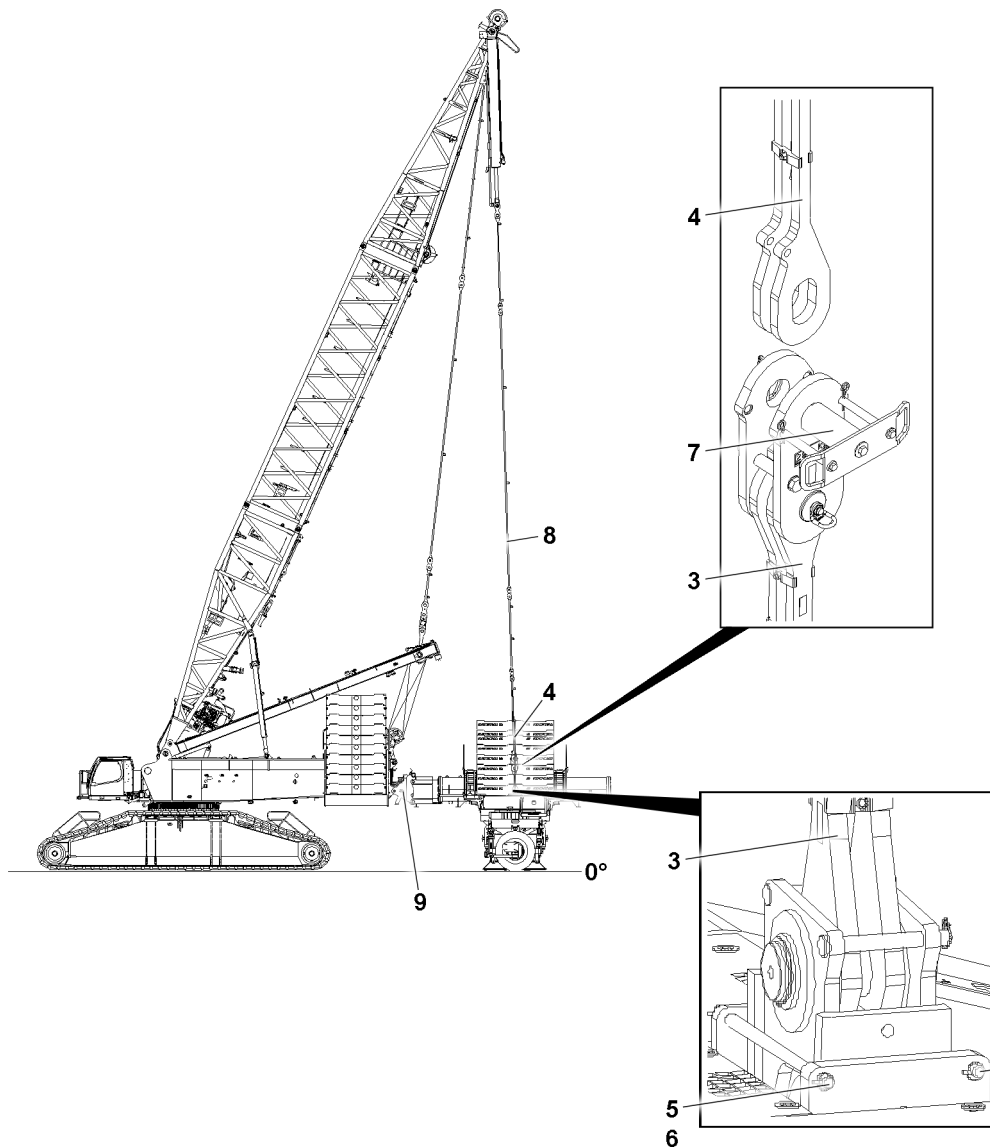


Fig.163037: Assembling the ballast trailer guying on the ballast trailer – Pinning procedure

3	Guy rod	7	Pin
4	Guy rod	8	Ballast guy rod
5	Retaining pin	9	Adapter
6	Retaining element		

Make sure that the following prerequisites are met:

- The guy rods **3** are secured on both sides in the assembly position with the retaining pin **5** and retaining element **6**, see section “Assembling the pull brackets in the assembly position”.
- The pin **7** is unpinned.
- The guy rods **4** are removed from the transport position on the adapter **9** and pinned and secured with the ballast guy rods **8**.
- The extension ladder is assembled on the ballast trailer guide, see section “Assembling the extension ladder on the ballast trailer guide”.

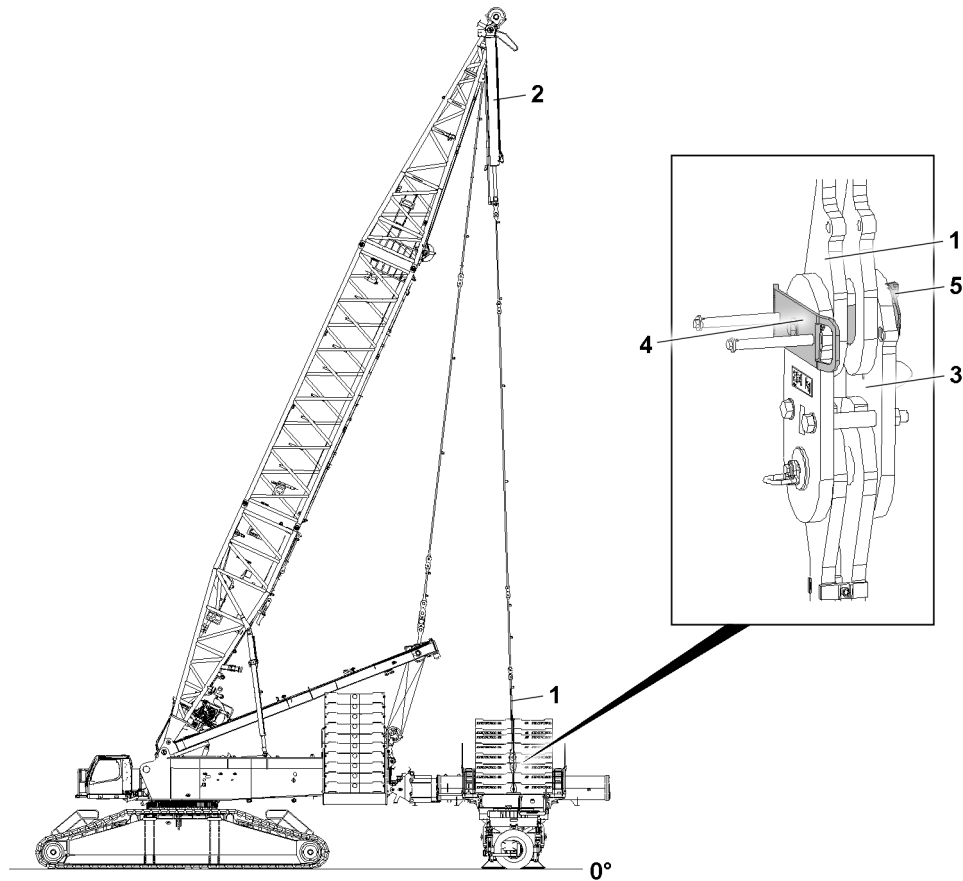


Fig.163039: Assembling the ballast trailer guying on the ballast trailer – Pin retention

- |   |               |   |                   |
|---|---------------|---|-------------------|
| 1 | Guy rod       | 4 | Pin               |
| 2 | Pull cylinder | 5 | Retaining element |
| 3 | Pull bracket  |   |                   |



#### Note

Retract / extend the pull cylinder **2**.

- ▶ Control the pull cylinders **2** from the crane cab or with the control panel, see section “Lifting and lowering the ballast trailer with the pull cylinders”.
- ▶ Operate the pull cylinder **2** with the radio remote control, see the “radio remote control operating instructions”.

- ▶ Position the guy rod **1** with the aid of the pull cylinder **2** such that it can be pinned with the pull bracket **3**.

When the pin bores align:

- ▶ Insert the pin **4**.
- ▶ Secure the pin **4** with the retaining element **5**.
- ▶ Repeat the procedure in the same way as described above for the other guy rods **1**.

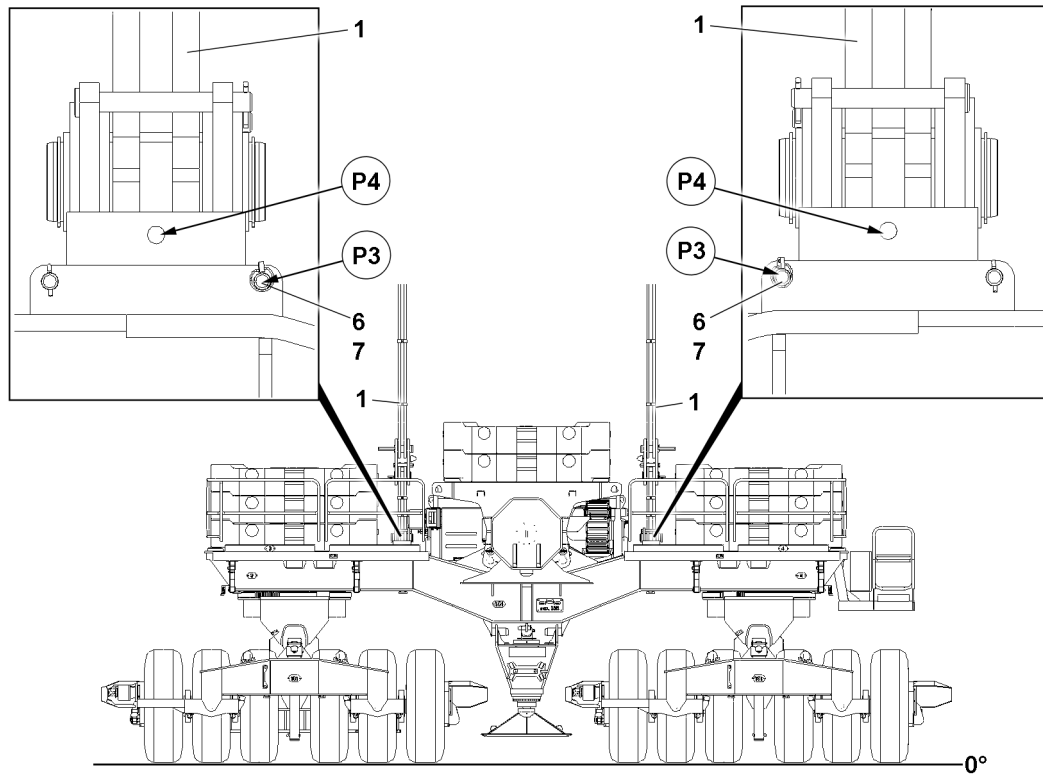


Fig.163040: Assembling the ballast trailer guying on the ballast trailer – Assembling the retaining element in the park position

- |   |               |   |                   |
|---|---------------|---|-------------------|
| 1 | Guy rod       | 7 | Retaining element |
| 6 | Retaining pin |   |                   |



#### CAUTION

Hands in the danger zone!

Danger of crushing.

When releasing the retaining pins, the guy rods can tip to the side.

- ▶ Keep hands away from the danger zone.

Only the retaining pins located on the inside are assembled from the assembly position **P3** in the park position **P4**.

- ▶ Release the retaining pin **6**: Remove the retaining elements **7**.
- ▶ Release the guy rod **1**: Remove the retaining pin **6** in positions **P3**.
- ▶ Insert the retaining pin **6** in the park positions **P4**.
- ▶ Secure the retaining pin **6** with retaining elements **7**.
- ▶ When the retaining pins **6** are pinned and secured on both sides in the park position **P4**:
- ▶ Retract the pull cylinder **2**.

#### Result:

- The ballast trailer guying is tensioned.

## 13 Ballasting the ballast trailer

Make sure that the following prerequisites are met:

- The ballast trailer is properly assembled and secured.
- An auxiliary crane is on hand.
- The ground on which the ballasting is carried out is sufficiently level and load-bearing.

## 13.1 Derrick ballast composition



### Note

- ▶ Ballast plates with 5 t , 7.5 t and 10 t can be used combined.
- ▶ Examples of derrick ballast combinations are listed below.
- ▶ Individual weights are rounded.

### 13.1.1 Component weight for the Set up program

Component	Weight	Set up value <sup>1)</sup>
Relevant guying weight for derrick boom length 33 m (D-33)	5.3 t	5 t
Relevant guying weight for derrick boom length 39 m (D-39)	6.1 t	6 t
Relevant guide weight 14 m - 19 m	15 t	15 t
Relevant guide weight 18 m - 23 m	17.5 t	17.5 t
Relevant ballast trailer weight	62.5 t	60 t

*Component weight for the Set up program*

1) rounded

### 13.1.2 Derrick ballast weights



### Note

- ▶ Change positioned ballast plates within the permissible range to implement other derrick ballast weights.



### Note

Derrick ballast in travel operation with a set up crane.

- ▶ To drive the crane (crawler operation) without derrick ballast, it is normally sufficient for the guying from the derrick ballast to the ballast trailer to be completely unloaded, see chapter 4.10.
- ▶ Observe the specifications for travel operation.

Derrick ballast	Composition	Individual weight	Quantity
5 t	Relevant guying weight (D-33) <sup>1)</sup>	5 t	No. 1

*Derrick ballast combination 5 t*

1) For (D-39) the weight for the relative guying is 1 t higher.

Derrick ballast	Composition	Individual weight	Quantity
80 t	Relevant guying weight (D-33) <sup>1)</sup>	5 t	No. 1
	Relevant guide weight 14 m - 19 m	15 t	No. 1
	Relevant ballast trailer weight	60 t	No. 1
	Without ballast plates	0 t	-

*Derrick ballast combination 80 t*

1) For (D-39) the weight for the relative guying is 1 t higher.

Derrick ballast	Composition	Individual weight	Quantity
82.5 t	Relevant guying weight (D-33) <sup>1)</sup>	5 t	No. 1
	Relevant ballast trailer with guide weight 18 m - 23 m	17.5 t	No. 1
	Relevant ballast trailer weight	60 t	No. 1
	Without ballast plates	0 t	-

#### Derrick ballast combination 82.5 t

1) For (D-39) the weight for the relative guying is 1 t higher.

Derrick ballast	Composition	Individual weight	Quantity
400 t	Relevant guying weight (D-33) <sup>1)</sup>	5 t	No. 1
	Relevant ballast trailer with guide weight 14 m - 19 m	15 t	No. 1
	Relevant ballast trailer weight	60 t	No. 1
	Ballast plates	10 t	Qty 32

#### Derrick ballast combination 400 t

1) For (D-39) the weight for the relative guying is 1 t higher.

Derrick ballast	Composition	Individual weight	Quantity
400 t	Relevant guying weight (D-33) <sup>1)</sup>	5 t	No. 1
	Relevant ballast trailer with guide weight 18 m - 23 m	17.5 t	No. 1
	Relevant ballast trailer weight	60 t	No. 1
	Ballast plates	7.5 t	No. 1
	Ballast plates	10 t	No. 31

#### Derrick ballast combination 400 t

1) For (D-39) the weight for the relative guying is 1 t higher.

## 13.2 Permissible ballast assemblies

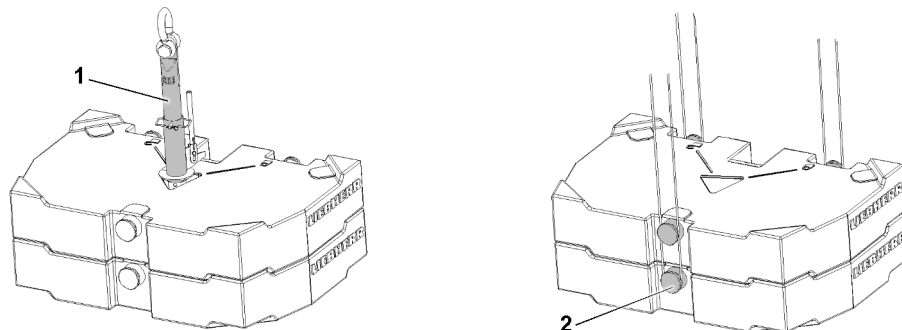


Fig.163049: Lifting the ballast plates together

1 Twistlock receptacle stud

2 Bitt



**WARNING**

Overload of the counterweight assembly fastening points!

If more than the permissible number of counterweights are lifted together, then the fastening points can be overloaded.

The counterweights and components can fall down.

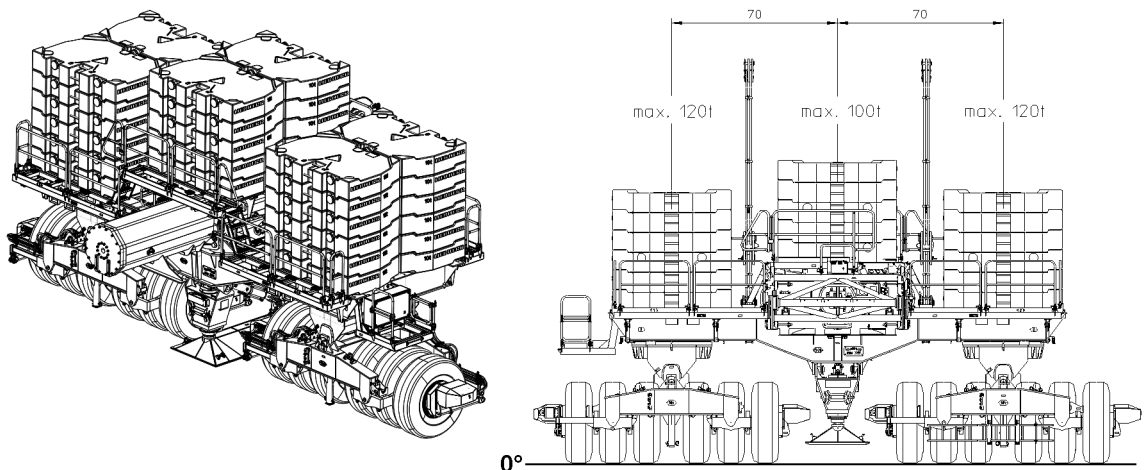
Death, severe bodily injuries, property damage.

- ▶ Fasten only the maximum permissible number of counterweights per stroke.

Individual weight	Maximum number of the same counterweight plates per stroke over	
	Ballast plate	Twistlock receptacle stud
5.0 t	2	1
7.5 t	2	2
10.0 t	2	2

*Lifting the ballast plates*

### 13.3 Ballasting rules



*Fig.159322: Ballasting the ballast trailer*

**WARNING**

Failure to observe the ballasting rules!

Death, severe bodily injuries, property damage.

- ▶ The ground on which ballasting takes place must be level ( $\pm 1^\circ$ ) and have an adequate load bearing capacity.
- ▶ Always place the ballast plates symmetrically, in reference to the longitudinal axis.
- ▶ Stack the ballast plates according to the load chart and the erection / take-down charts.
- ▶ The relevant weight of the guying (D-33) is 5 t.
- ▶ The relevant weight of the guying (D-39) is 6 t.
- ▶ The maximum permissible ballasting of the ballast trailer may not exceed 340 t.
- ▶ The maximum permissible total weight of the ballast trailer inclusive ballast plates is 400 t.
- ▶ The outer ballast stacks must always weigh the same and have the same height after ballasting.
- ▶ The outer ballast stacks can differ in stack height from the inner ballast stacks.
- ▶ Secure all ballast plates so they cannot move and fall down.
- ▶ Do not stack more than 25 t on a 5 t ballast plate.
- ▶ Replace damaged ballast plates immediately with new ballast plates.
- ▶ Observe the weight signs on the ballast pallets.

**Note**

Ballast plates with and without Twistlock:

- ▶ Ballast plates without Twistlock can differ slightly in height.

**Note**

▶ Ballast plates with 5 t , 7.5 t and 10 t can be used combined.

- ▶ Examples of central ballast combinations with ballast plates 10 t are shown below.

### 13.4 Variation 1: Placing the ballast plates, fastening system: "Twistlock"

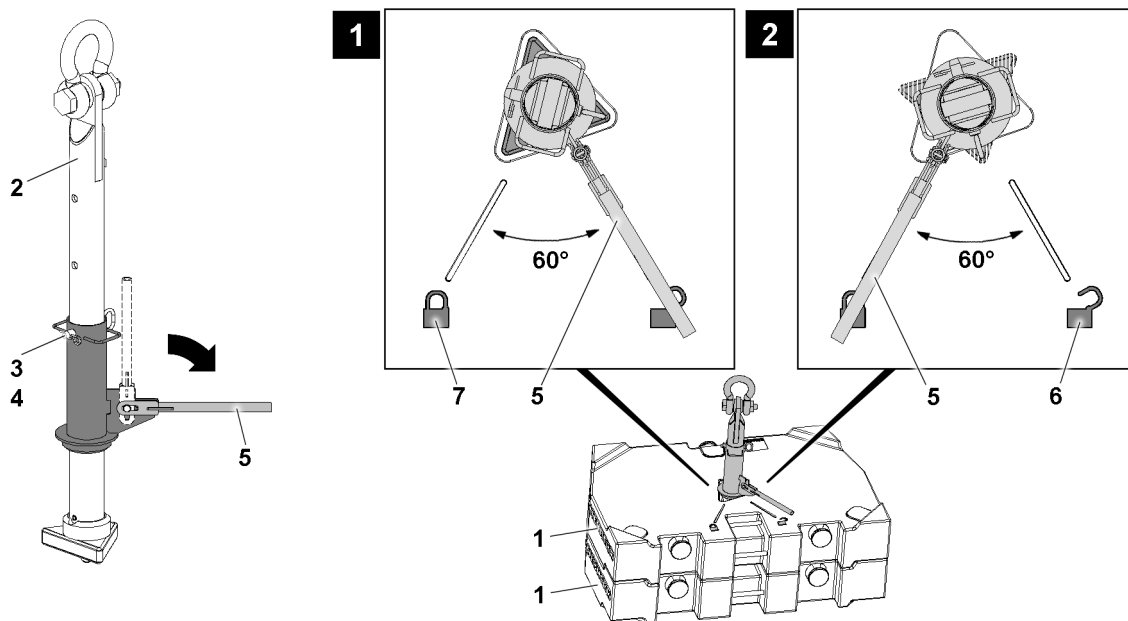


Fig.157149: Ballast plates, fastening system: "Twistlock"

- |   |                   |   |                 |
|---|-------------------|---|-----------------|
| 1 | Ballast plate     | 5 | Lever           |
| 2 | Receptacle stud   | 6 | "Unlocked" icon |
| 3 | Pin               | 7 | "Locked" icon   |
| 4 | Retaining element |   |                 |

**WARNING**

Use of damaged ballast plates 1!

Death, severe bodily injuries, property damage.

- ▶ Replace damaged ballast plates 1.

- ▶ Check if the ballast plate 1 is damaged.

If the ballast plate 1 is damaged:

- ▶ Replace the ballast plate 1.
- ▶ Check if the length of the receptacle stud 2 is properly adjusted.

If the length of the receptacle stud 1 is to be adjusted:

- ▶ Release and unpin the pin 3.
- ▶ Adjust the length of the receptacle stud by moving the receptacle stud 2.
- ▶ Insert the pin 3 and secure it with the retaining element 4.

**WARNING**

Lifting of impermissible ballast assemblies!

If more than the permissible ballast plates **1** are lifted with the receptacle stud **2**, the receptacle stud **2** is overloaded and will be damaged.

Death, severe bodily injuries, property damage.

- ▶ Apply the ballast plates **1** individually or as an assembly see section "Permissible ballast assemblies".

- ▶ Fasten the receptacle stud **2** to the auxiliary crane and guide it into the ballast plate(s) **1**.
- ▶ Pull the lever **5** up and fold it down.
- ▶ Turn the lever **5** from the "unlocked" icon **6** to the "locked" icon **7** and lift slightly.

**Result:**

- The receptacle stud **2** is locked with the ballast plate **1**, see illustration **2**.

**WARNING**

The receptacle stud is not completely locked!

If the receptacle stud **2** is not correctly locked, the Twistlock system can open by itself.

The ballast plates **1** can fall down.

Death, severe bodily injuries, property damage.

- ▶ Make sure, when initiating a stroke, that the lever **5** points directly to the "Locked" icon **7** of the ballast plates **1**.

**Note**

- ▶ During a stroke, a locked Twistlock system cannot release by itself due to its gravitational retention.
- ▶ During a stroke, a locked Twistlock system cannot be released by hand due to its gravitational retention.

- ▶ Lift the ballast plate(s) **1**.

**WARNING**

Imprecise positioning of the ballast plate(s) **1**!

Death, severe bodily injuries, property damage.

The ballast plate(s) **1** can fall down.

- ▶ Make sure that the ballast plate(s) **1** are correctly centered.

- ▶ Take the ballast plate(s) **1** down individually or as an assembly onto the centerings of the divisible ballast pallet "VarioTray", or of another ballast plate.

When the ballast plate(s) **1** are taken down:

- ▶ Turn the lever **5** from the "locked" icon **7** to the "unlocked" icon **6**.

**Result:**

- The receptacle stud **2** is unlocked, see illustration **1**.
- ▶ Carefully pull the receptacle stud **2** out of the ballast plate(s) **1**.
- ▶ Stack the ballast plates **1** according to the load chart, observe the ballasting rules.

## 13.5 Variation 2: Placing the ballast plates, fastening points: "Bitt"

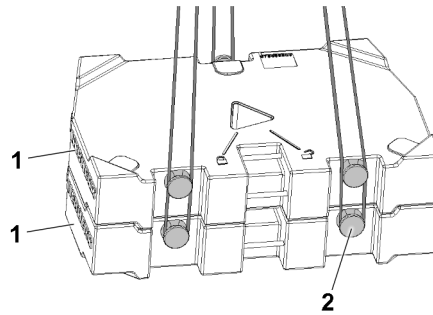


Fig.163050: Ballast plates, fastening points: "Bitt"

1 Ballast plate

2 Bitt



### WARNING

Use of damaged ballast plates 1!  
Death, severe bodily injuries, property damage.

- ▶ Replace damaged ballast plates 1.

- ▶ Check if the ballast plate 1 is damaged.

If the ballast plate 1 is damaged:

- ▶ Replace the ballast plate 1.



### WARNING

Lifting of impermissible ballast assemblies!

If more than the permissible ballast plates 1 are lifted, the bits 2 are overloaded and the ballast plates 1 can fall down.

Death, severe bodily injuries, property damage.

- ▶ Apply the ballast plates 1 individually or as an assembly, 3 fastening points, see section "Permissible ballast assemblies".



### WARNING

Incorrect fastening!

If fastening equipment cannot be fastened correctly and if it is not secured to prevent it from loosening up, loads can fall down.

Death, severe bodily injuries, property damage.

- ▶ Make sure that the fastening equipment is correctly attached to the bits 2 and secured to prevent it from loosening up.

- ▶ Place always only one ballast plate on each outer centering device on the ballast trailer frame.

When one ballast plate has been placed on each outer centerings of the ballast trailer frame:

- ▶ Place the ballast plates individually or as an assembly of maximum two plates alternately on the left and right with the auxiliary crane.

When the ballast plate(s) 1 are taken down:

- ▶ Remove the fastening equipment on the bits 2.
- ▶ Stack the ballast plates according to the load chart, observe the danger notes.

## 14 Working with the ballast trailer



### WARNING

The crane can topple over!

If the ballast trailer is lifted off the ground past the **maximum permissible** 250 mm, then the crane can topple over to the rear if the load rips off.

Death, severe bodily injuries, property damage.

- ▶ Do not lift the ballast trailer more than 250 mm off the ground.

### 14.1 Turning the ballast trailer off

Make sure that the following prerequisites are met:

- The incline of the base / travel route of the ballast trailer is  $0^\circ \pm 1.5^\circ$ .
- The base / travel route of the ballast trailer is sufficiently level and capable of supporting the load.
- The ballast trailer guide is fully retracted.

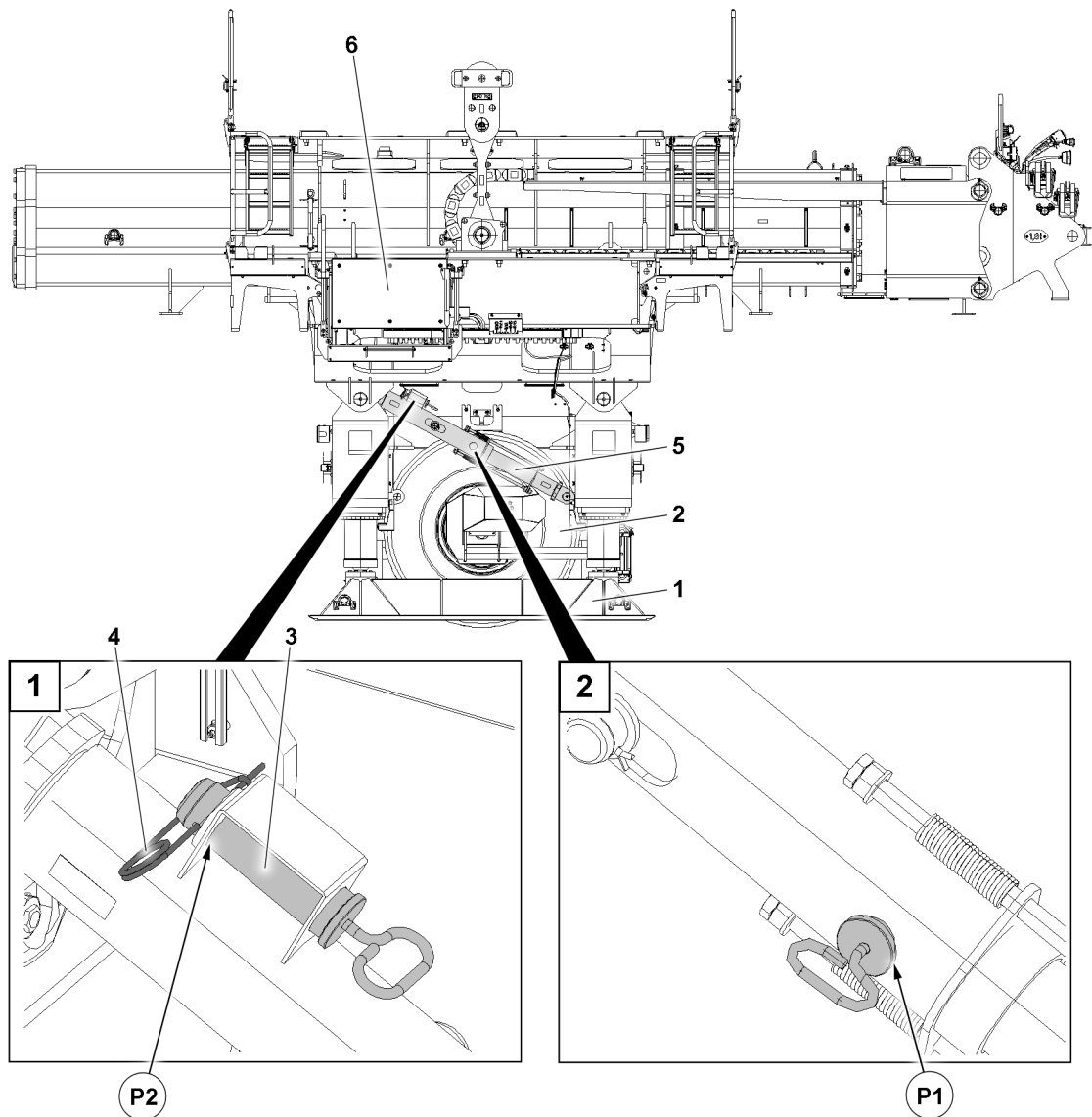


Fig.162993: Pin points with ballast trailer turned off

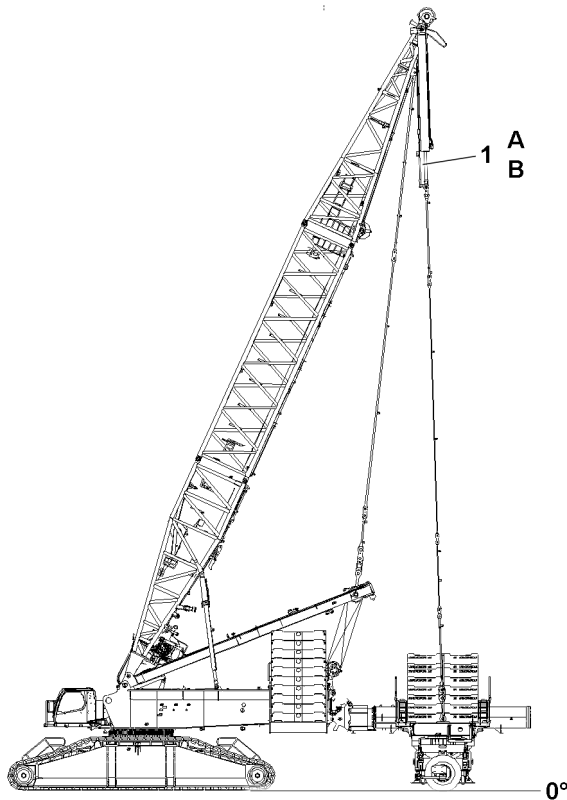
- ▶ Extend the support 1 until the tires 2 are relieved.

**WARNING**

The pin **3** on the strut **5** is not inserted!  
 Death, severe bodily injuries, property damage.  
 Toppling ballast trailer **6**.

- ▶ Before assembly and disassembly of the ballast trailer **6** on the turntable, insert the pin **3** in the strut **5** (position **P1**).
- 
- ▶ Release the pin **3**.
  - ▶ Unpin the pin **3** from the park position **P2**.
  - ▶ Pin the strut **5**: Insert the pin **3** in point **P1**.
  - ▶ Secure the pin **3** with the retaining element **4**.

## 14.2 Lifting and lowering the ballast trailer with the pull cylinders



*Fig.163051: Lifting and lowering the ballast trailer with the pull cylinders*

The pull cylinders **1** in the derrick ballast guying can be operated in different ways:

- Operating buttons on the crane operator cab instrument panel
- Control panel -A1230
- Master switch MS1 in the corresponding master switch assignment
  - Select the master switch assignment for master switch MS1, see chapter 4.05.
- Operation with the radio remote control (BTT-E)
  - Operation with the manual control lever in the corresponding assembly menu, see the radio remote control operating instructions.

**Note**

- ▶ If the ballast trailer is raised or lowered, then the horizontal alignment of the ballast trailer is automatically regulated by a level sensor.
- ▶ For a ballast utilization of **more than or equal** to 90 percent, the level sensor regulates the pull cylinder **1** to a difference of 1 cm.
- ▶ With a ballast utilization of **less** than 90 %, the level sensor regulates the ballast trailer level to  $\pm 2.5^\circ$ . This makes it possible to set down the ballast trailer on a ground slope of up to  $2.5^\circ$ .
- ▶ As soon as the ballast trailer has been lifted completely off the ground and hangs freely, by turning on the "Derrick ballast lifted" function, the turning and driving functions can be released independently of the steering program.
- ▶ From a ground slope of  $\pm 1.5^\circ$ , driving with the ballast trailer is no longer possible or only with limits.

**DANGER**

Danger of accident!

Death, severe bodily injuries, property damage.

- ▶ When lifting or lowering the ballast trailer, pay attention to the horizontal alignment of the ballast trailer.
- ▶ When lifting and lowering the ballast trailer, check the forces in the D-guyings regularly on the LICCON monitor. If the difference in forces between "derrick ballast guying A" and "derrick ballast guying B" is too large, an acoustic warning sounds and the values on the LICCON monitor blink, refer to section "Differential force monitoring of ballast guying".
- ▶ When carrying out the "Stop cylinder A" or "Stop cylinder B" function, the level sensor is bypassed and the ballast trailer can be inclined within the limited angle range. This is only permitted when stopping the ballast trailer on uneven ground and using utmost caution.

### 14.2.1 Lifting the ballast trailer

Lift the ballast trailer with the operating buttons on the crane operator cab instrument panel

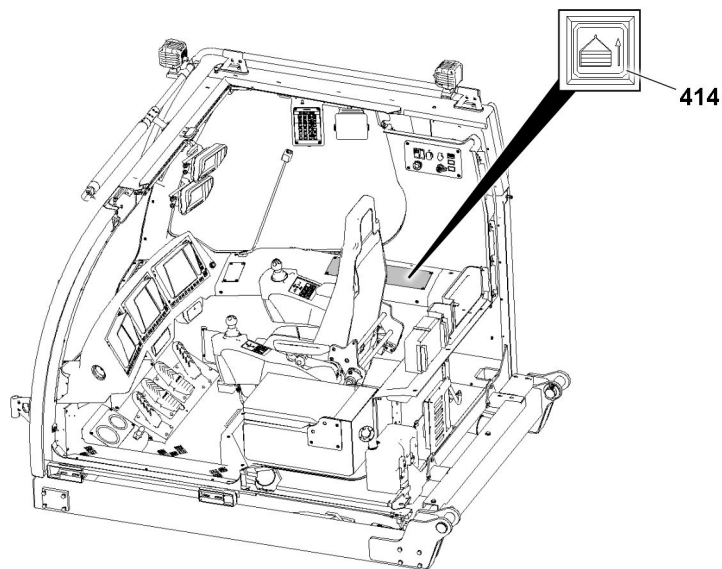


Fig. 159326: Lifting the ballast trailer using the operating buttons on the crane operator cab instrument panel

- ▶ Press the button **414**.

**Result:**

- The piston rods of the pull cylinders retract together.
- The ballast trailer is raised.

### Lifting the ballast trailer with control panel -A1230

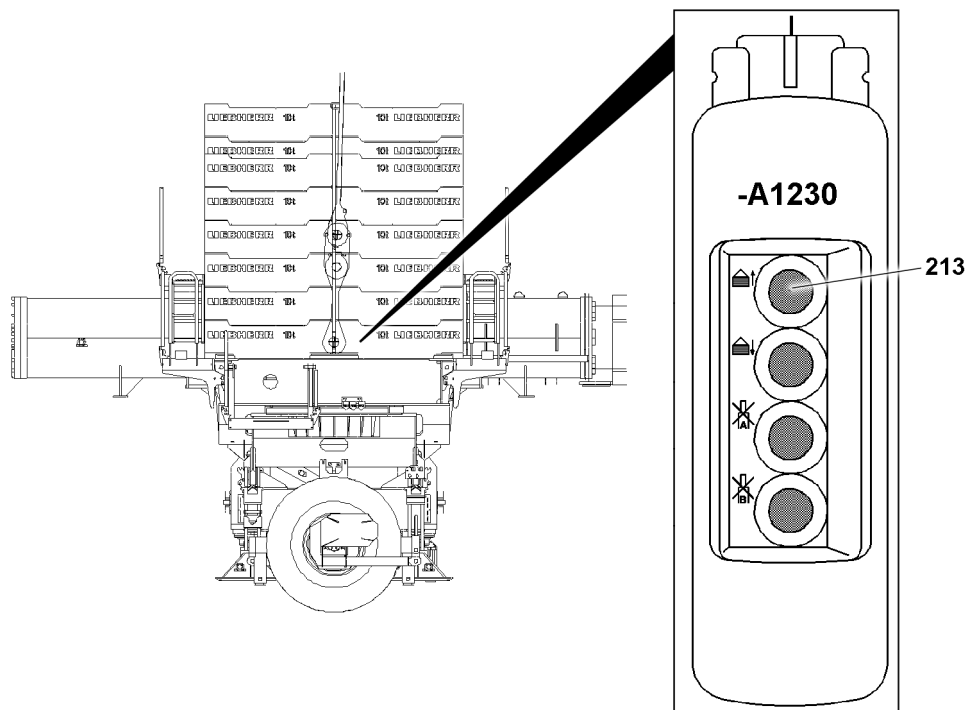


Fig.159327: Lifting the ballast trailer with control panel -A1230

- Press the button **213**.

#### Result:

- The piston rods of the pull cylinders retract together.
- The ballast trailer is raised.

### Lifting the ballast trailer with master switch 1

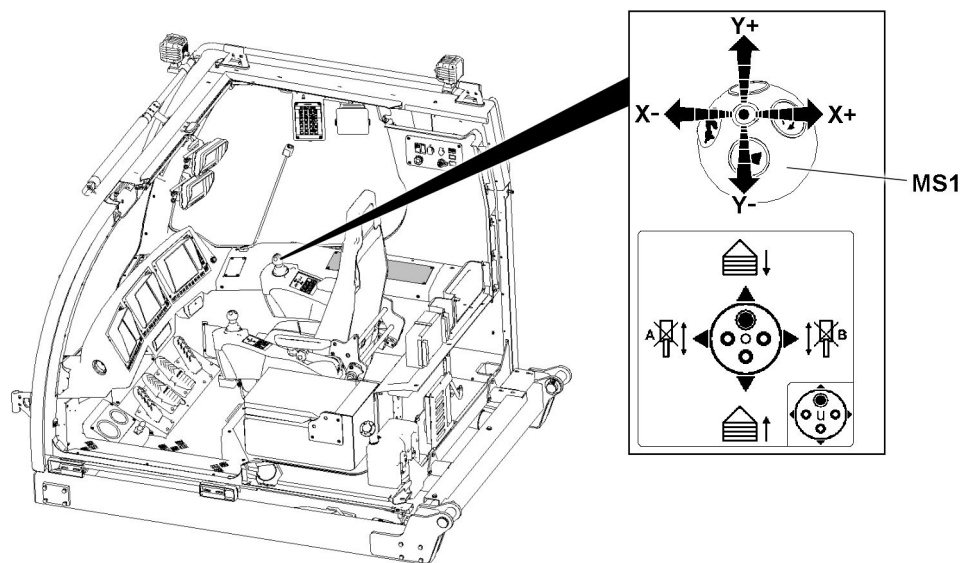


Fig.159328: Lifting the ballast trailer with master switch 1

- Move the master switch **MS1** in direction **Y-**.

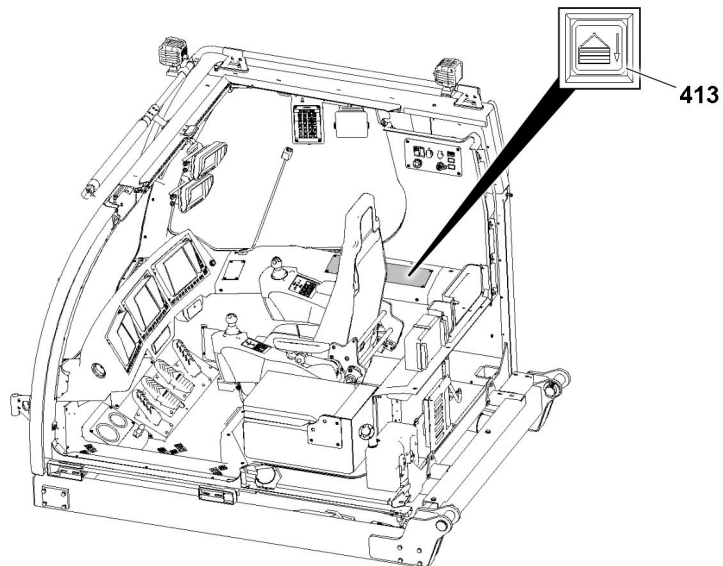


**Result:**

- The piston rods of the pull cylinders retract together.
- The ballast trailer is raised.

## 14.2.2 Lowering the ballast trailer

Lowering the ballast trailer with the operating buttons on the crane operator cab instrument panel



*Fig.159329: Lowering the ballast trailer with the operating buttons on the crane operator cab instrument panel*

- ▶ Press the button **413**.

**Result:**

- The piston rods of the pull cylinders extend together.
- The ballast trailer is lowered.

### Lowering the ballast trailer with control panel -A1230

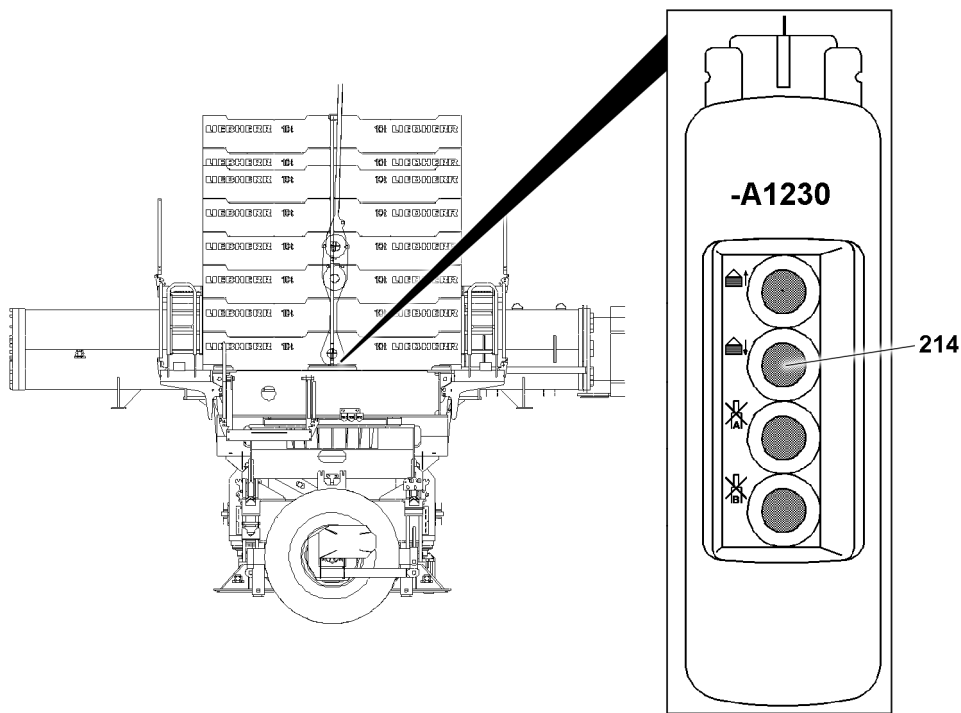


Fig.159330: Lowering the ballast trailer with control panel -A1230

- ▶ Press the button **214**.

#### Result:

- The piston rods of the pull cylinders extend together.
- The ballast trailer is lowered.

### Lowering the ballast trailer with master switch 1

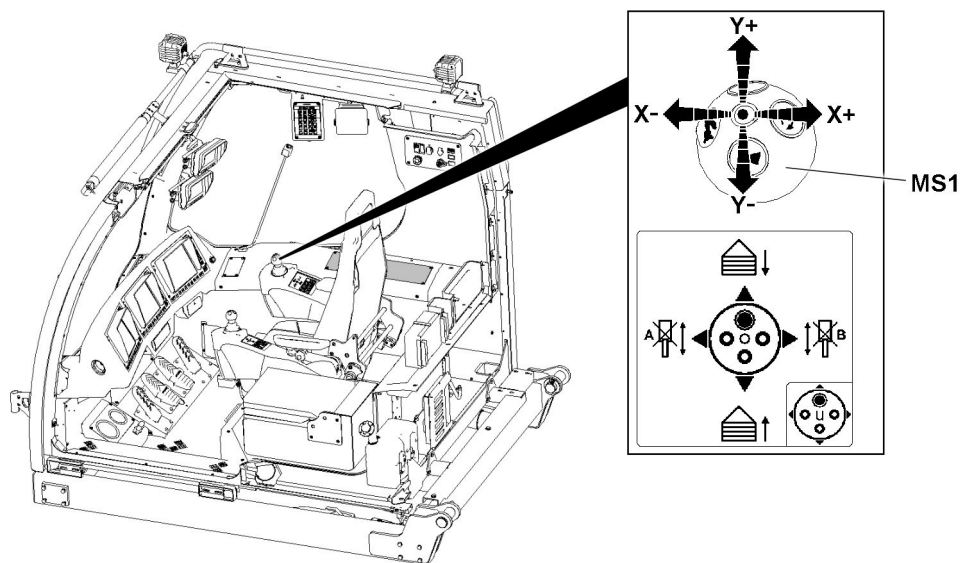
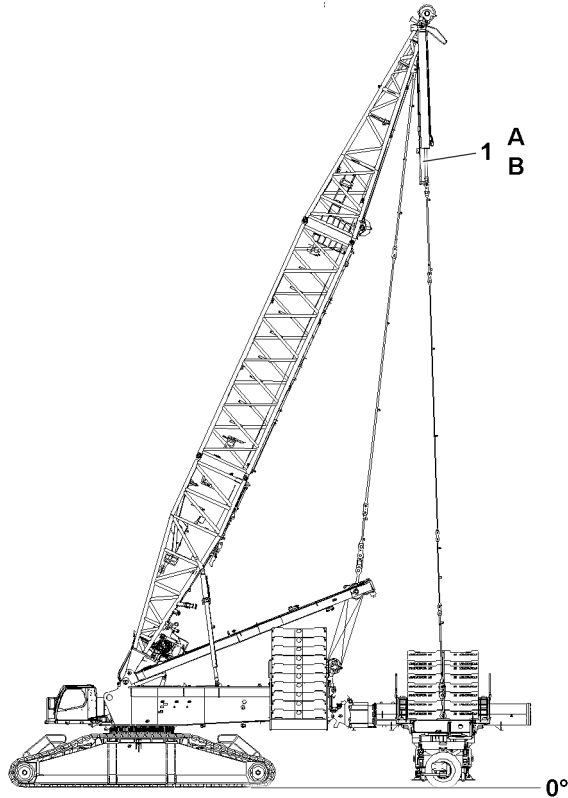


Fig.159328: Lowering the ballast trailer with master switch 1

- ▶ Move the master switch **MS1** in direction **Y+**.

**Result:**

- The piston rods of the pull cylinders extend together.
- The ballast trailer is lowered.

**14.2.3 Equalizing the ballast trailer position**

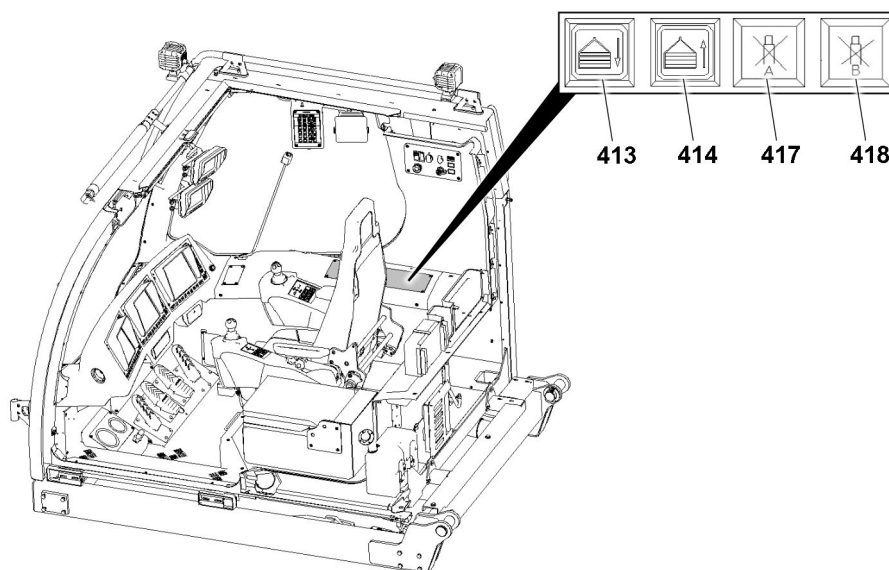
*Fig.163051: Equalizing the ballast trailer position*

The position of the ballast trailer can be equalized with different extension lengths of the pull cylinders 1 (pull cylinder A and pull cylinder B).

Blocking the pull cylinder has the following effects:

- Block the pull cylinder (A) when lifting:
  - The piston rod of the pull cylinder (A) stops.
  - The piston rod of pull cylinder (B) retracts.
  - Side (B) of the ballast trailer lifts up.
- Block the pull cylinder (B) when lifting:
  - The piston rod of the pull cylinder (B) stops.
  - The piston rod of pull cylinder (A) retracts.
  - Side (A) of the ballast trailer lifts up.
- Block the pull cylinder (A) when lowering:
  - The piston rod of the pull cylinder (A) stops.
  - The piston rod of pull cylinder (B) extends.
  - Side (B) of the ballast trailer lowers.
- Block the pull cylinder (B) when lowering:
  - The piston rod of the pull cylinder (B) stops.
  - The piston rod of pull cylinder (A) extends.
  - Side (A) of the ballast trailer lowers.

### Blocking the pull cylinder with the operating buttons on the crane operator cab instrument panel



*Fig.159332: Blocking the pull cylinder with the operating buttons on the crane operator cab instrument panel*

When pull cylinder (A) should be blocked when lifting:

- ▶ Press the button **414** and the button **417**.

When pull cylinder (B) should be blocked when lifting:

- ▶ Press the button **414** and the button **418**.

When pull cylinder (A) should be blocked when lowering:

- ▶ Press the button **413** and the button **417**.

When pull cylinder (B) should be blocked when lowering:

- ▶ Press the button **413** and the button **418**.

### Blocking the pull cylinder with control panel -A1230

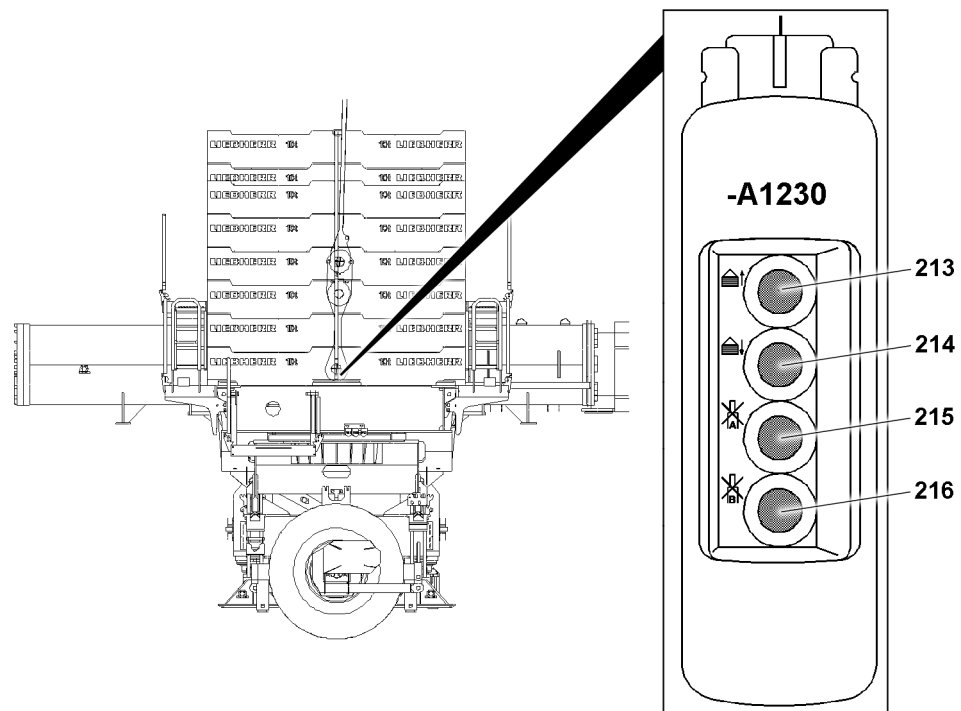


Fig.159333: Blocking the pull cylinder with control panel -A1230

When pull cylinder (A) should be blocked when lifting:

- ▶ Press the button **213** and the button **215**.

When pull cylinder (B) should be blocked when lifting:

- ▶ Press the button **213** and the button **216**.

When pull cylinder (A) should be blocked when lowering:

- ▶ Press the button **214** and the button **215**.

When pull cylinder (B) should be blocked when lowering:

- ▶ Press the button **214** and the button **216**.

### Blocking the pull cylinder with master switch 1

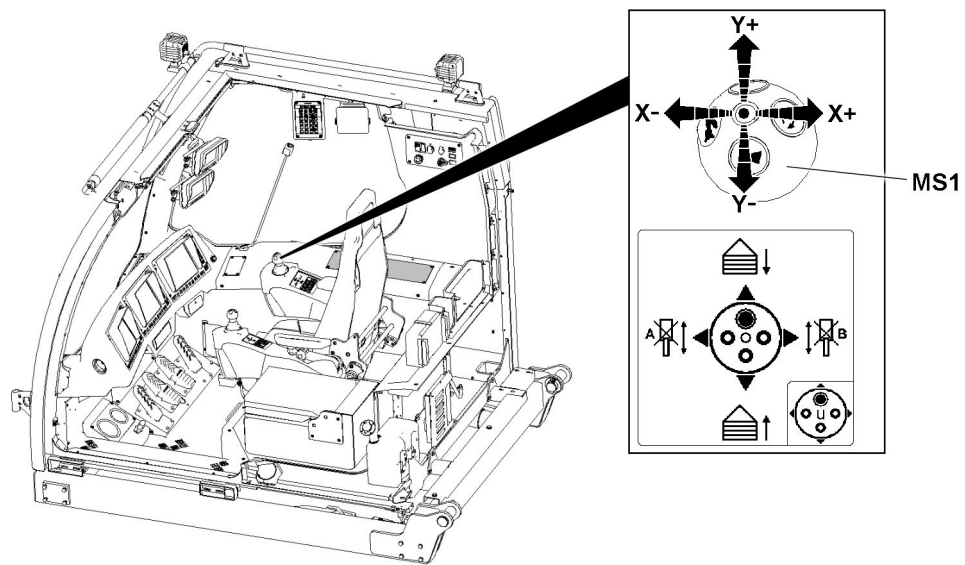


Fig.159328: Blocking the pull cylinder with master switch 1

When pull cylinder (A) should be blocked when lifting:

- ▶ Deflect the master switch **MS1** diagonally in direction **X-** and direction **Y-**.

When pull cylinder (B) should be blocked when lifting:

- ▶ Deflect the master switch **MS1** diagonally in direction **X+** and direction **Y-**.

When pull cylinder (A) should be blocked when lowering:

- ▶ Deflect the master switch **MS1** diagonally in direction **X-** and direction **Y+**.

When pull cylinder (B) should be blocked when lowering:

- ▶ Deflect the master switch **MS1** diagonally in direction **X+** and direction **Y+**.

### 14.3 Setting the ballast trailer radii

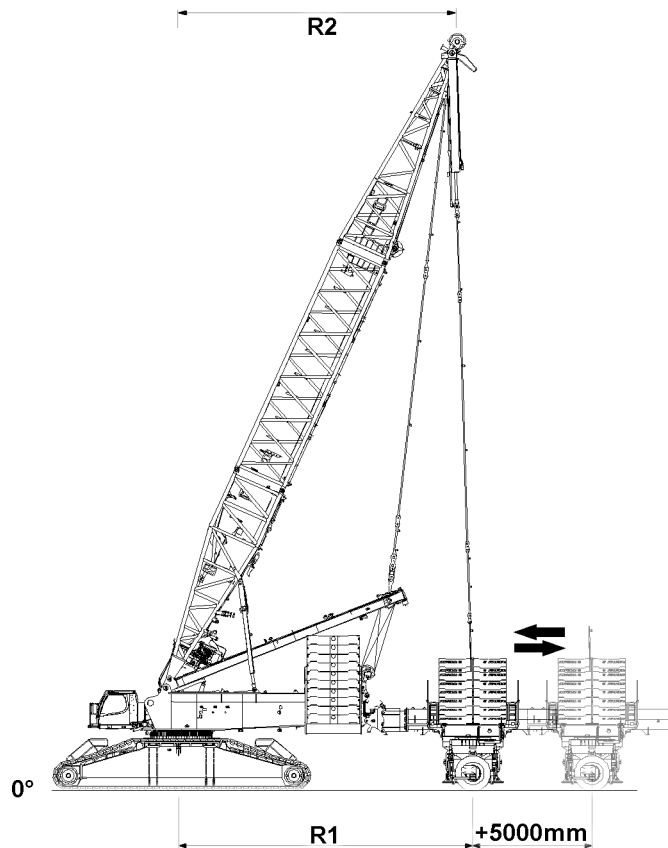


Fig.159334: Setting the ballast trailer radii

The ballast trailer radius can be adjusted steplessly across a path of 5000 mm.

The ballast trailer is equipped with a telescopic ballast trailer guide. This allows the derrick ballast radius to be adjusted to suit the environment or type of lifting work. The set derrick ballast radius **R1** is displayed on the LICCON monitor.

Pay attention to the difference between the derrick ballast radius **R1** and the derrick radius **R2**.

The ballast trailer radius can be adjusted using the following control units:

- With master switch MS2 (crane cab)
  - Manual adjustment
  - Ballast automatic
- With the operating buttons on the instrument panel (crane cab)
  - Manual adjustment only
- With control panel -A1230
  - Manual adjustment only
  - See section “Operating elements on the control panels”.
- With the radio remote control (BTT-E)
  - Manual adjustment only
  - See the radio remote control operating instructions



### Note

- ▶ The release for telescoping the ballast trailer guide out and in is only given when the wheel sets are in “towing mode”, see section “Towing”.
- ▶ If the ballast trailer is supported for assembly on the turntable, then it is possible to telescope the ballast trailer guide out and in with reduced pressure.
- ▶ When telescoping the ballast trailer guide out, constantly monitor the derrick ballast radius **R1** on the LICCON monitor.
- ▶ The crane operator may not blindly rely on the derrick ballast radius measurement, he must think for himself and check if the length sensor measure functions correctly, see chapter 4.02.

## 14.3.1 Telescoping the ballast trailer guide out

By telescoping the ballast trailer guide out, the ballast trailer radius is enlarged.

Make sure that the following prerequisite is met:

- The wheel sets of the ballast trailer are in the “Towing” position

### Calling up the master switch assignment for ballast functions

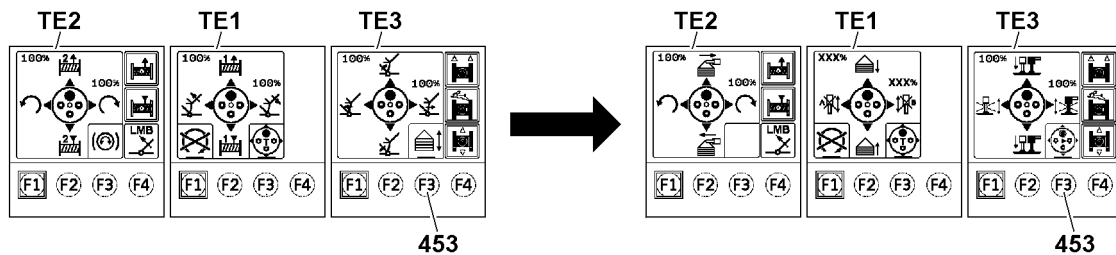


Fig.155182: Calling up the master switch assignment for ballast functions

Make sure that the following prerequisite is met:

- An operating mode with derrick ballast is set up.
- ▶ Press the F3 key **453** on the touch display **TE3**.

### Result:

- The master switch assignment for the ballast functions is called up.
- **Note:** The master switch assignment for the ballast trailer support cylinder appears only when an operating mode with a ballast trailer is set up.



### Telescoping the ballast trailer guide out with the ballast automatic

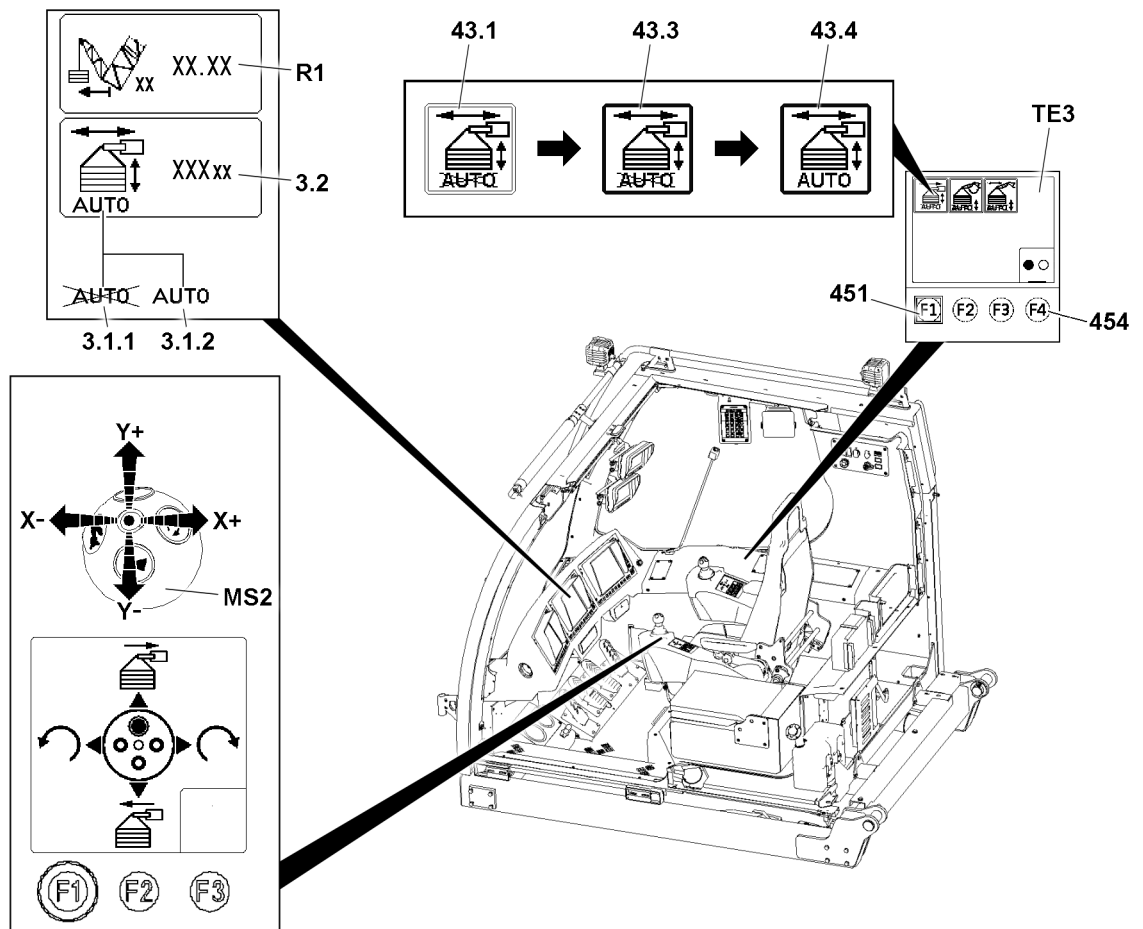


Fig.159335: Telescoping the ballast trailer guide out with the ballast automatic

Make sure that the following prerequisite is met:

- The master switch assignment for the ballast functions is called up.

- ▶ Press the F1-key **451** on the touch display **TE3** until the selection menu is displayed.
- ▶ Select the *ballast trailer ballast automatic deselected / turned off* icon **43.1** by touching it briefly with a finger tip (less than one second).

#### Result:

- The *ballast trailer ballast automatic* is selected.
- The *ballast trailer ballast automatic selected / turned off* icon **43.3** is displayed.

- ▶ Press the function key **454**.

#### Result:

- The *ballast trailer ballast automatic* is turned on.
- The *ballast trailer ballast automatic selected / turned on* icon **43.4** is displayed.

- ▶ Move the master switch **MS2** in direction **Y-**.

#### Result:

- The ballast trailer guide moves out.
- The ballast automatic adjusts the pull cylinder automatically in order to keep the saved value **3.2** (situation-dependent F1-force or ballast trailer inclination).

To turn the ballast automatic off again:

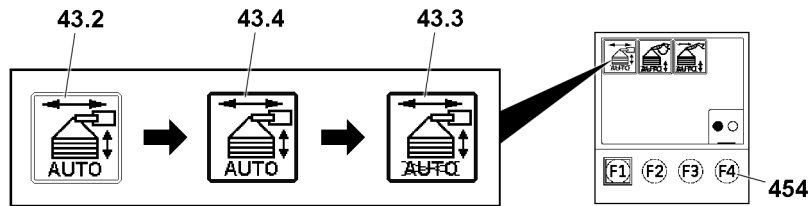


Fig.159622: Switching off ballast trailer ballast automatic

- ▶ Select the *ballast trailer ballast automatic deselected / turned on* icon **43.2** by touching it briefly with a finger tip (less than one second).

**Result:**

- The *ballast trailer ballast automatic* is selected.
- The *ballast trailer ballast automatic selected / turned on* icon **43.4** is displayed.

- ▶ Press the function key **454**.

**Result:**

- The *ballast trailer ballast automatic* is turned off.
- The *derrick adjustment selected / turned off* icon **43.3** is displayed.

**Telescoping the ballast trailer guide out manually (operating buttons on the instrument panel)**

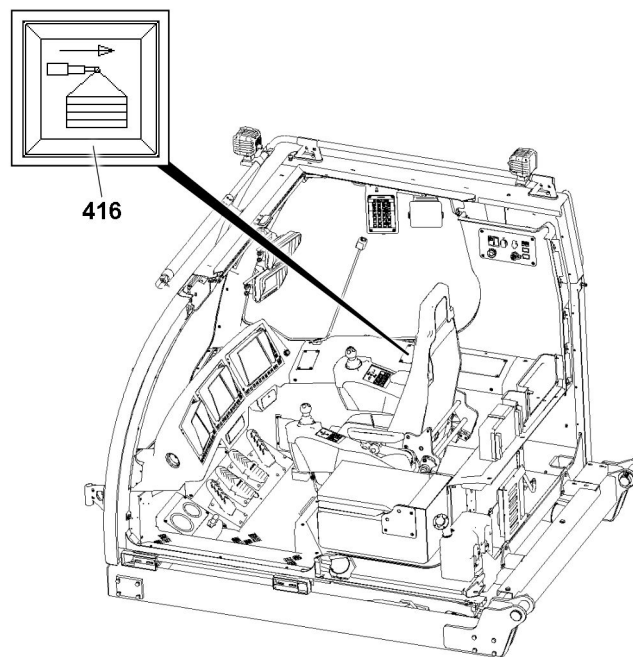


Fig.159336: Telescoping the ballast trailer guide out manually (operating buttons on the instrument panel)

- ▶ Press the button **416**.

**Result:**

- The ballast trailer guide moves out.
- ▶ Observe the force display in the derrick guying  $F1_{min}$ - $F1_{max}$  and the ballast trailer inclination.

### Telescoping the ballast trailer guide out manually (master switch MS2)

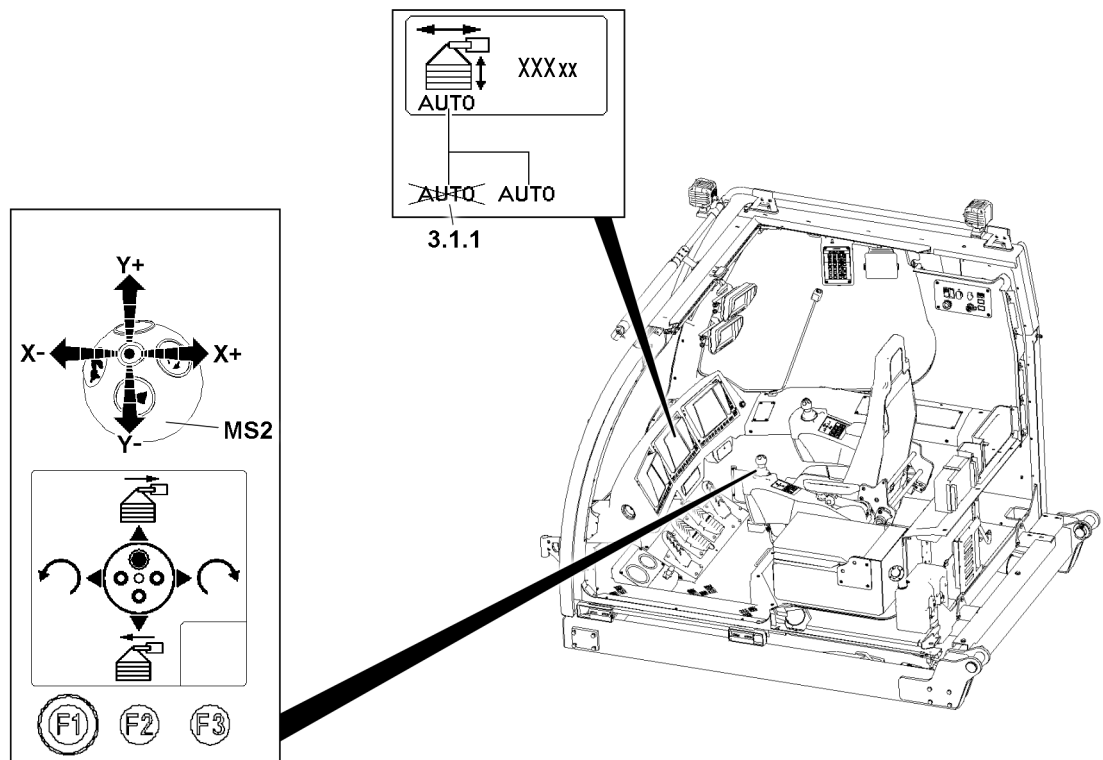


Fig.159337: Telescoping the ballast trailer guide out manually (master switch MS2)

Make sure that the following prerequisite is met:

- Ballast automatic is turned off, the ballast automatic status **3.1.1** appears.

- ▶ Move the master switch **MS2** in direction **Y-**.

**Result:**

- The ballast trailer guide moves out.
- ▶ Observe the force display in the derrick guying  $F1_{\min}$ - $F1_{\max}$  and the ballast trailer inclination.

### 14.3.2 Telescoping the ballast trailer guide in

By telescoping the ballast trailer guide in, the ballast trailer radius is reduced.

Make sure that the following prerequisite is met:

- The wheel sets of the ballast trailer are in the “Towing” position

### Telescoping the ballast trailer guide in with the ballast automatic

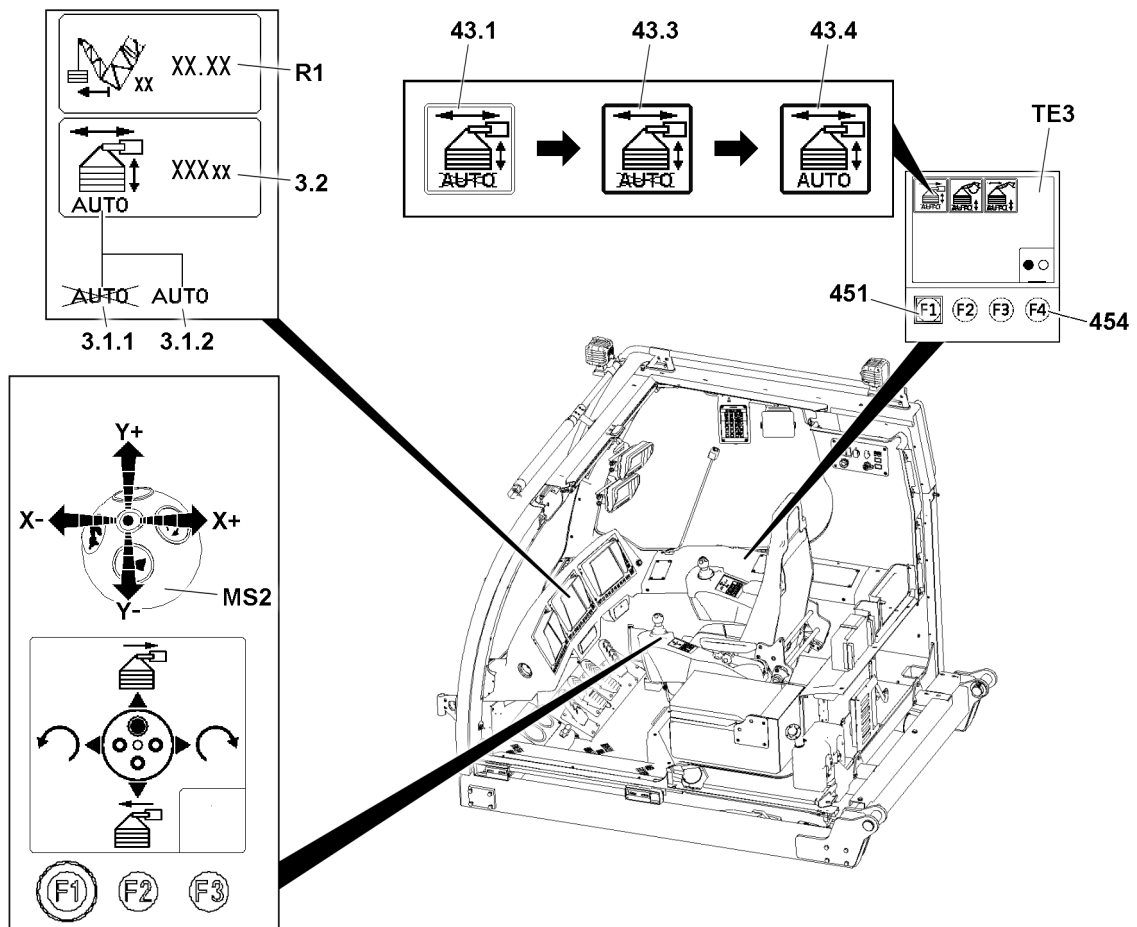


Fig.159335: Telescoping the ballast trailer guide in with the ballast automatic

Make sure that the following prerequisite is met:

- The master switch assignment for the ballast functions is called up.
- ▶ Press the F1-key **451** on the touch display **TE3** until the selection menu is displayed.
- ▶ Select the *ballast trailer ballast automatic deselected / turned off* icon **43.1** by touching it briefly with a finger tip (less than one second).

#### Result:

- The *ballast trailer ballast automatic* is selected.
- The *ballast trailer ballast automatic selected / turned off* icon **43.3** is displayed.

- ▶ Press the function key **454**.

#### Result:

- The *ballast trailer ballast automatic* is turned on.
- The *ballast trailer ballast automatic selected / turned on* icon **43.4** is displayed.

- ▶ Move the master switch **MS2** in direction **Y+**.

#### Result:

- The ballast trailer guide retracts.
- The ballast automatic adjusts the pull cylinder automatically in order to keep the saved value **3.2** (situation-dependent F1-force or ballast trailer incline).

To turn the ballast automatic off again:

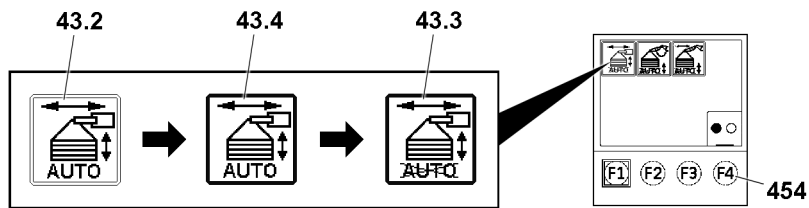


Fig.159622: Switching off ballast trailer ballast automatic

- ▶ Select the *ballast trailer ballast automatic deselected / turned on* icon **43.2** by touching it briefly with a finger tip (less than one second).

**Result:**

- The *ballast trailer ballast automatic* is selected.
- The *ballast trailer ballast automatic selected / turned on* icon **43.4** is displayed.

- ▶ Press the function key **454**.

**Result:**

- The *ballast trailer ballast automatic* is turned off.
- The *derrick adjustment selected / turned off* icon **43.3** is displayed.

**Telescoping the ballast trailer guide in manually (operating buttons on the instrument panel)**

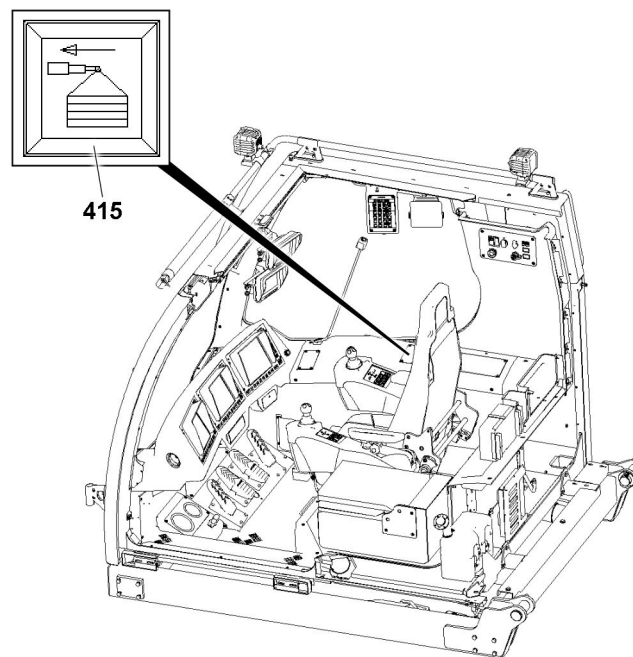


Fig.159339: Telescoping the ballast trailer guide in manually (operating buttons on the instrument panel)

- ▶ Press the button **415**.

**Result:**

- The ballast trailer guide retracts.
- ▶ Observe the force display in the derrick guying  $F1_{min}$ - $F1_{max}$  and the ballast trailer inclination.

### Telescoping the ballast trailer guide in manually (master switch MS2)

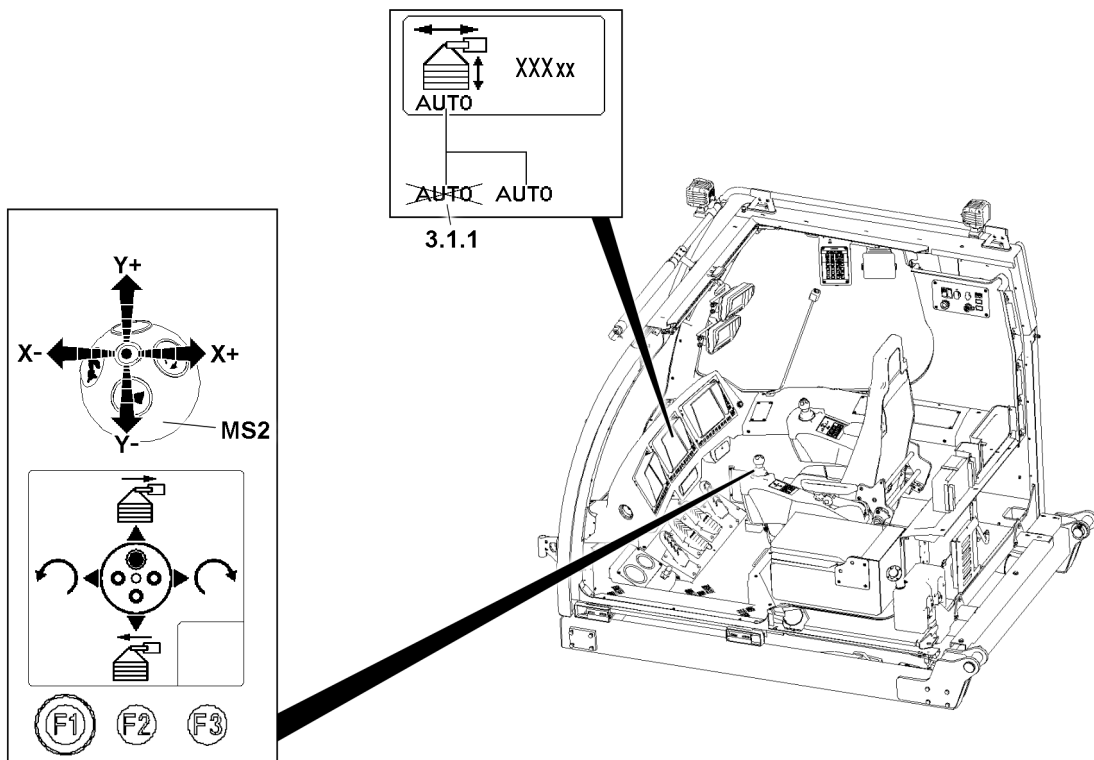


Fig.159337: Telescoping the ballast trailer guide in manually (master switch MS2)

Make sure that the following prerequisite is met:

- Ballast automatic is turned off, the ballast automatic status **3.1.1** appears.
- The master switch assignment for the ballast functions is called up.

- ▶ Move the master switch **MS2** in direction **Y+**.

**Result:**

- The ballast trailer guide retracts.
- ▶ Observe the force display in the derrick guying  $F1_{min}$ - $F1_{max}$  and the ballast trailer inclination.

## 14.4 Steering programs



### WARNING

Danger when moving the wheel sets on the ballast trailer!  
Death, severe bodily injuries, property damage.

- ▶ The crane operator as well as any operating personnel must make sure that there are no persons in the danger zone.
- ▶ It is prohibited for anyone to remain between the wheel sets for all setting / adjustment work on the ballast trailer.
- ▶ It is prohibited for anyone to remain between the wheel sets when selecting the various steering programs.



### WARNING

Wheels running with the ballast trailer lifted!  
Death, severe bodily injuries, property damage.  
When the ballast trailer lifts up, it is possible that the wheels continue running.

- ▶ No persons may remain within the danger zone.

### 14.4.1 Overview of the steering programs

The crane has the following computer controlled steering programs.

#### Towing steering program

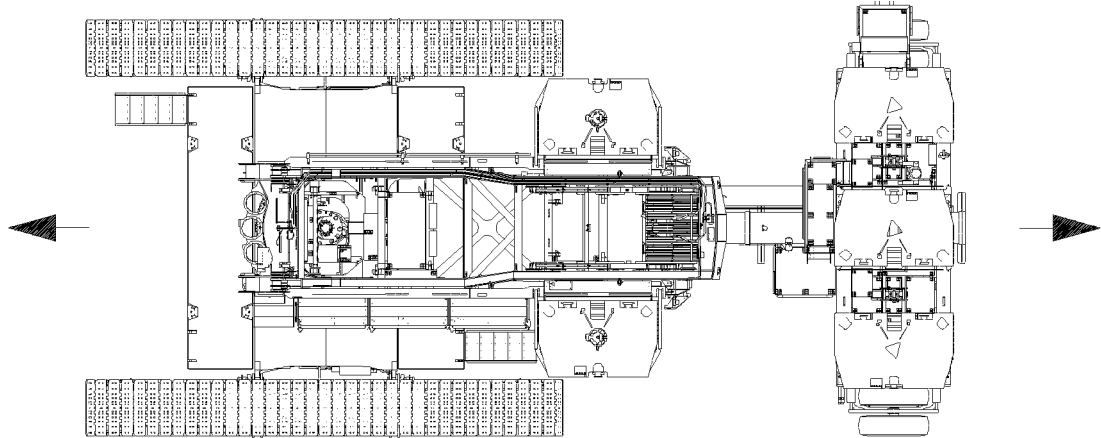


Fig.159342: Example for crane in the Towing steering program

#### Parallel travel steering program

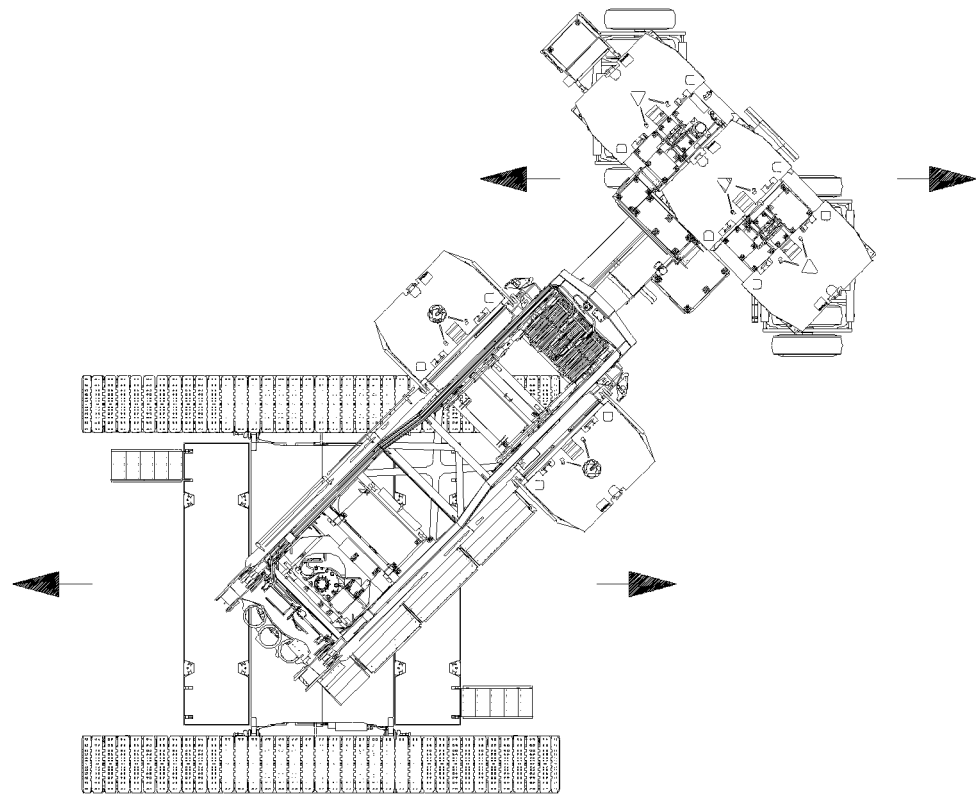


Fig.159343: Example for crane in the Parallel travel steering program

LWE/LR 1800-1-0-000/27200-07-02/en

### Circular travel steering program

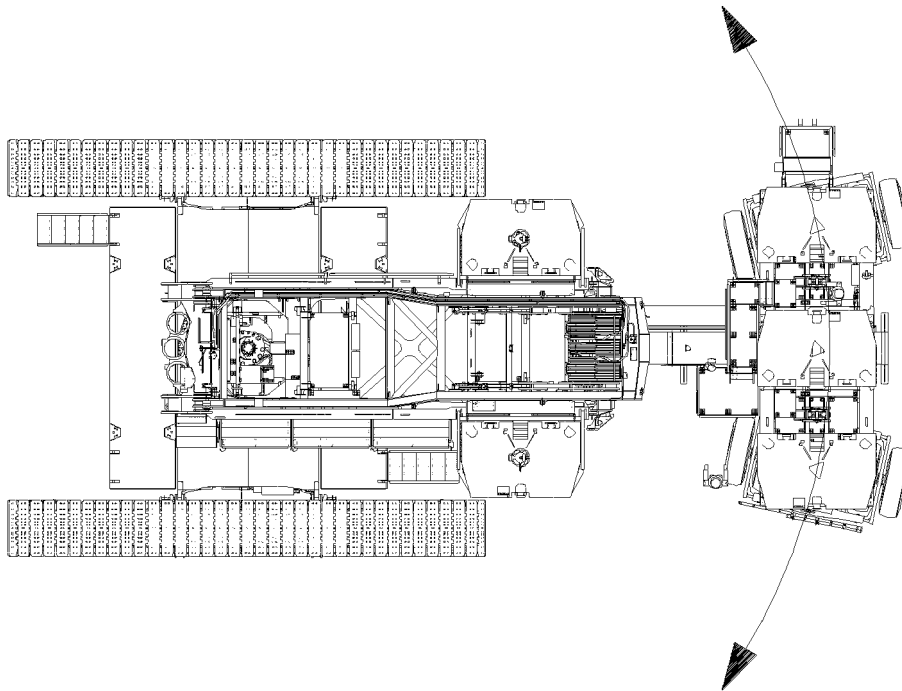


Fig.159344: Example for crane in the Circular travel steering program

### Corrective steering steering program

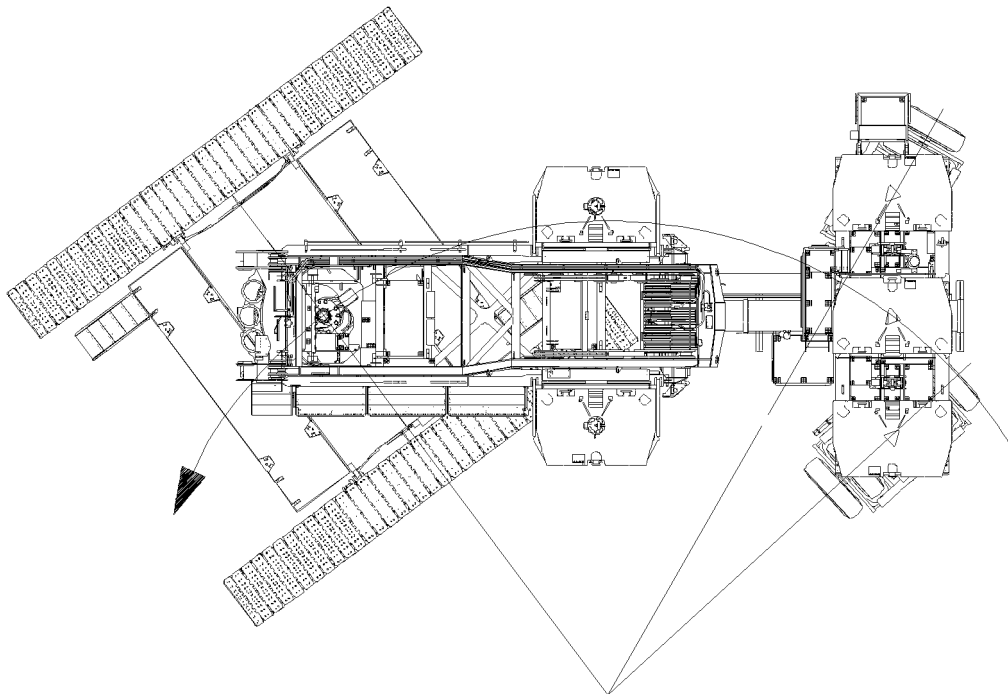


Fig.159341: Example for crane in the "Corrective steering" steering program

## 14.4.2 Selecting the steering program

If an incorrect steering program is activated on the ballast trailer, necessary crane functions cannot be carried out and / or controlled.



In order to carry out necessary crane functions, the following is necessary:

- Either all steering programs must be deactivated (all steering program indicator lights are off)
- Or a certain steering program must be activated (steering program indicator light on)

In order to operate the crane functions, it may be necessary to activate the necessary steering program for the desired crane function.

- Driving the crawler requires towing, parallel travel or corrective steering steering program
- Telescoping the ballast trailer guide in / out requires the towing steering program
- Turning the turntable requires circular travel steering program

### 14.4.3 Wheel set adjustment procedure for the steering programs

The adjustment procedure for the various steering programs is identical.

Pressing the steering program buttons automatically adjust the wheel sets.

The wheel sets are steered correctively from the crane cab, or from the control panel on the ballast trailer.

The manual adjustment of the wheel sets for assembly purposes is only possible with the control panel on the ballast trailer and via radio with the BTT-E.



#### Note

- ▶ If the ballast trailer is **not loaded**, the wheel sets can be adjusted without relieving the tires.
- ▶ If the ballast trailer is **loaded**, the ballast trailer must be raised first with the support cylinders until the tires are relieved.

### 14.4.4 Supporting the ballast trailer to align the wheel sets with the support cylinders



#### DANGER

Danger of accident due to crane overload!

By raising the ballast trailer with the support cylinders, the force in test point 1 (MS1) can increase to the permissible maximum value. The extension of the support cylinders is then turned off.

- ▶ Monitor the display of test point 1 (F1-force) on the LICCON monitor and stop the extending of the support cylinders in time before the shut-off, see chapter 4.02.



#### Note

Ballast trailer support cylinders extended until the maximum value of test point 1 (F1-force) is reached:

Release the test point 1 (F1-force):

- ▶ If possible, for example: Increase the pulled derrick ballast or luff up the main boom / accessory or place down the load.



#### Note

- ▶ By selecting the corresponding master switch assignment, the support cylinders of the ballast trailer can also be operated with the master switch MS3.

#### Lifting the ballast trailer with the support cylinders on both sides



#### Note

- ▶ The support cylinders of the ballast trailer must always be extended evenly.
- ▶ Keep the actual value test point 1 (F1-force) in the permissible range.
- ▶ The end points are shown on the visual display on LICCON monitor LM2.

### Extending both support cylinders using the control panel -A1210 and lifting the ballast trailer

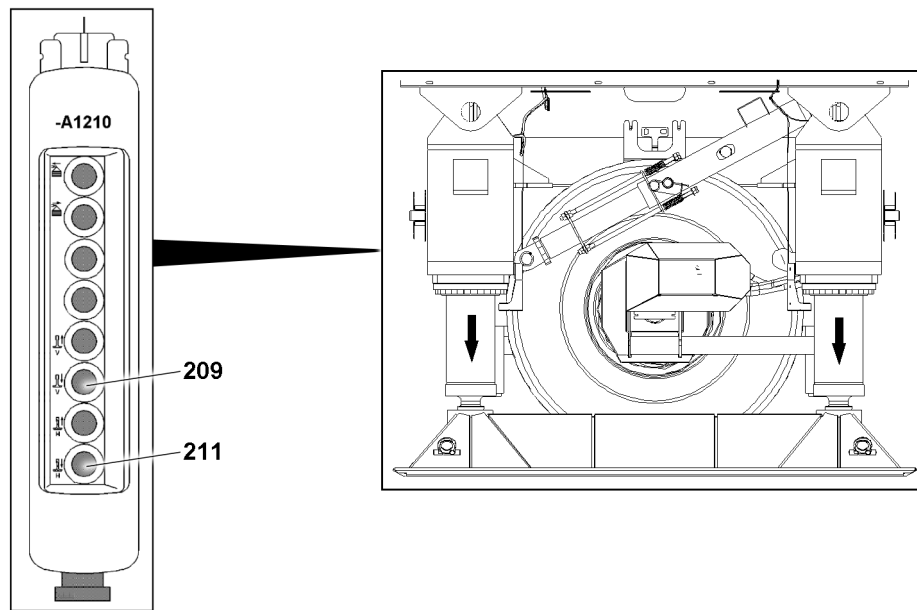


Fig.159345: Extending both support cylinders using the control panel -A1210 and lifting the ballast trailer

- Press the button 209 and button 211 on the control panel -A1210.

### Extending the support cylinder using the button on the instrument panel and lifting the ballast trailer

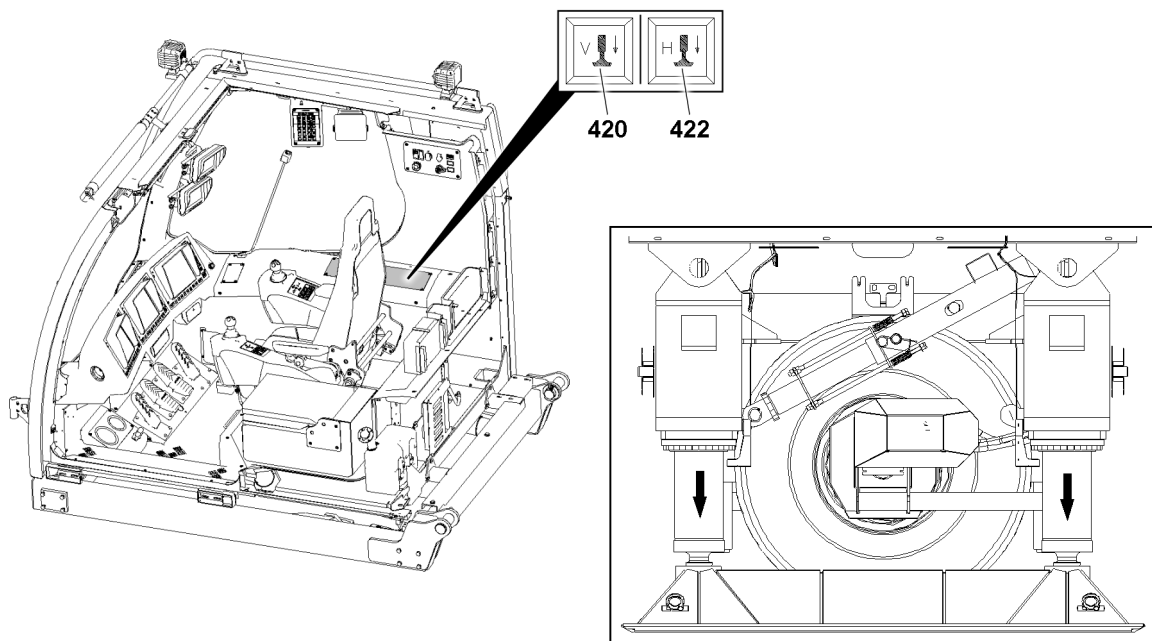


Fig.159346: Extending the support cylinder using the button on the instrument panel and lifting the ballast trailer

- Press the button 420 and button 422 in the crane cab.

### Extending the support cylinders using master switch MS3 and lifting the ballast trailer

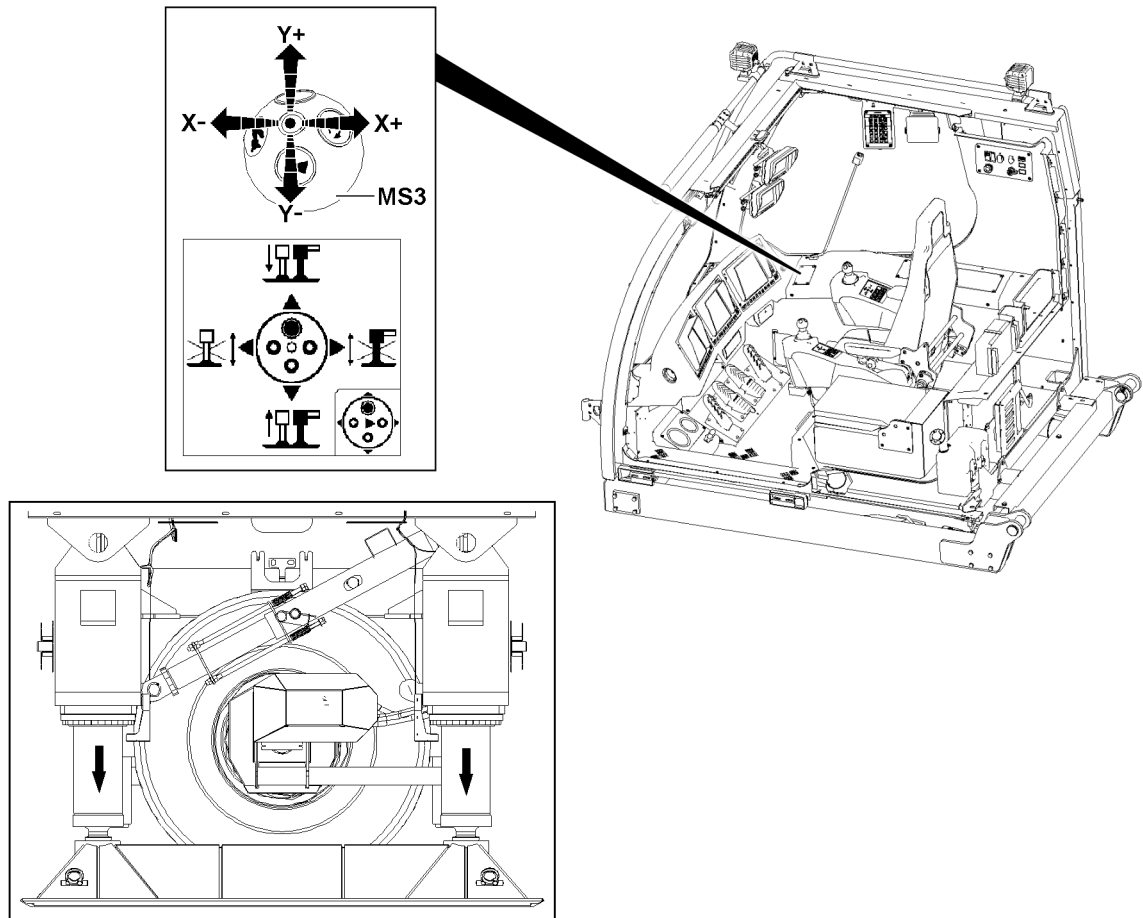


Fig.159347: Extending the support cylinders using master switch MS3 and lifting the ballast trailer

- Move the master switch **MS3** forward (direction **Y+**).

#### Operating the support cylinders individually

To compensate for the incline position or uneven ground, the support cylinders can be operated in the front or rear individually.

Retract or extend the support cylinder to the front using the control panel -A1210.

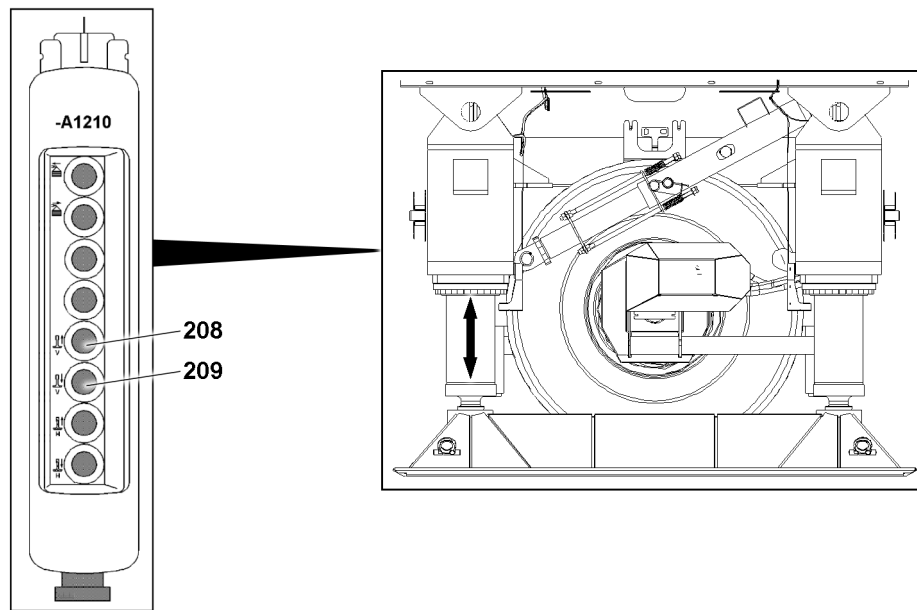


Fig.159348: Retract or extend the support cylinder to the front using the control panel -A1210.

If the front support cylinder is to be retracted:

- ▶ Press the button 208 on the control panel -A1210.

If the front support cylinder is to be extended:

- ▶ Press the button 209 on the control panel -A1210.

Retracting or extending the support cylinder to the front using the button on the instrument panel

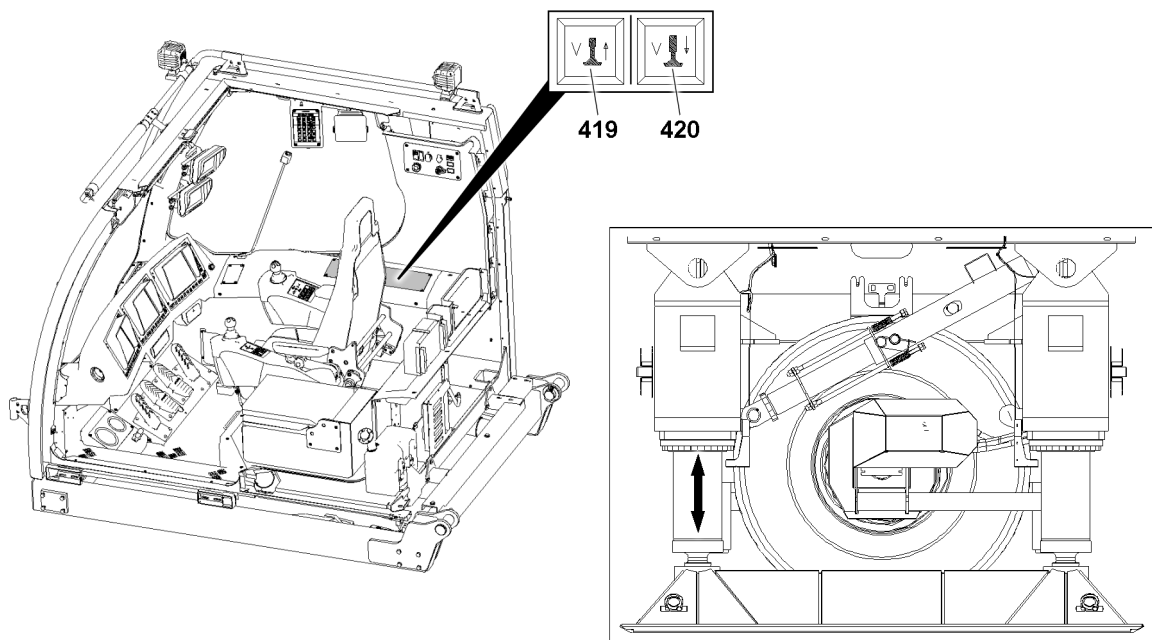


Fig.159349: Retracting or extending the support cylinder to the front using the button on the instrument panel

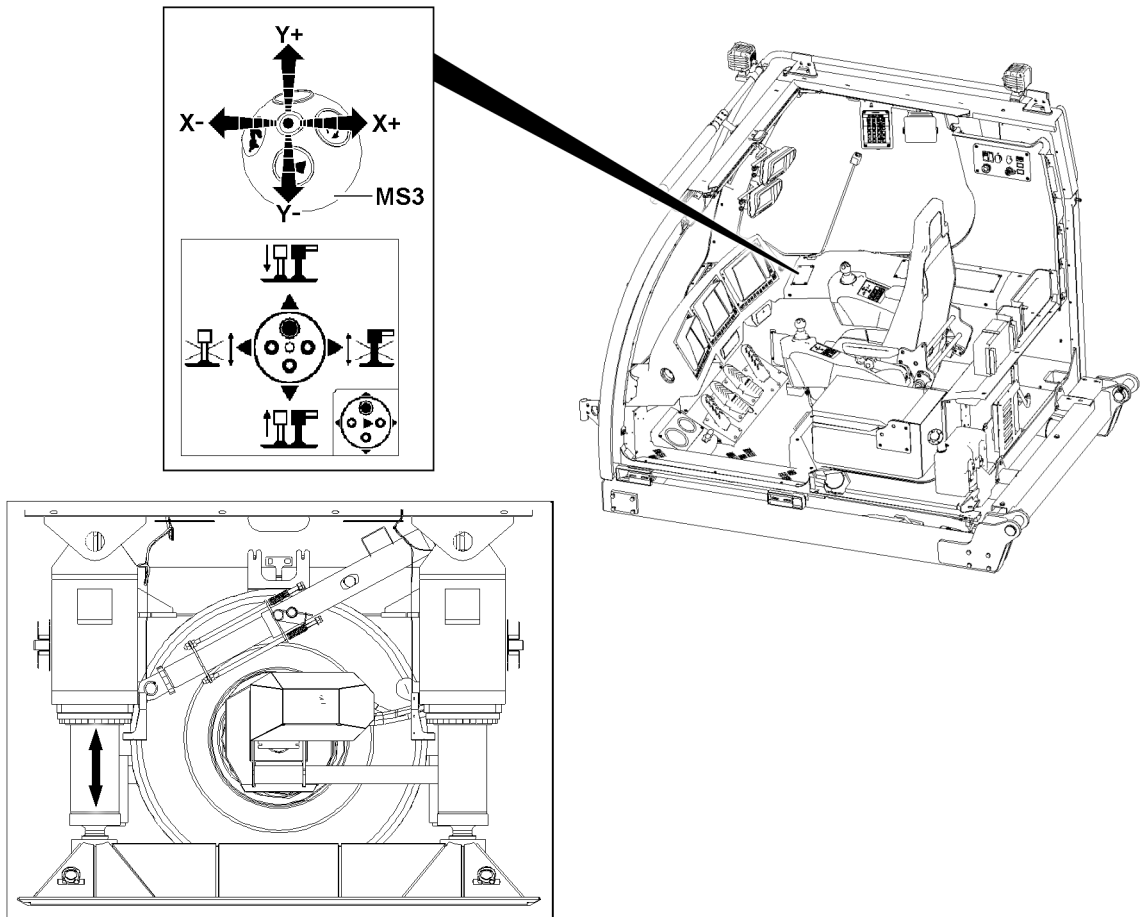
If the front support cylinder is to be retracted:

- ▶ Press the button 419 in the crane cab.

If the front support cylinder is to be extended:

- ▶ Press the button **420** in the crane cab.

**Retract or extend the support cylinder to the front using master switch MS3.**



*Fig.159350: Retract or extend the support cylinder to the front using master switch MS3.*

If the front support cylinder is to be retracted:

- ▶ Move the master switch **MS3** to the rear left (direction **X-Y-**).

If the front support cylinder is to be extended:

- ▶ Move the master switch **MS3** to the front left (direction **X-Y+**).

Retract or extend the support cylinder to the rear using the control panel -A1210.

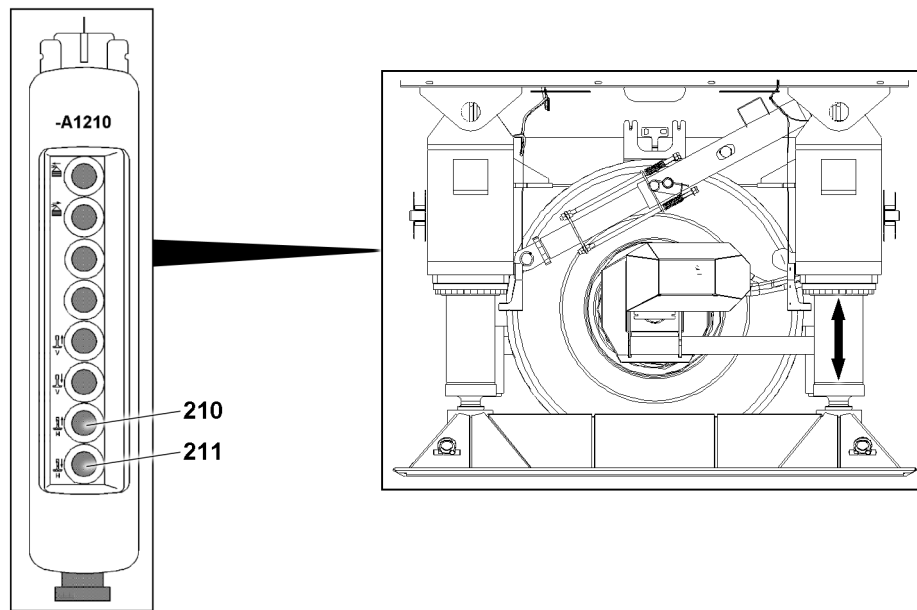


Fig.159351: Retract or extend the support cylinder to the rear using the control panel -A1210.

If the rear support cylinder is to be retracted:

- ▶ Press the button **210** on the control panel -A1210.

If the rear support cylinder is to be extended:

- ▶ Press the button **211** on the control panel -A1210.

Retracting or extending the support cylinder to the rear using the button on the instrument panel.

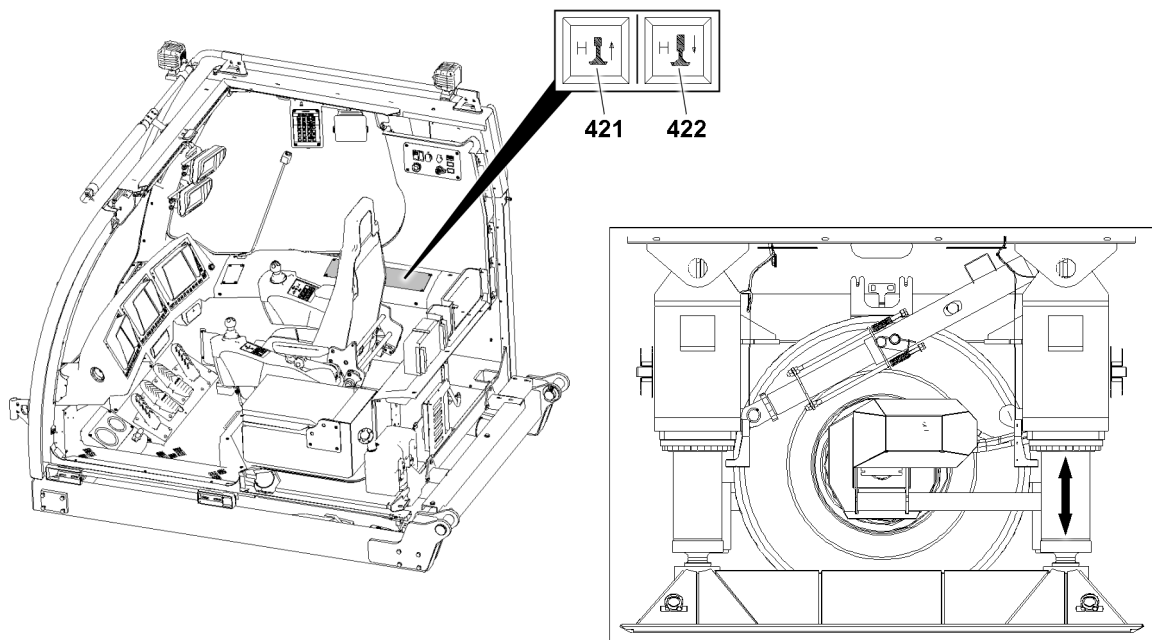


Fig.159352: Retracting or extending the support cylinder to the rear using the button on the instrument panel

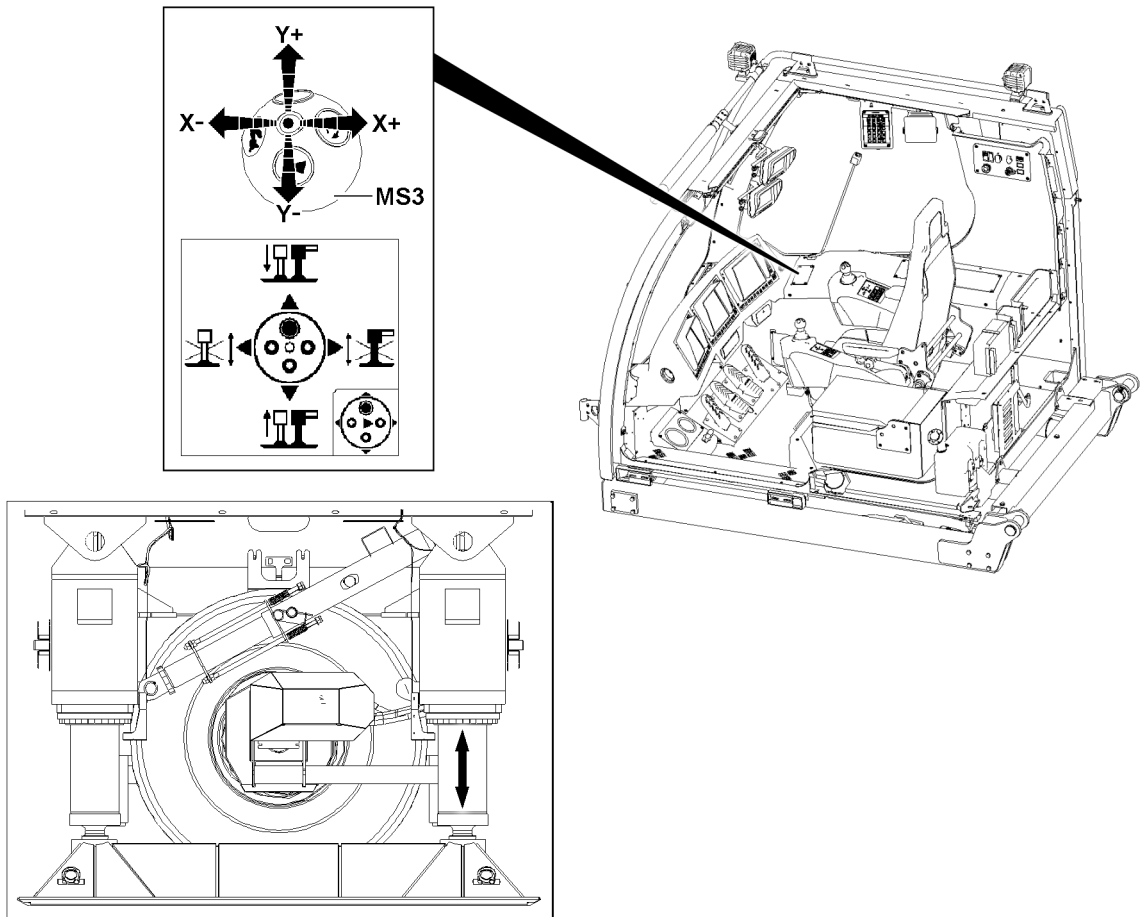
If the rear support cylinder is to be retracted:

- ▶ Press the button **421** in the crane cab.

If the rear support cylinder is to be extended:

- ▶ Press the button **422** in the crane cab.

**Retracting or extending the support cylinder to the rear using master switch MS3.**



*Fig.159353: Retracting or extending the support cylinder to the rear using master switch MS3*

If the rear support cylinder is to be retracted:

- ▶ Move the master switch **MS3** to the rear right (direction **X+Y-**).

If the rear support cylinder is to be extended:

- ▶ Move the master switch **MS3** to the front right (direction **X+Y+**).

**Lowering the ballast trailer with the support cylinders on both sides**



**Note**

- ▶ The support cylinders of the ballast trailer must always be extended evenly.
- ▶ The end points are shown on the visual display on LICCON monitor LM2.

### Retracting both support cylinders completely using the control panel -A1210

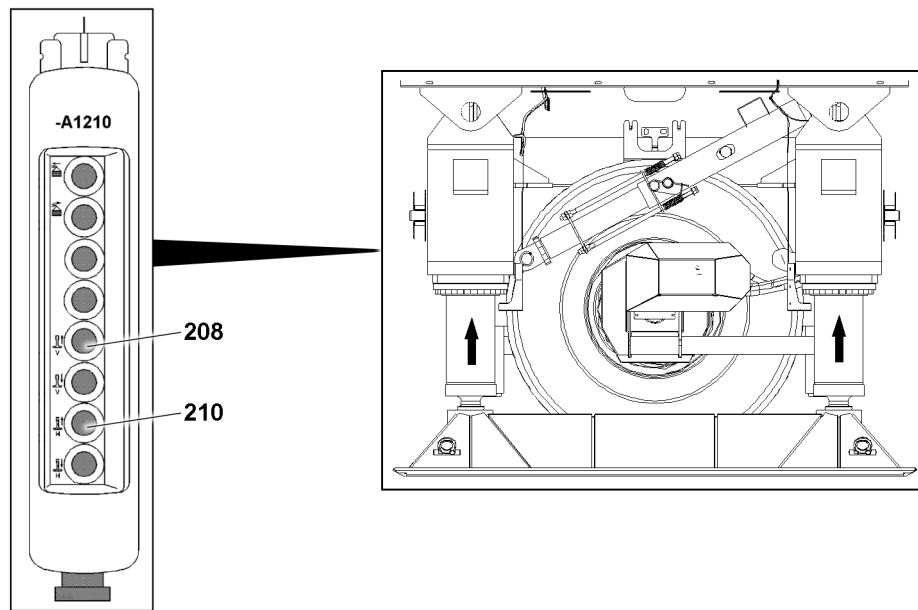


Fig.159354: Retracting both support cylinders completely using the control panel -A1210

- Press the button **208** and button **210** on the control panel **-A1210** until both support cylinders are fully retracted.

### Retracting the support cylinders completely using the buttons on the instrument panel

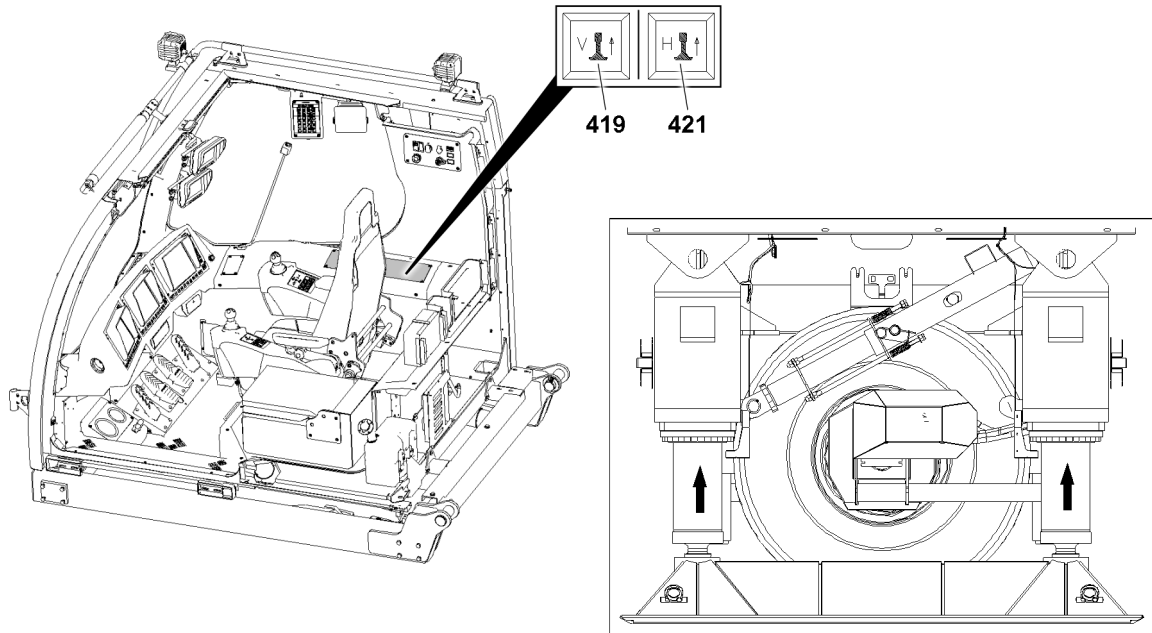


Fig.159355: Retracting the support cylinders completely using the buttons on the instrument panel

- Press the button **419** and button **421** until both support cylinders are fully retracted.



Retract the support cylinders completely using master switch MS3

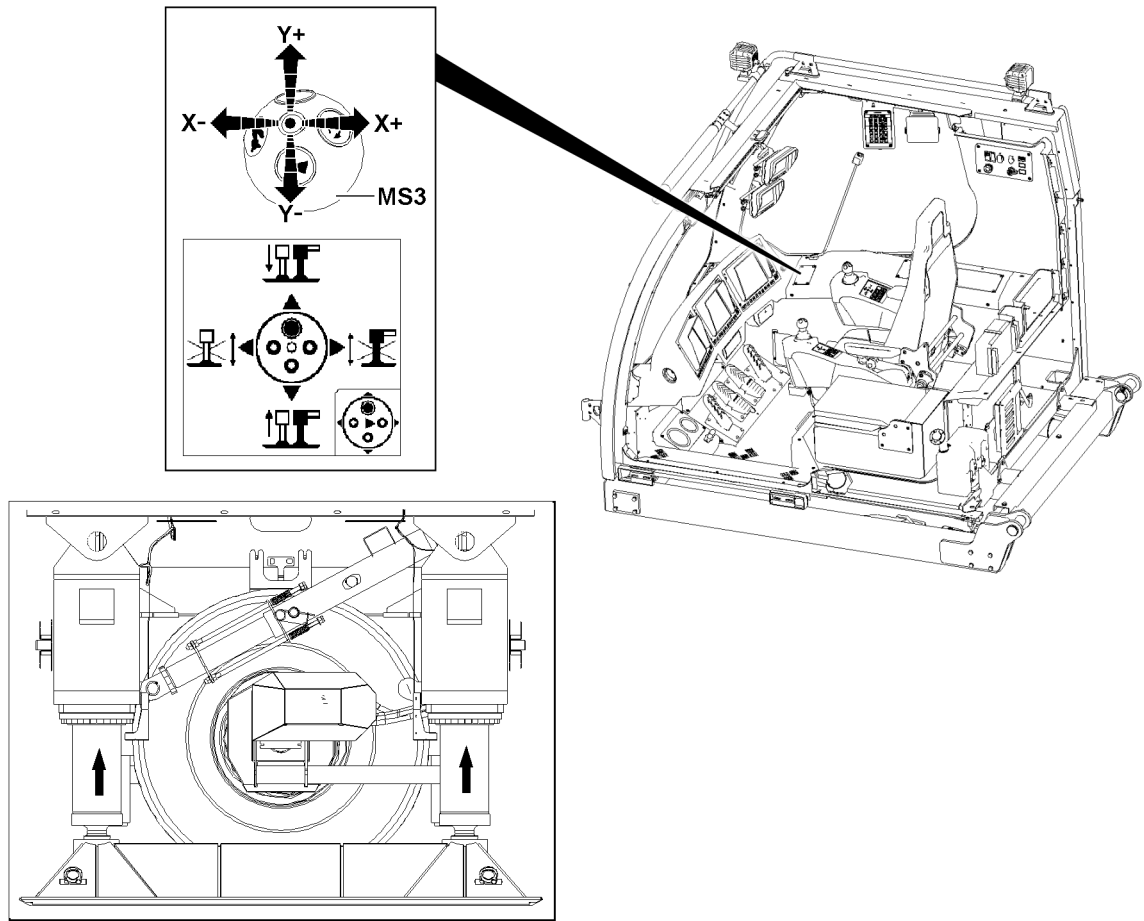


Fig.159356: Retract the support cylinders completely using master switch MS3

- ▶ Move the master switch **MS3** to the rear (direction Y-) until both support cylinders are fully retracted.

### 14.4.5 Towing

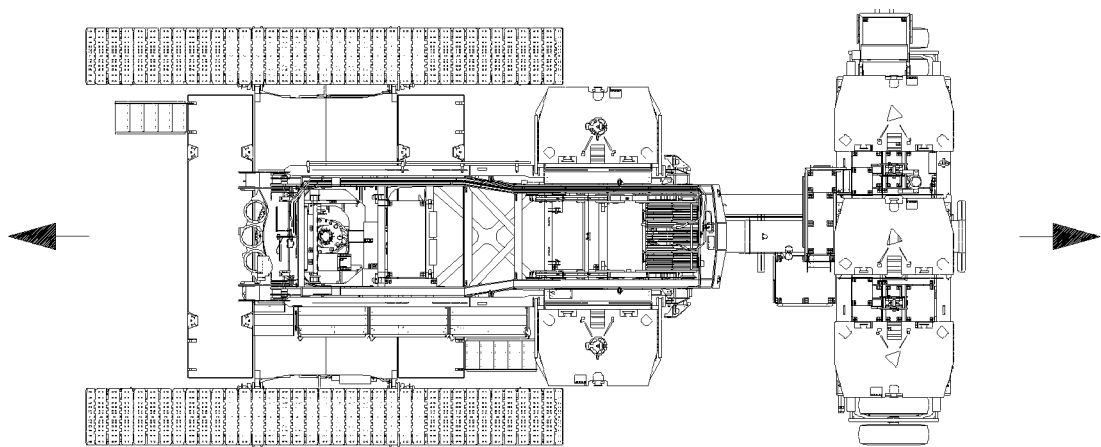


Fig.159357: Towing

LWE/LR 1800-1-0-000/27200-07-02/en

### Aligning the wheel sets in the towing position

Make sure that the following prerequisite is met:

- The ballast trailer is raised over the support cylinders to the point where the wheel sets are relieved.

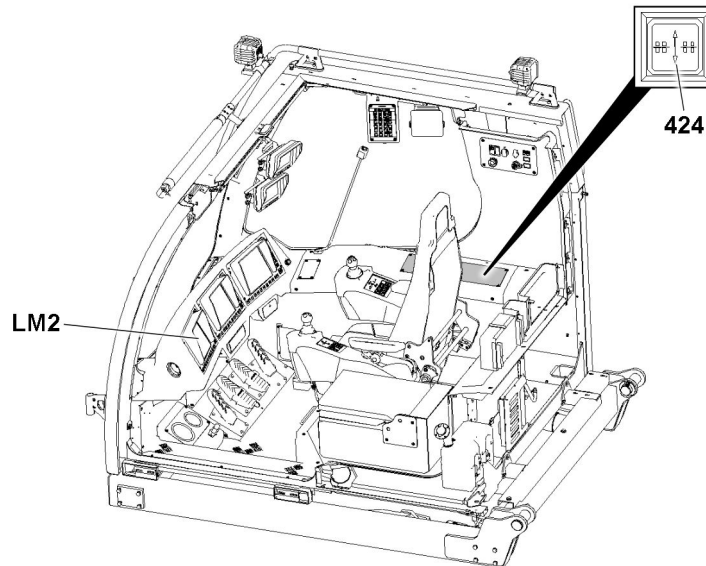


Fig.159358: Aligning the wheel sets in the towing position

- ▶ Press the button **424**.

#### Result:

- The wheel sets of the ballast trailer are aligned in the towing position.
- During the turning procedure of the wheel sets, the indicator light in the button **424 blinks**.
- When the towing position is reached, the **indicator light** in the button lights up **424**.
- A visual display appears on the LICCON monitor **LM2**.



#### Note

- ▶ The release to drive the crane in the “Towing” steering program is only made when both wheel sets are in the travel direction (neutral position) and the support cylinders are fully retracted.
  - ▶ Check the settings of the wheel sets and the support cylinders before driving the crane.
- 
- ▶ Retract the support cylinders completely, see section “Supporting the ballast trailer to align the wheel sets with the support cylinders”.
  - ▶ Check the visual display on the LICCON monitor **LM2**.



#### Note

- ▶ If one of the wheel sets deviates from the specified angle, the indicator light in the button **424** blinks and the wheel sets must be aligned again.

When the indicator light in the button **424** blinks:

- ▶ Check the towing position of the wheel sets on the visual display on the LICCON monitor **LM2**.
- ▶ Re-align the wheel sets in the towing position.

### Corrective steering of the wheel sets

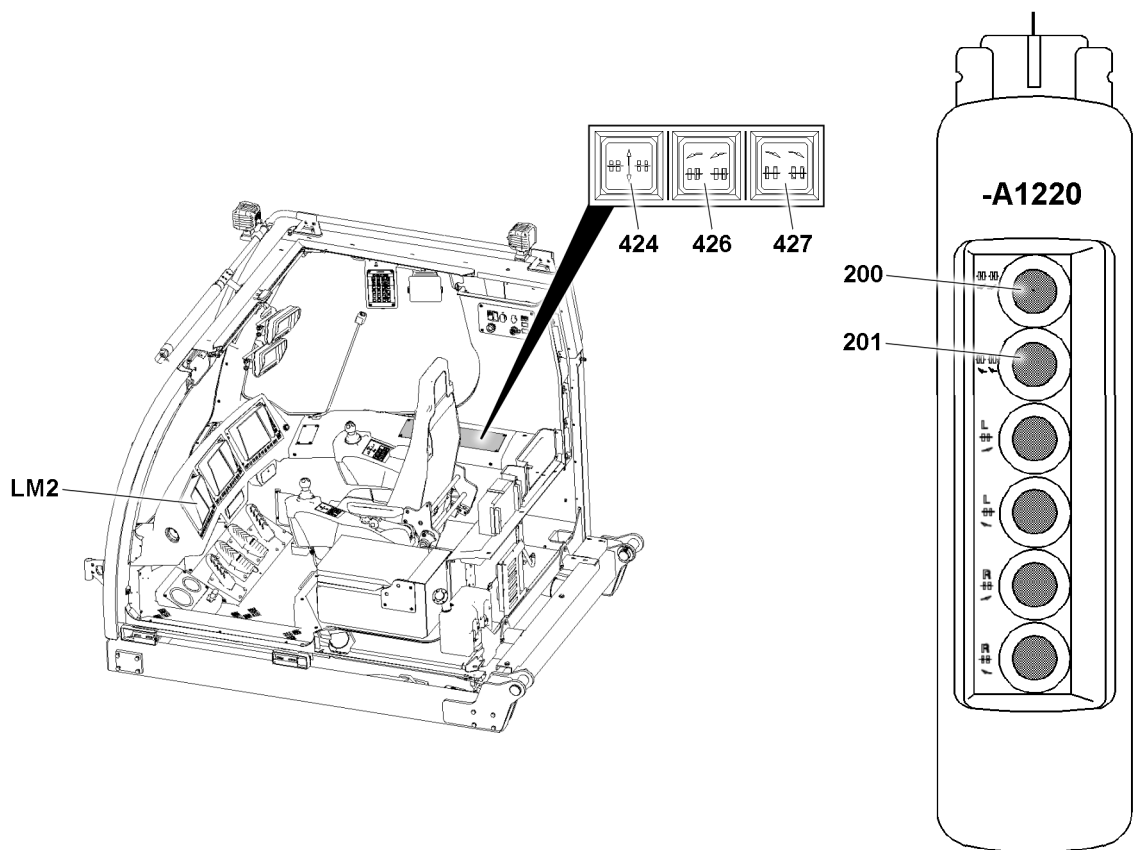


Fig.159359: Corrective steering of the wheel sets

Observe the special section “Corrective steering”.

#### NOTICE

Damage to the ballast trailer!

Through corrective steering of wheel sets while at a standstill, the ballast trailer can be damaged.

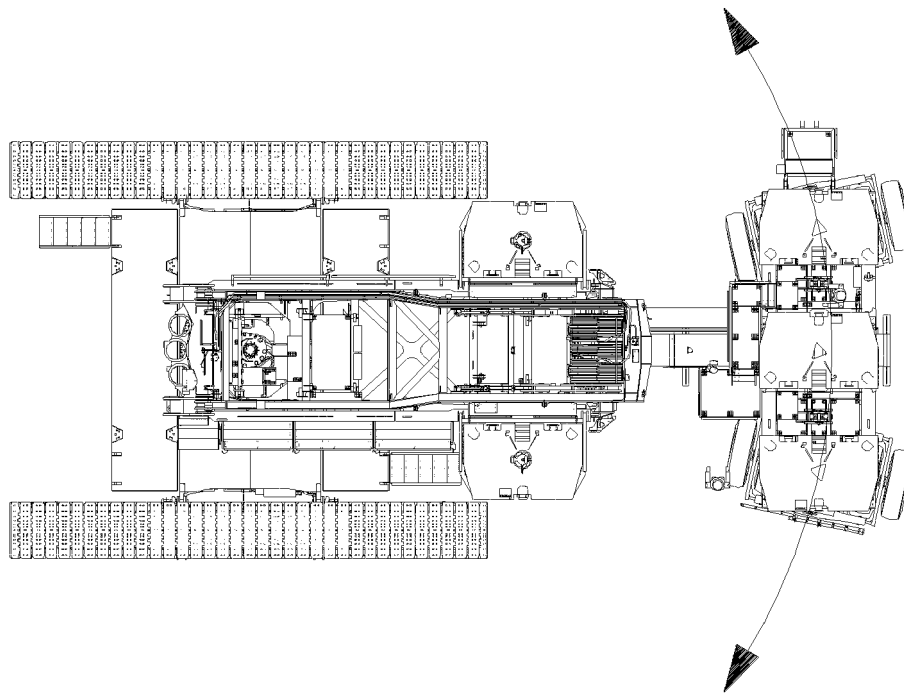
- ▶ If the ballast trailer is ballasted, the corrective steering of the wheel sets at a standstill is **prohibited**.
- ▶ When the ballast trailer is ballasted, the corrective steering of the wheel sets is only permissible while driving.
- ▶ Monitor the distortion of the tires.



#### Note

- ▶ Changing from the “Towing” steering program to the “Corrective steering” steering program and back is possible while driving the crawler.
- ▶ If the “Corrective steering” steering program is switched to the “Towing” steering program then the “indicator light in the button” **424 blinks** until the towing position of the wheel sets is reached.
- ▶ If one of the wheel sets deviates from the specified limit angle, the “indicator light in the button” **424** blinks and the wheel sets must be reset as described above.
- ▶ **In general, the following applies:** The wheel sets only move if either the button **427**, the button **426**, or the button **424** in the crane cab, or the button **200** or the button **201** on the control panel is pressed in the respective steering program or if the crawler is driven.

### 14.4.6 Circular travel

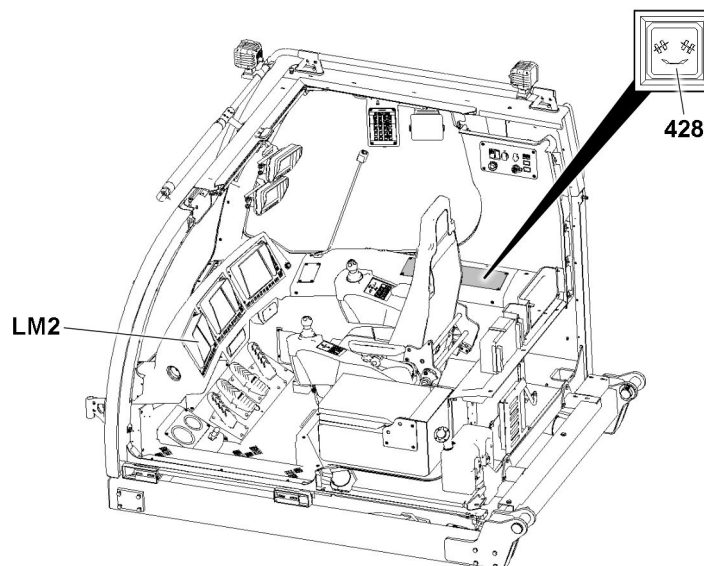


*Fig.159360: Circular travel*

Make sure that the following prerequisite is met:

- The ballast trailer guide is telescoped out to the required derrick ballast radius.

#### Aligning the wheel sets in the circular travel position



*Fig.159361: Aligning the wheel sets in the circular travel position*

Make sure that the following prerequisite is met:

- The ballast trailer is raised over the support cylinders to the point where the wheel sets are relieved.

- ▶ Press the button **428**.

**Result:**

- The ballast trailer wheel sets are aligned in the circular travel position.
- During the turning procedure of the wheel sets, the indicator light in the button **428** blinks.
- When the circular travel position is reached, the indicator light in the button **428** lights up.
- A visual display appears on the LICCON monitor **LM2**.

**Note**

- ▶ The release for turning the turntable in the “Circular travel” steering program is only made when both wheel sets are in the turning position (circular travel) and the support cylinders are completely retracted.
  - ▶ Check the settings for the wheel sets and support cylinders before inspecting turning of the turntable.
- 
- ▶ Retract the support cylinders completely, see section “Supporting the ballast trailer to align the wheel sets with the support cylinders”.
  - ▶ Check the visual display on the LICCON monitor **LM2**.

**Note**

- ▶ If one of the wheel sets deviates from the specified angle, the indicator light in the button **428** blinks and the wheel sets must be aligned again.

When the indicator light in the button **428** blinks:

- ▶ Check the circular travel position of the wheel sets on the visual display on the LICCON monitor **LM2**.
- ▶ Re-aligning the wheel sets in the circular travel position.

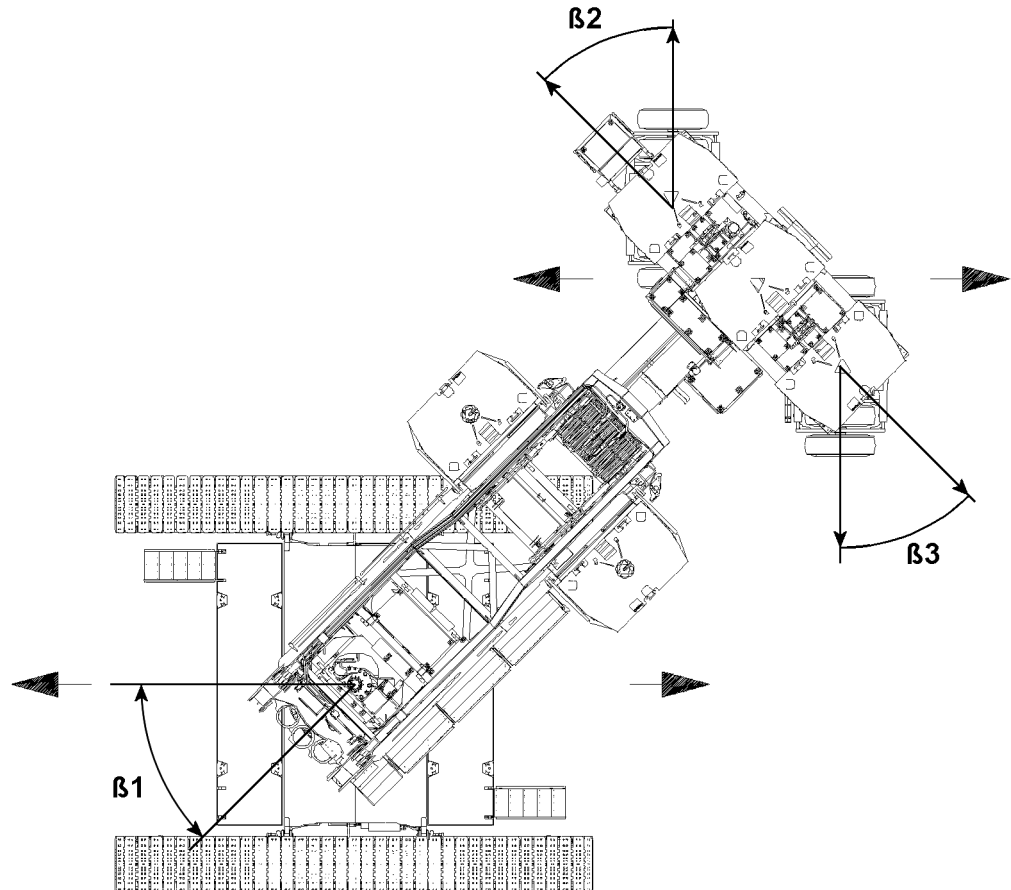
**14.4.7 Parallel travel**

Fig.159362: Parallel travel

**NOTICE**

Damage to the crane and the ballast trailer!

Due to steering movements on the crawler travel gear during parallel travel, the crane and the ballast trailer can be significantly damaged.

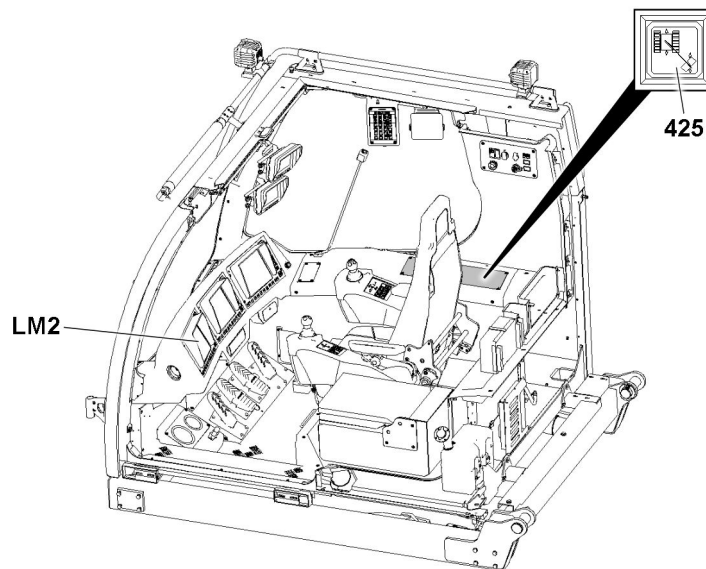
- ▶ During parallel travel, steering the crawler travel gear is **prohibited**.
- ▶ Driving the crane in parallel travel is only permissible when "Crawler parallel travel" is selected, otherwise there is no release of the travel gear.
- ▶ For parallel travel, the side tire distortion on the wheel sets must be observed by an instructed person over the entire travel route of the crane. If the tires distort by more than 100 mm, then the position of the wheel sets must be corrected.

**Note**

- ▶ Independently of whether the ballast trailer stands on the ground or is lifted off the ground, the wheel sets must always stand in a "Parallel travel" position.
- ▶ In deviating position for the wheel sets, the control turns itself off.
- ▶ To drive the crane with the ballast trailer in the parallel travel steering program, "Crawler operation parallel travel" must be selected on the crane.

**Note**

- ▶ The travel drive of the crawler is locked until the wheel sets are in the parallel travel position.
- ▶ When driving the crawler, the slewing gear brake of the crane remains applied, hydraulic coasting is opened.
- ▶ If the angles  $\beta_2$  and  $\beta_3$  deviate in relation to  $\beta_1$  by more than the permissible tolerance, the crawler travel gear is stopped, the indicator light in the button **425** blinks.
- ▶ The crawler travel gear be driven again only after renewed alignment of the wheel sets to the required specified angle.
- ▶ If "Crawler parallel travel" is selected, the crawler and the ballast trailer move straight forward on appropriate terrain.

**Aligning the wheel sets in the parallel travel position**

*Fig.159363: Aligning the wheel sets in the parallel travel position*

Make sure that the following prerequisite is met:

- The ballast trailer is raised over the support cylinders to the point where the wheel sets are relieved.
- ▶ Press the button **425**.

**Result:**

- The ballast trailer wheel sets are aligned in the parallel travel position.
  - During the turning procedure of the wheel sets, the indicator light in the button **425 blinks**.
  - When the parallel travel position is reached, the indicator light in the button **425 lights up**.
  - A visual display appears on the LICCON monitor **LM2**.
- ▶ Retract the support cylinders completely, see section “Supporting the ballast trailer to align the wheel sets with the support cylinders”.
  - ▶ Check the visual display on the LICCON monitor **LM2**.

**Note**

- ▶ If one of the wheel sets deviates from the specified angle, the indicator light in the button **425 blinks** and the wheel sets must be aligned again.

When the indicator light in the button **425 blinks**:

- ▶ Check the parallel position of the wheel sets on the visual display on the LICCON monitor **LM2**.
- ▶ Re-align the wheel sets in the parallel travel position.

### 14.4.8 Steering and corrective steering of the wheel sets

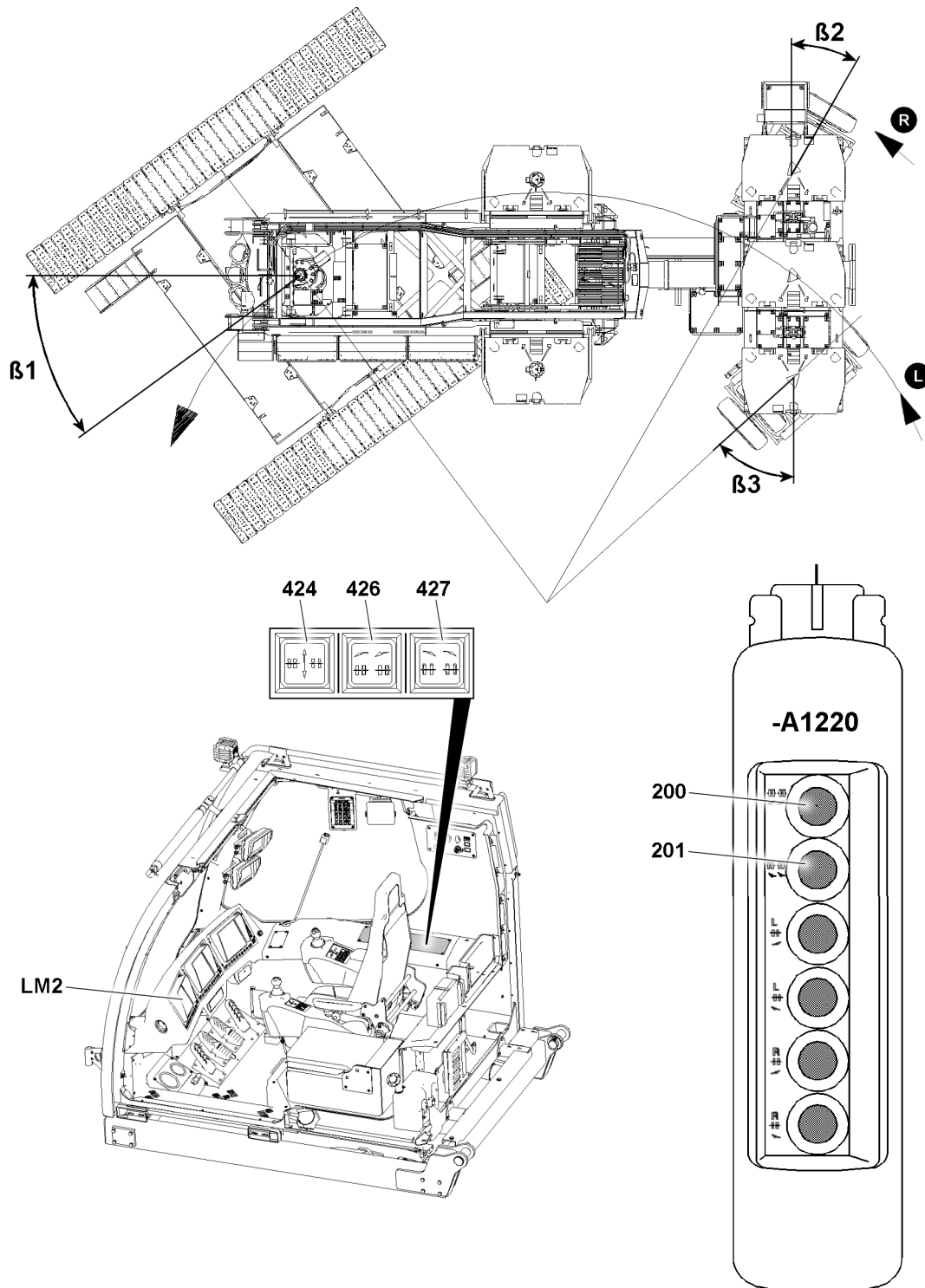


Fig.159364: Steering and corrective steering of the wheel sets

The right wheel set is regulated by the computer-controlled steering program so that there is always a center steering position. The angle  $\beta_1$  is determined by the driving of the crawler and the angle  $\beta_2$  is determined by the steering of the operator, whereby the angle  $\beta_3$  is continually corrected. Switching from the "Corrective steering" steering program to the "Towing" steering program and back, after achieving the towing position, is possible while driving the crawler. If the "Corrective steering" steering program is selected from the "Towing" program, the indicator light in the button **427** and the indicator light in the button **426** light up.



**Note**

- ▶ The left wheel set can be steered to the specified limit angle  $\beta_3$ . It is not possible to steer beyond this limit angle.
- ▶ The right wheel set is corrected to follow the center steering position. If the right correctively steered wheel set cannot follow the left wheel set, then the left wheel set is stopped until the right correctively steered wheel set has caught up.
- ▶ If the right wheel set still deviates from the specified limit angle, the indicator light in the button **427** and the indicator light in the button **426** blink and it is necessary to begin again with "Towing".
- ▶ If the crawler is driven and exceeds the angle  $\beta$ , the turntable automatically switches the specified value into the "Towing" steering program. The axles are swung back to the initial towing position ( $0^\circ$  or  $180^\circ$ ). The indicator light in the button **427**, the indicator light in the button **426** and the indicator light in the button **424** blink.
- ▶ When the towing position is reached, manual corrective steering can continue. The indicator light in the button **424** lights up, also a visual display appears on LICCON monitor LM2.
- ▶ **In general, the following applies:** The wheel sets only move during corrective steering if either the button **427** or the button **426** from the crane cab, **or** the button **200** or the button **201** on the control panel is pressed in the respective steering program or if the crawler is driven.

Make sure that the following prerequisites are met:

- Crawler operation is turned on.
- The "Towing" steering program is selected **and** the wheel sets are in the towing position, see section Towing.
- The indicator light in the button **424** illuminates.
- The settings are checked.

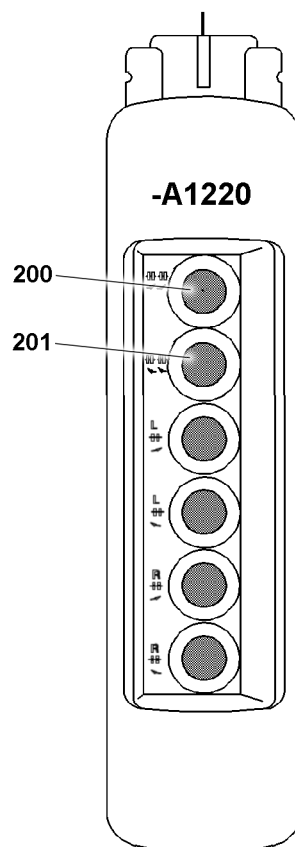
**Turning the wheel set using the control panel -A1220**

Fig.159365: Turning the wheel set using the control panel -A1220

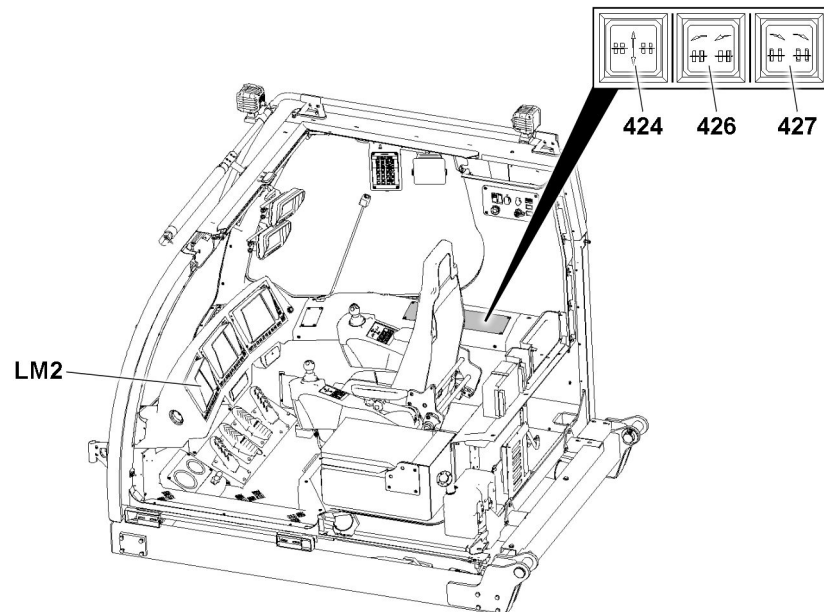
When the wheel set should be turned to the right:

- ▶ Press the button **200** on the control panel **-A1220**.

When the wheel set should be turned to the left:

- ▶ Press the button **201** on the control panel -A1220.

**Turn the wheel set using the buttons on the instrument panel**



*Fig.159366: Turn the wheel set using the buttons on the instrument panel*

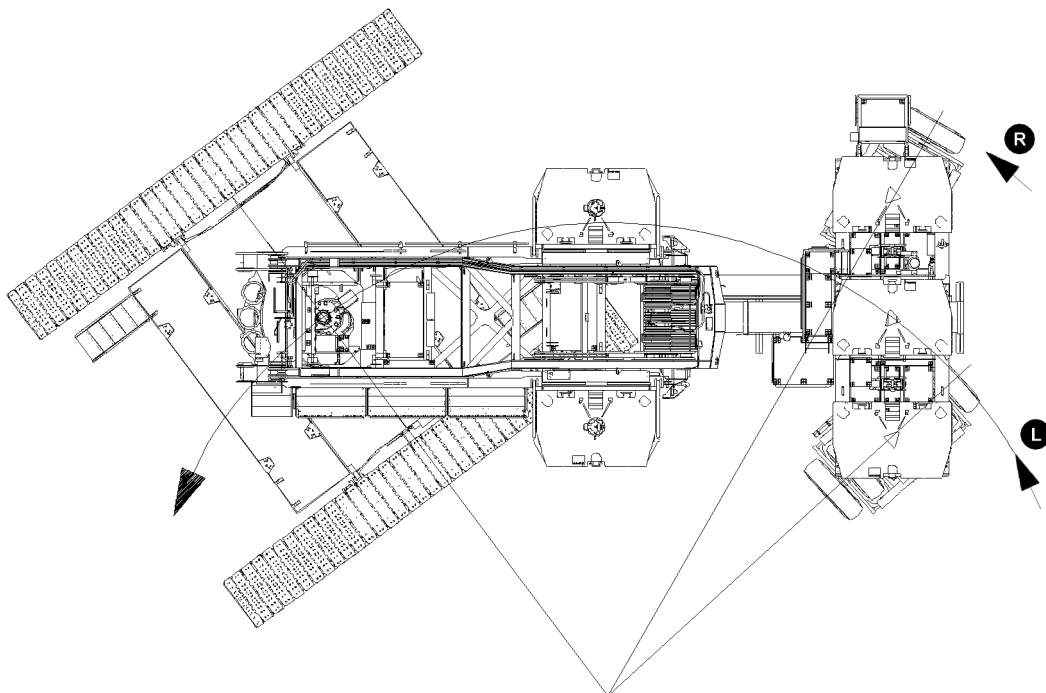
When the wheel set should be turned to the right:

- ▶ Press the button **427** in the crane cab.

When the wheel set should be turned to the left:

- ▶ Press the button **426** in the crane cab.

#### 14.4.9 Wheel set manual operation for assembly / emergency operation



*Fig.159367: Wheel set manual operation for assembly / emergency operation*

The ballast trailer is equipped with a program which allows for each wheel set to be turned individually for assembly / emergency operation.

Make sure that the following prerequisite is met:

- The ballast trailer is raised over the support cylinders to the point where the wheel sets are relieved.

### Turning the wheel sets individually

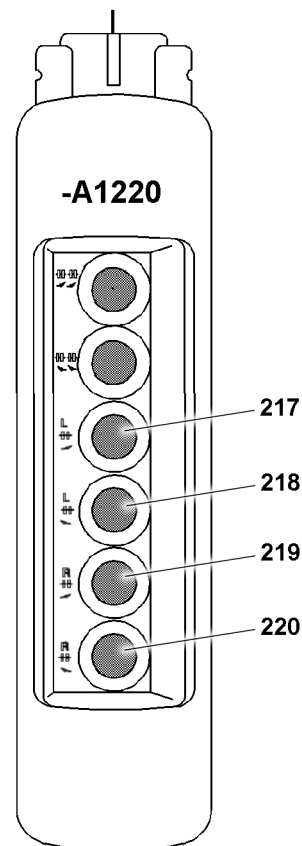


Fig.159368: Turning the wheel sets individually

To set the wheel sets, the buttons on the control panel **-A1220** must be pressed.

### Turning the wheel sets individually using the control panel -A1220

- ▶ Press the button **217** on the control panel **-A1220**.

**Result:**

- The left wheel set turns to the right.

- ▶ Press the button **218** on the control panel **-A1220**.

**Result:**

- Turn left wheel set to the left.

- ▶ Press the button **219** on the control panel **-A1220**.

**Result:**

- Turn right wheel set to right.

- ▶ Press the button **220** on the control panel **-A1220**.

**Result:**

- Turn right wheel set to the left.

### Turning the wheel sets individually using the BTT-E

- ▶ See chapter 6.08.

## 14.4.10 Deactivating steering programs for assembly / disassembly purposes

If an incorrect steering program is activated on the ballast trailer, crane functions that are necessary for assembly / disassembly purposes may not be carried out and / or controlled.



### Note

- ▶ When both ballast trailer guide / turntable connection pins are correctly pinned, both limit switches are actuated. If the limit switches are actuated, only the crane functions released by the steering program can be carried out. If the correct steering program is not selected, certain crane movements are not possible.
- ▶ If the ballast trailer guide / turntable connection pin points do not align, the crane and the ballast trailer must be aligned with each other correctly.



### WARNING

Ballast trailer guide / turntable connection only partially pinned!

If only one pin of the ballast trailer guide / turntable connection is correctly pinned, crane function monitoring is limited.

If no steering program is turned on, the turntable can be turned, the crane can be driven and the ballast trailer guide can be telescoped.

It is possible to operate the crane incorrectly and damage it.

- ▶ The crane driver is responsible for ensuring compliance with the specifications of the operating instructions regarding ballast trailer assembly / disassembly.
- ▶ Always carry out the crane movements with extreme caution and at the lowest possible speed.

In order to carry out crane functions necessary for assembly / disassembly purposes, the following is necessary:

- either all steering programs must be deactivated (all steering program indicator lights are off)
- or a certain steering program must be activated (steering program indicator light on)
- turning the turntable requires circular travel, driving the crane and telescoping the ballast trailer guide require towing.

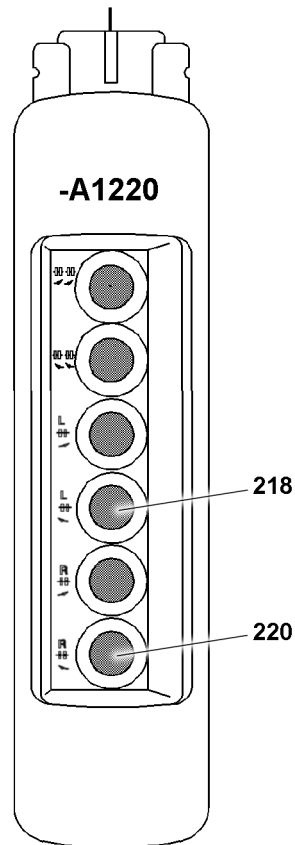


Fig.159369: Control panel -A1220



#### Note

Deactivating a steering program (crane cab)

All steering programs are deactivated when there is no illuminated steering program indicator light.

- ▶ Crane cab: A steering program is deactivated by briefly pressing (less than one second) a button for another steering program. If the indicator light of another steering program lights up permanently as a result, then this steering program is active and must also be turned off.
- ▶ Control panel **-A1220**: Press the button **218** or button **220** to switch to manual operation and deactivate all steering programs.

## Deactivating the towing steering program

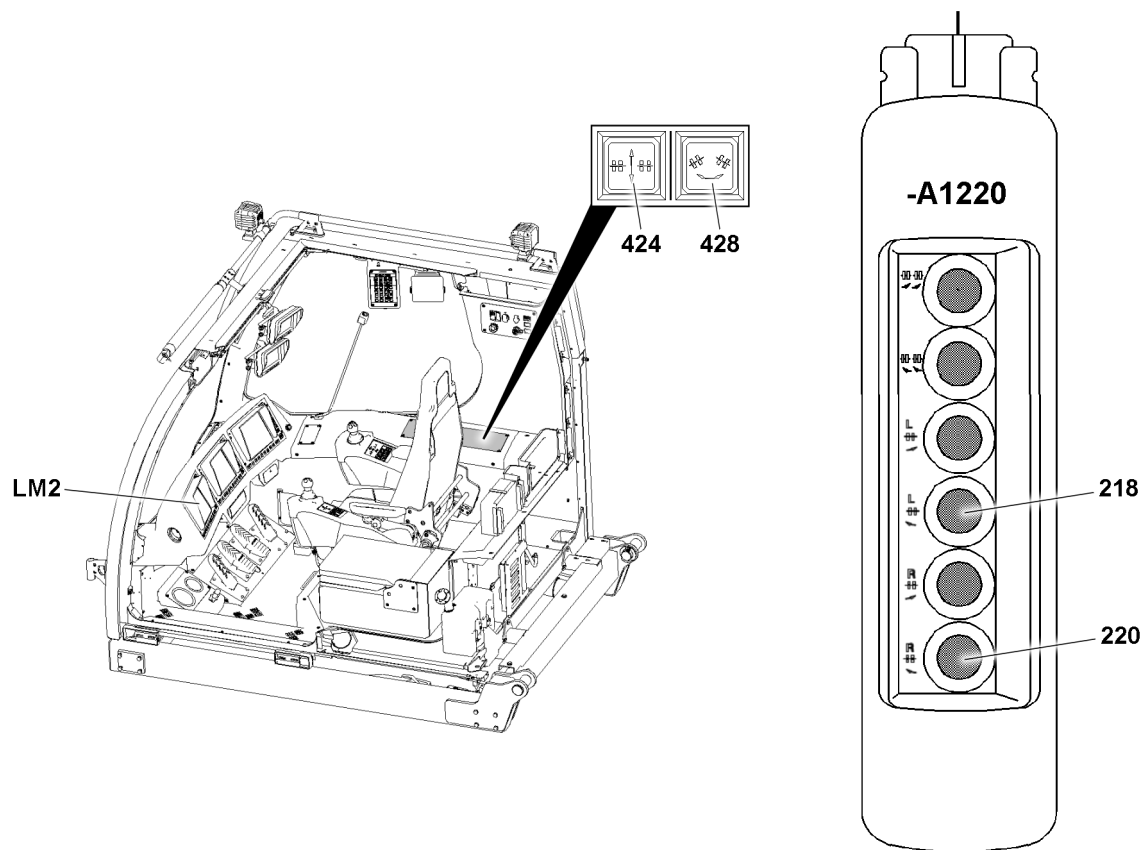


Fig.159370: Deactivating the towing steering program

On the control panel **-A1220**:

- ▶ Briefly press the button **218** or button **220** (for one second).

**Result:**

- The towing steering program is deactivated.
- No steering program is active.

**or:**

In the crane cab:

- ▶ Briefly press the *circular travel* button **428** (less than one second).

**Result:**

- When the *towing* button **424** indicator light is off: The towing steering program is deactivated.
- The *circular travel* button **428** indicator light must also remain off. Otherwise, deactivate the circular travel steering program.

## Deactivating the parallel travel steering program

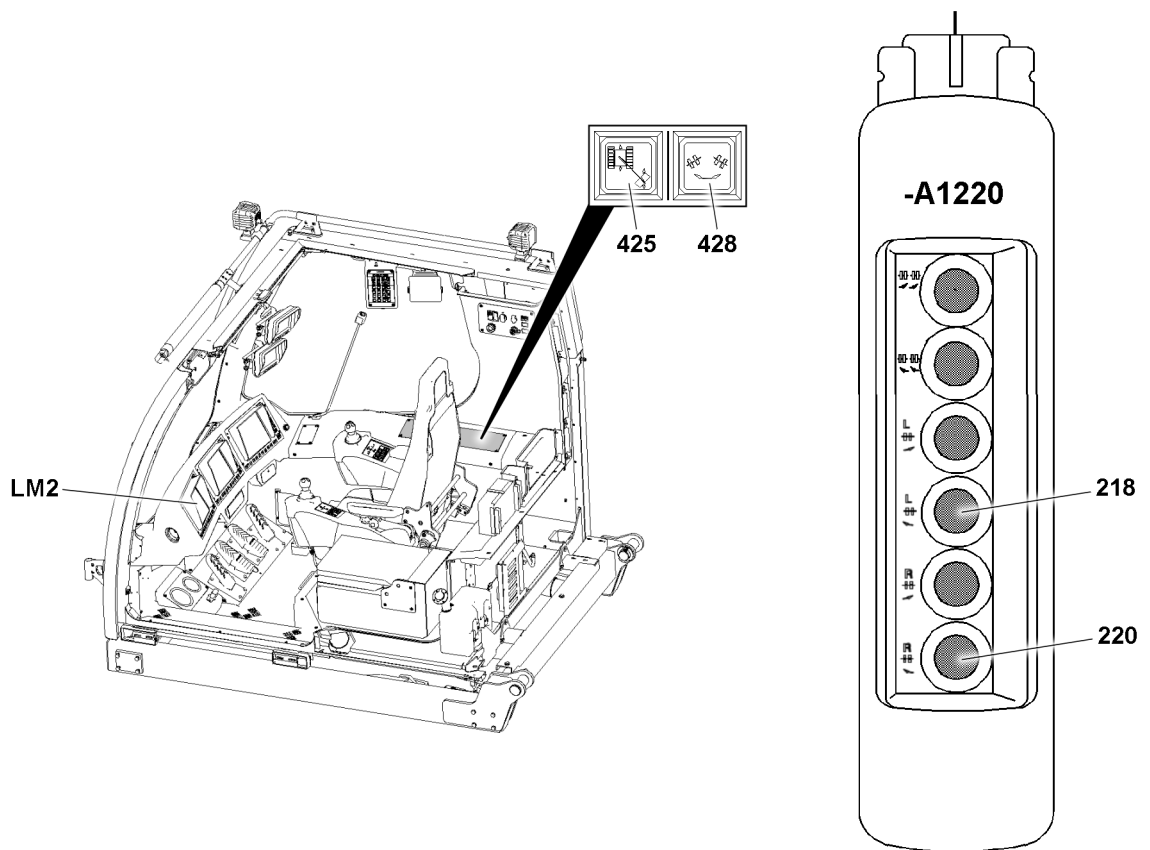


Fig.159371: Deactivating the parallel travel steering program

On the control panel **-A1220**:

- ▶ Briefly press the button **218** or button **220** (for one second).

**Result:**

- The parallel travel steering program is deactivated.
- No steering program is active.

**or:**

In the crane cab:

- ▶ Briefly press the *circular travel* button **428** (less than one second).

**Result:**

- When the *parallel travel* button **425** indicator light is off: The parallel travel steering program is deactivated.
- The *circular travel* button **428** indicator light must also remain off. Otherwise, deactivate the circular travel steering program.

### Deactivating the circular travel steering program

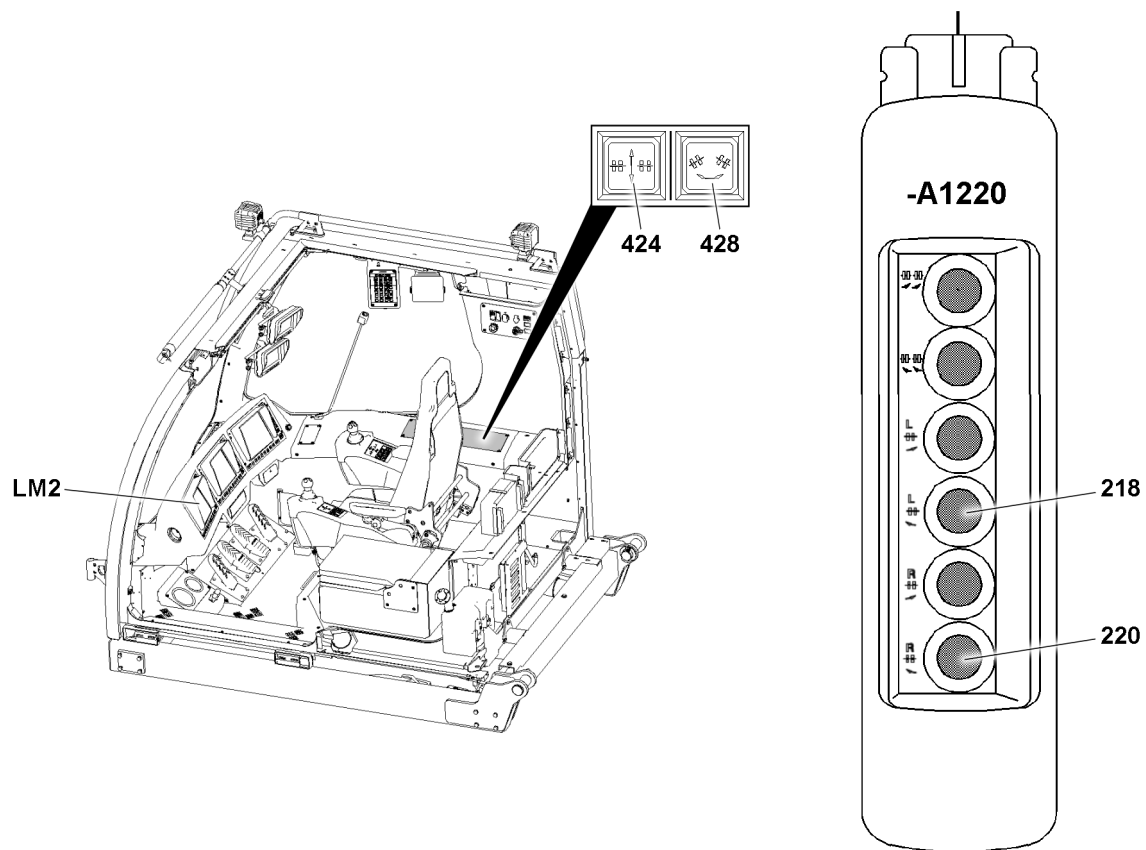


Fig.159372: Deactivating the circular travel steering program

On the control panel **-A1220**:

- ▶ Briefly press the button **218** or button **220** (for one second).

**Result:**

- The circular travel steering program is deactivated.
- No steering program is active.

**or:**

In the crane cab:

- ▶ Briefly press the *towing* button **424** (less than one second).

**Result:**

- When the *circular travel* button **428** indicator light is off: The circular travel steering program is deactivated.
- The *towing* button **424** indicator light must also remain off. Otherwise, deactivate the towing steering program.

## 14.5 Driving the ballast trailer

When the ballast trailer has ground contact, it is driven using various crane movements / steering programs:

- Through towing when driving the crane
- Through parallel travel when driving the crane
- Through circular travel when turning the crane superstructure
- Through corrective steering when driving the crane



**Note**

- ▶ It is only permitted to drive the ballast trailer on level ground capable of supporting the load.
- ▶ Driving over obstacles is not permitted.

**DANGER**

The crane can topple over!

In case of non-permissible level difference between the ballast trailer road surface and the crane position level, the entire crane system can be pulled back suddenly.

The relapse cylinders can thereby run into the mechanical block position and be significantly damaged.

The crane can topple over.

Death, severe bodily injuries, property damage.

- ▶ Do not exceed or fall below the permissible level difference between the ballast trailer road surface and the crane placement level.

**NOTICE**

Piston rod on block!

If the piston rod of the extension cylinder is already on block through telescoping out or in of the ballast trailer guide, there is no pressure protection. In this situation, the pressure relief valves on the piston and ring side are ineffective.

The extension cylinder can be significantly damaged.

- ▶ It is prohibited to retract or extend the piston rod to the block position.

### 14.5.1 Safety instructions

#### Case 1: The boom system is pulled to the rear

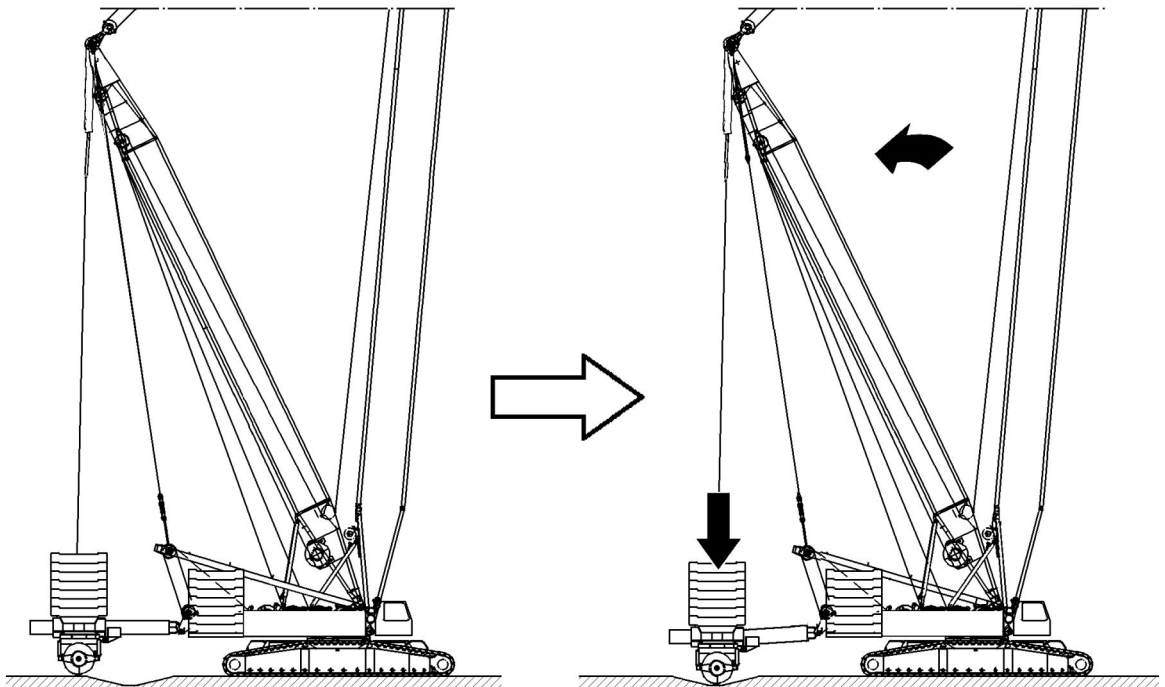


Fig.159373: Case 1a: The boom system is pulled to the rear

When driving the crane or turning the crane superstructure, the ballast trailer lowers due to the level differences (depressions). In this way, the crane stays at its level. As a result, the entire boom system can pull back in an uncontrolled manner.

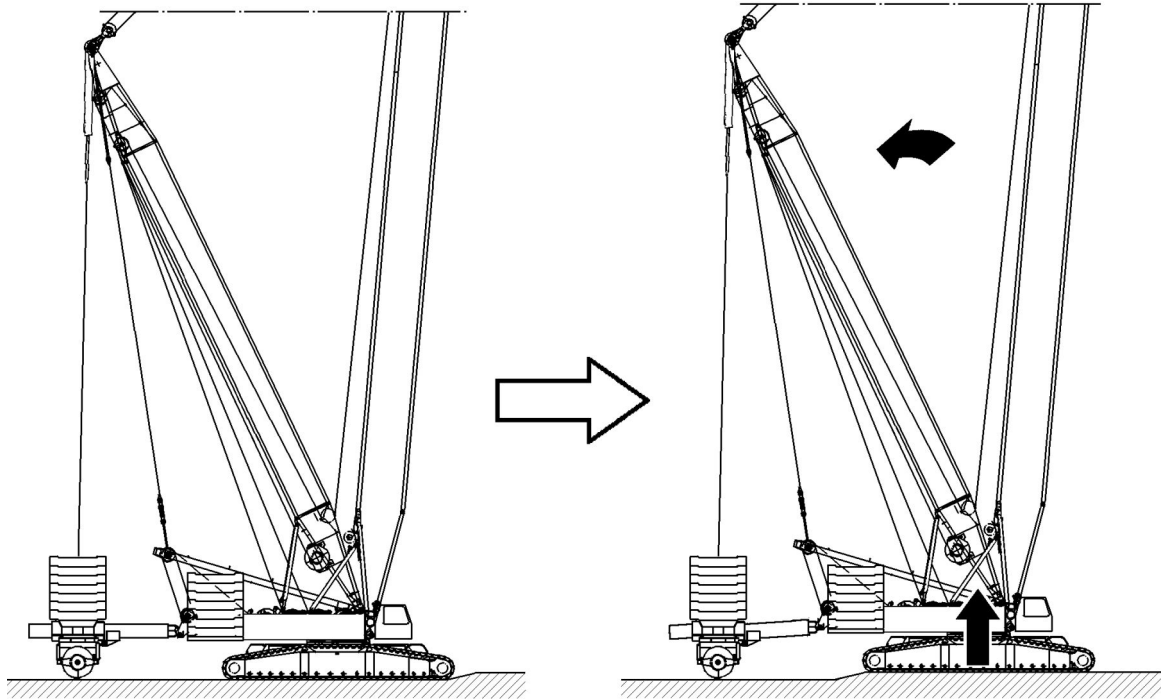


Fig.159374: Case 1b: The boom system is pulled to the rear

When driving the crane, the crane lifts up due to the level differences (elevations). In this way, the ballast trailer stays at its level. As a result, the entire boom system can pull back in an uncontrolled manner.

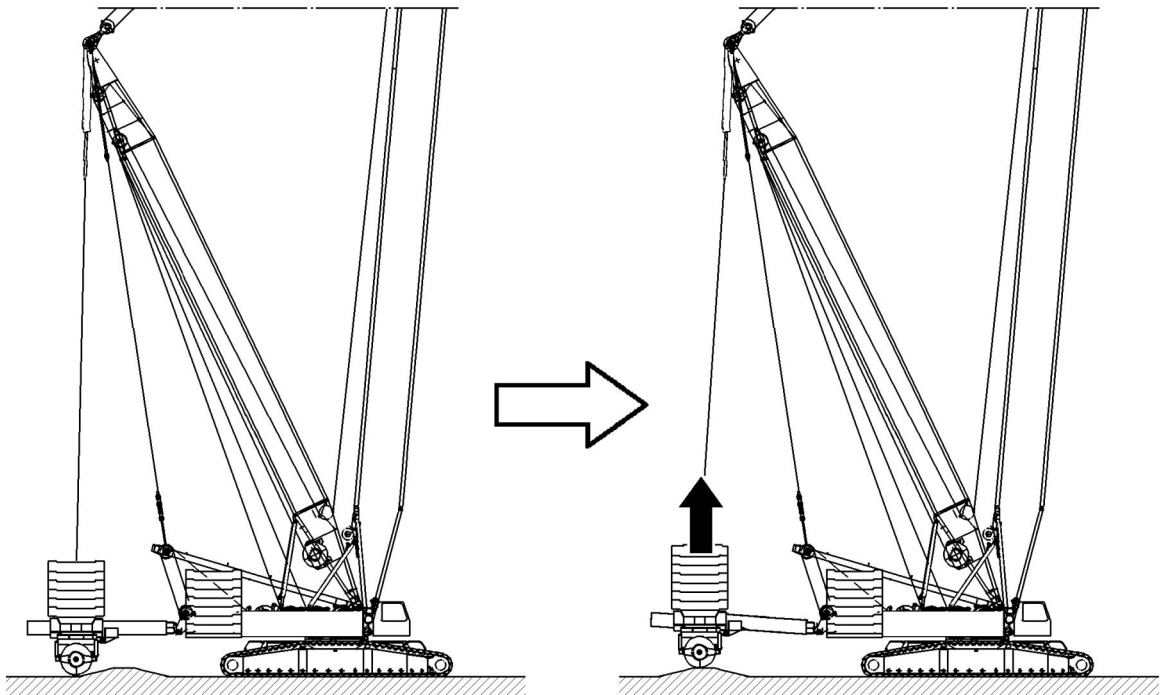
**Examples of possible consequences of a pulled back boom system:**

- In the case of a steeply positioned boom system, block positions / damage to the relapse cylinder can result
- The minimum force  $F1^{\min}$  (test point 1) can be fallen below
- The force in the ballast trailer guying increases, the pulled derrick ballast lifts up
- The limit angles of the load chart can be exceeded



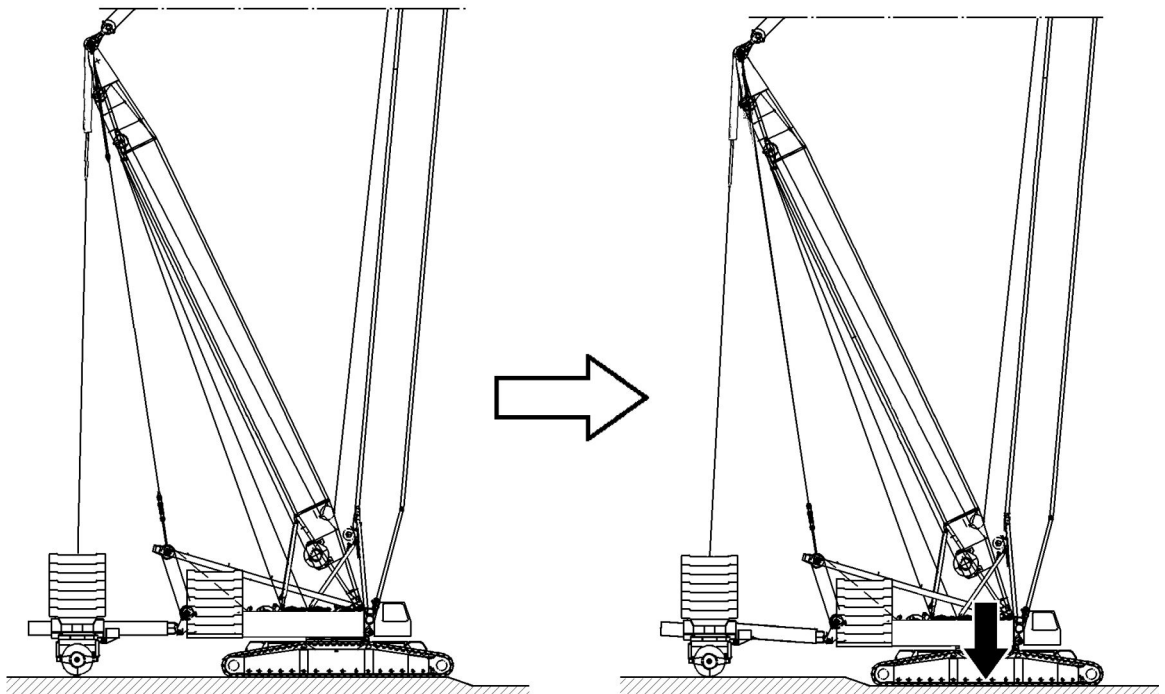
**Note**

- ▶ Due to the “Main boom relapse cylinder on block” or “Derrick relapse cylinder on block” shut-offs, in crane operation with ballast trailer, the “driving the crawler” and “turning the crane superstructure” movements are automatically turned off.
- ▶ Due to the “minimum force  $F1$  (test point 1) fallen below” shut-off, in crane operation with a ballast trailer, the “driving the crawler” and “turning” movements are **not** turned off.

**Case 2: The ballast trailer guying is relieved**

*Fig.159375: Case 2a: The ballast trailer guying is relieved*

When driving the crane or turning the crane superstructure, the ballast trailer lifts up due to the level differences (elevations). In this way, the crane stays at its level. As a result, the ballast trailer guying is released in an uncontrolled manner.



*Fig.159376: Case 2b: The ballast trailer guying is relieved*

When driving the crane or if the crane lowers due to the level differences (depressions). In this way, the ballast trailer stays at its level. As a result, the ballast trailer guying is released in an uncontrolled manner.

**Examples of possible consequences of releasing the ballast trailer guying:**

- The maximum force  $F1^{\max}$  (test point 1) may not be exceeded
- The limit angles of the load chart can be exceeded

**Note**

- ▶ Due to the “maximum force  $F1^{\max}$  (test point 1) exceeded” shut-off, during crane operation with a ballast trailer, the “driving the crawler” and “turning” movements are **not** turned off.

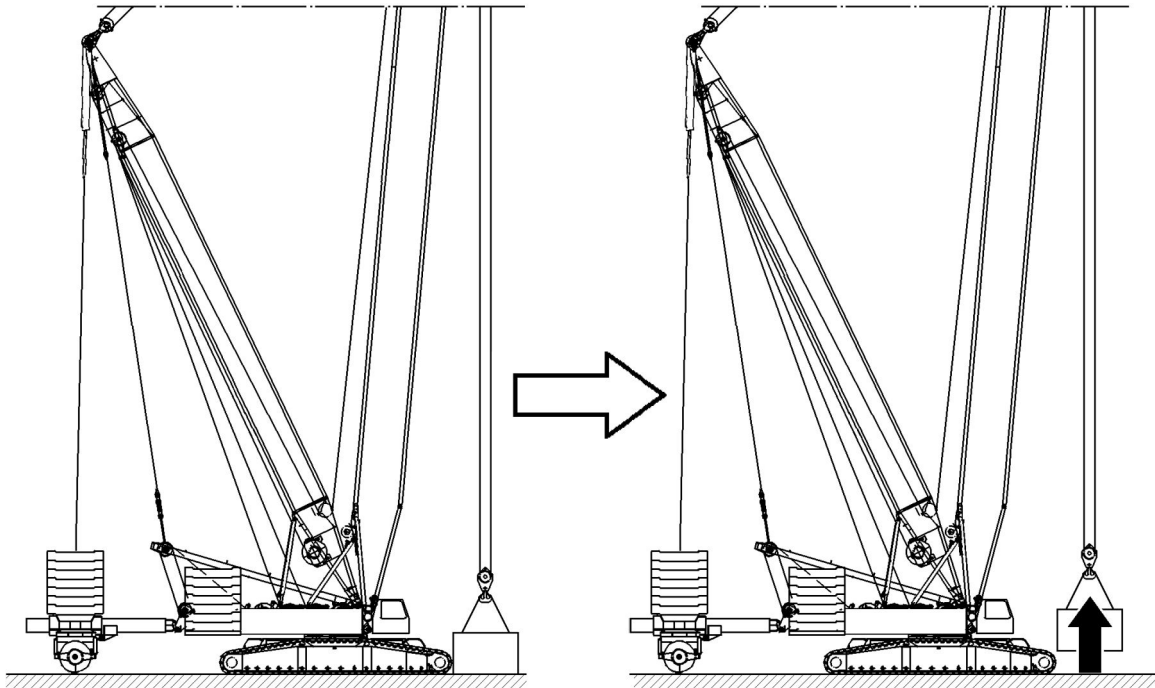
**Case 3: The load momentum is increased**

Fig.159377: Case 3a: The load momentum is increased

The load momentum is increased when picking up the load. The crane and boom system are loaded more.

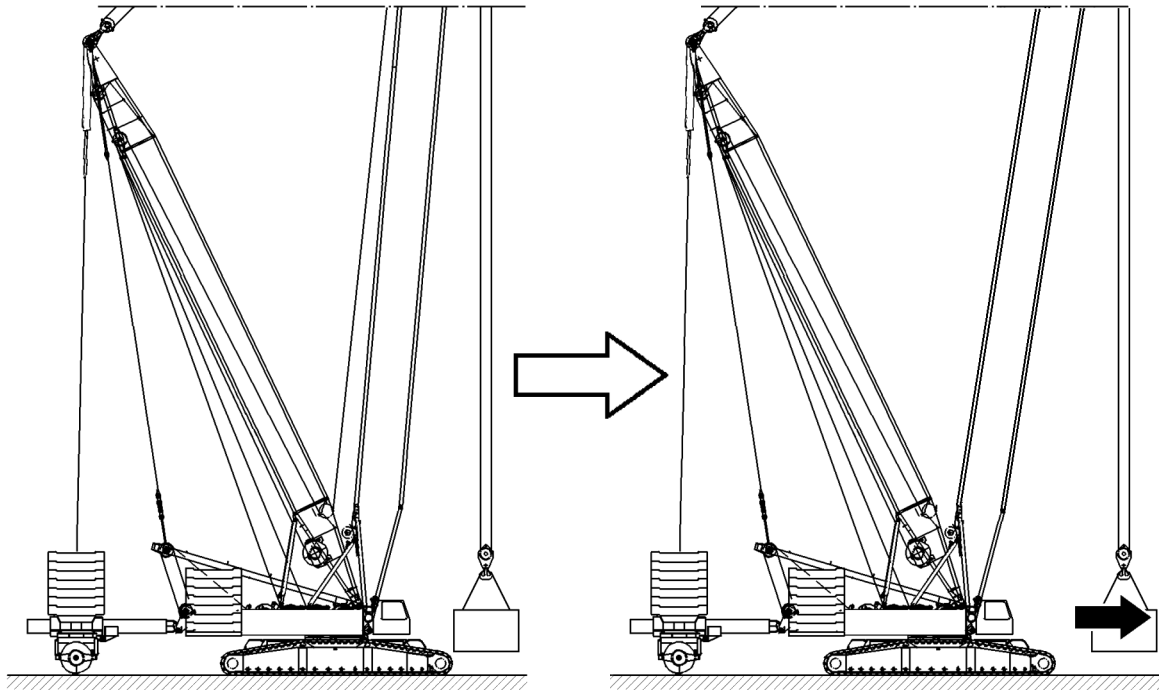


Fig.159378: Case 3b: The load momentum is increased

The load momentum is increased when the boom radius of the load is increased. The crane and boom system are loaded.

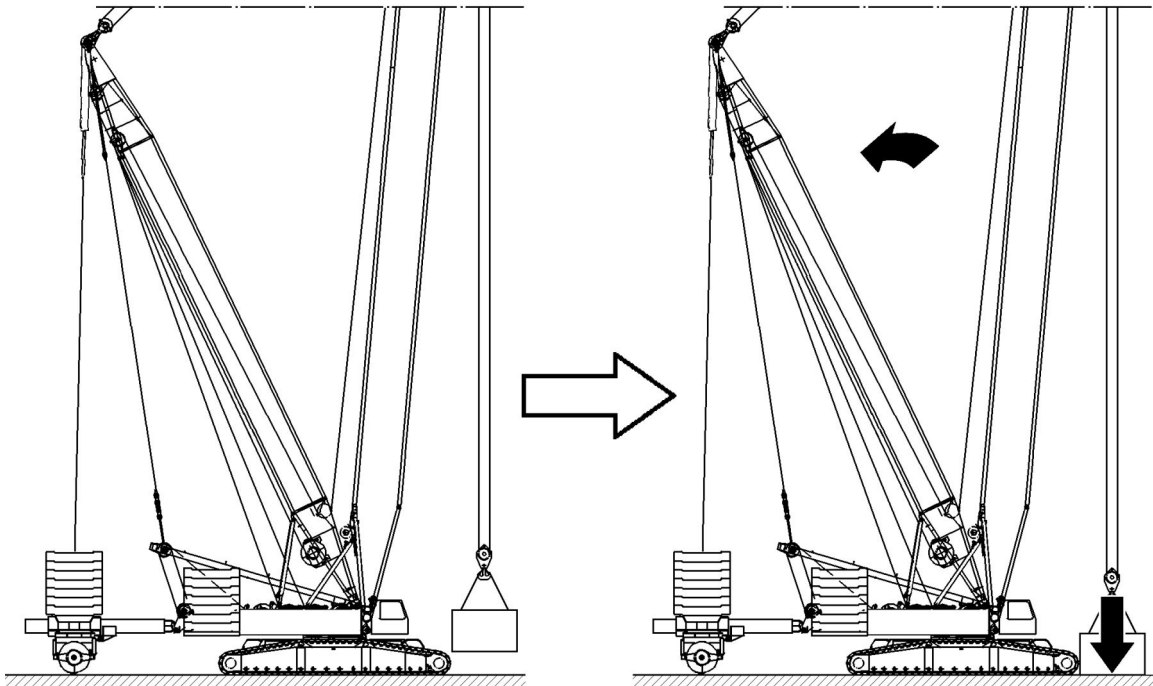
**Examples of possible consequences of an increased load momentum:**

- The maximum force  $F1^{\max}$  (test point 1) may not be exceeded
- The force in the ballast trailer guying increases, the pulled derrick ballast lifts up
- The limit angles of the load chart can be exceeded



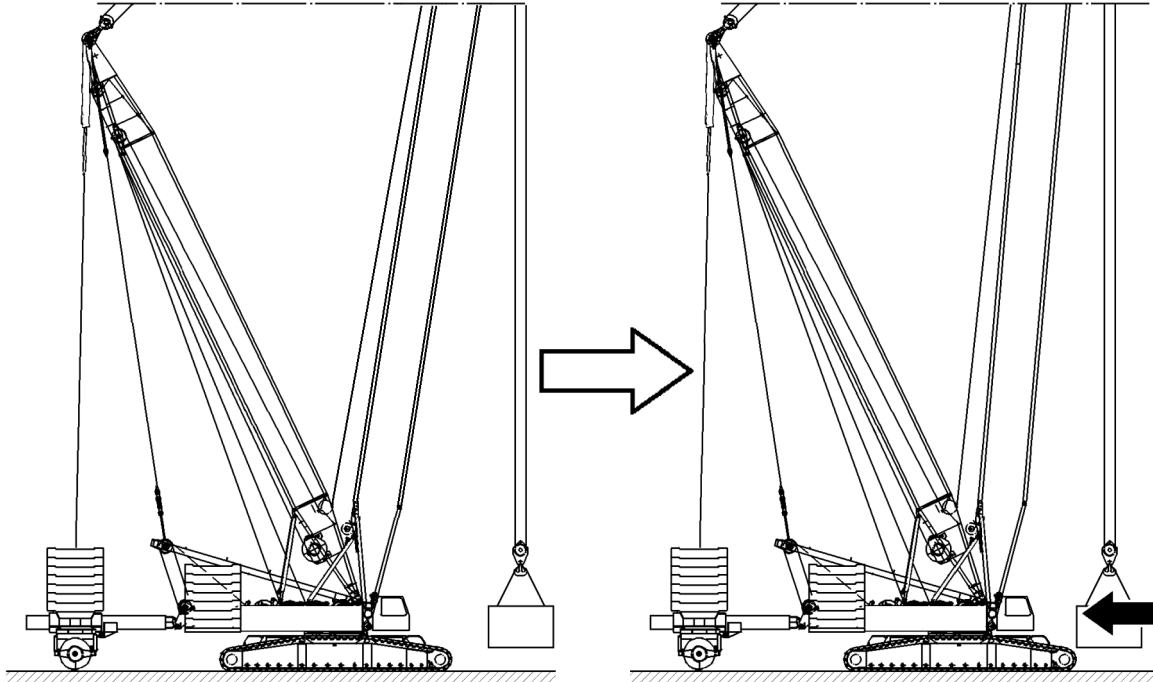
**Note**

- ▶ Due to the “maximum force  $F1^{\max}$  (test point 1) exceeded” shut-off, during crane operation with a ballast trailer, the “driving the crawler” and “turning” movements are **not** turned off.

**Case 4: The load momentum is decreased**

*Fig.159379: Case 4a: The load momentum is decreased*

When the load is set down, the crane and boom system are relieved. The load momentum is decreased. As a result, the boom system can move backward.



*Fig.159380: Case 4b: The load momentum is decreased*

When decreasing the load boom radius, the crane and boom system are relieved. The load momentum is decreased. The crane and boom system are loaded less by the load.

**Examples of possible consequences of a decreased load momentum:**

- The minimum force  $F1^{\min}$  (test point 1) can be fallen below
- The pulled derrick ballast is reduced
- The limit angles of the load chart can be exceeded

### 14.5.2 Test point 1 (F1-load display)



#### WARNING

Danger of accident when driving the crane with load and ballast trailer!

If when driving the crane with a load - this also applies for "circular travel" - the ballast trailer is raised due to ground unevenness, the force in test point 1 (F1-load display) increases immediately and the crane will be overloaded.

If the ballast trailer sinks while driving due to ground unevenness, the force on test point 1 (F1-load display) drops and the ballast trailer lifts off the ground, or the entire boom system is pulled backward. The crane can topple over and personnel can be severely injured or killed.

- ▶ The crane operator must constantly observe the displays on the LICCON monitor while driving the crane.
- ▶ The crane operator must act anticipatorily. Already when an advance warning appears in test point 1 (F1-load display), it is necessary to act accordingly: By actuating the pull cylinders of the derrick ballast, correct the load / force on test point 1 (F1-load display) until it is in a permissible operating range. The permissible extension lengths of the pull cylinders must be observed.

### 14.5.3 Relapse cylinder

When the steepest operating position of the main boom is reached, luffing up is turned off by the LICCON overload protection in all operating modes.



#### Note

- ▶ However, in certain cases the movement of the entire crane system to the rear can cause the relapse cylinders to mechanically latch in the block position.

#### Relapse cylinder block position

#### NOTICE

Damage to the relapse cylinder and the boom!

Through level difference between the ballast trailer and crane route, the boom can suddenly be pulled backward and the relapse cylinder can go into the block position.

The relapse cylinder or the boom can be damaged.

- ▶ Make sure before starting travel operation, or before turning the crane superstructure, that the travel route of the crane or the ballast trailer circular path is even and capable of supporting the load.

In normal crane operation without bypass of the LICCON overload protection, a block position is not possible. Should a block position still occur, the movement is shut off and the boom limitation icon shown on the crane operating screen indicates which block position has been started up.

With this boom limitation icon it is to be determined which limit switch on which relapse cylinder has been actuated. Reverse the last movement which was carried out until the corresponding limit switch is released again.

### 14.5.4 Maximum permissible ground unevenness

Level changes between the standing levels of the crane and the ballast trailer, in the case of towing, parallel and circular travel, a maximum deviation may not be exceeded depending on the ballast trailer radius, see section "Ground unevenness".

**WARNING**

The crane can topple over!

By exceeding the maximum permissible level difference in reference to the standing levels of the crane and ballast trailer, the crane can topple over.

Death, severe bodily injuries, property damage.

- ▶ Do not exceed a level difference in reference to the standing levels between the crane and the ballast trailer, see section "Ground unevenness".
- ▶ Level changes within the maximum permissible deviation must be carried out slowly and evenly.
- ▶ Do not exceed or undershoot the maximum permissible lateral inclination of the crane and ballast trailer.

If when driving the crane a LMB shut-off occurs that is caused by an impermissible incline of the ballast trailer, then this shut-off is displayed in the *Derrick ballast guying* icon on LICCON monitor 2. This shut-off can be bypassed in order to leave an impermissible inclination and reach a permissible inclination range, see chapter 4.02.

**Compensating for ground unevenness**

Ground unevenness can be compensated for by lifting or lowering the ballast trailer within the permissible range, see section "Ground unevenness".

**Note**

- ▶ See section "Lifting and lowering the ballast trailer with the pull cylinders".

**WARNING**

The crane can topple over!

If the ballast trailer is lifted off the ground past the **maximum permissible level difference**, then the crane can topple over to the rear if the load rips off.

Death, severe bodily injuries, property damage.

- ▶ Lift the ballast trailer off the ground only up to the maximum permissible level difference depending on the ballast trailer radius, see section "Ground unevenness".

**14.5.5 Ballast trailer drive****Note**

- ▶ Only for crane types with a ballast trailer drive\*.



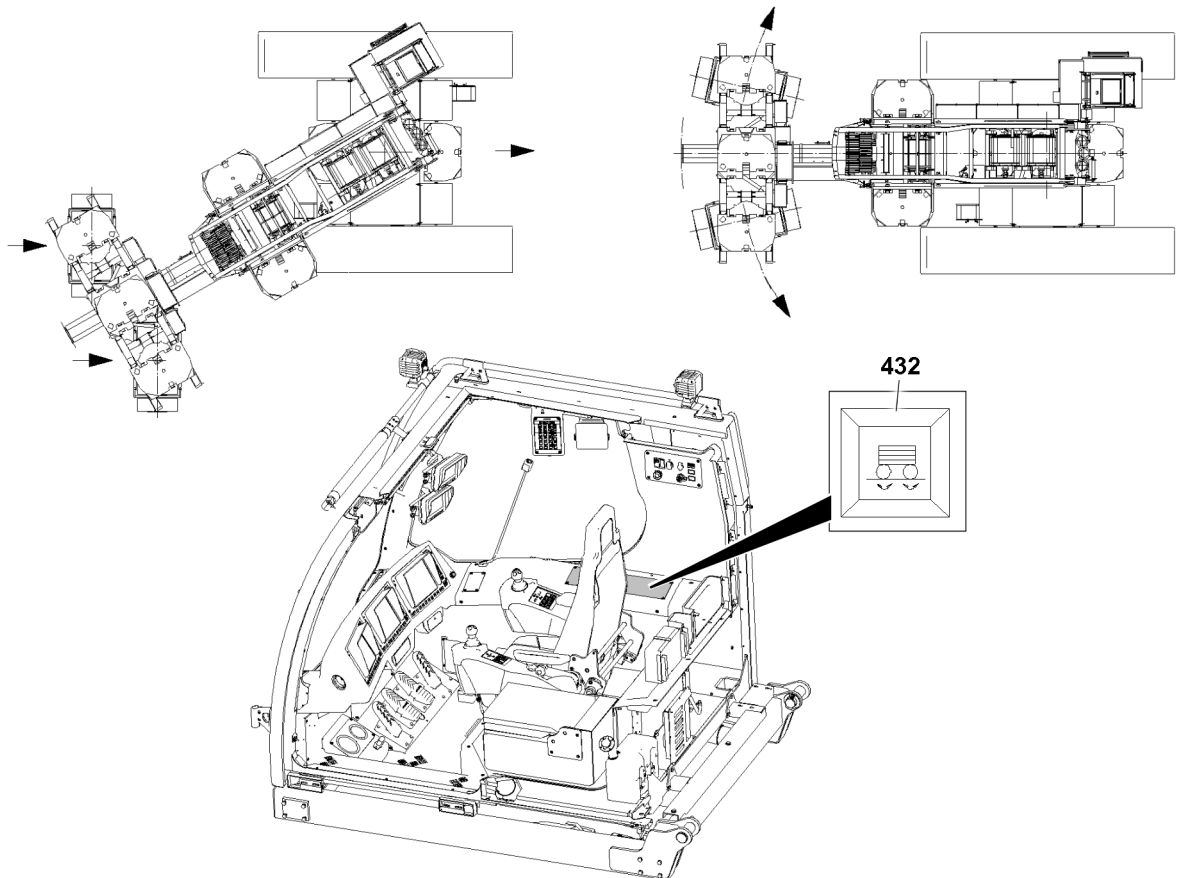


Fig.159381

A ballast trailer wheel set is equipped with its own drive. The drive is activated in the crane cab.

The drive is a proportionally adjustable drive which is regulated depending on the turning or travel speed.

If the ballast utilization is more than 90 %, then the drive is turned off to prevent the wheels from slipping.

**Note**

- ▶ The drive can only be activated in circular and parallel travel.
- ▶ The additional drive may be required when driving over uneven ground.

If the road surface is level, no additional drive is required.

Add the drive only when no turning / travel movement occurs when the control lever is deflected.

Turn the drive on with the switch **432** in the crane cab.

**Note**

- ▶ Turn the drive off as soon as the unlevel ground has been passed.
- ▶ Turn the drive off with the switch **432** in the crane cab.

### 14.5.6 Braking the ballast trailer with the slewing gear brake

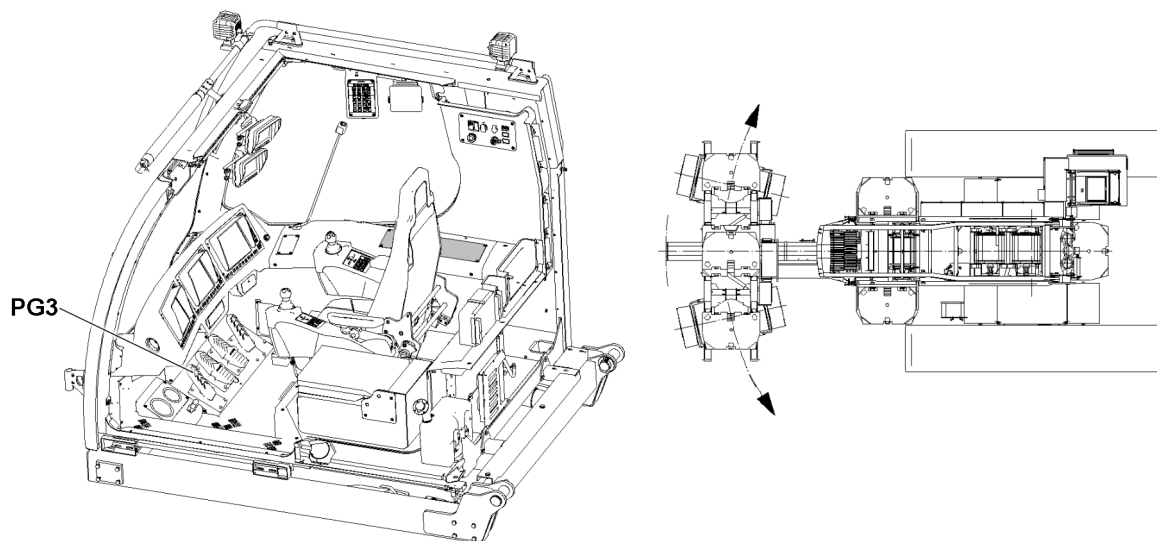


Fig.159623: Braking the ballast trailer with the slewing gear brake

The ballast trailer can be braked with the slewing gear brake pedal **PG3** if the current slewing gear speed is less than 10 % of the maximum permissible slewing speed with the ballast trailer.



#### Note

► For the maximum slewing gear speed, see chapter 1.03.

Example of crane LR 1800:

- Maximum slewing gear speed: 0.67 rpm
- Permissible speed of the slewing gear with ballast trailer: 0.067 rpm
- 10 % of the permissible speed for braking is then 0.0067 rpm

### 14.5.7 Derrick ballast lifted button

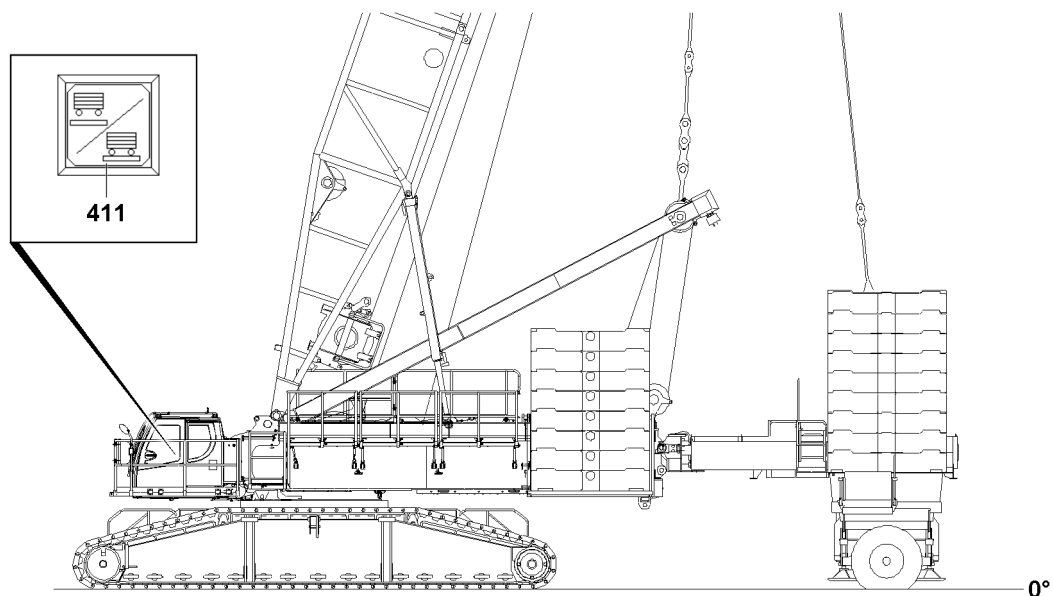


Fig.159384: Derrick ballast lifted button

	Derrick ballast lifted button <b>411</b> , pressed		Derrick ballast lifted		Slewing gear brake		Hydraulic slewing gear coasting	
	Yes	No	Yes	No	Open	Closed	Open	Closed
Driving the crawler		X		X	X		X	
Driving the crawlers	X		X			X	X	

With “driving the crawler” and *derrick ballast lifted* button **411** not pressed, that is “ballast trailer not lifted”, the slewing gear brake as well as the hydraulic slewing gear coasting are opened. If proceeding with “driving the crawler” with **lifted off ballast trailer** (constant visual check), the *derrick ballast lifted* button **411** must be used to turn on the “derrick ballast lifted” function.



### DANGER

Danger of accident!

If the ballast trailer is lifted off the ground during “driving the crawler” in the “towing” steering program, the danger exists that the wind turns the turntable to the side.

- ▶ After lifting the ballast trailer off, the *derrick ballast lifted* button **411** must be turned on immediately, so that the slewing gear brake remains closed for “driving the crawler”, however the hydraulic coasting remains open.
- ▶ However, if the wheel sets of the ballast trailer are not aligned accordingly, the ballast trailer or the crane will be damaged.

### NOTICE

Danger of accidents when turning or driving!

If the lifted off ballast trailer scrapes on the ground - with the *derrick ballast lifted* button **411** turned on - when turning or driving the crane, then the ballast trailer and the crane can be significantly damaged.

- ▶ If the ballast trailer has been lifted off the ground and derrick ballast lifted button **411** is actuated, then it must be checked that the wheels **do not scrape on the ground**. An instructed person must check visually.
- ▶ It is prohibited to remain in the danger zone.



### Note

- ▶ If the ballast trailer is suspended above the ground, the wheel sets can be in any position. If the “derrick ballast lifted” function is turned on, the crane turning and driving are possible.



### Note

- ▶ When the “derrick ballast lifted” function is turned on, it is possible to turn the turntable or to drive the crane even though the wheel sets of the ballast trailer are not set to “Circular travel”, “Towing” or “Parallel travel”.

### Activate the “Derrick ballast lifted” function:

- ▶ Press the *derrick ballast lifted* button **411**.

### Result:

- The LED in the *Derrick ballast lifted* button **411**.
- A visual display appears on the left LICCON monitor (LM2).



### Note

- ▶ A visual display on the left LICCON monitor shows the current status.

### Turn off the “Derrick ballast lifted” function:

- ▶ Press the *derrick ballast lifted* button **411** again.

**Result:**

- The LED in the *Derrick ballast lifted* button **411** turns off.
- A visual display appears on the left LICCON monitor.

### 14.5.8 Defined ballast trailer operation

---

**DANGER**

Danger of accident!

If the ballast trailer is operated in an undefined condition, it can result in severe accidents up to toppling of the crane.

Death, severe bodily injuries, property damage.

- ▶ The ballast trailer must always be in a defined condition.
  - ▶ Operation of the ballast trailer in an undefined state is prohibited.
- 

The ballast trailer may not be raised or set down when driving, rather this be done **before** starting to travel.

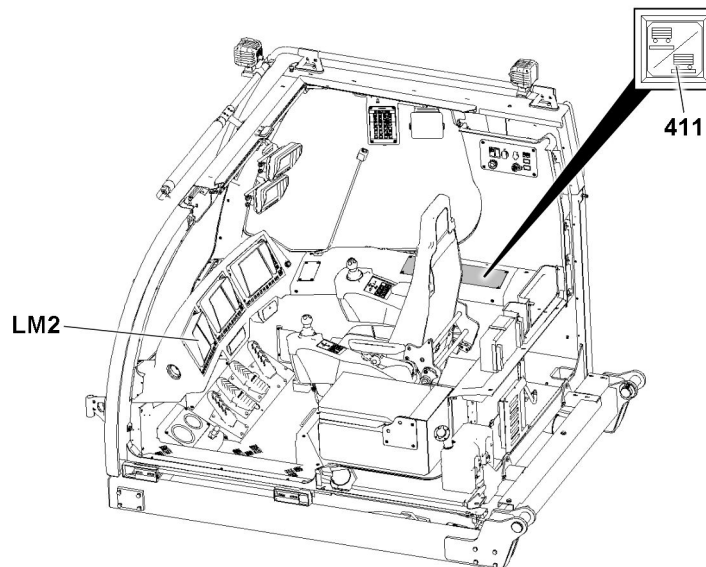
**Ballast trailer lifted**

Fig.159385: Ballast trailer lifted

“Ballast trailer defined lifted from the ground” means:

The ballast trailer is lifted from the ground and the *derrick ballast lifted* button **411** is pressed. This does **not** open the slewing gear brake when “driving the crawler”. It should be ensured that the wind cannot turn the turntable.

Make sure that the following prerequisites are met:

- The ballast trailer has been completely lifted off the ground.
- The *derrick ballast lifted* button **411** is pressed.
- The LED in the *Derrick ballast lifted* button **411** turns off.
- A visual display appears on LICCON monitor LM2.

## Ballast trailer on the ground

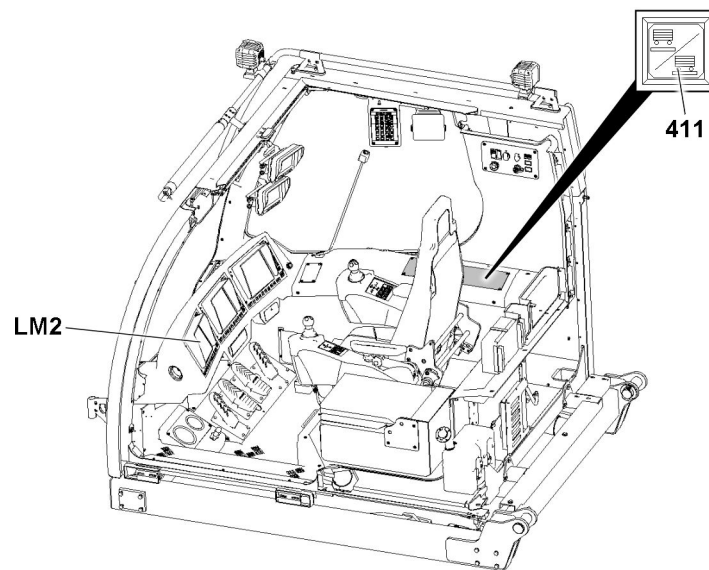


Fig.159385: Ballast trailer on the ground

“Ballast trailer defined on the ground” means:

That the ballast trailer and its residual load are resting on the ballast trailer tires and the *derrick ballast lifted* button **411** is **not** pressed. This residual load is large enough to prevent the wind from turning the turntable, if the slewing gear brake is opened when actuating “driving the crawler”.

Make sure that the following prerequisites are met:

- The ballast trailer is positioned with a residual load on the ground.
- The *derrick ballast lifted* button **411** is **not** pressed.

### 14.5.9 Undefined ballast trailer operation



#### **DANGER**

Danger of accident!

If the ballast trailer is operated in an undefined condition, it can result in severe accidents up to toppling of the crane.

Death, severe bodily injuries, property damage.

- ▶ The ballast trailer must always be in a defined condition.
- ▶ Operation of the ballast trailer in an undefined state is prohibited.

### Ballast trailer lifted

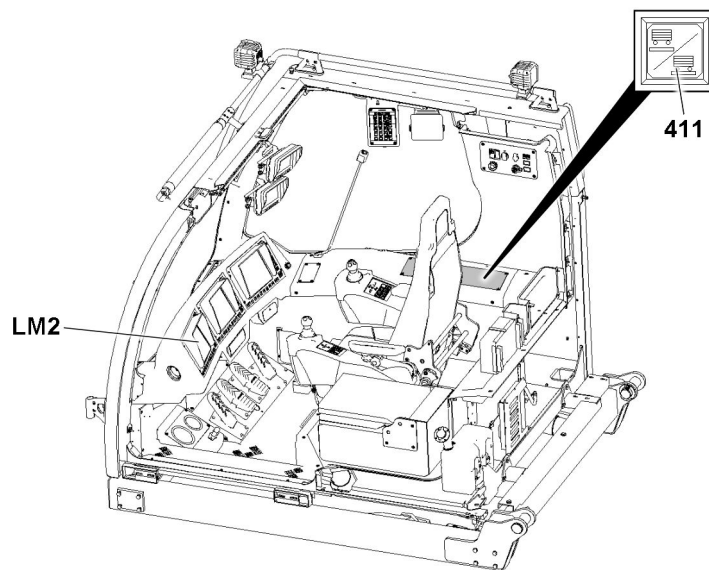


Fig.159385: Ballast trailer lifted



#### Note

- ▶ Only operate the ballast trailer in a defined condition.

“Ballast trailer undefined lifted off the ground” means:

That the ballast trailer with a residual load of approx 1 t is placed on the ballast trailer tires and the *derrick ballast lifted* button **411** is pressed. As a result, the slewing gear brake does **not** open when cornering the “crawler” and the ballast trailer tires or the slewing gear brake slip.

### Ballast trailer on the ground

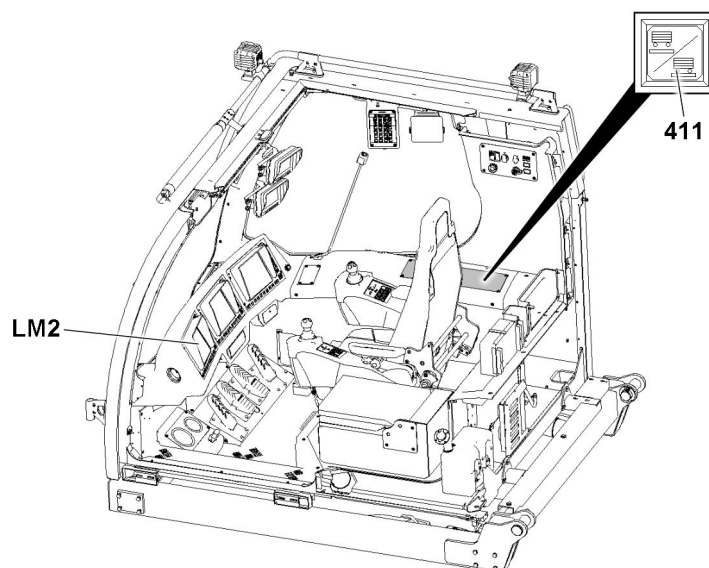


Fig.159385: Ballast trailer on the ground



#### Note

- ▶ Only operate the ballast trailer in a defined condition.



**DANGER**

**Swinging load!**

Severe accidents can occur due to swinging loads.  
Death, severe bodily injuries, property damage.

- ▶ Operation of the ballast trailer in an undefined state is prohibited.

“Ballast trailer undefined on the ground” means: That the ballast trailer with a residual load of approx 1 t is placed on the ballast trailer tires and the *derrick ballast lifted* button **411** is **not** pressed. This residual load is so small that the wind can turn the turntable, if the slewing gear brake opens when actuating “driving the crawler”.

## 14.6 Crane operation with the derrick ballast

### 14.6.1 Safety instructions



**Note**

- ▶ The test points must be checked for function before starting crane operation.
- ▶ The weight of the load to be lifted must be known.
- ▶ There may be no obstacles within the slewing range of the crane and the derrick ballast if there is a suspended ballast trailer.
- ▶ The lifting the derrick ballast must be monitored by the crane operator or a guide.
- ▶ Before setting down the load and the suspended derrick ballast, the crane operator must make sure that a safe placement is ensured.
- ▶ The placement level of the ballast trailer, at the end of the load hoist, must be level, horizontal and have sufficient load bearing capacity to safely take on the weight of the ballast trailer.



**DANGER**

**Danger of accident due to angular pull!**

The crane can topple over by angular pull of the load.  
Death, severe bodily injuries, property damage.

- ▶ Angular pull is prohibited.
- ▶ When picking up the load, it must be ensured that the derrick ballast, the center of rotation of the turntable and the load are in one line.

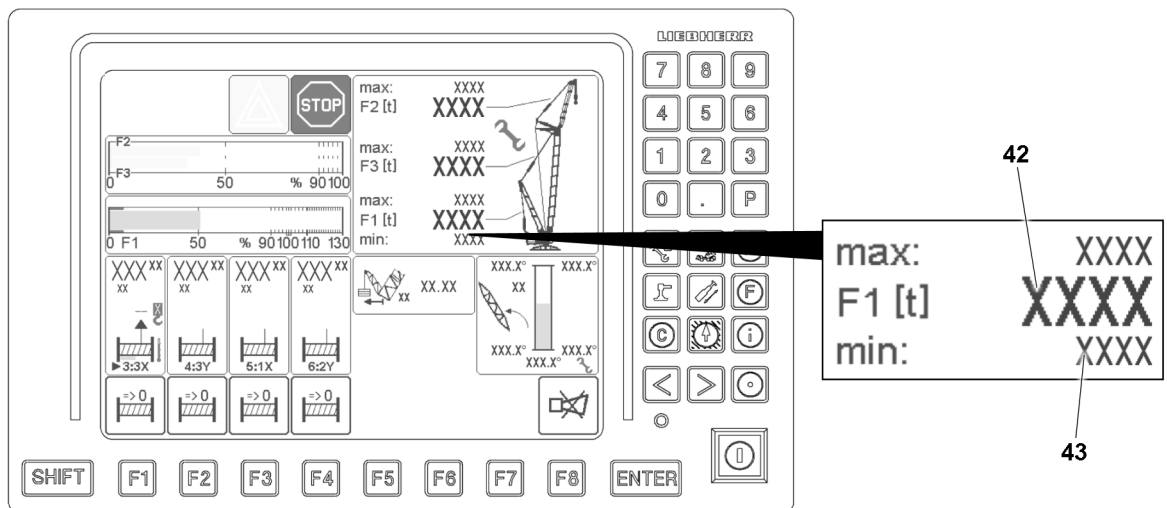


Fig.159386: Crane operation with the derrick ballast

When picking up the load, the guying between the derrick ballast and derrick end section must be relieved to the point where the F1-actual force ( $F1_{actual}$ ) **42** is greater than the F1 minimum force ( $F1_{min}$ ) **43**.

LWE/LR 1800-1-0-000/27200-07-02/en

**DANGER**

Danger of accident!

If the guying between the SA-frame and the derrick end section is without force ( $F_{1-\min}$  is fallen below), then this can lead to uncontrolled movements of the boom system and cause the crane to topple over.

- ▶ The guying between the SA-frame and the derrick end section (test point F1) may never be without power.
- ▶ The F1-minimum force ( $F_{1-\min}$ ) **43** may not be fallen below.

### 14.6.2 LICCON overload protection

On cranes with derrick ballast, during crane operation also under load, by increasing or reducing the derrick ballast, the maximum load or the minimum load required for the balance of the crane, can be increased or decreased.

**Note**

- ▶ The suspended ballast and the ballast trailer are generally referred to as the **derrick ballast**.
- ▶ The fixed compensation weight that is installed on the turntable is generally referred to as the **counterweight**.

Make sure that the following prerequisites are met:

- The actually placed derrick ballast has been entered and confirmed in the Set up program, see chapter 4.02.
- The derrick ballast is placed according to the load chart.
- The derrick boom is in the operating position.

#### Checking the settings of the LICCON overload protection

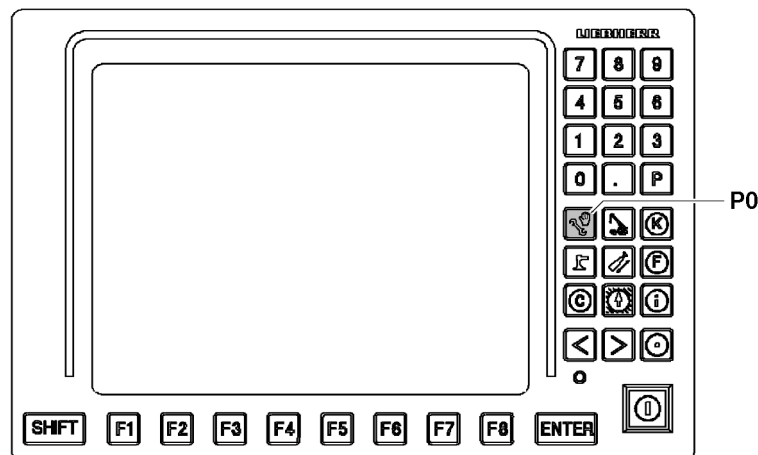


Fig.128886: LICCON monitor

**P0** Program key

**WARNING**

Incorrectly set overload protection!

If the actual set up configuration of the crane deviates from the entries and settings in the Set up program, then the overload protection is not correctly set.

An incorrectly set overload protection calculates the actual load incorrectly and transmits faulty display values.

The crane can be overloaded without being noticed and topple over.

This could result in serious accidents.

- ▶ The entries and settings in the set up program must match the actual set up configuration of the crane.



**Note**

- ▶ Set the LICCON overload protection in the Set up program, see chapter 4.02.

- ▶ Press the program key **P0**.

**Result:**

- The Set up program is called up.
- ▶ On the monitor display of the Set up program, check if the LICCON overload protection is set according to the specifications in the load chart and the actual set up configuration of the crane.

**Crane operation****Note**

- ▶ For crane operation with the ballast trailer, the specifications must be observed and adhered to, see chapter 4.02.

**WARNING**

Danger of toppling the crane!

The jerky execution / braking of turning maneuvers can cause the load or suspended derrick ballast to swing.

This can cause the boom to break or the crane to topple over.

Death, severe bodily injuries, property damage.

- ▶ There may be no persons or obstacles within the slewing range of the crane and the ballast trailer.
- ▶ While turning, a guide must watch the main boom, D-boom and derrick ballast for a danger of collision.
- ▶ The turning movement or braking must be initiated extremely carefully when turning with a load and suspended derrick ballast.

**Note**

- ▶ For crane operation, observe the section “lifting and lowering the ballast trailer with pull cylinders” and “ballasting guying differential force monitoring”.

- ▶ Observe the extension condition of the pull cylinder and the inclination of the ballast trailer.

### 14.6.3 F-load display for operating modes with derrick ballast

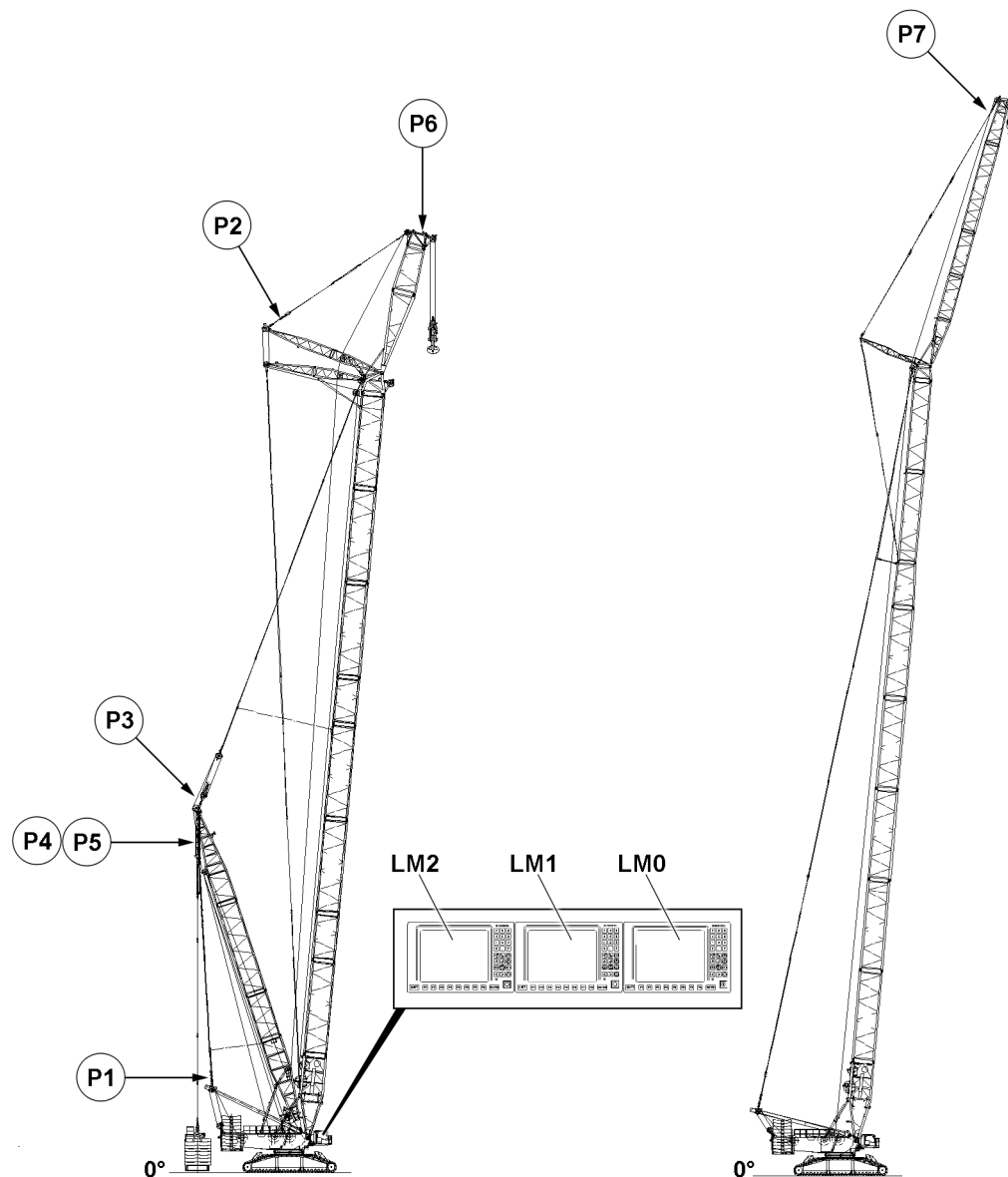


Fig.159387: F-load displays

**LM0** LICCON monitor 0

**LM2** LICCON Monitor 2

**LM1** LICCON monitor 1

Assignment of test points for operating modes with derrick ballast:

- Force in the guying between A-frame and derrick head:
  - Test point 1 in point **P1** = force F1
  - The display is shown on the F-load display on the central LICCON monitor **LM1**
- Force in the guying between the WA-frame and accessory head:
  - Test point 2 in point **P2** = force F2
  - The display is shown on the F-load display on the central LICCON monitor **LM1**
  - Note:** Only for the respective boom system.
- Force in the guying between the main boom head and the derrick head:
  - Test point 3 in point **P3** = force F3
  - The display is shown on the F-load display on the central LICCON monitor **LM1**
- Force in the guying between the derrick ballast and derrick head:
  - Test point 4 / 5 in point **P4 / P5** = force F4 / F5

- The display is shown on the display of the derrick ballast on the left LICCON monitor **LM2**
- Force on the boom nose pressure test bracket:
  - Test point 6 in point **P6** = force F6
  - The display is shown on the actual load display on the right LICCON monitor **LM0**  
**Note:** Only with an available boom nose.
- Force in the guying between the FA-frame and the accessory head:
  - Test point 11 in point **P7** = force F11
  - The display is shown on the actual load display in the center LICCON monitor **LM0**  
**Note:** Only for the respective boom system.

**Note**

- ▶ For a detailed description of the displays for crane operation with derrick ballast, see chapter 4.02.

**WARNING**

Overloading / toppling of the crane!

If the permissible values of the F-load display are exceeded / fallen below, then the crane can be overloaded.

This could result in serious accidents.

- ▶ Adhere to the permissible values of the F-load display.

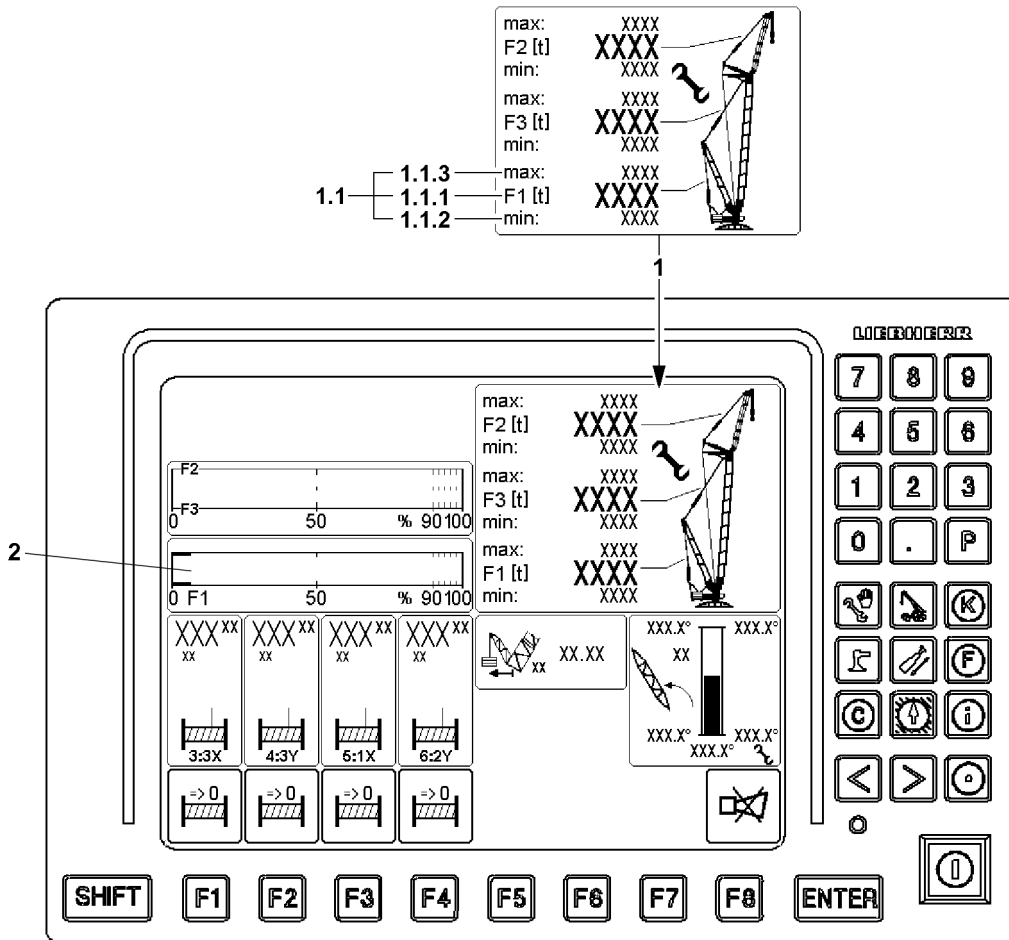
**Note**

The values of the F-load display depend on the set up configuration of the crane and the crane geometry.

The values of the F-load display change continuously when the crane is moved.

- ▶ Monitor the F-load display continuously.

**Force F1 (test point 1)**



*Fig.159388: Force F1 (test point 1)*

The force F1 (test point MS1) is determined in the guying between the A-frame and the derrick head and displayed on the LICCON monitor as operating force  $F1_{actual}$ .

Display values of force F1 (test point MS1) on the F-load display 1:

- F1-maximum ( $F1_{max}$ ) **1.1.3** = maximum value F1-force
- F1-actual value ( $F1_{actual}$ ) **1.1.1** = actual value F1-force (operating force F1)
- F1-minimum ( $F1_{min}$ ) **1.1.2** = minimum value F1-force

Structure of the F1-utilization bar **2**:

- Ratio of operating force  $F1_{actual}$  to F1 maximum force

**Force F2 (test point 2) and force F3 (test point 3)**

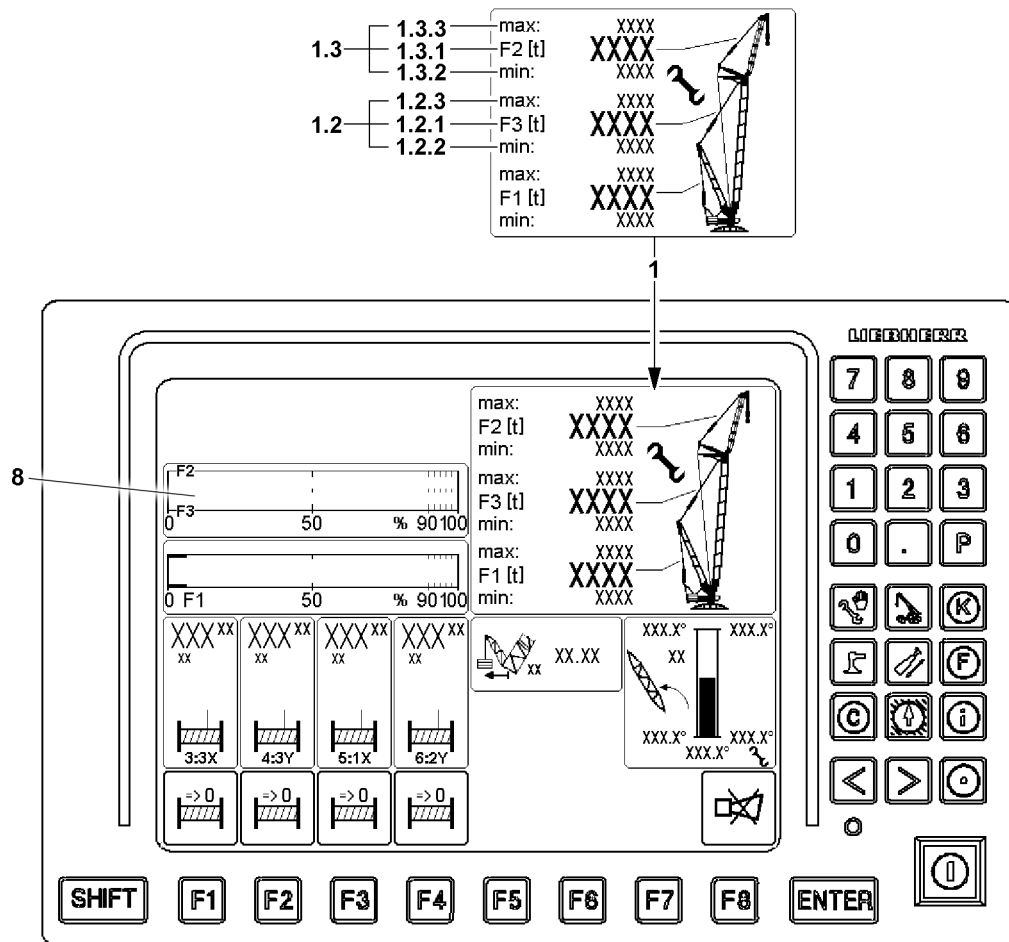


Fig.159389: Force F2 (test point 2) and force F3 (test point 3)

The force F2 (test point 2) is determined between the WA-frame and the accessory head and displayed on the LICCON monitor as operating force  $F2_{actual}$ . A display is shown only with the respective boom system.

The force F3 (test point 3) is determined between the main boom head and the derrick head and displayed on the LICCON monitor as operating force  $F3_{actual}$ .

Display values of force F2 (test point MS2) on the F-load display 1:

- F2-maximum ( $F2_{max}$ ) **1.3.3** = maximum value F2-force
- F2-actual value ( $F2_{actual}$ ) **1.3.1** = actual value F2-force (operating force F2)
- F2-minimum ( $F2_{min}$ ) **1.3.2** = minimum value F2-force

Display values of force F3 (test point MS3) on the F-load display 1:

- F3-maximum ( $F3_{max}$ ) **1.2.3** = maximum value F3-force
- F3-actual value ( $F3_{actual}$ ) **1.2.1** = actual value F3-force (operating force F3)
- F3-minimum ( $F3_{min}$ ) **1.2.2** = minimum value F3-force

Structure of the F2 / F3-utilization bar **8**:

- Ratio of operating force  $F2_{actual}$  to F2 maximum force  $F2_{max}$
- Ratio of operating force  $F3_{actual}$  to F3 maximum force  $F3_{max}$
- The F2/F3-utilization bars **8** appear only in assembly operation

During crane operation, the display values are displayed for informational purposes only. A special monitoring does not occur.

In assembly operation the display values are monitored. The limit values may not be exceeded.

LWE/LR 1800-1-0-000/27200-07-02/en

### Force F4 / F5 (test point 4 / 5)

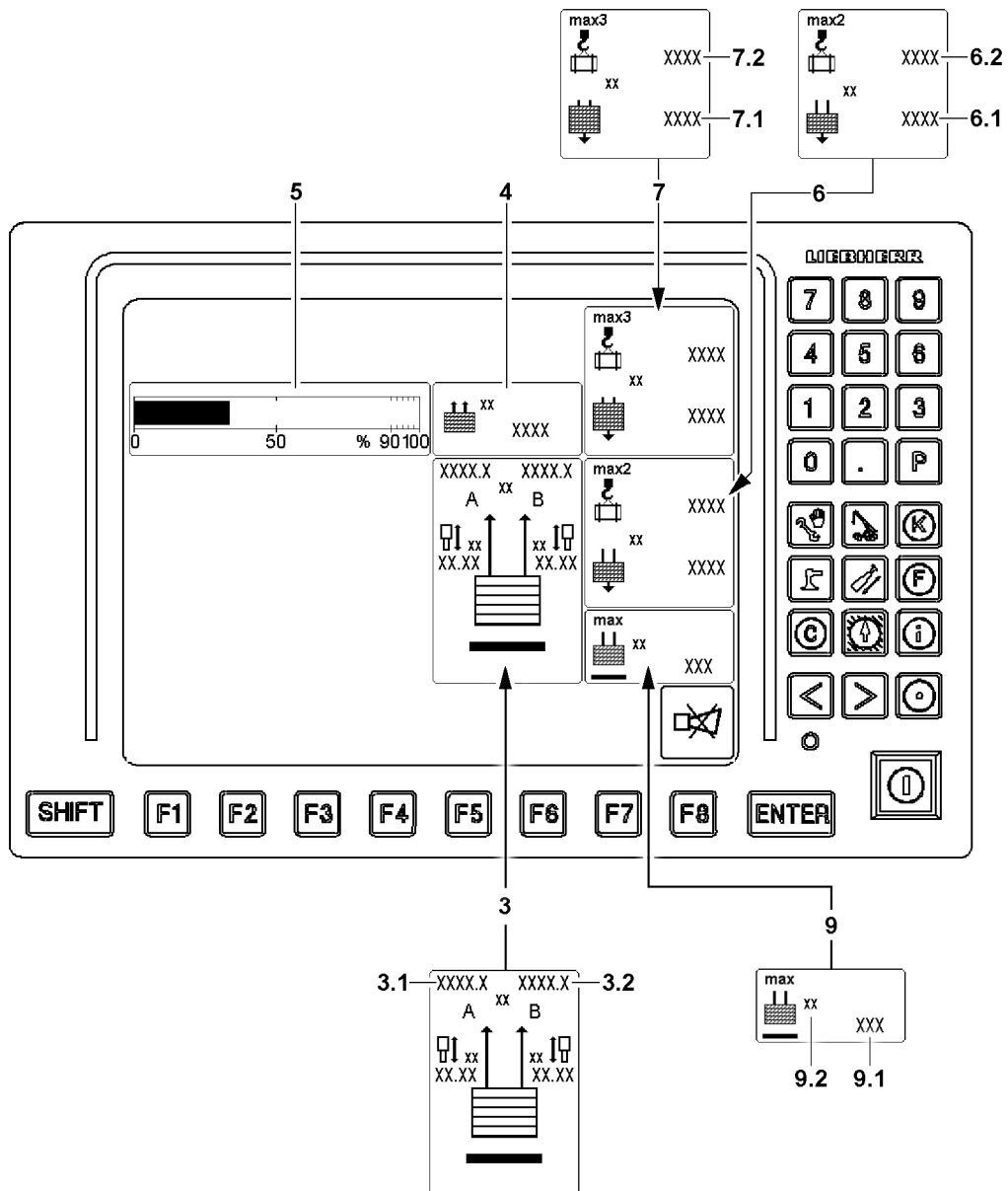


Fig.159390: Force F4 / F5 (test point 4 / 5)

The forces F4 / F5 (test point MS4 / MS5) are effective in the guy rods from the derrick ballast to the derrick head.

The existing forces in the guy rods are calculated from four pressure sensors, which are installed on the pull cylinders.

Test points guying A (left) are:

- Test point 4A = pressure sensor ring surface left (force F4A)
- Test point 5A = pressure sensor piston surface left (force F5A)

Test points guying B (right) are:

- Test point 4B = pressure sensor ring surface right (force F4B)
- Test point 5B = pressure sensor piston surface right (force F5B)

Display value of force F4 / F5 (test point 4 / 5) in the Derrick ballast guying 3 icon:

- Force in derrick ballast guying A 3.1
- Force in derrick ballast guying B 3.2

Derrick ballast display values:

- Currently pulled derrick ballast =  $BA_{pulled}$  **4**
- Current utilization of derrick ballast = Derrick ballast utilization bar **5**
- Currently placed derrick ballast =  $BA_{placed}$  **6.1**

The sum of derrick ballast guying A **3.1** and derrick ballast guying B **3.2** is used to calculate the pulled derrick ballast  $BA_{pulled}$  **4**.

If the ballast still has ground contact, then only the part of the ballast that is pulled up by the D-guying is displayed. The remaining part is lying on the ground.

Structure of the derrick ballast utilization bar **5**:

- Ratio of pulled derrick ballast ( $BA_{pulled}$  **4**) to placed derrick ballast ( $BA_{placed}$  **6.1**)

**Additional displays on LICCON monitor LM2**

“Load max2” icon **6** (see section “Utilization conditions”)

- **6.1**  $BA_{placed}$  (Input value in the set up program)  
Currently placed derrick ballast
- **6.2** Load<sub>max2</sub>  
Possible load with currently placed derrick ballast

“Load max3” icon **7** (see section “Utilization conditions”)

- **7.1**  $BA_{max}$  (highest value in the Set up program)  
Maximum derrick ballast according to the load chart
- **7.2** Load<sub>max3</sub>  
Possible load with maximum derrick ballast according to the load chart

**Maximum liftable derrick ballast**

The *maximum liftable derrick ballast* **9** refers to the current crane condition and indicates the maximum derrick ballast that can be lifted off the ground with the pull cylinder or, in case of the VarioTray, off the suspended ballast palette without falling below the  $F1_{min}$  force.

- **9** *Maximum liftable derrick ballast* icon
- **9.1** Maximum liftable derrick ballast
  - Maximum derrick ballast
- **9.2** Measuring unit
  - Measuring unit for display values in the *Maximum liftable derrick ballast* icon **9**: [t] or [lb]

**Force F11 test point 11**

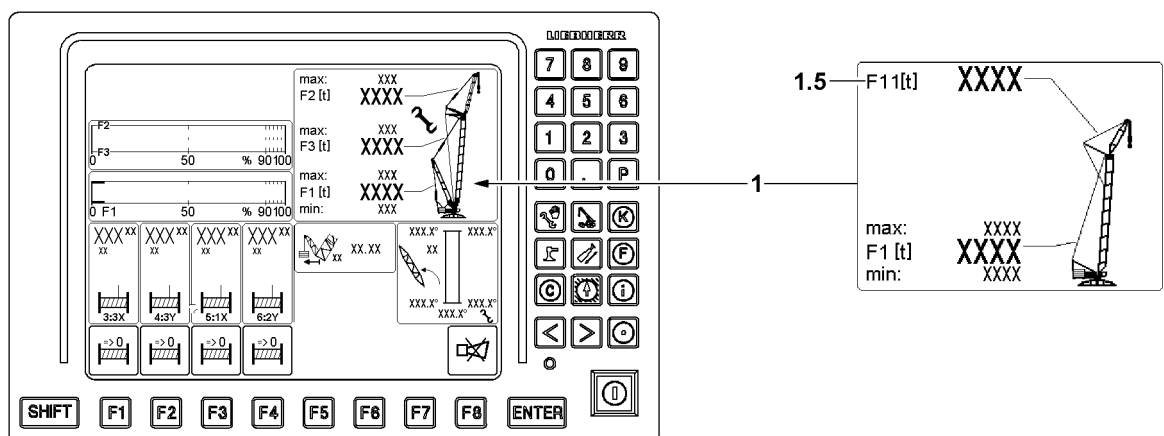


Fig.163662: LICCON force F11 — LICCON monitor LM1

Display values of force F11 (test point MS11) on the F-load display **1**:

- **1.5** F11-actual value ( $F11_{actual}$ )

LWE/LR 1800-1-0-000/27200-07-02/en

- Current actual value F11-force (operating force F11)

#### 14.6.4 Additional displays on LICCON monitor LM1

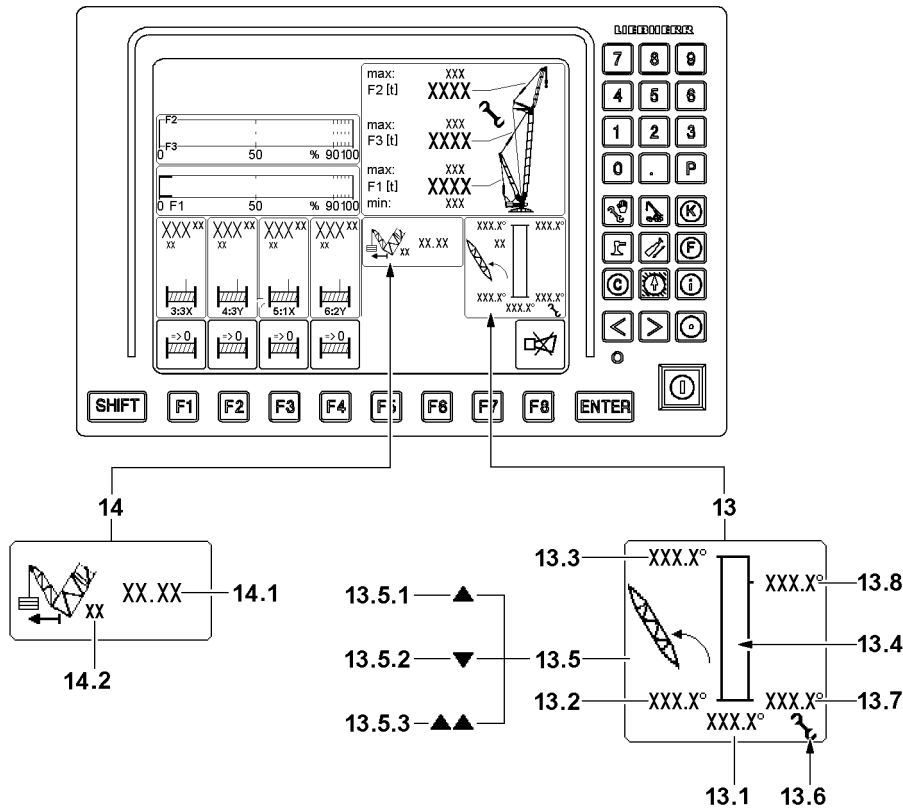


Fig.163661: Derrick ballast angle indicator — LICCON monitor LM1

Derrick boom angle indicator:

- **13** Derrick angle
  - Current actual angle of the derrick boom
  - Actual angle **13.1** red: **Warning!** Derrick boom angle in the impermissible range
- **13.2** Minimum angle
  - Minimum angle of the Derrick boom to the front (to the horizontal)
- **13.3** Maximum angle
  - Maximum angle of the Derrick boom to the front (to the horizontal)
- **13.4** Bar graph
  - Graphic illustration of the derrick angle as a bar graph in relation to the minimum / maximum value.
  - It appears in green and red, depending on the situation
  - Column **13.4** green: Derrick boom angle in the permissible range
  - Column **13.4** red: **Warning!** Derrick boom angle in the impermissible range
- **13.5** Derrick alarm function
  - **13.5.1** Up arrow: Derrick boom maximum angle exceeded
  - **13.5.2** Down arrow: Derrick boom minimum angle fallen below
  - **13.5.3** Double up arrow: Derrick boom relapse press in the block position
- **13.6** Assembly icon
  - The *assembly* icon **13.6** appears when a defined angle range for the derrick boom for erection and take-down of the boom system is specified.
- **13.7** Assembly minimum angle
  - Assembly: Minimum angle of the Derrick boom to the front (to the horizontal)



- **13.8** Maximum angle Assembly
  - Assembly: Maximum angle of the Derrick boom to the front (to the horizontal)

Derrick ballast boom radius display:

- **14** *Derrick ballast* boom radius
- **14.1** Boom radius value
  - Current boom radius value of the derrick ballast
  - Measured from the center of the slewing ring to the center of the derrick ballast
- **14.2** Measuring unit
  - Measuring unit of boom radius value

### 14.6.5 Monitoring of crane utilization in operating modes with derrick ballast

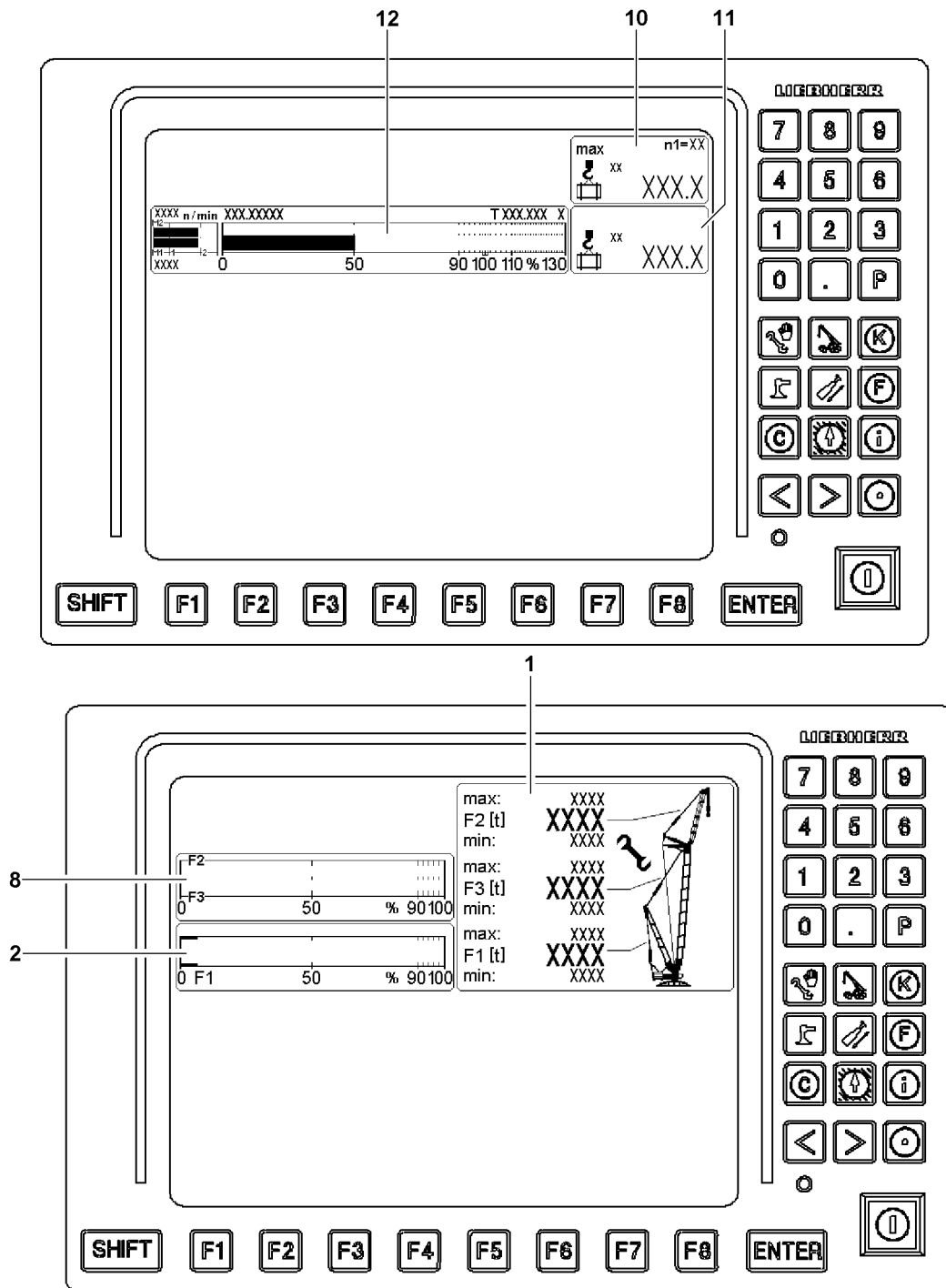


Fig.159391: Monitoring of crane utilization in operating modes with derrick ballast

LWE/LR 1800-1-0-000/27200-07-02/en

**Note**

- ▶ The icon illustrations of the LICCON monitors are examples and may not match your crane.
- ▶ The icon illustrations of the LICCON monitors can deviate in number, arrangement and depiction of the icons on your crane.
- ▶ Observe chapter 4.02.

**WARNING**

Incorrect display values!

If the display values do not increase correspondingly when lifting known weights, an erroneous display value may be present.

If the crane is operated with erroneous display values, then the crane can be overloaded.

This could result in serious accidents.

- ▶ When lifting the hook block off the ground check if the display value for the actual load increases correspondingly.
- ▶ When lifting the derrick ballast off the ground check if the display value for the pulled derrick ballast ( $BA_{\text{pulled}}$ ) increases correspondingly.
- ▶ When lifting the load off the ground check if the display value for the actual load increases correspondingly.

In operating modes with derrick ballast, the monitoring of the crane utilization includes, but is not limited to:

- **Monitoring of load momentum:** via the “Maximum load” icon **10**, “Actual load” icon **11** and the “utilization bar diagram” **12**
- **Utilization conditions:** support the crane driver with additional display values
- **Monitoring of the F-load display 1:** supported by the F1-utilization bar **2** and possibly the F2/F3-utilization bar **8**

**Overload monitoring in operating mode with derrick ballast**

In operating modes with derrick ballast, the “maximum load for the current crane condition” is monitored two ways:

1. Monitoring of maximum load on the LICCON monitor 0
2. Monitoring of test point 1-operational maximum force LICCON monitor 1

Monitoring of maximum load on the LICCON monitor 0

It monitors the “maximum load according to the load chart and reeving”.

In operating modes with derrick ballast, this is the maximum load of the current crane condition. It is shown on LICCON monitor 0. The current utilization of the crane results from the load utilization bar (1) on LICCON monitor 0.

If the load utilization bar reaches 90 %, an advance warning is given in the form of a “notice icon” and a “SHORT HORN” on LICCON monitor 0.

At 100 % on the load utilization bar, the shut-off of all load momentum increasing movements with the “stop icon” and the acoustical warning “HORN” occurs on LICCON monitor 0.

**Note**

- ▶ The “maximum load of the current crane condition” can possibly be increased further, refer to section “Utilization conditions”.

Monitoring of test point 1-operational maximum force (=  $F1_{\text{max}}$  operation)

It is shown on LICCON monitor 1. When  $F1$  is greater than  $F1_{\text{max-shut-off value}}$ , a shut off of all movements that could increase load momentum occurs with the “stop icon” and the acoustic warning “HORN” on LICCON monitor 1.

**Note**

- ▶ The maximum load can be safely monitored by the “LICCON overload protection” itself.
- ▶ The “F1<sub>max</sub> monitoring” is an additional monitoring function, which prevents the overload of the crane parallel to the “LICCON overload protection”.
- ▶ When the permissible maximum load cannot be lifted because an “F1<sub>max</sub> shut-off” has stopped the crane before, then the current “F1-force” must be reduced by increasing the pulled ballast.
- ▶ Make sure that the ballast weighing and the shut-off to the maximum load function reliably.

**WARNING**

Danger of accident!

- ▶ The test point 1-Operation-Maximum force not only depends on the current set up configuration but also on the force of the pulled derrick ballast measured with the pressure sensors in the pull cylinders.
- ▶ If the pulled derrick ballast is larger, then the maximum permissible F1<sub>max</sub> force is generally reduced and vice versa.
- ▶ Precisely monitor the ballast weighing and the value for the pulled derrick ballast.

**DANGER**

The crane can topple over!

If the pulled derrick ballast value has been incorrectly determined and is too low, the calculated F1<sub>max</sub> may be too high and the crane could be overloaded or topple over without this becoming evident.

- ▶ Carefully monitor the displays on the LICCON monitor.

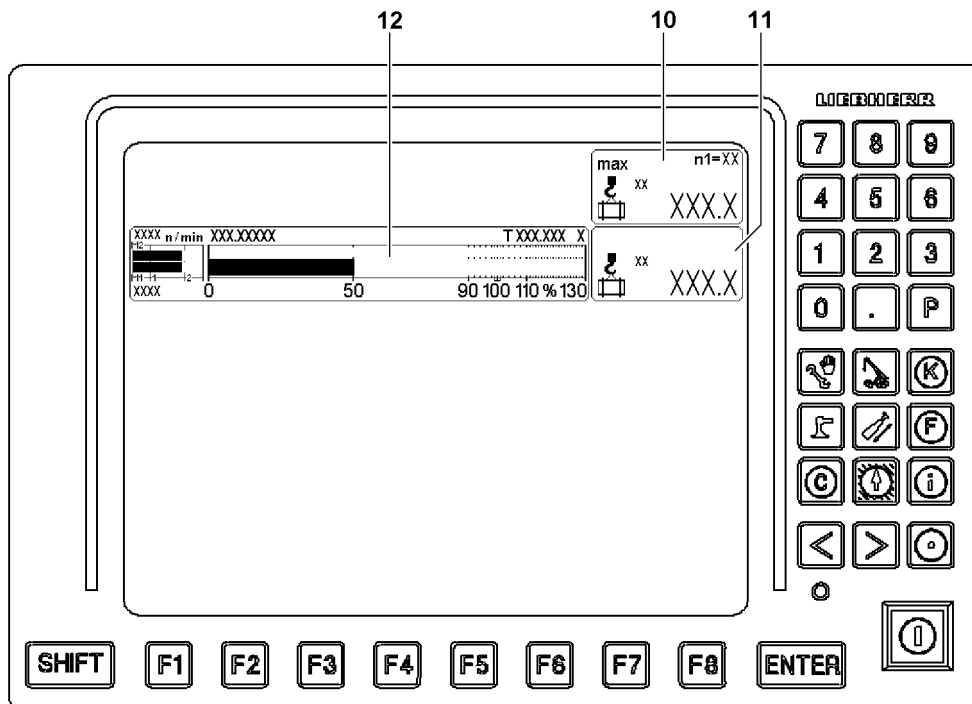
**Monitoring of load momentum**

Fig.159392: Monitoring of load momentum

Monitoring of the “maximum load according to the load chart and reeving”.

During crane operation, the actual load is compared with the maximum load that may be lifted in the current crane configuration. The values are displayed in the “maximum load” icon 10 and the “actual load” icon 11. The current percentage utilization is displayed as the “utilization bar diagram” 12 on the right LICCON monitor.

The color of the utilization bar in the “utilization bar diagram” **12** also indicates the crane utilization:

- Blue / green utilization bar (below 90 %): Utilization in the permissible range
- Utilization bar yellow (90 % to 100 %): Advance warning - utilization just before impermissible range
- Utilization bar red (above 100 %): Warning - utilization in impermissible range



**Note**

► Procedure for optimum utilization of “maximum load according to load chart and reeving”, see section “Utilization conditions”.

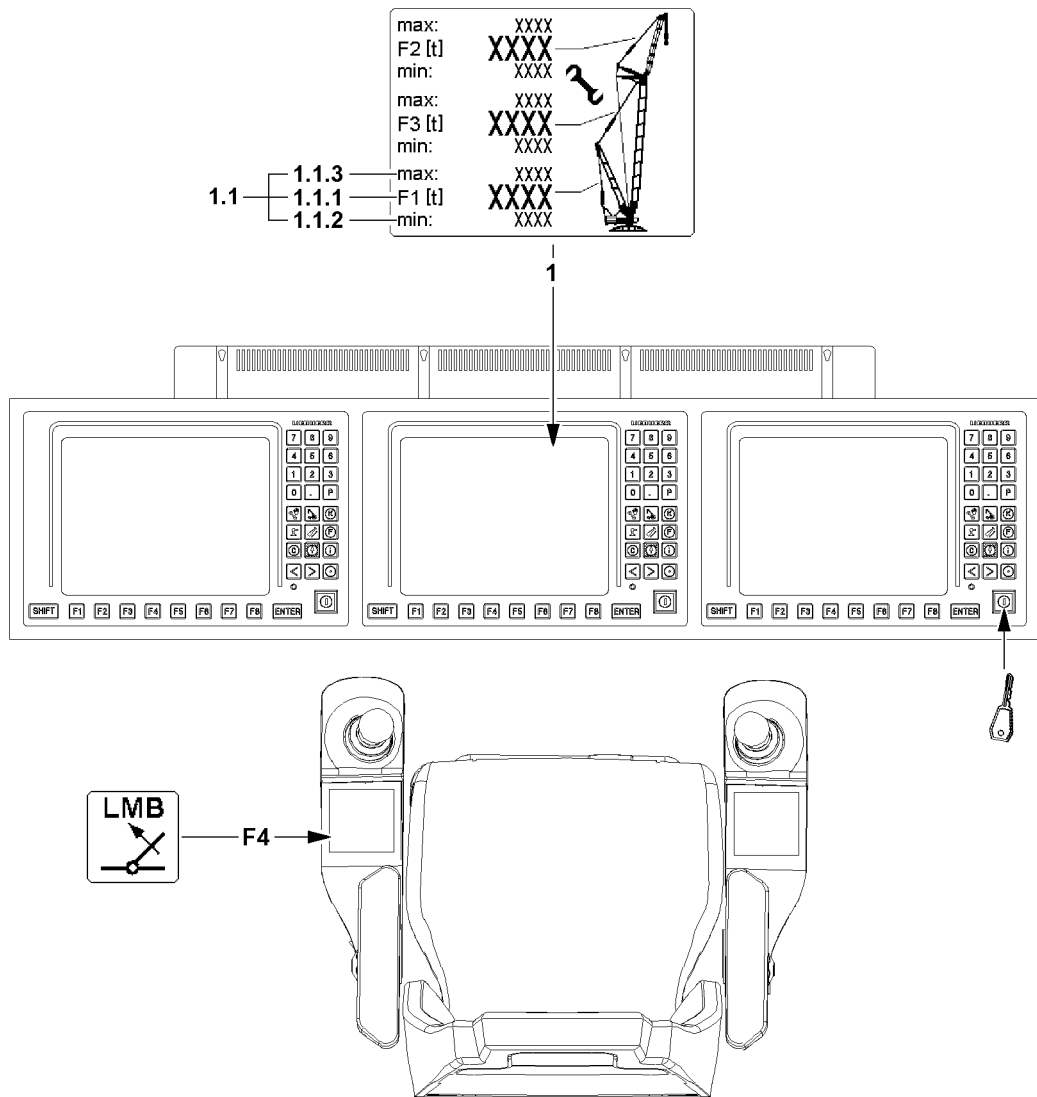


Fig.159393: Monitoring of load momentum

LWE/LR 1800-1-0-000/27200-07-02/en

**WARNING**

Intervention of the LICCON overload protection functionality!

When accessing the functionality of the LICCON overload protection by activating assembly operation, the LICCON overload protection is totally deactivated, bypassed or limited.

It is possible to exceed several shut-off limits of the LICCON overload protection simultaneously or one after the other.

It is possible to carry out crane movements, which are not monitored by the LICCON overload protection.

Without the LICCON overload protection, no additional protection against overload of the crane via the crane control is present.

This could result in serious accidents.

- ▶ When accessing the functionality of the LICCON overload protection, take into account that the LICCON overload protection is deactivated totally or is limited.
- ▶ When accessing the functionality of the LICCON overload protection, chapter 4.02 must be observed.

**WARNING**

The crane can topple over!

In assembly operation the LICCON overload protection is deactivated.

In the event of deliberate improper use, the crane could collapse, the boom can break off or the crane can topple over.

Personnel can be killed.

This can result in significant property damage.

- ▶ Activate the assembly operation only when the consequences are known.
- ▶ Enter the set up configuration correctly into the LICCON computer system.
- ▶ Observe the erection / take down charts.
- ▶ Crane operation with deactivated LICCON overload protection is prohibited.
- ▶ In assembly operation only load torque reducing crane movements may be carried out until a permissible operating and load range.
- ▶ The crane operator carries complete and sole responsibility for his actions if the LICCON overload protection is deactivated.

Utilization conditions

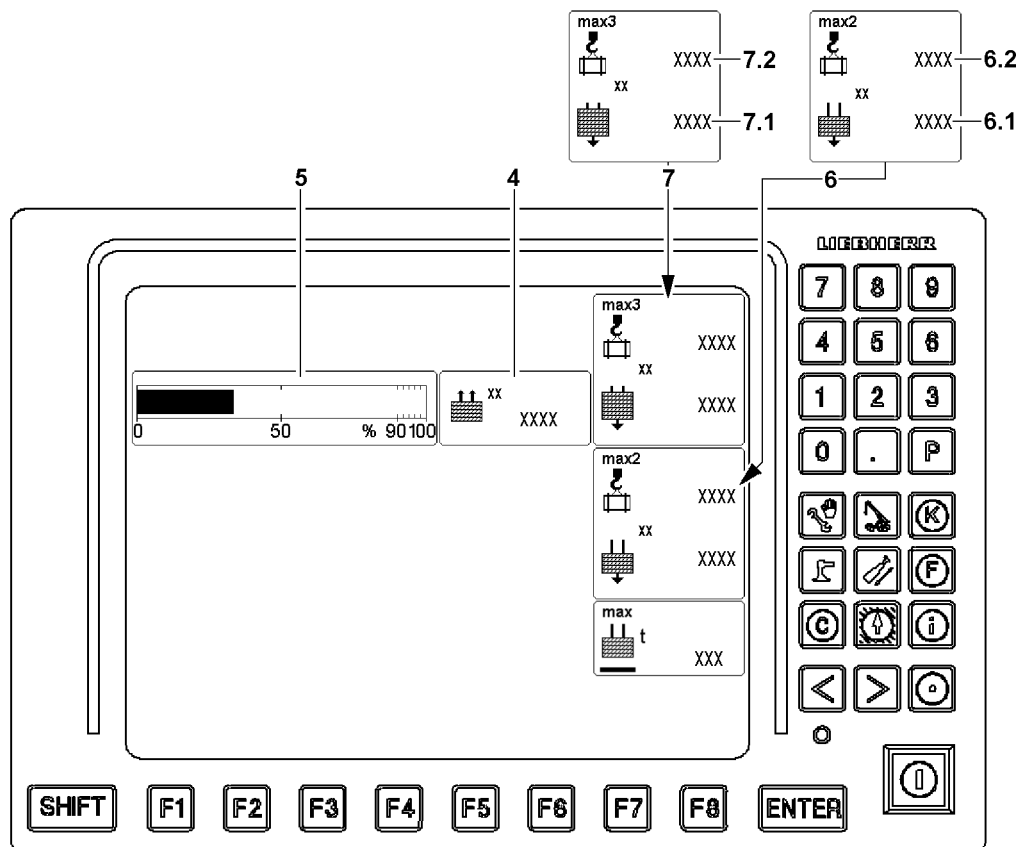
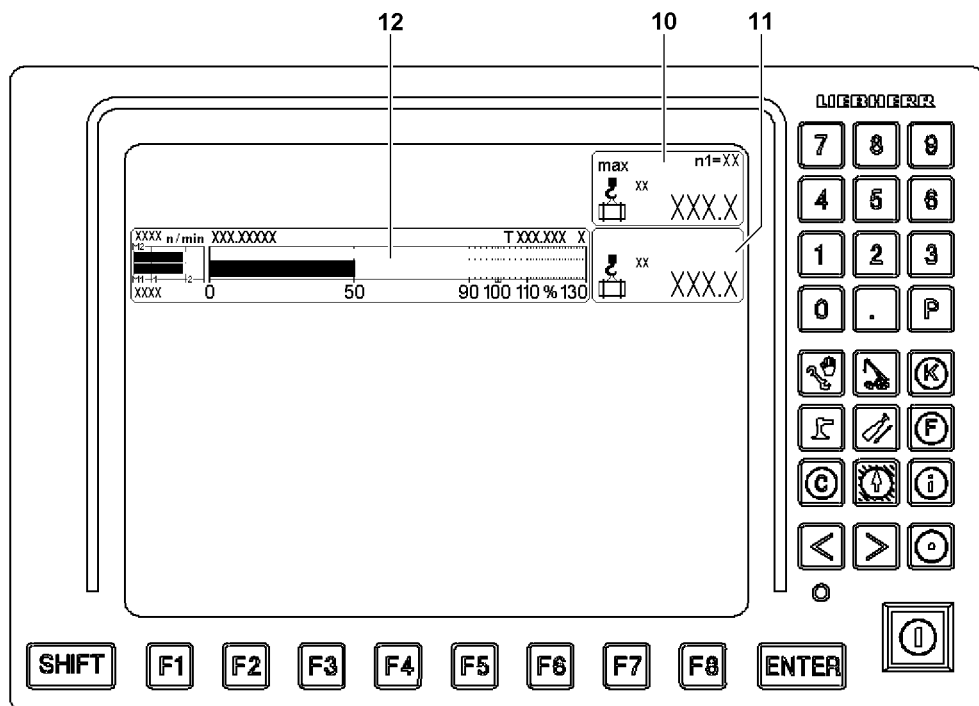


Fig.159394: Utilization conditions

The current percentage utilization of the crane is displayed as the “utilization bar diagram” 10 on the right LICCON monitor.

Additional displays:

- 6 “Load max2” icon

LWE/LR 1800-1-0-000/27200-07-02/en

- Currently placed derrick ballast =  $BA_{\text{placed}}$  **6.1** (Input value in the set up program)
- Possible load with currently placed derrick ballast =  $Load_{\text{max2}}$  **6.2**
- **7** “Load max3” icon
  - Maximum derrick ballast according to load chart =  $BA_{\text{max}}$  **7.1** (Highest value in the Set up program)
  - Possible load with maximum derrick ballast according to load chart =  $Load_{\text{max3}}$  **7.2**

**Maximum load**, right LICCON monitor:

- The maximum load in the current operating condition is reached when the utilization bar shows 100 % in the “utilization bar diagram” **12**.  
This is the case when the “utilization of the crane according to the load chart and reeving” reaches 100 % (values in the “Maximum load” icon **10** and the “actual load” icon **11** are equal).  
If the “maximum load” **10** is smaller than or equal to  $load_{\text{max2}}$  **6.2**, then an increase can be obtained under some circumstances:
  - By increasing the pulled derrick ballast  $BA_{\text{pulled}}$  **4**, if the derrick ballast utilization bar **5** is not yet at 100 % (derrick ballast not suspended).
  - By increasing the derrick ballast when the  $BA_{\text{placed}}$  **6.1** is smaller than  $BA_{\text{max}}$  **7.1**.
  - By changing the derrick ballast radius within the permissible range, see the load chart manual or the LICCON job planner.

**max2-load**, “load max2” icon **6**:

- The highest possible load in the current operating condition “**max2-load**” is reached when the “utilization bar diagram” **12** displays 100 % **and** the derrick ballast utilization bar **5** is at 100 % (Derrick ballast is completely lifted off the ground).  
This is the case when the value in “Actual load” icon **11** is the same as  $load_{\text{max2}}$  **6.2**.  
If the  $load_{\text{max2}}$  **6.2** is smaller than or equal to  $load_{\text{max3}}$  **7.2**, then an increase can be obtained under some circumstances:
  - By increasing the derrick ballast by loading additional ballast plates (increase  $BA_{\text{placed}}$  **6.1** to  $BA_{\text{max}}$  **7.1**).

**max3-load**, “load max3” icon **7**:

- The highest possible load at the maximum derrick ballast in current operating condition “**max3-load**” is reached when the “utilization bar diagram” **12** displays 100 % **and** the derrick ballast utilization bar **5** is at 100 % (maximum derrick ballast according to load chart is placed and is completely lifted off the ground).  
This is the case when the value in “Actual load” icon **11** is the same as  $load_{\text{max3}}$  **7.2**.
- The maximum derrick ballast according to the load chart is placed and completely pulled.  
Further increase of the derrick ballast is impermissible.



### Monitoring of F1-maximum force

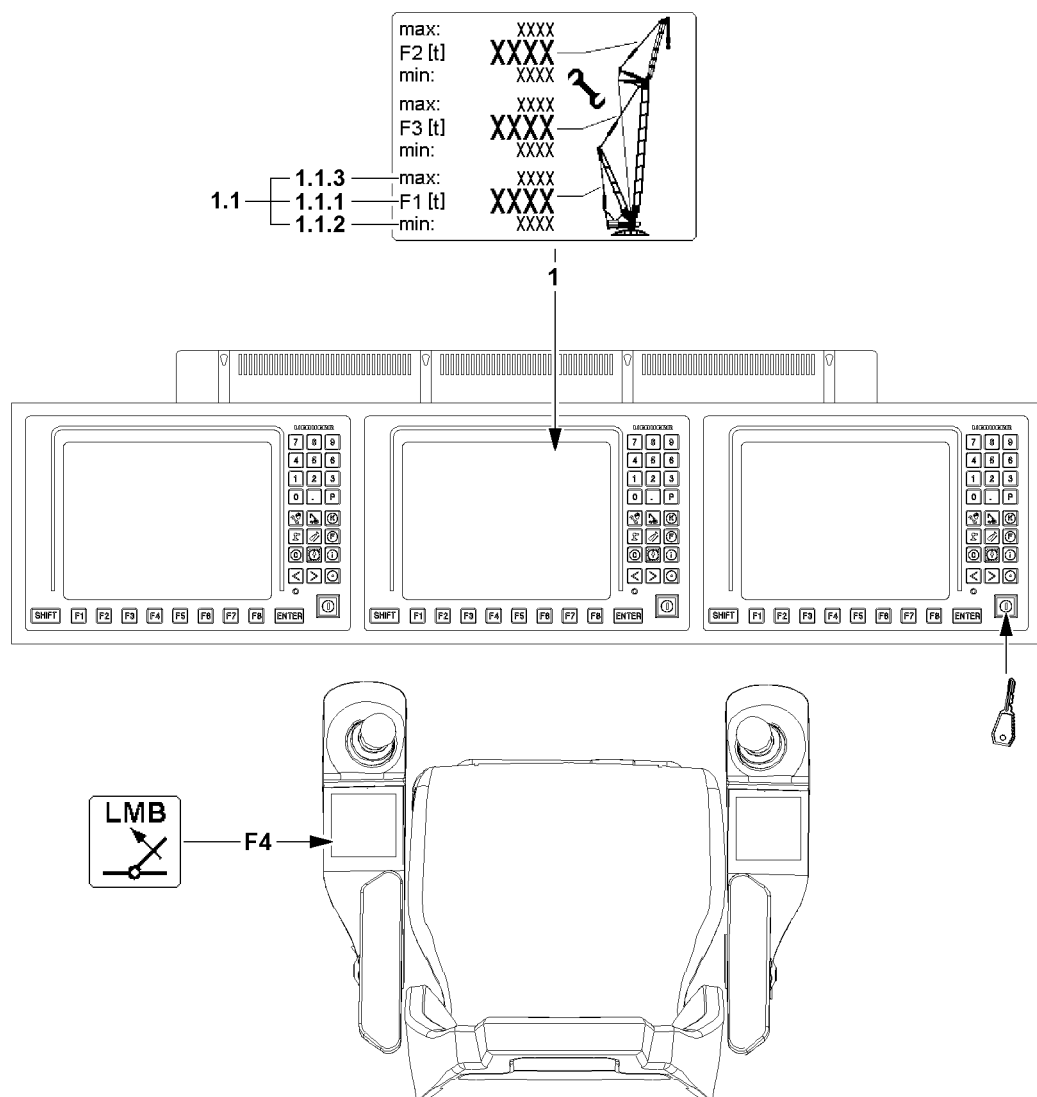


Fig.159393: Monitoring of F1-maximum force

Display values of force F1 (test point MS1) on the F-load display **1**:

- F1-maximum ( $F1_{\max}$ ) **1.1.3** = maximum value F1-force
- F1-actual value ( $F1_{\text{actual}}$ ) **1.1.1** = actual value F1-force (operating force F1)
- F1-minimum ( $F1_{\min}$ ) **1.1.2** = minimum value F1-force

The display values of force F1 (test point 1) are displayed permanently on the LICCON monitor. When F1-actual value ( $F1_{\text{actual}}$ ) **1.1.1** is greater than F1-maximum ( $F1_{\max}$ ) **1.1.3** a shut-off of all load moment increasing movements occurs.

**WARNING**

Intervention of the LICCON overload protection functionality!

When accessing the functionality of the LICCON overload protection by activating assembly operation, the LICCON overload protection is totally deactivated, bypassed or limited.

It is possible to exceed several shut-off limits of the LICCON overload protection simultaneously or one after the other.

It is possible to carry out crane movements, which are not monitored by the LICCON overload protection.

Without the LICCON overload protection, no additional protection against overload of the crane via the crane control is present.

This could result in serious accidents.

- ▶ When accessing the functionality of the LICCON overload protection, take into account that the LICCON overload protection is deactivated totally or is limited.
- ▶ When accessing the functionality of the LICCON overload protection, chapter 4.02 must be observed.

**Note**

The limit value for the F1-maximum force depends not only on the set up configuration and the crane geometry, but also on the pulled derrick ballast.

- ▶ If the pulled derrick ballast is larger, then the limit value for the F1-minimum force is generally reduced.
- ▶ If the pulled derrick ballast is smaller, then the limit value for the F1-maximum force is generally increased.

**Note**

By engaging the assembly operation the limit value for the F1-maximum force can be exceeded by a few tons. This makes it possible to reset a crane movement, which has caused the shutoff.

- ▶ Reset shut-off triggered by reverse crane movement.

**Monitoring of F1-minimum force**

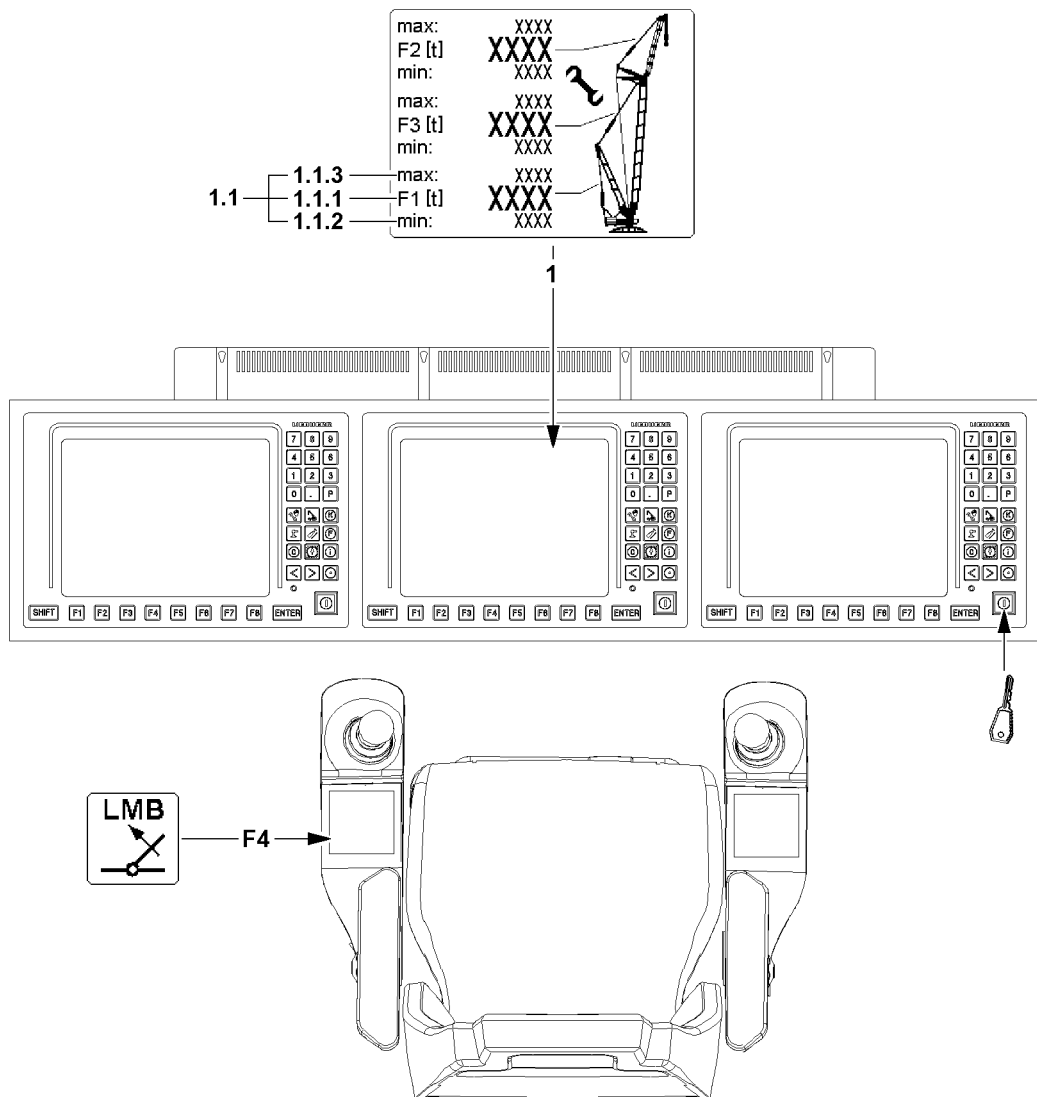


Fig.159393: Monitoring of F1-minimum force

Display values of force F1 (test point MS1) on the F-load display **1**:

- F1-maximum ( $F1_{max}$ ) **1.1.3** = maximum value F1-force
- F1-actual value ( $F1_{actual}$ ) **1.1.1** = actual value F1-force (operating force F1)
- F1-minimum ( $F1_{min}$ ) **1.1.2** = minimum value F1-force



**WARNING**

Uncontrolled movements of the boom system!

If the guying between the A-frame and the derrick head (test point 1) becomes powerless, then this can lead to uncontrollable movements of the boom system.

This could result in serious accidents.

- ▶ The guying between the A-frame and the derrick head (test point 1) may never be without power.
- ▶ Relieve the D-guying between the derrick head and the derrick ballast to the point where the F1-actual value ( $F1_{actual}$ ) **1.1.1** is greater than the F1-minimum ( $F1_{min}$ ) **1.1.2**.

LWE/LR 1800-1-0-000/27200-07-02/en

**WARNING**

Intervention of the LICCON overload protection functionality!

When accessing the functionality of the LICCON overload protection by activating assembly operation, the LICCON overload protection is totally deactivated, bypassed or limited.

It is possible to exceed several shut-off limits of the LICCON overload protection simultaneously or one after the other.

It is possible to carry out crane movements, which are not monitored by the LICCON overload protection.

Without the LICCON overload protection, no additional protection against overload of the crane via the crane control is present.

This could result in serious accidents.

- ▶ When accessing the functionality of the LICCON overload protection, take into account that the LICCON overload protection is deactivated totally or is limited.
- ▶ When accessing the functionality of the LICCON overload protection, chapter 4.02 must be observed.

**Note**

By engaging the assembly operation the limit value for the F1-minimum force can be fallen below by a few tons. This makes it possible to reset a crane movement, which has caused the shutoff.

- ▶ Reset shut-off triggered by reverse crane movement.

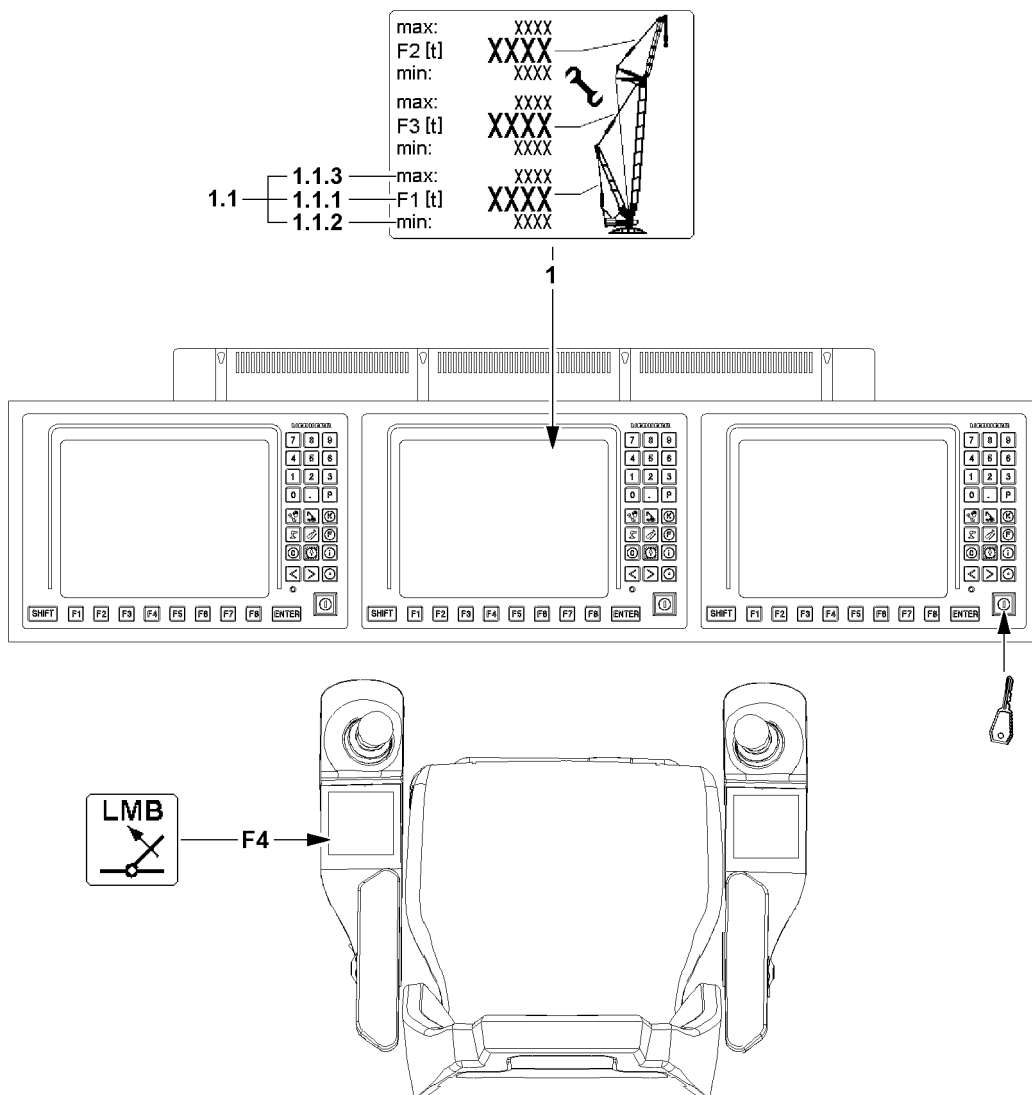


Fig.159393: Monitoring of F1-minimum force

**WARNING**

Independent movement of the boom system when increasing load momentum!

If the F1-minimum force is fallen below, the guying between the A-frame and the derrick head can become powerless.

If the guying between the A-frame and the derrick head is powerless and the “Derrick ballast is on the ground” at the same time, the derrick ballast can suddenly lift off the ground due to the increase in load momentum.

As a result, the boom system can move forward suddenly. Strong oscillating movements of the derrick ballast and load can be the result.

The crane can be overloaded and severe accidents can be the result.

- ▶ Keep the F1-actual value ( $F1_{\text{actual}}$ ) **1.1.1** above the F1-minimum ( $F1_{\text{min}}$ ) **1.1.2**.
- ▶ It is prohibited to fall below the F1-minimum force.

**WARNING**

Autonomous movement of the boom system when decreasing the load momentum!

If the F1-minimum force is fallen below, the guying between the A-frame and the derrick head can become powerless.

If the guying between the A-frame and the derrick head is powerless and the “derrick ballast is suspended” at the same time, the derrick ballast can suddenly set down on the ground due to decrease of the load momentum.

As a result, the boom system can move backward suddenly. As a result, the relapse cylinders can be pressed on block, be overloaded and damaged. Strong oscillating movements of the derrick ballast and load can be the result.

The crane can be overloaded and severe accidents can be the result.

- ▶ Keep the F1-actual value ( $F1_{\text{actual}}$ ) **1.1.1** above the F1-minimum ( $F1_{\text{min}}$ ) **1.1.2**.
- ▶ It is prohibited to fall below the F1-minimum force ( $F1_{\text{min}}$ ).

The following applies:

- After a shut-off due to falling below the F1-minimum ( $F1_{\text{min}}$ ) **1.1.2** the F1-actual value ( $F1_{\text{actual}}$ ) **1.1.1** must be increased by a crane movement. If the derrick ballast is suspended, this can be achieved by setting down the ballast.
- When picking up the load, the D-guying between the derrick ballast and the derrick head must be relieved to the point where the F1-actual value ( $F1_{\text{actual}}$ ) **1.1.1** is greater than the F1-minimum ( $F1_{\text{min}}$ ) **1.1.2**.
- When increasing the load momentum, and the limit value F1-minimum ( $F1_{\text{min}}$ ) **1.1.2** is fallen below, an already set down derrick ballast can lose contact with the ground and lift off.
- When decreasing the load momentum, and the limit value F1-minimum ( $F1_{\text{min}}$ ) **1.1.2** is fallen below, an already “suspended derrick ballast” can be put down on the ground.
- If the assembly operation is activated and the F1-force continues to drop below the minimum force  $F1_{\text{min}}$ , then the  $F1_{\text{min}}$  shut-off can no longer be bypassed.

Limitations from 50 % pulled derrick ballast

If more than 50 % of the set derrick ballast is being pulled (derrick ballast utilization bar **5** greater than 50 %) and the F1-minimum ( $F1_{\text{min}}$ ) **1.1.2** is fallen below at the same time, all crane movements that increase load momentum are turned off.

Limitations from 90 % pulled derrick ballast

If more than 90 % of the set derrick ballast is being pulled (derrick ballast utilization bar **5** greater than 90 %) and the F1-minimum ( $F1_{\text{min}}$ ) **1.1.2** is fallen below at the same time, all crane movements that increase load torque and all crane movements that decrease load momentum are turned off. This also turns off the “spooling out” movement of the winch.

## 14.6.6 Checking the length sensor value on the ballast trailer



### CAUTION

Danger of accident!

If the derrick ballast radius is measured incorrectly, due to the incorrect radius a maximum load capacity and a F1-operational-max force that are too large will be calculated.

The crane will be overloaded unnoticed as a result and can topple over.

Death, severe bodily injuries, property damage.

- ▶ The crane driver may not rely blindly on the derrick ballast radius measurement, but he must think for himself and check, if the measurement is still working correctly.
- ▶ If the derrick ballast is fully telescoped out or in, the “Derrick ballast radius” display must show almost the end position of the ballast trailer radius, see section “Radii”.
- ▶ Depending on the installed intermediate sections, the end positions also change.



### Note

- ▶ When telescoping the ballast trailer guide, the indicator must change the “Derrick ballast radius” display on the LICCON monitor according to the movement of the derrick ballast. If this is not the case, the crane operator can immediately recognize that if the length sensor rope drum jams when spooling in or out.
  - ▶ When telescoping out and in and no length change on the rope length sensor occurs, then an error is issued.
  - ▶ If a length change is recognized without actuation, then the pressure supply for the ballast trailer is turned off, the error must be remedied.
- 
- ▶ When telescoping the derrick ballast in and out, the “Derrick ballast radius” display must be observed carefully on the LICCON monitor.

## 14.6.7 Difference force monitoring of ballast guying

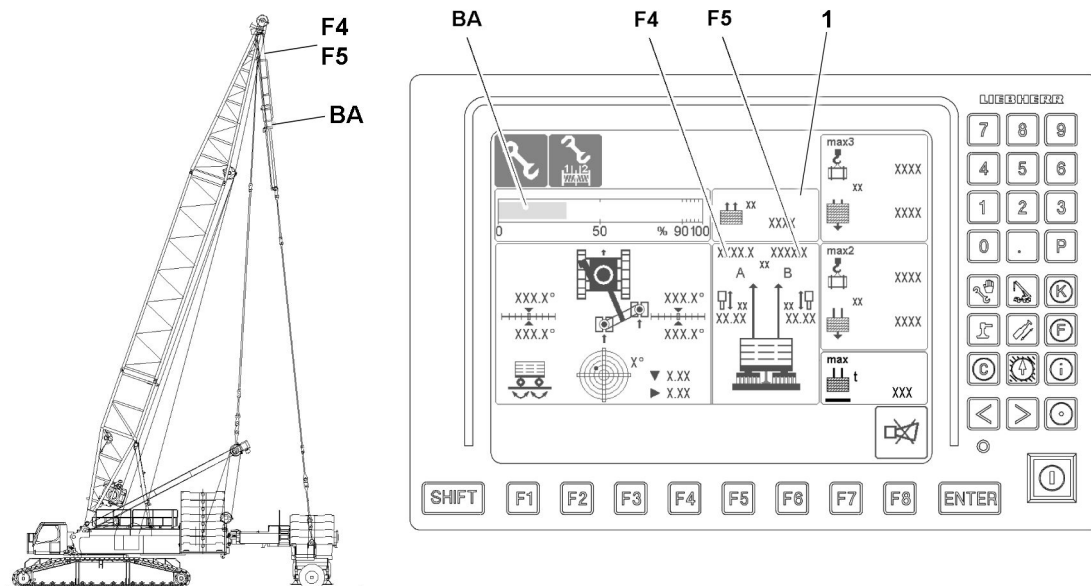


Fig. 159396: Difference force monitoring of ballast guying

In operating modes with derrick ballast, the difference of the forces between derrick guying A and B is monitored on LICCON monitor 1. If the difference exceeds a permissible value, an acoustic warning is issued and the two force values blink.

After reaching the specified limit value of the difference force threshold, the “guying A” F4 and “guying B” F5 displays blink. The color on the display changes to red and the “Ballast up” and “Ballast down” function is stopped. The differential force must then be lowered again.

The assembly icon appears when the “difference force monitoring - derrick ballast guying” shut-off is bypassed. The shut-off is bypassed using the set up key on the right LICCON monitor.

If a cylinder movement leads to an additional deterioration in the differential force, the movement of the ballast cylinder is turned off. The display “Pulled derrick ballast” **1** also blinks and the color changes to red. Subsequently, it is only possible to drive out of the shut-off using a permissible differential force with the LMB emergency operation (RFID sensor).



#### **WARNING**

Danger of accident due to damaged crane components!

Too large a difference between the derrick ballast guying A and B can have the result that the derrick ballast arrives in an impermissible inclined position, and thereby the derrick end section, the ballast guide or other crane components may be damaged.

Death, severe bodily injuries, property damage.

- ▶ The forces in the derrick ballast guying A and B must be carefully monitored on the LICCON monitor.

#### **Exceeding the limit value can have the following causes:**

- Picking up the load by:  
Relieving the tires on the ballast trailer or flexing of the turntable.
- The ground under the derrick ballast is uneven.
- The crane is leaning to one side.
- The derrick ballast is loaded on one side.
- The force measurement in one derrick ballast guying is incorrect.

#### **The crane driver must recognize the correct cause and take countermeasures:**

- An error message appears.
- The error, which caused the one-sided force, must be remedied.
- The following measures are permitted providing the ground is only slightly uneven:  
Lock one pull cylinder and with the other pull cylinder lift the derrick ballast or “Derrick ballast lower” activate until the difference between the forces A and B is smaller.
- If the sensor values are implausible: Check if the pressure sensors for the ballast weighing supply plausible values and replace them, if necessary.

## **15 Removing ballast trailer ballast**

Make sure that the following prerequisites are met:

- The ballast trailer frame is pinned with the turntable.
- An auxiliary crane is on hand.
- The ground on which ballast is being removed is sufficiently level and load-bearing.

### 15.1 Permissible ballast assemblies

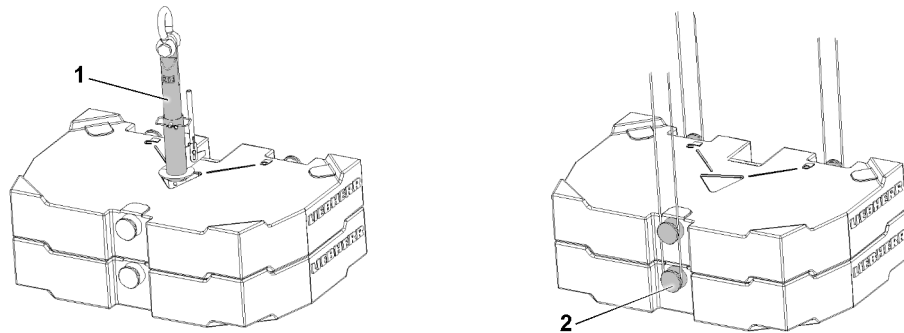


Fig.163049: Lifting the ballast plates together

- 1 Twistlock receptacle stud
- 2 Bitt



**WARNING**

Overload of the counterweight assembly fastening points!  
 If more than the permissible number of counterweights are lifted together, then the fastening points can be overloaded.  
 The counterweights and components can fall down.  
 Death, severe bodily injuries, property damage.  
 ► Fasten only the maximum permissible number of counterweights per stroke.

Individual weight Ballast plate	Maximum number of the same counterweight plates per stroke over	
	Twistlock receptacle stud	Bitt
5.0 t	2	1
7.5 t	2	2
10.0 t	2	2

Lifting the ballast plates

### 15.2 Ballast removal rules

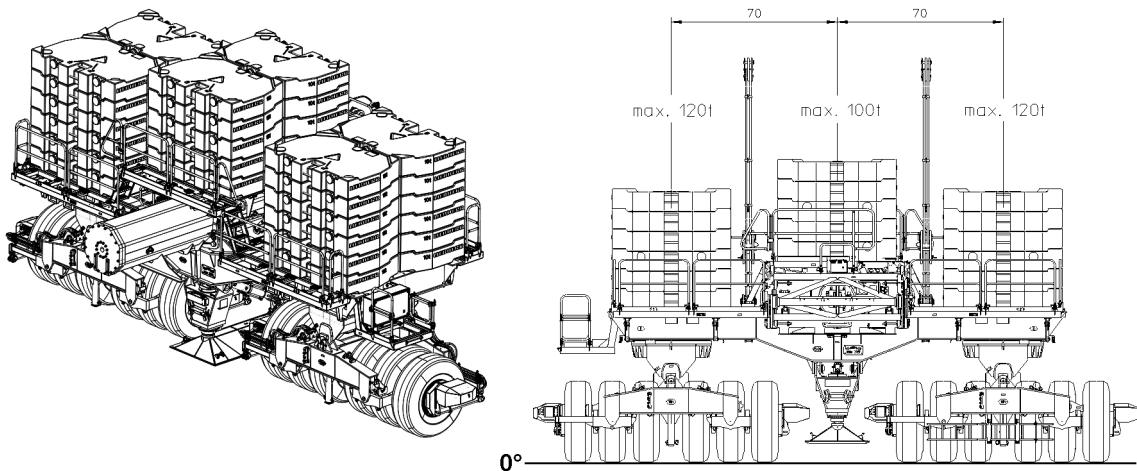


Fig.159322: Removing ballast trailer ballast

LWE/LR 1800-1-0-000/27200-07-02/en



**WARNING**

Failure to observe the ballast removal rules!  
Death, severe bodily injuries, property damage.

- ▶ The ground on which the ballast is removed must be level and have an adequate load bearing capacity.
- ▶ Always take the ballast plates down symmetrically, in reference to the longitudinal axis.
- ▶ It is necessary to start with the two outer ballast stacks.
- ▶ The maximum permissible difference during the ballast removal procedure between the right and left ballast stacks is 20 t.
- ▶ Replace damaged ballast plates immediately with new ballast plates.
- ▶ Observe the weight signs on the ballast pallets.

**WARNING**

Failure to observe the stability and tipping safety specifications!  
Death, severe bodily injuries, property damage.

- ▶ Make sure that only a quantity of ballast plates are removed from the ballast trailer in order to guarantee **at all times** the stationary stability of the ballast trailer after unpinning on the turntable.
- ▶ See section "Stability and tipping safety".

**WARNING**

Lifting of the ballast plates!  
Death, severe bodily injury, property damage.

- ▶ Make sure that permissible quantity of the ballast plates is not exceeded during simultaneous lifting, see section "Permissible ballast assemblies".

**Note**

- ▶ The struts can be used as a ladder on the stacked ballast plates.

**Note**

- ▶ The ballast plates are marked with their own weights.

## 15.3 Variation 1: Removing the ballast plates, fastening system: "Twistlock"

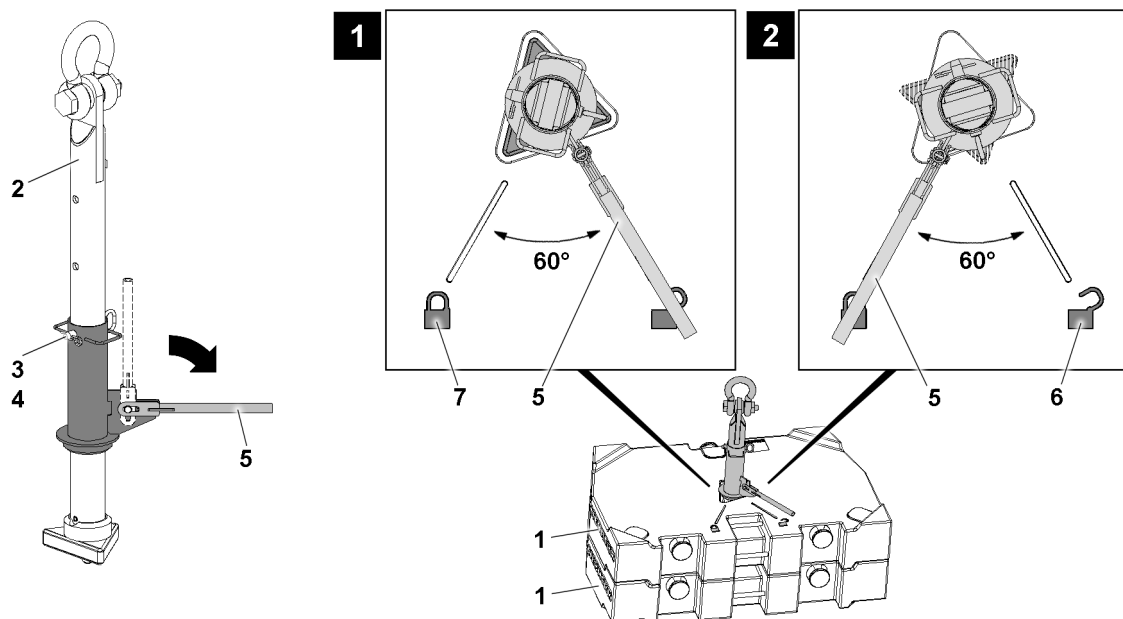


Fig.157149: Ballast plates, fastening system: "Twistlock"

- |   |                   |   |                 |
|---|-------------------|---|-----------------|
| 1 | Ballast plate     | 5 | Lever           |
| 2 | Receptacle stud   | 6 | "Unlocked" icon |
| 3 | Pin               | 7 | "Locked" icon   |
| 4 | Retaining element |   |                 |



### WARNING

Use of damaged ballast plates **1**!  
Death, severe bodily injuries, property damage.

- ▶ Replace damaged ballast plates **1**.

- ▶ Check if the ballast plate **1** is damaged.

If the ballast plate **1** is damaged:

- ▶ Replace the ballast plate **1**.
- ▶ Check if the length of the receptacle stud **2** is properly adjusted.

If the length of the receptacle stud **1** is to be adjusted:

- ▶ Release and unpin the pin **3**.
- ▶ Adjust the length of the receptacle stud by moving the receptacle stud **2**.
- ▶ Insert the pin **3** and secure it with the retaining element **4**.



### WARNING

Lifting of impermissible ballast assemblies!

If more than the permissible ballast plates **1** are lifted with the receptacle stud **2**, the receptacle stud **2** is overloaded and will be damaged.

Death, severe bodily injuries, property damage.

- ▶ Apply the ballast plates **1** individually or as an assembly see section "Permissible ballast assemblies".

- ▶ Fasten the receptacle stud **2** to the auxiliary crane and guide it into the ballast plate(s) **1**.
- ▶ Pull the lever **5** up and fold it down.
- ▶ Turn the lever **5** from the "unlocked" icon **6** to the "locked" icon **7** and lift slightly.

**Result:**

- The receptacle stud **2** is locked with the ballast plate **1**, see illustration **2**.
- ▶ Lift the ballast plate(s) **1** individually or as an assembly with the receptacle stud **2**.
- ▶ Remove the ballast plate(s) **1** from the ballast stack or the divisible ballast pallet “VarioTray”.

When the ballast plate(s) **1** are taken down:

- ▶ Turn the lever **5** from the “locked” icon **7** to the “unlocked” icon **6**.

**Result:**

- The receptacle stud **2** is unlocked, see illustration **1**.
- ▶ Carefully pull the receptacle stud **2** out of the ballast plate(s) **1**.

## 15.4 Variation 2: Removing the ballast plates, fastening points: “Bitt”

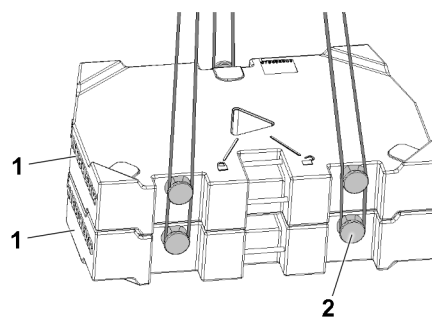


Fig.163050: Ballast plates, fastening points: “Bitt”

**1** Ballast plate

**2** Bitt

**WARNING**

Use of damaged ballast plates **1**!  
Death, severe bodily injuries, property damage.

- ▶ Replace damaged ballast plates **1**.
- ▶ Check if the ballast plate **1** is damaged.

If the ballast plate **1** is damaged:

- ▶ Replace the ballast plate **1**.

**WARNING**

Lifting of impermissible ballast assemblies!  
If more than the permissible ballast plates **1** are lifted, the bits **2** are overloaded and the ballast plates **1** can fall down.

Death, severe bodily injuries, property damage.

- ▶ Apply the ballast plates **1** individually or as an assembly, 3 fastening points, see section “Permissible ballast assemblies”.

**WARNING**

Incorrect fastening!

If fastening equipment cannot be fastened correctly and if it is not secured to prevent it from loosening up, loads can fall down.

Death, severe bodily injuries, property damage.

- ▶ Make sure that the fastening equipment is correctly attached to the bits **2** and secured to prevent it from loosening up.
- ▶ Fasten the ballast plate(s) **1** individually or as an assembly to the auxiliary crane.
- ▶ Lift the ballast plate(s) **1**.

- ▶ Remove the ballast plate(s) **1** from the ballast stack or the divisible ballast pallet “VarioTray”.

When the ballast plate(s) **1** are taken down:

- ▶ Remove the fastening equipment on the bits **2**.

## 16 Prerequisites for disassembly

Make sure that the following prerequisites are met:

- The incline of the base / travel route of the ballast trailer is  $0^\circ \pm 1.5^\circ$ .
- The incline of the base / travel route of the crawler travel gear is  $0^\circ \pm 0.3^\circ$ .
- The base / travel route of the ballast trailer and crawler travel gear is sufficiently level and capable of supporting the load.
- The boom equipment is taken down.
- An auxiliary crane and a lifting platform are available.
- The ballast retainers are removed.
- The ballast trailer steering program(s) are deactivated, see section “Deactivating steering programs for assembly / disassembly purposes”.
- The LICCON overload protection must remain set in accordance with the set up configuration of the erected and operational crane.
- The LICCON overload protection settings have been compared with the actual set up configuration.

## 17 Preparing the ballast trailer for disassembly from the crane

Make sure that the following prerequisites are met:

- The ballast trailer guide is fully retracted.
- The ground absorbs the surface pressure **F1** and surface pressure **F2** of the ballast trailer, see the charts in section “Specific ballasting for stability and tipping safety”.

The specific ballasting that must lie on the ballast trailer depends on:

- The assembled components of the ballast trailer guide.
- Radius of the ballast trailer during disassembly of the turntable.



### WARNING

Impermissible ballasting!

If the ballast trailer is insufficiently ballasted, then the ballast trailer can tip over when unpinning the turntable.

Death, severe bodily injuries, property damage.

- ▶ Make sure when unpinning the ballast trailer **1** that it is ballasted according to the ballast trailer radius, see section “Specific ballasting for stability and tipping safety”.
- ▶ Make sure that the ground is prepared according to the ground pressure, see section “Specific ballasting for stability and tipping safety”.

Specific ballasting, see section “Specific ballasting for stability and tipping safety”.

- ▶ Select the specific ballasting.
- ▶ Place the specific ballasting on the ballast trailer, see section “Ballasting the ballast trailer”.

## 18 Disassembling the ballast trailer from the crane

### 18.1 Supporting the ballast trailer

Make sure that the following prerequisites are met:

- The ballast trailer is pinned and secured on the turntable on both sides.
- The electrical and hydraulic connection lines are connected.
- Observe the “assembly conditions of the ballast trailer”.
- The ballast trailer guide is retracted until the shut-off is caused by the control.
- The crane is horizontally aligned.
- The ground absorbs the surface pressure **F1** and surface pressure **F2** of the ballast trailer, see the charts in section “Specific ballasting for stability and tipping safety”.
- Specific ballast is lying on the ballast trailer.

#### 18.1.1 Pinning the strut on the ballast trailer

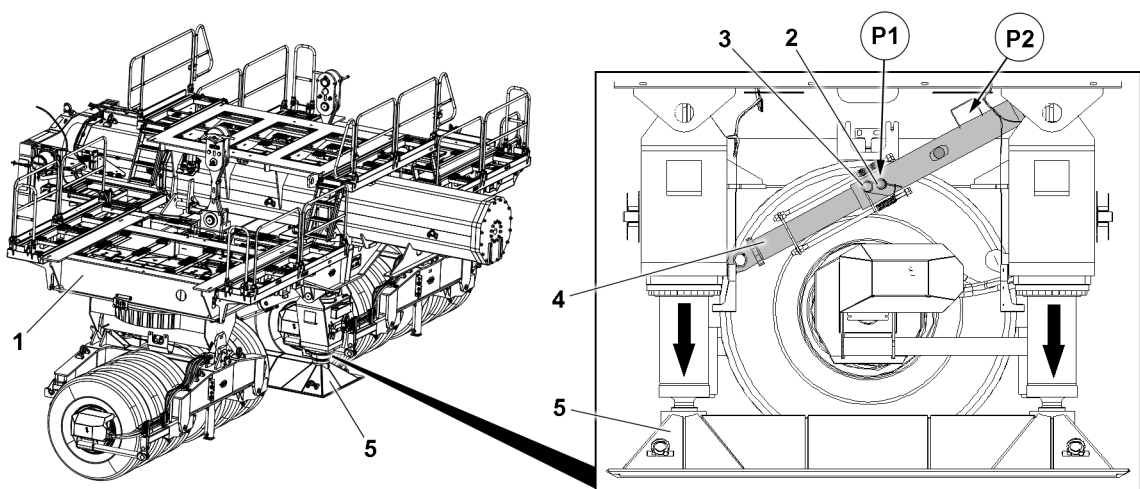


Fig.163052: Supporting the ballast trailer – Pinning the strut on the ballast trailer

1	Ballast trailer	4	Strut
2	Pin	5	Support
3	Retaining element		



#### WARNING

The strut is not pinned!

If the ballast trailer is not assembled on the turntable and is not ballasted according to the ballast trailer radius, the ballast trailer can tip over.

Death, severe bodily injuries, property damage.

- ▶ Prior to disassembly of the ballast trailer on the turntable, the pin **2** must be pinned in the strut **4** of the ballast trailer **1** in the operating position **P1** and secured with the retaining element **3**.
  - ▶ The support **5** is extended to the point where the tires are relieved.
- 
- ▶ Release the pin **2** in the park position **P2** and unpin.
  - ▶ Insert the pin **2** in the operating position **P1** and secure with the retaining element **3**.

## 18.1.2 Extending the support cylinders

### Extending the support cylinders 1 using the control panel -A1210

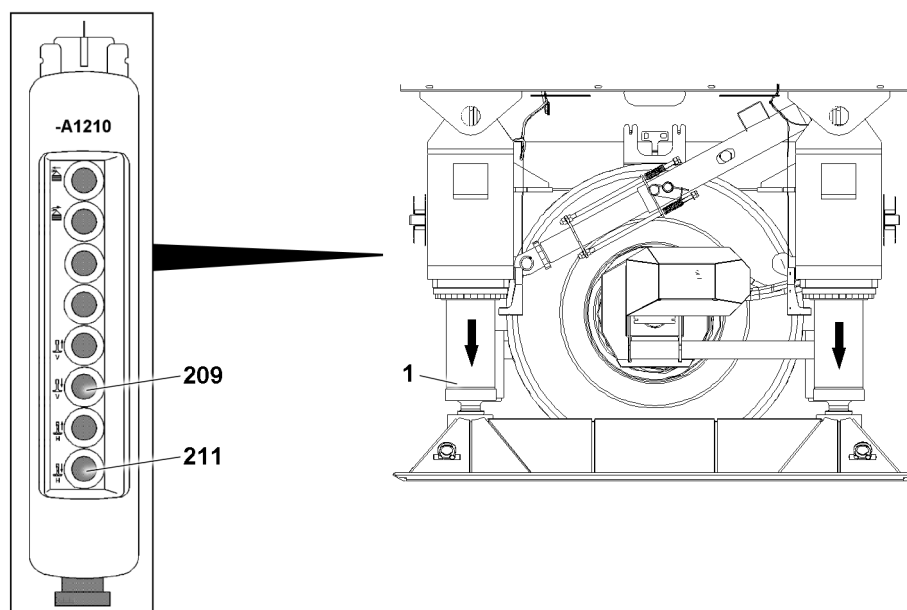


Fig.163067: Extending the support cylinders using the control panel -A1210

**1** Support cylinder  
**209** Button

**211** Button  
 - Control panel  
**A12**  
**10**

- Press the button **209** and button **211** on the control panel **-A1210**.

### Extending the support cylinder 1 using the button on the crane cab instrument panel

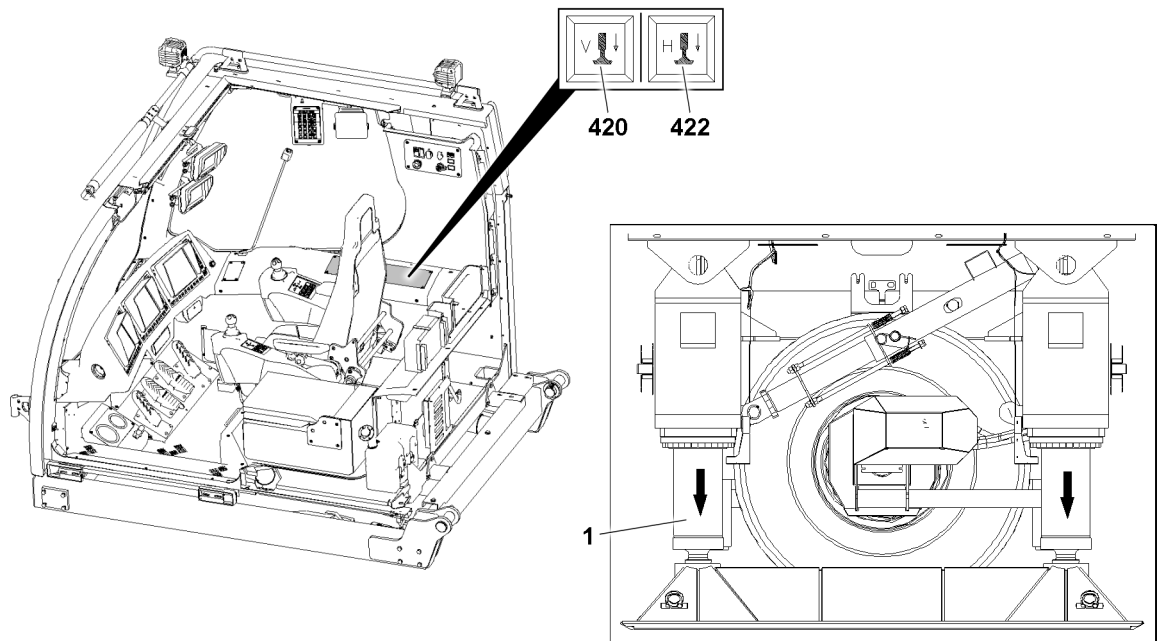


Fig.163085: Extending the support cylinder using the button on the crane cab instrument panel

**1** Support cylinder  
**420** Button

**422** Button

- ▶ Press the button **420** and button **422** in the crane cab.

### Extending the support cylinder 1 using master switch 3

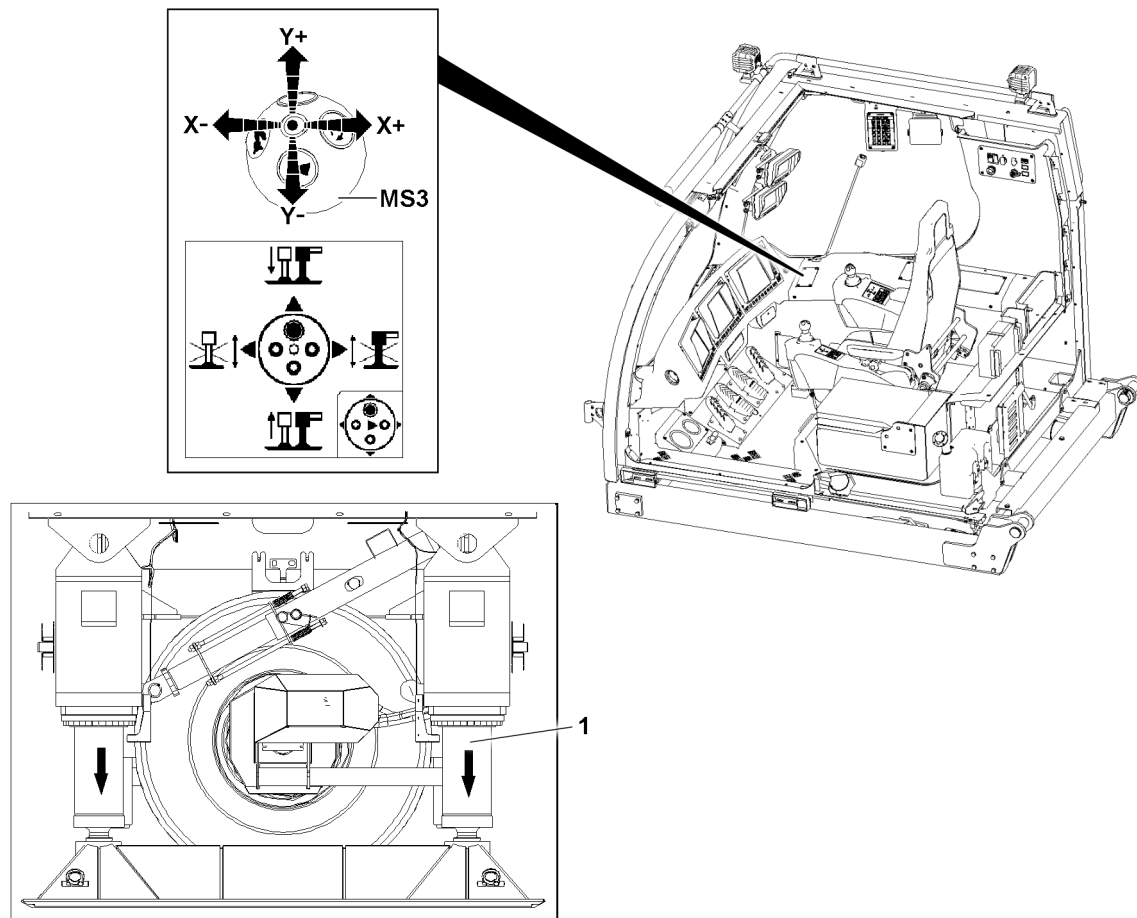


Fig.163086: Extending the support cylinders using master switch 3

1 Support cylinder

MS3 Master switch

When the corresponding master switch assignment is selected:

- ▶ Move the master switch **MS3** in direction **Y+**.

## 18.2 Extending the electrical and hydraulic connections between the turntable and the ballast trailer

Depending on the local circumstances at the job location of the crane, it may be necessary when assembling / disassembling the ballast trailer to extend the electrical lines between the turntable and the ballast trailer with the extension lines.

This can ensure that after unpinning the ballast trailer guides from the turntable, they can be retracted enough so that the slewing range of the turntable is not limited by the ballast trailer guide.



### WARNING

Danger of accident due to loss of pressure or leakage!  
Death, severe bodily injuries, property damage.

- ▶ Make sure that the specifications for establishing and releasing hydraulic and electrical connections are observed.
  - ▶ See section "Work on the electrical connections".
  - ▶ See section "Work on the hydraulic connections".
- 
- ▶ Assemble the electrical extension lines between the turntable and the ballast trailer.
  - ▶ Assemble the hydraulic extension lines between the turntable and the ballast trailer.



### 18.3 Assembling the extension ladder on the ballast trailer guide

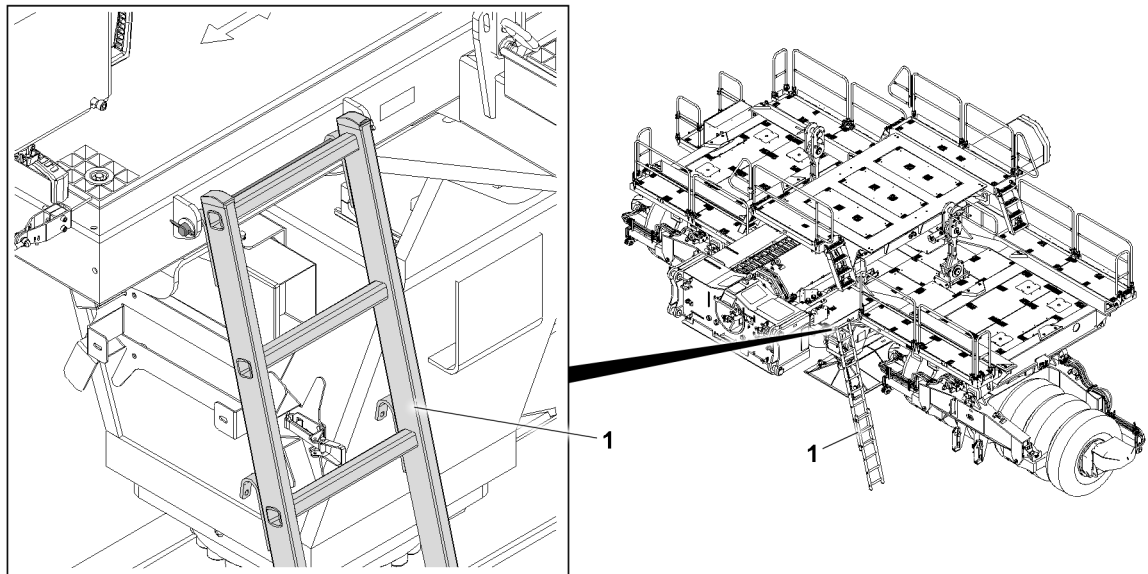


Fig.163023: Assembling the extension ladder on the ballast trailer guide

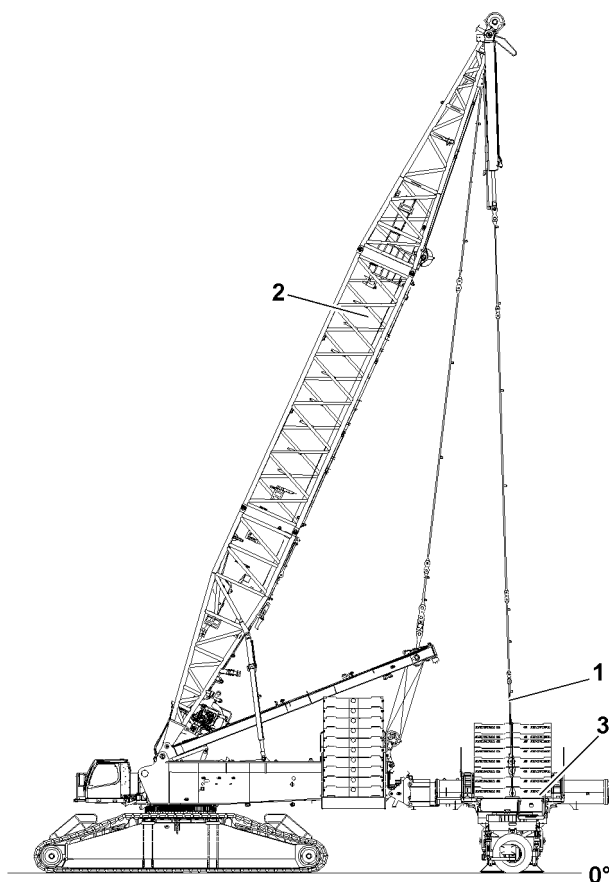
1 Extension ladder



#### Note

► Assembly of the extension ladder 1, see chapter 2.06.

## 18.4 Disassembling the ballast trailer guying from the ballast trailer



*Fig.163034: Disassembling the ballast trailer guying from the ballast trailer – Overview*

**1** Guy rod

**2** Ballast trailer

Make sure that the following prerequisite is met:

- The guy rods **1** are relieved.
- The extension ladder is assembled on the ballast trailer guide, see section “Assembling the extension ladder on the ballast trailer guide”.

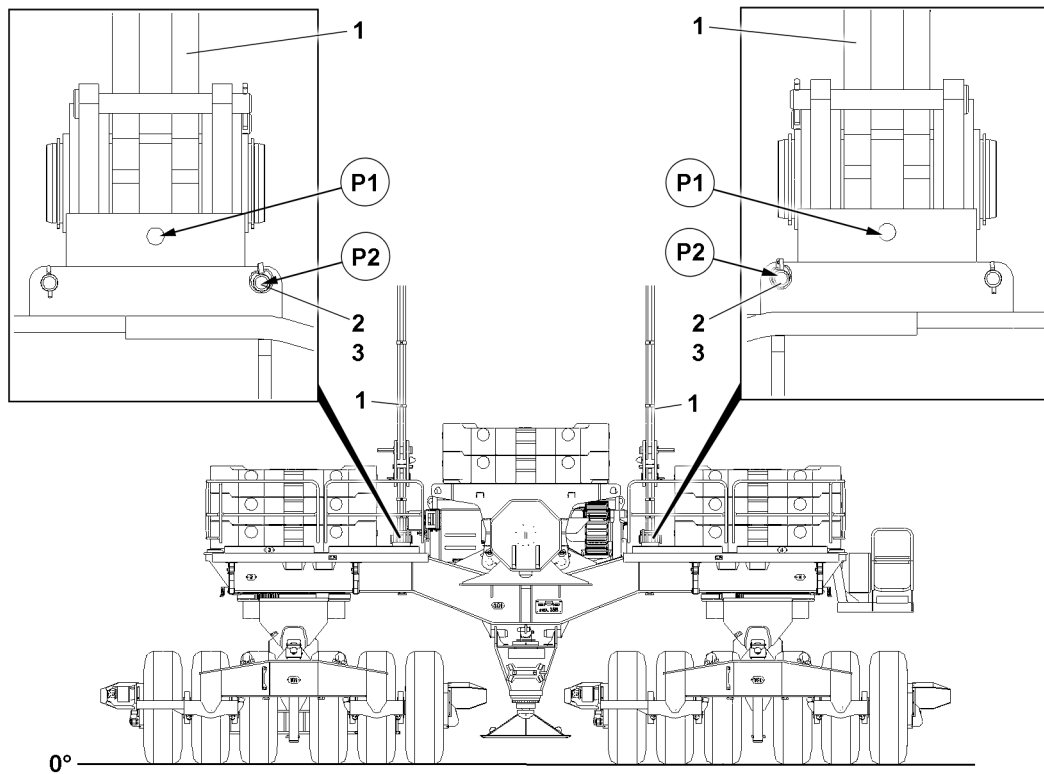


Fig.163068: Disassembling the ballast trailer guying from the ballast trailer – Assembling the retaining element in the operating position

- |   |                        |   |                   |
|---|------------------------|---|-------------------|
| 1 | Ballast trailer guying | 3 | Retaining element |
| 2 | Retaining pin          |   |                   |

- ▶ Adjust the derrick ballast based on the ballast trailer guide with respect to the derrick boom radius.

#### Problem remedy

Can the derrick ballast not be adjusted with respect to the derrick boom radius?

- ▶ Secure the ballast trailer guying 1 with the auxiliary crane.
- ▶ Release the retaining pin 2: Remove the retaining element 3.
- ▶ Remove the retaining pin 2 in positions P1.
- ▶ Insert the retaining pin 2 in the operating position P2.
- ▶ Secure the retaining pin 2 with the retaining element 3.

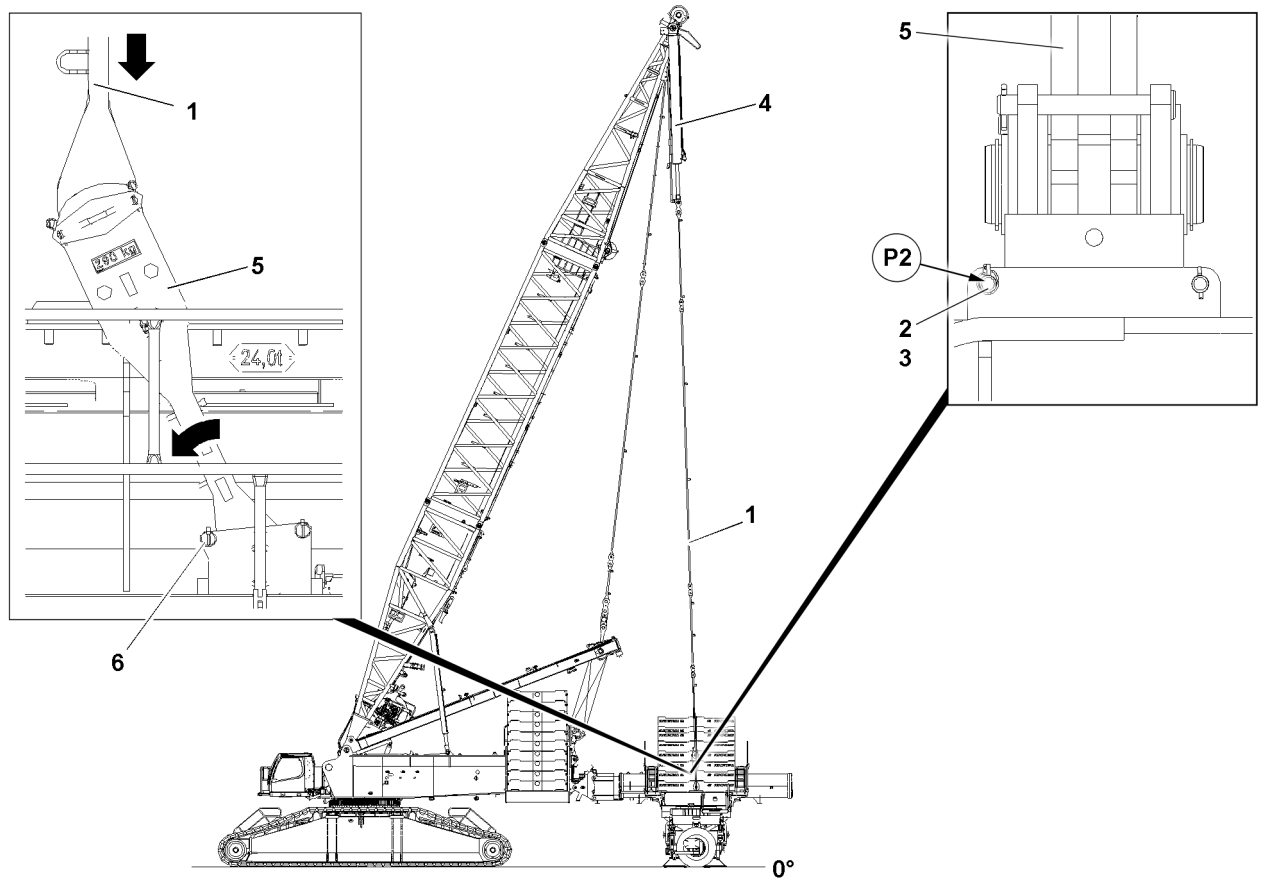


Fig.163069: Disassembling the ballast trailer guying from the ballast trailer – Taking down the pull bracket

- |   |                        |   |               |
|---|------------------------|---|---------------|
| 1 | Ballast trailer guying | 4 | Pull cylinder |
| 2 | Retaining pin          | 5 | Pull bracket  |
| 3 | Retaining element      | 6 | Pin           |

When the retaining pin 2 is pinned on both sides in the operating position P2:

- ▶ Extend the pull cylinder 4 until the pull bracket 5 is placed on the pin 6.

**Result:**

- The ballast trailer guying 1 is relieved.

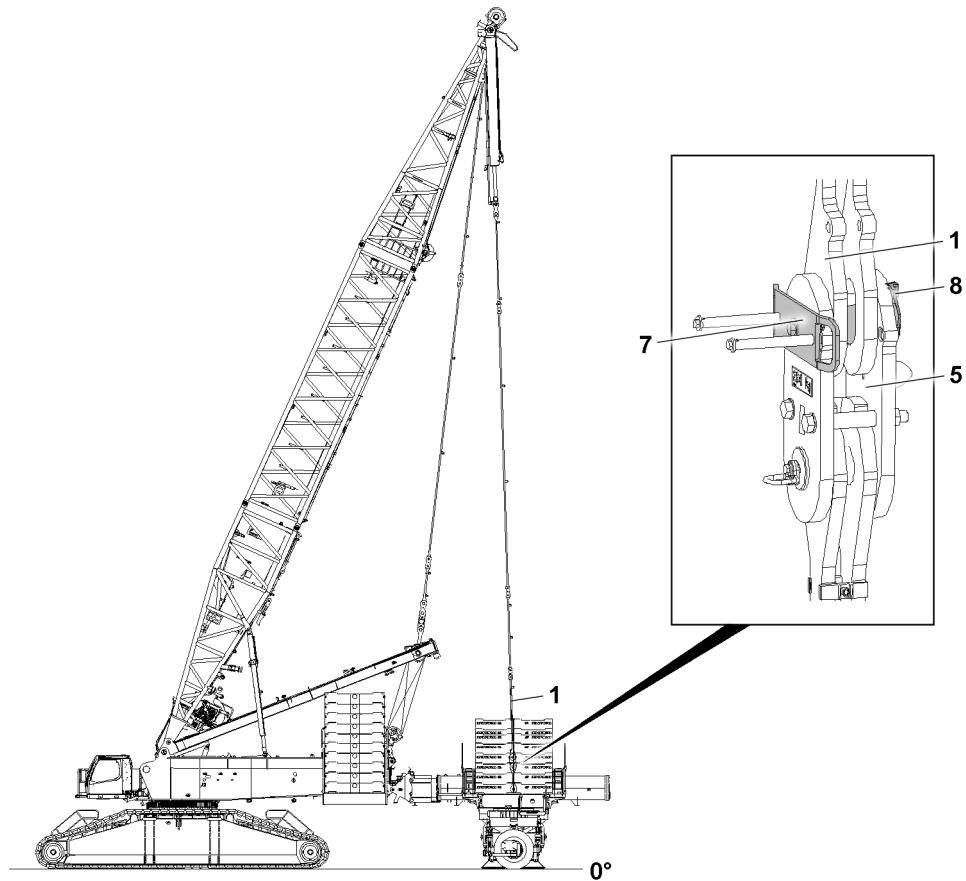


Fig.163070: Disassembling the ballast trailer guying from the ballast trailer – Securing the pin

- |   |                        |   |                   |
|---|------------------------|---|-------------------|
| 1 | Ballast trailer guying | 7 | Pin               |
| 5 | Pull bracket           | 8 | Retaining element |



#### WARNING

Tipping of the unsecured pull brackets!  
Severe bodily injuries, property damage.

- ▶ Secure the pull brackets **5** before unpinning the ballast trailer guying **1**.



#### WARNING

The guy rods are not secured to prevent them from swinging back and forth.  
The ballast trailer guying **1** can sway during the unpinning procedure.  
Death, severe bodily injuries, property damage.

When the derrick ballast is not adjusted based on the derrick boom radius:

- ▶ Make sure that the ballast trailer guying **1** is secured just above the pull brackets **5** by the auxiliary crane to prevent it from swinging.
- ▶ Remove the retaining element **8**.
- ▶ Unpinning the pin **7**

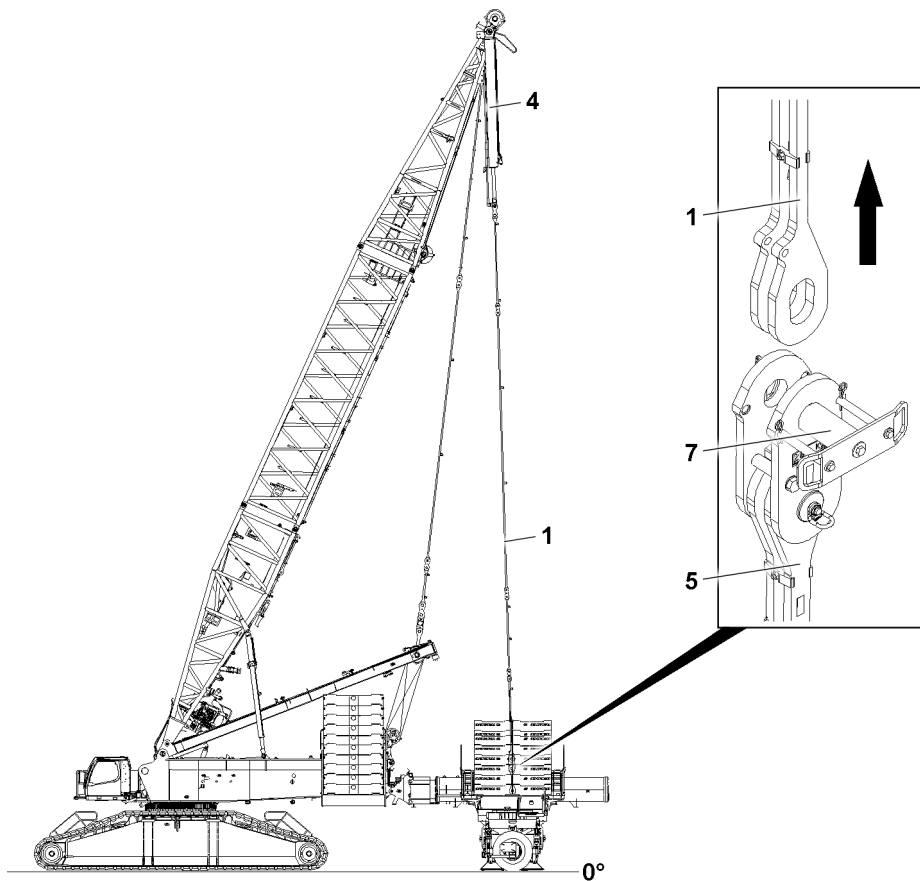


Fig.163071: Disassembling the ballast trailer guying from the ballast trailer – Inserting pins in the transport position

1	Ballast trailer guying	7	Pin
4	Pull cylinder	8	Retaining element
5	Pull bracket		



#### Note

Retract / extend the pull cylinder 4:

- ▶ Control the pull cylinders 4 from the crane cab or with the control panel, see section “Lifting and lowering the ballast trailer with the pull cylinders”.
- ▶ Operate the pull cylinder 4 with the radio remote control, see the “radio remote control operating instructions”.

- ▶ When the pins 7 are unpinned: Lift the ballast trailer guying 1 out of the pull bracket 5 using the pull cylinder 4.

When the derrick ballast is not adjusted based on the derrick boom radius:

- ▶ Swing the unpinned ballast trailer guyings 1 with the auxiliary crane into the vertical position.

When the ballast trailer guyings 1 are in the vertical position:

- ▶ Insert the pin 7.
- ▶ Secure the pin 7 with the retaining element 8.

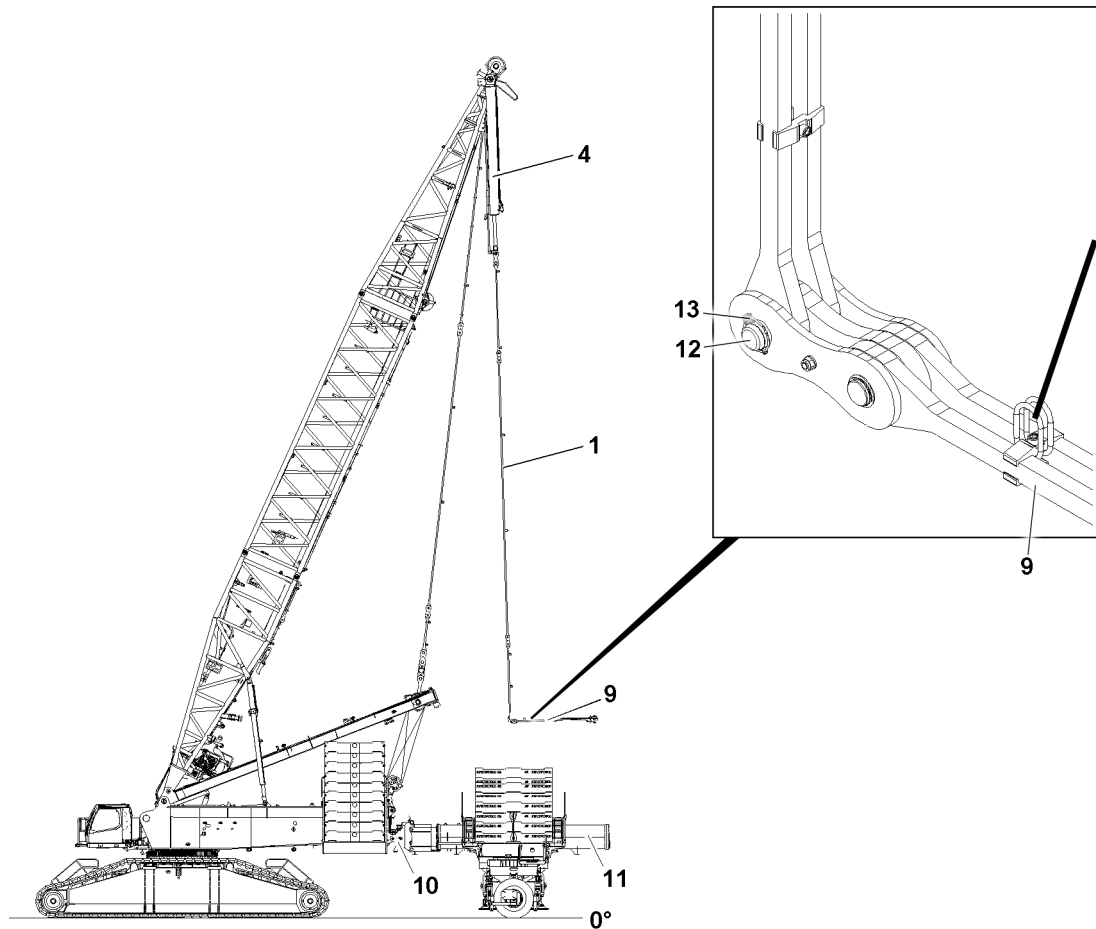


Fig.163055: Disassembling the ballast trailer guying from the ballast trailer – Disassembling the guy rod

- |    |                        |    |                       |
|----|------------------------|----|-----------------------|
| 1  | Ballast trailer guying | 11 | Ballast trailer guide |
| 4  | Pull cylinder          | 12 | Pin                   |
| 9  | Guy rod                | 13 | Retaining element     |
| 10 | Adapter                |    |                       |



#### Note

- ▶ The transport position for the guy rods 9 is located on the adapter 10. The guy rods 9 are assembled on the adapter 10 only after it is disassembled from the ballast trailer guide 11.
- 
- ▶ Fasten the guy rod 9 to the auxiliary crane.
  - ▶ Lift the guy rod 9 until it hangs horizontally.
  - ▶ Remove the retaining element 13.
  - ▶ Unpin the pin 12.
  - ▶ Take the guy rod 9 down in a suitable location.
  - ▶ Retract the pull cylinder 4 and pull the ballast trailer guying 1 up.
  - ▶ Repeat the procedure in the same way as described above for the other side of the ballast trailer guying 1.

## 18.5 Unpinning the ballast trailer from the turntable

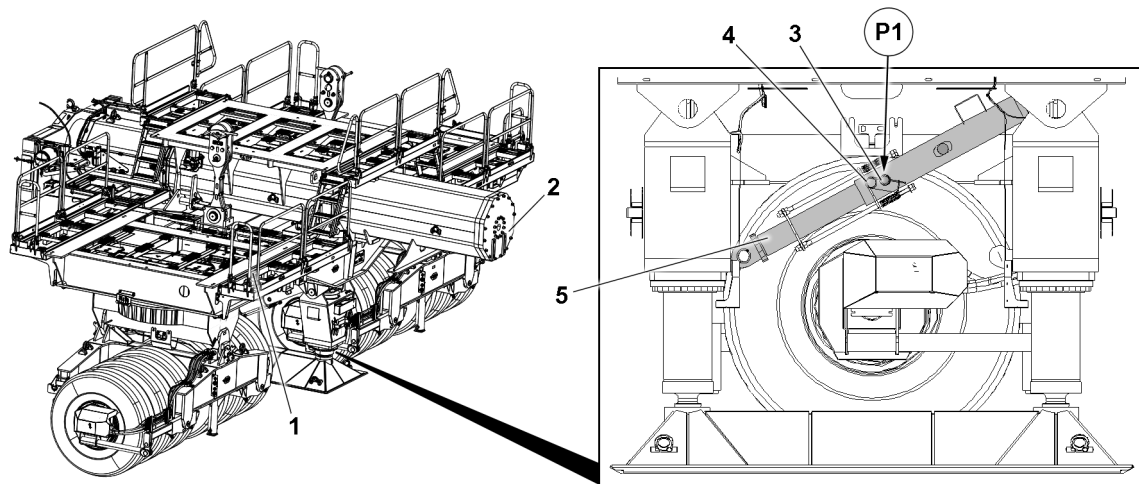


Fig.163056: Unpinning the ballast trailer from the turntable – Pinned strut

- |   |                       |   |                   |
|---|-----------------------|---|-------------------|
| 1 | Ballast trailer       | 4 | Retaining element |
| 2 | Ballast trailer guide | 5 | Strut             |
| 3 | Pin                   |   |                   |



### WARNING

Impermissible ballasting!

If the ballast trailer **1** is insufficiently ballasted, then the ballast trailer **1** can tip over when unpinning the turntable.

Death, severe bodily injuries, property damage.

- ▶ Make sure when unpinning the ballast trailer **1** that it is ballasted according to the ballast trailer radius, see section “Specific ballasting for stability and tipping safety”.
- ▶ Make sure that the ground is prepared according to the ground pressure, see section “Specific ballasting for stability and tipping safety”.



### Note

- ▶ For disassembly of the ballast trailer **1**, the electrical and hydraulic connection must be established from the ballast trailer **1** to the turntable to be able to control the support cylinders if necessary, see section “Extending the electrical and hydraulic connections between the turntable and the ballast trailer **1**”.
- ▶ The “Ballast UP / DOWN” releases are independent of whether the ballast trailer **1** is attached, providing the conditions in the shut-off diagram are fulfilled.
- ▶ The “Ballast UP” release allows the retraction of the pull cylinder and support cylinder.
- ▶ The “Ballast DOWN” release allows the extension of the pull cylinder and support cylinder.
- ▶ This means that the support cylinder and the pull cylinder can be actuated, even if the “Ballast trailer pinned” signal is not present.

Make sure that the following prerequisites are met:

- The ballast trailer **1** is supported.
- The ballast trailer **1** is ballasted symmetrically according to the ballast trailer radius, see section “Specific ballasting for stability and tipping safety”.
- The pin **3** in the strut **5** is inserted in the operating position and secured with the retaining element **4**, see section “Pinning the strut on the ballast trailer”.



### 18.5.1 Unpinning procedure

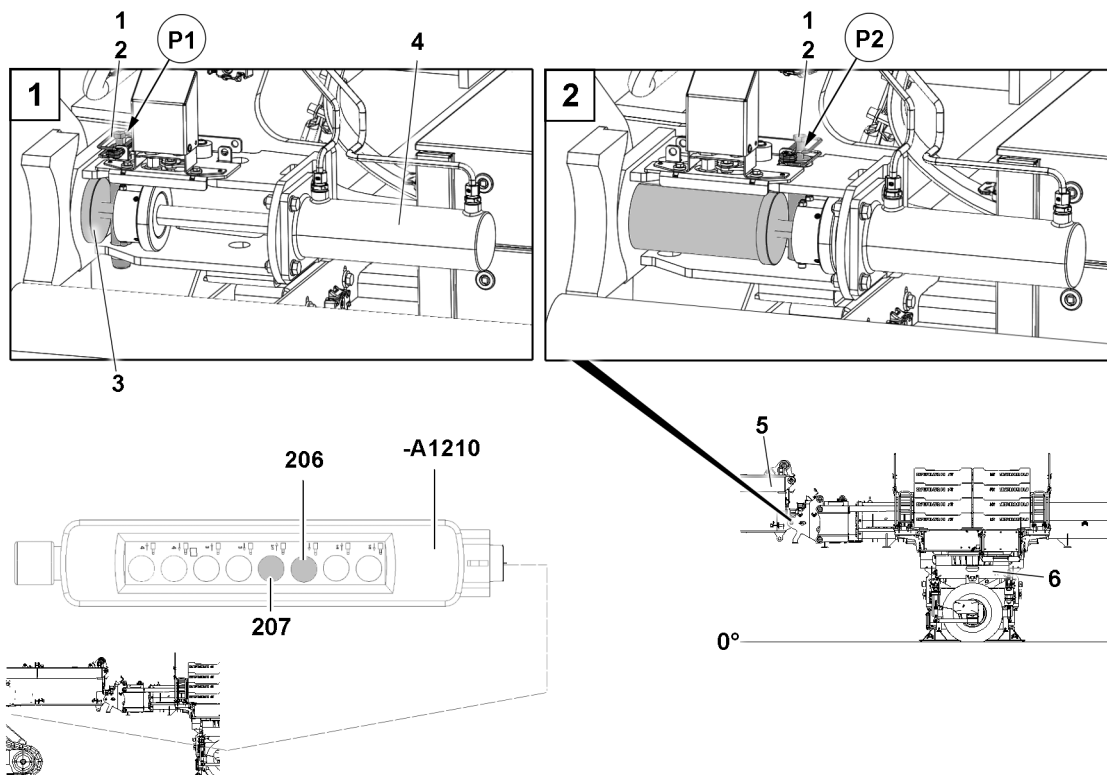


Fig.163057: Unpinning the ballast trailer from the turntable – Unpinning procedure

- |   |                   |   |                      |
|---|-------------------|---|----------------------|
| 1 | Pin               | 4 | Pin pulling cylinder |
| 2 | Retaining element | 5 | Turntable            |
| 3 | Pin               | 6 | Ballast trailer      |

- ▶ Remove the retaining element 2.
- ▶ Unpin the pin 1 in point P1.

**Result:**

- The pin 3 is released.

- ▶ Press the button 206 on the control panel -A1210.

**Result:**

- The pin pulling cylinders 4 retract.
- The pins 3 are unpinning on the turntable 4.



**Note**

- ▶ For disassembly of the ballast trailer 6, if the “turning” or “driving” functions are required to unpin the ballast trailer, the respective active ballast trailer operating mode “turning released”, “driving released” or “parallel driving released” must be deactivated.
- ▶ When the ballast trailer is installed, the stated releases are not activated, i.e. turning and driving the crane is possible until both limit switches report that the ballast trailer is pinned.

**NOTICE**

Damage to the ballast trailer **6** or the turntable **5**!

If, due to tension when unpinning the ballast trailer **6** on the turntable **5**, only one pin **3** is unpinned (signal "Ballast trailer installed" is no longer present), the crane control no longer recognizes the ballast trailer **6** as installed, even though the ballast trailer **6** is still connected to the turntable **5** with the second pin **3**.

Due to the missing signal, "Ballast trailer installed", it is possible to turn the turntable **5**, to drive the crane or to telescope the ballast trailer guide out or in.

This can significantly damage the crane or the ballast trailer **6**.

- ▶ All crane movements are to be limited to a "minimum degree" and must be driven with extreme caution and the lowest possible speed.
- ▶ After unpinning the second pin **3**, it must be checked again if both pins **3** are completely unpinned.

- ▶ Perform a visual inspection.
- ▶ Insert the pin **1** in point **P2**.
- ▶ Secure the pin **1** with the retaining element **2**.

When both pins **3** are unpinned and secured:

- ▶ Remove the crane.

### 18.5.2 Disconnecting the hydraulic and electric connections between the ballast trailer and turntable

Make sure that the following prerequisites are met:

- The pressure in the hydraulic system has been released.

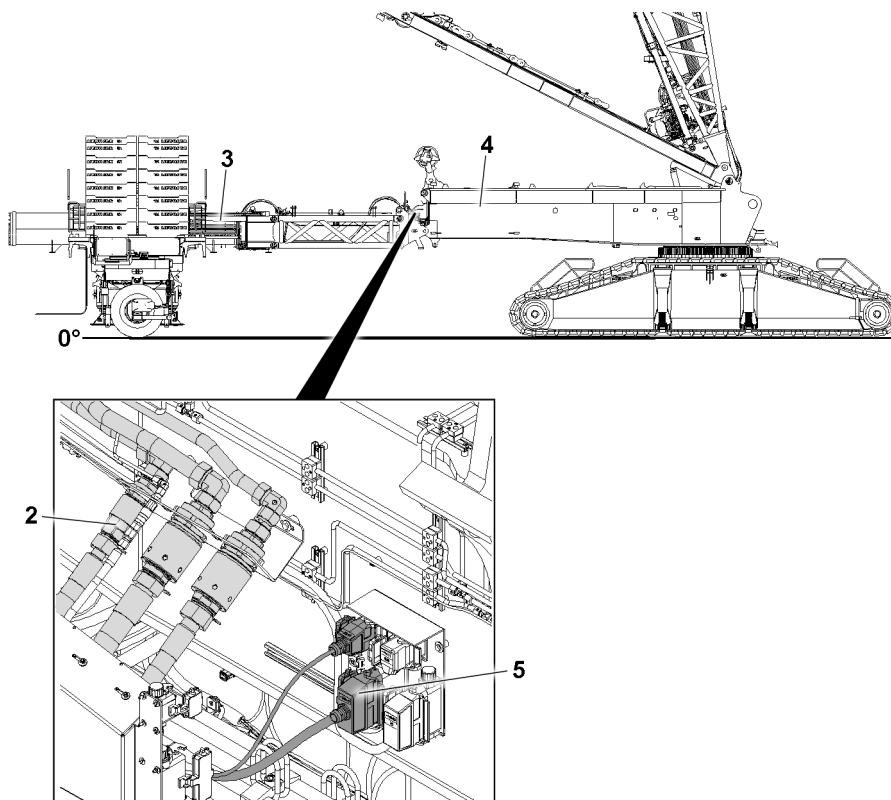


Fig.163041: Disconnecting the hydraulic and electric connections between the ballast trailer and turntable

- |          |                      |          |                       |
|----------|----------------------|----------|-----------------------|
| <b>2</b> | Hydraulic connection | <b>4</b> | Turntable             |
| <b>3</b> | Ballast trailer      | <b>5</b> | Electrical connection |

**Note**

- ▶ Exemplary illustration – Applies for disconnection between the turntable and both the intermediate section as well as the adapter.
- 
- ▶ Disconnect the hydraulic connections **2** between the ballast trailer **3** and the turntable **4**, see the hydraulic diagram.
  - ▶ Store the hydraulic hoses properly.
  - ▶ Assemble protective caps on the coupling parts.

**NOTICE**

The ignition switch is not in position 0!

If live current carrying electrical connections are disconnected or connected, then there is the danger that components can be damaged.

The crane functions can be limited.

- ▶ De-energize the electrical connections before disconnection or connection. Set the ignition switch to position 0.
- 
- ▶ Set the ignition switch to position "0".
  - ▶ Disconnect the electrical connections **5** between the ballast trailer **3** and the turntable **4**, see the wiring diagram.
  - ▶ Close all unused electrical connections that have a dummy plug with the dummy plug.

## 18.6 Disassembling the extension ladder on the ballast trailer guide

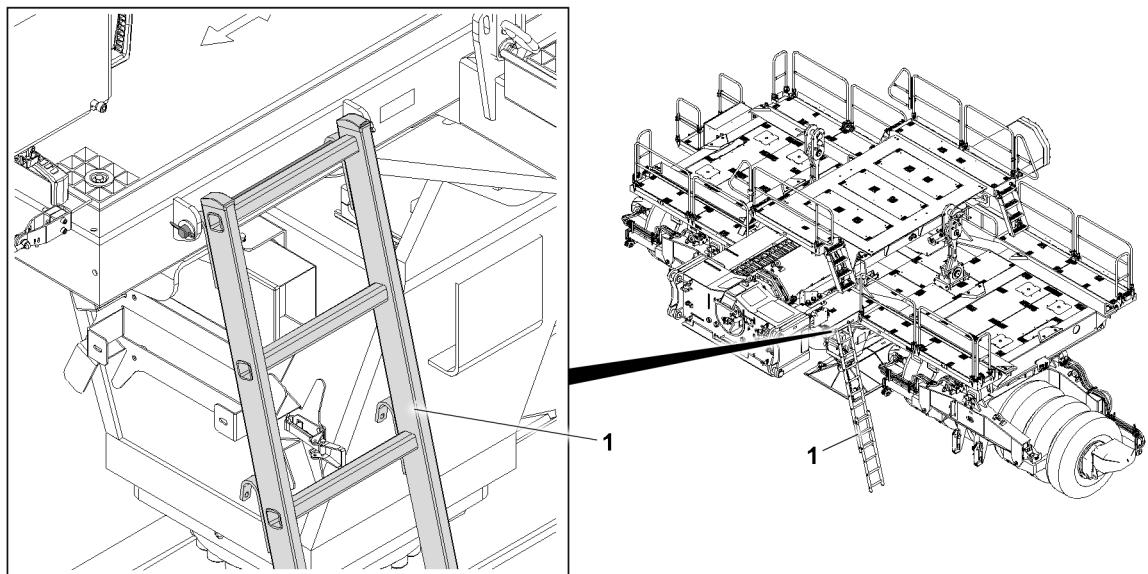


Fig.163023: Disassembling the extension ladder on the ballast trailer guide

- 1** Extension ladder

**Note**

- ▶ Disassembly of the extension ladder **1**, see chapter 2.06.

## 19 Disassembling the ballast trailer

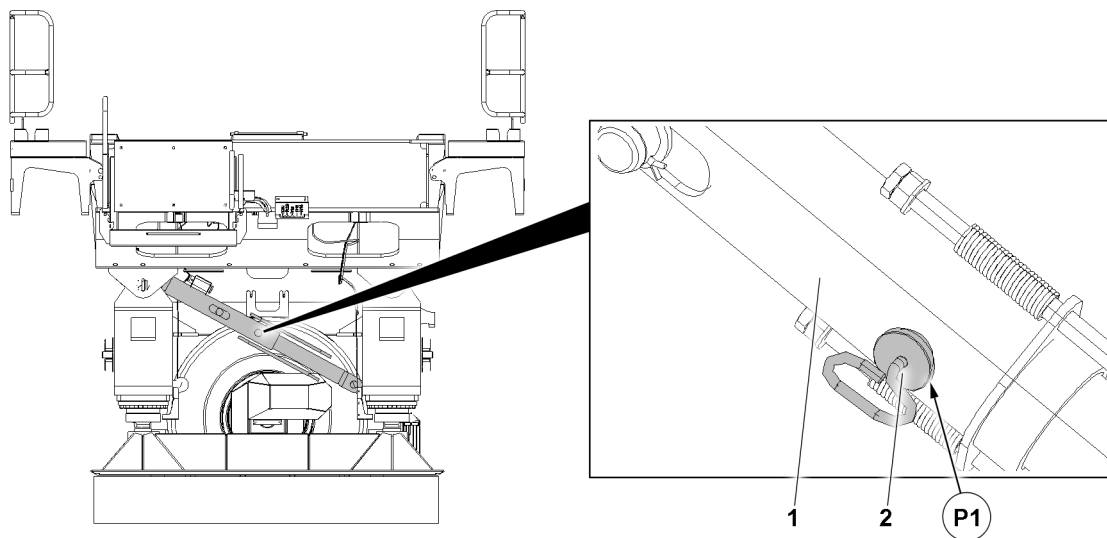


Fig.163022: Assembling the ballast trailer guide on the ballast trailer

**1** Strut

**2** Pin

Make sure that the following prerequisites are met:

- The incline of the base / travel route of the ballast trailer is  $0^\circ \pm 1.5^\circ$ .
- The base / travel route of the ballast trailer is sufficiently level and capable of supporting the load, see “Specific ballasting for stability and tipping safety”.
- The permissible level difference lies below the tolerance range, see section “Permissible level difference”.
- The ballast trailer is supported.
- The strut **1** is secured in the operating position. The pin **2** is inserted in point **P1** and secured with the retaining element.
- The ballast trailer is ballasted according to its assembly condition, see section “Specific ballasting for stability and tipping safety”.
- The ballast trailer guide is telescoped in all the way.

## 19.1 Disassembling the ballast trailer guide from the ballast trailer

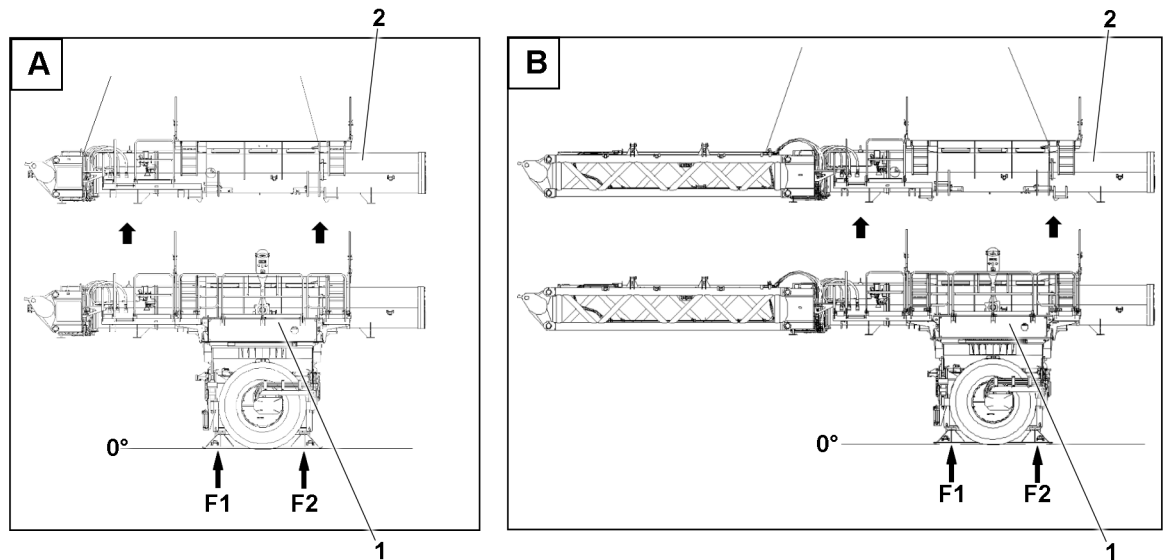


Fig.163058: Disassembling the ballast trailer guide from the ballast trailer – Variations

- |          |  |          |                       |
|----------|--|----------|-----------------------|
| <b>A</b> | Disassemble the ballast trailer guide with the adapter from the ballast trailer                          | <b>1</b> | Ballast trailer       |
| <b>B</b> | Disassemble the ballast trailer guide with the intermediate section and adapter from the ballast trailer | <b>2</b> | Ballast trailer guide |



### Note

- ▶ The disassembly of the ballast trailer guide Variation **A** is identical to the disassembly of the ballast trailer guide Variation **B**.
- ▶ The disassembly of the ballast trailer guide **2** is described as an example based on variation **A** and applies in the same manner for variation **B**.

### 19.1.1 Assembling the extension ladder on the ballast trailer guide



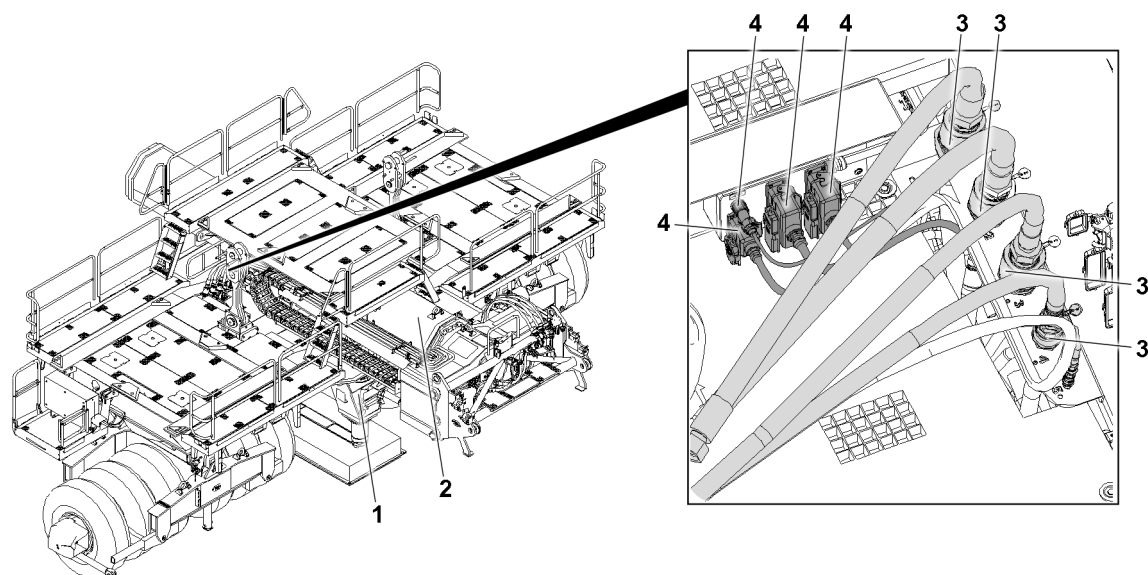
### Note

- ▶ Assembly of the extension ladder, see chapter 2.06.

### 19.1.2 Disconnecting the electrical and hydraulic connections between the ballast trailer and the ballast trailer guide

Make sure that the following prerequisites are met:

- The pressure in the hydraulic system has been released.



*Fig.163072: Disassembling the ballast trailer guide on the ballast trailer – Disconnecting the electrical and hydraulic connections*

- |          |                       |          |                        |
|----------|-----------------------|----------|------------------------|
| <b>1</b> | Ballast trailer       | <b>3</b> | Hydraulic connections  |
| <b>2</b> | Ballast trailer guide | <b>4</b> | Electrical connections |

- ▶ Disconnect the hydraulic connections **3** between the ballast trailer guide **2** and the ballast trailer **1**, see the hydraulic diagram.
- ▶ Store the hydraulic hoses properly.
- ▶ Assemble protective caps on the coupling parts.
- ▶ Disconnect the electrical connections **4** between the ballast trailer guide **2** and the ballast trailer **1**, see the wiring diagram.
- ▶ Close all unused electrical connections that have a dummy plug with the dummy plug.

### 19.1.3 Unpinning the ballast trailer guide

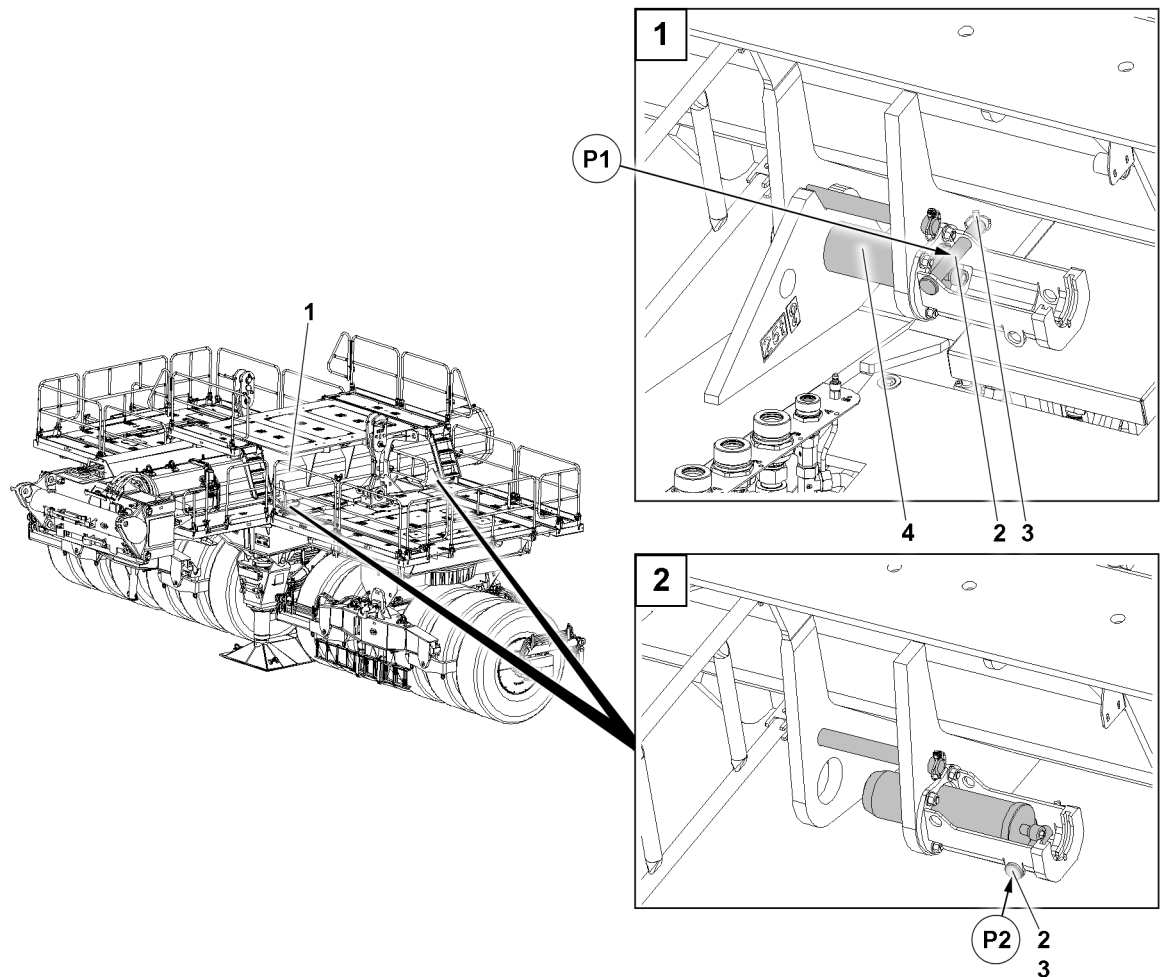


Fig.163059: Disassembling the ballast trailer guide on the ballast trailer – Unpinning the ballast trailer guide

- |   |                       |   |                   |
|---|-----------------------|---|-------------------|
| 1 | Ballast trailer guide | 3 | Retaining element |
| 2 | Retaining pin         | 4 | Pin               |

The ballast trailer guide **1** is uninned in four positions from the ballast trailer.

- ▶ Fasten the ballast trailer guide **1** to the auxiliary crane, see section “Fastening points”
- ▶ Remove the retaining element **3**.
- ▶ Unpin the retaining pin **2** in position **P1**.
- ▶ Unpin the pin **4** with the pin pulling device.
- ▶ Insert the retaining pin **2** in position **P2**.
- ▶ Secure the retaining pin **2** with the retaining element **3**.
- ▶ Lift the ballast trailer guide **1** with auxiliary crane and remove.
- ▶ Take the ballast trailer guide **1** down in a suitable location.

## 19.2 Disassembling the ballast trailer guide

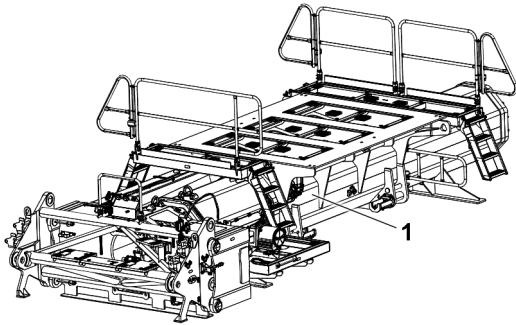


Fig.163061: Disassembling the ballast trailer guide – Prerequisites

Make sure that the following prerequisites are met:

- The ballast trailer guide 1 is fully retracted.
- The ballast trailer guide 1 is lying on the ground.

### 19.2.1 Assembling the length sensor in the transport position

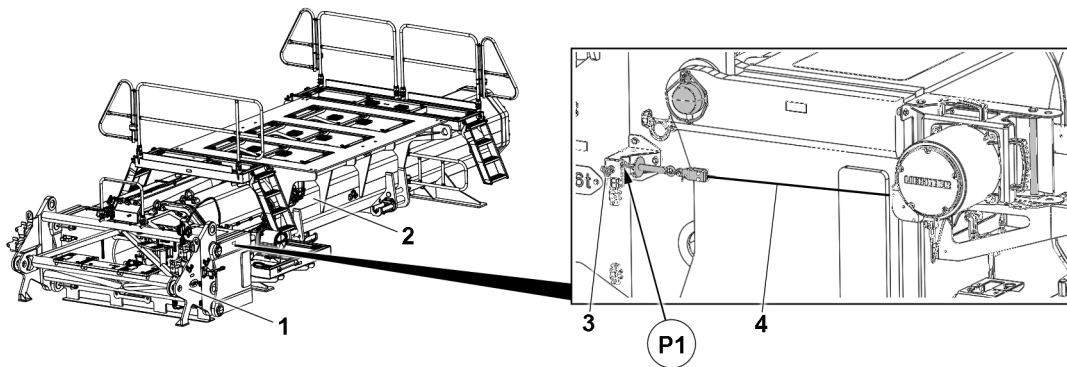


Fig.163062: Assembling the length sensor in the transport position – Coiling the length sensor line from the adapter

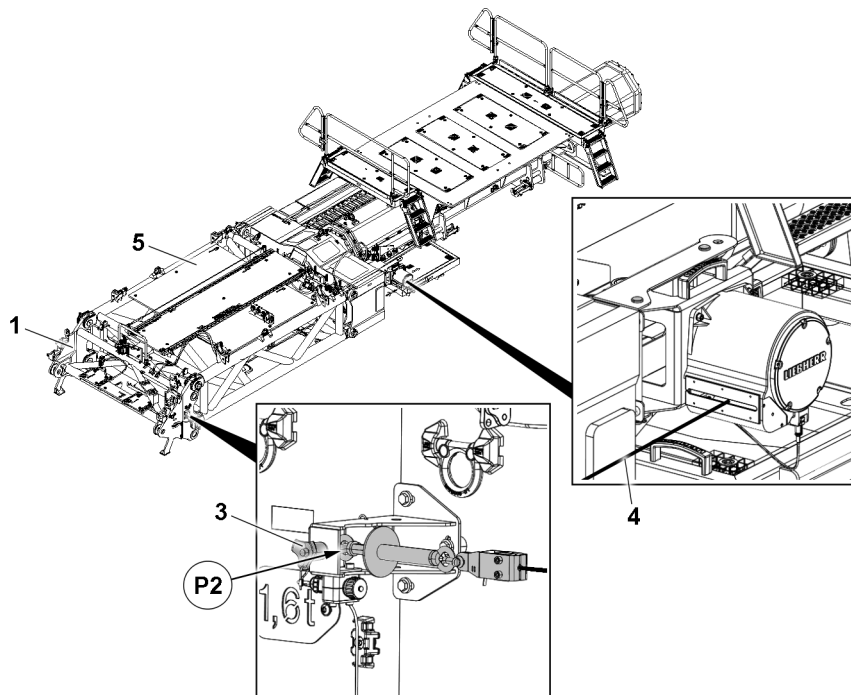
- |   |  |
|---|--|
| <p>1 Adapter</p> <p>2 Ballast trailer guide</p> | <p>3 Retaining element</p> <p>4 Length sensor line</p> |
|---|--|

When the adapter 1 is assembled on the ballast trailer guide 2:

- ▶ Release the retaining element 3 in position P1.



- ▶ Coil the length sensor line **4**  
or



*Fig.163063: Assembling the length sensor in the transport position – Coiling the length sensor line from the intermediate section*

- |                            |                               |
|----------------------------|-------------------------------|
| <b>1</b> Adapter           | <b>4</b> Length sensor line   |
| <b>3</b> Retaining element | <b>5</b> Intermediate section |

When the adapter **1** is assembled on the intermediate section **5**:

Release the retaining element **3** in position **P2**.

- ▶ Coil the length sensor line **4**

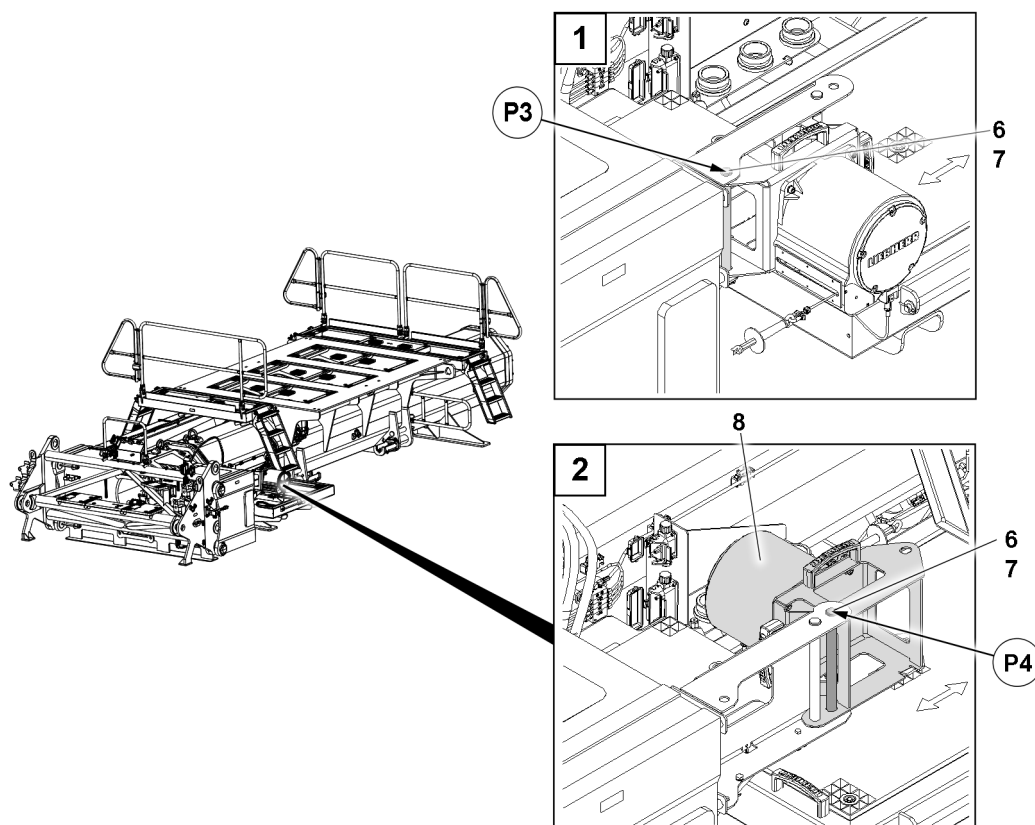


Fig.163064: Assembling the length sensor in the transport position

6 Pin

7 Retaining element

8 Length sensor

- ▶ Release and unpin the pin **6** in position **P3**.
- ▶ Swing the length sensor **8** into the transport position.
- ▶ Insert the pin **6** in position **P4**.
- ▶ Secure the pin **6** with the retaining element **7**.

## 19.2.2 Disassembling the adapter from the ballast trailer guide or intermediate section

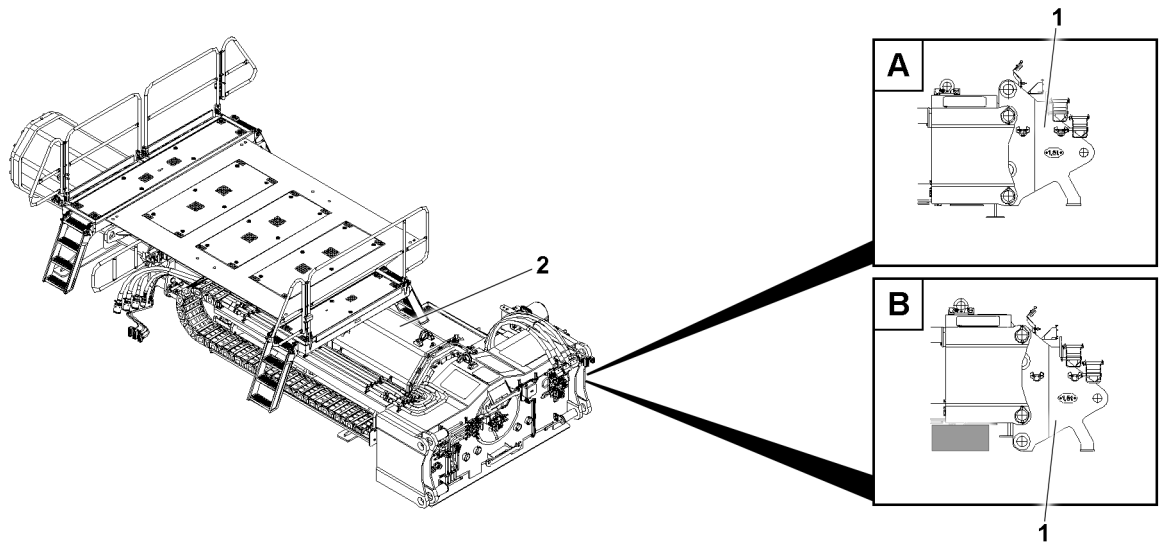


Fig.163011: Disassembling the adapter from the ballast trailer guide or intermediate section – Variations

**1** Adapter

**2** Ballast trailer guide

The unpinning procedure for the adapter **1** from the ballast trailer guide **2** is identical to the unpinning procedure for the adapter **1** from an intermediate section.

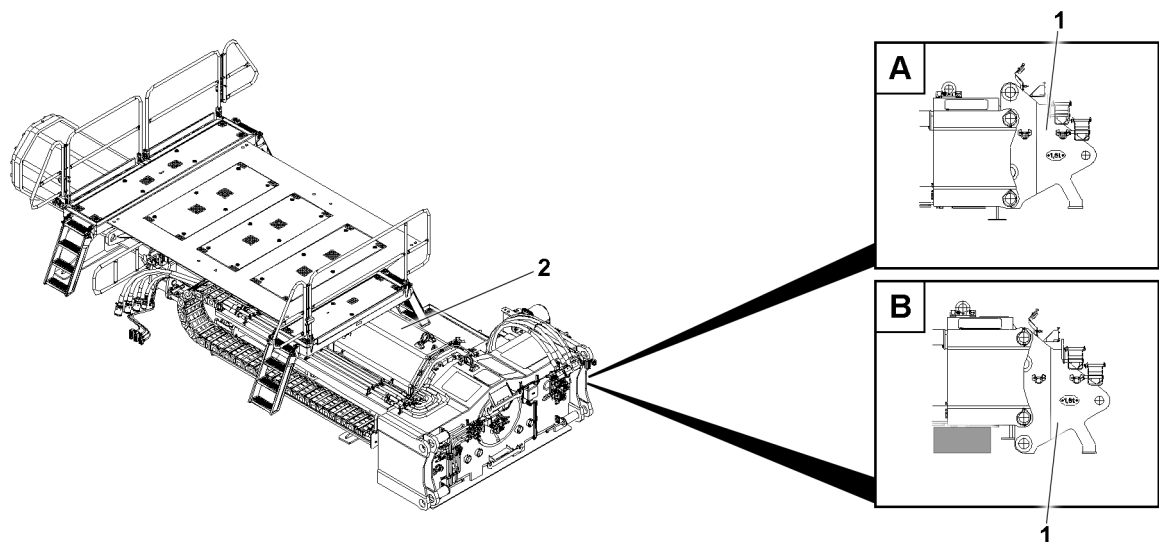
The unpinning procedure is described based on an example and applies in the same way for the unpinning procedure of the adapter **1** from an intermediate section.

Crane with Quick Connection (Variation A)

- In the case of a crane with Quick Connection (Variation A) the ballast trailer guide **2** is lying on the ground.

Crane without Quick Connection (Variation B)

- If the crane does not have the Quick-Connection (Variation B), the ballast trailer guide **2** is supported additionally about 300 mm.

**Optional: Supporting the ballast trailer guide**

*Fig.163011: Disassembling the adapter from the ballast trailer guide or intermediate section – Variations*

1 Adapter

2 Ballast trailer guide

For a crane with Quick Connection:

- Take the ballast trailer 2 down on the ground.  
or

For a crane without Quick Connection:

Support the ballast trailer guide 2 approx. 300 mm.

### Disconnecting the electrical and hydraulic connections between the adapter and the guide

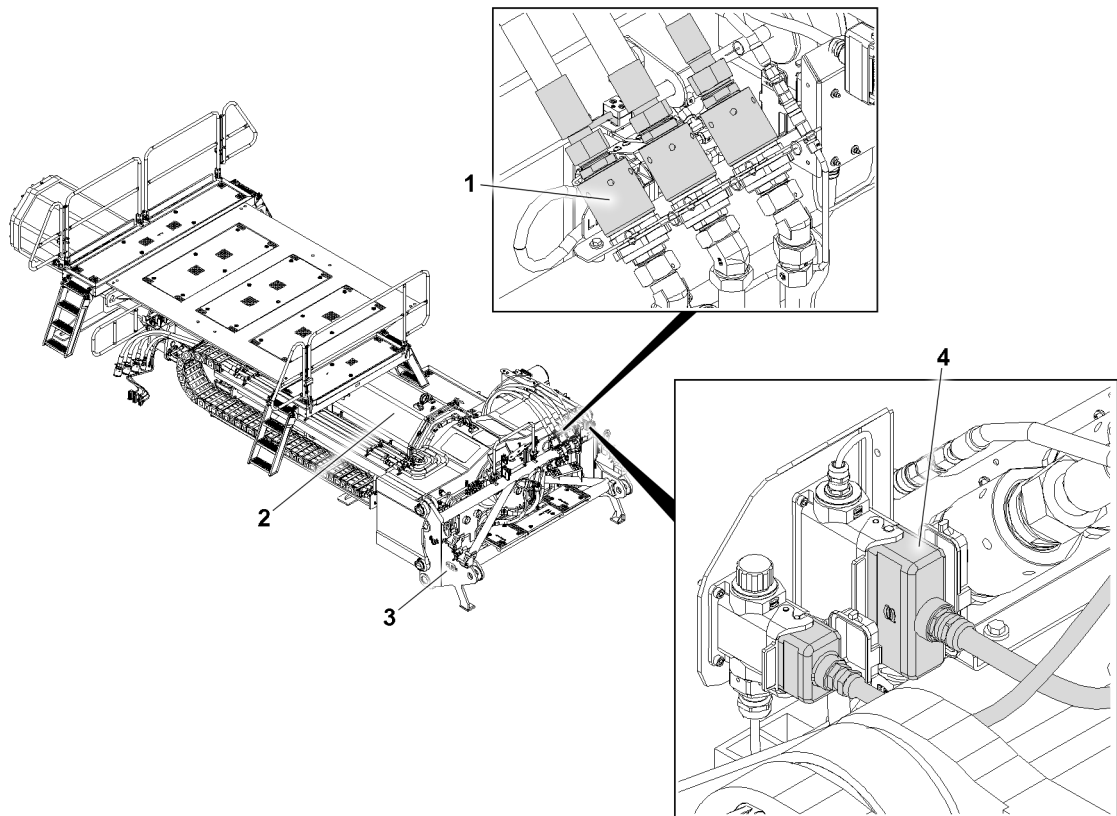
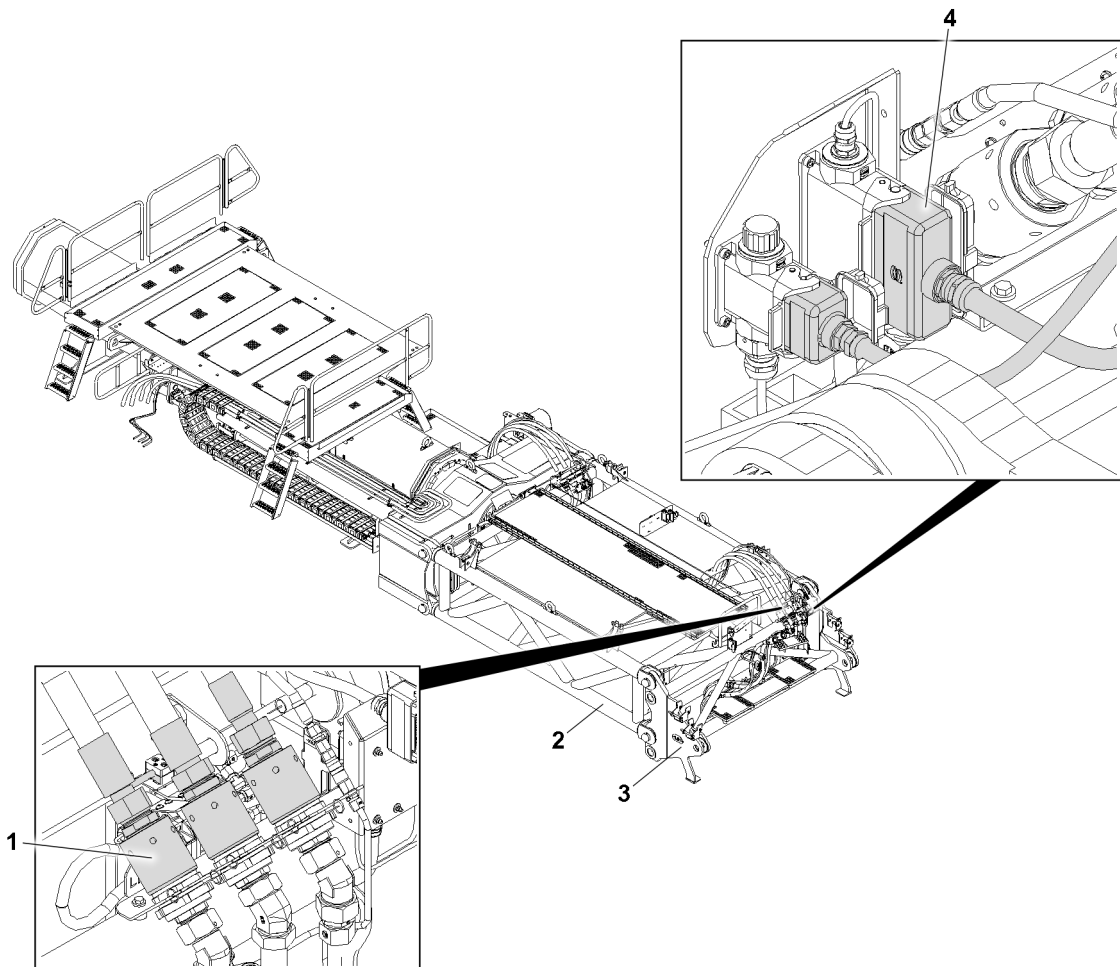


Fig.163019: Disconnecting the hydraulic and electrical connections between the ballast trailer guide and the adapter

- |   |                       |   |                       |
|---|-----------------------|---|-----------------------|
| 1 | Hydraulic connection  | 3 | Adapter               |
| 2 | Ballast trailer guide | 4 | Electrical connection |

- ▶ Disconnect the hydraulic connections **1** between the ballast trailer guide **2** and the adapter **3**, see the hydraulic diagram.
- ▶ Store the hydraulic hoses properly.
- ▶ Assemble protective caps on the coupling parts.
- ▶ Disconnect the electrical connections **4** between the ballast trailer guide **2** and the adapter **3**, see the wiring diagram.
- ▶ Close all unused electrical connections that have a cap with the cap.

**Optional: Disconnecting the electrical and hydraulic connections between the adapter and the intermediate section**



*Fig.163020: Disconnecting the electrical and hydraulic connections between the adapter and the intermediate section*

- |          |                      |          |                       |
|----------|----------------------|----------|-----------------------|
| <b>1</b> | Hydraulic connection | <b>3</b> | Adapter               |
| <b>2</b> | Intermediate section | <b>4</b> | Electrical connection |

- ▶ Disconnect the hydraulic connections **1** between the intermediate section **2** and the adapter **3**, see the hydraulic diagram.
- ▶ Store the hydraulic hoses properly.
- ▶ Assemble protective caps on the coupling parts.
- ▶ Disconnect the electrical connections **4** between the intermediate section **2** and the adapter **3**, see the wiring diagram.
- ▶ Close all unused electrical connections that have a cap with the cap.

## Unpinning procedure

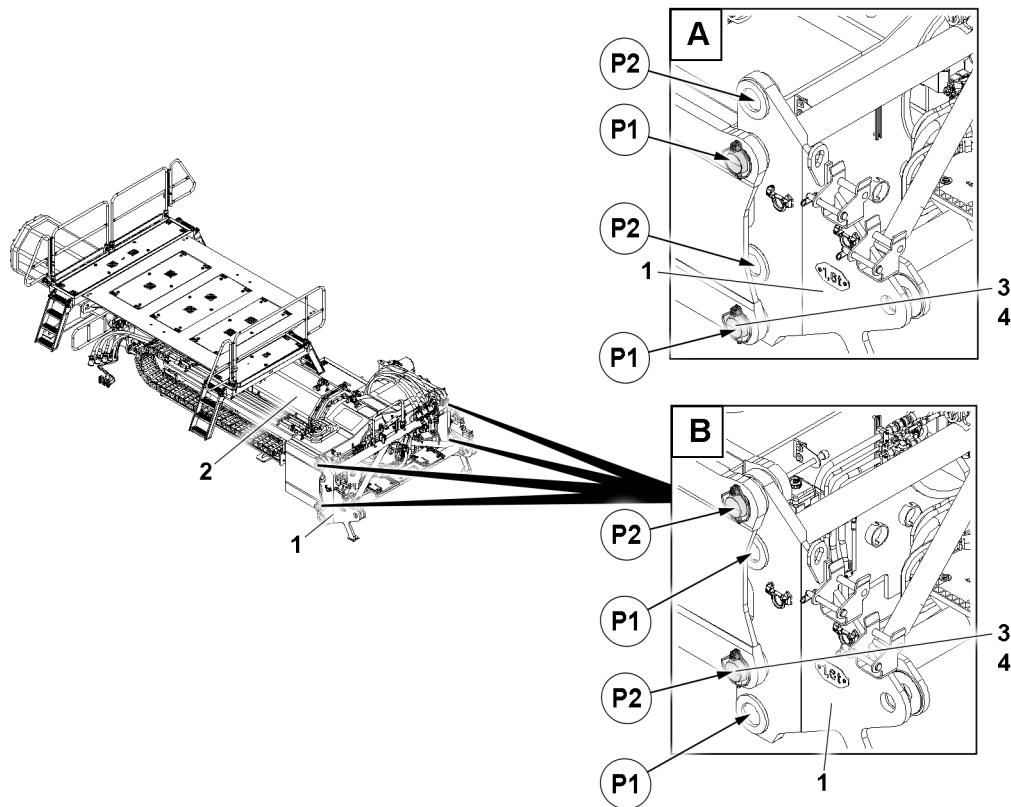


Fig.163015: Disassembling the adapter from the ballast trailer guide or intermediate section – Unpinning procedure

- |   |                       |   |                   |
|---|-----------------------|---|-------------------|
| 1 | Adapter               | 3 | Pin               |
| 2 | Ballast trailer guide | 4 | Retaining element |

► Fasten the adapter 1 to the auxiliary crane, see section “Fastening points”.

The adapter 1 is unpinned four times from the ballast trailer guide 2 (positions P1 or positions P2).



### WARNING

Hands in the danger zone

When unpinning the adapter, fingers and hands can be crushed.

► Do not reach with your hands into the danger zone.

A pin pulling device is used to unpin the pins 3.

- Remove the retaining element 4.
- Unpin the pin 3.
- Repeat the procedure in the same way as described above for all four pins 3.

When all four pins 3 are unpinned:

► Remove the adapter 1 with the auxiliary crane.

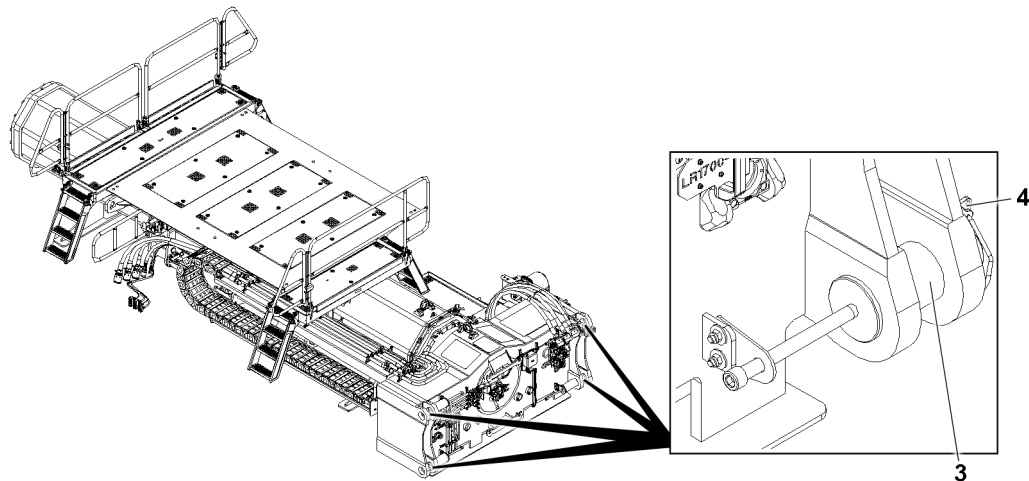


Fig.163065: Disassembling the adapter from the ballast trailer guide or intermediate section – Securing the pins in the transport position

- |  |                                   |
|--|-----------------------------------|
| <p><b>3</b> Pin</p> <ul style="list-style-type: none"> <li>▶ Insert the pin <b>3</b>.</li> <li>▶ Secure the pin <b>3</b> with the retaining element <b>4</b>.</li> <li>▶ Repeat the procedure for all four pins <b>3</b>.</li> </ul> | <p><b>4</b> Retaining element</p> |
|--|-----------------------------------|

### 19.2.3 Optional: Disassembling the intermediate section from the ballast trailer guide

**Disconnecting the electrical and hydraulic connections between the intermediate section and the ballast trailer guide**

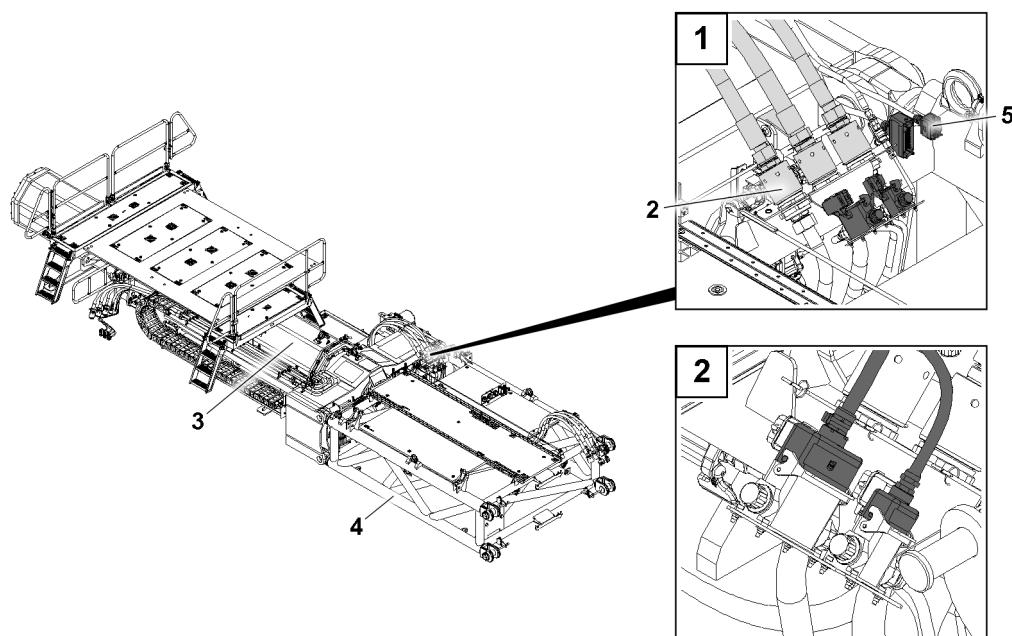


Fig.163014: Disconnecting the electrical and hydraulic connections between the intermediate section and the ballast trailer guide

- |   |   |
|---|---|
| <p><b>2</b> Hydraulic connection</p> <p><b>3</b> Ballast trailer guide</p> <ul style="list-style-type: none"> <li>▶ Disconnect the hydraulic connections <b>2</b> between the ballast trailer guide <b>3</b> and the intermediate section <b>4</b>, see the hydraulic diagram.</li> </ul> | <p><b>4</b> Intermediate section</p> <p><b>5</b> Electrical connections</p> |
|---|---|



- ▶ Store the hydraulic hoses properly.
- ▶ Assemble protective caps on the coupling parts.
- ▶ Disconnect the electrical connections **5** between the ballast trailer guide **3** and the intermediate section **4**, see the wiring diagram.
- ▶ Close all unused electrical connections that have a cap with the cap.

### Unpinning procedure

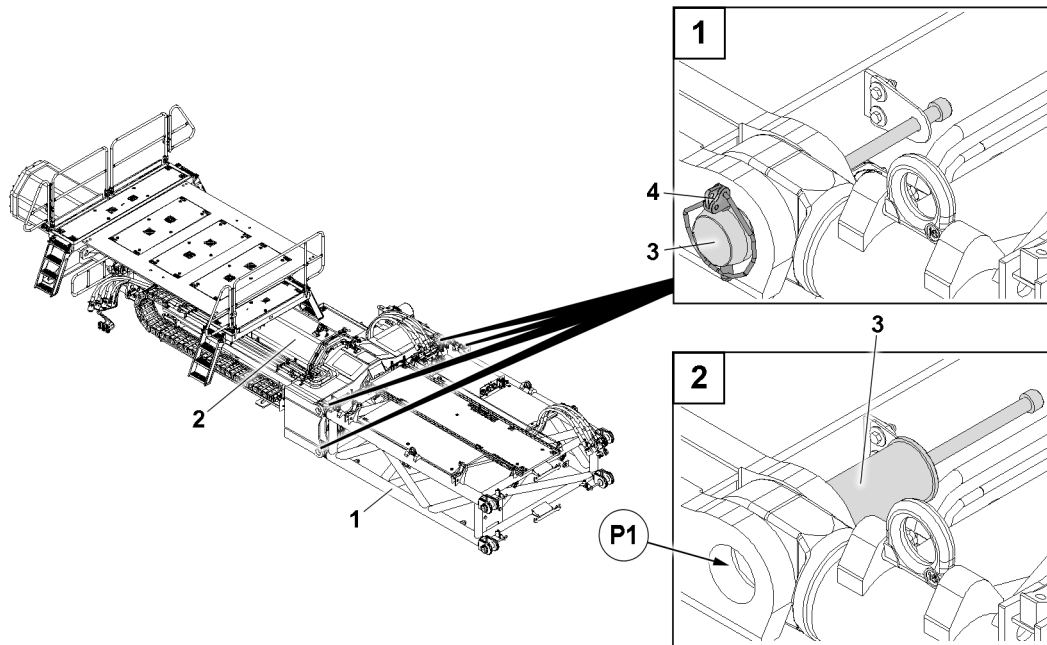


Fig.163066: Disassembling the intermediate section from the guide – Unpinning procedure

- |                                |                            |
|--------------------------------|----------------------------|
| <b>1</b> Adapter               | <b>3</b> Pin               |
| <b>2</b> Ballast trailer guide | <b>4</b> Retaining element |

- ▶ Fasten the intermediate section **1** to the auxiliary crane, see section “Fastening points”.

The intermediate section **1** is unpinned four times from the ballast trailer guide **2** in positions **P1**.



### WARNING

Danger of crushed limbs!

When unpinning the intermediate section **1**, fingers and hands can be crushed.

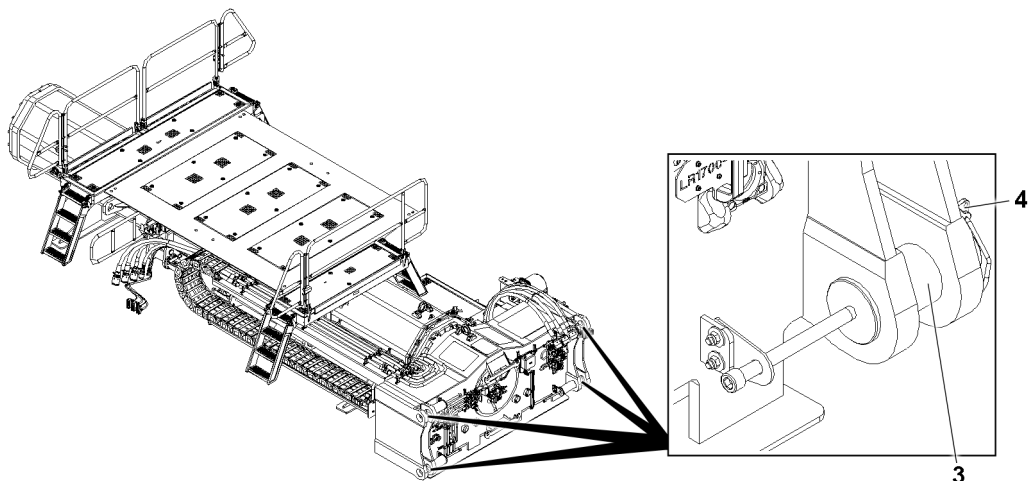
- ▶ Do not reach with your hands into the danger zone.

A pin pulling device is used to unpin the pins **3**.

- ▶ Remove the retaining element **4**.
- ▶ Unpin the pin **3**.
- ▶ Repeat the procedure in the same way as described above for all four pins **3**.

When all four pins **3** are unpinned:

- ▶ Remove the adapter **1** with the auxiliary crane.



*Fig.163065: Disassembling the intermediate section from the guide – Securing the pins in the transport position*

**3** Pin

**4** Retaining element

- ▶ Insert the pin **3**.
- ▶ Secure the pin **3** with the retaining element **4**.
- ▶ Repeat the procedure for all four pins **3**.

#### 19.2.4 Disassembling the ladder and railing on the ballast trailer guide



##### Note

- ▶ For the disassembly of ladders and railings, see chapter 2.06.

### 19.3 Assembling the guy rods in the transport position

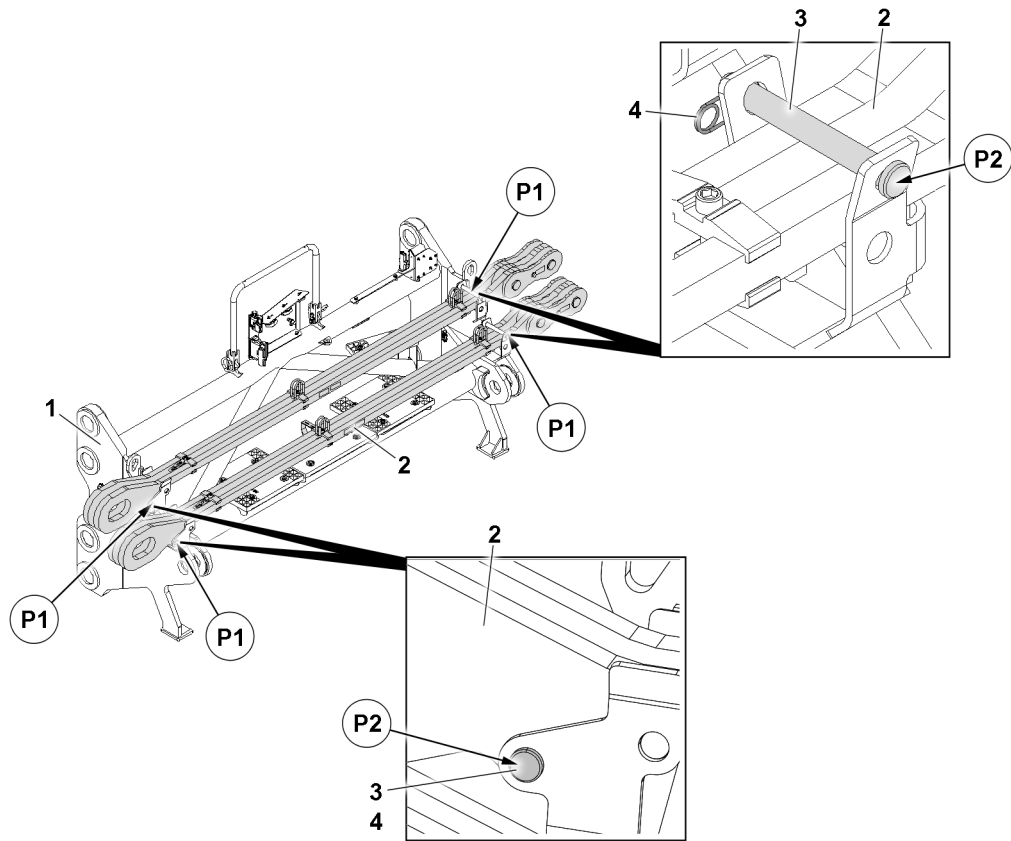


Fig.163060: Assembling the guy rods in the transport position

1	Adapter	3	Retaining pin
2	Guy rod	4	Retaining element

When the adapter 1 is disassembled, the guy rods 2 that were disassembled before disconnecting the ballast trailer from the turntable can be assembled in the transport position P1.

- ▶ Remove the retaining element 4.
- ▶ Unpin the retaining pin 3.
- ▶ Fasten the guy rods 2 to the auxiliary crane, see section "Fastening points".
- ▶ Take the guy rods 2 down in positions P1 on the adapter 5.
- ▶ Insert the retaining pins 3 in positions P2.
- ▶ Secure the retaining pin 3 with retaining elements 4.

## 19.4 Disassembling the ballast trailer

### 19.4.1 Assembling the extension ladder on the ballast trailer

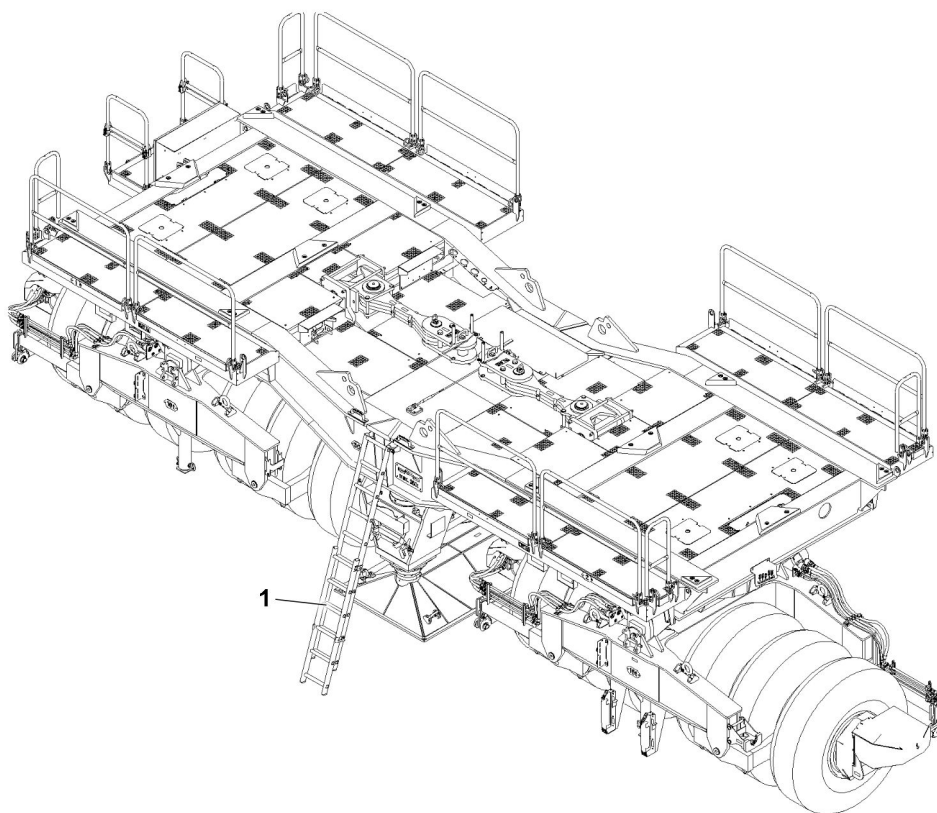


Fig.163003: Assembling the extension ladder on the ballast trailer

1 Extension ladder



#### Note

► Assembly of the extension ladder 1, see chapter 2.06.

### 19.4.2 Assembling the pull brackets in the transport position

Make sure that the following prerequisites are met:

- The guy rods are unpinned.
- The ballast trailer guide is disassembled.

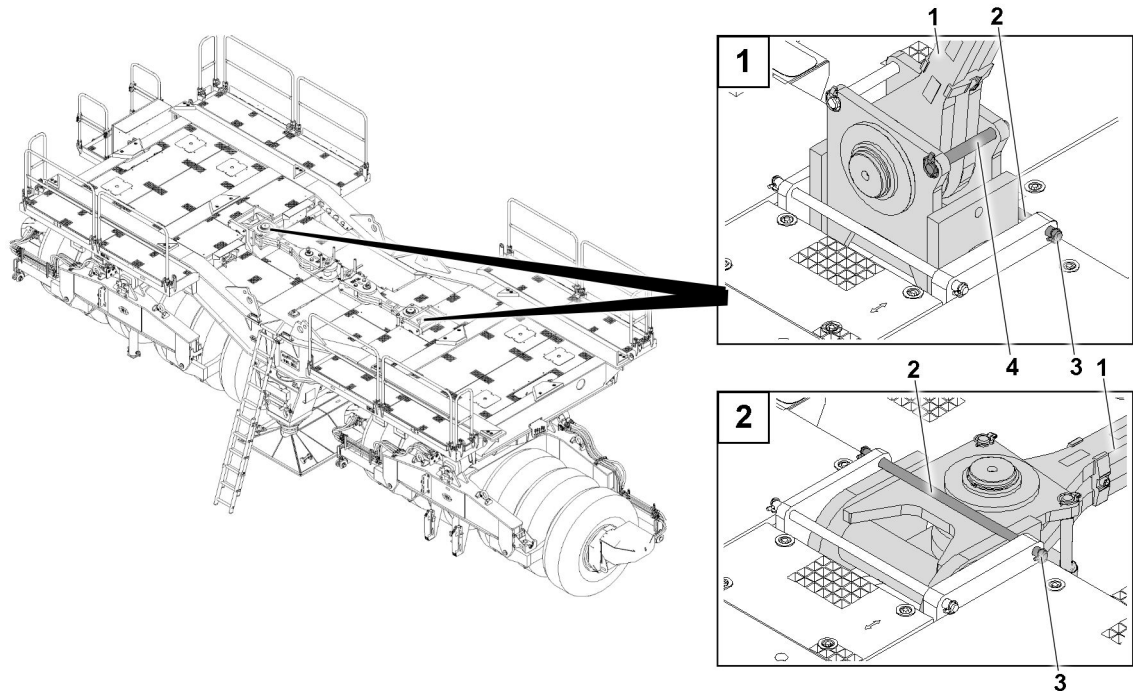


Fig.163073: Assembling the pull brackets in the assembly position

- |   |              |   |                   |
|---|--------------|---|-------------------|
| 1 | Pull bracket | 3 | Retaining element |
| 2 | Pin          | 4 | Pin               |

- ▶ Fasten the pull bracket 1 to the auxiliary crane.
- ▶ Tension the fastening equipment slightly.



#### WARNING

##### Unsecured pull bracket

If the pull bracket 1 is unsecured, it can swing down by itself due to its own weight when unpinning the pin 3.

Death, severe bodily injuries, property damage.

- ▶ Make sure that the pull bracket is held by the auxiliary crane during unpinning.
  - ▶ Make sure that no persons reach into the danger zone during the entire procedure.
- 
- ▶ Release the pull bracket 1 from the operating position: Remove the retaining element 3 and unpin the retaining pin 2.
  - ▶ Take the pull bracket 1 down horizontally with the auxiliary crane.
  - ▶ Secure the pull bracket 1 in the transport position: Insert the pin 2 and secure it with the retaining element 3.
- When the pull bracket 1 is taken down and secured in the transport position:
- ▶ Remove the auxiliary crane.
  - ▶ Take the second pull bracket 1 down in the same way as described above.

### 19.4.3 Disassembling the platforms

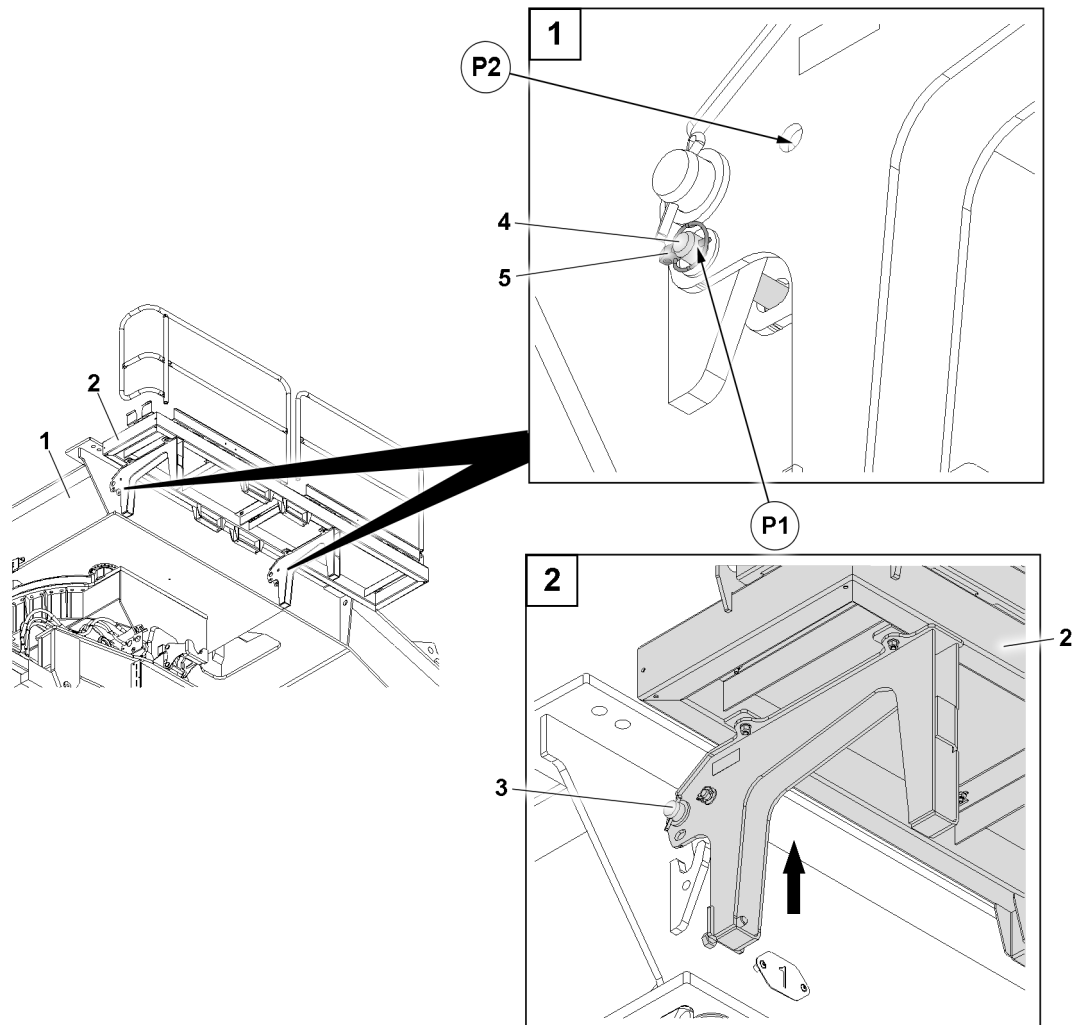


Fig.163074: Assembling the platforms – Connecting and pinning

- |   |                 |   |                   |
|---|-----------------|---|-------------------|
| 1 | Ballast trailer | 4 | Pin               |
| 2 | Platform        | 5 | Retaining element |
| 3 | Pin             |   |                   |



#### Note

- ▶ The disassembly of the platforms **2** is described based on the example of one platform **2**.
- ▶ Fasten the platform **2** to the auxiliary crane, see section “Fastening points”.
- ▶ Release the pin **4** from the operating position **P1** and unpin.
- ▶ Insert the pin **4** in the transport position **P2** and secure with the retaining element **5**.
- ▶ Lift the platform **2** from the ballast trailer **1** with the auxiliary crane and take it down in a suitable location.
- ▶ Remove the auxiliary crane.

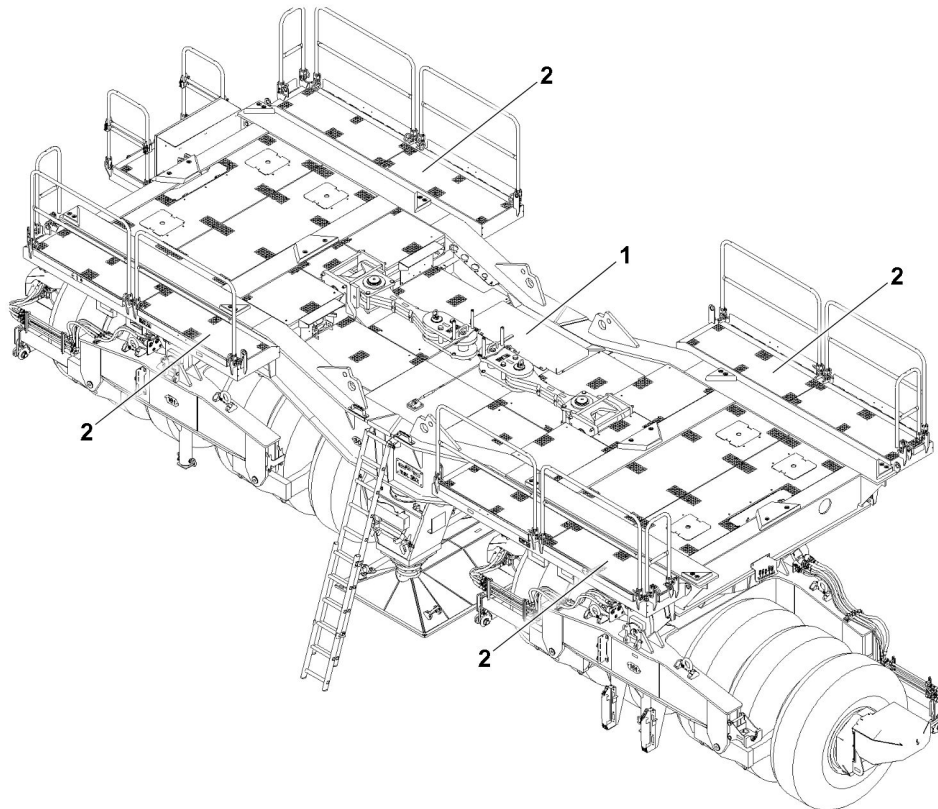


Fig.163006: Assembling the platforms

1 Ballast trailer

2 Platform

- ▶ Disassemble all platforms 2 in the same way as described above from the ballast trailer 1.

#### 19.4.4 Disassembling the railing on the ballast trailer and platforms



##### Note

- ▶ Disassembly of the railing, see chapter 2.06.

### 19.4.5 Disconnecting the hydraulic connections

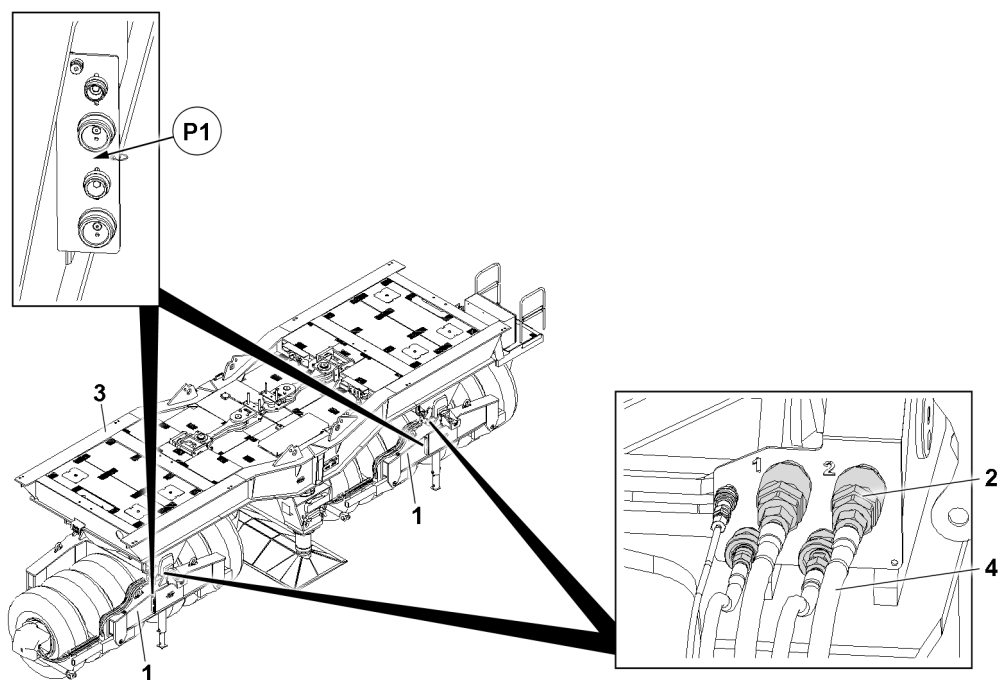


Fig.163118: Establishing the hydraulic connections

- |   |                      |   |                       |
|---|----------------------|---|-----------------------|
| 1 | Hydraulic line       | 3 | Wheel set             |
| 2 | Hydraulic connection | 4 | Ballast trailer frame |

The disconnection procedure is described based on one wheel set **1** as an example and applies in the same way for the second wheel set **1**.

Make sure that the following prerequisites are met:

- The pressure in the hydraulic system has been released.
- ▶ Disconnect the hydraulic connections **2** between the wheel set **1** and the ballast trailer frame **3**, see the hydraulic diagram.
- ▶ Assemble the hydraulic lines **4** in the park position **P1**.



### 19.4.6 Disconnecting the connection to the central lubrication system

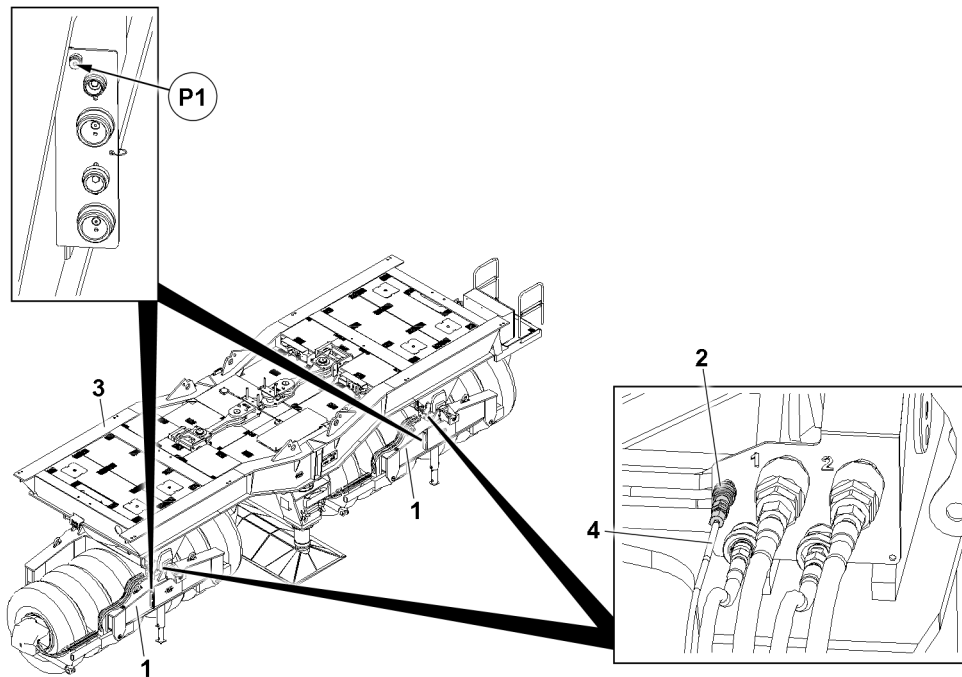


Fig.163119: Establishing the connection to the central lubrication system

- |   |                                       |   |                       |
|---|---------------------------------------|---|-----------------------|
| 1 | Wheel set                             | 3 | Ballast trailer frame |
| 2 | Central lubrication system connection |   |                       |

The disconnection procedure is described based on one wheel set **1** as an example and applies in the same way for the second wheel set **1**.

- ▶ Disconnect the connection **2** for the central lubrication system between the wheel set **1** and the ballast trailer frame **3**.
- ▶ Assemble the line **4** in the park position **P1**.

### 19.4.7 Disassembling the extension ladder on the ballast trailer

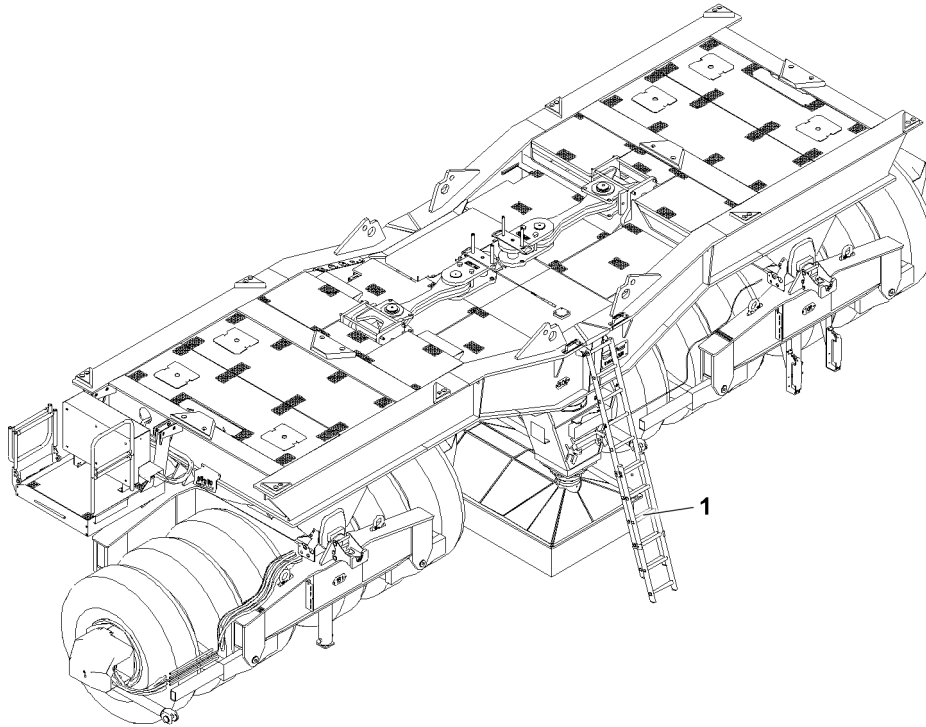


Fig.163076: Disassembling the extension ladder on the ballast trailer

1 Extension ladder



#### Note

► Disassembly of the extension ladder 1, see chapter 2.06.

### 19.4.8 Disassembling the first wheel set

Make sure that the following prerequisites are met:

- The ground must be level and have adequate load bearing capacity.
- An auxiliary crane is available.

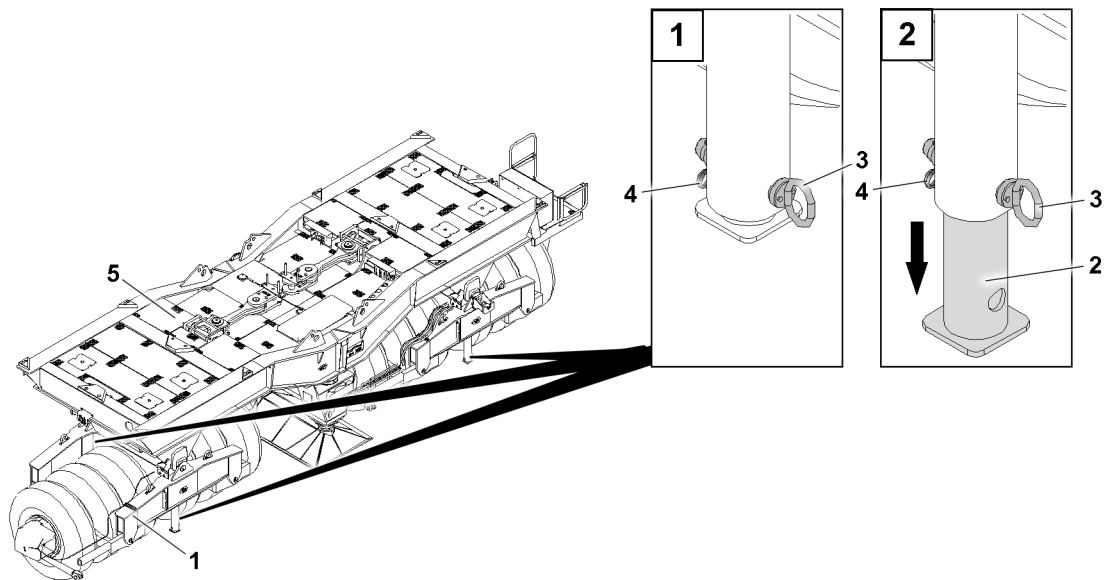


Fig.163075: Disassembling the first wheel set – extending the auxiliary support

- |   |                              |   |                   |
|---|------------------------------|---|-------------------|
| 1 | Wheel set                    | 4 | Retaining element |
| 2 | Extendable auxiliary support | 5 | Frame             |
| 3 | Pin                          |   |                   |

The extendable auxiliary supports **2** must be assembled four times on both sides of the wheel set **1** in the operating position. The procedure is described based on one side as an example.

- ▶ Remove the retaining element **4**.
- ▶ Unpin the pin **3**.
- ▶ Pull the extendable auxiliary support **2** out into the operating position.
- ▶ Insert the pin **3**.
- ▶ Secure the pin **3** with the retaining element **4**.
- ▶ Assemble the extendable auxiliary support **2** on the other side of the wheel set in the same way in the operating position.
- ▶ Assemble the extendable auxiliary supports in the same way on the second wheel set in the operating position.

**Result:**

- The frame **5** is secured to prevent it from tipping over.
- ▶ Connect the ballast trailer to the external hydraulic aggregate.  
**or**  
Connect the ballast trailer using the electrical extension cable and the hydraulic extension hoses to the crane turntable, see the wiring diagram and the hydraulic diagram.

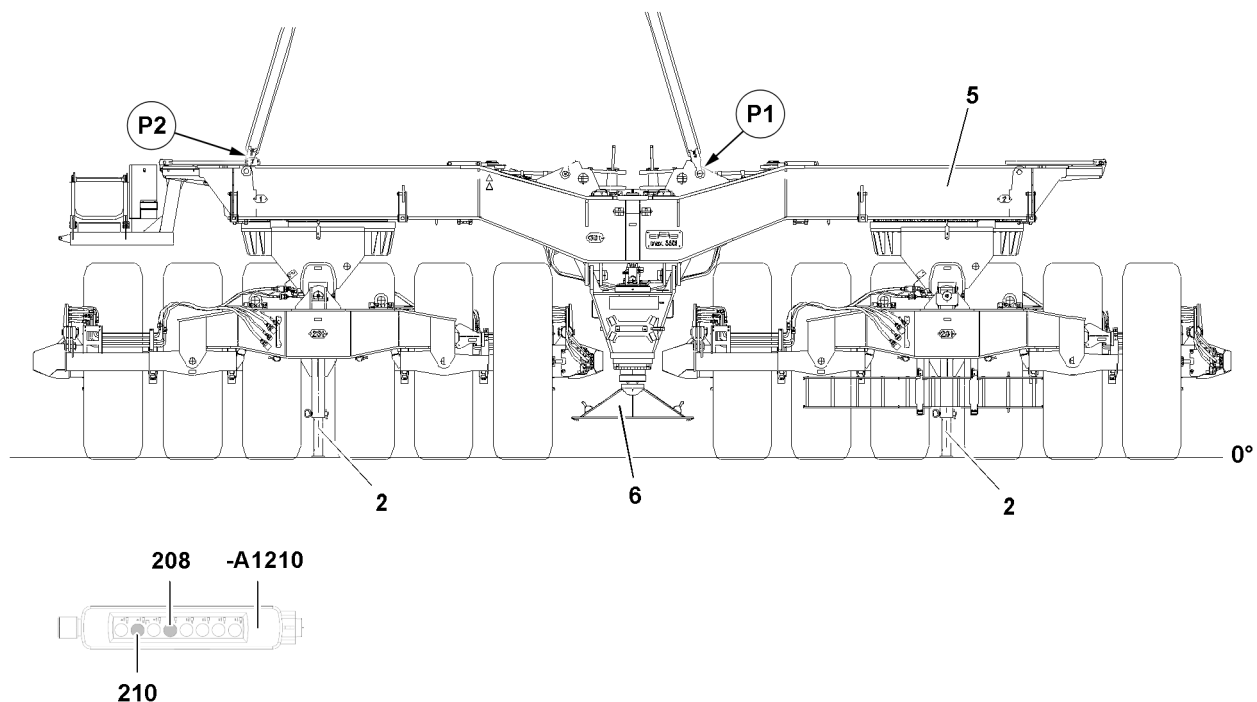


Fig.163077: Disassembling the first wheel set – retracting the support

**2** Auxiliary support  
**5** Frame

**6** Support

► Fasten the frame **5** to the auxiliary crane (fastening points **P1** and fastening points **P2**).

When the extendable auxiliary supports **2** are extended and secured:

► Press the button **208** and button **210** on the control panel **-A1210**.

**Result:**

– The support **6** retracts.

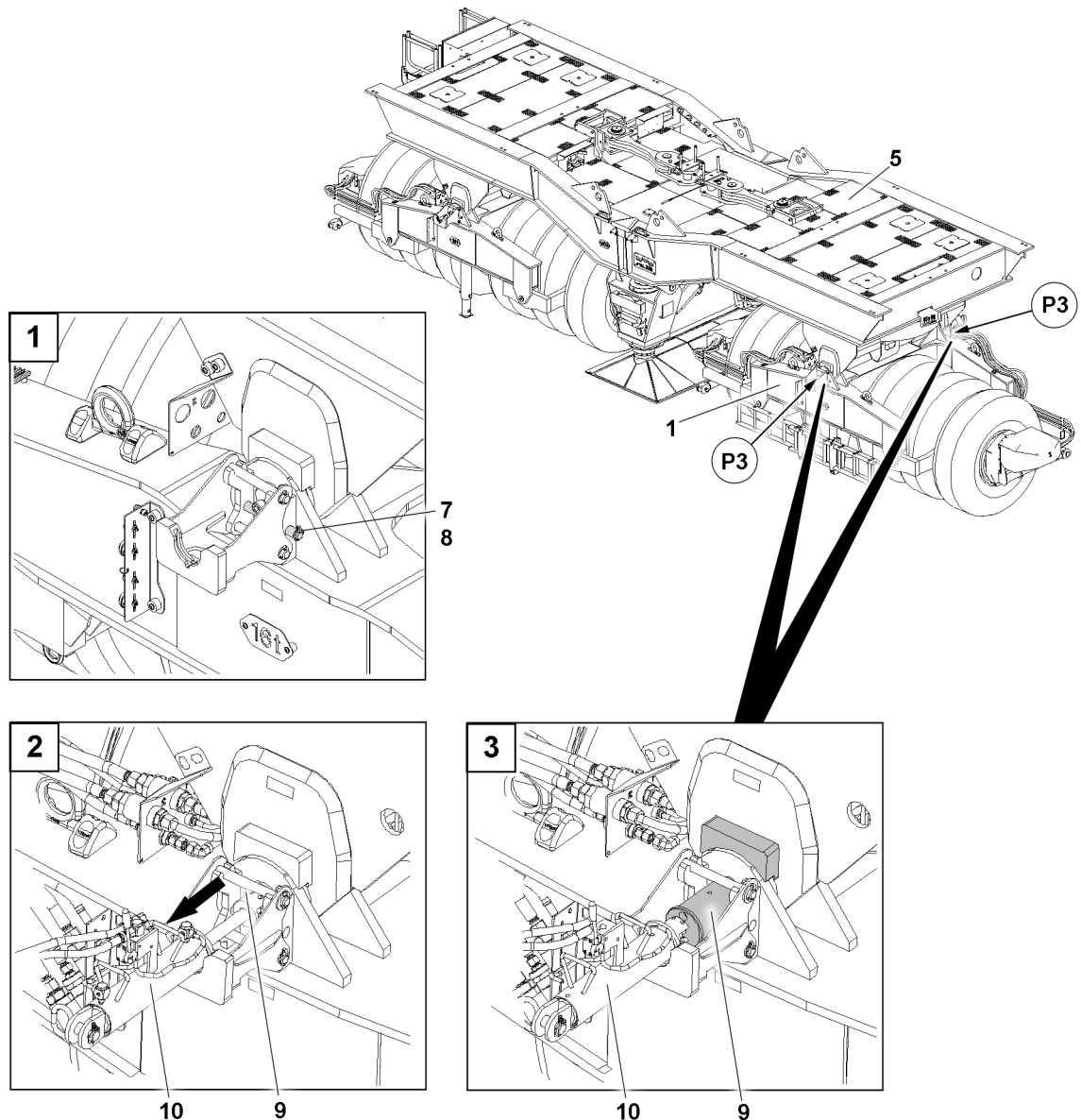


Fig.163078: Disassembling the first wheel set – unpinning the wheel set

1	Wheel set	8	Retaining pin
5	Frame	9	Pin
7	Retaining element	10	Pin pulling device



#### Note

- ▶ The frame **5** and wheel set are unpinned in two points **P3**.
- ▶ The unpinning procedure is described based on the example of one unpinning point.

- ▶ Remove the retaining element **7**.
- ▶ Unpin the retaining pin **8**.
- ▶ Unpin the pin **9** with the pin pulling device **10**.
- ▶ Lift the frame **5**.
- ▶ Take the guide **5** down in a suitable location.

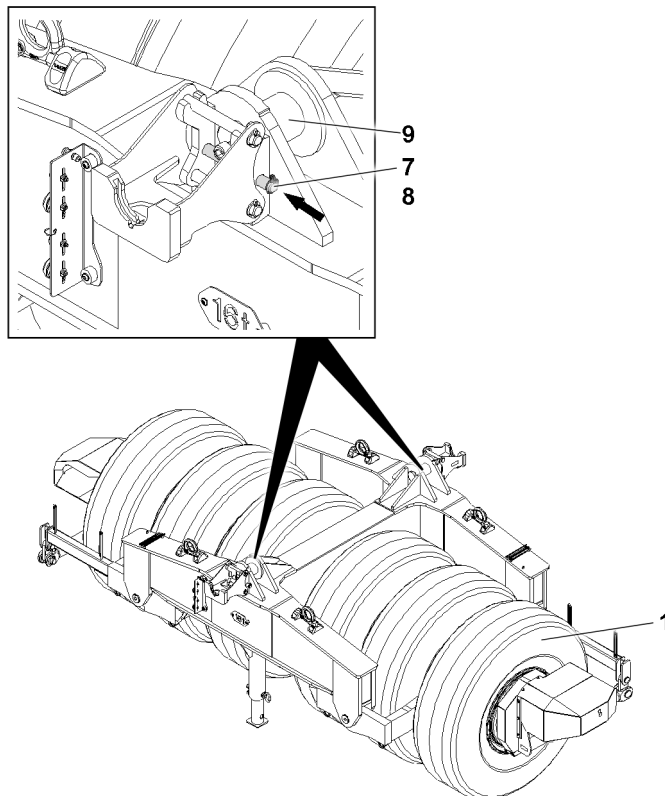


Fig.163079: Disassembling the first wheel set – inserting the pin for transport

- |   |                   |   |               |
|---|-------------------|---|---------------|
| 1 | Wheel set         | 8 | Retaining pin |
| 7 | Retaining element | 9 | Pin           |

When the frame is disconnected from the wheel set 1:

- ▶ Insert the pin 9 again.
- ▶ Insert the retaining pin 8.
- ▶ Secure the retaining pin 8 with the retaining element 7.

#### 19.4.9 Disassembling the second wheel set

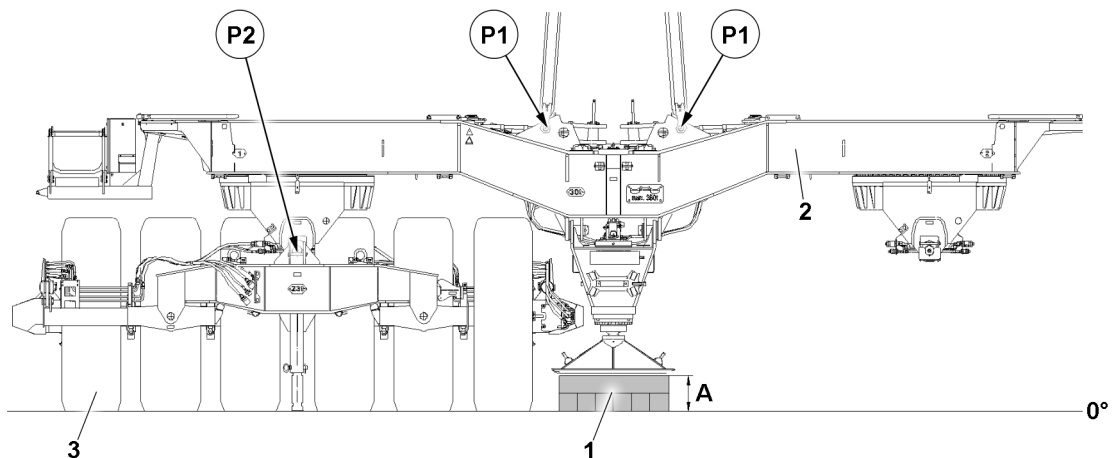


Fig.163080: Disassembling the second wheel set

- |   |              |   |           |
|---|--------------|---|-----------|
| 1 | Substructure | 3 | Wheel set |
| 2 | Frame        |   |           |

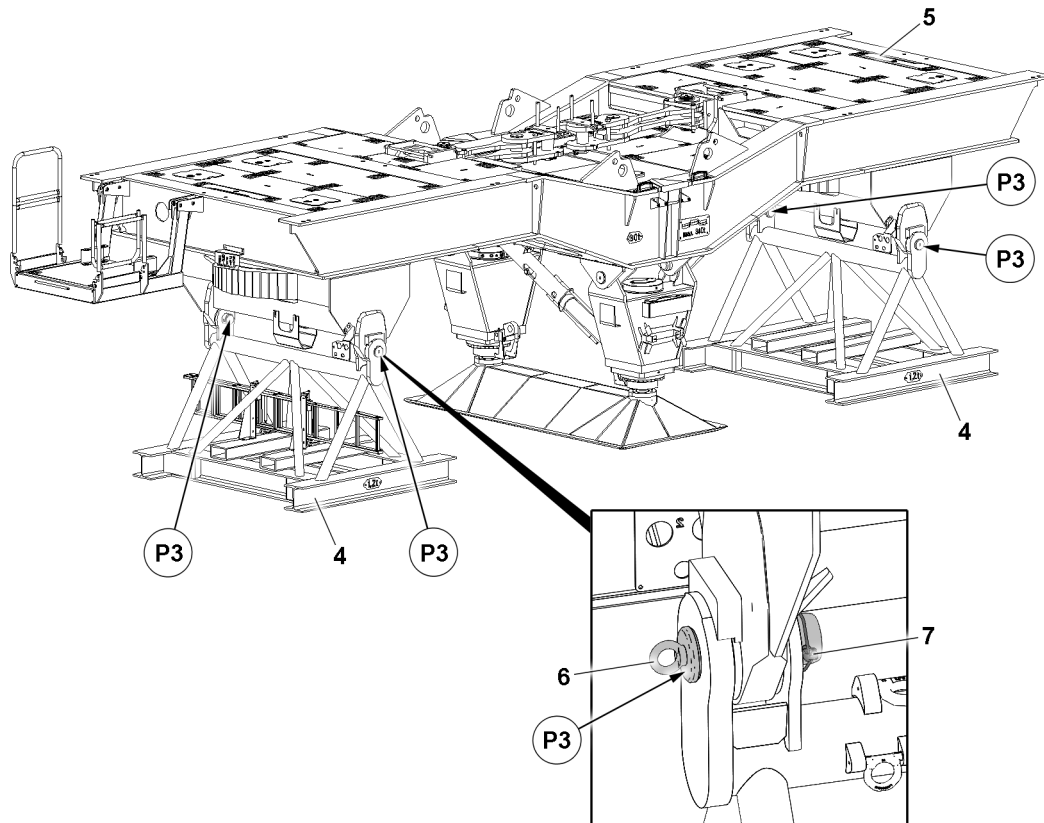
- ▶ Build up the substructure 1 for the frame 2 approx. 330 mm (dimension A)

- ▶ Lift the frame **2** and the second wheel set **3** with the auxiliary crane and set down on level ground and on the substructure **1**.
- ▶ Connect the frame **2** to the fastening points **P1** on the auxiliary crane.

**Note**

- ▶ The disassembly of the second wheel set **3** is identical to the disassembly of the first wheel set.
- ▶ Disassembly of the second wheel set **3**, see section "Disassembling the first wheel set".

- ▶ Unpin the frame **2** in point **P2**.
- ▶ Lift the frame **2** with the auxiliary crane.



*Fig.163081: Assembling the transport devices*

**4** Transport device  
**5** Frame

**6** Pin  
**7** Locking pin

- ▶ Erect two transport devices **4** at a distance of 7000 mm between the pin points **P3**.
- ▶ Set down the frame **5** on the transport devices **4** and secure with the pin **6** and linch pin **7**.
- ▶ Remove the auxiliary crane.

## 20 Emergency operation in case of a defective control module of the ballast trailer control

### 20.1 Emergency operation of the ballast trailer

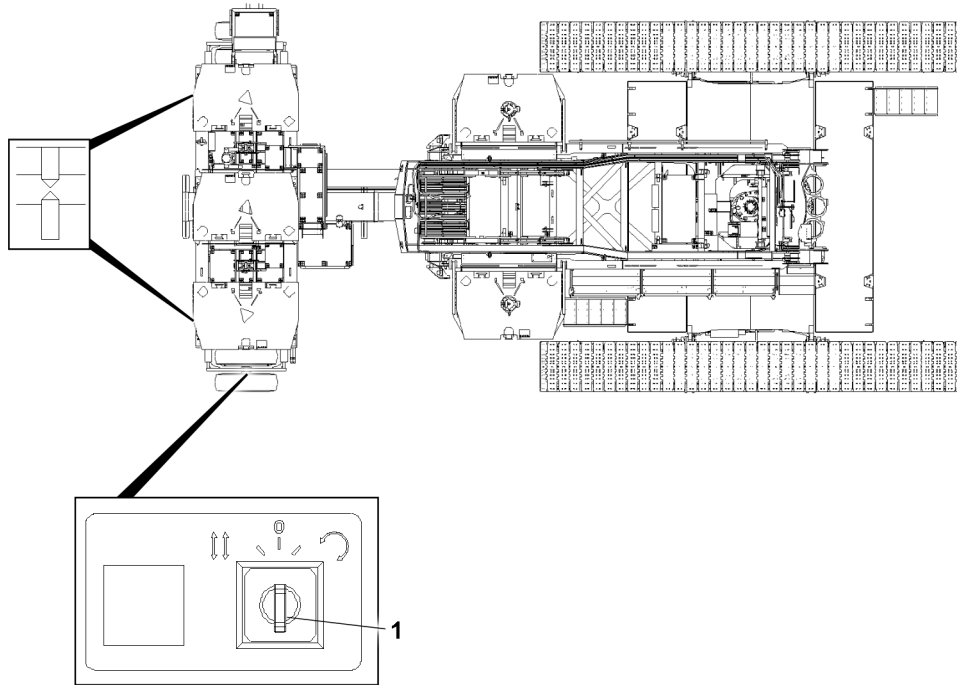


Fig.163082: Emergency operation of the ballast trailer

#### 1 Key switch

In case of a defect in the control module of the ballast trailer control, the electronic steering of the ballast trailer can no longer be actuated.

The "Towing" and "Circular travel" signals are no longer transmitted by the ballast trailer control to the crane control.

However, by actuating the key switch **1** in the control cabinet on the ballast trailer, the ballast trailer control can be bypassed.

#### Key switch positions

- 0 (center) = no emergency operation
- I (left) = emergency operation towing
- II (right) = circular travel emergency operation

#### NOTICE

Damage to the ballast trailer!

By turning the key switch **1**, the "Towing" or "Circular travel" signal is released in the crane control, even though the wheel sets could potentially be incorrectly aligned.

This can result in severe damage to the ballast trailer or the crane.

- ▶ Operate the key switch **1** only if the electronics fail.
- ▶ Before driving the crane, check the alignment of the wheel sets.
- ▶ All travel movements may only be conducted with utmost caution, minimum acceleration and careful braking.
- ▶ If the key switch **1** is activated, then the crane operator bears the full and sole responsibility for his actions.



**WARNING**

Danger of accident due to faulty operation!

If the key switch **1** is activated, there is an increased danger of accident due to the bypassed ballast trailer control.

Death, severe bodily injuries, property damage.

- ▶ It is prohibited to remain within the danger zone of the ballast trailer.
- ▶ The alignment of wheel sets is to be monitored manually, visual inspection.
- ▶ Emergency operation should only be carried out by authorized personnel. They must be aware of all related supervisory tasks and hazards.
- ▶ If the key switch **1** is activated, then the crane operator bears the full and sole responsibility for his actions.

## 20.2 Emergency operation - towing

Make sure that the following prerequisites are met:

- The ballast trailer is properly assembled.
- Crawler operation is activated.

### 20.2.1 Lifting the ballast trailer with the support cylinders

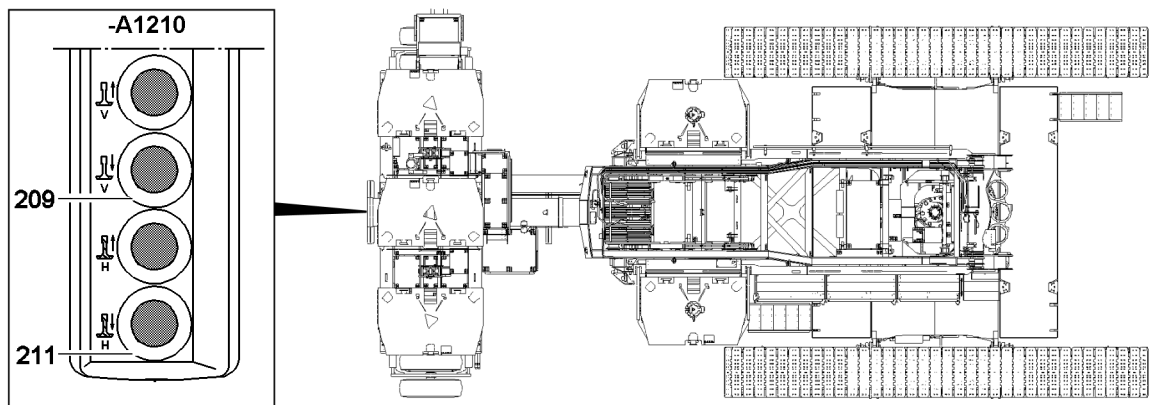


Fig.159610: Lifting the ballast trailer with the support cylinders

**Note**

- ▶ The support cylinders of the ballast trailer must always be extended evenly.

#### Extend the front and rear support cylinders:

- ▶ Press the button **209** and the button **211**.

## 20.2.2 Aligning the wheel sets in the towing position

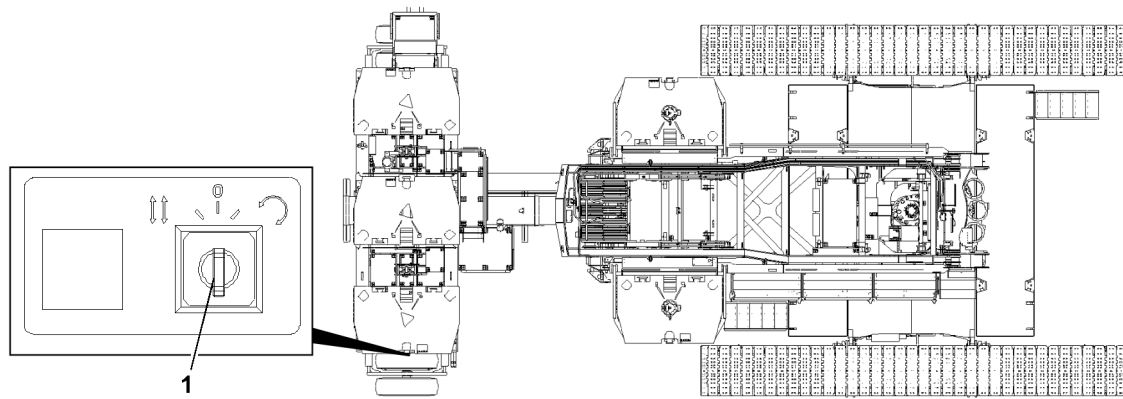


Fig.163083: Aligning the wheel sets in the towing position

### 1 Key switch

To be able to align the wheel sets in the towing position, the ballast trailer must be lifted with the support cylinders.

Make sure that the following prerequisites are met:

- The ballast trailer is lifted via the support cylinders to the point where the wheel sets are relieved.
- ▶ Turn the key switch **1** on the ballast trailer to the “left”.



### Note

- ▶ By turning the key switch **1** to the “left” position, the “Towing” command is passed on to the crane and emergency operation is turned on.

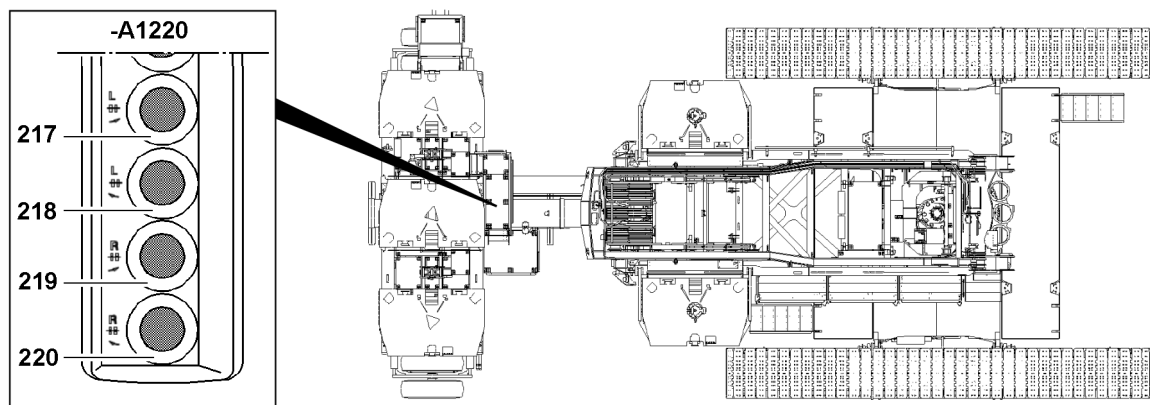


Fig.159612: Aligning the wheel sets in the towing position

When the wheel sets are relieved:

- ▶ Press the button **217** or button **218** on the control panel **-A1220** and align the left wheel set in the towing position.
- ▶ Press the button **219** or button **220** on the control panel **-A1220** and align the right wheel set in the towing position.
- ▶ Check the settings.

### 20.2.3 Lowering the ballast trailer with the support cylinders

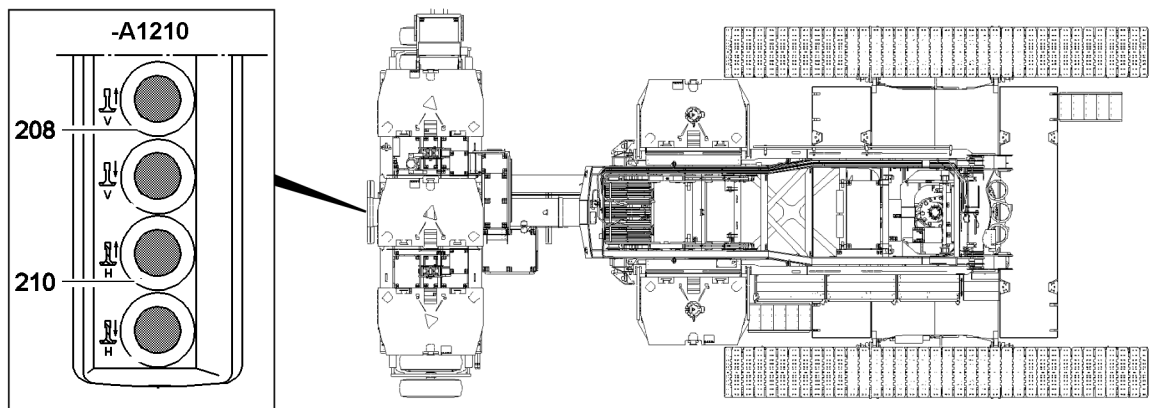


Fig.159613: Lowering the ballast trailer with the support cylinders



#### Note

- ▶ The support cylinders of the ballast trailer must always be retracted evenly.

#### Retract the support cylinders completely on the front and rear:

- ▶ Press the button **208** and the button **210**.

#### Result:

- The support cylinders retract.
- ▶ Retract the support cylinders completely.

### 20.2.4 Towing

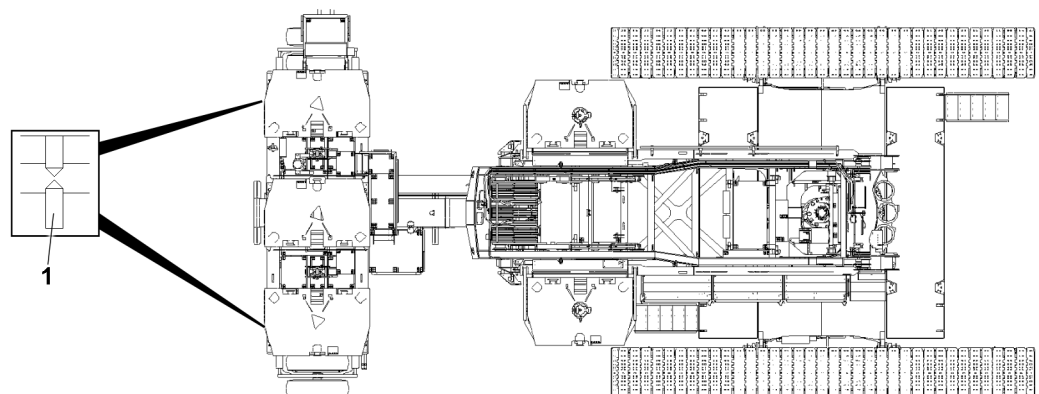


Fig.163084: Towing

- 1 Angle alignment

Make sure that the following prerequisite is met:

- The wheel sets are in the towing position.

---

#### NOTICE

Damage to the ballast trailer!

If the angle settings on the wheel sets are not monitored while driving in emergency operation, it can lead to significant damage to the wheel sets.

- ▶ The angle alignment **1** of the wheel sets must be constantly checked.
  - ▶ Constantly monitor the alignment of the wheel sets while driving.
  - ▶ If the wheel sets become excessively deformed, then they must be realigned.
- 

## 20.3 Emergency operation - Circular travel

Make sure that the following prerequisites are met:

- The ballast trailer is properly assembled.

### 20.3.1 Lifting the ballast trailer with the support cylinders

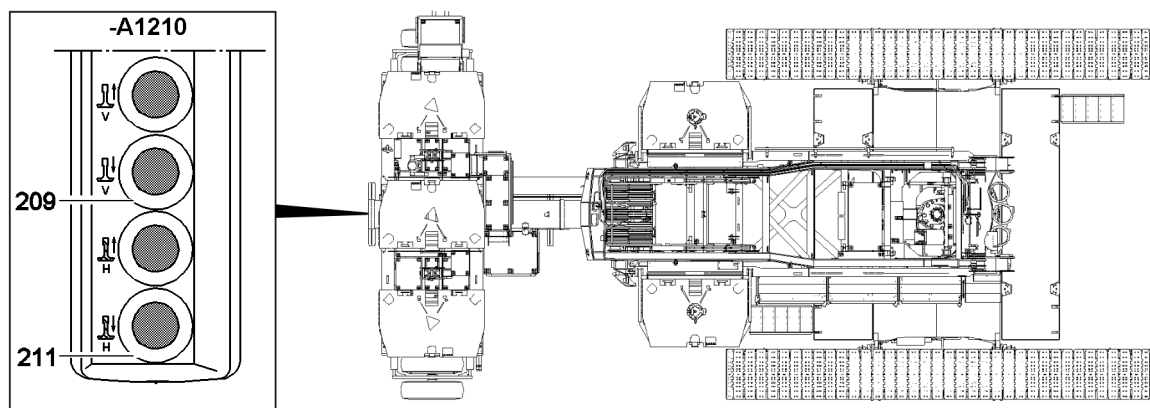


Fig.159610: Lifting the ballast trailer with the support cylinders



#### Note

- ▶ The support cylinders of the ballast trailer must always be extended evenly.
- 

**Extend the front and rear support cylinders:**

- ▶ Press the button **209** and the button **211**.

### 20.3.2 Aligning the wheel sets in the circular travel position

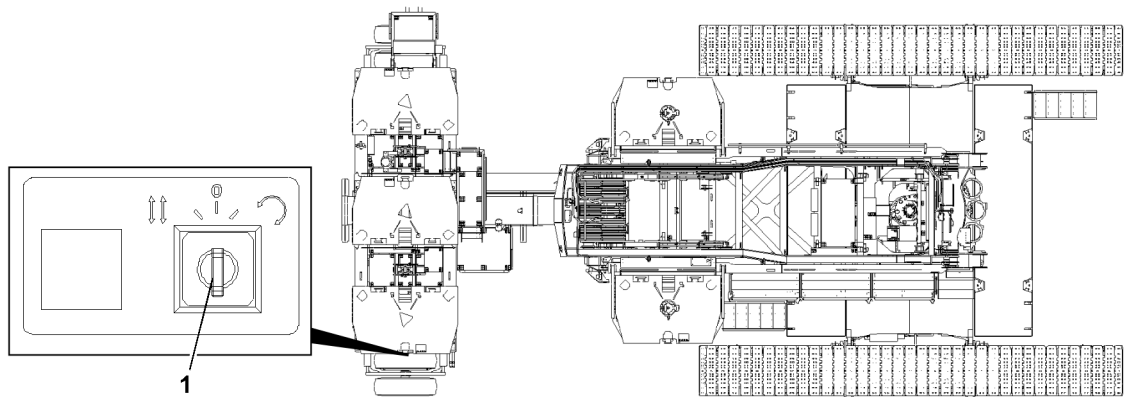


Fig.163083: Aligning the wheel sets in the circular travel position

**1** Key switch

To be able to align the wheel sets in the circular travel position, the ballast trailer must be lifted with the support cylinders.

Make sure that the following prerequisites are met:

- The ballast trailer is lifted via the support cylinders to the point where the wheel sets are relieved.
- ▶ Turn the key switch **1** on the ballast trailer to the “right”.



**Note**

- ▶ By turning the key switch **1** to the “right” position, the “Circular travel” command is transmitted to the crane and emergency operation is turned on.
- ▶ During emergency operation, the support can only be actuated from the control panel **-A1210** on the ballast trailer.

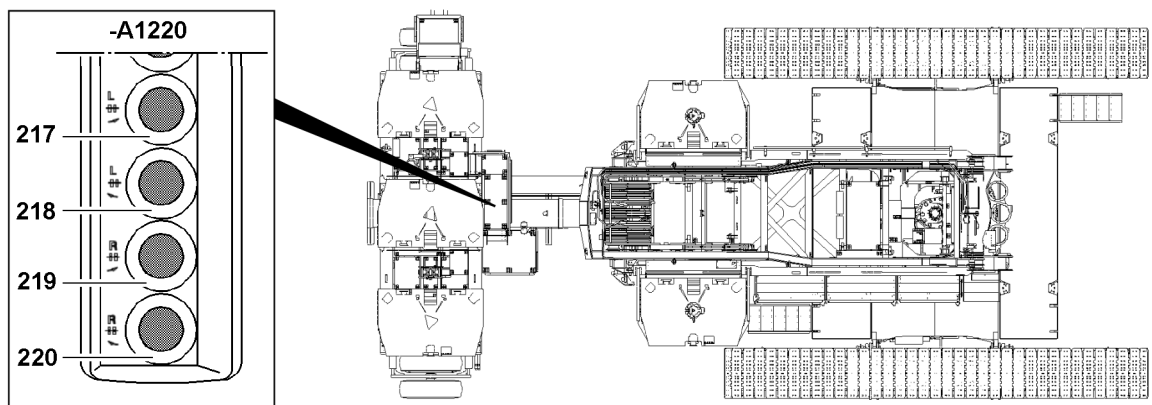


Fig.159612: Aligning the wheel sets in the circular travel position

When the wheel sets are relieved:

- ▶ Press the button **217** or button **218** on the control panel **-A1220** and align the left wheel set in the circular driving position.
- ▶ Press the button **219** or button **220** on the control panel **-A1220** and align the right wheel set in the circular driving position.
- ▶ Check the settings.

### 20.3.3 Lowering the ballast trailer with the support cylinders

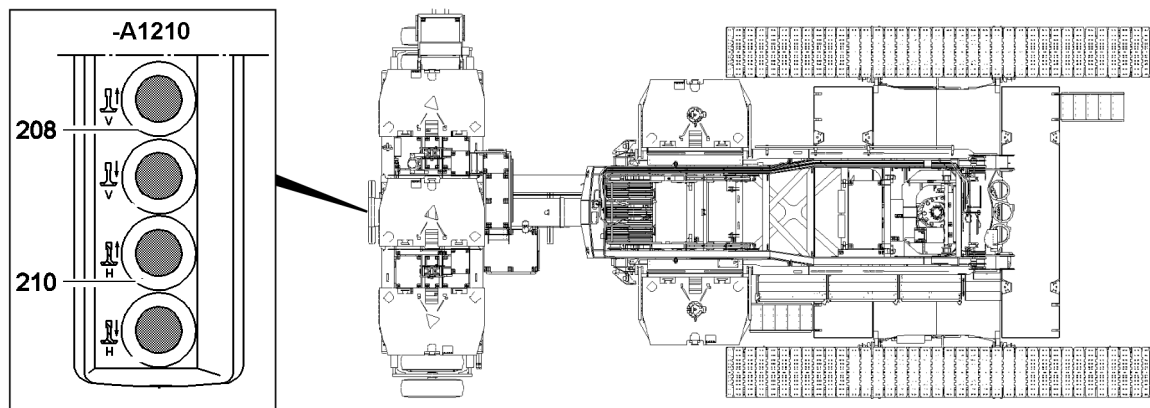


Fig.159613: Lowering the ballast trailer with the support cylinders



#### Note

- ▶ The support cylinders of the ballast trailer must always be retracted evenly.

#### Retract the support cylinders completely on the front and rear:

- ▶ Press the button **208** and the button **210**.

#### Result:

- The support cylinders retract.
- ▶ Retract the support cylinders completely.

### 20.3.4 Circular travel

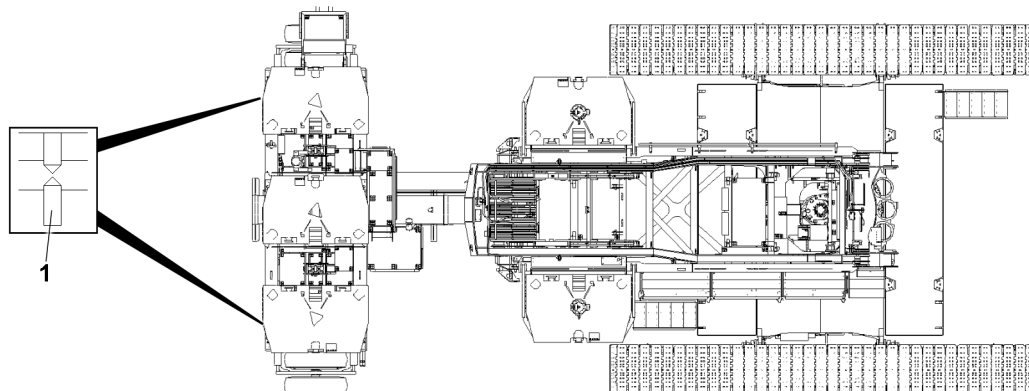


Fig.163084: Circular travel

- 1 Angle alignment

Make sure that the following prerequisites are met:  
– The wheel sets are in the circular travel position.

---

**NOTICE**

Failed monitoring of the wheel set alignment!

If the angle settings on the wheel sets are not monitored while driving in emergency operation, it can lead to significant damage to the wheel sets.

- ▶ The angle alignment **1** of the wheel sets must be constantly checked.
  - ▶ Constantly monitor the alignment of the wheel sets while driving.
  - ▶ If the wheel sets become excessively deformed, then they must be realigned.
- 

## 21 Ballast trailer maintenance intervals / maintenance instructions



---

**Note**

- ▶ See chapter 7.02.50 and chapter 7.04.50.
-

---

Empty page!

LWE/LR 1800-1-0-000/27200-07-02/en



## 5.36 Derrick ballast - suspended ballast

1 Content distributed in multiple chapters.

---

2

# 1 Content distributed in multiple chapters.



---

**Note**

The content of chapter 5.36 is divided into the following chapters 5.36.xx.

- ▶ Observe chapter 5.36.10 and the following chapters.
  - ▶ Observe the exact designation in the following chapters 5.36.xx.
  - ▶ Consider all chapters 5.36.xx together.
-

## 5.36.50 Ballast pallet - V-frame

1	Safety	2
2	Product description	2
3	Component overview	4
4	Fastening points	7
5	Pull cylinder extension conditions	10
6	Permissible ballast assemblies	10
7	Derrick ballast radii	11
8	Permissible lifting heights	15
9	Assembling	24
10	Crane operation	74
11	Disassembling	115

# 1 Safety

Observe the safety instructions before assembly and disassembly:

- Information regarding personal protective equipment. See chapter 2.04.
- Information regarding crane operation. See chapter 2.04.
- Information regarding fall protection equipment. See chapter 2.06.
- Information regarding walking surfaces and stepping surfaces. See chapter 2.07.
- Technical safety instructions for assembly and disassembly. See chapter 5.01.



## WARNING

Crane movements carried out without approval of the guide!

Death, severe bodily injuries, property damage.

- ▶ For all work, observe the instructions of the guide. If necessary, use walkie-talkies.
- ▶ The crane operator and guide must monitor the danger zone.



## WARNING

When lifting / lowering and positioning crane components, there is a danger of impacts / crushing!

Death, severe bodily injuries, property damage.

- ▶ Make sure that personnel cannot be caught by crane components.

To protect limbs:

- ▶ Guide the crane components with suitable aids.



## WARNING

Oscillating load!

Danger of impact and crushing, property damage.

- ▶ To guide and position crane structures, always use an aid. A guide rope, for example.
- ▶ Make sure that there are no persons or obstacles within the danger zone.
- ▶ Make sure that the guide rope is long enough.

## 2 Product description

This chapter describes the following derrick ballast variations:

- Suspended ballast with divisible ballast pallet “VarioTray” (without suspended ballast guide)
- Suspended ballast with divisible ballast pallet “VarioTray” with suspended ballast guide “V-frame”

This crane type has an additional derrick ballast variation, which will be described in another chapter of these operating instructions:

- Ballast trailer



## Note

Designation of the ballast types:

- ▶ The suspended ballast and the ballast trailer are generally described as the derrick ballast.
- ▶ The ballast installed on the turntable is generally referred to as the counterweight.
- ▶ The ballast installed on the crawler travel gear is generally referred to as the central ballast.

### 2.1 Functionality

The divisible ballast pallet is referred to as the ballast pallet “VarioTray”.

The divisible ballast pallet “VarioTray” is a system that has a small ballast pallet (also called the Vario pallet) docked in the center of the large ballast plate (also called base plate). The ballast plates are distributed on both ballast pallets.

- Example of use: The derrick ballast required for crane operation is located on the smaller ballast pallet. After erection, the smaller ballast pallet can be unpinned from the large ballast pallet. As a result, no individual ballast plates must be removed to reduce the ballast.

The derrick boom angle, derrick ballast, weight and utilization are displayed on the LICCON monitors. After assembly on the ground, the derrick ballast is raised for crane operation with the hydraulic cylinders in the D-guying.

The required derrick ballast radius is set by adjusting the derrick boom or the suspended ballast guide "V-frame".

Crane operation with the derrick ballast without suspended ballast guide\* "V-Frame\*" is called "B operation".

Crane operation with derrick ballast with suspended ballast guide\* "V-frame\*" is referred to as "BV operation".

Controlling the ballast functions (pull cylinder / derrick ballast guide / ballast automatic), see chapter 4.05.

The D-guying contains two pull cylinders (pull cylinder A and pull cylinder B). These pull cylinders are used to lift or lower the derrick ballast.

## 2.2 Variations

LR 1800–1.0 has two suspended ballast variations with a divisible ballast pallet "VarioTray":

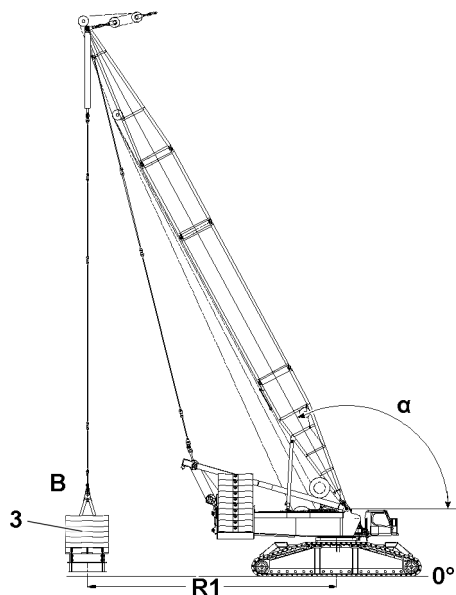


Fig.163665: Suspended ballast variation B

**3** Divisible ballast pallet "VarioTray"       $\alpha$  Derrick angle  
**R1** Derrick ballast radius

### Variation 1

- Divisible ballast pallet "VarioTray" **3** **without** suspended ballast guide
  - The derrick ballast radius **R1** is adjusted only by adjusting the derrick angle  $\alpha$ .

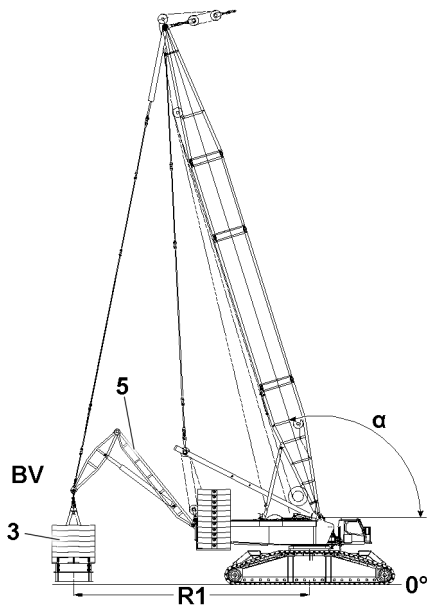


Fig.163667: Suspended ballast variation BV

- |          |   |           |                        |
|----------|---|-----------|------------------------|
| <b>3</b> | Divisible ballast pallet "VarioTray"    | <b>R1</b> | Derrick ballast radius |
| <b>5</b> | Suspended ballast guide frame "V-frame" | <b>α</b>  | Derrick angle          |

#### Variation 2

- Divisible ballast pallet "VarioTray" **3** with suspended ballast guide frame "V-frame" **5**
  - The derrick angle  $\alpha$  must be set separately of the derrick ballast radius **R1**.
  - The derrick ballast radius **R1** is set by adjusting the suspended ballast guide frame "V-frame" **5**.

## 3 Component overview

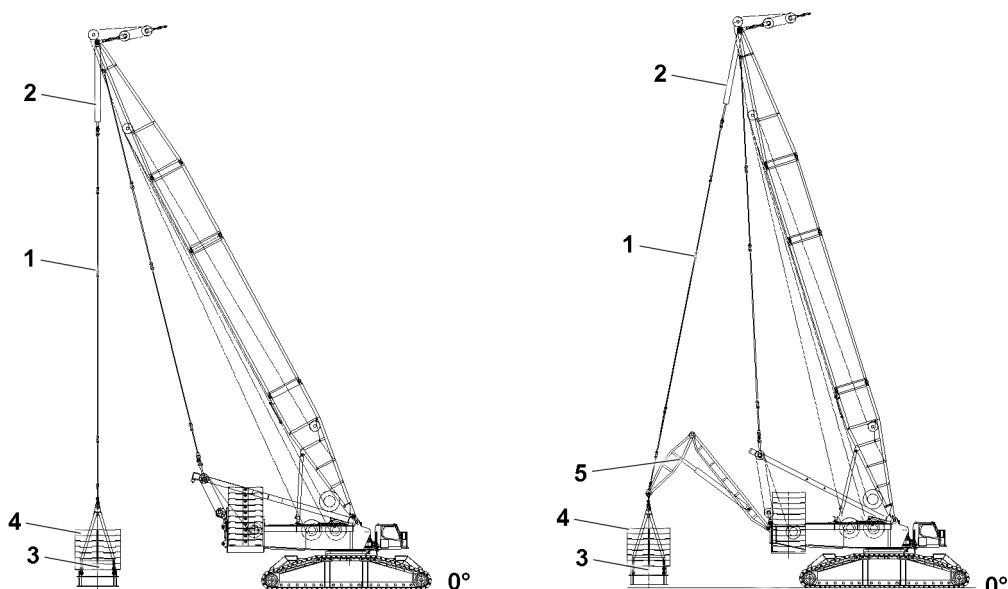


Fig.151427: Component overview

- |          |                                      |          |                                      |
|----------|--------------------------------------|----------|--------------------------------------|
| <b>1</b> | D-guy rods                           | <b>4</b> | Ballast plate                        |
| <b>2</b> | Pull cylinder                        | <b>5</b> | Suspended ballast guide "V-frame" BV |
| <b>3</b> | Divisible ballast pallet "VarioTray" |          |                                      |

**Note**

- ▶ The crane components are marked with their own weight.
- ▶ Dimensions and weights, see chapter 1.03.

Position	Component
1	D-guy rods
2	Pull cylinder
3	Divisible ballast pallet "VarioTray"
4	Ballast plates
5	Suspended ballast guide "V-frame" BV

### 3.1 Component overview for the divisible ballast pallet "VarioTray"

#### 3.1.1 Divisible ballast pallet "VarioTray"

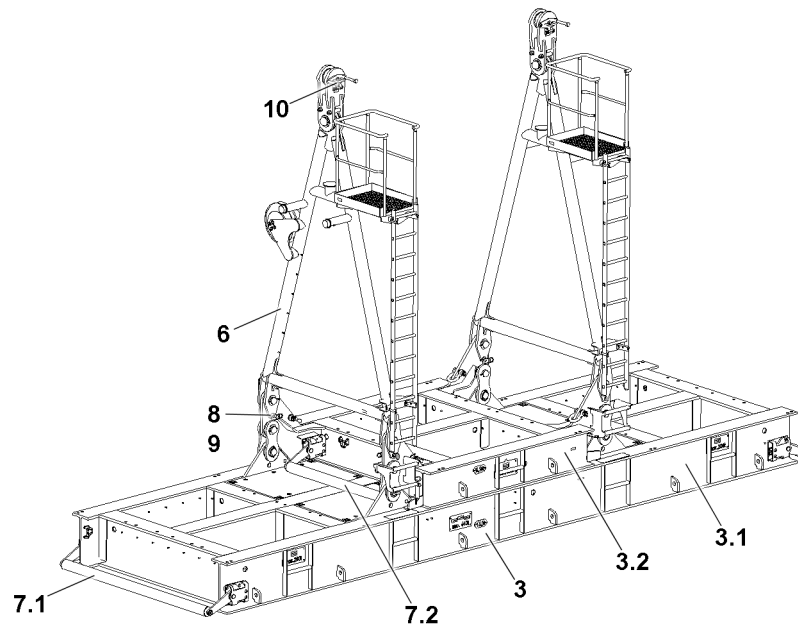


Fig.151428: Divisible ballast pallet "VarioTray"

- |     |                                      |     |                       |
|-----|--------------------------------------|-----|-----------------------|
| 3   | Divisible ballast pallet "VarioTray" | 7.2 | Ground contact roller |
| 3.1 | Large ballast pallet                 | 8   | Retaining pin         |
| 3.2 | Small ballast pallet                 | 9   | Retaining element     |
| 6   | Erection rack                        | 10  | Connector pin         |
| 7.1 | Ground contact roller                |     |                       |

Position	Component
3	Divisible ballast pallet "VarioTray"
3.1	Large ballast pallet
3.2	Small ballast pallet
6	Erection rack
7.1	Ground contact roller
7.2	Ground contact roller

Position	Component
8	Retaining pin
9	Retaining element
10	Connector pin

### 3.1.2 Lashing lugs

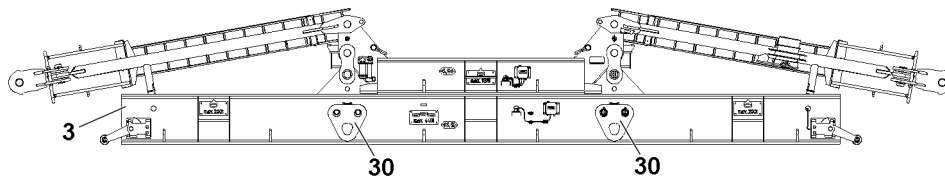


Fig.151429: Lashing lugs

3 Divisible ballast pallet "VarioTray"      30 Lashing lug

Position	Component
30	Lashing lugs



#### Note

► Lashing lugs for fastening the divisible ballast pallet "VarioTray" with the auxiliary crane.

## 3.2 Component overview for the suspended ballast guide "V-frame"

### 3.2.1 Pivot section with end pivot section

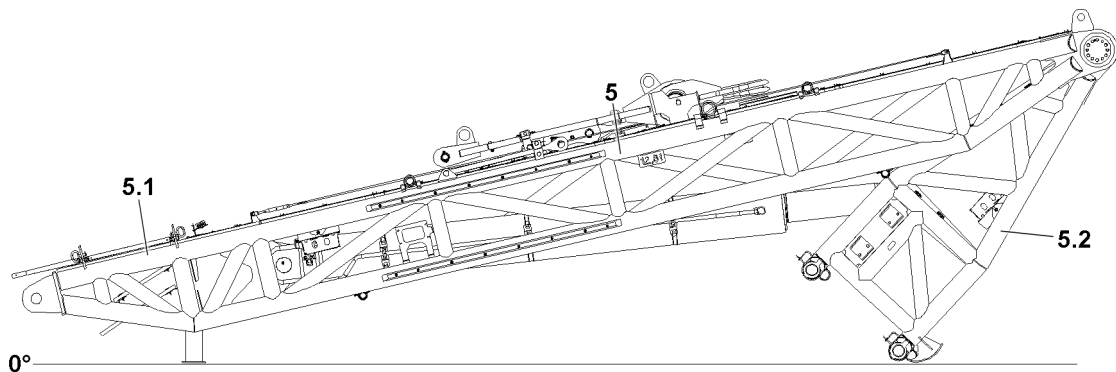


Fig.155399: Component overview – Pivot section with end pivot section

5 Suspended ballast guide "V-frame"      5.2 End-pivot section  
5.1 Pivot section

Position	Component
5	Suspended ballast guide "V-frame"
5.1	Pivot section
5.2	End-pivot section



### 3.2.2 End section

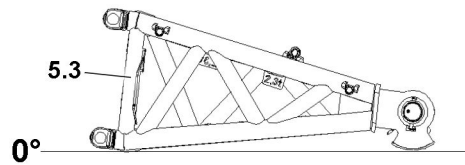


Fig.155400: Component overview – end section

#### 5.3 End section

Position	Component
5.3	End section

### 3.2.3 Guy rod

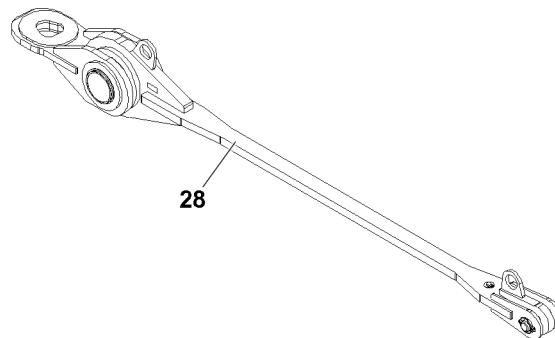


Fig.155401: Component overview – guy rod

#### 28 Guy rod

Position	Component
28	Guy rod

## 4 Fastening points



#### WARNING

Falling crane components!  
Death, severe bodily injuries, property damage.

- ▶ Make sure that the crane components are properly fastened to the respective fastening points.
- ▶ Make sure that the fastening equipment has the appropriate length and a sufficient load bearing capacity.
- ▶ Pay attention and adhere to the labels on the fastening points on the crane components.

## 4.1 Fastening points for suspended ballast components

### 4.1.1 Divisible ballast pallet “VarioTray”

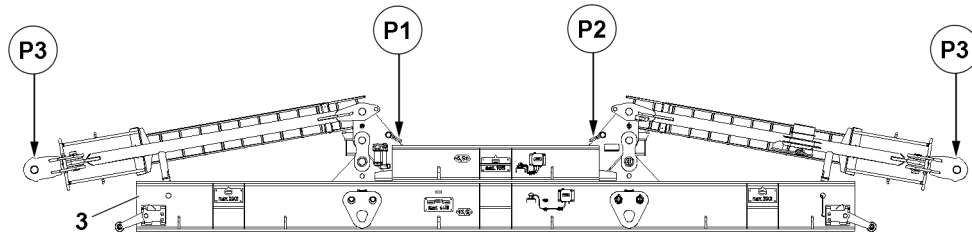


Fig.151430: Divisible ballast pallet “VarioTray”

#### 3 Divisible ballast pallet “VarioTray”



#### Note

► Fastening points P1 and P2: Minimum rope length 6 m.

Fastening points	
P1 and P2	Divisible ballast pallet “VarioTray”
P3	Erection rack

### 4.1.2 Ballast plates

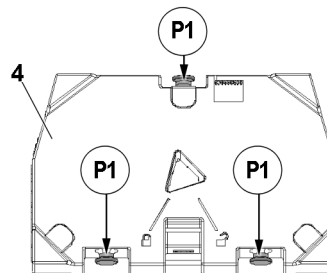


Fig.151431: Ballast plates

#### 4 Ballast plate

Fastening points	
P1	Ballast plates 5 t / 7.5 t / 10 t

## 4.2 Fastening points for suspended ballast guide “V-frame” components

### 4.2.1 Pivot section with end pivot section

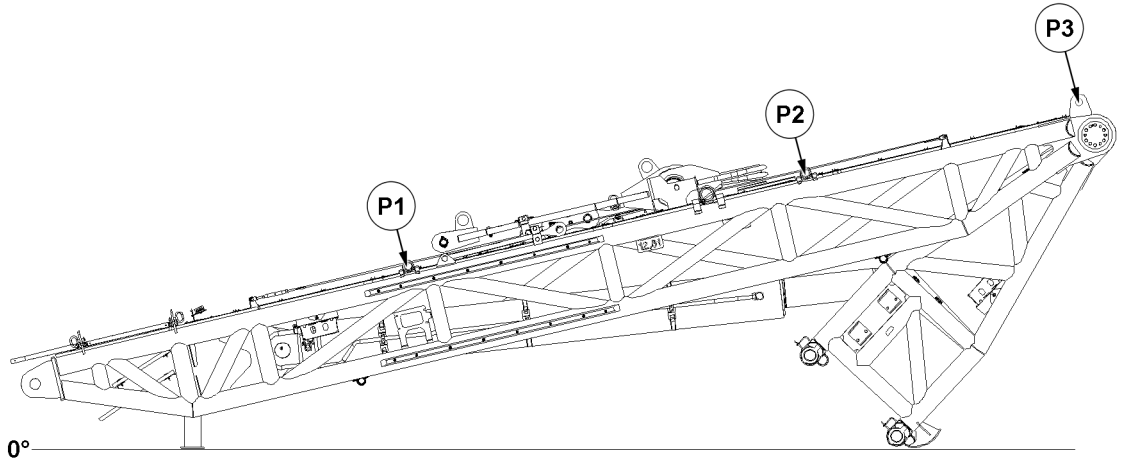


Fig.155404: Pivot section

Fastening points	
P1 and P2	Pivot section with end pivot section
P3	Assembling the pivot section with end pivot section

### 4.2.2 End section

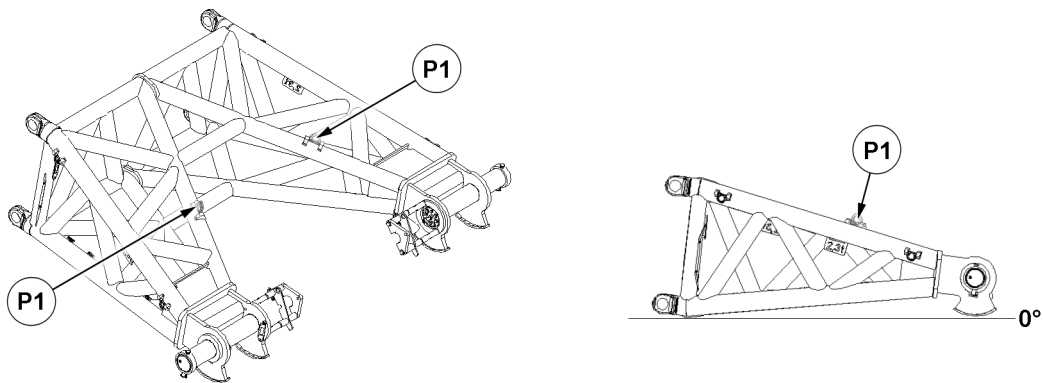


Fig.155405: End section

Fastening points	
P1	End section

LWE/LR 1800-1-0-000/27200-07-02/en

### 4.2.3 Guy rods

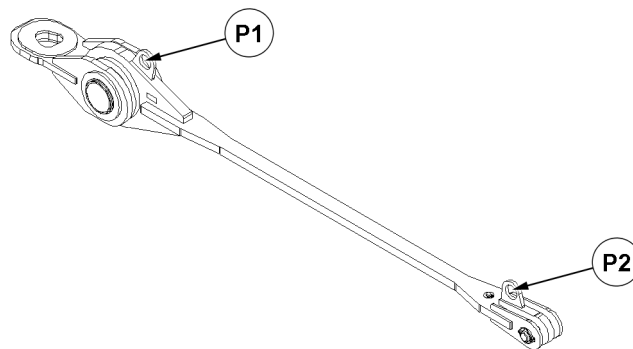


Fig.155406: Fastening points for guy rods

Fastening points	
P1 and P2	Guy rod

## 5 Pull cylinder extension conditions



Fig.163664: Derrick pull cylinder operating window

Extension conditions	
I	Pull cylinder retracted
II	Pull cylinder extended
Stroke	4750 mm

## 6 Permissible ballast assemblies

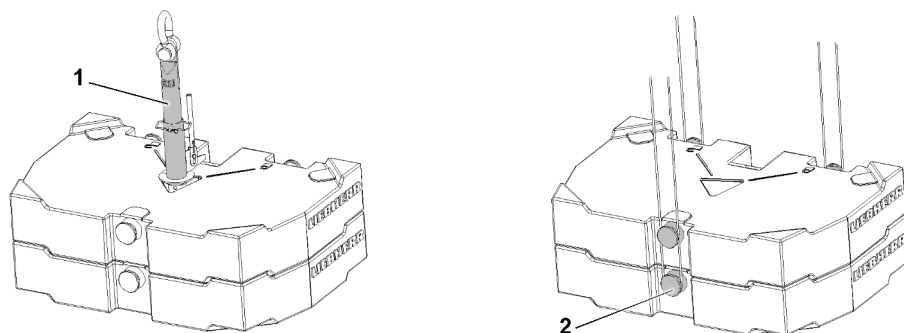


Fig.162195: Permissible ballast assemblies

1 Twistlock receptacle stud

2 Bitt

**WARNING**

Overload of the receptacle stud and ballast plates!

If more than the permissible number of ballast plates are lifted with the receptacle stud Twistlock 1, the receptacle stud Twistlock 1 and the ballast plates will be overloaded and damaged.

If more than the permissible number of ballast plates are fastened with the bitt 2 and lifted, the bitt 2 will be overloaded and damaged.

The ballast plates can fall down.

Death, severe bodily injuries, property damage.

- ▶ Fasten and lift only the maximum permissible number of ballast plates per stroke.
- ▶ Observe the following chart!

Individual weight Ballast plate	Maximum number of same ballast plates per stroke over	
	Twistlock receptacle stud	Bitt
5.0 t	2	1
7.5 t	2	2
10.0 t	2	2

*Permissible ballast assemblies*

## 7 Derrick ballast radii

The displays on the LICCON monitor for the derrick ballast radius and the derrick angle are described in section "Additional displays on LICCON monitor LM1".

### 7.1 Derrick ballast without suspended ballast guide

#### 7.1.1 Derrick boom 33 m

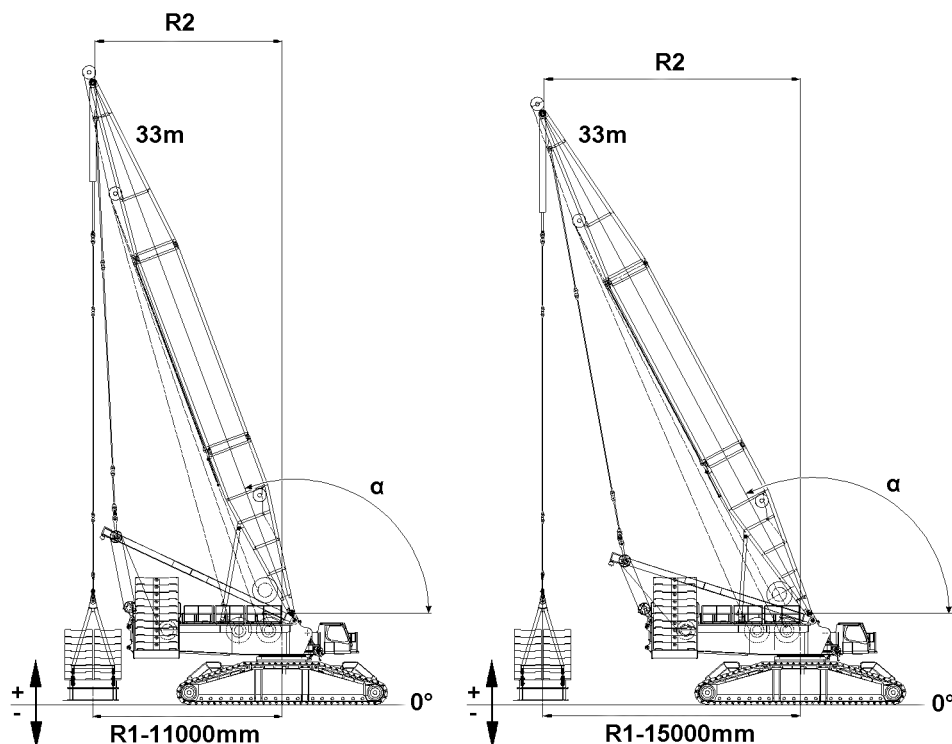


Fig.163666: Derrick ballast without suspended ballast guide – derrick boom 33 m

**Note**

- ▶ **No** suspended ballast guide is installed between the turntable and the divisible ballast pallet “Vari-oTray”.
- ▶ The derrick ballast radius **R1** or derrick ballast radius **R2** is adjusted only by adjusting the derrick angle  $\alpha$ .
- ▶ The intermediate positions of the derrick ballast radius is interpolated by the LICCON computer system.

When the crane stands on horizontal ground:

- ▶ If the derrick ballast radius **R1** and derrick radius **R2** are identical.

The following derrick ballast radii are possible with the derrick boom 33 m:

- R1 = 11 m – 15 m

### 7.1.2 Derrick boom 39 m

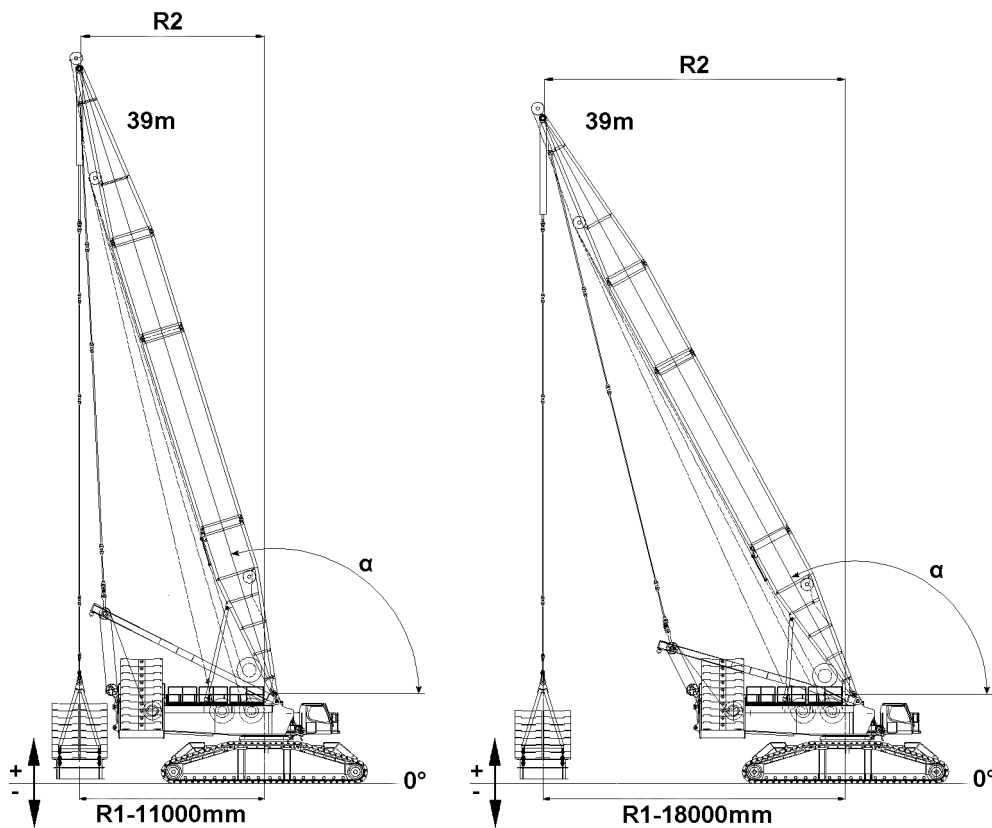


Fig.163668: Derrick ballast without suspended ballast guide – derrick boom 39 m

**Note**

- ▶ **No** suspended ballast guide is installed between the turntable and the divisible ballast pallet “Vari-oTray”.
- ▶ The derrick ballast radius **R1** or derrick ballast radius **R2** is adjusted only by adjusting the derrick angle  $\alpha$ .
- ▶ The intermediate positions of the derrick ballast radius is interpolated by the LICCON computer system.

When the crane stands on horizontal ground:

- ▶ If the derrick ballast radius **R1** and derrick radius **R2** are identical.

The following derrick ballast radii are possible with the derrick boom 39 m:

- R1 = 11 m – 18 m

## 7.2 Derrick ballast with suspended ballast guide “V-frame”

### 7.2.1 Derrick boom 33 m

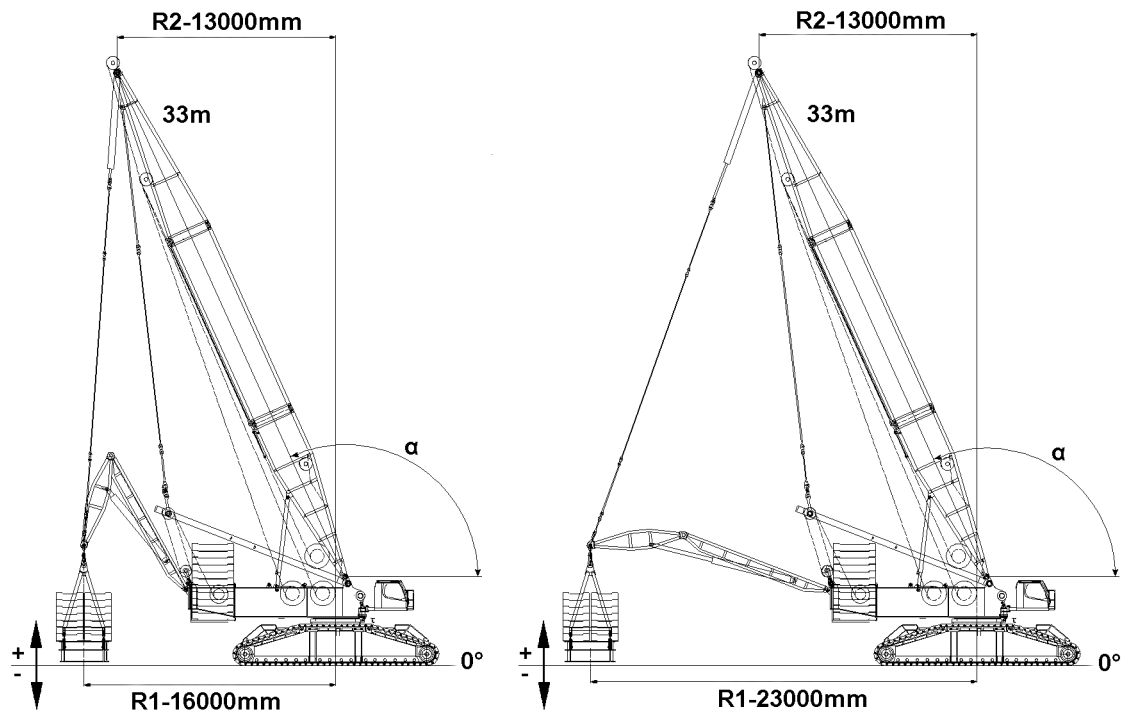


Fig.163669: Derrick ballast with suspended ballast guide “V-frame” – derrick boom 33 m



#### Note

- ▶ The suspended ballast guide “V-frame” is installed between the turntable and the divisible ballast pallet “VarioTray”.
- ▶ The derrick ballast radius **R1** and the derrick radius **R2** are **not** identical.
- ▶ In the case of a derrick boom with 33 m and a derrick radius **R2** = 13 m the derrick angle  $\alpha$  = 114.3°.
- ▶ The intermediate positions of the derrick ballast radius is interpolated by the LICCON computer system.

With the derrick boom 33 m with “V-frame” the derrick ballast radius is possible steplessly between  $R1 = 16$  m and  $R1 = 23$  m.

## 7.2.2 Derrick boom 39 m

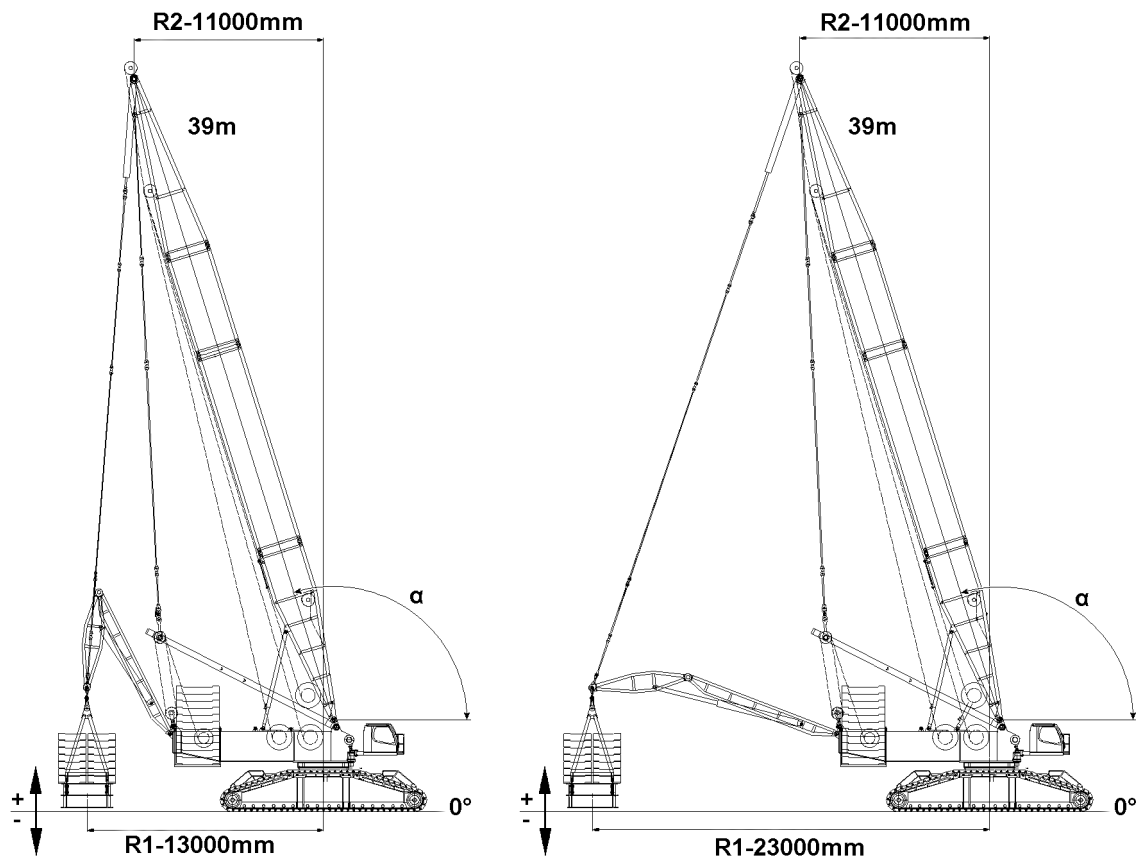


Fig.163670: Derrick ballast with suspended ballast guide "V-frame" – derrick boom 39 m



### Note

- ▶ The suspended ballast guide "V-frame" is installed between the turntable and the divisible ballast pallet "VarioTray".
- ▶ The derrick ballast radius **R1** and the derrick radius **R2** are **not** identical.
- ▶ In the case of a derrick boom with 39 m and a derrick radius **R2** = 11 m the derrick angle  $\alpha$  = 107.3°.
- ▶ The intermediate positions of the derrick ballast radius is interpolated by the LICCON computer system.

With the derrick boom 39 m with "V-frame" the derrick ballast radius is possible steplessly between  $R1 = 14$  m and  $R1 = 23$  m.



## 8 Permissible lifting heights

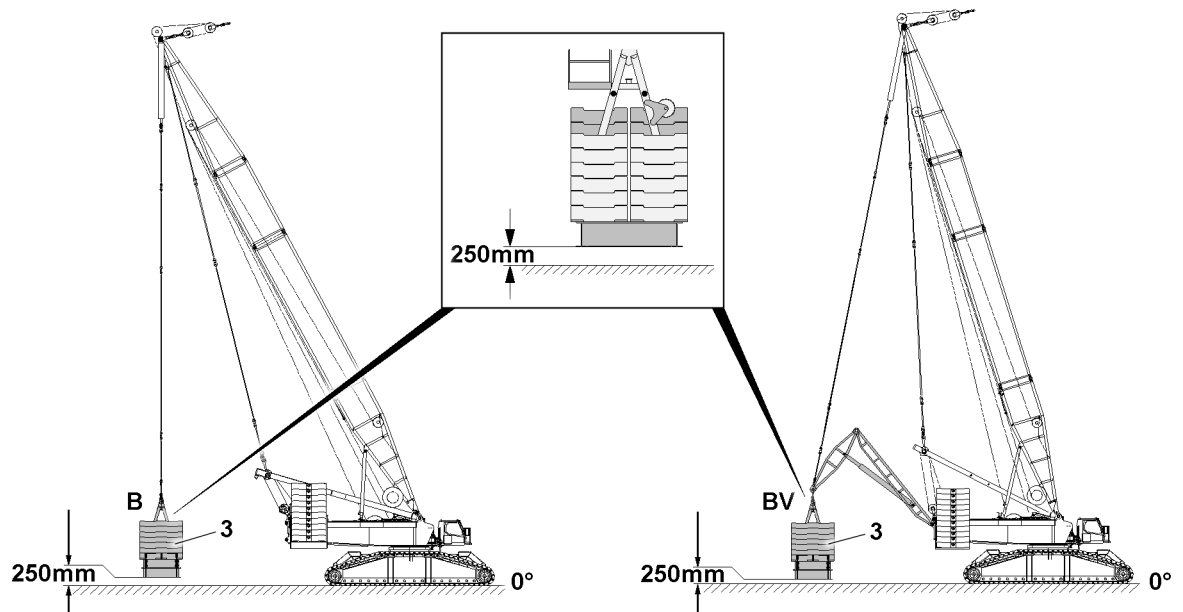


Fig.154807: Maximum permissible lifting height of the derrick ballast pallet of 250 mm above ground

3 Divisible ballast pallet "VarioTray"

Maximum permissible lifting height of the large ballast pallet		Maximum permissible lifting height of the small ballast pallet	
Assembly operation <sup>1)</sup>	Crane operation <sup>2)</sup>	Assembly operation <sup>1)</sup>	Crane operation <sup>2)</sup>
1000 mm	250 mm	1500 mm	250 mm

1) Without load on the main boom

2) With load on the main boom



### WARNING

Lifting the derrick ballast higher than the maximum permissible 250 mm !

If the derrick ballast is lifted up off the ground during crane operation beyond the maximum permissible 250 mm , the crane can topple over to the rear if the load rips off.

Death, severe bodily injuries, property damage.

- Make sure that the derrick ballast is not lifted more than 250 mm off the ground during crane operation.

## 8.1 Derrick ballast without suspended ballast guide

### 8.1.1 Derrick boom 33 m

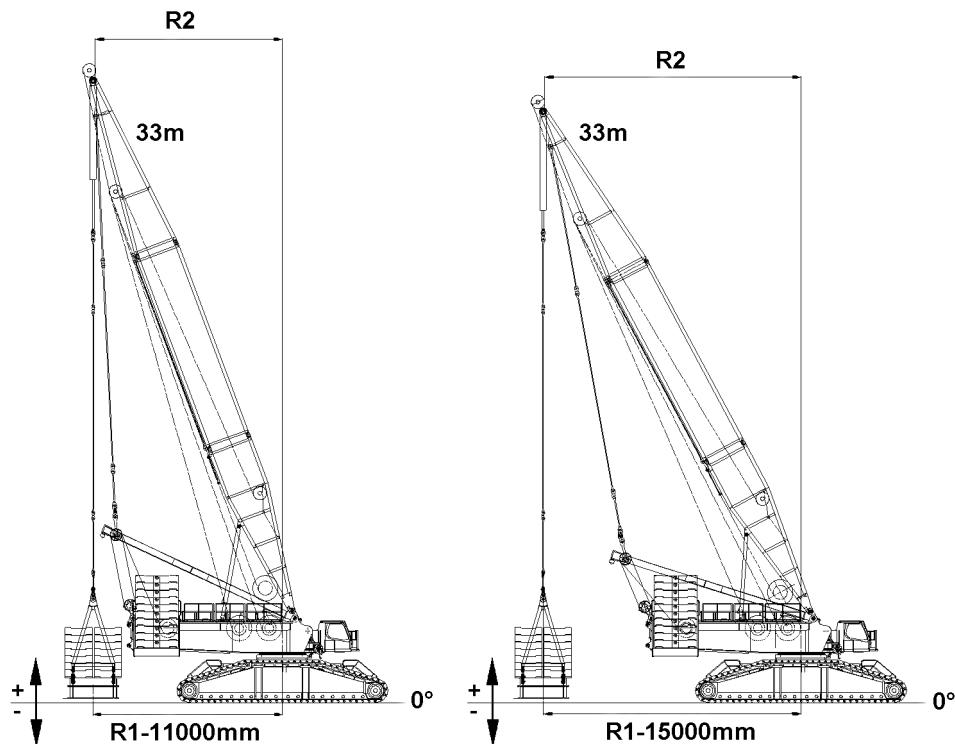


Fig.151438: Permissible lifting heights for the small ballast pallet – derrick boom 33 m



#### Note

- ▶ No suspended ballast guide is installed between the turntable and the divisible ballast pallet “Vari-oTray”.



#### Note

- ▶ The intermediate positions of the derrick ballast radius is interpolated by the LICCON computer system.

#### Large ballast pallet (base pallet)

Lifting heights of the pull cylinder above / below the crane base (with switch position):

Radius R1 = 11 m	
Above the base	+3278 mm
Below the base	-1522 mm

Radius R1 = 13 m	
Above the base	+2453 mm
Below the base	-2347 mm

LWE/LR 1800-1-0-000/27200-07-02/en

Radius R1 = 15 m	
Above the base	+1470 mm
Below the base	-3330 mm

**Small ballast pallet (Vario pallet)**

Lifting heights of the pull cylinder above / below the crane base (with switch position):

Radius R1 = 11 m	
Above the base	+3978 mm
Below the base	-822 mm

Radius R1 = 13 m	
Above the base	+3153 mm
Below the base	-1647 mm

Radius R1 = 15 m	
Above the base	+2170 mm
Below the base	-2630 mm

**8.1.2 Derrick boom 39 m**

LWE/LR 1800-1-0-000/27200-07-02/en

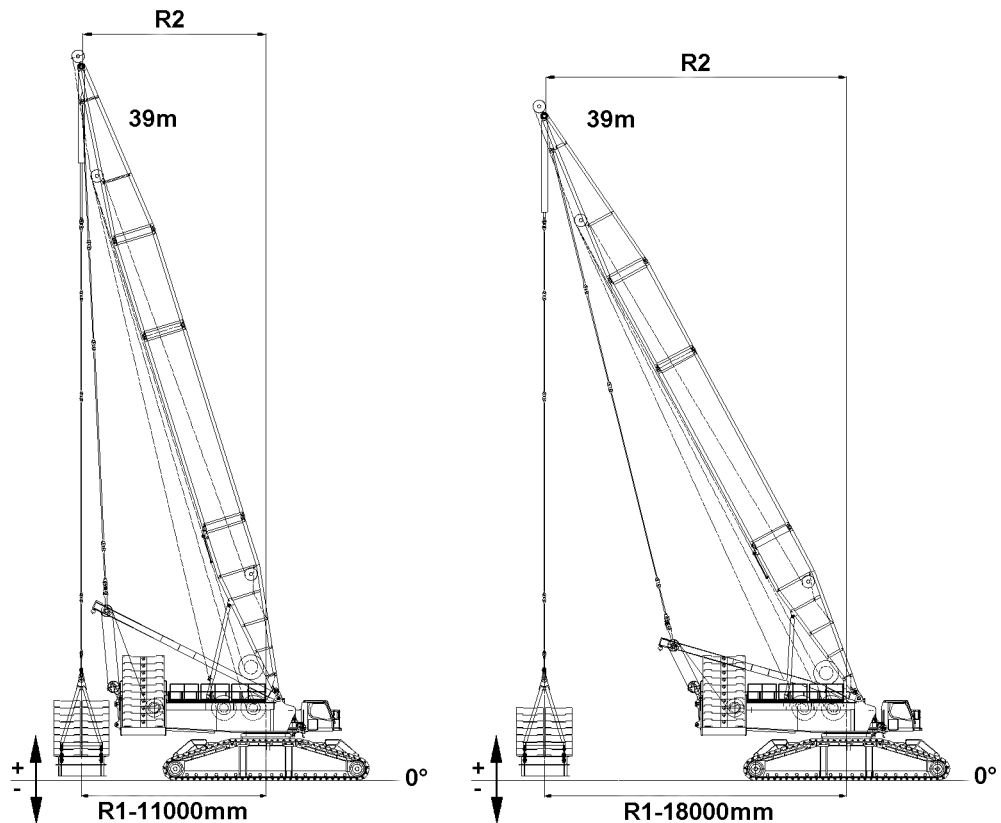


Fig.151437: Permissible lifting heights for the small ballast pallet – derrick boom 39 m

**Note**

- ▶ No suspended ballast guide is installed between the turntable and the divisible ballast pallet “Vari-oTray”.

**Note**

- ▶ The intermediate positions of the derrick ballast radius is interpolated by the LICCON computer system.

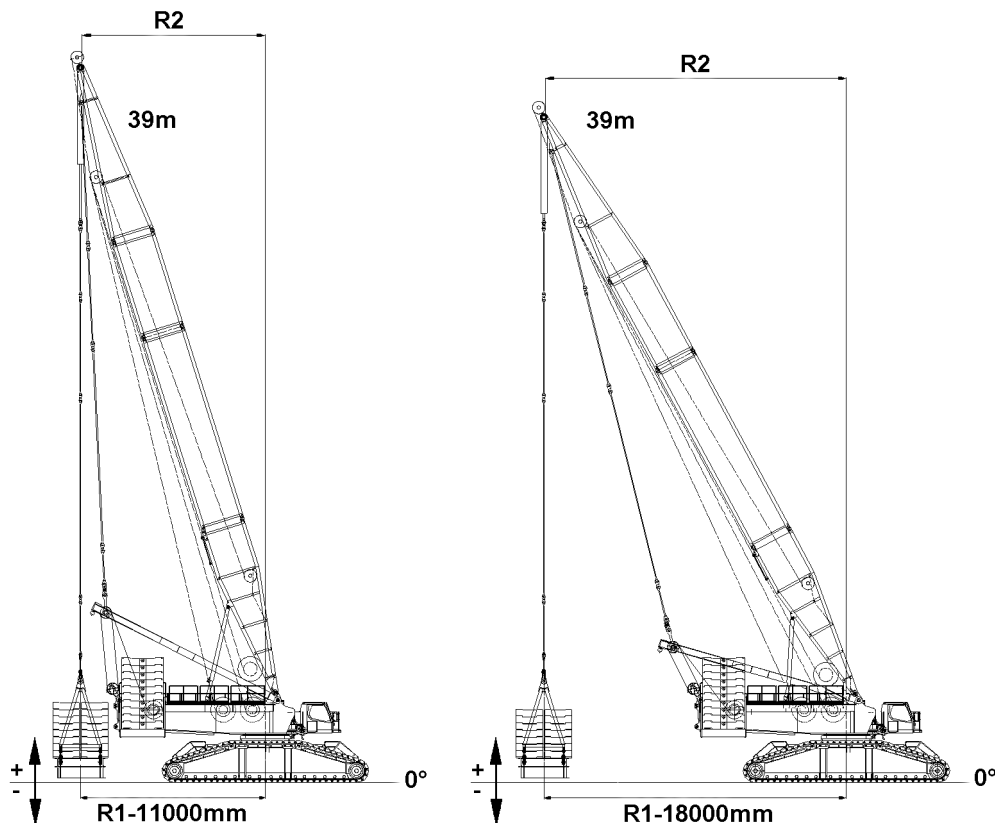
**Large ballast pallet (base pallet)**

Fig.151437: Permissible lifting heights for the small ballast pallet – derrick boom 39 m

Lifting heights of the pull cylinder above / below the crane base (with switch position):

Radius R1 = 11 m	
Above the base	+3619 mm
Below the base	-1181 mm

Radius R1 = 13 m	
Above the base	+2936 mm
Below the base	-1864 mm

Radius R1 = 15 m	
Above the base	+2129 mm
Below the base	-2671 mm

LWE/LR 1800-1-0-000/27200-07-02/en

Radius R1 = 18 m	
Above the base	+669 mm
Below the base	-4131 mm

### Small ballast pallet (Vario pallet)

Lifting heights of the pull cylinder above / below the crane base (with switch position):

Radius R1 = 11 m	
Above the base	+4319 mm
Below the base	-481 mm

Radius R1 = 13 m	
Above the base	+3636 mm
Below the base	-1164 mm

Radius R1 = 15 m	
Above the base	+2829 mm
Below the base	-1971 mm

Radius R1 = 18 m	
Above the base	+1369 mm
Below the base	-3431 mm

## 8.2 Derrick ballast with suspended ballast guide “V-frame”



### WARNING

Toppling of the crane due to impermissible lifting heights of the suspended ballast pallet off the placement surface!

The crane is moved and the suspended ballast has unplanned ground contact.

Unplanned change of load distribution.

The crane can tilt over to the front.

- ▶ Comply with the permissible lifting heights of the suspended ballast pallet off the placement surface.
- ▶ The movement of the suspended ballast pallet must be observed by personnel.



### WARNING

Toppling of the crane due to impermissible lifting heights of the suspended ballast pallet off the placement surface!

The suspended ballast pallet cannot be taken down onto the ground via shut-off:

Unplanned change of load distribution.

The crane can tilt over to the rear.

- ▶ Comply with the permissible lifting heights of the suspended ballast pallet off the placement surface.
- ▶ The movement of the suspended ballast pallet must be observed by personnel.

## 8.2.1 Derrick boom 33 m with large ballast pallet (base pallet)

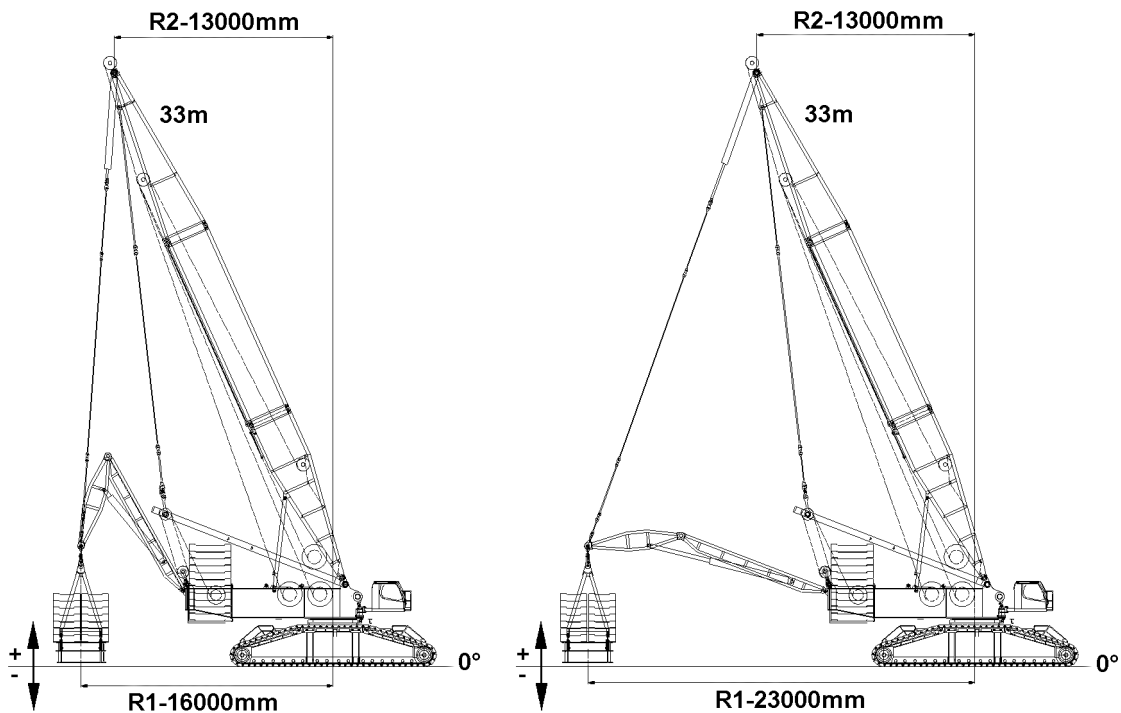


Fig.155409: Derrick ballast with suspended ballast guide "V-frame" – derrick boom 33 m



### Note

- The suspended ballast guide "V-frame" is installed between the turntable and the divisible ballast pallet "VarioTray".

Lifting heights of the pull cylinder above / below the crane base (with switch position):

Radius R1 = 16 m	
Large ballast pallet (base pallet) with small ballast pallet (Vario pallet)	
Above the base	+250 mm
Below the base	Not permissible

Radius R1 = 19 m	
Large ballast pallet (base pallet) with small ballast pallet (Vario pallet)	
Above the base	+1000 mm
Below the base	-500 mm

Radius R1 = 23 m	
Large ballast pallet (base pallet) with small ballast pallet (Vario pallet)	
Above the base	+1000 mm
Below the base	-500 mm

LWE/LR 1800-1-0-000/27200-07-02/en

### 8.2.2 Derrick boom 33 m with small ballast pallet (Vario pallet)

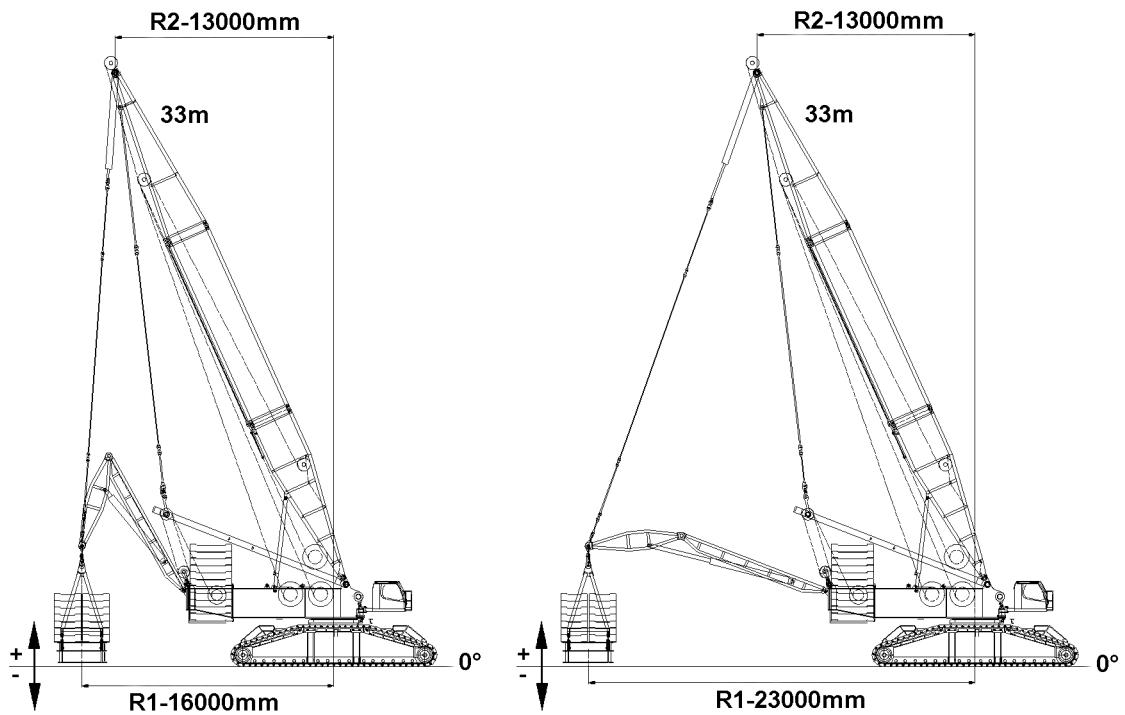


Fig.155409: Derrick boom 33 m with small ballast pallet "VarioTray"



**Note**

- ▶ The suspended ballast guide "V-frame" is installed between the turntable and the divisible ballast pallet "VarioTray".

Lifting heights of the pull cylinder above / below the crane base (with switch position):

Radius R1 = 16 m	
Small ballast pallet (Vario pallet)	
Above the base	+250 mm
Below the base	Not permissible

Radius R1 = 19 m	
Small ballast pallet (Vario pallet)	
Above the base	+1500 mm
Below the base	-500 mm

Radius R1 = 23 m	
Small ballast pallet (Vario pallet)	
Above the base	+1500 mm
Below the base	-500 mm

LWE/LR 1800-1-0-000/27200-07-02/en

### 8.2.3 Derrick boom 33 m with large ballast pallet (base pallet)

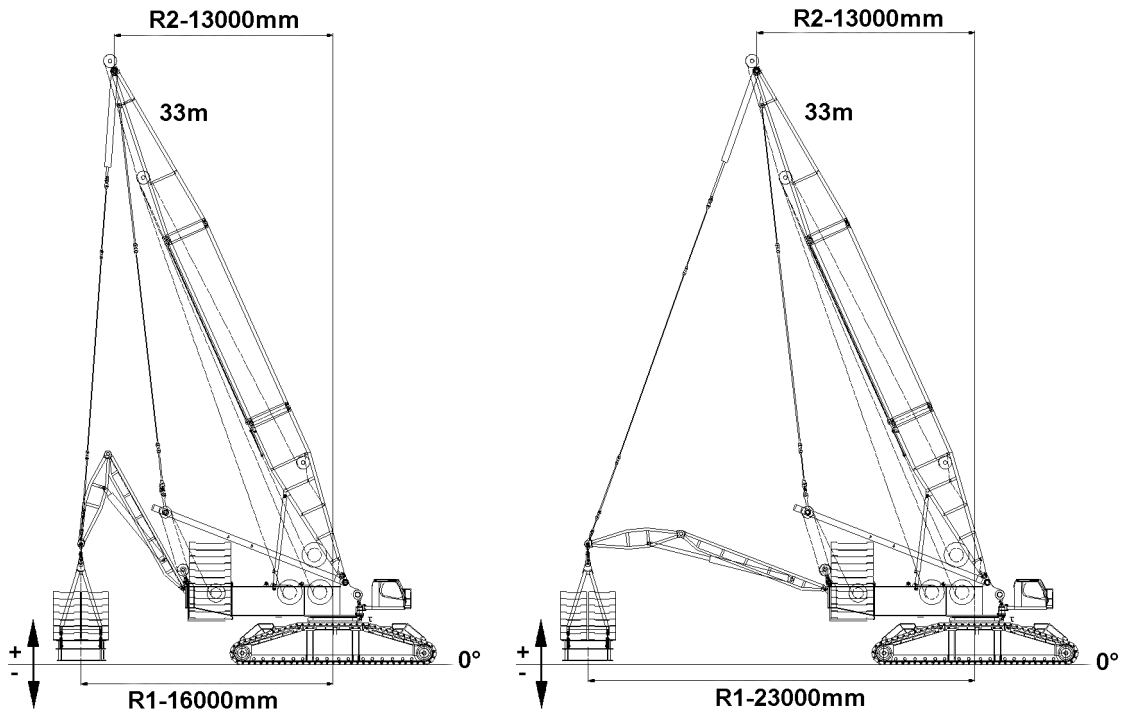


Fig.155409: Derrick boom 33 m with divisible ballast pallet "VarioTray"



#### Note

- The suspended ballast guide "V-frame" is installed between the turntable and the divisible ballast pallet "VarioTray".

Lifting heights of the pull cylinder above / below the crane base (with switch position):

Radius R1 = 14 m	
Large ballast pallet (base pallet) with small ballast pallet (Vario pallet)	
Above the base	+250 mm
Below the base	Not permissible

Radius R1 = 18 m	
Large ballast pallet (base pallet) with small ballast pallet (Vario pallet)	
Above the base	+1000 mm
Below the base	-500 mm

Radius R1 = 23 m	
Large ballast pallet (base pallet) with small ballast pallet (Vario pallet)	
Above the base	+1000 mm
Below the base	-500 mm

LWE/LR 1800-1-0-000/27200-07-02/en



### 8.2.4 Derrick boom 39 m with small ballast pallet (Vario pallet)

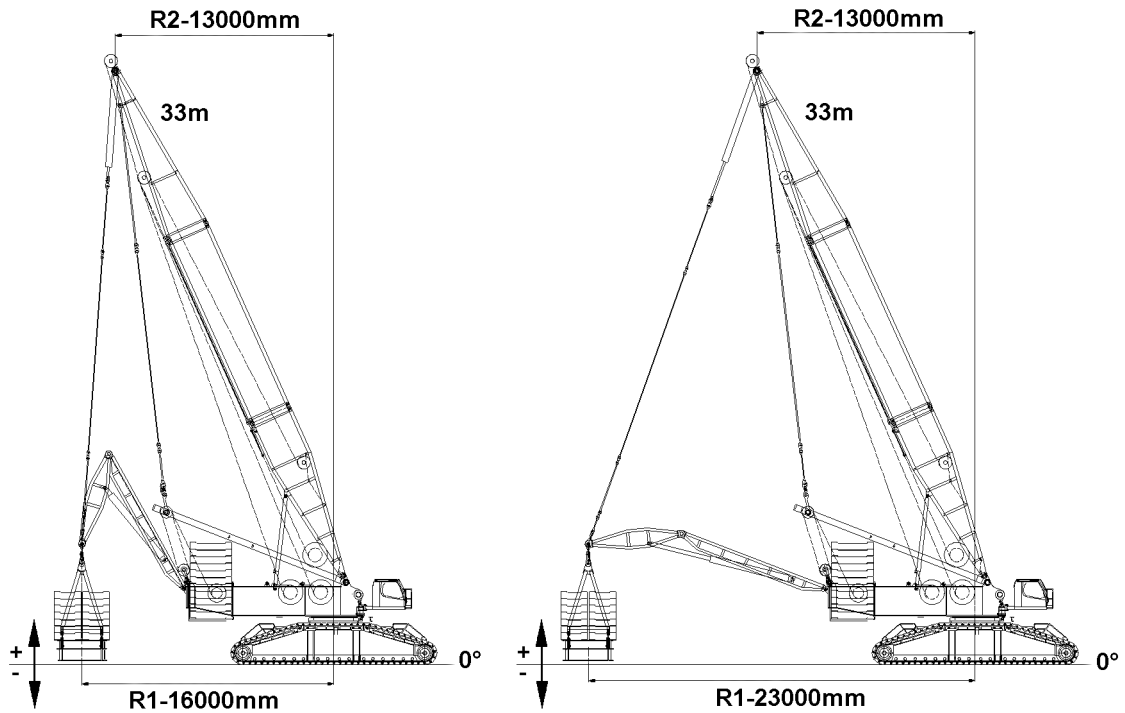


Fig.155409: Derrick boom 39 m with small ballast pallet "VarioTray"



**Note**

- ▶ The suspended ballast guide "V-frame" is installed between the turntable and the divisible ballast pallet "VarioTray".

Lifting heights of the pull cylinder above / below the crane base (with switch position):

Radius R1 = 14 m	
Small ballast pallet (Vario pallet)	
Above the base	+250 mm
Below the base	Not permissible

Radius R1 = 18 m	
Small ballast pallet (Vario pallet)	
Above the base	+1500 mm
Below the base	-500 mm

Radius R1 = 23 m	
Small ballast pallet (Vario pallet)	
Above the base	+1500 mm
Below the base	-500 mm

LWE/LR 1800-1-0-000/27200-07-02/en

## 9 Assembling

### 9.1 General safety

Observe the safety instructions before assembly and disassembly:

- Information regarding personal protective equipment. See chapter 2.04.
- Information regarding the 3-point support. See chapter 2.04.10.
- Information regarding crane operation. See chapter 2.04.
- Information regarding fall protection equipment. See chapter 2.06.
- Information regarding walking surfaces and stepping surfaces. See chapter 2.07.
- Technical safety instructions for assembly and disassembly. See chapter 5.01.

#### 9.1.1 Safety - assembly



##### **WARNING**

Danger of falling!

During assembly / disassembly, inspection and maintenance work, assembly personnel must be secured with appropriate aids to prevent them from falling.

Death, severe bodily injuries, property damage.

- ▶ All work at a height, when there is a danger of falling, must be carried out with suitable aids.
- ▶ If aids are not available and work cannot be carried out from the ground, then assembly personnel must secure themselves with the supplied fall arrest system to prevent falling, see chapter 2.04.
- ▶ If fall protection equipment is available, then it must be used, see chapter 2.06.
- ▶ When lifting, lowering, swinging crane parts in and out, no persons may remain in the danger zone.
- ▶ When closing or opening boom systems during boom assembly or boom disassembly, no persons may remain on the boom system or in the danger zone.
- ▶ If railings are present on the components, then they must be brought into the corresponding position and secured for assembly / disassembly work.
- ▶ Only step on the aids, ladders and catwalks with clean shoes.
- ▶ Keep aids, ladders and catwalks free of heavy dirt, snow, frost and ice.
- ▶ During all assembly and disassembly work, maintenance work and inspections, travel or crane operation is prohibited.
- ▶ Remaining on a suspended load is prohibited.
- ▶ Stepping or walking on crane components and lattice sections with an incline of more than 20° is prohibited.



##### **WARNING**

Working without aids!

Death, severe bodily injuries, property damage.

When assembling and disassembling crane components with the auxiliary crane, they can start to swing back and forth.

When lifting / lowering and positioning crane components, there is an increased danger of impact / crushing.

- ▶ Make sure that personnel cannot be caught by components.
- ▶ When working in a danger zone: Use aids to protect limbs.
- ▶ Guide components with suitable aids to minimize oscillation.



##### **WARNING**

Crane movements without approval of the guide!

Death, severe bodily injuries, property damage.

- ▶ For all work, observe the instructions of the guide. If necessary, use walkie-talkies.
- ▶ The crane operator and guide must monitor the danger zone.
- ▶ For all assembly / disassembly work, the crane driver of the main crane must be in voice contact with the crane driver / crane drivers of the auxiliary crane / auxiliary cranes.
- ▶ For assembly / disassembly tasks, the crane driver may only initiate crane movements when the responsible guide has explicitly released the movement.

**WARNING**

Overload of the crane!

If the permissible display values of the F-load display are exceeded / fallen below, then the crane can be overloaded.

This could result in serious accidents.

- ▶ Observe and adhere to the display values on the LICCON monitors.
- ▶ Observe and adhere to the specifications regarding the limit values on the assembly drawings.

**Note**

Crane assembly with the auxiliary crane.

When installed components are lifted or set down with the auxiliary crane, the changed F-forces may have an effect on the boom system. The display values on the F-load displays can change and shut-offs can occur.

When installed components are lifted or set down with the auxiliary crane:

- ▶ Observe the F-load displays on the crane to be monitored.
- ▶ If necessary, correct the position of the boom system (F-forces) on the crane to be assembled.
- ▶ Before each new assembly step, the F1-force is in the middle between the minimum and maximum force.

**9.1.2 Safety when working at a height****WARNING**

3-point support not adhered to!

Personnel can fall, death, severe bodily injuries.

- ▶ Adhere to the 3-point support.
- ▶ Adhere to the prerequisites and conditions for the use of leaning ladders.

**WARNING**

Working with unsuitable aids!

▶ All work at a height, when there is a danger of falling, must be carried out with suitable aids.

▶ If aids are not available and work cannot be carried out from the ground, then assembly personnel must secure themselves with the supplied fall arrest system to prevent falling, see chapter 2.04.

**9.1.3 Safety - pin connections****DANGER**

Do not disconnect the auxiliary crane until the component is completely pinned and secured!

Death, severe bodily injuries, property damage.

If a component is disengaged from the auxiliary crane before it is pinned, then it can fall.

- ▶ Do not disconnect the auxiliary crane until the component is pinned and secured.

**WARNING**

Unsecured pins!

If the pins are not secured with the provided retaining element, the pins can release during crane operation! This can cause the crane to topple over!

Death, severe bodily injuries, property damage.

- ▶ Make sure that all pins are inserted and secured!

**9.1.4 Safety - fastening****DANGER**

Incorrect fastening of the erection racks!

Death, severe bodily injuries, property damage.

- ▶ First place the fastening equipment around the cross strut and then fasten to the bitt.

**WARNING**

Use of incorrect fastening points!

Death, severe bodily injuries, property damage.

- ▶ Use the fastening points indicated on the crane components.
- ▶ Pay attention to the labels on the fastening points on the lattice sections and crane components.

**WARNING**

Incorrect length of the fastening equipment!

Death, severe bodily injuries, property damage.

- ▶ Select fastening equipment with a suitable length.

**WARNING**

Use of fastening equipment with unsuitable load capacity!

Death, severe bodily injuries, property damage.

- ▶ Use fastening equipment with a sufficient load carrying capacity.

### 9.1.5 Prerequisites for assembly

Make sure that the following prerequisites are met:

- The crane is positioned on a sufficiently load-bearing surface.
- The crane is horizontally aligned.
- An auxiliary crane is available.
- The derrick boom is properly assembled on the turntable.
- The main boom is properly assembled on the turntable.
- The derrick boom is in the crane operating position.
- For normal assembly, the main boom is lying on the ground on the substructure.
- With a special assembly, the main boom is in the BV operation operating window in chart column DB- 0 t
- The central ballast has been installed on the crawler center section according to the load chart.
- The counterweight is installed on the turntable according to the load chart.
- The LICCON overload protection has been set according to the data in the load chart.
- The LICCON overload protection settings have been compared with the actual set up configuration.
- The limit switches have been checked for their mechanical function.
- The maximum ground unevenness for the placement surface of the derrick ballast is  $\pm 1^\circ$ .

## 9.2 Assembling the suspended ballast

Make sure that the following prerequisites are met:

- The crane is positioned on a sufficiently load-bearing surface.
- The crane is horizontally aligned.
- An auxiliary crane is available.
- The derrick boom is properly assembled on the turntable.
- The main boom is properly assembled on the turntable.
- The derrick boom is in the crane operating position.
- The main boom is lying on the substructure on the ground.
- The central ballast has been installed on the turntable according to the load charts or the erection and take-down charts.
- The counterweight has been installed on the turntable according to the load charts or the erection and take-down charts.
- The LICCON overload protection has been set according to the data in the load chart.
- The LICCON overload protection settings have been compared with the actual set up configuration.
- The limit switches have been checked for their mechanical function.
- The ballast pallet VarioTray is assembled in the operating position, see section “Assembling the divisible ballast pallet “VarioTray””.

### 9.2.1 Assembling the D-guy rods on the erection racks

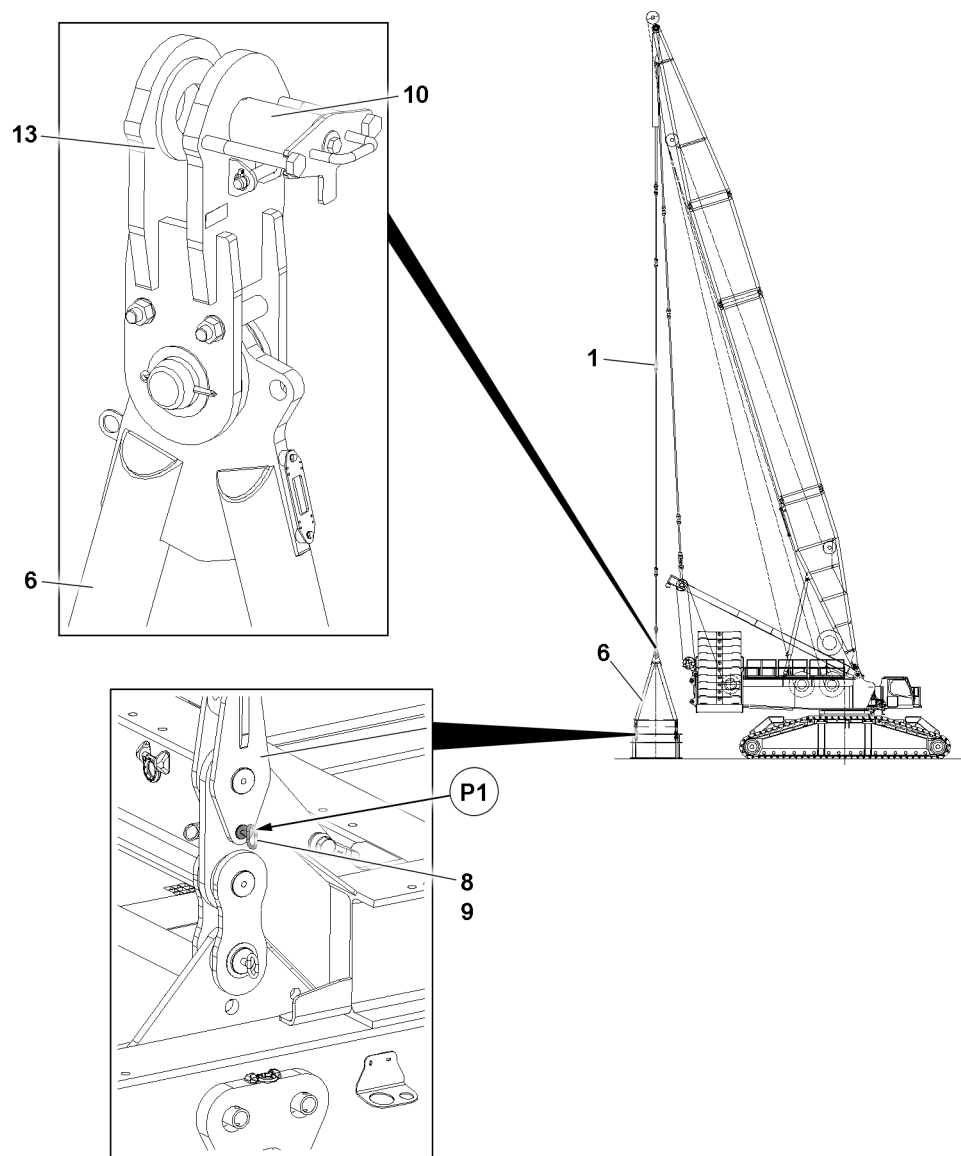


Fig.155456

- |          |               |           |               |
|----------|---------------|-----------|---------------|
| <b>1</b> | D-guy rods    | <b>10</b> | Connector pin |
| <b>6</b> | Erection rack | <b>13</b> | Bracket       |
| <b>8</b> | Retaining pin |           |               |

Make sure that the following prerequisites are met:

- The D-guy rods **1** hang over the brackets **13** of the erection racks **6**.
- The erection racks **6** are erected and secured with four retaining pins **8** and four retaining elements **9** in positions **P1**.
- The derrick boom is set to the required radius / derrick angle.
- The connector pins **10** are unpinned.

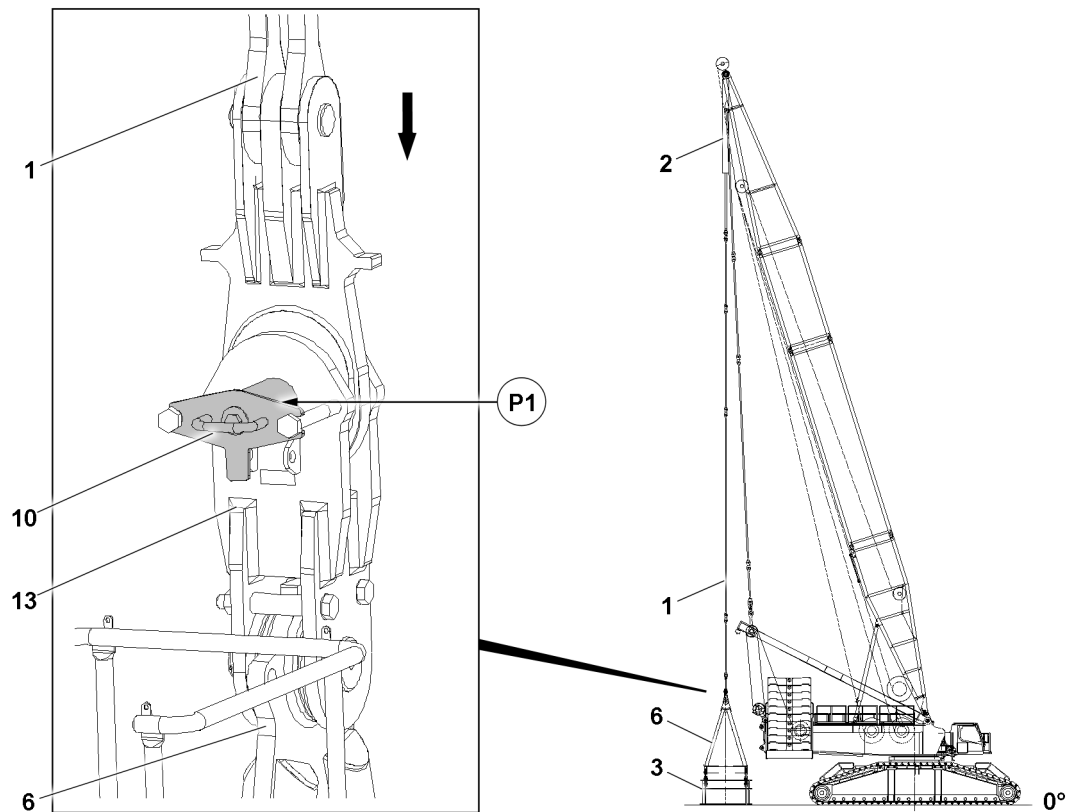


Fig.155411: Assembling the D-guy rods on the erection racks – Prerequisites

- |   |                         |
|---|-------------------------|
| <b>1</b> D-guy rods                           | <b>6</b> Erection rack  |
| <b>2</b> Pull cylinder                        | <b>10</b> Connector pin |
| <b>3</b> Divisible ballast pallet "VarioTray" | <b>13</b> Bracket       |

- ▶ Position the D-guy rods **1**, by extending the piston rods on the pull cylinders **2**, between the brackets **13** of the erection rack **6**.



#### Note

Retract / extend the pull cylinders **2**:

- ▶ Control the pull cylinders **2** from the crane cab, see the section "Lifting and lowering the derrick ballast using the pull cylinders".
- ▶ Operate the pull cylinder **2** with the radio remote control, see the "radio remote control operating instructions".

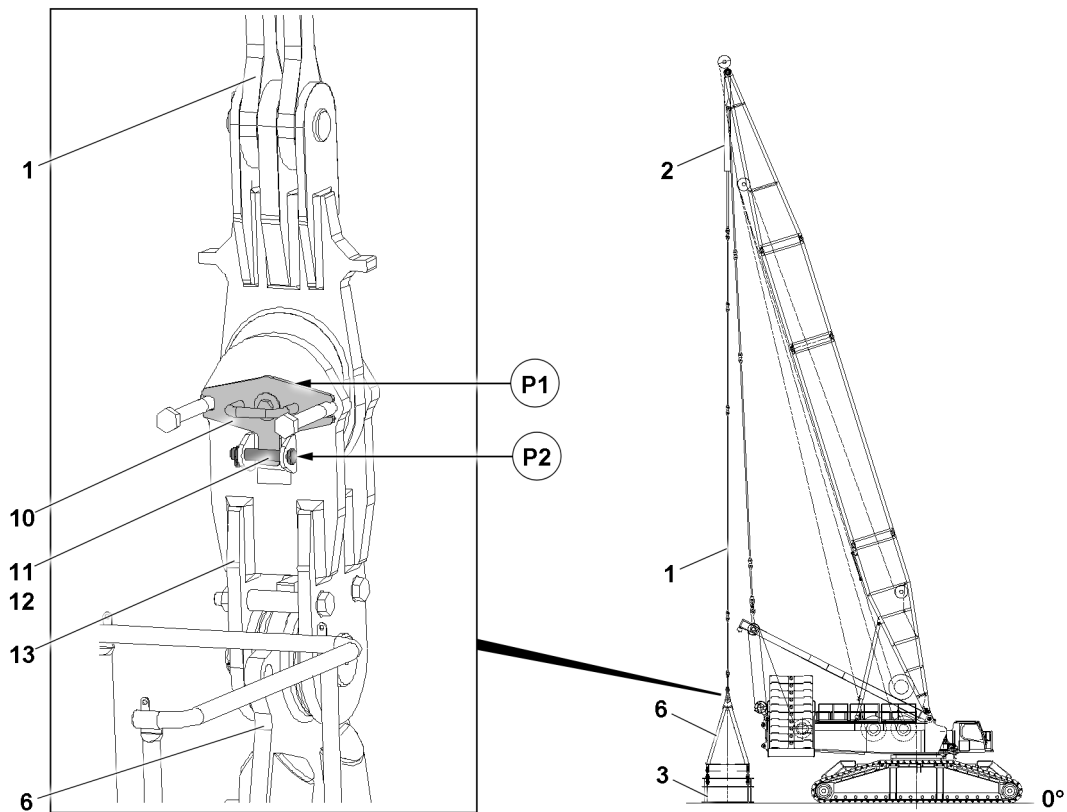


Fig.155412: Assembling the D-guy rods on the erection racks – Pinning procedure

1	D-guy rods	10	Connector pin
2	Pull cylinder	11	Retaining pin
3	Divisible ballast pallet "VarioTray"	12	Retaining element
6	Erection rack	13	Bracket

- ▶ Pin the D-guy rods **1** on the brackets **13** and secure.
- ▶ Insert the connector pin **10** in position **P1**.



#### WARNING

Unsecured connector pin **10**!

If the connector pins **10** are not secured with the retaining pin **11** and retaining element **12**, the connector pins **10** can loosen up by themselves during crane operation.

This can cause the crane to topple over.

Death, severe bodily injuries, property damage.

- ▶ Make sure that the connector pins **10** are secured.

- ▶ Insert the retaining pin **11** in position **P2** and secure with the retaining element **12**.
- ▶ Pin the second erection rack **6** on the D-guy rods **1**.



#### WARNING

Uncontrolled swinging of the divisible ballast pallet "VarioTray"!

If the divisible ballast pallet "VarioTray" **3** is lifted, it can start to swing.

Death, severe bodily injuries, property damage.

- ▶ It is prohibited to remain in the danger zone.
- ▶ Secure the divisible ballast pallet "VarioTray" with auxiliary ropes.

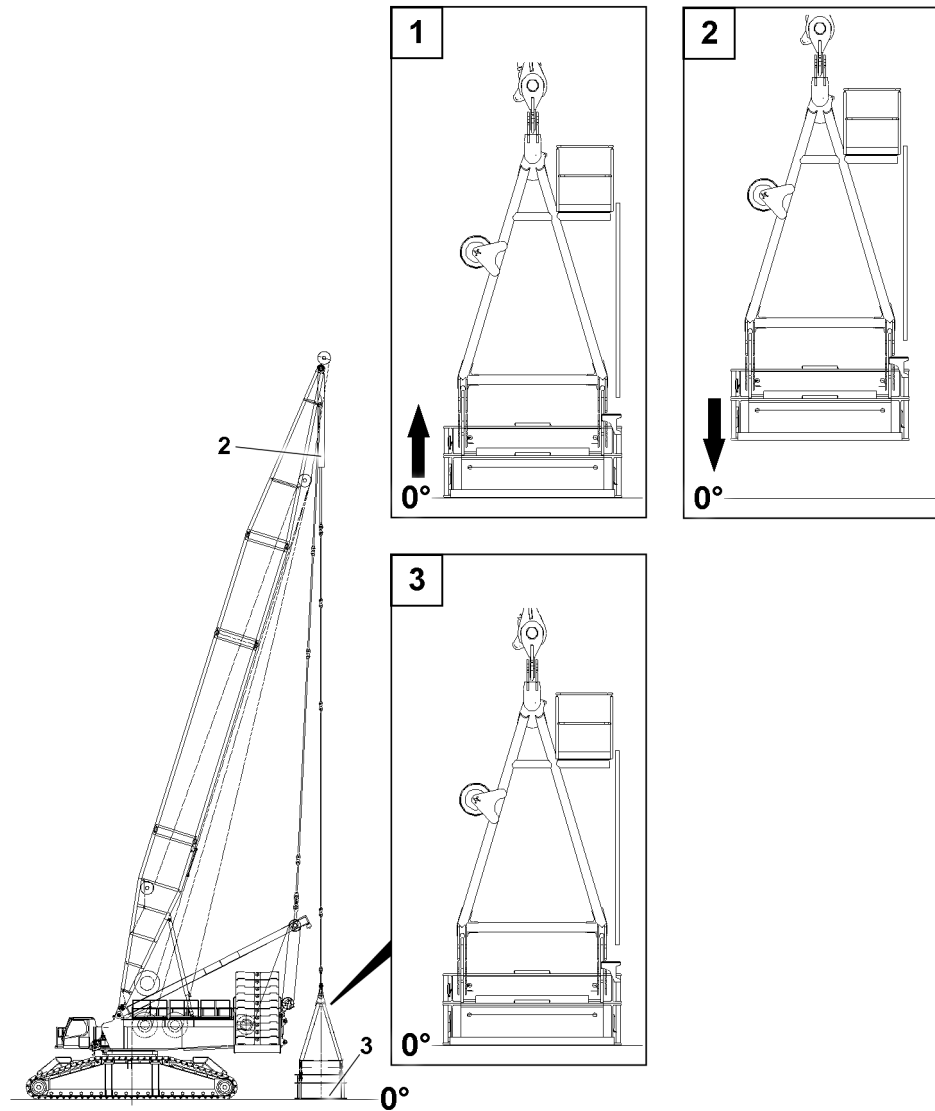


Fig. 155459

- ▶ Lift the empty divisible ballast pallet "VarioTray" 3 with the pull cylinders 2 and then set it down again.

**Result:**

- The divisible ballast pallet "VarioTray" 3 is thereby precisely placed vertically under the derrick boom head.

**Note**

The maximum ground unevenness for setting down the ballast pallet with ballast plates positioned on it is  $\pm 1^\circ$  in the longitudinal and lateral direction.

- ▶ Align the ballast pallet horizontally in time before positioning the ballast plates!
- ▶ Align the divisible ballast pallet "VarioTray" 3 horizontally.



## 9.2.2 Establishing the electrical connection from the suspended ballast to the turntable

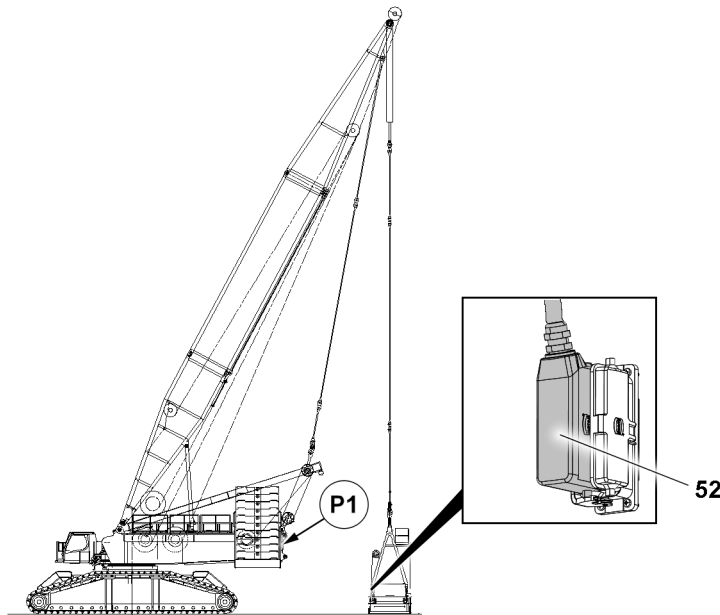


Fig.163647: Establishing the electrical connection from the suspended ballast to the turntable

Make sure that the following prerequisites are met:

- The suspended ballast is placed down on the ground.
- The electrical line **-X1100** is plugged into the terminal box **+S1100G** (large ballast pallet).

### NOTICE

The ignition switch is not in position 0!

If live electrical connections are disconnected / connected, then there is the danger that components can be damaged.

The crane functions can be limited.

- ▶ De-energize the electrical connections before disconnection / connection: Set the ignition switch to position 0.

### NOTICE

Damage due to unutilized pull relief!

The electrical components are tensioned and can therefore be damaged.

- ▶ Use the pull relief.
- ▶ Move the ignition switch to position 0.

Establish the electrical connection from the suspended ballast to the turntable:

- ▶ Insert the plug of the electrical line **52** into the turntable in position **P1**.



### Note

- ▶ Establish the electrical connections from the suspended ballast to the turntable, see the “wiring diagram”.

**NOTICE**

Damage to the electrical connections due to dirt, moisture and corrosion!

If unrequired electrical connections are not closed with their respective caps, the electrical connections can be damaged.

If the covers are removed from the electrical connections or control cabinets are opened, then moisture can infiltrate.

- ▶ Always properly close off all **non**-required electrical connections with their protective caps.
- ▶ Protect the electrical connections from water infiltration, this applies especially in the case of rain or snow.

**Note**

If **non**-required electrical connections are not closed with their respective dummy plugs, the electrical connections can be damaged.

- ▶ A malfunction can occur without bridging.
  - ▶ Observe the “wiring diagram”.
- 
- ▶ As a rule, close off non-required electrical connections (for example for accessories that are not installed) with the respective dummy plugs / dust caps.

### 9.2.3 Ballasting the suspended ballast

**Note**

- ▶ Ballast the suspended ballast, see section “Ballasting the divisible ballast pallet “VarioTray””.

## 9.3 Assembling the suspended ballast with the suspended ballast guide “V-frame”

Make sure that the following prerequisites are met:

- The crane is horizontally aligned.
- The derrick boom is properly assembled on the turntable.
- The main boom is properly assembled on the turntable.
- The central ballast has been installed on the crawler travel gear according to the load charts and / or the erection and take-down charts.
- The counterweight has been installed on the turntable according to the load charts or the erection and take-down charts.
- The LICCON overload protection has been set according to the data in the load chart.
- The LICCON overload protection settings have been compared with the actual set up configuration.
- An auxiliary crane is available.

### 9.3.1 Assembling the suspended ballast guide “V-frame” on the turntable frame with the main boom taken down

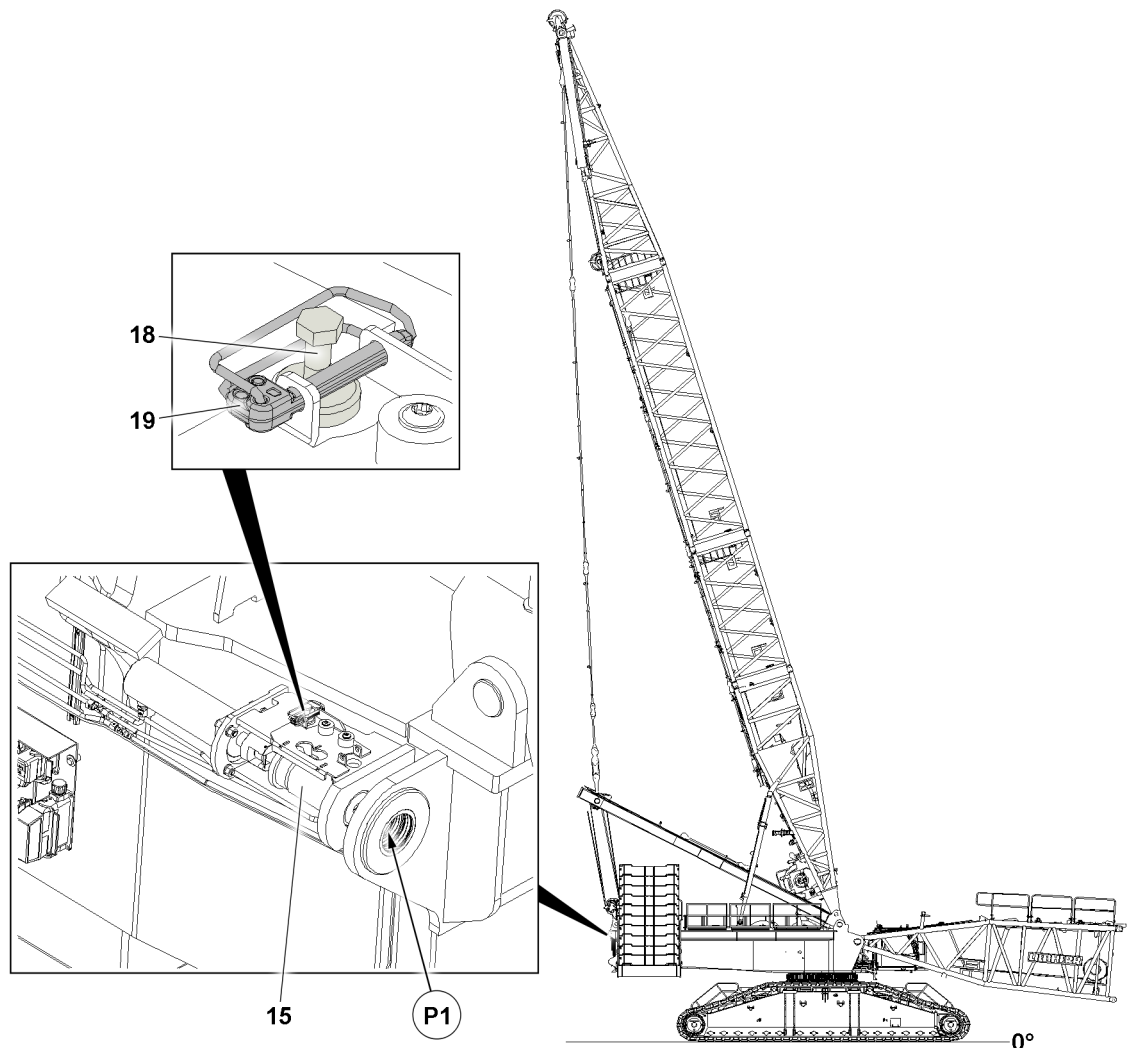


Fig.155415: Assembling the suspended ballast guide “V-frame” on the turntable frame – Prerequisites

- |                         |                             |
|-------------------------|-----------------------------|
| <b>15</b> Pin           | <b>19</b> Retaining element |
| <b>18</b> Retaining pin |                             |

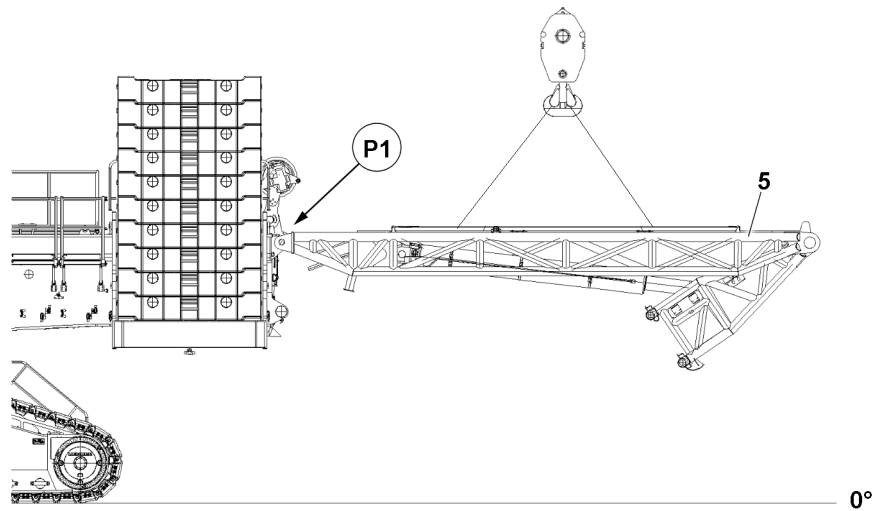
Make sure that the following prerequisites are met:

- The main boom is lying on the substructure on the ground.
- A lifting platform or other aids are available.
- An auxiliary crane is available.
- Both pins **15** are unpinned in positions **P1**.
- The railings on the suspended ballast guide “V-frame” **5** are assembled in the operating position, see chapter 2.06.
- The derrick angle is set in the BV operation operating window.
  - With derrick boom D 33 m , the derrick angle is set to 114.3°.
  - With derrick boom D 39 m , the derrick angle is set to 107.3°.

The suspended ballast guide “V-frame” **5** is pinned in two positions **P1**. The pinning procedure is described for one pin **15** as an example.

The pinning cylinders are operated using the radio remote control, see the “radio remote control” operating instructions.

- ▶ Remove the retaining element **19** and unpin the retaining pin **18**.



*Fig.155414: Lifting the suspended ballast guide "V-frame"*

#### **5** Suspended ballast guide "V-frame"

- ▶ Fasten the suspended ballast guide "V-frame" **5** to the auxiliary crane, see section "Fastening points".
- ▶ Lift the suspended ballast guide "V-frame" **5** to the pin positions **P1** on the rear of the turntable.

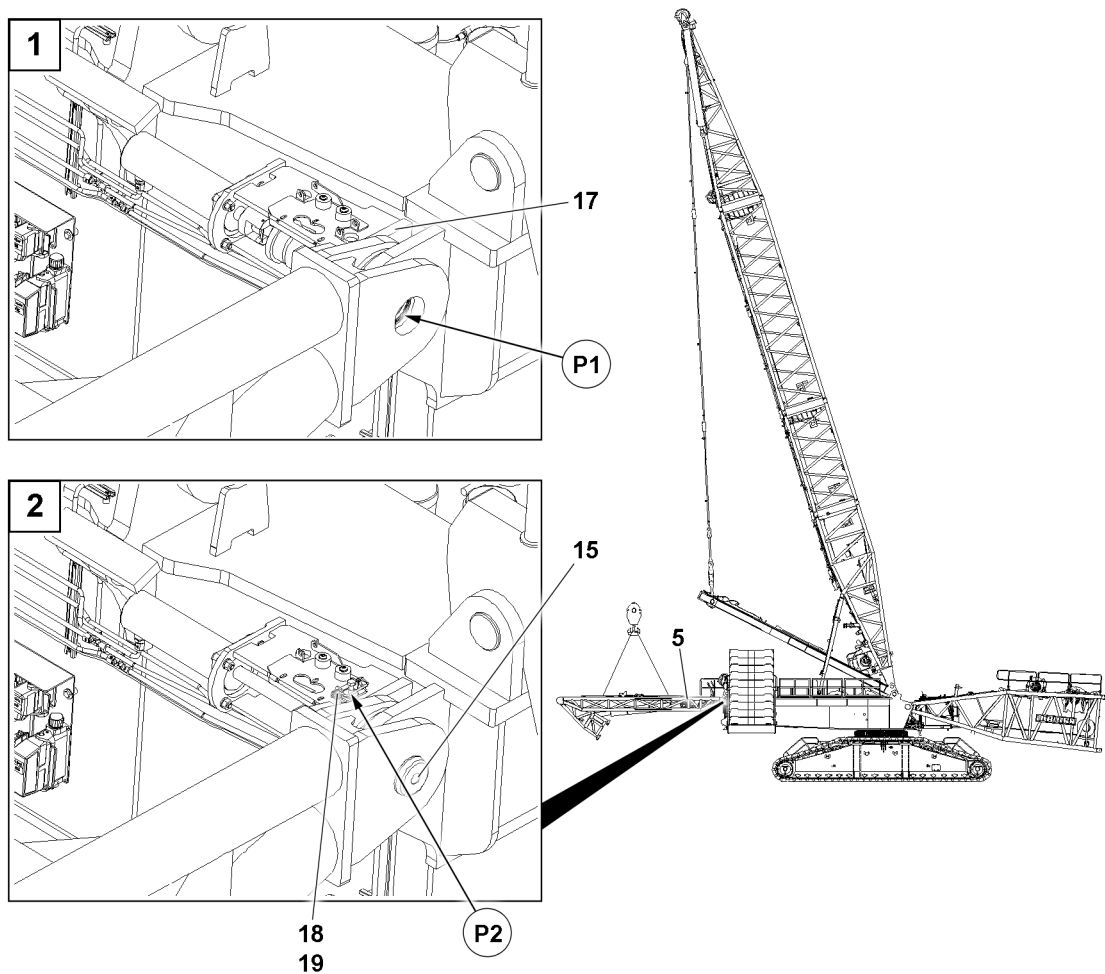


Fig.155416: Pinning the suspended ballast guide "V-frame"

- |    |                                   |    |                   |
|----|-----------------------------------|----|-------------------|
| 5  | Suspended ballast guide "V-frame" | 18 | Retaining pin     |
| 15 | Pin                               | 19 | Retaining element |
| 17 | Centering                         |    |                   |

- ▶ Position the "V-frame" suspended ballast guide 5 in the centering devices 17.

**Result:**

- The pin points **P1** of the turntable and suspended ballast guide "V-frame" 5 align.
- ▶ Insert the pin 15 on both sides.



**WARNING**

The crane can topple over!

If the pins 15 are not secured with retaining pins 18 and retaining elements 19, the pins 15 loosen up by themselves during crane operation.

Death, severe bodily injuries, property damage.

- ▶ Make sure that the pins 15 are secured with a retaining pin 18 and retaining element 19.
- ▶ Secure the pin 15: Insert the retaining pin 18 in position P2 and secure with the retaining element 19.

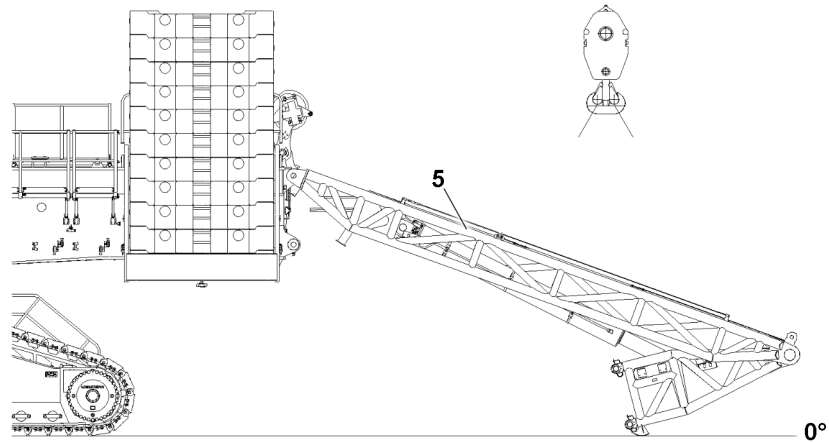


Fig.151447: Taking down the suspended ballast guide "V-frame"

**5** Suspended ballast guide "V-frame"

- ▶ Take the suspended ballast guide "V-frame" **5** down with the auxiliary crane.
- ▶ In the Set up program, change to the "BV-operation" operating mode.

### 9.3.2 Special assembly: Assembling the suspended ballast guide “V-frame” on the turntable frame with the main boom erected

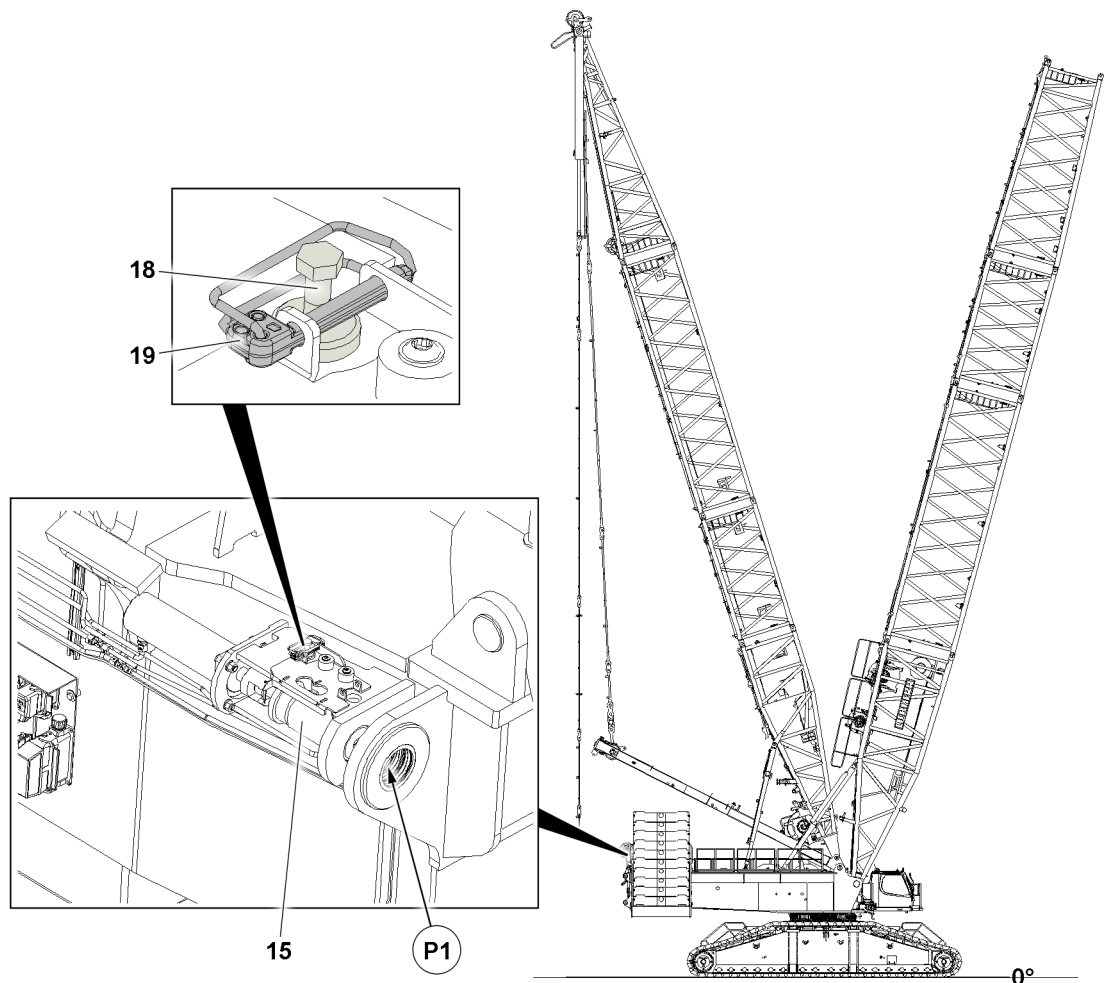


Fig.162981: Assembling the suspended ballast guide “V-frame” on the turntable frame – Prerequisites

- |                         |                             |
|-------------------------|-----------------------------|
| <b>15</b> Pin           | <b>19</b> Retaining element |
| <b>18</b> Retaining pin |                             |

Make sure that the following prerequisites are met:

- The suspended ballast guide is disassembled.
- The main boom is in the BV operation operating window in chart column DB- 0 t.
- A lifting platform or other aids are available.
- The derrick angle is set in the BV operation operating window.
  - With derrick boom D 33 m , the derrick angle is set to 114.3°.
  - With derrick boom D 39 m , the derrick angle is set to 107.3°.
- An auxiliary crane is available.
- Both pins **15** are unpinned in positions **P1**.
- The railing on the suspended ballast guide “V-frame” **5** is assembled in the operating position, see chapter 2.06.
- The central ballast is installed according to later BV operation.

The suspended ballast guide “V-frame” **5** is pinned in two positions **P1**. The pinning procedure is described based on one pin **15** as an example.

The pinning cylinders are operated using the radio remote control, see the “radio remote control” operating instructions.

- ▶ Remove the retaining element **19** and unpin the retaining pin **18**.

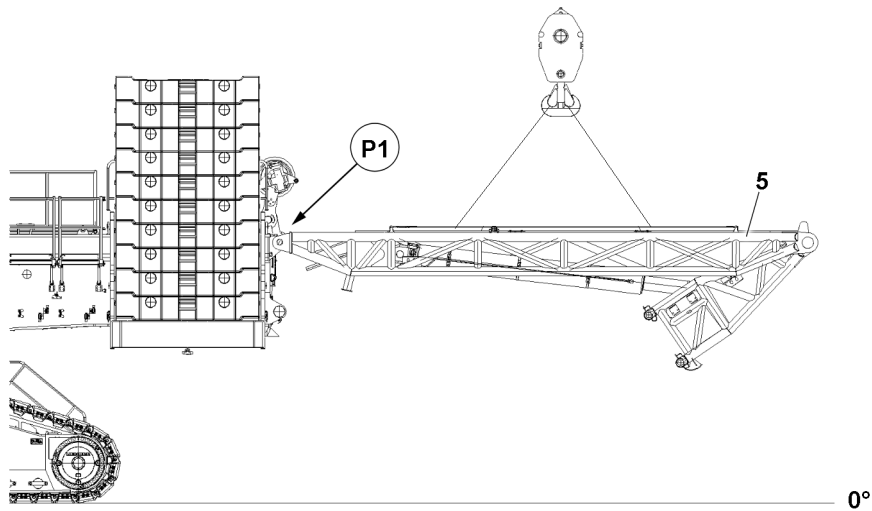


Fig.155414: Lifting the suspended ballast guide "V-frame"

#### 5 Suspended ballast guide "V-frame"

- ▶ Fasten the suspended ballast guide "V-frame" **5** to the auxiliary crane, see section "Fastening points".
- ▶ Lift the suspended ballast guide "V-frame" **5** to the pin positions **P1** on the rear of the turntable.



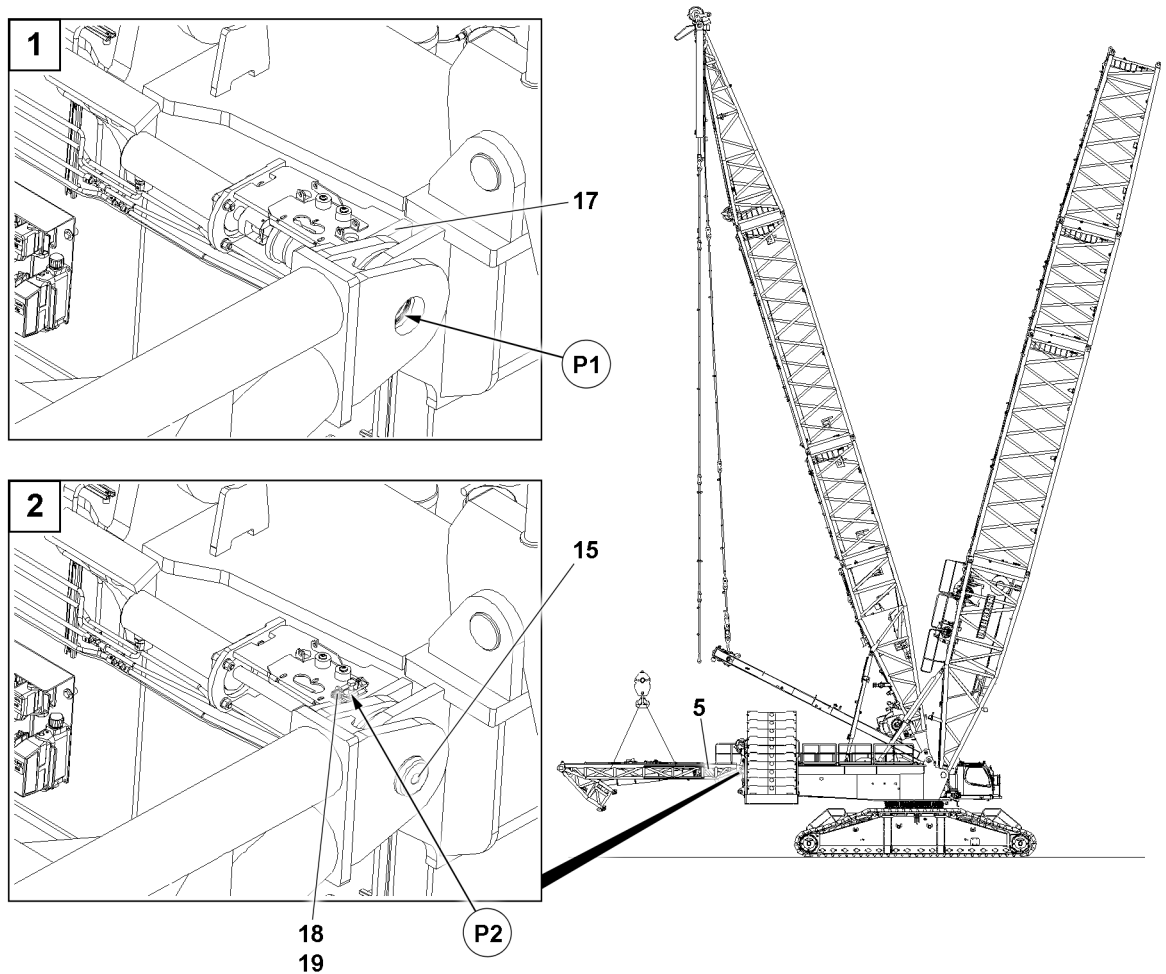


Fig.162982: Pinning the suspended ballast guide "V-frame"

- |    |                                   |    |                   |
|----|-----------------------------------|----|-------------------|
| 5  | Suspended ballast guide "V-frame" | 18 | Retaining pin     |
| 15 | Pin                               | 19 | Retaining element |
| 17 | Centering device                  |    |                   |

- ▶ Position the "V-frame" suspended ballast guide **5** in the centering devices **17**.

**Result:**

- The pin points **P1** of the turntable and suspended ballast guide "V-frame" **5** align.
- ▶ Insert the pin **15** on both sides.



**WARNING**

The crane can topple over!

If the pins **15** are not secured with retaining pins **18** and retaining elements **19**, the pins **15** loosen up by themselves during crane operation.

Death, severe bodily injuries, property damage.

- ▶ Make sure that the pins **15** are secured with a retaining pin **18** and retaining element **19**.
- ▶ Secure the pin **15**: Insert the retaining pin **18** in position **P2** and secure with the retaining element **19**.

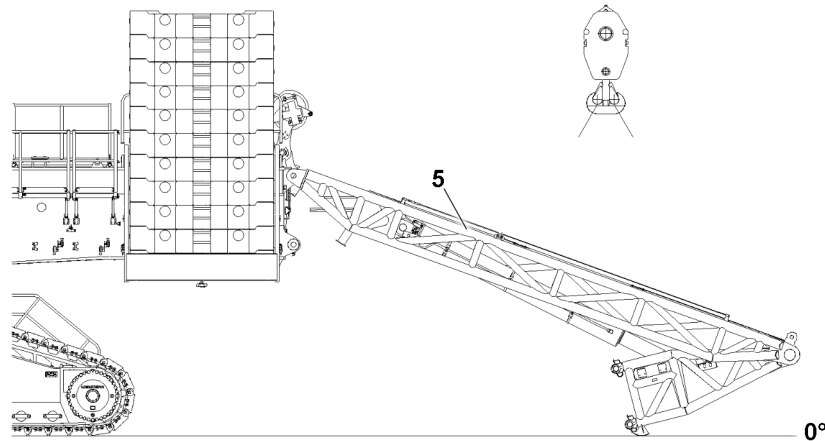


Fig.151447: Taking down the suspended ballast guide "V-frame"

#### 5 Suspended ballast guide "V-frame"

- ▶ Take the suspended ballast guide "V-frame" 5 down with the auxiliary crane.
- ▶ In the Set up program, change to the "BV-operation" operating mode.

### 9.3.3 Establishing the electrical connection from the pivot section of the suspended ballast guide to the turntable

Make sure that the following prerequisites are met:

- The suspended ballast guide is taken down.

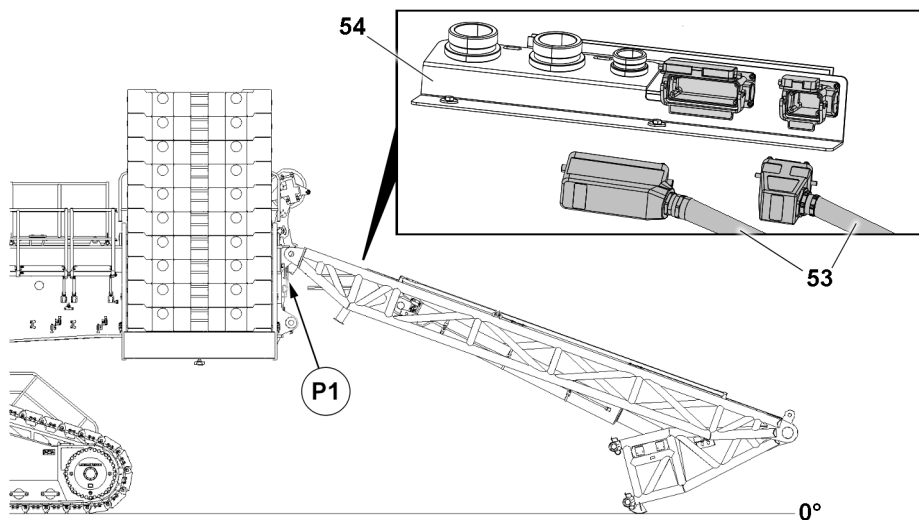


Fig.163644: Establishing the electrical connection from the pivot section of the suspended ballast guide to the turntable

53 Electrical lines

54 Parking bracket



#### WARNING

The crane can topple over due to incomplete assembly!

If the electrical connection between the suspended ballast guide "V-frame" and the turntable is not established, the crane control cannot determine the crane geometry.

If the crane geometry is not determined, the crane can be overloaded and topple over.

- ▶ After installing the suspended ballast guide "V-frame", establish the electrical connection from the suspended ballast guide "V-frame" to the turntable.

**WARNING**

Toppling crane due to incorrect set up configuration!

If an incorrect set up configuration is entered in the LICCON computer system, the incorrect load chart is set.

If the incorrect load chart is set, the crane can be overloaded and topple over.

- ▶ After installing the suspended ballast guide “V-frame”, enter the correct set up configuration in the LICCON computer system.

**NOTICE**

The ignition switch is not in position 0!

If live electrical connections are disconnected / connected, then there is the danger that components can be damaged.

The crane functions can be limited.

- ▶ De-energize the electrical connections before disconnection / connection: Set the ignition switch to position 0.

- ▶ Move the ignition switch to position 0.

Establish the electrical connection from the pivot section of the suspended ballast guide to the turntable:

- ▶ Unplug the plug of the electrical lines **53** on the parking bracket **54** and insert in the connection point in position **P1**.

**Note**

- ▶ Establish the electrical connection from the pivot section of the suspended ballast guide to the turntable, see the “wiring diagram”.

**NOTICE**

Damage to the electrical connections due to dirt, moisture and corrosion!

If unrequired electrical connections are not closed with their respective caps, the electrical connections can be damaged.

If the covers are removed from the electrical connections or control cabinets are opened, then moisture can infiltrate.

- ▶ Always properly close off all **non**-required electrical connections with their protective caps.
- ▶ Protect the electrical connections from water infiltration, this applies especially in the case of rain or snow.

**Note**

If **non**-required electrical connections are not closed with their respective dummy plugs, the electrical connections can be damaged.

- ▶ A malfunction can occur without bridging.
- ▶ Observe the “wiring diagram”.
- ▶ As a rule, close off non-required electrical connections (for example for accessories that are not installed) with the respective dummy plugs / dust caps.

### 9.3.4 Establishing the hydraulic connections from the suspended ballast guide “V-frame” to the turntable

The hydraulic connections are established with quick couplings.

Make sure that the following prerequisites are met:

- The suspended ballast guide “V-frame” is taken down.

The hydraulic connections are established with quick couplings.

When using quick couplings to connect the hydraulic lines, make sure that the coupling procedure is carried out correctly.

**WARNING**

Pressure in the hydraulic lines!

If the pressure supply is not interrupted before connecting / releasing the hydraulic lines, the hydraulic oil can escape with high pressure.

Death, severe bodily injuries, property damage.

- ▶ Release the pressure in the hydraulic system before connecting / disconnecting: Interrupt the pressure supply and wait a short time.

**WARNING**

Loss of pressure or leakage!

Incorrectly coupled or self-loosening quick couplings (return lines in particular) can result in serious accidents due to component failure.

Death, severe bodily injuries, property damage.

- ▶ Check that the quick couplings have been properly connected before starting work with the crane.
- ▶ Connect the coupling components (sleeve and connector) and screw them together with the knurled nut.
- ▶ Tighten the hydraulic coupling by hand. Turn the knurled nut until it reaches a tangible, fixed stop position.
- ▶ Establish the hydraulic connections, see the Hydraulic diagram.

### 9.3.5 Pinning the D-guy rods in the assembly position on the “V-frame” pivot section

**Note**

- ▶ The main views of the illustrations that are used are examples.
- ▶ The main boom can either be erected or taken down.

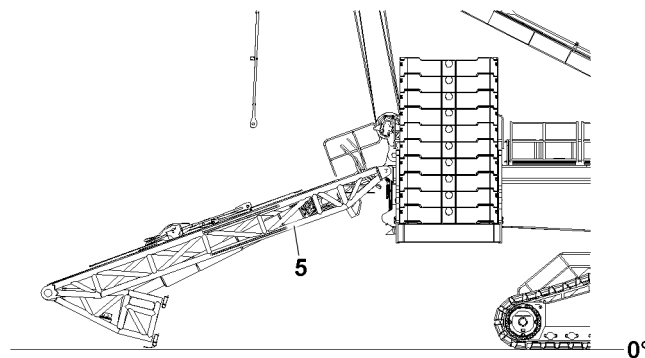
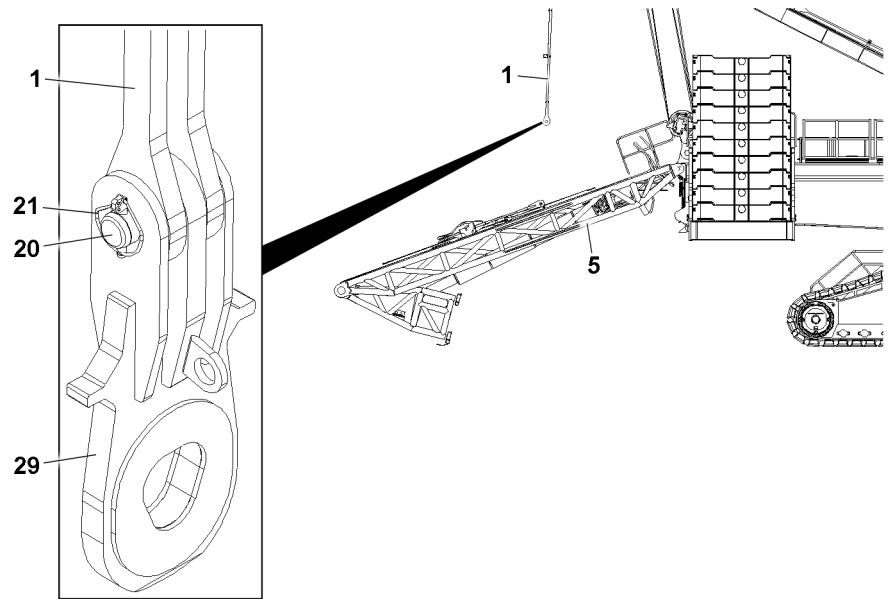


Fig.155434: Pinning the D-guy rods in the assembly position on the “V-frame” pivot section – Prerequisites

#### 5 Suspended ballast guide “V-frame”

Make sure that the following prerequisites are met:

- The suspended ballast guide “V-frame” **5** is taken down on the ground.



*Fig.155435: Pinning the D-guy rods in the assembly position on the “V-frame” pivot section – Unpinning the brackets*

- |           |                                   |           |                   |
|-----------|-----------------------------------|-----------|-------------------|
| <b>1</b>  | D-guy rods                        | <b>21</b> | Retaining element |
| <b>5</b>  | Suspended ballast guide “V-frame” | <b>29</b> | Bracket           |
| <b>20</b> | Pin                               |           |                   |

- ▶ Check if the brackets **29** are removed on both sides.

The brackets **29** must be removed on both sides of the D-guy rods **1**. The disassembly is described for one bracket **29** as an example.

When brackets **29** are assembled:

- ▶ Fasten the brackets **29** to the auxiliary crane.
- ▶ Remove the retaining element **21**.
- ▶ Unpin the pin **20**.
- ▶ Take down the bracket **29** in a suitable location.

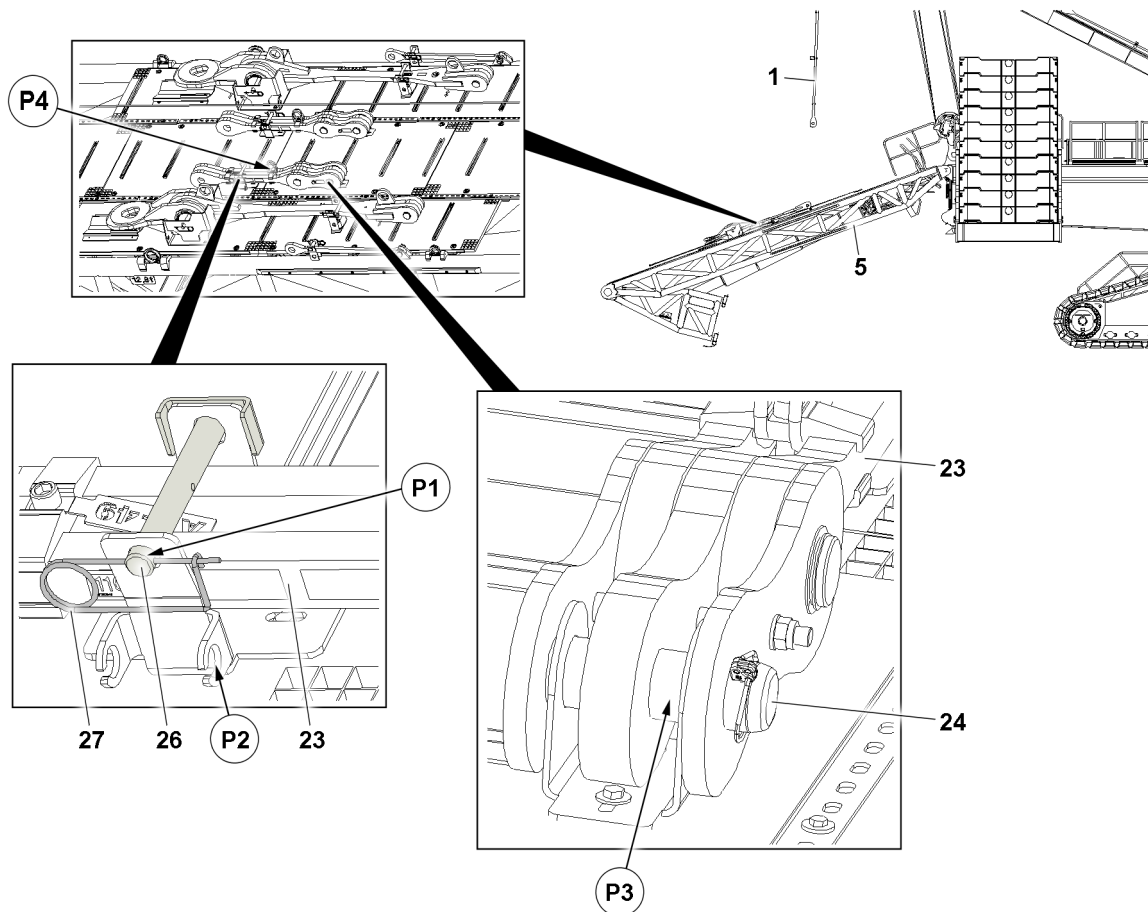


Fig.155417: Pinning the D-guy rods in the assembly position on the "V-frame" pivot section – Releasing the guy rods

1	D-guy rods	24	Pin
5	Suspended ballast guide "V-frame"	26	Pin
23	Guy rod	27	Retaining element



### DANGER

Incorrect length of the D-guy rods!  
The crane can topple over.

Death, severe bodily injuries, property damage.

If the guy rods **23** are installed with a derrick boom length of 33 m, the movements of the V-frame are incorrectly calculated.

- ▶ Make sure that guy rods **23** are assembled only with a derrick boom length of 39 m.

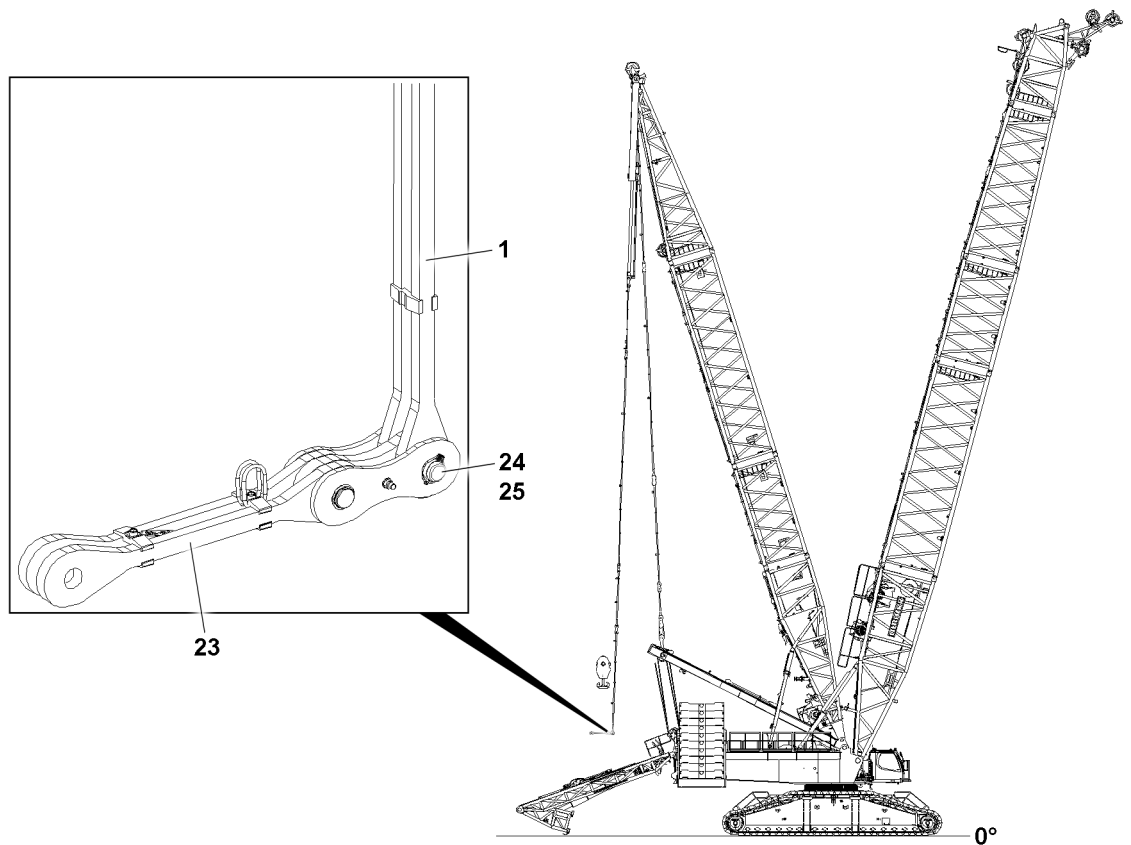


### Note

- ▶ The guy rods **23** are assembled only with an installed derrick boom with 39 m. This assembly step is eliminated with a derrick boom length of 33 m.

The guy rods **23** are pinned on both sides on the D-guy rods **1**. The pinning procedure is described for one guy rod **23** as an example.

- ▶ Release the guy rod **23** in position **P1**: Release and unpin the pin **26**.
- ▶ Insert the pin **26** in the park position **P2**.
- ▶ Secure the pin **26** in park position **P2** with the retaining element **27**.
- ▶ Release the guy rod **23** in position **P3**: Release and unpin the pin **24**.
- ▶ Fasten the guy rod **23** in position **P4** to the auxiliary crane.



*Fig.155418: Pinning the D-guy rods in the assembly position on the “V-frame” pivot section – Pinning the guy rods*

<b>1</b>	D-guy rods	<b>24</b>	Pin
<b>23</b>	Guy rod	<b>25</b>	Retaining element

- ▶ Position the guy rod **23** so it can be pinned on the D-guy rods **1**.
- ▶ Insert the pin **24**.
- ▶ Secure the pin **24** with the retaining element **25**.
- ▶ Lower the guy rod **23**.
- ▶ Remove the fastening equipment.
- ▶ Repeat the procedure for the second guy rod **23** the same way as described before.

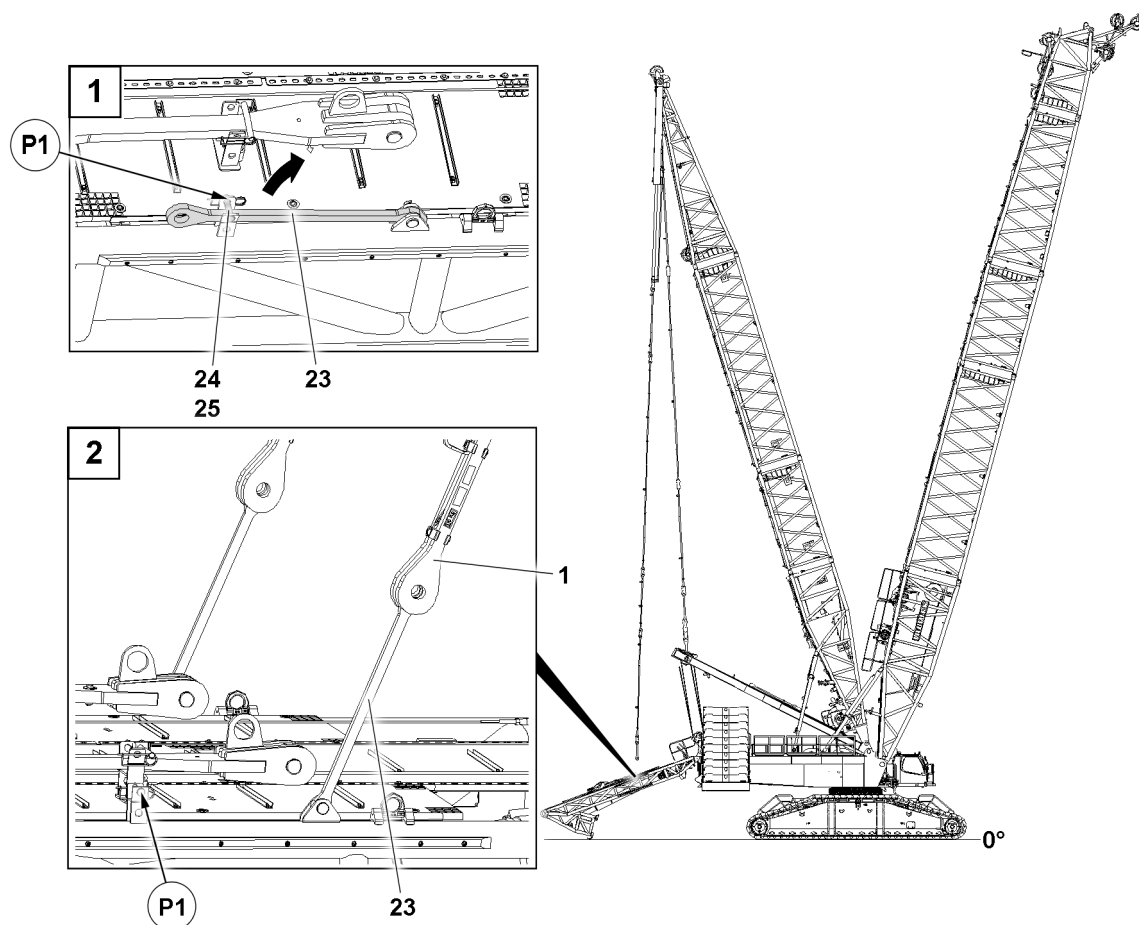


Fig.155419: Pinning the D-guy rods in the assembly position on the "V-frame" pivot section – Positioning the guy rods

- |    |            |    |                   |
|----|------------|----|-------------------|
| 1  | D-guy rods | 24 | Retaining pin     |
| 23 | Guy rod    | 25 | Retaining element |

- ▶ Release the guy rod **23**: Release the retaining pin **24** in position **P1** and unpin.
- ▶ Swing the guy rod **23** up and position it so that it can be pinned on the D-guy rods **1**.
- ▶ Insert the retaining pin **24** in position **P1** and secure with the retaining element **25**.



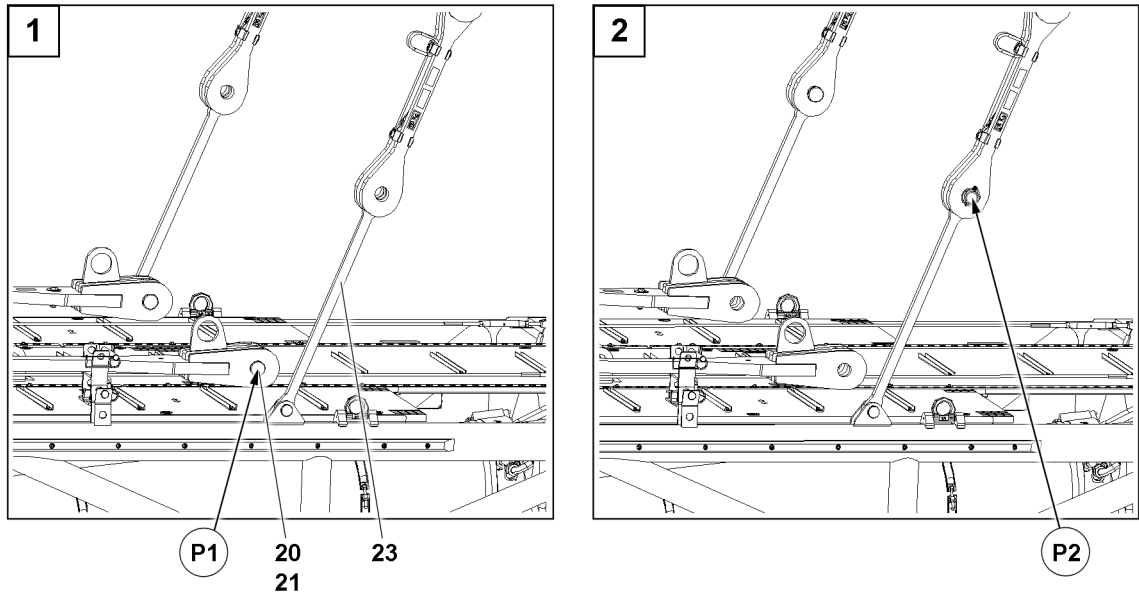


Fig.155420: Pinning the D-guy rods in the assembly position on the “V-frame” pivot section – Pinning the guy rods

- 20 Pin
- 21 Retaining element
- 23 Guy rod

- ▶ Release and unpin the pin 20 in position P1.
- ▶ Insert the pin 20 in position P2.
- ▶ Secure the pin 20 with the retaining element 21.
- ▶ Repeat the procedure the same way for the second guy rod 23.

### 9.3.6 Assembling the end section

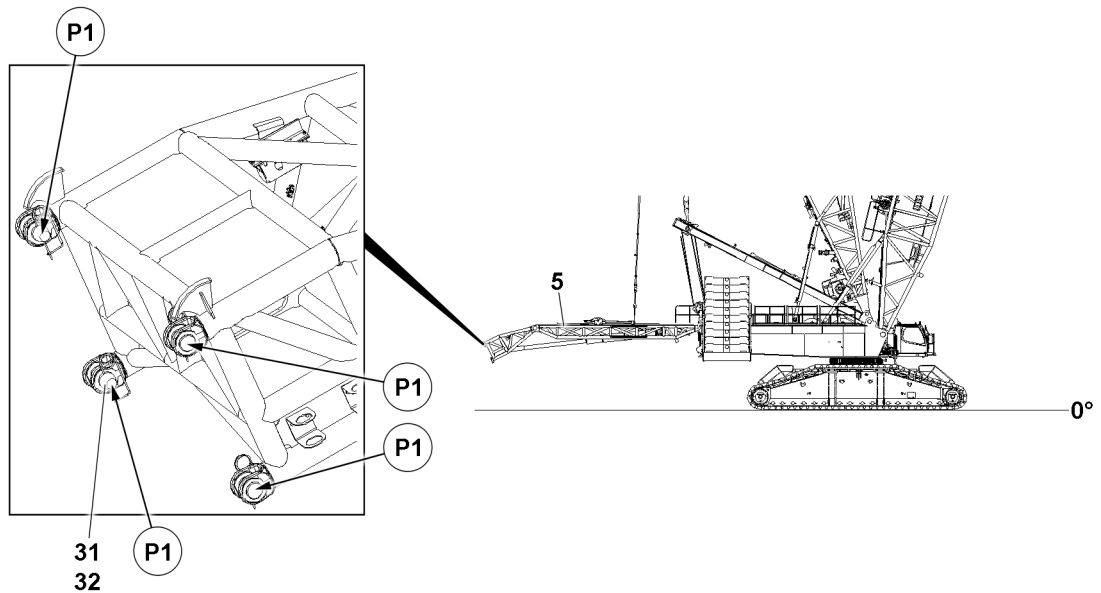


Fig.155421: Assembling the end section – Prerequisites

- 5 Suspended ballast guide “V-frame”
- 31 Pin
- 32 Retaining element

LWE/LR 1800-1-0-000/27200-07-02/en

**WARNING**

Impermissible load of the suspended ballast guide “V-frame”!

If the pull cylinder is retracted and extended unevenly, the suspended ballast guide “V-frame” **5** can be damaged.

Death, severe bodily injuries, property damage.

- ▶ Retract and extend both pull cylinders in the same position.
- ▶ Retract and extend both pull cylinders synchronously.

- ▶ Lift the suspended ballast guide “V-frame” **5** with the pull cylinders.
- ▶ Completely extend the suspended ballast guide “V-frame” **5**: Move the cylinder to the end position.
- ▶ Check if the pins **31** are pinned in positions **P1**.

When the pins **31** are pinned in positions **P1**:

- ▶ Unpin the pin **31**.

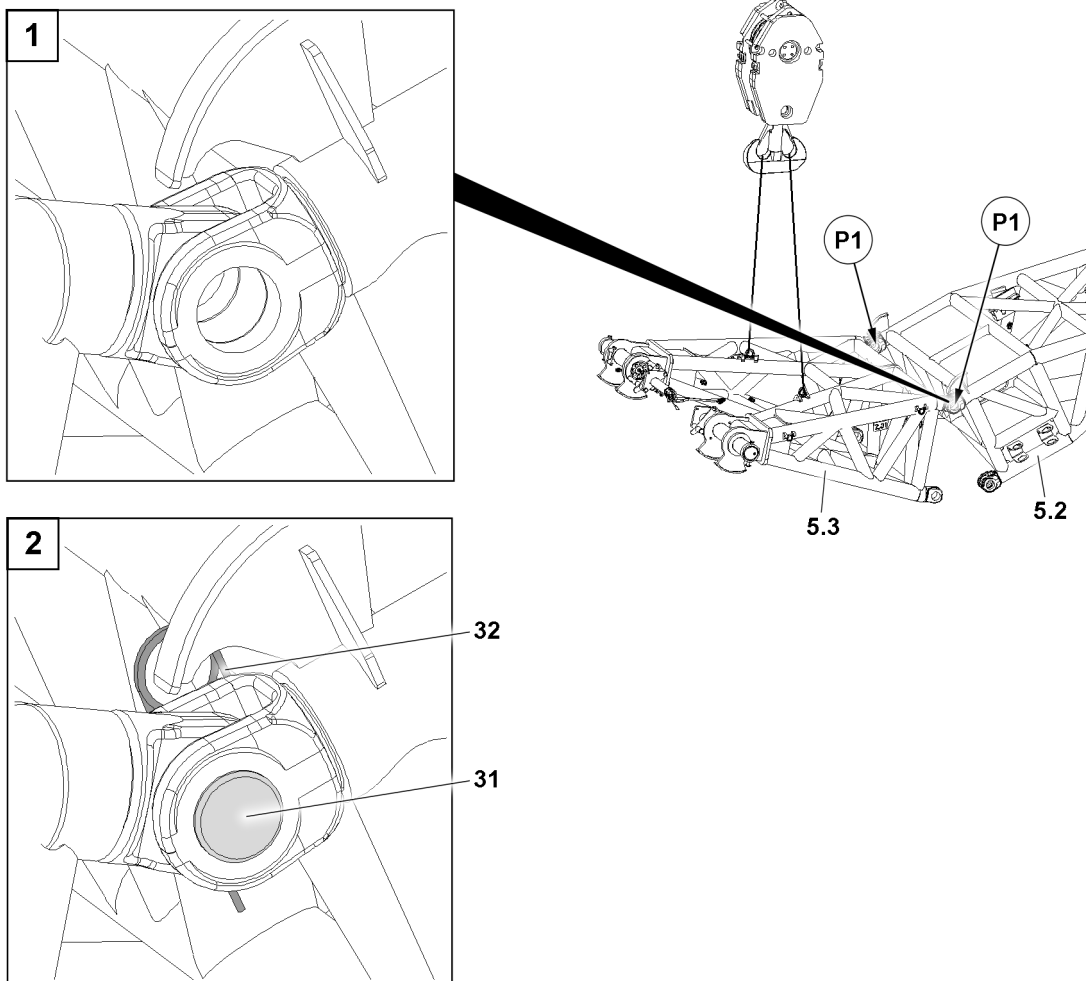


Fig.155422: Assembling the end section — Pinning the end section on top

<b>5.2</b> Pivot section	<b>31</b> Pin
<b>5.3</b> End section	<b>32</b> Retaining element

The end section **5.3** is pinned on the top in two positions **P1**. The pinning procedure is described for one pin **31** as an example:

- ▶ Fasten the end section **5.3** to the auxiliary crane.
- ▶ Lift the end section **5.3** to the pin positions **P1** in the pivot section **5.2**.

When the pin bores align:

- ▶ Insert the pin **31** in position **P1** and secure with the retaining element **32**.

- ▶ Repeat the procedure the same way for the second pin **31**.

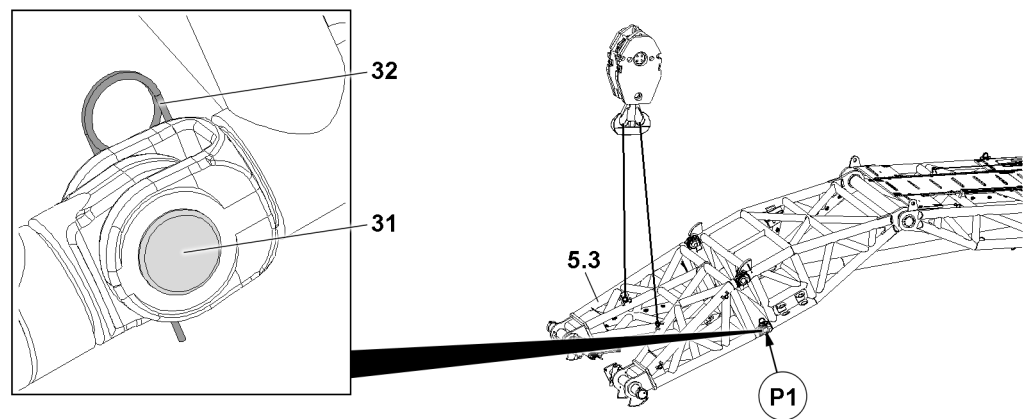


Fig.155423: Assembling the end section — Pinning the end section at the bottom

**5.3** End section  
**31** Pin

**32** Retaining element

The end section **5.3** is pinned on the bottom in two positions **P1**. The pinning procedure is described for one pin **31** as an example:

- ▶ Lower the end section **5.3** with the auxiliary crane until the pin bores align.

When the pin bores align:

- ▶ Insert the pin **31** in position **P1** and secure with the retaining element **32**.
- ▶ Repeat the procedure the same way for the second pin **31**.

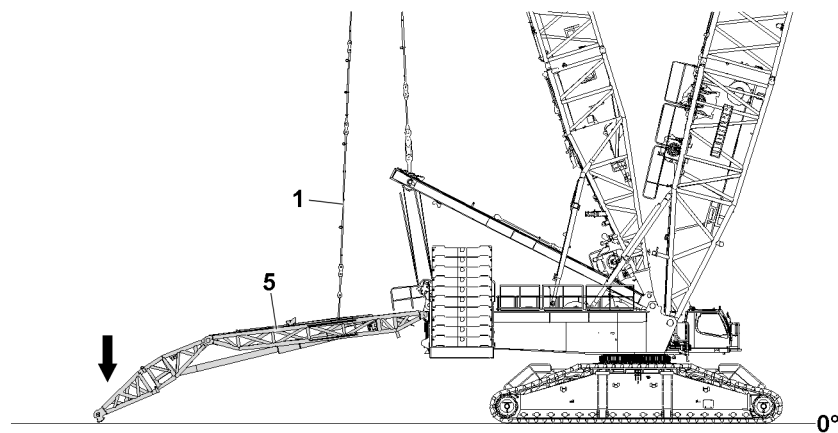


Fig.155424: Assembling the end section — Placing the suspended ballast guide “V-frame” on the ground

**1** D-guy rods

**5** Suspended ballast guide “V-frame”

- ▶ Place the suspended ballast guide “V-frame” **5** on the ground until the D-guy rods **1** are relieved.

### 9.3.7 Establishing the electrical connection from the end section to the pivot section of the suspended ballast guide

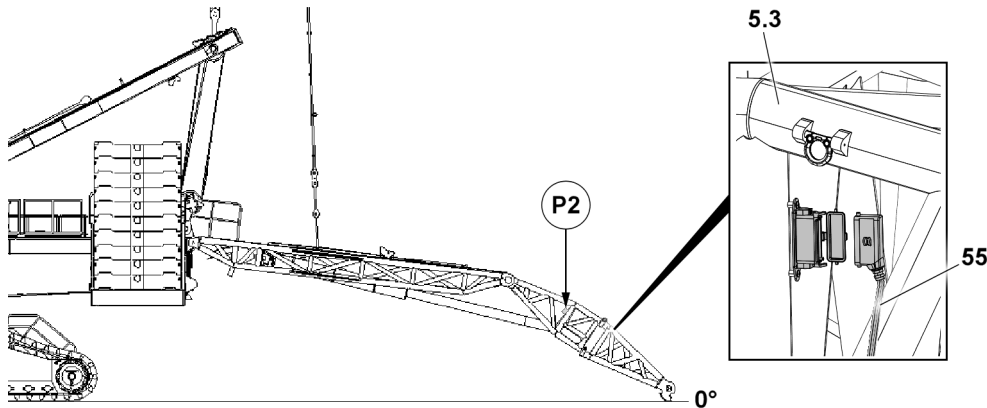


Fig. 163645: Establishing the electrical connection from the end section to the pivot section of the suspended ballast guide

**55** Electrical line

**5.3** End section

Make sure that the following prerequisites are met:

- The suspended ballast guide is taken down.

#### NOTICE

The ignition switch is not in position 0!

If live electrical connections are disconnected / connected, then there is the danger that components can be damaged.

The crane functions can be limited.

- ▶ De-energize the electrical connections before disconnection / connection: Set the ignition switch to position 0.

- ▶ Move the ignition switch to position 0.

Establish the electrical connection from the end section to the pivot section of the suspended ballast guide:

- ▶ Unplug the plug of the electrical line **55** on the end section **5.3** and insert it in position **P2**.



#### Note

- ▶ Establish the electrical connection from the end section to the pivot section of the suspended ballast guide, see the “wiring diagram”.

#### NOTICE

Damage to the electrical connections due to dirt, moisture and corrosion!

If unrequired electrical connections are not closed with their respective caps, the electrical connections can be damaged.

If the covers are removed from the electrical connections or control cabinets are opened, then moisture can infiltrate.

- ▶ Always properly close off all **non**-required electrical connections with their protective caps.
- ▶ Protect the electrical connections from water infiltration, this applies especially in the case of rain or snow.



#### Note

If **non**-required electrical connections are not closed with their respective dummy plugs, the electrical connections can be damaged.

- ▶ A malfunction can occur without bridging.
- ▶ Observe the “wiring diagram”.

- ▶ As a rule, close off non-required electrical connections (for example for accessories that are not installed) with the respective dummy plugs / dust caps.

### 9.3.8 Assembling the guy rods in the transport position

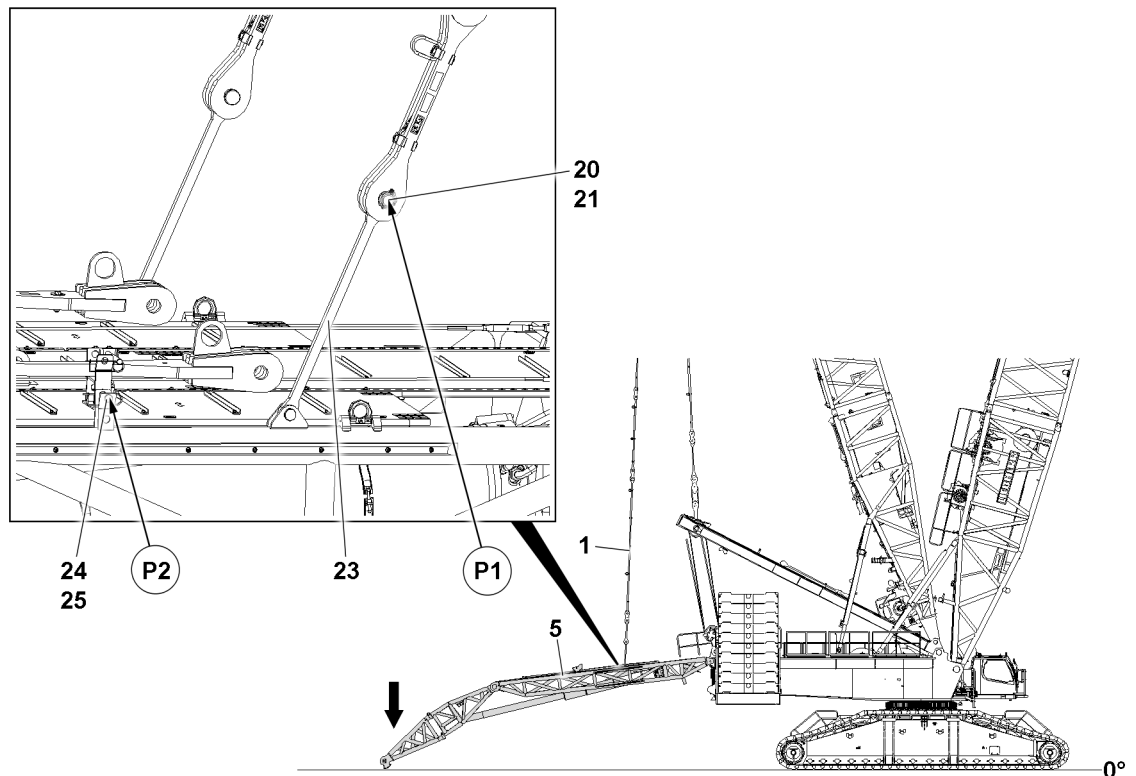


Fig.155425: Assembling the guy rods in the transport position – Take-down procedure

1	D-guy rods	23	Guy rod
5	Suspended ballast guide "V-frame"	24	Retaining pin
20	Pin	25	Retaining element
21	Retaining element		

- ▶ Release and unpin the pin **20** in position **P1**.



#### WARNING

Uncontrolled swinging of the guy rod **23**!  
Danger of crushed limbs.

- ▶ Keep hands away from the danger zone.
  - ▶ Secure the guy rod with a suitable aid to prevent uncontrolled swinging.
- 
- ▶ Swing the guy rod **23** down.
  - ▶ Secure the guy rod **23** with the retaining pin **24** and retaining element **25** in the transport position **P2**.

### 9.3.9 Assembling the guy rods on the D-guy rods

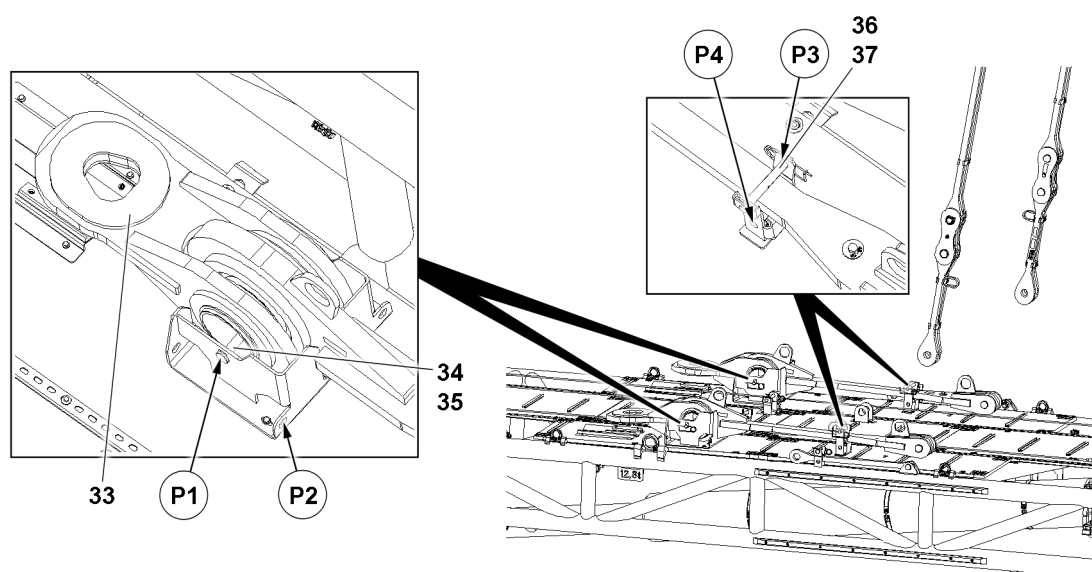


Fig.155426: Assembling the guy rods on the D-guy rods – Releasing the guy rods

<b>33</b>	Guy rod	<b>36</b>	Pin
<b>34</b>	Pin	<b>37</b>	Retaining element
<b>35</b>	Retaining element		

- ▶ Release the guy rods **33** on both sides in position **P1**: Release and unpin the pin **34**.
- ▶ Insert the pin **34** in the park position **P2**.
- ▶ Secure the pin **34** in the park positions **P2** with retaining elements **35**.
- ▶ Release the guy rods **33** on both sides in position **P3**: Release and unpin the pin **36**.
- ▶ Insert the pin **36** in the park position **P4**.
- ▶ Secure the pin **36** in the park positions **P4** with retaining elements **37**.

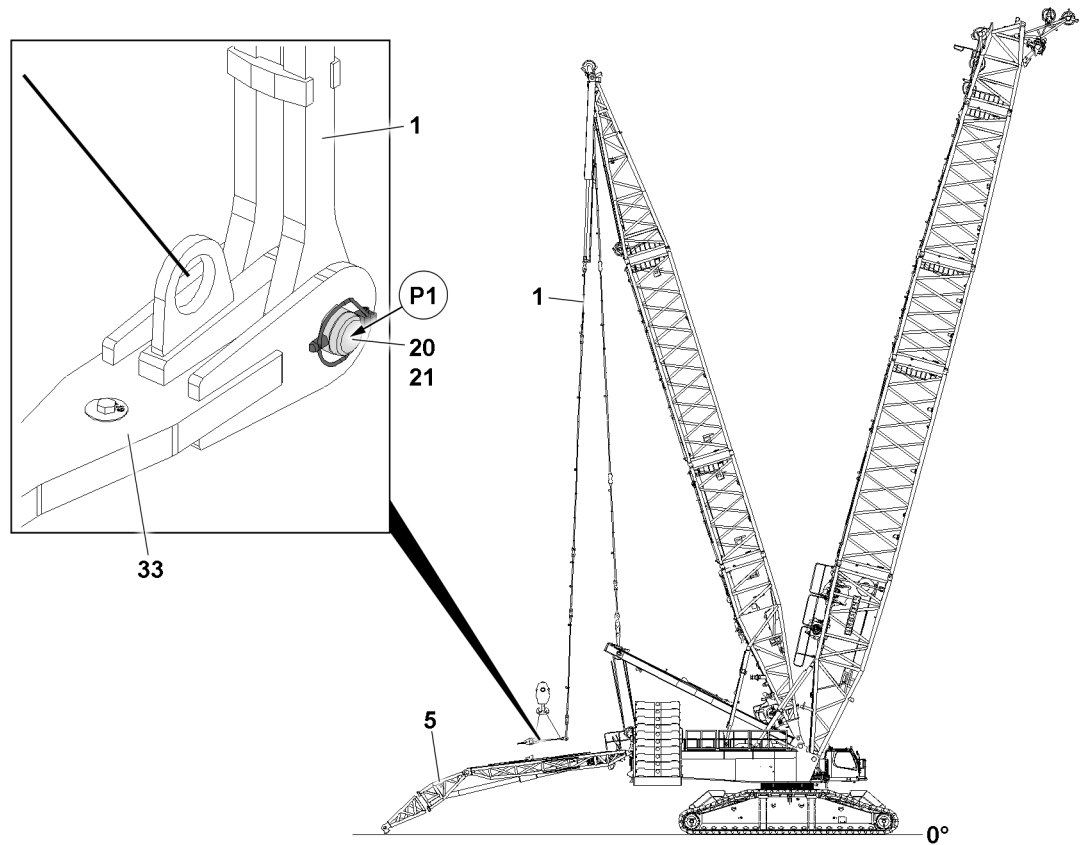


Fig.155427: Assembling the guy rods on the D-guy rods – Pinning procedure

- |    |                                   |    |                   |
|----|-----------------------------------|----|-------------------|
| 1  | D-guy rods                        | 21 | Retaining element |
| 5  | Suspended ballast guide "V-frame" | 33 | Guy rod           |
| 20 | Pin                               |    |                   |

The guy rods **33** are pinned on both sides on the D-guy rods **1**. The pinning procedure is described for one guy rod **33** as an example.

- ▶ Fasten the guy rod **33** to the auxiliary crane.
- ▶ Position the guy rod **33** so it can be pinned on the D-guy rods **1**.
- ▶ Insert the pin **20**.
- ▶ Secure the pin **20** with the retaining element **21**.
- ▶ Lower the guy rod **33** to the side next to the suspended ballast guide "V-frame" **5**.
- ▶ Remove the fastening equipment.
- ▶ Repeat the procedure for the second guy rod **33** the same way as described before.

### 9.3.10 Assembling the D-guy rods on the suspended ballast guide "V-frame"

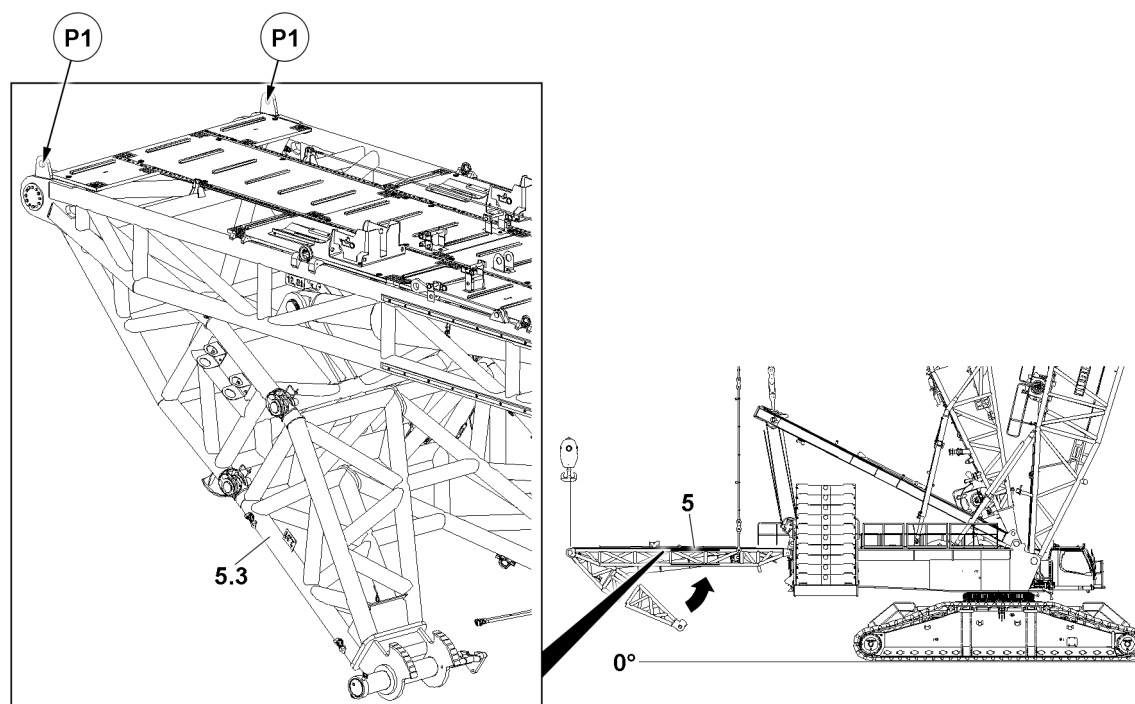


Fig.155428: Assembling the D-guy rods on the suspended ballast guide "V-frame" – Fastening the suspended ballast guide "V-frame" to the auxiliary crane

**5** Suspended ballast guide "V-frame"      **5.3** End section

Fasten the suspended ballast guide and fold the end section **5.3** in:

- ▶ Fasten the "V-frame" suspended ballast guide **5** in the points **P1** to the auxiliary crane.
- ▶ Retract the pull cylinder until the end section **5.3** is approx. 2.4 m off the ground.
- ▶ Fold in the end section **5.3** of the suspended ballast guide "V-frame" **5**.

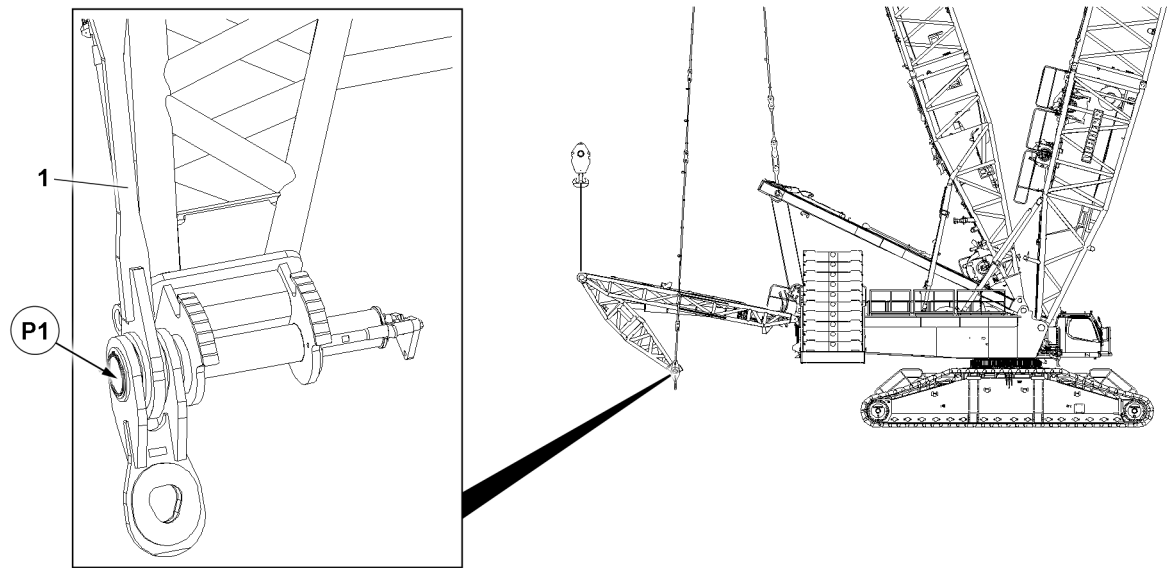
When the derrick boom 33 m is assembled:

- ▶ Set the derrick angle to 115.3°.

When the derrick boom 39 m is assembled:

- ▶ Set the derrick angle to 108.3°.





*Fig.155429: Assembling the D-guy rods on the suspended ballast guide "V-frame" – Positioning the guy rods*

**1** D-guy rods

► Position the D-guy rods **1** to permit pinning in position **P1**.

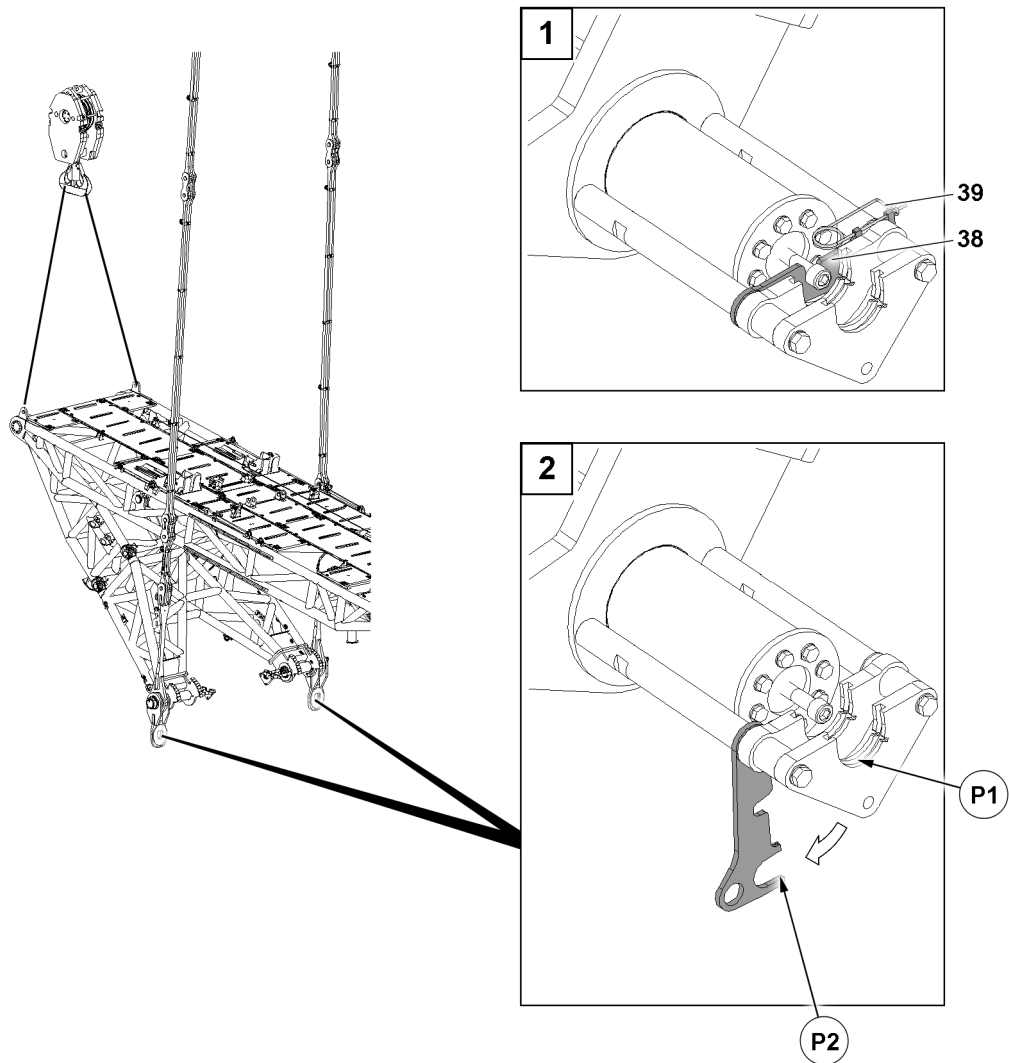


Fig.155430: Assembling the D-guy rods on the suspended ballast guide "V-frame" – Releasing the pin

**38** Retaining element

**39** Retaining element

- ▶ Remove the retaining element **39**.
- ▶ Fold the retaining element **38** down.
- ▶ Connect the pin pulling device in position **P1**.
- ▶ Assemble the retaining element **39** in position **P2**.

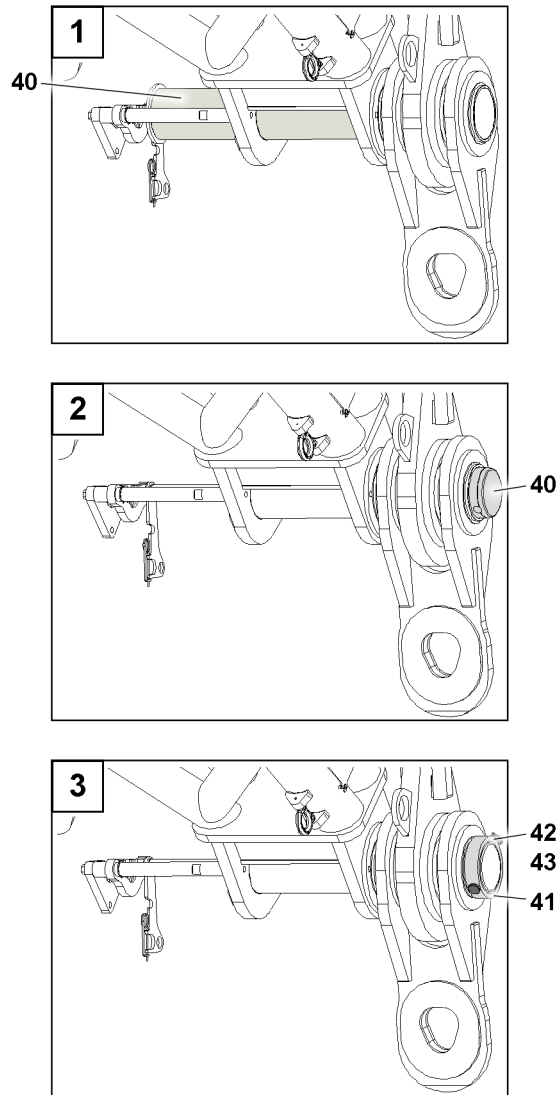


Fig.155431: Assembling the D-guy rods on the suspended ballast guide "V-frame" – Pinning procedure

- |                          |                             |
|--------------------------|-----------------------------|
| <b>40</b> Pin            | <b>42</b> Retaining pin     |
| <b>41</b> Retaining ring | <b>43</b> Retaining element |

- ▶ Insert the pin **40**.



#### WARNING

Unsecured pin!

If the pins **40** are not secured with the retaining elements, they can loosen up by themselves during crane operation.

Death, severe bodily injuries, property damage.

- ▶ Make sure that the pins **40** are secured.
- 
- ▶ Push the retaining ring **41** over the pins **40**.
  - ▶ Insert the retaining pin **42**.
  - ▶ Secure the retaining pin **42** with the retaining element **43**.

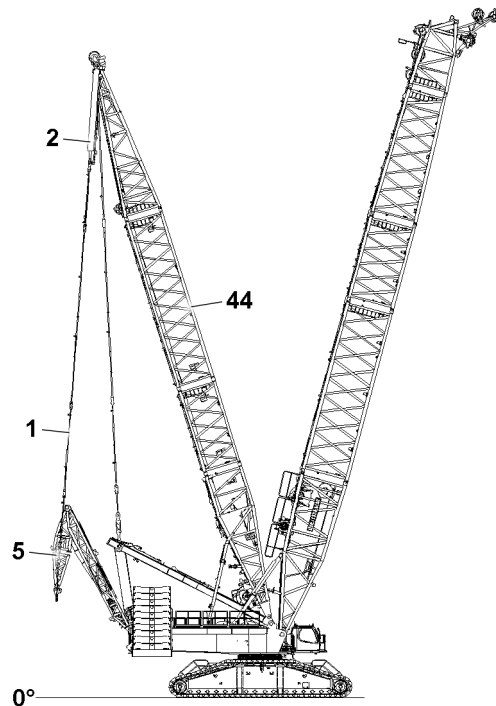


Fig.155432: Assembling the D-guy rods on the suspended ballast guide “V-frame” – Bringing the suspended ballast guide “V-frame” into the operating position

- |   |               |    |                                   |
|---|---------------|----|-----------------------------------|
| 1 | D-guy rods    | 5  | Suspended ballast guide “V-frame” |
| 2 | Pull cylinder | 44 | Derrick boom                      |

- ▶ Until the suspended ballast guide “V-frame” **5** is connected securely to the D-guy rods **1**: Lower the auxiliary crane and retract the pull cylinder **2** at the same time.

When the suspended ballast guide “V-frame” **5** is connected securely to the D-guy rods **1**:

- ▶ Remove the auxiliary crane.
- ▶ Retract the pull cylinder **2** completely.

When the derrick boom 33 m is assembled:

- ▶ Set the derrick angle to 114.3°.

When the derrick boom 39 m is assembled:

- ▶ Set the derrick angle to 107.3°.

**Result:**

- The suspended ballast guide “V-frame” **5** is ready for operation.

## 9.4 Assembling the divisible ballast pallet “VarioTray”



**DANGER**

Use of an incorrect ballast pallet!

If a ballast pallet other than the divisible ballast pallet “VarioTray” is used, the control does not calculate the correct distance between the ballast pallet and the ground. The ballast pallet can be set down unintentionally or lifted too far. The crane can be overloaded and topple over. Death, severe bodily injuries, property damage.

- ▶ Make sure that only a divisible ballast pallet “VarioTray” is used during BV operation.

**DANGER**

Danger of accident during assembly / disassembly of the erection racks!

When you disassemble unsecured or unsupported erection racks, the erection racks can fall down or tip over.

Death, severe bodily injuries, property damage.

- ▶ Never unpin the retaining pins from unsecured or unsupported erection racks.
- ▶ It is prohibited for anyone to remain under the erection racks or within the entire danger zone during the pinning and unpinning procedure.

### 9.4.1 Setting the divisible ballast pallet “VarioTray” to the assembly position

- ▶ Set the derrick boom to the required radius.

**Note**

- ▶ Fastening points, see section “Fastening points”.

- ▶ Connect the divisible ballast pallet “VarioTray” to the auxiliary crane and position it within the slewing range of the crane under the D-guy rods on the derrick boom.

**Note**

- ▶ Set down the divisible ballast pallet “VarioTray” in the lengthwise direction of the turntable for easier assembly on the D-guy rods.

- ▶ Align the divisible ballast pallet “VarioTray” horizontally.

### 9.4.2 Erecting the erection racks

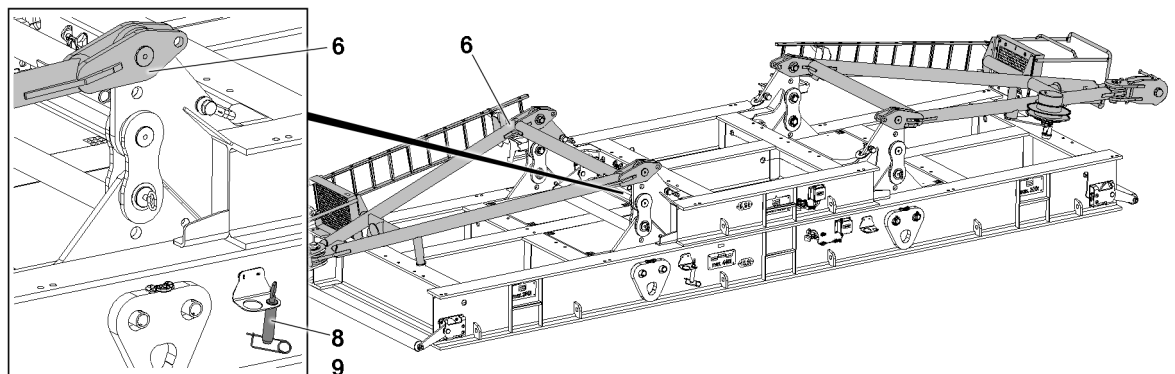


Fig.155385: Divisible ballast pallet “VarioTray” in the transport position

6 Erection rack  
8 Retaining pin

9 Retaining element

**Note**

- ▶ The assembly of the erection racks is described based on the example of one erection rack.

The erection rack **6** is pinned on both sides. The pinning procedure is described for one retaining pin **8** as an example.

- ▶ Connect the erection rack **6** to the auxiliary crane.
- ▶ Remove the retaining element **9** on both sides from the park position and unpin the retaining pin **8**.

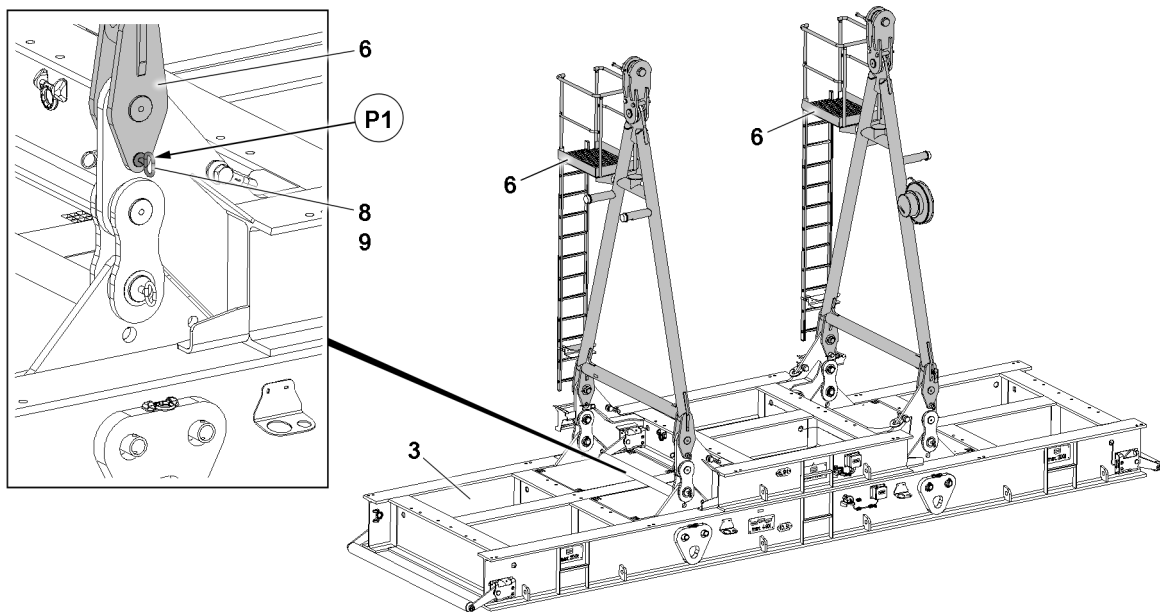


Fig.155384: Positioning the erection racks vertically

- |   |                                      |   |                   |
|---|--------------------------------------|---|-------------------|
| 3 | Divisible ballast pallet "VarioTray" | 8 | Retaining pin     |
| 6 | Erection rack                        | 9 | Retaining element |



### DANGER

Danger of accident during assembly / disassembly of the erection racks **6**!

The erection racks **6** must hang securely on the auxiliary crane, otherwise they could fall down and kill or severely injure personnel.

- ▶ The two erection racks **6** must be locked and secured in a vertical position with retaining pins **8**. Only then may the auxiliary crane be removed.
- ▶ Never unpin the retaining pins **8** from unsecured or unsupported erection racks **6**.
- ▶ It is prohibited for anyone to remain under the erection racks **6** or within the entire danger zone during the pinning and unpinning procedure.

- ▶ Position the erection rack **6** vertically with the auxiliary crane.
- ▶ Insert the retaining pin **8** in point **P1** on both sides and secure with the retaining element **9**.

When the erection rack **6** is set up and secured:

- ▶ Remove the auxiliary crane.



### WARNING

Danger of accident!

The two erection racks must be locked and secured in a vertical position during crane operation, as otherwise they could fall down.

Death, severe bodily injuries, property damage.

In the case of crane operation with a divisible ballast pallet "VarioTray", the retaining pins **8** remain pinned in point **P1**.

- ▶ Make sure that the retaining pins **8** are pinned in point **P1**.
- ▶ Erect the second erection rack **6**.

## 9.5 Pinning the suspended ballast guide “V-frame” on the divisible ballast pallet “VarioTray”

### 9.5.1 Pinning the suspended ballast guide “V-frame”

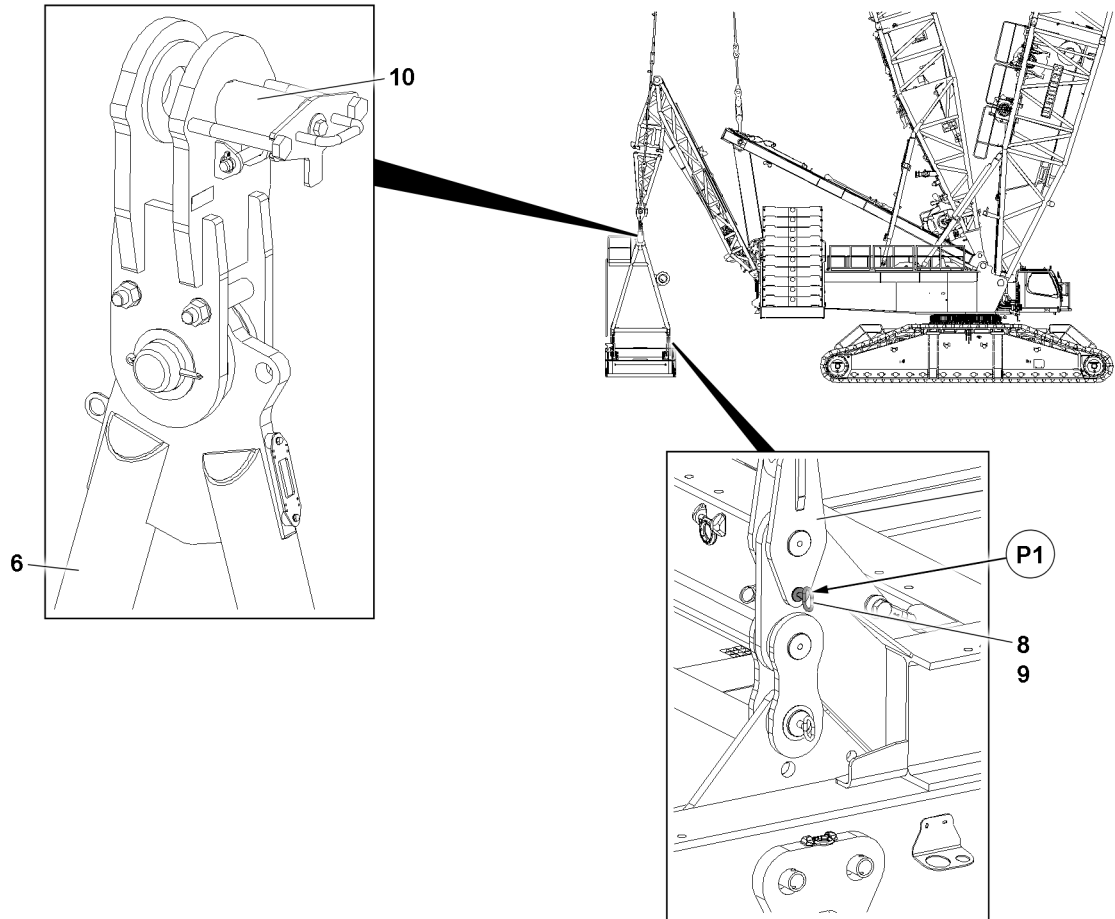


Fig.155433: Pinning the suspended ballast guide “V-frame” on the divisible ballast pallet “VarioTray” – Prerequisites

- |          |                |           |                   |
|----------|----------------|-----------|-------------------|
| <b>6</b> | Erection racks | <b>9</b>  | Retaining element |
| <b>8</b> | Retaining pin  | <b>10</b> | Connector pin     |

Make sure that the following prerequisites are met:

- The derrick boom is set to the required radius.
- The erection racks **6** are erected and secured with four retaining pins **8** and four retaining elements **9** in positions **P1**.
- The connector pins **10** are unpinned.

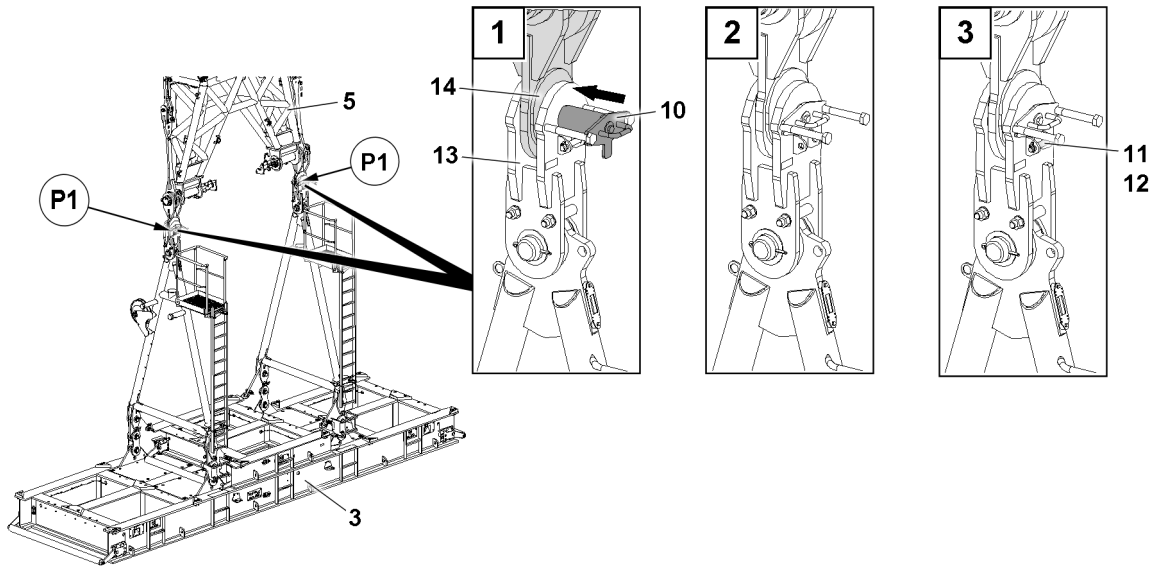


Fig.155436: Pinning the suspended ballast guide "V-frame" on the divisible ballast pallet "VarioTray" – Pinning procedure

<b>3</b>	Divisible ballast pallet "VarioTray"	<b>11</b>	Retaining pin
<b>5</b>	Suspended ballast guide "V-frame"	<b>12</b>	Retaining element
<b>6</b>	Erection rack	<b>13</b>	Bracket
<b>10</b>	Connector pin	<b>14</b>	Bracket

The divisible ballast pallet "VarioTray" **3** is pinned in two positions **P1**. The pinning procedure is described for one pin as an example.

- ▶ Position the suspended ballast guide "V-frame" **5** over the divisible ballast pallet "VarioTray" **3**.
- ▶ Lower the brackets **14** of the suspended ballast guide "V-frame" by extending the piston rods on the pull cylinders into the brackets **13** until the pin bores align.



#### Note

Retract / extend the pull cylinders:

- ▶ Control the pull cylinders from the crane cab, see the section "Lifting and lowering the derrick ballast using the pull cylinders".
- ▶ Operate the pull cylinder with the radio remote control, see the "radio remote control operating instructions".

Pin the brackets **14** to the brackets **13** and secure.

- ▶ Insert the connector pin **10**.



#### WARNING

Danger of accident!

If the connector pins **10** are not secured with the retaining pin **11**, then they can loosen up by themselves during crane operation.

This can cause the crane to topple over.

Death, severe bodily injuries, property damage.

- ▶ Make sure that the connector pins **10** are secured with retaining pins **11** and retaining elements **12**.

- ▶ Insert the retaining pin **11** and secure with the retaining element **12**.
- ▶ Pin the second erection rack **6** in the same manner to the suspended ballast guide "V-frame" **5**.



## 9.5.2 Establishing the electrical connection from the suspended ballast to the suspended ballast guide

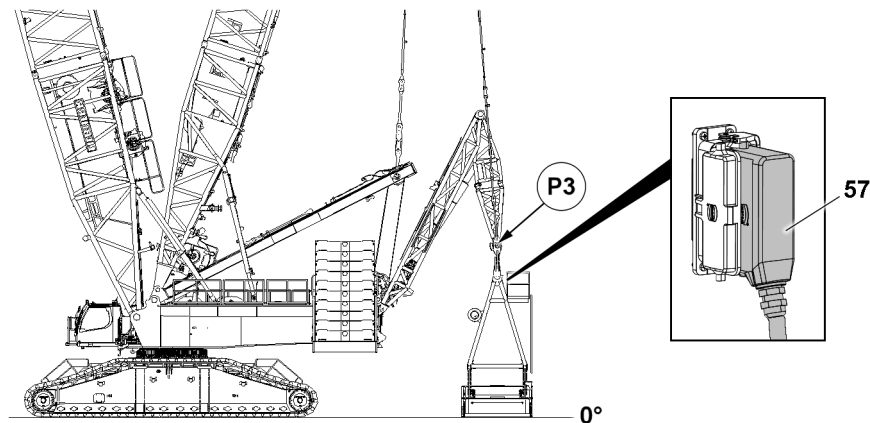


Fig.163646: Establishing the electrical connection from the suspended ballast to the suspended ballast guide

### NOTICE

The ignition switch is not in position 0!

If live electrical connections are disconnected / connected, then there is the danger that components can be damaged.

The crane functions can be limited.

- ▶ De-energize the electrical connections before disconnection / connection: Set the ignition switch to position 0.
- ▶ Move the ignition switch to position 0.

Establish the electrical connection from the suspended ballast to the suspended ballast guide:

- ▶ Insert the plug of the electrical line **57** in position **P3**.



### Note

- ▶ Establish the electrical connection from the suspended ballast to the suspended ballast guide, see the "wiring diagram".

### NOTICE

Damage to the electrical connections due to dirt, moisture and corrosion!

If unrequired electrical connections are not closed with their respective caps, the electrical connections can be damaged.

If the covers are removed from the electrical connections or control cabinets are opened, then moisture can infiltrate.

- ▶ Always properly close off all **non**-required electrical connections with their protective caps.
- ▶ Protect the electrical connections from water infiltration, this applies especially in the case of rain or snow.



### Note

If **non**-required electrical connections are not closed with their respective dummy plugs, the electrical connections can be damaged.

- ▶ A malfunction can occur without bridging.
- ▶ Observe the "wiring diagram".
- ▶ As a rule, close off non-required electrical connections (for example for accessories that are not installed) with the respective dummy plugs / dust caps.

### 9.5.3 Electrical connections on the ballast pallet

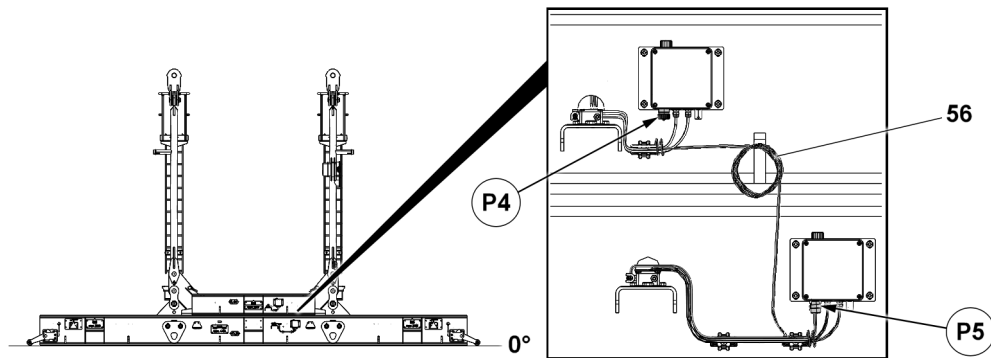


Fig.163650: Electrical connections on the ballast pallet

Make sure that the following prerequisites are met:

- The “small” ballast pallet and the “large” ballast pallet are pinned together.

#### NOTICE

The ignition switch is not in position 0!

If live electrical connections are disconnected / connected, then there is the danger that components can be damaged.

The crane functions can be limited.

- ▶ De-energize the electrical connections before disconnection / connection: Set the ignition switch to position 0.

#### NOTICE

Danger of damage to the electrical lines on the suspended ballast!

If the electrical line **56** is not wound up and looped-in, it can be damaged when setting down the suspended ballast.

- ▶ Wind up and loop in the electrical line **56**.

- ▶ Move the ignition switch to position 0.
- ▶ Wind up and loop in the electrical line **56**.

For the installation of the suspended ballast pallet, the “large” ballast pallet must be connected.

- ▶ Establish the electrical connection for operation of the “large” ballast pallet: Connect the electrical line **56** to the terminal box in position **P5**, see also the “Wiring diagram”.

#### Result:

- The electrical line **-X1100** is plugged into the terminal box **+S1100G** (large ballast pallet).



#### WARNING

Incorrect ballast pallet inserted!

The connection to the “small” ballast pallet (electric line **56** on the terminal box in position **P4**) is only permissible for the sole operation of the “small” ballast pallet.

- ▶ Observe section, Disconnecting the “divisible ballast pallet “VarioTray” from each other”.

#### NOTICE

Damage to the electrical connections due to dirt, moisture and corrosion!

If unrequired electrical connections are not closed with their respective caps, the electrical connections can be damaged.

If the covers are removed from the electrical connections or control cabinets are opened, then moisture can infiltrate.

- ▶ Always properly close off all **non**-required electrical connections with their protective caps.
- ▶ Protect the electrical connections from water infiltration, this applies especially in the case of rain or snow.

**Note**

If **non**-required electrical connections are not closed with their respective dummy plugs, the electrical connections can be damaged.

- ▶ A malfunction can occur without bridging.
- ▶ Observe the “wiring diagram”.

- ▶ As a rule, close off non-required electrical connections (for example for accessories that are not installed) with the respective dummy plugs / dust caps.

### 9.5.4 Aligning the suspended ballast

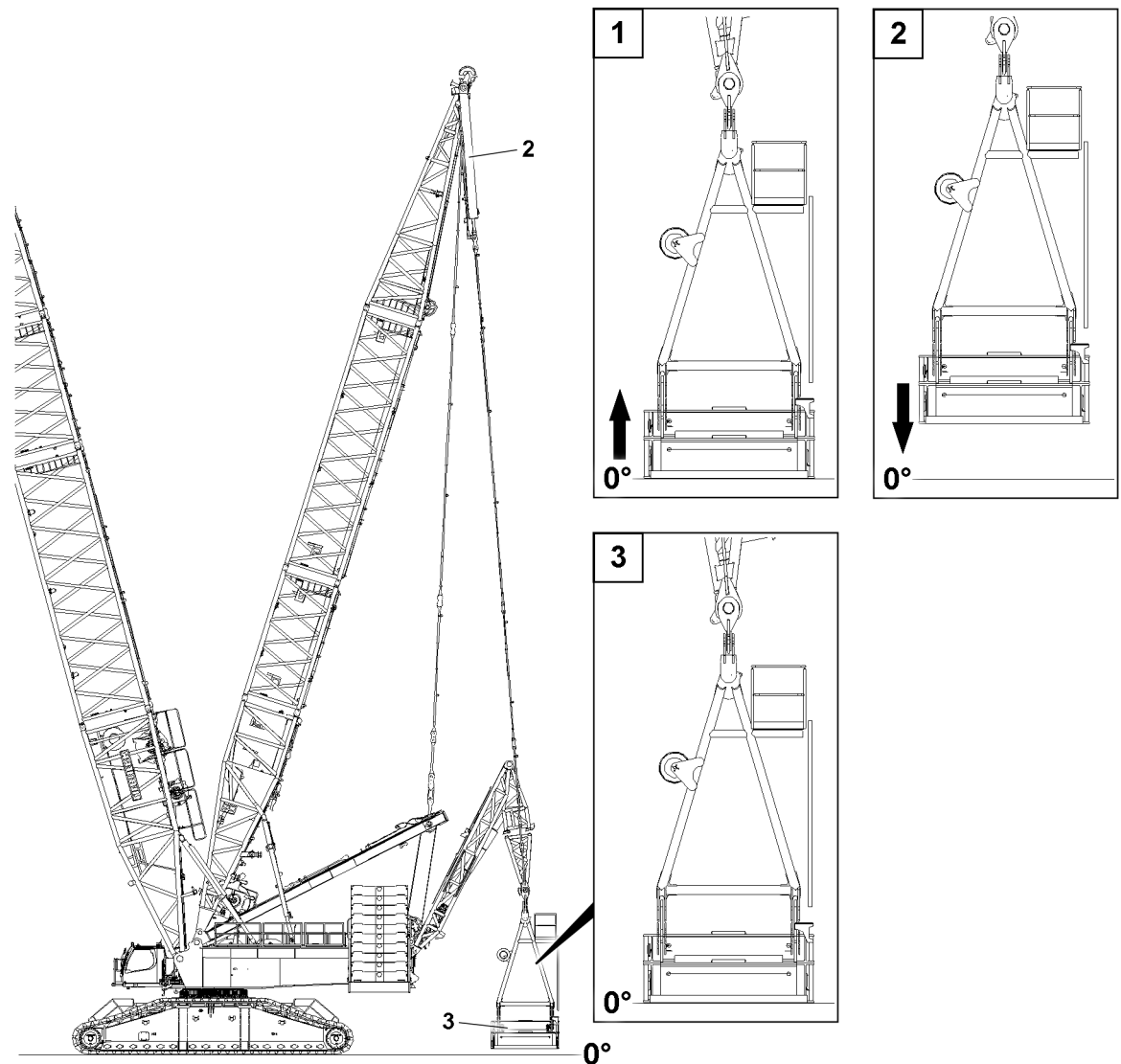


Fig.155437: Pinning the divisible ballast pallet “VarioTray” – Erecting the divisible ballast pallet “VarioTray”

2 Pull cylinder

3 Divisible ballast pallet “VarioTray”

**WARNING**

Uncontrolled swinging of the divisible ballast pallet “VarioTray”!

If the divisible ballast plate “VarioTray” 3 is lifted, it can start swinging. Death, severe bodily injuries, property damage.

- ▶ It is prohibited to remain in the danger zone.
- ▶ Secure the divisible ballast pallet “VarioTray” with auxiliary ropes.

- ▶ Lift the empty divisible ballast pallet “VarioTray” **3** with the pull cylinders **2** and then set it down again.

**Result:**

- The divisible ballast pallet “VarioTray” **3** is vertically aligned.

**Note**

The maximum ground unevenness for setting down the ballast pallet with ballast plates positioned on it is  $\pm 1^\circ$  in the longitudinal and lateral direction.

- ▶ Align the ballast pallet horizontally in time before positioning the ballast plates!
- ▶ Align the divisible ballast pallet “VarioTray” **3** horizontally.

## 9.6 Ballasting the divisible ballast pallet “VarioTray”

Make sure that the following prerequisites are met:

- The divisible ballast pallet “VarioTray” is properly installed and secured.
- The divisible ballast pallet “VarioTray” is positioned flat on the ground and has a maximum longitudinal and lateral incline of  $\pm 1^\circ$ .
- An auxiliary crane is on hand.
- The consoles for ballast centering are properly installed and secured in the operating position.

### 9.6.1 Derrick ballast composition

**Note**

- ▶ Ballast plates with 5 t , 7.5 t and 10 t can be used combined.
- ▶ Examples of derrick ballast combinations are listed below.
- ▶ Individual weights are rounded.

**Note**

- ▶ Change positioned ballast plates within the permissible range to implement other derrick ballast weights.

**Note**

Derrick ballast in travel operation with a set up crane.

- ▶ For driving the crane (crawler operation) without derrick ballast it is normally sufficient when the ballast pallet is removed.
- ▶ Observe the specifications for travel operation.

#### Component weights for the Set up program

Component	Weight	Set up value <sup>1)</sup>
Relevant guying weight for D-33	5.3 t	5 t
Relevant guying weight for D-39	6.1 t	6 t
Relevant suspended ballast guide V-frame weight	5.0 t	5 t
Small ballast pallet	5.9 t	6 t
Large ballast pallet	13.5 t	- <sup>2)</sup>
Complete ballast pallet	19.4 t	19 t

#### Component weights for the Set up program

1) rounded

2) cannot be installed without small ballast pallet

**Derrick ballast weights for B-operation****Note**

- The different weight of the guying for the derrick boom 33 m (D-33) and derrick boom 39 m (D-39) has an effect of approx. 1 t on the derrick ballast.

Derrick ballast	Composition	Individual weight	Quantity
6 t (5 t) <sup>1)</sup>	Relevant guying weight D-39	6 t	No. 1

*Derrick ballast combination 6 t for B-operation*

1) For guying D-33

Derrick ballast	Composition	Individual weight	Quantity
12 t (11 t) <sup>1)</sup>	Relevant guying weight D-39	6 t	No. 1
	Small ballast pallet	6 t	No. 1
	Without ballast plates	0 t	-

*Derrick ballast combination 12 t for B-operation*

1) For guying D-33

Derrick ballast	Composition	Individual weight	Quantity
25 t (24 t) <sup>1)</sup>	Relevant guying weight D-39	6 t	No. 1
	Complete ballast pallet	19 t	No. 1
	Without ballast plates	0 t	-

*Derrick ballast combination 25 t for B-operation*

1) For guying D-33

Derrick ballast	Composition	Individual weight	Quantity
212 t (211 t) <sup>1)</sup>	Relevant guying weight D-39	6 t	No. 1
	Small ballast pallet	6 t	No. 1
	Ballast plates	10 t	No. 20

*Derrick ballast combination 212 t for B-operation (maximum ballasting on small ballast pallet - the large ballast plate is not installed)*

1) For guying D-33

Derrick ballast	Composition	Individual weight	Quantity
400 t (399 t) <sup>1)</sup>	Relevant guying weight D-39	6 t	No. 1
	Complete ballast pallet	19 t	No. 1
	Ballast plates	7.5 t	No. 2
	Ballast plates	10 t	Qty 36

*Derrick ballast combination 400 t for B-operation*

1) For guying D-33

### Derrick ballast weights for BV-operation



#### Note

- The different weight of the guying for the derrick boom 33 m (D-33) and derrick boom 39 m (D-39) has an effect of approx. 1 t on the derrick ballast.

Derrick ballast	Composition	Individual weight	Quantity
11 t (10 t) <sup>1)</sup>	Relevant guying weight D-39	6 t	No. 1
	Relevant suspended ballast guide V-frame weight	5 t	No. 1

#### Derrick ballast combination 11 t for BV-operation

1) For guying D-33

Derrick ballast	Composition	Individual weight	Quantity
17 t (16 t) <sup>1)</sup>	Relevant guying weight D-39	6 t	No. 1
	Relevant suspended ballast guide V-frame weight	5 t	No. 1
	Small ballast pallet	6 t	No. 1
	Without ballast plates	0 t	-

#### Derrick ballast combination 17 t for BV-operation

1) For guying D-33

Derrick ballast	Composition	Individual weight	Quantity
30 t (29 t) <sup>1)</sup>	Relevant guying weight D-39	6 t	No. 1
	Relevant suspended ballast guide V-frame weight	5 t	No. 1
	Complete ballast pallet	19 t	No. 1
	Without ballast plates	0 t	-

#### Derrick ballast combination 30 t for BV-operation

1) For guying D-33

Derrick ballast	Composition	Individual weight	Quantity
217 t (216 t) <sup>1)</sup>	Relevant guying weight D-39	6 t	No. 1
	Relevant suspended ballast guide V-frame weight	5 t	No. 1
	Small ballast pallet	6 t	No. 1
	Ballast plates	10 t	No. 20

#### Derrick ballast combination 217 t for BV-operation (maximum ballasting on small ballast pallet - the large ballast plate is not installed)

1) For guying D-33

Derrick ballast	Composition	Individual weight	Quantity
400 t (399 t) <sup>1)</sup>	Relevant guying weight D-39	6 t	No. 1
	Relevant suspended ballast guide V-frame weight	5 t	No. 1
	Complete ballast pallet	19 t	No. 1
	Ballast plates	10 t	Qty 37

Derrick ballast combination 400 t for BV-operation

1) For guying D-33

## 9.6.2 Ballasting procedure

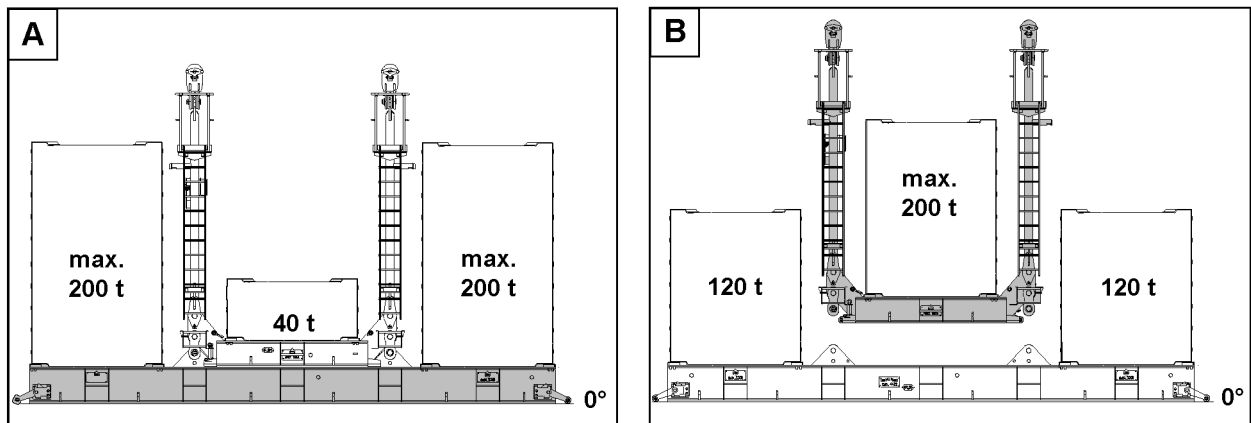


Fig.158781: Ballasting the divisible ballast pallet "VarioTray" – Maximum permissible overall weight of the ballast plates

Ballast pallet "VarioTray" comprised of the small and large ballast pallet. The ballast palette "VarioTray" is designed for a payload on the ballast plates of 440 t. The ballast plates must be distributed on the large ballast pallet and the small ballast pallet. The following two examples each show the maximum ballasting.

- For variation **A**, the **large ballast pallet** is ballasted with a maximum payload of 2 x 200 t on the ballast plates. Therefore the small ballast pallet may be ballasted with a maximum of 40 t on the ballast plates.
- For variation **B**, the **small ballast pallet** is ballasted with a maximum payload of 200 t on the ballast plates. Therefore the large ballast pallet may be ballasted with a maximum of 2 x 120 t on the ballast plates.



### WARNING

The crane can topple over!

If the following danger notes are not observed, the crane can topple over.

Death, severe bodily injuries, property damage.

- ▶ Ballast the ballast pallet "VarioTray" according to the erection / take-down charts and the load charts.
- ▶ The ballast palette "VarioTray" is designed for a payload on the ballast plates of 440 t.
- ▶ On the small ballast pallet, place a maximum of 200 t ballast plates.
- ▶ On the large ballast pallet, place a maximum of 2x200 t ballast plates.
- ▶ It is prohibited to exceed the maximum placed ballast plates on the large ballast pallet or the small ballast pallet.
- ▶ Observe the weight signs on the ballast pallets.

**WARNING**

Incorrect ballast plate stacking!

If the sequence is not observed when stacking the ballast plates, the ballast plates can be damaged or the stack can fall over.

Death, severe bodily injuries, property damage.

- ▶ When stacking the ballast plates, make sure that no more than 25 t is stacked on a 5 t ballast plate.
- ▶ When stacking the ballast plates, make sure that no more than 25 t is stacked on a 7.5 t ballast plate.

**WARNING**

Failure to observe the ballasting rules!

Death, severe bodily injuries, property damage.

- ▶ The ground on which ballasting takes place must be level ( $\pm 1^\circ$ ) and have an adequate load bearing capacity.
- ▶ Stack the ballast plates according to the load chart and the erection / take-down charts.
- ▶ Always place the ballast plates symmetrically, in reference to the longitudinal axis.
- ▶ The relevant weight of the guying (D-33) is 5 t.
- ▶ The relevant weight of the guying (D-39) is 6 t.
- ▶ The relevant weight of the suspended ballast guide V-frame is 5 t.
- ▶ The empty weight of the divisible ballast pallet "VarioTray" is 19 t.
- ▶ The maximum permissible weight of the divisible ballast pallet "VarioTray" inclusive ballast plates is 400 t.
- ▶ Observe the total weight of the derrick ballast, see section "Derrick ballast composition".
- ▶ The stack height on the outer ballast stack may differ from the stack height of the middle ballast stack.
- ▶ It is necessary to start with the two center ballast stacks.
- ▶ At first only maximum 20 t ballast may be placed per ballast stack.
- ▶ When ballasting the double stacks, the weight difference between front and rear may be maximum 10 t.
- ▶ The maximum permissible difference during the ballasting procedure between the right and left ballast stacks is 25 t.
- ▶ The center ballast stacks may have a maximum difference of 10 t after ballasting.
- ▶ Replace damaged ballast plates immediately with new ballast plates.
- ▶ Observe the weight signs on the ballast pallets.

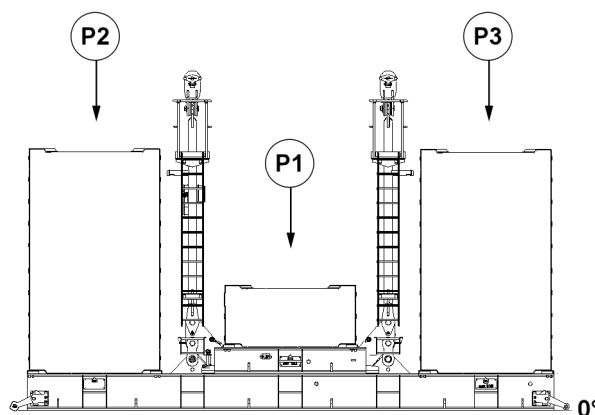


Fig.163651: Ballast stack positions

**WARNING**

Exceeding permissible quantity of ballast plates!

Death, severe bodily injury, property damage.

- ▶ Make sure that permissible quantity of the ballast plates is not exceeded during simultaneous lifting, see section "Permissible ballast assemblies".



**Note**

- ▶ The struts can be used as a ladder on the stacked ballast plates.

- ▶ Climb onto the ladder.
- ▶ Ballast in position **P1** until the selected derrick ballast is fully positioned.
- ▶ Climb off the ladder.

When the position **P1** is completely fitted with ballast plates:

- ▶ Ballast in position **P2** and position **P3** until the selected derrick ballast is fully positioned.

**WARNING**

Different heights or different weights of the ballast stacks!  
Death, severe bodily injuries, property damage.

- ▶ Make sure that after ballasting, the outer ballast stacks have the same height.
- ▶ Make sure that after ballasting, the outer ballast stacks have the same weight.
- ▶ Check if the ballast stacks in position **P2** and position **P3** have the same height.

If the ballast stacks in position **P2** and position **P3** have different heights:

- ▶ Reballast until the ballast stack in position **P2** and position **P3** have the same height.
- ▶ Check if the ballast stacks in position **P2** and position **P3** have the same weight.

If the ballast stacks in position **P2** and position **P3** have different weights:

- ▶ Reballast until the ballast stack in position **P2** and position **P3** weigh the same.

**WARNING**

Lateral offset of more than 50 mm !

Death, severe bodily injuries, property damage.

If the maximum permissible offset is exceeded, ballast plates or the ballast stack can slip and fall down.

- ▶ Observe the maximum permissible lateral offset in position **P1**, position **P2** and position **P3**.
- ▶ Make sure that the lateral offset of a ballast stack does not exceed the maximum permissible 50 mm.

- ▶ Check if there is a lateral offset of more than 50 mm between the bottom and top ballast plate of a ballast stack.

If there is a lateral offset on a ballast stack of more than 50 mm between the bottom and top ballast plate:

- ▶ Reposition the ballast plates until the lateral offset is less than 50 mm.

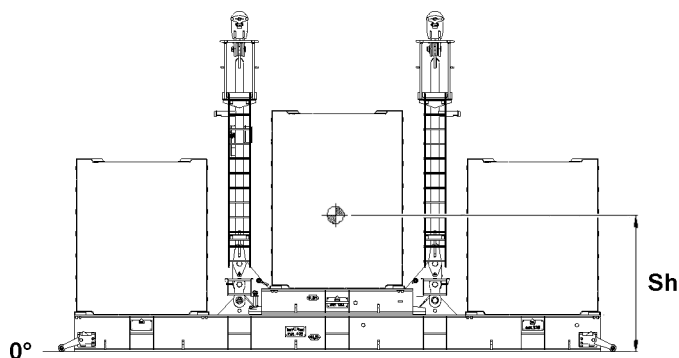


Fig.151456: Center of gravity of the divisible ballast pallet "VarioTray"

**Sh** Height of center of gravity

**WARNING**

Ballast center of gravity outside of the tolerance range!  
Death, severe bodily injuries, property damage.

▶ The maximum permissible ballast center of gravity height **Sh** of 2800 mm may not be exceeded.

▶ Check if the ballast center of gravity lies within the tolerance.

If the ballast center of gravity lies outside of the tolerance:

▶ Reballast until the ballast center of gravity lies within the tolerance.

### 9.6.3 Placing the ballast plates, fastening system: "Twistlock"

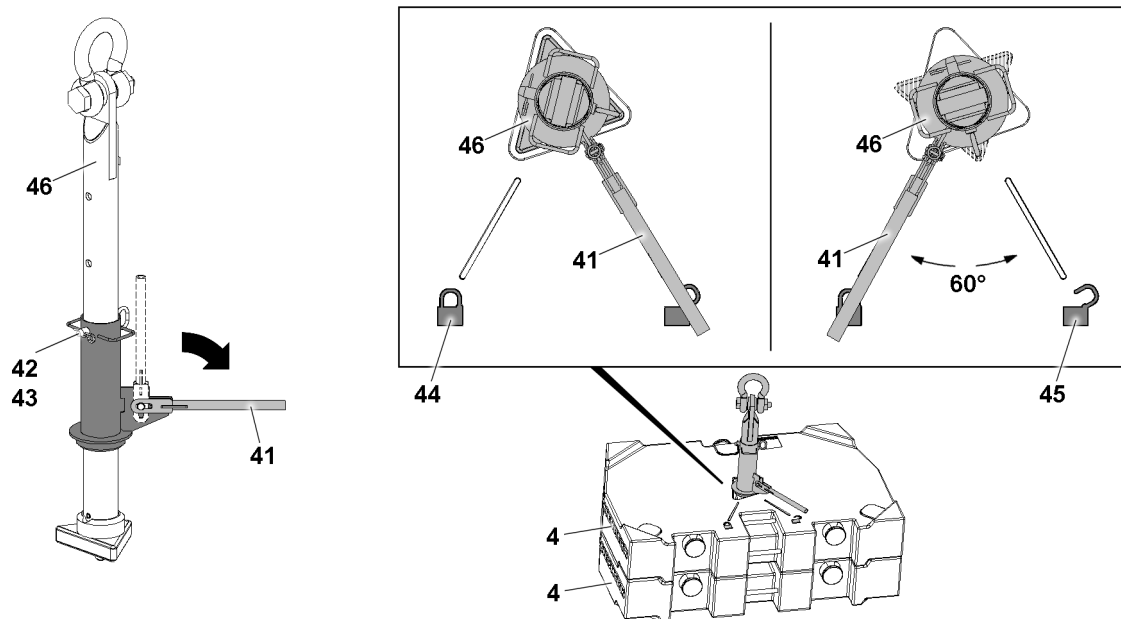


Fig.155372: Ballast plates, fastening system: "Twistlock"

<b>4</b>	Ballast plate	<b>44</b>	Icon
<b>41</b>	Lever	<b>45</b>	Icon
<b>42</b>	Pin	<b>46</b>	Receptacle stud
<b>43</b>	Retaining element		

**WARNING**

Danger of accident!

If more than the permissible two ballast plates **4** are lifted with the receptacle stud **46**, the receptacle stud **46** will be overloaded and can be damaged.

Death, severe bodily injuries, property damage.

▶ Make sure that the ballast plates **4** are placed correctly in the centerings.

▶ Replace damaged ballast plates **4**.

To stack the ballast plate(s) **4**, use the receptacle stud **46**.

Before the receptacle stud **46** is guided into the ballast plates **4**, it must be ensured that the length of the receptacle stud **46** is set correctly. The length of the receptacle stud **46** can be adjusted with the pin **42**.

If the length of the receptacle stud **46** is to be adjusted:

- ▶ Release and unpin the pin **42**.
- ▶ Adjust the length of the receptacle stud by moving the receptacle stud **46**.
- ▶ Insert the pin **42** and secure it with the retaining element **43**.
- ▶ Fasten the receptacle stud **46** to the auxiliary crane and guide it into the ballast plate(s) **4**.
- ▶ Pull the lever **41** up and fold it down.
- ▶ Turn the lever **41** 60° until the lever **41** points to the icon **44**.

**Result:**

- The receptacle stud **46** is locked with the ballast plate **4**.
- ▶ Lift always one ballast plate **4** with the receptacle stud **46** and take it down carefully on the outer centerings of the divisible ballast pallet “VarioTray” **3**.

When the ballast plate **4** has been taken down on the outer centerings of the divisible ballast pallet “VarioTray” **4**:

- ▶ Turn the lever **41** 60° until the lever **41** points to the icon **45**.

**Result:**

- The receptacle stud **46** is unlocked.
- ▶ Carefully pull the receptacle stud **46** out of the ballast plate(s) **4**.
- ▶ Stack the ballast plate(s) **4** correctly, observe the danger notes.

### 9.6.4 Placing the ballast plates, fastening points: “Bitt”

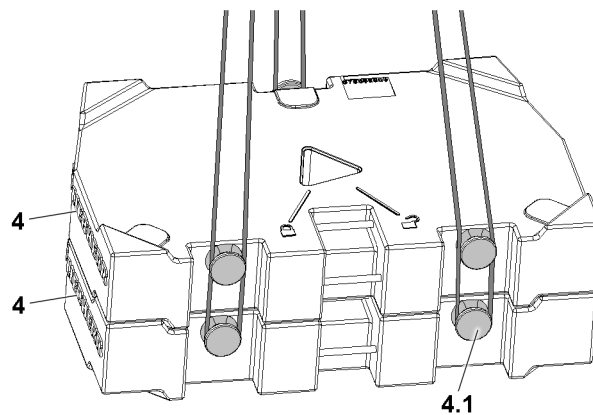


Fig.151458: Ballast plates, fastening points: “Bitt”

**4** Ballast plate

**4.1** Bitt

**WARNING**

Falling ballast plates **4**!

If more than the permissible two ballast plates **4** are lifted, then the bits **4.1** are overloaded and the ballast plates **4** can fall down.

Death, severe bodily injuries, property damage.

- ▶ Place the ballast plates **4** individually or as a package, maximum 20 t , 3 fastening points.
- ▶ Replace damaged ballast plates **4** immediately.

**WARNING**

Incorrect handling of the fastening equipment!

If the fastening equipment is not attached correctly and if it is not secured sufficiently to prevent it from loosening up, the ballast plates **4** can fall down.

Death, severe bodily injuries, property damage.

- ▶ Make sure that the fastening equipment is correctly attached to the bits **4.1** and that it is secured sufficiently to prevent it from loosening up.
  - ▶ Always place only one ballast plate **4** on the outer centerings on the divisible ballast pallet “VarioTray”.
- When a ballast plate **4** has been placed on each of the outer centerings of the divisible ballast pallet “VarioTray”:
- ▶ Place the ballast plates **4** individually or as an assembly of maximum two plates alternately on the left and right with the auxiliary crane.
  - ▶ Stack the ballast plates **4** correctly, observe the danger notes.

## 10 Crane operation



### DANGER

Use of an incorrect ballast pallet!

If a ballast pallet other than the divisible ballast pallet "VarioTray" is used, the control does not calculate the correct distance between the ballast pallet and the ground. The ballast pallet can be set down unintentionally or lifted too far. The crane can be overloaded and topple over.

Death, severe bodily injuries, property damage.

- ▶ Make sure that only a divisible ballast pallet "VarioTray" is used during BV operation.



### WARNING

The crane can topple over due damaged or missing components!

The crane can topple over.

Death, severe bodily injuries, property damage.

- ▶ Make sure that the crane in a flawless technical condition.



### WARNING

The crane can topple over due to incomplete assembly!

If the suspended ballast "V-frame" is installed but the electrical connection between the turntable and the suspended ballast guide "V-frame" is not established, the crane control cannot determine the crane geometry.

If the crane geometry is not determined, the crane can be overloaded and topple over.

- ▶ If the suspended ballast guide "V-Frame" is installed, the electrical connection must be established from the turntable via the "V-Frame" to the suspended ballast pallet.
- ▶ Only if the suspended ballast guide "V-Frame" is not installed may the electrical connection between the turntable and the suspended ballast pallet be established directly.



### WARNING

Toppling crane due to incorrect set up configuration!

If an incorrect set up configuration is entered in the LICCON computer system, the incorrect load chart is set.

If the incorrect load chart is set, the crane can be overloaded and topple over.

- ▶ After installing the suspended ballast guide "V-frame", enter the correct set up configuration in the LICCON computer system.



### WARNING

Collision between the derrick guying and the suspended ballast guide "V-frame" when adjusting the derrick ballast radius!

Death, severe bodily injuries, property damage.

- ▶ When adjusting the derrick ballast radius smaller than 16 m, a guide must monitor the clearance between the suspended ballast guide "V-frame" and the derrick guying.



### WARNING

Collision of components due to a defective incline sensor!

If the incline sensor is defective or missing, the collision monitoring between the SA-frame roller set and the suspended ballast guide "V-frame" is not active.

Death, severe bodily injuries, property damage.

- ▶ When adjusting the suspended ballast guide "V-frame" and / or the SA-frame, a guide must monitor the clearance.

**WARNING**

Danger of accident due to a missing / defective ground contact roller on the ballast pallet "VarioTray"! In case of a missing / defective ground contact roller, safety shut-off is not active.

The ground contact of the ballast pallet is not detected.

The crane can be overloaded and topple over.

Death, severe bodily injuries, property damage.

- ▶ Replace the missing / defective ground contact roller immediately.
- ▶ During operation of the suspended ballast guide "V-Frame", a guide must check if the ballast pallet "VarioTray" has 250 mm of clearance to the ground.

**WARNING**

Danger of collision!

With small derrick ballast radii, the derrick ballast plates can collide with the winch IV control rope when lifting the derrick ballast off the ground.

Death, severe bodily injuries, property damage.

- ▶ Make sure that a guide monitors the lifting of the derrick ballast up off the ground.
- ▶ Adjust the lifting height of the derrick ballast.
- ▶ See chapter 2.04, section "Derrick ballast - suspended ballast".

**WARNING**

The crane can topple over!

The jerky execution or braking of turning maneuvers can cause the load and / or suspended ballast to swing.

If the load and / or the suspended ballast collides with obstacles then the crane can be damaged or impeded.

Oscillating movements, damage or impediments can cause the crane to topple over.

This could result in serious accidents.

- ▶ Initiate or slow down crane movements with load and / or suspended derrick ballast extremely sensitively.
- ▶ There may be no persons and / or objects within the working range / danger zone of the crane.
- ▶ During crane operation additional personnel (guide) must monitor and secure the working range / danger zone of the crane from a safe position.

**WARNING**

The crane can topple over when not operating!

The tipping moment can be exceeded due to the "V-frame" folding down by itself when the ballast pallet "VarioTray" is lifted.

The crane can be overloaded and topple over.

Death, severe bodily injuries, property damage.

- ▶ When the crane is out of operation, the ballast pallet "VarioTray" must be placed on the ground.

**DANGER**

Steering with an attached load!

Death, severe bodily injuries, property damage.

- ▶ Steering with the crawler with a suspended load is prohibited.

**DANGER**

Driving on inclines or slopes!

Death, severe bodily injuries, property damage.

- ▶ Driving on inclines or slopes is prohibited.

**WARNING**

The ballast pallet is inclined!

- ▶ The ground on which the divisible ballast pallet “VarioTray” is set down must be level and have an adequate load bearing capacity.
- ▶ The ground on which the divisible ballast pallet “VarioTray” is set down may have a maximum longitudinal and lateral incline of  $\pm 1^\circ$ .

## 10.1 LICCON overload protection

### 10.1.1 Checking the settings of the LICCON overload protection

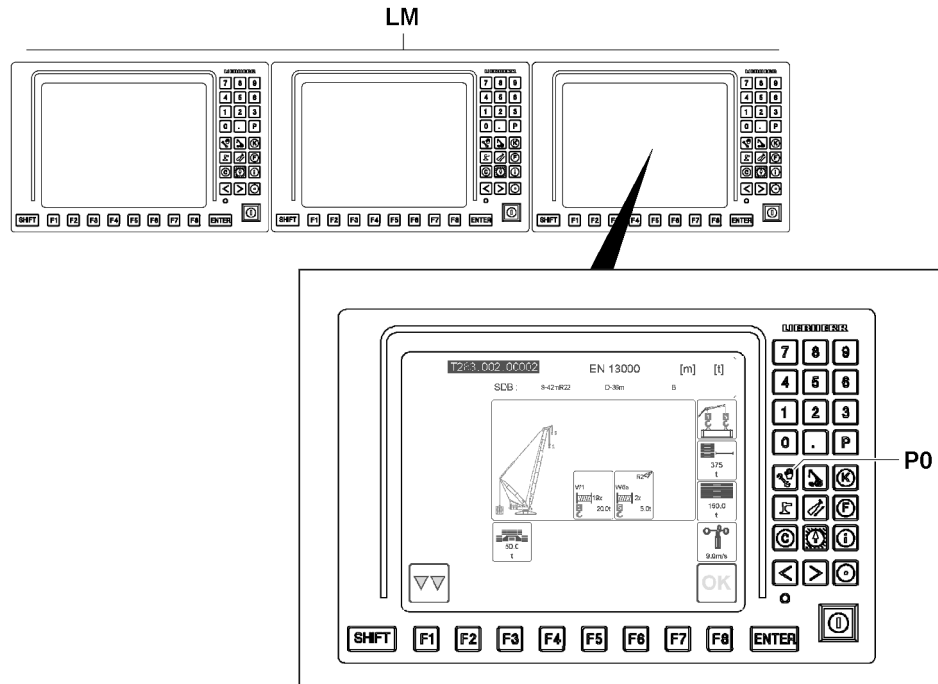


Fig.163485: LICCON monitors

**LM** LICCON monitors

**P0** Program button

Make sure that the following prerequisites are met:

- The derrick ballast is placed according to the load chart.
- The actually placed derrick ballast has been entered and confirmed in the Set up program, see chapter 4.02.
- The derrick boom is in the operating position.

**WARNING**

Incorrectly set overload protection!

Death, severe bodily injuries, property damage.

If the actual set up configuration of the crane deviates from the entries and settings in the Set up program, then the overload protection is not correctly set.

An incorrectly set overload protection calculates the actual load incorrectly and transmits faulty display values.

The crane can be overloaded without being noticed and topple over.

- ▶ The entries and settings in the Set up program match the actual set up configuration of the crane.

**Note**

- ▶ Set the LICCON overload protection in the Set up program, see chapter 4.02.
- ▶ Press the program button **P0** on the LICCON monitor.

**Result:**

- The Set up program is called up.
- ▶ On the monitor display of the Set up program check if the LICCON overload protection is set according to the specifications in the load chart and the actual set up configuration of the crane.

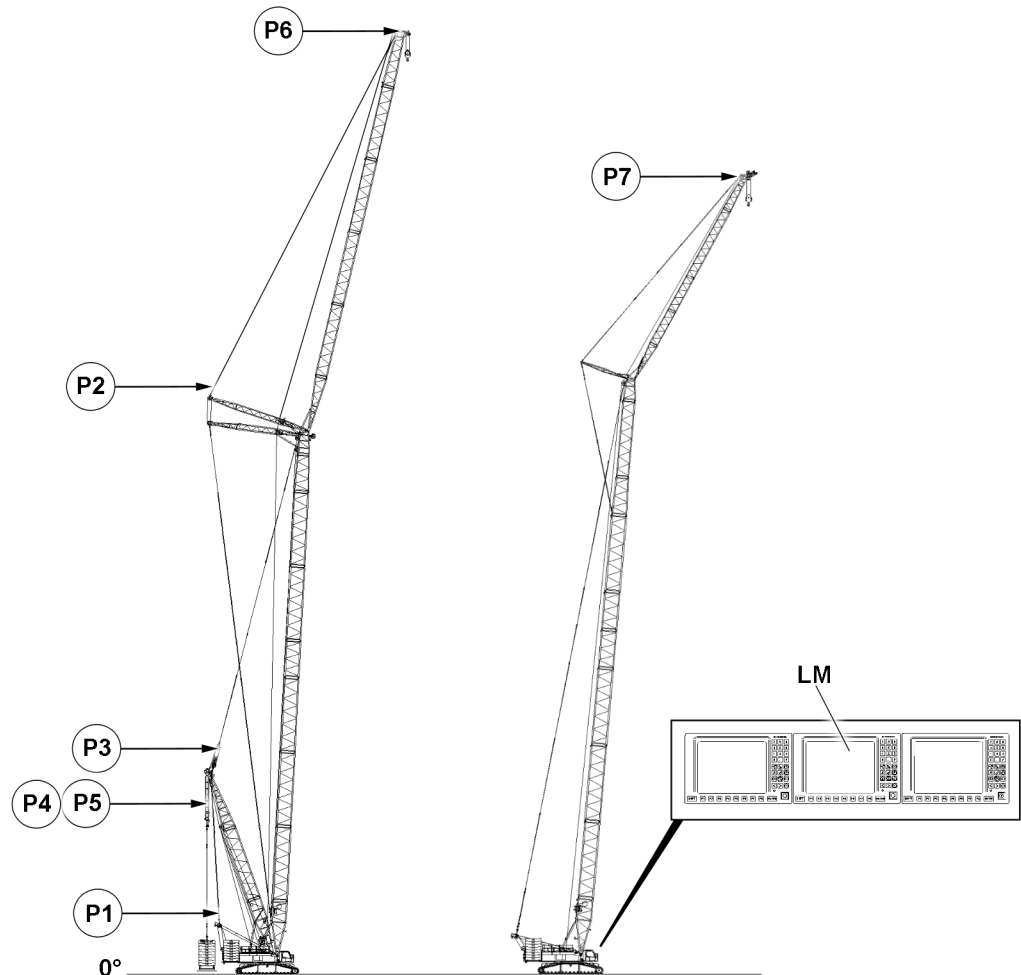
**10.1.2 F-load display for operating modes with derrick ballast**

Fig.157159: F-load display for operating modes with derrick ballast – Test points overview

**LM** LICCON monitor

Assignment of test points for operating modes with derrick ballast:

Force in the guying between A-frame and derrick head:

- Test point 1 in point **P1** = force F1
- The display is shown on the F-load display on the central LICCON monitor **LM**

Force in the guying between the WA-frame and accessory head:

- Test point 2 in point **P2** = force F2
- The display is shown on the F-load display on the central LICCON monitor **LM**
- **Note:** Only for the respective boom system.

Force in the guying between the main boom head and the derrick head:

- Test point 3 in point **P3** = force F3
- The display is shown on the F-load display on the central LICCON monitor **LM**

Force in the guying between the derrick ballast and derrick head:

- Test point 4/5 in point **P4/5** = force F4/5
- The display is shown on the display of the derrick ballast on the left LICCON monitor **LM**

Force on the boom nose pressure test bracket:

- Test point 6 in point **P6** = force F6
- The display is shown on the actual load display on the right LICCON monitor **LM**
- **Note:** Only with an available boom nose.



**Note**

► For a detailed description of the displays for crane operation with derrick ballast, see chapter 4.02.



**WARNING**

Overloading / toppling of the crane!

If the permissible display values of the F-load display are exceeded / fallen below, then the crane can be overloaded.

This could result in serious accidents.

- Observe and adhere to the display values on the LICCON monitors.
- Observe and adhere to the specifications regarding the limit values on the assembly drawings.



**Note**

The values of the F-load display depend on the set up configuration of the crane and the crane geometry.

The values of the F-load display change continuously when the crane is moved.

- Monitor the F-load display continuously.

**Force F1 (test point 1)**

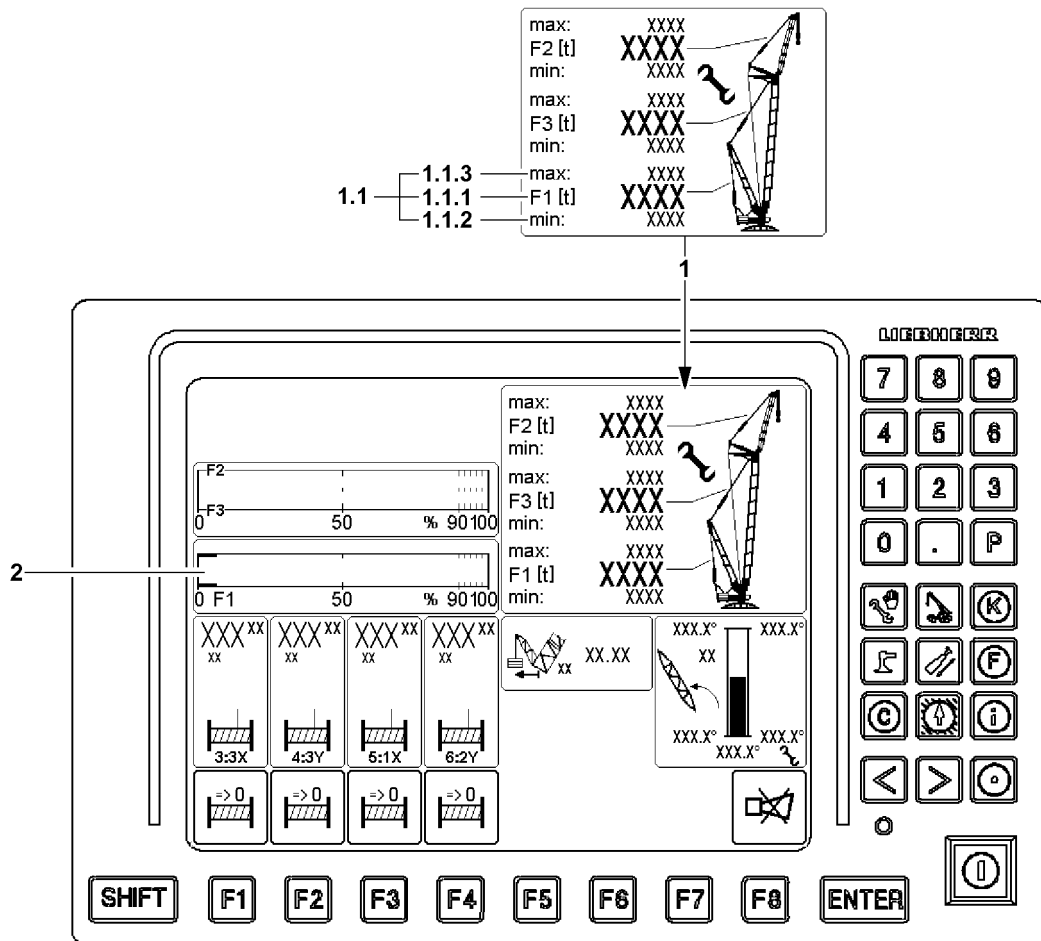


Fig.164067: LICCON Force F1 display

LWE/LR 1800-1-0-000/27200-07-02/en



The force F1 (test point MS1) is determined in the guying between the SA-frame and the derrick head and displayed on the LICCON monitor as operating force  $F1_{actual}$ .

Display values of force F1 (test point MS1) on the F-load display 1:

- 1.1.3 F1-maximum ( $F1_{max}$ )  
F1-force maximum value
- 1.1.1 F1-actual value ( $F1_{actual}$ )  
Current actual value F1-force (operating force F1)
- 1.1.2 F1-minimum ( $F1_{min}$ )  
F1-force minimum value

Structure of the F1-utilization bar 2:

- Ratio of operating force  $F1_{actual}$  to F1 maximum force

**Force F2 (test point 2) and force F3 (test point 3)**

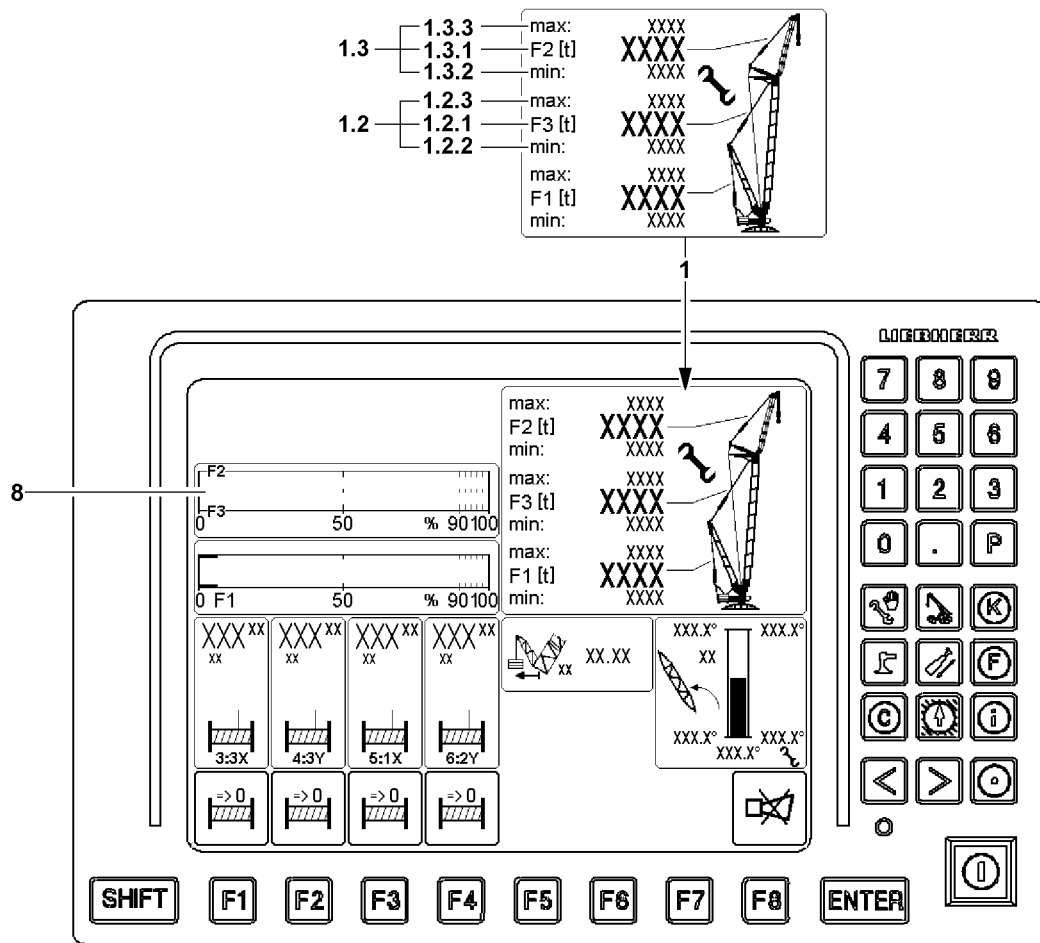


Fig.164072: LICCON Force F2 and Force F3 display

The force F2 (test point 2) is determined between the WA-frame and the accessory head and displayed on the LICCON monitor as operating force  $F2_{actual}$ . A display is shown only with the respective boom system.

The force F3 (test point 3) is determined between the main boom head and the derrick boom head and displayed on the LICCON monitor as operating force  $F3_{actual}$ .

Display values of force F2 (test point MS2) on the F-load display 1:

- 1.3.3 F2-maximum ( $F2_{max}$ )  
F2-force maximum value
- 1.3.1 F2-actual value ( $F2_{actual}$ )  
Current actual value F2-force (operating force F2)

LWE/LR 1800-1-0-000/27200-07-02/en

- **1.3.2** F2-minimum ( $F2_{\min}$ )  
F2-force minimum value

Display values of force F3 (test point MS3) on the F-load display **1**:

- **1.2.3** F3-maximum ( $F3_{\max}$ )  
F3-force maximum value
- **1.2.1** F3-actual value ( $F3_{\text{actual}}$ )  
Current actual value F3-force (operating force F3)
- **1.2.2** F3-minimum ( $F3_{\min}$ )  
F3-force minimum value

Structure of the F2 / F3-utilization bar **8**:

- Ratio of operating force  $F2_{\text{actual}}$  to F2 maximum force  $F2_{\max}$
- Ratio of operating force  $F3_{\text{actual}}$  to F3 maximum force  $F3_{\max}$
- The F2/F3-utilization bars **8** appear only in assembly operation

During crane operation, the display values are displayed for informational purposes only. A special monitoring does not occur.

In assembly operation the display values are monitored. The limit values may not be exceeded.

**Force F4/5 (test point 4/5)**

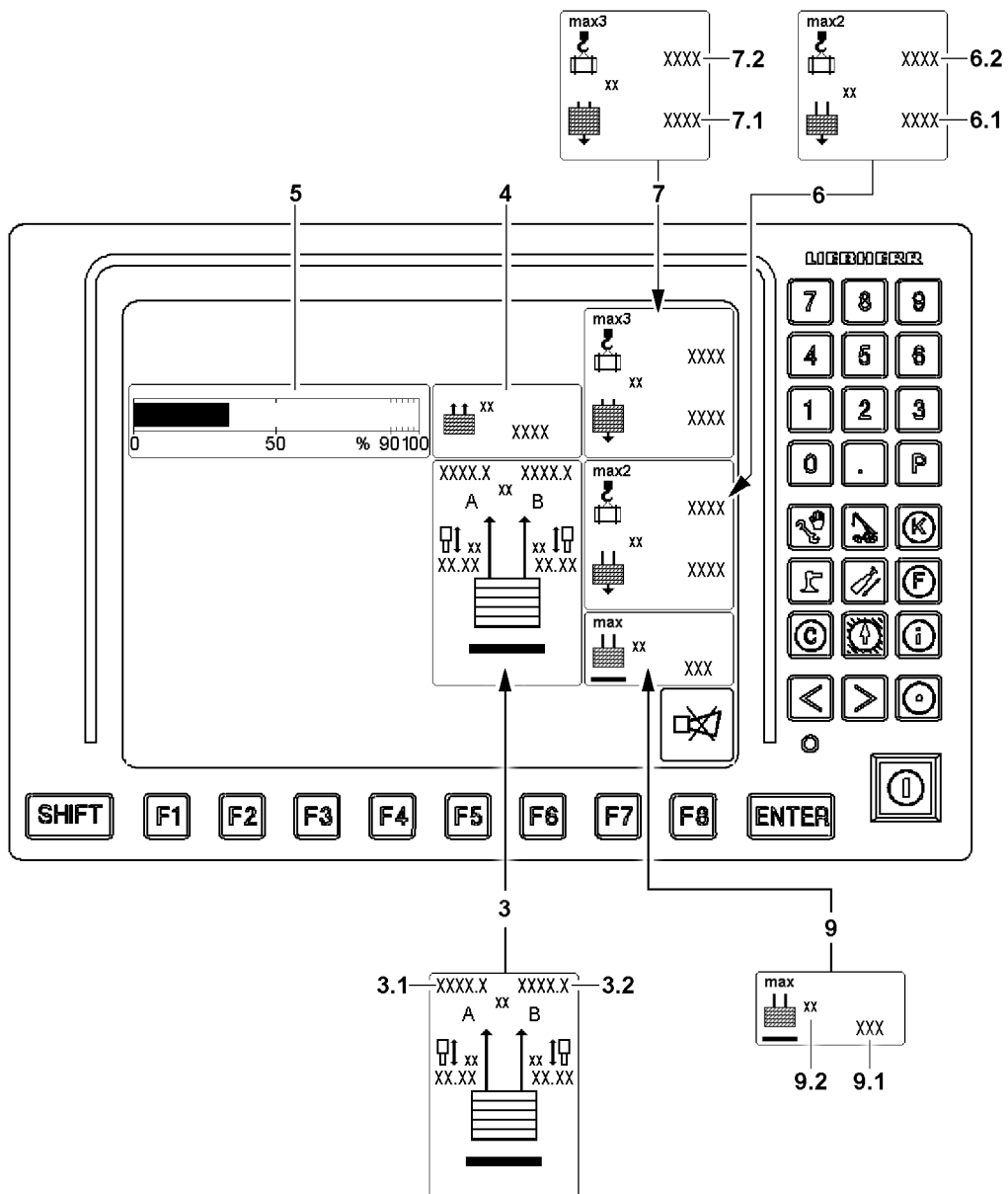


Fig.164068: LICCON Force F4/5 display - LICCON monitor LM2

The forces F4/5 (test point 4/5) are effective in the guy rods from the derrick ballast to the derrick head.

The existing forces in the guy rods are calculated from four pressure sensors, which are installed on the pull cylinders.

Test points guying A (left) are:

- Test point 4A  
Left ring surface pressure sensor (force F4A)
- Test point 5A  
Left piston surface pressure sensor (force F5A)

Test points guying B (right) are:

- Test point 4B  
Right ring surface pressure sensor (force F4B)
- Test point 5B  
Right piston surface pressure sensor (force F5B)

LWE/LR 1800-1-0-000/27200-07-02/en

Display values of force F4/5 (test point 4/5) in the Guying derrick ballast **3** icon:

- **3.1** Force in derrick ballast guying A
- **3.2** Force in derrick ballast guying B

Derrick ballast display values:

- **4**  $BA_{\text{pulled}}$   
Currently pulled derrick ballast
- **5** Derrick ballast utilization bar  
Current utilization of the derrick ballast
- **6.1**  $BA_{\text{placed}}$   
Currently placed derrick ballast

The sum of derrick ballast guying A **3.1** and derrick ballast guying B **3.2** is used to calculate the pulled derrick ballast  $BA_{\text{pulled}}$  **4**.

If the ballast still has ground contact, then only the part of the ballast that is pulled up by the D-guying is displayed. The remaining part is lying on the ground.

Structure of the derrick ballast utilization bar **5**:

- Ratio of pulled derrick ballast ( $BA_{\text{pulled}}$  **4**) to placed derrick ballast ( $BA_{\text{placed}}$  **6.1**)

### Maximum liftable derrick ballast

The *maximum liftable derrick ballast* **9** refers to the current crane condition and indicates the maximum derrick ballast that can be lifted off the ground with the pull cylinder or, in case of the VarioTray, off the suspended ballast palette without falling below the  $F_{1\text{min}}$  force.

- **9** *Maximum liftable derrick ballast* icon
- **9.1** Maximum liftable derrick ballast  
Maximum derrick ballast
- **9.2** Measuring unit  
Measuring unit for display values in the *Maximum liftable derrick ballast* icon **9**: [t] or [lb]

### Additional displays on LICCON monitor LM2

“Load max2” icon **6** (see section “Utilization conditions”)

- **6.1**  $BA_{\text{placed}}$  (Input value in the set up program)  
Currently placed derrick ballast
- **6.2**  $Load_{\text{max2}}$   
Possible load with currently placed derrick ballast

“Load max3” icon **7** (see section “Utilization conditions”)

- **7.1**  $BA_{\text{max}}$  (Highest value in the Set up program)  
Maximum derrick ballast according to the load chart
- **7.2**  $Load_{\text{max3}}$   
Possible load with maximum derrick ballast according to the load chart

**Force F11 test point 11**

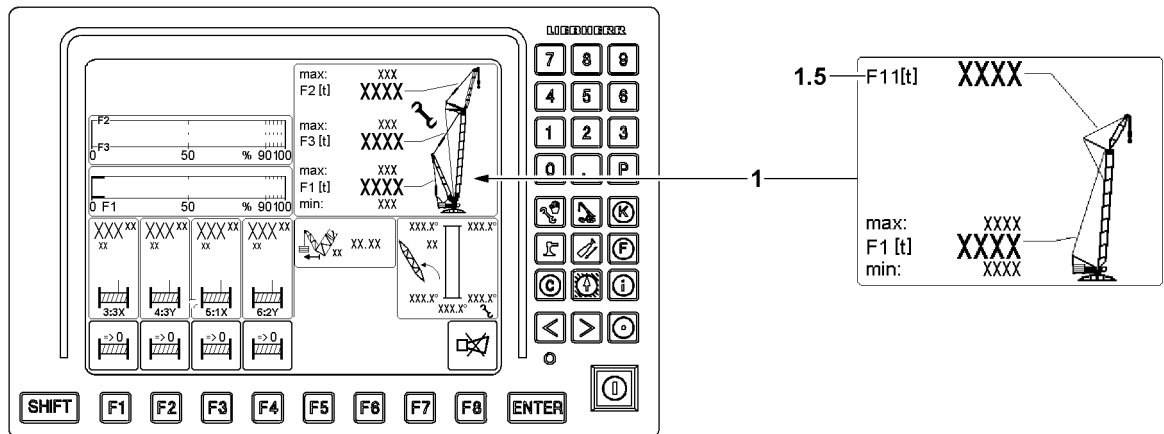


Fig.163662: LICCON force F11 — LICCON monitor LM1

Display values of force F11 (test point MS11) on the F-load display 1:

- **1.5** F11-actual value ( $F_{11\text{actual}}$ )  
Current actual value F11-force (operating force F11)

**10.1.3 Additional displays on LICCON monitor LM1**

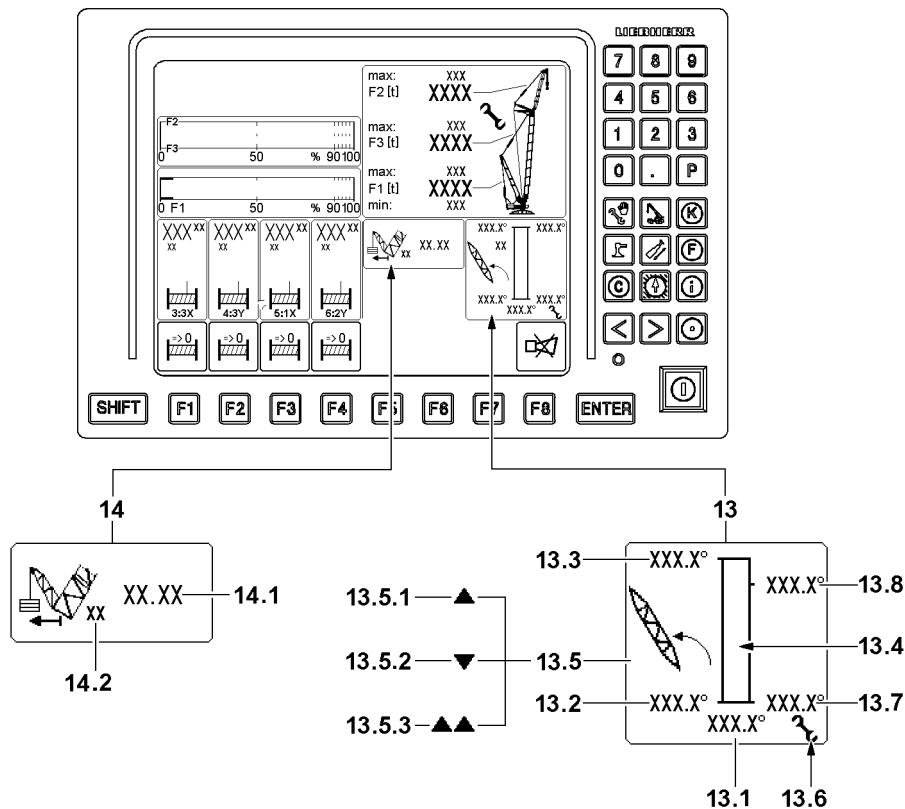


Fig.163661: Derrick ballast angle indicator — LICCON monitor LM1

Derrick boom angle indicator

- **13** Derrick angle
- **13.1** Actual angle  
Current actual angle of the derrick boom  
Actual angle **13.1** red: **Warning!** Derrick boom angle in the impermissible range
- **13.2** Minimum angle

LWE/LR 1800-1-0-000/27200-07-02/en

- Minimum angle of the Derrick boom to the front (to the horizontal)
  - **13.3** Maximum angle  
Maximum angle of the Derrick boom to the front (to the horizontal)
  - **13.4** Bar graph  
Graphic illustration of the derrick angle as a bar graph in relation to the minimum / maximum value.  
It appears in green and red, depending on the situation  
Column **13.4** green: Derrick boom angle in the permissible range  
Column **13.4** red: **Warning!** Derrick boom angle in the impermissible range
  - **13.4** Bar graph  
Graphic illustration of the derrick angle as a bar graph in relation to the minimum / maximum value.  
It appears in green and red, depending on the situation  
Column **13.4** green: Derrick boom angle in the permissible range  
Column **13.4** red: **Warning!** Derrick boom angle in the impermissible range
  - **13.5** Derrick alarm function
    - 13.5.1** Up arrow: Derrick boom maximum angle exceeded
    - 13.5.2** Down arrow: Derrick boom minimum angle fallen below
    - 13.5.3** Double up arrow: Derrick boom relapse press in the block position
  - **13.6** *Assembly* icon  
The *assembly* icon **13.6** appears when a defined angle range for the derrick boom for erection and take-down of the boom system is specified.
  - **13.7** *Assembly* minimum angle  
Assembly: Minimum angle of the Derrick boom to the front (to the horizontal)
  - **13.8** *Assembly* maximum angle  
Assembly: Maximum angle of the Derrick boom to the front (to the horizontal)
- Derrick ballast boom radius display:
- **14** *Derrick ballast* boom radius
  - **14.1** Boom radius value  
Current boom radius value of the derrick ballast  
Measured from the center of the slewing ring to the center of the derrick ballast
  - **14.2** Measuring unit  
Measuring unit of boom radius value

### 10.1.4 Monitoring of crane utilization in operating modes with derrick ballast

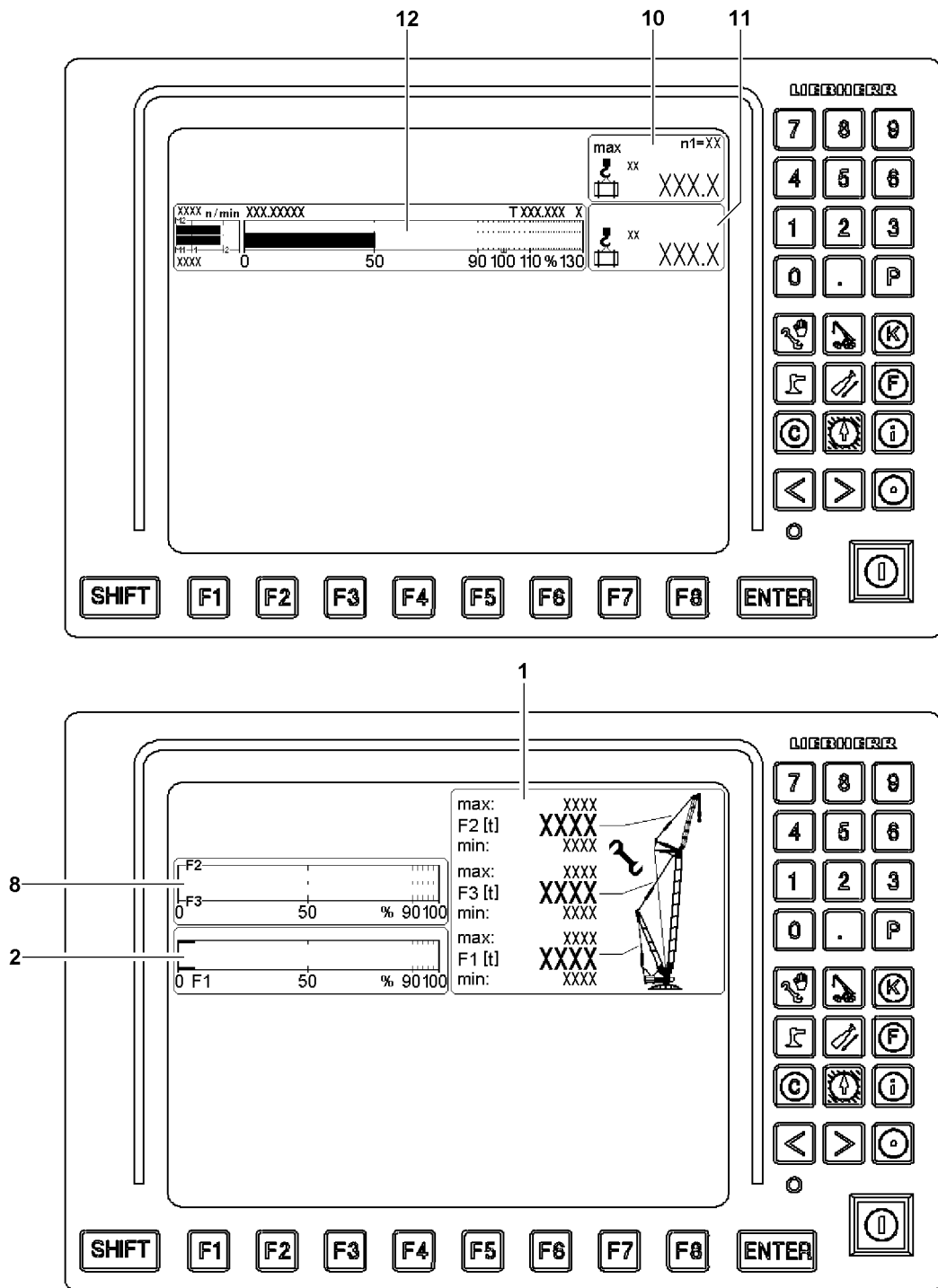


Fig.164070: Monitoring of crane utilization in operating modes with derrick ballast

Display values of the F-load display:

- 1 "F-load display" icon field  
Type and scope of numeric displays depends on the set up configuration and the operating situation.
- 2 "F1-utilization bar" icon field  
Display bar for graphic illustration of F1-force.
- 8 F2/F3-utilization bar icon field  
Display bar for graphic illustration of F2/F3-force.
- 10 "Maximum load display" icon field

LWE/LR 1800-1-0-000/27200-07-02/en

- Displays the maximum load.
- **11** “Actual load” icon field  
Displays the actual load.
- **12** “Utilization bar diagram icon field”  
Displays the bar diagram for the utilization.



#### Note

- ▶ The icon illustrations of the LICCON monitors are examples and may not match your crane.
- ▶ The icon illustrations of the LICCON monitors can deviate in number, arrangement and depiction of the icons on your crane.
- ▶ Observe chapter 4.02.



#### WARNING

Incorrect display values!

If the display values do not increase correspondingly when lifting known weights, an erroneous display value may be present.

If the crane is operated with erroneous display values, then the crane can be overloaded.

This could result in serious accidents.

- ▶ When lifting the hook block off the ground check if the display value for the actual load increases correspondingly.
- ▶ When lifting the derrick ballast off the ground check if the display value for the pulled derrick ballast (BA<sub>pulled</sub>) increases correspondingly.
- ▶ When lifting the load off the ground check if the display value for the actual load increases correspondingly.

In operating modes with derrick ballast, the monitoring of the crane utilization includes, but is not limited to:

- **Monitoring of load momentum**  
Via the “Maximum load” icon **10**, “Actual load” icon **11** and the “utilization bar diagram” **12**.
- **Utilization conditions**  
Support the crane driver with additional display values.
- **Monitoring the F-load display**  
The F-load display **1** is supported on the display by the F1-utilization bar **2** and the F2/F3-utilization bar **8**.

#### Monitoring of load momentum

Monitoring of the “maximum load according to the load chart and reeving”.

During crane operation, the actual load is compared with the maximum load that may be lifted in the current crane configuration. The values are displayed in the “maximum load” **10** icon and the “actual load” icon **11**. The current percentage utilization is displayed as a “utilization bar diagram” **12** on the right LICCON monitor.

The color of the utilization bar in the “utilization bar diagram” **12** also indicates the crane utilization:

- Blue / green utilization bar (below 90 %): Utilization in the permissible range
- Utilization bar yellow (90 % to 100 %): Advance warning - utilization just before impermissible range
- Utilization bar red (above 100 %): Warning - utilization in impermissible range



#### Note

- ▶ Procedure for optimum utilization of “maximum load according to load chart and reeving”, see section “Utilization conditions”.



**WARNING**

Intervention of the LICCON overload protection functionality!

When accessing the functionality of the LICCON overload protection by activating assembly operation, the LICCON overload protection is totally deactivated, bypassed or limited.

It is possible to exceed several shut-off limits of the LICCON overload protection simultaneously or one after the other.

It is possible to carry out crane movements, which are not monitored by the LICCON overload protection.

Without the LICCON overload protection, no additional protection against overload of the crane via the crane control is present.

This could result in serious accidents.

- ▶ When accessing the functionality of the LICCON overload protection, take into account that the LICCON overload protection is deactivated totally or is limited.
- ▶ When accessing the functionality of the LICCON overload protection, chapter 4.02 must be observed.

**WARNING**

The crane can topple over!

In assembly operation the LICCON overload protection is deactivated.

In the event of deliberate improper use, the crane could collapse, the boom can break off or the crane can topple over.

Personnel can be killed.

This can result in significant property damage.

- ▶ Activate the assembly operation only when the consequences are known.
- ▶ Enter the set up configuration correctly into the LICCON computer system.
- ▶ Observe the erection / take down charts.
- ▶ Crane operation with deactivated LICCON overload protection is prohibited.
- ▶ In assembly operation only load torque reducing crane movements may be carried out until a permissible operating and load range.
- ▶ The crane operator carries complete and sole responsibility for his actions if the LICCON overload protection is deactivated.

Utilization conditions

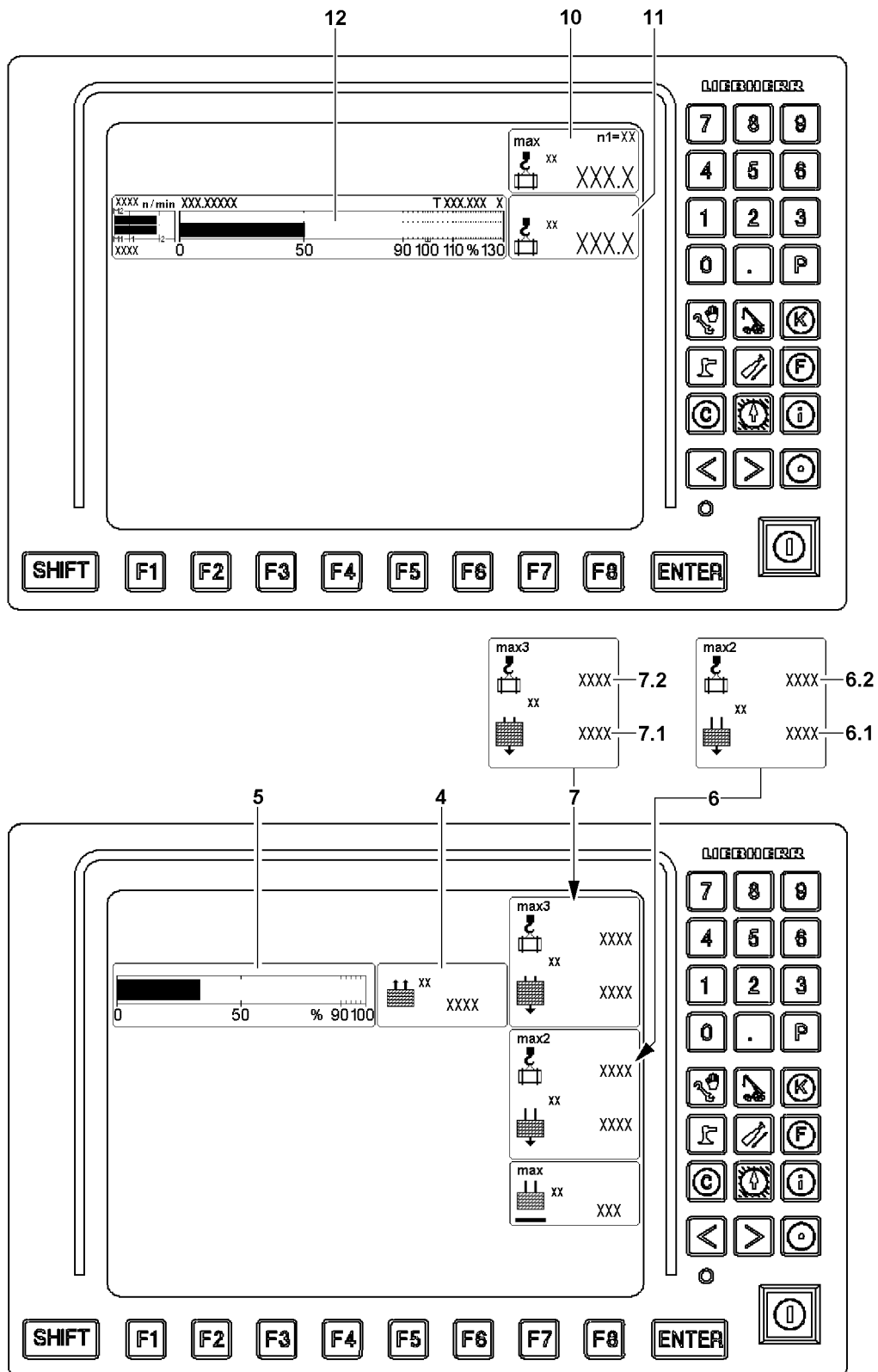


Fig.164071: Utilization conditions

The current percentage utilization of the crane is displayed as “bar diagram utilization” 12 in the right LICCON monitor.

Additional displays:

LWE/LR 1800-1-0-000/27200-07-02/en

“Load max2” icon **6**

- **6.1**  $BA_{\text{placed}}$  (Input value in the set up program)  
Currently placed derrick ballast
- **6.2**  $Load_{\text{max2}}$   
Possible load with currently placed derrick ballast

“Load max3” icon **7**

- **7.1**  $BA_{\text{max}}$  (Highest value in the Set up program)  
Maximum derrick ballast according to the load chart
- **7.2**  $Load_{\text{max3}}$   
Possible load with maximum derrick ballast according to the load chart

**Maximum load**, right LICCON monitor:

- The maximum load in the current operating condition is reached when the utilization bar shows 100 % in the “utilization bar diagram” **12**.  
This is the case when the “utilization of the crane according to the load chart and reeving” reaches 100 % (values in the “Maximum load” **10** icon and the “actual load” icon **11** are equal).  
If the “maximum load” **10** is smaller than or equal to  $load_{\text{max2}}$  **6.2**, then an increase can be obtained under some circumstances:
  - By increasing the pulled derrick ballast  $BA_{\text{pulled}}$  **4**, if the derrick ballast utilization bar **5** is not yet at 100 % (derrick ballast not suspended).
  - By increasing the derrick ballast when the  $BA_{\text{placed}}$  **6.1** is smaller than  $BA_{\text{max}}$  **7.1**.
  - By changing the derrick ballast radius within the permissible range, see the load chart manual or the LICCON job planner.

**Max2-load**, “load max2” icon **6**:

- The highest possible load in the current operating condition “**max2-load**” is reached when the “utilization bar diagram” **12** displays 100 % **and** the derrick ballast utilization bar **5** is at 100 % (Derrick ballast is completely lifted off the ground).  
This is the case when the value in the “Actual load” icon **11** is the same as  $load_{\text{max2}}$  **6.2**.  
If the  $load_{\text{max2}}$  **6.2** is smaller than or equal to  $load_{\text{max3}}$  **7.2**, then an increase can be obtained under some circumstances:
  - By increasing the derrick ballast by loading additional ballast plates (increase  $BA_{\text{placed}}$  **6.1** to  $BA_{\text{max}}$  **7.1**).

**Max3-load**, “load max3” icon **7**:

- The highest possible load at the maximum derrick ballast in current operating condition “**max3-load**” is reached when the “utilization bar diagram” **12** displays 100 % **and** the derrick ballast utilization bar **5** is at 100 % (maximum derrick ballast according to load chart is placed and is completely lifted off the ground).  
This is the case when the value in the “Actual load” icon **11** is the same as  $load_{\text{max3}}$  **7.2**.
- The maximum derrick ballast according to the load chart is placed and completely pulled.  
Further increase of the derrick ballast is impermissible.

## Monitoring the F-load display

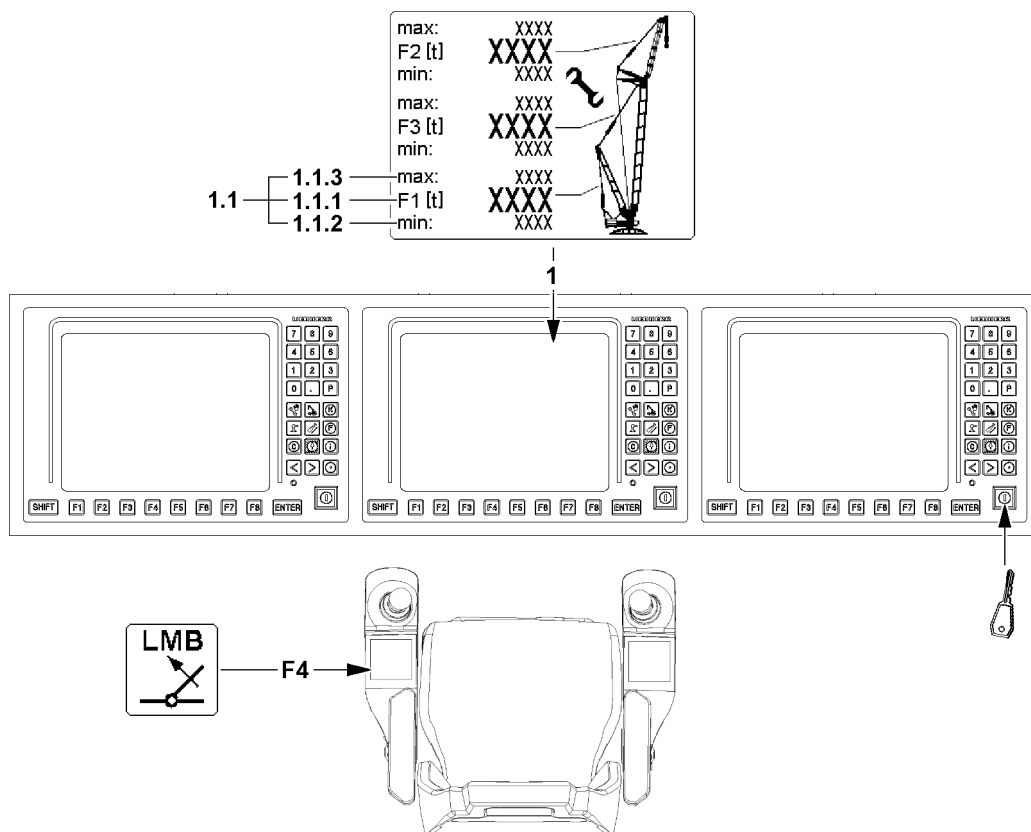


Fig.151470: Monitoring the F-load display

- |              |  |              |                            |
|--------------|--|--------------|----------------------------|
| <b>1</b>     | F-load display icon field                | <b>1.1.2</b> | F1-minimum ( $F1_{\min}$ ) |
| <b>1.1</b>   | F-load display F1                        | <b>1.1.3</b> | F1-maximum ( $F1_{\max}$ ) |
| <b>1.1.1</b> | F1-actual value ( $F1_{\text{actual}}$ ) |              |                            |

### Monitoring of F1-maximum force

Display values of force F1 (test point MS1) on the F-load display **1**:

- **1.1.3** F1-maximum ( $F1_{\max}$ )  
F1-force maximum value
- **1.1.1** F1-actual value ( $F1_{\text{actual}}$ )  
Current actual value F1-force (operating force F1)
- **1.1.2** F1-minimum ( $F1_{\min}$ )  
F1-force minimum value

The display values of force F1 (test point 1) are displayed on the LICCON monitor. When F1-actual value ( $F1_{\text{actual}}$ ) **1.1.1** is greater than F1-maximum ( $F1_{\max}$ ) **1.1.3** a shut-off of all load moment increasing movements occurs.

**WARNING**

Intervention of the LICCON overload protection functionality!

When accessing the functionality of the LICCON overload protection by activating assembly operation, the LICCON overload protection is totally deactivated, bypassed or limited.

It is possible to exceed several shut-off limits of the LICCON overload protection simultaneously or one after the other.

It is possible to carry out crane movements, which are not monitored by the LICCON overload protection.

Without the LICCON overload protection, no additional protection against overload of the crane via the crane control is present.

This could result in serious accidents.

- ▶ When accessing the functionality of the LICCON overload protection, take into account that the LICCON overload protection is deactivated totally or is limited.
- ▶ When accessing the functionality of the LICCON overload protection, chapter 4.02 must be observed.

**Note**

The limit value for the F1-maximum force depends not only on the set up configuration and the crane geometry, but also on the pulled derrick ballast.

- ▶ If the pulled derrick ballast is larger, then the limit value for the F1-minimum force is generally reduced.
- ▶ If the pulled derrick ballast is smaller, then the limit value for the F1-maximum force is generally increased.

**Note**

By engaging the assembly operation the limit value for the F1-maximum force can be exceeded by a few tons. This makes it possible to reset a crane movement, which has caused the shutoff.

When the limit value should be exceeded:

- ▶ Exceeding the maximum value of the F-load display in crane operation, see chapter 4.20.
- ▶ Reset shut-off triggered by reverse crane movement.

Monitoring of F1-minimum force

Display values of force F1 (test point MS1) on the F-load display **1**:

- **1.1.3** F1-maximum ( $F1_{\max}$ )  
F1-force maximum value
- **1.1.1** F1-actual value ( $F1_{\text{actual}}$ )  
Current actual value F1-force (operating force F1)
- **1.1.2** F1-minimum ( $F1_{\min}$ )  
F1-force minimum value

**WARNING**

Uncontrolled movements of the boom system!

If the guying between the SA-frame and the derrick boom head (test point 1) becomes powerless, then this can lead to uncontrollable movements of the boom system.

This could result in serious accidents.

- ▶ The guying between the SA-frame and the derrick boom head (test point 1) may never be without power.
- ▶ Relieve the D-guying between the derrick boom head and the derrick ballast to the point where the F1-actual value ( $F1_{\text{actual}}$ ) **1.1.1** is greater than the F1-minimum ( $F1_{\min}$ ) **1.1.2**.

**WARNING**

Intervention of the LICCON overload protection functionality!

When accessing the functionality of the LICCON overload protection by activating assembly operation, the LICCON overload protection is totally deactivated, bypassed or limited.

It is possible to exceed several shut-off limits of the LICCON overload protection simultaneously or one after the other.

It is possible to carry out crane movements, which are not monitored by the LICCON overload protection.

Without the LICCON overload protection, no additional protection against overload of the crane via the crane control is present.

This could result in serious accidents.

- ▶ When accessing the functionality of the LICCON overload protection, take into account that the LICCON overload protection is deactivated totally or is limited.
- ▶ When accessing the functionality of the LICCON overload protection, chapter 4.02 must be observed.

**Note**

The limit value for the F1-maximum force depends not only on the set up configuration and the crane geometry, but also on the pulled derrick ballast.

- ▶ If the pulled derrick ballast is larger, then the limit value for the F1-minimum force is generally reduced.
- ▶ If the pulled derrick ballast is smaller, then the limit value for the F1-maximum force is generally increased.

**Note**

By engaging the assembly operation the limit value for the F1-minimum force can be fallen below by a few tons. This makes it possible to reset a crane movement, which has caused the shutoff.

- ▶ Reset shut-off triggered by reverse crane movement.

**WARNING**

Independent movement of the boom system when increasing load momentum!

If the F1-minimum force is fallen below, the guying between the SA-frame and the derrick boom head can become powerless.

If the guying between the SA-frame and the derrick boom head is powerless and the "Derrick ballast is on the ground" at the same time the derrick ballast can suddenly lift off the ground due to increase of the load momentum.

As a result, the boom system can move forward suddenly. Strong oscillating movements of the derrick ballast and load can be the result.

The crane can be overloaded and severe accidents can be the result.

- ▶ Keep the F1-actual value ( $F1_{\text{actual}}$ ) **1.1.1** above the F1-minimum ( $F1_{\text{min}}$ ) **1.1.2**.
- ▶ It is prohibited to fall below the F1-minimum force.

**WARNING**

Autonomous movement of the boom system when decreasing the load momentum!

If the F1-minimum force is fallen below, the guying between the SA-frame and the derrick boom head can become powerless.

If the guying between the SA-frame and the derrick boom head is powerless and the "derrick ballast is suspended" at the same time, the derrick ballast can suddenly set down on the ground due to decrease of the load momentum.

As a result, the boom system can move backward suddenly. As a result, the relapse cylinders can be pressed on block, be overloaded and damaged. Strong oscillating movements of the derrick ballast and load can be the result.

The crane can be overloaded and severe accidents can be the result.

- ▶ Keep the F1-actual value ( $F1_{\text{actual}}$ ) **1.1.1** above the F1-minimum ( $F1_{\text{min}}$ ) **1.1.2**.
- ▶ It is prohibited to fall below the F1-minimum force ( $F1_{\text{min}}$ ).

The following applies:

- After a shut-off due to falling below the F1-minimum ( $F1_{\min}$ ) **1.1.2** the F1-actual value ( $F1_{\text{actual}}$ ) **1.1.1** must be increased by a crane movement. If the derrick ballast is suspended, this can be achieved by setting down the ballast.
- When picking up the load, the D-guying between the derrick ballast and the derrick boom head must be relieved to the point where the F1-actual value ( $F1_{\text{actual}}$ ) **1.1.1** is greater than F1-minimum ( $F1_{\min}$ ) **1.1.2**.
- When increasing the load momentum, and the limit value F1-minimum ( $F1_{\min}$ ) **1.1.2** is fallen below, an already set down derrick ballast can lose contact with the ground and lift off.
- When decreasing the load momentum, and the limit value F1-minimum ( $F1_{\min}$ ) **1.1.2** is fallen below, an already “suspended derrick ballast” can be put down on the ground.
- If the assembly operation is activated and the F1-force continues to drop below the minimum force  $F1_{\min}$ , then the  $F1_{\min}$  shut-off can no longer be bypassed.

Limitations from 50 % pulled derrick ballast

If more than 50 % of the set derrick ballast is being pulled (utilization bar derrick ballast **5** greater than 50 %) and the F1-minimum ( $F1_{\min}$ ) **1.1.2** is fallen below at the same time, all crane movements that increase load torque are turned off.

Limitations from 90 % pulled derrick ballast

If more than 90 % of the set derrick ballast is being pulled (derrick ballast utilization bar **5** greater than 90 %) and the F1-minimum ( $F1_{\min}$ ) **1.1.2** is fallen below at the same time, all crane movements that increase load torque and all crane movements that decrease load momentum are turned off. This also turns off the “spooling out” movement of the winch.

### 10.1.5 Monitoring of pull cylinders in the block position

The pull cylinders (also called ballast lift cylinders) of the derrick ballast are equipped with length sensors and limit switches for monitoring.

In crane operation, the monitoring of the pull cylinders on block position is always active. If there is the danger of a block position, then only that direction of the pull cylinders can be moved which improves the condition. The other direction is unbyassably blocked. As long as the length sensors and the limit switches function correctly, the pull cylinders cannot get into a block position.



#### WARNING

Problem at monitoring of pull cylinders!

If the length sensors or limit switches are defective or missing, then the monitoring of the pull cylinders is not active.

Without monitoring, the pull cylinders can be moved without restriction, as a result, a block position is possible.

At a block position, the pressure measurements of the pull cylinders become inexact and the values are incorrectly calculated.

The overload protection calculates the actual load incorrectly and transmits faulty display values.

The crane can be overloaded and topple over.

This could result in serious accidents.

► Observe the display values and possible error messages.

► If length sensors or limit switches are defective or missing, monitor the pull cylinders manually.

The following applies:

- The display values of the pull cylinders must function and be plausible.

### 10.1.6 Monitoring the lateral incline of the divisible ballast pallet “VarioTray”

The divisible ballast pallet “VarioTray” is equipped with an incline sensor for monitoring.

The monitoring of the lateral incline of the divisible ballast pallet “VarioTray” is always active. If the maximum lateral incline is reached, then the pull cylinders can only be moved in the directions that im-

prove the condition. The other directions are unbyassably blocked. Therefore the ballast can only be put down with the ballast pallet "VarioTray" when the terrain incline is not greater than the maximum permissible lateral inclination when setting down the ballast pallet.



#### Note

- ▶ The maximum **permissible** lateral inclination of the divisible ballast pallet "VarioTray" is  $\pm 2.5^\circ$  when lifted.
- ▶ The maximum **permissible** lateral inclination of the divisible ballast pallet "VarioTray" is  $\pm 1^\circ$  when set down.
- ▶ If the ballast trailer is lifted or lowered using the pull cylinders, then the horizontal alignment of the ballast pallet is automatically adjusted by both length sensors of the pull cylinders.
- ▶ For a ballast utilization of **more than** or **equal to** 90 percent, the level sensor adjusts the pull cylinder to a difference of 1 cm.
- ▶ With a ballast utilization of **less than** 90 percent, the level sensor monitors the derrick ballast level to  $\pm 2.5^\circ$ .



#### WARNING

Defective incline sensor!

If an incline sensor is defective or missing, the monitoring of the lateral incline of the suspended ballast is not active.

The pull cylinders can be moved without restriction and the derrick ballast can be overturned as a result.

This could result in serious accidents.

- ▶ Observe the display values and possible error messages.
- ▶ If an incline sensor is defective, monitor the lateral incline of the derrick ballast manually.

The following applies:

- The display values of the lateral incline of the derrick ballast must function and be plausible.

### 10.1.7 Derrick ballast guying difference force monitoring

In operating modes with derrick ballast the forces of the derrick ballast guyings A and B are displayed in the LICCON monitor.



#### WARNING

Danger of accident!

If the forces in the derrick ballast guyings A and B are too high, then this can lead to an overload of the crane. Components can fail and severe accidents can be the result.

- ▶ Load the derrick ballast guyings A and B evenly.

After reaching the specified limit value of the difference force threshold, the displays of the pulled ballast of pull cylinder A and B blink and become red, the function ballast up / down is stopped. The difference force must be lowered again.

If the difference of the forces of the derrick ballast guyings A and B exceeds the limit value, then this can have various causes:

- Flexing of the turntable
- The ground under the derrick ballast is uneven
- The crane is leaning to one side
- The derrick ballast is loaded on one side
- The force measurement in one D-guying is incorrect

The crane driver must recognize the correct cause and take countermeasures:

- The error, which caused the one-sided force, must be remedied.
- If the sensor values are implausible: Stop crane operation and find the cause and remedy it.

#### Bypassing the shut-off of the function ballast up / down

- The following measures are permitted providing the ground is only slightly uneven:



Control the individual pull cylinders in such a way that the difference between the forces becomes smaller. Ensure that the derrick ballast is not tilted at an inadmissible angle with respect to the crane, otherwise the "V-frame" suspended ballast guide and attachments will be damaged.

- ▶ Carry out the following: Activate assembly operation, see chapter 4.02.

**Result:**

- The shut-off of the function ballast up / down is bypassed.
- An assembly icon appears on the left LICCON monitor.
- ▶ Press the button Ballast "up" or button Ballast "down" **and** the stop button on the desired side at the same time, see section "Lifting / setting down / equalizing the derrick ballast".

---

**Problem remedy**

The display of the entire pulled ballast is shown blinking red. An LMB-Stop was triggered. All crane functions were stopped.

The crane driver has moved the pull cylinders into the incorrect direction and further exceeded the limit value for the difference force threshold.

- ▶ Move the pull cylinders again into the correct (other) direction and align the ballast in such a way that the displays of the pulled ballast of pull cylinder A and B are again in the permissible range.
- 
- ▶ Activate assembly operation again.

**Result:**

- The shut-off of the function ballast up / down is bypassed again.
- All other crane functions are still suppressed.
- ▶ Move the pull cylinders into the correct direction.




---

**DANGER**

Overload of the crane!

If the pull cylinders are moved into the incorrect direction after a new bypass of the function ballast up / down, the crane will be overloaded.

This could result in serious accidents.

- ▶ Monitor the display values and move the pull cylinders in the correct direction (values of pull cylinder A and B become closer).
  - ▶ If unsure: Contact Liebherr Customer Service.
- 

- ▶ Find and remedy the error that led to the shut-off of the "Ballast up / down" function.

## 10.2 Function check of the ground contact switches on the large ballast pallet

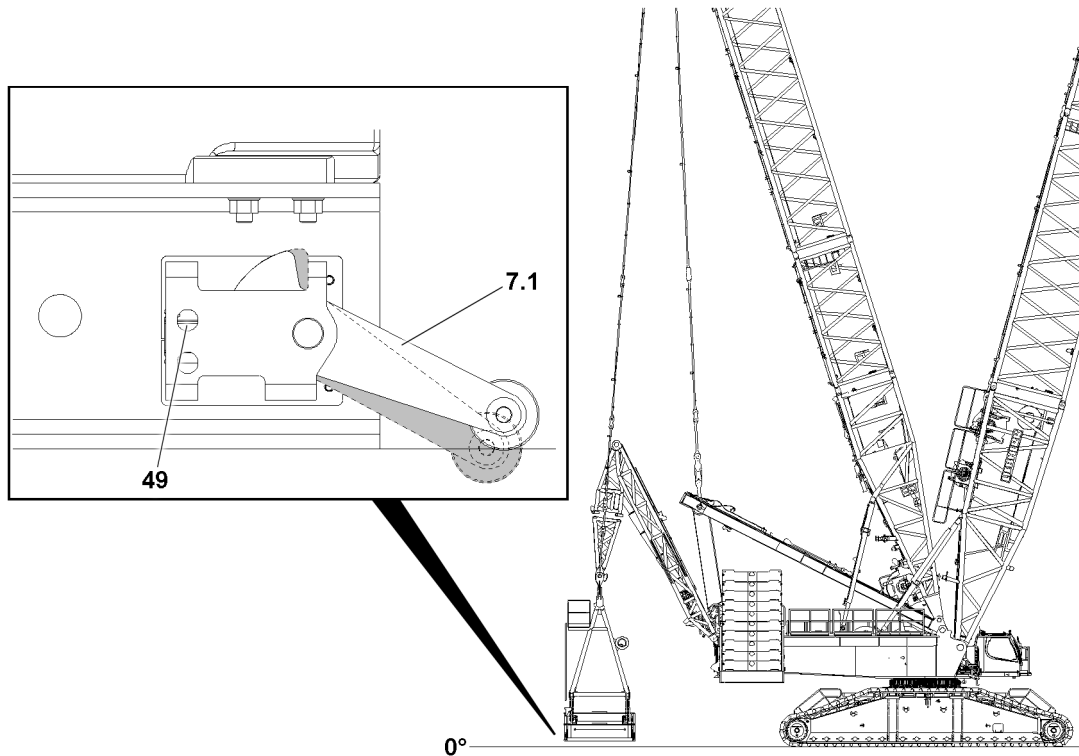


Fig.163643: Ground contact switch function check

7.1 Ground contact roller

49 Ground contact switch

Make sure that the following prerequisites are met:

- The electrical connection to the suspended ballast is established.
- The electrical line **X1100** is plugged into the terminal box **+S1100G** (large ballast pallet).
- The suspended ballast pallet is placed down on the ground.
- The LICCON monitor displays the “Derrick ballast has ground contact” icon.



### Note

- ▶ Each ground contact roller **7.1** has 2 ground contact switches **49**.
- ▶ Check each of the 4 ground contact switches **49** individually.



### DANGER

Danger of accident if the derrick ballast touches the ground!

If the terrain is very uneven, the danger exists that the derrick ballast rests on the ground even if a ground contact switch **49** was not actuated.

- ▶ The ground must be horizontal and level enough so that when the suspended ballast pallet comes into contact with the ground at least one ground contact roller **7.1** is actuated.



### DANGER

Defective or hard to move ground contact switch **49**!

Death, severe injuries, property damage.

If a ground contact switch **49** is defective or hard to move, the “turning the turntable” and “driving the crawler” functions do not turn off. The crane topples over.

- ▶ Make sure that both ground contact switches **49** are easy to move.
- ▶ Make sure that all ground contact switches **49** trigger the display “Derrick ballast has ground contact” when actuated.

- ▶ Lift the ballast pallet and observe if the ground contact rollers **7.1** move easily.

When the large ballast pallet is lifted:

- ▶ Check if the “Derrick ballast lifted” icon appears on the LICCON monitor.
- ▶ Actuate each ground contact switch **49** individually and manually so that the “Derrick ballast has ground contact” icon is displayed on the LICCON monitor.
- ▶ Set the large ballast pallet down.

**Result:**

- The large ballast pallet ground contact switches **49** are checked for function.

**Problem remedy**

Is the ground contact roller hard to move or defective?

- ▶ Contact Liebherr Customer Service.

## 10.3 Disconnecting the divisible ballast pallets “VarioTray” from each other



**WARNING**

Derrick ballast lifted higher than the maximum permissible height!

If the derrick ballast is lifted up off the ground above the maximum permissible height, the crane can topple over to the rear if the load rips off.

Death, severe bodily injuries, property damage.

- ▶ Make sure that the derrick ballast is not lifted higher than the maximum permissible height off the ground, see section “Permissible lifting heights”.



**WARNING**

The crane can topple over!

During the attaching / setting down procedure, the small ballast pallet swings out past the maximum permissible 250 mm, up to 1500 mm over the ground.

If the small ballast pallet is lifted past the maximum permissible 250 mm off the ground, then the crane can be topple over to the rear if the load rips off.

Death, severe bodily injuries, property damage.

- ▶ Make sure that the small ballast pallet is lifted or set down from the large ballast pallet **without** a load on the hook.

### 10.3.1 Establishing the electrical connection for sole operation of the “small” ballast palette

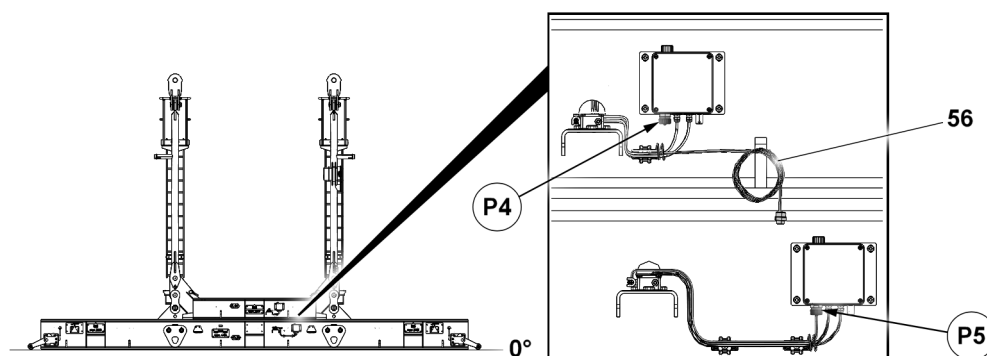


Fig.163649: Establishing the electrical connection for sole operation of the “small” ballast palette

**NOTICE**

The ignition switch is not in position 0!

If live electrical connections are disconnected / connected, then there is the danger that components can be damaged.

The crane functions can be limited.

- ▶ De-energize the electrical connections before disconnection / connection: Set the ignition switch to position 0.

**NOTICE**

Danger of damage to the electrical lines on the suspended ballast!

If the electrical line **56** is not wound up and looped-in, it can be damaged when setting down the suspended ballast.

- ▶ Wind up and loop in the electrical line **56**.

- ▶ Move the ignition switch to position 0.

- ▶ Wind up and loop in the electrical line **56**.

Establish the electrical connection for sole operation of the “small” ballast palette:

- ▶ Connect the plug of the electrical line **56** to the terminal box in position **P4**.

**Note**

- ▶ Establishing the electrical connection for sole operation of the “small” ballast palette, see the “wiring diagram”.

**NOTICE**

Damage to the electrical connections due to dirt, moisture and corrosion!

If unrequired electrical connections are not closed with their respective caps, the electrical connections can be damaged.

If the covers are removed from the electrical connections or control cabinets are opened, then moisture can infiltrate.

- ▶ Always properly close off all **non**-required electrical connections with their protective caps.
- ▶ Protect the electrical connections from water infiltration, this applies especially in the case of rain or snow.

**Note**

If **non**-required electrical connections are not closed with their respective dummy plugs, the electrical connections can be damaged.

- ▶ A malfunction can occur without bridging.

- ▶ Observe the “wiring diagram”.

- ▶ As a rule, close off non-required electrical connections (for example for accessories that are not installed) with the respective dummy plugs / dust caps.

**Result:**

- The plug of the electrical line **-X1100** is plugged into the terminal box **+S1100K** (small ballast pallet).

### 10.3.2 Unpinning the small ballast pallet “VarioTray”

Make sure that the following prerequisites are met:

- The divisible ballast pallet “VarioTray” is properly installed and secured on the derrick ballast guying or on the “V-frame” suspended ballast guide.
- The divisible ballast pallet “VarioTray” is positioned flat on the ground and has a maximum longitudinal and lateral incline of  $\pm 1^\circ$ .
- The electrical connection between the turntable and the small ballast pallet “VarioTray” is established.
- The ground contact rollers are easy to move.
- The ballast plates are installed on the large ballast pallet according to the load chart or the erection and take-down charts.
- Ballast plates are installed on the small ballast pallet according to the load chart or the erection and take-down charts.

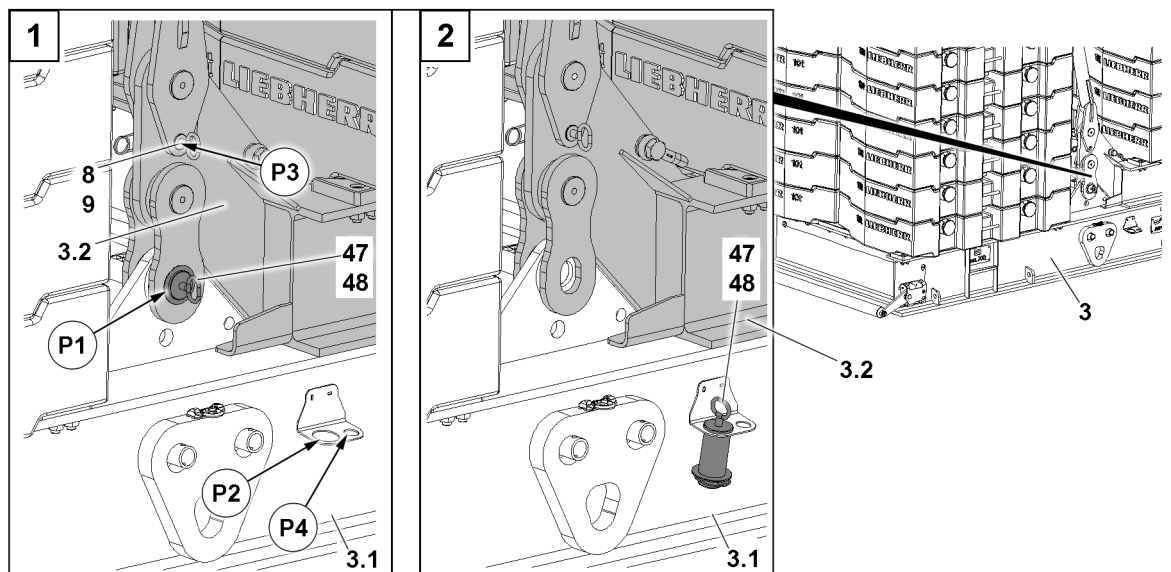


Fig.155373: Unpinning the small ballast pallet “VarioTray”

<b>3</b>	Divisible ballast pallet “VarioTray”	<b>9</b>	Retaining element
<b>3.1</b>	Large ballast pallet	<b>47</b>	Pin
<b>3.2</b>	Small ballast pallet	<b>48</b>	Retaining element
<b>8</b>	Retaining pin		

The small ballast pallet **3.2** is unpinned in four positions **P1**. The unpinning procedure is described for one pin **47** as an example.

- ▶ Remove the retaining element **48** and unpin the pin **47**.
- ▶ Repeat the procedure the same way for all pins **47**.

#### Result:

- The small ballast pallet **3.2** is disconnected from the large ballast pallet **3.1**.
- ▶ Insert the pin **47** in the park position **P2** and secure with the retaining element **48**.

If retaining pins **8** are installed in the positions **P3**:

- ▶ Remove the retaining element **9** and unpin the retaining pin **8** in position **P3**.
- ▶ Insert the retaining pin **8** in the park position **P4** and secure with the retaining element **9**.
- ▶ Enter the new derrick ballast weight in the Set up program.

### 10.3.3 Function check of the ground contact switches on the small ballast pallet

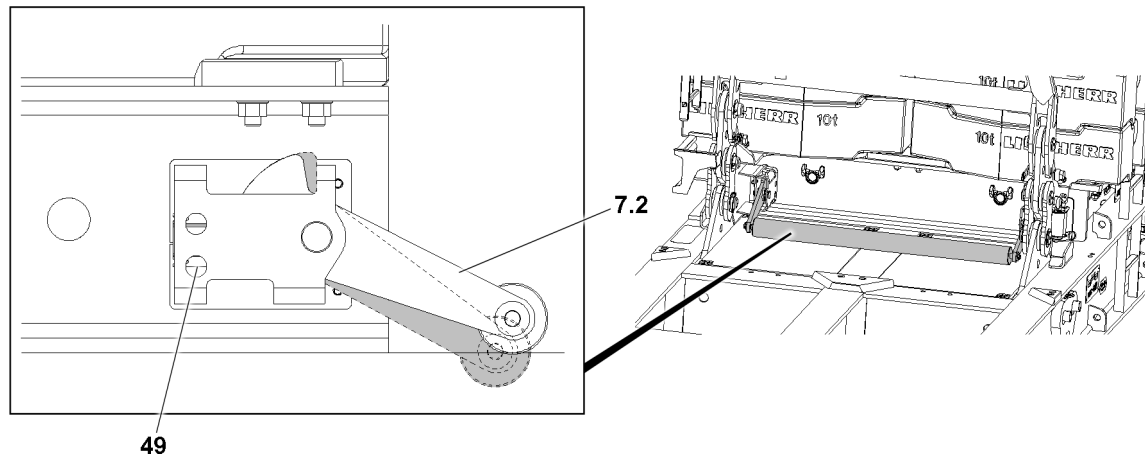


Fig.155374: Function check before lifting the derrick ballast – Checking the ground contact rollers

**7.2** Ground contact roller

**49** Ground contact switch

Make sure that the following prerequisites are met:

- The plug of the electrical line **-X1100** is plugged into the terminal box **+S1100K** (small ballast pallet).
- The small ballast pallet is placed on the large ballast pallet.
- The LICCON monitor displays the “Derrick ballast has ground contact” icon.
- The new derrick ballast weight is set in the Set up program.



#### Note

- ▶ Each ground contact roller **7.2** has 2 ground contact switches **49**.
- ▶ Check each of the 4 ground contact switches **49** individually.



#### DANGER

Danger of accident if the derrick ballast touches the ground!

- ▶ If the small ballast pallet touches the ground, **at least one** ground contact switch **49** must be actuated via the ground contact roller **7.2**.
- ▶ The “turning the turntable” and “driving the crawler” crane movements turn off.



#### DANGER

Defective or hard to move ground contact switch **49**!

Death, severe injuries, property damage.

If a ground contact switch **49** is defective or hard to move, the “turning the turntable” and “driving the crawler” functions do not turn off. The crane topples over.

- ▶ Make sure that both ground contact switches **49** are easy to move.
- ▶ Make sure that both ground contact switches **49** trigger the display “Derrick ballast has ground contact” when actuated.

- ▶ Lift the ballast pallet and observe if the ground contact rollers **7.2** move easily.

When the small ballast pallet is lifted:

- ▶ Check if the “Derrick ballast lifted” icon appears on the LICCON monitor.
- ▶ Actuate each ground contact switch **49** individually and manually so that “Derrick ballast has ground contact” is displayed on the LICCON monitor.
- ▶ Place the small ballast pallet down on the large ballast pallet.

#### Result:

- The small ballast pallet ground contact switches **49** are checked for function.

**Problem remedy**

Is the ground contact roller **7.2** hard to move or defective?

- ▶ Contact Liebherr Customer Service.

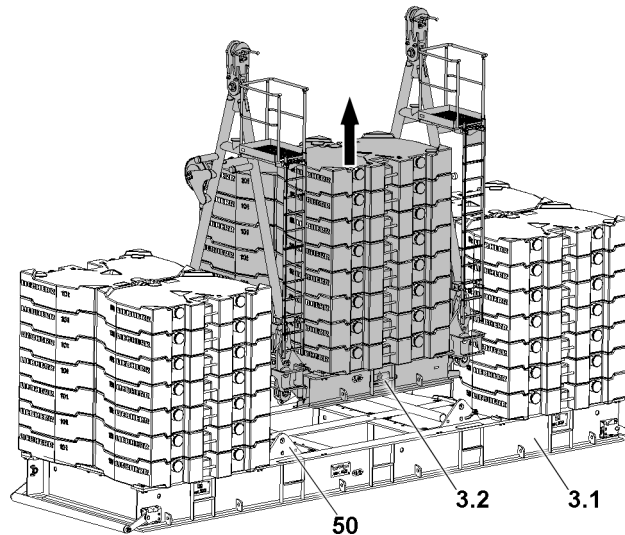
**10.3.4 Lifting the small ballast pallet “VarioTray”**

Fig.155375: Lifting the small ballast pallet “VarioTray”

**3.1** Large ballast pallet

**50** Plate

**3.2** Small ballast pallet

Make sure that the following prerequisites are met:

- The small ballast pallet **3.2** is disconnected from the large ballast pallet **3.1**.

**WARNING**

Tipping ballast plates!

If the crane is turned after the small ballast pallet **3.2** is lifted, the small ballast pallet **3.2** will tip over the ballast plates of the large ballast pallet **3.1**.

Death, severe bodily injuries, property damage.

- ▶ Make sure that the crane is never turned directly after lifting the small ballast pallet **3.2**.
  - ▶ The large ballast pallet **3.1** must always be set down outside of the slewing range of the crane.
- 
- ▶ Lift the small ballast pallet **3.2** until it is suspended over the plates **50** of the large ballast pallet **3.1**: Actuate the pull cylinder, see section “Carrying out crane movements”.

**10.4 Connecting the ballast pallets “VarioTray” with each other****WARNING**

Derrick ballast lifted higher than the maximum permissible height!

If the derrick ballast is lifted up off the ground above the maximum permissible height, the crane can topple over to the rear if the load rips off.

Death, severe bodily injuries, property damage.

- ▶ Make sure that the derrick ballast is not lifted higher than the maximum permissible height off the ground, see section “Permissible lifting heights”.

**WARNING**

The crane can topple over!

During the attaching / setting down procedure, the small ballast pallet swings out past the maximum permissible 250 mm, up to 1500 mm over the ground.

If the small ballast pallet is lifted past the maximum permissible 250 mm off the ground, then the crane can be topple over to the rear if the load rips off.

Death, severe bodily injuries, property damage.

- ▶ Make sure that the small ballast pallet is lifted or set down from the large ballast pallet **without** a load on the hook.

### 10.4.1 Putting down the small ballast pallet “VarioTray”

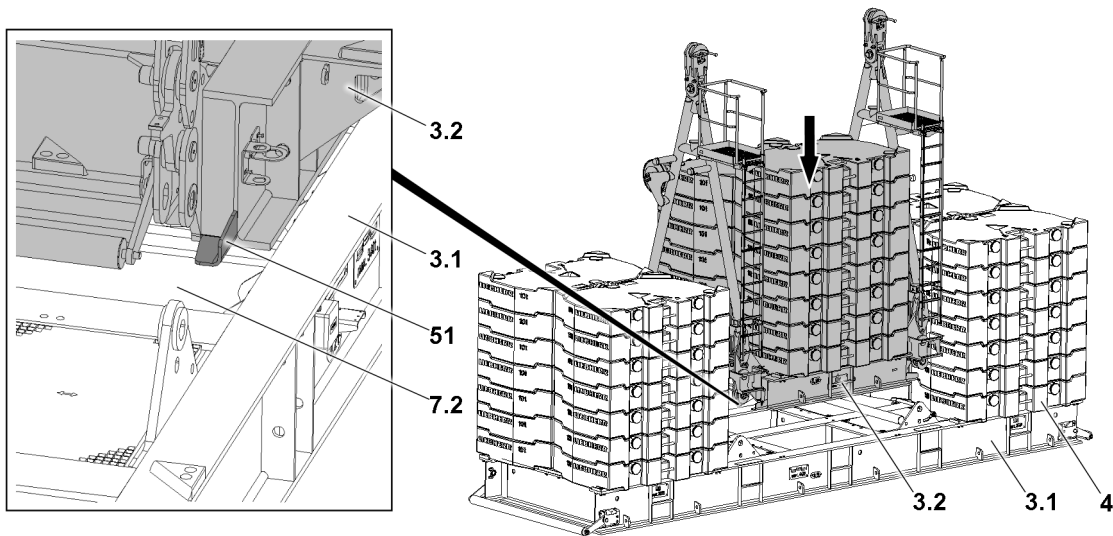


Fig.155376: Putting down the small ballast pallet “VarioTray”

- |     |                      |     |                       |
|-----|----------------------|-----|-----------------------|
| 3.1 | Large ballast pallet | 7.2 | Ground contact roller |
| 3.2 | Small ballast pallet | 51  | Centering device      |
| 4   | Ballast plate        |     |                       |

Make sure that the following prerequisites are met:

- The large ballast pallet **3.1** is positioned flat on the ground and has a maximum longitudinal and lateral incline of  $\pm 1^\circ$ .
- The small ballast pallet **3.2** is located over the pin locations of the large ballast pallet **3.1**.
- The ground contact rollers **7.2** are easy to move.
- The ballast plates **4** are installed on the large ballast pallet **3.1** according to the load chart or the erection and take-down charts.

**WARNING**

Danger of fatal injury due to tipping ballast plates **4**!

If the crane is turned when setting down the small ballast pallet **3.2**, the small ballast pallet **3.2** will tip over the ballast plates **4** of the large ballast pallet **3.1**.

Death, severe bodily injuries, property damage.

- ▶ Make sure that the crane is never turned while setting down the small ballast pallet **3.2**.

**Note**

- ▶ When setting down the small ballast pallet **3.2**, use the centerings **51** on the small ballast pallet **3.2** as a guide.
- ▶ Put the small ballast pallet **3.2** down on the large ballast pallet **3.1**: Actuate the pull cylinder, see section “Carrying out crane movements”.



### 10.4.2 Pinning the small ballast pallet “VarioTray”

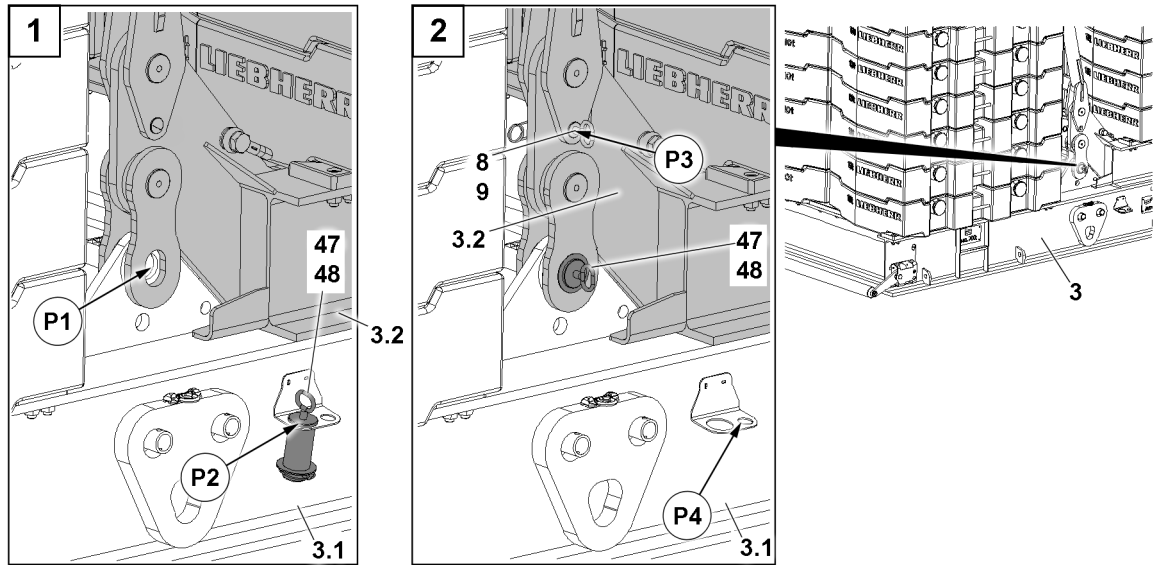


Fig.155377: Pinning the small ballast pallet “VarioTray”

<b>3</b>	Divisible ballast pallet “VarioTray”	<b>8</b>	Retaining pin
<b>3.1</b>	Large ballast pallet	<b>9</b>	Retaining element
<b>3.2</b>	Small ballast pallet	<b>47</b>	Pin
<b>6</b>	Erection rack	<b>48</b>	Retaining element

Make sure that the following prerequisites are met:

- The small ballast pallet **3.2** is lying completely on the large ballast pallet **3.1**.
- The pin bores of the small ballast pallet **3.2** and the large ballast pallet **3.1** align.

The small ballast pallet **3.2** is pinned in four positions **P1**. The pinning procedure is described for one pin **47** as an example.

- ▶ Remove the retaining element **48** and unpin the pin **47** from the park position **P2**.
- ▶ Insert the pin **47** in position **P1** and secure with the retaining element **48**.
- ▶ Repeat the procedure the same way for all four pins **47**.

**Result:**

- The small ballast pallet **3.2** is pinned with the large ballast pallet **3.1**.

The erection racks **6** are secured in four positions **P3** by retaining pins **8**. The pinning procedure is described for one retaining pin **8** as an example.

- ▶ Remove the retaining element **9** and unpin the retaining pin **8** from the park position **P4**.
- ▶ Insert the retaining pin in position **P3** and secure with the retaining element **9**.
- ▶ Set the new derrick ballast weight in the Set up program.

### 10.4.3 Establishing the electrical connection for operation of the “large” ballast pallet

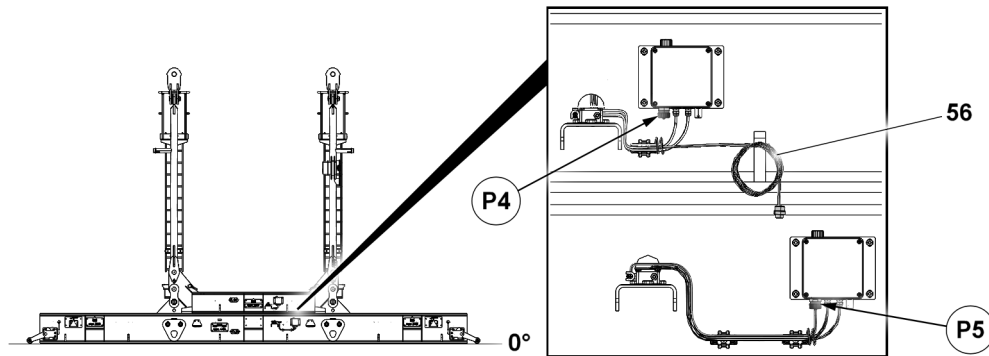


Fig.163649: Establishing for sole operation with the “large” ballast pallet

#### NOTICE

The ignition switch is not in position 0!

If live electrical connections are disconnected / connected, then there is the danger that components can be damaged.

The crane functions can be limited.

- ▶ De-energize the electrical connections before disconnection / connection: Set the ignition switch to position 0.

#### NOTICE

Danger of damage to the electrical lines on the suspended ballast!

If the electrical line **56** is not wound up and looped-in, it can be damaged when setting down the suspended ballast.

- ▶ Wind up and loop in the electrical line **56**.
- ▶ Move the ignition switch to position 0.
- ▶ Wind up and loop in the electrical line **56**.

Establish the electrical connection for operation with the “large” ballast pallet:

- ▶ Connect the plug of the electrical line **56** to the terminal box in position **P5**.



#### Note

- ▶ Establish the electrical connection for operation with the “large” ballast pallet, see the “wiring diagram”.

#### NOTICE

Damage to the electrical connections due to dirt, moisture and corrosion!

If unrequired electrical connections are not closed with their respective caps, the electrical connections can be damaged.

If the covers are removed from the electrical connections or control cabinets are opened, then moisture can infiltrate.

- ▶ Always properly close off all **non**-required electrical connections with their protective caps.
- ▶ Protect the electrical connections from water infiltration, this applies especially in the case of rain or snow.



#### Note

If **non**-required electrical connections are not closed with their respective dummy plugs, the electrical connections can be damaged.

- ▶ A malfunction can occur without bridging.
- ▶ Observe the “wiring diagram”.

- ▶ As a rule, close off non-required electrical connections (for example for accessories that are not installed) with the respective dummy plugs / dust caps.

**Result:**

- The electrical line **-X1100** is plugged into the terminal box **+S1100G** of the (large ballast pallet).

## 10.5 Lifting, lowering and equalizing the derrick ballast via the pull cylinders

**Note**

- ▶ For an overview of the displays on the LICCON monitors, see chapter 4.02.

**WARNING**

Incorrect display values!

If the display values do not increase correspondingly when lifting known weights, an erroneous display value may be present.

If the crane is operated with erroneous display values, then the crane can be overloaded.

This could result in serious accidents.

- ▶ When lifting the derrick ballast off the ground check if the display value for the pulled derrick ballast  $BA_{\text{pulled}}$  increases correspondingly.

**WARNING**

Danger of accident due to unsafe ground!

If the crane is operated on insufficient ground, there is a danger of accident.

- ▶ The ground in the entire working area of the crane must be level and of sufficient load carrying capacity, in order to be able to securely absorb the encountered surface pressures.
- ▶ Before setting down the load or the derrick ballast, the crane operator must make sure that the intended placement surface is suitable. A safe set down of load and derrick ballast must be ensured.

**WARNING**

Uncontrolled movements of the boom system!

If the guying between the SA-frame and the derrick boom head (test point 1) becomes powerless, then this can lead to uncontrollable movements of the boom system.

This could result in serious accidents.

- ▶ The guying between the SA-frame and the derrick boom head (test point 1) may never be without power.

**WARNING**

The crane can topple over!

If the derrick ballast is lifted more than 0.25 m above the ground, then the crane can fall over to the rear if the load rips off.

- ▶ Do not lift the derrick ballast more than 0.25 m off the ground.

**DANGER**

Danger of accident!

If the following notes are not observed, personnel can be severely injured or killed.

In addition, this can result in damaging the derrick ballast.

- ▶ Pay attention to the horizontal alignment of the derrick ballast when lifting and lowering the derrick ballast.
- ▶ When lifting and lowering the derrick ballast, check the forces in the D-guyings regularly on LICCON monitor 1. If the difference of forces between “derrick ballast guying A” and “derrick ballast guying B” is too large, an acoustic warning sounds and the values on the LICCON monitor 1 blink, see section “Differential force monitoring of Derrick ballast guying”.
- ▶ When adjusting manually (block pull cylinder A or pull cylinder B) the regulation is deactivated and the derrick ballast can be inclined within the limited angle range. This is exclusively permitted when setting down the derrick ballast on uneven ground and only by observing utmost caution.

**Note**

- ▶ The suspended ballast and the ballast trailer are generally referred to as the **derrick ballast**.
- ▶ The fixed compensation weight that is installed on the turntable is generally referred to as the **counterweight**.
- ▶ An additional person for carrying out crane operation is generally referred to as a **guide**.

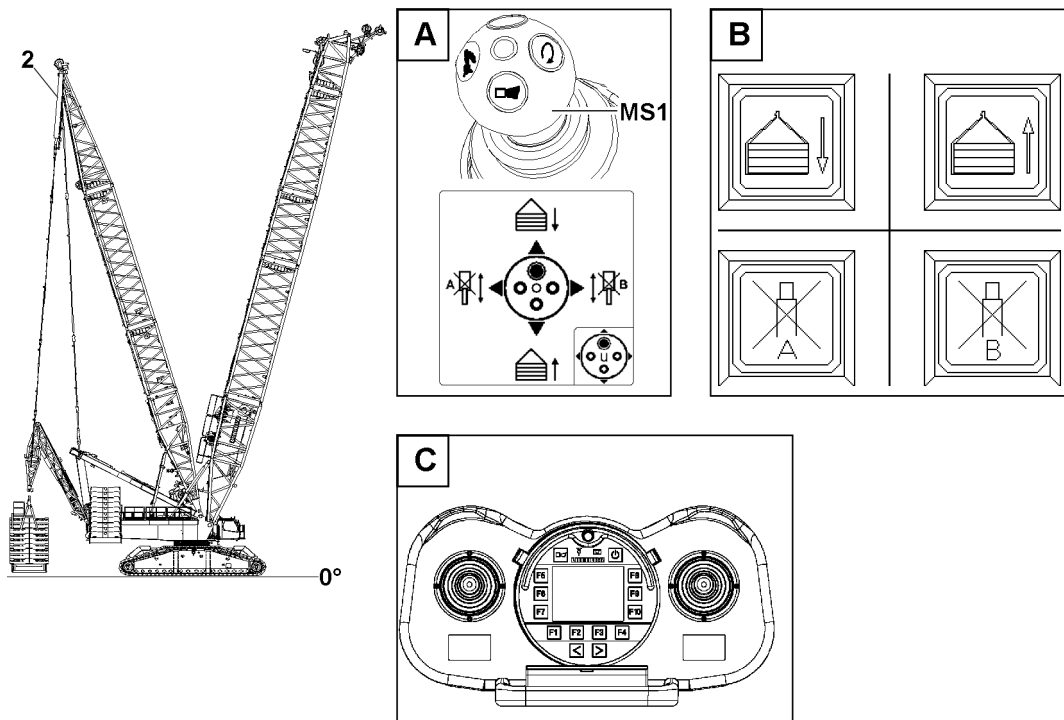


Fig.155440: Lifting and lowering the derrick ballast using the pull cylinders

## 2 Pull cylinder

**Note**

Automatic adjustment of the horizontal alignment of the ballast pallet!

- ▶ If the ballast trailer is lifted or lowered using the pull cylinders, then the horizontal alignment of the ballast pallet is automatically adjusted by both length sensors of the pull cylinders.
- ▶ For a ballast utilization of **more than** or **equal to** 90 percent, the level sensor adjusts the pull cylinder to a difference of 1 cm.
- ▶ With a ballast utilization of **less than** 90 percent, the level sensor monitors the derrick ballast level to  $\pm 2.5^\circ$ .

The pull cylinders **2** in the derrick ballast guying can be operated in different ways:

- Operation with the master switch **MS1** in the corresponding master switch assignment, see variation **A**.
  - Select the master switch assignment for master switch MS1, see chapter 4.01.
- Operation with operating buttons on the instrument panel, see variation **B**.

There is an additional operating option in assembly operation:

- Operation with the radio remote control (BTT-E), see variation **C**.
  - Operation with the manual control lever in the corresponding assembly menu, see the radio remote control operating instructions.

During crane operation with derrick ballast, the required maximum / minimum load can be actively influenced.

This is made possible by increasing or reducing the derrick ballast. Depending on the situation, this procedure is also possible under load.

Make sure that the following prerequisites are met:

- The test points must be checked for function before crane operation.
- The weight of the load to be lifted must be known.
- The height of the support surface / placement surface of the derrick ballast is not exceeded or fallen below, see section “Derrick ballast radii and lifting heights of the derrick ballast”.
- The support surface / placement surface of the derrick ballast must be level and have a sufficient load bearing capacity.
- The support surface / placement surface of the derrick ballast may have a maximum longitudinal and lateral incline of  $\pm 1^\circ$ .
- The support surface / placement surface of the derrick ballast must be able to safely absorb the surface pressure.
- There may not be any obstacles in the slewing range of the crane, derrick ballast and load.
- Additional personnel is instructed to monitor and secure the working range / danger zone of the crane from a safe distance.
- A permanent acoustic / visual connection between the crane operator and the additional personnel is available.
- A guide or the crane driver must monitor the lifting and setting down of the derrick ballast and the load.
- The lifted derrick ballast is monitored by a guide or the crane operator.

The following applies:

- When picking up the load, the D-guying between the derrick ballast and the derrick boom head must be relieved so that the operating force  $F1_{\text{actual}}$  is greater than the limit value for the F1-minimum force.
- Before picking up the load or the derrick ballast, make sure that the following components are on one line:
  - The load
  - The center of rotation of the turntable
  - The derrick ballast

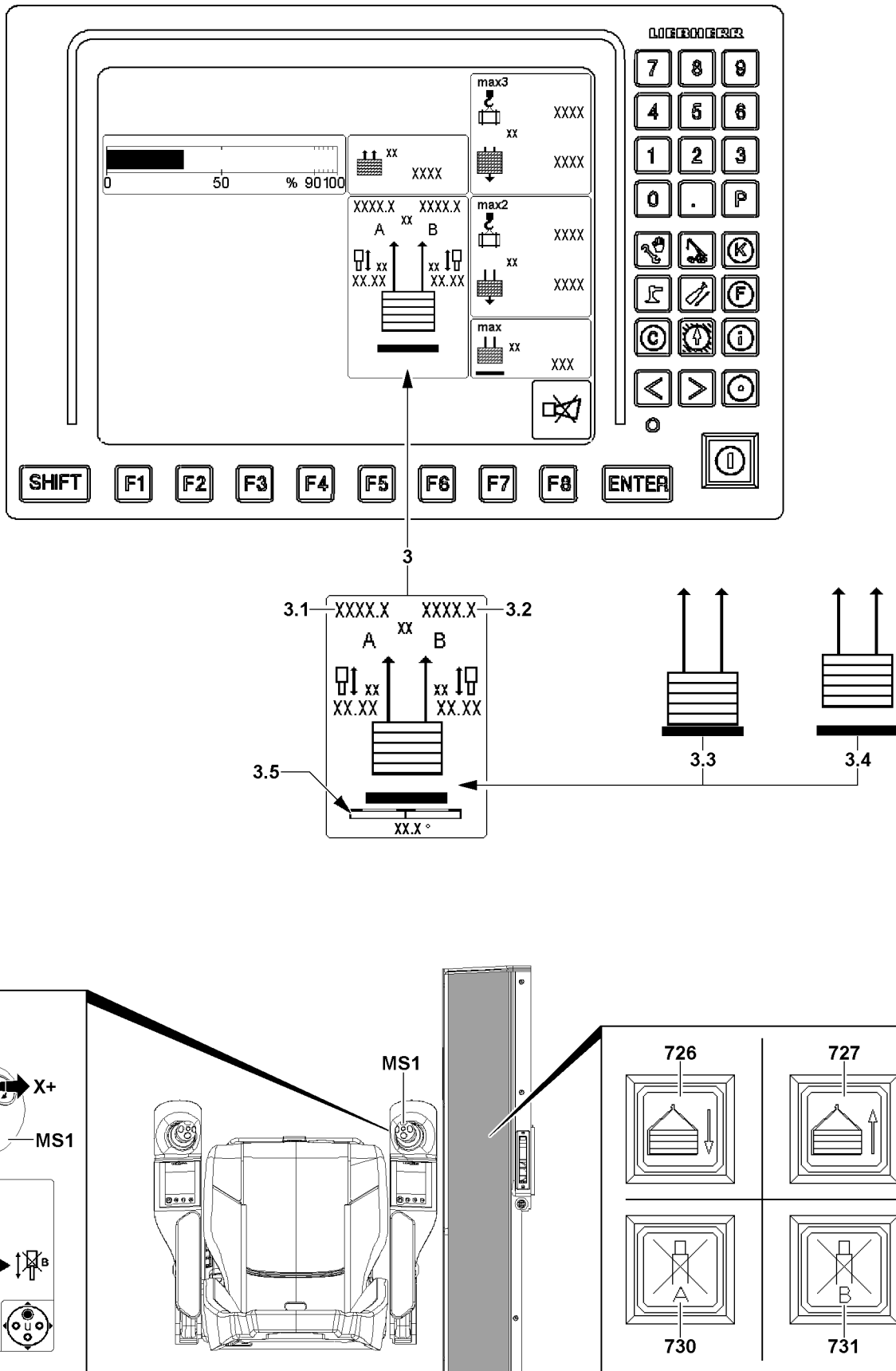


Fig.151472: Lifting / setting down the derrick ballast

<b>3</b>	Derrick ballast guying icon field	<b>3.4</b>	“Derrick ballast lifted” icon	<b>730</b>	Button: Lock pull cylinder A
<b>3.1</b>	Force in derrick ballast guying A	<b>3.5</b>	Incline indicator	<b>731</b>	Button: Lock pull cylinder B
<b>3.2</b>	Force in derrick ballast guying B	<b>726</b>	Button: Lower the derrick ballast	<b>MS1</b>	Master switch 1
<b>3.3</b>	“Derrick ballast has ground contact” icon	<b>727</b>	Button: Lift the derrick ballast		

### 10.5.1 Lifting the derrick ballast

The lifting of the derrick ballast is monitored by the LICCON computer system. Normally the crane operator does not have to do anything. However, if corrective measures or preventative measures should be necessary, observe the following section “Equalizing the derrick ballast”.

- ▶ Lift the derrick ballast: Press the button **727**.
- or
- Move the master switch **MS1** in direction **Y-**.

#### Result:

- The piston rods of the pull cylinders retract together.
- The derrick ballast is lifted.
- The divisible ballast pallet “VarioTray” loses all ground contact:  
The ground contact switches are no longer actuated, the “Derrick ballast lifted off” icon **3.4** appears.  
The “turning the turntable” and “driving the crawler” crane movements are released.

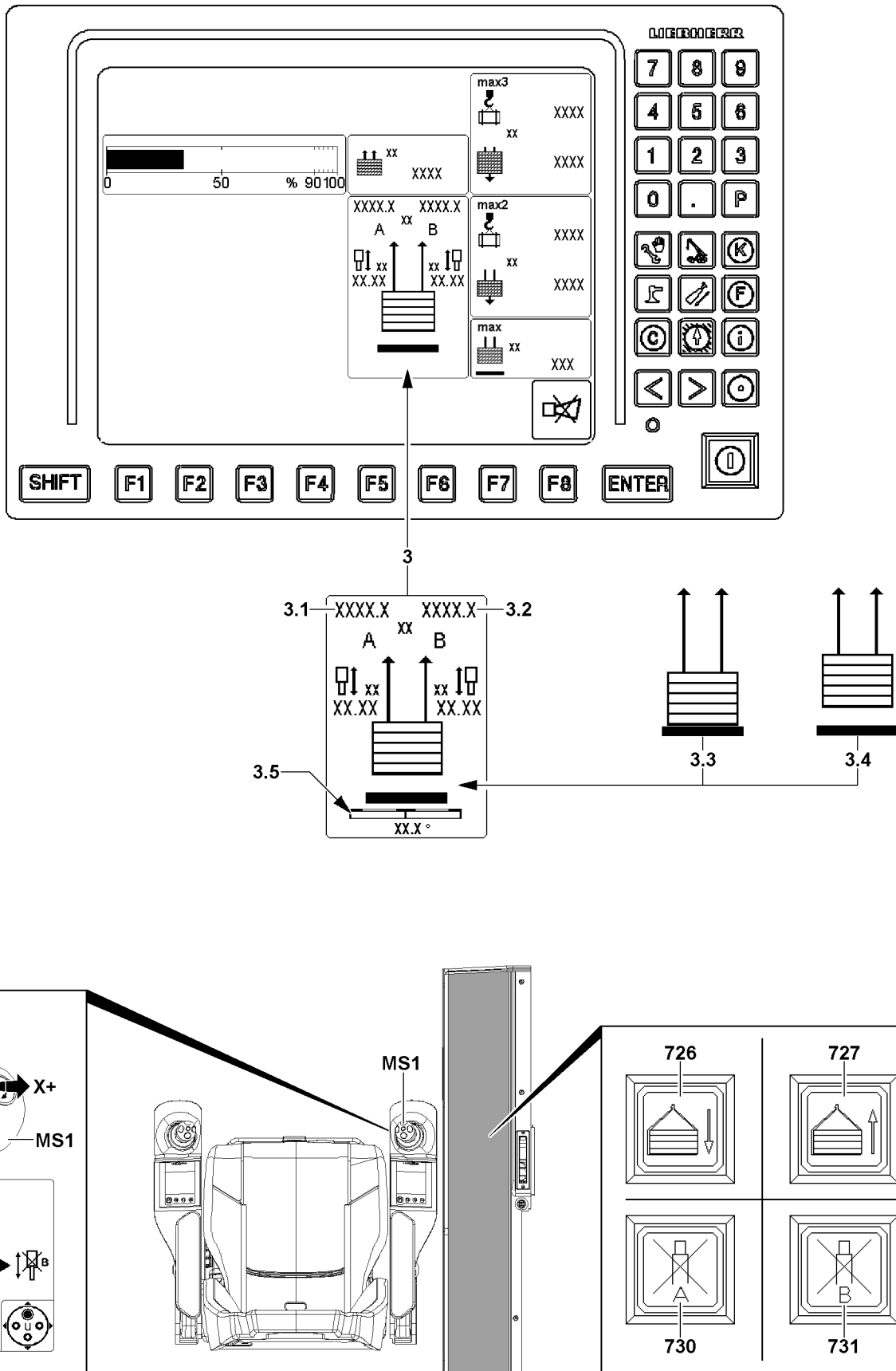
### 10.5.2 Lowering the derrick ballast

The setting down of the derrick ballast is monitored by the LICCON computer system. Normally the crane operator does not have to do anything. However, if corrective measures or preventative measures should be necessary, observe the following section “Equalizing the derrick ballast”.

- ▶ Lower the derrick ballast: Press the button **726**.
- or
- Move the master switch **MS1** in direction **Y+**.

#### Result:

- The piston rods of the pull cylinders extend together.
- The derrick ballast is countersunk
- When the divisible ballast pallet “VarioTray” touches the ground:  
The ground contact switches are actuated, the “Derrick ballast has ground contact” icon **3.3** appears.  
The “turning the turntable” and “driving the crawler” crane movements are blocked.



LWE/LR 1800-1-0-000/27200-07-02/en

Fig.151472: Equalizing the derrick ballast



<b>3</b>	Derrick ballast guying icon field	<b>3.4</b>	“Derrick ballast lifted” icon	<b>730</b>	Button: Lock pull cylinder A
<b>3.1</b>	Force in derrick ballast guying A	<b>3.5</b>	Incline indicator	<b>731</b>	Button: Lock pull cylinder B
<b>3.2</b>	Force in derrick ballast guying B	<b>726</b>	Button: Lower the derrick ballast	<b>MS1</b>	Master switch 1
<b>3.3</b>	“Derrick ballast has ground contact” icon	<b>727</b>	Button: Lift the derrick ballast		

### 10.5.3 Equalizing the derrick ballast



#### WARNING

Danger of accident!

The placement surface for the divisible ballast pallet “VarioTray” must be level, horizontal and of sufficient load bearing capacity, otherwise the divisible ballast pallet “VarioTray” can tip over. This could result in serious accidents.

- ▶ Check the incline of the crane during the set down procedure.
- ▶ Check the incline of the divisible ballast pallet “VarioTray” with the incline display **3.5**.
- ▶ Monitor the difference forces (derrick ballast guying A **3.1** to derrick ballast guying B **3.2**).
- ▶ It is strictly prohibited for anyone to stand under the divisible ballast pallet “VarioTray” or within the entire danger zone during the set down procedure.

If a limit value in the difference force monitoring (Ratio of derrick ballast guying A **3.1** to derrick ballast guying B **3.2**) or the incline display **3.5** is exceeded, the derrick ballast must be equalized.

Block the pull cylinder (A) when lifting:

- ▶ Press the button **727** and the button **730**.
- or
- Deflect the master switch **MS1** diagonally in direction **X-** and direction **Y-**.

#### Result:

- The piston rod of the pull cylinder (A) stops.
- The piston rod of pull cylinder (B) retracts.
- Side (B) of the derrick ballast lifts up.

Block the pull cylinder (B) when lifting:

- ▶ Press the button **727** and the button **731**.
- or
- Deflect the master switch **MS1** diagonally in direction **X+** and direction **Y-**.

#### Result:

- The piston rod of the pull cylinder (B) stops.
- The piston rod of pull cylinder (A) retracts.
- Side (A) of the derrick ballast lifts up.

Block the pull cylinder (A) when lowering:

- ▶ Press the button **726** and the button **730**.
- or
- Deflect the master switch **MS1** diagonally in direction **X-** and direction **Y+**.

#### Result:

- The piston rod of the pull cylinder (A) stops.
- The piston rod of pull cylinder (B) extends.
- Side (B) of the derrick ballast lowers.

Block the pull cylinder (B) when lowering:

- ▶ Press the button **726** and the button **731**.  
**or**  
Deflect the master switch **MS1** diagonally in direction **X+** and direction **Y+**.

**Result:**

- The piston rod of the pull cylinder (B) stops.
- The piston rod of pull cylinder (A) extends.
- Side (A) of the derrick ballast lowers.

## 10.6 Changing the radius of the suspended ballast guide “V-frame”

**WARNING**

Oscillating ballast pallet!

Death, severe bodily injuries, property damage.

- ▶ It is prohibited to remain in the entire danger zone.

Make sure that the following prerequisites are met:

- The test points must be checked for function before crane operation.
- The weight of the load to be lifted must be known.
- The support surface / placement surface of the derrick ballast must be level and have a sufficient load bearing capacity.
- The support surface / placement surface of the derrick ballast may have a maximum longitudinal and lateral incline of  $\pm 1^\circ$ .
- The support surface / placement surface of the derrick ballast must be able to safely absorb the surface pressure.
- The height of the support surface / placement surface of the derrick ballast is not exceeded or fallen below, see section “Derrick ballast radii and lifting heights of the derrick ballast”.
- There may not be any obstacles in the slewing range of the crane, derrick ballast and load.
- Additional personnel is instructed to monitor and secure the working range / danger zone of the crane from a safe distance.
- A permanent acoustic / visual connection between the crane operator and the additional personnel is available.
- A guide or crane driver must observe the adjustment of the suspended ballast radius.

### 10.6.1 Extending the suspended ballast guide “V-frame”

**WARNING**

Suspended ballast guide “V-Frame” extended too quickly!

The tipping moment of the crane to the rear becomes too large, force F1 becomes too small.

The crane can be overloaded and topple over to the rear.

Death, severe bodily injuries, property damage.

- ▶ Select the extension speed as required by the load momentum.
- ▶ Select the extension speed such that the F1 load display on the LICCON monitor is in the permissible range.

**WARNING**

Suspended ballast guide “V-Frame” extended too slowly!

The tipping moment of the crane to the front becomes too large, force F1 becomes too large.

The crane can be overloaded and topple over to the front.

Death, severe bodily injuries, property damage.

- ▶ Select the extension speed as required by the load momentum.
- ▶ Select the extension speed such that the F1 load display on the LICCON monitor is in the permissible range.

**Note**

In assembly operation, it is possible to operate the movement with the radio remote control (BTT-E).

- ▶ Operation with the radio remote control, see the radio remote control operating instructions.

Make sure that the following prerequisites are met:

- The master switch assignment for the ballast function is called up.

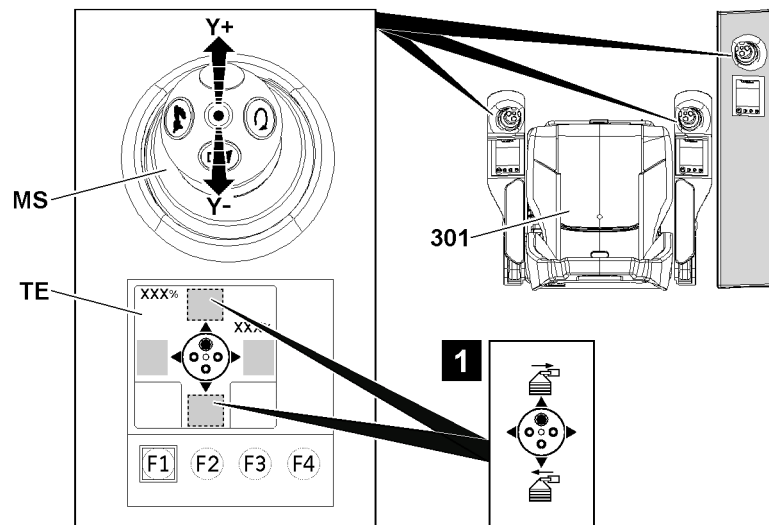


Fig.155168: Extending the suspended ballast guide “V-frame”

**MS** Master switch

**301** Seat contact switch

**Y-** Direction

- ▶ Move the master switch **MS** in direction **Y-**.

**Result:**

- The derrick ballast guide extends.

## 10.6.2 Retracting the suspended ballast guide “V-frame”



### WARNING

Suspended ballast guide “V-Frame” retracted too quickly!

The tipping moment of the crane to the front becomes too large, force F1 becomes too large.

The crane can be overloaded and topple over to the front.

Death, severe bodily injuries, property damage.

- ▶ Select the extension speed as required by the load momentum.
- ▶ Select the extension speed such that the F1 load display on the LICCON monitor is in the permissible range.



### WARNING

Suspended ballast guide “V-Frame” retracted too slowly!

The tipping moment of the crane to the rear becomes too large, force F1 becomes too small.

The crane can be overloaded and topple over to the rear.

Death, severe bodily injuries, property damage.

- ▶ Select the extension speed as required by the load momentum.
- ▶ Select the extension speed such that the F1 load display on the LICCON monitor is in the permissible range.



### Note

In assembly operation, it is possible to operate the movement with the radio remote control (BTT-E).

- ▶ Operation with the radio remote control, see the radio remote control operating instructions.

Make sure that the following prerequisites are met:

- The master switch assignment for the ballast function is called up.

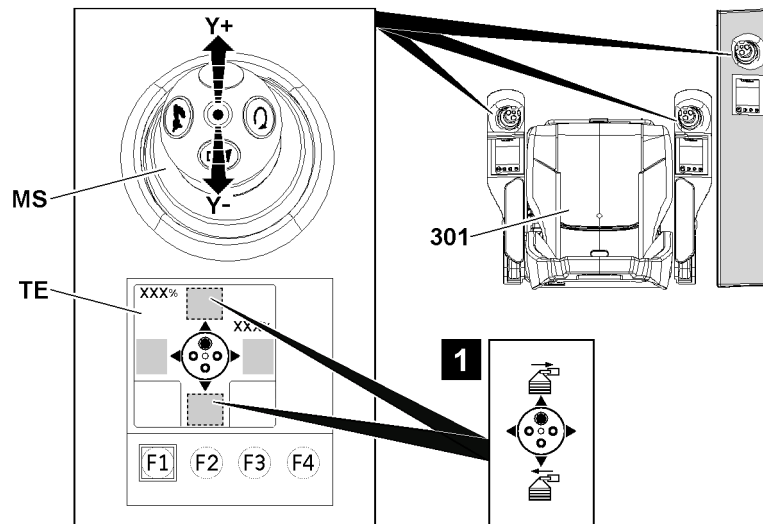


Fig.155168: Retracting the suspended ballast guide “V-frame”

**MS** Master switch  
**Y-** Direction

**301** Seat contact switch

- Move the master switch **MS** in direction **Y+**.

### 10.7 Crawler operation with derrick ballast

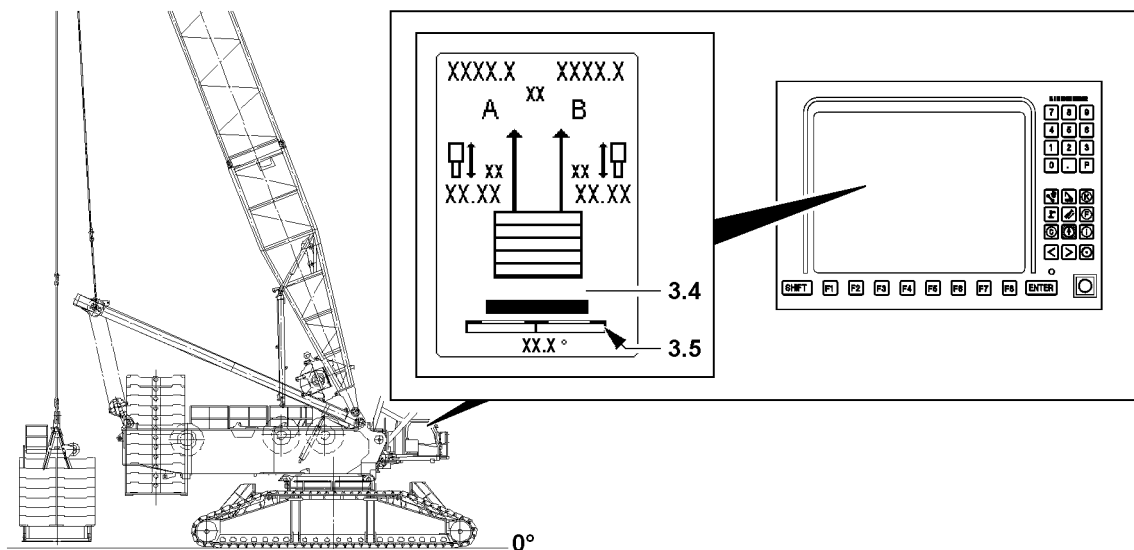


Fig.151473: Crawler operation with derrick ballast

**3.4** “Derrick ballast lifted” icon

**3.5** Incline indicator



**Note**

- Driving the crawler crane, see chapter 4.10.
- The release for driving the crawler takes place only when all 4 ground contact switches detect that there is no ground contact.

#### 10.7.1 Driving the crawler

Driving with suspended derrick ballast.

**WARNING**

Prerequisites for driving are not met, load or derrick ballast are oscillating too much!

If the specifications from chapter 4.10 are not observed, there is a danger of accident.

If the suspended load or the suspended derrick ballast starts to swing too much, then the crane operator can lose control of the crane.

If the following prerequisites are not observed, the crane can topple over.

This could result in serious accidents.

- ▶ Observe the specifications in chapter 4.10.
- ▶ Do not exceed the maximum permissible driving speed of the crawler.
- ▶ Avoid jerky driving movements.
- ▶ Avoid oscillation of the suspended load and the suspended derrick ballast. Turn and drive slowly.
- ▶ The attached load and suspended derrick ballast must be secured to prevent it from swinging. If oscillating movements should occur, set the load / derrick ballast as fast as possible down on the ground. Hereby pay attention to the limit values of the load moment display and the F-load display.
- ▶ Steering the crawler with suspended load and / or installed derrick ballast is prohibited.
- ▶ Uphill and downhill inclines and lateral inclines may only be driven within the permissible angle range.

Make sure that the following prerequisites are met:

- Observe the specifications in chapter 4.10.
- Pay special attention to the limitations for crawler operation with derrick ballast.
- The ground is suitable for crawler operation with derrick ballast.
- The ground can safely absorb the resulting surface pressure.
- The derrick ballast is lifted off the ground.
- The “Derrick ballast lifted off” icon **3.4** appears on the LICCON monitor.
- The derrick ballast is horizontally aligned (observe the incline display **3.5**).

## 11 Disassembling

### 11.1 General safety

Observe the safety instructions before assembly and disassembly:

- Information regarding personal protective equipment. See chapter 2.04.
- Information regarding the 3-point support. See chapter 2.04.10.
- Information regarding crane operation. See chapter 2.04.
- Information regarding fall protection equipment. See chapter 2.06.
- Information regarding walking surfaces and stepping surfaces. See chapter 2.07.
- Technical safety instructions for assembly and disassembly. See chapter 5.01.

### 11.1.1 Safety - disassembly



#### WARNING

Danger of falling!

During assembly / disassembly, inspection and maintenance work, assembly personnel must be secured with appropriate aids to prevent them from falling.

Death, severe bodily injuries, property damage.

- ▶ All work at a height, when there is a danger of falling, must be carried out with suitable aids.
- ▶ If aids are not available and work cannot be carried out from the ground, then assembly personnel must secure themselves with the supplied fall arrest system to prevent falling, see chapter 2.04.
- ▶ If fall protection equipment is available, then it must be used, see chapter 2.06.
- ▶ When lifting, lowering, swinging crane parts in and out, no persons may remain in the danger zone.
- ▶ When closing or opening boom systems during boom assembly or boom disassembly, no persons may remain on the boom system or in the danger zone.
- ▶ If railings are present on the components, then they must be brought into the corresponding position and secured for assembly / disassembly work.
- ▶ Only step on the aids, ladders and catwalks with clean shoes.
- ▶ Keep aids, ladders and catwalks free of heavy dirt, snow, frost and ice.
- ▶ During all assembly and disassembly work, maintenance work and inspections, travel or crane operation is prohibited.
- ▶ Remaining on a suspended load is prohibited.
- ▶ Stepping or walking on crane components and lattice sections with an incline of more than 20° is prohibited.



#### WARNING

Working without aids!

Death, severe bodily injuries, property damage.

When assembling and disassembling crane components with the auxiliary crane, they can start to swing back and forth.

When lifting / lowering and positioning crane components, there is an increased danger of impact / crushing.

- ▶ Make sure that personnel cannot be caught by components.
- ▶ When working in a danger zone: Use aids to protect limbs.
- ▶ Guide components with suitable aids to minimize oscillation.



#### WARNING

Crane movements without approval of the guide!

Death, severe bodily injuries, property damage.

- ▶ For all work, observe the instructions of the guide. If necessary, use walkie-talkies.
- ▶ The crane operator and guide must monitor the danger zone.
- ▶ For all assembly / disassembly work, the crane driver of the main crane must be in voice contact with the crane driver / crane drivers of the auxiliary crane / auxiliary cranes.
- ▶ For assembly / disassembly tasks, the crane driver may only initiate crane movements when the responsible guide has explicitly released the movement.



#### WARNING

Overload of the crane!

If the permissible display values of the F-load display are exceeded / fallen below, then the crane can be overloaded.

This could result in serious accidents.

- ▶ Observe and adhere to the display values on the LICCON monitors.
- ▶ Observe and adhere to the specifications regarding the limit values on the assembly drawings.

**Note**

Crane disassembly with the auxiliary crane.

When installed components are lifted or set down with the auxiliary crane, the changed F-forces may have an effect on the boom system. The display values on the F-load displays can change and shut-offs can occur.

When installed components are lifted or set down with the auxiliary crane:

- ▶ Observe the F-load displays on the crane to be disassembled.
- ▶ If necessary, correct the position of the boom system (F-forces) on the crane to be assembled.
- ▶ Before each new disassembly step, the F1-force is in the middle between the minimum and maximum force.

**11.1.2 Safety when working at a height****WARNING**

3-point support not adhered to!

Personnel can fall, death, severe bodily injuries.

- ▶ Adhere to the 3-point support.
- ▶ Adhere to the prerequisites and conditions for the use of leaning ladders.

**WARNING**

Working with unsuitable aids!

- ▶ All work at a height, when there is a danger of falling, must be carried out with suitable aids.
- ▶ If aids are not available and work cannot be carried out from the ground, then assembly personnel must secure themselves with the supplied fall arrest system to prevent falling, see chapter 2.04.

**11.1.3 Safety - pin connections****DANGER**

Do not disconnect the auxiliary crane until the component is completely pinned and secured!

Death, severe bodily injuries, property damage.

If a component is disengaged from the auxiliary crane before it is pinned, then it can fall.

- ▶ Do not disconnect the auxiliary crane until the component is pinned and secured.

**WARNING**

Unsecured pins!

If the pins are not secured with the provided retaining element, the pins can release during crane operation! This can cause the crane to topple over!

Death, severe bodily injuries, property damage.

- ▶ Make sure that all pins are inserted and secured!

**11.1.4 Safety - fastening****DANGER**

Incorrect fastening of the erection racks!

Death, severe bodily injuries, property damage.

- ▶ First place the fastening equipment around the cross strut and then fasten to the bitt.

**WARNING**

Use of incorrect fastening points!

Death, severe bodily injuries, property damage.

- ▶ Use the fastening points indicated on the crane components.
- ▶ Pay attention to the labels on the fastening points on the lattice sections and crane components.

**WARNING**

Incorrect length of the fastening equipment!  
 Death, severe bodily injuries, property damage.  
 ► Select fastening equipment with a suitable length.

**WARNING**

Use of fastening equipment with unsuitable load capacity!  
 Death, severe bodily injuries, property damage.  
 ► Use fastening equipment with a sufficient load carrying capacity.

### 11.1.5 Prerequisites for disassembly

Make sure that the following prerequisites are met:

- The crane is properly supported and horizontally aligned.
- An auxiliary crane is available.
- The counterweight is installed on the turntable according to the load chart.
- The maximum ground unevenness for the placement surface of the derrick ballast is  $\pm 1^\circ$ .
- For normal disassembly, the main boom is lying on the ground on the substructure.
- With a special disassembly, the main boom is in the BV operation operating window in chart column DB- 0 t
- The LICCON overload protection has been set according to the data in the load chart.
- The LICCON overload protection settings have been compared with the actual set up configuration.

## 11.2 Securing the erection racks against falling down

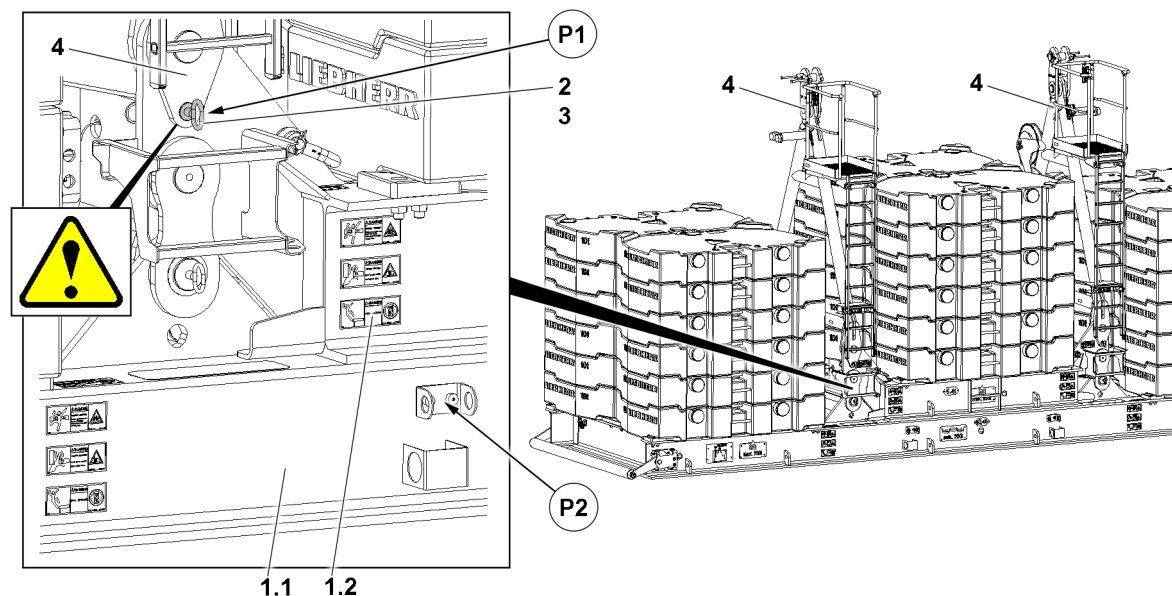


Fig.157166: Securing the erection racks against falling down

- |                          |                     |
|--------------------------|---------------------|
| 1.1 Large ballast pallet | 3 Retaining element |
| 1.2 Small ballast pallet | 4 Erection rack     |
| 2 Connector pin          |                     |

The description applies in the same way for both erection racks 4.

The erection rack 4 is pinned in the two positions P1. The pinning procedure is described for one retaining pin as an example.

- Remove the retaining element 3.
- Unpin the retaining pin 2 from the park position P2.
- Insert the retaining pin 2 in the operating position P1.



- ▶ Secure the retaining pin **2** with the retaining element **3**.

**Result:**

- The erection rack **4** is secured in the vertical position.

## 11.3 Removing the ballast on the divisible ballast pallet “VarioTray”

Make sure that the following prerequisites are met:

- The crane is horizontally aligned.
- An auxiliary crane is available.
- The counterweight has been installed on the turntable according to the load charts or the erection and take-down charts.
- The support surface / placement surface of the derrick ballast must be level and have a sufficient load bearing capacity.
- The support surface / placement surface of the derrick ballast may have a maximum longitudinal and lateral incline of  $\pm 1^\circ$ .
- The LICCON overload protection has been set according to the data in the load chart.
- The LICCON overload protection settings have been compared with the actual set up configuration.
- The two erection racks are be locked and secured in a vertical position with retaining pins.

### 11.3.1 Setting down the derrick ballast

Make sure that the following prerequisites are met:

- A guide or the crane driver must monitor the setting down of the derrick ballast.
- ▶ Extend the piston rods, see section “Carrying out crane movements”.

**Result:**

- The derrick ballast is lowered.
- ▶ When the ballast pallet touches the ground, the ground contact switches are actuated.

**Result:**

- The **turning the turntable** and **driving the crawler** crane movements turn off.

### 11.3.2 Removing the ballast plates

**WARNING**

The crane can topple over!

If the following danger notes are not observed, the ballast plates or the ballast stack can slip on the divisible ballast pallet “VarioTray” and fall down.

Death, severe bodily injuries, property damage.

- ▶ The ground on which the ballast is removed from the divisible ballast pallet “VarioTray” must be level and have adequate load bearing capacity.
- ▶ Always lift up the ballast plates symmetrically, in reference to the longitudinal axis.
- ▶ It is necessary to start with the two outer ballast stacks.
- ▶ The difference for the center ballast stack may not be more than a maximum of one ballast plate while removing the ballast.
- ▶ The ballast on both outer ballast stacks can be removed with ballast assemblies of two ballast plates each.
- ▶ The difference between both outer ballast stacks may not be more than maximum 25 t when removing the ballast.
- ▶ Replace damaged ballast plates immediately with new ballast plates.
- ▶ Observe the weight signs on the ballast pallets.

### Removing the ballast plates, fastening system: "Twistlock"

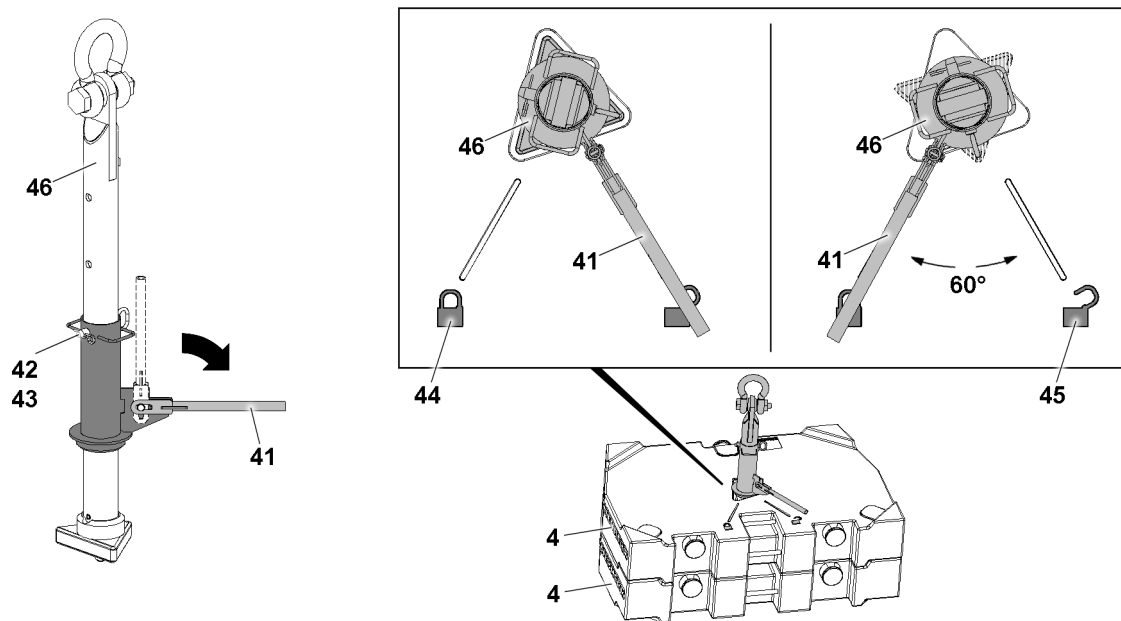


Fig.155372: Removing the ballast plates, fastening system: "Twistlock"

<b>4</b>	Ballast plate	<b>44</b>	Icon
<b>41</b>	Lever	<b>45</b>	Icon
<b>42</b>	Pin	<b>46</b>	Receptacle stud
<b>43</b>	Retaining element		



#### WARNING

Danger of accident!

If more than the permissible two ballast plates **4** are lifted with the receptacle stud **46**, the receptacle stud **46** will be overloaded and can be damaged.

Death, severe bodily injuries, property damage.

- ▶ Make sure that the ballast plates **4** are placed correctly in the centerings.
- ▶ Replace damaged ballast plates **4**.

To lift up the ballast plate(s) **4**, use the receptacle stud **46**.

Before the receptacle stud **46** is guided into the ballast plates **4**, it must be ensured that the length of the receptacle stud **46** is set correctly. The length of the receptacle stud **46** can be adjusted with the pin **42**.

If the length of the receptacle stud **46** is to be adjusted:

- ▶ Release and unpin the pin **42**.
- ▶ Adjust the length of the receptacle stud by moving the receptacle stud **46**.
- ▶ Insert the pin **42** and secure it with the retaining element **43**.
- ▶ Fasten the receptacle stud **46** to the auxiliary crane and guide it into the ballast plate(s) **4**.
- ▶ Pull the lever **41** up and fold it down.
- ▶ Turn the lever **41** 60° until the lever **41** points to the icon **44**.

#### Result:

- The receptacle stud **46** is locked with the ballast plate(s) **4**.
- ▶ Lift the ballast plate **4** with the receptacle stud **46** and remove it carefully from the ballast stack.
- ▶ Turn the lever **41** 60° until the lever **41** points to the icon **45**.

#### Result:

- The receptacle stud **46** is unlocked.
- ▶ Carefully pull the receptacle stud **46** out of the ballast plate(s) **4**.

- ▶ Alternately remove the ballast plate(s) **4** on both sides.

#### Removing the ballast plates, fastening system: "Bitt"

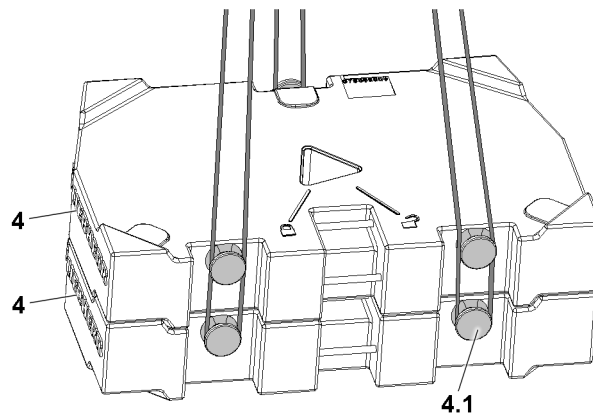


Fig.151458: Removing the ballast plates, fastening system: "Bitt"

**4** Ballast plate

**4.1** Bitt



#### WARNING

Falling ballast plates **4**!

If more than the permissible two ballast plates **4** are lifted, then the bits **4.1** are overloaded and the ballast plates **4** can fall down.

Death, severe bodily injuries, property damage.

- ▶ Lift the ballast plates **4** individually or as a package, maximum 20 t , 3 fastening points.
- ▶ Replace damaged ballast plates **4** immediately.



#### WARNING

Incorrect handling of the fastening equipment!

If the fastening equipment is not attached correctly and if it is not secured sufficiently to prevent it from loosening up, the ballast plates **4** can fall down.

Death, severe bodily injuries, property damage.

- ▶ Make sure that the fastening equipment is correctly attached to the bits **4.1** and that it is secured sufficiently to prevent it from loosening up.
- ▶ Lift the ballast plates **4** individually or as an assembly of maximum two plates alternately on the left and right with the auxiliary crane.

## 11.4 Disassembling the suspended ballast

### 11.4.1 Disconnecting the electrical connection from the suspended ballast to the turntable

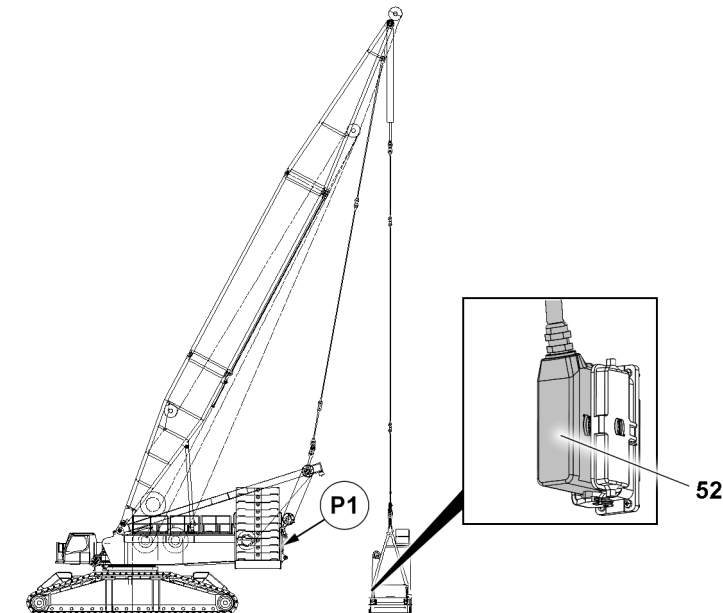


Fig.163647: Disconnecting the electrical connection from the suspended ballast to the turntable

#### NOTICE

The ignition switch is not in position 0!

If live electrical connections are disconnected / connected, then there is the danger that components can be damaged.

The crane functions can be limited.

- ▶ De-energize the electrical connections before disconnection / connection: Set the ignition switch to position 0.

#### NOTICE

Damage due to unutilized pull relief!

The electrical components are tensioned and can therefore be damaged.

- ▶ Use the pull relief.
- ▶ Move the ignition switch to position 0.

Disconnect the electrical connection between the suspended ballast and the turntable:

- ▶ Unplug the plug of the electrical line **52** in position **P1**.



#### Note

- ▶ Disconnect the electrical connection between the suspended ballast and the turntable, see the "wiring diagram".

**NOTICE**

Damage to the electrical connections due to dirt, moisture and corrosion!

If unrequired electrical connections are not closed with their respective caps, the electrical connections can be damaged.

If the covers are removed from the electrical connections or control cabinets are opened, then moisture can infiltrate.

- ▶ Always properly close off all **non**-required electrical connections with their protective caps.
- ▶ Protect the electrical connections from water infiltration, this applies especially in the case of rain or snow.

**Note**

If **non**-required electrical connections are not closed with their respective dummy plugs, the electrical connections can be damaged.

- ▶ A malfunction can occur without bridging.
  - ▶ Observe the “wiring diagram”.
- 
- ▶ As a rule, close off non-required electrical connections (for example for accessories that are not installed) with the respective dummy plugs / dust caps.

### 11.4.2 Disassembling the suspended ballast on the D-guy rods

**Note**

- ▶ This section describes the disassembly of the suspended ballast **without** the suspended ballast guide “V-frame”.

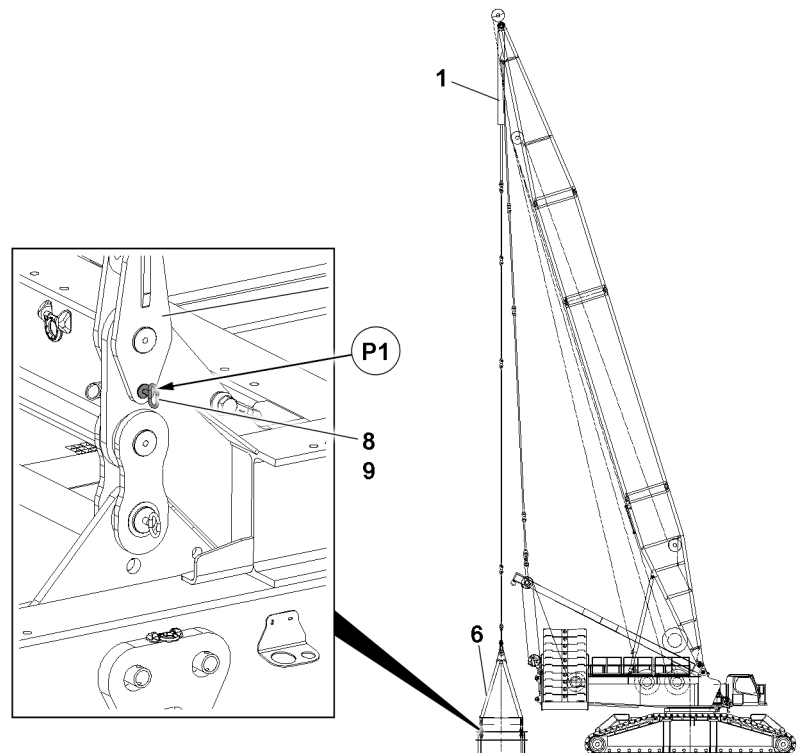


Fig.155455: Disassembling the suspended ballast — Prerequisites

- 6** Erection racks  
**8** Retaining pin

- 9** Retaining element

**DANGER****Falling erection racks 6!**

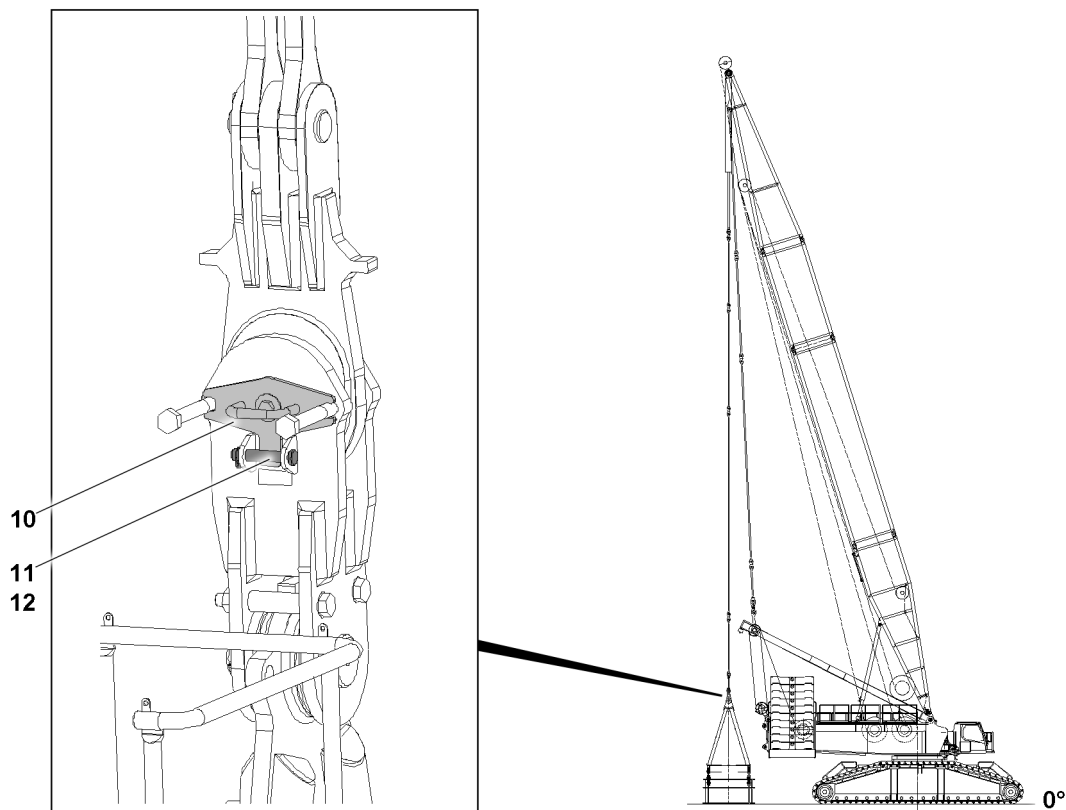
If the erection racks **6** are not secured with retaining pins **8** and retaining elements **9**, the erection racks **6** will fall down uncontrolled when unpinning the D-guy rods.

Death, severe bodily injuries, property damage.

- ▶ The two erection racks **6** must be locked and secured in a vertical position with retaining pins **8**. Only then may the D-guy rods **1** be removed.
- ▶ It is prohibited for anyone to remain under the erection racks **6** as well as within the entire danger zone.

Make sure that the following prerequisites are met:

- The erection racks **6** are secured with four retaining pins **8** and four retaining elements **9** in positions **P1**.
- The ballast plates are disassembled.



*Fig.155457: Disassembling the suspended ballast — Prerequisites*

- |                         |                             |
|-------------------------|-----------------------------|
| <b>10</b> Connector pin | <b>12</b> Retaining element |
| <b>11</b> Retaining pin |                             |

- ▶ Remove the retaining element **12** and unpin the retaining pin **11**.
- ▶ Unpin the connector pin **10**.

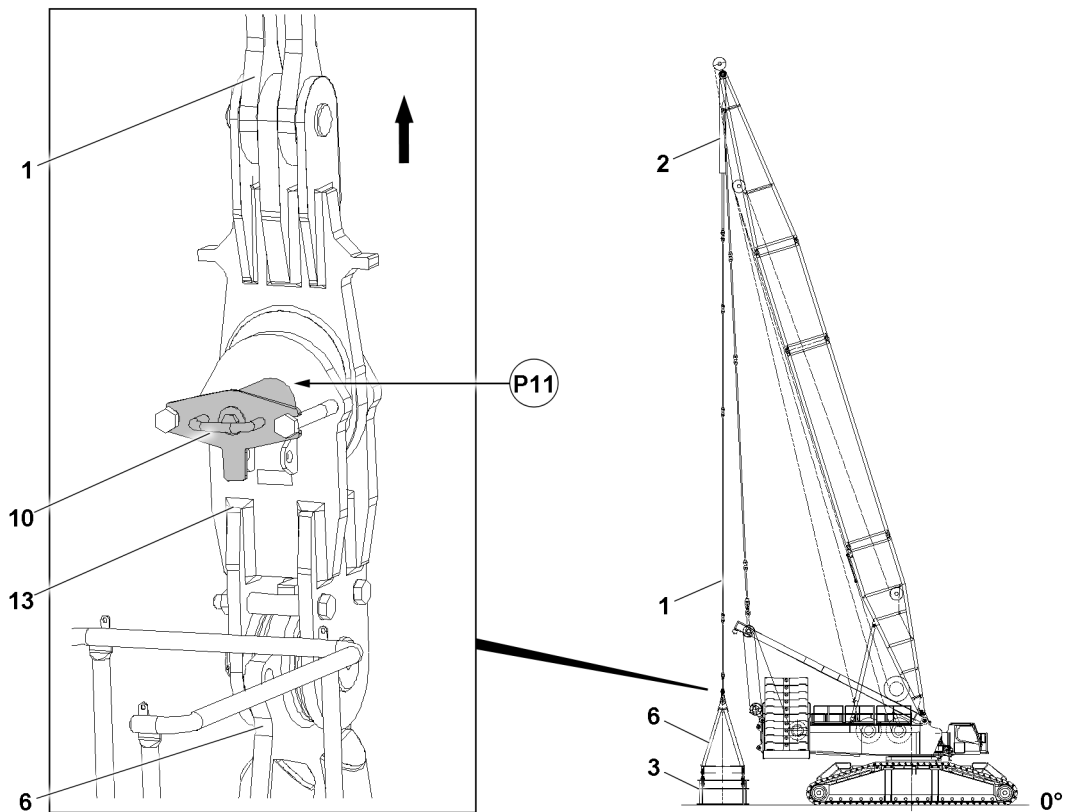


Fig.151476: Unpinning procedure

- |   |                                      |    |               |
|---|--------------------------------------|----|---------------|
| 1 | D-guy rods                           | 6  | Erection rack |
| 2 | Pull cylinder                        | 10 | Connector pin |
| 3 | Divisible ballast pallet "VarioTray" | 13 | Bracket       |

- ▶ Drive out the D-guy rods **1** by retracting the piston rods on the pull cylinders **2** from the brackets **13** of the erection rack **6**.



#### Note

Retract / extend the pull cylinders **2**:

- ▶ Control the pull cylinders **2** from the crane cab, see the section "Lifting and lowering the derrick ballast using the pull cylinders".
- ▶ Operate the pull cylinder **2** with the radio remote control, see the "radio remote control operating instructions".

- ▶ Insert the connector pin **10** again in point **P11**.
- ▶ Secure the connector pin with the retaining pin and the retaining element.

#### Result:

- The connector pin **10** is secured.

## 11.5 Disassembling the suspended ballast on the suspended ballast guide “V-frame”

### 11.5.1 Disconnecting the electrical connections from the suspended ballast to the suspended ballast guide

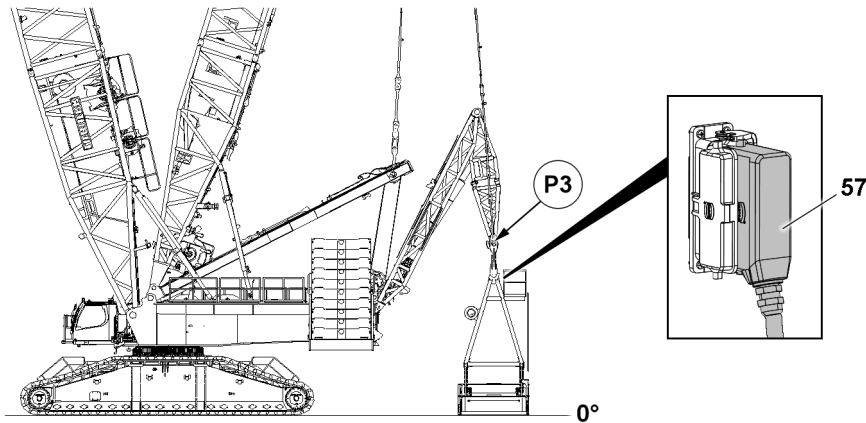


Fig.163646: Disconnecting the electrical connection from the suspended ballast guide to the suspended ballast

#### NOTICE

The ignition switch is not in position 0!

If live electrical connections are disconnected / connected, then there is the danger that components can be damaged.

The crane functions can be limited.

- ▶ De-energize the electrical connections before disconnection / connection: Set the ignition switch to position 0.

- ▶ Move the ignition switch to position 0.

Disconnect the electrical connections between the suspended ballast and the suspended ballast guide:

- ▶ Unplug the plug of the electrical line **57** in position **P3**.
- ▶ Insert the plug of the electrical line **57** at the erection rack in the park position.



#### Note

- ▶ Disconnect the electrical connections between the suspended ballast guide and the suspended ballast, see the “wiring diagram”.

#### NOTICE

Damage to the electrical connections due to dirt, moisture and corrosion!

If unrequired electrical connections are not closed with their respective caps, the electrical connections can be damaged.

If the covers are removed from the electrical connections or control cabinets are opened, then moisture can infiltrate.

- ▶ Always properly close off all **non**-required electrical connections with their protective caps.
- ▶ Protect the electrical connections from water infiltration, this applies especially in the case of rain or snow.



**Note**

If **non**-required electrical connections are not closed with their respective dummy plugs, the electrical connections can be damaged.

- ▶ A malfunction can occur without bridging.
- ▶ Observe the “wiring diagram”.

- ▶ As a rule, close off non-required electrical connections (for example for accessories that are not installed) with the respective dummy plugs / dust caps.

### 11.5.2 Disassembling the suspended ballast on the suspended ballast guide “V-frame”

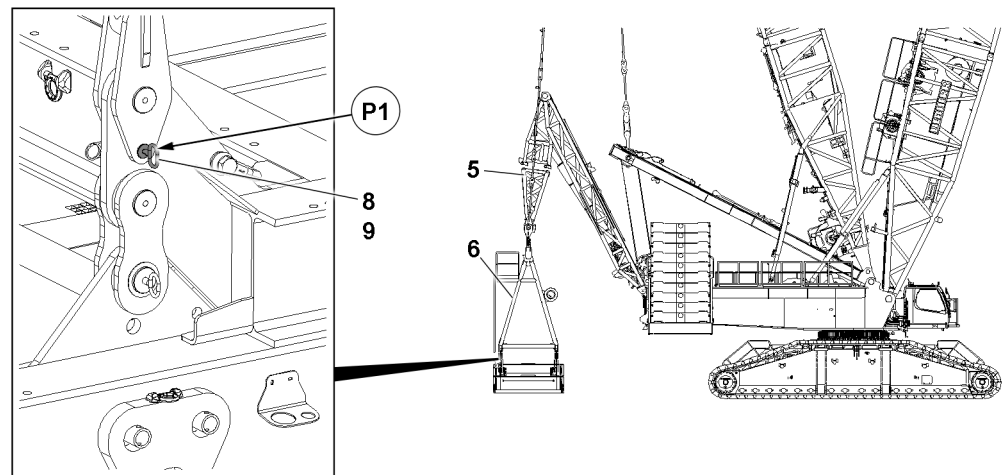


Fig.155458: Disassembling the suspended ballast on the suspended ballast guide “V-frame” – Prerequisites

<b>5</b>	Suspended ballast guide “V-frame”	<b>8</b>	Retaining pin
<b>6</b>	Erection rack	<b>9</b>	Retaining element

**DANGER**

Falling erection racks **6**!

If the erection racks **6** are not secured with retaining pins **8** and retaining elements **9**, then they will fall down uncontrolled when unpinning the D-guy rods.

Death, severe bodily injuries, property damage.

- ▶ The two erection racks **6** must be locked and secured in a vertical position with retaining pins **8** and retaining elements **9**. Only then unpin from the “V-frame” suspended ballast guide **5**.
- ▶ It is prohibited for anyone to remain under the erection racks **6** as well as within the entire danger zone.

Make sure that the following prerequisites are met:

- The derrick angle is set in the BV operation operating window.
  - Derrick boom D 33 m is set to 114.3°.
  - Derrick boom D 39 m is set to 107.3°.
- The erection racks **6** are secured with four retaining pins **8** and four retaining elements **9** in positions **P1**.
- The ballast plates are disassembled.
- The electrical connection from the suspended ballast to the suspended ballast guide is disconnected.

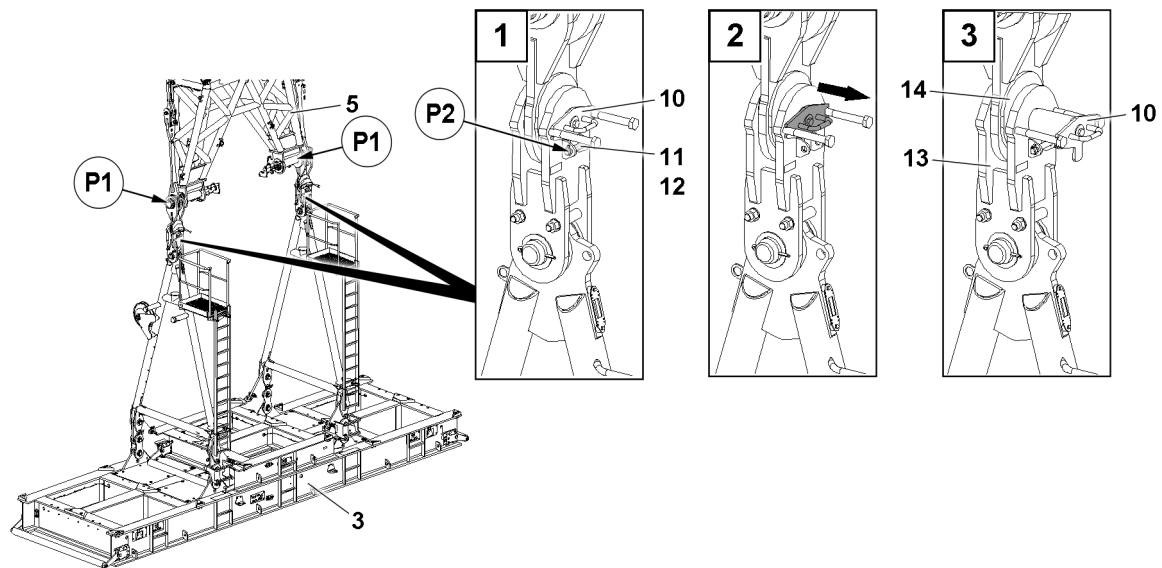


Fig.155443: Disassembling the suspended ballast on the suspended ballast guide “V-frame” – Unpinning procedure

3	Divisible ballast pallet “VarioTray”	11	Retaining pin
5	Suspended ballast guide “V-frame”	12	Retaining element
10	Pin		

The divisible ballast pallet “VarioTray” 3 is unpinned in two positions P1. The pinning procedure is described for one pin 10 as an example.

- ▶ Remove the retaining element 12 in position P2 and unpin the retaining pin 11.
- ▶ Unpin the pin 10.



#### Note

Retract / extend the pull cylinders:

- ▶ Control the pull cylinders from the crane cab, see the section “Lifting and lowering the derrick ballast using the pull cylinders”.
- ▶ Operate the pull cylinder with the radio remote control, see the “radio remote control operating instructions”.

- ▶ Pull the bracket 14 out of the lashing lug 13 by lifting the pull cylinders.
- ▶ Insert the pin 10 again.
- ▶ Secure the pin 10 with the retaining pin 11 and the retaining element 12 in position P2.

#### Result:

- The connector pin 10 is secured.

## 11.6 Assembling the divisible ballast pallet “VarioTray” in the transport position

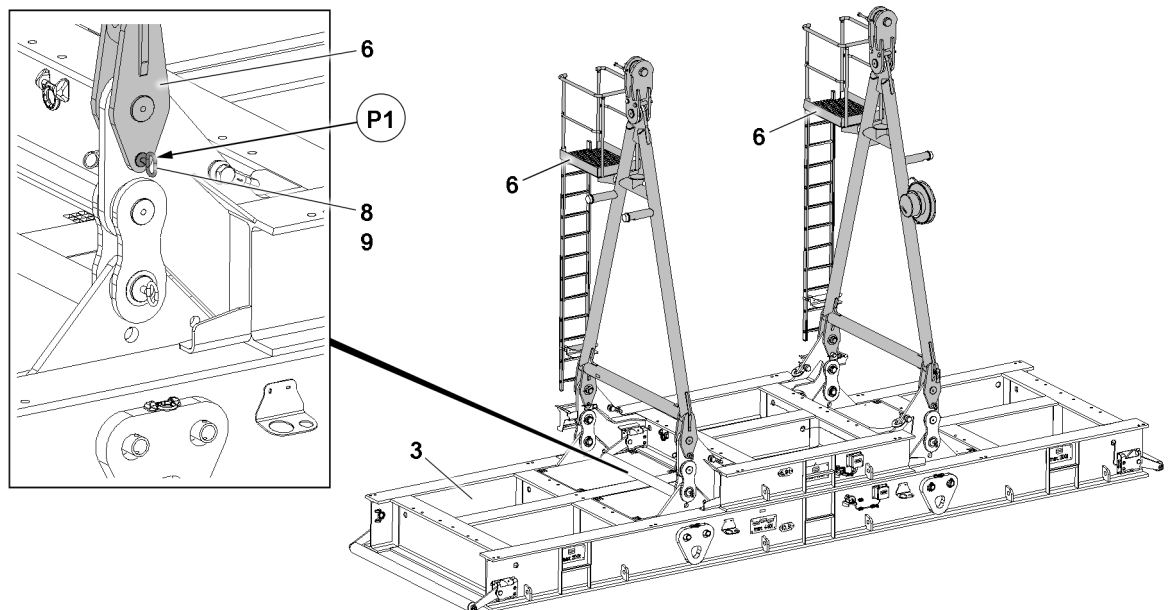


Fig.155384: Assembling the divisible ballast pallet “VarioTray” in the transport position – Removing the retaining pins

3	Divisible ballast pallet “VarioTray”	8	Retaining pin
6	Erection rack	9	Retaining element



### Note

- ▶ The disassembly of the erection racks **6** is described based on the example of one erection rack **6**.

The erection rack **6** is released on both sides. The releasing procedure is described for one retaining pin **8** as an example.

- ▶ Connect the erection rack **6** to the auxiliary crane.



### DANGER

Danger of accident during assembly / disassembly of the erection racks **6**!

The erection racks **6** must hang securely on the auxiliary crane, otherwise the erection racks **6** could fall down and kill or severely injure personnel.

- ▶ Make sure that the erection rack **6** hangs safely on the auxiliary crane.
- ▶ Never unpin the retaining pins **8** from unsecured erection racks **6**.
- ▶ It is prohibited for anyone to remain under the erection racks **6** or within the entire danger zone during the pinning and unpinning procedure.

When the erection rack **6** is safely held by the auxiliary crane:

- ▶ Remove the retaining element **9** on both sides in position **P1** and unpin the retaining pin **8**.

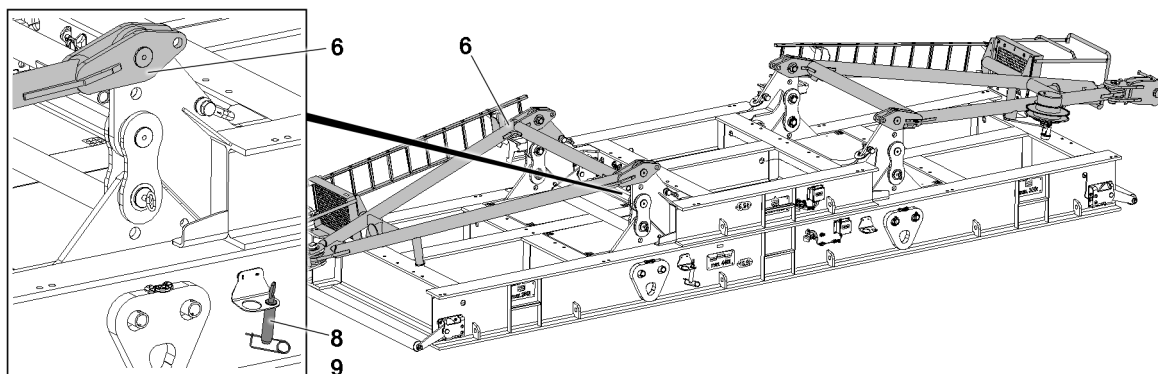


Fig.155385: Assembling the divisible ballast pallet “VarioTray” in the transport position – Divisible ballast pallet “VarioTray” in the transport position

- |   |               |   |                   |
|---|---------------|---|-------------------|
| 6 | Erection rack | 9 | Retaining element |
| 8 | Retaining pin |   |                   |

- ▶ Lower the erection rack **6** with the auxiliary crane until the rubber cushions touch the frame.
- ▶ Insert the retaining pin **8** on both sides in the park position and secure with the retaining element **9**.
- ▶ Remove the auxiliary crane.
- ▶ Take down the second erection rack **6** in the same way as described above.

## 11.7 Disassembling the suspended ballast guide “V-frame”

### 11.7.1 Unpinning the D-guy rods on the end section

Make sure that the following prerequisites are met:

- The divisible ballast pallet “VarioTray” is disconnected from the suspended ballast guide “V-frame”.
- The derrick boom is set to the upper angle limit (OGWD).

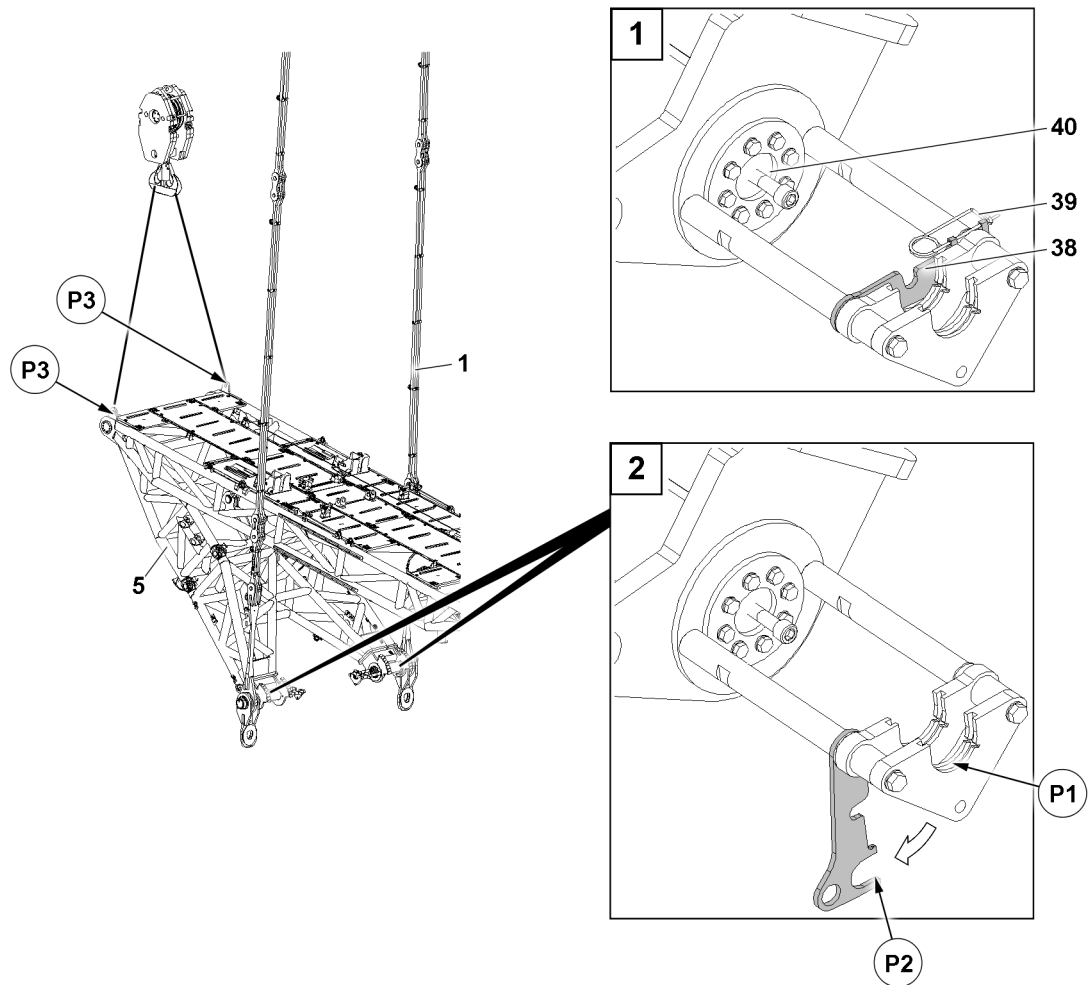


Fig.155444: Unpinning the D-guy rods on the end section – Connecting the pin pulling device

1	D-guy rods	39	Retaining element
5	Suspended ballast guide "V-frame"	40	Pin
38	Retaining element		



### Note

Upper limit angle (OGWD) of the derrick boom:

- ▶ Derrick boom D 33 m is set to 115.3°.
- ▶ Derrick boom D 39 m is set to 108.3°.

If the divisible ballast pallet "VarioTray" is disconnected from the suspended ballast guide "V-frame" 5:

- ▶ Drive the crane away from the divisible ballast pallet "VarioTray".
- ▶ Extend the pull cylinder until the pin 40 is approx. 2.4 m off the ground.
- ▶ Fasten the suspended ballast guide "V-frame" 5 in the positions P3 to the auxiliary crane.
- ▶ Lift the suspended ballast guide "V-frame" 5 with the auxiliary crane until the D-guy rods 1 are relieved.

The unpinning procedure is described based on one pin 40 as an example and applies in the same way for both pins 40.

- ▶ Remove the retaining element 39.
- ▶ Fold the retaining element 38 down.
- ▶ Connect the retaining element 39 in position P2.
- ▶ Connect the pin pulling device in position P1.

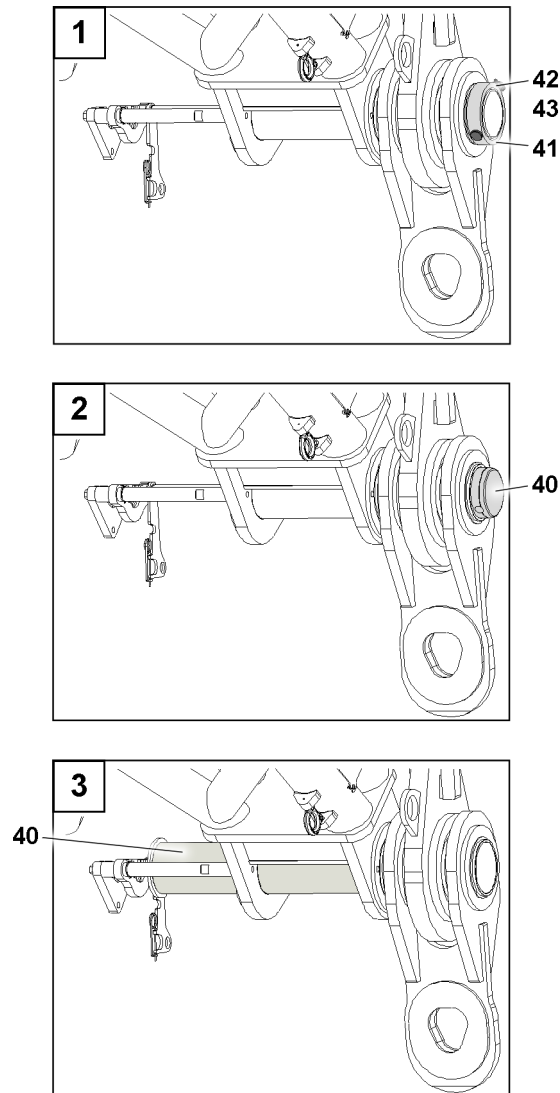


Fig.155445: Unpinning the D-guy rods on the end section – Unpinning the pins

40 Pin  
41 Retaining ring

42 Retaining pin  
43 Retaining element



### WARNING

Swinging D-guy rods!

Death, severe bodily injuries, property damage.

When unpinning the D-guy rods, they swing uncontrolled in the direction of the turntable.

► Make sure that the D-guy rods are secured before unpinning.

- Remove the retaining element **43** and unpin the retaining pin **42**.
- Remove the retaining ring **41**.
- Unpin the pin **40**.
- Guide the D-guy rods to the side next to the suspended ballast guide "V-frame".
- Repeat the procedure the same way for the second pin **40**.

### 11.7.2 Taking the suspended ballast guide “V-frame” down onto the ground

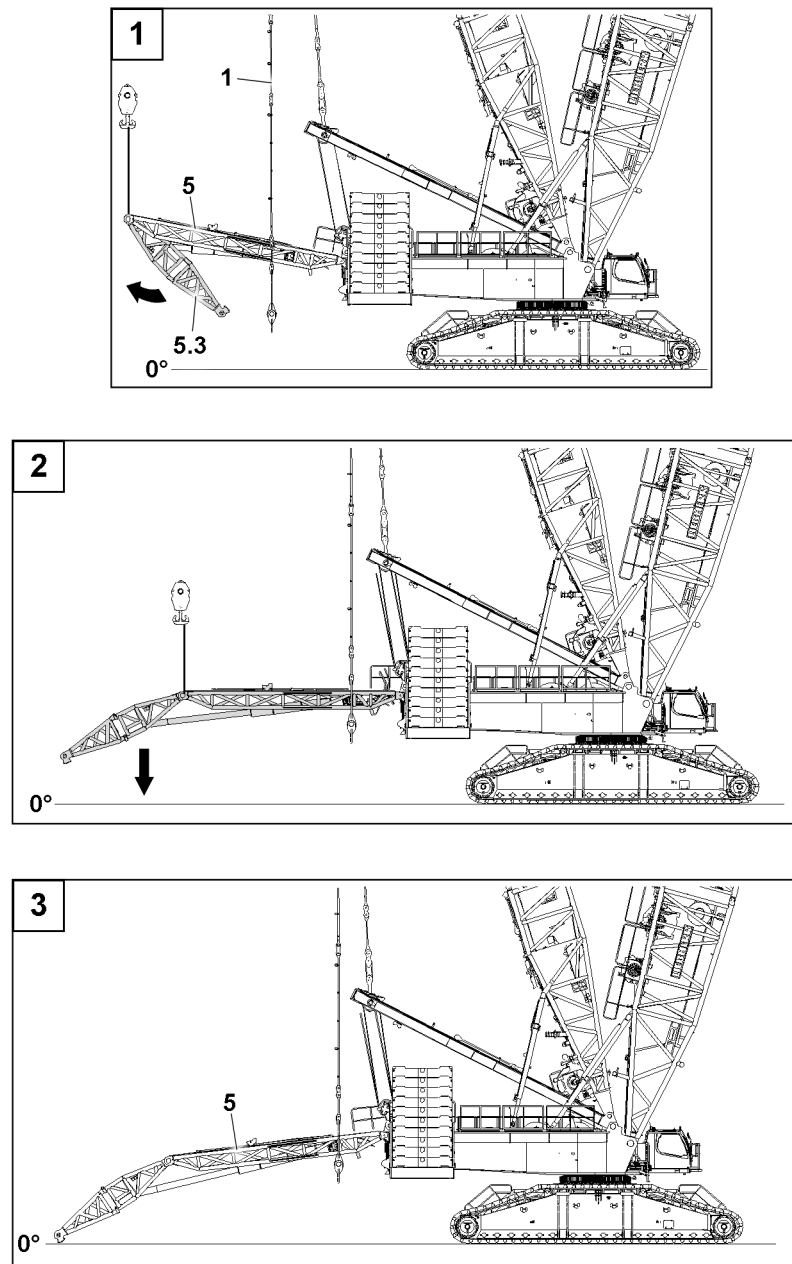


Fig.155446: Taking the suspended ballast guide “V-frame” down onto the ground

- |          |                                   |            |             |
|----------|-----------------------------------|------------|-------------|
| <b>1</b> | D-guy rods                        | <b>5.3</b> | End section |
| <b>5</b> | Suspended ballast guide “V-frame” |            |             |

Make sure that the following prerequisites are met:

- The D-guy rods **1** are disassembled from the suspended ballast guide “V-frame” **5**.
- ▶ Unfold the end section **5.3** completely.
- ▶ Lower the suspended ballast guide “V-frame” **5** to the ground with the auxiliary crane.
- ▶ Remove the auxiliary crane.

### 11.7.3 Assembling the guy rods in the transport position

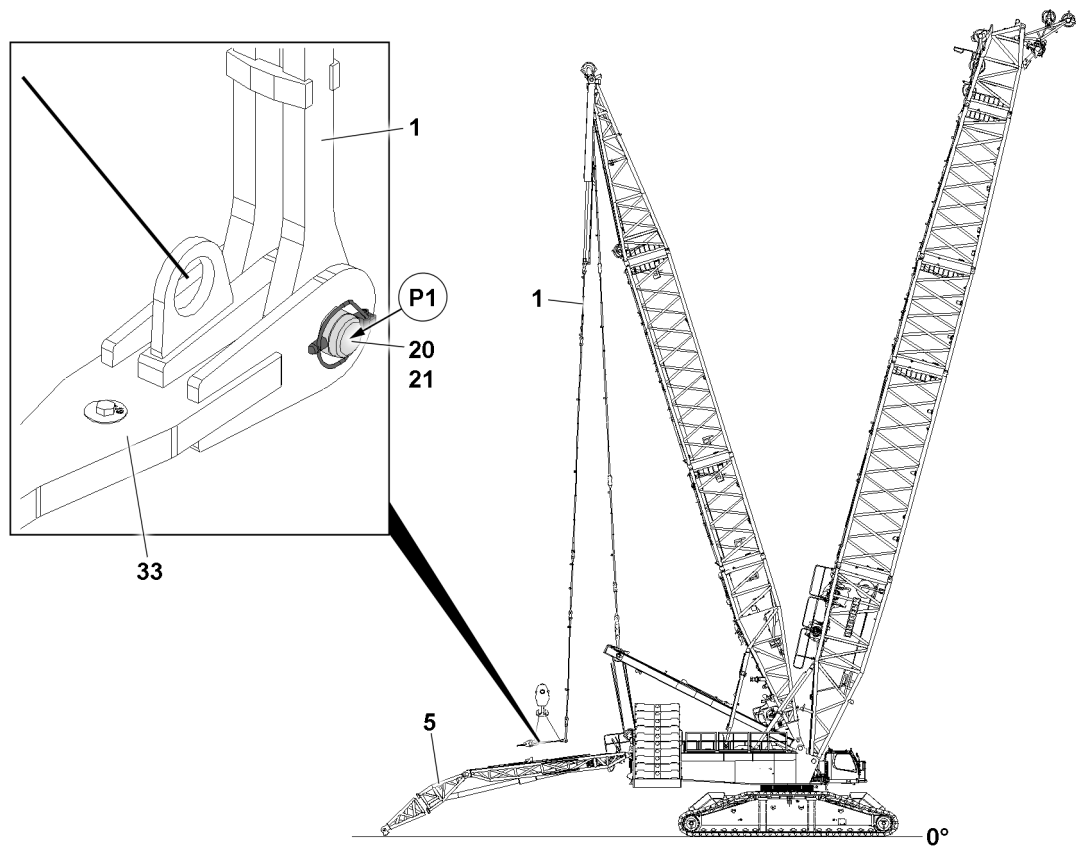


Fig.155427: Assembling the guy rods in the transport position – Unpinning procedure

1	D-guy rods	21	Retaining element
20	Pin	33	Guy rod

Make sure that the following prerequisites are met:

- The suspended ballast guide “V-frame” **5** is taken down on the ground.

The guy rods **33** are unpinned on both sides on the D-guy rods **1**. The unpinning procedure is described for one guy rod **33** as an example.

- ▶ Fasten the guy rod **33** to the auxiliary crane.
- ▶ Lift the guy rod **33** to the horizontal position.



#### WARNING

Swinging D-guy rods **1**!

The D-guy rods **1** can swing during unpinning due to their own weight.  
Death, severe bodily injuries, property damage.

- ▶ Make sure that the D-guy rods **1** are hanging vertically and cannot swing back and forth.
- ▶ Position the guy rod **33** such that it can be unpinned.
- ▶ Remove the retaining element **21**.
- ▶ Unpin the pin **20**.



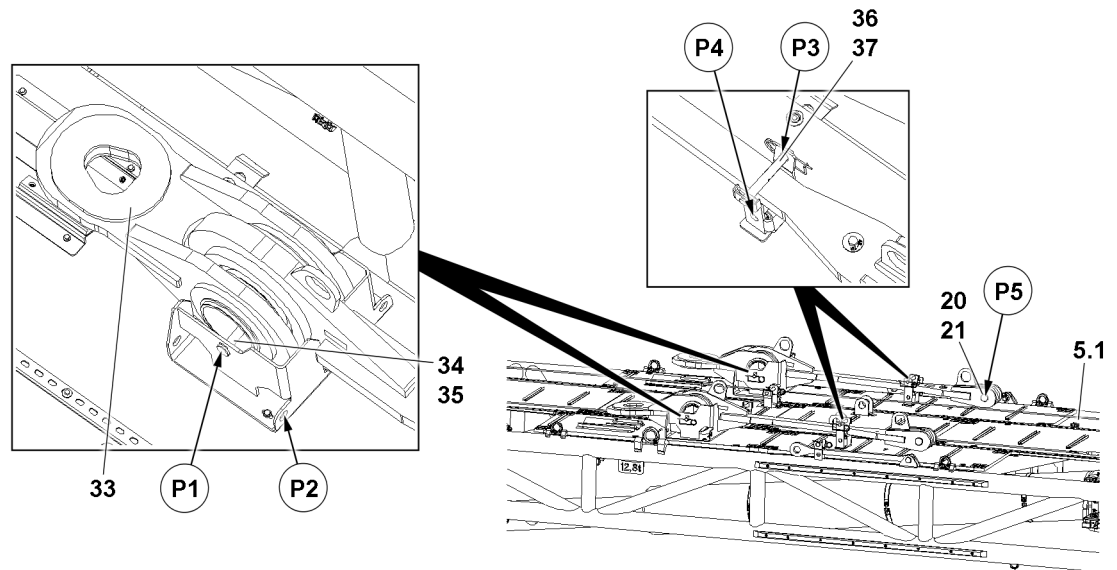


Fig.155447: Assembling the guy rods in the transport position — Assembling the guy rods in the park position

5.1	Pivot section	34	Pin
20	Pin	35	Retaining element
21	Retaining elements	36	Pin
33	Guy rod	37	Retaining element

- ▶ Take the guy rod **33** down in the park position on the pivot section **5.1**.
- ▶ Remove the fastening equipment.
- ▶ Release and unpin the pin **34** in the park position **P2**.
- ▶ Secure the pin **34** in the retaining position **P1** with the retaining element **35**.
- ▶ Release and unpin the pin **36** in the park position **P4**.
- ▶ Secure the pin **36** in the retaining position **P4** with the retaining element **37**.
- ▶ Insert the pin **20** in positions **P5** and secure with retaining elements **21**.
- ▶ Repeat the procedure for the second guy rod **33** the same way as described before.

#### 11.7.4 Disconnect the electrical connection of the suspended ballast guide to the end section:

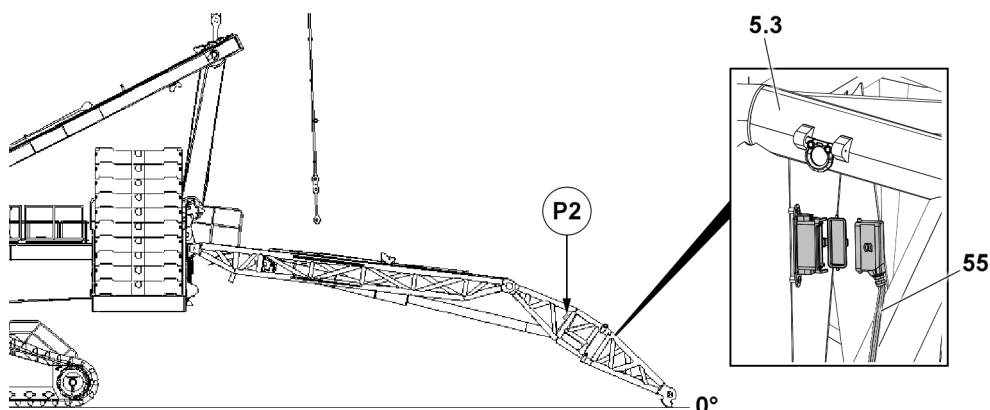


Fig.163660: Disconnect the electrical connection of the suspended ballast guide to the end section:

55	Electrical line	5.3	End section
----	-----------------	-----	-------------

**NOTICE**

The ignition switch is not in position 0!

If live electrical connections are disconnected / connected, then there is the danger that components can be damaged.

The crane functions can be limited.

- ▶ De-energize the electrical connections before disconnection / connection: Set the ignition switch to position 0.

- ▶ Move the ignition switch to position 0.

Disconnect the electrical connection of the suspended ballast guide to the end section:

- ▶ Unplug the plug of the electrical line **55** in position **P2**.
- ▶ Bring the electrical line **55** at the end section **5.3** into the park position.

**Note**

- ▶ Disconnect the electrical connection of the suspended ballast guide to the end section, see the "wiring diagram".

**NOTICE**

Damage to the electrical connections due to dirt, moisture and corrosion!

If unrequired electrical connections are not closed with their respective caps, the electrical connections can be damaged.

If the covers are removed from the electrical connections or control cabinets are opened, then moisture can infiltrate.

- ▶ Always properly close off all **non**-required electrical connections with their protective caps.
- ▶ Protect the electrical connections from water infiltration, this applies especially in the case of rain or snow.

**Note**

If **non**-required electrical connections are not closed with their respective dummy plugs, the electrical connections can be damaged.

- ▶ A malfunction can occur without bridging.
  - ▶ Observe the "wiring diagram".
- ▶ As a rule, close off non-required electrical connections (for example for accessories that are not installed) with the respective dummy plugs / dust caps.

### 11.7.5 Disassembling the end section

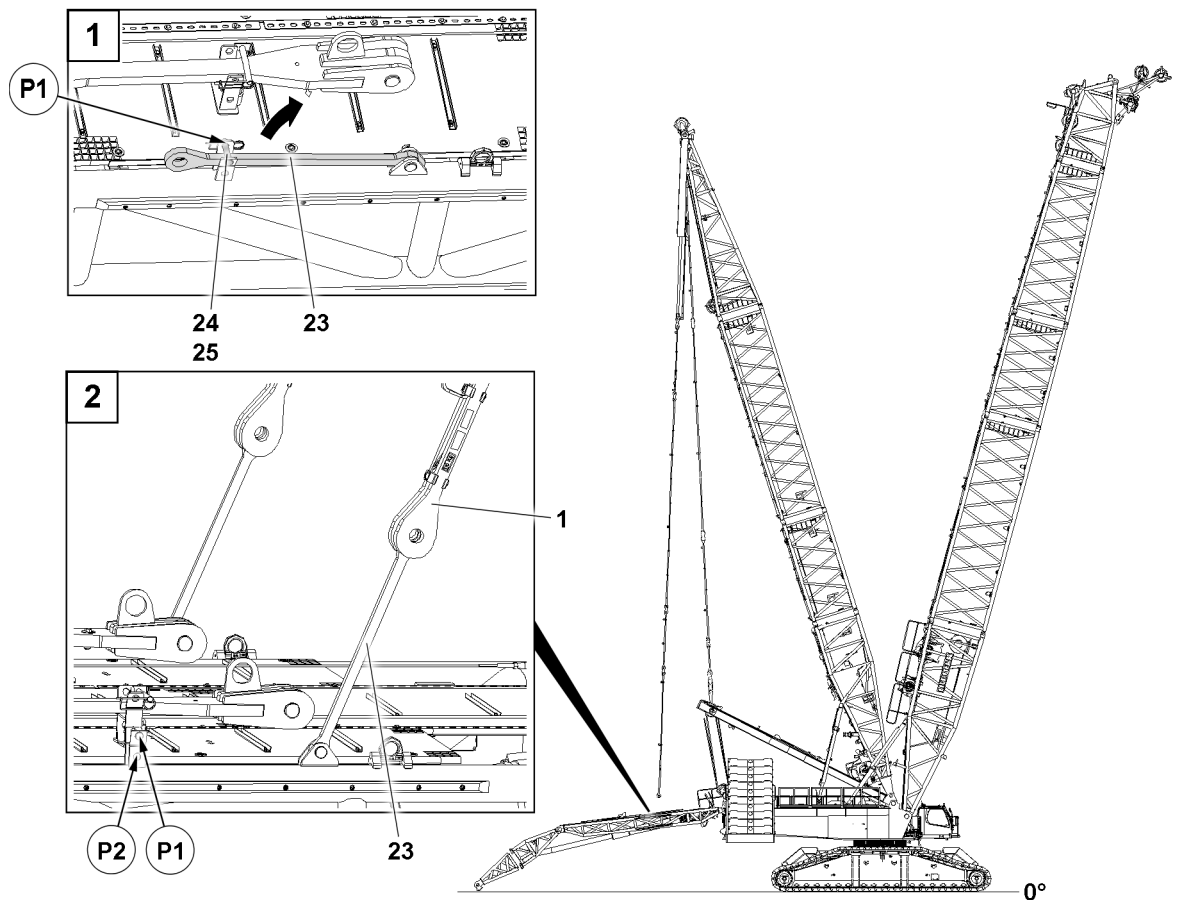


Fig.155450: Disassembling the end section – Assembling the guy rods

- |    |            |    |                   |
|----|------------|----|-------------------|
| 1  | D-guy rods | 24 | Retaining pin     |
| 23 | Guy rod    | 25 | Retaining element |



#### WARNING

Uncontrolled swinging of the guy rod **23**!  
Danger of crushed limbs.

- ▶ Keep hands away from the danger zone.
- ▶ Secure the guy rod **23** with a suitable aid to prevent uncontrolled swinging.

When the derrick boom 33 m is assembled:

- ▶ Set the derrick angle to 114.3°.

When the derrick boom 39 m is assembled:

- ▶ Set the derrick angle to 107.3°.

Bring the guy rod **23** into the transport position:

- ▶ Release the guy rod **23**: Release the retaining pin **24** in position **P1** and unpin.
- ▶ Swing the guy rod **23** up and position it so that it can be pinned on the D-guy rods **1**.
- ▶ Insert the retaining pin **24** in position **P2** and secure with the retaining element **25**.

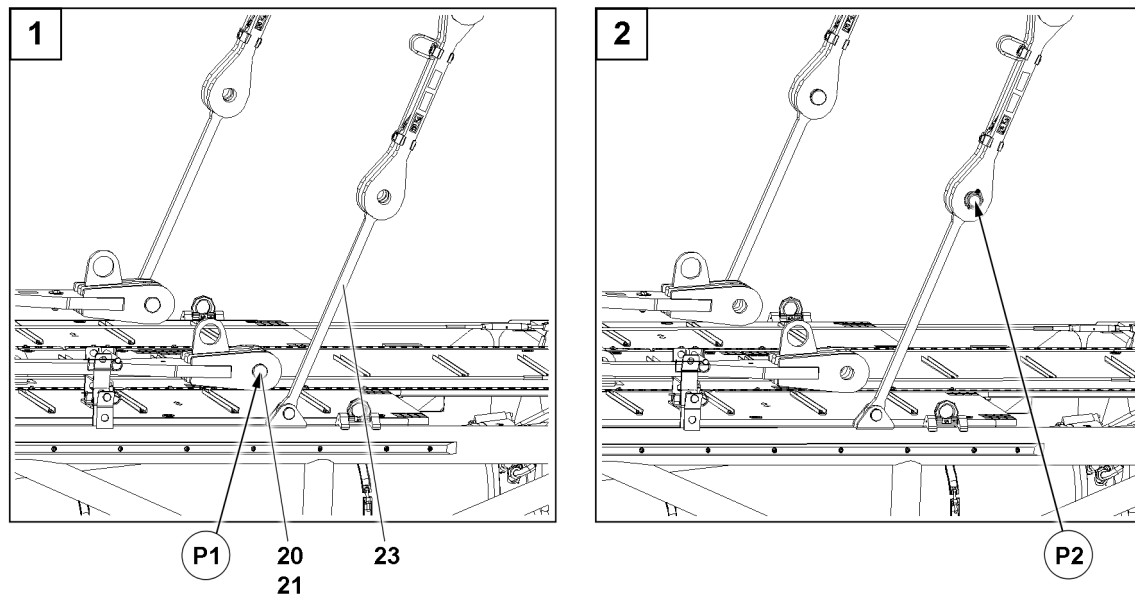


Fig.155420: Disassembling the end section – Pinning the guy rods

20 Pin  
21 Retaining element  
23 Guy rod

- ▶ Release and unpin the pin 20 in position P1.
- ▶ Insert the pin 20 in position P2.
- ▶ Secure the pin 20 with the retaining element 21.
- ▶ Repeat the procedure the same way for the second guy rod 23.

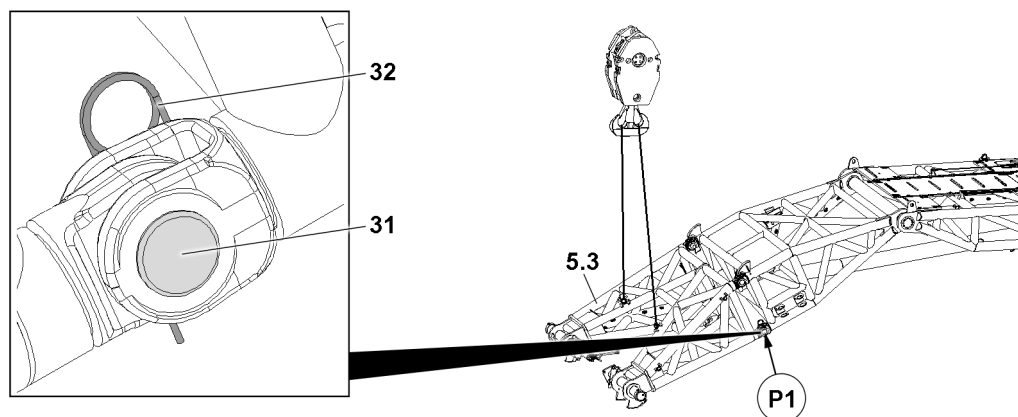


Fig.155423: Disassembling the end section – Unpinning the end section at the bottom

5.3 End section  
31 Pin  
32 Retaining element

- ▶ Lift the suspended ballast guide “V-frame” 5 with the pull cylinders.
- ▶ Fasten the end section 5.3 to the auxiliary crane.
- ▶ Tension the fastening equipment slightly.

The end section 5.3 is uninned on the bottom in two positions P1. The unpinning procedure is described for one pin 31 as an example.

- ▶ Release the pin 31 in position P1 and unpin.
- ▶ Repeat the procedure the same way for the second pin 31.

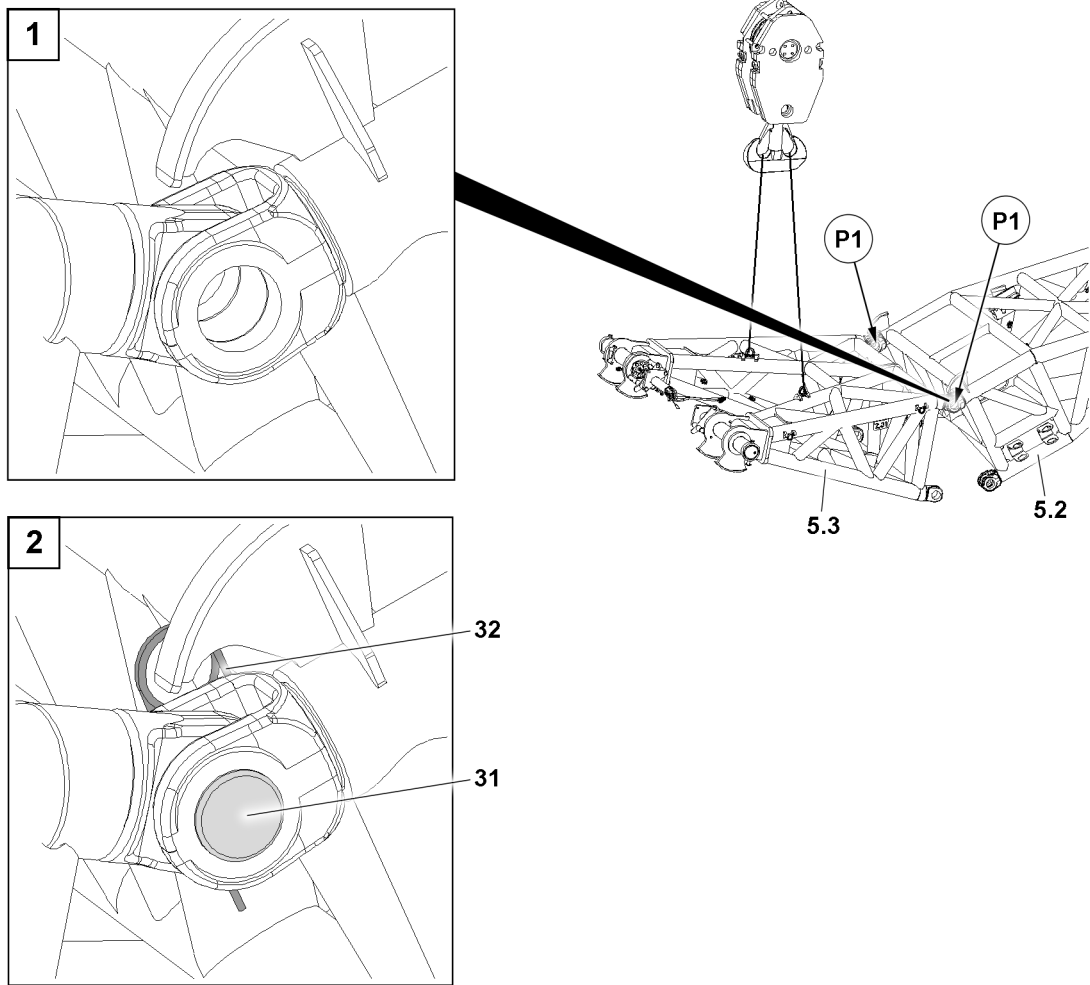


Fig.155422: Disassembling the end section – Unpinning the end section at the top

- |                          |                             |
|--------------------------|-----------------------------|
| <b>5.2</b> Pivot section | <b>31</b> Pin               |
| <b>5.3</b> End section   | <b>32</b> Retaining element |

► Lift the end section **5.3** with the auxiliary crane until it can be uninned in positions **P1**.

The end section **5.3** is uninned on the top in two positions **P1**. The unpinning procedure is described for one pin **31** as an example.

- Release the pin **31** in position **P1** and unpin.
- Repeat the procedure the same way for the second pin **31**.
- Take the end section **5.3** down with the auxiliary crane in a suitable location.

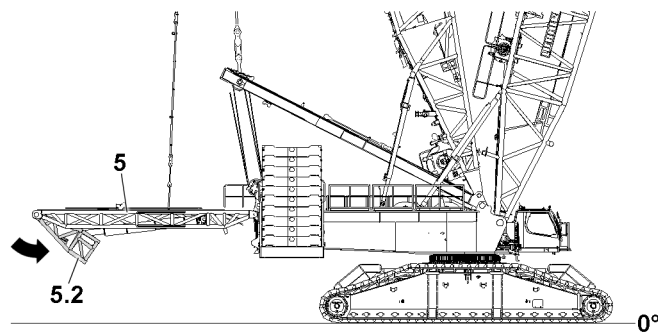


Fig.155451: Disassembling the end section – Folding in the pivot section

- |  |                          |
|--|--------------------------|
| <b>5</b> Suspended ballast guide "V-frame" | <b>5.2</b> Pivot section |
|--|--------------------------|

LWE/LR 1800-1-0-000/27200-07-02/en

- ▶ Fold in the pivot section **5.2** completely: Move the cylinder to the end position.
- ▶ Take the suspended ballast guide "V-frame" **5** down onto the ground.

### 11.7.6 Assembling the guy rods in the transport position

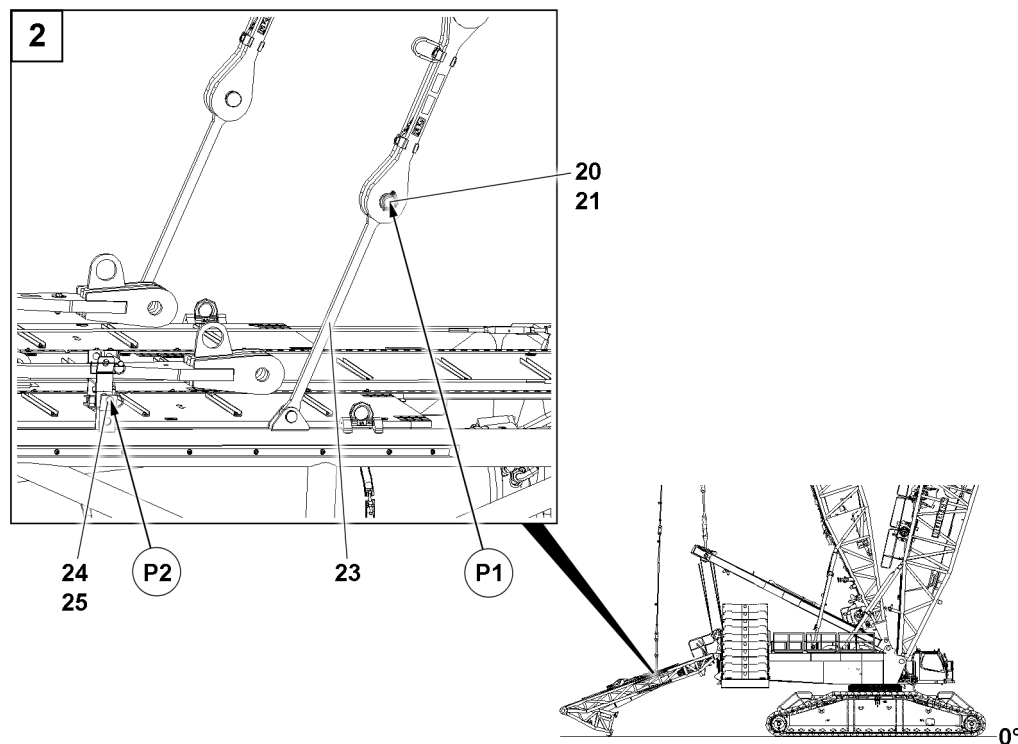


Fig.155452: Assembling the guy rods in the transport position

<b>20</b> Pin	<b>24</b> Retaining pin
<b>21</b> Retaining element	<b>25</b> Retaining element
<b>23</b> Guy rod	

- ▶ Release and unpin the pin **20** in position **P1**.



#### WARNING

Uncontrolled swinging of the guy rod **23**!  
Danger of crushed limbs.

- ▶ Keep hands away from the danger zone.
- ▶ Swing the guy rod **23** down.
- ▶ Secure the guy rod **23** with the retaining pin **24** and retaining element **25** in the transport position **P2**.

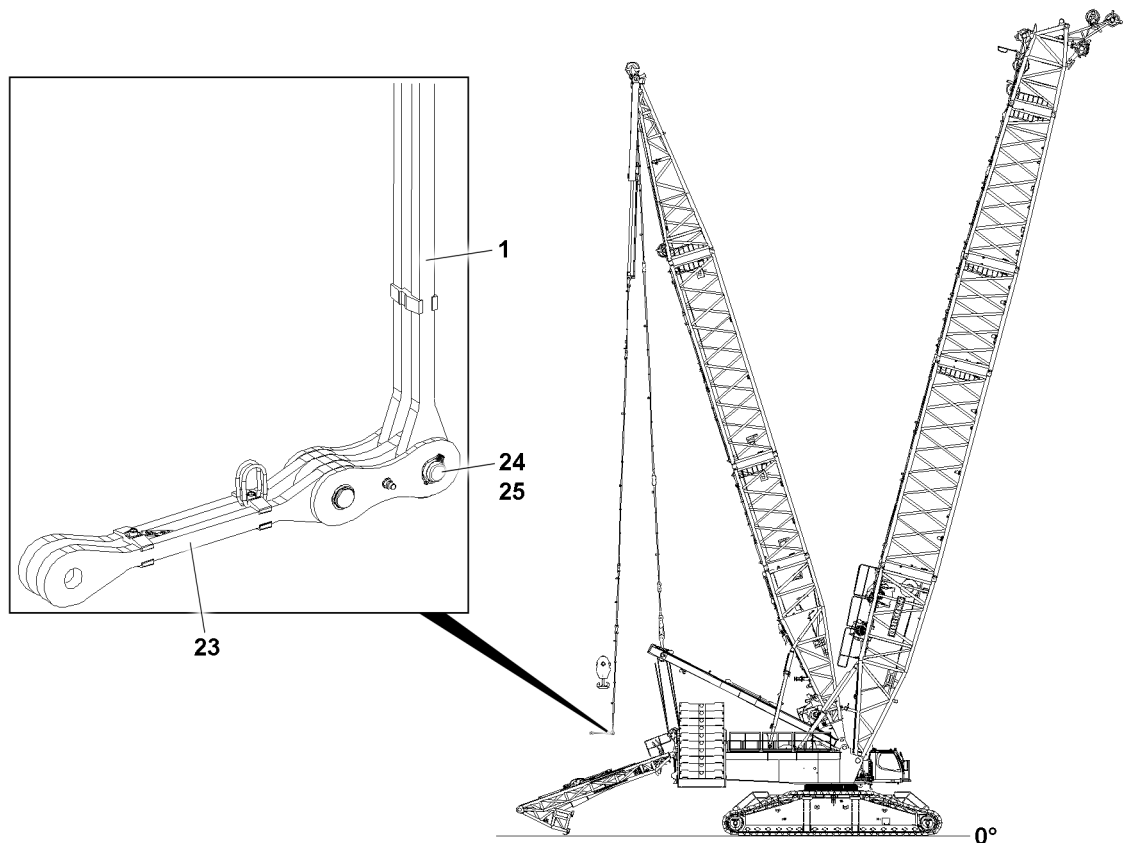


Fig.155418: Assembling the guy rods in the transport position — unpinning the guy rods

- |    |            |    |                   |
|----|------------|----|-------------------|
| 1  | D-guy rods | 24 | Pin               |
| 23 | Guy rod    | 25 | Retaining element |



#### Note

- ▶ The guy rods **23** are installed only when the derrick boom with 39 m is assembled. This disassembly step is eliminated with a derrick boom length of 33 m.

The guy rods **23** are unpinned on both sides on the D-guy rods **1**. The unpinning procedure is described for one guy rod **23** as an example.

- ▶ Fasten the guy rod **23** to the auxiliary crane.
- ▶ Lift the guy rod **23** to the horizontal position.



#### WARNING

Swinging D-guy rods **1**!

The D-guy rods **1** can swing during unpinning due to their own weight.  
Death, severe bodily injuries, property damage.

- ▶ Make sure that the D-guy rods **1** are hanging vertically and cannot swing back and forth.
- ▶ Position the guy rod **23** such that it can be unpinned.
- ▶ Remove the retaining element **25**.
- ▶ Unpin the pin **24**.

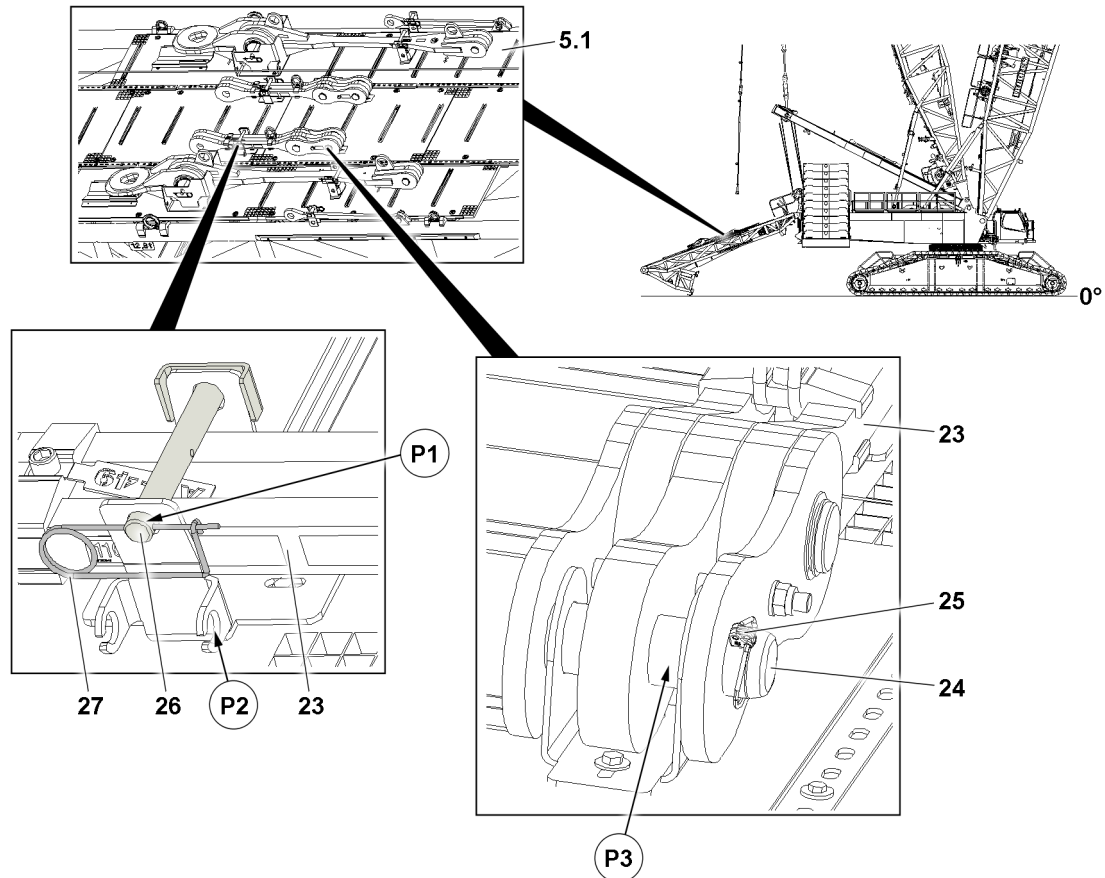


Fig.155448: Assembling the guy rods in the transport position — Securing the guy rods in the retaining position

5.1	Pivot section	25	Retaining element
23	Guy rod	26	Pin
24	Pin	27	Retaining element

- ▶ Take the guy rod **23** down in the park position on the pivot section **5.1**.
- ▶ Remove the fastening equipment.
- ▶ Release and unpin the pin **26** in the park position **P2**.
- ▶ Secure the pin **26** in the retaining position **P1** with the retaining element **27**.
- ▶ Secure the pin **24** in the retaining position **P3** with the retaining element **25**.
- ▶ Repeat the procedure for the second guy rod **23** the same way as described before.



### 11.7.7 Disconnecting the electrical connection from the suspended ballast guide to the turntable

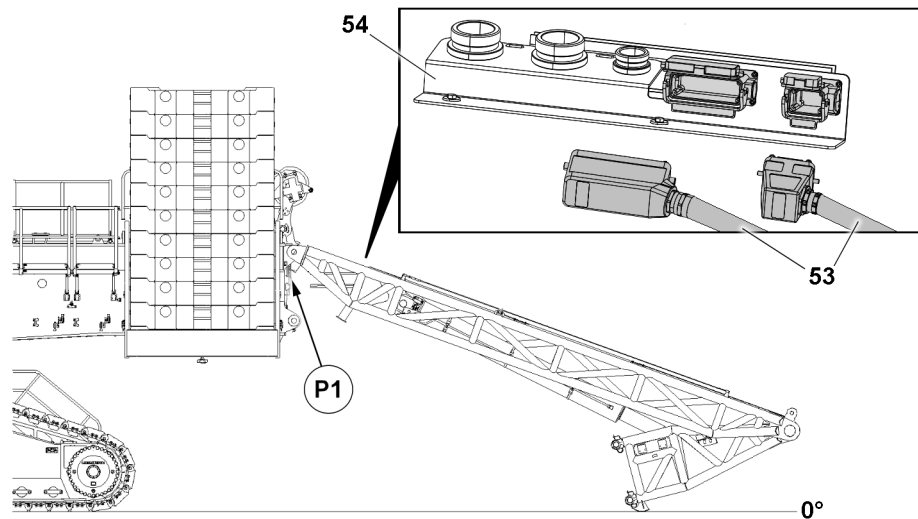


Fig.163644: Disconnecting the electrical connection from the suspended ballast guide to the turntable

**53** Electrical lines

**53** Parking bracket

#### NOTICE

The ignition switch is not in position 0!

If live electrical connections are disconnected / connected, then there is the danger that components can be damaged.

The crane functions can be limited.

- ▶ De-energize the electrical connections before disconnection / connection: Set the ignition switch to position 0.

- ▶ Move the ignition switch to position 0.

Disconnect the electrical connection from the suspended ballast guide to the turntable:

- ▶ Unplug the plug of the electrical lines **53** in position **P1**.
- ▶ Bring the electrical lines **53** in the parking bracket **54** into the park position.



#### Note

- ▶ Disconnecting the electrical connection from the suspended ballast guide to the turntable, see the "wiring diagram".

#### NOTICE

Damage to the electrical connections due to dirt, moisture and corrosion!

If unrequired electrical connections are not closed with their respective caps, the electrical connections can be damaged.

If the covers are removed from the electrical connections or control cabinets are opened, then moisture can infiltrate.

- ▶ Always properly close off all **non**-required electrical connections with their protective caps.
- ▶ Protect the electrical connections from water infiltration, this applies especially in the case of rain or snow.



#### Note

If **non**-required electrical connections are not closed with their respective dummy plugs, the electrical connections can be damaged.

- ▶ A malfunction can occur without bridging.
- ▶ Observe the "wiring diagram".

- ▶ As a rule, close off non-required electrical connections (for example for accessories that are not installed) with the respective dummy plugs / dust caps.

### 11.7.8 Disconnecting the hydraulic connections from the suspended ballast guide “V-frame” to the turntable

The hydraulic connections are established with quick couplings.

When using quick couplings to disconnect the hydraulic lines, make sure that the coupling procedure is carried out correctly.



#### WARNING

Pressure in the hydraulic lines!

If the pressure supply is not interrupted before connecting / releasing the hydraulic lines, the hydraulic oil can escape with high pressure.

Death, severe bodily injuries, property damage.

- ▶ Release the pressure in the hydraulic system before connecting / disconnecting: Interrupt the pressure supply and wait a short time.

- ▶ Release the hydraulic coupling by hand.
- ▶ Disconnect the hydraulic connections, see the Hydraulic diagram.
- ▶ Protect the hydraulic connections against contamination with caps.

### 11.7.9 Disassembling the suspended ballast guide “V-frame” from the turntable frame with the main boom taken down

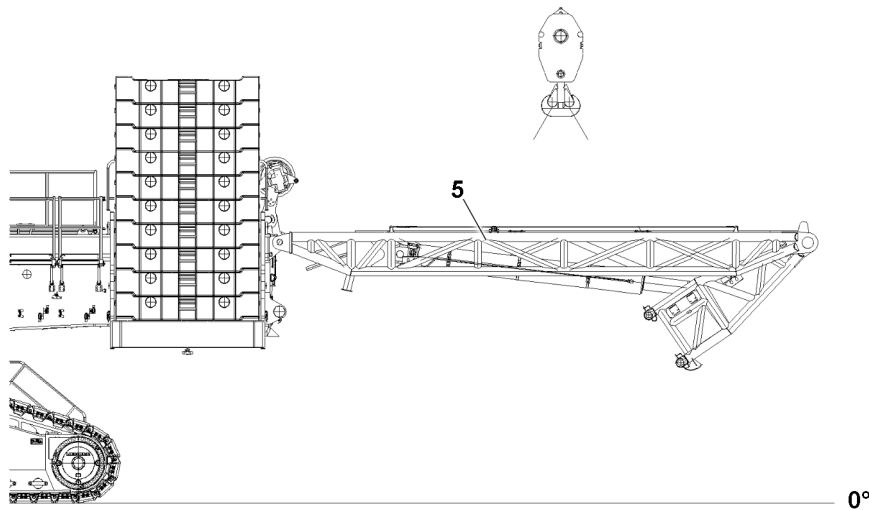


Fig.155453: Disassembling the suspended ballast guide “V-frame” from the turntable — Fastening the suspended ballast guide “V-frame” to the auxiliary crane

#### 5 Suspended ballast guide “V-frame”

- ▶ Fasten the “V-frame” suspended ballast guide **5** to the auxiliary crane.
- ▶ Lift the suspended ballast guide “V-frame” **5** with the auxiliary crane.

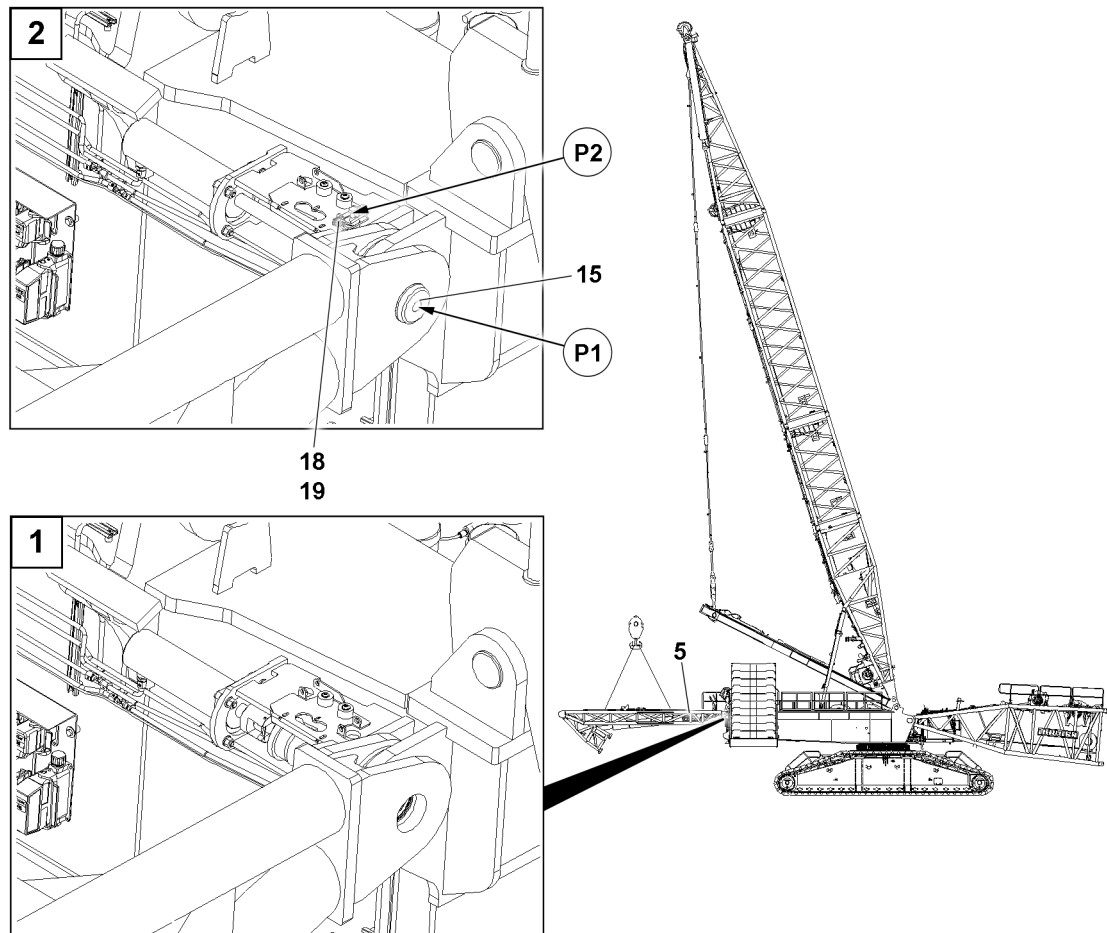


Fig.155454: Disassembling the suspended ballast guide “V-frame” from the turntable – Unpinning the suspended ballast guide “V-frame”

5	Suspended ballast guide “V-frame”	18	Retaining pin
15	Pin	19	Retaining element

The suspended ballast guide “V-frame” **5** is pinned in two points **P1**. The unpinning procedure is described for one pin as an example:

- ▶ Release the pin **15**: Remove the retaining element **19** in point **P2** and unpin the retaining pin **18**.

When the suspended ballast guide “V-frame” **5** is held securely by the auxiliary crane:

- ▶ Unpin the pin **15**.

When both pins **15** are unpinned:

- ▶ Remove the suspended ballast guide “V-frame” **5** with the auxiliary crane and take it down on the substructure.
- ▶ Insert the pin **15**.
- ▶ Secure the pin **15**: Insert the retaining pin **18** in point **P2** and secure with the retaining element **19**.
- ▶ In the Set up program, change to the “B-operation” operating mode.

### 11.7.10 Special assembly: Disassembling the suspended ballast guide “V-frame” from the turntable frame with the main boom erected

Make sure that the following prerequisites are met:

- The main boom is in the BV operation operating window in chart column DB- 0 t.
- A lifting platform or other aids are available.
- The derrick angle is set in the BV operation operating window.
  - With derrick boom D 33 m , the derrick angle is set to 114.3°.
  - With derrick boom D 39 m , the derrick angle is set to 107.3°.
- An auxiliary crane is available.

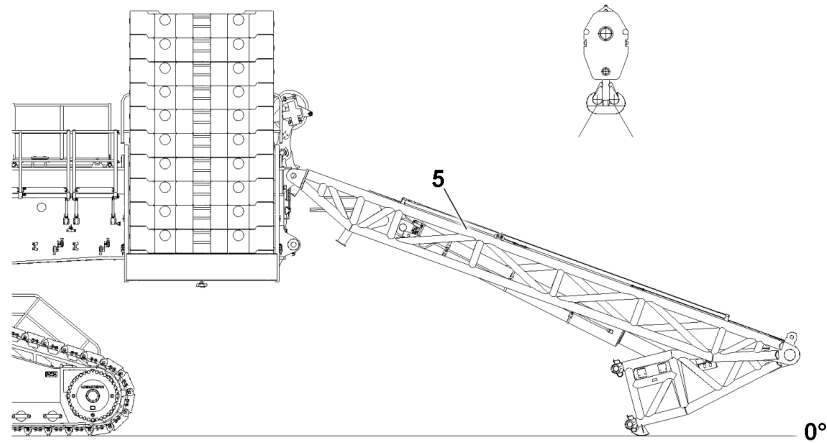


Fig.151447: Fastening the suspended ballast guide “V-frame” to the auxiliary crane

**5** Suspended ballast guide “V-frame”

- ▶ Fasten the suspended ballast guide “V-frame” **5** to the auxiliary crane, see section “Fastening points”.

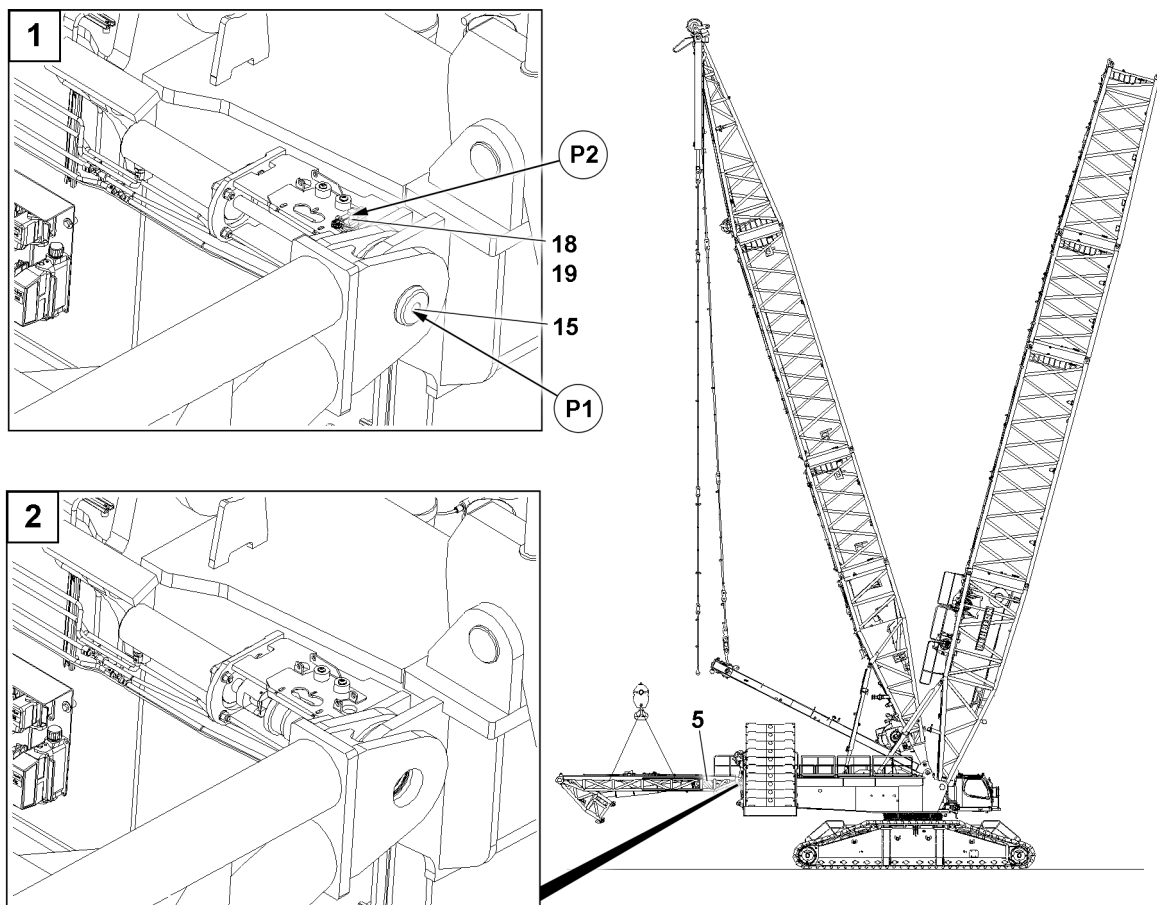


Fig.162985: Unpinning the suspended ballast guide “V-frame”

- |  |                             |
|--|-----------------------------|
| <b>5</b> Suspended ballast guide “V-frame” | <b>18</b> Retaining pin     |
| <b>15</b> Pin                              | <b>19</b> Retaining element |

LWE/LR 1800-1-0-000/27200-07-02/en

- ▶ Lift the suspended ballast guide “V-frame” **5** horizontally with the auxiliary crane.

The suspended ballast guide “V-frame” **5** is unpinned in two positions **P1**. The pinning procedure is described based on one pin **15** as an example.

The pinning cylinders are operated using the radio remote control, see the “radio remote control” operating instructions.

- ▶ Remove the retaining element **19** and unpin the retaining pin **18**.
- ▶ Unpin the pin **15** on both sides.

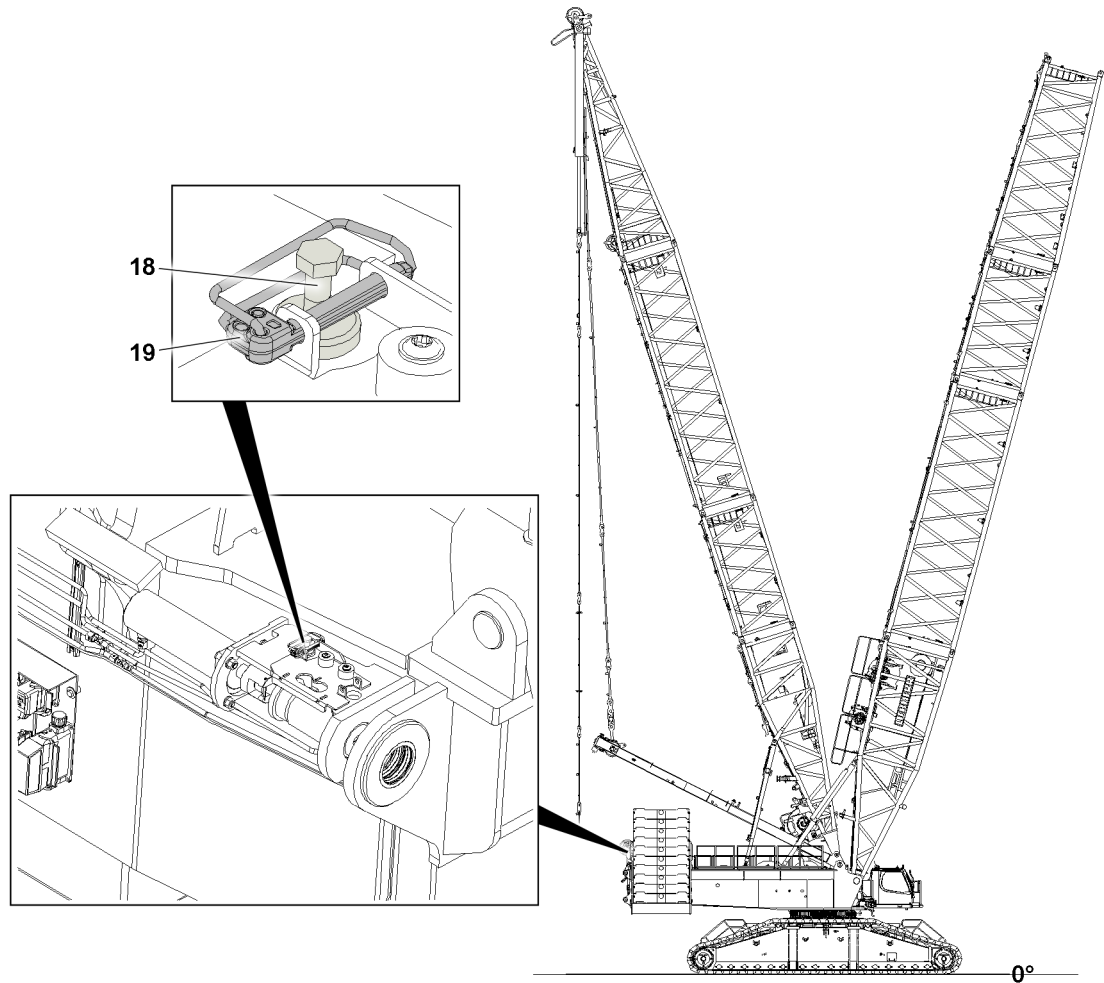


Fig.162986: Securing the pins in the transport position

**18** Retaining pin

**19** Retaining element

- ▶ Insert the retaining pin **18** and secure with the retaining element **19**.
- ▶ In the Set up program, change to the “B-operation” operating mode.

---

Empty page!

LWE/LR 1800-1-0-000/27200-07-02/en

## 5.36.90 Use of foreign ballast on ballast pallet

- 1 Handling recommendation for the use of external ballast on Liebherr suspended ballast pallets
- 

2

# 1 Handling recommendation for the use of external ballast on Liebherr suspended ballast pallets



## WARNING

Error when using external ballast!

- ▶ The crane operator is fully responsible for the use of external ballast.



## Note

- ▶ The Liebherr suspended ballast pallet is also referred to as the ballast pallet.

Liebherr-Werk Ehingen confirms that the use of external ballast on the ballast pallet delivered from the factor is permissible according to the following prerequisites:

- The weight and center of gravity of the external ballast and of the external ballast stack must be known and documented. The weight may deviate maximum +2.5 % / -0 % from the specifications in the operating manual.
- Center of gravity <sup>1)</sup> of the ballasting / ballast pallet: The location of the center of gravity must comply with the factory-provided suspended ballast. In particular, the height of the center of gravity may not be exceeded in any case. If the specifications are not observed, there is the danger that the ballast palette tips over or fails due to a deviating center of gravity.
- The ballasting rules in the operating manual must be complied with, in particular those in reference to the symmetric utilization of the ballast pallet.
- The external ballast must be placed flat on the ballast pallet <sup>2)</sup>.
- The external ballast must be secured against moving <sup>3)</sup>.
- If the space requirement with external ballast is greater than the space requirement with Liebherr ballast plates, there is the risk that external ballast with smaller and larger <sup>4)</sup> ballast radii collides with the turntable / ballast guide. For this reason it is necessary to monitor the movement area of the ballast pallet (continuously) and limit it if necessary.

1) Depending on the crane type: For the ballast pallet center of gravity, see the operating manual, or if not indicated contact customer service at Liebherr-Werk Ehingen GmbH.

2) Liebherr ballast plates have support points defined by their shape and may only be loaded on these support points.

3) Liebherr ballast plates are secured by their shape to prevent them from moving.

4) Danger of collision in the case of a large ballast radius only during operation with the V-frame and a correspondingly high center ballast stack.



## 5.38 Main boom

1	Safety	2
2	Component overview	3
3	Fastening points	3
4	Assembling	9
5	Assembling the S/SL boom at an incline	23
6	Assembling the boom system with the substructure	25
7	Performing the function checks	27
8	Erecting the boom system	28
9	Operating the crane	32
10	Disassembling	32
11	Disassembling the S/SL boom at an incline	46
12	Disassembling the boom system with the substructure	48

# 1 Safety

Observe the safety instructions before assembly and disassembly:

- Information regarding personal protective equipment. See chapter 2.04.
- Information regarding fall protection equipment. See chapter 2.06.
- Information regarding accesses to the crane. See chapter 2.07.
- Information regarding accessible surfaces. See chapter 2.07.



## WARNING

Danger of falling!

During assembly / disassembly, inspection and maintenance work, assembly personnel must be secured with appropriate aids to prevent them from falling.

Death, severe bodily injuries, property damage.

- ▶ All work at a height, when there is a danger of falling, must be carried out with suitable aids.
- ▶ If aids are not available and work cannot be carried out from the ground, then assembly personnel must secure themselves with the supplied fall arrest system to prevent falling, see the Crane operating instructions, chapter 2.04.
- ▶ If fall protection equipment is available, then it must be used, see the Crane operating instructions, chapter 2.06.
- ▶ When lifting, lowering, swinging crane parts in and out, no persons may remain in the danger zone.
- ▶ If railings are present on the components, then they must be brought into the corresponding position and secured for assembly / disassembly work.
- ▶ Only step on the aids, ladders and catwalks with clean shoes.
- ▶ Keep aids, ladders and catwalks free of heavy dirt, snow and ice.
- ▶ During all assembly and disassembly work, maintenance work and inspections, travel or crane operation is prohibited.
- ▶ Remaining on a suspended load is prohibited.
- ▶ Stepping or walking on crane components and lattice sections with an incline of more than 20° is prohibited.
- ▶ For all assembly work, the crane operator of the main crane must be in voice contact with the crane operator / crane operators of the auxiliary crane / auxiliary cranes.
- ▶ For the assembly / disassembly tasks, the crane operator may only initiate crane movements when the responsible guide has explicitly released the movement.



## WARNING

Danger of impact / crushing!

When assembling / disassembling crane components with the auxiliary crane, crane components can start to swing back and forth.

When lifting / lowering and positioning crane components, there is an increased danger of impact / crushing.

Death, severe bodily injuries, property damage.

- ▶ Make sure that personnel cannot be caught by components.
- ▶ When working in a danger zone: Use aids to protect limbs.
- ▶ Guide components with suitable aids to minimize oscillation.



## DANGER

The component can fall down!

If the corresponding component is disengaged from the auxiliary crane before the corresponding component is pinned, then the corresponding component can fall down.

Death, severe bodily injuries, property damage.

- ▶ Do not disconnect the auxiliary crane until the respective component is pinned and secured.

**WARNING**

Danger of falling!

During assembly and disassembly of crane components, personnel must be secured with appropriate aids to prevent them from falling.

Death, severe bodily injuries, property damage.

- ▶ Use personal protective equipment.

**WARNING**

Falling of the boom lattice sections!

If the boom lattice sections are not pinned and secured correctly, then they can fall down.

Death, severe bodily injuries, property damage.

- ▶ Insert or unpin both pins on the same horizontal level, i.e. **left and right**.
- ▶ Standing under the boom lattice sections or within the entire danger zone during the main boom pinning and unpinning procedure is prohibited.
- ▶ Safely secure the pins in the storage locations as well as in the receptacles.
- ▶ It is prohibited to lean the ladder against the component to be disassembled.

**WARNING**

Danger of accident due to unintended actuation of the master switch!

During assembly and disassembly of the boom system with the radio remote control, the unintended actuation of the master switch, (the “turning” function in particular), can lead to the uncontrolled movement of the boom system and therefore dangerous situations for personnel.

Death, severe bodily injuries, property damage.

- ▶ During assembly and disassembly of the boom system with the radio remote control: Observe and adhere to the specifications in chapter 5.31 and chapter 6.08.

## 2 Component overview

**Note**

- ▶ For boom components (boom lattice sections), such as the H-pivot section, L/S/H-intermediate sections, SL/HS-reducers and the S/L-end sections, as well as dimensions and weights, see chapter 1.03.
- ▶ Combination of the various boom systems, see the Rod plan and chapter 5.03.

## 3 Fastening points

**WARNING**

Fastening equipment can be ripped off!

Death, severe bodily injuries, property damage.

- ▶ Make sure that the fastening equipment has a sufficient load carrying capacity and the required minimum length.
- ▶ Make sure that the auxiliary crane(s) have a sufficient load carrying capacity.
- ▶ Pay attention and adhere to the labels on the fastening points on the boom lattice sections and crane components.
- ▶ Make sure that there are no persons in the danger zone.

**WARNING**

Components incorrectly fastened!

Death, severe bodily injuries, property damage.

- ▶ Fasten the components only in the intended fastening points on both sides.

**WARNING**

Overload of fastening points!

If the fastening points are overloaded, they can rip off and the component can fall down.  
Death, severe bodily injuries, property damage.

- ▶ Make sure that the fastening points are not overloaded.
- ▶ Observe the maximum permissible suspended loads.

**Note**

- ▶ The H, S and L-intermediate sections are available in various system dimensions.
- ▶ The distance between the fastening points can vary, depending on the respective H, S or L-intermediate section.
- ▶ The boom lattice section must be fastened on both sides to the fastening points.

### 3.1 H-pivot section fastening points

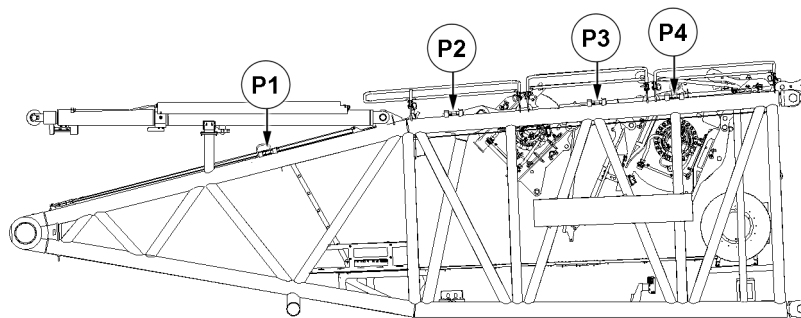


Fig.154342: H-pivot section fastening points

Fastening points	
P1 + P4	H-pivot section, complete
P2 + P3	H-pivot section with winch 5, WA-frame 2 guy rods
P1 + P4	H-pivot section with winch 5
P2 + P3	H-pivot section with winch 5 and 4, WA-frame 2 guy rods

### 3.2 H-intermediate section 6 m fastening points

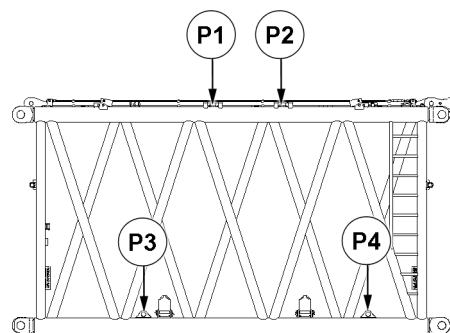


Fig.154344: H-intermediate section 6 m fastening points

Fastening points	
P1 + P2 or P3 + P4	H-intermediate section 6 m

### 3.3 H-intermediate section 12 m fastening points

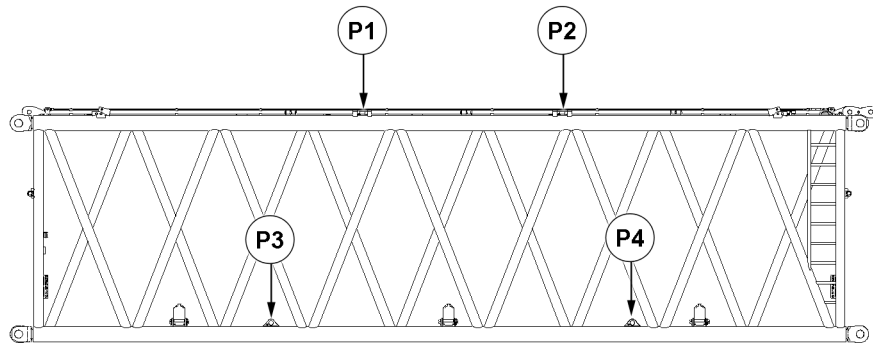


Fig.154343: H-intermediate section 12 m fastening points

Fastening points	
P1 + P2 or P3 + P4	H-intermediate section 12 m

### 3.4 HS-reducer 9 m fastening points

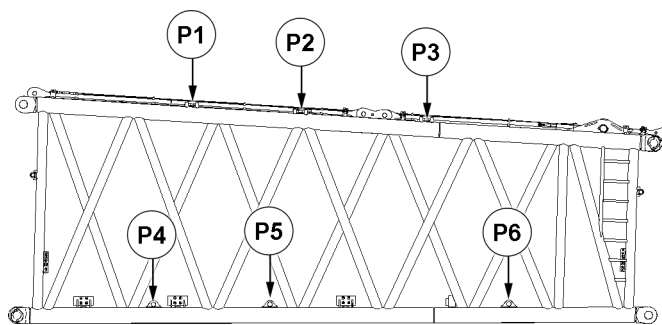


Fig.154345: HS-reducer 9 m fastening points

Fastening points	
P2 + P3 or P5 + P6	HS-reducer 9 m

LWE/LR 1800-1-0-000/27200-07-02/en

Fastening points	
P1 + P3 or P4 + P6	HS-reducer 9 m + SL-reducer 6 m

### 3.5 S-intermediate section 6 m fastening points

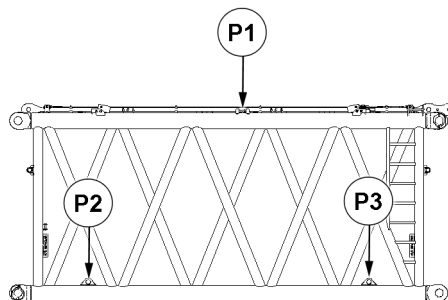


Fig.154347: S-intermediate section 6 m fastening points

Fastening points	
P1 or P2 + P3	S-intermediate section 6 m

### 3.6 S-intermediate section 12 m fastening points

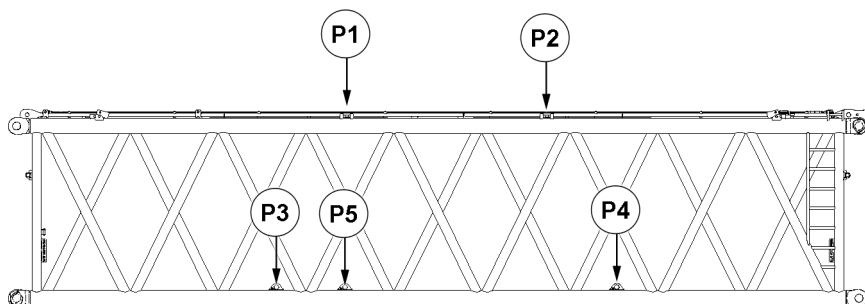


Fig.154346: S-intermediate section 12 m fastening points

Fastening points	
P1 + P2 or P3 + P4	S-intermediate section 12 m

### 3.7 SL-reducer 6 m fastening points

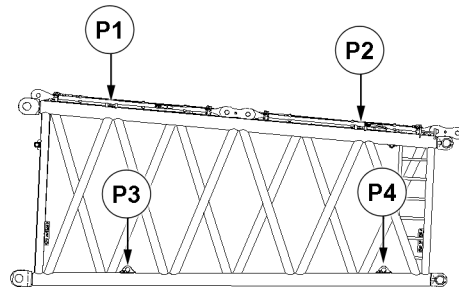


Fig.154348: SL-reducer 6 m fastening points

Fastening points	
P1 + P2 or P3 + P4	SL-reducer 6 m

### 3.8 L-intermediate section 6 m fastening points

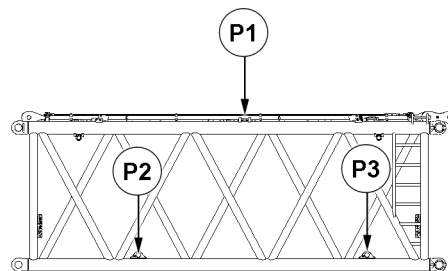


Fig.154350: L-intermediate section 6 m fastening points

Fastening points	
P1 or P2 + P3	L-intermediate section 6 m

LWE/LR 1800-1-0-000/27200-07-02/en

### 3.9 L-intermediate section 12 m fastening points

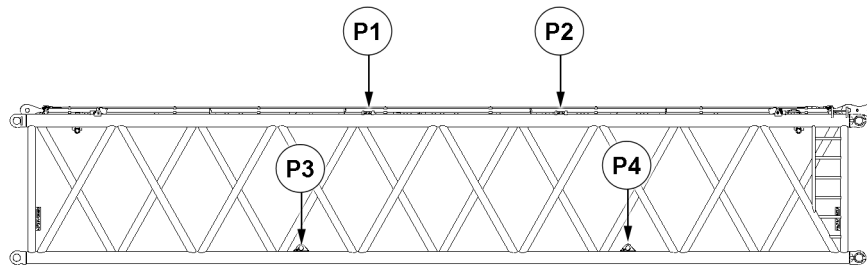


Fig.154349: L-intermediate section 12 m fastening points

Fastening points	
P1 + P2 or P3 + P4	L-intermediate section 12 m

### 3.10 L-end section fastening points

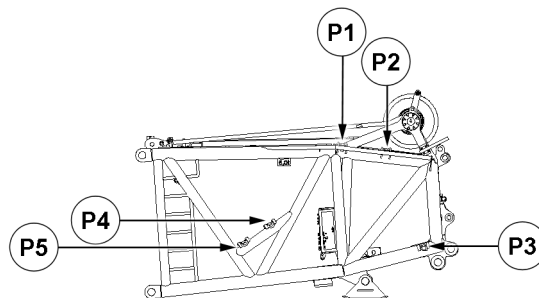


Fig.154351: L-end section fastening points

Fastening points	
P1	L-end section without roller set (fastening equipment > 4.5 m)
P2	L-end section with roller set (fastening equipment > 4.5 m)
P5 + P3	L-end section without roller set (fastening equipment > 6 m)
P4 + P3	L-end section with roller set (fastening equipment > 6 m)



### 3.11 S-end section fastening points

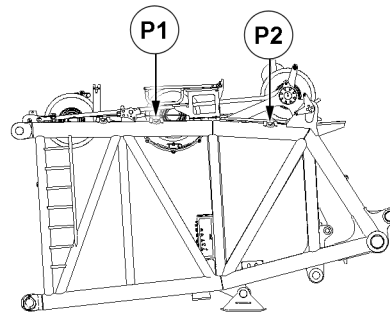


Fig.154352: S-end section fastening points

Fastening points	
P1 + P2	S-end section

## 4 Assembling



### Note

- ▶ The assembly is described based on the example of the SL-boom.
- ▶ For the combination of the boom lattice sections, observe and adhere to the Rod plan and chapter 5.03.



### WARNING

The crane can topple over!

If the specifications listed below are **not** observed, the crane can collapse, the main boom can break off or the crane can topple over.

Death, severe bodily injuries, property damage.

- ▶ For the combination of the boom lattice sections, observe and adhere to the Rod plan and chapter 5.03.
- ▶ During assembly / disassembly operations, observe and adhere to the instructions in chapter 5.01.



### WARNING

Danger of fatal injury due to falling components!

The pins can loosen up by themselves at the pin connections and cause components to fall down. Death, severe bodily injuries, property damage.

- ▶ All pins must be secured after assembly with the intended retaining elements. Check visually.

Make sure that the following prerequisites are met:

- The ground is able to safely take on the entire operating weight of the crane including the load to be lifted.
- The crane is horizontally aligned.
- An auxiliary crane with sufficient load bearing capacity is available.
- An assembly scaffolding or a work platform is available.
- Winch 1 and winch 2 are properly assembled and secured on the turntable.
- The SA-frame is properly assembled and secured on the turntable.
- The transport retainers for the guy rods on the SA-frame are removed.
- The central ballast has been installed on the crawler travel gear according to the load chart or the erection and take-down charts.
- The counterweight has been installed on the turntable according to the load chart or the erection and take-down charts.
- The LICCON overload protection has been set according to the data in the load chart.

## 4.1 Turning the turntable into the assembly position



### WARNING

The crane can topple over!

If the following conditions are not met before turning the turntable - **without** an installed main boom - the crane can topple over.

Death, severe bodily injuries, property damage.

- ▶ Observe the assembly conditions, see chapter 3.06.
- ▶ Observe the specifications in the erection and take-down charts.
- ▶ Observe the specifications in the load charts.

### NOTICE

Danger of collision!

When assembling on the side, there is a danger of collision between the H-pivot section and the crawler carrier.

Property damage.

- ▶ When assembling on the side, support the H-pivot section.
- ▶ Turn the turntable into the assembly position according to the erection and take-down charts.

## 4.2 Swinging the railing on the H-pivot section into the operating position



### WARNING

Danger of falling!

Death, severe bodily injuries, property damage.

- ▶ Assembly personnel must secure themselves for assembly / disassembly of railings and protective devices with an approved fall arrest system to prevent them from falling.
- ▶ For assembly and disassembly work, maintenance and inspection work on the H-pivot section, all railings and protective devices must be properly assembled and secured.

Make sure that the following prerequisites are met:

- The ground is able to safely take on the weight of the H-pivot section.
- The H-pivot section is lying completely on the ground.
- ▶ For the assembly / disassembly of railings and protective devices, see chapter 2.06.

## 4.3 Swinging the camera holder into the operating position

- ▶ Swing the camera holder into the operating position.
- ▶ Secure the camera holder in the operating position.

## 4.4 Assembling winch 5 and winch 6 on the H-pivot section



### Note

- ▶ Assemble winch 5 on the H-pivot section, see chapter 3.07.50.
- ▶ Bring winch 5 into the operating position, see chapter 3.07.50.



### Note

- ▶ Assemble winch 6 on the H-pivot section, see chapter 3.07.60.
- ▶ Bring winch 6 into the operating position, see chapter 3.07.60.

## 4.5 Exceeding the shut-off limits of the LICCON overload protection for assembly operation

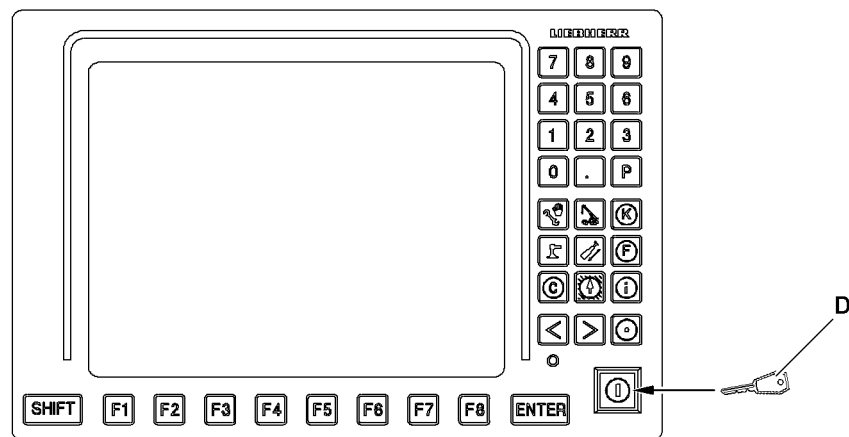


Fig.119109: LICCON monitor with assembly icon



### Note

- ▶ See chapter 4.02 and chapter 4.20.



### WARNING

Danger of accident due to the “Exceedance of shut-off limits of the LICCON overload protection” function!

If the shut-off limits of the LICCON overload protection are exceeded, there is no additional protection against crane overload.

Due to erroneous operation or deliberate misuse, the crane could collapse, the boom system can break off or the crane can topple over.

Death, severe bodily injuries, property damage.

- ▶ The “Exceedance of shut-off limits of the LICCON overload protection” function is only permissible in emergencies and for assembly purposes.
  - ▶ The function “Exceeding the shut off limits of the LICCON overload protection” may only be actuated by persons who know the effects of their actions regarding the function “Exceeding the shut off limits of the LICCON overload protection”.
  - ▶ The “Exceedance of shut off limits of the LICCON overload protection” function requires the presence of an authorized person and must be performed with utmost caution.
  - ▶ Crane operation with the “Exceedance of shut off limits of the LICCON overload protection” function activated is prohibited.
- ▶ Exceeding the shut off limits of the LICCON overload protection: Activate assembly operation.

**Result:**

- The shut off limits of the LICCON overload protection are exceeded.
- The assembly icon appears on the LICCON monitor.

**Note**

- ▶ See chapter 4.02 and chapter 4.20.

## 4.6 Unpinning the H-connector pins on the turntable

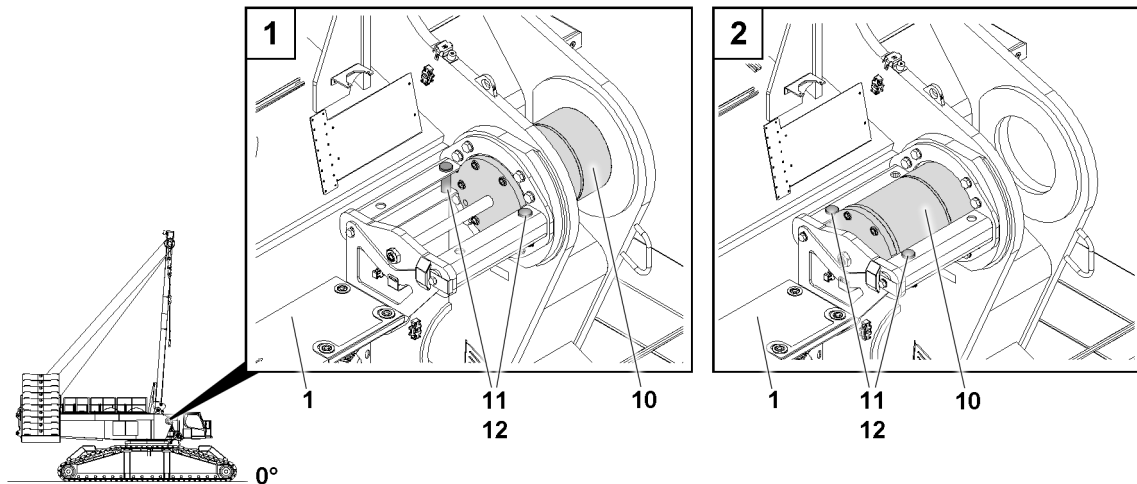


Fig.155765: Unpinning the H-connector pins on the turntable

**Note**

- ▶ Electrical connections, see the wiring diagram.
- ▶ Hydraulic connections, see Hydraulic diagram.
- ▶ For BTT display / operating element operation, see chapter 5.31.

**Note**

- ▶ In the transport condition, the H-connector pins **10** are pinned on the turntable **1** and secured with the retaining pins **11**.

**Note**

- ▶ The unpinning procedure is the same for both sides.

Make sure that the following prerequisites are met:

- The SA-frame is positioned vertically.
- The crane engine is running.

**WARNING**

Unpin or insert the H-connector pins **10**!

Danger of crushing. Limbs can be crushed or severed.

- ▶ During the unpinning procedure or pinning procedure, make sure that no persons are in the danger zone.
- ▶ Do **not** reach into the danger zone of the connector pins.
- ▶ Release the H-connector pin **10**: Remove the retaining element **12** and unpin the retaining pin **11**.
- ▶ Unpin the H-connector pin **10**: Actuate the BTT.
- ▶ Secure the H-connector pin **10**: Insert the retaining pin **11**.
- ▶ Secure the retaining pin **11**: Attach the retaining element **12**.
- ▶ Unpin the second H-connector pin **10**, actuate the BTT.

## 4.7 Assembling the H-pivot section on the turntable

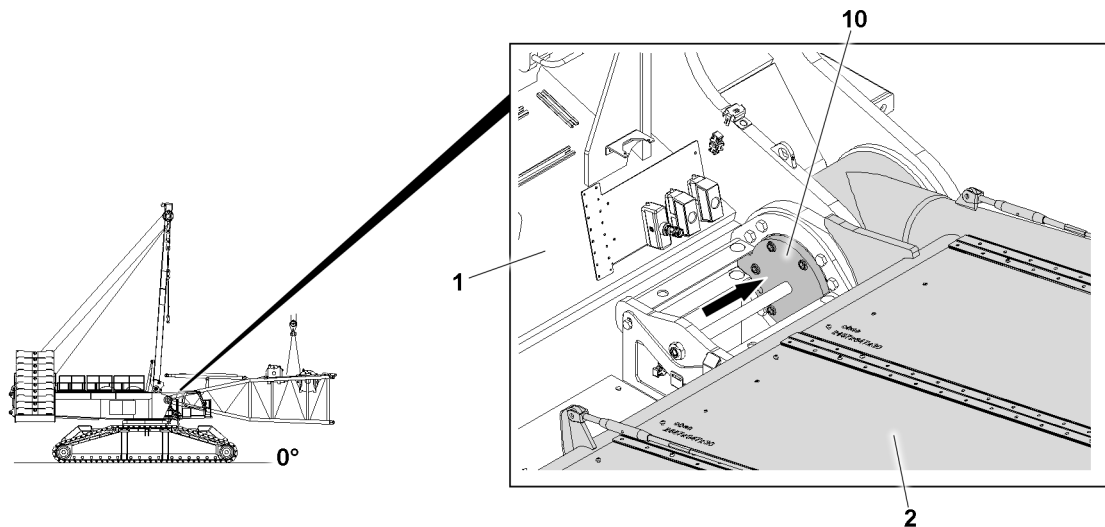


Fig.155766: Pinning the H-pivot section on the turntable

Make sure that the following prerequisites are met:

- The H-connector pins **10** are completely unpinned.
- The crane engine is running.

### NOTICE

Swinging in of the H-pivot section!

The H-pivot section can collide with the pin points on the turntable **1**. The H-connector pin **10** or the H-pivot section can be damaged.

- ▶ Make sure that the H-connector pins **10** are completely unpinned before assembly of the H-pivot section.



### Note

- ▶ Assemble the boom combinations according to the supplied Rod plans.

The fastening points on the H-pivot section **2** must be selected in such a way that the H-pivot section **2** hangs horizontally on the auxiliary crane during assembly. See section "Fastening points".

- ▶ Fasten the H-pivot section **2** to the auxiliary crane.
- ▶ Swing the H-pivot section **2** in with the auxiliary crane to the pin points on the turntable.



### WARNING

Suspended H-pivot section!  
Death, severe bodily injuries.

- ▶ Stepping on the H-pivot section when suspended is prohibited.
- ▶ Insert the H-pivot section **2** in the centerings on the turntable **1**.

### Result:

- Align the pin bores.

The pinning procedure is the same for both H-connector pins:

- ▶ Pin the H-connector pin **10**: Actuate the BTT.

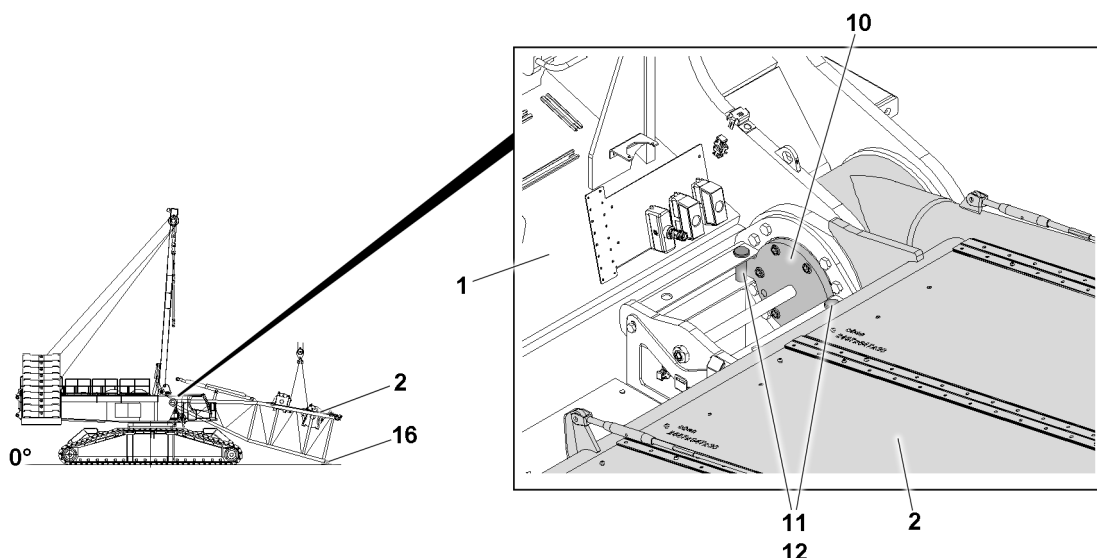


Fig.155767: Taking the H-pivot section down on the substructure on the ground

#### NOTICE

Take-down of the assembled H-pivot section!

If the maximum permissible negative angle is exceeded due to uneven ground, then the H-pivot section and turntable can be damaged.

Property damage.

- ▶ The permissible negative angle range of the H-pivot section may not be exceeded, see section "Assembling the S/SL boom at an incline".
- ▶ Observe the specifications in the chart "Assembly conditions on crawlers", see chapter 3.06.



#### WARNING

Incline position of the installed H-pivot section!

The mounting condition of the installed H-pivot section is selected so that the 20° incline position of the walking surfaces is not exceeded.

Death, severe bodily injuries.

- ▶ Support the H-pivot section.

When the H-connector pins **10** are completely pinned on both sides:

- ▶ Lower the H-pivot section **2** carefully and at a slow speed onto the substructure **16** on the ground.



#### DANGER

Falling H-pivot section!

Death, severe bodily injuries, property damage.

- ▶ Secure the H-connector pin **10** between the H-pivot section **2** and the turntable **1** after the pinning procedure immediately with the retaining pins **11**.

When the H-pivot section **2** is taken down on the substructure **16** on the ground:

- ▶ Secure the H-connector pin **10**: Insert the retaining pin **11** on both sides.
- ▶ Secure the retaining pin **11**: Attach the retaining elements **12**.

#### Result:

- The H-pivot section **2** is pinned and secured on the turntable **1**.
- ▶ Remove the auxiliary crane.

## 4.8 Establishing the electric and hydraulic connections on the H-pivot section

### 4.8.1 Establishing the electrical connections



#### Note

- ▶ To establish the electrical connections on the H-pivot section: Use the wiring diagram.

Make sure that the following prerequisite is met:

- The H-pivot section is completely assembled and placed on the substructure.
- ▶ Establish the electrical connections.
- ▶ Make sure that all electrical connections to the H-pivot section have been established.



#### WARNING

Dummy plugs are **not** assembled!

If the dummy plugs are not fit on the non-required electrical connections, then malfunctions or functional limitations can occur on the crane.

- ▶ Close off all **unnecessary** electrical connections, which have a dummy plug, with dummy plugs.
- ▶ Observe the wiring diagram.
- ▶ As a rule, close off non-required electrical connections (for example for accessories that are not assembled) with the respective dummy plugs.

#### NOTICE

Property damage due to dirt and / or corrosion!

If **unnecessary** electrical connections are **not** closed off with the respective protective caps, then dirt and / or corrosion can damage the electrical connections.

This could result in malfunctions.

- ▶ Make sure that all non-required electrical connections are always closed off properly.
- ▶ Observe the wiring diagram.
- ▶ Properly close off the electrical connections without dummy plugs with the corresponding protective caps.

### 4.8.2 Establishing the hydraulic connections

The hydraulic connections are established with quick couplings.

When connecting and releasing hydraulic lines with quick couplings, make sure that the coupling procedure is carried out correctly.



#### DANGER

**Incompletely** coupled quick couplings, self-loosening of quick couplings!

Serious accidents due to component failure.

Danger of accident due to loss of pressure or leakage.

- ▶ Check that the quick couplings (especially the return lines) have been properly connected before using the crane.



#### WARNING

Pressure in the hydraulic lines!

If the pressure supply is not interrupted before connecting / releasing the hydraulic lines, the hydraulic oil can escape with high pressure.

Death, severe bodily injuries, property damage.

- ▶ Release the pressure in the hydraulic system before connecting / disconnecting: Interrupt the pressure supply and wait a short time.

**Note**

- ▶ To connect or release the hydraulic lines with quick couplings, see chapter 5.01.
- ▶ Connect the coupling components (sleeve and connector) and screw them together with the knurled nut.
- ▶ Tighten the hydraulic coupling by hand. Turn the knurled nut until it reaches a tangible, fixed stop position.
- ▶ Establish the hydraulic connections, see the Hydraulic diagram.

## 4.9 Assembling the boom system

**Note**

- ▶ The pinning procedure is the same for both sides of the boom lattice section.
- ▶ The pinning procedure is the same for both levels at the “top” and at the “bottom”.
- ▶ The pinning procedure is the same for all boom lattice sections of the boom system.

**Note**

- ▶ The H-intermediate sections **5** are pinned with the pin pulling cylinder **14**, see chapter 5.30.
- ▶ The pin pulling cylinders **14** are shown as an example.

**Note**

- ▶ For the fastening of boom lattice sections, observe and adhere to section “Fastening points”.

### 4.9.1 Installing the HS-reducer on the H-pivot section

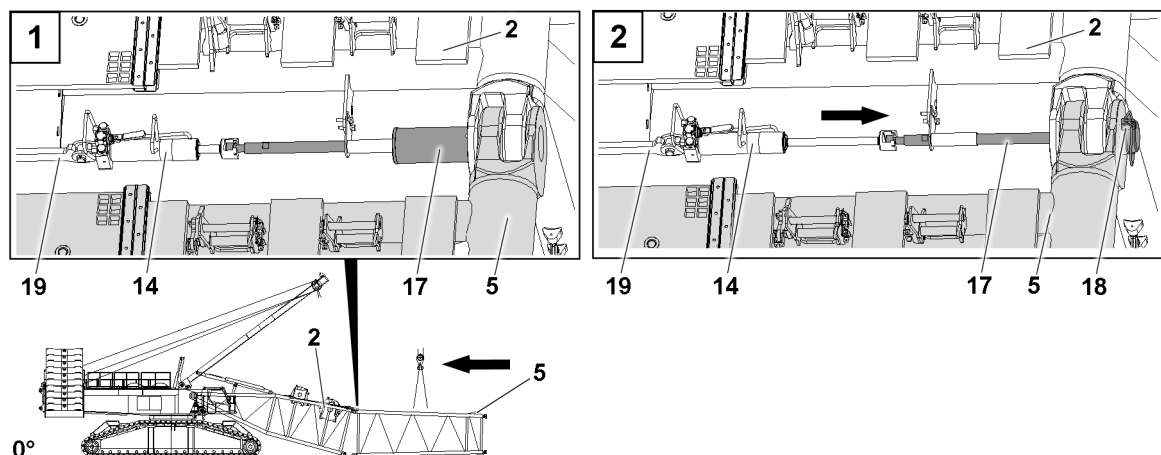


Fig.155768: Assembling the HS-reducer

Make sure that the following prerequisites are met:

- The H-pivot section is properly pinned and secured on the turntable.
- The H-pivot section is taken down properly on the substructure on the ground.
- Winch 5 is properly installed on the H-pivot section (only if winch 5 is required for the upcoming crane operation).
- Winch 6 is properly assembled on the H-pivot section (only if winch 6 is required for the upcoming crane operation).
- The connector pins **17** on the H-pivot section **2** are fully unpinned.

- ▶ Fasten the HS-reducer section **5** to the auxiliary crane and align with the H-pivot section **2**.

Prerequisite for an individual pin point: The pin pulling cylinder **14** is inserted in the pin pulling device **19** and connected to the connector pin **17**.



When the pin bores align at the “top”:

- ▶ Insert the connector pins **17** on both sides to the stop: Actuate the pin pulling cylinder **14**.
- ▶ Secure both connector pins **17** with retaining elements **18**.

When the HS-reducer **5** is pinned and secured on the H-pivot section **2** on “top”:

- ▶ Lower the HS-reducer **5** onto the substructure on the ground.
- ▶ Remove the auxiliary crane.

#### 4.9.2 Continuing main boom assembly

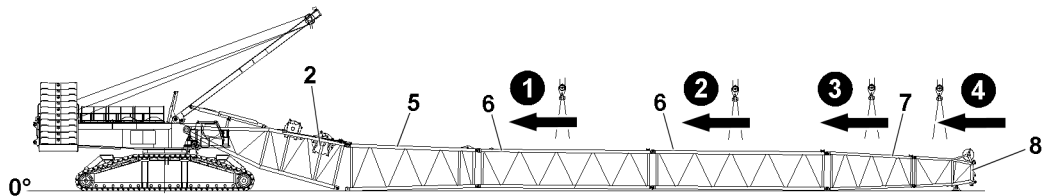


Fig.155769: Main boom assembly



#### Note

- ▶ The following description is an example and will be described by means of the S-intermediate section.
- ▶ The assembly of the S-intermediate section, SL-reducer, L-intermediate section, S-end section, L-end section is identical.

Make sure that the following prerequisites are met:

- The connector pins **17** on the S-intermediate sections - in direction of the expansion of the boom system - are completely unpinned.
- The HS-reducer **5** is lying properly on the ground or on the substructure.



#### WARNING

Impermissible assembly of the main boom!

The crane can topple over. Death, severe bodily injuries, property damage.

- ▶ The combination of the various boom systems must be taken from the Rod plan and must be observed.
- ▶ Observe the data in chapter 5.01 and chapter 5.03.
- ▶ Make sure that all pin connections are secured after assembly.
- ▶ Support the boom system during assembly and disassembly, see section “Assembling the S/SL-boom at an incline” and “Assembling the boom system with the substructure”.

When the connector pins **17** on the HS-reducer **5** are fully unpinned:

- ▶ Fasten the L-intermediate section **6** to the auxiliary crane and swing in to the pin points on the HS-reducer **5**.

When the “top” and “bottom” pin bores align:

- ▶ Insert the connector pins **17** at the “top” on both sides with the pin pulling cylinder to the stop.
- ▶ Secure both connector pins **17** with a retaining element **18**.

When the connector pins **17** at the “top” are fully pinned to the stop and secured on both sides:

- ▶ Insert the connector pin **17** at the “bottom” with the pin pulling cylinder to the stop.
- ▶ Secure both connector pins **17** with a retaining element **18**.
- ▶ Remove the auxiliary crane.
- ▶ Assemble the S-intermediate section **6**.
- ▶ Assemble the SL-reducer **7**.
- ▶ Assemble the L-end section **8**.

### 4.9.3 Pinning the SA-frame guying on the H-pivot section

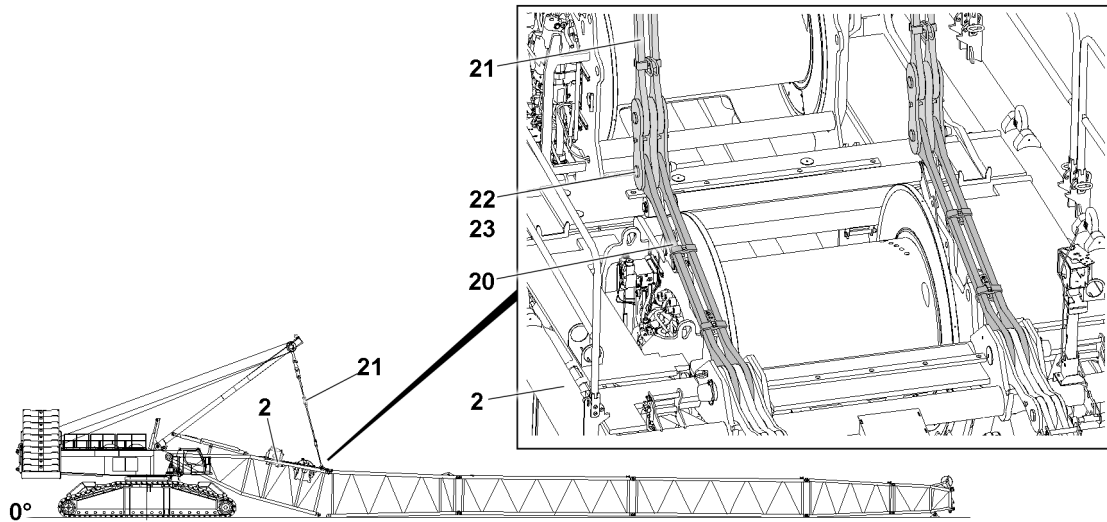


Fig.155770: Lowering the upper pulley block and pinning it on the H-pivot section

Make sure that the following prerequisites are met:

- The boom system is completely assembled.
  - All lattice sections are properly pinned with each other.
  - All pin connections are properly pinned and secured.
  - The auxiliary crane is removed.
- ▶ Remove the retaining elements **23** from the rods **21** and unpin the pin **22**.
  - ▶ Luff the SA-frame down to the front until the pin bores of the SA-frame guying **21** and the rods **20** align.
- When the pin bores align:
- ▶ Insert the pin **22** completely on both sides.
  - ▶ Secure the pin **22**: Attach the retaining element **23**.
  - ▶ Lift the SA-frame until the guying is tensioned.

### 4.9.4 Closing the boom system

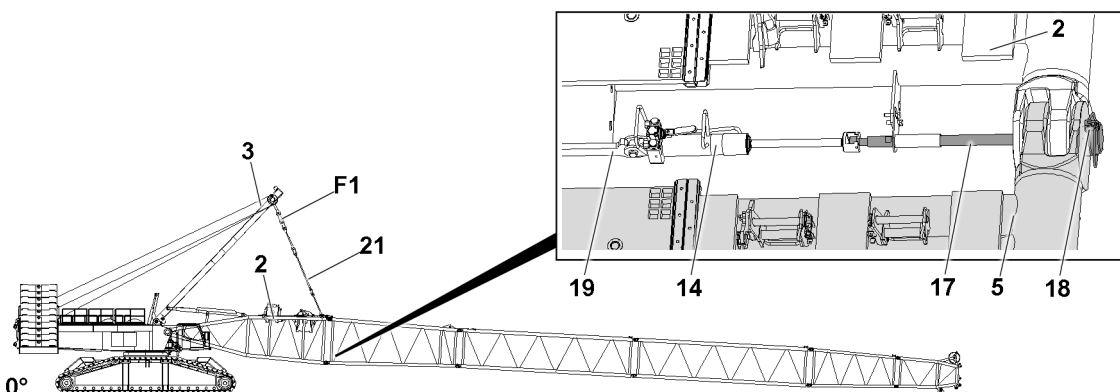


Fig.155773: Pinning the SA-frame guying on the H-pivot section



#### Note

- ▶ The actual forces in test point 1 **F1** - which are used during the closing procedure of the boom system - are displayed on LICCON monitor 1.
- ▶ Note the actual forces in test point 1 **F1** and keep it ready for the disassembly of the boom system.

**Note**

- ▶ Counterweight and central ballast, see the Erection chart depending on the boom length.

**WARNING**

Permissible F1 total force exceeded!  
Overload of the crane.

- ▶ During the “closing procedure” of the boom system, the maximum permissible F1-total force ( $F_{1_{max}}$ ) of **125 t** in test point 1 **F1** may **not** be exceeded.
- ▶ The closing of different boom systems with the SA-frame **3** is only permissible up to certain maximum boom lengths.
- ▶ The end section may **not** lift off the ground during closing procedure of the boom system, it must be lying on the ground.
- ▶ Make sure that there are no persons on the boom system or in the danger zone during the closing procedure.
- ▶ Observe the specifications in the erection charts.

**NOTICE**

Boom covered / run on the block when closing!  
The components can be overloaded.

- ▶ Lift the boom maximum to the point where the bores in the lower pin locations align between the pivot section and the intermediate section.

**DANGER**

Overload of the crane!  
Death, severe bodily injuries, property damage.

- ▶ During the “closing procedure” of the boom system, the maximum permissible F1-total force ( $F_{1_{max}}$ ) of **125 t** in test point 1 **F1** may **not** be exceeded.
- ▶ The closing of different boom systems with the SA-frame **3** is only permissible up to certain maximum boom lengths.
- ▶ The end section may **not** lift off the ground during closing procedure of the boom system, it must be lying on the ground.
- ▶ Make sure that there are no persons on the boom system or in the danger zone during the closing procedure.
- ▶ Observe the specifications in the erection charts.

**Maximum permissible force**

Maximum permissible force	
Test point 1 <b>F1</b>	125 t

- ▶ Until the pin bores align: Pull up the H-pivot section **2** with the SA-frame **3**.
- ▶ Insert the pin pulling cylinder **14** in the pin pulling device **19**.

When the pin bores align on the “bottom”.

- ▶ Insert the connector pins **17** with the pin pulling cylinders on both sides to the stop: Actuate the pin pulling cylinder **14**.
- ▶ Secure the connector pin **17**: Attach the safety element **18**.

**Note**

- ▶ The **ACTUAL** force in the test point **F1** is displayed on LICCON monitor 1. Note the displayed **ACTUAL** force.
- ▶ When **unpinning** with the same **ACTUAL** force in the test point **F1**, tension the SA-frame guying **3**.

When the boom system is closed and the pins on the H-pivot section are properly pinned and secured on the bottom:

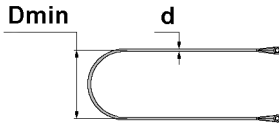
- ▶ Relieve the SA-frame guying between the SA-frame and H-pivot section by lowering the SA-frame **3**.

## 4.9.5 Assembling the guying

### Auxiliary guying

An auxiliary guying must be assembled depending on the boom system, see the rod plan.

Fiber guy ropes are used for the auxiliary guying. Comply with the following regulations.



$$D_{min} = 20 \times d$$

Fig.160908: Fiber guy rope: Calculation of minimum permissible bending diameter

Formula element	Meaning
Dmin	Minimum permissible bending diameter
d	Rope diameter

Minimum permissible bending diameter: Definition of the formula elements



### WARNING

Impermissible assembly of fiber guy ropes!

The fiber guy ropes can rip.

Death, severe bodily injuries, property damage.

- ▶ Before assembling the fiber guy ropes, check if the fiber guy ropes are rigidly frozen or covered with ice. See chapter 5.01.
- ▶ Do **not** assemble fiber guy ropes that are rigidly frozen or covered with ice.
- ▶ Do **not** use buckled, knotted or twisted fiber guy ropes.
- ▶ Never fall below the minimum permissible bending diameter **Dmin** of **20** x rope diameter **d**.
- ▶ Do **not** assemble damaged fiber guy ropes.
- ▶ Make sure that the identification of the fiber guy rope on the rod plan and the identification on the individual fiber guy ropes are identical. Identify the fiber guy rope, see chapter 5.01.
- ▶ Make sure that the operating temperature of the fiber guy ropes of -40 °C to +60 °C is **not** fallen below or exceeded.
- ▶ Check the fiber guy ropes for damage prior to assembly, after disassembly and after exceptional events, see chapter 8.16.
- ▶ Comply with the maintenance intervals, see chapter 7.03.50.
- ▶ Replace damaged fiber guy ropes.
- ▶ Observe the notes regarding the proper transport and storage of the fiber guy ropes, see chapter 2.04.
- ▶ Observe the instructions for the proper handling of fiber guy ropes, see chapter 5.01.
- ▶ Only fasten the fiber guy ropes in the permissible range with belt loops, see chapter 5.01.

### Assembling the guy rods



### WARNING

Failure to perform inspection and maintenance on the guy rods!

Death, severe bodily injuries, property damage.

- ▶ Inspect the guy rods before every assembly, see chapter 8.15.
- ▶ The S-guy rods must be assembled and secured, see the Rod plan. The numbering in the rod plan must be identical to the numbering on the guy rods.
- ▶ Make sure that the inspection and maintenance intervals are adhered to.

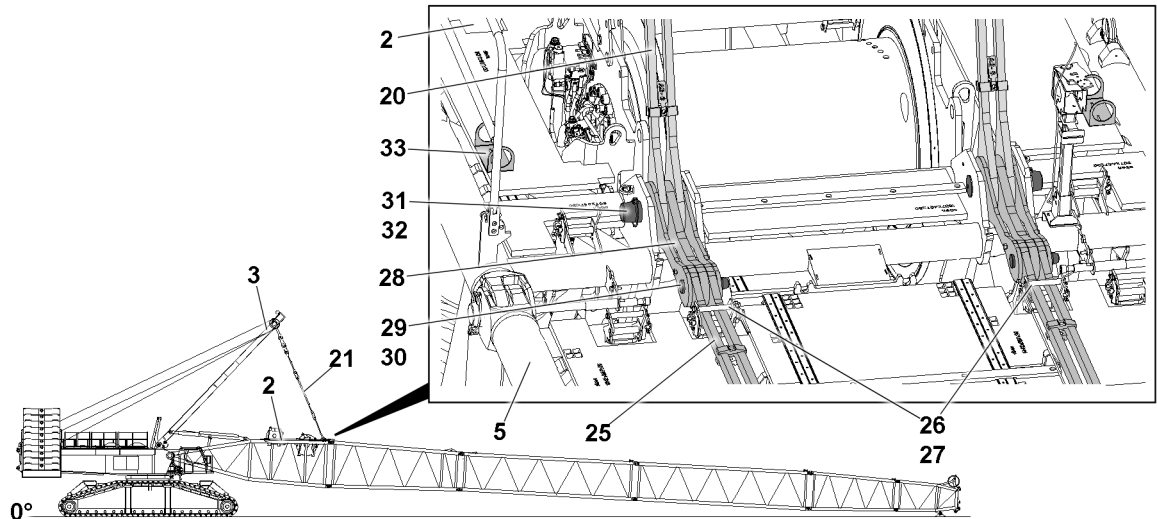


Fig.155774: Connecting the guy rods to the boom system

The guy rods are taken down and secured for transport on the intermediate sections. Before assembly of the guy rods, release the transport retainers.

- ▶ Release the guy rods **25**: Remove the safety element **27** and unpin the pin **26**.
- ▶ Insert the pin **26** in park position and secure.
- ▶ Pin the guy rods **25** with the guy rods **28**: Insert the pin **29** and secure it with the safety element **30**.

#### NOTICE

Property damage!

If the pins of the guy rods are not pinned from the “inside” to the “outside”, the hoist rope can scrape on the pins and be damaged.

- ▶ Always insert the guy rod pins from the “inside” to the “outside”, see the Rod plan.

Pin the subsequent guy rods with each other and secure them properly.



#### Note

- ▶ For the combination of the various boom lattice sections refer to the Rod plan.



#### WARNING

Unutilized guy rods on the boom system!  
Death, severe bodily injuries, property damage.

- ▶ Non-required guy rods must be removed from the lattice sections, see chapter 5.01.
- ▶ Remove non-required guy rods from the lattice sections.



#### DANGER

The boom system can suddenly fold down!

If the guy rods **28** are unpinned on the H-pivot section before the lower pins **29** are inserted, the boom system can fold down.

Death, severe bodily injuries, property damage.

- ▶ Do not unpin the guy rods **28** on the H-pivot section until the lower pins **29** have been inserted and secured.
- ▶ Unpin the guy rods **28** from the assembly position: Remove the safety element **32** and unpin the pin **31**.
- ▶ Insert and secure the pin **31** in the park position in the retainer **33**.

#### Assembling the auxiliary guying

This section is valid solely for the boom with the auxiliary guying.

**WARNING**

Temperatures below 0 °C: Fiber guy ropes that are rigidly frozen or covered with ice!  
Buckling of the fiber guy ropes. The fiber guy ropes can rip.  
Death, severe bodily injuries, property damage.

- ▶ While the main boom guying is tensioned, check if the fiber guy ropes are rigidly frozen or covered with ice.
  - ▶ Do **not** bend fiber guy ropes that are rigidly frozen or covered with ice.
  - ▶ Do **not** erect boom systems with fiber guy ropes that are rigidly frozen or covered with ice (for example auxiliary guying, guying for the F-jib).
  - ▶ Observe the instructions in chapter 5.01.
- 
- ▶ Assemble the auxiliary guying, see chapter 5.01 and chapter 5.03.
  - ▶ Erect the SA-frame until the auxiliary guying can be assembled.
  - ▶ Assemble the auxiliary guying.
  - ▶ Ensure that the guy rods are properly pinned and secured with each other.
  - ▶ Make sure that the auxiliary guying is properly pinned and secured.
  - ▶ Erect the SA-frame until the guying is tensioned.

#### 4.9.6 Establishing the electrical connections on the boom end section

Make sure that the following prerequisites are met:

- The intermediate sections are properly assembled and secured on the ground.
- The boom end section is properly assembled and secured.
- The electrical connections to the boom end section have been established.
- The airplane warning light, wind speed sensor and all sensors are properly installed and secured on the boom end section.
- The hoist limit switches are properly installed and secured on the pulley head / pulley heads.

**NOTICE**

Damage to the electrical connections!

If the electrical connection from the cable drum on the H-pivot section to the terminal box on the H-pivot section is established first before the connection to the terminal box on the boom end section, the electrical connection can be damaged when spooling out the cable drum.

- ▶ Establish first the electrical connection from the cable drum in the H-pivot section to the terminal box on the boom end section and then the electrical connection from the terminal box in the H-pivot section to the cable drum.

**Note**

- ▶ To establish the electrical connections on the boom system: Use the wiring diagram.
- 
- ▶ Establish the electrical connections.
  - ▶ Make sure that all electrical connections on the boom system are established.

**WARNING**

Malfunction if dummy plugs are not installed!

If the dummy plugs are not fit on the non-required electrical connections, then malfunctions or functional limitations can occur on the crane.

- ▶ Make sure that all non-required electrical connections, which have a dummy plug, are closed off with dummy plugs.
  - ▶ Observe the wiring diagram.
- 
- ▶ As a rule, close off non-required electrical connections (for example for accessories that are not assembled) with the respective dummy plugs.

**NOTICE**

Property damage due to dirt and / or corrosion!

If unnecessary electrical connections are not closed off with the respective protective caps, then dirt and / or corrosion can damage the electrical connections.

This could result in malfunctions.

- ▶ Make sure that all non-required electrical connections are always closed off properly.
  - ▶ Observe the wiring diagram.
- 
- ▶ Properly close off the electrical connections without dummy plugs with the corresponding protective caps.

## 5 Assembling the S/SL boom at an incline

**WARNING**

The crane can topple over!

If the following requirements are not observed, the crane can topple over.

Death, severe bodily injuries, property damage.

- ▶ Observe and adhere to the requirements and instructions in section "Assembling the S/SL boom".
- ▶ Observe the specifications in the erection and take-down charts.

**WARNING**

The crane can topple over!

If the crane is not horizontal, then it can be overloaded when erecting / taking down the boom system and topple over.

Death, severe bodily injuries, property damage.

- ▶ Observe and adhere to the requirements and instructions for assembly on uneven ground, see chapter 5.01.
- ▶ Observe and adhere to the requirements and instructions for the selection of the location, see chapter 2.04.
- ▶ Make sure that the placement level of the crane is level and horizontal.
- ▶ Make sure that the crane is horizontally aligned.

**NOTICE**

Negative angle!

Overload of the main boom during the erection procedure.

Damage to the boom system.

- ▶ The permissible negative angle range of the boom system may not be exceeded.
- ▶ Negative angles in the erection and take-down charts are to be observed.
- ▶ If necessary, the boom end section must be supported with suitable and sufficiently load bearing materials.

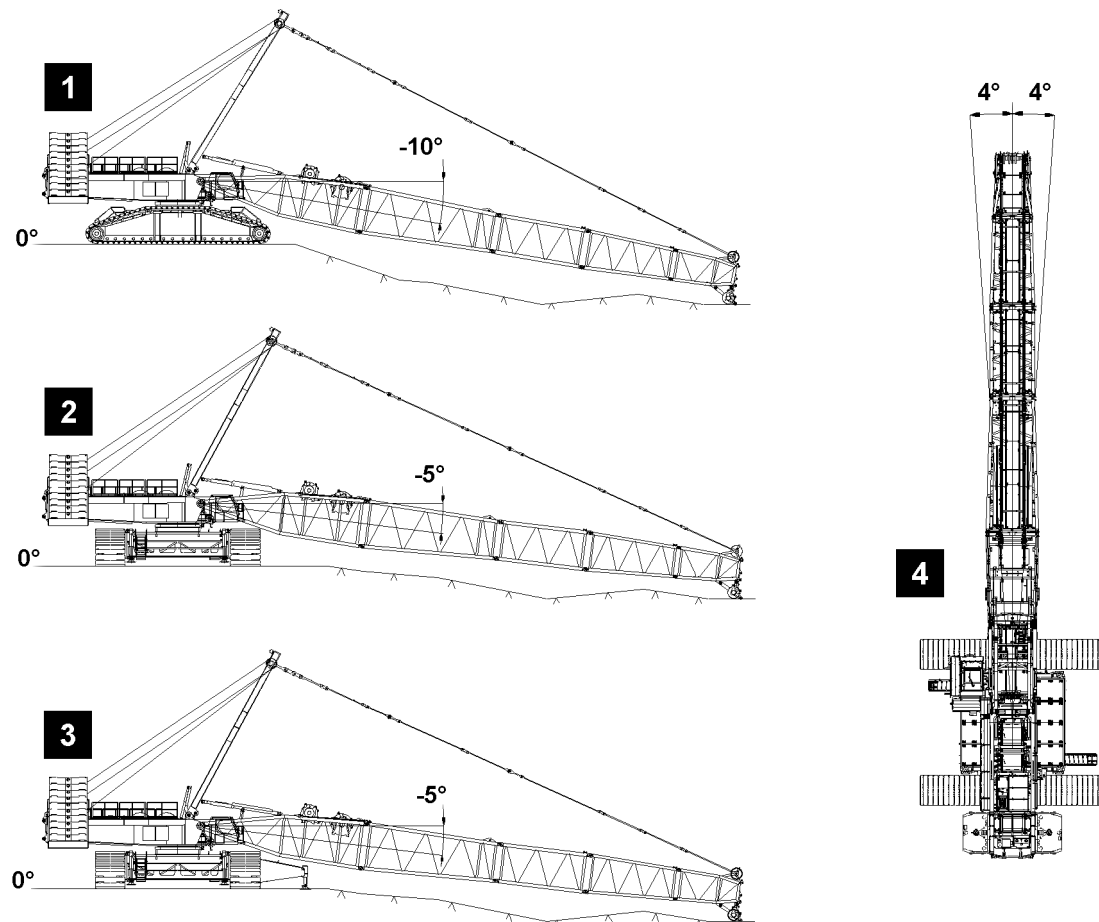


Fig.155771: Negative angle range of the boom system

Illustration	Angle type	Maximum negative angle
1	Maximum inspected angle	To the front $-10^{\circ}$
2	Collision angle	To the side $-5^{\circ}$
3	Collision angle	To the side with auxiliary support $-5^{\circ}$

Illustration	Angle type	Maximum slewing range
4	Maximum slewing range	To the side with auxiliary support $\pm 4^{\circ}$

## 5.1 Assembling the S/SL-boom at an incline



### Note

- The procedure for the assembly of the boom system at an incline is the same as the assembly of the boom system on level ground, see section "Assembling the S-/SL-boom".

### NOTICE

Damage to the H-pivot section!

If the maximum permissible negative angle is exceeded due to uneven ground, then the H-pivot section can be damaged.

Property damage.

- The permissible negative angle range of the H-pivot section may not be exceeded.



**WARNING**

The crane can topple over!

Death, severe bodily injuries, property damage.

- ▶ The combination of the various boom systems must be taken from the rod plan and must be adhered to.
- ▶ The specifications in chapter 5.01 and chapter 5.03 must be observed.
- ▶ Make sure that all pin connections are secured after assembly.
- ▶ Support the boom system during assembly and disassembly.

- ▶ Assemble the boom system, see section “Assembling the S/SL-boom”.

## 6 Assembling the boom system with the substructure

If the assembly conditions for the assembly of the boom system are restricted due to the terrain at the job site, then it is possible to assemble the boom system with the substructure.

**WARNING**

Impermissible flexation!

Overload of the main boom.

- ▶ Make sure that from a main boom length of 114 m , the main boom is supported on the auxiliary guying.

**WARNING**

General danger notes!

- ▶ Secure all pins after assembly with the intended retaining elements.
- ▶ Inspect the guy rods regularly, see chapter 8.15.
- ▶ Secure the main boom with the substructure or auxiliary crane, see chapter 5.01.
- ▶ It is prohibited for anyone to remain under the main boom or in the entire danger zone during the pinning and unpinning procedure of the boom lattice sections.

**WARNING**

The crane can topple over!

Death, severe bodily injuries, property damage.

- ▶ For assembly and disassembly of the main boom with the substructure, observe chapter 5.01.
- ▶ The “actual force” in test point **F1** is shown on LICCON monitor 1.
- ▶ Observe the assembly conditions, see chapter 3.06.
- ▶ The data in the erection and take-down charts as well as the load charts must be observed.
- ▶ The combination of the various boom systems must be taken from the rod plan and must be adhered to.

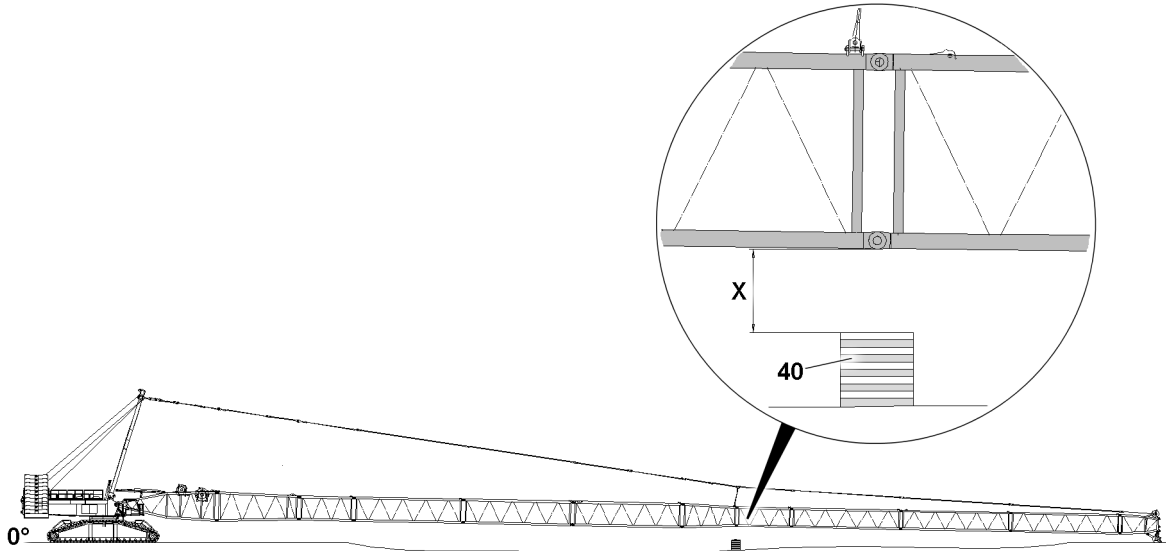


Fig. 155772: Boom system with the substructure (shown as an example)

40 Substructure

X Maximum distance<sup>1)</sup>

<sup>1)</sup> X corresponds to the maximum permissible flexation of the boom system



#### Note

- ▶ For the maximum distance **X**, see the separately supplied drawing “Support assembly drawing”.
- ▶ The point in which the boom system must be supported depends on the corresponding operating mode, see the separately supplied drawings “General support assembly drawing”.

- ▶ Install the H-pivot section, see section “Assembling the H-pivot section on the turntable”.
- ▶ Install the boom system to the point in which it must be supported according to the separately supplied rod plans and drawings “Support assembly drawing” for the individual operating modes, “General support assembly drawing”.
- ▶ Close the boom system on the H-pivot section.
- ▶ Assemble the boom system further according to the separately supplied rod plans and drawings “Support assembly drawing” for the individual operating modes, “General support assembly drawing”.

#### NOTICE

Negative angle!

Overload of the main boom during the erection procedure.

Damage to the boom system.

- ▶ Negative angles in the erection and take-down charts are to be observed.
- ▶ If necessary, the boom end section must be supported with suitable and sufficiently load bearing materials.

#### NOTICE

Main boom **not** supported before the erection procedure!

Overload of the main boom during the erection procedure.

Damage to the boom system.

- ▶ Make sure that the maximum distance **X** is never exceeded.
- ▶ Support the main boom with suitable materials with sufficient load bearing capacity in the marked area, see illustration.

- ▶ Close and support the boom system on the auxiliary guying.

## 7 Performing the function checks



### WARNING

Malfunctioning safety equipment!  
Death, severe bodily injuries, property damage.

- ▶ Crane operation with non-functioning safety equipment is **prohibited**.
- ▶ Start crane operation only after all safety equipment have been checked and are functioning correctly.



### Note

- ▶ The function of the individual limit switches must be checked before erection of the boom system.
- ▶ The function of the limit switch initiators must be checked in the test system, see the Diagnostics manual.



### Note

- ▶ If a function check on the limit switches or on the safety equipment does not lead to the desired shut offs, then the plug connections on the connector boxes or the components itself must be checked.
- ▶ If no visible connection errors or component defects can be found, contact Liebherr Customer Service.

Make sure that the following prerequisites are met:

- All electrical connections have been established.
- The crane engine is running.
- The corresponding operating mode is set on the LICCON monitor.
- The actuator levers of the limit switches have been checked for easy movement and are lubricated.

### 7.1 Wind speed sensor

- ▶ Check the movement and the function of the wind speed sensor.

### 7.2 Airplane warning light

- ▶ Turn the airplane warning light on, see chapter 4.01.
- ▶ Check the function visually.

### 7.3 Hoist limit switch

- ▶ Actuate the hoist limit switch manually on the pulley head.

#### Result:

- The hoist winch turns off in the lifting direction.
- The hoist top icon on LICCON monitor 0 blinks.
- The hoist limit switch is functioning.

### 7.4 Checking the main boom “steep position” limit switch



### Note

- ▶ The limit switch functions have to be checked individually before erection.
- ▶ Cover the limit switch initiators on the relapse cylinders of the main boom individually with a metal plate.

#### Result:

- The limit switch is actuated manually.
- The spool up function of winch 4 turns off.

- The “Boom limitation” icon appears on LICCON monitor 0.

## 8 Erecting the boom system



### WARNING

The crane can topple over!

In crane operation with bypassed LICCON overload protection, the crane can topple over.

Death, severe bodily injuries, property damage.

- ▶ The boom radii specified in the load chart may not be exceeded or fallen below, even if there is no load on the hook.

If required in the erection and take down chart:

- ▶ Carry the hook block along with the auxiliary crane.



### WARNING

The crane can topple over!

Death, severe bodily injuries, property damage.

- ▶ Observe the technical safety instructions, see chapter 5.01.
- ▶ Make sure that the relapse cylinders of the main boom are completely extended before erection of the boom system.
- ▶ Do not allow slack rope to build up on winch 4.



### WARNING

Falling hoist rope!

Death, severe bodily injuries, property damage.

- ▶ Reeve the hoist rope in properly before the erection procedure with a sufficient length on the roller set / roller sets of the end section, see chapter 4.06, chapter 5.11.50 and the reeving plans.
- ▶ The hoist rope must be constantly monitored during the erection procedure.
- ▶ Make sure that there are no persons in the danger zone.

Make sure that the following prerequisites are met:

- The crane is horizontally aligned.
- The guy rods are properly assembled.
- Non-required guy rods are removed from the lattice sections.
- All electrical connections have been established.
- All hydraulic connections have been established.
- The function checks were carried out properly.
- All limit switches and warning devices are functioning.
- The counterweight has been installed on the turntable according to the erection and take-down charts.
- The central ballast is installed in the crane chassis according to the erection and take-down charts.
- The pin connections are secured.
- The feet on the L-end section are removed (only for operation with the S or L-end section).
- The hoist rope has been correctly inserted in the rope pulleys and is prevented from jumping out with the rope retaining pins.
- There are no loose parts on the boom system.
- The boom system is free of snow, frost and ice.
- The LICCON overload protection has been set according to the data in the load chart.
- The load weighing was carried out on the boom system and the hook block weight has been entered on the LICCON monitor, see the chapter 4.02.
- The LICCON overload protection settings have been compared with the actual set up configuration.
- The LICCON overload protection is exceeded.
- The assembly icon is visible on the LICCON monitor.
- No personnel or obstacles are within the danger zone.

## 8.1 Extending the relapse cylinders of the main boom

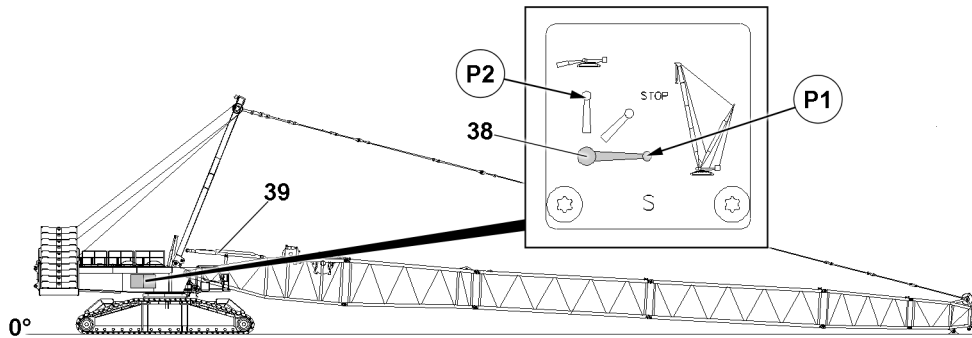


Fig.155776: Extending the relapse cylinders of the main boom / erecting the boom system



### WARNING

The crane can topple over!  
Death, severe bodily injuries, property damage.

- ▶ Extend the relapse cylinder of the main boom **39** completely before erecting the boom system.
- ▶ Secure the ball valve **38** during crane operation to prevent inadvertent actuation.

Ball valve positions	
Position (P)	Function
1	Crane operation, extend the piston rod
2	Assembly, retract the piston rod
STOP	The piston rod cannot be retracted / extended

Relapse cylinder of the main boom, ball valve positions

- ▶ Extend the relapse cylinders of the main boom **39**: Set the ball valve **38** to position **P1**.

### Result:

- The piston rods of the main boom relapse cylinders **39** extend.

The ball valve **38** is secured by closing the cabinet door and removing the key.

- ▶ Close the cabinet door and pull out the key.
- ▶ Hand the key to an authorized person.

## 8.2 Erection procedure



### DANGER

The crane can topple over!  
▶ It is prohibited to turn the crane superstructure while erecting the boom system.  
▶ Adhere to the specifications in the erection and take-down charts.

If auxiliary guying is assembled on the boom. Comply with the following regulations.

**WARNING**

Temperatures below 0 °C: Fiber guy ropes that are rigidly frozen or covered with ice!  
Buckling of the fiber guy ropes. The fiber guy ropes can rip.  
Death, severe bodily injuries, property damage.

- ▶ While erecting the boom system, check if the fiber guy ropes are rigidly frozen or covered with ice.
- ▶ Do **not** bend fiber guy ropes that are rigidly frozen or covered with ice.
- ▶ Do **not** erect boom systems with fiber guy ropes that are rigidly frozen or covered with ice (for example auxiliary guying, guying for the F-jib).
- ▶ Observe the instructions in chapter 5.01.

Make sure that the following prerequisite is met:

- The load weighing was carried out on the boom system and the hook block weight has been entered on the LICCON monitor, see the chapter 4.02.

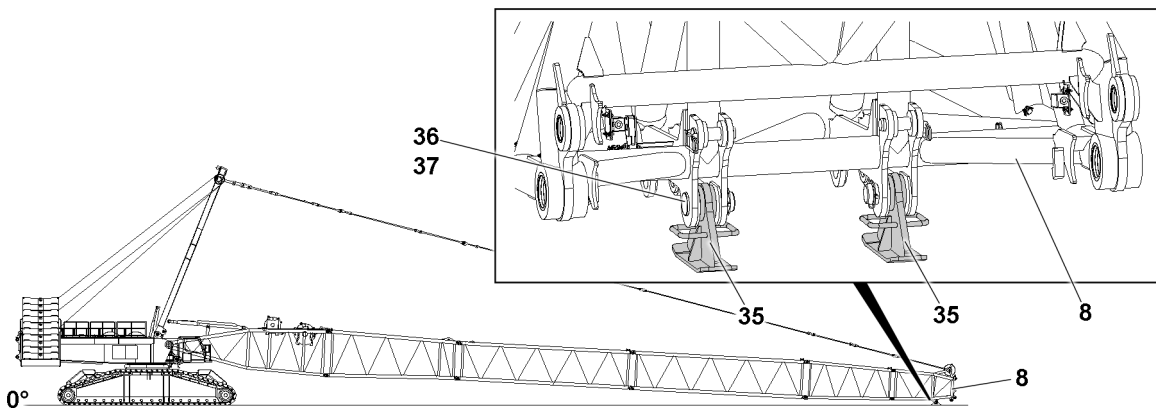
**8.2.1 Disassembling the foot on the L-end section**

Fig.155775: Foot

- ▶ Unpin the feet **35**: Remove the retaining element **37** and unpin the pin **36**.
- ▶ Erect the boom system until the L-end section **8** lifts off the ground.

**Result:**

- The feet **35** remain on the ground.

**8.2.2 Assembling the roller set****Note**

- ▶ Roller set assembly is only necessary for a main boom with an S or L-end section.

**Note**

- ▶ The assembly of the roller set is described in chapter 5.14.

When the roller set is properly assembled on the end section:

- ▶ Route the hoist limit switch from the end section forward on the roller set, pay attention and adhere to the wiring diagram.

### 8.2.3 Reeving the hook block in



#### WARNING

Danger of accident due to side wind!

If the slewing gear brake is released after reeving in / reeving out the hook block / load hook, then the crane can turn uncontrolled in strong side wind.

The crane can collide with near-by structures or objects.

Death, severe bodily injuries, property damage.

- ▶ Make sure that the current wind speed does not exceed the values from the wind speed chart when releasing the slewing gear brake.

Make sure that the following prerequisites are met:

- The crane is horizontally aligned.
- The slewing gear brake is applied.

#### NOTICE

Danger of slack rope formation!

Slack rope can form if the hoist winch is spooled out too fast during the reeving procedure.

- ▶ When reeving the hoist rope in with the assembly winch, observe chapter 5.11.50.
- ▶ Make sure that the hoist rope is tensioned during the entire reeving procedure.



#### WARNING

Falling hoist rope!

Death, severe bodily injuries, property damage.

- ▶ Reeve in the hoist rope before the erection procedure with sufficient length on the boom system.
- ▶ The hoist rope must be constantly monitored during erection.
- ▶ Do not enter the danger zone.

- ▶ Reeve the hoist rope properly and secure it to the rope fixed point: Reeving, see the Reeving plan.
- ▶ Pin and secure the rope retainers on the rope pulleys.
- ▶ Attach the hoist limit switch weight, see chapter 4.06.

### 8.2.4 Erecting the boom system



#### WARNING

The crane can topple over!

In crane operation with bypassed LICCON overload protection, the crane can topple over.

There is then no additional protection against crane overload.

Death, severe bodily injuries, property damage.

- ▶ The boom radii specified in the load chart may not be exceeded or fallen below, even if there is no load on the hook.
- ▶ Crane operation with bypassed LICCON overload protection is prohibited.



#### Note

- ▶ When the lowest operating position of the boom system is reached, the set load chart of the LICCON overload protection is activated.
- ▶ The maximum load icon displays a load number in "t" instead of the "???" display.

- ▶ Luff the boom system up to the lowest operating position.

When the boom system has reached the lowest operating position:

- ▶ Make sure that the assembly icon on the LICCON monitor turns off.

#### Result:

- The LICCON overload protection is active.

## 9 Operating the crane

### 9.1 Preparing for crane operation



#### Note

- ▶ Observe the notes, see chapter 4.02, chapter 4.04, chapter 4.05, chapter 4.08 and chapter 5.01.

Make sure that the following prerequisites are met:

- The LICCON overload protection is active.
- The LICCON overload protection has been set according to the data in the load chart.



#### WARNING

The crane can topple over!

- ▶ Check the horizontal position of the crane before and during crane operation.
- ▶ If the crane operator leaves the cab, even for a short time, the operating mode setting must be checked and reset if necessary before resuming crane operation.

#### 9.1.1 Checking the settings

- ▶ Check the function of the overload protection by running against the operating positions “on top” and “bottom”.
- ▶ Check the hoist limit switch by running against the hoist limit switch weight.

## 10 Disassembling

Make sure that the following prerequisites are met:

- The ground is able to safely take on the total operating weight of the crane.
- The crane is horizontally aligned.
- An auxiliary crane with sufficient load bearing capacity is available.
- An assembly scaffolding or a work platform is available.
- The central ballast has been installed on the crawler travel gear according to the load chart or the erection and take-down charts.
- The counterweight has been installed on the turntable according to the load chart or the erection and take-down charts.
- The LICCON overload protection has been set according to the data in the load chart.

### 10.1 Disassembling the central ballast



#### WARNING

The crane can topple over!

Death, severe bodily injuries, property damage.

- ▶ Observe the erection and take-down charts.
- ▶ If a central ballast is required for taking down the boom system, then leave the central ballast on the crane.

When no central ballast is required for taking down the boom system:

- ▶ Disassemble the central ballast, see chapter 3.03.



## 10.2 Turning the turntable into the disassembly position



### WARNING

The crane can topple over!

Death, severe bodily injuries, property damage.

- ▶ Observe the specifications in the erection and take-down charts.
- ▶ Observe the data in the load charts.

- ▶ Turn the turntable to the disassembly position according to the erection and take-down charts.

## 10.3 Luffing the boom system down



### WARNING

The crane can topple over!

Death, severe bodily injuries, property damage.

- ▶ Observe the technical safety instructions, see chapter 5.01.
- ▶ Observe the specifications in the erection and take-down charts.

If auxiliary guying is assembled on the boom. Comply with the following regulations.



### WARNING

Temperatures below 0 °C: Fiber guy ropes that are rigidly frozen or covered with ice!

Buckling of the fiber guy ropes. The fiber guy ropes can rip.

Death, severe bodily injuries, property damage.

- ▶ While taking down the boom system, check if the fiber guy ropes are rigidly frozen or covered with ice.
- ▶ Do **not** bend fiber guy ropes that are rigidly frozen or covered with ice.
- ▶ Do **not** take down boom systems with fiber guy ropes that are rigidly frozen or covered with ice (for example auxiliary guying, guying for the F-jib).
- ▶ Observe the instructions in chapter 5.01.

### NOTICE

Damage to the crane!

If the maximum permissible negative angle is exceeded when luffing the boom system down due to uneven ground, then the crane can be damaged.

Property damage.

- ▶ The permissible negative angle range of the boom system may not be exceeded, see section "Disassembling the S/SL boom at an incline".
- ▶ Support the boom system, see section "Disassembling the boom system with the substructure".



### Note

- ▶ The luff down movement is turned off as soon as the lowest operating position of the boom system is reached.
- ▶ When the lowest operating position of the boom system is reached, the load display in the maximum load icon turns off and instead of the load display appears the display "???".
- ▶ Alarm functions appear on the crane operating screen.

### NOTICE

Damage to the boom components!

Taking down the boom system can lead to a collision between the hook block and the pulley head.

The boom components can be severely damaged.

- ▶ Luff the boom system down at the same time and spool the hoist winch out.
- ▶ When luffing the boom system down, the SA-frame must remain in the operating position until the L-end section is lying on the ground or on a substructure or it is safely held by an auxiliary crane.
- ▶ Luff the boom system down to the **lowest** operating position.

**Result:**

- The luff down movement is turned off.
- The “STOP” icon appears on the LICCON monitor.
- The horn icon appears on the LICCON monitor.

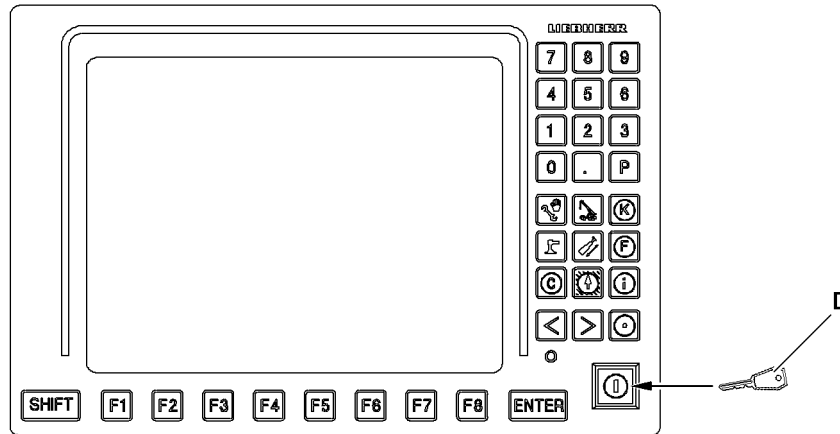


Fig. 119109

**WARNING**

Danger of accident due to the “Exceedance of shut-off limits of the LICCON overload protection” function!

If the shut-off limits of the LICCON overload protection are exceeded, there is no additional protection against crane overload.

Due to erroneous operation or deliberate misuse, the crane could collapse, the boom system can break off or the crane can topple over.

Death, severe bodily injuries, property damage.

- ▶ The “Exceedance of shut-off limits of the LICCON overload protection” function is only permissible in emergencies and for assembly purposes.
- ▶ The function “Exceeding the shut off limits of the LICCON overload protection” may only be actuated by persons who know the effects of their actions regarding the function “Exceeding the shut off limits of the LICCON overload protection”.
- ▶ The “Exceedance of shut off limits of the LICCON overload protection” function requires the presence of an authorized person and must be performed with utmost caution.
- ▶ Crane operation with the “Exceedance of shut off limits of the LICCON overload protection” function activated is prohibited.

- ▶ Exceeding the shut off limits of the LICCON overload protection: Activate assembly operation.

**Result:**

- The shut-off limits of the LICCON overload protection are exceeded.
- The assembly icon appears on the LICCON monitor.

**Note**

- ▶ See chapter 4.02 and chapter 4.20.

- ▶ At the same time, spool the hoist winch out and luff the boom system down until the hook block touches the ground.
- ▶ Disassemble the hoist limit switch weight and reeve the hook block out.
- ▶ Remove the hook block with the auxiliary crane.

When the hook block is removed under the boom head:

- ▶ Continue to luff the boom system down until the roller set / roller sets of the boom head are just above the ground.

## 10.4 Spooling the hoist rope up



### WARNING

Spooling up of the hoist rope!

Death, severe bodily injuries, property damage.

- ▶ All rope retaining pins / pipes on the boom system are removed.
- ▶ Slowly spool up the hoist rope over the rope pulleys back to the winch.
- ▶ Make sure that no personnel is within the danger zone!

### NOTICE

Overspooled winch!

If the hoist rope is pulled under the winch when spooling up, then the adjustment of the cam limit switch can change.

A new adjustment by the customer service of Liebherr-Werk Ehingen GmbH is required.

- ▶ Stop the winch in time, with sufficient rope reserve.
- ▶ Do **not** overspool the winch.

- ▶ Spool the hoist rope up.

## 10.5 Disassembling the roller set

### NOTICE

Danger of property damage!

During the disassembly of the roller set, the electrical connections to the hoist limit switches can be damaged.

- ▶ Remove the hoist limit switches on the roller set.
- ▶ Before disassembly of the roller set, route the hoist limit switches from the roller set back to the end section.



### Note

- ▶ The disassembly of the roller set is described in chapter 5.14.

## 10.6 Assembling the feet on the L-end section

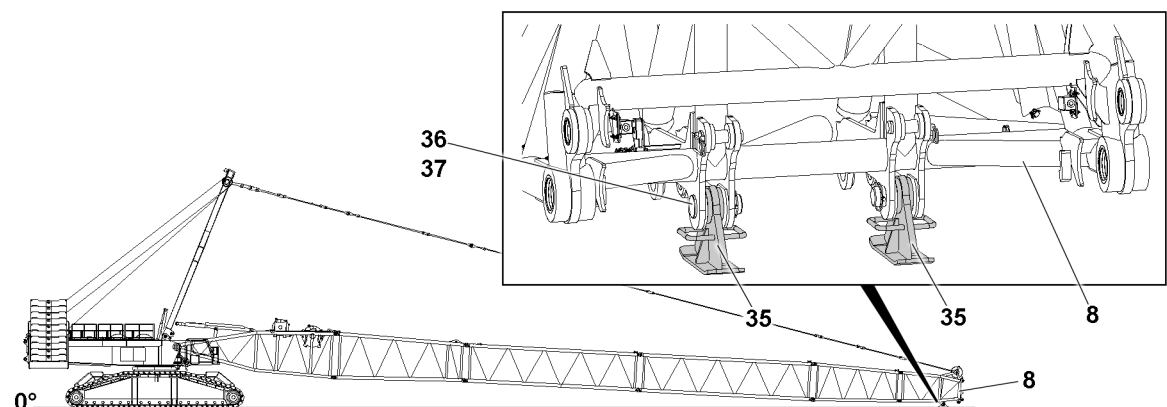


Fig.155775: Assembling the feet



### Note

- ▶ Pinning the feet is only necessary for the main boom with an S or L-end section.

Make sure that the following prerequisites are met:

- The hook block is properly unreeved and removed.
- The hoist limit switches are on the L-end section.
- The roller set is disassembled.

### NOTICE

Damage to the crane!

If the maximum permissible negative angle is exceeded when luffing the boom system down due to uneven ground, then the crane can be damaged.

Property damage.

- ▶ The permissible negative angle range of the boom system may not be exceeded, see section “Disassembling the S/SL boom at an incline”.
- ▶ Support the boom system, see section “Disassembling the boom system with the substructure”.

- ▶ Position the feet **35** under the L-end section **8**.
- ▶ Luff the main boom down until the pin bores in the L-end section **8** and the feet align.
- ▶ Insert the pin **36**.
- ▶ Secure the pin **36**: Attach the retaining element **37**.
- ▶ Take the main boom down completely.

## 10.7 Retracting the relapse cylinder of the main boom

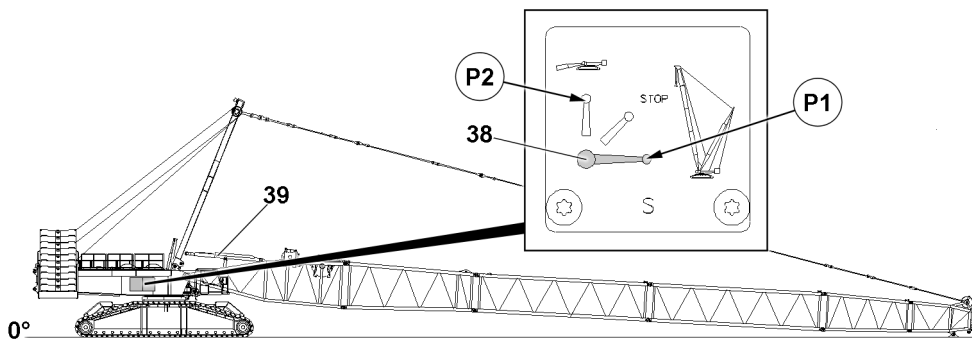


Fig.155776: Luffing the boom system down / retracting the relapse cylinder of the main boom

Make sure that the following prerequisite is met:

- The crane engine is running.

Ball valve positions	
Position (P)	Function
1	Crane operation, extend the piston rod
2	Assembly, retract the piston rod
STOP	The piston rod cannot be retracted / extended

*Relapse cylinder of the main boom, ball valve positions*

- ▶ Retract the relapse cylinder of the main boom **39**: Set the ball valve **38** to position **P2**.

### Result:

- The piston rods of the main boom relapse cylinders **39** retract.

The ball valve **38** is secured by closing the cabinet door and removing the key.

- ▶ Close the cabinet door and pull out the key.
- ▶ Hand the key to an authorized person.

## 10.8 Disconnecting the electrical connections on the boom head

Make sure that the following prerequisite is met:

- The main boom is taken down onto the ground.

---

### NOTICE

Damage to the cable drum or cable!

If the cable of the cable drum is not properly spooled up on the cable drum after unplugging the boom end section, then the cable drum or the cable can be significantly damaged.

- ▶ Spool the cable drum up after unplugging.
- 
- ▶ Spool the cable drum up and secure it to prevent inadvertent spooling out.

---

### NOTICE

**Non-assembled protective caps!**

If non-required electrical connections are not closed off, then dirt and / or corrosion can damage the electrical connections. This could result in malfunctions.

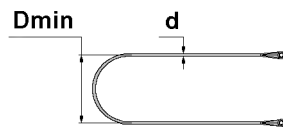
- ▶ Always properly close off all **non**-required electrical connections with their protective caps.
  - ▶ Observe the wiring diagram.
- 
- ▶ Disconnect the electrical connections and store the plugs and cables properly.

## 10.9 Disassembling the guying

### 10.9.1 Auxiliary guying

An auxiliary guying is assembled depending on the boom system, see the rod plan.

Fiber guy ropes are used for the auxiliary guying. Comply with the following regulations.



$$D_{min} = 20 \times d$$

Fig.160908: Fiber guy rope: Calculation of minimum permissible bending diameter

Formula element	Meaning
Dmin	Minimum permissible bending diameter
d	Rope diameter

Minimum permissible bending diameter: Definition of the formula elements

**WARNING**

Impermissible disassembly of fiber guy ropes!

The fiber guy ropes can be damaged.

Death, severe bodily injuries, property damage.

- ▶ Before disassembling the fiber guy ropes, check if the fiber guy ropes are rigidly frozen or covered with ice. See chapter 5.01.
- ▶ Do **not** disassemble fiber guy ropes that are rigidly frozen or covered with ice.
- ▶ Do **not** bend, knot or twist the fiber guy ropes.
- ▶ Never fall below the minimum permissible bending diameter **D<sub>min</sub>** of **20** x rope diameter **d**.
- ▶ Check the fiber guy ropes for damage prior to assembly, after disassembly and after exceptional events, see chapter 8.16.
- ▶ Comply with the maintenance intervals, see chapter 7.03.50.
- ▶ Replace damaged fiber guy ropes.
- ▶ Observe the notes regarding the proper transport and storage of the fiber guy ropes, see chapter 2.04.
- ▶ Observe the instructions for the proper handling of fiber guy ropes, see chapter 5.01.
- ▶ Only fasten the fiber guy ropes in the permissible range with belt loops, see chapter 5.01.

Make sure that the following prerequisites are met:

- The main boom is lying on the substructure on the ground.
- The guying is relieved.

### 10.9.2 Disassembling the auxiliary guying

This section is valid solely only for the boom with the assembled auxiliary guying.

- ▶ Observe the specifications for fiber guy ropes.
- ▶ Luff the SA-frame down until the auxiliary guying can be disassembled.
- ▶ Disassemble the auxiliary guying.

### 10.9.3 Disassembling the guy rods

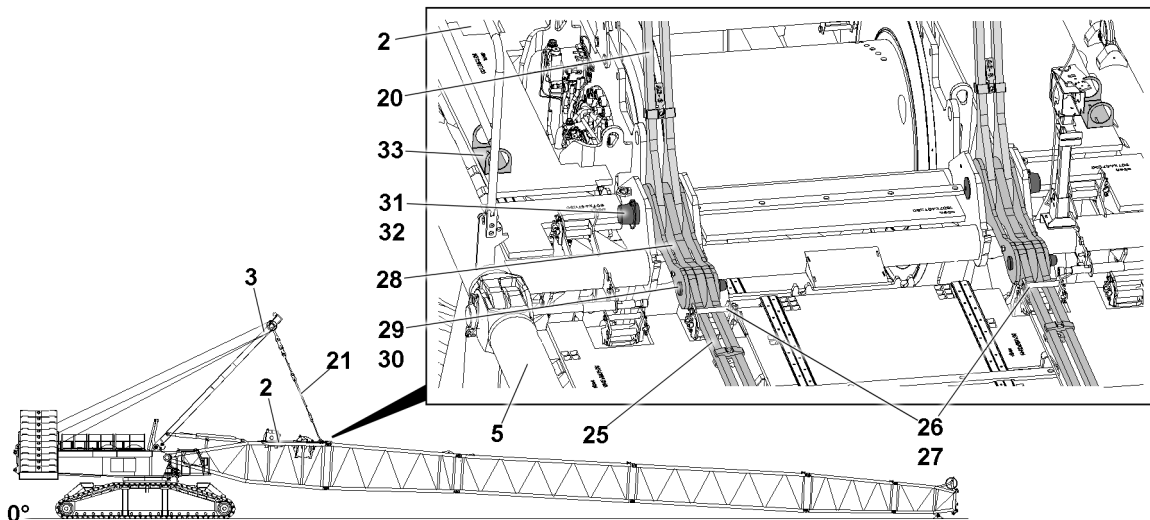


Fig.155774: Taking down the main boom guy rods

- ▶ Luff the SA-frame **3** down until the guy rods **25** are taken down into the transport receptacles of the intermediate sections.
- ▶ Unpin the pin **26** from the park position.
- ▶ Secure the guy rods **25** in the transport receptacles: Insert the pin **26** and secure it with the safety element **27**.
- ▶ Unpin the pin **31** from the park position in the retainer **33**.
- ▶ Pin the guy rods **20** in the assembly position: Insert the pin **31**.
- ▶ Secure the pin **31**: Attach the safety element **32**.

- ▶ Disconnect the guy rods **25** from the guy rods **28** of the intermediate sections: Remove the safety element **30** and unpin the pin **29**.

**WARNING**

The crane can topple over!

- ▶ Make sure that the end section of the boom system does **not** lift off the ground when tensioning the SA-frame guying.

When the guy rods **20** are pinned in the assembly position with the H-pivot section **2**:

- ▶ Luff the SA-frame **3** up until the guy rods **20** are tensioned.

## 10.10 Opening the boom system

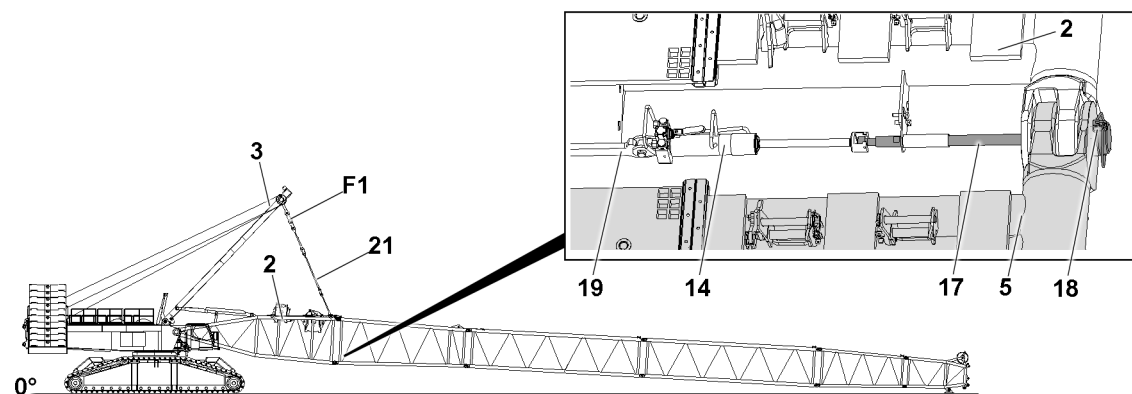


Fig.155773: Opening the boom system and unpinning on both sides on the “bottom”

Make sure that the following prerequisites are met:

- The SA-frame guying **21** is pinned in the assembly position.
- No personnel or obstacles are in the danger zone.

**WARNING**

Overload of the crane!

Death, severe bodily injuries, property damage.

- ▶ During the “opening procedure” of the boom system, the maximum permissible F1-total force of **125 t** in the test point **F1** may not be exceeded.
- ▶ Lifting and opening the respective main boom is only permissible by observing the maximum permissible boom lengths and total forces.
- ▶ The boom end section may **not** lift off the ground while “opening” the boom system.
- ▶ Make sure that there are no persons on the boom system or in the danger zone when opening.

**Note**

- ▶ The actual force in the test point **F1** that is exerted while tensioning the boom system is shown on LICCON monitor 1.

- ▶ Observe the actual force in the test point **F1** that was noted when closing the boom system (assembly).

When the boom system is pretensioned, the pins are easier to unpin. Pins and lugs are not damaged.

- ▶ Spool up winch 3 until the guying is tensioned with the same actual force in test point 1 as when closing the boom system.

Prerequisite for an individual pin point: The pin pulling cylinder **14** is inserted in the pin pulling device **19** and connected to the connector pin **17**.

- ▶ Remove the safety elements **18** on both sides at the “bottom” and unpin the connector pins **17**.

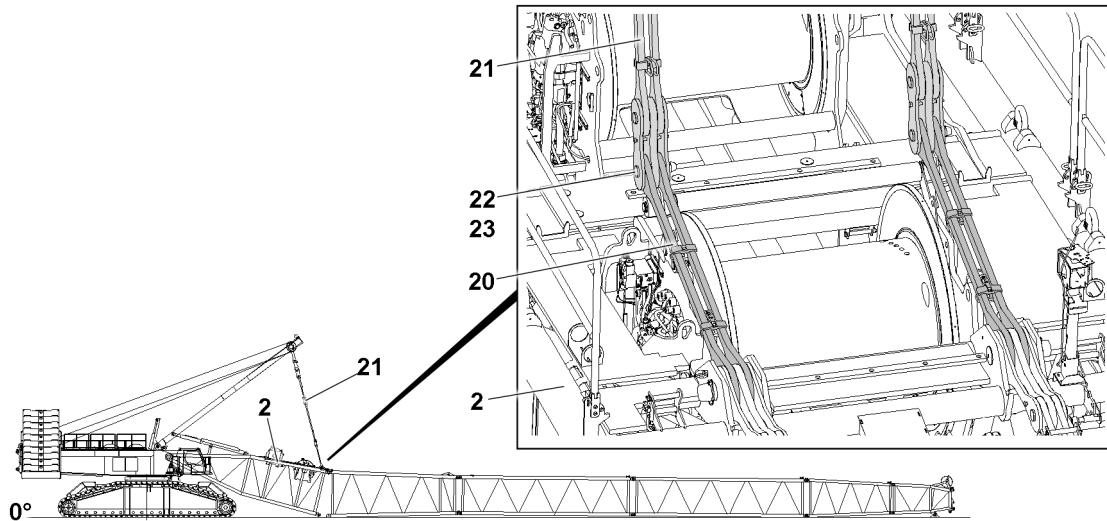


Fig.155770: Lowering the boom system

#### NOTICE

Damage to the H-pivot section!

If the maximum permissible negative angle is exceeded due to uneven ground, then the H-pivot section can be damaged.

Property damage.

- ▶ The permissible negative angle range of the H-pivot section may not be exceeded, see section "Disassembling the S/SL boom at an incline".

#### NOTICE

Danger of property damage!

When lowering the boom system, crane components can be damaged.

- ▶ Make sure that the H-pivot section **2** is not lowered directly onto the ground.
- ▶ Lower the H-pivot section **2** onto the substructure when opening the boom system.
- ▶ Lower the boom system carefully onto the substructure on the ground.
- ▶ Disconnect the SA-frame guying: Unpin the guy rods **21** on the guy rods **20**.
- ▶ Remove the safety elements **23** on both sides and unpin the pin **22**.



#### Note

- ▶ Install and secure the guy rods, which are not required during assembly of the boom system and were removed from the lattice sections, properly in the transport retainers of the lattice sections.
- ▶ Place the guy rods that are not required on the lattice sections and pin and secure them.
- ▶ Disassemble the boom system properly.

## 10.11 Disassembling the boom system



#### Note

- ▶ The unpinning procedure is the same for both sides of the boom lattice section.
- ▶ The unpinning procedure is the same for both levels at the "top" and at the "bottom".
- ▶ The unpinning procedure is the same for all boom lattice sections of the boom system.



#### Note

- ▶ The H-intermediate sections are pinned with the pin pulling cylinder **14**, see chapter 5.30.
- ▶ The pin pulling cylinders **14** are shown as an example.



**Note**

- ▶ For the fastening of boom lattice sections, observe and adhere to section “Fastening points”.

### 10.11.1 Removing the L-end section on the SL-reducer

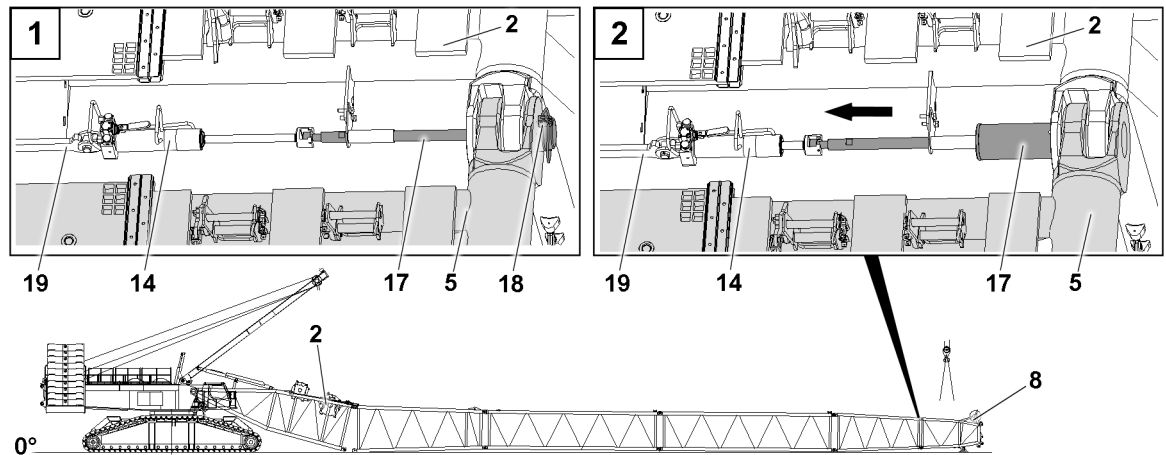


Fig.155777: Disassembling the boom lattice sections, L-end section example

Prerequisite for an individual pin point: The pin pulling cylinder **14** is inserted in the pin pulling device **19** and connected to the connector pin **17**.

- ▶ Fasten the L-end section **8** to the auxiliary crane.
- ▶ Remove the safety elements **18** on both sides at the “bottom”.
- ▶ Unpin the connector pin **17**: Actuate the pin pulling cylinder **14**.
- ▶ Remove the safety elements **18** on both sides at the “top”.
- ▶ Unpin the connector pin **17**: Actuate the pin pulling cylinder **14**.

When the connector pins **17** at the “top” and “bottom” are fully unpinned:

- ▶ Remove the L-end section **8** with the auxiliary crane and take it down.
- ▶ Remove the auxiliary crane.
- ▶ Insert all connector pins **17** for transport and secure with the safety elements **18**.

### 10.11.2 Continuing main boom disassembly

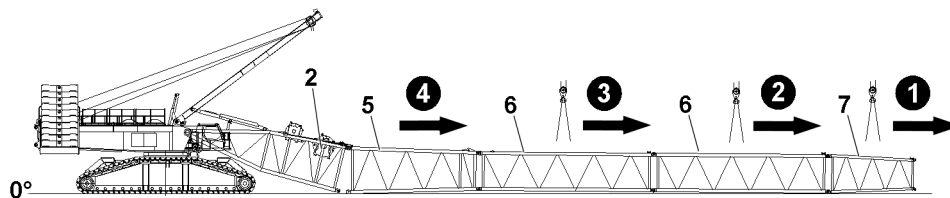


Fig.155778: Main boom disassembly

**Note**

- ▶ The following description is an example and will be described by means of the SL-reducer **7**.
- ▶ The disassembly of the HS-reducer, S-intermediate section, SL-reducer, L-intermediate section, S-end section, L-end section is identical.

- ▶ Fasten the SL-reducer **7** to the auxiliary crane.
- ▶ Remove the safety elements **18** on both sides at the “bottom”.
- ▶ Unpin the connector pin **17**: Actuate the pin pulling cylinder **14**.

- ▶ Remove the safety elements **18** on both sides at the “top”.
- ▶ Unpin the connector pin **17**: Actuate the pin pulling cylinder **14**.

When the connector pins **17** at the “top” and “bottom” are fully unpinned:

- ▶ Remove the SL-reducer **7** with the auxiliary crane and take it down.
- ▶ Remove the auxiliary crane.
- ▶ Disassemble the S-intermediate sections **6**.
- ▶ Disassemble the HS-reducer **5**.
- ▶ Insert all connector pins **17** for transport and secure with the safety elements **18**.

## 10.12 Disconnecting the electric and hydraulic connections on the H-pivot section

### 10.12.1 Disconnecting the electrical connections

Make sure that the following prerequisite is met:

- The H-pivot section is lying on the ground on the substructure.
- ▶ Disconnect the electrical connections, see the wiring diagram.
- ▶ Close off the electrical connections properly with dummy plugs or protective caps.

### 10.12.2 Disconnecting the hydraulic connections

The hydraulic connections are established with quick couplings.

When using quick couplings to disconnect the hydraulic lines, make sure that the coupling procedure is carried out correctly.



#### **WARNING**

Pressure in the hydraulic lines!

If the pressure supply is not interrupted before connecting / releasing the hydraulic lines, the hydraulic oil can escape with high pressure.

Death, severe bodily injuries, property damage.

- ▶ Release the pressure in the hydraulic system before connecting / disconnecting: Interrupt the pressure supply and wait a short time.
- ▶ Release the hydraulic coupling by hand.
- ▶ Disconnect the hydraulic connections, see the Hydraulic diagram.
- ▶ Protect the hydraulic connections against contamination with caps.

## 10.13 Disassembling the H-pivot section on the turntable

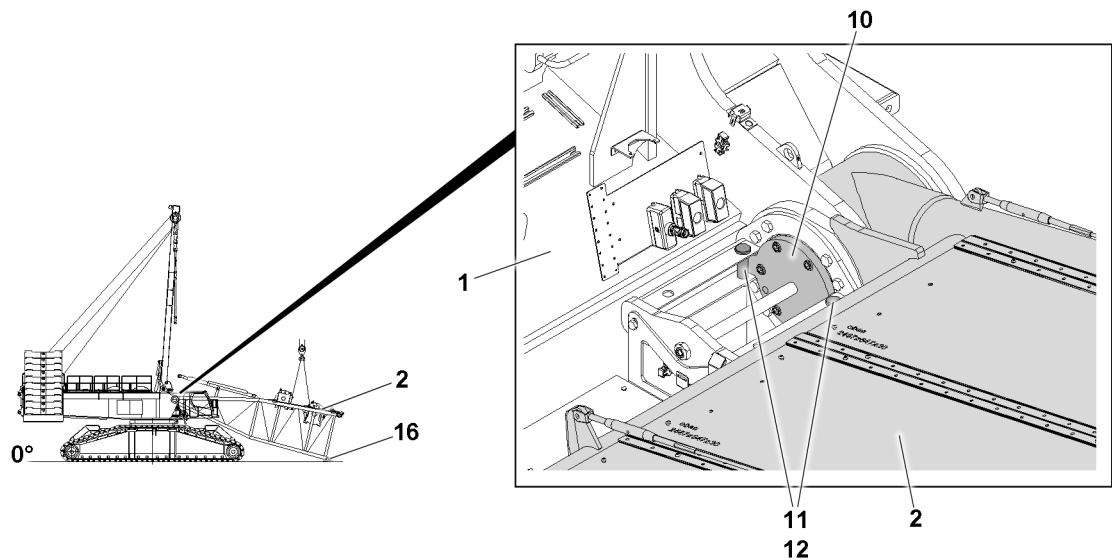


Fig.155767: Releasing the H-connector pin

Make sure that the following prerequisites are met:

- The hydraulic connections on the H-pivot section are properly disconnected.
- The hydraulic connections on the H-pivot section are properly closed off with caps.
- The electrical connections on the H-pivot section are properly disconnected.
- The electrical connections are properly closed off with dummy plugs (see the wiring diagram).
- The crane engine is running.
- An auxiliary crane with sufficient load bearing capacity is available.



### WARNING

General danger note!

- ▶ Insert and secure all pins after disassembly in the intended transport receptacles.



### WARNING

Incline position of the installed H-pivot section!

The mounting condition of the installed H-pivot section is selected so that the 20° incline position of the walking surfaces is not exceeded.

Death, severe bodily injuries.

- ▶ Support the H-pivot section.

- ▶ Release the H-connector pin **10**: Remove the retaining element **12** and unpin the retaining pin **11**.

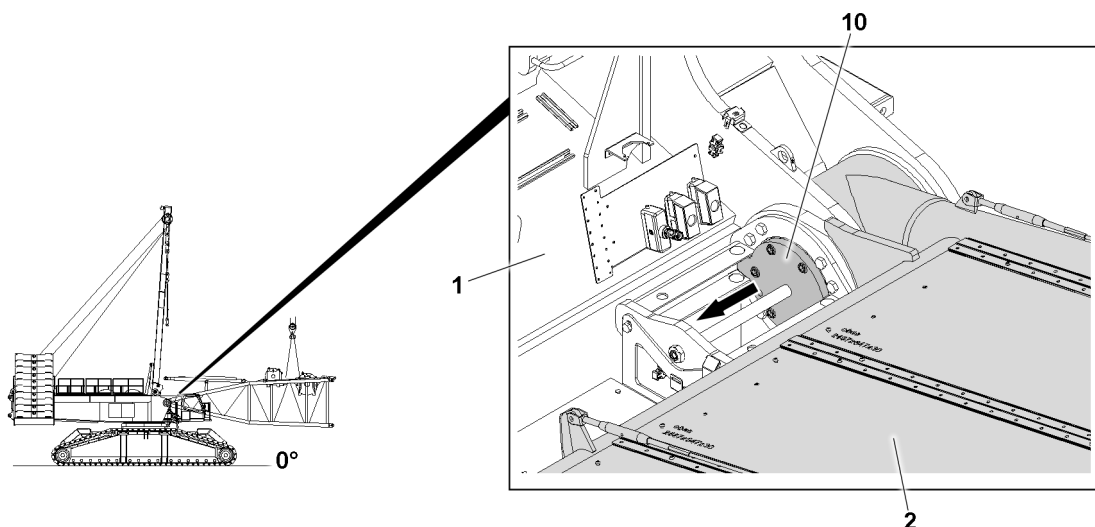


Fig.155779: Unpinning the H-pivot section on the turntable



#### Note

- ▶ The unpinning procedure is the same for both H-connector pins.



#### WARNING

Falling H-pivot section!

Death, severe bodily injuries, property damage.

- ▶ Make sure that the H-pivot section **2** is safely held by the auxiliary crane before unpinning the H-connector pins **10**.



#### Note

- ▶ The fastening points on the H-pivot section **2** must be selected in such a way that the H-pivot section **2** hangs horizontally on the auxiliary crane during disassembly. See section "Fastening points".
- ▶ For BTT display / operating element operation, see chapter 5.31.



#### WARNING

Suspended H-pivot section!

Death, severe bodily injuries.

- ▶ Stepping on the H-pivot section when suspended is prohibited.
- ▶ Fasten the H-pivot section **2** properly to the auxiliary crane.
- ▶ Lift the H-pivot section **2** with the auxiliary crane to the horizontal.
- ▶ Unpin the H-connector pin **10**: Actuate the BTT.

#### NOTICE

Swing the H-pivot section **2** out from the turntable!

Damage to the turntable and the H-pivot section **2**.

- ▶ Slowly swing the H-pivot section **2** out with the auxiliary crane and at low speed from the turntable.
- ▶ Support the H-pivot section **2** before taking it down onto the ground.

When the H-connector pins **10** on the H-pivot section **2** are fully unpinning on both sides:

- ▶ Swing the H-pivot section **2** out from the turntable **1** with the auxiliary crane and take it down.
- ▶ Remove the auxiliary crane.

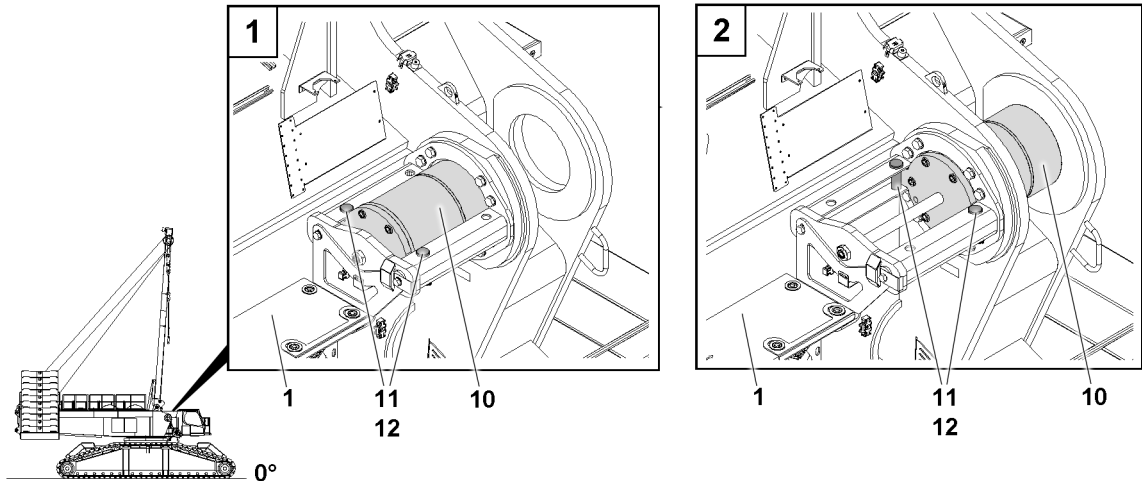


Fig.155780: H-connector pins in the transport condition



**Note**

- ▶ In the transport condition, the H-connector pins **10** are pinned on the turntable **1** and secured with the retaining pins **11**.

When the H-pivot section **1** is disassembled on the turntable:

- ▶ Pin the H-connector pins **10** again completely: Actuate the BTT.
- ▶ Secure the H-connector pin **10**: Attach the retaining elements **12**.

## 10.14 Disassembling winch 5 and winch 6 on the H-pivot section



**Note**

- ▶ Bring winch 5 into the operating position, see chapter 3.07.50.
- ▶ If necessary, disassemble winch 5 on the H-pivot section, see chapter 3.07.50.



**Note**

- ▶ Bring winch 6 into the operating position, see chapter 3.07.60.
- ▶ If necessary, disassemble winch 6 on the H-pivot section, see chapter 3.07.60.

## 10.15 Swinging the camera holder into the transport position

- ▶ Swing the camera holder into the transport position.
- ▶ Secure the camera holder in the transport position.

## 10.16 Swinging the railing on the H-pivot section into the transport position



**WARNING**

Danger of falling!

Death, severe bodily injuries, property damage.

- ▶ Assembly personnel must secure themselves for assembly / disassembly of railings and protective devices with an approved fall arrest system to prevent them from falling.
- ▶ For assembly and disassembly work, maintenance and inspection work on the H-pivot section, all railings and protective devices must be properly assembled and secured.

Make sure that the following prerequisites are met:

- The ground is able to safely take on the weight of the H-pivot section.
- The H-pivot section is lying completely on the ground.

- ▶ For the assembly / disassembly of railings and protective devices, see chapter 2.06.

## 11 Disassembling the S/SL boom at an incline



### WARNING

The crane can topple over!

If the following requirements are not observed, the crane can topple over.

Death, severe bodily injuries, property damage.

- ▶ Observe and adhere to the requirements and instructions in section "Assembling the S/SL boom".
- ▶ Observe the specifications in the erection and take-down charts.



### WARNING

The crane can topple over!

If the crane is not horizontal, then it can be overloaded when erecting / taking down the boom system and topple over.

Death, severe bodily injuries, property damage.

- ▶ Observe and adhere to the requirements and instructions for assembly on uneven ground, see chapter 5.01.
- ▶ Observe and adhere to the requirements and instructions for the selection of the location, see chapter 2.04.
- ▶ Make sure that the placement level of the crane is level and horizontal.
- ▶ Make sure that the crane is horizontally aligned.

### NOTICE

Damage to the crane!

If the maximum permissible negative angle is exceeded due to uneven ground, then the crane can be damaged.

Property damage.

- ▶ The permissible negative angle range of the boom system may not be exceeded.

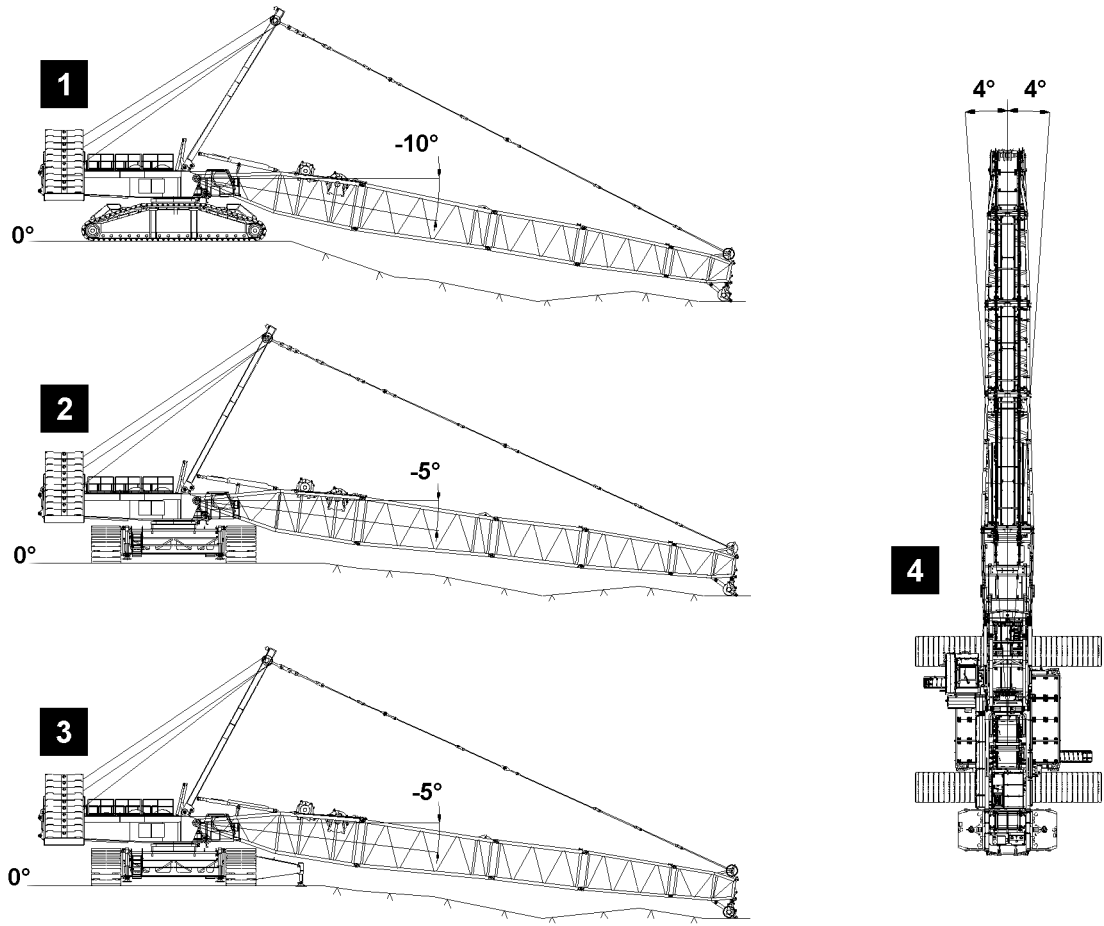


Fig.155771: Negative angle range of the boom system

Illustration	Angle type	Maximum negative angle
1	Maximum inspected angle	To the front -10°
2	Collision angle	To the side -5°
3	Collision angle	To the side with auxiliary support -5°

Illustration	Angle type	Maximum slewing range
4	Maximum slewing range	To the side with auxiliary support +/-4°

### 11.1 Disassembling the S/SL-boom at an incline



**Note**

- ▶ The procedure for the disassembly of the boom system at an incline is the same as the disassembly of the boom system on level ground, see section “Disassembling the S-/SL-boom”.

**NOTICE**

Damage to the H-pivot section!

If the maximum permissible negative angle is exceeded due to uneven ground, then the H-pivot section can be damaged.

Property damage.

- ▶ The permissible negative angle range of the H-pivot section may not be exceeded.

LWE/LR 1800-1-0-000/27200-07-02/en

- ▶ Disassemble the H-pivot section, see section “Disassembling the S-/SL-boom”.

**WARNING**

The crane can topple over!

Death, severe bodily injuries, property damage.

- ▶ The combination of the various boom systems must be taken from the rod plan and must be adhered to.
- ▶ The specifications in chapter 5.01 and chapter 5.03 must be observed.
- ▶ Support the boom system during assembly and disassembly.

- ▶ Disassemble the boom system, see section “Disassembling the S/SL-boom”.

## 12 Disassembling the boom system with the substructure

If the disassembly conditions for the disassembly of the boom system are restricted due to the terrain at the job site, then it is possible to assemble the boom system with the substructure.

**WARNING**

Impermissible flexation!

Overload of the main boom.

- ▶ Make sure that from a main boom length of 114 m, the main boom is supported on the auxiliary guying.

**WARNING**

General danger notes!

- ▶ Secure all pins after disassembly with the provided retaining elements.
- ▶ Inspect the guy rods regularly, see chapter 8.15.
- ▶ Secure the main boom with the substructure or auxiliary crane, see chapter 5.01.
- ▶ It is prohibited for anyone to remain under the main boom or in the entire danger zone during the pinning and unpinning procedure of the boom lattice sections.

**WARNING**

The crane can topple over!

Death, severe bodily injuries, property damage.

- ▶ For assembly and disassembly of the main boom with the substructure, observe chapter 5.01.
- ▶ The “actual force” in test point **F1** is shown on LICCON monitor 1.
- ▶ Observe the assembly conditions, see chapter 3.06.
- ▶ The data in the erection and take-down charts as well as the load charts must be observed.
- ▶ The combination of the various boom systems must be taken from the rod plan and must be adhered to.



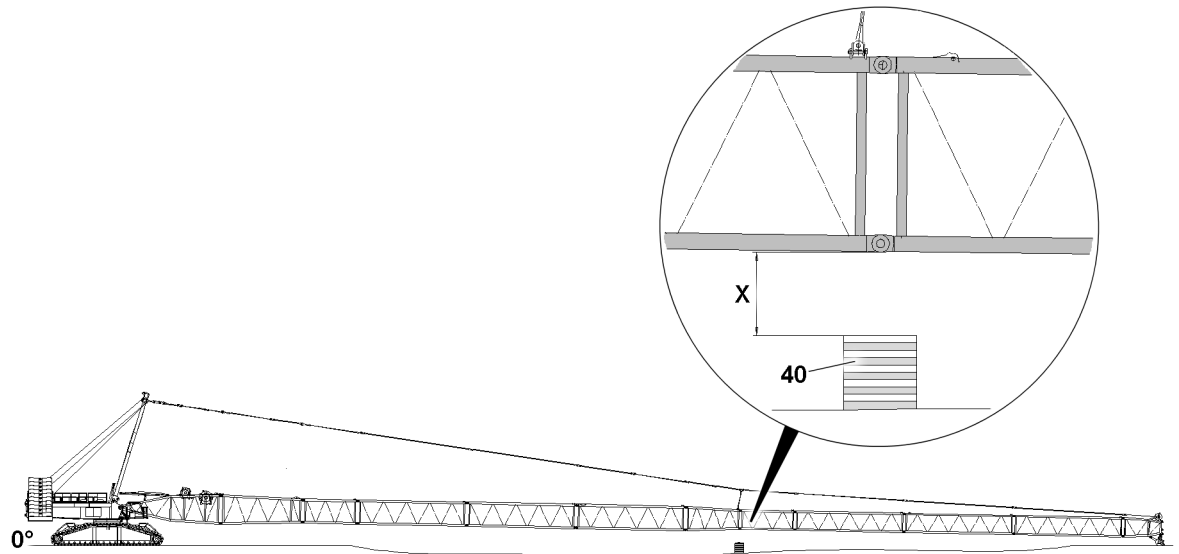


Fig.155772: Boom system with the substructure (shown as an example)

**40** Substructure **X** Maximum distance<sup>1)</sup>

<sup>1)</sup> X corresponds to the maximum permissible flexation of the boom system



#### Note

- ▶ For the maximum distance **X**, see the separately supplied drawing “Support assembly drawing”.
- ▶ The point in which the boom system must be supported depends on the corresponding operating mode, see the separately supplied drawings “General support assembly drawing”.

#### NOTICE

Negative angle!

Overload of the main boom.

Damage to the boom system.

- ▶ Negative angles in the erection and take-down charts are to be observed.
- ▶ If necessary, the boom end section must be supported with suitable and sufficiently load bearing materials.

#### NOTICE

Main boom **not** supported before the take-down procedure!

Overload of the main boom.

Damage to the boom system.

- ▶ Make sure that the maximum distance **X** is never exceeded.
- ▶ Support the main boom with suitable materials with sufficient load bearing capacity in the marked area, see illustration.

- ▶ Support the boom system and open it on the auxiliary guying.
- ▶ Remove the boom system, see section “Disassembling”.
- ▶ Remove the H-pivot section, see section “Disassembling the H-pivot section on the turntable”.

---

Empty page!

LWE/LR 1800-1-0-000/27200-07-02/en

## 5.39 Main boom with derrick boom

1	Safety	2
2	Component overview	3
3	Fastening points	4
4	Assembling	10
5	Installing the boom system preassembled on the turntable	22
6	Assembling the boom system with the substructure	23
7	Assembling the main boom guying	25
8	Establishing the electrical connections on the boom end section	29
9	Performing the function checks	29
10	Erecting the boom system	30
11	Operating the crane	36
12	Disassembling	37

# 1 Safety

Observe the safety instructions before assembly and disassembly:

- Information regarding personal protective equipment. See chapter 2.04.
- Information regarding fall protection equipment. See chapter 2.06.
- Information regarding accesses to the crane. See chapter 2.07.
- Information regarding accessible surfaces. See chapter 2.07.



## WARNING

Danger of falling!

During assembly / disassembly, inspection and maintenance work, assembly personnel must be secured with appropriate aids to prevent them from falling.

Death, severe bodily injuries, property damage.

- ▶ All work at a height, when there is a danger of falling, must be carried out with suitable aids.
- ▶ If aids are not available and work cannot be carried out from the ground, then assembly personnel must secure themselves with the supplied fall arrest system to prevent falling, see the Crane operating instructions, chapter 2.04.
- ▶ If fall protection equipment is available, then it must be used, see the Crane operating instructions, chapter 2.06.
- ▶ When lifting, lowering, swinging crane parts in and out, no persons may remain in the danger zone.
- ▶ If railings are present on the components, then they must be brought into the corresponding position and secured for assembly / disassembly work.
- ▶ Only step on the aids, ladders and catwalks with clean shoes.
- ▶ Keep aids, ladders and catwalks free of heavy dirt, snow and ice.
- ▶ During all assembly and disassembly work, maintenance work and inspections, travel or crane operation is prohibited.
- ▶ Remaining on a suspended load is prohibited.
- ▶ Stepping or walking on crane components and lattice sections with an incline of more than 20° is prohibited.
- ▶ For all assembly work, the crane operator of the main crane must be in voice contact with the crane operator / crane operators of the auxiliary crane / auxiliary cranes.
- ▶ For the assembly / disassembly tasks, the crane operator may only initiate crane movements when the responsible guide has explicitly released the movement.



## WARNING

Danger of impact / crushing!

When assembling / disassembling crane components with the auxiliary crane, crane components can start to swing back and forth.

When lifting / lowering and positioning crane components, there is an increased danger of impact / crushing.

Death, severe bodily injuries, property damage.

- ▶ Make sure that personnel cannot be caught by components.
- ▶ When working in a danger zone: Use aids to protect limbs.
- ▶ Guide components with suitable aids to minimize oscillation.



## DANGER

The component can fall down!

If the corresponding component is disengaged from the auxiliary crane before the corresponding component is pinned, then the corresponding component can fall down.

Death, severe bodily injuries, property damage.

- ▶ Do not disconnect the auxiliary crane until the respective component is pinned and secured.

**WARNING**

Danger of falling!

During assembly and disassembly of crane components, personnel must be secured with appropriate aids to prevent them from falling.

Death, severe bodily injuries, property damage.

- ▶ Use personal protective equipment.

**WARNING**

Falling of the boom lattice sections!

If the boom lattice sections are not pinned and secured correctly, then they can fall down.

Death, severe bodily injuries, property damage.

- ▶ Insert or unpin both pins on the same horizontal level, i.e. **left and right**.
- ▶ Standing under the boom lattice sections or within the entire danger zone during the main boom pinning and unpinning procedure is prohibited.
- ▶ Safely secure the pins in the storage locations as well as in the receptacles.
- ▶ It is prohibited to lean the ladder against the component to be disassembled.

**WARNING**

Danger of accident due to unintended actuation of the master switch!

During assembly and disassembly of the boom system with the radio remote control, the unintended actuation of the master switch, (the "turning" function in particular), can lead to the uncontrolled movement of the boom system and therefore dangerous situations for personnel.

Death, severe bodily injuries, property damage.

- ▶ During assembly and disassembly of the boom system with the radio remote control: Observe and adhere to the specifications in chapter 5.31 and chapter 6.08.

**WARNING**

D-boom falling to the rear!

If the relapse cylinders of the D-boom are not completely extended before erection, then the D-boom can fall backward when erecting it into operating position.

Death, severe bodily injuries, property damage.

- ▶ Make sure that the relapse cylinders of the D-boom are completely extended.

## 2 Component overview

**Note**

- ▶ For boom components (boom lattice sections), such as the H-pivot section, L/S/H-intermediate sections, SL/HS-reducers and the S/L-end sections, as well as dimensions and weights, see chapter 1.03.
- ▶ Combination of the various boom systems, see the Rod plan and chapter 5.03.

## 3 Fastening points



### WARNING

Fastening equipment can be ripped off!  
Death, severe bodily injuries, property damage.

- ▶ Make sure that the fastening equipment has a sufficient load carrying capacity and the required minimum length.
- ▶ Make sure that the auxiliary crane(s) have a sufficient load carrying capacity.
- ▶ Pay attention and adhere to the labels on the fastening points on the boom lattice sections and crane components.
- ▶ Make sure that there are no persons in the danger zone.



### WARNING

Components incorrectly fastened!  
Death, severe bodily injuries, property damage.

- ▶ Fasten the components only in the intended fastening points on both sides.



### WARNING

Overload of fastening points!  
If the fastening points are overloaded, they can rip off and the component can fall down.  
Death, severe bodily injuries, property damage.

- ▶ Make sure that the fastening points are not overloaded.
- ▶ Observe the maximum permissible suspended loads.



### Note

- ▶ The H, S and L-intermediate sections are available in various system dimensions.
- ▶ The distance between the fastening points can vary, depending on the respective H, S or L-intermediate section.
- ▶ The boom lattice section must be fastened on both sides to the fastening points.

### 3.1 H-pivot section fastening points

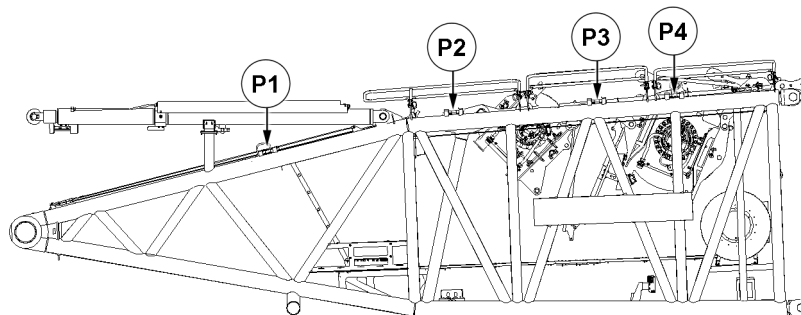


Fig.154342: H-pivot section fastening points

Fastening points	
P1 + P4	H-pivot section, complete
P2 + P3	H-pivot section with winch 5, WA-frame 2 guy rods
P1 + P4	H-pivot section with winch 5
P2 + P3	H-pivot section with winch 5 and 4, WA-frame 2 guy rods

### 3.2 H-intermediate section 6 m fastening points

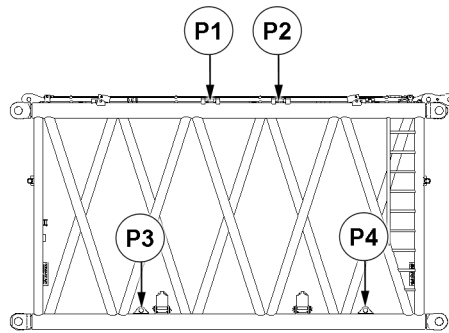


Fig.154344: H-intermediate section 6 m fastening points

Fastening points	
P1 + P2 or P3 + P4	H-intermediate section 6 m

### 3.3 H-intermediate section 12 m fastening points

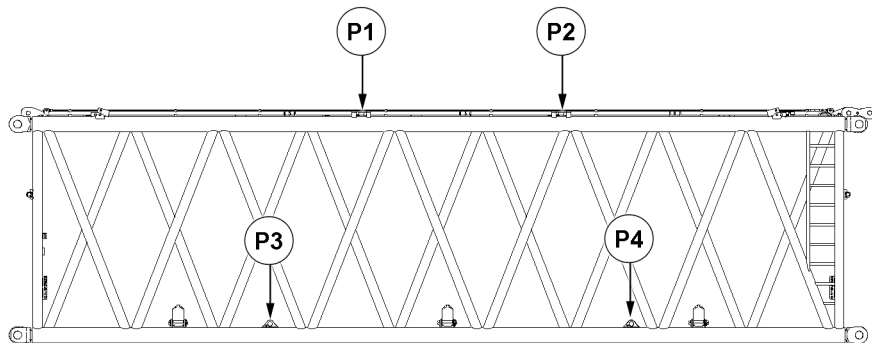


Fig.154343: H-intermediate section 12 m fastening points

Fastening points	
P1 + P2 or P3 + P4	H-intermediate section 12 m

LWE/LR 1800-1-0-000/27200-07-02/en

### 3.4 HS-reducer 9 m fastening points

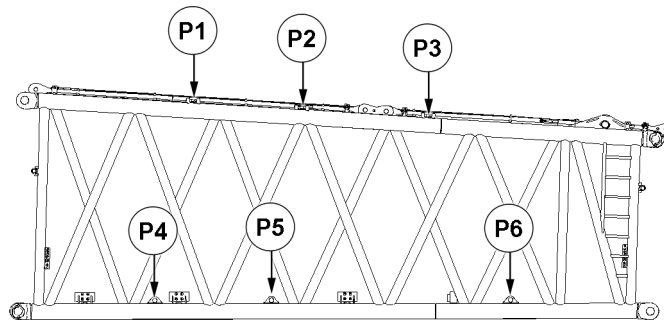


Fig.154345: HS-reducer 9 m fastening points

Fastening points	
P2 + P3 or P5 + P6	HS-reducer 9 m

Fastening points	
P1 + P3 or P4 + P6	HS-reducer 9 m + SL-reducer 6 m

### 3.5 S-intermediate section 6 m fastening points

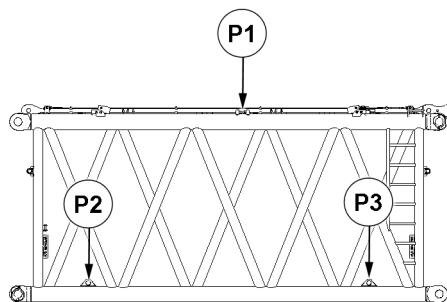


Fig.154347: S-intermediate section 6 m fastening points

Fastening points	
P1 or P2 + P3	S-intermediate section 6 m



### 3.6 S-intermediate section 12 m fastening points

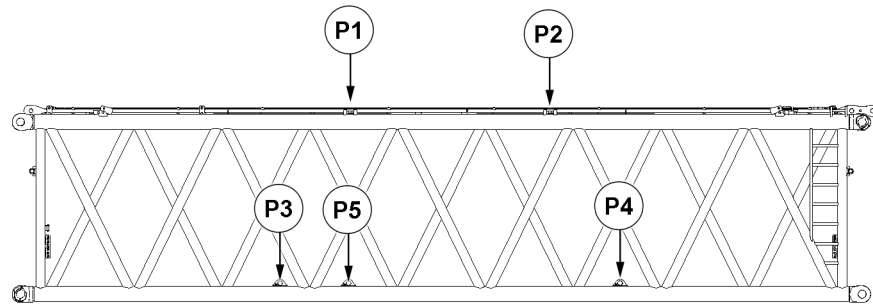


Fig.154346: S-intermediate section 12 m fastening points

Fastening points	
P1 + P2 or P3 + P4	S-intermediate section 12 m

### 3.7 SL-reducer 6 m fastening points

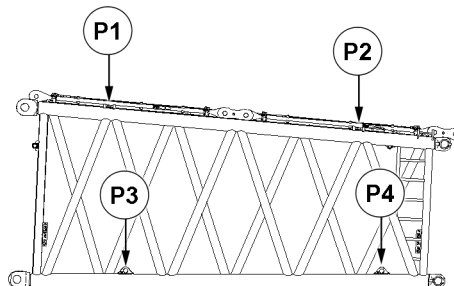


Fig.154348: SL-reducer 6 m fastening points

Fastening points	
P1 + P2 or P3 + P4	SL-reducer 6 m

LWE/LR 1800-1-0-000/27200-07-02/en

### 3.8 L-intermediate section 6 m fastening points

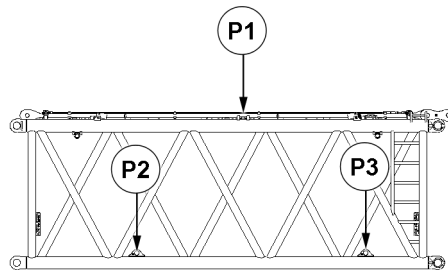


Fig.154350: L-intermediate section 6 m fastening points

Fastening points	
P1 or P2 + P3	L-intermediate section 6 m

### 3.9 L-intermediate section 12 m fastening points

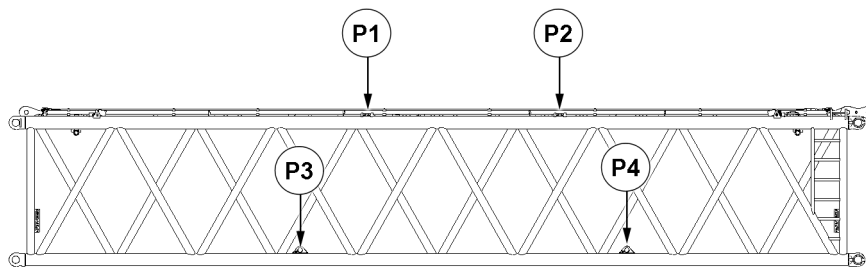


Fig.154349: L-intermediate section 12 m fastening points

Fastening points	
P1 + P2 or P3 + P4	L-intermediate section 12 m

### 3.10 L-end section fastening points

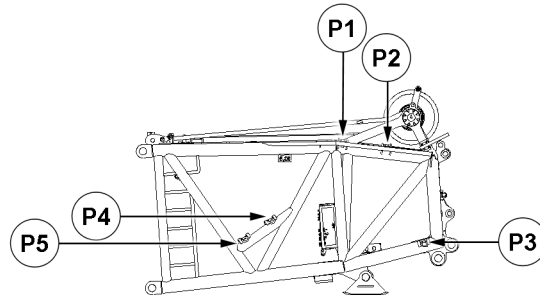


Fig.154351: L-end section fastening points

Fastening points	
P1	L-end section without roller set (fastening equipment > 4.5 m)
P2	L-end section with roller set (fastening equipment > 4.5 m)
P5 + P3	L-end section without roller set (fastening equipment > 6 m)
P4 + P3	L-end section with roller set (fastening equipment > 6 m)

### 3.11 S-end section fastening points

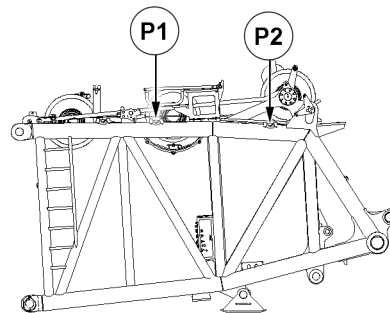


Fig.154352: S-end section fastening points

Fastening points	
P1 + P2	S-end section

LWE/LR 1800-1-0-000/27200-07-02/en

## 4 Assembling

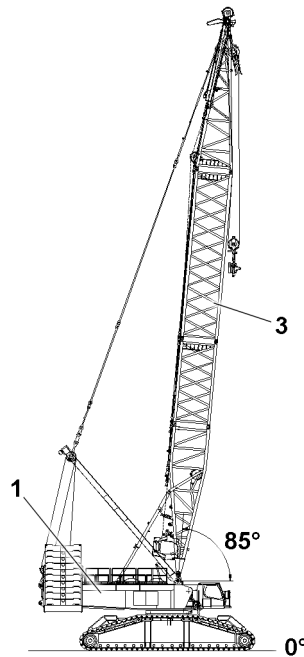


Fig.154353: D-boom in the assembly position (85°)



### Note

- ▶ Boom systems differ due to the combination of the boom lattice sections.
- ▶ The assembly is described on the example of the H-boom.
- ▶ For the combination of the boom lattice sections: Observe and adhere to the Rod plan and chapter 5.03.

Make sure that the following prerequisites are met:

- The ground is able to safely take on the entire operating weight of the crane including the load to be lifted.
- The crane is horizontally aligned.
- The SA-frame is properly assembled and secured on the turntable **1**.
- Winch 1 and winch 2 are properly assembled and secured on the turntable **1**.
- The D-boom **3** is completely assembled and secured.
- The D-boom **3** is erected to 85°.
- An auxiliary crane with sufficient load bearing capacity is available.
- An assembly scaffolding or a work platform is available.
- The central ballast has been installed on the crawler travel gear according to the load chart or the erection and take-down charts.
- The counterweight has been installed on the turntable according to the load chart or the erection and take-down charts.
- The LICCON overload protection has been set according to the data in the load charts and / or the erection and take-down charts.
- The LICCON overload protection settings have been checked for completeness and correctness.

## 4.1 Turning the turntable into the assembly position



### WARNING

The crane can topple over!

If the following conditions are not met before turning the turntable - **without** an installed main boom - the crane can topple over.

Death, severe bodily injuries, property damage.

- ▶ Observe the assembly conditions, see chapter 3.06.
- ▶ Observe the specifications in the erection and take-down charts.
- ▶ Observe the specifications in the load charts.

### NOTICE

Danger of collision!

When assembling on the side, there is a danger of collision between the H-pivot section and the crawler carrier.

Property damage.

- ▶ When assembling on the side, support the H-pivot section.
- ▶ Turn the turntable into the assembly position according to the erection and take-down charts.

## 4.2 Swinging the railing on the H-pivot section into the operating position



### WARNING

Danger of falling!

Death, severe bodily injuries, property damage.

- ▶ Assembly personnel must secure themselves for assembly / disassembly of railings and protective devices with an approved fall arrest system to prevent them from falling.
- ▶ For assembly and disassembly work, maintenance and inspection work on the H-pivot section, all railings and protective devices must be properly assembled and secured.

Make sure that the following prerequisites are met:

- The ground is able to safely take on the weight of the H-pivot section.
- The H-pivot section is lying completely on the ground.
- ▶ For the assembly / disassembly of railings and protective devices, see chapter 2.06.

## 4.3 Swinging the camera holder into the operating position

- ▶ Swing the camera holder into the operating position.
- ▶ Secure the camera holder in the operating position.

## 4.4 Assembling winch 5 and winch 6 on the H-pivot section



### Note

- ▶ Assemble winch 5 on the H-pivot section, see chapter 3.07.50.
- ▶ Bring winch 5 into the operating position, see chapter 3.07.50.



### Note

- ▶ Assemble winch 6 on the H-pivot section, see chapter 3.07.60.
- ▶ Bring winch 6 into the operating position, see chapter 3.07.60.

## 4.5 Exceeding the shut-off limits of the LICCON overload protection for assembly operation

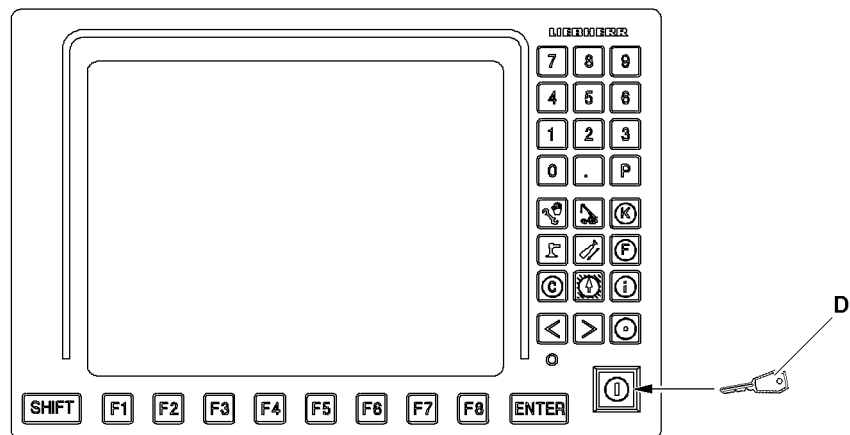


Fig.154386: LICCON monitor with assembly icon



### Note

► See chapter 4.02 and chapter 4.20.



### WARNING

Danger of accident due to the “Exceedance of shut-off limits of the LICCON overload protection” function!

If the shut off limits of the LICCON overload protection are exceeded, there is no additional protection against crane overload.

Due to erroneous operation or deliberate misuse, the crane could collapse, the main boom can break off or the crane can topple over.

Death, severe bodily injuries, property damage.

- The “Exceeding the shut-off limits of the LICCON overload protection” function is only permissible in emergencies and for assembly purposes.
- The “Exceeding the shut-off limits of the LICCON overload protection” function may only be actuated by persons who know the effects of their actions regarding the function “Exceeding the shut off limits of the LICCON overload protection”.
- The “Exceeding the shut-off limits of the LICCON overload protection” function requires the presence of an authorized person and must be performed with utmost caution.
- Crane operation with the “Exceedance of shut-off limits of the LICCON overload protection” function activated is prohibited.

- Exceeding the shut off limits of the LICCON overload protection: Activate assembly operation.

### Result:

- The shut off limits of the LICCON overload protection are exceeded.
- The assembly icon appears on the LICCON monitor.

## 4.6 Unpinning the H-connector pins on the turntable

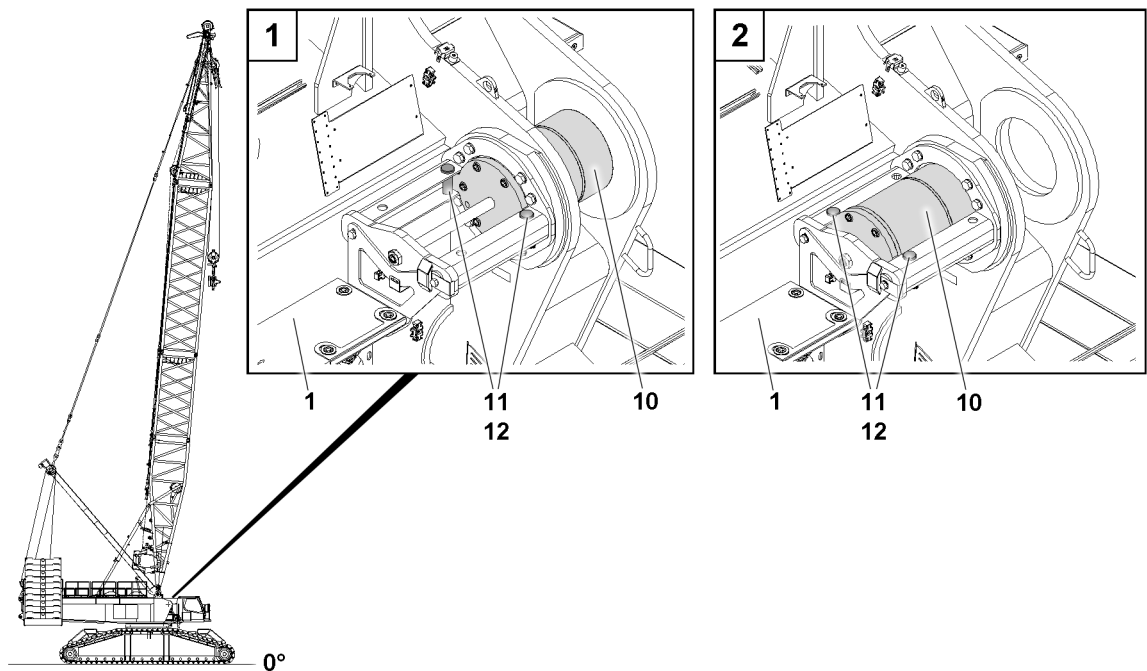


Fig.154358: Unpinning the connector pins on the turntable



### Note

- ▶ Electrical connections, see the wiring diagram.
- ▶ Hydraulic connections, see Hydraulic diagram.
- ▶ For BTT display / operating element operation, see chapter 5.31.

In the transport condition, the H-connector pins **10** are pinned on the turntable **1** and secured with the retaining pins **11**.

Make sure that the following prerequisites are met:

- The D-boom is erected to 85°.
- The crane engine is running.



### DANGER

Danger of fatal injury due to falling components!

The pins can loosen up by themselves at the pin connections and cause components to fall down. Death, severe bodily injuries, property damage.

- ▶ All pins must be secured after assembly with the intended retaining elements. Check visually.



### WARNING

Unpin or insert the H-connector pins **10**!

Danger of crushing. Limbs can be crushed or severed.

- ▶ During the unpinning procedure or pinning procedure, make sure that no persons are in the danger zone.
- ▶ Do **not** reach into the danger zone of the connector pins.

The unpinning procedure is the same for both H-connector pins:

- ▶ Release the H-connector pin **10**: Remove the retaining element **12** and unpin the retaining pin **11**.
- ▶ Unpin the H-connector pin **10**: Actuate the BTT.
- ▶ Secure the H-connector pin **10**: Insert the retaining pin **11**.
- ▶ Secure the retaining pin **11**: Attach the retaining element **12**.
- ▶ Unpin the second H-connector pin **10**, actuate the BTT.

## 4.7 Assembling the H-pivot section on the turntable

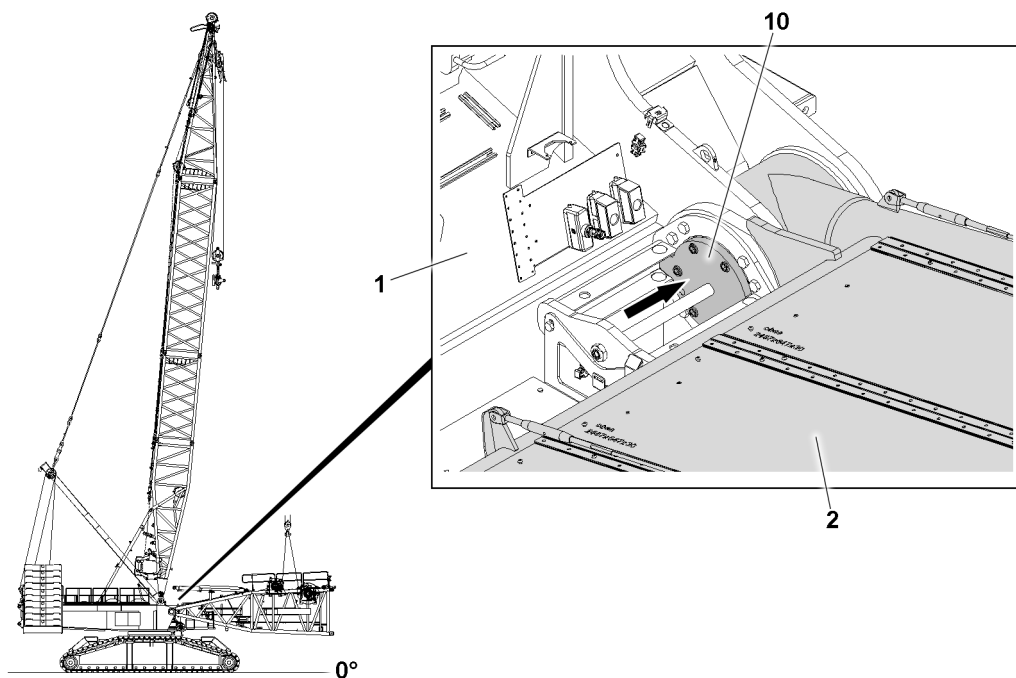


Fig.154359: Pinning the H-pivot section on the turntable

### NOTICE

Swinging in of the H-pivot section!

The H-pivot section can collide with the pin points on the turntable **1**. The H-connector pin **10** or the H-pivot section can be damaged.

- ▶ Make sure that the H-connector pins **10** are completely unpinned before assembly of the H-pivot section.



### WARNING

The crane can topple over!

If the specifications listed below are **not** observed, the crane can collapse, the main boom can break off or the crane can topple over.

Death, severe bodily injuries, property damage.

- ▶ Observe and adhere to the specifications in chapter 5.01 and chapter 5.03.
- ▶ Secure all pins after assembly with the intended retaining elements.
- ▶ Inspect the guy rods regularly, see chapter 8.15.

Make sure that the following prerequisites are met:

- The H-connector pins **10** are completely unpinned.
- The crane engine is running.

The fastening points on the H-pivot section **2** must be selected in such a way that the H-pivot section **2** hangs horizontally on the auxiliary crane during assembly. See section “Fastening points”.

- ▶ Fasten the H-pivot section **2** to the auxiliary crane.
- ▶ Swing the H-pivot section **2** in with the auxiliary crane to the pin points on the turntable.



### WARNING

Suspended H-pivot section!

Death, severe bodily injuries.

- ▶ Stepping on the H-pivot section when suspended is prohibited.
- ▶ Insert the H-pivot section **2** in the centerings on the turntable **1**.



**Result:**

- Align the pin bores.

The pinning procedure is the same for both H-connector pins:

- ▶ Pin the H-connector pin **10**: Actuate the BTT.

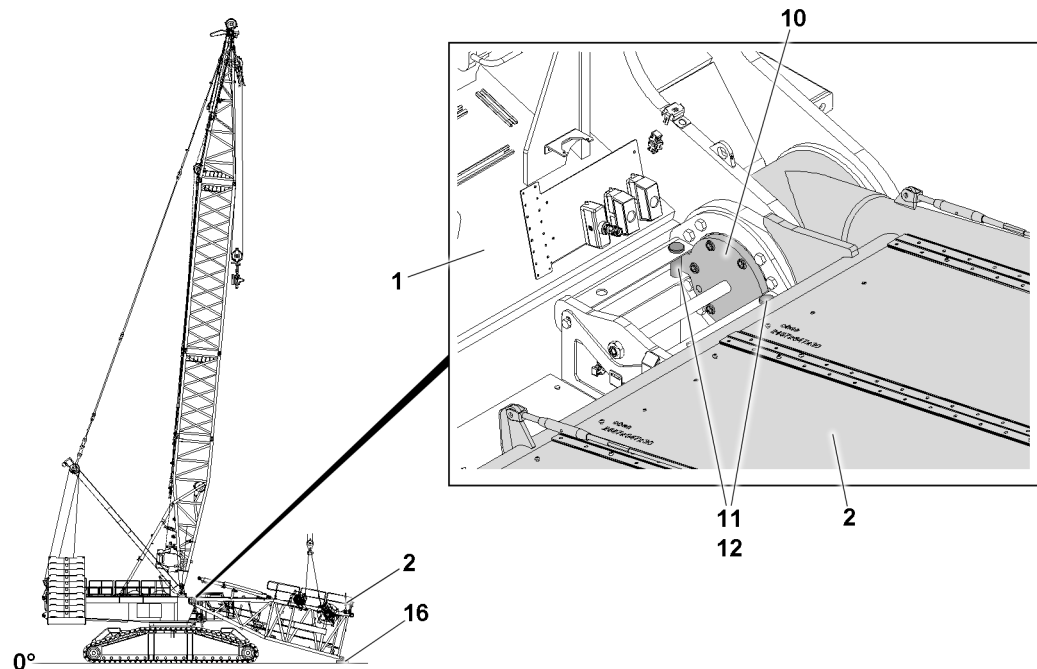


Fig.154360: Taking the H-pivot section down on the substructure on the ground

**NOTICE**

Take-down of the assembled H-pivot section!  
The H-pivot section or the turntable can be damaged.

- ▶ After assembly on the turntable, lower the H-pivot section **2** carefully onto the substructure **16** on the ground.
- ▶ Observe the specifications in the chart “Assembly conditions on crawlers”, see chapter 3.06.

**WARNING**

Incline position of the installed H-pivot section!

The mounting condition of the installed H-pivot section is selected so that the 20° incline position of the walking surfaces is not exceeded.

Death, severe bodily injuries.

- ▶ Support the H-pivot section.

When the H-connector pins **10** are completely pinned on both sides:

- ▶ Lower the H-pivot section **2** carefully and at a slow speed onto the substructure **16** on the ground.

**DANGER**

Falling H-pivot section!

Death, severe bodily injuries, property damage.

- ▶ Secure the H-connector pin **10** between the H-pivot section **2** and the turntable **1** after the pinning procedure immediately with the retaining pins **11**.

When the H-pivot section **2** is taken down on the substructure **16** on the ground:

- ▶ Secure the H-connector pin **10**: Insert the retaining pin **11** on both sides.
- ▶ Secure the retaining pin **11**: Attach the retaining elements **12**.

**Result:**

- The H-pivot section **2** is pinned and secured on the turntable **1**.
- ▶ Remove the auxiliary crane.

## 4.8 Establishing the electric and hydraulic connections on the H-pivot section

### 4.8.1 Establishing the electrical connections

**Note**

- ▶ To establish the electrical connections on the H-pivot section: Use the wiring diagram.

Make sure that the following prerequisite is met:

- The H-pivot section is completely assembled and placed on the substructure.
- ▶ Establish the electrical connections.
- ▶ Make sure that all electrical connections to the H-pivot section have been established.

**WARNING**

Dummy plugs are **not** assembled!

If the dummy plugs are not fit on the non-required electrical connections, then malfunctions or functional limitations can occur on the crane.

- ▶ Close off all **unnecessary** electrical connections, which have a dummy plug, with dummy plugs.
  - ▶ Observe the wiring diagram.
- 
- ▶ As a rule, close off non-required electrical connections (for example for accessories that are not assembled) with the respective dummy plugs.

**NOTICE**

Property damage due to dirt and / or corrosion!

If **unnecessary** electrical connections are **not** closed off with the respective protective caps, then dirt and / or corrosion can damage the electrical connections.

This could result in malfunctions.

- ▶ Make sure that all non-required electrical connections are always closed off properly.
  - ▶ Observe the wiring diagram.
- 
- ▶ Properly close off the electrical connections without dummy plugs with the corresponding protective caps.

### 4.8.2 Establishing the hydraulic connections

The hydraulic connections are established with quick couplings.

When connecting and releasing hydraulic lines with quick couplings, make sure that the coupling procedure is carried out correctly.

**DANGER**

**Incompletely** coupled quick couplings, self-loosening of quick couplings!

Serious accidents due to component failure.

Danger of accident due to loss of pressure or leakage.

- ▶ Check that the quick couplings (especially the return lines) have been properly connected before using the crane.

**WARNING**

Pressure in the hydraulic lines!

If the pressure supply is not interrupted before connecting / releasing the hydraulic lines, the hydraulic oil can escape with high pressure.

Death, severe bodily injuries, property damage.

- ▶ Release the pressure in the hydraulic system before connecting / disconnecting: Interrupt the pressure supply and wait a short time.

**Note**

- ▶ To connect or release the hydraulic lines with quick couplings, see chapter 5.01.
- ▶ Connect the coupling components (sleeve and connector) and screw them together with the knurled nut.
- ▶ Tighten the hydraulic coupling by hand. Turn the knurled nut until it reaches a tangible, fixed stop position.
- ▶ Establish the hydraulic connections, see the Hydraulic diagram.

## 4.9 Assembling the boom system

**Note**

- ▶ The pinning procedure is the same for both sides of the boom lattice section.
- ▶ The pinning procedure is the same for both levels at the “top” and at the “bottom”.

**Note**

- ▶ The pinning procedure is the same for all boom lattice sections of the boom system.

**Note**

- ▶ The H-intermediate sections **5** are pinned with the pin pulling cylinder **14**, see chapter 5.30.
- ▶ The pin pulling cylinders **14** are shown as an example.

**Note**

- ▶ For the fastening of boom lattice sections, observe and adhere to section “Fastening points”.

### 4.9.1 Installing the H-intermediate section on the H-pivot section

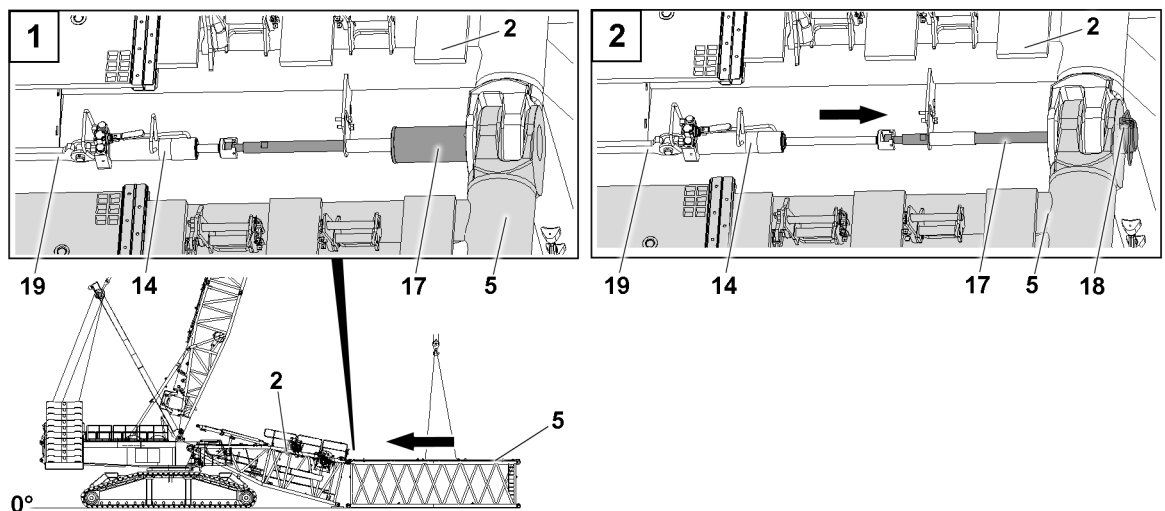


Fig.154361: Assembly of the H-intermediate section

Make sure that the following prerequisites are met:

- The H-pivot section is properly pinned and secured on the turntable.
- The H-pivot section is taken down properly on the substructure on the ground.
- Winch 5 is properly installed on the H-pivot section (only if winch 5 is required for the upcoming crane operation).
- Winch 6 is properly assembled on the H-pivot section (only if winch 6 is required for the upcoming crane operation).
- The connector pins **17** on the H-pivot section **2** are fully unpinned.



### WARNING

Unsecured pins, impermissible retaining elements!  
Falling of components. The crane can topple over.

- ▶ Secure all connector pins **17** after assembly with the intended retaining elements **18**.
- ▶ Fasten the first H-intermediate section **5** to the auxiliary crane and align it with the H-pivot section **2**.

Prerequisite for an individual pin point: The pin pulling cylinder **14** is inserted in the pin pulling device **19** and connected to the connector pin **17**.

When the pin bores align at the “top”:

- ▶ Insert the connector pin **17** on both sides to the stop: Actuate the pin pulling cylinder **14**.
- ▶ Secure both connector pins **17** with retaining elements **18**.

When the first H-intermediate section **5** is pinned and secured to the H-pivot section **2** at the “top”:

- ▶ Lower the H-intermediate section **5** onto the substructure on the ground.
- ▶ Remove the auxiliary crane.

## 4.9.2 Continuing main boom assembly

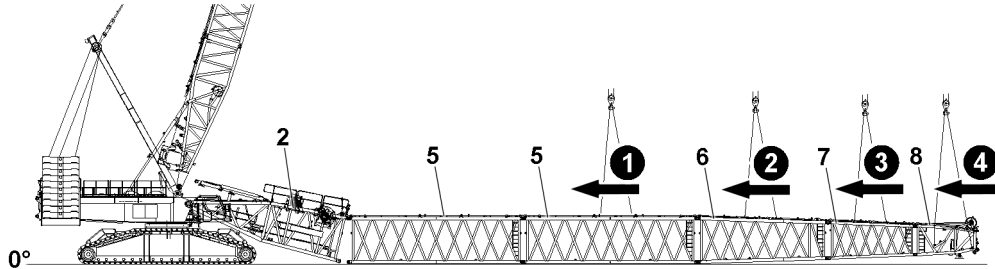


Fig.154362: Main boom assembly



### Note

- ▶ The following description is an example and will be described by means of the H-intermediate section.
- ▶ The assembly of the HS-reducer, S-intermediate section, SL-reducer, L-intermediate section, S-end section, L-end section is identical.

Make sure that the following prerequisites are met:

- The connector pins **17** on the H-intermediate sections - in direction of the expansion of the boom system - are completely unpinned.
- The first H-intermediate section **5** is lying properly on the ground or on the substructure.

**WARNING**

Impermissible assembly of the main boom!

The crane can topple over. Death, severe bodily injuries, property damage.

- ▶ The combination of the various boom systems must be taken from the Rod plan and must be observed.
- ▶ Observe the data in chapter 5.01 and chapter 5.03.
- ▶ Make sure that all pin connections are secured after assembly.
- ▶ Support the boom system during assembly and disassembly with assembly shoes.

When the connector pins **17** on the first H-intermediate section **5** are fully unpinned:

- ▶ Fasten the second H-intermediate section **5** to the auxiliary crane and swing in to the pin points on the first H-intermediate section **5**.

When the pin bores of the first and second H-intermediate section align at the “top” and “bottom”:

- ▶ Insert the connector pin **17** at the “top” on both sides with the pin pulling cylinder to the stop.
- ▶ Secure both connector pins **17** with a retaining element **18**.

When the connector pins **17** at the “top” are fully pinned to the stop and secured on both sides:

- ▶ Insert the connector pin **17** at the “bottom” with the pin pulling cylinder to the stop.
- ▶ Secure both connector pins **17** with a retaining element **18**.
- ▶ Remove the auxiliary crane.
- ▶ Assemble the HS-reducer **6**.
- ▶ Assemble the SL-reducer **7**.
- ▶ Assemble the L-end section **8**.

### 4.9.3 Pinning the upper pulley block on the H-pivot section

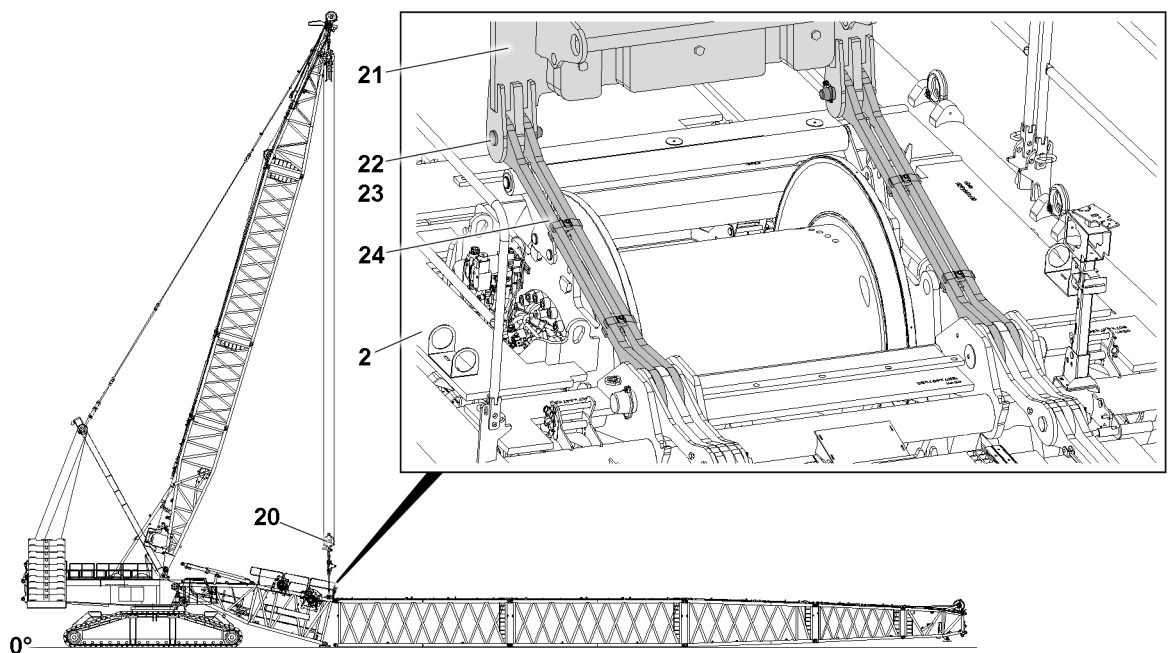


Fig. 154363: Lowering the upper pulley block and pinning it on the H-pivot section

Make sure that the following prerequisites are met:

- The auxiliary weight **21** on the upper pulley block **20** is assembled, see chapter 5.05.
  - The H-pivot section **2** is pinned and secured on the turntable.
  - The H-pivot section **2** is lying on the ground on the substructure.
  - The boom system is properly assembled and secured.
  - The auxiliary crane is removed.
- ▶ Luff down the D-boom to the front and lower the upper pulley block **20** until the auxiliary weight **21** is hanging vertically over the rods **24**.
  - ▶ Remove the retaining elements **23** from the rods **24** and unpin the pin **22**.

When the pins **22** are fully removed on both sides:

- ▶ Lower the upper pulley block **20** until the pin bores of the rods **24** and the auxiliary weight **21** align.

When the pin bores align:

- ▶ Insert the pin **22** completely on both sides.
- ▶ Secure the pin **22**: Attach the retaining element **23**.
- ▶ Luff down the D-boom to the front and lift the upper pulley block **20** until the guying is tensioned.

#### 4.9.4 Closing the boom system

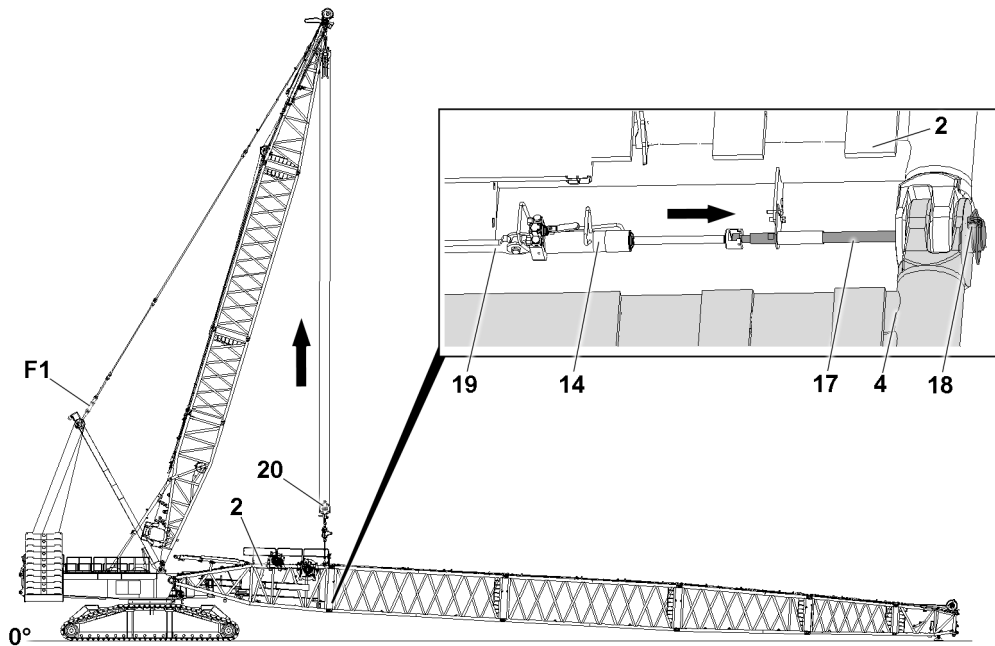


Fig.154364: Closing the boom system and pinning on both sides at the “bottom”

Make sure that the following prerequisite is met:

- The upper pulley block **20** is pinned and secured correctly with the rods **24** on the H-pivot section **2**.



#### WARNING

Overload of the crane!  
Death, severe bodily injuries, property damage.

- ▶ During the “closing procedure” of the boom system, the maximum permissible F1-total force of **250 t** in test point **F1** may not be exceeded.
- ▶ The boom end section of the corresponding boom system may **not** lift off the ground during the “closing procedure”.
- ▶ Make sure that there are no persons on the boom system or in the danger zone during the closing procedure.
- ▶ Remove main boom guy rods that are **not** required from the boom lattice sections, see chapter 5.01.
- ▶ Observe the drawings “Support assembly drawing” for the individual operating modes and “General support assembly drawing”.

Close the boom system with the upper pulley block:

- ▶ Lift the boom system with the upper pulley block **20** until the pin bores at the “bottom” align.



#### Note

- ▶ The actual force in the test point **F1** that is exerted during the closing procedure of the boom system is shown on LICCON monitor 1.

- ▶ Note the actual force in the test point **F1** and keep it ready for the opening of the boom system (disassembly).

Prerequisite for an individual pin point: The pin pulling cylinder **14** is inserted in the pin pulling device **19** and connected to the connector pin **17**.

- ▶ Pin the connector pins **17** on both sides at the "bottom".
- ▶ Secure the connector pin **17**: Attach the retaining elements **18**.



### WARNING

The main boom can fold down!

Danger of fatal injury: By unpinning the upper pulley block **20** on the H-pivot section **2**, the main boom can suddenly fold down if the main boom is not properly pinned and secured on the "bottom".

Death, severe bodily injuries, property damage.

- ▶ It is prohibited for anyone to remain under the raised boom system during the pinning / unpinning procedure.
- ▶ Unpin the upper pulley block **20** on the H-pivot section **2** only when it is ensured that the H-pivot section **2** is properly pinned and secured at the "top" and "bottom" with the H-intermediate section.

When the main boom is "closed":

- ▶ Lower the upper pulley block **20** until the rods **24** are touching winch 5.
- ▶ Unpin the auxiliary weight **21** on the rods **24**: Remove the retaining elements **23** on both sides and unpin the pin **22**.

## 4.9.5 Disassembling the auxiliary weight

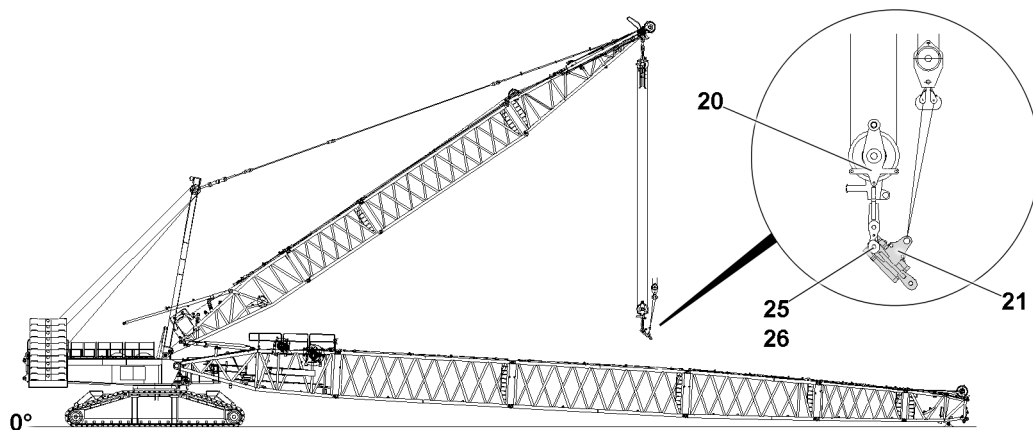


Fig.154365: Disassembling the auxiliary weight

- ▶ Luff down the D-boom to the front and lower the upper pulley block **20** until the auxiliary weight **21** can be disassembled.
- ▶ Fasten the auxiliary weight **21** to the auxiliary crane.
- ▶ Lift the auxiliary weight **21** with the auxiliary crane until the auxiliary weight hangs horizontally.



### WARNING

Laterally swinging auxiliary weight!

The auxiliary weight can swing laterally by itself due to its own weight during unpinning, see illustration.

Death, severe bodily injuries, property damage.

- ▶ Make sure that there are no persons within the danger zone during the entire pin procedure.
- ▶ Make sure that no persons reach into the danger zone during the entire pin procedure.
- ▶ Disassemble the auxiliary weight **21**: Remove the retaining elements **26** and unpin the pin **25**.
- ▶ Take the auxiliary weight **21** down on the ground with the auxiliary crane, see chapter 5.05.

## 5 Installing the boom system preassembled on the turntable

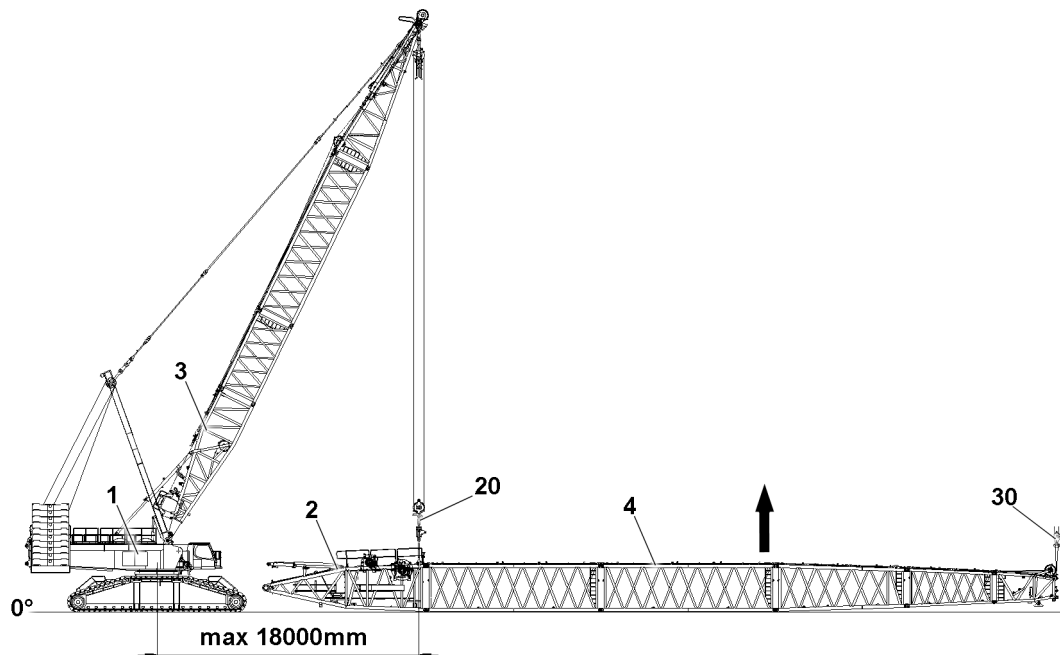


Fig.154366: Installing the preassembled main boom on the turntable



### Note

- ▶ The procedure for the assembly of the boom system on the ground is the same as the assembly of the boom system that is described in the section “Assembling the boom system”. The difference is that the H-pivot section **2** is lying on the ground, see section “Assembling the boom system”.

Make sure that the following prerequisites are met:

- The main boom is completely assembled on the ground.
- All pin connections are properly secured.

### NOTICE

Impermissible assembly!

The crane can topple over.

Death, severe bodily injuries, property damage.

- ▶ Assembly of the “preassembled” boom system is not permitted for main booms that have to be supported.



### WARNING

Impermissible boom radius!

The crane can topple over.

Death, severe bodily injuries, property damage.

- ▶ Observe the maximum boom radius of the D-boom of 18000 mm.

- ▶ Pin the upper pulley block **20** with the H-pivot section **2**.

- ▶ Lift the main boom **4** with the D-boom **3** and auxiliary crane **30** in to the pin points on the turntable **1**.

or

- ▶ Move the main boom **4** with the D-boom **3** and auxiliary crane **30** until the pin points between the H-pivot section **2** and the turntable **1** align.

- ▶ Pin and secure the main boom **4** properly on the turntable **1**.



- ▶ Use the auxiliary crane **30** to lower the main boom **4** to the ground.

## 6 Assembling the boom system with the substructure

If the assembly conditions for the assembly of the boom system are restricted due to the terrain at the job site, then it is possible to assemble the boom system with the substructure.



### WARNING

General danger notes!

- ▶ Secure all pins after assembly with the intended retaining elements.
- ▶ Inspect the guy rods regularly, see chapter 8.15.
- ▶ Secure the main boom with the substructure or auxiliary crane, see chapter 5.01.
- ▶ It is prohibited for anyone to remain under the main boom or in the entire danger zone during the pinning and unpinning procedure of the boom lattice sections.



### WARNING

The crane can topple over!

Death, severe bodily injuries, property damage.

- ▶ For assembly and disassembly of the main boom with the substructure, observe chapter 5.01.
- ▶ The “actual force” in test point **F1** is shown on LICCON monitor 1.
- ▶ Observe the assembly conditions, see chapter 3.06.
- ▶ The data in the erection and take-down charts as well as the load charts must be observed.
- ▶ Refer to the rod plan for the division of the boom lattice sections.

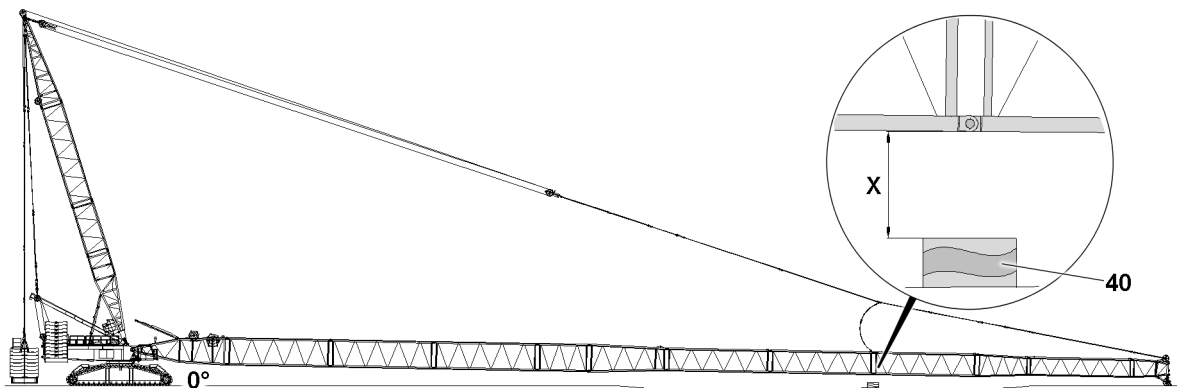


Fig. 154373: Boom system with the substructure (shown as an example)

**40** Substructure

**X** Maximum distance<sup>1)</sup>

<sup>1)</sup> X corresponds to the maximum permissible flexation of the boom system



### Note

- ▶ For the maximum distance **X**, see the separately supplied drawing “Support assembly drawing”.
- ▶ The point in which the boom system must be supported depends on the corresponding operating mode, see the separately supplied drawings “General support assembly drawing”.

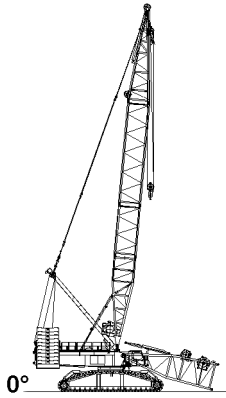


Fig.154374: Installing the H-pivot section (shown as an example)

- ▶ Install the H-pivot section, see section “Assembling the H-pivot section on the turntable”.

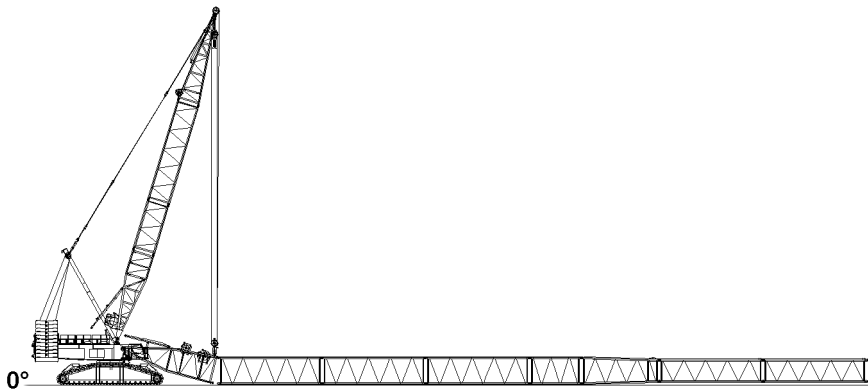


Fig.154375: Assembling the boom system (shown as an example)

- ▶ Install the boom system to the point in which it must be supported according to the separately supplied rod plans and drawings “Support assembly drawing” for the individual operating modes, “General support assembly drawing”.

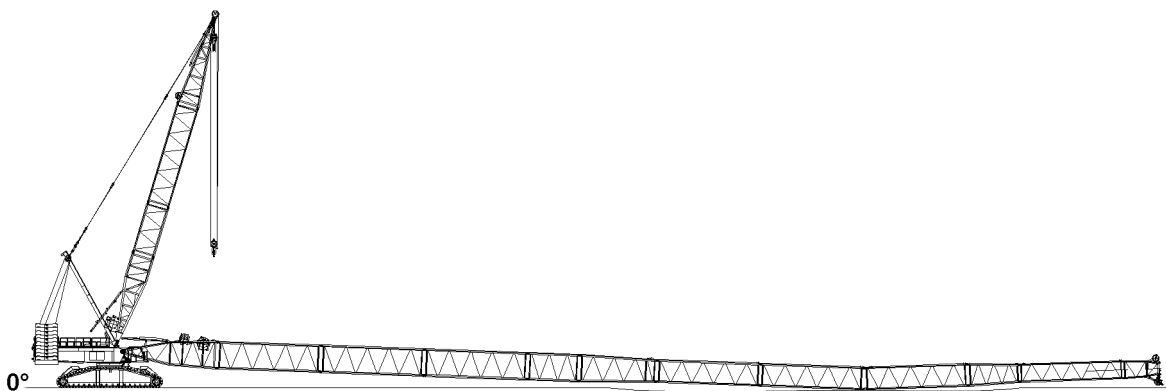


Fig.154376: Further assembling of the boom system (shown as an example)

- ▶ Close the boom system on the H-pivot section with adjustment or auxiliary crane.
- ▶ Assemble the boom system further according to the separately supplied rod plans and drawings “Support assembly drawing” for the individual operating modes, “General support assembly drawing”.

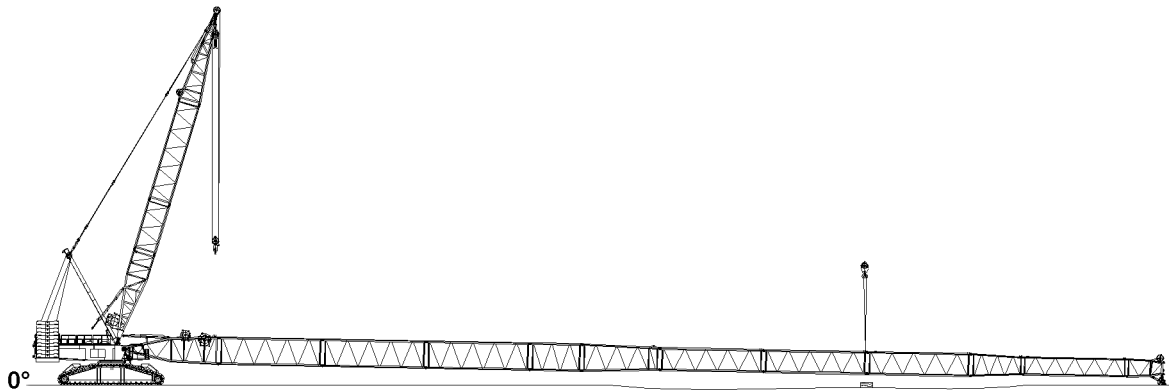


Fig.154377: Closing and supporting the boom system (shown as an example)

#### NOTICE

Negative angle!

Overload of the main boom during the erection procedure.

Damage to the boom system.

- ▶ Negative angles in the erection and take-down charts are to be observed.
- ▶ If necessary, the boom end section must be supported with suitable and sufficiently load bearing materials.

#### NOTICE

Main boom **not** supported before the erection procedure!

Overload of the main boom during the erection procedure.

Damage to the boom system.

- ▶ Make sure that the maximum distance **X** is never exceeded.
- ▶ Support the main boom with suitable materials with sufficient load bearing capacity in the marked area, see illustration.

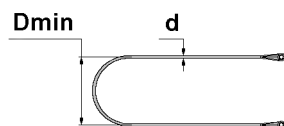
- ▶ Close and support the boom system.

## 7 Assembling the main boom guying

### 7.1 Auxiliary guying

An auxiliary guying must be assembled depending on the boom system, see the rod plan.

Fiber guy ropes are used for the auxiliary guying. Comply with the following regulations.



$$D_{min} = 20 \times d$$

Fig.160908: Fiber guy rope: Calculation of minimum permissible bending diameter

Formula element	Meaning
Dmin	Minimum permissible bending diameter
d	Rope diameter

Minimum permissible bending diameter: Definition of the formula elements

**WARNING**

Impermissible assembly of fiber guy ropes!

The fiber guy ropes can rip.

Death, severe bodily injuries, property damage.

- ▶ Before assembling the fiber guy ropes, check if the fiber guy ropes are rigidly frozen or covered with ice. See chapter 5.01.
- ▶ Do **not** assemble fiber guy ropes that are rigidly frozen or covered with ice.
- ▶ Do **not** use buckled, knotted or twisted fiber guy ropes.
- ▶ Never fall below the minimum permissible bending diameter **D<sub>min</sub>** of **20** x rope diameter **d**.
- ▶ Do **not** assemble damaged fiber guy ropes.
- ▶ Make sure that the identification of the fiber guy rope on the rod plan and the identification on the individual fiber guy ropes are identical. Identify the fiber guy rope, see chapter 5.01.
- ▶ Make sure that the operating temperature of the fiber guy ropes of -40 °C to +60 °C is **not** fallen below or exceeded.
- ▶ Check the fiber guy ropes for damage prior to assembly, after disassembly and after exceptional events, see chapter 8.16.
- ▶ Comply with the maintenance intervals, see chapter 7.03.50.
- ▶ Replace damaged fiber guy ropes.
- ▶ Observe the notes regarding the proper transport and storage of the fiber guy ropes, see chapter 2.04.
- ▶ Observe the instructions for the proper handling of fiber guy ropes, see chapter 5.01.
- ▶ Only fasten the fiber guy ropes in the permissible range with belt loops, see chapter 5.01.

Make sure that the following prerequisites are met:

- The main boom is supported.
- **Or** the main boom is lying on the ground.
- The D-boom is lowered to the front.

## 7.2 Assembling the main boom guy rods

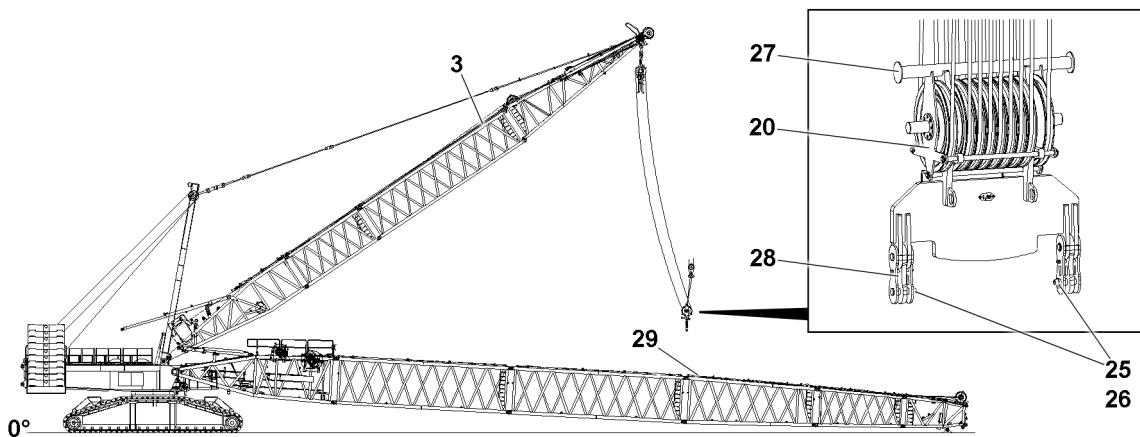


Fig.154367: Positioning the upper pulley block, main boom guy rod pin points

The main boom guy rods are taken down and secured on the boom lattice sections during transport. Before assembly of the main boom guy rods, release the transport retainers.

**WARNING**

Neglected inspection and maintenance on the main boom guy rods!

Death, severe bodily injuries, property damage.

- ▶ Inspect the main boom guy rods before every assembly, see chapter 8.15.
- ▶ Assemble and secure the main boom guy rods, see the rod plan. Make sure that the numbering in the rod plan is identical to the numbering on the main boom guy rods.
- ▶ Adhere to the inspection intervals and maintenance intervals.

**WARNING**

Incorrect assembly of the main boom guy rods!  
Death, severe bodily injuries, property damage.

- ▶ Assemble the main boom guy rods according to the rod plan.

The upper pulley block **20** can be positioned with an auxiliary crane in the direction of the boom head above the main boom guy rods **29**.

- ▶ To position the upper pulley block **20**, loop it around the pipe **27**.
- ▶ Lower the D-boom **3** to the front and position the upper pulley block **20** above the pin points of the main boom guy rods **29**.
- ▶ Release and unpin the transport retainers of the main boom guy rods **29**.

**NOTICE**

Impermissible pinning of the main boom guy rod pins!

If the pins of the main boom guy rods are not pinned from the “inside” to the “outside”, the hoist rope can scrape on the pins and be damaged.

- ▶ Always insert the pins of the main boom guy rods from the “inside” to the “outside”, see the rod plan.
- ▶ Pin the required main boom guy rods with each other: Insert the pin from the “inside” to the “outside” and secure with retaining elements.
- ▶ Assemble the guying according to the Rod plan, pin and secure it properly.
- ▶ Make sure that all required main boom guy rods of the boom system are pinned and secured.

**WARNING**

Unused main boom guy rods on the main boom!

If main boom guy rods are on the boom lattice sections that are not required for crane operation, then there is a danger of accident.

Death, severe bodily injuries, property damage.

- ▶ Remove main boom guy rods that are not required from the boom lattice sections, see chapter 5.01.
- ▶ Remove main boom guy rods that are **not** required from the boom lattice sections.
- ▶ Position the upper pulley block **20** until the lug **28** and main boom guy rods **29** can be pinned.
- ▶ Pin the upper pulley block **20** with the main boom guy rods **29**: Insert the pins **25** on both sides.
- ▶ Secure the pin **25**: Attach the retaining elements **26**.

## 7.3 Assembling the auxiliary guying

This section is valid solely only for the boom with the auxiliary guying.

- ▶ Assemble the auxiliary guying, see chapter 5.01 and chapter 5.03.
- ▶ Erect the D-boom **3** and spool out winch **3** at the same time until the auxiliary guying can be assembled.
- ▶ Assemble the auxiliary guying.
- ▶ Ensure that the guy rods are properly pinned and secured with each other.
- ▶ Make sure that the auxiliary guying is properly pinned and secured.

## 7.4 Erecting the D-boom

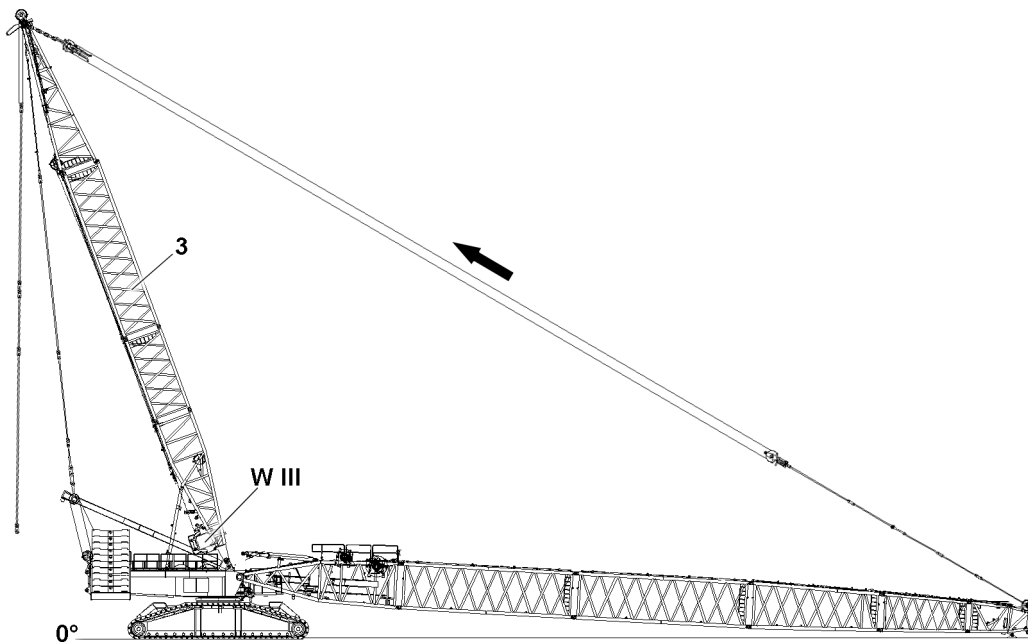


Fig.154368: D-boom in the operating position, tensioning the guying



### WARNING

Lifting of the boom system!

Death, severe bodily injuries, property damage.

- ▶ The boom system may **not** be raised when erecting the D-boom **3** into the operating position.
- ▶ Make sure that the boom system remains in its initial position during erection.

### NOTICE

Winch **3 WIII** spooled out too quickly during the erection procedure of the D-boom!

Slack rope formation.

- ▶ Make sure that the rope of winch **3 WIII** is tensioned during the entire erection procedure of the D-boom.

If auxiliary guying is assembled on the boom. Comply with the following regulations.



### WARNING

Temperatures below 0 °C: Fiber guy ropes that are rigidly frozen or covered with ice!

Buckling of the fiber guy ropes. The fiber guy ropes can rip.

Death, severe bodily injuries, property damage.

- ▶ While the main boom guying is tensioned, check if the fiber guy ropes are rigidly frozen or covered with ice.
- ▶ Do **not** bend fiber guy ropes that are rigidly frozen or covered with ice.
- ▶ Do **not** erect boom systems with fiber guy ropes that are rigidly frozen or covered with ice (for example auxiliary guying, guying for the F-jib).
- ▶ Observe the instructions in chapter 5.01.

- ▶ Erect the D-boom **3** in the operating position and spool out winch **3 WIII** at the same time.

When the D-boom **3** is in the operating position:

- ▶ Tension the main boom guying between the D-end section and the boom end section.

## 8 Establishing the electrical connections on the boom end section

Make sure that the following prerequisites are met:

- The H-intermediate sections are properly assembled and secured on the ground.
- The boom end section is properly assembled and secured.
- The airplane warning light, wind speed sensor and all sensors are properly assembled and secured on the boom end section.
- The hoist limit switches are properly installed and secured on the pulley head / pulley heads.

### NOTICE

Electrical connections established in an impermissible order!

The electrical connection is damaged when spooling out the cable drum.

- ▶ First step: Establish the electrical connection from the cable drum on the H-pivot section to the terminal box on the boom end section.
- ▶ Second step: Establish the electrical connection from the terminal box in the H-pivot section to the cable drum.



### Note

- ▶ To establish the electrical connections on the main boom: Use the wiring diagram.

- ▶ Establish the electrical connections.
- ▶ Make sure that all electrical connections on the main boom are established.



### WARNING

Dummy plugs are **not** assembled!

If the dummy plugs are not fit on the non-required electrical connections, then malfunctions or functional limitations can occur on the crane.

- ▶ Close off all **unnecessary** electrical connections, which have a dummy plug, with dummy plugs.
- ▶ Observe the wiring diagram.
- ▶ As a rule, close off non-required electrical connections (for example for accessories that are not assembled) with the respective dummy plugs.

### NOTICE

**Non-assembled protective caps!**

If non-required electrical connections are not closed off, then dirt and / or corrosion can damage the electrical connections. This could result in malfunctions.

- ▶ Always properly close off all **non**-required electrical connections with their protective caps.
- ▶ Observe the wiring diagram.
- ▶ Properly close off the electrical connections without dummy plugs with the corresponding protective caps.

## 9 Performing the function checks



### WARNING

Malfunctioning safety equipment!

Death, severe bodily injuries, property damage.

- ▶ Crane operation with non-functioning safety equipment is **prohibited**.
- ▶ Start crane operation only after all safety equipment have been checked and are functioning correctly.

**Note**

- ▶ The function of the individual limit switches must be checked before erection of the boom system.
- ▶ The function of the limit switch initiators must be checked in the test system, see the Diagnostics manual.

**Note**

- ▶ If a function check on the limit switches or on the safety equipment does not lead to the desired shut-offs, then the plug connections on the connector boxes or the components itself must be checked.

If no visible connection errors or component defects can be found:

- ▶ Contact Customer Service at Liebherr-Werk Ehingen GmbH.

Make sure that the following prerequisites are met:

- All electrical connections are established.
- The crane engine is running.
- The corresponding operating mode is set on the LICCON monitor.
- The actuator levers of the limit switches have been checked for easy movement and are lubricated.

## 9.1 Wind speed sensor

- ▶ Check the movement and the function of the wind speed sensor.

## 9.2 Airplane warning light

- ▶ Turn the airplane warning light on, see chapter 4.01.
- ▶ Check the function visually.

## 9.3 Hoist limit switch

- ▶ Actuate the hoist limit switch manually on the pulley head.

**Result:**

- The hoist winch turns off in upward movement.
- The hoist top icon on LICCON monitor 0 blinks.
- The hoist limit switch is functioning.

## 9.4 Checking the main boom “steep position” limit switch

**Note**

- ▶ The limit switch functions have to be checked individually before erection.

- ▶ Cover the limit switch initiators on the relapse cylinders of the main boom individually with a metal plate.

**Result:**

- The limit switch is actuated manually.
- The spool up function of winch 3 turns off.
- The “Boom limitation” icon appears on LICCON monitor 0.

# 10 Erecting the boom system

**DANGER**

The crane can topple over!

- ▶ It is prohibited to turn the crane superstructure while erecting the main boom.
- ▶ Adhere to the specifications in the erection and take-down charts.



**WARNING**

Crane operation with bypassed LICCON overload protection!

The protection against overload of the crane is deactivated. In the case of an overload, the crane can topple over.

Death, severe bodily injuries, property damage.

- ▶ The boom radii specified in the load chart may not be exceeded or fallen below, even if there is no load on the hook.
- ▶ Do **not** operate the crane with LICCON overload protection bypassed.

If required in the erection and take-down chart:

- ▶ Carry the hook block along with the auxiliary crane.

**WARNING**

The crane can topple over!

Death, severe bodily injuries, property damage.

- ▶ Observe the technical safety instructions, see chapter 5.01.
- ▶ Make sure that the relapse cylinders of the main boom are completely extended before erection of the boom system.
- ▶ Do not allow slack rope to build up on winch 4.

**WARNING**

Falling hoist rope!

Death, severe bodily injuries, property damage.

- ▶ Reeve the hoist rope in before the erection procedure with a sufficient length on the roller set / roller sets of the boom end section.
- ▶ The hoist rope must be constantly monitored during the erection procedure.
- ▶ Make sure that there are no persons in the danger zone.

If auxiliary guying is assembled on the boom system. Comply with the following regulations.

**WARNING**

Temperatures below 0 °C: Fiber guy ropes that are rigidly frozen or covered with ice!

Buckling of the fiber guy ropes. The fiber guy ropes can rip.

Death, severe bodily injuries, property damage.

- ▶ While erecting the boom system, check if the fiber guy ropes are rigidly frozen or covered with ice.
- ▶ Do **not** bend fiber guy ropes that are rigidly frozen or covered with ice.
- ▶ Do **not** erect boom systems with fiber guy ropes that are rigidly frozen or covered with ice (for example auxiliary guying, guying for the F-jib).
- ▶ Observe the instructions in chapter 5.01.

Make sure that the following prerequisites are met:

- The crane is horizontally aligned.
- The main boom guy rods are properly assembled.
- Main boom guy rods that are not required are removed from the boom lattice sections.
- All electrical connections are established.
- All hydraulic connections are established.
- The function checks were carried out properly.
- All limit switches and warning devices are functioning.
- The counterweight has been installed on the turntable according to the erection and take-down charts.
- The central ballast is installed in the crane chassis according to the erection and take-down charts.
- All pin connections are secured.
- The hoist rope has been correctly inserted in the rope pulleys and is prevented from jumping out with the rope retaining pins.
- There are no loose parts on the main boom.
- The main boom is free of snow, frost and ice.
- The LICCON overload protection has been set according to the data in the load chart.
- The load weighing was carried out on the boom system and the hook block weight has been entered on the LICCON monitor, see the chapter 4.02.
- The LICCON overload protection settings have been compared with the actual set up configuration.
- The LICCON overload protection is exceeded.
- The assembly icon is visible on the LICCON monitor.
- No personnel or obstacles are within the danger zone.

## 10.1 Assembling the derrick ballast



### WARNING

The crane can topple over!

Death, severe bodily injuries, property damage.

- ▶ Observe the erection and take-down charts.
- ▶ If derrick ballast is required for erecting the boom system, assemble the derrick ballast.

If derrick ballast is required for erecting the boom system:

- ▶ Assemble the derrick ballast, see chapter 5.36.

## 10.2 Extending the relapse cylinders of the main boom

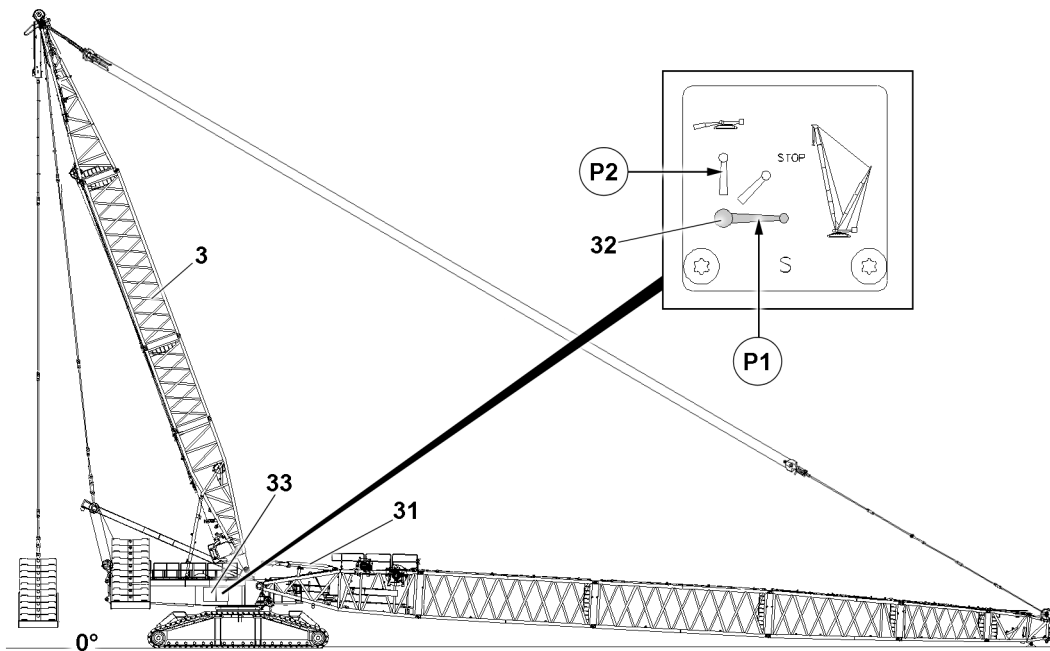


Fig.154369: Relapse cylinder of the main boom, ball valve positions



### WARNING

Impermissible prerequisites before erection!

The crane can topple over. Death, severe bodily injuries, property damage.

- ▶ Extend the relapse cylinder of the main boom **31** completely before erecting the boom system.
- ▶ Secure the ball valve **32** during crane operation to prevent inadvertent actuation.

Position (P)	Function
1	Crane operation, extend the piston rod
2	Assembly, retract the piston rod
STOP	The piston rod cannot be retracted / extended

Relapse cylinder of the main boom, ball valve positions

- ▶ Set the ball valve **32** to position **P1**.

### Result:

- The piston rods of the main boom relapse cylinders **31** extend.

The ball valve **32** is secured by closing the cabinet door **33** and removing the key.

- ▶ Close the cabinet door **33** and pull out the key.
- ▶ Hand the key to an authorized person.

### 10.3 Disassembling the feet on the L-end section

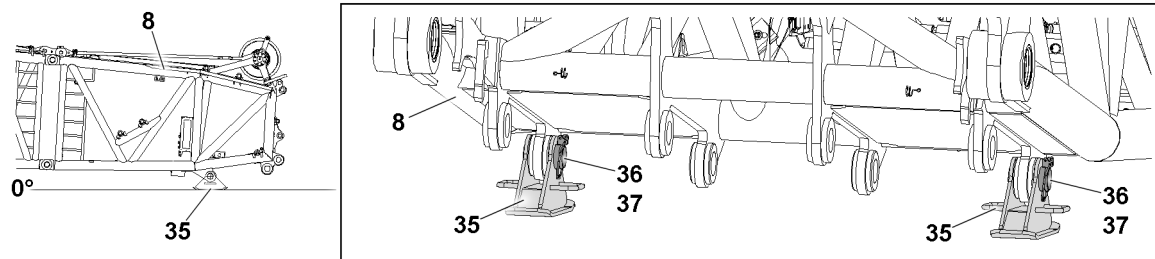


Fig.154370: Disassembling the feet



#### Note

► Unpinning the feet is also necessary for the main boom with an S-end section.

- Unpin the feet **35**: Remove the retaining element **37** and unpin the pin **36**.
- Erect the main boom until the L-end section **8** lifts off the ground.

#### Result:

- The feet **35** remain on the ground.

### 10.4 Assembling the roller set

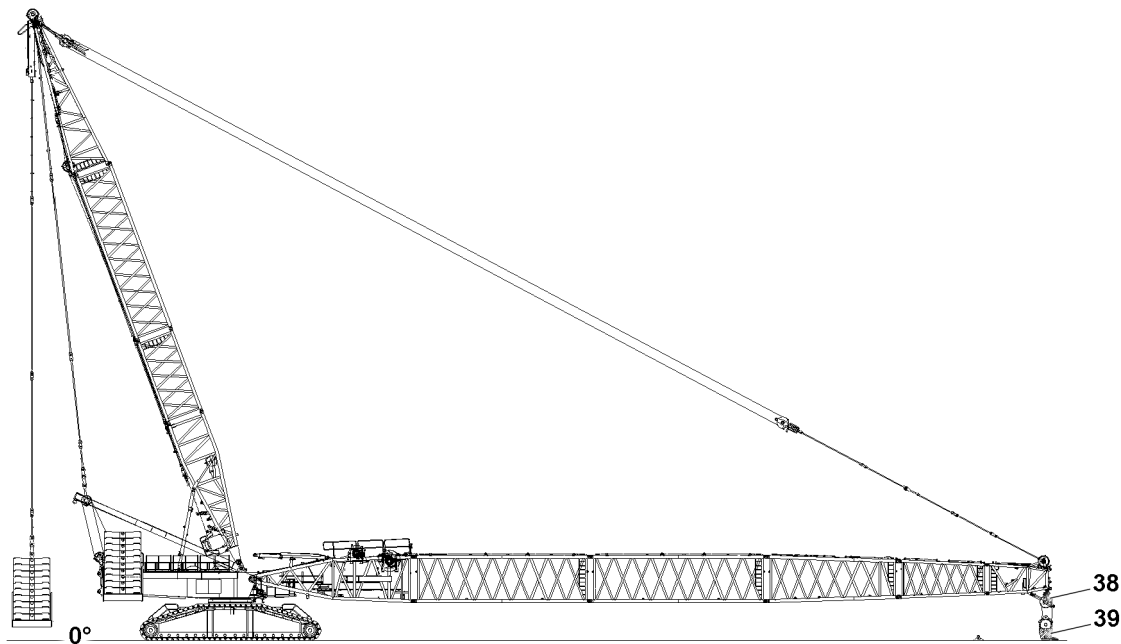


Fig.154371: Assembling the roller set and reeving in the hook block



#### Note

► Assembly of the roller set **38**, see chapter 5.14.

When the roller set **38** is properly assembled on the L-end section:

- Route the hoist limit switch from the L-end section forward on the roller set **38**, pay attention to the wiring diagram.

## 10.5 Reeving the hook block in



### WARNING

Danger of accident due to side wind!

If the slewing gear brake is released after reeving in / reeving out the hook block / load hook, then the crane can turn uncontrolled in strong side wind.

The crane can collide with near-by structures or objects.

Death, severe bodily injuries, property damage.

- ▶ Make sure that the current wind speed does not exceed the values from the wind speed chart when releasing the slewing gear brake.

Make sure that the following prerequisites are met:

- The slewing gear brake is applied.

### NOTICE

Danger of slack rope formation!

Slack rope can form if the hoist winch is spooled out too fast during the reeving procedure.

- ▶ Make sure that the hoist rope is tensioned during the entire reeving procedure.



### WARNING

Falling hoist rope!

Death, severe bodily injuries, property damage.

- ▶ Reeve in the hoist rope before the erection procedure with sufficient length on the boom system.
- ▶ The hoist rope must be constantly monitored during erection.
- ▶ Do not enter the danger zone.

- ▶ Place the hook block **39** under the roller set **38**.
- ▶ Reeve the hoist rope in properly and secure in the rope fixed point, see chapter 4.06 and reeving plan.
- ▶ Pin and secure the rope retainers on the rope pulleys, see chapter 4.06.
- ▶ Attach the hoist limit switch weight, see chapter 4.06.

## 10.6 Erecting the boom system

Make sure that the following prerequisites are met:

- Crane ballasting (counterweight, central ballast, derrick ballast and / or auxiliary ballast) is carried out according to the load charts and / or the erection and take-down charts.



### WARNING

Crane operation with bypassed LICCON overload protection!

The protection against overload of the crane is deactivated. In the case of an overload, the crane can topple over.

Death, severe bodily injuries, property damage.

- ▶ The boom radii specified in the load chart may not be exceeded or fallen below, even if there is no load on the hook.
- ▶ Do **not** operate the crane with LICCON overload protection bypassed.



### Note

- ▶ When the lowest operating position of the boom system is reached, the set load chart of the LICCON overload protection is activated.
- ▶ The maximum load icon displays a load number in "t" instead of the "???" display.

- ▶ Luff the boom system up to the lowest operating position.

When the boom system has reached the lowest operating position:

- ▶ Make sure that the assembly icon on the LICCON monitor turns off.

**Result:**

- The LICCON overload protection is active.

## 11 Operating the crane

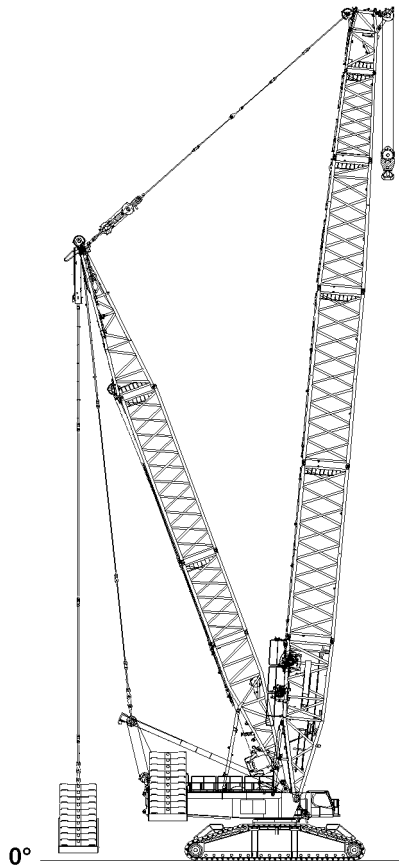


Fig.154372: Crane

### 11.1 Preparing for crane operation

**Note**

- ▶ Observe the notes, see chapter 4.02, chapter 4.04, chapter 4.05, chapter 4.08 and chapter 5.01.

Make sure that the following prerequisites are met:

- The LICCON overload protection is active.
- The LICCON overload protection has been set according to the data in the load chart.

**WARNING**

The crane can topple over!

- ▶ Check the horizontal position of the crane before and during crane operation.
- ▶ If the crane operator leaves the cab, even for a short time, the operating mode setting must be checked and reset if necessary before resuming crane operation.

#### 11.1.1 Checking the settings

- ▶ Check the function of the overload protection by running against the operating positions “on top” and “bottom”.
- ▶ Check the hoist limit switch by running against the hoist limit switch weight.

## 12 Disassembling



### Note

- ▶ Boom systems differ due to the combination of the boom lattice sections.
- ▶ The disassembly is described on the example of the H-boom.

Make sure that the following prerequisites are met:

- The ground is able to safely take on the total operating weight of the crane.
- The crane is horizontally aligned.
- An auxiliary crane with sufficient load bearing capacity is available.
- An assembly scaffolding or a work platform is available.
- The central ballast has been installed on the crawler travel gear according to the load chart or the erection and take-down charts.
- The counterweight has been installed on the turntable according to the load chart or the erection and take-down charts.
- The LICCON overload protection has been set according to the data in the load charts and / or the erection and take-down charts.
- The LICCON overload protection settings have been checked for completeness and correctness.

### 12.1 Disassembling the derrick ballast



#### WARNING

The crane can topple over!

Death, severe bodily injuries, property damage.

- ▶ Observe the erection and take-down charts.
- ▶ If a derrick ballast is required for taking down the boom system, then leave the derrick ballast on the crane.

If derrick ballast is not required for taking down the boom system:

- ▶ Disassemble the derrick ballast, see chapter 5.36.

### 12.2 Disassembling the central ballast



#### WARNING

The crane can topple over!

Death, severe bodily injuries, property damage.

- ▶ Observe the erection and take-down charts.
- ▶ If a central ballast is required for taking down the boom system, then leave the central ballast on the crane.

When no central ballast is required for taking down the boom system:

- ▶ Disassemble the central ballast, see chapter 3.03.

### 12.3 Turning the turntable into the disassembly position



#### WARNING

The crane can topple over!

Death, severe bodily injuries, property damage.

- ▶ Observe the specifications in the erection and take-down charts.
- ▶ Observe the data in the load charts.

- ▶ Turn the turntable to the disassembly position according to the erection and take-down charts.

## 12.4 Luffing the boom system down



### WARNING

The crane can topple over!

Death, severe bodily injuries, property damage.

- ▶ Observe the technical safety instructions, see chapter 5.01.
- ▶ Observe the specifications in the erection and take-down charts.

If auxiliary guying is assembled on the boom system. Comply with the following regulations.



### WARNING

Temperatures below 0 °C: Fiber guy ropes that are rigidly frozen or covered with ice!

Buckling of the fiber guy ropes. The fiber guy ropes can rip.

Death, severe bodily injuries, property damage.

- ▶ While taking down the boom system, check if the fiber guy ropes are rigidly frozen or covered with ice.
- ▶ Do **not** bend fiber guy ropes that are rigidly frozen or covered with ice.
- ▶ Do **not** take down boom systems with fiber guy ropes that are rigidly frozen or covered with ice (for example auxiliary guying, guying for the F-jib).
- ▶ Observe the instructions in chapter 5.01.

### NOTICE

Damage to the boom components!

Taking down the boom system can lead to a collision between the hook block and the pulley head.

The boom components can be severely damaged.

- ▶ Luff the boom system down at the same time and spool the hoist winch out.
- ▶ When luffing the boom system down, the D-boom must remain in operating position until the main boom is lying on the substructure or until the boom end section is lying on the ground, or the main boom is safely held by an auxiliary crane.



### Note

- ▶ The luff down movement is turned off as soon as the lowest operating position of the main boom is reached.
- ▶ When the lowest operating position of the main boom is reached, the load display in the maximum load icon turns off and instead of the load display appears the display “???”.  
▶ Alarm functions appear on the crane operating screen.
- ▶ Luff the main boom down to the **lowest** operating position.

### Result:

- The luffing movement is turned off.
- The “STOP” icon appears on the LICCON monitor.
- The horn icon appears on the LICCON monitor.



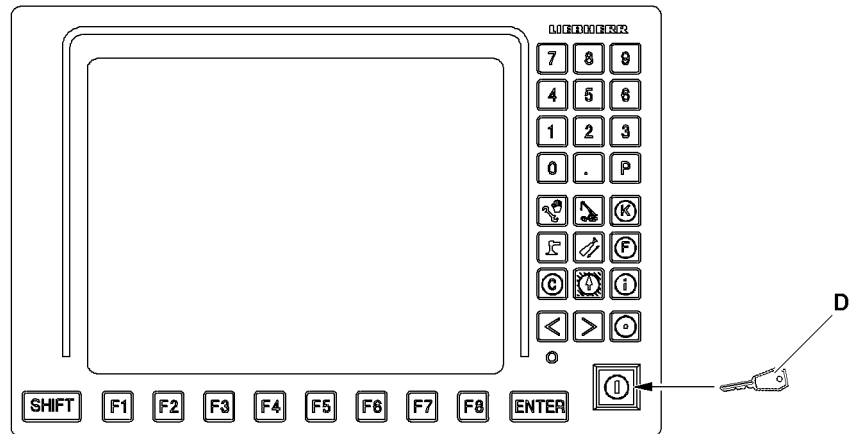


Fig.154386: LICCON monitor with assembly icon



### WARNING

Danger of accident due to the “Exceedance of shut-off limits of the LICCON overload protection” function!

If the shut off limits of the LICCON overload protection are exceeded, there is no additional protection against crane overload.

Due to erroneous operation or deliberate misuse, the crane could collapse, the main boom can break off or the crane can topple over.

Death, severe bodily injuries, property damage.

- ▶ The “Exceedance of shut-off limits of the LICCON overload protection” function is only permissible in emergencies and for assembly purposes.
- ▶ The function “Exceeding the shut off limits of the LICCON overload protection” may only be actuated by persons who know the effects of their actions regarding the function “Exceeding the shut off limits of the LICCON overload protection”.
- ▶ The “Exceedance of shut off limits of the LICCON overload protection” function requires the presence of an authorized person and must be performed with utmost caution.
- ▶ Crane operation with the “Exceedance of shut off limits of the LICCON overload protection” function activated is prohibited.

- ▶ Exceeding the shut off limits of the LICCON overload protection: Activate assembly operation.

### Result:

- The shut off limits of the LICCON overload protection are exceeded.
- The assembly icon appears on the LICCON monitor.



### Note

- ▶ See chapter 4.02 and chapter 4.20.

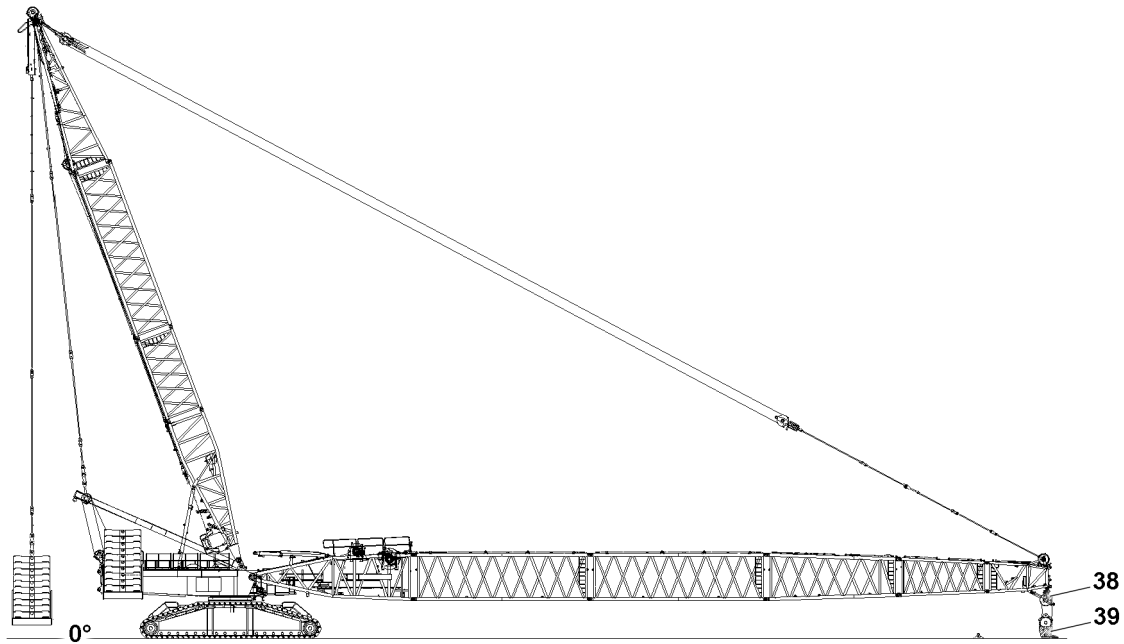


Fig.154371: Reeving out the hook block and disassembling the roller set

- ▶ At the same time, spool the hoist winch out and luff the boom system down until the hook block **39** touches the ground.
- ▶ Disassemble the hoist limit switch weight and reeve the hook block **39** out.
- ▶ Remove the hook block **39** with the auxiliary crane.

When the hook block **39** under the boom end section is removed:

- ▶ Luff the boom system down until the roller set / roller sets are just above the ground.

## 12.5 Spooling the hoist rope up



### WARNING

Spooling up of the hoist rope!  
Death, severe bodily injuries, property damage.

- ▶ All rope retaining pins / pipes on the boom system are removed.
- ▶ Slowly spool up the hoist rope over the rope pulleys back to the winch.
- ▶ Make sure that no personnel is within the danger zone!

### NOTICE

Overspoiled winch!

If the hoist rope is pulled under the winch when spooling up, then the adjustment of the cam limit switch can change.

A new adjustment by the customer service of Liebherr-Werk Ehingen GmbH is required.

- ▶ Stop the winch in time, with sufficient rope reserve.
- ▶ Do **not** overspool the winch.

- ▶ Spool the hoist rope up.

## 12.6 Disassembling the roller set

### NOTICE

Danger of property damage!

During the disassembly of the roller set, the electrical connections to the hoist limit switches can be damaged.

- ▶ Remove the hoist limit switches on the roller set.

- ▶ Before disassembly of the roller set **38**, route the hoist limit switch from the roller set **38** back to the boom head.

**Note**

- ▶ Disassembly of the roller set **38**, see chapter 5.14.

## 12.7 Assembling the feet on the L-end section

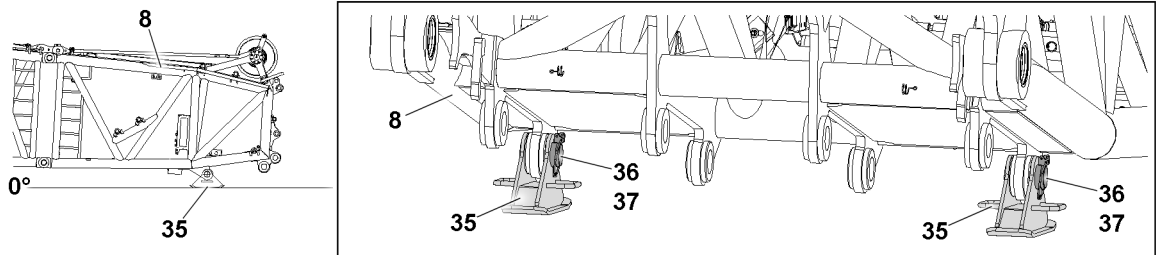


Fig.154370: Assembling the feet

**Note**

- ▶ Pinning the feet is also necessary for the main boom with an S-end section.

Make sure that the following prerequisites are met:

- The hook block is properly unreeved and removed.
- The hoist limit switches are on the L-end section.
- The roller set **38** is disassembled.

**NOTICE**

Damage to the crane!

If the maximum permissible negative angle is exceeded due to uneven ground, then the crane can be damaged.

Property damage.

- ▶ The permissible negative angle range of the boom system may not be exceeded.
- ▶ For general danger notes, see section “Assembling the boom system with the substructure”.
- ▶ Support the main boom if necessary.

- ▶ Position the feet **35** under the L-end section **8**.
- ▶ Luff the main boom down until the pin bores of the L-end section **8** and the feet **35** align.
- ▶ Insert the pin **36**.
- ▶ Secure the pin **36** with the retaining element **37**.
- ▶ Take the main boom down completely.

## 12.8 Retracting the relapse cylinder of the main boom

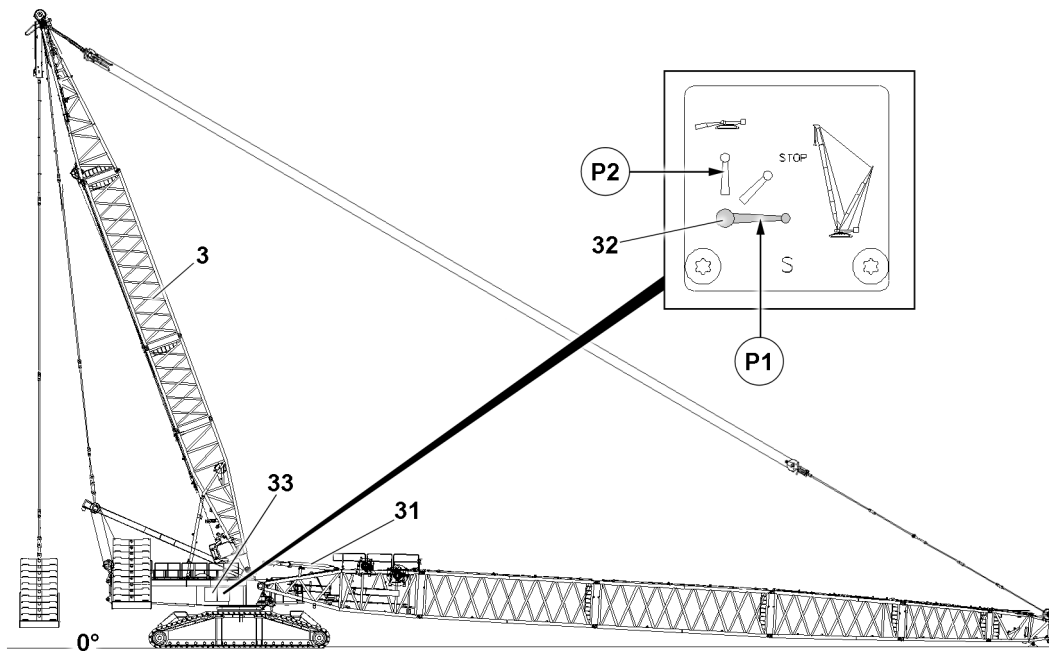


Fig.154369: Relapse cylinder of the main boom, ball valve positions

Position (P)	Function
1	Crane operation, extend the piston rod
2	Assembly, retract the piston rod
STOP	The piston rod cannot be retracted / extended

### Relapse cylinder of the main boom, ball valve positions

- ▶ Retract the relapse cylinder of the main boom **31**: Set the ball valve **32** to position **P2**.

#### Result:

- The piston rods of the main boom relapse cylinders **31** retract.

The ball valve **32** is secured by closing the cabinet door **33** and removing the key.

- ▶ Close the cabinet door **33** and pull out the key.
- ▶ Hand the key to an authorized person.

## 12.9 Disconnecting the electrical connections on the boom head

Make sure that the following prerequisite is met:

- The main boom is taken down onto the ground.

### NOTICE

Damage to the cable drum or cable!

If the cable of the cable drum is not properly spooled up on the cable drum after unplugging the boom end section, then the cable drum or the cable can be significantly damaged.

- ▶ Spool the cable drum up after unplugging.
- ▶ Spool the cable drum up and secure it to prevent inadvertent spooling out.

**NOTICE****Non-assembled protective caps!**

If non-required electrical connections are not closed off, then dirt and / or corrosion can damage the electrical connections. This could result in malfunctions.

- ▶ Always properly close off all **non**-required electrical connections with their protective caps.
- ▶ Observe the wiring diagram.

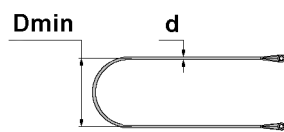
- ▶ Disconnect the electrical connections and store the plugs and cables properly.

## 12.10 Disassembling the main boom guying

### 12.10.1 Auxiliary guying

An auxiliary guying is assembled depending on the boom system, see the rod plan.

Fiber guy ropes are used for the auxiliary guying. Comply with the following regulations.



$$D_{min} = 20 \times d$$

Fig.160908: Fiber guy rope: Calculation of minimum permissible bending diameter

Formula element	Meaning
Dmin	Minimum permissible bending diameter
d	Rope diameter

*Minimum permissible bending diameter: Definition of the formula elements*

**WARNING**

Impermissible disassembly of fiber guy ropes!

The fiber guy ropes can be damaged.

Death, severe bodily injuries, property damage.

- ▶ Before disassembling the fiber guy ropes, check if the fiber guy ropes are rigidly frozen or covered with ice. See chapter 5.01.
- ▶ Do **not** disassemble fiber guy ropes that are rigidly frozen or covered with ice.
- ▶ Do **not** bend, knot or twist the fiber guy ropes.
- ▶ Never fall below the minimum permissible bending diameter **Dmin** of 20 x rope diameter **d**.
- ▶ Check the fiber guy ropes for damage prior to assembly, after disassembly and after exceptional events, see chapter 8.16.
- ▶ Comply with the maintenance intervals, see chapter 7.03.50.
- ▶ Replace damaged fiber guy ropes.
- ▶ Observe the notes regarding the proper transport and storage of the fiber guy ropes, see chapter 2.04.
- ▶ Observe the instructions for the proper handling of fiber guy ropes, see chapter 5.01.
- ▶ Only fasten the fiber guy ropes in the permissible range with belt loops, see chapter 5.01.

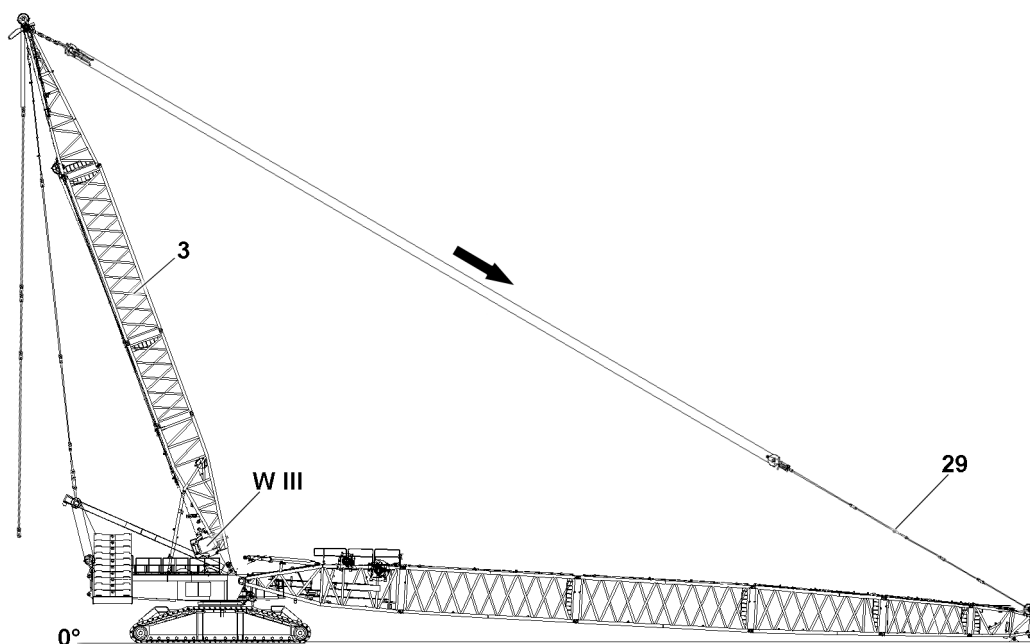


Fig. 154378: Taking down the main boom guy rods

#### NOTICE

Danger of slack rope formation!

If the D-boom is luffed down too quickly during disassembly of the main boom guy rods, slack rope formation can occur.

- ▶ Make sure that the rope of winch 3 is tensioned during the entire luff down procedure of the D-boom.

Make sure that the following prerequisites are met:

- The main boom is lying on the substructure on the ground.
- The guying is relieved.
- The derrick ballast is disassembled. Disassemble the derrick ballast, see chapter 5.36.

### 12.10.2 Disassembling the auxiliary guying

This section is valid solely only for the boom with the assembled auxiliary guying.

- ▶ Observe the specifications for fiber guy ropes.
- ▶ Luff the D-boom 3 down to the front and at the same time spool out winch 3 **WIII** until the auxiliary guying can be disassembled.
- ▶ Disassemble the auxiliary guying, see chapter 5.01 and chapter 5.03.

### 12.10.3 Disassembling the main boom guy rods

- ▶ Luff the D-boom 3 down to the front and spool up winch 3 **WIII** at the same time until the main boom guy rods 29 are taken down in the transport receptacles of the boom lattice sections.

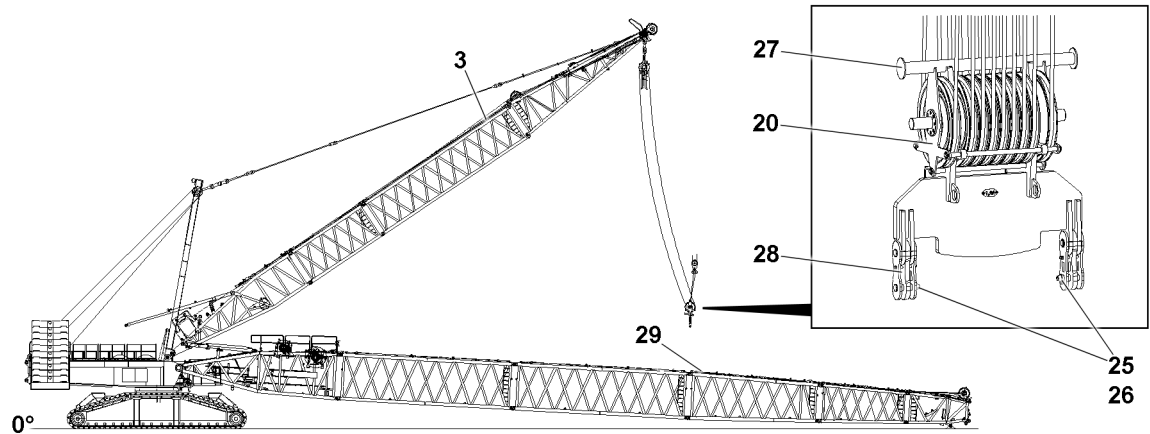


Fig.154367: Guy rod pin points

**WARNING**

Laterally swinging upper pulley block!

The upper pulley block can swing laterally by itself due to its own weight when it is unpinned. Death, severe bodily injuries, property damage.

- ▶ Make sure that there are no persons in the danger zone during the entire unpinning procedure.
- ▶ Make sure that no persons reach into the danger zone during the entire unpinning procedure.

- ▶ To hold the upper pulley block **20**, loop it around the pipe **27**.
- ▶ Fasten the upper pulley block **20** to the auxiliary crane and hold it in position with the auxiliary crane.

When the upper pulley block **20** is safely held by the auxiliary crane:

- ▶ Unpin the main boom guy rods **29** on the upper pulley block **20**: Remove the retaining elements **26** on both sides and unpin the pin **25**.
- ▶ Secure the main boom guy rods **29** in the transport receptacles of the boom lattice sections: Insert and secure the pin.
- ▶ Carefully spool up winch **3 Will** and guide the upper pulley block **20** with the auxiliary crane until the upper pulley block **20** hangs vertically.
- ▶ Disconnect the auxiliary crane from the upper pulley block **20**.

## 12.11 Assembling the auxiliary weight

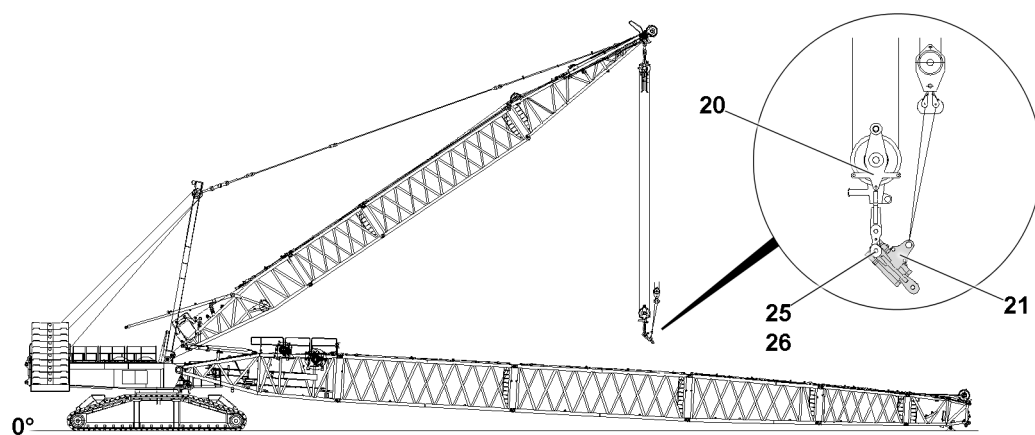


Fig.154365: Assembling the auxiliary weight

**NOTICE**

Adjustment of the upper pulley block without auxiliary weight!

The rope is spooled with a low rope pull.

Property damage.

- ▶ Make sure that the auxiliary weight **21** is properly assembled on the upper pulley block **20**.

- ▶ Luff up the D-boom and position the upper pulley block **20** so that the auxiliary weight **21** can be installed.
- ▶ Fasten the auxiliary weight **21** to the auxiliary crane.

**WARNING**

Laterally swinging auxiliary weight!

The auxiliary weight can swing laterally by itself due to its own weight during unpinning, see illustration.

Death, severe bodily injuries, property damage.

- ▶ Make sure that there are no persons within the danger zone during the entire pin procedure.
  - ▶ Make sure that no persons reach into the danger zone during the entire pin procedure.
- 
- ▶ Assemble the auxiliary weight **21**: Insert the pin **25** on both sides.
  - ▶ Secure the pin **25**: Attach the retaining elements **26**.
  - ▶ Swing the auxiliary weight **21** downward with the auxiliary crane.
  - ▶ Remove the auxiliary crane.

## 12.12 Pinning the upper pulley block on the H-pivot section

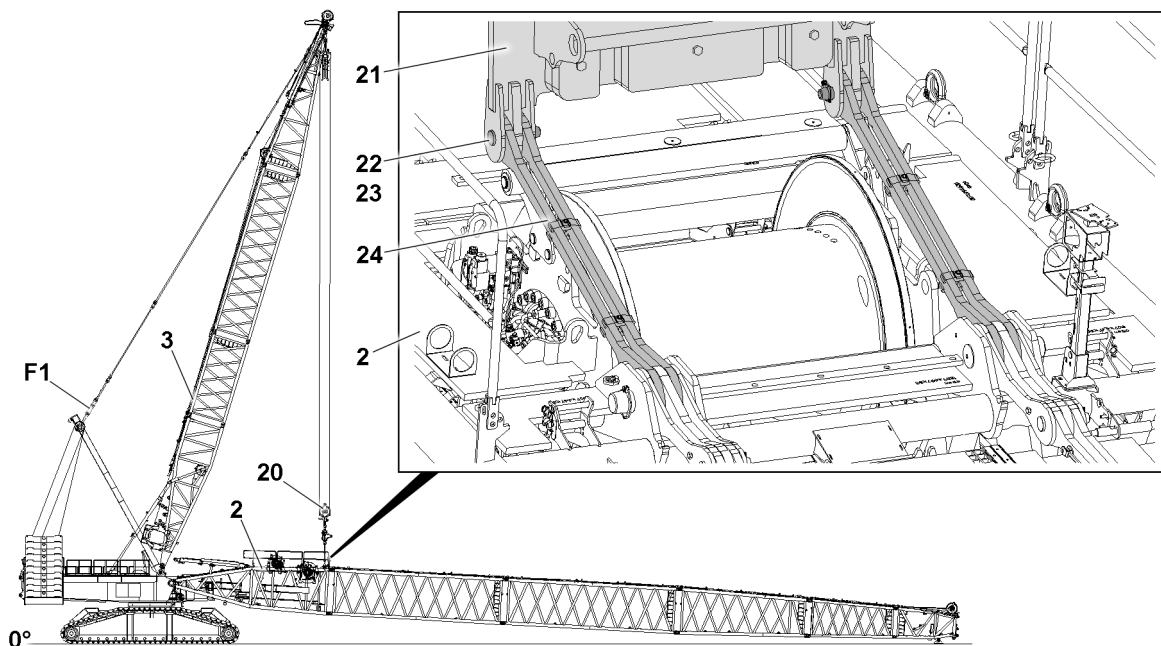


Fig.154379: Pinning the upper pulley block on the H-pivot section

Make sure that the following prerequisites are met:

- The auxiliary weight **21** is assembled.
- ▶ Erect the D-boom **3** until the upper pulley block **20** hangs vertically above the H-pivot section **2**.
- ▶ Position the upper pulley block **20** vertically above the rods **24**.
- ▶ Remove the retaining elements **23** from the rods **24** and unpin the pin **22**.

When the pins **22** are fully removed on both sides:

- ▶ Lower the upper pulley block **20** until the pin bores of the rods **24** and the auxiliary weight **21** align.



When the pin bores align:

- ▶ Insert the pin **22** completely on both sides.
- ▶ Secure the pin **22** with the retaining elements **23**.

## 12.13 Opening the boom system

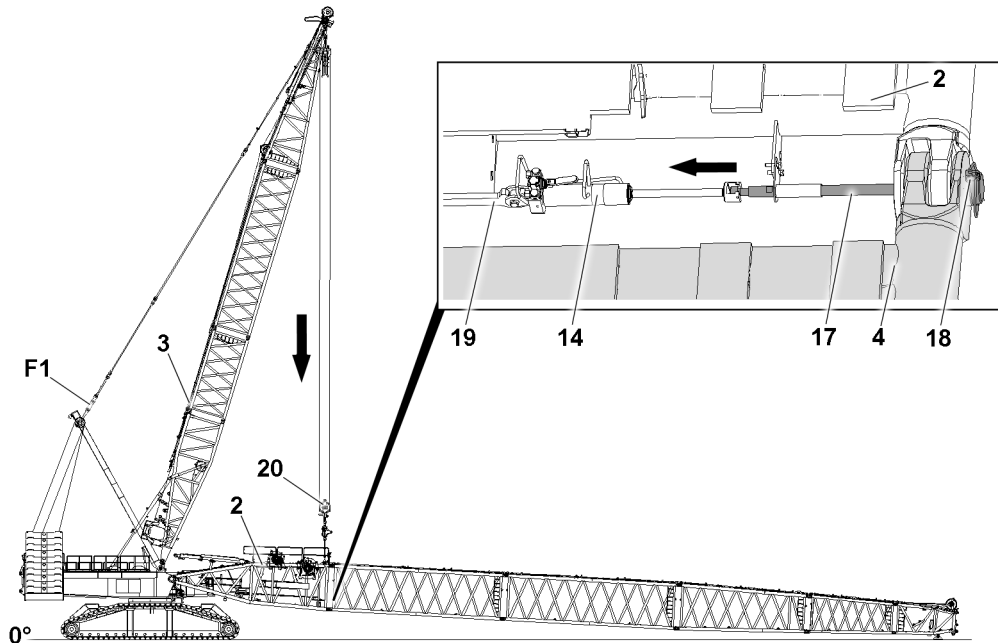


Fig.154380: Opening the boom system and unpinning on both sides on the “bottom”

Make sure that the following prerequisites are met:

- The upper pulley block is pinned on the H-pivot section.
- No personnel or obstacles are in the danger zone.



### WARNING

Overload of the crane!

Death, severe bodily injuries, property damage.

- ▶ During the “opening procedure” of the boom system, the maximum permissible F1-total force of **250 t** in the test point **F1** may not be exceeded.
- ▶ Lifting and opening the respective main boom is only permissible by observing the maximum permissible boom lengths and total forces.
- ▶ The boom end section may **not** lift off the ground while “opening” the boom system.
- ▶ Make sure that there are no persons on the boom system or in the danger zone when opening.



### Note

- ▶ The actual force in the test point **F1** that is exerted while tensioning the boom system is shown on LICCON monitor 1.
- ▶ Observe the actual force in the test point **F1** that was noted when closing the boom system (assembly).

When the boom system is pretensioned, the pins are easier to unpin. Pins and lugs are not damaged.

- ▶ Spool up winch 3 until the guying is tensioned with the same actual force in test point 1 as when closing the boom system.

Prerequisite for an individual pin point: The pin pulling cylinder **14** is inserted in the pin pulling device **19** and connected to the connector pin **17**.

- ▶ Remove the safety elements **18** on both sides at the “bottom” and unpin the connector pins **17**.

---

#### NOTICE

Lowering of the boom system!

Damage to crane components.

- ▶ Make sure that the H-pivot section **2** is **not** lowered directly onto the ground.
  - ▶ Lower the H-pivot section **2** onto the substructure when opening the boom system.
- 

When the connector pins **17** are fully unpinned at the “bottom”:

- ▶ Lower the boom system carefully onto the substructure on the ground.

When the main boom is “open”:

- ▶ Lower the upper pulley block **20** until the rods **24** are touching winch 5.
  - ▶ Unpin the auxiliary weight **21** on the rods **24**: Remove the retaining elements **23** on both sides and unpin the pin **22**.
- 



#### Note

- ▶ Install and properly secure the main boom guy rods that are not required that have been removed from the boom lattice sections during the assembly of the boom system in the transport retainers of the boom lattice sections.
- 

- ▶ Place the main boom guy rods that were disassembled during assembly on the boom lattice sections, pin and secure.
- 

## 12.14 Disassembling the boom system



#### Note

- ▶ The unpinning procedure is the same for both sides of the boom lattice section.
  - ▶ The unpinning procedure is the same for both levels at the “top” and at the “bottom”.
- 



#### Note

- ▶ The unpinning procedure is the same for all boom lattice sections of the boom system.
- 



#### Note

- ▶ The H-intermediate sections are pinned with the pin pulling cylinder **14**, see chapter 5.30.
  - ▶ The pin pulling cylinders **14** are shown as an example.
- 



#### Note

- ▶ For the fastening of boom lattice sections, observe and adhere to section “Fastening points”.
-

### 12.14.1 Removing the L-end section on the SL-reducer

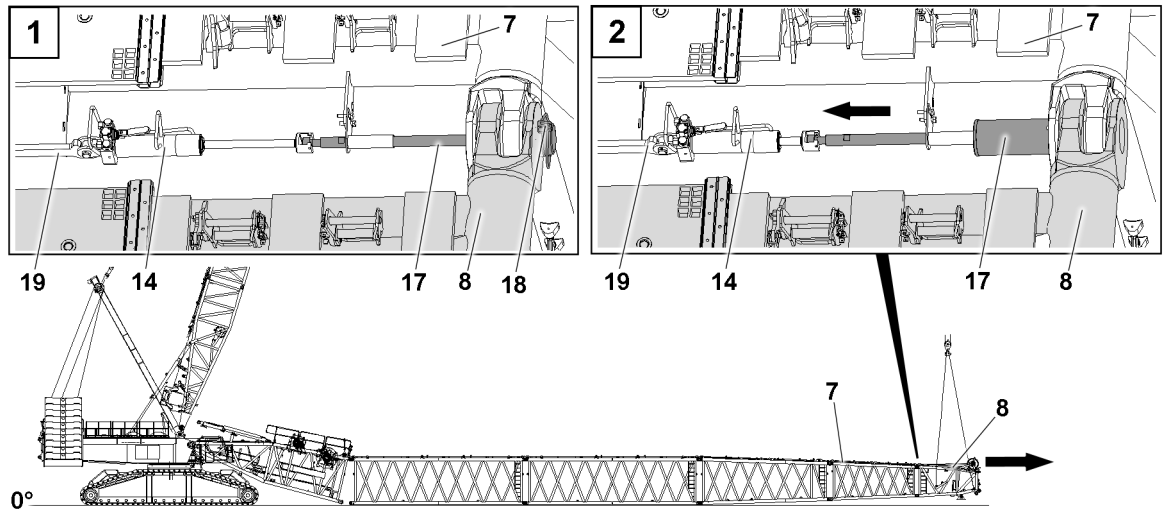


Fig.154381: Disassembling the boom lattice sections, L-end section example

Prerequisite for an individual pin point: The pin pulling cylinder 14 is inserted in the pin pulling device 19 and connected to the connector pin 17.

- ▶ Fasten the L-end section 8 to the auxiliary crane.
- ▶ Remove the safety elements 18 on both sides at the “bottom”.
- ▶ Unpin the connector pin 17: Actuate the pin pulling cylinder 14.
- ▶ Remove the safety elements 18 on both sides at the “top”.
- ▶ Unpin the connector pin 17: Actuate the pin pulling cylinder 14.

When the connector pins 17 at the “top” and “bottom” are fully unpinned:

- ▶ Remove the L-end section 8 with the auxiliary crane and take it down.
- ▶ Remove the auxiliary crane.
- ▶ Insert all connector pins 17 for transport and secure with the safety elements 18.

### 12.14.2 Continuing main boom disassembly

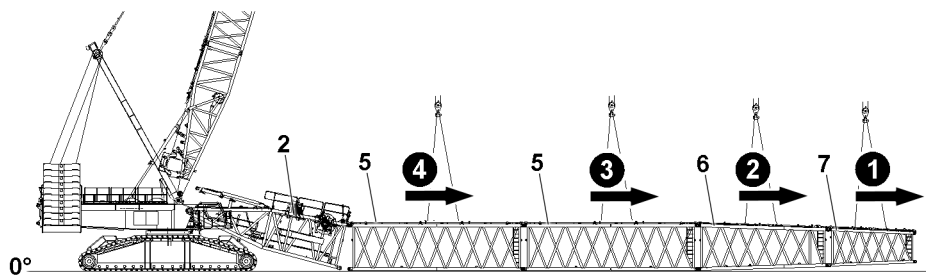


Fig.154382: Main boom disassembly



#### Note

- ▶ The following description is an example and will be described by means of the H-intermediate section.
- ▶ The disassembly of the HS-reducer, S-intermediate section, SL-reducer, L-intermediate section, S-end section, L-end section is identical.

- ▶ Fasten the SL-reducer 7 to the auxiliary crane.
- ▶ Remove the safety elements 18 on both sides at the “bottom”.
- ▶ Unpin the connector pin 17: Actuate the pin pulling cylinder 14.
- ▶ Remove the safety elements 18 on both sides at the “top”.

- ▶ Unpin the connector pin **17**: Actuate the pin pulling cylinder **14**.

When the connector pins **17** at the “top” and “bottom” are fully unpinned:

- ▶ Remove the SL-reducer **7** with the auxiliary crane and take it down.
- ▶ Remove the auxiliary crane.
- ▶ Disassemble the HS-reducer **6**.
- ▶ Disassemble the H-intermediate sections **5**.
- ▶ Insert all connector pins **17** for transport and secure with the safety elements **18**.

## 12.15 Disconnecting the electric and hydraulic connections on the H-pivot section

### 12.15.1 Disconnecting the electrical connections

Make sure that the following prerequisite is met:

- The H-pivot section is lying on the ground on the substructure.
- ▶ Disconnect the electrical connections, see the wiring diagram.
- ▶ Close off the electrical connections properly with dummy plugs or protective caps.

### 12.15.2 Disconnecting the hydraulic connections

The hydraulic connections are established with quick couplings.

When using quick couplings to disconnect the hydraulic lines, make sure that the coupling procedure is carried out correctly.



#### **WARNING**

Pressure in the hydraulic lines!

If the pressure supply is not interrupted before connecting / releasing the hydraulic lines, the hydraulic oil can escape with high pressure.

Death, severe bodily injuries, property damage.

- ▶ Release the pressure in the hydraulic system before connecting / disconnecting: Interrupt the pressure supply and wait a short time.
- ▶ Release the hydraulic coupling by hand.
- ▶ Disconnect the hydraulic connections, see the Hydraulic diagram.
- ▶ Protect the hydraulic connections against contamination with caps.

## 12.16 Disassembling the H-pivot section on the turntable

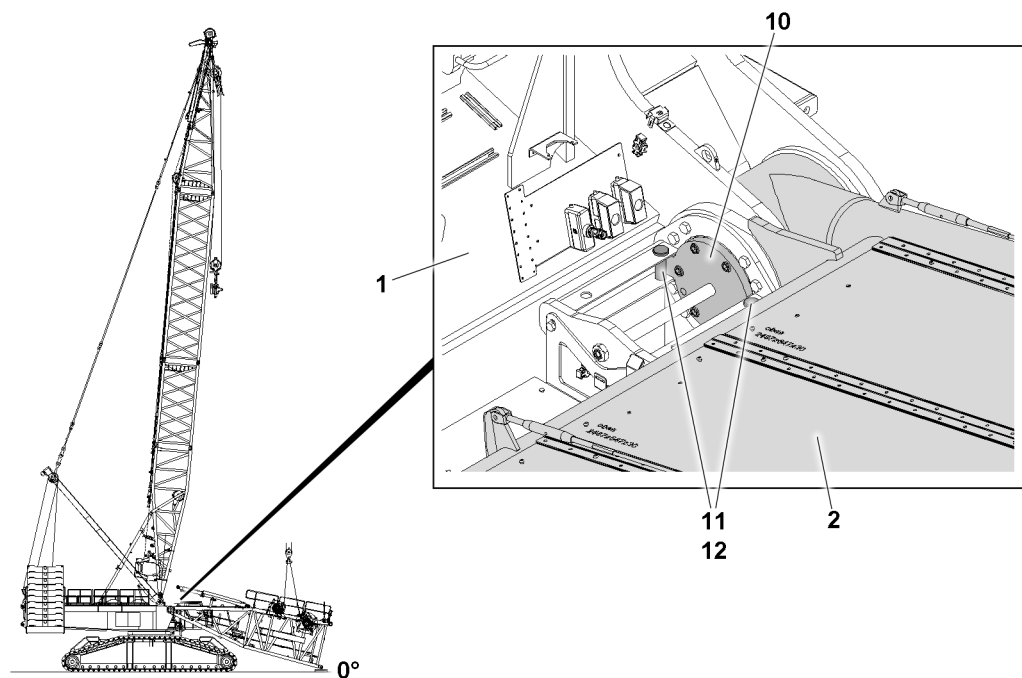


Fig.154384: Releasing the H-connector pin

Make sure that the following prerequisites are met:

- The hydraulic connections on the H-pivot section are properly disconnected.
- The hydraulic connections on the H-pivot section are properly closed off with caps.
- The electrical connections on the H-pivot section are properly disconnected.
- The electrical connections are properly closed off with dummy plugs (see the wiring diagram).
- The crane engine is running.
- An auxiliary crane with sufficient load bearing capacity is available.



### WARNING

General danger note!

- ▶ Insert and secure all pins after disassembly in the intended transport receptacles.



### WARNING

Incline position of the installed H-pivot section!

The mounting condition of the installed H-pivot section is selected so that the 20° incline position of the walking surfaces is not exceeded.

Death, severe bodily injuries.

- ▶ Support the H-pivot section.
- ▶ Release the H-connector pin **10**: Remove the retaining element **12** and unpin the retaining pin **11**.

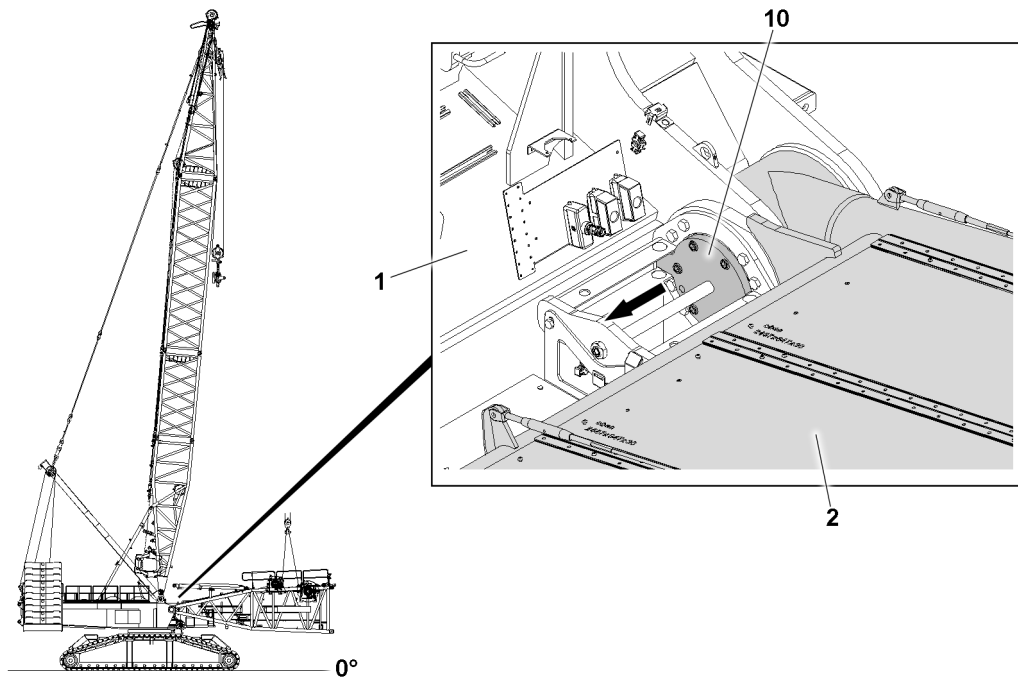


Fig.154383: Unpinning the H-pivot section on the turntable



#### Note

- ▶ The unpinning procedure is the same for both H-connector pins.



#### WARNING

Falling H-pivot section!  
Death, severe bodily injuries, property damage.

- ▶ Make sure that the H-pivot section **2** is safely held by the auxiliary crane before unpinning the H-connector pins **10**.



#### Note

- ▶ The fastening points on the H-pivot section **2** must be selected in such a way that the H-pivot section **2** hangs horizontally on the auxiliary crane during disassembly. See section "Fastening points".
- ▶ For BTT display / operating element operation, see chapter 5.31.



#### WARNING

Suspended H-pivot section!  
Death, severe bodily injuries.

- ▶ Stepping on the H-pivot section when suspended is prohibited.
- ▶ Fasten the H-pivot section **2** properly to the auxiliary crane.
- ▶ Lift the H-pivot section **2** with the auxiliary crane to the horizontal.
- ▶ Unpin the H-connector pin **10**: Actuate the BTT.

#### NOTICE

Swing the H-pivot section **2** out from the turntable!  
Damage to the turntable and the H-pivot section **2**.

- ▶ Slowly swing the H-pivot section **2** out with the auxiliary crane and at low speed from the turntable.
- ▶ Support the H-pivot section **2** before taking it down onto the ground.

When the H-connector pins **10** on the H-pivot section **2** are fully uninned on both sides:

- ▶ Swing the H-pivot section **2** out from the turntable with the auxiliary crane and take it down.
- ▶ Remove the auxiliary crane.

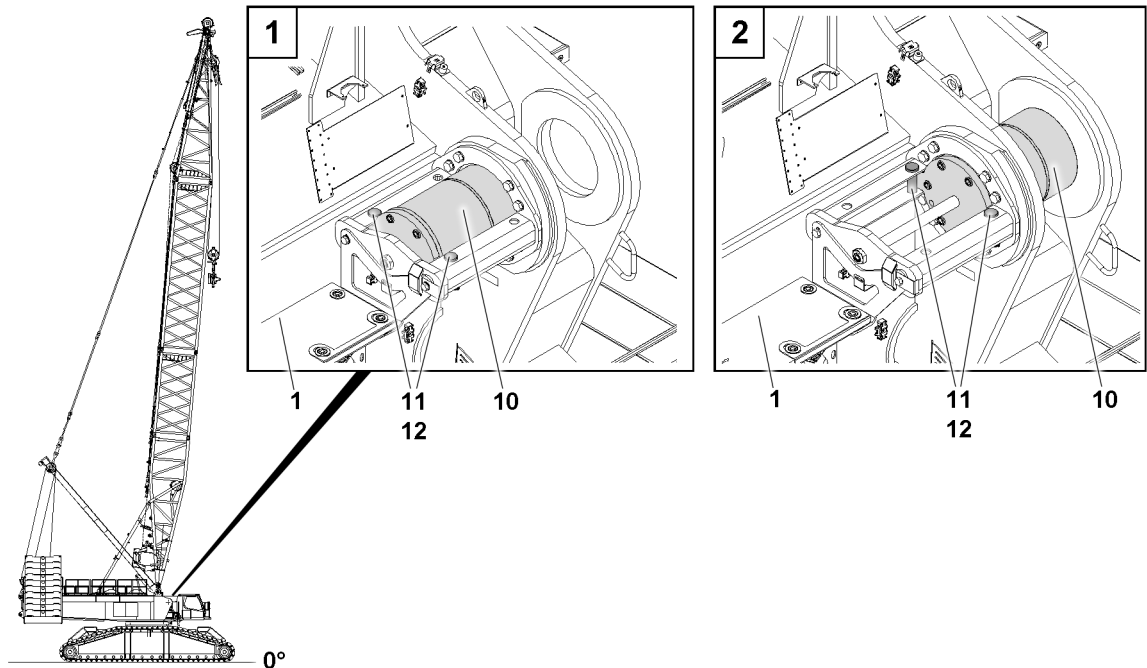


Fig.154385: H-connector pins in the transport condition



**Note**

- ▶ In the transport condition, the H-connector pins **10** are pinned on the turntable **1** and secured with the retaining pins **11**.

When the H-pivot section **1** is disassembled on the turntable:

- ▶ Pin the H-connector pins **10** again completely: Actuate the BTT.
- ▶ Secure the H-connector pin **10**: Attach the retaining elements **12**.

## 12.17 Disassembling winch 5 and winch 6 on the H-pivot section



**Note**

- ▶ Bring winch 5 into the operating position, see chapter 3.07.50.
- ▶ If necessary, disassemble winch 5 on the H-pivot section, see chapter 3.07.50.



**Note**

- ▶ Bring winch 6 into the operating position, see chapter 3.07.60.
- ▶ If necessary, disassemble winch 6 on the H-pivot section, see chapter 3.07.60.

## 12.18 Swinging the camera holder into the transport position

- ▶ Swing the camera holder into the transport position.
- ▶ Secure the camera holder in the transport position.

## 12.19 Swinging the railing on the H-pivot section into the transport position



### WARNING

Danger of falling!

Death, severe bodily injuries, property damage.

- ▶ Assembly personnel must secure themselves for assembly / disassembly of railings and protective devices with an approved fall arrest system to prevent them from falling.
- ▶ For assembly and disassembly work, maintenance and inspection work on the H-pivot section, all railings and protective devices must be properly assembled and secured.

Make sure that the following prerequisites are met:

- The ground is able to safely take on the weight of the H-pivot section.
- The H-pivot section is lying completely on the ground.
- ▶ For the assembly / disassembly of railings and protective devices, see chapter 2.06.



## 5.61 Roller cart

1	Component overview	2
2	Fastening points for the roller cart	2
3	Moving the roller cart	3
4	Crane assembly	4
5	Crane removal	7

# 1 Component overview

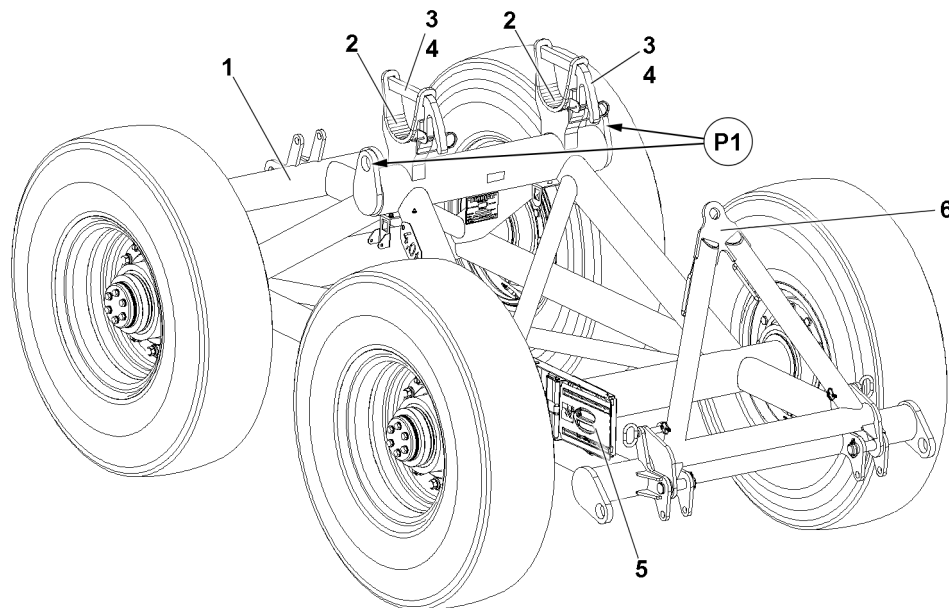


Fig.151421: Component overview



## Note

- ▶ The roller cart is marked with its own weight.
- ▶ In the case of tires filled with compressed air, the tire air pressure for the roller cart is 8.5 bar.

Position	Component
1	Roller cart
2	Receptacle
3	Locking element
4	Retaining element
5	Chock
6	Drawbar

## 2 Fastening points for the roller cart



### WARNING

Component incorrectly fastened!

Life-threatening situations can arise due to improper or incorrect fastening of the corresponding components.

Death, severe bodily injuries, property damage.

- ▶ Fasten the components only on the intended fastening points on both sides.
- ▶ Fastening of components and description of fastening points, see Crane operating instructions, chapter 5.01.

Fastening points	
P1	Roller cart

### 3 Moving the roller cart

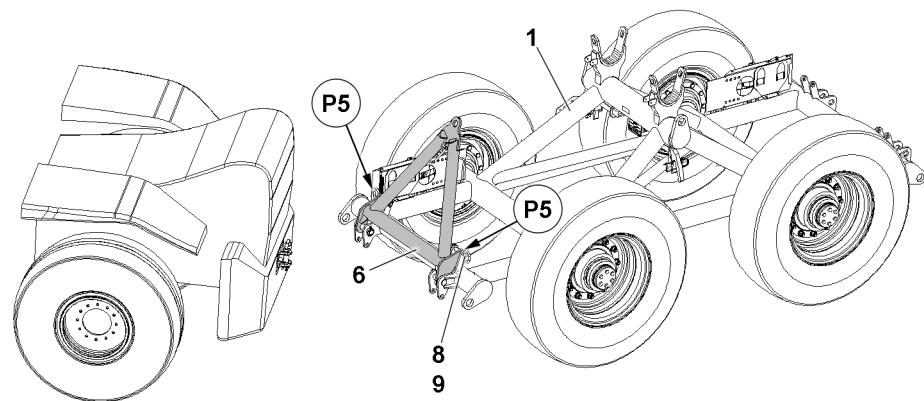


Fig.155876: Moving the roller cart

Make sure that the following prerequisites are met:

- A locomotive cart with sufficient pull force is available.
- The roller cart **1** is secured with chocks to prevent it from rolling away.



#### WARNING

Drawbar swinging down!

The drawbar can swing down in an uncontrolled manner due to its own weight when unpinning in point **P5**.

Death, severe bodily injuries, property damage. Fingers and hands can be crushed.

- ▶ For safety reasons, **two** persons must always be used when unpinning.
- ▶ When unpinning the pin connection, hold the drawbar.
- ▶ Do not reach with your hands into the danger zone.

- ▶ Release the drawbar **6**: Remove the retaining element **9** and unpin the pin **8**.
- ▶ Swing the drawbar **6** down.

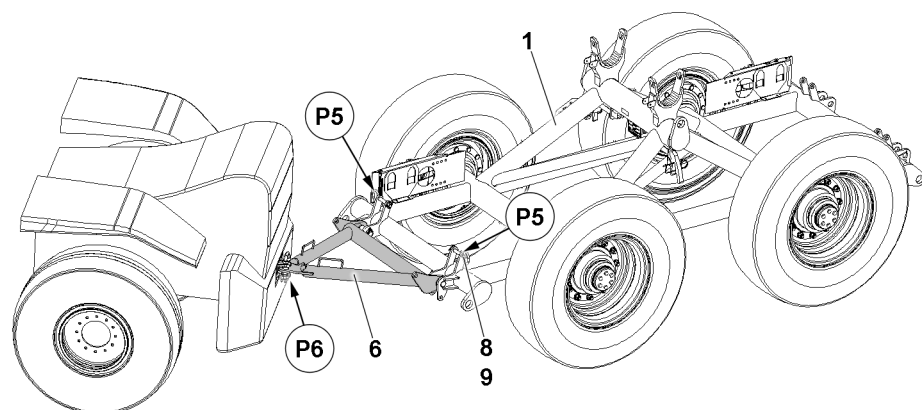


Fig.155877: Moving the roller cart



#### Note

- ▶ Connect the locomotive cart with the roller cart, see Operating instructions for the locomotive cart.
- ▶ Connect the drawbar **6** with the locomotive cart in point **P6**.

The roller cart **1** is disconnected from the locomotive cart:

- ▶ Secure the roller cart **1** with chocks to prevent it from rolling off.

- ▶ Swing the drawbar **6** up and secure in point **P5**.

## 4 Crane assembly

### 4.1 Positioning the roller cart under the boom end section

Make sure that the following prerequisites are met:

- An auxiliary crane with sufficient load bearing capacity is available.
- The W-boom is properly fastened on the auxiliary crane, see chapter 5.01.
- The W-boom is lifted off the ground with the auxiliary crane.

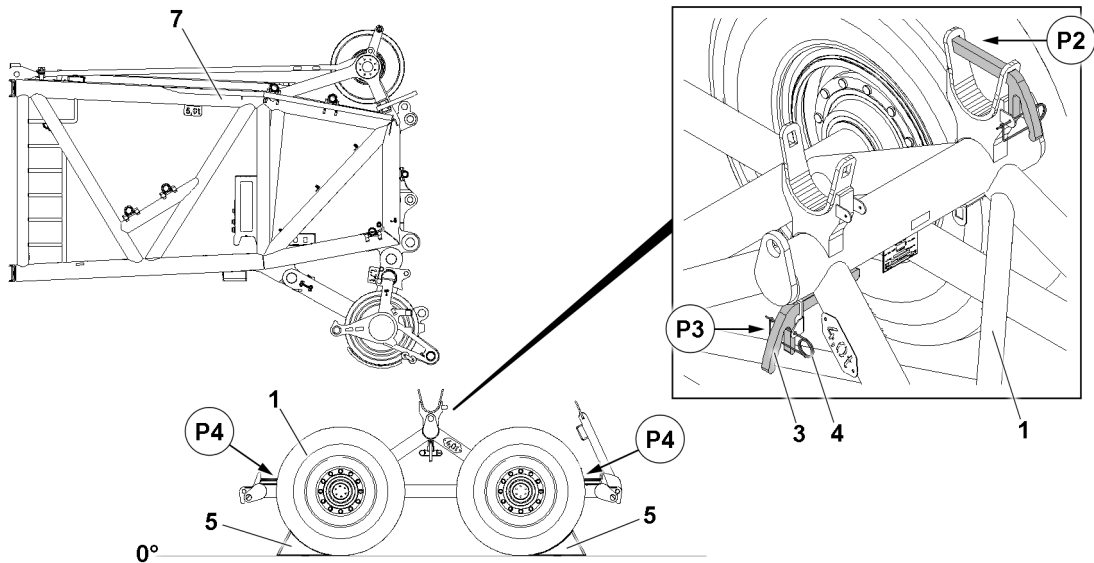


Fig.151422: Roller cart under the boom end section

- ▶ Remove the retaining element **4** in point **P2** and unplug the locking element **3**.
- ▶ Insert the locking element **3** in point **P3** in the park position and secure with the retaining element **4**.
- ▶ Position the roller cart **1** below the roller set of the boom end section **7**.
- ▶ Remove the chocks **5** from the transport retainer on the roller cart **1** in point **P4**.
- ▶ Secure the roller cart **1** with chocks **5** to prevent it from rolling off: Push the chocks **5** on the left and right hand side tightly under the wheels.

### 4.2 Lowering the boom end section in the roller cart



#### WARNING

Danger of accident when taking down the boom end section **7** in the roller cart!  
Death, severe bodily injuries, property damage.

- ▶ Make sure that the roller cart **1** is properly positioned under the roller set(s).
- ▶ Make sure, when taking down the boom end section **7** in the roller cart, that no personnel is within the danger zone.

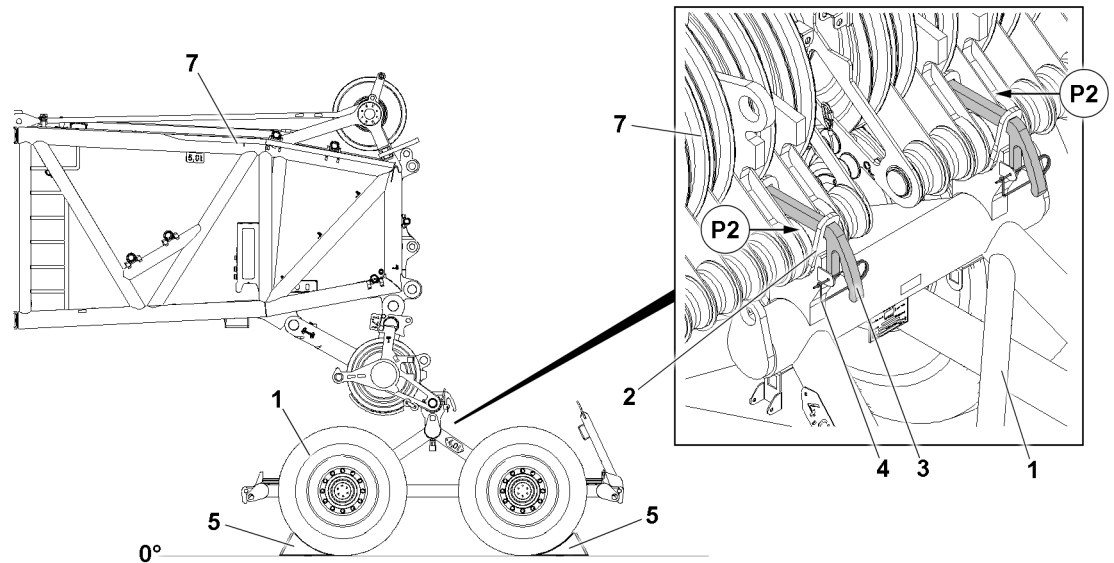


Fig.151423: Lowering the boom end section in the roller cart

- ▶ Slowly lower the boom end section 7 with the auxiliary crane until the carrier rollers of the roller set are laying in the receptacles 2 of the roller cart 1.
- ▶ Remove the locking element 3 from the park position.
- ▶ Secure the roller cart 1 with the locking element 3 and retaining element 4 in point P2.
- ▶ Remove the chocks 5 from the wheels.
- ▶ Secure the chocks 5 again in the transport retainers on the roller cart 1.

### 4.3 Disassembling the roller cart

When the boom system has reached a certain angle, the roller cart 1 is no longer required. Before lifting the W-boom system off, remove the roller cart 1.



#### WARNING

Overload of crane!

If the roller cart 1 is not removed before erecting the boom system all the way, the crane can be overloaded and topple over.

Death, severe bodily injuries, property damage.

- ▶ Make sure that the roller cart 1 is removed before the W-boom lifts off the ground.

Make sure that the following prerequisite is met:

- The boom system has reached a certain angle.

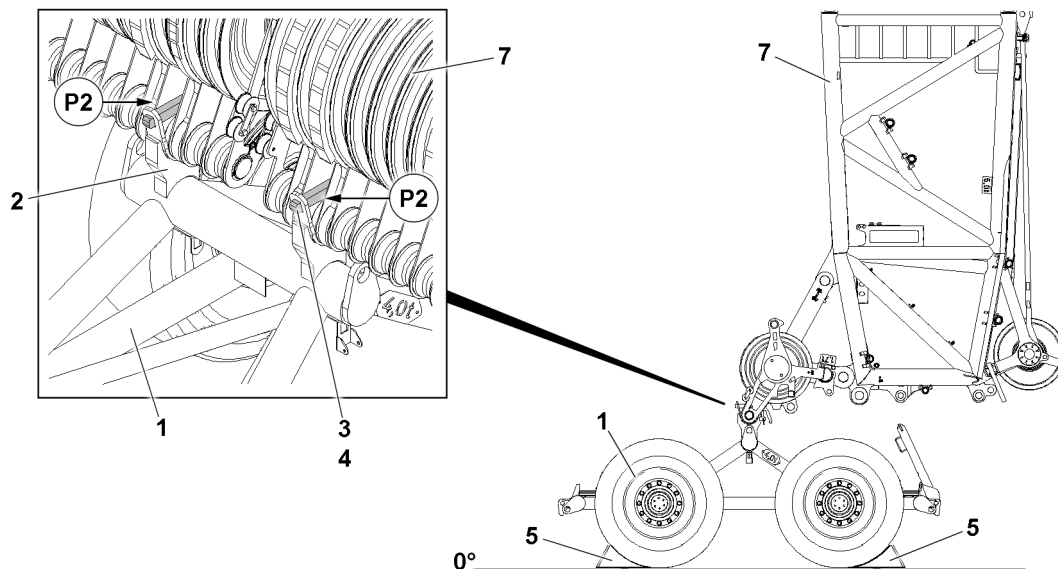


Fig.151424: Disassembling the roller cart

- ▶ Remove the chocks **5** from the transport retainer on the roller cart **1**.
- ▶ Secure the roller cart **1** with chocks **5** to prevent it from rolling off: Push the chocks **5** on the left and right hand side tightly under the wheels.
- ▶ Release the roller cart **1**: Remove the retaining element **4** in point **P2** and unplug the locking element **3**.

**Result:**

- The boom system **7** can be luffed up.

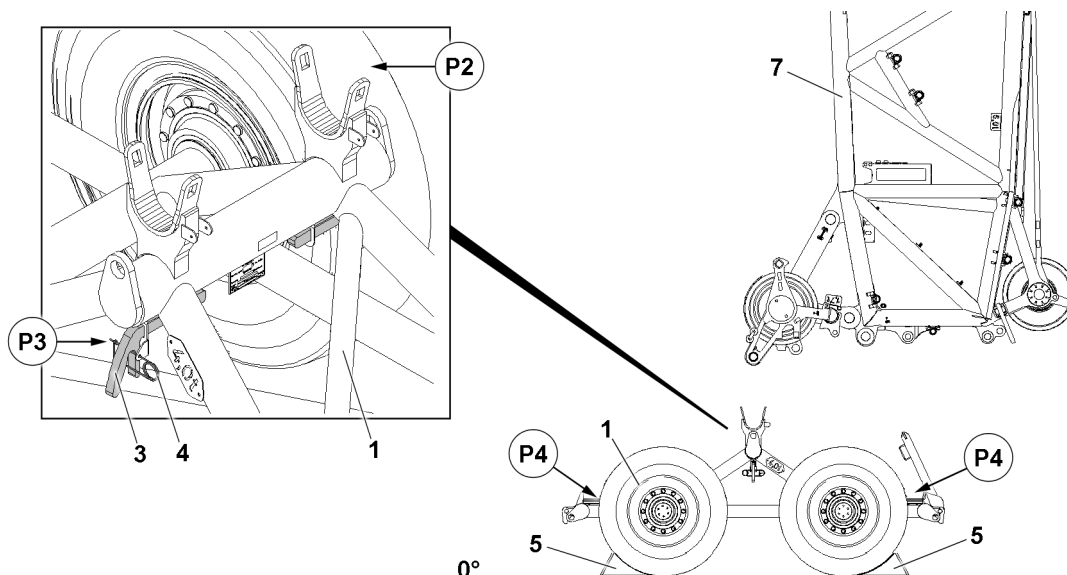


Fig.151425: Roller cart under the boom end section

- ▶ Insert the locking element **3** in point **P3** in the park position and secure with the retaining element **4**.
- ▶ Luff the boom system up.

When the boom system is luffed up:

- ▶ Remove the chocks **5** from the roller cart **1**.
- ▶ Secure the chocks **5** on the transport receptacle in point **P4**.
- ▶ Remove the roller cart **1**.

## 5 Crane removal

### 5.1 Positioning the roller cart under the boom end section

Make sure that the following prerequisites are met:

- The locking element **3** is in the park position in point **P3**.
- An auxiliary crane with sufficient load bearing capacity is available.

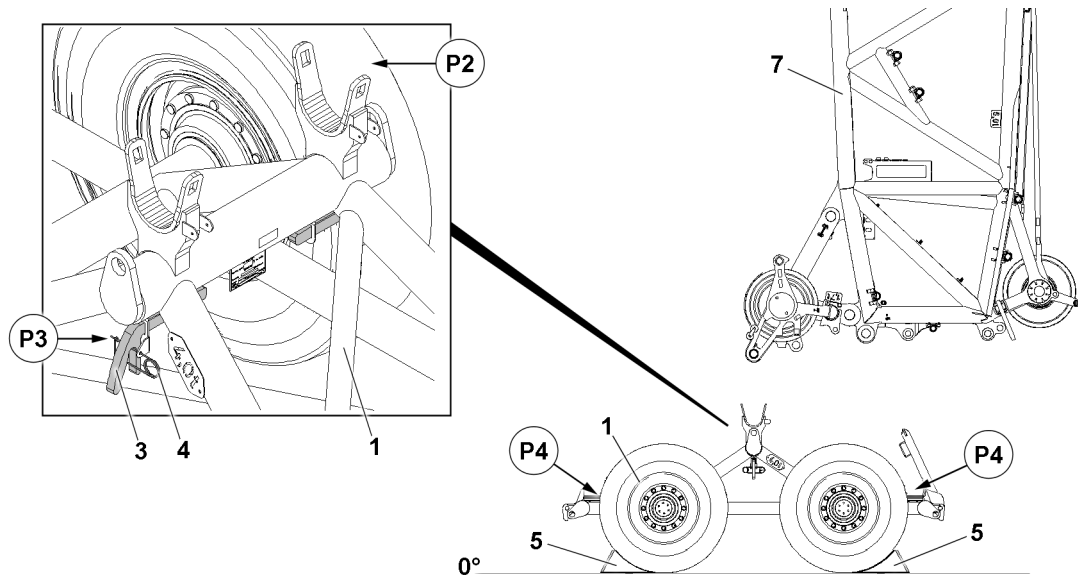


Fig.151425: Roller cart under the boom end section

- ▶ Position the roller cart **1** below the roller set of the boom end section **7**.
- ▶ Remove the chocks **5** from the transport retainer on the roller cart **1** in point **P4**.
- ▶ Secure the roller cart **1** with chocks **5** to prevent it from rolling off: Push the chocks **5** on the left and right hand side tightly under the wheels.

### 5.2 Lowering the boom end section in the roller cart



#### WARNING

Danger of accident when taking down the boom end section in the roller cart!  
Death, severe bodily injuries, property damage.

- ▶ Make sure that the roller cart **1** is properly positioned under the roller set(s).
- ▶ Make sure, when taking down the boom end section in the roller cart, that no personnel is within the danger zone.

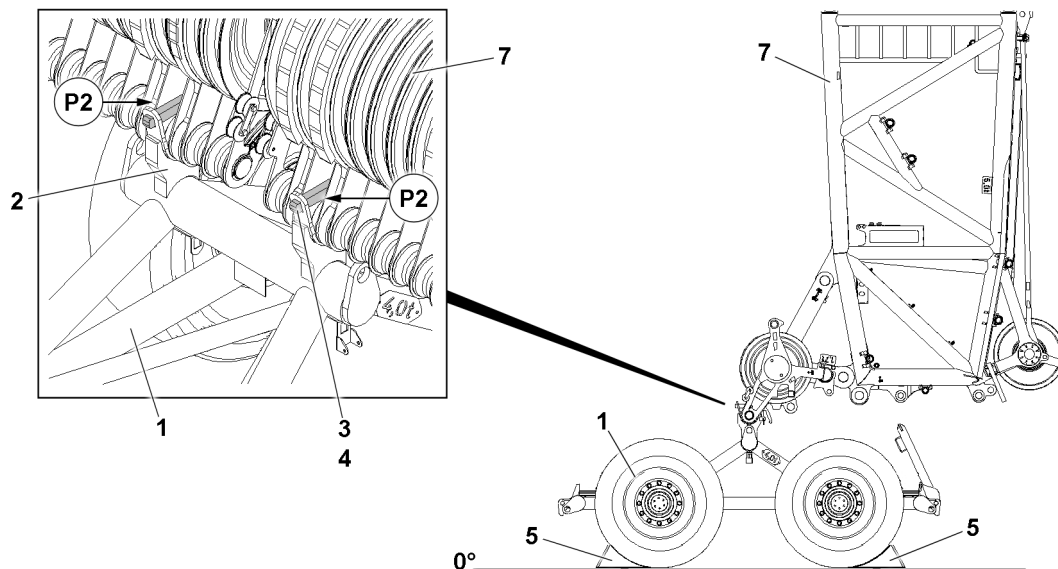


Fig.151424: Lowering the boom end section in the roller cart

- ▶ Slowly lower the boom until the carrier rollers of the roller set are placed in the receptacles **2** of the roller cart **1** in point **P2**.
- ▶ Remove the locking element **3** from the park position.
- ▶ Secure the roller cart **1** with the locking element **3** and retaining element **4** in point **P2**.
- ▶ Remove the chocks **5** from the wheels.
- ▶ Secure the chocks **5** again in the transport retainers on the roller cart **1**.

**Result:**

- The boom system can be luffed down.

### 5.3 Disassembling the roller cart

Make sure that the following prerequisites are met:

- The boom is luffed down.
- An auxiliary crane with sufficient load bearing capacity is available.
- The W-boom is properly fastened on the auxiliary crane, see chapter 5.01.
- The W-boom is lifted off the ground with the auxiliary crane.



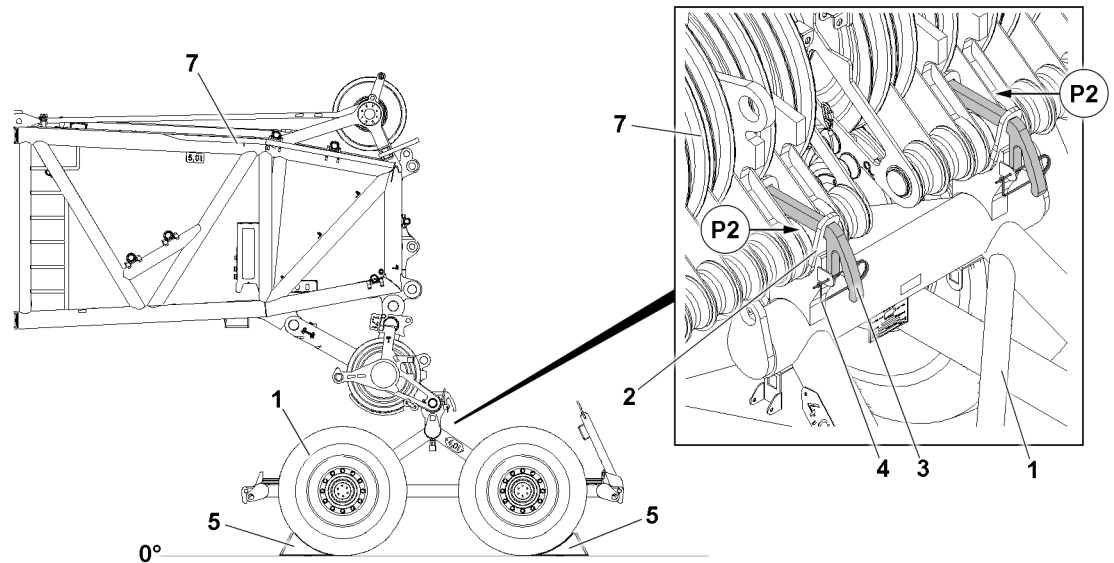


Fig.151423: Disassembling the roller cart

- ▶ Secure the roller cart 1 with chocks 5 to prevent it from rolling off: Push the chocks 5 on the left and right hand side tightly under the wheels.
- ▶ Secure the boom end section 7 in point P2: Remove the retaining element 4 in point P2 and unplug the locking element 3.

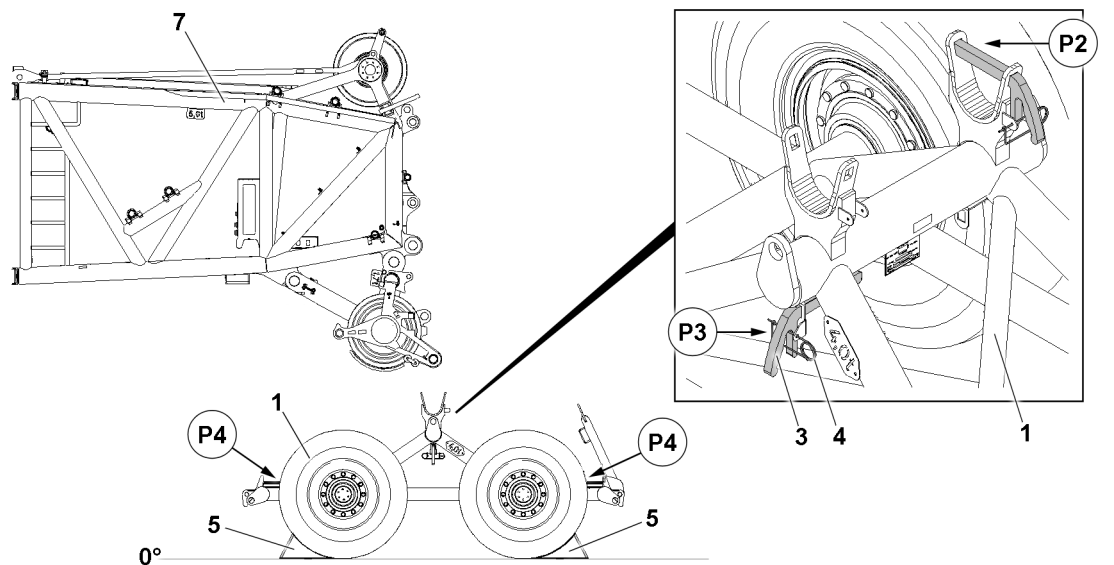


Fig.151422: Roller cart under the boom end section

- ▶ Plug the locking element 3 in the park position in point P3 and secure with the retaining element 4.
- ▶ Slowly lift the boom with the auxiliary crane until the receptacles 2 of the roller cart 1 are free.
- ▶ Remove the chocks 5 from the wheels.
- ▶ Secure the chocks 5 again in the transport retainers in point P4 on the roller cart 1.
- ▶ Remove the roller cart 1.
- ▶ When the roller cart 1 is removed: Take down the boom onto ground with a suitable load bearing capacity.

---

Empty page!

LWE/LR 1800-1-0-000/27200-07-02/en

## 5.70 Camera

1	Component overview	3
2	Safety guidelines	4
3	Assembling the camera	5
4	Assembling the cable drum on the auxiliary boom	7
5	Assembling the transmitter / receiver retainer	9
6	Establishing the electrical connections	11
7	Radio interference	14
8	Checking the electrical connections	15
9	Disconnecting the electrical connections	15
10	Transporting the camera	15

*Fig.195219*

# 1 Component overview

The illustrations in this chapter are an example. The installation of the camera is described as an example. The attached retainers are located at times in other positions than as shown.

Carry out the assembly of the camera depending on the crane structure.

The luffing jib "W" and fixed jib "F" are generally referred to as the auxiliary boom.

## 1.1 Camera

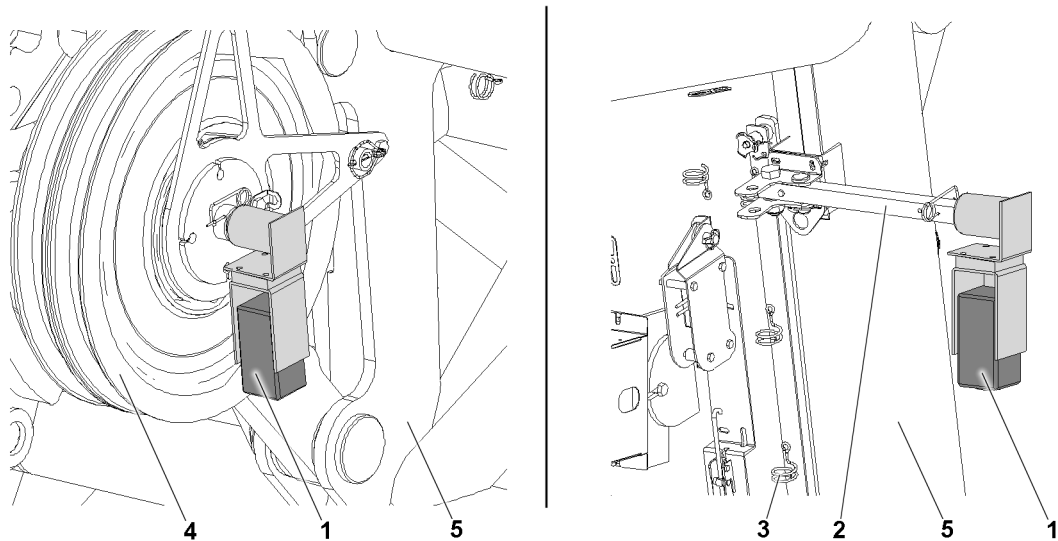


Fig.147708: Camera

- |   |                       |   |            |
|---|-----------------------|---|------------|
| 1 | Camera                | 4 | Roller set |
| 2 | Camera mount retainer | 5 | Boom       |
| 3 | Cable retainer        |   |            |

## 1.2 Transmitter / receiver

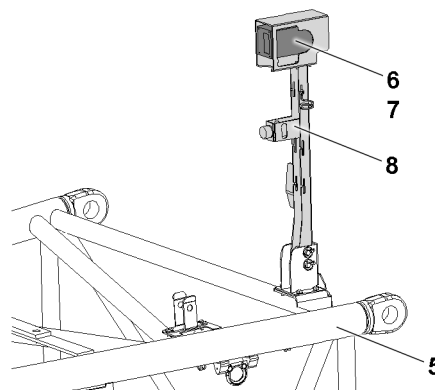


Fig.147709: Transmitter / receiver

- |   |             |   |                                 |
|---|-------------|---|---------------------------------|
| 5 | Boom        | 7 | Receiver                        |
| 6 | Transmitter | 8 | Transmitter / receiver retainer |

## 1.3 Cable drum

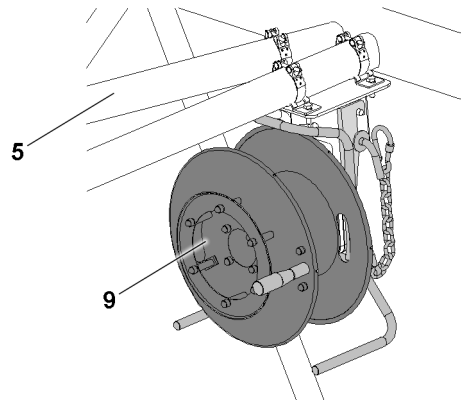


Fig.147710: Cable drum

5 Boom

9 Cable drum

## 2 Safety guidelines



### WARNING

Danger of falling!

During assembly / disassembly, inspection and maintenance work, assembly personnel must be secured with appropriate aids to prevent them from falling.

Death, severe bodily injuries, property damage.

- ▶ All work at a height, when there is a danger of falling, must be carried out with suitable aids.
- ▶ If aids are not available and work cannot be carried out from the ground, then assembly personnel must secure themselves with the supplied fall arrest system to prevent falling, see the Crane operating instructions, chapter 2.04.
- ▶ If fall protection equipment is available, then it must be used, see the Crane operating instructions, chapter 2.06.
- ▶ When lifting, lowering, swinging crane parts in and out, no persons may remain in the danger zone.
- ▶ When closing or opening boom systems during boom assembly or boom disassembly, no persons may remain on the boom system or in the danger zone.
- ▶ If railings are present on the components, then they must be brought into the corresponding position and secured for assembly / disassembly work.
- ▶ Only step on the aids, ladders and catwalks with clean shoes.
- ▶ Keep aids, ladders and catwalks free of heavy dirt, snow, frost and ice.
- ▶ During all assembly and disassembly work, maintenance work and inspections, travel or crane operation is prohibited.
- ▶ Remaining on a suspended load is prohibited.
- ▶ Stepping or walking on crane components and lattice sections, which have an incline of more than 20° is prohibited.
- ▶ For all assembly work, the crane driver of the main crane must be in voice contact with the crane driver / crane drivers of the auxiliary crane / auxiliary cranes.
- ▶ For assembly tasks, the crane driver may only initiate crane movements when the responsible guide has explicitly released the movement.

**WARNING**

Incorrect handling of the fastening equipment!

If fastening equipment cannot be attached correctly and if it is not secured sufficiently to prevent it from loosening up, loads can fall down.

Death, severe bodily injuries, property damage.

- ▶ Make sure that the fastening equipment is correctly attached on the fastening points and that it is secured sufficiently to prevent it from loosening up.

**WARNING**

Danger of impact / crushing!

When installing / removing crane components with the auxiliary crane, crane components can start to swing back and forth.

When lifting / lowering and positioning crane components, there is an increased danger of impacts / crushing.

Death, severe bodily injuries, property damage.

- ▶ Make sure that personnel cannot be caught by components.
- ▶ Make sure that there are no persons between the components to be assembled / disassembled and the crawler travel gear.
- ▶ Make sure that the crane is horizontally aligned.
- ▶ When working in danger zones: Use aids to protect limbs.
- ▶ Guide components with suitable aids to minimize oscillation.

### 3 Assembling the camera

When assembling the camera on the roller set or on the camera mount retainer, the assembly procedure and the process are identical for all boom variations.

The installation of the camera is described as an example. The attached retainers are located at times in other positions than as shown.

Carry out the assembly of the camera depending on the crane structure.

The camera changes its angle automatically so that it is aligned vertically, gravity related.

The swing angle is limited by design.

### 3.1 Assembling the camera on the roller set

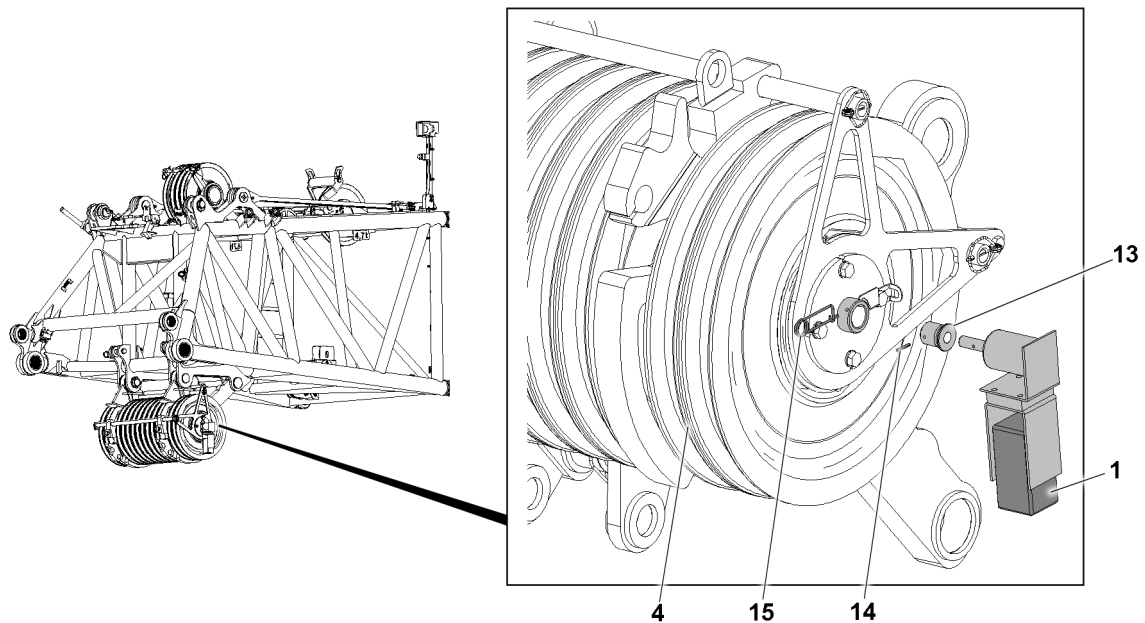


Fig.147713: Assembling the camera on the roller set

Make sure that the following prerequisites are met:

- The boom system is completely assembled.
- The boom system is lying on the ground.
- ▶ Remove the sleeve **13** on the roller set **4**: Remove the retaining element **15** and pull out the sleeve **13**.
- ▶ Remove the spring pin **14** on the sleeve **13**.
- ▶ Guide the camera **1** into the sleeve **13**.
- ▶ Secure the camera **1** in the sleeve **13**: Stick in the spring pin **14**.

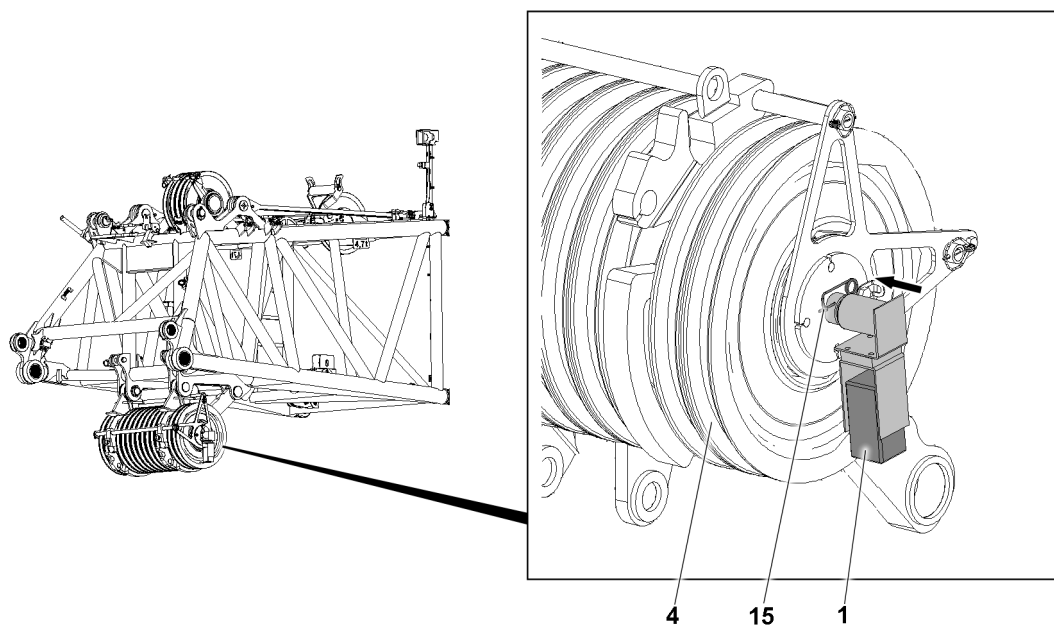


Fig.147714: Assembling the camera on the roller set

- ▶ Guide the camera **1** with the sleeve **13** into the roller set **4** to the stop.
- ▶ Secure the camera **1** in the roller set **4**: Assemble the retaining element **15**.



### 3.2 Assembling the camera on the camera mount retainer

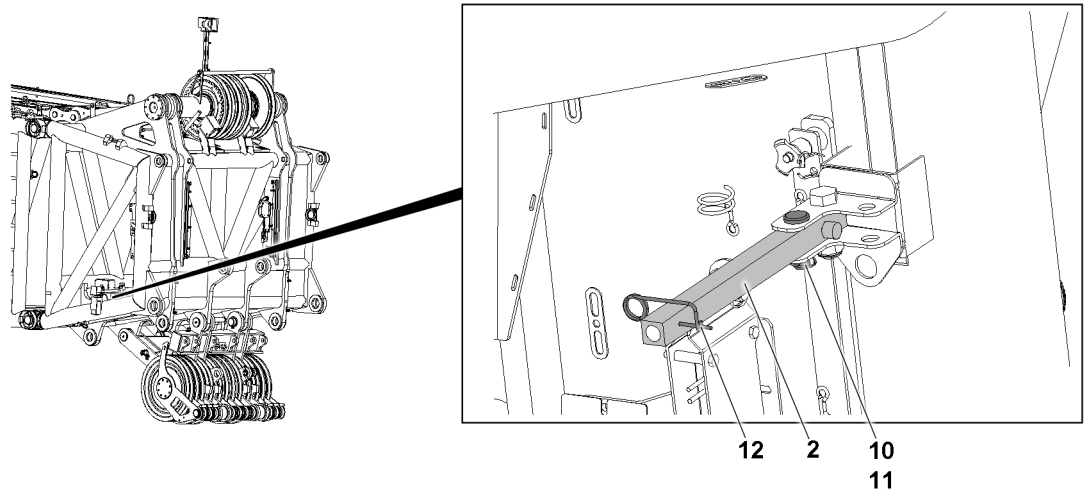


Fig.147711: Assembling the camera on the camera mount retainer

Make sure that the following prerequisites are met:

- The boom system is completely assembled.
- The boom system is lying on the ground.
- ▶ Remove the retaining element **12**.
- ▶ Release the camera mount retainer **2** from the transport position: Remove the retaining element **11** and unpin the pin **10**.

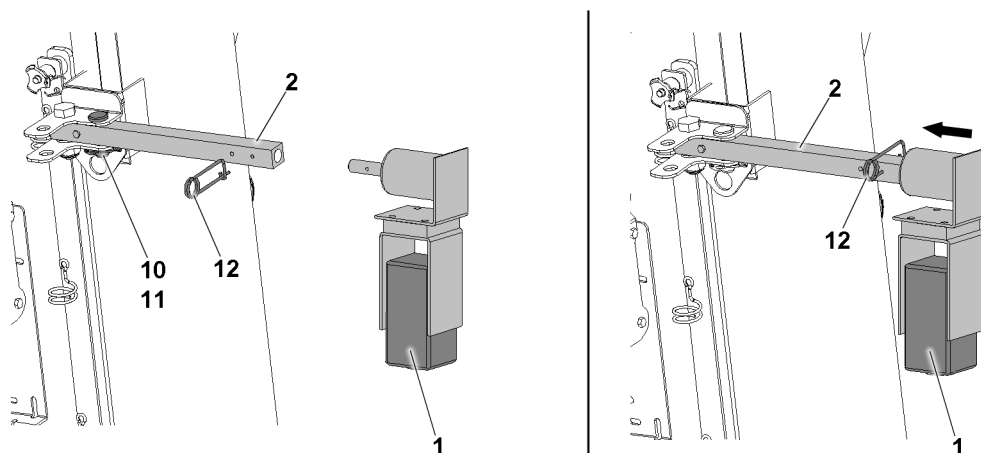


Fig.147712: Assembling the camera on the camera mount retainer

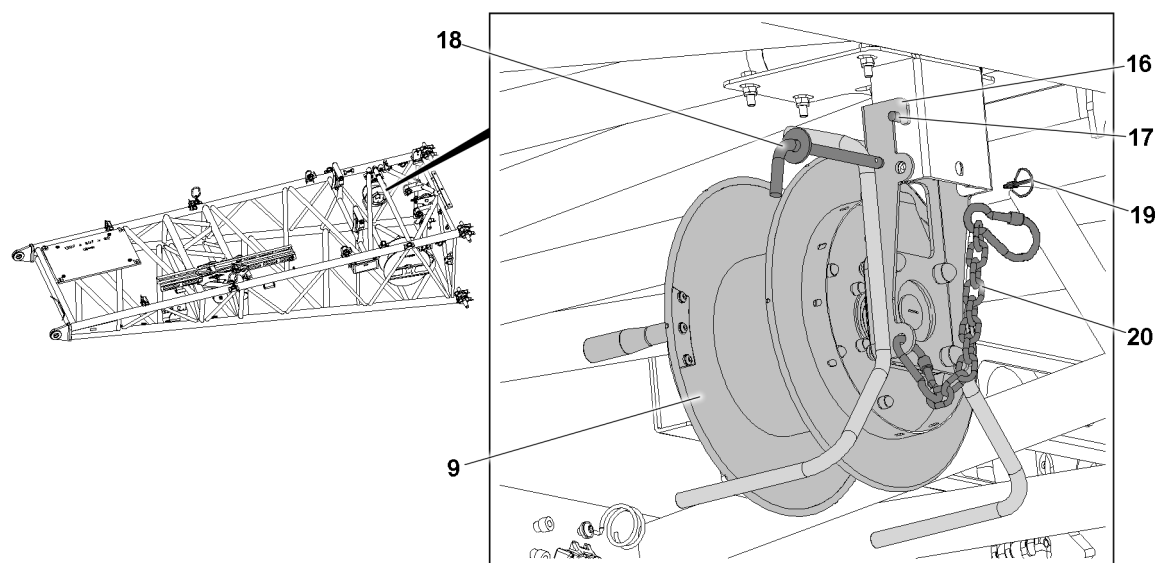
- ▶ Swing the camera mount retainer **2** into the operating position.
- ▶ Secure the camera mount retainer **2** in the operating position: Insert the pin **10** and secure it with the retaining element **11**.
- ▶ Guide the camera **1** into the camera mount retainer **2**.
- ▶ Secure the camera **1** in the camera mount retainer **2**: Assemble the retaining element **12**.

## 4 Assembling the cable drum on the auxiliary boom

For the assembly of the cable drum on the auxiliary boom, the assembly procedure and the process are identical for all boom variations.

The installation of the cable drum is described as an example. The attached retainers are located at times in other positions than as shown.

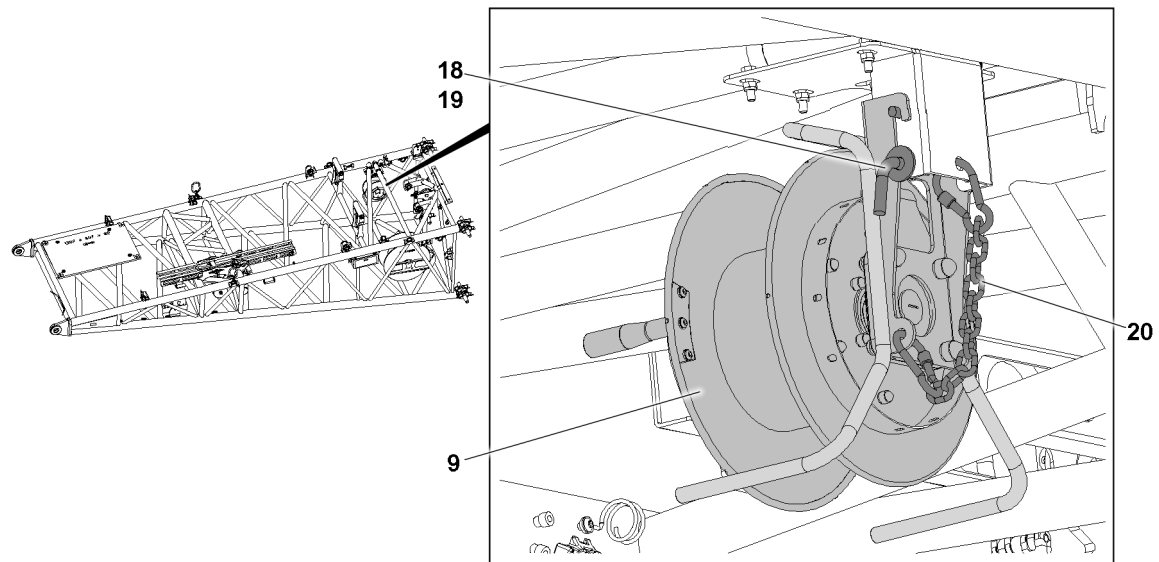
Carry out the assembly of the cable drum depending on the crane structure.



*Fig.147715: Assembling the cable drum*

Make sure that the following prerequisites are met:

- The boom system is completely assembled.
- The boom system is lying on the ground.
- ▶ Remove the retaining element **19** on the cable drum **9** and unpin the socket pin **18**.
- ▶ Attach the cable drum **9** with the retainer **16** on the pin **17**.



*Fig.147716: Assembling the cable drum*

- ▶ Secure the cable drum **9**: Insert the socket pin **18** and secure with the retaining element **19**.
- ▶ Attach the retaining chain **20** of the cable drum **9**.

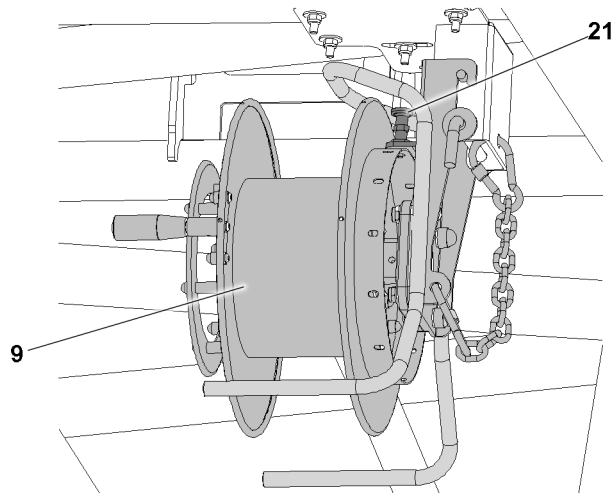


Fig.147717: Locking the cable drum

To ensure that the cable drum 9 does not rotate inadvertently, the cable drum must be locked.

- Lock the cable drum 9 with the detent pin 21.

## 5 Assembling the transmitter / receiver retainer

For the assembly of the transmitter / receiver retainer, the assembly procedure and the process are identical for all boom variations.

The installation of the transmitter / receiver retainer is described as an example. The attached retainers are located at times in other positions than as shown.

Carry out the assembly of the transmitter / receiver retainer depending on the crane structure.

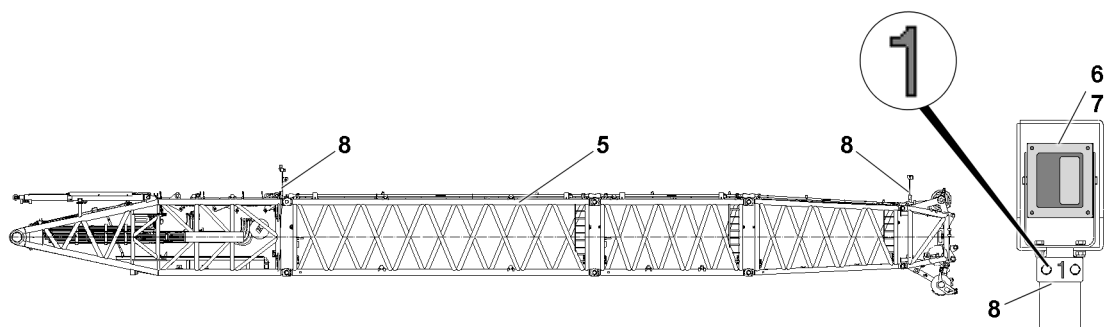


Fig.147769: Assembling the transmitter / receiver retainer



### Note

- The transmitter / receiver pair with the number 1 must always be assembled on the main boom.

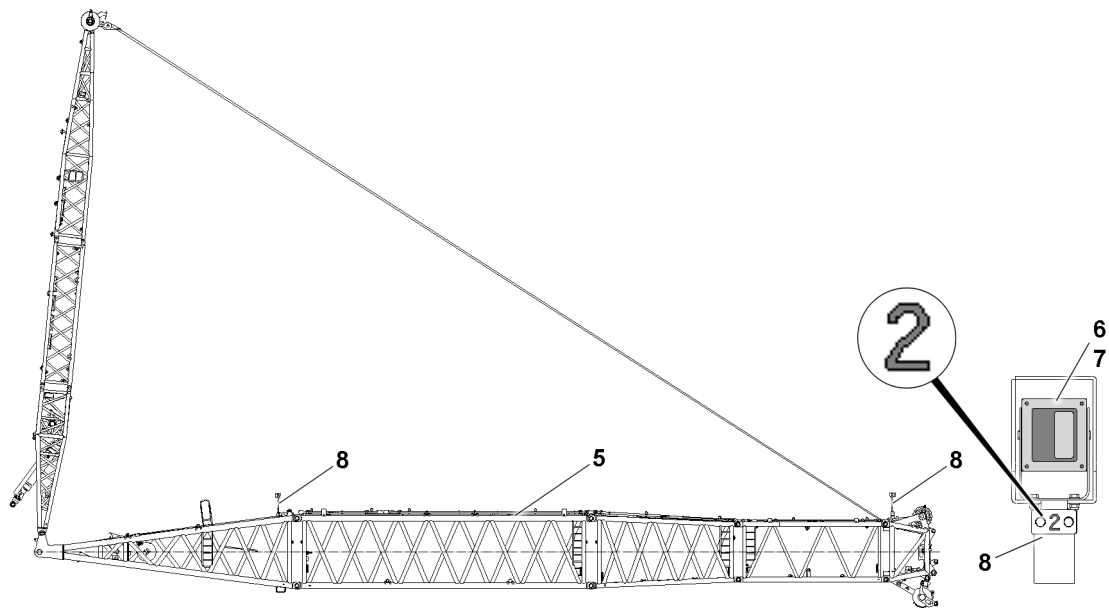


Fig. 147770: Assembling the transmitter / receiver retainer



**Note**

- ▶ The transmitter / receiver pair with the number 2 must always be assembled on the auxiliary boom.

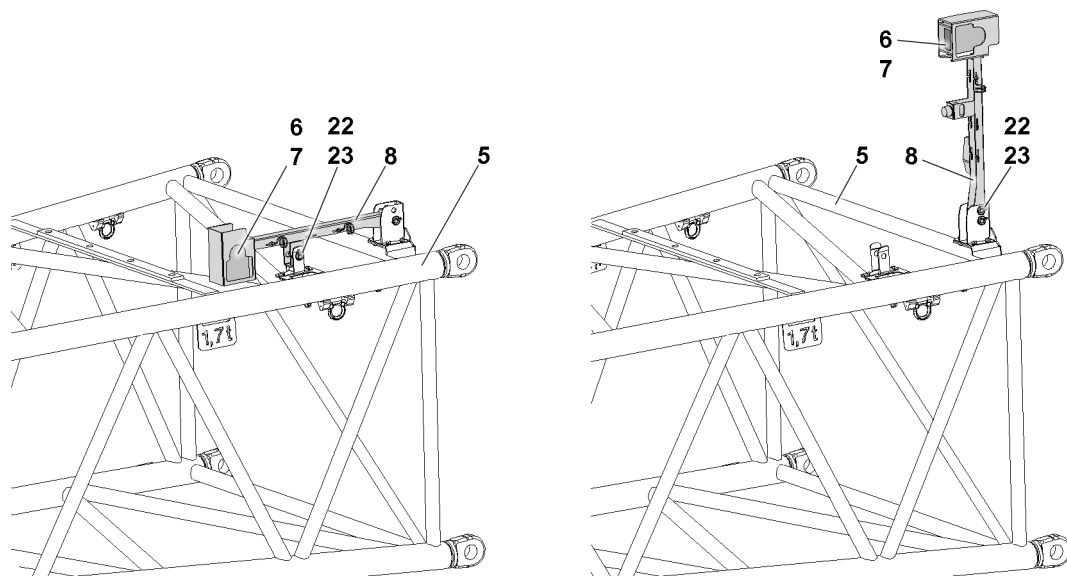


Fig. 147768: Transmitter / receiver retainer

- ▶ Release the transmitter / receiver retainer 8 from the transport position: Remove the retaining element 23 and unpin the pin 22.
- ▶ Swing the transmitter / receiver retainer 8 into the operating position.
- ▶ Secure the transmitter / receiver retainer 8 in the operating position: Insert the pin 22 and secure it with the retaining element 23.

## 6 Establishing the electrical connections

### 6.1 Radio operation

The electrical connections are established differently depending on the equipment.

There are the following variations:

- Camera on the main boom, see illustration 1.
- Camera on the auxiliary boom - radio, see illustration 2.
- Camera on the auxiliary boom - cable, see illustration 3.
- Camera on the auxiliary boom - cable drum see illustration 4.

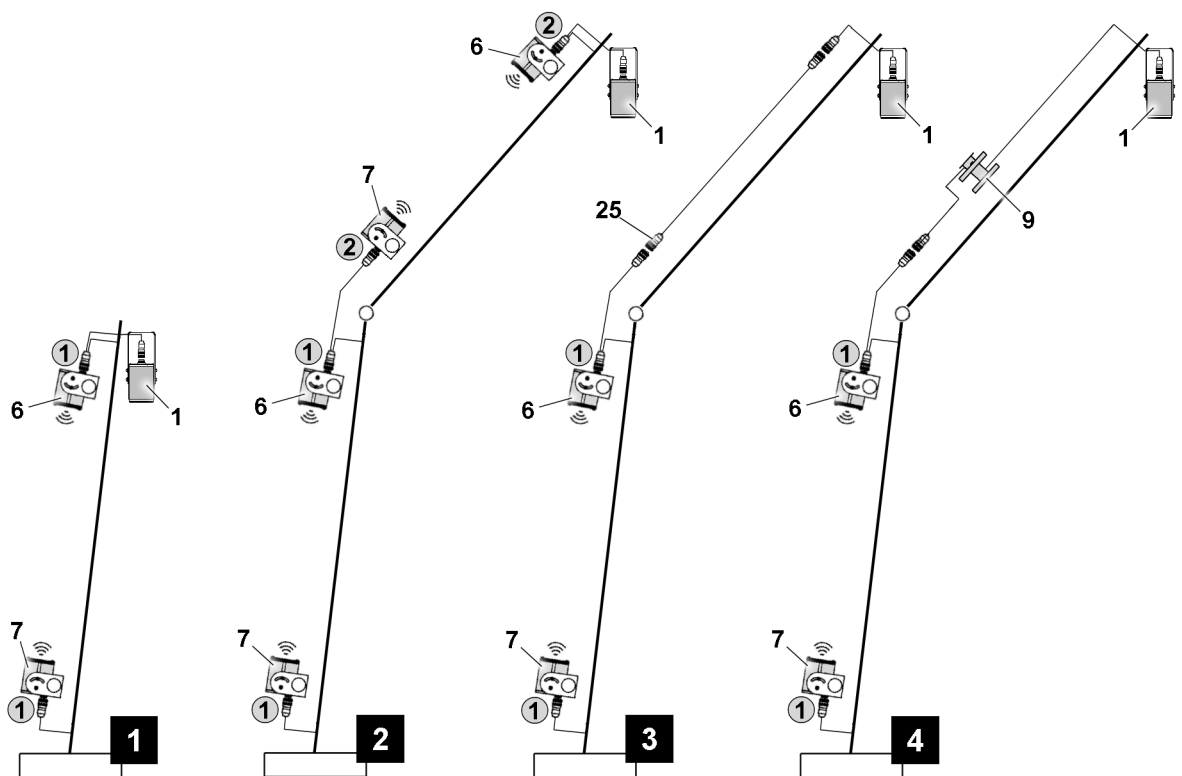


Fig.147775: Camera monitoring variations

#### 6.1.1 Camera on the main boom, see illustration 1

Make sure that the following prerequisites are met:

- The camera is assembled on the main boom.
- The transmitter and receiver are assembled on the main boom.



#### Note

- ▶ Establish the electrical connections, see the Electric wiring diagram.
- ▶ Connect the cable from the camera 1 with the transmitter 6 on the main boom.

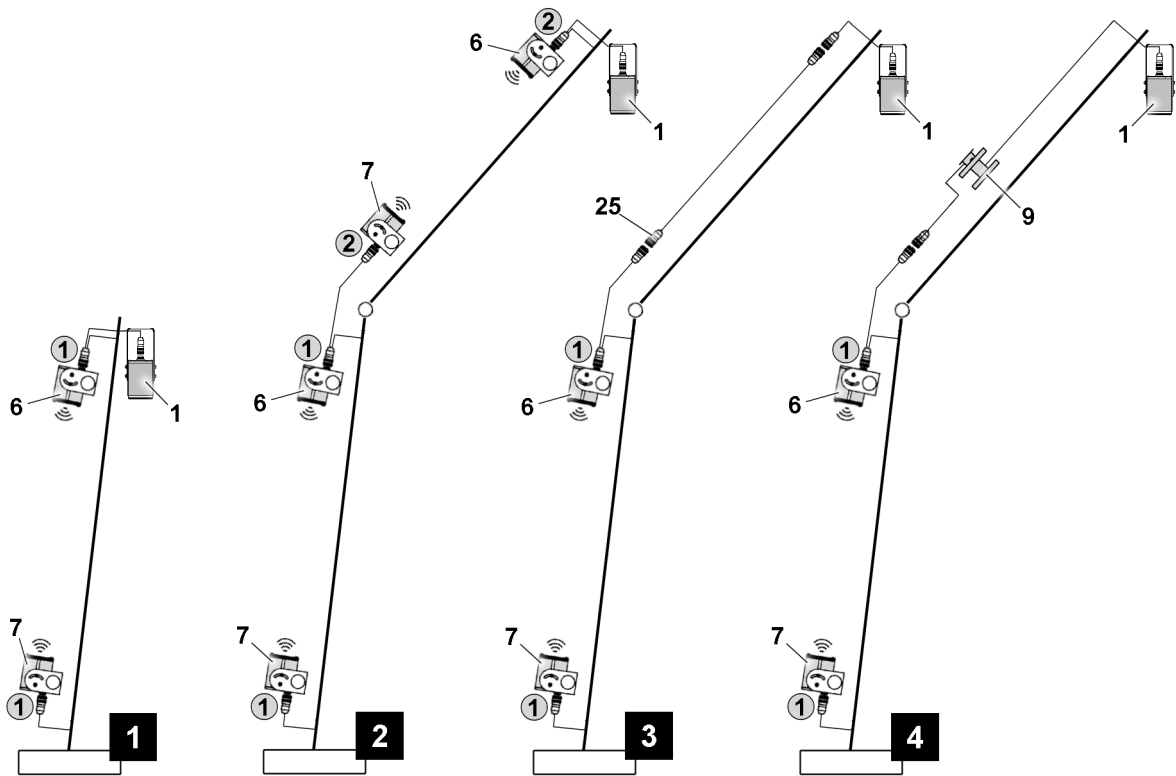


Fig.147775

### 6.1.2 Camera on the auxiliary boom - radio, see illustration 2

Make sure that the following prerequisites are met:

- The camera is installed on the auxiliary boom.
- The transmitter and receiver are assembled on the main boom.
- The transmitter and receiver are assembled on the auxiliary boom.



#### Note

- ▶ Establish the electrical connections, see the Electric wiring diagram.

- ▶ Connect the cable from the camera 1 with the transmitter 6 on the auxiliary boom.
- ▶ Make sure that the receiver 7 on the auxiliary boom is connected with the transmitter 6 on the main boom.

### 6.1.3 Camera on the auxiliary boom - cable, see illustration 3

Make sure that the following prerequisites are met:

- The camera is installed on the auxiliary boom.
- The transmitter and receiver are assembled on the main boom.



#### Note

- ▶ Establish the electrical connections, see the Electric wiring diagram.



#### Note

- ▶ In the case of distances of less than 10 m between the transmitter 6 and receiver 7, the screen image may be disturbed in the case of oversteering.
- ▶ Use the cable, see the Electric wiring diagram.
- ▶ Connect the cable from the camera 1 with the cable 25 on the auxiliary boom.
- ▶ Secure the cable 25 on the auxiliary boom.

- ▶ Connect the cable **25** with the cable of the transmitter **6** on the main boom.

### 6.1.4 Camera on the auxiliary boom - cable drum see illustration 4

Make sure that the following prerequisites are met:

- The camera is installed on the auxiliary boom.
- The transmitter and receiver are assembled on the main boom.
- The cable drum is assembled and secured on the auxiliary boom.



#### Note

- ▶ Establish the electrical connections, see the Electric wiring diagram.
- ▶ Connect the longer cable of the cable drum **9** with the camera **1** on the auxiliary boom.
- ▶ Secure the longer cable of the cable drum **9** on the auxiliary boom, see section “Securing the cable”.
- ▶ Connect the shorter cable of the cable drum **9** with the cable of the transmitter **6** on the main boom.

## 6.2 Luffing range

When the boom angle is changed, also the position of the camera **1** changes.

The swinging movement of the camera **1** changes the necessary cable length.

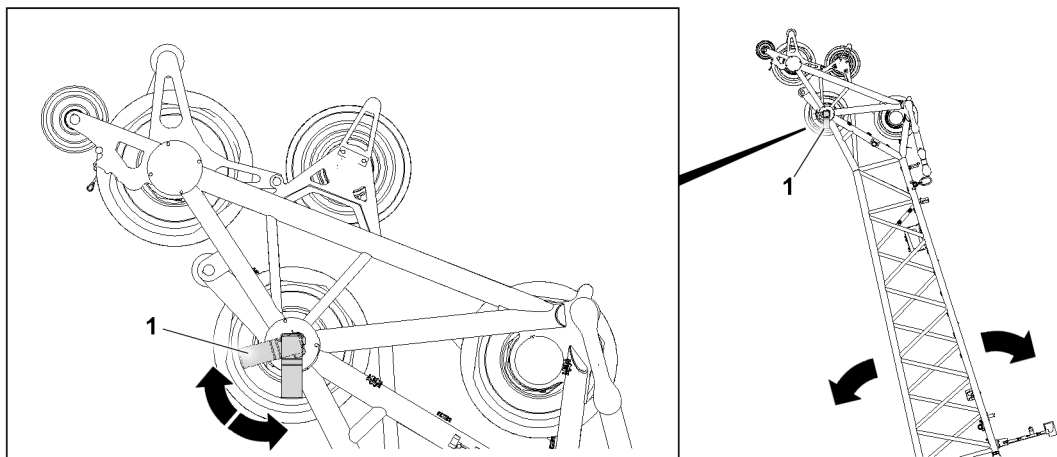


Fig.147773: Boom luffing range and camera slewing range

#### NOTICE

Cable length too short!  
The cable tears, property damage.

- ▶ Make sure that enough cable length is available for the swinging movement of the camera **1**.
- ▶ Check the cable length.

## 6.3 Securing the cable

#### NOTICE

Cable in the luffing range of the auxiliary boom!  
The cable tears, property damage.

- ▶ Make sure that the cable for the camera and cable drum is not in the luffing range of the auxiliary boom.

**NOTICE**

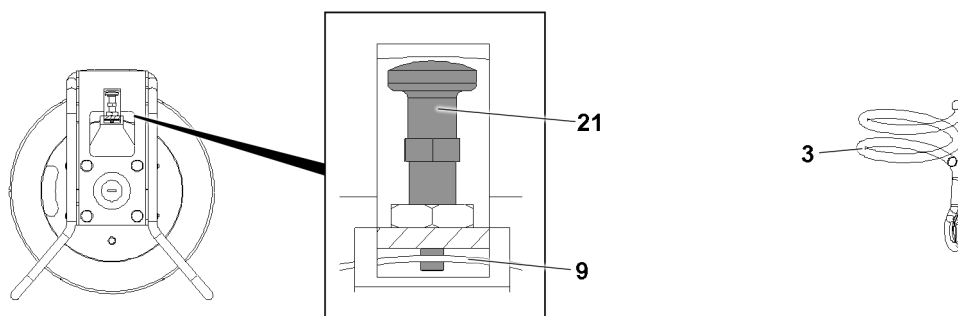
Cable in the working range of other components!

The cable tears, property damage.

- ▶ Make sure that the cable for the camera and cable drum is not in the working range of other components.

Other components are, for example:

- Hoist rope
- Rope pulleys

**6.3.1 Cable drum**

*Fig.147771: Locking the cable drum*

- ▶ Feed the longer cable in the cable retainer **3** on the auxiliary boom.

The longer cable of the cable drum must be secured by the pull release installed on the cable.

If the longer cable is connected with the camera:

- ▶ Secure the pull release on the auxiliary boom.
- ▶ Feed the shorter cable in the cable retainer **3** on the auxiliary boom.

To ensure that the cable drum **9** does not rotate inadvertently, the cable drum **9** must be locked.

- ▶ Insert the detent pin **21**.

**6.3.2 Camera**

- ▶ Attach the cable in the cable retainer **3**.

**7 Radio interference**

The range of the radio signal can fluctuate due to local conditions.

The ranges on the boom strongly depend on the proximity to metal structures, surfaces or obstacles.

The transmitter and the receiver must have a visual connection and must be aligned with each other

In the case of distances of less than 10 m between the transmitter and receiver, the screen image may be disturbed in the case of oversteering.

- ▶ In the case of distances of less than 10 m between the transmitter and receiver, see the Electric wiring diagram and section "Camera on the auxiliary boom - cable".



## 8 Checking the electrical connections

- ▶ Make sure that the camera image is displayed on the monitor.

## 9 Disconnecting the electrical connections

When the electrical connections are separated, protective caps must be installed to protect the electrical connections from damage.

- ▶ Disconnect the electrical connections, see the Electric wiring diagram

When a protective cap is available:

- ▶ Install the protective cap.

## 10 Transporting the camera

To prevent the camera from being damaged, the camera must be protected by the supplied case.

- ▶ Disconnect the electrical connections to the camera.
- ▶ Remove the camera.
- ▶ Store the camera in the supplied case and transport it.

---

Empty page!

LWE/LR 1800-1-0-000/27200-07-02/en

## 5.72 Outside drive aggregate

1	External drive assembly overview	2
2	Component overview	2
3	Fastening points for the drive assembly	4
4	Installing the drive assembly	5
5	Operating the drive assembly	12
6	Removing the drive assembly	20

# 1 External drive assembly overview

For description of the external drive assembly, see the provided manufacturer documentation.

The external drive assembly is also indicated as an additional drive system, drive assembly or APU.

Additional drive system for installation on the crane superstructure for maintaining the on-board voltage, air conditioning the crane cab and preheating the hydraulic oil\* in the tank when the crane engine is shut off.

The functions can be activated manually or automatically (ECO-Mode).

To observe the maintenance intervals, the drive assembly must remain with its associated crane as the operating hours of the drive assembly are displayed / counted on the operating unit in the crane cab.

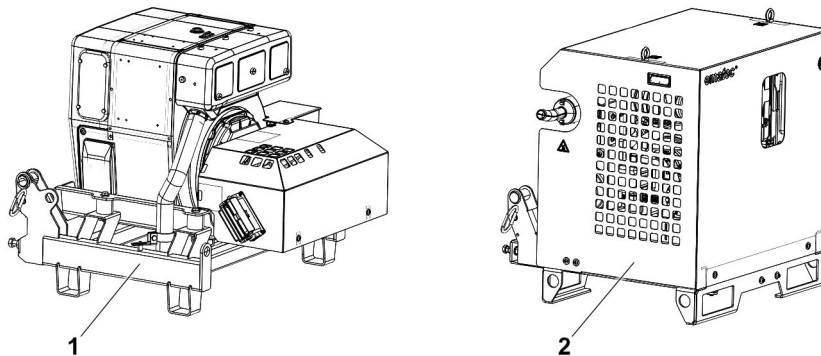


Fig.164073: Drive assembly overview

Position	Component
1	Drive assembly
2	Hydraulic oil preheating* drive assembly

Drive assembly overview

## 2 Component overview



### Note

- A component view of a drive assembly is shown as an example.

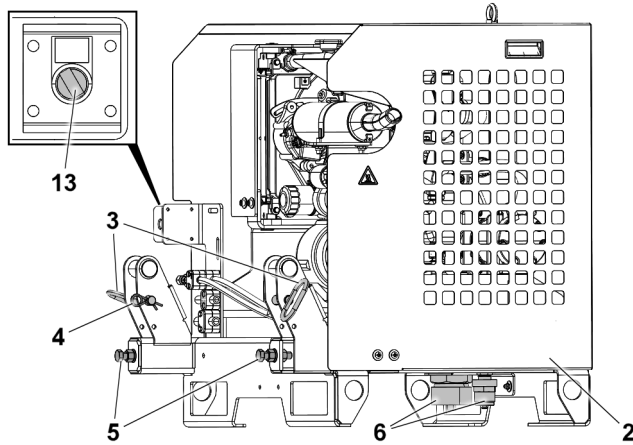


Fig.164075: Drive assembly component overview

Position	Component
2	Drive assembly
3	Retaining pin
4	Retaining element
5	Adjusting screw
6	Hydraulic oil preheating* connections <b>Note:</b> Only for a drive assembly with hydraulic oil preheating
13	Rotary switch for change over between the air conditioning system and hydraulic oil preheating* <b>Note:</b> Only for a drive assembly with hydraulic oil preheating

Drive assembly component overview

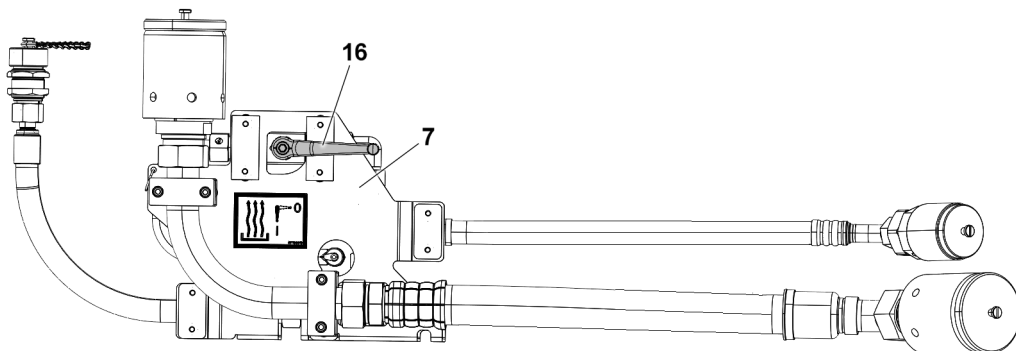


Fig.164074: Hydraulic unit component overview

Position	Component
7	Hydraulic unit for hydraulic oil preheating*
16	Ball valve

Hydraulic unit component overview

LWE/LR 1800-1-0-000/27200-07-02/en

**Note**

- The hydraulic unit 7 must be released for the crane type.

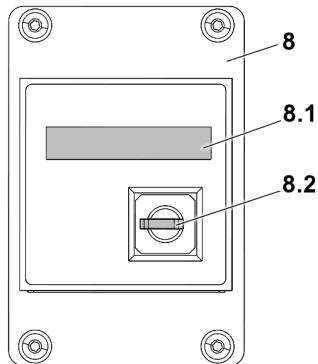


Fig.164076: Operating unit component overview

Position	Component
8	Operating unit in the crane cab
8.1	Operating unit display With operating hour meter of the APU
8.2	APU ignition switch

Operating unit component overview

### 3 Fastening points for the drive assembly

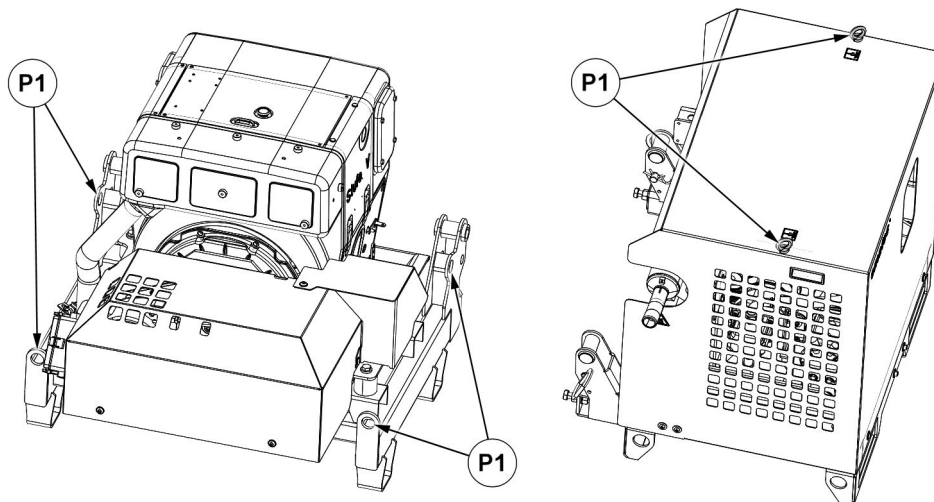


Fig.164077: Drive assembly fastening points

Point	Component
P1	Fastening points

Drive assembly fastening points

**WARNING**

Component incorrectly fastened!

Life-threatening situations can arise due to improper or incorrect fastening of the corresponding components.

Death, severe bodily injuries, property damage.

- ▶ Fasten the components only in the intended fastening points on both sides.

## 4 Installing the drive assembly

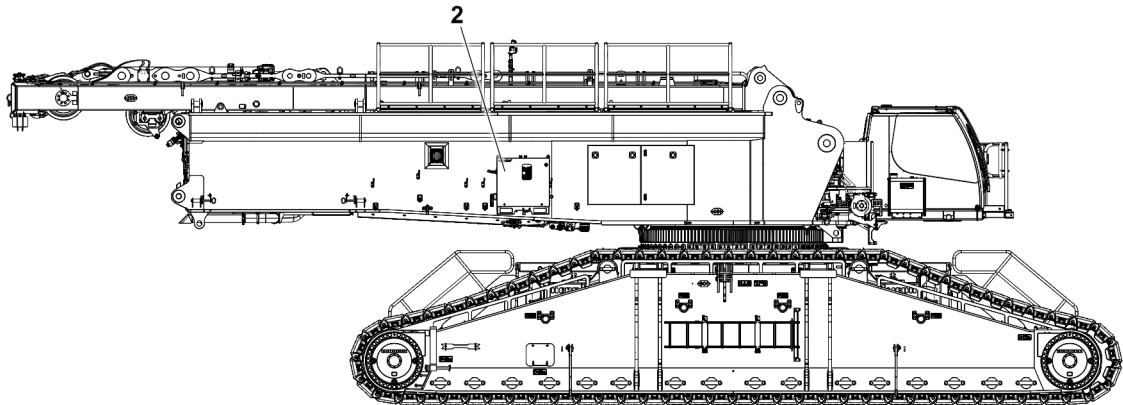


Fig.164104: Installing the drive assembly

**WARNING**

Danger of falling!

During assembly / disassembly, inspection and maintenance work, assembly personnel must be secured with appropriate aids to prevent them from falling.

Death, severe bodily injuries, property damage.

- ▶ All work at a height, when there is a danger of falling, must be carried out with suitable aids.
- ▶ If aids are not available and work cannot be carried out from the ground, then assembly personnel must secure themselves with the supplied fall arrest system to prevent falling, see the Crane operating instructions, chapter 2.04.
- ▶ If fall protection equipment is available, then it must be used, see the Crane operating instructions, chapter 2.06.
- ▶ When lifting, lowering, swinging crane parts in and out, no persons may remain in the danger zone.
- ▶ If railings are present on the components, then they must be brought into the corresponding position and secured for assembly / disassembly work.
- ▶ It is prohibited to lean the ladder against the component to be disassembled.
- ▶ Only step on the aids, ladders and catwalks with clean shoes.
- ▶ Keep aids, ladders and catwalks free of heavy dirt, snow and ice.
- ▶ During all assembly and disassembly work, maintenance work and inspections, travel or crane operation is prohibited.
- ▶ Remaining on a suspended load is prohibited.
- ▶ Stepping and walking on crane components and lattice sections with an incline of more than 20° is prohibited.
- ▶ For all assembly work, the crane operator of the main crane must be in voice contact with the crane operator / crane operators of the auxiliary crane / auxiliary cranes.
- ▶ For the assembly / disassembly tasks, the crane operator may only initiate crane movements when the responsible guide has explicitly released the movement.

**WARNING**

Danger of impact / crushing!

When assembling / disassembling crane components with the auxiliary crane, crane components can start to swing back and forth.

When lifting / lowering and positioning crane components, there is an increased danger of impact / crushing.

Death, severe bodily injuries, property damage.

- ▶ Make sure that personnel cannot be caught by components.
- ▶ When working in a danger zone: Use aids to protect limbs.
- ▶ Guide components with suitable aids to minimize oscillation.

**WARNING**

The component can fall down!

If the corresponding component is disengaged from the auxiliary crane before the corresponding component is pinned, then the corresponding component can fall down.

Death, severe bodily injuries, property damage.

- ▶ Do not disconnect the auxiliary crane until the respective component is pinned and secured.

**Note**

Additional base for the installation of the drive assembly **2**.

- ▶ Turn the turntable or use an additional platform to enlarge the base.



## 4.1 Connecting the drive assembly to the turntable

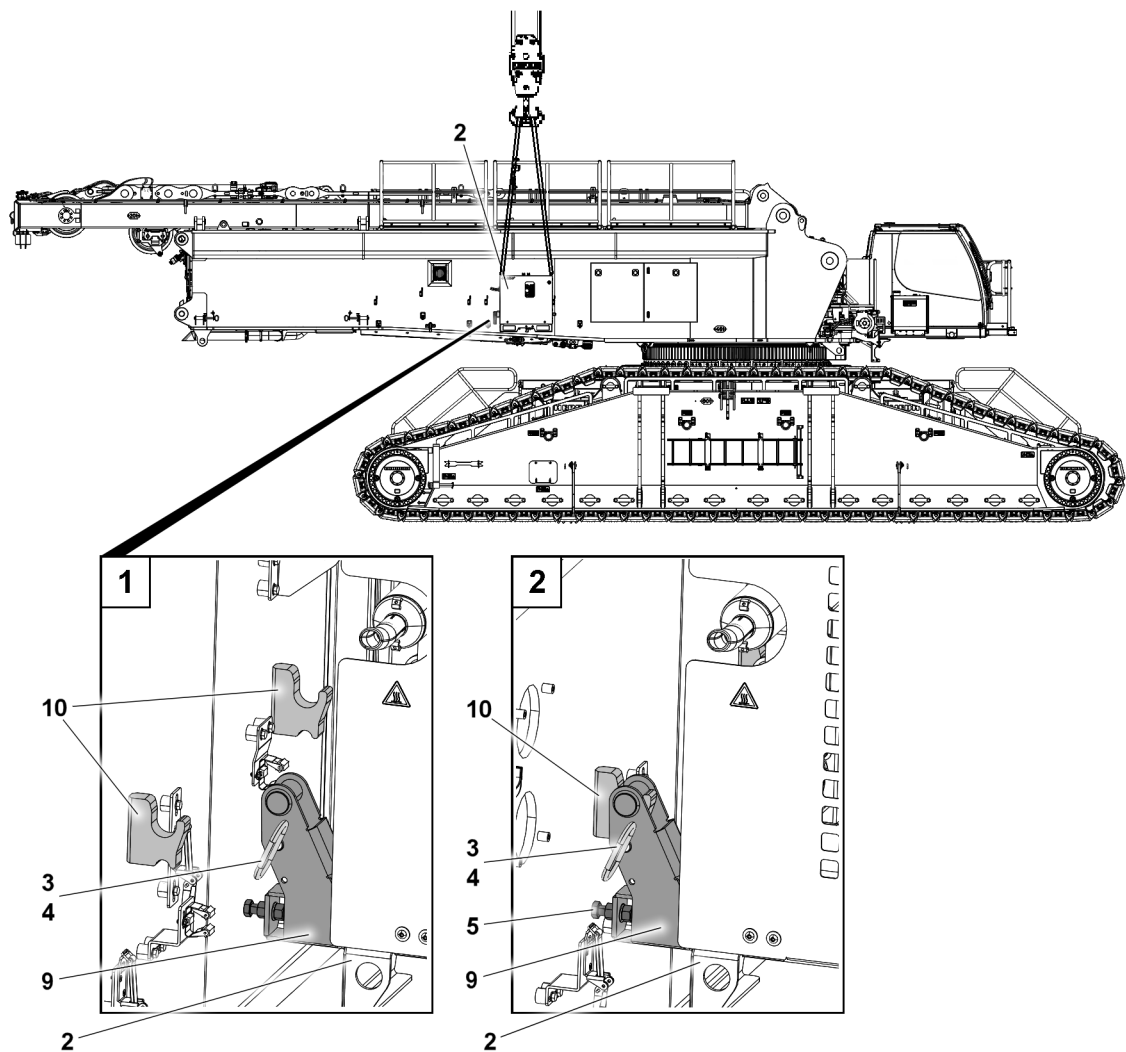


Fig.164105: Connecting the drive assembly

2	Drive assembly	5	Adjusting screw
3	Retaining pin	9	Support frame
4	Retaining element	10	Bracket



### Note

- ▶ The assembly / disassembly of the drive assembly is identical and is described based on the example of the drive assembly 2 with hydraulic oil preheating\*.



### WARNING

- Impermissible fastening equipment!  
The drive assembly 2 can fall down.  
Death, severe bodily injuries, property damage.
- ▶ Use only inspected fastening equipment.

Make sure that the following prerequisites are met:

- The crane is horizontally aligned.
- A sufficient base is available.
- Personal protective equipment has been put on and is being used.
- ▶ Fasten the drive assembly 2 to the auxiliary crane and swing it into the assembly position.
- ▶ Remove the retaining elements 4 on both sides on the retaining pin 3.

- ▶ Unpin the retaining pin **3** on both sides.
- ▶ Connect the drive assembly **2** with the support frame **9** on both sides in the lugs **10**.
- ▶ Insert the retaining pins **3** on both sides and secure with the retaining elements **4**.

If the retaining pins **3** cannot be inserted:

- ▶ Loosen the adjusting screw **5** on both sides and adjust until the retaining pin **3** can be inserted.
- ▶ Tighten the adjustment adjusting screw **5** on both sides.
- ▶ Remove the auxiliary crane.

## 4.2 Establishing the connections between the drive assembly and the turntable

The drive assembly is ready for operation when it is completely installed and all connections are established.

Establish all connections:

- Establish the electrical connections.
- Connect the air conditioning lines.
- Connect the fuel lines.
- Establish the hydraulic connections.

**Note:** Only for drive assemblies with hydraulic oil preheating\*

### 4.2.1 Establishing the electrical connections

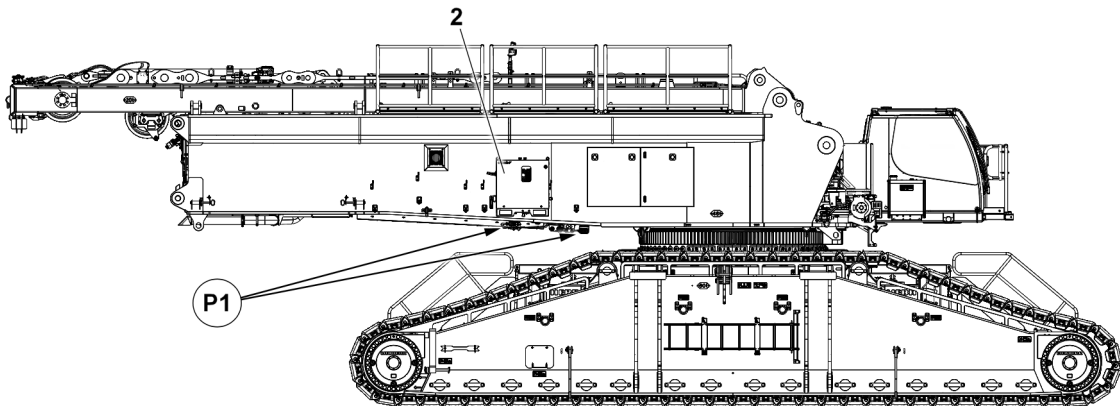


Fig.164106: Establishing the electrical connections

Make sure that the following prerequisites are met:

- The crane ignition switch is in position "0".
- The APU ignition switch is in position "0".

#### NOTICE

Damage to components!

If live electrical connections are disconnected / connected, then there is the danger that components can be damaged.

The crane functions can be limited.

- ▶ De-energize the electrical connections before disconnection / connection. Set the ignition switch to the "0" position.

Establish the electrical connection from the assembly drive **2** to the turntable:

- ▶ Plug the electrical lines from the drive assembly **2** into the connection points in position **P1**.

**Note**

- ▶ Establish the electrical connection from the assembly drive to the turntable, see the “wiring diagram”.
- ▶ Observe the colors of the plug and socket (red, blue, black).

**NOTICE**

Damage to the electrical connections due to dirt, moisture and corrosion!

If unrequired electrical connections are not closed with their respective caps, the electrical connections can be damaged.

If the covers are removed from the electrical connections or control cabinets are opened, then moisture can infiltrate.

- ▶ Always properly close off all **non**-required electrical connections with their protective caps.
- ▶ Protect the electrical connections from water infiltration, this applies especially in the case of rain or snow.

**Note**

If **non**-required electrical connections are not closed with their respective dummy plugs, the electrical connections can be damaged.

- ▶ A malfunction can occur without bridging.
- ▶ Observe the “wiring diagram”.

- ▶ As a rule, close off non-required electrical connections (for example for accessories that are not installed) with the respective dummy plugs / dust caps.

## 4.2.2 Connecting the air conditioning lines

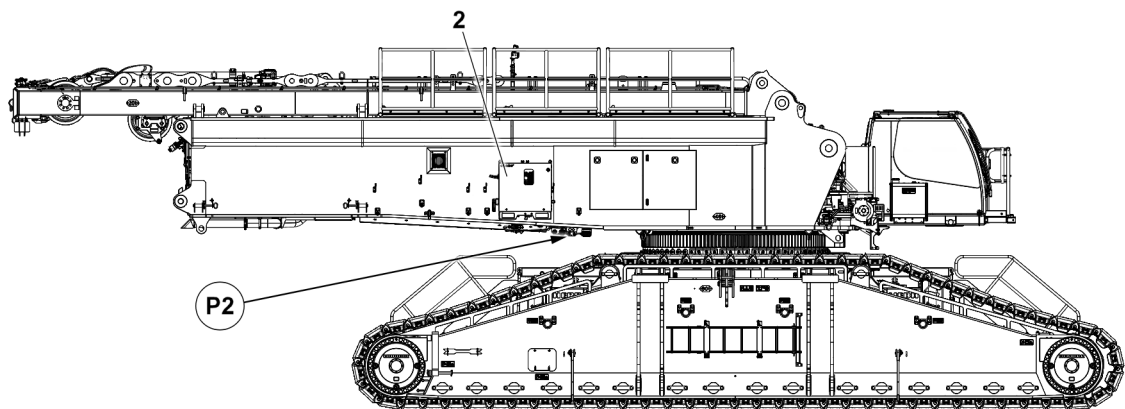


Fig.164107: Connecting the air conditioning lines

Make sure that the following prerequisites are met:

- The crane ignition switch is in position “0”.
- The APU ignition switch is in position “0”.

**WARNING**

Leaking refrigerant!

If the air conditioning system is not turned off before connecting / disconnecting the air conditioning lines, refrigerant can leak.

Danger of suffocation, severe bodily injuries, property damage.

- ▶ Make sure that the air conditioning system is turned off: Set the crane ignition switch and APU ignition switch to the “0” position.

**NOTICE**

Loss of pressure or leakage!

Climate control lines that are not completely tightened or that release by themselves can cause the failure of the air conditioning system.

- ▶ Check that the air conditioning lines have been properly connected before starting crane operations.

Screw the air conditioning lines from the drive assembly **2** into the connection points in position **P2**.

- ▶ Use a screw wrench to tighten the air conditioning lines hand-tight.

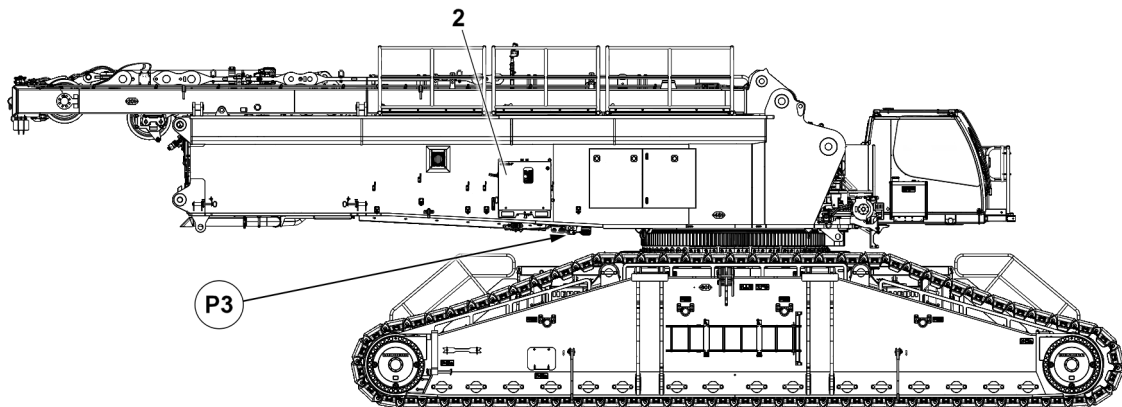
**4.2.3 Connecting the fuel lines**

Fig.164108: Connecting the fuel lines

Make sure that the following prerequisites are met:

- The crane ignition switch is in position “0”.
- The APU ignition switch is in position “0”.

The fuel lines are connected using quick couplings.

When using quick couplings to connect the fuel lines, make sure that the coupling procedure is carried out correctly.

**WARNING**

Escaping fuel!

If the fuel supply is not interrupted before connecting / disconnecting the fuel lines, fuel can escape. If the quick couplings are not fully coupled, fuel can escape.

Danger of fire, danger of slipping and environmental pollution.

- ▶ Release the pressure in the fuel system before connecting / disconnecting: Interrupt the fuel supply.
- ▶ Check that the quick couplings have been properly connected before starting work with the crane.

Screw the fuel lines from the drive assembly **2** into the connection points in position **P3**.

- ▶ Connect the coupling components (sleeve and connector) and screw them together with the knurled nut.
- ▶ Tighten the fuel lines by hand. Turn the knurled nut until it reaches a tangible, fixed stop position.

## 4.2.4 Establishing the hydraulic connections

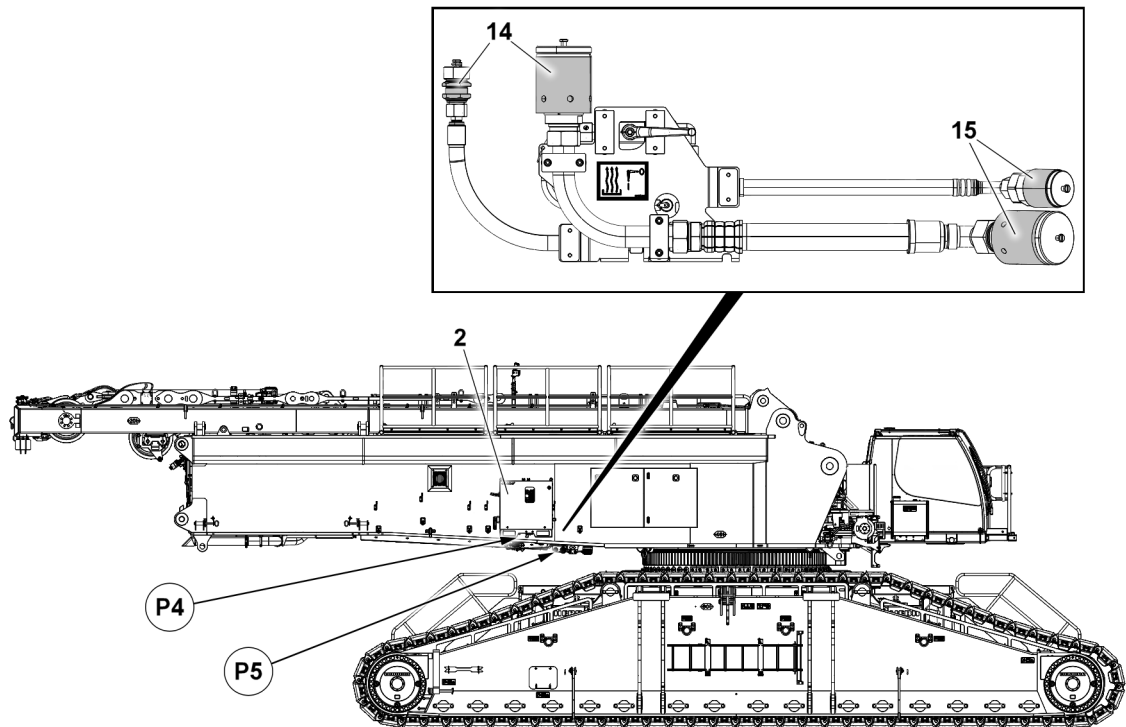


Fig.164109: Establishing the hydraulic connections

- |           |   |           |                                     |
|-----------|---|-----------|-------------------------------------|
| <b>2</b>  | Drive assembly                                      | <b>P4</b> | Drive assembly connection           |
| <b>14</b> | Coupling components to the drive aggregate          | <b>P5</b> | Emergency control supply connection |
| <b>15</b> | Coupling components to the emergency control supply |           |                                     |

Make sure that the following prerequisites are met:

- The crane ignition switch is in position “0”.
- The APU ignition switch is in position “0”.

The hydraulic connections are established with quick couplings.

When using quick couplings to connect the hydraulic lines, make sure that the coupling procedure is carried out correctly.



### WARNING

Pressure in the hydraulic lines!

If the pressure supply is not interrupted before connecting / releasing the hydraulic lines, the hydraulic oil can escape with high pressure.

Death, severe bodily injuries, property damage.

- ▶ Release the pressure in the hydraulic system before connecting / disconnecting: Interrupt the pressure supply and wait a short time.



### WARNING

Loss of pressure or leakage!

Incorrectly coupled or self-loosening quick couplings (return lines in particular) can result in serious accidents due to component failure.

Death, severe bodily injuries, property damage.

- ▶ Check that the quick couplings have been properly connected before starting work with the crane.

**Note**

- ▶ Establish the hydraulic connection from the assembly drive **2** to the turntable, see the “hydraulic diagram”.

Screw the hydraulic lines into the drive assembly **2** and the emergency control supply:

- Coupling components **14** in the connection points in position **P4**
- Coupling components **15** in the connection points in position **P5**
- ▶ Connect the coupling components (sleeve and connector) and screw them together with the knurled nut.
- ▶ Tighten the hydraulic coupling by hand. Turn the knurled nut until it reaches a tangible, fixed stop position.

## 5 Operating the drive assembly

- Description of the function
- Change over between the air conditioning system and hydraulic oil preheating\*
- Operating the drive assembly manually
- Drive assembly in ECO mode

### 5.1 Description of the function

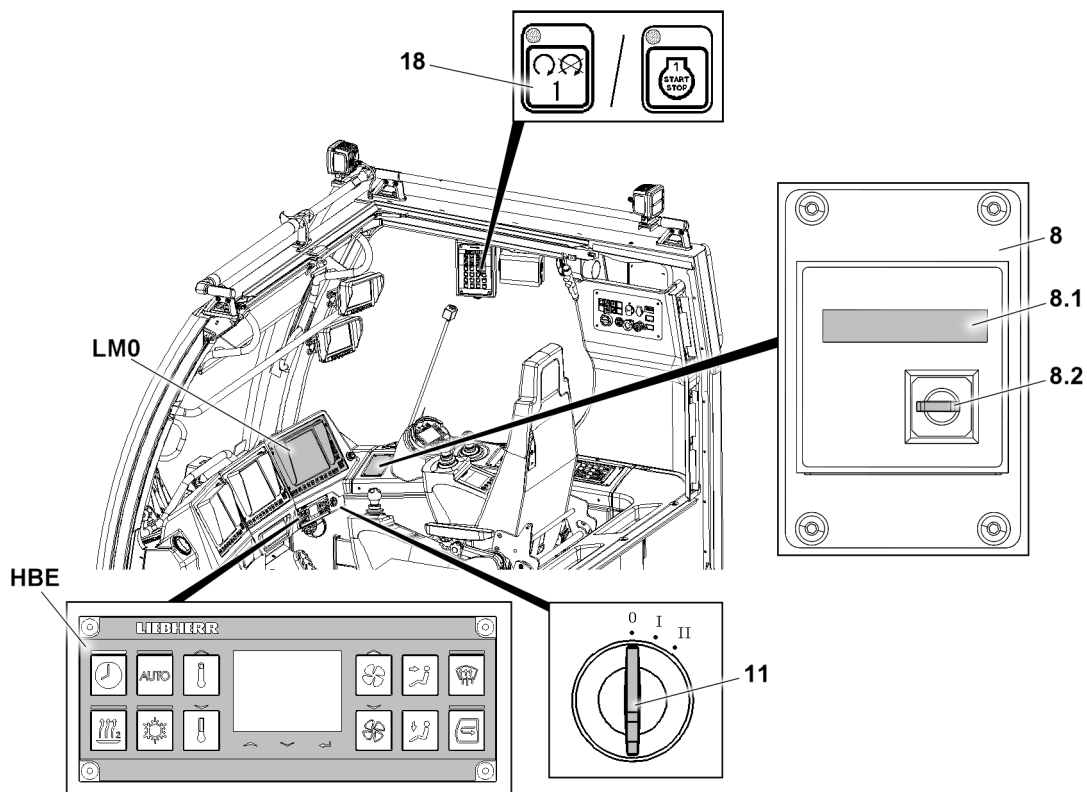


Fig.164085: Operating elements in the crane cab

- |                                   |                                      |
|-----------------------------------|--------------------------------------|
| <b>8</b> APU operating unit       | <b>18</b> Engine START / STOP button |
| <b>8.1</b> Operating unit display | <b>LMO</b> LICCON monitor 0          |
| <b>8.2</b> APU ignition switch    | <b>HBE</b> Heater control unit       |
| <b>11</b> Crane ignition switch   |                                      |

Crane ignition switch	APU ignition switch	Description
Off	Off	Everything off
On	Off	Normal crane operation
Off	On	Manual drive assembly
On	On	Drive assembly in ECO-Mode <sup>1)</sup>

1) Observe the prerequisites, see section "Drive assembly in ECO mode".

## 5.2 Change over between the air conditioning system and hydraulic oil preheating\*

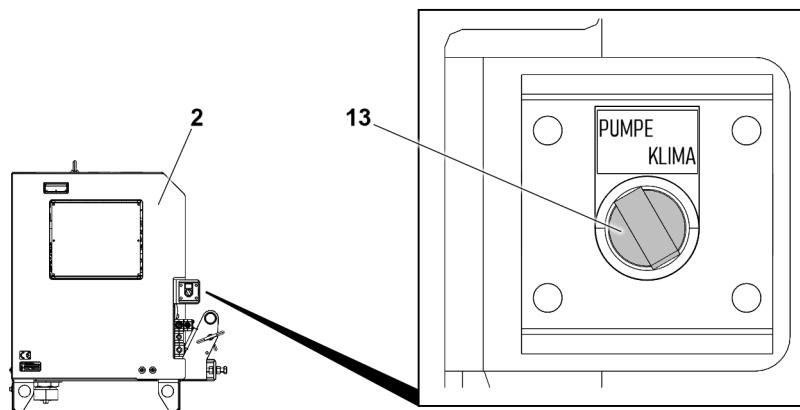


Fig.164095: Change over between the air conditioning system and hydraulic oil preheating\*, PUMP switch position selected

The rotary switch **13** can be used to change over the drive assembly **2**:

- Air conditioning system, AIR CONDITIONING switch position
- Hydraulic oil preheating, PUMP switch position

### NOTICE

Damage to components!

If changing between the air conditioning system and hydraulic oil preheating while the drive assembly is running, components can be damaged.

- ▶ Set the APU ignition switch to the "0" position.

### NOTICE

Damage to components!

If the drive assembly is turned on when the hydraulic unit for hydraulic oil preheating is not connected and the rotary switch is set to PUMP, components can be damaged.

- ▶ Connect the hydraulic unit prior to use of hydraulic oil preheating.

If hydraulic oil preheating should not take place:

- ▶ Turn the rotary switch **13** to the AIR CONDITIONING position.

Make sure that the following prerequisite is met:

- The APU ignition switch is in position "0".

Switching from hydraulic oil preheating to the air conditioning system

- ▶ Turn the rotary switch **13** from the PUMP position to the AIR CONDITIONING position.

### Result:

- The drive assembly is set to the air conditioning system.

Switching from the air conditioning system to hydraulic oil preheating, only with a connected hydraulic unit.

- ▶ Turn the rotary switch **13** from the PUMP position to the AIR CONDITIONING position.

**Result:**

- The drive assembly is set to hydraulic oil preheating.

## 5.3 Operating the drive assembly manually

### 5.3.1 Turning the drive assembly on manually: Charging the battery

Make sure that the following prerequisites are met:

- The drive assembly is ready for operation.
- The crane ignition switch is in position “0”.
- The APU ignition switch is in position “0”.
- The drive assembly is set to the air conditioning system, see section “Switching between the air conditioning system and hydraulic oil preheating\*”.



**Note**

The drive assembly uses the crane fuel reserve.

- ▶ Provide a sufficient fuel reserve.

- ▶ Turn the APU ignition switch to position “I”.

**Result:**

- The APU starts automatically after successful preheating.
- The crane battery is being charged.
- ▶ Check the tightness of all fuel lines, air conditioning lines and hydraulic connections between the drive assembly and the turntable.

**Problem remedy**

Does the APU not start?

Check the display on the operating unit of the APU in the crane.

If hydraulic oil preheating is present, check the position of the rotary switch.

- ▶ Restart the APU.

When this measure does not help:

- ▶ Contact Customer Service at Liebherr-Werk Ehingen.



### 5.3.2 Turning the drive assembly on manually: Charging the battery / hydraulic oil preheating\*

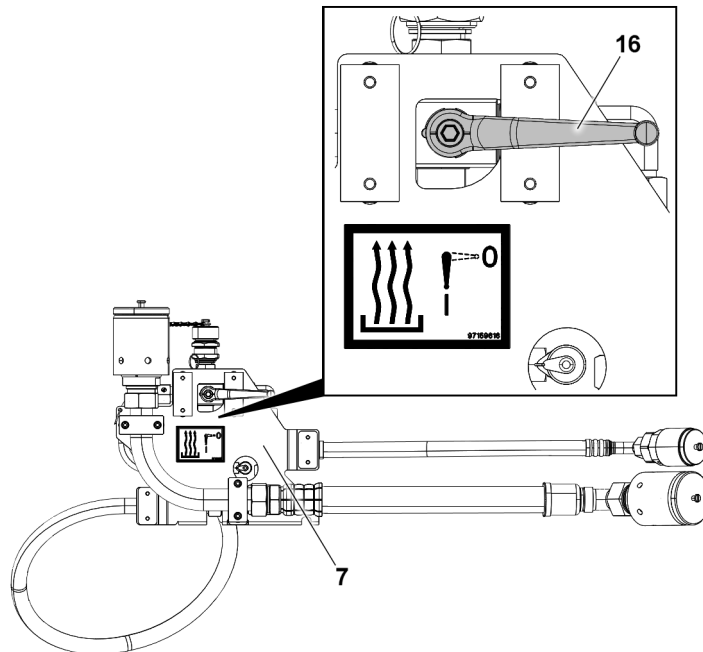


Fig.164096: Turning hydraulic oil preheating on

Make sure that the following prerequisites are met:

- The drive assembly is ready for operation.
- The crane ignition switch is in position “0”.
- The APU ignition switch is in position “0”.
- The drive assembly is set to the hydraulic oil preheating, see section “Switching between the air conditioning system and hydraulic oil preheating\*\*”.



#### Note

- ▶ Hydraulic oil preheating can only be turned on manually and used only in ECO mode.



#### Note

The drive assembly uses the crane fuel reserve.

- ▶ Provide a sufficient fuel reserve.
- ▶ Set the ball valve **16** of the hydraulic unit **7** to position “0”.
- ▶ Turn the APU ignition switch to position “I”.

#### Result:

- The APU starts automatically after successful preheating.
- The crane battery is being charged.
- The hydraulic oil is circulating unpressurized, no hydraulic oil preheating.

#### Problem remedy

Does the APU not start?

Check the display on the operating unit of the APU in the crane.

- ▶ Restart the APU.

When this measure does not help:

- ▶ Contact Customer Service at Liebherr-Werk Ehingen.

- ▶ Check the tightness of all fuel lines, air conditioning lines and hydraulic connections between the drive assembly and the turntable.

When the drive assembly is running smoothly:

- ▶ Set the ball valve **16** of the hydraulic unit **7** to position "I".

**Result:**

- Hydraulic oil preheating\* is active.



**Note**

The crane engine and drive assembly cannot run at the same time.

If the crane engine is started while the drive assembly is running, the drive assembly stops automatically. If the crane engine is stopped again, the drive assembly tries to start again, even if the ball valve **16** is set incorrectly.

- ▶ Observe the error message on the operating unit display.

When the drive assembly stops:

- ▶ Set the ball valve to the "0" position.

### 5.3.3 Turning the drive assembly off manually

- ▶ Set the APU ignition switch to the "0" position.

**Result:**

- The drive assembly stops and is not restarted when the crane engine is "off".



**Note**

- ▶ When hydraulic oil preheating is active, before restarting the ball valve must be switched to position "0", see section "Turning the drive assembly on manually: Charging the battery / hydraulic oil preheating\*".

## 5.4 Drive assembly in ECO mode

ECO mode is the automatic shut-off of the crane engine and activation of the drive assembly.

**Note:** ECO mode can only be used when the drive assembly is set to the air conditioning system, see section "Switching between the air conditioning system and hydraulic oil preheating\*".

ECO mode is always turned on automatically when the crane engine ignition is turned on while the drive assembly is running. When the crane engine starts, the drive assembly is shut off automatically and switched to standby. Now ECO mode monitors if the conditions for shutting off the crane engine automatically are fulfilled. If all conditions are fulfilled, the crane engine is shut off automatically.

If the crane engine is not shut off automatically by the ECO mode, the APU ignition switch must be switched to position "0", which turns off ECO mode.

### 5.4.1 Icons on the crane operation operating screen

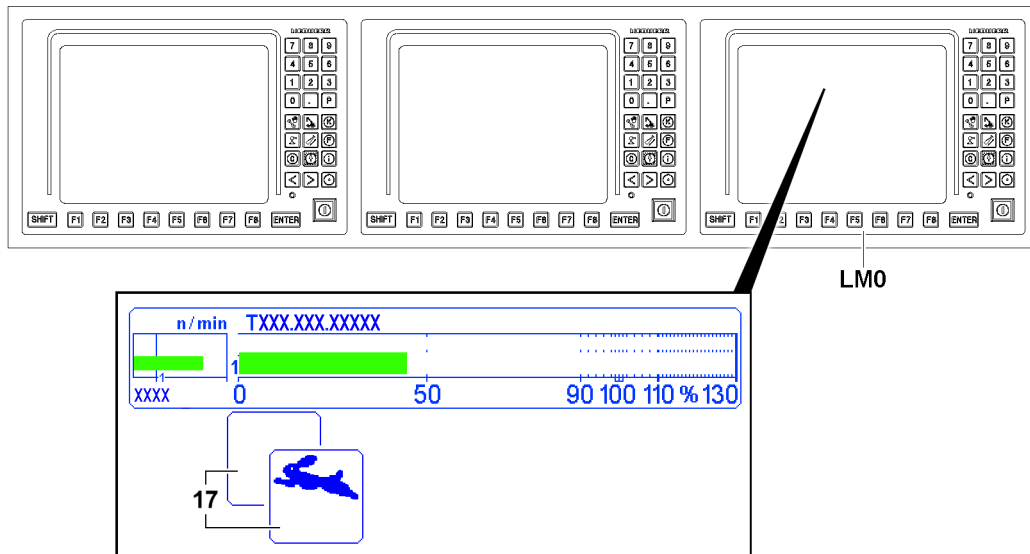


Fig.164093: ECO mode status


17 Rapid gear display field

LMO LICCON monitor 0

The status of ECO mode is shown in the *rapid gear display field 17* on the LICCON monitor **LMO**. In this case it is irrelevant if the rapid gear is turned on or not.

Icon	Description	
	ECO mode <b>off</b> <sup>1)</sup>	
–	Crane engine on / off	APU off <sup>2)</sup>
	ECO mode <b>on</b> <sup>1)</sup>	
Lights up	Crane engine off	APU on
	Note: Fuel is saved, the crane control remains active, the air conditioning system can still be operated.	
	ECO mode <b>is in standby</b>	
Blinks	The crane engine starts	The APU stops
	ECO mode <b>is in standby</b>	
Lights up	Crane engine on	APU off
	ECO mode <b>is in standby</b>	
Blinks	The wait time for automatic engine stop elapses	
	Crane engine just before automatic stopping	APU just before automatic starting

LWE/LR 1800-1-0-000/27200-07-02/en

Icon	Description
 Blinks	<b>ECO mode is in standby</b> The wait time has elapsed, the conditions for automatic engine stop are not fulfilled Crane engine on   APU off

#### ECO mode status

- 1) The icon switches 120 seconds after the crane engine and APU off switch from "ECO mode on" to "ECO mode off".
- 2) The APU ignition switch must be in position "0".

### 5.4.2 Turning ECO mode on

Make sure that the following prerequisite is met:

- The drive assembly is operating, see section "Turning the drive assembly on manually: Charging the battery".
- ▶ Switch the crane ignition switch to position "I".

#### Result:

- The ECO mode icon appears after 40 seconds.

### 5.4.3 Crane operation with ECO mode turned on

When ECO mode is activated, the crane can be operated normally.

The crane engine is turned on / off using the engine START / STOP button. Alternatively the crane ignition switch can be used.

When the crane engine is off:

- ▶ Press the engine START / STOP button.

#### Result:

- The crane engine starts.
- ECO mode goes into standby.



#### Note

ECO mode is in standby.

- ▶ As soon as ECO mode is in standby, the wait time starts to elapse, see section Using "ECO mode".



#### Note

When the crane engine is turned off using the START/STOP button and the APU ignition switch is in position "I", ECO mode turns on and the drive assembly starts.

- ▶ To turn off ECO mode during crane operation, set the APU ignition switch to position "0".

When the crane engine is running:

- ▶ Press the engine START / STOP button.

#### Result:

- The crane engine stops.
- The APU starts.
- The air conditioning system can be used further via the heater control unit.

### 5.4.4 Using ECO mode

When ECO mode is turned on, crane control switches off after the wait time has elapsed and all conditions for automatic stop of the crane engine are fulfilled.

- ▶ Start the crane engine with the START / STOP button.

The wait time elapses when the following conditions are fulfilled:

- The APU ignition switch is in position "I".

- ECO mode is turned on.
- Radio operation is not active.
- All master switches and pedals are in the zero position.
- Idling speed is not increased.

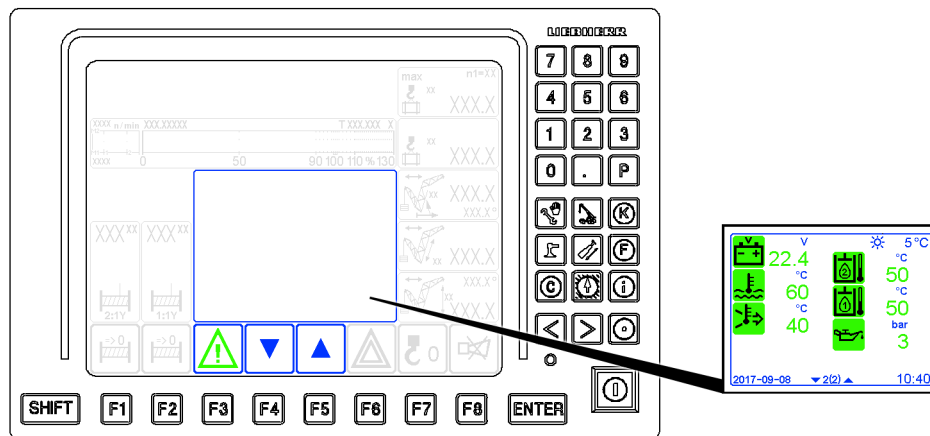


Fig.164092: Individual control displays

Conditions for automatic engine stop:

- The wait time has elapsed.
- The coolant temperature is between 50 °C and 100 °C.
- Hydraulic oil temperature  $\geq 25$  °C.
- Ambient temperature  $\geq 0$  °C.
- No assembly operation / emergency operation is active.
- The slewing gear brake is engaged.
- DPF regeneration is not active.
- LMB utilization  $< 15$  %.



#### Note

- ▶ The crane engine can be turned off using this function a maximum of ten times per day.

If automatic engine shut-off should be possible:

- ▶ Make sure that all prerequisites are fulfilled.

### 5.4.5 Turning ECO mode off

Make sure that the following prerequisite is met:

- ECO mode is active or in standby.
- ▶ Set the APU ignition switch to the “0” position.  
or  
Switch the crane ignition switch to position “0”.

## 6 Removing the drive assembly

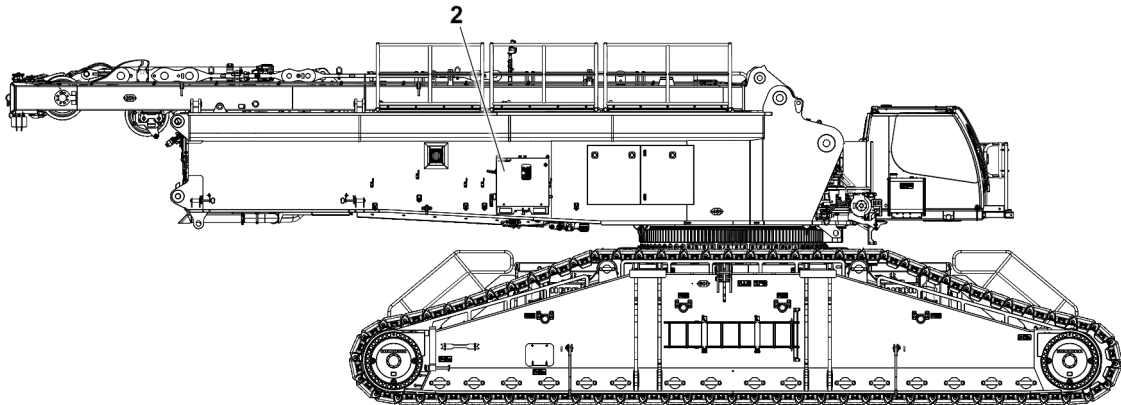


Fig.164104: Removing the drive assembly



### WARNING

Danger of falling!

During assembly / disassembly, inspection and maintenance work, assembly personnel must be secured with appropriate aids to prevent them from falling.

Death, severe bodily injuries, property damage.

- ▶ All work at a height, when there is a danger of falling, must be carried out with suitable aids.
- ▶ If aids are not available and work cannot be carried out from the ground, then assembly personnel must secure themselves with the supplied fall arrest system to prevent falling, see the Crane operating instructions, chapter 2.04.
- ▶ If fall protection equipment is available, then it must be used, see the Crane operating instructions, chapter 2.06.
- ▶ When lifting, lowering, swinging crane parts in and out, no persons may remain in the danger zone.
- ▶ If railings are present on the components, then they must be brought into the corresponding position and secured for assembly / disassembly work.
- ▶ It is prohibited to lean the ladder against the component to be disassembled.
- ▶ Only step on the aids, ladders and catwalks with clean shoes.
- ▶ Keep aids, ladders and catwalks free of heavy dirt, snow and ice.
- ▶ During all assembly and disassembly work, maintenance work and inspections, travel or crane operation is prohibited.
- ▶ Remaining on a suspended load is prohibited.
- ▶ Stepping and walking on crane components and lattice sections with an incline of more than 20° is prohibited.
- ▶ For all assembly work, the crane operator of the main crane must be in voice contact with the crane operator / crane operators of the auxiliary crane / auxiliary cranes.
- ▶ For the assembly / disassembly tasks, the crane operator may only initiate crane movements when the responsible guide has explicitly released the movement.



### WARNING

Danger of impact / crushing!

When assembling / disassembling crane components with the auxiliary crane, crane components can start to swing back and forth.

When lifting / lowering and positioning crane components, there is an increased danger of impact / crushing.

Death, severe bodily injuries, property damage.

- ▶ Make sure that personnel cannot be caught by components.
- ▶ When working in a danger zone: Use aids to protect limbs.
- ▶ Guide components with suitable aids to minimize oscillation.

**DANGER**

The component can fall down!

If the corresponding component is disengaged from the auxiliary crane before the corresponding component is pinned, then the corresponding component can fall down.

Death, severe bodily injuries, property damage.

- ▶ Do not disconnect the auxiliary crane until the respective component is pinned and secured.

**Note**

Additional base for the removal of the drive assembly 2.

- ▶ Turn the turntable or use an additional platform to enlarge the base.

## 6.1 Disconnecting the connections between the drive assembly and the turntable

Disconnect all connections:

- Disconnect the electrical connections.
- Disconnect the fuel lines.
- Disconnect the air conditioning lines.
- Disconnect the hydraulic connections.

**NOTICE**

Damage to components!

If the fuel lines, air conditioning lines and electrical lines are not wound up on the side support, they can be damaged when the drive assembly is set down.

- ▶ Wind up all disconnected lines on the side support of the drive assembly.

### 6.1.1 Disconnecting the electrical connections

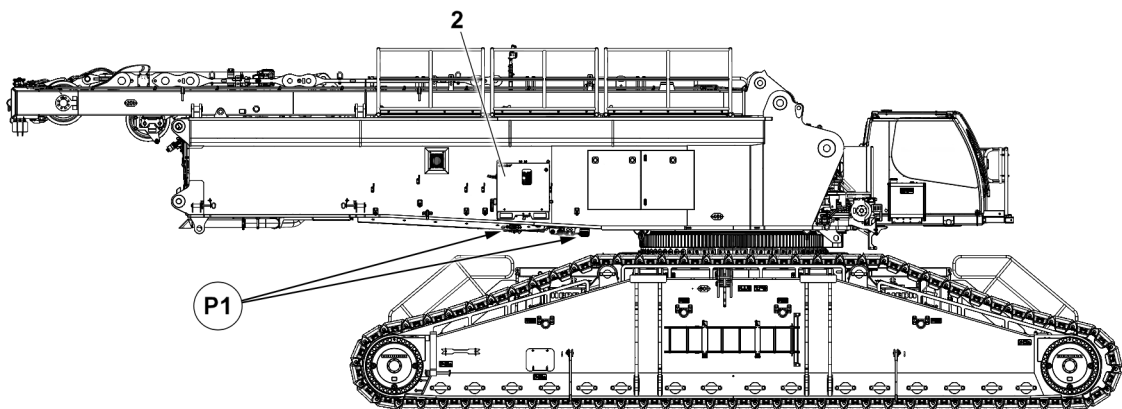


Fig.164106: Disconnecting the electrical connections

**NOTICE**

Damage to components!

If live electrical connections are disconnected / connected, then there is the danger that components can be damaged.

The crane functions can be limited.

- ▶ De-energize the electrical connections before disconnection / connection. Set the ignition switch to the "0" position.

- ▶ Switch the crane ignition switch to position "0".
- ▶ Set the APU ignition switch to the "0" position.

Disconnect the electrical connection from the assembly drive to the turntable:

- ▶ Unplug the electrical lines from the drive assembly **2** from the connection points in position **P1**.



#### Note

- ▶ Disconnect the electrical connection from the assembly drive to the turntable, see the “wiring diagram”.

#### NOTICE

Damage to the electrical connections due to dirt, moisture and corrosion!

If unrequired electrical connections are not closed with their respective caps, the electrical connections can be damaged.

If the covers are removed from the electrical connections or control cabinets are opened, then moisture can infiltrate.

- ▶ Always properly close off all **non**-required electrical connections with their protective caps.
- ▶ Protect the electrical connections from water infiltration, this applies especially in the case of rain or snow.



#### Note

If **non**-required electrical connections are not closed with their respective dummy plugs, the electrical connections can be damaged.

- ▶ A malfunction can occur without bridging.
- ▶ Observe the “wiring diagram”.

- ▶ As a rule, close off non-required electrical connections (for example for accessories that are not installed) with the respective dummy plugs / dust caps.
- ▶ Wind up the electrical lines on the side support of the drive assembly **2**.

### 6.1.2 Disconnecting the fuel lines

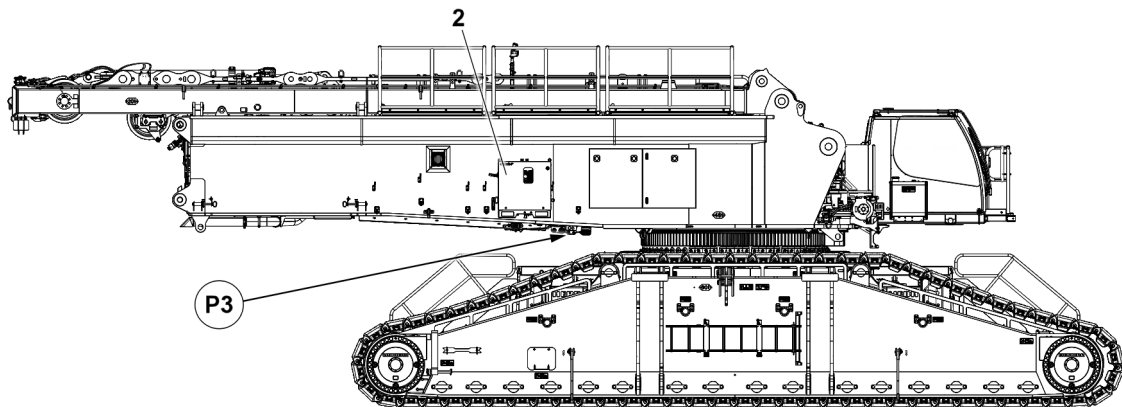


Fig.164108: Disconnecting the fuel lines

Make sure that the following prerequisites are met:

- The crane ignition switch is in position “0”.
- The APU ignition switch is in position “0”.

The fuel lines are connected using quick couplings.

When using quick couplings to disconnect the fuel lines, make sure that the coupling procedure is carried out correctly.



**WARNING**

Escaping fuel!

If the fuel supply is not interrupted before connecting / disconnecting the fuel lines, fuel can escape.  
If the quick couplings are not fully coupled, fuel can escape.

Danger of fire, danger of slipping and environmental pollution.

▶ Interrupt the fuel supply: Set the crane ignition switch and APU ignition switch to the "0" position.

- ▶ Release the fuel lines from the drive assembly **2** in position **P3** by hand.
- ▶ Protect the fuel lines and connections from contamination with caps.
- ▶ Wind up the fuel lines on the side support of the drive assembly **2**.

### 6.1.3 Disconnecting the air conditioning lines

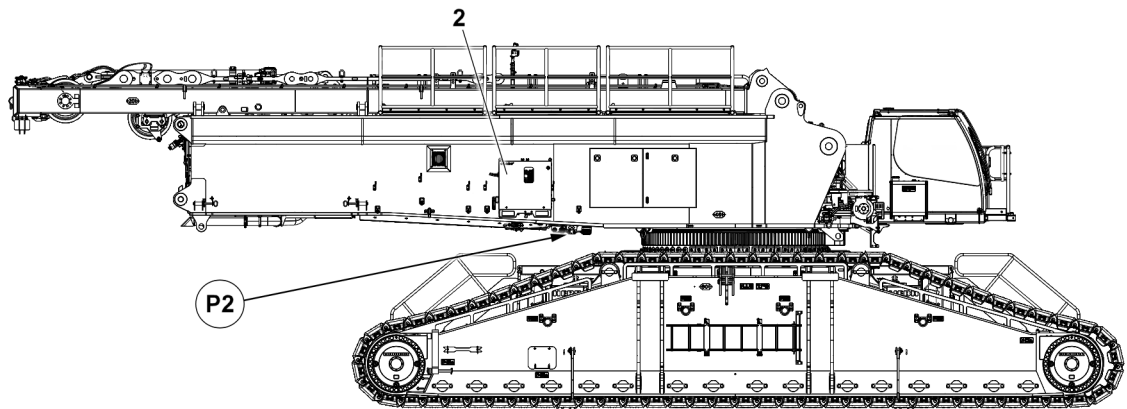


Fig.164107: Disconnecting the air conditioning lines

Make sure that the following prerequisites are met:

- The crane ignition switch is in position "0".
- The APU ignition switch is in position "0".

**WARNING**

Leaking refrigerant!

If the air conditioning system is not turned off before connecting / disconnecting the air conditioning lines, refrigerant can leak.

Danger of suffocation, severe bodily injuries, property damage.

▶ Make sure that the air conditioning system is turned off: Set the crane ignition switch and APU ignition switch to the "0" position.

- ▶ Release and screw off the air conditioning lines from the drive assembly **2** in position **P2**.
- ▶ Protect the air conditioning lines and connections from contamination with caps.
- ▶ Wind up the air conditioning lines on the side support of the drive assembly **2**.

### 6.1.4 Disconnecting the hydraulic connections

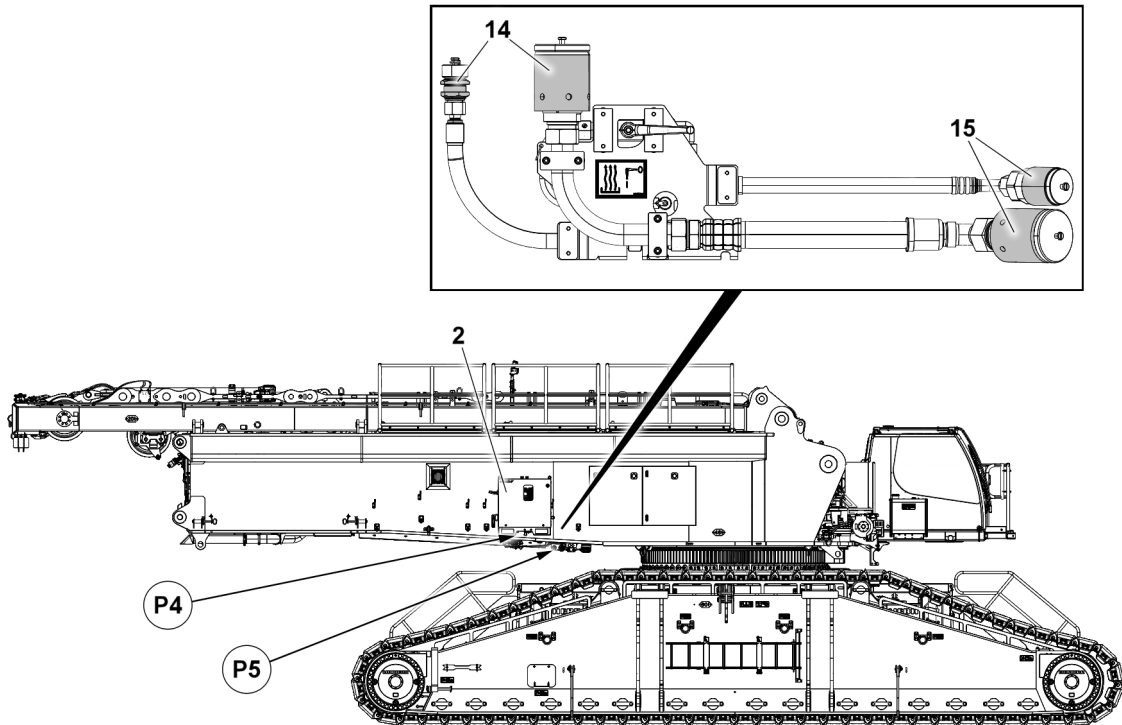


Fig.164109: Disconnecting the hydraulic connections

- |           |   |           |                                     |
|-----------|---|-----------|-------------------------------------|
| <b>2</b>  | Drive assembly                                      | <b>P4</b> | Drive assembly connection           |
| <b>14</b> | Coupling components to the drive aggregate          | <b>P5</b> | Emergency control supply connection |
| <b>15</b> | Coupling components to the emergency control supply |           |                                     |

Make sure that the following prerequisites are met:

- The crane ignition switch is in position “0”.
- The APU ignition switch is in position “0”.

The hydraulic connections are established with quick couplings.

When using quick couplings to disconnect the hydraulic lines, make sure that the coupling procedure is carried out correctly.



#### WARNING

Pressure in the hydraulic lines!

If the pressure supply is not interrupted before connecting / releasing the hydraulic lines, the hydraulic oil can escape with high pressure.

Death, severe bodily injuries, property damage.

- ▶ Release the pressure in the hydraulic system before connecting / disconnecting: Interrupt the pressure supply and wait a short time.

- ▶ The rotary switch on the drive assembly is set to the “AIR CONDITIONING” position, see section “Switching between the air conditioning system and hydraulic oil preheating\*”.
- ▶ Release the coupling components **14** manually from the connection point in position **P4**.
- ▶ Release the coupling components **15** manually from the connection point in position **P5**.
- ▶ Protect the hydraulic connections against contamination with caps.
- ▶ Remove the hydraulic unit and store it.

## 6.2 Disconnecting the drive assembly from the turntable

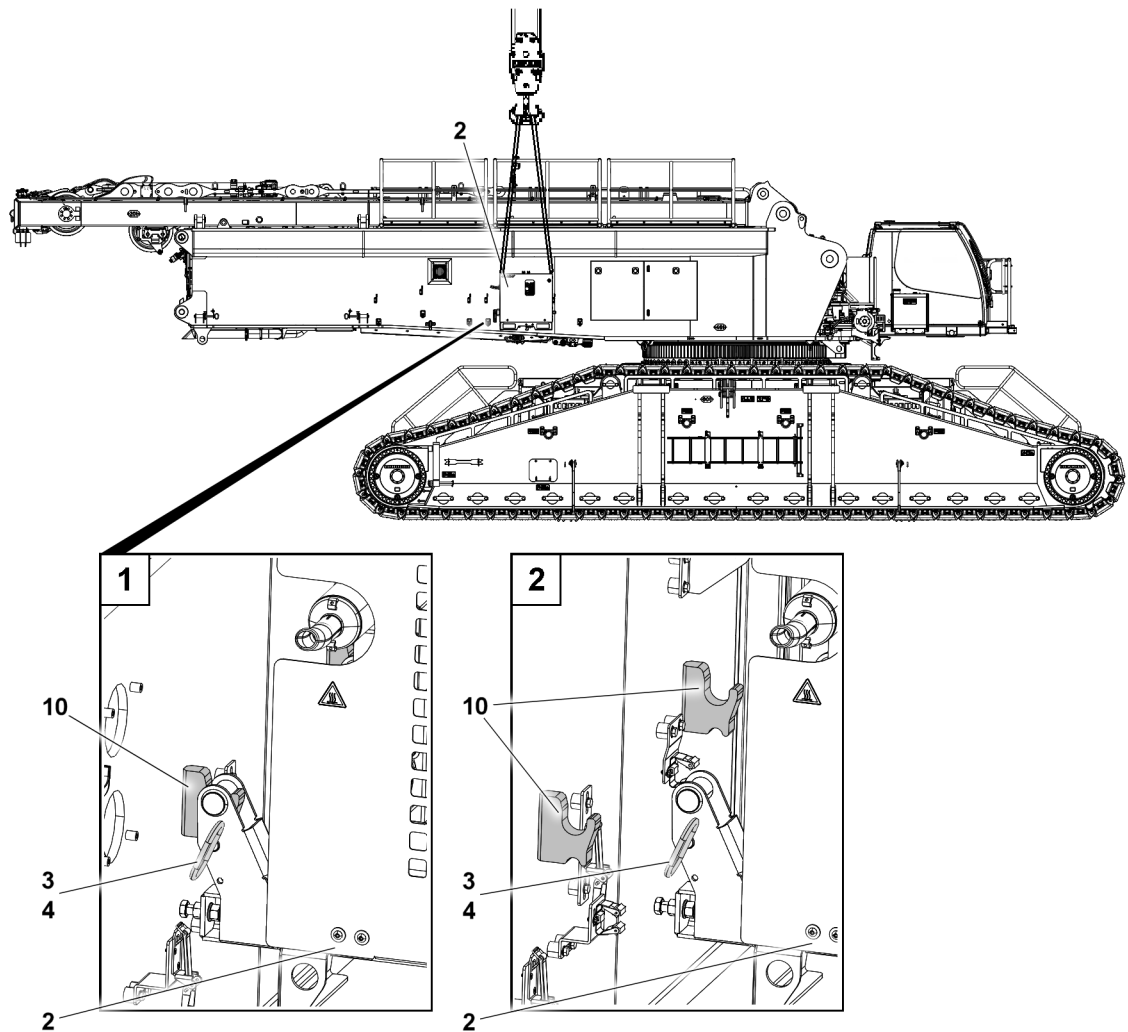


Fig.164110: Disconnecting the drive assembly

- |   |                |    |                   |
|---|----------------|----|-------------------|
| 2 | Drive assembly | 4  | Retaining element |
| 3 | Retaining pin  | 10 | Bracket           |



### Note

- ▶ The assembly / disassembly of the drive assembly is identical and is described based on the example of the drive assembly 2 with hydraulic oil preheating\*.



### WARNING

Impermissible fastening equipment!  
The drive assembly 2 can fall down.  
Death, severe bodily injuries, property damage.

- ▶ Use only inspected fastening equipment.

Make sure that the following prerequisites are met:

- The crane is horizontally aligned.
- A sufficient base is available.
- Personal protective equipment has been put on and is being used.
- All electrical connections, fuel lines, air conditioning lines and hydraulic connections are disconnected.

- ▶ Fasten the drive assembly 2 to the auxiliary crane.
- ▶ Remove the retaining elements 4 on both sides on the retaining pin 3.

- ▶ Unpin the retaining pin **3** on both sides.
- ▶ Lift the drive assembly **2** out of the lugs **10**.
- ▶ Insert the retaining pins **3** on both sides and secure with the retaining elements **4**.
- ▶ Swing the drive assembly **2** away.

## 5.75 Wind speed sensor / airplane warning light

1	Safety	2
2	Description	2
3	Transport	2
4	Wind speed sensor mounting positions	3
5	Wind speed sensor alignment / mounting	7
6	Wind speed sensor assembly	8
7	Wind speed sensor disassembly	10

# 1 Safety

Observe the safety instructions prior to assembly / disassembly.

- General safety information: See chapter 2.04.
- Information regarding personal protective equipment: See chapter 2.04.
- Information regarding the use of ladders: See chapter 2.04.10.
- For information regarding securing against falling: See chapter 2.06.

---

## NOTICE

The b and the auxiliary boom are assembled or disassembled with the attachment parts!  
The attachment parts can be damaged.

- ▶ **After** the hook block or the load hook is installed: Install the attachment parts.
  - ▶ **Before** the hook block or the load hook is removed: Remove the attachment parts.
- 

Attachment parts are:

- Camera (not available for all crane types)
- Airplane warning light (obstruction light)
- Wind speed sensor
- Hoist limit switch weight with chain

The illustrations in this chapter are examples. The installation of the wind speed sensor is described as an example. The retainers are at times located in other positions than as shown.

## 2 Description



### WARNING

The crane can topple over!  
Death, severe bodily injuries, property damage.

- ▶ Make sure that at least one wind speed sensor is always installed on the boom system.
- 

There is always at least one wind speed sensor installed at the highest point of the boom system.

The wind speed sensor measures the wind speed on the boom jib and shows the current wind speed on the LICCON monitor in the crane cab.

During the assembly of a W-lattice jib, a wind speed sensor is to be installed on the WA-frame II because, during the erection of the W-boom system, it initially represents the highest point on the system and is therefore to be monitored.



### Note

- ▶ In addition, an airplane warning light can also be installed on the carrier on which the wind speed sensor is installed.
  - ▶ To ensure better understanding, only the “carrier” and the “wind speed sensor” are discussed in the remainder of the chapter.
- 



### Note

- ▶ Display of the wind speed, see chapter 4.02.
- 

## 3 Transport

### 3.1 LR crane types

When transporting the different LR crane types, the carrier **2** is stored in separate transport boxes.

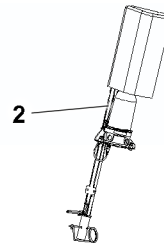


Fig.155071: Carrier 2 with cover hood

2 Carrier

### 3.2 LR 11000

When transporting the LR 11000, depending on the delivery condition of the crane, up to two carriers 2 are installed in the transport retainers on the S-pivot section 1.

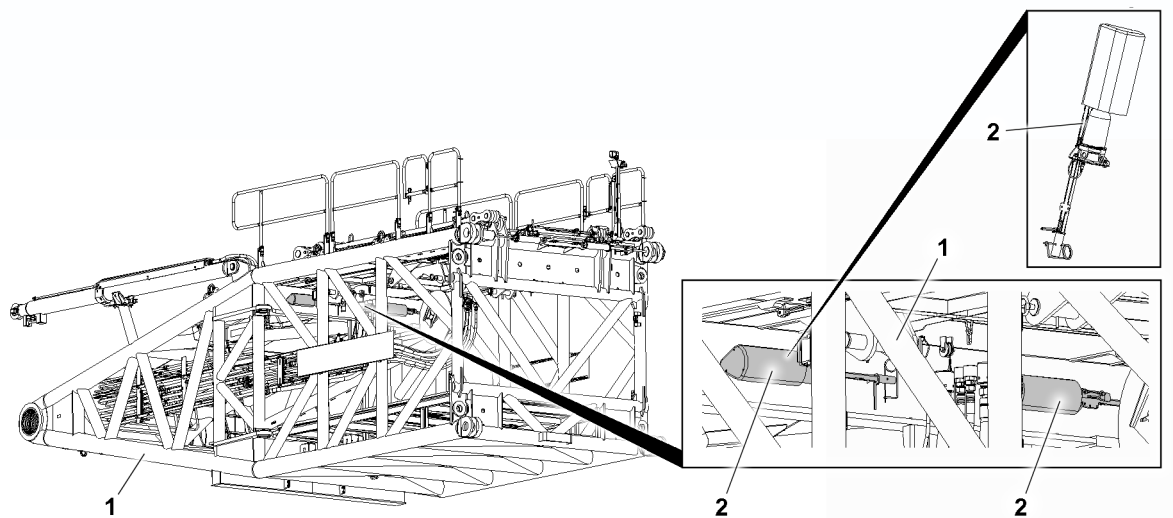


Fig.155070: Wind speed sensor in transport position on the LR 11000

1 S-pivot section (LR 11000)

2 Carrier

## 4 Wind speed sensor mounting positions

Depending on the boom configuration, the wind speed sensor is installed on the respective end section or boom system.



#### Note

► The following illustrations of the boom end sections are examples and may not match your crane.

## 4.1 Mounting positions on S-end section and on boom nose

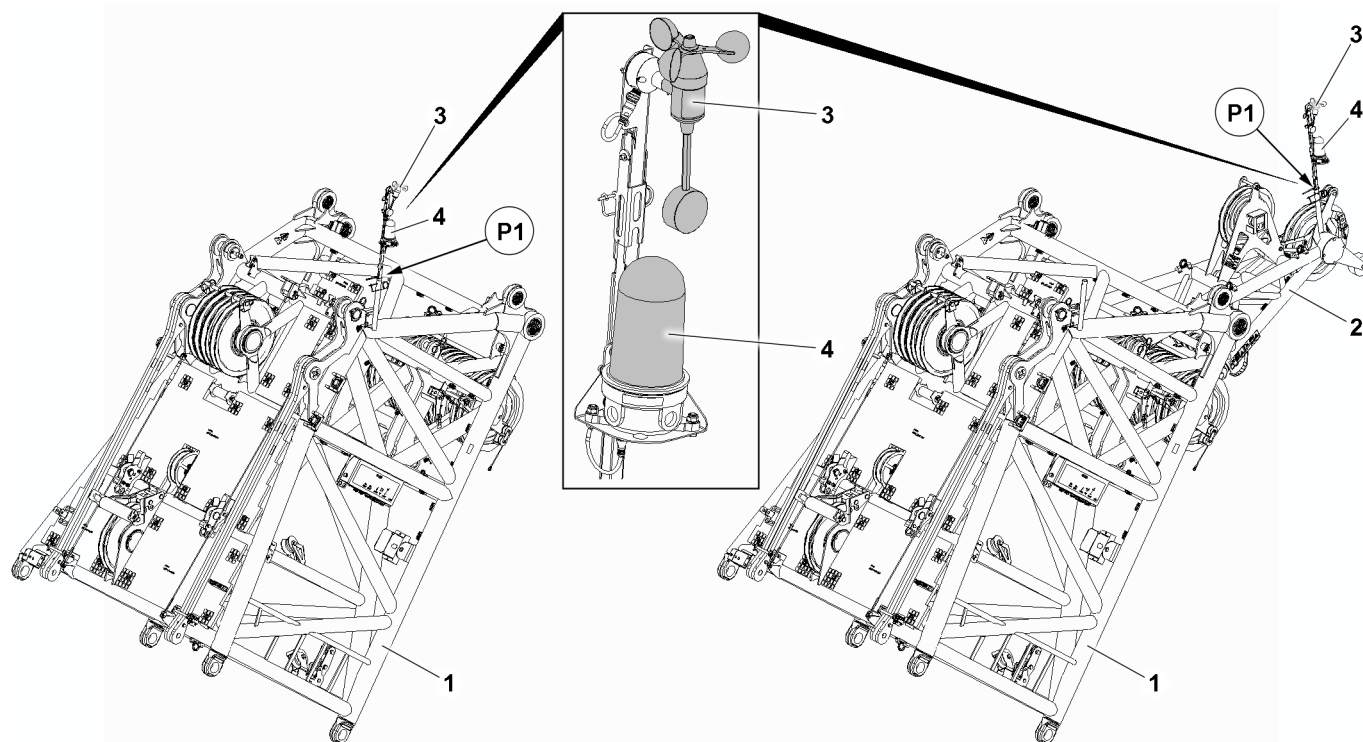


Fig.155000: Mounting positions on S-end section and on boom nose

- |   |               |   |  |    |                                     |
|---|---------------|---|--|----|-------------------------------------|
| 1 | S-end section | 3 | Wind speed sensor                          | P1 | Wind speed sensor mounting position |
| 2 | Boom nose     | 4 | Airplane warning light (obstruction light) |    |                                     |



### 4.2 Mounting positions on L-end section and on boom nose

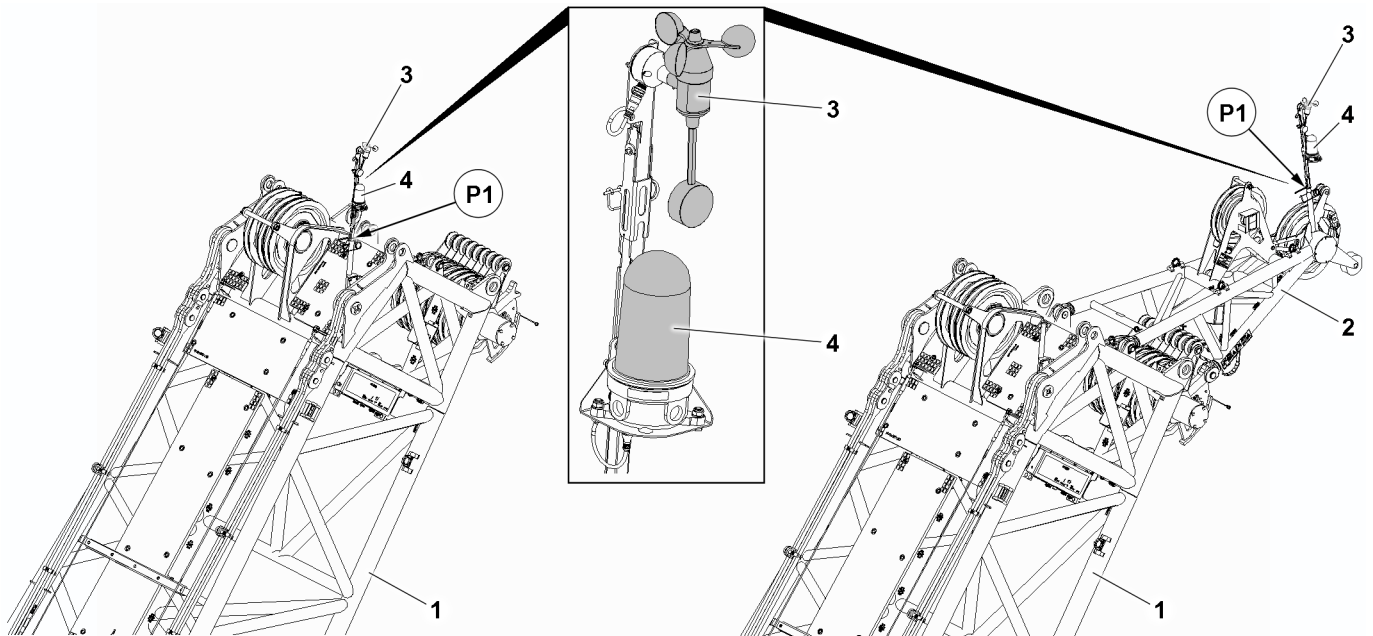


Fig.155001: Mounting positions on L-end section and on boom nose

- |   |               |   |  |    |                                     |
|---|---------------|---|--|----|-------------------------------------|
| 1 | L-end section | 3 | Wind speed sensor                          | P1 | Wind speed sensor mounting position |
| 2 | Boom nose     | 4 | Airplane warning light (obstruction light) |    |                                     |

### 4.3 Mounting positions on the F-end section

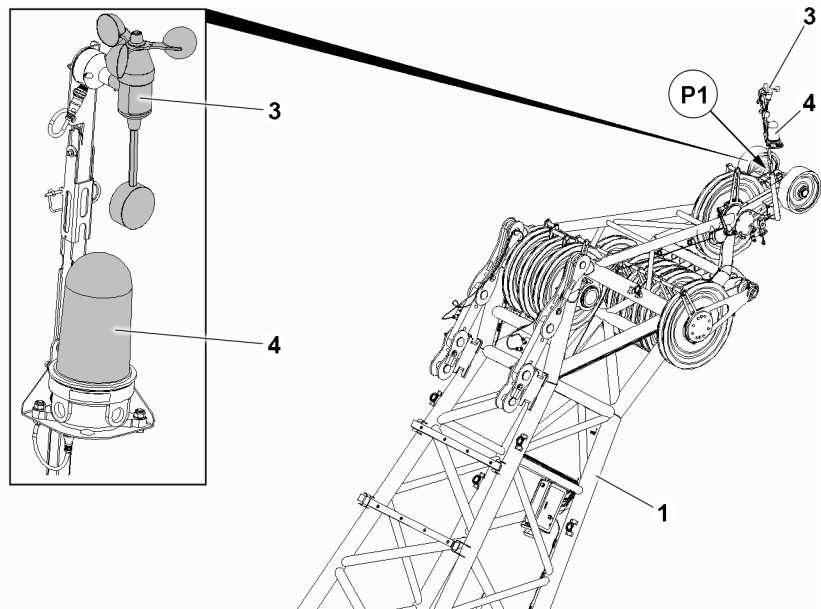


Fig.155002: Mounting positions on the F-end section

- |   |                   |    |  |
|---|-------------------|----|--|
| 1 | F-end section     | 4  | Airplane warning light (obstruction light) |
| 3 | Wind speed sensor | P1 | Wind speed sensor mounting position        |

LWE/LR 1800-1-0-000/27200-07-02/en

## 4.4 Mounting position on the WA-frame II end section



### Note

- The wind speed sensor on the WA-frame II is used to record the wind speed before and during the erection of W-lattice jibs.

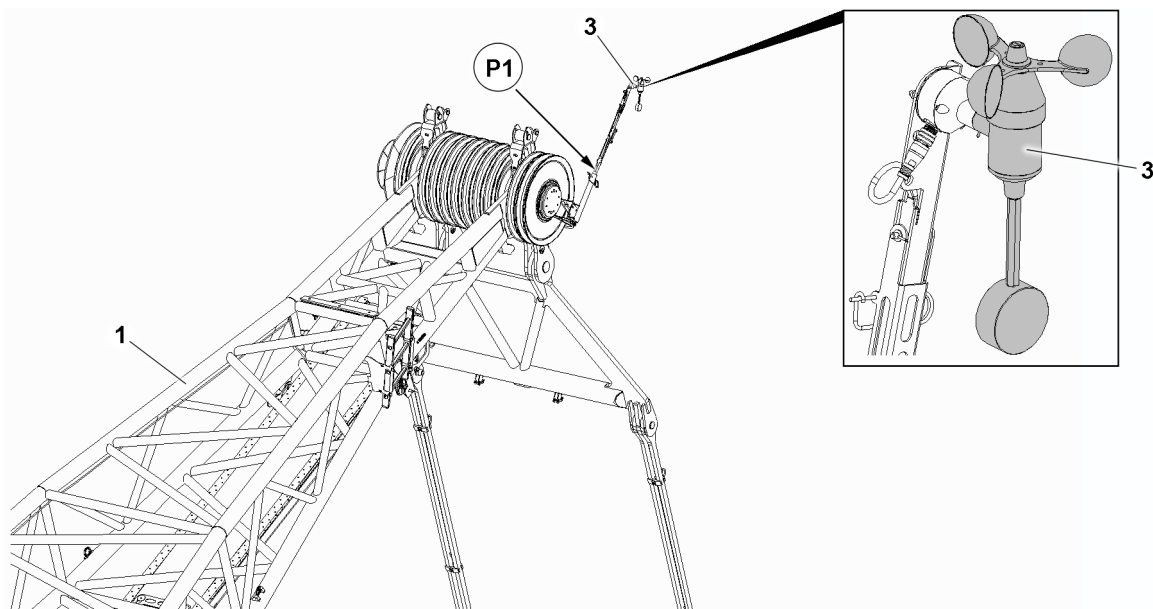


Fig.155073: Mounting position on the WA-frame II end section

- |   |                         |    |                                     |
|---|-------------------------|----|-------------------------------------|
| 1 | WA-frame II end section | P1 | Wind speed sensor mounting position |
| 3 | Wind speed sensor       |    |                                     |

## 5 Wind speed sensor alignment / mounting

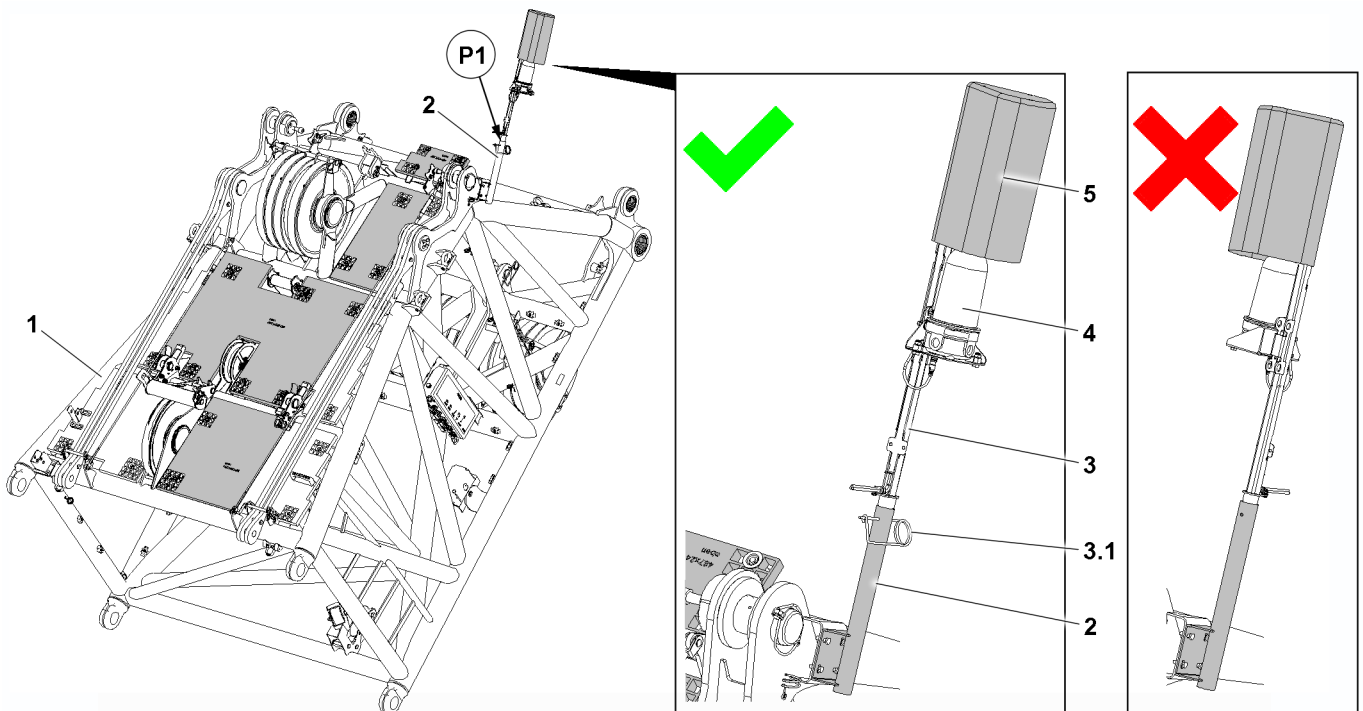


Fig.155006: Installing the wind speed sensor



### WARNING

Wind speed sensor incorrectly assembled!

The wind speed will not be correctly recorded and incorrect values will be transmitted.

The crane can topple over.

Death, severe bodily injuries, property damage.

▶ Make sure that the wind speed sensor is installed correctly on the boom head.

▶ Install the wind speed sensor according to the illustration.

## 6 Wind speed sensor assembly

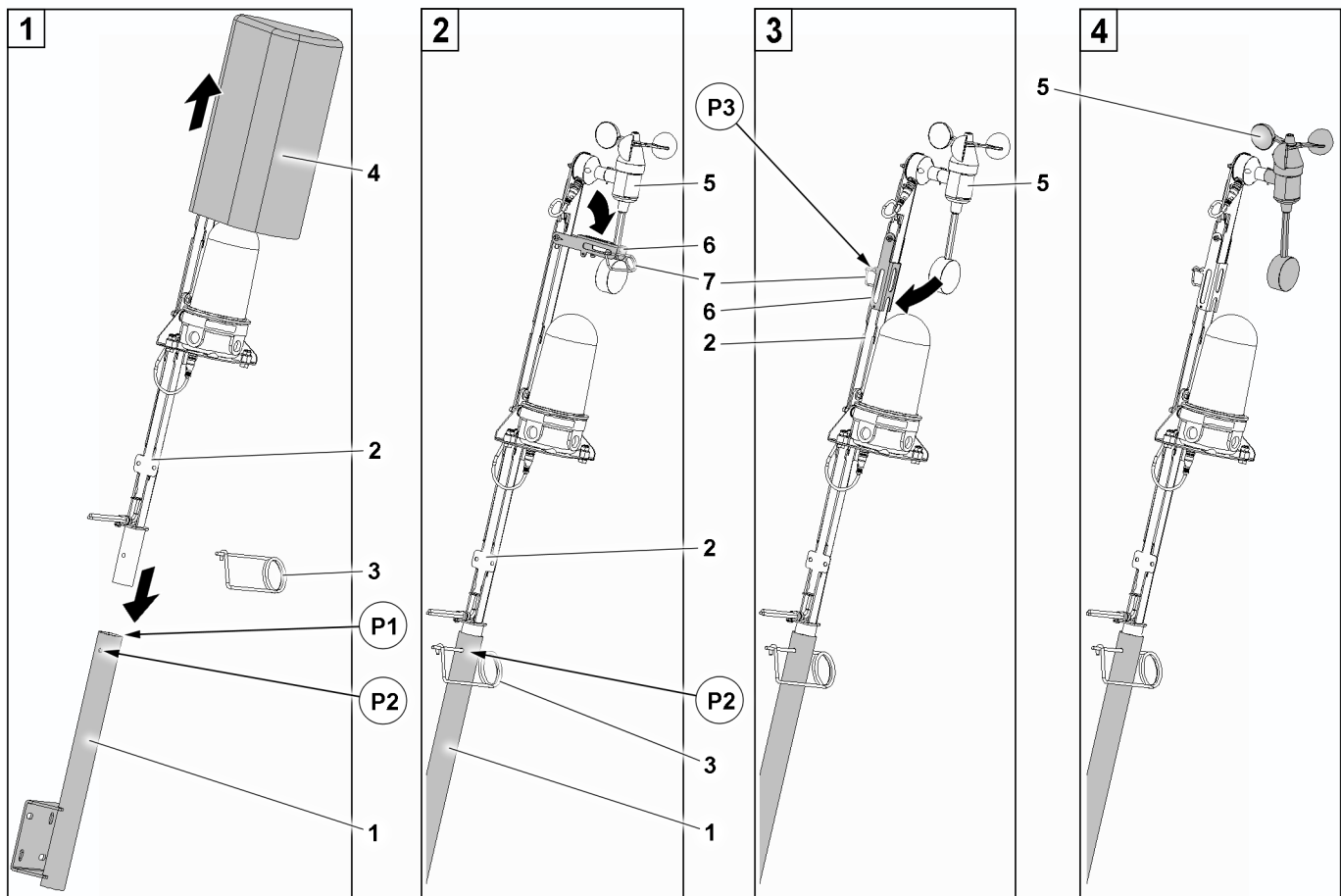


Fig.155005: Installing the wind speed sensor

- |   |                   |   |                    |   |                   |
|---|-------------------|---|--------------------|---|-------------------|
| 1 | Retainer          | 4 | Cover hood         | 7 | Retaining element |
| 2 | Carrier           | 5 | Wind speed sensor  |   |                   |
| 3 | Retaining element | 6 | Transport retainer |   |                   |

### 6.1 Disassembling the wind speed sensor

Make sure that the following prerequisites are met:

- The boom system is on the ground.
- The boom head is near the ground.
- During assembly on the WA-frame II:  
The boom system is on the ground.
- A working platform or aerial work platforms are available.



#### WARNING

Danger of falling during assembly!  
Death, severe bodily injuries, property damage.

- ▶ Make sure that suitable climbing aids are used.
- ▶ Use personal protective equipment to prevent falling.
- ▶ When using ladders, make sure that they are properly secured against falling over, see chapter 2.04.10.

**NOTICE**

Danger of damage!

The wind speed sensor **5** can be damaged.

- ▶ Before assembly of the carrier **2**, carefully remove the cover hood **4**.

- ▶ Release and remove the cover hood **4** on the carrier **2**.
- ▶ Position the carrier **2** in the correct installation position over the holder **1**.
- ▶ Insert the carrier **2** at point **P1** in the holder **1**.
- ▶ Properly secure the carrier **2** in plugged condition at point **P2** with the retaining element **3**.

When the carrier **2** is properly assembled:

- ▶ Release the transport retainer **6** on the wind speed sensor **5**: Remove the retaining element **7**.
- ▶ Swing the transport retainer **6** down in the direction of the arrow.
- ▶ Fold the transport retainer **6** in all the way on the carrier **2** and properly secure at point **P3** with the retaining element **7**.

**Result:**

- The wind speed sensor **5** can now move freely and automatically aligns itself horizontally due to the pendulum.

## 6.2 Establishing the electrical connections

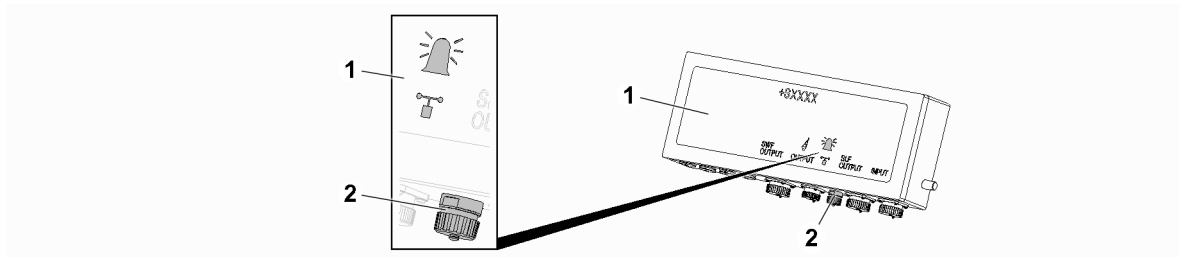


Fig.155072: Establishing the electrical connections on the terminal box

1 Terminal box

2 Cap

**Note**

- ▶ The establishment of the electrical connections is described as an example.
- ▶ Pay attention to the Electrical wiring diagram.

### 6.2.1 Establishing the electrical connections to the terminal box

- ▶ Unscrew the cap **2** on the terminal box **1**.
- ▶ Properly insert the plug from the wind speed sensor in the socket on the end section terminal box.
- ▶ Properly insert the plug from the airplane warning light in the socket on the end section terminal box.

### 6.2.2 Checking the electrical connections

- ▶ Check that the plug connections of the wind speed sensor and the airplane warning light have been connected correctly.

## 6.3 Function test

### 6.3.1 Checking the wind speed sensor



#### WARNING

The crane can topple over!

Death, severe bodily injuries, property damage.

- ▶ Make sure that the wind speed sensor has been checked before erecting the boom system.
- ▶ Make sure that the wind speed sensor is functioning properly.

Check the wind speed sensor for easy movement and proper function:

- ▶ Manually operate the cup anemometer of the wind speed sensor.
- ▶ Check the display and function of the wind speed sensor on the LICCON monitor.

If the wind speed sensor is defective or does not function properly:

- ▶ Replace a defective wind speed sensor immediately.

### 6.3.2 Checking the airplane warning light

- ▶ Turn on the airplane warning light in the crane cab and check function, see chapter 4.01.

If the airplane warning light is defective or does not function properly:

- ▶ Replace the defective airplane warning light immediately.

## 7 Wind speed sensor disassembly

Make sure that the following prerequisites are met:

- The boom system is on the ground.
- The boom head is near the ground.
- During disassembly on the WA-frame II:  
The boom system is on the ground.
- A working platform or aerial work platforms are available.

### 7.1 Disconnecting the electrical connection

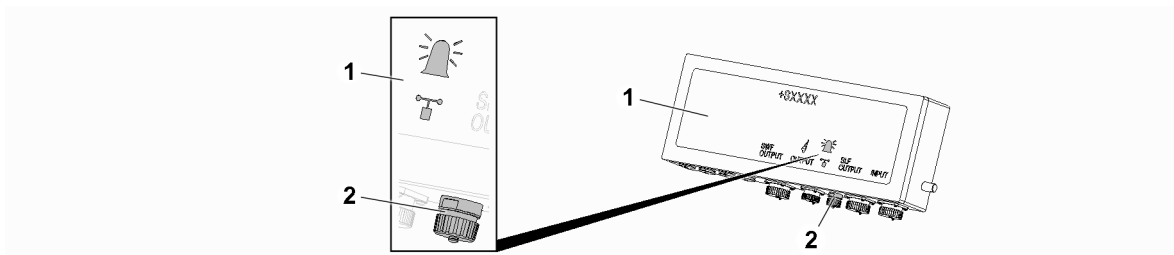


Fig.155072: Electrical connections (terminal box exemplary)

- |                |       |
|----------------|-------|
| 1 Terminal box | 2 Cap |
|----------------|-------|



#### Note

- ▶ Properly disconnect the electrical connections.
- ▶ Properly release the plug from the wind speed sensor on the terminal box for the end section.
- ▶ Properly release the plug from the airplane warning light on the terminal box for the end section.
- ▶ Seal the socket on the terminal box 1 properly with a cap 2.

## 7.2 Disassembling the wind speed sensor

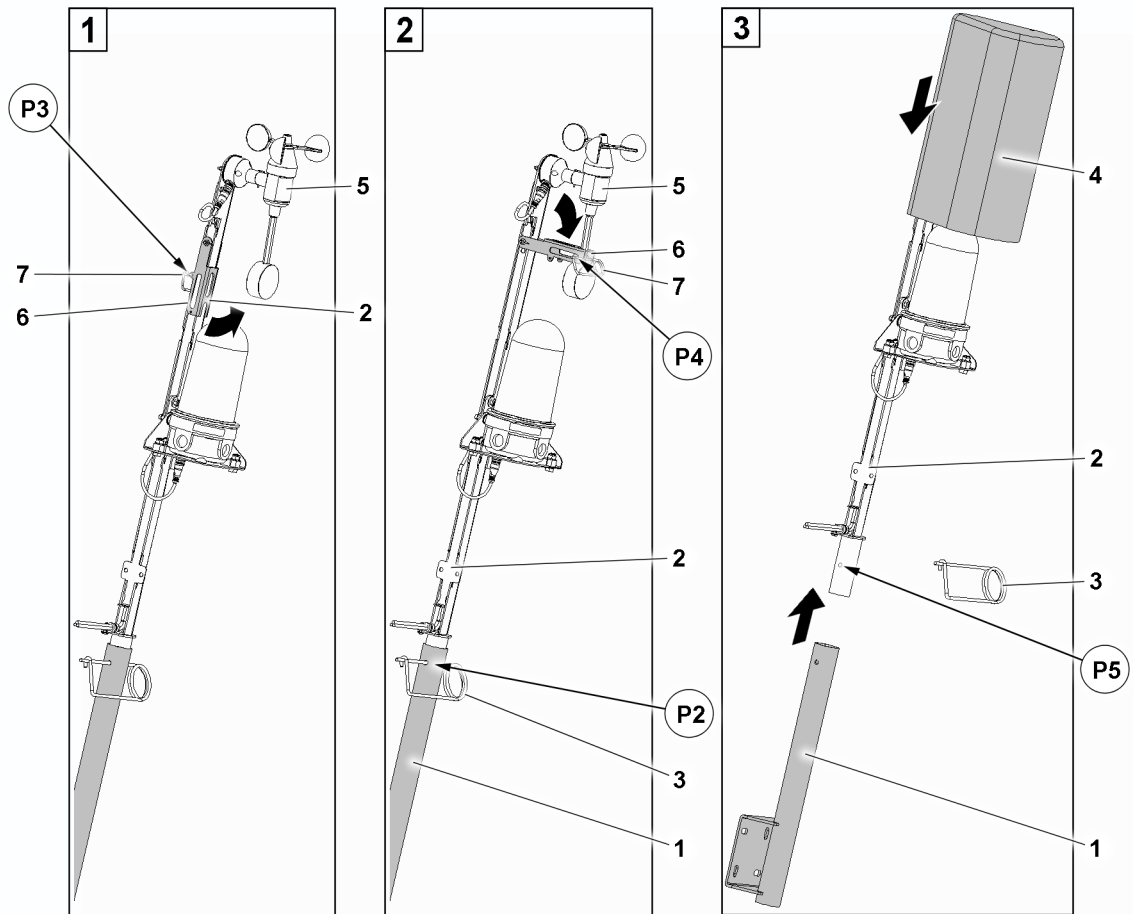


Fig.155074: Disassembling the wind speed sensor

- |   |                   |   |                    |
|---|-------------------|---|--------------------|
| 1 | Retainer          | 5 | Wind speed sensor  |
| 2 | Carrier           | 6 | Transport retainer |
| 3 | Retaining element | 7 | Retaining element  |
| 4 | Cover hood        |   |                    |

Make sure that the following prerequisites are met:

- The electrical connections are separated.

- ▶ Remove the retaining element 7 on the transport retainer 6 at point P3.
- ▶ Swing the transport retainer 6 upward.
- ▶ Position the wind speed sensor 5 and lock it with the transport retainer 6.

If the wind speed sensor 5 is locked:

- ▶ Secure the transport retainer 6 with the retaining element 7 at point P4.

When the wind speed sensor 5 with transport retainer 6 is properly secured:

- ▶ Pull the cover hood 4 over the wind speed sensor 5 and fasten it.
- ▶ Remove the retaining element 3 at point P2 on the holder 1.
- ▶ Pull the carrier 2 upward out the holder 1.
- ▶ Retaining element 3 at point P5 on the carrier 2

## 7.3 Transporting the wind speed sensor

---

### NOTICE

Danger of damage!

If the wind speed sensor **5** is not properly locked and protected for transport, it can be damaged or completely destroyed.

- ▶ Do not load the wind speed sensor **5** with other components.
  - ▶ Make sure that the wind speed sensor **5** cannot slip during transport.
- 

Make sure that the following prerequisites are met:

- The wind speed sensor **5** is properly locked on the carrier.
  - The cover hood **4** is properly fastened.
- ▶ Place the carrier **2** down in the transport box.



---

## 6 Auxiliary equipment

LWE/LR 1800-1-0-000/27200-07-02/en

---

LWE/LR 1800-1-0-000/27200-07-02/en

## 6.01 Heater / engine preheating

1 Heater / engine preheating

2

LWE/LR 1800-1-0-000/27200-07-02/en

# 1 Heater / engine preheating

**Note**

▶ See chapter 6.02.

## 6.02 Crane operator's cab heater / engine preheating / air conditioning system

1	Climate control system	2
2	Safety instructions	2
3	Climate control	4
4	Air distribution	12
5	Defrosting the window	13
6	Air supply	14
7	Set the auxiliary heater heat distribution	14
8	Operating the timer	15
9	Air heater*	17
10	Checking the fuel reserve	18

# 1 Climate control system

The climate control system consists of multiple components:

- Crane superstructure auxiliary heater for the climate control of the crane cab.
- Crane superstructure climate control system for the climate control of the crane cab.
- Air heater\* for heating the crane cab.
- Drive assembly air conditioning system\* as an additional drive unit.

Depending on the crane type, optionally there is an drive assembly air conditioning system\* for the climate control of the driver's cab as long as the crane engine is not used when at a standstill. Furthermore, the electrical power supply is maintained during this time and the batteries are charged.

It is not possible to heat the crane cab without switching on the auxiliary heater.

Cooling of the crane cab is possible in a limited manner only without the climate control system switched on.

Keep the air intake and the air filter of the climate control system free of:

- Ice
- Snow
- Contaminants
- Objects

For efficient climate control, close the windows and door of the crane cab.

## 2 Safety instructions

Observe the country specific regulations for the operation of climate control systems.



### Note

- ▶ For the operating instructions, maintenance and safety instructions of the auxiliary heater, see the documentation from the manufacturer.



### Note

- ▶ For the operating instructions, maintenance and safety instructions of the air heater\*, see the documentation from the manufacturer.



### Note

- ▶ For the operating instructions, maintenance and safety instructions of the drive assembly air conditioning system\*, see the documentation from the manufacturer.



### WARNING

Danger of accident due to bad visibility!

A window that is fogged up, icy or dirty impedes the view of the crane operator.

- ▶ Only drive / operate the crane with good visibility through the windows.



### WARNING

Danger of poisoning and suffocation in enclosed areas!

- ▶ Do **not** operate the auxiliary heater, air heater\* or the drive assembly air conditioning system\* in closed rooms.



### WARNING

Danger of poisoning and suffocation!

After turning the auxiliary heater off, there is an after-run phase.

During the after-run phase, exhaust gases are still emitted.

- ▶ Ensure sufficient ventilation.

Areas with a danger of explosion and fires:

- Gas stations and refueling facilities.
- Locations where vapors, gases or dust can form.
- Locations with easily flammable materials or fluids.




---

### WARNING

Danger of explosion and fires!

- ▶ Do **not** operate the auxiliary heater or air heater\* if there is a danger of explosion or fires.
- 

### NOTICE

Damage to the electronics!

If temperatures are exceeded in the working area of the auxiliary heater and the air heater\*, permanent damage may be caused to the electronics.

- ▶ Make sure that a temperature of 85° is not exceeded in the working area of the auxiliary heater and the air heater\*.
- 

Signs of a defective auxiliary heater or air heater\*:

- Significant smoke development
  - Unusual combustion noise
  - Fuel odor
- 

### NOTICE

Auxiliary heater or air heater\* defective!

- ▶ Turn off the auxiliary heater or air heater\*.
  - ▶ Take the auxiliary heater or air heater\* out of operation: Shut off the power supply to the auxiliary heater or air heater\*.
  - ▶ Before turning it on again: Have the auxiliary heater or air heater\* checked by authorized and trained service personnel.
- 

### NOTICE

Damage to the climate control systems!

- ▶ Adjust the operating fluids in time to the ambient temperatures.
- ▶ Operate the auxiliary heater, air heater\* and climate control system at least once a month for 10 minutes.
- ▶ Regularly burn-off the burner of the auxiliary heater. See chapter 7.05.

Repair work on the climate control systems:

- ▶ Contact Customer Service at Liebherr-Werk Ehingen and coordinate the procedure.
- 

### NOTICE

Deep discharge of the battery!

When the crane engine is turned off, operating the auxiliary heater can discharge the batteries. A long-term programmed turn on time for the auxiliary heater can discharge the batteries.

- ▶ Make sure that the battery charge is sufficient.
-

### 3 Climate control

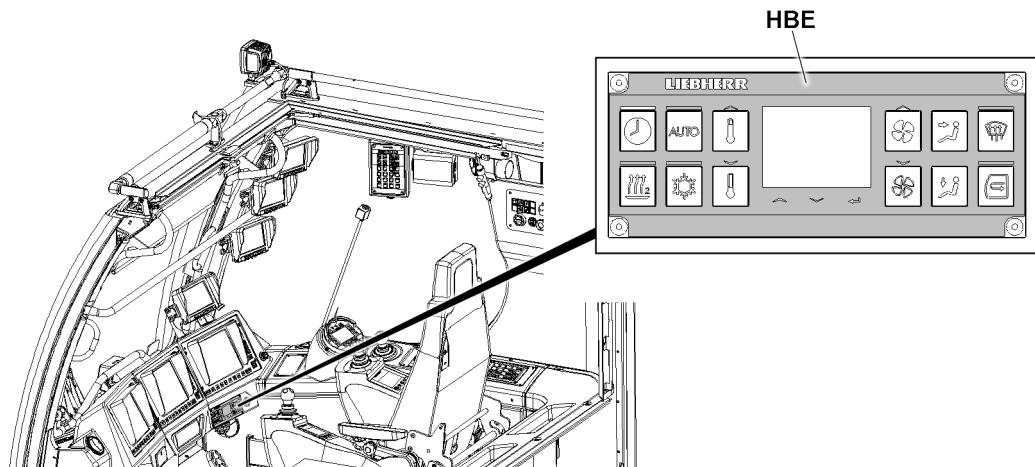


Fig.151953: Heater control unit **HBE**

The climate control of the crane cab is controlled using the heater control unit **HBE**.

The climate control in the crane cab can:

- Be automatically regulated in automatic operation.
- Be manually regulated in manual operation.

#### 3.1 Heater control unit operating elements

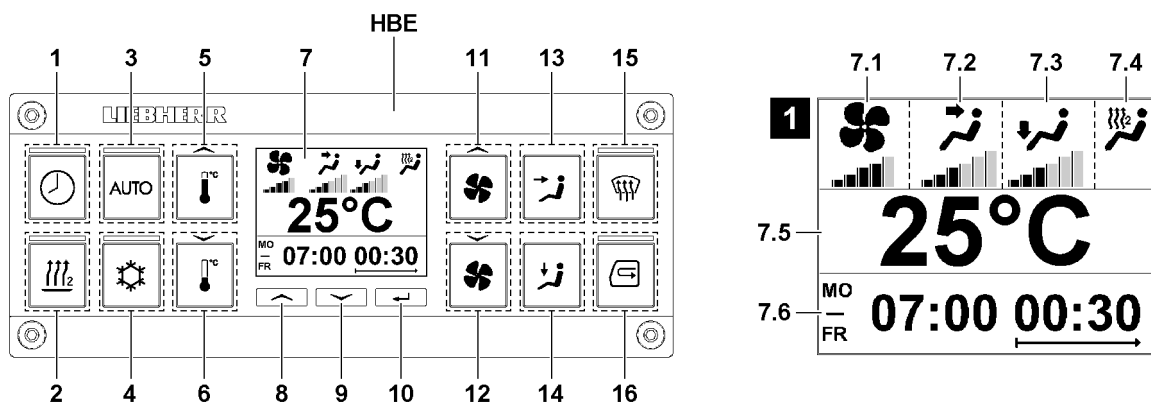


Fig.151956: Heater control unit operating elements

- 1** *Timer key*
  - Setting the timer for auxiliary heater and turning it on / off
  - The LED lights up: The timer for the auxiliary heater is turned on
- 2** *Auxiliary heater key*
  - Control the auxiliary heater:
    - Turn the auxiliary heater on
    - Turn the auxiliary heater off
  - The LED lights up: The auxiliary heater is turned on
- 3** *Automatic operation key*
  - Switching between automatic operation and manual operation
  - The LED lights up: Automatic operation is turned on, automatic control of heater settings
  - LED off: Manual operation is turned on, manual adjustment of the heater settings



- 4 *Climate control system key*
  - Control the climate control system:
    - Turn the climate control system on
    - Turn the climate control system off
  - The LED lights up: The auxiliary heater is turned on / ready to operate  
Note: During automatic operation, the luminous LED signals that the climate control system is ready for operation and can be switched on / off as required using the control.
- 5 *Increase temperature key*
- 6 *Decrease temperature key*
- 7 *Display*

Display of the current settings, see illustration 1:

  - 7.1 Fan stage
  - 7.2 Head area air distribution
  - 7.3 Foot area air distribution
  - 7.4 Heat distribution
  - 7.5 Temperature
  - 7.6 Setting the time
- 8 *Up selection key*
- 9 *Down selection key*
- 10 *Confirm entry key*
- 11 *Increase fan stage key*
- 12 *Decrease fan stage key*
- 13 *Head area air distribution key*
  - Increase air distribution in the head area
  - Note: Each key press decreases at the same time the air distribution to the foot area
- 14 *Foot area air distribution key*
  - Increase air distribution in the foot area
  - Note: Each key press decreases at the same time the air distribution to the head area
- 15 *Defrost window key*
  - *Defrost window* function on / off
  - The LED lights up: The *defrost window* function is turned on
- 16 *Recirculating air key*
  - Recirculating air on / off
  - The LED lights up: Recirculating air is turned on

## 3.2 Turning the heater control unit on and off

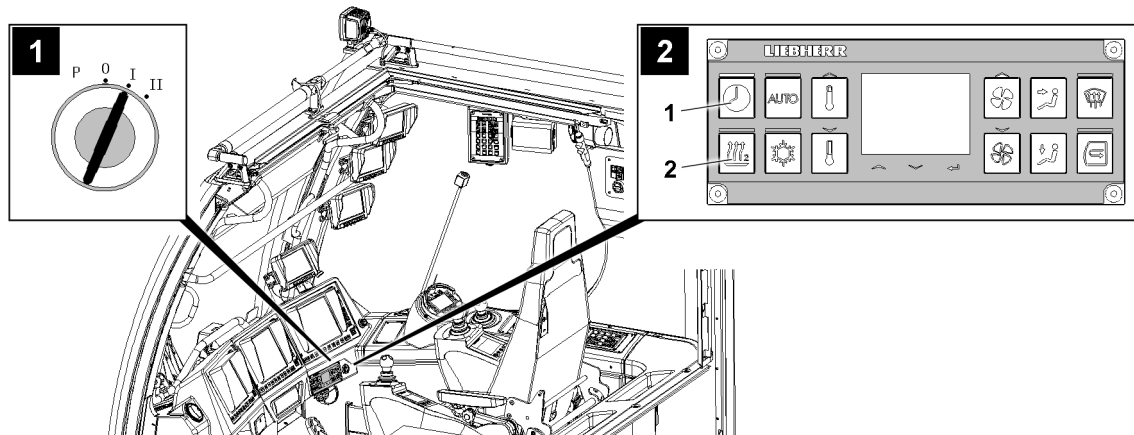


Fig.151954: Turning the heater control unit on and off

The heater control unit is turned on and ready to operate:

- With ignition turned on
- After being turned on manually with the ignition turned off



### Note

At very low temperatures, the display of the heater control unit may not display anything initially.

- ▶ When turning on the heater control unit, wait until the display can be read.

### 3.2.1 Turning the heater control unit on and off via the ignition

- ▶ Turn the heater control unit on: Turn on the ignition with the ignition switch, see illustration 1.

#### Result:

- The heater control unit turns on.
- ▶ Turn the heater control unit off: Turning the ignition off with the ignition switch.

#### Result:

- The heater control unit turns off after a short time.

### 3.2.2 Turning the heater control unit on and off manually

See illustration 2:

Make sure that the following prerequisite is met:

- The ignition is off.

#### Turning the heater control unit on

- ▶ Press the *timer* button 1 until the heater control unit turns on.  
or  
Press the *auxiliary heater* key 2 until the heater control unit turns on.

#### Turning the heater control unit off

The heater control unit cannot be turned off directly. To increase operating safety, there are partially automated processes for turning off the heater control unit.

**Note**

- ▶ As long as the auxiliary heater is operating, the heater control unit will not turn off.
- ▶ When the auxiliary heater is turned off, the heater control unit turns off automatically after a short period of time.

When the auxiliary heater is turned off:

- ▶ Do not press any button on the heater control unit for at least ten seconds.

**Result:**

- The heater control unit turns off after a short time.

When the auxiliary heater is still operating:

- ▶ The separate turning off of the heater control unit is not necessary and also not possible.

**Result:**

- As soon as the auxiliary heater is turned off by the automatic control, also the heater control unit turns off automatically after a short period of time.

When the auxiliary heater is still operating, but should be turned off:

- ▶ See section "Turning the auxiliary heater on and off".

**Result:**

- As soon as the auxiliary heater is turned off, the heater control unit turns off automatically after a short period of time.

### 3.3 Switching between automatic operation and manual operation

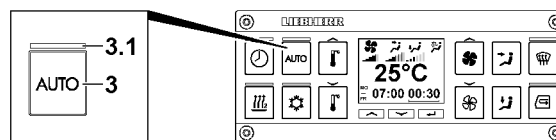


Fig.145964: Switching between automatic operation and manual operation

#### 3.3.1 Turning on automatic operation

Make sure that the following prerequisite is met:

- The LED **3.1** is off.
- ▶ Press the *automatic operation* key **3**.

**Result:**

- The LED **3.1** lights up: The automatic operation is turned on.
- The heater settings are automatically adjusted.

**Note**

In automatic operation:

- ▶ If the heater settings are changed extensively by hand, the climate control switches to manual operation.

#### 3.3.2 Turning manual operation on

Make sure that the following prerequisite is met:

- The LED **3.1** lights up.
- ▶ Press the *automatic operation* key **3**.

**Result:**

- The LED **3.1** turns off: Manual operation is turned on.
- The heater settings must be adjusted manually.

## 3.4 Automatic operation

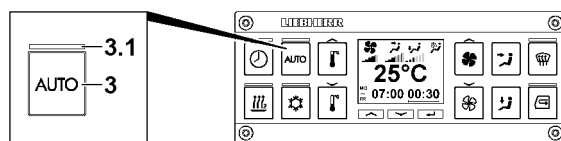


Fig.145964: Automatic operation - the LED 3.1 is on

Automatic operation is only turned on when the LED 3.1 over the *automatic operation* key 3 lights up

Automatic operation automatically regulates the climate control to reach the set temperature and keep it constant.

The following settings are automatically adjusted:

- Warm air supply
- Fan stage
- Air supply
- Auxiliary heater
- Climate control system

### 3.4.1 Adjusting the temperature

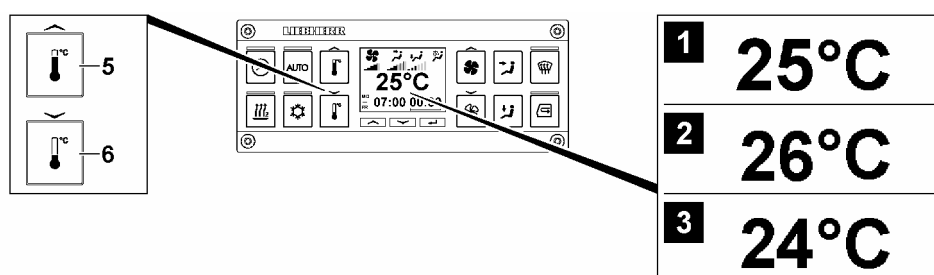


Fig.145967: Adjusting the temperature

The target temperature of 25°C is used as the initial setting, see illustration 1.

To increase the temperature:

- ▶ Press the *increase temperature* key 5.

**Result:**

- The set value increases, see illustration 2.

To decrease the temperature setting:

- ▶ Press the *decrease temperature* key 6.

**Result:**

- The set value decreases, see illustration 3.

#### Problem remedy

Is the cooling capacity of the climate control system insufficient?

The recirculated air filter, fresh air filter or capacitor could be dirty.

- ▶ Check the filter for impurities. If necessary, clean or replace.
- ▶ Check the condenser for impurities and clean, if necessary.

When all these measures do not help:

- ▶ Contact the Service Dept. at Liebherr-Werk Ehingen.

## 3.5 Manual operation

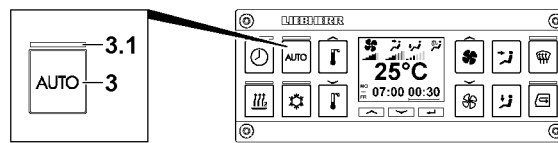


Fig.145964: Manual operation - the LED 3.1 is off

Manual operation is only turned on when the LED 3.1 over the *automatic operation* key 3 does not light up.

In manual operation all settings must be carried out manually.

### 3.5.1 Turning the auxiliary heater on and off

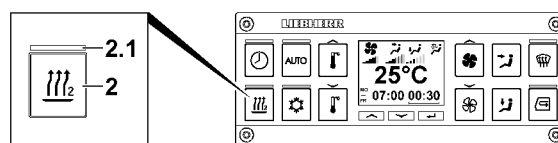


Fig.145963: Turning the auxiliary heater on and off



#### Note

Protection against auxiliary heater overheating

- ▶ If the temperature of the heat carrier is too high, the auxiliary heater turns off automatically.

#### Turning the auxiliary heater on



#### Note

- ▶ If the ignition is turned off while the auxiliary heater is turned on, the auxiliary heater continues to run with an automatic shut off delay for up to 30 minutes.
- ▶ If the ignition is turned on while the auxiliary heater is turned off, the auxiliary heater runs for 30 minutes.
- ▶ If the auxiliary heater must be turned on at a certain time when the ignition is turned off, the timer must be programmed, see section "Operating the timer".

Make sure that the following prerequisites are met:

- The LED 2.1 is off.
- Sufficient fuel for the auxiliary heater has been added.
- With the auxiliary heater turned on, sufficient ventilation is ensured.
- With the auxiliary heater turned on, the crane is located in an area where operation of the auxiliary heater is permitted.

- ▶ Press the *auxiliary heater* key 2.

#### Result:

- The LED 2.1 lights up: The auxiliary heater is turned on.

#### Turning the auxiliary heater off

Make sure that the following prerequisite is met:

- The LED 2.1 lights up.
- ▶ Press the *auxiliary heater* key 2.

#### Result:

- The LED 2.1 turns off: The auxiliary heater is turned off.

### 3.5.2 Turning the climate control system on and off

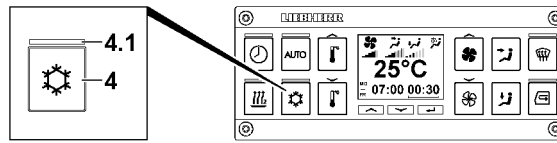


Fig.145965: Turning the climate control system on and off

The climate control system is responsible for cooling and dehumidifying the air in the crane cab.

The humidity is reduced considerably when the climate control system is switched on. This counteracts the fogging up of the windows.

The maximum cooling output is reached when:

- The air supply is switched to recirculating air.
- The fan stage is set to maximum output.
- The temperature stage is set to the lowest value.
- All outlet nozzles in the crane cab are open.
- The door and windows of the crane cab are closed.



#### Note

Protection against condenser freezing

- ▶ If the outside temperature is too low, the climate control system turns off automatically.

#### Turning the climate control system on

Make sure that the following prerequisites are met:

- The crane engine is running.
  - The LED 4.1 is off.
- ▶ Press the *climate control system* key 4.

#### Result:

- The LED 4.1 lights up: The climate control system is turned on.

#### Problem remedy

Is the cooling capacity of the climate control system insufficient?

The recirculated air filter, fresh air filter or capacitor could be dirty.

- ▶ Check the filter for impurities. If necessary, clean or replace.
- ▶ Check the condenser for impurities and clean, if necessary.

When all these measures do not help:

- ▶ Contact the Service Dept. at Liebherr-Werk Ehingen.

#### Turning the climate control system off

Make sure that the following prerequisite is met:

- The LED 4.1 lights up.
- ▶ Press the *climate control system* key 4.

#### Result:

- The LED 4.1 turns off: The climate control system is turned off.

### 3.5.3 Adjusting the temperature

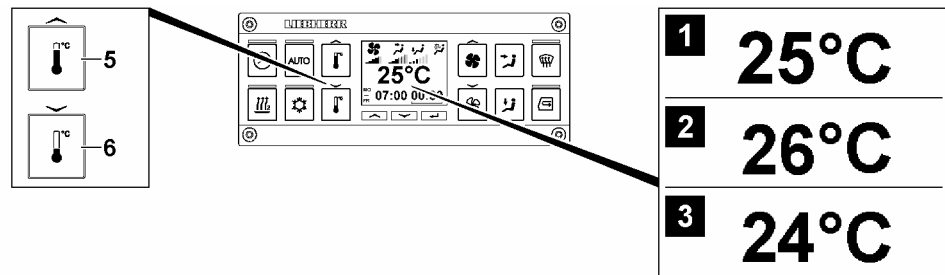


Fig.145967: Adjusting the temperature

Make sure that the following prerequisites are met:

- Turn the auxiliary heater on to heat the crane cab.
- Turn the climate control system on to cool the crane cab.

The target temperature of 25°C is used as the initial setting, see illustration 1.

To increase the temperature:

- ▶ Press the *increase temperature* key 5.

**Result:**

- The set value increases, see illustration 2.

To decrease the temperature setting:

- ▶ Press the *decrease temperature* key 6.

**Result:**

- The set value decreases, see illustration 3.

### 3.5.4 Adjusting the fan stage

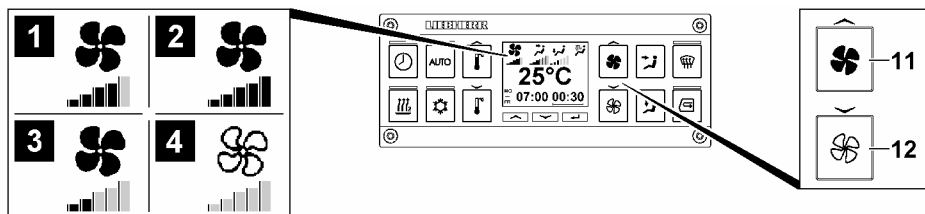


Fig.145969: Adjusting the fan stage in manual operation

Fan stage *four* is used as the initial setting, see illustration 1.

To increase the fan stage:

- ▶ Press the *increase fan stage* key 11.

**Result:**

- Fan stage *five* is displayed, see illustration 2.

To decrease the fan stage:

- ▶ Press the *decrease fan stage* key 12.

**Result:**

- Fan stage *three* is displayed, see illustration 3.



**Note**

- ▶ When the fan is switched off, the fan icon is displayed not filled out, see illustration 4.

## 4 Air distribution

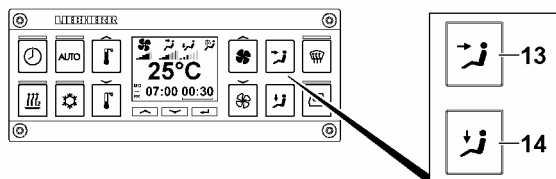


Fig.151957: Air distribution

- **13** Head area air distribution key
  - Increase air distribution in the head area
  - Note: Each key press decreases at the same time the air distribution to the foot area
- **14** Foot area air distribution key
  - Increase air distribution in the foot area
  - Note: Each key press decreases at the same time the air distribution to the head area

### 4.1 Increasing air distribution in the head area

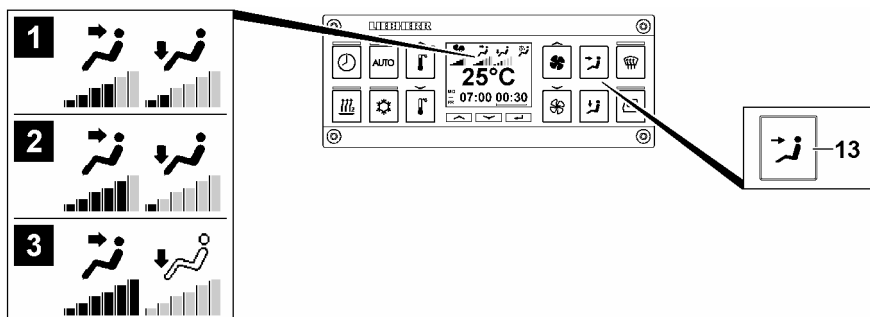


Fig.151958: Increasing air distribution in the head area

Level *four* in the head area is used as the initial setting, see illustration 1.

To increase the level in the head area:

- ▶ Press the *Head area air distribution* key **13**.

#### Result:

- Level *five* is displayed in the head area, see illustration 2.
- The level in the foot area is decreased accordingly.



#### Note

At the highest level in the head area, the air distribution to the foot area is turned off.

- ▶ When the air distribution to the foot area is turned off, the icon is displayed not filled out, see illustration 3.



## 4.2 Increasing air distribution in the foot area

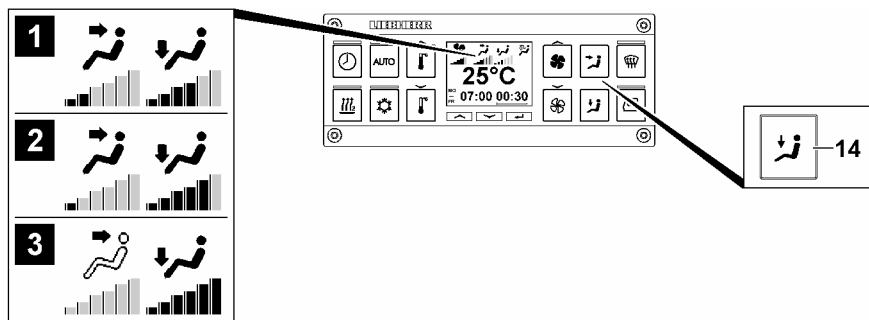


Fig.151959: Increasing air distribution in the foot area

Level four in the foot area is used as the initial setting, see illustration 1.

To increase the level in the foot area:

- ▶ Press the *Foot area air distribution* key 14.

### Result:

- Level five is displayed in the foot area, see illustration 2.
- The level in the head area is decreased accordingly.



### Note

At the highest level in the foot area, the air distribution to the head area is turned off.

- ▶ When the air distribution to the head area is turned off, the icon is displayed not filled out, see illustration 3.

## 5 Defrosting the window

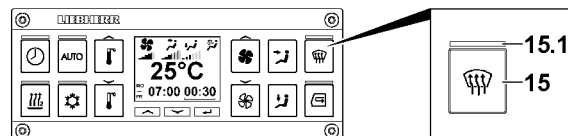


Fig.145973: Turning the defrost window function on / off

### 5.1 Turning the *defrost window* function on

Make sure that the following prerequisites are met:

- The outlet nozzles in the A-pillars and instrument panel are open and directed evenly towards the front window.
- The LED 15.1 is off.

- ▶ Press the *defrost window* key 15.

### Result:

- The LED 15.1 lights up: The *defrost window* function is turned on.

### 5.2 Turning the *defrost window* function off

Make sure that the following prerequisite is met:

- The LED 15.1 lights up.

- ▶ Press the *defrost window* key 15.

**Result:**

- The LED 15.1 turns off: The *defrost window* function is turned off.

## 6 Air supply

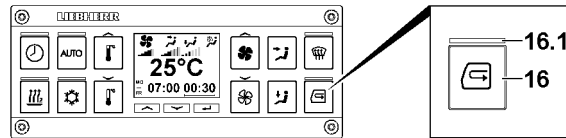


Fig.145970: Air supply

When recirculating air is turned on, the air is circulated in the crane cab.

When recirculating air is turned off, fresh air is introduced from the outside.

### 6.1 Turning recirculating air on

Make sure that the following prerequisite is met:

- The LED 16.1 is off.
- ▶ Press the *recirculating air* key 16.

**Result:**

- The LED 16.1 lights up: Recirculating air is turned on.

### 6.2 Turning recirculating air off

Make sure that the following prerequisite is met:

- The LED 16.1 lights up.
- ▶ Press the *recirculating air* key 16.

**Result:**

- The LED 16.1 turns off: Recirculating air is turned off.

## 7 Set the auxiliary heater heat distribution

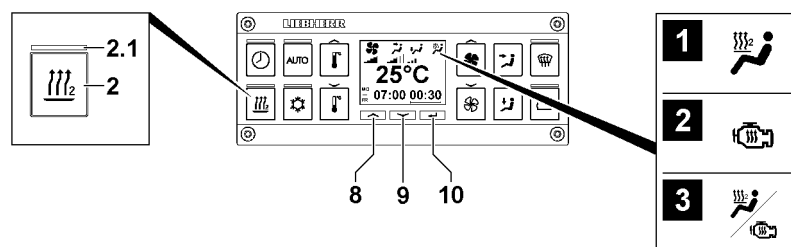


Fig.145966: Set the auxiliary heater heat distribution

The heat generated by the auxiliary heater can be used for:

- Cab heating, icon illustration 1
- Engine preheating, icon illustration 2
  - **Note:** Only for cranes with engine preheating\*.
- A combination of cab heating and engine preheating, icon illustration 3
  - **Note:** Only for cranes with engine preheating\*.

Make sure that the following prerequisite is met:

- The auxiliary heater is off, the LED **2.1** does not light up.
- ▶ Press the auxiliary heater key **2** for about three seconds.

**Result:**

- The selection mode is activated.
- The icon for the current setting blinks.

Switch through the selection possibilities:

- ▶ Press the *up selection* key **8**.
- or
- ▶ Press the *down selection* key **9**.

**Result:**

- With each press of the key: The flashing icon switches between illustration **1**, illustration **2** and illustration **3**.

Confirm the selection:

- ▶ Press the *confirm entry* key **10**.

**Result:**

- The selected icon is shown statically on the display.
- The heat distribution is set.

## 8 Operating the timer

The auxiliary heater can be turned on at any time using the timer.



**WARNING**

Danger of suffocation and explosion!

Only when the auxiliary heater is turned on if sufficient ventilation is ensured and no danger of explosion exists:

- ▶ Activate the timer.



**Note**

- ▶ Pay attention to a sufficient fuel reserve for the auxiliary heater.

### 8.1 Programming the timer

The following applies when the timer for the auxiliary heater turns on:

- The fan stage is generally set to 30 %.
- The previously set air supply and air distribution is taken over.
- Operation of the auxiliary heater ends after the set time. Automatic start does not take place after another 7 days.

Make sure that the following prerequisites are met:

- At the programmed start time for the timer, the ignition is turned off.
- Sufficient fuel for the auxiliary heater has been added.
- With the auxiliary heater turned on, sufficient ventilation is ensured.
- With the auxiliary heater turned on, the crane is located in an area where operation of the auxiliary heater is permitted.

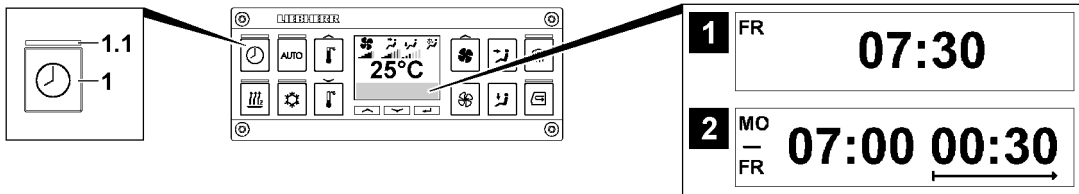


Fig.145976: Timer turned on / off

- When the timer is turned off, the system time appears on the display, see illustration 1.  
The system time includes the day of the week and time.  
The system time is the determining factor for the timer.
- When the timer is turned on, the *start time and running time* appears on the display, see illustration 2  
The start time includes the day of the week / days of the week and time.

If the LED 1.1 does not light up:

- ▶ Press the *timer* key 1.

**Result:**

- The LED 1.1 lights up: The timer is turned on.
- The *start time and running time* display appears, see illustration 2.

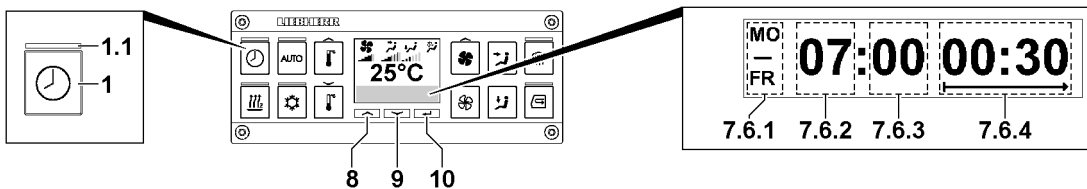


Fig.145977: Programming the timer

If the LED 1.1 lights up:

- ▶ Press the *timer* key 1 for approx. three seconds.

**Result:**

- The turn on day 7.6.1 blinks.

The following can be set as the turn on day 7.6.1:

- Single day of the week
- Daily from Monday to Friday
- Daily from Monday to Sunday

When the turn on day 7.6.1 blinks:

- ▶ Set the turn on day 7.6.1: Press the *up selection* key 8 or the *down selection* key 9. If the key is pressed longer, it is increased / decreased automatically.
- ▶ Accept the turn on day 7.6.1: Press the *confirm entry* key 10.

**Result:**

- The turn on day 7.6.1 is set.
- The turn on time *hour* 7.6.2 blinks.

When the turn on time *hour* 7.6.2 blinks:

- ▶ Set the turn on time *hour* 7.6.2: Press the *up selection* key 8 or the *down selection* key 9. If the key is pressed longer, it is increased / decreased automatically.
- ▶ Accept the turn on time *hour* 7.6.2: Press the *confirm entry* key 10.

**Result:**

- The turn on time *hour* 7.6.2 is set.
- The turn on time *minute* 7.6.3 blinks.

When the turn on time *minute 7.6.3* blinks:

- ▶ Set the turn on time *minute 7.6.3*: Press the *up selection key 8* or the *down selection key 9*. If the key is pressed longer, it is increased / decreased automatically.
- ▶ Accept the turn on time *minute 7.6.3*: Press the *confirm entry key 10*.

**Result:**

- The turn on time *minute 7.6.3* is set.
- The turn on duration **7.6.4** blinks.

When the turn on duration **7.6.4** blinks:

- ▶ Set the turn on duration **7.6.4**: Press the *up selection key 8* or the *down selection key 9*. If the key is pressed longer, it is increased / decreased automatically.
- ▶ Accept the turn on duration **7.6.4**: Press the *confirm entry key 10*.

**Result:**

- The turn on duration **7.6.4** is set.

Ending timer programming:

- ▶ Press the *confirm entry key 10*



**Note**

- ▶ In the case of cranes with engine preheating, the heat distribution must then be checked / set, see section "Setting the auxiliary heater heat distribution".
- ▶ After programming the timer, the set heat distribution will be displayed briefly.
- ▶ When the ignition is turned off and the auxiliary heater is not activated, the heat distribution is displayed permanently.

## 9 Air heater\*



**Note**

- ▶ The installation position of the rotary switch **1** can vary depending on the crane type.

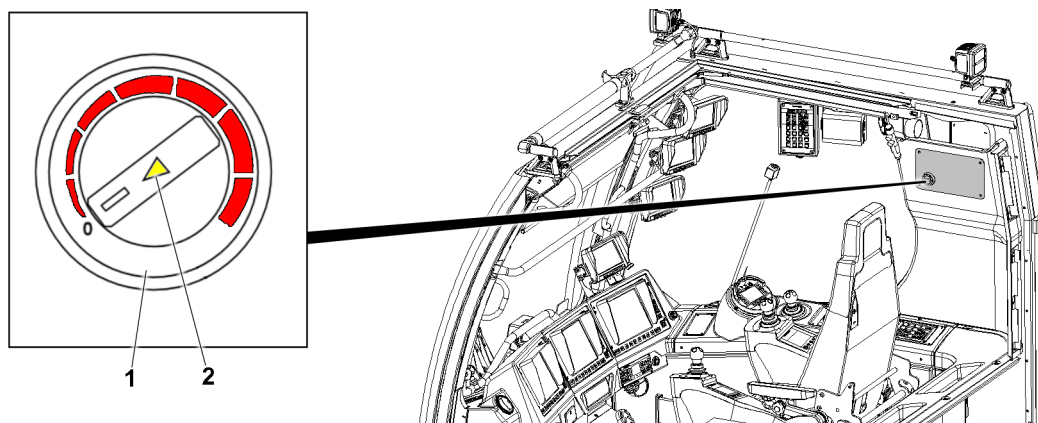


Fig.154731: Air heater\*

### 9.1 Turning the air heater\* on

For description of the air heater\*, see the documentation from the manufacturer.

- ▶ Turn the rotary switch **1** to the desired temperature.

**Result:**

- The LED 2 lights up: The *heating* function is turned on.

**9.2 Turning the air heater\* off**

- ▶ Set the rotary switch 1 to "0".

**Result:**

- The LED 2 turns off: The *heating* function is turned off.

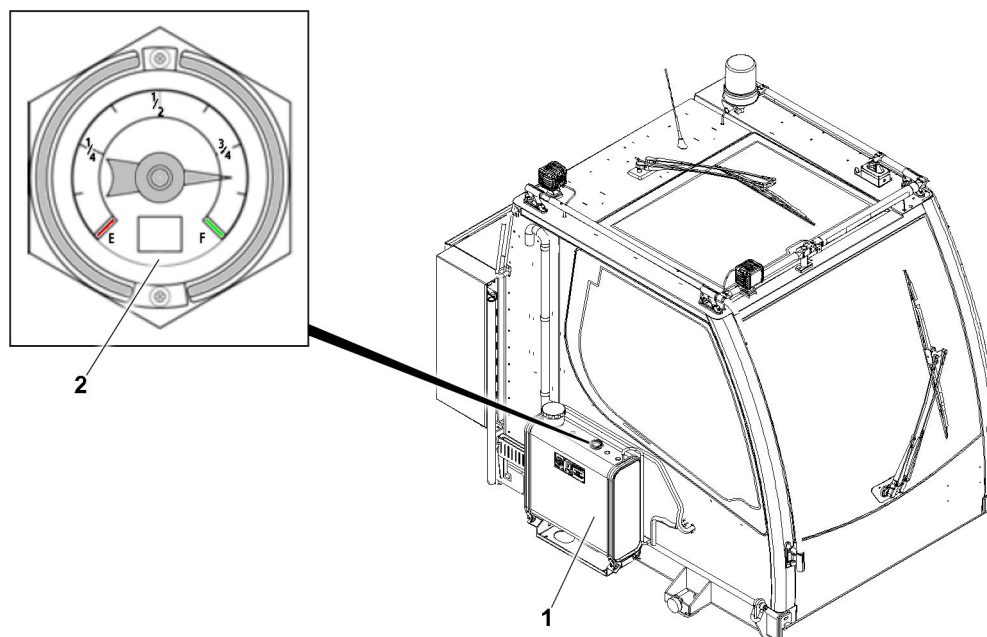
**10 Checking the fuel reserve**

Fig.154732: Checking the fuel reserve

The fill level of the fuel container 1 is displayed by a level indicator 2.

Make sure that the following prerequisite is met:

- The crane and the crane operator cab are horizontally positioned.
- ▶ Check the fill level on the level indicator 2.

If fuel must be added:

- ▶ Add fuel, see chapter 7.05.

## 6.05 Emergency take down

1	Emergency control	2
2	Emergency control with assembly plate Variation 1 (V1)	9
3	Emergency control of slewing gear(s) with assembly plate Variation 1 (V1)	15
4	Emergency control with assembly plate(s) Variation 2 (V2)	19
5	Emergency control slewing gear(s) with assembly plate(s) Variation 2 (V2)	31
6	Completing emergency control	31

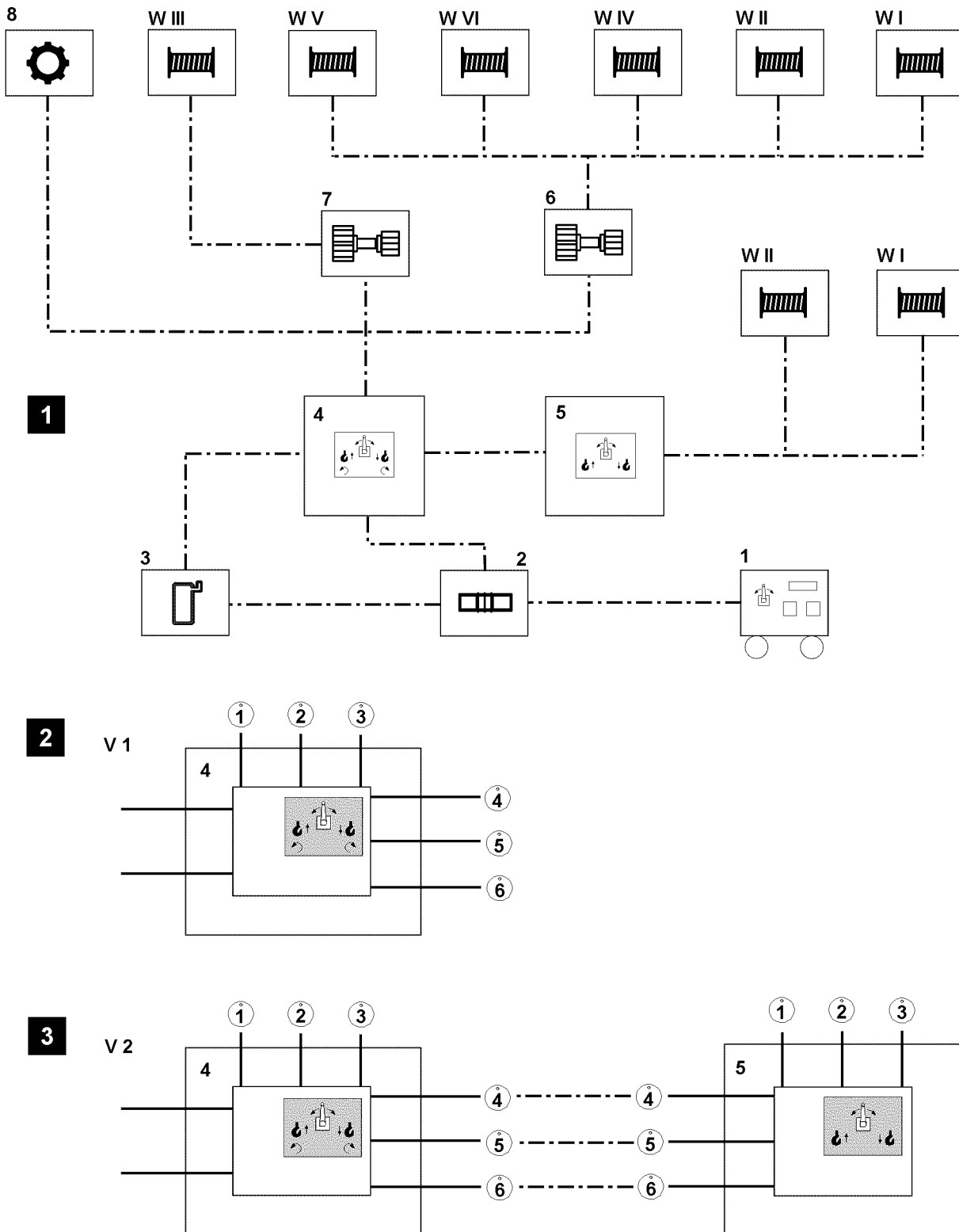


Fig.121033: Piping plan Emergency operation

# 1 Emergency control



**Note**

► The illustrations in this chapter are examples and may not apply exactly to your crane.

LWE/LR 1800-1-0-000/27200-07-02/en



**Note**

- ▶ Before you start with preparations for emergency operation, check which of the following assembly plates you have available to carry out the emergency operation.

There are two **different** variations of assembly plates.

With variation 1 **V1**, all winches, which are equipped with the respective auxiliary hydraulic for emergency control and the slewing gear can be actuated, each individually, see illustration 1 and illustration 2.

With variation 2 **V2**, which consists of two assembly plates, all winches, which are equipped with the respective auxiliary hydraulic for emergency control can be actuated, each individually, **or** winch 1 **WI** and winch 2 **WII** can be actuated in parallel operation or the slewing gear can be actuated individually, see illustration 1 and illustration 3.

Position	Component
1	Emergency operation aggregate
2	Hydraulic transformer
3	Oil container
4	Assembly plate emergency operation
5	Assembly plate parallel operation
6	Adapter 1
7	Adapter 2
8	Slewing gear
<b>W I - W VI</b>	Winch 1 <b>WI</b> to winch 6 <b>WVI</b>

*Component overview*

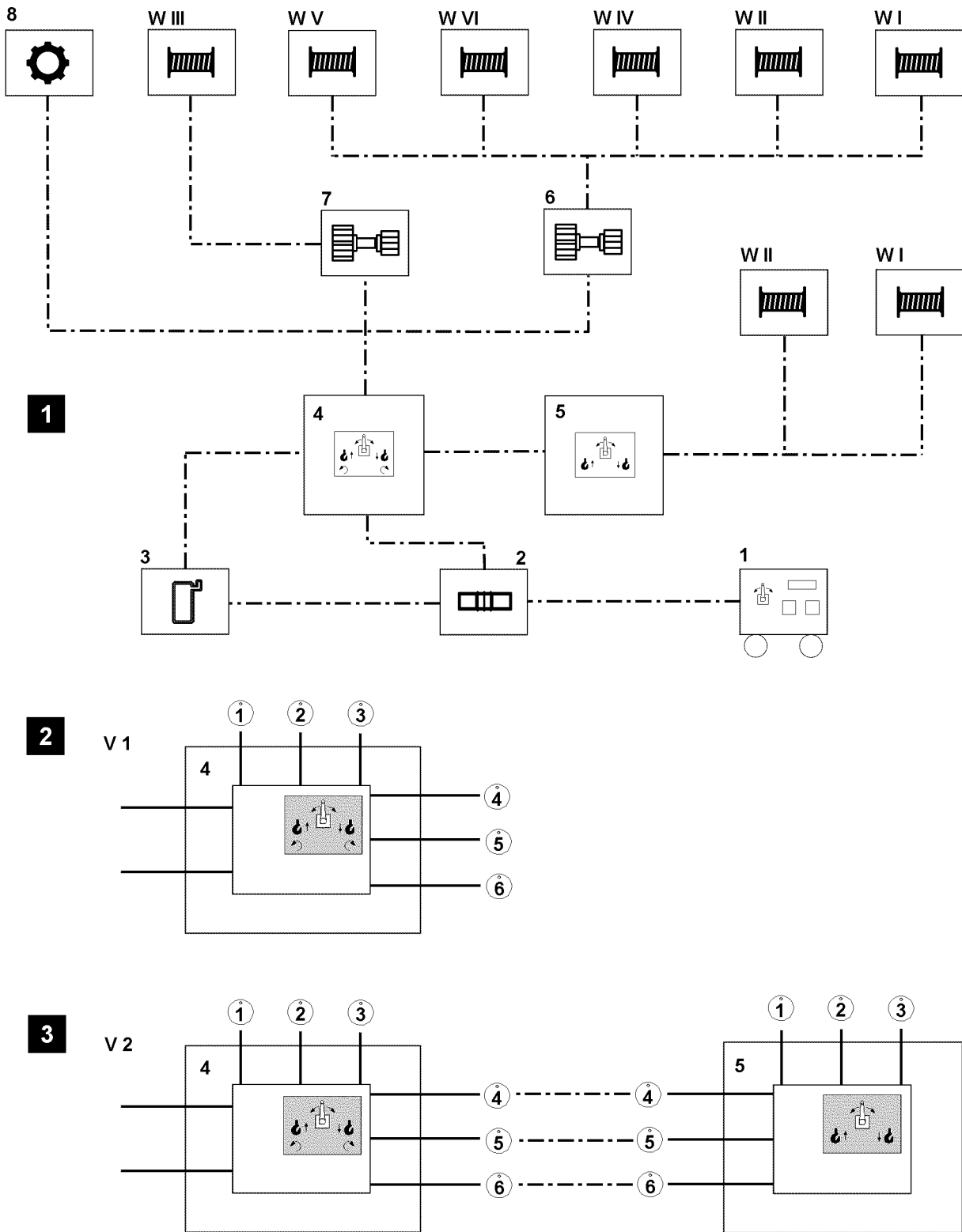


Fig.121033: Piping plan Emergency operation

LWE/LR 1800-1-0-000/27200-07-02/en

## 1.1 General danger notes



### DANGER

Significant danger of accident during emergency control!

During an emergency control, crane movements are no longer monitored by the LICCON computer system.

In the event of improper operation or deliberate misuse, the crane can topple over.

There is an increased risk of accident if the following danger notes are not observed.

Personnel can be severely injured or killed.

This could result in high property damage.

► All danger notes are to be observed and maintained.

### General danger notes!

1. **Emergency control of the crane superstructure may only be carried out:**

- To remove a dangerous situation.
- After consultation with customer service at LIEBHERR-Werk Ehingen GmbH.
- By authorized personnel who are knowledgeable of the hydraulic circuit diagram, the connection diagram and carrying out emergency control.
- By authorized personnel who are aware of the risks of emergency control.
- To carry out load reducing movements.

2. The danger zone must be blocked off.

3. No persons or objects may remain in the danger zone.

4. If a load is on the hook, then it must first be set down to relieve the boom.

5. During emergency control, all safety equipment, with the exception of “winch spooled out” are automatically bypassed.

6. In the event of a problem or failure of the LICCON computer system, each step must be carried out and checked with extreme caution and care, since a visual check on the LICCON monitor is no longer possible. Visual check.

7. All crane movements must be carried out with extreme caution and at the lowest speed.

8. The crane operator must be in visual contact with auxiliary personnel or guides.



### Note

Please note!

► The hydraulic supply for the crane can, to the extent that the crane has been equipped, take place through an emergency unit\*. If this is not the case, the crane must be taken down by using auxiliary cranes.



### WARNING

The crane can topple over!

► The boom may only be luffed down if the stability of the crane permits this action, observe and adhere to the data in the load charts.

► When taking down the boom, the information in the erection and take down charts must be observed and adhered to.

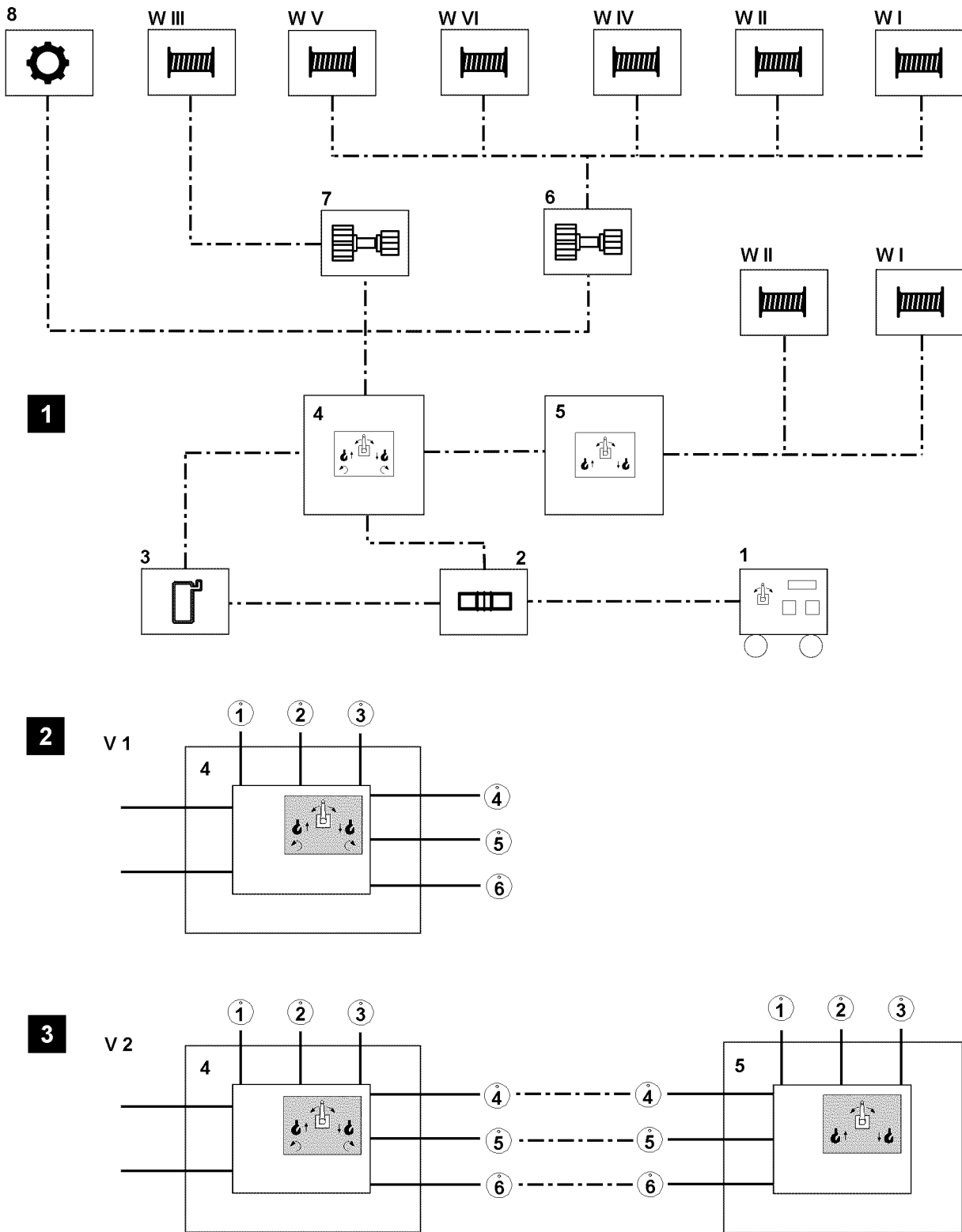


Fig.121033: Piping plan Emergency operation

LWE/LR 1800-1-0-000/27200-07-02/en

## 1.2 Handling of assembly plates



### WARNING

Falling assembly plates!

Non-secured assembly plates can fall down when carrying out the emergency control.

Personnel can be severely injured or killed.

- ▶ For emergency control, secure the assembly plates with the chains to prevent them from falling down.
- ▶ Do not secure the assembly plates near movable crane components.

## 1.3 Prerequisites for emergency control



### Note

- ▶ Due to different line diameters on the hydraulic lines, they cannot be connected incorrectly, in addition, the hydraulic connections are identified with numbers.

Make sure that the following prerequisites are met:

- The hydraulic schematic is available.
- The hydraulic system is functional.
- An emergency operation aggregate **1** is available.
- A “hydraulic transformer **2**” is available.
- The assembly plate(s) are available.
- Adapter **6** and adapter **7** are available.
- The dust caps for the hydraulic connections are removed.
- The pressure in the hydraulic system has been relieved.

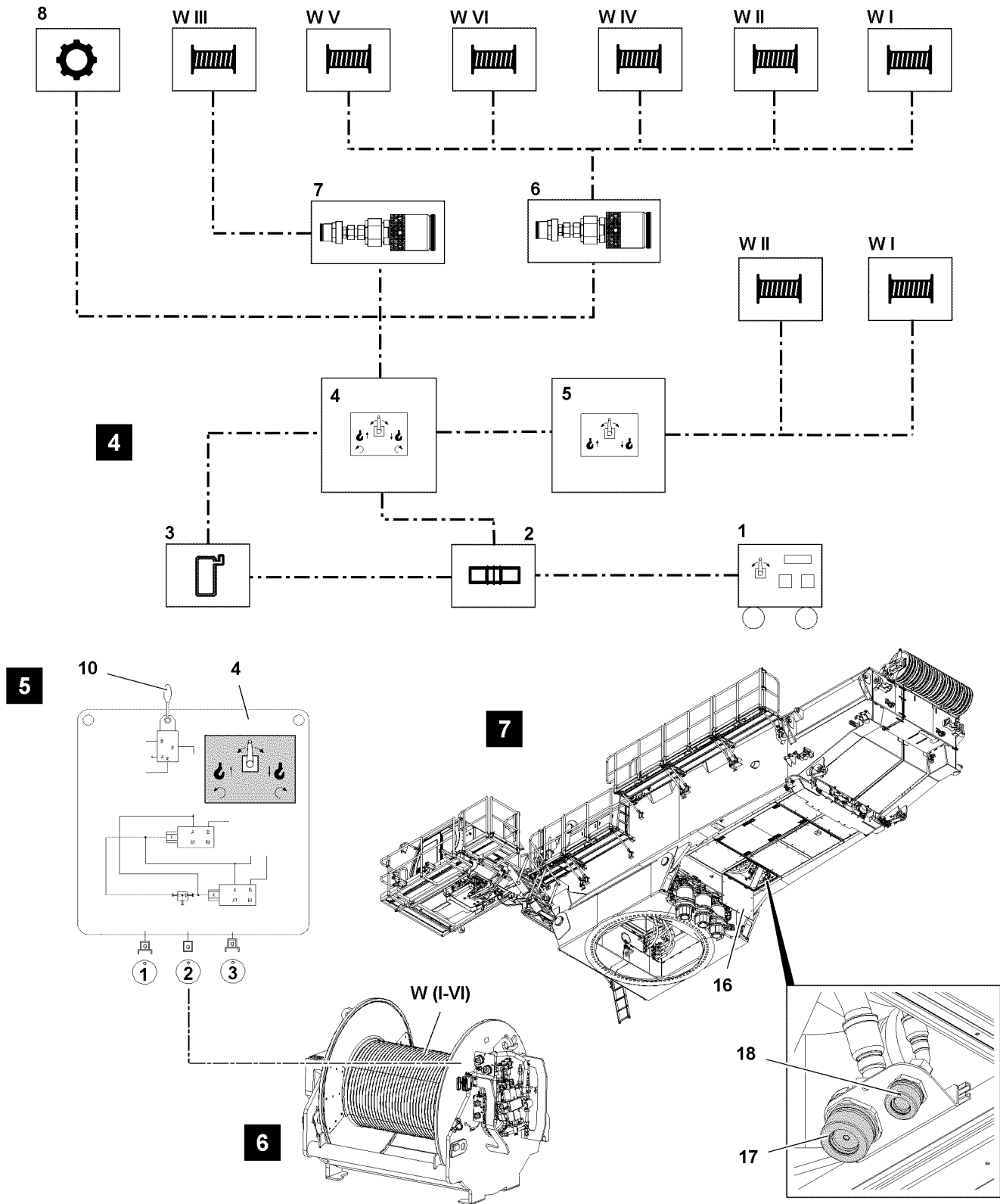


Fig.121034: Emergency control with assembly plate Variation 1 (V1)

LWE/LR 1800-1-0-000/27200-07-02/en

## 2 Emergency control with assembly plate Variation 1 (V1)



### Note

- Carrying out emergency control is identical for all winches and is described on the example of one winch.

Numbering						
	Connections of assembly plate					
	Connection 1 "lift"		Connection 2 "lower"		Connection 3 "brake"	
Winch 1 <b>WI</b>	<b>1</b> <sup>1)</sup>	<b>1</b> <sup>2)</sup>	<b>2</b> <sup>1)</sup>	<b>2</b> <sup>2)</sup>	<b>5</b> <sup>1)</sup>	<b>5</b> <sup>2)</sup>
Winch 2 <b>WII</b>	<b>1</b> <sup>1)</sup>	<b>1</b> <sup>2)</sup>	<b>2</b> <sup>1)</sup>	<b>2</b> <sup>2)</sup>	<b>5</b> <sup>1)</sup>	<b>5</b> <sup>2)</sup>
Winch 3 <b>WIII</b>	<b>1</b> <sup>1)</sup>	<b>5</b> <sup>2)</sup>	<b>2</b> <sup>1)</sup>	<b>6</b> <sup>2)</sup>	<b>5</b> <sup>1)</sup>	<b>W3</b> <sup>2)</sup>
Winch 4 <b>WIV</b>	<b>1</b> <sup>1)</sup>	<b>1</b> <sup>2)</sup>	<b>2</b> <sup>1)</sup>	<b>2</b> <sup>2)</sup>	<b>5 or 6</b> <sup>1)</sup>	<b>5/6</b> <sup>2)</sup>
Winch 5 <b>WV</b>	<b>1</b> <sup>1)</sup>	<b>7</b> <sup>2)</sup>	<b>2</b> <sup>1)</sup>	<b>6</b> <sup>2)</sup>	<b>5</b> <sup>1)</sup>	<b>W5</b> <sup>2)</sup>
Winch 6 <b>WVI</b>	<b>1</b> <sup>1)</sup>	<b>9</b> <sup>2)</sup>	<b>2</b> <sup>1)</sup>	<b>8</b> <sup>2)</sup>	<b>5</b> <sup>1)</sup>	<b>W6</b> <sup>2)</sup>

### Numbering of hydraulic connections

- <sup>1)</sup> - Identification (numbering) on winches  
<sup>2)</sup> - Identification (numbering) on piping plan

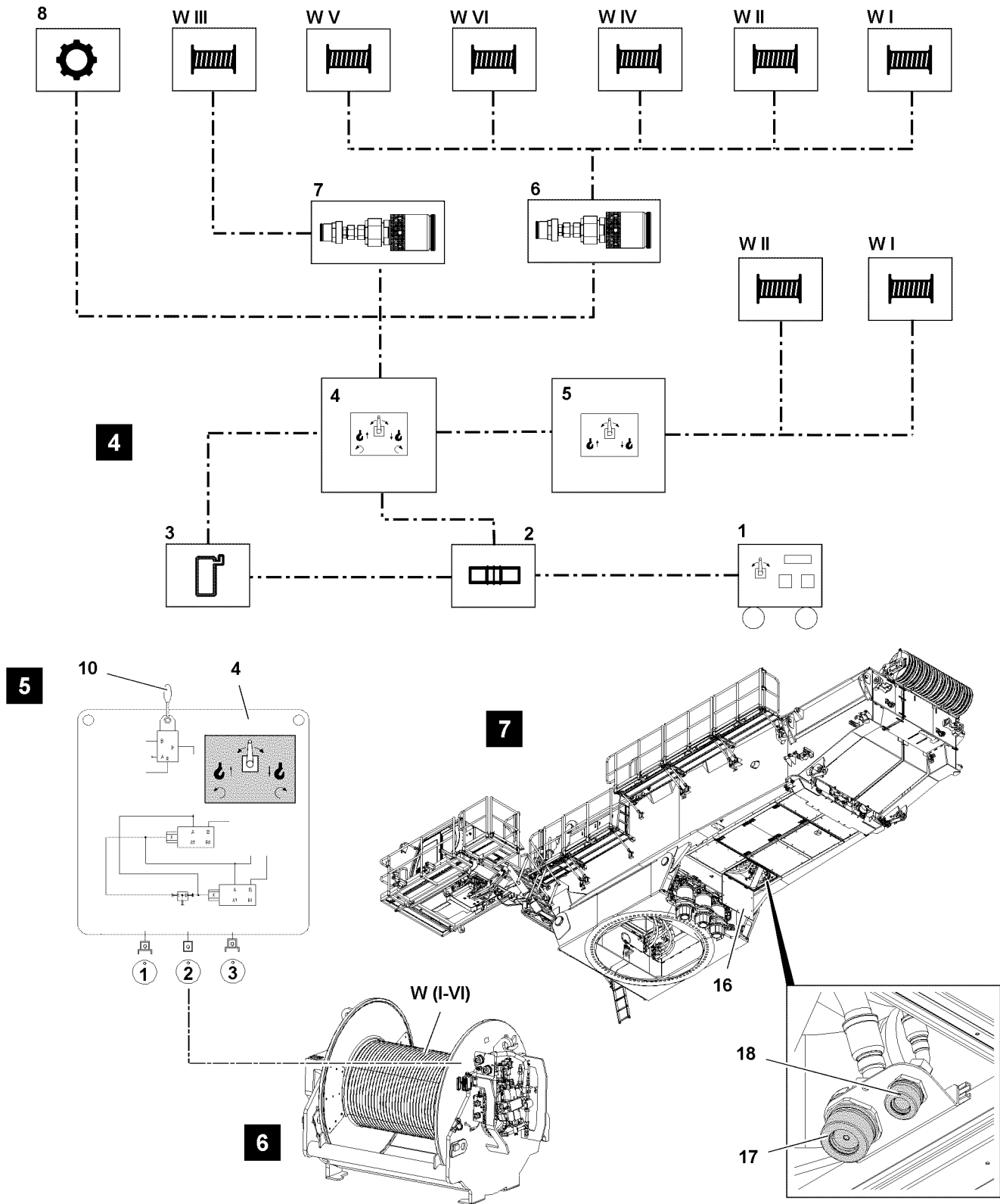


Fig.121034: Emergency control with assembly plate Variation 1 (V1)

LWE/LR 1800-1-0-000/27200-07-02/en



## 2.1 Establishing the hydraulic connections



### WARNING

Danger due to hydraulic pressure!

If the hydraulic lines are under pressure when releasing the connections, assembly personnel can be severely injured.

- ▶ Relieve the pressure in the hydraulic lines before releasing.
- ▶ Make sure that the engine is turned off.

- ▶ Establish the hydraulic connections from the emergency operation aggregate\* **1** to the transformer **2**, see illustration **4**.



### WARNING

Cover swinging down!

The cover **16** can swing down by itself due to its own weight when releasing the connections, see illustration **7**.

Personnel can be injured.

- ▶ When releasing the connections, hold the cover **16**.

- ▶ Open the cover **16**, see illustration **7**.
- ▶ Establish the hydraulic connection from the hydraulic transformer **2** to the suction line **17** of the oil tank **3** on the turntable of the crane, see illustration **4** and illustration **7**.
- ▶ Establish the hydraulic connection from the turntable of the crane (oil tank **3**, return line **18**) to the Assembly plate emergency operation **4**, see illustration **4** and illustration **7**.
- ▶ Establish the hydraulic connection (pressure line) from the hydraulic transformer **2** to the assembly plate emergency operation **4**, see illustration **4**.
- ▶ Release the hydraulic connections on the corresponding winch.



### Note

- ▶ Pay attention to the numbering of the hydraulic lines, see chart.

- ▶ Establish the hydraulic connection from the assembly plate emergency operation **4** to the winch through adapter **6** or adapter **7**, see illustration **4**, illustration **5** and illustration **6**.

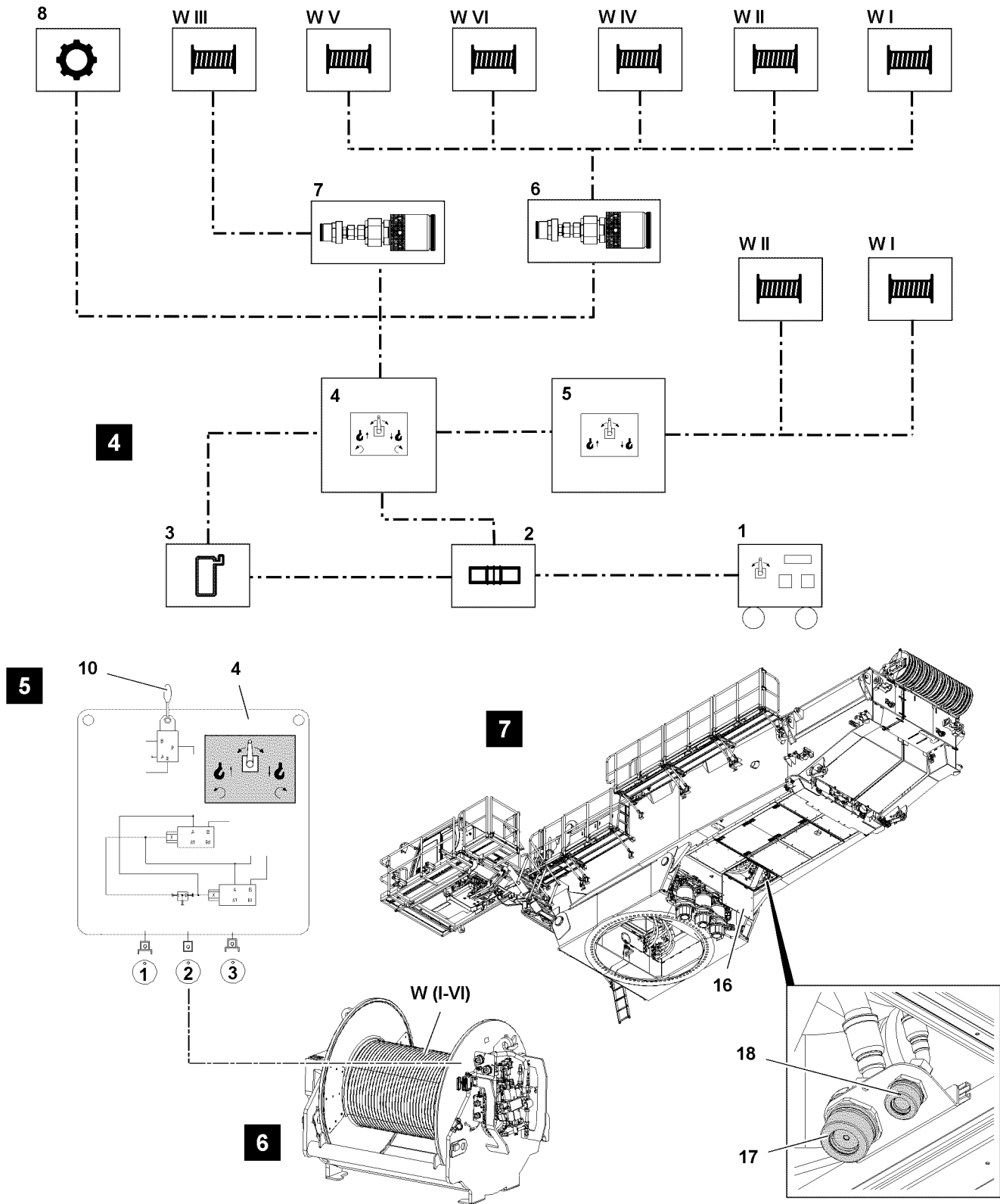


Fig.121034: Emergency control with assembly plate Variation 1 (V1)

LWE/LR 1800-1-0-000/27200-07-02/en

## 2.2 Starting the emergency operation aggregate



### Note

- ▶ Start the emergency operation aggregate, see Operating instructions for emergency operation aggregate.
- ▶ The engine rpm on the emergency operation aggregate can be set via a separate speed regulation.

## 2.3 Emergency control winches

### 2.3.1 Function selection on the assembly plate emergency operation



### Note

- ▶ The crane movements are actuated and the speed of the respective crane movement is determined via the ball valve **10**.

With the ball valve **10** on the assembly plate emergency operation **4** the following movements for the winches are preselected:

- Lift or lower
- ▶ Preselect crane movement: Set the ball valve **10** in the respective direction and carry out the respective crane movement carefully, see illustration **5**.

### 2.3.2 Spooling the winch out

- ▶ Spool the winch out: Set the ball valve **10** for the assembly plate emergency operation **4** in “lower” direction.

#### Result:

- The winch spools out.

### 2.3.3 Spooling the winch up

- ▶ Spool the winch up: Set the ball valve **10** for the assembly plate emergency operation **4** in “lift” direction.

#### Result:

- The winch spools up.

## 2.4 Disconnecting the hydraulic connections

Make sure that the following prerequisites are met:

- The emergency control is completed.
- The pressure in the hydraulic system has been relieved.
- ▶ Disconnect the hydraulic connections from the winch to the assembly plate emergency operation **4**.
- ▶ Disassemble adapter **6** or adapter **7**.
- ▶ Close off the hydraulic connections of the winch with dust caps.
- or**
- ▶ Reconnect the winch to the hydraulic system of the crane.

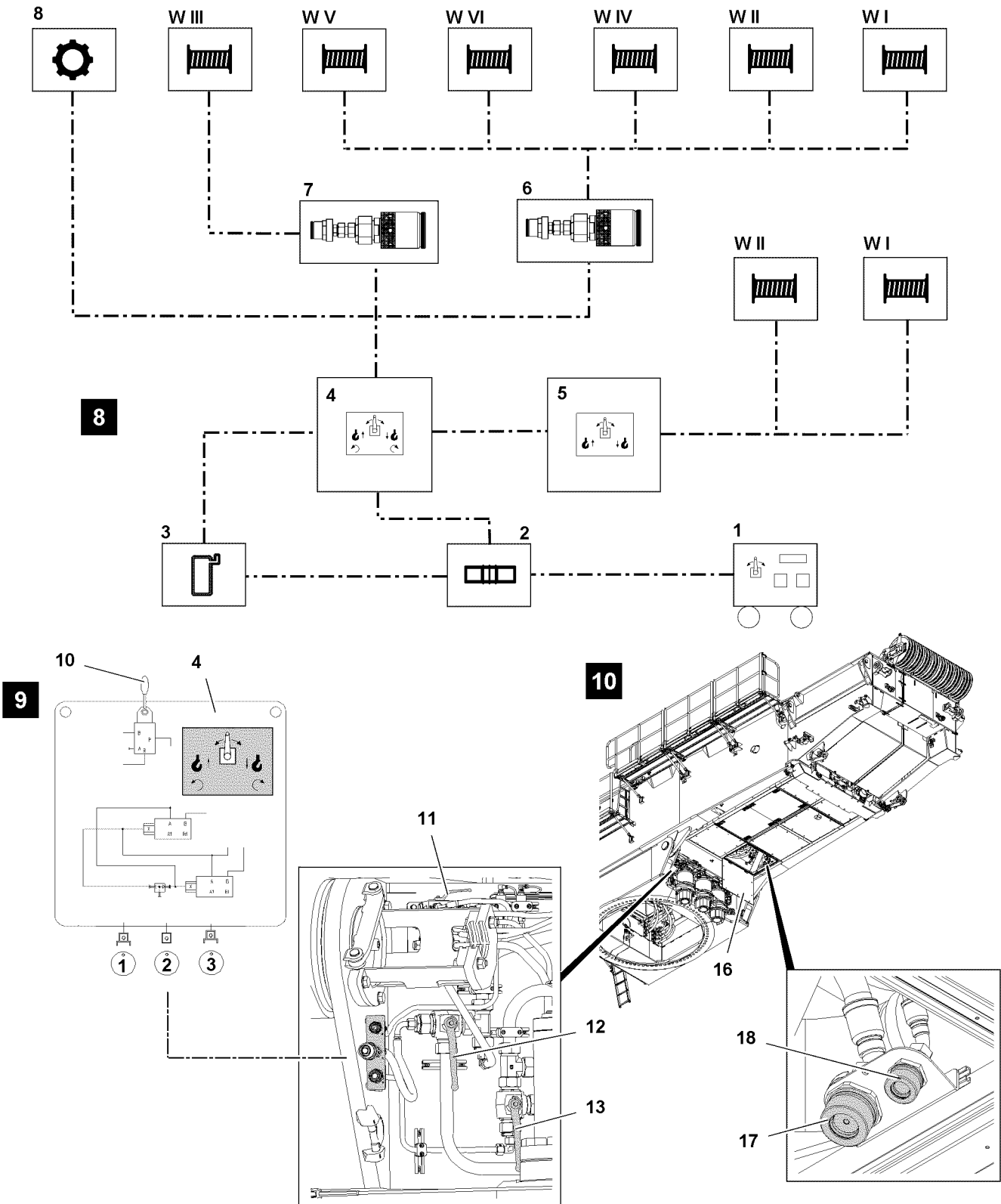


Fig.121035: Emergency control of slewing gear(s) with assembly plate Variation 1 (V1)

LWE/LR 1800-1-0-000/27200-07-02/en

## 3 Emergency control of slewing gear(s) with assembly plate Variation 1 (V1)



### WARNING

Danger due to hydraulic pressure!

If the hydraulic lines are under pressure when releasing the connections, assembly personnel can be severely injured.

- ▶ Relieve the pressure in the hydraulic lines before releasing.



### Note

- ▶ The crane movements are actuated and the speed of the respective crane movement is determined via the ball valve **10**.

With the ball valve **10** on the assembly plate emergency operation **4** the following movements are pre-selected:

- turn left
- turn right

### 3.1 Establishing the hydraulic connection to the slewing gears



### WARNING

Danger due to hydraulic pressure!

If the hydraulic lines are under pressure when releasing the connections, assembly personnel can be severely injured.

- ▶ Relieve the pressure in the hydraulic lines before releasing.
- ▶ Make sure that the engine is turned off.

- ▶ Establish the hydraulic connections from the emergency operation aggregate\* **1** to the transformer **2**, see illustration **8**.



### WARNING

Cover swinging down!

The cover **16** can swing down by itself due to its own weight when releasing the connections, see illustration **10**.

Personnel can be injured.

- ▶ When releasing the connections, hold the cover **16**.

- ▶ Open the cover **16**, see illustration **10**.
- ▶ Establish the hydraulic connection from the hydraulic transformer **2** to the suction line **17** of the oil tank **3** on the turntable of the crane, see illustration **8** and illustration **10**.
- ▶ Establish the hydraulic connection from the turntable of the crane (oil tank **3**, return line **18**) to the Assembly plate emergency operation **4**, see illustration **8** and illustration **10**.
- ▶ Establish the hydraulic connection (pressure line) from the hydraulic transformer **2** to the assembly plate emergency operation **8**, see illustration **8**.



### Note

- ▶ Pay attention to the numbering of the hydraulic lines.

- ▶ Establish the hydraulic connections for the Assembly plate emergency operation **4** to the slewing gear **8** on the turntable “ball valves for emergency control”, see illustration **8**, illustration **9** and illustration **10**.

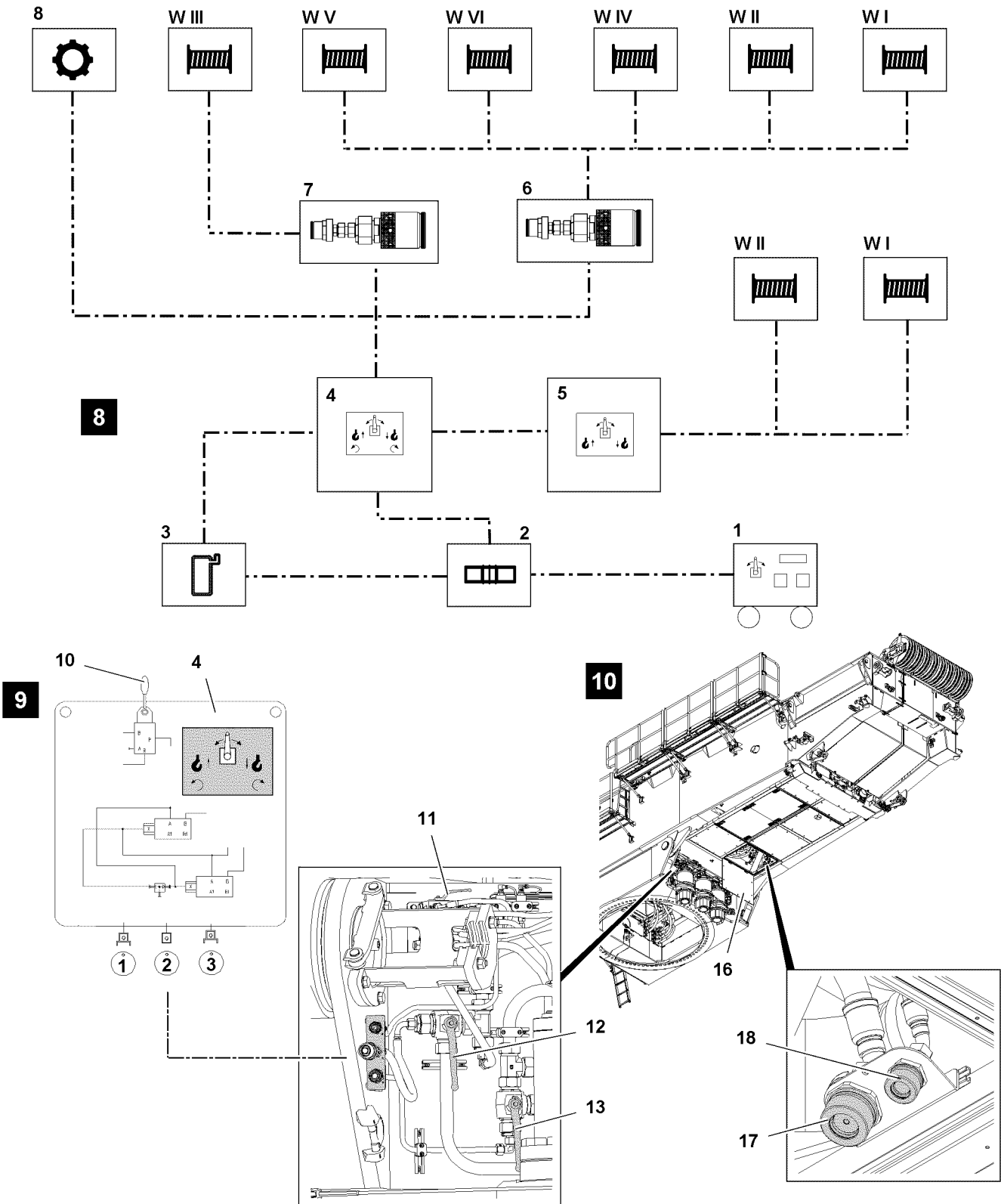


Fig.121035: Emergency control of slewing gear(s) with assembly plate Variation 1 (V1)

### 3.2 Turning the turntable to the left

- ▶ Set the ball valve 11 into emergency control position.
- ▶ Set the ball valve 12 into emergency control position.
- ▶ Set the ball valve 13 into emergency control position.

LWE/LR 1800-1-0-000/27200-07-02/en

- ▶ Turn the turntable to the left: Carefully set the ball valve **10** for the assembly plate emergency operation **4** in “turn left” direction, see illustration **9**.

**Result:**

- The turntable turns to the left.

### 3.3 Turning the turntable to the right

- ▶ Set the ball valve **11** into emergency control position.
- ▶ Set the ball valve **12** into emergency control position.
- ▶ Set the ball valve **13** into emergency control position.
- ▶ Turn the turntable to the right: Carefully set the ball valve **10** for the assembly plate emergency operation **4** in “turn right” direction, see illustration **9**.

**Result:**

- The turntable turns to the right.

### 3.4 Disconnecting the hydraulic connections

Make sure that the following prerequisites are met:

- The emergency control is completed.
- The pressure in the hydraulic system has been relieved.

Disconnect the hydraulic connections to the assembly plate emergency operation **4**.

- ▶ Change the ball valve **11** in crane operation position.
- ▶ Change the ball valve **12** in crane operation position.
- ▶ Change the ball valve **13** in crane operation position.

When the ball valve **11**, ball valve **12** and ball valve **13** are changed to crane operation position:

- ▶ Disconnect the hydraulic connections from the slewing gear **8** on the turntable “ball valves for emergency control” to the assembly plate emergency operation **4**.
- ▶ Close off the hydraulic connections with dust caps.

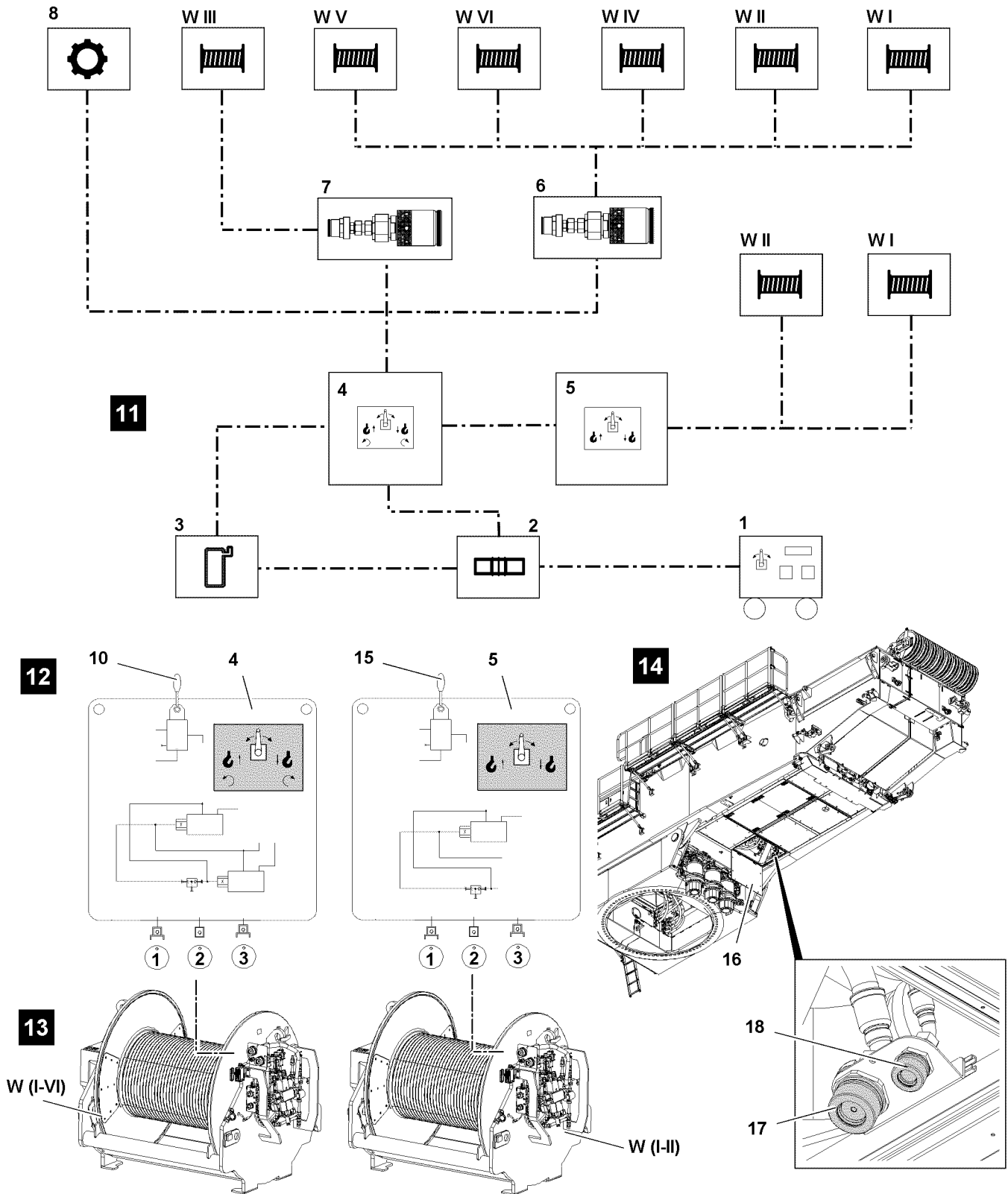


Fig.121036: Emergency control with assembly plate(s) Variation 2 (V2)

LWE/LR 1800-1-0-000/27200-07-02/en



## 4 Emergency control with assembly plate(s) Variation 2 (V2)



### Note

- Carrying out emergency control is identical for all winches and is described on the example of one winch.

Numbering						
	Connections of assembly plate					
	Connection 1 "lift"		Connection 2 "lower"		Connection 3 "brake"	
Winch 1 <b>WI</b>	<b>1</b> <sup>1)</sup>	<b>1</b> <sup>2)</sup>	<b>2</b> <sup>1)</sup>	<b>2</b> <sup>2)</sup>	<b>5</b> <sup>1)</sup>	<b>5</b> <sup>2)</sup>
Winch 2 <b>WII</b>	<b>1</b> <sup>1)</sup>	<b>1</b> <sup>2)</sup>	<b>2</b> <sup>1)</sup>	<b>2</b> <sup>2)</sup>	<b>5</b> <sup>1)</sup>	<b>5</b> <sup>2)</sup>
Winch 3 <b>WIII</b>	<b>1</b> <sup>1)</sup>	<b>5</b> <sup>2)</sup>	<b>2</b> <sup>1)</sup>	<b>6</b> <sup>2)</sup>	<b>5</b> <sup>1)</sup>	<b>W3</b> <sup>2)</sup>
Winch 4 <b>WIV</b>	<b>1</b> <sup>1)</sup>	<b>1</b> <sup>2)</sup>	<b>2</b> <sup>1)</sup>	<b>2</b> <sup>2)</sup>	<b>5</b> or <b>6</b> <sup>1)</sup>	<b>5/6</b> <sup>2)</sup>
Winch 5 <b>WV</b>	<b>1</b> <sup>1)</sup>	<b>7</b> <sup>2)</sup>	<b>2</b> <sup>1)</sup>	<b>6</b> <sup>2)</sup>	<b>5</b> <sup>1)</sup>	<b>W5</b> <sup>2)</sup>
Winch 6 <b>WVI</b>	<b>1</b> <sup>1)</sup>	<b>9</b> <sup>2)</sup>	<b>2</b> <sup>1)</sup>	<b>8</b> <sup>2)</sup>	<b>5</b> <sup>1)</sup>	<b>W6</b> <sup>2)</sup>

### Numbering of hydraulic connections

<sup>1)</sup> - Identification (numbering) on winches

<sup>2)</sup> - Identification (numbering) on piping plan

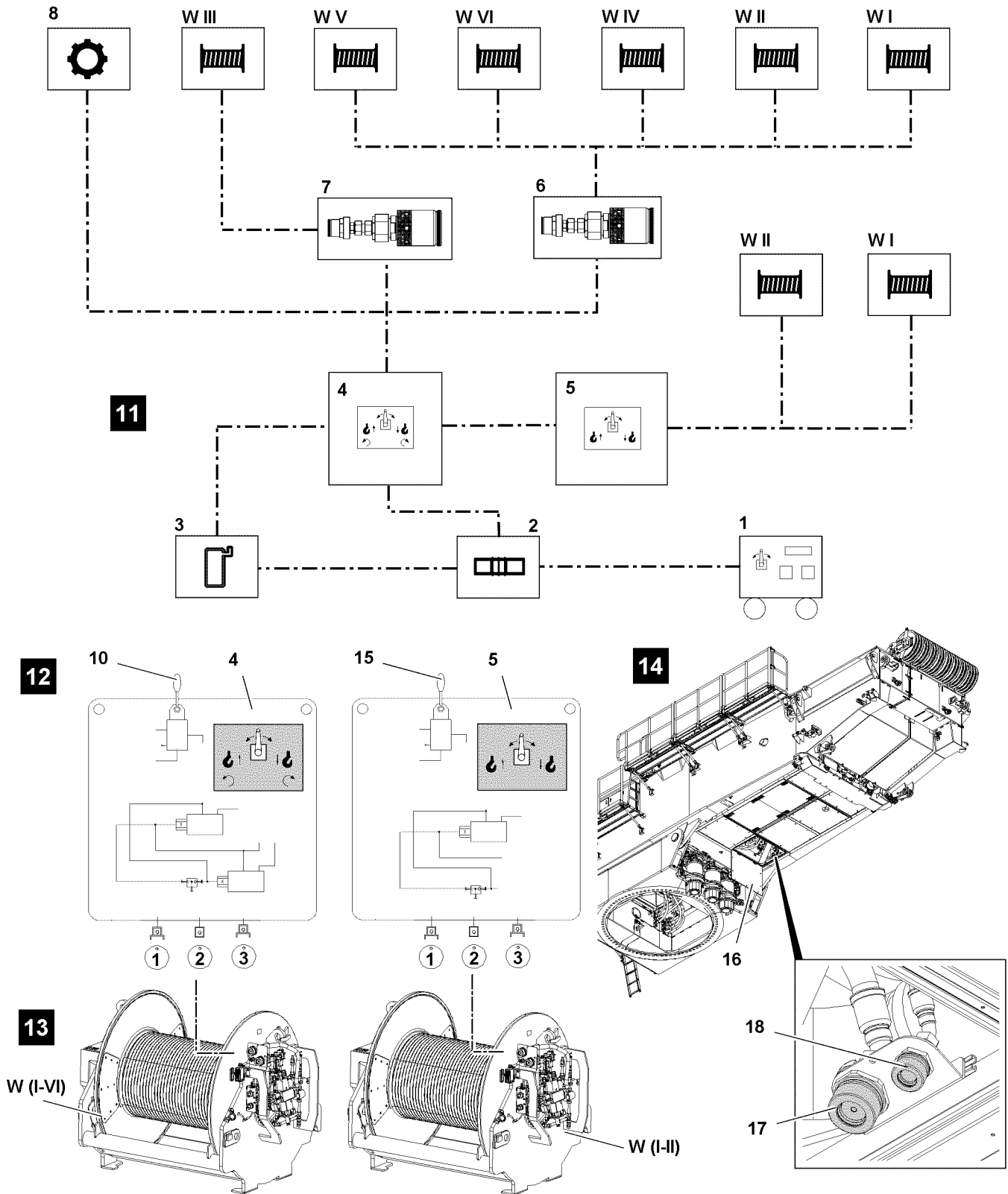


Fig.121036: Emergency control with assembly plate(s) Variation 2 (V2)

LWE/LR 1800-1-0-000/27200-07-02/en

## 4.1 Establishing the hydraulic connections



### WARNING

Danger due to hydraulic pressure!

If the hydraulic lines are under pressure when releasing the connections, assembly personnel can be severely injured.

- ▶ Relieve the pressure in the hydraulic lines before releasing.
- ▶ Make sure that the engine is turned off.

- ▶ Establish the hydraulic connections from the emergency operation aggregate\* 1 to the transformer 2, see illustration 11.



### WARNING

Cover swinging down!

The cover 16 can swing down by itself due to its own weight when releasing the connections, see illustration 14.

Personnel can be injured.

- ▶ When releasing the connections, hold the cover 16.

- ▶ Open the cover 16, see illustration 14.
- ▶ Establish the hydraulic connection from the hydraulic transformer 2 to the suction line of the oil tank 3 on the turntable of the crane, see illustration 11 and illustration 14.
- ▶ Establish the hydraulic connection from the turntable of the crane (oil tank 3, return line) to the assembly plate emergency operation 4, see illustration 11 and illustration 14.
- ▶ Establish the hydraulic connection (pressure line) from the hydraulic transformer 2 to the assembly plate emergency operation 4, see illustration 11.
- ▶ Establish the hydraulic connection from the assembly plate emergency operation 4 to the assembly plate parallel operation 5, see illustration 11 and illustration 12.
- ▶ Release the hydraulic connections on the corresponding winch.



### Note

- ▶ Pay attention to the numbering of the hydraulic lines, see chart.

- ▶ Establish the hydraulic connection from the assembly plate emergency operation 4 to the winch through adapter 6 or adapter 7, see illustration 11 and illustration 13.
- ▶ Establish the hydraulic connection from the assembly plate parallel operation 5 to the winch 1 WI, see illustration 11 and illustration 13.

**or**

Establish the hydraulic connection from the assembly plate parallel operation 5 to the winch 2 WII, see illustration 11 and illustration 13.

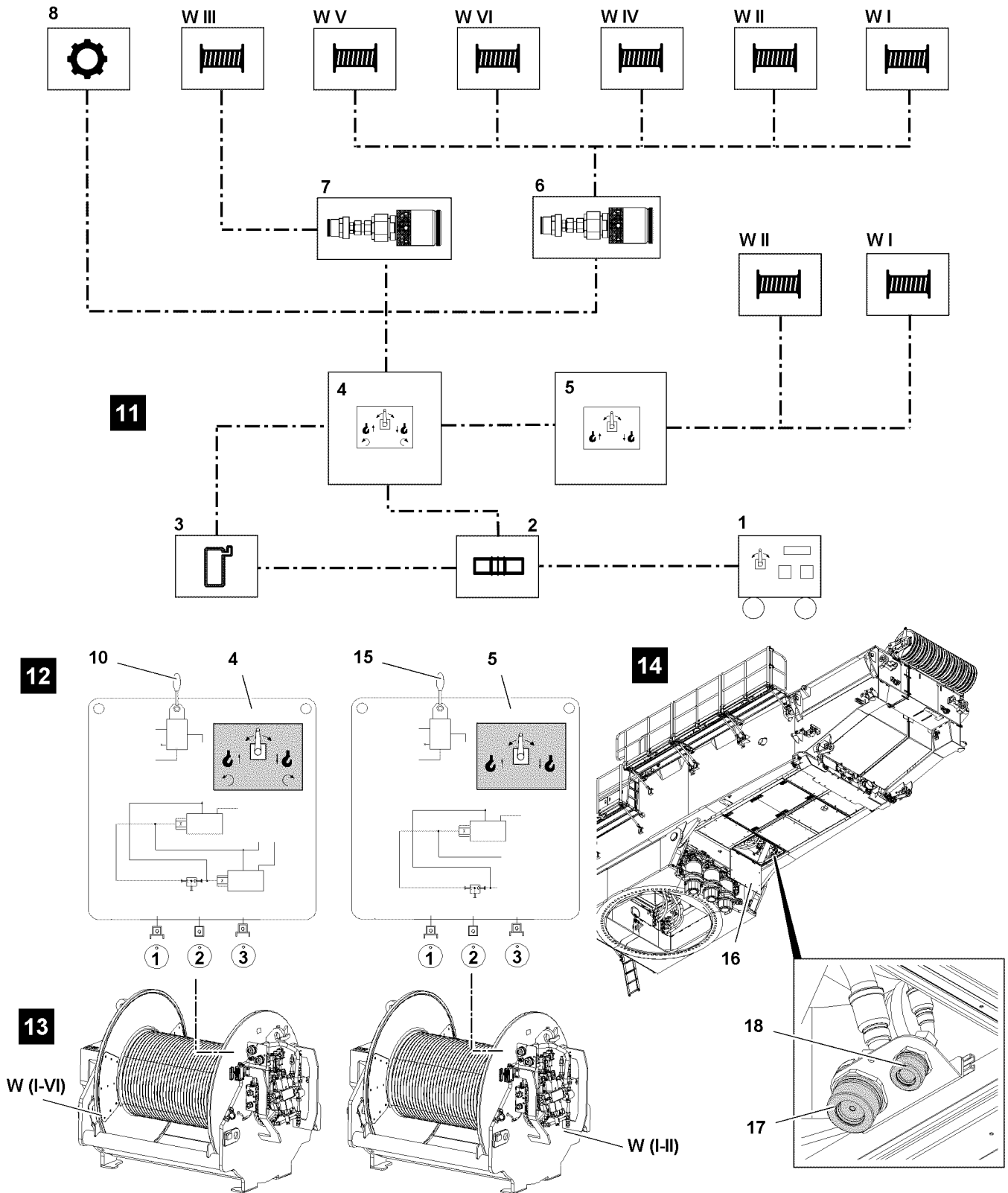


Fig.121036: Emergency control with assembly plate(s) Variation 2 (V2)

LWE/LR 1800-1-0-000/27200-07-02/en

## 4.2 Starting the emergency operation aggregate



### Note

- ▶ Start the emergency operation aggregate, see Operating instructions for emergency operation aggregate.
- ▶ The engine rpm on the emergency operation aggregate can be set via a separate speed regulation.

## 4.3 Emergency control of winches, individual operation



### Note

- ▶ The crane movements are actuated and the speed of the respective crane movement is determined via the ball valve **10** and ball valve **15**.

### 4.3.1 Function selection on the assembly plate emergency operation

With the ball valve **10** on the assembly plate emergency operation **4** the following movements for the winches are preselected:

- Lift or lower

- ▶ Preselect crane movement: Set the ball valve **10** in the respective direction and carry out the respective crane movement carefully.

### 4.3.2 Function selection on the assembly plate parallel operation

With the ball valve **15** on the assembly plate parallel operation **5** the following movements for winch 1 **WI** or winch 2 **WII** are preselected:

- Lift or lower

- ▶ Preselect crane movement: Set the ball valve **15** in the respective direction and carry out the respective crane movement carefully.

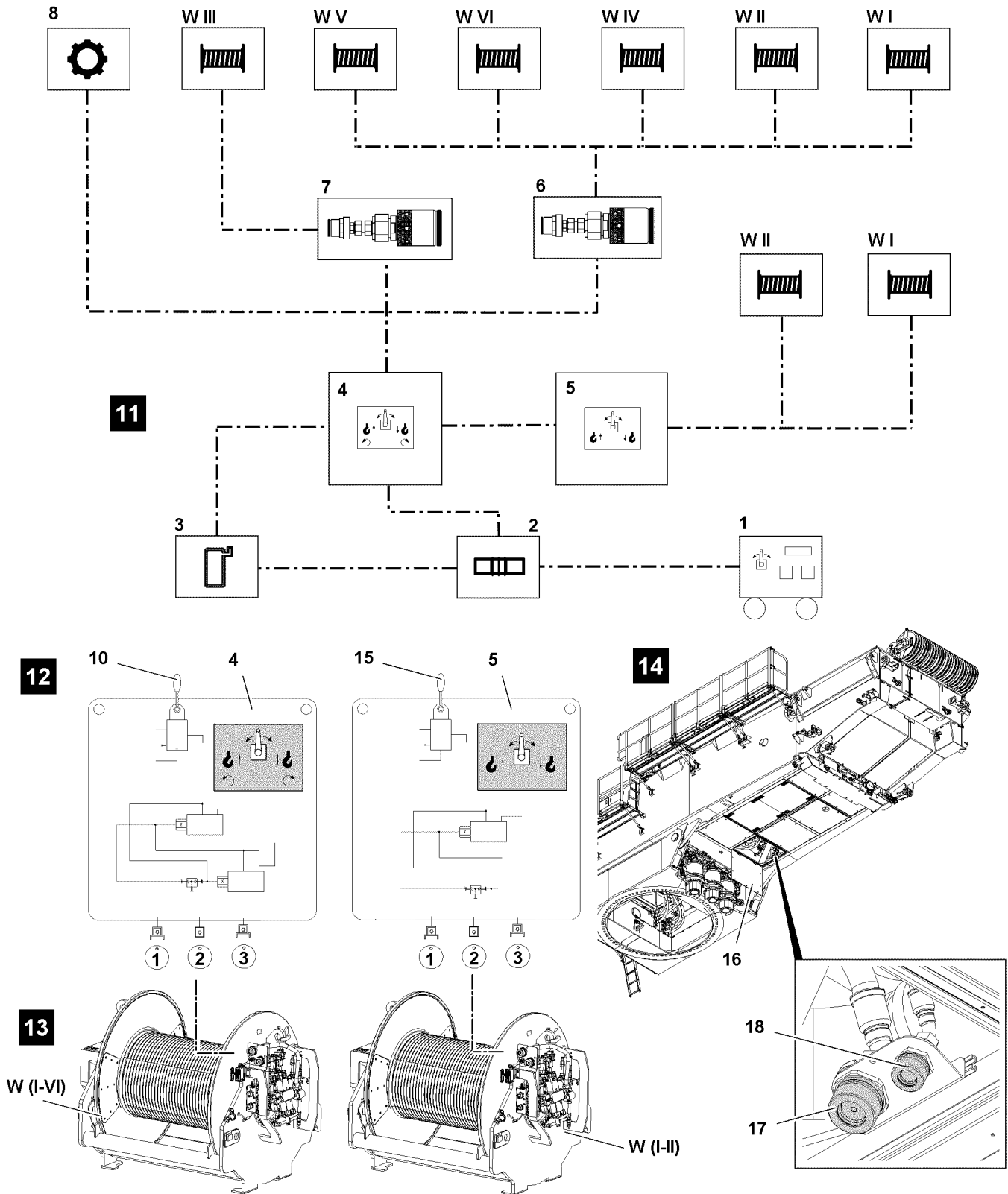


Fig.121036: Emergency control with assembly plate(s) Variation 2 (V2)

### 4.3.3 Spooling the winch out

- Spool the winch out: Set the ball valve **10** for the assembly plate emergency operation **4** in “lower” direction.
- or
- Set the ball valve **15** on the assembly plate parallel operation **5** in “lower” direction.

**Result:**

- The winch spools out.

#### 4.3.4 Spooling the winch up

- ▶ Spool the winch up: Set the ball valve **10** for the assembly plate emergency operation **4** in “lift” direction.

**or**

Carefully set the ball valve **15** on the assembly plate parallel operation **5** in “lift” direction.

**Result:**

- The winch spools up.

#### 4.3.5 Disconnecting the hydraulic connections

Make sure that the following prerequisites are met:

- The emergency control is completed.
- The pressure in the hydraulic system has been relieved.
- ▶ Disconnect the hydraulic connections from the respective winch to the respective assembly plates.
- ▶ Close off the hydraulic connections of the winch with dust caps.

**or**

Reconnect the winch to the hydraulic system of the crane.

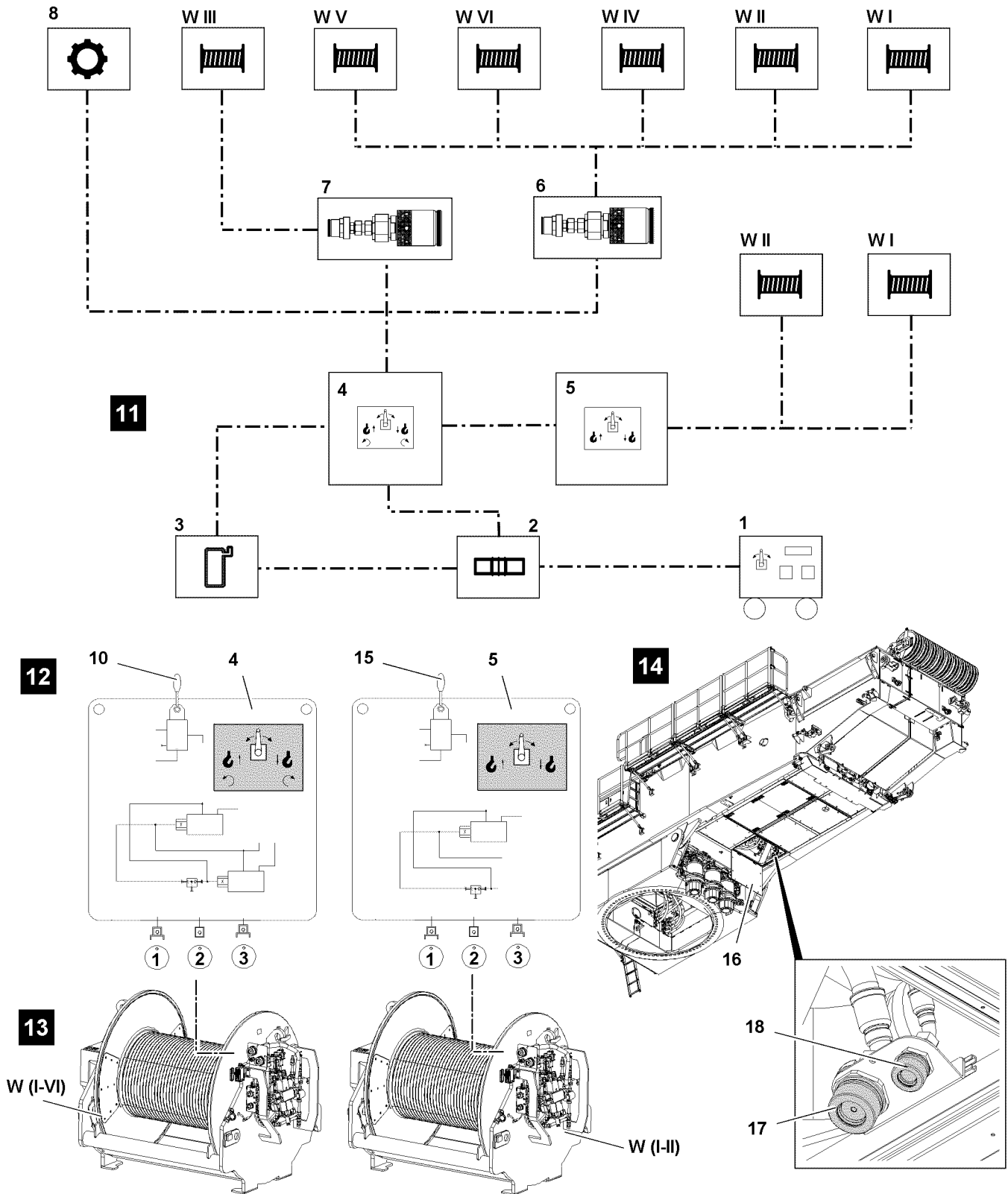


Fig.121036: Emergency control of winches, parallel operation winch 11I2

### 4.4 Emergency control of winches, parallel operation winch 11I2



**Note**

- The crane movements are actuated and the speed of the respective crane movement is determined via the ball valve 10 and ball valve 15.

LWE/LR 1800-1-0-000/27200-07-02/en



**WARNING**

Danger of accident!

If the following notes are not observed, dangerous situations can arise.

Personnel can be severely injured or killed.

- ▶ If winch 1 **WI** and winch 2 **WII** are actuated in emergency control in parallel operation, then it must be ensured that the hook blocks are horizontally aligned.
- ▶ Always actuate winch 1 **WI** and winch 2 **WII** simultaneously.

#### 4.4.1 Establishing the hydraulic connections to the winches

Make sure that the following prerequisite is met:

- The pressure in the hydraulic system has been relieved.
- ▶ Release the hydraulic connections on winch 1 **WI** and winch 2 **WII**.

**Note**

- ▶ Pay attention to the numbering of the hydraulic lines.
- 
- ▶ Establish the hydraulic connection from the assembly plate emergency operation **4** to winch 1 **WI** through adapter **6**.  
**or**  
Establish the hydraulic connections of assembly plate parallel operation **5** to winch 2 **WII**.
  - ▶ Establish the hydraulic connections of the assembly plate emergency operation **4** to winch 2 **WII** through adapter **6**.  
**or**  
Establish the hydraulic connections of assembly plate parallel operation **5** to winch 1 **WI**.

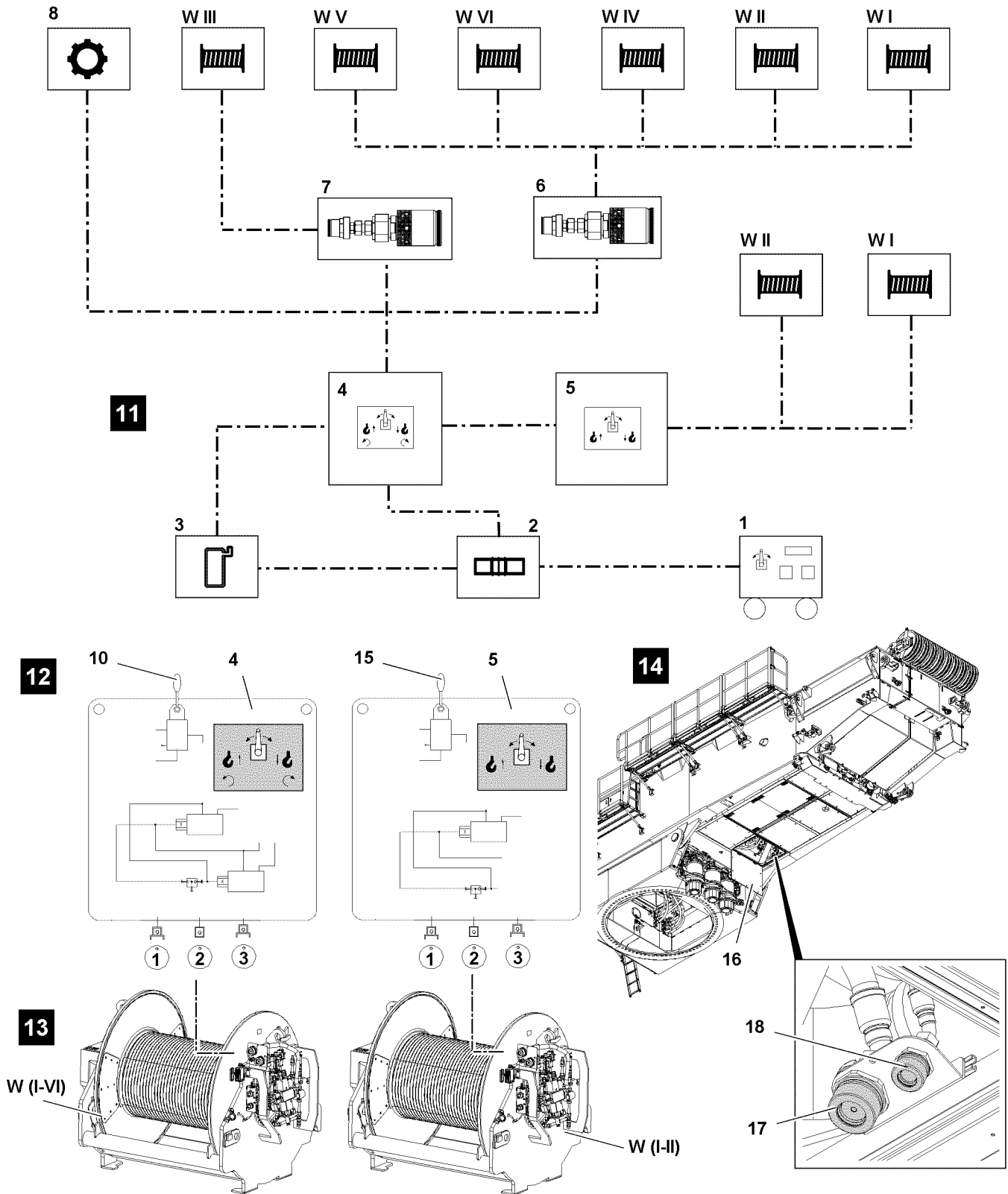


Fig.121036: Emergency control of winches, parallel operation winch 11I2

### 4.4.2 Spooling the winches out



**Note**

- Check which winch you have connected to which assembly plate.

LWE/LR 1800-1-0-000/27200-07-02/en

- ▶ Spool out winch 1 **WI** or winch 2 **WII**: Set the ball valve **10** for the assembly plate emergency operation **4** in “lower” direction.  
**or**  
Set the ball valve **15** on the assembly plate parallel operation **5** in “lower” direction.

**Result:**

- Winch 1 **WI** or winch 2 **WII** spools out.

#### 4.4.3 Spooling the winches up

**Note**

- ▶ Check which winch you have connected to which assembly plate.

- ▶ Spool up winch 1 **WI** or winch 2 **WII**: Set the ball valve **10** for the assembly plate emergency operation **4** in “lift” direction.  
**or**  
Carefully set the ball valve **15** on the assembly plate parallel operation **5** in “lift” direction.

**Result:**

- Winch 1 **WI** or winch 2 **WII** spools up.

#### 4.4.4 Disconnecting the hydraulic connections

Make sure that the following prerequisites are met:

- The emergency control is completed.
- The pressure in the hydraulic system has been relieved.
- ▶ Disconnect the hydraulic connections of winch 1 **WI** and winch 2 **WII** to the respective assembly plates.
- ▶ Close off the hydraulic connections of the winch with dust caps.  
**or**  
Reconnect the winch to the hydraulic system of the crane.

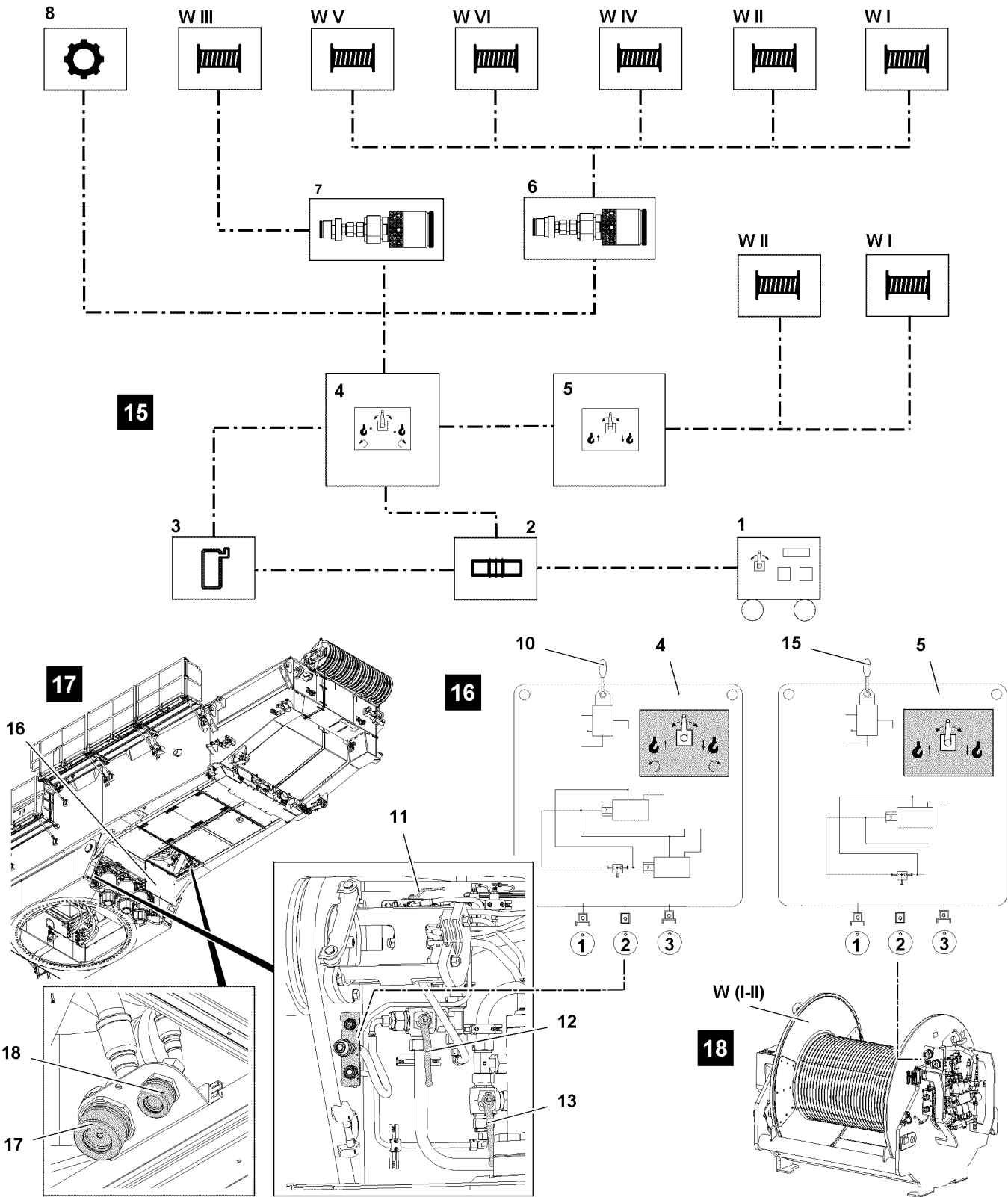


Fig.121037: Emergency control slewing gear(s) with assembly plate(s) Variation 2 (V2)

LWE/LR 1800-1-0-000/27200-07-02/en

## 5 Emergency control slewing gear(s) with assembly plate(s) Variation 2 (V2)



### WARNING

Danger due to hydraulic pressure!

If the hydraulic lines are under pressure when releasing the connections, assembly personnel can be severely injured.

- ▶ Relieve the pressure in the hydraulic lines before releasing.



### Note

- ▶ The slewing movement is actuated and the speed of the slewing movement is determined via the ball valve **10** on the assembly plate emergency operation **4**.



### Note

- ▶ Pay attention to the numbering of the hydraulic lines.



### Note

- ▶ “Emergency control slewing gear(s) with assembly plate(s) Variation 2 **VII**” is identical with “Emergency control slewing gear(s) with assembly plate Variation 1 **VI**” except that for Variation 2 **VII** the assembly plate parallel operation **5** is additionally connected.
- ▶ Connection of hydraulic lines and turning the turntable, see section “Emergency control slewing gear(s) with assembly plate Variation 1 **VI**”.

## 6 Completing emergency control

### 6.1 Procedure



### Note

- ▶ Turn the emergency operation aggregate off, see Operating instructions for emergency operation aggregate.
- ▶ Turn the emergency operation aggregate\* **1** off.
- ▶ Disconnect the hydraulic connections and close them off with dust caps.

---

Empty page!

LWE/LR 1800-1-0-000/27200-07-02/en

## 6.08 Radio remote control

1 Radio remote control

2

LWE/LR 1800-1-0-000/27200-07-02/en

# 1 Radio remote control

**Note**

- ▶ See the separate radio remote control operating instruction.



---

## 7 Maintenance and service

LWE/LR 1800-1-0-000/27200-07-02/en

---

LWE/LR 1800-1-0-000/27200-07-02/en

## 7.01 Maintenance and service - General

1	Safety	2
2	Warranty and coverage	7
3	Liebherr Customer Service	7
4	Taking an oil sample	8
5	Taking care of the crane	8
6	Storage	14
7	Recommendation for safe disposal	15

# 1 Safety



## WARNING

Maintenance instructions **not** adhered to!

Death, severe injury, increased wear and failure of components.

- ▶ Observe the following listed safety instructions and the generally applicable safety rules.
- ▶ Adhere to the maintenance intervals.
- ▶ Carry out only applicable maintenance tasks.
- ▶ Repair and maintenance tasks are to be carried out carefully.
- ▶ For aggregates and components: Follow the operating instructions of the manufacturer.

## 1.1 Personnel



## WARNING

Personnel requirements **not** adhered to!

**Improper** maintenance. Death, severe bodily injuries, property damage.

- ▶ Adhere to the areas of responsibility and personnel requirements.
- ▶ Comply with the personnel requirements within the scope of the respective maintenance tasks.
- ▶ Have the repair tasks performed exclusively by authorized and trained service personnel.
- ▶ Make sure that only authorized persons are in the danger zone.

The operator commissions maintenance personnel and authorized and trained service personnel according to the maintenance and inspection schedule.

### 1.1.1 Maintenance technician

The maintenance technician has the following responsibilities:

- The maintenance technician is responsible for the crane maintenance assigned to him according to the maintenance and inspection schedule and to guarantee safe and satisfactory operation. Maintenance personnel carries out all required maintenance work in compliance with the manufacturer's maintenance and inspection schedule and within the framework of a systematic procedure for creating a safe working environment.
- The maintenance technician shall have read and understood the operating instructions and the maintenance instructions.
- The maintenance technician wears the personal protective equipment necessary for the respective work procedure in accordance with the operating instructions and national regulations.
- The maintenance technician shall not make any alterations or repairs to the crane that exceed his technical knowledge (welding, for example) without consulting with the manufacturer and receiving written approval.
- The maintenance technician uses only original spare parts from Liebherr-Werk Ehingen GmbH.
- The maintenance technician contacts his supervisors when the information in the operating instructions or maintenance instructions is not sufficient.

### 1.1.2 Authorized and trained service technician

The service technician has the following responsibilities:

- He is responsible for carrying out the assigned crane maintenance and repairs to guarantee safe and satisfactory operation. The technician carries out all required maintenance work in compliance with the manufacturer's maintenance and inspection schedule and within the framework of a systematic procedure for creating a safe working environment.
- The technician wears the personal protective equipment necessary for the respective work procedure in accordance with the operating instructions and national regulations.
- The technician only carries out work for which he was authorized and trained to carry out by Liebherr-Werk Ehingen GmbH or a Liebherr service point.

## 1.2 Description of intervals and tasks



### Note

- ▶ Fill quantities and designations of service fluids and lubricants are specified in the Service fill.

The maintenance intervals and scope of maintenance are described in several chapters.

#### For crane maintenance, observe the following chapters:

- Crane operating instructions, chapter 7.02: Maintenance intervals - Crane chassis <sup>1)</sup>
- Crane operating instructions, chapter 7.02.50: Maintenance intervals Ballast trailer\*<sup>1)</sup>
- Crane operating instructions, chapter 7.03: Maintenance intervals - Crane superstructure <sup>1)</sup>
- Crane operating instructions, chapter 7.03.50: Maintenance intervals - Crane boom <sup>1)</sup>
- Crane operating instructions, chapter 7.04: Maintenance instructions - Crane chassis <sup>2)</sup>
- Crane operating instructions, chapter 7.04.50: Ballast trailer maintenance instructions <sup>2)</sup>
- Crane operating instructions, chapter 7.05: Maintenance instructions - Crane superstructure <sup>2)</sup>
- Crane operating instructions, chapter 7.05.50: Crane boom maintenance instructions <sup>2)</sup>
- Crane operating instructions, chapter 7.06: Fill quantities, lubrication plan
- Crane operating instructions, chapter 7.07: Service fluids and lubricants

<sup>1)</sup> These chapters contain a list of maintenance intervals for all maintenance tasks.

<sup>2)</sup> For aggregates, observe and adhere additionally to the instructions of the manufacturer.

## 1.3 Maintenance intervals

Use the following rules for interval determination:

- Carry out maintenance and inspection tasks on the crane chassis after reaching the specified driven mileage, operating hours or calendar intervals. The interval that occurs first is the deciding factor.
- Carry out maintenance and inspection tasks on the crane superstructure after reaching the specified operating hours or calendar intervals. The interval that occurs first is the deciding factor.
- The maintenance intervals complement each other. If a higher interval is coming up, then carry out the tasks according to the lower interval also.

## 1.4 Securing against start up



### WARNING

Impermissible travel or crane operation during maintenance or repair tasks!

Death, severe injury, severe property damage.

- ▶ Make sure that travel and crane operation is not possible during maintenance and repair tasks.
- ▶ Show clearly with signs that maintenance or repair tasks are being carried out on the mobile crane.
- ▶ Use signs which show without a doubt that it travel operation and crane operation are prohibited.
- ▶ Adhere to the national regulations regarding tagging on mobile crane and signs.
- ▶ Turn the engine on the crane superstructure and the crane chassis off.
- ▶ Apply the “parking brake crane chassis”.

If possible:

- ▶ Lock the driver's cab and the crane cab.
- ▶ Hand the ignition key from the crane superstructure and the crane chassis to an authorized person.

## 1.5 Securing against falls



### WARNING

Personnel is **not** secured against falls!

During maintenance tasks on the crane superstructure or boom, personnel must be secured with appropriate safety measures to prevent them from falling. If this is **not** observed, working personnel can fall and be killed or severely injured.

- ▶ For all tasks on the crane where there is a danger of falling, take suitable safety measures.
- ▶ The crane superstructure or the boom may **not** be accessed without suitable aids.
- ▶ Suitable aids are, for example: Lifting platforms, scaffoldings, ladders, assembly platforms, auxiliary crane.
- ▶ If railings are present on the crane superstructure, then they must be swung into operating position and secured for all tasks. See the Crane operating instructions, chapter 2.06.
- ▶ Only step on such aids with clean shoes.
- ▶ Keep aids clean, free of snow and ice.
- ▶ If tasks cannot be carried out using these aids or from the ground, then the maintenance personnel must be protected from falling using approved fall arrest systems. See the Crane operating instructions, chapter 2.04.
- ▶ It is prohibited to step on the driver's cab or cab roof and specially marked surfaces. See the Crane operating instructions, chapter 2.05



### WARNING

Dirty slip-resistant mats!

Fall

- ▶ Keep slip-resistant mats clean and free of snow and ice!
- ▶ Only step on slip-resistant mats with clean shoes!
- ▶ Replace or renew missing or damaged slip-resistant mats!

## 1.6 Preventing fires



### WARNING

Excess fuel, excess oil in engine compartment during operation!

Death, severe injury, fire damage.

- ▶ Check the diesel engine after repairs and Service tasks but also in regular intervals for leaking oil and fuel.
- ▶ Fix the leaks. Replace damaged components.
- ▶ Do **not** spill service fluids.



### WARNING

Disregard of general safety regulations during tasks on the fuel system or on the electrical system!

Severe burns, fire damage.

- ▶ Disconnect the battery from the power supply.
- ▶ Do **not** smoke.
- ▶ Do **not** work near open flames.
- ▶ Keep a functioning fire extinguisher ready.

**WARNING**

Sound insulation mats are contaminated with fuel, engine oil, gear oil, hydraulic oil or solvents!  
The sound insulation mats can ignite. Severe burns, fire damage.

- ▶ Remove any polluted sound insulation mats **immediately** and **replace immediately** with **Original Liebherr spare parts**.

If there are sound insulation mats in the chassis near the starter:

- ▶ **Immediately remove** any sound insulation mats located in an area of 0.5 m around the starter and **do not replace them**

If there are sound insulation mats in the superstructure in the engine compartment flap:

- ▶ **Immediately remove** the sound insulation mats and **do not replace them**.
- ▶ Also observe and adhere to the section "Sound insulation mats".

## 1.7 Protecting against burns

**WARNING**

Hot surfaces!  
Severe burns.

- ▶ Let any components to be maintained or inspected cool off.
- ▶ Let hot components cool off.
- ▶ Avoid contact with hands and skin.
- ▶ Wear personal protective equipment and suitable protective gloves.

**WARNING**

Hot service fluids!  
Severe burns.

- ▶ Let hot service fluids cool off.
- ▶ Avoid contact with hands, skin and eyes.
- ▶ Wear safety goggles.
- ▶ Wear personal protective equipment and suitable protective gloves.

**WARNING**

Electric short circuit!  
Severe burns.

- ▶ Prevent short circuits in the electrical system, especially on the battery.
- ▶ Replace or change missing or defective protective insulation.

## 1.8 Protecting from scalding

**WARNING**

The cooling system is pressurized!  
When the coolant reservoir is opened, hot coolant can escape explosively.  
Severe scalding.

When the engine is warm:

- ▶ Do **not** open the cover of the coolant reservoir.
- ▶ To protect face, hands and arms from hot steam of hot coolant, cover the cap with a large rag when opening.

## 1.9 Rotating parts



### WARNING

Rotating parts, ignition system on running engine!  
The cooler fan can turn on suddenly.  
Death, severe injury.

- ▶ Proceed especially careful.
- ▶ Do **not** reach into rotating parts.
- ▶ Never reach into the cooler fan when the engine is hot.

## 1.10 Using permissible service fluids

### NOTICE

Impermissible service fluid added!  
Destruction of components. Failure of the crane.

- ▶ Only add the service fluid that is specified on the sign on the respective service fluid container.
- ▶ Keep the service fluid absolutely pure.

## 1.11 Protecting against the hazards of service fluids



### WARNING

Contact with service fluids!  
Health risk.

- ▶ Make sure that personnel are aware of first aid measures.
- ▶ Use personal protective equipment depending on the service fluid.
- ▶ Observe and adhere to the safety data sheets of the service fluid manufacturer.



### WARNING

Impermissible handling of service fluids!  
Environmental risk.

- ▶ Make sure that the service fluids are **not** released in the environment.
- ▶ Immediately collect spilled service fluids using suitable material.
- ▶ Observe and adhere to the safety data sheets of the service fluid manufacturer.

## 1.12 Replacing damaged crane components



### WARNING

Damaged crane components **not** replaced!  
Death, severe injury, failure of components.

- ▶ Service the crane components according to the data in the maintenance intervals, the maintenance guidelines and the chart for service fluids and lubricants.
- ▶ Replace damaged crane components immediately.

## 1.13 After replacement of components

Type of oil, see data tag and supplied "Service fill".

The following instructions must be observed when replacing components such as the engine, transmission or axle:



**WARNING**

Maintenance of a replaced component **not** carried out!

- ▶ Before start up, be sure to refill with the correct type of oil to the center of the minimum / maximum mark.
- ▶ Carry out first maintenance. See chapter "Maintenance intervals".
- ▶ Adhere to regular maintenance intervals.
- ▶ Follow the break-in instructions. See the Crane operating instructions, chapter 2.02.

## 1.14 Tire size

When changing certain tire sizes, the mobile crane must be modified.

Contact Liebherr customer service to change the following tire sizes:

- From 385/95 R 25 to 445/95 R 25
- From 385/95 R 25 to 525/80 R 25
- From 445/95 R 25 to 385/95 R 25
- From 525/80 R 25 to 385/95 R 25

## 2 Warranty and coverage

**NOTICE**

Maintenance intervals and maintenance guidelines **not** adhered to, impermissible lubricants used!  
Damage, failure of crane components.

The warranty for the respective crane component is voided.

- ▶ Service the crane components according to the data in the maintenance intervals, the maintenance guidelines and the chart for service fluids and lubricants.

**NOTICE**

Use of **non**-original Liebherr spare parts and **non**-original Liebherr service fluids!

In the event that replacement parts are used that are **not** original Liebherr replacement parts and **not** original Liebherr service fluids and lubricants, Liebherr-Werk Ehingen GmbH excludes all liability for system functionality as well as for the parts.

- ▶ Use only original Liebherr spare parts.

**Note**

- ▶ Original Liebherr replacement parts have been tested for crane operation and may be used without risking safety.

The buyer is entitled to warranty or coverage only:

- When only original Liebherr spare parts are used.
- When Liebherr service fluids and Liebherr lubricants are used for the Liebherr crane.

## 3 Liebherr Customer Service

Liebherr mobile cranes, whether truck-mounted, mobile or crawler cranes - are technically advanced products, which prove their worth daily even under tough conditions.

The high technical standards of these cranes provide functional security, resistance to failure and ease of maintenance.

Liebherr is continuously developing the drive and control components. The combination of well proven units and modern manufacturing methods produces cranes that are safe to operate and easy to maintain.

Several hundred cranes are built every year for the international market, supported by international service.

Liebherr's "After Sales Service" plays an important role at Liebherr in ensuring operational readiness and high crane availability.

With Liebherr, Service begins when the crane is handed over. Your crane operators will be professionally trained in line with their level of knowledge and we devote much time to this.

We also train your workshop staff in all crane-specific matters, because we know that they can deal with more than just minor repairs themselves. Often there are specialists who can quickly and reliably carry out crane repairs.

We have special service advisers available who will solve any problems you may have. This phone contact saves time and money. You should take advantage of it as soon as possible.

Our service technicians are specialists with years of experience, who can be deployed from local support points. Naturally these experts have specialized knowledge and special tools.

But before you call these specialists, it is worth making use of the facilities for getting advice mentioned above.

## 4 Taking an oil sample



### Note

- ▶ Liebherr recommends taking oil samples for the gears, engines and hydraulic system in regular intervals.
- ▶ Based on the trend analysis of the oil analysis results, changes can be determined in the lubricity of the oil and increased component wear.



### WARNING

Tasks on components and operating fluids at operating temperature!

Burns.

- ▶ Carry out all tasks with utmost caution.
- ▶ Wear protective clothing.

Make sure that the following prerequisites are met:

- Oil has a normal operating temperature.
- ▶ Always take oil in the same location.
- ▶ Take oil always according to the same method.
- ▶ Do **not** take oil right after an oil change.
- ▶ Do **not** take oil immediately after larger amounts of oil have been added.



### Note

Recommendation:

- ▶ Fill oil into original laboratory sample containers.
- ▶ Fill oil exclusively in a clean and dry sample container.

## 5 Taking care of the crane

### 5.1 Washing the crane

In order to ensure a consistent surface quality, the crane must be washed regularly. See the maintenance intervals, chapter 7.02, chapter 7.03, chapter 7.03.50. Clean the crane in particular after contact with highly corrosive materials or highly adherent contaminants.

Highly adherent contaminants are:

- Residual road salt
- Oils, grease and fuel
- Insect remains
- Rust film
- Tar splashes, concrete splatter

Check the crane for corrosion and paint damage. See the maintenance intervals, chapter 7.02, chapter 7.03chapter 7.03.50. If detected, have corrosion and paint damage removed by authorized and trained service personnel.

---

#### NOTICE

Impermissible cleaning agent!  
Damage to the surface.

- ▶ Do not use aggressive cleaning agents.
- ▶ Do not use scouring cleaning agents.
- ▶ Do not use a phosphate based cleaner.
- ▶ Do not solvents or cleaning agents that contain solvents.
- ▶ Only use cleaning agents with a pH value that is less than / equal to 12.
- ▶ Make sure that the cleaning agent and water ratio of 3% is not exceeded.
- ▶ Rinse with clear water (not salt water).

Make sure that the following prerequisites are met:

- The crane is switched off and secured against unauthorized start up.
- The crane has cooled down.
- The battery master switch is turned off.

### 5.1.1 High pressure cleaner

The water jet of a circular jet nozzle can cause damage to the tires or parts of the travel gear that cannot be seen exteriorly.

---

#### NOTICE

High pressure cleaner with circular jet nozzle used!  
Damaged components could fail unexpectedly.

- ▶ Do not use a high pressure cleaner with a circular jet nozzle.
- ▶ Replace damaged components.




---

#### CAUTION

Hot steam and water pressure!  
Burns.

- ▶ Wear personal protective equipment.

Do **not** expose the following components to a water jet:

- Inside of the driver's cab and cab
- Electric motor
- Electrical plug connections, line drums and power distributor
- Control units
- Transmitter
- Relay circuit boards and fuse circuit boards
- Hydraulic block
- Intake manifolds for combustion air
- Seals
- Bellows
- Gear shafts
- Retracted sliding beams
- Sealing lips on slewing ring connections
- Radial shaft sealing rings on winches
- Slewing gears

- Hoist rope, control rope, assembly rope
- Piston rods
- Slip-resistant mats
- Signs
- Overflow container on the equipment
- Generator
- Lighting
- Wind speed sensor / airplane warning light
- Bearing on the rope pulleys
- Carrier rollers
- Swivel joints
- Pin points
- Head camera inclusive of the transmitter and receiver unit
- Hand pump on the folding jib

The crane can be cleaned with the high pressure cleaner. The water pressure, minimum distance and water temperature are specified in the following chart:

Washing painted surfaces		
Water pressure	Minimum distance	Water temperature
maximum 150 bar	30 cm to 40 cm	60 °C

*Adjusting the high pressure cleaner*

Washing surfaces covered with film		
Water pressure	Minimum distance	Water temperature
maximum 150 bar	80 cm	60 °C

*Adjusting the high pressure cleaner*

Washing surfaces protected against corrosion with Carlofon 81		
Water pressure	Minimum distance	Water temperature
maximum 30 bar	30 cm to 40 cm	40 °C

*Adjusting the high pressure cleaner*

Clean electrical systems, cables, cable harnesses and sound insulation mats with low pressure.

- ▶ Before cleaning, cover all openings.
- ▶ Wash the crane and equipment with a high pressure cleaner.
- ▶ Lubricate the crane and equipment.



#### Note

Environmental pollution!

- ▶ Dispose of auxiliary and cleaning materials contaminated with oil according to national and international regulations and directives.
- ▶ Only direct cleaning water through the oil separator of the drainage system.

## 5.1.2 Exhaust system

### NOTICE

Ingress of water, steam or cleaning substances into the AGN-module!

Sensors and electrics for the exhaust aftertreatment can be destroyed, the coating of the catalytic converter can be washed off.

- ▶ Before cleaning, let the AGN system cool down (surface temperature 50 °C).
- ▶ Before cleaning, cover all openings.
- ▶ Make sure that **no** fluids and **no** dirt gets into the tailpipe opening of the AGN module.
- ▶ During cleaning, maintain a sufficient distance from the tailpipe opening.

## 5.1.3 Sound insulation mats

### NOTICE

Improper cleaning (tools or cleaning methods)!

Sound insulation mats can be destroyed or damaged.

- ▶ Remove severe contamination with suitable tools, for example with soft plastic scrapers.
- ▶ Do **not** use tools with sharp edges.
- ▶ Use high pressure cleaners **exclusively** with extreme caution and with a sufficient distance to the sound insulation mats and with low water pressure.
- ▶ Do **not** use solvents for cleaning.

If sound insulation mats are contaminated with fuel, engine oil, gear oil, hydraulic oil or solvents:

- ▶ Observe and adhere to the section "Preventing fires".

## 5.1.4 Slip-resistant mats



### WARNING

Heavily worn slip-resistant mats!

People can slip and fall down from the crane.

- ▶ Replace heavily worn slip-resistant mats.
  - ▶ Do **not** wax slip-resistant mats.
- 
- ▶ Before every access: Check the slip-resistant mats for slip resistance and cleanliness.
  - ▶ If dirty: Clean the slip-resistant mats with a brush with hard plastic bristles.
  - ▶ For cleaning the surfaces, use commercially available cleaners.
  - ▶ Flush with water.

## 5.1.5 Driver's cab and crane cab



### Note

- ▶ The steering wheel, center console, instrument panel cover, floor covering and dirty upholstery in the driver's cab and the crane cab should only be cleaned with warm water mixed with dishwashing detergent.
- ▶ Keep the driver's cab and crane cab free from trash.

## 5.1.6 Ladders

- ▶ Remove any dirt on the ladders.
- ▶ Make sure that the grooves on the rungs are free of dirt.

## 5.2 Protecting the crane against corrosion

### NOTICE

Aggressive environmental conditions!  
Crane components can corrode and be damaged.  
▶ Protecting the crane against corrosion

The corrosion protection agent **Carlofon 81** must be reapplied regularly according to wear. See the maintenance intervals, chapter 7.02, chapter 7.03 chapter 7.03.50.

The corrosion protection agent **Metacorin 822** must be reapplied regularly according to wear on the mechanically machined, blank surfaces. See the maintenance intervals, chapter 7.02, chapter 7.03 chapter 7.03.50.

The corrosion protection agent **Liebherr Cylinder Protect** must be reapplied regularly on the chrome-plated piston rods. See the maintenance intervals, chapter 7.02, chapter 7.03 chapter 7.03.50.



### WARNING

Improper corrosion protection!  
Injury to the respiratory system, suffocation.  
▶ Wear a respirator mask.

### NOTICE

Improper corrosion protection!  
Damage to the crane.

- ▶ Make sure that crane corrosion protection is carried out only by authorized and trained service personnel.
- ▶ Make sure that the inspection and reconditioning intervals are not exceeded.

Make sure that the following prerequisites are met:

- A sufficient quantity of corrosion protection agent is available.
- Appropriate tools and aids are available.
- The crane is switched off and secured against unauthorized start up.
- The crane has cooled down.
- The battery master switch is turned off.
- Protective equipment is worn.

### 5.2.1 Crane

- ▶ Wash the crane thoroughly with a high pressure cleaner.
- ▶ Let the crane dry.

If corrosion or paint damage is found:

- ▶ Remove the corrosion and paint damage.

The following surfaces must be masked prior to corrosion protection:

- Walking surfaces and stepping surfaces
- Vents on brake valves and control valves
- Vents and drains on electrical equipment
- Mechanically machined, blank surfaces
- Piston rods



### WARNING

Walking surfaces and stepping surfaces **not** masked!  
Personnel can slip and fall down.

- ▶ Mask walking surfaces and stepping surfaces prior to corrosion protection.
- ▶ All surfaces that should **not** be corrosion protected should be masked.
- ▶ Protect the crane against corrosion with **Carlofon 81**.
- ▶ Remove the masking.



## 5.4 Protecting the crane against corrosion for shutdown



### Note

- ▶ Before shutting down the crane, contact the Service department at Liebherr-Werk Ehingen GmbH.

## 6 Storage

If the conditions in this section are observed, the crane can be stored as long as necessary.

### 6.1 Storage conditions

- ▶ Store the crane in a dry hall.

### 6.2 Decommissioning

Make sure that the following prerequisites are met:

- The crane is carefully washed.
- Corrosion and paint damage on the crane have been removed.
- Worn or damaged components have been replaced.

In the case of cranes with the battery master switch in the chassis and superstructure, both battery master switches must be turned off.

- ▶ Turn the battery master switch off.

In the case of cranes with a superstructure engine and a chassis engine, the batteries in the chassis and superstructure must be removed.

- ▶ Remove the batteries properly.

### 6.3 Maintenance

In the case of cranes with a fuel tank in the chassis and superstructure, both fuel tanks must be filled.

- ▶ Fill up the fuel tank completely.
- ▶ Apply approved lubricants in all lube points.
- ▶ Replace all operating fluids.
- ▶ Check the crane for leaking fluids.

If fluids are leaking from the crane:

- ▶ fix the leak.

In the case of cranes with a superstructure engine and a chassis engine, both engines must be started once a month.

- ▶ Start the engine once a month.

The specified maintenance interval must be observed even if the crane is in storage.

- ▶ Service the crane according to the maintenance interval.

### 6.4 Returning to service

#### NOTICE

Impermissible start up!

Damage to the crane.

- ▶ Make sure that the crane is supplied with approved lubricants.
- ▶ Make sure that the oil levels are correct.
- ▶ Only operate the crane in a perfect condition.



In the case of cranes with a superstructure engine and a chassis engine, the batteries must be installed in the chassis and superstructure.

- ▶ Install the batteries properly.
- ▶ Turn on the battery master switch.
- ▶ Put the crane in operation.

## 7 Recommendation for safe disposal

### 7.1 Service fluids and lubricants



#### WARNING

Service fluids and lubricants are dangerous waste products!

- ▶ Dispose of service fluids and lubricants separately.
- ▶ Service fluids and lubricants may **not** be disposed of in the ground, bodies of waters, wastewater systems, sewers or in the groundwater.
- ▶ Dispose of service fluids and lubricants in an environmentally safe manner.
- ▶ When disposing of service fluids and lubricants, observe and follow the applicable regulations of the responsible authorities.
- ▶ Observe and adhere to the safety data sheets of the service fluid manufacturer and the lubricant manufacturer.

Service fluids and lubricants are:

- Fuels
- Coolant
- Urea
- Engine oils, gear oils
- Hydraulic fluids
- Brake fluids
- Window washer concentrate
- Greases

### 7.2 Batteries



#### WARNING

Batteries contain harmful substances!

- ▶ Do **not** dispose of batteries in regular household trash.
- ▶ Collect batteries separately and send them for environmentally safe disposal.
- ▶ Leave batteries at a qualified workshop or at a licensed collection points for used batteries.

### 7.3 Prevention of improper machine use

After the end of its service life, the crane must be made unusable by cutting the load bearing crane structures, and in particular the steel structures. This can be done by means of flame cutting.

After the machine's service life has ended:

- ▶ Make the machine unusable.

### 7.4 Disposing of the machine

The crane owner is responsible for disposal.

- ▶ Separate the metals.

If the counterweights are made of concrete:

- ▶ Brake the steel parts out of the counterweight. Dispose of the concrete or recycle it.

Rope pulleys and bearing shoes in the boom are made out of PA6.

Due to the markings on the plastic parts, it is possible to dispose of them properly.

- ▶ Separate the plastic parts.
- ▶ Separate the remaining parts (for example, rubber, glass).
- ▶ Sort all parts.
- ▶ Take all parts to a licensed collection point for reusable materials and send them for recycling.

## 7.01.10 Service system

1	Description	2
2	Safety instructions	2
3	Calling up the service system	2
4	<i>Service system</i> operating interface	3
5	<i>Service system</i> function key line	5
6	Maintenance is due	5
7	Selecting the maintenance status	6
8	Resetting the maintenance status	7

# 1 Description

The service system is only available when a diesel particle filter is installed.

The service system is a function of the BSE test system.

For further functions of the BSE test system, see the Diagnostics manual.

# 2 Safety instructions

Observe and comply with chapter 2.04, chapter 2.06, chapter 2.07.

Observe and comply with chapter 7.01.

## NOTICE

Maintenance interval exceeded!

The crane functions can fail. Death, severe bodily injuries.

Components can be damaged. Property damage.

When the error message in the LICCON computer system displays that maintenance is due:

- ▶ Make sure that the defined maintenance activities are carried out, see chapter 7.02, section "maintenance personnel".

When maintenance activities have been carried out completely:

- ▶ Reset the respective maintenance status in the service system.

# 3 Calling up the service system

Make sure that the following prerequisite is met:

- The *Crane operation* program is visible on the LICCON monitor.

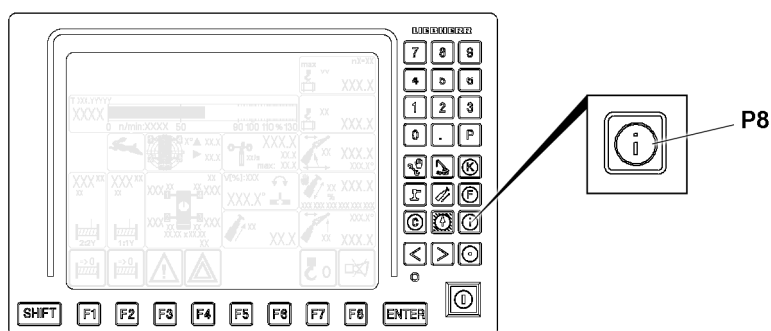


Fig.152484: Crane operation program

- ▶ Press the program key **P8**.

**Result:**

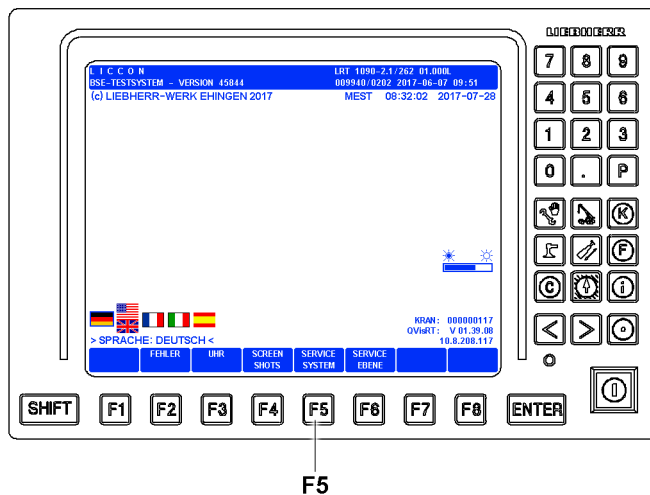


Fig.147628: BSE test system, start screen

– The BSE test system start screen is visible on the LICCON monitor.

▶ Press the function key **F5**.

**Result:**

– The service system operating interface is visible on the LICCON monitor.

## 4 Service system operating interface

### 4.1 Operating hour meter

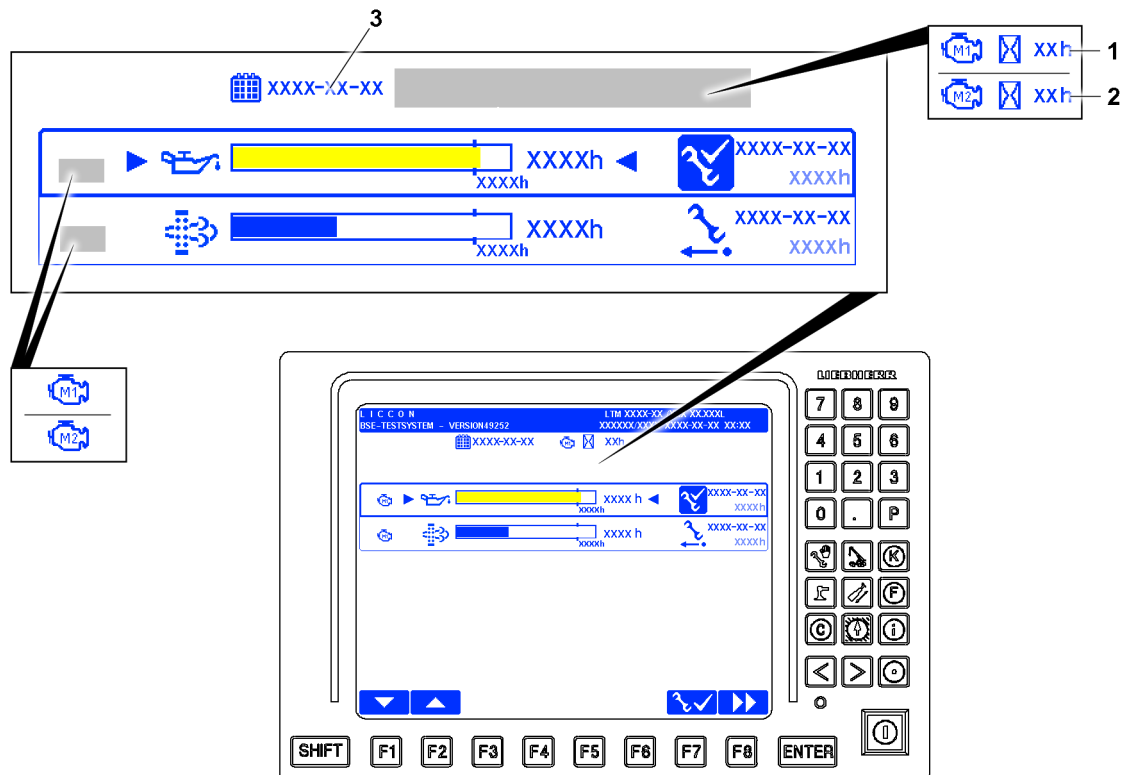


Fig.165547: Service system (example) operating interface

LWE/LR 1800-1-0-000/27200-07-02/en

Depending on the crane type, there are different displays for the operating hours:

- 1 Crane superstructure diesel engine operating hours (engine 1)
- 2 Crane superstructure diesel engine operating hours (engine 2)
  - Only available for certain cranes.
- 3 Current date (year-month-day)

## 4.2 Maintenance status overview

For each diesel engine, the following maintenance statuses are displayed in pairs on the service system operating interface:

- Engine oil maintenance status
- Diesel particle filter (DPF) maintenance status

### 4.2.1 Crane engine (engine 1)

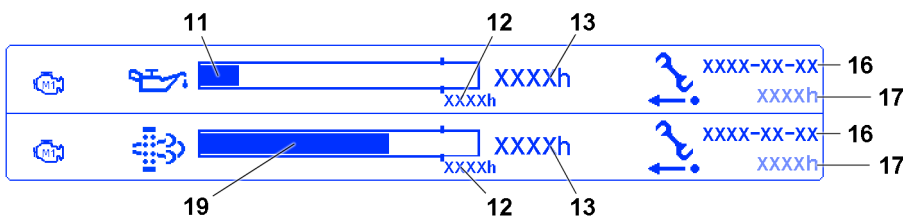


Fig.165548: Crane engine maintenance status

- |   |  |
|---|--|
| <p><b>11</b> Bar diagram: Graphic display of the engine oil (engine 1) maintenance status</p> <p><b>12</b> Maintenance interval in hours</p> <p><b>13</b> Elapsed interval hours since the last maintenance</p> | <p><b>16</b> Date of last maintenance (year-month-day)</p> <p><b>17</b> Interval hours at the last maintenance (only available for certain cranes)</p> <p><b>19</b> Bar diagram: Graphic display of the diesel particle filter (engine 1) maintenance status</p> |
|---|--|

### 4.2.2 Crane engine (engine 2)



**Note**

► The display is only visible if there are two diesel engines in the crane superstructure.

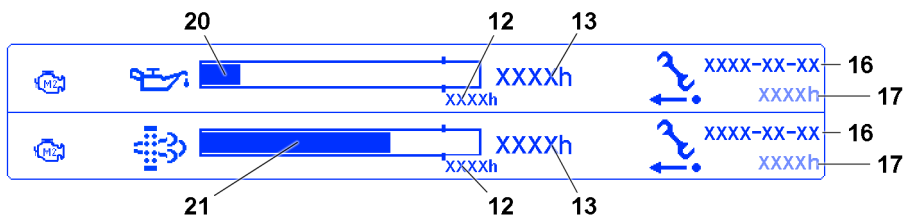


Fig.165549: Crane engine maintenance status

- |  |   |
|--|---|
| <p><b>12</b> Maintenance interval in hours</p> <p><b>13</b> Elapsed interval hours since the last maintenance</p> <p><b>16</b> Date of last maintenance (year-month-day)</p> | <p><b>17</b> Interval hours at the last maintenance (only available for certain cranes)</p> <p><b>20</b> Bar diagram: Graphic display of the engine oil (engine 2) maintenance status</p> <p><b>21</b> Bar diagram: Graphic display of the diesel particle filter (engine 2) maintenance status</p> |
|--|---|

LWE/LR 1800-1-0-000/27200-07-02/en

## 5 Service system function key line

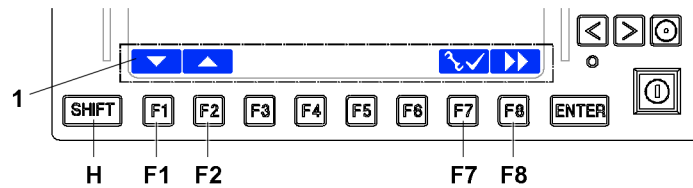


Fig.154729: Service system function key line

The function key line consists of function keys **F1** to **F8** and the function key icon bar **1** above it.

- F1** Function key
  - Navigation in the *service system* operating interface, downward: Change maintenance status
- F2** Function key
  - Navigation in the *service system* operating interface, upward: Change maintenance status
- F7** Function key
  - If pressed together with the *SHIFT H* key: Reset the maintenance status
- F8** Function key
  - Call up the *BSEtest system* start screen

## 6 Maintenance is due

Error messages on the BTT or on the LICCON monitor draw attention to pending maintenance:

- When a maintenance interval has almost been reached, an error message is displayed.
- The maintenance that is due is indicated in an error text or can be read on the displays in the service system.
- When a maintenance interval has been reached 100 % or was exceeded, the bar diagram is displayed in “yellow”.

### 6.1 Engine oil change interval

The maintenance interval for the engine oil is a dynamically calculated interval that depends on the operating conditions of the crane.

#### NOTICE

According to the error message the engine oil was **not** changed!

The DPF can not be regenerated any more. Reduction of engine output.

- ▶ Pay attention to the error message: Change the engine oil immediately.

Error no.	Error text	Assignment
8DD69C	Engine oil change interval almost reached - observe the influence on DPF regeneration!	Superstructure
8DD69D	Engine oil change interval reached - attention DPF re-generation not possible!	Superstructure

*BSEtest system error messages: Engine oil*

The engine oil change is a maintenance activity that is assigned the *engine oil* maintenance status.

- ▶ Carry out all defined maintenance activities, see chapter 7.02, section “engine oil maintenance status”.

When maintenance activities have been carried out completely:

- ▶ Call up the service system.
- ▶ Reset the *engine oil* maintenance status.

## 6.2 DPF filter element change interval

The maintenance interval for the diesel particle filter (DPF) is a dynamically calculated interval that depends on the operating conditions of the crane.

### NOTICE

According to the error message the DPF filter element was **not** changed!

Reduction of engine output.

- ▶ Pay attention to the error message: Replace the DPF filter element immediately.

Error no.	Error text	Assignment
8DD079	Particle filter DPF cleaning interval reached, replace the DPF filter element	Superstructure
8DD07A	Particle filter DPF cleaning interval reached, replace the DPF filter element - reduction!	Superstructure

*BSEtest system error messages: Diesel particle filter (DPF)*

The DPF filter element change is a maintenance activity that is assigned the *diesel particle filter (DPF)* maintenance status.

- ▶ Carry out all defined maintenance activities, see chapter 7.02, section “diesel particle filter (DPF) maintenance status”.

When maintenance activities have been carried out completely:

- ▶ Call up the service system.
- ▶ Reset the *diesel particle filter (DPF)* maintenance status.

## 7 Selecting the maintenance status

Display elements differentiate the condition for the maintenance status:

- Selected maintenance status
- Unselected maintenance status

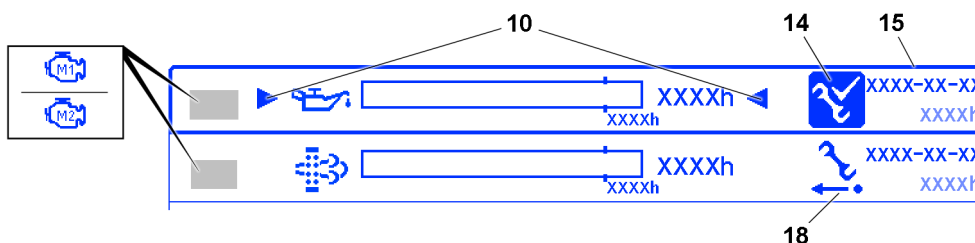


Fig.166801: Maintenance status, display elements, service system

- 10 Arrow
- 14 Selected maintenance status icon
- 15 Frame for selected maintenance status
- 18 Maintenance status not selected icon

Definition of the function keys, see section “service system function key line”.

- ▶ Until the selected maintenance status is selected: Press the function keys.



## 8 Resetting the maintenance status

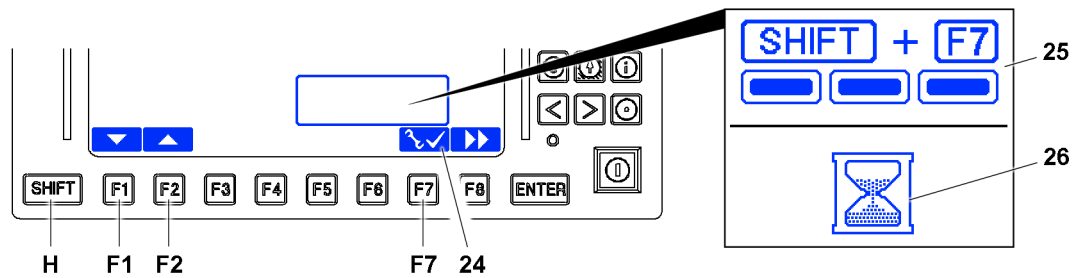


Fig.164829: Resetting the maintenance status

### 8.1 Resetting the engine oil maintenance status

Make sure that the following prerequisite is met:

- The diesel engine is turned off.
- The icon **24** is visible.

- ▶ Use the function key **F1** and function key **F2** to select the maintenance status that must be reset.

**Result:**

- The selected maintenance status is marked visually, see section “Maintenance status”.
- ▶ Press the SHIFT key **H** and function key **F7** at the same time and hold them.

**Result:**

- The display **25** is visible.
- ▶ Hold the SHIFT key **H** and function key **F7** until the display **26** appears.
- ▶ Wait until the display **26** is hidden.

**Result:**

- The selected maintenance status is reset to **0 hours**.
- The date is updated.

### 8.2 Resetting the diesel particle filter maintenance status

Make sure that the following prerequisite is met:

- The diesel engine is turned off.
- The icon **24** is visible.

The maintenance interval for the diesel particle filter (DPF) can only be reset with a daily code.

The icon over the function key **F7** for resetting the maintenance interval for the diesel particle filter (DPF) appears only when entering the daily code.

- ▶ For registered customers: Call up the daily code at [www.myliebherr.com](http://www.myliebherr.com).
- or
- Request the daily code from the Service Dept. at Liebherr-Werk Ehingen GmbH.
- ▶ Enter the daily code on the service level in the *BSE test system*, see the Diagnostics manual.
- ▶ Use the function key **F1** and function key **F2** to select the maintenance status that must be reset.

**Result:**

- The maintenance status is marked visually, see section “Maintenance status”.
- ▶ Press the SHIFT key **H** and function key **F7** at the same time and hold them.

**Result:**

- The display **25** is visible.
- ▶ Hold the SHIFT key **H** and function key **F7** until the display **26** appears.
- ▶ Wait until the display **26** is hidden.

**Result:**

- The selected maintenance status is reset to **0 hours**.
- The date is updated.

## 7.02 Maintenance intervals - Crawler chassis

1 Maintenance and inspection schedule

2

LWE/LR 1800-1-0-000/27200-07-02/en

# 1 Maintenance and inspection schedule



## Note

- ▶ Carry out maintenance work after reaching the specified operating hours or calendar intervals. The interval that occurs first is the deciding factor.
- ▶ The maintenance intervals complement each other. If a higher interval is coming up, then carry out the work according to the lower interval also.
- ▶ The operating hour meter of the crawler travel gear is the determining factor for the operator hour intervals.
- ▶ The "crawler travel gear" operating hour meter\* is located in the control cabinet.

First maintenance After	Operating hour intervals			Calendar intervals			Work to be carried out	O.K.
	10 h	100 h	1000 h	Daily	Weekly	An- nually		
<b>Safety systems</b>								
						X	Personal protective equipment Follow the instructions of the manufacturer	☐
						X	Height rescue system Follow the instructions of the manufacturer	
<b>Fall protection equipment</b>								
						X	Check protection points	☐
						X	Check safety ropes	
						X	Check the ladders for technically immaculate condition	
						X	Check railings, steps and pedestals for safe function	
						X	Check catwalks and gratings for safe function	
<b>Crane surface</b>								
					X		Check accessible surfaces for cleanliness	☐
						X	Check accessible surfaces for completeness and slip resistance	
						X	Check labels for completeness and legibility	
<b>Rigging and fastening points</b>								
				2)			Check the condition and mounting	☐
						X	Check for continued suitability by an expert	

LWE/LR 1800-1-0-000/27200-07-02/en

First maintenance After	Operating hour intervals			Calendar intervals			Work to be carried out	O.K.
	10 h	100 h	1000 h	Daily	Weekly	Annually		
<b>Travel gear</b>								□
			X			X	Planetary gear, miter gear: Check the oil level	
			X			X	If the brake has a self-contained oil chamber: Check the oil level	
			X			X	Checking for leaks	
			X			X	Brake: Check the function	
	X						Grease the sprocket bearing if it is not lubricated via the central lubrication system	
		X					Check the tightness of the mounting screws	
		500 h					Check the gear oil via an oil analysis	
250 h			1000 h			every 4 years	Planetary gear, miter gear: Change the gear oil	
			4000 h			every 4 years	If the brake has a self-contained oil chamber: Change the gear oil	
<b>Crawler carrier</b>								□
		X					Check track rollers, carrier rollers with oil lubrication for leaks	
	X						Grease the track rollers, carrier rollers if they are not lubricated via the central lubrication system	
	X				every 4 weeks		Check the wear on the roll-off surfaces of the track rollers / carrier rollers, replace the track rollers / carrier rollers if necessary	
	X				every 4 weeks		Check for wear on the glide rails	
						X	Grease the guide rails on the sliding section	
						X	If present: Lubricate the consoles	
					every 4 weeks		Lubricate the connector pins between crawler carrier and crawler center section or crawler carrier and cross carriers	

LWE/LR 1800-1-0-000/27200-07-02/en

First maintenance After	Operating hour intervals			Calendar intervals			Work to be carried out	O.K.
	10 h	100 h	1000 h	Daily	Weekly	An- nually		
<b>Crawler chain</b>								
		X					Check the connector pin retainer	□
		X					Check for damage	
	X				every 4 weeks		Check the chain tension, retension the crawler chain if necessary	
	X						Check the wear on the bores of the outrigger pads, replace the outrigger pads if necessary	
	X						Check the wear on the connector pins of the outrigger pads, replace the pins if necessary	
	X				every 4 weeks		Check the wear on the roll-off surfaces of the outrigger pads / track rollers, replace the outrigger pads if necessary	
					every 4 weeks		Check for wear on the sprocket wheels and the transport cams of the outrigger pads	
<b>Mechanical auxiliary support</b>								
						X	Lubricate the connector pin to the crawler carrier	□
						X	Check the support spindles. Grease if necessary	
<b>Hydraulic assembly support</b>								
					X		Check the hydraulic cylinder for leaks	□
						X	Check the support beam for ease of movement and grease	
						X	Lubricate the bearing points of the support beams	
						X	Check the sight gauge, adjust if necessary	
<b>Crane support</b>								
					X		Check the hydraulic cylinder for leaks	□
						X	Check the support beam for ease of movement and grease	
						X	Lubricate the struts	
						X	Lubricate the mounting pins on the struts	
						X	Lubricate the support plate bearing	

First maintenance After	Operating hour intervals			Calendar intervals			Work to be carried out	O.K.
	10 h	100 h	1000 h	Daily	Weekly	An- nually		
<b>Concrete ballast plates / concrete catwalks</b>								
				X			Check for damage	
				4)		X	Have an authorized inspector check that the fastening points are fit tightly and for continued suitability	
<b>Pin connections</b>								
					every 2 months <sup>3)</sup>		Check the retainer of the pin connections	<input type="checkbox"/>
					every 2 months <sup>3)</sup>		Check the pins and / or connection elements for damage, visual inspection	
					every 2 months <sup>3)</sup>		Check the retaining elements for damage, visual inspection	
<b>Rotary connection</b>								
			X				For the variation with grease lubrication: Lubricate	<input type="checkbox"/>
<b>Hydraulic cylinder</b>								
					X		Checking for leaks	<input type="checkbox"/>
<b>Hydraulic hose lines</b>								
				X			Check for leaks and damage	<input type="checkbox"/>
						X	Have safe working condition checked by an expert	
<b>Central lubrication system</b>								
					every 3 months <sup>1)</sup>		Carry out intermediate lubrication (in case of a central lubrication system with the control unit)	<input type="checkbox"/>
					every 6 months		Carry out intermediate lubrication (in case of a central lubrication system with the control unit)	
		X					Checking the function	
	8 h			X			Check the lubricant level	

<sup>1)</sup> If the crane is not moved

<sup>2)</sup> Before every start up: perform a visual inspection.

<sup>3)</sup> Also for cranes used for a long period of time.

<sup>4)</sup> And at each assembly / disassembly.

---

Empty page!

LWE/LR 1800-1-0-000/27200-07-02/en



## 7.02.50 Maintenance intervals - Ballast trailer

1 Maintenance and inspection schedule

2

LWE/LR 1800-1-0-000/27200-07-02/en

# 1 Maintenance and inspection schedule



## Note

- ▶ Carry out maintenance work after reaching the specified operating hours or calendar intervals. The interval that occurs first is the deciding factor!
- ▶ The maintenance intervals complement each other. If a higher interval is coming up, then also carry out the work according to the lower interval!

First maintenance After	Operating hour intervals			Calendar intervals			Work to be carried out	O.K.
	10 h	100 h	1000 h	Daily	Weekly	Annually		
<b>Fall protection equipment</b>								
						X	Check protection points	
						X	Check safety ropes	
						X	Check the ladders for technically immaculate condition	
						X	Check railings, steps and pedestals for safe function	
						X	Check catwalks and gratings for safe function	
<b>Ballast trailer surface</b>								
					X		Check accessible surfaces for cleanliness	
						X	Check accessible surfaces for completeness and slip resistance	
						X	Check labels for completeness and legibility	
<b>Rigging and fastening points</b>								
				<sup>2)</sup>			Check the condition and mounting	
						X	Check for continued suitability by an authorized inspector, inspection expert	
<b>Tires</b>								
					X		Check for external damage and distortion	
	X						Check wheel nuts for tight seating, retighten if necessary	
						Every 5 years	Replace tires; have further service life confirmed by an authorized inspector of the tire manufacturer	
<b>Wheel hubs</b>								
						X	Lubricate the wheel hubs with the grease gun	
<b>Axle link</b>								
						X	Lubricate	

First maintenance	Operating hour intervals			Calendar intervals			Work to be carried out	O.K.
	After	10 h	100 h	1000 h	Daily	Weekly		
<b>Hydraulic cylinder</b>								
						X	Checking for leaks	
<b>Hydraulic hose lines</b>								
				X			Check for leaks and damage	
						X	Check for a safe condition by an authorized inspector, inspection expert	
<b>Travel drive</b>								
						X	Check the tightness of the mounting screws	
						X	Checking for leaks	
						X	Checking the oil level	
						Every 5 years	Change the gear oil if necessary	
<b>Slewing gear</b>								
						X	Check the tightness of the mounting screws	
						X	Checking for leaks	
						X	Checking the oil level	
						Every 5 years	Change the gear oil if necessary	
<b>Central lubrication system</b>								
				X			Check the fill level of the central lubrication system. The grease container must be filled when the fill level has dropped below 1/4 of the container volume.	
						X	Checking the function	
<b>Pin connections</b>								
						Every 2 months <sup>3)</sup>	Check the retainer of the pin connections	
						Every 2 months <sup>3)</sup>	Check the pins and / or connection elements for damage, visual inspection	
						Every 2 months <sup>3)</sup>	Check the retaining elements for damage, visual inspection	
<b>Emergency control</b>								
						X	Checking the function	

<sup>2)</sup> before every start up: Perform a visual inspection

<sup>3)</sup> also for cranes used for a long period of time

---

Empty page!

LWE/LR 1800-1-0-000/27200-07-02/en

## 7.03 Maintenance intervals - Crane superstructure

1 Maintenance and inspection schedule

---

2

LWE/LR 1800-1-0-000/27200-07-02/en

# 1 Maintenance and inspection schedule



## Note

- ▶ Carry out maintenance work after reaching the specified operating hours or calendar intervals. The interval that occurs first is the deciding factor!
- ▶ The maintenance intervals complement each other. If a higher interval is coming up, then also carry out the work according to the lower interval!

First maintenance	Operating hour intervals			Calendar intervals			Work to be carried out	O.K.
	after	250 h	500 h	1000 h	Daily	Weekly		
<b>Safety systems</b>								
						X	Personal protective equipment	<input type="checkbox"/>
							Follow the instructions of the manufacturer	
						X	Height rescue system	
							Follow the instructions of the manufacturer	
<b>Fall protection equipment</b>								
						X	Check protection points	<input type="checkbox"/>
						X	Check safety ropes	
						X	Check the ladders for technically immaculate condition	
						X	Lubricating the ladders	
						X	Check railings, steps and pedestals for safe function	
						X	Check catwalks and gratings for safe function	
<b>Crane surface</b>								
					X		Check accessible surfaces for cleanliness	<input type="checkbox"/>
						X	Check accessible surfaces for completeness and slip resistance	
						X	Check labels for completeness and legibility	
<b>Rigging and fastening points</b>								
				2)			Check the condition and mounting	<input type="checkbox"/>
						X	Check for continued suitability by an authorized inspector, inspection expert	

LWE/LR 1800-1-0-000/27200-07-02/en

First maintenance	Operating hour intervals			Calendar intervals			Work to be carried out	O.K.
	after	250 h	500 h	1000 h	Daily	Weekly		
<b>Load handling equipment and assembly aids</b>								<input type="checkbox"/>
				2)			Check for cracks, damage, wear and distortion	
						X	Have the fastening equipment checked by an authorized person, authorized inspector	
<b>Fastening equipment and load securing devices</b>								<input type="checkbox"/>
				2)			Observe and adhere to the manufacturer's instructions	
				X 2)			Check the grommets and cable laid fastening rope for damage, operational safety, proper identification. Take-down criteria, see chapter 8.01	
						X	Have the fastening equipment checked by an authorized person, authorized inspector	
<b>Fire extinguishing system</b>								<input type="checkbox"/>
						X	Carry out a visual inspection of the system	
							For all other maintenance tasks, observe the instructions of the fire extinguishing system manufacturer	
						every 5 years	Replace trigger elements and extinguisher tank	

First maintenance	Operating hour intervals			Calendar intervals			Work to be carried out	O.K.
	after	250 h	500 h	1000 h	Daily	Weekly		
<b>Diesel engine</b>								□
					X		Visual inspection (leaks, contamination, damage)	
				X			Check the oil level on the LICCON monitor	
		X					Checking the oil level with the dipstick	
			X <sup>14) 15)</sup>				Change the engine oil, replace the oil filter and oil separator filter insert	
			or in the case of an error message: The interval and be reduced depending on the individual load duty cycle.					
			X				Check the ribbed V-belt	
			X				Check the condition of the belt drive, replace if required	
			every 5000 h			every 5 years	Replace the belt drive	
100 h			X				Check the condition and fastening of the intake and exhaust system and check for leaks	
			X				Check the engine mount and diesel engine brackets for tight seating	
			every 10000 h			X	Check the heat flange	
			every 10000 h				Replace the heat flange	
			X				Check the valve clearance	
			X				Check the engine control unit mount, sensors, actuators, cable holders and plugs for damage	
<b>Cooling system</b>								□
				X			Checking the coolant level	
					X		Check the cooling system for leaks	
						X	Check the concentration of the anti-freeze in the coolant	
			every 6000 h			every 4 years	Change the coolant	



First maintenance	Operating hour intervals			Calendar intervals			Work to be carried out	O.K.	
	after	250 h	500 h	1000 h	Daily	Weekly			An- nually
<b>Fuel system</b>								<input type="checkbox"/>	
					X		Check the lubrication oil system and fuel system for leaks		
			X				Check the condition and mounting of the fuel system		
100 h			X				Draining the sediment in the fuel tank		
					X		Check fuel preliminary filter, drain water if necessary		
			X				Servicing the fuel preliminary filter		
			X				Replace the fuel fine filter		
<b>Urea system</b>								<input type="checkbox"/>	
						X	Check the filter strainer in the tank fitting of the urea tank, replace if necessary		
<b>Exhaust system*</b>								<input type="checkbox"/>	
				X			Visual inspection: Check the exhaust system for leaks and damage		
			X				Check the profile clamps		
			every 5000 h				Replace the diesel particle filter*		
			or in the case of an error message						
						X	Visual inspection: Check the lines and electronic plug		
<b>Air filter system</b>								<input type="checkbox"/>	
					X		If present: Clean the dust discharge valve		
						X <sup>13)</sup>	Replace the air filter main element		
						X	If present: Replace the air filter safety element		
<b>Pump distributor gear</b>								<input type="checkbox"/>	
				X			Checking for leaks		
					X		Checking the oil level with the dipstick		
200 h			2000 h			X	Change the gear oil		

First maintenance	Operating hour intervals			Calendar intervals			Work to be carried out	O.K.
	after	250 h	500 h	1000 h	Daily	Weekly		
<b>Central lubrication system</b>								□
					every 3 months		Activate intermediate lubrication	
					every 6 months <sup>1)</sup>		Activate intermediate lubrication	
		X					Check the function	
					X		Check the fill level in the grease container	
<b>Slewing ring connection</b>								□
	X						Lubricate the gear ring and the slewing gear pinion	
						X <sup>1)</sup>	Lubricate the slewing ring connection	
250 h			1500 h			X	Check the tightness of the mounting screws	
						X	Check the tilt play	
<b>Slewing gear</b>								□
250 h			X			X	Check the tightness of the mounting screws	
				X			Checking for leaks	
					X		Checking the oil level with the dipstick	
250 h			4000 h			every 4 years	Change the gear oil	
<b>Slewing gear brakes</b>								□
				X			Checking for leaks	
						X	Check the function	
<b>Press on pulleys of rope winches</b>								□
	X					X	Grease the guides	

First maintenance	Operating hour intervals			Calendar intervals			Work to be carried out	O.K.
	after	250 h	500 h	1000 h	Daily	Weekly		
<b>Winches</b>								
			X			X	Check the tightness of the mounting screws	□
				X			Check for damage and distortion	
				X			Checking for leaks	
				<sup>2) 6)</sup>	X		Checking the oil level with the dipstick	
		X					Recommendation: Check the gear oil (oil analysis)	
250 h			3000 h			every 3 years	Change the gear oil	
			1500 h			X	If grease fittings are available for the winch bearings that can be lubricated <sup>4)</sup> : Lubricate the space between the V-ring / winch bearing	
			200 h			X	When winches with a gear ring drive are present: Check the condition of the tooth flanks; the determining factor is operating hours of the winch	
						X	Check the remaining theoretical service life by an authorized inspector	
						every 4 years	Check of the remaining theoretical service life by an inspection expert	
<b>Winch brakes</b>								
			X			X	Checking for leaks	□
			X			X	Check the function	
<b>Hydraulic system</b>								
				X			Check the oil level on the LICCON monitor	□
					X		If present: Check the oil level on the fuel level display of the hydraulic oil tank	
					X		Checking for leaks	
250 h		X				X	Replace the pressure filter element	
250 h		X				X	Replace the return filter inserts	
250 h		X				X	Replace the breather and vent filter	
500 h			X			X	Check the hydraulic oil: Take an oil sample and have it checked by the oil supplier (required degree of purity: 20/18/15)	
		X <sup>4)</sup>				X <sup>4)</sup>	Have the pretension pressure of the hydro reservoir (nitrogen) checked by authorized and trained service personnel	

LWE/LR 1800-1-0-000/27200-07-02/en

First maintenance	Operating hour intervals			Calendar intervals			Work to be carried out	O.K.
	after	250 h	500 h	1000 h	Daily	Weekly		
<b>Hydraulic cylinder</b>								
				2) 6)	X		Checking for leaks	□
				2) 5) 6)	every 12 weeks		Lubricate the bearings	
<b>Hydraulic hose lines</b>								
				X			Check for leaks and damage	□
						X	Check for a safe condition by an authorized inspector, inspection expert	
<b>Compressed air system</b>								
					X		Checking for leaks	□
					X		Check operating pressure	
					X		Check shut off pressure	
					X		Automatic drain valve: Check the function	
					X		Draining water from the compressed air tank	
						X	Replace air dryer granular cartridges	
						X	Clean the air dryer preliminary filter	
<b>Relapse supports</b>								
				5) 6)	every 3 months		Lubricate the bearings	□
				2) 6)			Check the oscillation guard for easy movement	
<b>Relapse cylinder</b>								
				2) 6)	X		Checking for leaks	□
				5) 6)	every 3 months		Lubricate the bearings	
		X		2) 6)		X	Have the pretension pressure (nitrogen) checked by an authorized and trained service technician	
		X		2) 6)		X	Check the oil quantity	
<b>A-frame</b>								
		X					Lubricate the bearing	□
				2) 6)		X	Check the lever for the limit switch on the A-frame 3 for easy movement and reset of the spring	
				2) 6)		X	Check the rods with guide rail on A-frame 2 and A-frame 3 for easy movement and distortion	

First maintenance	Operating hour intervals			Calendar intervals			Work to be carried out	O.K.
	after	250 h	500 h	1000 h	Daily	Weekly		
<b>Pneumatic springs</b>								
		X		2) 5) 6)		X	Check for function and damage	<input type="checkbox"/>
<b>Concrete ballast plates (ballast container) (only LR 13000)</b>								
				X			Check for damage	<input type="checkbox"/>
						every 5 years	have checked by the licensing agency	
<b>Rope pulleys</b>								
			X				Check for wear, damage, cracks and easy movement	<input type="checkbox"/>
						X	Have the wear, damage, cracks and ease of movement checked by an authorized person, authorized inspector	
			X				Check the groove diameter	
			X				Lubricate the bearings	
<b>Carrier rollers</b>								
				2) 6)		X	Check for damage, lead-in tracks and ease of movement	<input type="checkbox"/>
				2) 6)		X	Check the tightness of the mounting screws	
<b>Bearings</b>								
						X	Check the retaining elements	<input type="checkbox"/>
<b>Pin connections</b>								
					every 2 months <sup>10)</sup>		Check the retainer of the pin connections	<input type="checkbox"/>
					every 2 months <sup>10)</sup>		Check the pins and / or connection elements for damage, visual inspection	
					every 2 months <sup>10)</sup>		Checking the retaining elements for damage, visual inspection	
<b>Window washing system</b>								
				X			Check the fill level of the window washing fluid	<input type="checkbox"/>
<b>Emergency control</b>								
						X	Check the function	<input type="checkbox"/>

LWE/LR 1800-1-0-000/27200-07-02/en

First maintenance	Operating hour intervals			Calendar intervals			Work to be carried out	O.K.
	after	250 h	500 h	1000 h	Daily	Weekly		
<b>Overload protection</b>								□
				X			Check the function	
		X				X	Length sensor: Check the function	
		X				X	Check the length sensor rope for damage	
<b>Remote diagnostics device</b>								□
						X	Check the function	
						X	Check the validity of the SIM card	
<b>Electrical system</b>								□
						X	Check the bulbs, fuses, lines and cable connections	
					X <sup>3)</sup>		Check the batteries	
					every 6 months		Check the batteries	
<b>Heating-air conditioning device</b>								□
					every 4 weeks		Operate the climate control system for 15 min and check the function	
						X	Replace the filter insert	
<b>Cab auxiliary heater*, Engine preheating auxiliary heater*</b>								□
				X			Check the fill level of the fuel container	
				X			Check the fill level in the expansion tank	
					every 4 weeks <sup>8)</sup>		Operate and check the function for 15 min with the engine cold and the highest fan stage.	
					X <sup>9)</sup>		Operate and burn-off the burner for 15 min with the engine cold and the highest fan stage.	
						X <sup>12)</sup>	Have the water heater checked by an authorized and trained service technician	
						every 2 years	Have the fluid in the heating system replaced by an authorized and trained service technician	
			3000 h				Have the burner of the heating system replaced by an authorized and trained service technician	
						every 10 years	Have the heat exchanger of the heater replaced by an authorized and trained service technician	

First maintenance	Operating hour intervals			Calendar intervals			Work to be carried out	O.K.
	after	250 h	500 h	1000 h	Daily	Weekly		
<b>Air heater auxiliary heater*</b>								
						every 4 weeks <sup>8)</sup>	operate and check the function for 15 min with the highest fan stage	□
						X <sup>9)</sup>	operate and free-burn the burner for 15 min with the highest fan stage	
						X <sup>12)</sup>	Have the air heater checked by an authorized and trained service technician	
			3000 h				Have the burner of the heating system replaced by an authorized and trained service technician	
						every 10 years	Have the heat exchanger of the heater replaced by an authorized and trained service technician	
<b>Crane cab</b>								
				X			Instrument panels: Check the function	□
				X			Indicator lights: Check the function	
		X				X	Sliding or incline device: Checking the function	
		X				X	Lubricate the bearings of the sliding or incline device	
<b>Suspended ballast</b>								
						X	Check the fall protection equipment	□
						X	Check the frame, suspension and guide section for distortion and cracks	
<b>Crane superstructure</b>								
				<sup>11)</sup>	X		Wash the crane superstructure	□
				<sup>11)</sup>		every 6 months	Check the crane superstructure for corrosion and paint damage	
<b>Crane superstructure, protected against corrosion</b>								
						every 6 months	Check the corrosion protection for wear, and if necessary reapply protection	□
						every 2 months	Check the corrosion protection on mechanically machined, blank surfaces for wear and reapply the corrosion protection if necessary	
						every 3 months	Check the corrosion protection on the chrome-plated piston rods for wear, and if necessary reapply the corrosion protection	

LWE/LR 1800-1-0-000/27200-07-02/en

Maintenance intervals, see the separate equipment manufacturer's operating instructions	Work to be carried out	O.K.
<b>Climate control system drive assembly (optional for certain cranes)</b>		□
For a description of the operating hour meter on the control unit in the crane cab, see chapter 5.72.	Maintenance activities, see the separate equipment manufacturer's operating instructions	

- 1) If the crane is not moved.
- 2) Before every start up: performing a visual inspection.
- 3) In hot climate zones: every month.
- 4) Observe the crane superstructure maintenance instructions, chapter 7.05.
- 5) And as necessary.
- 6) And during assembly.
- 7) In Great Britain: every 6 months.
- 8) Outside of the heating period.
- 9) During the heating period.
- 10) Also for cranes used for a long period of time.
- 11) Each time after the crane is used if possible.
- 12) Before and after every heating period.
- 13) Or if the maintenance display activates, or error message.
- 14) The interval is reduced in the case of alternative oil specifications, see the see separate engine manufacturer's operating instructions.
- 15) The interval depends on the sulfur content in the permissible fuel for the respective emissions level, see the see separate engine manufacturer's operating instructions.



## 7.03.50 Maintenance intervals - Crane boom

1 Maintenance and inspection schedule

---

2

LWE/LR 1800-1-0-000/27200-07-02/en

# 1 Maintenance and inspection schedule



## Note

- ▶ Carry out maintenance work after reaching the specified operating hours or calendar intervals. The interval that occurs first is the deciding factor!
- ▶ The maintenance intervals complement each other. If a higher interval is coming up, then also carry out the work according to the lower interval!

First maintenance after	Operating hour intervals			Calendar intervals			Work to be carried out	O.K.
	250 h	500 h	1000 h	Daily	Weekly	Annually		
<b>Safety systems</b>								<input type="checkbox"/>
						X	Personal protective equipment Follow the instructions of the manufacturer	<input type="checkbox"/>
						X	Height rescue system Follow the instructions of the manufacturer	
<b>Fall protection equipment</b>								<input type="checkbox"/>
						X	Check protection points	<input type="checkbox"/>
						X	Check safety ropes	
						X	Check the ladders for technically immaculate condition	
						X	Check railings, steps and pedestals for safe function	
						X	Check catwalks and gratings for safe function	
<b>Crane boom surface</b>								<input type="checkbox"/>
					X		Check accessible surfaces for cleanliness	<input type="checkbox"/>
						X	Check accessible surfaces for completeness and slip resistance	
						X	Check labels for completeness and legibility	
<b>Rigging and fastening points</b>								<input type="checkbox"/>
				2)			Check the condition and mounting	<input type="checkbox"/>
						X	Check for continued suitability by an authorized inspector, inspection expert	
<b>Load handling equipment and assembly aids</b>								<input type="checkbox"/>
				2)			Check for cracks, damage, wear and distortion	<input type="checkbox"/>
						X	Check for continued suitability by an authorized inspector, inspection expert	

First maintenance after	Operating hour intervals			Calendar intervals			Work to be carried out	O.K.
	250 h	500 h	1000 h	Daily	Weekly	Annually		
<b>Fastening equipment and load securing devices</b>								<input type="checkbox"/>
				2)			Observe and adhere to the manufacturer's instructions	
				X 2)			Check the grommets and cable laid fastening rope for damage, operational safety, proper identification. Take-down criteria, see chapter 8.01	
						X	Have the fastening equipment checked by an authorized person, authorized inspector	
<b>Lattice sections</b>								<input type="checkbox"/>
						X	Check for cracks, damage and distortion checked by an authorized person, authorized inspector	
						X	Check protection points	
						X	Check safety ropes	
						X	Check railings and pedestals for safe function	
						X	Check catwalks and gratings for safe function	
				X 2) 6)	X	X	Grease the lube points of lattice sections	
<b>Guy rods</b>								<input type="checkbox"/>
						X	Check for cracks, damage and distortion by an authorized person, inspection expert	
				2) 6)		X	Checking the retaining elements	
						X	Check labels for completeness and legibility	
				X 6)		X	Lubricate the lube points of guy rods	

First maintenance after	Operating hour intervals			Calendar intervals			Work to be carried out	O.K.
	250 h	500 h	1000 h	Daily	Weekly	Annually		
<b>Fiber guy ropes</b>								
				X			Check the rope, grommet and rope end connection for damage and distortion	□
					X		Check rope for dirt. If necessary, wash or spray the rope with clean water. After cleaning: Dry the rope in the air at approx. 20 °C.	
				7)			Check the thimble and rope end connection, see chapter 8.16	
				7)			Check the rope layers, see chapter 8.16	
				7)			Check the rope for buckles, see chapter 8.16	
						X	Check the rope for kinks, see chapter 8.16	
<b>Relapse supports</b>								
				5) 6)	every 3 months		Lubricate the bearings	□
				X 2) 6)			Check the oscillation guard for easy movement	
<b>Relapse cylinder</b>								
				X 2) 6)	X		Check for leaks	□
				5) 6)	every 3 months		Lubricate the bearings	
		X		X 2) 6)		X	Check pretension pressure (nitrogen)	
		X		X 2) 6)		X	Check the oil quantity	
<b>Hydraulic hose lines</b>								
				X			Check for leaks and damage	□
						X	Check for a safe condition by an authorized inspector, inspection expert	
<b>Hydraulic cylinder</b>								
					X		Check for leaks	□
				5) 6)	every 3 months		Lubricate the bearings	
<b>Hydraulic pressure accumulator (nitrogen)</b>								
		X 4)				X 4)	Check pretension pressures	□

First maintenance after	Operating hour intervals			Calendar intervals			Work to be carried out	O.K.
	250 h	500 h	1000 h	Daily	Weekly	Annually		
<b>Rope pulleys</b>								
				<sup>5) 6)</sup>	X		Check the groove base for cleanliness	□
			X	X		X	Check for wear, damage, cracks and easy movement	
			3000 h			every 3 years	Lubricate the bearings	
<b>Carrier rollers</b>								
				X <sup>2)</sup>			Check for damage and distortion	□
			X			X	Check for wear, damage and easy movement	
			X			X	Check the tightness of the mounting screws	
<b>Auxiliary guying</b>								
				<sup>6)</sup>		X	Check the rope connection between the guy point and the lattice section	□
				<sup>6)</sup>		X	Check for cracks, damage and distortion	
<b>Pin connections</b>								
					every 2 months <sup>8)</sup>		Check the retainer of the pin connections	□
					every 2 months <sup>8)</sup>		Check the pins and / or connection elements for damage, visual inspection	
					every 2 months <sup>8)</sup>		Checking the retaining elements for damage, visual inspection	
<b>Crane ropes</b>								
				X			Check the rope and rope end connection for damage and distortion	□
				<sup>5)</sup>	monthly		Check, grease by expert personnel	
						X	Check by an authorized inspector	
						every 4 years	Check by an inspection expert	

LWE/LR 1800-1-0-000/27200-07-02/en

First maintenance after	Operating hour intervals			Calendar intervals			Work to be carried out	O.K.
	250 h	500 h	1000 h	Daily	Weekly	Annually		
<b>Hook blocks</b>								□
				X <sup>3)</sup>			Check of the load hook for distortion, wear, damage and cracks by the crane operator	
			X	X		X	Check rope pulleys for distortion, wear, damage and cracks	
			3000 h			every 3 years	Lubricate rope pulley bearings	
	100 h			<sup>5)</sup>	every 3 months		Lubricate the pressure bearings	
	100 h			<sup>5)</sup>	every 3 months		Lubricate the radial bushing	
	100 h			<sup>5)</sup>	every 3 months		Lubricate suspension of hook beam	
				<sup>5)</sup>	every 6 months		Replace batteries on incline sensor	
						X	Load hook: Check the distance (y)	
						X	Check of the load hook for distortion, wear, damage and cracks by an authorized person	
						every 4 years	Check of the load hook for distortion, wear, damage and cracks by an inspection expert	

<sup>2)</sup> Before every start up: perform a visual inspection.

<sup>3)</sup> Before starting crane operation: perform a visual inspection.

<sup>4)</sup> Observe the crane superstructure maintenance instructions, chapter 7.05.

<sup>5)</sup> And as necessary.

<sup>6)</sup> And during assembly.

<sup>7)</sup> Before assembly and before disassembly.

<sup>8)</sup> Also for cranes used for a long period of time.

## 7.04 Maintenance instructions - Crane chassis

1	Safety	2
2	Travel gear	2
3	Central lubrication system	7
4	Crawler carrier	7
5	Crawler chain	8
6	Hydraulic hose lines	21
7	Ladders	21

# 1 Safety

Before performing maintenance activities, observe the safety instructions:

- General safety information: See chapter 2.04.
- Information regarding personal protective equipment: See chapter 2.04.
- Information regarding ladders: See chapter 2.04.10.
- Information regarding fall protection equipment on the crane: See chapter 2.06.
- Information regarding accesses to the crane: See chapter 2.07.
- Information regarding maintenance and service: See chapter 7.01.

## 2 Travel gear

The travel gear consists of the following components:

- Planetary gear
- Miter gear with brake



### Note

- ▶ The planetary gear and the miter gear have separate, different sized oil chambers: Check the oil levels of the transmission independently of each other.
- ▶ Inspection ports for checking the oil level in the planetary gear and the miter gear can differ in design.

The number of crawler carrier drives differs depending on the configuration of the crane.

### 2.1 Checking for leaks

#### NOTICE

**Leaky transmission!**

Transmission damage

- ▶ Check the travel gear for leaks according to the maintenance schedule.

- ▶ Check the travel gear for leaks: Perform a visual inspection.

When the travel gear leaks:

- ▶ Have the travel gear sealed by authorized and trained service personnel.

### 2.2 Planetary gear



#### WARNING

Spilled gear oil!

Danger of slipping.

- ▶ Danger of slipping, pay attention.
- ▶ Use personal protective equipment depending on the operating materials.
- ▶ Immediately collect spilled gear oil using suitable material. See the safety data sheet from the manufacturer of the operating fluid.

#### NOTICE

Dirt inside the transmission!

Transmission damage. Increased wear and shorter service life of the components.

- ▶ Maintain extreme cleanliness during all work.
- ▶ Make sure that **no** dirt gets inside the transmission.



## 2.2.1 Checking the oil level

### NOTICE

Insufficient oil!

Transmission damage

- ▶ Check the oil level according to the maintenance schedule and add gear oil if necessary.

Make sure that the following prerequisites are met:

- The crane is in a horizontal position.
- The travel gear has been at a standstill for two minutes before checking the oil level: The gear oil has drained back completely.

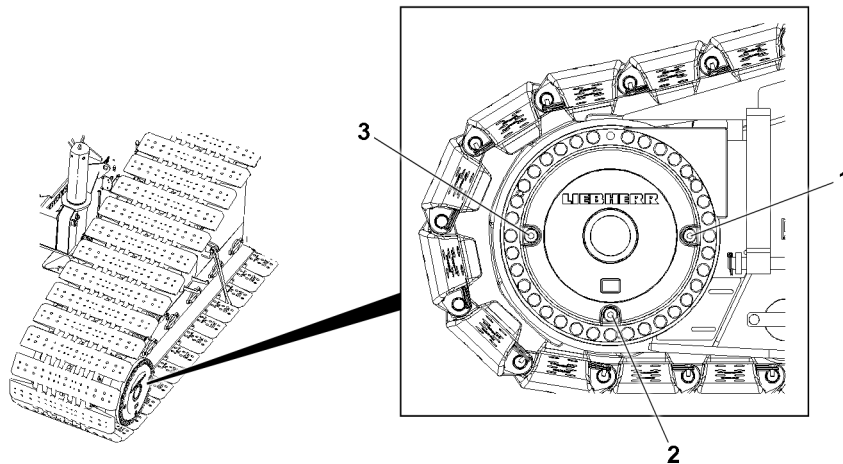


Fig.155914: Planetary gear, maintenance ports

- |  |   |
|--|---|
| <p><b>1</b> Control plug, inspection port</p> <p><b>2</b> Drain plug</p> | <p><b>3</b> Control plug, inspection port</p> |
|--|---|



### WARNING

Hot components, hot operating materials!

Severe burns, scalding.

- ▶ Let components cool off to below 50 °C.
- ▶ Avoid contact with hands, skin and eyes.
- ▶ Wear safety goggles.
- ▶ Wear heat-resistant protective equipment: Wear protective gloves and work clothing.

There is **no** separate filler port on the planetary gear. Filling gear oil in the inspection port

- ▶ Unscrew the control plug **1** or control plug **3**.

The oil level must be at the lower edge of the inspection port.

- ▶ Perform a visual inspection.
- ▶ Screw in the control plug with a new seal and tighten.

### Problem remedy

When opening the control plug, does oil emerge?

Depending on the position of the gears in the planetary gear, the oil level can be higher than the inspection port.

- ▶ Add the same amount of gear oil that emerged.

### Problem remedy

The oil level is **not** at the lower edge of the inspection port?

- ▶ Unscrew the second control plug.
- ▶ Add gear oil in one inspection port until gear oil starts to overflow in the second inspection port.
- ▶ Screw in the control plugs with a new seal and tighten.

**Problem remedy**

Excessive oil consumption or loss of oil?

- ▶ Find the cause and remedy it.

If the cause cannot be remedied:

- ▶ Contact Customer Service at Liebherr-Werk Ehingen GmbH.

**2.2.2 Changing the gear oil**

Make sure that the following prerequisites are met:

- The crane is in a horizontal position.
- The travel gear is at the operating temperature.
- A suitably sized container for the used oil is on hand.

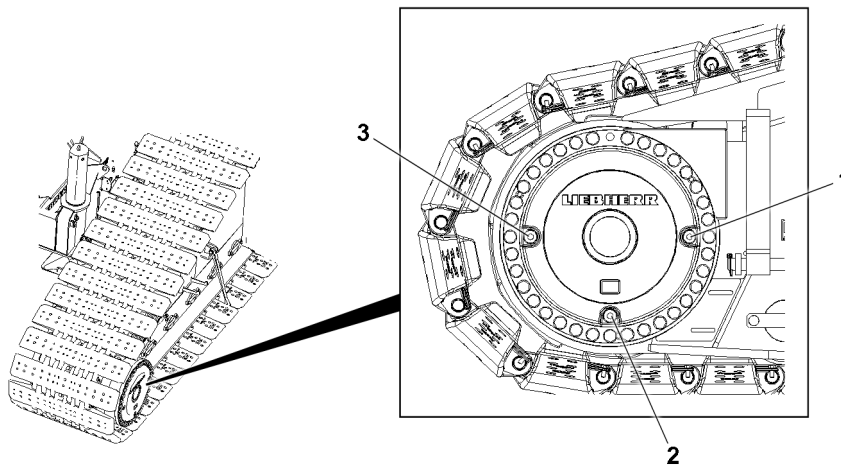


Fig.155914: Planetary gear, maintenance ports

- |  |  |
|--|--|
| <p>1 Control plug, inspection port</p> <p>2 Drain plug</p> | <p>3 Control plug, inspection port</p> |
|--|--|

**WARNING**

Hot components, hot operating materials!

Severe burns, scalding.

- ▶ Let components cool off to below 50 °C.
- ▶ Avoid contact with hands, skin and eyes.
- ▶ Wear safety goggles.
- ▶ Wear heat-resistant protective equipment: Wear protective gloves and work clothing.

- ▶ Collect the gear oil: Position a container under the drain plug **2**.
- ▶ Unscrew the control plug **1** and control plug **3**.
- ▶ Drain the gear oil: Unscrew the drain plug **2**.

When gear oil is completely drained:

- ▶ Screw in the drain plug **2** with a new seal and tighten.
- ▶ Add gear oil in one inspection port until gear oil starts to overflow in the second inspection port.
- ▶ Screw in the control plugs with a new seal and tighten.

## 2.3 Miter gear



### WARNING

Spilled gear oil!

Danger of slipping.

- ▶ Danger of slipping, pay attention.
- ▶ Use personal protective equipment depending on the operating materials.
- ▶ Immediately collect spilled gear oil using suitable material. See the safety data sheet from the manufacturer of the operating fluid.

### NOTICE

Dirt inside the transmission!

Transmission damage. Increased wear and shorter service life of the components.

- ▶ Maintain extreme cleanliness during all work.
- ▶ Make sure that **no** dirt gets inside the transmission.

### 2.3.1 Checking the oil level

### NOTICE

Insufficient oil!

Transmission damage.

- ▶ Check the oil level and add gear oil if necessary.

Make sure that the following prerequisites are met:

- The crane is in a horizontal position.
- The travel gear has been at a standstill for two minutes before checking the oil level: The gear oil has drained back completely.

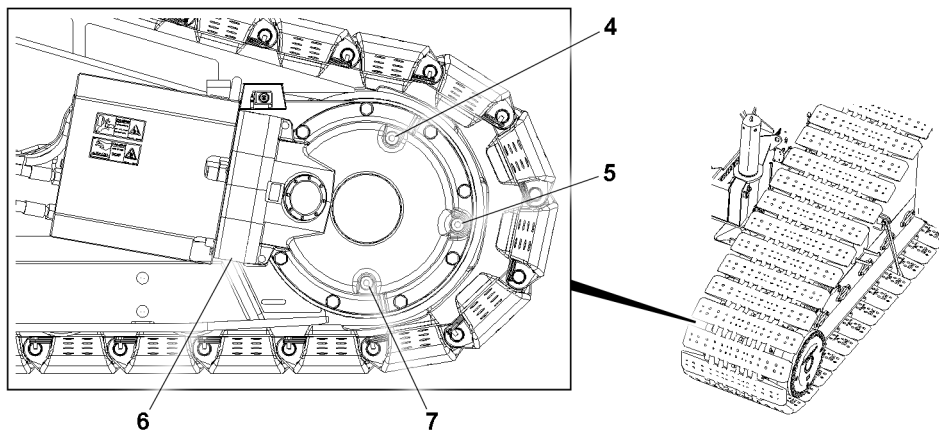


Fig.155915: Miter gear, maintenance ports

- |  |   |
|--|---|
| <p><b>4</b> Filler plug, filler port</p> <p><b>5</b> Control plug, inspection port</p> | <p><b>6</b> Drain plug</p> <p><b>7</b> Drain plug</p> |
|--|---|



### WARNING

Hot components, hot operating materials!

Severe burns, scalding.

- ▶ Let components cool off to below 50 °C.
- ▶ Avoid contact with hands, skin and eyes.
- ▶ Wear safety goggles.
- ▶ Wear heat-resistant protective equipment: Wear protective gloves and work clothing.

- ▶ Unscrew the control plug **5**.

The oil level must be at the lower edge of the inspection port **5**.

- ▶ Perform a visual inspection.
- ▶ Screw in the control plug **5** with a new seal and tighten.

---

#### Problem remedy

Is the oil level **not** at the lower edge of the inspection port?

- ▶ Unscrew the filler plug **4**.
  - ▶ Fill gear oil in the filler port **4** until gear oil starts to run out of the control port.
  - ▶ Screw in the filler plug **4** with a new seal and tighten.
- 

#### Problem remedy

Excessive oil consumption or loss of oil?

- ▶ Find the cause and remedy it.

If the cause cannot be remedied:

- ▶ Contact Customer Service at Liebherr-Werk Ehingen GmbH.
- 

## 2.3.2 Changing the gear oil

Make sure that the following prerequisites are met:

- The crane is in a horizontal position.
- The travel gear is at the operating temperature.
- A suitably sized container for the used oil is on hand.

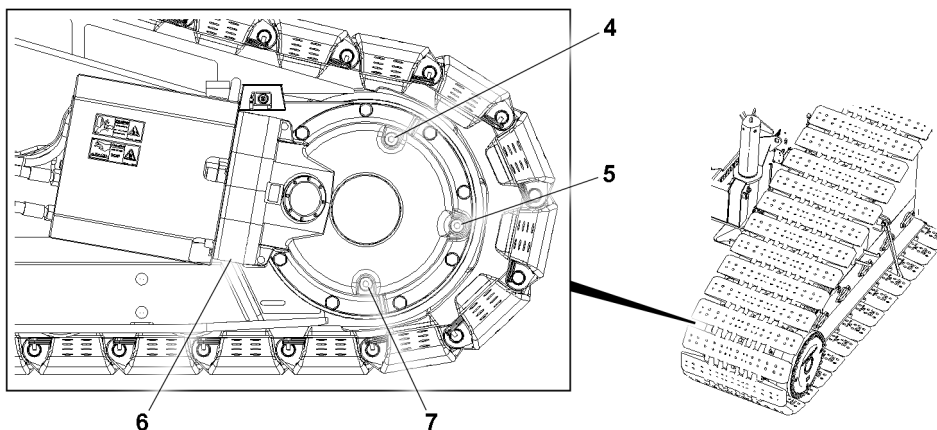


Fig.155915: Miter gear, maintenance ports

- |          |                               |          |            |
|----------|-------------------------------|----------|------------|
| <b>4</b> | Filler plug, filler port      | <b>6</b> | Drain plug |
| <b>5</b> | Control plug, inspection port | <b>7</b> | Drain plug |



#### WARNING

Hot components, hot operating materials!  
Severe burns, scalding.

- ▶ Let components cool off to below 50 °C.
- ▶ Avoid contact with hands, skin and eyes.
- ▶ Wear safety goggles.
- ▶ Wear heat-resistant protective equipment: Wear protective gloves and work clothing.

- ▶ Collect the gear oil: Place a container under the drain plug **7** and under the drain plug **6**.
- ▶ Unscrew the filler plug **4**.
- ▶ Drain the gear oil: Unscrew the drain plug **7** and drain plug **6**.

When gear oil is completely drained:

- ▶ Screw in the drain plug **7** with a new seal and tighten.
- ▶ Screw in the drain plug **6** with a new seal and tighten.

- ▶ Fill gear oil in the filler port **4** until gear oil starts to run out of the control port.
- ▶ Screw in the control plug **5** with a new seal and tighten.
- ▶ Screw in the filler plug **4** with a new seal and tighten.

### 3 Central lubrication system

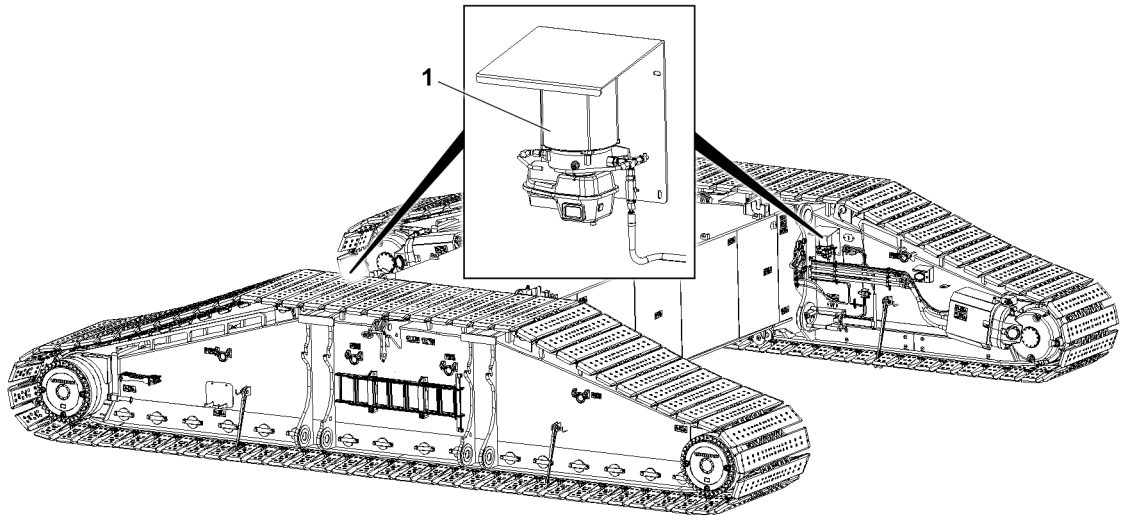


Fig.155919: Crane chassis central lubrication system

- 1 Central lubrication system



**Note**

- ▶ For maintenance and operation of the central lubrication system, see chapter 7.05.

### 4 Crawler carrier



**Note**

- ▶ The illustrations in this section are only examples and details can differ from the supplied crane.

## 4.1 Checking the glide rails for signs of wear

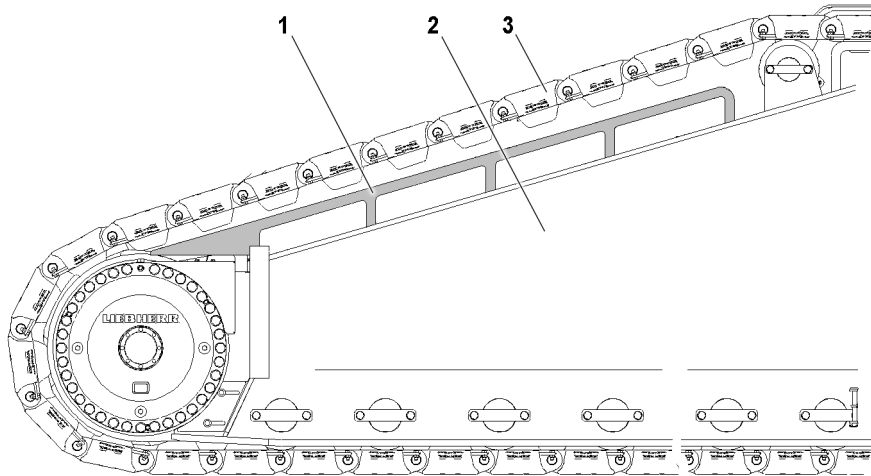


Fig.155916: Glide rails

- |   |                        |
|---|------------------------|
| <p>1 Glide rails</p> <p>2 Crawler carrier</p> | <p>3 Crawler chain</p> |
|---|------------------------|

### NOTICE

The chain tension is too low!

The crawler chain **3** damages the glide rail **1**. Damage to the crawler chain or on the steel structure of the crawler carrier.

▶ Check the chain tensioning according to intervals.

▶ Visual inspection: Check the glide rails **1** for signs of wear.

If the glide rails **1** are deformed or traces of wear are visible, carry out the following measures:

- ▶ Replace the glide rails **1**.
- ▶ Tension the crawler chain **3**.

## 5 Crawler chain



### Note

- ▶ The illustrations in this section are only examples and details can differ from the supplied crane.

During crawler operation, the components of the crawler travel gear are subject to wear caused by operation.

In order to continuously guarantee safe and effective crane operation, components must be checked at the specified maintenance intervals and replaced if necessary, see the chapter 7.02.



### WARNING

Maintenance interval exceeded!

Failure to observe the specified maintenance intervals can lead to increased crane failure time as well as to damage to the crawler travel gear.

Death, severe bodily injuries, property damage.

- ▶ Observe and adhere to the maintenance intervals, see chapter 7.02.
- ▶ The crane operator is responsible for complying with the maintenance intervals, properly performing the specified maintenance tasks as well as initiating the corresponding measures as a result of the inspection results.

**WARNING**

Slipping down of the crawler chain when separating the crawler chain!  
Death, severe bodily injuries, property damage.

- ▶ Secure the outrigger pads before separating to prevent them from slipping.
- ▶ Have the crawler chain disconnected by authorized and trained service personnel.

## 5.1 Checking the connector pin retainer

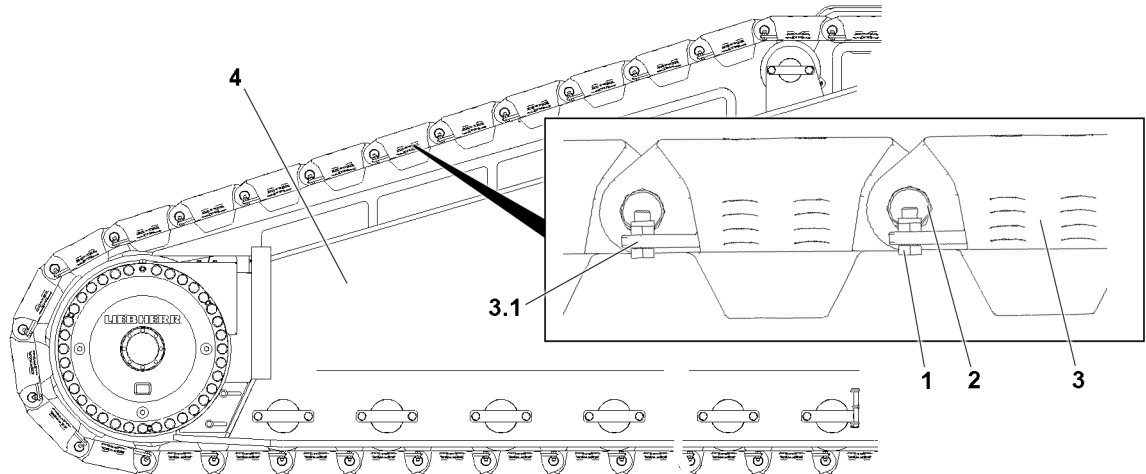


Fig.155917: Connector pin retainer

- |                 |                       |
|-----------------|-----------------------|
| 1 Retainer      | 3.1 Bore              |
| 2 Connector pin | 4 Crawler travel gear |
| 3 Outrigger pad |                       |

**NOTICE**

The retainer 1 for the connector pins 2 is missing!

The connector pin 2 can fall out of the bores 3.1 in the outrigger pad 3. Property damage to the crawler travel gear 4.

- ▶ Check that the retainer 1 is properly seated according to the intervals.

- ▶ Check if all retainers 1 are present.

If a retainer 1 is **not** available:

- ▶ Replace the retainer 1.
- ▶ Check that retainer 1 is properly seated.

If the retainer 1 is loose:

- ▶ Tighten the retainer 1.

## 5.2 Checking the chain tension

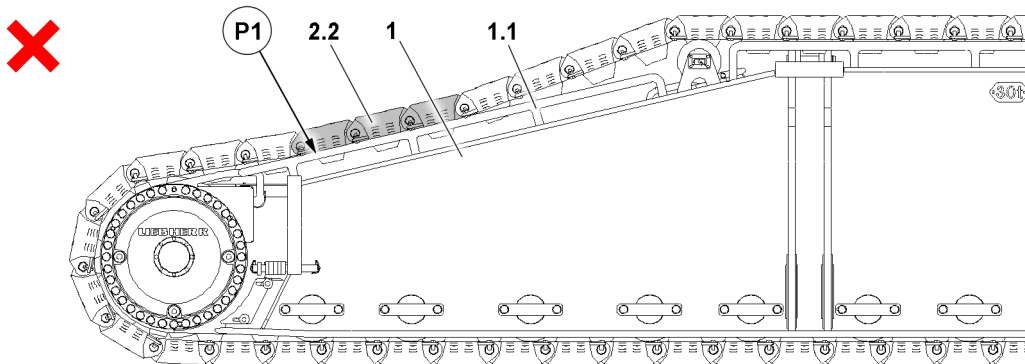
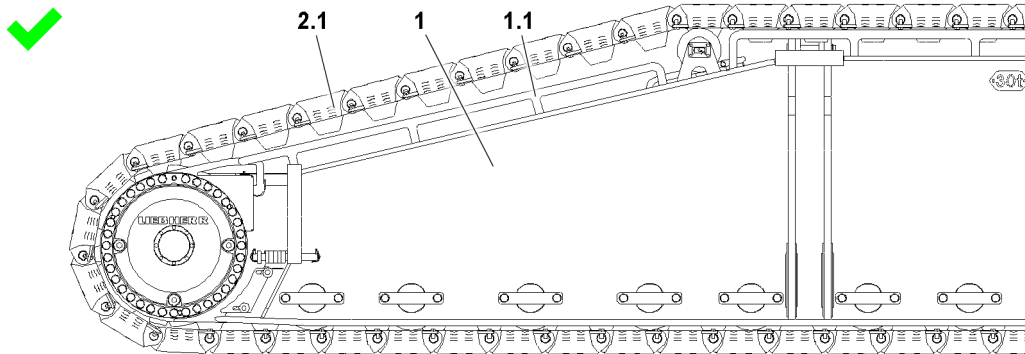


Fig.155920: Checking the chain tension

1 Crawler carrier  
1.1 Glide rails

2.1 The chain tension is OK  
2.2 The crawler chain is sagging too much

### NOTICE

The chain tension is too low!

Damage to the crawler chain or on the steel structure of the crawler carrier.

- ▶ Observe and adhere to the maintenance intervals, see chapter 7.02.
- ▶ Retension the crawler chain **immediately**.

The following applies in the case of crawler carriers 1 without glide rails 1.1 or with worn glide rails 1.1:

- ▶ Make sure that the outrigger pad cams never come into contact with the base steel structure of the crawler carrier. Always retension the crawler chain early on.

### The following applies:

- ▶ The crane driver bears full responsibility for damage resulting from a non-tensioned crawler chain.

The crawler chain must be retensioned at the latest when three outrigger pads 2.2 in position P1 are laying flat on the glide rails 1.1 on the crawler carrier 1.

- ▶ Check the chain tension for sagging.

If required:

- ▶ Tension the crawler chain.
- ▶ Check the glide rails for signs of wear.

If the glide rails are worn:

- ▶ Contact Customer Service at Liebherr-Werk Ehingen GmbH.



## 5.3 Tensioning the crawler chain



### Note

- ▶ New crawler travel gear: As the components run in toward each other, the crawler chain lengthens initially more.

When all spacer plates are set and the crawler chain **cannot** be tensioned any further:

- ▶ Remove a outrigger pad early on so that the crawler chain can be tensioned.
- ▶ Have the outrigger pad removed by authorized and trained service personnel.

### NOTICE

Foreign particles!

Damage to the crawler chains and the travel drive.

- ▶ Before tensioning the crawler chains: Check the crawler chains and the travel drives for foreign particles, and clean them if necessary.

Make sure that the following prerequisites are met:

- The crane is in a horizontal position.
- Crane operation/driving is set.

### 5.3.1 Inserting the tension cylinder in the crawler carrier opening

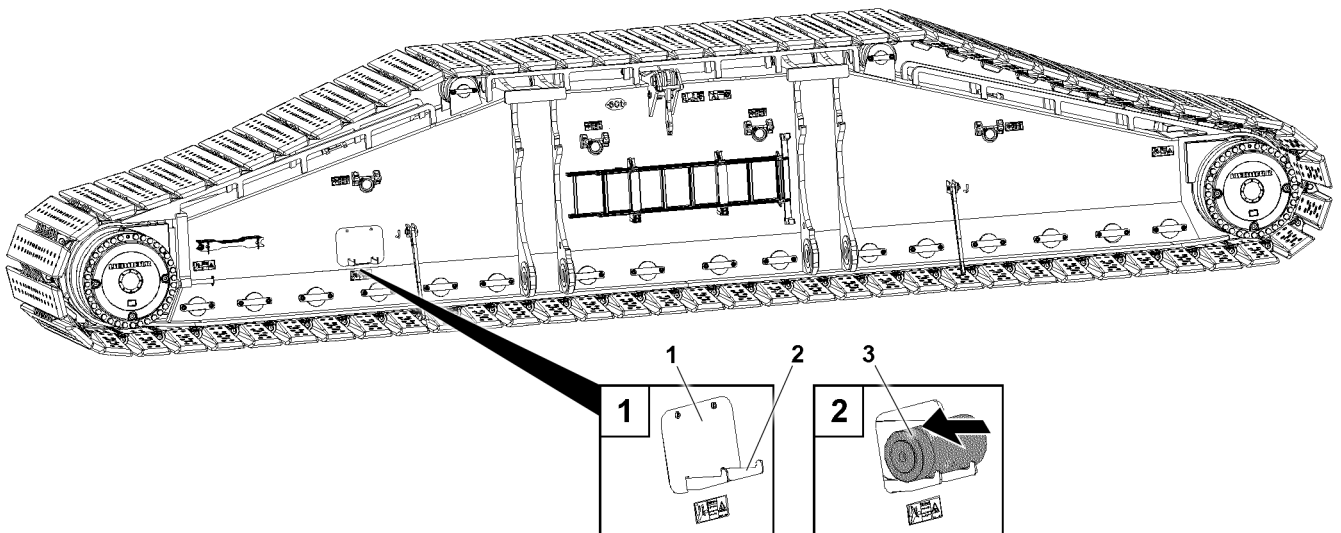


Fig.155921: Inserting the tension cylinder in the crawler carrier opening

- |                  |                     |                  |
|------------------|---------------------|------------------|
| 1                | 2                   | 3                |
| Maintenance flap | Cylinder receptacle | Tension cylinder |

Make sure that the following prerequisites are met:

- An auxiliary crane for transporting the tension cylinder **3** is present.
- ▶ Remove the maintenance flap **1**.

### NOTICE

Sliding the tension cylinder into the crawler carrier opening!

Hydraulic connections can be damaged.

- ▶ Make sure that the hydraulic connections of the tension cylinder point forward to the crawler carrier opening when sliding it in.
- ▶ Fasten the tension cylinder **3** to the auxiliary crane.
- ▶ Lift the tension cylinder **3** with the auxiliary crane off the cylinder receptacle **2** and remove the fastening equipment.

- ▶ Until the tension cylinder **3** is centered in the “working position”: Slide the tension cylinder **3** into the crawler carrier opening.

### 5.3.2 Establishing the hydraulic connection

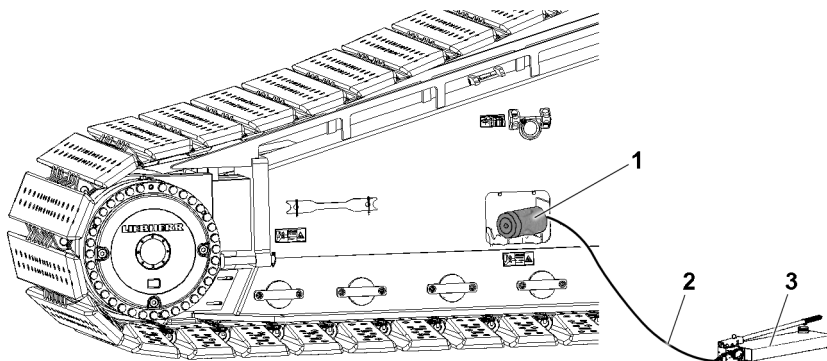


Fig.155926: Tension cylinder, hydraulic connection with the hand lever pump

- |   |                  |   |                |   |                 |
|---|------------------|---|----------------|---|-----------------|
| 1 | Tension cylinder | 2 | Hydraulic line | 3 | Hand lever pump |
|---|------------------|---|----------------|---|-----------------|

- ▶ Properly assemble the hydraulic line **2** on the tension cylinder **1** and hand lever pump **3**.

### 5.3.3 Tensioning the crawler chain



#### Note

- ▶ The spacers maintain the chain tension.

Make sure that the following prerequisites are met:

- The tension cylinder is properly inserted in the crawler carrier opening.
- The hydraulic connection between the tension cylinder and the hand lever pump is established.

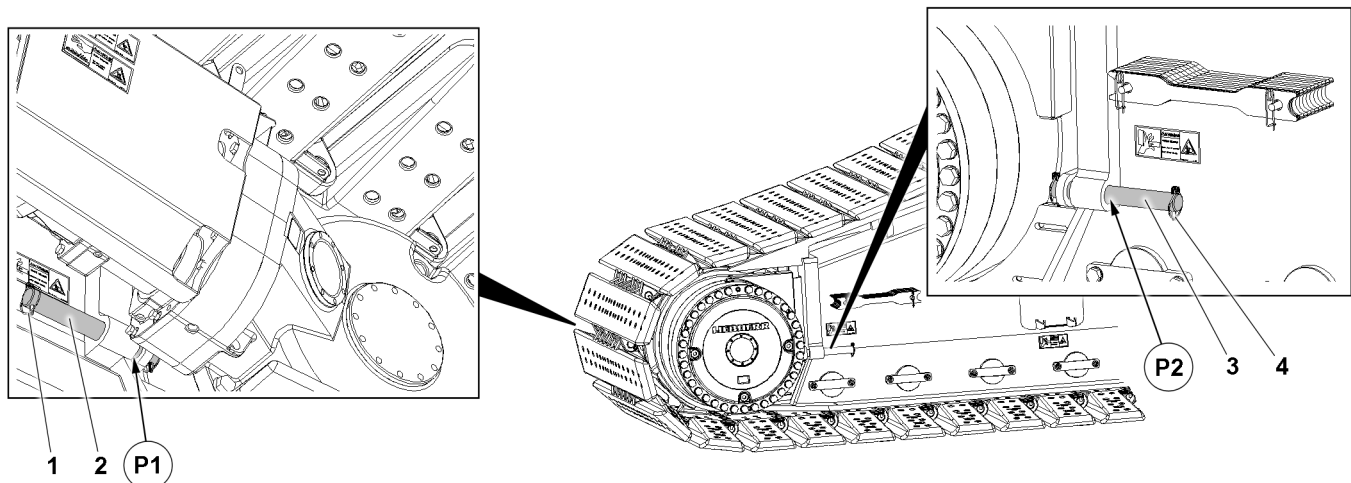


Fig.155922: Crawler carrier, retainer for spacers, both sides

- |   |                   |   |                   |
|---|-------------------|---|-------------------|
| 1 | Retaining element | 3 | Guide rod         |
| 2 | Guide rod         | 4 | Retaining element |

The spacers are secured on both side on the outside of the crawler carrier:

- In position **P1** with the guide rod **2**
- In position **P2** with the guide rod **3**
- ▶ Remove the retaining element **P2** in position **3** and unpin the guide rod **3**.

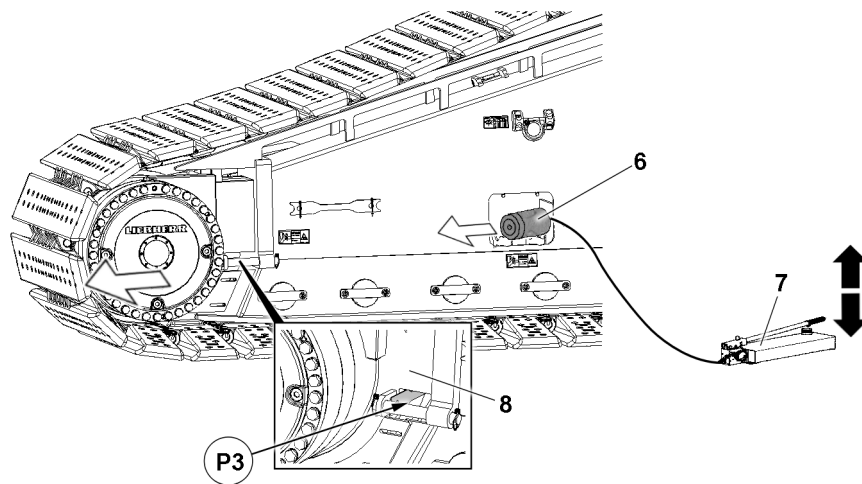


Fig.155925: Tensioning the crawler chain with the tension cylinder and the hand lever pump

- 6 Tension cylinder  
7 Hand lever pump  
8 Sliding section

By extending the tension cylinder, **6** the sliding section **8** is moved in direction of the arrow.



#### WARNING

Extension of the tension cylinder!  
Crushing and shearing off body parts, such as: fingers, hands and arms.  
Death, severe injury, property damage.

When the tension cylinder is extended:

- ▶ Keep personnel away from the crawler carrier.
  - ▶ Stop work on the crawler carrier.
- 
- ▶ Operate the hand lever pump **7** until the hand lever pump **7** can no longer be moved.

#### Result:

- The tension cylinder **6** extends.
- The crawler chain is tensioned.
- There is an opening for the spacers in position **P3**.

#### Problem remedy

The crawler chain **cannot** be tensioned?

The stroke on the tension cylinder is **not** sufficient.

- ▶ Contact Customer Service at Liebherr-Werk Ehingen GmbH.
- ▶ Have the outrigger pad removed by authorized and trained service personnel.

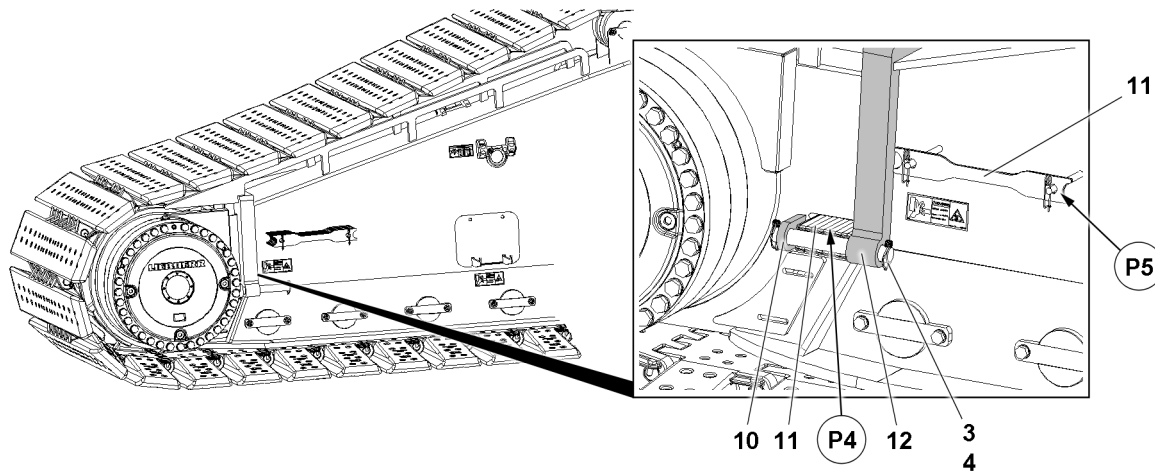


Fig.155924: Adding spacers

3	Guide rod	10	Stop	12	Stop
4	Retaining element	11	Spacer		

The spacers are available in different sizes and must be combined.

- ▶ Remove the spacers **11** from the transport receptacle in position **P5**.
- ▶ In position **P4**, insert as many spacers **11** as fit into the gap between the stop **10** and the stop **12**.
- ▶ Secure the spacers **11** with the guide rod **3** and locking pin **4**.
- ▶ Secure the remaining spacers **11** in the transport receptacle in position **P5**.



#### WARNING

Retracting of the tension cylinder!  
Crushing and shearing off body parts, such as: fingers, hands and arms.  
Death, severe injury, property damage.

When the tension cylinder is retracted:

- ▶ Keep personnel away from the crawler carrier.
  - ▶ Stop work on the crawler carrier.
- 
- ▶ Relieve the tension cylinder **6** with the hand lever pump **7**.
  - ▶ After the tension procedure, drive the crawler back and forth by one crawler length in "straight forward travel" operating mode.

#### Result:

- The tension of the crawler chain is reduced.
- ▶ Check the distance of the crawler chain to the steel structure of the crawler carrier, see section "Checking the chain tension".

If required:

- ▶ Repeat the tension procedure of the crawler chain and insert additional spacers **11**.

### 5.3.4 Removing the tension cylinder from the crawler carrier

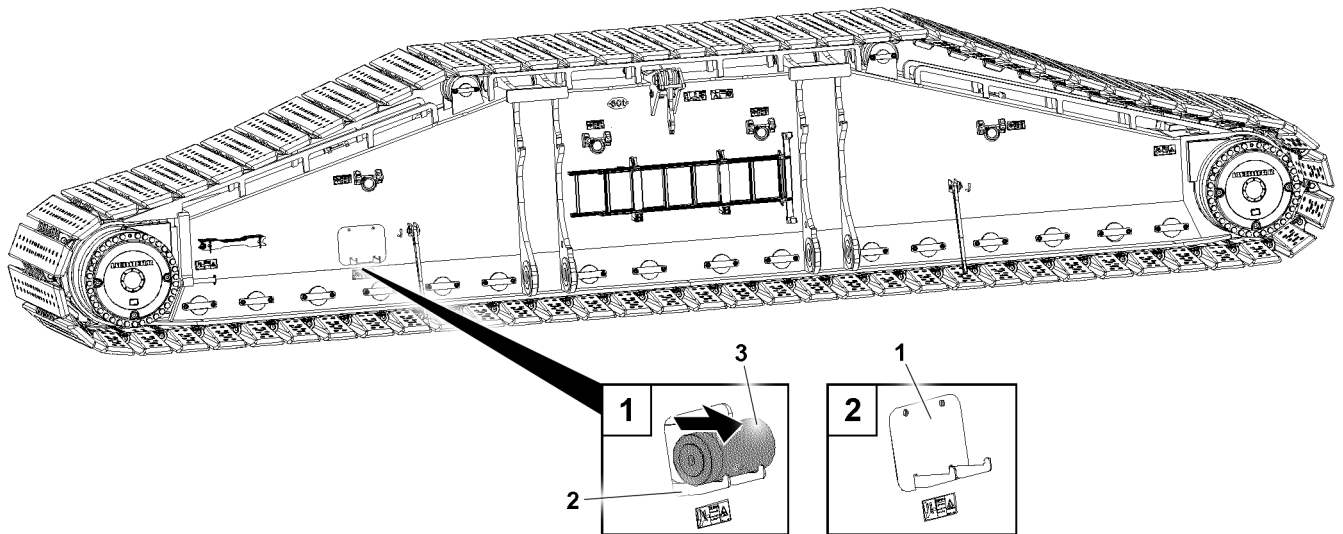


Fig.155927: Removing the tension cylinder

- 1 Maintenance flap                      2 Cylinder receptacle                      3 Tension cylinder

Make sure that the following prerequisites are met:

- The crawler chain is tensioned.
  - The spacers are properly inserted.
  - The spacers are properly secured with pins.
  - The tension cylinder is fully retracted.
  - An auxiliary crane for transporting the tension cylinder **3** is present.
- ▶ Disconnect the hydraulic connection: Properly disassemble the hydraulic lines on the tension cylinder and hand lever pump.

#### NOTICE

Removal of the tension cylinder in the crawler carrier opening!  
Hydraulic connections can be damaged.

- ▶ Pull the tension cylinder carefully out of the crawler carrier opening in the cylinder receptacle.
- ▶ Pull the tension cylinder **3** out of the crawler carrier opening in the cylinder receptacle **2**.
- ▶ Fasten the tension cylinder **3** to the auxiliary crane.
- ▶ Remove the tension cylinder **3** with the auxiliary crane from the cylinder receptacle **2**.
- ▶ Assemble the maintenance flap **1** properly in position.

### 5.4 Checking the crawler chain for signs of wear



#### WARNING

Exceeding the wear limits on the outrigger pads, pins or track rollers!  
Crawler chain can be ripped off. The crane can topple over. Death, severe injuries.

- ▶ Make spot checks of the outrigger pads, pins and track rollers within the specified intervals.
- ▶ Visually check the track rollers on a random basis. Always check the first and the last track roller on the crawler carrier.

When a wear limit on the component is reached:

- ▶ Replace the component or have it reworked by authorized and trained service personnel.

### 5.4.1 Replacing the outrigger pad

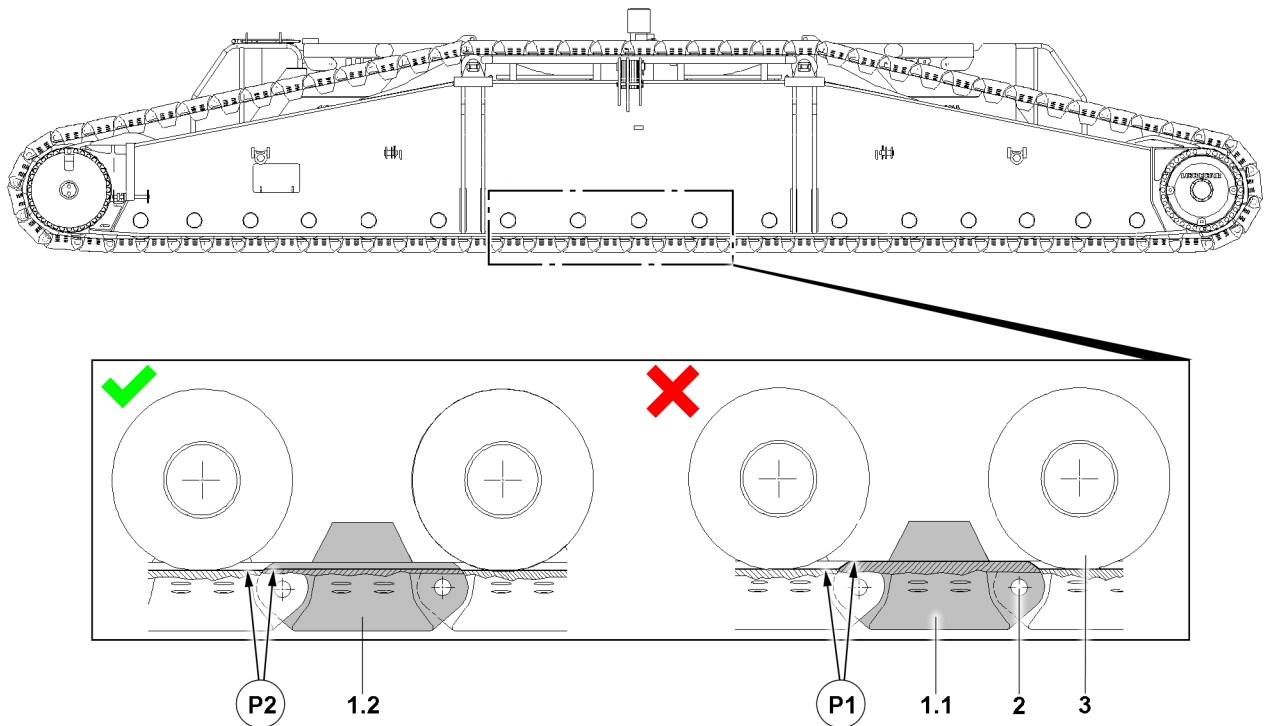


Fig.144711: Outrigger pads, height differences

<b>P1</b>	Height difference	<b>1.1</b>	Replaced outrigger pad, less wear	<b>2</b>	Pin
<b>P2</b>	No height difference	<b>1.2</b>	Replaced outrigger pad, similar degree of wear	<b>3</b>	Track roller

#### NOTICE

Significant height differences between the individual outrigger pads, see position **P1!**  
Increased mechanical stress on the outrigger pads **1.1** and the track rollers **3**. Property damage.

If one individual outrigger pad must be replaced:

- ▶ Do **not** replace the outrigger pad with an outrigger pad **1.1** with a much lower degree of wear.
- ▶ Replace a worn outrigger pad with an outrigger pad **1.2** that shows a similar degree of wear, see position **P2**.

The wear of the outrigger pad **1**, pin **2** and track rollers **3** depends on various factors:

- Length of travel route
- Frequency of driving in curves
- Friction ratios between the outrigger pad **1** and ground
- Evenness of the ground
- Type of ground
- Load bearing capacity of the ground / base
- Position of the total center of gravity
- Load on the hook
- Placed ballast on the crane

Make sure that the following prerequisites are met:

- The crawler chain is separated.

If one individual outrigger pad **1** must be replaced:

- ▶ Have the outrigger pads replaced by authorized and trained service personnel.

## 5.4.2 Checking the sprocket wheels and transport cams

### NOTICE

Dimension and association of wear on pins, bore and run in depth on the outrigger pads!  
Increased wear on the sprocket wheels and transport cams. Expensive and extensive repairs.

- ▶ Check the sprocket wheels and transport cams of the outrigger pads for wear.



### Note

When the sprocket wheels and outrigger pads are worn or damaged due to operation:

- ▶ Damage can be repaired by repair welds according to welding guidelines or repair instructions from Liebherr-Werk Ehingen GmbH.
- ▶ Contact Customer Service at Liebherr-Werk Ehingen GmbH.

## 5.4.3 Measuring the pins and bores on the outrigger pads

### NOTICE

Wear limits at the connections to the outrigger pads exceeded!  
Damage to the sprocket wheels. Excessively strong chain stretch.  
Increased wear on the glide rails, sprocket wheels and transport cams of the outrigger pads.  
Expensive and extensive repairs.

- ▶ Check the pin diameter within the specified intervals.
- ▶ Check the bore diameter within the specified intervals.

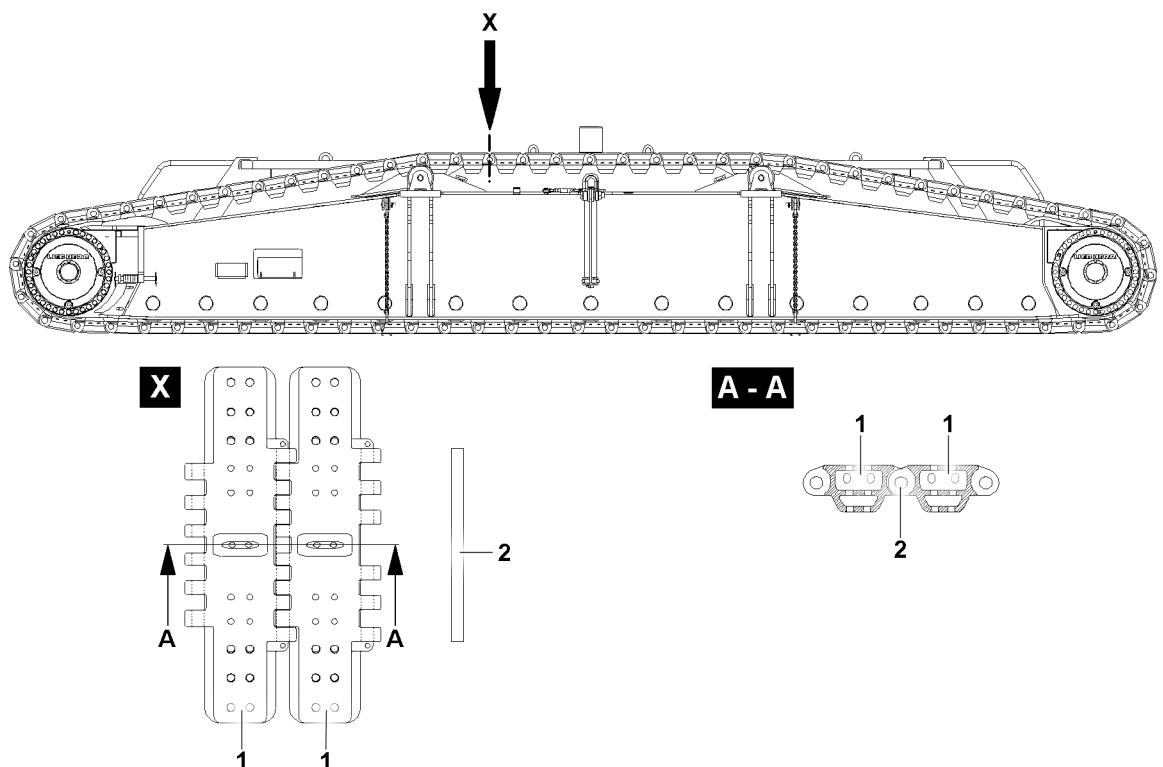


Fig.144710: Pins and bores on the outrigger pads

The outrigger pads 1 of the crawler chain are connected by pins 2.

Make sure that the following prerequisites are met:

- The crawler chain is separated.

The pins and bores on the outrigger pads are checked randomly.

Component	Initial diameter	Minimum permissible diameter
Pin	50 mm	49 mm

#### Pin wear limits

When one pin **2** falls below the permissible diameter:

- ▶ Replace the pin **2**.

Component	Initial diameter	Maximum permissible diameter
Outrigger pad bore	53 mm	56 mm

#### Outrigger pad bore wear limits

When one bore exceeds the permissible diameter:

- ▶ Replace the outrigger pad **1**.

### 5.4.4 Checking the roll off surfaces of the outrigger pad and track roller

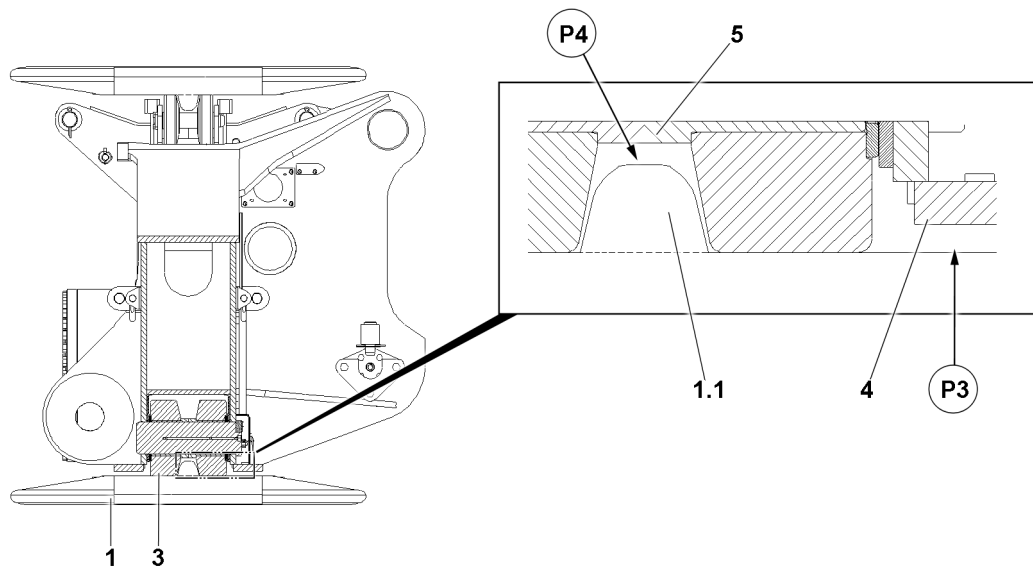


Fig.144714: Components that are damaged when the wear limits are exceeded

When the wear limits are exceeded, the minimum distances between the following components are fallen below:

- Position **P3**: Between the outrigger pad **1** and base belt **4**
- Position **P4**: Between the transport cams **1.1** and track roller body **5**

#### NOTICE

Outrigger pad **1** after reaching the wear limit **not** repaired or replaced!

The transport cams **1.1** are worn or severed.

The outrigger pad **1** can be destroyed and cause property damage to the crawler carrier.

- ▶ Fix or replace the outrigger pad **1** after reaching the wear limit.

#### NOTICE

Track roller **3** **not** replaced after reaching the wear limit!

The track rollers **3** can fail and cause damage to the crawler carrier and the outrigger pad **1**.

- ▶ Replace the track rollers **3** after reaching the wear limit.



**NOTICE**

Bulges on the outrigger pads **1** and the track rollers **3** are too large!  
 Increased wear on the crawler travel gear. Considerable property damage.  
 ► Grind off bulges in time.



**WARNING**

Improper procedure!  
 Death, severe bodily injuries, property damage.  
 ► Have all crawler chain repair work performed by authorized and trained service personnel.

Make sure that the following prerequisites are met:  
 – The crawler chain is relieved.

**Measuring the run-in depth of the outrigger pads**

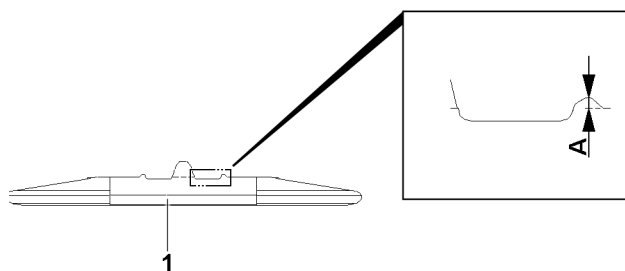


Fig.144713: Outrigger pad bulge

- Check the bulge **A** on the outrigger pad **1**.
- When the bulge **A** scrapes on the base belt of the crawler carrier:
- Grind the bulge off.

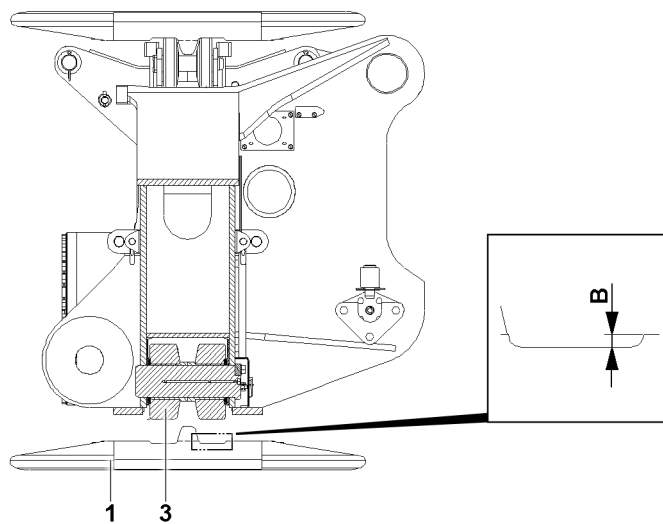


Fig.144712: Outrigger pad run-in depth

Component	Maximum permissible run-in depth B
Outrigger pad <b>1</b>	8 mm

*Outrigger pad run-in depth*

LWE/LR 1800-1-0-000/27200-07-02/en

When the permissible run-in depth **B** is exceeded:

- ▶ Repair or replace the outrigger pad **1**.



#### Note

When the maximum run-in depth **B** is reached or the running surfaces are significantly worn:

- ▶ The outrigger pads **1** can be repaired by repair welds according to welding guidelines or repair instructions from Liebherr-Werk Ehingen GmbH.
- ▶ Contact Customer Service at Liebherr-Werk Ehingen GmbH.

#### Measuring the wear limits on the track rollers

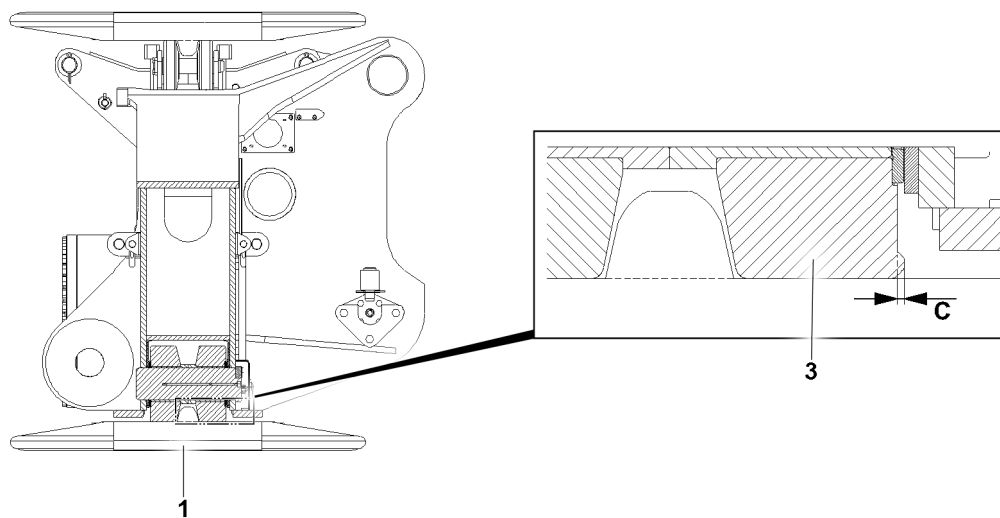


Fig.144715: Track roller bulge

Component	Initial diameter	Minimum permissible diameter
Track roller <b>3</b>	370 mm	366 mm

#### Track roller diameter

- ▶ Measure the diameter of the track roller **3** in the center of the running surface.

When one track roller **3** falls below the permissible diameter:

- ▶ Replace the track roller **3**.

Component	Maximum permissible bulge <b>C</b>
Track roller <b>3</b>	3 mm

#### Track roller bulge

When the permissible bulge is exceeded:

- ▶ Grind the bulge **C** off.

## 6 Hydraulic hose lines

### 6.1 Servicing hydraulic hose lines

**Note**

▶ See chapter 7.05.

---

## 7 Ladders

### 7.1 Servicing the ladders

**Note**

▶ See chapter 7.05.

---

---

Empty page!

LWE/LR 1800-1-0-000/27200-07-02/en

## 7.04.50 Maintenance instructions - Ballast trailer

1	Safety	2
2	Establishing the prerequisites for maintenance	2
3	Ballast trailer tires	2
4	Hydraulic hose lines	2
5	Slewing gear	3
6	Wheel set drive	6
7	Central lubrication system	10

# 1 Safety

Before performing maintenance activities, observe the safety instructions:

- General safety information: See chapter 2.04.
- Information regarding personal protective equipment: See chapter 2.04.
- Information regarding ladders: See chapter 2.04.10.
- Information regarding fall protection equipment on the crane: See chapter 2.06.
- Information regarding accesses to the crane: See chapter 2.07.
- Information regarding maintenance and service: See chapter 7.01.

## 2 Establishing the prerequisites for maintenance



### Note

- ▶ For all maintenance work, use operating fluids and lubricants according to the service fill.
  - ▶ Observe the ballast trailer maintenance intervals, see chapter 7.02.50.
- 
- ▶ Make sure that all catwalks and railings are assembled in the operating position.
  - ▶ Put the crane and ballast trailer in a horizontal position.
  - ▶ Climb onto the crane: Use the stairs, platform, catwalk and ladder.
  - ▶ Turn the diesel engine off.
  - ▶ Secure the diesel engine against an inadvertent start.
  - ▶ Turn the battery master switch off.

## 3 Ballast trailer tires

### 3.1 Ballast trailer tires



### Note

- ▶ See chapter 2.15.

### 3.2 Ballast trailer tires and disk wheels



### Note

- ▶ See chapter 8.01.

## 4 Hydraulic hose lines



### Note

- ▶ See chapter 7.05.

## 5 Slewing gear



### WARNING

Smoking, fire, open flames, electrical discharges!

Danger of fire: Gear oil is easily flammable.

Death, severe bodily injuries, property damage.

- ▶ Before the refueling procedure, turn the heating systems off, for example the auxiliary heater or the flame start system.
- ▶ When adding gear oil, forbid fire, open flames and smoking.



### WARNING

Hot components, hot operating materials!

Severe burns, scalding.

- ▶ Let components cool off to below 50 °C.
- ▶ Wear heat-resistant protective equipment: Wear protective gloves and work clothing.



### WARNING

Spilled gear oil!

Danger of slipping.

- ▶ Danger of slipping, pay attention.
- ▶ Use personal protective equipment depending on the operating materials.
- ▶ Immediately collect spilled gear oil using suitable material. See the safety data sheet from the manufacturer of the operating fluid.



### WARNING

Significant oil loss!

Uncontrolled load movements

Death, severe bodily injury, transmission damage.

- ▶ Contact Customer Service at Liebherr-Werk Ehingen GmbH.

### NOTICE

Insufficient oil!

Transmission damage.

- ▶ Check the oil level and add gear oil if necessary.

### NOTICE

Dirt inside the transmission!

Transmission damage. Increased wear and shorter service life of the components.

- ▶ Maintain extreme cleanliness during all work.
- ▶ Make sure that **no** dirt gets inside the transmission.

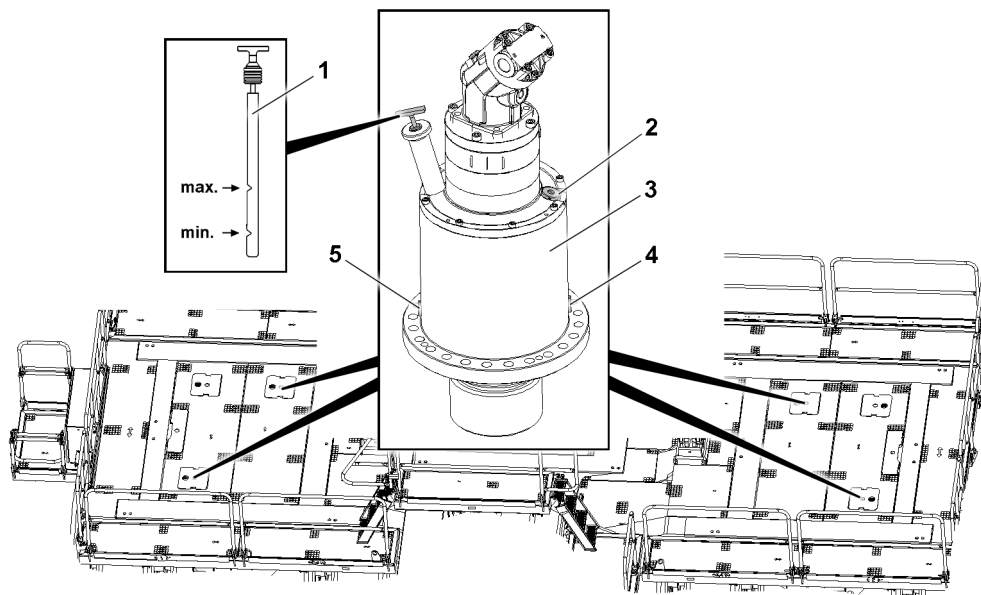


Fig.159201: Slewing gears, ballast trailer

- |   |                                  |   |                                |
|---|----------------------------------|---|--------------------------------|
| 1 | Dipstick                         | 4 | Oil drain plug, oil drain port |
| 2 | Oil filler plug, oil filler port | 5 | Oil drain plug, oil drain port |
| 3 | Slewing gear                     |   |                                |

## 5.1 Checking for leaks

### NOTICE

Slewing gear **not** tight!

Failure of the slewing gear.

Damage to the slewing gear and significant property damage possible.

- ▶ Repair the leaky slewing gear and replace the slewing gear, if in doubt.

- ▶ Check visually if every slewing gear is tight.

## 5.2 Checking the oil level

### NOTICE

**Impermissible** oil level!

Too little gear oil causes lubricating problems and reduces the service life of the gear.

Too much gear oil causes more displacement work and overheats the gear.

- ▶ Check the oil level.

If required:

- ▶ Add or drain gear oil.

Make sure that the following prerequisites are met:

- The ballast trailer is in horizontal position.
- The slewing gear has been stopped for at least two minutes.
- The slewing gear is warm.

The procedure is described for one slewing gear as an example.

- ▶ Pull out the dipstick **1** and wipe it off.
- ▶ Insert the dipstick **1** and pull it out.

The oil level must be visible between the minimum and maximum marks on the dipstick **1**.

When the oil level has dropped below the minimum mark:

- ▶ Until the oil level is visible between both marks on the dipstick **1**: Add gear oil in the filler port.



- ▶ Check the oil level.
- ▶ Insert the dipstick **1**.
- ▶ Make sure that oil level is checked in every slewing gear **3**.

#### Problem remedy

Repeated excessive oil consumption or loss of oil?

- ▶ Find the cause and remedy it.

If the cause cannot be remedied:

- ▶ Contact Customer Service at Liebherr-Werk Ehingen GmbH.

## 5.3 Changing the gear oil

Make sure that the following prerequisites are met:

- The ballast trailer is in horizontal position.
- The slewing gear has been stopped for at least two minutes.
- The slewing gear is warm.
- The oil collection container must have a suitable filling volume.

#### NOTICE

Seal ring **not** replaced!

Oil loss. Considerable wear and damage to the slewing gear.

- ▶ Use the seal rings on the maintenance ports only once.

#### NOTICE

Different operating fluids mixed!

Transmission damage.

- ▶ Do **not** mix synthetic oils with mineral oils.

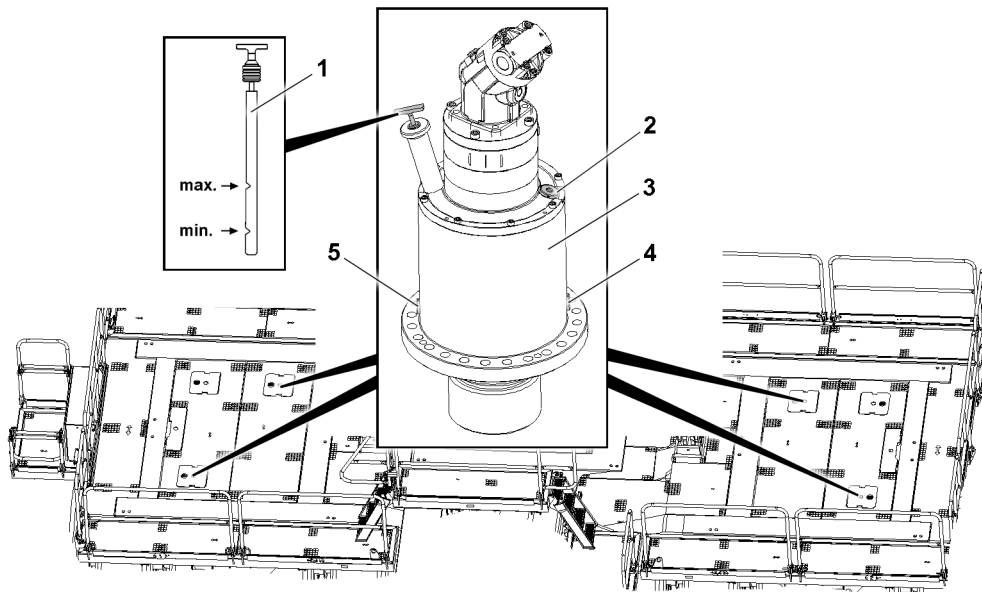


Fig. 159201: Slewing gears, ballast trailer

- |                                    |                                  |
|------------------------------------|----------------------------------|
| 1 Dipstick                         | 4 Oil drain plug, oil drain port |
| 2 Oil filler plug, oil filler port | 5 Oil drain plug, oil drain port |
| 3 Slewing gear                     |                                  |

The procedure is described for one slewing gear as an example.

- ▶ Pull out the dipstick **1**.
- ▶ Unscrew the oil filler plug **2**.
- ▶ Drain the gear oil: Select the oil drain plug **4** or oil drain plug **5**.

- ▶ Collect the gear oil: Position a container under the oil drain plug **4**.
- ▶ Drain the gear oil: Unscrew the oil drain plug **4**.

When gear oil is completely drained:

- ▶ Clean the oil drain plug **4** and sealing surface on the housing.
- ▶ Install the oil drain plug **4** with a new seal and tighten.
- ▶ Until gear oil is visible between the minimum and maximum marks on the dipstick **1**: Fill gear oil in the oil filler port **2**.
- ▶ Insert the dipstick **1**.
- ▶ Check the oil level.
- ▶ Install the oil filler plug **2** with a new seal and tighten.
- ▶ Make sure that gear oil is changed in every slewing gear **3**.

---

#### Problem remedy

Repeated excessive oil consumption or loss of oil?

- ▶ Find the cause and remedy it.

If the cause cannot be remedied:

- ▶ Contact Customer Service at Liebherr-Werk Ehingen GmbH.
- 

## 6 Wheel set drive



#### WARNING

Smoking, fire, open flames, electrical discharges!

Danger of fire: Gear oil is easily flammable.

Death, severe bodily injuries, property damage.

- ▶ Before the refueling procedure, turn the heating systems off, for example the auxiliary heater or the flame start system.
  - ▶ When adding gear oil, forbid fire, open flames and smoking.
- 



#### WARNING

Hot components, hot operating materials!

Severe burns, scalding.

- ▶ Let components cool off to below 50 °C.

- ▶ Wear heat-resistant protective equipment: Wear protective gloves and work clothing.
- 



#### WARNING

Spilled gear oil!

Danger of slipping.

- ▶ Danger of slipping, pay attention.

- ▶ Use personal protective equipment depending on the operating materials.

- ▶ Immediately collect spilled gear oil using suitable material. See the safety data sheet from the manufacturer of the operating fluid.
- 



#### WARNING

Uncontrolled load movement due to strong oil loss!

Death, severe bodily injury, transmission damage.

- ▶ In the case of considerable oil loss, contact Customer Service at Liebherr-Werk Ehingen GmbH.
- 

#### NOTICE

Insufficient oil!

Transmission damage.

- ▶ Check the oil level and add gear oil if necessary.
-

**NOTICE**

Dirt inside the transmission!

Transmission damage. Increased wear and shorter service life of the components.

- ▶ Maintain extreme cleanliness during all work.
- ▶ Make sure that **no** dirt gets inside the transmission.

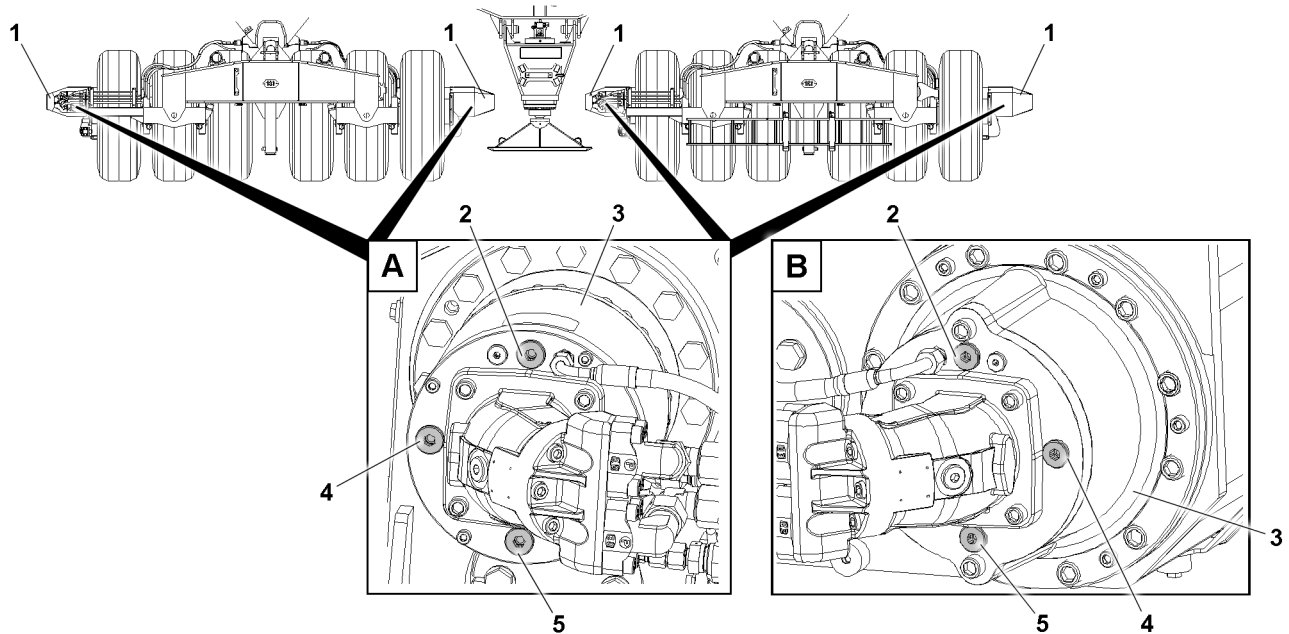


Fig.159204: Wheel set drive, ballast trailer

<b>A</b>	Variation	<b>2</b>	Oil filler plug, oil filler port	<b>5</b>	Oil drain plug, oil drain port
<b>B</b>	Variation	<b>3</b>	Wheel set drive		
<b>1</b>	Hood	<b>4</b>	Oil level plug, oil level port		

## 6.1 Checking for leaks

**NOTICE**

Wheel set drive **not** tight!

Failure of the wheel set drive.

Damage to the wheel set drive and significant property damage possible.

- ▶ Repair the leaky wheel set drive and replace the wheel set drive, if in doubt.

- ▶ Check visually if there are any leaks in every wheel set drive.

## 6.2 Checking the oil level

**NOTICE**

**Impermissible** oil level!

Too little gear oil causes lubricating problems and reduces the service life of the gear.

Too much gear oil causes more displacement work and overheats the gear.

- ▶ Check the oil level.

If required:

- ▶ Add or drain gear oil.

Make sure that the following prerequisites are met:

- The ballast trailer is in horizontal position.
- The wheel set drive has been stopped for at least two minutes.
- The wheel set drive is warm.

The procedure is described for one wheel set drive as an example.

- ▶ Disassemble the hood **1**.
- ▶ Unscrew the oil level plug **4**.

The oil level must be at the lower edge of the oil level port **4**.

- ▶ Perform a visual inspection.

If gear oil must be added:

- ▶ Unscrew the oil filler plug **2**.
- ▶ Fill gear oil in the oil filler port **2** until gear oil starts to run out of the oil filler port **4**.

---

#### NOTICE

Seal ring **not** replaced!

Oil loss. Considerable wear and damage to the wheel set drive.

- ▶ Use the seal rings on the maintenance ports only once.

- 
- ▶ Install the oil level plug **4** with a new seal and tighten.
  - ▶ Install the oil filler plug with a new seal and tighten.
  - ▶ Assemble the hood **1**.
  - ▶ Make sure that oil level is checked in every wheel set drive **3**.

---

#### Problem remedy

Repeated excessive oil consumption or loss of oil?

- ▶ Find the cause and remedy it.

If the cause cannot be remedied:

- ▶ Contact Customer Service at Liebherr-Werk Ehingen GmbH.
- 

## 6.3 Changing the gear oil

Make sure that the following prerequisites are met:

- The ballast trailer is in horizontal position.
- The wheel set drive has been stopped for at least two minutes.
- The wheel set drive is warm.
- The oil collection container must have a suitable filling volume.

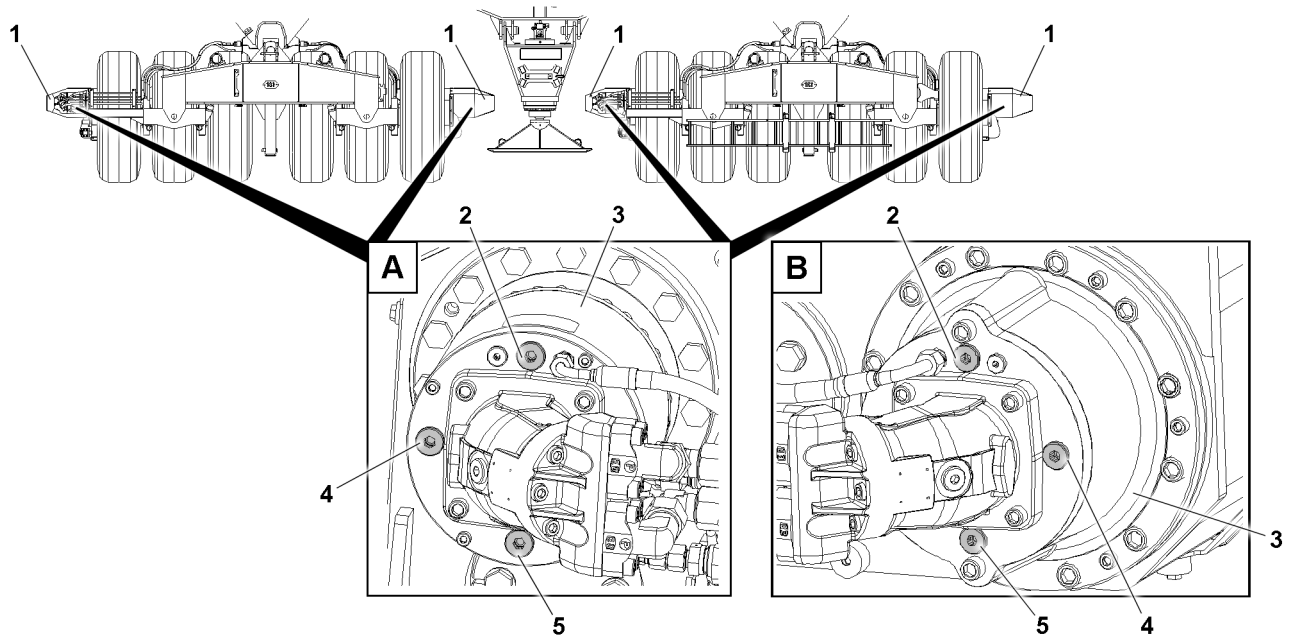


Fig.159204: Wheel set drive, ballast trailer

<b>A</b>	Variation	<b>2</b>	Oil filler plug, oil filler port	<b>5</b>	Oil drain plug, oil drain port
<b>B</b>	Variation	<b>3</b>	Wheel set drive		
<b>1</b>	Hood	<b>4</b>	Oil level plug, oil level port		

The procedure is described for one wheel set drive as an example.

- ▶ Disassemble the hood **1**.
- ▶ Unscrew the oil filler plug **2**.
- ▶ Unscrew the oil level plug **4**.
- ▶ Collect the gear oil: Position a container under the oil drain plug **5**.
- ▶ Drain the gear oil: Unscrew the oil drain plug **5**.

When gear oil is completely drained:

- ▶ Clean the oil drain plug **5** and sealing surface on the housing.
- ▶ Install the oil drain plug **5** with a new seal ring and tighten.
- ▶ Fill gear oil in the oil filler port until gear oil starts to run out of the oil filler port **4**.
- ▶ Install the oil level plug **4** with a new seal and tighten.
- ▶ Install the oil filler plug **2** with a new seal and tighten.
- ▶ Assemble the hood **1**.
- ▶ Make sure that gear oil is changed in every wheel set drive **3**.

## 7 Central lubrication system

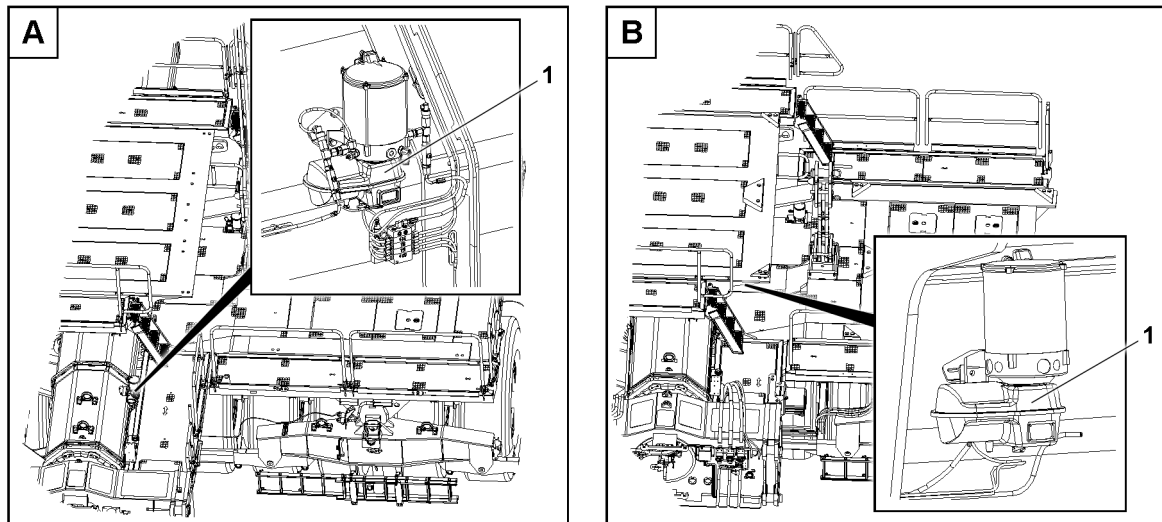


Fig.159202: Central lubrication system, ballast trailer guide

A Variation  
B Variation

1 Central lubrication system

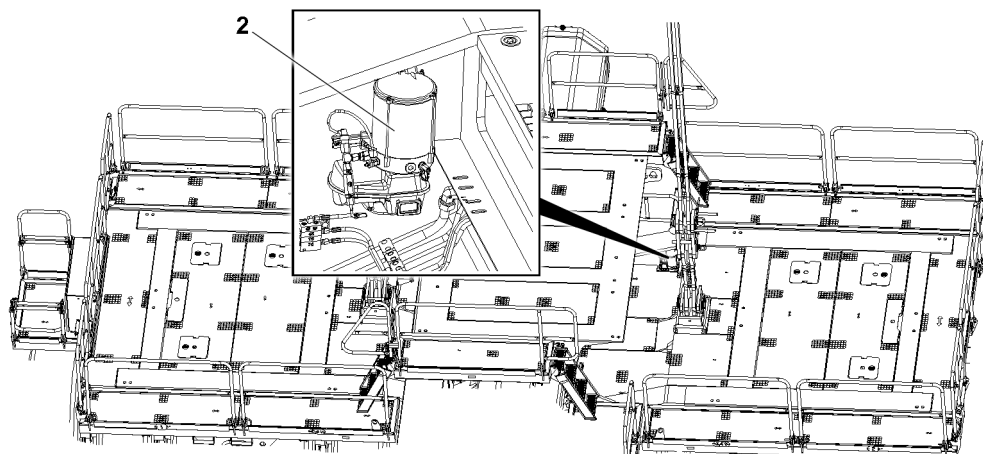


Fig.159203: Central lubrication system, ballast trailer

2 Central lubrication system

Ballast trailer: The lube points in the bearings of the following components are supplied with lubricant:

- Drive shaft
- Roller ring connection
- Rotary connection



### Note

► For maintenance and operation of the central lubrication system, see chapter 7.05.

## 7.05 Maintenance instructions - Crane superstructure

1	Safety	2
2	Establishing the prerequisites for maintenance	2
3	Fall protection equipment	2
4	Diesel engine	3
5	Cooling system	9
6	Fuel system	15
7	Urea system*	24
8	Exhaust system	27
9	Air filter system	29
10	Pump distributor gear	32
11	Central lubrication system	35
12	Slewing ring connection	42
13	Slewing gear	44
14	Winches	47
15	Assembly winch	50
16	Crane cab heating-air conditioner device	51
17	Crane cab auxiliary heater*	53
18	Air heater*	56
19	Drive assembly air conditioning system*	57
20	Hydraulic system	58
21	Hydraulic hose lines	66
22	Compressed air system	67
23	Electrical system	68
24	Window washing system	72
25	Ballast trailer*	73

# 1 Safety

Before performing maintenance activities, observe the safety instructions:

- General safety information: See chapter 2.04.
- Information regarding personal protective equipment: See chapter 2.04.
- Information regarding ladders: See chapter 2.04.10.
- Information regarding fall protection equipment on the crane: See chapter 2.06.
- Information regarding accesses to the crane: See chapter 2.07.
- Information regarding maintenance and service: See chapter 7.01.

## 2 Establishing the prerequisites for maintenance

- ▶ Align the crane horizontally.

When the SA-frame is assembled:

- ▶ Bring the SA-frame into the operating position.
- ▶ Make sure that the crane is fully assembled.
- ▶ Make sure that all catwalks and railings are assembled in the operating position.
- ▶ Climb onto the crane: Use the stairs, platform, catwalk and ladder.

## 3 Fall protection equipment

### 3.1 Lubricating the ladders

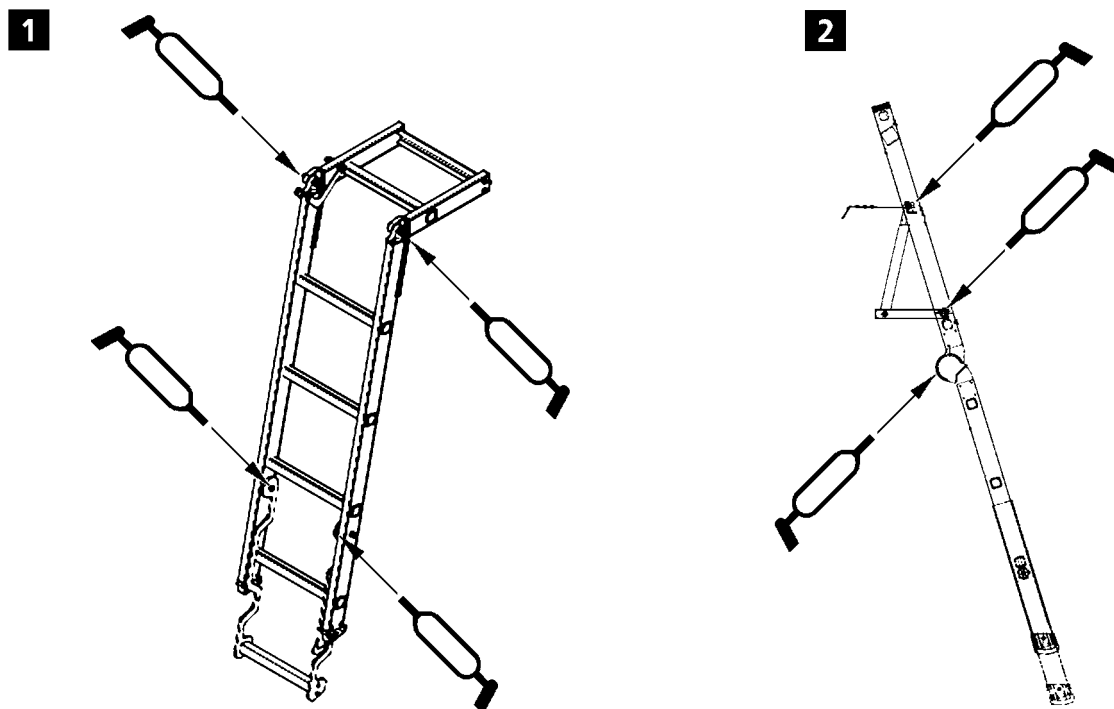


Fig.109766



**WARNING**

The following safety instructions were **not** observed!

Danger of falling. Death, severe bodily injuries, property damage.

- ▶ Observe and adhere to the assembly and safety instructions for ladders.
- ▶ Observe and adhere to the safety signs on the ladders.
- ▶ Install and secure the ladders properly.
- ▶ Do **not** use damaged ladders and replace them immediately.
- ▶ Have ladders repaired exclusively at authorized expert repair shops.

Make sure that the following prerequisites are met:

- The prerequisites for maintenance are established, see section “Establishing the prerequisites for maintenance”.
- The diesel engine is turned off.
- The ignition key is pulled out.
- The battery master switch is turned off.
- A grease gun is available.
- ▶ Grease joints and pivot points on the ladders and check them for easy movement, see illustration 1 and illustration 2.

When damage is present:

- ▶ Have ladders repaired by authorized and trained service personnel.

## 4 Diesel engine

**WARNING**

Hot components, hot operating materials!

Severe burns, scalding.

- ▶ Let components cool off to below 50 °C.
- ▶ Avoid contact with hands, skin and eyes.
- ▶ Wear safety goggles.
- ▶ Wear heat-resistant protective equipment: Wear protective gloves and work clothing.

### 4.1 Checking the oil level on the LICCON monitor

Make sure that the following prerequisites are met:

- The prerequisites for maintenance are established, see section “Establishing the prerequisites for maintenance”.
- The crane is in a horizontal position.
- The diesel engine has been turned off for at least 30 min.
- The ignition is turned on.

**NOTICE**

Impermissible engine oil level!









Engine damage.

- ▶ Remedy the problem and observe the error message.
- ▶ Establish a permissible oil level.

The engine oil level is monitored by the LICCON computer system.

Call up the monitoring functions and *engine oil level* individual control display, see chapter 4.02.

*Engine oil level* conditions, see following chart.

Status	Filling level	Meaning
1	 	Between min and max The oil level is OK.
2	 	Lower than the min The oil level is too low.
3	 	Higher than the max The oil level is overfilled.
4	 	The question mark is visible. Measurement is not possible. Establish the prerequisites for testing.

#### Engine oil level conditions

The oil level display must be between 0 and 100.

- ▶ Check the oil level, add engine oil if necessary. See the section “Checking the oil level with the dipstick”.

#### Problem remedy

Is the oil level higher than the max?

- ▶ Find the cause and remedy it.

If the cause cannot be remedied:

- ▶ Contact Customer Service at Liebherr-Werk Ebingen GmbH.

#### Problem remedy

Is there an excessive oil consumption or loss of oil?

- ▶ Find the cause and remedy it.

If the cause cannot be remedied:

- ▶ Contact Customer Service at Liebherr-Werk Ebingen GmbH.

## 4.2 Checking the oil level with the dipstick

### NOTICE

Impermissible engine oil level!

Engine damage.

- ▶ Remedy the problem and observe the error message.
- ▶ Establish a permissible oil level.

Make sure that the following prerequisites are met:

- The prerequisites for maintenance are established, see section “Establishing the prerequisites for maintenance”.
- The diesel engine is turned off.
- The ignition key is pulled out.
- The diesel engine has been turned off for at least 30 min.
- The battery master switch is turned off.

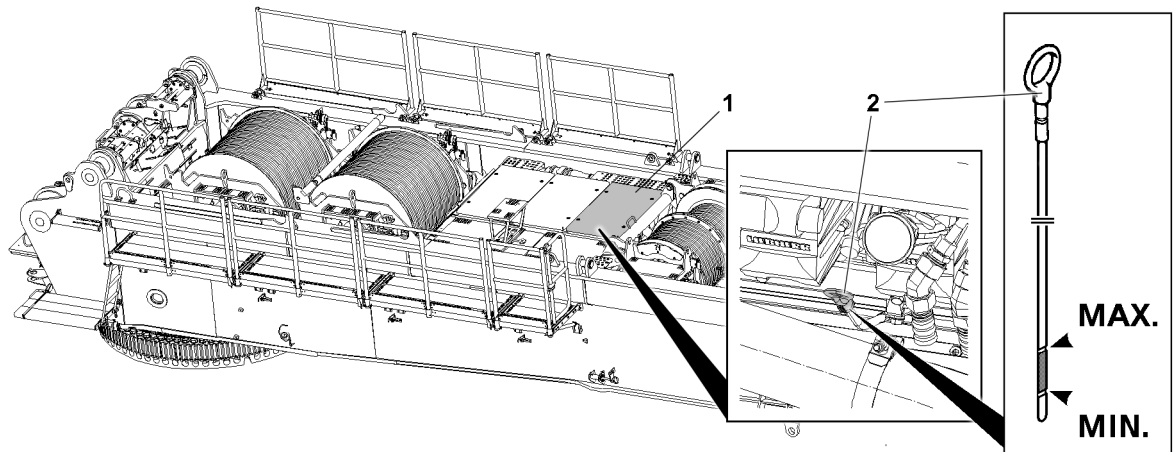


Fig.158531: Diesel engine dipstick

- 1 Cover 2 Dipstick

- ▶ Remove the cover **1**.
- ▶ Pull out the dipstick **2** and wipe it off.
- ▶ Insert the dipstick **2** and pull it out.

The engine oil must be visible between both marks on the dipstick **2**.

- ▶ Check the oil level.

Oil filler port, see section "Changing the engine oil and replacing the oil filter".

When the oil level has dropped below the minimum mark:

- ▶ Add engine oil until the oil level is visible between both marks on the dipstick **2**.
- ▶ Insert the dipstick **2**.
- ▶ Assemble the cover **1**.

---

#### Problem remedy

Is the oil level above the maximum mark?

- ▶ Find the cause and remedy it.

If the cause cannot be remedied:

- ▶ Contact Customer Service at Liebherr-Werk Ehingen GmbH.
- 

#### Problem remedy

Is there an excessive oil consumption or loss of oil?

- ▶ Find the cause and remedy it.

If the cause cannot be remedied:

- ▶ Contact Customer Service at Liebherr-Werk Ehingen GmbH.
- 

### 4.3 Checking the belt drive

Make sure that the following prerequisites are met:

- The prerequisites for maintenance are established, see section "Establishing the prerequisites for maintenance".
- The diesel engine is turned off.
- The ignition key is pulled out.
- The diesel engine, cooling system und exhaust system have cooled off for at least 30 min.
- The battery master switch is turned off.

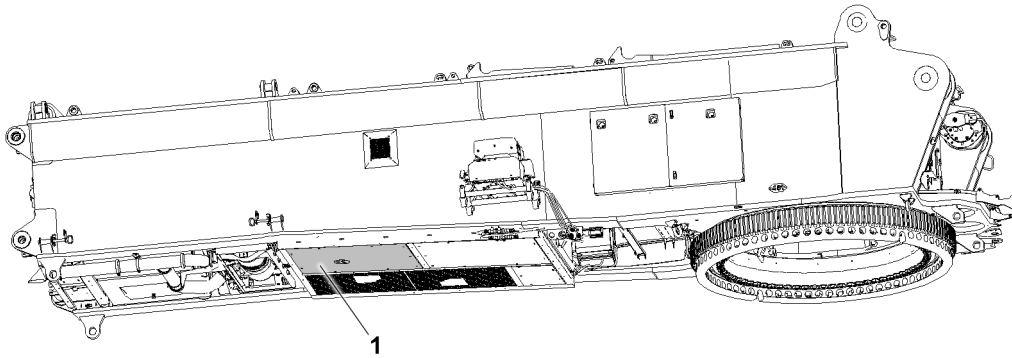


Fig.158532: Belt drive, diesel engine access

- ▶ Remove the cover 1.
- ▶ Check the belt drive, see the separate operating instructions from the engine manufacturer.
- ▶ Assemble the cover 1.

#### 4.4 Replace the belt drive

Make sure that the following prerequisites are met:

- The prerequisites for maintenance are established, see section “Establishing the prerequisites for maintenance”.
- The diesel engine is turned off.
- The ignition key is pulled out.
- The diesel engine, cooling system und exhaust system have cooled off for at least 30 min.
- The battery master switch is turned off.
- A new ribbed V-belt is available.

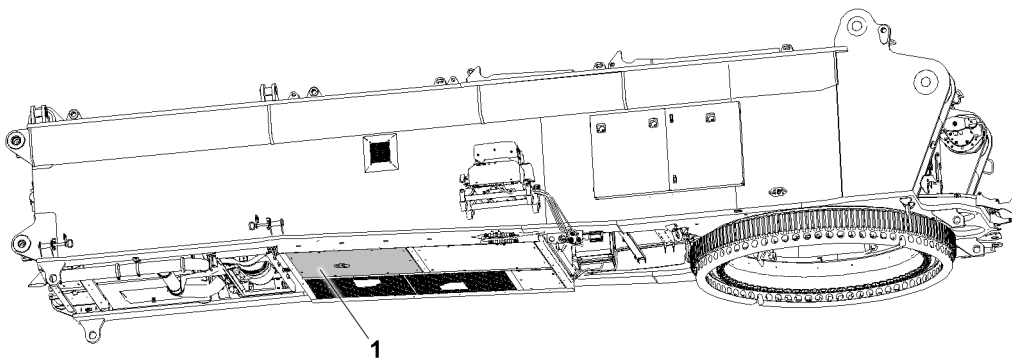


Fig.158532: Belt drive, diesel engine access

- ▶ Remove the cover 1.
- ▶ Check the belt drive, see the separate operating instructions from the engine manufacturer.
- ▶ Assemble the cover 1.

#### 4.5 Checking the heat flange

Make sure that the following prerequisites are met:

- The prerequisites for maintenance are established, see section “Establishing the prerequisites for maintenance”.
- The diesel engine is turned off.
- The ignition key is pulled out.
- The diesel engine, cooling system und exhaust system have cooled off for at least 30 min.
- The battery master switch is turned off.

- ▶ Check the heat flange, see the separate operating instructions from the engine manufacturer.

## 4.6 Replacing the heat flange

Make sure that the following prerequisites are met:

- The prerequisites for maintenance are established, see section “Establishing the prerequisites for maintenance”.
  - The diesel engine is turned off.
  - The ignition key is pulled out.
  - The diesel engine, cooling system und exhaust system have cooled off for at least 30 min.
  - The battery master switch is turned off.
- ▶ Replace the heat flange, see the separate operating instructions from the engine manufacturer.

## 4.7 Changing the engine oil and replacing the oil filter



### WARNING

Impermissible conditions for the engine oil!  
Danger of fire. Death, severe bodily injuries, property damage.

- ▶ Turn the heating systems off, for example the auxiliary heater or the flame start system.

When engine oil is filled:

- ▶ Exclude heat, sparks, flames and sources of ignition.
- ▶ Avoid high temperatures and direct sunlight.

Make sure that the following prerequisites are met:

- The prerequisites for maintenance are established, see section “Establishing the prerequisites for maintenance”.
- The diesel engine is turned off.
- The ignition key is pulled out.
- The diesel engine, cooling system und exhaust system have cooled off for at least 30 min.
- The engine is hot.
- The battery master switch is turned off.
- A suitably sized container for the used engine oil is on hand.
- The required quantity of engine oil is available, see the service fill.
- A new oil filter is available.
- A drain hose for draining the engine oil is available, see the on-board tools.
- An assembly scaffolding or a work platform is available.

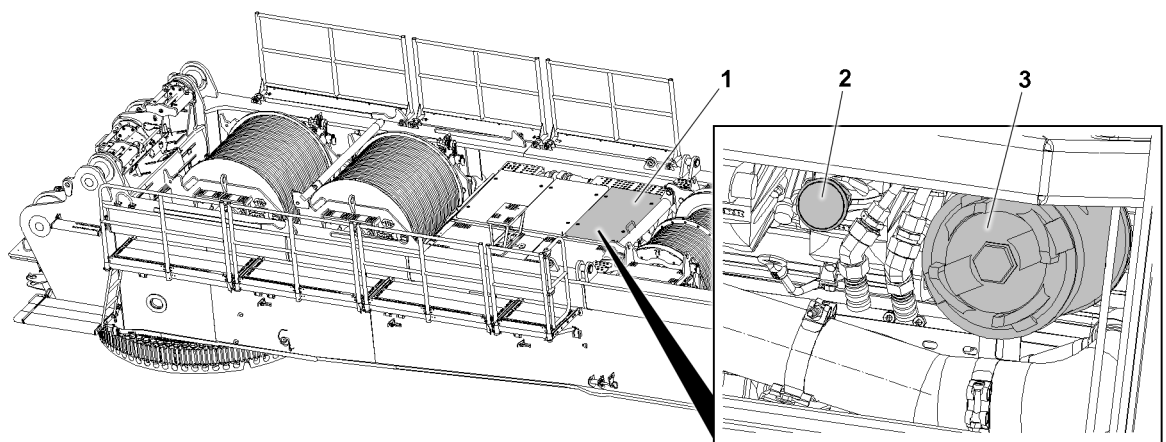


Fig.158533: Oil filler port and oil filter, diesel engine

- |   |                 |   |            |
|---|-----------------|---|------------|
| 1 | Cover           | 3 | Oil filter |
| 2 | Oil filler port |   |            |

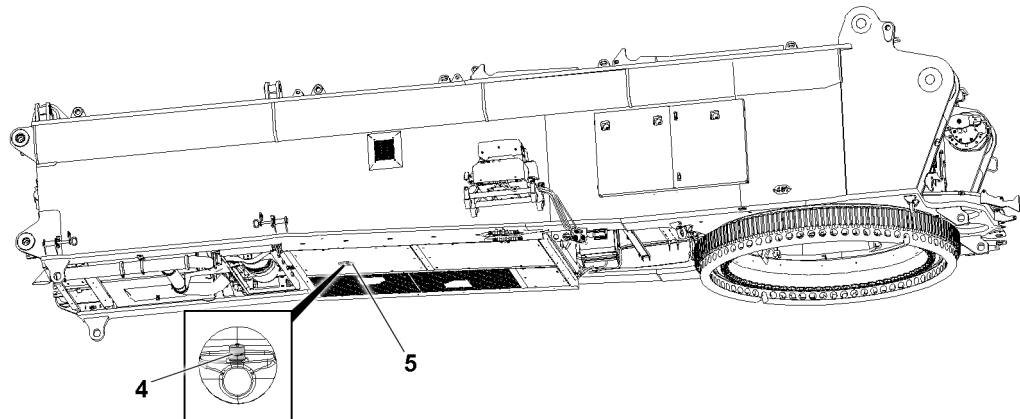


Fig.158534: Oil drain port, diesel engine

4 Oil drain port

5 Cover

Access to the bottom side of the turntable with "aids for work at a height". Observe and adhere to the information in chapter 2.04.

- ▶ Position an assembly scaffolding or a work platform.
- ▶ Remove the cover 1 and cover 5.



#### WARNING

Spilled engine oil!

Danger of slipping.

- ▶ Danger of slipping, pay attention.
- ▶ Use personal protective equipment depending on the operating materials.
- ▶ Immediately collect spilled engine oil using suitable material. See the safety data sheet from the manufacturer of the operating fluid.

- ▶ Change the engine oil, see the separate operating instructions from the engine manufacturer.
- ▶ Replace the oil filter 3, see the separate operating instructions from the engine manufacturer.
- ▶ Assemble the cover 1 and cover 5.

## 4.8 Replacing the oil separator filter insert

Make sure that the following prerequisites are met:

- The prerequisites for maintenance are established, see section "Establishing the prerequisites for maintenance".
- The diesel engine is turned off.
- The ignition key is pulled out.
- The diesel engine, cooling system und exhaust system have cooled off for at least 30 min.
- The battery master switch is turned off.
- New oil separator filter inserts are available.

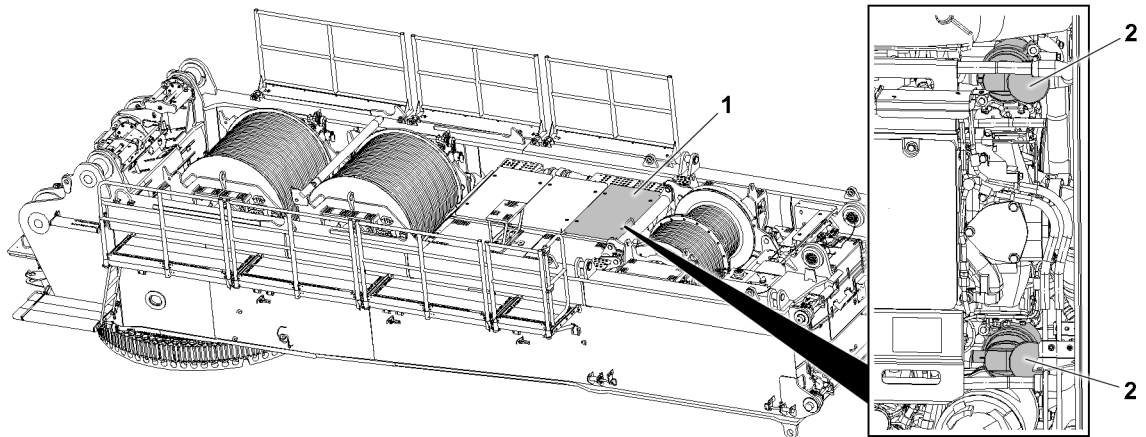


Fig.158535: Oil separator filter insert, diesel engine

1 Cover

2 Oil separator filter insert

- ▶ Remove the cover 1.
- ▶ Replace the oil separator filter insert 2, see the separate operating instructions from the engine manufacturer.
- ▶ Assemble the cover 1.

## 4.9 Checking the valve clearance

Make sure that the following prerequisites are met:

- The prerequisites for maintenance are established, see section “Establishing the prerequisites for maintenance”.
- The diesel engine is turned off.
- The ignition key is pulled out.
- The diesel engine, cooling system und exhaust system have cooled off for at least 30 min.
- The battery master switch is turned off.
- ▶ Check and set the valve clearance, see the separate operating instructions from the engine manufacturer.

## 5 Cooling system

### NOTICE

Impermissible coolant!

Engine damage.

- ▶ Do **not** mix different coolants.
- ▶ Do **not** thin Liebherr-Fertig-Mix (Liebherr Ready Made Mix).

When adding coolant:

- ▶ Use exclusively the same coolant with the same color.

### 5.1 Checking the coolant level

Make sure that the following prerequisites are met:

- The prerequisites for maintenance are established, see section “Establishing the prerequisites for maintenance”.
- The diesel engine is turned off.
- The ignition key is pulled out.
- The diesel engine, cooling system und exhaust system have cooled off for at least 30 min.
- The battery master switch is turned off.

The coolant level is monitored by the LICCON computer system.





**Problem remedy**

Excessive coolant consumption or coolant loss?

- ▶ Find the cause and remedy it.

If the cause cannot be remedied:

- ▶ Contact Customer Service at Liebherr-Werk Echingen GmbH.

## 5.2 Checking the concentration of the antifreeze in the coolant

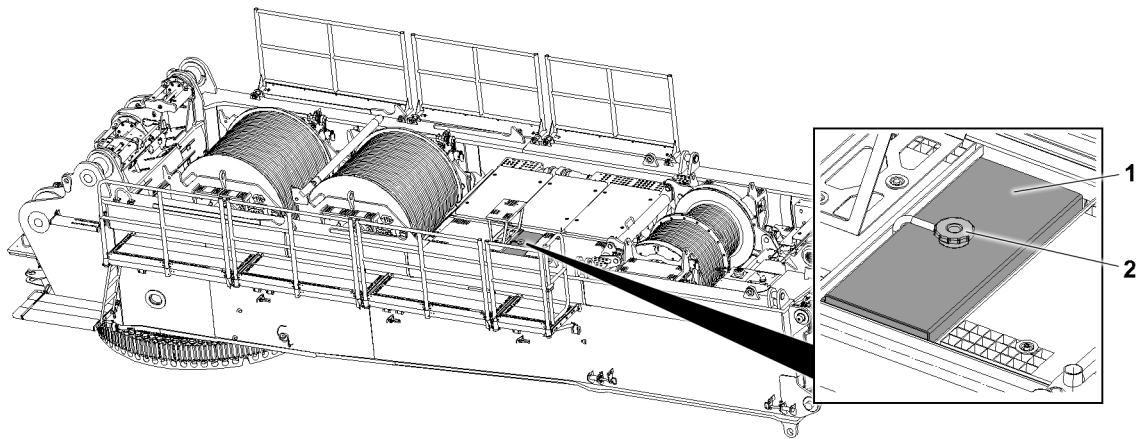


Fig.158536: Coolant expansion tank

- |          |                        |          |       |
|----------|------------------------|----------|-------|
| <b>1</b> | Coolant expansion tank | <b>2</b> | Cover |
|----------|------------------------|----------|-------|

Make sure that the following prerequisites are met:

- The prerequisites for maintenance are established, see section “Establishing the prerequisites for maintenance”.
- The diesel engine is turned off.
- The ignition key is pulled out.
- The diesel engine, cooling system und exhaust system have cooled off for at least 30 min.
- The battery master switch is turned off.

**WARNING**

Hot pressurized coolant!

Severe scalding, severe burns.

- ▶ Only open the coolant expansion tank when the coolant has cooled off.
- ▶ Wait until the coolant has cooled off.
- ▶ Wear personal protective equipment.

- ▶ Wait until the coolant has cooled off.
- ▶ Release excess pressure: Turn the cover **2** on the filler neck of the coolant expansion tank **1** to the first notch.
- ▶ Remove the cover **2**.
- ▶ Remove the coolant sample.

The concentration of the antifreeze must be between 50% and 60%.

- ▶ Check the concentration of the antifreeze.

If the concentration of the antifreeze is impermissible:

- ▶ Correct the concentration of the antifreeze, see the separate operating instructions from the engine manufacturer.

If the coolant must be drained:

- ▶ Drain the coolant, see section “Changing the coolant”.

## 5.3 Changing the coolant



### Note

When the coolant is changed:

- ▶ Empty the cooling system completely and flush it.



### WARNING

Spilled coolant!

Danger of slipping.

- ▶ Danger of slipping, pay attention.
- ▶ Use personal protective equipment depending on the operating materials.
- ▶ Immediately collect spilled coolant using suitable material. See the safety data sheet from the manufacturer of the operating fluid.

Make sure that the following prerequisites are met:

- The prerequisites for maintenance are established, see section “Establishing the prerequisites for maintenance”.
- The diesel engine is turned off.
- The ignition key is pulled out.
- The diesel engine, cooling system und exhaust system have cooled off for at least 30 min.
- The battery master switch is turned off.
- A suitably sized container for the used coolant is on hand.
- A drain hose for draining the engine oil is available, see the on-board tools.
- The required quantity of coolant is available, see the service fill.
- An assembly scaffolding or a work platform is available.

### 5.3.1 Draining the coolant



### WARNING

Hot pressurized coolant!

Severe scalding, severe burns.

- ▶ Only open the coolant expansion tank when the coolant has cooled off.
- ▶ Wait until the coolant has cooled off.
- ▶ Wear personal protective equipment.

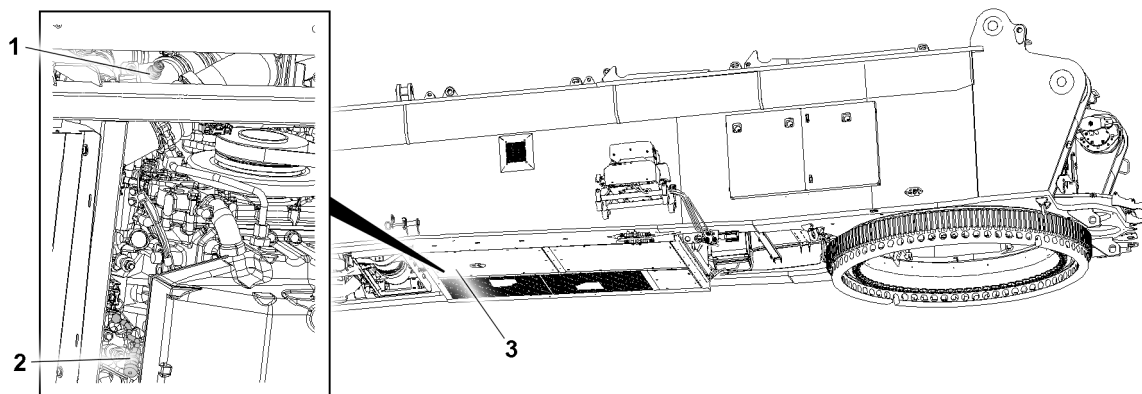


Fig.158507: Coolant draining positions

- |   |                                    |   |       |
|---|------------------------------------|---|-------|
| 1 | Drain valve in the coolant circuit | 3 | Cover |
| 2 | Drain valve in the diesel engine   |   |       |

- ▶ Remove the cover from the filler neck on the coolant expansion tank, see section “Checking the coolant level”.

Access to the bottom side of the turntable with "aids for work at a height". Observe and adhere to the information in chapter 2.04.

- ▶ Position an assembly scaffolding or a work platform.
- ▶ Remove the cover **3**.
- ▶ Screw the protective caps from the drain valve **1** and drain valve **2**.
- ▶ Collect the coolant: Position a container under the drain valve **1**.

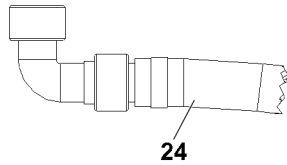


Fig.153600

- ▶ Screw the drain hose **24** to the drain valve **1** and drain the coolant fully.
- ▶ Remove the drain hose **24**.
- ▶ Screw the protective cap onto the drain valve **1**.
- ▶ Collect the coolant: Position a container under the drain valve **2**.
- ▶ Screw the drain hose **24** to the drain valve **2** and drain the coolant fully.
- ▶ Remove the drain hose **24**.
- ▶ Screw the protective cap onto the drain valve **2**.
- ▶ Assemble the cover **3**.

After draining the coolant: Fill up the coolant.

### 5.3.2 Filling up the coolant

---

#### NOTICE

Impermissible coolant!

Engine damage.

- ▶ Do **not** mix different coolants.
- ▶ Do **not** thin Liebherr-Fertig-Mix (Liebherr Ready Made Mix).

When adding coolant:

- ▶ Use exclusively the same coolant with the same color.
- 

Different coolants are differentiated by different colors.

Coolants contain antifreeze fluid.

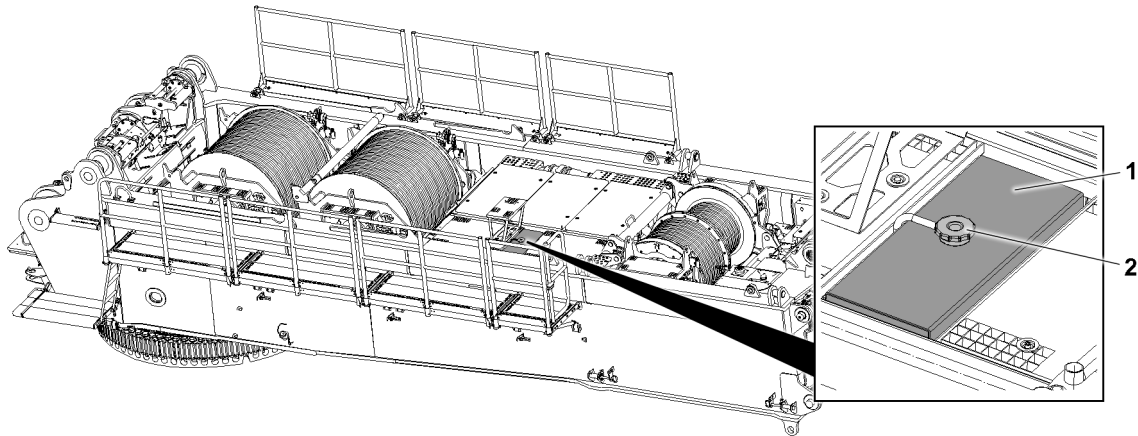


Fig.158536: Coolant expansion tank

- 1 Coolant expansion tank                      2 Cover

Make sure that the following prerequisites are met:

- The cover is removed from the filler neck on the coolant expansion tank.
- The coolant is fully drained.
- Protective caps are screwed onto the drain valves.
- Permissible coolant is available, see the service fill.
- The required quantity of coolant is available.

- ▶ Add coolant up to the lower edge of the riser tube.

The Diesel engine and auxiliary heater create a connected coolant circuit. When draining the diesel engine coolant, the coolant for the auxiliary heater is also drained. When refilling the system, the coolant circuit must be bled completely.

- ▶ Start the diesel engine.
- ▶ Set the heater to “hot”.

**Result:**

- The diesel engine is bled.
- ▶ Until no more air bubbles are visible: Observe the coolant in the coolant expansion tank 1.
- ▶ Set the heater to “cold”.

**Result:**

- The auxiliary heater is bled.
- ▶ Until no more air bubbles are visible: Observe the coolant in the coolant expansion tank 1.

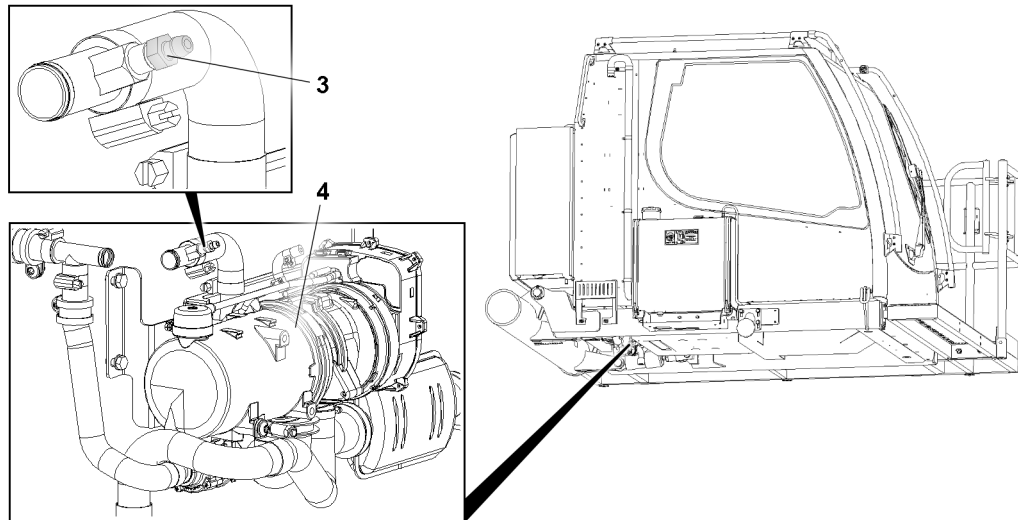


Fig.159235: Water heater, crane cab

**3** Breather valve

**4** Water heater

To ensure that it can be fully bled, the coolant circuit on the water heater **4** must be opened.

- ▶ Until coolant starts to come out: Open the breather valve **3** and keep it open.

**Result:**

- The coolant circuit is bled.

When the coolant circuit is completely bled:

- ▶ Screw the cover **2** onto the coolant expansion tank **1** and close firmly.
- ▶ Let the diesel engine warm up until the coolant temperature reaches at least 80 °C.
- ▶ Turn off the diesel engine and let it cool off.
- ▶ Check the coolant level, see section "Checking the coolant level".

## 6 Fuel system

### 6.1 Safety



**WARNING**

Impermissible conditions for the fuel!

Danger of fire. Death, severe bodily injuries, property damage.

- ▶ Turn the heating systems off, for example the auxiliary heater or the flame start system.

When working on the fuel system or adding fuel:

- ▶ Exclude heat, sparks, flames and sources of ignition.



**WARNING**

Spilled fuel!

Danger of slipping.

- ▶ Danger of slipping, pay attention.
- ▶ Use personal protective equipment depending on the operating materials.
- ▶ Immediately collect spilled fuel using suitable material. See the safety data sheet from the manufacturer of the operating fluid.

## 6.2 Add fuel

Make sure that the following prerequisites are met:

- The prerequisites for maintenance are established, see section “Establishing the prerequisites for maintenance”.
- The diesel engine is turned off.
- The ignition key is pulled out.
- The battery master switch is turned off.
- The heating systems are turned off, for example the auxiliary heater, flame start system.

---

### NOTICE

Impermissible fuel!

Severe damage to the engine and fuel system.

- ▶ Make sure that the minimum fuel requirements are fulfilled, see the separate operating instructions from the engine manufacturer.
  - ▶ Do **not** mix fuels.
- 

### NOTICE

Dirt in the fuel system!

Damage to components. Increased wear and shorter service life of the components.

- ▶ Make sure that no dirt gets inside the fuel system.
- 



### WARNING

Fall from a working height of greater than 4 m !

- ▶ Ensure a 3-point support.
  - ▶ Use personal protective equipment to prevent falling.
- 
- ▶ Follow the notes and instructions, see chapter 2.04.10, chapter 2.06 and chapter 2.07.

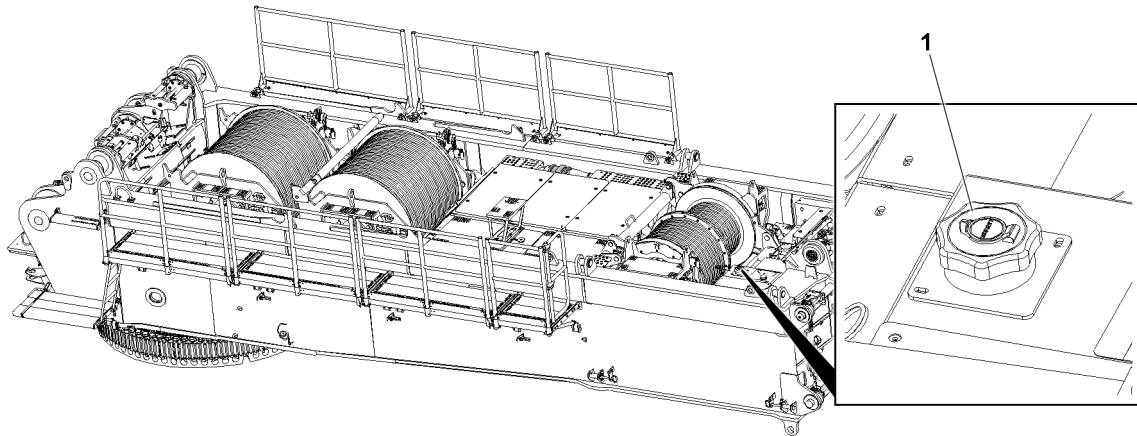


Fig.158538: Fuel tank

- ▶ Remove the cover 1.
- ▶ Use the fuel nozzle such that **no** fuel can escape.
- ▶ Insert the fuel nozzle as deep as possible into the filler neck.
- ▶ Until the fuel nozzle turns off: Add fuel.

When the refueling procedure is done:

- ▶ Remove the fuel nozzle from the filler neck and secure it from falling down.



### WARNING

Do **not** overfill the fuel tank!

Escaping fuel.

- ▶ Make sure that the fuel tank is tightly closed.
-

- ▶ Tighten the cover **1** completely.

### Problem remedy

Was impermissible fuel added?

- ▶ Do **not** turn the ignition on.
- ▶ Have the fuel tank and fuel lines completely drained by authorized and trained service personnel.

## 6.3 Replacing the fuel fine filter

Make sure that the following prerequisites are met:

- The prerequisites for maintenance are established, see section “Establishing the prerequisites for maintenance”.
- The diesel engine is turned off.
- The ignition key is pulled out.
- The battery master switch is turned off.
- New fuel fine filters are available.

The fuel system is automatically bled when the ignition is turned on.

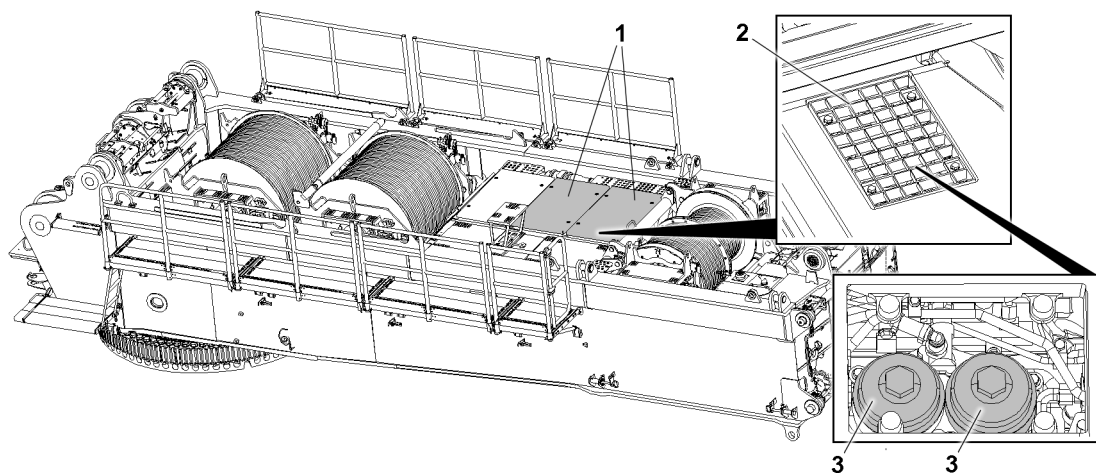


Fig.158539: Fuel fine filter

- 1 Cover
- 2 Grating

- 3 Fuel fine filter



### WARNING

Hot components, hot operating materials!  
Severe burns, scalding.

- ▶ Let components cool off to below 50 °C.
- ▶ Avoid contact with hands, skin and eyes.
- ▶ Wear safety goggles.
- ▶ Wear heat-resistant protective equipment: Wear protective gloves and work clothing.

- ▶ Remove the cover **1**.
- ▶ Open the grating **2**.
- ▶ Replace the fuel fine filter **3**, see the separate operating instructions from the engine manufacturer.
- ▶ Turn on the battery master switch.

When the fuel fine filter has been replaced:

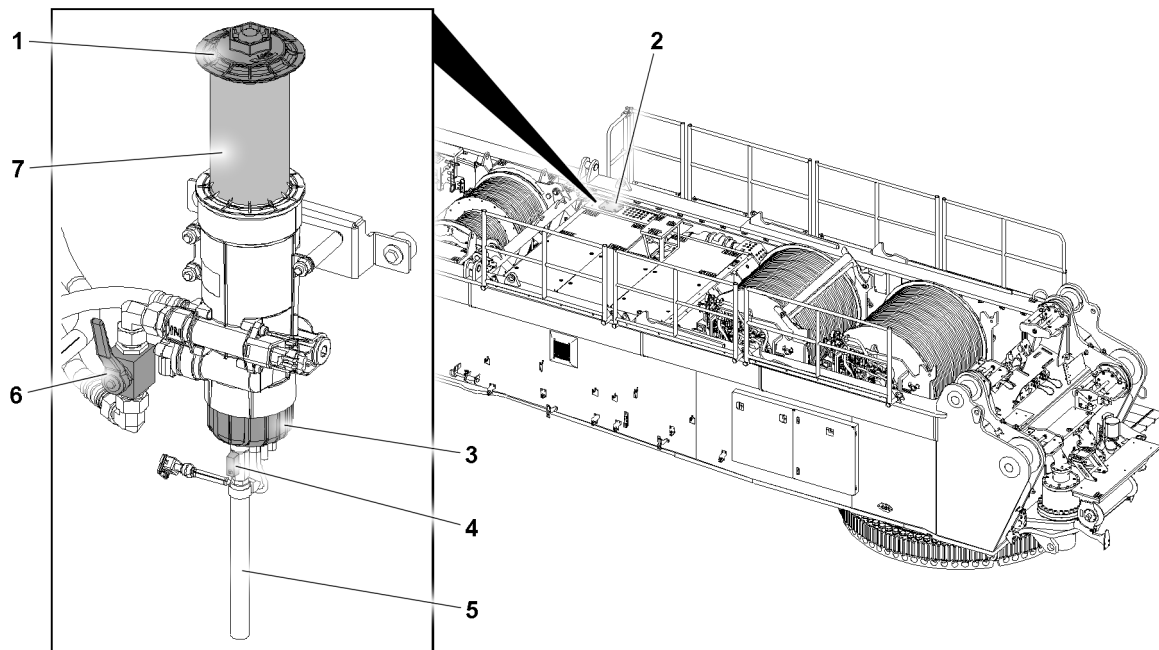
- ▶ Turn the ignition on and wait 1 minute.
- ▶ Start the diesel engine.

**Problem remedy**

Does the starting procedure remain unsuccessful after approx. 20 seconds?

- ▶ Turn the ignition off.
- ▶ Wait for 1 minute.
- ▶ Turn the ignition on and wait 1 minute.
- ▶ Start the diesel engine.

## 6.4 Checking the fuel preliminary filter



*Fig.158541: Fuel preliminary filter*

The fuel preliminary filter must be drained in the following situations:

- An error message is displayed.
- The fuel-water mixture is visible in the water manifold **3**.

Make sure that the following prerequisites are met:

- The prerequisites for maintenance are established, see section “Establishing the prerequisites for maintenance”.

When fuel preliminary filter must be drained:

- ▶ Follow the instructions in the section “Draining the fuel preliminary filter”.

## 6.5 Draining the fuel preliminary filter

Make sure that the following prerequisites are met:

- The prerequisites for maintenance are established, see section “Establishing the prerequisites for maintenance”.
- The diesel engine is turned off.
- The ignition key is pulled out.
- The battery master switch is turned off.
- A container for the fuel-water mixture with sufficient collection capacity is available.



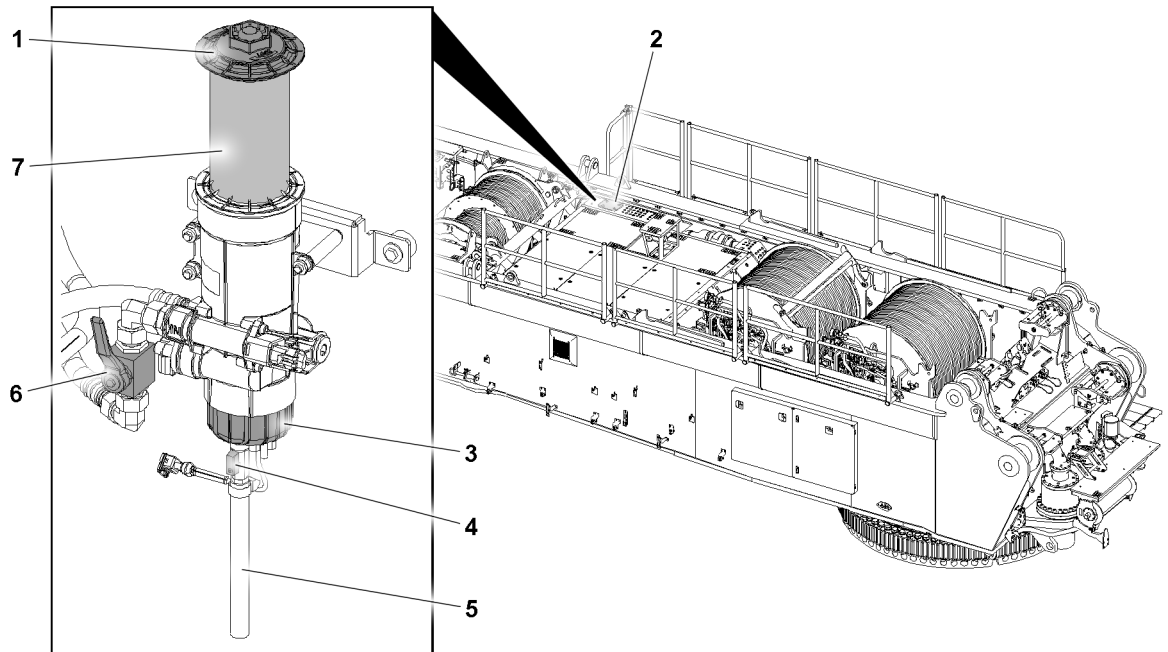


Fig.158541: Fuel preliminary filter

- |   |                |   |               |
|---|----------------|---|---------------|
| 1 | Cover          | 5 | Hose          |
| 2 | Cover          | 6 | Ball valve    |
| 3 | Water manifold | 7 | Filter insert |
| 4 | Drain valve    |   |               |



#### Note

Recommendation!

- ▶ Before draining the fuel preliminary filter, place cleaning rags underneath it.

- ▶ Remove the cover **2**.
- ▶ Collect the fuel-water mixture: Position a container under the hose **5**.
- ▶ When the fuel-water mixture is completely drained: Open the drain valve **4**.
- ▶ Close the drain valve **4**.
- ▶ Remove the container and dispose of the fuel-water mixture.
- ▶ Assemble the cover **2**.
- ▶ Turn on the battery master switch.
- ▶ Turn the ignition on and wait 1 minute.
- ▶ Start the diesel engine.

#### Problem remedy

Does starting the engine remain unsuccessful after approx. 20 seconds?

- ▶ Turn the ignition off.
- ▶ Wait for 1 minute.
- ▶ Turn the ignition on and wait 1 minute.
- ▶ Start the engine.

## 6.6 Servicing the fuel preliminary filter

Maintenance of the fuel preliminary filter consists of the following tasks:

- Take the fuel system out of service.
- Replace the filter insert.
- Clean the water manifold.
- Put the fuel system in operation.

### 6.6.1 Taking the fuel system out of service

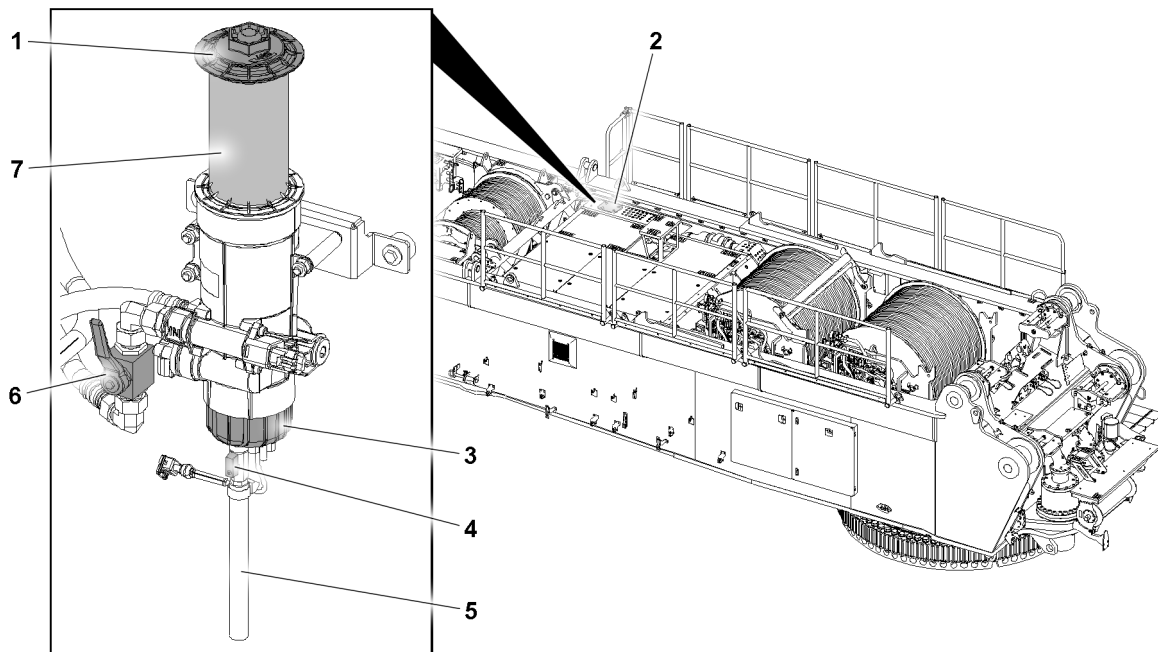


Fig.158541: Fuel preliminary filter

- |   |                |   |               |
|---|----------------|---|---------------|
| 1 | Cover          | 5 | Hose          |
| 2 | Cover          | 6 | Ball valve    |
| 3 | Water manifold | 7 | Filter insert |
| 4 | Drain valve    |   |               |

Make sure that the following prerequisites are met:

- The prerequisites for maintenance are established, see section “Establishing the prerequisites for maintenance”.
- The diesel engine is turned off.
- The ignition key is pulled out.
- The battery master switch is turned off.
- A container for the fuel with sufficient collection capacity is available.
- A new filter insert **7** is available.
- A new seal for the water manifold **3** is available.



#### Note

- ▶ Prior to maintenance of the fuel preliminary filter, Liebherr-Werk Ehingen recommends placing cleaning rags underneath it.
- ▶ Remove the cover **2**.
- ▶ Close the ball valve **6**.

## 6.6.2 Replacing the filter insert

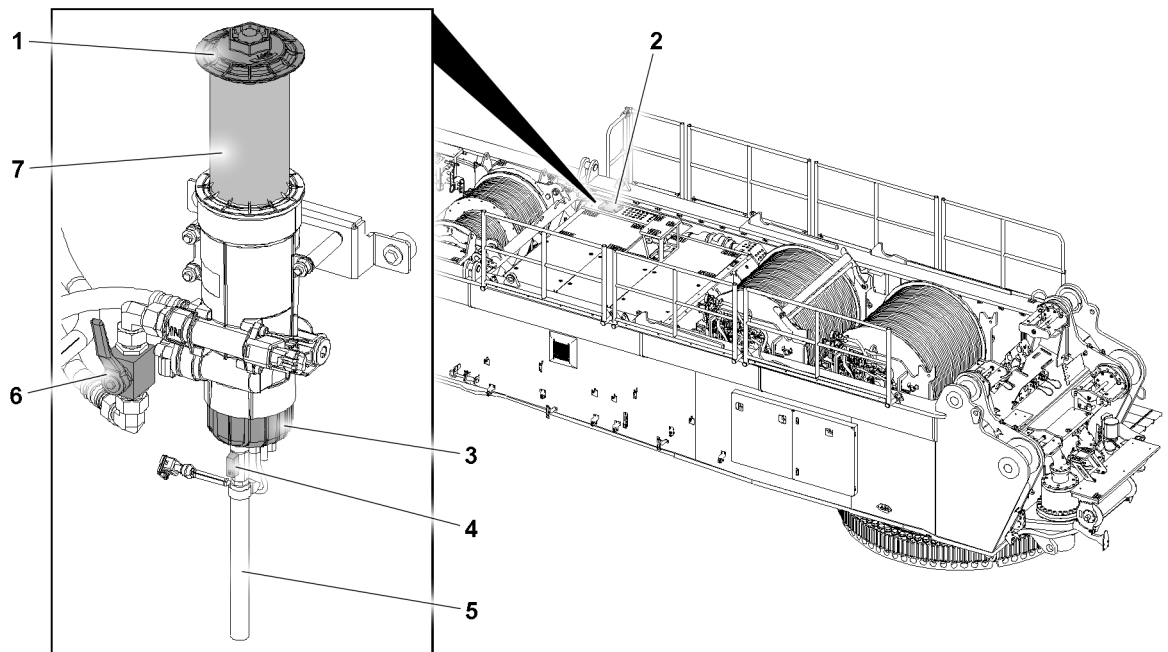


Fig.158541: Fuel preliminary filter

- |   |                |   |               |
|---|----------------|---|---------------|
| 1 | Cover          | 5 | Hose          |
| 2 | Cover          | 6 | Ball valve    |
| 3 | Water manifold | 7 | Filter insert |
| 4 | Drain valve    |   |               |

The filter insert **7** must be replaced in the following situations:

- According to the maintenance intervals.
- **Or** when an error message is shown.

Make sure that the following prerequisites are met:

- The ball valve **6** is closed.

### NOTICE

Dirt!

Destruction of the Common Rail System.

- ▶ Make sure that **no** dirt gets into the inside of the filter insert **7**.
- ▶ Do **not** release or open the fuel lines and injection lines.
- ▶ Do **not** reuse a used filter insert.

- ▶ Remove the cover **2**.
- ▶ Collect the fuel: Position a container under the fuel preliminary filter.
- ▶ Screw off the cover **1**.
- ▶ Remove the cover **1** with the filter insert **7**.
- ▶ Remove the filter insert **7** from the cover **1**.
- ▶ Place the new filter insert **7** on the cover **1**.

A new seal ring is provided with the replacement filter insert.

- ▶ Replace the seal ring on the cover **1**.
- ▶ Wet the seal ring with fuel.
- ▶ Assemble the cover **1** with the filter insert **7** and tighten with tightening torque of 40 Nm.
- ▶ Assemble the cover **2**.

**Problem remedy**

Does the filter insert need to be replaced regularly in short intervals?

Dirt entered the fuel tank during refueling.

- ▶ Drain the sediments, see section "Draining the sediments out of the fuel tank".

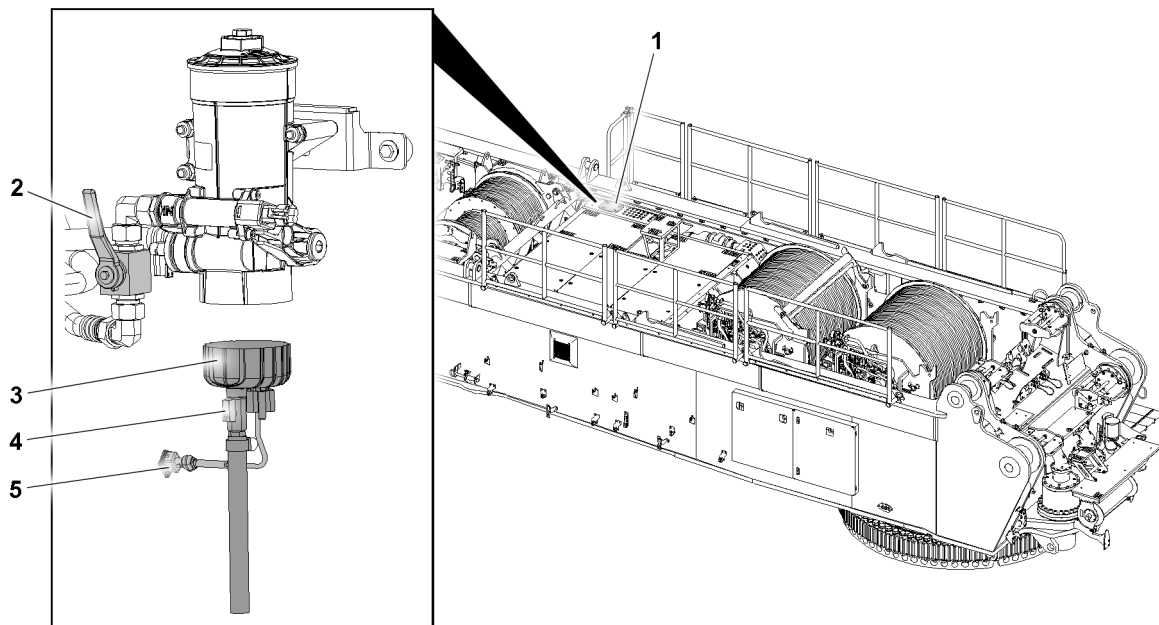
**6.6.3 Cleaning the water manifold**

Fig.158542: Fuel preliminary filter

- |   |                |   |                 |
|---|----------------|---|-----------------|
| 1 | Cover          | 4 | Drain valve     |
| 2 | Ball valve     | 5 | Plug connection |
| 3 | Water manifold |   |                 |

Make sure that the following prerequisites are met:

- The ball valve **2** is closed.
- A container with sufficient capacity has been positioned below the drain valve **4**.

**NOTICE**

Dirt!

Destruction of the Common Rail System.

- ▶ Make sure that **no** dirt gets into the inside of the filter insert.
  - ▶ Do **not** release or open the fuel lines and injection lines.
  - ▶ Do **not** reuse a used filter insert.
- 
- ▶ Remove the cover **1**.
  - ▶ Drain the fuel: Open the drain valve **4** until the fuel has drained fully.
  - ▶ Release the plug connection **5** of the water lever sensor.
  - ▶ Screw off the water manifold **3**.
  - ▶ Clean the water manifold **3**.
  - ▶ Assemble a new seal on the water manifold **3** and wet it with diesel.
  - ▶ Tighten the water manifold **3** with maximum tightening torque of 5 Nm.
  - ▶ Close the drain valve **4**.
  - ▶ Remove the container and dispose of the fuel.

## 6.6.4 Putting the fuel system in operation

Make sure that the following prerequisites are met:

- The fuel preliminary filter insert is replaced.
- The water manifold is clean.
- The drain valve is closed.
- ▶ Open the ball valve **2**.
- ▶ Assemble the cover **1**.
- ▶ Turn on the battery master switch.

The fuel system is automatically bled when the ignition is turned on.

- ▶ Turn the ignition on and wait 1 minute.
- ▶ Start the engine.

### Problem remedy

Does the starting procedure remain unsuccessful after approx. 20 seconds?

- ▶ Turn the ignition off.
- ▶ Wait for 1 minute.
- ▶ Turn the ignition on and wait 1 minute.
- ▶ Start the engine.

## 6.7 Draining the sediment in the fuel tank

Make sure that the following prerequisites are met:

- The prerequisites for maintenance are established, see section “Establishing the prerequisites for maintenance”.
- The diesel engine is turned off.
- The ignition key is pulled out.
- The battery master switch is turned off.
- A container for the fuel with sufficient collection capacity is available.
- A drain hose for draining the sediment is available, see the on-board tools.
- Assembly scaffolding or a turntable is available.

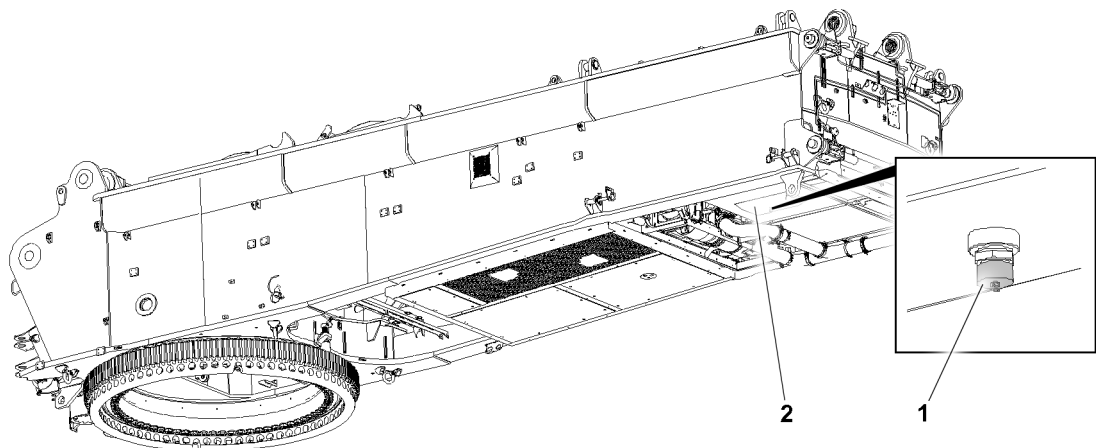


Fig.158540: Fuel tank, drain valve

**1** Drain valve

**2** Fuel tank

Access to the bottom side of the turntable with “aids for work at a height”. Observe and adhere to the information in chapter 2.04.

- ▶ Position an assembly scaffolding or a work platform.
- ▶ Screw the protective cover on the drain valve **1**.
- ▶ Collect the fuel: Position a container under the drain valve **1**.

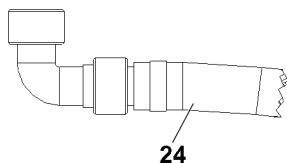


Fig.153600

- ▶ Until fuel starts to come out: Screw the drain hose **24** onto the drain valve **1**.
- ▶ Drain the sediment.
- ▶ Remove the drain hose **24**.
- ▶ Screw the protective cap onto the drain valve **1**.

**Problem remedy**

Does the fuel preliminary filter insert still need to be replaced at short intervals?

Coarse sediment is present in the fuel tank.

- ▶ The fuel tank must be cleaned: Contact Customer Service at Liebherr-Werk EHINGEN.

## 7 Urea system\*

**Note**

- ▶ Applies exclusively if the diesel engine is equipped with an exhaust aftertreatment system SCR.

### 7.1 Safety

**WARNING**

Ammonia vapors!

If the cover of the urea tank is opened at high temperatures, ammonia vapors can emerge. Irritation of eyes and mucous membranes.

- ▶ Keep the urea tank closed at high temperatures.
- ▶ Do **not** breathe in ammonia vapors.

**WARNING**

Spilled urea solution!

Danger of slipping.

- ▶ Danger of slipping, pay attention.
- ▶ Use personal protective equipment depending on the operating materials.
- ▶ Immediately collect spilled urea solution using suitable material. See the safety data sheet from the manufacturer of the operating fluid.

**NOTICE**

Spilled urea solution!

Affected surfaces can corrode.

Environmental risk.

- ▶ Rinse the affected surfaces immediately with lots of water.
- ▶ Do **not** overfill the container.
- ▶ Refuel using a fuel nozzle.

## 7.2 Adding urea solution

### NOTICE

Admixing of special additives and diluting the urea solution!  
The legally required emissions standards are not observed.  
Destruction of the exhaust aftertreatment system.

- ▶ Do **not** mix or dilute the urea solution with special additives.
- ▶ Make sure that **no** dirt gets into the inside of the urea tank.
- ▶ Only fill permissible operating materials in the urea tank.

Make sure that the following prerequisites are met:

- The prerequisites for maintenance are established, see section “Establishing the prerequisites for maintenance”.
- The diesel engine is turned off.
- The ignition key is pulled out.
- The battery master switch is turned off.
- The heating systems are turned off, for example the auxiliary heater, flame start system.



### WARNING

Fall from a working height of greater than 4 m !

- ▶ Ensure a 3-point support.
  - ▶ Use personal protective equipment to prevent falling.
- 
- ▶ Follow the notes and instructions, see chapter 2.04.10, chapter 2.06 and chapter 2.07.

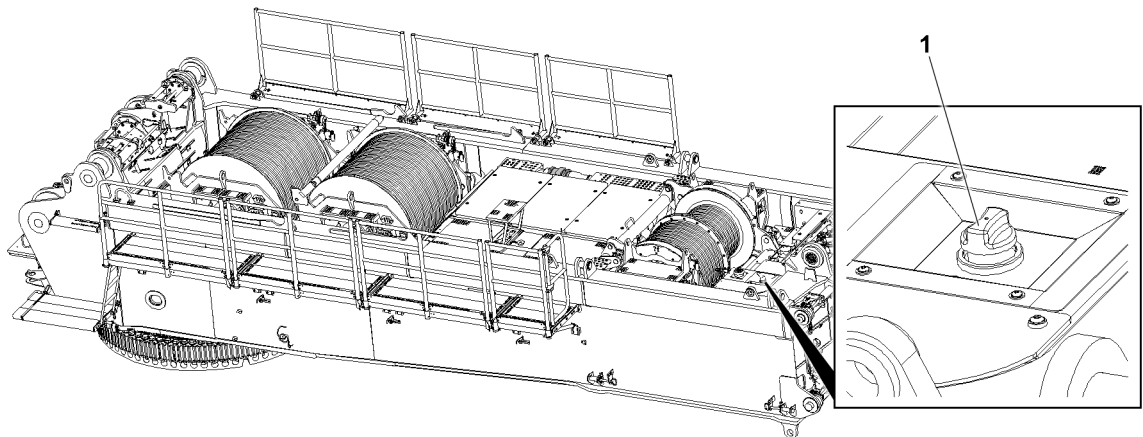


Fig.158543: Urea system

- ▶ Remove the cover 1.
- ▶ Use the fuel nozzle such that **no** urea solution can escape.
- ▶ Insert the fuel nozzle as deep as possible into the filler neck.



### WARNING

Urea tank overfilled!

Urea solution expands at temperature fluctuations: Crack formation in the urea tank.  
Emerging urea solution.

- ▶ Do **not** overfill the urea tank.
- 
- ▶ Until the fuel nozzle turns off: Add urea solution.

When the refueling procedure is done:

- ▶ Remove the fuel nozzle from the filler neck and secure it from falling down.

**WARNING**

Urea tank **not** tightly closed!  
Emerging urea solution.

- ▶ Make sure that the urea tank is tightly closed.
- ▶ Tighten the cover **1** completely.

## 7.3 Urea tank: Replacing the filter strainer in the tank fitting

**NOTICE**

Dirt in the urea tank!  
Destruction of urea system.

- ▶ Make sure that **no** dirt gets into the inside of the urea tank.

If the filter strainer is dirty or damaged, the filter strainer must be cleaned or replaced.

Make sure that the following prerequisites are met:

- The prerequisites for maintenance are established, see section “Establishing the prerequisites for maintenance”.
- The diesel engine is turned off.
- The ignition key is pulled out.
- The battery master switch is turned off.
- The heating systems are turned off, for example the auxiliary heater, flame start system.
- A new filter strainer is available.

### 7.3.1 Filter strainer Variation 1

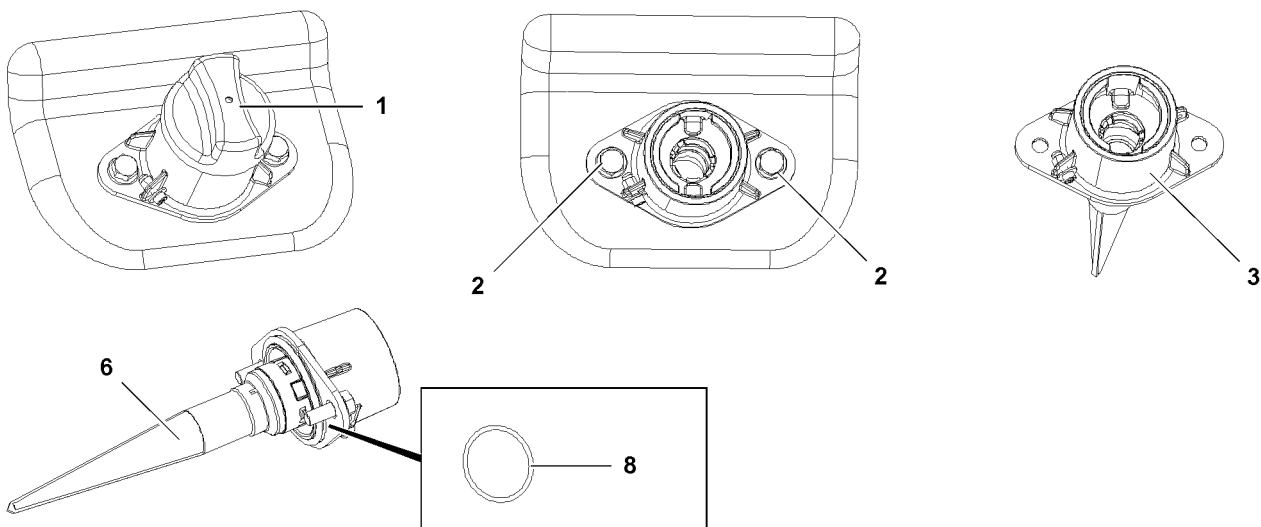


Fig.124111: Urea tank filter strainer

- ▶ Make sure that the variation of the tank fitting **3** corresponds to the illustration.
- ▶ Remove the cover **1** of the urea tank.
- ▶ Unscrew the screws **2** and remove the tank fitting **3**.
- ▶ Clean the filter strainer **6** with water.

When the filter strainer **6** is damaged:

- ▶ Replace the filter strainer **6**.
- ▶ Check the seal **8** for damage.

When the seal **8** is damaged:

- ▶ Replace the seal **8**.
- ▶ Install the tank fitting **3** with the seal **8** and spacer properly.



**NOTICE**

Tightening torque too high!  
Destruction of urea tank.

- ▶ Tighten the screws **2** with a maximum tightening torque of 8 Nm.
- ▶ Properly screw in and tighten the screws **2**.
- ▶ Close the urea tank with the cover **1**.

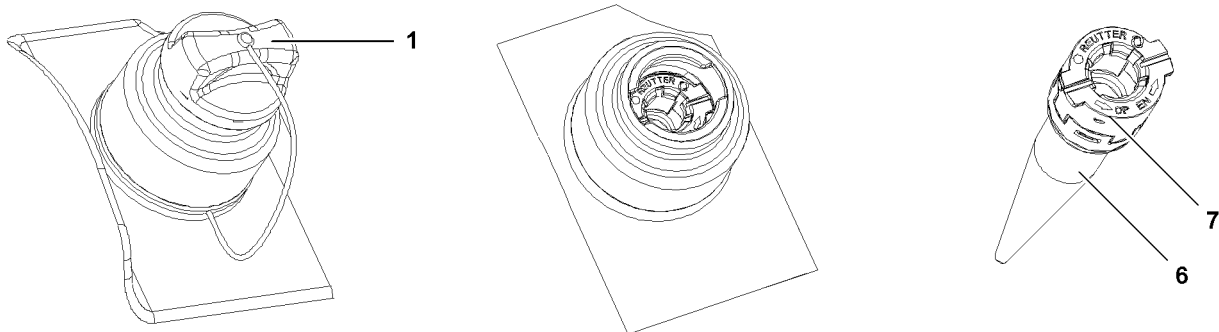
**7.3.2 Filter strainer Variation 2**

Fig.124112: Urea tank filter strainer

- ▶ Make sure that the version of the filter unit **7** corresponds to the illustration.
- ▶ Remove the cover **1** of the urea tank.
- ▶ Remove the filter unit **7**.
- ▶ Clean the filter strainer **6** with water.

When the filter strainer **6** is damaged:

- ▶ Replace the filter strainer **6**.
- ▶ Close the urea tank with the cover **1**.

**8 Exhaust system**

The equipment with the diesel particle filter depends on the emissions level of the diesel engine.

**WARNING**

Hot components!  
Severe burns possible.

- ▶ Before parts that could be hot can be touched: Let the exhaust system cool off to below 50 °C.
- ▶ Wear heat-resistant protective equipment: Wear protective gloves and work clothing.

**8.1 Checking the exhaust system for leaks and damage**

- ▶ Check the exhaust gas aftertreatment component group for tightness and damage, see the separate operating instructions from the engine manufacturer.

**8.2 Checking the profile clamps**

- ▶ Check the profile clamps, see the separate operating instructions from the engine manufacturer.

## 8.3 Replace the diesel particle filter\*

### 8.3.1 Ordering the filter module

Make sure that the following prerequisites are met:

- The diesel particle filter must be replaced.

The filter modules will be replaced (AT). Prior to removal and installation, an AT filter module must be ordered.

Registered customers can order the AT filter module at [www.myliebherr.com](http://www.myliebherr.com).

- ▶ Order the AT filter module, see the separate operating instructions from the engine manufacturer.

### 8.3.2 Removing the filter module

Make sure that the following prerequisites are met:

- An AT filter module is available.
- The prerequisites for maintenance are established, see section “Establishing the prerequisites for maintenance”.
- The diesel engine is turned off.
- The ignition key is pulled out.
- The diesel engine, cooling system und exhaust system have cooled off for at least 30 min.
- The battery master switch is turned off.
- Two people are present for disassembly.

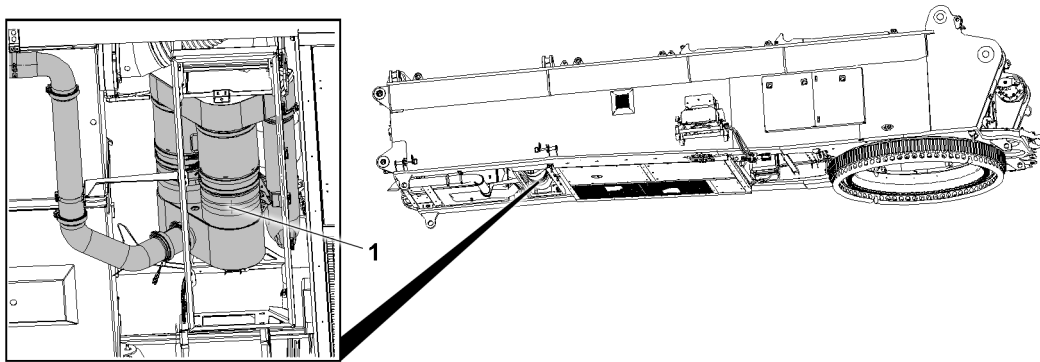


Fig.160912: Diesel particle filter



#### WARNING

Overhead assembly!

Falling components. Crushing and head injuries are possible.

- ▶ Make sure that a second person is available for assembly.

Access to the bottom side of the turntable with “aids for work at a height”. Observe and adhere to the information in chapter 2.04.

- ▶ Remove the filter module 1, see the separate operating instructions from the engine manufacturer.

### 8.3.3 Packing the filter module for transport

Make sure that the following prerequisites are met:

- The dirty filter module has been removed.
- The dirty filter module is **not** damaged.
- ▶ Pack the filter module for transport, see the separate operating instructions from the engine manufacturer.
- ▶ Send the filter module to an authorized Liebherr service location for cleaning.

### 8.3.4 Installing the AT filter module

Make sure that the following prerequisites are met:

- The dirty filter module has been removed.
- An AT filter module is available.
- The prerequisites for maintenance are established, see section “Establishing the prerequisites for maintenance”.
- The diesel engine is turned off.
- The ignition key is pulled out.
- The diesel engine, cooling system und exhaust system have cooled off for at least 30 min.
- The battery master switch is turned off.
- Two people are present for assembly.

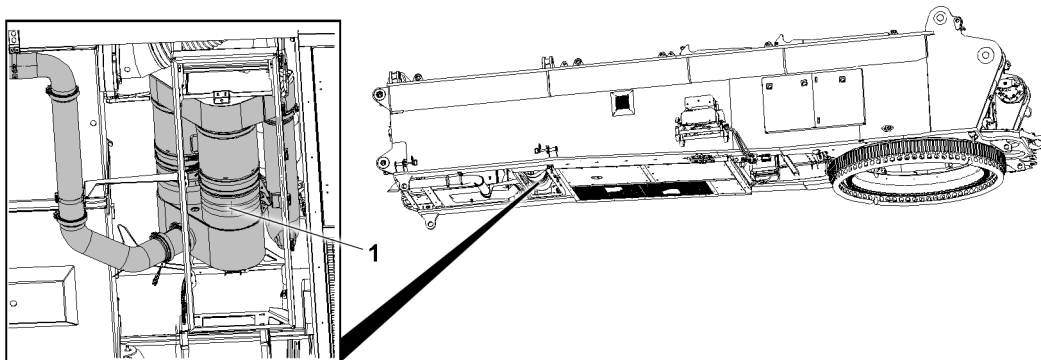


Fig.160912: Diesel particle filter



#### WARNING

Overhead assembly!

Falling components. Crushing and head injuries are possible.

- ▶ Make sure that a second person is available for assembly.

Access to the bottom side of the turntable with “aids for work at a height”. Observe and adhere to the information in chapter 2.04.

- ▶ Install the AT filter module **1**, see the separate operating instructions from the engine manufacturer.

### 8.3.5 Resetting the maintenance interval for the diesel particle filter

Make sure that the following prerequisites are met:

- An AT filter module is installed.
- ▶ Turn on the battery master switch.
- ▶ Turn the ignition on.
- ▶ Reset the maintenance interval for the diesel particle filter, see chapter 7.01.10.

## 9 Air filter system

### 9.1 Cleaning the dust discharge valve

#### NOTICE

The dust discharge valve is missing!

The service life of the air filter can be reduced.

- ▶ Operate the diesel engine only with the dust discharge valve.

Make sure that the following prerequisites are met:

- The prerequisites for maintenance are established, see section “Establishing the prerequisites for maintenance”.
- The diesel engine is turned off.
- The ignition key is pulled out.

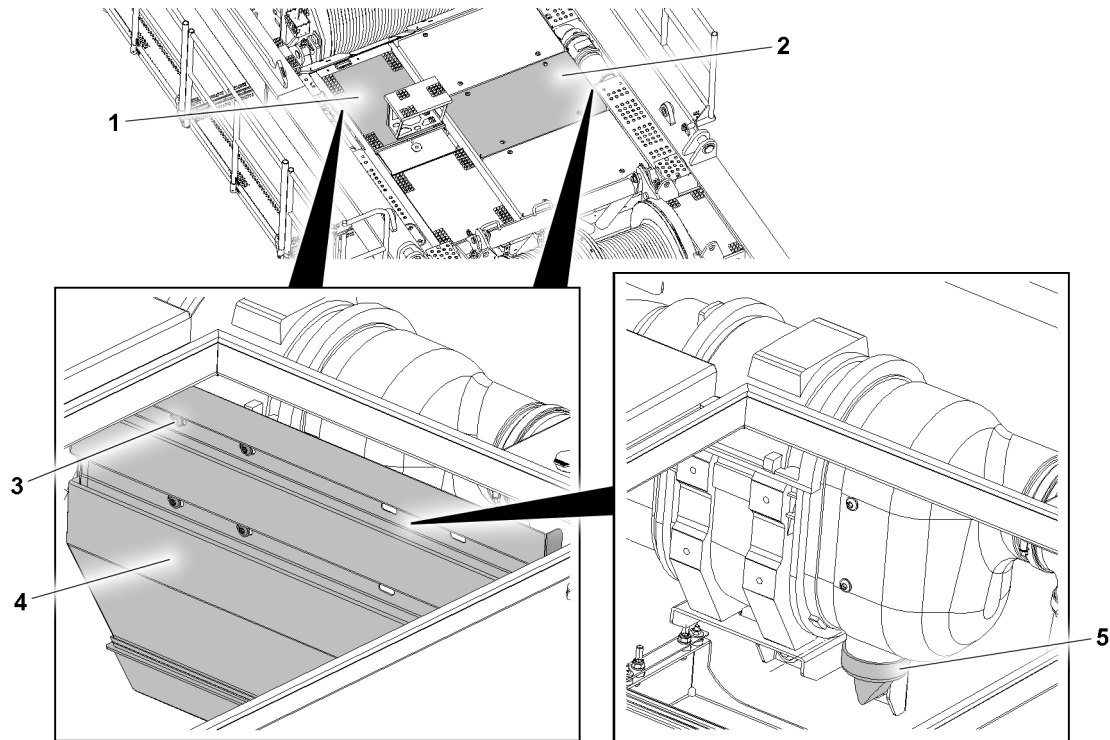


Fig.158556: Air filter dust discharge valve

- |   |         |   |                      |
|---|---------|---|----------------------|
| 1 | Grating | 4 | Cover                |
| 2 | Cover   | 5 | Dust discharge valve |
| 3 | Screw   |   |                      |

- ▶ Remove the grating **1** and the cover **2**.
- ▶ Remove the cover **4**: Remove four screws **3**.
- ▶ Continue to compress the dust discharge valve **5** until the dust discharge valve **5** opens.

**Result:**

- Dust and deposits release from the dust discharge valve **5**.

**Problem remedy**

Dust and deposits do **not** release from the dust discharge valve **5**!

- ▶ Disassemble the dust discharge valve **5**: Remove the hose clamp. Turn the dust discharge valve **5** and pull it out from below from the outlet pipe.

When the dust discharge valve **5** is disassembled:

- ▶ Clean the dust discharge valve **5** manually.

If the dust discharge valve **5** is damaged:

- ▶ Replace the dust discharge valve **5**.


## 9.2 Replacing the air filter

Make sure that the following prerequisites are met:

- The prerequisites for maintenance are established, see section “Establishing the prerequisites for maintenance”.
- The diesel engine is turned off.
- The ignition key is pulled out.
- A new air filter is available.

The air filter and the air duct are monitored by the LICCON computer system.

Call up the monitoring functions and *air filter* individual control display, see chapter 4.02.

Status	Icon	Icon color	Meaning
1		Green	The air filter system is OK.
2		Yellow	The air filter is dirty or the air supply is blocked.

*Air filter conditions*

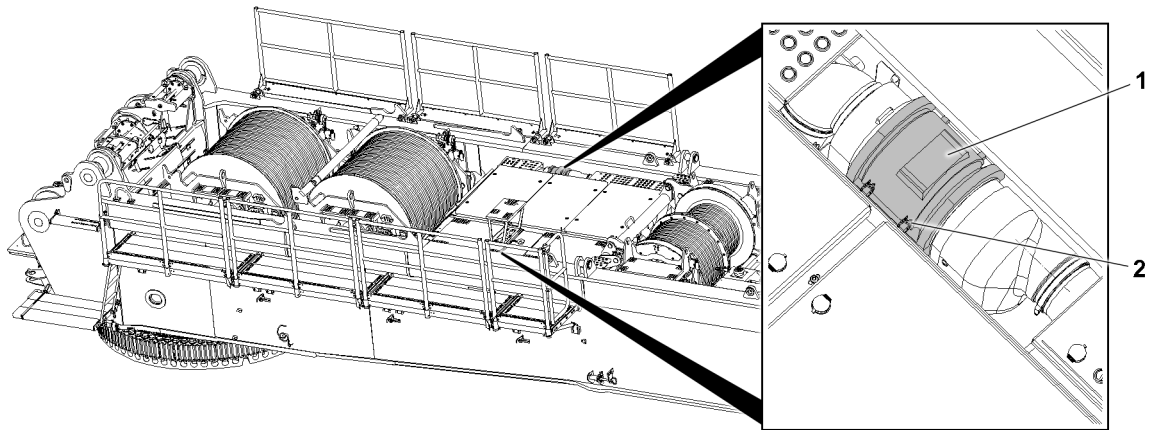


Fig.158537: Air filter system

1 Cover

2 Lock

- ▶ Check the intake and air duct for foreign particles, clean if necessary.

If air filter must be replaced:

- ▶ Open the locks **2**.
- ▶ Remove the cover **1**.
- ▶ Remove the air filter.
- ▶ Replace the air filter.
- ▶ Position the cover **1** and close the locks **2**.

# 10 Pump distributor gear

## 10.1 Safety



### WARNING

Impermissible conditions for the gear oil!

Danger of fire. Death, severe bodily injuries, property damage.

- ▶ Turn the heating systems off, for example the auxiliary heater or the flame start system.

When the gear oil is filled:

- ▶ Exclude heat, sparks, flames and sources of ignition.
- ▶ Avoid high temperatures and direct sunlight.



### WARNING

Hot components, hot operating materials!

Severe burns, scalding.

- ▶ Let components cool off to below 50 °C.
- ▶ Avoid contact with hands, skin and eyes.
- ▶ Wear safety goggles.
- ▶ Wear heat-resistant protective equipment: Wear protective gloves and work clothing.



### WARNING

Spilled gear oil!

Danger of slipping.

- ▶ Danger of slipping, pay attention.
- ▶ Use personal protective equipment depending on the operating materials.
- ▶ Immediately collect spilled gear oil using suitable material. See the safety data sheet from the manufacturer of the operating fluid.



### WARNING

Significant oil loss!

Uncontrolled load movements

Death, severe bodily injury, transmission damage.

- ▶ Contact Customer Service at Liebherr-Werk Ehingen GmbH.

### NOTICE

Dirt inside the transmission!

Transmission damage. Increased wear and shorter service life of the components.

- ▶ Maintain extreme cleanliness during all work.
- ▶ Make sure that **no** dirt gets inside the transmission.

## 10.2 Checking the oil level with the dipstick

Make sure that the following prerequisites are met:

- The prerequisites for maintenance are established, see section “Establishing the prerequisites for maintenance”.
- The diesel engine is turned off.
- The ignition key is pulled out.
- The pump distributor gear has cooled off for at least 30 min.
- The transmission has warmed up.
- The battery master switch is turned off.

**NOTICE**

Insufficient oil!

Transmission damage.

- ▶ Check the oil level, add gear oil if necessary.

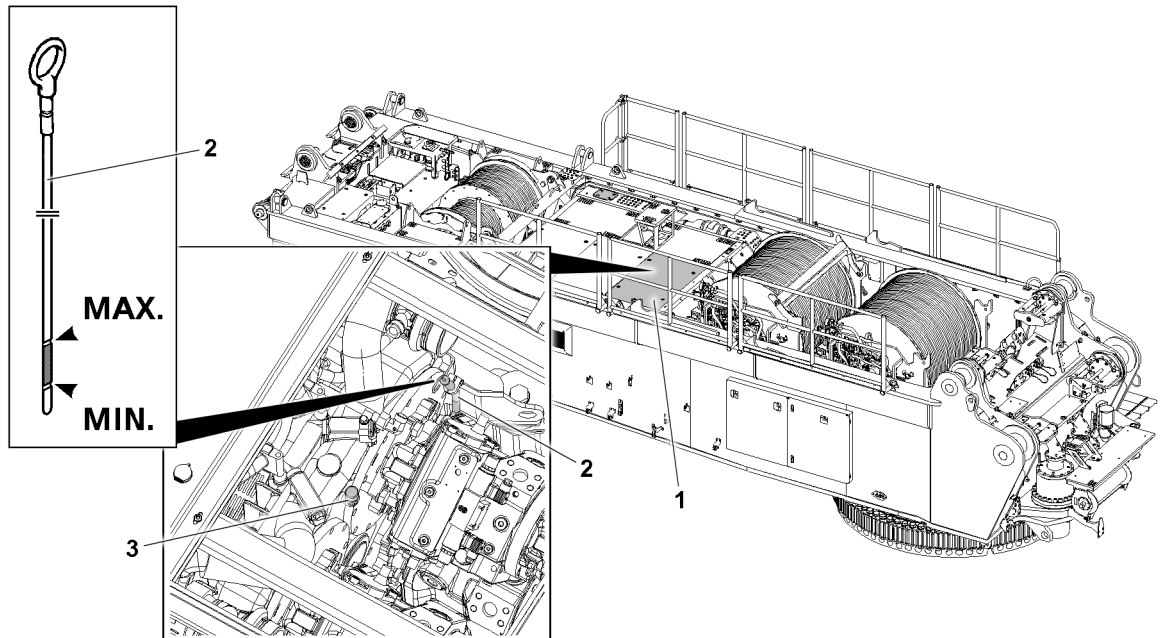


Fig.158557: Pump distributor gear, turntable from the top

- |   |          |   |                          |
|---|----------|---|--------------------------|
| 1 | Cover    | 3 | Filler plug, filler port |
| 2 | Dipstick |   |                          |

- ▶ Remove the cover 1.
- ▶ Pull out the dipstick 2 and wipe it off.
- ▶ Insert the dipstick 2 and pull it out.

The oil level must be visible between the minimum and maximum marks on the dipstick 2.

- ▶ Check the oil level.
- ▶ Insert the dipstick 2.

When the oil level has dropped below the minimum mark:

- ▶ Fill gear oil in the filler port 3 until the oil level is visible between both marks on the dipstick.
- ▶ Assemble the cover 1.

**Problem remedy**

Repeated excessive oil consumption or loss of oil?

- ▶ Find the cause and remedy it.

If the cause cannot be remedied:

- ▶ Contact Customer Service at Liebherr-Werk Ehingen GmbH.

## 10.3 Changing the gear oil

Make sure that the following prerequisites are met:

- The prerequisites for maintenance are established, see section “Establishing the prerequisites for maintenance”.
- The diesel engine is turned off.
- The ignition key is pulled out.
- The pump distributor gear has cooled off for at least 30 min.
- The transmission has warmed up.
- The battery master switch is turned off.
- A suitably sized container for the used gear oil is on hand.
- The required quantity of gear oil is available, see the service fill.
- An assembly scaffolding or a work platform is available.

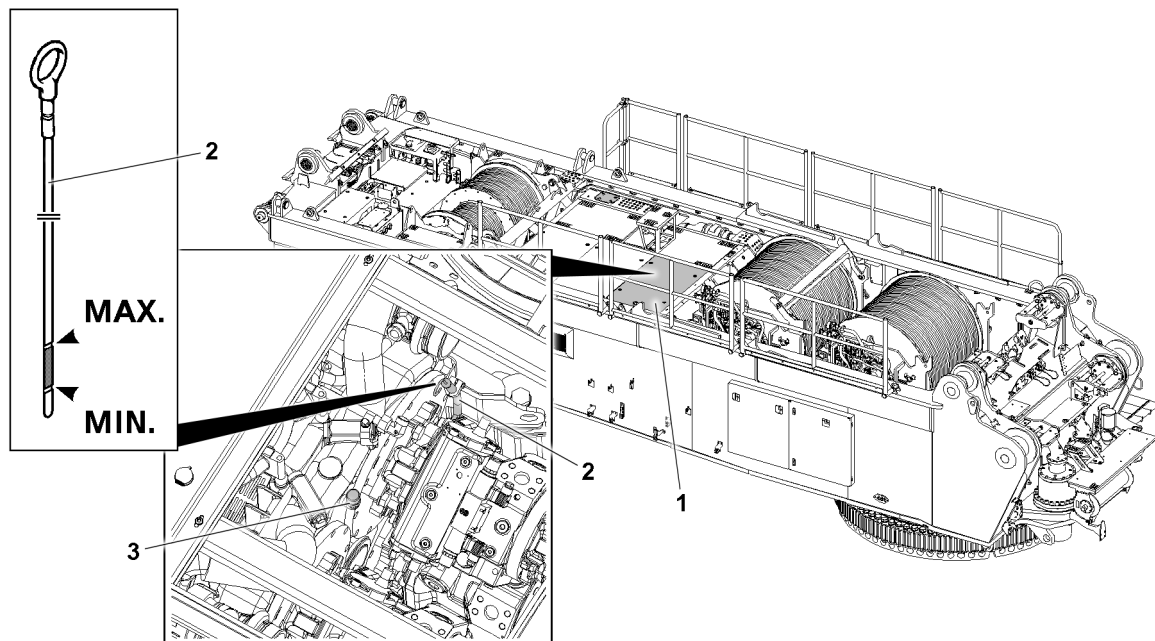


Fig.158557: Pump distributor gear, turntable from the top

- |                                  |                                   |
|----------------------------------|-----------------------------------|
| <p>1 Cover</p> <p>2 Dipstick</p> | <p>3 Filler plug, filler port</p> |
|----------------------------------|-----------------------------------|

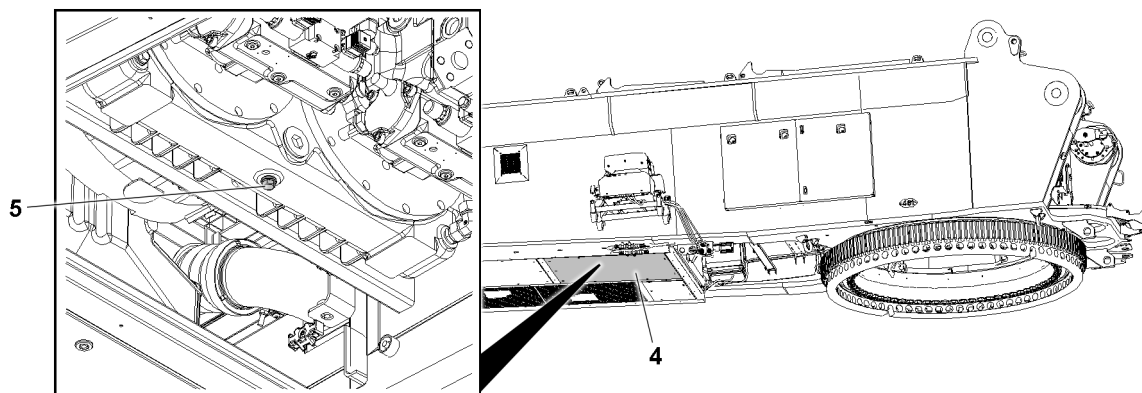


Fig.158558: Pump distributor gear, turntable from the bottom

- |   |                     |
|---|---------------------|
| <p>4 Cover</p> <p>▶ Remove the cover 1.</p> <p>▶ Unscrew the filler plug 3.</p> | <p>5 Drain plug</p> |
|---|---------------------|



Access to the bottom side of the turntable with "aids for work at a height". Observe and adhere to the information in chapter 2.04.

- ▶ Position an assembly scaffolding or a work platform.
- ▶ Remove the cover **4**.
- ▶ Collect the gear oil: Position a container under the drain plug **5**.
- ▶ Drain the gear oil: Unscrew the drain plug **5**.

When the gear oil is drained:

- ▶ Clean the drain plug **5** and sealing surface on the housing.
- ▶ Screw in the drain plug **5** with a new seal and tighten.
- ▶ Fill gear oil in the filler port **3** until the gear oil is visible between both marks on the dipstick **2**.
- ▶ Screw in the filler plug **3** with a new seal.
- ▶ Check the oil level with the dipstick.
- ▶ Assemble the cover **1** and cover **4**.

---

#### Problem remedy

Repeated excessive oil consumption or loss of oil?

- ▶ Find the cause and remedy it.

If the cause cannot be remedied:

- ▶ Contact Customer Service at Liebherr-Werk Ehingen GmbH.
- 

## 11 Central lubrication system

### 11.1 Safety




---

#### WARNING

Problems in the central lubrication system!  
Failure of lubrication. Corrosion. Limitation of crane functions.  
Personal injury. Property damage. Environmental risk.

- ▶ Remedy the problem with the central lubrication system immediately.
- 

#### NOTICE

Dirt in the lubrication system!  
Damage to central lubrication system. Failure of lubrication.

- ▶ Maintain extreme cleanliness during all work.
  - ▶ Make sure that **no** dirt gets inside the lubrication system.
- 

#### NOTICE

Crane is **not** being moved for longer than three months!  
Insufficient lubrication. Property damage.

- ▶ Check the function of the central lubrication system.
  - ▶ Carry out intermediate lubrication until lubricant emerges in all lube points.
  - ▶ Repeat the respective crane movement several times.
  - ▶ Carry out intermediate lubrications again.
-

## 11.2 Superstructure

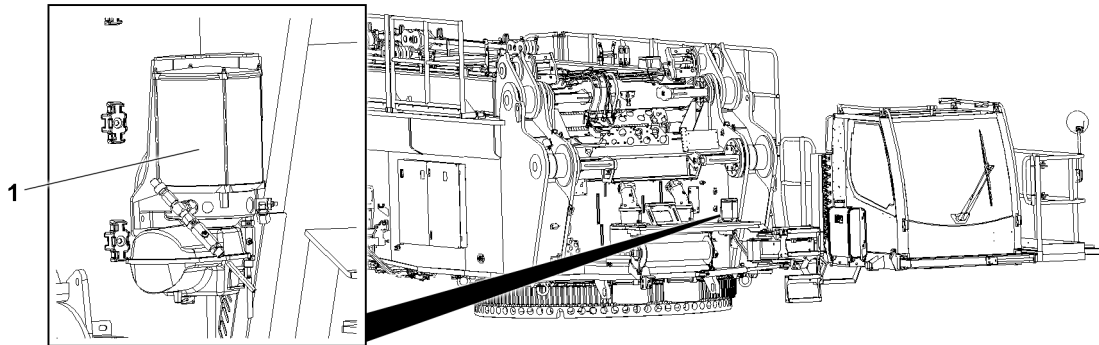


Fig.158559: Central lubrication system, superstructure

The lube points in the bearings of the following components are supplied with lubricant:

- Slewing ring
- Pivot section
- Cab swinging arm
- Assembly winch
- A-frame rocker
- A-frame
- Winch 1
- Winch 2
- Winch 3
- Winch 5
- Winch 6
- Roller block bearing

## 11.3 Ballast trailer\*



### Note

- ▶ Central lubrication system on the ballast trailer, see chapter 7.04.50.

### 11.4 Operating and control elements

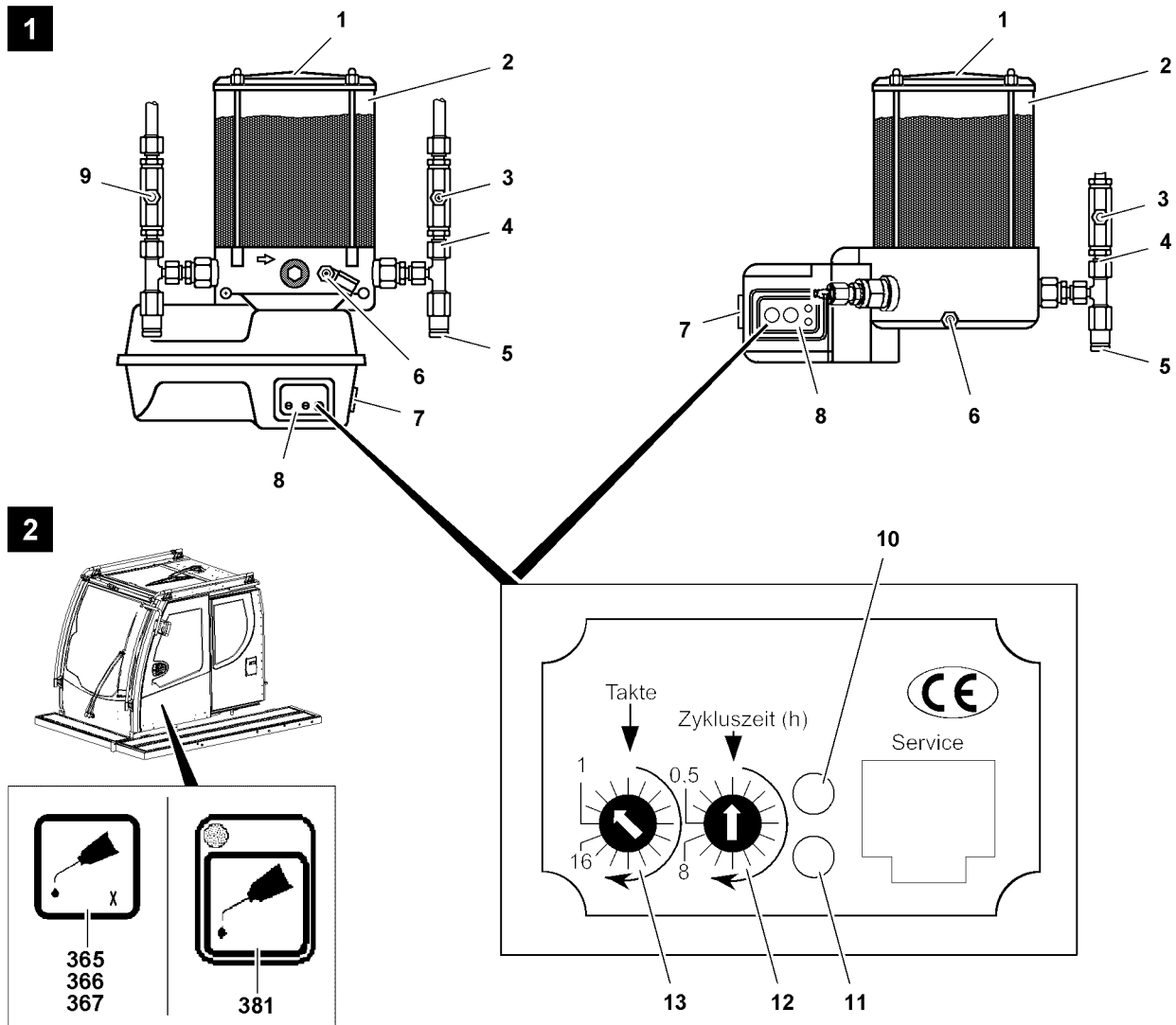


Fig.145952: Central lubrication system, operating and control elements

- |                                   |                                   |   |
|-----------------------------------|-----------------------------------|---|
| 1 Grease container cover          | 7 Intermediate greasing button    | 13 Latched switch lube cycles             |
| 2 Grease container                | 8 Control element                 | 365 Indicator light lubrication circuit 1 |
| 3 Lubrication line grease fitting | 9 Lubrication line grease fitting | 366 Indicator light lubrication circuit 2 |
| 4 Pump outlet                     | 10 LED red                        | 367 Indicator light lubrication circuit 3 |
| 5 Pressure relief valve           | 11 LED green                      | 381 Intermediate greasing button          |
| 6 Grease container grease fitting | 12 Latched switch cycle time      |   |



**Note**

- ▶ In the crane operator's cab, the operating conditions and problems are displayed using the indicator light 365, indicator light 366 and indicator light 367, see illustration 2.
- ▶ Crane operator's cab indicator lights, see chapter 4.01.

LWE/LR 1800-1-0-000/27200-07-02/en

LED red 11	LED green 10	Operating condition
Lights up for 1.5 seconds	Lights up for 1.5 seconds	Operational readiness after ignition on
Off	Lights up	Lubrication is active (during lube cycles)
Turns on/blinks continuously	See section "Diagnostics and troubleshooting"	

*Control element, LED conditions*

## 11.5 Operating the central lubrication system

### 11.5.1 Lubrication cycle



#### Note

The lubrication time and the cycle time are set in the factory.

- ▶ Do **not** change the settings.

**Cycle time:** Time from start of one lubrication to the start of another lubrication.

The cycle time is set with the latched switch **12**.

**Lube cycles:** Number of strokes, during which lubricant is supplied by the pump cylinder.

The number of lube pulses for a lubrication cycle is set with the latched switch **13**.

### 11.5.2 Checking the function

Make sure that the following prerequisites are met:

- The ignition is turned on.



#### Note

- ▶ Problems with the central lubrication system, see section "Diagnostics and troubleshooting".

When lubricant emerges on all lube points, then the central lubrication system functions error-free.

- ▶ Check the function: Activate intermediate lubrication.
- ▶ Trigger intermediate lubrication until lubricant emerges in all lube points.

### 11.5.3 Activating intermediate lubrication

Manual intermediate lubrication is carried out, for example:

- If the crane has not been moved for longer than three months.
- After washing the crane.



#### Note

- ▶ When intermediate lubrication is carried out, the pump starts the lubrication cycle again. The lubrication cycle is reset.

Several lube pulses may be required until lubricant emerges in all lube points.

- ▶ On the central lubrication system: Press the button **7**.

**or**

- In the crane cab: Press the button **381**.

## 11.6 Servicing the central lubrication system



### WARNING

Fall from a working height of greater than 4 m !

- ▶ Ensure a 3-point support.
- ▶ Use personal protective equipment to prevent falling.

Make sure that the following prerequisites are met:

- The prerequisites for maintenance are established, see section “Establishing the prerequisites for maintenance”.
- The diesel engine is turned off.
- The ignition key is pulled out.

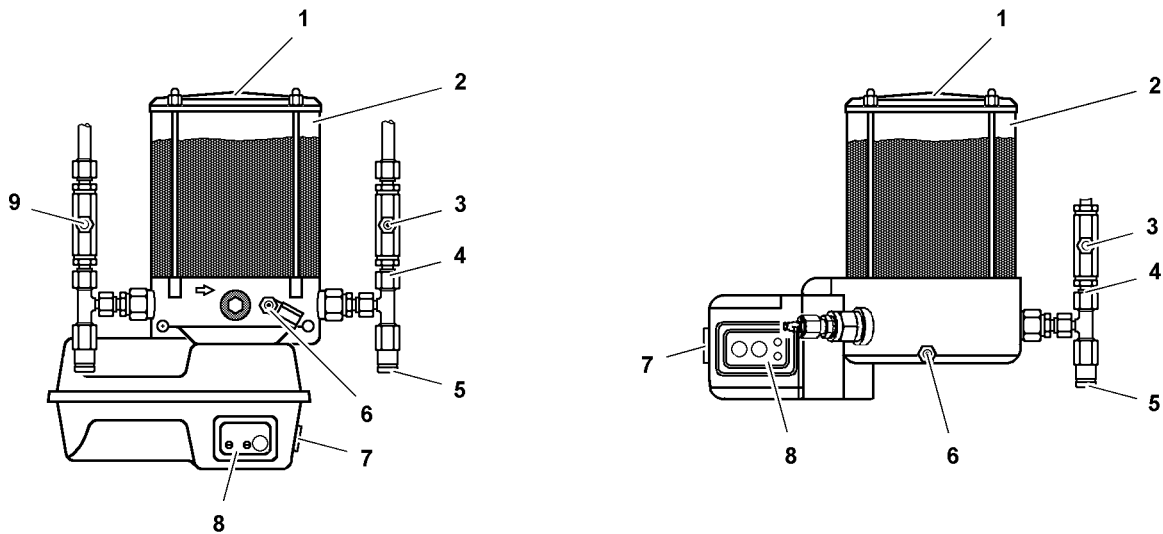


Fig.144843: Central lubrication system, operating and control elements

1	Grease container cover	4	Pump outlet	7	Intermediate greasing button
2	Grease container	5	Pressure relief valve	8	Control element
3	Lubrication line grease fitting	6	Grease container grease fitting	9	Lubrication line grease fitting

### 11.6.1 Checking the fill level in the grease container

The grease container must be filled when the lubricant level has dropped below 1/4 of the container content.

- ▶ Check the fill level and fill the grease container if necessary.

### 11.6.2 Filling the grease container

Make sure that the following prerequisites are met:

- The prerequisites for maintenance are established, see section “Establishing the prerequisites for maintenance”.
- The required quantity of lubricant is available, see the service fill.

### NOTICE

No lubricant!

Dry run of components. Property damage.

- ▶ Make sure that the grease container 2 is filled.
- ▶ Make sure that all grease fittings are clean.

When the grease container is completely empty:

- ▶ Follow the instructions in section “Bleeding the central lubrication system”.

- ▶ Fill the grease container **2** with a grease pump on the grease fitting **6**.

### 11.6.3 Bleeding the central lubrication system

If the grease container **2** is empty, it may be necessary to bleed the central lubrication system.

- ▶ Fill the grease container **2** with a grease pump via the grease fitting **6**.
- ▶ Unscrew the main line from the pump outlet **4**.
- ▶ Trigger additional intermediate lubrications until there are no more air bubbles in the emerging lubricant at the pump outlet **4**.
- ▶ Connect the main line.
- ▶ Carry out intermediate lubrication until lubricant emerges in all lube points.

### 11.6.4 Filling the lubrication lines

---

#### NOTICE

No lubrication!

Dry run of components. Property damage.

- ▶ After every repair on greased components, fill the lubrication lines with grease.
- ▶ Make sure that all grease fittings are clean.

- 
- ▶ Fill lube lines with a grease pump on the grease fitting **3** (and grease fitting **9**).  
**or**  
Carry out intermediate lubrication until lubricant emerges in all lube points.

## 11.7 Diagnostics and troubleshooting

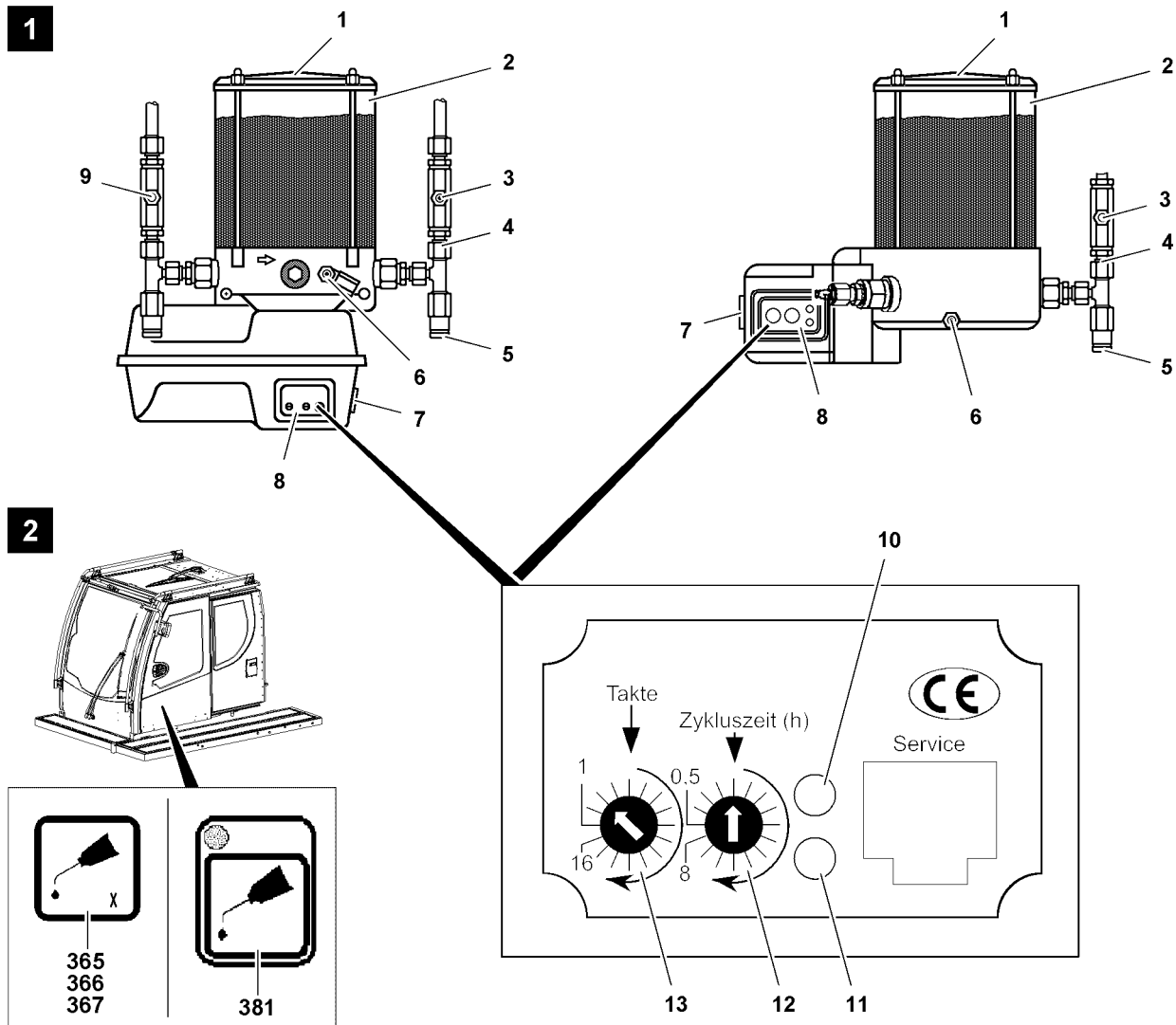


Fig.145952: Central lubrication system, operating and control elements

1 Grease container cover	7 Intermediate greasing button	13 Latched switch lube cycles
2 Grease container	8 Control element	365 Indicator light lubrication circuit 1
3 Lubrication line grease fitting	9 Lubrication line grease fitting	366 Indicator light lubrication circuit 2
4 Pump outlet	10 LED red	367 Indicator light lubrication circuit 3
5 Pressure relief valve	11 LED green	381 Intermediate greasing button
6 Grease container grease fitting	12 Latched switch cycle time	

### 11.7.1 Problem signals on the control element



#### Note

- ▶ In the crane operator's cab, the operating conditions and problems are displayed using the indicator light 365, indicator light 366 and indicator light 365, see illustration 2.
- ▶ Crane operator's cab indicator lights, see chapter 4.01.

Status LEDs		Cause	Remedy
LED red 10	LED green 11		
Blinks once in two seconds	Blinks once in two seconds	Cycle error	Repair the system, contact Customer Service at Liebherr-Werk Ebingen GmbH.
Blinks once a second	Off	CPU error, memory error	Repair the system, contact Customer Service at Liebherr-Werk Ebingen GmbH.
Lights up	Off	Grease level too low (depending on the system type)	Filling the grease container

*Diagnostics for problem signals on the control element 8*

### 11.7.2 Problems on central lubrication system

Lubrication system status	Cause	Remedy
Lubricant emerges via the pressure relief valve <b>5</b>	The lubrication system is blocked	Repair the system, contact Customer Service at Liebherr-Werk Ebingen GmbH.
<b>No</b> lubricant emerges from the system	The grease container is empty <b>or</b> the electric pump is defective	Fill the grease container <b>or</b> repair the system, contact Customer Service at Liebherr-Werk Ebingen GmbH.

*Diagnostics for central lubrication system problems*

### 11.7.3 Resetting a problem

- ▶ Press the button 7.

**Result:**

- Problem signal on control element turns off.

When a problem signal occurs again:

- ▶ Contact Customer Service at Liebherr-Werk Ebingen GmbH.

## 12 Slewing ring connection



**WARNING**

Impermissible set up configuration when turning the crane superstructure!

The crane can topple over. Death, severe bodily injuries, property damage.

- ▶ Enter and activate the load chart for the *360° turning* crane operation in the LICCON overload protection.
- ▶ Set up the crane according to the set up configuration for the *360° turning* load chart.



## 12.1 Lubricating the gear ring and the slewing gear pinion



### WARNING

Turning of the crane superstructure!

Pulling in and crushing of body parts. Death, severe bodily injuries.

- ▶ Work only when the crane superstructure is at a standstill.
- ▶ Protect fingers from being pulled in. Keep a distance.

Make sure that the following prerequisites are met:

- The prerequisites for maintenance are established, see section “Establishing the prerequisites for maintenance”.
- The diesel engine is turned off.
- The ignition key is pulled out.

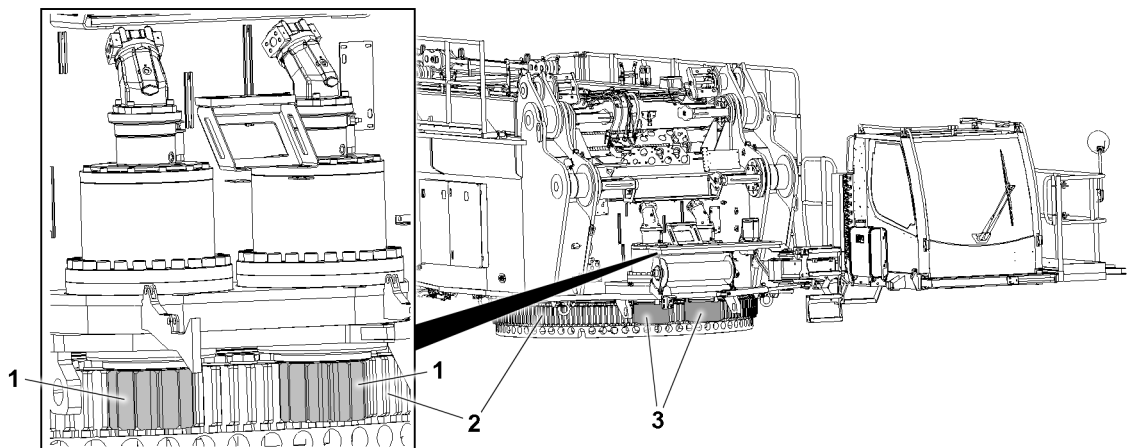


Fig.158560: Slewing gear

- |   |                     |   |       |
|---|---------------------|---|-------|
| 1 | Slewing gear pinion | 3 | Cover |
| 2 | Gear ring           |   |       |

Grease the gear ring **2** and the slewing gear pinion **1** to ensure the best possible protection against corrosion.

- ▶ Remove the cover **3**.
- ▶ Grease the gear ring **2** and the slewing gear pinion **1** externally.
- ▶ Assemble the cover **3**.

## 12.2 Lubricating the slewing ring connection



### WARNING

Persons in the slewing range!

Crushing danger, death, severe bodily injuries.

- ▶ Monitor the slewing range.
- ▶ Make sure that there are **no** persons within the slewing range.
- ▶ Before initiating the turning movement, give a warning signal (horn).



### WARNING

Obstacle in the slewing range!

Danger of collision, property damage.

- ▶ Make sure that there is **no** obstacle within the slewing range of the crane and the crane components.

Make sure that the following prerequisites are met:

- The prerequisites for maintenance are established, see section “Establishing the prerequisites for maintenance”.
- The load chart for the *360° turning* crane operation is entered in the LICCON overload protection and is active.
- The crane is equipped according to the set up configuration for a *360° turning* load chart.
- The diesel engine is turned on.
- ▶ Manually trigger intermediate lubrication on the central lubrication system.  
**or**  
Lubricate with the external lubrication pump.
- ▶ Turn the crane superstructure slowly.
- ▶ Carry out lubrication until lubricant emerges on the sealing lips.
- ▶ Stop the slewing movement of the crane superstructure.

## 13 Slewing gear

### 13.1 Safety



#### WARNING

Impermissible conditions for the gear oil!  
Danger of fire. Death, severe bodily injuries, property damage.

- ▶ Turn the heating systems off, for example the auxiliary heater or the flame start system.

When the gear oil is filled:

- ▶ Exclude heat, sparks, flames and sources of ignition.
- ▶ Avoid high temperatures and direct sunlight.



#### WARNING

Hot components, hot operating materials!  
Severe burns, scalding.

- ▶ Let components cool off to below 50 °C.
- ▶ Avoid contact with hands, skin and eyes.
- ▶ Wear safety goggles.
- ▶ Wear heat-resistant protective equipment: Wear protective gloves and work clothing.



#### WARNING

Spilled gear oil!  
Danger of slipping.

- ▶ Danger of slipping, pay attention.
- ▶ Use personal protective equipment depending on the operating materials.
- ▶ Immediately collect spilled gear oil using suitable material. See the safety data sheet from the manufacturer of the operating fluid.



#### WARNING

Significant oil loss!  
Uncontrolled load movements  
Death, severe bodily injury, transmission damage.

- ▶ Contact Customer Service at Liebherr-Werk Ehingen GmbH.

#### NOTICE

Insufficient oil!  
Transmission damage.

- ▶ Check the oil level and add gear oil if necessary.

**NOTICE**

Dirt inside the transmission!

Transmission damage. Increased wear and shorter service life of the components.

- ▶ Maintain extreme cleanliness during all work.
- ▶ Make sure that **no** dirt gets inside the transmission.

## 13.2 Checking the oil level with the dipstick

Make sure that the following prerequisites are met:

- The prerequisites for maintenance are established, see section “Establishing the prerequisites for maintenance”.
- The diesel engine is turned off.
- The ignition key is pulled out.
- The slewing gear has been stationary for at least 2 min.
- The transmission has warmed up.
- The battery master switch is turned off.

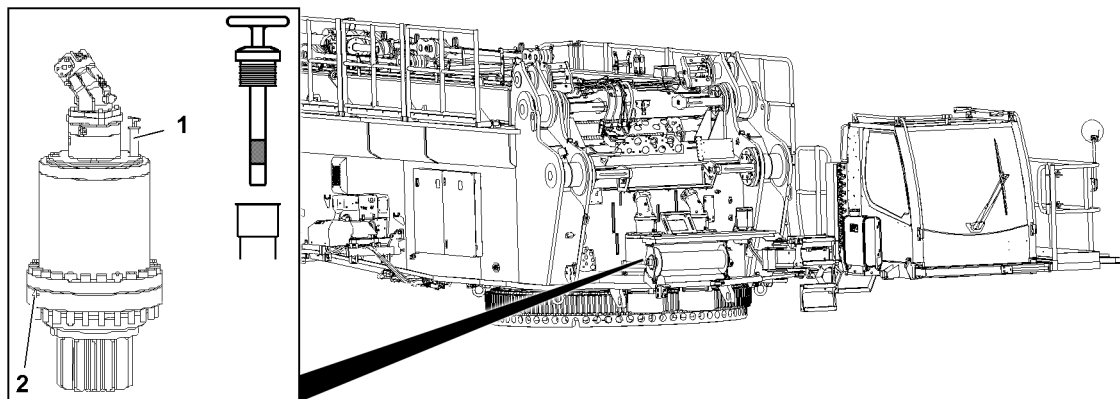


Fig.158567: Slewing gear

1 Dipstick

2 Drain plug

- ▶ Pull out the dipstick **1** and wipe it off.
- ▶ Insert the dipstick **1** and pull it out.

The oil level must be visible between the minimum and maximum marks on the dipstick **1**.

When the oil level has dropped below the minimum mark:

- ▶ Until the oil level is visible between both marks on the dipstick **1**: Add gear oil in the filler port.
- ▶ Check the oil level.
- ▶ Insert the dipstick **1**.

### Problem remedy

Repeated excessive oil consumption or loss of oil?

- ▶ Find the cause and remedy it.

If the cause cannot be remedied:

- ▶ Contact Customer Service at Liebherr-Werk Ehingen GmbH.

## 13.3 Slewing gear: Changing the gear oil

Make sure that the following prerequisites are met:

- The prerequisites for maintenance are established, see section "Establishing the prerequisites for maintenance".
- The diesel engine is turned off.
- The ignition key is pulled out.
- The slewing gear has cooled off for at least 30 min.
- The transmission has warmed up.
- The battery master switch is turned off.
- A suitably sized container for the used gear oil is on hand.
- The required quantity of gear oil is available, see the service fill.

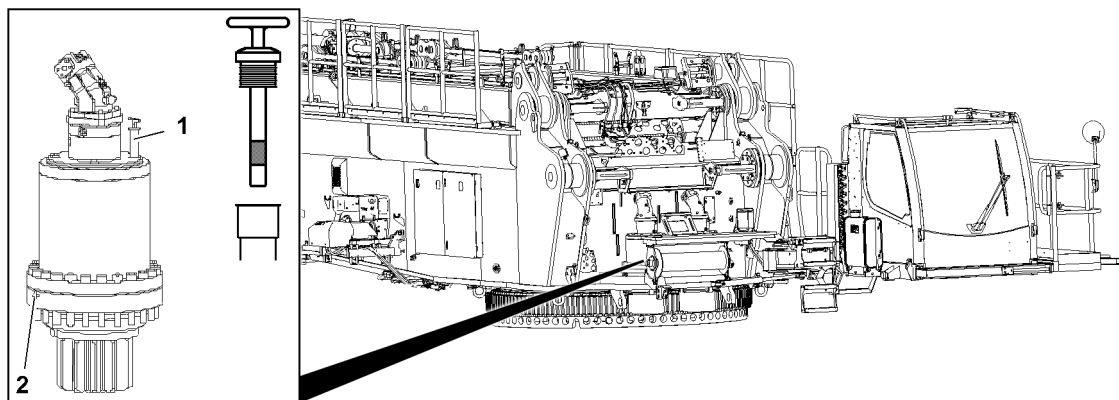


Fig.158567: Slewing gear

1 Dipstick

2 Drain plug

- ▶ Pull out the dipstick **1**.
- ▶ Collect the gear oil: Position a container under the drain plug **2**.
- ▶ Drain the gear oil: Unscrew the drain plug **2**.

When the gear oil is drained:

- ▶ Clean the drain plug **2** and sealing surface on the housing.
- ▶ Screw in the drain plug **2** with a new seal and tighten.
- ▶ Until gear oil is visible between the minimum and maximum marks on the dipstick **1**: Add gear oil in the filler bore.
- ▶ Insert the dipstick **1**.
- ▶ Check the oil level.

### Problem remedy

Repeated excessive oil consumption or loss of oil?

- ▶ Find the cause and remedy it.

If the cause cannot be remedied:

- ▶ Contact Customer Service at Liebherr-Werk Ehingen GmbH.

# 14 Winches

## 14.1 Safety



### WARNING

Impermissible conditions for the gear oil!

Danger of fire. Death, severe bodily injuries, property damage.

- ▶ Turn the heating systems off, for example the auxiliary heater or the flame start system.

When the gear oil is filled:

- ▶ Exclude heat, sparks, flames and sources of ignition.
- ▶ Avoid high temperatures and direct sunlight.



### WARNING

Hot components, hot operating materials!

Severe burns, scalding.

- ▶ Let components cool off to below 50 °C.
- ▶ Avoid contact with hands, skin and eyes.
- ▶ Wear safety goggles.
- ▶ Wear heat-resistant protective equipment: Wear protective gloves and work clothing.



### WARNING

Spilled gear oil!

Danger of slipping.

- ▶ Danger of slipping, pay attention.
- ▶ Use personal protective equipment depending on the operating materials.
- ▶ Immediately collect spilled gear oil using suitable material. See the safety data sheet from the manufacturer of the operating fluid.



### WARNING

Significant oil loss!

Uncontrolled load movements

Death, severe bodily injury, transmission damage.

- ▶ Contact Customer Service at Liebherr-Werk Ehingen GmbH.

### NOTICE

Insufficient oil!

Transmission damage.

- ▶ Check the oil level and add gear oil if necessary.

### NOTICE

Dirt inside the transmission!

Transmission damage. Increased wear and shorter service life of the components.

- ▶ Maintain extreme cleanliness during all work.
- ▶ Make sure that **no** dirt gets inside the transmission.

### 14.2 Winch overview

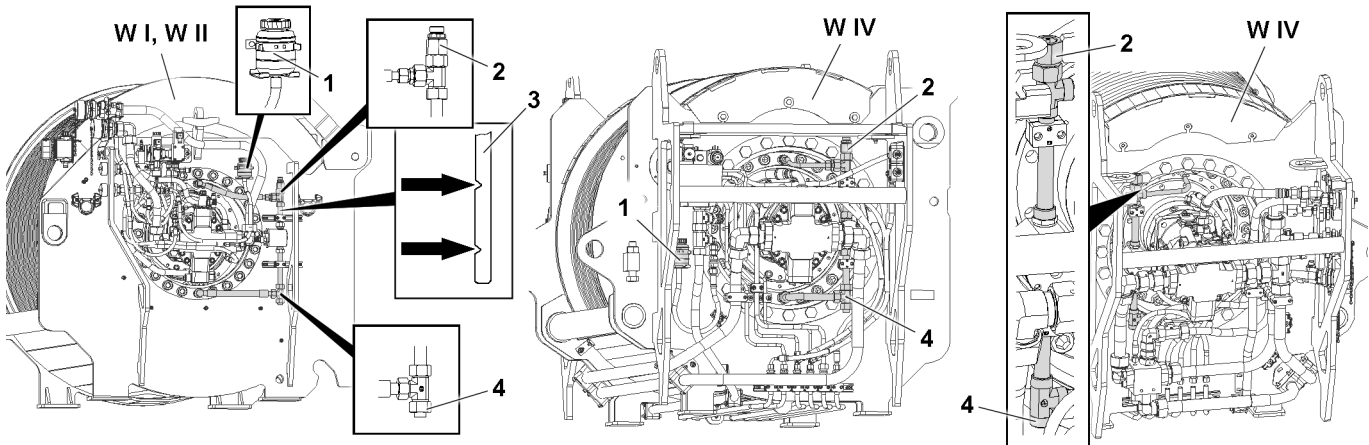


Fig.159212: Winches Turntable

- |                                |                                  |                                |
|--------------------------------|----------------------------------|--------------------------------|
| <b>W I</b> Winch 1             | <b>1</b> Overflow container      | <b>4</b> Drain cap, drain port |
| <b>W II</b> Winch 2            | <b>2</b> Filler cap, filler port |                                |
| <b>W IV</b> Winch 4, two sides | <b>3</b> Dipstick                |                                |

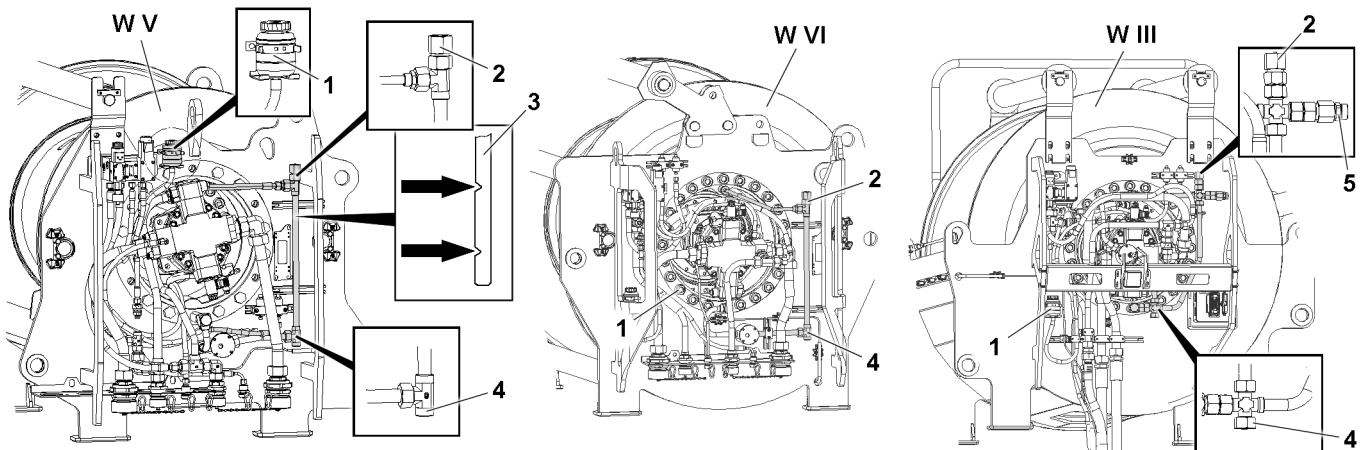


Fig.159211: Winches Pivot section Boom system

- |                      |                                  |                                      |
|----------------------|----------------------------------|--------------------------------------|
| <b>W III</b> Winch 3 | <b>1</b> Overflow container      | <b>4</b> Drain cap, drain port       |
| <b>W V</b> Winch 5   | <b>2</b> Filler cap, filler port | <b>5</b> Breather cap, breather hole |
| <b>W VI</b> Winch 6  | <b>3</b> Dipstick                |                                      |

LWE/LR 1800-1-0-000/27200-07-02/en

## 14.3 Winch gear

### 14.3.1 Checking the oil level with the dipstick

Make sure that the following prerequisites are met:

- The prerequisites for maintenance are established, see section “Establishing the prerequisites for maintenance”.
- Winch 1, winch 2 and winch 4 are assembled and the crane is horizontal.
- Or: Winch 1, winch 2 and winch 4 are disassembled and horizontally aligned.
- The diesel engine is turned off.
- The ignition key is pulled out.
- The battery master switch is turned off.
- The winch gear has been stationary for at least 2 min.
- The transmission has warmed up.

“Checking the oil level” with winch 3 is only possible in certain positions:

- Winch 3 is assembled and the D-pivot section is horizontally aligned.
- Or: Winch 3 is disassembled and horizontally aligned.

“Checking the oil level” with winch 5 and winch 6 is only possible in certain positions:

- Winch 5 and winch 6 are assembled and the S-pivot section horizontally aligned.
- Or: Winch 5 and winch 6 are disassembled and horizontally aligned.

This procedure is described for one winch as an example.

- ▶ Open the filler cap **2**.
- ▶ Pull out the dipstick **3** and wipe it off.
- ▶ Insert the dipstick **3** and pull it out.

The oil level must be visible between the minimum and maximum marks on the dipstick **3**.

- ▶ Check the oil level.

If gear oil is added when Winch 3 is installed and the D-pivot section is in the transport position:

- ▶ Open the breather cap **5**.

When the oil level has dropped below the minimum mark:

- ▶ Fill gear oil in the filler port **2** until the oil level is visible between both marks on the dipstick.
- ▶ Insert the dipstick **1**.
- ▶ Securely close the filler port **2** and breather hole **5**.
- ▶ Make sure that oil level is checked in every winch.

---

#### Problem remedy

Repeated excessive oil consumption or loss of oil?

- ▶ Find the cause and remedy it.

If the cause cannot be remedied:

- ▶ Contact Customer Service at Liebherr-Werk Ehingen GmbH.
-

### 14.3.2 Changing the gear oil

Make sure that the following prerequisites are met:

- The prerequisites for maintenance are established, see section “Establishing the prerequisites for maintenance”.
- Winch 1, winch 2 and winch 4 are disassembled and horizontally aligned.
- Winch 3 is assembled and the D-pivot section is horizontally aligned.
- Or: Winch 3 is disassembled and horizontally aligned.
- Winch 5 and winch 6 are assembled and the S-pivot section horizontally aligned.
- Or: Winch 5 and winch 6 are disassembled and horizontally aligned.
- The diesel engine is turned off.
- The ignition key is pulled out.
- The battery master switch is turned off.
- The winch gear has cooled off for at least 30 min.
- The transmission has warmed up.
- A suitably sized container for the used gear oil is on hand.
- The required quantity of gear oil is available, see the service fill.

This procedure is described for one winch as an example.

If changing the oil on winch 3:

- ▶ Open the breather cap **5**.
- ▶ Open the filler cap **2**.
- ▶ Pull out the dipstick **3**.
- ▶ Collect the gear oil: Position a container under the drain cap **4**.
- ▶ Drain the gear oil: Open the drain cap **4**.

When the gear oil is drained:

- ▶ Clean the drain cap **4** and sealing surface on the screw connection.
- ▶ Tighten the drain cap **4** with a new seal.
- ▶ Fill gear oil through the filler port **2** until the gear oil is visible between the minimum and maximum mark on the dipstick **3**.
- ▶ Insert the dipstick **3**.
- ▶ Firmly close the filler port **2**.

If changing the oil on winch 3:

- ▶ Securely close the filler port **5**.
- ▶ Make sure that gear oil is changed in every winch.

### 14.3.3 Checking the overflow container

When hydraulic oil is found in the overflow container **1**:

- ▶ Dispose of the hydraulic oil properly.

## 15 Assembly winch

### 15.1 Changing the gear oil



#### WARNING

Impermissible conditions for the gear oil!

Danger of fire. Death, severe bodily injuries, property damage.

- ▶ Turn the heating systems off, for example the auxiliary heater or the flame start system.

When the gear oil is filled:

- ▶ Exclude heat, sparks, flames and sources of ignition.
- ▶ Avoid high temperatures and direct sunlight.



**WARNING**

Spilled gear oil!

Danger of slipping.

- ▶ Danger of slipping, pay attention.
- ▶ Use personal protective equipment depending on the operating materials.
- ▶ Immediately collect spilled gear oil using suitable material. See the safety data sheet from the manufacturer of the operating fluid.

Make sure that the following prerequisites are met:

- The prerequisites for maintenance are established, see section “Establishing the prerequisites for maintenance”.
- The assembly winch is spooled out.
- The winch mark is on top.
- The diesel engine is turned off.
- The ignition key is pulled out.
- The battery master switch is turned off.
- The winch gear has cooled off for at least 30 min.
- The transmission has warmed up.
- A suitably sized container for the used gear oil is on hand.
- The required quantity of gear oil is available, see the service fill.

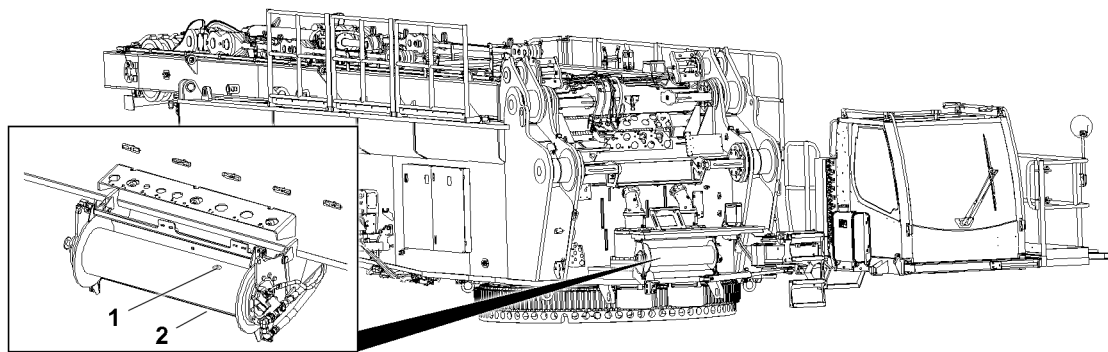


Fig.158575: Assembly winch

1 Filler plug, filler port

2 Drain plug

**WARNING**

Fall from a working height of greater than 4 m !

- ▶ Ensure a 3-point support.
- ▶ Use personal protective equipment to prevent falling.
- ▶ Unscrew the filler plug 1.
- ▶ Collect the gear oil: Position a container under the drain plug 2.
- ▶ Drain the gear oil: Unscrew the drain plug 2.

When the gear oil is drained:

- ▶ Clean the drain plug 2 and sealing surface on the housing.
- ▶ Screw in the drain plug 2 with a new seal and tighten.
- ▶ Fill gear oil in the filler port 1.
- ▶ Screw in the filler plug 1 with a new seal and tighten.

## 16 Crane cab heating-air conditioner device

### 16.1 Replacing the filter insert

The crane operator's cab can be tilted upward for maintenance work.

**WARNING**

Tipping of the crane cab!  
Danger of crushing.

- ▶ Make sure that no persons or objects are in the danger zone of the crane operator's cab.
- ▶ Make sure that the crane cab is horizontally aligned.

Make sure that the following prerequisites are met:

- The prerequisites for maintenance are established, see section “Establishing the prerequisites for maintenance”.
- The crane cab is horizontally aligned.
- The diesel engine is turned off.
- The ignition key is pulled out.
- The battery master switch is turned off.
- A new filter insert is available.
- An assembly scaffolding or a work platform is available.

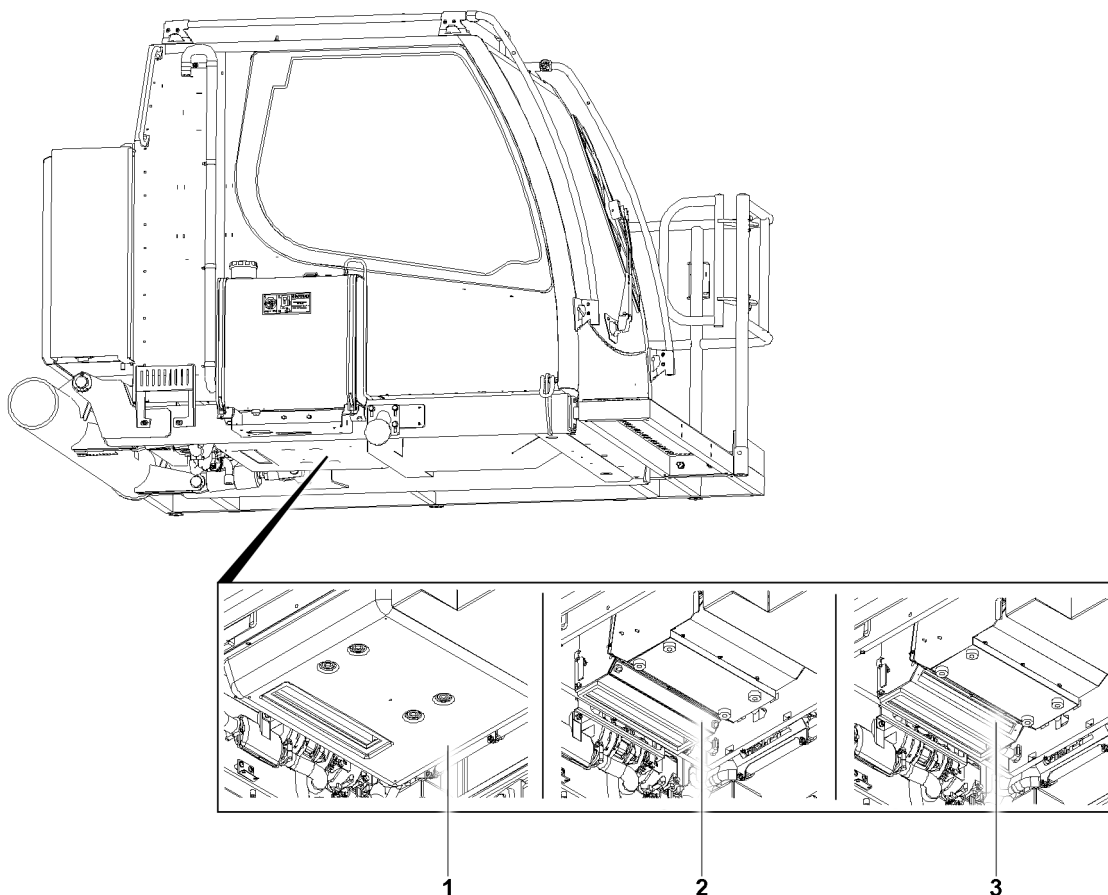


Fig.144829: Filter insert, heating-air conditioning device

- |   |                               |
|---|-------------------------------|
| <p><b>1</b> Housing</p> <p><b>2</b> Cover</p> | <p><b>3</b> Filter insert</p> |
|---|-------------------------------|

Access to the bottom side of the turntable with “aids for work at a height”. Observe and adhere to the information in chapter 2.04.

- ▶ Position an assembly scaffolding or a work platform.
- ▶ Remove the housing **1** and the cover **2**.
- ▶ Remove the filter insert **3** and replace it.
- ▶ Assemble the cover **2** and housing **1**.

## 17 Crane cab auxiliary heater\*

### 17.1 Checking the fill level of the fuel container

Make sure that the following prerequisites are met:

- The prerequisites for maintenance are established, see section “Establishing the prerequisites for maintenance”.

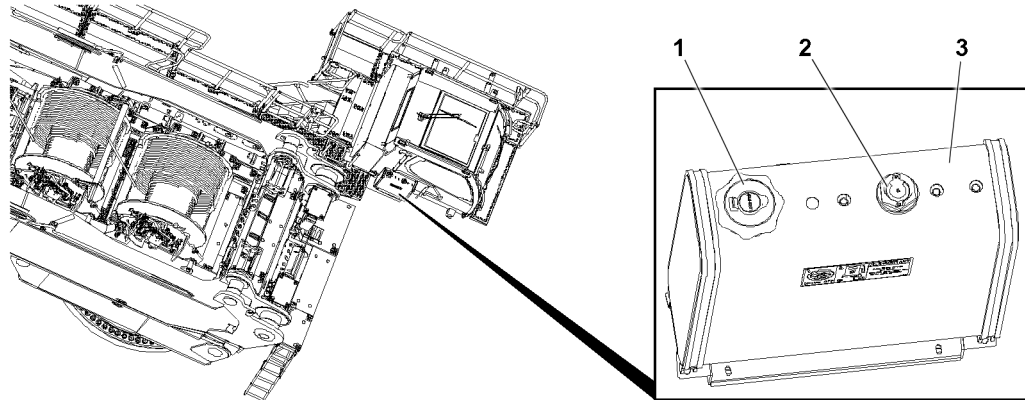


Fig.157757: Fuel container, auxiliary heater

- |   |                    |   |                |
|---|--------------------|---|----------------|
| 1 | Cover              | 3 | Fuel container |
| 2 | Fuel level display |   |                |

The fill level of the fuel container **3** is displayed by a level indicator **2**.

- Marking F: The fuel container is full.
- Marking E: The fuel container is empty.

- ▶ Check the fill level on the level indicator **2**.

If fuel must be added:

- ▶ Only add permissible fuel.
- ▶ Add fuel, see section “Adding fuel”.

### 17.2 Adding fuel



#### WARNING

Impermissible conditions for the fuel!

Danger of fire. Death, severe bodily injuries, property damage.

- ▶ Turn the heating systems off, for example the auxiliary heater or the flame start system.

When fuel is added:

- ▶ Exclude heat, sparks, flames and sources of ignition.



#### WARNING

Spilled fuel!

Danger of slipping.

- ▶ Danger of slipping, pay attention.
- ▶ Use personal protective equipment depending on the operating materials.
- ▶ Immediately collect spilled fuel using suitable material. See the safety data sheet from the manufacturer of the operating fluid.

Make sure that the following prerequisites are met:

- The prerequisites for maintenance are established, see section “Establishing the prerequisites for maintenance”.
- The diesel engine is turned off.
- The ignition key is pulled out.
- The battery master switch is turned off.
- The heating systems are turned off, for example the auxiliary heater, flame start system.

---

#### NOTICE

Impermissible fuel!

Severe damage to the engine independent heater.

- ▶ Make sure that the minimum fuel requirements are fulfilled, see the separate water heater operating instructions.
  - ▶ Select the fuel in relation to the weather and temperature conditions.
- 

#### NOTICE

Dirt in the fuel system!

Damage to components. Increased wear and shorter service life of the components.

- ▶ Make sure that no dirt gets inside the fuel system.
- 



#### WARNING

Fall from a working height of greater than 4 m !

- ▶ Ensure a 3-point support.
  - ▶ Use personal protective equipment to prevent falling.
- 
- ▶ Follow the notes and instructions, see chapter 2.04.10, chapter 2.06 and chapter 2.07.

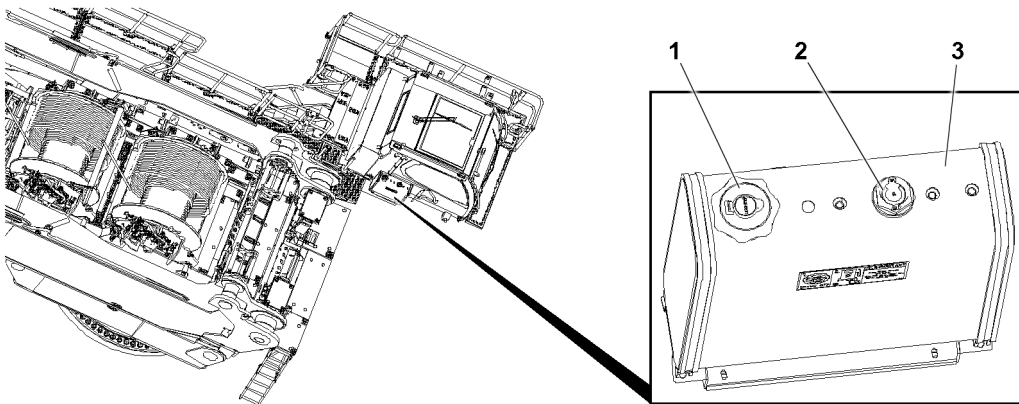


Fig.157757: Fuel container, auxiliary heater

- |   |                    |   |                |
|---|--------------------|---|----------------|
| 1 | Cover              | 3 | Fuel container |
| 2 | Fuel level display |   |                |

- ▶ Remove the cover 1.
- ▶ Use the fuel nozzle such that **no** fuel can escape.
- ▶ Insert the fuel nozzle as deep as possible into the filler neck.
- ▶ Until the fuel nozzle turns off: Add fuel.

When the refueling procedure is done:

- ▶ Remove the fuel nozzle from the filler neck and secure it from falling down.
- 



#### WARNING

Fuel tank **not** tightly closed!

Escaping fuel.

- ▶ Make sure that the fuel tank is tightly closed.
-

- ▶ Tighten the cover **1** completely.

---

#### Problem remedy

Was **impermissible** fuel added?

- ▶ Do **not** turn the ignition on.
  - ▶ Have the fuel container and fuel lines completely drained by authorized and trained service personnel.
- 

### 17.3 Bleeding the fuel line

If the fuel ran out, then the fuel line may have to be bled.



#### Note

- ▶ Contact Customer Service at Liebherr-Werk Ehingen.
- 

### 17.4 Checking the function

Operate the auxiliary heater at least once a month for 15 minutes.

Make sure that the following prerequisites are met:

- The air filters are not blocked.
- Combustion air infiltration and exhaust emission of the heater are free of foreign particles.
- If present: The pollen filter / dust filter of the heater are not blocked.
- The heating circuit is bled.
- The fuel line is bled.
- The heating circuit is cold.
- The LICCON computer system error memory does not contain any error messages regarding the auxiliary heater.
- The diesel engine is turned off.

- ▶ Turn on the auxiliary heater to the highest fan stage and run it for at least 15 min.

Wait a few minutes:

- ▶ Check the heat effect on the air vents.

### 17.5 Burning-off the burner

To prevent soot deposits in the burner of the auxiliary heater, free-burn the burner according to the maintenance interval. Burning off is used for the self-cleaning of the auxiliary heater burner.

Make sure that the following prerequisites are met:

- All outlet nozzles in the crane cab are open.
- The crane cab door is open.
- The interior temperature is set to the highest level.
- The fan stage is set to the highest level.
- The air supply is set to fresh air.
- The heater is in manual operation.

- ▶ Turn on the auxiliary heater to the highest fan stage and run it for at least 15 min.

### 17.6 Checking the water heater

Make sure that the following prerequisites are met:

- The prerequisites for maintenance are established, see section “Establishing the prerequisites for maintenance”.
- The diesel engine is turned off.
- The ignition key is pulled out.
- The battery master switch is turned off.
- The heating systems are turned off, for example the auxiliary heater, flame start system.
- The heater and the heating circuit are cold.

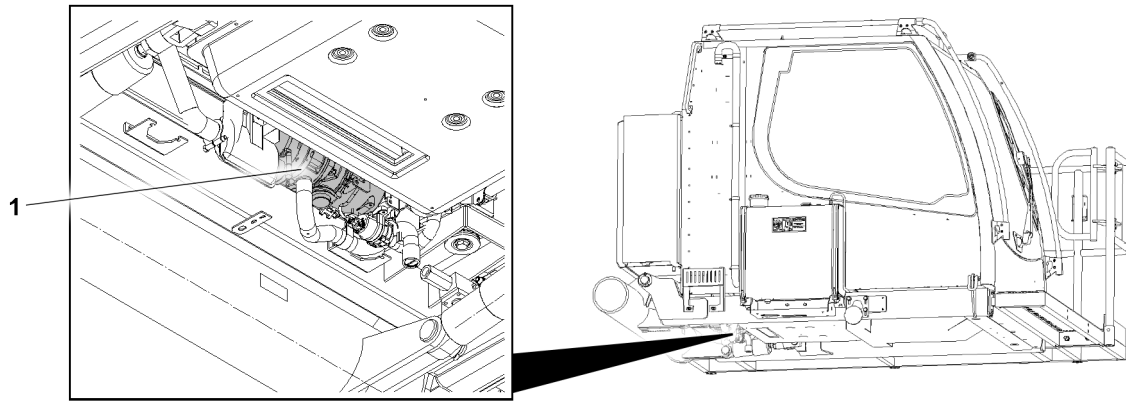


Fig.158561: Water heater, crane cab

For a complete description of the service work, see the workshop manual for the water heater 1.

- ▶ Check the electrical connections for corrosion and tight seating.
- ▶ Check the exhaust line and combustion air line for damage and free passage.
- ▶ Check the hoses for leaks and cracks.
- ▶ Check the circulation pump for leaks.
- ▶ Check the coolant circuit and coolant pump for leaks and cracks.
- ▶ Check the fuel line and fuel filter for leaks and cracks.

When separately installed:

- ▶ Check the fuel filter for free passage.

When the fuel filter is dirty:

- ▶ Replace the fuel filter.

The ratio of corrosion inhibitor - antifreeze in the heating circuit must be 33 % .

- ▶ Check the ratio of corrosion inhibitor - antifreeze in the heating circuit.

If too many cold-resistant fuels are changed:

- ▶ Operate the air heater for 15 min so that the fuel system is filled with the new fuel.

## 18 Air heater\*

### 18.1 Bleeding the fuel line

If the fuel ran out, then the fuel line may have to be bled.



#### Note

- ▶ Contact Customer Service at Liebherr-Werk Ehingen.

### 18.2 Checking the function

Make sure that the following prerequisites are met:

- Combustion air infiltration and exhaust emission of the heater are free of foreign particles.
- The fuel line is bled.
- The crane engine is turned off.

- ▶ Turn on the air heater to the highest fan stage and run it for at least 15 min.

Wait a few minutes:

- ▶ Check the heat effect on the air vents.

## 18.3 Checking the air heater

Make sure that the following prerequisites are met:

- The prerequisites for maintenance are established, see section “Establishing the prerequisites for maintenance”.
- The diesel engine is turned off.
- The ignition key is pulled out.
- The battery master switch is turned off.
- The heating systems are turned off, for example the auxiliary heater, flame start system.
- The heater and the heating circuit are cold.

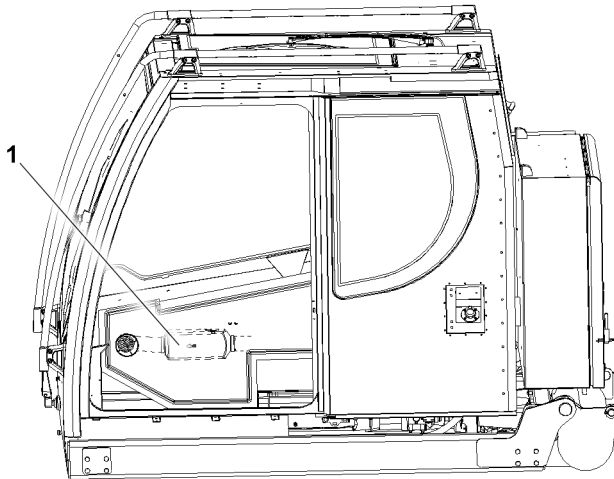


Fig.158562: Air heater, crane cab

For a complete description of the service work, see the workshop manual for the air heater 1.

- ▶ Check the heated air inlet and heated air outlet for dirt and foreign particles.
- ▶ Check the electrical connections for corrosion and tight seating.
- ▶ Check the exhaust line and combustion air line for damage and free passage.
- ▶ Check the circulation pump for leaks.
- ▶ Check the fuel line for leaks and cracks.

When separately installed:

- ▶ Check the fuel filter for free passage.

When the fuel filter is dirty:

- ▶ Replace the fuel filter.

If too many cold-resistant fuels are changed:

- ▶ Operate the air heater for 15 min so that the fuel system is filled with the new fuel.

## 19 Drive assembly air conditioning system\*

### 19.1 Servicing the drive assembly air conditioning system

Make sure that the following prerequisites are met:

- The prerequisites for maintenance are established, see section “Establishing the prerequisites for maintenance”.
- Winch 1 has been disassembled.
- The diesel engine is turned off.
- The ignition key is pulled out.
- The battery master switch is turned off.
- The heating systems are turned off, for example the auxiliary heater, flame start system.
- The components are cold.

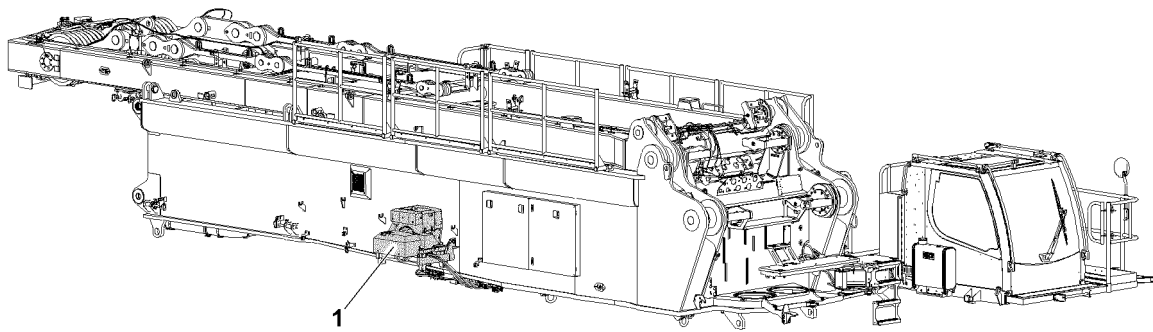


Fig.151930: Drive assembly, air conditioning system

The maintenance of the drive assembly air conditioning system\* 1 includes:

- Function test
- Inspections and maintenance work
- ▶ Observe and adhere to the safety instructions and maintenance instructions in the manufacturer's documentation.

## 20 Hydraulic system

### 20.1 Adding hydraulic oil



#### WARNING

Impermissible conditions for the hydraulic oil!

Danger of fire. Death, severe bodily injuries, property damage.

- ▶ Turn the heating systems off, for example the auxiliary heater or the flame start system.

When hydraulic oil is added:

- ▶ Exclude heat, sparks, flames and sources of ignition.
- ▶ Avoid high temperatures and direct sunlight.



#### WARNING

Spilled hydraulic oil!

Danger of slipping.

- ▶ Danger of slipping, pay attention.
- ▶ Use personal protective equipment depending on the operating materials.
- ▶ Immediately collect spilled hydraulic oil using suitable material. See the safety data sheet from the manufacturer of the operating fluid.

Make sure that the following prerequisites are met:

- The prerequisites for maintenance are established, see section “Establishing the prerequisites for maintenance”.
- The diesel engine is turned off.
- The ignition key is pulled out.
- The battery master switch is turned off.
- The heating systems are turned off, for example the auxiliary heater, flame start system.
- The required quantity of hydraulic oil is available, see the service fill.



**NOTICE**

Impermissible hydraulic oil!  
Severe damage to the hydraulic system.

- ▶ Make sure that the requirements for the hydraulic oil are fulfilled, see the service fill.
- ▶ Do **not** mix hydraulic oils.

**NOTICE**

Dirt in the hydraulic system!  
Damage to components. Increased wear and shorter service life of the components.

- ▶ Make sure that no dirt gets inside the hydraulic system.

**WARNING**

Fall from a working height of greater than 4 m !

- ▶ Ensure a 3-point support.
  - ▶ Use personal protective equipment to prevent falling.
- ▶ Follow the notes and instructions, see chapter 2.04.10, chapter 2.06 and chapter 2.07.

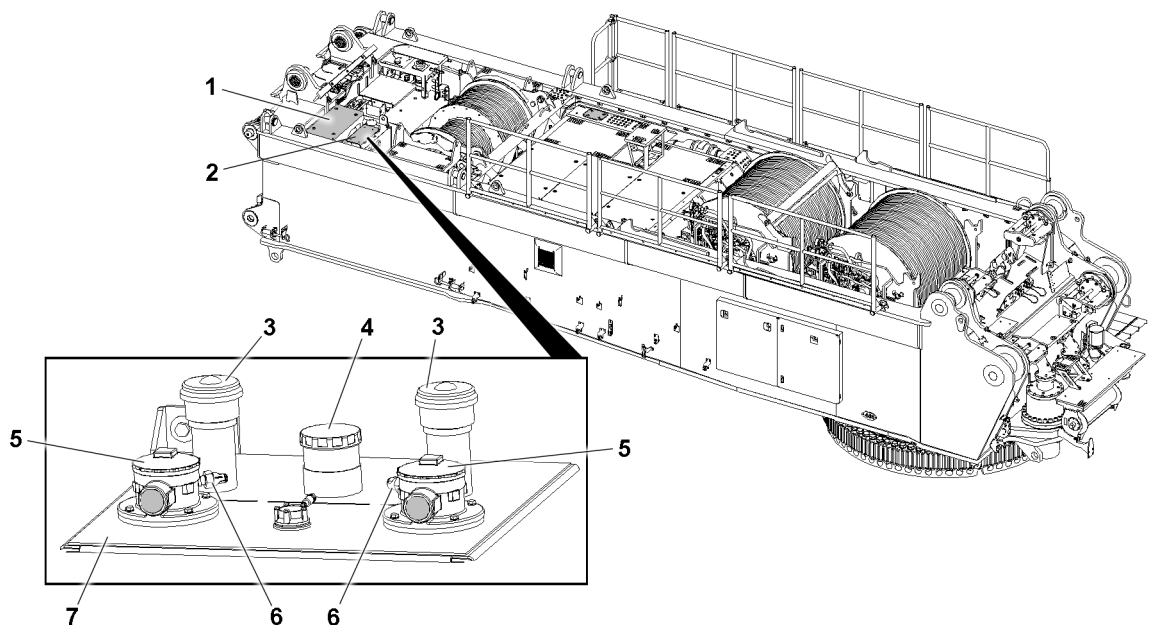


Fig.158563: Tank fittings, hydraulic system

- |   |                                |   |                       |
|---|--------------------------------|---|-----------------------|
| 1 | Cover                          | 5 | Cover (return filter) |
| 2 | Cover                          | 6 | Fouling indicator     |
| 3 | Cover (breather / vent filter) | 7 | Hydraulic tank        |
| 4 | Cover (filler neck)            |   |                       |

- ▶ Remove the cover 1 and cover 2.
- ▶ Remove the cover 4.
- ▶ Use the fuel nozzle such that **no** hydraulic oil is spilled.
- ▶ Insert the fuel nozzle as deep as possible into the filler neck.
- ▶ Until the fuel nozzle turns off: Add hydraulic oil.

When the refueling procedure is done:

- ▶ Remove the fuel nozzle from the filler neck and secure it from falling down.

**WARNING**

Hydraulic oil tank **not** tightly closed!  
 Danger of fire: Escaping hydraulic oil.  
 Environmental risk.

- ▶ Make sure that the hydraulic oil tank is tightly closed.
- 
- ▶ Tighten the cover **4** completely.
  - ▶ Assemble the cover **1** and cover **2**.

**Problem remedy**

Was impermissible hydraulic oil added?

- ▶ Do **not** turn the ignition on.
- ▶ Have the hydraulic oil tank and hydraulic lines completely drained by authorized and trained service personnel.

## 20.2 Checking the oil level on the LICCON monitor

**WARNING**

Considerable hydraulic oil loss!  
 Uncontrolled load movements. Death, severe bodily injury.

- ▶ In the case of considerable hydraulic oil loss, contact Customer Service at Liebherr-Werk Ehingen GmbH.

**WARNING**

Impermissible hydraulic oil level!  
 Malfunctioning of crane movements.

- ▶ Remedy the problem and observe the error message.
- ▶ Establish a permissible oil level.

Make sure that the following prerequisites are met:

- The prerequisites for maintenance are established, see section “Establishing the prerequisites for maintenance”.
  - The S and D boom systems are disassembled.
  - The B and BW ballast systems are disassembled.
  - The SA-frame is taken down or disassembled.
  - All hydraulic cylinders are retracted.
  - The diesel engine is turned off.
  - The ignition is turned on.
- ▶ Climb onto the crane: Use the stairs, platform, catwalk and ladder.
  - ▶ Make sure that the hydraulic oil reaches a temperature of 20 °C.

When the hydraulic temperature is lower than 20 °C:

- ▶ Warm up the hydraulic oil.
- or**

When the auxiliary equipment is available for ambient temperatures of less than -20 °C:  
 Warm up the hydraulic oil, see chapter 4.03.

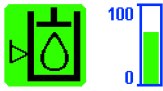



When the hydraulic temperature is higher than 20 °C:

- ▶ Let the hydraulic oil cool off.

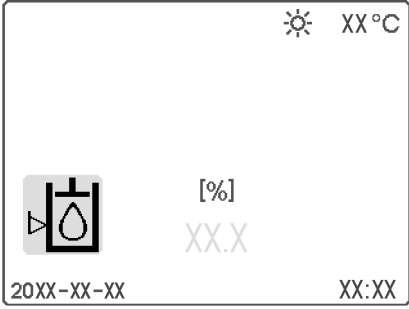
The hydraulic oil level is monitored by the LICCON computer system.

Call up the monitoring functions and the *hydraulic oil level* individual control display, see chapter 4.02.

Variations of the *hydraulic oil level* display, see the following charts.

Status	Filling level	Icon color	Meaning
1		Green	The oil level is OK.
2		Yellow	The oil level is too low.
3		Red	The oil level is too low.
4		Red	System errors

Hydraulic oil level conditions: Variation 1

Status	Fill level as a percentage	Icon color	Meaning
1		Green	The oil level is OK.
2		Yellow	The oil level is too low.
3		Red	The oil level is too low.

Hydraulic oil level conditions: Variation 2

- ▶ Check the hydraulic oil level.

#### Problem remedy

Is the hydraulic oil level too low?

Hydraulic oil loss.

- ▶ Find the cause of the problem and remedy it.
- ▶ Establish a permissible hydraulic oil level, see section "Adding hydraulic oil".

If the cause cannot be remedied or if there is again excessive loss of oil:

- ▶ Contact Customer Service at Liebherr-Werk Ehingen GmbH.

#### Problem remedy

Is a system error displayed?

Unknown problem.

- ▶ Find the cause of the problem and remedy it.

If the cause cannot be remedied:

- ▶ Contact Customer Service at Liebherr-Werk Ehingen GmbH.

## 20.3 Checking the breather / vent filter

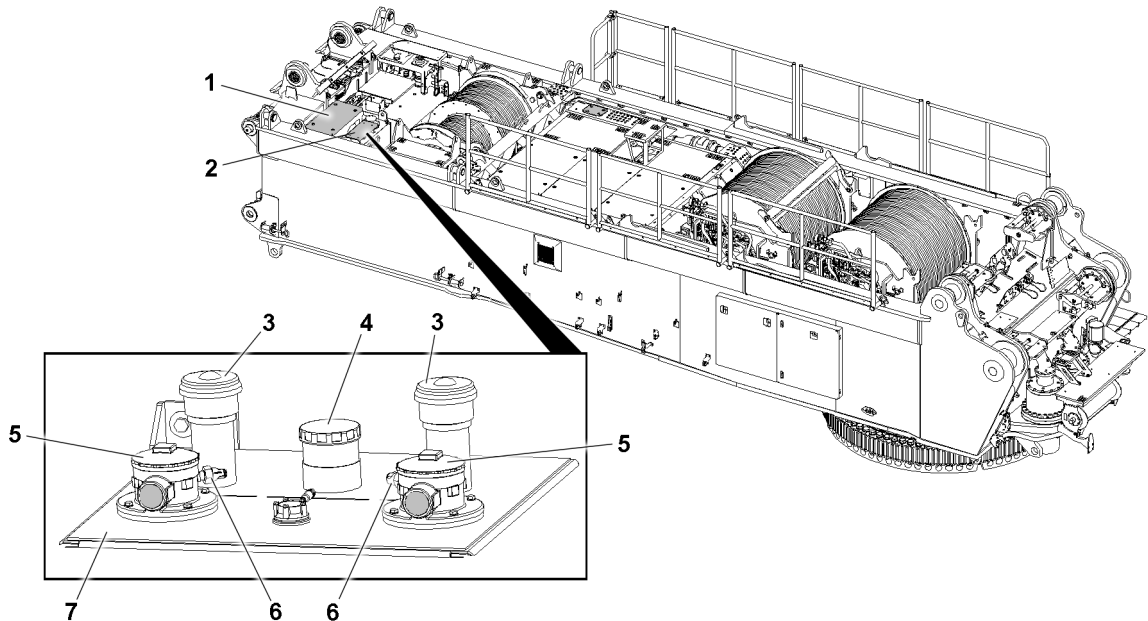


Fig.158563: Tank fittings, hydraulic system

- |   |                                |   |                       |
|---|--------------------------------|---|-----------------------|
| 1 | Cover                          | 5 | Cover (return filter) |
| 2 | Cover                          | 6 | Fouling indicator     |
| 3 | Cover (breather / vent filter) | 7 | Hydraulic tank        |
| 4 | Cover (filler neck)            |   |                       |

Make sure that the following prerequisites are met:

- The prerequisites for maintenance are established, see section “Establishing the prerequisites for maintenance”.
- The diesel engine is turned off.
- The ignition key is pulled out.
- The battery master switch is turned off.
- New vent filters / breather filters are available.



### WARNING

Fall from a working height of greater than 4 m !

- ▶ Ensure a 3-point support.
  - ▶ Use personal protective equipment to prevent falling.
- 
- ▶ Follow the notes and instructions, see chapter 2.04.10, chapter 2.06 and chapter 2.07.
  - ▶ Remove the cover 1 and cover 2.
  - ▶ Screw off the cover 3 from the breather / vent filter.
  - ▶ Check the vent filter for impurities (visual inspection).

When the vent filter is very dirty:

- ▶ Replace the vent filter.
- ▶ Position the cover 3 and tighten.
- ▶ Assemble the cover 1 and cover 2.
- ▶ Start the engine.
- ▶ Slowly run through all crane movements.

### Result:

- The hydraulic system is bled.
- ▶ Check the breather / vent filter for leaks.
- ▶ Check the oil level and add hydraulic oil if necessary.

## 20.4 Replacing the return filter inserts

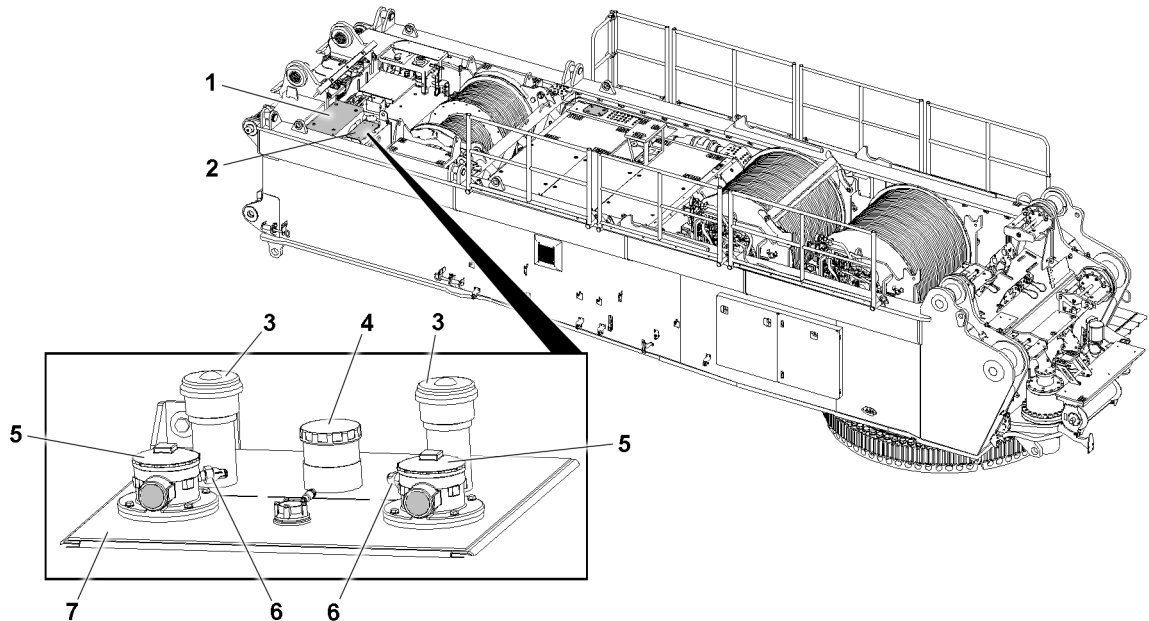


Fig.158563: Tank fittings, hydraulic system

- |   |                                |   |                       |
|---|--------------------------------|---|-----------------------|
| 1 | Cover                          | 5 | Cover (return filter) |
| 2 | Cover                          | 6 | Fouling indicator     |
| 3 | Cover (breather / vent filter) | 7 | Hydraulic tank        |
| 4 | Cover (filler neck)            |   |                       |

The return filter inserts must be replaced in the following situations:

- When the red bar display of the fouling indicator **6** is visible when the hydraulic oil is at operating temperature.
- When maintenance is due.

Make sure that the following prerequisites are met:

- The prerequisites for maintenance are established, see section “Establishing the prerequisites for maintenance”.
- The diesel engine is turned off.
- The ignition key is pulled out.
- The battery master switch is turned off.
- New return filters are available.



### WARNING

Fall from a working height of greater than 4 m !

- ▶ Ensure a 3-point support.
- ▶ Use personal protective equipment to prevent falling.

- ▶ Follow the notes and instructions, see chapter 2.04.10, chapter 2.06 and chapter 2.07.
- ▶ Remove the cover **1** and cover **2**.
- ▶ Screw off filter cover **5** from the return filter.
- ▶ Unscrew the filter inserts.
- ▶ Rinse out the filter housings.
- ▶ Clean the sealing surfaces on the cover **5** and filter housings.
- ▶ Insert new filter units.
- ▶ On the cover **5**: Oil the seal rings.
- ▶ Position the cover **5** and tighten.
- ▶ Remove the cover **1** and cover **2**.
- ▶ Start the engine.
- ▶ Slowly run through all crane movements.

**Result:**

- The hydraulic system is bled.
- ▶ Check the return filter for leaks.
- ▶ Check the oil level and add hydraulic oil if necessary.

## 20.5 Replacing the pressure filter element

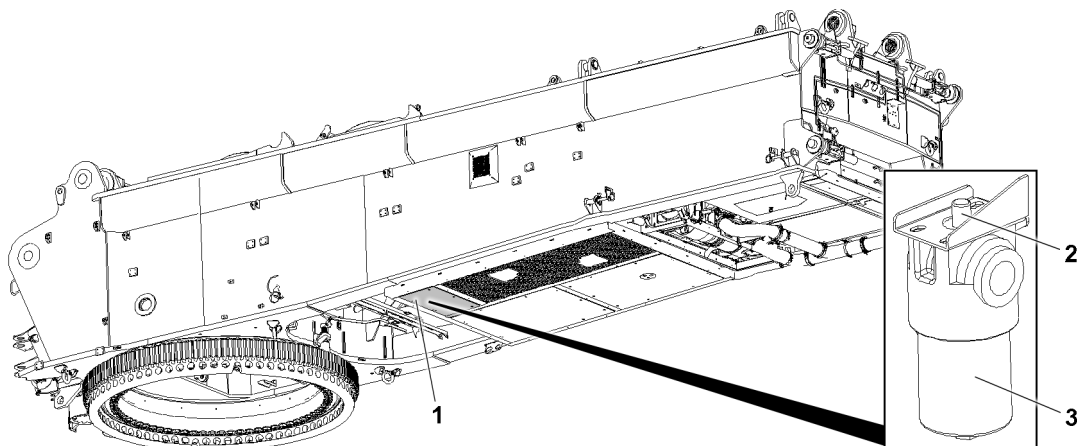


Fig.158564: Pressure filter element, hydraulic system

- |   |   |
|---|---|
| <p>1 Cover</p> <p>2 Fouling indicator</p> | <p>3 Filter element (pressure filter)</p> |
|---|---|

The pressure filter elements must be replaced in the following situations:

- When the red bar display of the fouling indicator **2** is visible when the hydraulic oil is at operating temperature.
- When maintenance is due.

Make sure that the following prerequisites are met:

- The prerequisites for maintenance are established, see section “Establishing the prerequisites for maintenance”.
- The diesel engine is turned off.
- The ignition key is pulled out.
- The battery master switch is turned off.
- New pressure filter elements are available.

Access to the bottom side of the turntable via the crane chassis catwalk.

- ▶ Follow the notes and instructions, see chapter 2.04.10, chapter 2.06 and chapter 2.07.

---

### NOTICE

Water inside the turntable!

Counterweight on the cover. Personnel can be drenched.

- ▶ Open the cover carefully on one side and let water flow out.
- ▶ Remove the cover **1**.




---

### WARNING

Hot components!

Severe burns possible.

- ▶ Before parts that could be hot can be touched: Let components cool off to below 50 °C.
- ▶ Wear heat-resistant protective equipment: Wear protective gloves and work clothing.
- ▶ Collect the hydraulic oil: Position a container under the pressure filter elements.
- ▶ Loosen the filter element **3**.
- ▶ Screw off and dispose of the filter element **3**.

- ▶ Clean the sealing surface on the filter bracket.
- ▶ Oil the seal ring on the new filter element **3**.
- ▶ Screw on the new filter element **3** and tighten.
- ▶ Assemble the cover **1**.
- ▶ Start the engine.
- ▶ Slowly run through all crane movements.

**Result:**

- The hydraulic system is bled.
- ▶ Check the filter element for leaks.
- ▶ Check the oil level and add hydraulic oil if necessary.

## 20.6 Checking the pretension pressure of the hydro reservoir

Various hydro reservoirs are installed in the hydraulic system.

The pretension pressures are specified in the hydraulic circuit diagram as well as on the individual hydro reservoirs.

The pretension pressure must be measured separately in each hydro reservoir.

Significantly fluctuating ambient temperatures occur:

- After transfer to countries with extremely warm or cold temperatures.
- In case of significant temperature differences between summer and winter.

---

### NOTICE

Changes of pressures in diaphragm reservoirs due to significantly fluctuating ambient temperatures!  
Damage to the hydraulic system.

- ▶ Check the gas accumulator pressures and correct if necessary.
- 

Make sure that the following prerequisites are met:

- The prerequisites for maintenance are established, see section “Establishing the prerequisites for maintenance”.
  - The diesel engine is turned off: The hydro reservoir is relieved on the fluid side.
  - The ignition key is pulled out.
  - The battery master switch is turned off.
  - Authorized and trained service personnel checks the pretension pressure of the hydro reservoir.
- 



### DANGER

Exceedance of the maximum permissible operating pressure!  
Danger of explosion. Death, severe bodily injuries, property damage.

- ▶ Make sure that the pressure in the nitrogen cylinder is below the maximum permissible operating pressure of the reservoir or the pressure gauge.

When the pressure in the nitrogen cylinder is less than the maximum permissible operating pressure of the accumulator and the pressure gauge:

- ▶ Switch the pressure reducing device between the bottle and the filling device.
  - ▶ Do not fill the hydro reservoir with air or oxygen under **any** circumstances.
  - ▶ Adhere to the national regulations regarding the inspection of pressurized containers.
- 

- ▶ Check the pretension pressure with a testing and filling device and correct, if necessary.

## 21 Hydraulic hose lines



### WARNING

Damaged and leaky hydraulic hose lines!  
Fire. Accident. Death, severe bodily injuries, property damage.

If leaky areas are found during the visual inspection:

- ▶ Have these leaky areas inspected immediately by authorized and trained service personnel and remedied.

If damage is found during the visual inspection:

- ▶ Have the hydraulic hose lines checked by an **expert person for hydraulic hose lines**.



### Note

- ▶ For the annual inspection of hydraulic hose lines and for definition of **expert person for hydraulic hose lines**, see chapter 8.06.

Hydraulic hose lines must be inspected **once a year** by an **expert person for hydraulic hose lines**.

The system must be visually inspected **before starting to work**.

### 21.1 Checking the hydraulic hose lines for damage

The hydraulic hose lines must be checked by an **expert person for hydraulic hose lines** when one of the following defects is found:

- Damage on the outer surface, such as chafe marks, cuts and cracks.
  - Brittleness due to aging of outer layer (cracks).
  - Distortion, such as splitting of hose layers, bubbles, crushed areas, kinks, twists.
  - Damage or distortion of hose fixtures or hose fitting (seal is endangered).
- ▶ Check the hydraulic hose lines for damage.

If one of the listed defects is found:

- ▶ Have the hydraulic hose lines checked by an **expert person for hydraulic hose lines**.
- ▶ Document conspicuous findings, decisions and replacements comprehensibly, see chapter 8.06.

### 21.2 Checking the hydraulic hose lines for leaks

- ▶ Check the crane for leaked hydraulic oil.
- ▶ Check the ground under the crane for leaks.

When the hydraulic system leaks:

- ▶ Have these leaky areas inspected by authorized and trained service personnel and remedied.

If one of the listed defects is found:

- ▶ Have the hydraulic hose lines checked by an **expert person for hydraulic hose lines**.
- or**
- ▶ Contact Customer Service at Liebherr-Werk Ehingen GmbH.
- ▶ Document conspicuous findings, decisions and replacements comprehensibly, see chapter 8.06.



## 22 Compressed air system

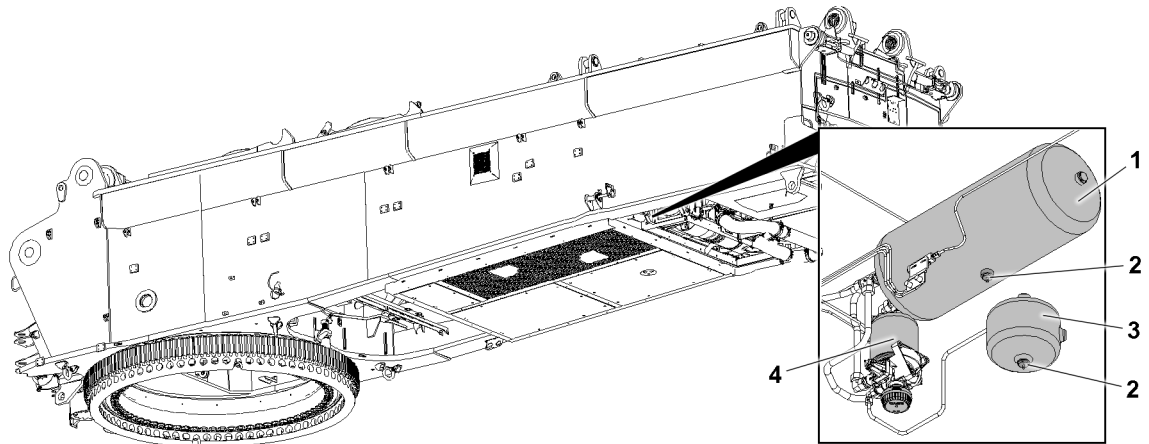


Fig.158565: Compressed air system

- |   |                     |   |                     |
|---|---------------------|---|---------------------|
| 1 | Compressed air tank | 3 | Compressed air tank |
| 2 | Valve pin           | 4 | Granular cartridge  |

### 22.1 Draining water from the compressed air tank

Make sure that the following prerequisites are met:

- The prerequisites for maintenance are established, see section “Establishing the prerequisites for maintenance”.
- The diesel engine is turned off.
- The ignition key is pulled out.
- The battery master switch is turned off.
- The compressed air tanks have cooled off.
- Assembly scaffolding or a turntable is available.

Access to the bottom side of the turntable with “aids for work at a height”. Observe and adhere to the information in chapter 2.04.

- ▶ Position an assembly scaffolding or a work platform.
- ▶ For each compressed air tank: Press the valve pin **2** and drain the water.

### 22.2 Replacing the granular cartridge of the air dryer

Make sure that the following prerequisites are met:

- The prerequisites for maintenance are established, see section “Establishing the prerequisites for maintenance”.
- The diesel engine is turned off.
- The ignition key is pulled out.
- The battery master switch is turned off.
- The granular cartridge has cooled off.
- New granular cartridges are available.
- Assembly scaffolding or a turntable is available.

---

#### NOTICE

Maintenance interval exceeded!

The drying and filtering power of the granular cartridge is reduced.

Condensation and dirt can accumulate in the compressed air system, which can cause erroneous functions of the compressed air system and the exhaust aftertreatment.

- ▶ Replace the granular cartridge according to maintenance intervals.
-

Access to the bottom side of the turntable with "aids for work at a height". Observe and adhere to the information in chapter 2.04.

- ▶ Position an assembly scaffolding or a work platform.

The granular cartridge 4 is under spring tension.



#### WARNING

**Uncontrolled** release of the granular cartridge!  
Severe bodily injuries, property damage.

- ▶ Release the granular cartridge carefully.
- ▶ Replace the granular cartridge 4.

## 23 Electrical system

### 23.1 Bulbs and fuses

#### NOTICE

Improper repair!

Damage to the electrical system.

- ▶ Defective fuses may **not** be bypassed with wire or similar.
- ▶ Only replace defective fuses with fuses that have the same current strength.
- ▶ Only replace defective bulbs with bulbs that have the same output.

When the same fuse or bulb becomes defective repeatedly:

- ▶ Check the electrical system.

### 23.2 Lines

- ▶ Make sure that all electrical lines are properly routed and fastened in their retainers.
- ▶ Fix any chafe marks or brittleness in the insulation and coverings immediately.
- ▶ Any installation lines that are **not** in perfect condition must be immediately and professionally replaced.

### 23.3 Batteries

#### 23.3.1 Safety



#### WARNING

Discharged batteries!











Danger of accident.

- ▶ Make sure that the batteries are charged while the crane is not in operation.
- ▶ Charge the batteries only with the Liebherr charger.



#### Note

- ▶ All safety signs on the batteries must always be complete and legible.
- ▶ Observe and adhere to the manufacturer's operating instructions.

Identification	Explanation
	Follow the guidelines on the battery, in the instruction manual and in the Crane operating instructions.
	Wear eye protection.
	Keep children away from acid and batteries.
	<b>Danger of explosion!</b> A highly explosive acoustic mixture is created when charging batteries.
	<b>Warning!</b> Fire, sparks, open flames and smoking are prohibited. Avoid spark formation when handling cables and electrical devices. Avoid short circuits.
	<b>Danger of chemical burns!</b> Battery acid is very caustic, for that reason: Wear protective gloves and eye protection. Do <b>not</b> tilt the battery, acid can emerge from the vent openings.
	<b>First aid:</b> If acid is splashed in an eye, rinse it immediately for several minutes with clear water and consult a physician immediately. Neutralize splashed acid on skin or clothing immediately with an antacid or soap and flush with lots of water. If acid was ingested, contact a physician immediately.
	<b>Warning!</b> Do <b>not</b> expose batteries unprotected to direct daylight. Discharged batteries can freeze. Store batteries frost free.
	<b>Disposal!</b> Dispose of old batteries at a collection point. During transport, observe the guidelines of the manufacturer. Never dispose of old batteries in general trash.
	<b>Back to the manufacturer!</b> Used batteries with this sign are reusable assets. Send batteries for recycling. Old batteries, which are <b>not</b> recycled must be disposed of as hazardous waste under observation of all regulations.



- ▶ Follow the notes and instructions, see chapter 2.04.10 and chapter 2.06.
- ▶ Make sure that the battery master switch is turned off.

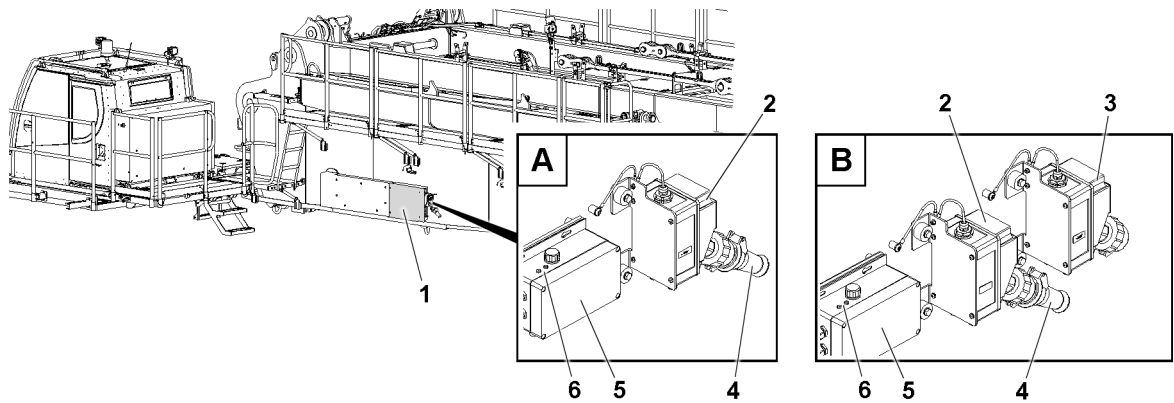


Fig.159209: External power supply, control cabinet

<b>A</b>	Variation 230 V	<b>3</b>	Bracket
<b>B</b>	Variation 110 V	<b>4</b>	Cable
<b>1</b>	Doors	<b>5</b>	Battery charger
<b>2</b>	Bracket	<b>6</b>	Indicator lights

Access to the control cabinet via the crane chassis.

- ▶ Remove the cover 1.

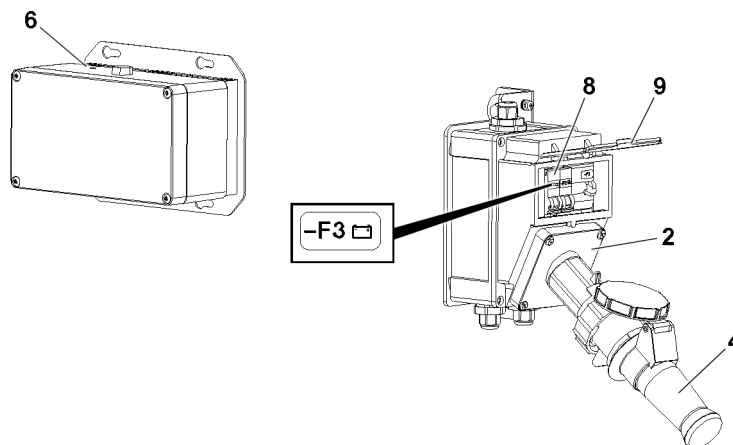


Fig.159208: External power supply, console

<b>2</b>	Bracket	<b>8</b>	Automatic fuse
<b>4</b>	Cable	<b>9</b>	Flap
<b>6</b>	Indicator light		

- ▶ Open the flap 9.
- ▶ Make sure that the automatic fuse 8 is turned on.

Variation A: The voltage of the external power supply must be 230 V.

Variation B: The voltage of the external power supply must be 110 V.

- ▶ Plug the cable 4 into the console 2.

**Result:**

- The indicator light 6 lights up.
- The batteries are charged.

**Problem remedy**

Are the indicator lights blinking?

Cable not connected or electrical problem.

- ▶ Make sure that the cable is plugged in.

If the problem cannot be remedied:

- ▶ Contact Customer Service at Liebherr-Werk Ebingen GmbH.

## 24 Window washing system

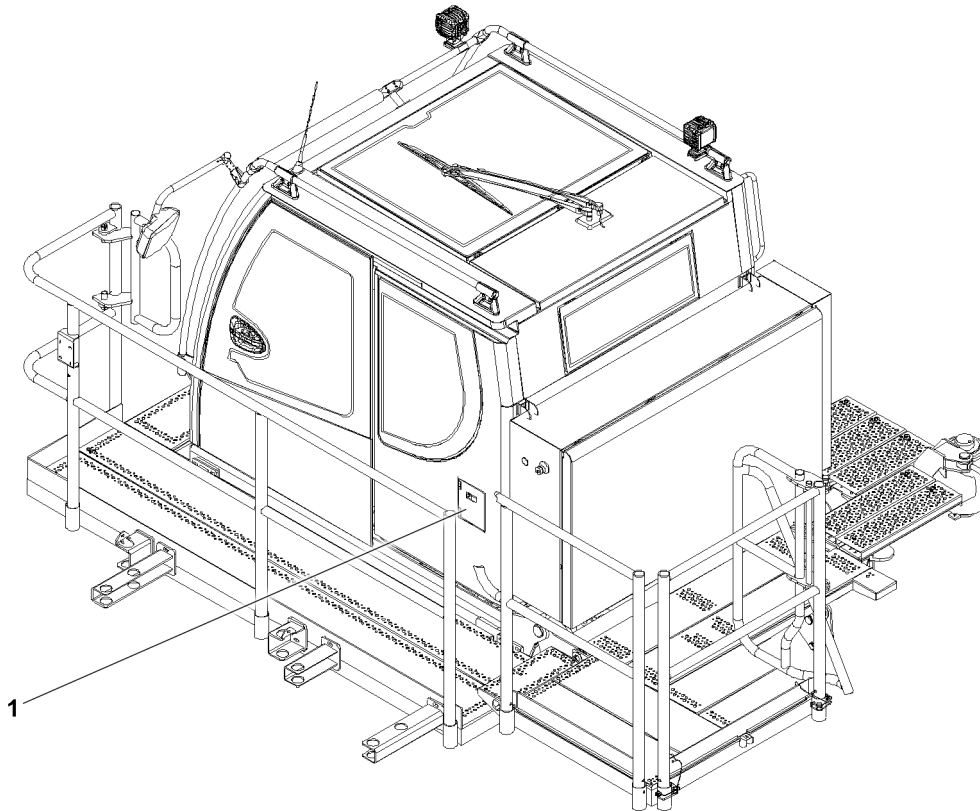


Fig.126509: Window washing system container

### 24.1 Checking the fill level of the cleaning fluid

The cleaning fluid must be replaced before the cold season.

Make sure that the following prerequisites are met:

- All catwalks and railings are assembled in the operating position.
- Cleaning fluid for refilling is available.

- ▶ Climb onto the crane: Use the stairs, platform, catwalk and ladder.

If operation during the cold season is planned:

- ▶ Carry out the operations in section “Replacing the cleaning fluid”.
- ▶ Open the container 1.
- ▶ Check the fill level of the cleaning fluid.

When the fill level is low:

- ▶ Add cleaning fluid.
- ▶ Close the container 1.

## 24.2 Replacing the cleaning fluid

Make sure that the following prerequisites are met:

- All catwalks and railings are assembled in the operating position.
- A container for the cleaning fluid with sufficient collection capacity is available.
- The required quantity of cleaning fluid is available.
- ▶ Open the container 1.
- ▶ Empty the container 1.
- ▶ Fill the container with a commercially available, frost resistant cleaning fluid.
- ▶ Close the container 1.

## 25 Ballast trailer\*



---

**Note**

- ▶ See chapter 7.04.50.
-

---

Empty page!

LWE/LR 1800-1-0-000/27200-07-02/en



## 7.05.50 Maintenance instructions - Crane boom

1	Lattice mast boom	3
2	Rope pulleys and guide pulleys	3
3	Crane ropes	4

*Fig.195219*

LWE/LR 1800-1-0-000/27200-07-02/en

# 1 Lattice mast boom

## 1.1 Lubricating the pin bores on the lattice sections and guy rods



### Note

- ▶ The following illustration is an example and may **not** exactly match your crane.

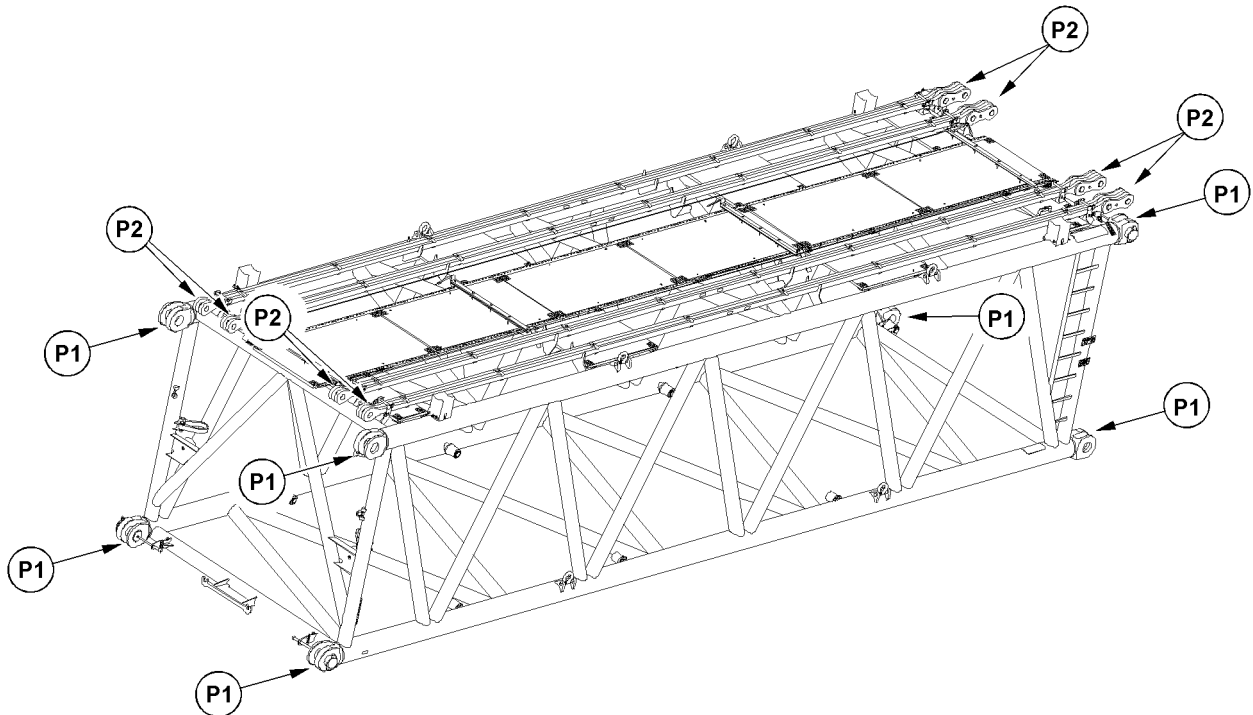


Fig.123861: Lube points on boom lattice sections and guy rods

Make sure that the following prerequisites are met:

- Safety measures against falling have been taken.
- The lattice sections are **not** installed on the crane.
- The lattice sections are lying on a load bearing substructure on the ground.



### Note

- ▶ For the pin bores on the lattice sections (positions **P1**) and the guy rods (positions **P2**), use special grease as lubricant. See chapter 7.07 and the service fill.
- ▶ Apply the grease on the pin bores over the entire circumference.
- ▶ The pin bores on the boom lattice sections and the guy rods are lubricated before assembly or after disassembly.

- ▶ Grease the pin bores on the boom lattice sections and the guy rods.

## 2 Rope pulleys and guide pulleys

### 2.1 Checking for mechanical damage

Ropes can cause mechanical damage, such as stress marks.

- ▶ Check guide pulleys and rope pulleys for mechanical damage.
- ▶ Check the surface of the guide pulley and the groove of the rope pulley for smoothness.

The actual groove diameter must be larger than the actual rope diameter.

- ▶ Check the actual groove diameter of the rope pulley.

## 2.2 Checking the bearings for easy movement

Stiff or blocked rope pulleys or compensation pulleys wear rapidly and unevenly and cause serious rope abrasion.

Ineffective compensation pulleys can lead to irregular rope tension.

- ▶ Check the rope pulleys for proper movement in their bearings.

When rope pulleys are **not** easily moveable in their bearings:

- ▶ Fix the bearings.

When the crane is at a standstill for a longer period of time:

- ▶ Turn the rope pulleys regularly.

## 2.3 Lubricating the bearings

Rope pulleys with a diameter of more than 25 mm can be lubricated.

### NOTICE

Lube pressure is too high!

When too much lubricant is introduced, then the lube pressure increases: Seal rings are pressed out.

- ▶ Meter the lube amount carefully.

- ▶ Turn the rope pulley and lubricate it.

# 3 Crane ropes

## 3.1 Personal protective equipment



### WARNING

Injury due to wires and skin irritation due to lubricant!

- ▶ When working with ropes, always wear work gloves.



### WARNING

Injuries if protective equipment is **not** worn!

- ▶ Wear hard hat, safety shoes and safety goggles.

## 3.2 Safe and problem-free operation



### WARNING

Wear, overload, incorrect use, damage, improper maintenance!

Failure of ropes. Death, severe injuries, property damage.

- ▶ Prevent failure of ropes: Observe and adhere to the following notes.

Carry out the following measures to ensure safe and problem-free rope operation:

- Service ropes and rope end connections regularly according to the maintenance intervals.
- Check ropes and rope end connections regularly according to the inspection intervals.
- When it is determined that the ropes should be withdrawn from service, do **not** continue to use them further.
- Exclude contact of rope with components except rope drive elements.
- Exclude contact of rope with structural parts, power lines or other objects within the surrounding area.
- Avoid corrosive and chemical surroundings.
- Avoid excessive soiling.

- Avoid excessive heat influence.
- Ensure proper condition of all elements of rope drive.
- Ensure proper spooling formation on the rope drum.
- Use the entire rope length of hoist ropes.
- Avoid slack rope formation on the drum.
- Do **not** bring outer twists into the rope.
- Avoid shock relief of the rope, such as sudden set down of the load.
- Avoid **non-permissible** angular pull, for example by pulling the load at an angle.

### 3.3 Temperature operating limits

Adhere the temperature operating limits for steel ropes. The determining factors are wire material, lubricant, rope end connections. See Manufacturer's specifications.

### 3.4 Qualification Maintenance personnel

Make sure that the following prerequisites are met:

- The maintenance personnel is trained and instructed in maintenance tasks.
- The maintenance personnel is assigned (authorized) for the maintenance by the crane operator.

### 3.5 Damage to the rope

**Rope removal criteria:** If severe damage reduces the operational safety, then the rope has reached the removal criteria.

This section provides an overview for possible damage to the rope. For clearer illustration, the distortions on the illustrations are exaggerated.

The displayed ropes show a condition, which is far above the removal criteria.

Damage to the rope causes uneven load distribution in the affected areas.

Damage to the rope is most often localized.

Typical examples of wire rope damage that can be recognized during maintenance work:

- Broken strands
- Wire breaks
- Damage to the rope end connection
- Reduction of rope diameter
- Localized increase of rope diameter
- Corrosion
- Flattenings
- Corkscrew-like distortion
- Basket formation
- Protruding, distorted inlay or braiding
- Loop formation
- Kinking, rope loops (grommets) pulled closed
- Buckles
- Influence of heat or electrical voltage, such as arcing

Occurrence of removal criteria for individual criteria, see chapter 8.04.

#### 3.5.1 Broken strands

A strand consists of several individual wires.

When a complete braid is broken, then the rope must be taken down.

#### 3.5.2 Broken wire

Externally visible broken wires are the result of wear caused by operation.

Additional types of broken wires:

- Broken wire in the inside of the rope
- Broken wire in the strand valleys
- Broken wire on a rope connection

A broken wire does **not** endanger the safety of the rope.

### 3.5.3 Damage to the rope end connection

Example of rope end connection damage:

- Traces of slipping between the locking clamp and the wire rope
- Corrosion
- Deformation
- Wear

### 3.5.4 Reduction of rope diameter

The rope diameter changes due to abrasion, settling and external influences.

Abrasion of cover wires of outer strands of rope due to frictional contact. Especially in those areas where ropes are in contact with the rope pulleys during start up or slow down of the load.

Wear is increased by lack of or incorrect lubrication and the effect of dust.

Abrasion reduces the tensile strength of steel ropes because the cross section of the steel is reduced.

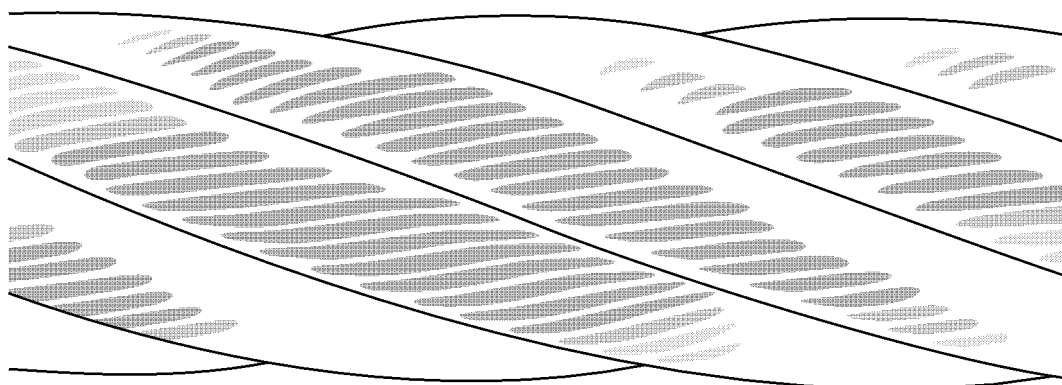
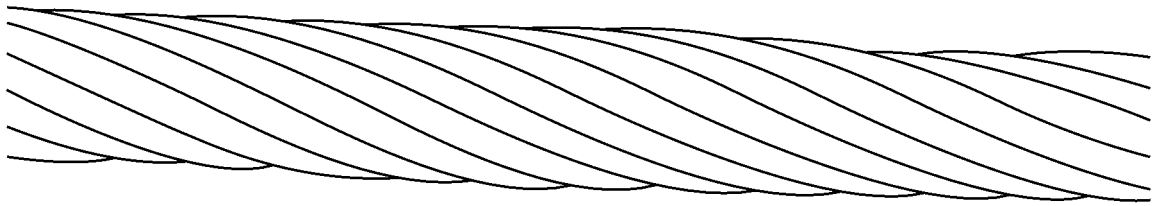


Fig.121001: External abrasion on the rope

When the rope diameter is reduced, the rope must be checked by **expert personnel for crane rope inspection**.

### 3.5.5 Localized increase of rope diameter

An increase, which occurs over a longer area of the rope can be caused by absorption of moisture in the fiber insert or due to corrosion in the inside of the rope.



*Fig.120992: Increase of rope diameter*

When a localized increase of the rope diameter is present, then the rope must be checked by **expert personnel for crane rope inspection**.

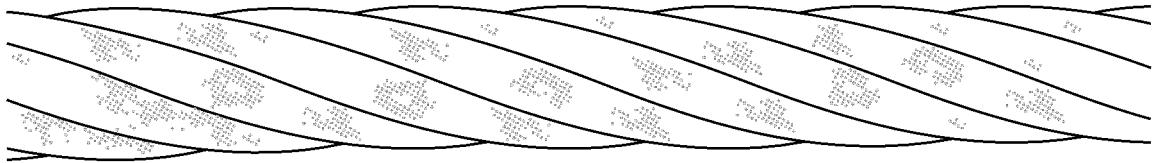
### 3.5.6 Corrosion

Corrosion occurs due to insufficient lubrication, in maritime climates and in an atmosphere polluted by industrial fumes.

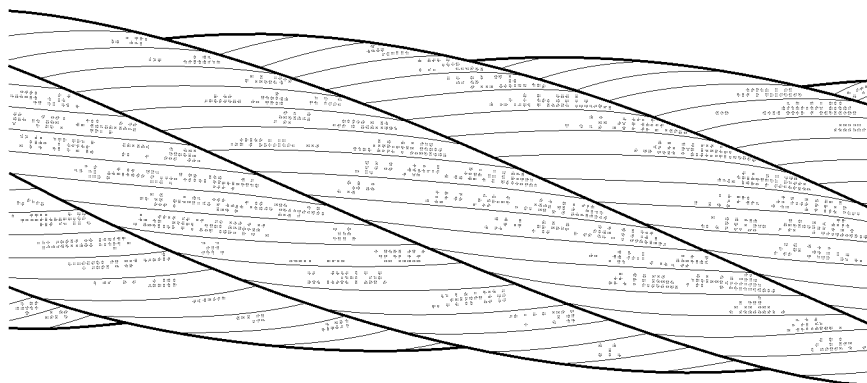
External corrosion is indicated by a rough wire surface. A superficial rust film can be wiped off.

Significant corrosion reduces the strength and elasticity of the rope due to the reduction of the rope diameter.

Inner corrosion is hard to detect.



*Fig.120994: External corrosion*



*Fig.120995: Magnification of external corrosion for better depiction*

When significant corrosion is present, the rope must be checked by **expert personnel for crane rope inspection**.

### 3.5.7 Flattening

Flattening occurs when the rope runs through the rope pulleys. In this area the rope wears quicker. Corrosion occurs faster on retaining ropes and guy ropes.

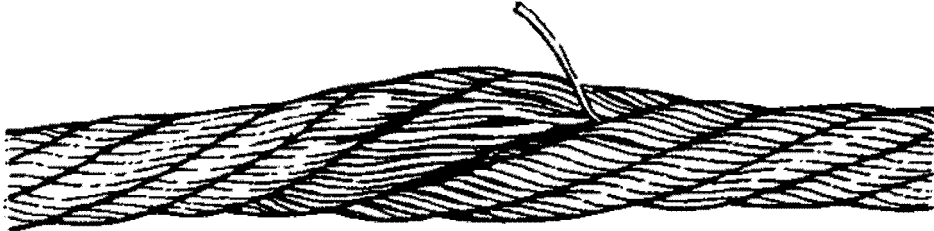


Fig.120997: Localized limited flattening, which leads to broken wires (single layer rope)

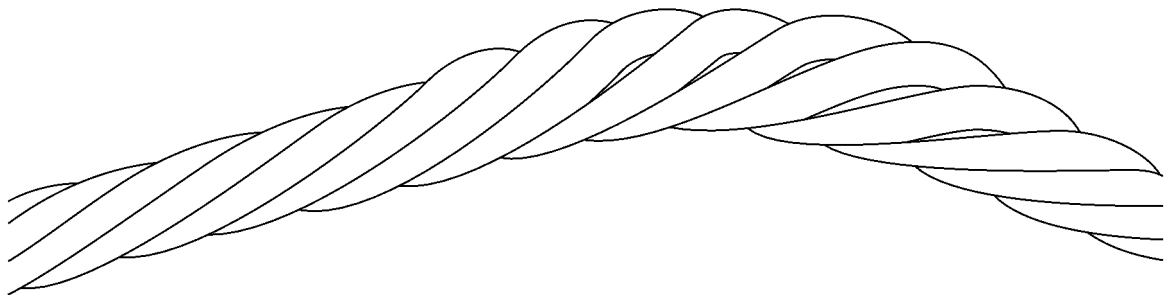


Fig.120996: Flattenings on multi layer windings

When flattening is present, the rope must be checked by **expert personnel for crane rope inspection**.

### 3.5.8 Corkscrew-like distortion

Distortion where the rope is in the form of a corkscrew along its longitudinal axis.

Corkscrew-like distortion causes rope wear, broken wires and bearing damage on rope pulleys.



Fig.120988: Corkscrew-like distortion

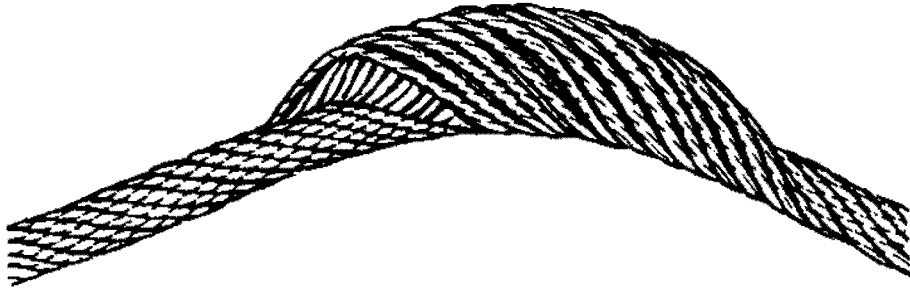
When corkscrew-like distortion is present, the rope must be checked by **expert personnel for crane rope inspection**.

### 3.5.9 Basket formation

This distortion occurs due to different layers between the outer strand layers and the inside of the rope.

Causes for basket formation are high angular pull angles during the run over the rope pulleys and run-in rope pulleys. Even load distribution over the entire cross-section is not possible.



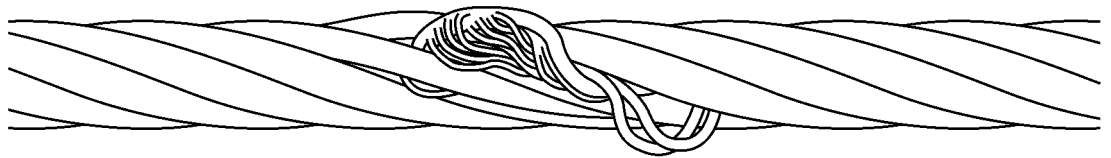


*Fig.120989: Basket formation*

When basket formation is present, then the rope must be taken down.

### 3.5.10 Protruding, distorted inlay, braiding

This distortion is a special form of basket formation: The insert or the core of the rope protrudes between the outer strands or an outer strand protrudes from the rope banding.



*Fig.120990: Protrusion of an insert (rope single layer)*

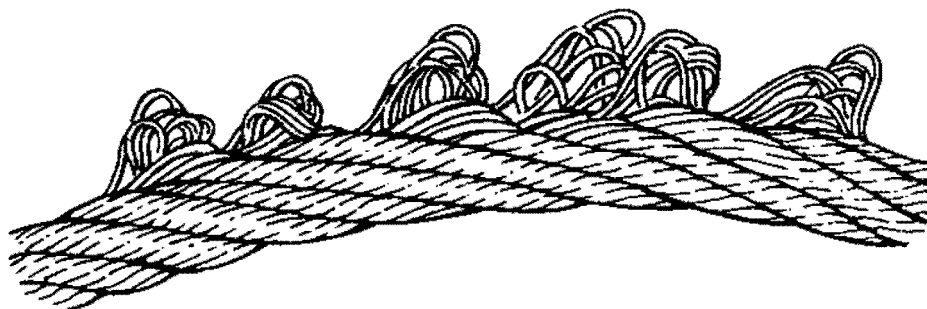


*Fig.120991: Distorted or protruding strand*

When the insert or a strand protrudes or is distorted, take the rope down. Have **expert personnel for crane rope inspection** check if the rope area with the distortion can be removed.

### 3.5.11 Loop formation

At loop formation individual wires protrude from the rope banding, when no broken wire ends can be seen.



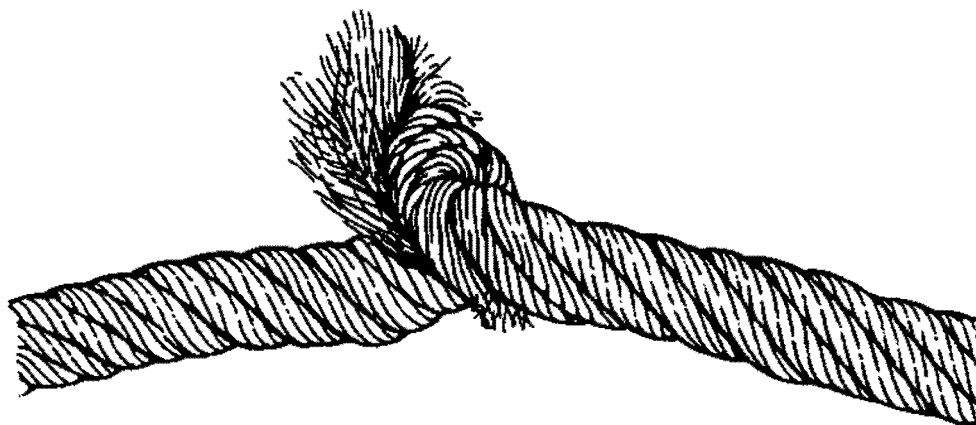
*Fig.120993: Emergence of individual wires*

When loop formation is present, take the rope down.

### **3.5.12 Kinking, rope loops (grommets) pulled closed**

Deformation, where a loop has formed in the rope, without the possibility to rotate around its own axis during a load. The rope is subjected to significant wear.

The rope is deformed. The strength remains only in part.



*Fig.120998: Severe kinking or knots*

When kinking or rope loops are present, take the rope down.

### **3.5.13 Buckles**

Buckles are angular deformations. The rope was damaged due to external influences. Strong deformations of the rope cause stronger wear.

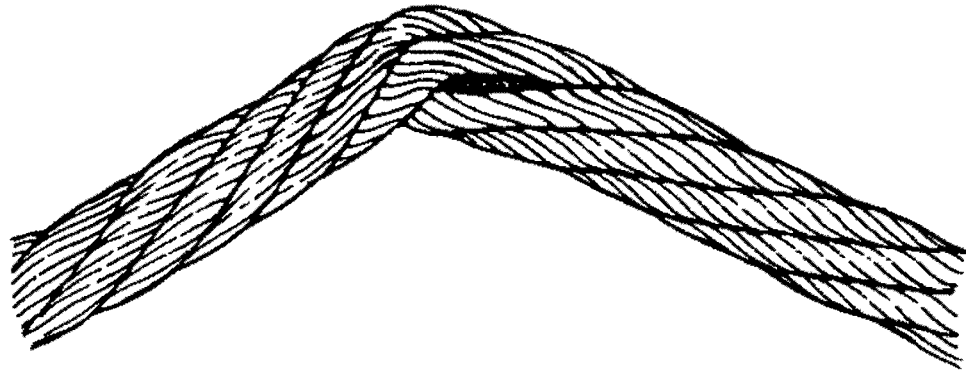


Fig.120999: Severe buckle

When buckles are present, take the rope down.

### 3.5.14 Effects of heat, arcs

Damage caused to the rope by welding work, for example.

Unusual heat impact is visible by tempering colors and loss of lubricant.

When heat impact has occurred on the rope, then the rope must be taken down.

## 3.6 Checking the ropes



### WARNING

Operation with a damaged rope!

Failure of rope. Death, severe injury, property damage.

When damage, wear and deformations are present:

- ▶ Have **expert personnel for crane rope inspection** determine if the rope has to be taken down.

The following sections describe the tasks for a **daily visual inspection**.

The crane operator can carry out a daily visual inspection if he is sufficiently trained in the tasks and considered to be able to do so.

### 3.6.1 Intervals

Intervals and situations where the daily visual inspection must be made:

- Daily, before starting to work
- In case of change of the reeving of the crane rope due to:
  - Transport
  - New reeving
  - Disassembly and assembly

### 3.6.2 Areas

The rope must be checked over the entire length.

The following areas must be checked with special care:

- Rope end connections
- Safety coils and fixed point on the winch
- Areas of the rope which run through the hook block.
- Areas of the rope that run over the rope pulleys or lay on the rope pulleys.
- Areas of the rope that are spooled on the winch, especially cross over areas.
- Areas of the rope which are laying above the compensation pulleys.
- Areas of the rope which are subjected to abrasion due to external components.

- All areas of the rope that are subjected to temperatures above 60°C.

### 3.6.3 Documentation of rope condition

Every visible change of the wire rope must be documented in the crane records.

### 3.6.4 Checking the lubrication



#### WARNING

Missing lubrication!

Functional problems. Inner and outer corrosion.

- ▶ Lubricate the rope regularly.
- ▶ Make sure that the rope is lubricated all around.
- ▶ Select manual or automatic lubrication procedures.

The lubrication must be checked at least once a **month**.

When the rope shows signs of drying out:

- ▶ Lubricate the rope, see section "Lubricating the rope".

### 3.6.5 Checking for wear and distortion

- ▶ Check all visible parts of the rope for wear and distortion.
- ▶ Check the rope end connections and fixed points especially carefully for wear, damage, cracks and distortion.
- ▶ Check pressed together rope end connection for slipping and traces on the rope.
- ▶ Check that the rope end connections on the cotter are fit tightly and correctly installed.



#### Note

- ▶ The maximum permissible number for broken wires over a certain rope length may **not** be exceeded.
- ▶ Determine the maximum permissible number of broken wires, see chapter 8.04.

- ▶ Check the rope end connection and rope area near the rope end connection for broken wires.

When broken wires are present on the rope:

- ▶ Remove the broken wire, see section "Removing broken wires".

When broken wires or damage is present on the rope end connection:

- ▶ Document visible changes of the rope condition.
- ▶ Have the rope checked by **expert personnel for crane rope inspection**.

When the rope can be shortened without reducing the operational safety:

- ▶ Shorten the rope, see section "Shortening the rope".

### 3.6.6 Checking the rope drive for spooling problems

Lacking pretension of the rope on the winch can cause spooling problems in multi layer spooling.

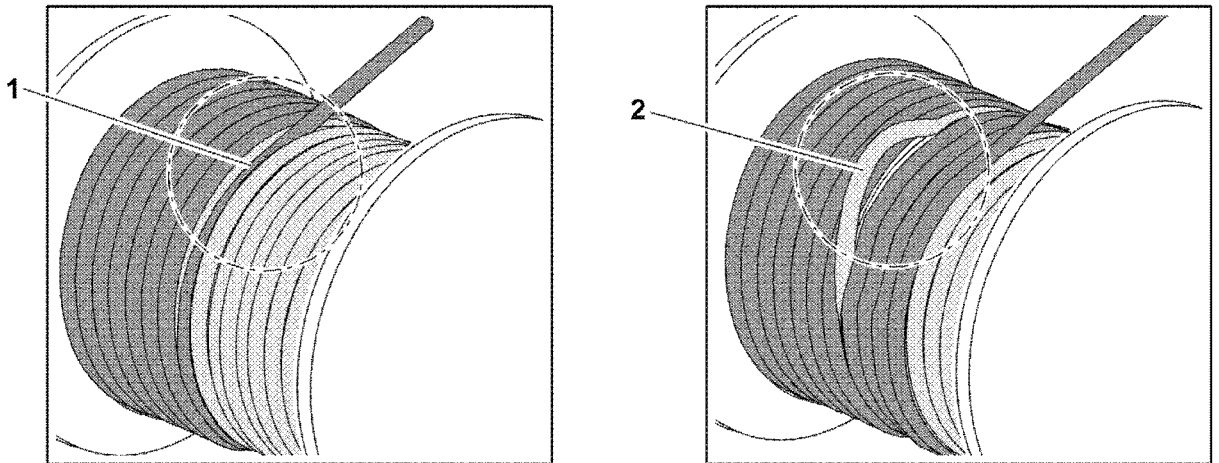


Fig.120967: Possible spooling problems on the rope winch

- 1** Cutting into the lower rope layers                      **2** Loop formation in the lower rope layers
- ▶ Check the spooling behavior of rope on the rope winch for cutting into the lower rope layers **1**.
  - ▶ Check the spooling behavior of rope on the rope winch for loop formation in the lower rope layers **2**.

When spooling defects are found:

- ▶ Renew the pretension, see section “Renewing the pretension of hoist ropes”.
- ▶ Document visible changes of the rope condition.
- ▶ Have the rope checked by **expert personnel for crane rope inspection**.

### 3.6.7 Checking the position of the rope

- ▶ Check the correct position of the rope on the rope pulleys.

When the rope is **not** correctly laying on the rope pulley:

- ▶ Have the rope and rope pulley checked by **expert personnel for crane rope inspection**.

### 3.6.8 Checking for corrosion

A superficial “rust film” can be wiped off.

- ▶ Do **not** clean the rope with solvents or cleaners.
- ▶ Clean the rope solely with a wire hand brush.
- ▶ Check rope for corrosion.

When the rope shows a rough surface:

- ▶ Document visible changes of the rope condition and have the rope checked by **expert personnel for crane rope inspection**.

If there is any uncertainty regarding the condition of the rope:

- ▶ Take the rope down or contact Liebherr Service.

### 3.6.9 Checking for flattenings

The rope is stressed more in the cross over area of the spooled up rope layers on the winch. The rope can be flattened as a result.

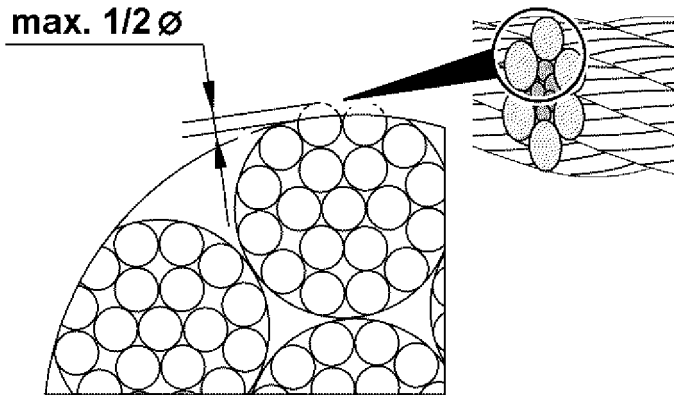


Fig.120966: Maximum flattening of wires on the outer strands

- ▶ Check the rope in the ascent zones of the rope spooling on the winch for flattenings.

When the outer braids are flattened more than half of the wire diameter:

- ▶ Document visible changes of the rope condition.
- ▶ Have the rope inspected by **expert personnel for crane rope inspection** or take the rope down.

When the rope can be shortened without reducing the operational safety:

- ▶ Shorten the rope on the rope drum fixed point, see section "Shortening the rope".

### 3.7 Checking the multi layer spooling for distortions

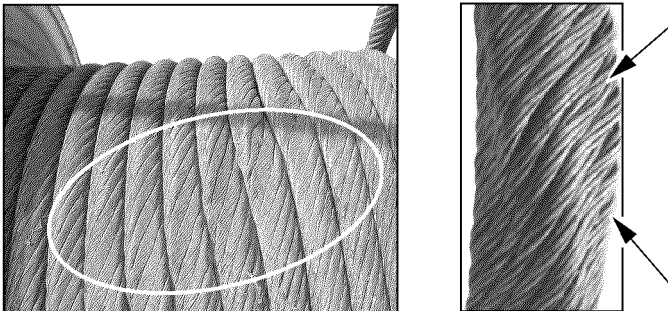


Fig.114002: Distortion of ropes in multi layer spooling

- ▶ Check the first rope layer of the winch for crushed areas and distortions.

When distortions are present:

- ▶ Have the rope checked by **expert personnel for crane rope inspection**.

### 3.8 Lubricating the rope



#### WARNING

Missing lubrication!

Functional problems. Inner and outer corrosion.

- ▶ Lubricate the rope regularly.
- ▶ Make sure that the rope is lubricated all around.
- ▶ Select manual or automatic lubrication procedures.

#### NOTICE

Too much or incorrect lubricant!

Excessive soiling. Wear on rope, on rope pulley and on winch. Recognition of take down criteria is impeded.

- ▶ Use lubricant, which is compatible with the rope and the original lubricant.

- ▶ Do **not** clean the rope with solvents or cleaners.
- ▶ Clean the rope solely with a wire hand brush.

Areas, which must be lubricated especially well are bending zones on winch and rope pulleys.

- ▶ Lubricate the rope.

### 3.9 Removing broken wires



#### CAUTION

Broken wires!

When working with a damaged rope, there is a danger of lacerations and pricking injuries.

- ▶ Wear protective gloves.

#### NOTICE

Broken wires!

Damage of other components in crane operation, for example rope pulleys and compensation pulleys.

- ▶ Remove broken wires.

Make sure that the following prerequisites are met:

- Suitable pliers are on hand.

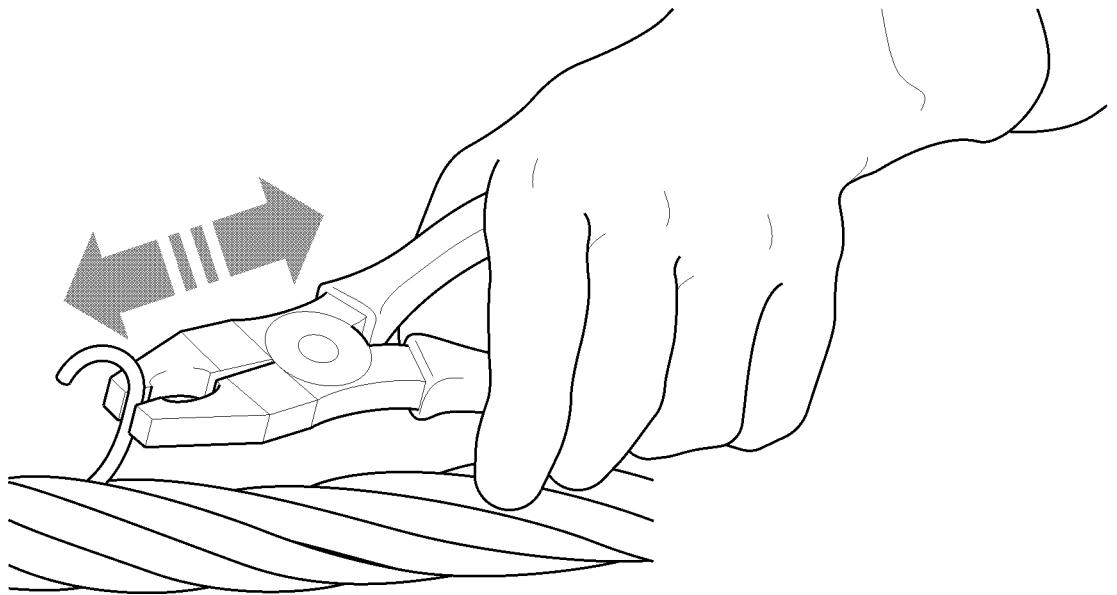


Fig.120979: Removing broken wire

- ▶ Grasp the wire on the upper end with pliers. Bend the wire back and forth until the wire breaks off in the braid valley.

The position of a broken wire is important for subsequent inspection. Individual broken wires are counted and are recorded later in the evaluation for withdrawal from service.

- ▶ Document the position of the broken wires in the crane record. Inspection checklist, see chapter 8.04.

## 3.10 Turning an extremely rotation-resistant hoist rope out



### WARNING

Damage of rope due to incorrect procedure!

- ▶ Use extreme caution for the following procedures.
- ▶ Observe the following instructions exactly.

The cause for the turn-in of the hook block can have various reasons.

Check the crane for the following peculiarities:

- Scrub marks: Are hoist rope scrub marks present on the crane components? If scrub marks are present, check the hoist rope run and correct it.
- Rope pulleys: Did the groove diameter become too small?
  - Groove diameter dimensional stability must be present.
  - If this is not the case, the rope pulley must be replaced.
- Rope lubrication: Has the hoist rope been sufficiently lubricated? If the rope surface is dry, the hoist rope must be re-lubricated.

If the crane does not display other peculiarities, the hoist rope must be spun out.

The following sections describe two methods of how to spin out the hoist rope. The methods must be applied in the described sequence.

### 3.10.1 Spinning out with single strand reeving

- ▶ Reeve in the single strand hoist rope.
- ▶ Extend the boom to the maximal boom length and hook height.
- ▶ Lower hooks to approximately 1 m above the ground and allow the hoist rope to spin out.
- ▶ With an empty hook block, carry out one complete hoist cycle.
- ▶ Lower the hook again to approximately 1 m above the ground and allow the hoist rope to spin out again.
- ▶ Reeve in the number of strands of hoist rope carefully and spin free where the twisting of the hook block is largest.
- ▶ Distribute the spin out to the entire rope length: Run at least two entire hoist cycles at maximum boom length and hook height.



### Note

When the hook block continues to turn in:

- ▶ Spin the rope out, see section "Spinning out by turning the hook block out".

### 3.10.2 Spinning out by turning out the hook block

Make sure that the following prerequisites are met:

- The hook block is reeved with the number of strands where the twisting is the largest.
- ▶ Extend the boom completely and lower the hook block.
- ▶ Fasten a load of approximately 10 % of the nominal rope pull to the hook block.

Before lifting the load, a helper must turn the twisted hook block to a straight position by hand until the rope strands no longer touch each other.

- ▶ Continue to turn the hook block by one entire turn.

### Result:

- The rope strands touch again.

### NOTICE

The hook block turns back under load in a straight position!

When the hook block turns back in a straight position:

- ▶ Release the hook block.



- ▶ Hold the hook block in the prescribed position until the load lifts off the ground.
- ▶ Move the load until approximately 15 m before the uppermost hook position of the completely extended boom.
- ▶ Lower load and set it down.

### 3.11 Renewing the pretension of hoist ropes



#### WARNING

Lacking pretension of the rope on the winch!  
Excessive rope wear in the lower spooling layers, gap formation, rope cutting in.

When the lower rope layers on the winch are hardly used or **not**:

- ▶ Renew the pretension in the entire rope regularly.
- ▶ Renew the crane rope pretension, see chapter 4.08.

### 3.12 Shortening the rope



#### WARNING

Distortions and mechanical damage!  
Operational safety significantly disturbed, uneven load distribution within the rope.

- ▶ Have the manufacturer check if the distorted and damaged area can be severed.

Visible form changes often occur localized or in short rope sections.

When a safe operation of the rope is ensured, a distorted and damaged area can be severed.

To shorten the rope there are different prerequisites:

- Rope shows flattenings in the incline range.
- Broken wires occur solely within the area of the rope end connection, the remaining rope is undamaged.

Cause	Dimension of the cut	Position	Note
Flattenings in the incline range	20 x rope diameter	Winch fixed point	Reset the rope once only.
Broken wires in the area of the rope end connection	Specification of the inspection expert	Rope end	—

*Shortening the rope: Differentiation depending on the causes*



#### DANGER

Minimum number of remaining coils on the winch fallen below!  
Rope releases or rips off, falling load. Death, severe injury, property damage.

- ▶ Make sure, after shortening the rope that **at least three remaining coils** remain on the winch in all working positions of the crane.

Make sure that the following prerequisites are met:

- The rope was shortened by authorized and trained expert personnel.

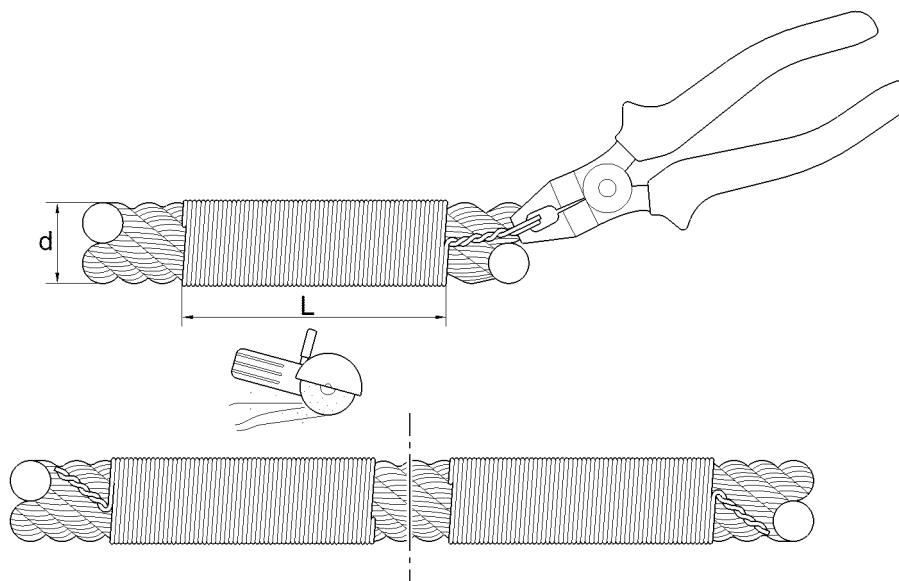


Fig.120972: Tying the rope before shortening it

**d** Rope nominal diameter

**L** Length of tie, at least  $2d$

The length of the tie **L** must be at least 2 times the nominal rope diameter ( $2d$ ).

The shortening of the rope in this section applies to a single layer rope. On rotation-resistance, parallel roped ropes it may be necessary to tie several times to prevent the rope from jumping open when it is cut.

- ▶ Tie the rope on both sides with wire.
- ▶ Twist the end of the wire with the pliers to prevent them from releasing.



#### WARNING

Danger of injury due to flying sparks!

- ▶ Wear safety goggles, safety clothing and safety gloves.
- ▶ Separate the rope vertically to the rope axis.
- ▶ Fasten the rope end connections on the rope according to the manufacturer's specifications.
- ▶ Remove the tie on both ends of the separation point from the rope.

## 7.06 Fill quantities, lubrication chart

1	Fill quantities	3
2	Lubrication schedule	4

*Fig.195219*

LWE/LR 1800-1-0-000/27200-07-02/en

# 1 Fill quantities



## WARNING

Handling poisonous operating fluids and lubricants!  
Poisoning, severe health damage.

When operating fluids are to be used, stored and disposed of:

- ▶ Observe and follow the printed instructions on the original containers.
- ▶ Store operating fluids exclusively in the closed original container.
- ▶ Keep children away from operating fluids. Keep operating fluids away from children.
- ▶ Dispose of operating items and lubricants in an environmentally safe manner.

## NOTICE

Damage on aggregates due to impermissible additives!

- ▶ Make sure that **no** impermissible additives are added to the operating fluids.



## Note

- ▶ Fill quantities and descriptions of service items and lubricants are specified in the Service fill.
- ▶ Fill the crane chassis, crane superstructure and equipment with the respective operating fluids.
- ▶ The specified fill quantities (change quantities) are orientation values. The marks on the dipsticks, inspection ports and sight gauges are decisive for filling.
- ▶ The equipment depends on the purchased scope of delivery.

On mobile cranes with truck chassis:

- ▶ Observe the maintenance intervals and maintenance notes of the truck chassis manufacturer.

## NOTICE

Danger of property damage!

- ▶ Do **not** mix different oil products!
- ▶ Do **not** mix synthetic oils with mineral oils!
- ▶ Adhere to the data in the Service fill!

## 1.1 Diesel engine

- ▶ Check the engine oil. See Maintenance intervals and maintenance instructions.
- ▶ Adhere to the operating instructions of the engine manufacturer.

## 1.2 Coolant system

### NOTICE

Property damage due to impermissible coolant!

- ▶ Do **not** mix different coolant products.
- ▶ Do **not** thin Liebherr-Fertig-Mix (Liebherr Ready Made Mix).

When adding coolant:

- ▶ Use exclusively the same coolant.

Coolants contain corrosion inhibitor - antifreeze fluid.

Add coolant only on the filler neck. See Service fill.



### Note

If the coolant is changed:

- ▶ Contact the Service Dept. at Liebherr-Werk Ehingen GmbH for procedure.
- ▶ Empty the cooling system completely and flush.

In exceptional cases, the coolant can be supplemented with different coolants.

**Note**

Supplementing the coolant with different coolants:

- ▶ Contact the Service Dept. at Liebherr-Werk Ebingen GmbH for procedure.
- ▶ Check the coolant level. See Maintenance intervals and maintenance instructions.

## 1.3 Transmission

- ▶ Check the gear oil. See Maintenance intervals and maintenance instructions.

## 1.4 Hydraulic system

**Note**

- ▶ The oil level must be in the center of the hydraulic oil level sight gauge at 20 °C oil temperature.

At lower hydraulic oil temperature:

- ▶ Warm up the hydraulic oil.

At higher hydraulic oil temperature:

- ▶ Cool off the hydraulic oil.
- ▶ Retract all hydraulic cylinders completely, for example luffing cylinder, telescoping cylinder.

On vehicles with level regulation:

- ▶ Lower the vehicle completely with the level regulation.

- ▶ Check the hydraulic oil. See Maintenance intervals and maintenance instructions.

## 2 Lubrication schedule

**Note**

- ▶ Grease the crane chassis, crane superstructure and equipment with the respective lubricants. See Service fill.
- ▶ The equipment depends on the purchased scope of delivery.

On mobile cranes with truck chassis:

- ▶ Observe the maintenance intervals and maintenance notes of the truck chassis manufacturer.

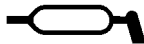


Fig.107729

**Note**

- ▶ Lube points are marked with a symbol.

## 7.07 Operating fluids and lubricants

1	Specified service fluids and lubricants for Liebherr cranes	3
---	---	---

---

LWE/LR 1800-1-0-000/27200-07-02/en

*Fig.195219*

LWE/LR 1800-1-0-000/27200-07-02/en



# 1 Specified service fluids and lubricants for Liebherr cranes

Information about the service fluids and lubricants that are approved for a mobile crane from Liebherr-Werk Ehingen GmbH can be found online at <https://lubricants.liebherr.com>.



## Note

► Observe and adhere to the specifications and notes in the safety data sheets.

No.	Crane components	Ambient temperature for driving and crane operation	
		-20 °C to +50 °C	-40 °C to +30 °C
1.1	Diesel engine <b>with</b> Exhaust aftertreatment	<b>LWE Id. No.: 11100934</b> <b>Liebherr Motoroil 5W-30 low ash</b> <b>or:</b> <b>LWE Id. No.: 10663796</b> <b>Liebherr Motoroil 10W-40 low ash</b> LH-00-ENG <sub>LA</sub> Observe the instructions of the engine manufacturer	<b>LWE Id. No.: 11100934</b> <b>Liebherr Motoroil 5W-30 low ash</b> <b>or:</b> <b>LWE Id. No.: 10663796</b> <b>Liebherr Motoroil 10W-40 low ash</b> LH-00-ENG <sub>LA</sub> Observe the instructions of the engine manufacturer <b>below -20 °C with pre-heating</b>
		<b>Note:</b> To improve the cold start ability of the diesel engine at an ambient temperature below -10 °C we recommend the use of Liebherr Motoroil 5W-30 low ash, <b>LWE Id. no.: 11100934</b>	
	Cummins B 6.7 <b>with</b> Exhaust aftertreatment	<b>LWE Id. No.: 10663796</b> <b>Liebherr Motoroil 10W-40 low ash</b> CES 20081 <b>and</b> 5W-40 <b>or</b> CES 20081 <b>and</b> 10W-40	CES 20081 <b>and</b> 0W-40
		<b>Note:</b> To improve the cold start ability of the Cummins diesel engine at an ambient temperature below -10°C, we recommend the use of engine oil according to CES 20081 <b>and</b> SAE viscosity grade 5W-40	
<b>Note:</b> For alternative oil specifications, see the separate engine manufacturer's operating instructions.			

No.	Crane components	Ambient temperature for driving and crane operation	
		-20 °C to +50 °C	-40 °C to +30 °C
1.2	Diesel engine <b>without</b> Exhaust aftertreatment	<b>LWE Id. No.: 10871536</b> <b>Liebherr Motoroil 5W-30</b> <b>or:</b> <b>LWE Id. No.: 861005308</b> <b>Liebherr Motoroil 10W-40</b> LH-00-ENG Observe the instructions of the engine manufacturer	<b>LWE Id. No.: 10871536</b> <b>Liebherr Motoroil 5W-30</b> <b>or:</b> <b>LWE Id. No.: 861005308</b> <b>Liebherr Motoroil 10W-40</b> LH-00-ENG Observe the instructions of the engine manufacturer <b>below -20 °C with pre-heating</b>
	<b>Note:</b> To improve the cold start ability of the diesel engine at an ambient temperature below -10 °C , we recommend the use of Liebherr Motoroil 5W-30, <b>LWE-Id no.: 10871536</b>		
	Cummins B 6.7 <b>without</b> Exhaust aftertreatment	<b>LWE Id. No.: 10663796</b> <b>Liebherr Motoroil 10W-40 low ash</b> CES 20078 and 5W-40 <b>or</b> CES 20078 and 10W-40	CES 20078 and 0W-40
<b>Note:</b> To improve the cold start ability of the Cummins diesel engine at an ambient temperature below -10°C, we recommend the use of engine oil according to CES 20078 <b>and</b> SAE viscosity grade 5W-40			
<b>Note:</b> For alternative oil specifications, see the separate engine manufacturer's operating instructions.			
2	Drive axle with differentials,  planetary gear and installed distributor gear	<b>LWE Id. No.: 861901008</b> <b>Liebherr Gear Hypoid 90 EP</b>  SAE 90 and API GL 5	<b>LWE Id. No.: 10425142</b> <b>Liebherr Syntogear Plus 75W-90</b>  SAE 75W-90 and API GL 5
3	Axle drive ZF DK-7	<b>LWE Id. No.: 861901008</b> <b>Liebherr Gear Hypoid 90 EP</b>  ZF TE-ML 05	<b>LWE Id. No.: 10425142</b> <b>Liebherr Syntogear Plus 75W-90</b>  ZF TE-ML 05
4.1	Vehicle distributor gear KESSLER  VG 1800, VG 2400, VG 2550, VG 2600, VG 2700, VG 3750, VG 3751  W 3750, W 3751	<b>LWE Id. No.: 861901008</b> <b>Liebherr Gear Hypoid 90 EP</b>  SAE 90 and API GL 5	<b>LWE Id. No.: 10425142</b> <b>Liebherr Syntogear Plus 75W-90</b>  SAE 75W-90 and API GL 5

No.	Crane components	Ambient temperature for driving and crane operation	
		-20 °C to +50 °C	-40 °C to +30 °C
4.2	Vehicle distributor gear with PTO for crane drive KESSLER VG 2700 with PTO VG 3751 with PTO	<b>LWE Id. No.: 10425142</b>  <b>Liebherr Syntogear Plus 75W-90</b> SAE 75W-90 and API GL 5	<b>LWE Id. No.: 10425142</b>  <b>Liebherr Syntogear Plus 75W-90</b> SAE 75W-90 and API GL 5
4.3	Vehicle distributor gear ZF Passau, STEYR PUCH VG 1200, VG 1600, VG 2000, VG 3800	<b>LWE Id. No.: 861901008</b>  <b>Liebherr Gear Hypoid 90 EP</b> ZF TE-ML 19	<b>LWE Id. No.: 10425142</b>  <b>Liebherr Syntogear Plus 75W-90</b> ZF TE-ML 19
4.4	Distributor gear for the electrohydraulic crane drive	<b>LWE Id. No.: 861900608</b>  <b>Liebherr Hydraulic-Gear ATF</b> or <b>SAE 75W-90 und API GL 5</b>	
5	Miter gear for crane drive	<b>LWE Id. No.: 10425142</b>  <b>Liebherr Syntogear Plus 75W-90</b> SAE 75W-90 and API GL 5	<b>LWE Id. No.: 10425142</b>  <b>Liebherr Syntogear Plus 75W-90</b> SAE 75W-90 and API GL 5
6	Displacement gear (drop box) ZF Passau, STEYR PUCH	<b>LWE Id. No.: 861901008</b>  <b>Liebherr Gear Hypoid 90 EP</b> ZF TE-ML 19	<b>LWE Id. No.: 10425142</b>  <b>Liebherr Syntogear Plus 75W-90</b> ZF TE-ML 19
7.1	Pump distributor gear filled with mineral-oil-based gear oil	<b>LWE Id. No.: 861901008</b>  <b>Liebherr Gear Hypoid 90 EP</b> SAE 90 and API GL 5 <b>NOTICE: May not be mixed with other oils!</b>	<b>LWE Id. No.: 10330289</b>  <b>Liebherr Syntogear Plus 75W-90</b> SAE 75W-90 and API GL 5 <b>NOTICE: May not be mixed with other oils!</b>
7.2	Pump distributor gear filled with polyglycol-oil-based (PG) gear oil	<b>LWE Id. No.: 10665030</b>  <b>Liebherr Gear PG 220</b> CLP PG, DIN 51 502 CLP (PG) 220, DIN 51517-3 <b>NOTICE: May not be mixed with other oils!</b>	<b>LWE Id. No.: 10664125</b>  <b>Liebherr Gear PG 150</b> CLP PG, DIN 51 502 CLP (PG) 150, DIN 51517-3 <b>NOTICE: May not be mixed with other oils!</b>

LWE/LR 1800-1-0-000/27200-07-02/en

No.	Crane components	Ambient temperature for driving and crane operation	
		-20 °C to +50 °C	-40 °C to +30 °C
7.3	Pump distributor gear filled with polyalphaolefine-based (PAO) gear oil	<b>LWE Id. No.: 10190390</b> <b>Liebherr Syntogear Plus 220</b>  CLP HC, DIN 51 502 CLP (HC) 220, DIN 51517-3 <b>NOTICE: May not be mixed with other oils!</b>	<b>LWE Id. No.: 10190390</b> <b>Liebherr Syntogear Plus 220</b>  CLP HC, DIN 51 502 CLP (HC) 220, DIN 51517-3 <b>NOTICE: May not be mixed with other oils!</b>
7.4	Pump distributor gear LTC 1055-3.1	<b>LWE Id. No.: 10425142</b> <b>Liebherr Syntogear Plus 75W-90</b>  SAE 75W-90 and API GL 5	<b>LWE Id. No.: 10425142</b> <b>Liebherr Syntogear Plus 75W-90</b>  SAE 75W-90 and API GL 5
8.1	Powershift transmission ZF torque converter WG 120, WG 150, WG 180, WG 181, WG 200, WG 201	<b>LWE Id. No.: 861005308</b> <b>Liebherr Motoroil 10W-40</b>  ZF TE-ML 03	<b>LWE Id. No.: 861900608</b> <b>Liebherr Hydraulic-Gear ATF</b> ZF TE-ML 03  <b>below -20 °C run until warm according to the operating instructions</b>
8.2	Powershift transmission ZF torque converter WG 251* ZF ERGOPOWER WG 210, WG 260, WG 310  * also for ambient temperatures above -10 °C	<b>LWE Id. No.: 861900608</b> <b>Liebherr Hydraulic-Gear ATF</b>  ZF TE-ML 03	<b>LWE Id. No.: 861900608</b> <b>Liebherr Hydraulic-Gear ATF</b> ZF TE-ML 03  <b>below -20 °C run until warm according to the operating instructions</b>
9	Powershift transmission CLARK	<b>LWE Id. No.: 861005308</b> <b>Liebherr Motoroil 10W-40</b>  SAE 10W-40 and ACEA E4	<b>LWE Id. No.: 861900608</b> <b>Liebherr Hydraulic-Gear ATF</b> ATF Dexron II D and ALLISON C4  <b>below -20 °C run until warm according to the operating instructions</b>
10	Displacement gear (drop box) ALLISON	<b>LWE Id. No.: 861005308</b> <b>Liebherr Motoroil 10W-40</b>  SAE 10W-40 and API CF, ACEA E4	<b>LWE Id. No.: 861900608</b> <b>Liebherr Hydraulic-Gear ATF</b> ALLISON C4  <b>below -20 °C run until warm according to the operating instructions</b>

No.	Crane components	Ambient temperature for driving and crane operation	
		-20 °C to +50 °C	-40 °C to +30 °C
11.1	Automatic transmission ALLISON CLBT 740, CLBT 750, CLBT 754, CLBT 755 HT 755, HD 4560	<b>LWE Id. No.: 861900608</b> <b>Liebherr Hydraulic-Gear ATF</b> ALLISON C4	<b>LWE Id. No.: 861903708</b> <b>CASTROL Transynd</b> ALLISON C4  <b>below -20 °C</b> run until warm according to the operating instructions
11.2	Automatic transmission ZF	<b>LWE Id. No.: 861900608</b> <b>Liebherr Hydraulic-Gear ATF</b> ZF TE-ML 14	<b>LWE Id. No.: 861900608</b> <b>Liebherr Hydraulic-Gear ATF</b> ZF TE-ML 14  <b>below -20 °C</b> run until warm according to the operating instructions
12.1	Automatic transmission ZF AS-Tronic ZF TC-Tronic (basic gear) ZF TC-Tronic HD (basic gear)	<b>LWE Id. No.: 10218305</b> <b>ZF-Ecofluid M</b> ZF TE-ML 02	<b>LWE Id. No.: 10218305</b> <b>ZF-Ecofluid M</b> ZF TE-ML 02  <b>below -20 °C</b> preheat the gear according to the operating instructions
12.2	Automatic transmission ZF TraXon ZF TraXon Torque (basic gear)	<b>LWE Id. No.: 10218305</b> <b>ZF-Ecofluid M</b> ZF TE-ML 02	<b>LWE Id. No.: 10218305</b> <b>ZF-Ecofluid M</b> ZF TE-ML 02  <b>below -20 °C</b> preheat the gear according to the operating instructions
13.1	Torque converter coupling ZF TC HD	<b>LWE Id. No.: 10218305</b> <b>ZF-Ecofluid M</b> ZF TE-ML 02	<b>LWE Id. No.: 10218305</b> <b>ZF-Ecofluid M</b> ZF TE-ML 02  <b>below -20 °C</b> preheat the gear according to the operating instructions
13.2	Torque converter coupling ZF TC 2	<b>LWE Id. No.: 861900608</b> <b>Liebherr Hydraulic-Gear ATF</b> ZF TE-ML 14	<b>LWE Id. No.: 861900608</b> <b>Liebherr Hydraulic-Gear ATF</b> ZF TE-ML 14
13.3	Wet starting clutch ZF Dynamic Perform	<b>LWE Id. No.: 12101837</b> <b>ZF-Ecofluid Life Plus</b> ZF TE-ML 25	<b>LWE Id. No.: 12101837</b> <b>ZF-Ecofluid Life Plus</b> ZF TE-ML 25
14	Transmission ZF ECO-Split	<b>LWE Id. No.: 10218305</b> <b>ZF-Ecofluid M</b> ZF TE-ML 02	<b>LWE Id. No.: 10218305</b> <b>ZF-Ecofluid M</b> ZF TE-ML 02

LWE/LR 1800-1-0-000/27200-07-02/en

No.	Crane components	Ambient temperature for driving and crane operation	
		-20 °C to +50 °C	-40 °C to +30 °C
15.1	Slewing gear filled with polyglycol-oil-based (PG) gear oil	<b>LWE Id. No.: 10665030</b> <b>Liebherr Gear PG 220</b>  CLP PG, DIN 51 502 CLP (PG) 220, DIN 51517-3 <b>NOTICE: May not be mixed with other oils!</b>	<b>LWE Id. No.: 10665030</b> <b>Liebherr Gear PG 220</b>  CLP PG, DIN 51 502 CLP (PG) 220, DIN 51517-3 <b>NOTICE: May not be mixed with other oils!</b>
15.2	Slewing gear filled with polyalphaolefine-based (PAO) gear oil	<b>LWE Id. No.: 10190390</b> <b>Liebherr Syntogear Plus 220</b>  CLP HC, DIN 51 502 CLP (HC) 220, DIN 51517-3 <b>NOTICE: May not be mixed with other oils!</b>	<b>LWE Id. No.: 10190390</b> <b>Liebherr Syntogear Plus 220</b>  CLP HC, DIN 51 502 CLP (HC) 220, DIN 51517-3 <b>NOTICE: May not be mixed with other oils!</b>
16.1	Rope winch filled with polyglycol-oil-based (PG) gear oil	<b>LWE Id. No.: 10665030</b> <b>Liebherr Gear PG 220</b>  CLP PG, DIN 51 502 CLP (PG) 220, DIN 51517-3 <b>NOTICE: May not be mixed with other oils!</b>	<b>LWE Id. No.: 10665030</b> <b>Liebherr Gear PG 220</b>  CLP PG, DIN 51 502 CLP (PG) 220, DIN 51517-3 <b>NOTICE: May not be mixed with other oils!</b>
16.2	Rope winch filled with polyalphaolefine-based (PAO) gear oil	<b>LWE Id. No.: 10190390</b> <b>Liebherr Syntogear Plus 220</b>  CLP HC, DIN 51 502 CLP (HC) 220, DIN 51517-3 <b>NOTICE: May not be mixed with other oils!</b>	<b>LWE Id. No.: 10190390</b> <b>Liebherr Syntogear Plus 220</b>  CLP HC, DIN 51 502 CLP (HC) 220, DIN 51517-3 <b>NOTICE: May not be mixed with other oils!</b>
16.3	Rope winch (tooth flanks) LR 12500-1.0 LR 13000	<b>LWE Id. No.: 11000948</b> <b>Liebherr Universalfett 9900</b>  KPF2N-25, DIN 51502	<b>LWE Id. No.: 12105012</b> <b>Liebherr Universalfett Arctic</b>  KPFHC1N-60, DIN 51502
17.1	Winch of Telescopic boom guying  filled with polyglycol-oil-based (PG) gear oil	<b>LWE Id. No.: 861901208</b> <b>Liebherr Gear PG 220</b>  CLP PG 220, DIN 51 502 CLP (PG) 220, DIN 51517-3  <b>NOTICE: May not be mixed with other oils!</b>	<b>LWE Id. No.: 861901208</b> <b>Liebherr Gear PG 220</b>  CLP PG 220, DIN 51 502 CLP (PG) 220, DIN 51517-3  <b>NOTICE: May not be mixed with other oils!</b>

No.	Crane components	Ambient temperature for driving and crane operation	
		-20 °C to +50 °C	-40 °C to +30 °C
17.2	Winch of Telescopic boom guying  filled with polyalphaolefine-based (PAO) gear oil	<b>LWE Id. No.: 10190390</b> <b>Liebherr Syntogear Plus 220</b> CLP HC, DIN 51 502 CLP (HC) 220, DIN 51517-3  <b>NOTICE: May not be mixed with other oils!</b>	<b>LWE Id. No.: 10190390</b> <b>Liebherr Syntogear Plus 220</b> CLP HC, DIN 51 502 CLP (HC) 220, DIN 51517-3  <b>NOTICE: May not be mixed with other oils!</b>
18.1	Crane hydraulics Crane chassis and crane superstructure Observe exceptions, see 18.2 and 18.3	<b>LWE Id. No.: 861903508</b> <b>Liebherr Hydraulic 37</b>	<b>LWE Id. No.: 10293807</b> <b>Liebherr Hydraulic Plus Arctic</b>
18.2	Crane hydraulics Crane chassis and crane superstructure LTM 11200-9.1 LTR 11200 LR-crane and LG-crane with LIC-CON 2 control LTC 1055-3.1	<b>LWE Id. No.: 10293807</b> <b>Liebherr Hydraulic Plus Arctic</b>	<b>LWE Id. No.: 10293807</b> <b>Liebherr Hydraulic Plus Arctic</b>
18.3	Crane hydraulics Crane chassis and crane superstructure for crane use in environmentally sensitive areas	<b>LWE Id. No.: 861000108</b> <b>Liebherr Hydraulic Plus 37</b>	
19	Brake system if hydraulically actuated	<b>LWE Id. No.: 861000108</b> <b>DOT 4</b> SAE J 1703e	<b>LWE Id. No.: 861000108</b> <b>DOT 4</b> SAE J 1703e
20	Clutch actuator	<b>LWE Id. No.: 861000108</b> <b>DOT 4</b> SAE J 1703e	<b>LWE Id. No.: 861000108</b> <b>DOT 4</b> SAE J 1703e
21	King pin bearing Gear shaft if <b>not</b> maintenance-free	<b>LWE Id. No.: 861301308</b> <b>Liebherr Spezialfett 9610 Plus</b> KP2K-20, DIN 51502	<b>LWE Id. No.: 10296825</b> <b>Liebherr Universalfett Arctic</b> KPFHC1N-60, DIN 51502
22.1	Glide and roller bearing roller bearing joint	<b>LWE Id. No.: 861301308</b> <b>Liebherr Spezialfett 9610 Plus</b> KP2K-20, DIN 51502	<b>LWE Id. No.: 10296825</b> <b>Liebherr Universalfett Arctic</b> KPFHC1N-60, DIN 51502
22.2	Rope pulley bearing	<b>LWE Id. No.: 10296825</b> <b>Liebherr Universalfett Arctic</b> KPFHC1N-60, DIN 51502	<b>LWE Id. No.: 10296825</b> <b>Liebherr Universalfett Arctic</b> KPFHC1N-60, DIN 51502

LWE/LR 1800-1-0-000/27200-07-02/en

No.	Crane components	Ambient temperature for driving and crane operation	
		-20 °C to +50 °C	-40 °C to +30 °C
23	Central lubrication system	<b>LWE Id. No.: 861301308</b> <b>Liebherr Spezialfett 9610 Plus</b> KP2K-20, DIN 51502	<b>LWE Id. No.: 10296825</b> <b>Liebherr Universalfett Arctic</b> KPFHC1N-60, DIN 51502
24.1	Slewing ring connection Roller bearing	<b>LWE Id. No.: 861301308</b> <b>Liebherr Spezialfett 9610 Plus</b> KP2K-20, DIN 51502	<b>LWE Id. No.: 10296825</b> <b>Liebherr Universalfett Arctic</b> KPFHC1N-60, DIN 51502
24.2	Slewing ring connection LR 12500-1.0 LR 13000	<b>LWE Id. No.: 11000948</b> <b>Liebherr Universalfett 9900</b> KPF2N-25, DIN 51502	<b>LWE Id. No.: 10296825</b> <b>Liebherr Universalfett Arctic</b> KPFHC1N-60, DIN 51502
25.1	Support plate with equalization	<b>LWE Id. No.: 10877698</b> <b>Loctite LB 8104</b> Silicone oil base <b>NOTICE: Do not use oils with another base!</b>	<b>LWE Id. No.: 10877698</b> <b>Loctite LB 8104</b> Silicone oil base <b>NOTICE: Do not use oils with another base!</b>
25.2	Sliding shoes for cab guidance on vehicle frame LTC 1045-3.1 LTC 1050-3.1	<b>LWE Id. No.: 861303608</b> <b>Liebherr Teleskopfett 9613 Plus</b> KP2K-30, DIN 51502	<b>LWE Id. No.: 861303608</b> <b>Liebherr Teleskopfett 9613 Plus</b> KP2K-30, DIN 51502
26	Sliding beam Plastic glide bearing Beam for track adjustment	<b>LWE Id. No.: 861303608</b> <b>Liebherr Teleskopfett 9613 Plus</b> KP2K-30, DIN 51502	<b>LWE Id. No.: 861303608</b> <b>Liebherr Teleskopfett 9613 Plus</b> KP2K-30, DIN 51502
27.1	Telescopic boom Lower shell outer slide bearing  Plastic glide bearing or corner guide top Cylinder guide in telescope end section Lock pocket in telescope end section (only for Telematik)	<b>LWE Id. No.: 861303608</b> <b>Liebherr Teleskopfett 9613 Plus</b> KP2K-30, DIN 51502	<b>LWE Id. No.: 861303608</b> <b>Liebherr Teleskopfett 9613 Plus</b> KP2K-30, DIN 51502



No.	Crane components	Ambient temperature for driving and crane operation	
		-20 °C to +50 °C	-40 °C to +30 °C
27.2	Telescopic boom LTC 1045-3.1 LTC 1050-3.1 Lower shell outer slide bearing Plastic glide bearing or corner guide top Cylinder guide in telescope end section Lock pocket in telescope end section (only for Telematik)	<b>LWE Id. No.: 11651459</b> <b>Bechem Berulub TCG 1 V</b>	<b>LWE Id. No.: 11651459</b> <b>Bechem Berulub TCG 1 V</b>
27.3	Telescopic boom LTM 1050-3.1 Lower shell outer slide bearing Plastic glide bearing or corner guide top Cylinder guide in telescope end section Lock pocket in telescope end section (only for Telematik)	<b>LWE Id. No.: 10878154</b> <b>Liebherr Sliding Paste TB 1</b>	<b>LWE Id. No.: 10878154</b> <b>Liebherr Sliding Paste TB 1</b>
28	Boom lock	<b>LWE Id. No.: 861301308</b> <b>Liebherr Spezialfett 9610 Plus</b> KP2K-20, DIN 51502	<b>LWE Id. No.: 10296825</b> <b>Liebherr Universalfett Arctic</b> KPFHC1N-60, DIN 51502
29	Gear ring rotary connection Slewing gear drive pinion	<b>LWE Id. No.: 861007708</b> <b>Liebherr RHS-Fluid</b> OGPF 0 S-20, DIN 51502	<b>LWE Id. No.: 861007708</b> <b>Liebherr RHS-Fluid</b> OGPF 0 S-20, DIN 51502
		<b>or</b> <b>LWE Id. No.: 861301508</b> <b>Liebherr gear protection RHY</b> OGPF 2 S-30, DIN 51502	<b>or</b> <b>LWE Id. No.: 861301508</b> <b>Liebherr gear protection RHY</b> OGPF 2 S-30, DIN 51502
30	Running rope	<b>LWE Id. No.: 10173371</b> <b>Liebherr WR-Lube SC</b> Adhesive grease	<b>LWE Id. No.: 10173371</b> <b>Liebherr WR-Lube SC</b> Adhesive grease
		<b>or</b> <b>LWE Id. No.: 10174262</b> <b>Liebherr WR-Lube SC</b> Adhesive grease	<b>or</b> <b>LWE Id. No.: 10174262</b> <b>Liebherr WR-Lube SC</b> Adhesive grease

LWE/LR 1800-1-0-000/27200-07-02/en

No.	Crane components	Ambient temperature for driving and crane operation	
		-20 °C to +50 °C	-40 °C to +30 °C
31	Radiator fluid Diesel engine and heating system	<b>LWE Id. No.: 10871121</b> <b>Liebherr Antifreeze OS Mix</b> Pre-mixed corrosion inhibitor / antifreeze <b>NOTICE: May not be diluted            and / or mixed with other cor-            rosion inhibitors / antifreeze!</b>	<b>LWE Id. No.: 10871121</b> <b>Liebherr Antifreeze OS Mix</b> Pre-mixed corrosion inhibitor / antifreeze <b>NOTICE: May not be diluted            and / or mixed with other cor-            rosion inhibitors / antifreeze!</b>
32.1	Crawler crane travel gear	see data tag	see data tag
32.2	Crawler crane with telescopic boom travel gear	see data tag	see data tag
33	Recovery winch	See the data tag and manufac- turer's specifications	See the data tag and manufac- turer's specifications
34	Recovery winch rope	See the manufacturer's specifi- cations	See the manufacturer's specifi- cations
35	Steering uncoupling LTC 1045-3.1 LTC 1050-3.1	<b>LWE Id. No.: 10800345</b> <b>Teflon-Spray</b>	<b>LWE Id. No.: 10800345</b> <b>Teflon-Spray</b>
36	Pin connections	<b>LWE Id. No.: 11000948</b> <b>Liebherr Universalfett 9900</b> KPF2N-25, DIN 51502	<b>LWE Id. No.: 11000948</b> <b>Liebherr Universalfett 9900</b> KPF2N-25, DIN 51502

---

## 8 Inspections of cranes

LWE/LR 1800-1-0-000/27200-07-02/en

---

LWE/LR 1800-1-0-000/27200-07-02/en

## 8.01 Periodic crane inspections

1	General information	2
2	Inspecting load bearing crane structures, especially steel structures	4
3	Inspecting the locking system of the telescopic boom	89
4	Inspection of the screws in the adjustment plates	91
5	Checking the safety ropes and anchor points	92
6	Inspecting the load handling equipment and assembly aids	94
7	Inspecting of fastening equipment	94
8	Inspecting the hydro reservoir	95
9	Inspecting the relapse cylinders	95
10	Inspecting the rope pulleys	96
11	Inspecting the carrier rollers	97
12	Inspecting the extension conditions of sliding beams	98
13	Inspecting the inclination sensor	99
14	Inspecting the function of the overload protection	100
15	Inspecting the pin connections	100
16	Inspecting the slewing ring connection	101
17	Inspecting the mounting of the load bearing equipment	101
18	Inspecting the tele extension with eccentric, illustration 1	103
19	Inspecting the change over pulleys, illustration 2	104
20	Inspecting the oil and fuel tanks	104

# 1 General information

This crane was tested at the manufacturer's facilities prior to shipment in accordance with the valid ISO, FEM and DIN Standards and DGUV 52 (DGUV 309-001).

The safety level achieved during initial start up may not be attainable during operation.

Examples of the root cause of such deviations include; e.g., wear and tear, corrosion, effects of external forces, changes in the environment and changes to the mode of operation.

The operator is responsible for taking the necessary steps to ensure that the level of safety is maintained.

Periodic inspections are regulated nationally in the BetrSichV.

The crane operator is therefore obligated to have the crane inspected by an **authorized inspector**, at intervals depending on the operational conditions but at least once per year, from the first day of vehicle registration.

Certain conditions of use require however shorter inspection intervals or tests.

Conditions of use, the shorter inspection intervals or inspections between the regular inspections require:

- High utilization of the crane and / or a greater number of load cycles.
- Ramming work and pulling work, see chapter 4.08.
- Operation at low temperatures, see chapter 2.08.
- Lifting of personnel, see chapter 2.04.
- Situations during which the crane was exposed to sudden loads.

When equipment parts from other cranes are used: Make sure that the inspections and inspection intervals are observed also for the replaced equipment parts.

The operator specifies an authorized inspector and assigns him to perform the tests and maintenance required nationally and by Liebherr-Werk Ehingen GmbH to ensure further, safe and reliable crane operation:

- Carry out the inspection tasks required by Liebherr-Werk Ehingen GmbH.
- Additional national inspection intervals must be monitored by the crane operator.

Every 4 operating years, in the 13th Operating year and thereafter at least annually, from the first day of vehicle registration, the crane must be inspected by an **inspection expert**.

Periodic inspection are principally a visual inspection, where the inspector appraises the condition of the crane and its components.



## WARNING

There is danger of weakening the supporting components when major changes or repairs are made to the crane!

- ▶ In this case, the operator must have the crane reinspected by an inspection expert before putting it back in service!

In addition, all respective local and national regulations apply.

### Authorized inspector

Authorized inspectors are those persons who through their professional training, their professional experience and their recent professional activity have the necessary knowledge for the inspection of work equipment.

### Authorized inspector for pressure containers

Authorized inspectors for pressure containers are authorized inspectors who additionally:

- Have relevant technical professional training.
- Have at least one year of experience with the manufacture, assembly, operation or maintenance of the equipment or components to be inspected in accordance with BetrSichV.
- Keep their knowledge about pressure-related hazards up to date by participating in training or instruction, in particular with regard to the following topics:
  - Design and manufacturing processes

- Equipment and safeguarding concepts
- Assembly, installation and operation / use
- Intended use
- Risk assessment
- Inspections, inspection periods, inspection procedures including assessment of the results
- Relevant influences and damage symptoms found in practice

### Inspection expert

Inspection experts are authorized inspectors who also:

- Have completed training as an engineer or have equivalent knowledge and experience in the subject area with which their activities are involved.
- Have at least three years of experience in the design, construction, maintenance or inspection of cranes, of which at least half a year were involved in the inspection activities of an inspection expert.
- Possess sufficient knowledge of the relevant regulations and rules.
- Have the necessary facilities for inspection and documentation.
- Keep their professional knowledge up to date.

To ensure the high safety standard of the crane, it is recommended, no later than the 12th year, in the 20th year, in the 26th year and then every 4 years, to have the crane undergo a **general inspection** by an **inspection expert**. At that time, in addition to the usual scope of inspection, all load carrying parts of the crane - the complete steel structure with all welding seams as well as all components and connecting devices - are to be subjected to a complete visual inspection. The following procedural notes for repeat inspections are to be observed for that.

The purpose of the inspections is to avoid accidents by detecting deficiencies early on. Any deficiencies found by the inspector must be documented, corrected and subsequently reinspected.

For safe crane operation, important components must be inspected for their percentage of utilization or their reusability. Based on this inspection a statement can be made about the suitability of the components for further operation.

A number of important examples of items that are particularly important during the periodic crane inspections are listed below. We wish to advise that the **authorized inspectors** or **inspection experts** take sole responsibility for the crane inspections that they carry out.



### Note

- ▶ The inspection may not be solely limited to the following positions shown in the sample component illustrations. Rather the **entire** crane structure must be subjected to a careful inspection!

A checklist is provided in the Crane operating instructions, chapter 8.90, to assist the inspector during the periodic inspections of Liebherr mobile and crawler cranes.

If the inspector has any questions they should be directed through the Service Department of Liebherr-Werk Ehingen GmbH to the technical departments.



### WARNING

Danger of accident!

- ▶ Adhere to the following inspection guidelines and intervals.

## 2 Inspecting load bearing crane structures, especially steel structures

### 2.1 Basic principles and procedure



#### DANGER

Danger of fatal injury!

The crane structures, particularly steel constructions, have to be checked by an **authorized inspector** or **inspection expert** at least once a year. If this is not the case, they could fail and cause fatal injury or seriously damage the crane!

- ▶ Crane structures, particularly steel constructions must be checked by an **authorized inspector** or an **inspection expert** at least once a year!
- ▶ Shorten the inspection intervals when the crane is subjected to above-average load spectrums, for example during handling operation or frequently erecting long boom systems.
- ▶ When the crane was subjected to excessive operating loads; e.g., due to an unusual impact, the crane structure, especially the steel structures must be inspected immediately!

Crane structures, especially steel structures, such as booms, turntables, chassis, support equipment (e.g., sliding beams or folding outriggers) must be carefully inspected, at the very least during the annual recommended crane inspections. Inspect welding seams especially through an intensive visual inspection.

If paint damage with corrosion (rust) is found on load carrying parts of the crane structure, especially on telescopic booms, lattice booms, lattice jibs, pull rods etc., then the rust must be removed, primed and painted.

In the case of an electrolyte process, such as corrosion in combination with water, atomic hydrogen is created, which leads to hydrogen induced corrosion with resulting cracks in high tensile fine grain construction steel.

If disassembly and assembly work on the crane is required to carry out the inspections, then they must be carried out by taking the manufacturer's data into account or in coordination with the crane manufacturer.

We would like to point out that the framework of mobile cranes is designed for a limited number of stress work cycles. This also determines the utilization or service life of the framework. The service life is not determined solely by the number of stress cycles. It also depends on the loads (load spectrum) applied during the time in operation.

Liebherr mobile and crawler cranes are designed for specific characteristics and movements, such as constant deployment of drive forces, only occasional operation and load conditions according to EN 13000.

Liebherr mobile and crawler cranes are designed for assembly operation and can only perform a limited number of load cycles ( $N=63000$ ). They are classified according to ISO 4301-2 in Class A1 and assigned according to ISO 4301-1 of collective class  $Q_1 = \text{light}$  ( $k_p = 0.125$ ).

Regular overload tests are **not** recommended. An overload check may be necessary after repair welding on load bearing parts. An overload inspection may also be necessary after a general overhaul or other changes to load bearing parts. Contact **Liebherr-Werk Ehingen GmbH** customer service for suitable test loads.



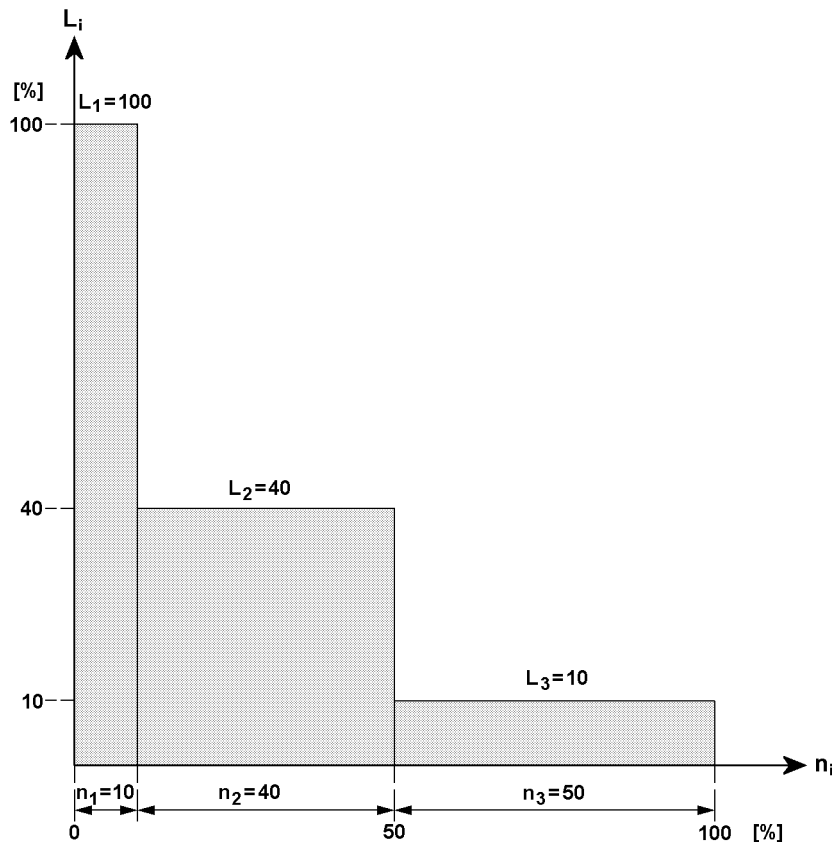


Fig. 104716: Load spectrum example: Grouped according to collective class  $Q_1 = \text{light}$  ( $k_p = 0.125$ )

$L_i$ : Load proportion in relation to maximum load [%]       $n_i$ : Load cycles in relation to maximum number [%]



#### Note

- ▶ The service life of Liebherr mobile and crawler cranes can be drastically reduced, for example when used in magnet, grabbing or handling operations!
- ▶ Repeated inspection of crane structure, especially the steel structure and the welding seams must then be carried out in shorter intervals than specified.

For that reason, the steel structures and the welding joints must be subjected to a visual intensive inspection by the **authorized inspector** or **inspection expert** during the specified periodic inspections.

If any damage, such as cracks or suspicion of cracks, are apparent on any part of the steel structure, the total extent of the damage must be determined by qualified specialists using appropriate material testing methods, such as magnetic crack detection, ultrasound or x-rays. Thereafter, the qualified personnel must determine whether or not the damaged area can be repaired by welding or by other means.



#### Note

- ▶ The scope and extent of all inspections remain the sole responsibility of the inspectors!
- ▶ The scope and results of tests should be documented to permit reproducibility. This documentation forms part of the crane records and should be safely stored during the entire service life of the crane!

## 2.2 Repair welding

Defects such as cracks or permanent deformations on load-bearing steel components must be immediately reported to Customer Service at **Liebherr-Werk Ehingen GmbH**.

The defect must immediately be appraised by an inspection expert according to standard welding technology rules. The inspection expert must immediately ascertain if the crane can continue to be safely operated due to danger of accident until a repair welding is performed.

Repair welding may solely be made in consultation and under the guidance of Customer Service at **Liebherr-Werk Ehingen GmbH** by authorized and trained expert personnel.



#### WARNING

Repair welding **not** according to regulations!  
Death, severe bodily injuries, property damage.

- ▶ Contact Customer Service at **Liebherr-Werk Ehingen GmbH**.
- ▶ Coordinate the procedure for repair welding with **Liebherr-Werk Ehingen GmbH**.



#### Note

Exclusion of liability!

In the case of repair welding that were not carried out by personnel from **Liebherr-Werk Ehingen GmbH** or by authorized personnel from **Liebherr-Werk Ehingen GmbH**, **Liebherr-Werk Ehingen GmbH** excludes all liability for system functionality as well as for the parts.

- ▶ Have repair welding performed only by personnel of **Liebherr-Werk Ehingen GmbH** or by personnel authorized by **Liebherr-Werk Ehingen GmbH**.

## 2.3 Description of test points

All welding seams must be checked completely in the following positions:

- Force transmission points
- Fastening points
- Pipe connections
- Pipe intersections
- Louvered plates
- Inserted plates
- Welded metal springs
- Connections of fork-finger joints
- Double walls
- Welded lifting lugs
- Welded eyehooks

## 2.4 Examples of test points

The following diagrams are examples of the load bearing welding structures. The welding joints or seams or steel structural zones that require inspection may be present more than once and in various forms. The joints or zones must be inspected all around in the locations identified by arrows.



#### DANGER

Incomplete welding seam inspection!  
Death, severe injuries, property damage.

The following diagrams are provided to assist the inspector. The illustrations are only examples and are not necessarily 100 % complete!

- ▶ Check all welding seams to be inspected.

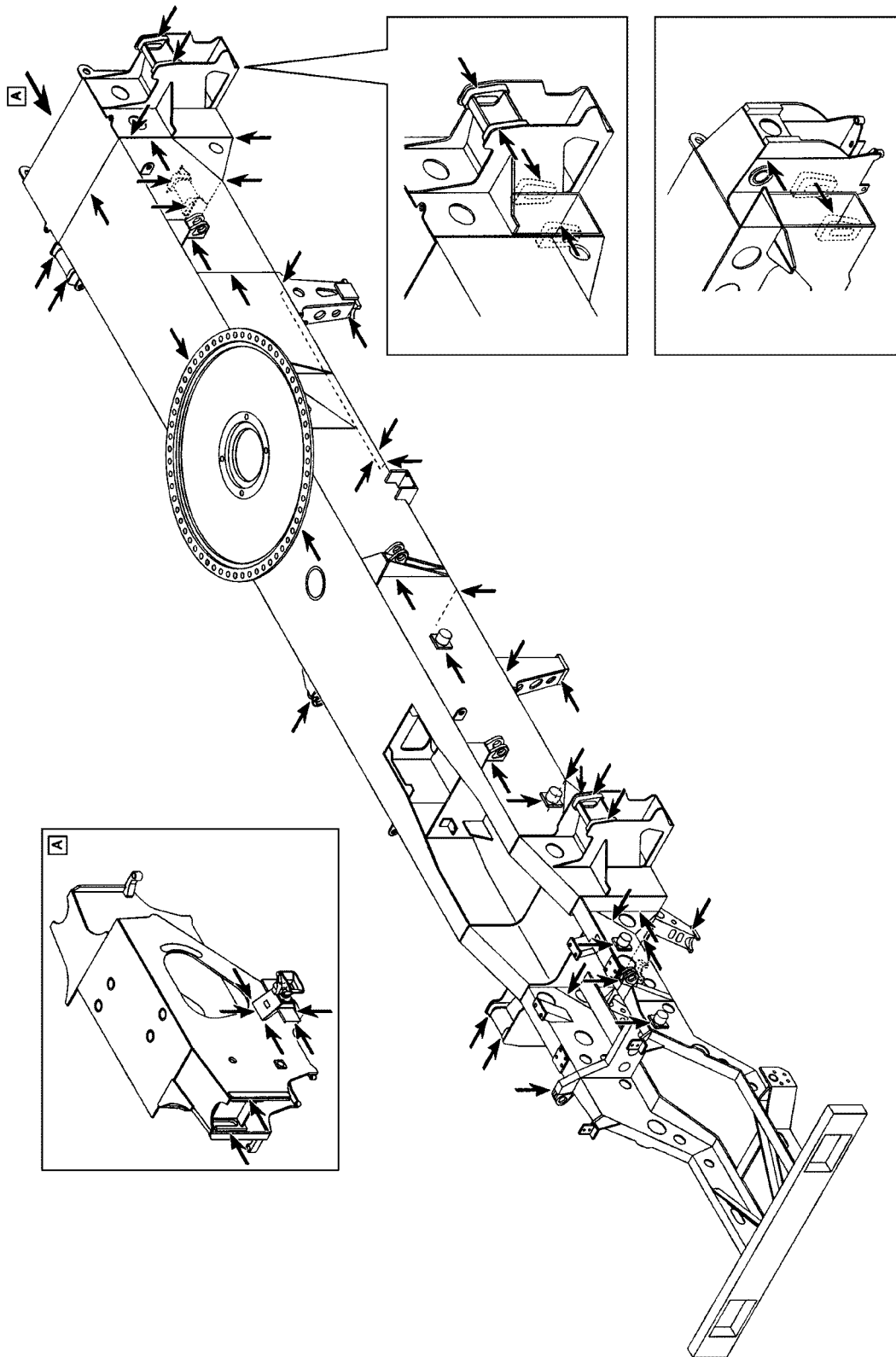


#### Note

- ▶ The welding seams in force transmission points to be inspected are marked by a circle.
- ▶ The welding seams to be checked are marked with arrows.

### 2.4.1 Crane chassis

#### Vehicle frame



LWE/LR 1800-1-0-000/27200-07-02/en

Fig.164852: Example of a vehicle frame

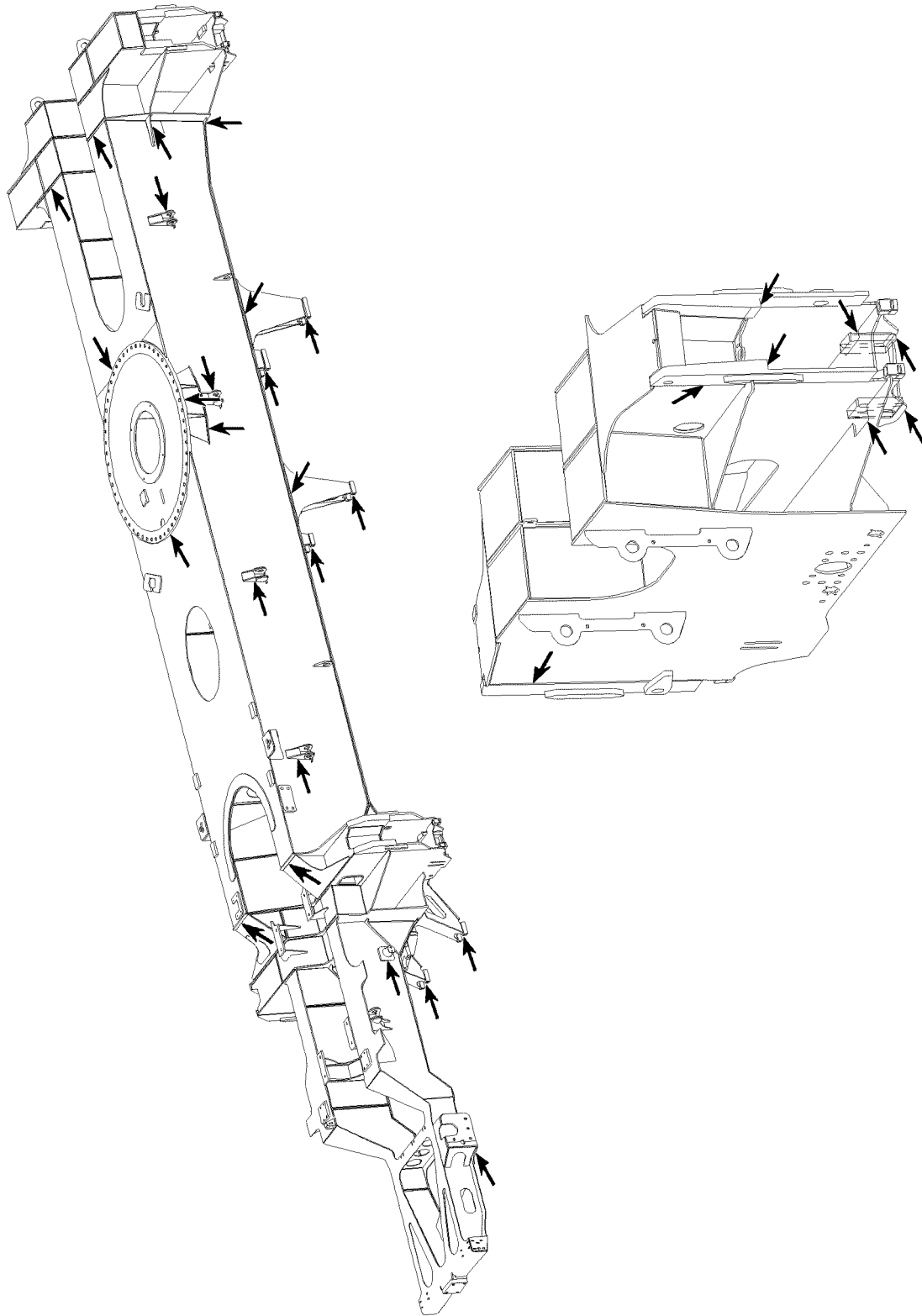


Fig.164853: Example of a vehicle frame

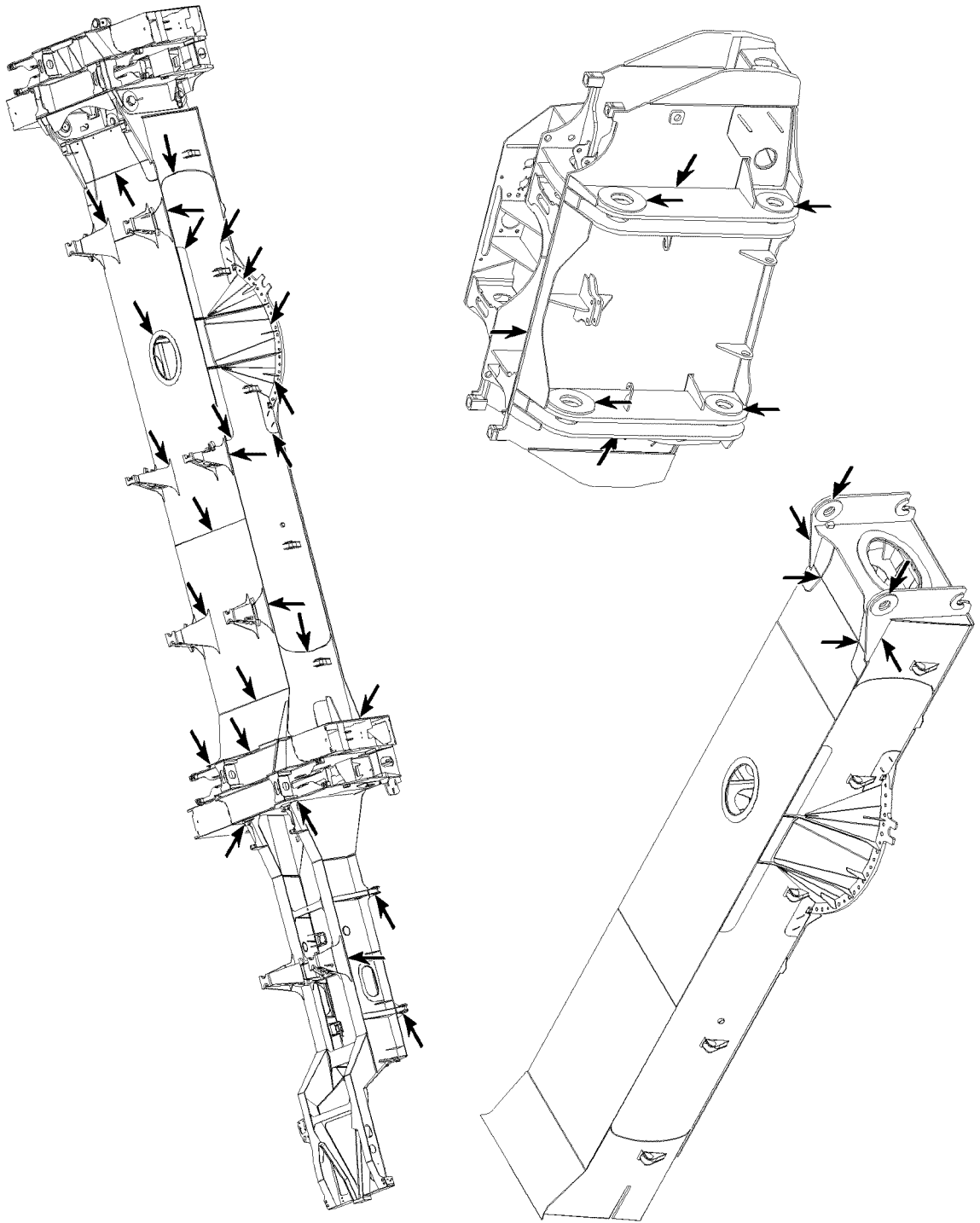
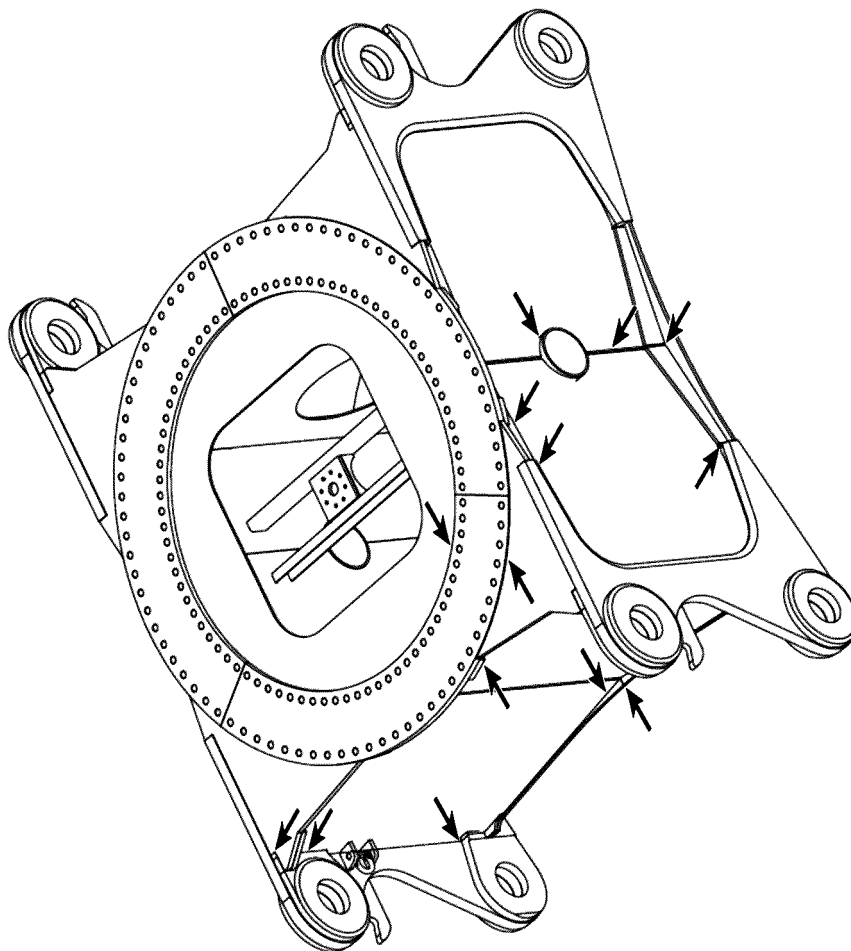


Fig.164854: Example of a vehicle frame

LWE/LR 1800-1-0-000/27200-07-02/en

**Crawler center section**

*Fig.164865: Example of a crawler center section*

LWE/LR 1800-1-0-000/27200-07-02/en

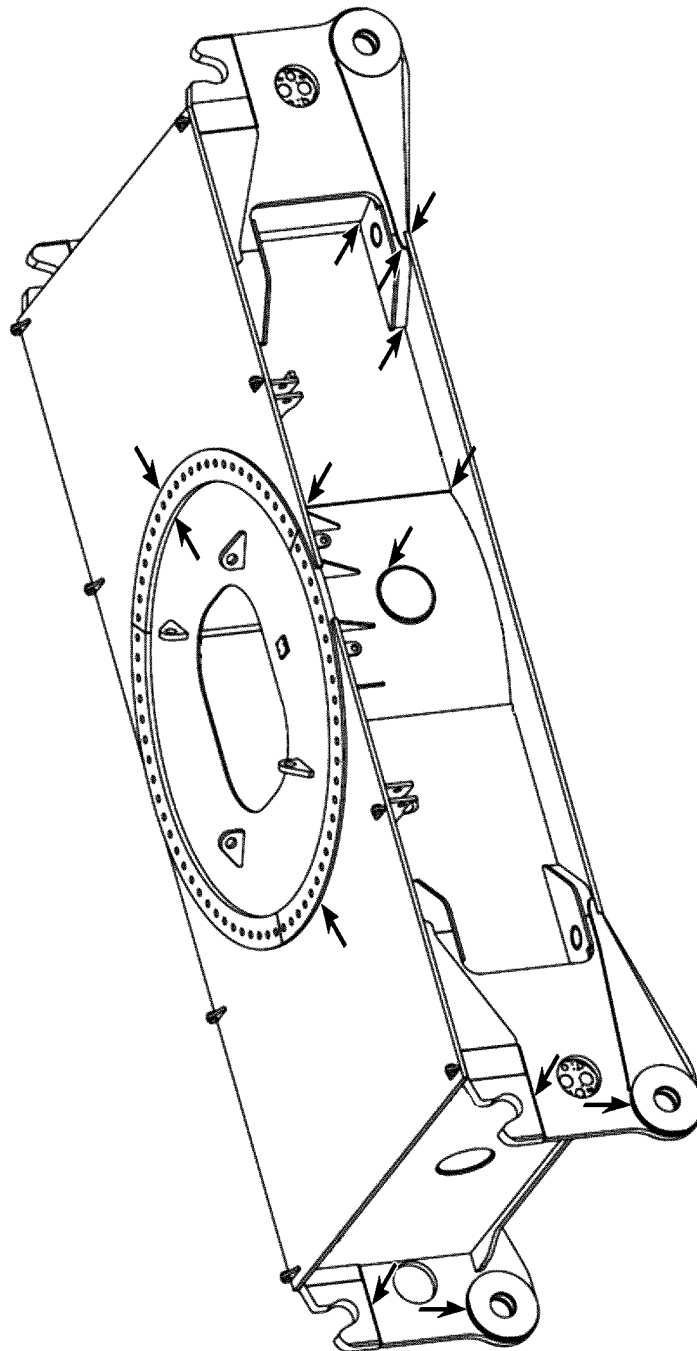


Fig.164866: Example of a crawler center section

LWE/LR 1800-1-0-000/27200-07-02/en

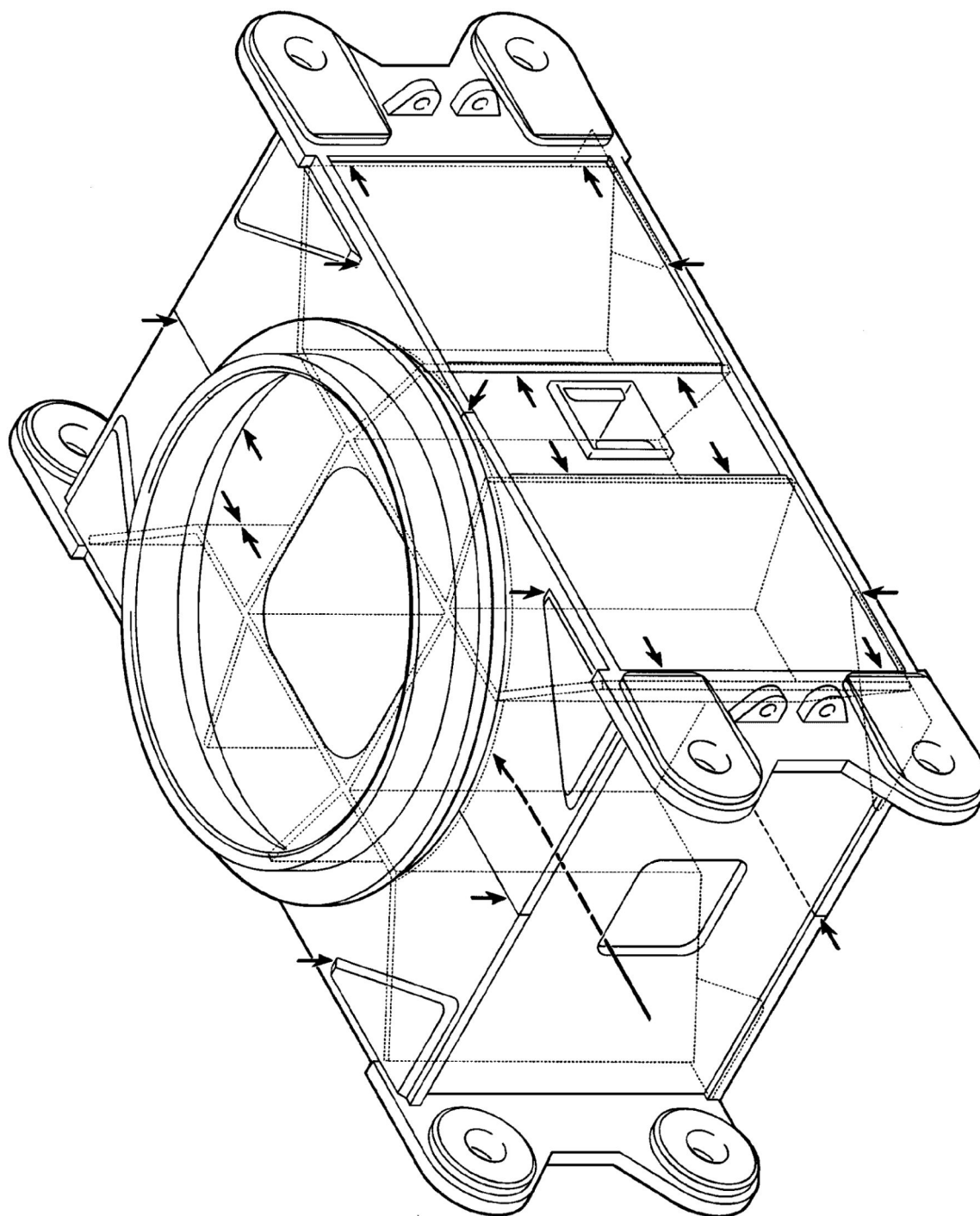


Fig.164867: Example of a crawler center section

LWE/LR 1800-1-0-000/27200-07-02/en



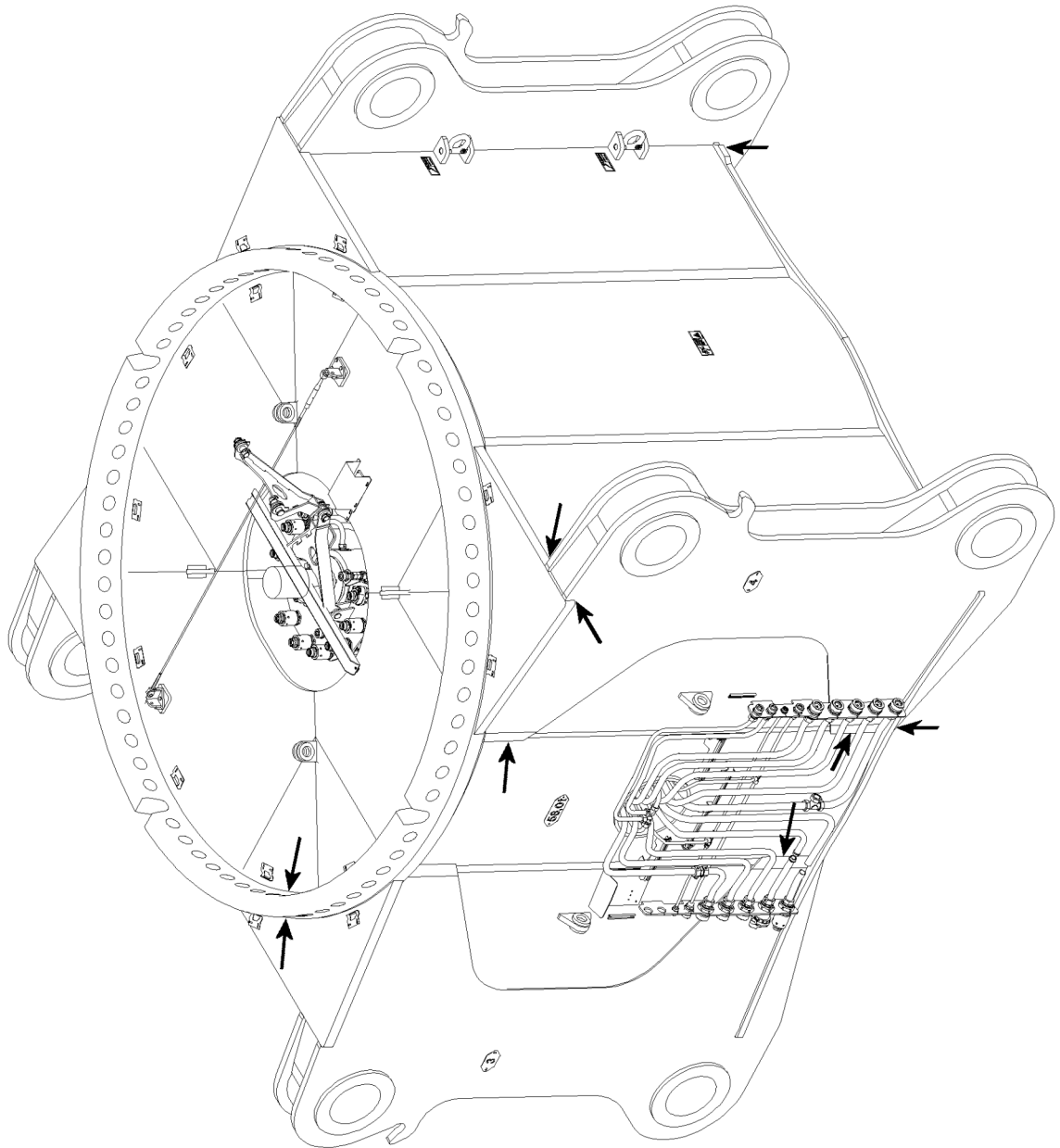


Fig.164868: Example of a crawler center section

LWE/LR 1800-1-0-000/27200-07-02/en

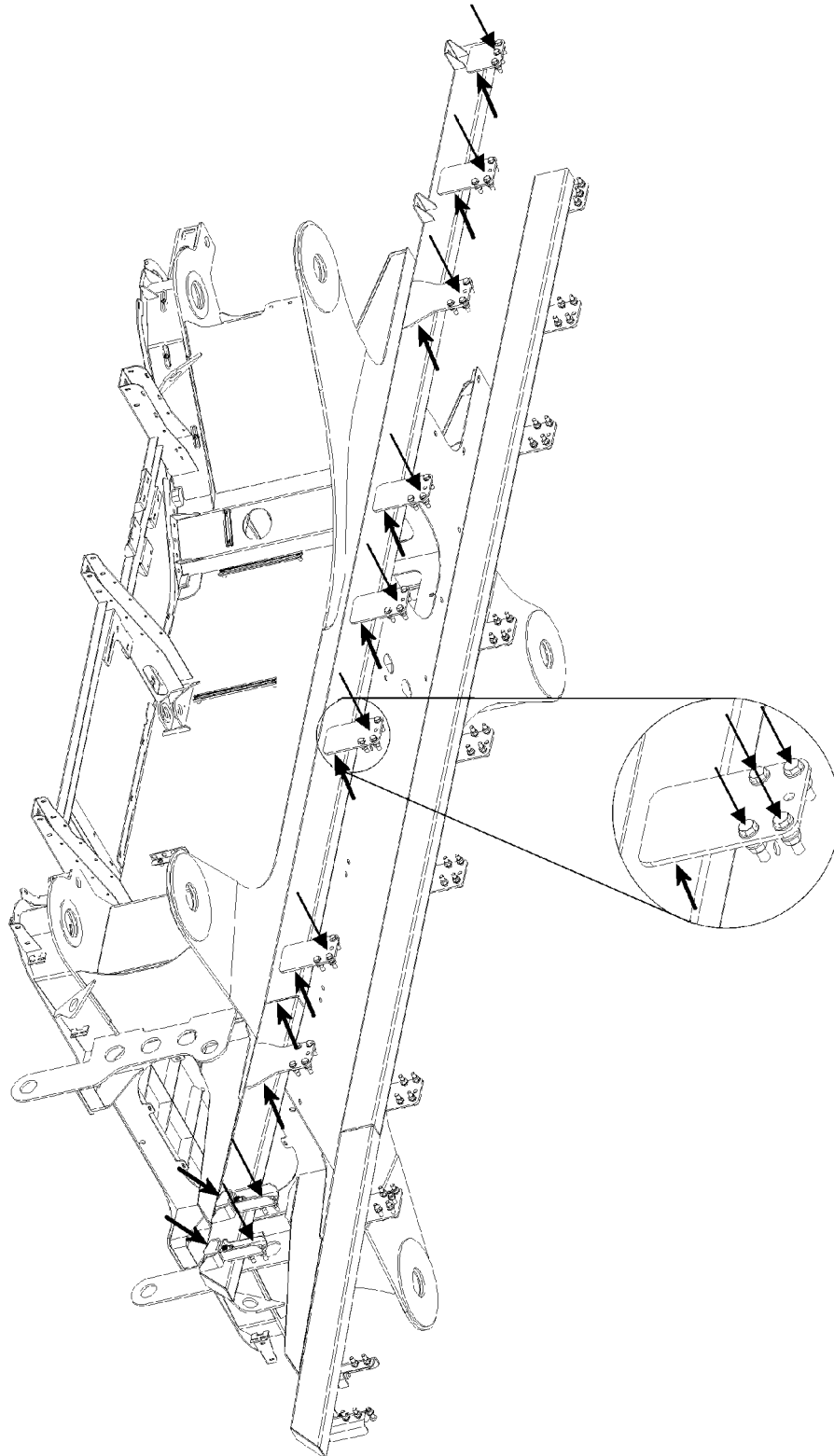
**Intermediate frame**

Fig.164856: Example of an intermediate frame

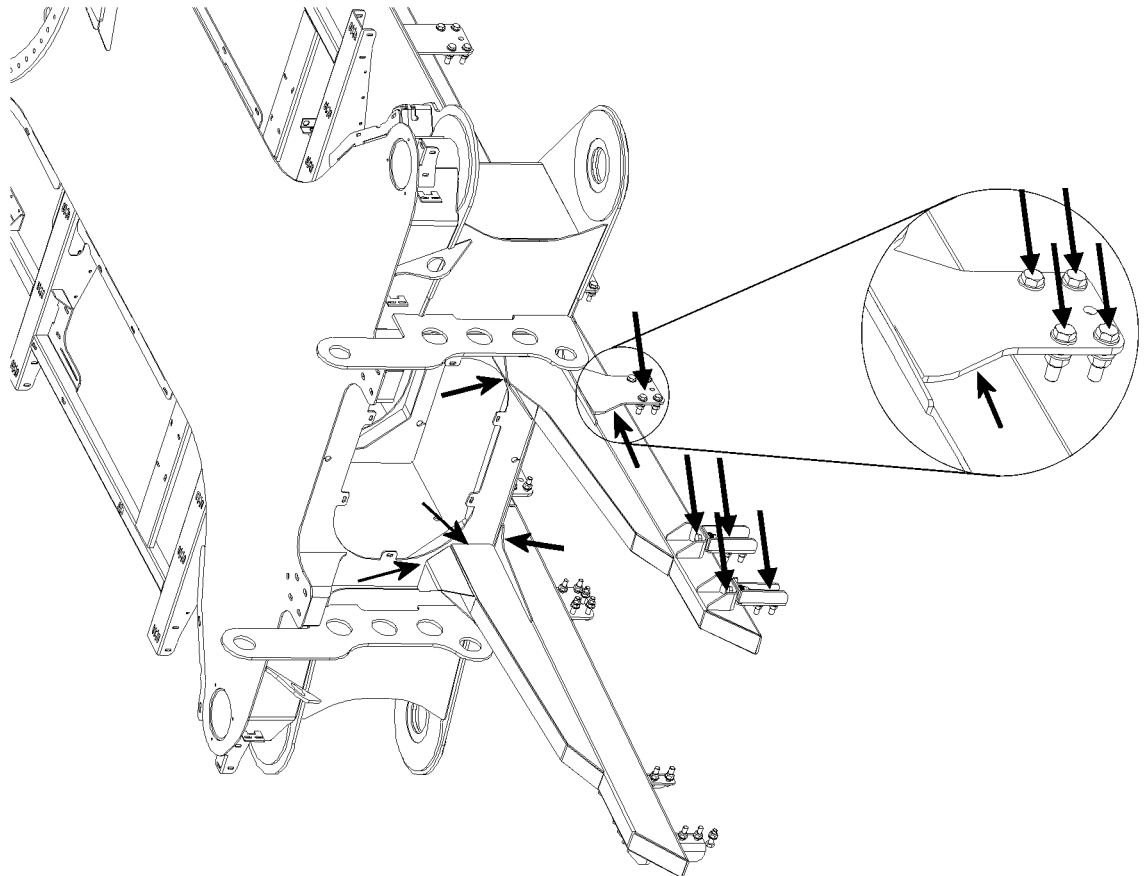


Fig.164857: Example of an intermediate frame

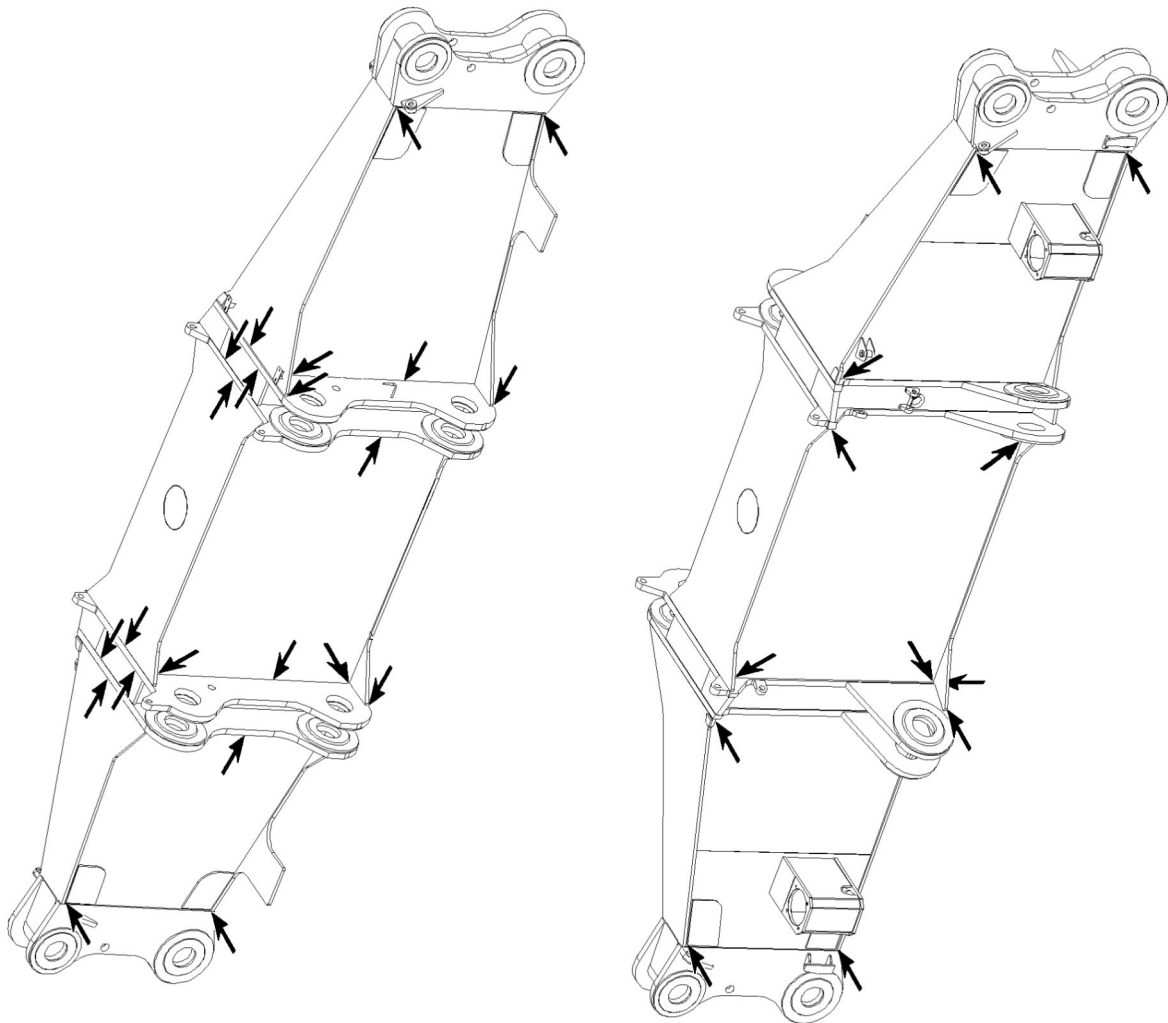
**Cross carrier**

Fig.164869: Example of a cross carrier

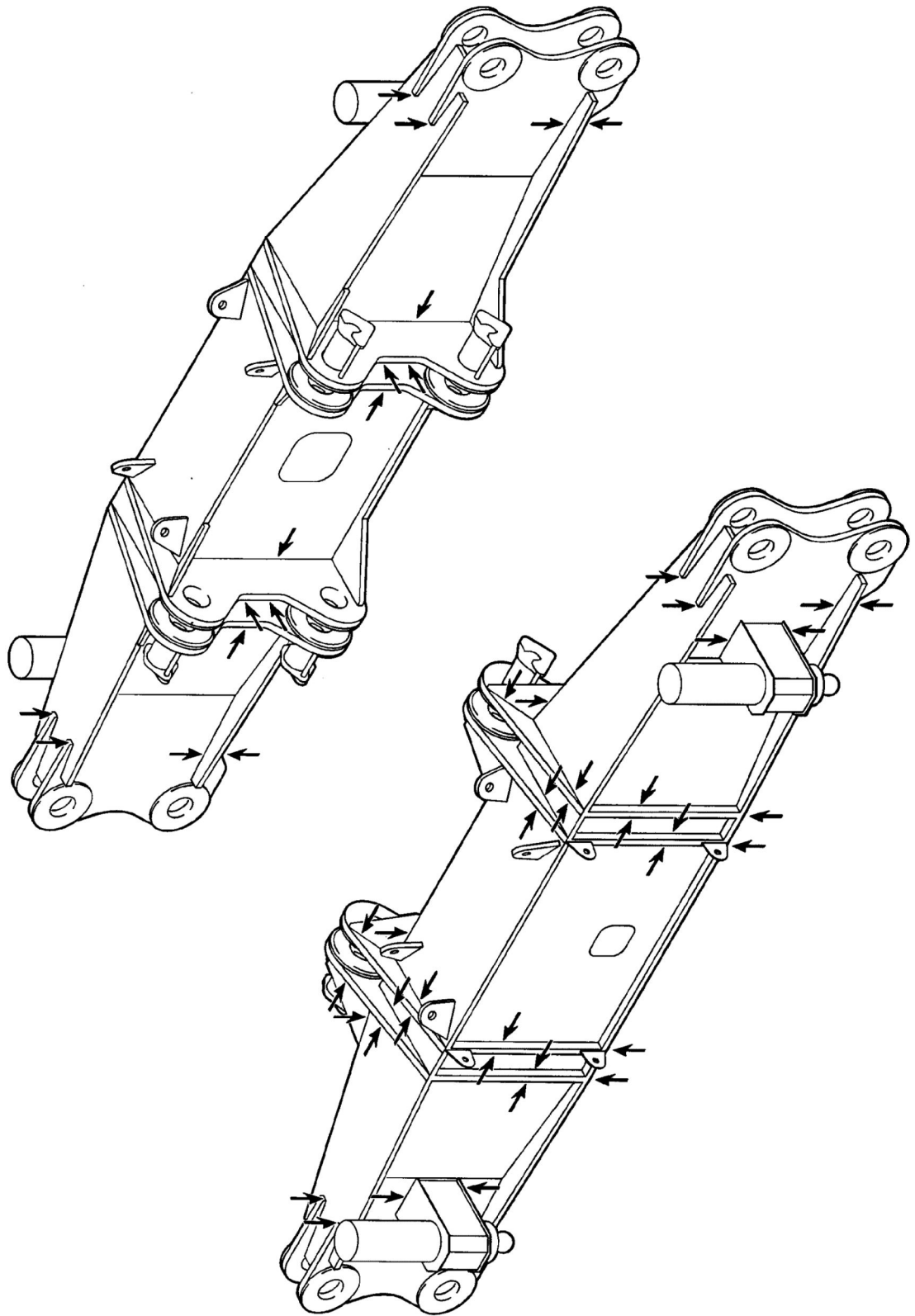


Fig.164870: Example of a cross carrier

LWE/LR 1800-1-0-000/27200-07-02/en

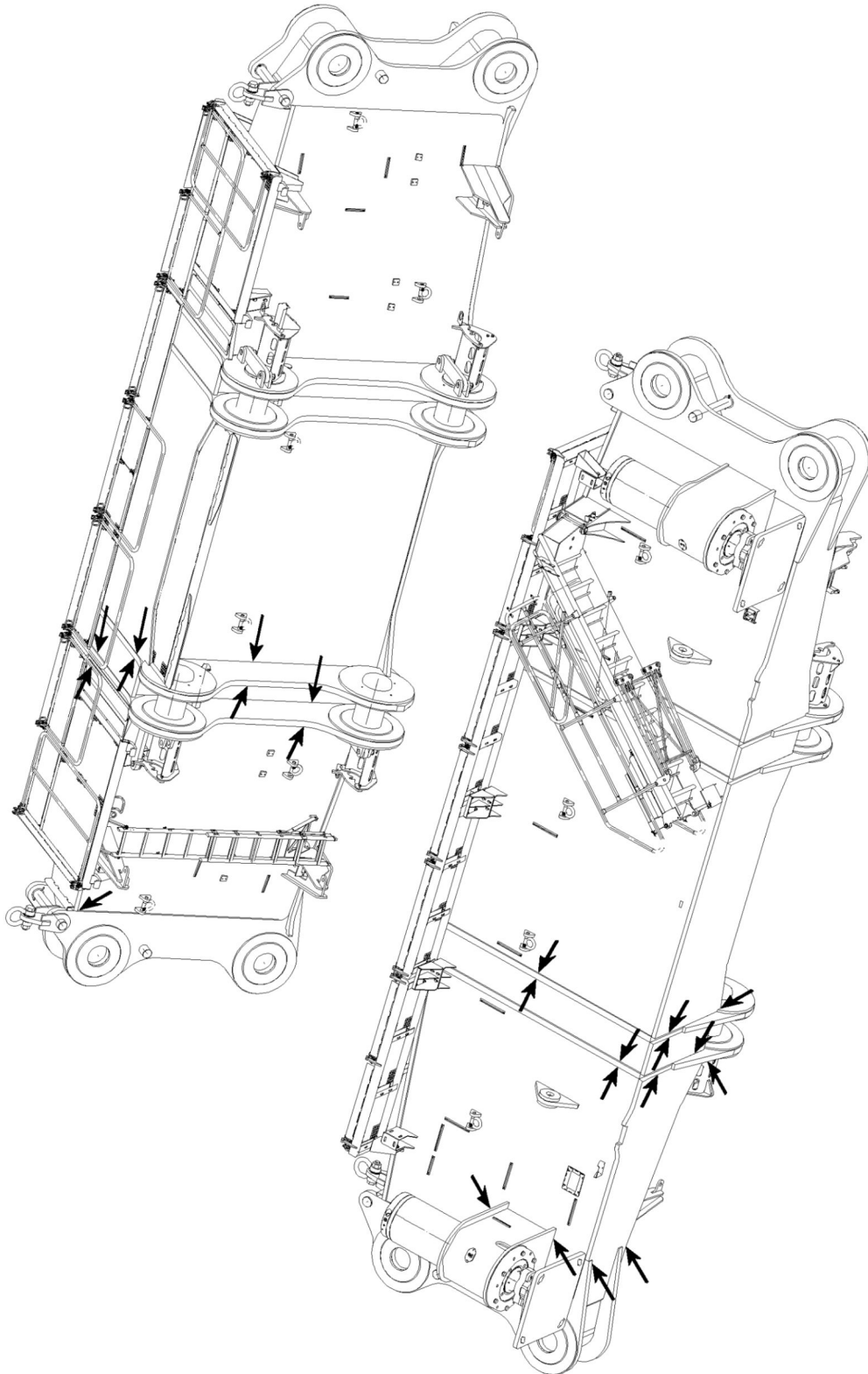


Fig.164871: Example of a cross carrier

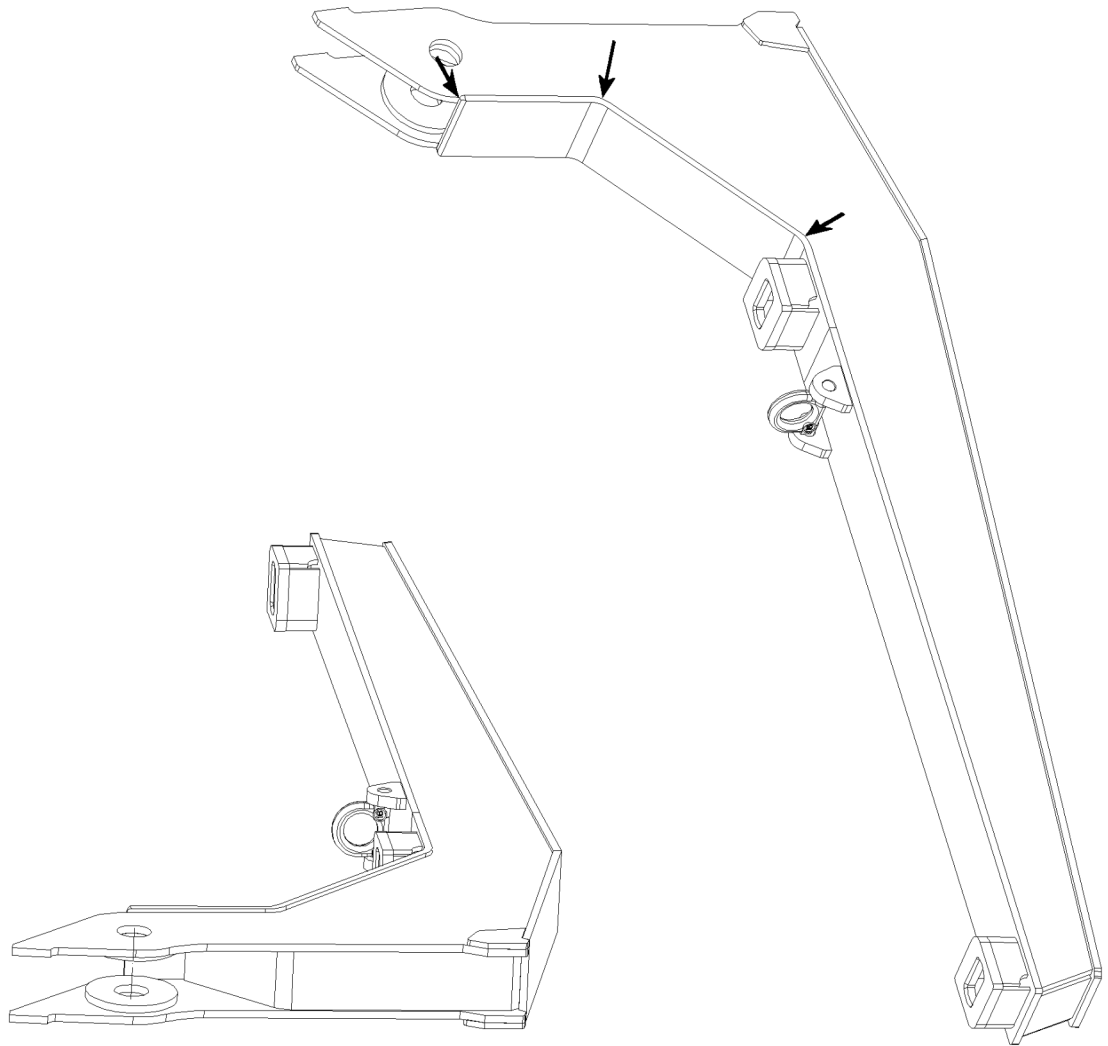
**Carrier for central ballast**

Fig.164872: Example of carrier for central ballast

LWE/LR 1800-1-0-000/27200-07-02/en

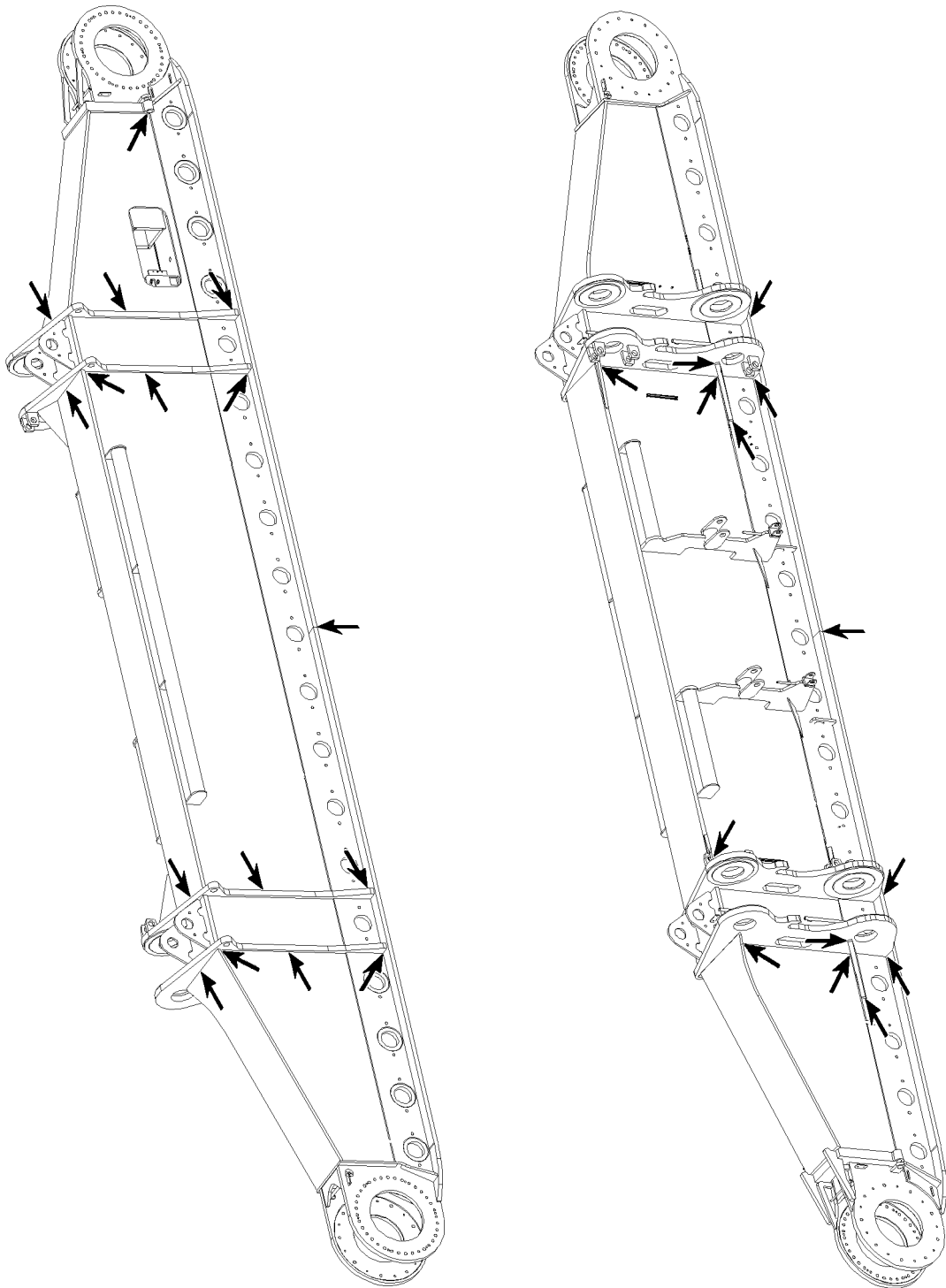
**Crawler carrier**

Fig.164873: Example of a crawler carrier



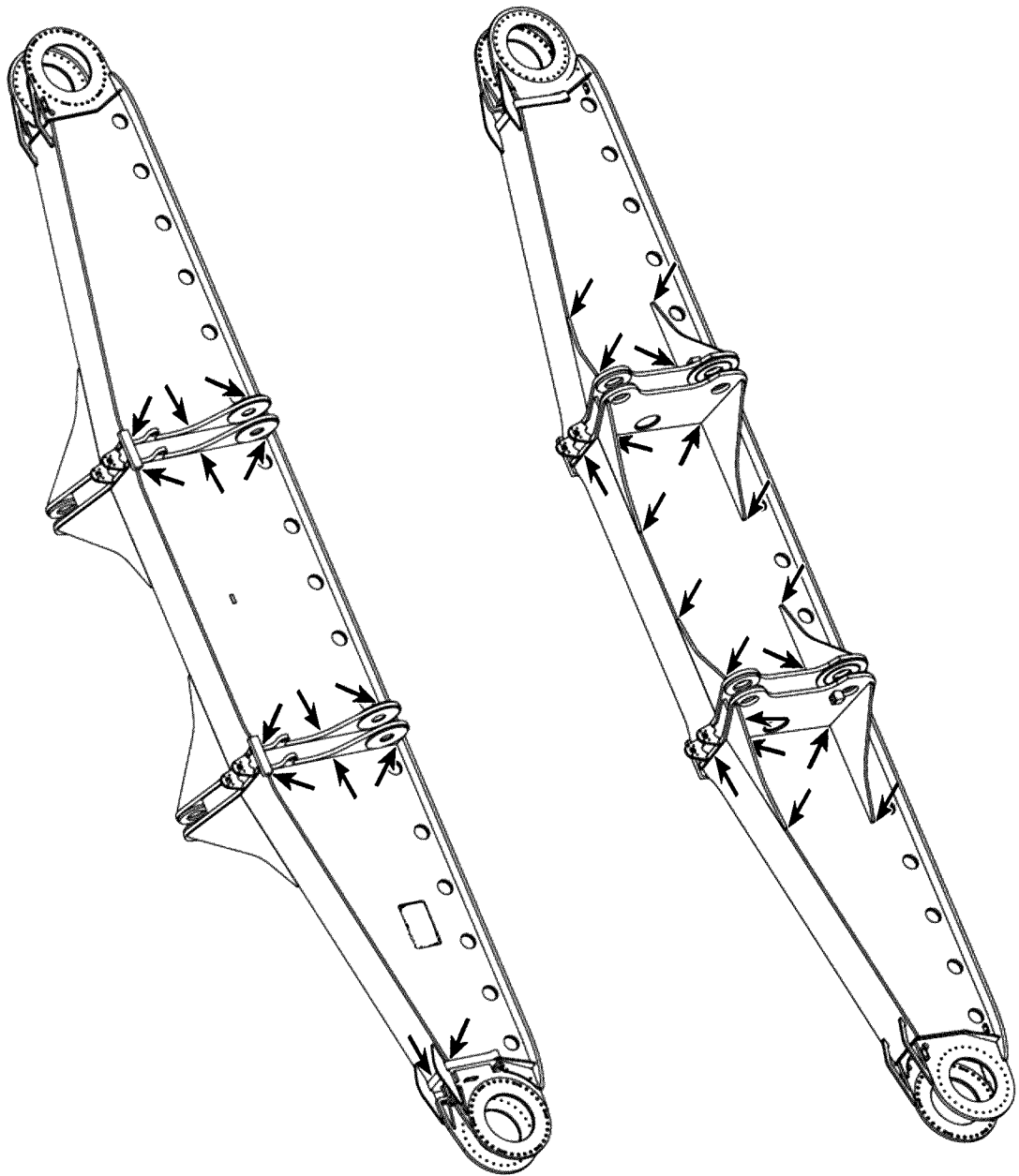


Fig.164874: Example of a crawler carrier

LWE/LR 1800-1-0-000/27200-07-02/en

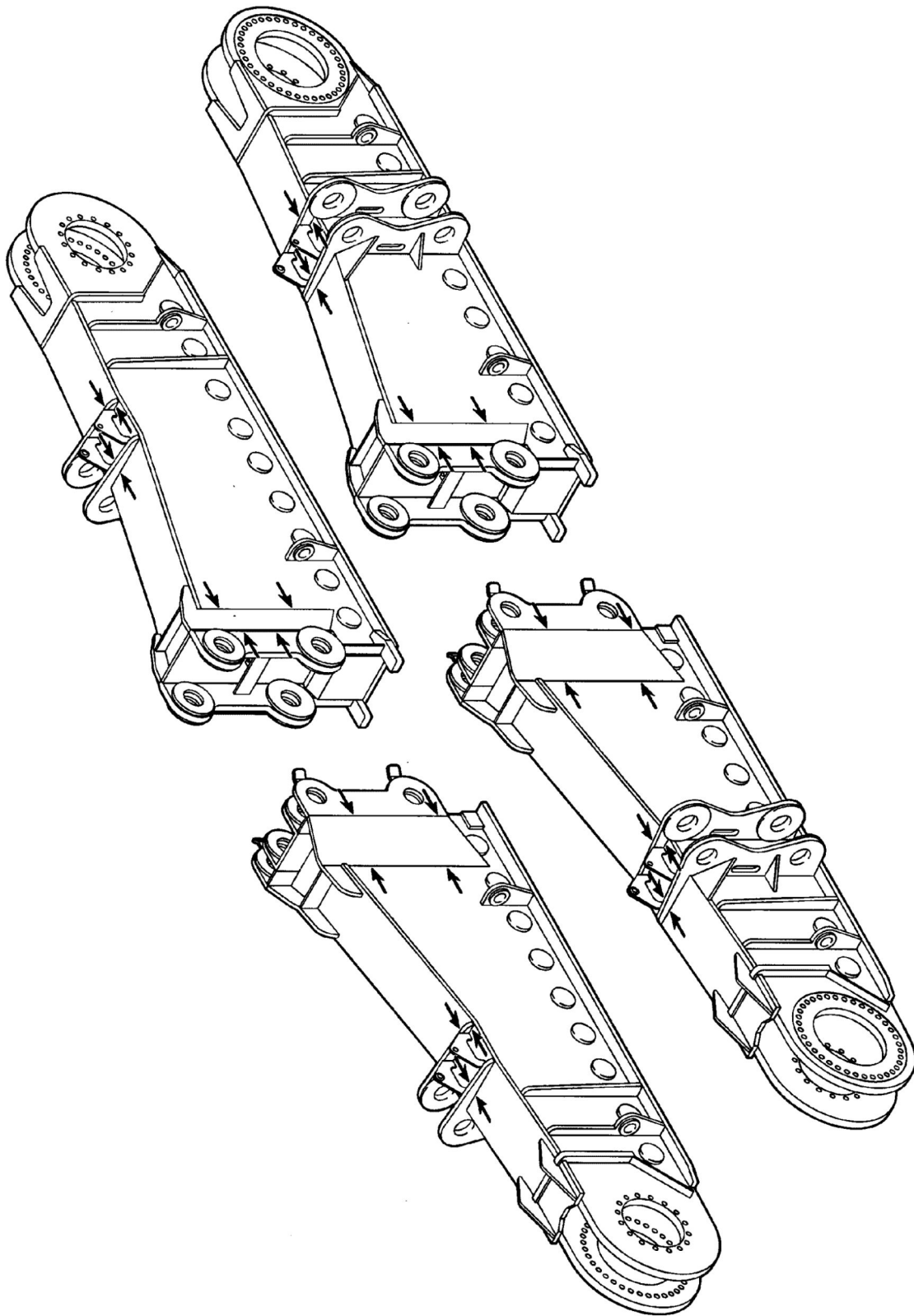


Fig.164875: Example of a crawler carrier

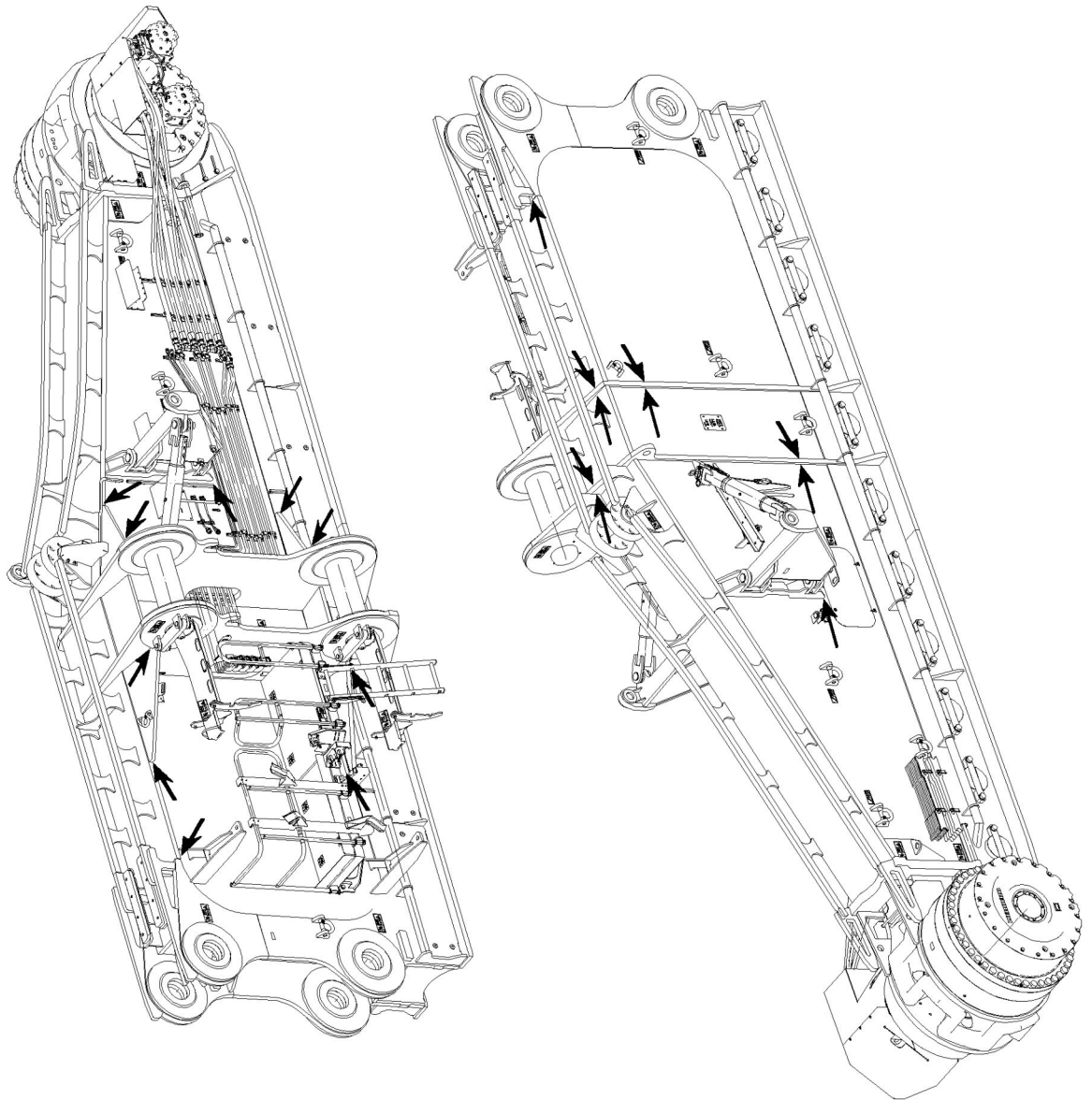


Fig.164876: Example of a crawler carrier

LWE/LR 1800-1-0-000/27200-07-02/en

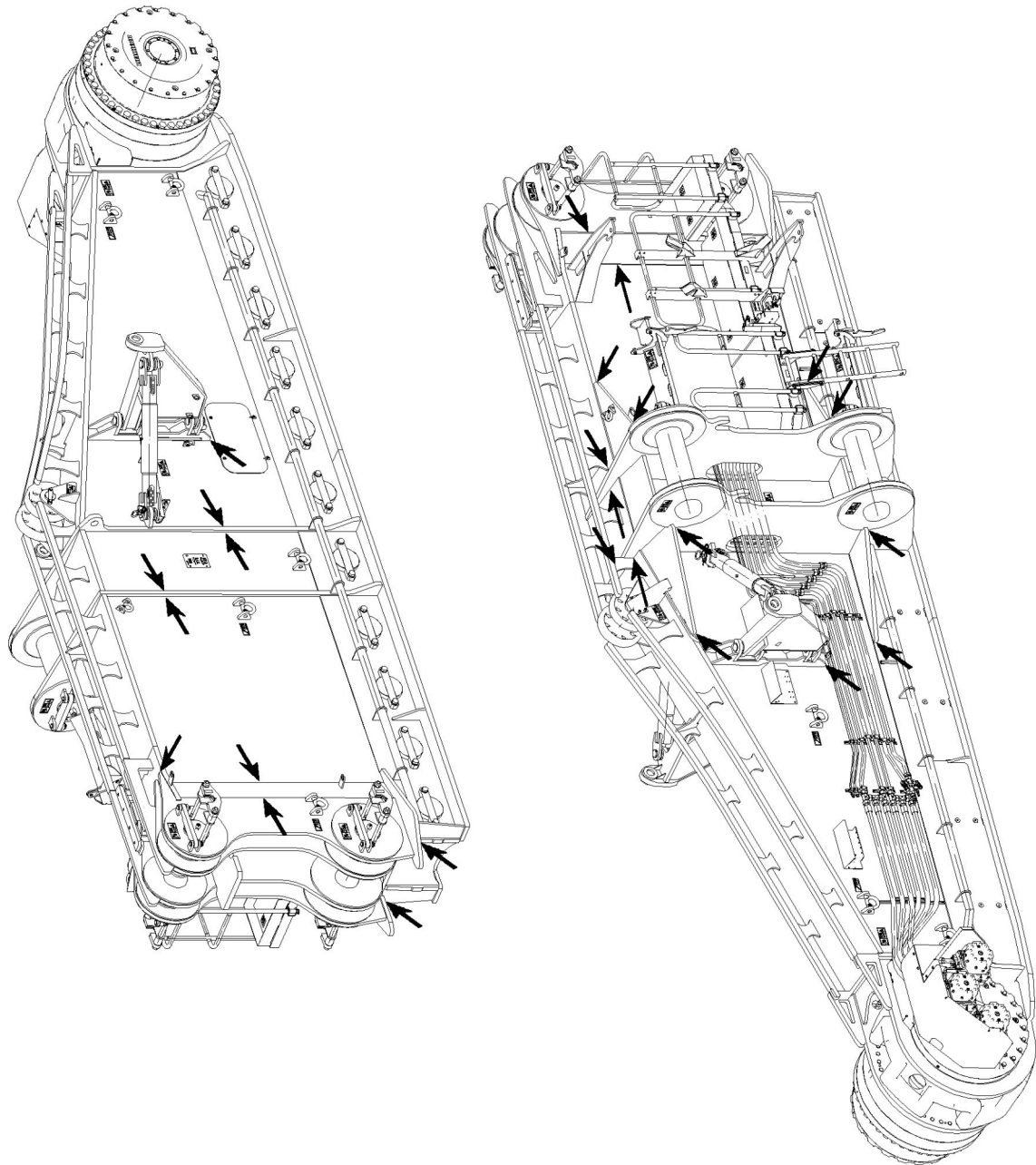
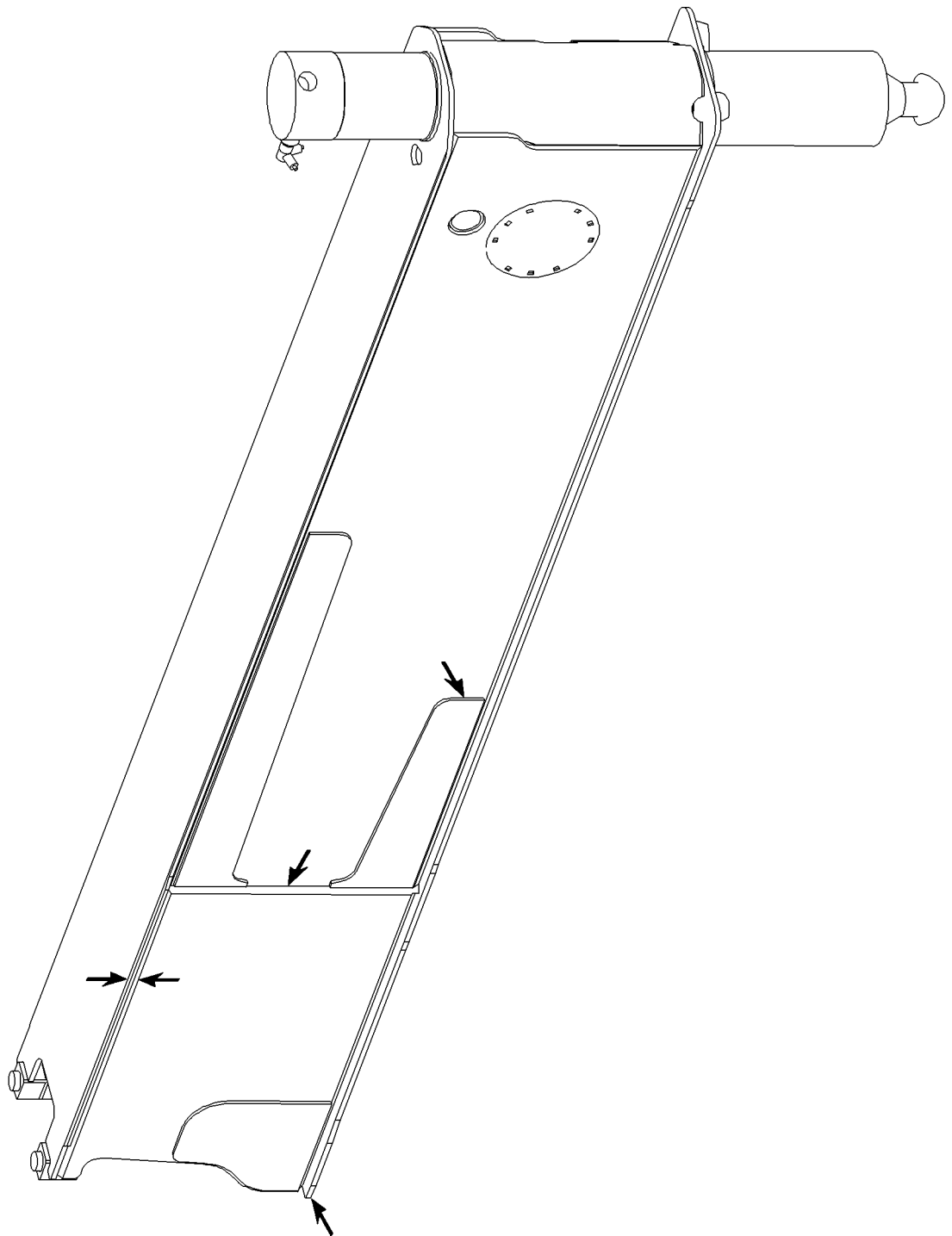


Fig.164877: Example of a crawler carrier

**Sliding beam**



LWE/LR 1800-1-0-000/27200-07-02/en

*Fig.164858: Example of a sliding beam*

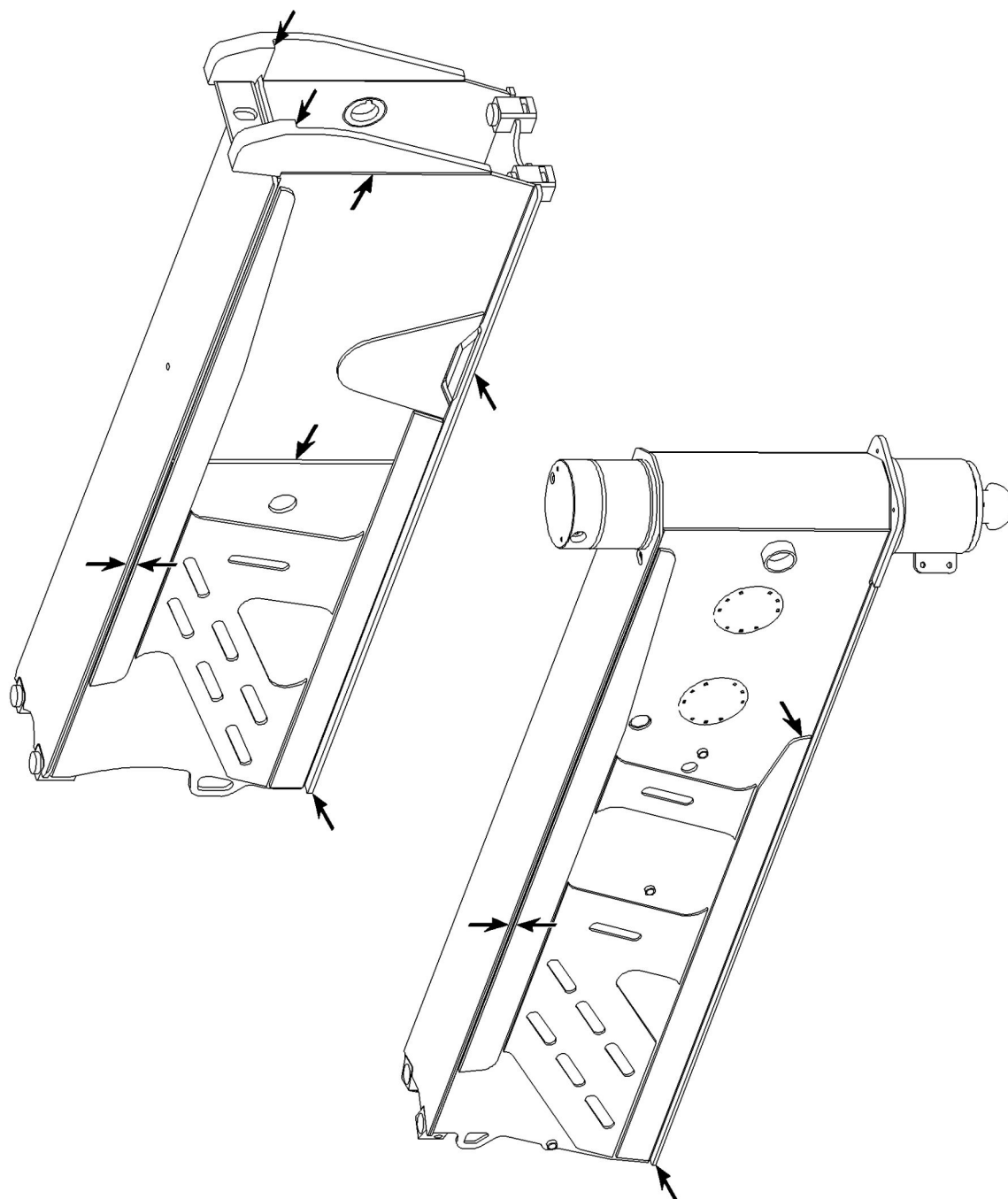


Fig.164859: Example of a sliding beam

LWE/LR 1800-1-0-000/27200-07-02/en

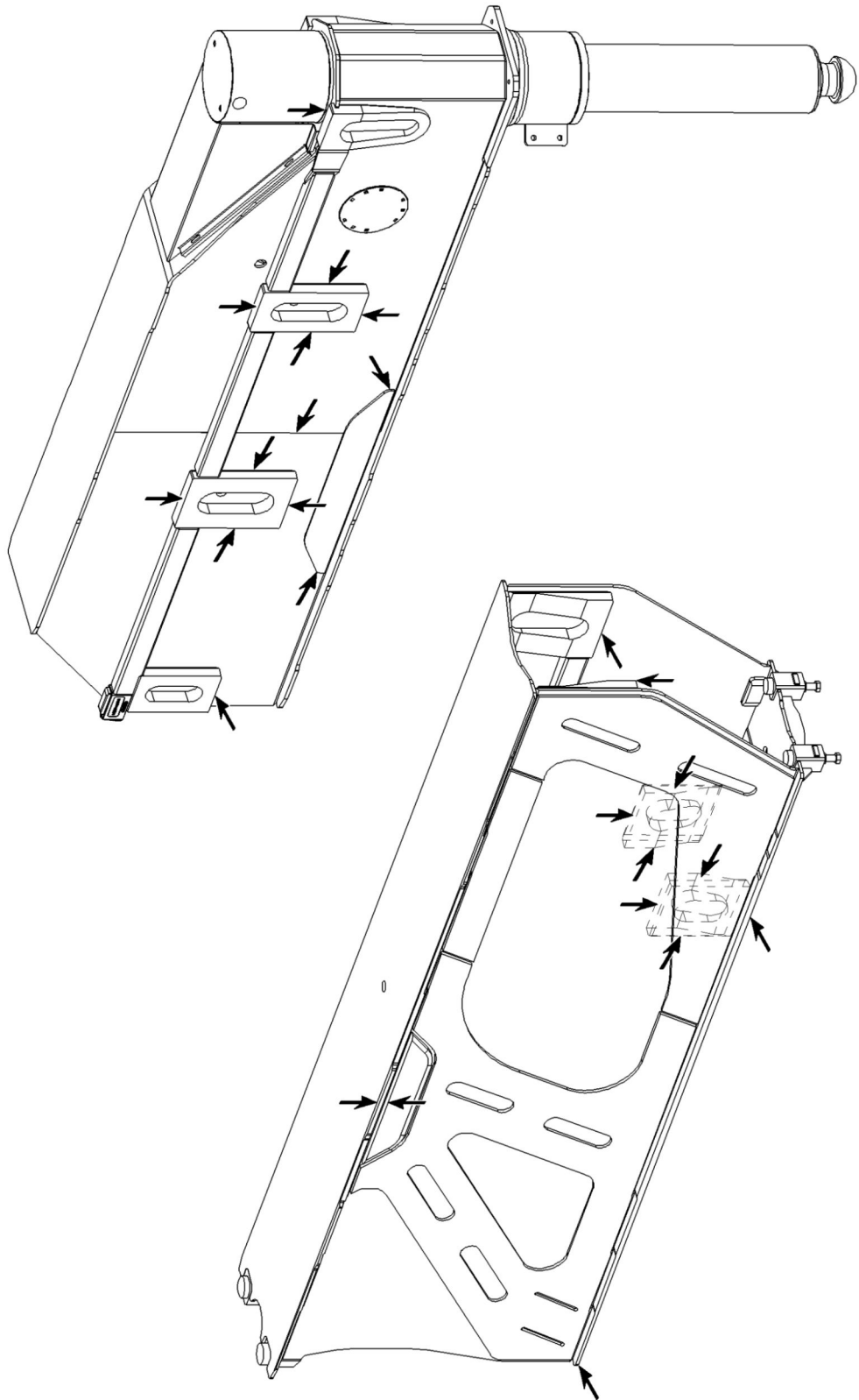


Fig.164860: Example of a sliding beam

LWE/LR 1800-1-0-000/27200-07-02/en

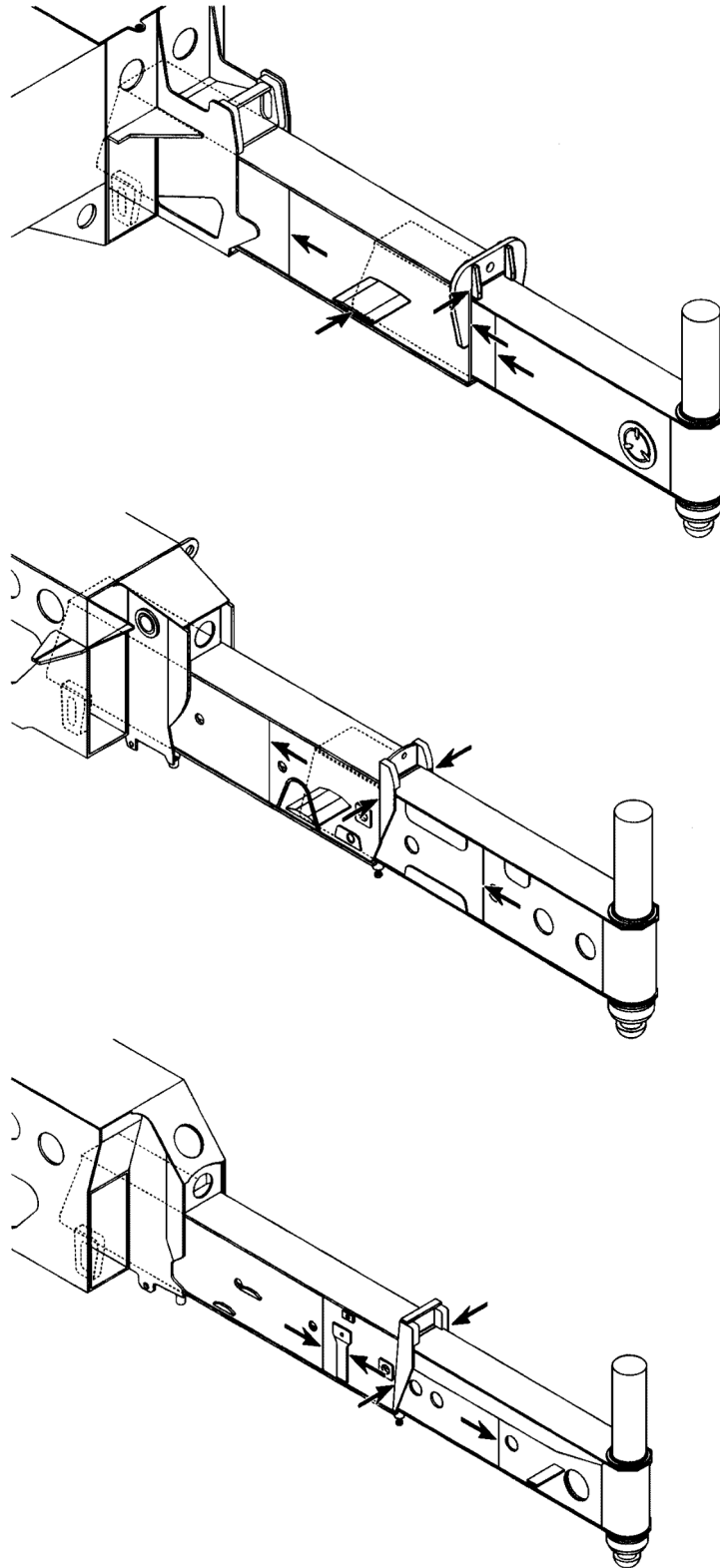
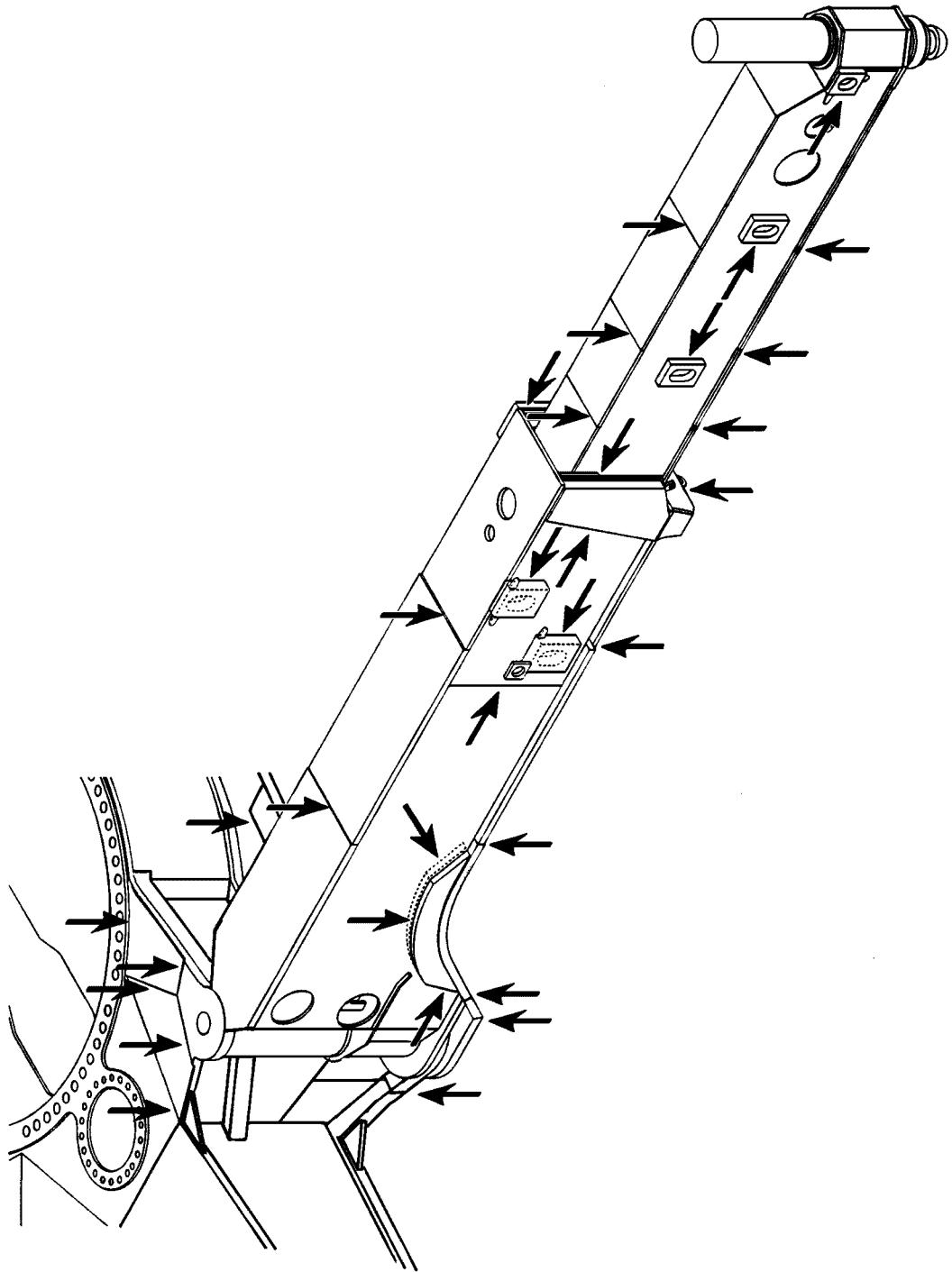


Fig.164861: Example of a sliding beam



**Swingable sliding beam**



*Fig.164862: Example of a swinging sliding beam*

LWE/LR 1800-1-0-000/27200-07-02/en

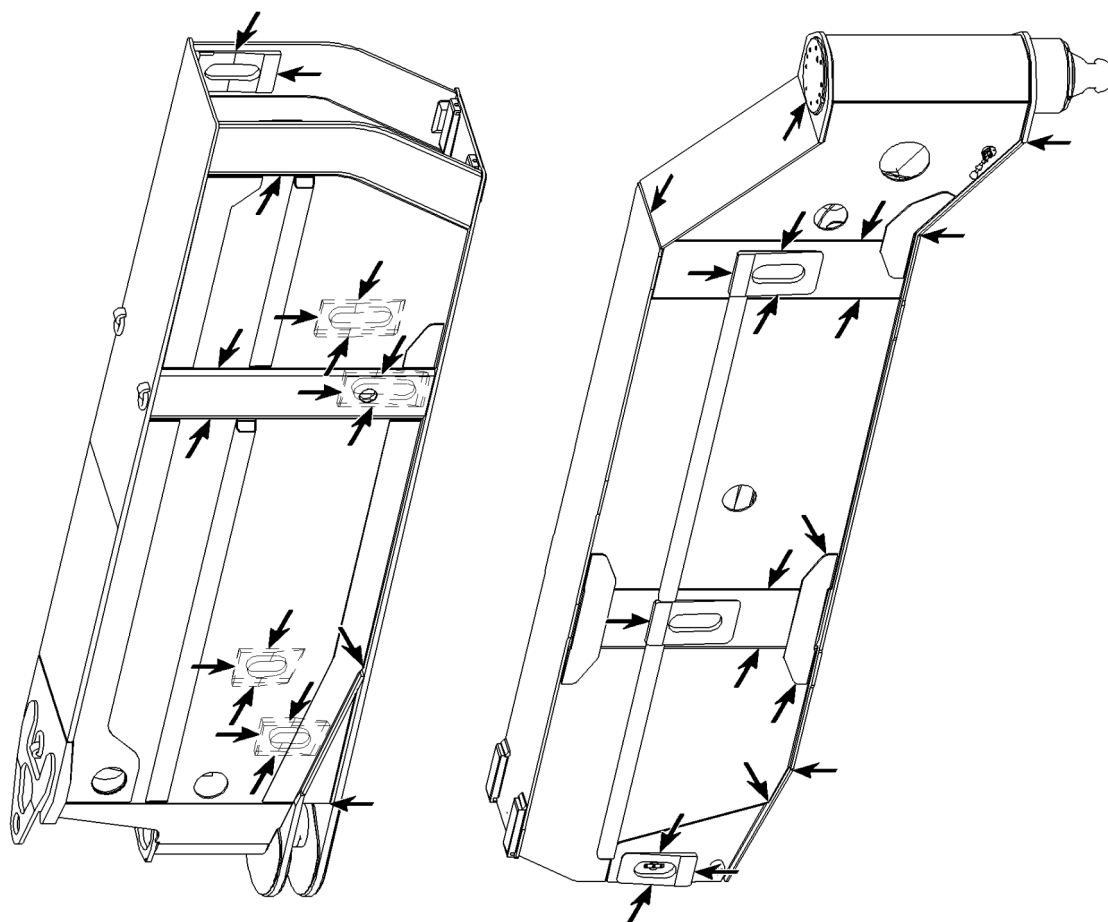


Fig.164863: Example of a swinging sliding beam

LWE/LR 1800-1-0-000/27200-07-02/en

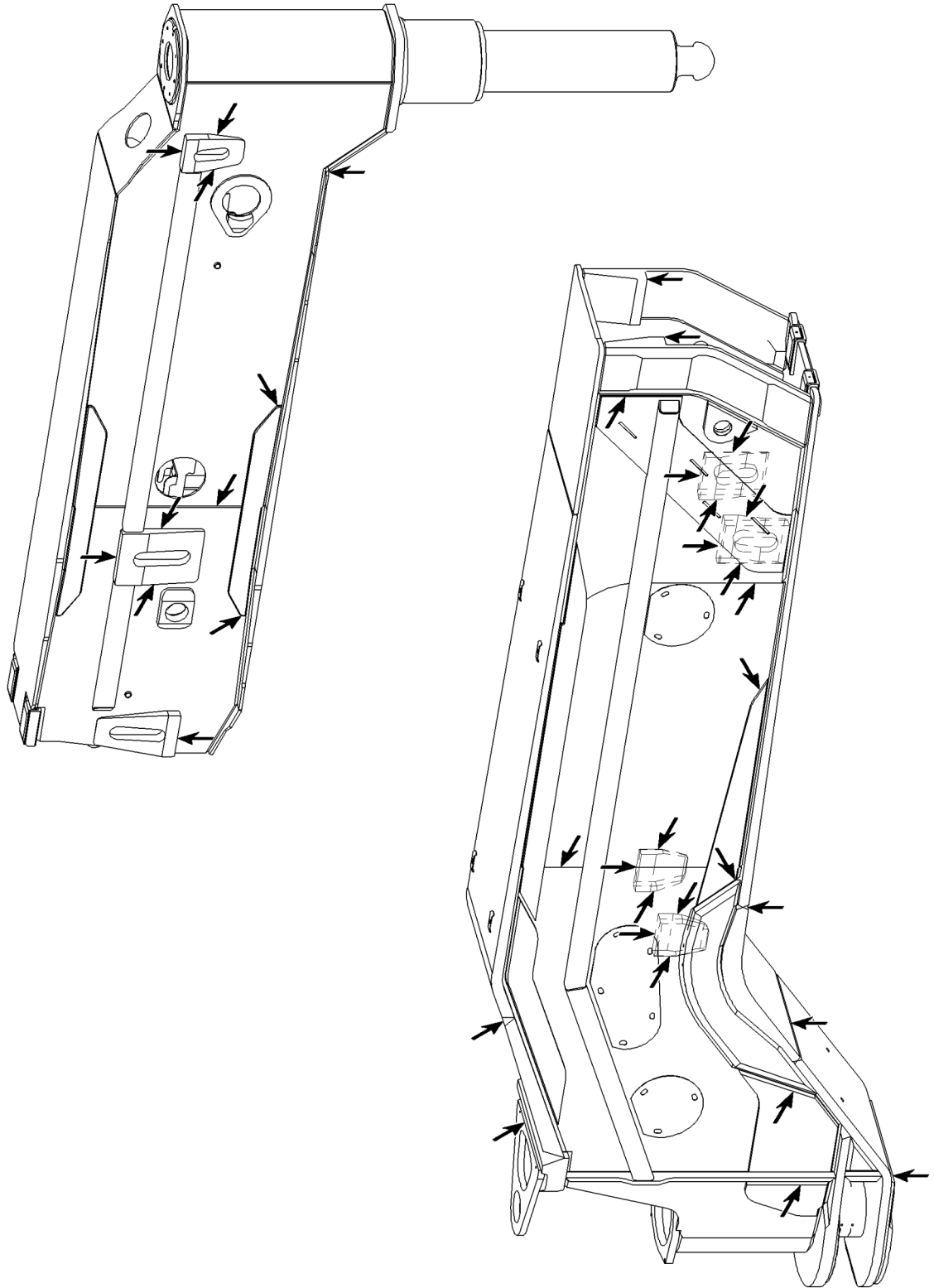


Fig.164864: Example of a swinging sliding beam

LWE/LR 1800-1-0-000/27200-07-02/en

## Disk wheels

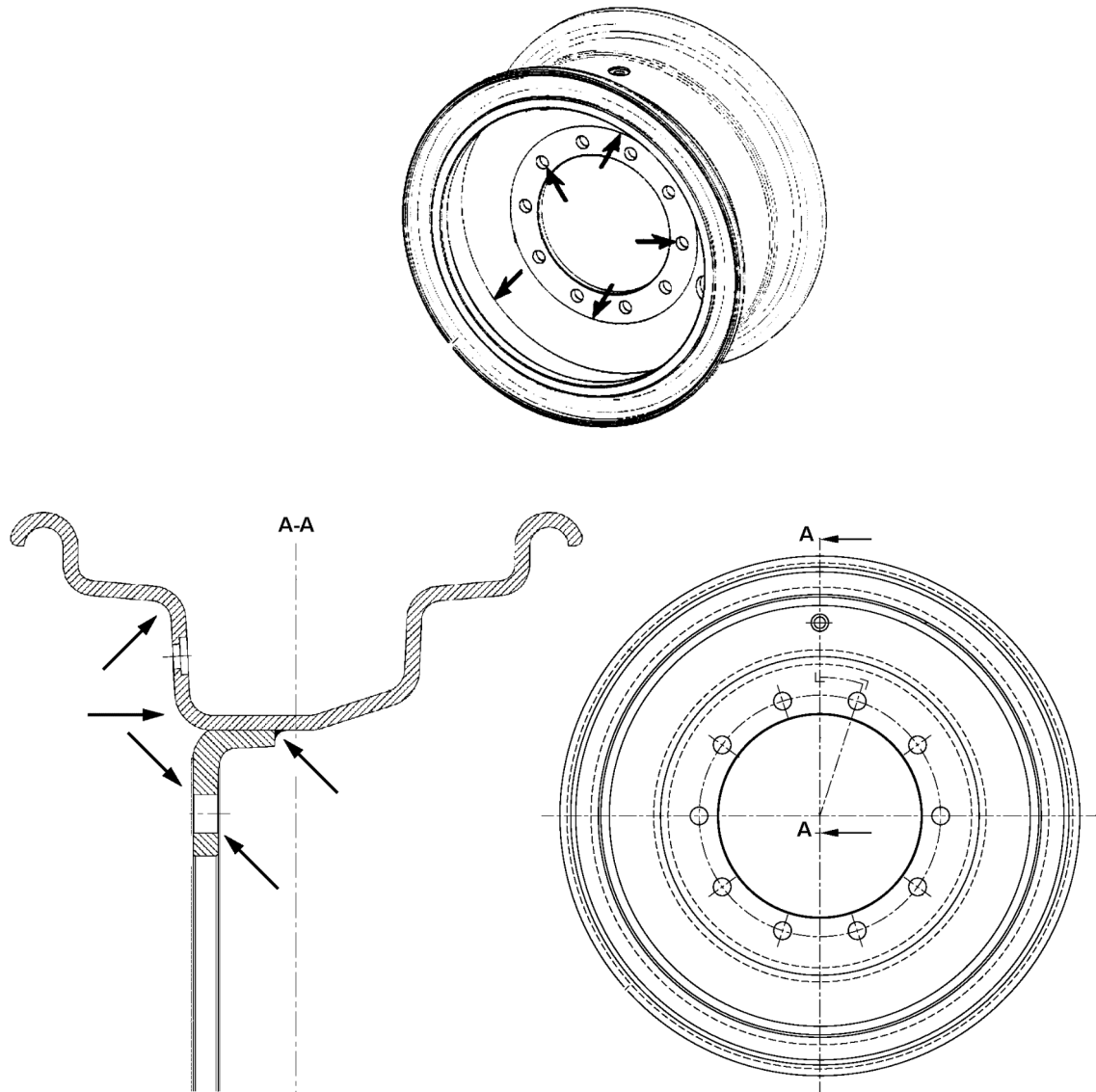


Fig.164850: Example of a 1-part disk wheel

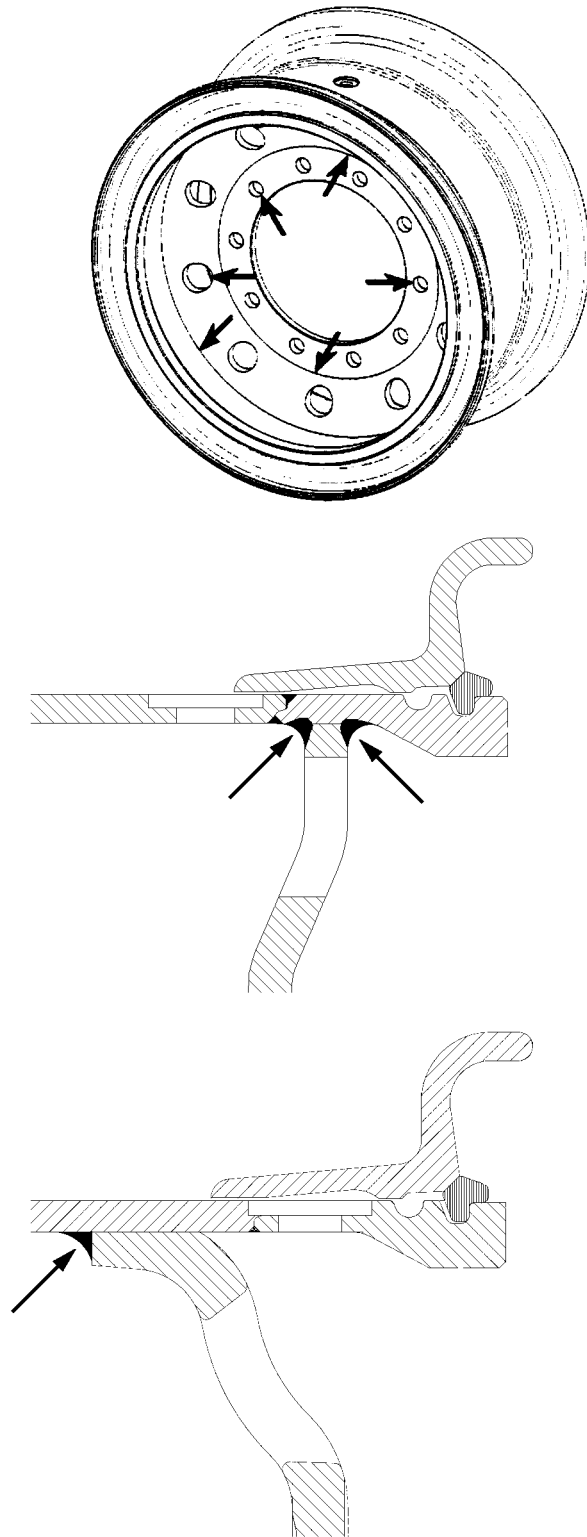
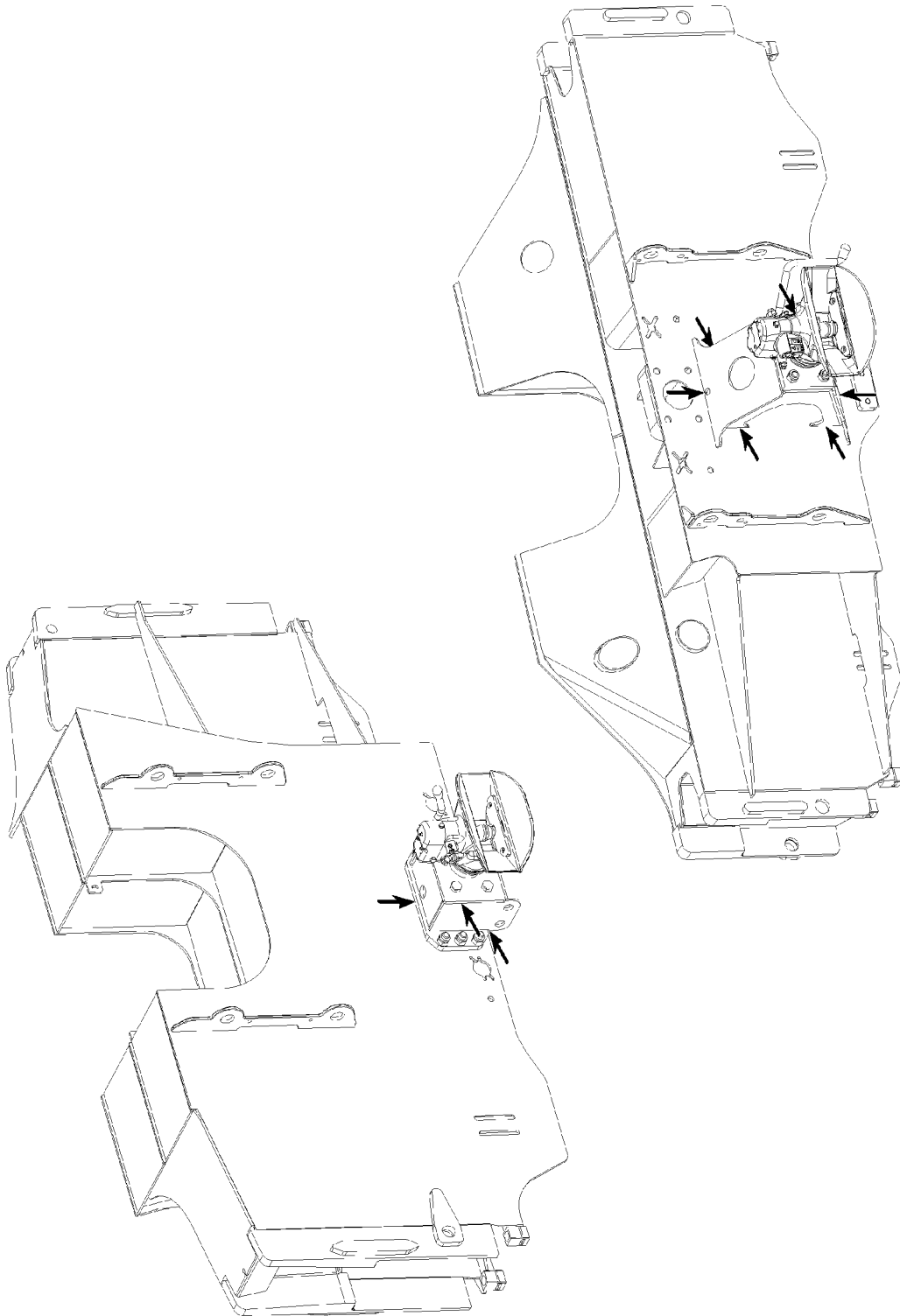


Fig.164851: Example of a 3-part disk wheel

LWE/LR 1800-1-0-000/27200-07-02/en

**Trailer coupling**

*Fig.164855: Example of a trailer coupling*

## 2.4.2 Crane superstructure

### Turntable frame

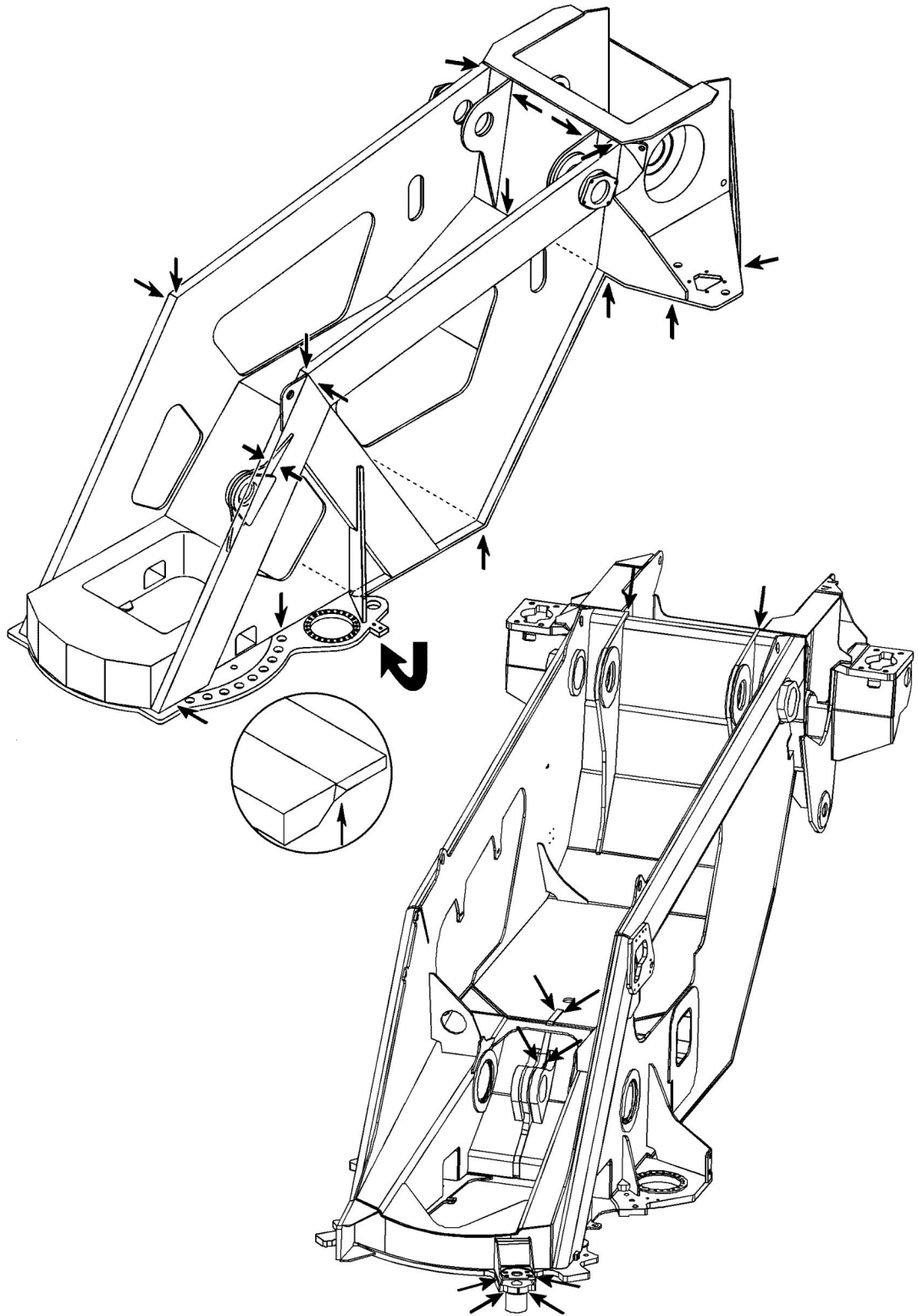


Fig.164878: Example of a turntable frame

LWE/LR 1800-1-0-000/27200-07-02/en

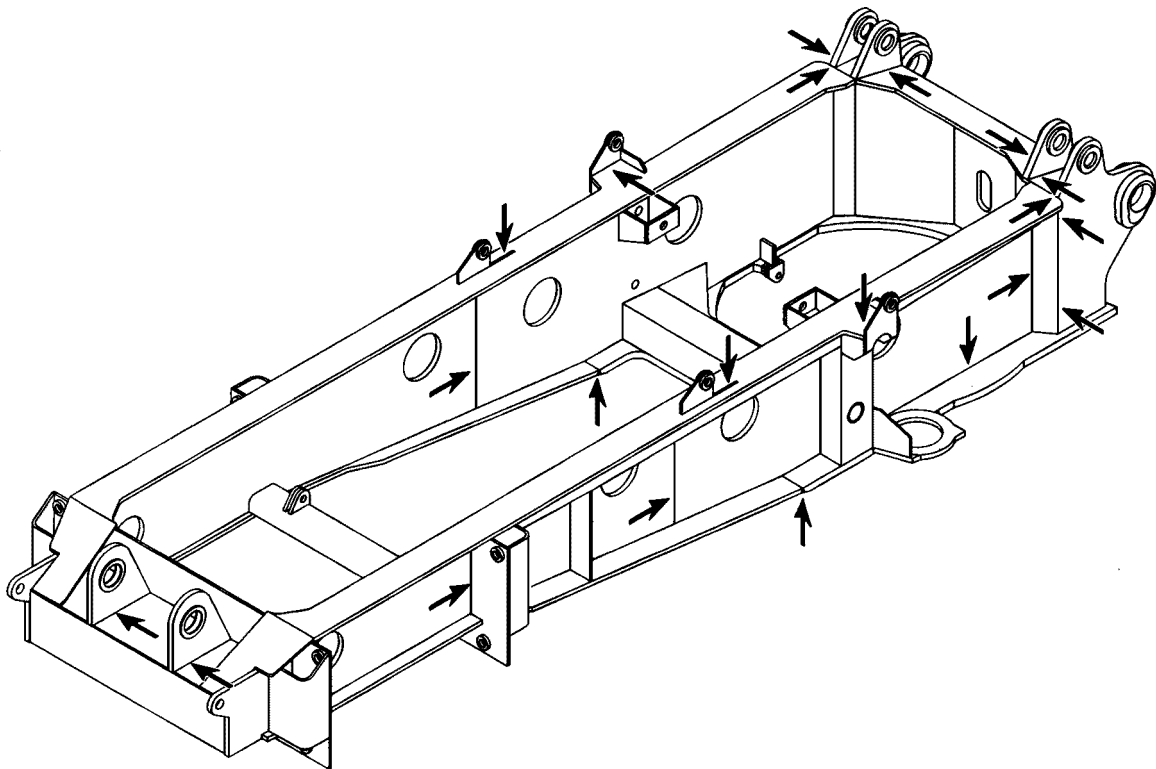


Fig.164879: Example of a turntable frame



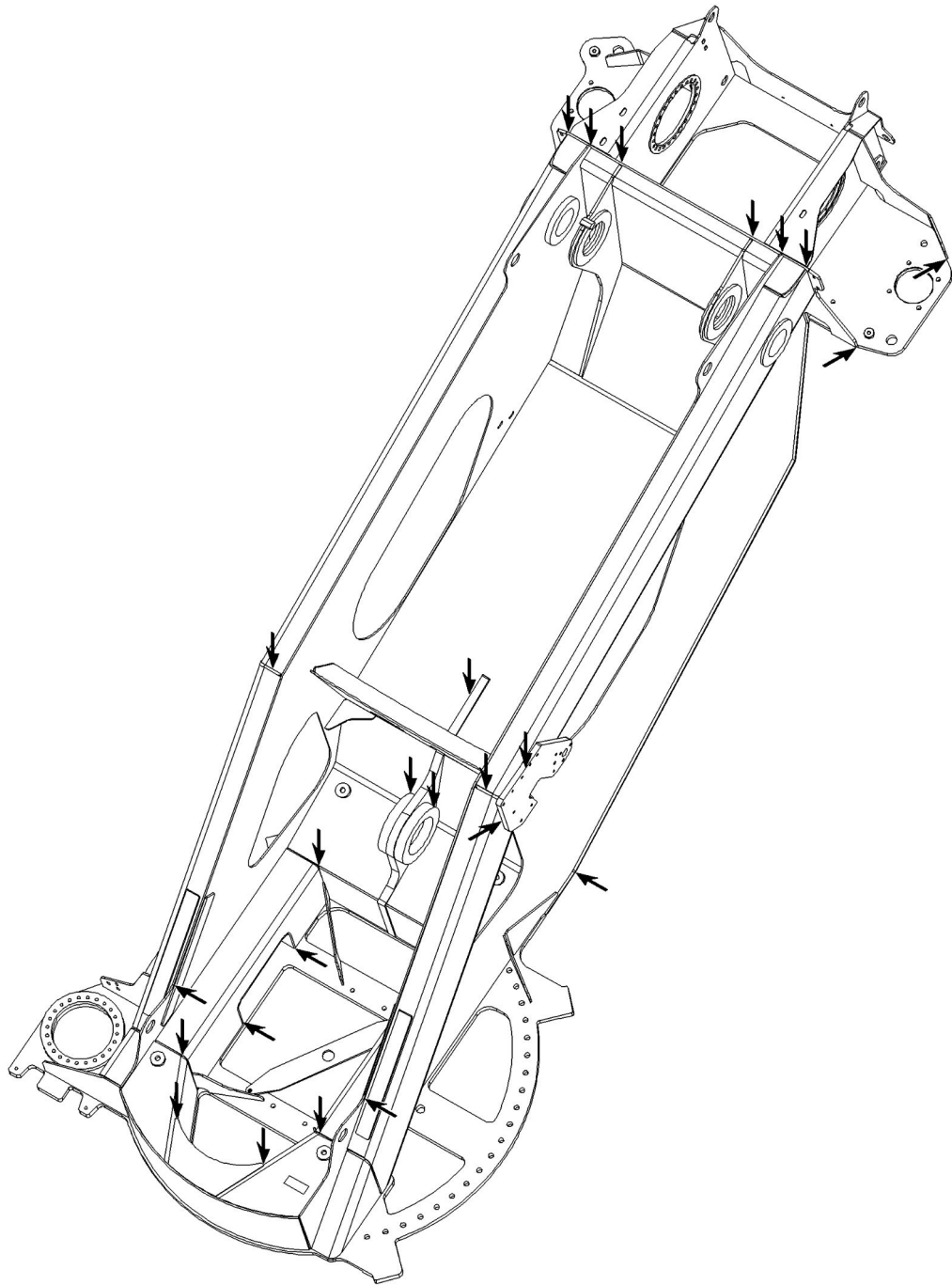


Fig.164880: Example of a turntable frame

LWE/LR 1800-1-0-000/27200-07-02/en

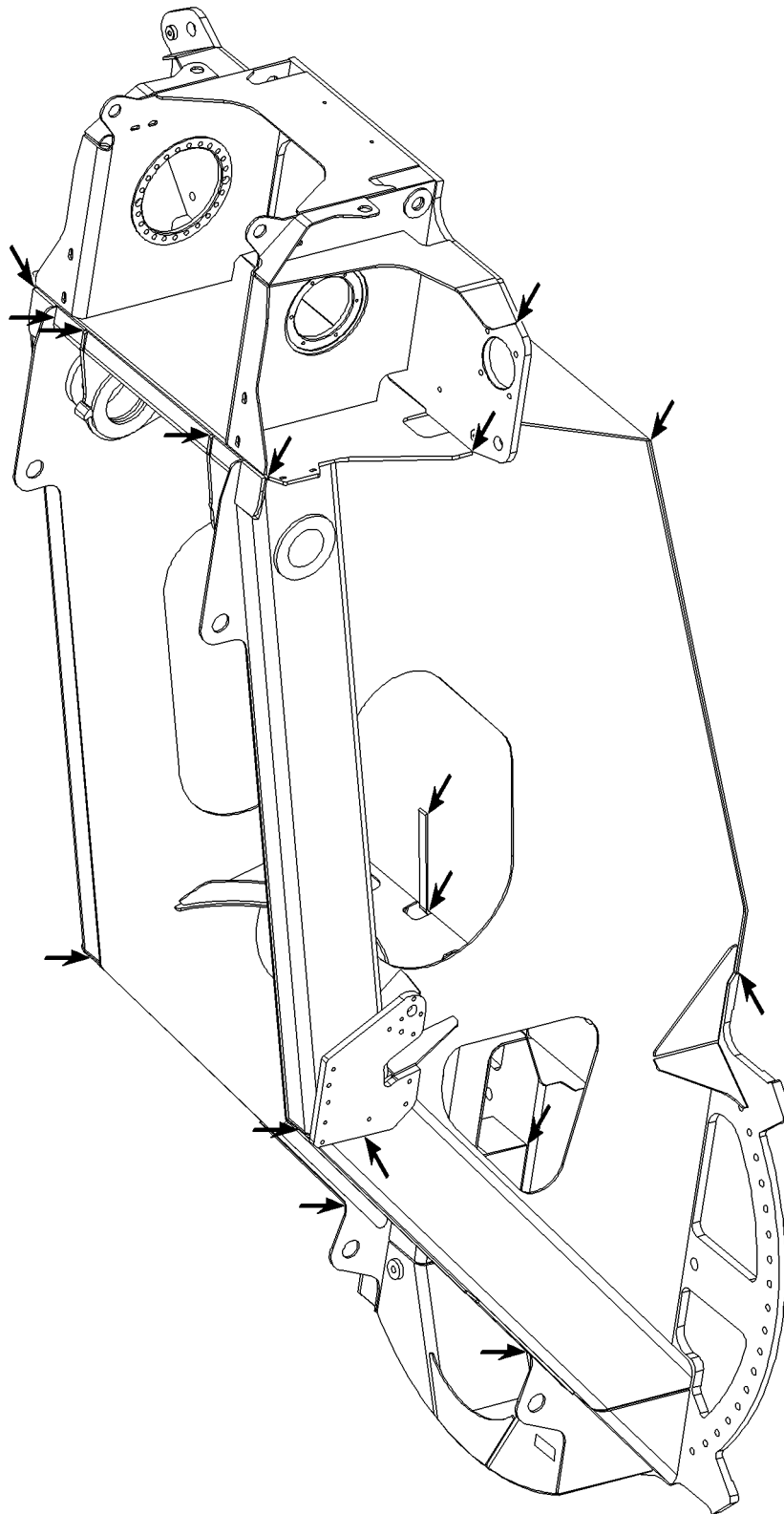


Fig.164881: Example of a turntable frame

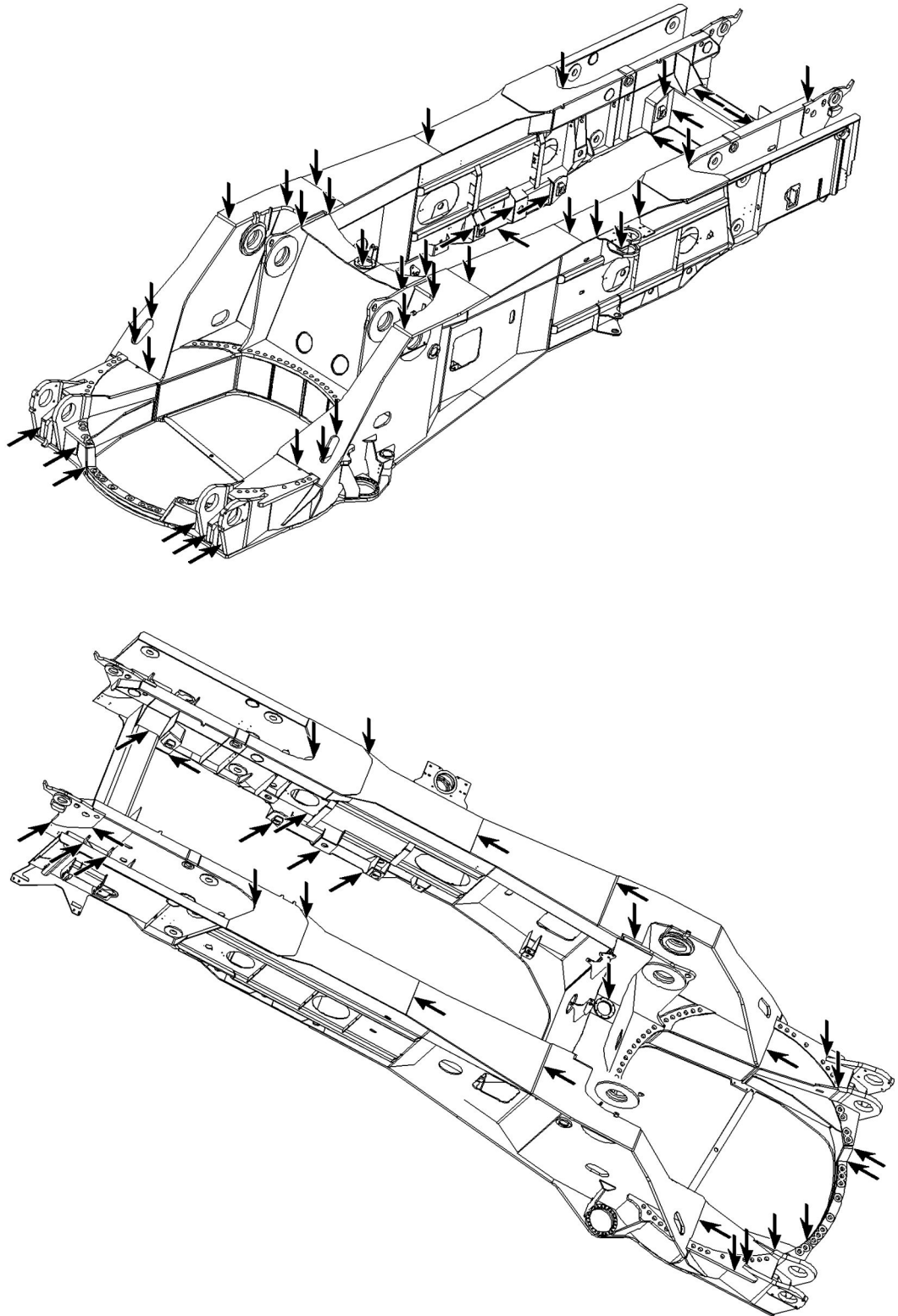


Fig.164882: Example of a turntable frame

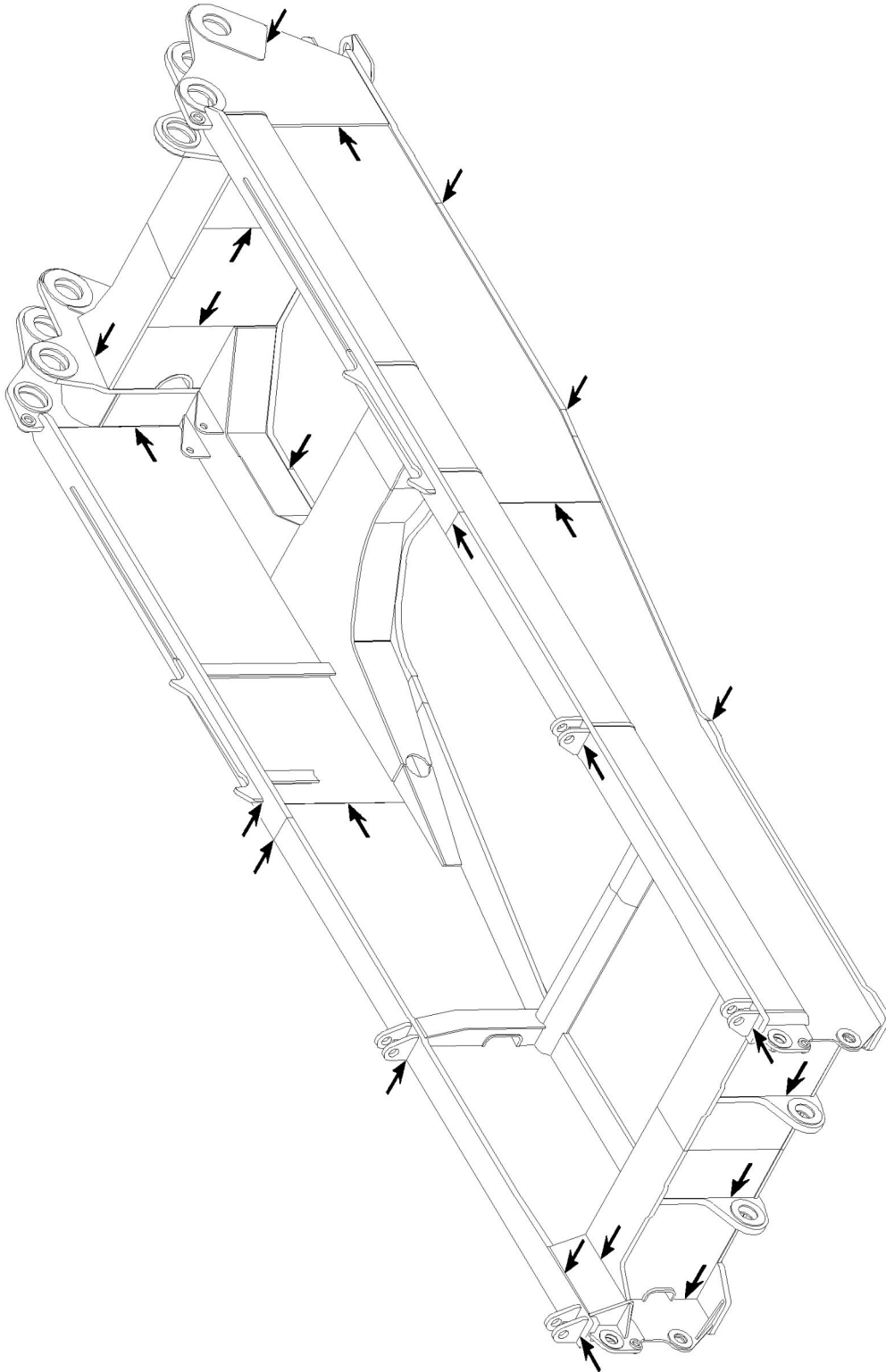


Fig.164883: Example of a turntable frame

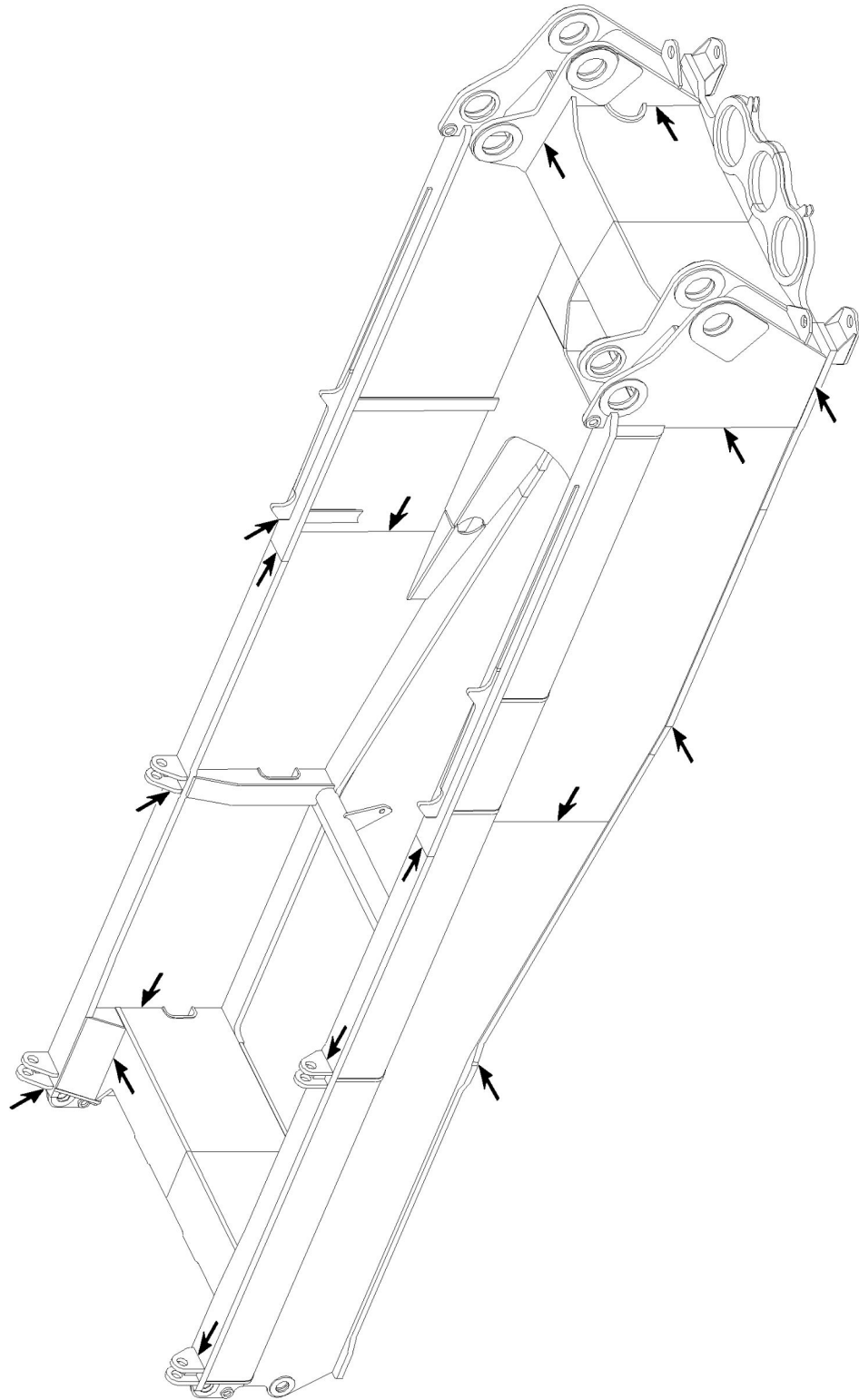


Fig.164884: Example of a turntable frame

LWE/LR 1800-1-0-000/27200-07-02/en

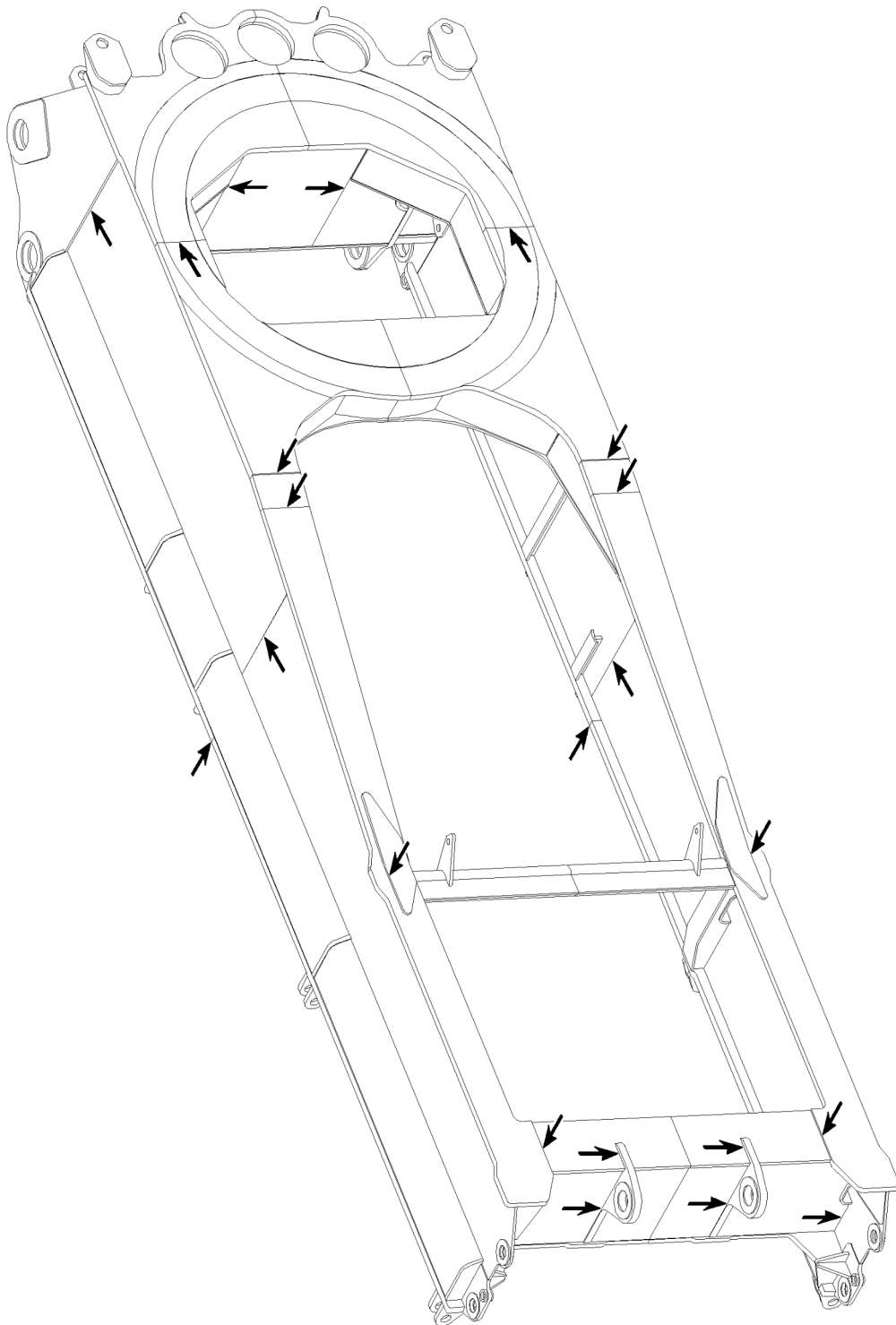


Fig.164885: Example of a turntable frame

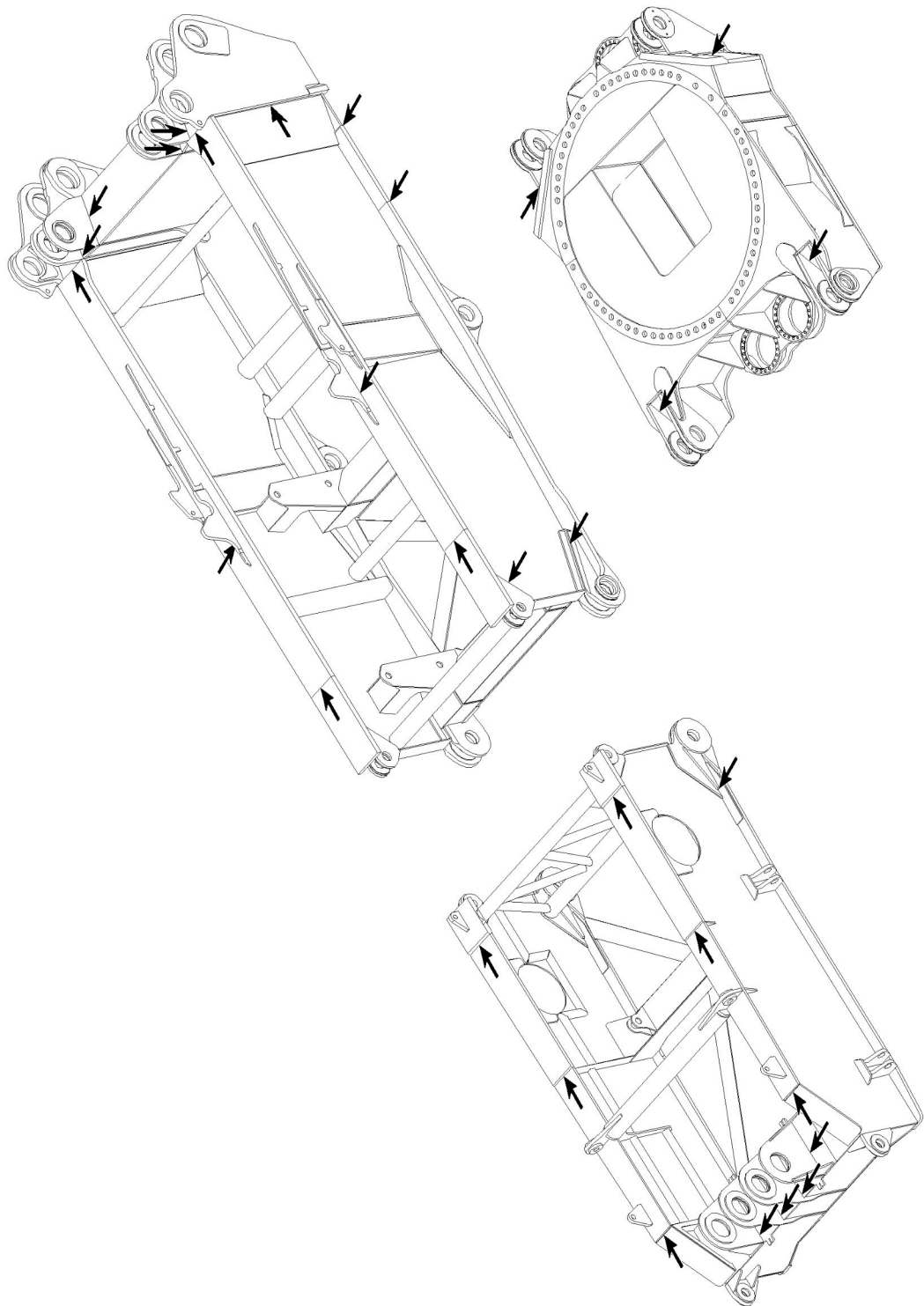


Fig.164886: Example of a turntable frame

LWE/LR 1800-1-0-000/27200-07-02/en

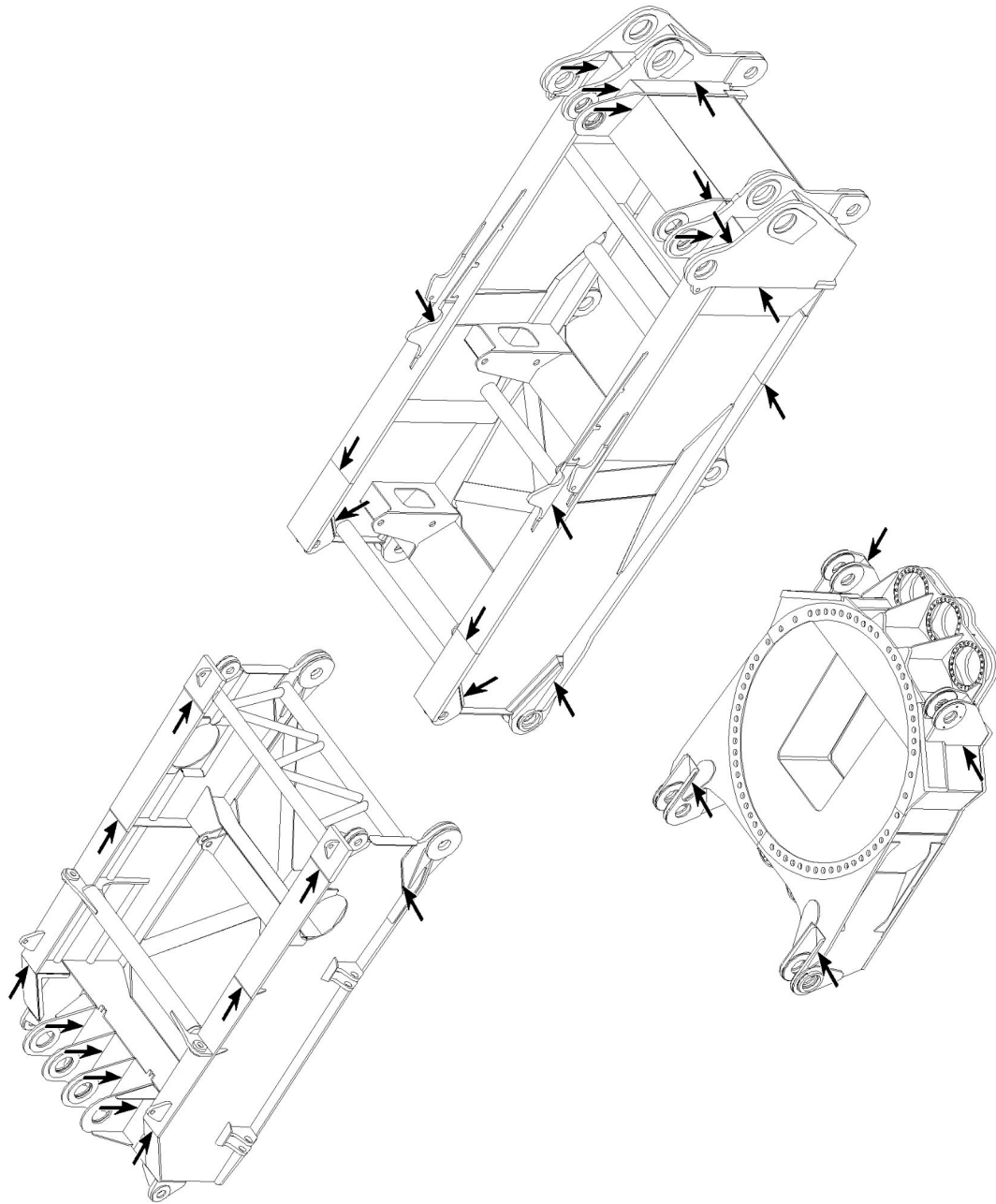


Fig.164887: Example of a turntable frame



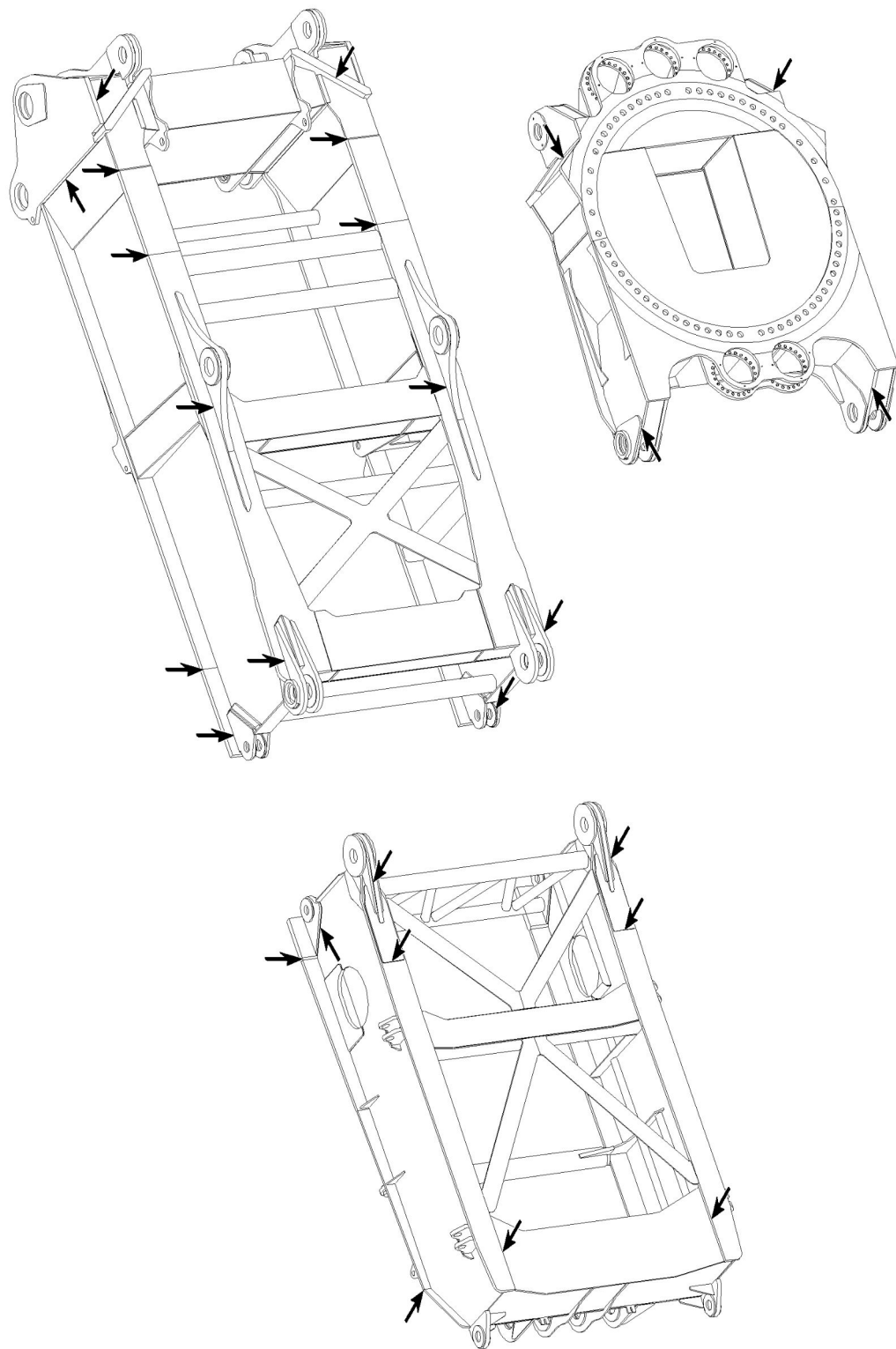


Fig.164888: Example of a turntable frame

LWE/LR 1800-1-0-000/27200-07-02/en

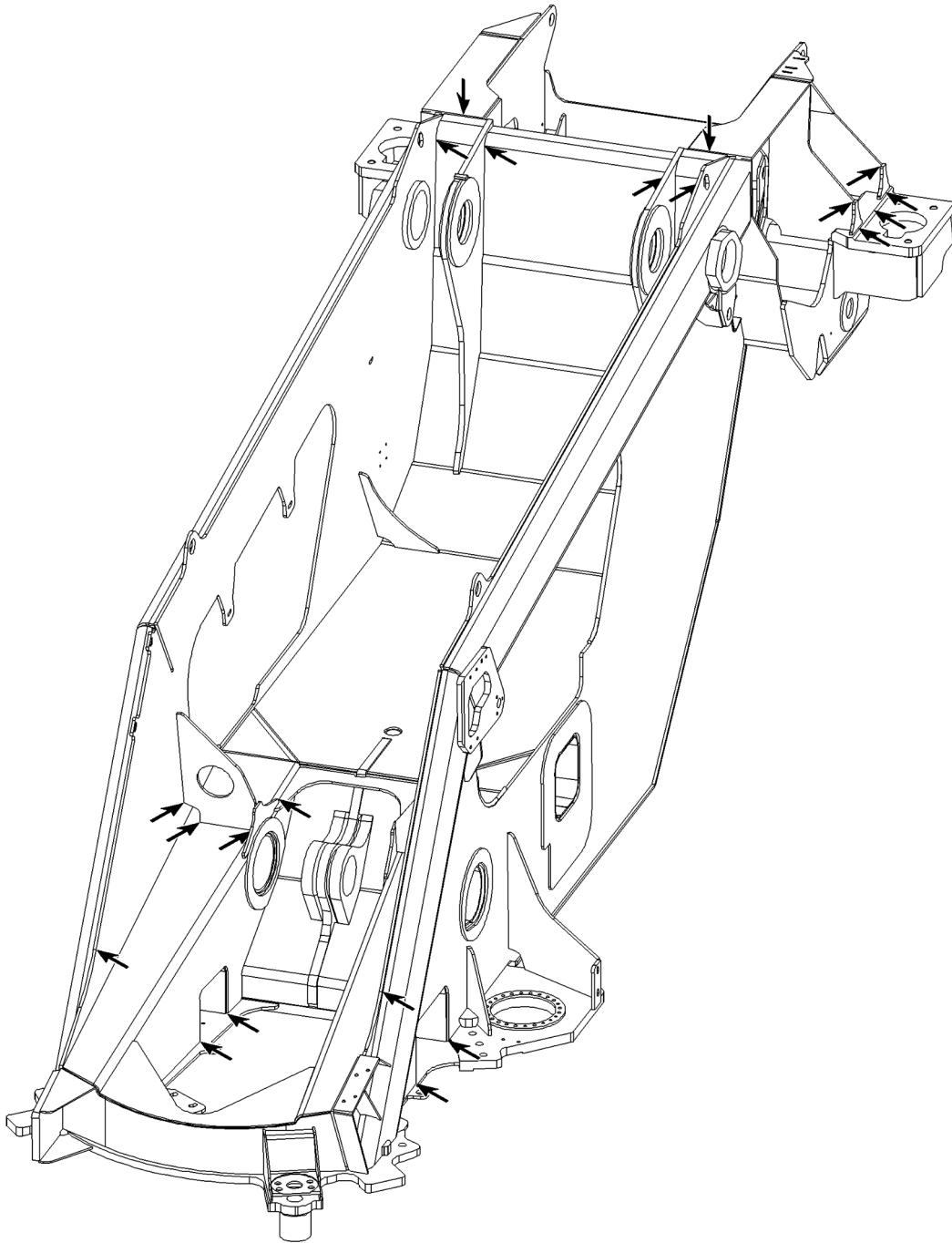


Fig.164889: Example of a turntable frame

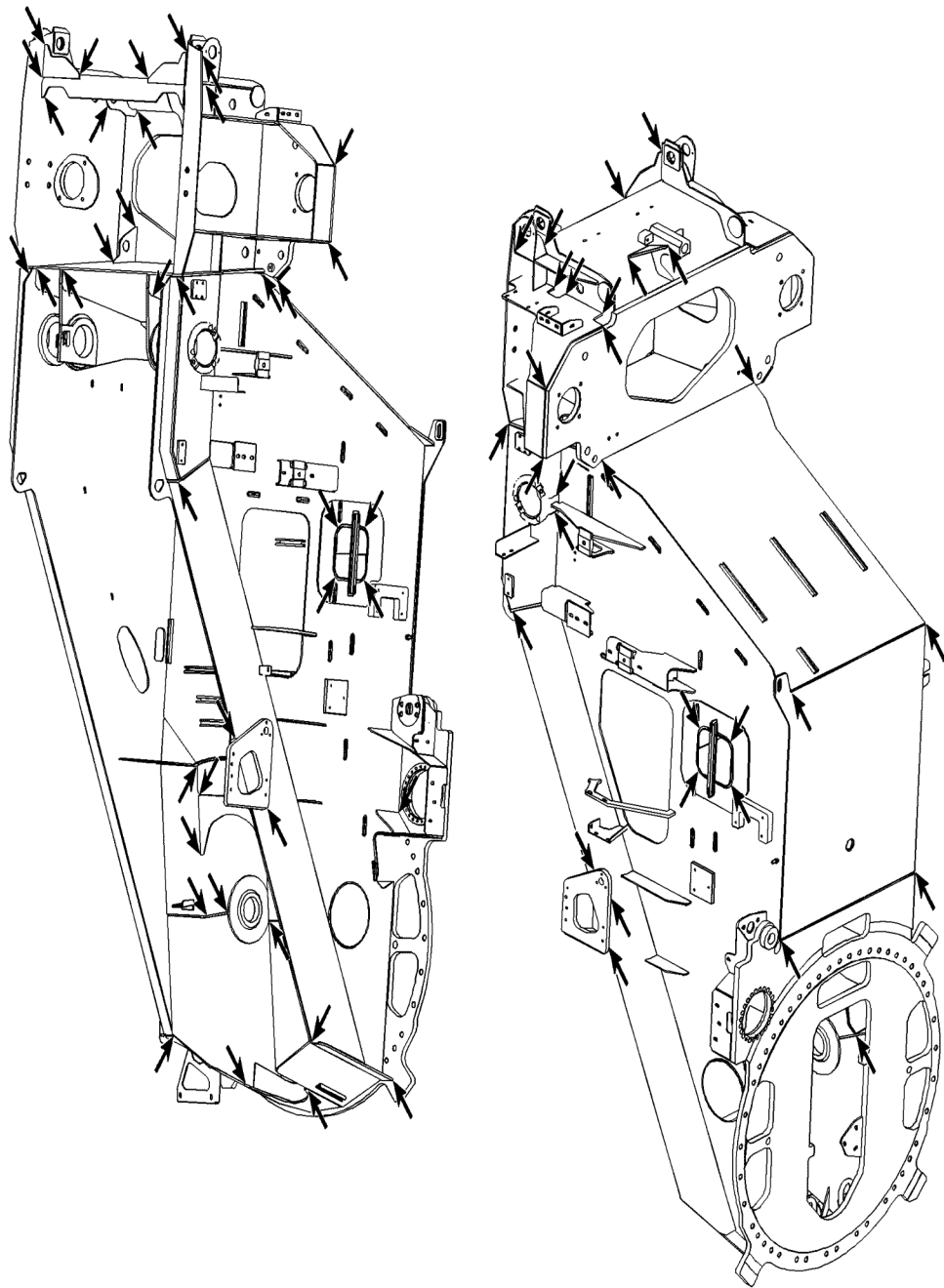


Fig.164890: Example of a turntable frame

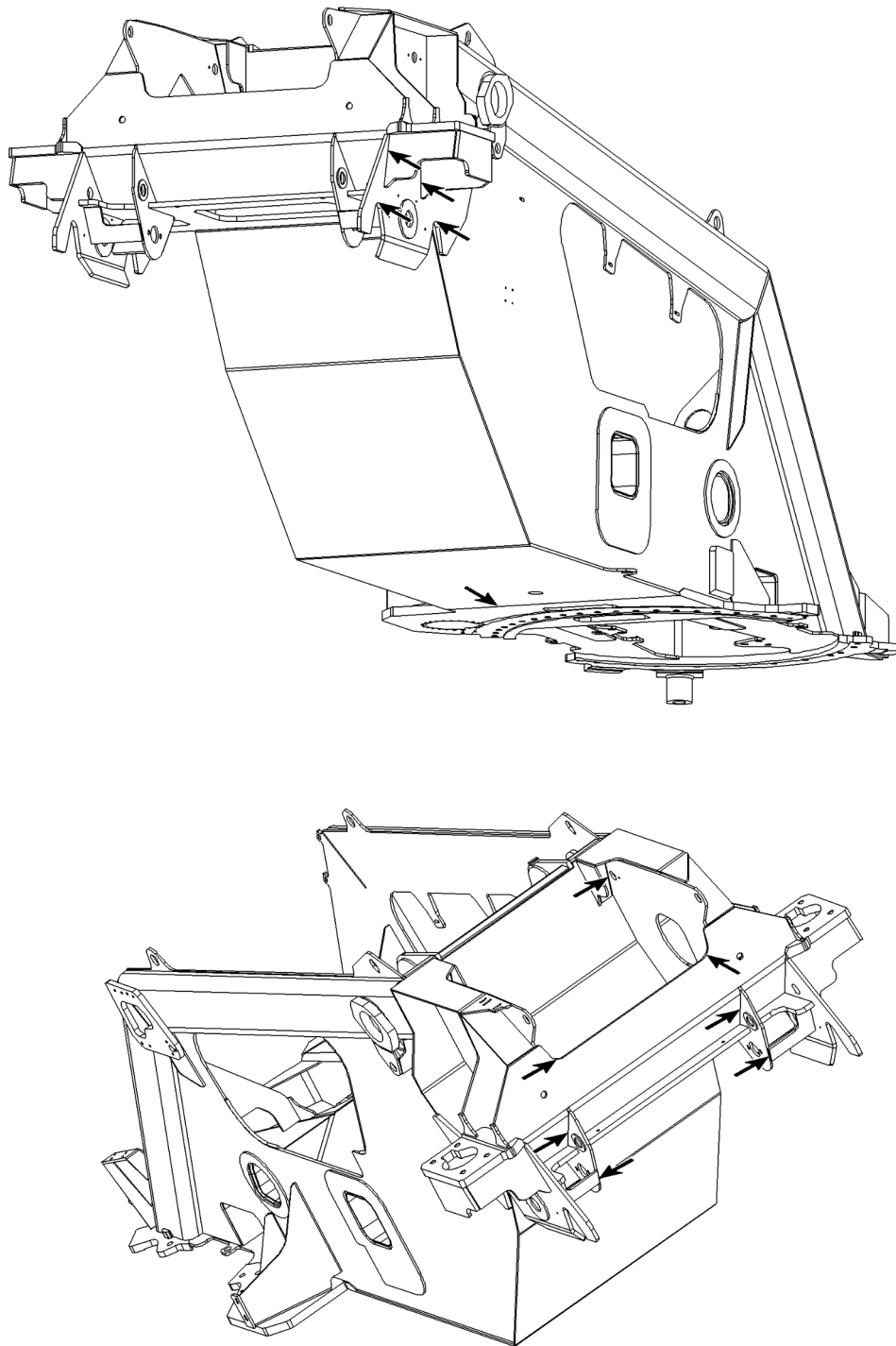
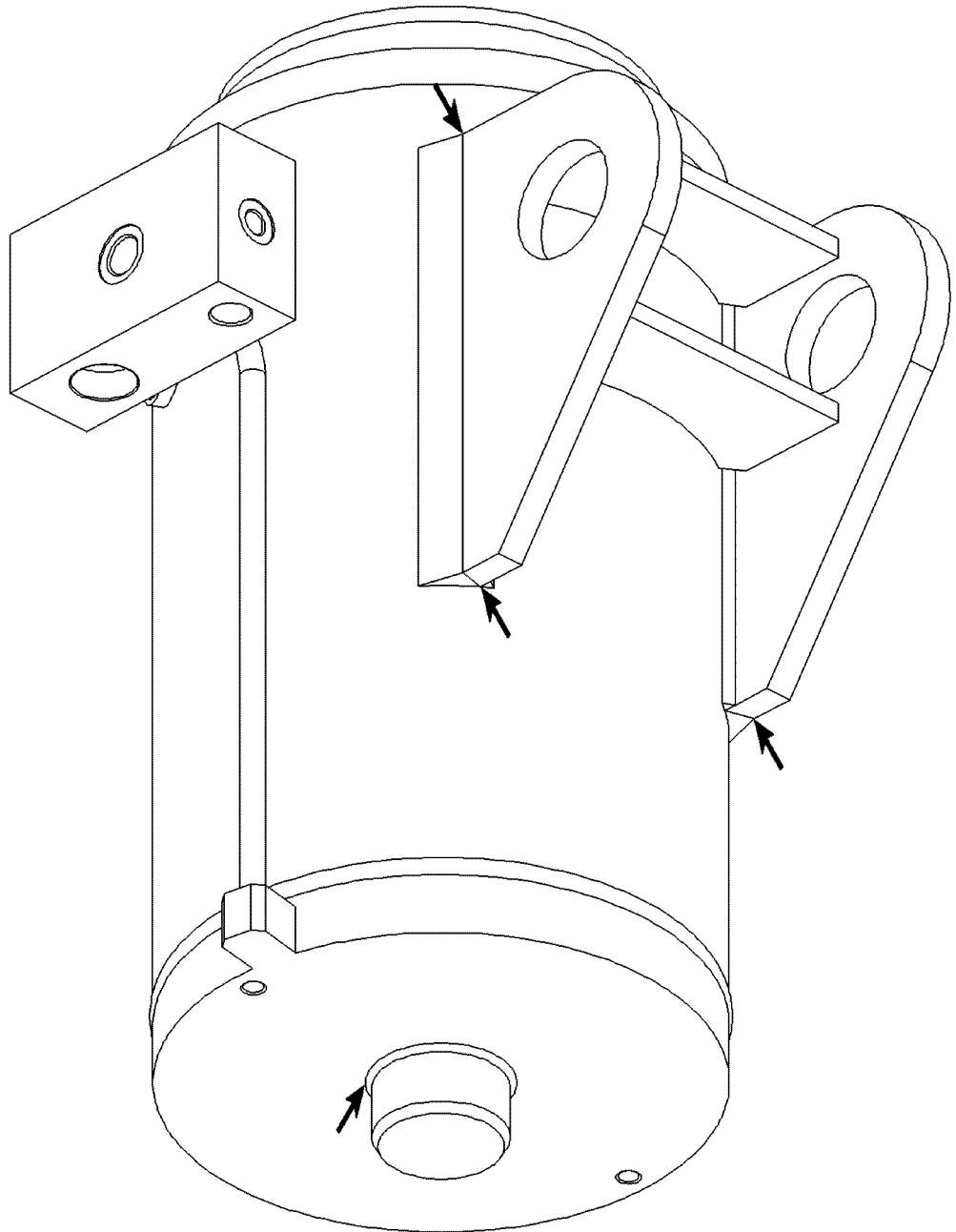


Fig.164891: Example of a turntable frame

**Ballast cylinder**



*Fig.164892: Example of a ballast cylinder*

LWE/LR 1800-1-0-000/27200-07-02/en

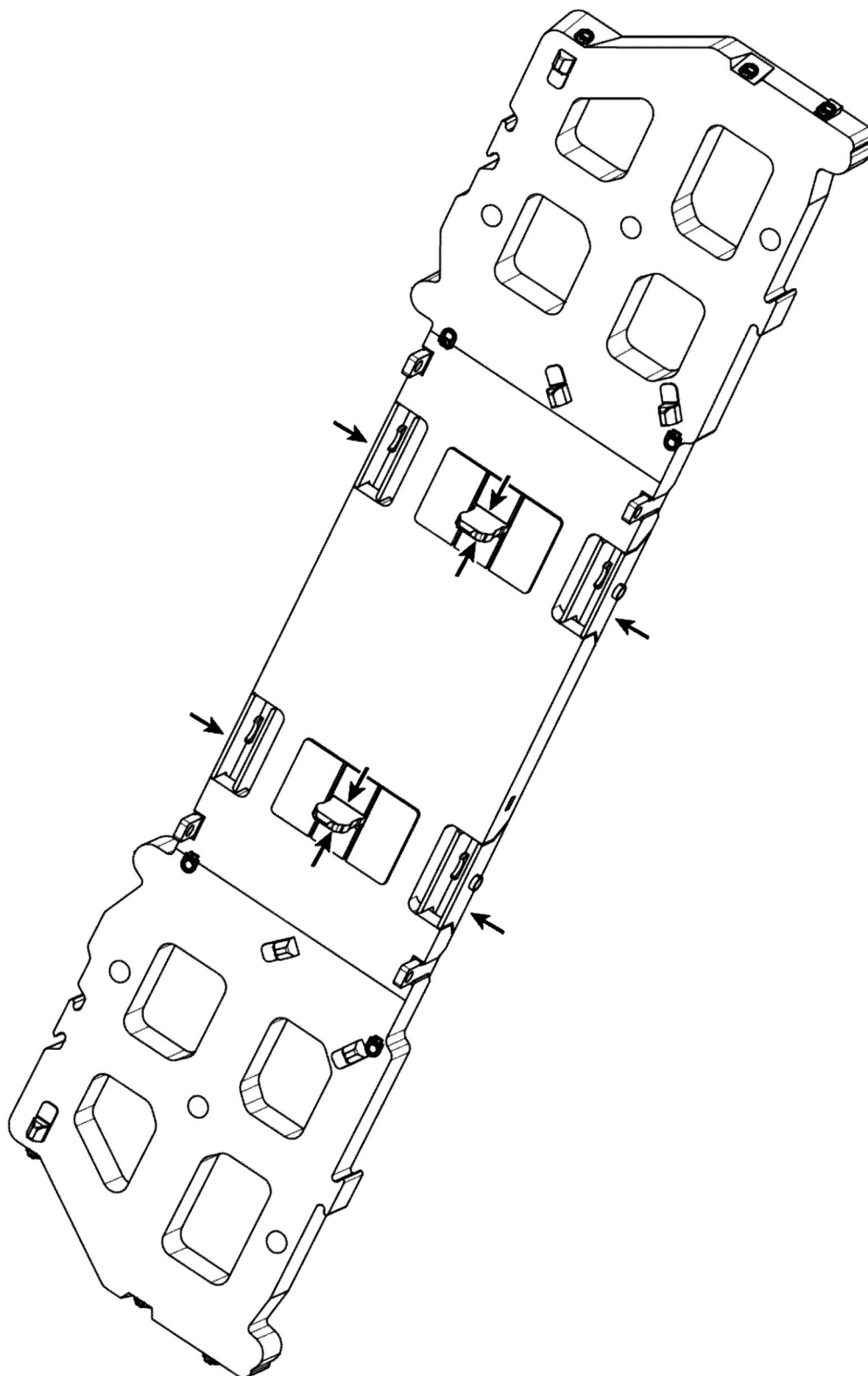
**Receptacle plate**

Fig.164893: Example of mounting plate

LWE/LR 1800-1-0-000/27200-07-02/en

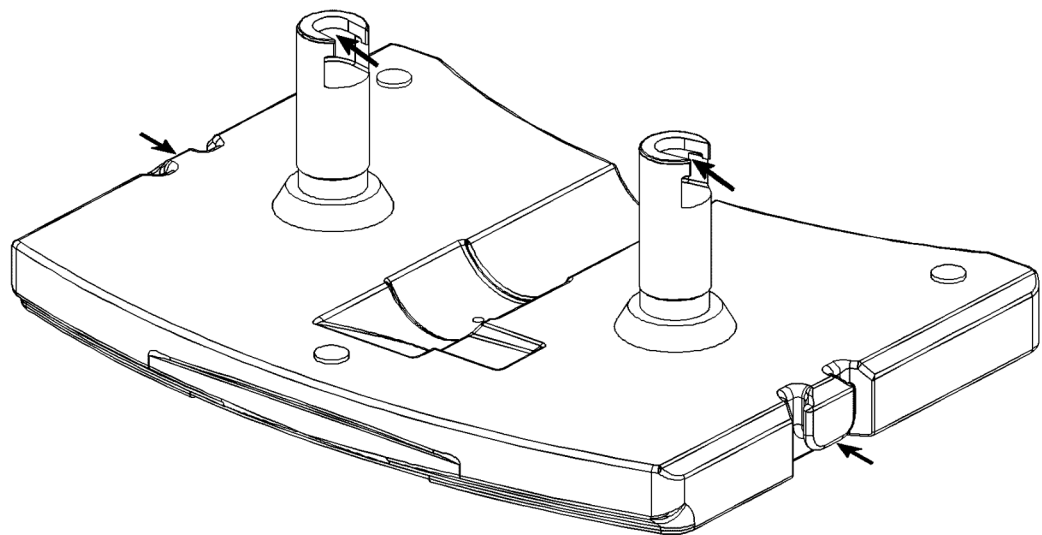
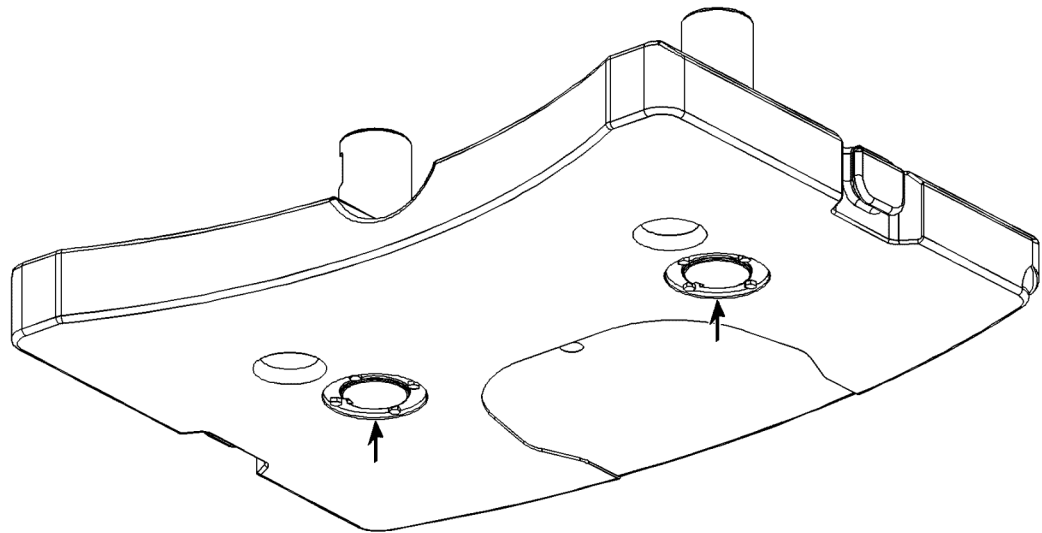
**Base plate**

Fig. 164894: Example of base plate

LWE/LR 1800-1-0-000/27200-07-02/en

## 2.4.3 Boom

### Pivot section

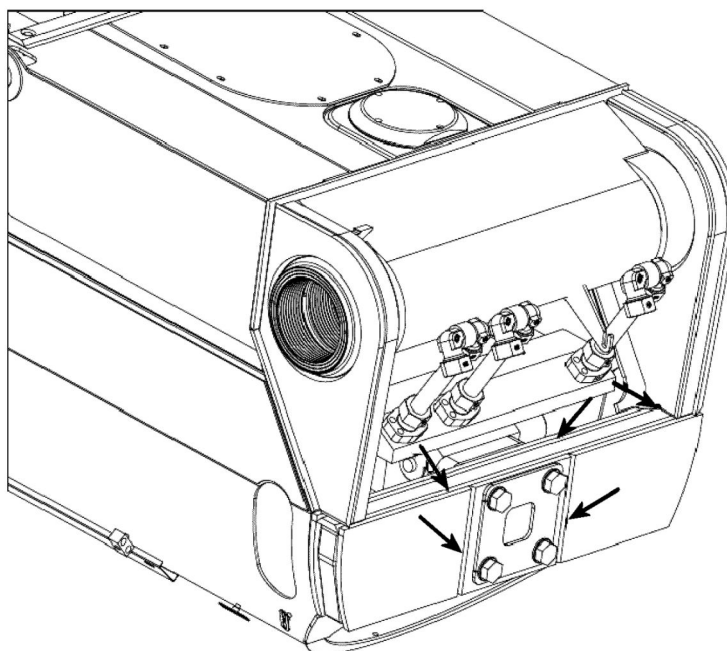
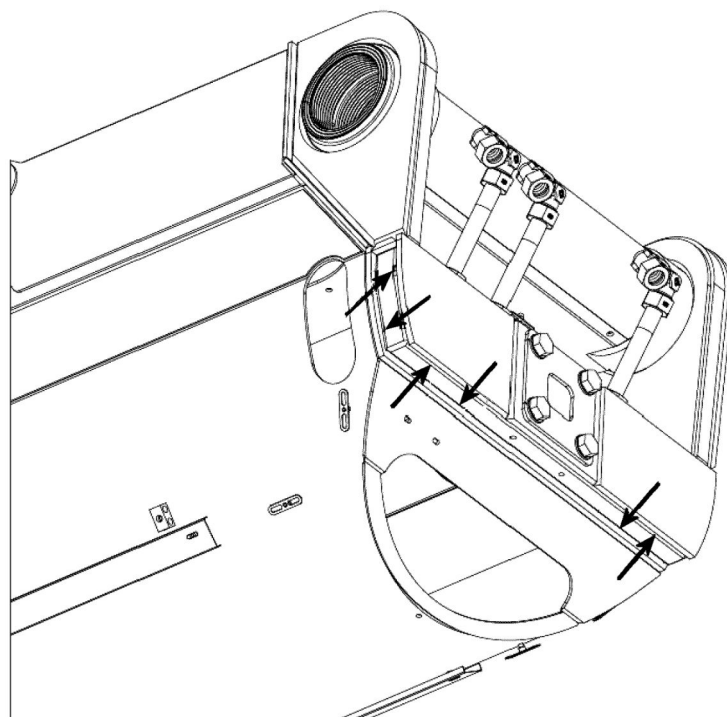


Fig.164895: Example of a pivot section

LWE/LR 1800-1-0-000/27200-07-02/en



### Telescopic boom

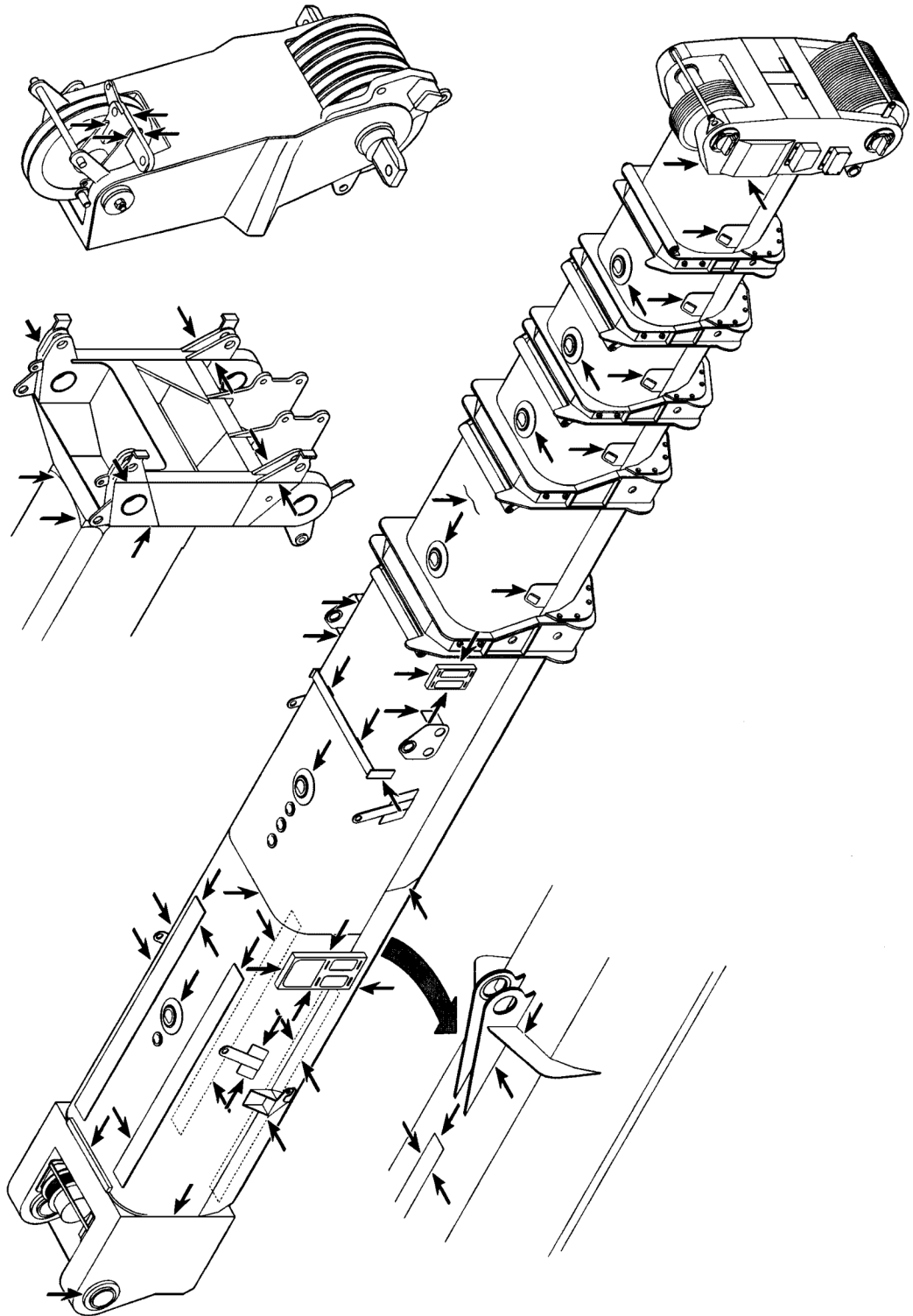


Fig.164896: Example of a telescopic boom

LWE/LR 1800-1-0-000/27200-07-02/en

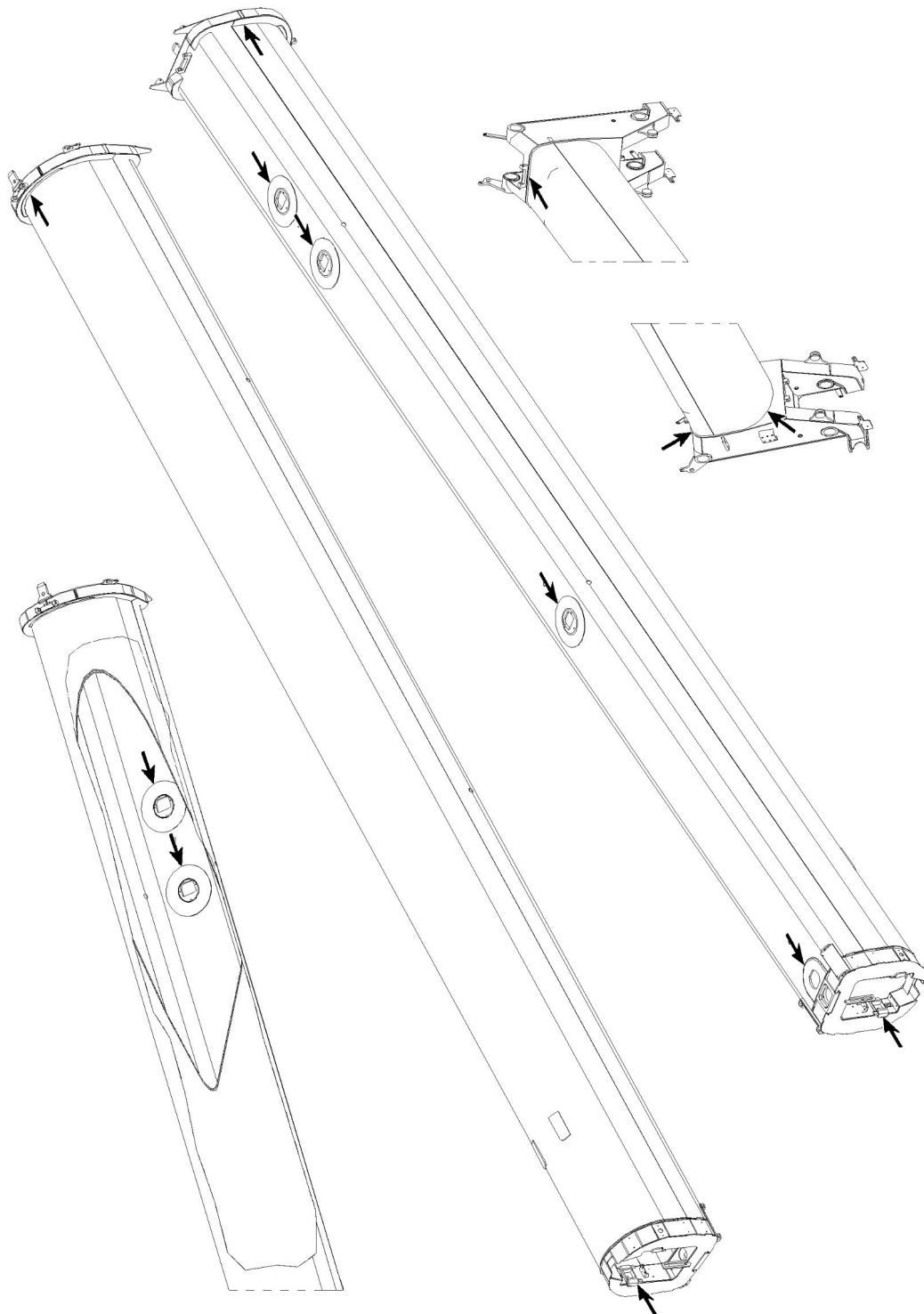


Fig.164897: Example of a telescopic boom

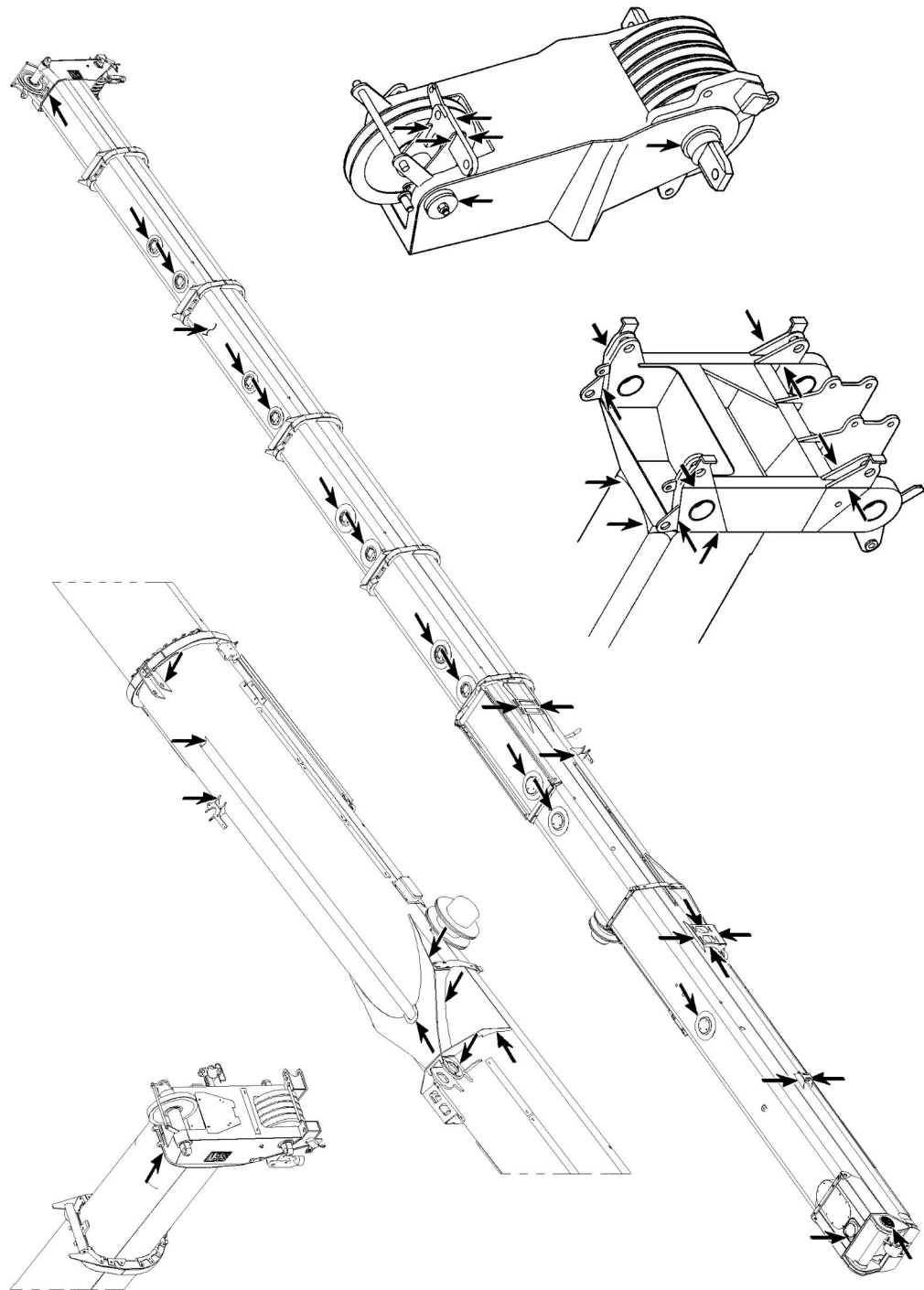


Fig.164898: Example of a telescopic boom

LWE/LR 1800-1-0-000/27200-07-02/en

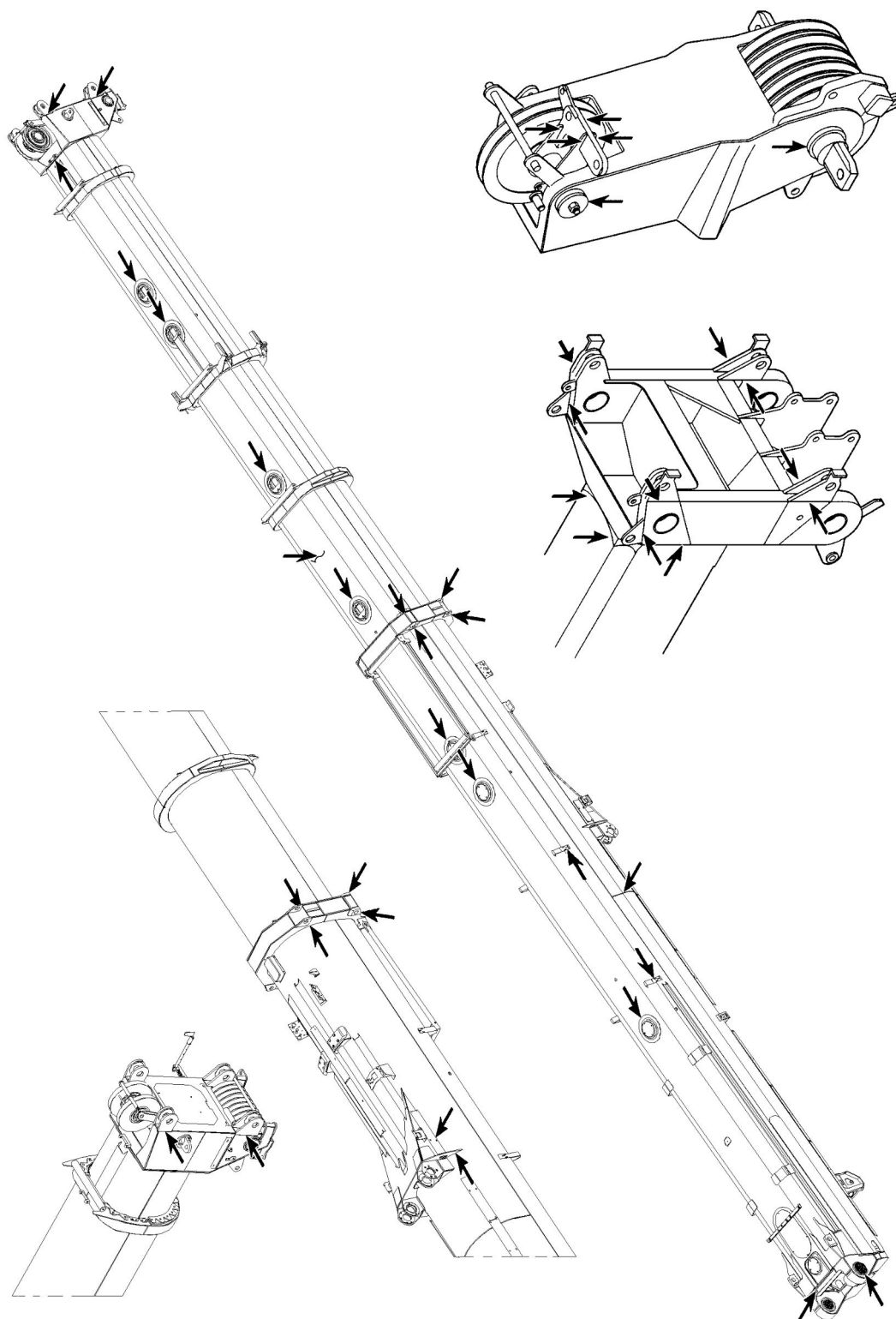


Fig.164899: Example of a telescopic boom

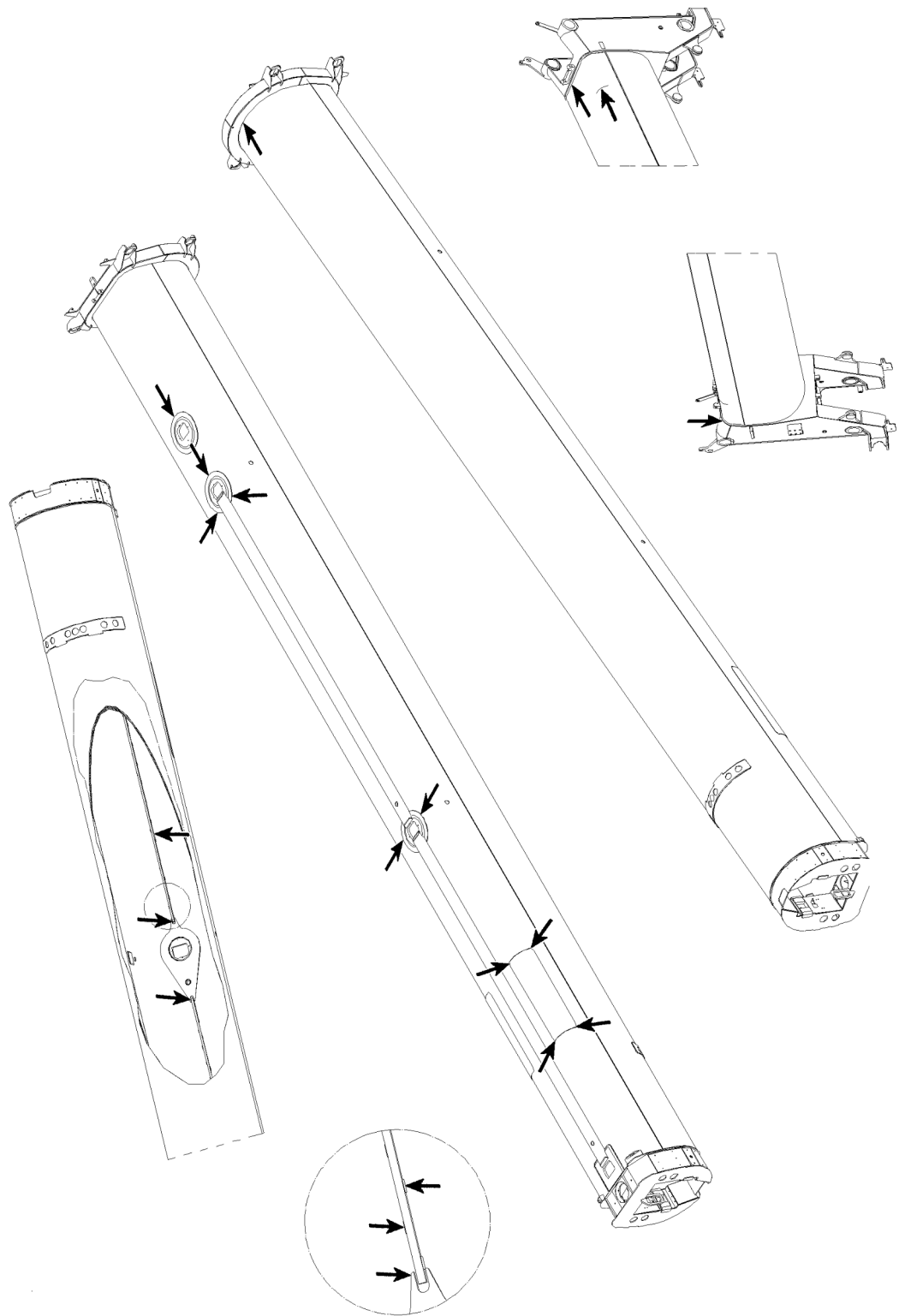


Fig.164900: Example of a telescopic boom

LWE/LR 1800-1-0-000/27200-07-02/en

### Telescopic boom push out mechanics

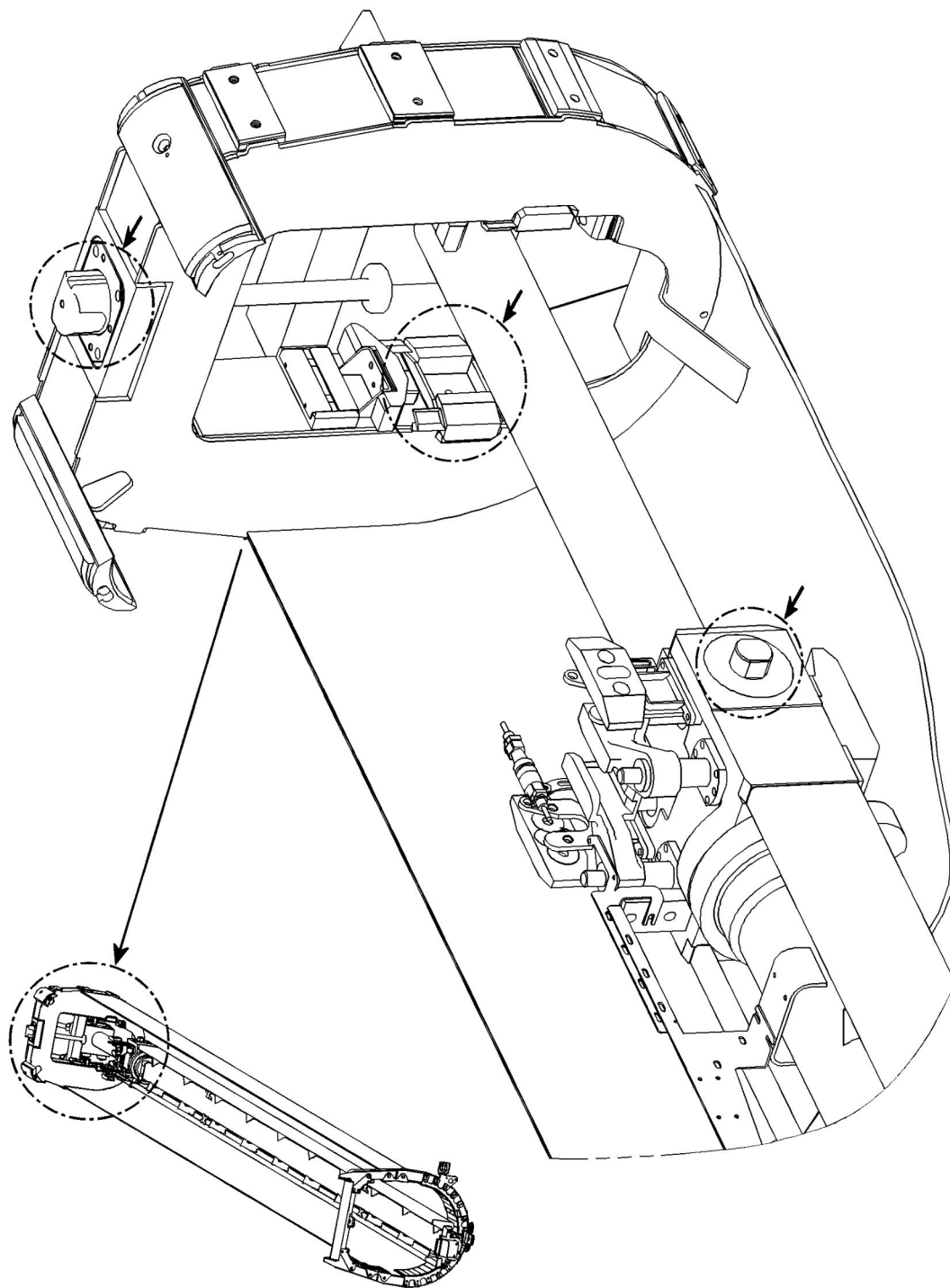


Fig.164901: Example of push out mechanics telescopic boom

LWE/LR 1800-1-0-000/27200-07-02/en

**Boom nose**

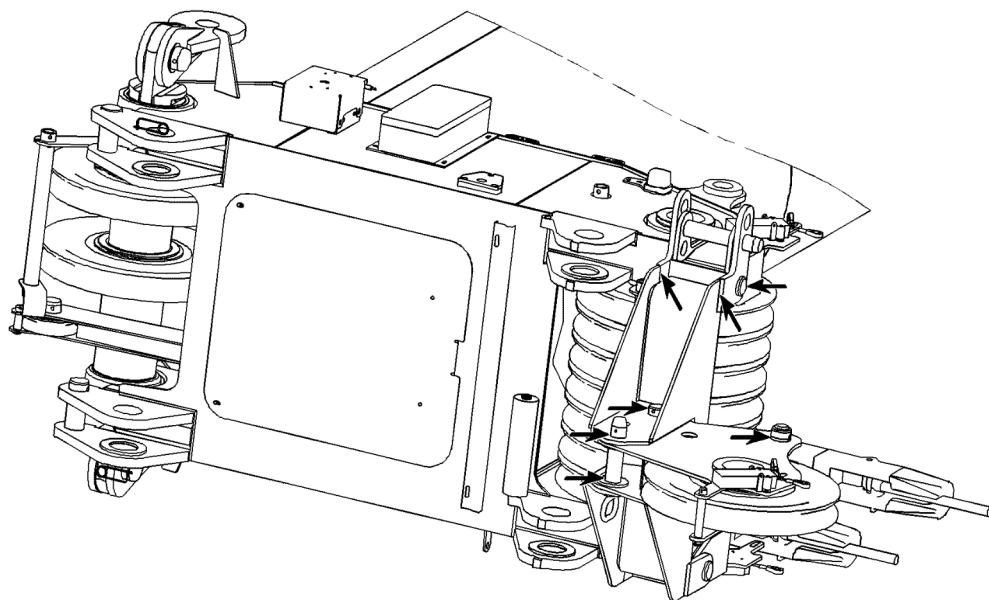
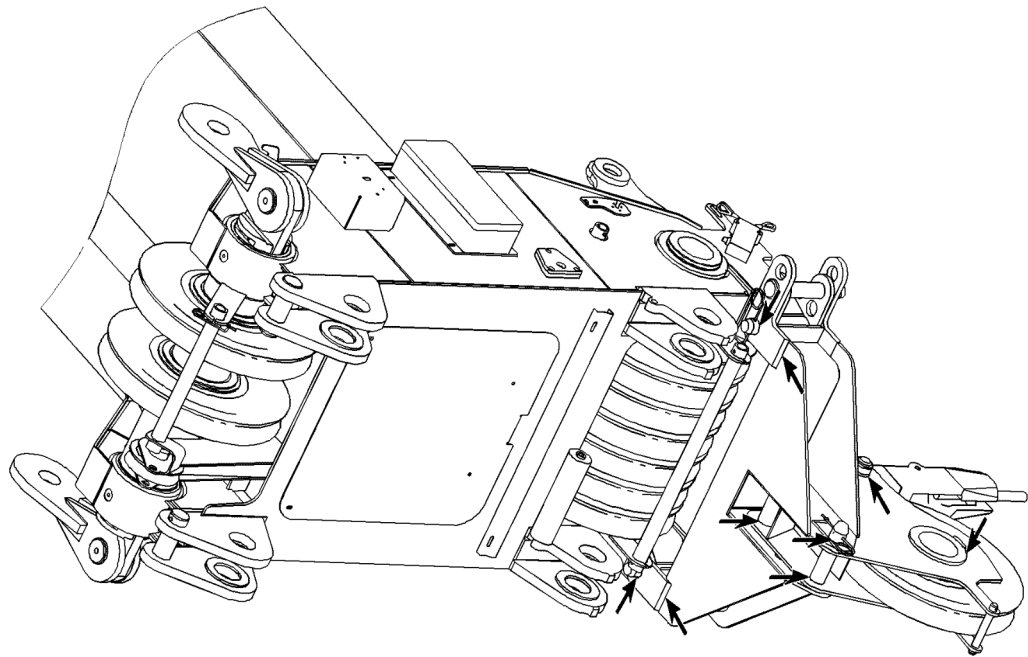


Fig.164902: Example of a boom nose

LWE/LR 1800-1-0-000/27200-07-02/en

### Dolly console

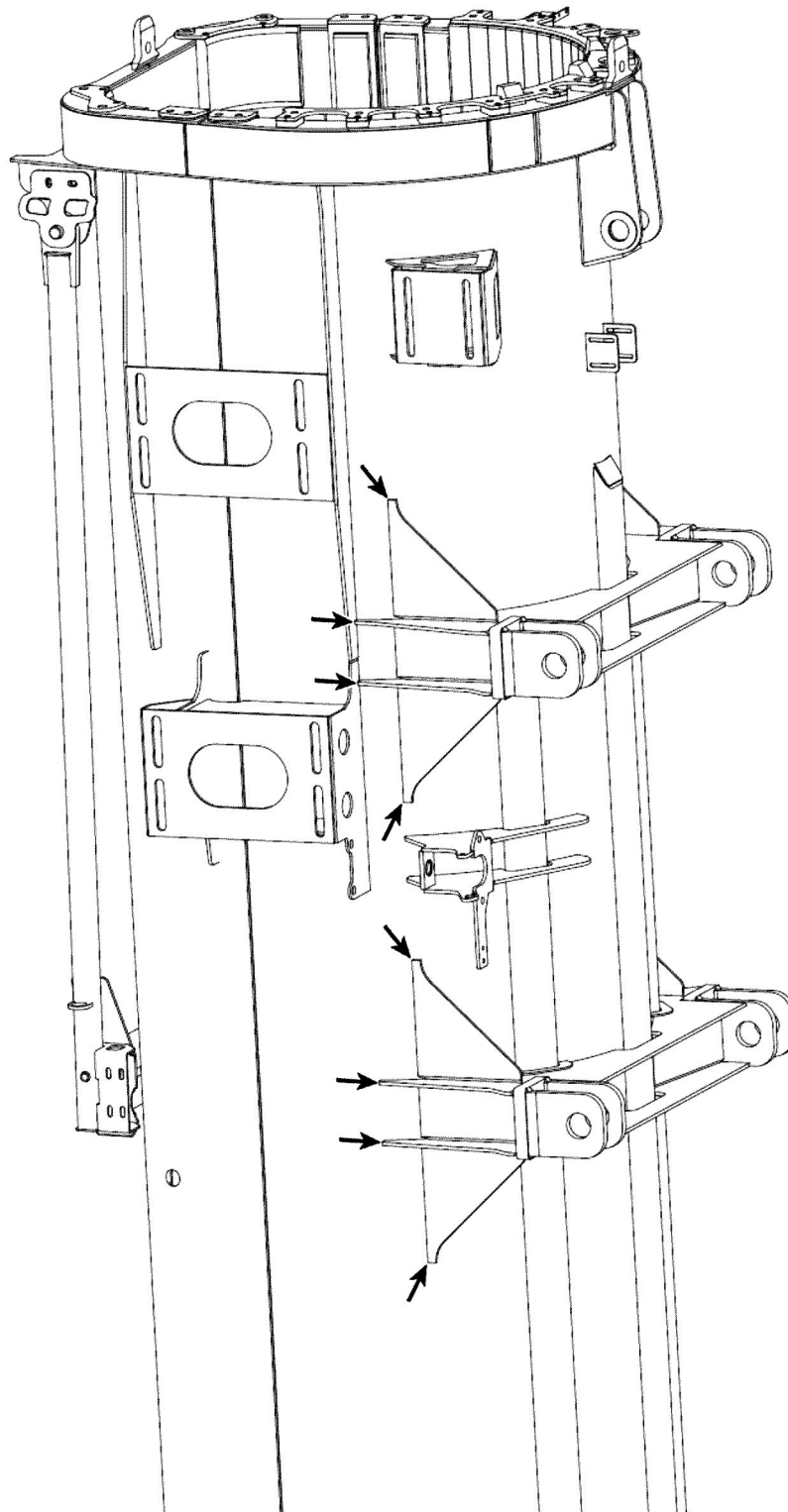


Fig.164903: Example of a dolly console

LWE/LR 1800-1-0-000/27200-07-02/en



### Lattice jib

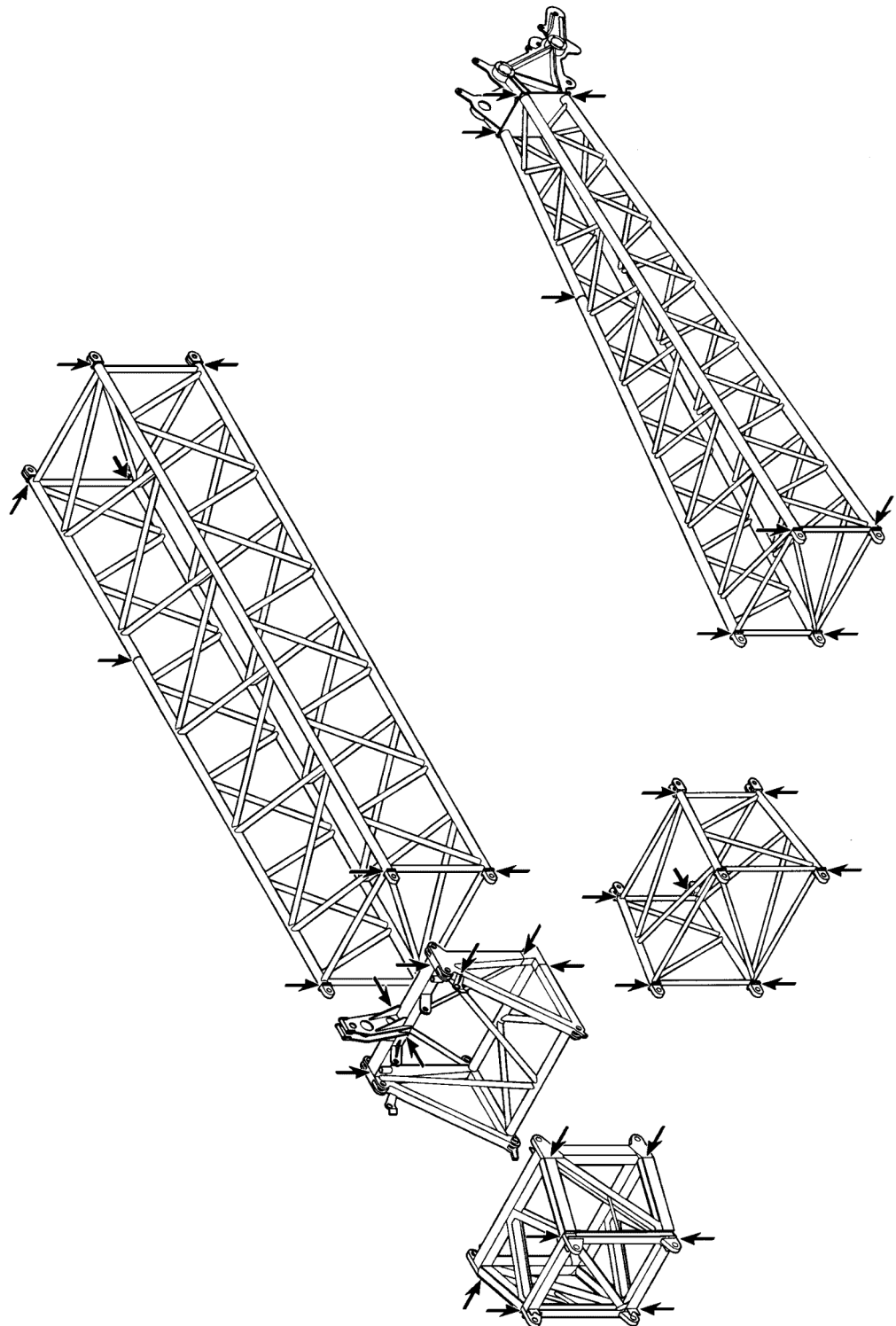


Fig.164904: Example of a lattice jib

LWE/LR 1800-1-0-000/27200-07-02/en

## NA/WA frame

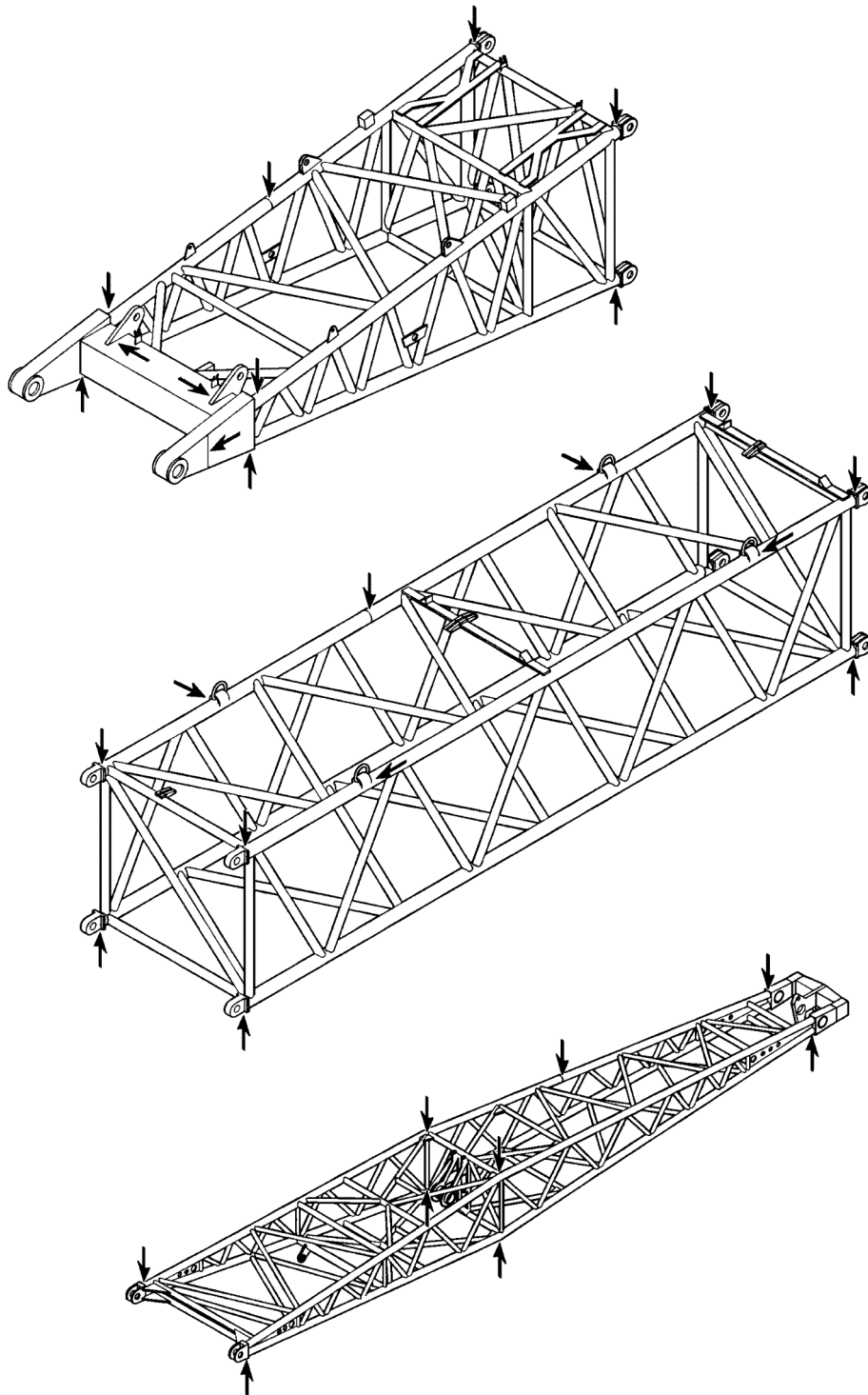
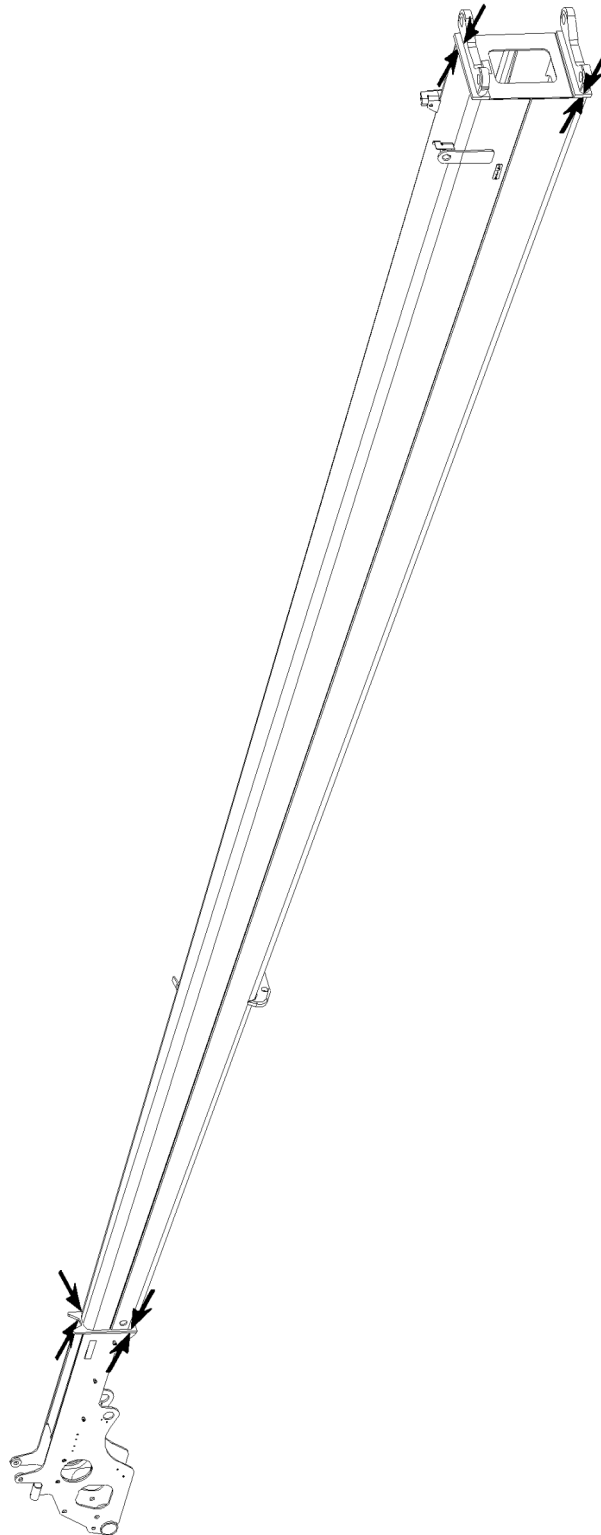


Fig.164905: Example of a NA/WA-frame

**End section**



*Fig.164906: Example of an end section*

LWE/LR 1800-1-0-000/27200-07-02/en

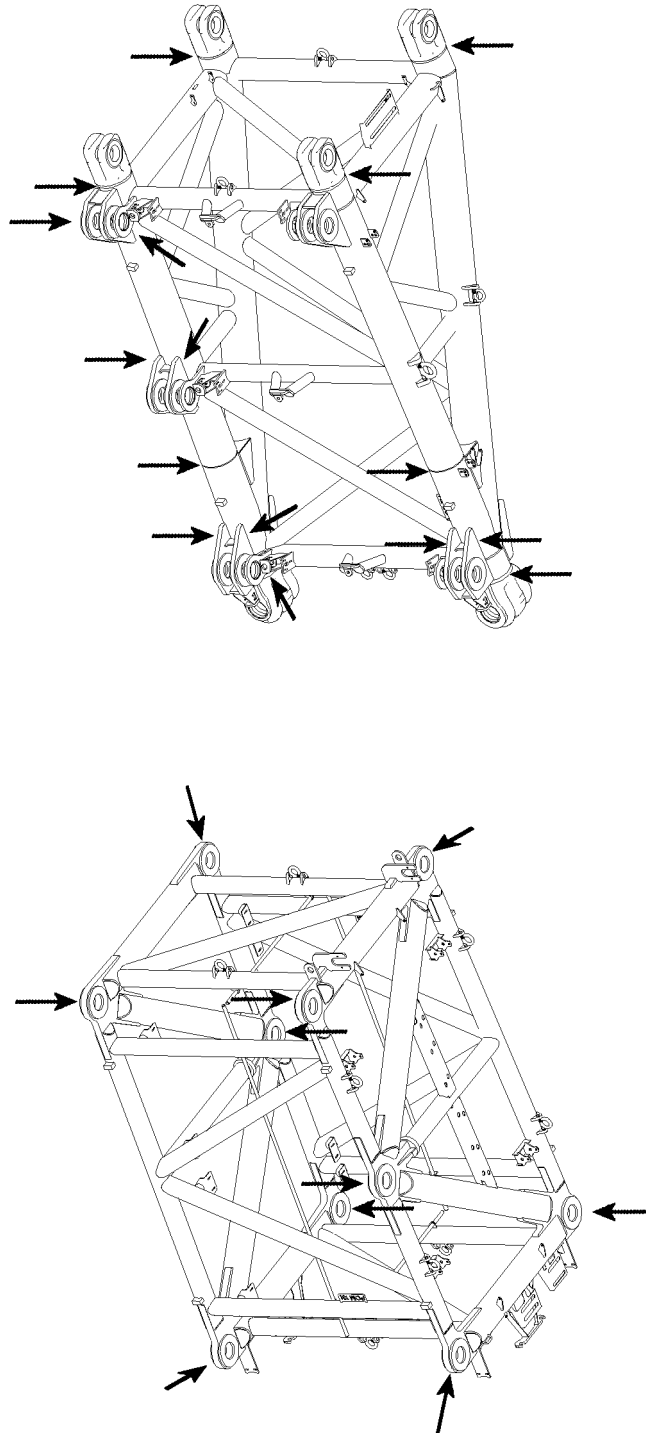
**P-adapter**

Fig.164914: Example of a P-adapter

Guy rods

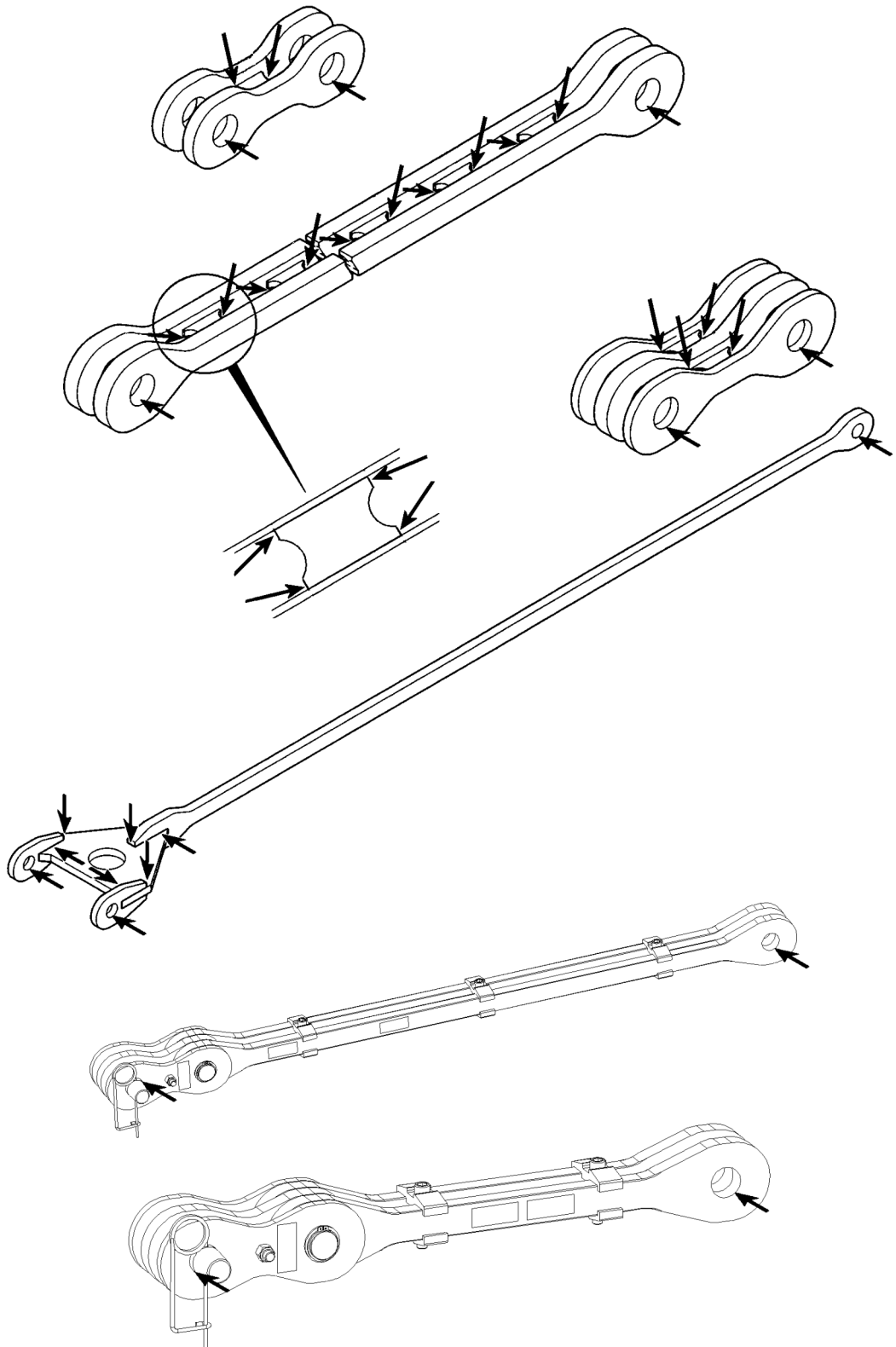


Fig.164915: Example of guy rods

LWE/LR 1800-1-0-000/27200-07-02/en

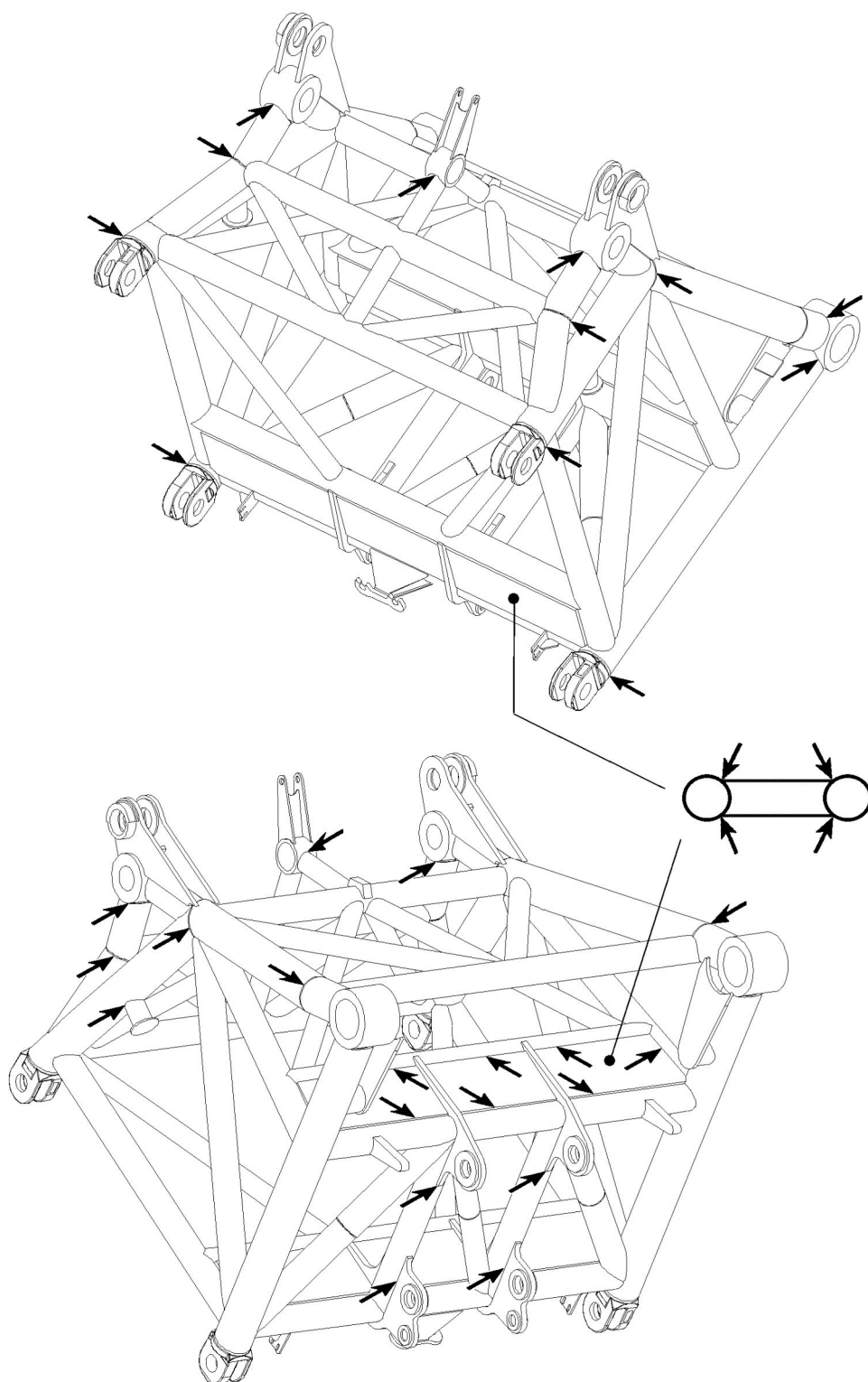
**W-connector head**

Fig.164910: Example of a W-connector head

**Assembly unit with lattice jib**

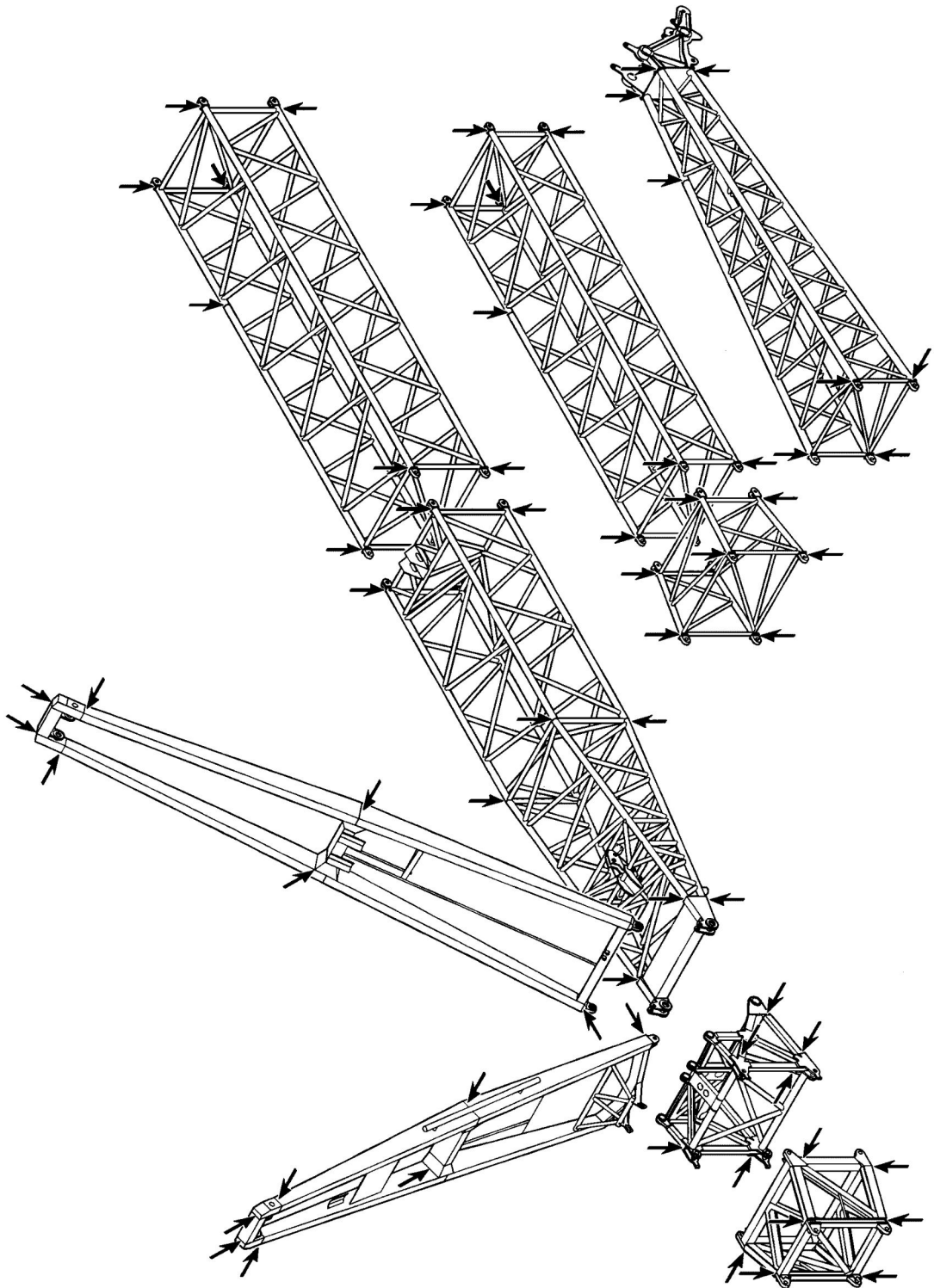


Fig.164911: Example of an assembly unit with lattice jib

LWE/LR 1800-1-0-000/27200-07-02/en

## NA-frames

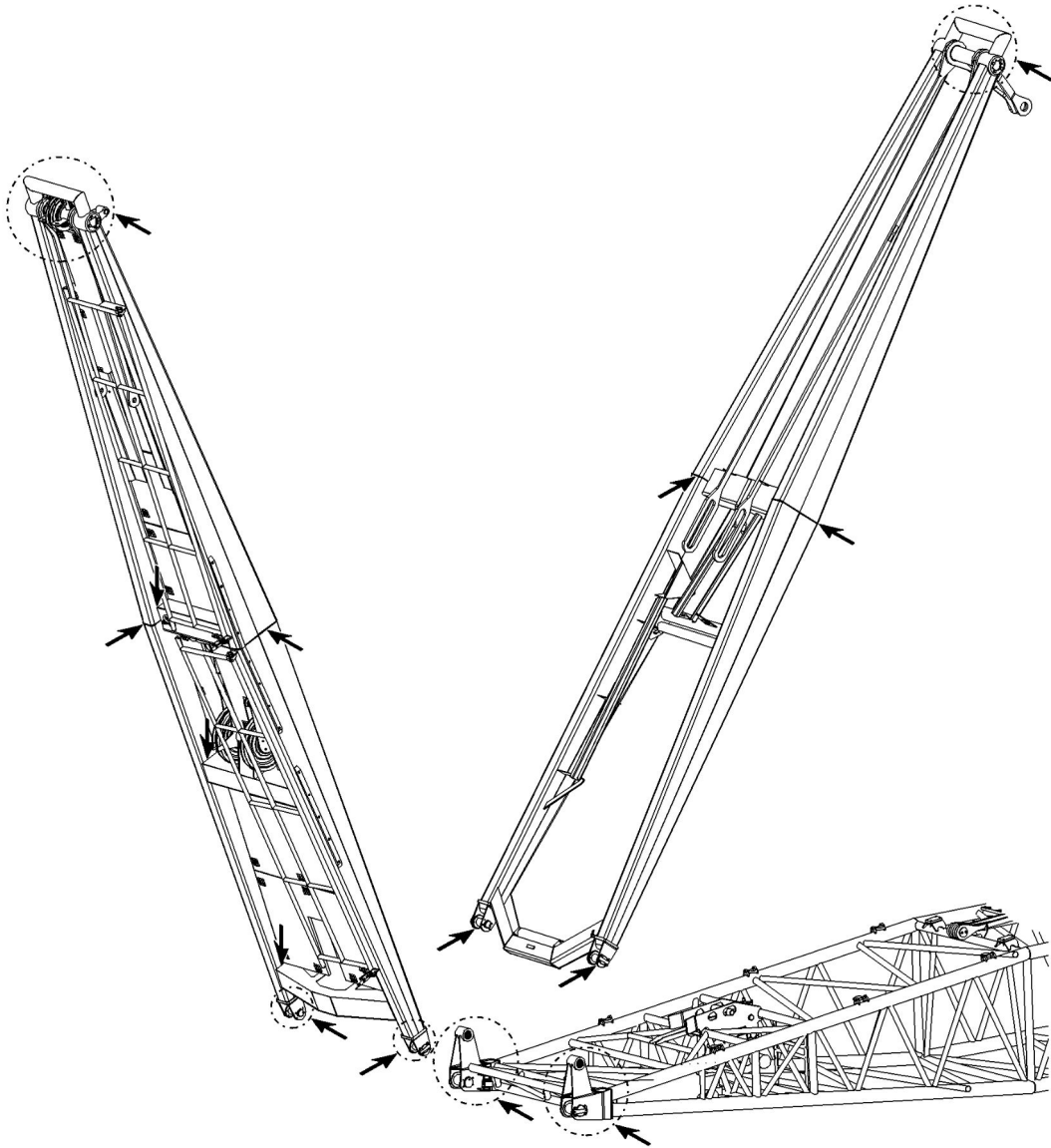


Fig.164912: Example of NA frames



### Pulley head

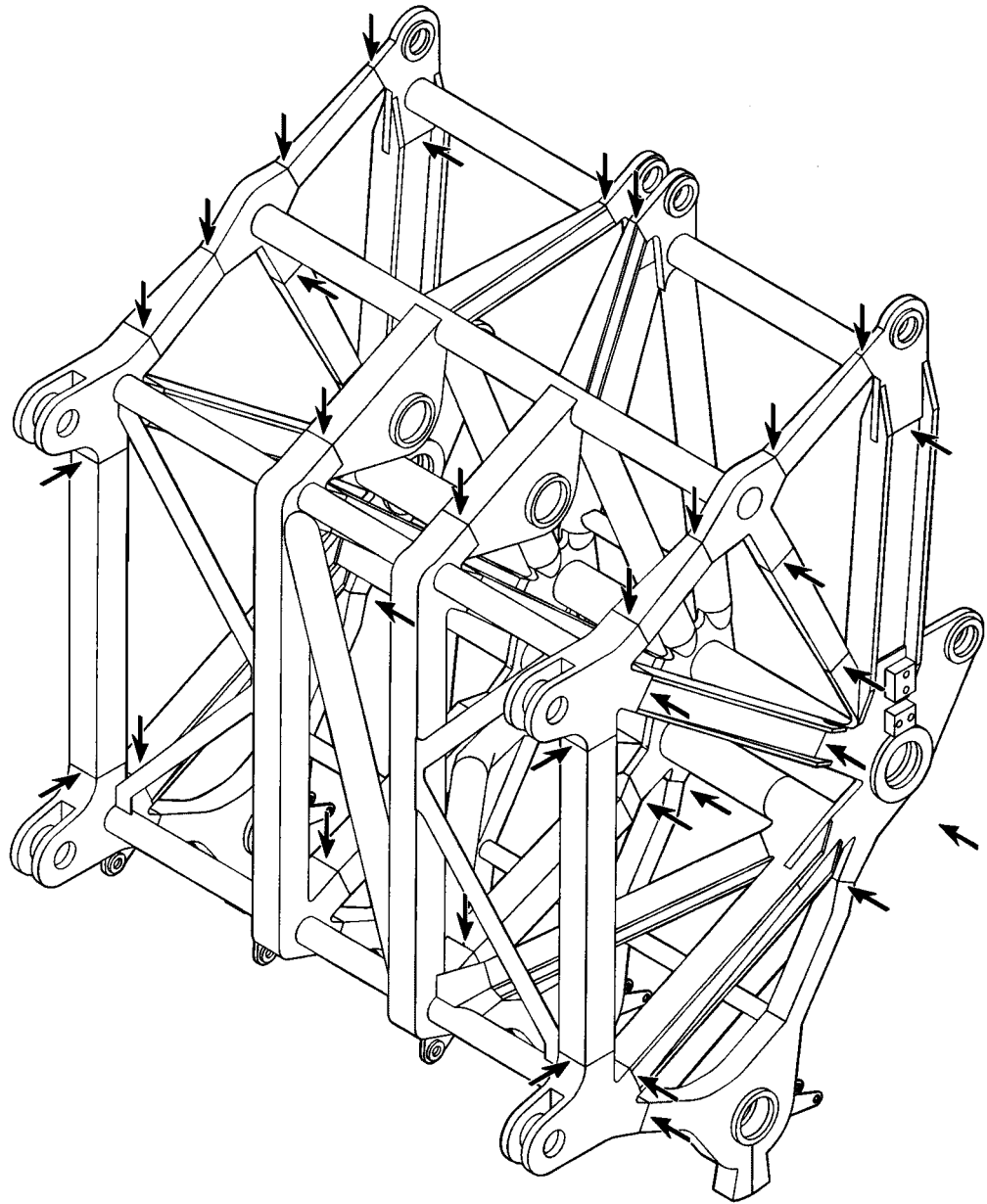


Fig.164913: Example of a pulley head

LWE/LR 1800-1-0-000/27200-07-02/en

## 2.4.4 Equipment

### Pivot section, adapter and boom nose

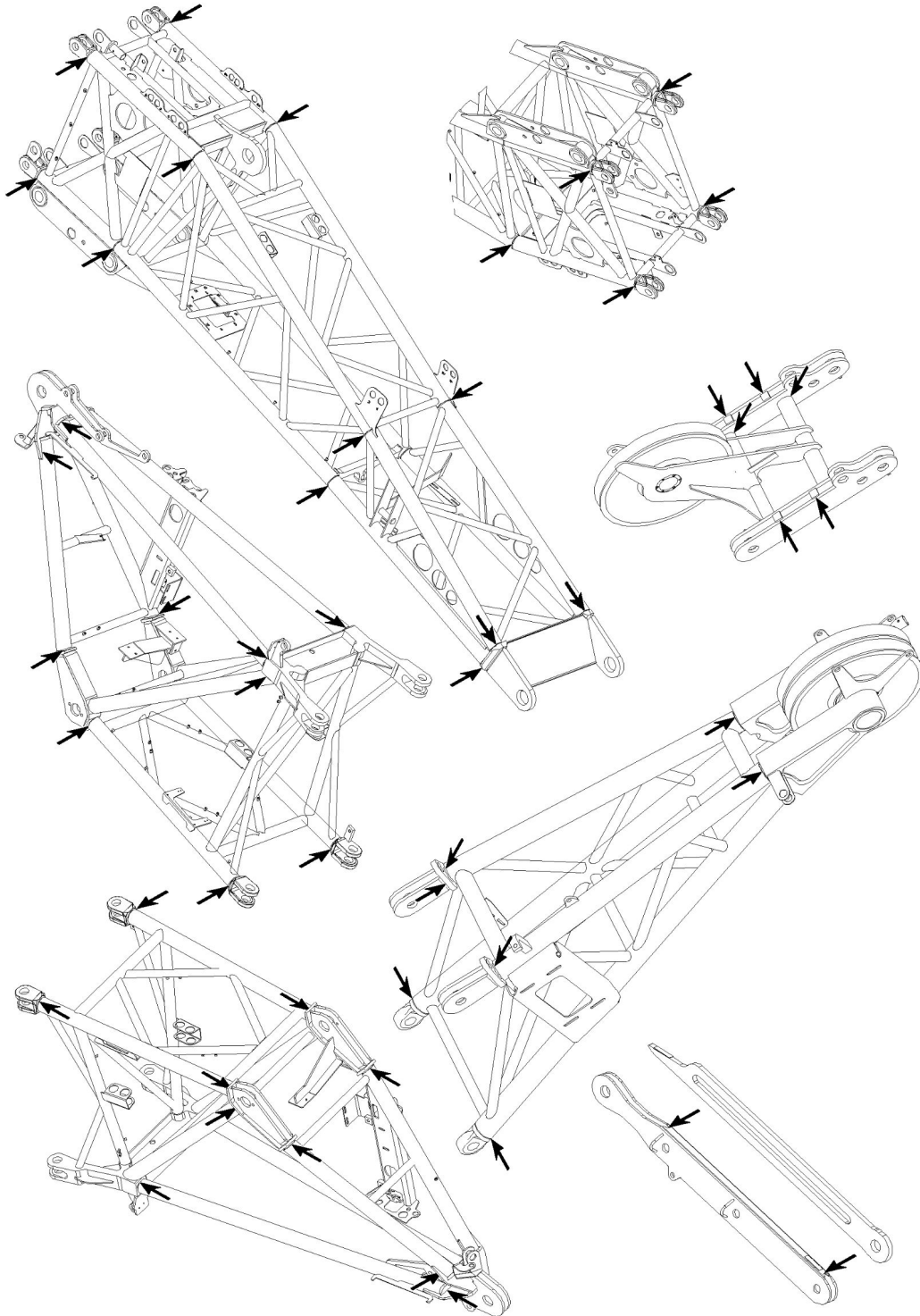


Fig.164907: Example of a pivot section, adapter and boom nose

LWE/LR 1800-1-0-000/27200-07-02/en

TA guying

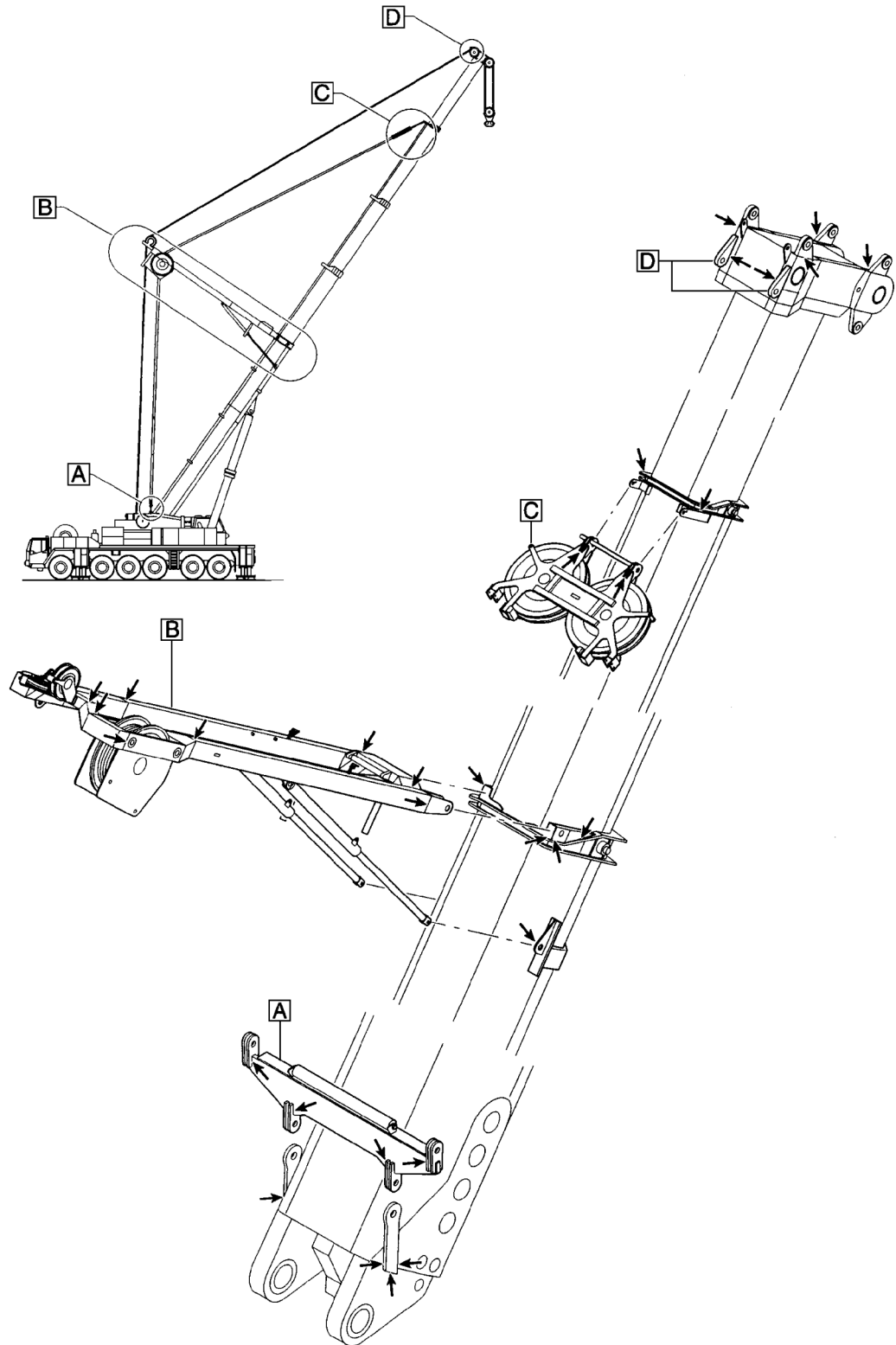


Fig.164916: Example of TA-guying

LWE/LR 1800-1-0-000/27200-07-02/en

## TY-guying

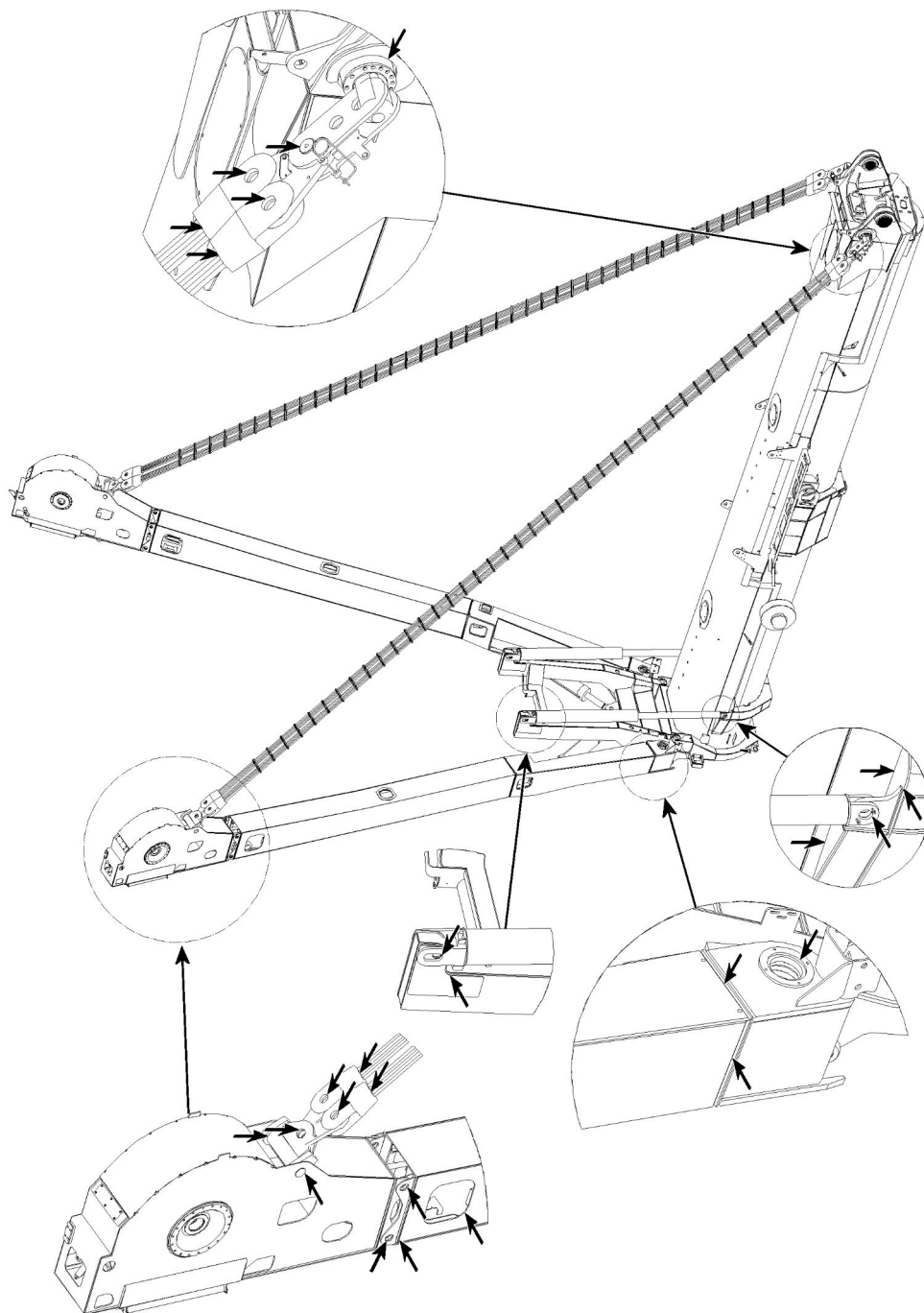


Fig.164917: Example of TY-guying

LWE/LR 1800-1-0-000/27200-07-02/en

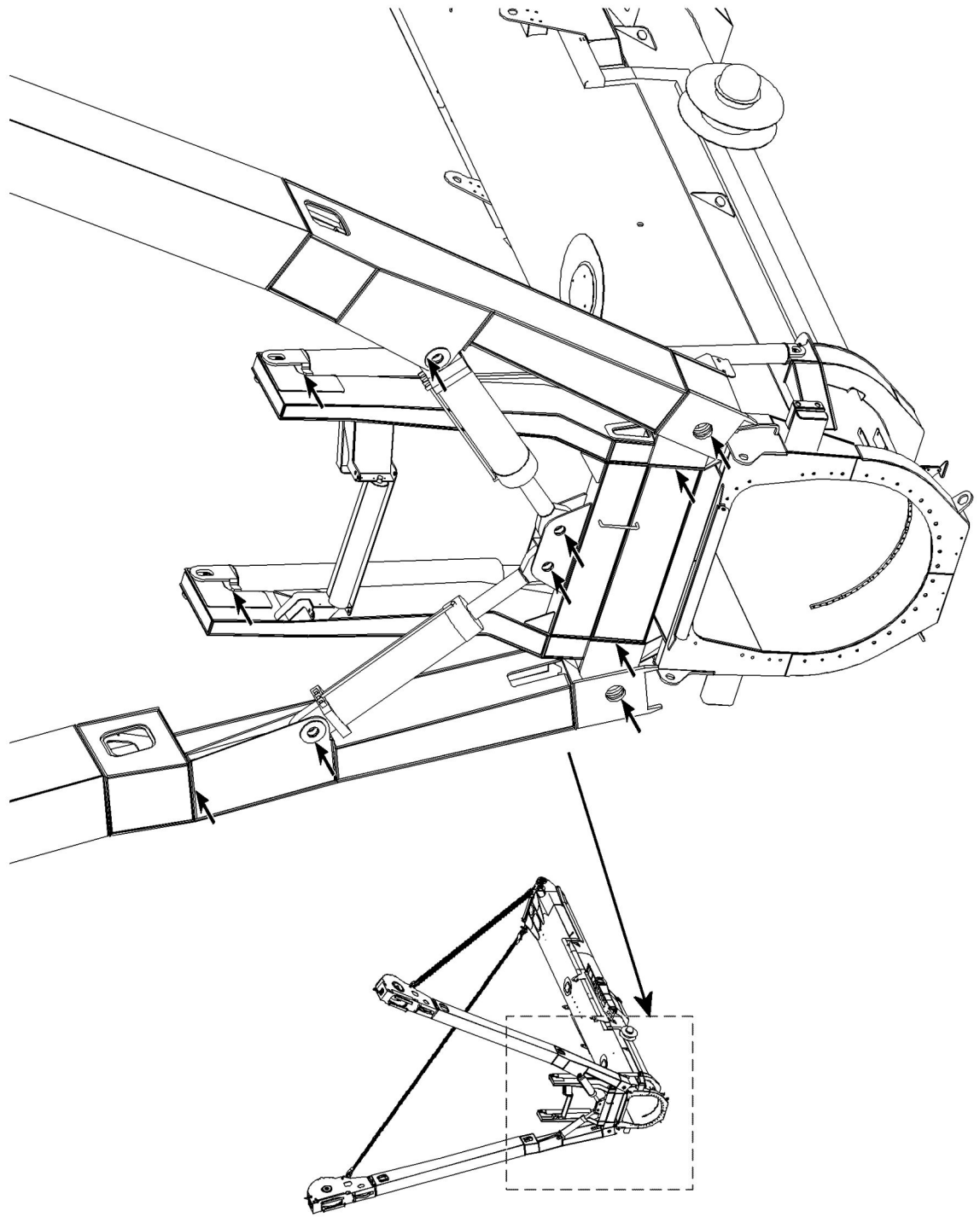


Fig.164918: Example of TY-guying

LWE/LR 1800-1-0-000/27200-07-02/en

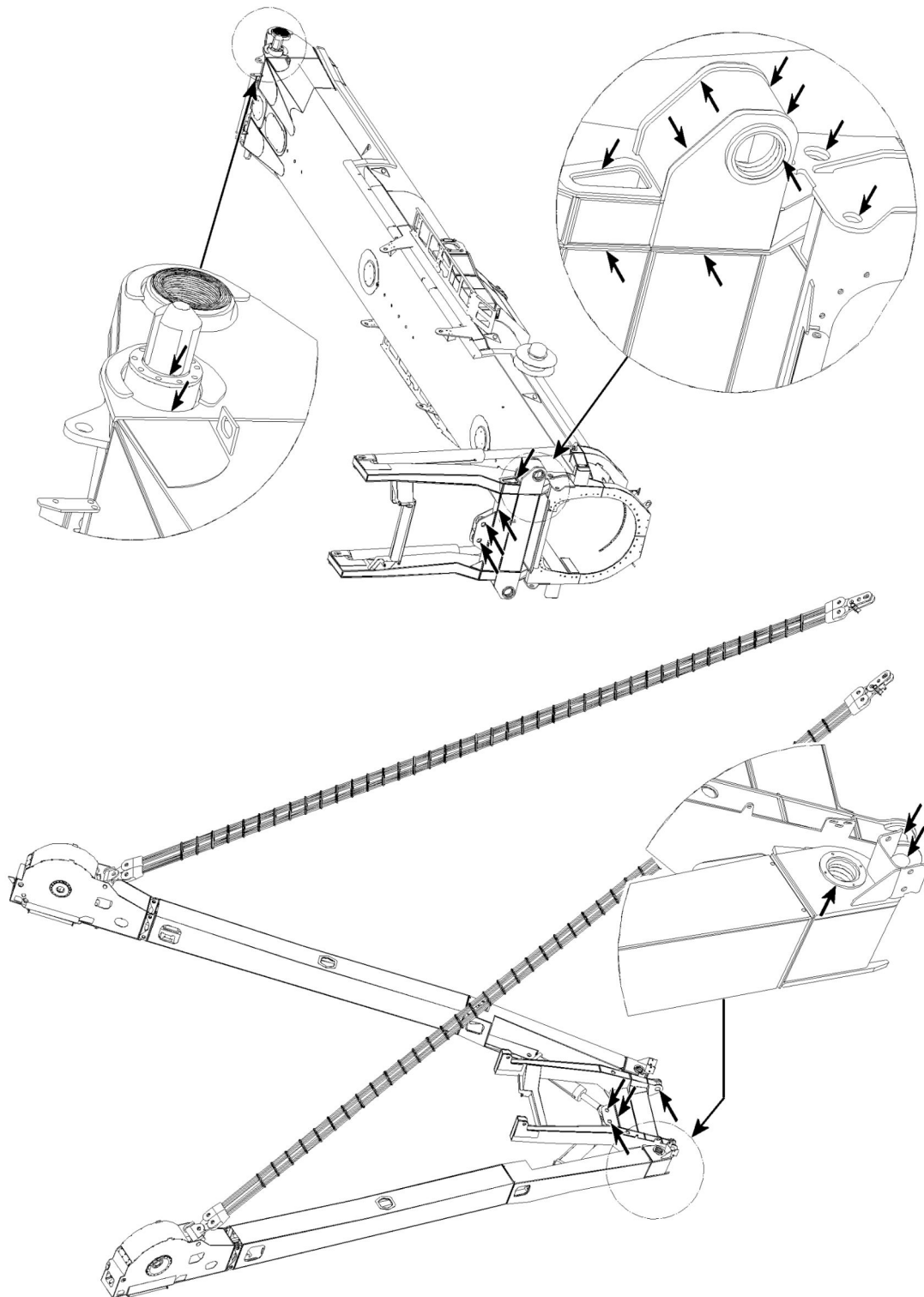


Fig.164919: Example of TY-guying

LWE/LR 1800-1-0-000/27200-07-02/en

Folding jib

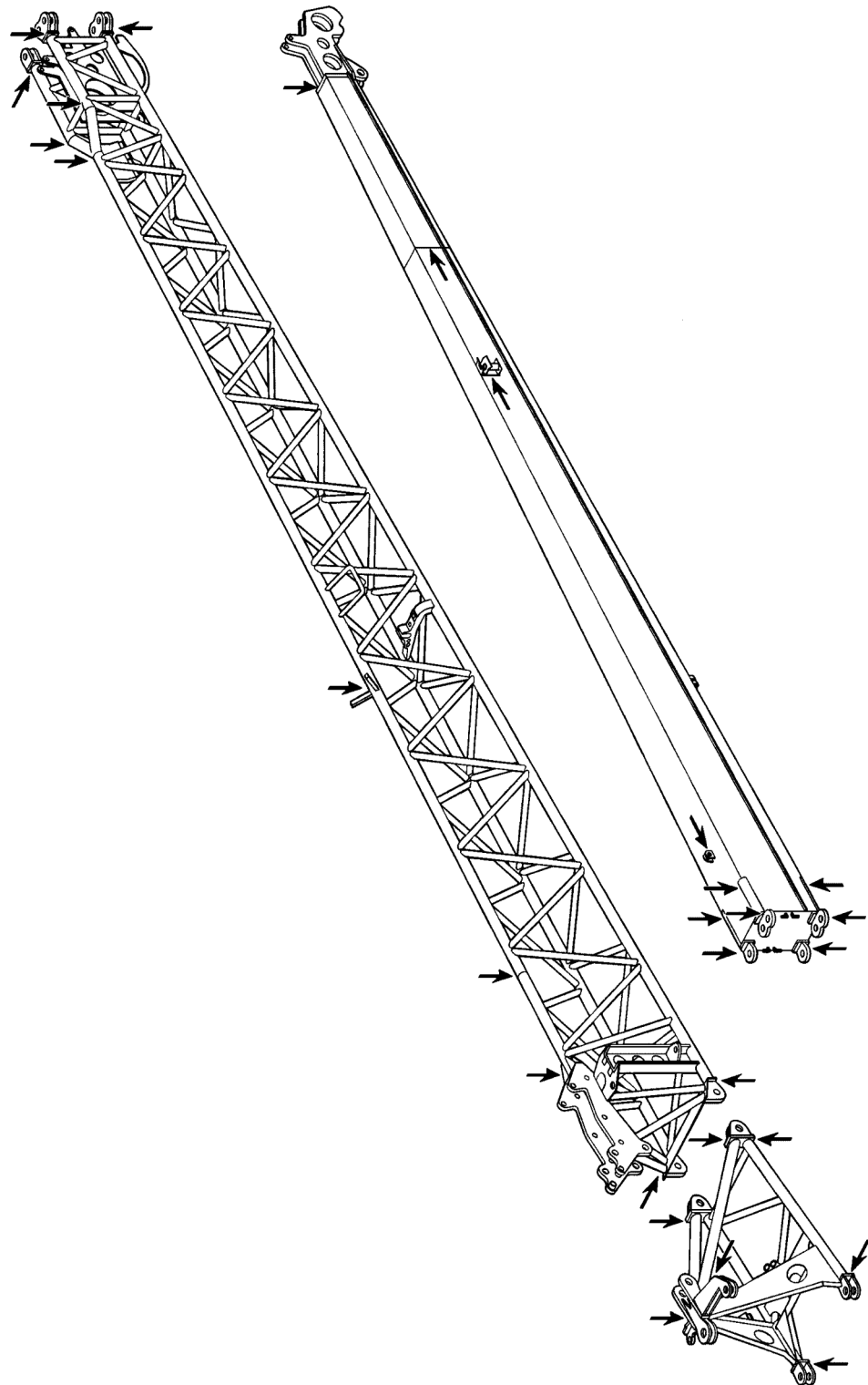


Fig.164908: Example of a folding jib

LWE/LR 1800-1-0-000/27200-07-02/en

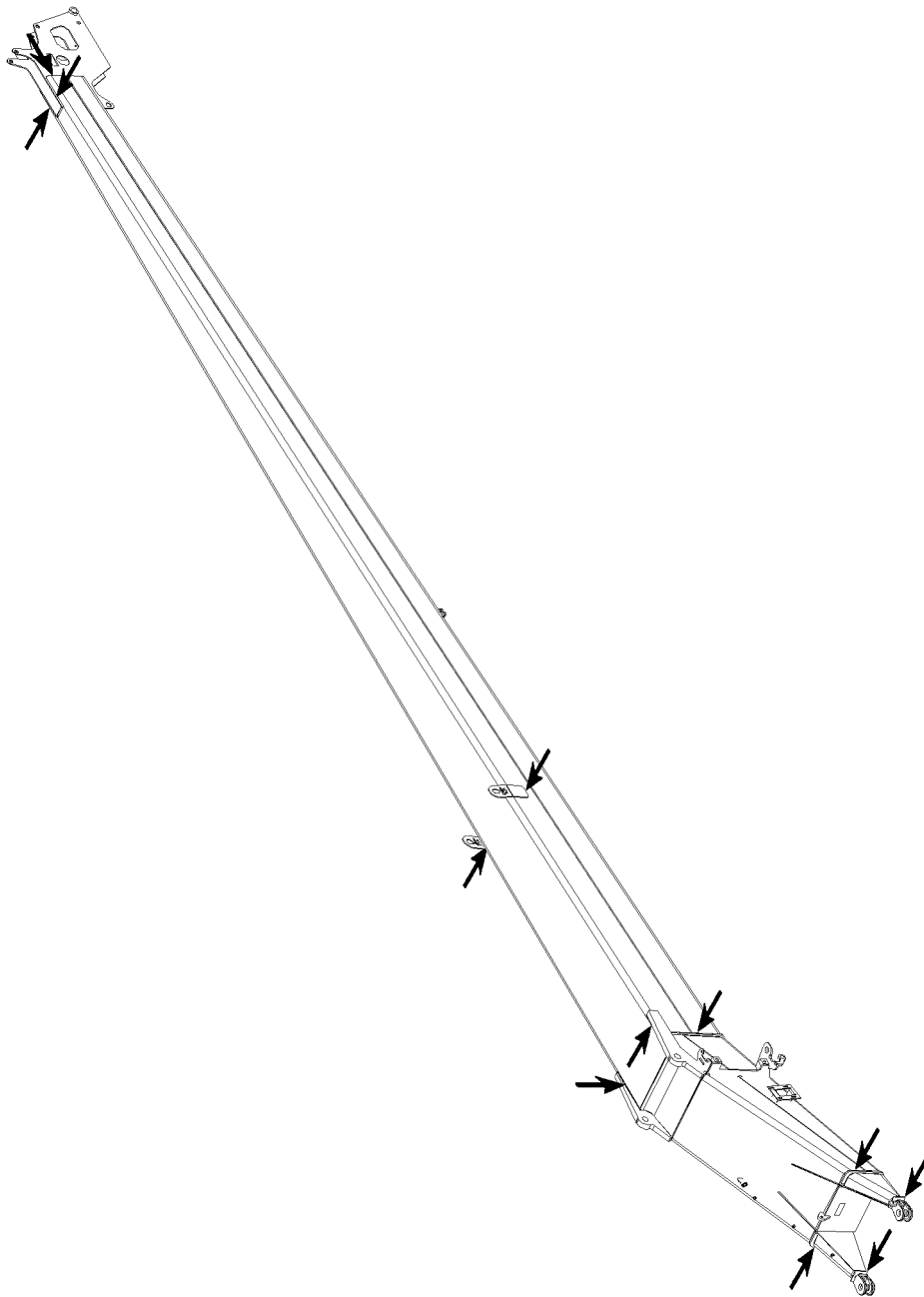
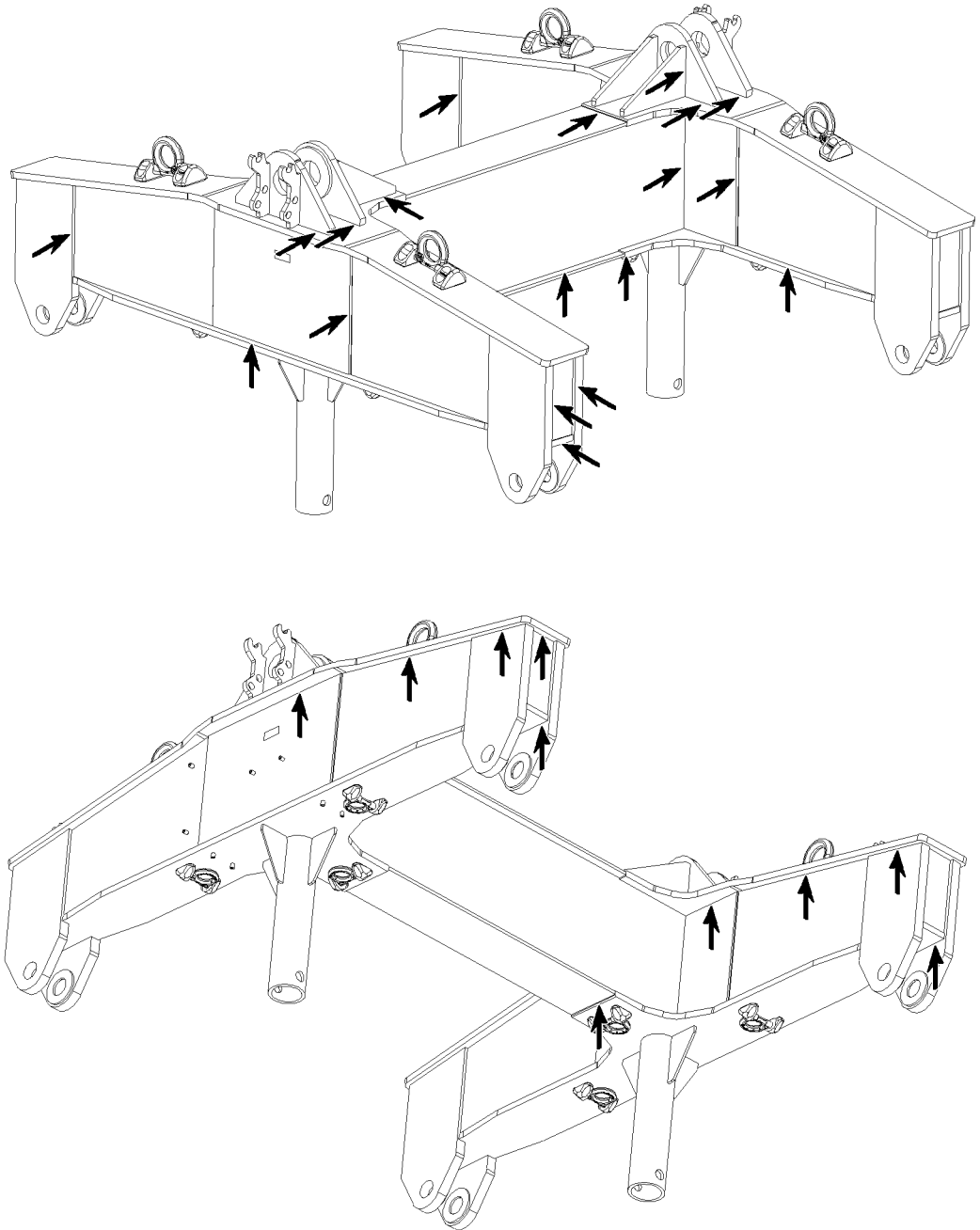


Fig. 164909: Example of a folding jib



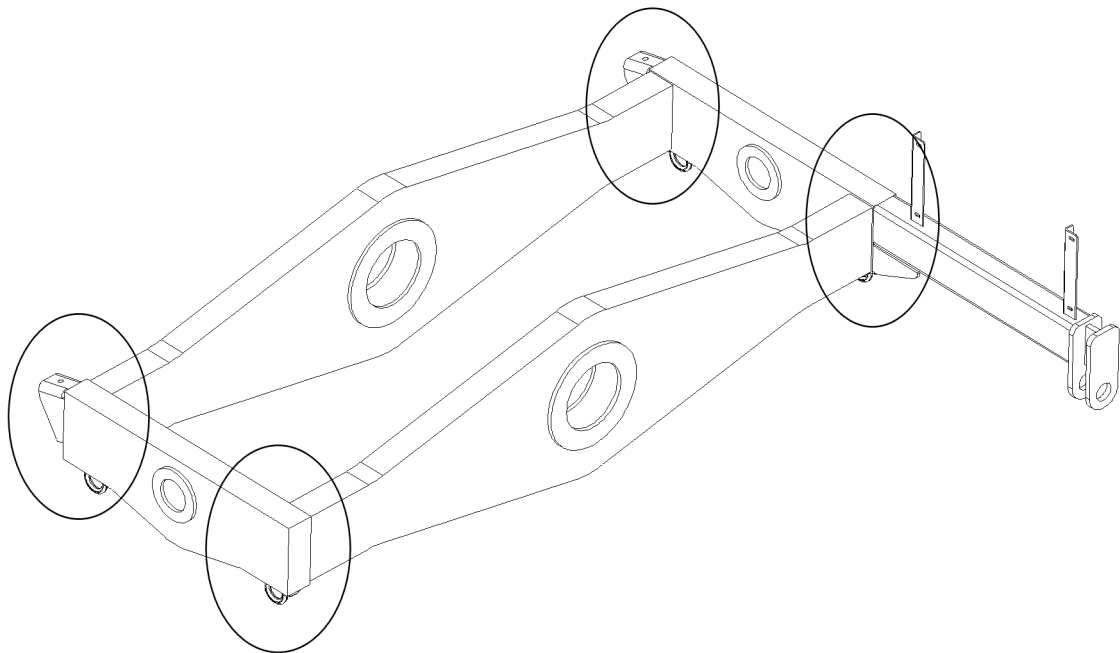
## 2.4.5 Ballast trailer

### Rocker



LWE/LR 1800-1-0-000/27200-07-02/en

Fig.164927: Example of a rocker

**Axle bracket**

*Fig.164928: Example of an axle bracket*

### Center pivot plate

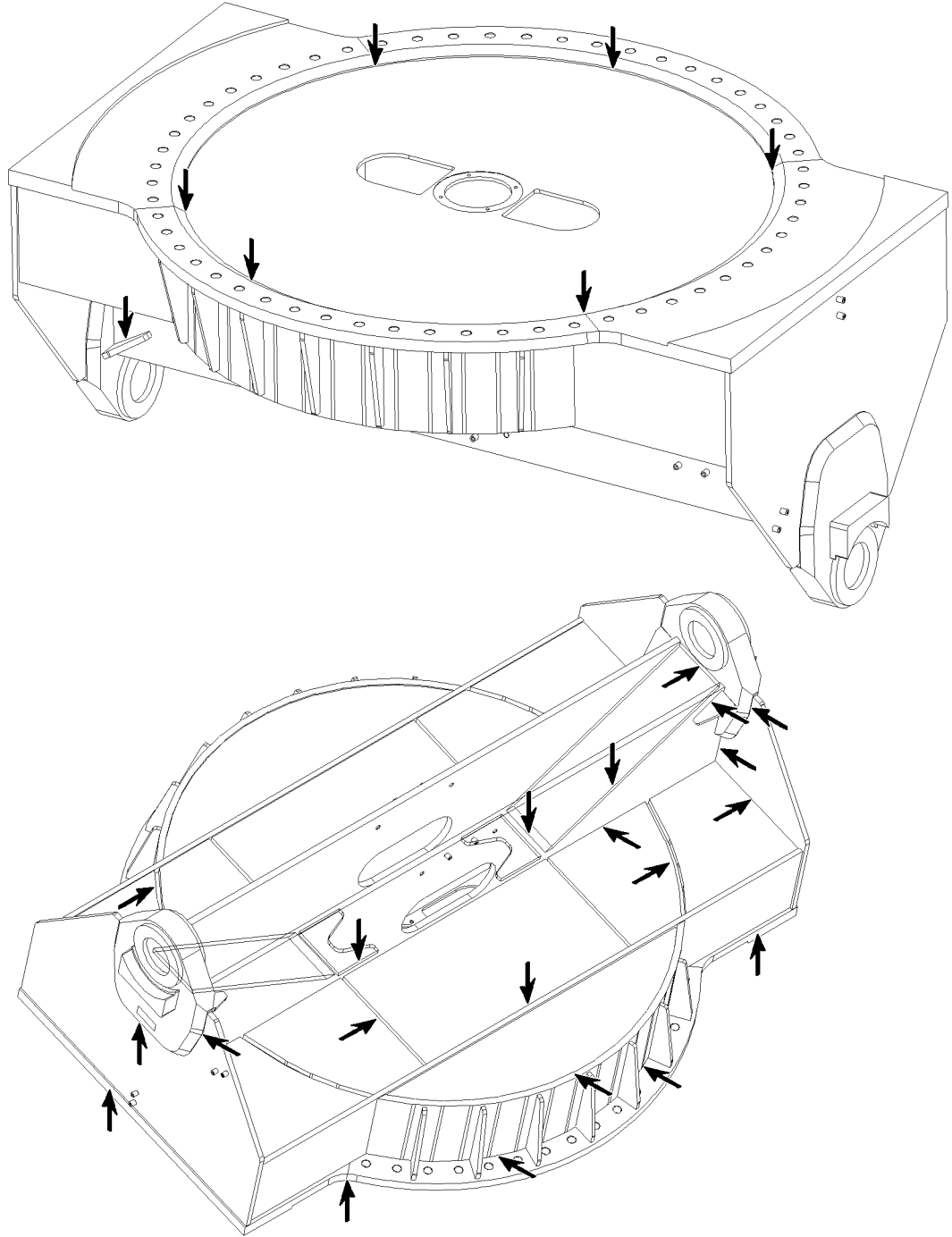


Fig.164929: Example of a center pivot plate

LWE/LR 1800-1-0-000/27200-07-02/en

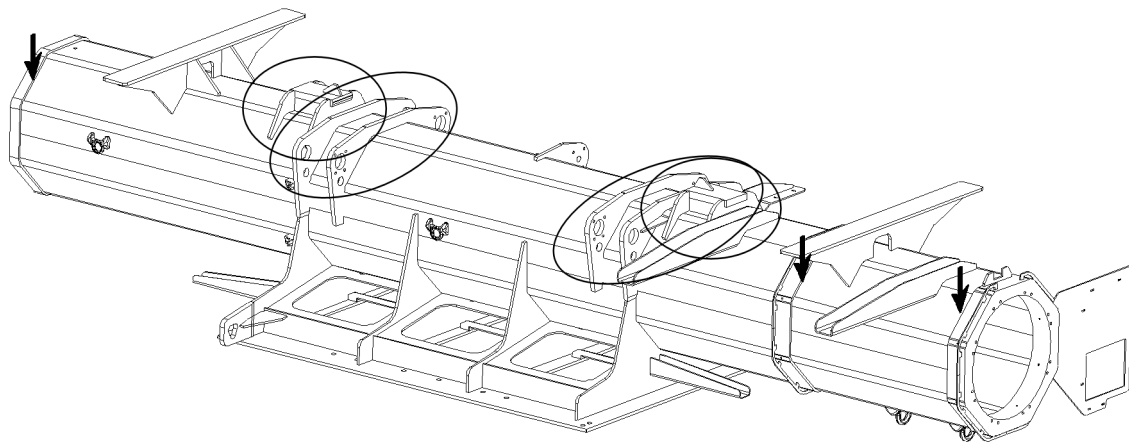
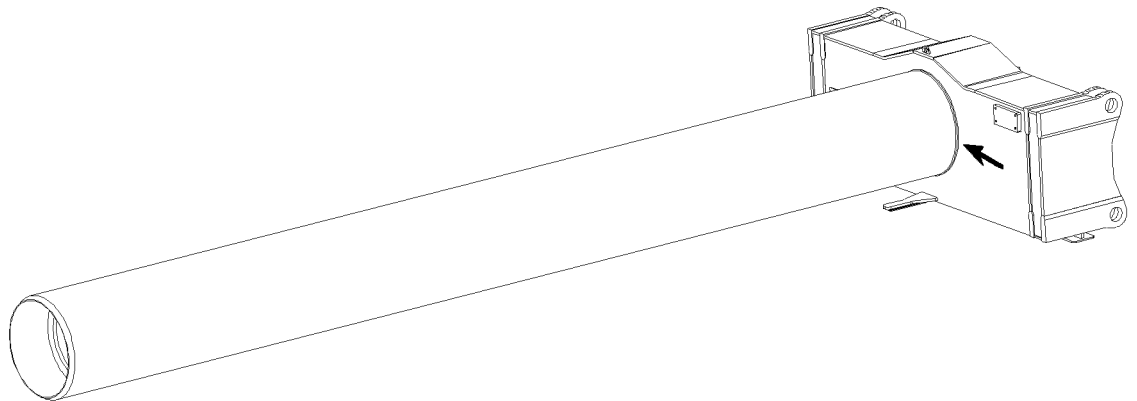
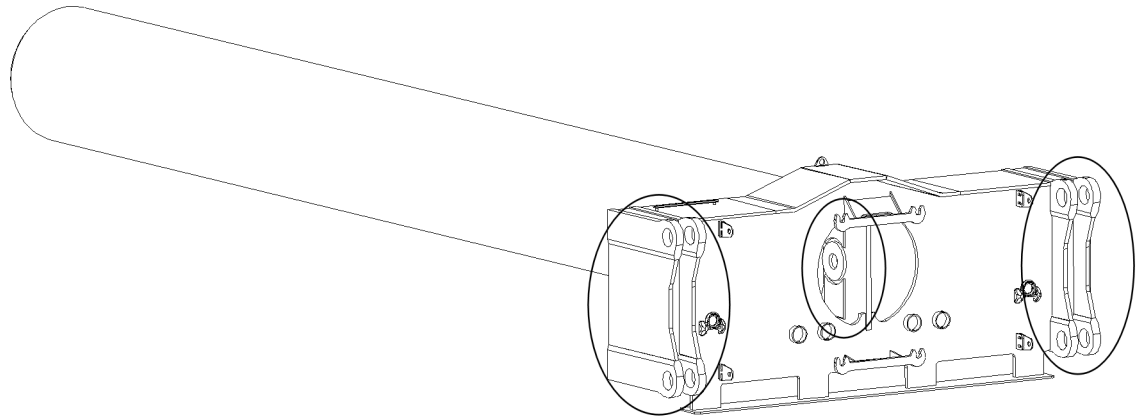
**Guide**

Fig.164930: Example of a guide

**Inner pipe**



*Fig.164931: Example of an inner pipe*

LWE/LR 1800-1-0-000/27200-07-02/en

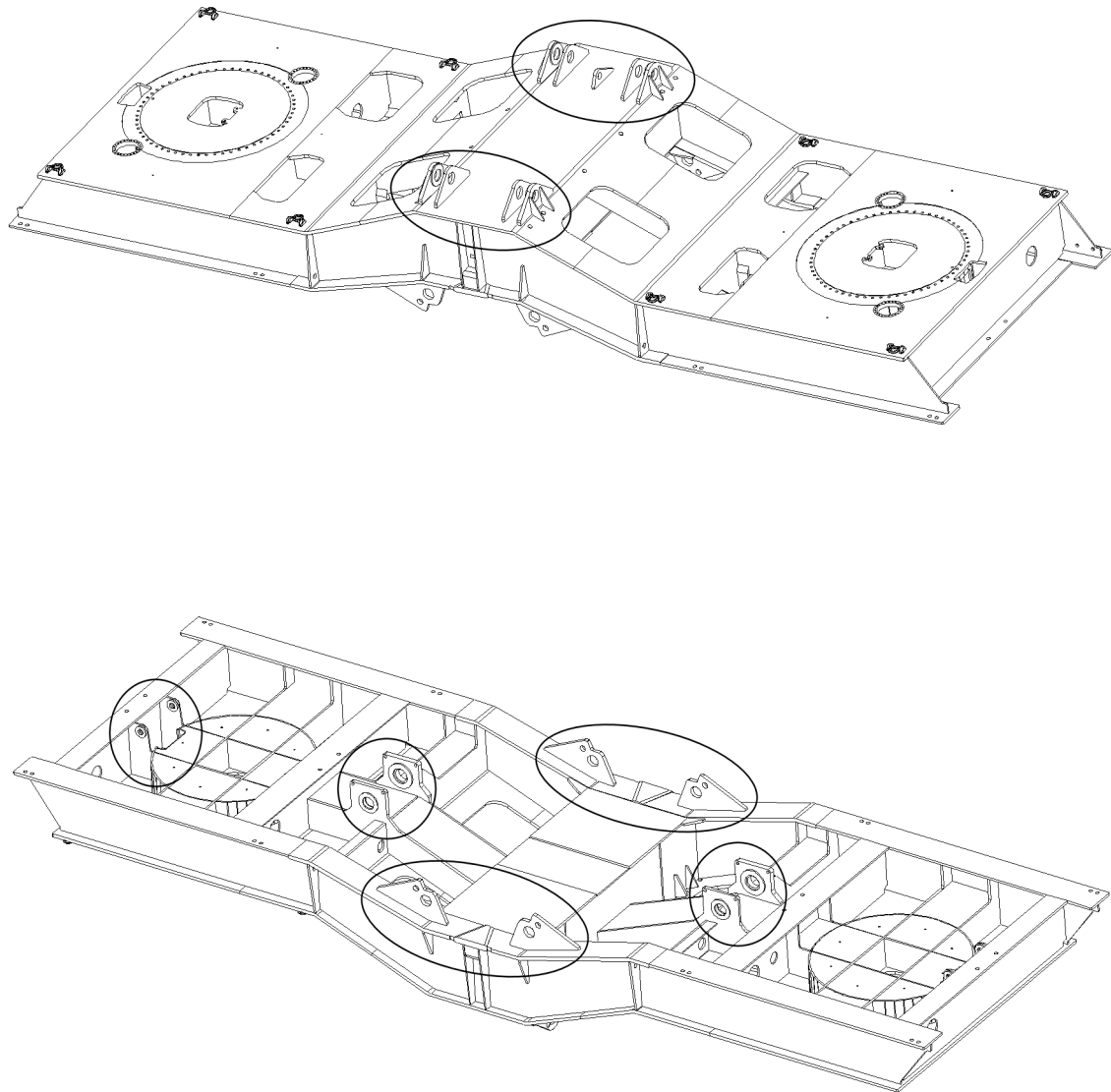
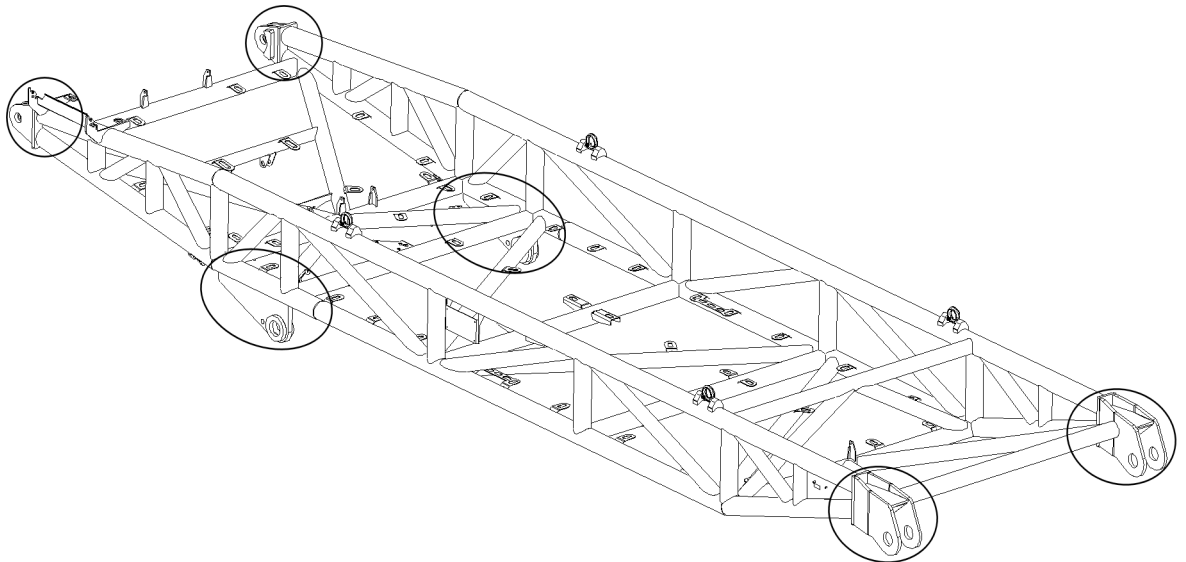
**Frame**

Fig.164932: Example of a frame

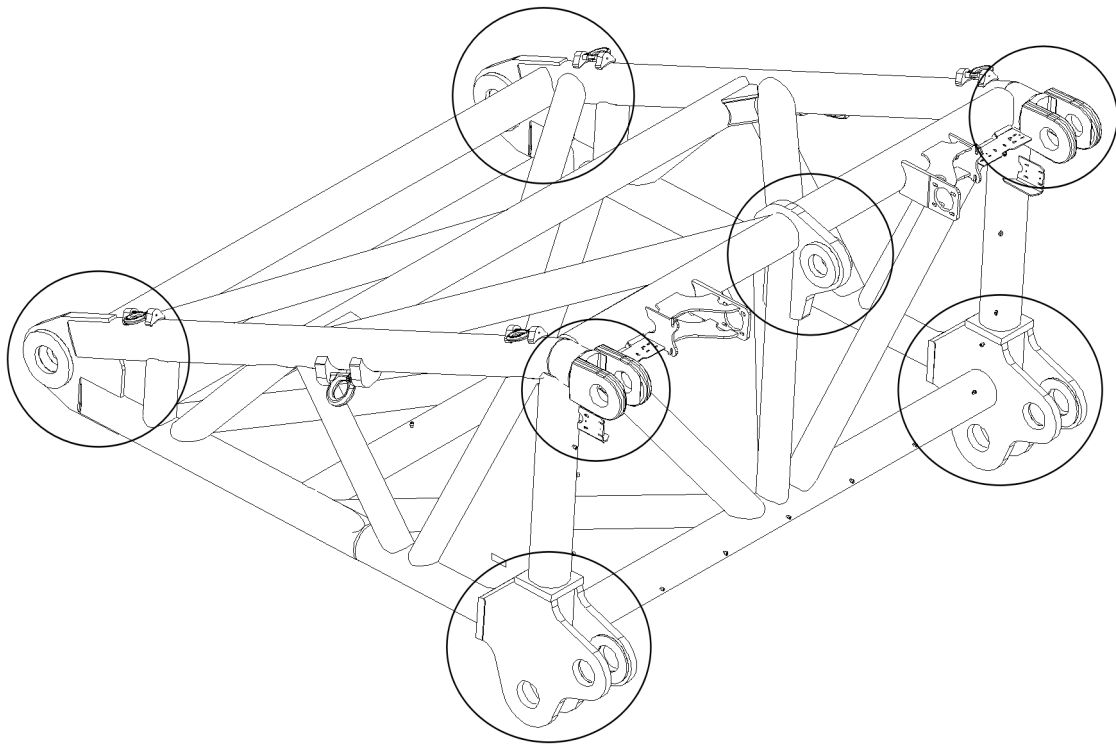
## 2.4.6 Suspended ballast guide “V-frame”

### Pivot section



LWE/LR 1800-1-0-000/27200-07-02/en

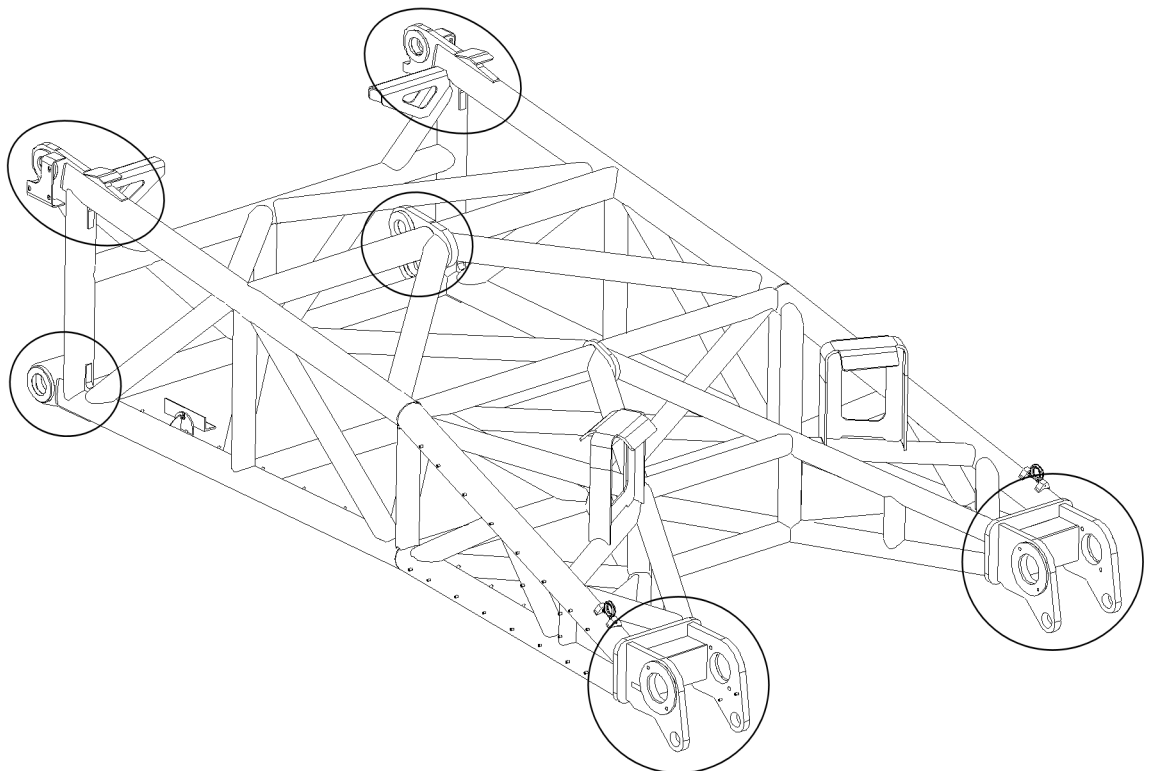
Fig.164933: Example of a pivot section

**End-pivot section**

*Fig.164934: Example of an end-pivot section*

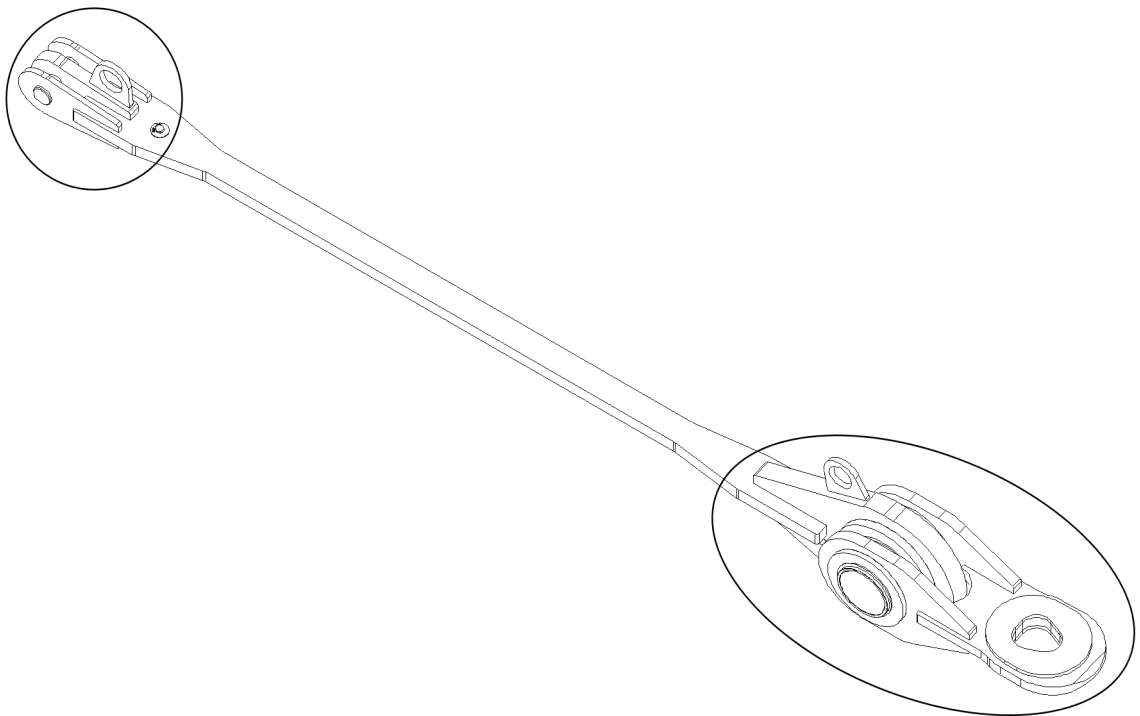


**End section**



*Fig.164935: Example of an end section*

LWE/LR 1800-1-0-000/27200-07-02/en

**Guy rod**

*Fig.164936: Example of guy rod*

## 2.5 Inspecting the rigging points and fastening points

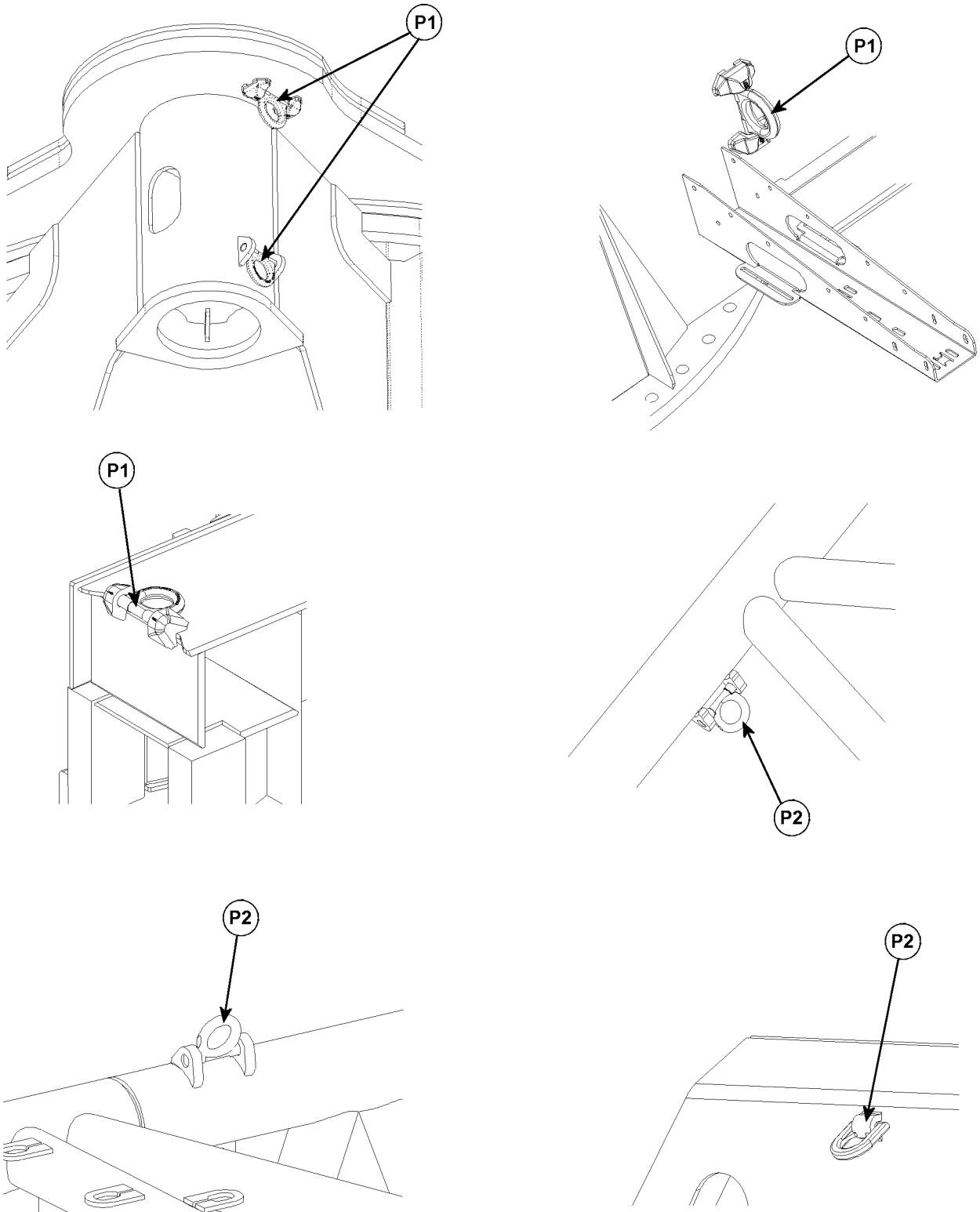


Fig.121160: Examples of rigging points and fastening points

**P1** Rigging points

**P2** Fastening points

LWE/LR 1800-1-0-000/27200-07-02/en

**WARNING**

Unsafe rigging point or fastening point!

The mobile crane or component can rip free and fall down.

When a rigging point or fastening point is not safe for operation:

- ▶ Have the rigging point or fastening point replaced by authorized and trained expert personnel.
- ▶ Avoid damage on the rigging device due to a sharp-edged load.

Make sure that the following damage does **not** occur:

- Crushing points
- Shearing points
- Catch points
- Impact points

Inspection criteria:

- Completeness of the rigging point.
- Distortion of carrying parts.
- Mechanical damage such as severe nicks.
- Changes in diameter due to wear.
- Significant corrosion (pitting).
- Cracks on carrying parts.
- Cracks or other damage on the welding seam.

Check the rigging points **P1** and fastening points **P2** before every start up and at regular intervals.

## 2.6 Inspecting the lattice sections

**Note**

- ▶ The illustration is only an example and is valid for all lattice sections!
- ▶ Check all diagonal and frame pipe connections!
- ▶ Check all bores of the fork - finger connections!

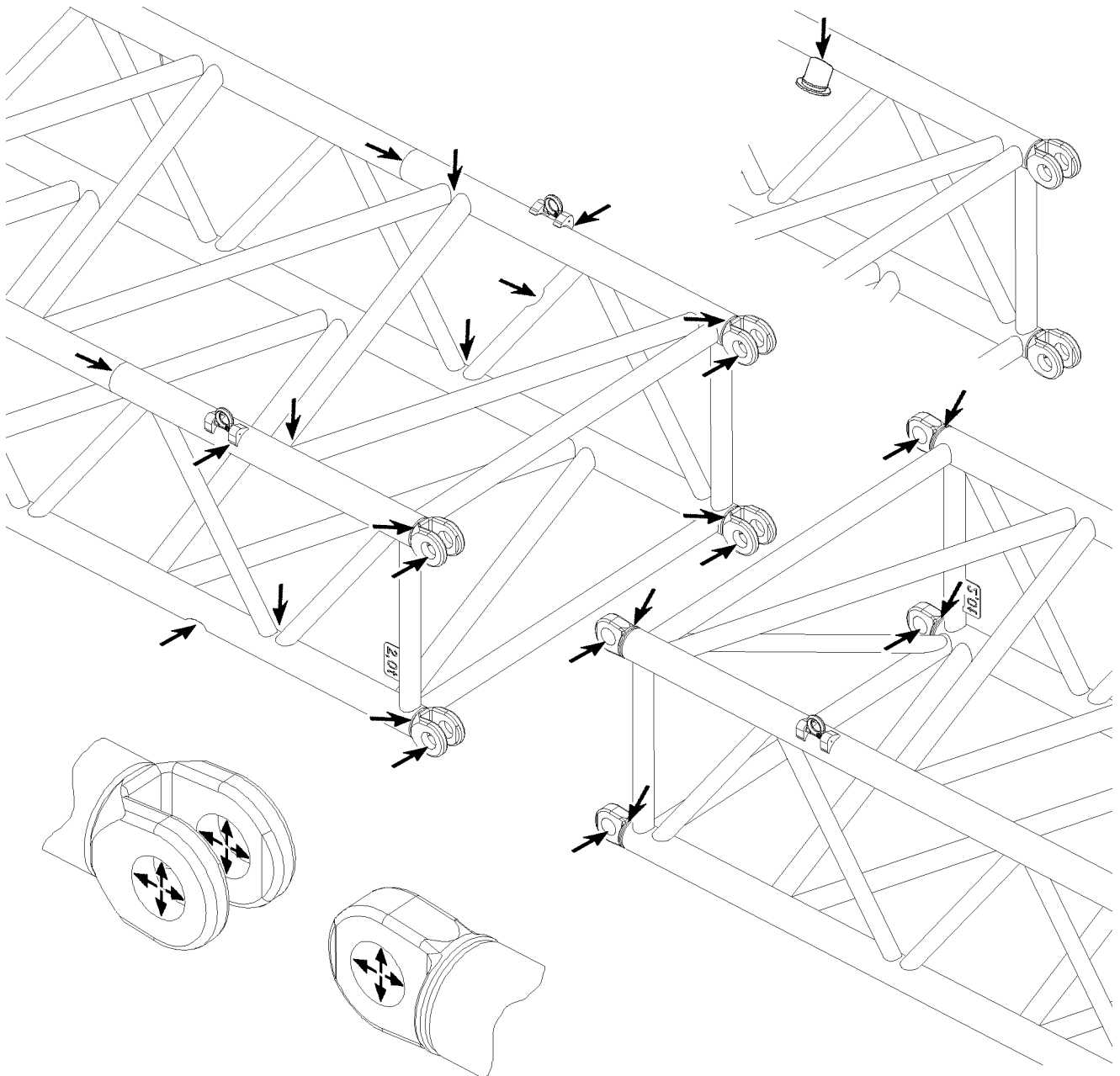


Fig.121023: Example of lattice sections

## 3 Inspecting the locking system of the telescopic boom

### 3.1 For cranes with pneumatic boom locking system

- For inspection of function, see chapter 8.11.
- For inspection of pin wear pattern, see chapter 8.11.
- For inspection of wear, see chapter 8.11.
- For inspection of safety control, see chapter 8.11.

### 3.2 For cranes with the Telematik telescopic boom system

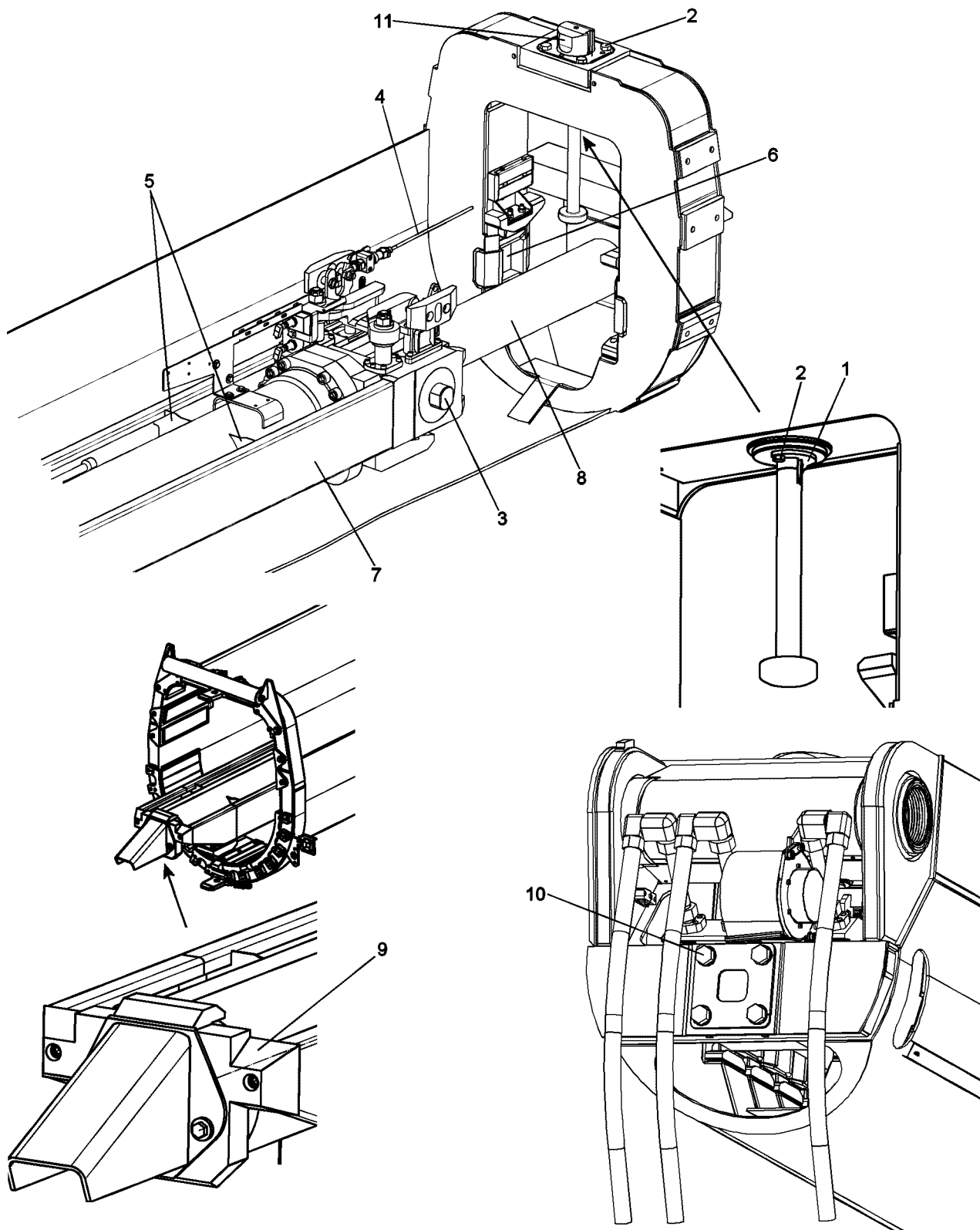
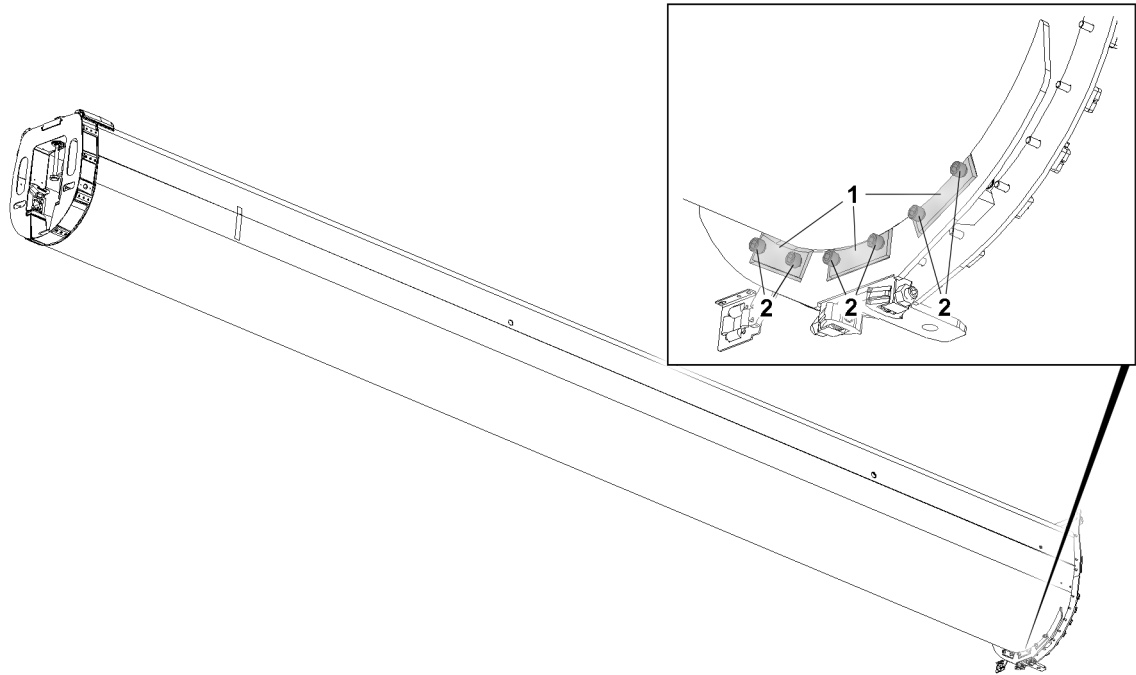


Fig.109286

- Inspection of the pull knob safety **1** and all mounting screws **2** for tight seating
- Inspection of twist guards for cylinder pinning **3** and telescopic boom pinning **11**
- Inspection of the length sensor rope **4** for damage
- Inspection of the cylinder barrel in the area of all welding seams **5** for crack formation
- Inspection of the locking pockets **6** for damage

- Grease the guide rail **7**
- In case of leakage: Inspection of the piston rod **8** for grooves
- Inspection of the wear pattern on the cylinder pinning **3** and the telescopic boom pinning **11**
- Inspection of guide rail **7** for distortion of contour
- Inspection of plastic guide **9** on the cylinder bottom for damage
- Inspection of all mounting screws **10** on the push out cylinder for tight seating

## 4 Inspection of the screws in the adjustment plates



*Fig.156447: Exemplary illustration of the adjustment plates on the telescope*

The adjustment plates **1** are **not** installed for all crane types.

Check that screws **2** in the adjustment plates **1** are firmly tightened according to the maintenance intervals.

## 5 Checking the safety ropes and anchor points

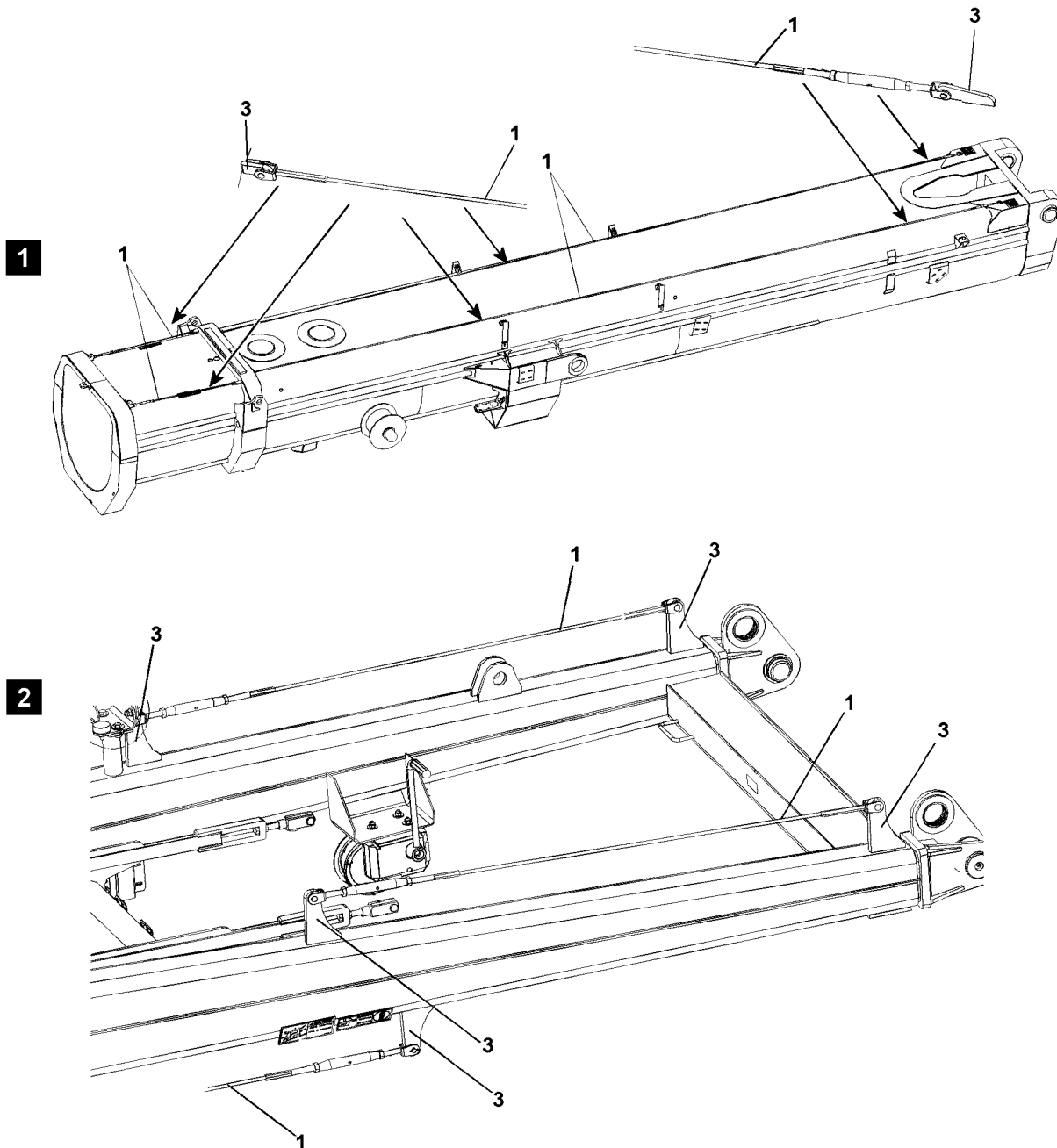


Fig.127130



### WARNING

Danger of falls due to damaged safety ropes or anchor points!

The safety ropes **1** and anchor points **3** must be checked **at least once a year** by an **authorized inspector** for safety and damage!

If any defects are found on the safety ropes **1** or anchor points **3** during the inspections, then the safety ropes **1** or anchor points **3** must be replaced immediately by authorized and trained specialists! If this is not observed, assembly personnel could be killed or fatally injured during a fall!

- ▶ The rope pretension on the safety ropes must be 800 N !
- ▶ Have damaged safety ropes **1** or anchor points **3** replaced immediately by trained expert personnel!



**Note**

Document the inspections in writing!

- ▶ The scope and results of tests should be documented to permit reproducibility. This documentation forms part of the crane records and should be safely stored during the entire service life of the crane.

## 5.1 Checking of rope pretension on telescopic booms, illustration 1

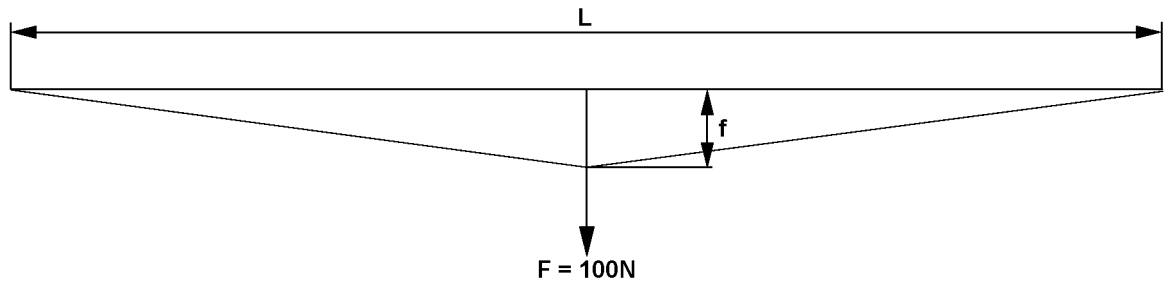


Fig.112738

The rope pretension must be 800 N. This can be checked with the aid of a spring balance, which is pulled centered on the safety rope. If the specified deflection ( $f$ ) depending on the rope length ( $L$ ) according to the following charts results for the raised load  $F = 100$  N then the rope pretension of 800 N is set correctly.

Rope pretension is 800 N if:					
Rope length (L)	1.0 m	1.5 m	2.0 m	2.5 m	3.5 m
Deflection (f)	15 mm	25 mm	30 mm	40 mm	55 mm

Rope pretension is 800 N if:					
Rope length (L)	5.5 m	7.5 m	9.5 m	11.5 m	13.5 m
Deflection (f)	85 mm	115 mm	145 mm	180 mm	215 mm

## 5.2 Inspecting the rope pretension on lattice sections, illustration 2

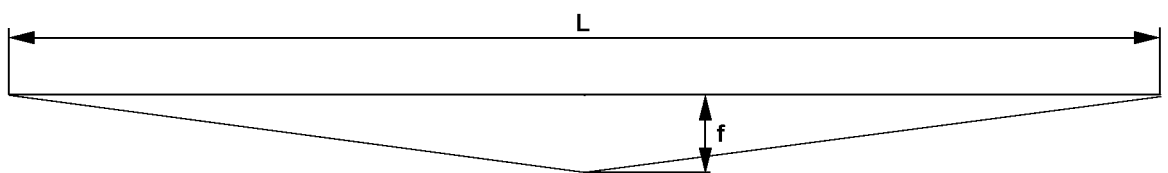


Fig.117747

The rope pretension is 800 N, if a sag ( $f$ ) according to the chart is present on the safety rope according to the rope length ( $L$ ).

Rope pretension is 800 N if:					
Rope length (L)	1.0 m	1.5 m	2.0 m	2.5 m	3.5 m
Deflection (f)	0	1 mm	2 mm	3 mm	6 mm

Rope pretension is 800 N if:					
Rope length (L)	5.5 m	7.5 m	9.5 m	11.5 m	13.5 m
Deflection (f)	15 mm	28 mm	45 mm	66 mm	90 mm

## 6 Inspecting the load handling equipment and assembly aids



### WARNING

Load handling equipment and / or assembly aids **not** inspected!

Death, severe bodily injuries, property damage.

- ▶ Inspect load handling equipment and / or assembly aids at least once a year.

The recurring inspection of the load handling equipment and / or assembly aids must be carried out once a year.

The inspections of load handling equipment and / or assembly aids must be recorded.

The welding seams must be subjected to a visual inspection.

Check load handling equipment and assembly aids for:

- Damage
- Wear
- Cracks

Replace damaged, worn or ripped load handling equipment and assembly aids immediately.

Repairs on load handling equipment and assembly aids may solely be made in consultation and under the instructions of the Customer Service at **Liebherr-Werk Ehingen GmbH** by authorized and trained expert personnel.



### Note

- ▶ Document the scope of the inspection and the results in writing and comprehensibly.
- ▶ Save the documentation as a part of the crane records for the entire service life of the crane.

## 7 Inspecting of fastening equipment



### WARNING

Fastening equipment **not** inspected!

Death, severe bodily injuries, property damage.

- ▶ Check the fastening equipment at least once a year.

The inspections of the fastening equipment must be recorded.

The welding seams must be subjected to a visual inspection.

Inspect the fastening equipment according to the specifications of the corresponding regulations and standards.

Replace damaged, worn or ripped fastening equipment immediately.



### Note

- ▶ Document the scope of the inspection and the results in writing and comprehensibly.
- ▶ Save the documentation as a part of the crane records for the entire service life of the crane.

## 7.1 Grommets and cable laid fastening rope

Observe and comply with the manufacturer's operating instructions.



### WARNING

Damaged grommets and cable laid fastening rope used!

The fastening ropes can fail. The load can fall down.

- ▶ Do **not** use grommets and cable laid fastening rope with a corresponding number of wire breaks.
- ▶ Do **not** use grommets and cable laid fastening rope with a corresponding amount of damage.

Do **not** use grommets and cable laid fastening rope if there is one of the following numbers of wire breaks:

- Wire breaks of more than 10 wires along a length of 3D
- Wire breaks of more than 15 wires along a length of 6D
- Wire breaks of more than 40 wires along a length of 30D

Do **not** use grommets and cable laid fastening rope in the case of the following damage:

- Strong rope distortion
- Rotary distortion
- Kinks, bends, basket formation
- Corrosion
- Corrosion of the zinc coating
- Opening of the splice
- Loosening or opening of the rope bond
- Displacement of the rope bond from its original position
- Lack of identification

## 8 Inspecting the hydro reservoir



### Note

- ▶ The national regulations for pressure container inspection must be observed!

The inspection of the hydro reservoir for specified gas pressure must be carried out by an **authorized inspector**, see chapter 7.04 and chapter 7.05.

## 9 Inspecting the relapse cylinders

The technical data required for "Inspecting the relapse cylinders" is provided on the relapse cylinders.



### WARNING

Fatal accidents due to defective relapse cylinders!

Loss of oil or corrosion can damage the relapse cylinders!

Safe crane operation is no longer ensured!

- ▶ Crane operation with defective relapse cylinders is prohibited!

### 9.1 Pressure testing the relapse cylinders

The relapse cylinders must be inspected annually by an **authorized inspector**. The purpose of the inspections is to avoid accidents by detecting deficiencies early on.

## 9.2 Checking the gas pressure and oil fill before start up



### WARNING

Fatal accidents due to defective relapse cylinders!  
Loss of oil or corrosion can damage the relapse cylinders!  
Safe crane operation is no longer ensured!

- ▶ Before every start up: Carry out a visual inspection for leaks, damage and corrosion on the relapse cylinders.
- ▶ If any defects are found, the relapse cylinders must be inspected by the cylinder manufacturer!

The gas pressure and the oil fill must be checked by an **authorized inspector** for pressure containers.

## 9.3 Inspecting the safety controls on the relapse cylinders

Inspecting the interlocking system or limit switches on the relapse cylinders and the boom A-frames, see chapter 8.12.

# 10 Inspecting the rope pulleys

## 10.1 Checking for damage and cracks



### DANGER

Danger of accident in case of damage or cracks!

- ▶ Replace rope pulley immediately!

Check the entire rope pulley assemblies for damage and cracks once a year.

If rope pulleys are subjected to any impacts (e.g., with buildings) or are otherwise overloaded, they must be visually inspected for damage or cracks immediately.

## 10.2 Checking the groove diameter

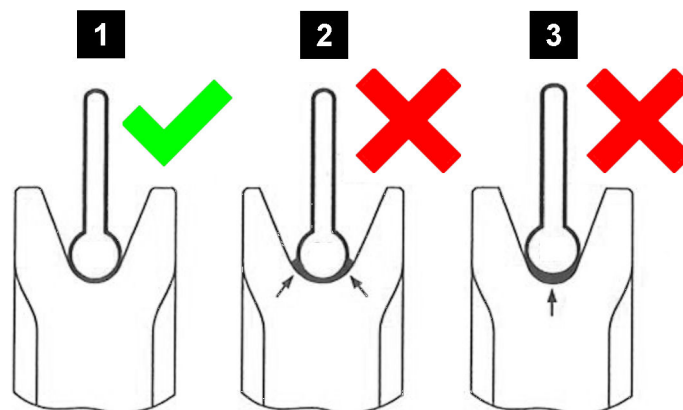


Fig.154258: Checking the groove diameter

- |   |                                     |
|---|-------------------------------------|
| <p>1 Groove diameter ok</p> <p>2 Groove diameter too wide</p> | <p>3 Groove diameter too narrow</p> |
|---|-------------------------------------|

### NOTICE

Worn rope pulleys!

The functionality and service life of the rope is reduced. Damage on rope.

- ▶ Before placing the rope, check the groove diameter of rope pulleys.

Visible wear on rope pulleys:

- Reduced groove diameter
- Negative impressions of the rope profile in the groove

Make sure that the following tools are available:

- Groove caliper

Make sure that the following prerequisites are met:

- All components to be inspected are cleaned.
- The rope does **not** obstruct the inspection of the components.



#### Note

- ▶ The actual groove diameter **must** be larger than the actual diameter of the rope!

The groove diameter of rope pulleys and winches must be at least 6 % larger than the nominal rope diameter.

Check the rope pulleys with a groove caliper for wear. When wear exists on the rope grooves: Repair or replace the rope pulleys.

## 11 Inspecting the carrier rollers

### 11.1 Performing a visual inspection



#### DANGER

Damaged carrier rollers!

Breakage and falling components. Death, severe bodily injuries, property damage.

- ▶ Carry out a visual inspection according to the maintenance intervals.
- ▶ Replace the carrier roller immediately.

The visual inspection must be carried out according to the following criteria:

- Wear
- Damage
- Cracks

Visible wear on carrier rollers:

- Negative imprints of the rope profile on the circumference of the carrier rollers
- Lead-in tracks

### 11.2 Checking the depth of the lead-in tracks



#### DANGER

Worn carrier rollers!

Breakage and falling components. Damage to ropes. Death, severe bodily injuries, property damage.

- ▶ Check the depth of the lead-in tracks.
- ▶ Replace worn carrier rollers immediately.

Make sure that the following prerequisites are met:

- All components to be inspected are cleaned.
- The rope does **not** obstruct the inspection of the components.

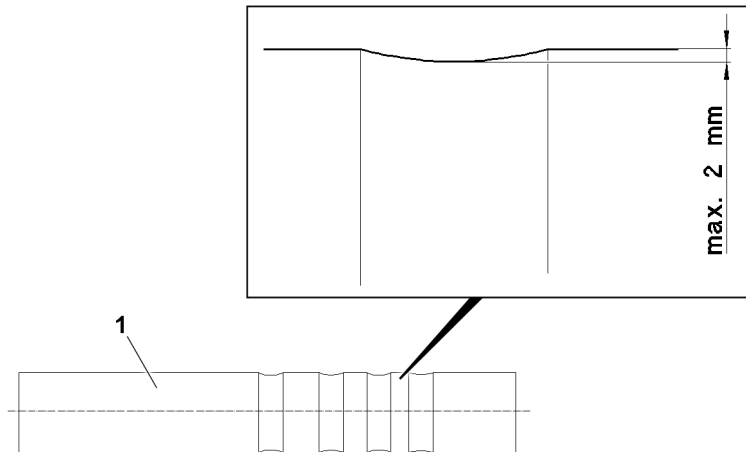


Fig.124864: Permissible depth of the lead-in tracks

1 Carrier roller

The depth of the lead-in tracks may be maximum 2 mm.

### 11.3 Checking the bearings for easy movement

Stiff or blocked carrier rollers wear unevenly and cause serious rope abrasion.

Ineffective carrier rollers can lead to irregular rope tension.

Tasks to check the carrier rollers:

- Check the carrier rollers for proper movement in their bearings.
- When carrier rollers are **not** easily moveable in their bearings: Fix the bearings.

### 11.4 Checking the tightening torque

The tightening torque of screws must be checked according to maintenance interval.

## 12 Inspecting the extension conditions of sliding beams

The extension conditions of the sliding beams must be inspected annually by an **authorized inspector**.

Check the extension conditions on every sliding beam:

- Check if the position 0 % of the LICCON display matches the actual condition of the sliding beam.
- Check if the 100 % position of the LICCON display matches the actual condition of the sliding beam.

## 13 Inspecting the inclination sensor

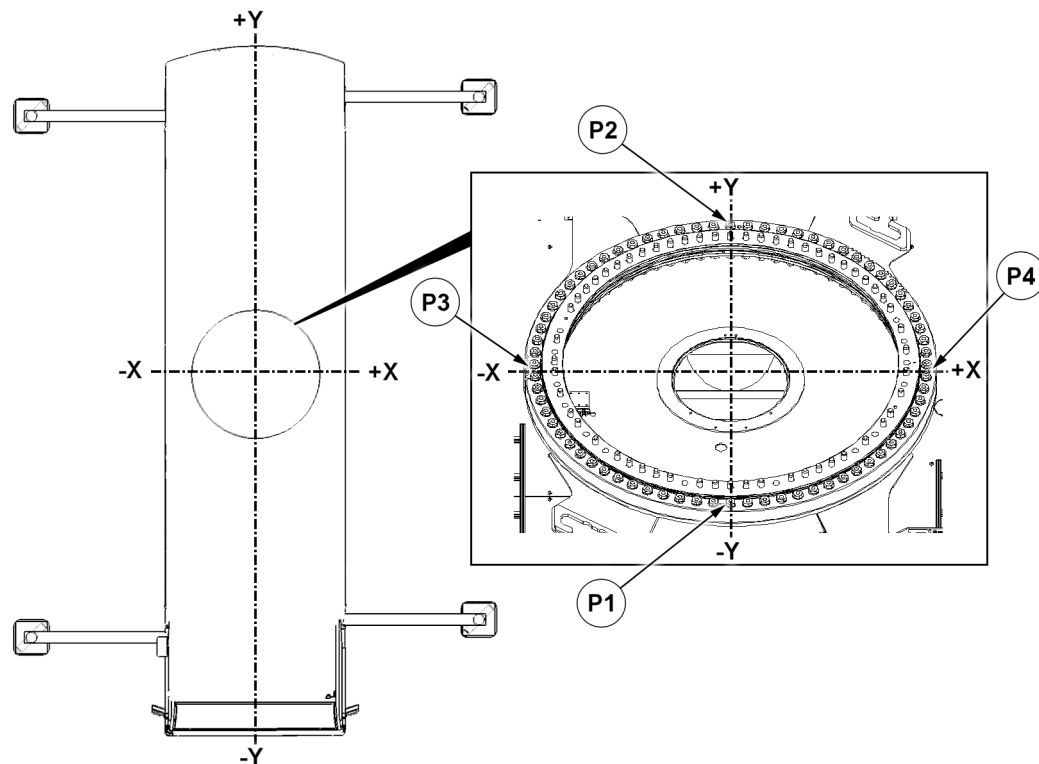


Fig.162529: Slewing ring connection inspection points

<b>X</b>	Lateral direction	<b>P2</b>	Lateral direction inspection points
<b>Y</b>	Longitudinal direction	<b>P3</b>	Longitudinal direction inspection points
<b>P1</b>	Lateral direction inspection points	<b>P4</b>	Longitudinal direction inspection points

The inclination sensor must be inspected annually by an authorized inspector.

For the test of the inclination sensor on the crane, an independent measuring device, such as a spirit level and a **machined** surface of the slewing ring connection are required. The digital spirit level must have a display accuracy of at least  $0.1^\circ$  or better.

The test of the inclination sensor must be carried out once in the lateral direction and once in the longitudinal direction with respect to the crane chassis.

The average inclinations determined with the digital spirit level must be compared afterward with the displayed incline values on the LICCON monitor or on the BTT.

The maximum permissible difference between the average inclinations of the digital spirit level and the values on the LICCON monitor or the BTT is  $\leq 0.2^\circ$ .



### DANGER

Difference of the inclination values greater than  $0.2^\circ$ !

The crane can topple over.

Death, severe bodily injury, property damage.

- ▶ Stop crane operation.
- ▶ Contact Customer Service at Liebherr-Werk Ehingen GmbH.



### Note

Inspection of the inclination sensor in the longitudinal direction with respect to the crane chassis **not** possible!

- ▶ Turn the crane superstructure  $90^\circ$ .
- ▶ Determine the incline values again.

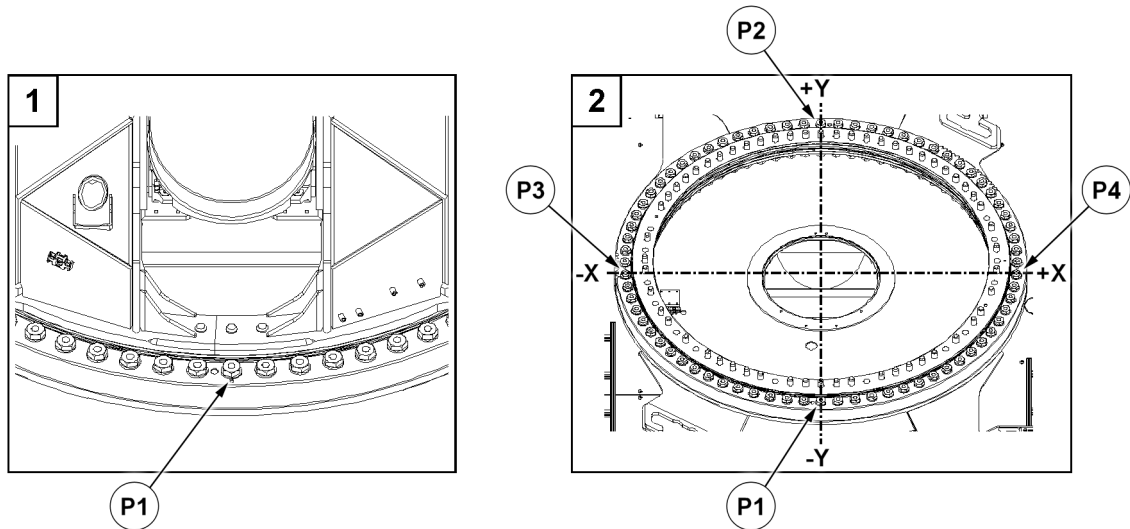


Fig.162524: Slewing ring connection inspection points

<b>X</b>	Lateral direction	<b>P2</b>	Lateral direction inspection points
<b>Y</b>	Longitudinal direction	<b>P3</b>	Longitudinal direction inspection points
<b>P1</b>	Lateral direction inspection points	<b>P4</b>	Longitudinal direction inspection points

Tasks for inspecting the inclination sensor on the crane

- For cranes with crane support: Support the crane.
- Align the crane horizontally to 0.0°.
- Disassemble the load handling equipment on the boom and remove it.
- For cranes with a telescopic boom: Telescope the telescopic boom in all the way.
- Pin the crane superstructure in the 180° position.
- Free the support surface for the digital spirit level of grease, paint and dirt.
- Check the inclination sensor in the lateral direction:  
Place the digital spirit level in the test point **P1** or test point **P2**.
- Check the inclination sensor in the longitudinal direction:  
Place the digital spirit level in the test point **P3** or test point **P4**.
- Compare the average inclinations determined with the digital spirit level with the displayed incline values on the LICCON monitor or on the BTT.

## 14 Inspecting the function of the overload protection

Position the longest boom at minimum and maximum radius: Check the load indicator, using the hook block as a test load.

The display reading may not deviate by more than 10 % off the true load value at these two extreme positions.

Measure the indicated radius for the longest boom at its minimum radius and at a boom angle of 45°.

The display readings may not deviate more than 10 % from the measured boom radius.

## 15 Inspecting the pin connections



### WARNING

Pin connections **not** inspected!  
Death, severe bodily injuries, property damage.

- ▶ Check the pin connections at least once a year.

The periodic inspection of all pin connections must be carried out once a year.



The inspections of the pin connection must be recorded.

Check the pin connections for:

- Properly secured pin connections
- Damage to the pins and / or connector elements
- Damage to the retaining elements

Replace damaged pins immediately.

Immediately replace damaged, bent or broken retaining elements.

Only replace damaged pins with identical pins.

Only replace damaged retaining elements with identical retaining elements.



#### Note

- ▶ Document the scope of the inspection and the results in writing and comprehensibly.
- ▶ Save the documentation as a part of the crane records for the entire service life of the crane.

## 16 Inspecting the slewing ring connection

### 16.1 Checking the tilt play

The wear of the slewing ring connection is determined by measuring the tilt play with the ring installed.

The permissible tilt play depends on the type of slewing ring connection.



#### WARNING

The tilt play of the slewing ring connection is too large!

If the permissible tilt play is exceeded, then safe crane operation is **no** longer possible.

Death, severe bodily injuries, property damage.

When the permissible tilt play is exceeded:

- ▶ Replace the slewing ring connection.

The determination of the tilt play must be carried out according to the **test instructions** of **Liebherr-Werk Ehingen GmbH**.

Request the test instructions and permissible tilt play: Contact Liebherr Customer Service.

## 17 Inspecting the mounting of the load bearing equipment

### 17.1 Checking the tightness of the mounting screws

The mounting screws must be checked for a tight fit during the annual crane inspection.

The mounting screws are pre-stressed at the factory, so that no loosening of the screw connections will occur during normal crane operation.

The screw connection may become overloaded and the mounting screws may be permanently stretched if the crane is overloaded or if the load is pulled free. The mounting screws must be checked immediately for a tight fit after an overload.

Check the tightening torque of the mounting screws of load bearing equipment for a tight fit:

- Slewing ring connection
- Winches
- Slewing gears
- Transmission

- Trailer coupling

If a mounting screw can be tightened, then the mounting screw is loose. Follow the instructions in section "Checking the mounting screws for damage".

## 17.2 Checking the mounting screws for damage

Completely unscrew the loose mounting screws and check in detail for damage.

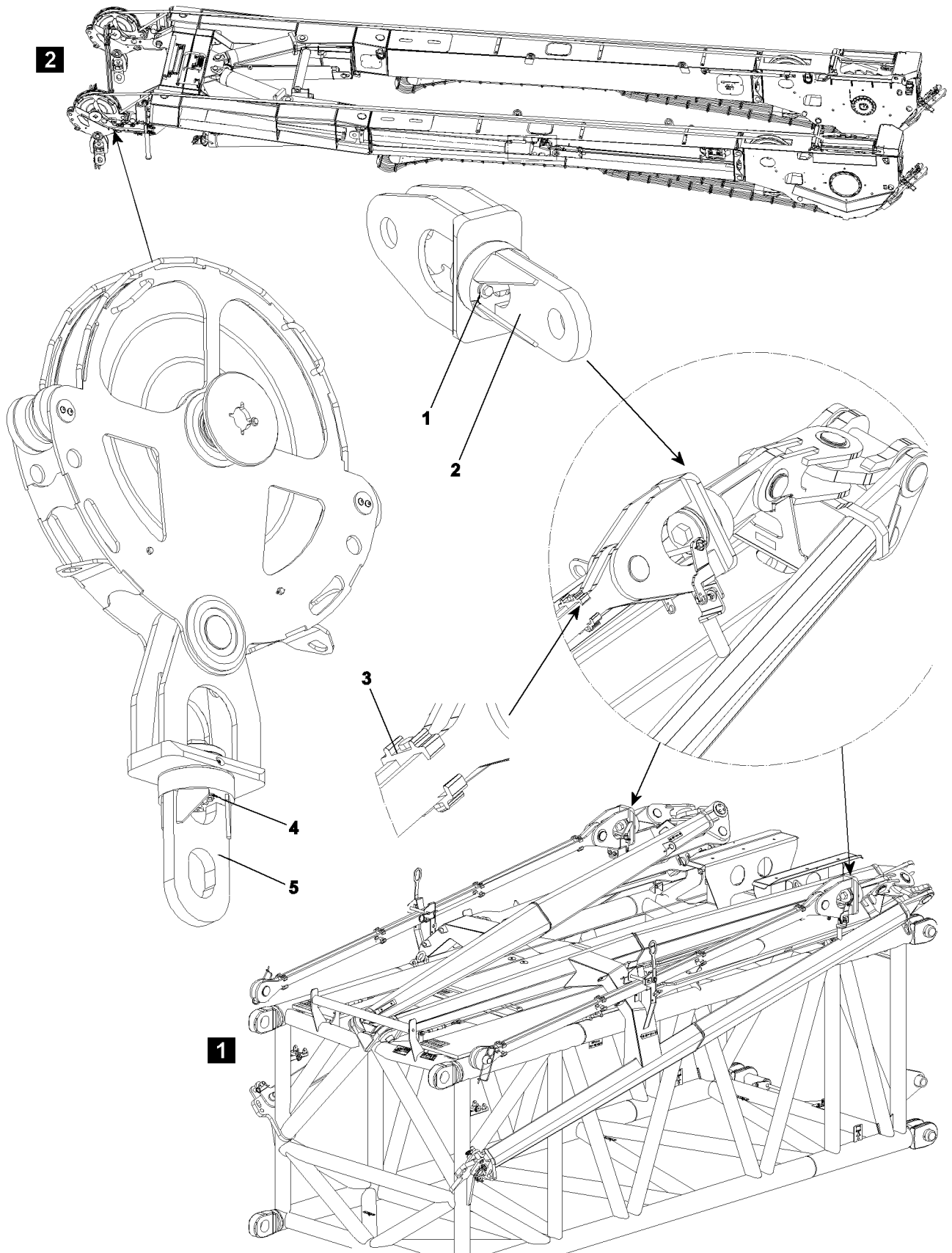
Completely unscrew the adjacent mounting screws and check in detail for damage.

Replace the mounting screw if any of the following damage is present:

- The mounting screw is stretched by more than 2 % (in relation to its original length).
- Cracks, permanent deformation or other damage is visible on the mounting screw.
- The mounting screw is uneven.
- There is pitting.
- The thread is hard to move.

If there is **no** damage, reuse the checked mounting screws (expansion screws) a maximum of two times.

# 18 Inspecting the tele extension with eccentric, illustration 1



LWE/LR 1800-1-0-000/27200-07-02/en

Fig. 109096

- Inspection of anti-rotation device **1** for damage and loose screw connection.
- Inspection of swivel **2** for easy turnability.
- Inspection of all clamps **3** for damage and function.

## 19 Inspecting the change over pulleys, illustration 2

- Inspection of anti-rotation device **4** for damage and loose screw connection.
- Inspection of swivel **5** for easy turnability.

## 20 Inspecting the oil and fuel tanks

Visually check the oil and fuel tanks at least once a year for leaks and safe mounting.

Repairs may only be carried out by authorized and trained specialists.

Improper repairs; e.g., welding, hard or soft soldering is not permitted, particularly if the Service department at Liebherr-Werk Ehingen GmbH has not been consulted!

## 8.03 Inspecting of winches

1	Inspecting the hoist and retracting winches	3
2	Inspection of the auxiliary reeving winch, recovery winch and spare wheel winch	5
3	Monitoring the winches	5

*Fig.195219*

LWE/LR 1800-1-0-000/27200-07-02/en

# 1 Inspecting the hoist and retracting winches

The hoist and retracting winches are designed in sealed planetary gear version. These gears are sized for long service life and the drive shafts and gears are designed for endurance.

Even though the hoist and retracting winches are designed for long life, an external visual inspection is not adequate, since their life can be significantly affected by bad maintenance (insufficient oil), using oil that does not meet specification requirements, defective seals, improper operation or overloading.

The annual inspection must therefore be carried out by an **expert** in accordance with the following specification.

The winches must be inspected by an **authorized inspector** every four years after the initial license.

Within the territorial validity of the BGV D6, after the 10th year in operation, counted from the first day of initial license, when the theoretical service life is not over, the winches must be checked annually by an **authorized inspector**.

## 1.1 Checking the groove diameter



### WARNING

Worn winches!

Damage of flanged disks, high rope wear, operational problems. Broken rope, falling load.

- ▶ Before placing the rope, check the groove diameter of winches.

Visible wear on winches:

- Reduced groove diameter.
- Mechanical damage, for example scrub marks or scouring on flanged disks

Make sure that the following tools are available:

- Groove caliber

Make sure that the following prerequisites are met:

- All components to be inspected are cleaned.
- The rope does **not** obstruct the inspection of the components.



### Note

- ▶ The groove radius may **not** be smaller than the actual diameter of the rope.

The groove diameter of rope pulleys and winches must be at least 6 % larger than the nominal rope diameter.

Check winches with a groove caliber for wear. When wear is present: Fix the winch or replace.

## 1.2 Inspection intervals

At least once a year, see Crane operating instructions, chapter 7.03.

## 1.3 Checking the oil level

Check the oil level with the dipstick.

For hoist and retracting winches **without** a dipstick, we recommend that the oil is drained and the amount compared to the specified oil quantity.

## 1.4 Evaluating oil color

Assume that the oil has been overheated if it is black and / or a burnt oil smell is detected. Change the oil.

## 1.5 Checking for solid foreign substances

In general, the oil must be analyzed by a qualified laboratory.

For simple testing, the following procedure can be used:

- Drip the used oil on a specified filter fleece.
- Visual inspection with a magnifying glass may reveal coarse particles.
- If coarse particles are found: Have the components of the oil analyzed by a qualified laboratory.

---

### NOTICE

Danger of property damage!

- ▶ Repairs may only be carried out by an authorized and trained expert personnel.
  - ▶ Replace damaged parts and change the gear oil.
- 

## 1.6 Visual inspection for leaks

The gears must be checked for leaks, since oil losses - in addition to polluting the environment - can lead to gear failure.

## 1.7 Checking the gear brakes

Check the brakes each time the gears are inspected.



### WARNING

Condition of gear and brakes incorrectly transmission evaluated!

The load can fall down, death, property damage.

- ▶ Only qualified personnel with specialized knowledge may be used to evaluate gears and brakes.
- 

In order to do so, proceed as follows:

- Make sure that the hoist rope is sufficiently pretensioned, in particular in the lower layer of the winch. See chapter 4.08.
- Attach a load, which creates the maximum rope pull in the uppermost layer of the coil with 1 strand, and raise it just off the ground by luffing it up.
- Block the winch brake:
  - For cranes with LICCON 1: "Release the winch brake" by unplugging the valve plug from the valve.
  - For cranes with LICCON 2: By activating the setting program for blocking the winch brake.
- Activate the winch in the lowering direction.

The brake may **not** slip during the test, which means that the winch may **not** turn.



### WARNING

The brake slips and the winch turns!

The load can fall down, death, property damage.

- ▶ Stop crane operation.
  - ▶ Contact Customer Service at Liebherr-Werk Ehingen GmbH.
- 

## 1.8 Documenting the completed inspection

The results of the annual inspections and maintenance work, including the steps taken, must be documented by the competent or authorized inspector, including attachments from the inspection labs and qualified service companies if applicable.

This documentation must be filed in the crane inspection log under the heading "Periodic inspections".



## 2 Inspection of the auxiliary reeving winch, recovery winch and spare wheel winch

The inspection of the auxiliary reeving winch, recovery winch and spare wheel winch regarding scope and content is made according to the manufacturer's instructions.

- Check the auxiliary reeving winch, recovery winch and spare wheel winch according to the manufacturer's instructions.
- Request data about the service life of the auxiliary reeving winch, recovery winch and spare wheel winch from the respective manufacturer.

## 3 Monitoring the winches

### 3.1 Theoretical service life

The designer of your crane used a theoretical total operating time when designing and sizing the winches. This resulted in the theoretical service life of the equipment.

The winches of your crane are classified according to ISO 4301/1 as follows:

Winches	Classification
Power train group:	M3
Load spectrum:	L1
Load spectrum factor Km:	0.125
Theoretical service life D:	3200 h



#### Note

- ▶ The “theoretic service life” is not equal to the real (true) service life of a winch!

The actual service life of the winch is affected by many additional outside factors; for example:

- Overloads caused by unapproved use of the crane.
- Inadequate maintenance: Oil is not changed in a timely manner
- Improper operation:
  - Extreme acceleration or deceleration of the load
  - Load falling into the ropes
- Maintenance errors:
  - Using the wrong type of oil
  - Too much or too little oil
  - Contamination during oil change
- Assembly errors during repair and maintenance
- **Undetected** leaks
- Incorrectly set safety equipment
- Hidden damage from accidents
- Extreme environmental conditions:
  - Low or high temperatures
  - Aggressive atmosphere
  - Dust and dirt

### 3.2 Used proportion of the theoretical service life

The crane operator is obligated to carry out an inspection of the crane at least once a year.

At this time, the actually used part of the theoretical service life must also be calculated. If necessary, the crane operator must contract an authorized inspector.

For the determination of the used part of the theoretical service life, the actual operating conditions (load spectrum) and the hoist gear operating hours for each inspection interval are to be determined. The operator is responsible for the documentation in the crane inspection log.

### 3.2.1 Determining the operating conditions (load spectrum)

The load spectrum of the crane is divided into groups, please refer to ISO 4301/1.

Select one of the following load spectrums and record it in the crane inspection log for the respective inspection interval based on the actual operating conditions. A more precise determination of the load spectrum is permissible.

#### Load spectrum class: Light L1

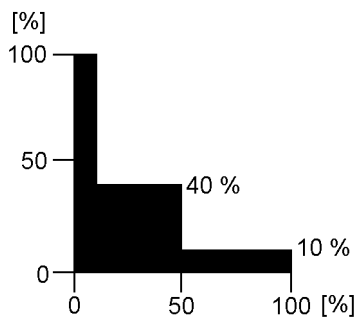


Fig.195234: Graphic illustration Load spectrum L1

#### Definition:

Power train or parts thereof are subjected to maximum stress only in exceptional cases, but normally only operate at very light loads.

#### Operating time rates:

- 10 % of the time at maximum load (dead load and 1/1 working load)
- 40 % of the time with dead load and 1/3 working load
- 50 % of the time only with dead load

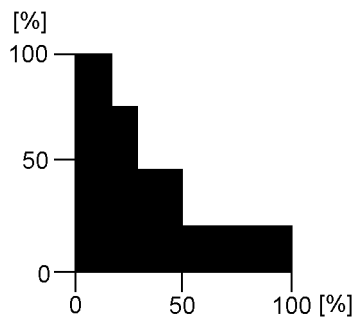
#### Factor of load spectrum:

$K_m = 0.125$



#### Note

- Load spectrum L1 with load spectrum factor  $K_m = 0.125$  is normally applied to cranes used for assembly operations!

**Load spectrum class: Medium L2***Fig.195235: Graphic illustration Load spectrum L2***Definition:**

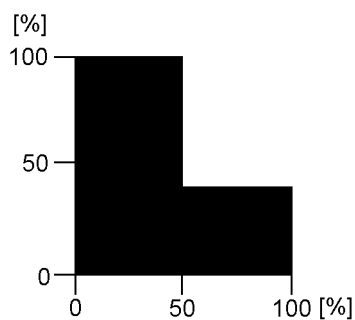
Power train or parts thereof are subjected to maximum load relatively often, but normally only operate at light load.

**Operating time rates:**

- 1/6 of the time at maximum load (dead load and 1/1 working load)
- 1/6 of the time with dead load and 2/3 working load
- 1/6 of the time with dead load and 1/3 working load
- 50 % of the time only with dead load

**Factor of load spectrum:**

$$K_m = 0.25$$

**Load spectrum class: Heavy L3***Fig.195236: Graphic illustration Load spectrum L3***Definition:**

Power train or parts thereof are frequently subjected to maximum load and normally operate at medium load.

**Operating time rates:**

- 50 % of the time at maximum load (dead load and 1/1 working load)
- 50 % of the time only with dead load

**Factor of load spectrum:**

$$K_m = 0.5$$

### Load spectrum class: Very heavy L4

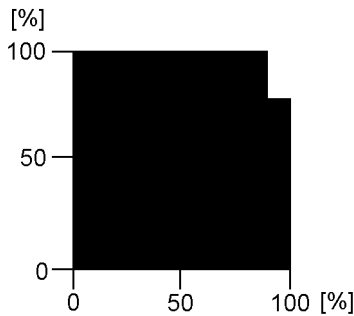


Fig.195237: Graphic illustration Load spectrum L4

#### Definition:

Power train or parts thereof are regularly subjected to near maximum loads.

#### Operating time rates:

- 90 % of the time at maximum load (dead load and 1/1 working load)
- 10 % of the time only with dead load

#### Factor of load spectrum:

$K_m = 1$

### 3.2.2 Determining the effective operating hours $T_i$

The effective operating hours calculated as follows must be entered into the crane inspection log for the respective inspection interval.

There are four different scenarios:

1. Operating hour meter installed on every winch.  
If an operating hour meter is installed on every winch in your crane, the effective operating hours  $T_i$  can be read directly during each inspection.
2. Operating hour meter installed for the overall crane drive.  
The winch proportion of the total superstructure operating hours must be estimated.  
For cranes used in assembly operations, the operating time for the hoist winches can be estimated generally at 20 % of the total operating hours of the superstructure.
3. One operating hour meter is used for both the crane engine and the crane drive.  
The winch proportion of the total crane operating hours must be estimated.  
For cranes used in assembly operations, the operating time for the superstructure can be estimated at 60 % of the total operating hours of the crane. If the hoist winch proportion is estimated at 20 % of the superstructure operating hours (see previous item), then the result in relation to the **total** operating hours of the crane is: 12 %.
4. No operating hour meter is available.  
In this case, the operator must estimate and document the actual operating hours of the winch.  
The approximate percentages stated above normally apply to main hoist winches. For auxiliary hoist winches or boom control winches, the proportion of the total operating hours can be significantly less and should therefore be estimated by the operator.

### 3.2.3 Determining the used proportion of the theoretical service life

For an inspection interval  $i$  (max. 1 year), the actually used proportion  $S_i$  of the theoretical Service life is derived from the formula:

$$S_i = \frac{K_{m_i}}{K_m} \times T_i$$

Fig.195230

Abbreviation	Explanation
$S_i$	Used proportion of the theoretical service life.
$K_m$	Load spectrum factor that was used to calculate the winch rates. This factor is provided in the Operating instructions.
$K_{m_i}$	Load spectrum factor for inspection interval $i$ according to section "Determining the operating conditions".
$T_i$	Effective operating hours for inspection interval $i$ according to section "Determining the effective operating hours $T_i$ ".

The actually used proportion is subtracted from the remaining theoretical service life  $D_i$  after each inspection interval (see example).

If the remaining theoretical service life is not long enough to cover the next projected operating period, a general overhaul of the winch is required.

If the theoretical service life  $D$  has been reached (see section on "Theoretical service life"), then the winch may only be operated after conducting a general overhaul.

**A general overhaul of the winch is required not later than 10 years after start up.**

The general overhaul must be arranged by the operator and carried out by the manufacturer or the manufacturer's authorized representatives and must be documented in the inspection log. After the general overhaul, the manufacturer or the manufacturer's authorized representative will define a new theoretical service life  $D$ .

When the design life has not been reached after 10 years, continued operation of the winch without a general overhaul is acceptable, when the crane's authorized inspector has confirmed the accuracy of the actual service life calculation by signing the crane inspection log at each authorized inspection interval.

In such a case, the authorized crane inspector must thoroughly inspect the winch. This comprises at least:

- External visual inspection (leaks damage, deformation, etc.).
- Oil check, especially for metal residues.
- Load test at minimum and maximum rope pull and at maximum possible speed in both cases. At least one layer must be spooled up. Pay particular attention to any unusual noises during this load test.

The authorized crane inspector must confirm this inspection in the crane inspection log and must make a statement regarding suitability of the winch for continued operation. The next inspection must take place before the end of the 12th operating year and annually thereafter.

### 3.3 Example

According to the manufacturer's operating instructions, a crane with a separate operating hour meter for the travel drive and the crane drive is classified as follows:

- Power train group: M3
- Load spectrum: Light L1
- Factor of load spectrum:  $K_m = 0.125$
- Theoretical service life:  $D = 3200$  h

Actual usage proportion  $S$  of the theoretical service life is calculated using the individual inspection intervals as follows:

### 3.3.1 First inspection (first year)

The crane was used for assembly work during the past year:

Load spectrum L1, in other words  $Km_1 = 0.125$ .

The superstructure operating hour meter indicates 800 h. The winch was operated about 20 % of the time; i.e.  $T_1 = 160$  h.

The actual usage proportion  $S$  of the theoretical service life at the time of the first inspection is therefore:

$$S_1 = \frac{0,125}{0,125} \times 160 \text{ h} = 160 \text{ h}$$

*Fig.195231*

Remaining theoretical service life:

$$D_1 = 3200 \text{ h} - 160 \text{ h} = 3040 \text{ h}$$

The above values are recorded in the crane inspection log.

### 3.3.2 Second inspection (second year)

The crane was used at a harbor for unloading work:

Load spectrum L3, in other words  $Km_2 = 0.5$ .

The superstructure operating hour meter indicates 2000 h ; i.e., this means that during this period:  $2000 \text{ h} - 800 \text{ h} = 1200 \text{ h}$  ( 800 h were used during the first year of operation)

The winch was operated about 40 % of the time; i.e.  $T_2 = 480$  h.

The actual usage proportion  $S_2$  of the theoretical service life at the time of the second inspection is therefore:

$$S_2 = \frac{0,5}{0,125} \times 480 \text{ h} = 1920 \text{ h}$$

*Fig.195232*

Remaining theoretical service life:

$$D_2 = 3040 \text{ h} - 1920 \text{ h} = 1120 \text{ h}$$

### 3.3.3 Third inspection (third year)

The crane was used for assembly work and occasionally at a harbor for unloading work:

Load spectrum L2, in other words  $Km_3 = 0.25$ .

The superstructure operating hour meter indicates 3000 h ; i.e., this means that during this period:  $3000 \text{ h} - 2000 \text{ h} = 1000 \text{ h}$  ( 2000 h were used during the first two years of operation)

The winch was operated about 30 % of the time; i.e.  $T_3 = 300$  h.

The actual usage proportion  $S_3$  of the theoretical service life at the time of the third inspection is therefore:

$$S_3 = \frac{0,25}{0,125} \times 300 \text{ h} = 600 \text{ h}$$

*Fig.195233*

Remaining theoretical service life:

$$D_3 = 1120 \text{ h} - 600 \text{ h} = 520 \text{ h}$$

### 3.4 Chart for determining the theoretically remaining service life

Chart 1 includes an example.

The remaining theoretical service life is to be documented in chart 2.

**Chart to determine the remaining theoretical service life of winch No. 1 (Main hoist winch)**

Crane type: LTM 1050  
 Fabrication No.: 0010 540 08  
 Put in service: 12345  
 Serial number of winch according to data tag: 0815  
 Last general overhaul performed on: .....  
 Configuration data of winch (see Operating Manual):  
 Drive gear group: M 3  
 Load collective: L 1  
 Factor of load collective Km: 0.125  
 Theoretical service life D: 3200 hrs.

$S_i$  = Used part of theoretical service life since last inspection  
 $D_i$  = Remaining theoretical service life  
 $D_{i-1}$  = Remaining theoretical service life after previous inspection  
 $Km$  = Factor of load collective, which was taken for calculation of winch.  
 $Km_i$  = Factor of load collective in inspection interval  $i$   
 $T_i$  = Effective operating hours in inspection interval  $i$

(\*) In the following pages, carry over the last line from the previous page.

Inspection interval No. (max. annually)	Date of initial service data of inspection	Operating conditions since last inspection (load collective)	Factor of load collective	Total crane operating hours	Operating hours of super-structure	Operating hours of super-structure since last inspection	Operating hours of winch	Operating hours of winch since last inspection $T_i$	Used part of theoretical service life $D_i = \frac{S_i}{Km_i} \times T_i$	Remaining theoretical service life $D_i = D_{i-1} - S_i$	Name of inspector	Signature	Remarks	Name of expert	Signature
(*) 0	10.06.90	-	-	-	0	0	0	0	0	3200					
1	05.06.91	L1	0,125	-	800	800	-	160 (20% of 800)	160	3040	Müller				
2	20.05.92	L3	0,5	-	2000	1200	-	480 (40% of 1200)	1920	1120	Huber				
3	18.05.93	L2	0,25	-	3000	1000	-	300 (30% of 1000)	600	520	Mair				
4															

**CAUTION: Perform general overhaul at least once every 10 years!** In case of deviation, see guidelines in this chapter.

General overhaul last performed on : .....



LWE/LR 1800-1-0-000/27200-07-02/en

**Chart to determine the remaining theoretical service life of winch No. ....**

- Crane type: .....
- Fabrication No.: .....
- Put in service: .....
- Serial number of winch according to data tag: .....
- Last general overhaul performed on: .....
- Configuration data of winch (see Operating Manual):  
 Drive gear group: M.....  
 Load collective: L.....  
 Factor of load collective Km: .....
- Theoretical service life D:  
 .....  
 \*) In the following pages, carry over the last line from the previous page.

- $S_i$  = Used part of theoretical service life since last inspection
- $D_i$  = Remaining theoretical service life
- $D_{i-1}$  = Remaining theoretical service life after previous inspection
- $Km$  = Factor of load collective, which was taken for calculation of winch. This factor is to be taken from the Operating Manual
- $Km_i$  = Factor of load collective in inspection interval  $i$
- $T_i$  = Effective operating hours in inspection interval  $i$

Fig.121552-en: Table 2

Inspection interval No. (max. annually)	Date of initial service data of inspection	Operating conditions since last inspection (load collective)	Factor of load collective	Total crane operating hours	Operating hours of super-structure	Operating hours of super-structure since last inspection	Operating hours of winch	Operating hours of winch since last inspection $T_i$	Used part of theoretical service life $D_i$ : $\frac{Km_i}{Km} \times T_i$ [h]	Remaining theoretical service life $D_i = D_{i-1} - S_i$ [h]	Name of inspector	Signature	Remarks	Name of expert	Signature	
i			$Km_i$	[h]	[h]	[h]	[h]	[h]	[h]	[h]						
(*)																

**CAUTION: Perform general overhaul at least once every 10 years!** In case of deviation, see guidelines in this chapter.  
 General overhaul last performed on : .....



## 8.04 Inspection of crane wire ropes

1	Crane ropes	3
2	Importance of inspection	3
3	Personal protective equipment	3
4	Inspection personnel qualification	3
5	Unscheduled inspection	3
6	Intervals	4
7	Areas	4
8	Documenting inspection results	5
9	Wire ropes and rope end connections	5
10	Degree of severity	8
11	Rope diameter abbreviations	8
12	Distortions and mechanical damage	8
13	Removal criteria overview	8
14	Checking for broken strands	10
15	Determining the number of broken wires	10
16	Checking the rope end connection	15
17	Checking the rope diameter	15
18	Corrosion	18
19	Corkscrew-like distortion	20
20	Basket formation	21
21	Protruding, distorted insert or strand	22
22	Loop formation	23
23	Kinking or rope loops pulled closed	24
24	Buckles	25
25	Effects of heat, arcs	26
26	Combined degree of severity	26
27	Flattenings	26
28	Current inspection checklist	31

*Fig.195219*

LWE/LR 1800-1-0-000/27200-07-02/en

# 1 Crane ropes

This chapter applies, for example, to the following crane ropes:

- Hoist ropes
- Control ropes for the boom system
- Control ropes of the telescopic boom with rope mechanism: Pull-out ropes and return ropes
- Guy ropes for boom system

# 2 Importance of inspection

**Rope removal criteria:** If severe damage reduces the operational safety, then the rope has reached the removal criteria.

The importance of regular inspections is demonstrated by:

- Evaluation of operational safety of ropes
- Determination of rope removal criteria
- Determination of next inspection

# 3 Personal protective equipment



## WARNING

Wires and lubricant!

Severe injury and skin irritation.

- ▶ When working with ropes, always wear work gloves.



## WARNING

Protective equipment **not** worn!

Severe injuries.

- ▶ Wear a hard hat, safety shoes and safety goggles.

# 4 Inspection personnel qualification

Make sure that the following prerequisites are met:

- Inspection personnel are **expert personnel for crane rope inspection**.
- **Expert personnel for crane rope inspection:**
  - Are trained in the inspection of crane ropes according to **DIN ISO 4309** and have practical experience in the evaluation of rope removal criteria.
  - Have practical experience in the evaluation of rope removal criteria according to **DIN ISO 4309**.
- Inspection personnel is assigned (authorized) to maintenance by the crane operator.

# 5 Unscheduled inspection

The rope must be inspected in the following situations:

- After unusual strain
- If non visible damage is suspected
- When a rope or the rope end connection is damaged
- When the rope has been placed again after disassembly
- When the rope has been out of service for longer than three months

## 6 Intervals

Intervals for crane inspection:

- According to determination by **expert personnel for crane rope inspection**
- Or **at least once a year**



### Note

- ▶ Shortening the inspection interval: The older a rope is the more frequently wire breaks will occur.

Determining factors for determination of inspection intervals are:

- Legal regulations in the country where the crane is operated
- Climate conditions under which the rope drive is utilized
- Power train group
- Results of previous inspections on a current or comparable machine and under comparable operating conditions
- Frequency and type of use of a rope
- Service life of rope

## 7 Areas



### WARNING

Broken wires and distortions on ropes in cross over areas!

Rope performance can be greatly reduced. Rope breakage. Death, severe injuries, property damage.

- ▶ Check rope cross over areas with particular diligence.

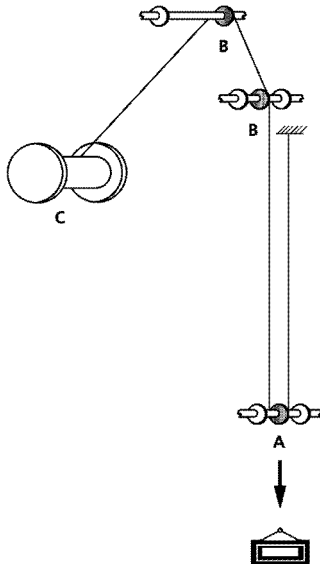


Fig.120969: Important inspection areas for multi-layer spooled up ropes

- |  |   |
|--|---|
| <p><b>A</b> Rope sections, which run in the area of the load rise into the lower rope pulleys (the load is raised here).</p> <p><b>B</b> Rope intake on the first rope pulley in the area of the load rise</p> | <p><b>C</b> Rope sections, which are subjected to the strongest effects in the cross over areas (maximum deflection angle).</p> |
|--|---|

The rope must be checked along the entire length.

The following areas must be checked with special care:

- Rope end connections
- Safety coils and fixed point on the winch
- Areas of the rope which run through the hook block.
- Areas of the rope that run over the rope pulleys or lay on the rope pulleys.
- Areas of the rope that are spooled on the winch, especially cross over areas.
- Areas of the rope which are laying above the compensation pulleys.
- Areas of the rope which are subjected to abrasion due to external components.
- All areas of the rope that are subjected to temperatures above 60 °C.

## 8 Documenting inspection results



### Note

- ▶ Document the results of the inspections in an inspection checklist.
- ▶ Template for an inspection checklist, see section “Current checklist”.

## 9 Wire ropes and rope end connections



### WARNING

Wire rope with impermissible rope end connection!

The wire rope can fail. The load can fall down.

Death, severe bodily injuries, property damage.

- ▶ Select the permissible rope type for the respective application.
- ▶ Select the permissible rope end connection for the respective rope type.
- ▶ Observe and adhere to the safety message on the lock.

Wire rope application	Rope type
Hoist rope	Rotation-resistant rope
Guy rope or control rope	Non-rotation-resistant rope
Auxiliary rope or assembly rope	Non-rotation-resistant rope

*Rope type depending on the application*

The type of rope that is selected determines the corresponding rope end connections.

### 9.1 Rotation-resistant ropes with rope end connections

Use rotation-resistant ropes as **hoist ropes**.

Rotation-resistant ropes are special ropes that produce extremely little torque and twisting at the rope end connection when they are under strain.

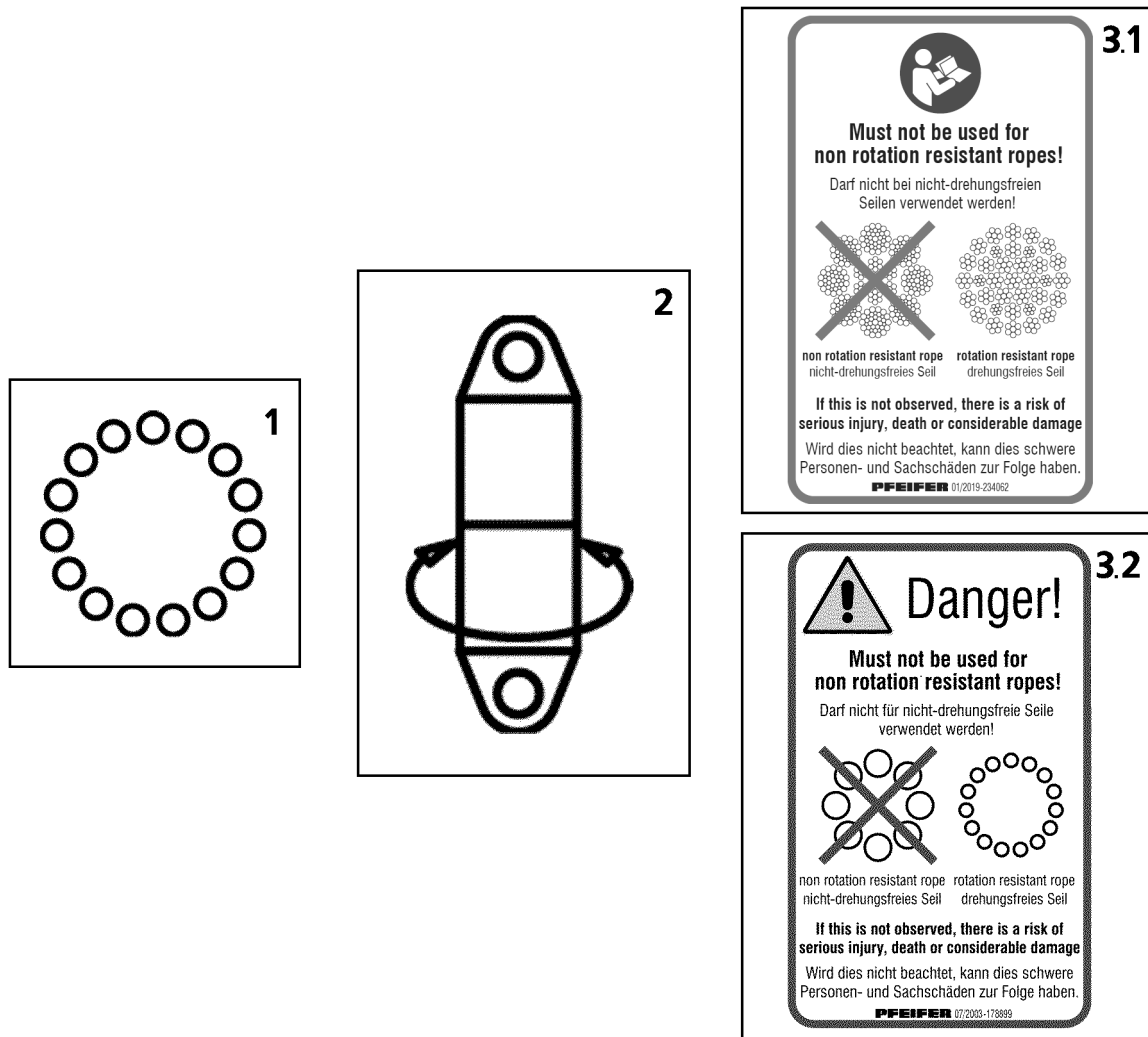


Fig.154083: Icons for rotation-resistant ropes with rope end connections

- |   |                                   |     |   |
|---|-----------------------------------|-----|---|
| 1 | Rotation-resistant rope icon      | 3.1 | Variation 1: Safety message on the PFEIFER lock |
| 2 | Rotating rope end connection icon | 3.2 | Variation 2: Safety message on the PFEIFER lock |

Typical rotation-resistant rope structures are wire ropes with 15 to 18 outer strands. Rotation-resistant ropes are symbolically depicted with 15 outer strands (circles), see illustration 1.

### 9.1.1 Non-rotating rope end connection



#### Note

- ▶ In the case of rotation-resistant ropes, Liebherr recommends the use of a lock **without** a swivel or a wedge lock. This can reduce the stress on the hoist ropes.

### 9.1.2 Rotating rope end connection



#### Note

- ▶ In the case of rotation-resistant ropes, Liebherr recommends **not** using a lock **with** a swivel and **not** to use a twist compensator / swivel.

To reduce a problematic turning behavior, the following rope end connections can be used in an individual case and after consultation with Liebherr customer service:

- Lock **with** swivel



- Twist compensator / swivel

## 9.2 Non-rotation-resistant ropes with rope end connections



### WARNING

Wire rope with impermissible rope end connection!

The wire rope can fail. The load can fall down.

Death, severe bodily injuries, property damage.

- ▶ Use a lock **without** a swivel or a wedge lock.
- ▶ **Never** use a lock **with** a swivel with non-rotation-resistant rope.
- ▶ **Never** use a twist compensator / swivel with a rotation-resistant rope.

Use a non-rotation-resistant rope as **guy ropes** or **control ropes**, **auxiliary ropes** or **assembly ropes**.

Non-rotation-resistant ropes generate high torque levels on the rope end connection under strain. For this reason, the rope ends must be protected from twisting using an appropriate rope end connection to prevent the wire rope from untwisting under strain.

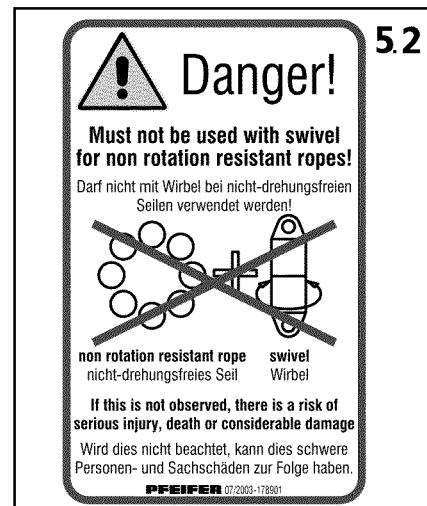
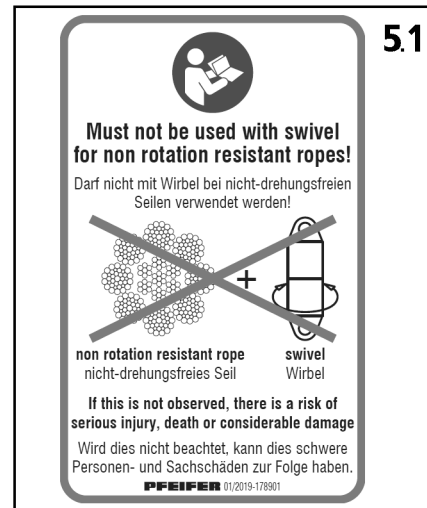
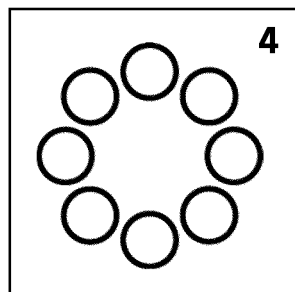


Fig.154084: Icons for non-rotation-resistant ropes with rope end connections

4 Non-rotation-resistant rope icon

5.2 Variation 2: Safety message on the PFEIFER lock / wedge lock

5.1 Variation 1: Safety message on the PFEIFER lock / wedge lock

Typical rotation-resistant rope structures are wire ropes with eight or ten outer strands. Non-rotation-resistant ropes are symbolically depicted with eight outer strands (circles), see illustration 4.

Only use non-rotation-resistant ropes with the following **non-rotating** rope end connection:

- Lock **without** swivel
- Wedge lock

A non-rotating rope end connection is also the mounting of the rope on the fixed point of the winch drum.

## 10 Degree of severity

The deciding factor for the removal criteria is which removal criteria are present and to which degree they occur.

When various removal criteria are **not** present to a full degree, then the removal criteria must be evaluated as a total entity. For every individual removal criteria a degree of severity must be determined (percentage value).

For a certain rope section the sum of individual degrees of severity results in a **combined degree of severity**, see section “Combined degree of severity”.

When the combined degree of severity is more than 100 %, then the rope must be taken down.

## 11 Rope diameter abbreviations

Abbreviations	Description
Rope nominal diameter <b>d</b>	Rope diameter, identification of rope
Reference diameter <b>d<sub>ref</sub></b>	Measured rope diameter of a straight rope section, directly after placing the rope
6d	Length of 6-fold rope nominal diameter
30d	Length of 30-fold rope nominal diameter

*Rope diameter abbreviations*

## 12 Distortions and mechanical damage



### WARNING

Distortions and mechanical damage!

Operational safety significantly disturbed, uneven load distribution within the rope.

- ▶ Have the manufacturer check if the distorted and damaged area can be severed.

Visible form changes often occur localized or in short rope sections.

When a safe operation of the rope is ensured, a distorted and damaged area can be severed.

## 13 Removal criteria overview

The following chart provides an overview between removal criteria and the respective method for inspection. The degree at which the removal criteria is reached is described.

The removal criteria is described in detail in the subsequent sections.

**Note**

When the rope for parallel operation has reached the removal criteria:

- ▶ Often, both ropes must be replaced. The new rope has a larger diameter and other elongation characteristics.

Removal criterion	Degree for removal criteria	Inspection method
Broken strands	One strand is broken	Visual check
Broken wires on ropes that run over rope pulleys and are spooled in multiple layers	Maximum number of broken wires reached, see Section Determining the number of broken wires	Count
Broken wire in the strand valleys	Two or more broken wires in strand valleys, on the contact points of two neighboring strands within an angular length (corresponds approx. to 6d)	Count
Broken wires in the area of the rope end connection	Two or more broken wires, according to the decision of <b>expert personnel for crane rope inspection</b>	Visual inspection, test with marlin spike
Broken wire nests	On occurrence	Visual check
Reduction rope diameter at even diameter reduction	Maximum reduction of rope diameter reached	Measurement, calculation
Localized increase of rope diameter	Maximum increase of rope diameter reached	Measurement
Significant corrosion	Surface of rope is significantly affected or rust film emerges, according to the decision of <b>expert personnel for crane rope inspection</b>	Visual check
Corkscrew-like distortion	Maximum permissible distortion reached	Measurement, calculation
Basket formation	On occurrence	Visual check
Wires or bunches of wires protruding from the rope	On occurrence, if more than one wire protrudes from the rope	Visual check
Flattenings	Larger than half of the diameter of the outer strand, according to decision of <b>expert personnel for crane rope inspection</b>	Visual check
Loop formation	Loops on several wires	Visual check
Kinking or remaining distortion	On occurrence	Visual check
Buckles or contusions	On occurrence, according to decision of <b>expert personnel for crane rope inspection</b>	Visual check

Removal criterion	Degree for removal criteria	Inspection method
Heat influence, electric voltage	Bluish discoloration, broken or melted wires	Visual check
Damage to the rope end connections: Material cracks, deformation, wear, corrosion, traces of slipping between the locking clamp and rope	According to decision of <b>expert personnel for crane rope inspection</b>	Visual inspection
Combined degree of severity	Degree of severity 100 % or above, according to the decision of <b>expert personnel for crane rope inspection</b>	Calculation of individual degrees of severity

*Removal criteria overview*

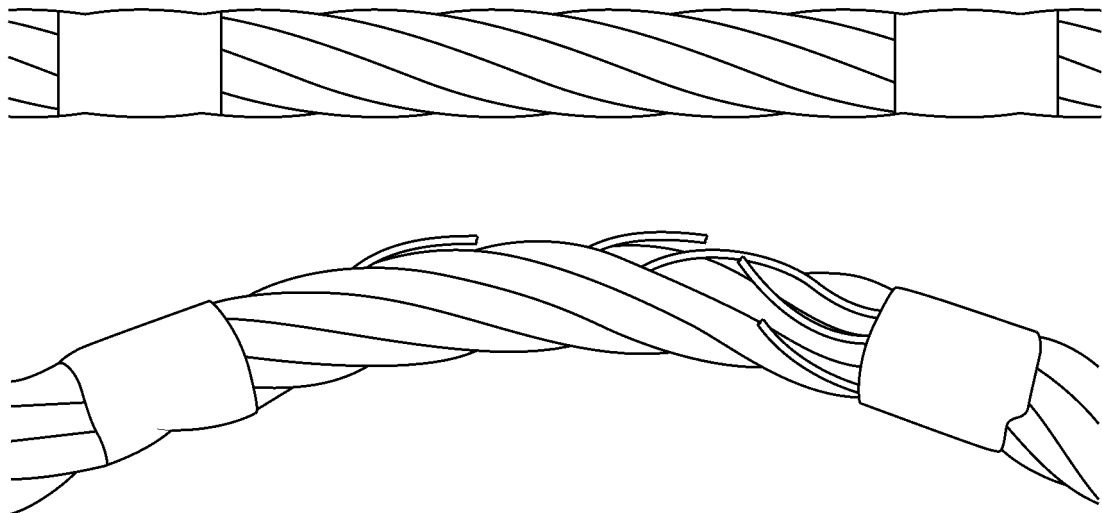
## 14 Checking for broken strands

A strand consists of several individual wires.

If a complete strand is broken:

- ▶ Take the rope down.

## 15 Determining the number of broken wires



*Fig.120980: Determine broken wires by bending*

By bending the rope, broken wires can be recognized better.

Make sure that the following prerequisites are met:

- The rope is clean.
- Inspection checklist is on hand.

## 15.1 Scattered broken wires

The following different rope types each have their own chart for the permissible number of broken wires:

- Single layer and parallel roped ropes
- Rotation-resistant ropes

The charts in this section are valid exclusively for **scattered broken wires**.

### 15.1.1 Wire break increase rate

The wire break increase rate is an increase of broken wires and can skyrocket with increasing use of the rope.

- ▶ Include the inspection checklists for the previous inspection and use it to draw a conclusion for the wire break rate increase.

### 15.1.2 Single layer and parallel roped ropes

Rope category number RCN	Total number of load carrying wires in the outer strand layer of rope <sup>1</sup> n	Number of visible outer wire breaks <sup>2</sup>					
		Rope sections, which run over steel pulleys and / or wind up on a single layer spooling drum (random distribution of broken wires)				Rope sections, which wind up on a multi layer drum <sup>3</sup>	
		Class M1 to M4, or class unknown <sup>4</sup>				All classes	
		Lang lay		Even lay		Lang lay and even lay	
		Over a length of 6d <sup>5</sup>	Over a length of 30d <sup>5</sup>	Over a length of 6d <sup>5</sup>	Over a length of 30d <sup>5</sup>	Over a length of 6d <sup>5</sup>	Over a length of 30d <sup>5</sup>
01	$n \leq 50$	2	4	1	2	4	8
02	$51 \leq n \leq 75$	3	6	2	3	6	12
03	$76 \leq n \leq 100$	4	8	2	4	8	16
04	$101 \leq n \leq 120$	5	10	2	5	10	20
05	$121 \leq n \leq 140$	6	11	3	6	12	22
06	$141 \leq n \leq 160$	6	13	3	6	12	26
07	$161 \leq n \leq 180$	7	14	4	7	14	28
08	$181 \leq n \leq 200$	8	16	4	8	16	32
09	$201 \leq n \leq 220$	9	18	4	9	18	36
10	$221 \leq n \leq 240$	10	19	5	10	20	38
11	$241 \leq n \leq 260$	10	21	5	10	20	42
12	$261 \leq n \leq 280$	11	22	6	11	22	44

Rope category number RCN	Total number of load carrying wires in the outer strand layer of rope <sup>1</sup>  n	Number of visible outer wire breaks <sup>2</sup>					
		Rope sections, which run over steel pulleys and / or wind up on a single layer spooling drum  (random distribution of broken wires)				Rope sections, which wind up on a multi layer drum <sup>3</sup>	
		Class M1 to M4, or class unknown <sup>4</sup>				All classes	
		Lang lay		Even lay		Lang lay and even lay	
		Over a length of 6d <sup>5</sup>	Over a length of 30d <sup>5</sup>	Over a length of 6d <sup>5</sup>	Over a length of 30d <sup>5</sup>	Over a length of 6d <sup>5</sup>	Over a length of 30d <sup>5</sup>
13	$281 \leq n \leq 300$	12	24	6	12	24	48
	$n > 300$	$0.04 \times n$	$0.08 \times n$	$0.02 \times n$	$0.04 \times n$	$0.08 \times n$	$0.16 \times n$

**Note:** Ropes with outer strands in the Seale type, number of wires per strand 19 or less (for example 6 × 19 Seale), are classified in this chart as two lines over the line, which would be defined due to the number of load carrying wires in the outer strands.

Number of visible broken wires (reached or exceeded) for removal criteria is reached, for **single-layer and parallel roped ropes according to DIN ISO 4309**

1) For the purpose of this international standard, fill wires are not considered to be load carrying wires and are not included in the value for n.

2) A broken wire has two ends (counted as one wire).

3) The values apply for damage in the cross over areas and the layers of coils due to deflection angles (not for rope sections, which run only over rope pulleys and do not spool up on the winch).

4) For ropes on the power train of groups M5 to M8 twice the number of broken wires listed can be used.

5) d = Rope nominal diameter

- ▶ Check the rope over the entire length for visible broken wires.

When visible broken wires are scattered:

- ▶ In the point of a broken wire, mark the rope sections at a length of 30d in both directions.
- ▶ Count visible broken wires in the marked rope sections and record them.
- ▶ Take the RCN (Rope category number) from the rope manufacturer's documentation.

When the make for single layer and parallel roped ropes is **not** listed in the chart:

- ▶ Determine the total number of load carrying wires in the rope: Add all wires in the strands of the outer layer, do **not** count fill wires.
- ▶ Compare the number of broken wires of each marked rope section 30d with the number of broken wires in the chart.

When the number of visible broken wires is less than what is listed in the chart:

- ▶ Inside the rope section with the most broken wires: Mark the rope section with the most broken wires on a length of 6d.
- ▶ Count visible broken wires in the marked rope section 6d and record them.
- ▶ Compare the number of broken wires of the marked rope section with the number of broken wires in the chart.

When the number of visible broken wires is equal to or greater than what is listed in the chart:

- ▶ Take the rope down.
- ▶ Enter the results in the inspection checklist.

### 15.1.3 Rotation-resistant ropes

Rope category number RCN	Total number of load carrying wires in the outer strands of rope <sup>1</sup>  n	Number of visible outer wire breaks <sup>2</sup>			
		Rope sections, which run over steel pulleys and / or wind up on a single layer spooling drum  (random distribution of broken wires)		Rope sections, which wind up on a multi layer drum <sup>3</sup>	
		Over a length of 6d <sup>4</sup>	Over a length of 30d <sup>4</sup>	Over a length of 6d <sup>4</sup>	Over a length of 30d <sup>4</sup>
21	4 strands n ≤ 100	2	4	2	4
22	3 or 4 strands n ≥ 100	2	4	4	8
	At least 11 strands in the outer layer				
23-1	71 ≤ n ≤ 100	2	4	4	8
23-2	101 ≤ n ≤ 120	3	5	5	10
23-3	121 ≤ n ≤ 140	3	5	6	11
24	141 ≤ n ≤ 160	3	6	6	13
25	161 ≤ n ≤ 180	4	7	7	14
26	181 ≤ n ≤ 200	4	8	8	16
27	201 ≤ n ≤ 220	4	9	9	18
28	221 ≤ n ≤ 240	5	10	10	19
29	241 ≤ n ≤ 260	5	10	10	21
30	261 ≤ n ≤ 280	6	11	11	22
31	281 ≤ n ≤ 300	6	12	12	24
	n > 300	6	12	12	24

**Note:** Ropes with outer strands in Seale type, number of wires in each strand 19 or less (for example 18 × 19 Seale - WSC), are classified in this chart as two lines over the line, which would be defined due to the number of load carrying wires in the outer strands.

*Number of visible broken wires (reached or exceeded) is achieved in the rope removal criteria, for **rotation-resistant** ropes according to **DIN ISO 4309***

- 1) For the purpose of this international standard, fill wires are not considered to be load carrying wires and are not included in the value for n.
- 2) A broken wire has two ends (counted as one wire).
- 3) The values apply for damage in the cross over areas and the layers of coils due to deflection angles (not for rope sections, which run only over rope pulleys and do not spool up on the drum).
- 4) d = Rope nominal diameter

- ▶ Check the rope over the entire length for visible broken wires.

When visible broken wires are scattered:

- ▶ In the point of a broken wire, mark the rope sections at a length of 30d in both directions.
- ▶ Count visible broken wires in the marked rope sections and record them.
- ▶ Take the RCN (Rope category number) from the rope manufacturer's documentation.

When the make for rotation-resistant ropes is **not** listed in the chart:

- ▶ Determine the total number of load carrying wires in the rope: Add all wires in the strands of the outer layer, do **not** count fill wires.

- ▶ Compare the number of broken wires of each marked rope section 30d with the number of broken wires in the chart.

When the number of visible broken wires is less than what is listed in the chart:

- ▶ Inside the rope section with the most broken wires: Mark the rope section with the most broken wires on a length of 6d.
- ▶ Count visible broken wires in the marked rope section 6d and record them.
- ▶ Compare the number of broken wires of the marked rope section with the number of broken wires in the chart.

When the number of visible broken wires is equal to or greater than what is listed in the chart:

- ▶ Take the rope down.
- ▶ Enter the results in the inspection checklist.

## 15.2 Broken wire in the strand valleys

The broken wires in these areas point to the fact that the condition in the inside of the rope is deteriorating.

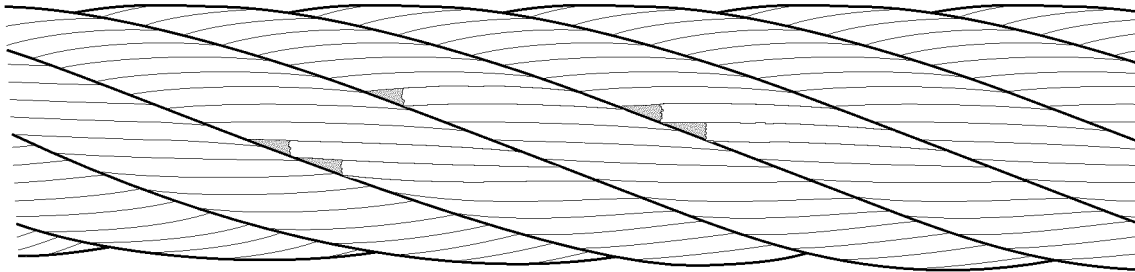


Fig.121005: Broken wire in the strand valleys

When two or more broken wires occur within a rope section of length 6d:

- ▶ Take the rope down.

## 15.3 Broken wires on rope end connections

- ▶ Check the area near the rope end connections and carefully check for broken wires.

Loose wires are a sign of broken wires in the rope end connection.

- ▶ Use a marlin spike to check for loose wires.

When broken wires are near a rope end connection and two or more wires are affected:

- ▶ Take the rope down.

**or**

When the remaining rope lengths fulfill the minimum number of remaining coils in all operating positions:

- ▶ Shorten the rope, see chapter 7.05.50.
- ▶ Attach the rope end connection.

## 15.4 Broken wires in rope sections that are not spooled up on the winch

When the broken wires are concentrated on one or two strands, the removal criteria can be present with fewer broken than what is specified in the chart (rope section in the length of 6d).

- ▶ Have the rope removal criteria determined by **expert personnel for crane rope inspection**.



## 15.5 Broken wire nests

When broken wires are very close to each other or when the broken wires are concentrated on one strand, then the rope must be taken down, even with fewer broken wires than what is specified in the chart (rope section 6d).

- ▶ Have the rope removal criteria determined by **expert personnel for crane rope inspection**.

## 16 Checking the rope end connection

The removal criteria are evaluated by the **expert personnel for crane rope inspection**.

Check for broken wires, see section "Broken wires on rope end connections".

### 16.1 Pressed rope end connection

Example of a pressed rope end connection: Locking clamp.

- ▶ Check the rope end connections for signs of possible slipping between the locking clamp and the wire rope.
- ▶ Check the rope end connections for material cracks.
- ▶ Check rope end connections for corrosion, deformation and wear.

### 16.2 Enlarged rope end connection

Example of an enlarged rope end connection: Locking cast sleeve.

- ▶ If present: Remove the beam.
- ▶ Check rope end connections for corrosion, deformation and wear.

If the rope connection is on a flat rope:

- ▶ Check the cone setting, see chapter 8.04.10.

### 16.3 Detachable rope end connection

Example of a detachable rope end connection: Wedge lock.

- ▶ Check that the rope end connections are fit tightly and correctly installed.
- ▶ Check the wire rope inside and at the outlet of the rope end connection. Check the rope according to the removal criteria in this chapter.

## 17 Checking the rope diameter

### 17.1 Even reduction of the rope diameter



#### WARNING

Spooling problems due to reduced rope diameter!

- ▶ Take the rope down even when the removal criteria according to **DIN ISO 4309** has not yet been reached.

The values in this section do **not** apply for rope sections damaged in cross over areas due to multi layer spooling on a winch.

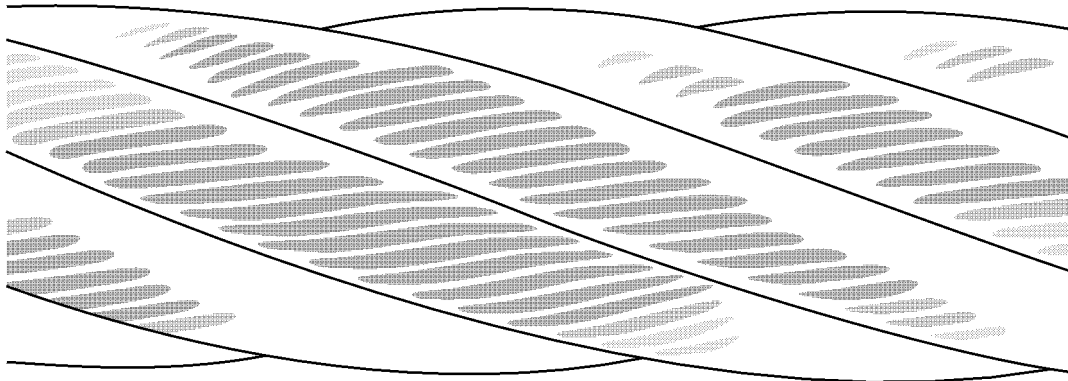


Fig.121001: External abrasion on the rope

The rope diameter changes due to abrasion, settling and external influences.

Abrasion of cover wires of outer strands of rope due to frictional contact. Especially in those areas where ropes are in contact with the rope pulleys during start up or slow down of the load.

Wear is increased by lack of or incorrect lubrication and the effect of dust.

Abrasion reduces the tensile strength of steel ropes because the cross-section of the steel is reduced.

Additional possible causes for reduction of rope diameter:

- Wear inside the rope
- Wear of fiber insert
- Breakage of a steel insert
- Broken inner strands

This section is valid only for the following ropes:

- Ropes, which wind up on single layer winches
- Ropes, which run through a steel rope pulley

$$d_v = \frac{d_{ref} - d_m}{d} \times 100 \%$$

Fig.121372: Reduction of rope diameter formula

$d_v$  = even reduction of the rope diameter  
 $d_{ref}$  = rope diameter determined before placement

$d_m$  = measured rope diameter  
 $d$  = rope nominal diameter: Take the value from inspection checklist.

The following chart applies exclusively for ropes, which wind up on single layer winches and / or run through a steel rope pulley.

Rope type	Even reduction of diameter $d_v$ (as a percentage of nominal rope diameter $d$ )	Classification of degree of severity	
		Description	%
	Less than 6 %	—	0
Single layer rope with fiber insert	6 % and above, but less than 7 %	Light	20
	7 % and above, but less than 8 %	Medium	40
	8 % and above, but less than 9 %	High	60
	9 % and above, but less than 10 %	Very high	80
	<b>10 % and above</b>	<b>Rope removal criteria</b>	<b>100</b>

LWE/LR 1800-1-0-000/27200-07-02/en

Rope type	Even reduction of diameter $d_v$ (as a percentage of nominal rope diameter $d$ )	Classification of degree of severity	
		Description	%
Single layer rope with steel insert or parallel roped rope	Less than 3.5 %	—	0
	3.5 % and above, but less than 4.5 %	Light	20
	4.5 % and above, but less than 5.5 %	Medium	40
	5.5 % and above, but less than 6.5 %	High	60
	6.5 % and above, but less than 7.5 %	Very high	80
	<b>7.5 % and above</b>	<b>Rope removal criteria</b>	<b>100</b>
Rotation-resistant rope	Less than 1 %	—	0
	1 % and above, but less than 2 %	Light	20
	2 % and above, but less than 3 %	Medium	40
	3 % and above, but less than 4 %	High	60
	4 % and above, but less than 5 %	Very high	80
	<b>5 % and above</b>	<b>Rope removal criteria</b>	<b>100</b>

*Degree of severity and removal criteria depending on rope type and even diameter reduction according to DIN ISO 4309*

The medium value from the smallest and the largest measured diameter results in the value for  $d_m$ .

- ▶ Measure rope diameter on several locations and calculate measured diameter  $d_m$ .
- ▶ Calculate even reduction  $d_v$  of rope diameter with formula.
- ▶ Read the degree of severity in the chart, depending on the rope type.
- ▶ Document the degree of severity in the inspection checklist.

When the degree of severity has reached 100 %:

- ▶ Take the rope down.

## 17.2 Localized reduction of rope diameter

Localized reductions of rope diameter point to the fact that a rope insert may have failed, for example.



*Fig. 120983: Localized reduction of rope diameter*

- ▶ Check the rope for localized reduction of rope diameter.

When a localized reduction of the rope diameter is found:

- ▶ Take the rope down.

## 17.3 Localized increases of rope diameter

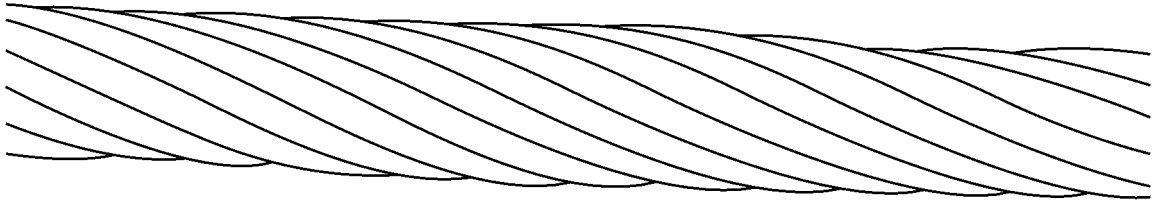


Fig.120992: Localized increase of rope diameter

An increase over a longer area of the rope can be caused by absorption of moisture in the fiber insert or due to corrosion inside of the rope.

Rope insert	Maximum increase of rope diameter during operation
Steel	5 %
Fiber	10 %

- ▶ Check the rope for increases in rope diameter.

When the increases exceed the maximum values:

- ▶ Take the rope down.

## 18 Corrosion

Corrosion occurs due to insufficient lubrication, in maritime climates and in an atmosphere polluted by industrial fumes.

External corrosion is indicated by a rough wire surface. A superficial rust film can be wiped off.

Significant corrosion reduces the strength and elasticity of the rope due to the reduction of the rope diameter.

Internal corrosion is hard to detect.

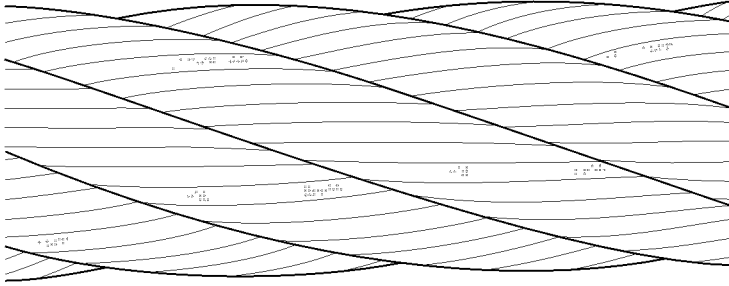
Do not use solvents to clean the **rope**.

Make sure that the following prerequisite is met:

- The rope is clean (wiped and brushed).

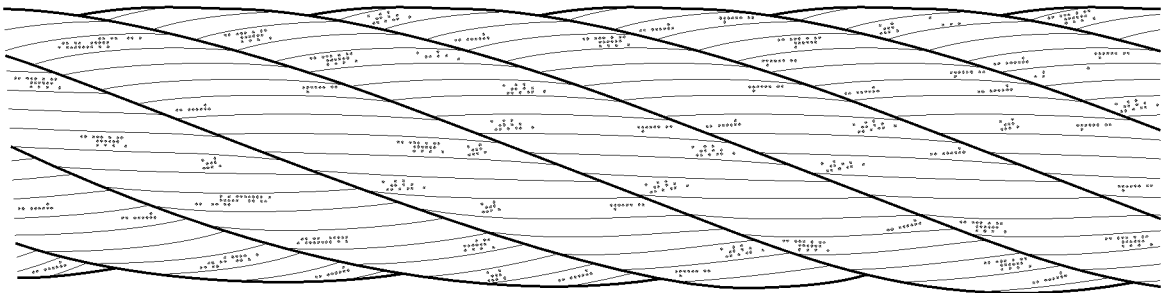
### 18.1 External corrosion

The various types of corrosion are classified and noted with the classification for removal criteria in percentages:

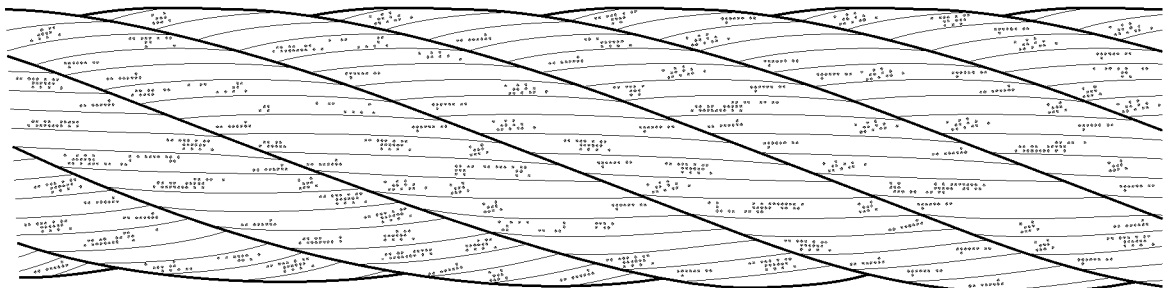


*Fig.120984: Light surface corrosion: Classification 0 % of removal criteria*

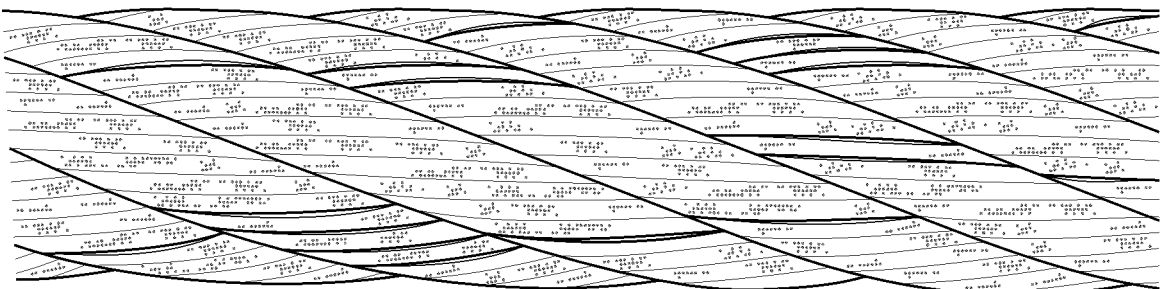
Light superficial corrosion (rust film) can be wiped off.



*Fig.120985: Surface feels rough: Classification 20 % of removal criteria*



*Fig.120986: Surface feels very rough: Classification 60 % of removal criteria*



*Fig.120987: Surface very decayed, spaces between individual wires can be easily recognized: Classification 100 % of removal criteria*

When 100 % of removal criteria is reached:

- ▶ Take the rope down.

## 18.2 Internal corrosion

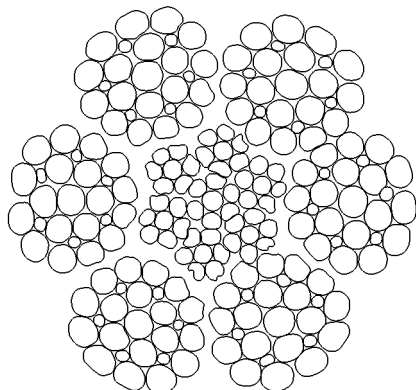


Fig.120982: Corrosion inside the rope

Internal corrosion is present when clearly visible corrosion particles migrate between the valleys of the outer strands: Classification 100 % removal criteria.

When internal corrosion is found:

- ▶ Have the rope removal criteria evaluated by **expert personnel for crane rope inspection** or take the rope down.

## 18.3 Friction corrosion

Friction corrosion occurs as a type of brown powder, which migrates from the inside of the rope to the outside: Classification 100 % of removal criteria.

- ▶ Check the rope diligently for friction corrosion.

If friction corrosion is found:

- ▶ Have the rope removal criteria evaluated by **expert personnel for crane rope inspection** or take the rope down.

## 19 Corkscrew-like distortion



Fig.120988: Corkscrew-like distortion

Distortion where the rope is in the form of a corkscrew along its longitudinal axis.

Effects of corkscrew-like distortion:

- Irregular rope drive
- Rope wear
- Broken wire
- Bearing damage on rope pulleys

If the distortion is very pronounced, then other components can be affected in their function when the affected rope section runs through in crane operation.

- ▶ Check the entire rope for corkscrew-like distortion.

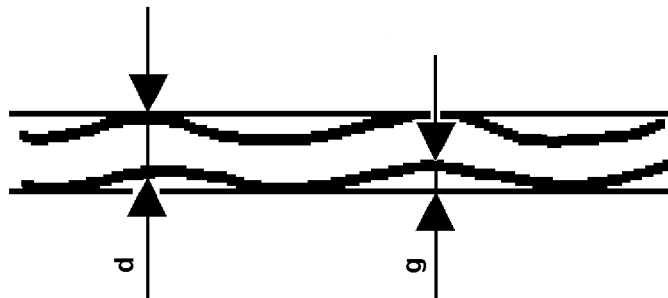


Fig.123988: Example of corkscrew-type distortion

**d** Rope nominal diameter

**g** Distance

Rope section	Conditions for removal criteria, formula
Straight rope section that does <b>not</b> run through or around a rope pulley or spool up on a winch	$g \geq \frac{1}{3} \times d$
Straight rope section that runs through or around a rope pulley or spools up on a winch	$g \geq \frac{1}{10} \times d$

When corkscrew-like distortion is present:

- ▶ Determine the rope nominal diameter **d** and distance **g** on the rope.
- ▶ Check the removal criteria with the formula.

When the removal criteria is reached:

- ▶ Take the rope down.

## 20 Basket formation

This distortion occurs due to different layers between the outer strand layers and the inside of the rope.

Causes for basket formation are high angular pull angles during the run over the rope pulleys and run-in rope pulleys. Even load distribution over the entire cross-section is not possible.

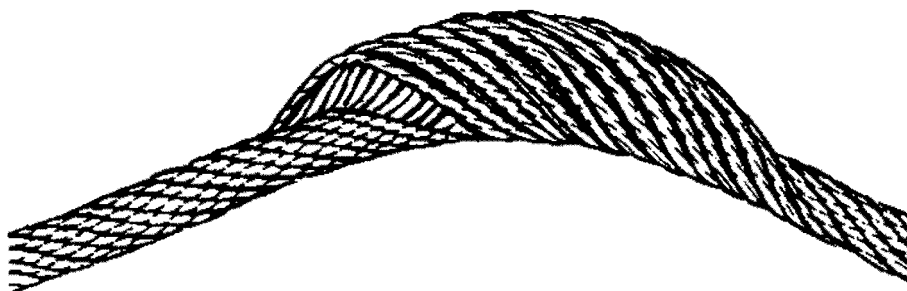


Fig.120989: Basket formation

- ▶ Check the entire rope for basket formation.

When basket formation is present:

- ▶ Take the rope down.

**Start of basket formation with continuous use of the same / similar boom system in parallel operation (only cranes with parallel operation of the hoist winches):**

---

#### NOTICE

Basket formation on the rope of winch 2 during parallel operation!

In the case of continuous use of the **same / similar** boom system in parallel operation, there is an increased danger of basket formation on the rope of winch 2.

When longer use with the **same** boom system is carried out:

- ▶ Increased check of the hoist rope when there are signs that basket formation is starting.

When continuous use with a **similar**<sup>1)</sup> boom system is carried out:

- ▶ Increased check of the hoist rope when there are signs that basket formation is starting.

When signs regarding the start of basket formation occur:

- ▶ Contact Liebherr Customer Service.
- 

1) Boom systems with small differences in total lengths or with a comparable rope run

- ▶ Counteract the start of basket formation in time.

## 21 Protruding, distorted insert or strand

This distortion is a special form of basket formation. The insert or the core of the rope protrudes between the outer strands or an outer strand protrudes from the rope banding.

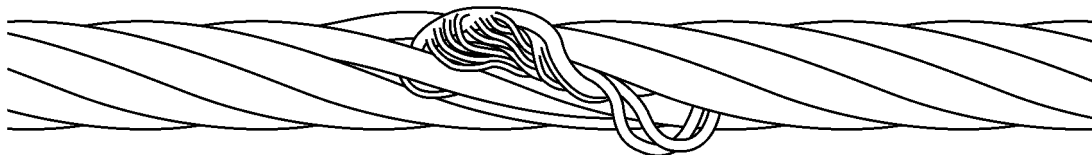


Fig.120990: Protrusion of an insert (rope single layer)





Fig.120991: Distorted or protruding strand

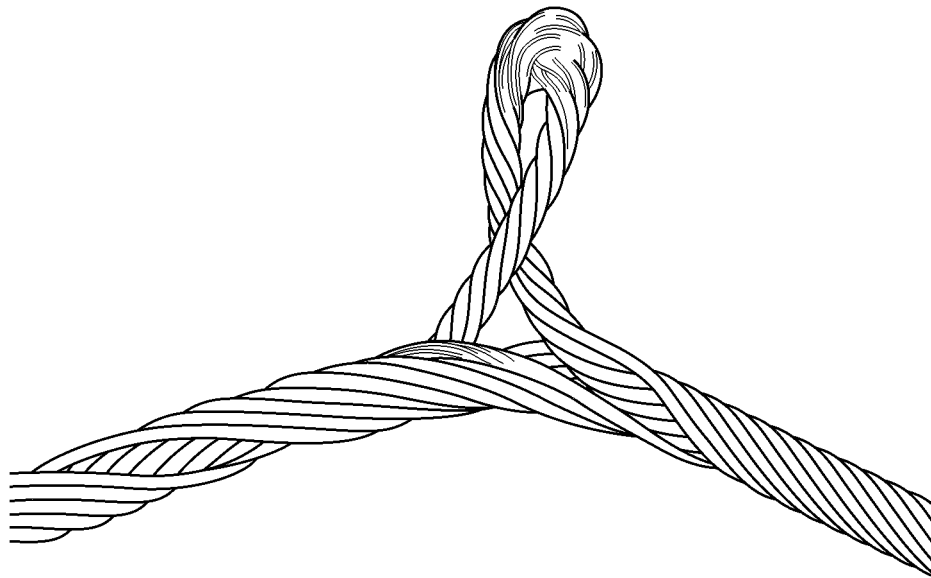


Fig.121373: Protrusion of rope insert on rotation-resistant rope

When the insert or a strand protrudes or is distorted, take the rope down. Have an authorized inspector for crane rope inspection check if the rope area with the distortion can be removed.

- ▶ Check the entire rope for protruding, distorted inserts or strands.

If a protruding, distorted insert or strand is present:

- ▶ Take the rope down.
- ▶ Have **expert personnel for crane rope inspection** check if the rope area with the distortion can be removed.

## 22 Loop formation

At loop formation individual or several wires protrude from the rope and bulge upward (bird-caging).

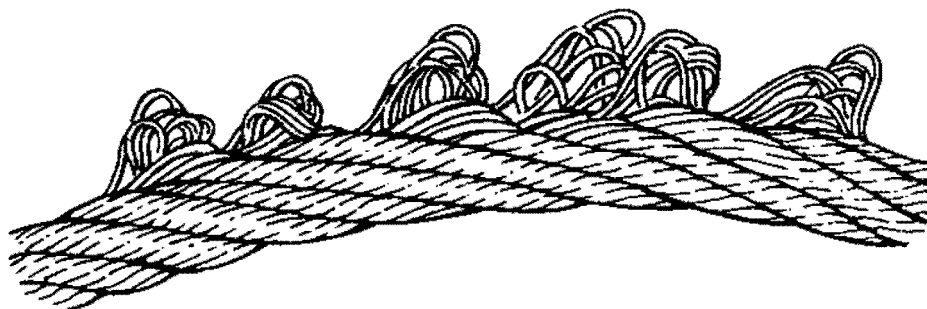
These areas are most often on the opposite side of the rope pulley groove.

Make sure that the following prerequisite is met:

- There are **no** broken wire ends.

If only a core wire of the rope insert protrudes through the outer strands, then the rope does not have to be taken down when:

- The wire can be removed.
- The wire does not disturb other elements of the rope drive.



*Fig.120993: Emergence of individual wires*

- ▶ Check rope for loop formation.

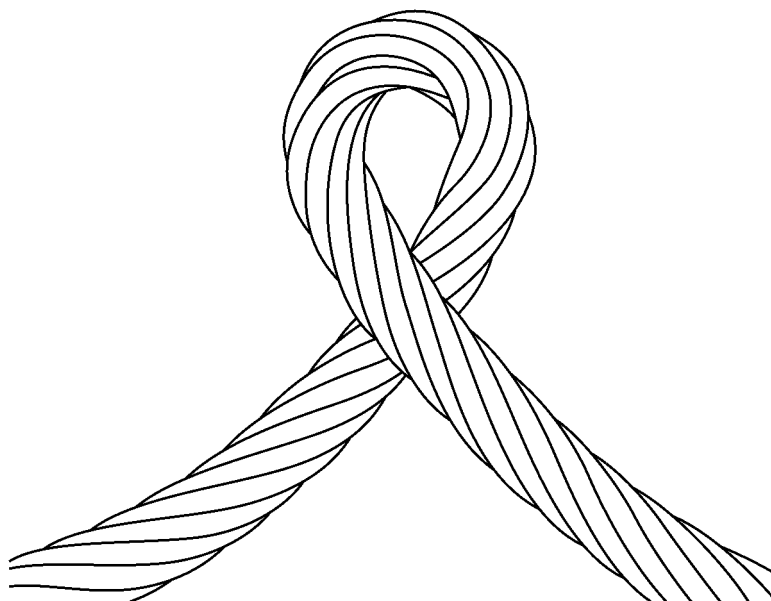
When only one core wire protrudes:

- ▶ Remove the core wire.

When several wires are affected by the loop formation:

- ▶ Take the rope down.

## 23 Kinking or rope loops pulled closed



*Fig.121007: Kinking or rope loop pulled closed*

With this deformation a loop has formed in the rope, without the possibility to rotate around its own axis during a load. The rope is subjected to significant wear.

The rope is significantly distorted. The strength remains only in part.

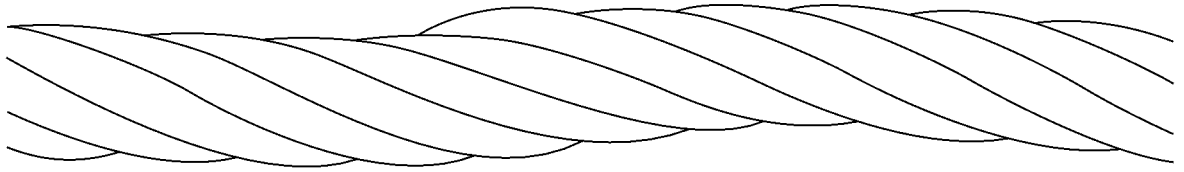


Fig.121002: Positive kinking

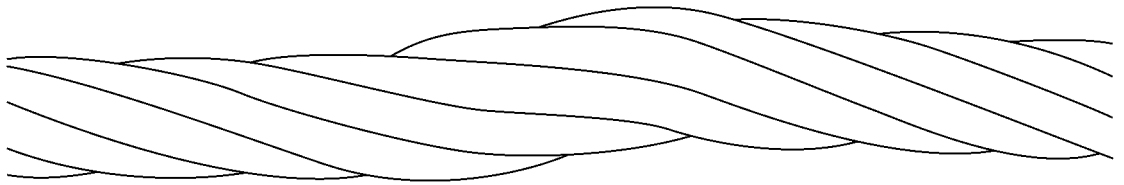


Fig.121003: Negative kinking

- ▶ Check the rope for kinking or rope loops pulled closed.

When kinking or rope loops pulled closed occur:

- ▶ Take the rope down.

## 24 Buckles

Buckles are angular deformations. The rope was damaged due to external influences. Strong deformations of the rope cause stronger wear.

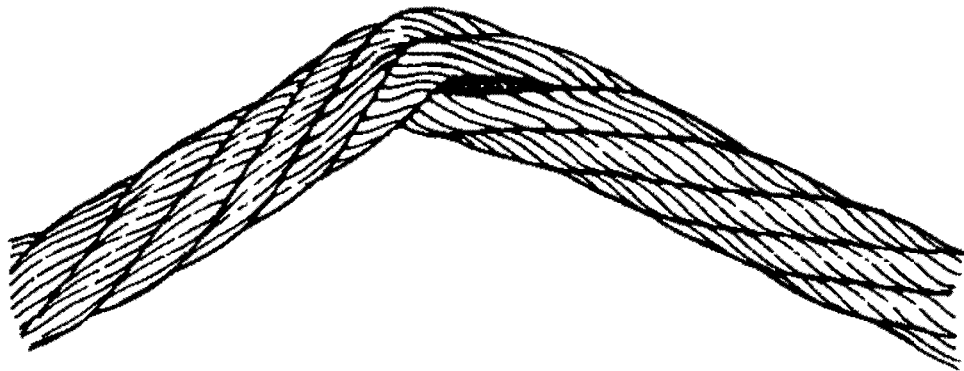


Fig.120999: Severe buckle

A buckle is a serious matter if a fold is visible on the underside of the rope.

When buckles are present:

- ▶ Have the rope inspected by **expert personnel for crane rope inspection**.

When a distortion and degree of severity permits further operation:

- ▶ Shorten the inspection interval.

When the removal criteria is reached:

- ▶ Take the rope down.

## 25 Effects of heat, arcs

Damage caused to the rope by welding work, for example.

Exceptional thermal effect is visible through tempering colors, the loss of lubricant and by localized melting of wires.

If a thermal effect has occurred on the rope:

- ▶ Take the rope down.

## 26 Combined degree of severity



### Note

- ▶ For a method to determine the effect of a combined degree of severity and damage on the rope, see **DIN ISO 4309**.

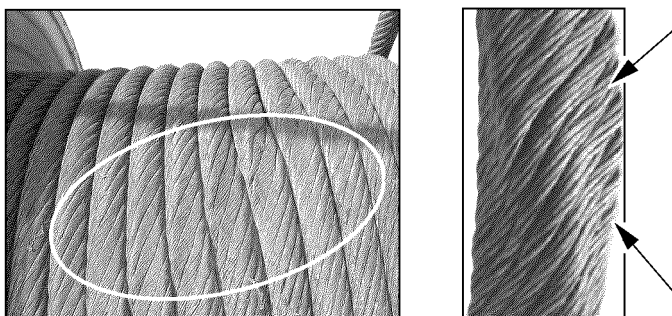
When the condition of the rope deteriorates, then often a combination of various causes occurs.

To determine the degree of severity, the **expert personnel for crane rope inspection** must:

- take different damage within a rope section into account
- evaluate the entire effect of the damage and the distortions
- decide about the operational safety of the rope
- evaluate if inspection intervals must be adjusted
- decide if the rope must be taken down

**When the combined degree of severity is more than 100 %, then the rope must be taken down.**

## 27 Flattenings



*Fig.114002: Flattenings*

Effects of flattenings on the rope:

- Rope sections with flattenings that **move over the rope pulleys** tend to have higher wear and a higher number of broken wires.
- Rope pulleys can be damaged.
- Flattenings on **stationary ropes** (guy ropes boom) promote quicker corrosion, especially in the areas where the outer strands have opened.

Flattened rope sections must be checked at shorter intervals for broken wires and corrosion.

## 27.1 Shortening the intervals

- ▶ Check the entire rope for flattenings.

When flattenings are present on stationary ropes:

- ▶ Shorten the intervals for rope inspection.

When it is **not** possible to shorten the intervals for the rope inspection:

- ▶ Take the rope down.

## 27.2 Improper mechanical damage

Improper mechanical damage occurs, for example, when the rope is trapped.

- ▶ Take the rope down immediately or shorten it, see chapter 7.05.50.

## 27.3 Operational transverse pressure

Operational transverse pressure causes flattenings, for example in the incline range of multi layer spooling.

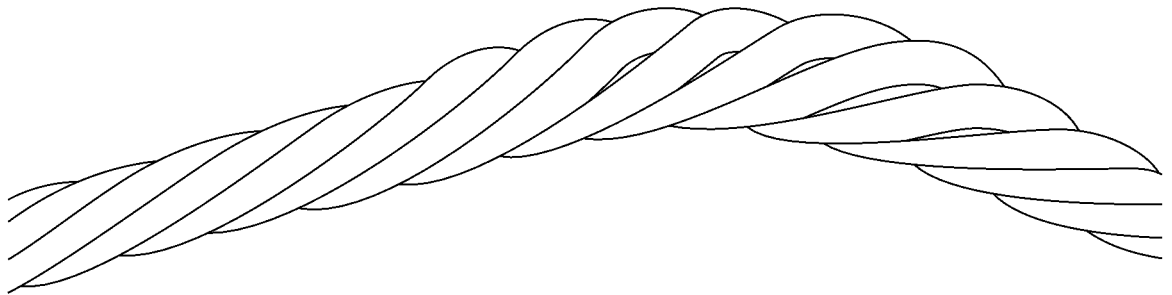


Fig.120996: Flattenings on multi-layer windings

- ▶ Check the two lowest rope layers of the winches for crushed areas and distortions.

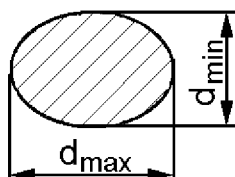


Fig.121006: Largest and smallest diameter in the distortion area

### Formula for calculating the distortion

$$V = \frac{d_{\max} - d_{\min}}{d} \times 100 \%$$

<b>V</b>	Rope distortion as a percentage
<b>d</b>	Rope nominal diameter
<b>d<sub>max</sub></b>	Largest diameter of the distortion area
<b>d<sub>min</sub></b>	Smallest diameter of distortion area

When distortions are present:

- ▶ Determine the number of broken wires. See section “Determining the number of broken wires”.

When the number of permissible broken wires is exceeded:

- ▶ Take the rope down.
- ▶ Calculate the rope distortion  $V$  with the formula and document it on the inspection checklist.

If the rope distortion  $V$  is greater than 5 %:

- ▶ Check the rope before every assembly and erection procedure.

If the rope distortion  $V$  is greater than 10 %:

- ▶ Document the degree of severity of 50 % in the inspection checklist.

If the rope distortion  $V$  is greater than 20 %:

- ▶ The degree of severity of 100 % is reached: Take the rope down.



#### Note

Flattenings in the Winch 4 control rope (WIV)

- ▶ Observe the following section "Flattenings in the Winch 4 control rope (WIV)".

## 27.4 Operational flattenings on ropes on winch 4 (WIV)

This applies only for the following crane types:

- LR1350 up to including LR11000
- LG1750

Operational flattenings on ropes of winch 4 (WIV) can be taken into consideration separately in this section according to the description.



#### WARNING

Rope destroyed!

Flattenings due to improper mechanical damage, for example by clamping the rope, cannot be evaluated in a standard manner.

When the flattenings did not occur due to a high traverse pressure not caused by operation in the cross over area of the multi-layer coil:

- ▶ Take the rope down immediately or remove the damaged section by shortening the rope.



#### Note

- ▶ Flattenings can cause the wire rope to be damaged faster, especially when running over the rope pulleys. Wire breaks occur and the rope pulley can be damaged.
- ▶ In the case of stationary ropes, flattened rope sections tend to corrode faster.

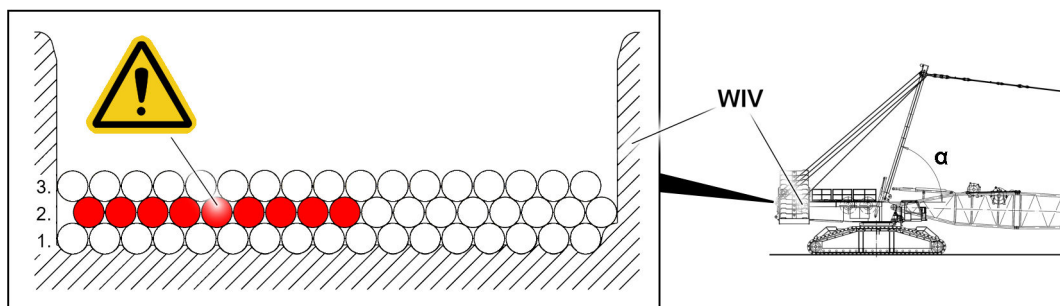


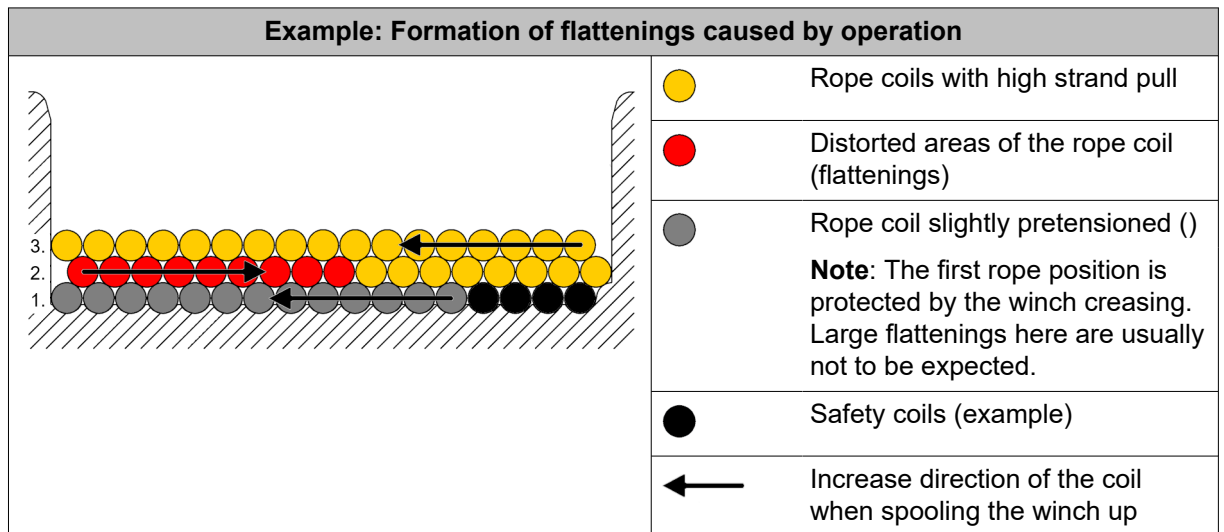
Fig.166542: Example of flattenings in the 2nd Rope layer (sectional view)

**For boom systems without the use of a derrick boom, the following applies:**

After frequent erection and take-down procedures of long main booms, individual rope coils on the winch **WIV** can have flattenings.

With high strand pull in the rope coils of the 3rd rope layer, the rope coils that are only slightly pretensioned due to operation of the 2nd rope layer are deformed.

The high strand pull in the 3rd rope layer occurs after the guying is almost tensioned. The angle  $\alpha$  (SA-frame angle position) that therefore occurs depends on the respective crane type and the length of the main boom.



The flattenings occur due to a high traverse pressure caused by operation in the cross over area of the multi-layer coil.

Rope sections with flattenings >20% do not lead to the removal criteria of the rope if the following two conditions are observed:

1. The concerned rope sections are checked before every erection procedure of the main boom by an authorized inspector. When doing so, the permissible number of wire breaks according to ISO 4309 is not exceeded.
2. **In the case of high strand pulls**, the distorted areas remain on the winch drum and are not present inside the rope drive. The minimum angle  $\alpha$  required for this is determined, documents and not fallen below.



#### Note

##### Remark concerning “high rope pulls”

- ▶ As the force in test point 1 (for  $F_{1\text{actual}}$ ) cannot be used to automatically infer the rope pull of winch 4 (WIV), this value cannot be used for the assessment.

### 27.4.1 Operational flattenings: Examples of impermissible assembly positions

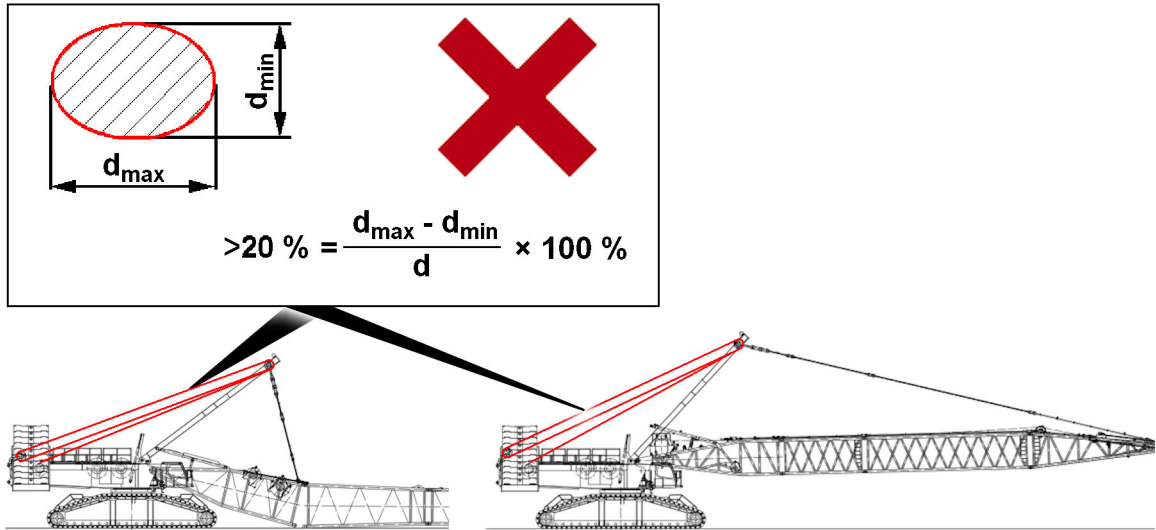


Fig.166551: **Impermissible with high rope pulls!**- rope section with flattening >20% in rope operation

Individual assembly positions are no longer permissible due to the limited operation **with high rope pulls**:

- SA-frame angle position smaller than the determined minimum angle  $\alpha^\circ$  - rope section with flattening >20% in rope operation.
- These are for example: closing / opening the main boom with the SA-frame, erecting / taking down the D-boom.

### 27.4.2 Operational flattenings: Examples of permissible assembly positions

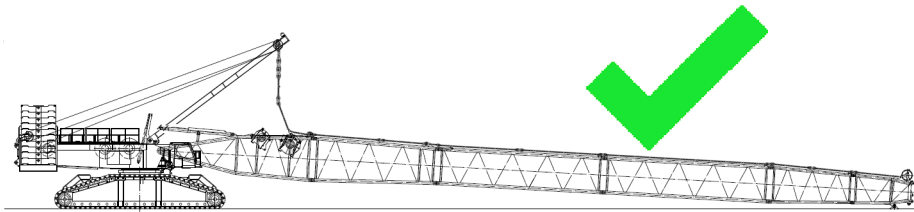


Fig.166556: **Permissible with moderate rope pulls!**- rope section with flattening >20% during rope operation

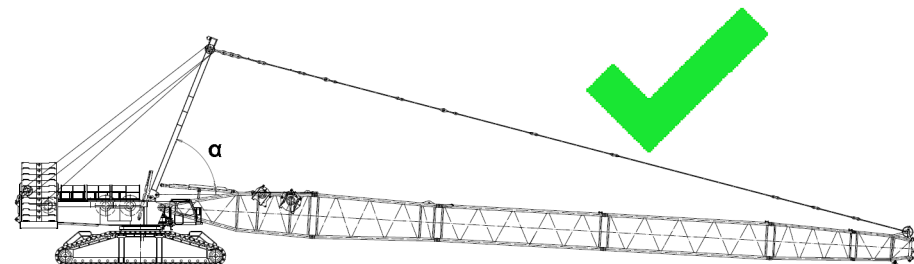


Fig.166555: **Permissible with a sufficiently large angle  $\alpha$ !**- Erecting / taking down the main boom

Assembly positions with moderate rope pulls are permissible with flattening >20%, for example:

- Luff the SA-frame down to the front in order to assemble the guy rods.
- Main boom erection / take-down, **sufficiently large** angle  $\alpha$  present. Rope sections with flattening >20% are on winch 4 (WIV) inside the rope coils.



# 28 Current inspection checklist

LWE/LR 1800-1-0-000/27200-07-02/en

<b>Crane and use:</b>		RCN <sup>3)</sup> :		Installation date:											
Rope application:		Nominal diameter:		Take-down date:											
Brand name:		<input type="radio"/> Right hand <input type="radio"/> Left hand		Minimum tensile strength											
Make <sup>1)</sup> :		<input type="radio"/> Lang's lay <input type="radio"/> Ordinary lay		Permissible number of visible external broken wires											
Direction of lay <sup>1)</sup> :		<input type="radio"/> IWRC <input type="radio"/> FC <input type="radio"/> WSC		Datum diameter											
Intermediate layer <sup>1)</sup> :		<input type="radio"/> Bare <input type="radio"/> Galvanized		Permissible diameter reduction: 6d: 30d:											
Wire surface <sup>1)</sup> :		Rope end connections:													
Date	Visible external broken wires				Diameter		Corrosion		Damage, deformation		Combined severity level <sup>2)</sup>	Name of expert for the wire rope	Signature		
	Number in length of	Position in the rope	Severity level <sup>2)</sup>	Measured	Actual reduction to datum diameter	Position in the rope	Severity level <sup>2)</sup>	Position in the rope	Severity level <sup>2)</sup>	Position in the rope				Severity level <sup>2)</sup>	
JJ/MM/TT	6d	30d	6d	30d	6d	30d	6d	30d	6d	30d	6d	30d	6d	30d	

<sup>1)</sup> Check where applicable.  
<sup>2)</sup> State extent of damage; slight or 20%; medium or 40%; high or 60%; very high or 80%; take-down or 100%  
<sup>3)</sup> RCN = Rope Category Number

Fig.121370-en: Template for current inspection checklist



## 8.05 Inspection of load hooks

1	Safety instructions	2
2	Inspection intervals	2
3	Checking the load hook	2

# 1 Safety instructions



## WARNING

The load hook did **not** pass the inspection!  
The load hook can rip. The fastened load can fall down.  
Death, severe bodily injuries, property damage.

If the load hook did **not** pass the inspection:

- ▶ Replace the load hook with the hook nut.
- ▶ Contact Customer Service at Liebherr-Werk Ehingen GmbH.



## WARNING

**Incorrect** remedy of defects!

The load hook can rip. The fastened load can fall down.  
Death, severe bodily injuries, property damage.

- ▶ Have defects remedied by authorized, trained expert personnel.



## WARNING

Welds on the load hook!

The load hook can rip. The fastened load can fall down.  
Death, severe bodily injuries, property damage.

- ▶ Do **not** weld the load hook, to repair defects, for example.

## 2 Inspection intervals

To detect defects in time and avoid accidents, observe the following instructions:

- Have the load hook checked as required, however **at least once a year** by an authorized inspector.
- Observe the national regulations concerning the inspection of load hooks.

## 3 Checking the load hook

The following points must be documented in the crane inspection log:

- Performance of the inspections
- Defects and damage
- Measures for remedying the defects and damage

### 3.1 Checking the load hook for distortion

#### 3.1.1 Hook shaft

If distortion is visible on the hook shaft:

- ▶ Replace the load hook with the hook nut.

#### 3.1.2 Hook jaw

##### Identifying the manufacturing method

Depending on the moment at which a load hook is delivered, the manufacturing method must be found in the various documentation:

- ▶ Manufacturing method, see the technical data in the load hook documentation.  
**or**  
▶ Manufacturing method, see the certificate of the load hook manufacturer in the crane inspection log.

### Checking the expansion of the hook jaw

The manufacturing method differs by the maximum permissible expansion of the hook jaw, see the following charts:

Load hook manufacturing method	Hook shape	Maximum permissible expansion of the hook jaw in reference to the respective initial dimension
Cast	Double hook	3 %
Forged	Double hook	10 %
Forged	Single hook	10 %

*Hook jaw: Dependency between the manufacturing method and maximum permissible expansion*

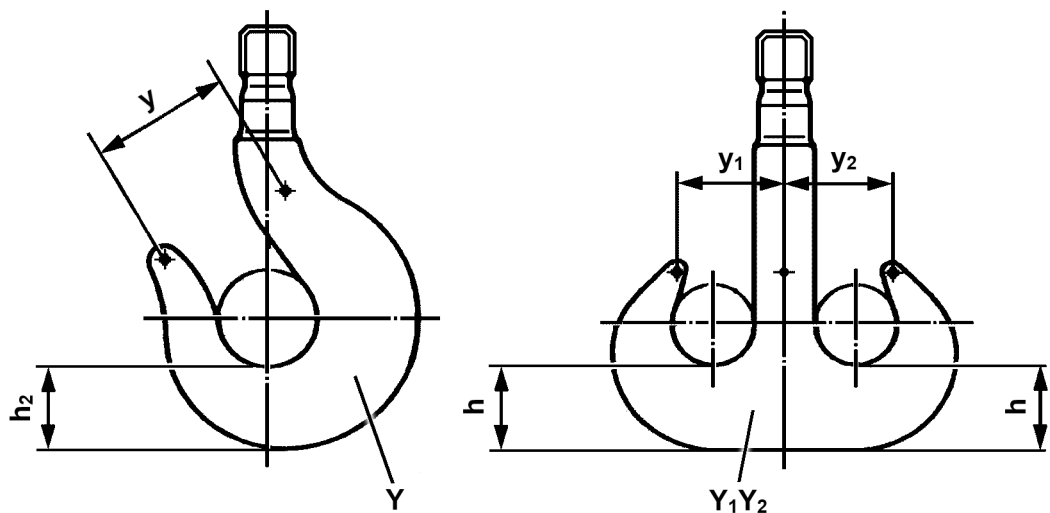


Fig.149076: Description of the measured distances on the load hook

The initial dimensions are indicated on the load hook, see chapter 2.05.10:

- Single hook: Initial dimension  $Y$
- Double hook: Initial dimension  $Y_1Y_2$
- ▶ Single hook: Distance  $y$  between the punch marks.
- ▶ Double hook: Measure the distance  $y_1$  and distance  $y_2$  between the punch marks.

When the available expansion of the hook jaw is larger than the maximum permissible expansion:

- ▶ Replace the load hook with the hook nut.

## 3.2 Checking the load hook for surface cracks

Make sure that the following prerequisites are met:

- Distortion is present.

Inspection is required in all points where distortion is present, mainly on the hook jaw.

If it is **not** possible to check the installed load hook:

- ▶ Remove the load hook: Contact Customer Service at Liebherr-Werk Ehingen GmbH.
- ▶ Prior to the inspection: Put the surfaces into a state in which surface cracks can be detected correctly.
- ▶ Check the load hook for surface cracks using a suitable procedure.

An authorized inspector must decide if the surface cracks can be repaired.

When the surface cracks have been repaired:

- ▶ Check if the load hook dimensions lie within the permissible tolerances. Contact Customer Service at Liebherr-Werk Ehingen GmbH.

When the surface cracks are **not** permissible:

- ▶ Replace the load hook with the hook nut.

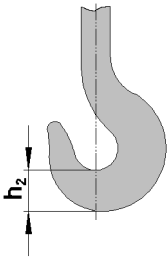
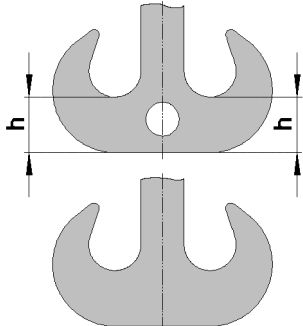
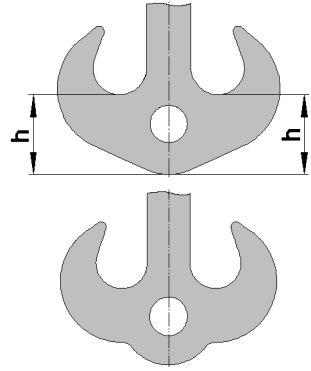
### 3.3 Checking the hook body for wear

#### 3.3.1 Hook base

The wear on the hook base may be maximum 5 % in reference to the respective initial dimension:

- Single hook: Initial dimension  $h_2$
- Double hook: Initial dimensions  $h$

The respective initial dimensions are provided in the following chart:

Hook number	Single hook	Double hook, shape A	Double hook, shape B
	$h_2$	$h$	$h$
			
4	67 mm	—	—
5	75 mm	—	—
6	85 mm	75 mm	—
8	95 mm	85 mm	—
10	106 mm	95 mm	130 mm
12	118 mm	106 mm	150 mm
16	132 mm	118 mm	174 mm
20	150 mm	132 mm	196 mm
25	170 mm	150 mm	218 mm
32	—	170 mm	242 mm
40	—	190 mm	271 mm
50	—	212 mm	308 mm
63	—	236 mm	353 mm
80	—	265 mm	399 mm
100	—	300 mm	449 mm
125	—	335 mm	500 mm
160	—	375 mm	530 mm

Hook number	Single hook	Double hook, shape A	Double hook, shape B
	$h_2$	$h$	$h$
200	—	425 mm	600 mm
250	—	475 mm	670 mm
320	—	530 mm	—
400	—	600 mm	—

Initial dimensions for wear on the hook base, single hooks and double hooks

- ▶ Single hook: Measure the ACTUAL dimension  $h_2$ .
- ▶ Double hook: Measure the ACTUAL dimension  $h$ .
- ▶ Determine the initial dimension depending on the hook shape with the chart.

When the wear on the hook base is 5 % greater than the initial dimension:

- ▶ Replace the load hook with the hook nut.

### 3.3.2 Surfaces

Surfaces with wear must be connected smoothly with the adjacent surfaces.

- ▶ Check surfaces with wear for sharp edges, grooves or other surface errors.

An authorized inspector must decide if the surface errors can be repaired.

When the surface errors have been repaired:

- ▶ Check if the load hook dimensions lie within the permissible tolerances. Contact Customer Service at Liebherr-Werk Ehingen GmbH.

When the wear is **not** permissible:

- ▶ Replace the load hook with the hook nut.

## 3.4 Checking the double hook for damage

Visible damage indicate **improper** fastening of the load.

Relevant areas for the inspection:

- Lower area on the hook shaft
- On every hook: Transition area from the hook shaft to the hook jaw

- ▶ Check the load hook for visual damage.

An authorized inspector must decide if the damage can be repaired.

When the damage has been repaired:

- ▶ Check if the load hook dimensions lie within the permissible tolerances. Contact Customer Service at Liebherr-Werk Ehingen GmbH.

When the damage is **not** permissible:

- ▶ Replace the load hook with the hook nut.

## 3.5 Checking the load hook for corrosion

Depending on the overall condition of the load hook, an inspection expert must decide if the hook thread must be checked for corrosion nicks.

If the hook thread must be checked:

- ▶ Determine the Liebherr ID no. and manufacturer of the load hook, see chapter 2.05.10.
- ▶ Request the assembly instructions for the load hook: Contact Customer Service at Liebherr-Werk Ehingen GmbH.
- ▶ Remove the load hook: Contact Customer Service at Liebherr-Werk Ehingen GmbH.
- ▶ Disassemble the hook nut according to the manufacturer's assembly instructions.
- ▶ Check the hook thread, hook nut and machined surfaces on the hook shaft for corrosion.

An inspection expert must decide if the corrosion nicks can be repaired.

When the corrosion nicks have been repaired:

- ▶ Check if the dimensions of the hook thread and the hook shaft lie within the permissible tolerances.  
Contact Customer Service at Liebherr-Werk Ehingen GmbH.

If an **impermissible** axial play is suspected on the hook nut:

- ▶ Contact Customer Service at Liebherr-Werk Ehingen GmbH.

When the corrosion is **not** permissible:

- ▶ Replace the load hook with the hook nut.

If the load hook passed the inspection:

- ▶ Follow the instructions in the section "Assembling the hook nut".

### 3.6 Assembling the hook nut

Make sure that the following prerequisites are met:

- The hook shaft, hook thread and hook nut fulfill all test criteria.
- The axial bearing is free of damage and turns easily.

If the axial bearing does **not** turn easily:

- ▶ Clean the axial bearing and replace the lubricant.

**or**

Replace the axial bearing.

If the axial bearing is damaged:

- ▶ Replace the axial bearing.

Before the assembly of the hook nut: Corrosion protection must be applied between the thread sides.

- ▶ Grease the threads of the hook nut.
- ▶ Assemble the hook nut according to the manufacturer's assembly instructions.

The type of sealing after assembly must correspond to the sealing before the inspection.

- ▶ Seal the transition between the hook thread and the hook nut thread.
- ▶ Install the load hook.

### 3.7 Checking the retaining elements

- ▶ Check if the anti-rotation device of the hook nut (axle retainer) is tightened.
- ▶ Check if the anti-rotation device of the hook nut functions.
- ▶ Check the function of the hook guard.

If the retaining element did **not** pass the inspection:

- ▶ Contact Customer Service at Liebherr-Werk Ehingen GmbH.



## 8.06 Inspection of hydraulic hose lines

1	Safety guidelines	3
2	Inspection intervals	3
3	Checking the end of the service life	3
4	Inspecting the hydraulic hose lines for damage	4
5	Inspecting the hydraulic hose lines for leaks	5
6	Documenting the inspection	5
7	Replacing hydraulic hose lines	5

*Fig.195219*

LWE/LR 1800-1-0-000/27200-07-02/en

# 1 Safety guidelines



## WARNING

Damaged and leaky hydraulic hose lines!  
Fire, accidents, death, severe injury, property damage.

If leaky areas are found:

- ▶ Have these leaky areas inspected immediately by authorized and trained expert personnel and remedied.

If damage is found:

- ▶ Have the hydraulic hose lines replaced exclusively by authorized and trained expert personnel.

If it is determined that the service life is over:

- ▶ Have the hydraulic hose lines replaced exclusively by authorized and trained expert personnel.

Make sure that the following prerequisite is met:

- A **competent person for hydraulic hose lines** inspects the hydraulic hose lines.

A **competent person for hydraulic hose lines** has the following knowledge:

- Knowledge and experience in hydraulic and mechanics
- Knowledge of all requirements regarding valid standards:
  - ISO 8331
  - ISO 2230
  - ISO 1402
  - ISO/TR
  - EN 853 to EN 857
  - National regulations
- **or:** Knowledge of all requirements regarding the valid German standards, for example:
  - DIN 20066:202-10
  - BGR 237 Feb 2008, BG-Regulation

## 2 Inspection intervals

The inspection of hydraulic hose lines must be carried out in the following intervals:

- when the crane is **up to 10 years** old, at least one inspection every twelve months
- when the crane is **older than 10 years**, at least one inspection every six months

## 3 Checking the end of the service life

Hydraulic hose lines have a limited service life.

When hydraulic hose lines are properly stored, installed and used, then the manufacturer guarantees a service life of at least 10 years.

The life expectancy of hydraulic hose lines can deviate significantly from the noted service life of hydraulic hose lines.



### Note

Special case: Active rear axle steering!

- ▶ The life expectancy of hydraulic hose lines is six years, including a storage period of maximum two years.

The life expectancy of a hydraulic hose line depends on various factors:

- Environmental influences, for example: Temperature, humidity, corrosive air
- Use

- Working cycles
- Number of bending cycles
- Friction
- Fluid

The following factors reduce the life expectancy significantly:

- Heat
- Repeated bending under pressure

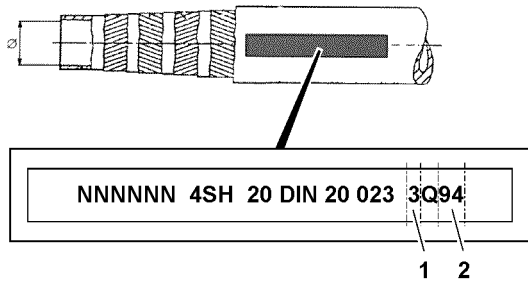


Fig.120159: Example for identification of hydraulic hose lines

The manufacturing date is marked on the fixtures or fittings.

- ▶ Read the quarter **1** of manufacture.
- ▶ Read the year **2** of manufacture.

When the life expectancy of a hydraulic hose line has been exceeded, then a **competent person** can decide **not** to replace the hydraulic hose line. Document the decisions, see section “Documenting the inspection”.

When the end of the service life is determined:

- ▶ Have the hydraulic hose lines replaced exclusively by authorized and trained expert personnel.

## 4 Inspecting the hydraulic hose lines for damage

Hydraulic hose lines must be replaced when one of the following damage is present:

- Damage on outer surface, such as chafe marks, cuts and cracks
- Brittleness due to aging of outer layer (cracks)
- Distortion, such as splitting of hose layers, bubbles, crushed areas, kinks, rotational stress
- Leakages
- Damage or distortion of hose fixtures or hose fitting (seal is endangered)
- Movement between hose and hose line, hose working itself loose from the fixture or the fitting
- Requirements for installation **not** observed
- Corrosion of fixture or fitting (solidness or function of fitting is endangered)

When the hydraulic hose line is **not** completely accessible:

- ▶ Remove the hydraulic hose line.

When the hydraulic hose line is protected with a protective hose:

- ▶ Check the hose protection for abrasion. Abrasion on a hose protective hose can indicate abrasion on the hydraulic hose line.
- ▶ Check hydraulic hose lines for distortion in pressureless and pressurized status and during bending.

When the hydraulic hose line is slightly damaged, then a **competent person** can decide **not** to replace the hydraulic hose line. Document the decisions, see section “Documenting the inspection”.

If damage is found:

- ▶ Have the hydraulic hose lines replaced exclusively by authorized and trained expert personnel.

## 5 Inspecting the hydraulic hose lines for leaks

- ▶ Check the crane for escaped hydraulic oil.
- ▶ Check the crane for leaks by visually checking the ground under the crane.

When the hydraulic system leaks:

- ▶ Have these leaks inspected immediately by authorized and trained expert personnel and remedied.  
**or**  
Contact Liebherr Service.

## 6 Documenting the inspection

Make sure that the following prerequisite is met:

- A **competent person for hydraulic hose lines** documents noticeable observations.

The following data about hydraulic hose lines is documented:

- Installation location
- Condition
- Date
- Time
- ▶ Document noticeable observations comprehensibly.

When the life expectancy of a hydraulic hose line has been exceeded or if the hydraulic hose line is slightly damaged, then a **competent person** can decide **not** to replace the hydraulic hose line.

When the hydraulic hose line is **not** replaced:

- ▶ Document decisions and replacements comprehensibly.
- ▶ Document the date for the next inspection comprehensibly.

## 7 Replacing hydraulic hose lines

To ensure maximum safety, sealing and service life, the following guidelines apply for replacement of hydraulic hose lines.



### WARNING

Impermissible spare parts!

Death, severe injury, property damage.

- ▶ Do **not** use repaired or used hydraulic hose lines.
- ▶ Use exclusively Original Liebherr spare parts.
- ▶ Use exclusively hydraulic hose lines according to manufacturer's specification (including fixtures, rubber piece goods and manufacturing process).

### NOTICE

Routing of hydraulic hose lines changed!

Abrasion. Incorrect bending radius. Stress. Shortened service life.

- ▶ Keep the routing of hydraulic hose lines.
- ▶ Inspect the hydraulic hose lines according to intervals.

- ▶ Adhere to the hose bending radii according to the manufacturer's specifications.
- ▶ Ensure the routing of hydraulic hose lines according to manufacturer's specifications (pressureless and pressurized condition).
- ▶ Ensure the distance between lines and structures.

If necessary:

- ▶ Check moving parts in the area of hydraulic hose lines.

When the hydraulic hose line is installed in straight direction:

- ▶ Ensure a sag of the hose.
- ▶ Avoid mechanical tension and twisting of the hose during installation.
- ▶ Fasten the hydraulic hose line according to manufacturer's specification.
- ▶ Do not cross hydraulic hose lines for high pressure and low pressure.
- ▶ Keep hydraulic hose lines away from hot components.

When hydraulic hose lines are in a surrounding with high temperatures:

- ▶ Install protective insulation according to manufacturer's specifications.

## 8.12 Inspection of safety controls on the relapse supports

1	S-boom relapse retainer	2
2	D-boom relapse retainer	5
3	W-lattice jib relapse retainer	7
4	F-lattice jib relapse retainer	16

# 1 S-boom relapse retainer

Two S-relapse cylinders prevent the main boom from falling backward.

## 1.1 Checking the limit switch initiators for function before erection

Before erecting the main boom **2**, check the function of the limit switch initiators.

Cover the limit switch initiators on the S-relapse cylinder **1** individually with a metal plate.

- The “luffing up” movement of the main boom **2** is turned off.
- The icon appears on the LICCON monitor.

## 1.2 Checking the limit switch initiators for function

In the steepest boom position, the luffing up movement is turned off by the actuated limit switch initiators on the cylinder.

- When the limit switches are actuated on the two S-relapse cylinders **1** the “luffing up” movement of the main boom **2** is turned off.
- The icon appears on the LICCON monitor.

### 1.2.1 Block position

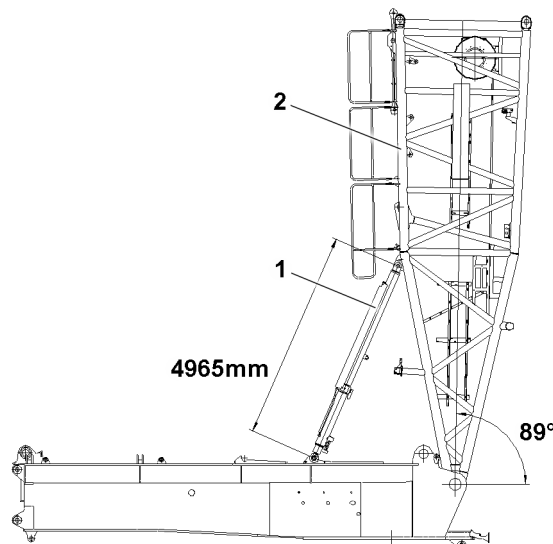


Fig.159073: Block position

**1** S-relapse cylinder

**2** Main boom

	Angle	S-relapse cylinder length
Block position	89°	4965 mm

Block position



### 1.2.2 Steepest position

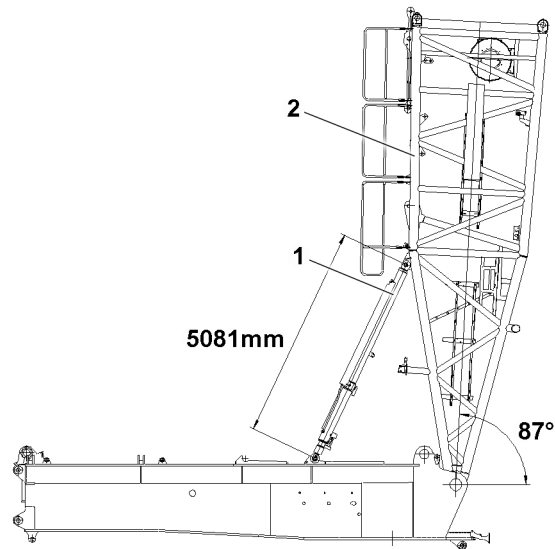


Fig.159074: Steepest position

- 1 S-relapse cylinder
- 2 Main boom

	Angle	S-relapse cylinder length
Steepest position	87°	5081 mm

*Steepest position*

### 1.2.3 Electric switch position

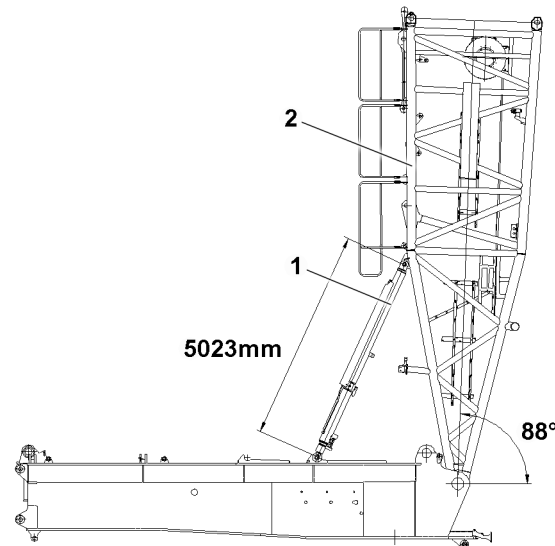


Fig.159075: Electric switch position

- 1 S-relapse cylinder
- 2 Main boom

	Angle	S-relapse cylinder length
Electric switch position	88°	5023 mm

*Electric switch position*

LWE/LR 1800-1-0-000/27200-07-02/en

### 1.2.4 S-relapse cylinder extended

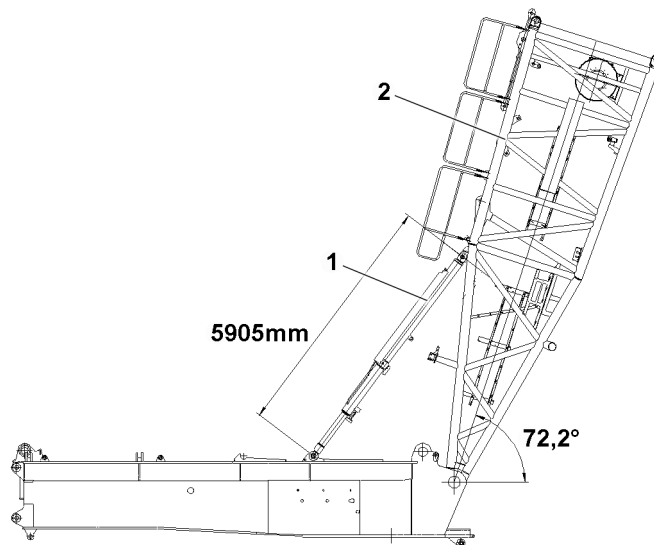


Fig.159076: S-relapse cylinder extended

- 1 S-relapse cylinder
- 2 Main boom

	Angle	S-relapse cylinder length
S-relapse cylinder extended	72.2°	5905 mm

*S-relapse cylinder extended*

### 1.2.5 Block position extended

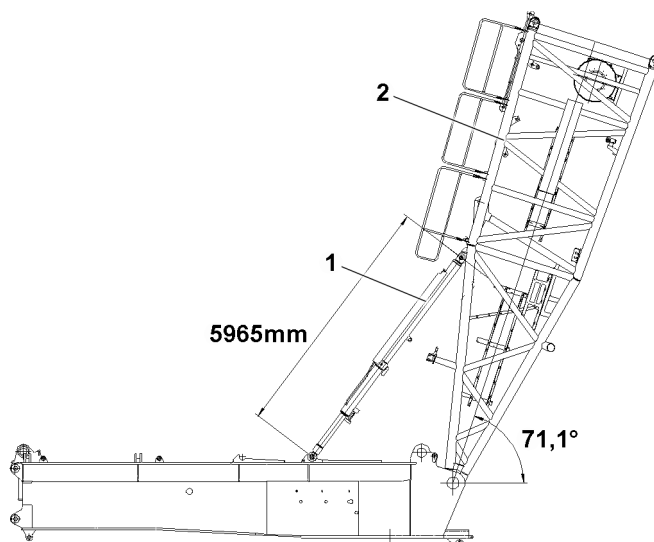


Fig.159077: Block position extended

- 1 S-relapse cylinder
- 2 Main boom

	Angle	S-relapse cylinder length
Block position extended	71.1°	5965 mm

*Block position extended*

LWE/LR 1800-1-0-000/27200-07-02/en

## 2 D-boom relapse retainer

Two D-relapse cylinders prevent the D-boom from falling backward.

### 2.1 Checking the limit switch initiators for function before erection

Before erecting the D-boom 2, check the function of the limit switch initiators.

Cover the limit switch initiators individually on the D-relapse cylinder 1 with a metal plate.

- “Spooling up” winch 4 is blocked.
- The icon appears on the LICCON monitor.

### 2.2 Checking the limit switch initiators for function

When the limit switches are actuated on the two S-relapse cylinders 1 the movement of the D-boom 2 is turned off.

- “Spooling up” winch 4 is blocked.
- The icon appears on the LICCON monitor.

#### 2.2.1 Block position

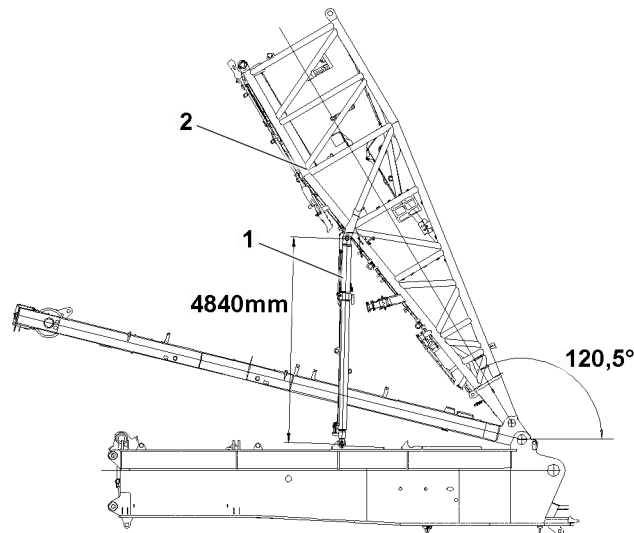


Fig. 159078: Block position

1 D-relapse cylinder

2 D-boom

	Angle	D-relapse cylinder length
Block position	120.5°	4840 mm

*Block position*

### 2.2.2 D-relapse cylinder extended

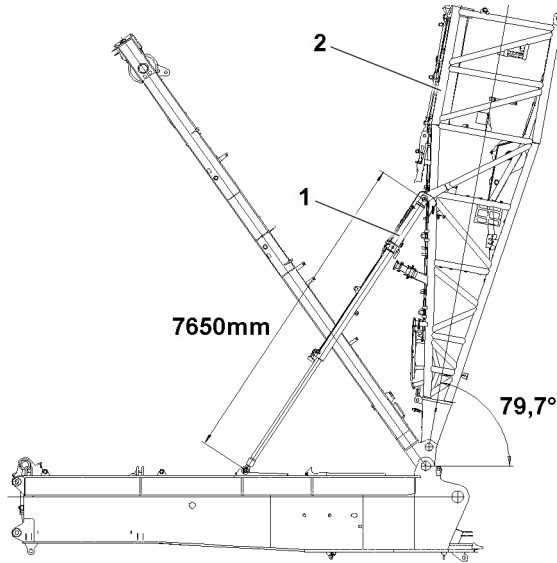


Fig.159079: D-relapse cylinder extended

- 1 D-relapse cylinder
- 2 D-boom

	Angle	D-relapse cylinder length
D-relapse cylinder extended	79.7°	7650 mm

D-relapse cylinder extended

### 2.2.3 Electric switch position

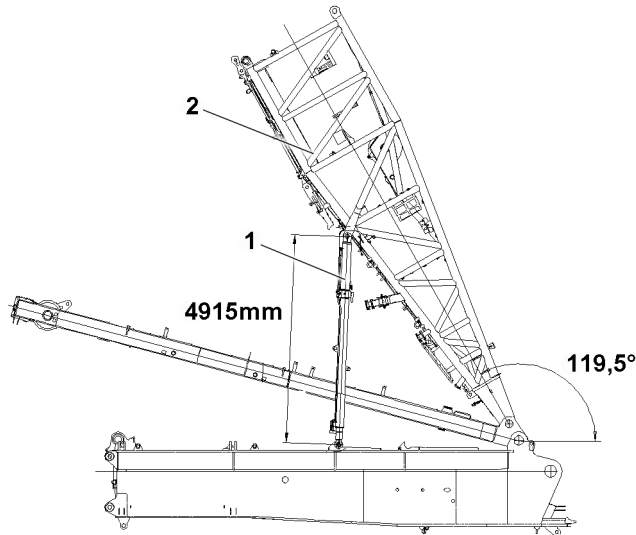


Fig.159080: Electric switch position

- 1 D-relapse cylinder
- 2 D-boom

	Angle	D-relapse cylinder length
Electric switch position	119.5°	4915 mm

Electric switch position

LWE/LR 1800-1-0-000/27200-07-02/en

### 2.2.4 D-relapse cylinder-turntable contact

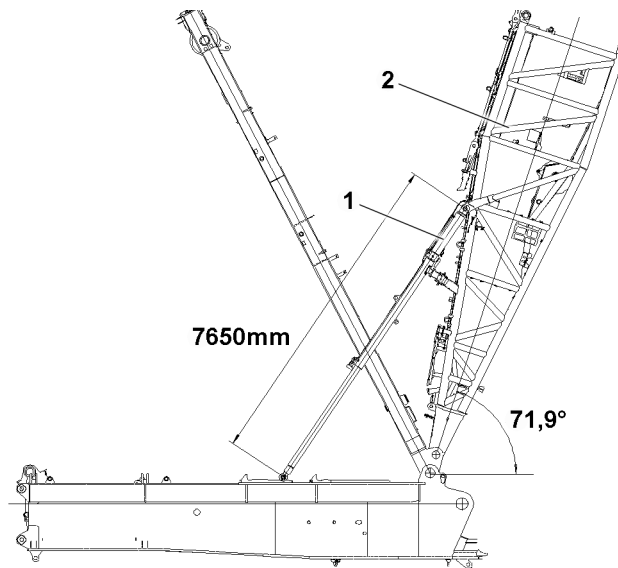


Fig.159081: D-relapse cylinder-turntable contact

- 1 D-relapse cylinder
- 2 D-boom

	Angle	D-relapse cylinder length
D-relapse cylinder-turntable contact	71.9°	7650 mm

D-relapse cylinder-turntable contact

## 3 W-lattice jib relapse retainer

### 3.1 Checking the limit switch initiators for function before erection

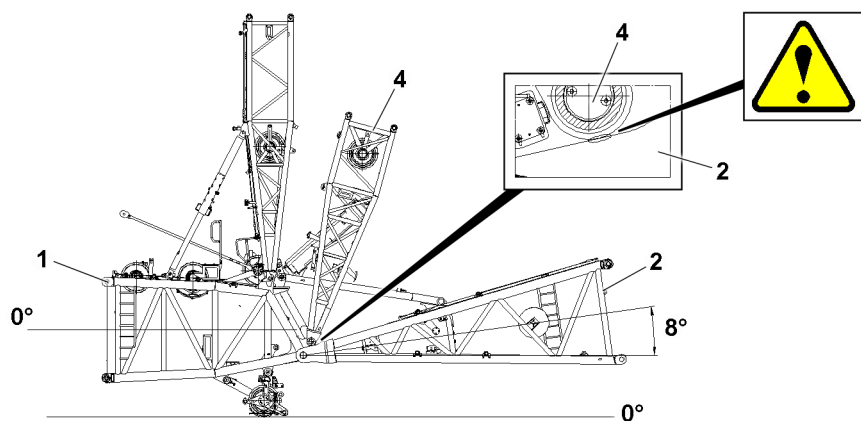


Fig.159086: Minimum permissible angle 8°

- 1 Main boom
- 2 W-lattice jib
- 4 WA-frame I

LWE/LR 1800-1-0-000/27200-07-02/en

**NOTICE**

Minimum permissible angle between the main boom **1** and the W-lattice jib **2** **not** observed!  
Collision and damage to components.

- ▶ Comply with the negative angle between the main boom **1** and the W-lattice jib **2** of less than 8°.

Reduce the angle if necessary:

- ▶ Lift the main boom.

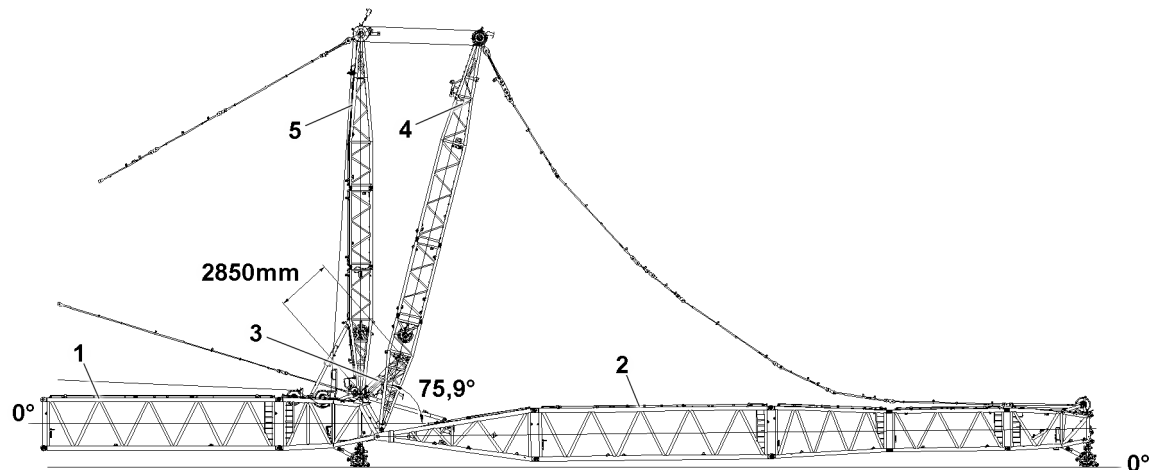


Fig.159082: W-relapse cylinder switch position

- |   |                  |   |             |
|---|------------------|---|-------------|
| 1 | Main boom        | 4 | WA-frame I  |
| 2 | W-lattice jib    | 5 | WA-frame II |
| 3 | Relapse cylinder |   |             |

	WA I angle	Main boom angle	Relapse cylinder length
W-relapse cylinder switch position	75.9°	0°	2850 mm

*W-relapse cylinder switch position*

Before erecting the boom **1**, check the shut off function of the W-relapse cylinder **3**.

Pull WA-frame I **4** and WA-frame II **5** together until the limit switch initiators on the W-relapse cylinder **3** switch.

- The W-control winch “spooling up” movement is turned off.
- The limit sign appears on the LICCON monitor, see chapter 4.02.

## 3.2 Steepest position

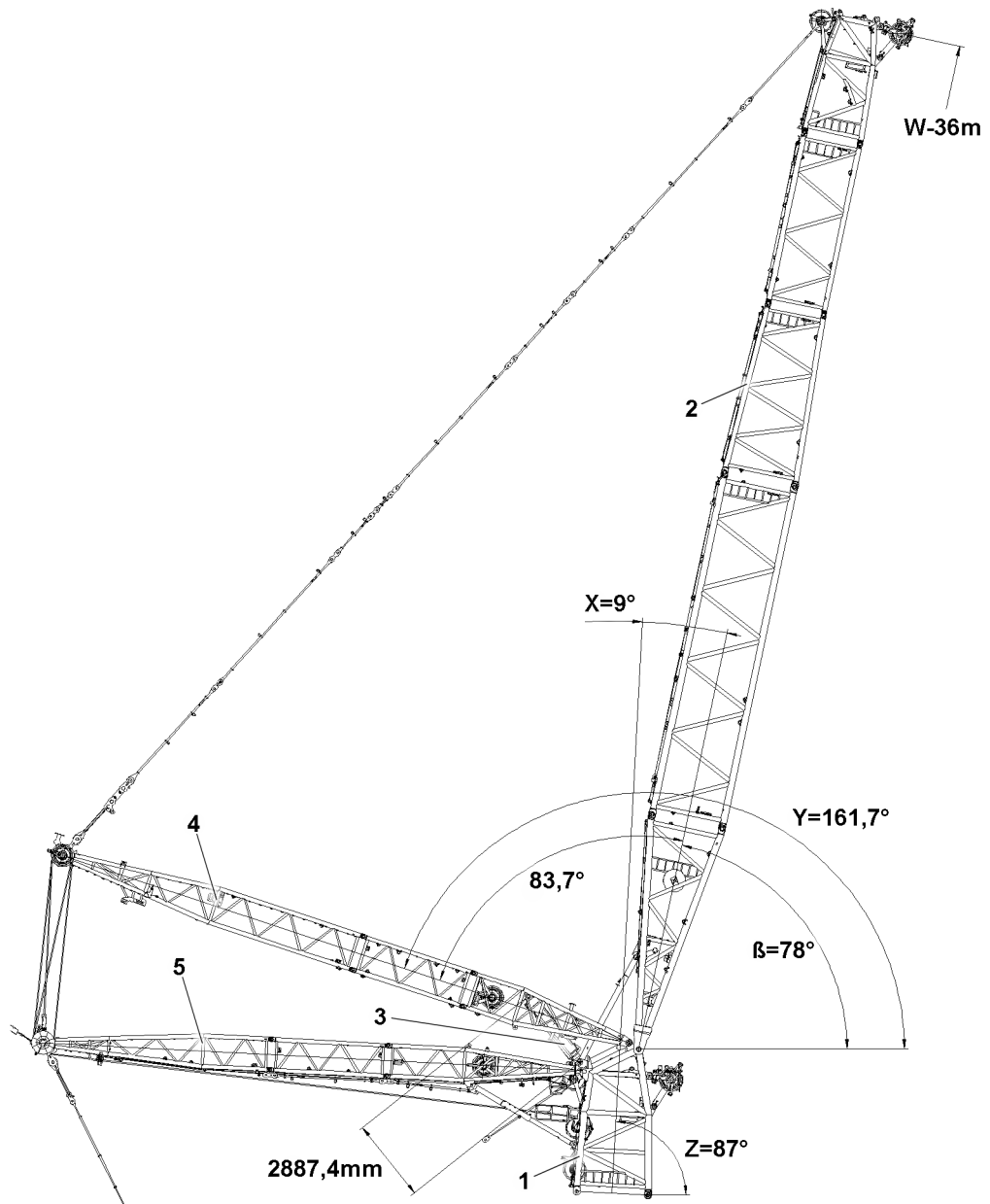


Fig.159083: Main boom erected // W-lattice jib "steepest position"

- |   |                  |   |             |
|---|------------------|---|-------------|
| 1 | Main boom        | 4 | WA-frame I  |
| 2 | W-lattice jib    | 5 | WA-frame II |
| 3 | Relapse cylinder |   |             |



### WARNING

The crane can topple over!

Death, severe bodily injuries, property damage.

- ▶ The approaching of the "steepest position" must be monitored by a guide.

The luffing up movement is turned off in the steepest position of the W-lattice jib 2.

Pull WA-frame I 4 and WA-frame II 5 together and luff up the W-lattice jib 2 until the steepest position is reached and the luffing up movement is switched off.

- The W-control winch "spooling up" movement is turned off.
- The auxiliary boom / accessory limit sign appears on the LICCON monitor, see chapter 4.02.

After successful test, reset the WA-frames to set up configuration, see chapter 5.07.

### 3.3 W-lattice jib test position

In the test position, the W-control winch movement is turned off by the actuated limit switch initiators on the cylinder.

- The W-control winch movement is turned off.
- The auxiliary boom / accessory limit sign appears on the LICCON monitor, see chapter 4.02.

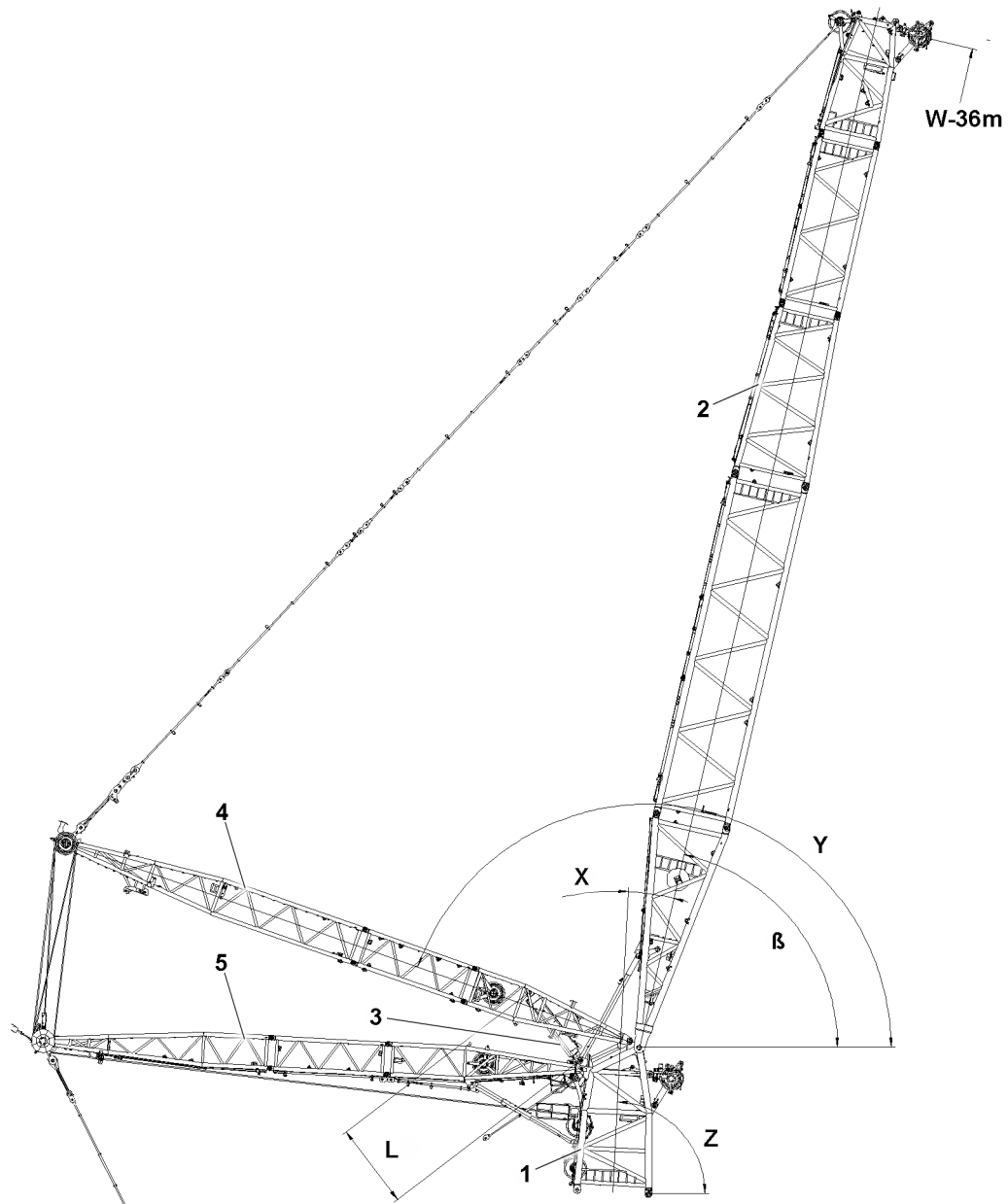


Fig.159084: Main boom erected // W-lattice jib test position

- |   |                  |   |             |
|---|------------------|---|-------------|
| 1 | Main boom        | 4 | WA-frame I  |
| 2 | W-lattice jib    | 5 | WA-frame II |
| 3 | Relapse cylinder |   |             |



	Angle				Cylinder length L
	X <sup>1)</sup>	Y <sup>2)</sup>	Z <sup>3)</sup>	$\beta$ <sup>4)</sup>	
End position specified by the control	10°	160.7° <sup>5)</sup>	87°	77°	2918 mm
“Relapse support in flap” switch position	9°	161.7°	87°	78°	2887.4 mm
“Relapse support in flap on block” block position	6.5°	164.4° <sup>5)</sup>	87°	80.5°	2806.5 mm
W-relapse cylinder extended all the way to stop on S-end section	57.9° <sup>5)</sup>	112°	87°	29.1° <sup>5)</sup>	4400 mm

*W-lattice jib test positions*

- <sup>1)</sup> X-angle between main boom and W-lattice jib.  
<sup>2)</sup> Y- angle between the horizontal and WA-frame I.  
<sup>3)</sup> Z- angle between the horizontal and the main-boom.  
<sup>4)</sup>  $\beta$ - angle between the horizontal and the W-lattice jib.  
<sup>5)</sup> Angle dependent on the length of the W-lattice jib.

### 3.4 “W-lattice jib downward 45° downward” switch setting

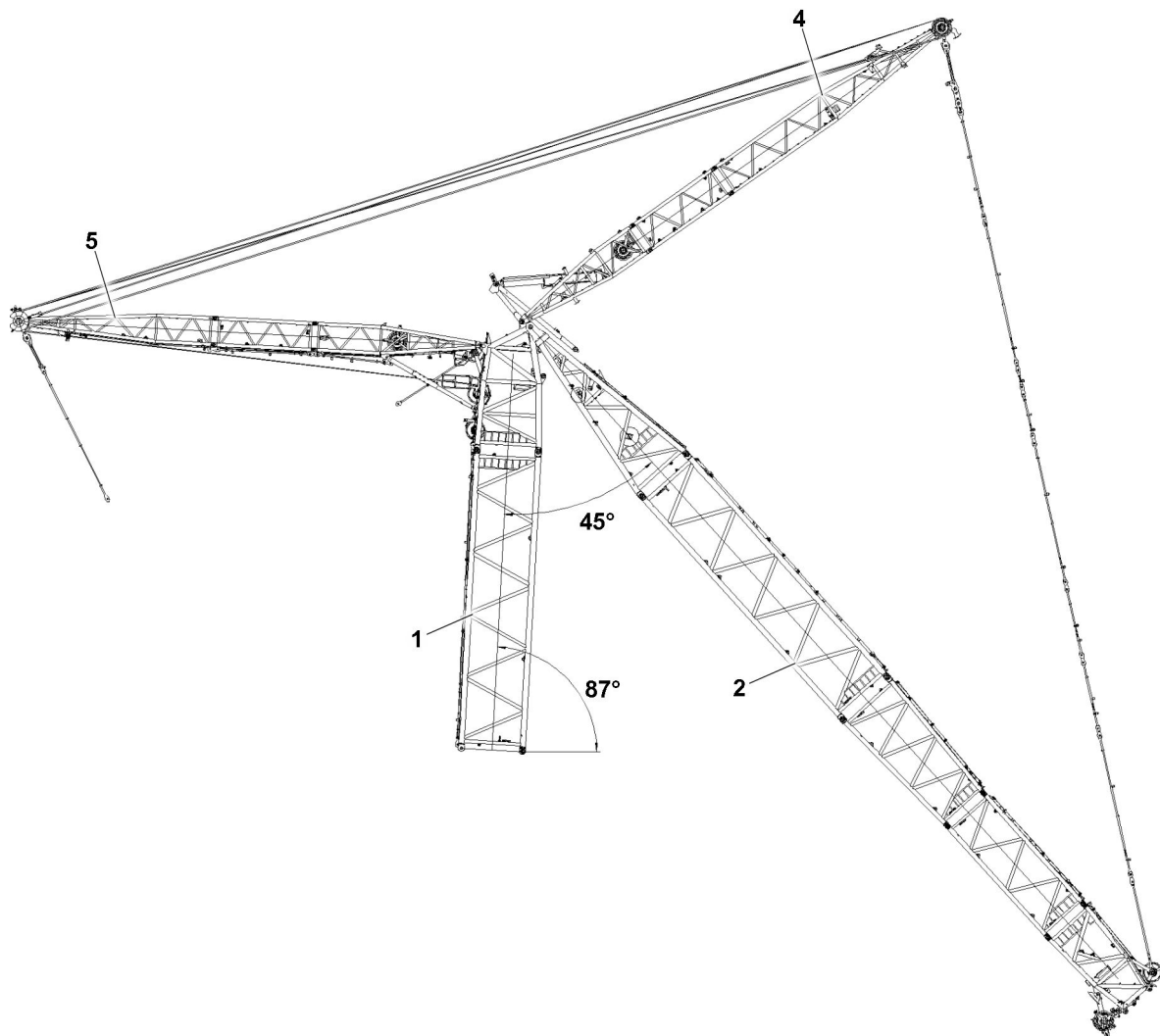


Fig.159085: “W-lattice jib downward 45° downward” switch setting

1	Main boom	4	WA-frame I
2	W-lattice jib	5	WA-frame II

Luff the W-lattice jib **2** down to until the “W-lattice jib downward 45° downward” switch setting switches.

- The W-control winch “spooling out” movement is turned off.
- The auxiliary boom / accessory limit sign appears on the LICCON monitor, see chapter 4.02.

### 3.5 Function check of limit switch initiators on the mechanical relapse support - flap

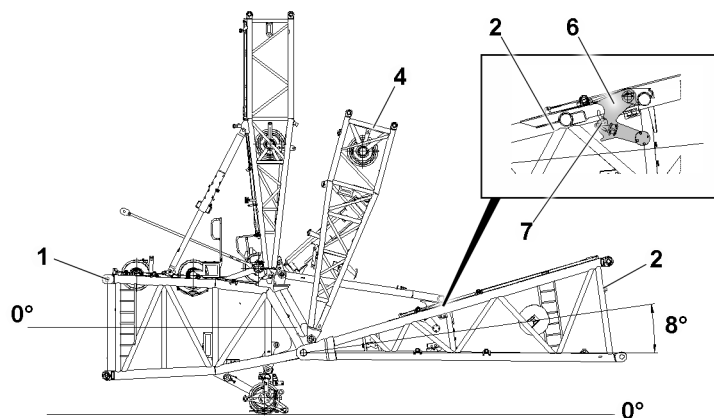


Fig.159087: Mechanical relapse support

- |   |               |   |              |
|---|---------------|---|--------------|
| 1 | Main boom     | 6 | Flap         |
| 2 | W-lattice jib | 7 | Limit switch |
| 4 | WA-frame I    |   |              |

In addition to the W-relapse cylinders, the W-lattice jib **2** is also secured by a mechanical relapse support, which engages in steepest lattice jib position in the flap **6** of the oscillation guard.

The limit switches **7** are manually checked in the taken down boom status.

- The luffing up movement of the W-lattice jib is turned off by the actuation of the limit switches on the oscillation guard.

The “flap in position” limit switches must be checked in the test system. Cover the limit switches with a metal plate.

- Check on the LSB screen if the limit switches switch.



#### DANGER

Danger of tipping over if the oscillation guard is hard to move!

If the flap **6** is hard to move, the mechanical relapse retainer will no longer function. The W-lattice jib can tip backwards uncontrolled and cause the crane to topple over. Death, severe bodily injuries, property damage.

- ▶ Before erecting the boom system, the flap **6** must be checked for easy movement over the entire slewing range.
- ▶ Make sure that the easy movement of the flap **6** is ensured before every crane application.
- ▶ Crane operation with a hard to move flap **6** is prohibited.



#### Note

- ▶ Depending on the angle of the W-lattice jib **2**, the position of the flap changes due to the pendulum weight.

Check the flap **6** for easy movement.

- At a 37° angle of the W-lattice jib, the flap **2** must be in position.

### 3.5.1 The flap can by pushed open

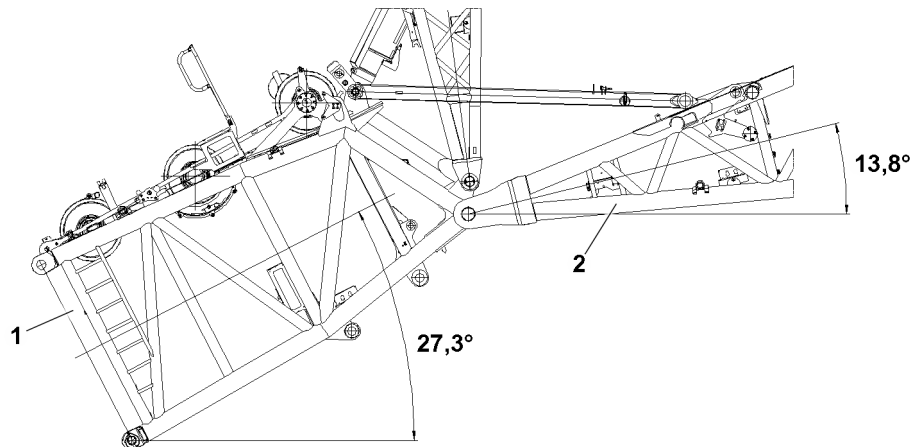


Fig.159088: The flap can by pushed open

1 Main boom

2 W-lattice jib

### 3.5.2 Flap can be pushed closed

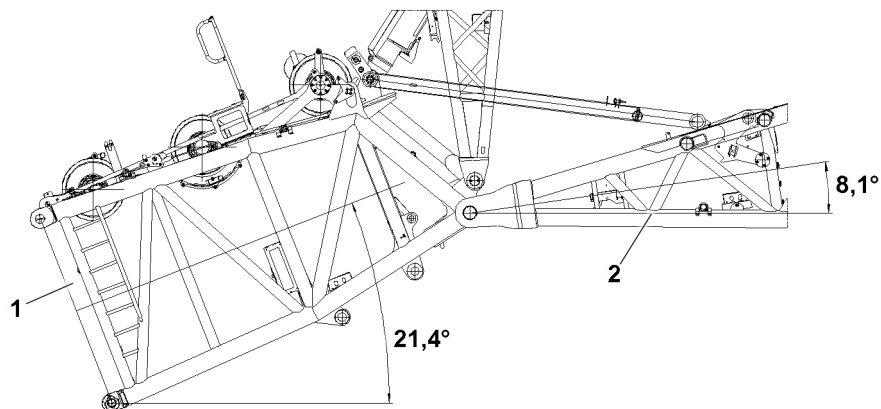


Fig.159089: Flap can be pushed closed

1 Main boom

2 W-lattice jib

### 3.5.3 Flap swung in at stop

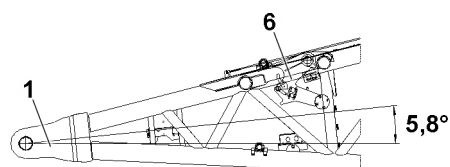


Fig.159091: Flap swung in at stop

2 W-lattice jib

6 Flap

### 3.5.4 Flap swung out to stop

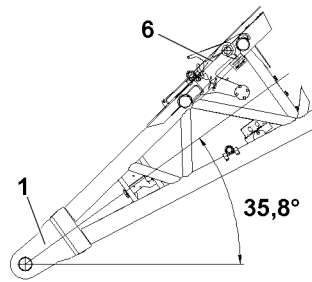


Fig.159092: Flap swung out to stop

2 W-lattice jib

6 Flap

### 3.5.5 Flap in position

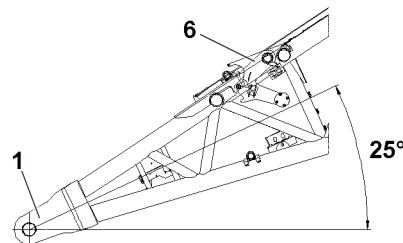


Fig.159093: Flap in position

2 W-lattice jib

6 Flap

## 3.6 Collision of the mechanical relapse support with the flap.



### DANGER

Danger of collision!

At an angle between the main boom and the W-lattice jib of **14.2°**, the mechanical relapse support collides with the flap **6**.

The W-lattice jib **2** can tip backwards uncontrolled and cause the crane to topple over. Death, severe bodily injuries, property damage.

- ▶ Make sure that no collision will occur between the relapse support and the flap.
- ▶ Perform a visual inspection.

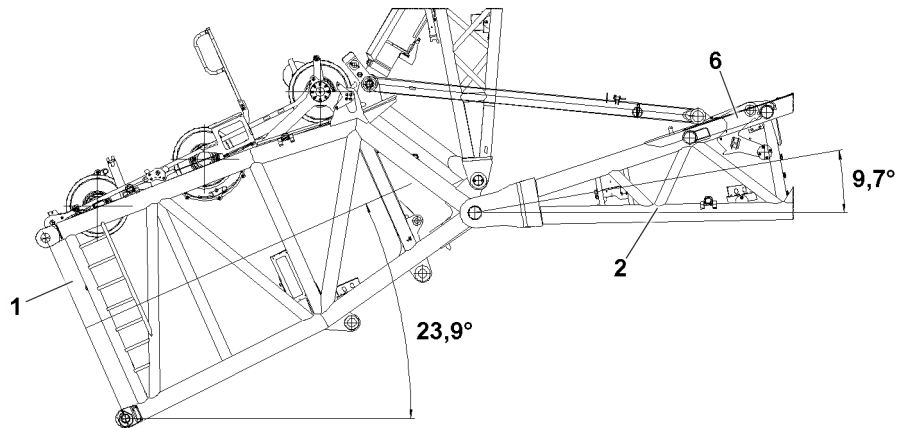


Fig.159090: Collision with the flap

- |   |               |   |                            |
|---|---------------|---|----------------------------|
| 1 | Main boom     | 6 | Flap                       |
| 2 | W-lattice jib | 8 | Mechanical relapse support |

Collision of the mechanical relapse support with the flap.

## 4 F-lattice jib relapse retainer

### 4.1 Checking the limit switch initiators for function before erection

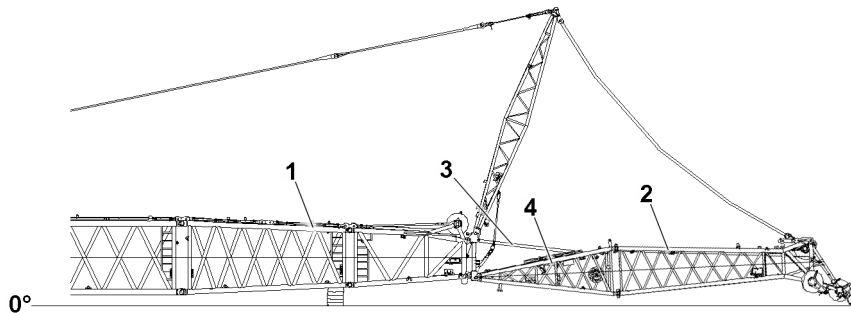


Fig.159099: F-lattice jib

- |   |               |   |                 |
|---|---------------|---|-----------------|
| 1 | Main boom     | 3 | Relapse support |
| 2 | F-lattice jib | 4 | Flap            |

Before erecting the F-lattice jib **2**, check the function of the limit switch initiators.

Cover the limit switch initiators individually with a metal plate.

- The movement is turned off.
- The auxiliary boom / accessory limit sign appears on the LICCON monitor, see chapter 4.02.

## 4.2 Relapse support flap

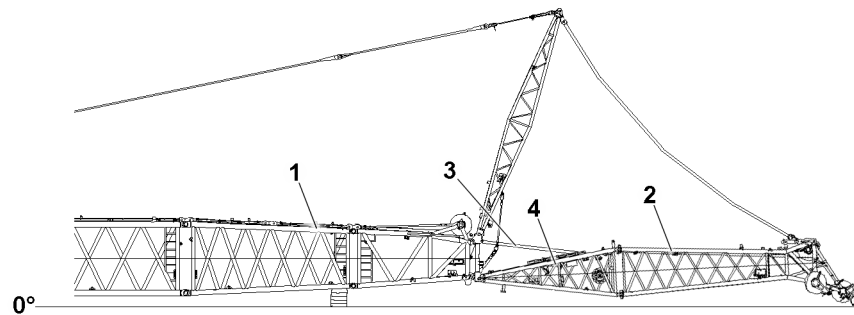


Fig.159099: F-lattice jib

- |   |               |   |                 |
|---|---------------|---|-----------------|
| 1 | Main boom     | 3 | Relapse support |
| 2 | F-lattice jib | 4 | Flap            |

The F-lattice jib **2** is secured by a mechanical relapse support **3**, which engages in the steepest lattice jib position in the flap **4** of the oscillation guard.

The movement of the F-lattice jib **2** is turned off by the actuated limit switches on the oscillation guard.



### DANGER

Danger of tipping over if the oscillation guard is hard to move!

If the flap **4** is hard to move, the mechanical relapse retainer will no longer function.

The F-lattice jib can tip backwards uncontrolled and cause the crane to topple over.

Death, severe bodily injuries, property damage.

- ▶ Before erecting the boom system, the flap **4** must be checked for easy movement over the entire slewing range.
- ▶ Make sure that the easy movement of the flap **4** is ensured before every crane application.
- ▶ Crane operation with a hard to move flap **4** is prohibited.

## 4.3 Function check of limit switch initiators on the mechanical relapse support - flap

### 4.3.1 Flap

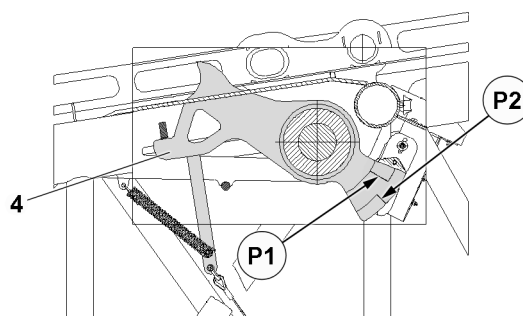


Fig.159100: Flap

- 4** Flap

Switching edges for the message:

- Switching edge for the “top flap” message, see Edge **P1**.
- Switching edge for the “bottom flap” message, see Edge **P2**.

### 4.3.2 Flap in the operating position

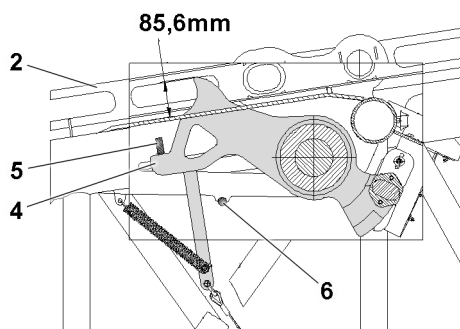


Fig.159095: Flap in the operating position

2 F-lattice jib

5 Stop 1

4 Flap

6 Stop 2

Flap 4 in the operating position. The flap is touching Stop 1 5. Folding jib 85.6 mm over the folding retainer.

### 4.3.3 “Top flap” switch position

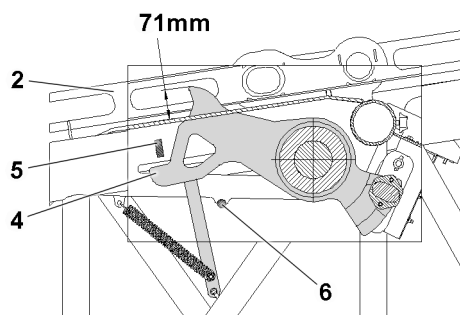


Fig.159096: “Top flap” switch position

2 F-lattice jib

5 Stop 1

4 Flap

6 Stop 2

“Topflap 4” switch position. Folding jib 71 mm over the folding retainer.

- Check the limit switch function in the test system.



#### 4.3.4 “Bottom flap” switch position

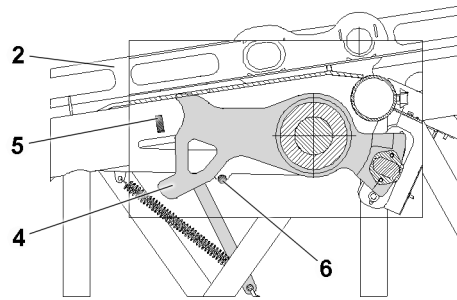


Fig. 159097: “Bottom flap” switch position

- |          |               |          |        |
|----------|---------------|----------|--------|
| <b>2</b> | F-lattice jib | <b>5</b> | Stop 1 |
| <b>4</b> | Flap          | <b>6</b> | Stop 2 |

“Bottom flap 4” switch position. Folding jib flush with the top of the folding retainer.  
 – Check the limit switch function in the test system.

#### 4.3.5 Bottom flap

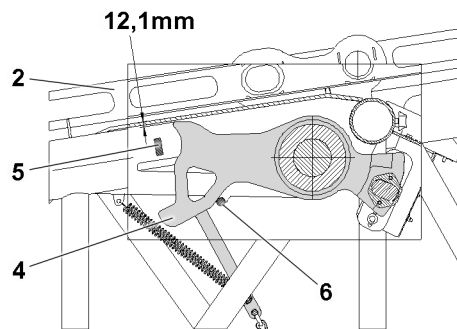


Fig. 159098: Bottom flap

- |          |               |          |        |
|----------|---------------|----------|--------|
| <b>2</b> | F-lattice jib | <b>5</b> | Stop 1 |
| <b>4</b> | Flap          | <b>6</b> | Stop 2 |

Bottom flap 4 The flap is touching Stop 2 6. Folding jib 12.1 mm below the folding retainer.

### 4.3.6 “Relapse support in flap on block” block position

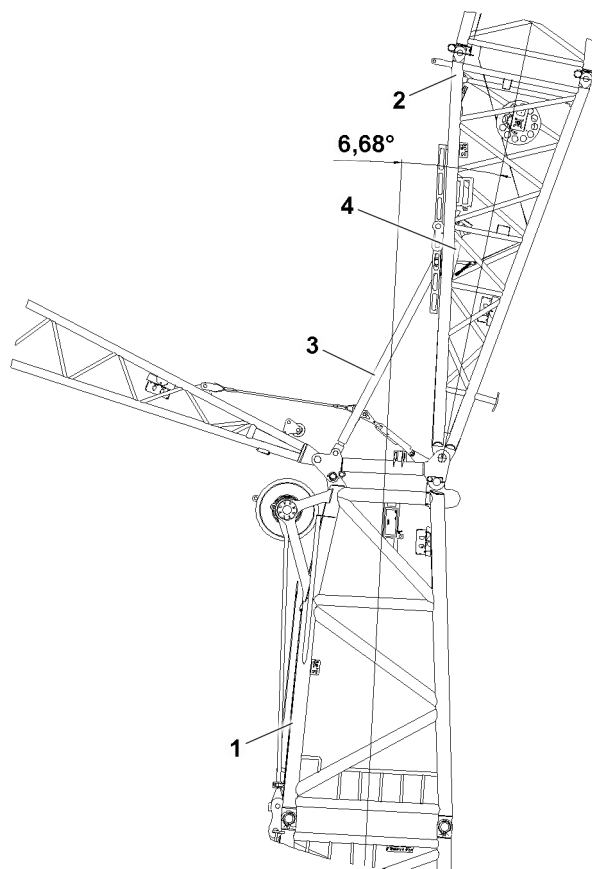


Fig.159094: “Relapse support in flap on block” block position

- |   |               |   |                 |
|---|---------------|---|-----------------|
| 1 | Main boom     | 3 | Relapse support |
| 2 | F-lattice jib | 4 | Flap            |

	Angle	Relapse support
Block position	6.68°	on block

*Block position*

## 8.14 Inspection of accumulator pressure in relapse cylinder

1	Checking the accumulator pressure in the W-relapse cylinder	2
2	Checking the accumulator pressure in the W-relapse cylinder, WA-frame 1 on the ground	3
3	Checking the accumulator pressure in the W-relapse cylinder, W-boom luffed up	4

# 1 Checking the accumulator pressure in the W-relapse cylinder

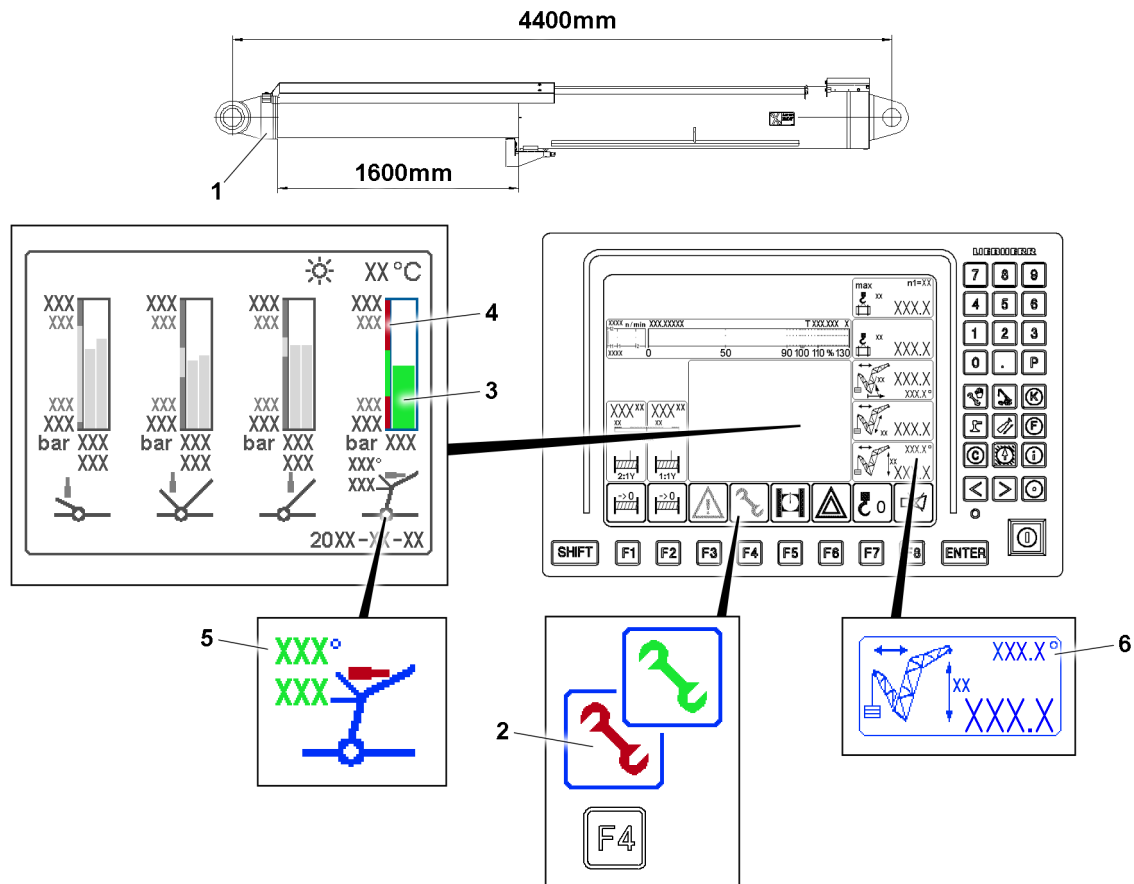


Fig.159101: W-relapse cylinder, crane illustration

- |   |                             |   |  |
|---|-----------------------------|---|--|
| 1 | W-relapse cylinder          | 4 | Pressure display scale (ideal pressure range, min / max. pressure range) |
| 2 | Warning icon                | 5 | WA-frame 1 angle (Y)   |
| 3 | Actual pressure bar display | 6 | W-boom angle ( $\beta$ )   |

Before and during crane operation, the accumulator pressure in the W-relapse cylinder **1** must be checked on the crane operating screen of the LICCON monitor, see, chapter 4.02.

The actual pressure shown must match the nominal pressure in the chart.

The specified nominal pressure depends on the ambient temperature.



## Note

- The maximum permissible difference between the actual and the nominal pressure is maximum  $\pm 10$  bar.

For a detailed description of the icons and displays, refer to chapter 4.02.

When the W-relapse cylinder accumulator pressure is within a **permissible** range:

- The warning icon **2** is **green**.
- The actual pressure bar display **3** is **green**.

When the W-relapse cylinder accumulator pressure is within an **impermissible** range:

- The warning icon **2** is **red**.
- The actual pressure bar display **3** is **red**.
- An error message is output.

**Note**

- ▶ If the actual pressure is in an impermissible range, contact Liebherr Customer Service.

## 2 Checking the accumulator pressure in the W-relapse cylinder, WA-frame 1 on the ground

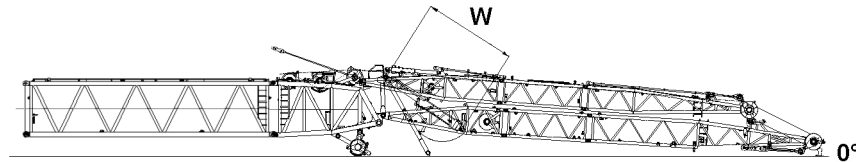


Fig.159127: W-relapse cylinder in the test position, WA-frame 1 on the ground

Make sure that the following prerequisites are met:

- The W-boom is assembled.
- The main boom is lying on the ground.
- WA-frame 1 is lying on the ground.
- The LICCON monitor displays the crane operation program.
- W-operation is set.
- WV-operation is not set.

	Cylinder length W	Stroke
W-relapse cylinder extended all the way	4400 mm	1600 mm

*W-relapse cylinder in the test position*

	Pressure			
	- 20 °C	0 °C	+ 20 °C	+ 40 °C
Nominal pressure	164.9 bar -5/+10 bar	178.0 bar -10/+10 bar	191.0 bar -10/+10 bar	204.0 bar -10/+5 bar

*Nominal pressure depending on the ambient temperature*

- ▶ Display the “Checking the accumulator pressure in the relapse cylinder” field: Press the function key F4.
- ▶ Make sure that the actual pressure bar display lies in the permissible pressure range.
- ▶ Make sure that the actual pressure bar display is green.
- ▶ Make sure that actual pressure is the same as the nominal pressure.

### 3 Checking the accumulator pressure in the W-relapse cylinder, W-boom luffed up

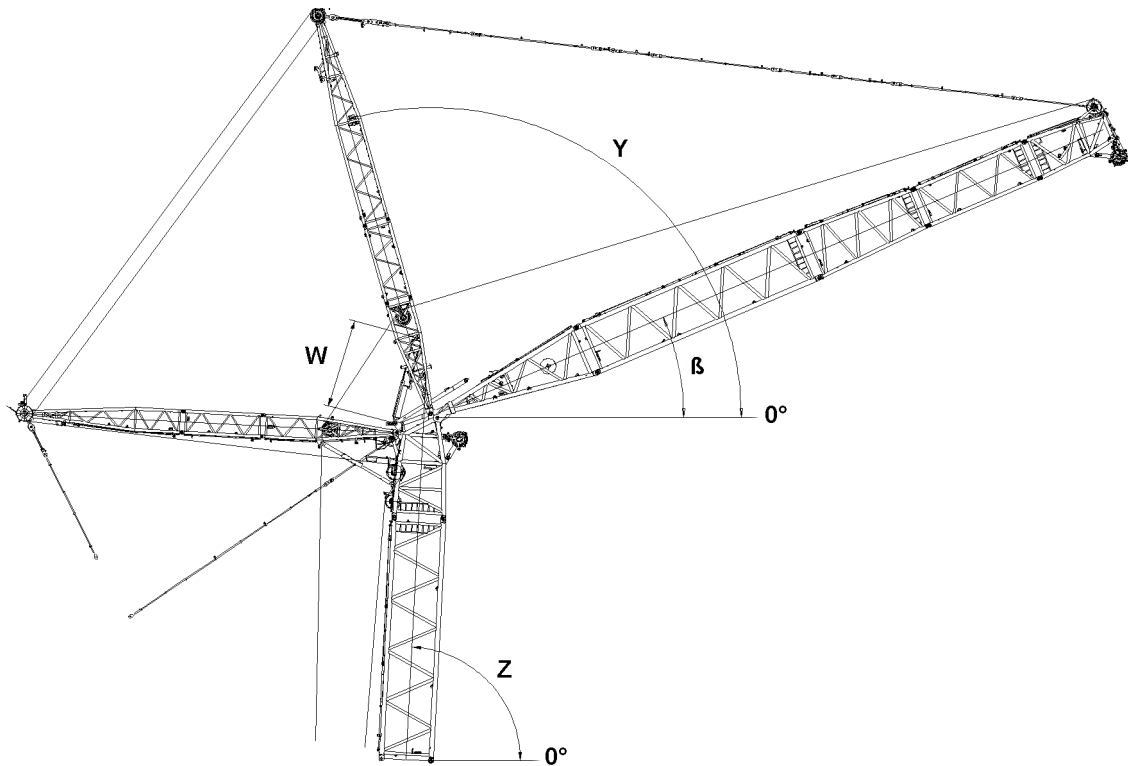


Fig.159102: W-relapse cylinder in the test position, W-boom luffed up

Make sure that the following prerequisites are met:

- The W-boom is completely assembled.
- The W-boom is luffed up.
- The LICCON monitor displays the crane operation program.
- W-operation is set.
- WV-operation is not set.

	Cylinder length W	Stroke	Angle		
			Y	Z	β
W-relapse cylinder extended all the way	4400 mm	1600 mm	112°	87°	29.1°

W-relapse cylinder in the test position

	Pressure			
	- 20 °C	0 °C	+ 20 °C	+ 40 °C
Nominal pressure	164.9 bar -5/+10 bar	178.0 bar -10/+10 bar	191.0 bar -10/+10 bar	204.0 bar -10/+5 bar

Nominal pressure depending on the ambient temperature

- ▶ Set the main boom and the W-boom to the angle specified in the chart, see the illustration and chart.
- ▶ Display the “Checking the accumulator pressure in the relapse cylinder” field: Press the function key F4.
- ▶ Make sure that the actual pressure bar display lies in the permissible pressure range.
- ▶ Make sure that the actual pressure bar display is green.

- ▶ Make sure that actual pressure is the same as the nominal pressure.

---

Empty page!

LWE/LR 1800-1-0-000/27200-07-02/en



## 8.15 Inspection of guy rods

1	Safety guidelines	3
2	Inspection intervals	3
3	Checking the guy rods	3

*Fig.195219*

LWE/LR 1800-1-0-000/27200-07-02/en

# 1 Safety guidelines



## WARNING

Damaged guy rods!

Accident. Death, severe injury, property damage.

- ▶ Crane operation with damaged guy rods **1** is prohibited.
- ▶ Replace damaged guy rods **1**.

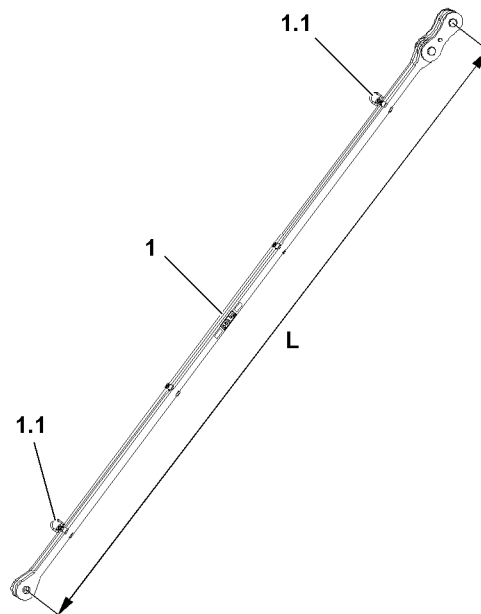


Fig.123845: Guy rod

Make sure that the following prerequisites are met:

- **Authorized and trained expert personnel** checks the guy rods **1**.
- A checklist for documentation of the inspection is on hand

## 2 Inspection intervals

The inspection of the guy rods **1** must be carried out in the following intervals:

- One inspection of the guy rods every 12 months by an expert.
- One inspection of the guy rods every four years by an authorized inspector.

After a load rip-off or overload of the crane:

- immediate inspection of guy rods by an expert

## 3 Checking the guy rods

### 3.1 Inspection



#### Note

- ▶ All inspections of the guy rods **1** must be documented.

The guy rods must be inspected in removed condition.

**WARNING**

The guy rods **1** can be ripped off!

If a damaged guy rod **1** is used further, it can rip off in crane operation.

Death, severe injury, property damage.

- ▶ Crane operation with damaged guy rods is prohibited.
- ▶ Repairs on guy rods **1** (for example: through welding) are prohibited.
- ▶ Replace damaged guy rods immediately.
- ▶ If one of the following stated damage is found, then the guy rods **1** may no longer be used.

### 3.2 Cracks and dents

- ▶ Check the guy rods **1** thoroughly through a visual inspection for cracks and dents.

**Problem remedy**

Damage to guy rods is not clearly evidenced through a visual inspection?

- ▶ Check the respective areas of the guy rods thoroughly, for example with a magnetic particle test.
- ▶ If damage is found: Replace the guy rods **1** immediately.

### 3.3 Elongation

**Note**

- ▶ The initial dimension **L** of the guy rods **1** refers to the bore spacing of the pin bores.
- ▶ The initial dimension **L** of the guy rods **1** is listed in the separate rod plan.
- ▶ Check the elongation of the guy rods **1** by measuring the guy rods.

**WARNING**

The guy rods can be ripped off!

The permissible elongation of the guy rods **1** may be a maximum of 0.2 %, for example 14 mm , at an initial dimension **L** of 7000 mm.

Death, severe injury, property damage.

- ▶ If the maximum permissible elongation is reached or exceeded: Replace the guy rods **1** immediately.
- ▶ If an elongation of the guy rods of more / equal to 0.2 % of the initial dimension **L** is proven: Replace the guy rods **1** immediately.

### 3.4 Wear

- ▶ Check the bores, pins and pin retainers for signs of wear.
- ▶ If respective wear is present in the stated areas: Replace the guy rods **1** immediately.

### 3.5 Ductile deformation

- ▶ If a guy rod **1** shows any ductile deformation: Replace the guy rod **1** immediately.

### 3.6 Paint / coating

- ▶ The guy rods **1** must be checked for paint damage or corrosion.
- ▶ If damage is present on the paint finish / coating: Repair the paint / coating of the guy rods **1** expertly.

**NOTICE**

Danger of property damage!

- ▶ Never store guy rods **1** in or near aggressive media, for example: Seawater.
- ▶ Always store the guy rods **1** properly and outside of aggressive media.

### 3.7 Fastening points

- ▶ Check the fastening points **1.1** of the guy rods **1** for damage.
- ▶ Replace damaged fastening points **1.1**.

---

Empty page!

LWE/LR 1800-1-0-000/27200-07-02/en

## 8.16 Inspection of fiber guy ropes

1	Safety instructions	2
2	Inspection personnel qualification	2
3	Unscheduled inspection	2
4	Inspection intervals	2
5	Documentation	3
6	Inspecting the fiber guy ropes	3

# 1 Safety instructions



## WARNING

Damaged fiber guy rope!  
Accident. Death, severe injury, property damage.

If damage is found:

- ▶ Have the fiber guy rope inspected by authorized and trained expert personnel.

When no final evaluation of the damage can be made:

- ▶ Send the fiber guy rope to the rope manufacturer for inspection and damage evaluation.

If it is found that a fiber guy rope cannot be used any longer or cannot be repaired:

- ▶ Replace the fiber guy rope.



## WARNING

Protective equipment **not** worn!  
Severe injuries

- ▶ Wear protective gloves, a hard hat, safety shoes and safety goggles.

## 2 Inspection personnel qualification

Make sure that the following prerequisites are met:

- **Authorized and trained expert personnel** inspects the fiber guy rope.
- **In case of doubt:** The rope manufacturer inspects the fiber guy rope.

The authorized and trained expert personnel has the following expertise:

- Knowledge about technical structure and the composition of fiber guy ropes
- Knowledge about relevant inspection criteria for fiber guy ropes
- Knowledge and experience in the use of various test procedures to determine the scope of the damage
- Knowledge and experience in the evaluation of rope damage on fiber guy ropes
- Knowledge about inspection intervals for the required inspections, as specified by the manufacturer
- Knowledge and experience in the evaluation if further use of the fiber guy ropes is permissible
- Knowledge about the required prerequisites for the inspection of fiber guy ropes, as specified by the manufacturer

## 3 Unscheduled inspection

If at least one of the following events occurs, the fiber guy rope must be inspected immediately:

- Load rip-off
- Overload of the crane
- Shock load of the rope
- Impact load, for example the impact of heavy objects
- Contact with excessively high temperatures, for example fires or flying sparks when grinding or welding
- Contact with chemicals
- After a storm, lightning

## 4 Inspection intervals

Maintenance intervals for the fiber guy rope, see chapter 7.03.50.



The fiber guy ropes must be inspected every year within the scope of the periodic inspections.

## 5 Documentation

Documented information about the fiber guy ropes together with a visual inspection provide a better basis for the rope manufacturer to make decisions and provide suggestions about the conditions and further use of the fiber guy ropes.

- ▶ Document events that led to an unscheduled inspection.
- ▶ Document the fire guy rope inspections and results.



### Note

- ▶ Liebherr-Werk Ehingen GmbH recommends documenting operating procedures and work procedures that are performed with a fiber guy rope.

## 6 Inspecting the fiber guy ropes



### WARNING

The fiber guy ropes can rip off!

Depending on the degree of severity of the damage, a damaged fiber guy rope can rip off during crane operation.

- ▶ To ensure safe crane operation: Continue to use damaged fiber guy ropes only after an extensive inspection and release by the rope manufacturer.

The inspection of the fiber guy ropes can be performed visually.

The fiber guy ropes must be inspected in a removed condition.

The degree of severity of possible damage and further use of the fiber guy ropes depends mainly on which layers of the rope structure and where and how they were damaged.

In case of obvious severe rope damage, safe crane operation should always be the priority and the respective fiber guy rope should be replaced.

If there is any doubt regarding the rope damage, only a detailed inspection of the fiber guy rope by the rope manufacturer can provide information if further use is possible or permissible.



### Note

- ▶ If one or more fiber guy ropes must be replaced: Contact Liebherr-Werk Ehingen GmbH customer service.

To determine the degree of severity of a damaged fiber guy rope, have the fiber guy rope inspected by the rope manufacturer.

The rope manufacturer decides after intensive inspection of the damage:

- If a repair of the fiber guy rope is possible
- If further use of the fiber guy rope is possible or useful

Only use the fiber guy rope again if the rope manufacturer declares that the damage is harmless and releases the fiber guy rope for further use.

## 6.1 Checking the date of manufacture

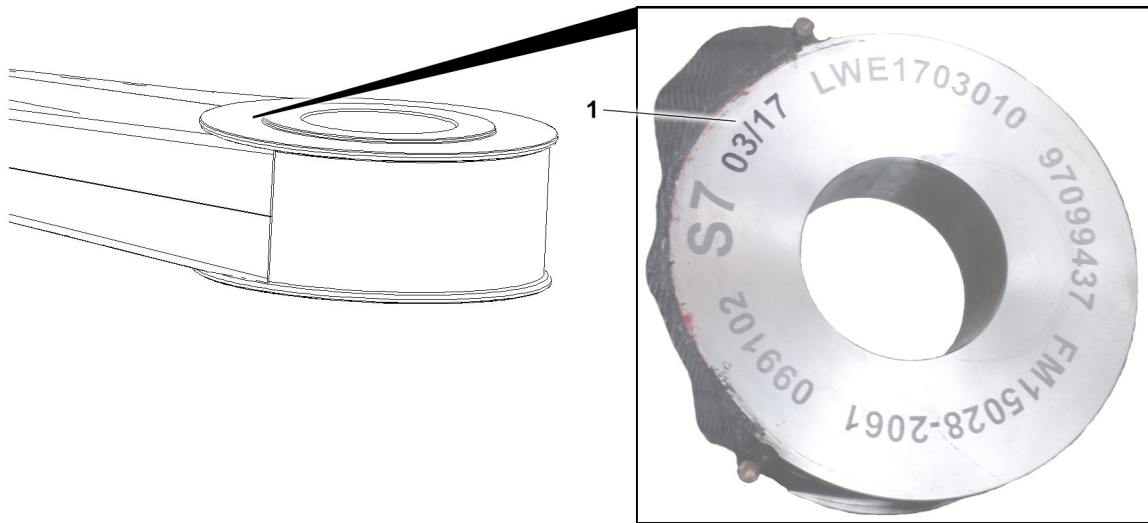


Fig.160913: Fiber guy rope, identification

► Check the date of manufacture **1** on the rope thimble.

If the date of manufacture is more than 25 years ago:

► Replace the fiber guy rope.

## 6.2 Checking the rope thimble and rope end connection

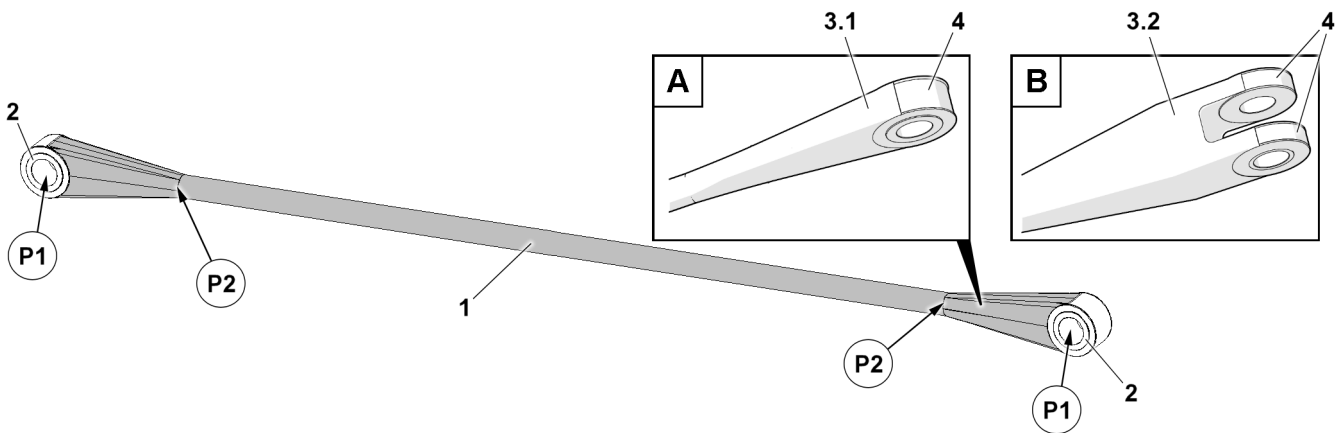


Fig.159238: Rope thimble and rope end connections

- |   |                |     |                                  |   |                  |
|---|----------------|-----|----------------------------------|---|------------------|
| 1 | Fiber guy rope | 3.1 | Rope end connection "Finger"     | 4 | Protective cover |
| 2 | Rope thimble   | 3.2 | Open rope end connections "Fork" |   |                  |



### DANGER

Damage in the area of the rope thimble or the rope end connection!

The load bearing capacity is significantly reduced. The rope thimble or rope end connection can rip if used further under load during crane operation.

Death, severe injury, property damage.

- Eliminate damaged fiber guy ropes prior to crane operation.
- Replace fiber guy ropes with a damaged rope thimble or rope end connection.

- Remove the fiber guy rope.

- ▶ Carry out a visual inspection of the rope thimble and rope end connections: Cracks, damage, deformation.
- ▶ Open rope end connections: Check if the pin bores in the fork halves align.
- ▶ Check the pin bores in the points **P1**: Expansion, elongation and diameter changes.
- ▶ Check the transitions between the rope and the rope end connection in points **P2**: Warps in the rope sheath.

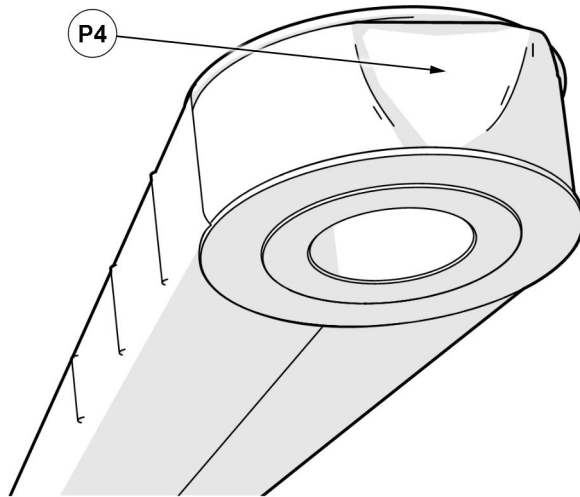


Fig.159926: Protective cover damaged

- ▶ Check the protective covers **4** for damage and deformation, for example see point **P4**.

When there are cracks or other severe damage:

- ▶ Replace the fiber guy rope.

If there is doubt regarding safe use:

- ▶ Contact Customer Service at Liebherr-Werk Ehingen GmbH.

### 6.3 Gap formation

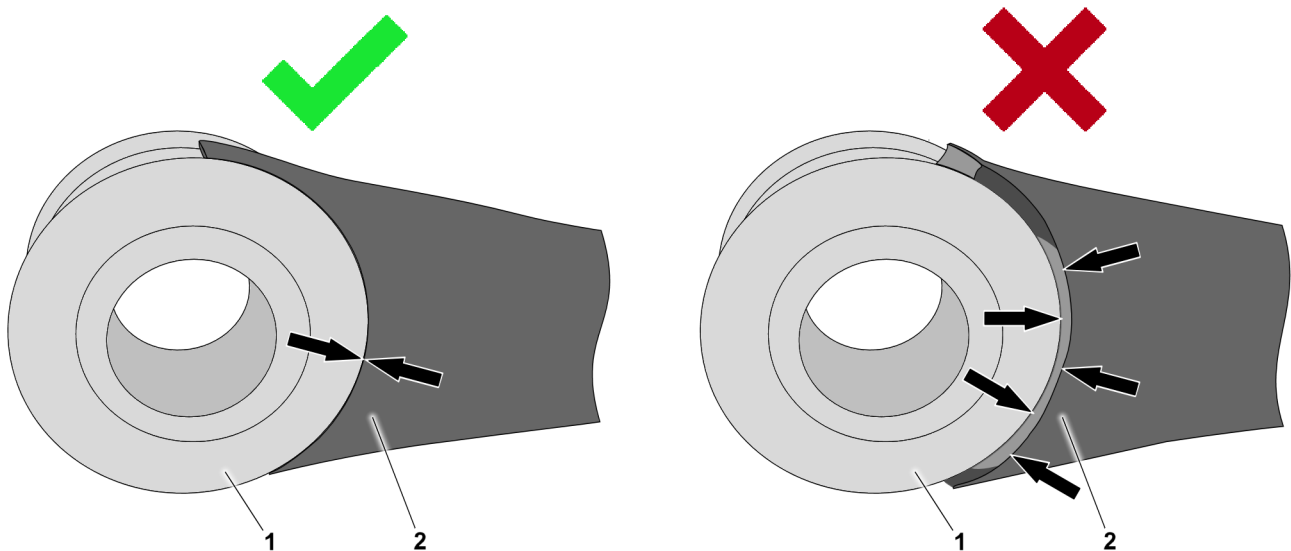


Fig.160910: Fiber guy rope, gap formation

1 Rope thimble

2 Rope sheath

**WARNING**

The rope sheath has detached from the rope thimble!  
Water and dirt can penetrate and damage the rope.  
The load bearing capacity is reduced. The fiber guy rope can rip if further used under load during crane operation.

- ▶ Eliminate damaged fiber guy ropes prior to crane operation.

When gap formation is visible:

- ▶ Replace the fiber guy ropes.

- ▶ Check if there is a visible gap between the rope thimble **1** and the rope sheath **2**.

If there is a visible gap:

- ▶ Remove the fiber guy rope.
- ▶ Replace the fiber guy rope.
- ▶ Contact Customer Service at Liebherr-Werk Ehingen GmbH.

## 6.4 Inspecting the rope layers

For the inspection, the following rope layers are crucial, to ensure that the degree of damage to the fiber guy rope can be assessed, proceed from the outside to the inside:

- Outer sheath layer
- Middle sheath layer
- Inner sheath layer (red)
- Suspension rope (yellow)

**Note**

- ▶ The damage shown below is an example.

### 6.4.1 Outer sheath layer damaged

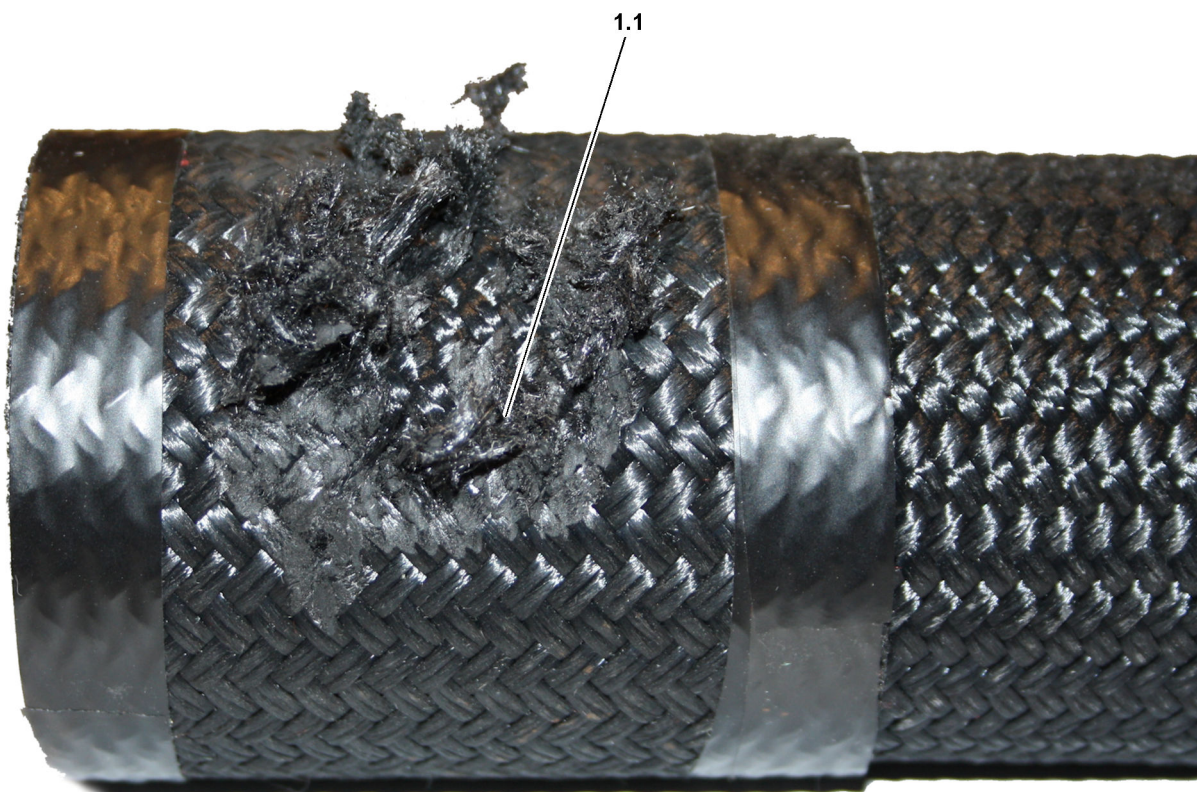


Fig.160903: Damage to the outer sheath layer

Degree of damage, condition of the fiber guy rope:

- The material of the outer sheath layer **1.1** is partially disintegrated.
  - The middle sheath layer is not damaged: No signs of disintegrated material.
- ▶ Remove the fiber guy rope.
  - ▶ Inspect the entire length of the fiber guy rope.



#### WARNING

Fiber guy rope ripping off!

If the outer sheath layer **1.1** is not properly repaired, then the outer sheath layer **1.1** can unravel widely if further used and the sheath layers underneath can be damaged.

Death, severe injury, property damage.

- ▶ Seal the outer sheath layer **1.1** with approved repair materials.

If only the outer sheath layer **1.1** is damaged:

- ▶ Carefully remove protruding fibers of the outer sheath layer with a sharp knife or scissors.

The outer sheath layer **1.1** must be repaired properly using approved repair materials.

- ▶ Apply resin or binder to the damaged area.  
or  
Mask the involved area with water-proof, self-adhesive tape.

#### Result:

- The fiber guy rope can be used further for crane operation.

If there is doubt regarding safe use:

- ▶ Contact Customer Service at Liebherr-Werk Ehingen GmbH.

### 6.4.2 Damaged middle sheath layer

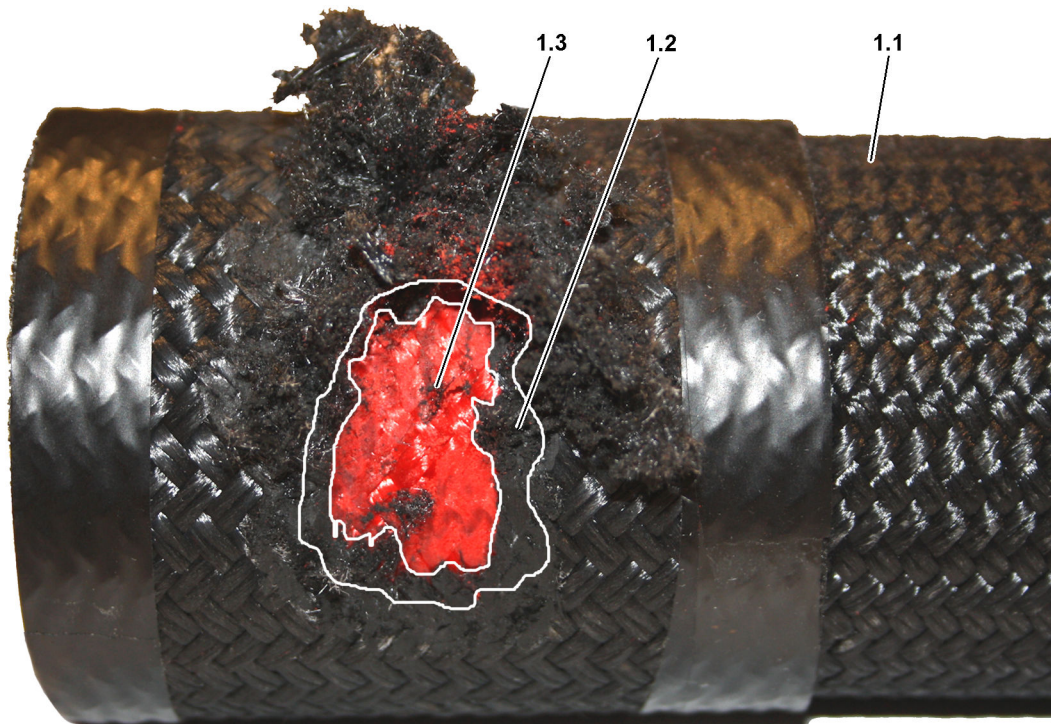


Fig.160902: Damage to the outer and middle sheath layers, inner sheath layer (red) is undamaged

- 1.1 Outer sheath layer
- 1.2 Middle sheath layer

- 1.3 Inner sheath layer (red)

Degree of damage, condition of the fiber guy rope:

- The outer sheath layer **1.1** is damaged
  - The middle sheath layer **1.2** is damaged.
  - The inner sheath layer (red **1.3** is visible and undamaged: No signs of disintegrated material.
- ▶ Remove the fiber guy rope.
  - ▶ Inspect the entire length of the fiber guy rope.



#### WARNING

Damaged fiber guy ropes can rip!

Damaged fiber guy ropes can rip off if further used under load in crane operation.

Death, severe injury, property damage.

- ▶ Eliminate damaged fiber guy ropes prior to crane operation.
- ▶ Replace the damaged fiber guy rope.

When the outer sheath layer **1.1** and middle sheath layer **1.2** are damaged:

- ▶ Replace the fiber guy rope.
- ▶ The fiber guy rope must be inspected by the rope manufacturer: Contact Customer Service at Liebherr-Werk Ehingen GmbH.

### 6.4.3 Inner sheath layer damaged

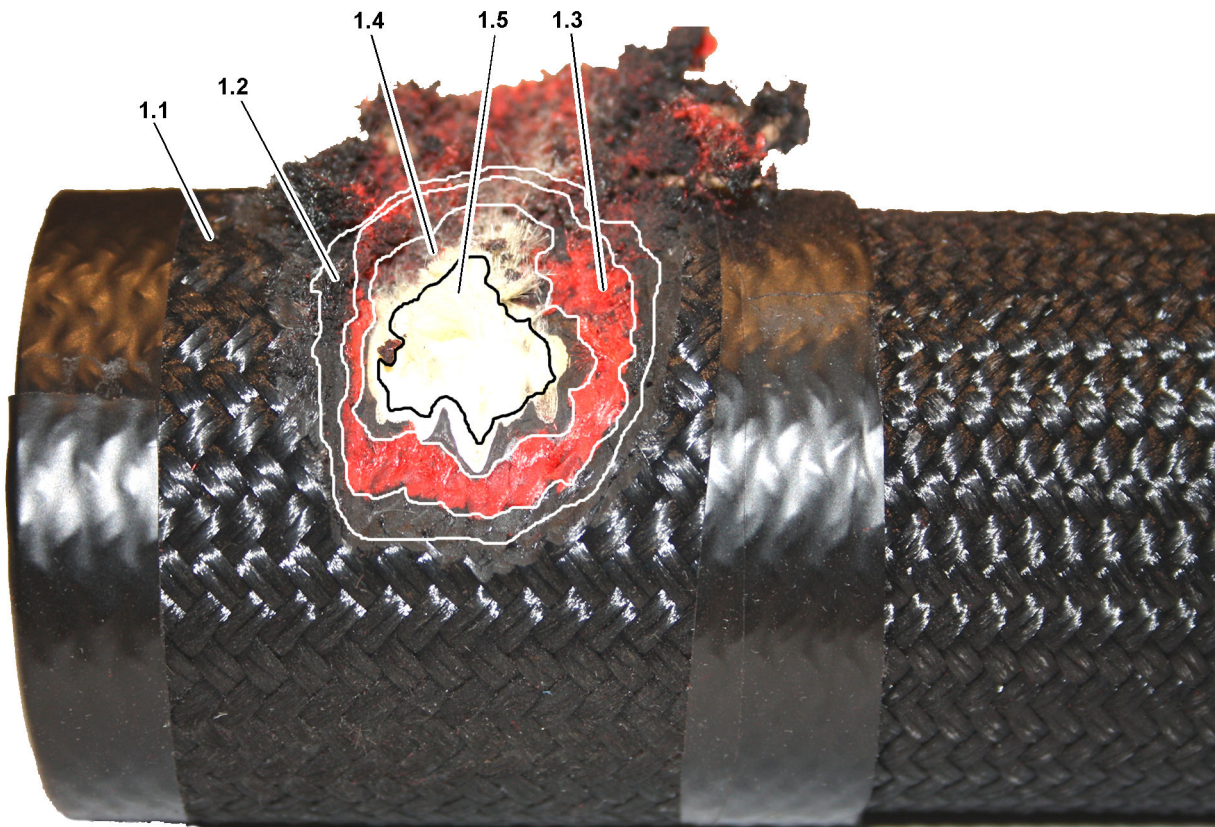


Fig.160901: Damage to the inner sheath layer (red)

- |                                |                                     |                                     |
|--------------------------------|-------------------------------------|-------------------------------------|
| <b>1.1</b> Outer sheath layer  | <b>1.3</b> Inner sheath layer (red) | <b>1.5</b> Suspension rope (yellow) |
| <b>1.2</b> Middle sheath layer | <b>1.4</b> Additional sheath layers |                                     |

Inspection criteria, condition of the fiber guy rope:

- The outer sheath layer **1.1** is damaged.
- The middle sheath layer **1.2** is damaged.
- The inner sheath layer (red) **1.3** is damaged.
- Under the middle sheath layer (red) **1.3**, the additional sheath layers **1.4** or in the worst case the suspension rope (yellow) **1.5** are visible or damaged.

**DANGER**

Damaged fiber guy ropes can rip off!

If the suspension rope (yellow) **1.5** is visible or damaged, the fiber guy rope pips off if further used under load during crane operation.

Death, severe injury, property damage.

- ▶ Eliminate damaged fiber guy ropes prior to crane operation.
- ▶ Replace the damaged fiber guy rope.

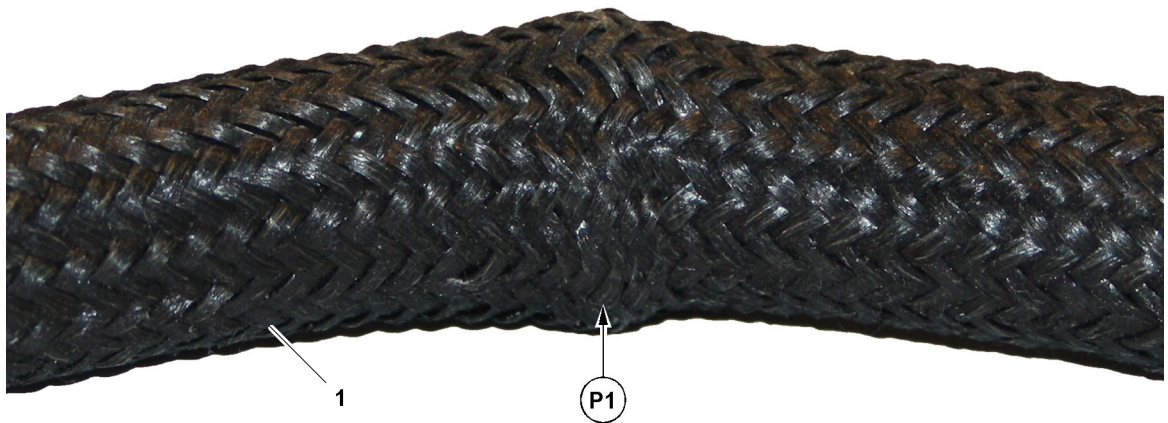
If all sheath layers are damaged, repair is **not** possible:

- ▶ Remove the fiber guy rope.
- ▶ Inspect the entire length of the fiber guy rope.
- ▶ Replace the fiber guy rope.
- ▶ Contact Customer Service at Liebherr-Werk Ehingen GmbH.

## 6.5 Buckles

Buckles are angular deformations.

The rope was damaged due to external influences.



*Fig.123618: Buckled fiber guy rope*

Inspection criteria, condition of the fiber guy rope:

- A non-tensioned rope has a deformation in the form of a “warp”.
- As the tensile stress increases, this deformation disappears.

A buckle is severe if a fold or compression well as a clear buckle is visible on one side of the fiber guy rope (for example in point **P1**).

When a buckle is present:

- ▶ Remove the fiber guy rope.
- ▶ Inspect the entire length of the fiber guy rope.

**DANGER**

Damaged fiber guy ropes can rip off!

If fiber guy ropes are buckled, then the load bearing capacity is significantly reduced.

The fiber guy rope can rip off if further used under load during crane operation.

Death, severe injury, property damage.

- ▶ Exclude buckled fiber guy ropes prior to crane operation.
- ▶ Replace the damaged fiber guy rope.

- ▶ Replace the fiber guy rope.
- ▶ The fiber guy rope must be inspected by the rope manufacturer: Contact Customer Service at Liebherr-Werk Ehingen GmbH.

---

Empty page!

LWE/LR 1800-1-0-000/27200-07-02/en



## 8.17 Inspection of ladders

1	Safety instructions	3
2	Inspection intervals	3
3	Inspecting the ladders	3
4	Inspection sheet and check list	3

*Fig.195219*

LWE/LR 1800-1-0-000/27200-07-02/en

# 1 Safety instructions



## WARNING

Damaged ladders!  
Accident. Death, severe injury, property damage.

If damage is found:

- ▶ Have ladders repaired by authorized and trained expert personnel.

If it is determined that the ladder cannot be repaired:

- ▶ Scrap the ladder immediately.

Make sure that the following prerequisite is met:

- **Authorized and trained expert personnel** inspects the ladders.

The authorized and trained expert personnel has the following expertise:

- Knowledge, experience and abilities in repairing ladders
- Is familiar with the necessary prerequisites as determined by the contractor for the inspection of ladders
- Has the knowledge about the type, scope and intervals for the required inspections as determined by the contractor

## 2 Inspection intervals

The inspection of ladders must be carried out in the following intervals:

- The contractor determines the **required** intervals
- But there must be at least one inspection every **12 months**

Intervals depend on:

- Operating conditions
- Frequency of use
- Operational demands during use
- Frequency and severity of defects found during previous inspections

## 3 Inspecting the ladders

Make sure that the following prerequisites are met:

- Ladder inspection sheets are on hand. For blank form, see section “Inspection form for the inspection of ladders and steps”.
- Check lists are on hand. For a blank form, see section “Check list for the inspection of ladders and steps”.
- ▶ For every ladder and every step: Enter the data in the ladder inspection form.  
**or**  
Get the ladder inspection form for ladders or steps.
- ▶ Check the ladders and steps according to the check list and document the results.
- ▶ Collect the ladder inspection forms and check lists in the crane documentation.

## 4 Inspection sheet and check list

A sample inspection form and check list for the inspection of ladders and steps are shown below.

## 4.1 Inspection form for the inspection of ladders and steps

Ladder inspection form	
Inventory no. of the ladder / step	
Location / installation location	
Ladder type	Multi-purpose ladder
	Stepladder
	Leaning ladder
	Leaning ladder with transition
	Vertical ladder
	Vertical ladder with transition aid
	Platform ladder
	Step
	Other
Ladder material	Aluminum
	Plastic
	Steel
	Stainless steel
Number of rungs / steps	
Ladder length / ladder shortened to	
Manufacturer / dealer	
Article / type number	
Date of purchase	
Date of selection	
Name of authorized inspector	
Next inspection	

*Inspection form for the inspection of ladders and steps*

*Fig.151627-en*

## 4.2 Check list for the inspection of ladders and steps

Ensure the recording of the systematic inspection of ladders and steps:

- Summarize the following checklist for an inspection book.

LWE/LR 1800-1-0-000/27200-07-02/en

Inspection criteria	1. Inspection		2. Inspection		3. Inspection		4. Inspection		5. Inspection	
	Yes	No	Yes	No	Yes	No	Yes	No	Yes	No
<b>1. Operating instructions</b> (decal on the ladder) Present and legible	<input type="checkbox"/>	<input type="checkbox"/>	<input type="checkbox"/>	<input type="checkbox"/>	<input type="checkbox"/>	<input type="checkbox"/>	<input type="checkbox"/>	<input type="checkbox"/>	<input type="checkbox"/>	<input type="checkbox"/>
<b>2. Beams and rungs / stringers and steps</b> Loose connections Damage, cracks, breaks, wear Dents, kinks Exposed fibers of glass-fiber reinforced plastic Paint / glaze significantly damaged (if applicable) Tie rod loose or damaged (if applicable) Platform loose or damaged (if applicable)	<input type="checkbox"/>	<input type="checkbox"/>	<input type="checkbox"/>	<input type="checkbox"/>	<input type="checkbox"/>	<input type="checkbox"/>	<input type="checkbox"/>	<input type="checkbox"/>	<input type="checkbox"/>	<input type="checkbox"/>
<b>3. Ladder locks (if applicable)</b> Belts, chains, bracing damaged Hinge spreader damaged	<input type="checkbox"/>	<input type="checkbox"/>	<input type="checkbox"/>	<input type="checkbox"/>	<input type="checkbox"/>	<input type="checkbox"/>	<input type="checkbox"/>	<input type="checkbox"/>	<input type="checkbox"/>	<input type="checkbox"/>
<b>4. Fixtures</b> Hinges, articulations, locks damaged or loose Sliding parts are well lubricated Locking elements do not engage	<input type="checkbox"/>	<input type="checkbox"/>	<input type="checkbox"/>	<input type="checkbox"/>	<input type="checkbox"/>	<input type="checkbox"/>	<input type="checkbox"/>	<input type="checkbox"/>	<input type="checkbox"/>	<input type="checkbox"/>
<b>5. Feet and accessories</b> Feet, tips, caps missing or damaged Cross beam, feet extension defective	<input type="checkbox"/>	<input type="checkbox"/>	<input type="checkbox"/>	<input type="checkbox"/>	<input type="checkbox"/>	<input type="checkbox"/>	<input type="checkbox"/>	<input type="checkbox"/>	<input type="checkbox"/>	<input type="checkbox"/>
<b>6. Other defects</b>	<input type="checkbox"/>	<input type="checkbox"/>	<input type="checkbox"/>	<input type="checkbox"/>	<input type="checkbox"/>	<input type="checkbox"/>	<input type="checkbox"/>	<input type="checkbox"/>	<input type="checkbox"/>	<input type="checkbox"/>
<b>Result of the inspection</b> The ladder is OK and can be used The ladder may only be used after it is repaired The ladder must be replaced DATE, SIGNATURE	<input type="checkbox"/>	<input type="checkbox"/>	<input type="checkbox"/>	<input type="checkbox"/>	<input type="checkbox"/>	<input type="checkbox"/>	<input type="checkbox"/>	<input type="checkbox"/>	<input type="checkbox"/>	<input type="checkbox"/>
<b>Sent for repair to:</b> DATE, SIGNATURE										
<b>Repair / ladder replaced:</b> DATE, SIGNATURE										

Fig.14994-en



## 8.20 Country-specific content

1 Country-specific content

2

LWE/LR 1800-1-0-000/27200-07-02/en

# 1 Country-specific content

**Note**

Chapter 8.20 has country-specific content

If supplementary content is available, it is described in the respective language.

- ▶ Observe the operating instructions in the language version of the country of use.



## 8.90 Inspection chart for cranes

1 Inspection chart for recurring inspections of Liebherr cranes

---

3

LWE/LR 1800-1-0-000/27200-07-02/en

*Fig.195219*

LWE/LR 1800-1-0-000/27200-07-02/en

# 1 Inspection chart for recurring inspections of Liebherr cranes

The following is a checklist to assist the inspector during the periodic inspections of Liebherr mobile and crawler cranes.

<b>Company:</b>	<b>Inspector:</b>
<b>Crane manufacturer: Liebherr</b>	<b>Crane type:</b>
<b>Serial number:</b>	<b>Stock number:</b>
<b>Year of construction:</b>	<b>Date:</b>
<b>Inspector's signature for No. 1 to 22:</b>	

1. inspection category: Crane document						
Component to be inspected	A	B	C	D	E	Comments
Crane inspection log						
Operating and installation instructions						
Crane control log						
Load chart manual						
Job planner						

2. inspection category: Signs / identification						
Component to be inspected	A	B	C	D	E	Comments
Factory tag						
Load data						
Operating instruction label						
Prohibition and command signs						
Other safety signs						

3. inspection category: Travel gear <sup>1</sup>						
Component to be inspected	A	B	C	D	E	Comments
Frame <sup>2</sup>						
Supports <sup>3</sup>						
Axles						
Wheels						
Tires						
Storage						
Transmission						
Universal drive shaft						
Leaf springs / springs						
Shock absorbers						

LWELR 1800-1-0-000/27200-07-02/en

3. inspection category: Travel gear <sup>1</sup>						
Component to be inspected	A	B	C	D	E	Comments
Steering						
Brakes						
Hydraulic axle suspension						

4. inspection category: Chassis <sup>1</sup>						
Component to be inspected	A	B	C	D	E	Comments
Coverings						
Accessible surfaces						
Counterweight holders <sup>2</sup>						
Towing devices						
Accesses, ladders						
Holding devices, handles						
Platforms, railings						
Retainer for hook block <sup>2</sup>						
Boom support <sup>2</sup>						

5. inspection category: Chassis - driver's cab <sup>1</sup>						
Component to be inspected	A	B	C	D	E	Comments
Doors						
Windows / windshields						
Window wiper						
Mirrors						
Seat						
Heater						
Ventilation						
Sound absorber						
Trip recorder						
First aid kit						
Spare bulbs						
Hazard warning triangle						
Safety vest						

6. inspection category: Chassis - drive <sup>1</sup>						
Component to be inspected	A	B	C	D	E	Comments
Combustion engine						
Exhaust system						
Fuel tank						

6. inspection category: Chassis - drive <sup>1</sup>						
Component to be inspected	A	B	C	D	E	Comments
Urea tank						
Fuel container						
Filter						
Sound absorber						
Engine mount						
Oil levels						
Fuel lines						
Urea lines						
Fuel lines						

7. inspection category: Chassis - hydraulics <sup>1</sup>						
Component to be inspected	A	B	C	D	E	Comments
Oil container						
Filter with maintenance indicator						
Pumps						
Motors						
Valves						
Lines						
Hoses						
Cylinders						
Pressure limiting valves						

8. inspection category: Chassis - compressed air system <sup>1</sup>						
Component to be inspected	A	B	C	D	E	Comments
Compressor						
Filter						
Air tanks						
Valves						
Lines						
Hoses						
Cylinders						

9. inspection category: Chassis - electrical system <sup>1</sup>						
Component to be inspected	A	B	C	D	E	Comments
Motors						
Generators						
Battery						

9. inspection category: Chassis - electrical system <sup>1</sup>						
Component to be inspected	A	B	C	D	E	Comments
Switches / buttons						
Lines						
Fuses						
Resistors						
Lighting						
Brake lights						
Blinkers						
Tail lights						
Working lights						
Signaling systems						
Indicator lights						
Battery switch						
Limit switches: Transmission, steering, drive train						
Support pressure indicator <sup>2</sup>						

10. inspection category: Chassis - control systems <sup>1</sup>						
Component to be inspected	A	B	C	D	E	Comments
Engine regulation						
Transmission						
Couplings						
Circuits						
Brakes						
Steering						
Control displays						
Engine shut off line						
Control of supports <sup>2</sup>						
Axle suspension						
Crane leveling						
Rear axle steering						

11. inspection category: Superstructure						
Component to be inspected	A	B	C	D	E	Comments
Frame						
Coverings						
Treads						
Storage						

11. inspection category: Superstructure						
Component to be inspected	A	B	C	D	E	Comments
Counterweights						
Relapse retainer						
Slewing ring connection: Tilt play						
Slewing ring connection: Mounting screws						
Slewing ring connection: Gears						
Slewing gear: Mounting screws						
Slewing gear: Gears						

12. inspection category: Superstructure - crane operator's cab						
Component to be inspected	A	B	C	D	E	Comments
Doors						
Windows / windshields						
Window wiper						
Mirrors						
Seat						
Heater						
Ventilation						
Muffler						
Joystick for working functions						
Gear shifts						
Retainer: Crushing / shear locations						

13. inspection category: Superstructure - Retaining and protection devices						
Component to be inspected	A	B	C	D	E	Comments
Accesses, ladders						
Handles						
Coverings						
Covers						
Hatches						
Treads						

14. inspection category: Superstructure - drive train						
Component to be inspected	A	B	C	D	E	Comments
Combustion engine						
Exhaust system						
Fuel tank						
Urea tank						

14. inspection category: Superstructure - drive train						
Component to be inspected	A	B	C	D	E	Comments
Fuel container						
Filter						
Sound absorber						
Engine mount						
Fuel lines						
Urea lines						
Fuel lines						

15. inspection category: Superstructure - hydraulic system						
Component to be inspected	A	B	C	D	E	Comments
Oil container						
Filter						
Pumps						
Motors						
Valves						
Lines						
Hoses						
Cylinders						
Pressure limiting valves						
Lowering brake valves						
Brake control: Hoist gear						
Brake control: Slewing gear						

16. inspection category: Superstructure - electrical system						
Component to be inspected	A	B	C	D	E	Comments
Motors						
Generators						
Batteries						
Switches / buttons						
Lines						
Fuses						
Resistors						
Lighting						
Signal lights						



17. inspection category: Superstructure - control systems						
Component to be inspected	A	B	C	D	E	Comments
Engine regulation						
Transmission						
Flexible couplings						
Circuits						
Engine shut off line						
Control displays						

18. inspection category: Superstructure - rope drives						
Component to be inspected	A	B	C	D	E	Comments
Winch 1 <sup>3</sup>						
Winch 2 <sup>3</sup>						
Winch 3 <sup>3</sup>						
Winch 4 <sup>3</sup>						
Winch 5 <sup>3</sup>						
Winch 6C <sup>3</sup>						
Winch 6 <sup>3</sup>						
Assembly winches <sup>3</sup>						
Rope pulleys						
Rope end connection						
Rope for winch 1						
Rope for winch 2						
Rope for winch 3						
Rope for winch 4						
Rope for winch 5						
Rope for winch 6C						
Rope for winch 6						
Rope for assembly winches						
Guy ropes						

19. inspection category: Superstructure - hook						
Component to be inspected	A	B	C	D	E	Comments
Pulleys						
Rope guards on pulleys						
Axle support						
Load hook						
Load hook mounting						
Hook retention						

20. inspection category: Superstructure - safety and switch systems						
Component to be inspected	A	B	C	D	E	Comments
Hoist emergency limit switch I						
Hoist emergency limit switch II						
Lowering emergency limit switch I						
Lowering emergency limit switch II						
Boom emergency limit switch I						
Boom emergency limit switch II						
Luffing jib: Boom limit switch I						
Luffing jib: Boom limit switch II						
Load torque limiter						
Angle indicator: Boom						
Angle indicator: Luffing jib						
Angle indicator: Slewing gear						
Safety equipment: Control						
Working range limitation						
Pressure sensor						
Speed sensor						
Wind sensor						
Sliding beam monitoring						
Support pressure indicator						
Incline indicator						
Length indicator: Boom radius, boom length						
Emergency off system						
Engine stop						

21. inspection category: Boom						
Component to be inspected	A	B	C	D	E	Comments
Weld structure						
Rope pulleys						
Change over pulleys feed mechanism						
Luffing cylinder						
Telescoping cylinder						
Boom extension ropes						
Boom retraction ropes						
Boom bearings						
Boom pinning						
Guy rods						
Guy ropes						

21. inspection category: Boom						
Component to be inspected	A	B	C	D	E	Comments
Control ropes						
Guide ropes						
Safety ropes						
Relapse cylinders						
Pin connections						

22. inspection category: Equipment						
Component to be inspected	A	B	C	D	E	Comments
Weld structure						
Rope pulleys						
Relapse cylinder						
Relapse support						
Oscillation guard						
A-frame bearings						
Pinning of components						
Guy rods with pinning						
Rods with guide rail on A-frame 2 and A-frame 3						
All limit switches with switch mechanism						
Pin connections						

*Inspection chart for periodic inspections of Liebherr mobile and crawler cranes*

**Inspection criteria:**

- A = Present / complete
- B = Condition / maintenance
- C = Function
- D = Repair / replace
- E = Re-inspection required

**Evaluation:**

- Satisfactory = x
- Unsatisfactory = -
- Not required = 0

**Comments:**

- <sup>1</sup> Inspection of the crane carrier vehicle road worthiness is also fulfilled if it has already been certified by the road traffic department certification authority. For cranes that are not certified for use on public roads, an expert or authorized inspector must conduct the required tests to validate the vehicle's road worthiness.
- <sup>2</sup> These inspections must be carried out by an authorized inspector even if it has passed the road traffic department test and is certified.
- <sup>3</sup> Inspection of the winches with respect to the actually used proportion of their service life.

---

Empty page!

LWE/LR 1800-1-0-000/27200-07-02/en

---

## 90 Appendix

LWE/LR 1800-1-0-000/27200-07-02/en

---

LWE/LR 1800-1-0-000/27200-07-02/en

# 90.01 Preface to the appendix

1 Foreword

---

3

LWE/LR 1800-1-0-000/27200-07-02/en

*Fig.195219*

LWE/LR 1800-1-0-000/27200-07-02/en



# 1 Foreword

This crane may only be used in a flawless technical condition and according to its mission as well as with constant awareness of safety and dangers. Any problems, which could affect safety, must be fixed immediately.



## Note

- ▶ Modifications on the crane may only be made with written approval by Liebherr-Werk Ehingen GmbH.

## 1.1 Change to the operating instructions

Changes to the operating instructions are received in the form of chapters. The chapter to be replaced must be removed from the operating instructions and replaced with the new chapter in the same location.

When you receive a change to the operating instructions:

- ▶ Remove the chapter to be replaced from the operating instructions.
- ▶ File the new chapter in the same location in the operating instructions.
- ▶ Destroy the replaced chapter.
- ▶ Fill out the change confirmation form in chapter 90.05 of the operating instructions.

## 1.2 Update to the operating instructions

Updates to the operating instructions, which you receive in the circular as Customer information, must be filed in the operating instructions in chapter 90.05.



Fig. 113870: Customer information decal

When you receive an update to the operating instructions:

- ▶ Attach the decals **1**, which are enclosed in the customer information to the footer of the respective chapter. See the following example.



## Note

Example: Update to the operating instructions!

If there is an update that concerns the operating instructions, chapter 2.04:

- ▶ Attach the decal **1** in the footer of chapter 2.04.
- ▶ File the update in chapter 90.05 of the operating instructions.
- ▶ Fill out the update confirmation form in chapter 90.05 of the operating instructions.

---

Empty page!

LWE/LR 1800-1-0-000/27200-07-02/en

## 90.05 Update confirmation

1	Change confirmation form	3
2	Update confirmation	3
3	Customer information	4

*Fig.195219*

LWE/LR 1800-1-0-000/27200-07-02/en



## 3 Customer information

---

# Index

## 1

11952500 – California Proposition 65 Label **2.05 - 2**

## 3

3-point support **2.04.10 - 25**

## 7

772563908 – Warning of high voltage **2.05 - 2**

772564008 – Slewing range **2.05 - 3**

772580408 – Limitation of maximum travel speed **2.05 - 3**

## 9

9402377 – Fastening point / lifting point **2.05 - 11**

9412158 – Reading the operating instructions **2.05 - 7**

97001802 – Falling platform **2.05 - 43**

97003109 – Accessing the step ladder **2.05 - 18**

97003110 – Folding the step ladder in and out **2.05 - 18**

97003112 – Maximum suspended load **2.05 - 25**

97004046 – Safety harness, maximum two persons **2.05 - 7**

97006167 – Identifying the support base **2.05 - 19, 2.05 - 19**

97008514 – Warning of head injuries **2.05 - 19**

97009799 – Data logger **2.05 - 20**

97011336 - Transport weights of the components **2.05 - 43**

97011689 – Danger of crushing **2.05 - 22**

97011690 – Overload of crane cab is prohibited **2.05 - 22**

97012095 – Maximum load **2.05 - 20**

97012737 – Danger of accident **2.05 - 24**

97012949 – Maximum load **2.05 - 20**

97016304 – Refueling **2.05 - 22**

97016392 – Crushing danger for feet **2.05 - 23**

97016911 – Danger of collision **2.05 - 36**

97017585 – Falling telescopic boom during disassembly / assembly **2.05 - 8**

97018351 – Falling telescopic boom during transport **2.05 - 8**

97018564 – Falling telescopic boom during transport **2.05 - 8**

97023034 – Disassembling **2.05 - 24**

97027147 – Overloading of the combi box is prohibited **2.05 - 9**

97033982 – Assembling / disassembling the Derrick pivot section **2.05 - 30**

97036732 – Access via 3-point support **2.05 - 24**

97036733 – Fastening point **2.05 - 9**

97036734 – Rigging point **2.05 - 41**

97036735 – Fastening point for lattice section **2.05 - 13**

97036736 – Fastening point for lattice sections **2.05 - 14**

97036917 – Maximum suspended load **2.05 - 25**

97037383 – Urea **2.05 - 26**

97037625 – Suspended load Fastening points / rigging points **2.05 - 11**

97037871 – Fastening points for lattice sections **2.05 - 15**

97037952 – Danger of fatal injury due to electric shock **2.05 - 26**

97038442 – Fastening point for lattice section **2.05 - 14**

97038452 – Fastening point for lattice sections **2.05 - 14**

97038454 – Fastening point for lattice sections **2.05 - 15**

97039035 – Assembly unit suspended load **2.05 - 17**

97039753 – Danger of stumbling **2.05 - 35**

97041305 – Overload of components **2.05 - 27**

97042730 – Falling luffing cylinder **2.05 - 26**

97042797 – Overload of components **2.05 - 27**

97046488 – Corrosion inhibitor - antifreeze fluids **2.05 - 23**

97047810 – Pinning brackets **2.05 - 27**

97053409 – Entanglement hazard during winch operation **2.05 - 21**

97053410 – Fastening equipment **2.05 - 15**

97057097 – Fastening point to turn the component **2.05 - 16**

97057524 – Fastening point for assembly of lattice sections **2.05 - 16**

97057767 – Fastening points for lattice sections **2.05 - 16**

97059339 – Suspended load Derrick pivot section **2.05 - 17**

97068257 – Fastening point for end section **2.05 - 17**

97068370 – Closing the cab door **2.05 - 21**

97068839 - Transport weights of the components / fastening length of the fastening equipment **2.05 - 44**

97069053 – Storage boxes open **2.05 - 21**

97070905 – Disassembling the auxiliary jib (boom nose) **2.05 - 28**

9707704 – Driving with the outrigger pad **2.05 - 29**

97077304 – Positioning the outrigger pad **2.05 - 28**

97094940 – Spark catcher **2.05 - 41**

97095312 – Suspended load and fastening points for counterweight frame **2.05 - 18**

97096132 – Fastening points for N-assembly unit **2.05 - 13**

97097951 – Counterweight **2.05 - 30**

97100047 – Retaining pins for erection rack **2.05 - 31**

97100629 – Connector pins for erection rack / guy rods **2.05 - 31**

97106824 – Installing the N-assembly unit **2.05 - 12**

97107101 – Unlocking the telescopic boom locking pin **2.05 - 32**  
 97107199 – Do not unlock the telescopic boom locking pin **2.05 - 32**  
 97124295 – Load stop **2.05 - 4**  
 97127242 – Assembly aid **2.05 - 5**  
 97128894 – Counterweight and counterweight radius **2.05 - 32**  
 97131530 – Reduced crawler crane track width **2.05 - 33**  
 97133617 – Hydraulic connection **2.05 - 6**  
 97137170 – Luffing cylinder and counterweight collision **2.05 - 4**  
 97140080 – Assembling the fixed lattice jib **2.05 - 12**  
 971494208 – Limitation of maximum travel speed **2.05 - 33**  
 97151252 – Hoist device **2.05 - 6**  
 971539808 – Warning notice for unpinning the auxiliary boom on the pulley head **2.05 - 34**  
 971539908 – Warning notice for unlocking the auxiliary boom **2.05 - 34**  
 97155791 – Rigging point **2.05 - 40**  
 97160549 – Oil change **2.05 - 42**  
 97164545 – Danger of injury for hands **2.05 - 38**  
 97165352 – Rigging point **2.05 - 40**  
 97167874 – Danger of injury for hands by the rope drive **2.05 - 38**  
 973974408 - Transport weights of the components **2.05 - 43**  
 973974608 - Transport weights of the components **2.05 - 43**  
 976624808 – Fastening the load **2.05 - 45**  
 977055908 – Fastening point for swingable sliding beam **2.05 - 33**  
 978673908 – Warning of suspended load **2.05 - 35**  
 978674008 – Access for unauthorized personnel prohibited **2.05 - 35**  
 978674108 – Warning of crushing danger **2.05 - 36**  
 978674308 – Radio remote control **2.05 - 36**  
 978674408 – Danger of burns to hands **2.05 - 37**  
 978674508 – Warning of rotating parts **2.05 - 37**  
 978674608 – Crushing danger for hands **2.05 - 37**  
 978674808 – Personal protective equipment **2.05 - 38, 2.05 - 39**  
 978674908 – Accessing the area is prohibited **2.05 - 39**  
 978675008 – Access prohibited **2.05 - 39**  
 978687408 – Rigging point **2.05 - 40**  
 978867108 – Danger of fatal injury due to electric shock **2.05 - 41**  
 979383308 – Oil change **2.05 - 42**  
 979561108 – Counterweight **2.05 - 42**

## A

Accelerating, changing the load **2.04 - 40**  
 Accepting the entries and settings **4.02 - 58**  
 Accepting the entries and settings of the operating mode category **4.02 - 34**

Accesses to the crane **2.07 - 1**  
 Access for LTR 1060 and LTR 1100 **2.04 - 33**  
 Access for LTR 1220 **2.04 - 34**  
 Access for LTR cranes **2.04 - 32**  
 Accessible surfaces **2.04 - 14**  
 Accessible walking surfaces and stepping surfaces **2.07 - 32**  
 Accessing via the front step **2.04 - 32**  
 Access stairs fastening points **2.06 - 29, 2.06 - 39**  
 Access to the crane cab below the cab door **2.04 - 29**  
 Access to the crane cab in front of the crane cab **2.04 - 30**  
 Access via an extendable step from the rear **2.04 - 31**  
 Acoustic / visual warnings outside the crane operator's cab **4.20 - 15**  
 Acoustic / visual warnings within the crane operator's cab **4.20 - 13**  
 Acoustic and optical warning devices **4.04 - 11**  
 Acoustic and optical warning signals **4.02 - 3**  
 Acoustic warning on LICCON monitor 0 **4.02 - 113**  
 Acoustic warning on LICCON monitor 1 **4.02 - 205**  
 Acoustic warning on LICCON monitor 2 **4.02 - 221**  
 Acoustic warning priority **4.02 - 113, 4.02 - 205, 4.02 - 221**  
 Activating intermediate lubrication **7.05 - 38**  
 Activating the bypass at assembly and disassembly **5.01 - 40**  
 Activating the bypass at crawler assembly and crawler disassembly **5.01 - 39**  
 Activating the rapid gear **4.05 - 14**  
 Actual load **4.02 - 3**  
 Actual load (current load) / net load **4.02 - 83**  
 Actual load display **4.08 - 15**  
 Actuating the seat contact button **4.05 - 15**  
 Actuation of winches and / or crane movements during assembly / disassembly **5.01 - 41**  
 Adapter **2.07 - 39**  
 Adapter LR 11000 **5.35 - 7**  
 Adapter LR 1700 **5.35 - 6**  
 Adapter LR 1800 **5.35 - 6**  
 Adapting to the wind speed **4.05 - 30**  
 Add fuel **7.05 - 16**  
 Adding fuel **7.05 - 53**  
 Adding hydraulic oil **7.05 - 58**  
 Adding urea solution **7.05 - 25**  
 Additional controls for certain crawler cranes **5.01 - 11**  
 Additional controls for cranes on tires on the front and supported on the rear **5.01 - 10**  
 Additional controls for cranes supported on the front and on tires on the rear **5.01 - 10**  
 Additional controls for cranes with a derrick boom **5.01 - 11**  
 Additional controls for cranes with crane support **5.01 - 10**  
 Additional controls for cranes with luffing auxiliary boom / accessories **5.01 - 11**



- Additional controls for freestanding crane operation (on tires) **5.01 - 10**
- Additional displays on LICCON monitor LM1 **5.35 - 158, 5.36.50 - 83**
- Additional displays on LICCON monitor LM2 **5.35 - 157, 5.36.50 - 82**
- Additional emergency operating modes **4.02 - 116**
- Additional notes **0.01 - 3**
- Additional risks **2.04 - 91**
- Additional specifications for radio incline sensor type 1 **4.05 - 38**
- Additional specifications for radio incline sensor type 2 **4.05 - 38**
- Additional step **2.07 - 14, 2.07 - 35**
- Additional step counterweight-bracket **2.06 - 24**
- Additional work **4.06 - 31**
- Adjusting the console horizontally **4.03 - 32**
- Adjusting the consoles **4.03 - 32**
- Adjusting the fan stage **6.02 - 11**
- Adjusting the incline **4.03 - 32**
- Adjusting the mechanical auxiliary support **3.04 - 5**
- Adjusting the reeving **4.08 - 14**
- Adjusting the temperature **6.02 - 8, 6.02 - 11**
- Adjusting winch 1 and winch 2 **4.05 - 35**
- Adjusting winch 1 and winch 2 for the first time **4.05 - 36**
- After a possible lightning strike to the crane **2.04 - 59**
- After replacement of components **7.01 - 6**
- Aids for working at a height **2.04 - 14**
- Air distribution **6.02 - 12**
- Air filter system **7.05 - 29**
- Air heater \* **4.01 - 57, 6.02 - 17, 7.05 - 56**
- Airplane warning light **5.07 - 49, 5.38 - 27, 5.39 - 30**
- Air supply **6.02 - 14**
- Alarm functions **4.02 - 97**
- Alarm functions of LICCON monitor 1 **4.02 - 203**
- Aligning rectangular support plates **3.01 - 8**
- Aligning the suspended ballast **5.36.50 - 65**
- Aligning the wheel sets in the circular travel position **5.35 - 122, 5.35 - 227**
- Aligning the wheel sets in the parallel travel position **5.35 - 124**
- Aligning the wheel sets in the towing position **5.35 - 120, 5.35 - 224**
- Alignment of the crane **2.04 - 53**
- Ambient temperature **0.01 - 12**
- Angle adjustment on the fixed lattice jib with mechanical adjustment **5.01 - 50**
- Angle sensor **4.04 - 18**
- Angular pull **4.08 - 11**
- Applying the parking brake **4.05 - 46**
- Areas **7.05.50 - 11, 8.04 - 4**
- Areas of responsibility for crane transport on floating devices **2.25 - 3**
- Areas of responsibility for operating conditions **2.25 - 2**
- Armrests **4.03 - 33**
- Arrangement of intermediate sections and guy rods on the booms / boom systems **5.03 - 2**
- Arrangement of the guy rods **5.03 - 5**
- Arrangement of the intermediate sections **5.03 - 4**
- Ascending / descending to the space of winch 1 and winch 2 **3.07.10 - 3, 3.07.20 - 3**
- Ascending and descending the assembly area of winch 1 with an installed winch **2.07 - 19**
- Ascending and descending the ballast trailer **2.07 - 27**
- Ascending and descending the ballast trailer guide **2.07 - 29, 2.07 - 30**
- Ascending and descending the ballast trailer plates **2.07 - 31**
- Ascending and descending the control cabinet platform **2.07 - 28**
- Ascending and descending the counterweight plates **2.07 - 21**
- Ascending and descending the counterweight platforms **2.07 - 20**
- Ascending and descending the crane cab **2.07 - 7**
- Ascending and descending the crane cab, "transport position" **2.07 - 6**
- Ascending and descending the crawler travel gear **2.07 - 2**
- Ascending and descending the D-pivot section **2.07 - 23**
- Ascending and descending the H-pivot section **2.07 - 22**
- Ascending and descending the lattice sections **2.07 - 24**
- Ascending and descending the slewing ring connection assembly area **2.07 - 18**
- Ascending and descending the suspended ballast plates **2.07 - 26**
- Ascending and descending the suspended ballast platform **2.07 - 25**
- Ascending and descending the turntable **2.07 - 8**
- Ascending and descending the turntable, "transport position" **2.07 - 5**
- Ascending and descending via the stairs **2.07 - 3**
- Ascending and descending winch 1 and 2 **2.07 - 17**
- Ascent **1.03 - 8**
- Assembling
- Assembling **5.07 - 11, 5.35 - 19, 5.36.50 - 24, 5.38 - 9, 5.39 - 10**
- Assembling / disassembling **5.01 - 31**
- Assembling / disassembling boom systems for supporting on ascending terrain (assembly / disassembly diagram) **5.01 - 80**
- Assembling / disassembling of boom systems for supporting on descending terrain (assembly / disassembly diagram) **5.01 - 83**
- Assembling / disassembling of hydraulic lines **5.01 - 38**
- Assembling / disassembling of lattice sections for lattice mast cranes **5.01 - 69**
- Assembling / disassembling on the turntable - guide telescoped in **5.35 - 15, 5.35 - 17**

Assembling / disassembling on the turntable - guide telescoped out **5.35 - 16, 5.35 - 18**  
Assembling / disassembling the adapter on the wedge lock **4.06 - 32**  
Assembling / disassembling the ballast trailer with the BTT-E **5.35 - 26**  
Assembling / disassembling the booms **5.01 - 42**  
Assembling / disassembling the counterweight **5.01 - 41**  
Assembling / disassembling the crane components **2.08 - 6**  
Assembling / disassembling the electrical lines **5.01 - 37**  
Assembling / disassembling the lattice sections on telescopic cranes with a luffing lattice jib **5.01 - 50**  
Assembling / disassembling the lattice sections on telescopic cranes with an auxiliary boom, with an auxiliary crane **5.01 - 61**  
Assembling / disassembling the lattice sections on telescopic cranes with an auxiliary boom, without an auxiliary crane **5.01 - 65**  
Assembling / disassembling the wedge lock **4.06 - 23**  
Assembling and disassembling **5.30 - 3**  
Assembling lattice sections **5.01 - 69**  
Assembling on the main boom **5.13 - 10**  
Assembling S-intermediate section 12m **5.07 - 41**  
Assembling the access stairs **2.06 - 29**  
Assembling the adapter on the ballast trailer guide or intermediate section **5.35 - 49**  
Assembling the adapter on the wedge lock **4.06 - 33**  
Assembling the airplane warning light and wind sensor on the L-end section **5.07 - 48**  
Assembling the auxiliary guying **5.07 - 47, 5.38 - 21, 5.39 - 27**  
Assembling the auxiliary guying on the main boom **5.03 - 17**  
Assembling the auxiliary guying on the main boom variation A **5.03 - 7**  
Assembling the auxiliary guying on the main boom variation B **5.03 - 10**  
Assembling the auxiliary guying on the W-boom **5.03 - 12, 5.03 - 19**  
Assembling the auxiliary weight **5.39 - 45**  
Assembling the ballast trailer **5.35 - 26**  
Assembling the ballast trailer guide on the ballast trailer **5.35 - 60**  
Assembling the ballast trailer guide on the ballast trailer / free-standing ballast trailer **5.35 - 14, 5.35 - 16**  
Assembling the ballast trailer guying on the ballast trailer **5.35 - 80**  
Assembling the ballast trailer on the crane **5.35 - 66**  
Assembling the block connector **5.19 - 18, 5.19 - 26**  
Assembling the boom nose 25 t **5.10 - 6**  
Assembling the boom system **5.38 - 16, 5.39 - 17**  
Assembling the boom systems on ascending terrain **5.01 - 80**  
Assembling the boom systems on descending terrain **5.01 - 83**

Assembling the boom system with the substructure **5.38 - 25, 5.39 - 23**  
Assembling the cable drum on the auxiliary boom **5.70 - 7**  
Assembling the cab platform **4.03 - 8**  
Assembling the camera **5.70 - 5**  
Assembling the camera on the camera mount retainer **5.70 - 7**  
Assembling the camera on the roller set **5.70 - 6**  
Assembling the catwalks **2.06 - 9**  
Assembling the catwalks in the operating position **2.06 - 15**  
Assembling the catwalks in the transport position **2.06 - 17**  
Assembling the central ballast **3.02 - 8, 3.03 - 9**  
Assembling the central ballast and assembly support **4.03 - 3**  
Assembling the central ballast brackets **3.03 - 10**  
Assembling the coding coupling **5.35 - 45**  
Assembling the counterweight bracket on the turntable **2.06 - 28**  
Assembling the counterweight brackets **4.07 - 8**  
Assembling the counterweight brackets on the turntable **4.07 - 8**  
Assembling the crawler carriers with SA-frame **3.01 - 11**  
Assembling the crawler carrier with the auxiliary crane **3.01 - 19**  
Assembling the cross beam without wheels **2.04.10 - 16**  
Assembling the cross beam with wheels **2.04.10 - 16**  
Assembling the D-boom **3.07.30 - 10**  
Assembling the D-boom in sections **5.05 - 10**  
Assembling the D-boom on the SA-frame **5.05 - 35**  
Assembling the D-end section on the D-intermediate section **5.05 - 42**  
Assembling the derrick ballast **5.39 - 32**  
Assembling the D-guy rods **5.05 - 29**  
Assembling the D-guy rods on the erection racks **5.36.50 - 27**  
Assembling the D-guy rods on the suspended ballast guide "V-frame" **5.36.50 - 54**  
Assembling the D-intermediate section on the D-intermediate section **5.05 - 41**  
Assembling the D-intermediate section on the D-pivot section **5.05 - 41**  
Assembling the divisible ballast pallet "VarioTray" **5.36.50 - 58**  
Assembling the divisible ballast pallet "VarioTray" in the transport position **5.36.50 - 129**  
Assembling the D-lattice sections **5.05 - 20**  
Assembling the D-pivot section on the SA-frame **5.05 - 38**  
Assembling the drawbar of the rotary connection on the turntable **3.02 - 14**  
Assembling the end section **5.36.50 - 47**  
Assembling the extension ladder on the ballast trailer **5.35 - 38, 5.35 - 210**

- Assembling the extension ladder on the ballast trailer guide **5.35 - 68, 5.35 - 183, 5.35 - 195**
- Assembling the FAB-guy ropes on the rocker on the FA-frame **5.13 - 17**
- Assembling the fall protection equipment on the turntable **3.02 - 6**
- Assembling the feet on the L-end section **5.38 - 35, 5.39 - 41**
- Assembling the F-guying **5.13 - 35**
- Assembling the F-guy ropes **5.13 - 36**
- Assembling the F-guy ropes on the FA-frame **5.13 - 20**
- Assembling the first central ballast bracket **3.03 - 12**
- Assembling the first crawler carrier with SA-frame **3.01 - 11**
- Assembling the first crawler carrier with the auxiliary crane **3.01 - 19**
- Assembling the first wheel set **5.35 - 27**
- Assembling the fixed lattice jib on the TF-adapter **5.01 - 47**
- Assembling the fixed point **5.14 - 9**
- Assembling the F-jib **5.13 - 7**
- Assembling the flying assembly guying **5.05 - 83**
- Assembling the guying **5.38 - 20**
- Assembling the guy rods **3.05 - 13, 5.35 - 56, 5.38 - 20**
- Assembling the guy rods in the transport position **5.35 - 209, 5.36.50 - 51, 5.36.50 - 134, 5.36.50 - 140**
- Assembling the guy rods on the D-guy rods **5.36.50 - 52**
- Assembling the guy ropes of the FAB-guying on the main boom **5.13 - 19**
- Assembling the H-guy rods on the H-pivot section **3.07.50 - 15, 3.07.50 - 25**
- Assembling the hoist limit switch weight **5.14 - 8**
- Assembling the hook block **5.19 - 7, 5.19 - 11, 5.19 - 16, 5.19 - 24**
- Assembling the hook nut **8.05 - 6**
- Assembling the H-pivot section on the turntable **3.07.50 - 16, 3.07.60 - 12, 5.38 - 13, 5.39 - 14**
- Assembling the ladder **2.04.10 - 14**
- Assembling the ladder and railing on the ballast trailer guide **5.35 - 44**
- Assembling the ladder on the access stairs **2.06 - 31**
- Assembling the lattice sections **5.07 - 45**
- Assembling the lattice sections on a luffing lattice jib **5.01 - 57**
- Assembling the lattice sections on an auxiliary boom with an auxiliary crane **5.01 - 61**
- Assembling the lattice sections on an auxiliary boom without an auxiliary crane **5.01 - 65**
- Assembling the length sensor in the operating position **5.35 - 51**
- Assembling the length sensor in the transport position **5.35 - 198**
- Assembling the load hook \* **4.06 - 16**
- Assembling the luffing pulley block **3.07.30 - 10**
- Assembling the main boom guying **5.39 - 25**
- Assembling the main boom guy rods **5.39 - 26**
- Assembling the mechanical auxiliary support **3.04 - 4**
- Assembling the platform ladder **2.04.10 - 16**
- Assembling the platforms **5.35 - 38**
- Assembling the preassembled boom unit on the S-end section **5.07 - 42**
- Assembling the pull brackets in the assembly position **5.35 - 42**
- Assembling the pull brackets in the transport position **5.35 - 210**
- Assembling the radio receiving unit **5.19.10 - 2, 5.19.10 - 3**
- Assembling the radio sender unit on the hook block **5.19.10 - 5, 5.19.10 - 7**
- Assembling the railing **4.03 - 9**
- Assembling the railing in the operating position **2.06 - 19, 2.06 - 46, 2.06 - 49, 2.06 - 54, 2.06 - 56**
- Assembling the railing in the transport position **2.06 - 21, 2.06 - 51, 2.06 - 55, 2.06 - 58**
- Assembling the railing on ballast trailer and platforms **5.35 - 38**
- Assembling the railing on the crane cab **2.06 - 14**
- Assembling the railing on the turntable in the operating position **2.06 - 23**
- Assembling the railing on the turntable in the transport position **2.06 - 23**
- Assembling the railings in the transport retainer **2.06 - 47**
- Assembling the retaining bracket on the counterweight bracket **2.06 - 27**
- Assembling the roller block on the cross beam **5.19 - 7, 5.19 - 12**
- Assembling the roller blocks on the cross beam **5.19 - 16, 5.19 - 24**
- Assembling the roller cart on the L-end section **5.07 - 51**
- Assembling the roller set **5.38 - 30, 5.39 - 34**
- Assembling the roller set / roller sets **5.14 - 4**
- Assembling the roller sets R9/R11 on the S or L end section **5.14 - 6**
- Assembling the rope retainer **5.07 - 28, 5.07 - 111**
- Assembling the S/SL boom at an incline **5.38 - 23**
- Assembling the S/SL-boom at an incline **5.38 - 24**
- Assembling the SA-frame **3.02 - 16**
- Assembling the second central ballast bracket **3.03 - 13**
- Assembling the second crawler carrier with the auxiliary crane **3.01 - 22**
- Assembling the second crawler carrier with the SA-frame **3.01 - 15**
- Assembling the second wheel set **5.35 - 32**
- Assembling the SL-reducer 6m **5.07 - 42**
- Assembling the stairs **2.06 - 5, 2.06 - 32**
- Assembling the stairs and catwalks **3.03 - 18**
- Assembling the step in the operating position **4.03 - 6**
- Assembling the suspended ballast **5.36.50 - 26**

Assembling the suspended ballast guide "V-frame" on the turntable frame with the main boom taken down **5.36.50 - 33**

Assembling the suspended ballast with the suspended ballast guide "V-frame" **5.36.50 - 32**

Assembling the transmitter / receiver retainer **5.70 - 9**

Assembling the turntable **4.03 - 3**

Assembling the wedge lock **4.06 - 30**

Assembling the wind sensor **5.07 - 12**

Assembling the W-lattice jib **5.07 - 41**

Assembling winch 1 **3.02 - 16, 3.07.10 - 5**

Assembling winch 2 **3.02 - 16, 3.07.20 - 5**

Assembling winch 3 **3.07.30 - 5**

Assembling winch 5 **3.07.50 - 3, 3.07.50 - 4**

Assembling winch 5 and winch 6 on the H-pivot section **5.38 - 11, 5.39 - 11**

Assembling winch 5 in the operating position **3.07.50 - 11**

Assembling winch 6 **3.07.60 - 3, 3.07.60 - 4**

Assembling winch 6 in the operating position **3.07.60 - 10**

Assembly / disassembly procedures **4.20 - 4**

Assembly aid **2.05 - 5**

Assembly conditions **3.06 - 1**

Assembly conditions for operation on crawlers **3.06 - 2**

Assembly drawings **5.01 - 33**

Assembly functions menu **5.31 - 43**

Assembly functions - pinning / unpinning the pins **5.31 - 45**

Assembly operating mode SA **4.05 - 61**

Assembly personnel **2.04 - 9**

Assembly plate Variation 1: Assembling / disassembling the radio receiving unit **5.19.10 - 3**

Assembly plate Variation 2: Assembling the radio receiving unit **5.19.10 - 5**

Assembly prerequisites **5.13 - 10**

Assembly procedure **5.10 - 6**

Assembly rope **1.03 - 5**

Assembly support menu **5.31 - 29**

Assembly unit with lattice jib **8.01 - 67**

Assembly variation V1 **5.13 - 10**

Assembly variation V1: Assembling the F-jib, larger than 12m **5.13 - 32**

Assembly variation V1: Assembling the F-jib 12m **5.13 - 31**

Assembly variation V1: Fixing the relapse support flap in the "flap down" position **5.13 - 20**

Assembly variation V1: Inserting the F-relapse support pin in the park position **5.13 - 30**

Assembly variation V1: Positioning the F-assembly unit on the F-connector head **5.13 - 12**

Assembly variation V1: Pulling the flap with the rope winch into the "flap down" position **5.13 - 36**

Assembly variation V1: Releasing the F-relapse support **5.13 - 15**

Assembly variation V1: Taking the F-assembly unit down on the ground **5.13 - 16**

Assembly variation V2 **5.13 - 10**

Assembly variation V2 flying assembly: Fixing the relapse support flap in the "flap down" position **5.13 - 21**

Assembly variation V2 flying assembly: F-relapse support pinned in the transport position **5.13 - 14**

Assembly variation V2 flying assembly: Inserting the F-relapse support pin in the park position **5.13 - 29**

Assembly variation V2 flying assembly: Positioning the F-jib 12m on the F-connector head **5.13 - 11**

Assembly winch **1.02 - 3, 7.05 - 50**

Assembly winch 1 **3.07.10 - 4**

Assembly winch 2 **3.07.20 - 4**

Assigning the fixed accessory **4.02 - 70**

Assigning the hoist winch (normal operation of hoist winch) **4.02 - 60**

Assigning the hoist winch (parallel operation of hoist winches) **4.02 - 62**

Assigning the reeving (normal operation of hoist winch) **4.02 - 64**

Assigning the reeving (parallel operation of hoist winch) **4.02 - 66**

Assignment of the crane superstructure to the travel direction **4.10 - 28**

Attaching and removing the load hook \* **4.06 - 15**

Attaching the hoist limit switch weight **4.06 - 19, 4.06 - 22**

Authorized and trained service technician **2.04 - 10, 7.01 - 2**

Authorized inspector **2.04 - 11**

Automatic operation **6.02 - 8**

Automatic regeneration of the diesel particle filter **4.03 - 21**

Automatic support **5.31 - 33**

Auxiliary boom / accessory limitation sign **4.02 - 101**

Auxiliary equipment **1.02 - 4, 2.08 - 2**

Auxiliary

guying **5.01 - 14, 5.38 - 20, 5.38 - 37, 5.39 - 25, 5.39 - 43**

Auxiliary guying fiber guy ropes **1.03 - 23**

Auxiliary operator **2.04 - 10**

Axle bracket **8.01 - 78**

## B

Backrest adjustment **4.03 - 27**

Ballast automatic \* **4.02 - 191**

Ballast conditions **4.07 - 6**

Ballast cylinder **8.01 - 49**

Ballast frame for central ballast **1.03 - 8**

Ballasting procedure **5.36.50 - 69**

Ballasting rules **5.35 - 87**

Ballasting the ballast trailer **5.35 - 84**

Ballasting the divisible ballast pallet "VarioT-ray" **5.36.50 - 66**

Ballasting the suspended ballast **5.36.50 - 32**

Ballast pallet - V-frame **5.36.50 - 1**

Ballast plate dimensions **3.03 - 6**

Ballast plate for central ballast **1.03 - 10**

Ballast plate for counterweight and derrick ballast **1.03 - 10**  
 Ballast plates **5.36.50 - 8**  
 Ballast plates to be placed diagonally to each other **3.03 - 6**  
 Ballast removal rules **5.35 - 174**  
 Ballast trailer **1.03 - 25, 2.06 - 59, 2.07 - 38, 5.35 - 5, 8.01 - 77**  
 Ballast trailer: Bypassing the end position limit value (only crane type LR 1500) **4.02 - 215**  
 Ballast trailer \* **4.02 - 212, 7.05 - 36, 7.05 - 73**  
 Ballast trailer adapter with pull rods **1.03 - 27**  
 Ballast trailer ballast automatic **4.02 - 191**  
 Ballast trailer drive **5.35 - 142**  
 Ballast trailer emergency operation **4.02 - 218**  
 Ballast trailer frame **1.03 - 26, 5.35 - 4**  
 Ballast trailer guide **1.03 - 26, 2.07 - 39**  
 Ballast trailer guide with adapter **5.35 - 8**  
 Ballast trailer guide with intermediate section and with adapter **5.35 - 9**  
 Ballast trailer guide without adapter **5.35 - 7**  
 Ballast trailer intermediate section **1.03 - 27**  
 Ballast trailer lifted **5.35 - 146, 5.35 - 148**  
 Ballast trailer maintenance intervals / maintenance instructions **5.35 - 229**  
 Ballast trailer on the ground **5.35 - 147, 5.35 - 148**  
 Ballast trailer radius 14m - 19m with derrick boom length of 33m **5.35 - 10**  
 Ballast trailer radius 14m - 19m with derrick boom length of 39m **5.35 - 11**  
 Ballast trailer radius 18m - 23m with derrick boom length of 33m **5.35 - 11**  
 Ballast trailer radius 18m - 23m with derrick boom length of 39m **5.35 - 12**  
 Ballast trailer tires **7.04.50 - 2, 7.04.50 - 2**  
 Ballast trailer tires and disk wheels **7.04.50 - 2**  
 Ballast trailer wheel set **1.03 - 26**  
 Ballast trailer with guide, an intermediate section and adapter **5.35 - 16**  
 Ballast trailer with guide and adapter **5.35 - 14**  
 Ball locking pin **5.01 - 28**  
 Base plate **8.01 - 51**  
 Basic principles and procedure **8.01 - 4**  
 Basic requirements **2.25 - 2**  
 Basket formation **7.05.50 - 8, 8.04 - 21**  
 Batteries **7.01 - 15, 7.05 - 68**  
 Batteries in the radio sender unit **5.19.10 - 9**  
 Battery compartments open: **5.19.10 - 10**  
 Battery-operated pin pulling cylinder **5.30 - 15, 5.30 - 15**  
 Battery voltage individual control display **4.02 - 129, 4.02 - 139**  
 Before starting to work **2.04 - 79**  
 Before the start of crane operation **2.04 - 11**  
 Bitt fastening point **5.01 - 35**  
 Bleeding the central lubrication system **7.05 - 40**  
 Bleeding the fuel line **7.05 - 55, 7.05 - 56**  
 Block position **8.12 - 2, 8.12 - 5**  
 Block position extended **8.12 - 4**

Block position of the relapse cylinders when setting down the load **5.01 - 11**  
 Boom **8.01 - 52**  
 Boom components **5.03 - 2**  
 Boom length **4.02 - 89**  
 Boom limitation **4.02 - 97**  
 Boom nose **8.01 - 59**  
 Boom nose 25t **1.03 - 24**  
 Boom nose lattice boom **5.10 - 1**  
 Boom on the ground function **4.02 - 203**  
 Boom radius **4.02 - 87**  
 Boom system limit switch **4.04 - 18**  
 Boom system position during erection / take-down **5.07 - 54**  
 Boom systems **1.02 - 4, 5.03 - 1**  
 Boom systems / boom combinations **1.02 - 4**  
 Bottom flap **8.12 - 19**  
 Braking the ballast trailer with the slewing gear brake **5.35 - 144**  
 Breaking away fixed loads **4.08 - 13**  
 Brief description **4.08 - 22**  
 Bringing the cab platform into the operating position **4.03 - 6**  
 Bringing the cab platform into the transport position **4.03 - 51**  
 Bringing the crane cab and cab platform into the operating position **3.02 - 13**  
 Bringing the crane cab into the operating position **4.03 - 5**  
 Bringing the crane cab into the transport position **3.02 - 20, 4.03 - 50, 4.03 - 53**  
 Bringing the cross beam into the operating position **2.04.10 - 15**  
 Bringing the cross beam into the transport position **2.04.10 - 15**  
 Bringing the ladder into the operating position **5.05 - 23**  
 Bringing the ladder into the transport position **5.05 - 70**  
 Bringing the leaning ladder into the transport position **2.04.10 - 19**  
 Bringing the pin into the transport position **3.02 - 25**  
 Bringing the protective roller on winch 2 into the assembly position; reeving in the hoist rope **3.07.20 - 11**  
 Bringing the protective roller on winch 2 into the operating position, crane operation **3.07.20 - 13**  
 Bringing the protective roller on winch 2 into the operating position, crane operation with the D-boom **3.07.20 - 14**  
 Bringing the pulley retainer into the operating position **5.05 - 26**  
 Bringing the pulley retainer on the D-end section into the transport position **5.05 - 61**  
 Bringing the pull test brackets into the operating position **5.05 - 24**  
 Bringing the pull test brackets into the transport position **5.05 - 64**

Bringing the radio receiving unit to the operating position from the transport position **5.19.10 - 4**  
Bringing the radio receiving unit to the transport position from the operating position **5.19.10 - 4**  
Bringing the radio sender unit and radio receiving unit into the park position **5.19.10 - 12**  
Bringing the railing on the counterweight brackets into the operating position **4.07 - 8**  
Bringing the railing on the counterweight brackets into the transport position **4.07 - 23**  
Bringing the stepladder into the transport position **2.04.10 - 20**  
Bringing winch 5 from the operating position into the transport position **3.07.50 - 26**  
Bringing winch 5 from the transport position into the operating position **3.07.50 - 29**  
Bringing winch 6 from the operating position into the transport position **3.07.60 - 20**  
Bringing winch 6 from the transport position into the operating position **3.07.60 - 23**  
Bringing winch 6 from transport position into the flat operating position **3.07.60 - 24**  
Broken strands **7.05.50 - 5**  
Broken wire **7.05.50 - 5**  
Broken wire in the strand valleys **8.04 - 14**  
Broken wire nests **8.04 - 15**  
Broken wires in rope sections that are not spooled up on the winch **8.04 - 14**  
Broken wires on rope end connections **8.04 - 14**  
BTT **3.01 - 5**  
BTT control unit **4.01 - 19**  
BTT display / operating element **5.31 - 2**  
BTT - Operating element **5.31 - 1**  
BTT operation **5.31 - 51**  
BTT start menu **5.31 - 16**  
Buckles **7.05.50 - 10, 8.04 - 25, 8.16 - 9**  
Bulbs and fuses **7.05 - 68**  
Burning-off the burner **7.05 - 55**  
Bypassing at assembly / disassembly **5.01 - 39**  
Bypassing at assembly and disassembly **5.01 - 40**  
Bypassing at crawler assembly / disassembly **5.01 - 39**  
Bypassing the difference force monitoring of derrick ballast guying **4.02 - 116**  
Bypassing the hoist limit switch **4.02 - 116**  
Bypassing the hoist top shut-off **4.20 - 51, 5.01 - 16**  
Bypassing the LICCON overload protection **5.01 - 15**  
Bypassing the overload protection **4.04 - 5, 5.01 - 14**  
Bypassing the overload protection: Failure of the overload protection **4.04 - 5**  
Bypassing the PAT overload protection **5.01 - 16**  
Bypassing the radio connection **5.31 - 55**  
Bypassing the seat contact button **4.05 - 15**  
Bypassing the shut-off of the function ballast up / down **5.36.50 - 94**

## C

Cable drum **5.70 - 4, 5.70 - 14**

Calculation example **4.10 - 5**  
Calculation examples **2.04 - 48**  
Calculation of required length of transfers on uphill / downhill slopes **4.10 - 4**  
California Proposition 65 **0.01 - 1**  
Calling up / closing the system screen **5.31 - 15**  
Calling up / masking the crane operation monitoring functions **4.02 - 121**  
Calling up and checking the monitoring functions of the LICCON computer system **4.03 - 12**  
Calling up the diesel particle filter load condition **4.03 - 20**  
Calling up the master switch assignment for ballast functions **4.05 - 49, 4.05 - 64, 5.35 - 102**  
Calling up the monitoring functions **4.02 - 133**  
Calling up the selection menu **4.05 - 56**  
Calling up the service system **7.01.10 - 2**  
Camera **5.70 - 1, 5.70 - 3, 5.70 - 14**  
Camera on the auxiliary boom - cable, see illustration 3 **5.70 - 12**  
Camera on the auxiliary boom - cable drum see illustration 4 **5.70 - 13**  
Camera on the auxiliary boom - radio, see illustration 2 **5.70 - 12**  
Camera on the main boom, see illustration 1 **5.70 - 11**  
Carrier for central ballast **8.01 - 19**  
Carrying out erection procedures **4.20 - 59**  
Carrying out take down procedures **4.20 - 61**  
Carrying out the assembly procedures **4.20 - 63**  
Carrying out the erection / take down procedures **4.20 - 55**  
Carrying out the erection procedure **5.07 - 64**  
Carrying out the take-down procedure **5.07 - 73**  
Carrying out the test procedure **4.02 - 242**  
Case 1: The boom system is pulled to the rear **5.35 - 135**  
Case 2: The ballast trailer guying is relieved **5.35 - 137**  
Case 3: The load momentum is increased **5.35 - 138**  
Case 4: The load momentum is decreased **5.35 - 140**  
Catwalk **2.06 - 9**  
Catwalk railing **2.06 - 18**  
CE marking **0.01 - 6**  
Center of gravity display on the LICCON monitor **4.10 - 7**  
Center of gravity of the counterweight **2.05 - 46**  
Center pivot plate **8.01 - 79**  
Central ballast **1.02 - 2, 3.03 - 1**  
Central ballast assembly **3.03 - 6**  
Central ballast combinations **3.03 - 5**  
Central lubrication system **7.04 - 7, 7.04.50 - 10, 7.05 - 35**  
Change confirmation form **90.05 - 3**  
Change over between the air conditioning system and hydraulic oil preheating \* **5.72 - 13**  
Change to the operating instructions **90.01 - 3**  
Changing and saving settings **4.02 - 239**

Changing over the winch 1 and winch 2 parallel operation regulation **4.05 - 33**  
 Changing over winch 1 and winch 2 parallel operation regulation **4.02 - 218**  
 Changing the coolant **7.05 - 12**  
 Changing the engine oil and replacing the oil filter **7.05 - 7**  
 Changing the master switch assignment **4.05 - 6**  
 Changing the radius of the suspended ballast guide "V-frame" **5.36.50 - 112**  
 Changing the set up configuration **4.03 - 45**  
 Changing the speed of the crane movement via the engine rpm **4.05 - 22**  
 Charge air temperature individual control display **4.02 - 130, 4.02 - 138**  
 Charging a battery with the Liebherr charger **7.05 - 70**  
 Chart for determining the theoretically remaining service life **8.03 - 11**  
 Checking before start up **4.03 - 9**  
 Checking for broken strands **8.04 - 10**  
 Checking for corrosion **7.05.50 - 13**  
 Checking for damage and cracks **8.01 - 96**  
 Checking for flattenings **7.05.50 - 13**  
 Checking for leaks **7.04 - 2, 7.04.50 - 4, 7.04.50 - 7**  
 Checking for mechanical damage **7.05.50 - 3**  
 Checking for solid foreign substances **8.03 - 4**  
 Checking for wear and distortion **7.05.50 - 12**  
 Checking of rope pretension on telescopic booms, illustration 1 **8.01 - 93**  
 Checking the accumulator pressure in the W-relapse cylinder **8.14 - 2**  
 Checking the accumulator pressure in the W-relapse cylinder, WA-frame 1 on the ground **8.14 - 3**  
 Checking the accumulator pressure in the W-relapse cylinder, W-boom luffed up **8.14 - 4**  
 Checking the air heater **7.05 - 57**  
 Checking the airplane warning light **5.10 - 10, 5.13 - 40, 5.75 - 10**  
 Checking the assembled coding coupling **5.35 - 45**  
 Checking the batteries **7.05 - 70**  
 Checking the battery voltage **4.03 - 16**  
 Checking the battery voltage on LICCON monitor **4.03 - 16**  
 Checking the battery voltage on the batteries **4.03 - 16**  
 Checking the bearings for easy movement **7.05.50 - 4, 8.01 - 98**  
 Checking the belt drive **7.05 - 5**  
 Checking the breather / vent filter **7.05 - 62**  
 Checking the center of gravity display on the LICCON monitor **4.03 - 17**  
 Checking the central lubrication systems **4.03 - 12**  
 Checking the chain tension **7.04 - 10**  
 Checking the concentration of the antifreeze in the coolant **7.05 - 11**  
 Checking the connection type **5.31 - 15**  
 Checking the connector pin retainer **7.04 - 9**  
 Checking the coolant level **4.03 - 11, 7.05 - 9**

Checking the crane **2.04 - 59**  
 Checking the crawler chain for signs of wear **7.04 - 15**  
 Checking the date of manufacture **8.16 - 4**  
 Checking the depth of the lead-in tracks **8.01 - 97**  
 Checking the diesel particle filter load condition (DPF) **4.03 - 14**  
 Checking the display for the incline in the LICCON monitor **4.03 - 19**  
 Checking the display for the surface pressure in the LICCON monitor **4.03 - 17**  
 Checking the double hook for damage **8.05 - 5**  
 Checking the electrical connections **5.70 - 15, 5.75 - 9**  
 Checking the end of the service life **8.06 - 3**  
 Checking the engine oil level **4.03 - 11, 4.03 - 15**  
 Checking the exhaust system for leaks and damage **7.05 - 27**  
 Checking the expansion of the hook jaw **8.05 - 3**  
 Checking the fill level in the grease container **7.05 - 39**  
 Checking the fill level of the cleaning fluid **7.05 - 72**  
 Checking the fill level of the fuel container **7.05 - 53**  
 Checking the filter for the hydraulic tank **4.03 - 11**  
 Checking the fuel level **4.03 - 13**  
 Checking the fuel preliminary filter **7.05 - 18**  
 Checking the fuel reserve **6.02 - 18**  
 Checking the function **7.05 - 38, 7.05 - 55, 7.05 - 56**  
 Checking the function of the safety equipment **5.05 - 49, 5.07 - 21, 5.07 - 49, 5.13 - 40**  
 Checking the gas pressure and oil fill before start up **8.01 - 96**  
 Checking the gear brakes **8.03 - 4**  
 Checking the gear oil fill level of the winches **4.02 - 241**  
 Checking the general condition of the crane **4.03 - 10**  
 Checking the glide rails for signs of wear **7.04 - 8**  
 Checking the groove diameter **8.01 - 96, 8.03 - 3**  
 Checking the guy rods **8.15 - 3**  
 Checking the heat flange **7.05 - 6**  
 Checking the hoist limit switch on the pulley head **5.10 - 10, 5.13 - 41**  
 Checking the hook body for wear **8.05 - 4**  
 Checking the horn **4.03 - 37**  
 Checking the hydraulic hose lines for damage **7.05 - 66**  
 Checking the hydraulic hose lines for leaks **7.05 - 66**  
 Checking the hydraulic oil level **4.03 - 16**  
 Checking the hydraulic tank **4.03 - 11**  
 Checking the labeling **5.01 - 2**  
 Checking the length sensor value on the ballast trailer **5.35 - 172**  
 Checking the limit switches in general **5.10 - 10, 5.13 - 41**  
 Checking the limit switch initiators for function **8.12 - 2, 8.12 - 5**  
 Checking the limit switch initiators for function before erection **8.12 - 2, 8.12 - 5, 8.12 - 7, 8.12 - 16**  
 Checking the load hook **8.05 - 2**

Checking the load hook for corrosion **8.05 - 5**  
Checking the load hook for distortion **8.05 - 2**  
Checking the load hook for surface cracks **8.05 - 3**  
Checking the lubrication **7.05.50 - 12**  
Checking the main boom "steep position" limit switch **5.38 - 27, 5.39 - 30**  
Checking the monitoring functions on the LICCON monitor **4.03 - 48**  
Checking the mounting screws for damage **8.01 - 102**  
Checking the multi layer spooling for distortions **7.05.50 - 14**  
Checking the oil level **7.04 - 3, 7.04 - 5, 7.04.50 - 4, 7.04.50 - 7, 8.03 - 3**  
Checking the oil level in the hydraulic tank **4.03 - 11**  
Checking the oil level on the LICCON monitor **7.05 - 3, 7.05 - 60**  
Checking the oil level with the dipstick **7.05 - 4, 7.05 - 32, 7.05 - 45, 7.05 - 49**  
Checking the operating and control instruments after start **4.03 - 47**  
Checking the overflow container **7.05 - 50**  
Checking the position of the rope **7.05.50 - 13**  
Checking the pretension pressure of the hydro reservoir **7.05 - 65**  
Checking the profile clamps **7.05 - 27**  
Checking the pull brackets **5.13 - 35**  
Checking the retaining elements **5.01 - 22, 8.05 - 6**  
Checking the roll off surfaces of the outrigger pad and track roller **7.04 - 18**  
Checking the rope diameter **8.04 - 15**  
Checking the rope drive for spooling problems **7.05.50 - 12**  
Checking the rope end connection **8.04 - 15**  
Checking the ropes **7.05.50 - 11**  
Checking the rope thimble and rope end connection **8.16 - 4**  
Checking the safety measures **2.04 - 54**  
Checking the safety ropes and anchor points **8.01 - 92**  
Checking the settings **5.07 - 69, 5.10 - 13, 5.13 - 43, 5.38 - 32, 5.39 - 36**  
Checking the settings of the LICCON overload protection **5.35 - 150, 5.36.50 - 76**  
Checking the set up configuration **5.35 - 68**  
Checking the sprocket wheels and transport cams **7.04 - 17**  
Checking the steel structures **5.01 - 2**  
Checking the tightening torque **8.01 - 98**  
Checking the tightness of the mounting screws **8.01 - 101**  
Checking the tilt play **8.01 - 101**  
Checking the urea reserve **4.03 - 14**  
Checking the valve clearance **7.05 - 9**  
Checking the water heater **7.05 - 55**  
Checking the winch oil level **4.03 - 11**  
Checking the window cleaning fluid **4.03 - 12**

Checking the wind speed sensor **5.10 - 10, 5.13 - 40, 5.75 - 10**  
Check list for the inspection of ladders and steps **8.17 - 4**  
Checks before starting to work with the crane **4.08 - 4**  
Chemicals **2.04 - 2**  
Circular travel **5.35 - 122, 5.35 - 228**  
Circular travel steering program **5.35 - 110**  
Cleaning the dust discharge valve **7.05 - 29**  
Cleaning the water manifold **7.05 - 22**  
Climate control **6.02 - 4**  
Climate control system **6.02 - 2**  
Climate control system control unit **4.01 - 20**  
Climate control system control unit buttons **4.01 - 20**  
Climate control system control unit display **4.01 - 22**  
Climbing down from lattice sections or booms **2.04 - 27**  
Climbing up / down the counterweight bracket **4.07 - 7**  
Climbing up and down the access stairs **2.07 - 14**  
Climbing up and down the catwalk turntable via the additional step **2.07 - 10**  
Climbing up and down the stairs **2.07 - 15**  
Climbing up and down the turntable catwalk **2.07 - 9**  
Climbing up and down the winch 4 assembly area **2.07 - 16**  
Climbing up to the lattice sections or booms **2.04 - 27**  
Close the battery compartments: **5.19.10 - 11**  
Close the radio sender unit: **5.19.10 - 10**  
Closing the assembly opening of winch 5 **3.07.50 - 23**  
Closing the assembly opening of winch 6 **3.07.60 - 18**  
Closing the boom system **5.38 - 18, 5.39 - 20**  
Closing the boom system (via the derrick boom) **5.01 - 91**  
Closing the boom system (via the SA-frame) **5.01 - 88**  
Closing the boom system - opening the boom system (via the derrick boom) **5.01 - 89**  
Closing the boom system - opening the boom system (via the SA-frame) **5.01 - 86**  
Closing the end section **5.01 - 44**  
Closing the fixed lattice jib **5.01 - 49**  
Closing the roof window **4.03 - 38**  
Closing the selection menu **4.05 - 58, 4.05 - 60**  
Code calibration **5.31 - 7**  
Collision of the mechanical relapse support with the flap. **8.12 - 15**  
Combined degree of severity **8.04 - 26**  
Comparison **4.02 - 3**  
Compensating for ground unevenness **5.35 - 142**  
Completing emergency control **6.05 - 31**  
Completing the D-boom assembly **5.05 - 36, 5.05 - 42**  
Component overview crawler travel gear **1.01 - 2**



Component overview for the divisible ballast pallet "VarioTray" **5.36.50 - 5**  
 Component overview for the suspended ballast guide "V-frame" **5.36.50 - 6**  
 Components **3.03 - 3**  
 Components of the supplied fall arrest system **2.04 - 22**  
 Component weight for the Set up program **5.35 - 85**  
 Component weights for the Set up program **5.36.50 - 66**  
 Compressed air system **7.05 - 67**  
 Connecting and climbing up the leaning ladder **2.04.10 - 33**  
 Connecting and pinning the access stairs **2.06 - 30**  
 Connecting the air conditioning lines **5.72 - 9**  
 Connecting the ballast pallets "VarioTray" with each other **5.36.50 - 101**  
 Connecting the BTB and the BTT **5.31 - 7**  
 Connecting the drive assembly to the turntable **5.72 - 7**  
 Connecting the erection rope with the hoist rope **5.07 - 94**  
 Connecting the fuel lines **5.72 - 10**  
 Connecting the hoist rope **4.06 - 16**  
 Connecting the hoist rope to the rope lock **4.06 - 10, 4.06 - 13**  
 Content distributed in multiple chapters. **5.36 - 2**  
 Continuing main boom assembly **5.38 - 17, 5.39 - 18**  
 Continuing main boom disassembly **5.38 - 41, 5.39 - 49**  
 Control bore auxiliary function \* **4.06 - 27**  
 Control cabinet panel **4.01 - 58**  
 Controlling the ballast functions (pull cylinder / derrick ballast guide / ballast automatic) **4.05 - 49**  
 Control measures before crane operation **5.01 - 9**  
 Control panel -A1210 **5.35 - 24**  
 Control panel -A1220 **5.35 - 25**  
 Control panel -A1230 **5.35 - 26**  
 Control platform **4.01 - 25, 4.03 - 31**  
 Control release **4.04 - 17**  
 Control ropes **1.03 - 5**  
 Conversion chart **0.01 - 14**  
 Conversion chart for wind force **2.04 - 62**  
 Coolant system **7.06 - 3**  
 Coolant temperature individual control display **4.02 - 129**  
 Cooling system **7.05 - 9**  
 Corkscrew-like distortion **7.05.50 - 8, 8.04 - 20**  
 Corrective steering of the wheel sets **5.35 - 121**  
 Corrective steering steering program **5.35 - 110**  
 Corrosion **7.05.50 - 7, 8.04 - 18**  
 Cotter pin **5.01 - 23**  
 Counterweight **1.02 - 3, 4.07 - 1**  
 Counterweight and / or ballast **2.04 - 82**  
 Counterweight bracket **2.06 - 53**  
 Counterweight platform **1.03 - 10, 2.07 - 47**  
 Counterweights **2.06 - 79**  
 Country-specific content **8.20 - 1, 8.20 - 2**  
 Cracks and dents **8.15 - 4**

Crane **2.04 - 91, 7.01 - 12**  
 Crane, assembled **3.80 - 3**  
 Crane and crane components **2.04 - 37**  
 Crane and crane component transport **3.80 - 1**  
 Crane assembly **5.61 - 4**  
 Crane cab **1.02 - 3, 2.04 - 28, 2.07 - 37, 4.03 - 33**  
 Crane cab / stepladder menu **5.31 - 39**  
 Crane cab and turntable barrier **2.07 - 13**  
 Crane cab auxiliary heater \* **7.05 - 53**  
 Crane cab control units **4.01 - 6**  
 Crane cab exterior installation parts **4.01 - 2**  
 Crane cab heating-air conditioner device **7.05 - 51**  
 Crane cab interior installation parts **4.01 - 3**  
 Crane cab railing **2.06 - 13**  
 Crane cab with incline adjustment **2.04 - 35**  
 Crane cab with securing bracket **2.04 - 35**  
 Crane chassis **2.07 - 33, 8.01 - 7**  
 Crane components **3.80 - 3**  
 Crane control **1.02 - 3**  
 Crane documentation **0.01 - 3**  
 Crane driver's seat **4.03 - 26**  
 Crane engine (engine 1) **7.01.10 - 4**  
 Crane engine (engine 2) **7.01.10 - 4**  
 Crane floodlight menu **5.31 - 46**  
 Crane geometry and load information **4.02 - 79**  
 Crane geometry quick test **4.04 - 3**  
 Crane grounding **2.04 - 56**  
 Crane incline **4.02 - 155**  
 Crane in operation **2.04 - 12**  
 Crane movements **5.35 - 19**  
 Crane on floating body **2.25 - 1**  
 Crane operation in case of thunderstorms **2.04 - 58**  
 Crane operation monitoring functions **4.02 - 117**  
 Crane operation monitoring functions variant 1 **4.02 - 118**  
 Crane operation with a load **2.04 - 80**  
 Crane operation with ECO mode turned on **5.72 - 18**  
 Crane operation with the derrick ballast **5.35 - 149**  
 Crane operator's cab heater / engine preheating / air conditioning system **6.02 - 1**  
 Crane operator's seat **4.01 - 25**  
 Crane operator (crane driver) **2.04 - 7**  
 Crane out of service **2.04 - 13**  
 Crane removal **5.61 - 7**  
 Crane rope pretension **4.08 - 20**  
 Crane ropes **7.05.50 - 4, 8.04 - 3**  
 Crane speeds **1.03 - 4**  
 Crane start-up at low temperatures **4.03 - 2**  
 Crane superstructure **1.02 - 2, 2.07 - 34, 8.01 - 35**  
 Crane superstructure start menu **5.31 - 19**  
 Crane surface pressure **1.03 - 5**  
 Cranes with a telescopic boom **2.08 - 6, 2.08 - 7**  
 Cranes with cam limit switch **5.01 - 3**  
 Cranes with electric mode **0.01 - 12**  
 Cranes with lattice mast boom **2.08 - 5, 2.08 - 7**  
 Cranes with winch speed sensor **5.01 - 3**  
 Crane transport on floating devices **2.25 - 3**  
 Crane types with an electronic engine oil level display **4.03 - 11**

Crane types without an electronic engine oil level display **4.03 - 11**  
 Crawler carrier **1.03 - 6, 7.04 - 7, 8.01 - 20**  
 Crawler carrier assembly **3.01 - 1**  
 Crawler carrier assembly menu **5.31 - 34**  
 Crawler carrier assembly - pinning / unpinning the pins **5.31 - 35**  
 Crawler catwalk **1.03 - 8**  
 Crawler center section **1.03 - 6, 8.01 - 10**  
 Crawler chain **7.04 - 8**  
 Crawler operating mode icons on touch display 3 (TE3) **4.10 - 27**  
 Crawler operation with derrick ballast **5.36.50 - 114**  
 Crawler travel gear **1.02 - 2, 1.02 - 2, 2.06 - 4**  
 Crawler travel gear control units **4.01 - 58**  
 Crawler travel gear operating and control instruments **5.31 - 9**  
 Crawler travel gear start menu **5.31 - 17**  
 Creeper gear or very slow movement **2.04 - 70**  
 Cross beams for platform ladder **2.04.10 - 15**  
 Cross carrier **8.01 - 16**  
 Current inspection checklist **8.04 - 31**  
 Curve illustration of load charts (PC) **5.07 - 59**  
 Curve illustration of the load charts (crane) **5.07 - 56**  
 Curve illustration program **4.02 - 221**  
 Customer information **90.05 - 4**  
 Cylinders **7.01 - 13**

## D

Damaged middle sheath layer **8.16 - 7**  
 Damage to the rope **7.05.50 - 5**  
 Damage to the rope end connection **7.05.50 - 6**  
 Danger of crushing **4.08 - 19**  
 Danger of falling **4.08 - 19**  
 Dangers on the crane **2.04 - 2**  
 Danger zone of the crane **2.04 - 12**  
 Data logger **0.01 - 2**  
 Data tag **0.01 - 5**  
 D-boom, relapse cylinder limit switch **5.05 - 50**  
 D-boom assembly on the crane **5.05 - 7**  
 D-boom assembly on the ground **5.05 - 34**  
 D-boom disassembly on the crane **5.05 - 53**  
 D-boom disassembly on the ground **5.05 - 80**  
 D-boom relapse retainer **8.12 - 5**  
 Deactivating steering programs for assembly / disassembly purposes **5.35 - 130**  
 Deactivating the bypass at crawler assembly and crawler disassembly **5.01 - 39**  
 Deactivating the circular travel steering program **5.35 - 134**  
 Deactivating the parallel travel steering program **5.35 - 133**  
 Deactivating the towing steering program **5.35 - 132**  
 Decommissioning **7.01 - 14**  
 Defined ballast trailer operation **5.35 - 146**  
 Definition of assembly conditions **3.06 - 3**  
 Definition of directional data for crawler cranes **0.01 - 13**

Definition of directional data for mobile cranes **0.01 - 13**  
 Definition of roles **2.04 - 5**  
 Defrosting the window **6.02 - 13**  
 Degree of severity **8.04 - 8**  
 D-end section **2.06 - 52, 2.07 - 45**  
 D-end section 10.5m **1.03 - 19**  
 D-end section fastening points **5.05 - 6**  
 Derrick ballast **4.02 - 209**  
 Derrick ballast - ballast trailer component overview **1.01 - 6**  
 Derrick ballast - ballast trailer - M-BW **5.35 - 1**  
 Derrick ballast boom radius display **4.02 - 189**  
 Derrick ballast composition **5.35 - 85, 5.36.50 - 66**  
 Derrick ballast guying difference force monitoring **5.36.50 - 94**  
 Derrick ballast guying difference force monitoring shut-off **4.02 - 217**  
 Derrick ballast lifted button **5.35 - 144**  
 Derrick ballast radii **5.36.50 - 11**  
 Derrick ballast - suspended ballast **2.04 - 83, 5.36 - 1**  
 Derrick ballast - suspended ballast component overview **1.01 - 5**  
 Derrick ballast utilization display **4.02 - 210**  
 Derrick ballast weights **5.35 - 85**  
 Derrick ballast weights for B-operation **5.36.50 - 67**  
 Derrick ballast weights for BV-operation **5.36.50 - 68**  
 Derrick ballast without suspended ballast guide **5.36.50 - 11, 5.36.50 - 16**  
 Derrick ballast with suspended ballast guide "V-frame" **5.36.50 - 13, 5.36.50 - 19**  
 Derrick boom **5.05 - 1**  
 Derrick boom 33m **5.36.50 - 13, 5.36.50 - 16**  
 Derrick boom 33m **5.36.50 - 11**  
 Derrick boom 33m with large ballast pallet (base pallet) **5.36.50 - 20, 5.36.50 - 22**  
 Derrick boom 33m with small ballast pallet (Vario pallet) **5.36.50 - 21**  
 Derrick boom  
 39m **5.36.50 - 12, 5.36.50 - 14, 5.36.50 - 17**  
 Derrick boom 39m with small ballast pallet (Vario pallet) **5.36.50 - 23**  
 Derrick boom angle indicator **4.02 - 189**  
 Derrick boom component overview **1.01 - 7**  
 Description  
 1.03.10 - 2, 4.05 - 2, 5.35 - 2, 5.75 - 2, 7.01.10 - 2  
 Description of acoustic / visual warnings **4.20 - 11**  
 Description of intervals and tasks **7.01 - 3**  
 Description of test points **8.01 - 6**  
 Description of the function **5.30 - 6, 5.30 - 15, 5.72 - 12**  
 Description using the example LR 1600-2, SL3F **4.08 - 22**  
 Destruction of a glass pane **2.04 - 36**  
 Detachable rope end connection **8.04 - 15**  
 Detaching the hoist rope **4.06 - 11, 4.06 - 14, 4.06 - 17**  
 Detent pin **5.01 - 26**

Determining the auxiliary boom / accessory variation **4.02 - 28**  
 Determining the effective operating hours Ti **8.03 - 8**  
 Determining the exact charge condition of the rechargeable battery **5.31 - 15**  
 Determining the main boom variation **4.02 - 21**  
 Determining the number of broken wires **8.04 - 10**  
 Determining the operating conditions (load spectrum) **8.03 - 6**  
 Determining the steepest main boom operating position **5.07 - 55**  
 Determining the used proportion of the theoretical service life **8.03 - 8**  
 Diagnostics and troubleshooting **7.05 - 41**  
 Did an error message occur? **5.31 - 53**  
 Diesel engine **1.02 - 2, 7.05 - 3, 7.06 - 3**  
 Diesel engine exhaust emissions **2.04 - 2**  
 Diesel particle filter (DPF) \* **4.03 - 20**  
 Diesel particle filter individual control display **4.02 - 128**  
 Difference force monitoring of ballast guying **5.35 - 172**  
 Dimensions **1.03 - 3**  
 Dimensions and weights of the crane components **1.03 - 6**  
 D-intermediate section **2.07 - 44**  
 D-intermediate section 12m **1.03 - 18**  
 D-intermediate section 2524.16 12m fastening points **5.05 - 5**  
 D-intermediate section 2524.20 6m fastening points **5.05 - 4**  
 D-intermediate section 6m **1.03 - 18**  
 Disabling automatic regeneration of the diesel particle filter **4.03 - 22**  
 Disassembling **5.07 - 79, 5.36.50 - 115, 5.38 - 32, 5.39 - 37**  
 Disassembling boom systems on ascending terrain **5.01 - 81**  
 Disassembling boom systems on descending terrain **5.01 - 85**  
 Disassembling lattice sections **5.01 - 71**  
 Disassembling on the main boom **5.13 - 48**  
 Disassembling S-intermediate section 12m **5.07 - 91**  
 Disassembling the 25 t boom nose **5.10 - 14**  
 Disassembling the access stairs **2.06 - 38**  
 Disassembling the adapter from the ballast trailer guide or intermediate section **5.35 - 201**  
 Disassembling the adapter on the wedge lock **4.06 - 33**  
 Disassembling the airplane warning light and wind sensor **5.07 - 117**  
 Disassembling the airplane warning light and wind sensor on the L-end section **5.07 - 83**  
 Disassembling the auxiliary guying **5.07 - 83, 5.38 - 38, 5.39 - 44**  
 Disassembling the auxiliary weight **5.39 - 21**  
 Disassembling the auxiliary weight and the S-luffing pulley block **5.05 - 57**

Disassembling the ballast trailer **5.35 - 194, 5.35 - 210**  
 Disassembling the ballast trailer from the crane **5.35 - 179**  
 Disassembling the ballast trailer guide **5.35 - 198**  
 Disassembling the ballast trailer guide from the ballast trailer **5.35 - 195**  
 Disassembling the ballast trailer guying from the ballast trailer **5.35 - 184**  
 Disassembling the block connector **5.19 - 21, 5.19 - 29**  
 Disassembling the boom system **5.38 - 40, 5.39 - 48**  
 Disassembling the boom system with the substructure **5.38 - 48**  
 Disassembling the catwalks **2.06 - 11**  
 Disassembling the central ballast **3.03 - 21, 5.38 - 32, 5.39 - 37**  
 Disassembling the central ballast brackets **3.03 - 25**  
 Disassembling the counterweight bracket on the turntable **2.06 - 41**  
 Disassembling the counterweight brackets **4.07 - 22**  
 Disassembling the counterweight brackets on the turntable **4.07 - 22**  
 Disassembling the crawler carrier with SA-frame **3.01 - 26**  
 Disassembling the crawler carrier with the auxiliary crane **3.01 - 32**  
 Disassembling the D-boom in sections **5.05 - 56**  
 Disassembling the D-boom on the ground **5.05 - 80**  
 Disassembling the D-end section on the D-intermediate section **5.05 - 84**  
 Disassembling the derrick ballast **5.39 - 37**  
 Disassembling the D-guy rods **5.05 - 66**  
 Disassembling the D-intermediate section on the D-intermediate section **5.05 - 84**  
 Disassembling the D-intermediate section on the D-pivot section **5.05 - 85**  
 Disassembling the D-lattice sections **5.05 - 75**  
 Disassembling the D-pivot section on the SA-frame **5.05 - 85**  
 Disassembling the drawbar of the rotary connection on the turntable **3.02 - 19**  
 Disassembling the electrical and hydraulic extension lines **5.35 - 72**  
 Disassembling the end section **5.36.50 - 137**  
 Disassembling the erection rope **5.07 - 105**  
 Disassembling the extension ladder on the ballast trailer **5.35 - 43, 5.35 - 216**  
 Disassembling the extension ladder on the ballast trailer guide **5.35 - 193**  
 Disassembling the FAB-guy ropes on the rocker on the FA-frame **5.13 - 69**  
 Disassembling the fall protection equipment on the turntable **3.02 - 25**  
 Disassembling the feet on the L-end section **5.39 - 34**  
 Disassembling the F-guy ropes **5.13 - 52**  
 Disassembling the first central ballast bracket **3.03 - 25**

Disassembling the first crawler carrier with the auxiliary crane **3.01 - 33**  
Disassembling the first crawler carrier with the SA-frame **3.01 - 27**  
Disassembling the first wheel set **5.35 - 216**  
Disassembling the fixed point **5.14 - 11**  
Disassembling the F-jib **5.13 - 47**  
Disassembling the foot on the L-end section **5.38 - 30**  
Disassembling the guying **5.38 - 37**  
Disassembling the guy rods **3.05 - 14, 5.38 - 38**  
Disassembling the guy ropes of the FAB-guying on the main boom **5.13 - 68**  
Disassembling the guy ropes on the FA-frame **5.13 - 67**  
Disassembling the H-guy rods on the H-pivot section **3.07.50 - 4, 3.07.50 - 18**  
Disassembling the hoist limit switch weight **5.14 - 12**  
Disassembling the hook block **5.19 - 9, 5.19 - 14, 5.19 - 20, 5.19 - 28**  
Disassembling the H-pivot section on the turntable **3.07.50 - 16, 3.07.60 - 13, 5.38 - 43, 5.39 - 51**  
Disassembling the ladder and railing on the ballast trailer guide **5.35 - 208**  
Disassembling the ladder on the access stairs **2.06 - 38**  
Disassembling the lattice sections **5.07 - 86**  
Disassembling the lattice sections on a luffing lattice jib **5.01 - 59**  
Disassembling the lattice sections on an auxiliary boom with an auxiliary crane **5.01 - 63**  
Disassembling the lattice sections on an auxiliary boom without an auxiliary crane **5.01 - 67**  
Disassembling the main boom guying **5.39 - 43**  
Disassembling the main boom guy rods **5.39 - 44**  
Disassembling the mechanical auxiliary support **3.04 - 6**  
Disassembling the platform on the counterweight bracket **2.06 - 44**  
Disassembling the platforms **5.35 - 212**  
Disassembling the preassembled boom unit **5.07 - 90**  
Disassembling the radio receiving unit **5.19.10 - 4**  
Disassembling the radio sender unit on the hook block **5.19.10 - 8**  
Disassembling the railing on the ballast trailer and platforms **5.35 - 213**  
Disassembling the retaining bracket on the counterweight bracket **2.06 - 42**  
Disassembling the roller block on the cross beam **5.19 - 10, 5.19 - 15**  
Disassembling the roller blocks on the cross beam **5.19 - 22, 5.19 - 30**  
Disassembling the roller cart **5.61 - 5, 5.61 - 8**  
Disassembling the roller cart on the luffing jib head **5.07 - 81**  
Disassembling the roller set **5.38 - 35, 5.39 - 40**  
Disassembling the roller set / roller sets **5.14 - 10**

Disassembling the roller sets R9/R11 on the S or L end section **5.14 - 12**  
Disassembling the S/SL boom at an incline **5.38 - 46**  
Disassembling the S/SL-boom at an incline **5.38 - 47**  
Disassembling the second central ballast bracket **3.03 - 26**  
Disassembling the second crawler carrier with SA-frame **3.01 - 31**  
Disassembling the second wheel set **5.35 - 220**  
Disassembling the SL-reducer 6m **5.07 - 91**  
Disassembling the stairs **2.06 - 7, 2.06 - 37**  
Disassembling the suspended ballast **5.36.50 - 122**  
Disassembling the suspended ballast guide "V-frame" **5.36.50 - 130**  
Disassembling the suspended ballast guide "V-frame" from the turntable frame with the main boom taken down **5.36.50 - 144**  
Disassembling the suspended ballast on the D-guy rods **5.36.50 - 123**  
Disassembling the suspended ballast on the suspended ballast guide "V-frame" **5.36.50 - 126, 5.36.50 - 127**  
Disassembling the wedge lock **4.06 - 34**  
Disassembling the wind speed sensor **5.75 - 8, 5.75 - 11**  
Disassembling the W-lattice jib **5.07 - 82**  
Disassembling winch 1 **3.07.10 - 13**  
Disassembling winch 2 **3.07.20 - 17**  
Disassembling winch 3 **3.07.30 - 10, 3.07.30 - 14**  
Disassembling winch 5 **3.07.50 - 16, 3.07.50 - 18**  
Disassembling winch 5 and winch 6 on the H-pivot section **5.38 - 45, 5.39 - 53**  
Disassembling winch 6 **3.07.60 - 13, 3.07.60 - 15**  
Disassembly prerequisites **5.13 - 48**  
Disassembly procedure **5.10 - 16**  
Disassembly variation V1 **5.13 - 49**  
Disassembly variation V1: Disassembling the F-jib, larger than 12m **5.13 - 54**  
Disassembly variation V1: Disassembling the F-jib 12m **5.13 - 52**  
Disassembly variation V1: Pinning the F-relapse support in the transport position **5.13 - 71**  
Disassembly variation V1: Pinning the relapse support pin in the stop position **5.13 - 57**  
Disassembly variation V2 **5.13 - 49**  
Disassembly variation V2 flying disassembly: Pinning the F-relapse support in the transport position **5.13 - 50**  
Disconnecting the air conditioning lines **5.72 - 23**  
Disconnecting the connections **3.07.10 - 12, 3.07.20 - 16**  
Disconnecting the connections between the drive assembly and the turntable **5.72 - 21**  
Disconnecting the connections from winch 1 to the turntable **3.07.10 - 11**  
Disconnecting the connections from winch 2 to the turntable **3.07.20 - 16**  
Disconnecting the connections of the central lubrication system to the

winch **3.07.10 - 12, 3.07.20 - 17, 3.07.50 - 18, 3.07.60 - 14**

Disconnecting the connections of the central lubrication system to winch 3 **3.07.30 - 14**

Disconnecting the connections to the central lubrication system **3.01 - 38**

Disconnecting the connections to the crawler carriers **3.01 - 38**

Disconnecting the connections to the SA-frame **3.05 - 17**

Disconnecting the connections to winch 3 **3.07.30 - 13**

Disconnecting the connections to winch 5 **3.07.50 - 17**

Disconnecting the connections to winch 6 **3.07.60 - 14**

Disconnecting the connection to the central lubrication system **3.05 - 18, 5.35 - 215**

Disconnecting the divisible ballast pallets "VarioTray" from each other **5.36.50 - 97**

Disconnecting the drive assembly from the turntable **5.72 - 25**

Disconnecting the electrical and hydraulic connections between the adapter and the guide **5.35 - 203**

Disconnecting the electrical and hydraulic connections between the ballast trailer and the ballast trailer guide **5.35 - 195**

Disconnecting the electrical and hydraulic connections between the intermediate section and the ballast trailer guide **5.35 - 206**

Disconnecting the electrical connection **5.75 - 10**

Disconnecting the electrical connection from the suspended ballast guide to the turntable **5.36.50 - 143**

Disconnecting the electrical connection from the suspended ballast to the turntable **5.36.50 - 122**

Disconnecting the electrical connections between the S-end section and the WA-frames **5.07 - 111**

Disconnecting the electrical connections between the S-end section and the W-boom **5.07 - 82**

Disconnecting the electrical connections from the suspended ballast to the suspended ballast guide **5.36.50 - 126**

Disconnecting the electrical connections on the boom head **5.38 - 37, 5.39 - 42**

Disconnecting the electrical connections on the D-boom **5.05 - 70**

Disconnecting the electrical connections to the D-pivot section **5.05 - 77**

Disconnecting the electrical connections to the S-luffing pulley block **5.05 - 58**

Disconnecting the electrical connections to the winch **3.07.10 - 12, 3.07.20 - 17, 3.07.50 - 18, 3.07.60 - 14**

Disconnecting the electrical connections to winch 3 **3.07.30 - 13**

Disconnecting the electric and hydraulic connections on the H-pivot section **5.38 - 42, 5.39 - 50**

Disconnecting the fuel lines **5.72 - 22**

Disconnecting the hydraulic and electric connections between the ballast trailer and turntable **5.35 - 192**

Disconnecting the hydraulic connections from the suspended ballast guide "V-frame" to the turntable **5.36.50 - 144**

Disconnecting the hydraulic connections on the D-boom **5.05 - 69**

Disconnecting the hydraulic connections to the D-pivot section **5.05 - 76**

Disconnecting the hydraulic connections to the winch **3.07.10 - 12, 3.07.20 - 17, 3.07.50 - 17, 3.07.60 - 14**

Disconnecting the hydraulic connections to winch 3 **3.07.30 - 13**

Disconnect the electrical connection of the suspended ballast guide to the end section: **5.36.50 - 135**

Disk wheels **8.01 - 32**

Dismantling the platform ladder **2.04.10 - 18**

Display for the inclination on the LICCON monitor **4.10 - 9**

Displaying the set limit values **4.02 - 171**

Displaying the settings window **4.02 - 237**

Displaying the setting value in the settings window **4.05 - 20**

Displaying the setting value on the operating screen **4.05 - 21**

Displaying the setting values on the touch displays **4.05 - 20**

Display of auxiliary functions **4.02 - 153**

Displays on the LICCON monitor **4.10 - 6**

Disposal **4.06 - 35**

Disposing of the machine **7.01 - 15**

Distortions and mechanical damage **8.04 - 8**

Distribution of the surface pressure **4.10 - 10**

Divisible ballast pallet "VarioTray" **5.36.50 - 5, 5.36.50 - 8**

Documentation **8.16 - 3**

Documentation of rope condition **7.05.50 - 12**

Documenting inspection results **8.04 - 5**

Documenting the completed inspection **8.03 - 4**

Documenting the inspection **8.06 - 5**

Dolly console **8.01 - 60**

Double hook block for parallel operation variation A **5.19 - 16**

Double hook block for parallel operation variation B **5.19 - 23**

Double hook block for single operation variation A **5.19 - 7**

Double hook block for single operation variation B **5.19 - 11**

DPF filter element change interval **7.01.10 - 6**

D-pivot section **2.07 - 44**

D-pivot section 10.5m with winch 3 and luffing pulley block **1.03 - 17**

D-pivot section fastening points **3.07.30 - 2, 5.05 - 2**

D-pivot section with fixed installed winch 3 **5.05 - 4**

D-pivot section with removable winch 3 **5.05 - 3**

Draining the coolant **7.05 - 12**

Draining the fuel preliminary filter **7.05 - 18**

Draining the sediment in the fuel tank **7.05 - 23**  
 Draining water from the compressed air tank **7.05 - 67**  
 D-relapse cylinder extended **8.12 - 6**  
 D-relapse cylinder-turntable contact **8.12 - 7**  
 Drive **1.02 - 2**  
 Drive assembly air conditioning system \* **4.01 - 60, 7.05 - 57**  
 Drive assembly air conditioning system \* control unit **4.01 - 19**  
 Drive assembly in ECO mode **5.72 - 16**  
 Driver's cab and crane cab **7.01 - 11**  
 Driving / swinging in the specified direction **2.04 - 72**  
 Driving forward **4.10 - 32, 4.10 - 38**  
 Driving from the crane cab **4.10 - 1**  
 Driving in curves forward to the left **4.10 - 33, 4.10 - 39**  
 Driving in curves forward to the right **4.10 - 33, 4.10 - 39**  
 Driving in curves in reverse to the left **4.10 - 34, 4.10 - 40**  
 Driving in curves in reverse to the right **4.10 - 34, 4.10 - 40**  
 Driving in reverse **4.10 - 32, 4.10 - 38**  
 Driving on side inclinations **4.10 - 18**  
 Driving the ballast trailer **5.35 - 134**  
 Driving the crane: Ballast trailer installed **4.10 - 18**  
 Driving the crane: Load chart available **4.10 - 13**  
 Driving the crane: No load chart is available **4.10 - 14**  
 Driving the crawler **5.36.50 - 114**  
 Driving the crawler crane **4.10 - 20**  
 Driving the crawler crane in normal travel **4.10 - 31**  
 Driving the crawler crane in parallel travel **4.10 - 37**  
 Driving the outrigger pad in the cross direction over a cavity with a crawler crane **1.03.10 - 33**  
 Driving the outrigger pad in the cross direction with a crawler crane **1.03.10 - 29, 1.03.10 - 32**  
 Driving uphill / downhill **4.10 - 15**  
 Driving uphill / downhill by changing the angle of the boom system **4.10 - 16**  
 Driving with a load on the hook and / or derrick ballast **4.10 - 14**  
 Driving with an extremely reduced load **2.04 - 78**  
 Driving with a reduced load **2.04 - 78**  
 Driving with a trailer **2.04 - 78**  
 Driving without a load on the hook and without derrick ballast **4.10 - 14**  
 Ductile deformation **8.15 - 4**

## E

EAC marking **0.01 - 6**  
 Editing the speed reduction **4.02 - 237**  
 Effects of heat, arcs **7.05.50 - 11, 8.04 - 26**  
 Electrical connections on the ballast pallet **5.36.50 - 64**  
 Electrical external power supply **4.03 - 39**  
 Electrical system **1.02 - 3, 7.05 - 68**  
 Electric switch position **8.12 - 3, 8.12 - 6**

Elongation **8.15 - 4**  
 Emergency control **6.05 - 2**  
 Emergency control of slewing gear(s) with assembly plate Variation 1 (V1) **6.05 - 15**  
 Emergency control of winches, individual operation **6.05 - 23**  
 Emergency control of winches, parallel operation winch 1II2 **6.05 - 26**  
 Emergency control slewing gear(s) with assembly plate(s) Variation 2 (V2) **6.05 - 31**  
 Emergency control winches **6.05 - 13**  
 Emergency control with assembly plate(s) Variation 2 (V2) **6.05 - 19**  
 Emergency control with assembly plate Variation 1 (V1) **6.05 - 9**  
 Emergency crane cab exit **2.04 - 16**  
 Emergency equipment **4.01 - 4**  
 Emergency exit - driver's cab **2.04 - 16**  
 Emergency exit through an open door **2.04 - 16**  
 Emergency exit through the open cab door **2.04 - 17**  
 Emergency exit through the open front window **2.04 - 17**  
 Emergency exit through the roof window with emergency release **2.04 - 18**  
 Emergency exit through the side window with emergency release **2.04 - 20**  
 Emergency hammer \* **2.04 - 36**  
 EMERGENCY OFF switch quick test **4.04 - 17**  
 Emergency operation - Circular travel **5.35 - 226**  
 Emergency operation in case of a defective control module of the ballast trailer control **5.35 - 222**  
 Emergency operation LICCON overload protection (according to EN 13000:2010) **4.02 - 116**  
 Emergency operation of the ballast trailer **5.35 - 222**  
 Emergency operation - towing **5.35 - 223**  
 Emergency release on the window handle **2.04 - 18**  
 Emergency situations **4.20 - 5**  
 Emergency stop (quick stop) **2.04 - 70**  
 EMERGENCY STOP switch / EMERGENCY OFF switch **4.04 - 17**  
 Emergency take down **6.05 - 1**  
 Endangering air traffic **2.04 - 13**  
 Ending crane operation **2.04 - 87**  
 Ending operation, no longer follow my instructions **2.04 - 70**  
 End-pivot section **8.01 - 84**  
 End section **5.36.50 - 7, 5.36.50 - 9, 8.01 - 63, 8.01 - 85**  
 End section BV suspended ballast guide (V-frame) **1.03 - 25**  
 Engine monitoring functions **5.31 - 24**  
 Engine oil change interval **7.01.10 - 5**  
 Engine oil level Bar diagram **4.02 - 140**  
 Engine oil level display, variation 1 **4.03 - 15**  
 Engine oil level display, variation 2 **4.03 - 15**  
 Engine oil level individual control display **4.02 - 128, 4.02 - 139**  
 Engine oil level Number value **4.02 - 140**

Engine oil pressure individual control display **4.02 - 130, 4.02 - 138**  
 Engine operation menu **5.31 - 22**  
 Engine preheating **2.08 - 4**  
 Engine regulation **4.10 - 25**  
 Engine rpm lock **4.05 - 12**  
 Enlarged rope end connection **8.04 - 15**  
 Entering / changing the maximum permissible surface pressure **4.03 - 18**  
 Entering the hook block weight **4.02 - 68**  
 Entering the maximum permissible surface pressure **4.10 - 9**  
 Environmental / component temperature below -20°C **2.08 - 3**  
 Equalizing the ballast trailer position **5.35 - 97**  
 Equalizing the derrick ballast **5.36.50 - 111**  
 Equipment **5.01 - 2, 8.01 - 70**  
 Equipment and spare parts **0.01 - 13**  
 Erecting / taking-down **5.01 - 93**  
 Erecting / taking down with crawler cranes **5.01 - 95**  
 Erecting / taking down with mobile cranes **5.01 - 94**  
 Erecting the boom **5.10 - 10, 5.13 - 41, 5.13 - 42, 5.13 - 43**  
 Erecting the boom system **5.38 - 28, 5.38 - 31, 5.39 - 30, 5.39 - 35**  
 Erecting the boom system with luffing jib **5.07 - 60**  
 Erecting the D-boom **5.05 - 43, 5.39 - 28**  
 Erecting the D-boom to 85° **5.05 - 51**  
 Erecting the D-relapse cylinder **5.05 - 10**  
 Erecting the erection racks **5.36.50 - 59**  
 Erecting the FA-frame **5.13 - 24**  
 Erecting the SA-frame **5.02 - 5**  
 Erecting WA-frame 2 **5.07 - 31**  
 Erecting WA-frame 2 to the pin position **5.07 - 32**  
 Erection procedure **5.02 - 6, 5.05 - 45, 5.13 - 42, 5.38 - 29**  
 Error messages **4.02 - 3**  
 Error messages by the LICCON computer system **4.04 - 11**  
 Establishing the connections **3.07.10 - 10, 3.07.20 - 10, 5.35 - 53**  
 Establishing the connections between the drive assembly and the turntable **5.72 - 8**  
 Establishing the connections from winch 1 to the turntable **3.07.10 - 9**  
 Establishing the connections from winch 2 to the turntable **3.07.20 - 9**  
 Establishing the connections of the central lubrication system to the winch **3.07.10 - 11, 3.07.20 - 11, 3.07.50 - 14, 3.07.60 - 12**  
 Establishing the connections of the central lubrication system to winch 3 **3.07.30 - 10**  
 Establishing the connections to the central lubrication system **3.01 - 25, 3.05 - 11**  
 Establishing the connections to the crawler carriers **3.01 - 24**  
 Establishing the connections to the SA-frame **3.05 - 10**

Establishing the connection to the central lubrication system **5.35 - 35**  
 Establishing the electrical connection for operation of the "large" ballast palette **5.36.50 - 104**  
 Establishing the electrical connection for sole operation of the "small" ballast palette **5.36.50 - 97**  
 Establishing the electrical connection from the end section to the pivot section of the suspended ballast guide **5.36.50 - 50**  
 Establishing the electrical connection from the pivot section of the suspended ballast guide to the turntable **5.36.50 - 40**  
 Establishing the electrical connection from the suspended ballast to the suspended ballast guide **5.36.50 - 63**  
 Establishing the electrical connection from the suspended ballast to the turntable **5.36.50 - 31**  
 Establishing the electrical connections between the S-end section and the WA-frames **5.07 - 20**  
 Establishing the electrical connections between the S-end section and the W-boom **5.07 - 49**  
 Establishing the electrical connections on the boom end section **5.38 - 22, 5.39 - 29**  
 Establishing the electrical connections on the D-boom **5.05 - 27**  
 Establishing the electrical connections to the D-pivot section **5.05 - 15**  
 Establishing the electrical connections to the S-luffing pulley block **5.05 - 49**  
 Establishing the electrical connections to the terminal box **5.75 - 9**  
 Establishing the electrical connections to the winch **3.07.10 - 10, 3.07.20 - 10, 3.07.50 - 14, 3.07.60 - 12**  
 Establishing the electrical connections to winch 3 **3.07.30 - 9**  
 Establishing the electric and hydraulic connections on the H-pivot section **5.38 - 15, 5.39 - 16**  
 Establishing the hydraulic and electrical connections between the ballast trailer guide and the adapter **5.35 - 55**  
 Establishing the hydraulic and electrical connections between the ballast trailer guide and the intermediate section **5.35 - 53**  
 Establishing the hydraulic and electrical connections between the intermediate section and the adapter **5.35 - 56**  
 Establishing the hydraulic and electric connections between the ballast trailer and turntable **5.35 - 73**  
 Establishing the hydraulic connection **7.04 - 12**  
 Establishing the hydraulic connections from the suspended ballast guide "V-frame" to the turntable **5.36.50 - 41**  
 Establishing the hydraulic connections on the D-boom **5.05 - 27**  
 Establishing the hydraulic connections to the D-pivot section **5.05 - 15**

Establishing the hydraulic connections to the winch **3.07.10 - 10, 3.07.20 - 10, 3.07.50 - 13, 3.07.60 - 11**  
Establishing the hydraulic connections to the winches **6.05 - 27**  
Establishing the hydraulic connections to winch 3 **3.07.30 - 9**  
Establishing the hydraulic connections to winch 3 **3.07.30 - 9**  
Establishing the hydraulic connections to winch 5 **3.07.50 - 13**  
Establishing the hydraulic connections to winch 6 **3.07.60 - 11**  
Establishing the hydraulic connection to the slewing gears **6.05 - 15**  
Establishing the prerequisites for maintenance **7.04.50 - 2, 7.05 - 2**  
EU Declaration of Conformity **0.01 - 6**  
Evaluating oil color **8.03 - 3**  
Even reduction of the rope diameter **8.04 - 15**  
Example **8.03 - 9**  
Example of a crane on crawler with derrick boom, suspended ballast and short (main) boom system **2.04 - 50**  
Example of crane on crawler with derrick boom, suspended ballast and long (main) boom system **2.04 - 50**  
Example of crane on supports **2.04 - 51**  
Examples for the distribution of surface pressure **4.10 - 11**  
Examples of test points **8.01 - 6**  
Examples of the load bearing capacity of the ground **2.04 - 48**  
Exceeding the maximum value of the F-load display in crane operation **4.20 - 43**  
Exceeding the shut off limits of the LICCON overload protection **4.02 - 115**  
Exceeding the shut off limits of the LICCON overload protection for assembly operation **5.02 - 5**  
Exceeding the shut-off limits of the LICCON overload protection for assembly operation **5.05 - 9, 5.05 - 56, 5.38 - 11, 5.39 - 12**  
Exhaust system **7.01 - 11, 7.05 - 27**  
Exhaust system cleaning procedure **4.03 - 25**  
Extendible step \* for cranes on tires **2.04 - 28**  
Extending / retracting the assembly cylinder **4.05 - 63**  
Extending / retracting the ballast trailer support cylinders **4.05 - 64**  
Extending / retracting the derrick ballast guide (increasing / decreasing the derrick ballast boom radius) **4.05 - 51**  
Extending the assembly cylinder **4.05 - 63**  
Extending the boom **2.04 - 76**  
Extending the derrick ballast guide **4.05 - 51**  
Extending the D-relapse cylinder **5.05 - 44**  
Extending the electrical and hydraulic connections between the turntable and the ballast trailer **5.35 - 68, 5.35 - 182**

Extending the pull cylinder and pinning with the guy rods **5.05 - 29**  
Extending the relapse cylinders of the main boom **5.38 - 29, 5.39 - 33**  
Extending the support cylinders **5.35 - 180**  
Extending the suspended ballast guide "V-frame" **5.36.50 - 112**  
Extension ladder **2.04.10 - 24**  
Extension ladder on the ballast trailer **2.06 - 73, 2.06 - 76**  
Extension ladder on the ballast trailer guide **2.06 - 77**  
Extension ladder on the control cabinet platform **2.06 - 78**  
External corrosion **8.04 - 18**  
External drive assembly overview **5.72 - 2**  
External power supply **4.01 - 59**  
External power supply via an external power source **4.03 - 39**  
External power supply via the aggregate \* **4.03 - 40**  
Eyehook fastening point **5.01 - 34**

## F

F1-display bar **4.02 - 187**  
F2/F3-display bar **4.02 - 187**  
Failure of components **4.20 - 5**  
Failure of sensor / limit switch **4.02 - 105**  
Failure of the overload protection **4.04 - 5**  
Falling below the minimum value of the F-load display in crane operation **4.20 - 47**  
Fall protection equipment **7.05 - 2**  
Fall protection equipment on the crane **2.06 - 1**  
F-assembly unit **5.13 - 4, 5.13 - 6**  
F-assembly unit with F-end section **1.03 - 20, 5.13 - 4**  
F-assembly unit without F-end section **1.03 - 19**  
Fastening **2.04 - 40, 5.35 - 22**  
Fastening device **2.04 - 91**  
Fastening multiple outrigger pads with a chain **1.03.10 - 7**  
Fastening multiple outrigger pads with a round sling **1.03.10 - 6**  
Fastening of guy rods **5.01 - 37**  
Fastening points and weights **3.03 - 4**  
Fastening points for boom nose 25 t **5.10 - 4**  
Fastening points for derrick components **5.05 - 2**  
Fastening points for roller set **5.14 - 3**  
Fastening points for suspended ballast components **5.36.50 - 8**  
Fastening points for suspended ballast guide "V-frame" components **5.36.50 - 9**  
Fastening points for the drive assembly **5.72 - 4**  
Fastening points for the roller cart **5.61 - 2**  
Fastening positions for assembly / disassembly of the lattice jib **5.01 - 43**  
Fastening system 1 **5.19 - 34**  
Fastening system 2 **5.19 - 36**  
Fastening system 3 **5.19 - 38**  
Fastening system 4 **5.19 - 40**



- Fastening the fiber guy ropes **5.01 - 7**  
 Fastening the individual outrigger pad **1.03.10 - 5**  
 Fastening the lattice sections **5.01 - 34, 5.01 - 36**  
 Fastening the load **4.08 - 7**  
 Fastening the load hook \* **4.06 - 16**  
 Fastening the multiple outrigger pads **1.03.10 - 6**  
 Fastening the outrigger pad **1.03.10 - 5**  
 Fastening the SA-frame to the auxiliary crane **3.05 - 5, 3.05 - 20**  
 F-connector head **1.03 - 22**  
 F-end section **1.03 - 22, 5.13 - 3, 5.13 - 6**  
 Fiber guy rope auxiliary guying **5.03 - 15**  
 Fiber guy ropes **2.04 - 38, 5.01 - 4**  
 Filling the grease container **7.05 - 39**  
 Filling the lubrication lines **7.05 - 40**  
 Filling the window washer system **4.03 - 36**  
 Filling up the coolant **7.05 - 13**  
 Fill quantities **7.06 - 3**  
 Fill quantities, lubrication chart **7.06 - 1**  
 Filter strainer Variation 1 **7.05 - 26**  
 Filter strainer Variation 2 **7.05 - 27**  
 F-intermediate section  
 12m **1.03 - 21, 5.13 - 3, 5.13 - 6**  
 F-intermediate section  
 3m **1.03 - 20, 5.13 - 2, 5.13 - 5**  
 F-intermediate section  
 6m **1.03 - 21, 5.13 - 3, 5.13 - 5**  
 First aid measures after rescue **2.04 - 28**  
 First inspection (first year) **8.03 - 10**  
 Fixed jib – F-system **5.13 - 1**  
 Fixing the fastening rope to the FA-frame **5.13 - 28**  
 Fixing the flap with the auxiliary rope to the F-pivot section **5.13 - 51**  
 F-jib 12m **5.13 - 7**  
 F-jib assembly steps **5.13 - 11**  
 F-jib assembly variations **5.13 - 10**  
 F-jib disassembly steps **5.13 - 49**  
 F-jib disassembly variations **5.13 - 48**  
 F-jib fastening points **5.13 - 4**  
 Flap **8.12 - 17**  
 Flap can be pushed closed **8.12 - 14**  
 Flap in position **8.12 - 15**  
 Flap in the operating position **8.12 - 18**  
 Flap swung in at stop **8.12 - 14**  
 Flap swung out to stop **8.12 - 15**  
 Flattening **7.05.50 - 8**  
 Flattenings **8.04 - 26**  
 F-lattice jib relapse retainer **8.12 - 16**  
 F-load display **4.02 - 183**  
 F-load display for operating modes with derrick ballast **5.35 - 152, 5.36.50 - 77**  
 Floating device **2.25 - 2**  
 Floating device, not supported **2.25 - 3**  
 Floating device, supported **2.25 - 3**  
 Flying assembly / disassembly of lattice sections **5.01 - 73**  
 Flying assembly of lattice sections **5.01 - 73**  
 Flying D-boom assembly **5.05 - 37**  
 Flying D-boom disassembly **5.05 - 82**  
 Flying disassembly of lattice sections **5.01 - 75**  
 Folding cross beam **2.04.10 - 15**  
 Folding jib **8.01 - 75**  
 Folding rope guard **5.19 - 6**  
 Folding the console **4.03 - 31**  
 Folding the grating into the installation position of winch 5 **3.07.50 - 5**  
 Folding the grating into the installation position of winch 6 **3.07.60 - 4**  
 Force distribution when driving on pressure distributor plates **4.10 - 23**  
 Force F1 (test point 1) **5.35 - 154, 5.36.50 - 78**  
 Force F11 test point 11 **5.35 - 157, 5.36.50 - 83**  
 Force F2 (test point 2) and force F3 (test point 3) **5.35 - 155, 5.36.50 - 79**  
 Force F4/5 (test point 4/5) **5.36.50 - 81**  
 Force F4 / F5 (test point 4 / 5) **5.35 - 156**  
 For cranes with pneumatic boom locking system **8.01 - 89**  
 For cranes with the Telematik telescopic boom system **8.01 - 90**  
 Foreword **90.01 - 3**  
 Forms of transport **3.80 - 2**  
 For your safety during assembly and disassembly **5.35 - 18**  
 F-pivot section **5.13 - 2, 5.13 - 5**  
 Frame **1.02 - 2, 8.01 - 82**  
 Friction corrosion **8.04 - 20**  
 Fuel reserve individual control display **4.02 - 127, 4.02 - 137**  
 Fuel system **7.05 - 15**  
 Functionality **5.36.50 - 2**  
 Function and actuation **5.02 - 3**  
 Function check **5.10 - 9**  
 Function check of limit switch initiators on the mechanical relapse support - flap **8.12 - 13, 8.12 - 17**  
 Function check of the ground contact switches on the large ballast pallet **5.36.50 - 96**  
 Function check of the ground contact switches on the small ballast pallet **5.36.50 - 100**  
 Function key line in the Set up program **4.02 - 14**  
 Function key line in the Working range limitation program **4.02 - 231**  
 Function keys in Crane cab / stepladder menu **5.31 - 39**  
 Function keys in the Assembly functions menu **5.31 - 43**  
 Function keys in the Assembly support menu **5.31 - 31**  
 Function keys in the Crane floodlight menu **5.31 - 46**  
 Function keys in the Crawler carrier assembly menu **5.31 - 35**  
 Function keys in the Engine monitoring functions **5.31 - 25**  
 Function keys in the Engine operation menu **5.31 - 23**  
 Function keys in the selection overview **5.31 - 22**  
 Function selection on the assembly plate emergency operation **6.05 - 13, 6.05 - 23**

Function selection on the assembly plate parallel operation **6.05 - 23**  
Function test **5.75 - 10**  
Further assembly steps **3.02 - 16**  
Further procedure **5.01 - 52**  
Further protective equipment **2.04 - 25**

## G

Gap formation **8.16 - 5**  
Gas pressure spring emergency release **2.04 - 19**  
General controls before crane operation **5.01 - 9**  
General danger notes **6.05 - 5**  
General information **8.01 - 2**  
General information regarding the BTT **5.31 - 9**  
General notes for assembly **4.06 - 26**  
General notes regarding the acoustic / optical warnings to the surrounding crane area **4.20 - 9**  
General safety **5.36.50 - 24, 5.36.50 - 115**  
General technical safety instructions for operation with a ballast trailer **2.15 - 1**  
Giving a warning signal **4.05 - 11**  
Gravity-actuated relapse retainer **4.04 - 18**  
Grommets and cable laid fastening rope **5.01 - 42, 8.01 - 95**  
Ground connection **1.01 - 6**  
Grounding for potential equalization **2.04 - 55**  
Grounding the load **2.04 - 56**  
Guide **2.04 - 9, 8.01 - 80**  
Guiding crane structures, lattice sections or crane components **5.01 - 33**  
Guiding the load **4.08 - 18**  
Buying the pivot section in flying mode with the derrick boom **5.01 - 77**  
Buying the pivot section in flying mode with the SA-frame **5.01 - 75**  
Guy rod **5.36.50 - 7, 8.01 - 86**  
Guy rods **5.01 - 13, 5.36.50 - 10, 8.01 - 65**  
Guy rods for telescopic cranes with luffing lattice jib **5.01 - 13**  
Guy rod transport retainer during assembly **5.01 - 50**  
Guy rod transport retainer during disassembly **5.01 - 52**  
Guy rope **1.03 - 5**

## H

Handling of assembly plates **6.05 - 7**  
Handling recommendation for the use of external ballast on Liebherr suspended ballast pallets **5.36.90 - 2**  
Handling the batteries: **5.19.10 - 10, 5.19.10 - 11**  
Hand signals **2.04 - 69**  
Hand signals for guidance **2.04 - 69**  
Hanging the extension ladder in the operating position **2.06 - 76, 2.06 - 77, 2.06 - 79**  
Heated crane components **2.04 - 4**  
Heater / climate control **4.03 - 30, 4.03 - 30**  
Heater / climate control indicator light **4.03 - 30**  
Heater / engine preheating **6.01 - 1, 6.01 - 2**

Heater / fan stages **4.03 - 30**  
Heater control unit operating elements **6.02 - 4**  
Height adjustment **4.03 - 29**  
Height-dependent wind speed **2.04 - 63**  
Hiding the settings window **4.02 - 240**  
Hiding the Speed reduction master switch setting window **4.05 - 22**  
Hiding the Test system menu operating interface **5.31 - 48**  
High pressure cleaner **7.01 - 9**  
Hinged ladders **2.04.10 - 19**  
H-intermediate section **2.07 - 40**  
H-intermediate section 12m **1.03 - 12**  
H-intermediate section 12m fastening points **5.38 - 5, 5.39 - 5**  
H-intermediate section 6m **1.03 - 11**  
H-intermediate section 6m fastening points **5.38 - 4, 5.39 - 5**  
Hoist gear, hoist rope **2.04 - 84**  
Hoist limit switch **4.02 - 107, 5.07 - 51, 5.38 - 27, 5.39 - 30**  
Hoist limit switch quick test **4.04 - 11**  
Hoist rope length **4.08 - 15**  
Hoist ropes **1.03 - 5**  
Hoist top shut-off **4.20 - 26**  
Hoist winch in parallel operation **4.05 - 28**  
Holding the luffing lattice jib **5.01 - 47**  
Hook base **8.05 - 4**  
Hook block incline sensors **5.19.10 - 1**  
Hook block or load hook fastening points for transport **5.19 - 4**  
Hook blocks **5.19 - 1**  
Hook jaw **8.05 - 2**  
Hook points **2.06 - 2, 2.06 - 48, 2.06 - 79**  
Hook shaft **8.05 - 2**  
Horizontal adjustment **4.03 - 26**  
Horizontal movements **2.04 - 72**  
Horn warning sound **4.02 - 113, 4.02 - 205, 4.02 - 221**  
H-pivot section **2.06 - 45, 2.07 - 40**  
H-pivot section 11m **1.03 - 11**  
H-pivot section fastening points **5.38 - 4, 5.39 - 4**  
HSDBV, HSLDBV/B/BW-boom **1.01 - 16**  
HSDWB/BW/BV-boom **1.01 - 18**  
HS-reducer **2.07 - 42**  
HS-reducer 9m **1.03 - 12**  
HS-reducer 9m fastening points **5.38 - 5, 5.39 - 6**  
Hydraulic aggregate **5.30 - 6**  
Hydraulic aggregate on crawlers **5.30 - 5**  
Hydraulic aggregate on wheels without "emergency control" function **5.30 - 4**  
Hydraulic aggregate on wheels with "emergency control" function **5.30 - 4**  
Hydraulically adjustable auxiliary boom **2.04 - 84**  
Hydraulic assembly cylinder **1.02 - 4**  
Hydraulic assembly support **1.02 - 4, 3.01 - 6**  
Hydraulic circuit 1 hydraulic oil temperature individual control display **4.02 - 130**

Hydraulic circuit 2 hydraulic oil temperature individual control display **4.02 - 130**  
Hydraulic hose lines **7.04 - 21, 7.04.50 - 2, 7.05 - 66**  
Hydraulic oil, diesel fuel, operating fluids **2.04 - 4**  
Hydraulic oil level, hydraulic oil, hydraulic oil pressure **5.30 - 8**  
Hydraulic oil level individual control display **4.02 - 129, 4.02 - 140**  
Hydraulic safety valves **4.04 - 18**  
Hydraulic system **7.05 - 58, 7.06 - 4**

## I

Icon explanation Start screen BTT **5.31 - 13**  
Icons in the Assembly support menu **5.31 - 30**  
Icons in the crane floodlight menu **5.31 - 46**  
Icons in the Crawler carrier assembly menu **5.31 - 34**  
Icons in the Engine monitoring functions **5.31 - 25**  
Icons in the Engine operation menu **5.31 - 23**  
Icons in the selection overview **5.31 - 21**  
Icons on the crane operation operating screen **5.72 - 17**  
Identification of sliding beam **2.05 - 44**  
Identification of track width retracted **2.05 - 45**  
Identifications on auxiliary weights **2.05.10 - 5**  
Identifications on auxiliary weights at delivery **2.05.10 - 5**  
Identifications on auxiliary weights for reorder **2.05.10 - 6**  
Identifications on single hook or double hook **2.05.10 - 4**  
Identifications on the hook block or load hook **2.05.10 - 3**  
Identifying the fiber guy rope **5.01 - 5**  
Identifying the manufacturing method **8.05 - 2**  
Impact protection **5.01 - 19**  
Importance of inspection **8.04 - 3**  
Important information about the BTT **5.31 - 5**  
Improper mechanical damage **8.04 - 27**  
Improvement of force ratio in the guying of the boom system **4.20 - 65**  
Incline adjustment **4.03 - 28**  
Increased corrosion **2.25 - 4**  
Increasing air distribution in the foot area **6.02 - 13**  
Increasing air distribution in the head area **6.02 - 12**  
Increasing the hook block weight **2.08 - 7, 4.08 - 24**  
Increasing the reeving number **4.08 - 24**  
Indicator lights **4.01 - 53**  
Indicator lights on the BKE **4.01 - 8**  
Individual control display Coolant temperature Single motor / Double motor **4.02 - 137**  
Individual control display Hydraulic oil temperature **4.02 - 139**  
Individual control display Urea reserve **4.02 - 138**  
Individual operation for winch 1 **4.05 - 32**  
Individual operation for winch 2 **4.05 - 32**  
Information about crane geometry and load in the SA-operating mode **4.02 - 93**

Information about erecting / taking down the boom system with the luffing jib **5.07 - 54**  
Information for the REACH regulation of the European Union **0.01 - 10**  
Information regarding the erection procedure **5.07 - 63**  
Information regarding the take-down procedure **5.07 - 72**  
Inner pipe **8.01 - 81**  
Inner sheath layer damaged **8.16 - 8**  
Inserting and unpinning the collar pins **5.01 - 18**  
Inserting and unpinning the double cone pins horizontally **5.01 - 18**  
Inserting and unpinning the double cone pins vertically **5.01 - 19**  
Inserting the connector pins for transport **3.07.50 - 23, 3.07.60 - 18**  
Inserting the pins **4.05 - 53**  
Inserting the tension cylinder in the crawler carrier opening **7.04 - 11**  
Inspecting before start up **2.04 - 89**  
Inspecting load bearing crane structures, especially steel structures **8.01 - 4**  
Inspecting of fastening equipment **8.01 - 94**  
Inspecting of winches **8.03 - 1**  
Inspecting the carrier rollers **8.01 - 97**  
Inspecting the change over pulleys, illustration 2 **8.01 - 104**  
Inspecting the extension conditions of sliding beams **8.01 - 98**  
Inspecting the fiber guy ropes **8.16 - 3**  
Inspecting the function of the overload protection **8.01 - 100**  
Inspecting the hoist and retracting winches **8.03 - 3**  
Inspecting the hydraulic hose lines for damage **8.06 - 4**  
Inspecting the hydraulic hose lines for leaks **8.06 - 5**  
Inspecting the hydro reservoir **8.01 - 95**  
Inspecting the inclination sensor **8.01 - 99**  
Inspecting the ladders **8.17 - 3**  
Inspecting the lattice sections **8.01 - 88**  
Inspecting the load handling equipment and assembly aids **8.01 - 94**  
Inspecting the locking system of the telescopic boom **8.01 - 89**  
Inspecting the mounting of the load bearing equipment **8.01 - 101**  
Inspecting the oil and fuel tanks **8.01 - 104**  
Inspecting the pin connections **8.01 - 100**  
Inspecting the relapse cylinders **8.01 - 95**  
Inspecting the rigging points and fastening points **8.01 - 87**  
Inspecting the rope layers **8.16 - 6**  
Inspecting the rope pretension on lattice sections, illustration 2 **8.01 - 93**  
Inspecting the rope pulleys **8.01 - 96**  
Inspecting the safety controls on the relapse cylinders **8.01 - 96**  
Inspecting the slewing ring connection **8.01 - 101**

Inspecting the tele extension with eccentric, illustration 1 **8.01 - 103**  
Inspecting tires and disk wheels **2.15 - 3**  
Inspection **8.15 - 3**  
Inspection chart for cranes **8.90 - 1**  
Inspection chart for recurring inspections of Liebherr cranes **8.90 - 3**  
Inspection form for the inspection of ladders and steps **8.17 - 4**  
Inspection intervals **8.03 - 3, 8.05 - 2, 8.06 - 3, 8.15 - 3, 8.16 - 2, 8.17 - 3**  
Inspection of accumulator pressure in relapse cylinder **8.14 - 1**  
Inspection of crane wire ropes **8.04 - 1**  
Inspection of fiber guy ropes **8.16 - 1**  
Inspection of guy rods **8.15 - 1**  
Inspection of hydraulic hose lines **8.06 - 1**  
Inspection of ladders **8.17 - 1**  
Inspection of load hooks **8.05 - 1**  
Inspection of safety controls on the relapse supports **8.12 - 1**  
Inspection of the auxiliary reeving winch, recovery winch and spare wheel winch **8.03 - 5**  
Inspection of the screws in the adjustment plates **8.01 - 91**  
Inspection personnel qualification **8.04 - 3, 8.16 - 2**  
Inspection sheet and check list **8.17 - 3**  
Installing the AT filter module **7.05 - 29**  
Installing the boom system preassembled on the turntable **5.39 - 22**  
Installing the drive assembly **5.72 - 5**  
Installing the extension ladder in the transport position **2.06 - 75**  
Installing the H-intermediate section on the H-pivot section **5.39 - 17**  
Installing the HS-reducer on the H-pivot section **5.38 - 16**  
Installing the mechanical auxiliary support on the crawler travel gear **3.04 - 4**  
Instructions for proper handling **5.01 - 6**  
Instructions for resuming crane movement **4.20 - 17**  
Instructions to personnel **2.04 - 11**  
Instrument panel **4.01 - 42**  
Integrated pneumatic system (IPS) **4.03 - 27**  
Intended use **0.01 - 11, 2.04 - 87, 2.04 - 89, 2.04.10 - 2, 2.25 - 2**  
Interface **4.01 - 59**  
Interfaces **4.01 - 5**  
Intermediate frame **8.01 - 14**  
Intermediate section **2.07 - 39, 5.35 - 7**  
Internal corrosion **8.04 - 20**  
Interrupting crane operation **2.04 - 84**  
Intervals **7.05.50 - 11, 8.04 - 4**  
Invalid chart name **4.02 - 25**  
Is the radio connection faulty? **5.31 - 54**

## J

Job planning **2.03 - 1**  
Jump starting the diesel engine **4.03 - 41**

## K

Key button Boom on the ground **4.20 - 63**  
Keypad **4.01 - 50, 4.01 - 55, 4.01 - 59**  
Kinking, rope loops (grommets) pulled closed **7.05.50 - 10**  
Kinking or rope loops pulled closed **8.04 - 24**

## L

Labeling of the load carriers **2.05.10 - 1**  
Ladder **2.06 - 52**  
Ladder access **2.04.10 - 25**  
Ladder categories **2.04.10 - 2**  
Ladder inspection **2.04.10 - 12**  
Ladders **2.04.10 - 1, 7.01 - 11, 7.04 - 21**  
Ladder safeguards **2.04.10 - 25**  
Ladders on the ballast trailer guide **2.06 - 71**  
Large ballast pallet (base pallet) **5.36.50 - 16, 5.36.50 - 18**  
Lashing lugs **5.36.50 - 6**  
Latch **5.01 - 27**  
Lattice jib **8.01 - 61**  
Lattice mast boom **7.05.50 - 3**  
Lattice sections **2.04 - 37**  
Lattice section with walking surfaces and stepping surfaces **5.01 - 20**  
Lead and lead compounds **2.04 - 3**  
Leaving the crane, ending work with the crane **2.04 - 12**  
Legal prerequisites **2.04 - 88**  
L-end section **2.07 - 43**  
L-end section 450t **1.03 - 16**  
L-end section fastening points **5.07 - 10, 5.38 - 8, 5.39 - 9**  
Leveling instrument quick test **4.04 - 9**  
Leveling instruments **4.04 - 9**  
Leveling instruments on the BTT operating element **4.04 - 9**  
Leveling instruments on the LICCON monitor **4.04 - 9**  
LICCON computer system **4.02 - 1, 4.04 - 3**  
LICCON computer system control unit **4.01 - 23**  
LICCON job planner **2.04 - 49**  
LICCON job planner (PC) **5.07 - 58**  
LICCON monitor 0 **4.02 - 4**  
LICCON Monitor 0 special functions **4.02 - 115**  
LICCON Monitor 0 winch display **4.02 - 165**  
LICCON monitor 1 **4.02 - 5**  
LICCON Monitor 1 winch display **4.02 - 195**  
LICCON monitor 2 **4.02 - 5**  
LICCON Monitor 2 special functions **4.02 - 217**  
LICCON monitors at system start **4.02 - 4**

- LICCON overload protection **4.04 - 3, 5.35 - 150, 5.36.50 - 76**
- Liebherr Customer Service **7.01 - 7**
- Lifting, lowering and equalizing the derrick ballast via the pull cylinders **5.36.50 - 105**
- Lifting / lowering a load with even speed **2.04 - 71**
- Lifting a load with two cranes **2.04 - 66**
- Lifting and lowering the ballast trailer with the pull cylinders **5.35 - 92**
- Lifting category **4.02 - 58**
- Lifting of personnel **2.04 - 87**
- Lifting slowly **2.04 - 71**
- Lifting the ballast plates together **3.03 - 9**
- Lifting the ballast trailer **5.35 - 93**
- Lifting the ballast trailer with the support cylinders **5.35 - 223, 5.35 - 226**
- Lifting the ballast trailer with the support cylinders on both sides **5.35 - 111**
- Lifting the boom **2.04 - 75**
- Lifting the boom and lower the load at the same time **2.04 - 77**
- Lifting the D-boom off the ground **5.05 - 45**
- Lifting the derrick ballast **5.36.50 - 109**
- Lifting the D-pivot section from the transport vehicle **3.07.30 - 6**
- Lifting the load **4.08 - 11, 4.08 - 16**
- Lifting the small ballast pallet "VarioT-ray" **5.36.50 - 101**
- Lifting the turntable from the crawler center section **3.02 - 24**
- Lifting the turntable from the transport vehicle **3.02 - 7**
- Lifting WA-frame 2 from the assembly supports **5.07 - 116**
- Lifting winch 1 from the flatbed trailer **3.07.10 - 5**
- Lifting winch 1 from the turntable **3.07.10 - 15**
- Lifting winch 2 from the flatbed trailer **3.07.20 - 5**
- Lifting winch 2 from the turntable **3.07.20 - 19**
- Lifting winch 3 from the transport vehicle **3.07.30 - 7**
- Lifting winch 3 out of the D-pivot section **3.07.30 - 14**
- Lifting winch 5 from the flatbed trailer **3.07.50 - 9**
- Lifting winch 5 out of the H-pivot section **3.07.50 - 22**
- Lifting winch 6 from the flatbed trailer **3.07.60 - 8**
- Lifting winch 6 out of the H-pivot section **3.07.60 - 17**
- Lifting with main winch **2.04 - 75**
- Lifting with the auxiliary winch **2.04 - 75**
- Light and / or heavy work **2.04.10 - 25**
- Lightning: Protective measures for the crane and load **2.04 - 59**
- Limitations from 50 % pulled derrick ballast **5.35 - 171, 5.36.50 - 93**
- Limitations from 90 % pulled derrick ballast **5.35 - 171, 5.36.50 - 93**
- Limit switch, general **5.07 - 50**
- Limit switch on the S-end section, "WA-Frame 1 bottom" position **5.07 - 50**
- Limit switch on the S-luffing pulley block **5.05 - 50**
- Limit switch on the W-pivot section **5.07 - 51**
- Limit switch pull cylinder on the D-end section **5.05 - 51**
- Lines **7.05 - 68**
- L-intermediate section **2.07 - 41**
- L-intermediate section 12m **1.03 - 15**
- L-intermediate section 12m fastening points **5.07 - 10, 5.38 - 8, 5.39 - 8**
- L-intermediate section 6m **1.03 - 15**
- L-intermediate section 6m fastening points **5.07 - 9, 5.38 - 7, 5.39 - 8**
- Load and reeving during crane operation **5.10 - 11**
- Load bearing crane structures **2.08 - 7**
- Load burdens on the ground on cranes on crawlers **2.04 - 47**
- Load burdens on the ground on cranes on supports **2.04 - 47**
- Load chart manual document **5.07 - 57**
- Load handling equipment **1.03 - 5**
- Loading the preassembled lattice jib **5.01 - 50**
- Load max **4.02 - 209**
- Load max2 **4.02 - 209**
- Load max3 **4.02 - 209**
- Loads on the ground **1.03.10 - 3**
- Loads on the ground due to crane operation **2.04 - 47**
- Load spectrum class: Heavy L3 **8.03 - 7**
- Load spectrum class: Light L1 **8.03 - 6**
- Load spectrum class: Medium L2 **8.03 - 7**
- Load spectrum class: Very heavy L4 **8.03 - 8**
- Load weighing **4.08 - 14**
- Load weighing and load display **4.08 - 13**
- Localized increase of rope diameter **7.05.50 - 6**
- Localized increases of rope diameter **8.04 - 18**
- Localized reduction of rope diameter **8.04 - 17**
- Locking / releasing the control winch **4.05 - 8**
- Locking / releasing the hoist winch **4.05 - 6**
- Locking / releasing the winch **4.05 - 6**
- Locking pin **5.01 - 25**
- Locking the control winch **4.05 - 8**
- Locking the hoist winch **4.05 - 7**
- Long guy rods **5.01 - 13**
- Loop formation **7.05.50 - 9, 8.04 - 23**
- Lowering slowly **2.04 - 72**
- Lowering the ballast trailer **5.35 - 95**
- Lowering the ballast trailer with the support cylinders **5.35 - 225, 5.35 - 228**
- Lowering the ballast trailer with the support cylinders on both sides **5.35 - 117**
- Lowering the boom **2.04 - 76**
- Lowering the boom and lift the load at the same time **2.04 - 77**
- Lowering the boom end section in the roller cart **5.61 - 4, 5.61 - 7**
- Lowering the crane **3.01 - 18, 3.01 - 23**
- Lowering the derrick ballast **5.36.50 - 109**
- Lowering the hook block **4.06 - 11, 4.06 - 14, 5.19 - 3**
- Lowering the load **4.08 - 17**
- Lowering the load hook **4.06 - 17**
- Lowering the load while stationary **2.04 - 72**

Lowering the relapse support **5.07 - 19**  
Lowering the SA-frame to the front and assembling the flying assembly guying **5.05 - 18**  
LR 11000 **5.75 - 3**  
LR crane types **5.75 - 2**  
L-shaped rope lock **4.06 - 3**  
Lubricating the bearings **7.05.50 - 4**  
Lubricating the gear ring and the slewing gear pinion **7.05 - 43**  
Lubricating the ladders **7.05 - 2**  
Lubricating the pin bores on the lattice sections and guy rods **7.05.50 - 3**  
Lubricating the rope **7.05.50 - 14**  
Lubricating the slewing ring connection **7.05 - 43**  
Lubrication cycle **7.05 - 38**  
Lubrication schedule **7.06 - 4**  
Luffing jib - W-system **5.07 - 1**  
Luffing range **5.70 - 13**  
Luffing the boom down **5.19 - 3**  
Luffing the boom system down **5.38 - 33, 5.39 - 38**  
Luffing the boom system up / down **4.05 - 40**  
Luffing the derrick boom down **4.05 - 43**  
Luffing the derrick boom up **4.05 - 43**  
Luffing the derrick boom up / down **4.05 - 43**  
Luffing the derrick boom up / down shut-off **4.20 - 27**  
Luffing the luffing lattice jib down **4.05 - 44**  
Luffing the luffing lattice jib up **4.05 - 44**  
Luffing the luffing lattice jib up / down **4.05 - 44**  
Luffing the main boom down **4.05 - 42**  
Luffing the main boom up **4.05 - 42**  
Luffing the main boom up / down **4.05 - 42**  
Luffing the SA-frame down **4.05 - 62**  
Luffing the SA-frame up **4.05 - 62**  
Luffing the SA-frame up / down **4.05 - 62**  
Luffing the S-boom down **5.13 - 44**  
Luff in with a suspended load **4.20 - 37**

## M

Machine related movements **2.04 - 75**  
Main boom **5.38 - 1**  
Main boom component overview **1.01 - 8**  
Main boom limitation signs **4.02 - 97**  
Main boom with derrick boom **5.39 - 1**  
Maintenance **2.08 - 7, 7.01 - 14**  
Maintenance and inspection schedule **7.02 - 2, 7.02.50 - 2, 7.03 - 2, 7.03.50 - 2**  
Maintenance and service - General **7.01 - 1**  
Maintenance instructions - Ballast trailer **7.04.50 - 1**  
Maintenance instructions - Crane boom **7.05.50 - 1**  
Maintenance instructions - Crane chassis **7.04 - 1**  
Maintenance instructions - Crane superstructure **7.05 - 1**  
Maintenance intervals **7.01 - 3**  
Maintenance intervals - Ballast trailer **7.02.50 - 1**  
Maintenance intervals - Crane boom **7.03.50 - 1**  
Maintenance intervals - Crane superstructure **7.03 - 1**  
Maintenance intervals - Crawler chassis **7.02 - 1**

Maintenance is due **7.01.10 - 5**  
Maintenance status overview **7.01.10 - 4**  
Maintenance technician **2.04 - 10, 7.01 - 2**  
Manually aligning the winch / hook block for individual operation **4.05 - 30**  
Manual operation **6.02 - 9**  
Manual rope winches **5.01 - 12**  
Manual support **5.31 - 32**  
Manufacturer **0.01 - 1, 2.04 - 6**  
Master switch / pedal sensor speed reduction **4.02 - 233**  
Master switch assignment **4.05 - 5**  
Master switch functions **4.05 - 10**  
Master switch MS1 **4.01 - 26**  
Master switch MS2 **4.01 - 34**  
Master switch MS3 **4.01 - 43**  
Maximum / minimum value F-load display during crane operation shut-off **4.20 - 23**  
Maximum climbing ability **4.10 - 16**  
Maximum liftable derrick ballast **4.02 - 216, 5.35 - 157, 5.36.50 - 82**  
Maximum load **4.02 - 81**  
Maximum load according to the load chart and reeving **4.02 - 3**  
Maximum permissible ground unevenness **5.35 - 141**  
Maximum sound power level **2.05 - 30**  
Maximum value F1 during crane operation shut-off **4.20 - 24**  
Measurement of wind speed **2.04 - 61**  
Measures in case of problems **5.31 - 53**  
Measuring the pins and bores on the outrigger pads **7.04 - 17**  
Measuring the run-in depth of the outrigger pads **7.04 - 19**  
Measuring the wear limits on the track rollers **7.04 - 20**  
Mechanical auxiliary support **1.02 - 4, 1.03 - 9, 3.04 - 1**  
Minimum rope coils **5.01 - 3**  
Minimum rope reeving / minimum hook block weight **2.05 - 47**  
Minimum value F1 during crane operation shut-off **4.20 - 24**  
Minimum value F3-load display during erection of the derrick boom fallen below **4.20 - 65**  
Minimum values or maximum values of F-load display reached **4.20 - 65**  
Miter gear **7.04 - 5**  
Mobile cranes **2.04 - 39**  
Monitor control unit **4.01 - 7**  
Monitored auxiliary functions **4.02 - 153**  
Monitoring by a designated person **2.04 - 7**  
Monitoring functions during crane operation variant 2 **4.02 - 133**  
Monitoring of crane utilization in operating modes with derrick ballast **5.35 - 160, 5.36.50 - 85**  
Monitoring of F1-maximum force **5.35 - 167, 5.36.50 - 90**

Monitoring of F1-minimum force **5.35 - 169, 5.36.50 - 91**  
 Monitoring of load momentum **5.35 - 162, 5.36.50 - 86**  
 Monitoring of maximum load on the LICCON monitor 0 **5.35 - 161**  
 Monitoring of pull cylinders in the block position **5.36.50 - 93**  
 Monitoring of test point 1-operational maximum force (= F1max operation) **5.35 - 161**  
 Monitoring the F-load display **5.36.50 - 90**  
 Monitoring the lateral incline of the divisible ballast pallet "VarioTray" **5.36.50 - 93**  
 Monitoring the surface pressure and center of gravity **4.02 - 147**  
 Monitoring the winches **8.03 - 5**  
 Mounting position on the WA-frame II end section **5.75 - 6**  
 Mounting positions on L-end section and on boom nose **5.75 - 5**  
 Mounting positions on S-end section and on boom nose **5.75 - 4**  
 Mounting positions on the F-end section **5.75 - 5**  
 Movement of crane components **5.35 - 21**  
 Movement on the crane **2.04 - 14, 5.35 - 19**  
 Moving away from me **2.04 - 73**  
 Moving both track chains **2.04 - 73**  
 Moving one crawler chain **2.04 - 74**  
 Moving the cab to the horizontal position **4.03 - 35**  
 Moving the roller cart **5.61 - 3**  
 Moving toward me **2.04 - 73**  
 Multi-purpose ladder with height adjustment **2.04.10 - 21**

## N

NA/WA frame **8.01 - 62**  
 NA-frames **8.01 - 68**  
 Negative longitudinal inclination **4.10 - 17**  
 Noise emission **1.03 - 4**  
 No load chart is available **4.02 - 115**  
 Nominal dimensions when assembling the wedge lock **4.06 - 26**  
 Non-intended use **2.25 - 2**  
 Non-rotating rope end connection **8.04 - 6**  
 Non-rotation-resistant ropes with rope end connections **8.04 - 7**  
 Note of sliding beam weight **2.05 - 46**  
 Note regarding the signs **2.05 - 2**  
 Numeric F-load display **4.02 - 183**

## O

Occurrence of an advance warning **4.02 - 109, 4.02 - 203**  
 Occurrence of a shut-off in the working range limitation **4.02 - 231**  
 One-part hoist limit switch weight **4.06 - 21**

Opening / closing cab doors and cab windows **4.03 - 37**  
 Opening / closing the roof window **4.03 - 38**  
 Opening the boom system **5.38 - 39, 5.39 - 47**  
 Opening the boom system (without derrick boom) **5.01 - 88, 5.01 - 92**  
 Opening the end section **5.01 - 46**  
 Opening the roof window **4.03 - 38**  
 Open the radio sender unit: **5.19.10 - 10**  
 Operating and control elements **7.05 - 37**  
 Operating and control instruments **3.01 - 4**  
 Operating and control unit - BKE **4.01 - 7**  
 Operating and load conditions **1.03 - 4**  
 Operating and monitoring instruments on the crane superstructure **4.01 - 1**  
 Operating buttons on the BKE **4.01 - 10**  
 Operating buttons on the BKE with release actuators **4.01 - 17**  
 Operating company **2.04 - 6**  
 Operating condition of crane **4.20 - 6**  
 Operating conditions **2.25 - 2**  
 Operating console **4.01 - 8**  
 Operating element on LICCON monitor 0 **4.02 - 7**  
 Operating element on LICCON monitor 1 **4.02 - 9**  
 Operating element on LICCON monitor 2 **4.02 - 10**  
 Operating elements for special cases during operation of the LICCON overload protection **4.20 - 3**  
 Operating elements for the crawler operation **4.10 - 24**  
 Operating elements in the Set up program **4.02 - 13**  
 Operating elements on the control panels **5.35 - 23**  
 Operating elements on the LICCON monitors **4.02 - 6**  
 Operating elements with master switch / pedal sensor speed reduction **4.02 - 233**  
 Operating fluids and lubricants **7.07 - 1**  
 Operating hour meter **4.01 - 56, 4.01 - 58, 7.01.10 - 3**  
 Operating interface **4.02 - 225**  
 Operating interface for the Gear oil fill level display **4.02 - 242**  
 Operating interface from the Test system menu **5.31 - 48**  
 Operating interface in the settings window for master switch / pedal sensor speed reduction **4.02 - 235**  
 Operating sequence 1 **4.01.10 - 3**  
 Operating sequence 2 **4.01.10 - 4**  
 Operating the ballast trailer support cylinders **4.05 - 63**  
 Operating the central lubrication system **7.05 - 38**  
 Operating the crane **5.13 - 43, 5.38 - 32, 5.39 - 36**  
 Operating the drive assembly **5.72 - 12**  
 Operating the drive assembly manually **5.72 - 14**  
 Operating the fast settings **4.02 - 237**  
 Operating the function using the touch function **4.01.10 - 3**  
 Operating the function with the F-keys **4.01.10 - 2**  
 Operating the support cylinders individually **5.35 - 113**

Operating the timer **6.02 - 15**  
Operating the window washer system **4.03 - 36**  
Operating the window wipers **4.03 - 35**  
Operating variations **4.01.10 - 2**  
Operating with telescopic boom and auxiliary boom **4.08 - 4**  
Operating with the tele lift truck **5.30 - 14**  
Operational flattenings: Examples of impermissible assembly positions **8.04 - 30**  
Operational flattenings: Examples of permissible assembly positions **8.04 - 30**  
Operational flattenings on ropes on winch 4 (WIV) **8.04 - 28**  
Operational transverse pressure **8.04 - 27**  
Optimizing measures for the travel route **4.10 - 4**  
Optional: Assembling the intermediate sections on the guide **5.35 - 47**  
Optional: Disassembling the intermediate section from the ballast trailer guide **5.35 - 206**  
Optional: Disconnecting the electrical and hydraulic connections between the adapter and the intermediate section **5.35 - 204**  
Optional: Replacing the coding coupling **5.35 - 46**  
Optional: Supporting the ballast trailer guide **5.35 - 202**  
Optional equipment and functions **0.01 - 14**  
Ordering the filter module **7.05 - 28**  
Order of the displays in the crane operation monitoring functions **4.02 - 119**  
Oscillation guard **5.07 - 50**  
Other operating elements **4.02 - 178**  
Outer sheath layer damaged **8.16 - 6**  
Outrigger pad LWE ID number 914618608 **1.03.10 - 24**  
Outrigger pad LWE ID number 914786508 **1.03.10 - 8**  
Outrigger pad LWE ID number 914786808 **1.03.10 - 10**  
Outrigger pad LWE ID number 914861908 **1.03.10 - 9**  
Outrigger pad LWE ID number 915236308 **1.03.10 - 11**  
Outrigger pad LWE ID number 915236408/915464608 **1.03.10 - 12**  
Outrigger pad LWE ID number 915696408 **1.03.10 - 25**  
Outrigger pad LWE ID number 918339808 **1.03.10 - 27**  
Outrigger pad LWE ID number 919427108 **1.03.10 - 30**  
Outrigger pad LWE ID number 919663108 **1.03.10 - 15**  
Outrigger pad LWE ID number 919663508 **1.03.10 - 17**  
Outrigger pad LWE ID number 919663608 **1.03.10 - 19**  
Outrigger pad LWE ID number 919663708 **1.03.10 - 21**  
Outrigger pads **1.03.10 - 1**

Outside drive aggregate **5.72 - 1**  
Overlapping of working ranges of several cranes **2.04 - 68**  
Overload monitoring in operating mode with derrick ballast **5.35 - 161**  
Overload protection **4.02 - 2**  
Overload protection bypass: Emergency situation (according to EN 13000:2010) **4.04 - 6**  
Overload protection bypass: Failure of overload protection (according to EN 13000:2010) **4.04 - 6**  
Overload protection quick test **4.04 - 3**  
Overview Load chart **4.20 - 18**  
Overview of acoustic / optical warnings **4.20 - 9**  
Overview of function key assignment **4.02 - 141**  
Overview of icons for monitoring functions **4.02 - 122, 4.02 - 134**  
Overview of the auxiliary weight fastening systems **5.19 - 31**  
Overview of the individual control displays **4.02 - 126, 4.02 - 137**  
Overview of the retaining elements **5.01 - 22**  
Overview of the steering programs **5.35 - 109**

## P

Packing the filter module for transport **7.05 - 28**  
P-adapter **8.01 - 64**  
Paint / coating **8.15 - 4**  
Pairing process **5.31 - 7**  
Parallel travel **5.35 - 123**  
Parallel travel steering program **5.35 - 109**  
Pedal carrier **4.01 - 23, 4.10 - 24**  
Performing a visual inspection **4.03 - 11, 8.01 - 97**  
Performing the function checks **5.02 - 4, 5.38 - 27, 5.39 - 29**  
Periodic crane inspections **8.01 - 1**  
Permissible ballast assemblies **4.07 - 5, 5.35 - 86, 5.35 - 174, 5.36.50 - 10**  
Permissible level difference **5.35 - 12**  
Permissible lifting heights **5.36.50 - 15**  
Permissible load configurations **1.03.10 - 3**  
Permissible side incline **5.35 - 13**  
Permissible support pressures on the outrigger pad [A-B-C] **2.05 - 29**  
Permissible support pressures on the outrigger pad [A-B-C-D] **2.05 - 29**  
Permissible turntable ballast / permissible ballast combinations **3.06 - 3**  
Personal protective equipment **2.04 - 20, 7.05.50 - 4, 8.04 - 3**  
Personnel **7.01 - 2**  
Personnel and qualification **2.04 - 90**  
Picking up and lowering overhead loads **4.08 - 24**  
Picking up the fastening equipment **4.08 - 21**  
Pin connections **5.01 - 17, 5.35 - 20**  
Pinning and unpinning with the pin pulling device (battery-operated pin pulling cylinder) **5.30 - 16**



Pinning and unpinning with the pin pulling device (hydraulic aggregate with pin pulling cylinder) **5.30 - 9**

Pinning or unpinning non-tensioned pins with high pressure **5.30 - 19**

Pinning or unpinning non-tensioned pins with low pressure **5.30 - 10, 5.30 - 11, 5.30 - 17, 5.30 - 18**

Pinning or unpinning pins, pin location variation I **5.30 - 10, 5.30 - 17**

Pinning or unpinning pins, pin location variation II **5.30 - 11, 5.30 - 18**

Pinning or unpinning tensioned pins with high pressure **5.30 - 10, 5.30 - 12, 5.30 - 17**

Pinning the auxiliary weight to the S-luffing pulley block **5.05 - 48**

Pinning the ballast trailer on the turntable **5.35 - 70**

Pinning the bracket in the middle position **5.13 - 14**

Pinning the change over pulley in the park position **5.07 - 29, 5.07 - 111**

Pinning the D-guy rods in the assembly position on the "V-frame" pivot section **5.36.50 - 42**

Pinning the D-pivot section on the SA-frame **5.05 - 12**

Pinning the FAB-guy ropes **5.13 - 26**

Pinning the FA-frame relapse retainer **5.13 - 70**

Pinning the F-assembly unit to the F-connector head **5.13 - 13**

Pinning the guy rods from the intermediate section **5.07 - 40**

Pinning the guy rods on the lattice sections **5.07 - 29, 5.07 - 46**

Pinning the platform on the counterweight bracket **2.06 - 25**

Pinning the pull brackets with the guy rods of the D-pivot section **5.05 - 32**

Pinning the pulley support with the turntable **3.05 - 11**

Pinning the relapse support to the relapse cylinder **5.07 - 104**

Pinning the rope pulley retainer in the transport retainer **5.13 - 70**

Pinning the rope pulley retainer to the FA-frame **5.13 - 29**

Pinning the SA-frame **3.05 - 6**

Pinning the SA-frame guying on the H-pivot section **5.38 - 18**

Pinning the SA-frame on the turntable **3.05 - 5**

Pinning the S-luffing pulley block on the pull test brackets **5.05 - 45**

Pinning the small ballast pallet "VarioTray" **5.36.50 - 103**

Pinning the strut on the ballast trailer **5.35 - 179**

Pinning the suspended ballast guide "V-frame" **5.36.50 - 61**

Pinning the suspended ballast guide "V-frame" on the divisible ballast pallet "VarioTray" **5.36.50 - 61**

Pinning the turntable with the Quick Connection (QC) **3.02 - 11**

Pinning the upper pulley block on the H-pivot section **5.39 - 19, 5.39 - 46**

Pinning the upper pulley block with the lower pulley block **5.05 - 58**

Pinning the WA-frame 2 guy rods **5.07 - 36**

Pinning the W-relapse supports **5.07 - 37**

Pinning WA-frame 1 on the S-end section **5.07 - 14**

Pinning WA-frame 2 on the S-end section **5.07 - 17**

Pinning winch 1 **3.07.10 - 7**

Pinning winch 2 **3.07.20 - 7**

Pinning winch 4 on the turntable **3.05 - 8**

Pin pulling cylinder **5.30 - 6, 5.30 - 6**

Pin pulling device **1.02 - 5, 5.30 - 1**

Pin pulling device (battery-operated pin pulling cylinder) **5.30 - 2, 5.30 - 15**

Pin pulling device (hydraulic aggregate with pin pulling cylinder) **5.30 - 2, 5.30 - 4**

Pin transport position **5.01 - 21**

Pivot section **8.01 - 52, 8.01 - 83**

Pivot section, adapter and boom nose **8.01 - 70**

Pivot section BV suspended ballast guide (V-frame) **1.03 - 24**

Pivot section with end pivot section **5.36.50 - 6, 5.36.50 - 9**

Placement width **1.03.10 - 3**

Placing a shorter crane rope **4.08 - 21**

Placing NA-frame 2 on assembly supports **5.07 - 12**

Placing the ballast plates **3.03 - 14, 4.07 - 10**

Placing the ballast plates, bitt fastening points **3.03 - 17**

Placing the ballast plates, fastening points: Bitt **4.07 - 13**

Placing the ballast plates, fastening points: "Bitt" **5.36.50 - 73**

Placing the ballast plates, fastening system: "Twistlock" **4.07 - 12, 5.36.50 - 72**

Placing the ballast plates, Twistlock fastening system **3.03 - 15**

Placing the extension ladder on the crane cab **4.03 - 3, 4.03 - 54**

Placing the hoist rope or the control rope **5.01 - 2**

Placing the turntable on the crawler center section **3.02 - 9**

Planetary gear **7.04 - 2**

Planning Crane operation **2.03 - 3**

Platform **5.35 - 5**

Platform fastening points **2.06 - 24, 2.06 - 43**

Platform ladder **2.04.10 - 16**

Pneumatic springs **5.01 - 11**

Positioning the adjustable end pulley **5.13 - 39**

Positioning the ballast trailer **5.35 - 59**

Positioning the connecting forks for pinning **5.01 - 20**

Positioning the roller cart under the boom end section **5.61 - 4, 5.61 - 7**

Positioning the stepladder **5.31 - 43**

Positioning the support plate off-center on the outrigger pad lying on the complete surface **1.03.10 - 16, 1.03.10 - 18, 1.03.10 - 20, 1.03.10 - 23**

Positioning the support plate off-center on the outrigger pad over a cavity **1.03.10 - 16, 1.03.10 - 19, 1.03.10 - 21, 1.03.10 - 23**

Positioning winch 3 **3.07.30 - 8**

Positive longitudinal inclination **4.10 - 17**

Possible makings on the data tag **0.01 - 5**

Possible weighing errors **4.08 - 14**

Power Save mode **4.02 - 245**

Power Save mode and Stand-by mode in the LIC-CON computer system **4.02 - 245**

Pre-assembling the ballast trailer **5.35 - 27**

Pre-assembling the ballast trailer guide **5.35 - 43**

Preassembling the D-boom on the ground **5.05 - 34**

Preassembling the W-pivot section and lattice section **5.07 - 41**

Preface **0.01 - 1**

Preface to the appendix **90.01 - 1**

Preheating the hydraulic oil **2.08 - 4**

Preheating the hydraulic oil with Hydraulic oil preheating \* **4.03 - 42**

Preheating time **2.08 - 3**

Preparatory work **5.30 - 9, 5.30 - 16**

Preparing for crane operation **5.13 - 43, 5.38 - 32, 5.39 - 36**

Preparing for driving the crane **4.10 - 10**

Preparing for erection of WA-frame 2 **5.07 - 30**

Preparing the ballast trailer for assembly on the crane **5.35 - 65**

Preparing the ballast trailer for disassembly from the crane **5.35 - 178**

Preparing the crawler carrier for assembly **3.01 - 10**

Preparing the crawler carrier for disassembly **3.01 - 26**

Preparing the F-assembly unit for transport **5.13 - 73**

Preparing the hook block **4.06 - 9, 4.06 - 13**

Preparing the pin locations on the turntable **3.05 - 4**

Preparing the ready-to-use / ready-to-transport extension ladder **2.06 - 74**

Preparing the turntable for pinning **5.35 - 69**

Preparing the turntable for removal from the crawler center section **3.02 - 18**

Prerequisites **2.04 - 90**

Prerequisites for assembly **5.35 - 23, 5.36.50 - 26**

Prerequisites for crane equipment and accessories **2.04 - 88**

Prerequisites for crane operation **4.05 - 4**

Prerequisites for disassembly **5.35 - 178, 5.36.50 - 118**

Prerequisites for driving the crane (crawler operation) **4.10 - 2**

Prerequisites for driving uphill / downhill without changing the angle of the boom system **4.10 - 17**

Prerequisites for emergency control **6.05 - 7**

Prerequisites for erecting the FA-frame **5.13 - 23**

Prerequisites for lifting of personnel **2.04 - 88**

Prerequisites for operation with lifting cage (cherry picker) **2.04 - 89**

Prerequisites for taking down the boom **5.13 - 44**

Preselecting the slewing speed **4.05 - 49**

Pressed rope end connection **8.04 - 15**

Pressure monitoring in the relapse cylinders **4.04 - 15**

Pressure testing the relapse cylinders **8.01 - 95**

Pretensioning the hoist rope with pretensioning ballast with two hook operation **4.08 - 24**

Preventing fires **7.01 - 4**

Prevention of improper machine use **7.01 - 15**

Problem signals on the control element **7.05 - 41**

Problems on central lubrication system **7.05 - 42**

Procedure **4.02 - 243, 6.05 - 31**

Procedure for shut-off of crane movement **4.20 - 1**

Procedure for special cases at operation of the LIC-CON overload protection **4.20 - 33**

Product description **1.02 - 1, 5.30 - 2, 5.36.50 - 2**

Programming the timer **6.02 - 15**

Protecting against burns **7.01 - 5**

Protecting against the hazards of service fluids **7.01 - 6**

Protecting from scalding **7.01 - 5**

Protecting the crane against corrosion **7.01 - 12**

Protecting the crane against corrosion for shutdown **7.01 - 14**

Protecting the crane against corrosion for storage **7.01 - 13**

Protruding, distorted inlay, braiding **7.05.50 - 9**

Protruding, distorted insert or strand **8.04 - 22**

PSAgA, rescue equipment and tools **2.04 - 90**

Pull cylinder extension conditions **5.36.50 - 10**

Pulley head **8.01 - 69**

Pulley head height **4.02 - 91**

Pulling back the hoist rope **5.13 - 50**

Pulling in the W-control rope on the WA-frames **5.07 - 27**

Pulling the extension ladder out **2.06 - 75**

Pulling the FA-frame in direction of the F-pivot section **5.13 - 62**

Pulling the flap with the rope winch into the "flap down" position **5.13 - 45**

Pulling the flap with the rope winch into the "flap up" position **5.13 - 37**

Pulling the hoist rope in **5.07 - 52, 5.13 - 39**

Pulling the hoist rope over the WA-frames **5.07 - 79**

Pulling the hoist rope to the S-end section **5.07 - 25**

Pulling the S-luffing pulley block to the D-end section and taking it down on the ground **5.05 - 21**

Pulling the W-control rope to the WA-frames **5.07 - 26**

Pump distributor gear **7.05 - 32**

Putting down D-pivot section with winch 3 **3.07.30 - 11**

Putting down the small ballast pallet "VarioTray" **5.36.50 - 102**

Putting the FA-frame in the operating position **5.13 - 27**

Putting the fuel system in operation **7.05 - 23**

## Q

Qualification Maintenance personnel **7.05.50 - 5**

## R

Radii **5.35 - 10**

Radio incline sensor type 1 **4.02 - 217**

Radio incline sensor type 2 **4.02 - 218**

Radio interference **5.70 - 14**

Radio operation **5.70 - 11**

Radio remote control **6.08 - 1, 6.08 - 2**

Radio sender unit and radio receiving unit park position **5.19.10 - 11**

Radio sender unit variation 1: **5.19.10 - 10**

Radio sender unit variation 2: **5.19.10 - 10**

Radio sending unit for the hook block incline indicator **5.19 - 2**

Railing in the crane cab transport retainer **2.06 - 13**

Railing in the transport retainer **2.06 - 19**

Railing on ballast trailer guide **2.06 - 65, 2.06 - 68**

Railing on the adapter arm **2.06 - 59**

Railing on the control cabinet platform **2.06 - 63**

Railing on the platform **2.06 - 61**

Railings **2.06 - 45, 2.06 - 49**

Ram work or pulling sheet piles **4.08 - 19**

Rapid gear **4.02 - 117**

Rapid gear (Power Plus) **4.05 - 13**

Readjusting winch 1 and winch 2 **4.05 - 37**

Receptacle plate **8.01 - 50**

Recommendation for safe disposal **7.01 - 15**

Reducing rope pull **2.08 - 6**

Reducing rope unwinding **4.08 - 21**

Reducing the central ballast for disassembly **3.02 - 17**

Reducing the maximum load **2.08 - 7**

Reducing the maximum permissible wind speed \* **4.02 - 159**

Reduction of rope diameter **7.05.50 - 6**

Reeving in / reeving out the hook block, rope end connection in the standard version **4.06 - 8**

Reeving in / reeving out the hook block, rope end connection with L-shaped rope lock **4.06 - 11**

Reeving in the hoist rope **4.06 - 5**

Reeving in the hoist rope with the assembly winch **4.06 - 6**

Reeving in the S-or main-boom adjustment (luffing pulley block) **3.07.30 - 10**

Reeving plans **4.15 - 1, 4.15 - 2**

Reeving the assembly winch rope in on the rope pulley retainer **5.13 - 59**

Reeving the assembly winch rope out **5.13 - 63**

Reeving the control rope in on the S-luffing pulley block **5.05 - 47**

Reeving the hoist rope in on the D-boom **5.05 - 32**

Reeving the hoist ropes out **5.05 - 59**

Reeving the hook block

in **4.06 - 9, 4.06 - 12, 5.13 - 42, 5.38 - 31, 5.39 - 35**

Reeving the hook block out **4.06 - 10, 4.06 - 14**

Reeving the ropes in **5.07 - 23**

Reeving the ropes out **5.07 - 105**

Reeving the W-control rope out on the WA-frames **5.07 - 108**

Reference texts **4.02 - 75**

Regenerating at a standstill of the diesel particle filter **4.03 - 23**

Relapse cylinder **5.07 - 21, 5.35 - 141**

Relapse cylinder / erection cylinder monitoring **4.02 - 143**

Relapse cylinder block position **5.35 - 141**

Relapse cylinders **5.01 - 11**

Relapse retainer: Checking the flap function **5.13 - 40**

Relapse support flap **8.12 - 17**

Releasing the assembly cylinder **3.05 - 12**

Releasing the brackets on WA-frame 1 **5.07 - 22**

Releasing the button block on the BTT **5.31 - 5**

Releasing the central ballast **3.03 - 20**

Releasing the control winch **4.05 - 9**

Releasing the counterweight **4.07 - 16**

Releasing the cross beam on WA-frame 1 **5.07 - 22**

Releasing the engine rpm lock **4.05 - 12**

Releasing the extension ladder from the transport position **2.06 - 75**

Releasing the FA-frame relapse retainer **5.13 - 16, 5.13 - 60**

Releasing the fastening rope on the FA-frame **5.13 - 58**

Releasing the hoist winch **4.05 - 7**

Releasing the parking brake **4.05 - 45**

Releasing the pull cylinder **5.05 - 28**

Releasing the tension belt from the crane cab **4.03 - 5**

Releasing the transport pinning of the rocker from the FA-frame **5.13 - 18**

Releasing the upper pulley block on the lower pulley block **5.05 - 22**

Removal criteria overview **8.04 - 8**

Removing ballast trailer ballast **5.35 - 173**

Removing broken wires **7.05.50 - 15**

Removing the ballast on the divisible ballast pallet "VarioTray" **5.36.50 - 119**

Removing the ballast plates **3.03 - 22, 4.07 - 19, 5.36.50 - 119**

Removing the ballast plates, fastening points: Bitt **3.03 - 24, 4.07 - 21**

Removing the ballast plates, fastening system: "Bitt" **5.36.50 - 121**

Removing the ballast plates, fastening system: "Twistlock" **4.07 - 20, 5.36.50 - 120**

Removing the ballast plates, Twistlock fastening system **3.03 - 23**

Removing the battery-operated pin pulling cylinder **5.30 - 19**

Removing the drive assembly **5.72 - 20**

Removing the fastening rope from the transport position **5.13 - 24**

Removing the filter module **7.05 - 28**

Removing the hoist limit switch weight **4.06 - 20, 4.06 - 23**  
Removing the ladder from the transport retainer **2.07 - 4**  
Removing the L-end section on the SL-reducer **5.38 - 41, 5.39 - 49**  
Removing the load hook \* **4.06 - 17**  
Removing the mechanical auxiliary support on the crawler travel gear **3.04 - 7**  
Removing the pin pulling cylinder **5.30 - 13**  
Removing the railings on the cab platform **4.03 - 51**  
Removing the rope retainer **5.07 - 24, 5.07 - 107**  
Removing the second crawler carrier with the auxiliary crane **3.01 - 37**  
Removing the tension cylinder from the crawler carrier **7.04 - 15**  
Renewing the pretension of hoist ropes **7.05.50 - 17**  
Repair welding **8.01 - 5**  
Replace the belt drive **7.05 - 6**  
Replace the diesel particle filter \* **7.05 - 28**  
Replacing damaged crane components **7.01 - 6**  
Replacing hydraulic hose lines **8.06 - 5**  
Replacing the air filter **7.05 - 31**  
Replacing the cleaning fluid **7.05 - 73**  
Replacing the filter insert **7.05 - 21, 7.05 - 51**  
Replacing the fuel fine filter **7.05 - 17**  
Replacing the granular cartridge of the air dryer **7.05 - 67**  
Replacing the heat flange **7.05 - 7**  
Replacing the oil separator filter insert **7.05 - 8**  
Replacing the outrigger pad **7.04 - 16**  
Replacing the pressure filter element **7.05 - 64**  
Replacing the railings for accessing the turntable **2.06 - 33**  
Replacing the return filter inserts **7.05 - 63**  
Rescue **2.04 - 91**  
Resetting a problem **7.05 - 42**  
Resetting the diesel particle filter maintenance status **7.01.10 - 7**  
Resetting the engine oil maintenance status **7.01.10 - 7**  
Resetting the maintenance interval for the diesel particle filter **7.05 - 29**  
Resetting the maintenance status **7.01.10 - 7**  
Restoring hoist rope pretension **4.08 - 22**  
Resuming crane operation **2.04 - 87**  
Retaining clips **5.01 - 29**  
Retaining elements **5.01 - 22**  
Retaining pin with the ring and spring retainer **5.01 - 30**  
Retracting / extending the pull cylinder (lifting / lowering the derrick ballast) **4.05 - 50**  
Retracting the assembly cylinder **4.05 - 63**  
Retracting the boom **2.04 - 76**  
Retracting the derrick ballast guide **4.05 - 52**  
Retracting the D-relapse cylinder **5.05 - 72**  
Retracting the pull cylinder **5.05 - 69**  
Retracting the relapse cylinder of the main boom **5.38 - 36, 5.39 - 42**

Retracting the support cylinders **5.35 - 76**  
Retracting the suspended ballast guide "V-frame" **5.36.50 - 113**  
Retrofitting old ladders **2.04.10 - 3**  
Returning to service **7.01 - 14**  
Rigging **3.80 - 3**  
Rigging device **3.80 - 3**  
Rigging plans **3.80 - 2, 3.80 - 3, 3.80 - 3**  
Rigging points **3.80 - 2**  
Rigging the guy rods on lattice booms on placed down boom system **5.01 - 95**  
Rigidly frozen fiber guy ropes **5.01 - 5**  
Rocker **8.01 - 77**  
Roller cart **1.03 - 27, 5.15 - 1, 5.15 - 2, 5.61 - 1**  
Roller set **1.03 - 23, 5.14 - 1**  
Roller set component overview **5.14 - 2**  
Rope diameter abbreviations **8.04 - 8**  
Rope end connections **4.06 - 2**  
Rope guard **5.19 - 5**  
Rope guard pin **5.19 - 6**  
Rope lock (standard version) **4.06 - 3**  
Rope pulleys **5.01 - 2**  
Rope pulleys and guide pulleys **7.05.50 - 3**  
Rope pulleys and hydraulic cylinders **2.08 - 8**  
Rope reeving **4.06 - 1, 4.06 - 35**  
Ropes **5.01 - 2**  
Rotating parts **7.01 - 6**  
Rotating rope end connection **8.04 - 6**  
Rotation-resistant ropes **8.04 - 13**  
Rotation-resistant ropes with rope end connections **8.04 - 5**  
Rules for the use of personnel protective equipment **2.04 - 20**

## S

S, SL-boom **1.01 - 10**  
Safe and problem-free operation **7.05.50 - 4**  
Safety and warning display **0.01 - 2**  
Safety - assembly **5.36.50 - 24**  
Safety - disassembly **5.36.50 - 116**  
Safety during assembly and disassembly **5.30 - 3**  
Safety equipment **0.01 - 13, 1.02 - 3, 4.04 - 1**  
Safety equipment on the crane **4.04 - 9**  
Safety - fastening **5.36.50 - 25, 5.36.50 - 117**  
Safety guidelines **5.70 - 4, 8.06 - 3, 8.15 - 3**  
Safety instructions in case of an external power supply **2.04 - 55**  
Safety locking pin **5.01 - 24**  
Safety of crane transport on floating devices **2.25 - 3**  
Safety - pin connections **5.36.50 - 25, 5.36.50 - 117**  
Safety ropes **2.06 - 3, 2.06 - 48**  
Safety signs **2.04.10 - 3**  
Safety when working at a height **5.36.50 - 25, 5.36.50 - 117**  
Safe working environment **2.04 - 4**  
SA-frame **2.07 - 36, 5.02 - 1**  
SA-frame assembly **3.05 - 1**  
SA-frame fastening points **3.05 - 4**

SA-frame with winch 4 **1.03 - 7**  
 Saving personnel **2.04 - 28**  
 S-boom relapse retainer **8.12 - 2**  
 Scattered broken wires **8.04 - 11**  
 Screen display in the Set up program **4.02 - 12**  
 Seat contact button **4.01 - 25, 4.05 - 15**  
 Seat cushion adjustment **4.03 - 29**  
 Second inspection (second year) **8.03 - 10**  
 Securing / releasing the central ballast **3.03 - 18**  
 Securing against falls **7.01 - 4**  
 Securing against start up **7.01 - 3**  
 Securing and unpinning the guy rods on the lattice sections **5.07 - 103**  
 Securing personnel on shut off crane **2.04 - 89**  
 Securing persons to prevent them from falling **2.04 - 26**  
 Securing the assembly cylinder **3.05 - 15**  
 Securing the cable **5.70 - 13**  
 Securing the central ballast **3.03 - 19**  
 Securing the counterweight **4.07 - 14**  
 Securing the crane cab with the tension belt in transport position **4.03 - 55**  
 Securing the cross beam **5.07 - 103**  
 Securing the cross beam on WA-frame 1 **5.07 - 99**  
 Securing the erection racks against falling down **5.36.50 - 118**  
 Securing the fastening rope in the transport position **5.13 - 66**  
 Securing the lugs on WA-frame 1 **5.07 - 97**  
 Securing the pull cylinder **5.05 - 69**  
 Securing the rocker in the transport position **5.13 - 68**  
 Securing the W-relapse support **5.07 - 86**  
 Selecting derrick ballast settings **4.02 - 33**  
 Selecting the abbreviation for the boom system **4.02 - 20**  
 Selecting the auxiliary boom / accessory **4.02 - 27**  
 Selecting the auxiliary boom / accessory for the first variation (V1) **4.02 - 29**  
 Selecting the auxiliary boom / accessory for the second variation (V2) **4.02 - 32**  
 Selecting the derrick boom **4.02 - 25**  
 Selecting the environmental / mechanical influence category **4.02 - 37**  
 Selecting the fast setting **4.02 - 239, 4.05 - 21**  
 Selecting the function on the touch display **TE3 4.10 - 29**  
 Selecting the lifting category **4.02 - 59**  
 Selecting the location **2.04 - 40**  
 Selecting the main boom for the first variation (V1) **4.02 - 22**  
 Selecting the main boom for the second variation (V2) **4.02 - 24**  
 Selecting the maintenance status **7.01.10 - 6**  
 Selecting the operating mode category **4.02 - 19**  
 Selecting the program category **4.02 - 37**  
 Selecting the set up completion category **4.02 - 37**  
 Selecting the steering program **5.35 - 110**  
 Selection overview **5.31 - 21**

Select the function using the touch function and then operate using the F-keys **4.01.10 - 3**  
 S-end section **2.06 - 49, 2.07 - 43**  
 S-end section 650t **1.03 - 14**  
 S-end section fastening points **5.07 - 11, 5.38 - 9, 5.39 - 9**  
 Separating the WA-frames **5.07 - 16**  
 Service fluids and lubricants **7.01 - 15**  
 Service system **7.01.10 - 1**  
 Service system function key line **7.01.10 - 5**  
 Service system operating interface **7.01.10 - 3**  
 Servicing hydraulic hose lines **7.04 - 21**  
 Servicing the central lubrication system **7.05 - 39**  
 Servicing the drive assembly air conditioning system **7.05 - 57**  
 Servicing the fuel preliminary filter **7.05 - 19**  
 Servicing the ladders **7.04 - 21**  
 Servo oil pressure monitoring in the winches **4.04 - 15**  
 Set the auxiliary heater heat distribution **6.02 - 14**  
 Setting down the derrick ballast **5.36.50 - 119**  
 Setting individual operation for winch 1 and winch 2 **4.05 - 31**  
 Settings and status displays on the BTT **5.31 - 15**  
 Setting the ballast trailer radii **5.35 - 101**  
 Setting the brightness on the BTT display **5.31 - 15**  
 Setting the central ballast **4.02 - 41**  
 Setting the central ballast: Specified settings distances **4.02 - 41**  
 Setting the central ballast: Stepless settings distances **4.02 - 42**  
 Setting the contrast on the BTT display **5.31 - 15**  
 Setting the counterweight **4.02 - 53**  
 Setting the counterweight: Specified settings distances **4.02 - 54**  
 Setting the counterweight: Stepless settings distances **4.02 - 55**  
 Setting the crane chassis **4.02 - 38**  
 Setting the derrick ballast radius **4.02 - 40**  
 Setting the derrick ballast weight **4.02 - 52**  
 Setting the divisible ballast pallet "VarioTray" to the assembly position **5.36.50 - 59**  
 Setting the D-pivot section down **3.07.30 - 15**  
 Setting the engine rpm lock **4.05 - 12**  
 Setting the extension ladder in the transport position **2.06 - 76, 2.06 - 78, 2.06 - 79**  
 Setting the incline range **4.02 - 45**  
 Setting the incline range: Specified settings distances **4.02 - 45**  
 Setting the incline range: Stepless settings distances **4.02 - 46**  
 Setting the limit value **4.02 - 171**  
 Setting the limit values for the load torque limiter for advance warning and shut-off **4.02 - 170**  
 Setting the load position **4.02 - 49**  
 Setting the operating mode via chart name (chart number) **4.02 - 17**  
 Setting the operating mode via the function keys **4.02 - 19**

Setting the project chart **4.02 - 48**  
 Setting the set up configuration in general **4.02 - 15**  
 Setting the set up functions **4.02 - 35**  
 Setting the slewing range **4.02 - 44**  
 Setting the speed reduction master switch **4.03 - 46**  
 Setting the wind speed **4.02 - 57**  
 Setting up parallel operation **4.05 - 29**  
 Setting up the crawler center section **3.03 - 10**  
 Set up program **4.02 - 11**  
 Shortening the intervals **8.04 - 27**  
 Shortening the rope **7.05.50 - 17**  
 Short horn warning  
 sound **4.02 - 113, 4.02 - 205, 4.02 - 221**  
 Show / hide settings window **4.02 - 243**  
 Showing the horizontal distance **2.04 - 74**  
 Showing the Speed reduction master switch setting window **4.05 - 21**  
 Showing the vertical distance **2.04 - 71**  
 Show the operating interface from the Test system menu **5.31 - 48**  
 Shut-off difference force monitoring of derrick ballast guying **4.20 - 29**  
 Shut-off due to error message **4.20 - 29**  
 Shut-off luffing the auxiliary boom / accessory up / down **4.20 - 21**  
 Shut-off luffing the main boom up / down **4.20 - 20**  
 Shut-off of crane movement **4.20 - 18**  
 Shut-off overload **4.20 - 19**  
 Shut-off parallel operation winch 1 and winch 2 **4.20 - 28**  
 Shut-off spooling the winch up / out **4.20 - 25**  
 Shutting off the crane movement **4.02 - 111, 4.02 - 203**  
 Side panel **4.01 - 55**  
 Side window **2.04 - 36**  
 Signs **2.05 - 2**  
 Signs on the crane **2.05 - 1**  
 Single layer and parallel roped ropes **8.04 - 11**  
 S-intermediate section **2.07 - 41**  
 S-intermediate section 12m **1.03 - 13**  
 S-intermediate section 12m fastening points **5.07 - 8, 5.38 - 6, 5.39 - 7**  
 S-intermediate section 6m **1.03 - 13**  
 S-intermediate section 6m fastening points **5.07 - 8, 5.38 - 6, 5.39 - 6**  
 Slack rope formation **5.19 - 3**  
 Slewing gear **1.02 - 3, 7.04.50 - 3, 7.05 - 44**  
 Slewing gear: Changing the gear oil **7.05 - 46**  
 Slewing gear brake on touch display 2 (TE2) **4.10 - 26**  
 Slewing gear brake pedal and slewing gear freewheeling **4.05 - 46**  
 Slewing gear parking brake **4.05 - 45**  
 Slewing range **4.02 - 161**  
 Slewing ring connection **7.05 - 42**  
 SLF, SLAF-boom **1.01 - 12**  
 Sliding beam **8.01 - 25**  
 Slinger **2.04 - 8**  
 Slip-resistant mats **7.01 - 11**  
 Slopes and excavations **2.04 - 44**  
 SL-reducer **2.07 - 42**  
 SL-reducer 6m **1.03 - 14**  
 SL-reducer 6m fastening points **5.07 - 9, 5.38 - 7, 5.39 - 7**  
 S-luffing pulley block auxiliary weight fastening points **5.05 - 7**  
 S-luffing pulley block fastening points **5.05 - 6**  
 Small ballast pallet (Vario pallet) **5.36.50 - 17, 5.36.50 - 19**  
 Sockets **4.01 - 56**  
 Sound insulation mats **7.01 - 11**  
 Special assembly: Assembling the suspended ballast guide "V-frame" on the turntable frame with the main boom erected **5.36.50 - 37**  
 Special assembly: Disassembling the suspended ballast guide "V-frame" from the turntable frame with the main boom erected **5.36.50 - 145**  
 Special cases during operation of the LICCON overload protection **4.20 - 4**  
 Special operating conditions **4.20 - 4**  
 Specifications according to the utilized radio incline sensor **4.05 - 33**  
 Specifications for radio incline sensor type 1 **4.05 - 34**  
 Specifications for radio incline sensor type 2 **4.05 - 34**  
 Specifications for the set up configuration for cranes with lattice mast with LICCON overload protection **5.01 - 33**  
 Specific ballasting for stability and tipping safety **5.35 - 14**  
 Specific warning display for ballast trailer assembly / disassembly **5.35 - 22**  
 Specified service fluids and lubricants for Liebherr cranes **7.07 - 3**  
 Speed reduction master switch / pedal sensor **4.05 - 19**  
 Spinning out by turning out the hook block **7.05.50 - 16**  
 Spinning out with single strand reeving **7.05.50 - 16**  
 Split pin **5.01 - 23**  
 Spooling out winch 1 **4.05 - 26**  
 Spooling out winch 1 and winch 2 in parallel operation **4.05 - 39**  
 Spooling out winch 2 **4.05 - 26**  
 Spooling out winch 5 **4.05 - 27**  
 Spooling out winch 6 **4.05 - 28**  
 Spooling the assembly winch out **4.05 - 66**  
 Spooling the assembly winch out / up **4.05 - 66**  
 Spooling the assembly winch up / out **4.05 - 65**  
 Spooling the assembly winch up constantly **4.05 - 68**  
 Spooling the hoist rope up **5.07 - 110, 5.38 - 35, 5.39 - 40**  
 Spooling the hoist winches up / out (load lifting / load lowering) **4.05 - 24**  
 Spooling the W-control rope up **5.07 - 109**  
 Spooling the winches out **6.05 - 28**  
 Spooling the winches up **6.05 - 29**

Spooling the winch out **6.05 - 13, 6.05 - 24**  
 Spooling the winch up **6.05 - 13, 6.05 - 25**  
 Spooling up loose hoist rope **5.19 - 3**  
 Spooling winch 1 and winch 2 up and out in parallel operation **4.05 - 39**  
 Spooling winch 1 and winch 2 up in parallel operation **4.05 - 39**  
 Spooling winch 1 up / out **4.05 - 25**  
 Spooling winch 2 up / out **4.05 - 26**  
 Spooling winch 5 up / out **4.05 - 27**  
 Spooling winch 6 up / out **4.05 - 28**  
 Spooling winch up 1 **4.05 - 25**  
 Spooling winch up 2 **4.05 - 26**  
 Spooling winch up 5 **4.05 - 27**  
 Spooling winch up 6 **4.05 - 28**  
 Spool up the assembly winch **4.05 - 67**  
 Spring retainer **5.01 - 25**  
 S-relapse cylinder extended **8.12 - 4**  
 Stability and tipping safety **5.35 - 12**  
 Stacking the outrigger pads **1.03.10 - 7**  
 Stairs **2.06 - 4**  
 Stairs barrier **2.07 - 12**  
 Stand-by mode **4.02 - 249**  
 Start disassembly: Resetting the railing on the turntable **2.06 - 35**  
 Starting and turning off the engine **4.03 - 46**  
 Starting operation, follow my instructions **2.04 - 69**  
 Starting the emergency operation aggregate **6.05 - 13, 6.05 - 23**  
 Starting the engine **4.03 - 47**  
 Starting the LICCON computer system (before engine start) **4.03 - 45**  
 Starting the LICCON computer system parallel to the engine **4.03 - 50**  
 Starting the program **4.02 - 225**  
 Starting the slewing movement of the crane superstructure with a strong side wind **4.05 - 47**  
 Starting to drive **2.04 - 77**  
 Start screen BTT **5.31 - 13**  
 Start up and shut down of crane **4.03 - 1**  
 Stationary stability **2.04.10 - 3**  
 Steepest position **8.12 - 3, 8.12 - 9**  
 Steering ability **4.10 - 12**  
 Steering and corrective steering of the wheel sets **5.35 - 126**  
 Steering programs **5.35 - 108**  
 Stop (normal stop) **2.04 - 69**  
 Stopping individual operation for winch 1 and winch 2 **4.05 - 33**  
 Stopping the mobile crane **2.04 - 78**  
 Stopping the slewing movement of the crane superstructure with a strong side wind **4.05 - 47**  
 Storage **7.01 - 14**  
 Storage conditions **7.01 - 14**  
 Structure of the operating mode category **4.02 - 16**  
 Substructure **3.80 - 3**  
 Suitable distribution of the surface pressure **4.10 - 12**  
 Superstructure **7.05 - 36**  
 Supplied cross beam **2.04.10 - 14**

Supplied fall arrest system **2.04 - 21**  
 Supplied fire extinguisher **2.04 - 26**  
 Supplied height rescue system **2.04 - 24**  
 Support **2.04 - 51**  
 Supporting lattice mast booms for erection **5.01 - 79**  
 Supporting lattice mast booms for take-down **5.01 - 80**  
 Supporting long lattice mast booms for erection and take-down **5.01 - 79**  
 Supporting the ballast trailer **5.35 - 36, 5.35 - 179**  
 Supporting the ballast trailer to align the wheel sets with the support cylinders **5.35 - 111**  
 Supporting the crane **2.04 - 52, 2.08 - 4**  
 Supporting the crane with a variable support **2.04 - 52**  
 Support plates **2.04 - 51, 3.01 - 7**  
 Surface pressure: Center of gravity in the front **4.10 - 12**  
 Surface pressure: Center of gravity in the middle **4.10 - 11**  
 Surface pressure: Center of gravity in the rear **4.10 - 11**  
 Surface pressure display on the LICCON monitor **4.10 - 8**  
 Surface pressures and force distribution when driving the crane **4.10 - 21**  
 Surface pressures in case of wind load on the boom **4.10 - 22**  
 Surfaces **8.05 - 5**  
 Suspended ballast **2.07 - 38**  
 Suspended ballast \* **4.02 - 211**  
 Suspended ballast ballast automatic **4.02 - 191**  
 Suspended ballast guide **2.07 - 48**  
 Suspended ballast guide "V-frame" **2.06 - 56, 8.01 - 83**  
 Suspended ballast guide "V-frame" pinning mechanism **4.02 - 192, 4.05 - 52**  
 Suspended ballast pallet **1.03 - 24**  
 Suspended load fastening point **2.05 - 10, 2.05 - 10, 2.05 - 11**  
 SW1-boom **1.01 - 14**  
 Swingable sliding beam **8.01 - 29**  
 Swinging in and positioning winch 1 **3.07.10 - 6**  
 Swinging in and positioning winch 2 **3.07.20 - 6**  
 Swinging in and positioning winch 5 **3.07.50 - 10**  
 Swinging in and positioning winch 6 **3.07.60 - 9**  
 Swinging the assembly pulley into the operating position **5.07 - 24, 5.07 - 107**  
 Swinging the camera holder into the operating position **5.38 - 10, 5.39 - 11**  
 Swinging the camera holder into the transport position **5.38 - 45, 5.39 - 53**  
 Swinging the change over pulley into the operating position **5.07 - 23, 5.07 - 106**  
 Swinging the crane cab **5.31 - 41**  
 Swinging the crane cab into the operating position **4.03 - 5**  
 Swinging the ladder into the operating position **2.06 - 71**

Swinging the ladder into the transport position **2.06 - 72**  
Swinging the railing into the operating position **2.06 - 60, 2.06 - 62, 2.06 - 64, 2.06 - 66, 2.06 - 69**  
Swinging the railing on the H-pivot section into the operating position **5.38 - 10, 5.39 - 11**  
Swinging the railing on the H-pivot section into the transport position **5.38 - 45, 5.39 - 54**  
Swinging the railings into the transport position **2.06 - 61, 2.06 - 63, 2.06 - 65, 2.06 - 67, 2.06 - 70**  
Swinging the stairs folding section into the operating position **2.07 - 3**  
Swinging the step into the transport position **4.03 - 52**  
Swinging the support into operating position **3.05 - 5**  
Swinging the support into the transport position **3.05 - 21**  
Switching between automatic operation and manual operation **6.02 - 7**  
Switching over parallel operation regulation **4.05 - 35**  
Switching the slewing gear to freewheeling **4.05 - 47**  
Symbols from 2018 **2.04.10 - 9**  
Symbols until the end of 2017 **2.04.10 - 4**  
System start of the LICCON computer system **4.02 - 4, 4.03 - 45**

## T

TA guying **8.01 - 71**  
Take down procedure **5.02 - 9**  
Taking an oil sample **7.01 - 8**  
Taking care of the crane **7.01 - 8**  
Taking down and securing the D-relapse cylinder in the transport position **5.05 - 78**  
Taking on a load **4.08 - 7**  
Taking on a load with an auxiliary crane **3.02 - 4**  
Taking on a load with cross beam **4.08 - 9**  
Taking on a load with two auxiliary cranes **3.02 - 5**  
Taking over the entries and settings from the Set up program **4.02 - 73**  
Taking over the entries and settings of the lifting category **4.02 - 73**  
Taking over the set up configuration that was previously set **4.03 - 45**  
Taking the boom down **5.10 - 14, 5.13 - 44**  
Taking the boom system down with the luffing jib **5.07 - 69**  
Taking the FA-frame down **5.13 - 64**  
Taking the fuel system out of service **7.05 - 20**  
Taking the lattice jib down into the roller cart **5.01 - 44**  
Taking the radio sender unit and radio receiving unit out of the park position **5.19.10 - 12**  
Taking the SA-frame down **5.02 - 9**  
Taking the S-luffing pulley block down in front of D-end section **5.05 - 42**

Taking the suspended ballast guide "V-frame" down onto the ground **5.36.50 - 133**  
Taking the WA-frames down **5.07 - 92, 5.07 - 99**  
TE1 touch display main menu: Boom and equipment assignment **4.01 - 29**  
TE1 touch display main menu: Functions and assignment **4.01 - 27**  
TE1 touch display main menu: Touch functions **4.01 - 28**  
TE1 touch display main menu: Winch assignment **4.01 - 28**  
TE2 touch display main menu: Functions and assignment **4.01 - 35**  
TE2 touch display main menu: Slewing gear and equipment assignment **4.01 - 37**  
TE2 touch display main menu: Touch functions **4.01 - 35**  
TE2 touch display main menu: Winch assignment **4.01 - 36**  
TE3 touch display main menu: Ballast trailer support assignment **4.01 - 48**  
TE3 touch display main menu: Boom and equipment assignment **4.01 - 46**  
TE3 touch display main menu: Functions and assignment **4.01 - 44**  
TE3 touch display main menu: Winch assignment **4.01 - 45**  
Technical data **1.03 - 1**  
Technical outrigger pad data for cranes with a lattice mast boom **1.03.10 - 24**  
Technical safety instructions **2.04 - 1**  
Technical safety instructions for assembly and disassembly **5.01 - 1**  
Technical track pad data for cranes with a telescopic boom **1.03.10 - 8**  
Tele lift truck hydraulic aggregate **5.30 - 5**  
Telescopic boom **4.08 - 21, 8.01 - 53**  
Telescopic boom distortion because of sunshine on one side **4.08 - 5**  
Telescopic boom push out mechanics **8.01 - 58**  
Telescoping crane movement **4.08 - 5**  
Telescoping the ballast trailer guide in **5.35 - 105**  
Telescoping the ballast trailer guide in manually (master switch MS2) **5.35 - 108**  
Telescoping the ballast trailer guide in manually (operating buttons on the instrument panel) **5.35 - 107**  
Telescoping the ballast trailer guide in with the ballast automatic **5.35 - 106**  
Telescoping the ballast trailer guide out **5.35 - 102**  
Telescoping the ballast trailer guide out manually (master switch MS2) **5.35 - 105**  
Telescoping the ballast trailer guide out manually (operating buttons on the instrument panel) **5.35 - 104**  
Telescoping the ballast trailer guide out with the ballast automatic **5.35 - 103**  
Temperature operating limits **7.05.50 - 5**  
Tensioning the crawler chain **7.04 - 11, 7.04 - 12**  
Terminology **1.01 - 1**



Terms and abbreviations **2.04 - 89**  
 Test brackets (force test boxes) **4.04 - 18**  
 Test point 1 (F1-load display) **5.35 - 141**  
 Test system menu **5.31 - 47**  
 The BTT display remains dark? **5.31 - 54**  
 The Crane operation program on LICCON monitor 0 **4.02 - 77**  
 The Crane operation program on LICCON monitor 1 **4.02 - 181**  
 The Crane operation program on LICCON monitor 2 **4.02 - 207**  
 The flap can be pushed open **8.12 - 14**  
 The function key line of LICCON monitor 0 **4.02 - 175**  
 The function key line of LICCON monitor 1 **4.02 - 201**  
 Theoretical service life **8.03 - 5**  
 Third inspection (third year) **8.03 - 10**  
 Three-part multi-purpose ladder **2.04.10 - 21**  
 Tilting the cab upward **4.03 - 35**  
 Tilting the crane cab **4.03 - 33**  
 Tires foamed with special foam **2.15 - 5**  
 Tire size **7.01 - 7**  
 Tires with air inflation **2.15 - 4**  
 To exceed the maximum permissible load moment **4.20 - 39**  
 Touch display **4.01.10 - 2**  
 Touch display menu operation **4.01.10 - 1**  
 Touch display TE1 **4.01 - 27**  
 Touch display TE1 function buttons **4.01 - 27**  
 Touch display TE1 "Block winch" menu **4.01 - 32**  
 Touch display TE1 "Block winch" menu: Assignment **4.01 - 32**  
 Touch display TE1 "Block winch" menu: Function key assignment **4.01 - 32**  
 Touch display TE1 "Block winch" menu: Touch functions **4.01 - 32**  
 Touch display TE2 **4.01 - 35**  
 Touch display TE2 function buttons **4.01 - 35**  
 Touch display TE2 "floodlight" menu **4.01 - 38**  
 Touch display TE2 "floodlight" menu: Assignment **4.01 - 39**  
 Touch display TE2 "floodlight" menu: Function key assignment **4.01 - 39**  
 Touch display TE2 "floodlight" menu: Touch functions **4.01 - 40**  
 Touch display TE2 "Hydraulic oil preheating / DPF filter" menu **4.01 - 41**  
 Touch display TE2 "Hydraulic oil preheating / DPF filter" menu: Assignment **4.01 - 41**  
 Touch display TE2 "Hydraulic oil preheating / DPF filter" menu: Function key assignment **4.01 - 41**  
 Touch display TE2 "Hydraulic oil preheating / DPF filter" menu: Touch functions **4.01 - 41**  
 Touch display TE3 **4.01 - 44**  
 Touch display TE3 automatic programs menu **4.01 - 48**  
 Touch display TE3 automatic programs menu: Assignment **4.01 - 48**  
 Touch display TE3 automatic programs menu: Touch functions **4.01 - 49**  
 Touch display TE3 function buttons **4.01 - 44**  
 Touch display TE3 "Drive crawler" menu: Touch functions **4.01 - 45**  
 Towing **5.35 - 119, 5.35 - 225**  
 Towing steering program **5.35 - 109**  
 Traffic endangerment and environmental damage **2.04 - 13**  
 Trailer coupling **8.01 - 34**  
 Transfer (between two cranes or two hooks) **2.04 - 74**  
 Transferring of responsibility **2.04 - 7**  
 Transmission **7.06 - 4**  
 Transmitter / receiver **5.70 - 3**  
 Transport **2.04 - 37, 5.75 - 2**  
 Transport company **3.80 - 2**  
 Transport device **5.35 - 3**  
 Transporting the camera **5.70 - 15**  
 Transporting the hook block **4.08 - 9**  
 Transporting the hook block or load hook with a forklift truck **5.19 - 5**  
 Transporting the wind speed sensor **5.75 - 12**  
 Transport receptacle **3.01 - 9**  
 Transport vehicle **3.80 - 2**  
 Travel gear **7.04 - 2**  
 Travel gear / hydraulic motors / track rollers **4.10 - 6**  
 Travel operation **2.04 - 77**  
 Travel power **1.02 - 2**  
 Travel route **4.10 - 3**  
 Triggering intermediate lubrication on the ballast trailer **5.35 - 74**  
 Turning / driving in reverse **2.04 - 78**  
 Turning an extremely rotation-resistant hoist rope out **7.05.50 - 16**  
 Turning backward to the left **4.10 - 35, 4.10 - 42**  
 Turning backward to the right **4.10 - 36, 4.10 - 42**  
 Turning crawler operating modes on / off **4.10 - 29**  
 Turning ECO mode off **5.72 - 19**  
 Turning ECO mode on **5.72 - 18**  
 Turning forward to the left **4.10 - 35, 4.10 - 41**  
 Turning forward to the right **4.10 - 35, 4.10 - 41**  
 Turning hydraulic oil preheating \* on **4.03 - 42**  
 Turning manual operation on **6.02 - 7**  
 Turning off the ballast automatic in the master switch assignment **4.05 - 61**  
 Turning off the derrick adjustment ballast automatic **4.05 - 58**  
 Turning off the guide adjustment ballast automatic **4.05 - 59**  
 Turning on and activating the vibration sensor **4.05 - 17**  
 Turning on automatic operation **6.02 - 7**  
 Turning on ballast trailer ballast automatic **4.05 - 57**  
 Turning on the ballast automatic in the master switch assignment **4.05 - 60**  
 Turning on the derrick adjustment ballast automatic **4.05 - 56**

Turning on the guide adjustment ballast automatic **4.05 - 57**  
 Turning on the heater and climate control system **4.03 - 33**  
 Turning on the spot to the left (counterclockwise direction) **4.10 - 36**  
 Turning on the spot to the right (clockwise) **4.10 - 37**  
 Turning parallel travel crawler operation on / off **4.10 - 30**  
 Turning rapid gear crawler operation on / off **4.10 - 31**  
 Turning recirculating air off **6.02 - 14**  
 Turning recirculating air on **6.02 - 14**  
 Turning the air heater \* off **6.02 - 18**  
 Turning the air heater \* on **6.02 - 17**  
 Turning the automatic programs off **4.05 - 58**  
 Turning the automatic programs on **4.05 - 56**  
 Turning the auxiliary heater off **6.02 - 9**  
 Turning the auxiliary heater on **6.02 - 9**  
 Turning the auxiliary heater on and off **6.02 - 9**  
 Turning the ballast automatic on / off **4.05 - 53**  
 Turning the ballast trailer ballast automatic off **4.05 - 59**  
 Turning the ballast trailer off **5.35 - 91**  
 Turning the BTT on using the ignition switch **5.31 - 51**  
 Turning the BTT on using the On / Off button **5.31 - 51**  
 Turning the climate control system off **6.02 - 10**  
 Turning the climate control system on **6.02 - 10**  
 Turning the climate control system on and off **6.02 - 10**  
 Turning the crane superstructure **4.05 - 44**  
 Turning the crane superstructure to the left **4.05 - 49**  
 Turning the crane superstructure to the right **4.05 - 49**  
 Turning the crane superstructure to the right / left **4.05 - 47**  
 Turning the defrost window function off **6.02 - 13**  
 Turning the defrost window function on **6.02 - 13**  
 Turning the drive assembly off manually **5.72 - 16**  
 Turning the drive assembly on manually: Charging the battery **5.72 - 14**  
 Turning the drive assembly on manually: Charging the battery / hydraulic oil preheating \* **5.72 - 15**  
 Turning the engine off **4.03 - 49, 4.03 - 49**  
 Turning the engine off in the event of danger **4.03 - 49**  
 Turning the Floodlight \* on / off **5.31 - 47**  
 Turning the heater control unit off **6.02 - 6**  
 Turning the heater control unit on **6.02 - 6**  
 Turning the heater control unit on and off **6.02 - 6**  
 Turning the heater control unit on and off manually **6.02 - 6**  
 Turning the heater control unit on and off via the ignition **6.02 - 6**  
 Turning the hydraulic oil preheating on **2.08 - 4**  
 Turning the rapid gear off **4.05 - 14**

Turning the turntable into the assembly position **5.05 - 9, 5.38 - 10, 5.39 - 11**  
 Turning the turntable into the disassembly position **3.02 - 17, 5.05 - 55, 5.38 - 33, 5.39 - 37**  
 Turning the turntable to the left **6.05 - 16**  
 Turning the turntable to the right **6.05 - 17**  
 Turning the vibration sensor off **4.05 - 18**  
 Turning the wheel sets individually **5.35 - 129**  
 Turn normal travel crawler operation on / off **4.10 - 30**  
 Turntable access barrier **2.07 - 10**  
 Turntable and transport receptacles **3.02 - 4**  
 Turntable assembly **3.02 - 1**  
 Turntable catwalks and railing **2.06 - 13**  
 Turntable component overview **1.01 - 3**  
 Turntable control units **4.01 - 57**  
 Turntable fastening points **3.02 - 3**  
 Turntable frame **1.02 - 2, 8.01 - 35**  
 Turntable railing **2.06 - 22**  
 Turntable with crawler center section with SA-frame **1.03 - 7**  
 Turntable without SA-frame **1.03 - 7**  
 Turntable with SA-frame, pulley support, winch 4 and transport receptacles **3.02 - 6**  
 Turntable with winch 1, winch 2 and transport receptacles **3.02 - 5**  
 Two-part hoist limit switch weight **4.06 - 18**  
 TY-guying **8.01 - 72**

## U

UKCA marking **0.01 - 6**  
 UK Declaration of Conformity **0.01 - 8**  
 Undefined ballast trailer operation **5.35 - 147**  
 Understanding of roles **2.04 - 6**  
 Unintended use **0.01 - 12**  
 Unpinning and disconnecting the access stairs **2.06 - 40**  
 Unpinning procedure **5.35 - 191, 5.35 - 205, 5.35 - 207**  
 Unpinning the auxiliary weight and taking it down on the ground **5.05 - 59**  
 Unpinning the ballast trailer from the turntable **5.35 - 190**  
 Unpinning the ballast trailer guide **5.35 - 197**  
 Unpinning the D-guy rods on the end section **5.36.50 - 130**  
 Unpinning the D-pivot section on the SA-frame **5.05 - 77**  
 Unpinning the FAB-guy ropes **5.13 - 61**  
 Unpinning the F-assembly unit from the F-connector head **5.13 - 71**  
 Unpinning the guy rods from the intermediate section **5.07 - 93**  
 Unpinning the guy rods on the lattice sections **5.07 - 84**  
 Unpinning the H-connector pins on the turntable **5.38 - 12, 5.39 - 13**  
 Unpinning the lattice components **5.01 - 79**

Unpinning the pin **4.05 - 53**  
 Unpinning the pin from the transport position **3.02 - 8**  
 Unpinning the preassembled boom unit on the S-end section **5.07 - 87**  
 Unpinning the pull brackets from the guy rods of the D-pivot section **5.05 - 68**  
 Unpinning the pulley support on the turntable **3.05 - 16**  
 Unpinning the relapse support **5.07 - 95**  
 Unpinning the rope pulley retainer from the transport retainer **5.13 - 22**  
 Unpinning the SA-frame **3.05 - 20**  
 Unpinning the SA-frame on the turntable **3.05 - 20**  
 Unpinning the S-luffing pulley block and taking it down on the ground **5.05 - 60**  
 Unpinning the small ballast pallet "VarioT-ray" **5.36.50 - 99**  
 Unpinning the turntable with the quick connection (QC) **3.02 - 21**  
 Unpinning the WA-frame 2 guy rods **5.07 - 98**  
 Unpinning WA-frame 1 on the S-end section **5.07 - 115**  
 Unpinning WA-frame 2 on the S-end section **5.07 - 112**  
 Unpinning winch 1 **3.07.10 - 13**  
 Unpinning winch 2 **3.07.20 - 18**  
 Unpinning winch 4 on the turntable **3.05 - 18**  
 Unpinning winch 5 **3.07.50 - 20**  
 Unpinning winch 6 **3.07.60 - 15**  
 Unscheduled inspection **8.04 - 3, 8.16 - 2**  
 Update confirmation **90.05 - 1, 90.05 - 3**  
 Update to the operating instructions **90.01 - 3**  
 Urea system \* **7.05 - 24**  
 Urea tank: Replacing the filter strainer in the tank fitting **7.05 - 26**  
 Urea tank individual control displays **4.02 - 127**  
 Used proportion of the theoretical service life **8.03 - 5**  
 Use of foreign ballast on ballast pallet **5.36.90 - 1**  
 Use of the mechanical auxiliary support **5.07 - 54**  
 User guidelines **2.04.10 - 12**  
 Using 1-strand height safety equipment **2.04 - 24**  
 Using 2-strand height safety equipment **2.04 - 24**  
 Using a hinged ladder as a leaning ladder **2.04.10 - 19**  
 Using a hinged ladders as a stepladder **2.04.10 - 20**  
 Using a wedge lock **4.06 - 33**  
 Using ECO mode **5.72 - 18**  
 Using permissible service fluids **7.01 - 6**  
 Using the Leaning ladder **2.04.10 - 28**  
 Using the leaning ladder as a transition **2.04.10 - 31**  
 Using the leaning ladder without the conical end section **2.04.10 - 29**  
 Using the pin pulling cylinder or battery-operated pin pulling cylinder in the vertical position. **5.30 - 20**  
 Using the platform ladder **2.04.10 - 36**  
 Using the stepladder **2.04.10 - 26**  
 Using the three-part multi-purpose ladder as a leaning ladder **2.04.10 - 22**

Using the three-part multi-purpose ladder as a stepladder **2.04.10 - 23**  
 Using the vertical ladder with transition aid **2.04.10 - 35**  
 Utilization bar diagram **4.02 - 85**  
 Utilization conditions **5.35 - 165, 5.36.50 - 88**

## V

Validity of the assembly steps for the respective assembly variation **5.13 - 11**  
 Validity of the disassembly steps for the respective disassembly variation **5.13 - 49**  
 Variation 1: Ballast automatic with selection menu **4.05 - 55**  
 Variation 1: Placing the ballast plates, fastening system: "Twistlock" **5.35 - 88**  
 Variation 1: Removing the ballast plates, fastening system: "Twistlock" **5.35 - 176**  
 Variation 2: Ballast automatic in the master switch assignment **4.05 - 60**  
 Variation 2: Placing the ballast plates, fastening points: "Bitt" **5.35 - 90**  
 Variation 2: Removing the ballast plates, fastening points: "Bitt" **5.35 - 177**  
 Variations **5.36.50 - 3**  
 Variation with fixed installed winch 3: Taking the S-luffing pulley block down into the transport receptacle on the D-pivot section **5.05 - 74**  
 Variation with fixed installed winch 3: Taking the S-luffing pulley block down onto the ground **5.05 - 17**  
 Variation with removable winch 3: Preparing the S-luffing pulley block for assembly **5.05 - 12**  
 Variation with removable winch 3: Taking the S-luffing pulley block down into the transport receptacle on the D-pivot section **5.05 - 73**  
 Variation with removable winch 3: Taking the S-luffing pulley block down onto the ground **5.05 - 16**  
 Vehicle frame **8.01 - 7**  
 Vehicle height **2.05 - 3**  
 Vertical movements **2.04 - 71**  
 Vibrations **1.03 - 4**  
 Vibration sensor **4.05 - 16**  
 Visual check for damage **4.08 - 4**  
 Visual inspection for leaks **8.03 - 4**

## W

WA-frame 1 end section and WA-frame 2 end section unit fastening points **5.07 - 5**  
 WA-frame 1 intermediate section 4m and WA-frame 2 intermediate section 4m unit fastening points **5.07 - 5**  
 WA-frame 1 pivot section and WA-frame 2 pivot section unit fastening points **5.07 - 5**  
 WA-frame 1 pivot section with WA-frame 1 end section and WA-frame 2 pivot section with WA-frame 2 end section unit fastening points **5.07 - 6**  
 WA-frame 1 pivot section with WA-frame 1 intermediate section 4m and WA-frame 2 pivot section with

WA-frame 2 intermediate section 4m unit fastening points **5.07 - 6**  
WA-frame 1 pivot section with WA-frame 1 intermediate section 4m WA-frame 1 end section and WA-frame 2 pivot section with WA-frame 2 intermediate section 4m, WA-frame 2 end section unit fastening points **5.07 - 7**  
WA-frame 2, end section **2.07 - 47**  
WA-frame 2 intermediate section **2.07 - 46**  
WA-frame 2 - pivot section **2.07 - 46**  
Walking on a boom component **5.01 - 97**  
Walking on lattice sections or booms **2.04 - 27**  
Walking on the telescopic boom **2.04 - 27**  
Walking surfaces and stepping surfaces **2.07 - 31**  
Warranty and coverage **7.01 - 7**  
Washing the crane **7.01 - 8**  
W-assembly unit 1 **1.03 - 16**  
W-assembly unit 2 **1.03 - 17**  
W-connector head **8.01 - 66**  
Wear **8.15 - 4**  
Wedge lock **4.06 - 5**  
Wedge lock with a bore for a clamp **4.06 - 27**  
Wedge lock without a bore for a clamp **4.06 - 28**  
Weights **5.01 - 12**  
Welding work on the load **2.04 - 91**  
Wheel set **5.35 - 4**  
Wheel set adjustment procedure for the steering programs **5.35 - 111**  
Wheel set drive **7.04.50 - 6**  
Wheel set manual operation for assembly / emergency operation **5.35 - 128**  
While working with the crane **2.04 - 12, 2.04 - 79**  
Winch 1 **1.02 - 4, 1.03 - 9**  
Winch 1; 2 and 4 **2.07 - 37**  
Winch 1 and winch 2 in parallel operation **4.05 - 37**  
Winch 1 and winch 2 parallel operation regulation **4.02 - 217**  
Winch 1 assembly **3.07.10 - 1**  
Winch 1 fastening points **3.07.10 - 2**  
Winch 2 **1.02 - 4, 1.03 - 9**  
Winch 2 assembly **3.07.20 - 1**  
Winch 2 fastening points **3.07.20 - 2**  
Winch 2 protective roller **3.07.20 - 11**  
Winch 3 **1.02 - 4**  
Winch 3 assembly **3.07.30 - 1**  
Winch 3 assembly **3.07.30 - 4**  
Winch 3 fastening points **3.07.30 - 3**  
Winch 4 **1.02 - 4**  
Winch 5 **1.02 - 4**  
Winch 5 assembly **3.07.50 - 1**  
Winch 5 fastening points **3.07.50 - 2**  
Winch 6 **1.02 - 4**  
Winch 6 assembly **3.07.60 - 1**  
Winch 6 fastening points **3.07.60 - 2**  
Winch assembly **3.07 - 1, 3.07 - 2**  
Winch component overview **1.01 - 4**  
Winches **1.02 - 3, 7.05 - 47**  
Winch gear **7.05 - 49**  
Winch limit switch quick test **4.04 - 15**

Winch overview **7.05 - 48**  
Winch spooled out limit switch **4.04 - 13**  
Wind influences **2.04 - 59**  
Wind influences during crane operation **2.04 - 65**  
Wind influences during erection and take-down **2.04 - 64**  
Wind influences for "Crane out of operation" **2.04 - 66**  
Window washing system **7.05 - 72**  
Window wiper / window washer system **4.03 - 35**  
Wind speed **4.02 - 157**  
Wind speed, wind gust speed and wind direction **2.04 - 61**  
Wind speed charts for a variable support **2.04 - 60**  
Wind speed sensor **4.04 - 13, 5.07 - 21, 5.07 - 49, 5.38 - 27, 5.39 - 30**  
Wind speed sensor / airplane warning light **5.75 - 1**  
Wind speed sensor alignment / mounting **5.75 - 7**  
Wind speed sensor assembly **5.75 - 8**  
Wind speed sensor disassembly **5.75 - 10**  
Wind speed sensor mounting positions **5.75 - 3**  
Wind speed sensor quick test **4.04 - 13**  
Winter operation **2.08 - 3**  
Wire break increase rate **8.04 - 11**  
Wire rope auxiliary guying **5.03 - 5**  
Wire ropes **4.06 - 2**  
Wire ropes and rope end connections **4.06 - 2, 8.04 - 5**  
Without marking **0.01 - 6**  
W-lattice jib relapse retainer **8.12 - 7**  
W-lattice jib test position **8.12 - 10**  
Working at a height **5.35 - 20**  
Working in low temperatures **2.08 - 1**  
Working in the vicinity of overhead electrical lines **4.08 - 19**  
Working in the vicinity of transmitters **2.04 - 57**  
Working on lattice sections or booms **2.04 - 27**  
Working on the telescopic boom head and / or auxiliary boom **2.04 - 26**  
Working range limitation program **4.02 - 225**  
Working with a high rope pull **4.08 - 21**  
Working with a load **4.08 - 1**  
Working with the ballast trailer **5.35 - 91**  
Work on the electrical connections **5.35 - 21**  
Work on the hydraulic connections **5.35 - 21**  
W-pivot section **2.07 - 45**  
W-pivot section 8m fastening points **5.07 - 7**

“

“Bottom flap” switch position **8.12 - 19**  
“Closing” the D-boom **5.05 - 22**  
“Flap in position” limit switch **5.07 - 51**  
“Hoist top” hoist limit switch **4.04 - 11**  
“Lower” lumbar area support **4.03 - 27**  
“Luffing jib bottom” limit switch **5.07 - 51**  
“Opening” the D-boom and taking it down **5.05 - 70**

---

“Relapse support in flap on block” block position **8.12 - 20**  
“Right flap” limit switch, mechanical relapse support in the flap **5.07 - 51**  
“Top flap” switch position **8.12 - 18**  
“Upper” lumbar area support **4.03 - 28**  
“W-lattice jib downward 45° downward” switch setting **8.12 - 12**