

# **LIEBHERR**

## **Crawler crane with telescopic boom**

**LTR 1220**

**LTR 1220-003**

## **Operating instructions**

**BAL No.: 24204-02-02**

Serial No.	
Date	

### **ORIGINAL OPERATING INSTRUCTIONS**

**The operating instructions are part of the crane and must be followed!**

**The operating instructions must always be available within reach!**

**All local regulations for crane operation must be observed!**

**Liebherr-Werk Ebingen GmbH**

Postfach 1361

**D-89582 Ebingen / Donau**

+49 (0) 7391 502-0

+49 (0) 7391 502-3399

info.lwe@liebherr.com

www.liebherr.com





# Preface

## Manufacturer

Liebherr - Werk Ehingen GmbH  
 P.O. Box 1361  
 D-89582 Ehingen / Donau  
 +49 (0) 7391 502-0  
 +49 (0) 7391 502-3399  
 info.lwe@liebherr.com  
 www.liebherr.com

## California Proposition 65

Proposition 65 of the US State of California warns against chemicals that are known to cause cancer and birth defects or other reproductive harm.

For additional information, see the website: [www.P65Warnings.ca.gov](http://www.P65Warnings.ca.gov).

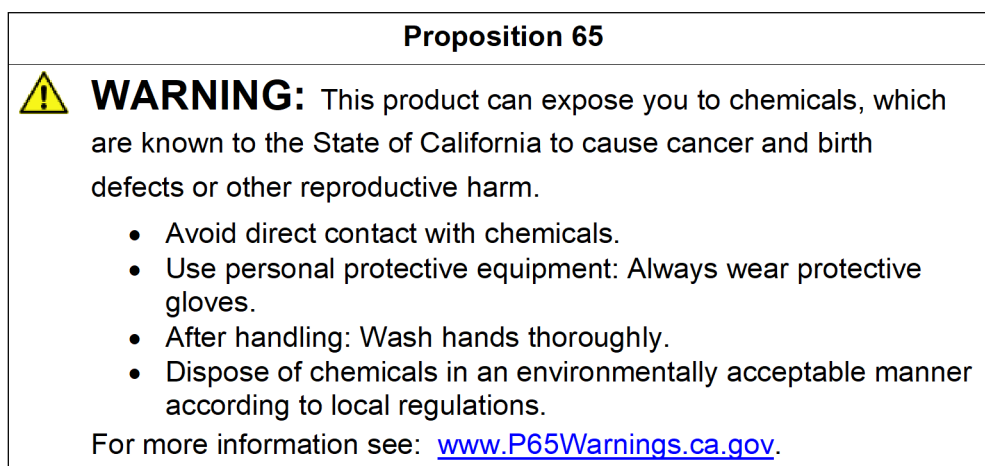


Fig.154660: Example of a Proposition 65 sign for USA: Chemicals

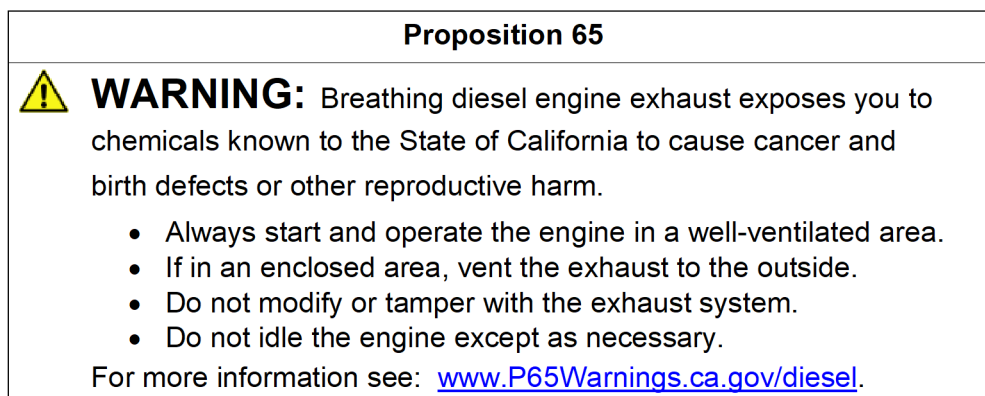


Fig.154661: Example of a Proposition 65 sign for USA: Diesel engine exhaust

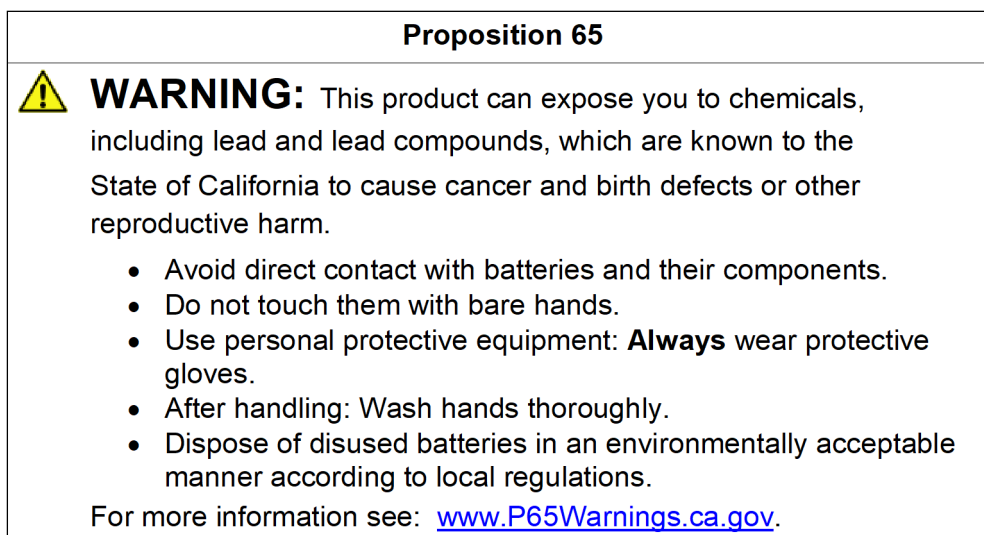


Fig.154662: Example of a Proposition 65 sign for USA: Lead and lead compounds

### General

This crane was built according to the state of technology and recognized safety technical regulations. Despite that, danger to body and life for the user and / or third persons or damage to the crane and / or other material assets is still possible.

This crane may only be used:

- when in a perfect technical condition.
- for destined use.
- by trained personnel, which acts in a safety and danger conscious way.
- when no safety relevant problems are present.
- when no modifications were made on the crane.

Any problems, which could affect safety must be fixed immediately.

Modifications to the crane may only be made with written approval by Liebherr-Werk Ehingen GmbH.

### Data logger

This crane is equipped with a data recording device. Among others, the following data is recorded:




- Date and time of day
- Entered set up configuration of the crane
- Actual load
- Percentage of crane utilization
- Boom radius (working radius)
- Main boom angle, luffing jib angle
- Total telescopic boom length, length of each telescopic section
- Every actuation of bypass devices

The recorded data can be read with a respective software.

### Safety and warning display

The safety and warning display is directed to all persons who work with the crane or are located nearby. Failure to observe the safety and warning display can lead to accidents.


The terms **DANGER**, **WARNING**, **CAUTION** and **NOTICE** used in the crane documentation are intended to point out certain rules of conduct to all persons working with the crane or are located nearby.

Warning signs	Signal word	Explanation
	<b>DANGER</b>	Designates a dangerous situation which will lead to death or serious injury if it is not prevented. <sup>1)</sup>
	<b>WARNING</b>	Designates a dangerous situation, which can lead to death or serious injury if it is not prevented. <sup>1)</sup>
	<b>CAUTION</b>	Designates a dangerous situation, which can lead to slight or medium-grade injuries if it is not prevented. <sup>1)</sup>
	<b>NOTICE</b>	Designates a dangerous situation, which can lead to property damage if it is not prevented.

<sup>1)</sup> This could also result in property damage.

### Additional notes

The term **Note** is used in the crane documentation to make all persons working with the crane or are located nearby aware of useful information and tips.

Sign	Signal word	Explanation
	<b>Note</b>	Designates useful information and tips.

### Crane documentation

The crane documentation is comprised of:

- all supplied documents on paper and in digital form.
- all supplied programs and applications.
- all subsequently supplied information, updates and addenda for the crane documentation.

The crane documentation:

- indicates how to use the crane safely
- supports the operators in using the permissible application possibilities of the crane
- provides information about the functionality of important components and systems



#### Note

Terminology in the crane documentation

Certain expressions are used in the crane documentation.

- ▶ In order to avoid misunderstandings, the same expressions should always be used.

If you find any errors or if any misunderstandings arise when reading the crane documentation, please contact Liebherr-Werk Ehingen GmbH immediately.



#### WARNING

Danger of accident due to incorrect operation of the crane!

Incorrect operation of the crane can lead to accidents.

Death, severe bodily injuries, property damage.

- ▶ Only authorized and trained expert personnel are permitted to work on the crane or have access to it.
- ▶ The crane documentation is part of the crane and must be accessible on the crane.
- ▶ The crane documentation and on-site regulations and specifications (such as accident prevention regulations) must be observed.

Using the crane documentation:

- **makes it easier** to become familiar with the crane.
- **avoids** problems due to improper operation.

Observing the crane documentation:

- **increases** reliability in use.
- **extends** the service life of the crane.
- **minimizes** repair costs and downtime.

The crane documentation must be accessible in the driver's cab or in the crane cab.



#### WARNING

Outdated version of crane documentation!

If subsequently supplied information, updates and addenda to the crane documentation are not observed and added, there is a danger of accident.

Death, severe bodily injuries, property damage.

- ▶ Add and observe all subsequently supplied information, updates and supplements for the crane documentation.
- ▶ Make sure that all involved persons always know of and understand the latest version of the crane documentation.

If there is any doubt regarding if the crane documentation is **not** up to date:

- ▶ Do **not** operate the crane. Contact Liebherr-Werk Ehingen GmbH.



#### WARNING

Crane documentation is not understood!

If parts of the crane documentation are not understood and the tasks are carried out on or with the crane, then there is a danger of accident.

Death, severe bodily injuries, property damage.

- ▶ Have any open questions clarified by Customer Service at Liebherr-Werk Ehingen GmbH before carrying out the respective task.

This documentation may not be reproduced or duplicated, distributed or used for purposes of competition, neither in part nor in excerpts. All rights are expressly reserved in accordance with copyright laws.

All accident prevention regulations, operating instructions, load charts etc. are based on the destined use of the crane.

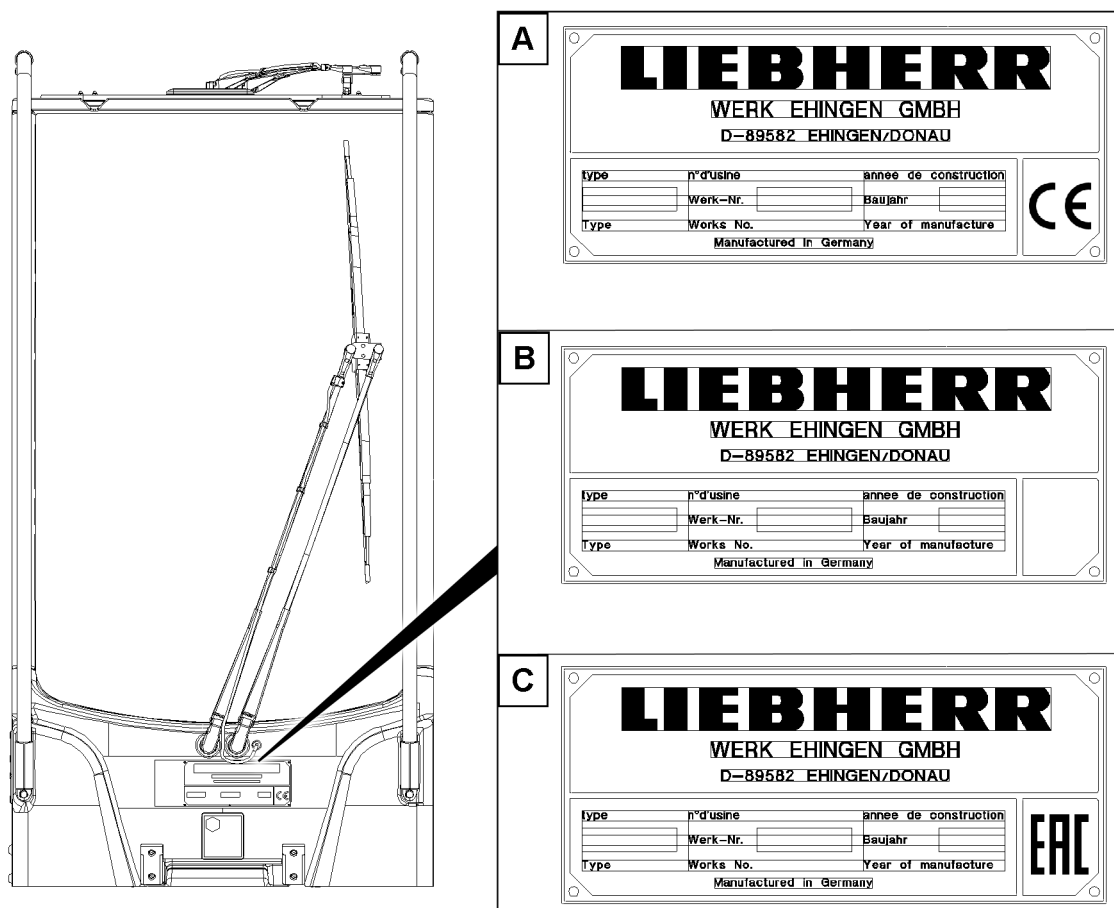


Fig.154689: Data tag shown as an example

- A** Data tag with CE mark  
**B** Data tag without CE mark  
**C** Data tag with EAC mark

### CE marking

The CE marking is a mark according to EU laws:

- Cranes with CE-marking are compliant with the European Directives applicable at the moment of placing the cranes on the market, and in particular European machinery directive 2006/42/EC and product standard EN 13000! Data tag Crane with CE-marking, see illustration **A**.
- Cranes that are operated outside the respective area of application of the European machinery directive do not require a CE marking. Crane data tag without CE marking, see illustration **B** and illustration **C**.
- It is prohibited to market and operate cranes without a CE marking, which do not meet the product-specific regulations valid in Europe, when a CE marking is specified for the country, especially in the single European market.
- European Union Directives prohibit operating cranes with a tipping load utilization of 85 % or a bypass device that does not comply with EN 13000 within the European Union or in countries that only permit a lower tipping load utilization! The local regulations apply. Cranes that do not comply with EN 13000 may not have the CE marking and therefore may not be operated in the European Union.

### EU Declaration of Conformity

Upon delivery of the equipment with a CE marking, the EU Declaration of Conformity according to Directive 2006/42/EC is provided directly after the cover sheet. The EU Declaration of Conformity is valid in the following form and language in all countries of the European Union, as well as in countries that recognise the Directives of the European Union. Keep the EU Declaration of Conformity in a safe place.

**Note**

- ▶ This declaration of conformity is only valid when this mobile crane meets the directives and standards stated in this EU Declaration of Conformity. This applies especially for the programming and function of the safety-relevant overload protection. The CE sign must be removed if changes were made on the crane, which do not conform to the stated directives and standards. These include in particular a tipping load utilization (85 % load charts) that are not permissible in Europe and a changed version of the bypass device for the overload protection.
  - ▶ If this modified mobile crane is re-imported later into a country which is within the validity range of the EC machine directive, then the importer is responsible for the verification and the written confirmation, that the condition of the mobile crane at importation into the EC meets the directives and standards, which are stated in this declaration of conformity.
  - ▶ The complete crane documentation must be complete and present in the official language of the community of the member state, in which the machine is placed into service and / or where it is operated.
  - ▶ For the verification and confirmation we recommend that the importer contacts the crane manufacturer or a person authorized by him.
  - ▶ After written confirmation of the importer and the mobile crane manufacturer, the mobile crane may be labelled again with a CE marking and the EU Declaration of Conformity becomes valid again. Therefore for this crane, the directives and standards valid at initial delivery continue to apply.
-



## EU Declaration of conformity

If changes are made to the equipment that were not approved in writing by Liebherr-Werk Ebingen GmbH, then this EU declaration of conformity becomes invalid.

Type of machine:	<b>Mobile crane</b>
Type:	<b>XXX</b>
Serial No.:	<b>XXX</b>
Year of construction:	<b>XXX</b>
Power output of the diesel engine:	<b>XXX kW / XXX rpm</b>
L <sub>WA</sub> measured <sup>1)</sup> :	<b>XXX dB</b>
L <sub>WA</sub> guaranteed <sup>1)</sup> :	<b>XXX dB</b>

We herewith declare that the above declared machine in its delivery condition complies with all relevant provisions of the following EU Directives:

- **Directive 2006/42/EC of the European Parliament on machinery**
- **Directive 2005/88/EC of the European Parliament amending the Directive 2000/14/EC relating to noise emission<sup>1)</sup>**
- **Directive 2014/53/EU of the European Parliament relating to the making available on the market of radio equipment**

Applied harmonized standards:

EN 13000:2010 + A1:2014      Cranes – Mobile cranes

Applied evaluation procedure according to Annex VIII of Directive 2000/14/EC

Name of the notified body:

TÜV Rheinland LGA Products GmbH, D-90014 Nürnberg, Identification No.: 0197

Authorized agent for the compilation of the technical documentation:

Head of Design Department  
Dr.-Hans-Liebherr-Straße 1  
89584 Ebingen/Donau

<sup>1)</sup> during crane operation

Ebingen

\_\_\_\_\_  
(Head of Design Department)

Liebherr-Werk Ebingen GmbH  
Dr.-Hans-Liebherr-Straße 1  
89584 Ebingen  
Germany  
15.10.2020\_en

# LIEBHERR

Fig. 159807-en: Reprint of the crane's EU Declaration of Conformity

### Intended use

The intended use of the crane consists solely in the vertical lifting and lowering of free and unfixed loads, whose weight and center of gravity are known.

To do so, a hook or hook block approved by Liebherr must be reeved on the hoist rope and it may only be operated within the permissible set up configurations.

Driving with the crane, with or without an attached load is only permissible if a corresponding driving or load chart is available. The set up configurations intended for it and the safety conditions must be observed according to the corresponding crane documentation.

Any other use or any other exceeding utilization is **not** destined use.

Destined use also includes the adherence of the required safety guidelines, conditions, prerequisites, set up conditions and working steps in the crane documentation (for example: Operating instructions, load charts, erection and take down charts, job planner).

The manufacturer is **not** liable for damage caused by non-destined use or improper use of the crane. Any associated risk it is carried solely by the owner, the operator and the user of the crane.

### Non-destined use

Non-destined use is:

- Working outside the permissible set up configurations according to the load chart.
- Working outside the permissible boom radii and slewing ranges according to the load chart.
- Selecting load charts, which do not correspond to the actual set up configuration.
- Selection of a set up configuration via code or via manual entry, which does not correspond to the actual set up configuration.
- Working with bypassed / deactivated safety equipment, for example bypassed load torque limiter or with bypassed hoist limit switch.
- Increasing the boom radius of the lifted load after a LMB shut-off, for example by diagonally pulling the load.
- Using the support pressure display as information in order to utilize the crane up to the tipping limit.
- Use of equipment parts that are not approved for the crane.
- Operation of the crane in an area exposed to explosion hazards.
- Using the crane at sports and recreational events, especially for "Bungee" jumps and / or "Dinner in the sky".
- On-road driving in an impermissible travel condition (axle load, dimension).
- Driving with the equipment in place in an impermissible travel condition.
- Pushing, pulling or lifting loads with the level control, the sliding beams or the support cylinders.
- Pushing, pulling or lifting loads by actuating the slewing gear, the luffing gear or the telescoping gear.
- Ripping stuck objects loose with the crane.
- Utilizing the crane for a longer period of time for material handling tasks.
- Releasing the crane suddenly (grab or dumping operation).
- Utilizing the crane when the weight of the load is suspended on the crane is changed, for example by filling a container suspended on the load hook, except:
  - The load torque limiter was checked before for function with a known load.
  - The crane cab is occupied.
  - The crane is operational.
  - The container size is selected in such a way that an overload of the crane with full load is eliminated within the valid utilized load chart.

The crane may **not** be used for:

- Fastening a stuck load for which the weight and center of gravity are not known and which is released only by flame cutting, for example.
- Letting persons drive along outside the driver's cab.
- Letting persons drive along outside the crane cab.
- Transporting personnel in the crane cab while driving.
- Transporting personnel with the load handling equipment and on the load.
- Transporting of persons with work baskets (cherry pickers), if the national regulations of the responsible work safety organization are not observed.
- Transporting loads and objects on the crane chassis.
- Transporting loads and objects on the crane superstructure.
- Transporting loads and objects on the ballast trailer.
- Transporting loads and objects on the suspended ballast.
- Transporting loads and objects on the boom lattice sections and / or the crane boom.
- Two hook operation without auxiliary equipment.



- Extended material handling operation.
- Crane operation on a floating device if the conditions in chapter „Crane on a floating device“ are not fulfilled and the written release by **Liebherr Werk Ehingen GmbH** is not present.

The crane documentation must be read and used by all persons who are involved in use, operation, assembly and maintenance of the crane.

### Ambient temperature

The crane is designed for an ambient temperature of -20 °C to +50 °C.

If the ambient temperature is lower than -20 °C the crane must be modified with „auxiliary equipment for working at low temperatures“.



#### WARNING

Working at low temperatures without the corresponding auxiliary equipment!  
The crane components can be damaged and fail. The load can rip off.  
Death, severe bodily injuries, property damage.

If the crane is operated at an ambient temperature lower than -20 °C:

- ▶ Make sure that the crane is equipped with the corresponding „auxiliary equipment for working at low temperatures“. Observe and comply with chapter 2.08.
- ▶ Use the operating fluids for the corresponding ambient temperature in time. Observe and comply with chapter 7.07.

### Safety equipment

Special attention must be paid to the safety equipment built into the crane. The safety equipment must constantly be checked for functionality. The crane may not be operated if the safety equipment are not working or not working correctly.



#### Note

Your motto must always be:

- ▶ **Safety first!**

The crane has been built in accordance with the European regulations for crane operation and travel operation and has been approved by the relevant authorities.

### Equipment and spare parts



#### WARNING

Danger of fatal injury if original equipment parts are **not** used!  
If the crane is operated with **not** original equipment parts, the crane can fail.  
Death, severe bodily injuries, property damage.

- ▶ Operate the crane only with original equipment parts!
- ▶ Crane operation with equipment parts, which do **not** belong to the crane is prohibited!
- ▶ If there is any doubt about the origin of equipment parts, contact Customer Service at Liebherr-Werk Ehingen GmbH.



#### WARNING

The crane permit and the manufacturer's warranty will become void!  
If any original installed parts are modified, manipulated or replaced (e.g. removal of parts, installation of non-original Liebherr parts), both the crane permit and the manufacturer's warranty will become void.

- ▶ Leave installed original parts unchanged.
- ▶ Do not remove installed original parts.
- ▶ Use only Original Liebherr spare parts.
- ▶ If there is any doubt about the origin of spare parts, contact Customer Service at Liebherr-Werk Ehingen GmbH.

For ordering equipment and spare parts, always keep the crane number handy and provide it.

### Definition of directional data for mobile cranes

**Driving forward:** Driving with the driver's cab on the front.

**Driving in reverse:** Driving with the taillights of the crane chassis on the front.

**Front, rear, right, left** in the **driver's cab** refer to the crane chassis. The driver's cab is always in the front.

**Front, rear, right, left** in the **crane cab** refer to the crane superstructure. Front is always in direction of the placed down boom.

**0° crane superstructure slewing angle:** The boom points in the longitudinal direction to the rear past the rear of the vehicle.

**180° crane superstructure slewing angle:** The boom points in the longitudinal direction to the front past the driver's cab.

### Definition of directional data for crawler cranes

**Driving forward** driving forward from the view of the crane operator seated in the crane cab. Turnable in 0° or 180° position.

**Driving reverse** driving backward from the view of the crane operator seated in the crane cab. Turnable in 0° or 180° position.

**Front, rear, right, left** always orient themselves on the **crawler travel gear** from the position of the chain tension devices. The chain tension devices on the crawler travel gear are always on the front.

**Front, rear, right, left** refer to the direction of view of the crane operator seated in the **crane cab**. Front is always in direction of the placed down boom.

### Optional equipment and functions

The equipment marked with \* and the functions are optionally available and are **not** part of the standard crane (optional equipment).

## Conversion chart

	Initial unit	Multiplication factor	Target unit
<b>Length</b>	mm	0.03937	in
	in	25.4000	mm
	mm	0.00328	ft
	ft	304.8	mm
	cm	0.39370	in
	in	2.5400	cm
	cm	0.0328	ft
	ft	30.48	cm
	m	39.37	in
	in	0.0254	m
	<b>m</b>	<b>3.281</b>	<b>ft</b>
	<b>ft</b>	<b>0.3048</b>	<b>m</b>
	km	0.62137	mile
	mile	1.6093	km
<b>Area</b>	cm <sup>2</sup>	0.155	in <sup>2</sup>
	in <sup>2</sup>	6.4516	cm <sup>2</sup>
	<b>m<sup>2</sup></b>	<b>10.764</b>	<b>ft<sup>2</sup></b>
	<b>ft<sup>2</sup></b>	<b>0.0929</b>	<b>m<sup>2</sup></b>
<b>Volume</b>	cm <sup>3</sup>	0.06102	in <sup>3</sup>
	in <sup>3</sup>	16.387	cm <sup>3</sup>
	m <sup>3</sup>	35.3147	ft <sup>3</sup>
	ft <sup>3</sup>	0.0283	m <sup>3</sup>
	l	0.001	m <sup>3</sup>
	m <sup>3</sup>	1000	l
	l	61.024	in <sup>3</sup>
	in <sup>3</sup>	0.016387	l
	l	0.0353	ft <sup>3</sup>
	ft <sup>3</sup>	28.32	l
	l	0.264178	US. liq. gal
	US. liq. gal	3.7853265	l

LWE/LTR 1220-003/24204-02-02/en

	Initial unit	Multiplication factor	Target unit
<b>Mass (weight)</b>	kg	2.20462	lb
	lb	0.45359	kg
	<b>t</b>	<b>2204.62</b>	<b>lb</b>
	<b>lb</b>	<b>0.0004536</b>	<b>t</b>
	t	1.1023	short ton US (tn. sh.)
	short ton US (tn. sh.)	0.90718	t
	<b>t</b>	<b>0.45359</b>	<b>kip</b>
	<b>kip</b>	<b>2.20462</b>	<b>t</b>
<b>Mass / length</b>	kg/m	0.055998	lb/in
	lb/in	17.857781	kg/m
	kg/m	0.67197	lb/ft
	lb/ft	1.48816	kg/m
<b>Force</b>	N	0.2248	lbf
	lbf	4.4483986	N
	<b>kN</b>	<b>224.809</b>	<b>lbf</b>
	<b>lbf</b>	<b>0.0044483986</b>	<b>kN</b>
<b>Turning moment</b>	Nm	8.85075	lbf·in
	lbf·in	0.112984	Nm
	Nm	0.73756	lbf·ft
	lbf·ft	1.3559	Nm
<b>Performance</b>	HP (DIN HP)	0.7355	kW
	kW	1.3596	HP (DIN HP)
<b>Speed</b>	m/s	39.37	in/s
	in/s	0.0254	m/s
	<b>m/s</b>	<b>3.28084</b>	<b>ft/s</b>
	<b>ft/s</b>	<b>0.3048</b>	<b>m/s</b>
	km/h	0.62137	mph (mi/h)
	mph (mi/h)	1.60935	km/h
	m/s	2.2369	mph (mi/h)
	mph (mi/h)	0.44704	m/s

	<b>Initial unit</b>	<b>Multiplication factor</b>	<b>Target unit</b>
<b>Pressure</b>	kPa (kN/m <sup>2</sup> )	0.01	bar
	bar	100	kPa (kN/m <sup>2</sup> )
	bar	14.5038	psi
	psi	0.06895	bar
	<b>kPa (kN/m<sup>2</sup>)</b>	<b>0.145038</b>	<b>psi</b>
	<b>psi</b>	<b>6.894759</b>	<b>kPa (kN/m<sup>2</sup>)</b>
	N/cm <sup>2</sup>	1.450377	psi
	psi	0.6894759	N/cm <sup>2</sup>
	N/m <sup>2</sup>	0.000145038	psi
	psi	6894.759	N/m <sup>2</sup>
	t/m <sup>2</sup>	204.81	lbs/ft <sup>2</sup>
	lbs/ft <sup>2</sup>	0.0048828	t/m <sup>2</sup>
<b>Load-related area</b>	m <sup>2</sup> /t	0.004882	ft <sup>2</sup> /lbs
	ft <sup>2</sup> /lb	204.81	m <sup>2</sup> /t
<b>Temperature</b>	°C	<b>([°C] · 1.8) + 32</b>	<b>°F</b>
	°F	<b>([°F] - 32) / 1.8</b>	<b>°C</b>

Conversion chart

---

Empty page!

LWE/LTR 1220-003/24204-02-02/en

---

# Contents

## 1 Description of crane

---

1.01 Terminology	1
1 Crane components	3
2 Auxiliary boom	7
3 Ground connection	8
1.02 Product description	1
1 Crawler travel gear	2
2 Crane superstructure	2
3 Auxiliary equipment	4
1.03 Technical data	1
1 Dimensions	3
2 Maximum surface pressure	3
3 Noise emission	3
4 Vibrations	3
5 Speeds	3
6 Ropes	4
7 Weights	4
8 Lifting heights	12
1.03.10 Outrigger pads	1
1 Description	2
2 Safety	2
3 Fastening the outrigger pad	5
4 Technical outrigger pad data for cranes with a telescopic boom	6
5 Technical outrigger pad data for cranes with a lattice mast boom	13

## 2 Safety

---

2.03 Job planning	1
1 Planning Crane operation	3
2.04 Technical safety instructions	1
1 Dangers on the crane	3
2 Danger zone of crane	5
3 Traffic endangerment and environmental damage	6
4 Endangering air traffic	6
5 Movement on the crane	7
6 Emergency exit	7
7 Personal protective equipment	9
8 Supplied fire extinguisher	15
9 Securing persons to prevent them from falling	16
10 Rescuing the assembly personnel	17
11 Crane cab	18
12 Transport	25
13 Fastening	27
14 Heated crane components	27

15	Crane operator responsibilities	28
16	Selecting the location	30
17	Slopes and excavations	34
18	Loads on the ground due to crane operation	37
19	Support	41
20	Aligning the crane	43
21	Checking the safety measures	44
22	Safety instructions in case of an external power supply	45
23	Grounding	45
24	Working in the vicinity of transmitters	47
25	Crane operation in case of thunderstorms	48
26	Wind influences	49
27	Lifting a load with two cranes	55
28	Overlapping of working ranges of several cranes	57
29	Hand signals for guidance	58
30	Travel operation	66
31	Crane operation	68
32	Lifting of personnel	76
33	Securing personnel on shut off crane	78
34	Welding work on the load	80
<b>2.04.10 Ladders</b>		<b>1</b>
1	Intended use	2
2	Safety instructions	2
3	Safety signs	3
4	Ladder inspection	12
5	User guidelines	12
6	Assembling the ladder	14
7	Ladder access	25
<b>2.05 Signs on the crane</b>		<b>1</b>
1	Signs	2
<b>2.05.10 Labeling of the load carriers</b>		<b>1</b>
1	Identifications on the hook block or load hook	3
2	Identifications on single hook or double hook	4
3	Identifications on auxiliary weights	5
<b>2.06 Fall protection equipment on the crane</b>		<b>1</b>
1	Safety	2
2	Hook points	2
3	Preparing the ladder	3
4	Telescopic boom	5
5	Auxiliary boom	7
6	Folding jib	8
7	Crane chassis	10
8	Crane superstructure	19
9	Counterweight frame	20
10	Transporting the ladder	21
<b>2.07 Accesses to the crane</b>		<b>1</b>
1	Safety	2



2	Ascending and descending the crane chassis	3
3	Entering and exiting the crane cab	4
4	Ascending and descending the crane superstructure	5
5	Walking surfaces and stepping surfaces	7

#### 2.08 Working in low temperatures 1

1	Auxiliary equipment	2
2	Safety	2
3	Environmental / component temperature below -20 °C	3
4	Maintenance	7

#### 2.25 Crane on floating body 1

1	Non-destined use	3
2	Destined use	3
3	Floating device	3
4	Operating conditions	3
5	Crane transport on floating devices	4
6	Increased corrosion	5

### 3 Crane assembly

#### 3.01 Crawler carrier assembly 1

1	Assembling the crawler carrier	3
2	Disassembling the crawler carriers	53

#### 3.01.20 Assembling the cross carrier on the crawler center section 1

1	Component description	3
2	Disassembly of cross carrier with bracket	5
3	Assembly of cross carrier with bracket	8
4	Disassembly Cross carrier with installed extension cylinder	11
5	Assembly Cross carrier with installed extension cylinder	14

#### 3.03 Central ballast 1

1	Central ballast combinations	3
2	Central ballast during start up	3
3	Assembling the central ballast	5
4	Disassembling the central ballast	17

#### 3.80 Crane and crane component transport 1

1	Safety	2
2	Crane	3
3	Crawler carrier	9
4	Dimensions and weights	10
5	Unloading and loading with the auxiliary crane	13
6	Unloading without an auxiliary crane	16
7	Loading without an auxiliary crane	31
8	Rigging	42
9	Securing	43

### 4 Operation of crane superstructure

#### 4.01 Operating and monitoring instruments on the crane superstructure 1

1	Operating and control instruments	3
---	-----------------------------------	---

2	Operating elements on the control panels	11
3	Roof instrument panel operating elements	39
4	Side panel	40
5	Control elements	41
6	Climate control	41
7	Operating elements on the operating and control unit (BKE)	46
4.02 LICCON computer system		1
1	General	2
2	System start of the LICCON computer system	4
3	Operating elements of the LICCON computer system	5
4	The set up program	7
5	Crane operation program	15
6	The Telescoping program	65
7	The working range limitation program*	74
8	Speed reduction master switch	78
9	Setting the operating mode of the slewing gear	82
10	Track width monitoring without shut-off of crane movement	84
11	Track width monitoring with shut off of crane movement*	85
12	ECO-Mode	88
13	Power-save mode and Stand-by mode in the LICCON computer system	94
4.03 Start up and shut down of crane		1
1	Inspections	2
2	Monitoring functions	5
3	Diesel particle filter (DPF)*	6
4	<i>Exhaust system</i> cleaning procedure	11
5	Crane driver's seat Version 1	12
6	Crane driver's seat Version 2	17
7	Control platform	19
8	Step	21
9	Crane cab	23
10	Hydraulic oil preheating*	26
11	LICCON computer system	27
12	Disengaging / engaging the coupling control on the pump distributor gear	30
13	Starting the engine	32
14	Turning the engine off	33
15	Indicator lights	35
16	Window wiper / window washer system	35
17	Hook block	36
4.03.50 Adjustment of the track width		1
1	Track widths and extension conditions	2
2	Track width set up configuration	2
3	Prior to track width adjustment	4
4	Variation A: Track width adjustment with the superstructure turned, one-side	6
5	Variation B: Track width adjustment without counterweight	10
6	Variation C: Adjusting the track width while driving	12
7	Track width adjustment operation	18
4.04 Safety equipment		1
1	General	3

2	Crane geometry quick test	3
3	Overload protection quick test	3
4	LICCON computer system	3
5	Safety equipment on the crane	9

#### 4.05 Crane operation 1

1	Description	2
2	Safety instructions	2
3	Prerequisites for crane operation	3
4	Master switch	3
5	Pinning the crane superstructure	9
6	Master switch assignment	10
7	Luffing	11
8	Lifting / lowering	13
9	Turning	17
10	Telescoping	22

#### 4.06 Rope reeving 1

1	Wire ropes and rope end connections	2
2	Hoist rope lug*	3
3	Moveable back pulley*	6
4	Hoist rope	7
5	Hook block	14
6	Load hook	18
7	Two-part hoist limit switch weight	20
8	One-part hoist limit switch weight	23
9	Wedge lock	26
10	Auxiliary pulley*	28
11	Rope reeving	29

#### 4.07 Counterweight 1

1	Overview of counterweight	3
2	Counterweight combinations	5
3	Fastening the counterweight plates and receptacle plate	7
4	Assembling the counterweight	11
5	Ballast monitoring	21
6	Counterweight error message	24
7	Disassembling the counterweight	27
8	Bluetooth Terminal (BTT) operating element	37

#### 4.08 Working with a load 1

1	Safety instructions	3
2	Checks before starting to work with the crane	4
3	Telescoping crane movement	5
4	Taking on a load	7
5	Load weighing and load display	13
6	Crane operation	18
7	Ram work or pulling sheet piles	19
8	Crane rope pretension	20

#### 4.10 Driving from the crane cab 1

1	Prerequisites for driving the crane (crawler operation)	2
---	---	---

2	Displays for center of gravity, surface pressure and incline on the LICCON monitor	6
3	Preparing for crane driving	13
4	Driving the crane: Load chart available	15
5	Driving the crane: No load chart is available	17
6	Crawler crane in crawler operation	20
<b>4.12 Two hook operation</b>		<b>1</b>
1	Auxiliary boom	3
2	Hook operation	7
3	Two hook operation monitored / Two hook operation not monitored	10
4	Safety instructions	11
5	Boom nose on telescopic boom	13
6	Auxiliary jib on the telescopic boom	14
7	Folding jib	15
8	Strong lattice jib	17
9	Fixed lattice jib	18
10	Boom nose on the fixed lattice jib	19
11	Auxiliary jib on the fixed lattice jib	21
12	Luffing lattice jib	22
13	Boom nose on the luffing lattice jib	23
14	Auxiliary jib on the luffing lattice jib	24
15	Lifting a joint load	26
<b>4.20 Procedure for shut-off of crane movement</b>		<b>1</b>
1	General	3
2	Instructions for resuming crane movement	19

## 5 Equipment

<b>5.01 Technical safety instructions for assembly and disassembly</b>		<b>1</b>
1	Equipment	2
2	Rope pulleys	2
3	Ropes	2
4	Fiber guy ropes	3
5	Control measures before crane operation	4
6	Relapse cylinders	6
7	Pneumatic springs	6
8	Manual rope winches	7
9	Weights	7
10	Guy rods	8
11	Auxiliary guying	9
12	Bypassing the overload protection	9
13	Bypassing the hoist top shut-off	11
14	Pin connections	12
15	Retaining elements	14
16	Assembling / disassembling	22
17	Erecting / taking-down	67
18	Walking on a boom component	71
<b>5.02 Folding jib - TK</b>		<b>1</b>
1	General	3
2	Assembling the folding jib	13

LWE/LTR 1220-003/24204-02-02/en

3	Reeving the hoist rope in	43
4	Changing over the mechanical folding jib from 0° to 22.5° or 45°	45
5	Hydraulic connections	57
6	Electrical connections	63
7	Erecting	73
8	Adjusting the folding jib angle hydraulically*	75
9	Changing over the mechanical folding jib from 22.5° or 45° to 0°	77
10	Reeving the hoist rope out	85
11	Disassembling the folding jib	87

5.09	Hoist gear 2	1
------	--------------	---

1	Component overview	3
2	Fastening points	3
3	Assembling winch 2 without the auxiliary crane	5
4	Assembling winch 2 with the auxiliary crane	11
5	Disassembling winch 2 without the auxiliary crane	13
6	Disassembling winch 2 with the auxiliary crane	19

5.10	Boom nose - telescopic boom	1
------	-----------------------------	---

1	General	3
2	Assembly	5
3	Disassembly	11

5.12	Jib boom	1
------	----------	---

1	General	3
2	Assembling the jib boom	5
3	Erecting	25
4	Reeving the hoist rope out	27
5	Disassembling the jib boom	29

5.19	Hook blocks	1
------	-------------	---

1	Procedure in case of slack rope	3
2	Hook block overview	5
3	Transporting the hook block / load hook	7
4	Installing the single blocks	9
5	Removing the single blocks	13

5.25	Telescopic boom extension	1
------	---------------------------	---

1	General	3
2	Assembly	5
3	Establishing the electrical / hydraulic connections	7
4	Erection	7
5	Disassembly	9

5.31	Bluetooth Terminal (BTT)	1
------	--------------------------	---

1	Display / operating element BTT	3
2	Start menu of the BTT	12
3	Settings and status displays on the BTT	17
4	Aligning the BTT with the crane	19
5	Crawler travel gear menu	21
6	Engine operation menu	29
7	Support menu	39
8	Assembly functions menu	49

9	Test system menu	67
10	BTT operation	69
11	Measures in case of problems	71

5.70 Camera		1
1	Safety instructions	3
2	Swinging the transmitter and receiver into the operating position	4
3	Bringing the camera to the assembly height	5
4	Bringing the cable drum to the assembly height	5
5	Assembling the camera on the telescopic boom	6
6	Assembling the cable drum on the telescopic boom	8
7	Assembling the cable drum on the auxiliary boom	9
8	Assembling the cable drum on the fixed jib	10
9	Assembling the cable drum on the luffing lattice jib	10
10	Assembling the camera on the auxiliary boom	10
11	Assembling the camera on the fixed jib	14
12	Assembling the camera on the luffing lattice jib	18
13	Establishing the electrical connections	22
14	Checking the electrical connections	33
15	Disconnecting the electrical connections	33
16	Swinging the transmitter and receiver into the transport position	33
17	Disassembling the camera	34
18	Disassembling the cable drum	35
19	Transporting the camera	36

5.75 Wind speed sensor / airplane warning light		1
1	Safety	3
2	Description	3
3	Disassembling the wind speed sensor in the transport position	4
4	Installing the wind speed sensor	4
5	Electrical connection	12
6	Disassembling the wind speed sensor	12
7	Assembling the wind speed sensor in the transport position	14
8	Transporting the wind speed sensor	15

5.80 Floodlight		1
1	Safety	2
2	Assembling the floodlight	2
3	Electrical connection	3
4	Disassembling the floodlight	4

## 6 Auxiliary equipment

6.02 Crane operator's cab heater / engine preheating / air conditioning system		1
1	Climate control systems	3
2	Safety instructions	3
3	Climate control	4
4	Air distribution	12
5	Defrosting the window	13
6	Air supply	14
7	Operating the timer	14
8	Air heater*	16

9	Checking the fill level of the fuel container*	17
6.05	Emergency take down	1
1	Emergency control	3

## 7 Maintenance and service

7.01	Maintenance and service - General	1
1	Safety	2
2	Warranty and coverage	7
3	Liebherr Customer Service	7
4	Taking an oil sample	8
5	Taking care of the crane	8
6	Storage	14
7	Recommendation for safe disposal	15
7.01.10	Service system	1
1	Description	2
2	Safety instructions	2
3	Calling up the service system	2
4	<i>Service system</i> operating interface	3
5	<i>Service system</i> function key line	6
6	Checking the maintenance status	6
7	Resetting the maintenance status	7
7.02	Maintenance intervals - Crawler chassis	1
1	Maintenance and inspection schedule	2
7.03	Maintenance intervals - Crane superstructure	1
1	Maintenance and inspection schedule	2
7.03.50	Maintenance intervals - Crane boom	1
1	Maintenance and inspection schedule	2
7.04	Maintenance instructions - Crane chassis	1
1	Servicing the travel gear	3
2	Crawler travel gear	9
3	Servicing the central lubrication system of the crawler carrier	21
4	Hydraulic hose lines	27
5	Ladders	28
7.05	Maintenance instructions - Crane superstructure	1
1	Safety	2
2	Diesel engine	2
3	Cooling system	5
4	Air filter system	10
5	Fuel system	12
6	Urea system*	21
7	Exhaust system*	24
8	Pump distributor gear	26
9	Central lubrication system	28
10	Slewing ring connection	32
11	Slewing gear(s)	34

12	Hoist gear(s)	39
13	Heating-air conditioning device	41
14	Cab auxiliary heater*	45
15	Engine preheating auxiliary heater*	49
16	Ventilation	52
17	Hydraulic system	53
18	Hydraulic hose lines	58
19	Compressed air system*	58
20	Electrical system	59
21	Ladders	63

7.05.50	Maintenance instructions - Crane boom	1
1	Telescopic boom	2
2	Rope pulleys and guide pulleys	5
3	Crane ropes	6

7.06	Fill quantities, lubrication chart	1
1	Fill quantities	3
2	Lubrication schedule	4

7.07	Operating fluids and lubricants	1
1	Specified service fluids and lubricants for Liebherr cranes	3

## 8 Inspections of cranes

8.01	Periodic crane inspections	1
1	General information	2
2	Inspecting load bearing crane structures, especially steel structures	4
3	Inspecting the locking system of the telescopic boom	79
4	Inspection of the screws in the adjustment plates	81
5	Checking the safety ropes and anchor points	82
6	Inspecting the load handling equipment and assembly aids	84
7	Inspecting of fastening equipment	84
8	Inspecting the diaphragm reservoir	85
9	Inspecting the relapse cylinders	85
10	Inspecting the rope pulleys	86
11	Inspecting the carrier rollers	87
12	Inspecting the extension conditions of sliding beams	88
13	Inspecting the function of the overload protection	88
14	Inspecting the pin connections	89
15	Inspecting the slewing ring connection	89
16	Inspecting the mounting of the load bearing equipment	90
17	Inspecting the tele extension with eccentric, illustration 1	91
18	Inspecting the change over pulleys, illustration 2	92
19	Inspecting the oil and fuel tanks	92

8.03	Inspecting of winches	1
1	Inspecting the hoist and retracting winches	3
2	Inspection of the auxiliary reeving winch, recovery winch and spare wheel winch	5
3	Monitoring the winches	5

8.04	Inspection of crane wire ropes	1
1	Crane ropes	3



2	Importance of inspection	3
3	Personal protective equipment	3
4	Qualification Inspection personnel	3
5	Unscheduled inspection	3
6	Intervals	4
7	Areas	4
8	Documenting inspection results	5
9	Wire ropes and rope end connections	5
10	Degree of severity	8
11	Abbreviations Rope diameter	8
12	Distortions and mechanical damage	8
13	Removal criteria Overview	8
14	Checking for broken strands	10
15	Determining the number of broken wires	10
16	Checking the rope end connection	15
17	Checking of rope diameter	15
18	Corrosion	18
19	Corkscrew-like distortion	20
20	Basket formation	21
21	Protruding, distorted insert or strand	22
22	Loop formation	23
23	Kinking or rope loops pulled closed	24
24	Buckles	25
25	Effects of heat, arcs	26
26	Combined degree of severity	26
27	Flattenings	26
28	Current checklist	29

8.05	Inspection of load hooks	1
------	--------------------------	---

1	Safety instructions	3
2	Inspection intervals	3
3	Checking the load hook	3

8.06	Inspection of hydraulic hose lines	1
------	------------------------------------	---

1	Safety guidelines	3
2	Inspection intervals	3
3	Checking the end of the service life	3
4	Inspecting the hydraulic hose lines for damage	4
5	Inspecting the hydraulic hose lines for leaks	5
6	Documenting the inspection	5
7	Replacing hydraulic hose lines	5

8.17	Inspection of ladders	1
------	-----------------------	---

1	Safety instructions	3
2	Inspection intervals	3
3	Inspecting the ladders	3
4	Inspection sheet and check list	3

8.90	Inspection chart for cranes	1
------	-----------------------------	---

1	Inspection chart for recurring inspections of Liebherr cranes	3
---	---	---

## 90 Appendix

---

90.01 Preface to the appendix	1
1 Foreword	3
90.05 Update confirmation	1
1 Change confirmation form	3
2 Update confirmation	3
3 Customer information	4

---

# 1 Description of crane

LWE/LTR 1220-003/24204-02-02/en

---

LWE/LTR 1220-003/24204-02-02/en

# 1.01 Terminology

1	Crane components	3
2	Auxiliary boom	7
3	Ground connection	8

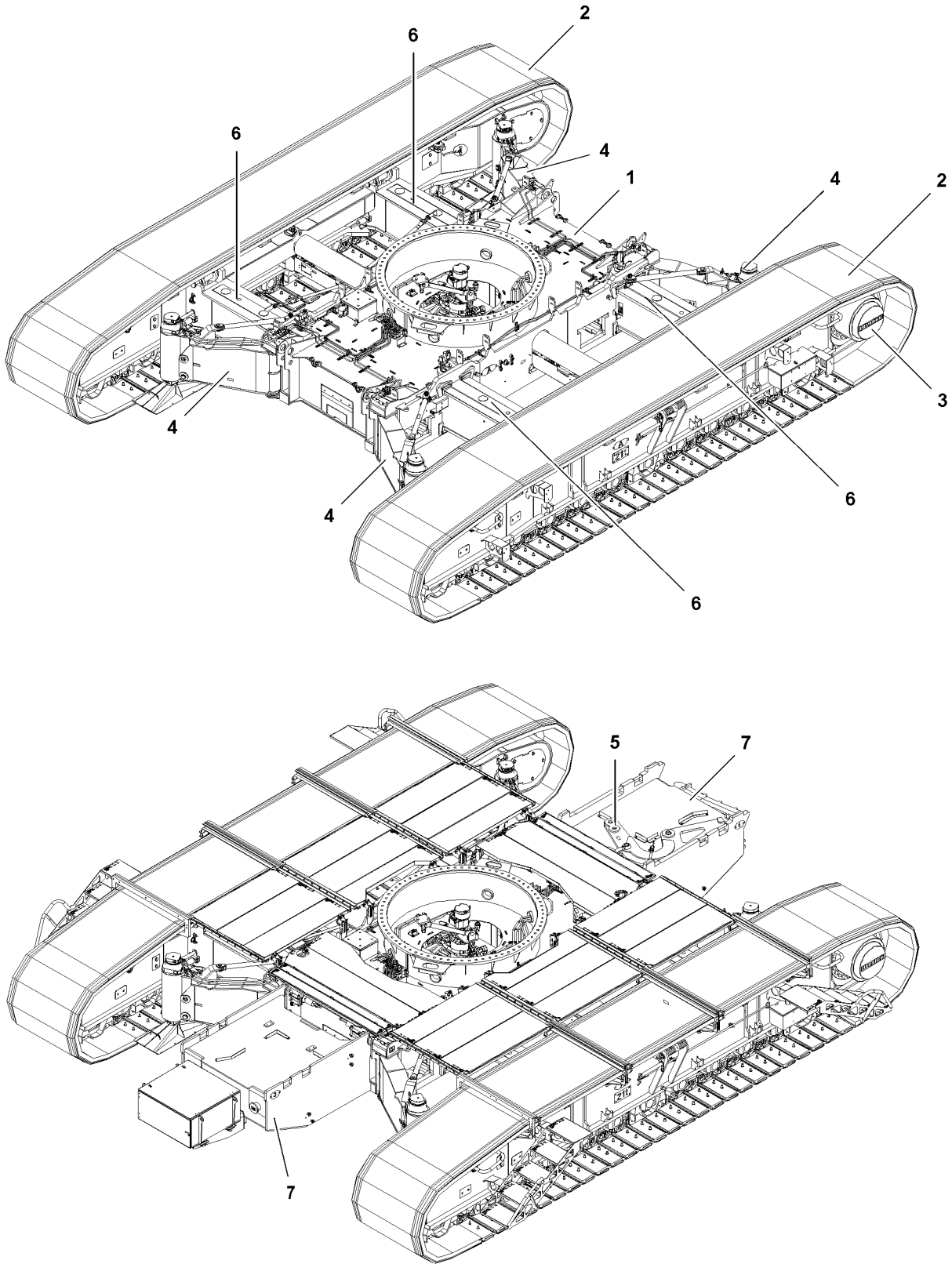


Fig.116848

LWE/LTR 1220-003/24204-02-02/en

# 1 Crane components

## 1.1 Crawler travel gear

- 1 Crawler center section
- 2 Crawler carrier
- 3 Travel gear
- 4 Hydraulic assembly support\*
- 5 Assembly device\*
- 6 Beams for track adjustment
- 7 Central ballast

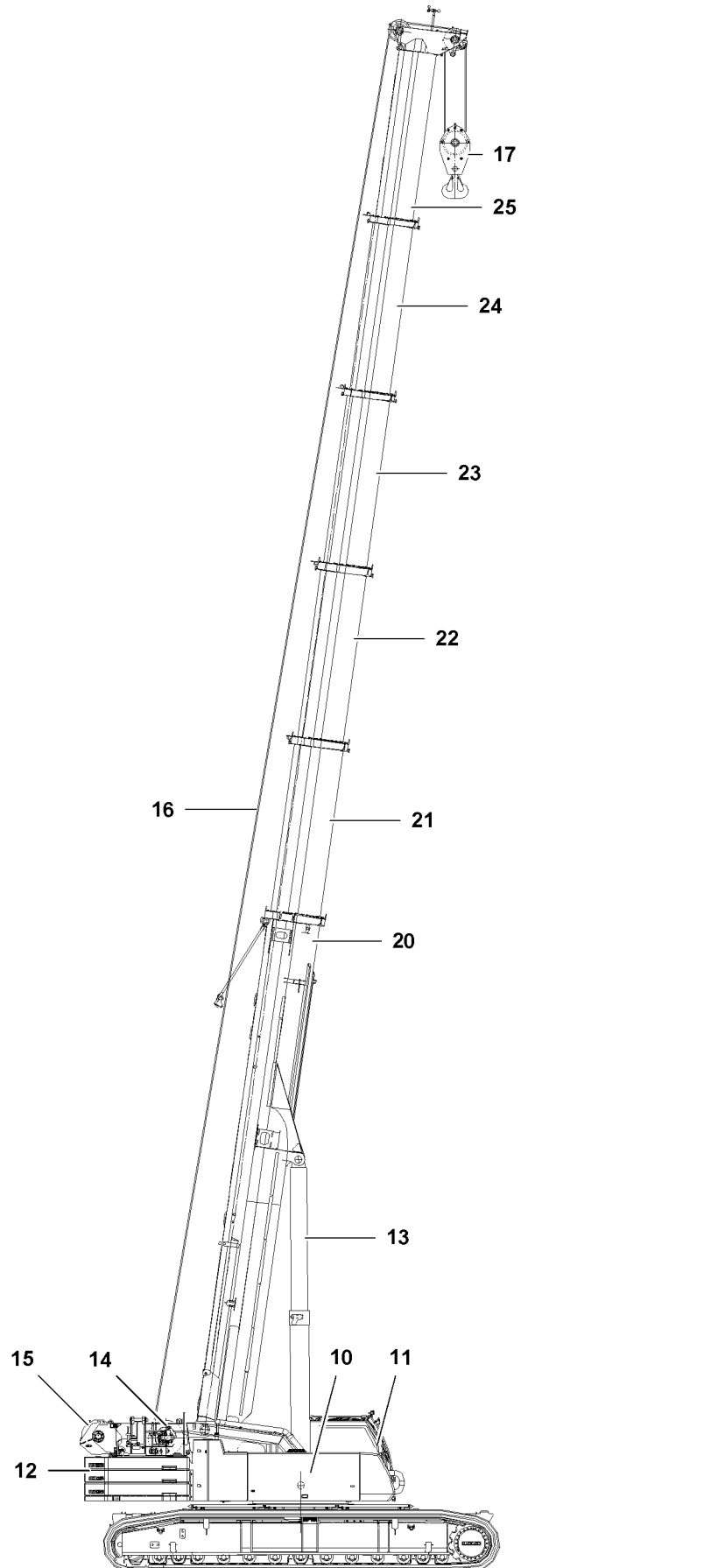


Fig.116849

LWE/LTR 1220-003/24204-02-02/en



## 1.2 Crane superstructure

- 10 Crane engine
- 11 Crane cab
- 12 Counterweight
- 13 Luffing cylinder
  - For telescopic boom adjustment
- 14 Winch 1
- 15 Winch 2\*
- 16 Hoist rope\*
- 17 Hook block\*

## 1.3 Telescopic boom (T)

- 20 Pivot section
- 21 Telescopic section 1
- 22 Telescopic section 2
- 23 Telescopic section 3
- 24 Telescopic section 4
- 25 Telescopic section 5

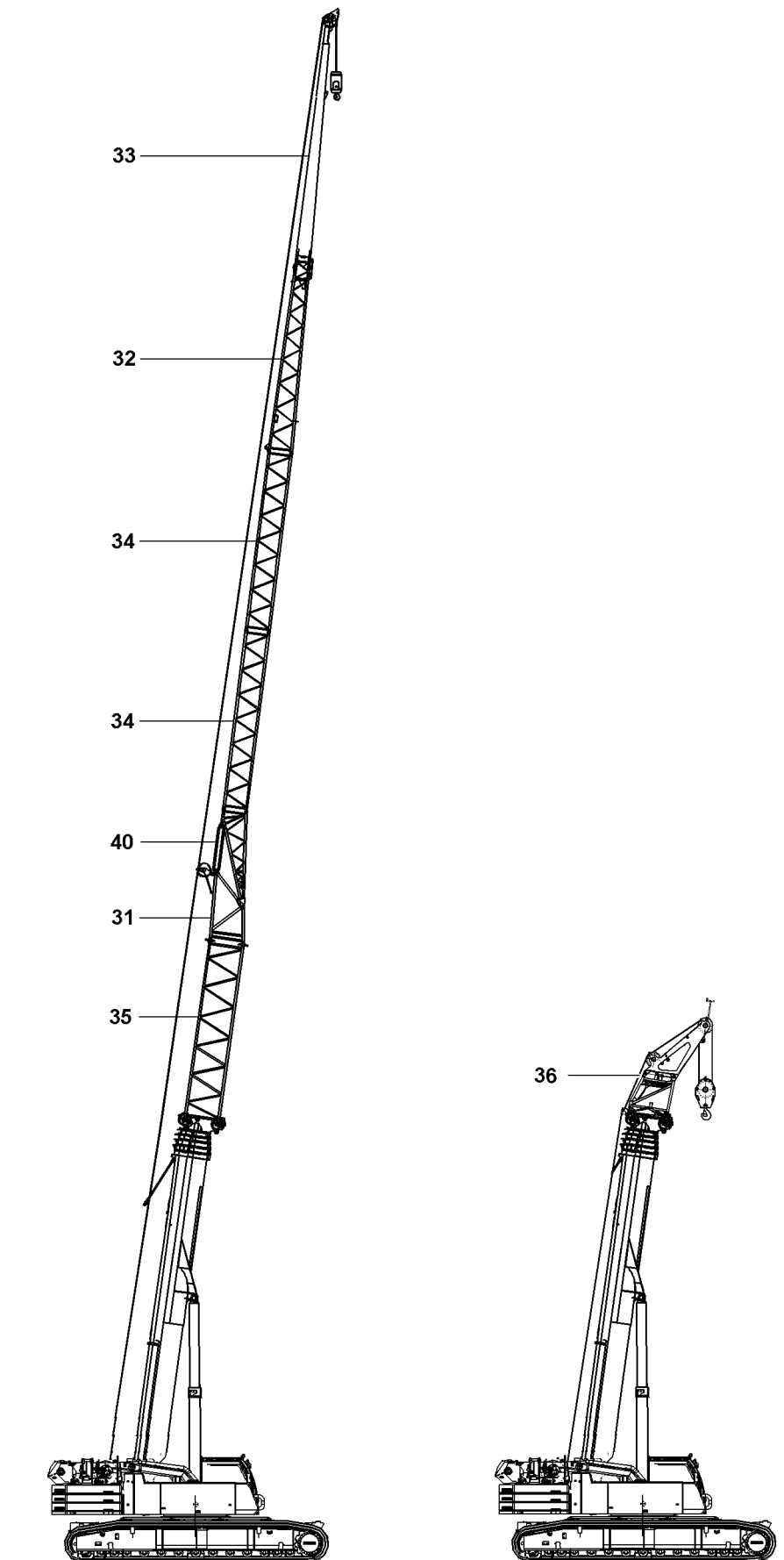


Fig.117322

LWE/LTR 1220-003/24204-02-02/en

## **2 Auxiliary boom**

### **2.1 Folding jib (TK)\***

- 31 Adapter
- 32 Pivot section
- 33 End section
- 34 Intermediate section

### **2.2 Folding jib with extension (TVK)\***

- 31 Adapter
- 32 Pivot section
- 33 End section
- 34 Intermediate section
- 35 Extension

### **2.3 Hydraulically adjustable folding jib (TNZK)\***

- 31 Adapter
- 32 Pivot section
- 33 End section
- 34 Intermediate section
- 40 Control cylinder

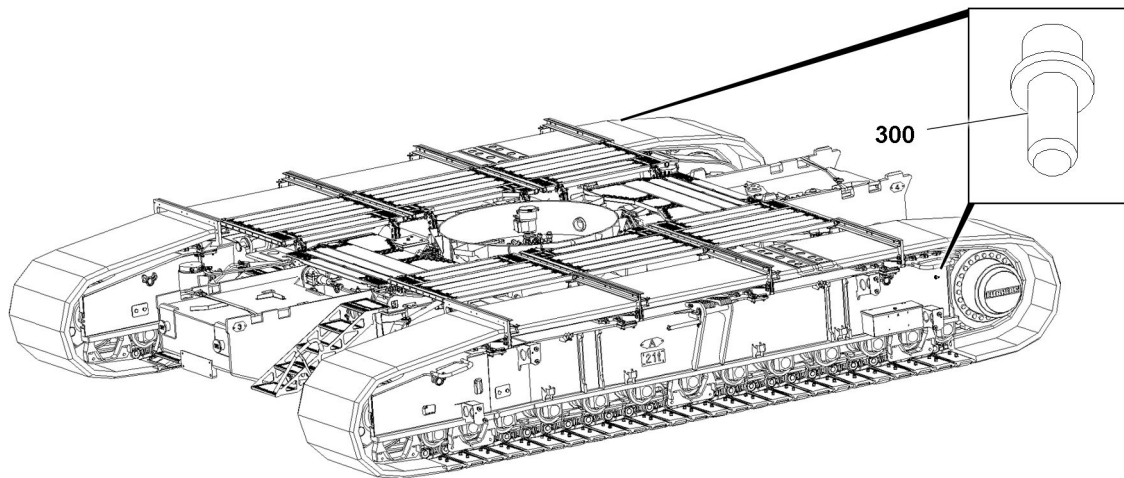
### **2.4 Hydraulically adjustable folding jib with extension (TVNZK)\***

- 31 Adapter
- 32 Pivot section
- 33 End section
- 34 Intermediate section
- 35 Extension
- 40 Control cylinder

### **2.5 Jib boom (THK)\***

- 36 Jib boom

### 3 Ground connection



*Fig.158651: Crawler carrier ground connection*

**300** Ground connection



---

#### Note

To ground the mobile crane:

- Observe and comply with the description in Crane operating instructions, chapter 2.04.
-

## 1.02 Product description

1	Crawler travel gear	2
2	Crane superstructure	2
3	Auxiliary equipment	4

# 1 Crawler travel gear

## 1.1 Frame

Torsion resistant box construction, consisting of crawler center section, two cross carriers and two crawler carriers. The crawler carriers can be removed from the telescoping beams. Hydraulic track width adjustment. Hydraulic assembly support.

## 1.2 Hydraulic track width adjustment

Track width adjustment is carried out via two independent, hydraulic cylinders.

## 1.3 Track

Crawler track with 1000 mm wide double grouser track pads.

## 1.4 Travel drive

Per crawler carrier, a hydraulic travel drive consisting of an axial piston adjusting motor, planetary gear with spring-loaded hydraulically-releasable travel brake. The crawler chains can be controlled synchronously as well as independently and counterrotating.

Travel speed: 0 -2.3 km/hr.

## 1.5 Central ballast

20.0 t , hook ballast at 10.0 t , mounting on the crawler center section.

# 2 Crane superstructure

## 2.1 Frame

In-house manufactured, weight-optimized and distortion-resistant welded structure made from high-strength, close-grained structural steel. A 3-row roller ring connection is used as the connecting element to the crawler travel gear, providing unlimited turning.

## 2.2 Engine

Diesel engine D 944 A7 is installed for this crane.

4-cylinder diesel, manufactured by Liebherr, water cooled.

The devices can be equipped with different exhaust aftertreatment systems.

Refer to the diesel engine operating instructions to see which engine exhaust aftertreatment system is installed in your crane.

### 2.2.1 Engine type D 944 A7-05

Engine exhaust emissions Stage V according to Regulation (EU) 2016/1628

Performance: 230 KW at 1800 rpm

Maximum torque: 1440 Nm at 1350 rpm

## 2.2.2 Engine type D 944 A7-04

Engine exhaust emissions Tier 4 according to EPA / CARB and ECE-R.96 performance range Q (previously Stage IV according to Directive 97/68/EC)

Performance: 230 KW at 1800 rpm

Maximum torque: 1440 Nm at 1350 rpm

## 2.2.3 Engine type D 944 A7-50

Engine exhaust emissions according to ECE R.49, K

Performance: 230 KW at 1800 rpm

Maximum torque: 1440 Nm at 1350 rpm

## 2.2.4 Engine type D 944 A7-03

Engine exhaust emissions according to ECE-R.96 performance range H (previously Stage IIIA according to Directive 97/68/EC)

Performance: 230 KW at 2100 rpm

Maximum torque: 1440 Nm at 1350 rpm

## 2.3 Crane drive

Diesel hydraulic with 5 axial piston adjusting pumps with servo control and power regulation.

One axial piston adjusting pump per auxiliary user, for supply pressure and for fan drive.

One toothed wheel pump to supply the hydraulic oil cooler.

## 2.4 Control

Electronic control by the LICCON-system (PLC control). Two 4-way manual control levers, self-centering. Infinitely variable control of all crane movements by adjusting the hydraulic pumps, additional speed control when adjusting the diesel engine rpm.

## 2.5 Hoist gear

Axial piston adjusting motor.

Liebherr rope winch with integrated planetary gear and spring-loaded stop brake.

## 2.6 Luffing gear

One differential cylinder with safety check valves.

## 2.7 Slewing gear

Axial piston fixed displacement motor, planetary gear, spring-loaded stop brake.

## 2.8 Crane driver's cab

Corrosion resistant steel cab, large field of visibility, safety glass, comfort design

The crane operator's cab can be tilted back 20° to improve visibility.

## 2.9 Safety equipment

LICCON2 overload protection system, hoist limitation, safety valves to prevent pipe and hose breakage, test system for service tasks.

## 2.10 Telescopic boom

Dent and distortion-resistant design made from high-strength, close-grained structural steel with oval boom profile, one pivot section and five telescopic sections. All telescopic sections are hydraulically extendable, independently of each other. Rapid-cycle telescoping system „Telematik“.

Boom length: 13.3 m to 60.0 m

## 2.11 Counterweight

Maximum 70.0 t counterweight\*

## 2.12 Electrical system

Modern data bus technology

# 3 Auxiliary equipment

## 3.1 Folding jib

12.2 m to 22.0 m long and can be installed below 0°, 22.5° or 45° to the telescopic boom.

Hydraulic cylinder for stepless adjustment of the folding jib from 0° to 45°.

## 3.2 Auxiliary jib

3.4 m

## 3.3 Telescopic boom extension

7 m long lattice section, as a result a 7 m higher coupling point for the folding jib

## 3.4 Intermediate section

Two 7 m long lattice sections to extend the folding jib.

## 3.5 Winch 2

For 2-hook operation or for operation with folding jib if the main hoist rope is to remain reeved.

## 3.6 Auxiliary counterweight

Two additional ballast plates with a weight of 10.0 t for a total counterweight of 70.0 t.



## 1.03 Technical data

1	Dimensions	3
2	Maximum surface pressure	3
3	Noise emission	3
4	Vibrations	3
5	Speeds	3
6	Ropes	4
7	Weights	4
8	Lifting heights	12

1

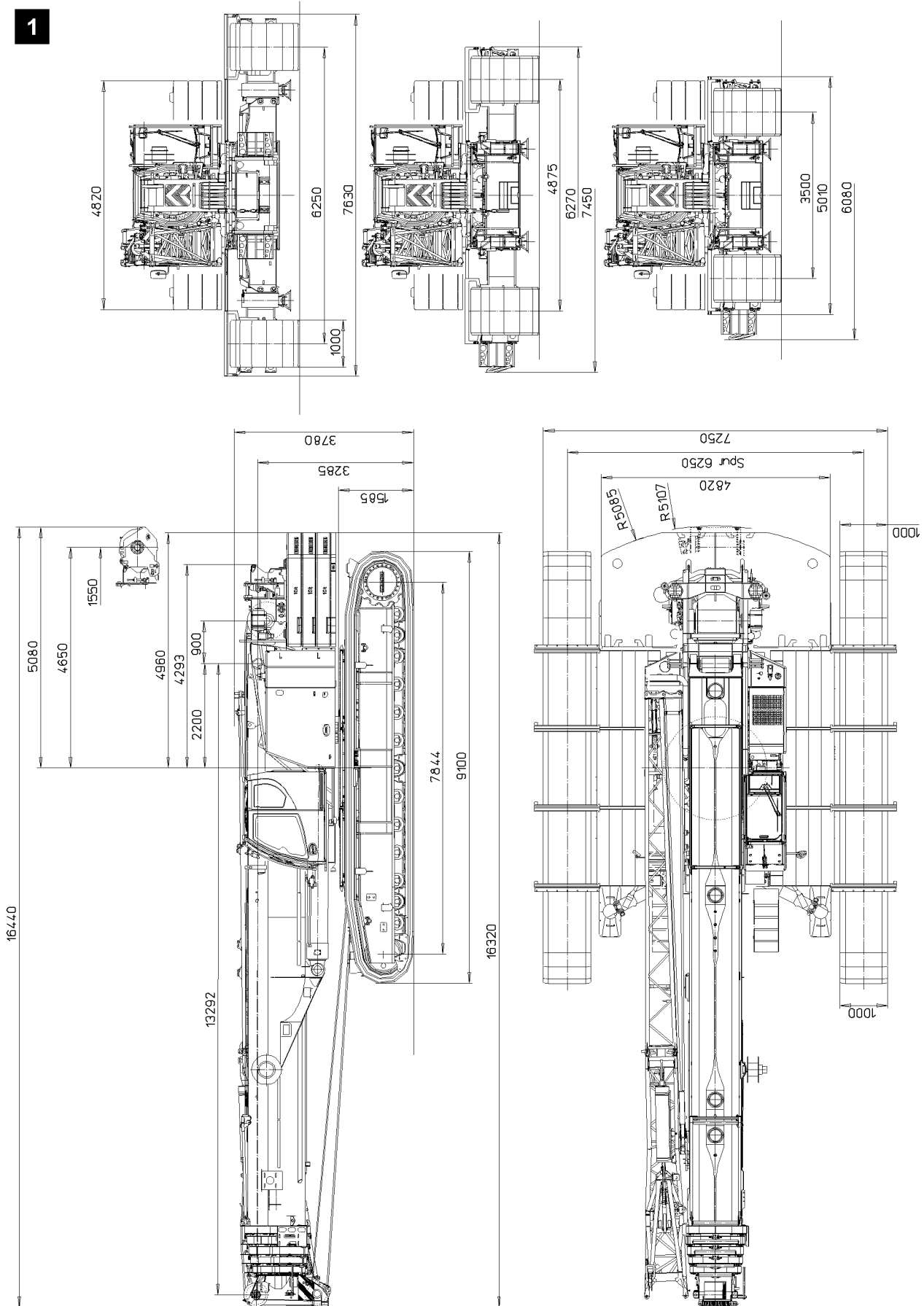


Fig.116835

LWE/LTR 1220-003/24204-02-02/en

# 1 Dimensions

See illustration 1.

## 2 Maximum surface pressure

	2-grouser pads 1.0 m	2-grouser pads 1.2 m *
Maximum surface pressure at nominal load	750 kN/m <sup>2</sup>	620 kN/m <sup>2</sup>

## 3 Noise emission

Crane cab control platform	
Sound pressure level [L <sub>pA</sub> ] according to EN 13000	73 dB(A)

## 4 Vibrations

Vibrations transferred to the operator	Value
Total vibration value to which the upper body limbs are exposed	Not more than 2.5 m/s <sup>2</sup>
Effective value of weighted acceleration to which the entire body is exposed.	Not more than 0.5 m/s <sup>2</sup>

## 5 Speeds

### 5.1 Travel speeds

Crane data	Value
Travel speeds	0 km/h to 2.3 km/h
Maximum permitted gradeability	47 %
Total propelling force	1130 kN

## 5.2 Crane speeds

Drives	Infinitely variable
Hoist gear 1	0 m/min – 130 m/min for single strand
Hoist gear 2	0 m/min – 130 m/min for single strand
Slewing gear	0 rpm – 1.5 rpm
Luffing gear	Approx. 50s 0.9 ° to 82 ° boom position
Telescoping	Approx. 420s for boom length 13.3 m – 60 m

## 6 Ropes

Components	Rope diameter	Rope category number RCN
Hoist rope 1	23 mm	See the rope certificate
Hoist rope 2	23 mm	See the rope certificate

## 7 Weights

### 7.1 Crawler crane

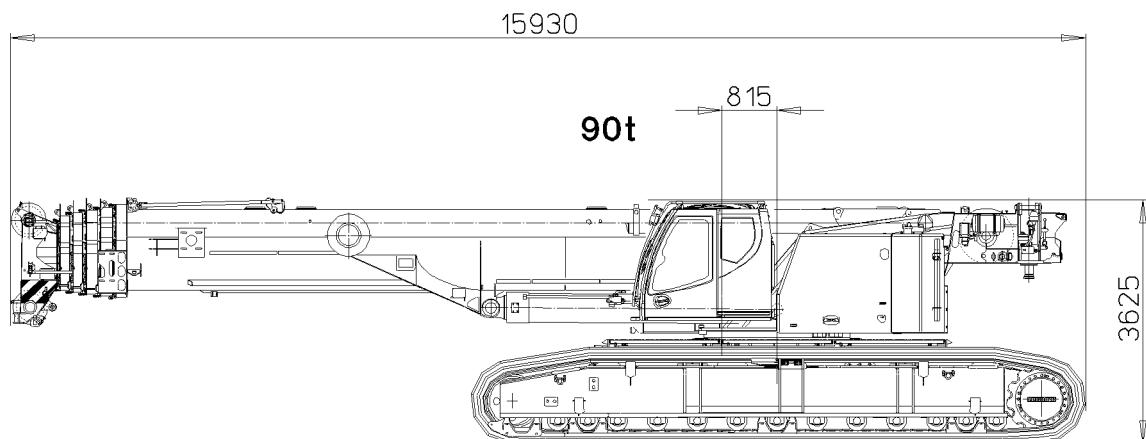


Fig.116840: Crawler crane

Component	Weight	Width
Crawler, complete, 2-grouser 1000 mm	90 t	5010 mm
Crawler center section		
Hydraulic support		
Cross carrier		

LWE/LTR 1220-003/24204-02-02/en

Component	Weight	Width
Superstructure		
Telescopic boom 60 m		
Narrow track		

## 7.2 Crawler center section

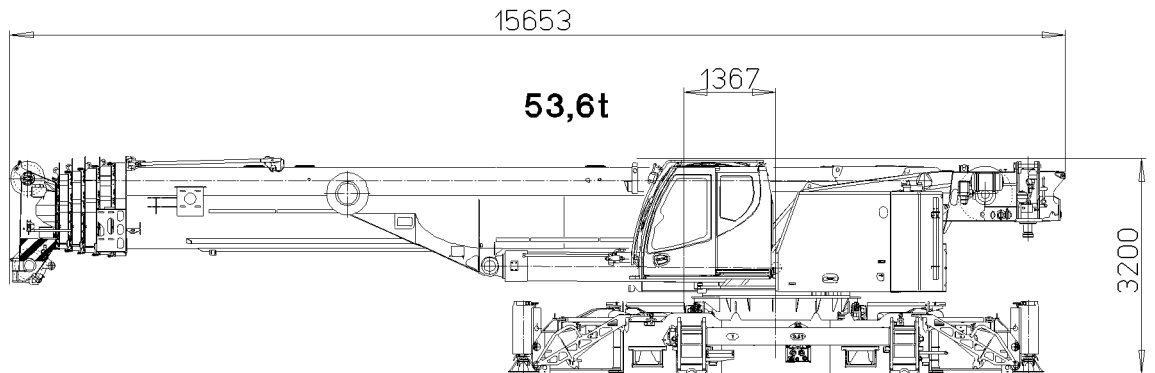


Fig.116841: Crawler center section

Component	Weight	Width
Crawler center section	53.6 t	3000 mm
Hydraulic support		
Cross carrier		
Superstructure		
Telescopic boom 60 m		

LWE/LTR 1220-003/24204-02-02/en

### 7.3 Crawler center section

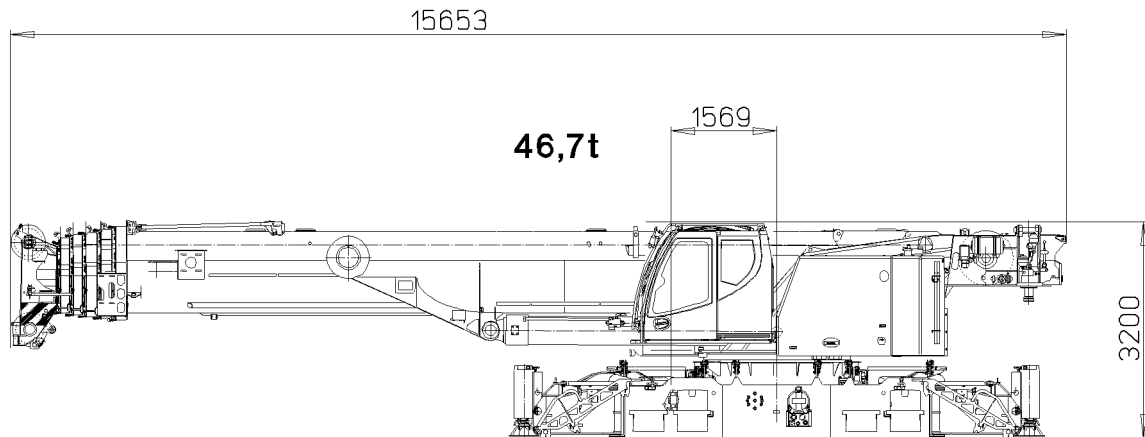


Fig.116842: Crawler center section

Component	Weight	Width
Crawler center section	46.7 t	3000 mm
Hydraulic support		
Superstructure		
Telescopic boom 60 m		

### 7.4 Complete crawler, 2-grouser pads 1000 mm

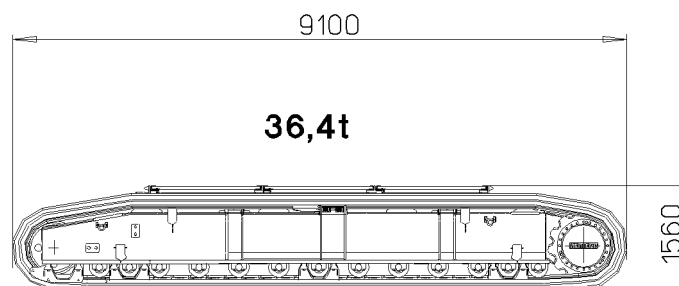


Fig.116843: Complete crawler, 2-grouser pads 1000 mm

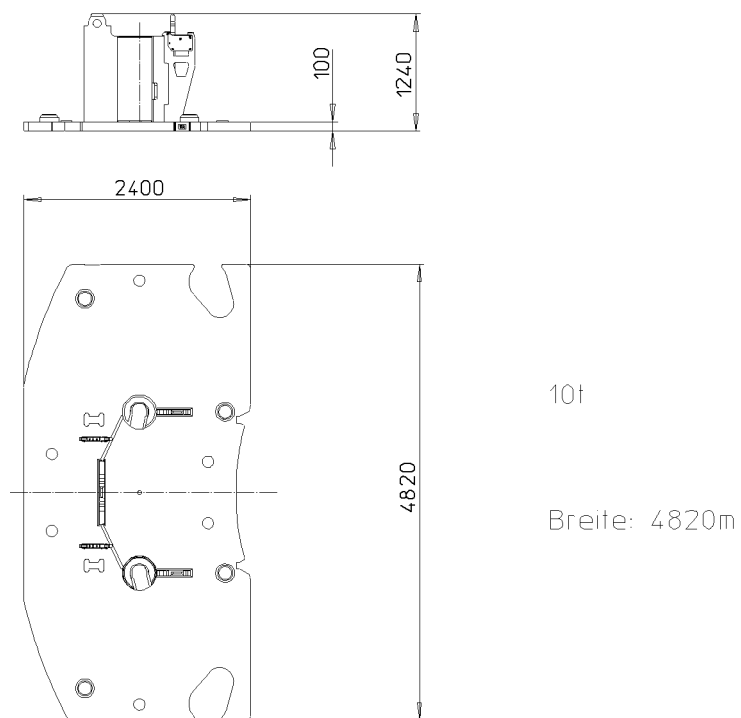
Component	Weight	Width
Complete crawler, 2-grouser pads 1000 mm	36.4 t	1000 mm

### 7.5 Outrigger pads

Outrigger pad width	Total weight
1.0 m without insertion plates	18.0 t
1.0 m with insertion plates	18.7 t
1.2 m without insertion plates	18.9 t
1.2 m with insertion plates	19.6 t

*Weight of the outrigger pads*

### 7.6 Receptacle plate



*Fig.116836: Receptacle plate*

Component	Weight
Receptacle plate	10.0 t

LWE/LTR 1220-003/24204-02-02/en

## 7.7 Counterweight plate

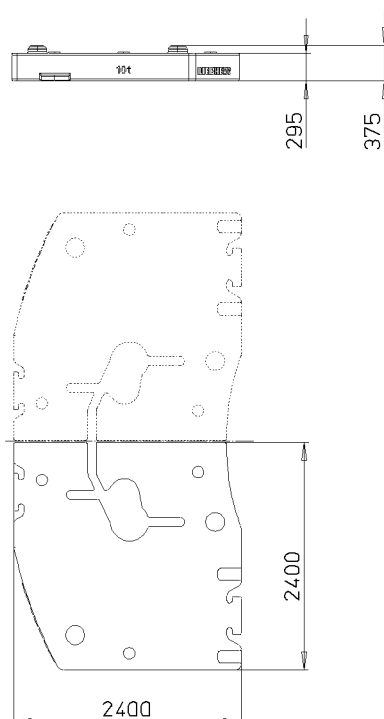


Fig.116837: Counterweight plate

Component	Weight
Counterweight plate	10.0 t

## 7.8 Central ballast 10 t

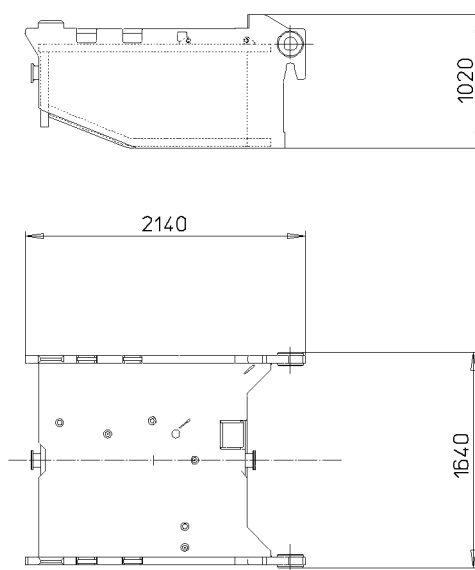


Fig.116839: Central ballast 10 t



Component	Weight
Central ballast	10.0 t

### 7.9 Hoist gear 2 with rope

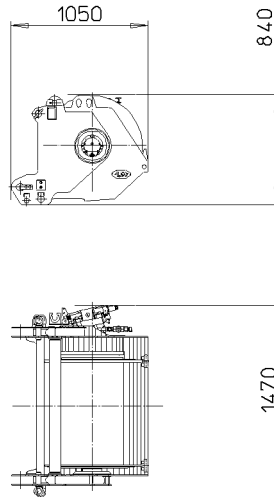


Fig.116838: Hoist gear 2 with rope

Component	Weight
Hoist gear 2 with rope	1.90 t

### 7.10 Tele extension 7 m

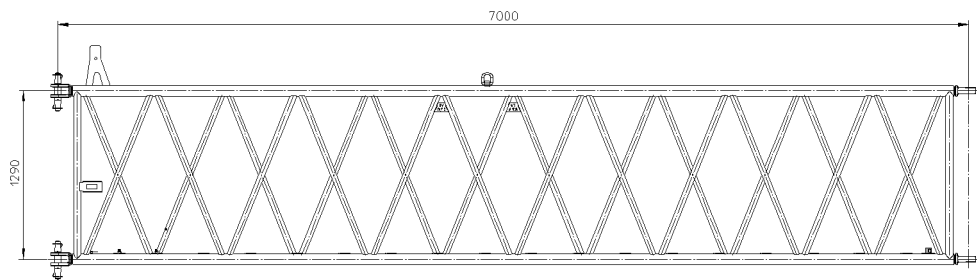


Fig.116847: NA-intermediate section 7 m

Component	Weight	Width
Tele extension 7 m	0.7 t	0.82 m

LWE/LTR 1220-003/24204-02-02/en

## 7.11 Special jib boom

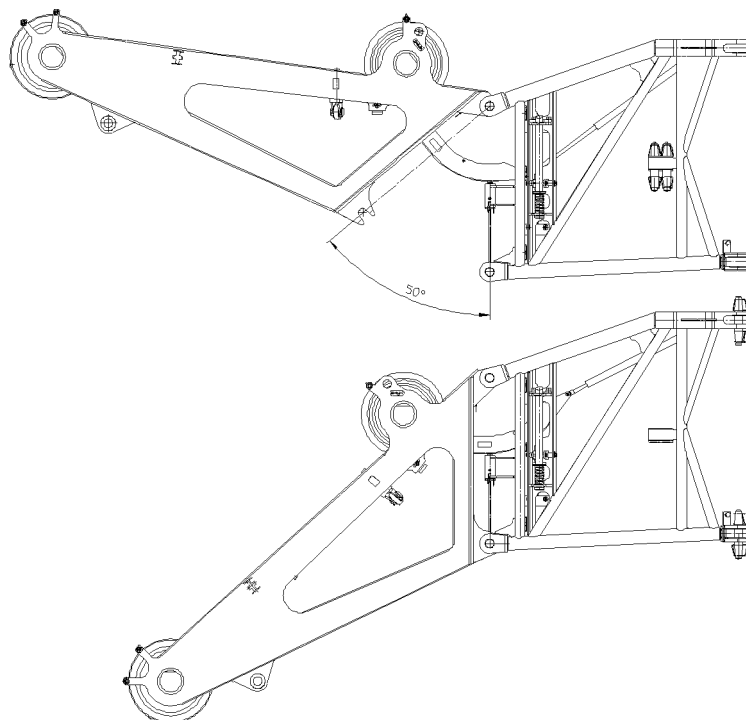


Fig.116844: Special jib boom

Component	Weight	Width
Special jib boom	0.750 t	0.82 m

## 7.12 Load hook

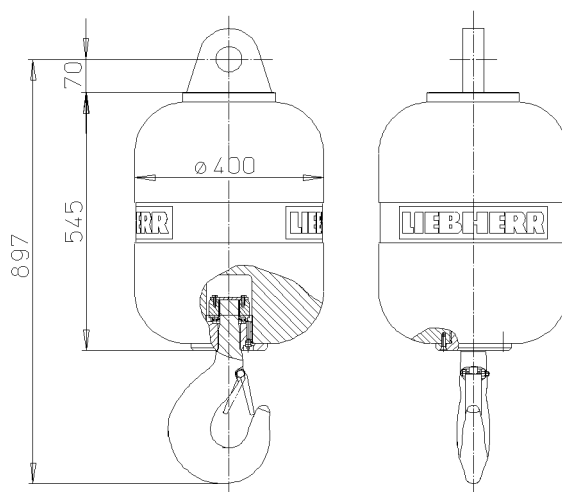


Fig.116845: Load hook

Component	Weight	Width
Load hook	0.5 t	0.4 m

### 7.13 Hook blocks

Component	Weight	Length	Width	Height
Hook block, 1-pulley	0.84 t	0.690 m	0.343 m	1.449 m
Hook block, 1-pulley	0.84 t	0.690 m	0.343 m	1.490 m
Hook block, 1-pulley	0.85 t	0.690 m	0.363 m	1.449 m
Hook block, 1-pulley	0.87 t	0.690 m	0.340 m	1.456 m
Hook block, 3-pulley	1.04 t	0.690 m	0.444 m	1.680 m
Hook block, 3-pulley	1.45 t	0.690 m	0.503 m	1.827 m
Hook block, 5-pulley	1.30 t	0.690 m	0.543 m	1.886 m
Hook block, 7-pulley	1.50 t	0.690 m	0.707 m	2.020 m
Hook block, 9-pulley	2.00 t	0.690 m	0.900 m	2.061 m
Hook block, 12-pulley	3.40 t	0.690 m	1.209 m	2.229 m

# 8 Lifting heights

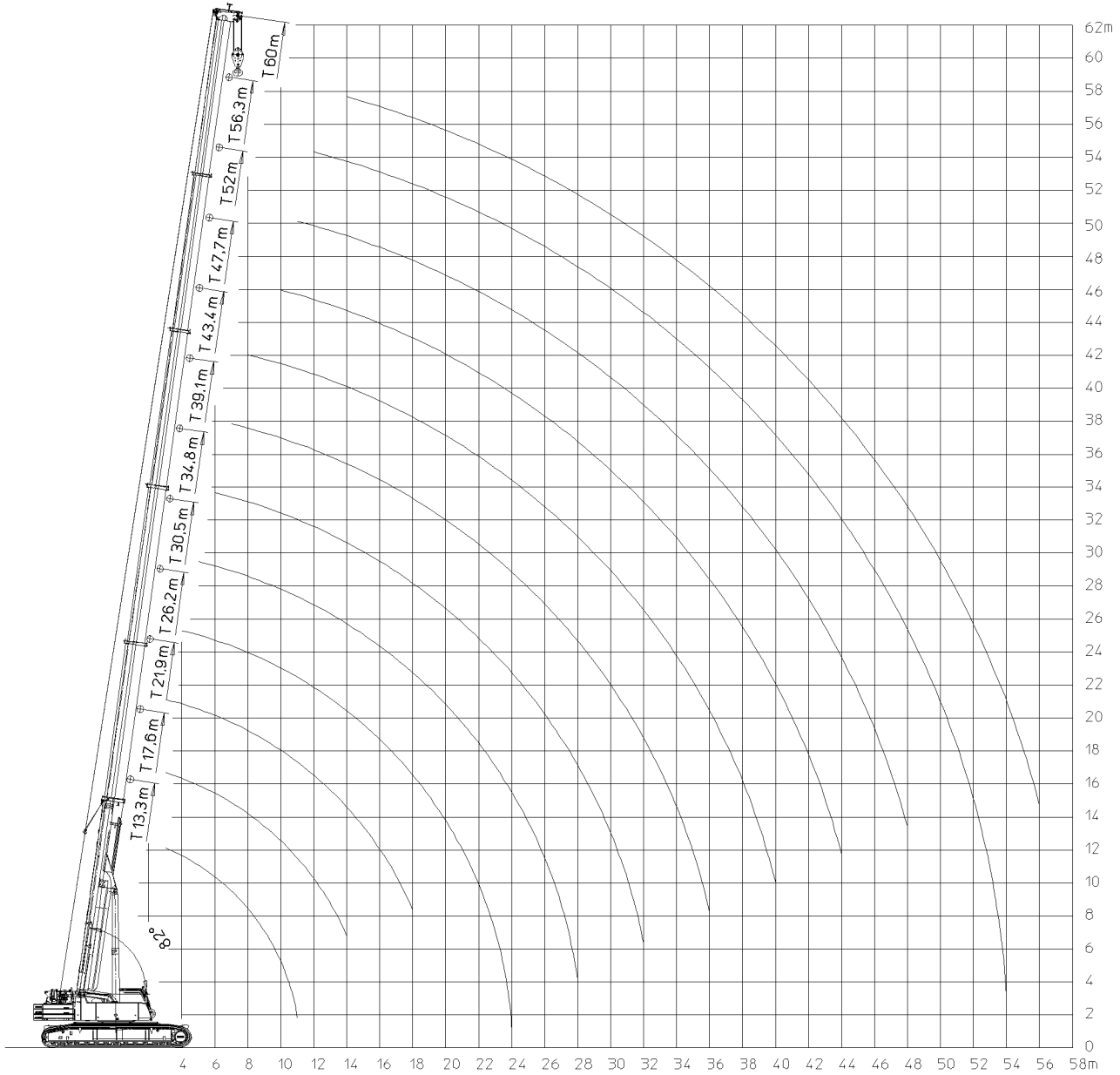


Fig.116832: Telescopic boom (T)

LWE/LTR 1220-003/24204-02-02/en

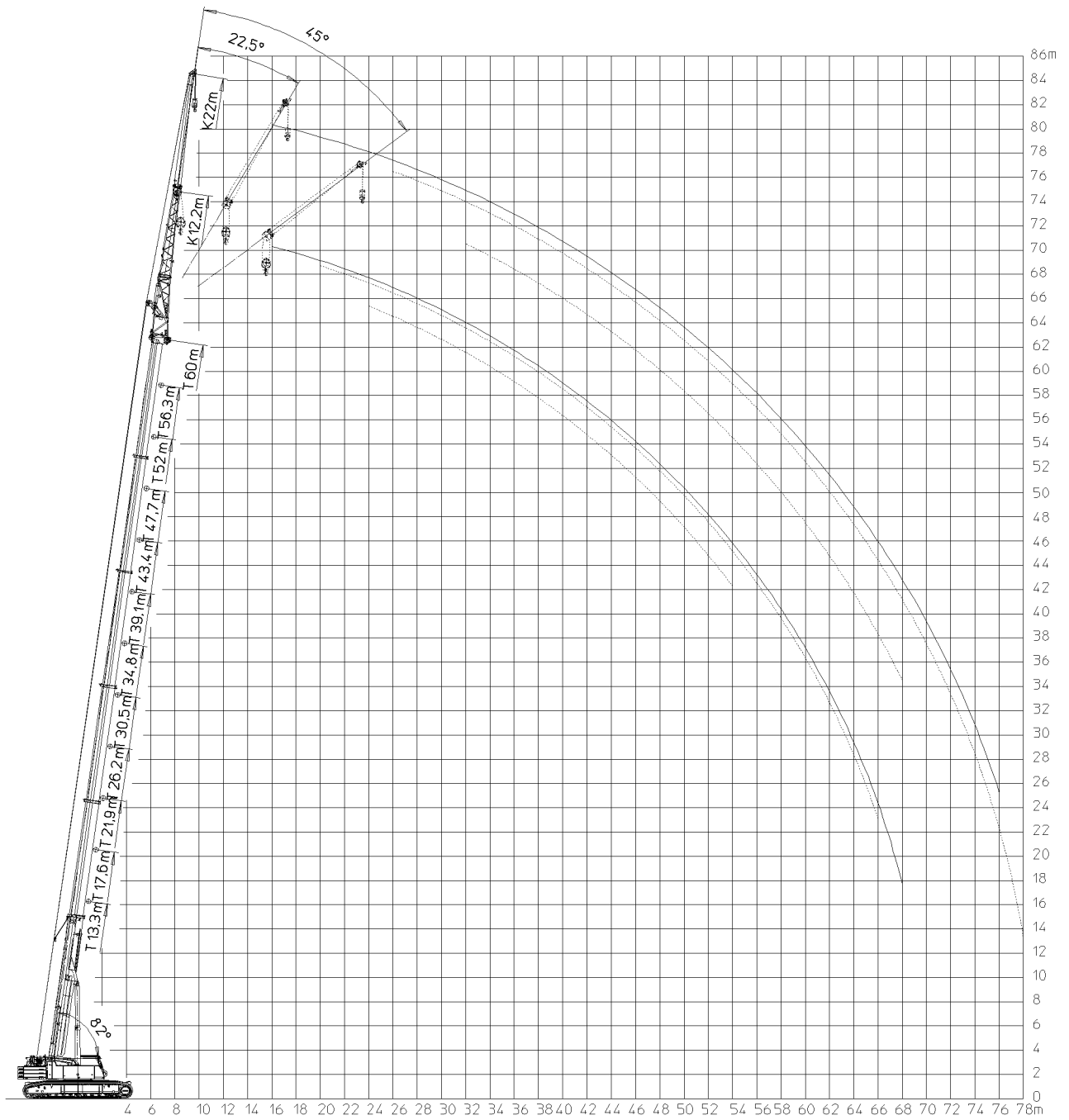


Fig.116833: Telescopic boom with folding jib (TK)

LWE/LTR 1220-003/24204-02-02/en

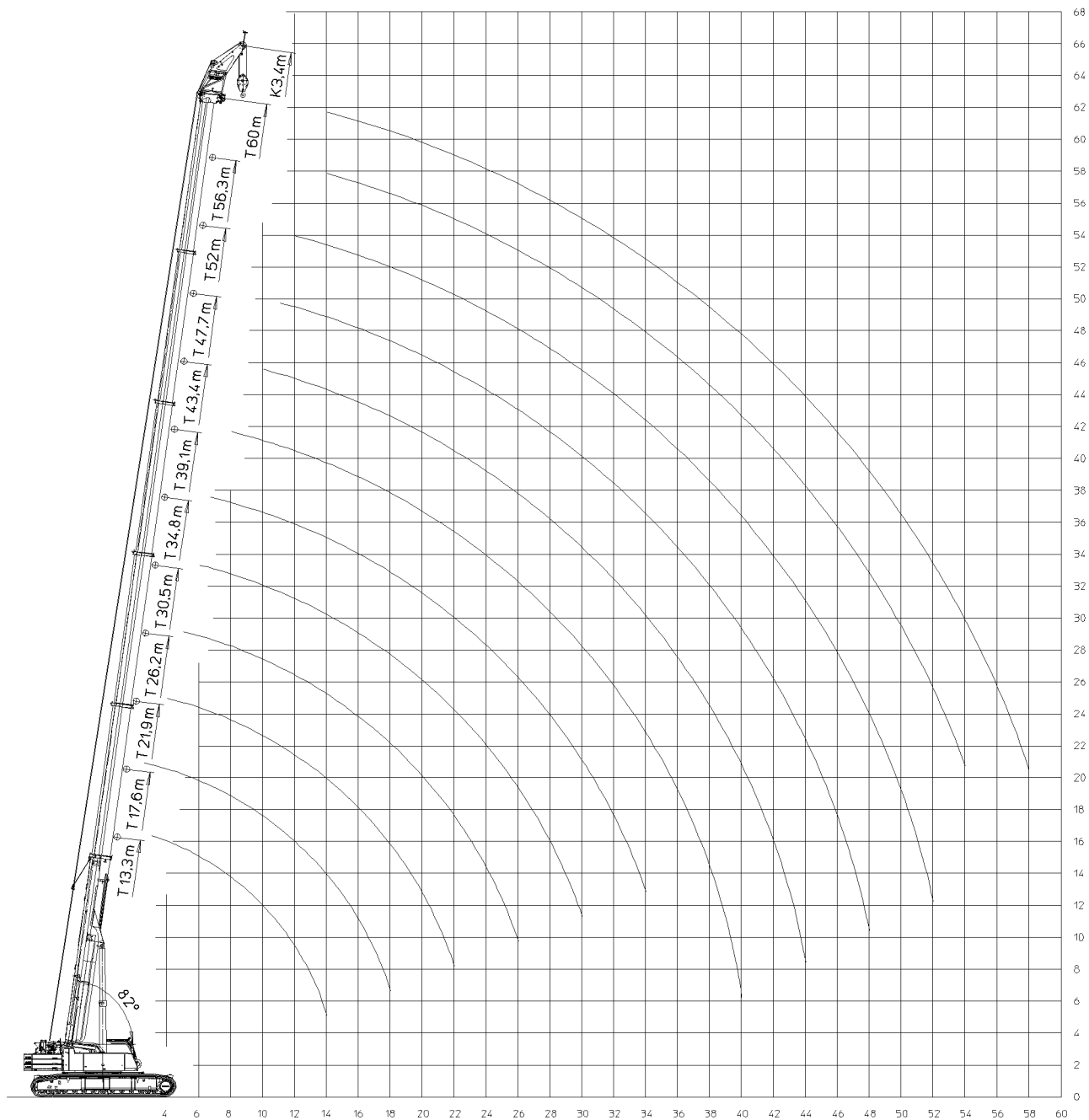


Fig.116834: Telescopic boom with jib boom (THK)

LWE/LTR 1220-003/24204-02-02/en

## 1.03.10 Outrigger pads

1	Description	2
2	Safety	2
3	Fastening the outrigger pad	5
4	Technical outrigger pad data for cranes with a telescopic boom	6
5	Technical outrigger pad data for cranes with a lattice mast boom	13

# 1 Description

By using the outrigger pads, the support load is distributed over a large area of the ground. Liebherr-Werk Ehingen GmbH offers different versions of outrigger pads. The outrigger pads suitable for the respective crane type can be taken via the corresponding LWE ID number from the following table „Track pads for support load distribution“.

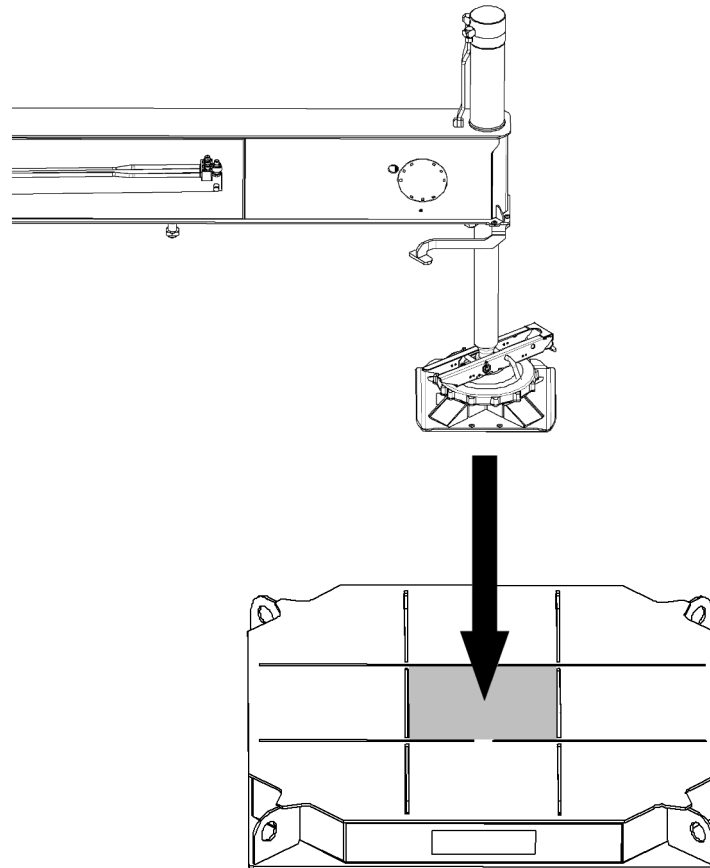


Fig.154813: Sample illustration of a outrigger pad for a crane with a telescopic boom

## 2 Safety

Before working with the outrigger pads, observe the safety instructions:

- General safety instructions, see chapter 2.04.
- Supporting the crane, see chapter 3.05.
- Installing and driving the outrigger pad (not for all crane types), see chapter 3.05.
- Assembling the outrigger pad (not for all crane types), see chapter 3.10.



### WARNING

Impermissible support plate substructure!

The crane can topple over.

Death, bodily injury, property damage.

- ▶ The ground must be able to safely absorb the occurring forces.
- ▶ Position a maximum of **one** support plate on **one** outrigger pad.
- ▶ Place the outrigger pads **centrally** below the support plates.
- ▶ The outrigger pad must be able to safely absorb the support force.



## 2.1 Placement width

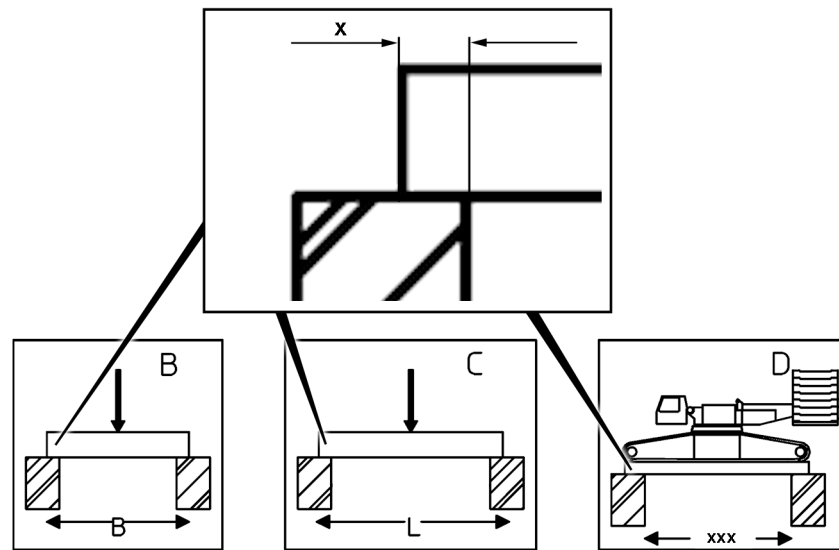


Fig.154918: Placement width  $x$



### WARNING

Placement width  $x$  **not** adhered to!  
The crane can topple over.  
Death, bodily injury, property damage.  
► Adhere to the placement width  $x$ .

## 2.2 Loads on the ground

When the crane is supported, significant forces (support forces) are transferred by the support cylinders via the support plates to the ground, see chapter 2.04. The same applies for crane operation on crawler. In this case, the forces (support forces) are transferred via the crawler plates to the ground.

- The ground must be able to safely withstand the resulting pressure. If the surface area of the crawler plates or support plates is inadequate, a substructure is required according to the load bearing capacity of the ground. Outrigger pads can be used for this.
- The support plate must be placed in the **center** on the outrigger pad. If off-center positioning is permitted, this is indicated for the corresponding outrigger pad with permissible support area.
- The required substructure for outrigger pads can be calculated from the load bearing capacity of the ground and the crawler pressures of the crane, see chapter 2.04. For the calculation examples, an even pressure distribution over the substructure surface is assumed.



### Note

► An even pressure distribution over the substructure surface can be obtained by centrally positioning the crawler or the support plates on the outrigger pad.

### 2.2.1 Permissible load configurations

Pressure forces distribute themselves differently on the ground depending on the support type and the support condition. The permissible load configurations are shown in the following illustration.

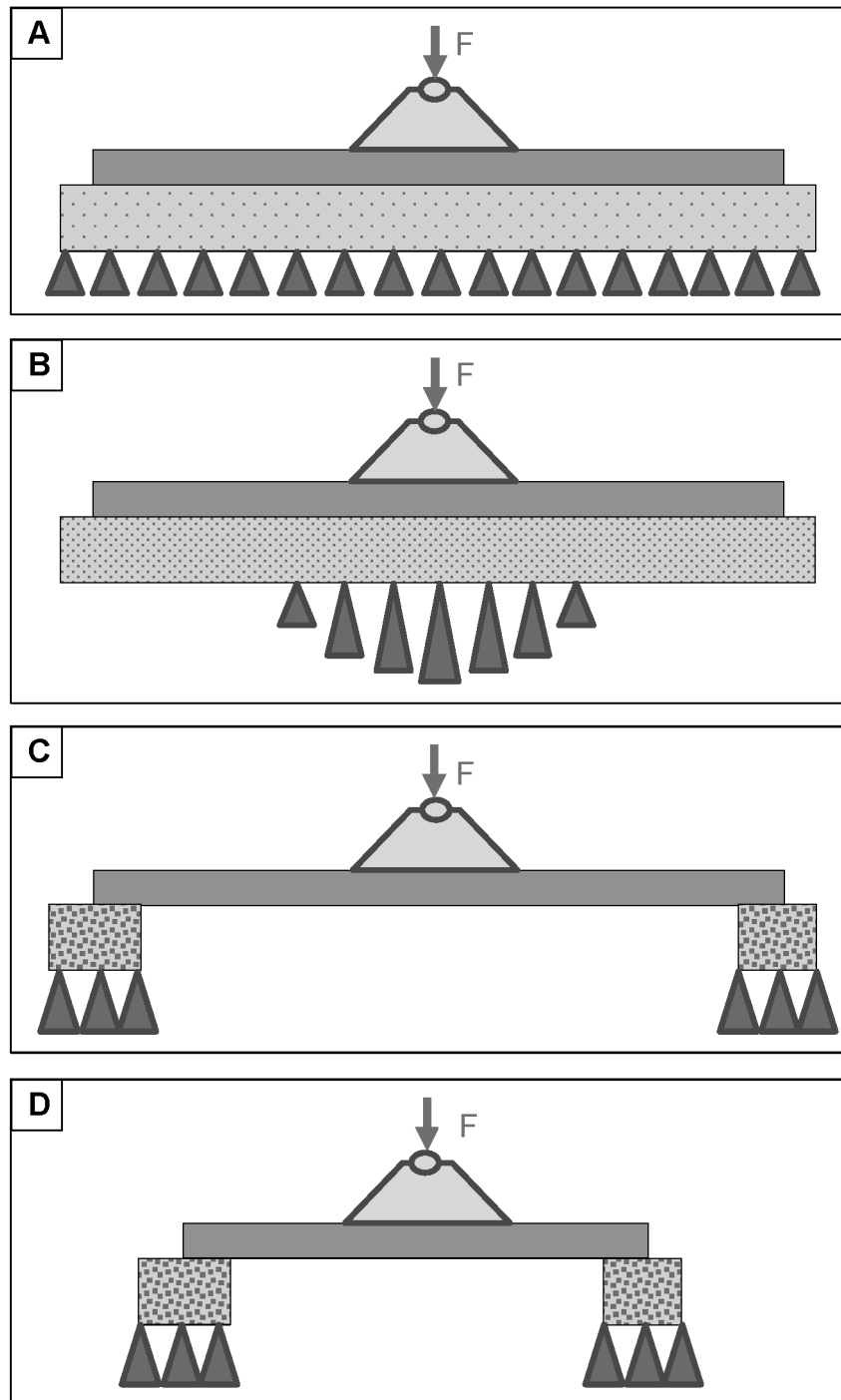


Fig.154921: Permissible load configurations

- |   |   |
|---|---|
| <b>A</b> Soft ground — even pressure distribution                       | <b>C</b> Bridge a cavity (longitudinal direction) — concentrated pressure distribution on the support surface |
| <b>B</b> Hard ground — concentrated pressure distribution in the middle | <b>D</b> Bridge a cavity (cross direction) — concentrated pressure distribution on the support surface        |

## 3 Fastening the outrigger pad



### WARNING

Incorrectly fastened outrigger pad!  
Death, severe bodily injury, property damage.

- ▶ Fasten a maximum of **one** outrigger pad.
- ▶ Fasten the outrigger pad to **all** fastening points.
- ▶ Use only approved and suitable fastening equipment.
- ▶ Always maintain a sufficient distance from the suspended load.
- ▶ Carry out all crane movements with suspended load precisely and with caution.

### 3.1 Fastening the outrigger pad

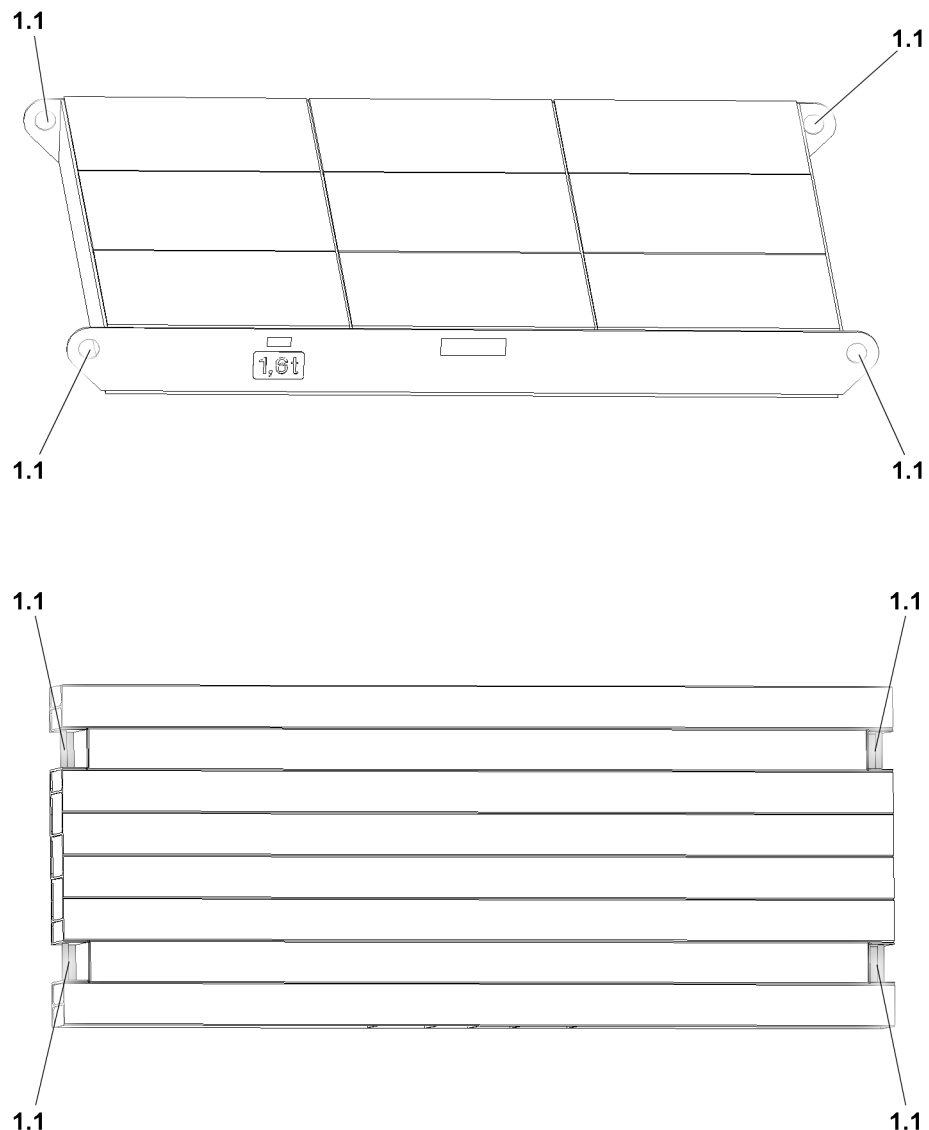


Fig.154993: Fastening points on the outrigger pads are shown as an example  
Fasten the outrigger pad to the fastening points 1.1.

## 4 Technical outrigger pad data for cranes with a telescopic boom

The following description of the outrigger pads only applies for supported crane operation.

### 4.1 Outrigger pad LWE ID number 914786508

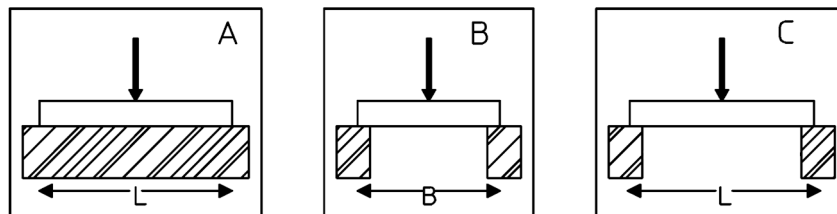


Fig.154815: Permissible support pressures

- A** The outrigger pad is placed completely on the surface
- B** The outrigger pad is positioned in the cross direction over a cavity
- C** The outrigger pad is placed in the longitudinal direction over a cavity

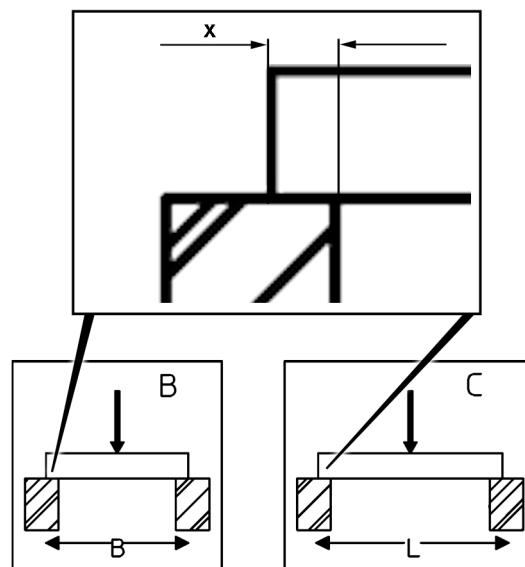


Fig.154911: Placement width  $x$

The placement width  $x$  must be at least 1.5 x height of the outrigger pad.

LWE ID number	Dimensions L x W x H <sup>1)</sup>	Surface	Mass	Permissible support pressures		
				A <sup>2)</sup>	B <sup>3)</sup>	C <sup>4)</sup>
914786508	1.0 x 1.0 x 0.12 m	1 m <sup>2</sup>	130 kg	100 t	100 t	100 t

#### Outrigger pads for support load distribution

- <sup>1)</sup> Dimensions in Length x Width x Height
- <sup>2)</sup> The outrigger pad is placed completely on the surface
- <sup>3)</sup> The outrigger pad is positioned in the cross direction over a cavity
- <sup>4)</sup> The outrigger pad is placed in the longitudinal direction over a cavity

## 4.2 Outrigger pad LWE ID number 914861908

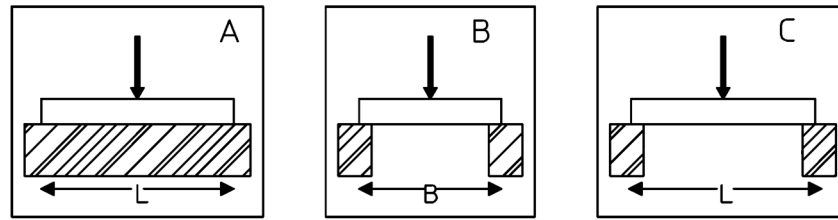


Fig.154815: Permissible support pressures

- A** The outrigger pad is placed completely on the surface
- B** The outrigger pad is positioned in the cross direction over a cavity
- C** The outrigger pad is placed in the longitudinal direction over a cavity

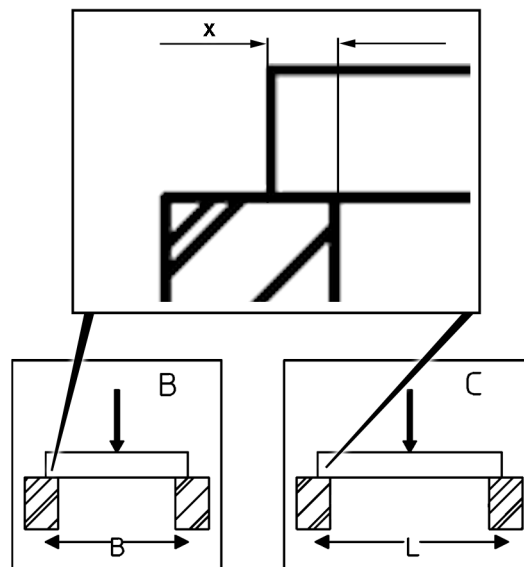


Fig.154911: Placement width x

The placement width **x** must be at least 1.5 x height of the outrigger pad.

LWE ID number	Dimensions L x W x H <sup>1)</sup>	Surface	Mass	Permissible support pressures		
				A <sup>2)</sup>	B <sup>3)</sup>	C <sup>4)</sup>
914861908	1.4 x 1.2 x 0.122 m	1.68 m <sup>2</sup>	232 kg	130 t	130 t	130 t

### Outrigger pads for support load distribution

- <sup>1)</sup> Dimensions in Length x Width x Height
- <sup>2)</sup> The outrigger pad is placed completely on the surface
- <sup>3)</sup> The outrigger pad is positioned in the cross direction over a cavity
- <sup>4)</sup> The outrigger pad is placed in the longitudinal direction over a cavity

LWE/LTR 1220-003/24204-02-02/en

### 4.3 Outrigger pad LWE ID number 914786808

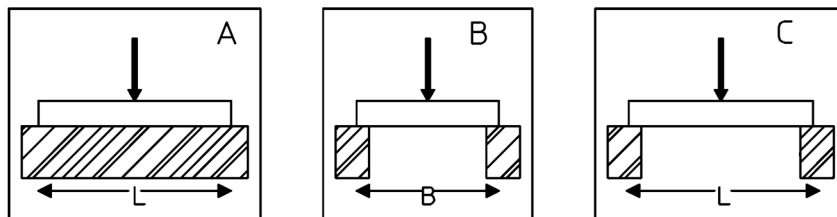


Fig.154815: Permissible support pressures

- A** The outrigger pad is placed completely on the surface
- B** The outrigger pad is positioned in the cross direction over a cavity
- C** The outrigger pad is placed in the longitudinal direction over a cavity

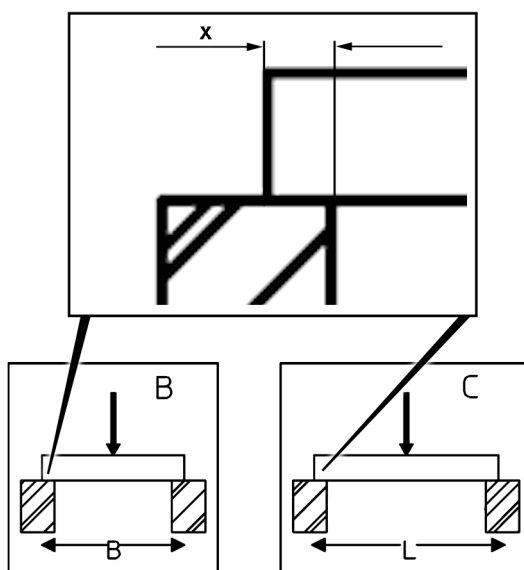


Fig.154911: Placement width *x*

The placement width *x* must be at least 1.5 x height of the outrigger pad.

LWE ID number	Dimensions L x W x H <sup>1)</sup>	Surface	Mass	Permissible support pressures		
				A <sup>2)</sup>	B <sup>3)</sup>	C <sup>4)</sup>
914786808	2.0 x 1.8 x 0.2 m	3.6 m <sup>2</sup>	555 kg	210 t	210 t	210 t

*Outrigger pads for support load distribution*

- <sup>1)</sup> Dimensions in Length x Width x Height
- <sup>2)</sup> The outrigger pad is placed completely on the surface
- <sup>3)</sup> The outrigger pad is positioned in the cross direction over a cavity
- <sup>4)</sup> The outrigger pad is placed in the longitudinal direction over a cavity

LWE/LTR 1220-003/24204-02-02/en

### 4.4 Outrigger pad LWE ID number 915236308

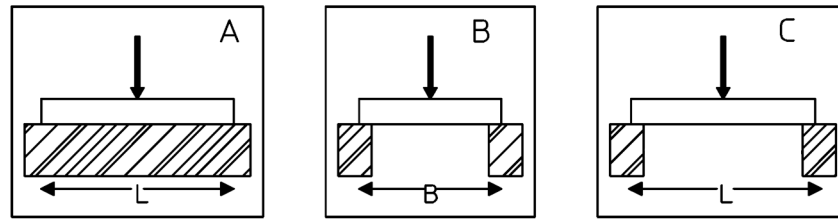


Fig.154815: Permissible support pressures

- A** The outrigger pad is placed completely on the surface
- B** The outrigger pad is positioned in the cross direction over a cavity
- C** The outrigger pad is placed in the longitudinal direction over a cavity

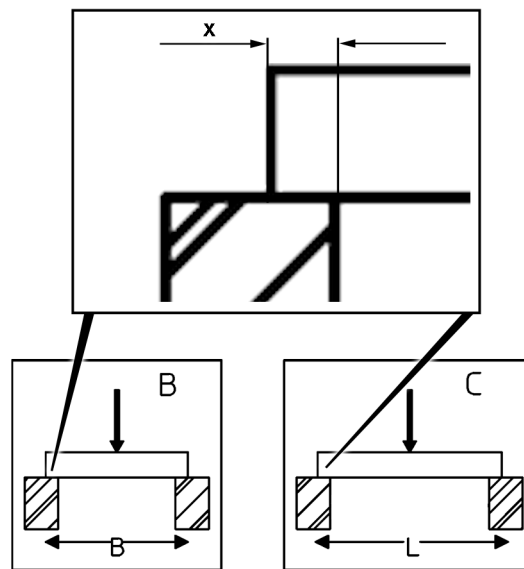


Fig.154911: Placement width x

The placement width **x** must be at least 1.5 x height of the outrigger pad.

LWE ID number	Dimensions L x W x H <sup>1)</sup>	Surface	Mass	Permissible support pressures		
				A <sup>2)</sup>	B <sup>3)</sup>	C <sup>4)</sup>
915236308	2.5 x 2.4 x 0.25 m	6 m <sup>2</sup>	1600 kg	320 t	320 t	320 t

*Outrigger pads for support load distribution*

- <sup>1)</sup> Dimensions in Length x Width x Height
- <sup>2)</sup> The outrigger pad is placed completely on the surface
- <sup>3)</sup> The outrigger pad is positioned in the cross direction over a cavity
- <sup>4)</sup> The outrigger pad is placed in the longitudinal direction over a cavity

LWE/LTR 1220-003/24204-02-02/en

#### 4.4.1 Positioning the support plate off-center on the outrigger pad

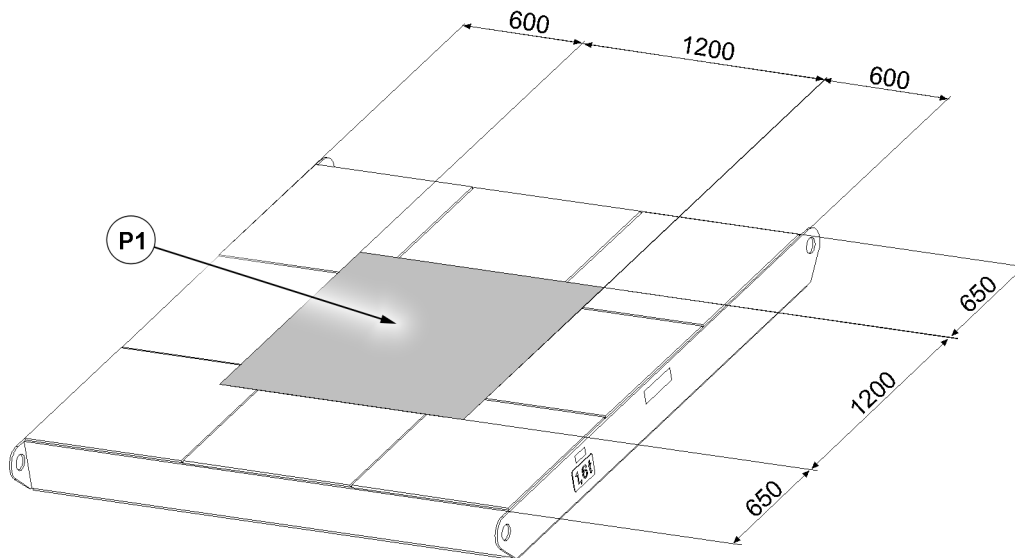


Fig.154923: Permissible placement surface for support plates

**P1** Support surface for support plates with permissible support pressure 320 t

An even pressure distribution over the substructure surface can be obtained by centrally positioning the support plates on the outrigger pad.



#### WARNING

Impermissible support plate substructure!  
The crane can topple over.  
Death, bodily injury, property damage.

► Place the outrigger pads **centrally** or according to the description under the support plates.

#### 4.5 Outrigger pad LWE ID number 915236408/915464608

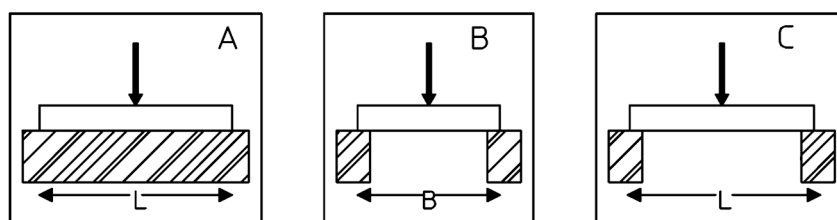


Fig.154815: Permissible support pressures

**A** The outrigger pad is placed completely on the surface  
**B** The outrigger pad is positioned in the cross direction over a cavity

**C** The outrigger pad is placed in the longitudinal direction over a cavity



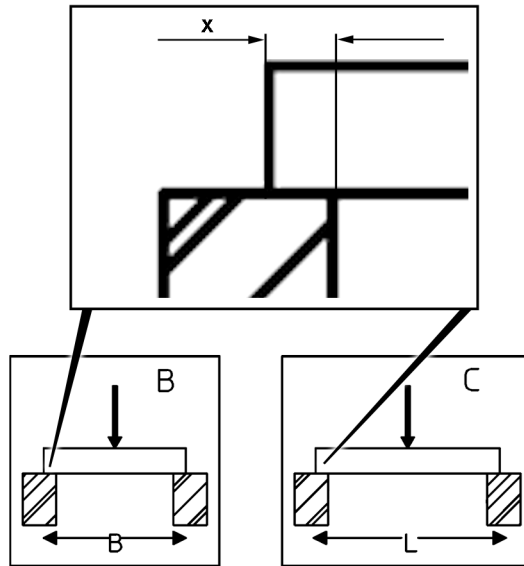


Fig.154911: Placement width x

The placement width x must be at least 1.5 x height of the outrigger pad.

LWE ID number	Dimensions L x W x H <sup>1)</sup>	Surface	Mass	Permissible support pressures		
				A <sup>2)</sup>	B <sup>3)</sup>	C <sup>4)</sup>
915236408/9154646 08	3.5 x 2.4 x 0.25 m	8.4 m <sup>2</sup>	2350 kg	320 t	320 t	320 t

**Outrigger pads for support load distribution**

- <sup>1)</sup> Dimensions in Length x Width x Height
- <sup>2)</sup> The outrigger pad is placed completely on the surface
- <sup>3)</sup> The outrigger pad is positioned in the cross direction over a cavity
- <sup>4)</sup> The outrigger pad is placed in the longitudinal direction over a cavity

LWE/LTR 1220-003/24204-02-02/en

### 4.5.1 Positioning the support plate off-center on the outrigger pad

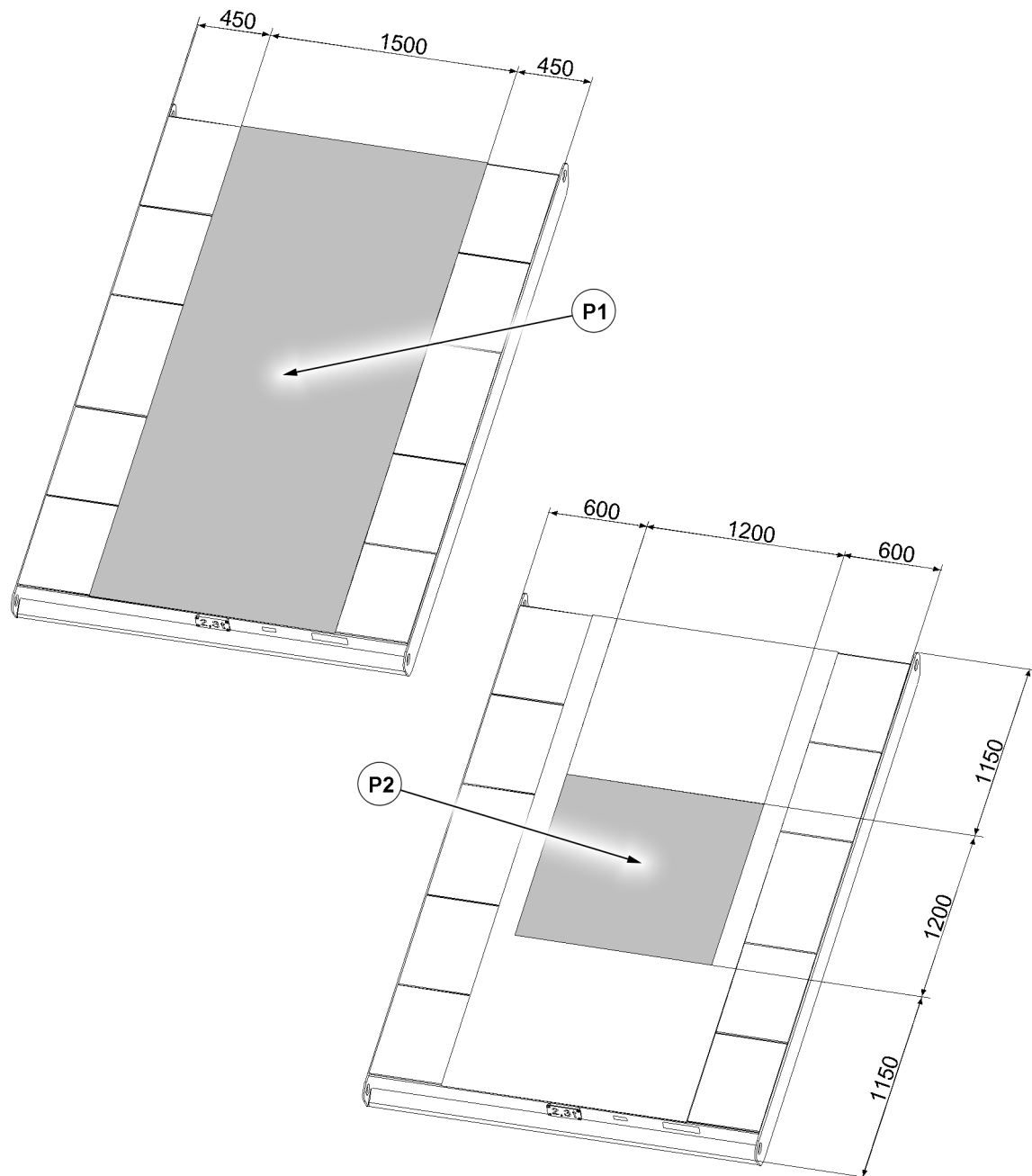


Fig. 154924: Permissible placement surface for support plates

**P1** Support surface for support plates with permissible support pressure up to 210 t

**P2** Support surface for support plates with permissible support pressure greater than 210 t up to 320 t

An even pressure distribution over the substructure surface can be obtained by centrally positioning the support plates on the outrigger pad.



#### WARNING

Impermissible support plate substructure!

The crane can topple over.

Death, bodily injury, property damage.

► Place the outrigger pads **centrally** or according to the description under the support plates.

## 5 Technical outrigger pad data for cranes with a lattice mast boom

The following description of the outrigger pads only applies for supported crane operation and in crane operation on crawler.

### 5.1 Outrigger pad LWE ID number 914618608

Observe the additional information:

- Installing and driving the outrigger pad, see chapter 3.05.

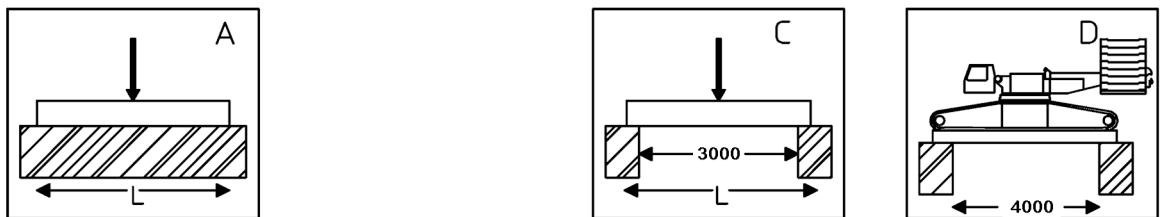


Fig.154942: Permissible support pressures

- A** The outrigger pad is placed completely on the surface
- C** The outrigger pad is placed in the longitudinal direction over a cavity
- D** The outrigger pad is placed in the longitudinal direction over a cavity and driven with the crawler crane



**Note**

- Driving the outrigger pads over a cavity is only permissible with the own weight of the crane (without a hoist load).

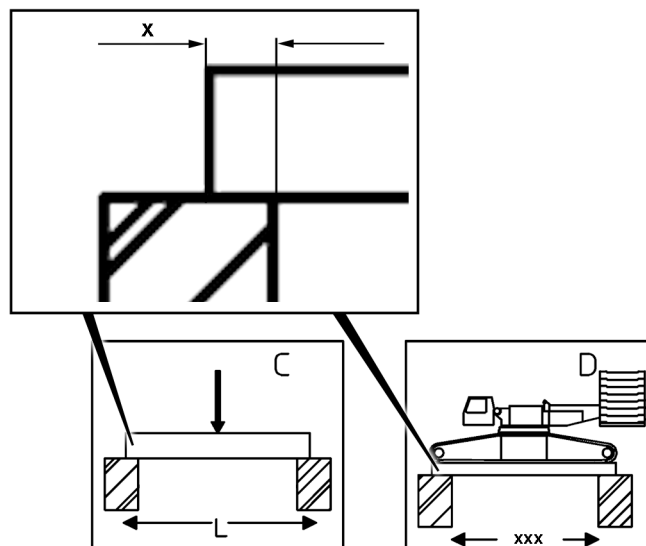


Fig.154941: Placement widths x

- C** The placement width must be at least 1.5 m.
- D** The placement width must be at least 1.0 m.

LWE/LTR 1220-003/24204-02-02/en

LWE ID number	Dimensions L x W x H <sup>1)</sup>	Surface	Mass	Permissible support pressures			
				A <sup>2)</sup>	B <sup>3)</sup>	C <sup>4)</sup>	D <sup>5)</sup>
914618608	6.0 x 2.4 x 0.3 m	14.4 m <sup>2</sup>	7800 kg	450 t		450 t	

### Outrigger pads for support load distribution

- 1) Dimensions in Length x Width x Height
- 2) The outrigger pad is placed completely on the surface
- 3) The outrigger pad is positioned in the cross direction over a cavity
- 4) The outrigger pad is placed in the longitudinal direction over a cavity
- 5) The outrigger pad is placed in the longitudinal direction over a cavity and driven with the crawler crane

## 5.1.1 Positioning the support plate off-center on the outrigger pad

Off-center positioning is only permitted if the outrigger pad lies across the entire circumference (not only on two sides) on ground that is at least 100 mm wide.

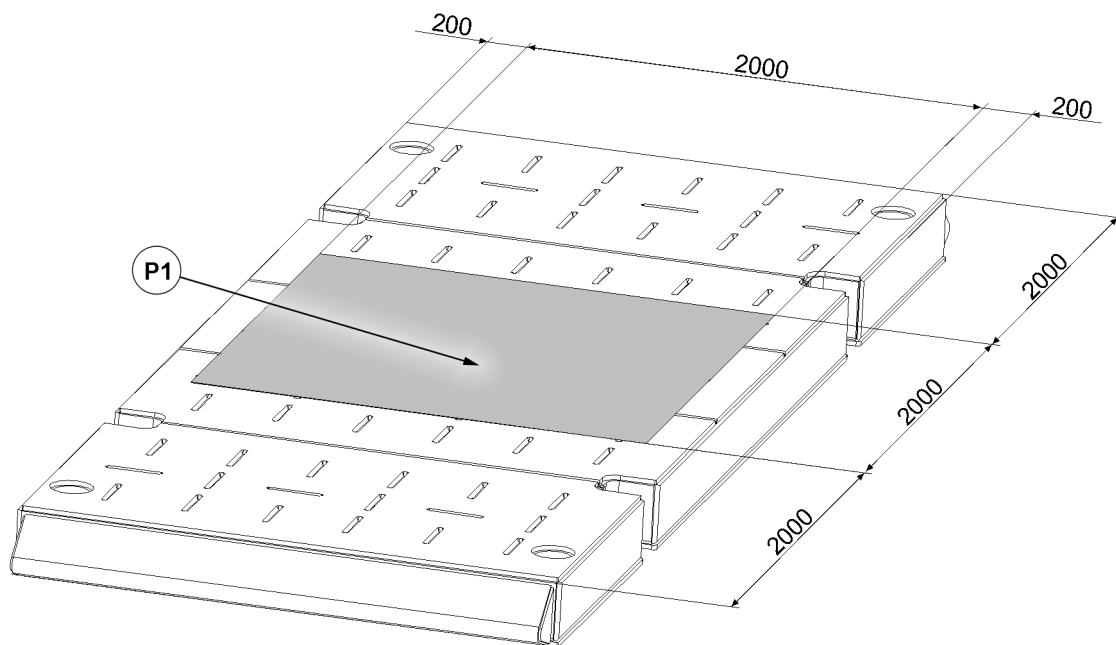


Fig.154926: Permissible placement surface for support plates

**P1** Support surface for support plates with permissible support pressure 450 t

An even pressure distribution over the substructure surface can be obtained by centrally positioning the support plates on the outrigger pad.



### WARNING

Impermissible support plate substructure!  
The crane can topple over.  
Death, bodily injury, property damage.

- ▶ Place the outrigger pads **centrally** or according to the description under the support plates.

## 5.2 Outrigger pad LWE ID number 915696408

Observe the additional information:

- Outrigger pad assembly, see chapter 3.10.

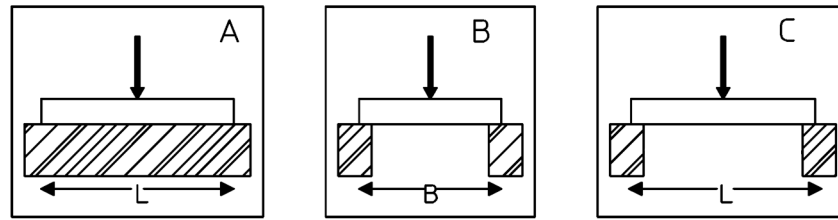


Fig.154815: Permissible support pressures

- A** The outrigger pad is placed completely on the surface
- B** The outrigger pad is positioned in the cross direction over a cavity
- C** The outrigger pad is placed in the longitudinal direction over a cavity

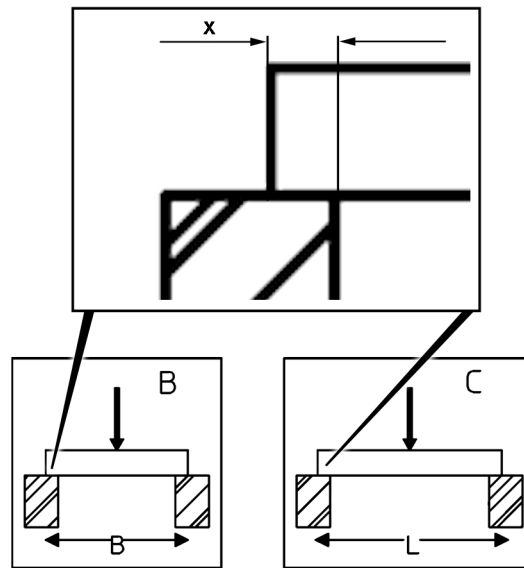


Fig.154911: Placement width *x*

The placement width *x* must be at least 2.5 x height of the outrigger pad.

LWE ID number	Dimensions L x W x H <sup>1)</sup>	Surface	Mass	Permissible support pressures		
				A <sup>2)</sup>	B <sup>3)</sup>	C <sup>4)</sup>
915696408	4.0 x 2.4 x 0.25 m	9.6 m <sup>2</sup>	3300 kg	450 t	450 t	450 t

**Outrigger pads for support load distribution**

- <sup>1)</sup> Dimensions in Length x Width x Height
- <sup>2)</sup> The outrigger pad is placed completely on the surface
- <sup>3)</sup> The outrigger pad is positioned in the cross direction over a cavity
- <sup>4)</sup> The outrigger pad is placed according to the longitudinal direction over a cavity

LWE/LTR 1220-003/24204-02-02/en

### 5.3 Outrigger pad **LWE ID number 918339808**

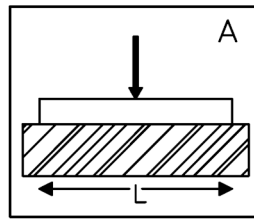


Fig.154917: Permissible support pressures

- A** The outrigger pad is placed completely on the surface

LWE ID number	Dimensions L x W x H <sup>1)</sup>	Surface	Mass	Permissible support pressures
				<b>A<sup>2)</sup></b>
918339808	6.0 x 2.4 x 0.4 m	14.4 m <sup>2</sup>	7900 kg	265 t

*Outrigger pads for support load distribution*

<sup>1)</sup> Dimensions in Length x Width x Height

<sup>2)</sup> The outrigger pad is placed completely on the surface

### 5.3.1 Positioning the support plate off-center on the outrigger pad

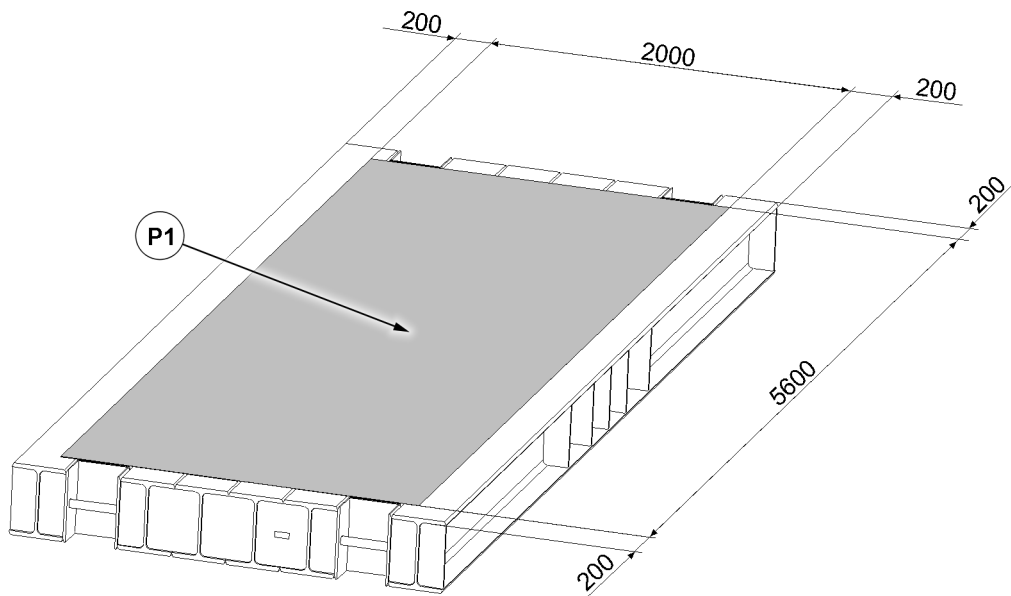


Fig.154925: Permissible placement surface for support plates

**P1** Support surface for support plates with permissible support pressure 265 t

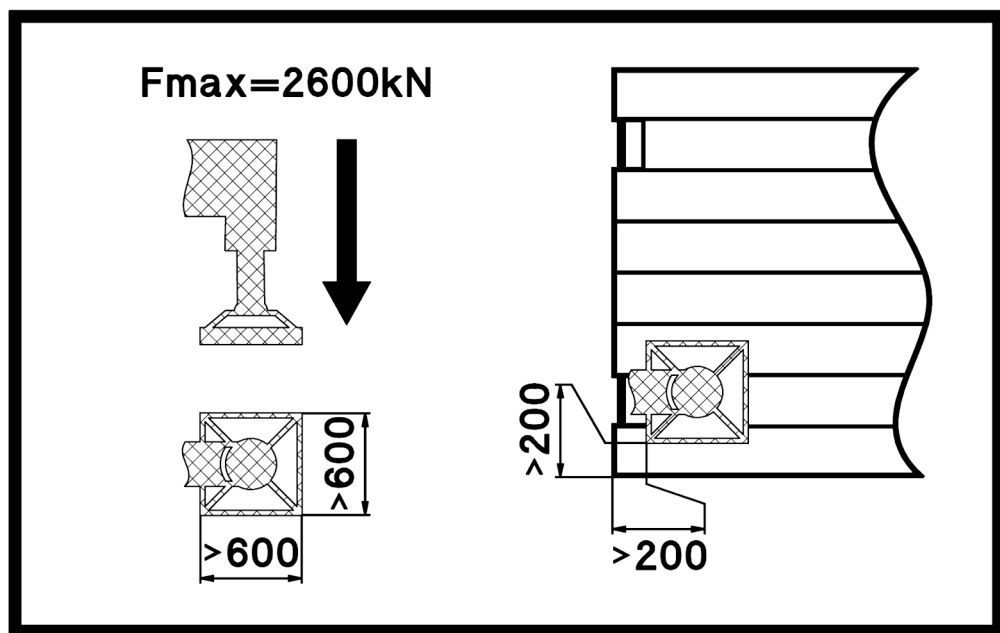


Fig.154913: The support plate is positioned off-center on the outrigger pad

LWE/LTR 1220-003/24204-02-02/en

An even pressure distribution over the substructure surface can be obtained by centrally positioning the support plates on the outrigger pad.



#### WARNING

Impermissible support plate substructure!

The crane can topple over.

Death, bodily injury, property damage.

► Place the outrigger pads **centrally** or according to the description under the support plates.

A support plate can be placed off-center on this outrigger pad. The minimum distance is 200 mm from the side edge of the outrigger pad. The side length of the support plate must be at least 600 mm.

### 5.3.2 Driving the outrigger pad in the cross direction with a crawler crane

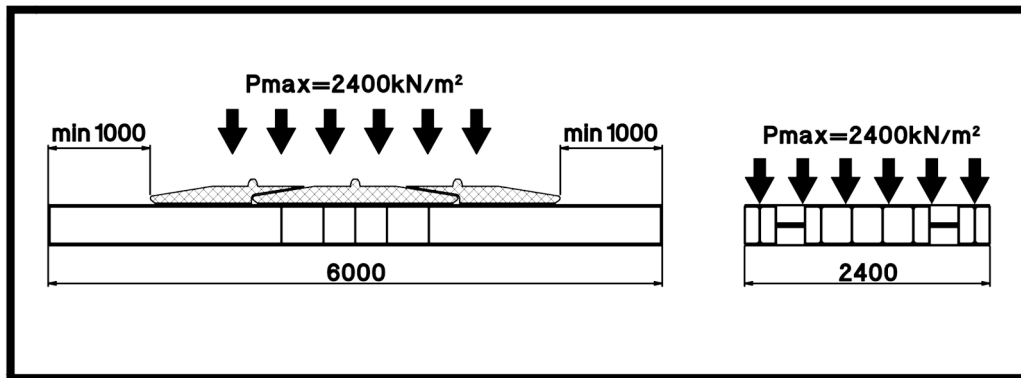


Fig.154912: Driving the outrigger pad in the cross direction with a crawler crane

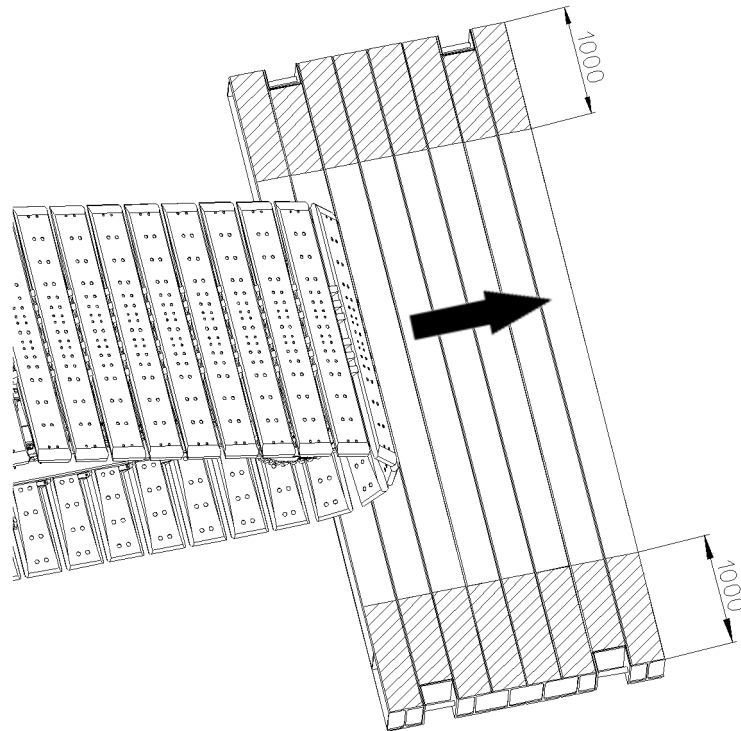


Fig.154922: Permissible driving range with the crawler crane

This outrigger pad can be driven in the cross direction with an approved crawler crane. The distance of at least 1000 mm to the side edges (longitudinal side) of the outrigger pad must be observed.



## 5.4 Outrigger pad LWE ID number 919427108

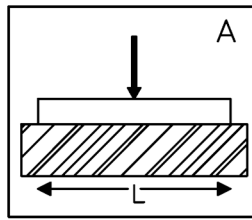


Fig.154917: Permissible support pressures

- A** The outrigger pad is placed completely on the surface



### Note

- Driving the outrigger pads over a cavity is only permissible with the own weight of the crane (without a hoist load).

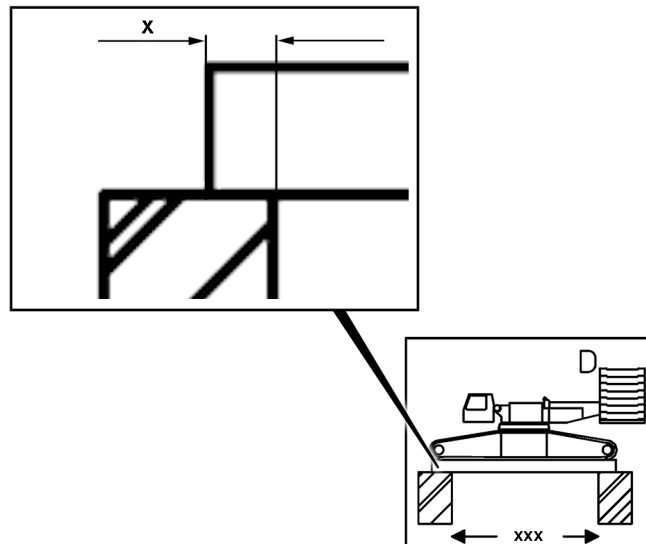


Fig.156550: Placement widths  $x$

- D** The placement width must be at least 0.5 m .
- D** The cavity may be maximum 1.0 m .

LWE ID number	Dimensions L x W x H <sup>1)</sup>	Surface	Mass	Permissible support pressures	
				A <sup>2)</sup>	D <sup>3)</sup>
919427108	4.0 x 2.4 x 0.2 m	9.6 m <sup>2</sup>	3200 kg	200 t for support plates with a placement surface of 0.6 x 0.6 m	
				310 t for support plates with a placement surface of 0.7 x 0.7 m	

#### Outrigger pads for support load distribution

<sup>1)</sup> Dimensions in Length x Width x Height

<sup>2)</sup> The outrigger pad is placed completely on the surface

<sup>3)</sup> The outrigger pad is placed in the longitudinal direction over a cavity and driven with the crawler crane

### 5.4.1 Positioning the support plate off-center on the outrigger pad

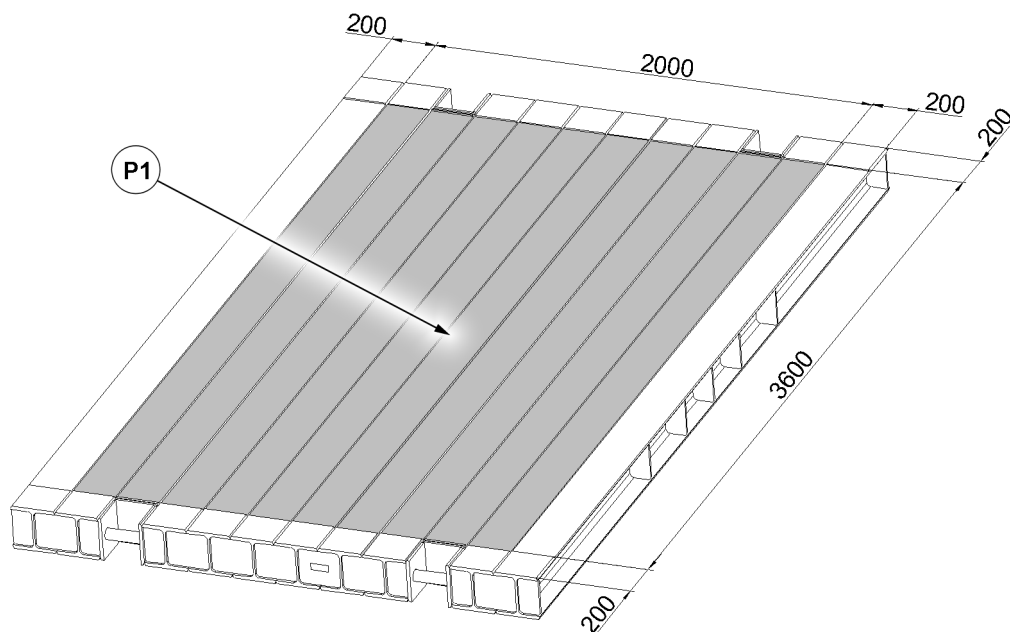


Fig.156546: Permissible placement surface for support plates

- P1** Support surface for support plates with placement surface of 600 x 600 mm with permissible support pressure of 265 t
- P1** Support surface for support plates with placement surface of 700 x 700 mm with permissible support pressure of 310 t

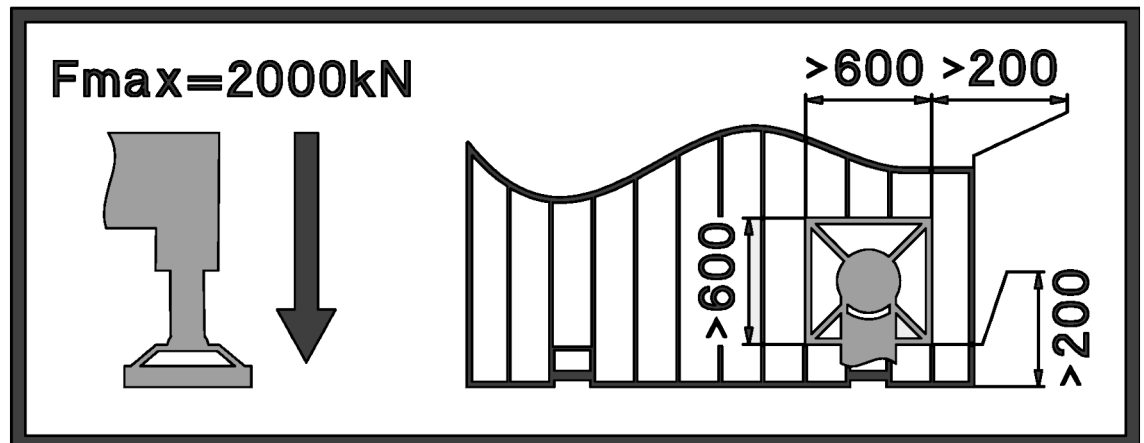


Fig.156549: The support plate is positioned off-center on the outrigger pad

An even pressure distribution over the substructure surface can be obtained by centrally positioning the support plates on the outrigger pad.



#### WARNING

Impermissible support plate substructure!  
The crane can topple over.  
Death, bodily injury, property damage.

- Place the outrigger pads **centrally** or according to the description under the support plates.

A support plate can be placed off-center on this outrigger pad. The minimum distance is 200 mm from the side edge of the outrigger pad. The side length of the support plate must be at least 600 mm.

#### 5.4.2 Driving the outrigger pad in the cross direction with a crawler crane

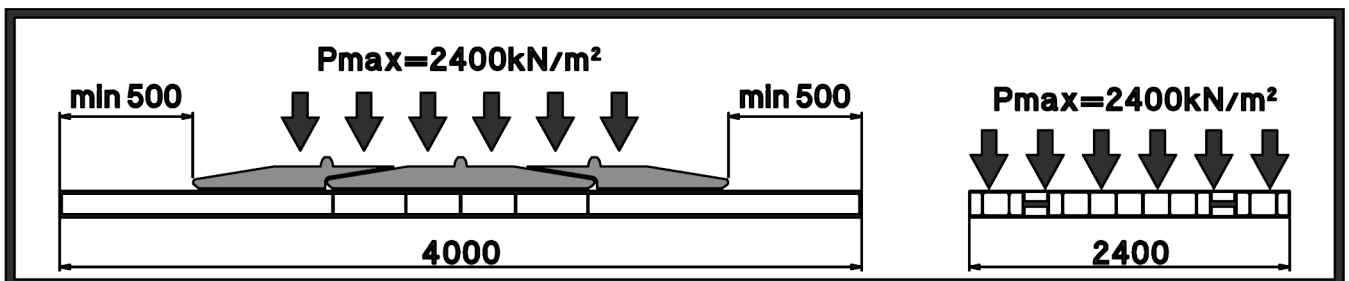


Fig.156548: Driving the outrigger pad in the cross direction with a crawler crane

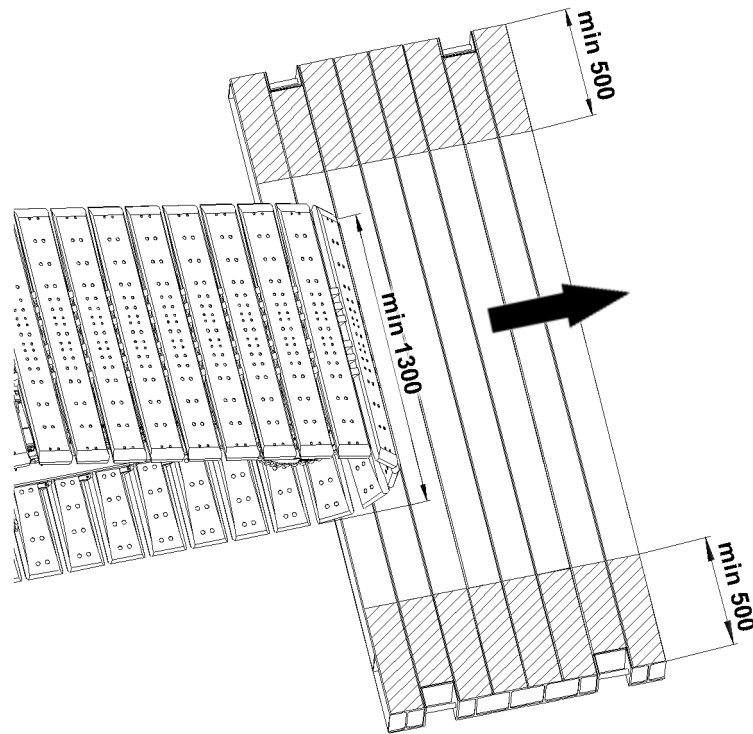


Fig.156547: Permissible driving range with the crawler crane

This outrigger pad can be driven in the cross direction with an approved crawler crane. The distance of at least 500 mm to the side edges (longitudinal side) of the outrigger pad must be observed. The support width of the crawler chain must be at least 1300 mm.

#### 5.4.3 Driving the outrigger pad in the cross direction over a cavity with a crawler crane

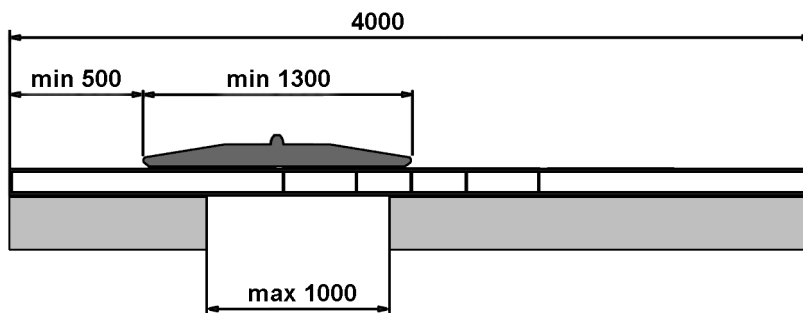


Fig.156551: Permissible driving range with the crawler crane

This outrigger pad can be driven in the cross direction over a cavity with an approved crawler crane. The distance of at least 500 mm to the side edges (longitudinal side) of the outrigger pad must be observed. The support width of the crawler chain must be at least 1300 mm. The cavity can have a maximum width of 1000 mm.

---

## 2 Safety

LWE/LTR 1220-003/24204-02-02/en

---

LWE/LTR 1220-003/24204-02-02/en

## 2.03 Job planning

1 Planning Crane operation

---

3

LWE/LTR 1220-003/24204-02-02/en

*Fig.195219*

LWE/LTR 1220-003/24204-02-02/en



# 1 Planning Crane operation

In addition to a perfectly working crane and a well-trained crew, the **planning for crane operation** is an important principle for safe crane operation.



---

## WARNING

Missing information!

Death, severe bodily injuries, property damage.

► Obtain the required information and adhere to it.

---

Obtain the following information before crane operation and adhere to it:

- Type of crane operation
- National laws and regulations
- Height and width clearance measurements
- When mobile crane: Job site, distance and travel route
- Space prerequisites at the job site
- Electrical transmission lines with voltage data
- Movement restrictions caused by buildings
- Weight and dimensions of the load(s) to be lifted
- Geometric form and air resistance coefficient of the load(s) to be lifted
- Required lifting height and boom projection
- Ground bearing capacity at the job site
- Required space for the assembly and disassembly of the crane
- Weather data and weather forecasts

Assemble the equipment for crane operation:

- Hook block / load hook
- Auxiliary boom
- Fastening equipment
- Counterweight
- Base materials for support plates

---

Empty page!

LWE/LTR 1220-003/24204-02-02/en

## 2.04 Technical safety instructions

1	Dangers on the crane	3
2	Danger zone of crane	5
3	Traffic endangerment and environmental damage	6
4	Endangering air traffic	6
5	Movement on the crane	7
6	Emergency exit	7
7	Personal protective equipment	9
8	Supplied fire extinguisher	15
9	Securing persons to prevent them from falling	16
10	Rescuing the assembly personnel	17
11	Crane cab	18
12	Transport	25
13	Fastening	27
14	Heated crane components	27
15	Crane operator responsibilities	28
16	Selecting the location	30
17	Slopes and excavations	34
18	Loads on the ground due to crane operation	37
19	Support	41
20	Aligning the crane	43
21	Checking the safety measures	44
22	Safety instructions in case of an external power supply	45
23	Grounding	45
24	Working in the vicinity of transmitters	47
25	Crane operation in case of thunderstorms	48
26	Wind influences	49
27	Lifting a load with two cranes	55
28	Overlapping of working ranges of several cranes	57
29	Hand signals for guidance	58
30	Travel operation	66
31	Crane operation	68
32	Lifting of personnel	76
33	Securing personnel on shut off crane	78
34	Welding work on the load	80

*Fig.195219*

LWE/LTR 1220-003/24204-02-02/en

**Note**

- ▶ The illustrations in this chapter are only examples. The illustrations may differ depending on the crane model.

# 1 Dangers on the crane

## 1.1 Chemicals

Proposition 65 of the US State of California warns against chemicals that are known to cause cancer and birth defects or other reproductive harm. For additional information, see the website: [www.P65Warnings.ca.gov](http://www.P65Warnings.ca.gov)

Proposition 65	
	<p><b>WARNING:</b> This product can expose you to chemicals, which are known to the State of California to cause cancer and birth defects or other reproductive harm.</p> <ul style="list-style-type: none"> <li>• Avoid direct contact with chemicals.</li> <li>• Use personal protective equipment: Always wear protective gloves.</li> <li>• After handling: Wash hands thoroughly.</li> <li>• Dispose of chemicals in an environmentally acceptable manner according to local regulations.</li> </ul> <p>For more information see: <a href="http://www.P65Warnings.ca.gov">www.P65Warnings.ca.gov</a>.</p>

Fig.154660: Example of a Proposition 65 sign for USA: Chemicals

**WARNING**

Chemicals!

Damage to health such as cancer and birth defects or other reproductive harm.

- ▶ Avoid direct contact with chemicals.
- ▶ Use personal protective equipment: **Always** wear protective gloves.
- ▶ After handling: Wash hands thoroughly.
- ▶ Dispose of chemicals in an environmentally acceptable manner according to local regulations.

## 1.2 Diesel engine exhaust emissions

Proposition 65 of the US State of California warns against diesel engine exhaust emissions that are known to cause cancer and birth defects or other reproductive harm. For additional information, see the website: [www.P65Warnings.ca.gov/diesel](http://www.P65Warnings.ca.gov/diesel)


<b>Proposition 65</b>	
	<p><b>WARNING:</b> Breathing diesel engine exhaust exposes you to chemicals known to the State of California to cause cancer and birth defects or other reproductive harm.</p> <ul style="list-style-type: none"> <li>• Always start and operate the engine in a well-ventilated area.</li> <li>• If in an enclosed area, vent the exhaust to the outside.</li> <li>• Do not modify or tamper with the exhaust system.</li> <li>• Do not idle the engine except as necessary.</li> </ul> <p>For more information see: <a href="http://www.P65Warnings.ca.gov/diesel">www.P65Warnings.ca.gov/diesel</a>.</p>

Fig.154661: Example of a Proposition 65 sign for USA: Diesel engine exhaust emissions



#### **WARNING**

Diesel engine exhaust emissions!

Damage to health such as cancer and birth defects or other reproductive harm.

- ▶ Always start and operate the diesel engine in properly ventilated spaces.
- ▶ If in enclosed areas: Direct the exhaust gas to the outside.
- ▶ Do not convert the exhaust system or make any other changes.
- ▶ Do not run the engine at idle speed for longer than necessary.

### 1.3 Lead and lead compounds

Proposition 65 of the US State of California warns against lead and lead compounds that are known to cause cancer and birth defects or other reproductive harm. For additional information, see the website: [www.P65Warnings.ca.gov](http://www.P65Warnings.ca.gov)


<b>Proposition 65</b>	
	<p><b>WARNING:</b> This product can expose you to chemicals, including lead and lead compounds, which are known to the State of California to cause cancer and birth defects or other reproductive harm.</p> <ul style="list-style-type: none"> <li>• Avoid direct contact with batteries and their components.</li> <li>• Do not touch them with bare hands.</li> <li>• Use personal protective equipment: <b>Always</b> wear protective gloves.</li> <li>• After handling: Wash hands thoroughly.</li> <li>• Dispose of disused batteries in an environmentally acceptable manner according to local regulations.</li> </ul> <p>For more information see: <a href="http://www.P65Warnings.ca.gov">www.P65Warnings.ca.gov</a>.</p>

Fig.154662: Example of a Proposition 65 sign for USA: Lead and lead compounds

**WARNING**

Batteries, battery poles, battery terminals and other battery components contain lead and lead compounds!

Damage to health such as birth defects and other reproductive harm.

- ▶ Avoid direct contact with batteries and their components.
- ▶ Do not touch them with bare hands.
- ▶ Use personal protective equipment: **Always** wear protective gloves.
- ▶ After handling: Wash hands thoroughly.
- ▶ Dispose of disused batteries in an environmentally acceptable manner according to local regulations.

## 1.4 Hydraulic oil, diesel fuel, operating fluids

**WARNING**

Due to technical defects or open tank covers, hydraulic oil, diesel fuel or service fluids spill out!

Dirt from the road and ground.

Traffic endangerment: Danger of skidding, death, severe bodily injuries.

Environmental pollution: Death, severe damage to health.

- ▶ Remedy the technical defect immediately.
- ▶ Securely close the tank cover after refuelling.
- ▶ Immediately and thoroughly remove traces of hydraulic oil, diesel fuel, operating fluids.
- ▶ Avoid skin contact with hydraulic oil, diesel fuel and operating fluids.
- ▶ Wear personal protective equipment.

**WARNING**

Hot hydraulic oil! Hot service fluids!

Severe burns, severe scalds and severe bodily injuries.

- ▶ Before all work: Let hot hydraulic oil and hot operating fluids cool off.
- ▶ Avoid contact with hot hydraulic oil and hot operating fluids.
- ▶ Wear personal protective equipment.

## 1.5 Heated crane components

**WARNING**

Heated crane components! Hot surfaces!

Severe burns.

This applies in particular to exhaust systems, engines and transmissions.

- ▶ Let the components cool down before touching them.
- ▶ Proceed with special caution near heated crane components.
- ▶ Avoid skin contact with hot surfaces.
- ▶ Use personal protective equipment, such as protective gloves.

# 2 Danger zone of crane

## 2.1 Crane in operation

The danger zone of the crane is made up of the areas which are accessed during crane operation by the load or by movements of the crane or the crane components.

**WARNING**

Do not stay in danger zone!

Personnel within the danger zone can be hit by falling loads or components.

Personnel in the danger zone can be caught by moving crane components or loads.

Fatal or severe injuries can be the result.

- ▶ Warn any personnel within the danger zone with the warning device of the crane.
- ▶ After the warning is issued, wait and ensure that no personnel remains within the danger zone.
- ▶ If required, block off the danger zone at a safety distance.

## 2.2 Crane out of service

Take the crane out of service, failure to comply with the regulations represents considerable danger for the entire area around the crane.

**WARNING**

Actual wind speed higher than the wind speed permitted for the crane set up configuration!

Personnel within the danger zone can be hit by a toppling crane or crane components.

- ▶ Make sure that the condition of the crane complies with the regulations and the wind speed charts.
- ▶ If required, block off the danger zone at a safety distance.

**WARNING**

Icing on the boom!

Personnel within the danger zone can be hit by a falling ice.

- ▶ Make sure that there is no personnel in the danger zone.
- ▶ If required, block off the danger zone at a safety distance.

## 3 Traffic endangerment and environmental damage

**WARNING**

Danger of slipping and skidding!

If the road becomes contaminated due to technical defects, open tank covers or leaking hydraulic oil, then this would pose a severe traffic endangerment.

Fatal accidents can result.

- ▶ Remove oil immediately and thoroughly.

## 4 Endangering air traffic

When working with crane, heights are reached which could endanger air traffic. This applies especially to areas near airports.

**WARNING**

Endangering air traffic!

If no protective measures are taken, this can result in endangerment to air traffic.

- ▶ Get the approval from agency responsible for air traffic.
- ▶ Install the airplane warning light on the boom head and turn it on.
- ▶ If the airplane warning lights is operated for a longer period of time, with the engine turned off, then the battery can be discharged and as the result the airplane warning light turns off. To prevent the battery from discharging, an external electrical power supply must be established.



## 5 Movement on the crane



### WARNING

Danger of slipping and falling!

The traction of steps, walkways and hand rails changes due to effects of the weather, such as wetness, ice, snow, frost and dirt.

Personnel can be severely injured or killed.

The crane can be damaged.

- ▶ Step on the walkways and steps only by taking the present conditions into account, such as icing in winter or dirt.
- ▶ Step or place a load only on the approved walkways and steps.
- ▶ Observe the signage.
- ▶ Replace damaged safety signs (warning signs) immediately.

## 6 Emergency exit

### 6.1 Emergency exit - driver's cab

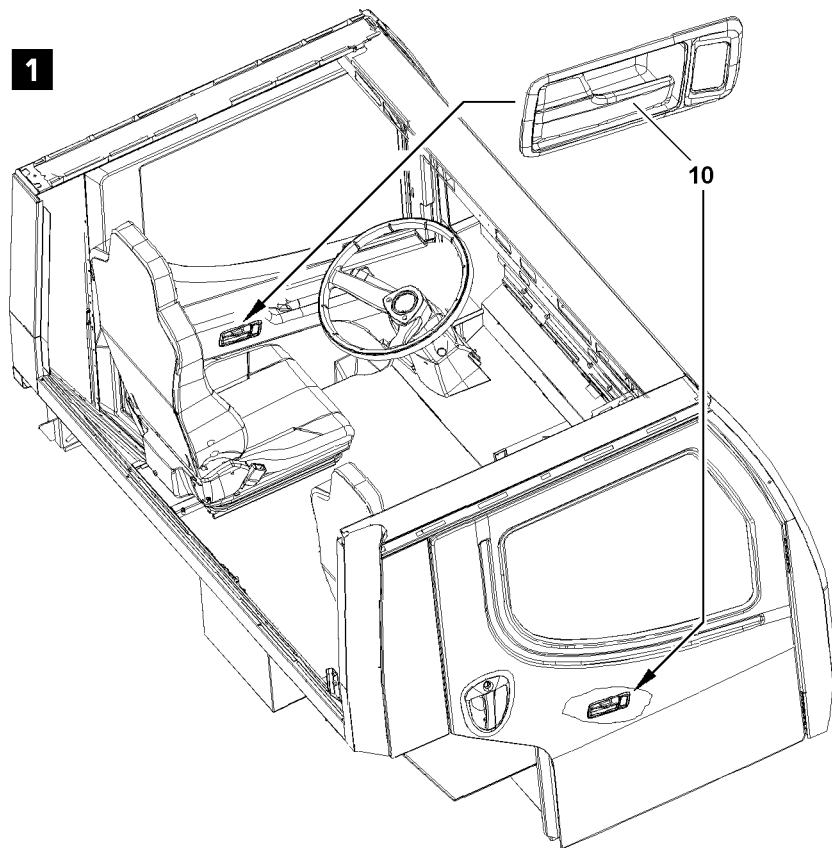


Fig.120932: Example of emergency exit - driver's cab

The driver's cab can be exited through the „left driver's door“ or the „right passenger door“, see illustration 1.



### Note

- ▶ Exit the driver's cab through the „left driver's door“ or the „right passenger door“, see illustration 1: Pull and open the door handle 10 on the „left driver's door“ or the „right passenger door“.

## 6.2 Emergency crane cab exit



### WARNING

Danger of falling!

If the crane driver cannot leave the crane cab through the door or if the crane cab is tilted, then there is a danger of falling during the emergency exit.

Death or severe injuries.

► Exit carefully in an emergency.

During the emergency exit there is an increase danger of accidents:

► Accept help from others.

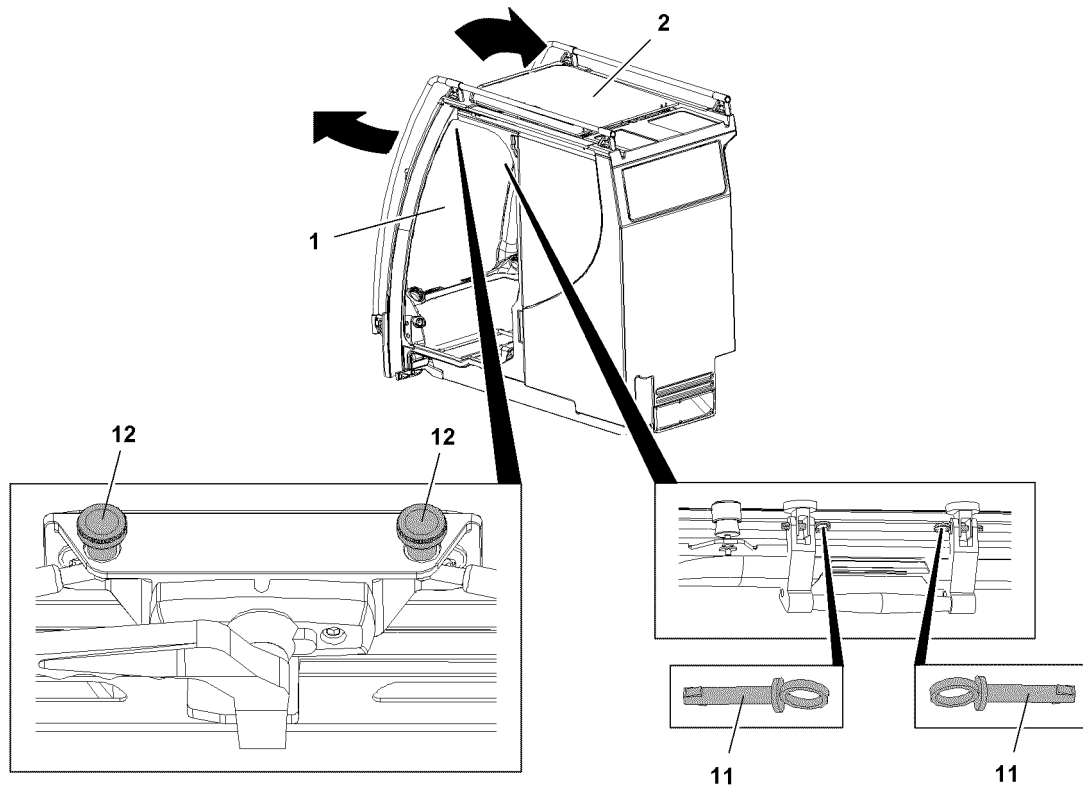


Fig.121111: Examples of emergency exit from the crane cab

If the emergency exit through the door is not possible, then the crane cab can be exited through additional openings.

The following openings are possible:

- 1 Front window
- 2 Roof window

### 6.2.1 Emergency exit through front window

- Unlock all turn handles.
- Open the front window 1.
- Leave the crane cab through the front window 1.

### 6.2.2 Emergency exit through the roof window

There are two ways to unlock the roof window 2 for the emergency exit:

- Unpin both pins 11.
- Release both thumbscrews 12.
- Unlock all turn handles.

- Unlock the roof window **2** for the emergency exit.
- Open the roof window **2**.
- Leave the crane cab through the roof window **2**.

### 6.2.3 Emergency exit with EMERGENCY hammer\*

Certain crane types carry an EMERGENCY hammer\* in the crane cab.

- Knock the front window out with the EMERGENCY hammer\* or a suitable object.
- Leave the crane cab.

## 7 Personal protective equipment

When working on the crane, the required personal protective equipment according to national regulations and accident prevention regulations must be provided and used.

Personal protective equipment includes the following:

- Supplied fall arrest system (safety harness and height safety equipment)
- Supplied height rescue system
- Head protection with chin strap
- Safety shoes
- Protective gloves
- Safety goggles
- Warning apparel
- Hearing protection
- Respiratory protection



### WARNING

Personal protective equipment when working on the crane not used!  
Death, severe bodily injuries.

The crane operator must ensure the following:

- ▶ The personal protective equipment is made available.
- ▶ The provided personal protective equipment is taken along and used.
- ▶ The operating instructions and maintenance instructions of the manufacturer for the personal protective equipment are observed and complied with.
- ▶ The product identifications are regularly checked for damage.
- ▶ Personal protective equipment with damaged product identification is replaced immediately.
- ▶ Damaged fall arrest systems with height rescue systems will be replaced immediately and handed over to an authorized inspector.
- ▶ Personal protective equipment is checked for damage and completeness before use.
- ▶ Defective or damaged personal protective equipment is replaced immediately with functioning protective equipment.

### 7.1 Supplied fall arrest system

When no other safety measures are possible for working in the presence of a fall hazard, the supplied fall arrest system must be used.

A fall with a fall arrest system cannot exclude an injury. The fall arrest system reduces however the severity of the injuries.



### WARNING

Persons not secured!  
Personnel can fall down. Death, severe bodily injuries.

- ▶ Use the supplied fall arrest system.

**WARNING**

Fall arrest system damaged!

Personnel can fall down. Death, severe bodily injuries.

- ▶ Do **not** use a damaged fall arrest system.
- ▶ Replace a damaged fall arrest system immediately with a new fall arrest system.
- ▶ Do **not** use the fall arrest system as fastening equipment for loads.
- ▶ Protect the fall arrest system from external influences.

The fall arrest system must be protected against the following external influences:

- Extreme temperatures
- Guiding the connecting devices over or around sharp edges
- Chemical influences
- Electrical influences
- Cuts, wear
- Climatic effects

**Note**

If the fall arrest system (safety harness and height safety equipment) is not available or is damaged:

- ▶ Order is from Liebherr-Werk Ehingen GmbH.

Identification and operating instructions

- The supplied fall arrest system must be clearly and permanently identified.
- If the identification is no longer legible, then the supplied fall arrest system must be immediately replaced and handed over to an authorized inspector.
- The operating instructions must be available in the language of the user country.
- If the crane and the relative personal protective equipment is sold to another country, then the purchaser must make sure that the complete documentation, such as the operating instructions, the manufacturer's operating instructions, inspection log and maintenance documents, are available in the language of the user country.

### 7.1.1 Safety harness with height safety equipment

The fall arrest system consists of the following components:

- Safety harness **1** approved according to **EN 361**
- Single strand height safety equipment **2** approved according to **EN 360** (for horizontal use and sharp edges)
- or two strand height safety equipment **3** approved according to **EN 360** (for horizontal use and sharp edges)

Fall arrest systems that are not obtained from Liebherr-Werk Ehingen GmbH are **not** designed for the crane structure.

**WARNING**

Impermissible fall arrest system!

Personnel can fall down. Death, severe bodily injuries.

- ▶ Utilize exclusively a fall arrest system from Liebherr-Werk Ehingen GmbH.

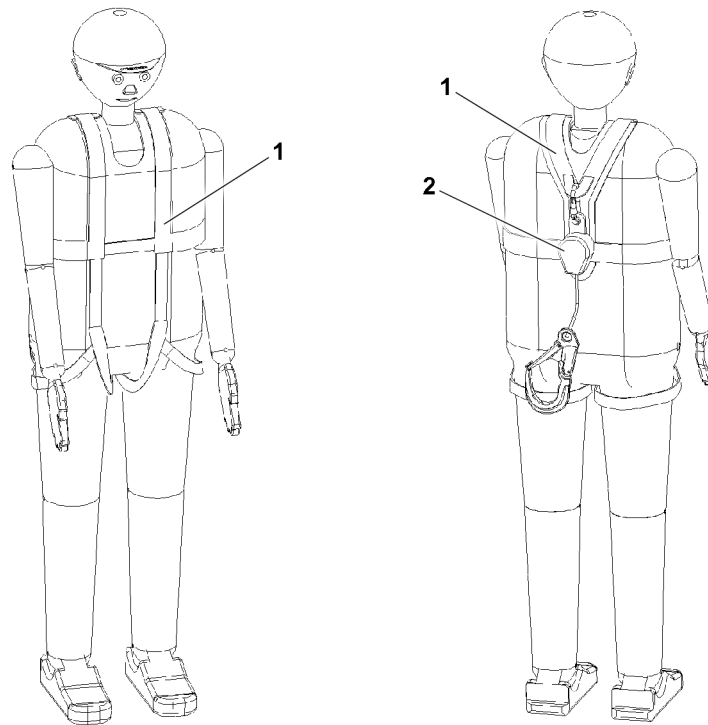


Fig.146453: Example of a safety harness 1 with a single strand height safety equipment 2

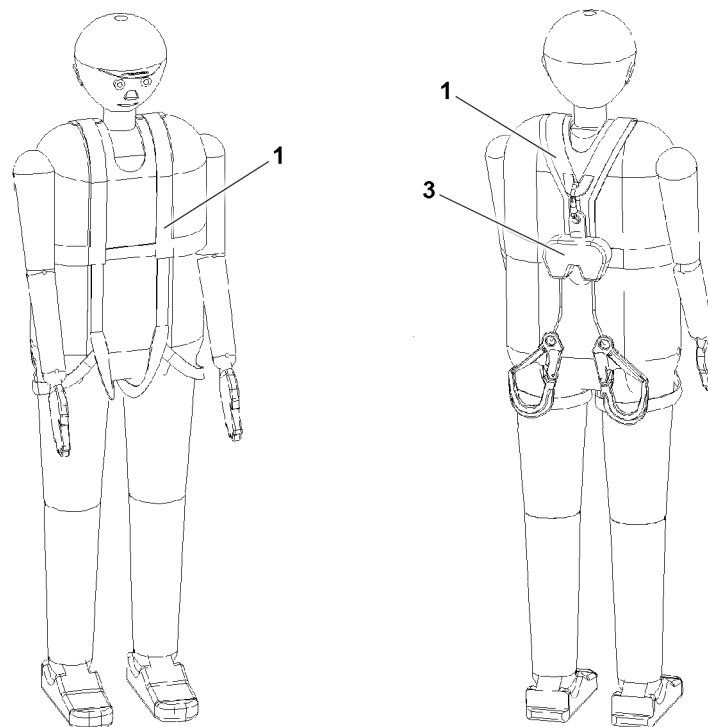


Fig.146454: Example of a safety harness 1 with a two strand height safety equipment 3

Prior to crane operation:

- Make sure that the fall arrest system is completely available and functional.
- Check the fall arrest system before use for visible defects. In the case of visible defects: Replace the fall arrest system immediately.

Handling the supplied fall arrest system:

- Observe and comply with the operating instructions of the fall arrest system.
- Check the fall arrest system before use for visible defects.

- The fall arrest system must be work where no other fall protection equipment, such as railings, can be installed for technical reasons.
- The fall arrest system is effective from a height of 2.5 m. The fall space must be free of obstacles.
- Do **not** change the configuration of the fall arrest system.
- Do **not** lengthen or shorten the fall arrest rope.
- A fall absorber is integrated in the height safety equipment. Do **not** use an additional fall absorber.
- Fasten the fall arrest system only to the hook points, safety ropes and fastening points designed for this purpose. See chapter 2.06.

Behavior in the case of a fall, damage or impairment of the functionality:

- In the case of damage or impairment of the functionality: Replace the fall arrest systems immediately and hand them over to an authorized inspector.
- After every fall: Take down the fall arrest system immediately and hand it over to an authorized inspector. The results must be documented in the fall arrest system inspection log book.
- Only after a written approval may the fall arrest system be reused. The approval must be provided in writing and documented.
- Fall arrest systems that are no longer approved must **not** be used. Unapproved fall arrest systems must be disposed of and replaced with new fall arrest systems.

Storage of the fall arrest system:

- Store the fall arrest system dry and without the effect of UV radiation in the corresponding transport bag.

The operator must ensure the following:

- Personnel must be instructed at least once a year on how to use the supplied fall arrest system (safety harness and height safety equipment) with practical exercises. Performance of the instruction and exercises must be documented.
- The safety harness and height safety equipment must be checked at least once a year by an authorized inspector. The results must be documented in the fall arrest system inspection log book.

### Single strand height safety equipment

The single strand height safety equipment is equipped with a belt strap. Single strand height safety equipment is provided for all cranes that do not have walking surfaces with safety ropes.

Use the supplied height safety equipment with extendable belt strap and snap hook with swivel according to **EN 362 Class A**.

### Two strand height safety equipment

The two strand height safety equipment is equipped with two belt straps. Height safety equipment with two belt straps are provided for cranes with walking surfaces and two ropes as fastening device on the left and right hand side of the walking surface, for example lattice sections, lattice booms, possibly telescopic booms or assembly units.

Use the supplied height safety equipment with two extendable belt straps and snap hooks with swivel according to **EN 362 Class A**.



#### WARNING

Height safety equipment incorrectly used!  
Personnel can fall down. Death, severe bodily injuries.

When two safety ropes are present on the booms, lattice sections or other components:

- ▶ Only use the height safety equipment with two belt straps.
- ▶ Hook one belt strap with snap hook for the fall arrest system per safety rope.
- ▶ When transferring to new safety equipment, a snap hook for the fall arrest system must **always** be hooked.

## 7.2 Height rescue system

The height rescue system is only supplied on certain crane types.

The height rescue system is an evacuation and rescue device. It is used to lift the fallen person to be able to unhook him from the height safety equipment and to lower him by rope.

The height rescue system consists of the following components:

- Rappelling rescue device
- Telescopic rod for hooking the snap hook on the safety harness



#### **WARNING**

Height rescue system not present!

Fallen person cannot be saved. Suspension trauma, death, severe bodily injuries.

- ▶ Always have the height rescue system ready.



#### **WARNING**

Height rescue system damaged!

Personnel cannot be saved.

- ▶ Do **not** use a damaged height rescue system.
- ▶ Replace a damaged height rescue system immediately with a new height rescue system.
- ▶ Protect the height rescue system from external influences.

The height rescue system must be protected against the following external influences:

- Extreme temperatures
- Chemical influences
- Electrical influences
- Cuts, wear
- Climatic effects

Prior to crane operation:

- Make sure that the height rescue system is completely available and functional.
- Check the height rescue system before use for visible defects. In the case of visible defects: Replace the height rescue system immediately.

Handling the height rescue system:

- Observe and comply with the operating instructions of the height rescue system.
- Do **not** change the configuration of the height rescue system.

Behavior in the case of a fall, damage or impairment of the functionality:

- In the case of damage or impairment of the functionality: Replace the height rescue system immediately and hand it over to an authorized inspector.
- After every use: Hand the height rescue system over to authorized inspector. The results must be documented in the height rescue system inspection log book.
- Only after a written approval may the height rescue system be reused. The approval must be provided in writing and documented.
- Height rescue systems that are no longer approved must **not** be used. Unapproved height rescue systems must be disposed of and replaced with new height rescue systems.

Storage of the height rescue system:

- Store the height rescue system dry and without the effect of UV radiation in the corresponding transport bag.

The operator must ensure the following:

- Personnel must be instructed at least once a year on how to use the height rescue system with practical exercises. Performance of the instruction and exercises must be documented.
- The height rescue system must be checked at least once a year by an authorized inspector. The results must be documented in the height rescue system inspection log book.

## **7.3 Hard hat**

Wear a hard hat with a chin strap, if head injuries are possible. For example, due to:

- Striking
- Falling, tipping or flying objects
- Oscillating objects

Replace the hard hat immediately, if:

- If it is struck with force
- It has visible defects
- The maximum service life specified by the manufacturer has been reached

An industrial hard hat can protect against striking fixed objects and falling or oscillating objects, but **not** against falling loads.



#### **WARNING**

Suspended and falling loads!

Death, severe bodily injuries.

- ▶ Do **not** remain under suspended loads.

## **7.4 Protective gloves**

Wear protective gloves, if hand injuries are possible. For example, due to:

- Pointy or sharp objects
- Hot surfaces

When working with ropes: Protective gloves must be puncture proof.

## **7.5 Safety shoes**

Wear safety shoes, if foot injuries are possible. For example, due to:

- Oscillating or falling parts
- Pointy or sharp objects
- Impact or trapping
- Slipping on slippery ground or surfaces

## **7.6 Warning apparel**

Avoid accidents: Wear reflecting, signal color warning clothing, when personnel must be visible and recognizable.

The „warning clothing“ category includes, for example:

- Safety vest
- Safety jacket
- Safety pants

## **7.7 Safety goggles**

Wear safety goggles when eye injuries are possible. For example, due to:

- Corrosive fluids
- Pressurized fluids
- Flying parts

## **7.8 Hearing protection**

Wear hearing protection when there is danger of hearing damage due to noise.

## **7.9 Respiratory protection**

Wear respiratory protection when there is danger of damage due to polluted air.

## **7.10 Aids for work at a height**

All work at a height, when there is a danger of falling, must be carried out with suitable aids.

Part of the category „Aids for working at a height“ are, for example:

- Work platforms



- Scaffolding
- Assembly platform
- Catwalks
- Ladders

When working at a height, working on a work platform, scaffolding, assembly platform, catwalk or similar is preferential to working on a ladder.



### **WARNING**

Persons not secured when working at a height!  
Personnel can fall down. Death, severe bodily injuries.

When work platforms, scaffolding, catwalks or similar are not available and the work cannot be carried out from the ground:

- ▶ Secure personnel with the supplied fall arrest system to prevent falling.

When fall protection equipment such as hook points, safety ropes and fastening points are available on the crane:

- ▶ Secure personnel with the fall arrest system to the fall protection equipment. See chapter 2.06.

When stepping on a ladder:

- ▶ Do not hold any objects in your hands.
- ▶ Adhere to the 3-point support. See chapter 2.04.10.

Rules when using the aids:

- Step on the ladder only with clean shoes.
- Keep it free from heavy dirt deposits.
- Keep it free of snow and ice.

## **8 Supplied fire extinguisher**

Storage of the fire extinguisher:

- To protect against damage, store the fire extinguisher in its designated location.

Before crane operation and travel operation:

- Make sure that the fire extinguisher is always freely accessible and functional.

After use:

- Have the fire extinguisher refilled immediately or replaced.

Replace the fire extinguisher immediately, if:

- It has visible defects.
- The fire extinguisher does not function.
- The inspection term specified by the manufacturer has been exceeded.
- The maximum service life specified by the manufacture has been reached.

The operator must ensure the following:

- Personnel must be instructed at least once a year on how to use the fire extinguisher with practical exercises. Performance of the instruction and exercises must be documented.
- The fire extinguisher must be checked by an authorized inspector according to the manufacturer's specifications and national regulations. The results must be documented.
- Non-functional and used fire extinguishers must be immediately repaired or replaced.

## 9 Securing persons to prevent them from falling



### WARNING

Danger of falling!

- ▶ Wear the supplied fall arrest systems (safety harnesses and height safety equipment) correctly.
- ▶ When accessing a ladder, do not hold any objects in your hands.
- ▶ When accessing a ladder, adhere to the 3-point support. See the Crane operating instructions, chapter 2.04.10.

### 9.1 Working on the telescopic boom head and / or auxiliary boom

When performing assembly or disassembly work on a ladder, people can fall down:

- A second person must be present to hand the necessary items to the person on the ladder.

Reeve the hoist rope in or out on the pulley head:

- For ladder work, use the supplied ladder: For fastening and hook points, see the Crane operating instructions, chapter 2.06.
- For cranes that carry a ladder along **with** a hook device:  
Use the hook device to secure the ladder.
- For cranes, which carry a ladder along **without** hook device:  
Use the rigging belt to secure the ladder.
- When ascending, the assembly personnel must ensure a 3-point support.
- If there is a danger of falling, the assembly personnel must hook themselves with the snap hooks of the fall arrest system on the fastening points and secure themselves against falling.

### 9.2 Walking on the telescopic boom



### WARNING

Danger of falling!

The assembly personnel can fall down by slipping on the telescopic boom and be killed or severely injured!

- ▶ The telescopic boom may only be accessed if assembly personnel is protected with suitable safety measures to prevent them from falling.
- ▶ If safety ropes are present on the telescopic boom, then the assembly personnel must hook themselves with the supplied fall arrest system on the safety ropes of the telescopic boom on the left and right with both snap hooks and secure themselves against falling.
- ▶ Without safety measures, it is **strictly** prohibited to step on the telescopic boom.

Assembly of the hoist rope or the TY-guying:

- During assembly, the assembly personnel must hook themselves on the fastening devices on the left and right with both snap hooks of the fall arrest system and secure themselves against falling.

### 9.3 Accessing the lattice sections or booms

Climbing the ladder:

- When ascending, the assembly personnel must ensure a 3-point support.

Changing from ladder to catwalk **without** transition aid:

- From a transition height above 1.8 m: **Before** transitioning, assembly personnel must hook at least one snap hook of the fall arrest system to a safety rope and secure themselves against falling.

Changing from ladder to catwalk **with** transition aid:

- **After** transitioning, the assembly personnel must hook at least one snap hook of the fall arrest system on a safety rope and secure themselves against falling.

## 9.4 Walking on lattice sections or booms

Walking on catwalks:

- When walking on catwalks, the assembly personnel must hook themselves on the safety ropes on the left and right with both snap hooks of the fall arrest system and secure themselves against falling.
- When changing the fall arrest system over to a new lattice section, the assembly personnel must be hooked with at least one snap hook of the fall arrest system to one item of safety equipment.

## 9.5 Working on lattice sections or booms

Pinning, unpinning the lattice sections of pull rods:

- During pinning, unpinning of lattice sections or pull rods, the assembly personnel must hook themselves on the safety ropes on the left and right with both snap hooks of the fall arrest system and secure themselves against falling.

Fastening the lattice sections:

- When fastening the lattice sections, the assembly personnel must hook themselves on the safety ropes on the left and right with both snap hooks of the fall arrest system and secure themselves against falling.

## 9.6 Descending from lattice sections or booms

Accessing the ladder **without** transition aid:

- From a transition height above 1.8 m: **Before** stepping on the ladder, assembly personnel must hook at least one snap hook of the fall arrest system to a safety rope and secure themselves against falling.
- When stepping on the ladder, the assembly personnel must ensure a 3-point support.
- The snap hook of the fall arrest system may only be unhooked after standing safely on the ladder (3-point support).

Accessing the ladder **with** transition aid:

- When stepping on the ladder, the assembly personnel must ensure a 3-point support.

Climbing down the ladder:

- When descending, the assembly personnel must ensure a 3-point support.

# 10 Rescuing the assembly personnel

The height rescue system is only supplied on certain crane types.

The height rescue system, consisting of the rappelling rescue device, is an evacuation and rescue device. It is used to lift the fallen person to be able to unhook him from the height safety equipment and to lower him by rope.



### WARNING

Danger of falling!

- ▶ The assembly personnel must be instructed and trained properly in the correct handling of the height rescue system. Annual practice instructions and drills must be carried out.
- ▶ The supplied height rescue system must be kept available.
- ▶ The operating instructions of the manufacturer for the height rescue system must be observed and adhered to.
- ▶ The height rescue system must be checked annually by authorized and trained expert personnel and documented in the inspection log book.

## 10.1 First aid measures after rescue



### WARNING

Danger of fatal injury!

- ▶ After the rescue, the patient must be positioned with the upper body raised (in seated or squatting position).
- ▶ Immediate flat position or even shock position can be fatal.

## 11 Crane cab

### 11.1 Extendible step\* for cranes on tires

An extendible step allows comfortable entry into the crane cab as well as safe exit from the crane cab to the crane chassis and safe access to the turntable.

The description for an „extendible step for cranes on tires“ only applies for cranes that drive on tyres.

Ascending and descending takes place via the ladder on the crane chassis. See chapter 2.07 „Accesses to the crane“.



### WARNING

Extendible step in the incorrect position!

Personnel can fall down. Death, severe bodily injuries.

- ▶ Make sure that the extendible step is in the correct position.

When directly accessing the crane cab via the ladder from the ground or when directly descending from the crane cab via the ladder to the ground:

- The extendible step must be **retracted**.

When accessing the crane cab via the crane chassis or the crane superstructure:

- The extendible step must be **extended**.

### 11.1.1 Accessing the crane cab via the ladder on the crane chassis

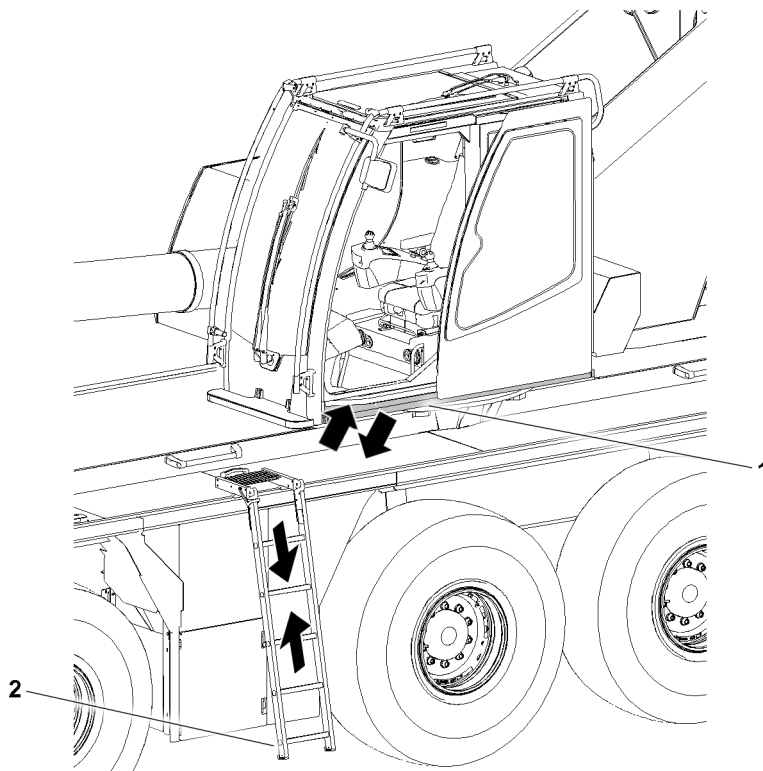


Fig.152871: Crane superstructure in the 0° position or 180° position: Step retracted

Prior to ascending to the crane cab via the ladder from the ground or before descending from the crane cab via the ladder **2** to the ground, the following prerequisites must be met:

- The crane superstructure is in the 0° position or 180° position.
- In the case of a crane cab with incline adjustment: The crane cab is in the horizontal position.
- The step **1** under the crane cab is **retracted**.
- The folding ladders are in the ascent and descent position.



#### WARNING

Extendible step in the incorrect position!

Personnel can fall down. Death, severe bodily injuries.

- ▶ Make sure that the extendible step is fully retracted.



#### WARNING

The step **1** cannot be retracted!

People can fall during ascent and descent via the ladder **2**. Death, severe bodily injuries.

- ▶ Guarantee safe ascent / descent: Set up suitable climbing aids, such as a platform or ladder.

### 11.1.2 Crane cab access on the crane chassis

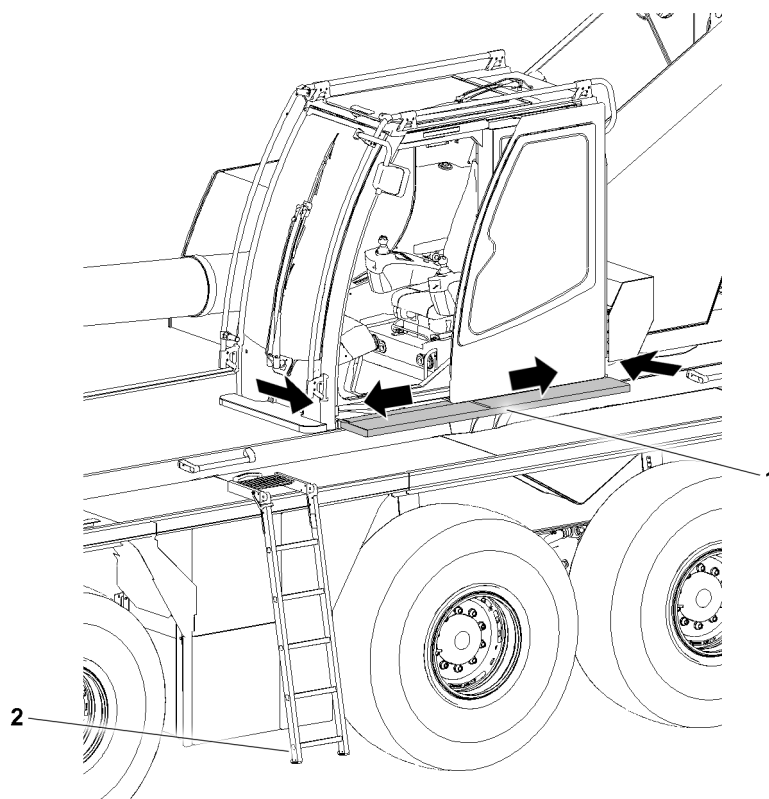


Fig.152870: Crane superstructure in the 0° position or 180° position: Step **extended**

When accessing the crane cab via the crane chassis or the crane superstructure the following prerequisites must be met:

- The extendible step **must** be extended.
- In the case of a crane cab with incline adjustment: The crane cab is in the horizontal position.



#### WARNING

Extendible step in the incorrect position!  
Personnel can fall down. Death, severe bodily injuries.

- ▶ Make sure that the extendible step is fully extended.

### 11.1.3 Crane cab access with a turned crane superstructure

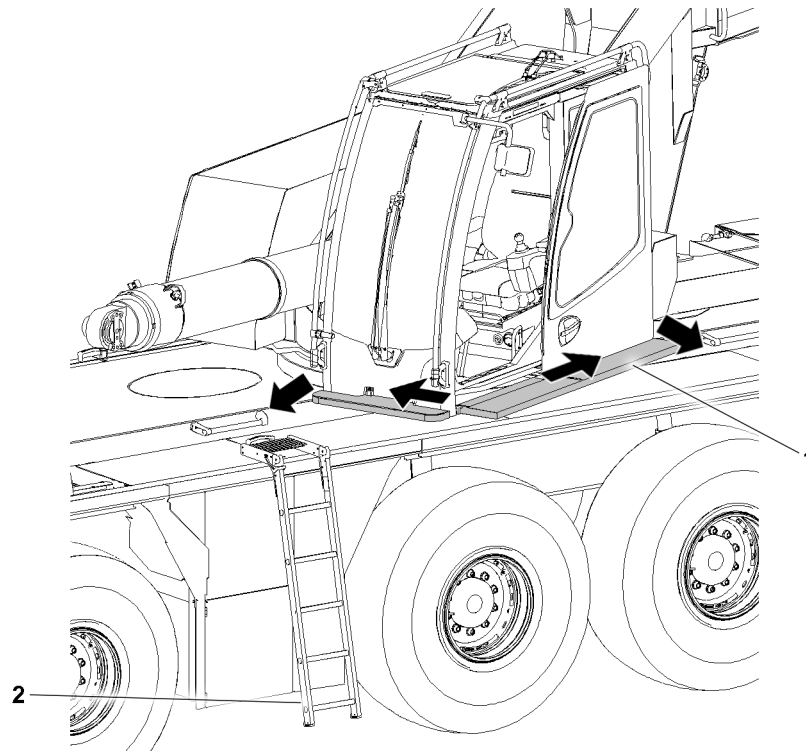


Fig.152872: Crane superstructure turned: Step **extended**

When accessing the crane cab with a turned crane superstructure, the following prerequisites must be met:

- The crane superstructure is swung to the point where a safe access to walkable surfaces of the crane chassis is ensured.
- The extendible step **must** be extended.
- In the case of a crane cab with incline adjustment: The crane cab is in the horizontal position.
- The folding ladders are in the ascent and descent position.



#### **WARNING**

Extendible step in the incorrect position!

Personnel can fall down. Death, severe bodily injuries.

- ▶ Make sure that the extendible step is fully extended.

## 11.2 Extendible step\* for LTR cranes

An extendible step allows comfortable entry into the crane cab as well as safe exit from the crane cab to the crane chassis and safe access to the turntable.

The description for an „extendible step for LTR cranes“ only applies for LTR cranes.

### 11.2.1 Extendible step for LTR 1060 and LTR 1100

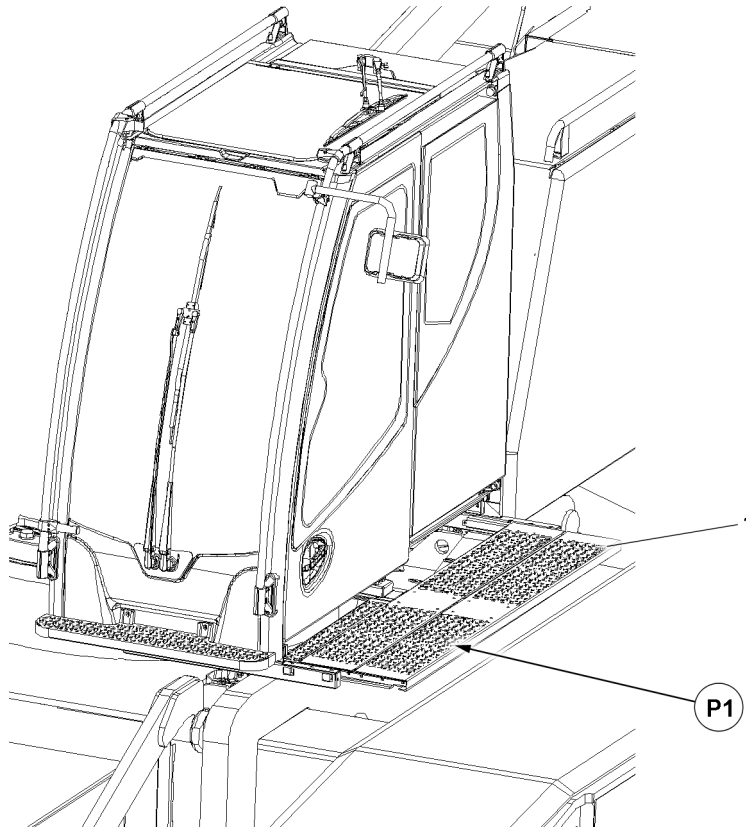


Fig.149549: Extendible step for LTR 1060 and LTR 1100

Ascending and descending takes place on the walking surfaces of the crawler chain. See chapter 2.07 „Accesses to the crane“.

Before entering or exiting the crane cab, the following prerequisites must be met:

- The crane superstructure is in the 0° position or 180° position.
- In the case of a crane cab with incline adjustment: The crane cab is in the horizontal position.
- The step **1** under the crane cab is extended in position **P1**.



#### WARNING

The crane superstructure is in 0°-position or in 180° position and the step **1** is **not** extended! Personnel can fall down. Death, severe bodily injuries.

- ▶ Before entering or exiting: Extend the step **1** completely.

If the step **1 cannot** be extended:

- ▶ Guarantee safe entry and exit: Set up suitable climbing aids, such as a platform or ladder.



#### WARNING

The crane **cannot** be brought into the safe 0° position or 180° position for ascent or descent via the walking surfaces of the crawler chain!

The distance between the step and the walking surfaces of the crawler chain is more than 300 mm. Personnel can fall down. Death, severe bodily injuries.

- ▶ Guarantee safe ascent and descent: Set up suitable climbing aids, such as a platform or ladder.



### 11.2.2 Extendible step for LTR 1220

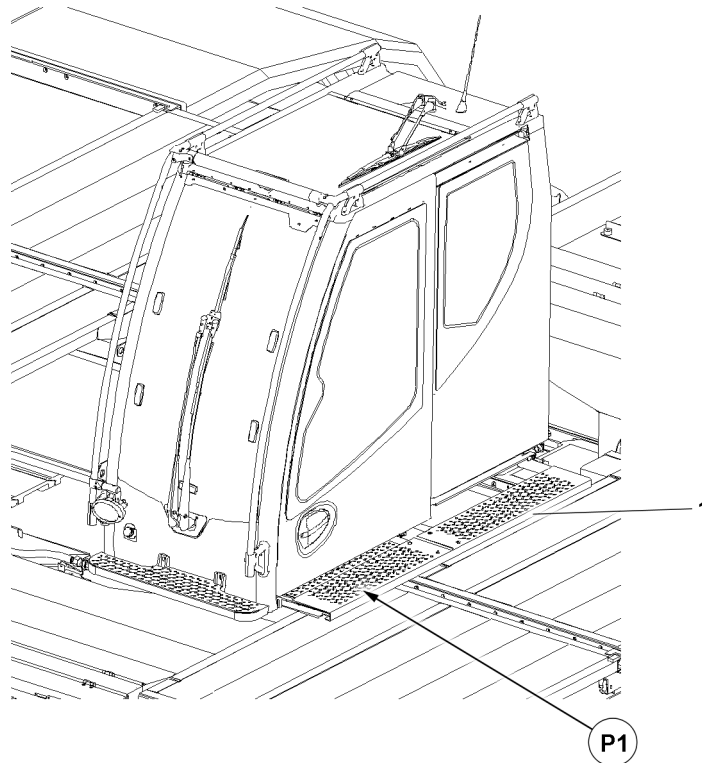


Fig.149550: Extendible step for LTR 1220

Ascending and descending takes place on the walking surfaces of the crawler chain. See chapter 2.07 „Accesses to the crane“.

Before entering or exiting the crane cab, the following prerequisites must be met:

- The crane superstructure is turned to the point where a safe access to walkable surfaces of the crane chassis is ensured.
- In the case of a crane cab with incline adjustment: The crane cab is in the horizontal position.
- The step 1 under the crane cab is extended in position P1.



#### WARNING

The crane **cannot** be brought into the safe 0° position or 180° position for ascent or descent via the walking surfaces of the crawler chain!

The distance between the step and the walking surfaces of the crawler chain is more than 300 mm. Personnel can fall, death, severe bodily injuries.

- ▶ Guarantee safe ascent and descent: Set up suitable climbing aids, such as a platform or ladder.

### 11.3 Crane cab with incline adjustment



#### WARNING

Danger of falling!

If the crane cab cannot be swung from an inclined position (for example 20° position) to the horizontal position, for example due to a problem, then utmost caution must be used when entering and exiting. Personnel can fall, death, severe bodily injuries.

- ▶ For safety reasons, we recommend making use of outside help.
- ▶ If necessary, have platforms or other suitable entry aids set up to ensure safe exit from the crane cab.

**WARNING**

Danger of accident!

If the door of the crane cab is opened in inclined position, then the door can move back suddenly. Hands can be crushed or injured.

- ▶ When the crane cab is in inclined position, open the door carefully.

## 11.4 Securing bracket

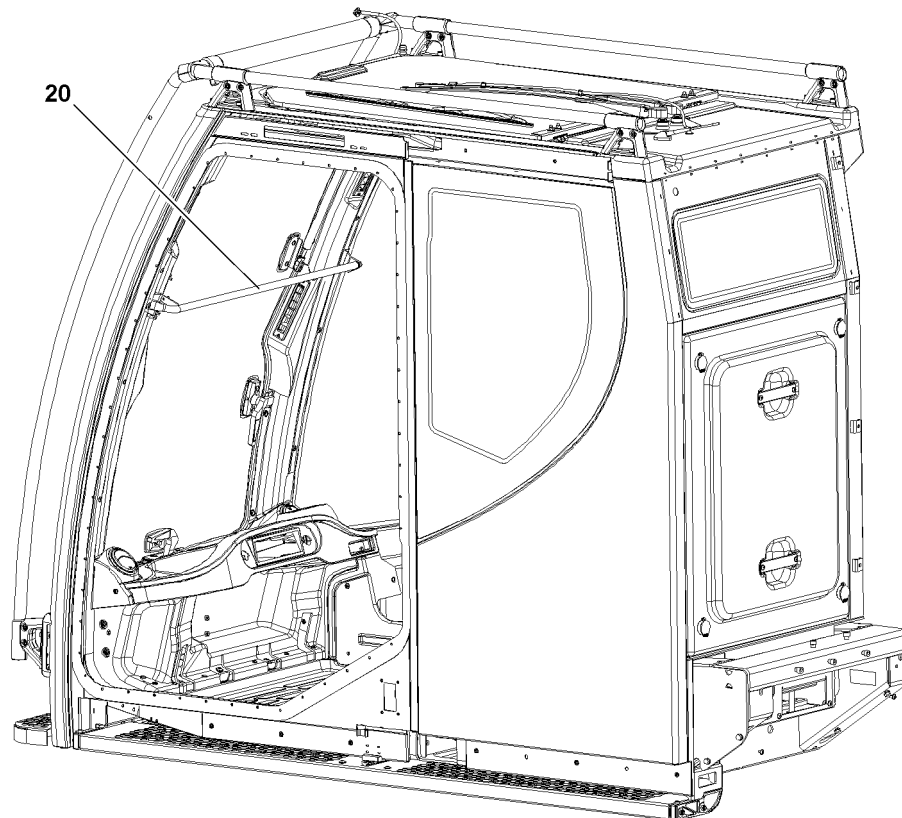


Fig.121158: Example of crane cab with securing bracket

**Note**

- ▶ The securing bracket **20** is installed to protect the crane operator from a danger of falling when the front window is open.
- ▶ Do not use the securing bracket **20** as a handle.

## 11.5 Closing the side window pane

**WARNING**

Danger of crushing!

Never close the side window pane carelessly or uncontrolled. Significant crushing injuries can occur.

- ▶ During closing, watch the side window pane as it moves up.
- ▶ Make sure that no personnel or objects are crushed.

## 12 Transport



### WARNING

Error during transport!

Death, severe bodily injuries, property damage.

- ▶ To avoid accidents, observe and follow the notes provided in the following sections.
- ▶ Observe the legal as well as country-specific regulations for load securing.



### WARNING

Falling of crane components!

If rigging devices are released and removed from crane components after transport, the crane components can slip or fall over.

Death, severe bodily injuries, property damage.

- ▶ Make sure that the crane components are fastened to the auxiliary crane after releasing the rigging devices.
- ▶ Make sure that the fastening equipment is tensioned before releasing the rigging devices on the crane components.

### 12.1 Crane and crane components

Follow the notes provided below to safely transport the crane and crane components:

- Close the crane cab and all cover doors.
- Use suitable transport vehicles.
- Use rigging devices with sufficient load capacity.
- Regularly check the rigging points and fastening points. See chapter 8.01.
- Properly support and secure the components on the transport vehicle.
- Use special transport devices. See chapter 3.80.
- Transporting a complete luffing lattice jib is prohibited.

### 12.2 Lattice sections

Follow the notes provided below to safely transport the telescoped lattice sections:

- Securely rig the lattice sections on the transport vehicle and secure them together in at least two independent points.
- When there are rigging points on the lattice sections: Secure each lattice section individually to the provided rigging points using suitable rigging elements and clamping elements on the transport vehicle.
- If there are no rigging points on the lattice sections: Secure each lattice section individually with suitable rigging devices and clamping elements to the transport vehicle.

## 12.3 Fiber guy ropes



### WARNING

Damage to the fiber guy ropes during storage and transport!

If the following prerequisites for storage and transport are not observed, then the load bearing capacity can be significantly reduced and the fiber guy ropes can rip off.

Death, severe bodily injuries, property damage.

- ▶ Make sure that minimum bending diameter during storage and transport of **20 x** rope diameter on the fiber guy ropes is **never** fallen below.
- ▶ Make sure that the fiber guy ropes are **not** kicked or knotted during storage and transport.
- ▶ Make sure that the fiber guy ropes are **not** twisted during storage and transport. Pay attention to the twist display - marker line along the longitudinal axis of the rope braid.
- ▶ Make sure that the fiber guy ropes do **not** lie over sharp edges during storage and transport and are pulled over them.
- ▶ Make sure that the fiber guy ropes are **not** thrown onto the ground or components.
- ▶ Make sure that the fiber guy ropes are **not** in contact with chemicals or acids during storage and transport.
- ▶ Make sure that the fiber guy ropes are **not** stored or transported together with other components.
- ▶ Store and transport the fiber guy ropes in the provided transport box.
- ▶ Inspect the fiber guy ropes regularly, see chapter 8.16.

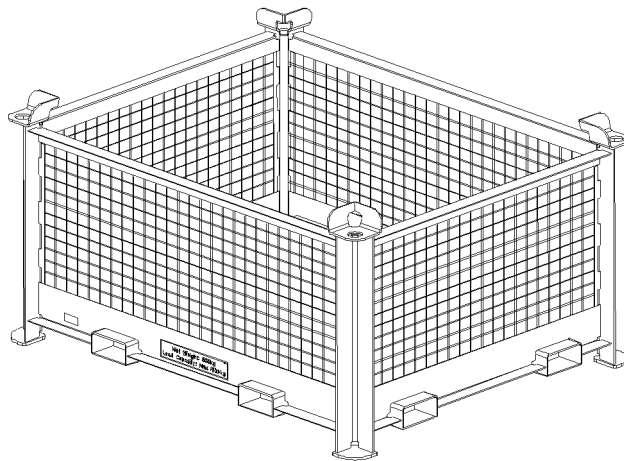


Fig.149503: Transport box for fiber guy ropes

## 12.4 Mobile cranes

Follow the notes provided below for the safe transport of mobile cranes:

- To ensure the largest possible frictional coefficient to the transport surface, clean the wheels before transport.
- When driving on the transport vehicle, check the easy movement of the vehicle with the aid of a guide to avoid hitting too hard.
- Apply the parking brake. See the Crane operating instructions, chapter 3.04.
- Lower the crane with the level control to obtain a center of gravity as low as possible. Level control, see Crane operating instructions, chapter 3.03
- Stopping the mobile crane: Place wedges under the wheels. See the Crane operating instructions, chapter 2.04.
- Close the driver's cab.

## 12.5 Accelerating, changing the load

### NOTICE

Permissible acceleration exceeded!  
Damage to the crane.

- ▶ Observe the maximum permissible longitudinal acceleration of 1.0 g.
- ▶ Observe the maximum permissible lateral acceleration of 0.8 g.
- ▶ Offloading and running is prohibited during rail transport.

If higher accelerations are expected (sea transport, rail transport, maneuvering operation):

- ▶ Carry out the special measures to secure the crane and crane components.

### NOTICE

Frequent dynamic load change!  
Premature fatigue of load bearing crane components.

- ▶ Demount and properly secure components with large masses.
- ▶ Prior to transport: Have the rigging points and crane structures checked for damage by an authorized inspector. See chapter 8.01.

## 13 Fastening



### WARNING

Defective fastening equipment or fastening points!  
The load can fall down.

- ▶ Make sure that the fastening points and fastening equipment are in a perfect condition.
- ▶ Regularly check the rigging points and fastening points. See the Crane operating instructions, chapter 8.01.
- ▶ Check the fastening equipment regularly. See the Crane operating instructions, chapter 8.01.



### WARNING

Load bearing capacity of the fastening equipment is **not** sufficient!  
The load can fall down.

- ▶ Determine the weight of the crane component to be fastened.
- ▶ Fasten the components solely with approved and sufficiently load bearing fastening equipment.



### WARNING

Component incorrectly fastened!  
The load can fall down.

- ▶ Attach the components only on the intended fastening points.

## 14 Heated crane components



### WARNING

Danger of burns!

You can get severely burnt on the surfaces of hot components.

This applies especially to exhaust systems, the engines and the respective gears in the crane chassis and in the crane superstructure.

- ▶ Let the components cool down before touching them.
- ▶ Proceed with special caution near heated crane components.

# 15 Crane operator responsibilities

## 15.1 General

The crane operator's primary responsibility is to use and operate the crane in a manner that is safe for both himself and others.

The following important safety instructions will help you achieve this.

Many crane accidents are caused by crane control errors.



### WARNING

Danger due to operating error!

- ▶ In your interest and in the interest of others, make sure that you know your crane. Also learn to recognize all dangers connected with the work to be carried out.

**Operating errors**, which are made again and again during travel operation or crane operation are especially careless while working, in particular:

- Swinging too quickly
- Stopping the load too quickly
- Pulling the load at an angle
- Allowing slack rope formation
- Overloading the crane
- Driving too fast with a load and / or equipment on an uneven road
- Error when fastening the load
- Unsuitable operation; especially angular pulling, breaking away stuck loads
- Wind action on suspended loads
- Errors during on-road driving, for example:
  - Overspeeding the engine when driving downhill
  - Driving with turned on differential lock
- Crashing into bridges, roofs or high voltage wires due to insufficient overhead clearance
- Inadequate support; support base, substructure under the support plates
- Errors during assembly or removal of booms
- Incorrect positioning of the crane when it is taken out of service
- Exceeding the permissible wind speeds in operation and when out of service

In many cases, crane damage is caused by improper maintenance:

- Insufficient oil, grease or antifreeze
- Contamination
- Broken cable wires, defective tires, worn components
- Emergency limit switch or load torque limiter (LMB) not operating properly
- Brake and clutch failure
- Hydraulic defects; for example cracked hoses
- Loose bolts

## 15.2 Working on the crane superstructure or boom



### WARNING

Danger of falling!

When working on the crane superstructure or boom, personnel must be secured with appropriate safety measures to prevent them from falling. If this is not observed, working personnel can fall and be killed or severely injured.

- ▶ For all work on the crane where there is a danger of falling, suitable safety measures must be taken.
- ▶ The crane superstructure or the boom may not be accessed without suitable aids.
- ▶ Suitable aids are, for example: Lifting platforms, scaffoldings, ladders, assembly platforms, auxiliary crane.
- ▶ If railing are present on the crane superstructure, then they must be swung into operating position and secured for all work, see Crane operating instructions, chapter 2.06.
- ▶ Step on aids and stepping surfaces on the crane only with clean shoes.
- ▶ Keep aids and stepping surfaces on the crane clean and free from snow and ice.
- ▶ If the work cannot be carried out with such aids nor from the ground, then the assembly personnel must secure themselves with supplied fall arrest systems to avoid falling, see section „Personal protective equipment“.
- ▶ It is prohibited to step on the driver's cab or crane cab roof and specially marked surfaces, see Crane operating instructions, chapter 2.05.

## 15.3 Obligations of the crane operator

1. Before starting to work, the crane operator must check the brake function and the emergency shut off devices. He must monitor the condition of the crane for obvious defects. On wireless controlled cranes, he must check the assignment of control unit and crane.
2. The crane operator must cease crane operation in case of problems endangering the safety.
3. The crane operator must report all defects on the crane to the appropriate supervisor, also to his replacement in case of crane change.
4. The crane operator must make sure that:
  - All control systems are set to neutral or idle position before release of the energy supply to the drive components.
  - The control systems are set to neutral or idle position and the energy supply is shut off before leaving the control platform.
  - When taking down the control unit for wireless control, the control unit is secured to prevent unauthorized persons from turning it on.
5. The crane operator must ensure that cranes subjected to wind are not operated past the limits which were set by the crane manufacturer, and that the boom is taken down at least when the critical wind speeds for the crane are reached and at the end of the work.
6. The crane operator must monitor the load for all crane movements or the load lifting devices when moving the crane without a load, if they could cause a dangerous situation. If observation is not possible, then the crane operator may move the crane only with the aid of a guide.
7. The crane operator must give warning signs when necessary.
8. The crane operator may not move loads over personnel.
9. Any loads attached by hand may only be moved by the crane operator after he received a clear sign from the person who attached the load, the guide or any other responsible party which was assigned to that task by the contractor. If signals must be used to communicate with the crane operator, then these signals must be agreed upon before use between the responsible party and the crane operator. If the crane operator determines that the loads are not properly attached, then he may not move these loads.
10. As long as a load is suspended on the crane, the crane operator must keep the control systems within reach. This does not apply for the towing of vehicles with towing cranes.
11. The crane operator may not run up operationally to end positions that are only limited by the emergency limit switches.
12. After a load torque limiter was triggered, the crane operator may not pick up an overload by pulling in / raising the boom.

13. The crane operator may **not** bypass the overload protection to increase the hoisting power of the crane.

## 16 Selecting the location

In the following illustrations 1 to 3 the possible situations are shown as an example.

It is very important to choose an appropriate placement location in order to minimize safety risks.

It must always be possible to take down the crane in order to take down the crane in a timely manner in the case of unexpected weather conditions.

It must always be possible to position the crane in a safe out of service position.



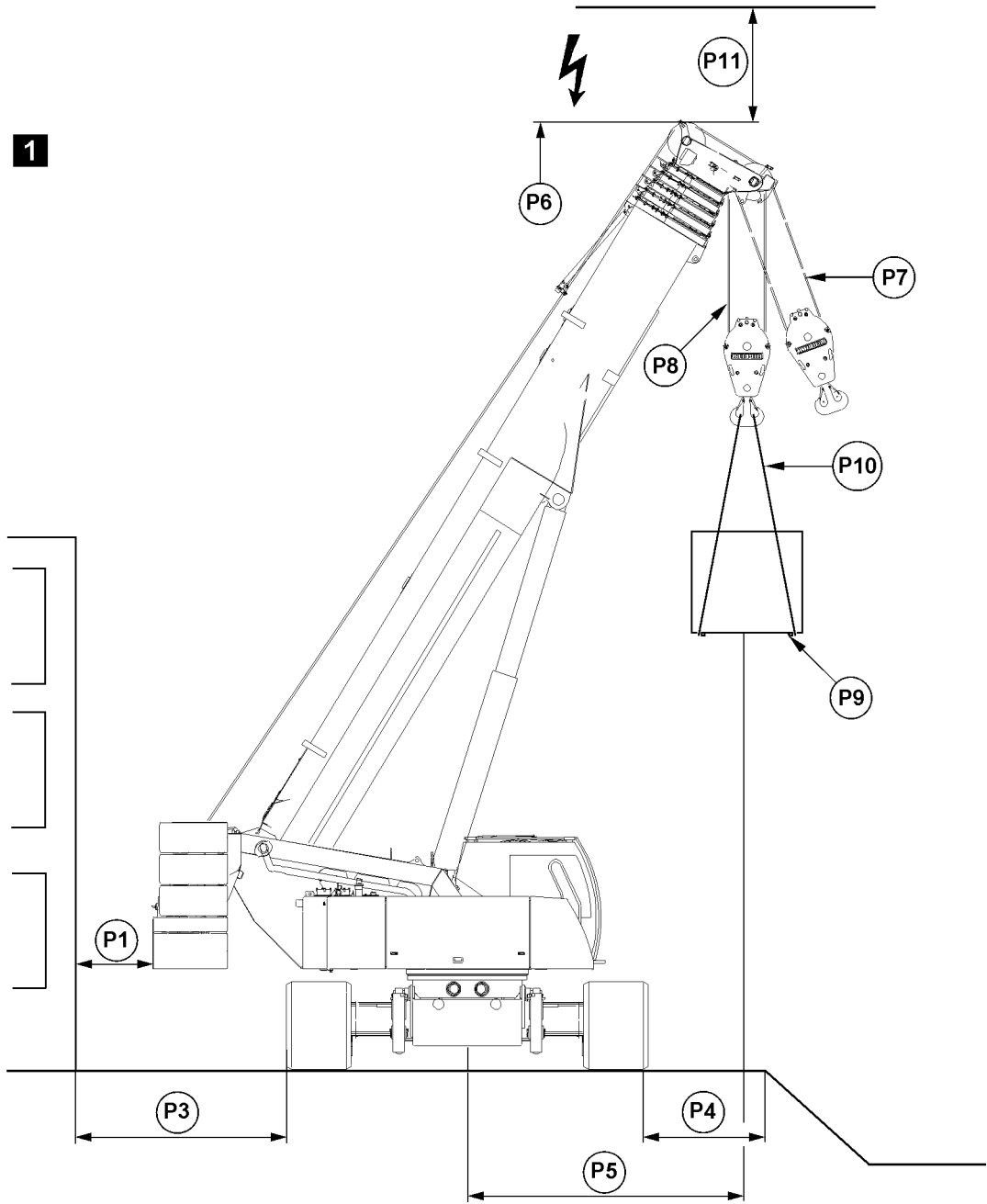


Fig.121166: Example of crawler crane with telescopic boom

LWE/LTR 1220-003/24204-02-02/en

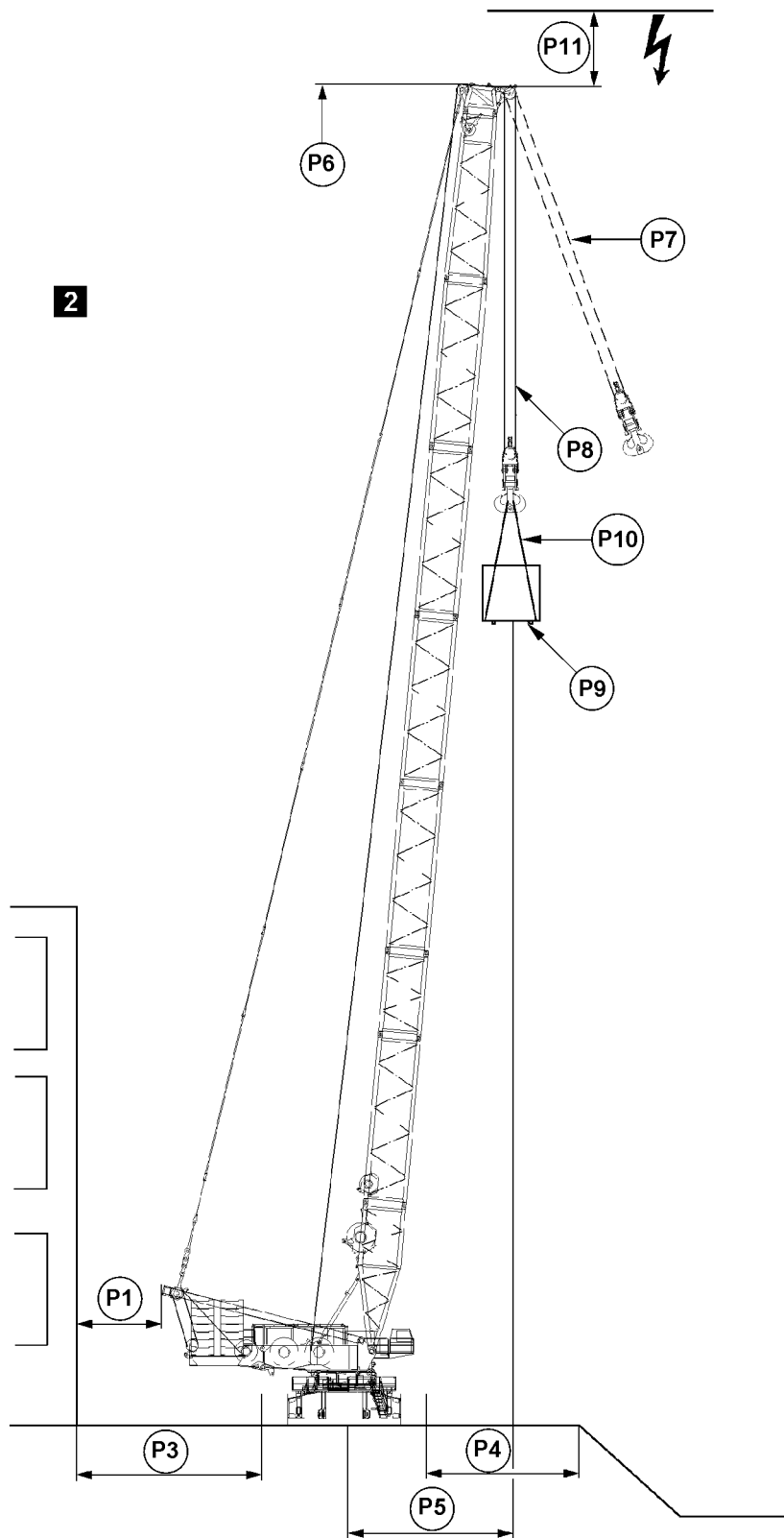


Fig.121167: Example of crawler crane with lattice mast boom

LWE/LTR 1220-003/24204-02-02/en

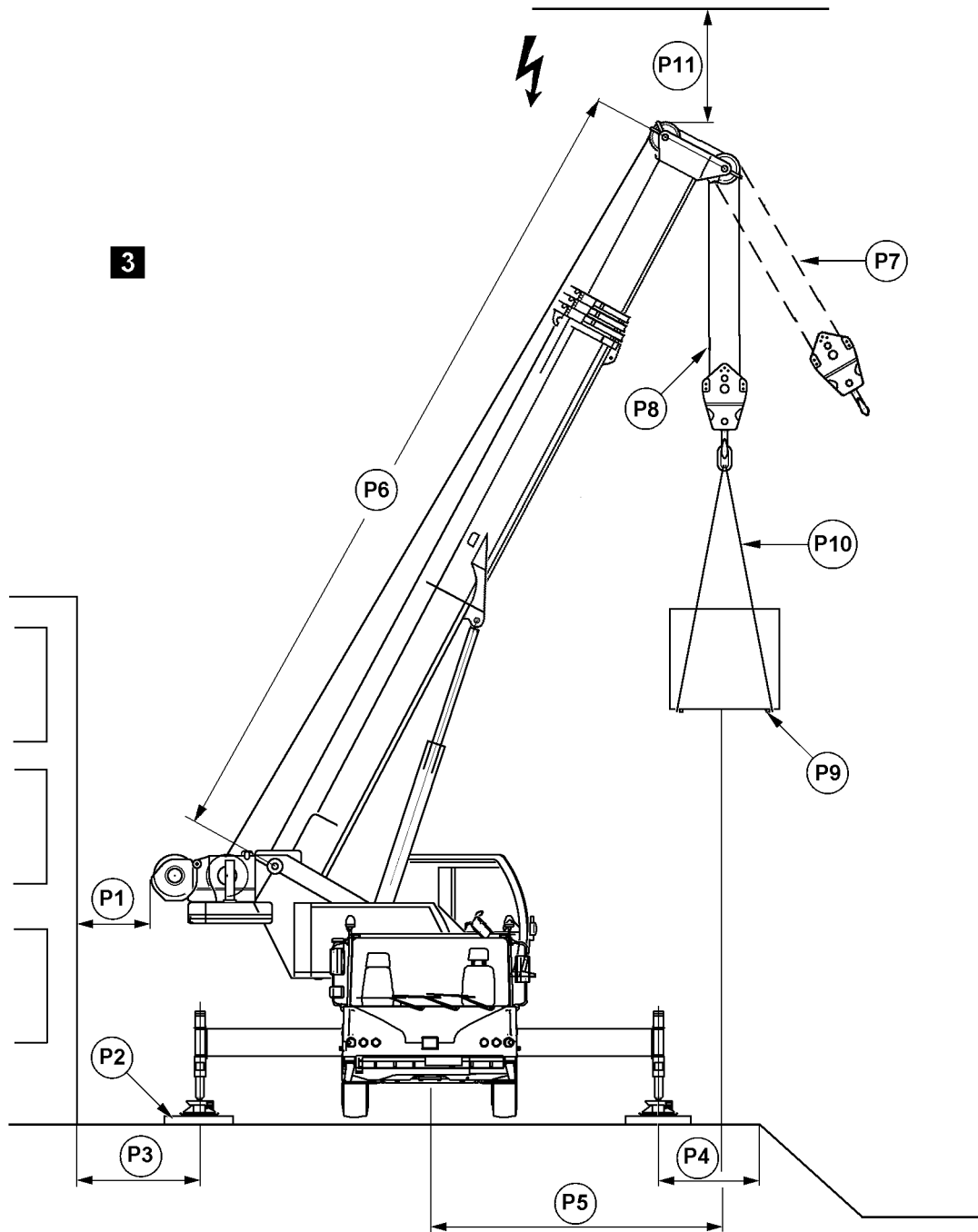


Fig.121168: Example of mobile cranes



### DANGER

Danger of accidents due to ground with **insufficient** load bearing capacity!

If the crane is supported or driven on ground with **insufficient** load bearing capacity, then the crane can topple over and kill personnel.

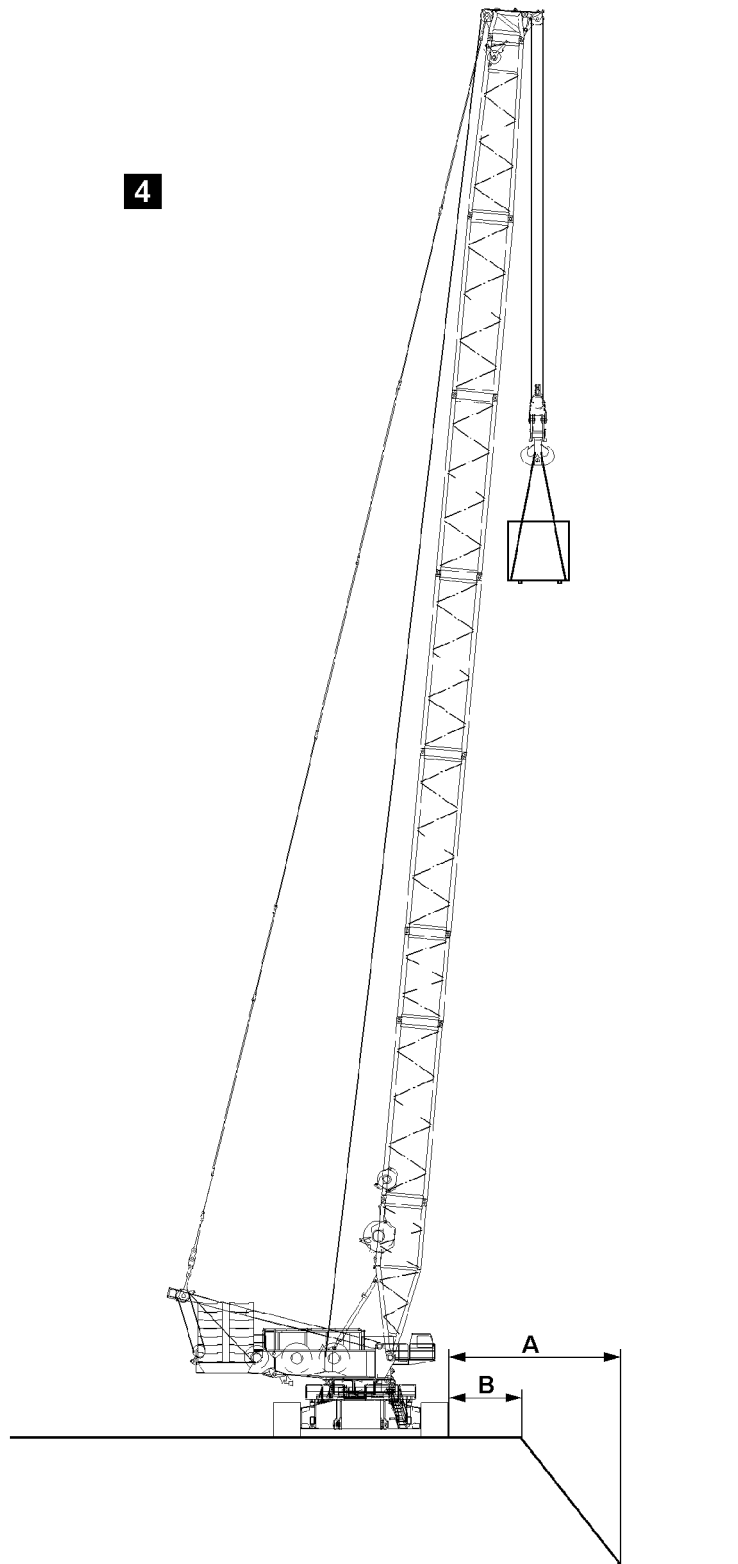
- ▶ Only support or drive the crane on ground with sufficient load bearing capacity.
- ▶ Act responsibly when planning and selecting the crane location and route.
- ▶ Observe the following points.

Sign	When selecting the placement location for the crane, observe and adhere to the following:
P1	Select the placement location in such a way that crane movements can be carried out without collision and that the supports can be extended to the support base specified in the load charts  Make sure that no personnel is injured or killed  Always keep a safety distance of 0.5 m. If this is not possible, block the danger zone off
P2	When crane support is required: Support the crane correctly and support the support plates large enough according to the load bearing capacity of the ground and the placement location
P3	Maintain a safety distance from basements or similar
P4	Maintain a safety distance from slopes or similar
P5	Select a boom radius as low as possible
P6	Select the correct boom length for the load case
P7	Angular pull is prohibited
P8	Select the correct reeving of the hoist rope for the load case
P9	Keep in mind the weight and the wind exposure surface of the load
P10	Select fastening equipment according to the weight of the load, the type of attachment and the incline angle
P11	Maintain a sufficient distance from overhead electrical wiring

## 17 Slopes and excavations

In the following illustrations 4 and 5 the possible situations are shown as an example.

The crane may not be set up too close to slopes or excavations. Maintain adequate safety distance **A** and safety distance **B** in accordance with the type of soil.



*Fig.121162: Example of crawler cranes*

- A** Distance from the bottom of excavation
- B** Distance from the excavation

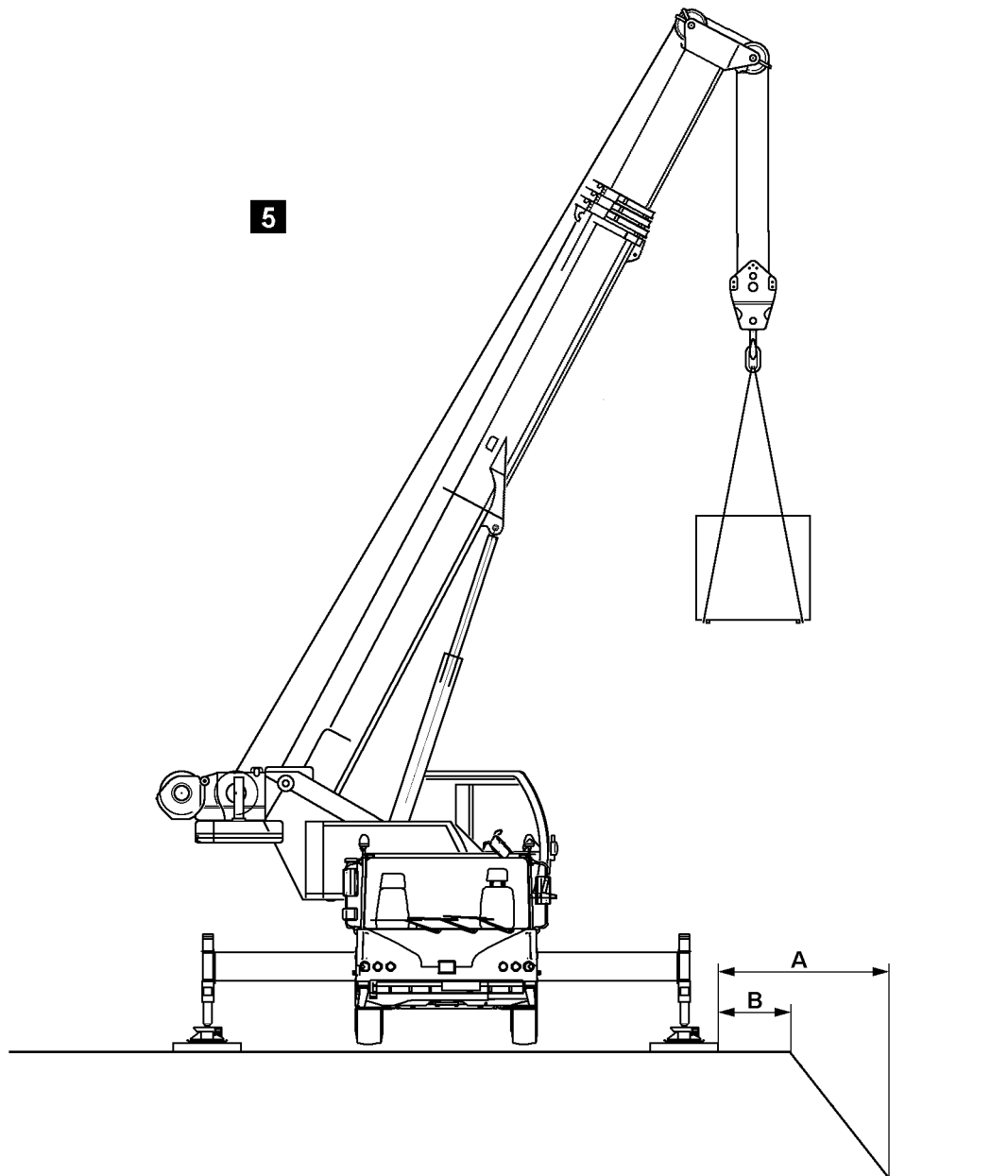


Fig.121163: Example of mobile cranes

- A** Distance from the bottom of excavation  
**B** Distance from the excavation



**WARNING**

Safety distance **A** or safety distance **B** are too small!  
 The edge or the slope or the edge of the excavation can cave in.  
 The crane can topple over. Death, severe bodily injuries, property damage.  
 ► Maintain the safety distance **A** and safety distance **B**.

Have the safety distance **A** and safety distance **B** calculated by a soil expert or geologist.

## 18 Loads on the ground due to crane operation



### Note

- ▶ Take into account that on a crane with high counterweight the crawler pressures or support forces at low load can be higher than at high load.

### 18.1 Load burdens on the ground on cranes on crawlers

For cranes on crawlers significant forces are transferred via the track pads of the crawlers into the ground (crawler pressures).

- The ground must be able to safely withstand the resulting pressure.
- If the area of the track pads is inadequate, then the crawlers must be supported from below according to the load bearing capacity of the ground.
- The required substructure can be calculated from the load bearing capacity of the ground and the crawler pressures of the crane.



### WARNING

Load bearing capacity of the ground insufficient!  
The ground can give, the crane can topple over.  
Death or severe bodily injuries.

- ▶ Support large enough, according to the load bearing capacity of the ground with suitable materials, such as wooden beams or steel plates.

To obtain an even pressure distribution over the substructure surface:

- ▶ Set the crawlers centered on the substructure.



### Note

- ▶ The respective ideal crawler pressure can be determined with the job planner program.

### 18.2 Load burdens on the ground on cranes on supports

When the crane is supported, significant forces (support forces) are transferred by the support cylinders via the support plates to the ground.

The ground must be able to safely withstand the resulting pressure.

If the support plate surface area is inadequate, then the support plates must be supported from below according to the load bearing capacity of the ground.

The required support surface areas can be calculated from the load bearing capacity of the ground and the support forces of the crane.



### WARNING

Load bearing capacity of the ground insufficient!  
The ground can give, the crane can topple over.  
Death or severe bodily injuries.

- ▶ Support large enough, according to the load bearing capacity of the ground with suitable materials, such as wooden beams or steel plates.

To obtain an even pressure distribution over the substructure surface:

- ▶ Set the support plates centered on the substructure.

## 18.3 Examples of the load bearing capacity of the ground

Soil type		Permissible ground pressure [kN/m <sup>2</sup> ]
1.	Organic ground: Peat, sludge, muck	0
2.	Uncompacted fill: Construction debris	0 to 100
3.	Non-cohesive ground: Sand, gravel, rocks and mix	200
4.	Cohesive soil:	
	a) Clayed silt, mixed with topsoil	120
	b) Silt, consisting of poor clay and coarse clay	130
	c) Plastic clay, consisting of potter's clay and fill	
	Stiff	90
	Semi-solid	140
	Solid	200
	d) Mixed granular ground, clay to sand, gravel and rocky areas	
	Stiff	150
	Semi-solid	220
	Solid	330
5.	Rock in evenly solid condition:	
	a) Brittle, with traces of decomposition	1500
	b) Not brittle	4000

*Examples: Permissible ground pressure of the ground*

If there is any doubt about the load bearing capacity of the ground at the placement location, soil tests must be carried out by an authorized inspector, for example with a ram penetrometer.

## 18.4 Calculation examples

The following are general calculation examples. The values are used only to explain the calculation steps. The crane specific values are in chapter 1.03 of the crane operating instructions.



<b>Example: Calculation of ground pressure of support plates for cranes on supports</b>		□
Support force according to Crane operating instructions, chapter 1.03 for example: 720 kN	720 kN	
Surface of square support plate with 550 mm side length according to the crane operating instructions, chapter 1.03, for example: $0.55 \text{ m} \times 0.55 \text{ m} = 0.3 \text{ m}^2$	0.3 m <sup>2</sup>	
80 % as carrying surface of support plate: $0.3 \text{ m}^2 \times 0.8 = 0.24 \text{ m}^2$	0.24 m <sup>2</sup>	
Ground pressure = Support force / load bearing surface support plate	$720 \text{ kN} / 0.24 \text{ m}^2 = 3000 \text{ kN/m}^2$	
Ground pressure per support:	<b>3000 kN/m<sup>2</sup></b>	

*Example: Calculation of ground pressure*

- The value of the ground pressure is far higher than the permissible ground pressure for all types of granular soil.
- If this crane is utilized on bedrock, gravel type of ground, permissible ground pressure 200 kN/m<sup>2</sup>, then the support surface must be increased.

<b>Example: Calculation of required support surface for cranes on supports</b>		□
Support force according to Crane operating instructions, chapter 1.03 for example: 720 kN	720 kN	
Ground pressure from chart <i>Permissible ground pressures</i> for example: 200 kN/m <sup>2</sup>	200 kN/m <sup>2</sup>	
Required support surface = Support force / permissible ground pressure	$720 \text{ kN} / 200 \text{ kN/m}^2 = 3.6 \text{ m}^2$	
Required support surface per support:	<b>3.6 m<sup>2</sup></b>	

*Example: Calculation of support surface*

- The surface of the substructure for each support plate must be at least **3.6 m<sup>2</sup>**.
- The height of the substructure must be selected depending on the load distribution angle.



#### Note

- ▶ The corresponding ideal support forces can be determined with the Job planner.

## 18.5 LICCON job planner

The calculation of support forces and crawler pressures with the LICCON job planner are based on idealized assumptions: level and homogenous ground, rigid crane structure, no consideration in regard to wind.

Side deformations of the boom system due to wind, incline position and elastic compliance of the steel structure can lead to increase of support forces or to increase of crawler pressures.

The determination of the values, taking wind load on the crane and the load into account, as well as the elastic deformation of the crane can only be carried out by the crane manufacturer or a qualified authorized inspector.

### 18.5.1 Example of crane on crawler with derrick boom, suspended ballast and short (main) boom system

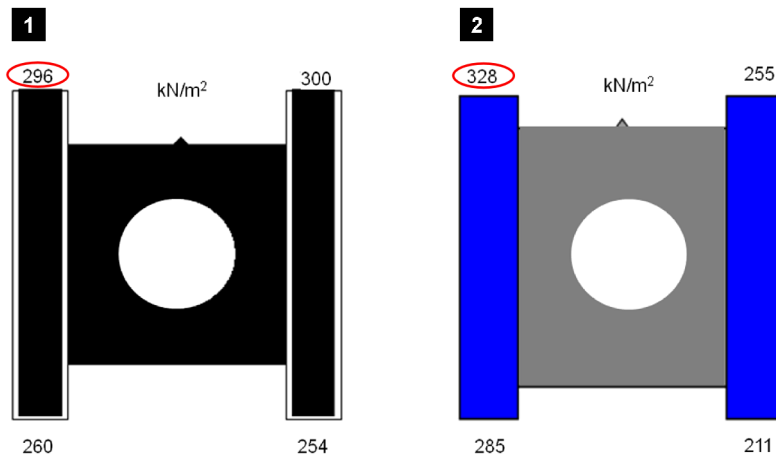


Fig.125052: Example of crane on crawler with derrick boom, suspended ballast and short (main) boom system

**Illustration 1:** Idealized crawler pressures from Job planner calculated with the aid of a rigid body system and no consideration regarding wind

**Illustration 2:** Idealized crawler pressures with consideration of elastic deformation and wind on crane and load

### 18.5.2 Example of crane on crawler with derrick boom, suspended ballast and long (main) boom system

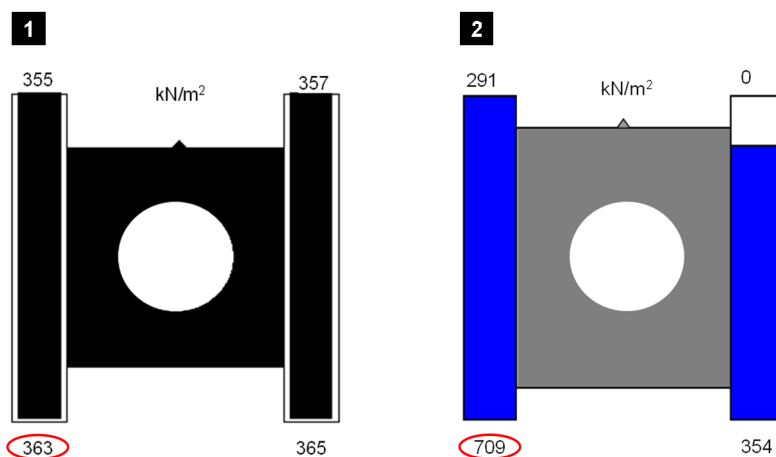


Fig.125053: Example of crane on crawler with derrick boom, suspended ballast and long (main) boom system

**Illustration 1:** Idealized crawler pressures from Job planner calculated with the aid of a rigid body system and no consideration regarding wind

**Illustration 2:** Idealized crawler pressures with consideration of elastic deformation and wind on crane and load

### 18.5.3 Example of crane on supports

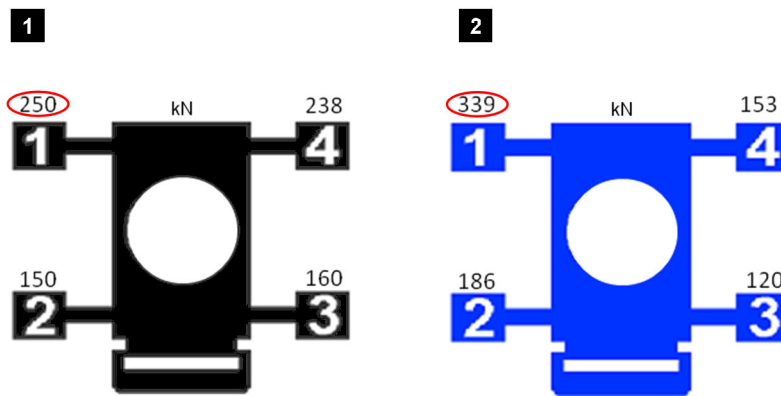


Fig.125054: Example of crane on supports

**Illustration 1:** Support forces from Job planner calculated with the aid of a rigid body system and no consideration regarding wind

**Illustration 2:** Support forces with consideration of elastic deformation and wind on crane and load

## 19 Support

### 19.1 Support plates

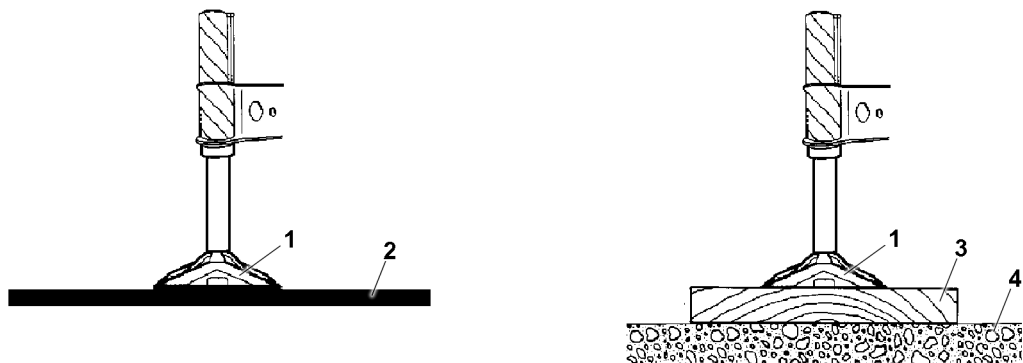


Fig.144244: Support plates

- |   |                                    |   |                                 |
|---|------------------------------------|---|---------------------------------|
| 1 | Support plate                      | 3 | Substructure                    |
| 2 | Ground (no substructure necessary) | 4 | Ground (substructure necessary) |

When supporting the crane, the support plates must lay horizontally on the ground or on the substructure.



**WARNING**

The support plates are **not** laying horizontally!  
The crane can topple over, death, property damage.

- ▶ Before supporting the crane, align the support plates horizontally.

LWE/LTR 1220-003/24204-02-02/en

## 19.2 Supporting the crane



### WARNING

The crane is **not** horizontally aligned!  
The crane can topple over, death, property damage.  
▶ Align the crane horizontally to 0.0° during the support procedure.



### DANGER

The crane can topple over!  
When actuating the supports with attached load and / or at loaded derrick ballast guying, the incline and the force conditions of the entire boom system change.  
There is **no** shut-off by the LICCON overload protection.  
The crane can topple over.  
Personnel can be severely injured or killed.  
▶ When a load is suspended it is prohibited to actuate the support.  
▶ When the derrick ballast guying is loaded it is prohibited to actuate the support.

It is absolutely essential that the crane be supported with the support base exactly in accordance with the load chart to ensure safe crane operation.

The correspondence of the sliding beams placement surfaces must be observed to ensure proper force transfer between the sliding beams.

The crane may only be supported in these extension conditions.



### WARNING

The crane can topple over!  
If only the sliding beams on the load side are extended, then the crane can topple over and kill personnel.  
▶ Push all four sliding beams and support cylinders out according to the data in the load chart and pin.  
▶ Do **not** support in intermediate positions between the support bases.  
▶ Pin the sliding beams to support base according to the load chart.  
▶ Fully insert and secure the pins.



### WARNING

Risk of toppling the crane due to incorrect extension of the sliding beams!  
The load suspended on the hook causes tension and deformation of the hoist rope and telescopic boom. The same applies for operation with lattice jib and guy ropes. If the load falls from the fastening ropes or if the fastening or hoist rope breaks in this situation, a sudden relief occurs. The boom snaps back quickly. This can cause the crane to topple over.  
Despite previous assumption, it might become necessary to swing the load to the opposite side. This can cause the crane to topple over.  
The boom and / or counterweight momentum may cause the crane to topple when turning from the longitudinal vehicle direction.  
▶ Extend all four sliding beams and support cylinders according to the data in the load chart.

## 19.3 Supporting the crane with a *variable support*

When supporting the crane with a *variable support* special measures are required. These measures are described in detail in the Crane operating instructions, chapter 6.26.

## 20 Aligning the crane

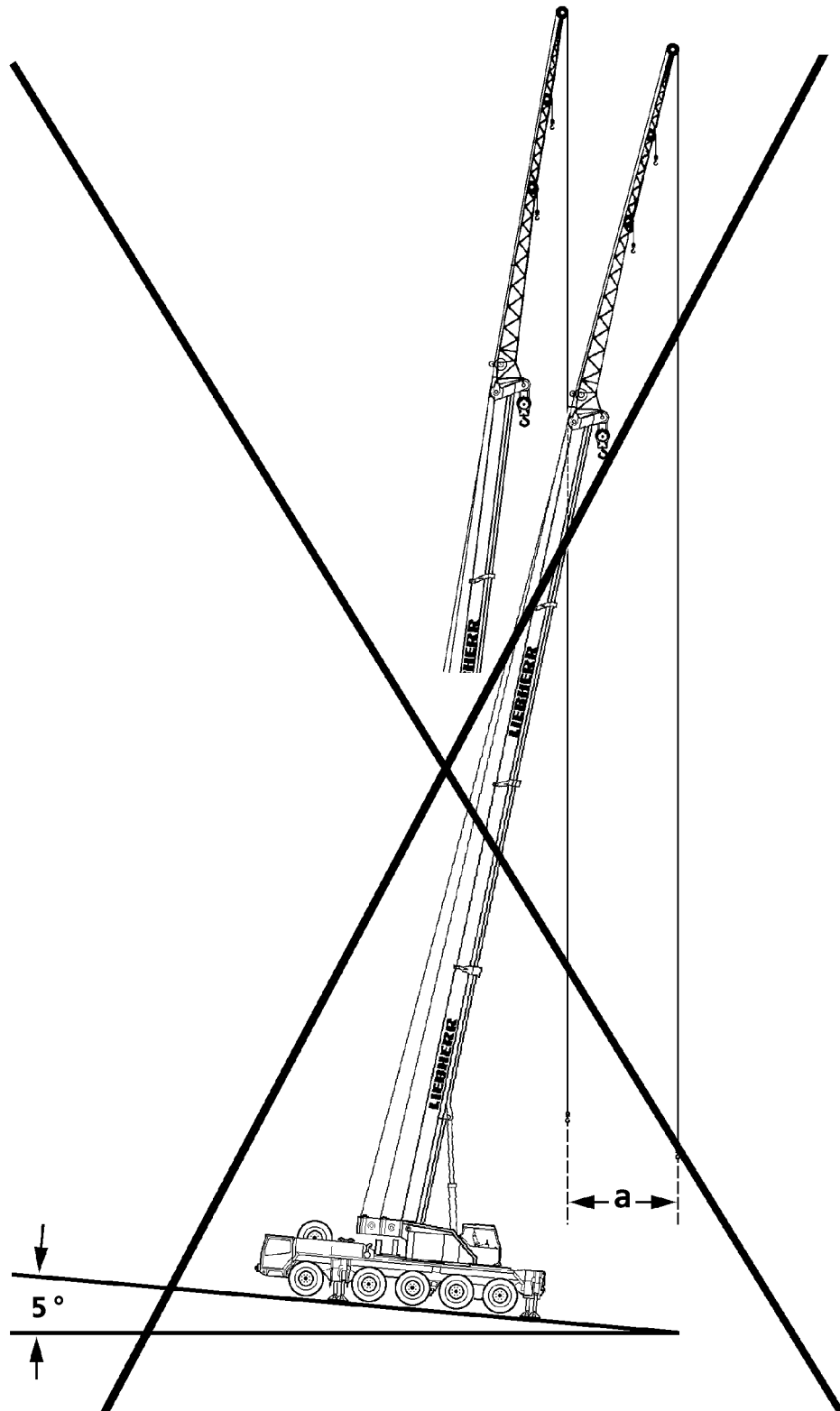


Fig.121164: Example of **non-permissible** incline position

In addition to the proper substructure for the supports, the horizontal alignment of the crane is of utmost importance for safe crane operation.

**DANGER**

The crane can topple over due to the incline position!

If the crane is positioned at an incline, and if the boom is turned towards the slope, then the boom radius is increased as a result.

It is possible that the slewing gear can no longer hold the crane superstructure and, in extreme cases, the crane can topple over.

Personnel can be severely injured or killed.

- ▶ Align the crane horizontally before starting crane operation.

If the horizontal alignment of the crane has to be readjusted:

- ▶ Set the load down on the ground before readjusting the crane.

For cranes on crawlers, readjustment is **not** possible:

- ▶ If possible, use load charts for limited terrain incline.

Example: At a boom length of 50 m, an incline position of the crane by only 5° at a boom radius of 10 m causes an increase of the radius of  $a = 4$  m.

## 21 Checking the safety measures

- The placement location has been selected so that all planned lifts included in the load chart for the erected set up configuration can be lifted.
- The load bearing capacity of the ground is adequate.
- There is safety distance to excavations and slopes.
- There are no live transmission wires within the working range of the crane.
- There are no obstacles that will hinder required crane movements.
- The crane is horizontally aligned.
- When crane support is required:
  - All four sliding beams and support cylinders have been extended according to the support base given in the load chart.
  - The sliding beams have been secured with pins to prevent them from moving.
  - The support plates are pinned and secured in the operating position.
- On mobile cranes:
  - The axle suspension is blocked.
  - The axles are relieved, which means the tires do not touch the ground.

## 22 Safety instructions in case of an external power supply



Fig.197720

A potential danger exists when supplying a crane with an external power supply from a low voltage distribution system (100 V AC to 400 V AC).

A special electrical hazard is present when a protective conductor is interrupted (caused by the mechanical stress on flexible supply lines or the service connection), loose terminal connections, high wire or contact resistance, mixed up conductors, defective or missing protective equipment (FI / fault interrupters) in combination with a body contact on the crane.



### WARNING

Danger of fatal injury if the body conducts current!

Water and / or defective devices can cause hazardous stray voltages when touched. The person touching the crane is subject to lethal currents.

- ▶ The external supply cable must be in good working order.

Make sure that the external flexible supply cable is in good working order.

Where applicable, we recommend the use of a power isolating transformer.

## 23 Grounding

### 23.1 Grounding the crane

For the location of the ground connection, see chapter 1.01 or chapter 3.01.

**WARNING**

Danger of fatal injury due to electric shock!

There is a danger of electrical shock, if the crane is not properly grounded.

- ▶ Properly ground the crane.
- ▶ Make sure that there is a potential equalization between the crane and the ground.

The crane must be grounded before start up:

- Near transmitters (radio and TV transmitters, radio stations, etc.)
- Near high frequency switching stations
- In case of severe possibility of thunderstorms or potential thunderstorms

The crane can become electrostatically charged, especially if the crane is equipped with synthetic support mats or if the support mats are placed on insulating materials (such as wooden planks).

## 23.2 Grounding the load

**WARNING**

Danger of fatal injury due to electric shock!

There is a danger of electrical shock, if the load is not properly grounded.

- ▶ Properly ground the load.
- ▶ Make sure that there is a potential equalization between the load and the ground.

The load must be grounded before start up:

- Near transmitters (radio and TV transmitters, radio stations, etc.)
- Near high frequency switching stations
- In case of severe possibility of thunderstorms or potential thunderstorms

The load can become electrostatically charged, even if the crane is grounded. This applies in particular if a hook block with pulleys made of synthetic material and non-conductive fastening equipment (for example plastic or manila ropes) are used.



## 24 Working in the vicinity of transmitters

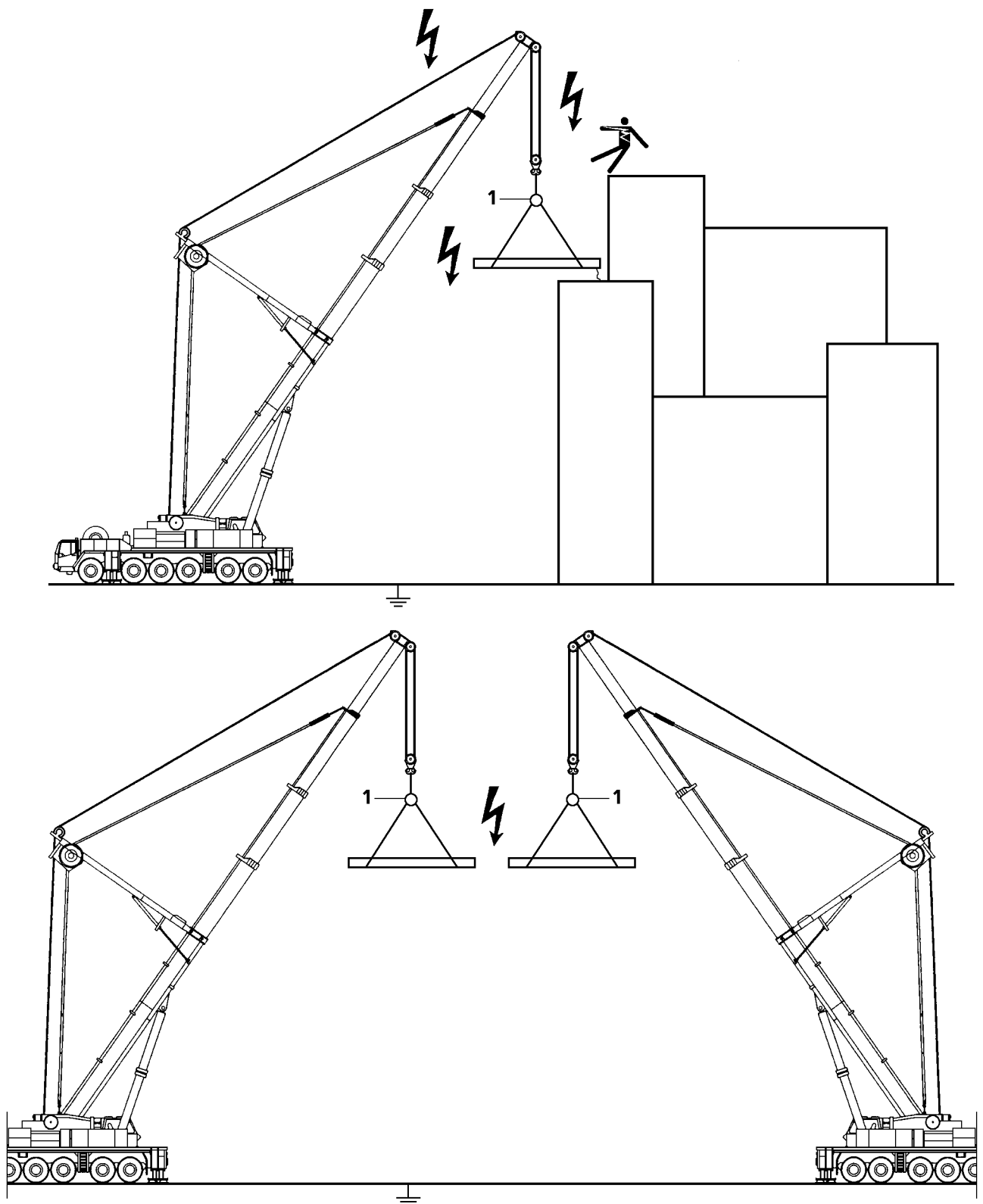


Fig.121165: Example of electrostatic charge

Strong electromagnetic fields are likely to be present if the construction site is close to a transmitter.

These electromagnetic fields can pose direct or indirect danger to persons or objects, for example:

- Effect on human organs due to temperature increase

- Danger of burns or inflammation due to temperature increase
- Spark or electric arc formation



### DANGER

Danger due to electromagnetic fields!

- ▶ Before operating a crane in the vicinity of transmitters, be sure to consult with Liebherr-Werk Ehingen GmbH.
- ▶ Also consult a high frequency specialist.

High frequency (HF) radiation from a transmitter requires supplementary work safety protection and special environmental specifications for crane operators and slingers:

1. Each crane must be „fully“ grounded. Check visually or with a simple continuity tester to ensure that ladder, crane cab and rope pulleys are grounded.
2. All personnel working on the crane or with large metal objects must protect themselves from burns by wearing non-conductive synthetic gloves and suitable clothing while working.
3. There is no need to panic if you feel your hand warm up. Always work under the assumption that the respective workpiece, structural steel member or carrier is „hot“.
4. The temperature of objects affected by high frequency radiation depends on their „size“. Cranes, carriers and coverings, for example, are „hotter“.
5. Contact with other crane loads is not permitted when operating the crane (arcing). Since defects caused by burns considerably reduce rope's load bearing capacity, any such occurrences must be reported immediately to the customer service of Liebherr-Werk Ehingen GmbH so that the ropes can be inspected.
6. An insulator **1** is required at all times between the crane load hook and fastening equipment. It is strictly prohibited to remove this insulator **1**.
7. Do not touch the ropes above the insulator **1**.
8. Loads that are attached to the crane may not be touched by any unprotected parts of the body after the load has been lifted or set down.
9. Do not work with a bare upper torso or in short pants, this is prohibited.
10. To minimize absorption of high-frequency radiation, larger loads should be transported horizontally if possible.
11. Loads must be grounded, or additional insulation used (rubber material between the object and gloves) when manual work is required.
12. Use a suitable measuring instrument to check the „temperature“ of the workpiece.  
For example, if 500 V can be measured on a workpiece at a distance of 1 cm to 2 cm, then the workpiece may not be touched with bare hands.  
The greater the distance, the higher the voltage is on the object:  
At 10 cm distance, approx. 600 V are present, at 30 cm distance approx. 2000 V are present.
13. When refueling the crane, it must be ensured that no sparks are created within a radius of 6 m, neither by handling larger metallic parts nor by other work.
14. To avoid secondary accidents, use personal protective equipment when working on components that are high off the ground.
15. Any accidents and unexpected events must immediately be reported to the local construction supervisor and the safety engineer.

## 25 Crane operation in case of thunderstorms

In weather conditions, which can include lightning:

- Stop work on the crane.
- If possible, take the load down.
- If possible, telescope the boom in and / or take it down in the boom receptacle and bring it into a safe condition.

If this is not possible, the crane cab must remain occupied by the crane operator to keep the crane and the load always under control.

**WARNING**

Danger of accidents due to lightning strikes!

- ▶ Make sure that there are no persons in the immediate area of the crane.

## 26 Wind influences

**Note**

- ▶ The wind speeds are valid for a 360° wind direction for a 3-second wind gust at the highest point of the crane.

**WARNING**

Disregard of permissible wind speeds!

If the permissible wind speeds are disregarded, the crane can topple over. Personnel can be severely injured or killed.

- ▶ It is prohibited to erect the crane to measure the wind speed.
- ▶ Observe the permissible wind speeds depending on the assembly / crane conditions and act accordingly, see following chart.

Assembly / crane conditions	Reference for permissible wind speed
Erection and take-down of various boom configurations	Wind speed charts and / or erection and take-down charts
Crane operation	Load chart manual
When the permissible wind speed according to the load charts is exceeded in crane operation, then <b>crane operation is prohibited</b>	Wind speed charts
Interruption of crane operation when crane remains equipped	Wind speed charts
Crane out of operation, when crane remains equipped	Wind speed charts

**Note**

No wind speed charts available!

For a set up configuration for which no wind speed charts are available:

- ▶ Observe and adhere the maximum wind speeds of the load charts.

The wind load on the crane boom has **not** been taken into account for the planning of crane operation with the LICCON job planner.

- As a result, the actual values of the support force and / or the crawler pressure can be significantly higher than the values determined with the LICCON Job planner.
- The wind affecting the crane and the load, the elastic distortion of the crane structure, incline position as well as wind exposure surface ( $A_w$ ) per ton of hoist load larger than 1.2 m<sup>2</sup>/t can significantly increase the support force and / or the crawler pressure.

**WARNING**

Increase of support force and / or the crawler pressure!

The resulting pressure on the ground becomes larger.

The permissible ground pressure can be exceeded.

- ▶ Do not exceed the permissible ground pressure.

**Note**

- ▶ The determining factor for all crane work in the actual wind speed at the job site of the crane.
- ▶ The current wind speed can be checked at the nearest weather bureau.
- ▶ Be aware that the wind speed on the boom jib is higher than near the ground.
- ▶ Always observe the national valid regulations.

## 26.1 Wind speed charts for a *variable support*

For *variable support*: Observe and adhere to the wind speed charts according to the support base for the smallest extension length of the sliding beams.

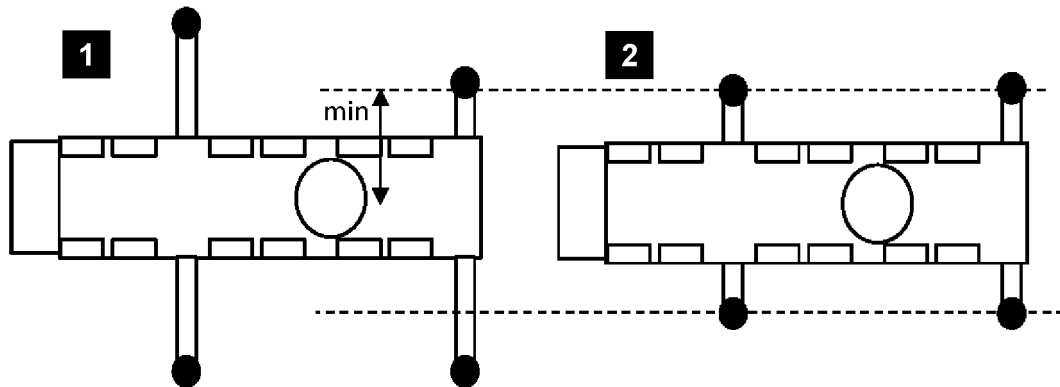


Fig.121577: Example of the selection of wind speed charts for a *variable support*

Example of the selection of wind speed charts for a *variable support*:

- The crane is supported with *variable support* according to illustration 1.
- Select wind speed charts according to the support base in illustration 2.

**Note**

No wind speed charts available!

If the smallest extension length of a sliding beam is less than those of the wind speed charts on hand:

- ▶ Observe and adhere the maximum wind speeds of the load charts.

## 26.2 Wind speed, wind gust speed and wind direction

The depiction of the wind is made by statement of wind speed (wind force), wind gust speed and wind direction.

High above the ground, the wind is less influenced by the surface condition of the ground. In the lower layers of the atmosphere, the wind speed is reduced by the ground friction. One differentiates between roughness of terrain, influence of obstacles and influence of terrain contours. Vegetation, buildings etc have great influence on the wind speed, wind gust speed and wind direction.

The site selection is thus especially important for wind measurement.

The wind speed, wind gust speed and wind direction are subject to significant time and local fluctuations. For that reason it is important to have reliable information regarding the expected wind speed, wind gust speed and wind direction during a load lift and to carry out exact wind measurements.

For mobile cranes, always assume a wind load of 360°. The determining factor is the „3 second gust speed“ on the highest point of the boom.

## 26.3 Measurement of wind speed

The anemometer installed on the crane boom measures the wind speed on the boom jib and shows the current wind speed in the crane cab.

The function of the anemometer must be checked every time before erection of the boom by manually actuating the shell start for easy movement and proper function.

Before lifting a load, especially with large wind exposure surface, the wind speed and the wind direction expected during the lift must be known. Information can be obtained for example at the local weather bureau. The determining factor is the „3 second gust speed“ on the highest point of the boom.



### WARNING

Overload of crane!

The acoustic wind warning is only issued if the standard wind exposure surface in the load chart is exceeded (wind surface per ton load: 1 m<sup>2</sup>, drag coefficient: 1.2) given wind speed.

If the permissible wind speed must be reduced for loads due to large wind exposure surfaces, no acoustic wind warning is issued.

There is no shut-off of crane movement.

- ▶ The wind exposure surface and the wind resistance coefficient for the load to be lifted must be known.
- ▶ The maximum permissible wind speed specified in the load chart must be reduced for large wind exposure surfaces as described in the load chart manual chapter "Wind influences during crane operation".

For safe determination of wind speed, the crane must be turned before application by 360°. The highest measured value while doing so must be compared with the „maximum permissible wind speed“ for the load according to the load chart. Thus the possibility that the result of the measurement is distorted due to nearby buildings, cranes or components is eliminated.

In gusty wind conditions, the probability of sudden high wind speed increases. In gusty wind conditions no large surface loads may be lifted.



### Note

- ▶ If in doubt and in case of questions for further information and / or training in the area of „Wind influences in crane operation“ contact the Customer Service at Liebherr-Werk Ehingen GmbH.

## 26.4 Conversion chart for wind force



### Note

- ▶ The influence of the wind on the surrounding is described clearly in the Beaufort scale to provide an orientation for the crane driver.
- ▶ The wind force of the Beaufort scale refers to the wind speed determined over 10 minutes at a height of 10 m.

Wind force		Wind speed		Effect of the wind Inland
Beaufort number	Designation	[m/s]	[km/h]	
0	Calm	0 to 0.2	1	Calm, smoke rises vertically
1	Slight air movement (draft)	0.3 to 1.5	1 to 5	Wind direction is shown only by observing the trail of smoke, not by the wind sock
2	Light breeze	1.6 to 3.3	6 to 11	Wind can be felt on the face, the leaves rustle, wind sock moves slightly
3	Gentle breeze	3.4 to 5.4	12 to 19	Leaves and small twigs in constant motion. Wind extends a flag
4	Moderate breeze	5.5 to 7.9	20 to 28	Swirls up dust and loose paper, moves twigs and thin branches

Wind force		Wind speed		Effect of the wind Inland
Beaufort number	Designation	[m/s]	[km/h]	
5	Fresh breeze	8.0 to 10.7	29 to 38	Small deciduous trees begin to sway, whitecaps form at sea
6	Strong breeze	10.8 to 13.8	39 to 49	Thicker branches move; telephone lines begin to whistle, umbrellas are difficult to use
7	Near gale	13.9 to 17.1	50 to 61	Entire trees swaying; difficult to walk into wind
8	Gale force wind	17.2 to 20.7	62 to 74	Breaks branches off trees, impedes walking in open areas considerably
9	Gale	20.8 to 24.4	75 to 88	Minor damage to property (chimney caps and roofing tile are blown off)
10	Severe storm	24.5 to 28.4	89 to 102	Trees are uprooted, significant damage to property
11	Violent storm	28.5 to 32.6	103 to 117	Extensive, widespread storm damage
12	Hurricane	32.7 and more	118 and more	Major destruction

Beaufort scale

## 26.5 Height dependant wind speed



### Note

- ▶ The maximum permissible wind speed ( $v_{max}$ ) and the maximum permissible wind speed according to the load chart ( $v_{max\_TAB}$ ) always refer to the 3 second wind gust speed, which is present at the maximum height of the crane.
- ▶ Instead of the 3 second wind gust speed, weather information services often report a wind speed ( $v_m$ ), which is averaged within a time period of 10 minutes (so-called 10 minute average). It refers to the wind force on the Beaufort scale, normally to the medium value of the wind speed, which is determined within a time from of 10 minutes at a height of 10 m above ground or above sea level.
- ▶ The determining factor for the calculation of the 3 second wind gust speed in maximum height of the crane is significantly higher than the average value of the wind speed, which is determined over a time of 10 minutes at a height of 10 m above ground.



### Note

- ▶ The following chart shows the 3-second wind gust speed depending on the height and the Beaufort number and / or the wind speed determined over a period of 10 minutes at a height of 10 m.
- ▶ With the aid of this chart the 3-second wind gust speed for a certain height can be determined.

Beaufort number	3	4	5 <sup>a</sup>	5	6	7 <sup>a</sup>	7	8	9	10
$v_m$ [m/s <sup>b</sup> ]	5.4	7.9	<b>10.1</b>	10.7	13.8	<b>14.3</b>	17.1	20.7	24.4	28.4
$z$ [m]	$v(z)$ [m/s]									
10	7.6	11.1	<b>14.1</b>	15.0	19.3	<b>20.0</b>	23.9	29.0	34.2	39.8
20	8.1	11.9	<b>15.2</b>	16.1	20.7	<b>21.5</b>	25.7	31.1	36.6	42.7
30	8.5	12.4	<b>15.8</b>	16.8	21.6	<b>22.4</b>	26.8	32.4	38.2	44.5
40	8.7	12.8	<b>16.3</b>	17.3	22.3	<b>23.1</b>	27.6	33.4	39.4	45.8
50	8.9	13.1	<b>16.7</b>	17.7	22.8	<b>23.6</b>	28.3	34.2	40.3	46.9

LWE/LTR 1220-003/24204-02-02/en

Beaufort number	3	4	5 <sup>a</sup>	5	6	7 <sup>a</sup>	7	8	9	10
60	9.1	13.3	<b>17.0</b>	18.0	23.3	<b>24.1</b>	28.8	34.9	41.1	47.9
70	9.3	13.5	<b>17.3</b>	18.3	23.6	<b>24.5</b>	29.3	35.5	41.8	48.7
80	9.4	13.7	<b>17.6</b>	18.6	24.0	<b>24.8</b>	29.7	36.0	42.4	49.4
90	9.5	13.9	<b>17.8</b>	18.8	24.3	<b>25.1</b>	30.1	36.4	42.9	50.0
100	9.6	14.1	<b>18.0</b>	19.1	24.6	<b>25.4</b>	30.4	36.9	43.4	50.6
110	9.7	14.2	<b>18.2</b>	19.2	24.8	<b>25.7</b>	30.8	37.2	43.9	51.1
120	9.8	14.3	<b>18.3</b>	19.4	25.1	<b>25.9</b>	31.1	37.6	44.3	51.6
130	9.9	14.5	<b>18.5</b>	19.6	25.3	<b>26.2</b>	31.3	37.9	44.7	52.0
140	10.0	14.6	<b>18.7</b>	19.8	25.5	<b>26.4</b>	31.6	38.2	45.1	52.5
150	10.0	14.7	<b>18.8</b>	19.9	25.7	<b>26.6</b>	31.8	38.5	45.4	52.9
160	10.1	14.8	<b>18.9</b>	20.1	25.9	<b>26.8</b>	32.1	38.8	45.7	53.2
170	10.2	14.9	<b>19.1</b>	20.2	26.0	<b>27.0</b>	32.3	39.1	46.0	53.6
180	10.3	15.0	<b>19.2</b>	20.3	26.2	<b>27.1</b>	32.5	39.3	46.3	53.9
190	10.3	15.1	<b>19.3</b>	20.4	26.4	<b>27.3</b>	32.7	39.5	46.6	54.2
200	10.4	15.2	<b>19.4</b>	20.6	26.5	<b>27.4</b>	32.8	39.8	46.9	54.6
<sup>a</sup> Wind stages for the crane in operation: 1 light $v_m = 10.1$ m/s at $z = 10$ m $v(z) = 14.1$ m/s $q(z) = 125$ N/m <sup>2</sup> 2 normal $v_m = 14.3$ m/s at $z = 10$ m $v(z) = 20.0$ m/s $q(z) = 250$ N/m <sup>2</sup>										
<sup>b</sup> Upper limit of Beaufort scale										

3-second wind gust speed depending on the height and the Beaufort number and / or the wind speed determined over a time of 10 minutes at a height of 10 m

Sign	Unit	Definition
$v_m$	[m/s]	Wind speed determined over a time of 10 minutes at a height of 10 m
$z$	[m]	Height above level ground
$v(z)$	[m/s]	Speed effective at height $z$ , decisive for the calculation of a 3 second gust
$q(z)$	[N/m <sup>2</sup> ]	At a height $z$ effective quasi-static dynamic pressure, determined from $v(z)$

Symbol

## 26.6 Wind influences during erection and take-down



### WARNING

The crane can topple over!

If a boom or a boom system is erected or taken down and the expected wind speeds are larger than the maximum permissible wind speeds according to the wind speed chart, then the crane can topple over and fatally injure personnel.

- ▶ If wind speeds are expected which are larger than the maximum permissible wind speeds for erection, then erection of the boom or erection of the boom system is prohibited.
- ▶ If wind speeds are expected, which are larger than the maximum permissible wind speeds for take-down, then the boom or the boom system must be taken down immediately.

**WARNING**

Wind speed higher than permissible!

When the permissible wind speed for „Crane out of operation“ is higher than the permissible wind speed for take-down: Take-down of the boom is not permissible in case of unexpected increase of wind speed.

The crane can topple over. Death, severe injury, property damage.

- ▶ If wind speeds are expected that are higher than the maximum permissible wind speeds for "Crane out of operation", then take the equipment and the boom down.
- ▶ Always take the boom down for safety reasons if weather conditions are unclear, see the Erection and take-down charts.
- ▶ Observe the permissible wind speeds for take-down.

## 26.7 Wind influences during crane operation

**WARNING**

The crane can topple over!

Unforeseeable factors, such as sudden wind gusts on the crane and the load cannot be exactly predicted in advance.

- ▶ The size and shape of the load has a significant influence on the permissible wind speed during crane operation.
- ▶ Carry out a professional job planning with authorized and trained expert personnel. All environmental conditions, such as weather forecast and wind speeds must be taken into account.
- ▶ The authorized and trained expert personnel must have sufficient knowledge in the area of „Wind influences in crane operation“.

**Note**

- ▶ Calculation examples are included in the load charts. If you need further information, contact Liebherr-Werk Ehingen GmbH.

Depending on crane application, for example:

1. Lifting of large surfaced loads.
2. Working with long boom combinations.
3. Erection and take-down of boom combinations.

The crane operator must check with appropriate information sources about the expected wind speeds, at:

1. The start of crane operation.
2. Interruption of crane operation.
3. Resumption of crane operation.

**WARNING**

The crane can topple over!

If the crane is operated at wind speeds which are larger than the maximum permissible wind speeds according to the load chart, then the crane can topple over and kill personnel.

- ▶ If wind speeds are expected that are larger than the maximum permissible wind speeds for the equipped crane, then the equipment and the boom must be taken down.
- ▶ If wind speeds are expected that are larger than the maximum permissible winds speeds for crane operation, then it is prohibited to lift a load.



## 26.8 Wind influences for „Crane out of operation“



### WARNING

The crane can topple over. Death, severe injury, property damage!

If the crane is taken out of operation in set up condition and the expected wind speeds are higher than the maximum permissible wind speeds according to the wind chart, then the crane can topple over and fatally injure personnel.

- ▶ If wind speeds are expected that are higher than the maximum permissible wind speeds for „Crane out of operation“, then take the equipment and the boom down.
- ▶ Always take the boom down for safety reasons if weather conditions are unclear, see the Erection and take-down charts.
- ▶ Observe the permissible wind speeds for take-down.

## 27 Lifting a load with two cranes

Before lifting a load with two cranes, the crane operator or a representative of the operator must determine the work sequence and assign a responsible supervisory person for the operation. The responsible supervisor must monitor the operation and remain in constant contact with the crane operators.



### WARNING

Overload and toppling of the cranes!

If the load is not lifted or lowered exactly evenly by both cranes, then the center of gravity changes. The cranes can be overloaded and topple over.

Personnel can be killed or seriously injured.

- ▶ Make sure that the cranes are horizontally aligned.
- ▶ Observe the national valid standards, regulations and accident prevention regulations.
- ▶ Determine the utilization degree of the cranes in operation, depending on the complexity of the load lift.
- ▶ Plan for sufficient safety reserves.
- ▶ Avoid side load on the boom.
- ▶ Carry out crane movements synchronously and slowly.



### Note

- ▶ The total weight and the center of gravity of the load must be known exactly.
- ▶ Carry out the job planning in detail and with care.
- ▶ Avoid fastening points below the center of gravity of the load.

When the operational conditions or the work to be carried out require:

- ▶ Set up an assembly plan and operating instructions for the operation.

In the drawing is shown how the center of gravity for the load changes if the load is lifted or lowered unevenly. Already a slight incline of the load can cause the crane to be overloaded.

If the load on crane 2 ( $F_2$ ) is lowered, the load on crane 1 ( $F_1$ ) increases. Crane 1 can thereby be overloaded.

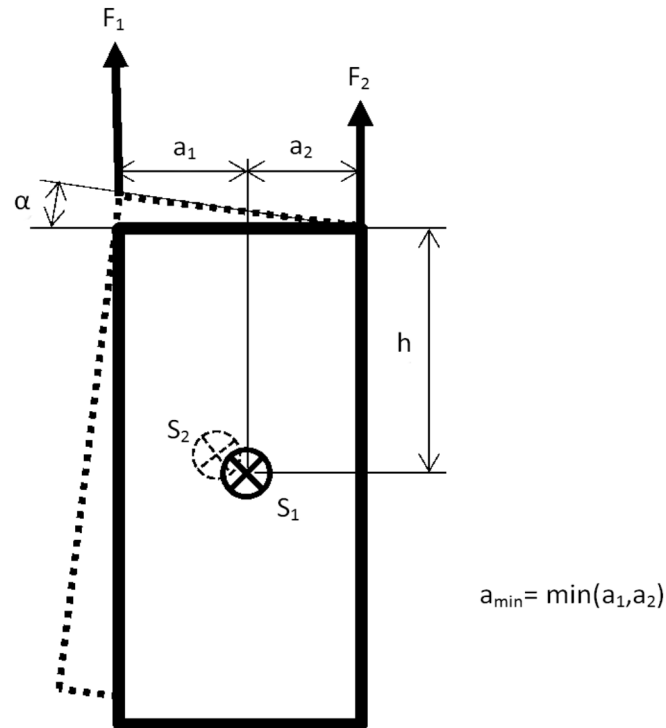


Fig.124126: Geometric conditions

$F_1$	Load on crane 1	$F_2$	Load on crane 2
$S_1$	Center of gravity of load	$S_2$	Center of gravity of load at incline position
$h$	Vertical distance between center of gravity of load and fastening points	$\alpha$	Angle of load at incline position
$a_1$	Horizontal distance between center of gravity of load and fastening point crane 1	$a_2$	Horizontal distance between center of gravity of load and fastening point crane 2
$a_{\min}$	Smallest horizontal distance between center of gravity of load and fastening point (minimum from $a_1$ and $a_2$ )		

The following diagram shows the dependence of the ratio of  $h/a_{\min}$  at a maximum permissible incline position of the load of  $3^\circ$  in reference to the permissible load utilization of cranes in percentages.

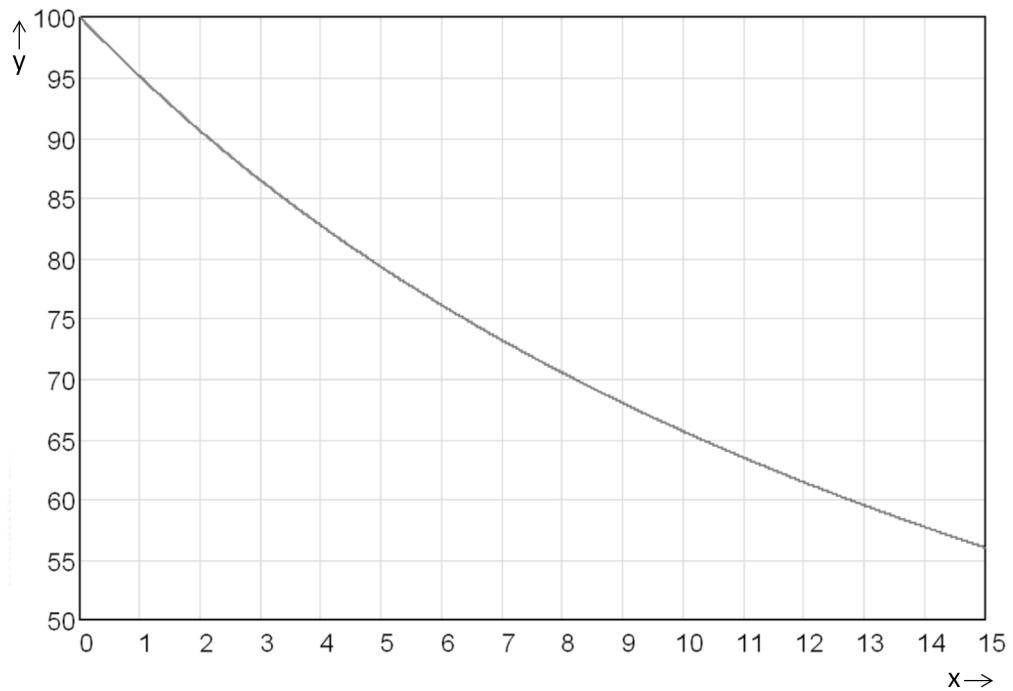


Fig.124127: Maximum permissible load utilization

**x** Ratio of  $h$  to  $a_{\min}$  **y** Maximum permissible load utilization in percentages, if  $\alpha$  is smaller or equal to  $3^\circ$

Example: A ratio  $h$  to  $a_{\min}$  of 6, when retaining the incline position of the load of maximum  $3^\circ$  results in a maximum permissible load utilization of both cranes of approx. 76 % each.

## 28 Overlapping of working ranges of several cranes



### WARNING

Danger of collision!

If the working ranges of several cranes overlap, there is a danger of collision.

Personnel can be injured or killed.

Significant property damage can result.

- ▶ The contractor or his representative must determine the work sequence in detail in advance.
- ▶ The contractor or his representative must ensure flawless communication between crane operators.
- ▶ The crane operators must ensure through calm operating mode, that no collisions occur due to uncontrolled movements. The crane operators must have been trained and instructed accordingly.

If the communication between the crane operators is not ensured by sound or visual connection, then suitable measures must be taken, such as using radio communication, guides or similar. When using derrick booms or TY-guying, it is necessary to proceed with extreme caution as these components protrude far past the rear turning radius of the turntable.



### Note

- ▶ If guides are used, then the signals must be agreed upon between them and the crane operators, see section „Hand signals for guidance“.

## 29 Hand signals for guidance

For all crane movements, the crane operator must always keep the load as well as the crane hook or load handling equipment when the crane is not loaded, in his field of vision.



### WARNING

Danger of accident if standing under suspended loads!

- ▶ Always keep loads in sight.
- ▶ Standing under suspended loads is prohibited.

If this is not possible, the crane operator may only operate the crane if he is signed by an assigned guide.

The operator may be guided by hand signals or a two-way radio. It must be ensured that there are no misunderstandings.



### WARNING

Danger of accident caused by misunderstood hand signals!

- ▶ Hand signals must be mutually agreed upon and clearly executed.
- ▶ In any case, the **national regulations** must be observed.

### 29.1 Hand signals

#### 29.1.1 Starting operation, follow my instructions

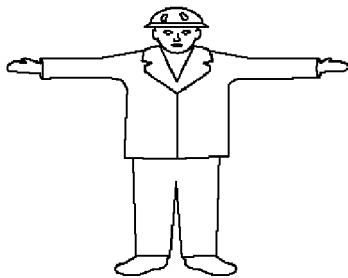


Fig.111700: Starting operation, follow my instructions

Both arms stretched out horizontally with hands open and palms directed to the front.

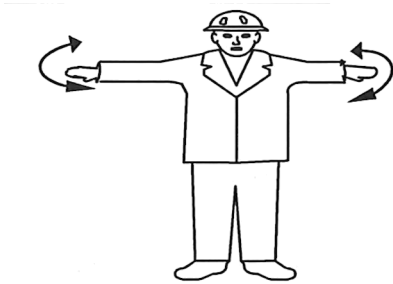
#### 29.1.2 Stop (normal stop)



Fig.144245: Stop (normal stop)

Arm stretched out, palm of hand facing down, move the arm horizontally backward and forward.

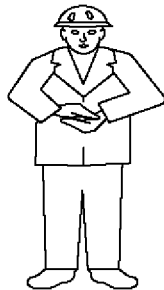
### 29.1.3 Emergency stop (quick stop)



*Fig.144246: Emergency stop (quick stop)*

Both arms stretched out, both hand palms facing down, move arms horizontally backward and forward.

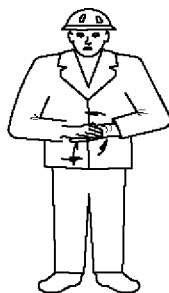
### 29.1.4 Ending operation, no longer follow my instructions



*Fig.111703: Ending operation, no longer follow my instructions*

Fold hands together at chest height in front of body.

### 29.1.5 Creeper gear or very slow movement



*Fig.111704: Creeper gear or very slow movement*

Rub palms together in circular motion. After this sign, all other applicable hand signals apply.

## 29.2 Vertical movements

### 29.2.1 Showing the vertical distance

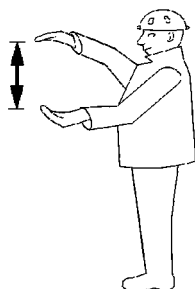


Fig.121364: Showing the vertical distance

Both arms stretched out in front of the body one on top of the other, with opposing palms.

### 29.2.2 Lifting / lowering a load with even speed



Fig.111706: Lifting / lowering a load with even speed

Lift one arm overhead with closed hand and index finger pointing upward, with small horizontal circular movements with forearm.

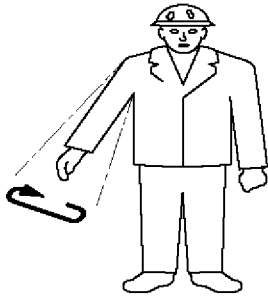
### 29.2.3 Lifting slowly



Fig.121365: Lifting slowly

Give lift signal with one hand, the other palm is not moving and positioned over the hand, which gives the signal.

### 29.2.4 Lowering the load while stationary



*Fig.111708: Lowering the load while stationary*

Point one arm away from the body, downward, with hand closed and index finger pointing down. Make small circular movements with forearm.

### 29.2.5 Lowering slowly

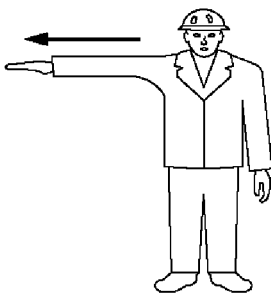


*Fig.121366: Lowering slowly*

Give lowering signal with one hand, do not move the other palm and hold it under the hand, pointing to the hand which gives the signal.

## 29.3 Horizontal movements

### 29.3.1 Driving / swinging in the specified direction



*Fig.111710: Driving / swinging in the specified direction*

Hold stretched out arm horizontally into the desired direction, with the hand open and the palm pointing down.

### 29.3.2 Moving away from me



Fig.111711: Moving away from me

Stretch out both arms simultaneously with forearms in front, with both hands open and the palms pointing down. Move the forearms repeatedly between the horizontal and vertical position up and down.

### 29.3.3 Moving toward me

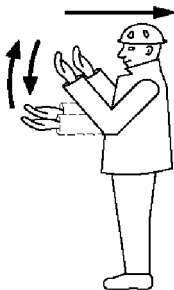


Fig.111712: Moving toward me

Stretch out both arms simultaneously with forearms vertically, with both hands open and the palms pointing to the rear. Move the forearms repeatedly up and down.

### 29.3.4 Moving both track chains

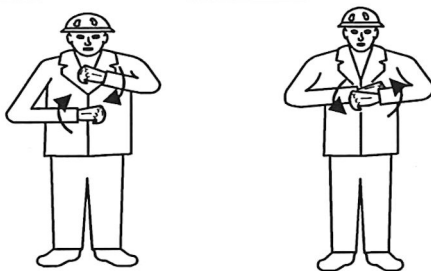


Fig.144247: Moving both track chains

Turn both fists around each other in front of the body in direction of the movement (forward or reverse).



### 29.3.5 Moving one crawler chain



Fig.144248: Moving one crawler chain

Lift one fist to show blockage of chain on one side. Turn the other fist vertically in front of the body to signal movement of the opposite chain.

### 29.3.6 Showing the horizontal distance

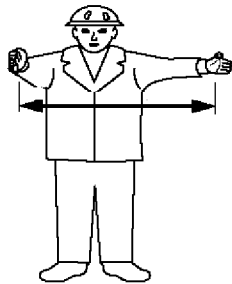


Fig.121380: Showing the horizontal distance

Keep both arms stretched out horizontally in front of the body with the palms opposite each other.

### 29.3.7 Transfer (between two cranes or two hooks)

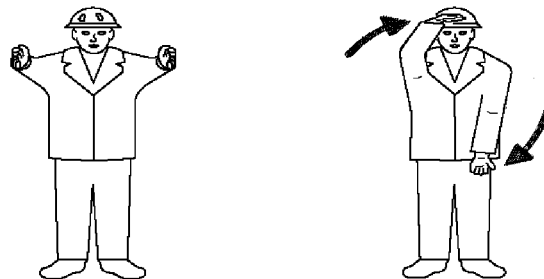


Fig.121368: Transfer (between two cranes or two hooks)

Hold both arms stretched out to the front, parallel and horizontally and turn by 90° in direction of the transfer.



#### WARNING

Load bearing capacity is **not** sufficient!

The crane can topple over, death, property damage.

- ▶ Make sure that the load bearing capacity of the individual crane and hook is sufficient even if the transfer of the load is suddenly asymmetric.

## 29.4 Machine related movements

### 29.4.1 Lifting with main winch

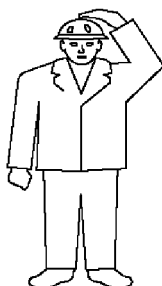


Fig.111719: Lifting with main winch

Place one hand on your head and hold the other arm on the side of the body.

After this signal all other hand signals apply only for the main winch.



#### Note

- ▶ If two or more main winches are present, then the signaller can show the number of the crane by pointing to it or signal with one finger.

### 29.4.2 Lifting with auxiliary winch

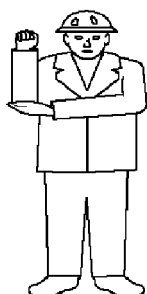


Fig.111720: Lifting with auxiliary winch

Hold one forearm vertically with closed hand and touch the elbow of this arm with the other hand.

After this signal all other hand signals apply only for the auxiliary winch.

### 29.4.3 Lifting the boom

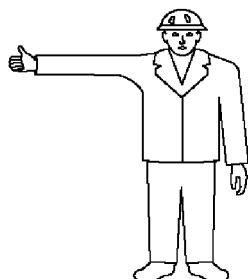
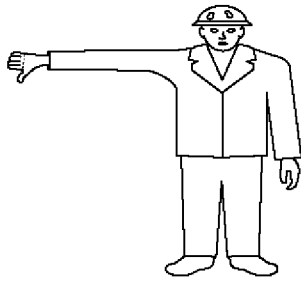


Fig.111721: Lifting the boom

Hold one arm horizontally with thumb directed upward.

### 29.4.4 Lowering the boom



*Fig.111722: Lowering the boom*

Hold one arm horizontally with thumb directed downward.

### 29.4.5 Extending the boom



*Fig.144249: Extending the boom*

Hold both hands (with closed fists) stretched out to the front, with both thumbs directed away from each other.

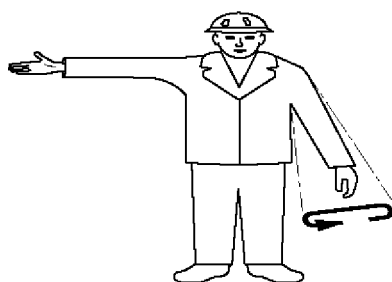
### 29.4.6 Retracting the boom



*Fig.144250: Retracting the boom*

Hold both hands (with closed fists) stretched out to the front, with both thumbs directed toward each other.

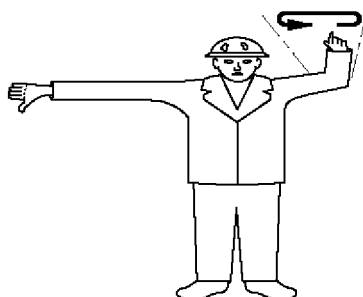
### 29.4.7 Lifting the boom and lower the load at the same time



*Fig.111725: Lifting the boom and lower the load at the same time*

Hold one arm stretched out horizontally with thumb directed upward and stretch the other arm downward and away from the body, make small flat circles with the forearm.

### 29.4.8 Lowering the boom and lift the load at the same time



*Fig.111726: Lowering the boom and lift the load at the same time*

Hold one arm stretched out with thumb pointing down, stretch the other forearm upward and make small flat circles.

## 30 Travel operation

### 30.1 Starting to drive

Before starting to drive the crane

- Close all doors.
- Keep the doors closed during the travel operation.

## 30.2 Turning / driving in reverse



### WARNING

Danger of accidents when turning or driving in reverse!

When turning or driving in reverse, personnel can be overlooked and killed.

Objects can be severely damaged.

- ▶ When turning or driving in reverse, the driver must act in such a way that he does not endanger other traffic participants.
- ▶ The driver may only drive in reverse or reset when persons or devices are **not** endangered. If this can **not** be ensured, then he must use a guide.
- ▶ An acoustical back up warning device will never replace the guide.
- ▶ Make sure that there are no persons or objects behind the vehicle when driving in reverse.
- ▶ Make sure that no personnel is injured or even killed.
- ▶ Make sure that no objects are damaged.
- ▶ Driving in reverse is only permissible at slow driving speed (maneuvering speed).
- ▶ Adhere to the national regulations.

## 30.3 Driving with a trailer

Driving with a trailer depends on the weight of the mobile crane. The minimum weight of the mobile crane in trailer mode is 70 percent of the permissible total weight.

Number of axles	Permissible total weight of the mobile crane	Minimum weight of the mobile crane in trailer mode
4	48000 kg	Approx. 33000 kg
5	60000 kg	Approx. 42000 kg
6	72000 kg	Approx. 50000 kg

### 30.3.1 Driving with a reduced load

The load of the vehicle crane has been reduced to a range between the permissible total weight and the minimum weight for trailer mode. The load of the vehicle crane can be reduced by disassembling equipment.

The vehicle crane has a different, strong braking behavior. The vehicle crane can reeve out.

### 30.3.2 Driving with an extremely reduced load

The load of the vehicle crane has been reduced to the minimum weight for trailer mode or less. The load of the vehicle crane can be reduced extremely for example by disassembling the telescopic boom and by disassembling other equipment.



### WARNING

Driving with a trailer with an extremely reduced load!

The mobile crane has a different, strong braking behavior. The mobile crane can reeve out. Danger of accident, death, property damage.

- ▶ In the case of an extremely reduced load, do **not** drive the crane vehicle with a trailer.

## 30.4 Stopping the mobile crane

Make sure that the following prerequisites are met:

- The mobile crane is standing on load bearing, level and tractive ground.
- The parking brake is applied.

**WARNING**

Parking brake is **not** applied!

The mobile crane can roll off, death, property damage.

- ▶ Park the mobile crane exclusively with applied parking brake.

- Turn off the ignition and pull out the ignition key.

When a battery master switch is present:

- Turn off the battery master switch and remove the switch cams.

**WARNING**

Downhill or uphill slope is too large!

The mobile crane can roll off, death, property damage.

- ▶ Park the mobile crane at an downhill or uphill slope of no more than maximum 18 %.

Under the following conditions the mobile crane must be additionally secured with wheel chocks to prevent it from rolling off:

- The mobile crane is parked on a slope or an incline.
- The mobile crane is defective, particularly when the brake system is defective.

**WARNING**

Wedges incorrectly placed!

The mobile crane can roll off, death, property damage.

- ▶ So that the wedges have an immediate braking action and hold the mobile crane in park position:  
Place all wedges tightly directly under the wheel.
- ▶ Place all specified wedges.
- ▶ All wedges must counteract the downhill slope force.

If necessary:

- Place the wedges.

## 31 Crane operation

### 31.1 Before starting to work

Before starting to work with the crane:

- Make sure that the cylinders are free of ice.
- Close all doors.
- Keep the doors closed during crane operation.

### 31.2 While working with the crane

**WARNING**

Defective crane!

Death, severe bodily injuries, property damage.

If an erroneous function of a crane movement is recognized during crane operation:

- ▶ Telescope the boom in all the way and take it down, find the source of the problem and remedy it.

**WARNING**

Relapse cylinder pressure loss!

The luffing lattice jib can luff uncontrollably.

If the luffing lattice jib is assembled

- ▶ Make sure that no persons or obstacles are in the luffing range or are located below the lattice jib.

**WARNING**

Relapse cylinder pressure loss!

The luffing lattice jib can luff uncontrollably due to slack rope on the luffing pulley block.

If an actuated luff down movement does not take place as expected:

- ▶ Immediately stop the luff down movement.
- ▶ Make sure that no slack rope has formed.

If slack rope has formed:

- ▶ Remedy the slack rope.

**NOTICE**

Freezing rain!

Property damage to the cylinder seals.

If freezing rain starts when working with the crane:

- ▶ Working with the crane is prohibited.
- ▶ Make sure that all cylinders are free of ice.

### 31.3 Crane operation with a load

**WARNING**

The crane can topple over!

If the crane is in condition which is **not** operationally safe, the crane can topple over or crane components can fall down.

Personnel can be severely injured or killed.

- ▶ Before starting to work, the crane operator must ensure that the crane is in operationally safe condition.
- ▶ If safe crane operation cannot be ensured by the crane operator, then crane operation is prohibited until an operationally safe condition for the crane is established.
- ▶ Safety equipment, for example: Load torque limiter, hoist limit switch, brakes must be fully functioning, otherwise crane operation is prohibited.

Make sure that the following prerequisites are met:

- The load torque limiter must be adjusted according to the current set up configuration of the crane.
- The loads given in the load chart may not be exceeded.
- The crane may never be subjected to a load that exceeds what is specified in the load charts.
- The weight, center of gravity and dimensions of the load to be lifted must be known.
- Load carriers, load handling and fastening equipment must be in accordance with specified requirements.

**Note**

- ▶ Make sure that the weight of the hook block and the weight of the fastening equipment is subtracted from the load given in the load chart, see the following chart.

Example:		
Maximum permissible load according to chart		30.000 t
Weight of the hook block	350 kg	- 0.350 t
Weight of the fastening rope	50 kg	- 0.050 t
Actual load capacity of the crane		= <b>29.600 t</b>

The weight of the load to be lifted, in this example, may not exceed **29.6 t**.

**DANGER**

There is a high danger of accidents should the following points not be observed!

- ▶ Observe the following points.

**There is a great danger of accident if:**

- The load torque limiter is not set in accordance with the current crane set up configuration and is therefore not able to provide proper protection.
- The load torque limiter is defective or taken out of operation.
- The hoist limit switches are defective or not functioning.
- For crawler cranes and mobile cranes with luffing lattice jib:  
The angle sensor and the force test brackets are not functioning.
- For mobile cranes and crawler cranes with support:  
The sliding beams of the hydraulic support are not extended to the dimensions specified in the load chart.
- On crawler cranes:  
The crawlers are not supported with stable base material sufficiently large for the ground conditions.
- For mobile cranes and crawler cranes with support:  
The support plates are not supported with stable materials large enough for the ground conditions.
- Angular pulling is performed.  
Angular pulling to the side is particularly dangerous, because the boom has only minimal lateral resistance momentum.

**Angular pull is prohibited.**

- Load attached during disassembly is too heavy and is freely suspended on the crane after release.
- The load hook is used to break away stuck loads.  
Even if the weight of a stuck load does not exceed the permissible load capacity, the crane can topple over backwards if the load is suddenly released due to the tension of the boom, which can cause it to tip backwards.
- Working when the wind is excessively strong.  
Comply with the load chart specifications.
- The crane is not levelled and the load is slewed in the direction of the slope.
- If improper control of crane movements cause the suspended load to swing like a pendulum.
- The loads and boom radii specified in the load charts are exceeded.
- When working in the vicinity of electricity transmission lines:
  - The electricity transmission lines were not turned off by expert electricians.
  - The danger zone was not covered or blocked off.

**WARNING**

Danger of current transfer!

If electricity transmission lines are not shut off nor covered nor blocked off, then there is an increased danger of accident due to current transfer.

- ▶ Adhere to the safety distance according to the following chart.

If the crane becomes electrified despite having taken all necessary precautions, proceed as follows:

- ▶ Remain calm.
- ▶ Do not leave the crane cab.
- ▶ Warn people outside: Stay in place and do not touch the crane.
- ▶ Move the crane away from the danger zone.

Nominal voltage	Safety distance	
Up to 50 kV	4 m	10 ft
More than 50 kV to 200 kV	5 m	15 ft
More than 200 kV to 350 kV	7 m	20 ft
More than 350 kV to 500 kV	8 m	25 ft



Nominal voltage	Safety distance	
More than 500 kV to 750 kV	11 m	35 ft
More than 750 kV to 1000 kV	14 m	45 ft
More than 1000 kV	Determination by power supplier or authorized electrician	Determination by power supplier or authorized electrician

*Safety distance to electrical power lines depending on the nominal voltage*

### 31.3.1 Counterweight and / or ballast

The type of counterweight and / or ballast required depends on the weight of the load to be lifted and the boom radius required for crane operation. The deciding factor for the selection of the counterweight and / or ballast is the data in the corresponding load chart.



#### **WARNING**

The crane can topple over!

If the counterweight and / or ballast is not installed according to the load chart, then the crane can topple over and fatally injure personnel.

- ▶ Install the counterweight and / or ballast according to the load chart.

### 31.3.2 Derrick ballast - suspended ballast

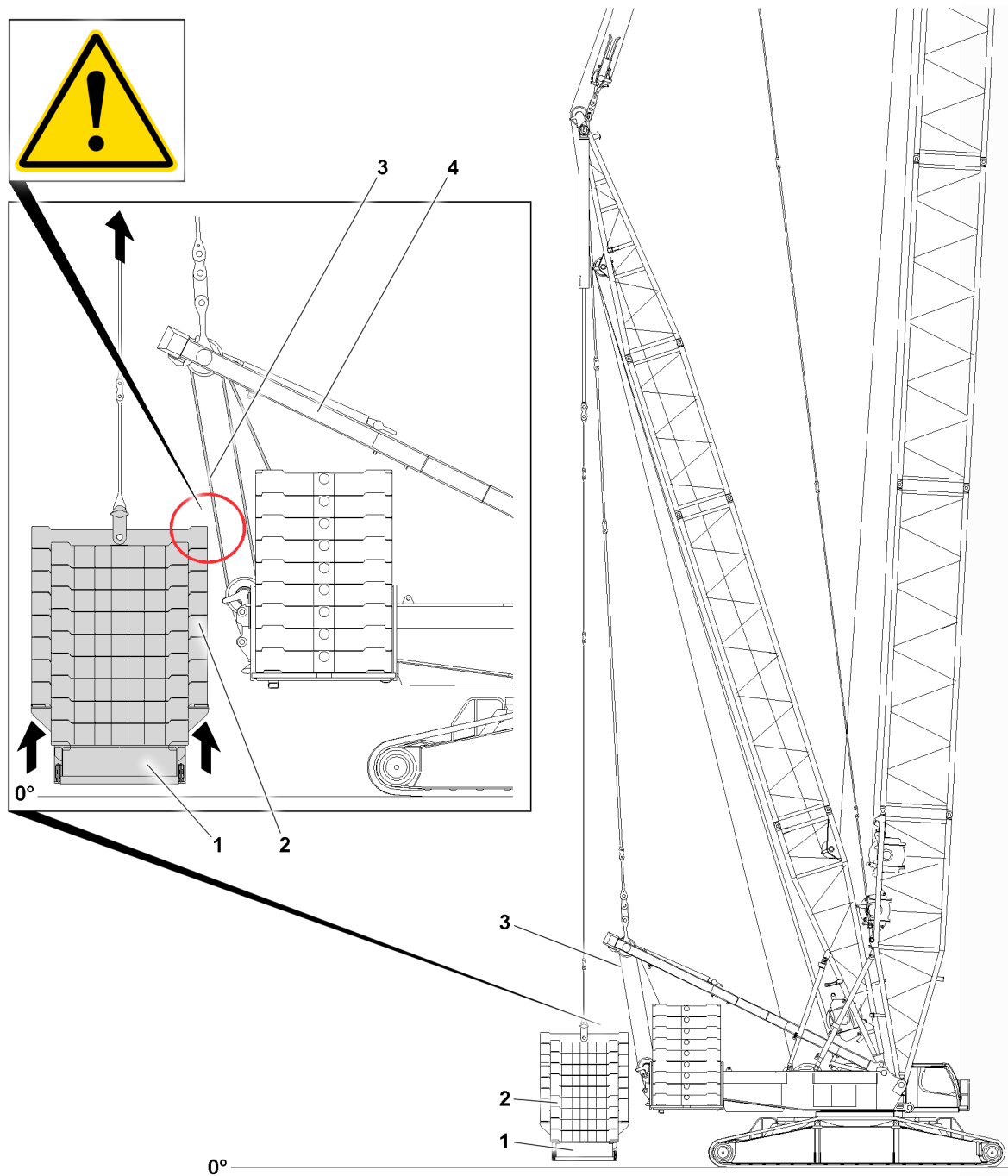


Fig.154801: Danger of collision when lifting the derrick ballast with small derrick ballast radii

- 1 Suspended ballast pallet
- 2 Derrick ballast plate
- 3 Winch 4 control rope
- 4 SA-frame

**WARNING**

Danger of collision!

With small derrick ballast radii, the derrick ballast plates **2** can collide with the winch **4** control rope **3** when lifting the derrick ballast up off the ground.

Death, severe bodily injuries, property damage.

- ▶ Make sure that a guide monitors the lifting of the derrick ballast up off the ground.
- ▶ Adapt the lifting height of the derrick ballast.

### 31.3.3 Hoist gear, hoist rope

The lifting capability of the crane depends on the pull force of the hoist gear and the number of possible hoist rope reevings. When using a single strand, the crane can only lift a load that is pulled by the hoist gear.

If the load to be lifted is heavier than the pull force of the hoist gear, then the hoist rope must be reeved as needed according to the principle of a pulley between the pulley head on the boom and the hook block.

When reeving, carefully observe the load chart specifications and the operating instructions.

**WARNING**

Hoist rope failure!

If the maximum pull force of the hoist gear is exceeded, the hoist rope can break or the hoist gear can be damaged.

The load can fall and kill personnel.

- ▶ Observe the maximum pull force of the hoist gear.

### 31.3.4 Hydraulically adjustable auxiliary boom

**WARNING**

Impermissible luffing of the auxiliary boom!

Damage to the auxiliary boom due to collision with the ground or other objects. Component failure.

Death, severe bodily injuries, property damage.

- ▶ Do **not** luff the auxiliary boom down onto the ground or other objects by means of hydraulic adjustment.
- ▶ Do **not** luff the auxiliary boom down onto the ground or other objects by means of luffing down the main boom.

## 31.4 Interrupting crane operation

**WARNING**

Impermissible weather conditions!

If the crane is exposed to impermissible weather conditions during interruption of crane operation, situations can occur which could bring the crane into an unsafe condition.

Toppling crane, death, severe bodily injuries, property damage.

- ▶ Get the weather forecast for the entire period during which the crane is set up.

If the predicted wind speeds are above the permissible values according to the load chart and / or the wind speed chart:

- ▶ Take the boom and equipment down in time before impermissible wind speeds occur. See Crane operating instructions, wind speed charts and Erection and take down charts.

When wind conditions are present, which are above the permissible values of the wind speed chart and the boom can no longer be taken down:

- ▶ Make sure that there is no danger for persons, crane and surrounding area. Secure the crane and surrounding area of the crane far enough against access. Warn persons in the surrounding area and bring them in safety.

A weather forecast includes information about:

- Changing weather conditions
- Wind
- Ice
- Precipitation
- Flooding
- Lightning



### WARNING

Defective crane!

Death, severe bodily injuries, property damage.

If a crane movement occurs during the interruption of crane operation:

- ▶ Make sure, when an unintentional crane movement occurs, for example as a result of leak, no danger for persons, crane and surrounding is created.

Leaks can occur all on pressurized hydraulic cylinders, for example on the following cylinders:

- Support cylinder
- Luffing cylinder
- Telescoping cylinder
- Control cylinder
- Relapse cylinders



### Note

- ▶ Movements can occur on hydraulic cylinders also as a result of changing oil temperature.



### WARNING

Set up crane is not supervised!

Situations during interruption of crane operation may occur which could cause the crane to become unsafe if left unsupervised.

Toppling crane, death, severe bodily injuries, property damage.

- ▶ Always watch the crane and keep it under control.

If the crane is in set up condition:

- ▶ Do **not** leave the crane.

If the crane can **not** be constantly kept under control:

- ▶ Take the equipment down and telescope the boom in and place it down.
- ▶ The boom on the crane may only be placed down if the predicted wind speeds according to the wind speed charts are less than the maximum permissible wind speeds during assembly and disassembly.
- ▶ Before the crane is unsupervised: Establish an emergency plan.
- ▶ Carry out the measures listed below.



### Note

- ▶ An emergency plan includes information how the crane is brought into a safe condition if an unforeseen event occurs.

If possible:

- Take down and secure the equipment, see the erection and take-down charts.
- Telescope the boom in and secure it. The crane boom may only be telescoped when the prevalent wind speed is lower than the wind speed indicated in the load chart for the boom.
- Take the boom down and secure it. The crane boom may only be placed down if the wind speeds are lower than the maximum permitted wind speeds according to the wind speed charts or does not exceed them according to the assembly / disassembly instructions.

On mobile cranes:

- Lift the axles to the maximum position and block the hydraulic suspension.

On lattice mast cranes:

- Set the Derrick ballast, if present, down on the ground.

- Place the load completely on the ground and unhook it from the crane hook.
- Remove the fastening ropes from the hook.
- Place the load completely on the ground and unhook it from the crane hook.
- Remove the fastening ropes from the hook.

When the hook block remains installed:

- Lift the hook block into the highest position.
- Make sure that the hook block does not touch other crane parts or obstacles.
- Make sure that all measures were taken to keep the crane in a safe condition if something happens.
- If possible, turn the engines off.
- Set all control levers into neutral position or into a locked position.
- Turn all secondary systems off, except systems that are required for restart.
- Establish the energy supply and functionality of safety equipment.
- Close off all control devices, which are not in use.
- Disconnect all control devices, which are connected with cables, if possible, and secure them to prevent unauthorized use.
- Secure control devices without cables to prevent unauthorized use.
- Make sure that the batteries in control devices without cables are charged.
- Make sure that access to the crane and operation for unauthorized personnel is excluded: Lock the driver's cab and the crane cab.
- Secure all keys to prevent unauthorized access.

If the construction site has limited space:

- The decision not to take the boom down while the crane is unsupervised can only be made by an authorized and qualified crane operator, who is familiar with the construction site.
- Make sure that no danger can occur for persons, crane and its surroundings should something unforeseen happen.
- Make sure for the duration of the interruption of crane operation, that the predicted wind speeds do not exceed the permissible values for the respective set up configuration, see wind speed chart.
- If the wind speed charts do not provide values for the set up condition, the permissible wind speed in the load chart shall be observed.

If crane operation with a set up crane is interrupted:

- Make sure measures are initiated in time by trained, qualified personnel to bring the crane into a safe condition if anything happens.
- Make sure that no danger can occur for persons, crane and its surroundings should something unforeseen happen.

If the predicted wind speeds are above the permissible values:

- Bring the boom and equipment in time into a permissible condition before impermissible wind speeds occur, depending on the predicted wind speed, or take it down completely on the ground. See Crane operating instructions, wind speed charts and Erection and take down charts.
- Telescope the telescopic boom in and luff down to 0°. Position the boom and auxiliary boom, see the Crane operating instructions, wind speed charts and erection and take-down charts.

**Situations are for example:**

- Vandalism
- The ground giving way due to severe rain
- Melting ice under the supports
- Storm and thunderstorm
- Storm and wind
- Lightning
- Flooding
- Earthquakes
- Landslides
- Washouts
- For mobile cranes and crawler cranes with support:  
Yielding of support cylinders (leak, temperature changes)
- For cranes with a telescopic boom:  
Yielding of luffing cylinders (leak, temperature changes)

- Yielding of luffing lattice jib relapse cylinders (leak, temperature changes)

## 31.5 Resuming crane operation

Before resuming crane operation, the crane operator is obligated, among others, but not exclusively, to check the crane condition, the safety equipment, as well as the environmental conditions.



### WARNING

Danger of accident!

When the crane operator leaves the crane cab:

- ▶ Before resuming work, check the operating mode setting and reset, if necessary.

## 31.6 Ending crane operation

Before the crane operator may leave the crane, the following prerequisites must be met:

- Place the load fully on the ground and unhook from the crane hook.
- On crane with telescopic boom: Telescope the telescopic boom in all the way and take the boom down in the boom receptacle.
- For a crane with a lattice mast boom: Take the lattice mast boom down and disassemble if necessary.
- Bring the control lever (master switch) to the 0-position.
- Apply the parking brake on the crane chassis.
- Turn the engine off and pull out the ignition key.
- When a battery master switch is present: Wait ten minutes after removing the ignition key. After these ten minutes have passed, turn off the battery master switch and pull off the switch cam.
- Lock the crane cab.
- Secure the crane to prevent unauthorized use.
- For mobile crane: Make sure that the driver's cab is **not** occupied. Lock the driver's cab. Secure the crane to prevent it from rolling off unintentionally, see section „Parking the vehicle“.
- Make sure that no danger can occur for persons, crane and its surroundings should something unforeseen happen.

# 32 Lifting of personnel

## 32.1 Intended use

- The destined use of the crane is **lifting of loads**.
- **Lifting of personnel** is **not** considered to be destined use of the crane.



### Note

- ▶ These instructions do **not** apply for work platforms, which are attached on the crane boom and are used to lift personnel. This subject is governed by international standards for mobile aerial work platforms.

**WARNING**

Non-designated use of the crane!

Personnel can be severely injured or killed.

- ▶ The crane is **not** intended to lift personnel.
- ▶ Lifting persons on the variable support is prohibited.
- ▶ The crane may **not** be used for recreational purposes and exhibitions, such as lifting personnel for shows, bungee jumping or Dinner in the sky.
- ▶ The crane may **not** be used for lifting of devices with personnel on them or under the device, such as lifting of tents.
- ▶ Exception: If lifting of personnel for special work situations is the least dangerous possibility to carry out the work, then personnel may be lifted or brought into a suspended position when using lifting cages (cherry pickers).

## 32.2 Prerequisites for lifting of personnel

Make sure that the following prerequisites are met:

- Lifting personnel with cranes is permissible by national and local laws in the country where this crane application is carried out.

**DANGER**

Lifting of personnel!

Accidents which occur when lifting personnel often result in severe injuries or even death.

- ▶ This exceptional application is within the scope of responsibility of the user and is only permitted if the requirements and instructions in the next sections are observed and adhered to.
- ▶ The company, the supervisor, the crane operator and auxiliary personnel must proceed especially carefully and safety conscious.
- ▶ Before the lifting procedure, a meeting must be held with all associated personnel.
- ▶ The following warning notes and safety regulations must be strictly observed.

### 32.2.1 Legal prerequisites

Make sure that the following prerequisites are met:

- Special arrangements were made for the use of the lifting cage (cherry picker) according to the requirements of national laws.
- If required by national laws: The use of the crane to lift personnel is reported to the state agency for occupational health and safety. The lifting procedure may possibly require a special permit.
- Before the implementation of the lifting procedure with the aid of a work-specific risk analysis for the possibility of rescuing personnel in emergencies was defined.
- To rescue personnel in emergencies, precautionary measures must be present on the crane, if they are required by national laws.
- The measures for safe operation near power lines, depending on the conditions on the job site and the national laws / national regulations were observed and adhered to.

### 32.2.2 Prerequisites for crane equipment and accessories

Make sure that the following prerequisites are met:

- The hoist gear to lift personnel must also be able to be moved in emergency operation.
- Before lifting personnel, the crane was inspected. No damage was found.
- The lifting cage (cherry picker) is utilized according to national laws and / or standards and according to intended purpose.
- Before lifting personnel, the lifting cage (cherry picker) was carefully inspected. No damage was found.
- Every emergency rescue device was inspected and its operational readiness was determined, if required by national laws.
- Any hooks in use must be equipped with a latch, which prevents the hook mouth to open. According to national laws, the latch must be manually closable or lockable or must automatically close via a spring.

### 32.2.3 Inspecting before start up

Make sure that the following inspections are made before starting up the lifting cage (cherry picker):

- On every new construction site and after every modification or repair: To ensure the operating safety of the lifting cage (cherry picker) and the lifting equipment, a test with 125 % of the nominal load carrying capacity of the lifting cage (cherry picker) without personnel must be carried out. During the test, the lifting cage (cherry picker) may only be lifted just above the ground.
- A test lift with loaded lifting cage (cherry picker) without personnel must be carried out. The weight in the lifting cage (cherry picker) for the test lift must be at least as large as the weight of the personnel and the weight with the work equipment carried along. For this test lift, the course of all planned movements of the lifting procedure must be simulated.
- This test lift must be carried out for every location on a construction site, where personnel must be carried.

### 32.2.4 Prerequisites for operation with lifting cage (cherry picker)

Make sure that the following prerequisites are met for operation with lifting cage (cherry picker):

- The personnel and technical prerequisites for safe use and operation of the emergency control of the crane are present.
- The emergency control for emergency rescue of the person in the lifting cage is functioning.
- The rope pull is limited to 50 % of the maximum rope pull.
- The crane is utilized only to 50 % of its maximum load bearing capacity of the valid load chart.
- Only the hoist gear lifting / lowering, turning and luffing crane movements may be performed.



#### WARNING

Superimposed crane movements with hydraulic auxiliary users!

Superimposed crane movements by actuating hydraulic auxiliary users can lead to the unwanted acceleration or deceleration of the safety cage movement.

- ▶ It is prohibited to superimpose crane movements with hydraulic auxiliary users to tilt the cab, for example.

## 33 Securing personnel on shut off crane

### 33.1 Terms and abbreviations

- PSAgA: Personal protective equipment to prevent falling
- HSG: Height safety device

### 33.2 Intended use

Cranes are **not** designed to protect personnel against falling.

When the following prerequisites are met, the personnel protection may be permissible:

- A justified individual case is present.
- A project-specific written risk assessment and work procedure for the precise case by the employer is on hand.
- The specific safety measures are strictly adhered to.

Limitations for movement and operation:

- Moving the secured person on the crane **from** job site and **to** job site is impermissible.
- Moving the secured person on the crane **from** job site and **to** job site is permissible only in case of a rescue operation.
- Operation of the crane by the secured person is impermissible.
- The crane is stopped off and secured against any movement.



## 33.3 Prerequisites



### WARNING

Prerequisites for personnel protection are **not** met!  
Danger of accident. Death, severe bodily injuries.

- ▶ Carry out the personnel protection on the shut off crane only when **all** prerequisites in this section have been met.

Make sure that the following prerequisites are met:

- The country-specific, legal regulations are being observed.
- The written risk assessment shows:
  - Technical protective measures with at least the same protective effect are **not** available.
  - The normal fastening devices can **not** be used.
  - Personnel protection on the shut off crane is the safest and most useful method to carry out this work.
- Last transport and personnel protection occur independent of each other:
  - Do **not** carry out personnel protection at the same time as load transport. Simultaneous personnel movement is impermissible.
  - Riding along on the load is impermissible.
- Determination of fastening points and rescue plan for the precise case is on hand from the employer.

### 33.3.1 Personnel and qualification

Make sure that the following prerequisites for personnel and qualification are met:

- The crane operator is suited and competent to operate the crane.
- Person, which is secured, must be trained in handling the PSAgA.
- The following persons are present on the job site and separately instructed:
  - A supervisor
  - The crane operator
  - The required number of rescue staff according to the rescue plan
- Access protection, fall protection on the shut off crane is made in accordance with the project-specific risk assessment on hand and the measures to be taken.
- The supervisor monitors the safe execution of work. He may **not** take part in the work.
- An effective communication must be ensured between crane operator and the secured person.

### 33.3.2 PSAgA, rescue equipment and tools

Make sure that the following prerequisites and measures are met:

- Use only HSG (height safety device) according to EN 360 in connection with a safety harness according to EN 361 to secure the person.
- Connecting device is suited for the occurring stress on the edges, see Manufacturer's documentation or device identification.
- Recurring inspections have been made. There are **no** visible defects present.
- At least 1 m connecting device of the maximum possible extension length of the HSG (height safety device) must remain in the housing.
- Fasten the HSG (height safety device) with two separate connecting devices (for example Securing on crane hook and on crane pulley block).
- Position the crane in such a way that the HSG (height safety device) is at least 5 m and plumb **over** the person, which is being secured.
- Do **not** exceed the maximum permissible deflection of the HSG (height safety device)
- Keep the required space **underneath** the person, which is being secured.
- All required objects (tools, building material) for the work are secured to prevent them from falling.

### 33.3.3 Crane

Make sure that the following prerequisites are met:

- The maintenance intervals and periodic crane inspections have been adhered to. There are **no** visible defects present.
- The load on the crane hook in any possible position is at least 600 kg , see Load chart (take the crane pulley block into account).
- Ensure sufficient load bearing capacity: For the load cases catching, pendular fall and possible angular pull adhere to the manufacturer's instructions.
- The crane is secured against movements and inadvertent movement (remote control is deactivated, crane control is activated).
- The overload protection is active.

### 33.4 Fastening device

Make sure that the following prerequisites are met:

- The crane hook is equipped with the hook safety.
- On the carrying device two connecting devices separated from each other can be fastened.
- HSG (height safety device) is redundantly fastened.
- Suitable fastening devices according to EN 795 Type B are on hand:
  - Round sling or fastening rope with steel core
  - Belt loop
- Textile components must be protected against greases, oils and other aggressive substances.
- Use only steel carabiners according to EN 362 with Tri-Lock function.

### 33.5 Rescue

A person in an accident must be lifted or lowered with the aid of the crane.

Carry out the following measures to ensure a safe rescue operation:

- Determine the rescue plan and rescue chain at the preparation of the mission.
- Ensure the rescue of a person involved in an accident immediately with locally available means and trained personnel.
- Have the rescue mission coordinated by another person, with visual and voice contact to the crane operator, ground personnel as well as to the person, which is rescued.

### 33.6 Additional risks

Make sure that the following risks are taken into account:

- Wind effect and environmental influences.
- Crushing and shearing points.
- Endangerment by additional cranes, for example material transport.

## 34 Welding work on the load



#### Note

- ▶ The load must also be grounded.

In case of welding work on the load, the screw clamp of the welding unit must be attached on the work piece to avoid current flow via hoist rope, crane superstructure or crane chassis.

## 2.04.10 Ladders

1	Intended use	2
2	Safety instructions	2
3	Safety signs	3
4	Ladder inspection	12
5	User guidelines	12
6	Assembling the ladder	14
7	Ladder access	25

# 1 Intended use

Ladders are mobile work equipment that can be used in different locations. Ladders can be used to perform minor work at heights in cases where the use of other equipment would not be appropriate.

Ladders are designated for the ascent and descent of personnel.

Ladders may only be used as described. Any other use is considered unintended use and is therefore forbidden.

The manufacturer is **not** liable for damage caused by unintended use or improper usage.

## 2 Safety instructions

The ladders are built according to the present level of technology and recognized safety technical regulations. Despite that, during their use dangers to life and physical condition of the user and / or third parties can occur.

Ladders may exclusively be used in a flawless technical condition and according to their missions as well as with constant awareness of safety and dangers.

Changes to the structure may exclusively be made with written approval of the manufacturer.

The ladders that are illustrated are an example. Ladders with the same functional principle may appear differently.



### WARNING

Safety instructions not observed!

Personnel can fall, death, severe bodily injuries.

- ▶ Observe and adhere to the assembly and safety instructions for ladders.
- ▶ Observe and adhere to the safety signs on the ladders.
- ▶ Install and secure the ladders properly.
- ▶ Use ladders exclusively if you are healthy enough to do this.
- ▶ Climb up / down with the 3-point support.
- ▶ Use the rungs as handles.
- ▶ Step into the rungs deep enough.
- ▶ Never bring the ladder to a new position during use.
- ▶ Do not use damaged ladders and replace them immediately.
- ▶ Repair the ladder exclusively through authorized service facilities.

### 2.1 Ladder categories

Ladders are divided into two categories according to the most up-to-date specifications:

- Ladders for industrial use
- Ladders for private use

Ladders for industrial use are tested according to the strictest criteria. Only use ladders for industrial use.

Ladders are marked according to their category allocation by a corresponding pictogram. See section „Safety signs“.

## 2.2 Stationary stability

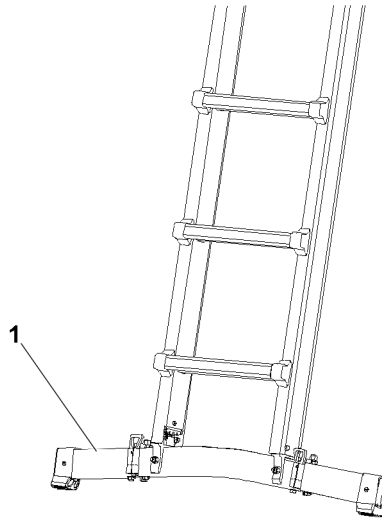


Fig.149993: Ladder with cross beam

According to the most up-to-date regulations, ladders with a length of more than 3 m must have a larger standing width. These ladders are equipped with a cross beam 1.

## 2.3 Retrofitting old ladders

It is not mandatory to retrofit old ladders. It is the responsibility of the industrial user to ensure, in accordance with the operational safety regulation by means of a risk assessment, that the safety of the work equipment is ensured for all work tasks.

Older ladders that no longer corresponds with the state of technology according to current regulations, can continue to be used, **if** their safety has been checked **and** guaranteed.




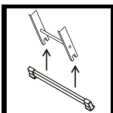

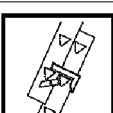
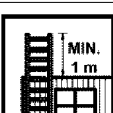

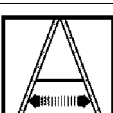
## 3 Safety signs

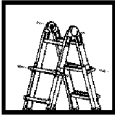
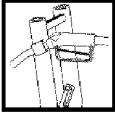
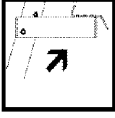





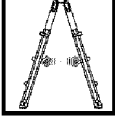
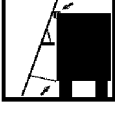


### Note

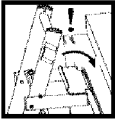
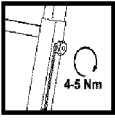








- ▶ The safety signs and instructions on the ladders must be complete and always legible.
- ▶ Observe and adhere to the manufacturer's operating instructions.

### 3.1 Symbols until the end of 2017


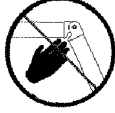








Sign	Explanation
	Read the operating instructions
	Maximum number of users on one ladder
	Maximum load
	In the case of ladders that have a cross beam, the cross beam must be assembled before the first use
	Correct set up angle 65° to 75°
	Before use: Engage the lift out safety
	Ladder overhang above the exit level
	Secure the upper / lower end of the ladder
	Before use: Tension the safety struts on stepladders

Sign	Explanation
	<p>Before use: Engage the locking pin joints and pull pin locks</p>
	<p>To open / close the tank cover and to ascent / descent: Insert the fuel nozzle into the retainer.</p>
	<p>Before setting up the ladder: Fold out the platform.</p>
	<p>Before use: Check the ladder for damage</p>
	<p>Check the legs of the ladder</p>
	<p>Do not use the three uppermost rungs of an extension ladders as rungs to stand on</p>
	<p>Do not use the four uppermost rungs / steps of a stepladder without a platform to stand on</p>
	<p>Do not use the two uppermost rungs of a stepladder with integrated extension ladder as rungs to stand on</p>
	<p>If hinged ladders are used as stepladders: Spread the ladder legs to the stop</p>
	<p>Place the upper placement angle flat. Hold the belt on tension</p>




LWE/LTR 1220-003/24204-02-02/en

Sign	Explanation
	Hook the hook on the platform of the refueling ladder on the vehicle
	Tightening the star knob on the beam extension tightly
	Do <b>not</b> use a damaged ladder
	Preclude any contaminants on the ground
	Make sure the upper end of the ladder is placed correctly. Place the ladder only on safe surfaces
	Only one person may climb up / down on any accessible leg of the ladder
	Avoid leaning out to the side. Keep the body's center of gravity between the ladder beams
	Face the ladder when climbing up / down the ladder
	Use the ladder only with suitable shoes
	Do not use a stepladder as a leaning ladder









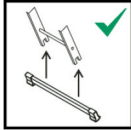









Sign	Explanation
	Do <b>not</b> use the inner section of multi-part hinged ladders without outer sections as a stepladder
	Crushing danger
	Set the ladder up on horizontal and solid ground
	Set the ladder up on solid ground
	Use the ladder in the correct set up direction
	Do not carry along bulky objects or objects over 10 kg on the ladder
	It is not permitted to step off the ladder to the side
	During transport, pay attention to danger due to power lines
	Do not use the ladder as a walkway
	Do not transport snow and ice shovels over the ladder Use hooks!











Sign	Explanation
	Danger due to shearing point
	Do not use the ladder with the cross beam folded in
	Do not use a ladder under the influence of drugs or alcohol
	Do not use a ladder to climb up to another lever
	Make sure that both ladder sections are opened completely and secured. Avoid an incorrect ladder position
	Only use the platform ladder with a locked spreader lock
	Only permissible ladder rungs / platforms may be used as standing and stepping surfaces Other surfaces such as placement surfaces for cable clips or attachment hooks may <b>not</b> be used as standing and stepping surfaces
	If a crossbars is part of the delivery scope of the mobile platform ladder: Only use a mobile platform ladder with the crossbar assembled
	If auxiliary weights are part of the delivery scope of the mobile platform ladder: Only use the platform ladder with the auxiliary weights assembled

Sign	Explanation
	If a foot brake is installed on the mobile platform ladder: Use the foot brake
	Make sure that the joint is locked
	In unfavorable weather conditions, do <b>not</b> use the ladder in the open






### 3.2 Symbols from 2018

Sign	Explanation
	Danger of falling!
	Read the operating instructions
	Maximum load
	Ladder for professional use
	Ladder for private use
	Maximum number of users on one ladder

Sign	Explanation
	<p>In the case of ladders that have a cross beam, the cross beam must be assembled before the first use</p>
	<p>Correct set up angle 65° to 75°</p>
	<p>Always keep a firm grip: When ascending and descending and when working on the ladder</p>
	<p>Ladder overhang above the exit level</p>
	<p>Before use: Engage the lift guards</p>
	<p>Do <b>not</b> use a damaged ladder</p>
	<p>Only use the ladder with the cross beam folded out</p>
	<p>Prior to use: The hinges and locks must be engaged</p>
	<p>Use the ladder in the correct set up direction</p>
	<p>Only use the ladder with appropriate footwear</p>

Sign	Explanation
	<p>Do <b>not</b> use the ladder if physically impaired or under the influence of drugs or alcohol.</p>
	<p>Do <b>not</b> use the ladder on uneven or unsteady surface</p>
	<p>Do <b>not</b> use the ladder on a slippery or contaminated surface</p>
	<p>Do <b>not</b> place the ladder on unsuitable surfaces</p>
	<p>Do <b>not</b> carry along bulky objects or objects over 10 kg on the ladder</p>
	<p>Do <b>not</b> use the top three rungs as rungs to stand on</p>
	<p>Avoid leaning out to the side. Keep the body's center of gravity between the ladder beams</p>
	<p>Avoid working with a side load</p>
	<p>Climb up and down the ladder while facing it</p>
	<p>Do <b>not</b> use a stepladder as a leaning ladder</p>

LWE/LTR 1220-003/24204-02-02/en

Sign	Explanation
	Prior to use: Tension the safety struts on stepladders
	For stepladders without a platform: Do <b>not</b> use the top two rungs as rungs to stand on
	It is not permitted to step off to the side from the ladder
	When transporting or using the ladder, be aware of any danger due to overhead wires
	Do <b>not</b> use the ladder as a walkway

## 4 Ladder inspection

Make sure that the following conditions are met:

- All ladders are inspected at least every 12 months. See chapter 8.17.
- The inspection may be made exclusively by authorized and trained expert personnel.
- The results of the inspection are documented.

## 5 User guidelines

Make sure that the following prerequisites are met before using the ladder:

- A risk evaluation had been made.  
The national legal regulations have been taken into account.
- People are physically able to use a ladder.
- The ladder is suited for the respective application.
- The ladder is complete and not damaged (visual inspection).
- The ladder is free of contaminants, such as:
  - Ice
  - Snow
  - Frost
  - Wet paint
  - Lubricants
- The legs of the ladders are not worn.
- Screws and connections have been checked for tight seating.
- The base is:

- Level
- Horizontal
- Slip-resistant
- Unmoveable

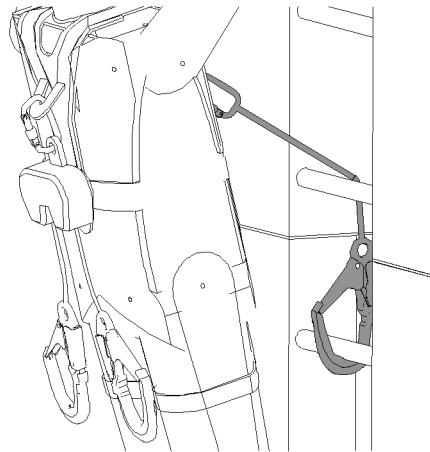
When climbing up the ladder:

- Set the ladder up in the correct set up angle.
- Secure the locking devices of the ladder.
- Tension the spreaders of the stepladder.
- Do **not** set up the ladder from above.
- Do **not** set the ladder on braces or steps.
- Avoid the risk of a collision with pedestrians, vehicles or doors.
- Place the leaning ladder only suitably stable contact surfaces with both rails.

When using the ladder:

- Make sure that no children are playing on the ladders.
- Subject the ladder to no more than maximum 150 kg.
- Use the ladder exclusively as described in section „Ladder access“.
- Do **not** use the ladder outside in strong wind.
- Do **not** subject the ladder horizontally to excessive loads in side assembly work.
- Face the ladder when climbing up or down the ladder.
- Step on the ladder with suitable shoes.
- Do not use the ladder as a walkway.
- Secure the ladder to prevent it from being knocked over inadvertently.
- For leaning ladders, do not step on the uppermost three steps / rungs, in reference to the ladder placement point.
- For stepladders, do not step on the uppermost two steps / rungs.
- Do not work too long on the ladder without pauses. Tiredness is a safety risk.
- When working on a ladder, hold on tightly with one hand.

If this is not possible: Take additional safety measures, such as: use the WORK POSITIONING SYSTEM (WPS).



*Fig.126746: Example of how to use the WPS*

For repair, maintenance and storage of a ladder:

- Have repairs and maintenance made by expert personnel according to the manufacturer's instructions.
- Store the ladders according to the manufacturer's instructions.

Before transporting the ladders:

- Lock and secure the ladders in their provided transport retainers.

## 6 Assembling the ladder

### 6.1 Supplied cross beam

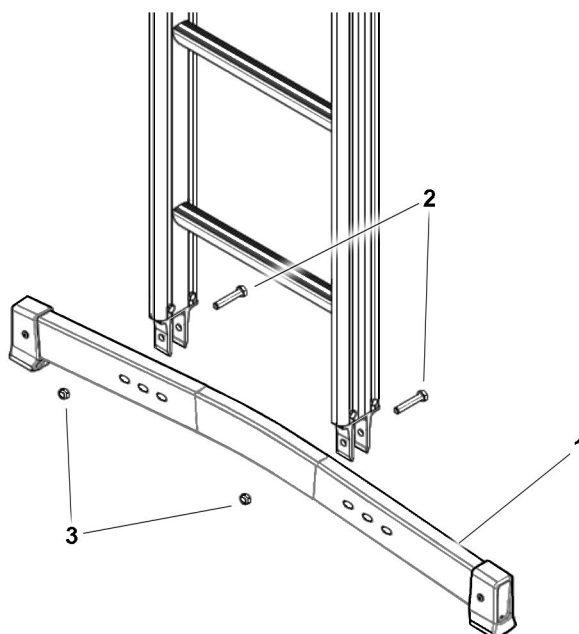


Fig.149565: Assembling the cross beam

Depending on the type of ladder and the delivery condition, the cross beam must be assembled prior to use.

Required tools:

- 2 x 13 mm wrenches
- The screws and nuts are included in the delivery scope.

Tightening torque:

- Approx. 8 Nm

- ▶ Position the cross beam **1** centrally between the cross beam fasteners.
- ▶ Secure the cross beam **1** with screws **2** and nuts **3**.
- ▶ Before using the ladder: Make sure that the screws **2** and nuts **3** are tightened correctly.



## 6.2 Folding cross beam

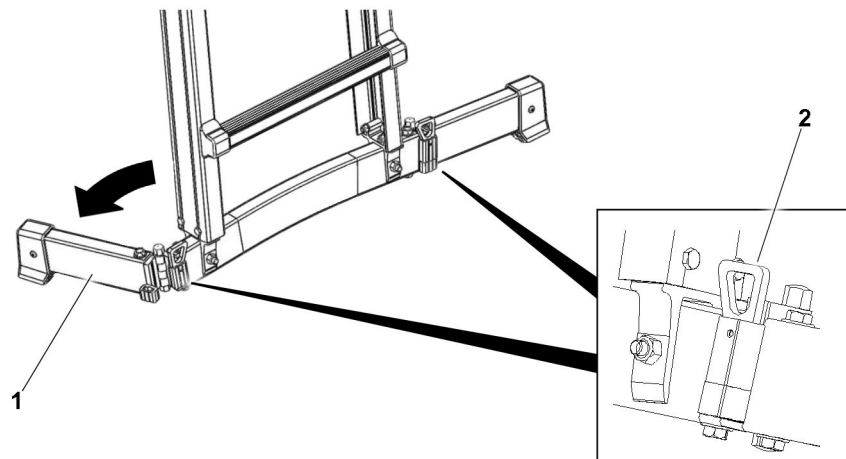


Fig.149566: Use the folding cross beam

Depending on the type of ladder, the folding cross beam must be brought into the operating position prior to use and brought to the transport position after use.

### 6.2.1 Bringing the cross beam into the operating position

- ▶ Swing the folding cross beam **1** on both sides into the operating position.
- ▶ Make sure that the retaining element **2** is engaged.
- ▶ Before using the ladder: Make sure that both retaining elements **2** have engaged.

### 6.2.2 Bringing the cross beam into the transport position

- ▶ Unlock the retaining element **2**.
- ▶ Swing the folding cross beam **1** on both sides into the transport position.
- ▶ Before storing the ladder: Make sure that both retaining elements **2** have engaged.

## 6.3 Cross beams for platform ladder

For platform ladders, the supplied cross beams must be assembled prior to use.

Required tools:

- 2 x 13 mm wrenches
- The screws and nuts are included in the delivery scope.

### 6.3.1 Assembling the cross beam without wheels

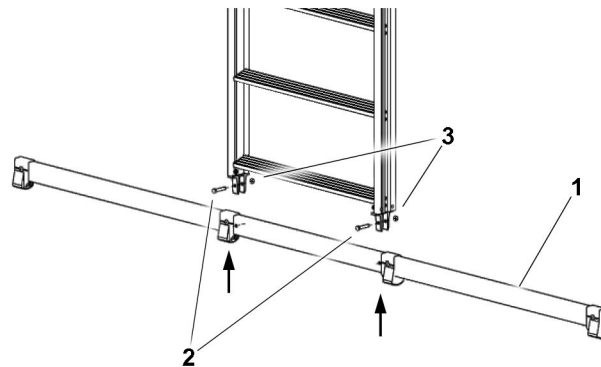


Fig.149595: Assembling the cross beam

- ▶ Position the cross beam 1 centrally between the cross beam fasteners.
- ▶ Secure the cross beam 1 with two screws 2 and two nuts 3.
- ▶ Tighten the screws 2 by hand.

### 6.3.2 Assembling the cross beam with wheels

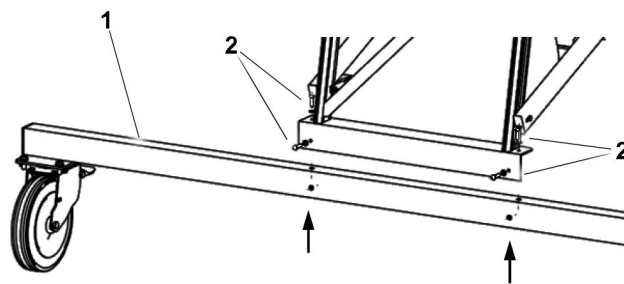


Fig.149596: Assembling the cross beam

- ▶ Position the cross beam 1 centrally between the cross beam fasteners.
- ▶ Secure the cross beam 1 with four screws 2 and four nuts.
- ▶ Tighten the screws 2 by hand.
- ▶ Before using the ladder: Make sure that all screws and nuts are correctly tightened.

## 6.4 Platform ladder

At least two people are required for ladder assembly and removal.

### 6.4.1 Assembling the platform ladder



#### WARNING

Platform ladder not correctly assembled!  
Personnel can fall down. Death, severe bodily injuries.

- ▶ Before the platform ladder is correctly assembled: Do **not** step on or load the platform ladder.

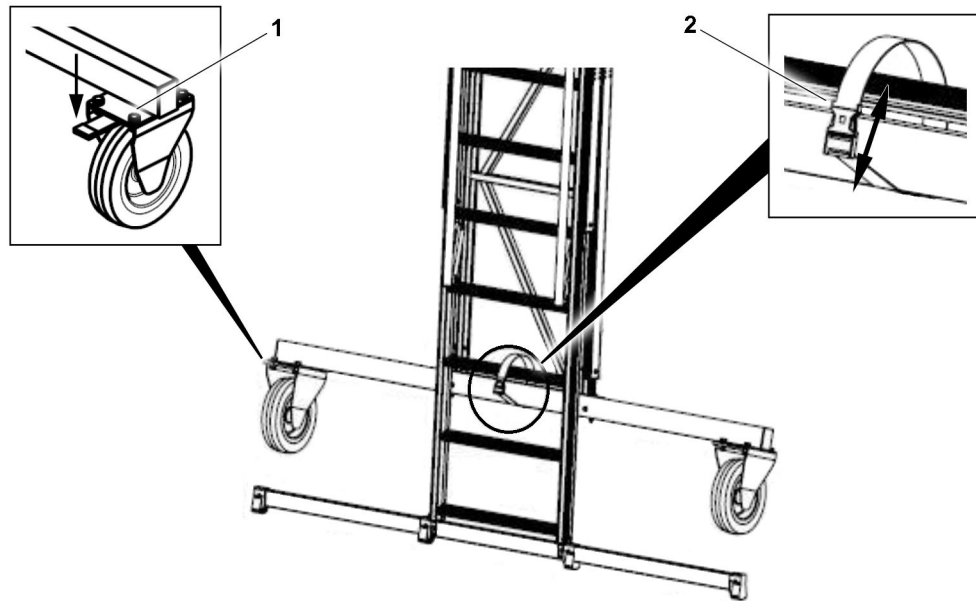


Fig.149597: Preparing the ladder

- ▶ Secure both pulleys 1.
- ▶ Erect the ladder with two people.
- ▶ Release the rigging belt 2.

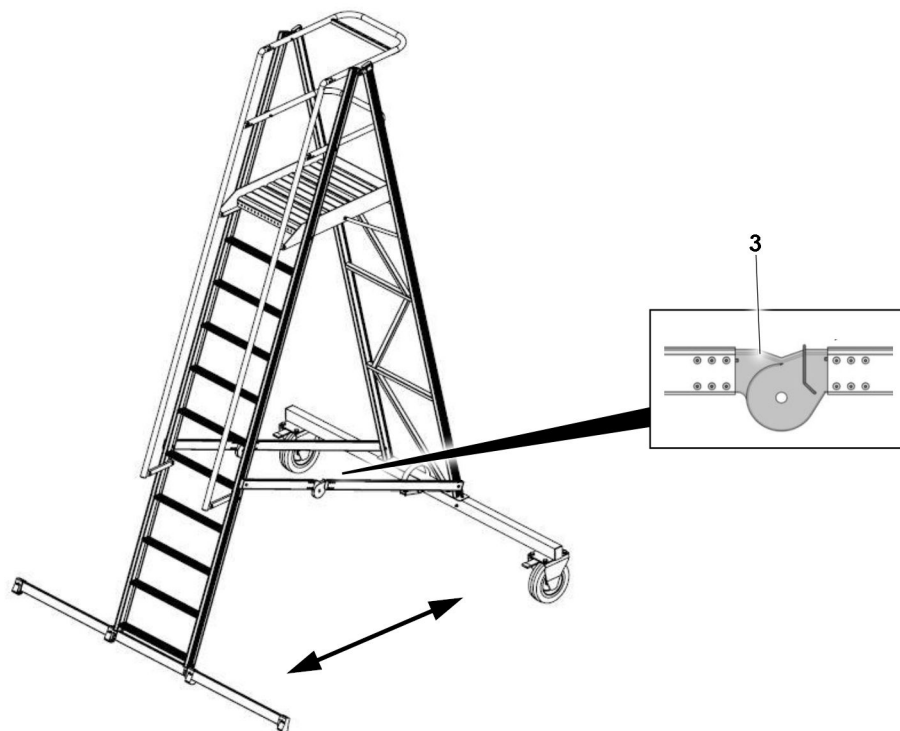


Fig.149598: Setting up the ladder

- ▶ Each half of the ladder is held by a person.
- ▶ Until both hinges 3 engage audibly: Carefully guide the ladder halves away from each other. When doing so, the platform surface will fold out automatically.

**Result:**

- The ladder is now assembled.

### 6.4.2 Dismantling the platform ladder

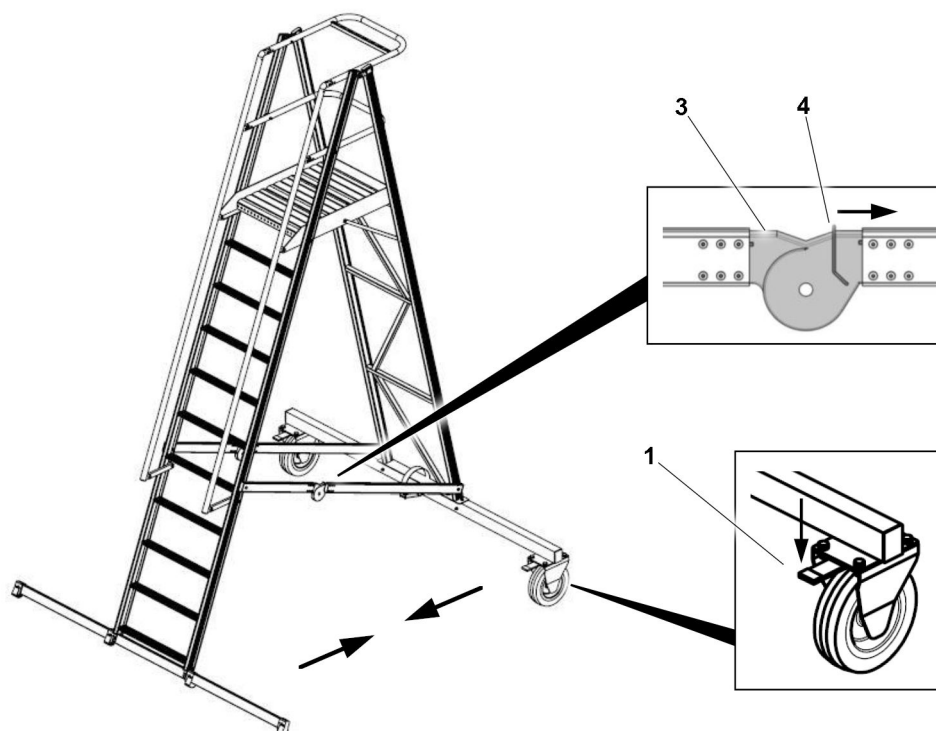


Fig.149599: Releasing the hinges

- ▶ Secure both pulleys 1.
- ▶ Unlock the locking bracket 4 in the hinge 3 on both sides.
- ▶ Each half of the ladder is held by a person.
- ▶ Carefully guide the ladder halves toward each other. When doing so, the platform surface will fold together automatically.

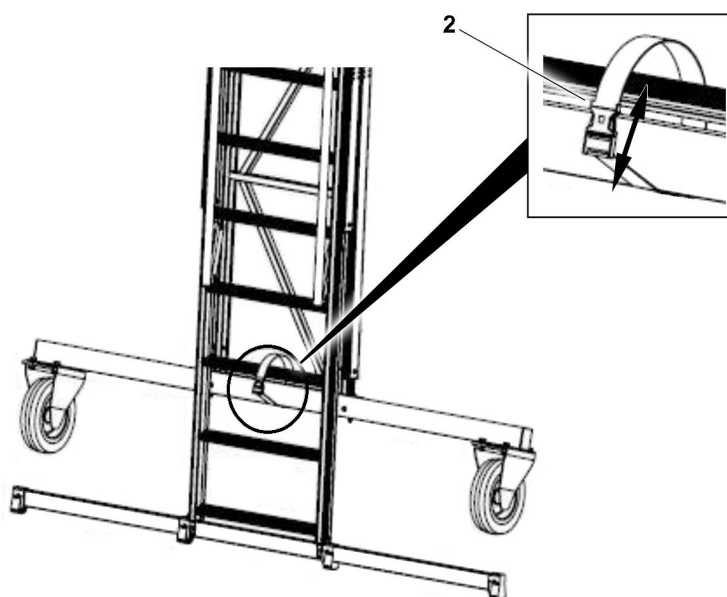


Fig.149600: Securing the ladder in the transport position

- ▶ Secure the rigging belt 2 on the cross beam and rung.
- ▶ Make sure that the clasp on the rigging belt 2 is closed.

**Result:**

- The ladder is dismantled and secured in the transport position.

## 6.5 Hinged ladders

The hinged ladder can be used as a leaning ladder or stepladder.

To adjust a part of the ladder, both hinges on opposite sides must be actuated.

### 6.5.1 Using a hinged ladder as a leaning ladder

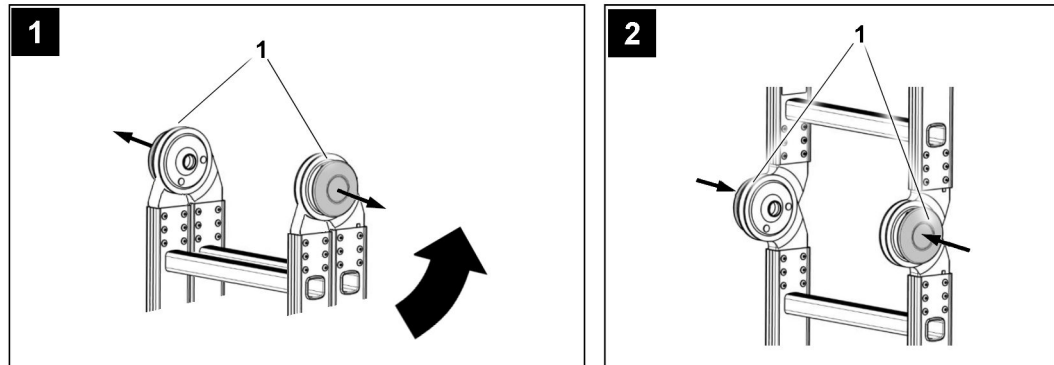


Fig.149567: Using a hinged ladder as a leaning ladder

- ▶ Release the hinges 1.
- ▶ Until the hinges 1 engage again: Spread out the legs to the stop.
- ▶ Before using the hinged ladder as a leaning ladder: Make sure that the hinges 1 have engaged.

### 6.5.2 Bringing the leaning ladder into the transport position

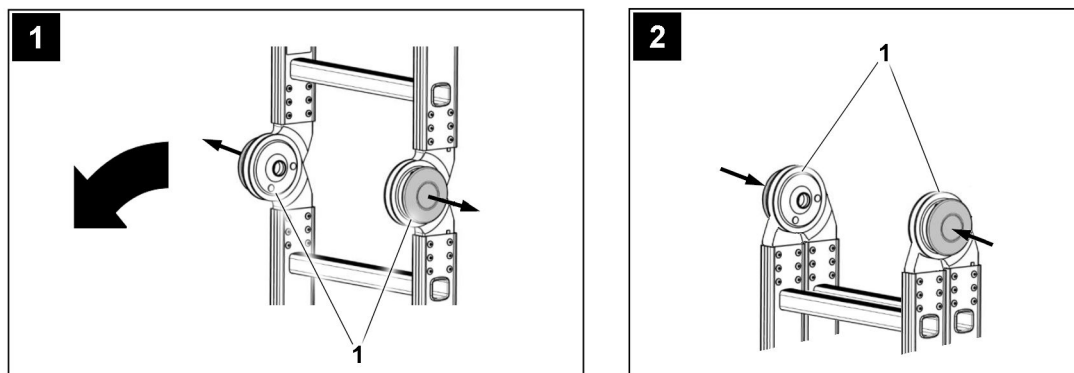


Fig.151625: Bringing the leaning ladder into the transport position

- ▶ Release the hinges 1.
- ▶ Until the legs lie together and the hinges 1 engage: Fold the legs together.

**Result:**

- The hinged ladder is now in the transport position. The hinged ladder can be stored.

### 6.5.3 Using a hinged ladders as a stepladder

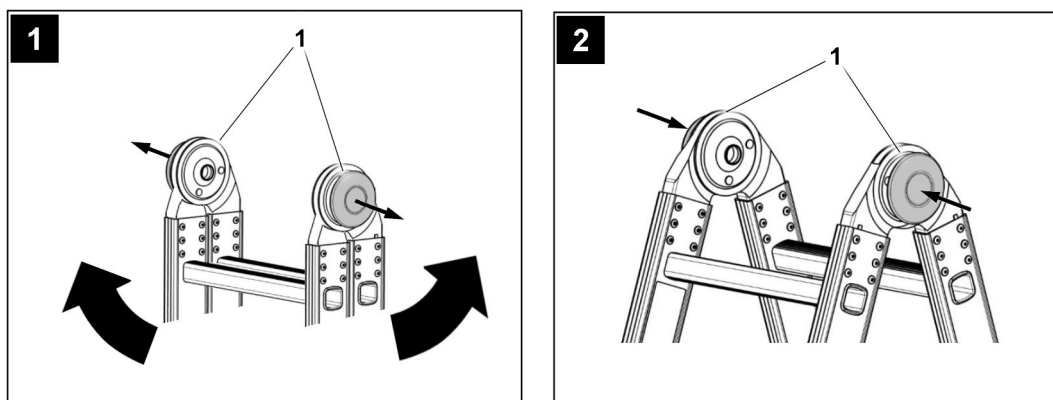


Fig.149568: Using a hinged ladders as a stepladder

- ▶ Release the hinges 1.
- ▶ Until the hinges 1 engage again: Spread out the legs.
- ▶ Before using the hinged ladder as a stepladder: Make sure that the hinges 1 have engaged.

### 6.5.4 Bringing the stepladder into the transport position

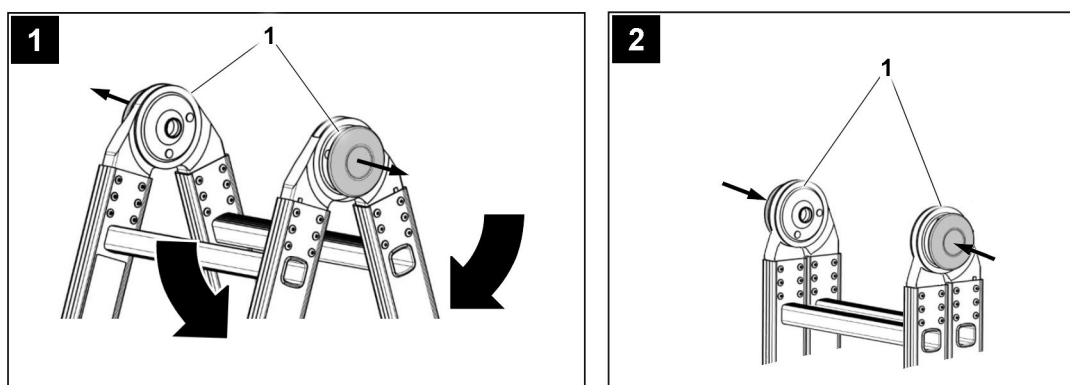


Fig.151607: Bringing the stepladder into the transport position

- ▶ Release the hinges 1.
- ▶ Until the legs lie together and the hinges 1 engage: Fold the legs together.

**Result:**

- The ladder is now in the transport position. The ladder can be stored.

## 6.6 Multi-purpose ladder with height adjustment

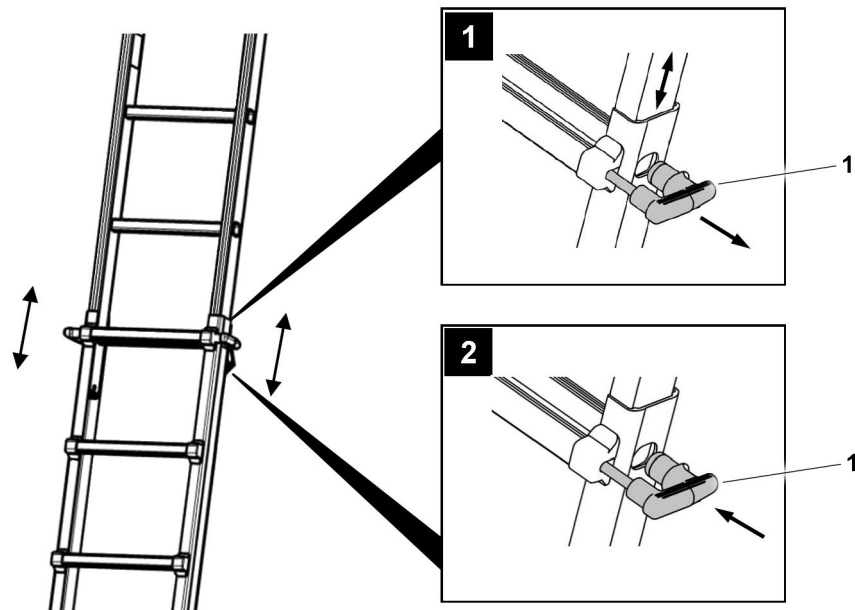


Fig.149570: Ladder with height adjustment

Multi-purpose ladders have a height adjustment device.

- ▶ Release the handle **1** on both sides.
- ▶ Pull out or push in the ladder to the desired length.
- ▶ Lock the ladder with the handle **1** on both sides.
- ▶ Before using the ladder: Make sure that both handles **1** have engaged.

## 6.7 Three-part multi-purpose ladder

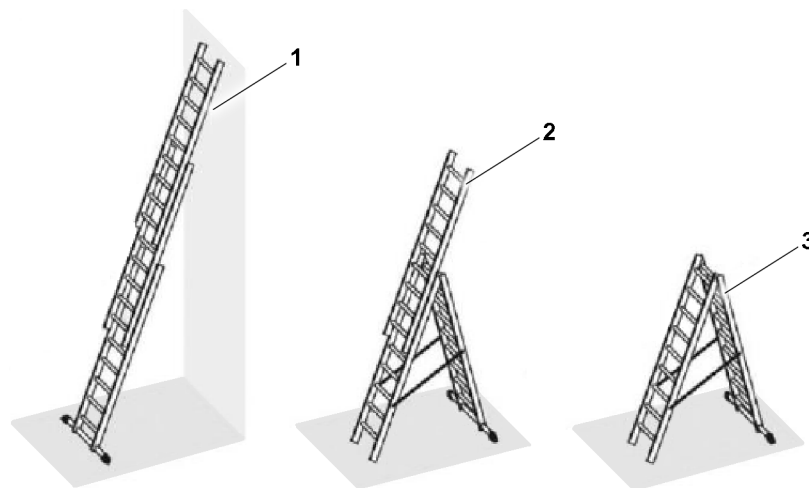
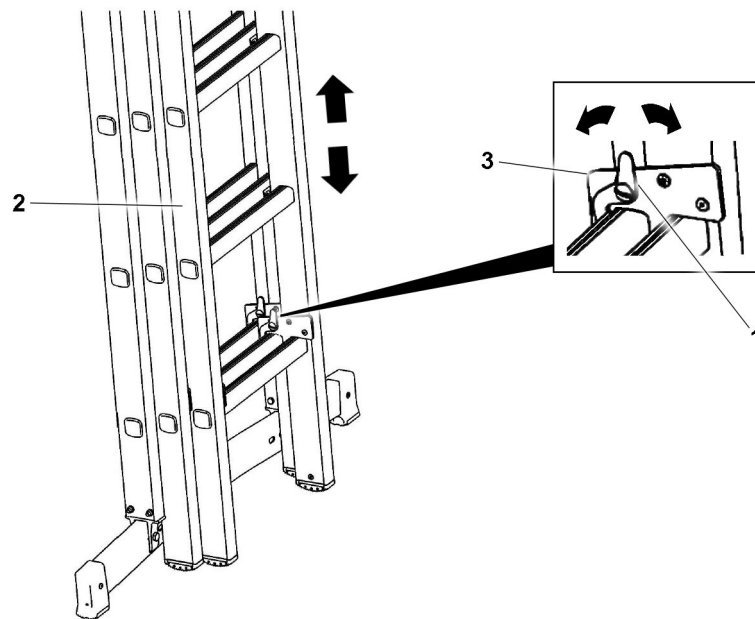


Fig.152833: Three-part multi-purpose ladder

The three-part multi-purpose ladder can be used as a leaning ladder **1**, stepladder with integrated extension ladder **2** or as a stepladder **3**.

### 6.7.1 Using the three-part multi-purpose ladder as a leaning ladder



*Fig.152834: Pushing out the ladder*

Push out the upper ladder section **2**:

- ▶ Release the lock **1**. Slightly lift up the upper ladder section **2** at the same time.
- ▶ Swing out the upper ladder section **2** and push it out to the desired length.
- ▶ Refit the securing hooks **3**.
- ▶ Make sure that the lock **1** engages.

Push out the middle ladder section:

- ▶ Pull out and lock the middle ladder section in the same manner.
- ▶ Make sure that the lock **1** engages.

**Result:**

- The ladder can now be used.

Push the ladder together:

- ▶ Push together and lock the middle ladder section.
- ▶ Subsequently push together and lock the upper ladder section.
- ▶ Make sure that the lock **1** engages.

**Result:**

- The ladder is now in the transport position. The ladder can be stored.



### 6.7.2 Using the three-part multi-purpose ladder as a stepladder

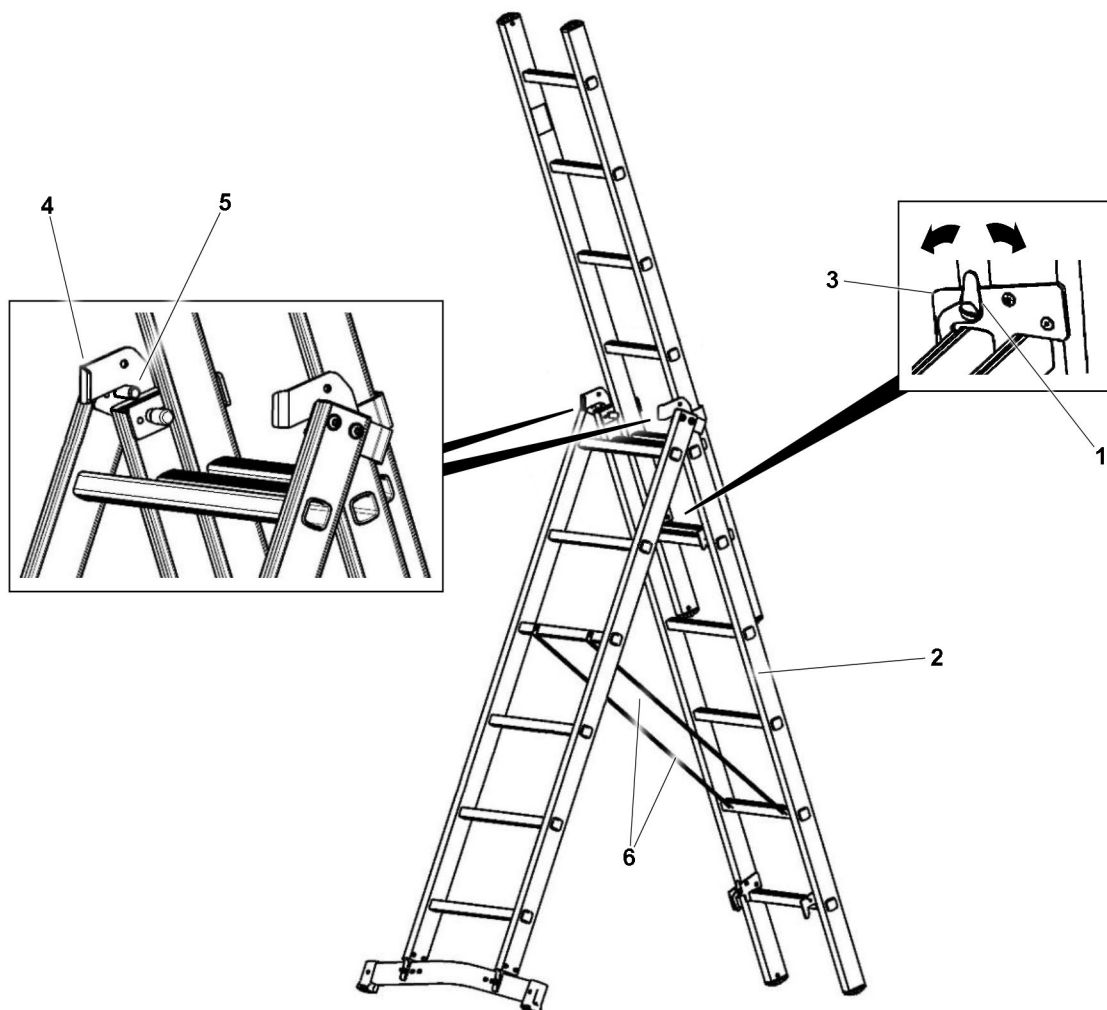


Fig.152835: Setting up the ladder

Push out the upper ladder section:

- ▶ Push out the upper ladder section to the desired length. See section „Using the three-part multi-purpose ladder as a leaning ladder“.

Swing out the middle ladder section 2:

- ▶ Release the lock 1. Slightly lift up the middle ladder section 2 at the same time.
- ▶ Until the contact point 5 of the bottom ladder section slides along the guide fitting 4 on both sides into the storage position: Spread out the legs.
- ▶ Make sure that the belt straps of the ladder locks 6 are tensioned.

**Result:**

- The ladder can now be used.

Bring the ladder into the transport position:

- ▶ Fold the middle and bottom ladder sections together.
- ▶ Push the upper ladder section together again.

**Result:**

- The ladder is now in the transport position. The ladder can be stored.

## 6.8 Extension ladder

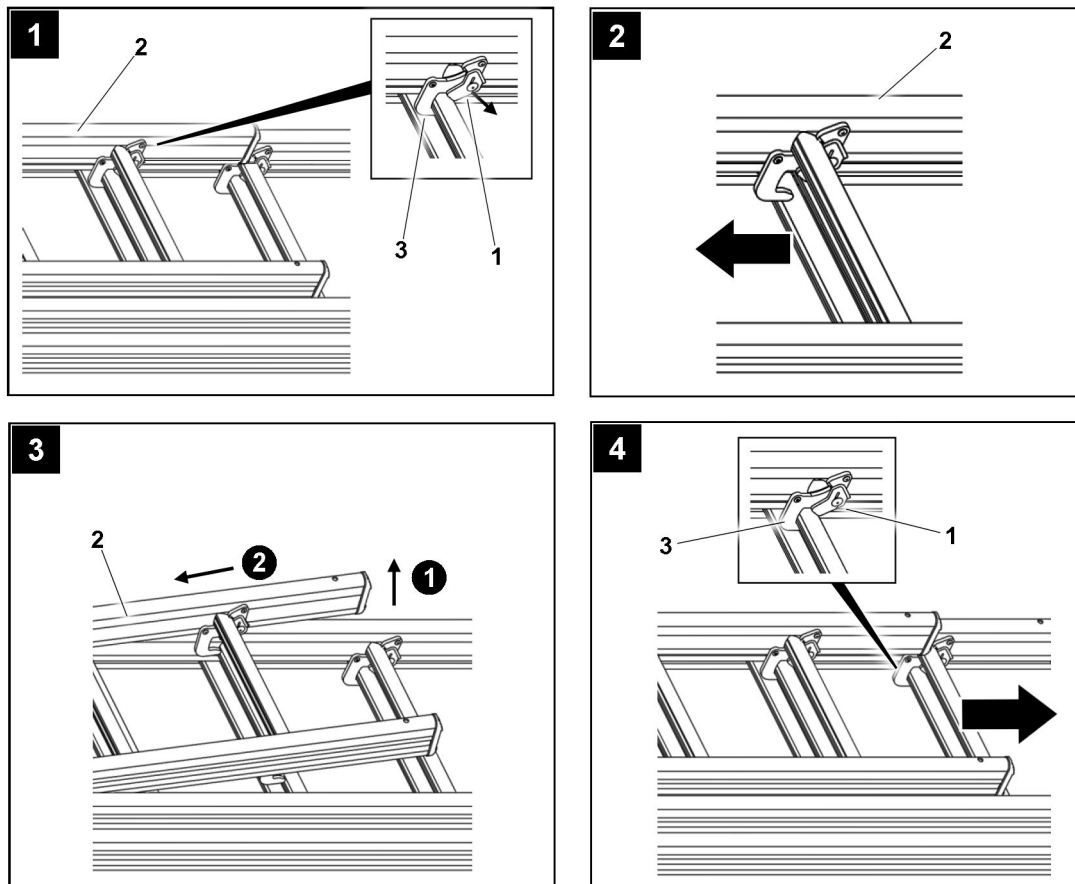


Fig.149569: Pushing out the ladder

Only pull out or push in the ladder when it is laid down.

Push out the upper ladder section:

- ▶ Release the lock 1 on the securing hook 3 on the upper ladder section 2.
- ▶ Move the upper ladder section 2 slightly at the same time.
- ▶ Now swing the ladder section 2 outward and push it out to the desired length.
- ▶ Refit the securing hooks 3.
- ▶ Make sure that the lock 1 re-engages.

Push out the middle ladder section:

- ▶ Pull out and lock the middle ladder section in the same manner.
- ▶ Make sure that the lock 1 engages.

### Result:

- The ladder can now be used.

Push the extension ladder together:

- ▶ Push together and lock the middle ladder section.
- ▶ Subsequently push together and lock the upper ladder section.
- ▶ Make sure that the lock 1 engages.

### Result:

- The ladder is now in the transport position. The ladder can be stored.

## 7 Ladder access

Wearing the personal protection equipment to prevent falling and the ladder safeguard depend on the type of work, among others.

### 7.1 Ladder safeguards

The ladder can be secured to prevent it from sliding away to the side by:

- Restraint device, for example: Tether or side stops on component
- Friction lock, for example: Rubber caps or plastic caps on the end of the ladder beam at direct placement on a surface

The ladder can be secured to prevent it from tipping to the rear by:

- The correct placement angle

### 7.2 3-point support

A 3-point support is ensured when:

- Two hands have a safe hold and one leg is standing safely.
- Two legs are standing safely and one hand has a safe hold.
- Two legs are standing safely in straddle position on a stepladder which can be accessed from both sides, on the third respective rungs / steps from the top. The user locks the ladder with the knees.
- Two legs are standing safely and at the same time, the body is leaned on higher rungs / steps of the leaning (extension) ladder. The center of gravity of the body must always be between the two ladder beams.
- A WORK POSITIONING SYSTEM (WPS) is used.

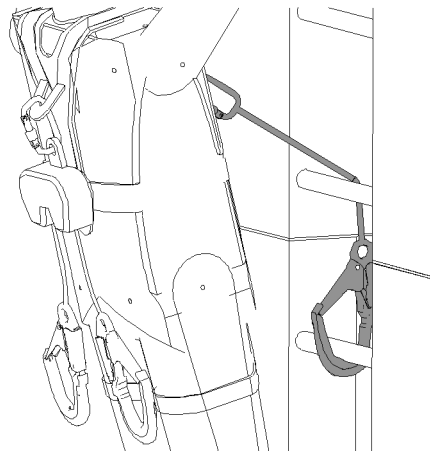


Fig.126746: Example of how to use the WPS

### 7.3 Light and / or heavy work

The following lists various light and heavy work

Examples for light work:

- Installing / removing retaining pins or spring retainers
- Fastening components, disengaging fastening equipment
- Pushing the transition aid out / in
- Establishing / disconnecting electrical or hydraulic connection between components
- Actuating the hand pump for the folding jib
- Reeving the auxiliary winch in / out
- Setting up / taking down foldable railings
- Carrying out maintenance and inspection work
- Refueling the crane chassis and / or crane superstructure

Examples for heavy work:

- Knocking the connector pins in / out
- Installing / removing the wind warning
- Reeving the hoist rope in / out
- Installing / removing the connector pin with assembly aid (hydraulic cylinder or mechanical assembly tool)
- Assembling / disassembling the rope lock

## 7.4 Using the stepladder

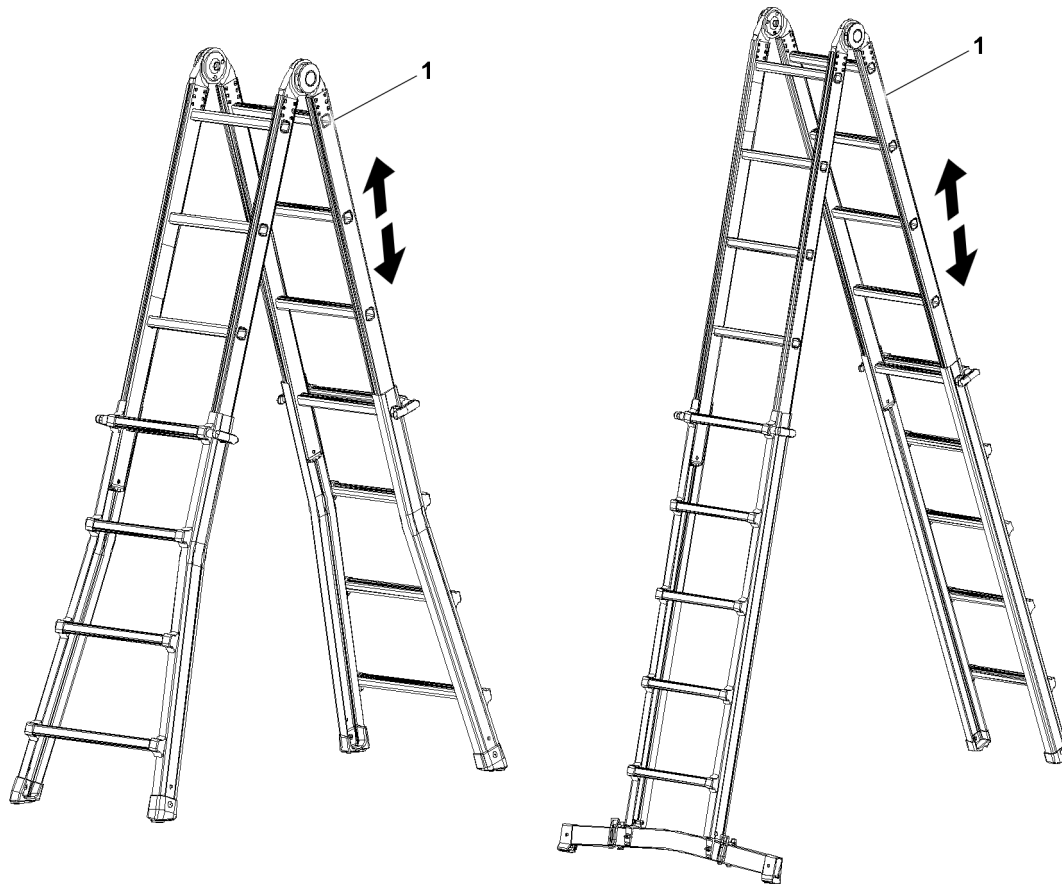


Fig.149996: Example of stepladders 1



### WARNING

Transitioning from a stepladder to other components!  
Personnel can fall, death, severe bodily injuries.

- ▶ Do **not** transition from a stepladder to other components.



### WARNING

3-point support not adhered to!  
Personnel can fall, death, severe bodily injuries.

- ▶ Adhere to the 3-point support.
- ▶ Adhere to the prerequisites and conditions for the use of stepladders.

Prerequisites for the use of stepladders 1:

- Make sure that the weight of the tool carried along does not weigh more than 10 kg.
- Make sure that stepladder 1 is set up stable.

Access	Work
Maximum rise to the third rung / step from the top	Maximum rise to the third rung / step from the top
3-point support required	3-point support required
	Rise to 1 m: Personal protective equipment to prevent falling not required
	Step height above 1 m to 7 m <b>Light work:</b> Personal protective equipment to prevent falling not required
	Step height above 1 m to 7 m <b>Heavy work:</b> Personal protective equipment to prevent falling required

*Conditions for access and work on stepladders 1*

## 7.5 Using the Leaning ladder

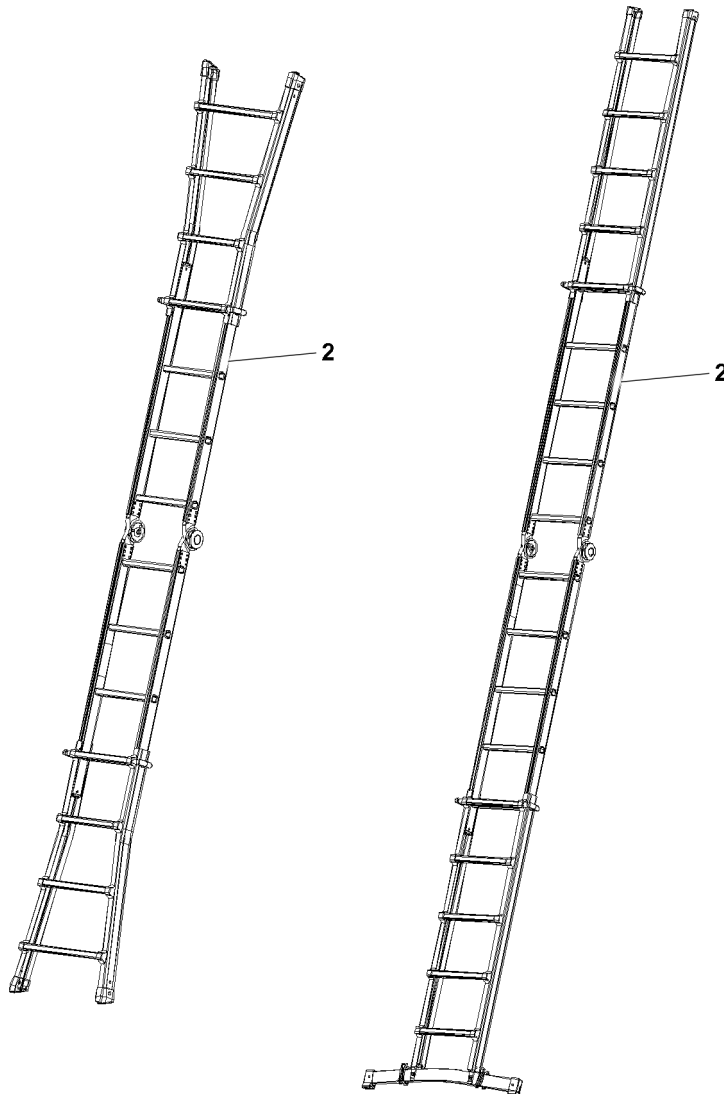


Fig.149997: Example of leaning ladders 2



### WARNING

3-point support not adhered to!  
Personnel can fall, death, severe bodily injuries.

- ▶ Adhere to the 3-point support.
- ▶ Adhere to the prerequisites and conditions for the use of leaning ladders.

#### Prerequisites for the use of leaning ladders 2:

- Make sure that the 3-point support is complied with.
- Make sure that the leaning ladder 2 is positioned on a level placement surface.
- Make sure that the leaning ladder 2 is placed at an incline angle of 65° to 75° (approx. 1:4) to the horizontal.
- Make sure that the ladder overhang when leaning it on components is selected in such a way that the leaning ladder 2 is safely placed when subjected to a load / flex due to ascending persons.
- Make sure that the weight of the tool carried along does not weigh more than 10 kg.

Access	Work
Maximum rise to the fourth rung / step from the top, in reference to the placement point	Maximum rise to the fourth rung / step from the top, in reference to the placement point
3-point support required	3-point support required
	Rise to 1 m: Ladder safeguard not required Personal protective equipment to prevent falling not required
	Step height above 1 m to 7 m <b>Light work:</b> Ladder safeguard required Personal protective equipment to prevent falling not required
	Step height above 1 m to 7 m <b>Heavy work:</b> Ladder safeguard and protection to prevent it from tipping to the rear required Personal protective equipment to prevent falling required

Conditions for access and work on leaning ladders 2

### 7.5.1 Using the leaning ladder without the conical end section

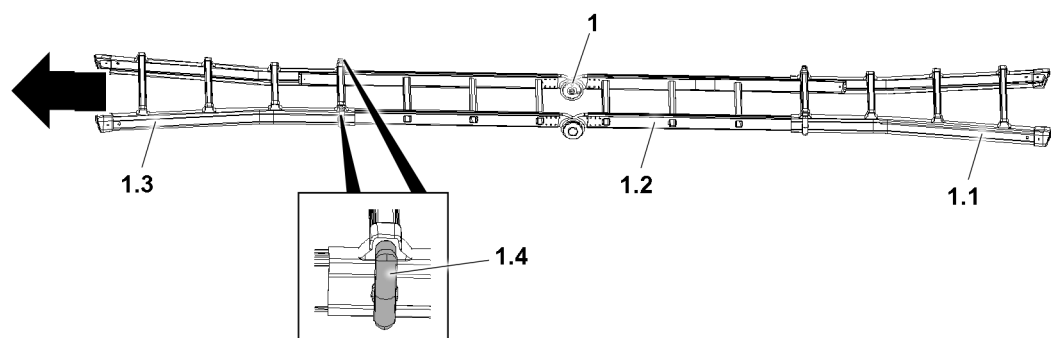


Fig.126873: Disassemble the conical end section 1.3.

The leaning ladder 1 consists of the following components:

- 1.1 Base
- 1.2 Center section
- 1.3 End section
- 1.4 Locks

When the conic end section 1.3 is wider than the leaning tube on the telescopic boom or the intended placement surface, the leaning ladder 1 cannot be placed fully expanded.

In order to position the leaning ladder 1 fully expanded, the end section 1.3 must be disassembled and removed.



#### CAUTION

Fingers in the spring range of the lock 1.4!  
Finger crushing when locking and unlocking.  
▶ Grip the lock 1.4 outside of the spring range.

- ▶ Release the locks **1.4** on the left and right.
- ▶ Slide the end section **1.3** out of the center section **1.2** and remove it.

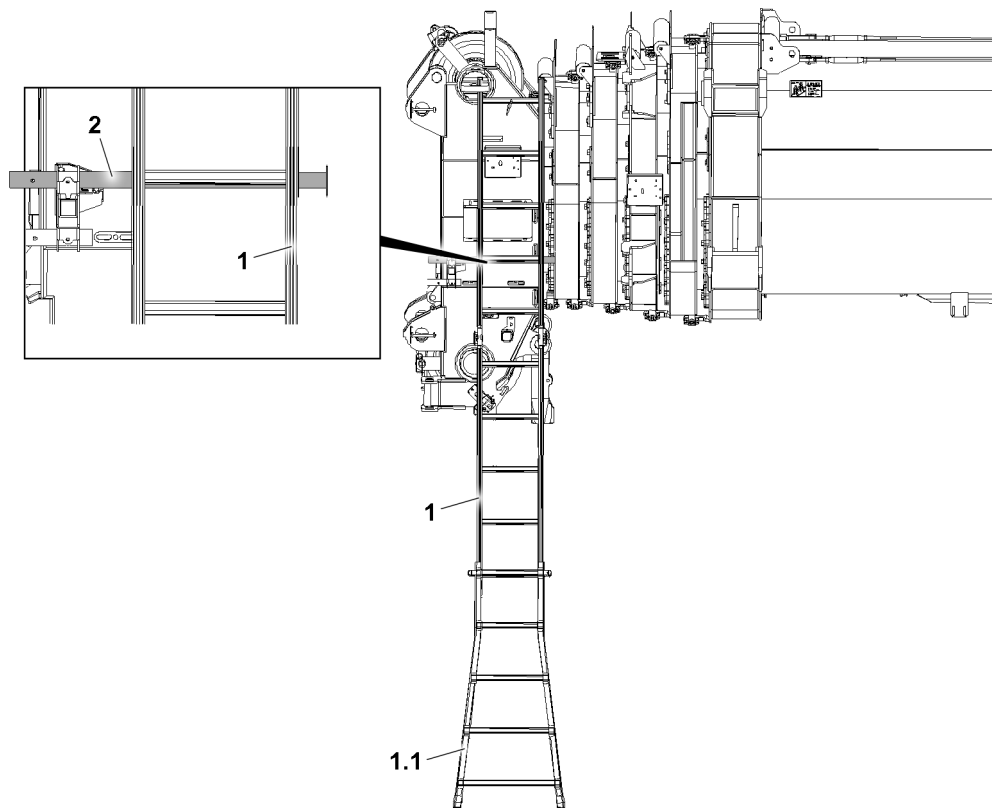


Fig.126874: Place the leaning ladder **1** on the leaning tube **2**

When placing the leaning ladder **1**, the base **1.1** must be placed on the ground.

- ▶ Place the leaning ladder **1** on the leaning tube **2** or the intended placement surface.



#### WARNING

The leaning ladder **1** is wider than the leaning tube **2** or the intended placement surface! The leaning ladder **1** can slip away when stepping on it and assembly personnel can fall down and be severely injured.

- ▶ When stepping on the leaning ladder **1** make sure that the leaning ladder **1** is **not** wider than the leaning tube **2** or the intended placement surface.
- ▶ Climb on the leaning ladder **1**. Carry out the assembly work.

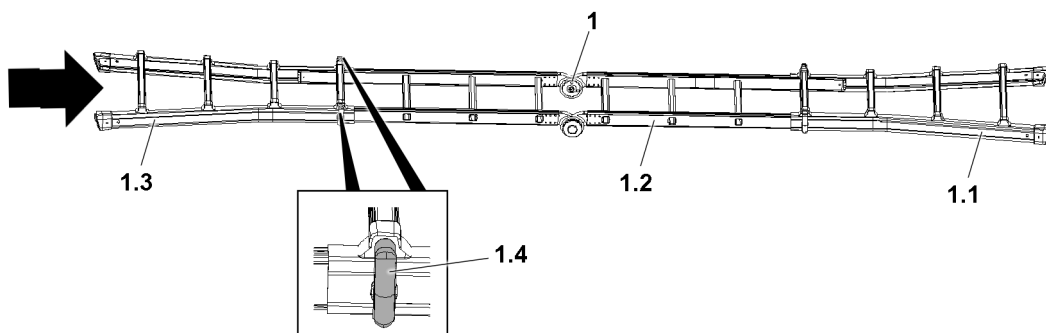


Fig.158064: Assemble the conical end section **1.3**.

Before leaving the jobsite, the conical end section **1.3** must be reinstalled.



**CAUTION**

Fingers in the spring range of the lock **1.4**!  
Finger crushing when locking and unlocking.

- ▶ Grip the lock **1.4** outside of the spring range.
- 
- ▶ Release the lock **1.4** on the left and right.
  - ▶ Insert the end section **1.3** in the central section **1.2** and push them together.
  - ▶ Secure the leaning ladder **1** in the transport position on the crane.

### 7.5.2 Connecting the leaning ladder to the ladder retainer and ascending

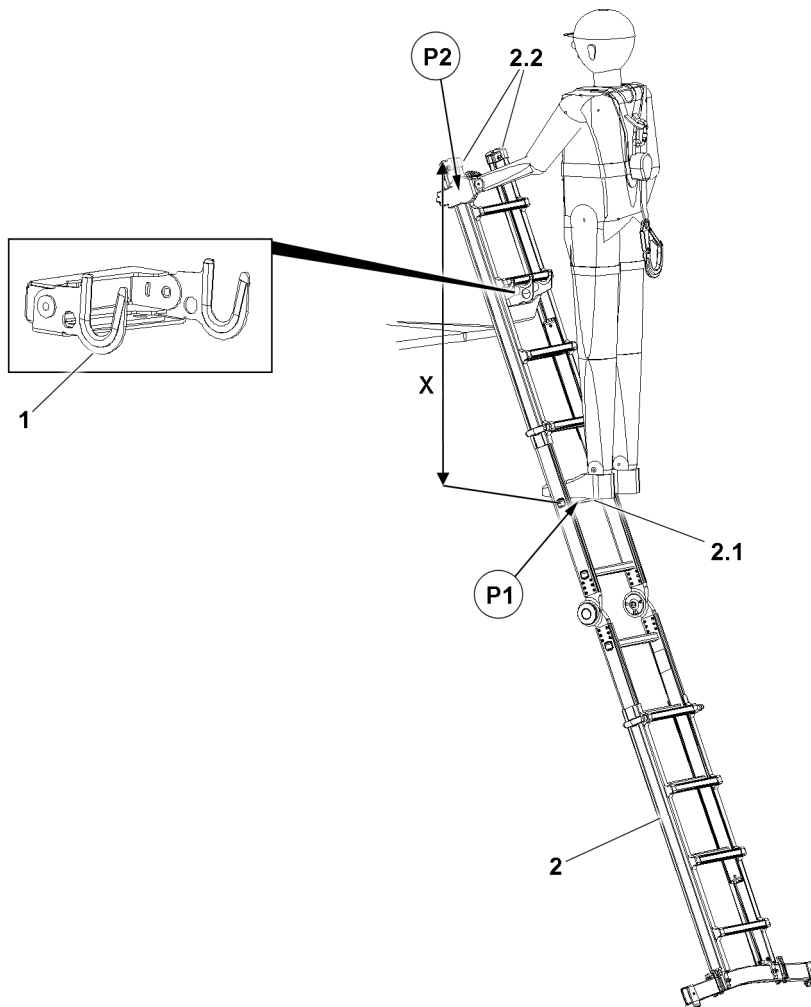


Fig.158063: The leaning ladder **1** is connected to the ladder retainer **1**

**WARNING**

The leaning ladder is not correctly connected and used!  
Personnel can fall, death, severe bodily injuries.

When the leaning ladder is connected to the ladder retainer:

- ▶ Adhere to the prerequisites and conditions for the use of the leaning ladder in the ladder retainer.
- ▶ Adhere to the 3-point support.

Prerequisites for the use of leaning ladders **1** when connected to the ladder retainer **1**:

- Make sure that leaning ladder **1** is set up stable.
- Make sure that the leaning ladder **1** is connected securely to the respective ladder retainer **1**.
- When ascending and descending: 3-point support observed.
- Ascend maximum to the last free rung **2.1** below the ladder retainer **1**.

- Make sure that the vertical mass **X** between the standing position **P1** on the rung **2.1** and the grip position **P2** on the ladder beam ends **2.2** is minimum 1 m.
- Make sure that personnel holds the grip position **P2** on the ladder beam ends **2.2**.

Access	Work
Maximum step height up to the last free rung below the ladder retainer	Maximum step height up to the last free rung below the ladder retainer
3-point support required	3-point support required
	Rise to 1 m: Personal protective equipment to prevent falling not required
	Step height above 1 m to 7 m <b>Light work:</b> Personal protective equipment to prevent falling not required
	Step height above 1 m to 7 m <b>Heavy work:</b> Personal protective equipment to prevent falling required

*Conditions for access and work on the leaning ladders 2 when connected to the ladder retainers.*

### 7.5.3 Using the leaning ladder as a transition

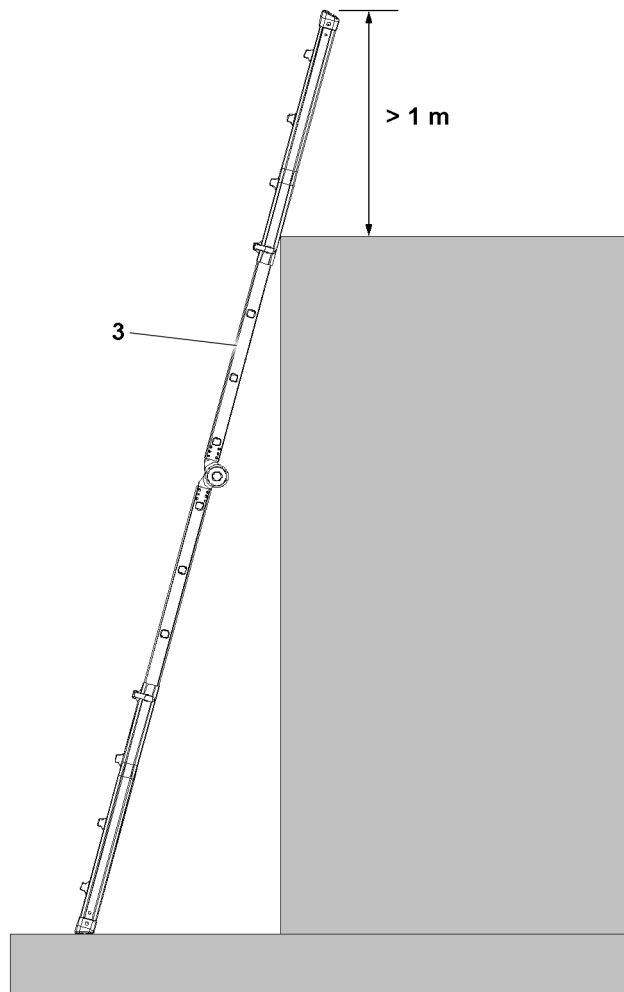


Fig.151626: Examples for leaning ladders with ladder overhang above the exit level

The leaning ladder can be used for transitioning.



#### WARNING

3-point support not adhered to!

Personnel can fall, death, severe bodily injuries.

- ▶ When transitioning, adhere to the 3-point support.
- ▶ Adhere to the prerequisites and conditions for the use of leaning ladders as a transition **3**.

Prerequisites for the use of leaning ladders as a transition **3**:

- Make sure that the leaning ladder **3** is positioned on a level placement surface.
- Make sure that the leaning ladder **3** is placed at an incline angle of 65° to 75° (approx. 1:4) to the horizontal.
- Make sure, for transitioning to higher work locations, when no other safehold possibilities are available, that the ladders beams of the leaning ladder go past the placement location by at least 1 m.
- Make sure that the transition area is slip-resistant.
- Make sure that the ladder position can be recognized from above.
- Make sure that the contact point of the ladder on the component is selected such that it will not be deformed or swing away due to the load of the person climbing up the ladder.
- Make sure that the weight of the tool carried along does not weigh more than 10 kg.

Access	Transition
Maximum rise to a rung / step below the placement edge	Maximum rise to a rung / step below the placement edge
3-point support required	3-point support required
Personal protective equipment to prevent falling not required	Personal protective equipment to prevent falling not required
	Rise to 1 m: Ladder safeguard not required
	Step height above 1 m to 7 m: Ladder safeguard required

Conditions for access and transition to leaning ladders with transition 3

## 7.6 Using the vertical ladder with transition aid

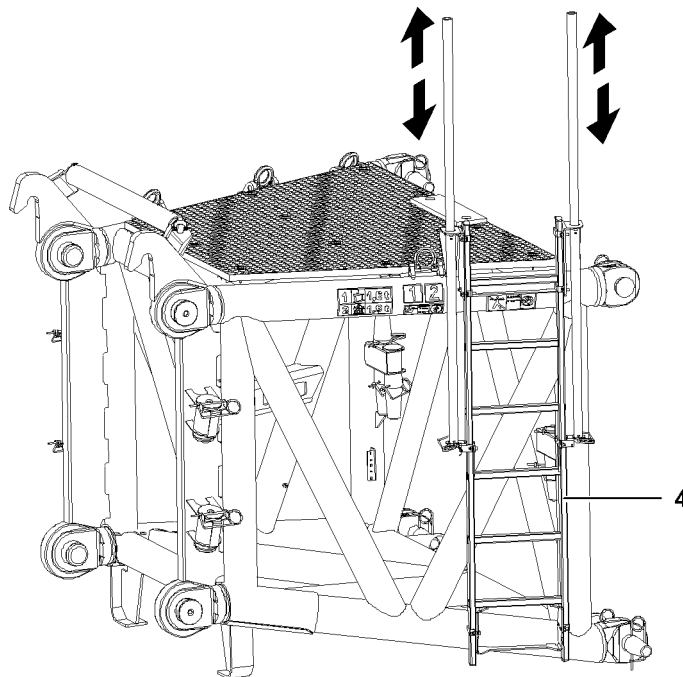


Fig.121178: Example for vertical ladder with transition aid



### WARNING

Persons not secured!  
Personnel can fall, death, severe injuries.

When using vertical ladders with transition aid 4:

- ▶ Adhere to the 3-point support.

Before transitioning:

- ▶ Hook the personal protective equipment to prevent falling on a suitable location (for example: uppermost rung, safety rope or separate hook point).
- ▶ Adhere to the prerequisites and conditions for the use of vertical ladders with transition aid 4.

Prerequisites for the use of vertical ladders with transition aid **4**:

- Make sure, a centered grip reachable from the transition edge and a possibility to support oneself with the second hand is present for transitioning.
- Make sure that the transition area is slip-resistant.
- Make sure that the ladder position can be recognized from above.
- Make sure that the weight of the tool carried along does not weigh more than 10 kg.

Access	Work
3-point support required	3-point support required
If necessary: Use a WORK POSITIONING SYSTEM (WPS) at a suitable hook point	If necessary: Use a WORK POSITIONING SYSTEM (WPS) at a suitable hook point

Conditions for access and work on vertical ladders with transition aid **4**

Ascent	Transition
3-point support required	3-point support required
Rise to 5 m: Personal protective equipment to prevent falling not required	Rise to 1.8 m: Without transition aid: Personal protective equipment to prevent falling not required
Rise above 5 m: Fall arrest system with moving along fall arrest device or back protection required	Rise above 1.8 m: Without transition aid: Personal protective equipment to prevent falling required

Conditions for ascent and transition to vertical ladders with / without transition aid **4**

## 7.7 Using the platform ladder

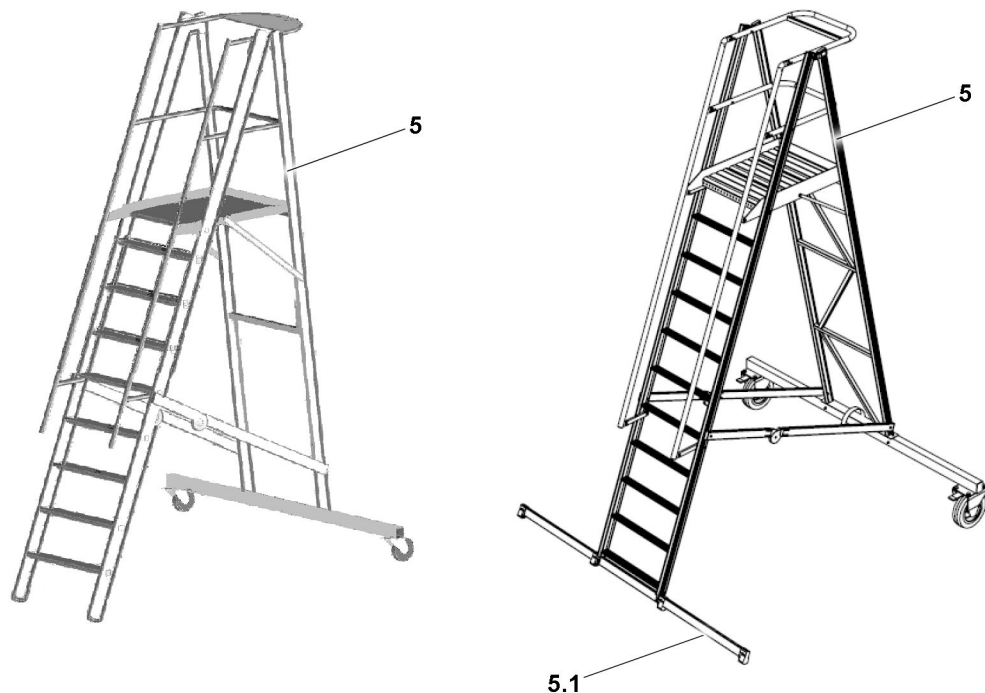


Fig.149995: Example of platform ladders

A platform ladder **5** with a cross beam **5.1** offers more stability. It is recommended to use a platform ladder with a cross beam.

LWE/LTR 1220-003/24204-02-02/en

**WARNING**

Transitioning from a platform ladder **5** to other components!

Personnel can fall, death, severe bodily injuries.

- ▶ Do **not** transition from a platform ladder **5** to other components.

**WARNING**

3-point support not adhered to!

Personnel can fall, death, severe bodily injuries.

When using platform ladders **5**:

- ▶ Adhere to the 3-point support.
- ▶ Adhere to the prerequisite and conditions for the use of platform ladders **5**.

Prerequisite for the use of platform ladders **5**:

- Make sure that the weight of the tool carried along does not weigh more than 10 kg.

Access	Working on the ladder	Working on the platform
Maximum rise to platform height	Maximum rise to platform height	Maximum height: Platform height
3-point support required	3-point support required	
	Rise to 1 m: Personal protective equipment to prevent falling not required	
	Step height above 1 m to 7 m <b>Light work:</b> Personal protective equipment to prevent falling not required	Platform height <b>Light work:</b> Personal protective equipment to prevent falling not required
	Step height above 1 m to 7 m <b>Heavy work:</b> Personal protective equipment to prevent falling required	Platform height <b>Heavy work:</b> Personal protective equipment to prevent falling required

*Conditions for access and work on platform ladders 5*

## 2.05 Signs on the crane

1 Signs

2

LWE/LTR 1220-003/24204-02-02/en

# 1 Signs

## 1.1 11952500 – California Proposition 65 Label

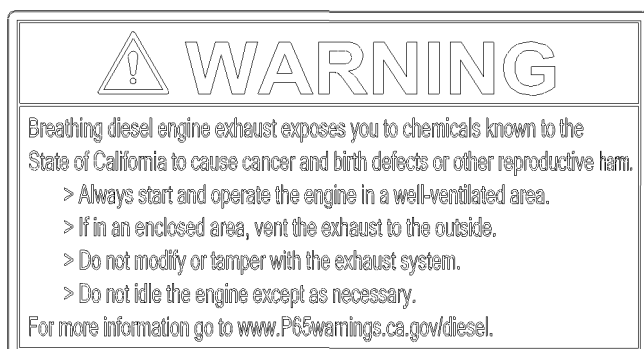


Fig.156191: California Proposition 65 Label



### WARNING

Diesel engine exhaust emissions!

Damage to health such as cancer and birth defects or other reproductive harm.

- ▶ Always start and operate the diesel engine in properly ventilated spaces.
- ▶ If in enclosed areas: Direct the exhaust gas to the outside.
- ▶ Do not convert the exhaust system or make any other changes.
- ▶ Do not run the engine at idle speed for longer than necessary.

## 1.2 7725039 – Warning of high voltage



Fig.116269: Warning of high voltage



### Note

- ▶ Only for certain countries.



### 1.3 772564008 – Slewing range



Fig.116270: Slewing range



**Note**

► Only for certain countries.

### 1.4 772580408 – Limitation of maximum travel speed



Fig.106035: Limitation of maximum travel speed

### 1.5 Vehicle height

Vehicle height	
970610408	
970629508	
970596108	
970608708	
979459108	

Vehicle height

LWE/LTR 1220-003/24204-02-02/en

**Note**

- ▶ Vehicle height x.x m (x.x ft).

## 1.6 97137170 – Luffing cylinder and counterweight collision

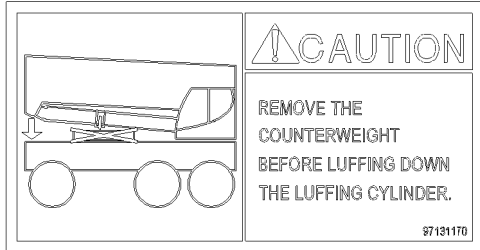


Fig.158141: Luffing cylinder and counterweight collision

**NOTICE**

Counterweight not disassembled from the crane chassis!

When taking the telescopic boom down, the luffing cylinder collides with the counterweight. Damage to the luffing cylinder and counterweight.

- ▶ Before taking the luffing cylinder down: Disassemble the counterweight.

## 1.7 97124295 – Load stop

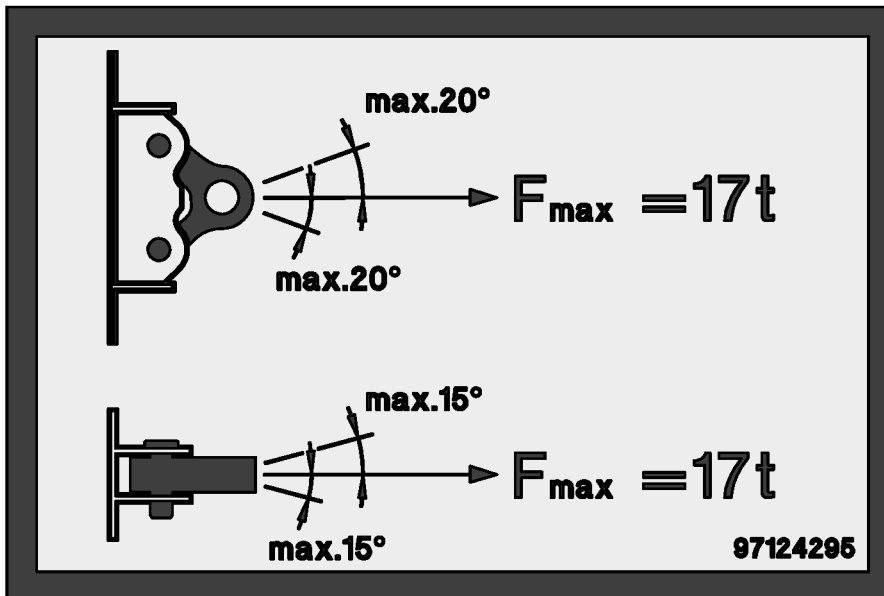


Fig.154929: Fastening the load according to the specifications on the sign

## 1.8 Assembly aid

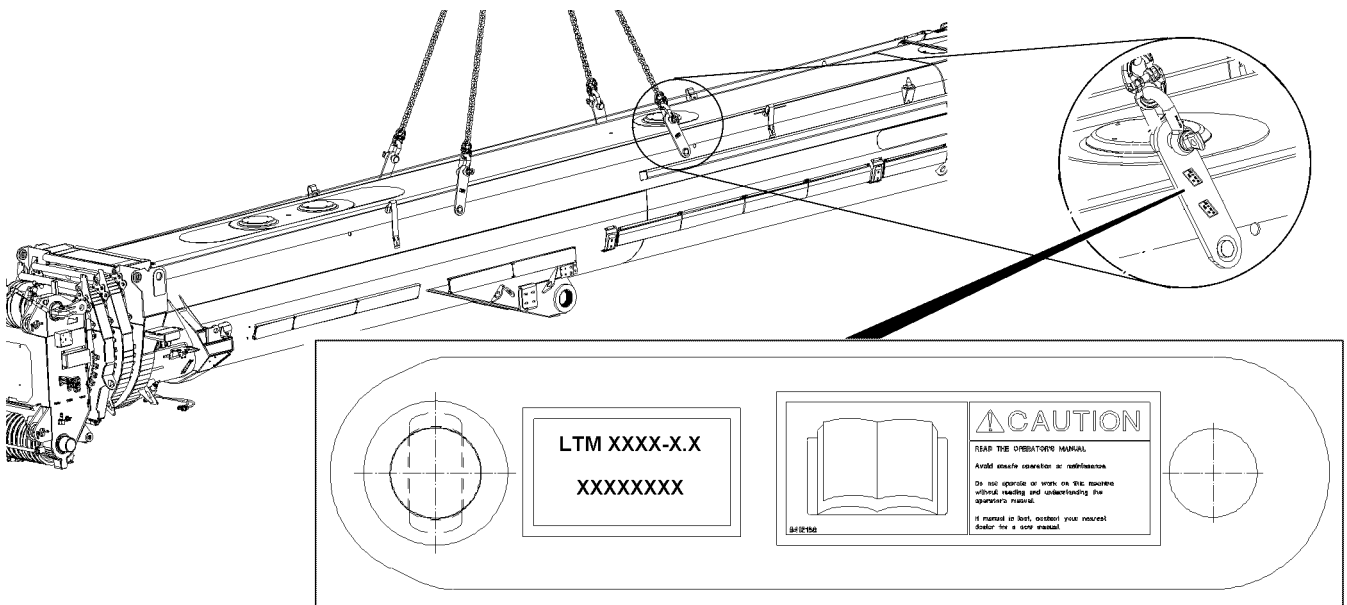


Fig.122741: Assembly aid



### WARNING

Wrong assembly aids used!

The telescopic boom can fall down. Death, property damage.

- ▶ To assemble and disassemble the telescopic boom: Use solely the assembly aids that belong to the crane.

## 1.9 97127242 – Assembly aid

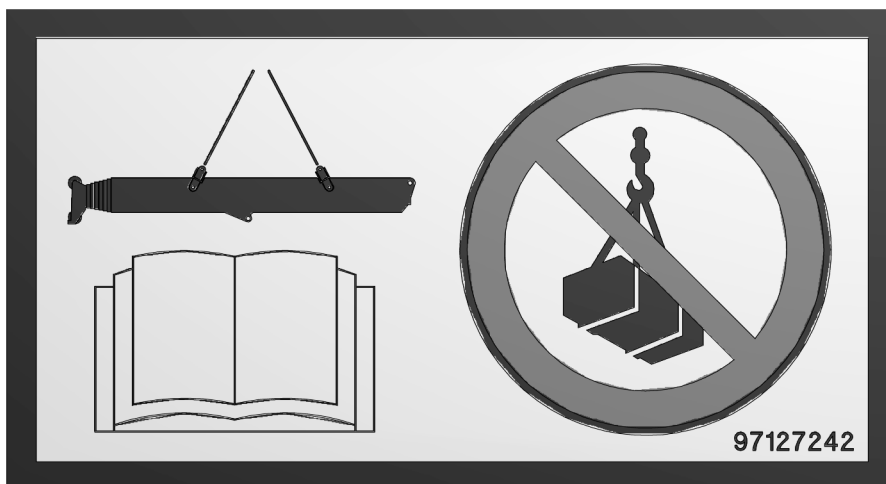


Fig.154928: Assembly aid



### WARNING

Wrong assembly aids used!

The telescopic boom can fall down. Death, property damage.

- ▶ To assemble and disassemble the telescopic boom: Use solely the assembly aids that belong to the crane.
- ▶ Only use the assembly aids to assemble and disassemble the telescopic boom.

## 1.10 9412158 – Reading the operating instructions

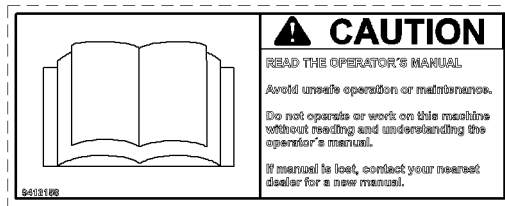


Fig.106048: Reading the operating instructions



### WARNING

Danger of accident due to non-observance of operating instructions!

If the operating instructions are not read or understood, then this can lead to unsafe operation and improper maintenance.

Accidents with bodily injuries and property damage can result.

- ▶ The crane may only be operated if the contents of the operating instructions have been read and understood.
- ▶ Replace lost or incomplete operating instructions immediately.

## 1.11 97004046 – Safety harness, maximum two persons



Fig.115119: Safety harness, maximum two persons



### DANGER

Danger of accidents due to overloaded safety ropes!

If safety ropes are used by more than two persons, then the safety ropes can be overloaded and fail in case of an accident.

Personnel can be severely injured or killed.

- ▶ Safety ropes are designed to secure a maximum of two persons against falling, one on the right and one on the left.

## 1.12 97017585 – Falling telescopic boom during disassembly / assembly

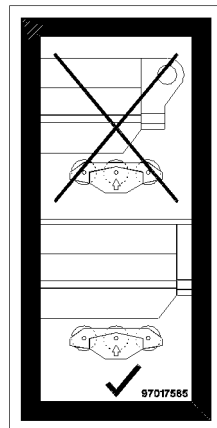


Fig.118467: Falling telescopic boom during disassembly / assembly



### WARNING

Death due to falling telescopic boom!

- ▶ Make sure that all pulleys are touching and supporting during the assembly and disassembly of the telescopic boom.

## 1.13 97018351 – Falling telescopic boom during transport!

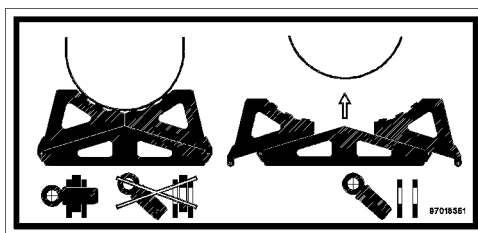


Fig.118466: Falling telescopic boom during transport



### WARNING

Fatal accidents due to falling telescopic boom during transport!

- ▶ Pin and secure the transport bracket on the left and right.

## 1.14 97018564 – Falling telescopic boom during transport!

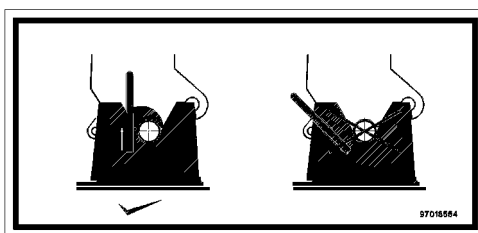


Fig.118533: Falling telescopic boom during transport

**WARNING**

Fatal accidents due to falling telescopic boom during transport!

- ▶ Lock the telescopic boom in the head receptacle.

## 1.15 97027147 – Overloading of the combi box is prohibited

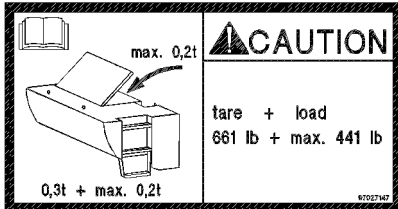


Fig.113829: Overloading of the combi box is prohibited

**WARNING**

Danger of overload!

If the combi box is subjected to a load of more than 0.2 t , the combi box can be damaged!

- ▶ The own weight of the combi box is 0.3 t and may be loaded with a maximum payload of 0.2 t.
- ▶ Do not subject the combi box to a weight of more than 0.2 t.

## 1.16 97036733 – Fastening point

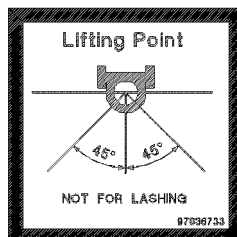


Fig.121184: Fastening point

**WARNING**

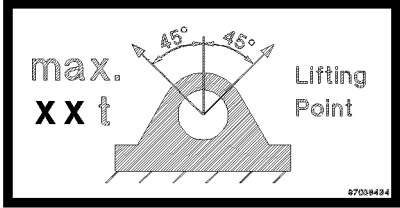
Damage to the fastening points!

- ▶ Use the fastening point solely to lift the load.
- ▶ Observe the maximum permissible fastening angle.

**Note**

- ▶ Fastening points and fastening angle.

### 1.17 Suspended load fastening point

Suspended load fastening point	
97038434	 <p style="text-align: center;"><i>Fastening point</i></p>
97037482	
97039068	



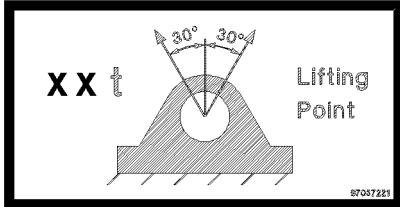
**WARNING**

Mortal danger if the load falls down!

If the maximum suspended load or the maximum fastening angle is exceeded, the load can fall down and kill personnel.

- ▶ Observe the maximum permissible suspended load and fastening angle.

### 1.18 Suspended load fastening point

Suspended load fastening point	
97037221	 <p style="text-align: center;"><i>Fastening point</i></p>
97037223	



**WARNING**

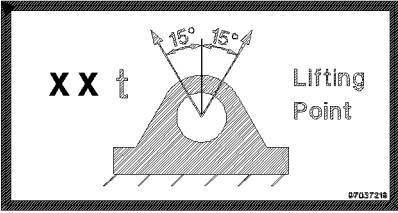
Mortal danger if the load falls down!

If the maximum suspended load or the maximum fastening angle is exceeded, the load can fall down and kill personnel.

- ▶ Observe the maximum permissible suspended load and fastening angle.

LWE/LTR 1220-003/24204-02-02/en

## 1.19 Suspended load fastening point

Suspended load fastening point	
97037219	 <p style="text-align: center;">Fastening point</p>



### WARNING

Mortal danger if the load falls down!

If the maximum suspended load or the maximum fastening angle is exceeded, the load can fall down and kill personnel.

- ▶ Observe the maximum permissible suspended load and fastening angle.

## 1.20 97037625 – Suspended load Fastening points / rigging points

LIFTING AND LASHING			
Type [t]	Lashing Capacity		
	LC-N [daN]	LC-Q [daN]	
4	4 000	2 000	
5,7	6 700	4 690	
10	10 000	7 000	
16	16 000	11 200	
31,5	31 500	22 050	

Fig.119988: Fastening points / rigging points



### Note

- ▶ Fastening points and rigging points.

## 1.21 9402377 – Fastening point / lifting point



Fig.127586: Fastening point / lifting point



### Note

- ▶ Fastening point / lifting point.



## 1.22 97106824 – Installing the N-assembly unit

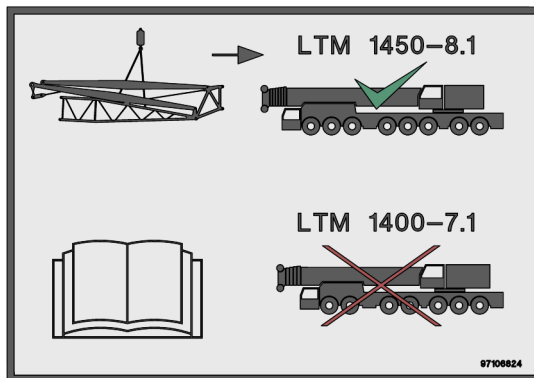


Fig.147594: Installing the N-assembly unit



### WARNING

N-assembly unit installed on an impermissible crane type!  
Death, severe bodily injuries, property damage.

- ▶ Use N-assembly units marked with this sign only for crane type LTM 1450-8.1.
- ▶ Observe and adhere to the operating instructions.

## 1.23 97096132 – Fastening points for N-assembly unit

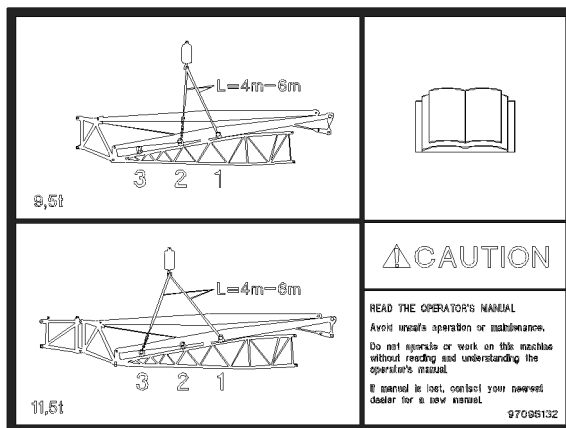


Fig.144774: Fastening points for N-assembly unit



### WARNING

Incorrectly selected fastening points!  
The N-assembly unit can tip over and kill personnel.

- ▶ Fasten the N-assembly unit only on the intended fastening points.
- ▶ Use fastening equipment with the correct strand length.
- ▶ Observe and adhere to the operating instructions.
- ▶ Replace lost or incomplete operating instructions immediately.

## 1.24 97036735 – Fastening point for lattice section

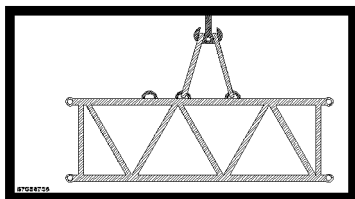


Fig.116266: Fastening point for lattice section



### Note

- ▶ Fastening points for lattice section.

## 1.25 97036736 – Fastening point for lattice sections

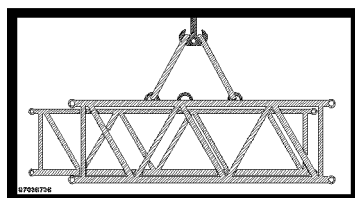


Fig.116267: Fastening point for lattice sections



### Note

- ▶ Fastening points for lattice sections.

## 1.26 97038442 – Fastening point for lattice section

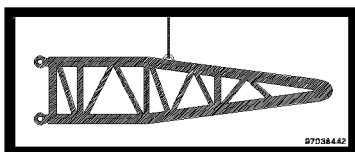


Fig.116288: Fastening point for lattice sections



### Note

- ▶ Fastening point for lattice section.

### 1.27 97038452 – Fastening point for lattice sections

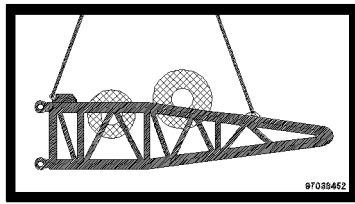


Fig.116289: Fastening point for lattice sections



**Note**

► Fastening points for lattice sections.

### 1.28 97038454 – Fastening point for lattice sections

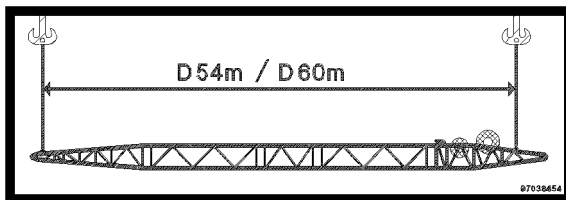


Fig.116290: Fastening point for lattice sections



**Note**

► Fastening points for lattice sections.

### 1.29 97037871 – Fastening points for lattice sections

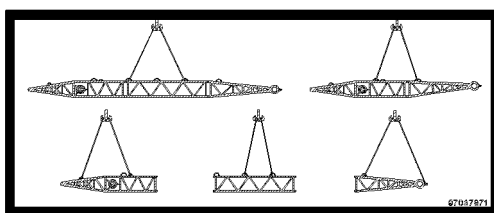


Fig.116292: Fastening points for lattice sections



**Note**

► Fastening points for lattice sections.

LWE/LTR 1220-003/24204-02-02/en

### 1.30 97053410 – Fastening equipment

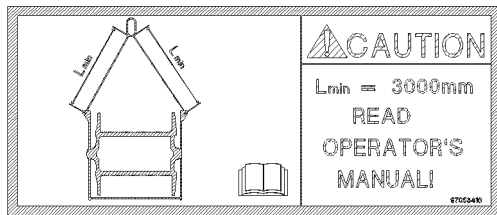


Fig.155031: Fastening equipment

#### NOTICE

The fastening equipment is too short!  
The fastening equipment is overloaded, the load can fall down.  
The assembly procedure cannot be carried out.

- ▶ Use fastening equipment with a minimum length of 3000 mm.
- ▶ Use only authorized fastening equipment with a suitable load bearing capacity.
- ▶ Observe and adhere to the operating instructions.

### 1.31 97057767 – Fastening points for lattice sections

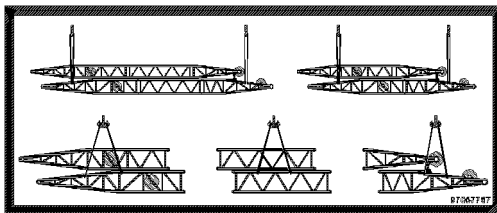


Fig.121181: Fastening points for lattice sections



#### Note

- ▶ Fastening points for lattice sections.

### 1.32 97057524 – Fastening point for assembly of lattice sections

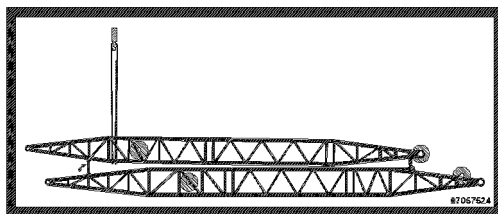


Fig.121182: Fastening point for assembly of lattice sections



#### Note

- ▶ Fastening point for assembly of lattice sections.

### 1.33 97057097 – Fastening point to turn the component

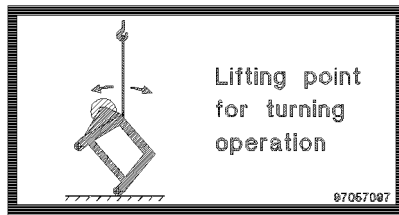


Fig.119987: Fastening point to turn the component



#### Note

- Fastening point to turn the component.

### 1.34 97039035 – Suspended load Assembly unit

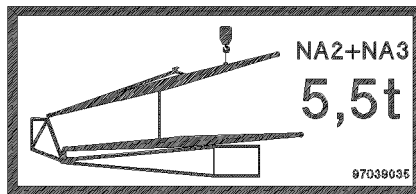


Fig.117348: Suspended load Assembly unit



#### Note

- Notice the suspended load.

### 1.35 97059339 – Suspended load Derrick pivot section

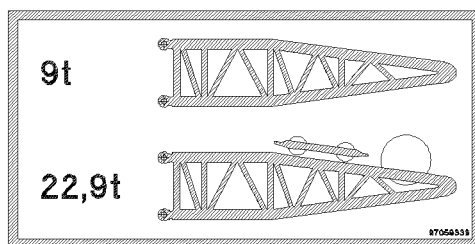


Fig.127469: Suspended load Derrick pivot section



#### Note

- Suspended load Derrick pivot section.
- Suspended load Derrick pivot section with rope winch and luffing pulley block.

### 1.36 Fastening point for end section

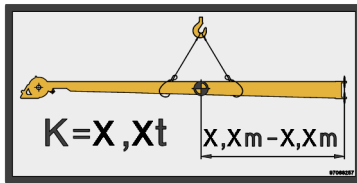


Fig.147595: Fastening point for end section

K = Weight in tons (t)

X.X to X.X = Distance of center of gravity in meters (m)



#### WARNING

End section improperly fastened!

The end section can tip over and fall down.

Death, severe bodily injuries, property damage.

- ▶ Fasten the end section only with two hooks.
- ▶ Select the fastening point such that the center of gravity is located within the fastening points.

### 1.37 97095312 – Suspended load and fastening points for counterweight frame

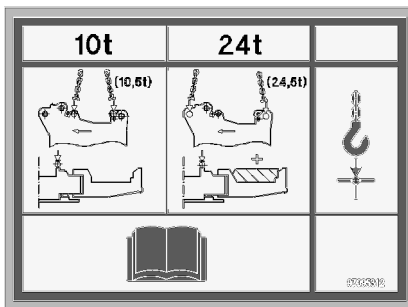


Fig.148126: Suspended load and fastening points for counterweight frame



#### Note

- ▶ Observe the suspended load and fastening points for counterweight frame.
- ▶ Observe and adhere to the operating instructions.

### 1.38 97003109 – Accessing the step ladder



Fig.109032: Accessing the step ladder

**WARNING**

Danger of falling!

If the step ladder is accessed before it is completely folded out, the assembly personnel can fall and be fatally injured.

- ▶ Before accessing the step ladder, fold the lowest step out.

### 1.39 97003110 – Folding the step ladder in and out

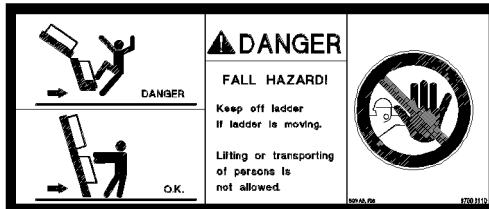


Fig.109033: Folding the step ladder in and out

**WARNING**

Danger of falling!

When folding the step ladder in or out or when driving the crane, no persons may remain on the step ladder or within the entire danger zone! Persons can fall from the step ladder or be killed as the step ladder folds in or out.

- ▶ Fold the step ladder in and out only if there are no persons within the danger zone.

### 1.40 97006167 – Identifying the support base

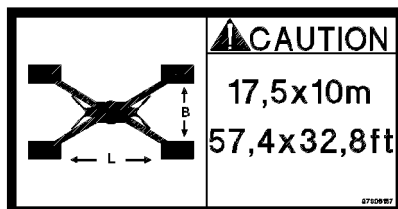


Fig.116285: Identifying the support base

**Note**

- ▶ The support beams are swung out / extended to a support base of 17.50 m x 10.0 m ; (57.4 ft x 32.8 ft).

### 1.41 97006167 – Identifying the support base

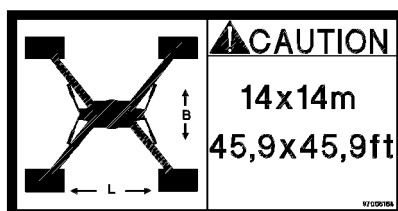


Fig.116286: Identifying the support base

**Note**

- ▶ The support beams are swung out / extended to a support base of 14.0 m x 14.0 m ; (45.9 ft x 45.9 ft).

## 1.42 97008514 – Warning of head injuries



Fig.110550: Warning of head injuries

**WARNING**

Head injuries!

Due to falling parts, personnel can be killed or severely injured.

Hitting the head can cause injuries.

- ▶ Protect your head with a hard hat.
- ▶ Proceed in an aware and safe manner.

## 1.43 97009799 – Data logger

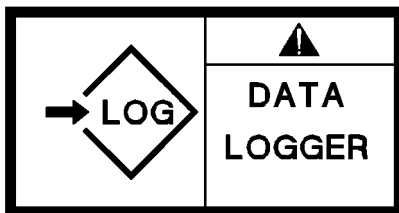


Fig.116261: Data logger

**Note**

- ▶ Data logger.

## 1.44 97012949 – Maximum load

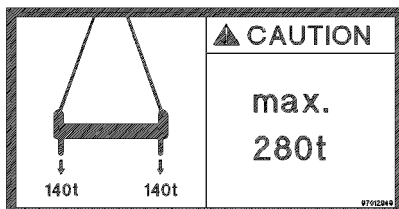


Fig.116263: Maximum load



**CAUTION**

Property damage due to overload!

If the cross beam is subjected to a higher load than permissible, damage can occur.

- ▶ Do not overload the cross beam.

## 1.45 97012095 – Maximum load

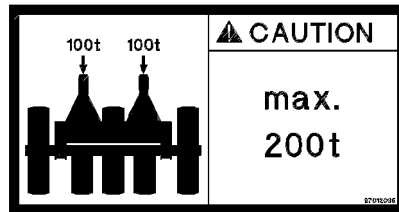


Fig.116265: Maximum load

**CAUTION**

Property damage due to overload!

If the roller cart is subjected to a higher load than permissible, damage can occur.

- ▶ Do not overload the roller cart.

## 1.46 97069053 – Storage boxes open

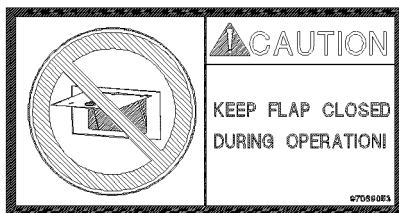


Fig.144736: Storage boxes open

**NOTICE**

Storage boxes open!

Damage of storage boxes.

- ▶ Before crane operation and before driving the crane, close the storage boxes.

## 1.47 97068370 – Closing the cab door

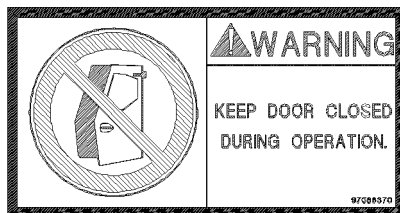


Fig.144737: Closing the cab door

**WARNING**

Cab door during crane operation **not** closed!

The crane operator can fall down.

Death, severe bodily injuries.

- ▶ Close the cab door during crane operation.

## 1.48 97053409 – Entanglement hazard during winch operation

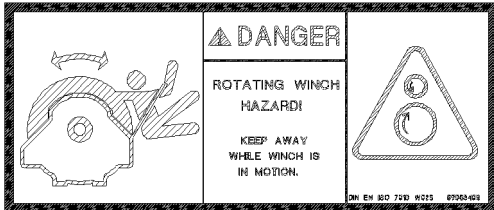


Fig.144738: Entanglement hazard during winch operation

**DANGER**

Entanglement hazard during winch operation!

Body parts can be caught and entangled.

Death, severe bodily injuries, property damage.

- ▶ Do **not** stand in the hazard area of the winch.

## 1.49 97011689 – Danger of crushing

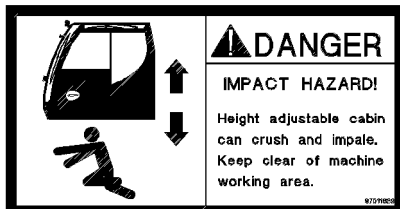


Fig.111047: Danger of crushing

**DANGER**

Danger of fatal injury!

- ▶ It is prohibited to remain within the danger zone of the cab.
- ▶ Stay away from the movement range of the cab.

## 1.50 97011690 – Overload of cab is prohibited

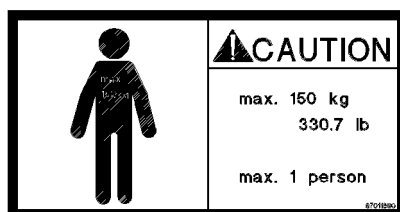


Fig.111048: Overload of cab is prohibited

**WARNING**

Danger of overload!

If the cab is subjected to a load of more than 150 kg then the cab or the telescoping arm can be damaged!

- ▶ Only one person at a time may remain in the cab!
- ▶ Do not subject the cab to a weight of more than 150 kg.

## 1.51 97016304 – Refueling

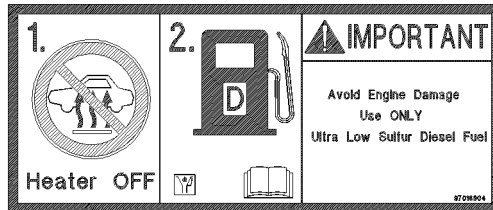


Fig.155029: Refueling

**WARNING**

Danger of fire and explosion!

- ▶ Turn the auxiliary heater\* off approx. 3 min before refueling the fuel tank.
- ▶ Before refueling the fuel tank, turn the engine off.

**NOTICE**

Property damage to the engine!

If incorrect fuel is added, the engine can be severely damaged.

- ▶ Refuel with fuel according to the Engine manufacturer's operating instructions.

## 1.52 97046488 – Corrosion inhibitor - antifreeze fluids

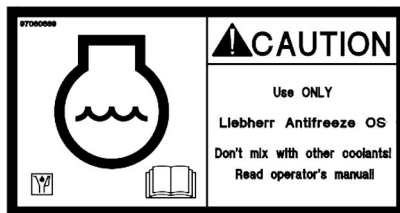


Fig.127585: Corrosion inhibitor - antifreeze fluids

**NOTICE**

Mixing of different corrosion inhibitor-antifreeze agents!

Damage to the cooling system.

- ▶ Fill the cooling system with corrosion inhibitor-antifreeze, see Service fill list.

### 1.53 97016392 – Crushing danger for feet



Fig.112474: Crushing danger for feet



#### WARNING

Crushing danger for feet!  
Feet can be trapped or crushed.

- ▶ Keep feet away from the crushing area.

### 1.54 97012737 – Danger of accident

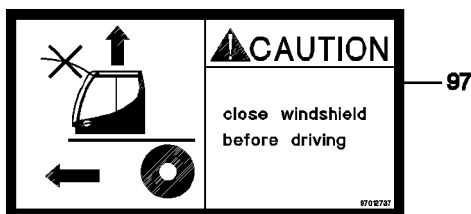


Fig.111748: Danger of accident



#### WARNING

Danger of accident!

- ▶ Close the windshield when driving.

### 1.55 97023034 – Disassembling

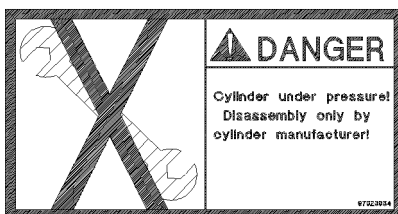


Fig.116264: Disassembling



#### DANGER

Danger of fatal injury due to repair!  
Cylinder is pressurized.  
Disassembly of the cylinder can result in death or serious injuries.

- ▶ The cylinder may only be removed by the manufacturer.

## 1.56 97036732 – Access via 3-point support

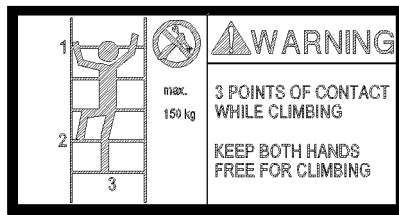


Fig.115172: Access via 3-point support



### DANGER

Access via 3-point support!

While climbing up and down via a ladder, assembly personnel can fall down and be injured severely.

- ▶ When climbing up and down, a 3-point support must be ensured.
- ▶ Use ladders only up to a weight of 150 kg.
- ▶ When climbing up and down, hands must be free.

A 3-point support is ensured when:

- Two legs are standing safely and one hand has a safe hold.
- Two hands have a safe hold and one leg is standing safely.

## 1.57 97003112 – Maximum suspended load

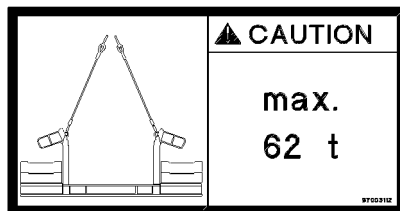


Fig.116282: Maximum suspended load



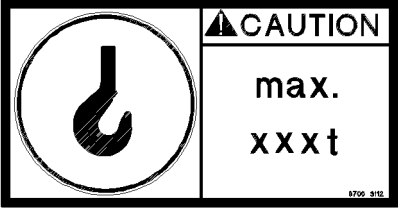
### WARNING

Maximum suspended load!

If the maximum suspended load of 62 t is exceeded, the load can fall down and kill personnel.

- ▶ Observe the maximum permissible suspended load.

## 1.58 97036917 – Maximum suspended load

	Suspended load fastening point
97047630	
97036917	
97047630	
97077237	



### WARNING

Mortal danger if the load falls down!

If the maximum suspended load is exceeded, the load can fall down and kill personnel.

- ▶ Observe the maximum permissible suspended load.

## 1.59 97037383 – Urea

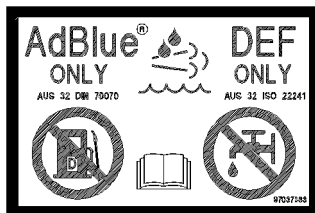


Fig.115173: Urea



### CAUTION

Property damage due to incorrect operating fluids!

When refilling urea and the urea which is specified by the engine manufacturer is not used, then damage can occur.

- ▶ Refill **exclusively** urea.
- ▶ See engine manufacturer's operating instructions.

## 1.60 97037952 – Warning of fatal electric shock

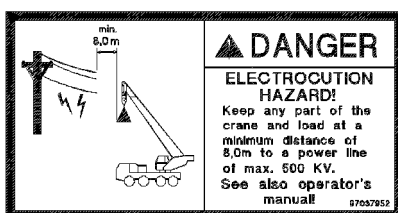


Fig.116280: Warning of fatal electric shock

**DANGER**

Danger of fatal injury due to electric shock!

If the boom or the hoist rope is under electric voltage, then death or severe injuries can occur if anyone touches the crane, the vehicle or the load.

- ▶ Keep a minimum distance of 8.0 m from current carrying parts.

## 1.61 97042730 – Falling luffing cylinder

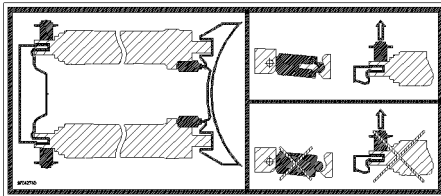


Fig.118465: Falling luffing cylinder

**WARNING**

Mortal danger if the luffing cylinders fall down!

- ▶ Make sure, before unpinning the luffing cylinder, that the erection cylinders are placed on both luffing cylinders.

## 1.62 97047810 – Pinning brackets

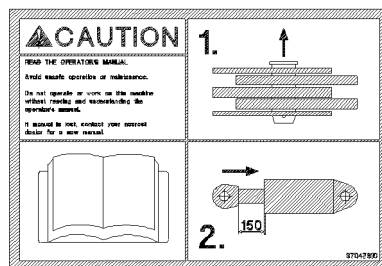


Fig.121709: Pinning brackets

**NOTICE**

Damage of brackets due to collision!

- ▶ Make sure, before pinning and unpinning, that the hydraulic cylinder is set to a distance of 150 mm.

## 1.63 97042797 – Overload of components

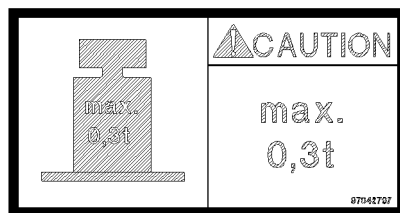


Fig.117347: Overload of components

**DANGER**

Danger of falling due to overload!

If a component, such as a sliding beam platform, is subjected to a weight of more than 0.3 t , then the sliding beam platform can break.

Personnel can fall down and be severely injured or killed.

- ▶ Subject the component (sliding beam platform) to no more than maximum 0.3 t.

## 1.64 97041305 – Overload of components

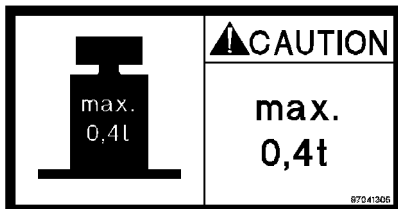


Fig.116792: Warning of overload of components

**DANGER**

Danger of falling due to overload!

If a component, such as a sliding beam platform, is subjected to a weight of more than 0.4 t , then the sliding beam platform can break.

Personnel can fall down and be severely injured or killed.

- ▶ Subject the component (sliding beam platform) to no more than maximum 0.4 t.

## 1.65 97070905 – Removing the auxiliary jib (boom nose)

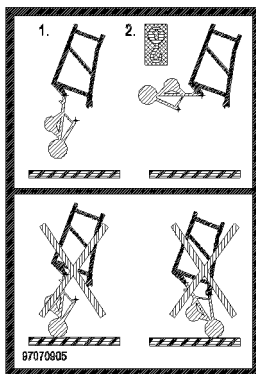


Fig.122645: Removing the auxiliary jib (boom nose)

**NOTICE**

Property damage

Before taking the N-head down:

- ▶ Remove the auxiliary jib (boom nose).



### 1.66 97077304 – Positioning the outrigger pad

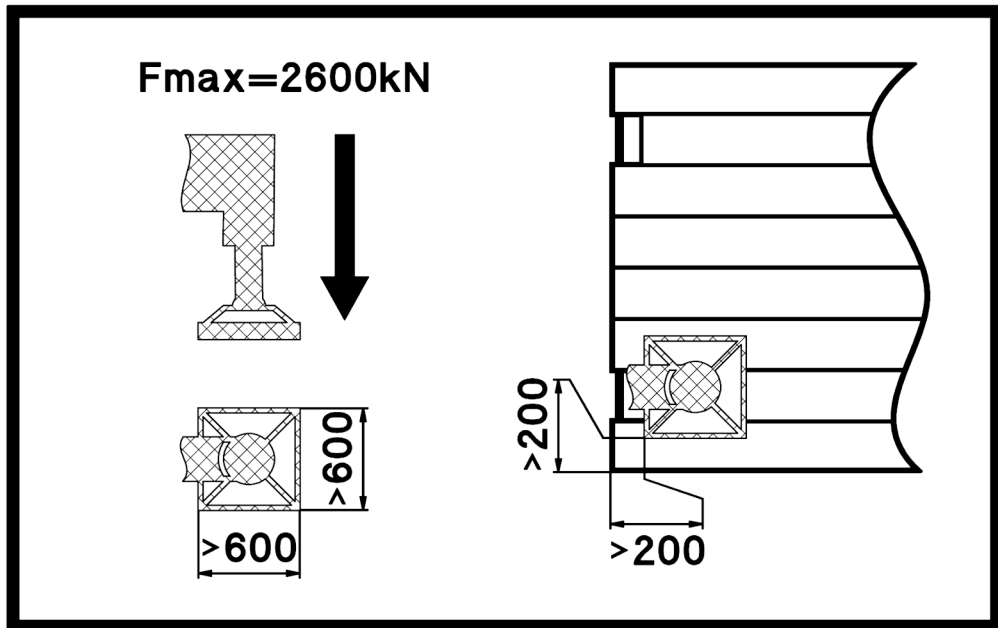


Fig.154913: Positioning the outrigger pad



**WARNING**

Outrigger pad incorrectly positioned!  
The crane can topple over. Death, property damage.

- ▶ Position the outrigger pad **in the center** or according to the description in chapter 1.03.10 under the support plate.

### 1.67 9707704 – Driving with the outrigger pad

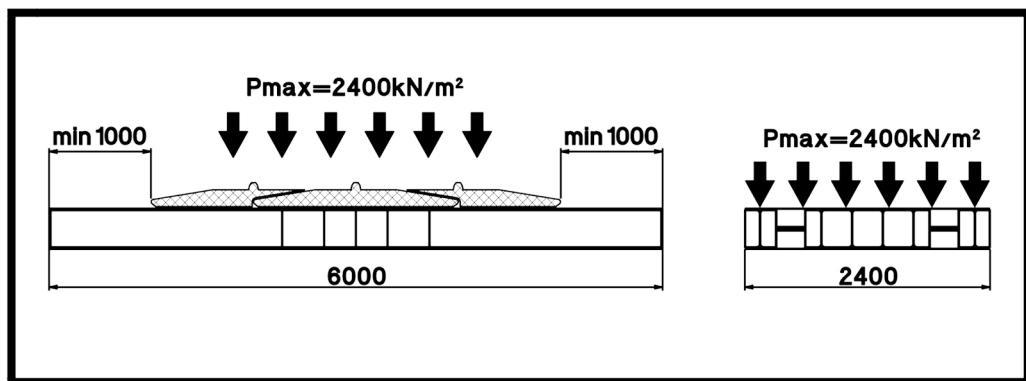


Fig.154912: Driving with the outrigger pad



**WARNING**

Outrigger pad incorrectly driven!  
The crane can topple over. Death, property damage.

- ▶ Drive with the outrigger pad according to the specifications on the sign.

LWE/LTR 1220-003/24204-02-02/en

## 1.68 Permissible support pressures on the outrigger pad [A-B-C]

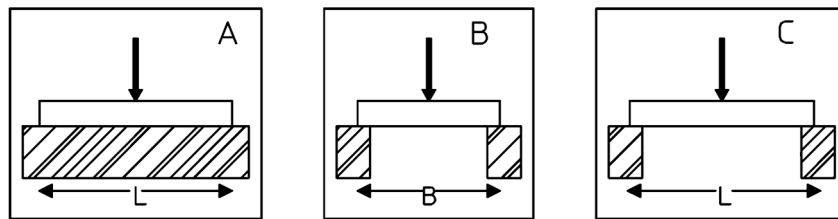


Fig.154815: Permissible support pressures on the outrigger pad for application cases [A-B-C]

## 1.69 Permissible support pressures on the outrigger pad [A-B-C-D]

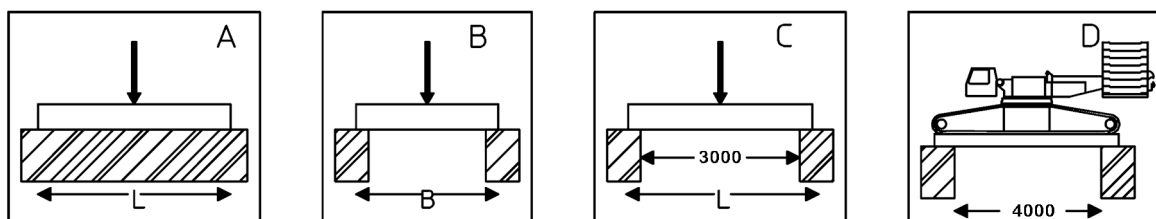


Fig.154816: Permissible support pressures on the outrigger pad for application cases [A-B-C-D]

## 1.70 97033982 – Assembling / disassembling the Derrick pivot section

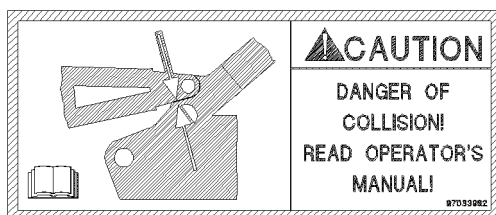


Fig.127470: Assembling / disassembling the Derrick pivot section

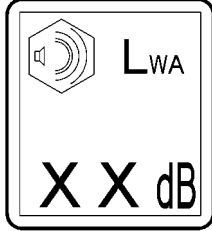
### NOTICE

Derrick pivot section assembly procedure carried out incorrectly!

Damage to the Derrick pivot section receptacle.

- ▶ Perform the assembly procedure according to the operating instructions.

### 1.71 Maximum sound power level

	Maximum sound power level
975809508	 <p>Maximum sound power level</p>
971693308	
971693408	
971693508	
971693608	



**Note**

- ▶ The maximum sound power level can be read on the outside of the crane operator's cab or in the CE declaration of conformity.

### 1.72 97097951 – Counterweight

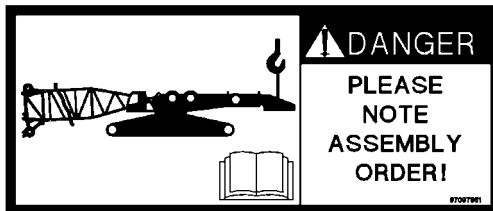


Fig.146805: Counterweight



**DANGER**

Counterweight not secured!  
Falling counterweight death, property damage.

- ▶ Observe and adhere to the operating instructions.
- ▶ Do not remove the auxiliary crane until the counterweight is pinned and secured on both sides with the turntable.

### 1.73 Retaining pins for erection rack 97100047



Fig.158614: Retaining pins for erection rack

LWE/LTR 1220-003/24204-02-02/en

**DANGER**

Retaining pins not inserted!

Falling ladder and erection rack, death, property damage.

- ▶ Before stepping on the erection rack ladder: Insert and secure the erection rack retaining pins.

## 1.74 Connector pins for erection rack / guy rods 97100629

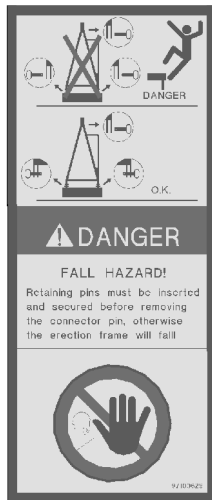


Fig.158615: Connector pins for erection rack / guy rods

**DANGER**

Unpin the erection rack / guy rods connector pins!

Falling ladder and erection rack, death, property damage.

Before unpinning the erection rack / guy rods:

- ▶ Insert and secure the erection rack retaining pins.

## 1.75 97107101 – Unlocking the telescopic boom locking pin

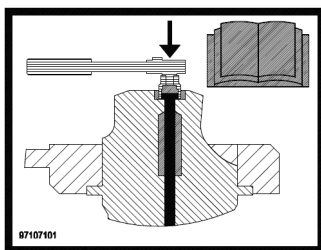


Fig.148421: Unlocking the telescopic boom locking pin

**Note**

- ▶ The locking pin may be unlocked according to the operating instructions.
- ▶ Observe and adhere to the operating instructions.

### 1.76 97107199 – Do not unlock the telescopic boom locking pin

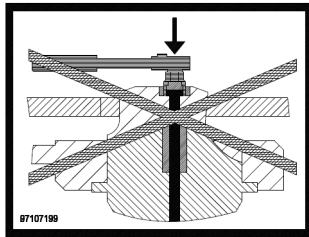


Fig.148422: Do not unlock the telescopic boom locking pin



**WARNING**

Impermissible telescopic boom locking pin unlocked!  
 The telescopic boom can retract in an uncontrolled manner.  
 Death, severe bodily injuries, property damage.

If a locking pin is marked with this sign:

- ▶ **Never** unlock the locking pin.

### 1.77 97128894 – Counterweight and counterweight radius

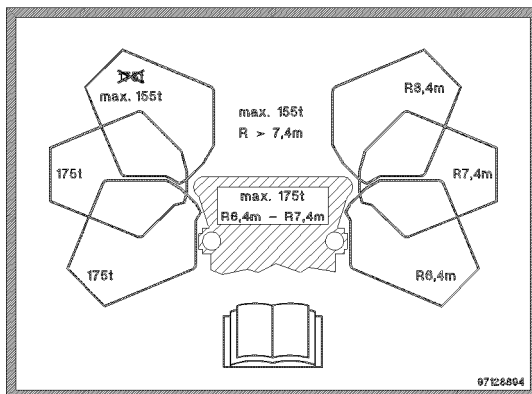


Fig.155030: Counterweight and counterweight radius

Counterweight radius	Maximum permissible counterweight
R- 6.4 m – R- 7.4 m	175.0 t
R- > 7.4 m	155.0 t



**Note**

- ▶ This notice sign indicates the maximum permissible counterweight for the different weight radii.
- ▶ Observe and adhere to the operating instructions.

LWE/LTR 1220-003/24204-02-02/en

## 1.78 97131530 – Reduced crawler crane track width

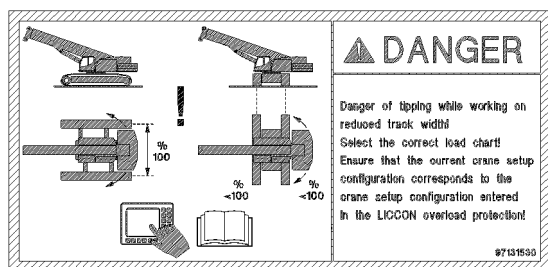


Fig.156174: Reduced crawler crane track width



### **DANGER**

Danger of tipping when working with a reduced track width!

- ▶ Select the correct load chart.
- ▶ Make sure that the actual crane set up configuration and the set up configuration entered in the LICCON overload protection match.

## 1.79 977055908 – Fastening point for swingable sliding beam

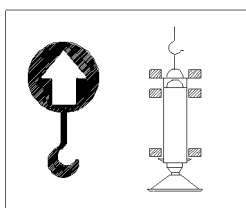


Fig.106894: Fastening point for swingable sliding beam

## 1.80 971494208 – Limitation of maximum travel speed

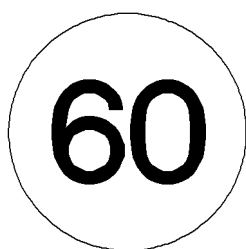


Fig.106034: Limitation of maximum travel speed

## 1.81 971539808 – Warning notice for unpinning the auxiliary boom on the pulley head

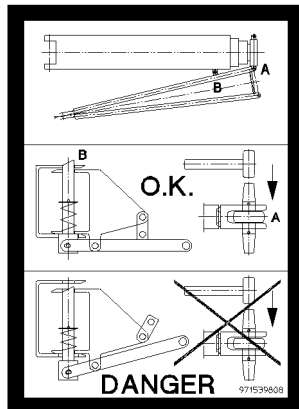


Fig.106040: Warning notice for unpinning the auxiliary boom on the pulley head



### **DANGER**

Danger of fatal injury!

If the auxiliary boom is not locked correctly to the pivot section, it can fall down. Personnel can be severely injured or killed.

- ▶ Unpinning the auxiliary boom on the pulley head is prohibited.

## 1.82 971539908 – Warning notice for unlocking the auxiliary boom

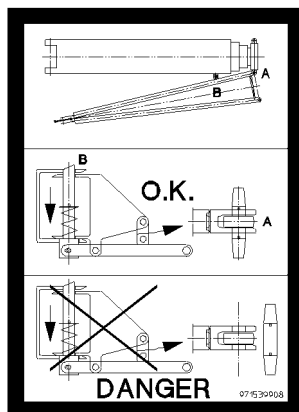


Fig.106041: Warning notice for unlocking the auxiliary boom



### **DANGER**

Danger of fatal injury!

If the auxiliary boom is not locked correctly to the pulley head, it can fall down. Personnel can be severely injured or killed.

- ▶ Unpinning the auxiliary boom on the pivot section is prohibited.

### 1.83 978673908 – Warning of suspended load

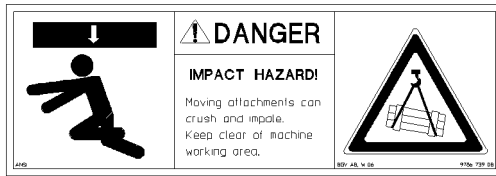


Fig.106026: Warning of suspended load



#### **DANGER**

Danger of fatal injury under suspended load!

- ▶ Standing under a suspended load is prohibited.
- ▶ Stay away from the working range of the machine.

### 1.84 978674008 – Access for unauthorized personnel prohibited



Fig.106037: Access for unauthorized personnel prohibited



#### **DANGER**

Danger of fatal injury!

If the crane or the working area is accessed by unauthorized personnel, life threatening injuries can occur as a result.

- ▶ It is prohibited for unauthorized personnel to enter the crane or the working area.

### 1.85 97039753 – Danger of stumbling

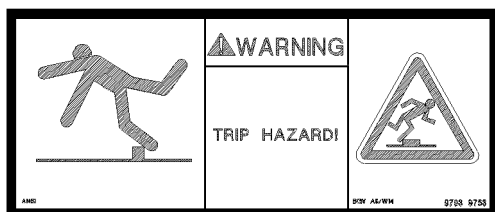


Fig.117346: Danger of stumbling



#### **WARNING**

Danger of stumbling!

- ▶ Move with caution.



## 1.86 978674108 – Warning of crushing danger

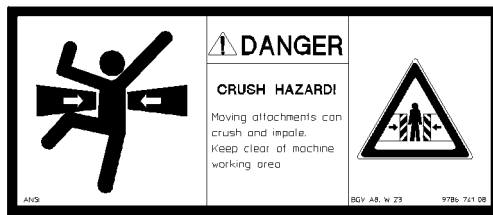


Fig.106027: Danger of crushing



### **DANGER**

Danger of fatal injury when remaining in areas with crushing danger!

- ▶ It is prohibited for anyone to remain in areas where there is a crushing danger.
- ▶ Stay away from the working range of the machine.

## 1.87 97016911 – Danger of collision

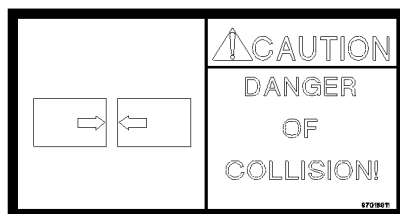


Fig.117344: Danger of collision

### **NOTICE**

Danger of collision!

- ▶ Avoid a collision.

## 1.88 978674308 – Radio remote control

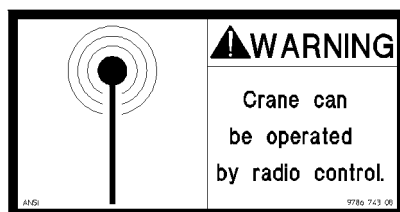


Fig.106047: Radio remote control



### **WARNING**

Danger of injury due to crane operation with radio remote control!

- ▶ The crane can be operated with radio remote control!
- ▶ During crane operation, it is prohibited for anyone to remain in the danger zone!

## 1.89 978674408 – Danger of burns to hands



Fig.106028: Danger of burns to hands



### WARNING

Danger of burns when touching hot surfaces!

- ▶ Do not touch hot surfaces.

## 1.90 978674508 – Warning of rotating parts

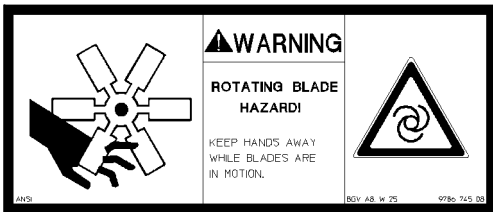


Fig.106029: Warning of rotating parts



### WARNING

Rotating parts!

The rotating fan blade can cause finger and hand injuries.

- ▶ Keep your hands away from the rotating fan blade.

## 1.91 978674608 - Crushing danger for hands



Fig.106030: Crushing danger for hands



### WARNING

Danger of injuries for hands!

Hands can be caught, trapped or crushed within the danger zone.

- ▶ Keep hands away from the danger zone!

## 1.92 978674808 – Personal protective equipment



Fig.123900: Personal protective equipment



### **DANGER**

Danger of falling!

- ▶ Use personal protective equipment.

## 1.93 978674908 – Accessing the area is prohibited



Fig.106038: Accessing the area is prohibited



### **WARNING**

Danger of accident!

If the prohibited area is accessed, accidents can occur.  
Personnel can be severely injured or killed.

- ▶ Do not access the prohibited area.

## 1.94 978675008 – Access prohibited



Fig.106039: Access prohibited



### **WARNING**

Danger of falling!

If the crane is accessed by unauthorized personnel, life threatening injuries can occur.

- ▶ Do not get on the crane.

## 1.95 978687408 – Rigging point



Fig.112475: Rigging point



### WARNING

Rigging point!

- ▶ Use the rigging point **solely** for rigging.
- ▶ Lifting on the rigging point is prohibited.

## 1.96 97036734 – Rigging point

NOT FOR LIFTING!			
Type (t)	Lashing Capacity		
	LC-N (daN)	LC-Q (daN)	
4	4 000	2 000	
8,7	8 700	4 000	
10	10 000	7 000	
18	18 000	11 200	
31,5	31 500	22 050	

Fig.116287: Rigging point



### WARNING

Rigging point!

- ▶ Use the rigging point **solely** for rigging.
- ▶ Lifting on the rigging point is **prohibited**.

## 1.97 978867108 – Warning of fatal electric shock

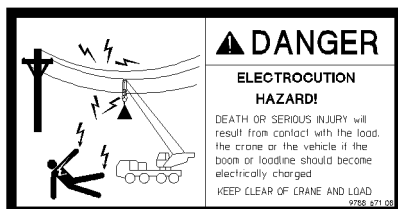


Fig.106814: Warning of fatal electric shock



### DANGER

Danger of fatal injury due to electric shock!

If the boom or the hoist rope is under electric voltage, then death or severe injuries can occur if anyone touches the crane, the vehicle or the load.

- ▶ Stay away from the crane and load.

## 1.98 97094940 – Spark catcher

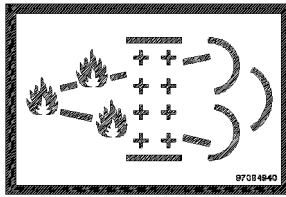


Fig.144735: Spark catcher



### Note

- ▶ The exhaust system is equipped with an integrated spark catcher.

## 1.99 979383308 – Oil change

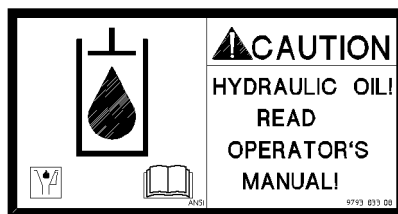


Fig.113827: Oil change



### CAUTION

Property damage due to oil change!

If the oil specified in the operating instructions is not used during the oil change, it can lead to damage.

- ▶ See the Crane operating instructions, chapter 7.07.

## 1.100 979561108 – Counterweight

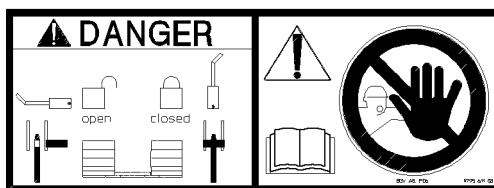


Fig.109026: Counterweight



### WARNING

The counterweight can fall down!

If the auxiliary crane is removed on the counterweight before the counterweight is locked on both sides with the turntable, then the counterweight will fall down and can fatally injure assembly personnel.

- ▶ Do not remove the auxiliary crane until the counterweight is locked and secured on both sides with the turntable. See the Crane operating instructions, chapter 4.07.

## 1.101 97001802 – Falling platform

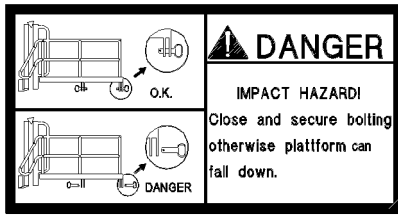


Fig.117345: Falling platform



### WARNING

Falling platform!

- ▶ Pin and secure the platform in assembly / disassembly position.

## 1.102 973974408 - Transport weights of the components

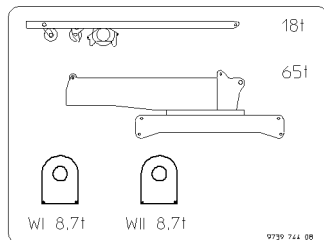


Fig.112440: Transport weights of the components

## 1.103 973974608 - Transport weights of the components

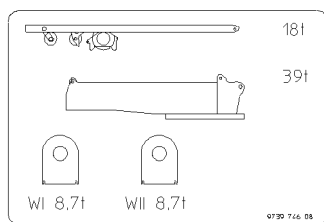


Fig.112441: Transport weights of the components

## 1.104 97011336 - Transport weights of the components

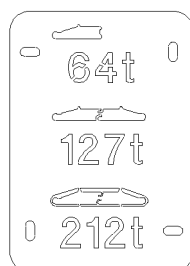


Fig.116271: Transport weights of the components

### 1.105 97068839 - Transport weights of the components / fastening length of the fastening equipment

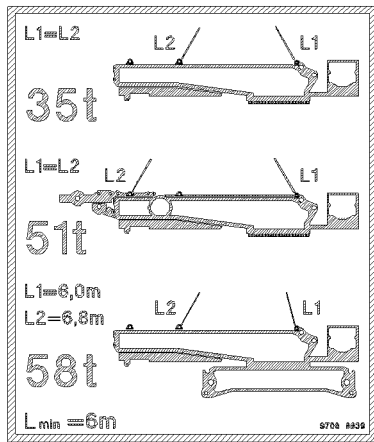


Fig.127587: Transport weights of the components / fastening length of the fastening equipment

### 1.106 Identification of sliding beam

Identification of sliding beam	
978675108	<p style="text-align: center;"><i>Identification of sliding beam</i></p>
978675208	
978772808	
978772908	
978809308	
978809408	
978809508	
978818408	
978818508	
978875908	
978902608	
978903108	
97029203	
978903208	
979126008	
979126108	
979210508	

LWE/LTR 1220-003/24204-02-02/en

	Identification of sliding beam
979210608	
979210608	
979210708	
979309108	
979309208	
97019140	
97003224	
979410808	

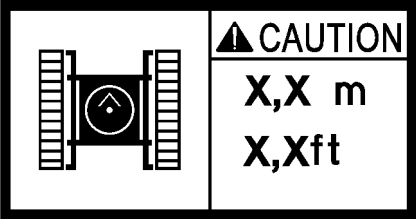
*Identification of sliding beam*



**Note**

- ▶ Extend the sliding beams to a support width of X.X m (X.X ft).

### 1.107 Identification Track width retracted

	Identification Track width retracted
97009840	 <p><i>Identification of track width</i></p>
97009841	
97017044	
97017045	
97017046	

*Identification of track width*



**Note**

- ▶ Track width retracted to x.xx m (x.x ft).

### 1.108 976624808 – Fastening the load



*Fig.116283: Fastening the load*





**WARNING**

Fastening the load is prohibited!  
 If the load is lifted on this point, the load can fall down and kill personnel.  
 ▶ Lifting the load on unmarked locations is prohibited.

**1.109 Note Weight sliding beams**

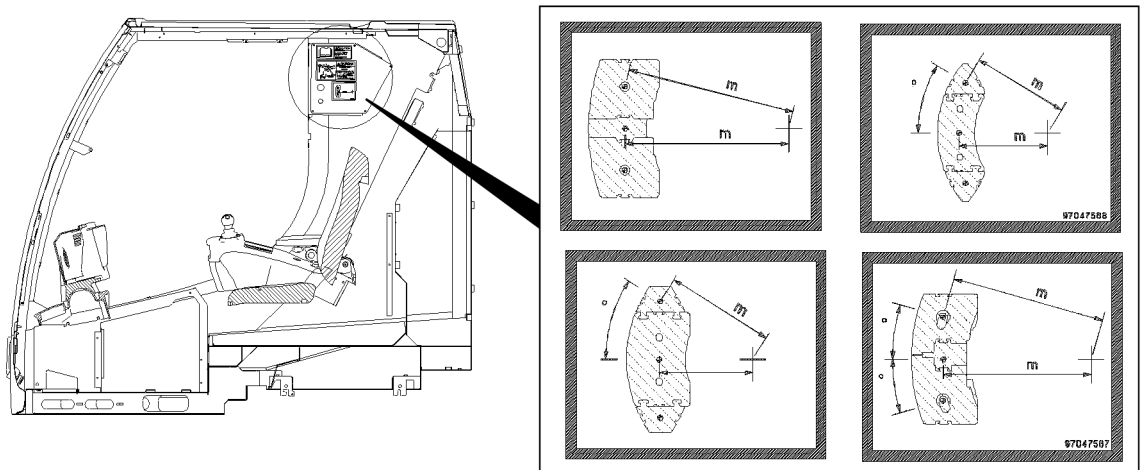
Weight of sliding beams	
979932008	<p style="text-align: center;"><i>Weight of sliding beams</i></p>
979932108	
979932708	
979932808	



**Note**

▶ Pay attention to the weight of the sliding beams.

**1.110 Center of gravity of the counterweight**



*Fig. 154058: Notice sign: Distance between center of gravity of counterweight and center of rotation*

The depicted notice sign are only examples and can differ depending on the crane type.

The notice signs are displayed in the crane operator's cab.



**Note**

▶ This notice sign indicates the distance between the center of rotation and the center of gravity of the counterweight.

LWE/LTR 1220-003/24204-02-02/en

Notice sign: Distance between center of gravity of counterweight and center of rotation			
Crane type	ID number notice sign	Crane type	ID number notice sign
LTM 1030-2.1	97096584	LTM 1230-5.1	97103719
LTM 1040-2.1	97095218		97103720
LTM 1050-3.1	97094881	LTM 1250-5.1	97070214
LTM 1055-3.1	97047566		97070215
LTM 1060-3.1	97051053	LTM 1300-6.2	97064080
LTM 1070-4.1	97095971	LTM 1350-6.1	97128099
LTM 1090-4.1	97092106	LTM 1450-8.1	97093816
	97092109		
LTM 1095-5.1	97047565	LTC 1050-3.1	97095960
LTM 1100-4.2	97094364	LTF 1045-4.1	97095046
LTM 1100-5.2	97095763	LTF 1060-4.1	97096030
LTM 1130-5.1	97055765	LTR 1060	97128100
LTM 1160-5.2	97081129		

### 1.111 Minimum rope reeving / minimum hook block weight

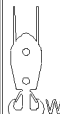

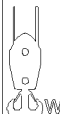


⚠ CAUTION					
LTM 1400-7.1			LTM 1450-8.1		
	 WT <sub>min</sub> =?	 n <sub>min</sub> =?		 WT <sub>min</sub> =?	 n <sub>min</sub> =?
TN			TN		
N-14,0m	3,1 t	n = 5	N-14,0m	3,1 t	n = 5
N-21,0m	2,6 t	n = 4	N-17,5m	2,6 t	n = 5
N-28,0m	1,4 t	n = 2	N-21,0m	2,6 t	n = 4
TN + 			N-24,5m	2,6 t	n = 4
N-14,0m	2,3 t	n = 3	N-28,0m	1,4 t	n = 2
N-21,0m	2,3 t	n = 2	TNH		
			N-14,0m	2,3 t	n = 3
			N-17,5m	1,8 t	n = 3
			N-21,0m	2,3 t	n = 2
			N-24,5m	1,8 t	n = 2

Fig.127972: Minimum rope reeving / minimum hook block weight with luffing lattice jib / boom nose



#### WARNING

Minimum rope reeving / minimum hook block weight not adhered to!  
 Too low hook block weight leads to the formation of slack rope.  
 Rope reeving too low, hoist rope is overloaded.  
 ► Adhere to the hook block weight and hoist rope reeving.

Example: LTM 1400-7.1

With a luffing lattice jib -TN **N-21 m** a hook block with a weight of **2.6 t** **must** be installed and minimum rope reeving of **4** must be used.

With a luffing lattice jib **N-21 m** and boom nose a hook block with a weight of **2.3 t must** be installed and minimum rope reeving of **2** must be used.

---

Empty page!

LWE/LTR 1220-003/24204-02-02/en

## 2.05.10 Labeling of the load carriers

1	Identifications on the hook block or load hook	3
2	Identifications on single hook or double hook	4
3	Identifications on auxiliary weights	5

*Fig.195219*

LWE/LTR 1220-003/24204-02-02/en

# 1 Identifications on the hook block or load hook

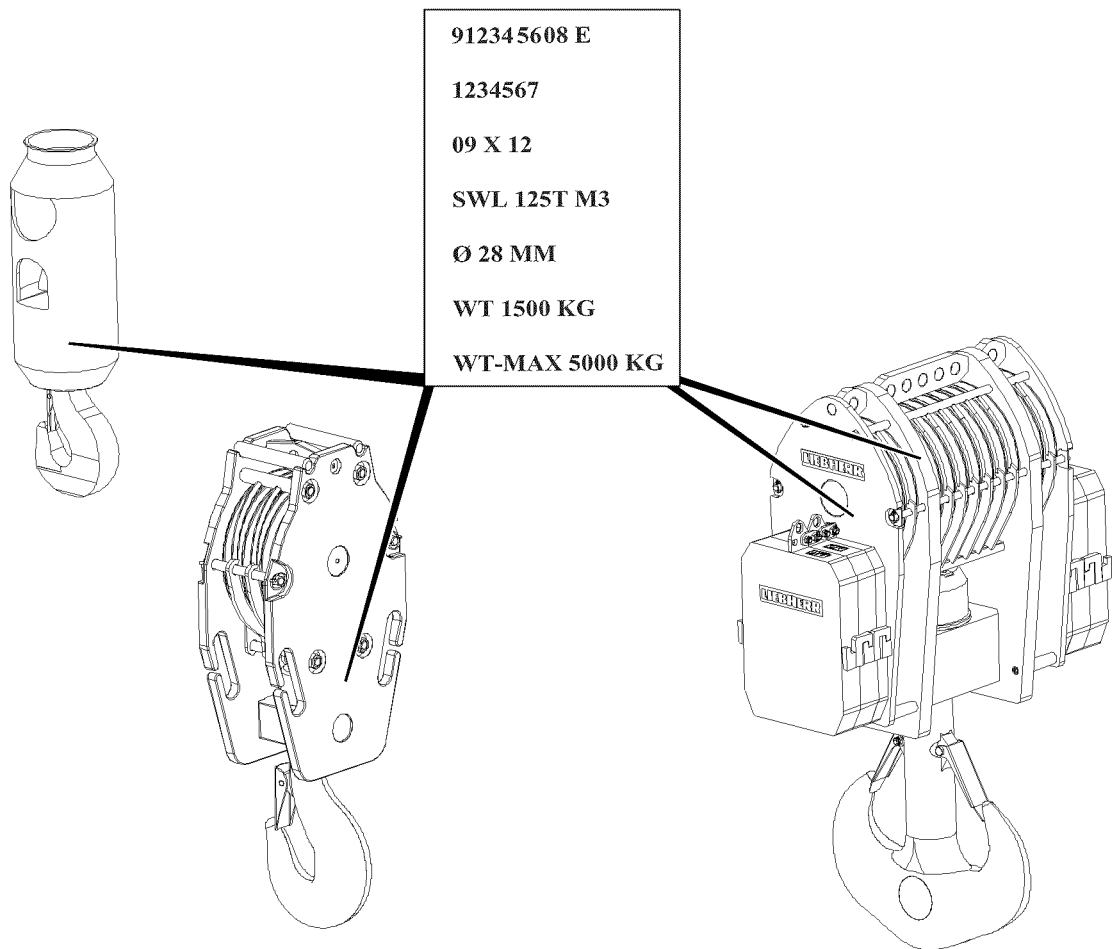


Fig.118509: Identifications on the hook block or load hook



## Note

- ▶ The load hooks and hook blocks approved for this crane type can be found in the load chart.
- ▶ The hook blocks shown are examples only and can deviate from the existing hook block.

Punch mark area	Explanation
912345608 E	Liebherr ID no., „E = entschärft (deburred)“
123456	Series or factory test number
09 X 12	Month of construction / supplier marks / year of construction
SWL 125T M3	SWL (Safe Working Load) = Load carrying capacity for power train group M3
Ø 28 mm	Hoist rope diameter
WT 1500 Kg	WT (Weight Tare) = Own weight (without auxiliary weights)

Punch mark area	Explanation
WT-MAX 5000 Kg	WT-Max = Maximum permissible own weight of lower pulley block and total number of progressively installed auxiliary weights
	Limits the number of installed auxiliary weights
	Determination via addition of assembled own weights (number of auxiliary weights + hook block)

Identifications on the hook block or load hook

## 2 Identifications on single hook or double hook

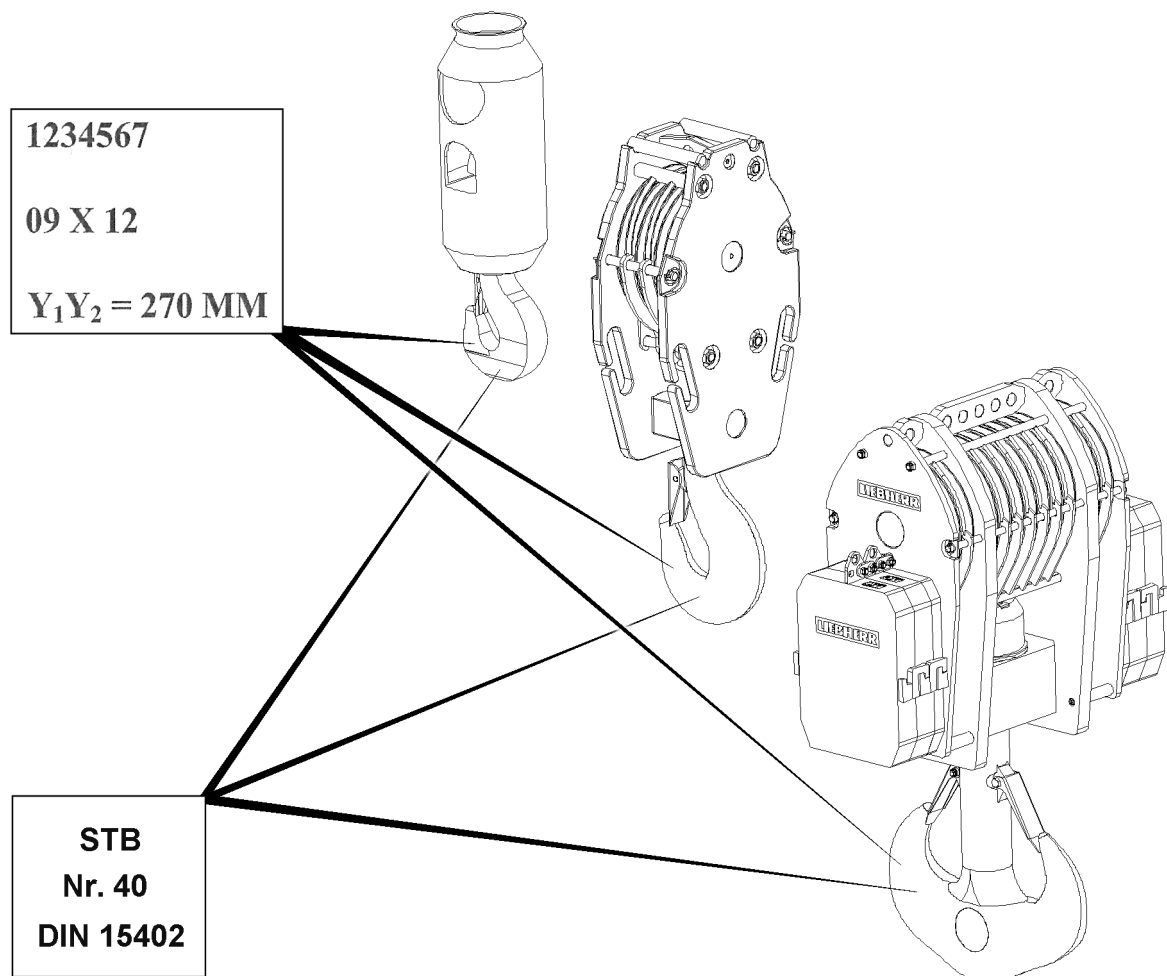


Fig.149061: Identifications on single hook or double hook

Punch mark area	Explanation
STB	Hook manufacturer
40-T	Hook number + strength class according to DIN 15 400
DIN	Hook shape according to DIN 15 401 /DIN 15 402
123456	Series or factory test number



Punch mark area	Explanation
09 X 12	Month of construction / supplier marks / year of construction
Y1Y2 = 270 mm	Dimension Y or dimension Y1 and dimension Y2 according to DIN (= Test dimensions for recurrent tests)

Identifications on single hook or double hook

### 3 Identifications on auxiliary weights

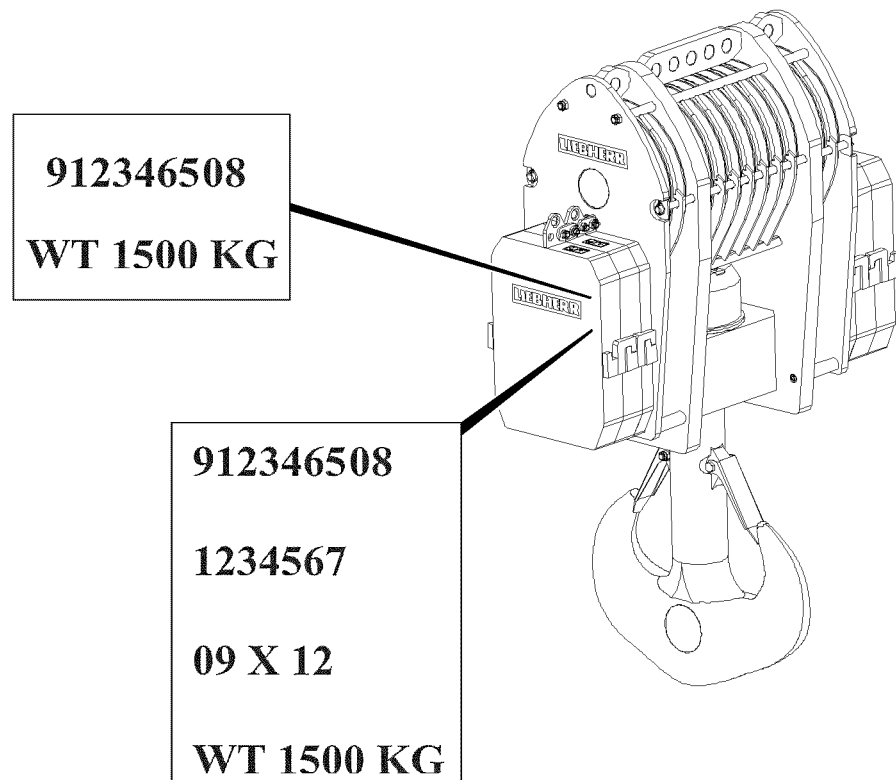


Fig.118511: Identifications on auxiliary weights



#### Note

- The own weight of the individual auxiliary weight is noted on the side on the respective auxiliary weight.

#### 3.1 Identifications on auxiliary weights at delivery

Punch mark area	Explanation
912346508	Liebherr ID no.
WT 1500 Kg	WT (Weight Tare) = Own weight of individual auxiliary weight

Identifications of auxiliary weights at delivery

### 3.2 Identifications on auxiliary weights for reorder

Punch mark area	Explanation
912346508	Liebherr ID no.
123456	Series or factory test number
09 X 12	Month of construction / supplier marks / year of construction
WT 1500 Kg	WT (Weight Tare) = Own weight of individual auxiliary weight

*Identifications of auxiliary weights at reorder*

## 2.06 Fall protection equipment on the crane

1	Safety	2
2	Hook points	2
3	Preparing the ladder	3
4	Telescopic boom	5
5	Auxiliary boom	7
6	Folding jib	8
7	Crane chassis	10
8	Crane superstructure	19
9	Counterweight frame	20
10	Transporting the ladder	21

# 1 Safety

Before accessing the crane, observe the safety instructions.

- General safety information: See chapter 2.04.
- Information regarding personal protective equipment: See chapter 2.04.
- Information regarding the use of safety ropes: See chapter 2.04.
- Information regarding the use of ladders: See chapter 2.04.10.
- Information regarding accesses to the crane: See chapter 2.07.



## WARNING

Assembly personnel **not** secured!

Assembly personnel can fall, death, severe bodily injuries.

- ▶ Assembly personnel must secure themselves to prevent falling.
- ▶ Move carefully and anticipatorily on the crane or components.
- ▶ Carry out all work, where there is a danger of falling with suitable aids.

If aids are not available and work cannot be carried out on the ground:

- ▶ Secure assembly personnel with the supplied fall arrest system to prevent falling.
- ▶ Attach the fall arrest system to the fastening points and hook points as well as to the safety ropes.
- ▶ Step on the aids, ladders and catwalks with clean shoes.
- ▶ Keep aids, ladders and catwalks free of heavy dirt, snow and ice.

## 2 Hook points

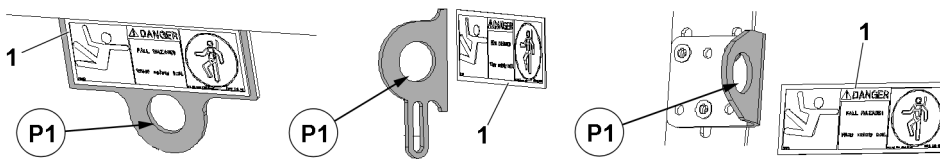


Fig.128291: Hook points shown as an example

On the various component groups, hook points **P1** are installed to which assembly personnel must secure themselves to avoid falling.



Fig.128300: Sign 1 on the hook point

The hook points **P1** are marked with signs 1.



## WARNING

Assembly personnel **not** secured!

Assembly personnel can fall, death, severe bodily injuries.

- ▶ Secure assembly personnel with the fall arrest system to the hook points **P1** to prevent falling.
- ▶ Only one person may be secured to each hook point **2**.

If necessary, fastening points can be used for connecting the fall arrest system to protect against falling.

**WARNING**

The hook points can be ripped off!

The load can fall down, death, severe bodily injuries, property damage.

- ▶ **Never** fasten loads or objects on the hook points.
- ▶ Do **not** use the hook points as fastening points.

### 3 Preparing the ladder

The ladders that are shown are examples and may appear differently with the same functional principle.

In the case of work that requires a ladder, the supplied ladder **11** with hook device **10** must be used.

**WARNING**

The ladder **11** can tip over!

Assembly personnel can fall, death, severe bodily injuries.

- ▶ Replace damaged ladders immediately.
- ▶ Use only the supplied ladder **11**.
- ▶ Do **not** hang the ladder freely suspended. Support the ladder on the ground.
- ▶ Set up the ladder **11** safely with safe access.
- ▶ Observe the safety instructions on the ladder **11**.

### 3.1 Installing the hook device on the ladder

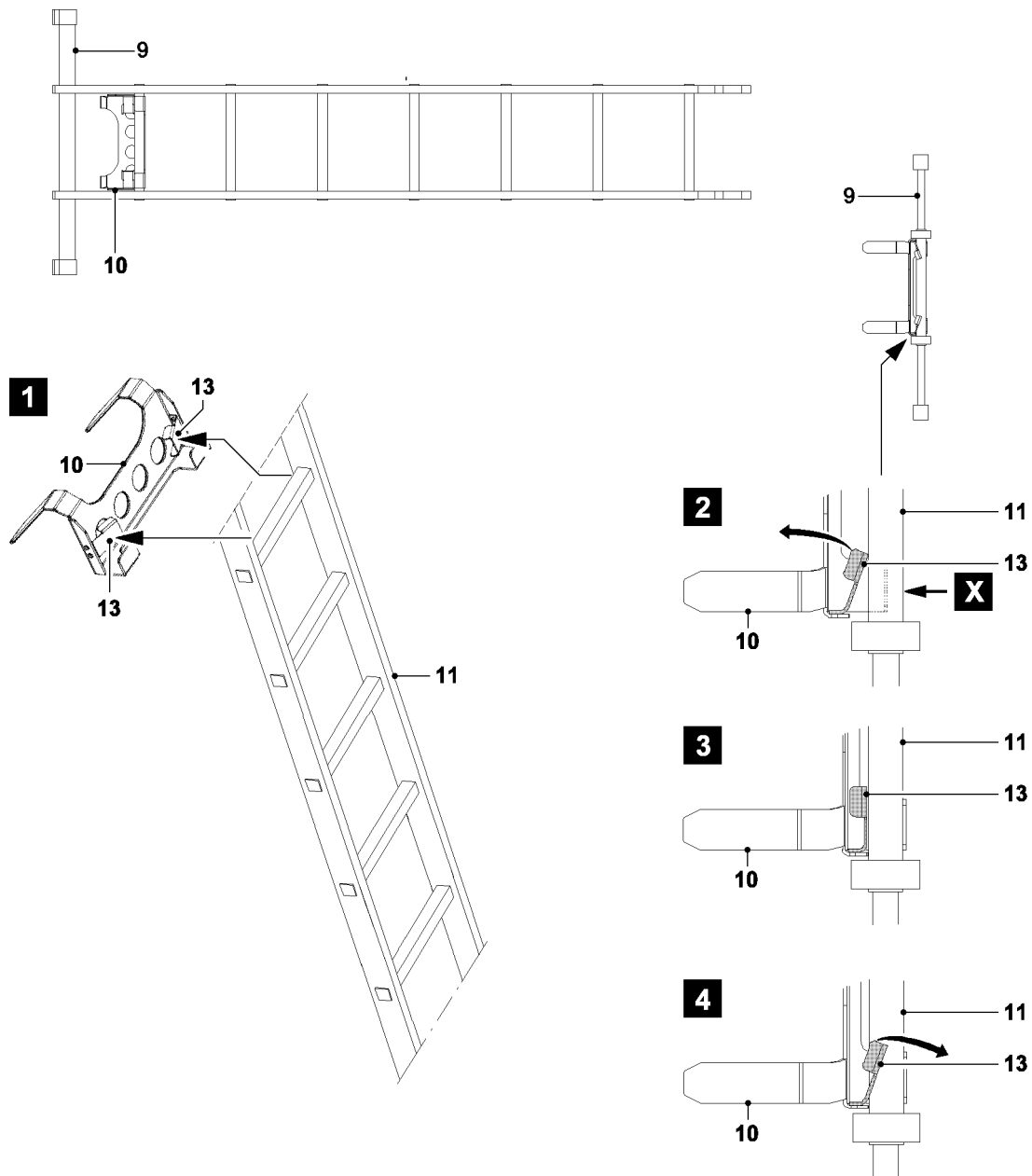


Fig.145022: Assembling the hook device

The ladder **11** is carried along on the central ballast.

Before using the ladder **11** as a leaning ladder, the hook device **10** must be installed on a rung.

- ▶ Press the ladder with the required rung against the locking plates **13** on the hook device **10** (point **X**), see illustration **1**, illustration **2**.

**Result:**

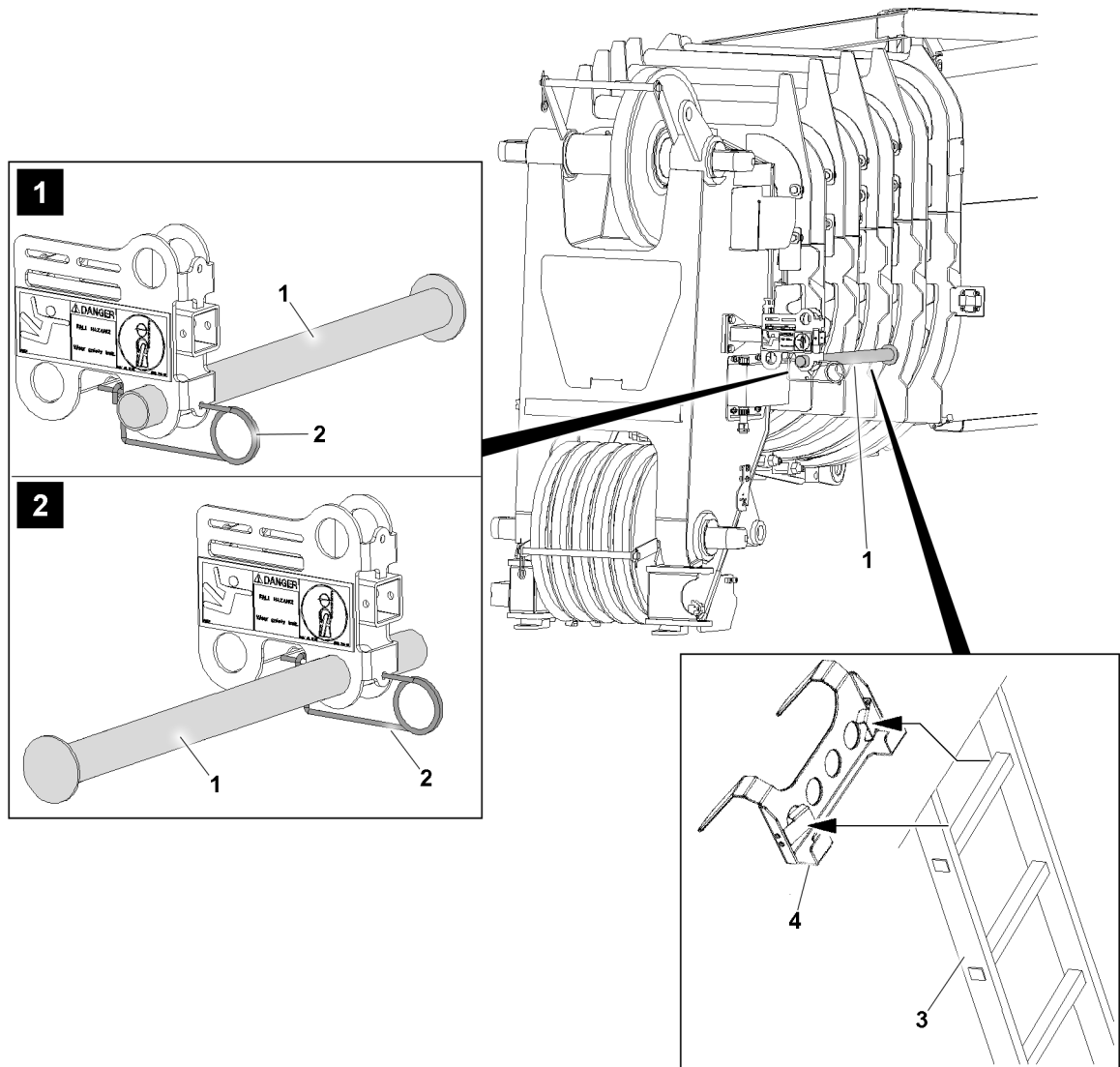
- The locking plates **13** spring in the direction of the arrow and release the receptacle on the hook device **10** for the rung, see illustration **3**.
- ▶ Push the hook device **10** „upward“.

**Result:**

- The locking plates **13** spring (arrow) „back“ into their original position by themselves and secure the rung, see illustration **4**.

## 4 Telescopic boom

### 4.1 Securing the ladder



*Fig.149048: Securing the ladder*

The illustration is exemplary. The structure of the telescopic boom depends on the crane type.

Assemble the retainer **1** to hang the ladder:

Depending on the required ladder position:

- ▶ Assemble the retainer **1** according to the illustration **1** or illustration **2**.
- ▶ Secure the retainer **1** with the spring retainer **2**.

**WARNING**

Ladder **not** secured!  
 Assembly personnel can fall, death, severe bodily injuries.

- ▶ Secure the ladder.
- 
- ▶ Hang the ladder **3** with the hook device **4** on the retainer **1**.

## 4.2 Hook points

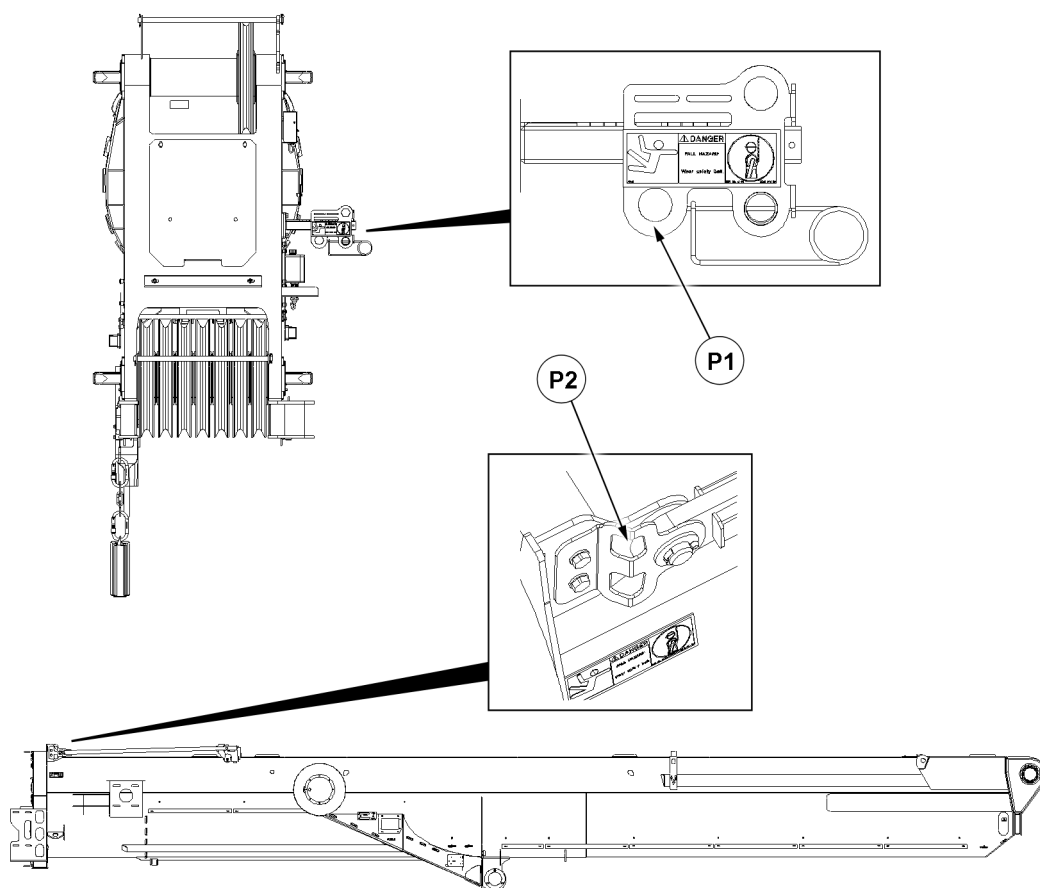


Fig. 149055: Hook points on the telescopic boom

Hook point **P1** and hook point **P2** are installed on the telescopic boom.

**WARNING**

Assembly personnel **not** secured!  
 Assembly personnel can fall down. Death, severe bodily injuries.

- ▶ Secure assembly personnel against falling.
- 
- ▶ Secure assembly personnel with the fall arrest system on the hook point **P1** or hook point **P2** to prevent falling.



## 5 Auxiliary boom

### 5.1 Hook points

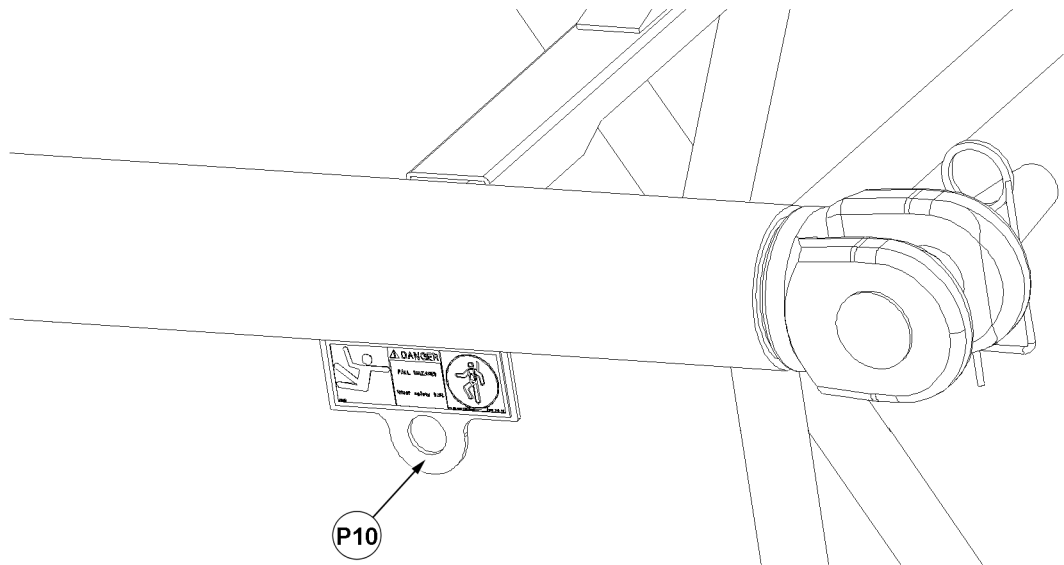


Fig.125231: Hook points on the auxiliary boom



#### **WARNING**

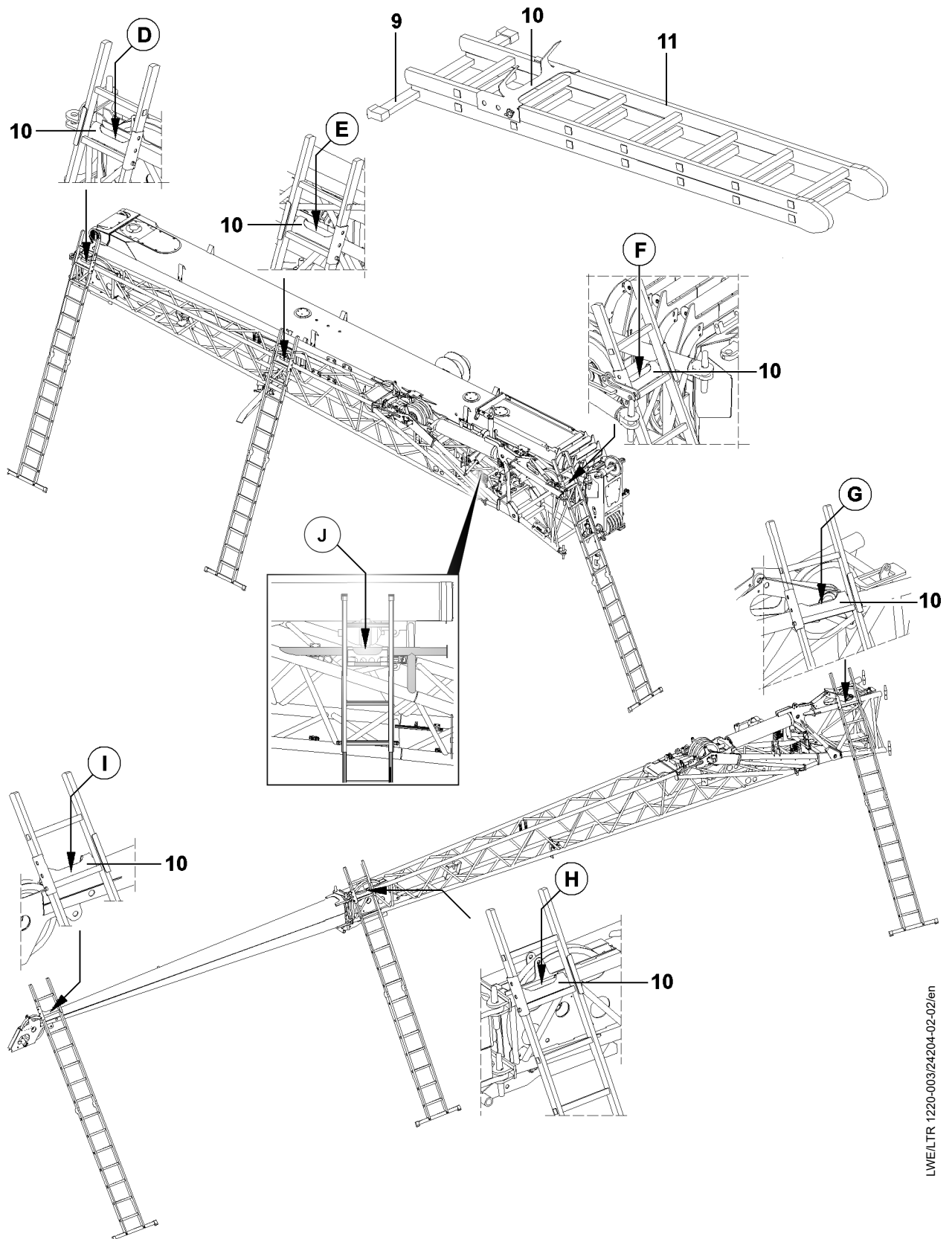
Assembly personnel not secured!

Assembly personnel can fall, death, severe bodily injuries.

- ▶ Secure assembly personnel against falling.
- ▶ Secure assembly personnel with the fall arrest system in position **P10** to prevent falling.

# 6 Folding jib

## 6.1 Securing the ladder



LWE/LTR 1220-003/24204-02-02/en

Fig.154856: Securing the ladder

The illustration is exemplary. The structure of the folding jib depends on the crane type.

For work on the folding jib and the folding jib extension, use the following hook positions for the ladder:

- **D** Hook position
- **E** Hook position
- **F** Hook position
- **G** Hook position
- **H** Hook position
- **I** Hook position
- **J** Hook position



### WARNING

Ladder **not** secured!

Assembly personnel can fall, death, severe bodily injuries.

- ▶ Secure the ladder.
  - ▶ Secure assembly personnel against falling.
- 
- ▶ Hang the ladder **11** with the hook device **10** in the respective hook position and set it up securely.
  - ▶ Secure assembly personnel with the fall arrest system to the hook points to prevent falling.

If no hook points are available:

- ▶ Secure assembly personnel with the fall arrest system to the struts to prevent falling.

## 6.2 Folding jib hook points

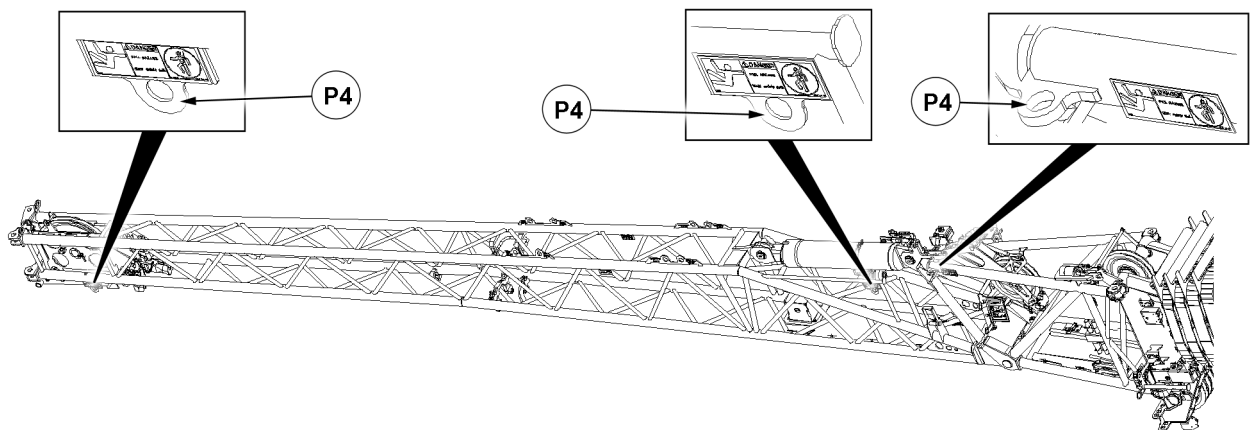


Fig.148461: Folding jib hook points



### WARNING

Assembly personnel **not** secured!

Assembly personnel can fall, death, severe bodily injuries.

- ▶ Secure assembly personnel against falling.
- 
- ▶ Secure assembly personnel with the fall arrest system on the respective hook point **P4** to prevent falling.
- or**

If no hook points are available:

- ▶ Secure assembly personnel to the struts to prevent falling.

## 7 Crane chassis



### WARNING

Missing or incorrectly assembled fall protection equipment!  
Assembly personnel can fall, death, severe bodily injuries.

- ▶ Make sure that all fall protection equipment, such as stairs, platforms, catwalks, ladders and railings have been correctly assembled and secured on the crane chassis.

### 7.1 Assembling the stairs

The stairs **1** are transported together with the crawler carriers.

Depending on the track width of the crawler travel gear, the four stairs **1** must be assembled on the crawler carrier, central ballast or the hydraulic auxiliary support. Adjusting the track width, see chapter 4.03.50.

Make sure that the following prerequisite is met:

- The engine is turned off.

#### 7.1.1 Detaching the stairs

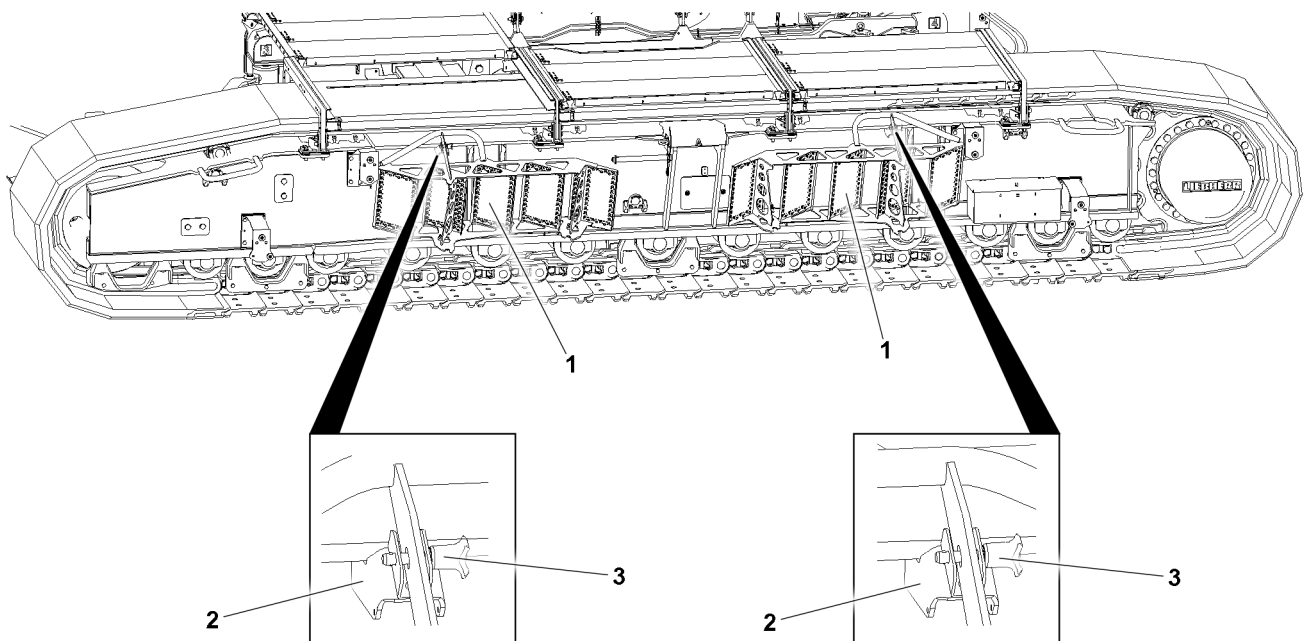


Fig.158665: Assembling the stairs

- ▶ Release and unpin the respective pins **3** on the retainer **2** on the crawler travel gear and remove the respective stairs **1**.

### 7.1.2 Assembling the stairs with a small track width

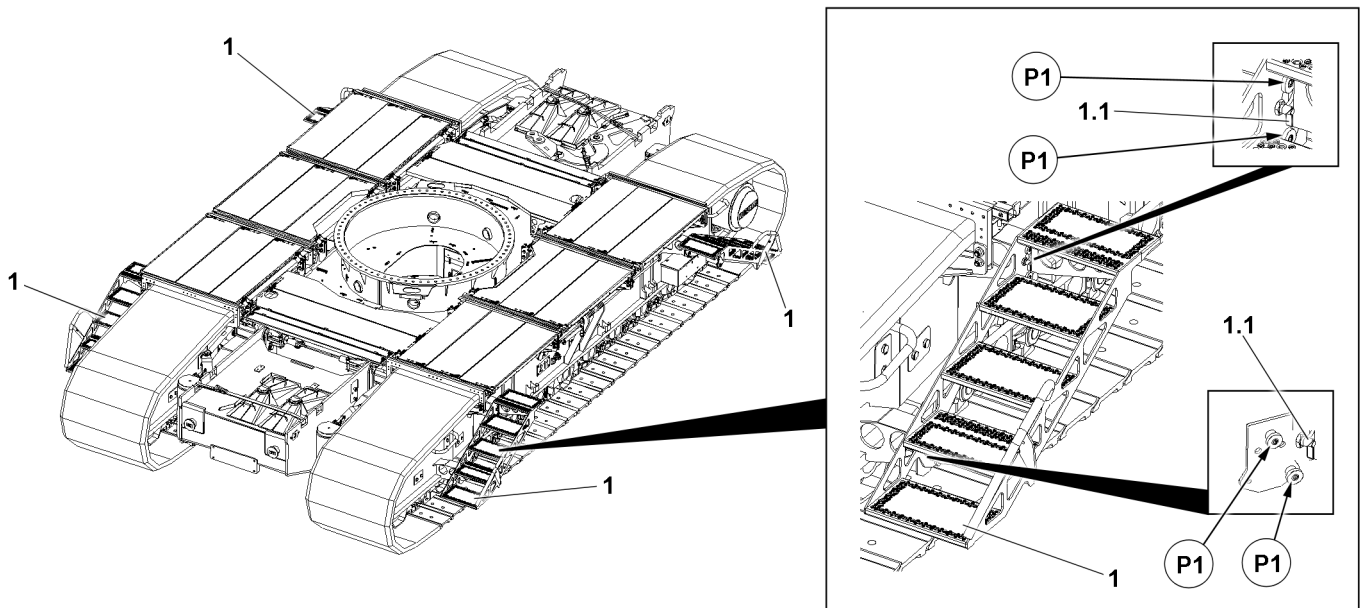


Fig.158663: Small track width with stairs 1

- ▶ Assemble all four stairs 1 on the crawler carrier.
- ▶ Connect the respective stairs 1 in the positions P1 to the respective crawler carrier in the operating position.
- ▶ Secure the respective stairs 1: Lock both latches 1.1.

### 7.1.3 Assembling the stairs with a medium track width

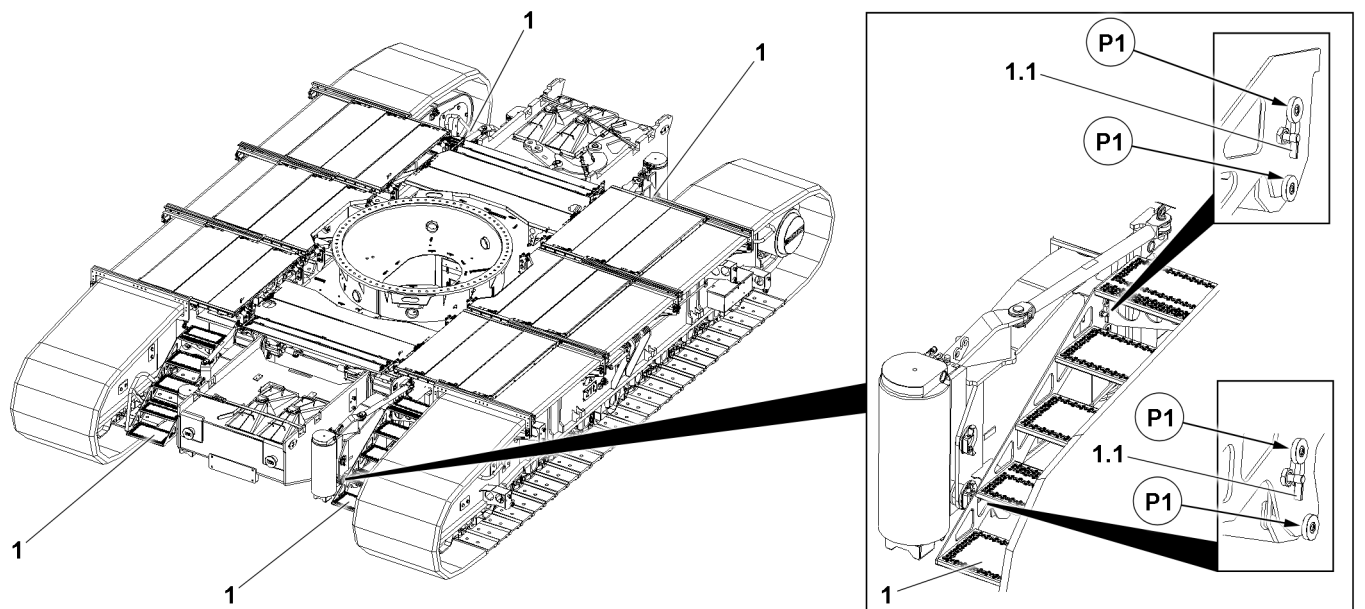


Fig.158662: Medium track width with stairs 1

- ▶ Assemble all four stairs 1 on the auxiliary supports.
- ▶ Connect the respective stairs 1 in the positions P1 to the respective auxiliary supports in the operating position.
- ▶ Secure the respective stairs 1: Lock both latches 1.1.

### 7.1.4 Assembling the stairs with a wide track width

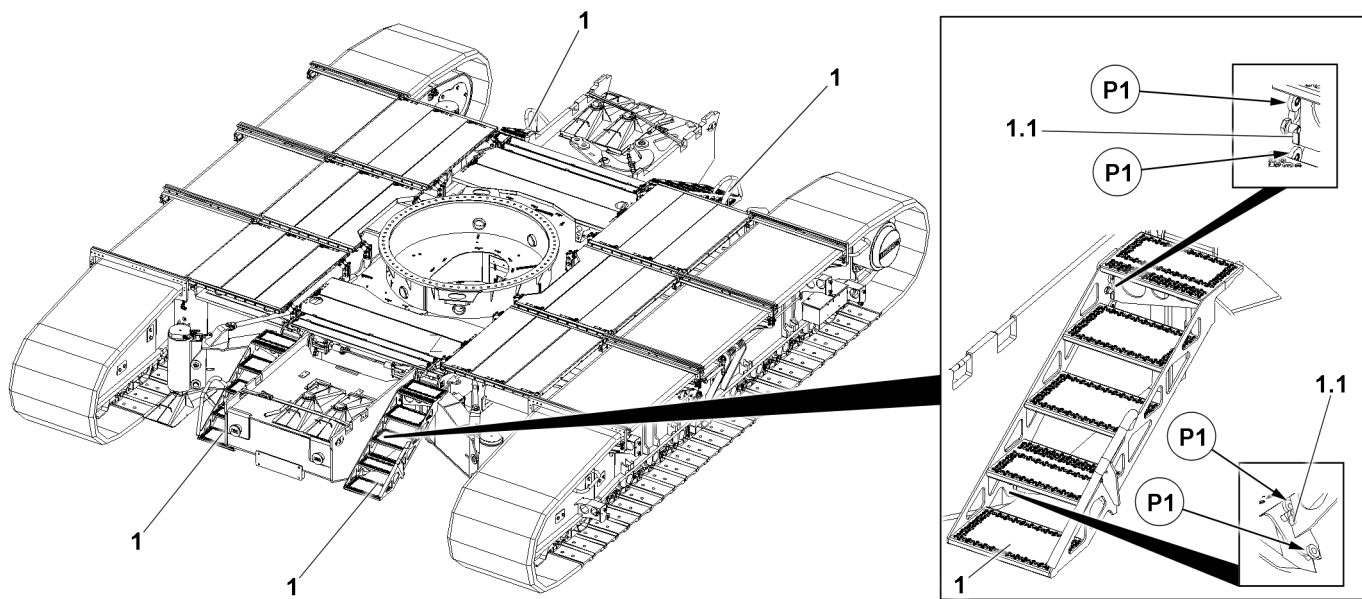


Fig.158661: Wide track width and supported with stairs 1

- ▶ Assemble all four stairs 1 on the central ballasts.
- ▶ Connect the respective stairs 1 in the positions P1 to the respective central ballast in the operating position.
- ▶ Secure the respective stairs 1: Lock both latches 1.1.

## 7.2 Assembling the sliding platforms



### WARNING

Missing or incorrectly assembled fall protection equipment!  
Assembly personnel can fall, death, severe bodily injuries.

- ▶ Make sure that all fall protection equipment, such as stairs, platforms, catwalks, ladders and railings have been correctly assembled and secured on the crane chassis.



### WARNING

Sliding platform overloaded!

The sliding platforms 4 can break.

Assembly personnel can fall, death, severe bodily injuries.

- ▶ Do not load the sliding platform 4 with a weight of **more** than 0.3 t.



### WARNING

Danger of crushing!

Fingers and hands can be crushed by moving parts.

- ▶ The sliding platforms 4 may only be assembled with a „wide track width and supported“ from the ground in the operating position or disassembled in the transport position

Make sure that the following prerequisite is met:

- The crawler travel gear is supported and extended to the wide track width.
- The engine is turned off.

### 7.2.1 Assembling the sliding platform in the operating position

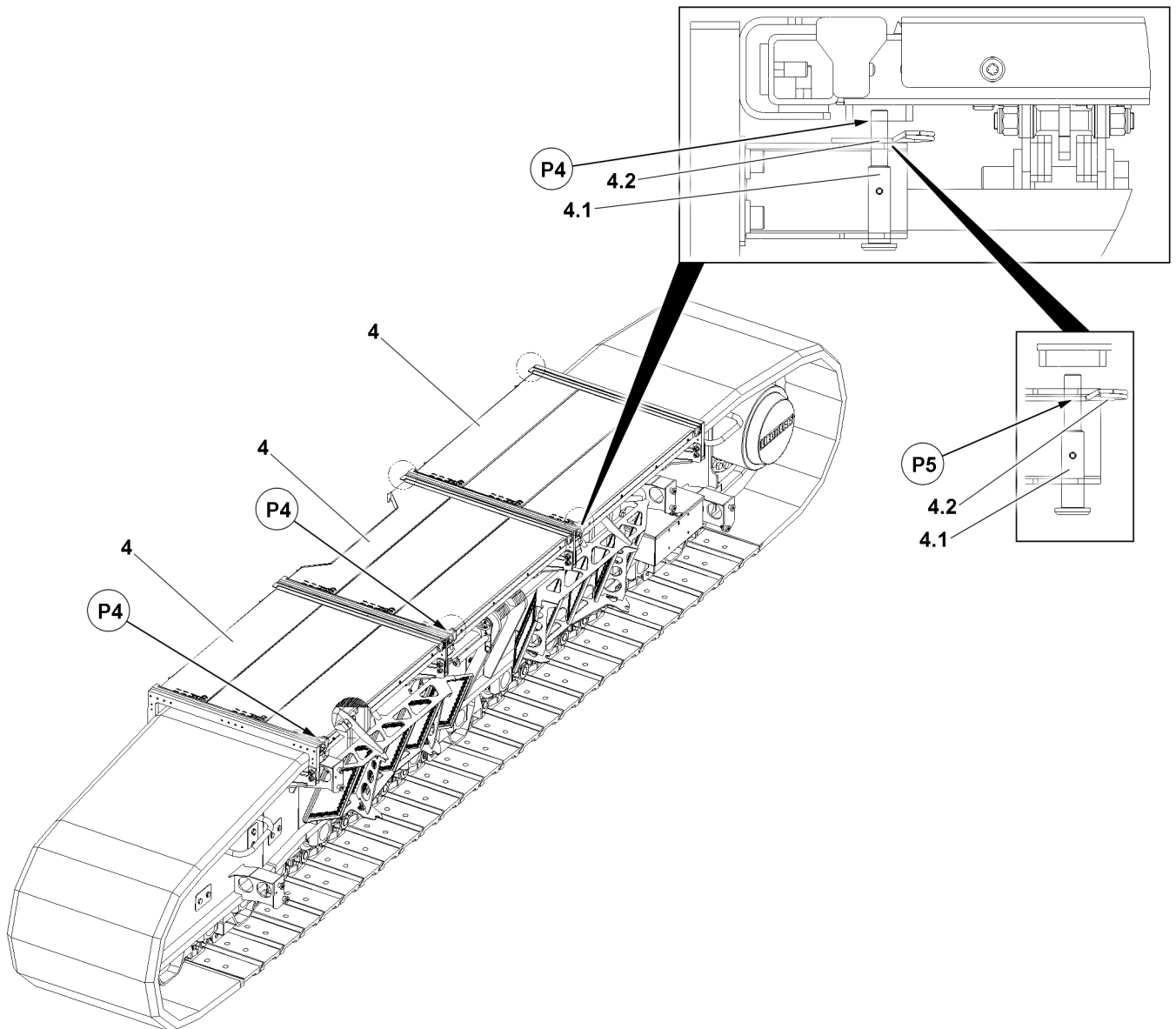


Fig.158671: Assembling the sliding platform in the operating position

The sliding platforms 4 are transported together with the crawler carriers.



#### WARNING

Moving parts!

Fingers and hands can be crushed.

Danger of falling due to low passage heights.

▶ When pushing the sliding platform 4 in or out, do not crush your fingers or hands.

▶ Release and unpin the outer 4.1 „pin“ in positions P4 on the respective crawler carrier.

#### Result:

– The respective pin 4.1 falls down into the stop position P5.

▶ Secure the respective pin 4.1 in the stop position P5 „at the bottom“ with the safety spring 4.2.

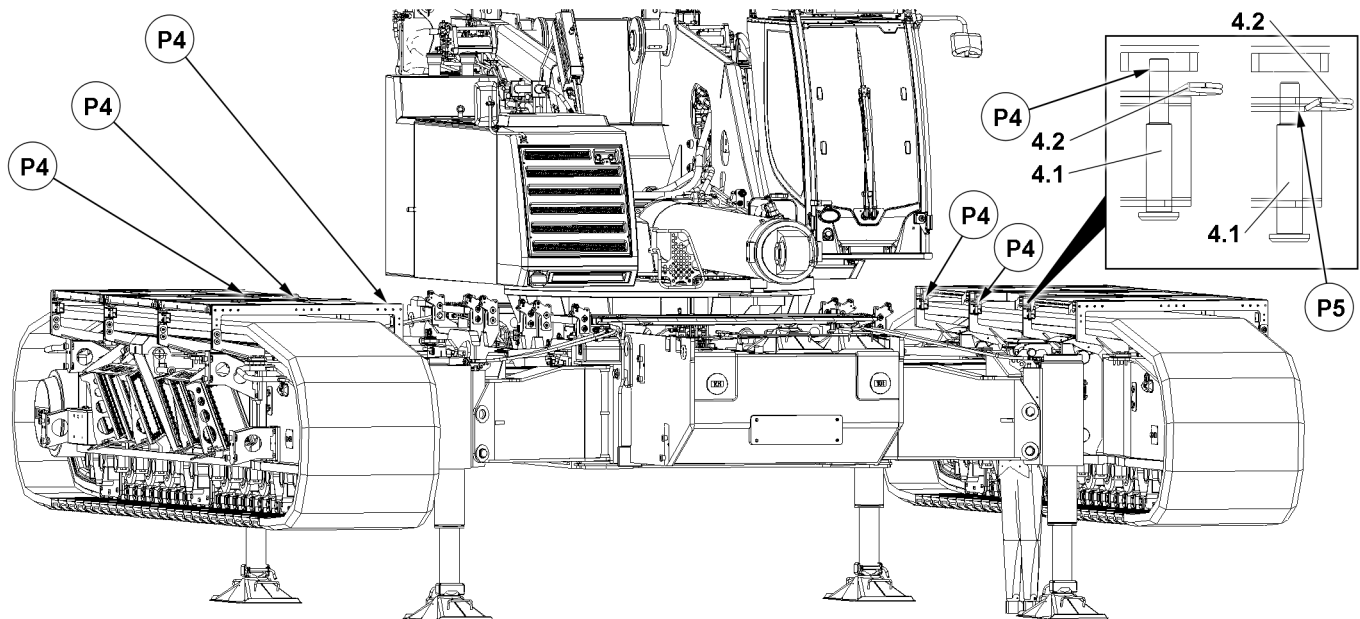


Fig.158670: Assembling the sliding platforms

- Release and unpin the inner 4.1 „pins“ in positions P4 on the respective crawler carrier.

**Result:**

- The respective pin 4.1 falls down into the stop position P5.
- Secure the respective pin 4.1 in the stop position P5 „at the bottom“ with the safety spring 4.2.

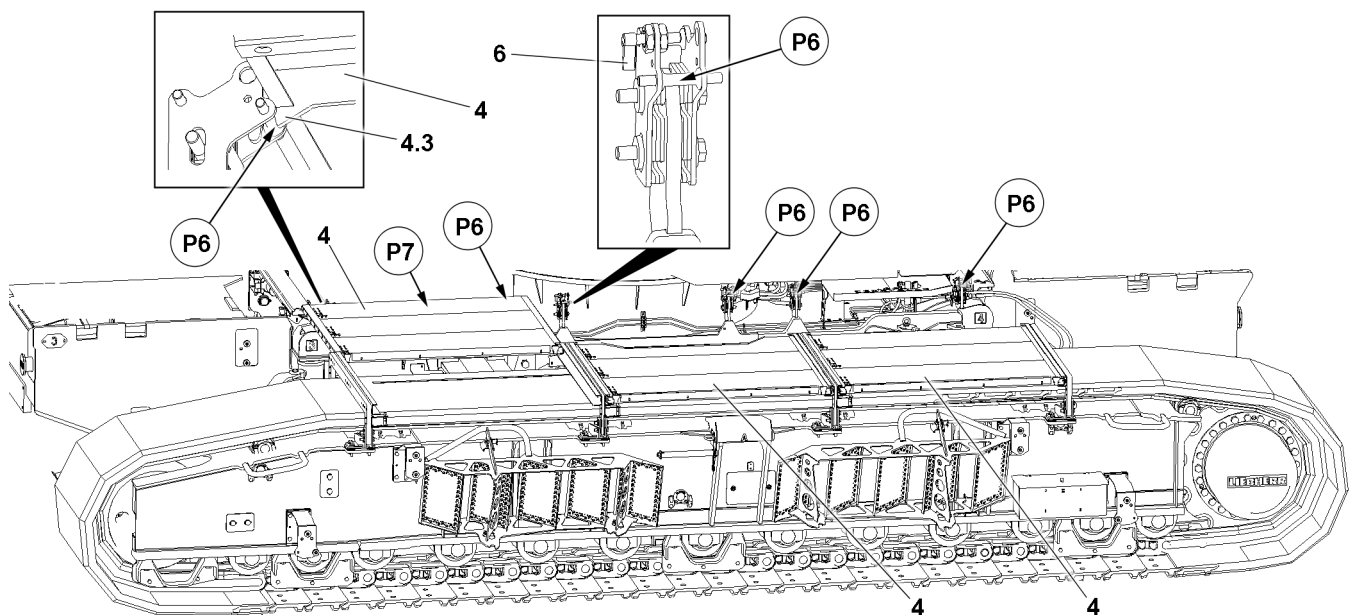


Fig.158674

- Grip the respective sliding platform 4 in position P7 and push out in the operating position to the crawler center section.
- Connect the respective sliding platform 4 in the respective positions P6 using both hooks 4.3.
- Secure the sliding platforms 4: Lock the respective latch 6 in the respective position P6.



## 7.2 Folding the front and rear cross-platforms

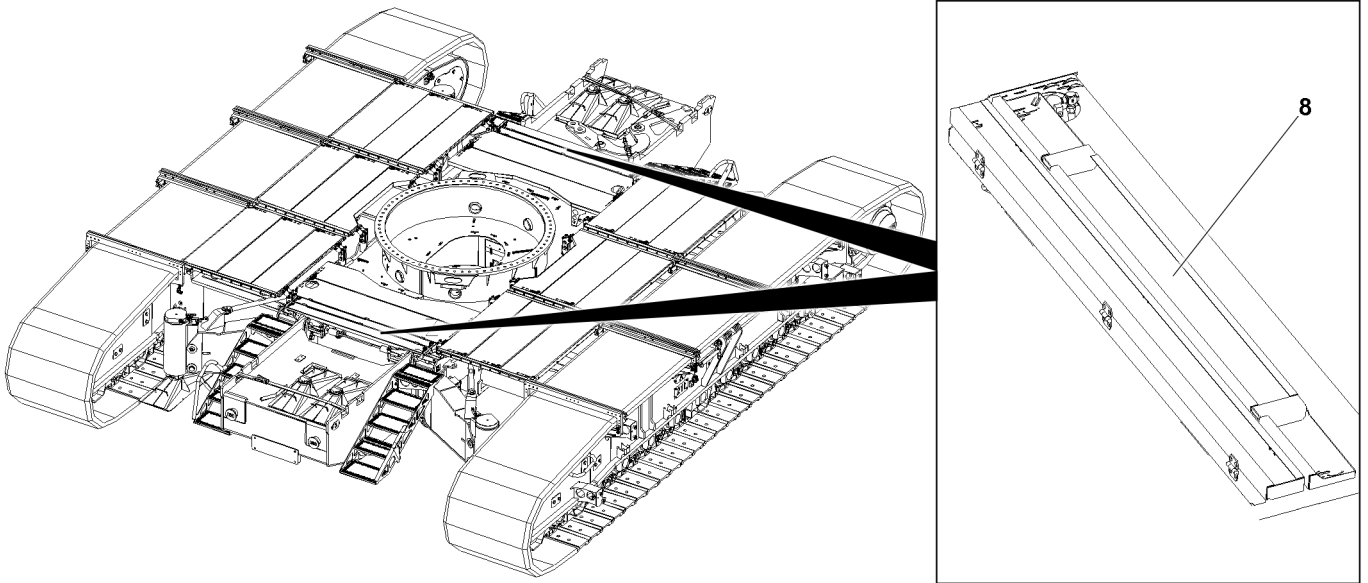


Fig.158675: Cross platforms

For the assembly and disassembly of the central ballast and maintenance work on the chassis, the cross platforms **8** can be folded back. The cross platforms **8** are not locked.



### WARNING

Moving parts!

Fingers and hands can be crushed.

- ▶ When folding the cross platform **8**, do not crush your fingers or hands.
- ▶ Do not reach into the hinge area of the cross platform **8**.

- ▶ If necessary: Fold back the cross-platforms **8**.

## 7.3 Disassembling the sliding platforms



### WARNING

Danger of crushing!

Fingers and hands can be crushed by moving parts.

- ▶ The sliding platforms **4** may only be assembled with a „wide track width and supported“ from the ground in the operating position or disassembled in the transport position

Make sure that the following prerequisite is met:

- The crawler travel gear is supported and extended to the wide track width.
- The engine is turned off.

### 7.3.1 Assembling the swing platform in the transport position

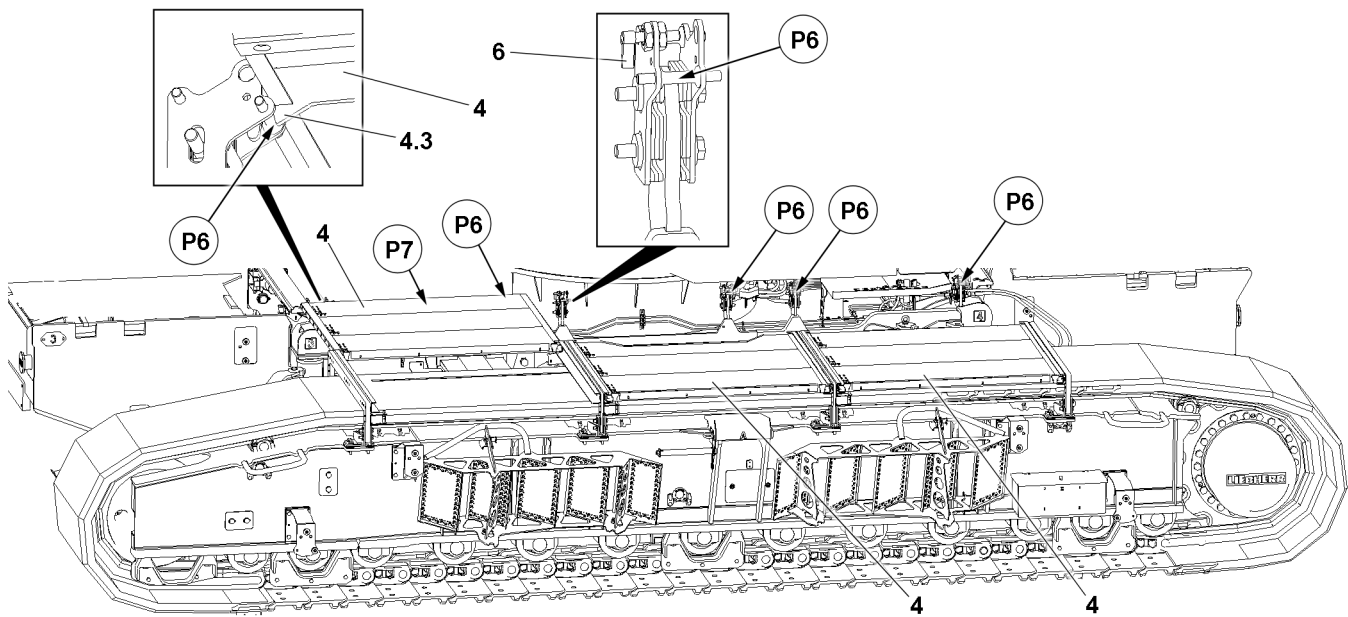


Fig.158674



#### WARNING

Moving parts!

Fingers and hands can be crushed.

Danger of falling due to low passage heights.

► When pushing the sliding platform 4 in or out, do not crush your fingers or hands.

- Release the sliding platforms 4: Unlock the respective latch 6 in the respective position P6.
- Disconnect the respective sliding platform 4 in the respective positions P6 using both hooks 4.3.
- Grip the respective sliding platform 4 in position P7 and push it in to the crawler carrier in the transport position until it can be pinned in the position P4 with the pins 4.1.

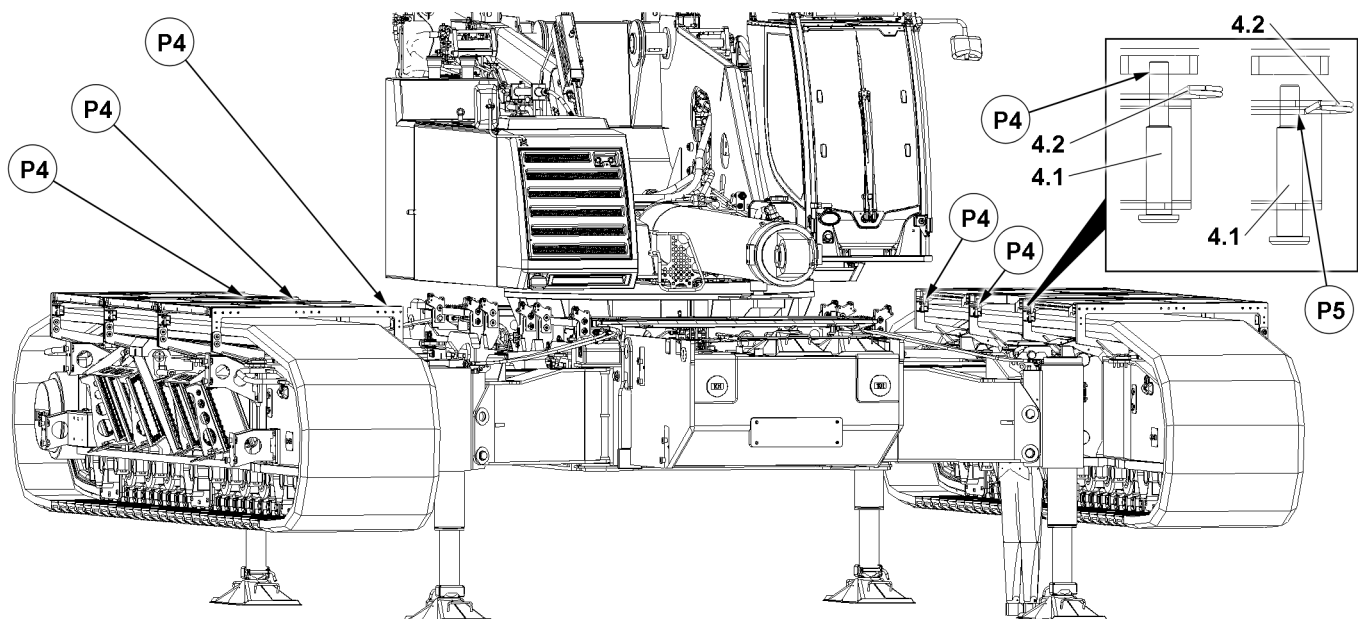
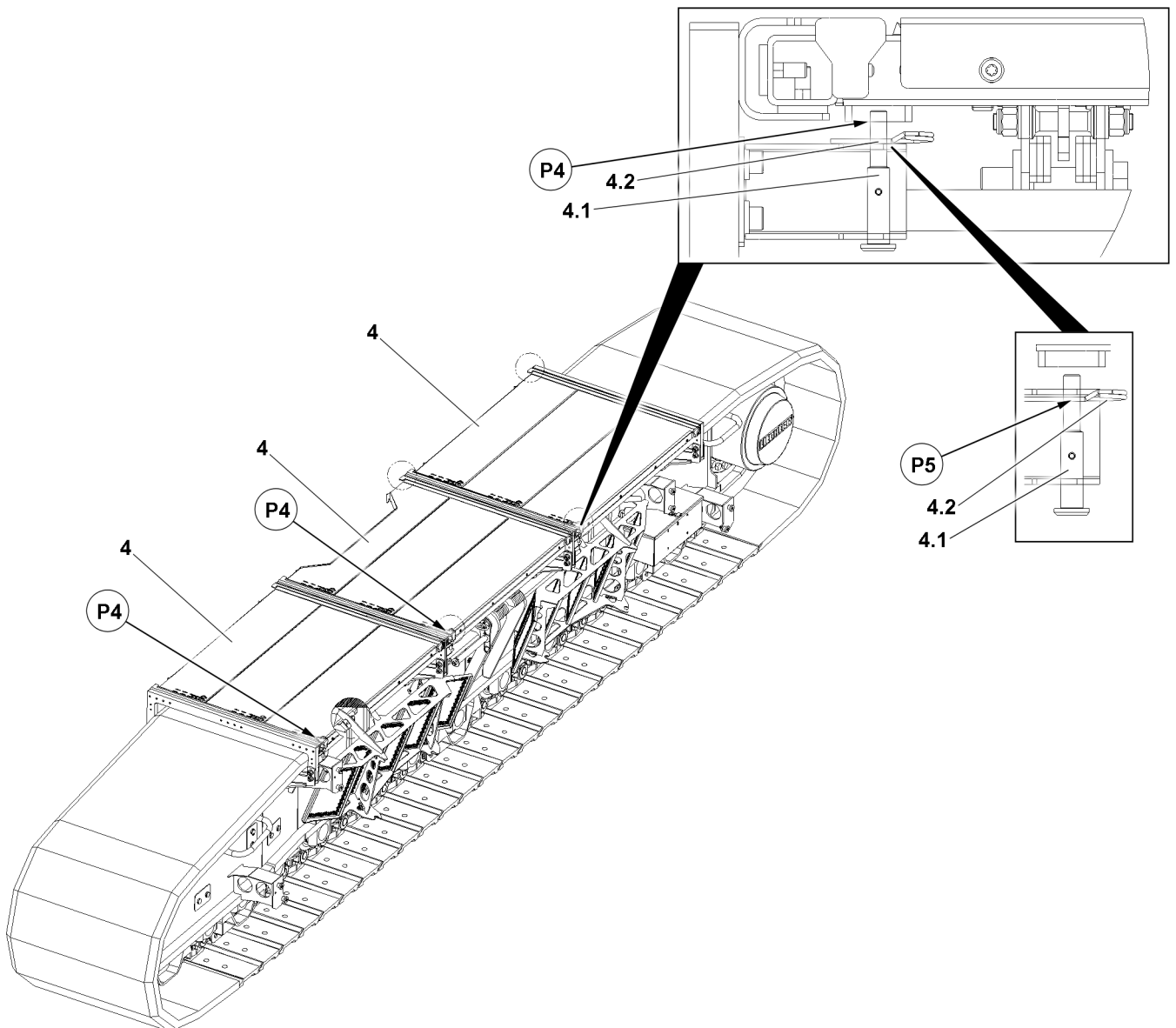


Fig.158670: Disassembling the sliding platforms

- In the stop position P5 „at the bottom“, remove the spring retainer 4.2 from the pin 4.1 and insert the respective pin 4.1 toward the top in position P4 and secure with the spring retainer 4.2.

- ▶ Pin and secure all inner 4.1 „pins“ in the positions **P4** on the respective crawler carrier with the sliding platforms 4.



*Fig.158671: Assembling the swing platform in the transport position*

- ▶ Pin and secure all outer 4.1 „pins“ in the positions **P4** on the respective crawler carrier with the sliding platforms 4 and with spring retainers 4.2.

## 7.4 Disassembling the stairs

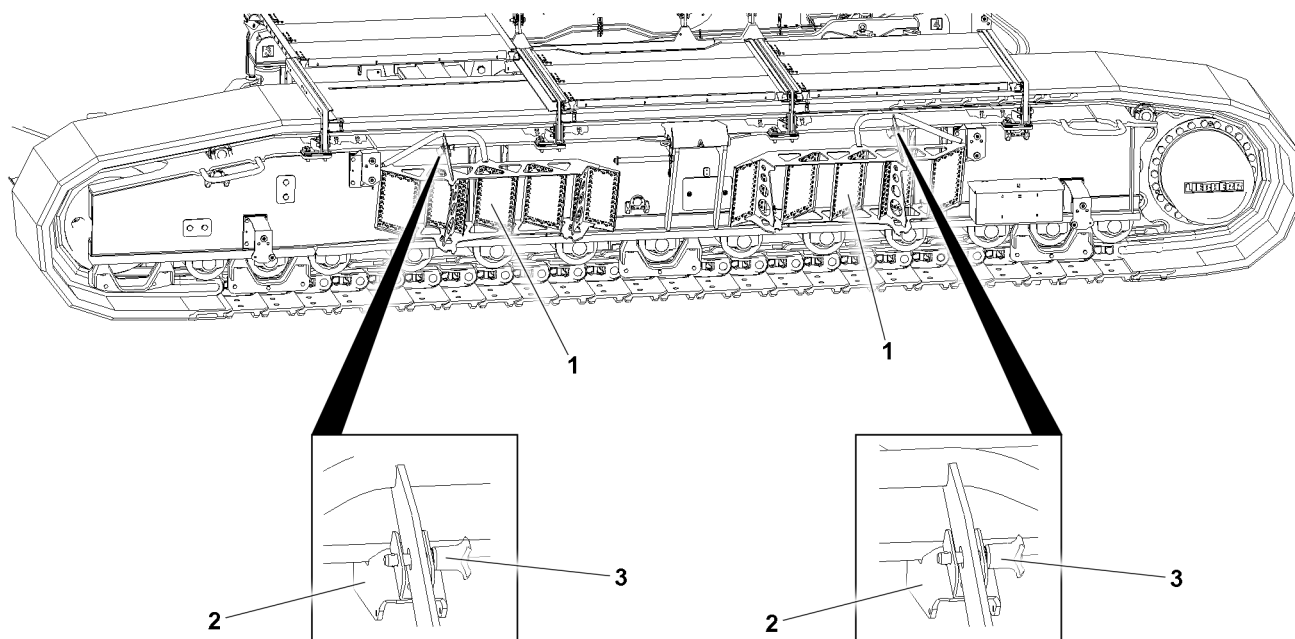


Fig.158665: Disassembling the stairs

Make sure that the following prerequisite is met:

- The engine is turned off.
- ▶ Disconnect the respective stairs **1** assembled on the crawler travel gear from the corresponding positions, see section „Assembling the stairs“.
- ▶ Insert the respective stairs **1** in the respective crawler carrier in the transport position in the lower bracket and secure the respective stairs **1** at the top with the pins **3** to the retainer **2**.

## 8 Crane superstructure

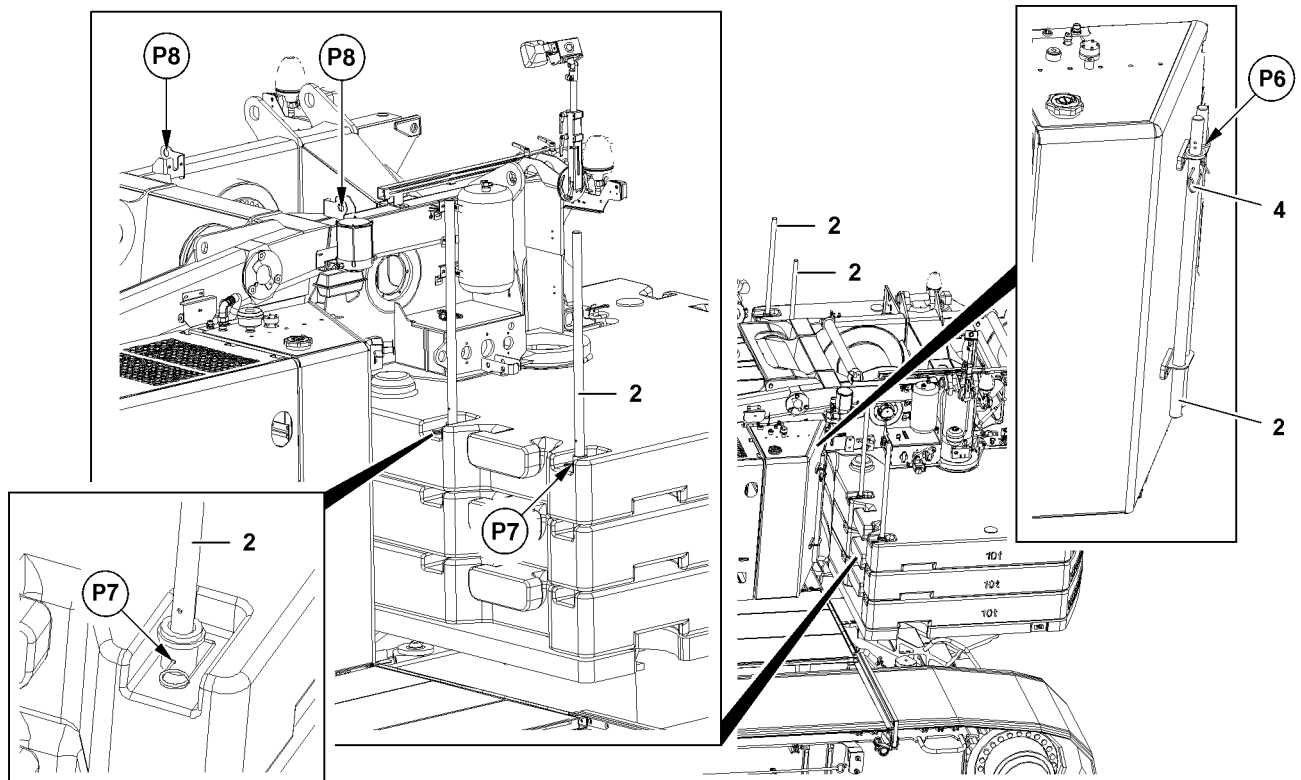


Fig.123719: Turntable

Make sure that the following prerequisite is met:

- The chassis platform is installed.

### 8.1 Assembling the retaining pipes in the working position

- ▶ Disassemble the retaining pipes 2 in the transport position P6.
- ▶ Assemble the retaining pipes 2 in the working position P7 and secure with the spring retainer 4.

### 8.2 Assembling the retaining pipes in the transport position

- ▶ Disassemble the retaining pipes 2 and assemble them in the transport position P6.
- ▶ Secure the retaining pipes 2 in the transport position P6 with the spring retainer 4.

### 8.3 Hook points



#### WARNING

Assembly personnel not secured!  
 Assembly personnel can fall, death, severe bodily injuries.

- ▶ Secure assembly personnel against falling.
- ▶ Secure assembly personnel with the fall arrest system to the hook point P6 or the hook points P8 to prevent falling.

## 9 Counterweight frame

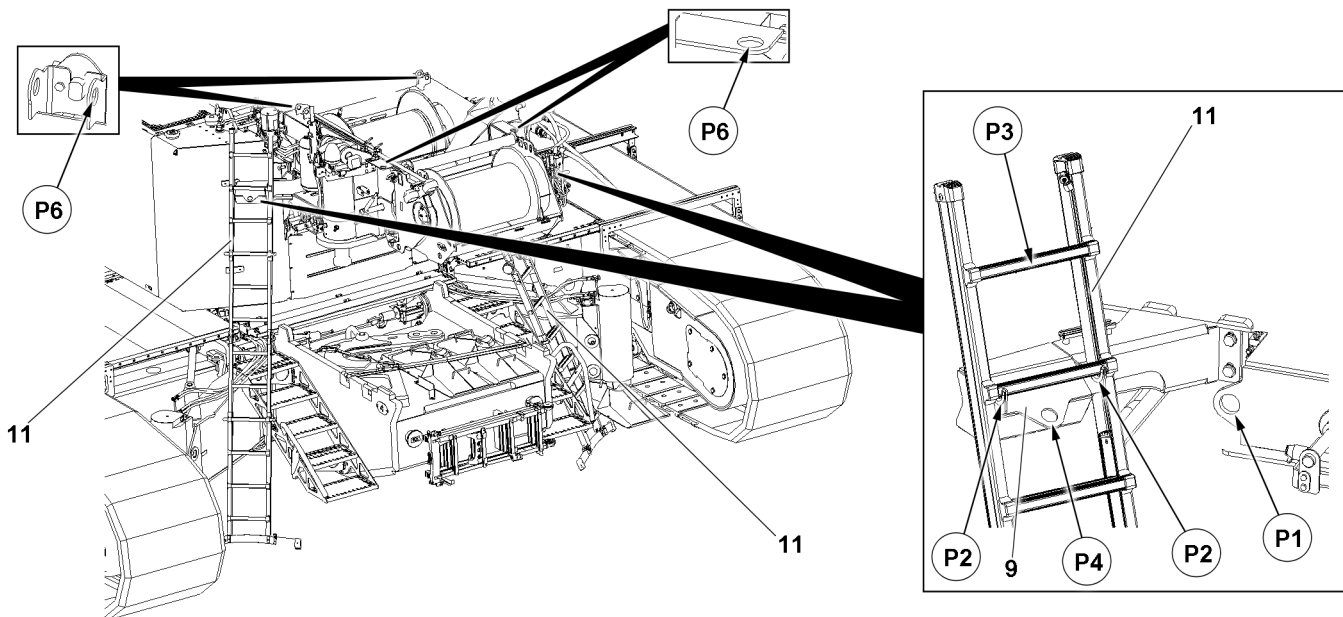


Fig.158679: Counterweight frame

### 9.1 Securing the ladder



#### WARNING

Ladder **not** secured!

If the following notes are not observed, personnel can fall down and be killed or severely injured!

- ▶ Set the ladder **11** up safely.
  - ▶ Attach the ladder **11** in the ladder retainer **9** in positions **P2** such that at least one ladder rung protrudes, see position **P3**.
- 
- ▶ Set up the ladder **11** on the left or right side of the turntable.

### 9.2 Hook points



#### WARNING

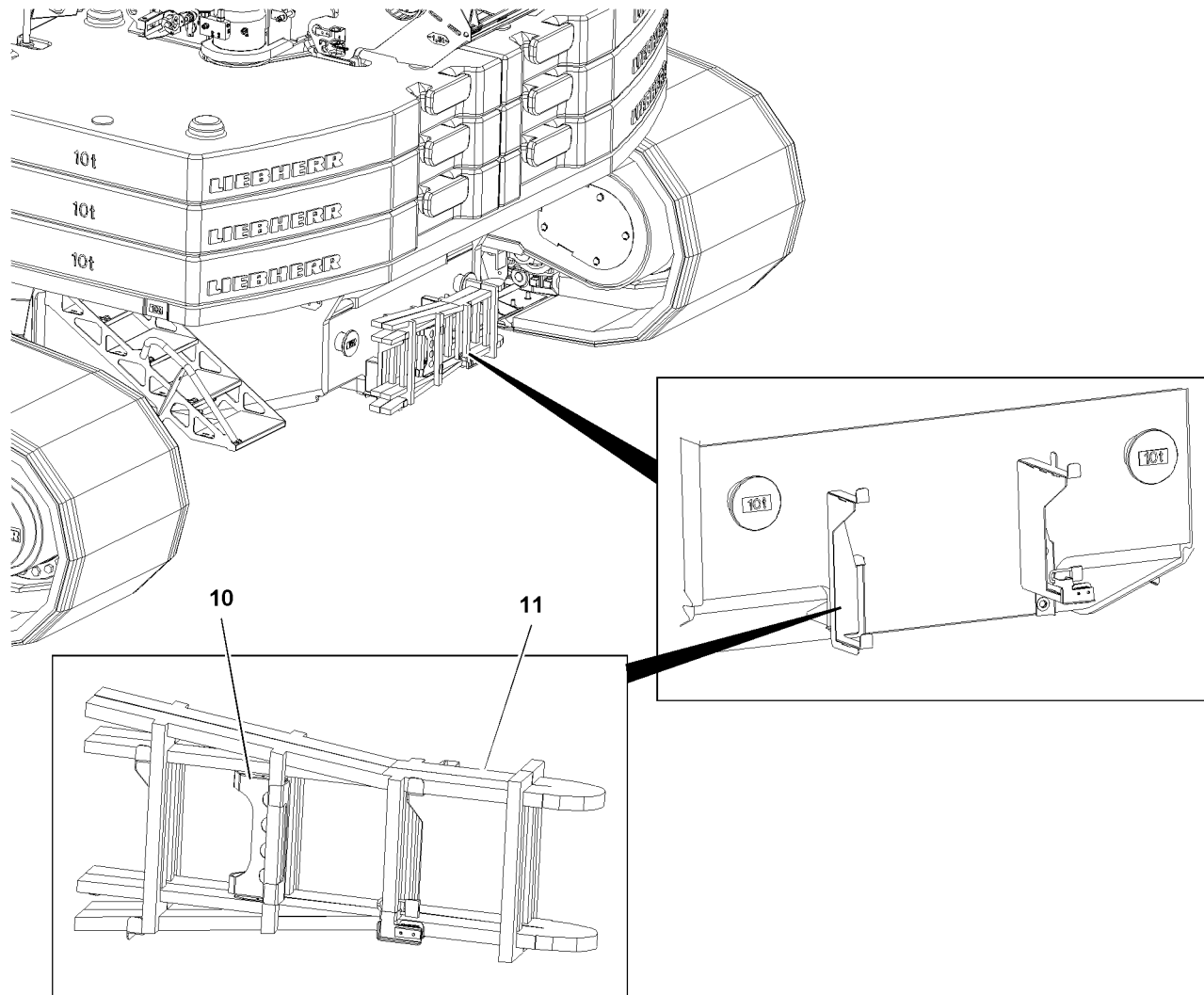
Assembly personnel not secured!

Assembly personnel can fall, death, severe bodily injuries.

- ▶ Secure assembly personnel against falling.
- 
- ▶ Secure assembly personnel with a fall arrest system to the respective hook point **P1**, hook point **P4** or hook point **P6** to prevent falling.

## 10 Transporting the ladder

### 10.1 Securing the ladder in the transport position



*Fig.149050: Securing the ladder in the transport position*

The ladder **11** must be safely installed for transport on the rear of the vehicle.

- ▶ Assemble the hook device **10** on the ladder **11** in such a way that the hooks of the hook device do not protrude past the dimensions of the ladder.
- ▶ Assemble and secure the ladder **11** with the hook device **10** in the transport position on the rear of the vehicle.
- ▶ Before starting to travel, check if the ladder **11** is properly assembled and secured.

---

Empty page!

LWE/LTR 1220-003/24204-02-02/en



## 2.07 Accesses to the crane

1	Safety	2
2	Ascending and descending the crane chassis	3
3	Entering and exiting the crane cab	4
4	Ascending and descending the crane superstructure	5
5	Walking surfaces and stepping surfaces	7

# 1 Safety

Before accessing the crane, observe the safety instructions.

- General safety information: See chapter 2.04.
- Information regarding personal protective equipment: See chapter 2.04.
- Information regarding the use of ladders: See chapter 2.04.10.
- Information regarding available hook points: See chapter 2.06.



---

## WARNING

Slippery surfaces, lack of stability!

Personnel can fall down. Death, severe bodily injuries.

- ▶ Keep ladders, walking surfaces and stepping surfaces free of objects and obstacles.
- ▶ Only step on ladders, walking surfaces and stepping surfaces with sufficiently clear height.
- ▶ Only step on ladders, walking surfaces and stepping surfaces with clean shoes.
- ▶ Keep ladders, walking surfaces and stepping surfaces free of heavy dirt, snow and ice.
- ▶ Stepping on ladders, walking surfaces and stepping surfaces by persons, including tools and equipment, weighing more than 150 kg is prohibited.
- ▶ Do **not** step on damaged ladders, walking surfaces and stepping surfaces and replace them immediately.
- ▶ Do **not** trip over attachment parts.
- ▶ Personnel must wear an approved fall arrest system and protective equipment before performing any work on the crane superstructure.

When fall protection equipment is **not** in the assembly / disassembly position or personnel is on **non**-walking surfaces and stepping surfaces:

- ▶ Personnel must hook themselves to the hook points and safety ropes with an approved fall arrest system to prevent falling.

---

## NOTICE

The handles can be ripped off.

- ▶ Do **not** use handles as rigging points.
  - ▶ Subject the handles to no more than maximum 100 kg.
-

## 2 Ascending and descending the crane chassis

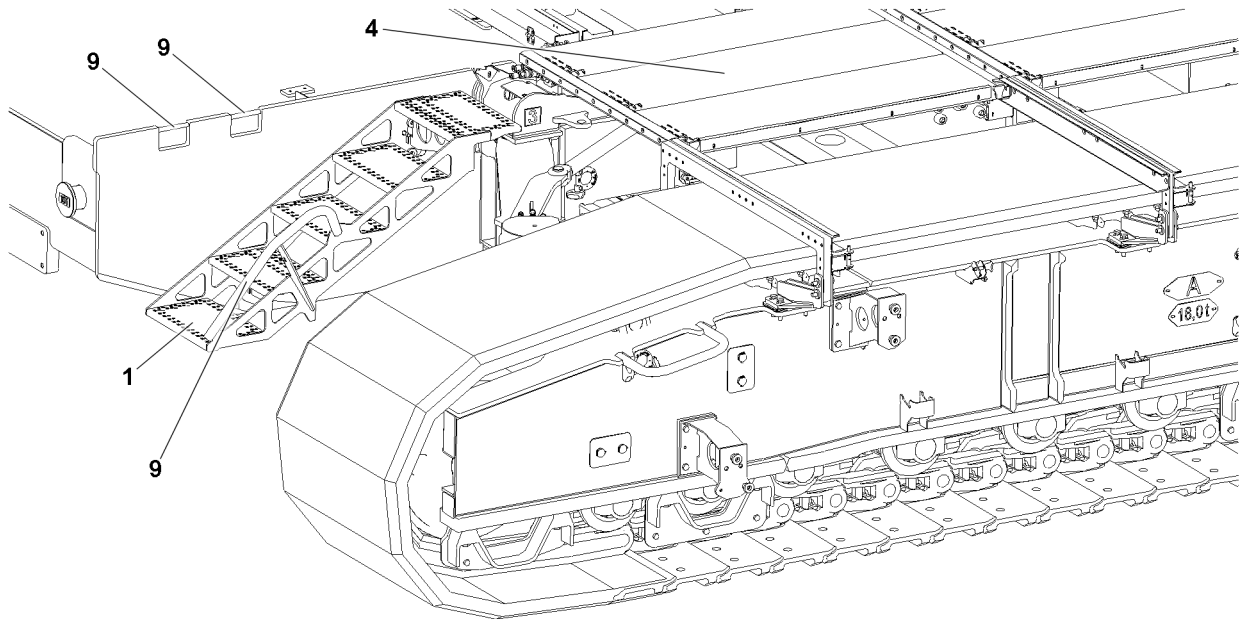


Fig.158676

Make sure that the following prerequisites are met:

- Personnel are wearing the personal protective equipment.
- Crawler carriers are assembled on both sides of the crane.



### WARNING

The access height from the ground is too high!  
Personnel can fall down, injuries.

- ▶ Make sure that the first step of the respective stairs **1** has a maximum access height of 600 mm.
- ▶ Use the stairs **1** for safe ascent and descent.
- ▶ The chassis may only be accessed via the assembled stairs **1** and the assembled sliding platforms **4** in the operating position.
- ▶ Use the handles **9** when on the stairs **1**.

### 2.1 Assembling the stairs and sliding platforms

Assembling and disassembling the stairs **1** and sliding platforms **4**, see chapter 2.06

### 3 Entering and exiting the crane cab

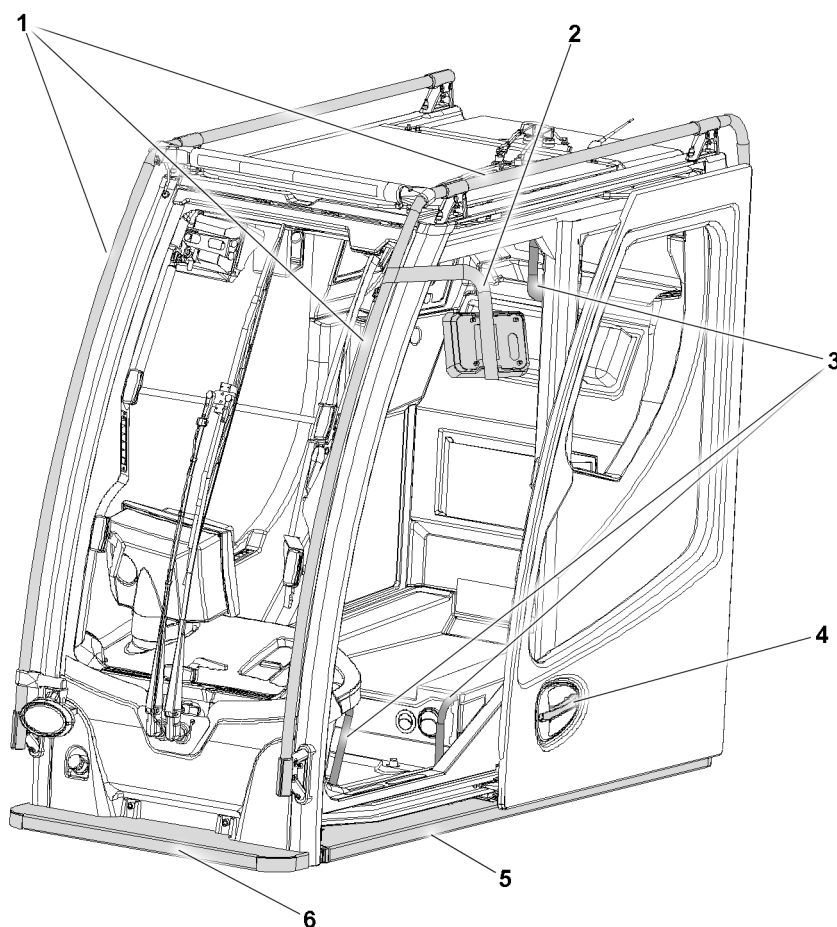


Fig.147865: Entering / exiting the crane cab

- |   |                |   |                        |
|---|----------------|---|------------------------|
| 1 | Handrail       | 4 | Door handle (exterior) |
| 2 | Outside mirror | 5 | Extendable step (side) |
| 3 | Handle         | 6 | Step (front)           |

Make sure that the following prerequisites are met:

- The step **5** is extended.



#### WARNING

Crane superstructure incorrectly aligned!

Personnel can fall when entering the crane cab. Death, severe bodily injuries.

Personnel can fall when exiting the crane cab. Death, severe bodily injuries.

- ▶ Align the crane superstructure is parallel (0° position or 180° position) with the crawler travel gear.



#### WARNING

Persons not secured!

Personnel can fall down. Death, severe bodily injuries.

When opening / closing the door of the crane cab and when entering the crane cab or exiting the crane cab:

- ▶ Adhere to the 3-point support. See chapter 2.04.10.

**WARNING**

Limbs can be trapped or crushed when opening / closing the crane cab door!  
Severe bodily injuries.

- ▶ Open and close the crane cab door carefully.
- ▶ Make sure that no limbs are within the movement range of the door.

**WARNING**

Hitting the outside mirror **2** of the crane cab!  
Head injuries possible when entering / exiting.

Before entering / exiting:

- ▶ Pay attention to the outside mirror.
- ▶ If necessary: Fold the outside mirror **2** to the side.
- ▶ Use personal protective equipment, such as a hard hat.

When opening / closing the door of the crane cab from the outside:

- ▶ Use the door handle **4**.

When opening / closing the door of the crane cab from the inside:

- ▶ Use the inner door handle.

When entering or exiting the crane cab:

- ▶ Use the provided step **5**, step **6**, hand rails **1** and handles **3**.

## 4 Ascending and descending the crane superstructure

Make sure that the following prerequisites are met:

- Personnel are wearing the personal protective equipment.
- The mobile crane is located on a level surface.
- The crane superstructure is aligned parallel (0° position or 180° position) with the crawler travel gear.

## 4.1 Ascending and descending the turntable

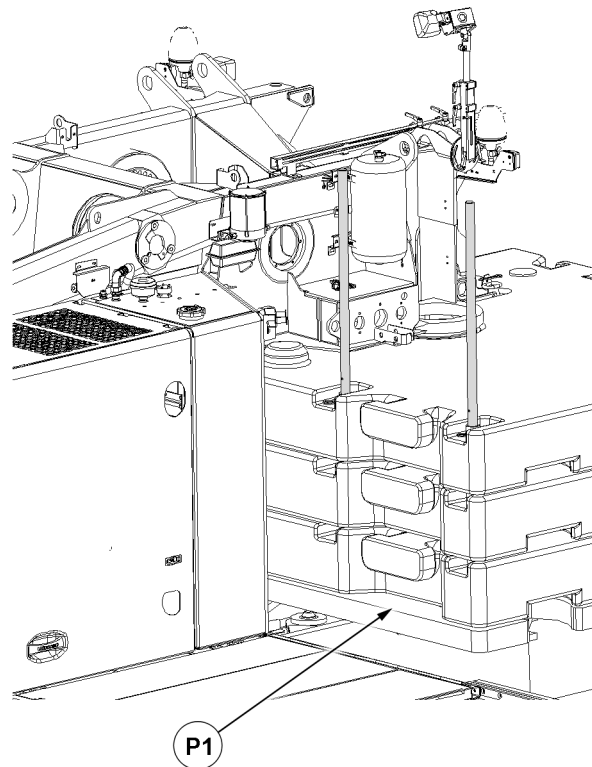


Fig.149036: Crane superstructure

Hook points: See chapter 2.06 „Fall protection equipment on the crane“.

- Ascend and descend in position P1.

## 4.2 Ascending and descending the counterweight frame

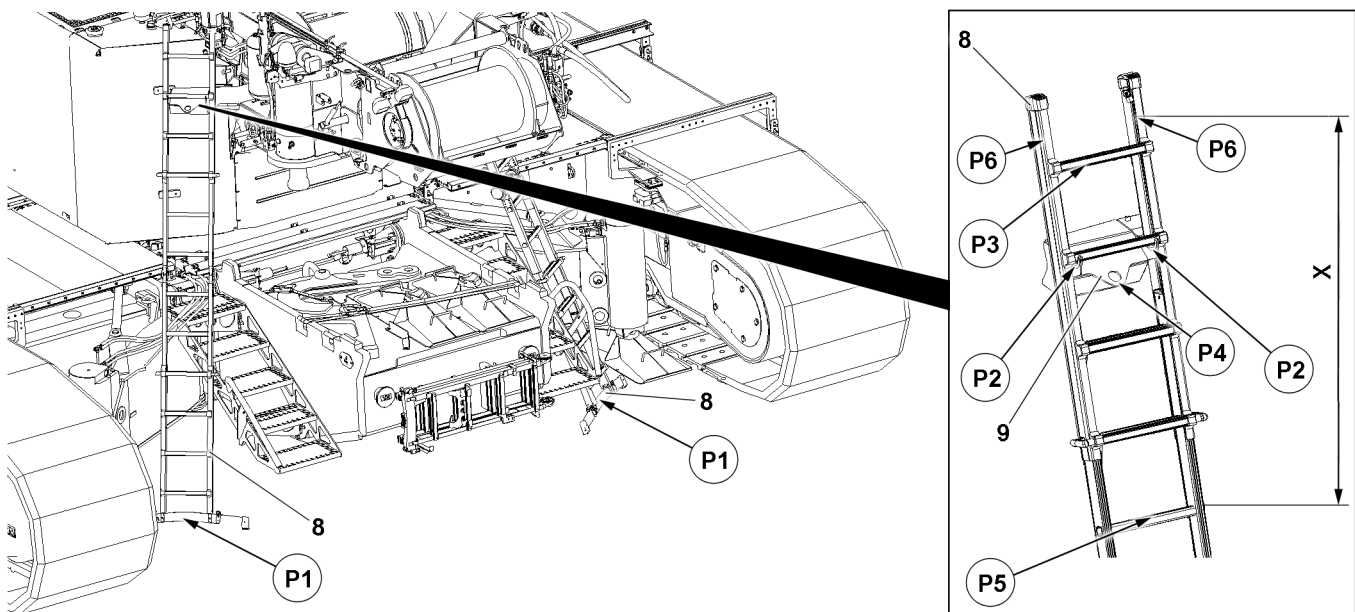


Fig.158678: Counterweight frame

Ladder protection and hook points: See chapter 2.06 „Fall protection equipment on the crane“.

LWE/LTR 1220-003/24204-02-02/en

Make sure that the following prerequisites are met:

- The crawler travel gear is set to the middle track width or the wide track width.
- ▶ Ascend and descend in the respective position **P1** on the left or right side of the turntable using the ladder **8**.



### WARNING

Danger of falling!

If the following notes are not observed, personnel can fall down and be killed or severely injured!

- ▶ Set the ladder **8** up safely.
- ▶ Attach the ladder **8** in the ladder retainer **9** in positions **P2** such that at least one ladder rung protrudes, see position **P3**.
- ▶ Climb up / down with the 3-point support, see chapter 2.04.10.
- ▶ Climb up maximum to the ladder rung in the stand position **P5**.
- ▶ The distance **X** between the stand position **P5** and the handle positions **P6**, must be greater than 1.1 m.
- ▶ Grasp the handle positions **P6**.
- ▶ Secure assembly personnel in position **P4** to prevent them from falling, see chapter 2.06.

## 5 Walking surfaces and stepping surfaces

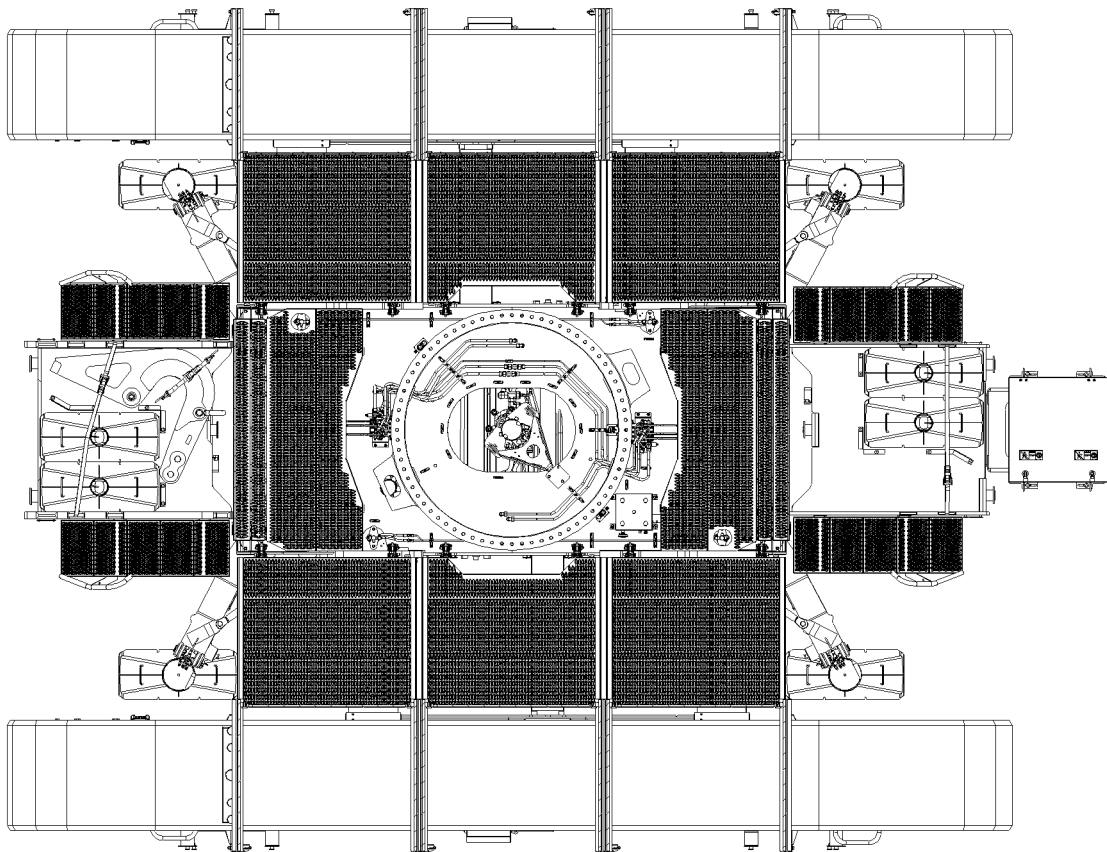


Fig.158664: Walking surfaces and stepping surfaces

**WARNING**

Danger of falling!

If the following notes are not observed, personnel can fall down and be killed or severely injured!

- ▶ Only step on accessible surfaces.
- ▶ Stepping on non-accessible surfaces is prohibited.
- ▶ Do not trip over attachment parts.
- ▶ Move with caution on the crane and equipment.
- ▶ Ladders, walking surfaces and stepping surfaces are free of objects and obstacles.
- ▶ Only step on ladders, walking surfaces and stepping surfaces with sufficiently clear height.
- ▶ Only step on ladders, walking surfaces and stepping surfaces with clean shoes.
- ▶ Keep ladders, walking surfaces and stepping surfaces free of heavy dirt, snow and ice.
- ▶ Do not set down any loads on the walking surfaces and stepping surfaces.
- ▶ With exclusive use by persons, observe the maximum point load of 3000 N on the walking surfaces and stepping surfaces.
- ▶ It is prohibited to step on the roof of the driver's cab.
- ▶ Secure personnel against falling. See chapter 2.06.

## 5.1 Accessible crane chassis walking surfaces and stepping surfaces



Fig.158677: Accessible walking surfaces and stepping surfaces

**Note**

- ▶ The accessible walking surfaces and stepping surfaces are marked with these cross hatches.

## 5.2 Non-accessible surfaces

**WARNING**

Danger of falling!

If surfaces are accessed that are **not** approved for access, personnel can slip and fall down! Personnel can be killed or injured.

When accessing surfaces, which are **not** approved for access, crane components can be damaged.

- ▶ Only step on accessible walking surfaces and stepping surfaces.
- ▶ Accessing surfaces that are **not** approved for access is prohibited.
- ▶ Stepping on surfaces with an incline of more than 5° is prohibited.



Fig.114702: Cross hatch - Non-accessible surfaces

**Note**

- ▶ The walking surfaces and stepping surfaces that are **not** approved for access are marked with these cross hatches.



## 2.08 Working in low temperatures

1	Auxiliary equipment	2
2	Safety	2
3	Environmental / component temperature below -20 °C	3
4	Maintenance	7

# 1 Auxiliary equipment

At ambient temperatures between -20 °C and +50 °C the crane can be operated and stored „without auxiliary equipment for working in low temperatures“.

At ambient temperatures below -20 °C , the crane must be modified and equipped with „auxiliary equipment for working at low temperatures“.



## WARNING

Working at low temperatures without the corresponding auxiliary equipment!  
The crane components can be damaged and fail. The load can rip off.  
Death, severe bodily injuries, property damage.

If the crane is operated at an ambient temperature lower than -20 °C:

- ▶ Make sure that the crane is equipped with the corresponding „auxiliary equipment for working at low temperatures“.
- ▶ Match the operating fluids in time to the ambient temperature.

# 2 Safety

Temperature changes cause technological changes to material properties in the case of steel / cast steel and many other materials.

Crane components made of steel / cast steel are very sensitive to sudden movements, impacts and shocks at decreasing negative temperatures.

This effect increases if the crane compacts are impacted with a load and / or large weights.

To ensure safe operation at low temperatures, the crane structure must be checked at short intervals for cracks.



## Note

- ▶ Observe and adhere to the instructions in chapter 8.01.



## DANGER

The crane can topple over!

Due to decreasing negative temperatures, crane components reach their technological load limits much earlier.

Crane components can break.

The crane can topple over.

Death, severe bodily injuries, property damage.

- ▶ For safe crane operation, the **temperature of the crane components is the deciding factor** and not the ambient temperature.
- ▶ For safe crane operation with component temperatures **down to -40 °C** , the crane must be equipped with „auxiliary equipment for working at low temperatures“.
- ▶ With component temperatures **below -40 °C** , do not operate the crane. In the case of doubt, contact Customer Service at Liebherr-Werk Ehingen GmbH.

## 3 Environmental / component temperature below -20 °C

### 3.1 Winter operation

Low temperatures, as well as snow, frost and ice can impair crane operation and cause problems on the crane.

Freezing takes place often at low temperatures.



#### WARNING

Snow, frost and ice on the accesses!

Personnel can fall from the accesses.

Death, severe bodily injuries, property damage.

- ▶ Remove the snow, frost and ice from all accesses, steps and catwalks.
- ▶ Remove the snow, frost and ice from the crane.

#### NOTICE

Snow, frost and ice on the crane components!

The crane components can be damaged and fail.

Cylinder seals can be destroyed by frozen piston rods.

- ▶ Remove the snow, frost and ice from the piston rods.
- ▶ Remove the snow, frost and ice from all rope pulleys and winches.
- ▶ Remove the snow, frost and ice from the hose drums and limit switches.



#### WARNING

Snow, frost and ice below the support plates or the crawler carriers!

The crane can slide.

Death, severe bodily injuries, property damage.

- ▶ Remove the snow, frost and ice on top and below the support plates.
- ▶ Remove the snow, frost and ice on top and below the crawler carrier.
- ▶ Remove the snow, frost and ice from the roadway.

Prerequisites for crane start up with component temperatures below -20 °C

- The hose drums and cables are easy to move.
- All rope pulleys are easily movable.
- The view from the crane cab is free.
- The mirrors are free of snow, frost and ice.
- Fastening equipment is approved for the ambient temperatures present.
- The load fastening points are approved for the ambient temperatures present.

### 3.2 Preheating time



#### WARNING

Limited crane control during radio operation!

In the case of falling negative temperatures, the LCD displays react increasingly slowly to changes made to images and icons on the displays.

In the case of minus temperatures below -25 °C, changes made to images and icons could be displayed with a considerable delay or not at all.

This can lead to dangerous situations if warnings are displayed with a delay.

Death, severe bodily injuries, property damage.

- ▶ If the component temperature of the radio remote control is below -25 °C: Preheat the radio remote control prior to start up.
- ▶ In the case of increasing sluggishness of the LCD displays during radio operation with temperatures below -25 °C: Warm up or preheat the radio remote control occasionally.

Crane components	Preheating time
Engine preheating up to start at -40 °C component temperature	45 minutes
Preheat the hydraulic system in the crane superstructure and the crane chassis	30 minutes
Preheat the crane cab / driver's cab for start up at the same time up to 5 °C	10 minutes
<b>Total preheating time</b>	<b>75 minutes</b>

- ▶ To ensure safe crane operation: Adhere to the preheating times.

### 3.3 Engine preheating

If the components temperature is lower than -20 °C the chassis engine and / or superstructure engine must be preheated before starting.

Depending on the crane type, a chassis engine and / or a superstructure engine is installed.

Pre-warming the chassis engine is described in chapter 6.01.

Pre-warming the superstructure engine is described in chapter 6.02.

- ▶ Preheat the chassis engine and / or the superstructure engine.
- ▶ Start the chassis engine and / or the superstructure engine.

When the chassis engine and / or the superstructure engine has reached its operating temperature:

- ▶ Turn off engine preheating.

### 3.4 Preheating the hydraulic oil

If the ambient temperature is lower than -20 °C the hydraulic oil must be preheated prior to crane operation.

#### NOTICE

Hydraulic oil **not** preheated!

The hydraulic system can be damaged during crane operation.

- ▶ Before starting crane operation, preheat the hydraulic oil to at least 20 °C.
- ▶ Retract and extend all the hydraulic cylinders in an unloaded state over the entire stroke multiple times.



#### WARNING

Persons in the area of the hoist movement!  
Death, severe bodily injuries, property damage.

- ▶ Observe the area of the hoist movement.
- ▶ Make sure that there are **no** persons in the area of the hoist movement.

#### 3.4.1 Turning the hydraulic oil preheating on

Make sure that the following prerequisites are met:

- The engine is running.
- Hydraulic oil preheating is available.

Hydraulic oil preheating is described in chapter 4.03.

- ▶ Turn the hydraulic oil preheating on.

When the hydraulic oil is preheated:

- ▶ Turn the hydraulic oil preheating off.

#### 3.4.2 Supporting the crane

Supporting the crane vehicle is described in chapter 3.05.

All support plates must be supported with suitable and stable materials.

If moveable support plates are not available, the support plates must be supported **on one side of the crane** with greased polyamide plates.



#### WARNING

No movable support plates or crane **not** supported with greased polyamide plates!

The sliding beams can bend. The support plates can suddenly move to the side.

The load can oscillate.

Death, severe bodily injuries, property damage.

► Use moveable support plates.

If there are no movable support plates available:

► Support the support plates **on one side of the crane** with greased polyamide plates.

If not sure if the crane has been equipped with support cylinders for an operating temperature down to  $-40\text{ }^{\circ}\text{C}$ , contact Customer Service at Liebherr-Werk Ehingen GmbH.

If the crane is **not** equipped with support cylinders for an operating temperature down to  $-40\text{ }^{\circ}\text{C}$ :

► When supporting, extend the support cylinder a maximum of 50 %.

The wheels must not come in to contact with the ground after the crane is supported.

► Support the support plates when necessary.

► Support the crane.

### 3.4.3 Cranes with lattice mast boom

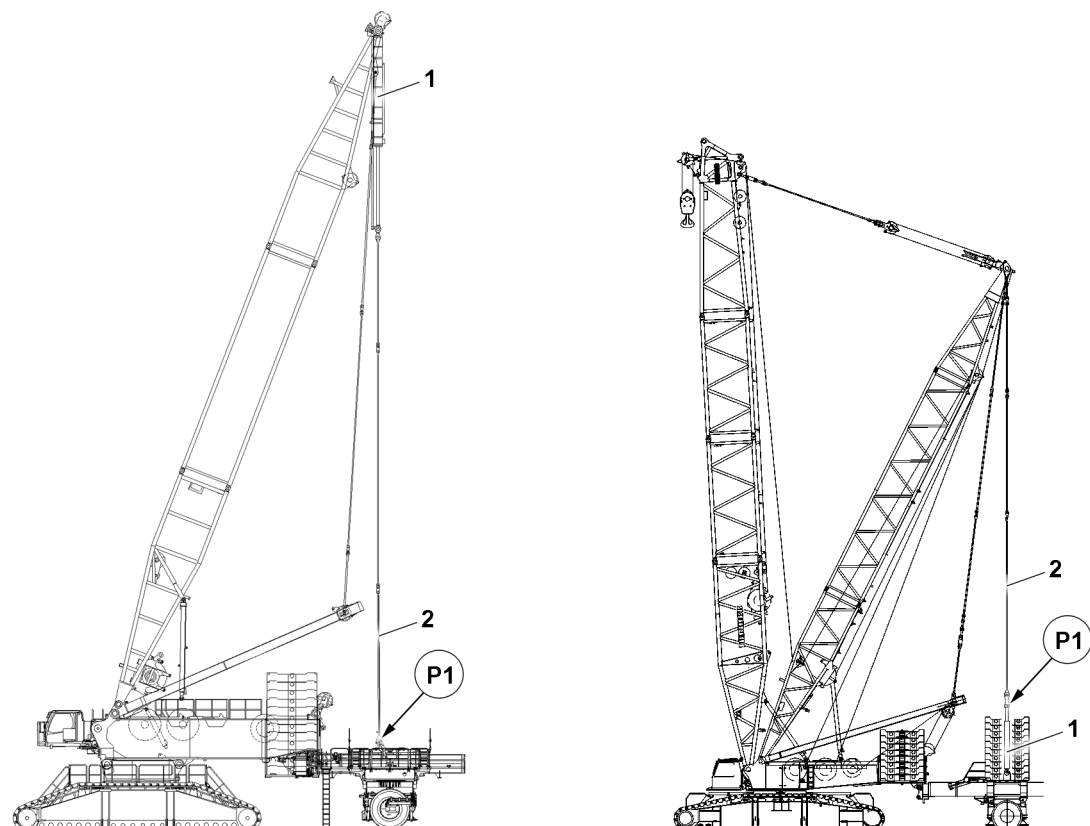


Fig.126875: Removing the guy rods on the derrick ballast

With component temperatures of less than  $-20\text{ }^{\circ}\text{C}$ , the pull cylinders must be preheated by means of retraction and extension. Before the pull cylinders can be preheated, the guy rods **2** must be removed in position **P1** on the derrick ballast.

Disassembly and assembly of the guy rods **2** on the derrick ballast is described in the Crane operating instructions, chapter 5.35 and chapter 5.36.

- ▶ Remove the guy rods **2** at position **P1** on the derrick ballast.

---

#### NOTICE

Danger of collision!

Damage of the guy rods, derrick ballast or other components.

- ▶ When retracting and extending the guy rods, avoid contact with other components.

- ▶ Retract and extend the pull cylinders **1** in an unloaded state over the entire stroke multiple times.

When additional hydraulic cylinders are installed on the crane with lattice mast:

- ▶ Retract and extend the hydraulic cylinders in an unloaded state over the entire stroke multiple times.

### 3.4.4 Cranes with a telescopic boom

Make sure that the following prerequisites are met:

- The crane is supported and horizontally aligned.
- There is no load on the hook.
- ▶ Retract and extend the luffing cylinder in an unloaded state over the entire stroke multiple times.
- ▶ Retract and extend the telescoping cylinder in an unloaded state over the entire stroke multiple times.

## 3.5 Assembling / disassembling the crane components

If the component temperature is lower than  $-20\text{ }^{\circ}\text{C}$ , there is an increased danger that in the case of impact and / or strong component contact that the crane components will be damaged as a result of their changed technological material properties. In particular counterweights and crane components made of cast steel are subject to a greater risk of damage due to impact at component temperatures below  $-20\text{ }^{\circ}\text{C}$ .

---

#### NOTICE

Striking of the crane component during assembly or disassembly!

Crane components can be damaged.

- ▶ Do **not** strike the crane component during assembly and disassembly.
  - ▶ Carry out all work slowly and with utmost caution.
- 

## 3.6 Reducing rope pull

When working with rope / component temperature below  $-20\text{ }^{\circ}\text{C}$ , Liebherr-Werk Ehingen GmbH recommends reducing the rope pull.

The rope pull on the hoist rope can be reduced by increasing the rope reeving.



#### Note

Increase of rope reeving!

Due to the increased rope reeving, the hoist rope length may not be sufficient for lowering the hook block to the ground.

- ▶ Pay attention to rope length.
- 

#### NOTICE

Rope reeving higher than specified in the load chart!

Danger of slack rope formation due to a too low hook block weight. Damage to the hoist rope.

- ▶ Increase the hook block weight accordingly.
  - ▶ Increase the rope reeving specified in the load chart.
  - ▶ If necessary: Increase the hook block weight.
-

### 3.7 Increasing the hook block weight

The calculation of the minimum required hook block weight is described in the load chart.

Rope / component temperature	Increasing the hook block weight
-21 °C to +30 °C	Increase the minimum required hook block weight by 10 %
-31 °C to +40 °C	Increase the minimum required hook block weight by 15 %

- ▶ Increase the required hook block weight depending on the rope or component temperature.
- ▶ Observe and adhere to the „hook block weight“ charts.



#### Note

- ▶ Observe and comply with the permissible hook block weights for erection and take-down of the boom systems in the erection and take down charts.

### 3.8 Crane operation

In case of an ambient / component temperature below -20 °C , crane operation requires an anticipatory working procedure adapted to the weather conditions.



#### WARNING

Sudden acceleration and deceleration of crane movements!

Crane components can break.

Death, severe bodily injuries, property damage.

- ▶ Accelerate and decelerate crane movements sensitively and with utmost caution.

#### 3.8.1 Reducing the maximum load

##### Cranes with lattice mast boom

In the case of cranes with pull cylinders in the derrick ballast guying, if the component temperature is between -30 °C and -40 °C the maximum derrick ballast must be reduced. The maximum load is also reduced due to the reduction of the maximum derrick ballast.



#### Note

- ▶ Take load reduction into account during job planning.

- ▶ Reduce the maximum derrick ballast by 15 % in case of component temperatures between -30 °C and -40 °C.

##### Cranes with a telescopic boom

Cranes with a telescopic boom: For component temperatures between -30 °C and -40 °C the maximum load must be reduced.

- ▶ Reduce the maximum load by 15 % in the case of component temperatures between -30 °C and -40 °C.

## 4 Maintenance

### 4.1 Load bearing crane structures

Checking the load bearing crane structure is described in Chapter 8.01.

- ▶ The load bearing crane structure must be visually inspected more often at low temperatures.

## 4.2 Rope pulleys and hydraulic cylinders

Checking the rope pulleys and hydraulic cylinders is described in Chapter 8.01.

- ▶ Rope pulleys and hydraulic cylinders must be visually inspected more often at low temperatures.



## 2.25 Crane on floating body

1	Non-destined use	3
2	Destined use	3
3	Floating device	3
4	Operating conditions	3
5	Crane transport on floating devices	4
6	Increased corrosion	5

*Fig.195219*

LWE/LTR 1220-003/24204-02-02/en

# 1 Non-destined use



## WARNING

### Non-destined use!

The boom can break off. The crane can topple over.  
Death, severe injuries, property damage.

- ▶ Only use the crane as intended.
- ▶ Comply with the operating conditions and notes provided in this chapter.

Liebherr mobile cranes and crawler cranes are **not** designed for special requirements according to „EN 13852-2, Cranes - Offshore cranes“ or other offshore specifications and regulations.

For a precise definition of **non**-destined use, see the preface to the crane operating instructions.

# 2 Destined use

Liebherr mobile cranes and crawler cranes are only designed for assembly work and erection work and can only withstand a limited number of load cycles.

Liebherr mobile cranes and crawler cranes are designed for special properties and movements: evenly distributed drive forces, only occasional operation and load conditions according to „EN 13000, Cranes - Mobile cranes“ and comparable international standards.

For a precise definition of destined use, see the preface to the crane operating instructions.

# 3 Floating device

The term floating device includes all floating devices such as barges and ships.

The floating device must fulfil the prerequisites for crane operation.

# 4 Operating conditions

Observe the areas of responsibility:

- The crane contractor and crane operator are responsible for ensuring that the conditions for crane operation at the job site are fulfilled. It is strongly recommended to consult a naval engineer.
- The correct functional, technical and static interaction between the crane and the floating device is the sole responsibility of the crane contractor and the crane operator. This must be clarified and checked before operating the crane on a floating device.

Observe the following to ensure the safe operation of the crane on floating devices:

- Comply with all country-specific, legal specifications and conditions.
- Perform a risk assessment according to the Occupational Safety and Health Act to ensure safe working conditions.
- Outrigger forces or crawler pressures generated by crane operation must be safely supported by the steel construction of the floating device.
- Assemble and operate the crane according to manufacturer specifications.
- Comply with the maximum permissible lateral deflection angle between the hoist rope and the rope pulley. The deflection angle consists of the lateral elastic deformation of the boom system, the inclination of the crane supporting surface and a possible diagonal pull on the hoist rope.

Maximum permissible deflection angle:

- 2.5° with a hoist rope diameter of less than 23 mm
- 5° with a hoist rope diameter of 23 mm or more
- The conditions when working on a floating device must correspond with the conditions on land.

- Lifting and lowering loads in very calm waters and on very calmly moving floating devices correspond to the lifting and lowering a load on land.

#### 4.1 Floating device, supported

Observe the following to ensure the safe operation of the crane on supported floating devices:

- For crawler cranes, observe the maximum permissible ground inclination of the crane of  $\pm 0.3^\circ$ , see the load charts.
- Supported cranes must be horizontally aligned ( $0^\circ$ ).

#### 4.2 Floating device, not supported

Observe the following to ensure the safe operation of the crane on **non** supported floating devices:

- Crane operation on a floating device is only permissible in very calm waters.
- Crane operation is only permissible on a floating device with a main boom (no derrick operation, no operation with luffing jib permitted).
- The inclination of the floating device may **not** exceed the maximum permissible ground inclination of the crane according to the load chart.
- Before the crane is operated on the floating device: The inclination of the floating device in the lateral and longitudinal direction must be calculated in advance. This incline results from the interaction of the crane with the floating device.
- Comply with the maximum permissible ground inclination according to the load charts:
  - $\pm 0.3^\circ$  for cranes operating on a crawler travel gear.
  - $0^\circ$  for cranes operating on outriggers.
- The load values must be reduced when the above indicated include values are exceeded.
- Load charts for higher permissible ground inclinations (for example  $1^\circ$ ,  $2^\circ$ ) can be provided upon request of LWE customers only for operation with a „main boom“ and with a „main boom + jib boom“.
- LTR 1060, LTR 1100 and LTR 1220 are programmed with load charts that permit operation up to a maximum ground inclination of  $4^\circ$ . The crane's respective maximum permissible ground inclination depends on the crane's operating mode.

## 5 Crane transport on floating devices

Observe the areas of responsibility:

- The crane contractor is solely responsible for transporting the crane on a floating device.
- The crane contractor and crane operator are responsible for the assembly and disassembly of the crane on the floating device.

Observe the following to ensure the safe transport of the crane on floating devices:

- Secure the crane during „transport on a floating device“ so that the following is prevented:
  - Damage and releasing of components on the crane
  - Slipping of the crane
  - Inadvertent turning of the superstructure
  - Capsizing of the floating device
- Transport at sea can have a negative impact on the structural strength / stability and the fatigue limit of the crane.

Make sure that the following measures are carried out prior to „transport on a floating device“:

- Take the boom down and support it using adequate means.
- With telescope cranes: Disassemble the counterweight plates and secure on the floating device.
- On crawler cranes: Support the turntable and counterweight using adequate means and secure against slipping.
- Observe and adhere to the specifications for transporting the crane and the crane components, see Crane operating instructions, chapter 3.80.

## 6 Increased corrosion

Extremely salty air near the sea can cause severe corrosion on the crane.

Increased corrosion can cause premature damage to the components (for example, the hydraulic cylinder, wire ropes, electrical and electronic components, driver's cab).

Submerging the hook block in water causes damage to the hook block and the rope.

The crane contractor and the crane operator are solely responsible for preventing severe corrosion.

Measures for preventing corrosion:

- Avoid direct contact between the crane and its components with salt water.
- Do **not** submerge the hook block in water.

Measures for detecting premature damage:

- Have the crane checked regularly and extensively by a qualified person.

---

Empty page!

LWE/LTR 1220-003/24204-02-02/en

---

## 3 Crane assembly

LWE/LTR 1220-003/24204-02-02/en

---

LWE/LTR 1220-003/24204-02-02/en



## 3.01 Crawler carrier assembly

1	Assembling the crawler carrier	3
2	Disassembling the crawler carriers	53

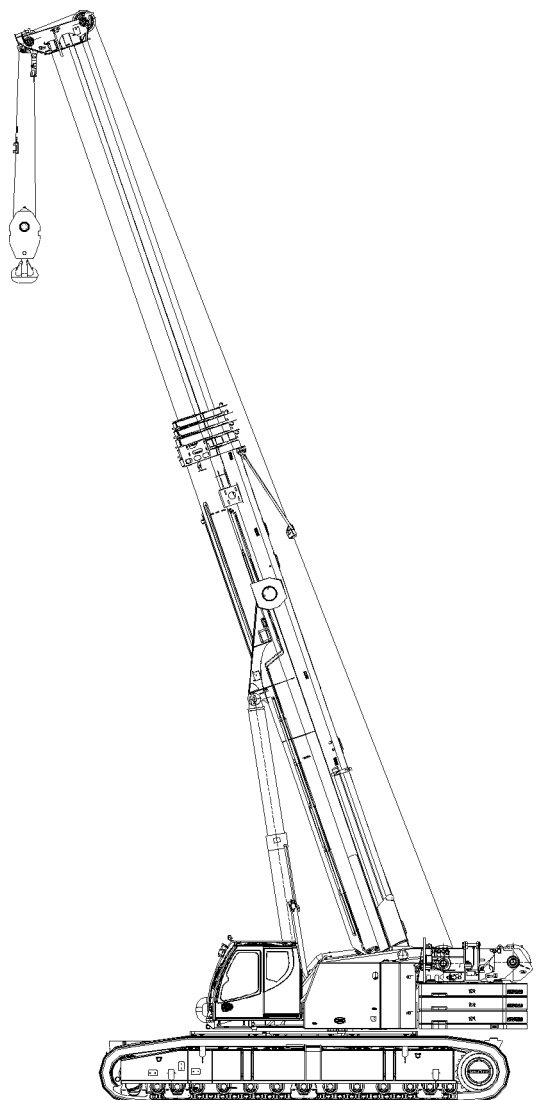
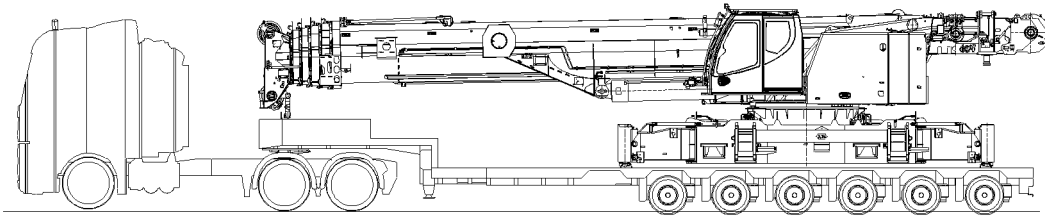


Fig.116874

LWE/LTR 1220-003/24204-02-02/en

# 1 Assembling the crawler carrier



## DANGER

Crane movement in **unsupported** status!

If the crane superstructure is turned or the boom erected, then the crane can tip over and severely or fatally injure personnel.

- ▶ Do not turn the crane superstructure when as the crane is resting on the transport vehicle.
- ▶ Do not turn erect the boom when as the crane is resting on the transport vehicle.
- ▶ Before carrying out crane movements, support the crane with the assembly support and align it horizontally.
- ▶ Adhere to the sequence of the assembly steps in this chapter.



## WARNING

Danger of falling!

During assembly / disassembly, inspection and maintenance work, personnel must be secured with appropriate aids to prevent them from falling! If this is not observed, assembly personnel could fall and suffer life-threatening or fatal injuries!

- ▶ The assembly personnel must always move carefully and anticipatory on the crane, the crane components or lattice sections!
- ▶ All work aloft, where there is a danger of falling must be carried out with suitable aids!
- ▶ If fall protection equipment is available, then it must be used!
- ▶ If aids are not available and work cannot be carried out from the ground, then the assembly personnel must secure themselves with the permissible fall arrest system to prevent falling, see Crane operating instructions, chapter 2.04!
- ▶ The fall arrest system must be attached on the fastening and hook points as well as on the safety ropes!
- ▶ Only step on the aids, ladders and catwalks with clean shoes!
- ▶ Keep aids, ladders and catwalks free of heavy dirt, snow and ice!



## WARNING

Danger of impact / crushing!

When installing / removing counterweight components with the auxiliary crane, crane components can start to swing back and forth!

When lifting / lowering and positioning crane components, there is an increased danger of impacts / crushing!

Personnel can be caught and severely injured or killed!

- ▶ Make sure that personnel cannot be caught by components!
- ▶ When working in danger zones: Use aids to protect limbs!
- ▶ Guide components with suitable aids to minimize oscillation!



## WARNING

Improper support!

If the crane is not properly supported from below, it can sink into the ground and cause it to topple over!

- ▶ The support must take on the weight of the crane safely!
- ▶ Use stable materials such as wood, steel plates or concrete slabs of a suitable size for support, depending on the ground conditions!



## Note

- ▶ Disassemble the transport devices and remove the transport retainers, see Crane operating instructions, chapter 3.80.

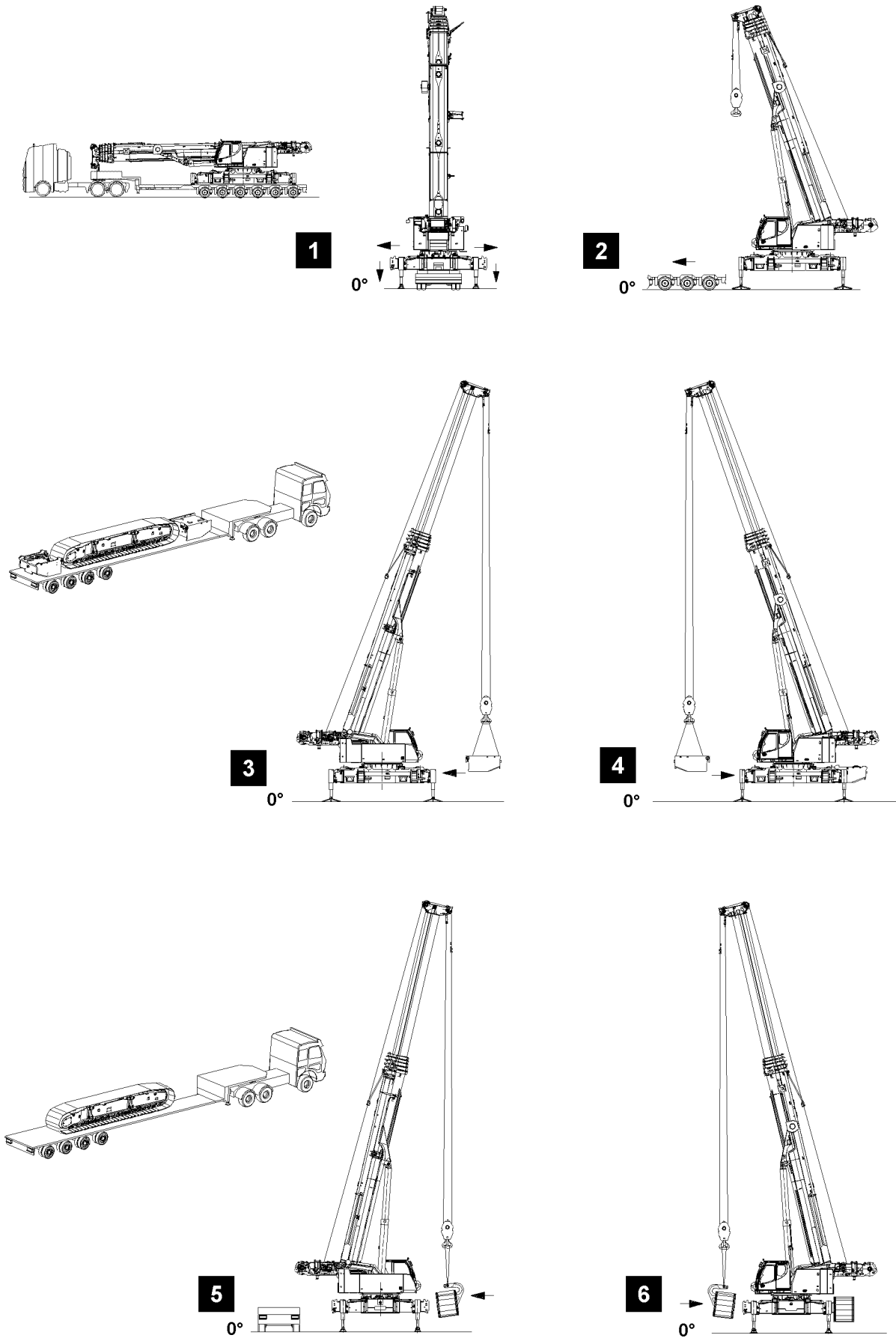


Fig.116872

## 1.1 Short description - „Assembling the crane“



### Note

- ▶ The short description of the assembly procedure is exclusively intended as an overview!
- ▶ The complete assembly description must be read and understood!

### Supporting the crane

- ▶ Move the cross carriers out, see illustration 1.
- ▶ Swing the brackets out, see illustration 1.
- ▶ Fasten the support plates on the support cylinders.
- ▶ Support the crane and level the crane.
- ▶ Luff the telescopic boom up, see illustration 2.
- ▶ Remove the transport vehicle, see illustration 2.

### Installing the central ballast



### Note

- ▶ Install the central ballast, see Crane operating instructions, chapter 3.03!

- ▶ Install the central ballast on the rear, see illustration 3.
- ▶ Install the central ballast on the front, see illustration 4.

### Install the crawler carrier „A“



### Note

- ▶ Pay attention to the identification on the crawler carrier and the cross carrier at assembly!

- ▶ Fasten the assembly device on the crane.
- ▶ Pin the assembly device with the crawler carrier „A“.
- ▶ Hang the crawler carrier „A“ on the cross carrier „A“, see illustration 5.
- ▶ Pin and secure the crawler carrier „A“ with the cross carrier „A“, see illustration 5.
- ▶ Remove the assembly device.

### Install the crawler carrier „B“

- ▶ Pin the assembly device with the crawler carrier „B“.
- ▶ Hang the crawler carrier „B“ on the cross carrier „B“, see illustration 6.
- ▶ Pin and secure the crawler carrier „B“ with the cross carrier „B“, see illustration 6.
- ▶ Remove the assembly device.

### Operating the travel gear

- ▶ Establish the hydraulic connections.
- ▶ Test the travel gear.

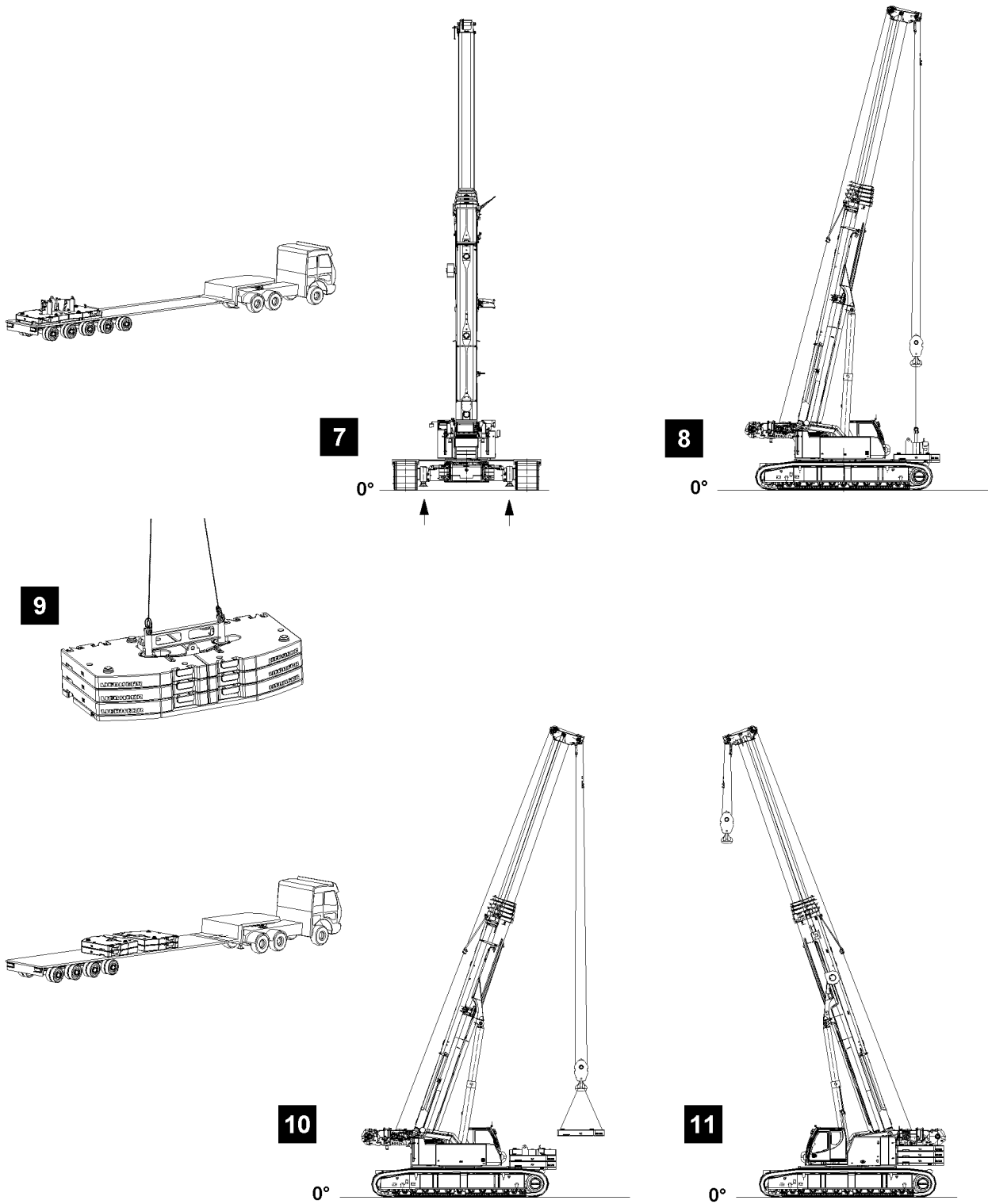


Fig.116873

### Retracting the support cylinders

- ▶ Retract the support cylinders completely, see illustration 7.

### Installing the walking platforms



---

**Note**

- ▶ Install the walking platforms, see Crane operating instructions, chapter 2.06!
- 

- ▶ Install the walking platforms, see illustration 7.

### Installing the counterweight

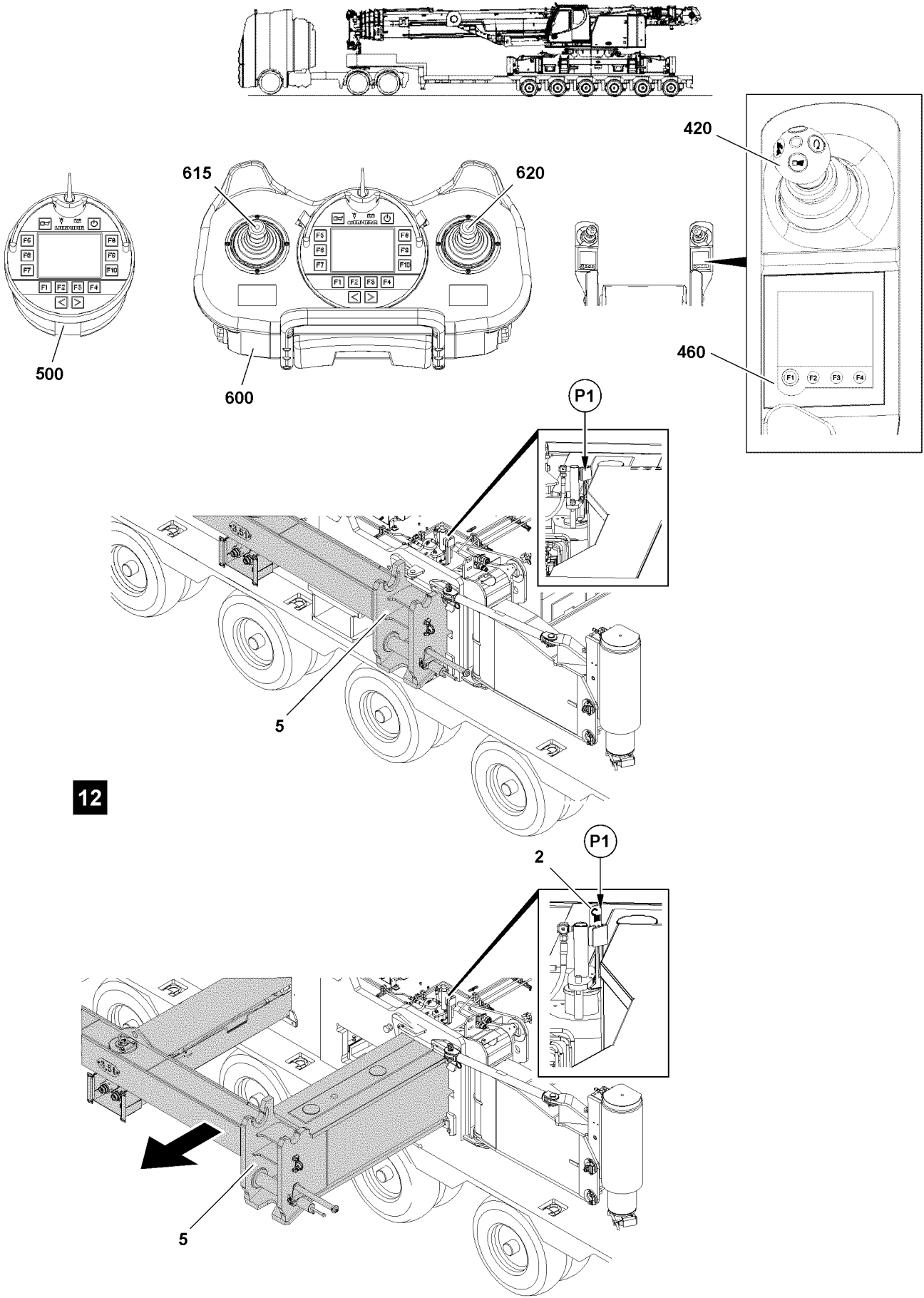


---

**Note**

- ▶ Install the counterweight, see Crane operating instructions, chapter 4.07!
- 

- ▶ Place the ballast base plate down.
- ▶ Stack the counterweight plates 10 t on the counterweight stack, see illustration 10.
- ▶ Turn the turntable and position it over the counterweight, see illustration 11.
- ▶ Connect and secure the counterweight with the turntable, see illustration 11.



12

Fig.116891

LWE/LTR 1220-003/24204-02-02/en



## 1.2 Extending the cross carriers

Make sure that the following prerequisite is met:

- No personnel is within the danger zone.



### Note

- ▶ The extension conditions of the cross carrier is displayed as percentage on the display on the Bluetooth™ Terminal (BTT), the radio remote control (BTT-E) and on the LICCON monitor!
- ▶ The cross carriers are only pinned on extension conditions of 0 %; 50 %; 100 %.
- ▶ The extension conditions of the cross carriers / crawler carriers are specified in the load chart.
- ▶ The pin points of the cross carriers are marked in percentages with tags on the cross carriers.

### 1.2.1 Extending the cross carrier with the BlueTooth™ Terminal

Make sure that the following prerequisite is met:

- On the display of the BTT, the menu overview is visible.

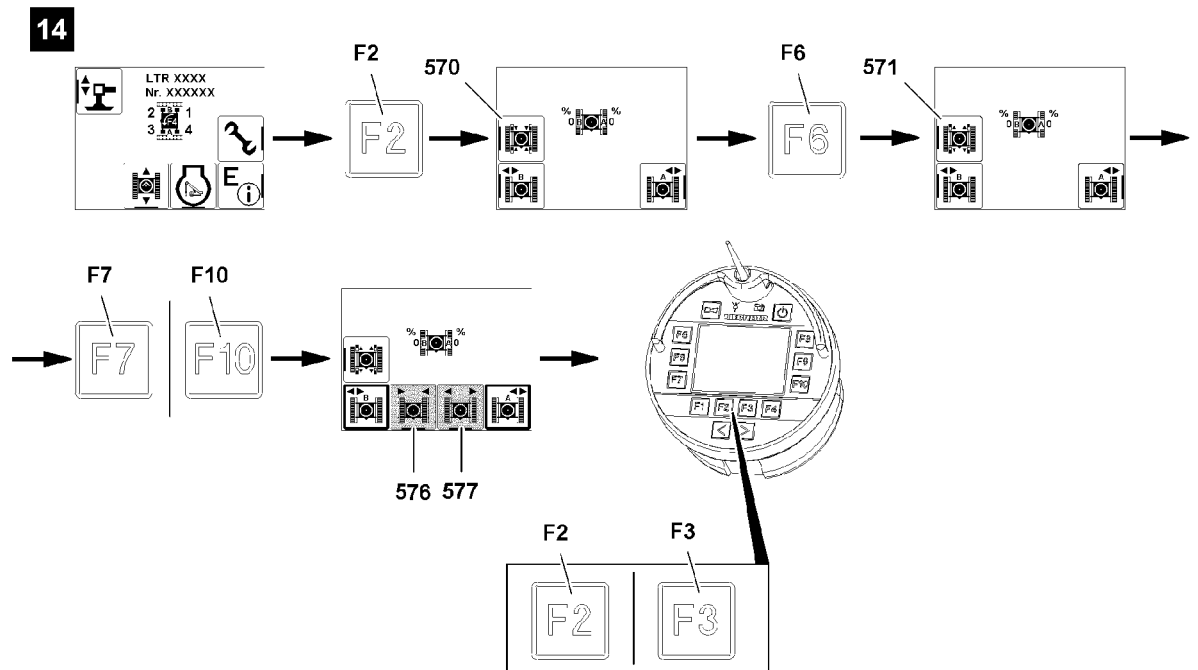


Fig.116896

#### Unpinning the cross carrier

- ▶ Call up the „Crawler travel gear“ menu: Press the function key **F2**, see illustration 14.

#### Result:

- Functions „Track width adjustment“ are visible.

When icon „Pin the cross carrier“ **570** is visible:

- ▶ Activate „Unpin the cross carrier“: Press the function key **F6**.

#### Result:

- Icon „Unpin the cross carrier“ **571** appears.

### Selecting the cross carrier

Before you retract or extend the cross carrier, select one of the cross carriers or both cross carriers:

- **F7** Function key
- **F10** Function key

In this and the following sections is described how both cross carriers are extended together. Alternatively you can also select and extend the cross carriers individually.

Depending on which cross carriers are selected, different icons for „retract crawler carrier“ and „extend crawler carrier“ appear, see Crane operating instructions, chapter 5.31.

- ▶ Select both cross carriers: Press function key **F7** and function key **F10**, see illustration 14.

#### Result:

- Icon „Retract crawler carrier“ **576** is visible.
- Icon „Extend crawler carrier“ **577** is visible.

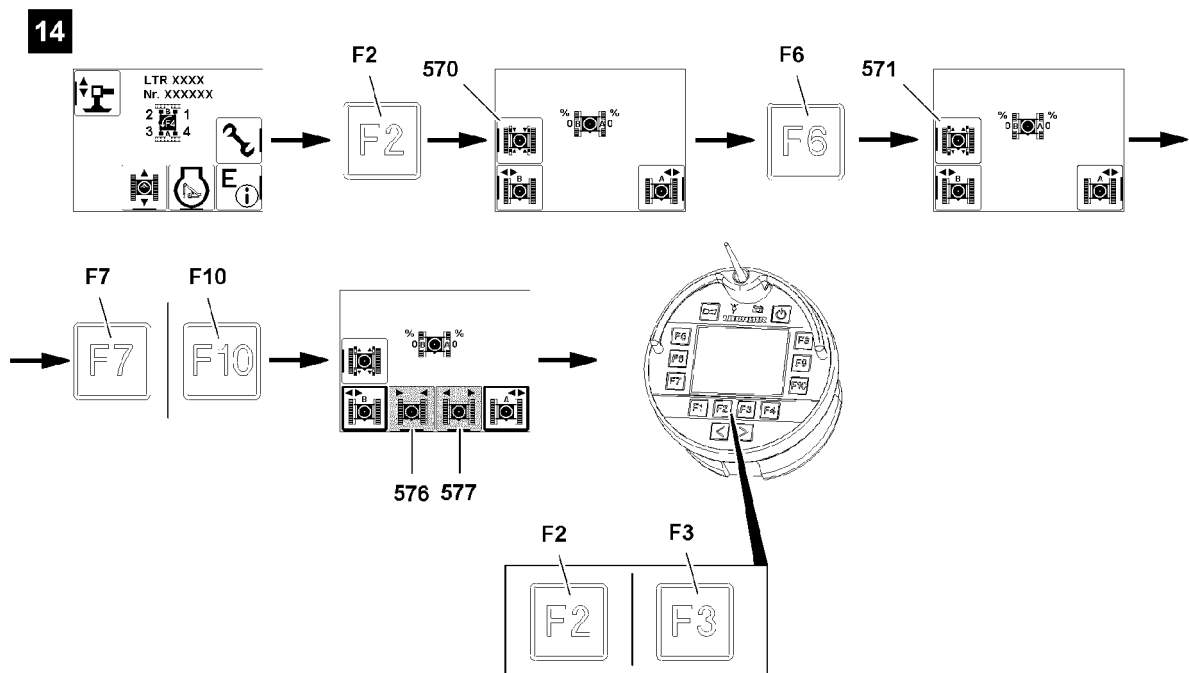


Fig. 116896

### Extending the cross carriers

To unpin the cross carriers on points **P1**, you have extend the cross carriers, see illustration 12.

You can check on points **P1** if the pins are completely pinned or unpinned:

- The pins are unpinned: Tags **2** are visible.
- The pins are pinned: Tags **2** are **not** visible.



#### WARNING

Crushing danger due to movement of cross carriers!

- ▶ Make sure that no personnel is within the danger zone of the cross carriers during „track width adjustment“.
- ▶ Differentiation of the cross carriers, see Crane operating instructions, chapter 5.31.

When „retracting the cross carrier“:

- ▶ Press the function key **F2**.

When „extending the cross carrier“:

- ▶ Press the function key **F3**.

**Result:**

- The pins are unpinned.

**Problem remedy**

Pins are not unpinned!

The pin is stuck: The position of the cross carriers prevents the pins from unpinning.

- ▶ Extend and retract the cross carriers again: Press the function keys until the pins are completely unpinned.

- ▶ Make sure that the pins are completely unpinned on points **P1**, see illustration **12**.

**Result:**

- The pins are unpinned.
- The cross carriers extend.

**Pinning the cross carriers**

Before the cross carriers reach the 100 % extension status:

- ▶ Activate „Pin the cross carrier“: Press the function key **F6**.

**Result:**

- Icon „pin the cross carrier“ **570** is visible.
- The pins are pinned.

**Problem remedy**

The pins are not pinned!

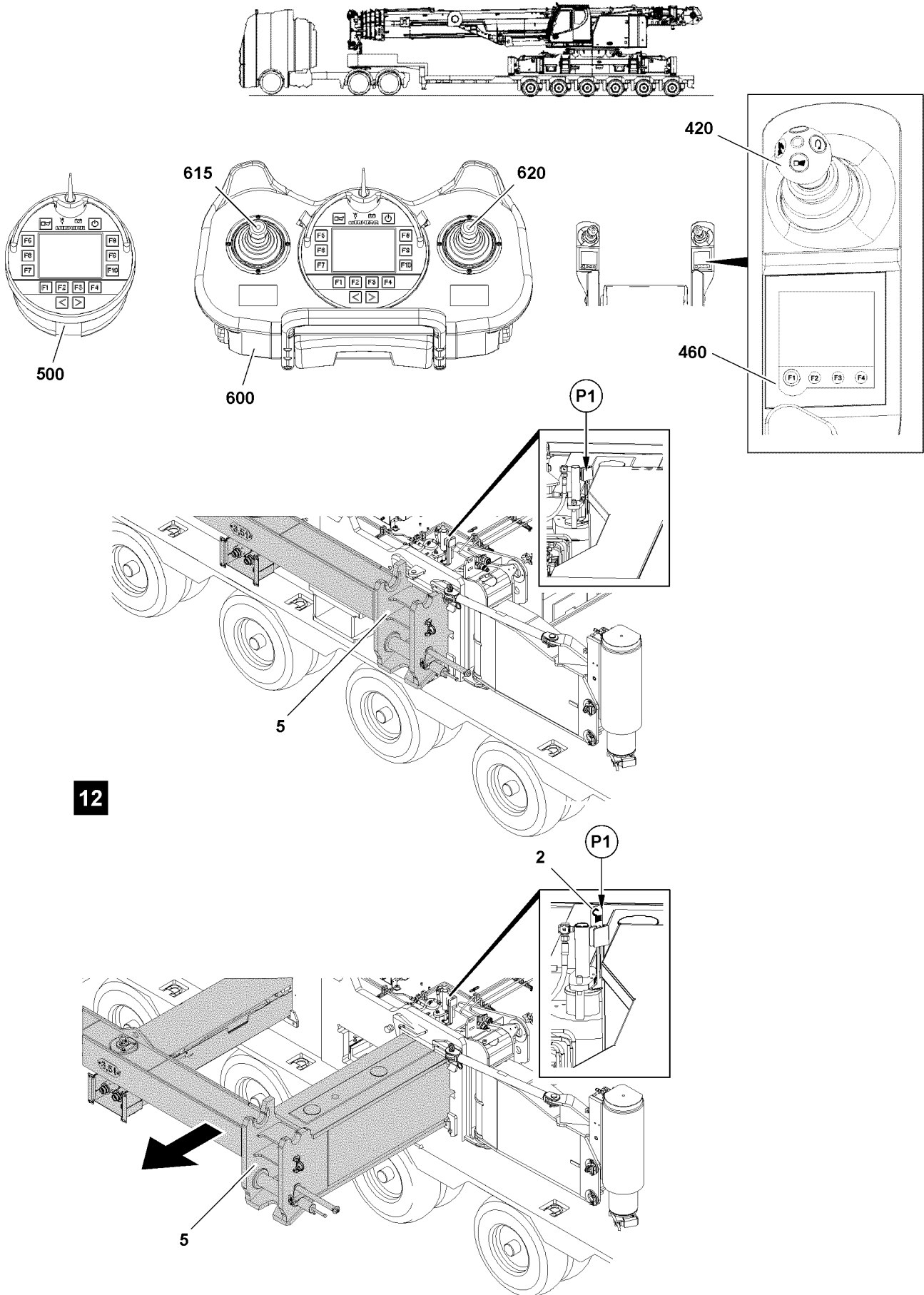
The pin is stuck: The position of the cross carriers prevents the pins from pinning.

- ▶ Extend and retract the cross carriers again: Press the function keys until the pins are completely pinned.

- ▶ Make sure that the pins are completely pinned on points **P1**, see illustration **12**.

**Result:**

- The pins are pinned.
- The cross carriers are extended and secured at 100 %.



12

Fig.116891

LWE/LTR 1220-003/24204-02-02/en

## 1.2.2 Extending the cross carriers from the crane operator's cab

Make sure that the following prerequisite is met:

- On the TE1 the „Master switch configuration“ menu is visible.

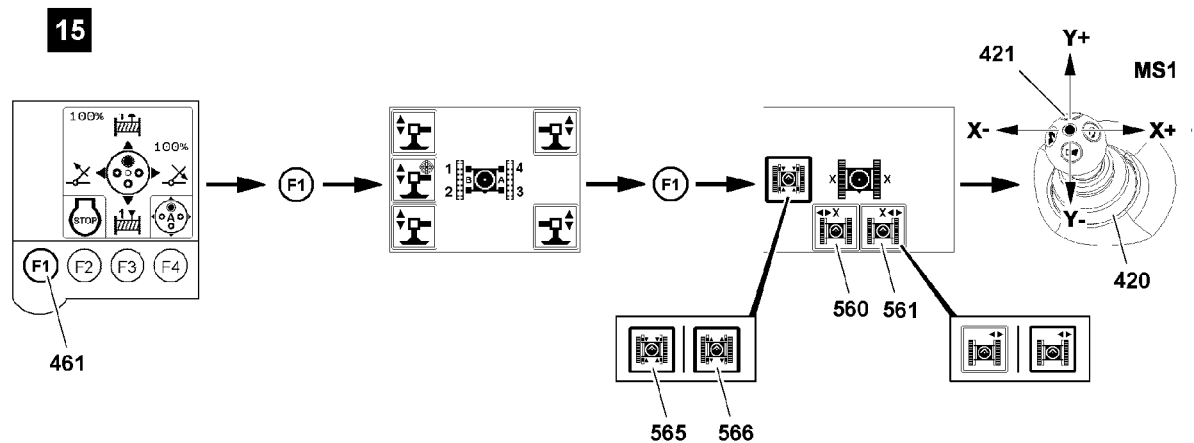


Fig.116897

### Unpinning the cross carrier

- ▶ Press the function key F1 **461**, see illustration 15.

#### Result:

- The „Support“ menu appears.

- ▶ Press function key F1 **461**.

#### Result:

- The „Track width adjustment“ menu appears.

When icon **565** „Pin the cross carrier“ is visible:

- ▶ Activate „Unpin the cross carrier“: Select the icon **565** („touch“).

#### Result:

- Icon „unpin cross carrier“ **566** is visible.

### Selecting the cross carrier

Before you retract or extend the cross carrier, select one of the cross carriers or both cross carriers:

- **560** Icon
- **561** Icon

In this and the following sections is described how both cross carriers are extended together. Alternatively you can also select and extend the cross carriers individually.

- ▶ Pay attention to cross carrier assignment.
- ▶ Select both cross carriers: Select the icon **560** and icon **561** („touch“).

#### Result:

- Selected icons with filled out frames: Cross carriers are selected.

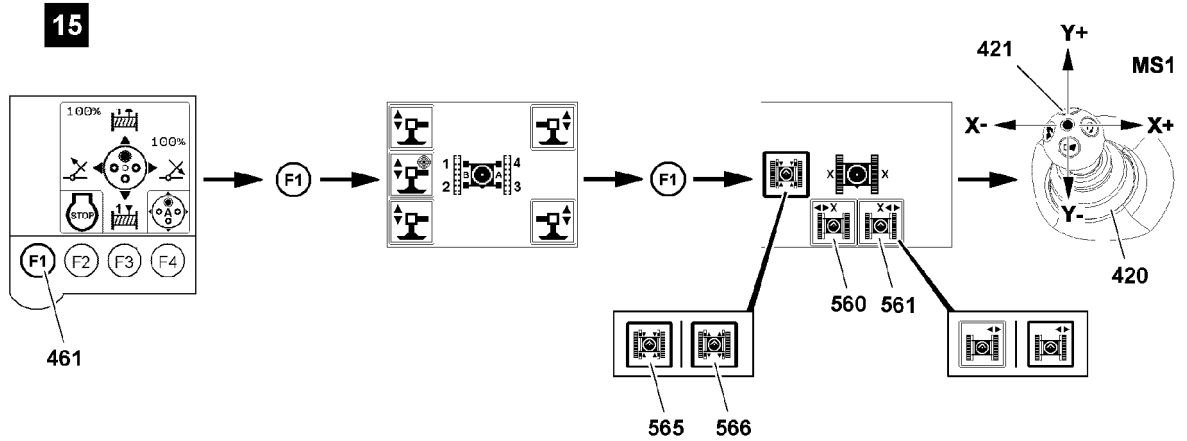


Fig.116897

### Extending the cross carriers

To unpin the cross carriers on points **P1**, you have to retract or extend the cross carriers, see illustration 12:

You can check on points **P1** if the pins are completely pinned or unpinned:

- The pins are unpinned: Tags **2** are visible.
- The pins are pinned: Tags **2** are **not** visible.



### WARNING

Crushing danger due to movement of cross carriers!

- ▶ Make sure that no personnel is within the danger zone of the cross carriers during „track width adjustment“.
- ▶ Differentiation of the cross carriers, see Crane operating instructions, chapter 4.01.

To initiate a movement, you have to release master switch MS1 **420** with the button **421**.

- ▶ Press the button **421** and hold.

When „retracting the cross carrier“:

- ▶ Move master switch MS1 **420** in direction X-.

When „extending the cross carrier“:

- ▶ Move master switch MS1 **420** in direction X+.

### Result:

- The pins are unpinned.

### Problem remedy

Pins are not unpinned!

The pin is stuck: The position of the cross carriers prevents the pins from unpinning.

- ▶ Extend and retract the cross carriers again: Move master switch MS1 **420** in direction X+ or X- until the pins are completely unpinned.

- ▶ Make sure that the pins are completely unpinned on points **P1**, see illustration 12.

### Result:

- The pins are unpinned.
- The cross carriers extend.

### Pinning the cross carriers

Before the cross carrier reaches the 100 % extension status:

- ▶ Activate „Pin the cross carrier“: Select icon **566** („touch“), see illustration 15.

**Result:**

- Icon **565** „pin cross carrier“ is visible.
- The pins are pinned.

---

**Problem remedy**

The pins are not pinned!

The pin is stuck: The position of the cross carriers prevents the pins from pinning.

- ▶ Extend and retract the cross carriers again: Move master switch MS1 **420** in direction X+ or X- until the pins are completely pinned.

- 
- ▶ Make sure that the pins are completely pinned on points **P1**, see illustration **12**.

**Result:**

- The pins are pinned.
- The cross carriers are extended and secured at 100 %.

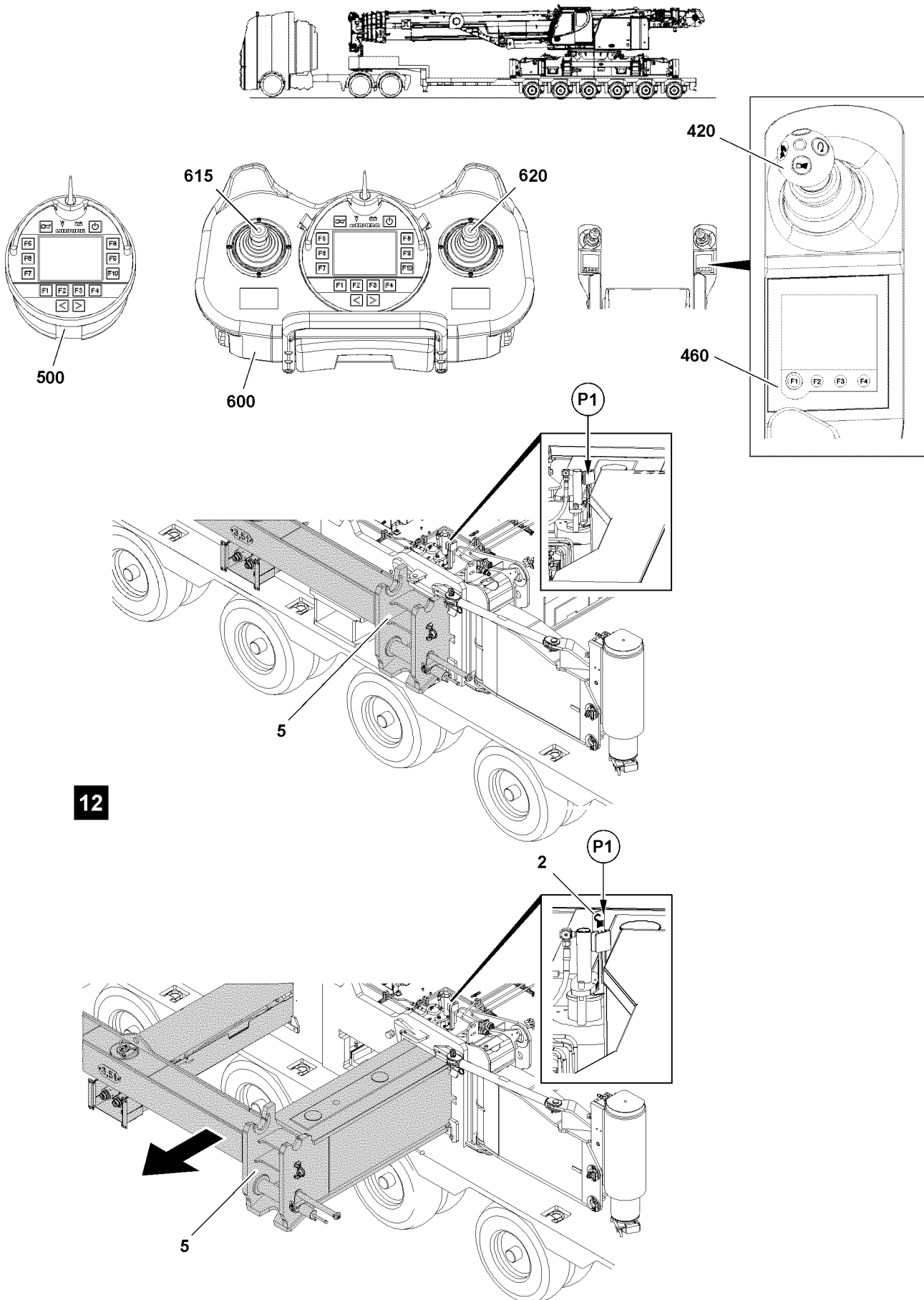


Fig.116891

LWE/LTR 1220-003/24204-02-02/en



### 1.2.3 Extending the cross carriers with the radio remote control\*

Make sure that the following prerequisite is met:

- On the display of the BTT-E, the menu overview is visible.

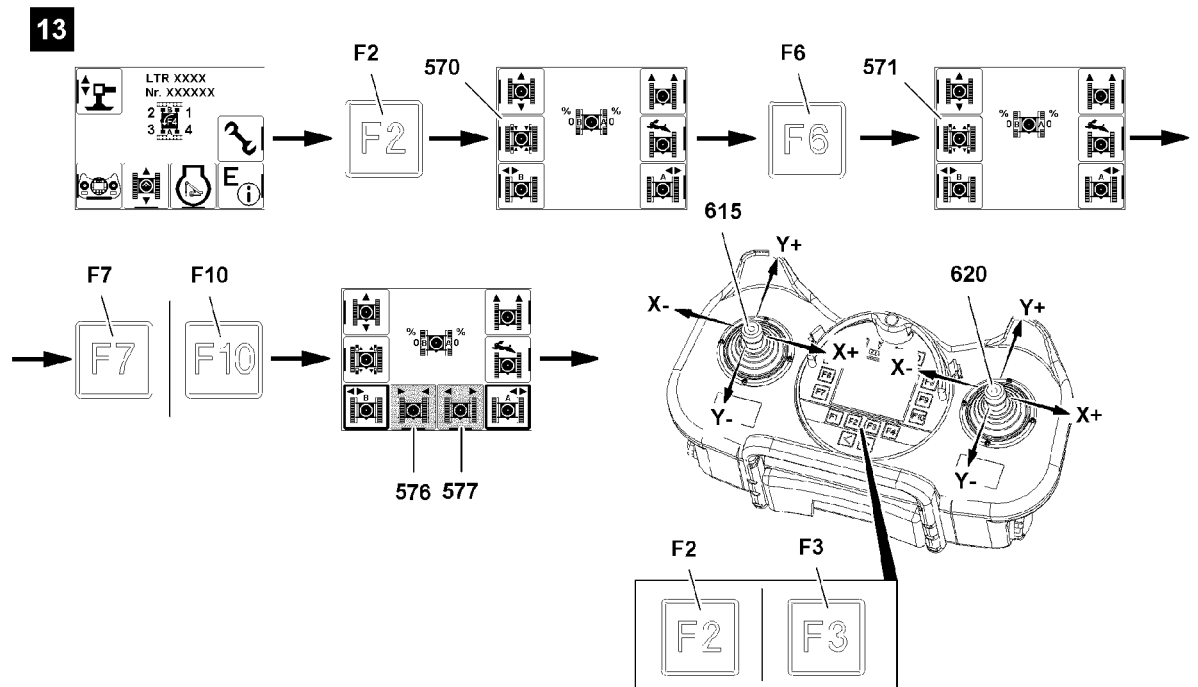


Fig.116893

#### Unpinning the cross carrier

- ▶ Call up the „Crawler travel gear“ menu: Press the function key **F2**, see illustration 13.

#### Result:

- Functions „Track width adjustment“ are visible.

When icon „Pin the cross carrier“ **570** is visible:

- ▶ Activate „Unpin the cross carrier“: Press the function key **F6**.

#### Result:

- Icon „Unpin the cross carrier“ **571** appears.

#### Selecting the cross carrier

Before you retract or extend the cross carrier, select one of the cross carriers or both cross carriers:

- **F7** Function key
- **F10** Function key

In this and the following sections is described how both cross carriers are extended together. Alternatively you can also select and extend the cross carriers individually.

Depending on which cross carriers are selected, different icons for „retract crawler carrier“ and „extend crawler carrier“ appear, see Crane operating instructions, chapter 6.08.

- ▶ Select both cross carriers: Press function key **F7** and function key **F10**, see illustration 13.

#### Result:

- Icon „Retract crawler carrier“ **576** is visible.
- Icon „Extend crawler carrier“ **577** is visible.

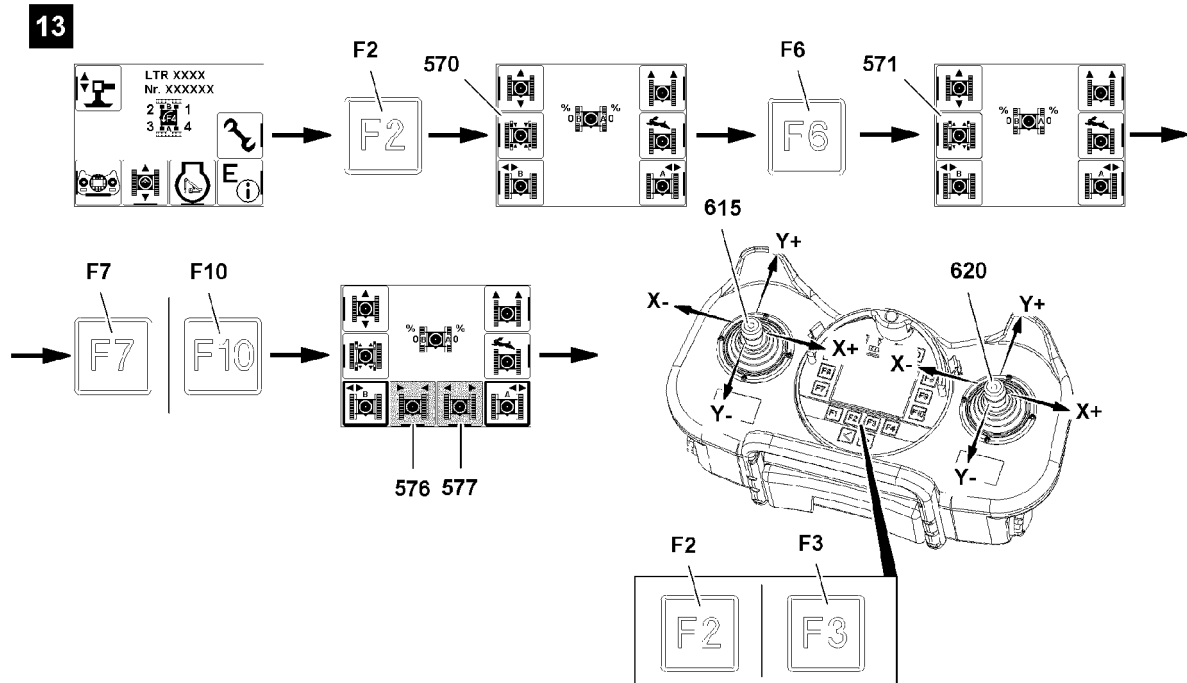


Fig. 116893

### Extending the cross carriers

To unpin the cross carriers on points **P1**, you have to extend the cross carriers, see illustration 12.

You can check on points **P1** if the pins are completely pinned or unpinned:

- The pins are unpinned: Tags **2** are visible.
- The pins are pinned: Tags **2** are **not** visible.



### WARNING

Crushing danger due to movement of cross carriers!

- ▶ Make sure that no personnel is within the danger zone of the cross carriers during „track width adjustment“.
- ▶ Differentiation of the cross carriers, see Crane operating instructions, chapter 6.08.

When both cross carriers are selected, then the operation is assigned to the following manual control levers on the BTT-E:

- Manual control lever **615** or manual control lever **620**

When „retracting the cross carrier“:

- ▶ Deflect the manual control lever in direction X-.
- or**
- Press the function key **F2**.

When „extending the cross carrier“:

- ▶ Deflect the manual control lever in direction X+.
- or**
- Press the function key **F3**.

### Result:

- The pins are unpinned.

---

**Problem remedy**

Pins are not unpinned!

The pin is stuck: The position of the cross carriers prevents the pins from unpinning.

- ▶ Extend and retract the cross carriers again: Deflect the manual control levers on the BTT-E in direction X+ or X- or press function keys until the pins are completely unpinned.

- 
- ▶ Make sure that the pins are completely unpinned on points **P1**, see illustration **12**.

**Result:**

- The pins are unpinned.
- The cross carriers extend.

**Pinning the cross carriers**

Before the cross carriers reach the 100 % extension status:

- ▶ Activate „Pin the cross carrier“: Press the function key **F6**.

**Result:**

- Icon „pin the cross carrier“ **570** is visible.
- The pins are pinned.

---

**Problem remedy**

The pins are not pinned!

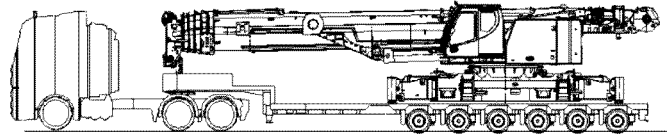
The pin is stuck: The position of the cross carriers prevents the pins from pinning.

- ▶ Extend and retract the cross carriers again: Deflect the manual control levers on the BTT-E in direction X+ or X- or press function keys until the pins are completely pinned.

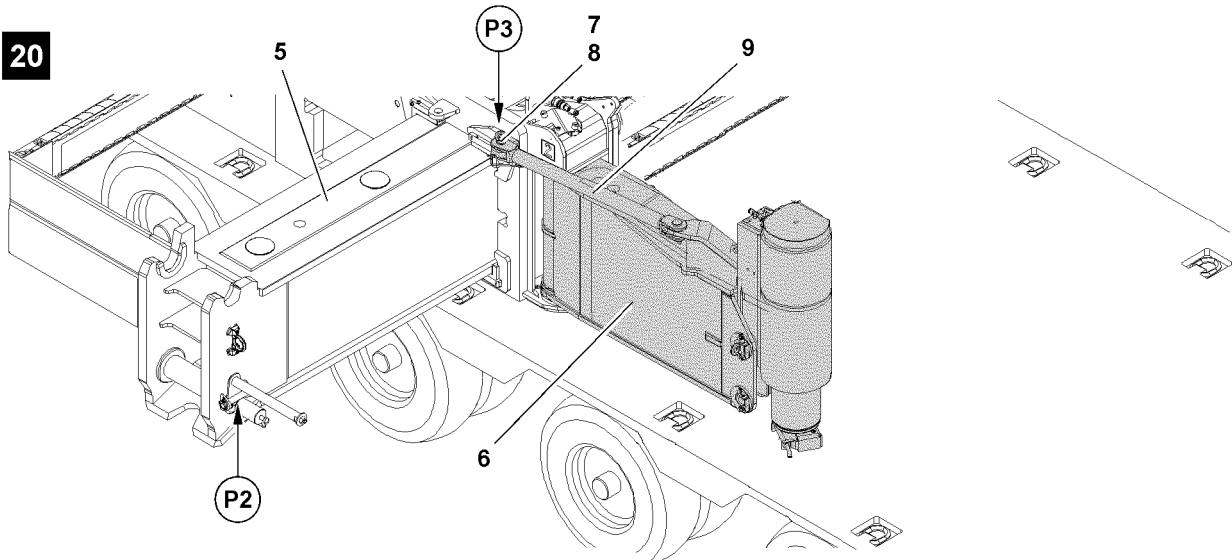
- 
- ▶ Make sure that the pins are completely pinned on points **P1**, see illustration **12**.

**Result:**

- The pins are pinned.
- The cross carriers are extended and secured at 100 %.



20



21

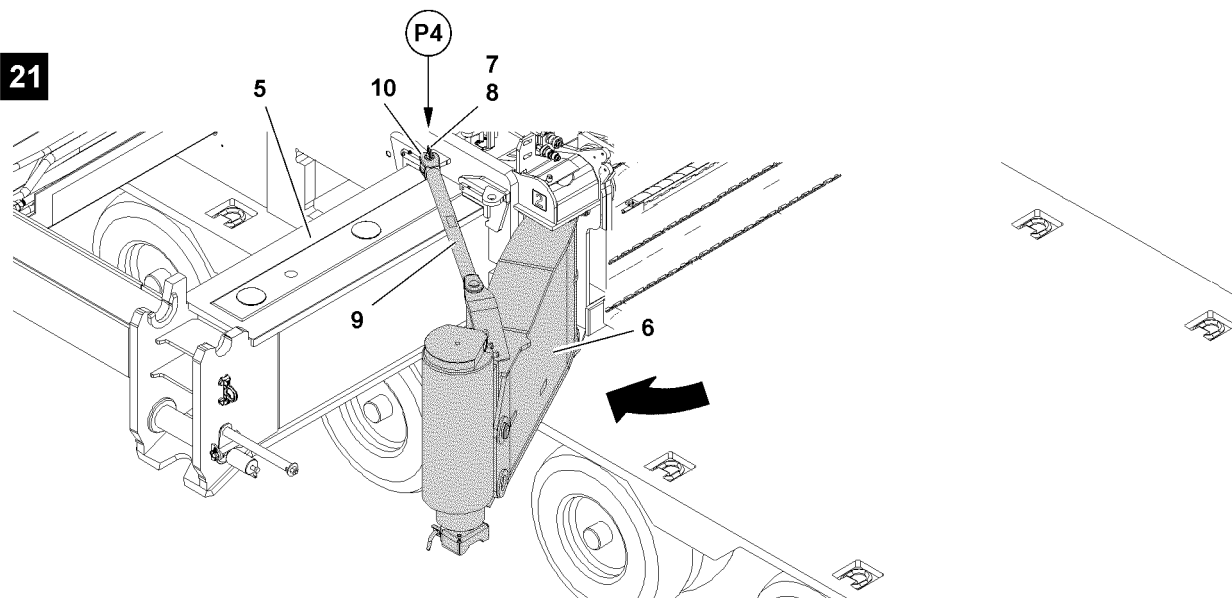


Fig.116875

## 1.3 Swinging the folding brackets out

Make sure that the following prerequisite is met:

- Both cross carriers **5** are 100 % extended and pinned.

---

### NOTICE

Damage to the pin pulling device!

If the cross carriers **5** are not extended when swinging the folding brackets **6**, then the pin pulling devices will be damaged at point **P2** when swinging the folding brackets!

- ▶ Make sure that the cross carriers **5** are extended before swinging the folding brackets **6**!
- ▶ Make sure that no persons or objects are within the danger zone when swinging the folding brackets **6**!

- 
- ▶ Remove the spring retainer **7** at point **P3**, see illustration **20**.
  - ▶ Unpin the pin **8** at point **P3**, see illustration **20**.
  - ▶ Remove the rod **9** from the connection.

### Result:

- The folding bracket **6** is released.
- ▶ Swing the folding bracket **6** out until the connection fork **10** of the rod can be pinned at point **P4**, see illustration **21**.

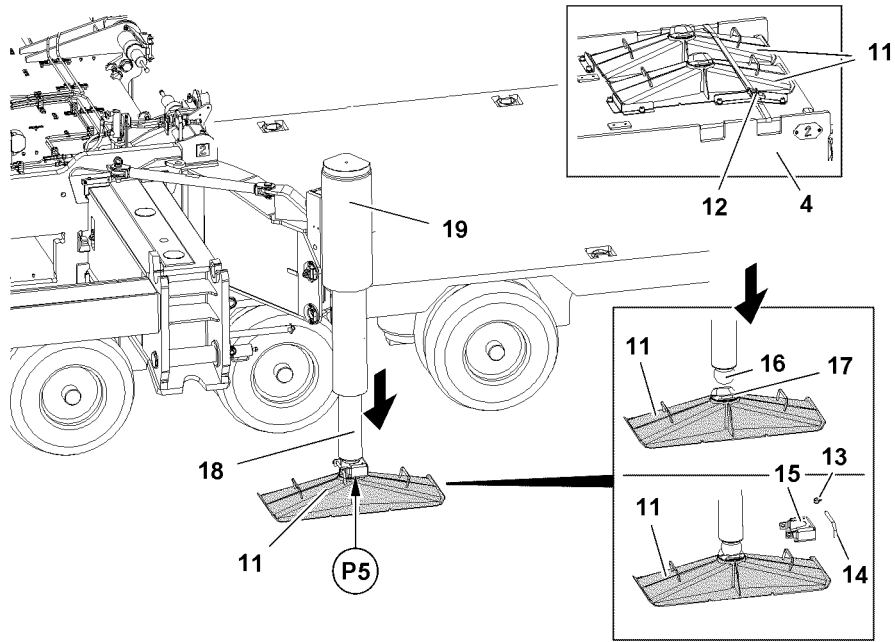
When the bores align at point **P4**:

- ▶ Insert the pin **8** at point **P4**, see illustration **21**.
- ▶ Insert the spring retainer **7** at point **P4**, see illustration **21**.

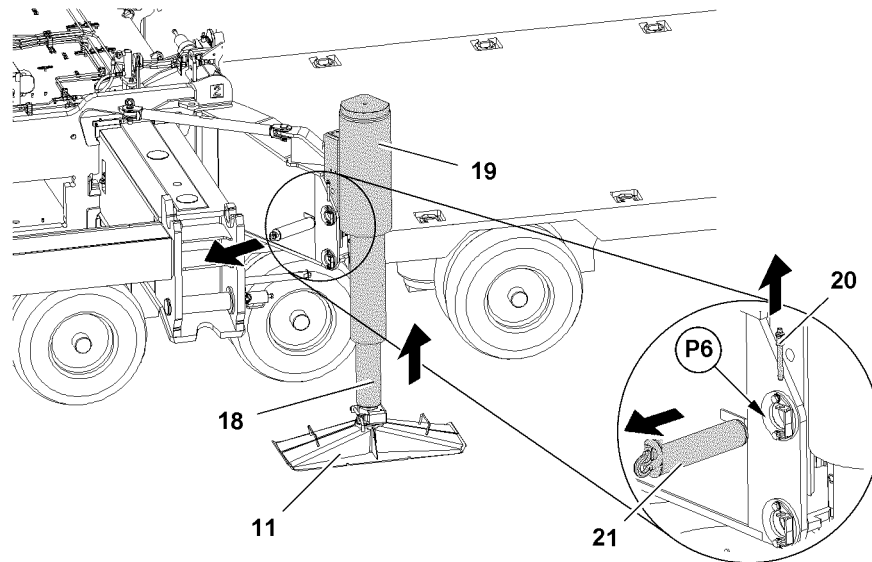
### Result:

- The folding bracket **6** is secured.
- ▶ Swinging all folding brackets out

22



23



24

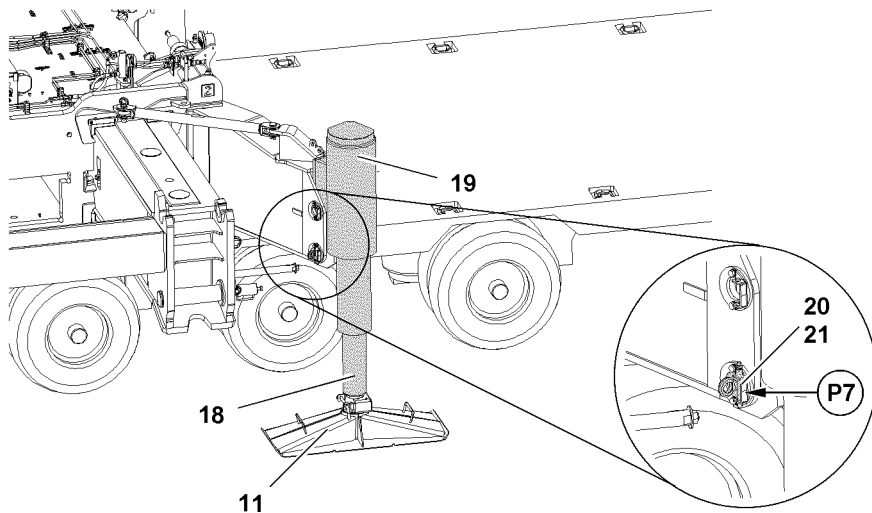


Fig.116876

LWE/LTR 1220-003/24204-02-02/en

## 1.4 Installing the support plates

### 1.4.1 Preparing the support plates for assembly



#### Note

- ▶ The support plates **11** are positioned for transport on the central ballast **4**!
- ▶ The weight of the support plate is 50 kg !
- ▶ For safety reasons, assemble the support plates **11** always with two persons!

- ▶ Remove the transport belts **12**, see illustration **22**.
- ▶ Remove the support plates **11** from the transport receptacle.



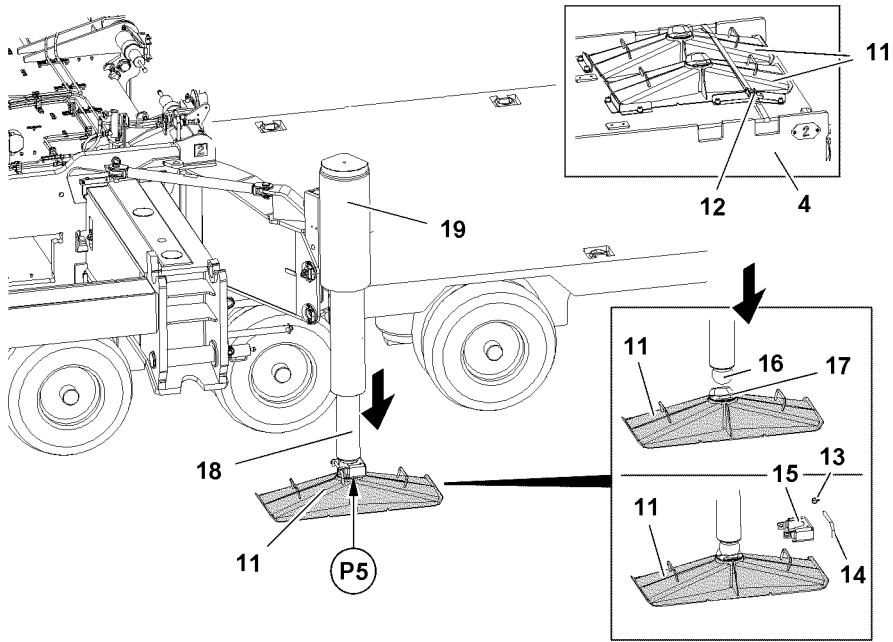
#### DANGER

The crane can topple over!

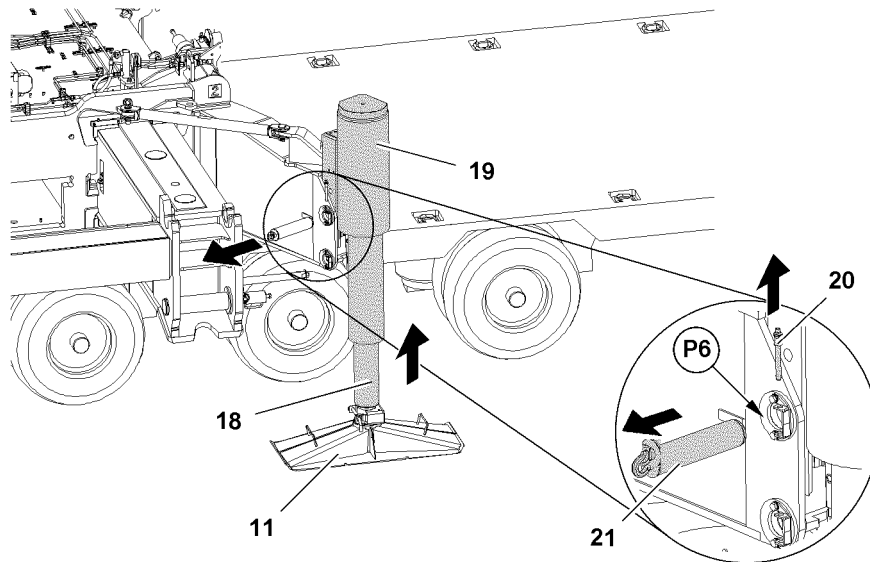
The crane can topple and fatally injure personnel if the support plates **11** are not properly supported.

- ▶ Make sure that the support plates are positioned on load bearing and horizontal ground.
  - ▶ Only use suitable materials for support!
  - ▶ Place the support bases under the center of the support plates!
  - ▶ Support all support plates **11** with the same materials!
  - ▶ Observe the track width of the flat bed trailer! The support material may not project into the driving track.
- 
- ▶ Place stable materials such as wood, steel plates or concrete slabs of a suitable size under the support plates **11**, depending on the ground conditions.
  - ▶ Place the support plates **11** under the support cylinder **19** and align them lengthwise to the transport vehicle.
  - ▶ Remove the safety locking pin **13** at point **P5** and unpin the pin **14**, see illustration **22**.
  - ▶ Pull out the retainer **15** from the ball head **16**, see illustration **22**.

22



23



24

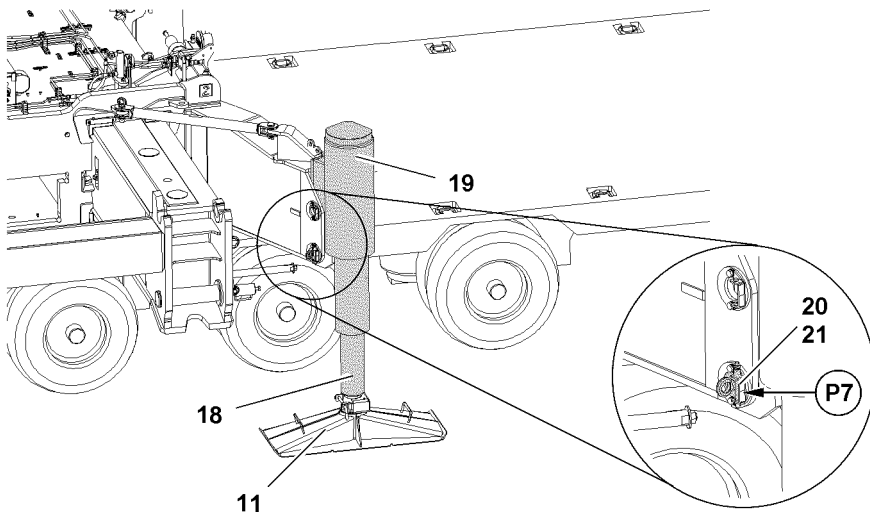


Fig.116876

LWE/LTR 1220-003/24204-02-02/en



## 1.4.2 Extending the piston rod with the BlueTooth™ Terminal

Make sure that the following prerequisite is met:

- On the display of the BTT, the menu overview is visible.

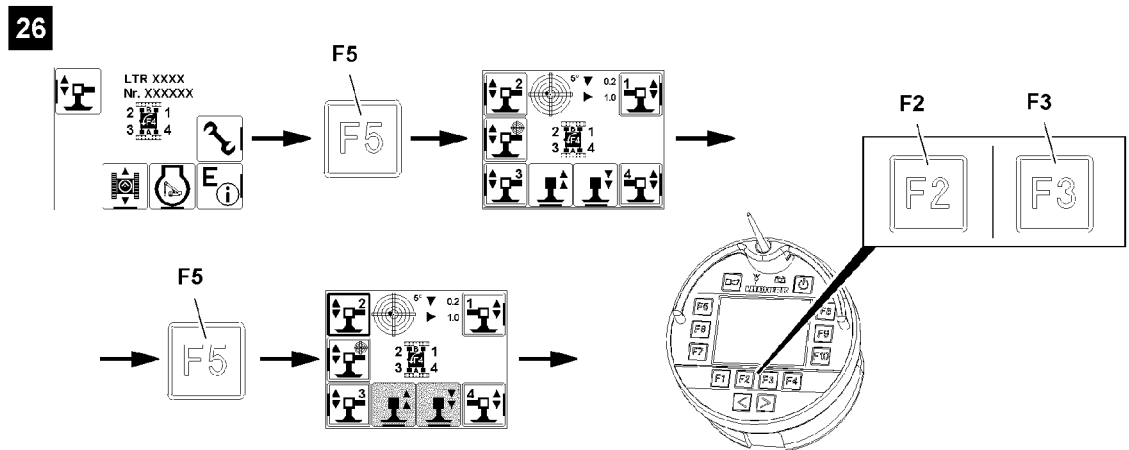


Fig.116899

- ▶ Press the function key **F5**, see illustration 26.

**Result:**

- The „Support“ menu is visible.

The support cylinders are marked with numbers depending on the alignment of the BTT.

Support cylinders are selected with function keys:

- **F5** Function key
- **F7** Function key
- **F8** Function key
- **F10** Function key

- ▶ Select support cylinder: Press the function key.

**Result:**

- Selected icons are visible with filled out frames: Support cylinders are selected.
- Support cylinders are ready for extension and retraction.

When „retracting the support cylinders“:

- ▶ Press the function key **F2**.

**Result:**

- Piston rod **18** retracts.

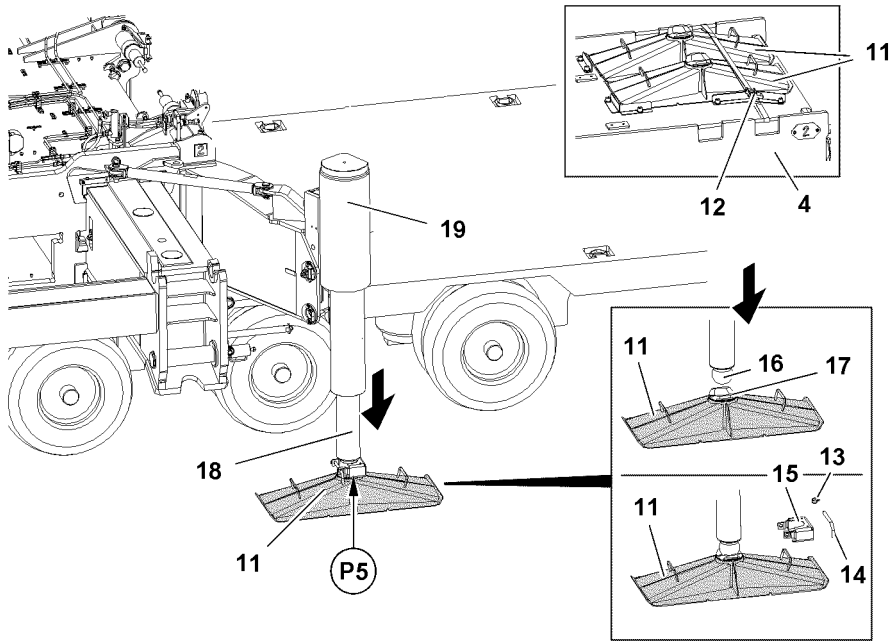
When „extending the support cylinders“:

- ▶ Press the function key **F3**.

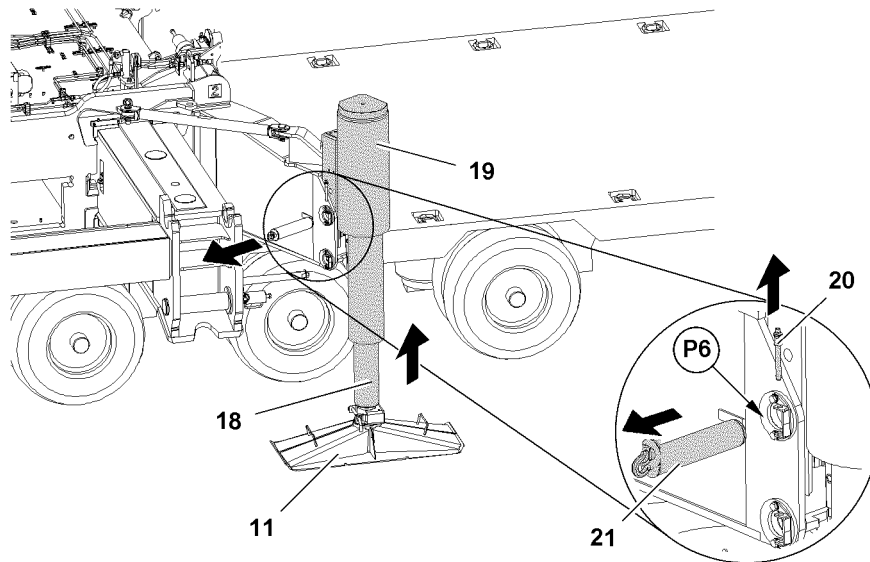
**Result:**

- Piston rod **18** extends.

22



23



24

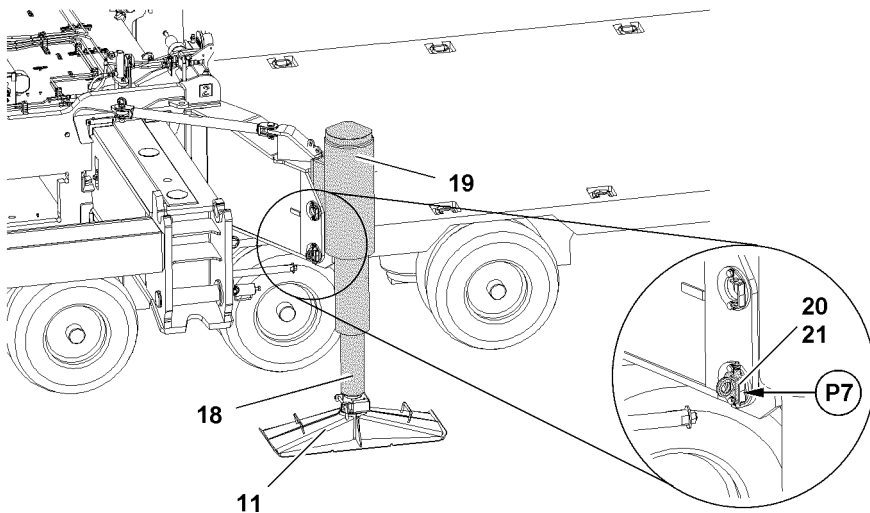


Fig.116876

LWE/LTR 1220-003/24204-02-02/en

### 1.4.3 Extending the piston rod from the crane operator's cab

Make sure that the following prerequisite is met:

- The „master switch assignment“ is visible on the touch display right (TE1).

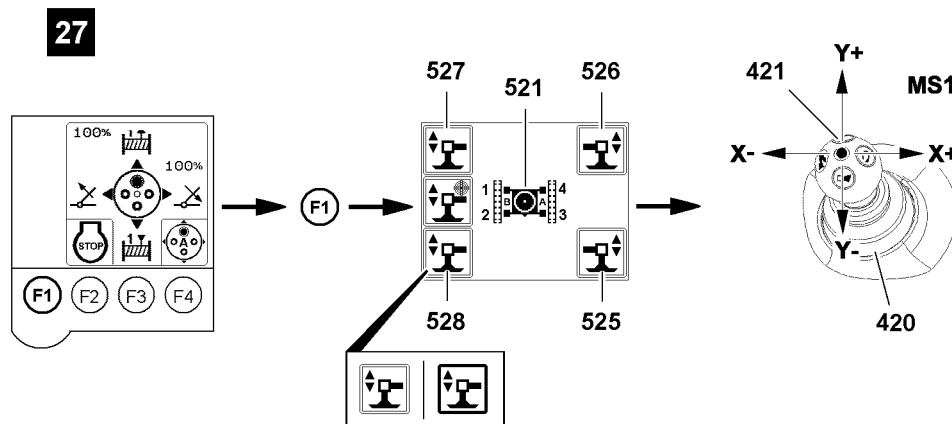


Fig. 116900

- ▶ Press the function key **F1**, see illustration 27.

**Result:**

- The „Support“ menu is visible.

The support cylinders are marked with numbers depending on the alignment of the turntable, see icon **521**.

Support cylinders are selected via touch functions:

- **525** Icon
- **526** Icon
- **527** Icon
- **528** Icon

- ▶ Select support cylinder: Select the icon („touch“).

**Result:**

- Selected icons are visible with filled out frames: Support cylinders are selected.
- Support cylinders are ready for extension and retraction.

When „retracting the support cylinders“:

- ▶ Deflect the manual control lever **421** in direction Y+.

**Result:**

- Piston rod **18** retracts.

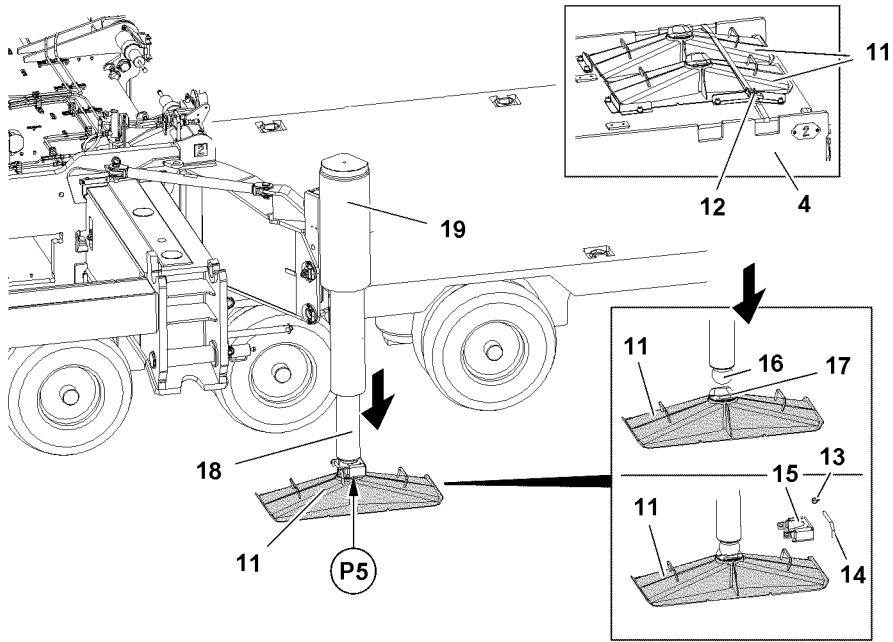
When „extending the support cylinders“:

- ▶ Deflect the manual control lever **421** in direction Y-.

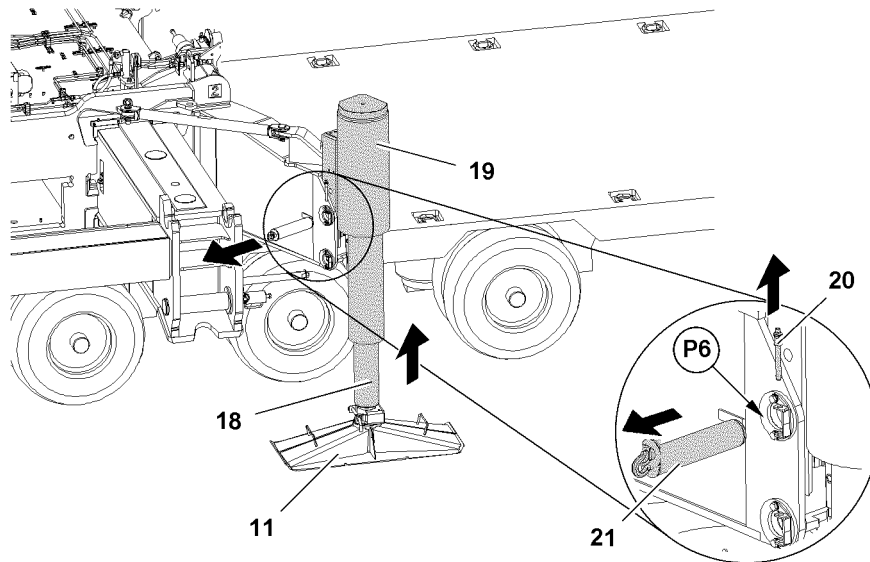
**Result:**

- Piston rod **18** extends.

22



23



24

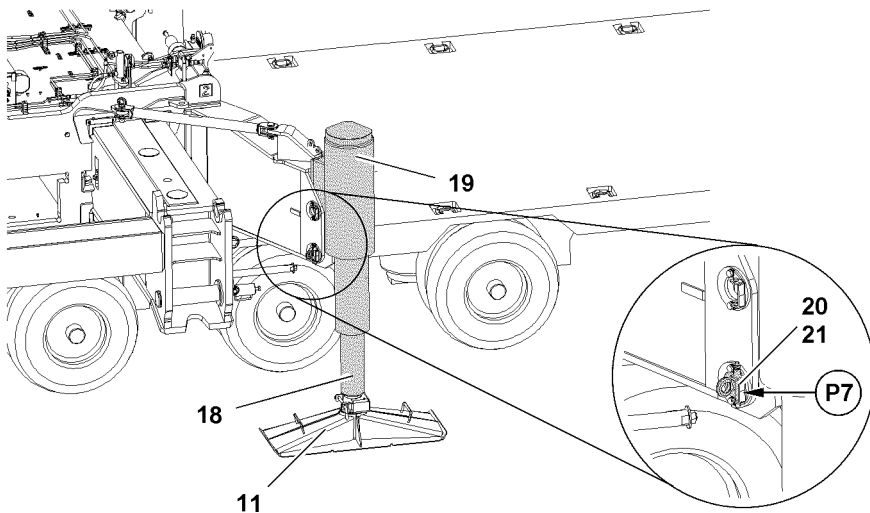


Fig.116876

LWE/LTR 1220-003/24204-02-02/en

### 1.4.4 Extending the piston rod with the radio remote control\*

Make sure that the following prerequisite is met:

- On the display of the BTT-E, the menu overview is visible.

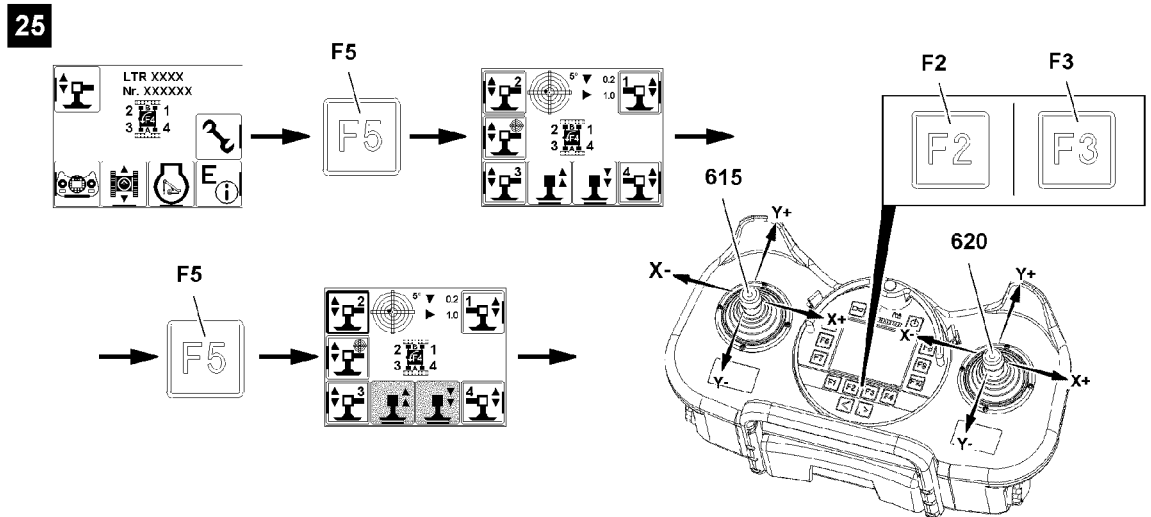


Fig.116898

- ▶ Press the function key **F5**, see illustration 25.

**Result:**

- The „Support“ menu is visible.

The support cylinders are marked with numbers depending on the alignment of the radio remote control.

Support cylinders are selected with function keys:

- **F5** Function key
- **F7** Function key
- **F8** Function key
- **F10** Function key

- ▶ Select support cylinder: Press the function key.

**Result:**

- Selected icons are visible with filled out frames: Support cylinders are selected.
- Support cylinders are ready for extension and retraction.

The support cylinders can be extended or retracted with both manual control levers.

When „retracting the support cylinders“:

- ▶ Deflect the manual control lever in direction Y+.
- or
- Press the function key **F2**.

**Result:**

- Piston rod **18** retracts.

When „extending the support cylinders“:

- ▶ Deflect the manual control lever in direction Y-.
- or
- Press the function key **F3**.

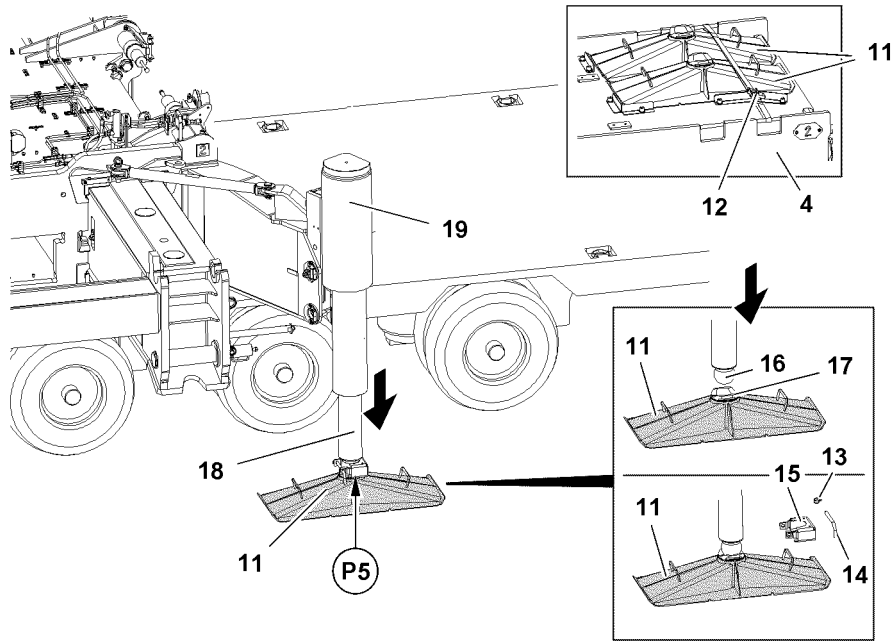
**Result:**

- Piston rod **18** extends.

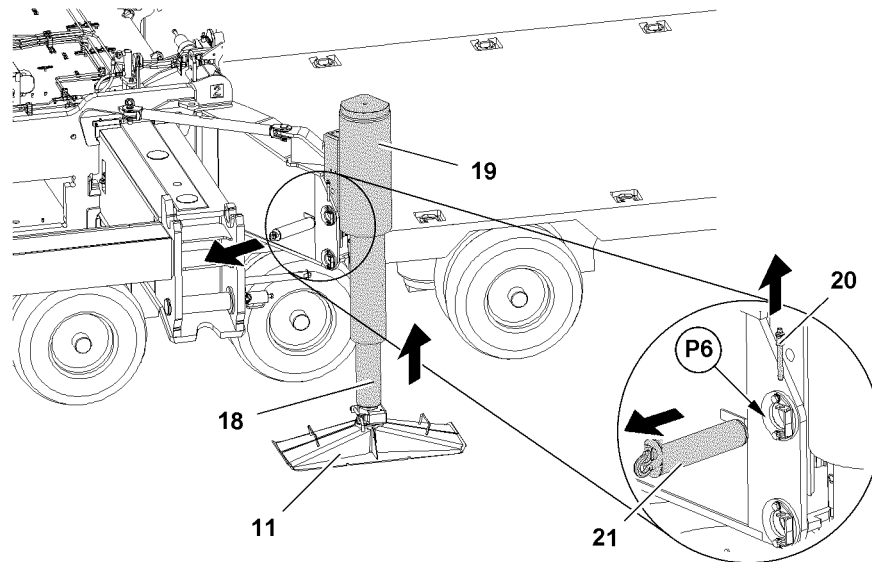
Empty page!

LWE/LTR 1220-003/24204-02-02/en

22



23



24

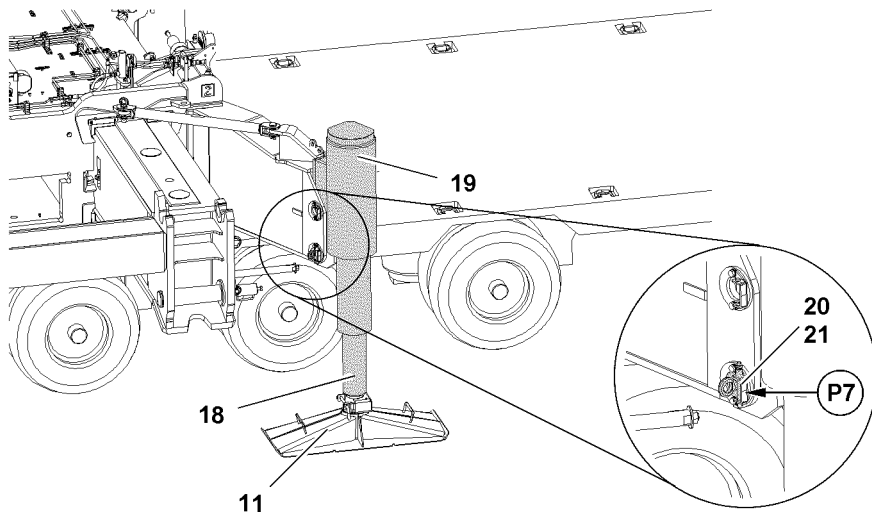


Fig.116876

LWE/LTR 1220-003/24204-02-02/en



## 1.5 Positioning the support cylinders in operating position

Make sure that the following prerequisites are met:

- All support plates **11** are pinned on support cylinders **19** and secured.
- The support cylinders **19** are extended to the ground.

### 1.5.1 Unpinning the support cylinders

- ▶ Release the pin **21**: Unpin locking ball pin **20**, see illustration **23**.
- ▶ Unpin the pin **21** at point **P6**, see illustration **23**.
- ▶ Retract the piston rod **18** until it can be pinned at point **P7**.
- ▶ Position all support cylinders in operating position.

### 1.5.2 Retracting the support cylinders



#### Note

- ▶ Retract support cylinders with BTT-E, BTT and TE1, see section „Installing the support plates“.
- ▶ Retract the support cylinders until the pin bores align at point **P7**.

### 1.5.3 Pinning the support cylinders

When the bores align at point **P7**:

- ▶ Insert the pin **21** at point **P7**, see illustration **24**.
- ▶ Secure the pin **21**: Insert the ball locking pin **20**.

#### Result:

- The support cylinder **19** is pinned and secured in operating position.

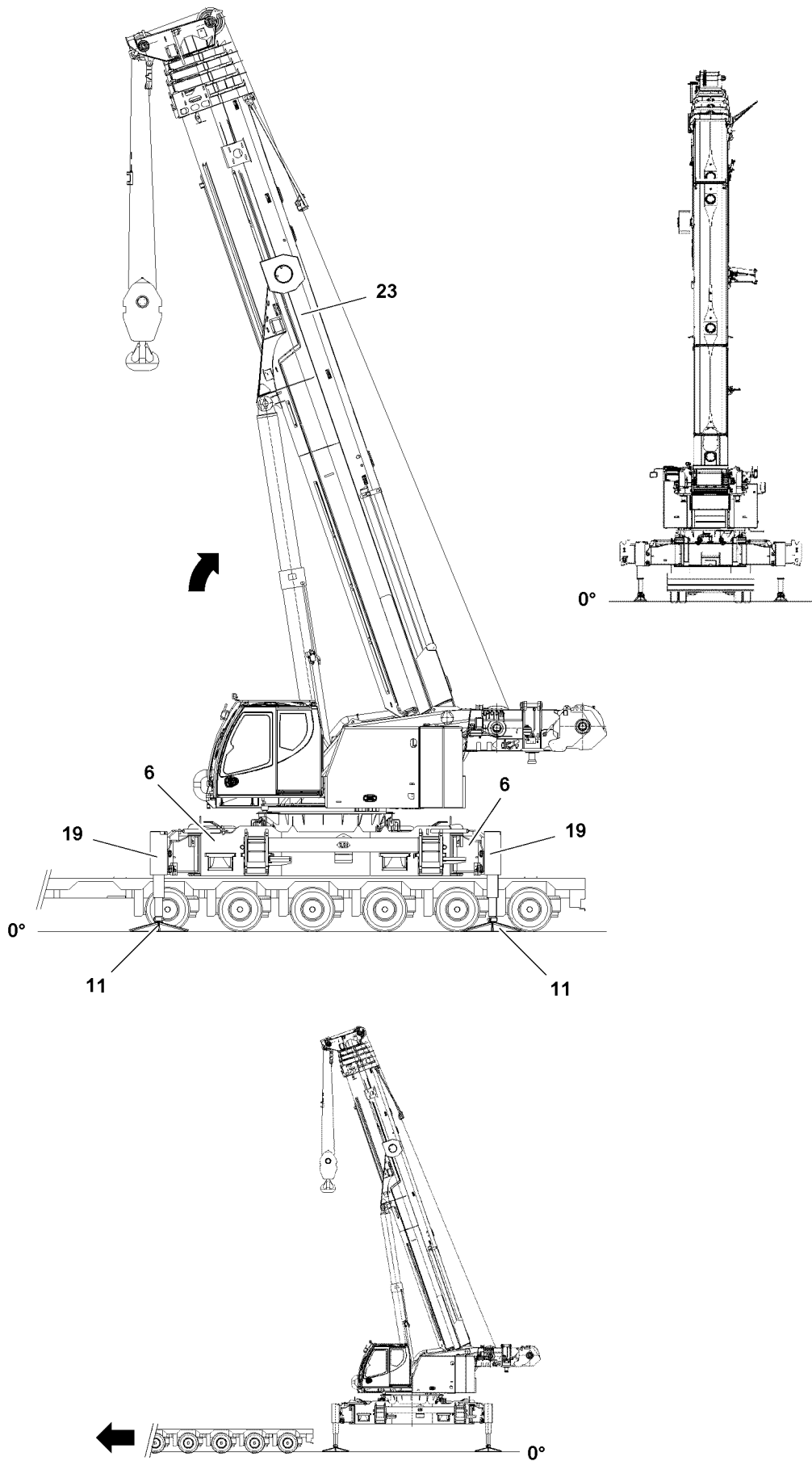


Fig.116877

LWE/LTR 1220-003/24204-02-02/en

## 1.6 Supporting the crane



### WARNING

Assembly support monitoring!

The assembly support is not monitored by the control!

The crane operator is obligated to check the assembly support before further assembly steps!

- ▶ Make sure that all folding brackets are swung and secured with rods!
- ▶ Make sure that all support plates are supported!



### WARNING

The crane can tip over!

If the crane is not aligned horizontally, it can tip over!

Personnel can be severely injured or killed!

- ▶ Make sure that the crane is horizontally aligned!



### Note

▶ The crane can be supported manually or automatically!

▶ At manual support, the support cylinders can be extended individually or all four simultaneously!



### WARNING

The crane can tip over!

When the automatic support is operated the crane is aligned automatically in horizontal direction!

- ▶ Make sure that the alignment is within the permitted tolerance and that all four support plates are touching the ground!



### WARNING

The crane can topple over!

At assembly / disassembly of the crawler carriers, if the values of the load chart are not adhered to, the crane can topple over at assembly / disassembly!

Personnel can be severely injured or killed!

This could result in high property damage!

- ▶ Observe and adhere to the values in the load chart for assembly / disassembly of the crawler carrier.

Make sure that the following prerequisites are met:

- No personnel is within the danger zone.
- The engine is running.
- All folding brackets **6** are folded out (no electronic monitoring).
- All support cylinders **19** are extended.
- All support plates **11** are supported.
- The LICCON overload protection is set:
  - Support base 4.4 m on supports
  - Central ballast 0 t
  - Counterweight 0 t
  - Without auxiliary boom / accessory
  - Slewing range

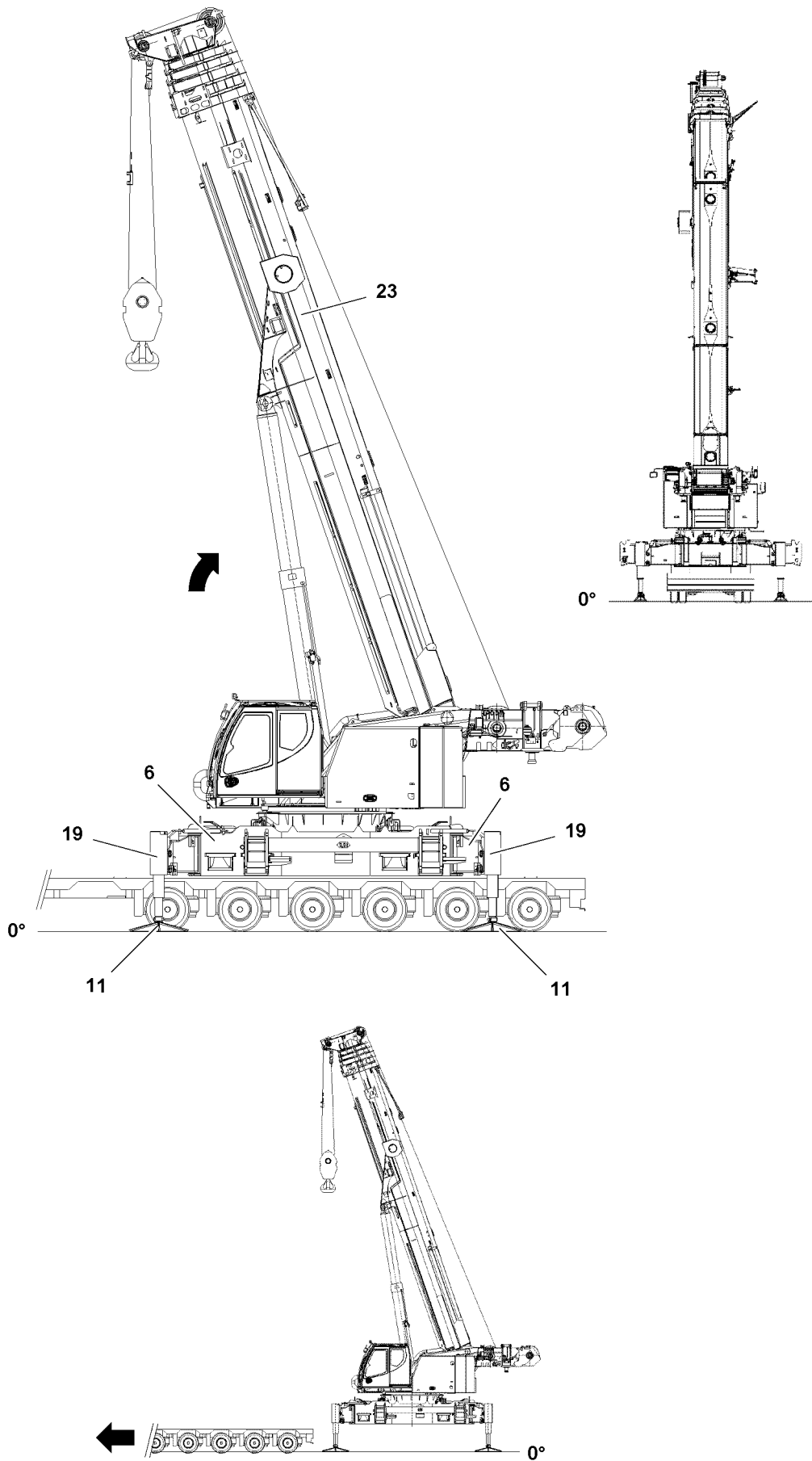


Fig.116877

LWE/LTR 1220-003/24204-02-02/en

### 1.6.1 Supporting the crane with the Bluetooth™ Terminal

Make sure that the following prerequisite is met:

- On the display of the BTT, the menu overview is visible.

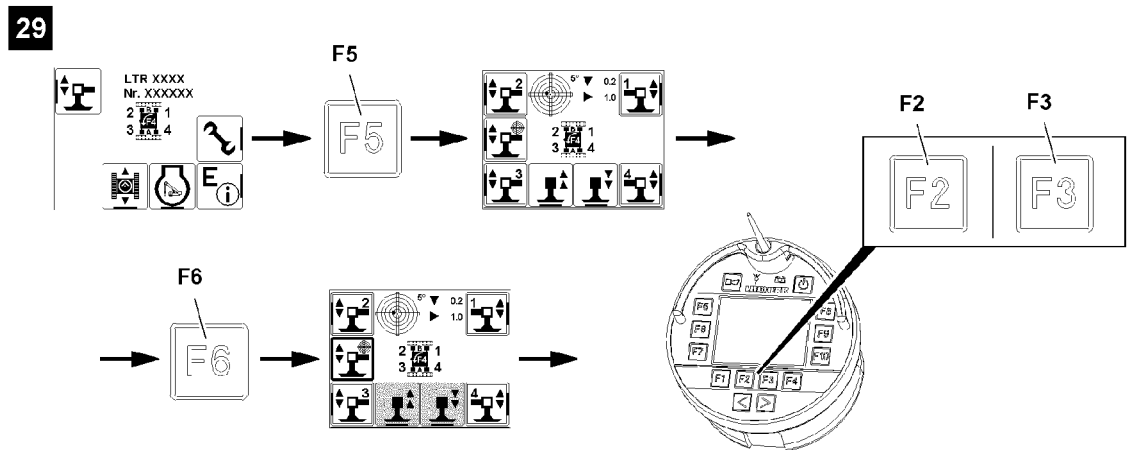


Fig.116904

- ▶ Press the function key **F5**, see illustration 29.

**Result:**

- The „Support“ menu is visible.

The support cylinders are marked with numbers depending on the alignment of the radio remote control.

The support automatic extends or retracts all support cylinders simultaneously and levels the crane during the support procedure automatically.

- ▶ Select the support automatic: Press the function key **F6**.

**Result:**

- Selected icon is visible with filled out frame: The support automatic is selected.
- Support cylinders are ready for extension and retraction.

When „retracting the support cylinders“:

- ▶ Press the function key **F2**.

**Result:**

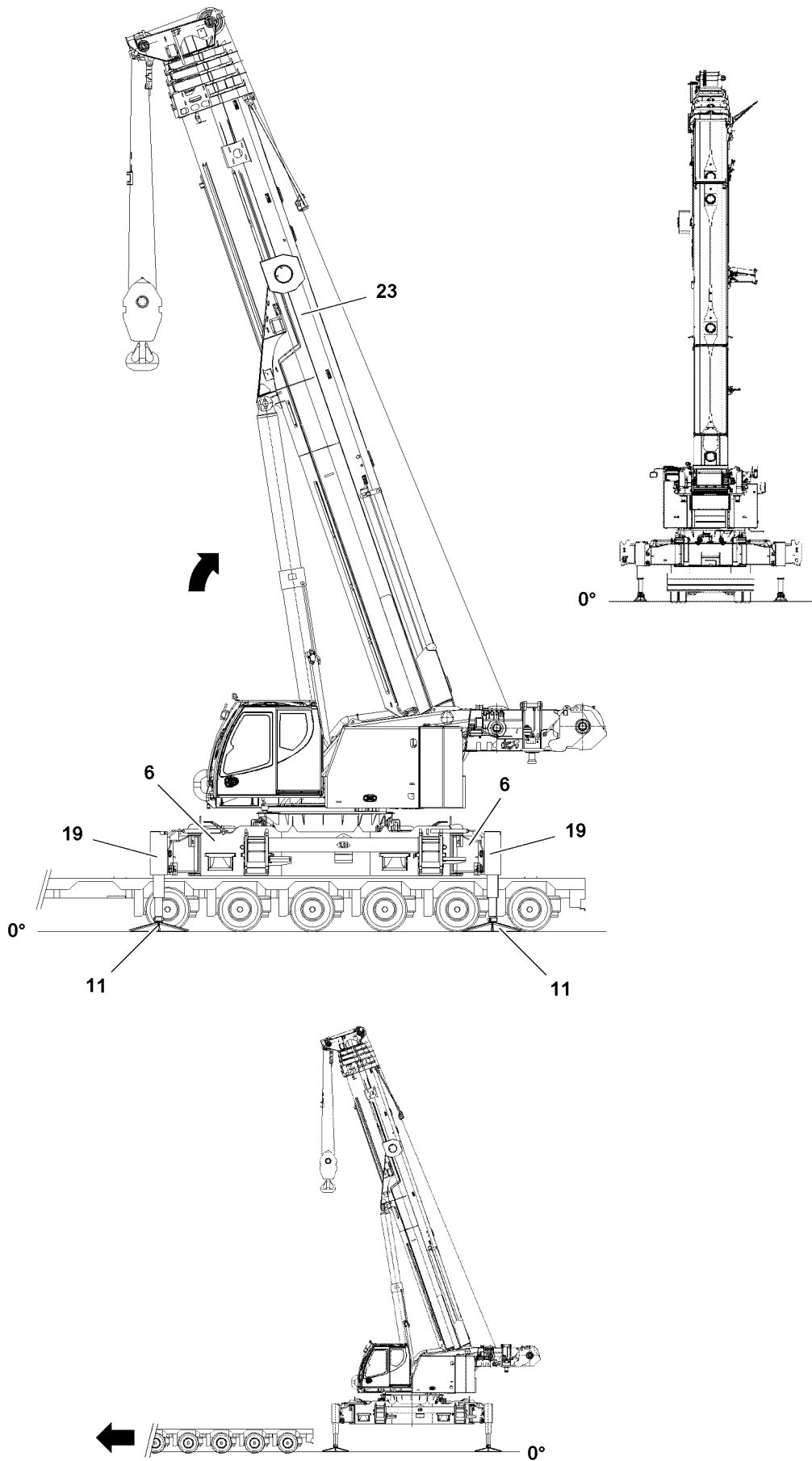
- The support cylinders **19** retract simultaneously.
- The crane is horizontally aligned.

When „extending the support cylinders“:

- ▶ Press the function key **F3**.

**Result:**

- The support cylinders **19** extend simultaneously.
- The crane is horizontally aligned.



LWE/LTR 1220-003/24204-02-02/en

Fig.116877

## 1.6.2 Supporting the crane from the crane operator's cab

Make sure that the following prerequisite is met:

- The „master switch assignment“ is visible on the touch display right (TE1).

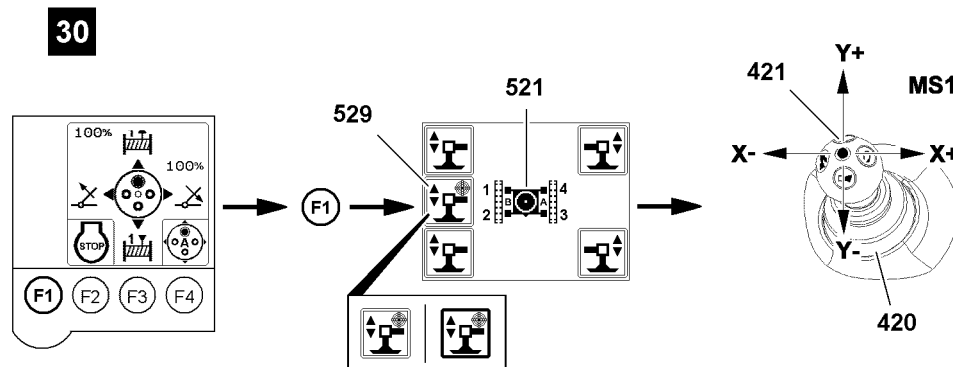


Fig. 116905

- ▶ Press the function key **F1**, see illustration 30.

### Result:

- The „Support“ menu is visible.

The support cylinders are marked with numbers depending on the alignment of the turntable, see icon **521**.

The support automatic extends or retracts all support cylinders simultaneously and levels the crane during the support procedure automatically.

- ▶ Select the support automatic: Select the icon **529** („touch“).

### Result:

- Selected icon is visible with filled out frame: The support automatic is selected.
- Support cylinders are ready for extension and retraction.

When „retracting the support cylinders“:

- ▶ Deflect the manual control lever **421** in direction Y+.

### Result:

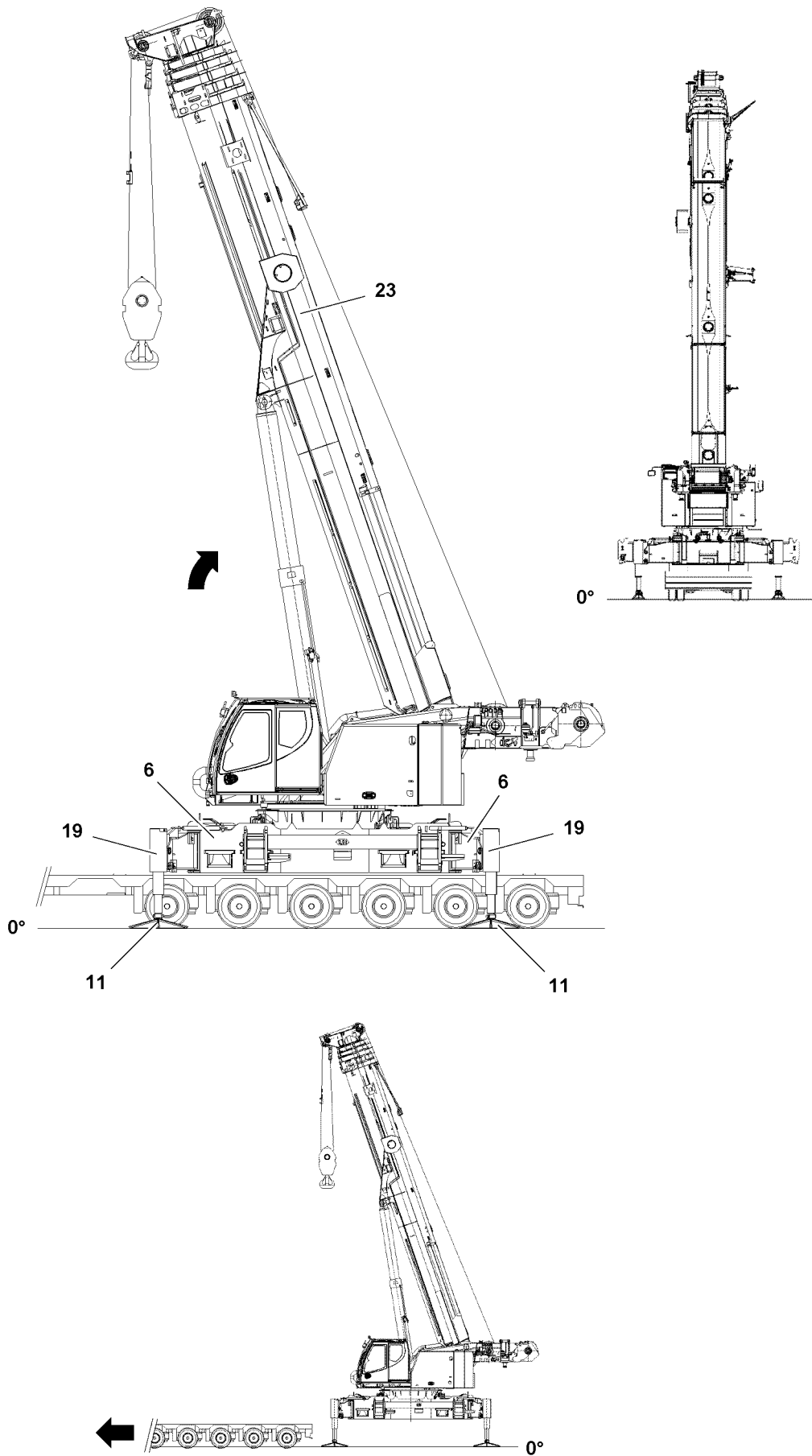
- The support cylinders **19** retract simultaneously.
- The crane is horizontally aligned.

When „extending the support cylinders“:

- ▶ Deflect the manual control lever **421** in direction Y-.

### Result:

- The support cylinders **19** extend simultaneously.
- The crane is horizontally aligned.



LWE/LTR 1220-003/24204-02-02/en

Fig.116877



### 1.6.3 Supporting the crane with the radio remote control\*

Make sure that the following prerequisite is met:

- On the display of the BTT-E, the menu overview is visible.

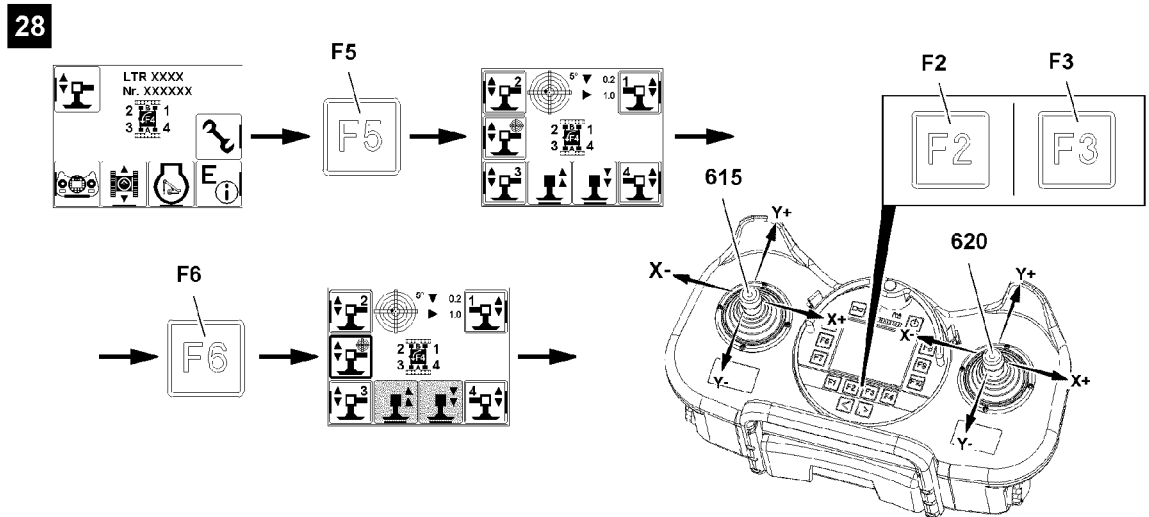


Fig. 116903

- ▶ Press the function key **F5**, see illustration 28.

**Result:**

- The „Support“ menu is visible.

The support cylinders are marked with numbers depending on the alignment of the radio remote control.

The support automatic extends or retracts all support cylinders simultaneously and levels the crane during the support procedure automatically.

- ▶ Select the support automatic: Press the function key **F6**.

**Result:**

- Selected icon is visible with filled out frame: The support automatic is selected.
- Support cylinders are ready for extension and retraction.

When „retracting the support cylinders“:

- ▶ Press the function key **F2**.

**Result:**

- The support cylinders **19** retract simultaneously.
- The crane is horizontally aligned.

When „extending the support cylinders“:

- ▶ Press the function key **F3**.

**Result:**

- The support cylinders **19** extend simultaneously.
- The crane is horizontally aligned.

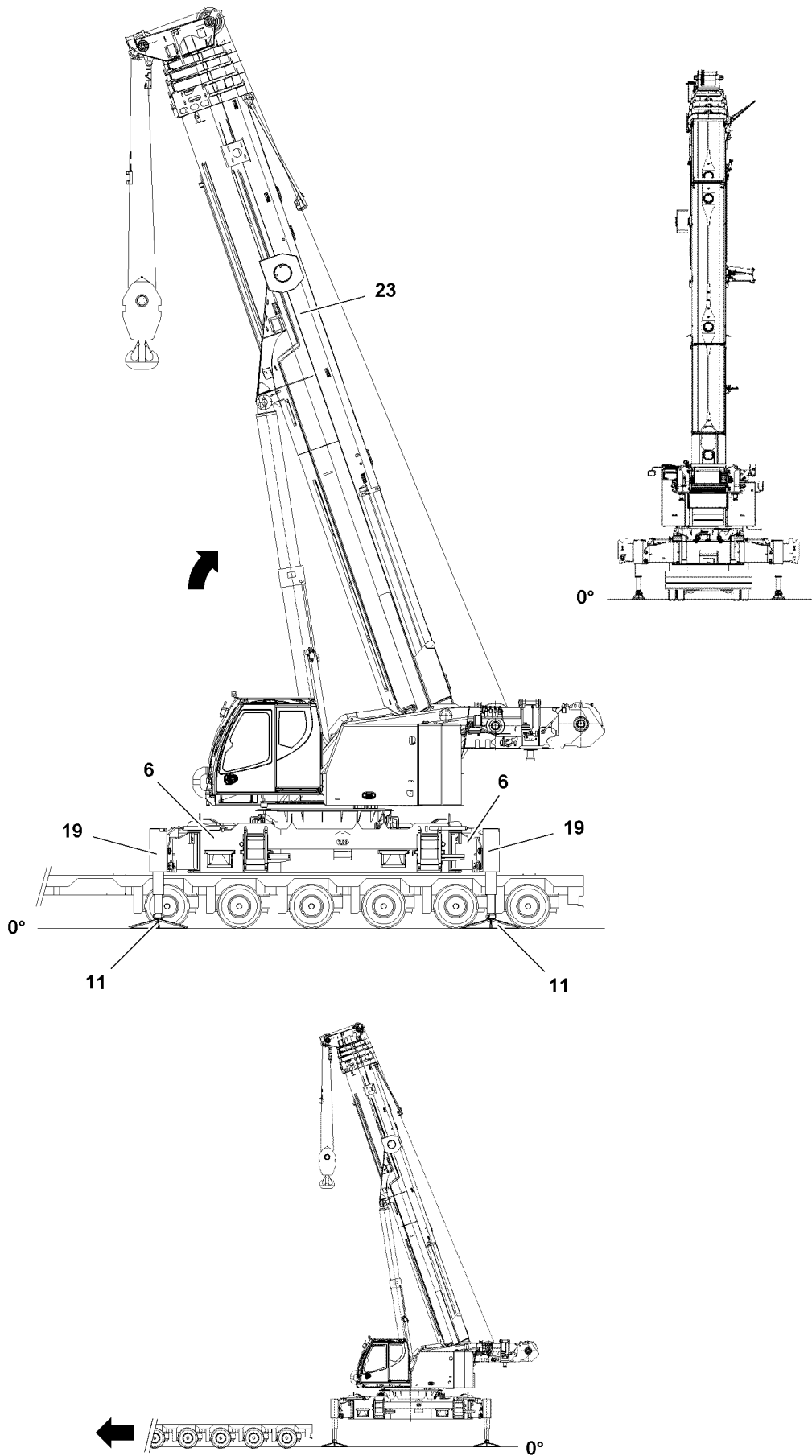


Fig.116877

LWE/LTR 1220-003/24204-02-02/en

## 1.7 Driving the transport vehicle out

Make sure that the following prerequisite is met:

- The crane is horizontally aligned.
  - The crane is supported high enough so that the transport vehicle can drive out from under the crane.
- ▶ Erect telescopic boom.
  - ▶ Drive the transport vehicle out from under the crane.

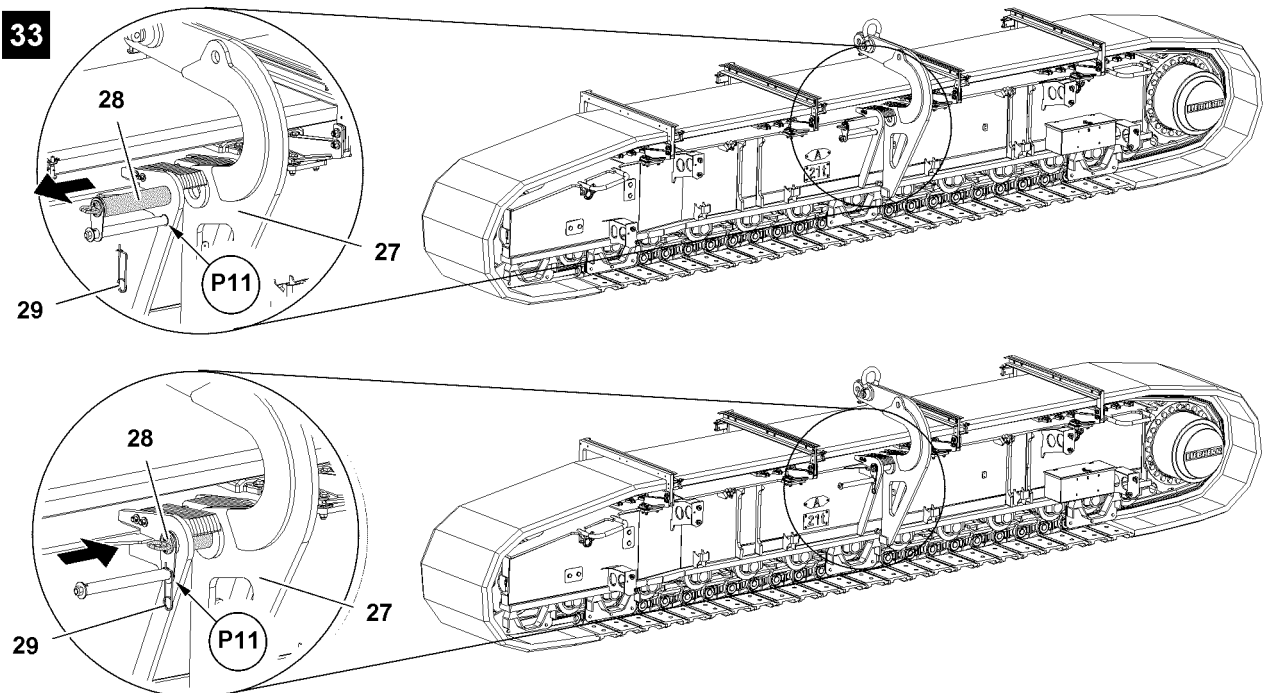
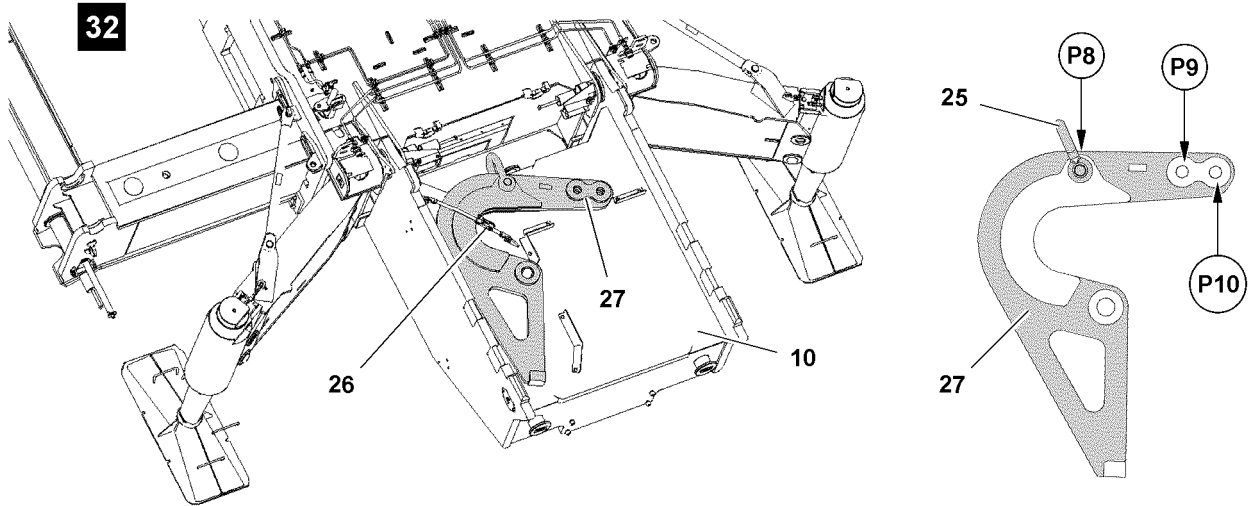
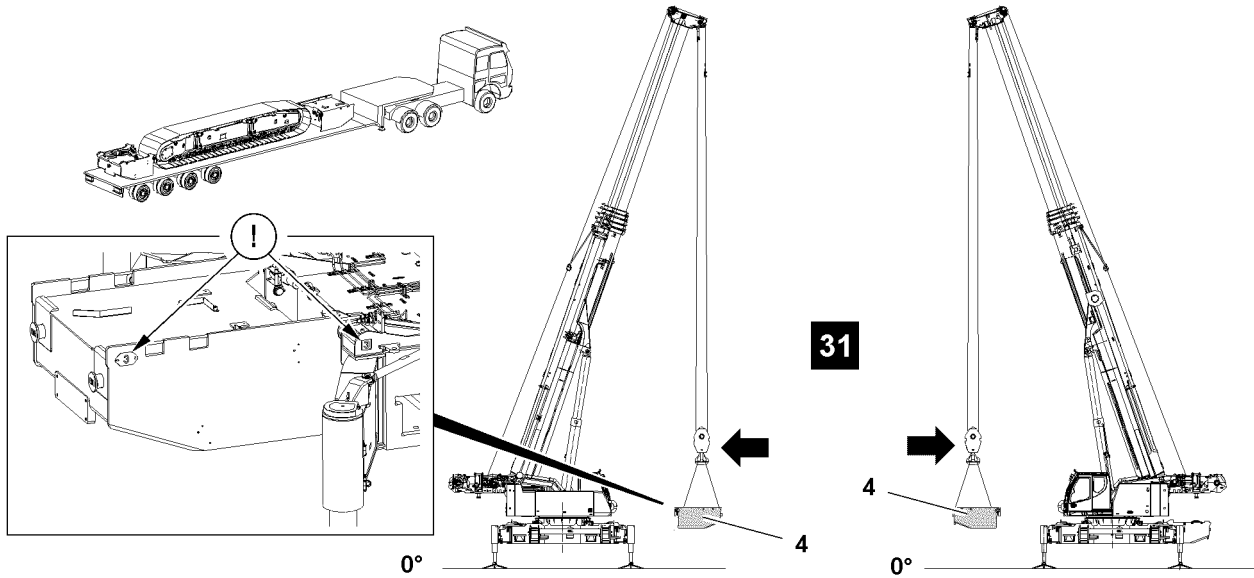


Fig.116878

LWE/LTR 1220-003/24204-02-02/en

## 1.8 Installing the central ballast



### Note

- ▶ Install the central ballast **4**, see Crane operating instructions, chapter 3.03!
- ▶ Install the central ballast **4**, see illustration **31**.

## 1.9 Assembling the crawler carrier

Make sure that the following prerequisites are met:

- No personnel is within the danger zone.
- All support cylinders are positioned in operating position.
- The central ballast is installed.
- Drive the crawler carriers are close as possible lengthwise to the crane.
- The LICCON overload protection is set:
  - Support base 4.4 m on supports
  - Central ballast 20 t
  - Counterweight 0 t
  - Without auxiliary boom / accessory
  - Slewing range



### Note

- ▶ For operation crane superstructure, see Crane operating instructions, chapter 4.01!

### 1.9.1 Preparing the assembly device

- ▶ Release the transport belt **26**, see illustration **32**.
- ▶ Fasten the crane at point **P8** on the shackle **25**.
- ▶ Lift the assembly device **27** with the crane and place it on the ground.
- ▶ Remove the shackle **25** at point **P8**, see illustration **32**.

Fastening point	Application
P8	Transport
P9	Assembly with incline
P10	Assembly 90°

- ▶ Fasten the crane at point **P9** on the shackle and lift the assembly device **27**.

### 1.9.2 Pinning the assembly device with the crawler carrier

- ▶ Remove the spring retainer **29** at point **P11** and unpin the pin **28**, see illustration **33**.
- ▶ Swing the assembly device **27** to the pin location.



### Note

- ▶ The position in which the crawler carrier remains balanced when lifting is set by the Liebherr-Werk!
- ▶ Insert the pin **28** at point **P11** and secure with spring retainer **29**, see illustration **33**.

### Result:

- The assembly device **27** is pinned and secured with the crawler carrier.

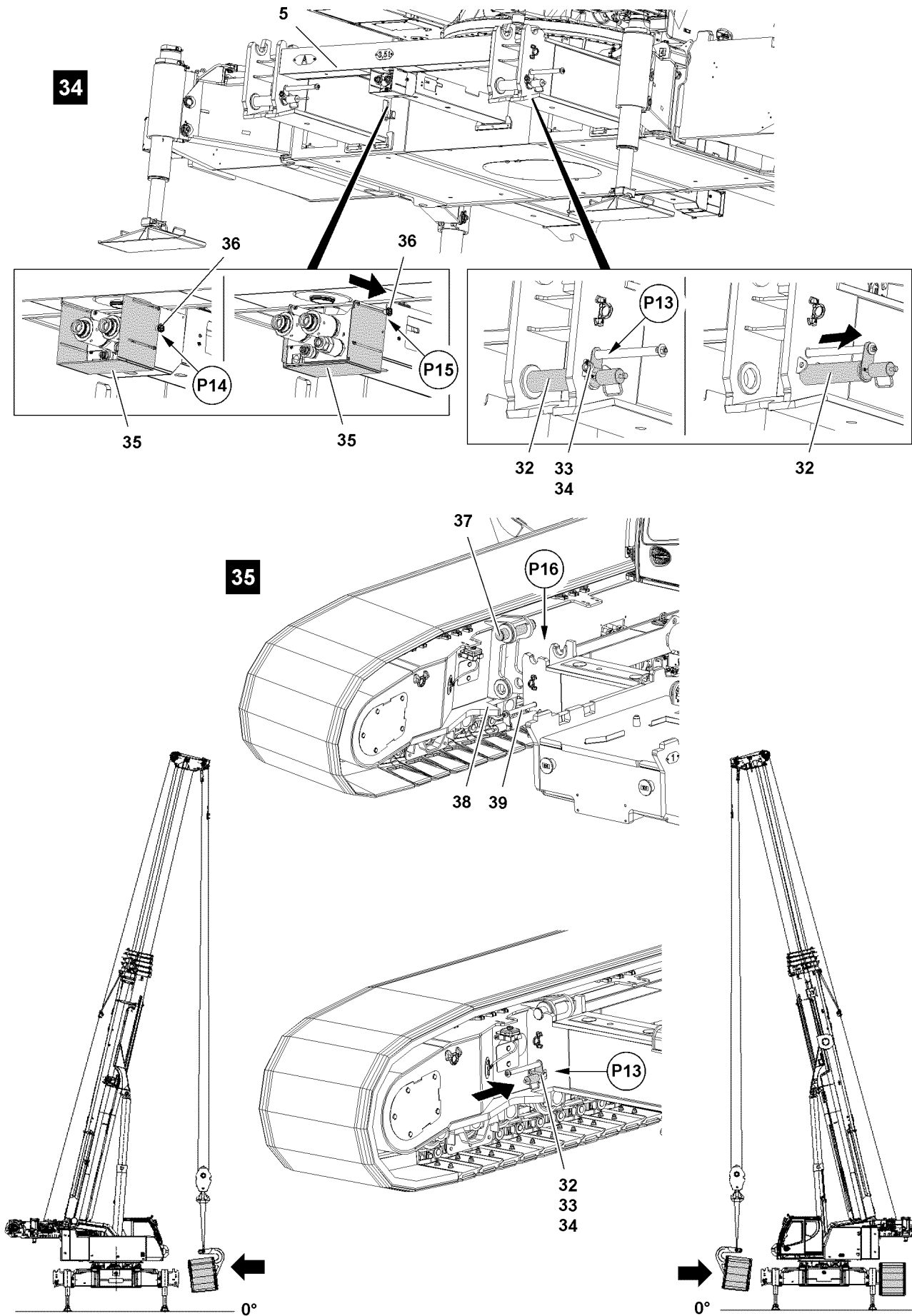


Fig.116879

LWE/LTR 1220-003/24204-02-02/en

### 1.9.3 Preparing the pin pulling device

#### NOTICE

Damage to the pin pulling device!

If the pins **32** are not unpinned at assembly of the cross carrier **5** then there is the danger that the pin pulling devices will be damaged!

▶ Make sure that the pins **32** on the cross carrier **5** are unpinned!

- ▶ Remove the safety locking pins **34** on both sides at point **P13**, see illustration **34**.
- ▶ Unpin the pins **33** on both sides at point **P13**, see illustration **34**.
- ▶ Unpin the pins **32** on both sides with the mechanical pin pulling device to the stop, see illustration **34**.

### 1.9.4 Sliding the protective plate on the cross carrier into assembly position

- ▶ Push the pin and pull the ball locking pins **36** out at point **P14** on both sides, see illustration **34**.
- ▶ Slide the protective plate **35**, see illustration **34**.
- ▶ Push the pin and insert the ball locking pins **36** at point **P15** on both sides, see illustration **34**.

### 1.9.5 Pinning the crawler carrier

Make sure that the following prerequisites are met:

- The assembly device is pinned and secured on the crawler carrier.
  - The pins **32** on the cross carrier are unpinned.
  - The protective plates **35** are in assembly position.
- ▶ Lift the crawler carrier „A“ and drive away the transport vehicle.



#### Note

▶ Pay attention to the identification on the crawler carrier and the cross carrier at assembly!

#### NOTICE

Damage to the pin pulling device!

To avoid damage on the pin pulling device **39** by the guide **38** on the crawler carrier, move the crawler carrier „A“ in to just over the edge of the cross carrier „A“!

- ▶ Do not move the crawler carrier „A“ in too high!
  - ▶ The crawler carrier assembly must be carried out exclusively with a guide!
  - ▶ Make sure that the guide is constantly in acoustic and visual contact with the crane operator!
- 
- ▶ Lower the crawler carrier „A“ with the pin **37** at point **P16** on the receptacles of the cross carrier „A“, see illustration **35**.
  - ▶ Swing the crawler carrier „A“ to the stop.
  - ▶ Pin the pins **32** on both sides at point **P13** with the mechanical pin pulling device to the stop, see illustration **35**.
  - ▶ Insert the pins **33** on both sides at point **P13** and secure with safety locking pin **34**, see illustration **35**.

#### Result:

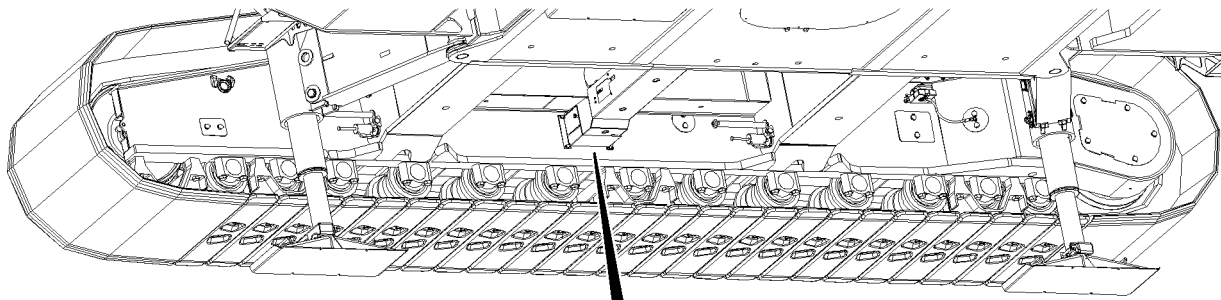
- Crawler carrier „A“ is pinned and secured.



#### Note

▶ The assembly of the crawler carrier „B“ is identical with the assembly of the crawler carrier „A“!

- ▶ Assemble the crawler carrier „B“.
- ▶ Unpin the assembly device and place it again in transport position on the central ballast.
- ▶ Secure the assembly device with the transport belt.



**36**

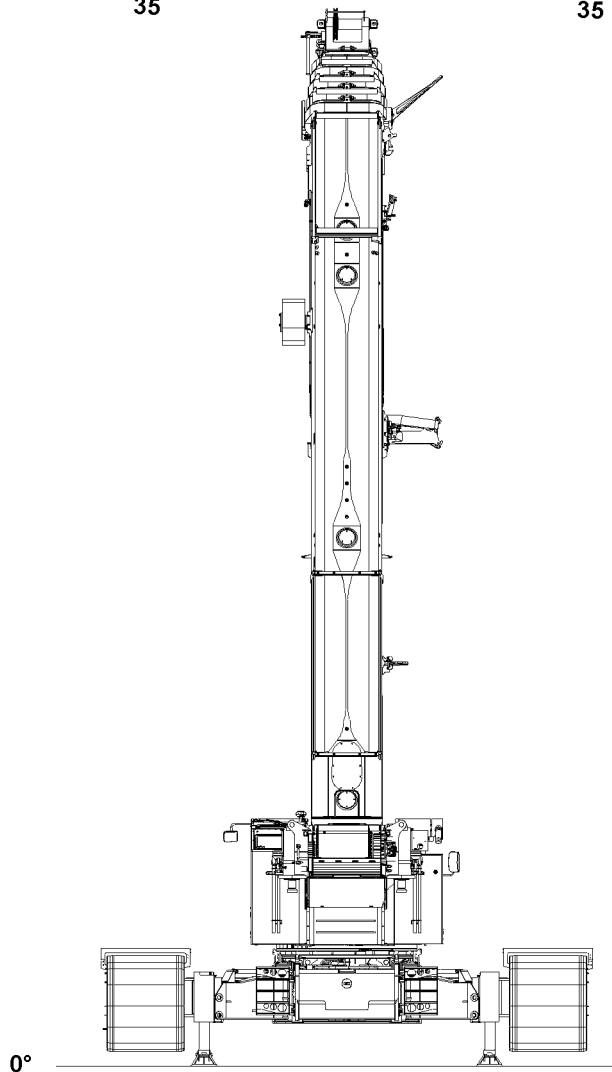
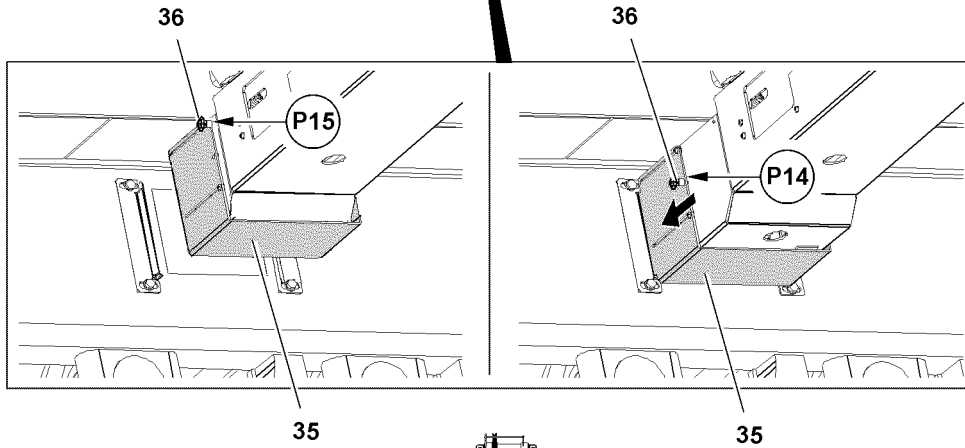


Fig.116880

LWE/LTR 1220-003/24204-02-02/en



## 1.10 Establishing the connection to the crawler carrier

Make sure that the following prerequisite is met:

- The crawler carrier is installed, pinned and secured.

### 1.10.1 Establishing the hydraulic connections to the crawler carrier

The hydraulic connections of the crawler carrier are made with quick couplings.

When connecting hydraulic lines with quick couplings, make sure that the coupling procedure is carried out correctly.



#### WARNING

Pressure in the hydraulic lines!

If the pressure supply is not interrupted before connecting / releasing the hydraulic lines, the hydraulic oil can escape with high pressure!

Personnel can be severely injured or killed!

- ▶ Release the pressure in the hydraulic system before connecting / disconnecting: Interrupt the pressure supply and wait for a short time!



#### WARNING

Loss of pressure or leakage!

Incorrectly coupled or self-loosening quick-release couplings (particularly return lines) can result in serious accidents due to component failure!

- ▶ Check that the quick couplings have been properly connected before using the crane!
- ▶ Connect the coupling components (sleeve and connector) and screw together with the hand-tightened nut.
- ▶ Tighten the hydraulic coupling by hand. Rotate the hand-tightened nut until it reaches a tangible, fixed stop position.
- ▶ Establish the hydraulic connections to the crawler carrier.

### 1.10.2 Establishing the electrical connections to the crawler carrier

- ▶ Establish the electrical connections to the crawler carrier, see separate electrical wiring diagram.

### 1.10.3 Establishing the connections of the central lubrication system to the crawler carrier

- ▶ Establish the connections of the central lubrication system to the crawler carrier.

### 1.10.4 Sliding the protective plate on the cross carrier into operating position

- ▶ Push the pin and pull the ball locking pins **36** out at point **P15** on both sides, see illustration **36**.
- ▶ Slide the protective plate **35**, see illustration **36**.
- ▶ Push the pin and insert the ball locking pins **36** at point **P14** on both sides, see illustration **36**.

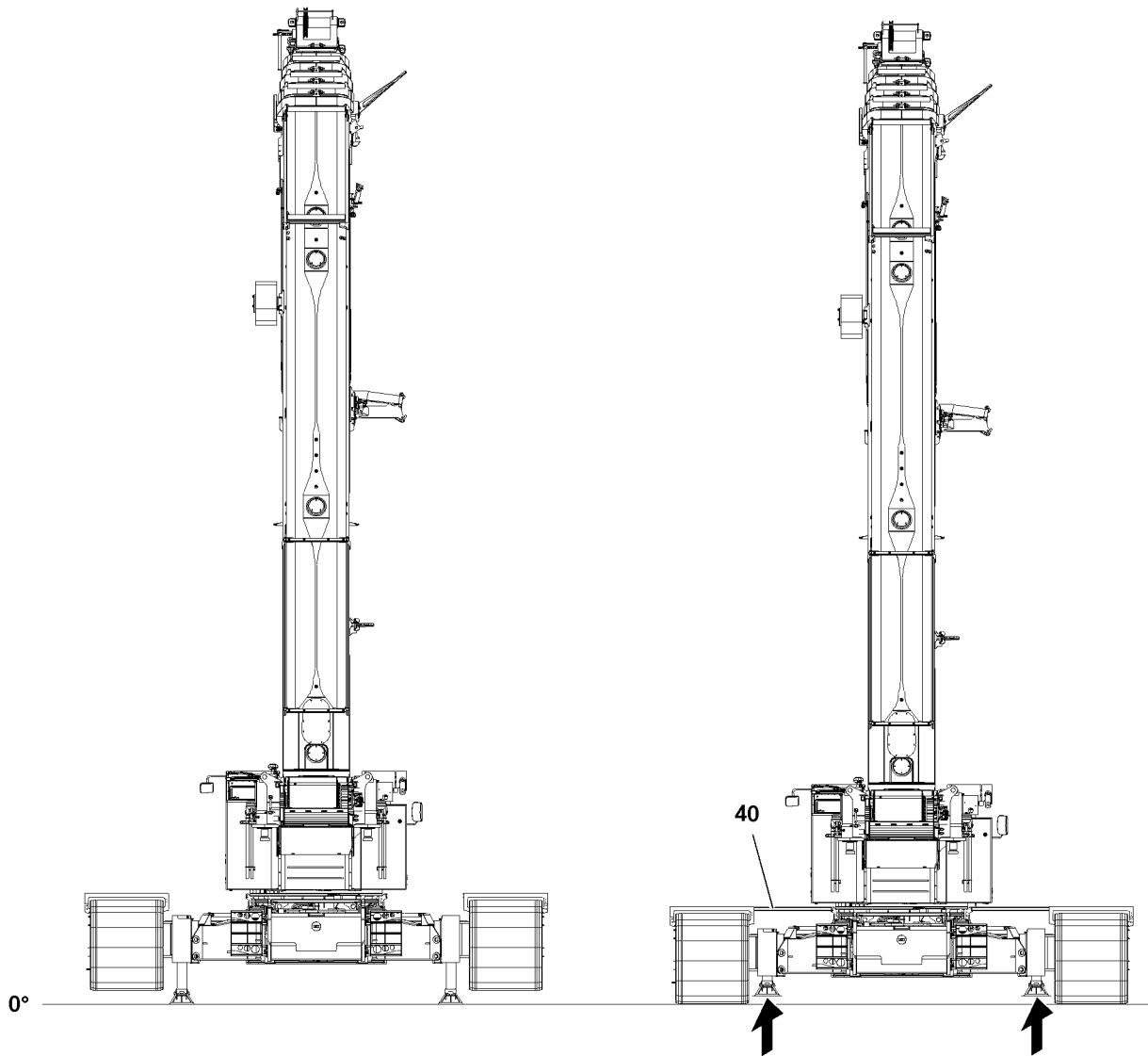


Fig.116881

## 1.11 Lowering the crane

Make sure that the following prerequisites are met:

- The crawler carriers are pinned and secured.
- The crawler carriers have been checked and tested for function.



---

### WARNING

Danger of crushing!

When lowering the crane, there is an increased danger of accidents due to crushing!

Personnel can be severely injured or killed!

- ▶ Make sure that there are no persons within the danger zone!
- 



---

### Note

- ▶ Retract support cylinders with BTT-E, BTT and TE1, see section „Supporting the crane“.
- 

- ▶ Lower the crane.
- 



---

### WARNING

Danger of falling!

- ▶ For further assembly steps, install the walking platforms **40** immediately.
- 

- ▶ Install the walking platforms **40**, see Crane operating instructions, chapter 2.06.
-

*Fig.195219*

LWE/LTR 1220-003/24204-02-02/en

## 2 Disassembling the crawler carriers



### DANGER

Crane movement in **unsupported** status!

If the crane superstructure is turned or the boom erected, then the crane can tip over and severely or fatally injure personnel.

- ▶ Do not turn the crane superstructure when as the crane is resting on the transport vehicle.
- ▶ Do not turn erect the boom when as the crane is resting on the transport vehicle.
- ▶ Before carrying out crane movements, support the crane with the assembly support and align it horizontally.
- ▶ Adhere to the sequence of the assembly steps in this chapter.



### WARNING

Danger of falling!

During assembly / disassembly, inspection and maintenance work, personnel must be secured with appropriate aids to prevent them from falling! If this is not observed, assembly personnel could fall and suffer life-threatening or fatal injuries!

- ▶ The assembly personnel must always move carefully and anticipatory on the crane, the crane components or lattice sections!
- ▶ All work aloft, where there is a danger of falling must be carried out with suitable aids!
- ▶ If fall protection equipment is available, then it must be used!
- ▶ If aids are not available and work cannot be carried out from the ground, then the assembly personnel must secure themselves with the permissible fall arrest system to prevent falling, see Crane operating instructions, chapter 2.04!
- ▶ The fall arrest system must be attached on the fastening and hook points as well as on the safety ropes!
- ▶ Only step on the aids, ladders and catwalks with clean shoes!
- ▶ Keep aids, ladders and catwalks free of heavy dirt, snow and ice!



### WARNING

Danger of impact / crushing!

When installing / removing counterweight components with the auxiliary crane, crane components can start to swing back and forth!

When lifting / lowering and positioning crane components, there is an increased danger of impacts / crushing!

Personnel can be caught and severely injured or killed!

- ▶ Make sure that personnel cannot be caught by components!
- ▶ When working in danger zones: Use aids to protect limbs!
- ▶ Guide components with suitable aids to minimize oscillation!



### WARNING

Improper support!

If the crane is not properly supported from below, it can sink into the ground and cause it to topple over!

- ▶ The support must take on the weight of the crane safely!
- ▶ Use stable materials such as wood, steel plates or concrete slabs of a suitable size for support, depending on the ground conditions!

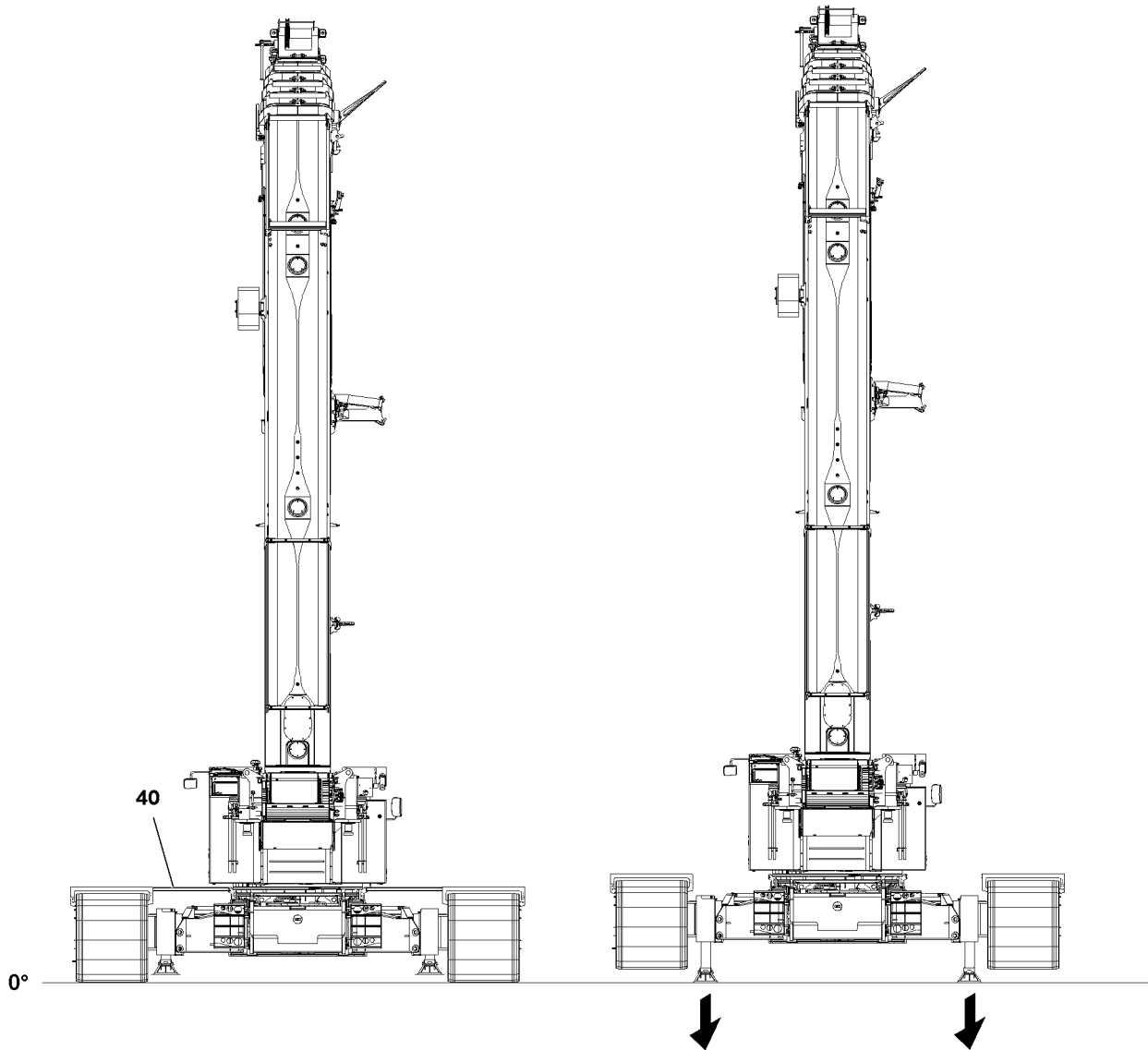


Fig.116882

LWE/LTR 1220-003/24204-02-02/en

## 2.1 Supporting the crane



### WARNING

The crane can tip over!  
If the crane is not aligned horizontally, it can tip over!  
Personnel can be severely injured or killed!

- ▶ Make sure that the crane is horizontally aligned!



### Note

- ▶ The crane can be supported manually or automatically!
- ▶ At manual support, the support cylinders can be extended individually or all four simultaneously!



### WARNING

Assembly support monitoring!  
The assembly support is not monitored by the control!  
The crane operator is obligated to check the assembly support before further disassembly steps!

- ▶ Make sure that all folding brackets are swung and secured with rods!
- ▶ Make sure that the support plates are positioned on load bearing and horizontal ground!
- ▶ Make sure that all support plates are supported!



### WARNING

The crane can tip over!  
When the automatic support is operated the crane is aligned automatically in horizontal direction!

- ▶ Make sure that the alignment is within the permitted tolerance and that all four support plates are touching the ground!



### WARNING

The crane can topple over!  
At assembly / disassembly of the crawler carriers, if the values of the load chart are not adhered to, the crane can topple over at assembly / disassembly!  
Personnel can be severely injured or killed!  
This could result in high property damage!

- ▶ Observe and adhere to the values in the load chart for assembly / disassembly of the crawler carrier.

Make sure that the following prerequisites are met:

- The set up location is level and has sufficient load bearing capacity.
- The telescopic boom is fully telescoped in.
- The crawlers are extended on wide track (100 %).
- Machines with fastening bits: Fastening bits are extended into operating position
- The counterweight on the turntable has been removed.
- The walking platforms **40** have been removed on the turntable.
- No personnel is within the danger zone.
- The engine is running.
- All folding brackets are folded out (no electronic monitoring).
- All support plates are supported.
- The LICCON overload protection is set:
  - Support base 4.4 m on supports
  - Central ballast 20 t
  - Counterweight 0 t
  - Without auxiliary boom / accessory
  - Slewing range

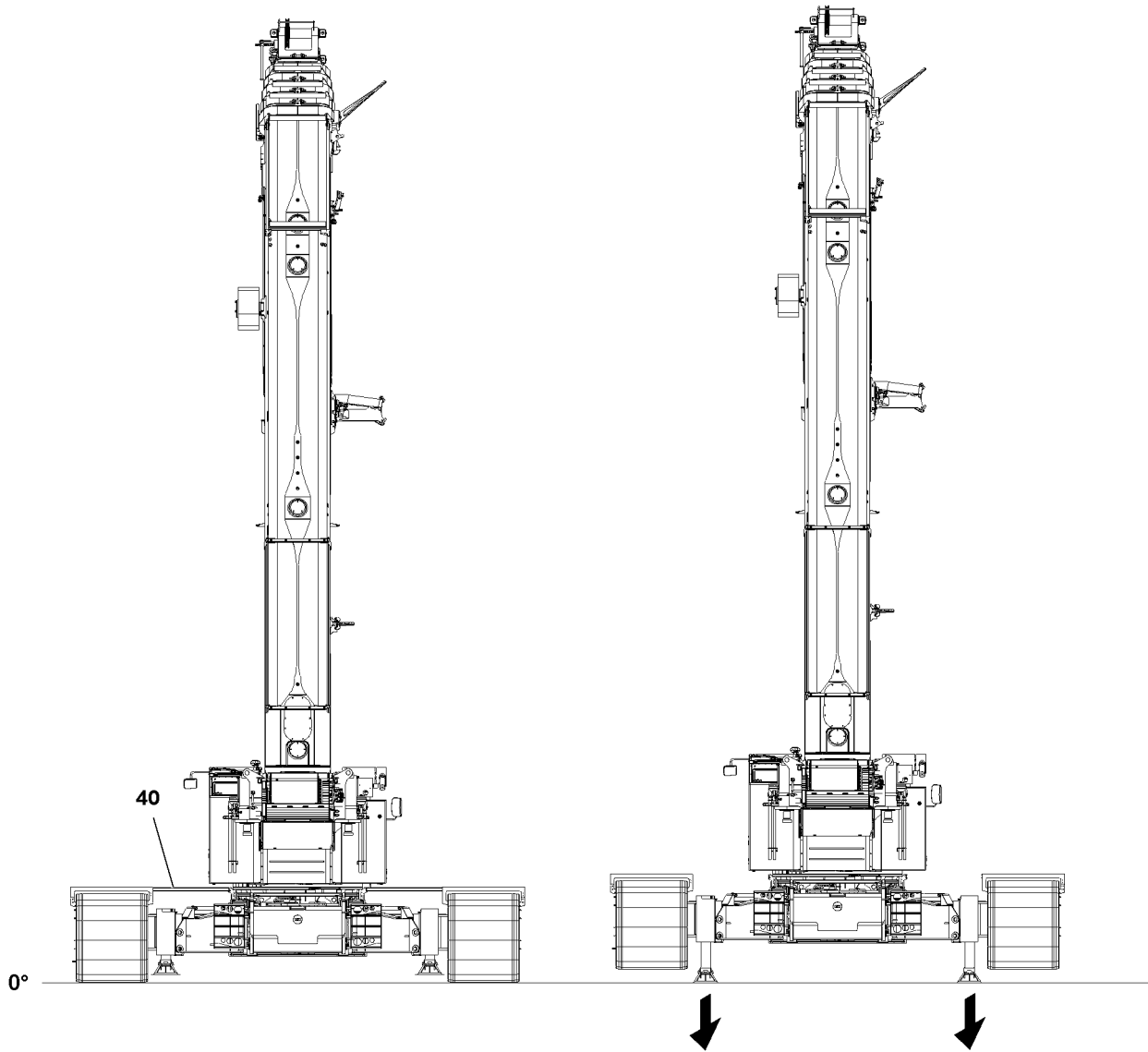


Fig.116882

LWE/LTR 1220-003/24204-02-02/en



## 2.1.1 Supporting the crane with the Bluetooth™ Terminal

Make sure that the following prerequisite is met:

- On the display of the BTT, the menu overview is visible.

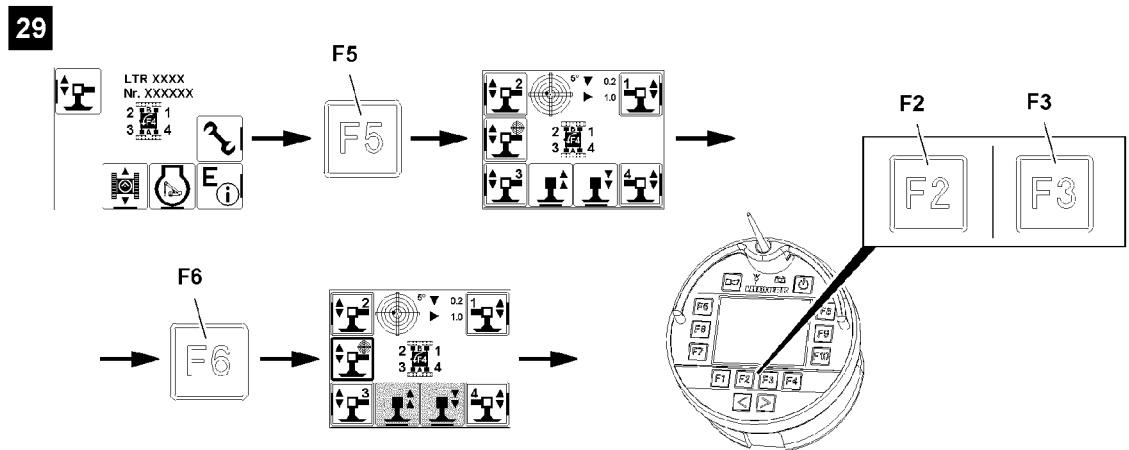


Fig.116904

- ▶ Press the function key **F5**, see illustration 29.

**Result:**

- The „Support“ menu is visible.

The support cylinders are marked with numbers depending on the alignment of the radio remote control.

The support automatic extends or retracts all support cylinders simultaneously and levels the crane during the support procedure automatically.

- ▶ Select the support automatic: Press the function key **F6**.

**Result:**

- Selected icon is visible with filled out frame: The support automatic is selected.
- Support cylinders are ready for extension and retraction.

When „retracting the support cylinders“:

- ▶ Press the function key **F2**.

**Result:**

- The support cylinders retract simultaneously.
- The crane is horizontally aligned.

When „extending the support cylinders“:

- ▶ Press the function key **F3**.

**Result:**

- The support cylinders extend simultaneously.
- The crane is horizontally aligned.

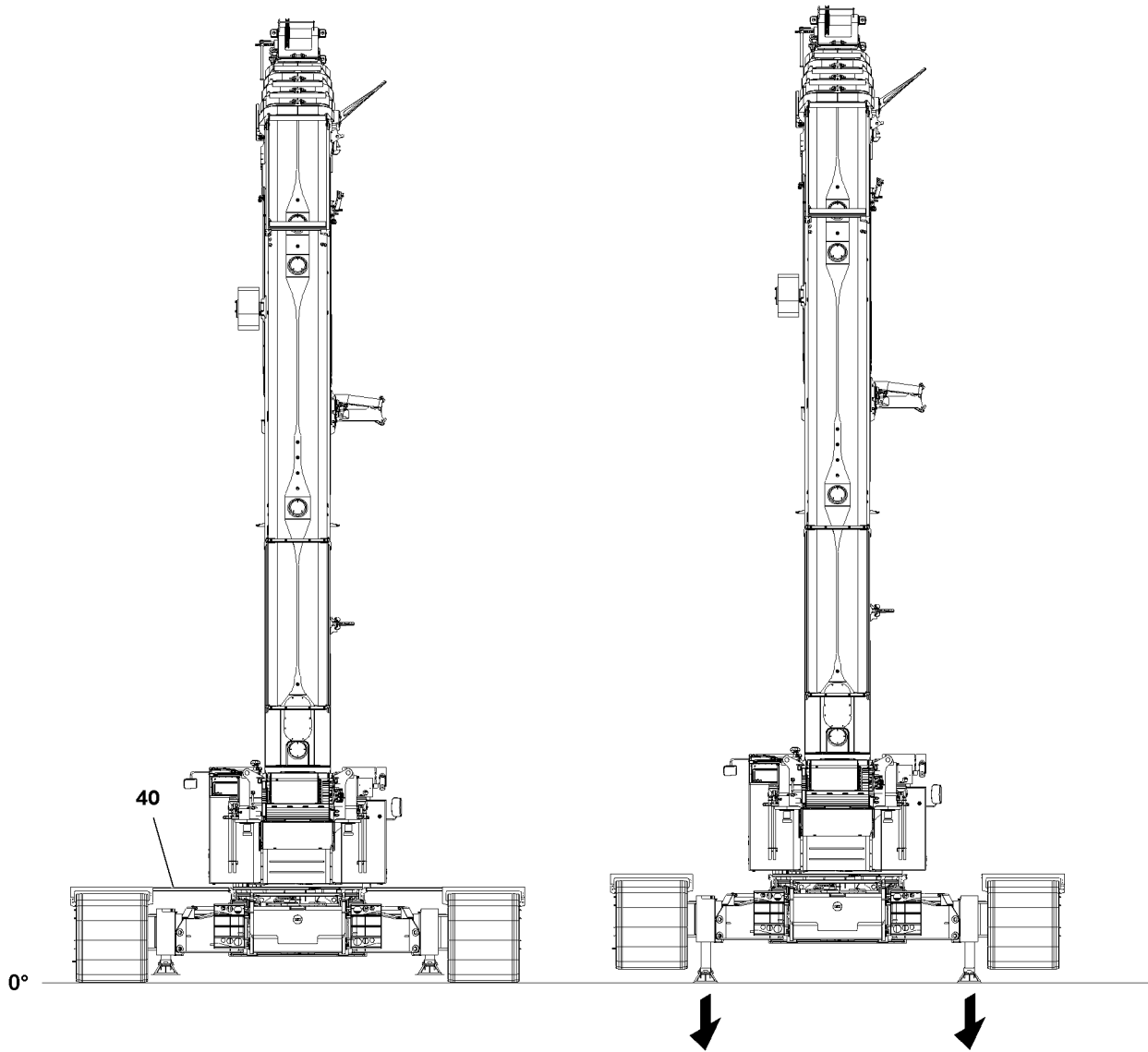


Fig.116882

LWE/LTR 1220-003/24204-02-02/en

## 2.1.2 Supporting the crane from the crane operator's cab

Make sure that the following prerequisite is met:

- The „master switch assignment“ is visible on the touch display right (TE1).

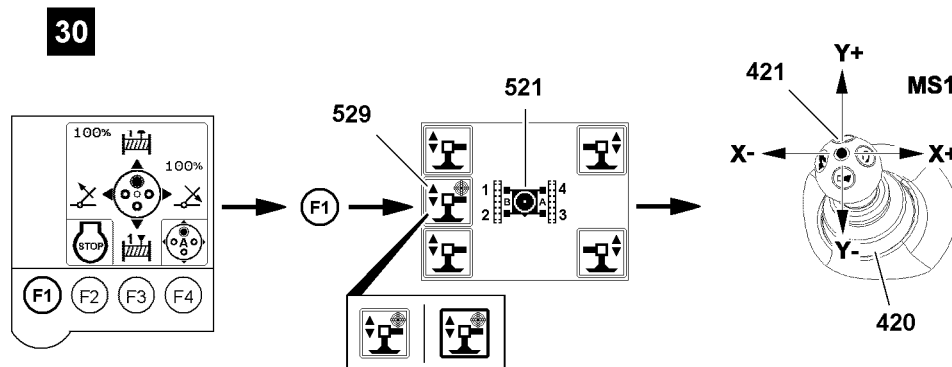


Fig. 116905

- ▶ Press the function key **F1**, see illustration 30.

### Result:

- The „Support“ menu is visible.

The support cylinders are marked with numbers depending on the alignment of the turntable, see icon **521**.

The support automatic extends or retracts all support cylinders simultaneously and levels the crane during the support procedure automatically.

- ▶ Select the support automatic: Select the icon **529** („touch“).

### Result:

- Selected icon is visible with filled out frame: The support automatic is selected.
- Support cylinders are ready for extension and retraction.

When „retracting the support cylinders“:

- ▶ Deflect the manual control lever **421** in direction Y+.

### Result:

- The support cylinders retract simultaneously.
- The crane is horizontally aligned.

When „extending the support cylinders“:

- ▶ Deflect the manual control lever **421** in direction Y-.

### Result:

- The support cylinders extend simultaneously.
- The crane is horizontally aligned.

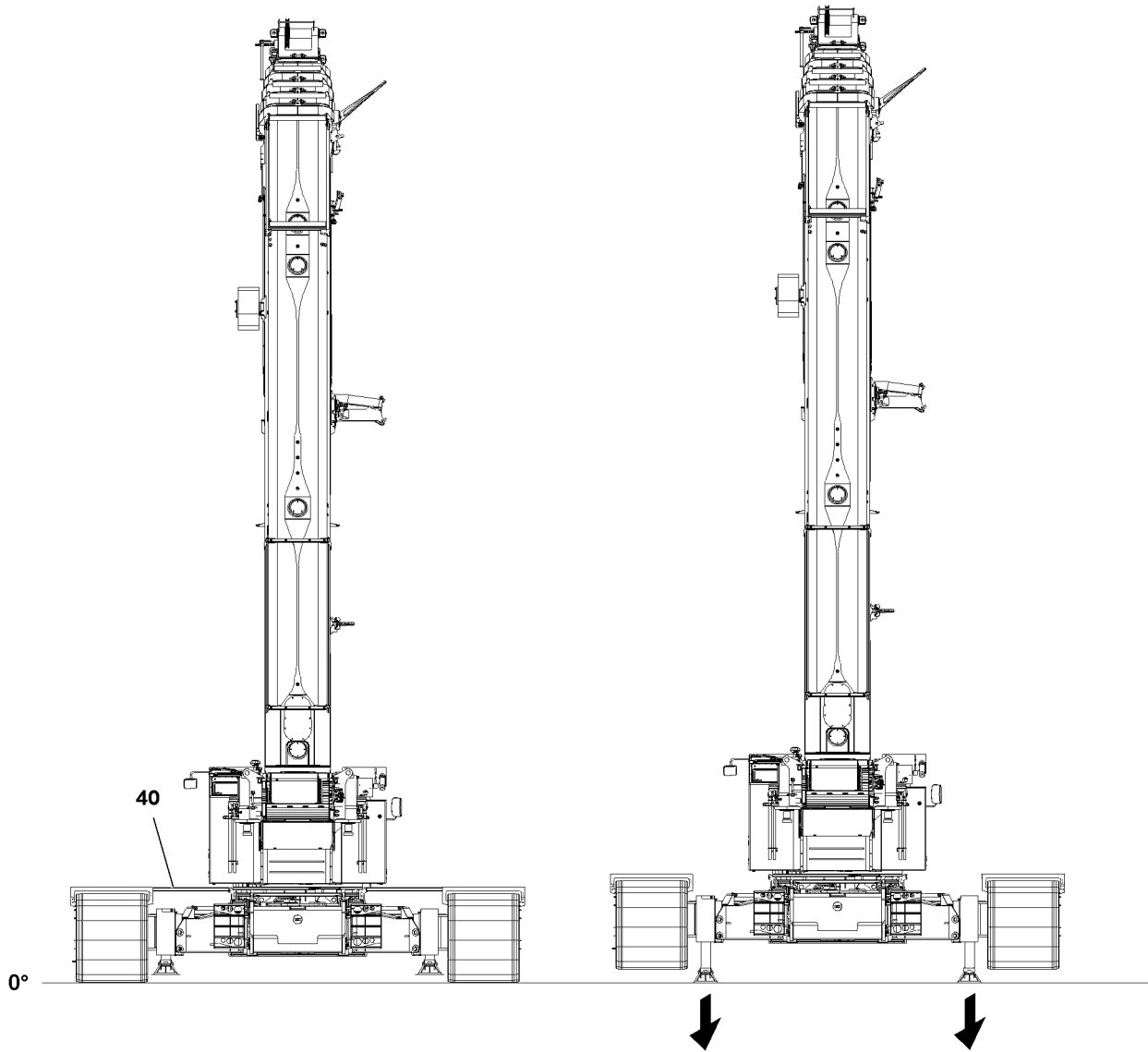


Fig.116882

LWE/LTR 1220-003/24204-02-02/en

### 2.1.3 Supporting the crane with the radio remote control\*

Make sure that the following prerequisite is met:

- On the display of the BTT-E, the menu overview is visible.

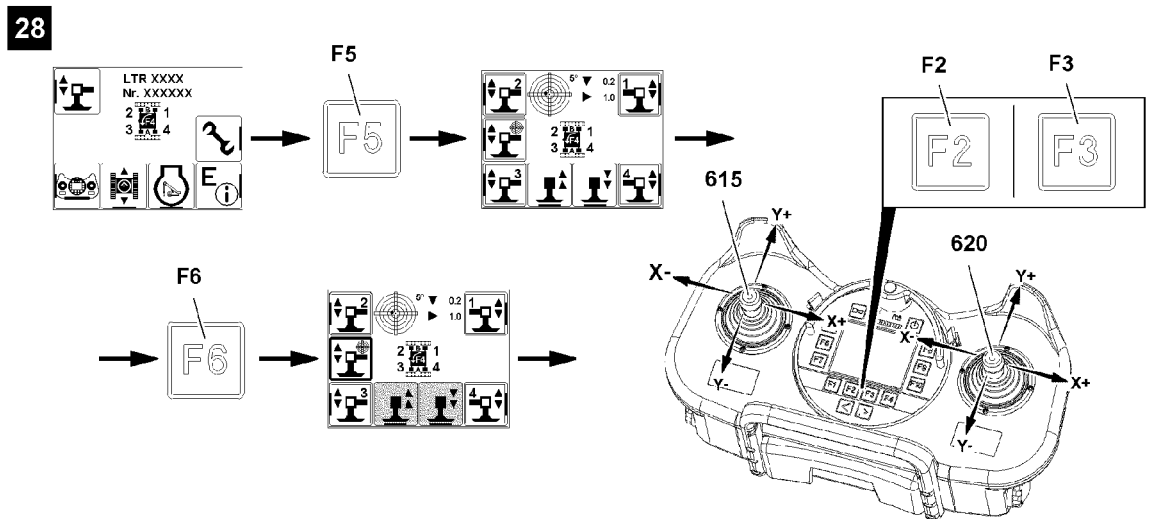


Fig. 116903

- ▶ Press the function key **F5**, see illustration 28.

**Result:**

- The „Support“ menu is visible.

The support cylinders are marked with numbers depending on the alignment of the radio remote control.

The support automatic extends or retracts all support cylinders simultaneously and levels the crane during the support procedure automatically.

- ▶ Select the support automatic: Press the function key **F6**.

**Result:**

- Selected icon is visible with filled out frame: The support automatic is selected.
- Support cylinders are ready for extension and retraction.

When „retracting the support cylinders“:

- ▶ Press the function key **F2**.

**Result:**

- The support cylinders retract simultaneously.
- The crane is horizontally aligned.

When „extending the support cylinders“:

- ▶ Press the function key **F3**.

**Result:**

- The support cylinders extend simultaneously.
- The crane is horizontally aligned.

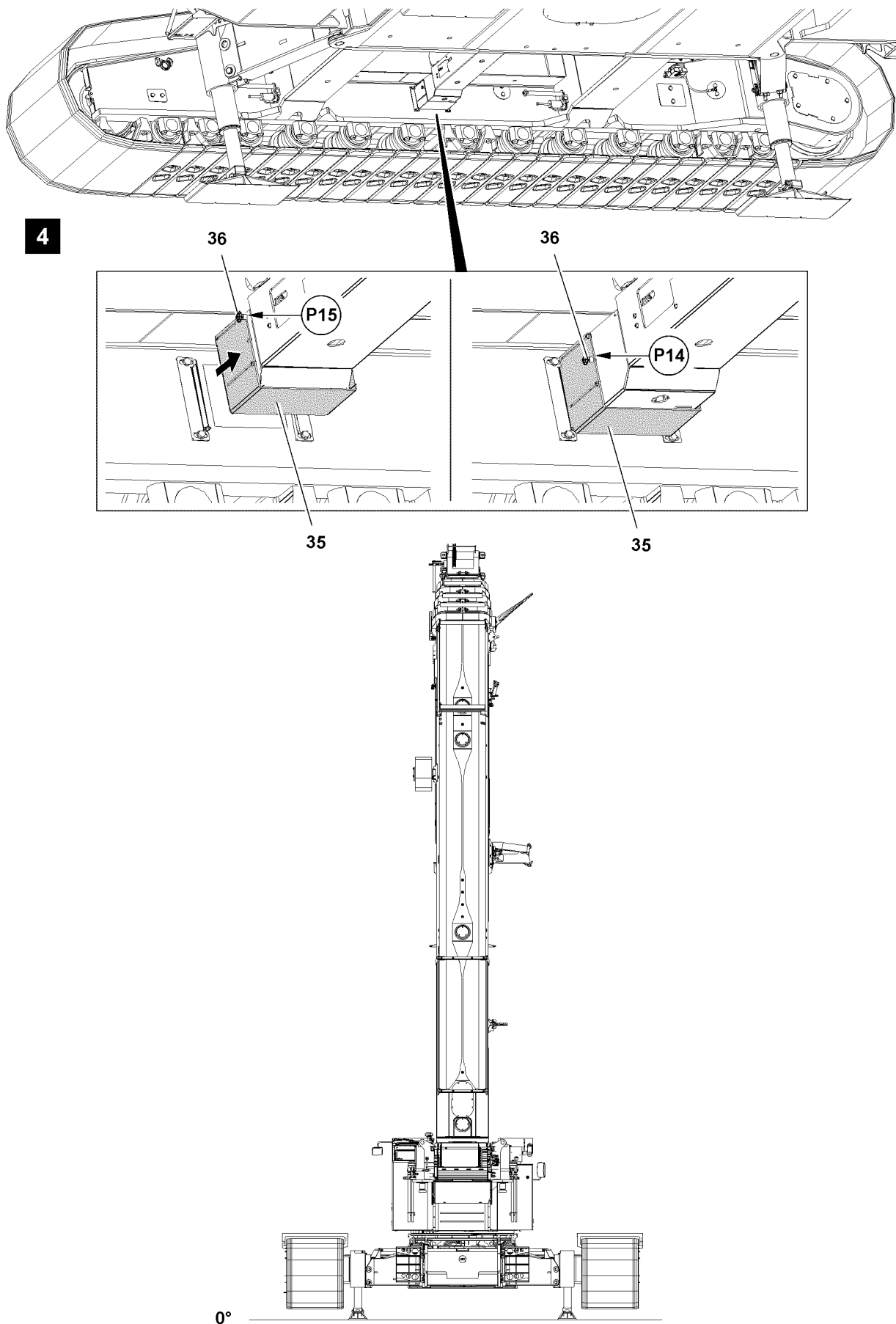


Fig.116901

LWE/LTR 1220-003/24204-02-02/en

## 2.2 Disconnecting the connections to the crawler carrier

Make sure that the following prerequisite is met:

- The crane is supported.

### 2.2.1 Sliding the protective plate on the cross carrier into assembly position

- ▶ Push the pin and pull the ball locking pins **36** out at point **P14** on both sides, see illustration **4**.
- ▶ Slide the protective plate **35**, see illustration **4**.
- ▶ Push the pin and insert the ball locking pins **36** at point **P15** on both sides, see illustration **4**.

### 2.2.2 Disconnecting the hydraulic connections to the crawler carrier

The hydraulic connections of the crawler carrier are made with quick couplings.

When disconnecting hydraulic lines with quick couplings, make sure that the coupling procedure is carried out correctly.



---

#### **WARNING**

Pressure in the hydraulic lines!

If the pressure supply is not interrupted before connecting / releasing the hydraulic lines, the hydraulic oil can escape with high pressure!

Personnel can be severely injured or killed!

- ▶ Release the pressure in the hydraulic system before connecting / disconnecting: Interrupt the pressure supply and wait for a short time!
- 
- ▶ Release the hydraulic coupling by hand.
  - ▶ Disconnect the hydraulic connections to the crawler carrier.
  - ▶ Protect hydraulic connections with caps from contamination.

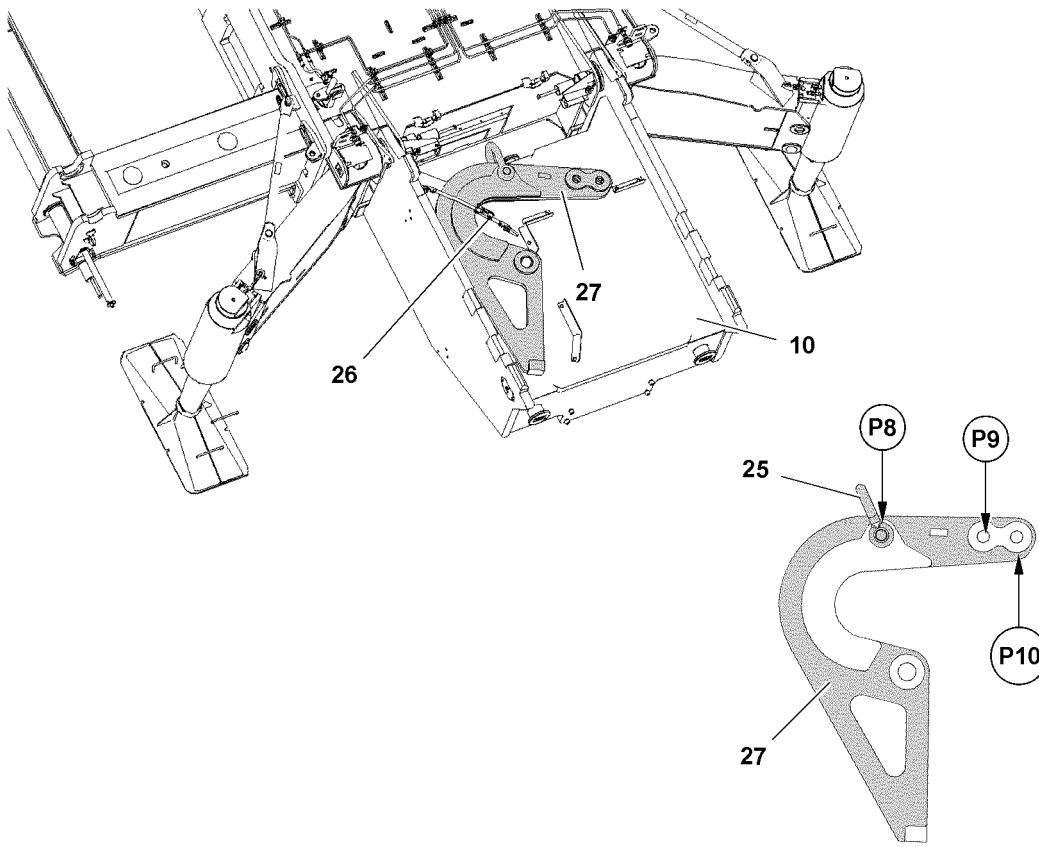
### 2.2.3 Disconnecting the electrical connections to the crawler carrier

- ▶ Disconnect the electrical connections to the crawler carrier, see separate electrical wiring diagram.

### 2.2.4 Disconnecting the connections of the central lubrication system to the crawler carrier

- ▶ Disconnect the connections of the central lubrication system to the crawler carrier.
- ▶ Protect the connections of the central lubrication system with caps from contamination.

5



6

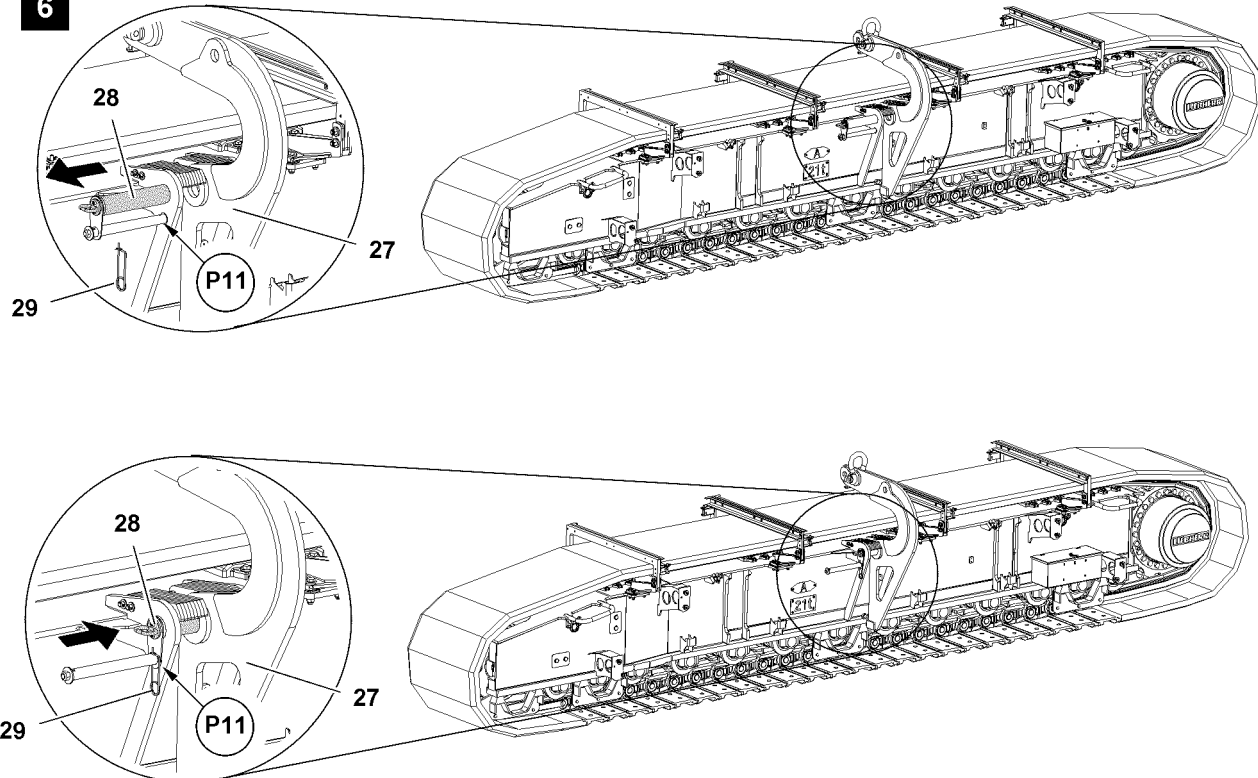


Fig.116883

LWE/LTR 1220-003/24204-02-02/en



## 2.3 Disassembling the crawler carriers

### 2.3.1 Preparing the assembly device

- ▶ Release the transport belt **26**, see illustration **5**.
- ▶ Fasten the crane at point **P8** on the shackle **25**.
- ▶ Lift the assembly device **27** with the crane and place it on the ground.
- ▶ Remove the shackle **25** at point **P8**, see illustration **5**.



#### Note

- ▶ For operation crane superstructure, see Crane operating instructions, chapter 4.00!

Fastening point	Application
P8	Transport
P9	Assembly with incline
P10	Assembly 90°

- ▶ Fasten the crane at point **P9** on the shackle and lift the assembly device **27**.

### 2.3.2 Pinning the assembly device with the crawler carrier

- ▶ Remove the spring retainer **29** at point **P11** and unpin the pin **28**, see illustration **6**.
- ▶ Swing the assembly device **27** to the pin location.



#### Note

- ▶ The position in which the crawler carrier remains balanced when lifting is set by the Liebherr-Werk!

- ▶ Insert the pin **28** at point **P11** and secure with spring retainer **29**, see illustration **6**.

#### Result:

- The assembly device **27** is pinned and secured.

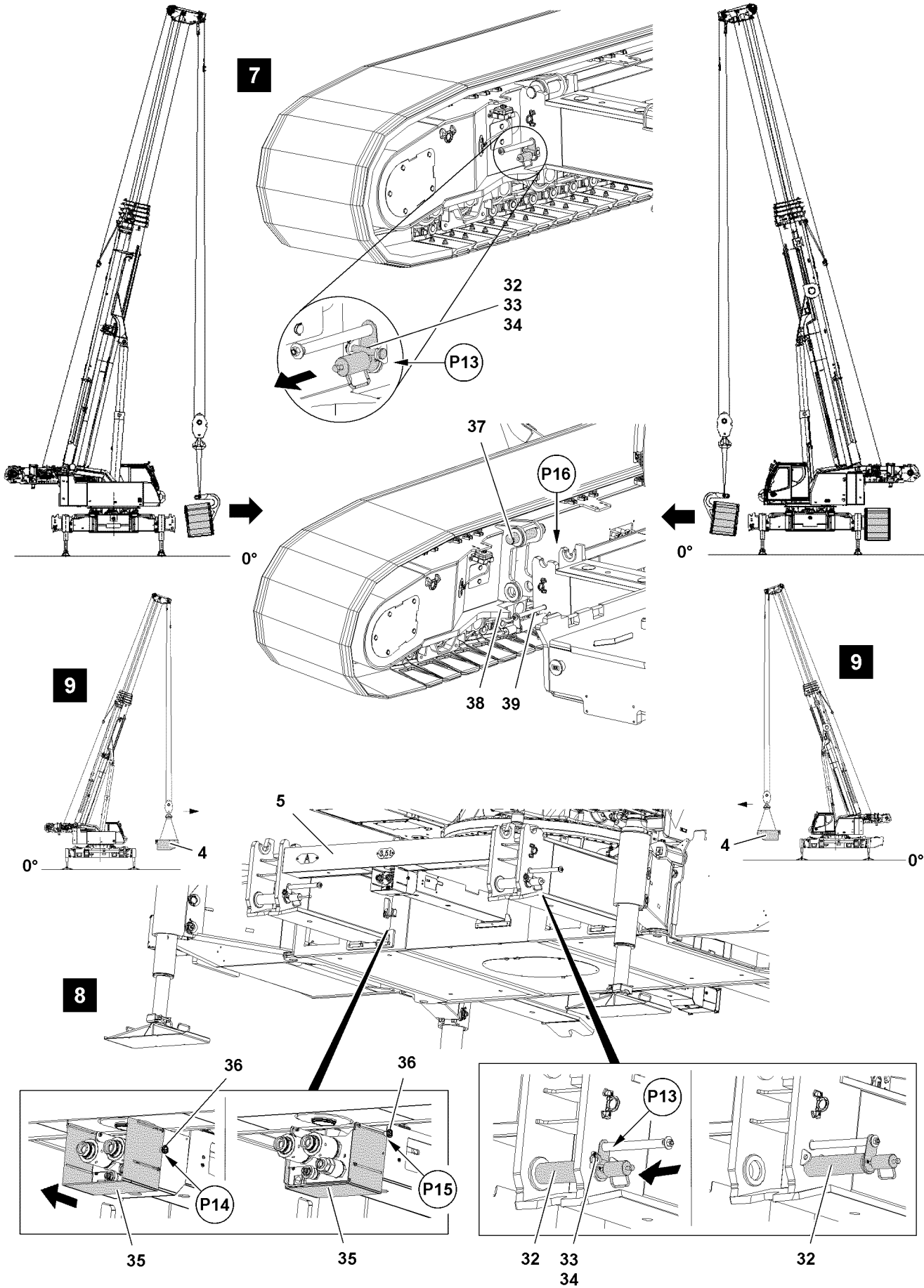


Fig.116884

LWE/LTR 1220-003/24204-02-02/en

### 2.3.3 Unpinning the crawler carrier

Make sure that the following prerequisites are met:

- Machines with fastening bits: Fastening bits are extended into operating position
- The assembly device is pinned and secured on the crawler carrier.
- ▶ Remove the safety locking pin **34** on both sides at point **P13** and unpin the pin **33**, see illustration 7.
- ▶ Unpin the pins **32** on both sides at point **P13** with the mechanical pin pulling device to the stop, see illustration 7.



#### WARNING

Swinging crawler carriers!

During the lifting procedure, due to the offset center of gravity, the crawler carrier swings away from the cross carrier!

- ▶ Make sure that there are no persons within the danger zone!

#### NOTICE

Damage to the pin pulling device!

To avoid damage on the pin pulling device by the guide **38** on the crawler carrier, move the crawler carrier „A“ out to just over the edge of the cross carrier „A“!

- ▶ Do not move the crawler carrier „A“ out too high!
- ▶ The crawler carrier assembly must be carried out exclusively with a guide!
- ▶ Make sure that the guide is constantly in acoustic and visual contact with the crane operator!
- ▶ Disengage the crawler carrier „A“ with the crane slowly from the receptacles at point **P16** of the cross carrier „A“, see illustration 7.
- ▶ Place the crawler carrier „A“ with the crane on the transport vehicle.

When the crawler carrier „A“ has been removed:

- ▶ Pin the pins **32** on both sides at point **P13** with the mechanical pin pulling device again to the stop, see illustration 8.
- ▶ Insert the pins **33** on both sides at point **P13** and secure with safety locking pin **34**, see illustration 8.
- ▶ Slide the protective plate **35**, see illustration 8.



#### Note

- ▶ The disassembly of the crawler carrier „B“ is identical with the disassembly of the crawler carrier „A“!
- ▶ Unpin the crawler carrier „B“ and place it with the crane on the transport vehicle.
- ▶ Unpin the assembly device and place it again in transport position on the central ballast.
- ▶ Secure the assembly device with the transport belt.

## 2.4 Disassembling the central ballast



#### Note

- ▶ Disassemble the central ballast, see Crane operating instructions, chapter 3.03!
- ▶ Disassemble the central ballast, see illustration 9.

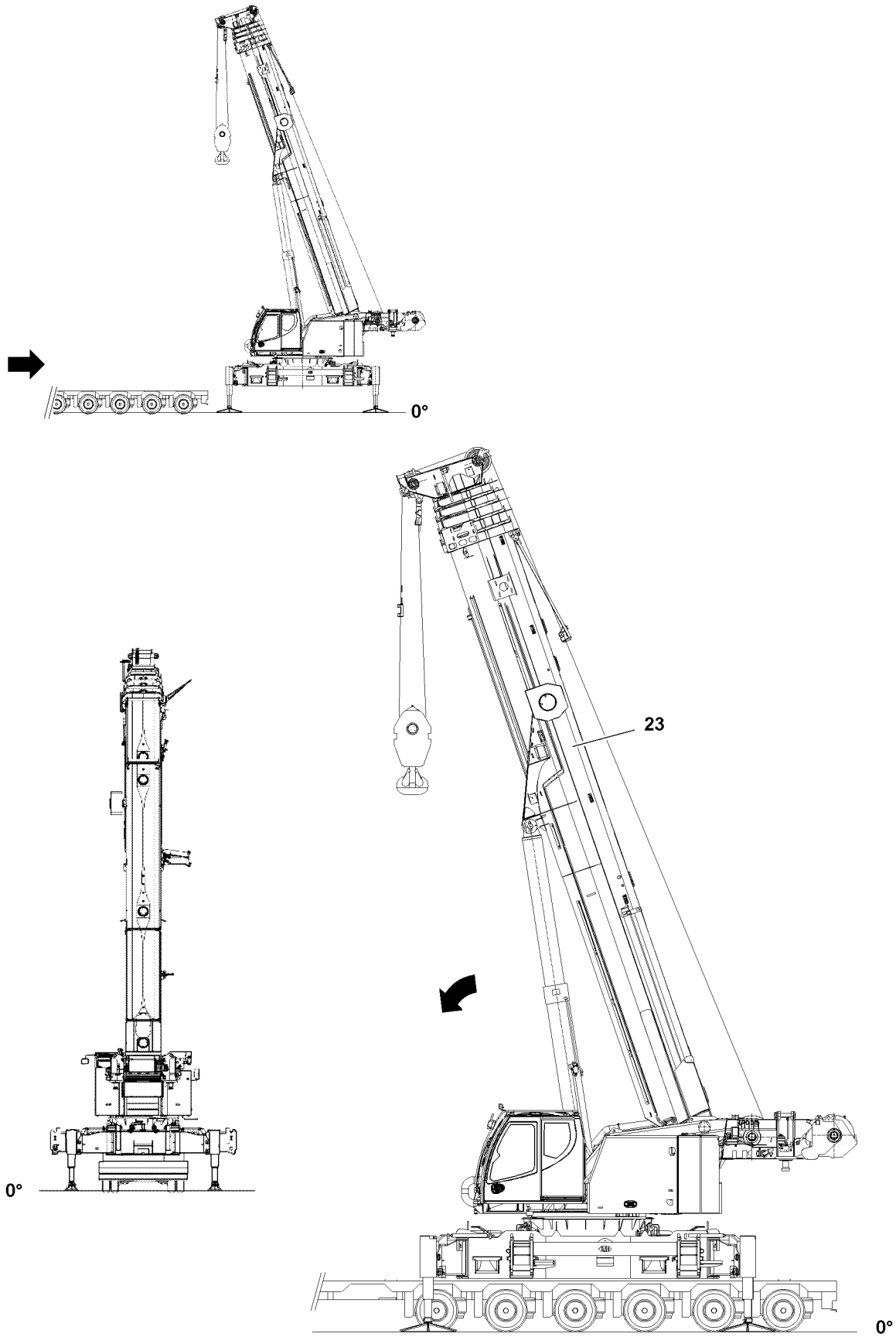


Fig.116885

LWE/LTR 1220-003/24204-02-02/en

## 2.5 Loading the crane onto the transport vehicle

### 2.5.1 Moving the transport vehicle in

Make sure that the following prerequisite is met:

- The crane is supported at a sufficient height to enable the transport vehicle to drive under the crane.



#### **DANGER**

The crane can topple over!

When driving in, the transport vehicle may be caught on a support cylinder and cause the crane to topple over!

- ▶ Driving the transport vehicle in may exclusively be carried out with a guide.
  - ▶ Make sure that the guide is constantly in acoustic and visual contact with the transport vehicle operator.
  - ▶ Make sure that the transport vehicle does not scrape on a support cylinder when moving it in.
- 
- ▶ Move the transport vehicle in, see illustration.
  - ▶ Align the telescopic boom **23** lengthwise to the transport vehicle and place it down.

### 2.5.2 Lowering the crane

Make sure that the following prerequisites are met:

- The crawler carriers have been removed.
- The central ballast has been removed.
- The transport vehicle has been moved in.
- The boom has been placed down.
- Wooden planks have been placed on the transport vehicle for the support.



#### **WARNING**

Danger of crushing!

When lowering the crane, there is an increased danger of accidents due to crushing!

Personnel can be severely injured or killed!

- ▶ Make sure that there are no persons within the danger zone!



#### **Note**

- ▶ Retract support cylinders with BTT-E, BTT and TE1, see section „Supporting the crane“.
- ▶ Lower the crane.

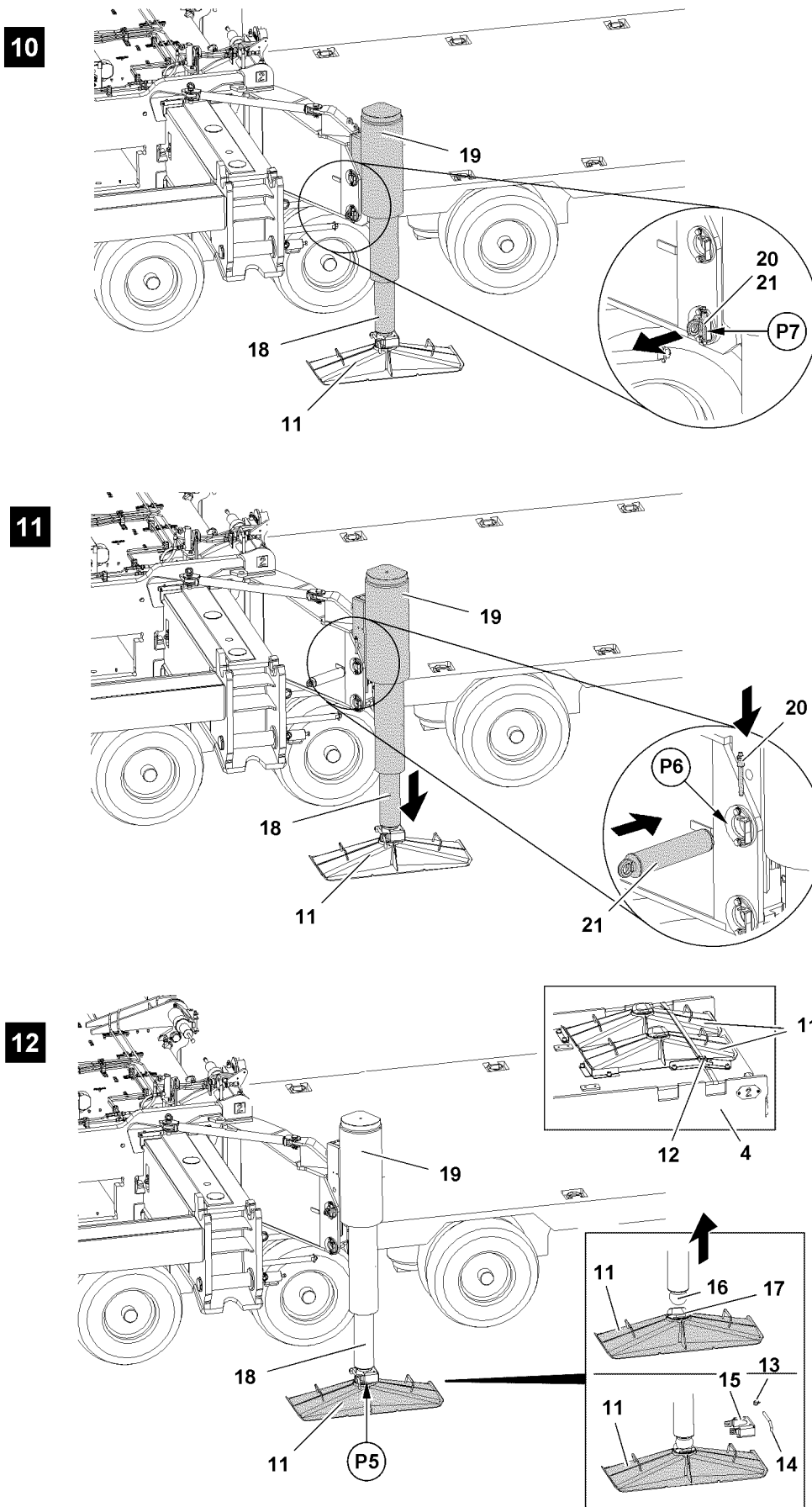


Fig.116886

LWE/LTR 1220-003/24204-02-02/en

## 2.5.3 Positioning the support cylinders in transport position

Make sure that the following prerequisite is met:

- The crane is laying completely on the transport vehicle.

### Unpinning the support cylinders

- ▶ Release the pin **21**: Unpin the ball locking pin **20** on point **P7**, see illustration **10**.
- ▶ Unpin the pin **21**.

### Extending the piston rod with the BlueTooth™ Terminal

Make sure that the following prerequisite is met:

- On the display of the BTT, the menu overview is visible.

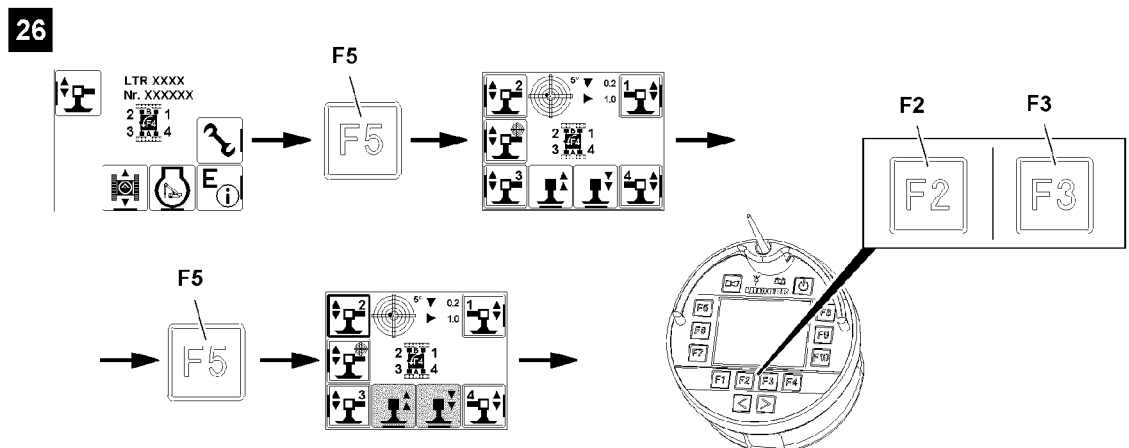


Fig.116899

- ▶ Press the function key **F5**.

#### Result:

- The „Support“ menu is visible.

The support cylinders are marked with numbers depending on the alignment of the radio remote control.

Support cylinders are selected with function keys:

- **F5** Function key
- **F7** Function key
- **F8** Function key
- **F10** Function key

- ▶ Select support cylinder: Press the function key.

#### Result:

- Selected icons are visible with filled out frames: Support cylinders are selected.
- Support cylinders are ready for extension and retraction.

The piston rods **18** extend until the support cylinder can be pinned on point **P6**, see illustration **11**.

When „retracting the support cylinders“:

- ▶ Press the function key **F2**.

#### Result:

- Piston rod **18** retracts.

When „extending the support cylinders“:

- ▶ Press the function key **F3**.

**Result:**

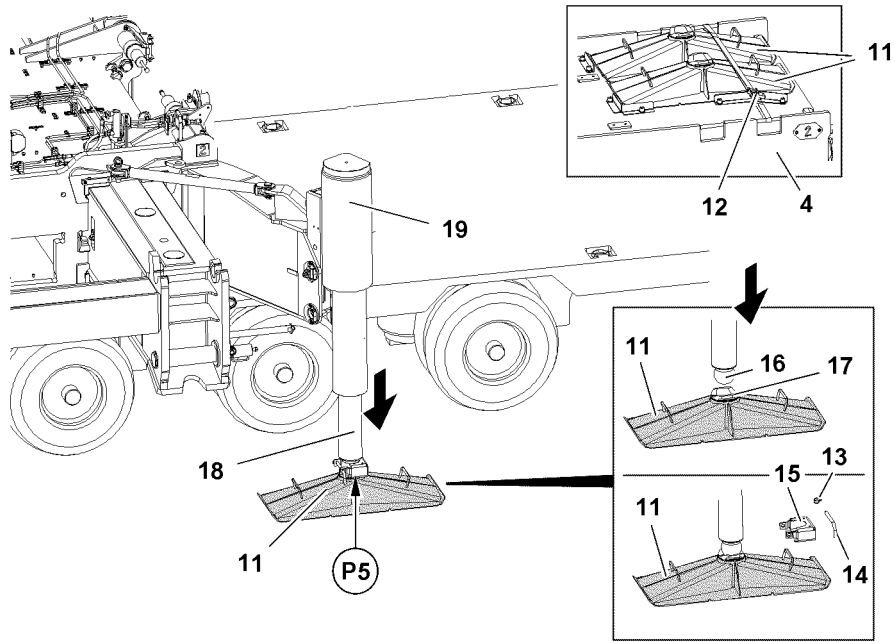
- Piston rod **18** extends.



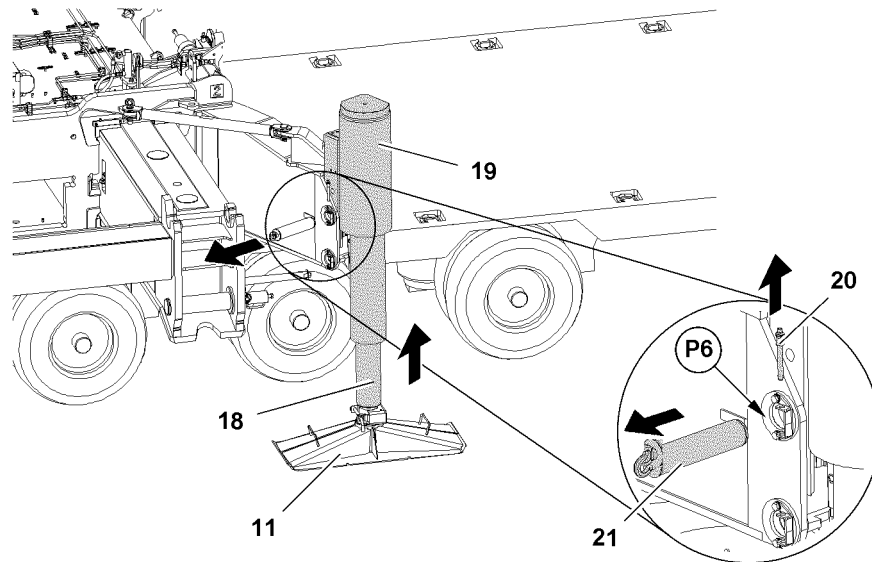
Empty page!

LWE/LTR 1220-003/24204-02-02/en

22



23



24

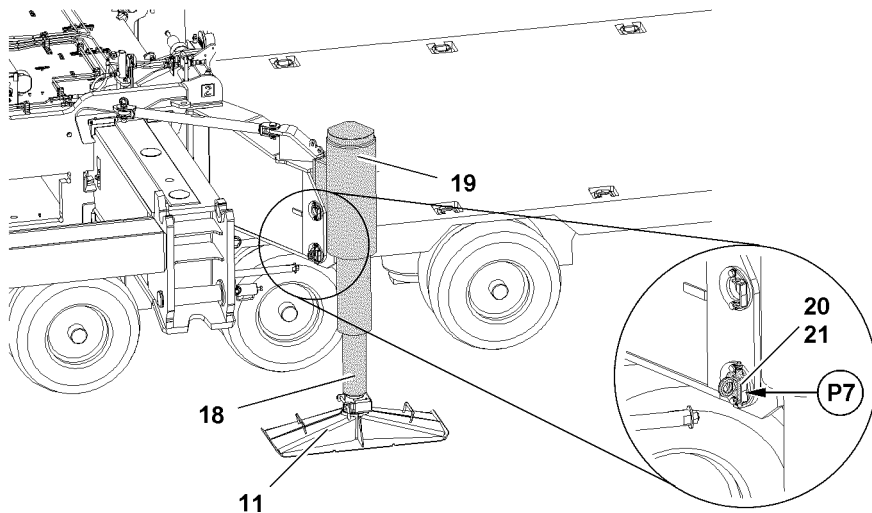


Fig.116876

LWE/LTR 1220-003/24204-02-02/en

### Extending the piston rod from the crane operator's cab

Make sure that the following prerequisite is met:

- The „master switch assignment“ is visible on the touch display right (TE1).

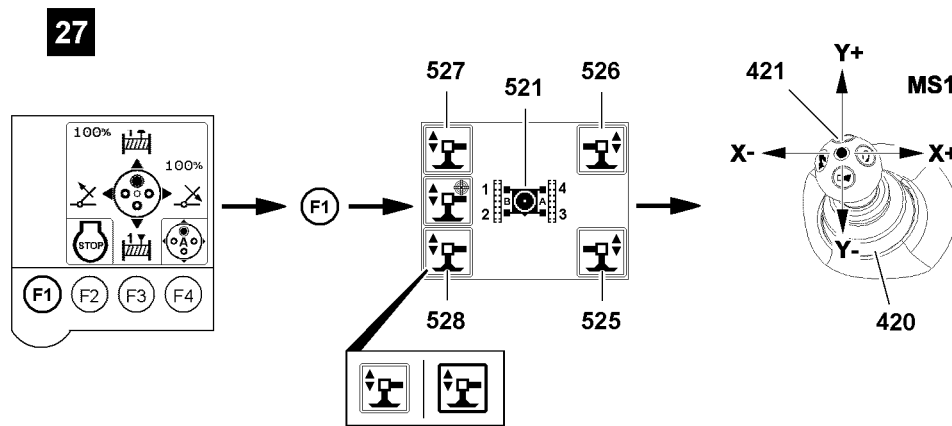


Fig.116900

- ▶ Press the function key **F1**.

#### Result:

- The „Support“ menu is visible.

The support cylinders are marked with numbers depending on the alignment of the turntable, see icon **521**.

Support cylinders are selected via touch functions:

- **525** Icon
- **526** Icon
- **527** Icon
- **528** Icon

- ▶ Select support cylinder: Select the icon („touch“).

#### Result:

- Selected icons are visible with filled out frames: Support cylinders are selected.
- Support cylinders are ready for extension and retraction.

The piston rods **18** extend until the support cylinder can be pinned on point **P6**, see illustration **11**.

When „retracting the support cylinders“:

- ▶ Deflect the manual control lever **421** in direction Y+.

#### Result:

- Piston rod **18** retracts.

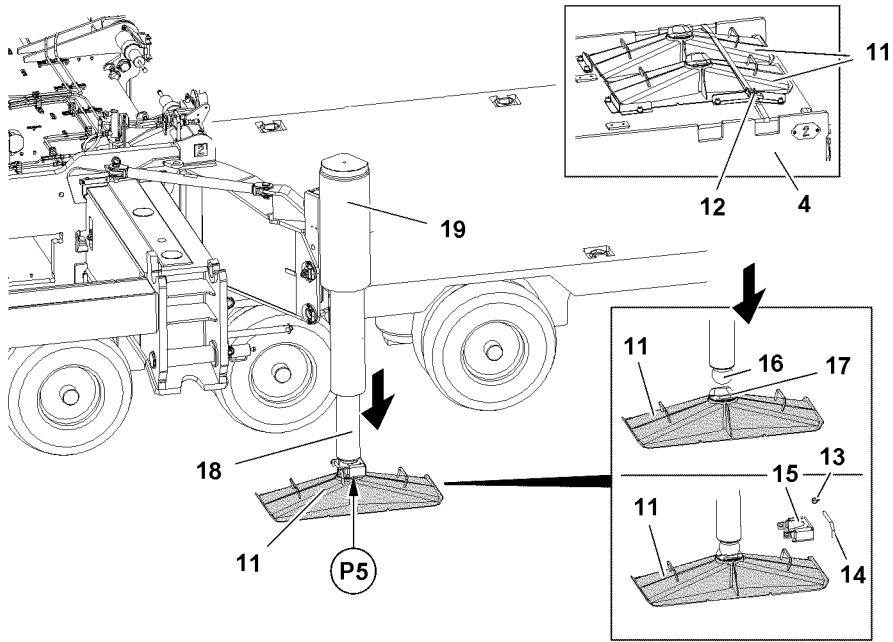
When „extending the support cylinders“:

- ▶ Deflect the manual control lever **421** in direction Y-.

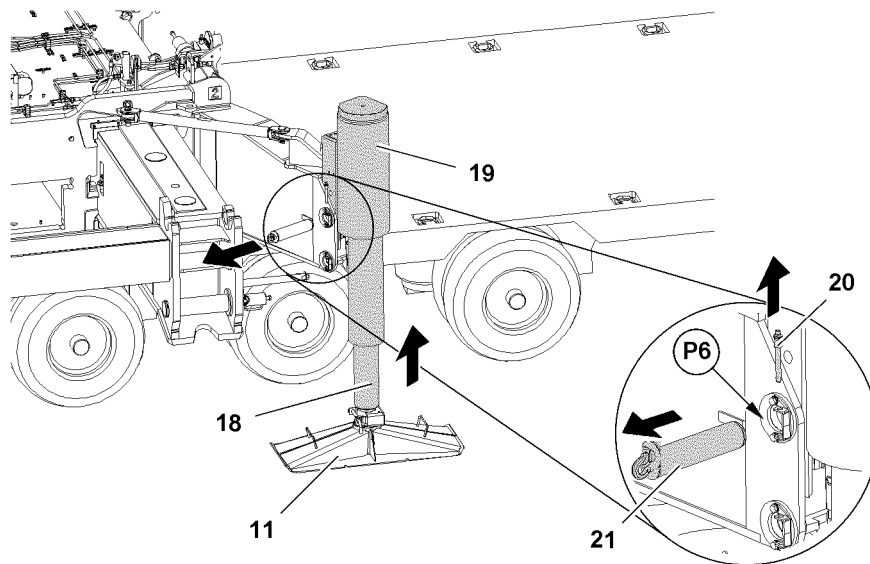
#### Result:

- Piston rod **18** extends.

22



23



24

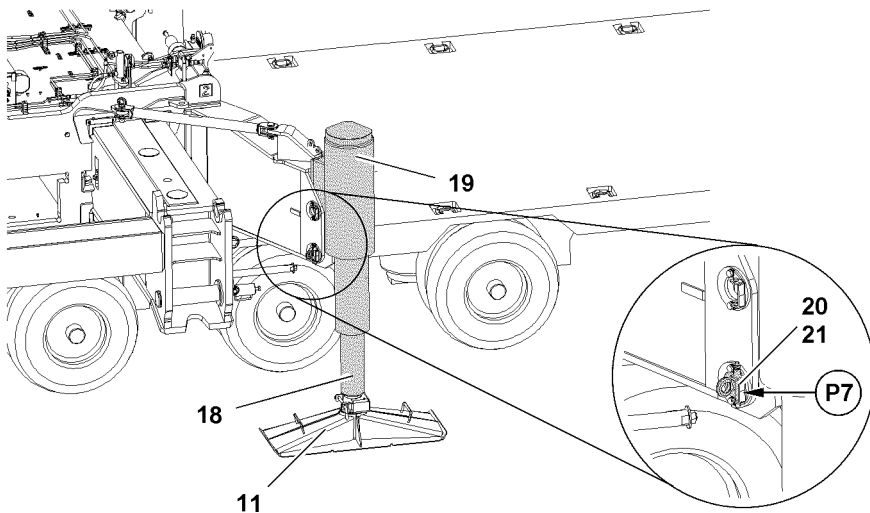


Fig.116876

LWE/LTR 1220-003/24204-02-02/en

### Extending the piston rod with the radio remote control\*

Make sure that the following prerequisite is met:

- On the display of the BTT-E, the menu overview is visible.

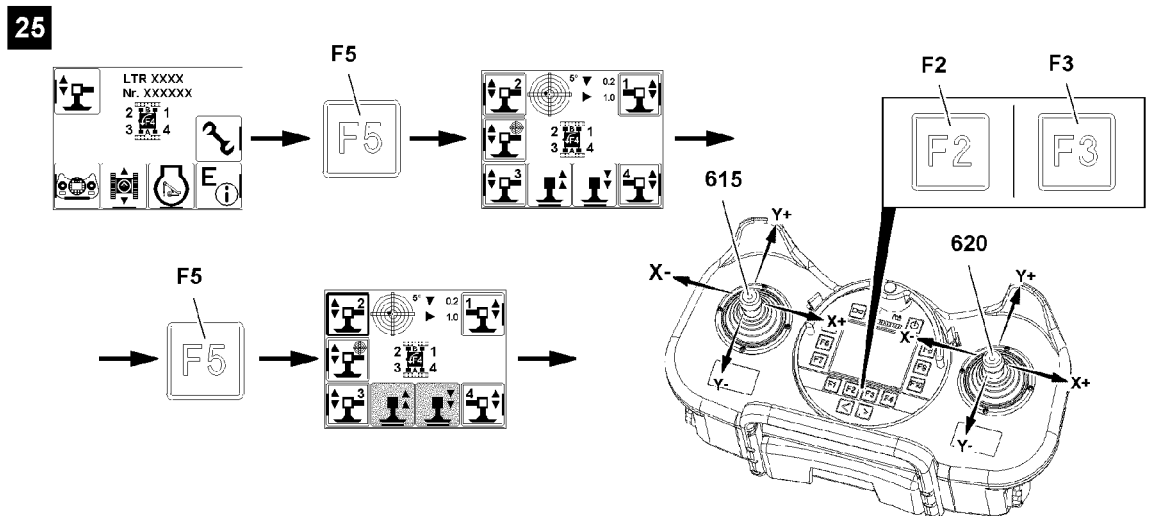


Fig.116898

- ▶ Press the function key **F5**.

#### Result:

- The „Support“ menu is visible.

The support cylinders are marked with numbers depending on the alignment of the radio remote control.

Support cylinders are selected with function keys:

- **F5** Function key
- **F7** Function key
- **F8** Function key
- **F10** Function key

- ▶ Select support cylinder: Press the function key.

#### Result:

- Selected icons are visible with filled out frames: Support cylinders are selected.
- Support cylinders are ready for extension and retraction.

The piston rods **18** extend until the support cylinder can be pinned on point **P6**, see illustration **11**.

The support cylinders can be extended or retracted with both manual control levers.

When „retracting the support cylinders“:

- ▶ Deflect the manual control lever in direction **Y+**.
- or
- Press the function key **F2**.

#### Result:

- Piston rod **18** retracts.

When „extending the support cylinders“:

- ▶ Deflect the manual control lever in direction **Y-**.
- or
- Press the function key **F3**.

**Result:**

- Piston rod **18** extends.

**Pinning the support cylinders**

- The pin bores align on point **P6**, see illustration **11**.
- ▶ Insert the pin **21** on point **P6**, see illustration **11**.
- ▶ Secure the pin **21**: Pin the ball locking pin **20** on point **P7**, see illustration **10**.

Empty page!

LWE/LTR 1220-003/24204-02-02/en

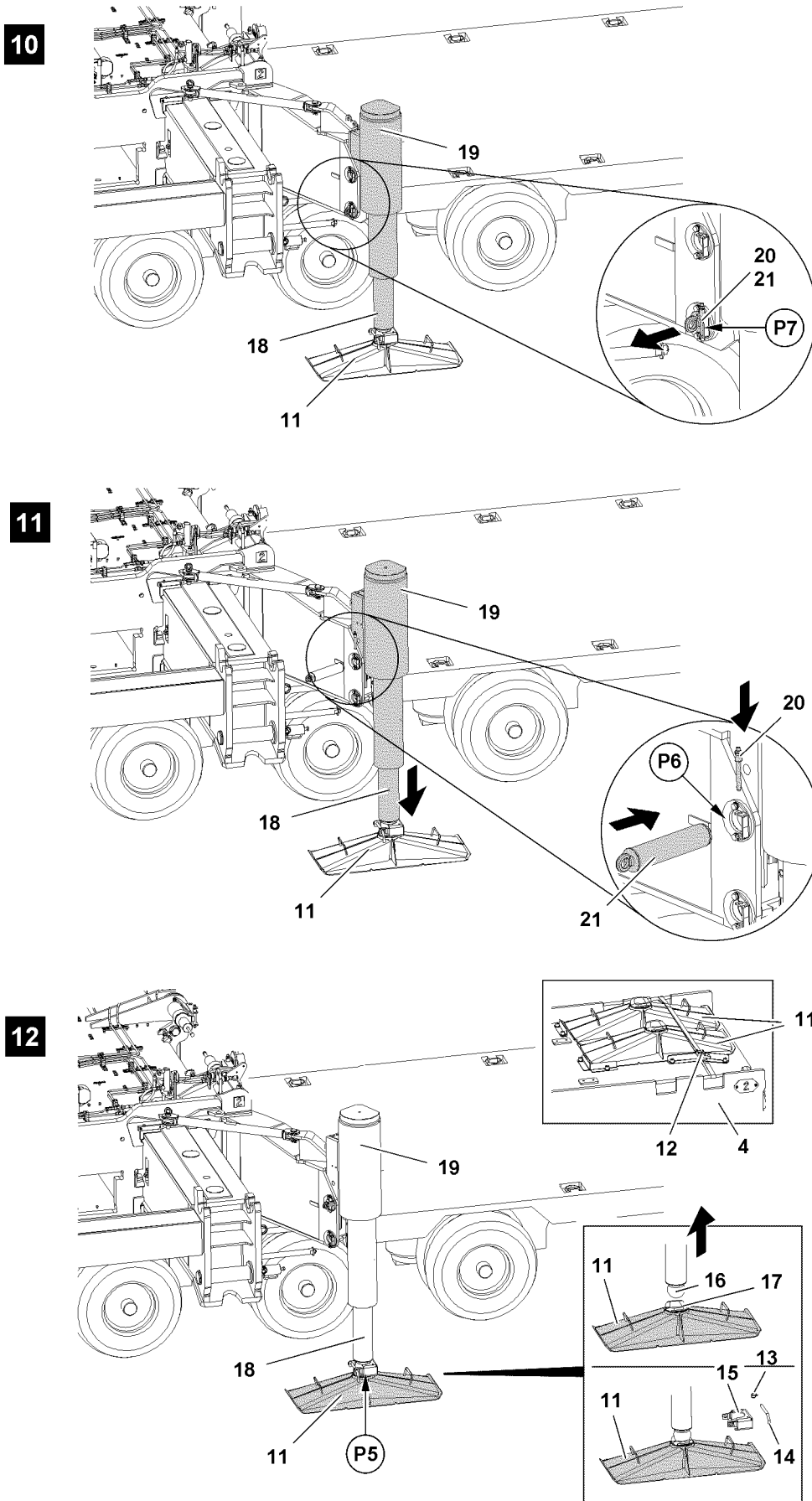


Fig.116886

LWE/LTR 1220-003/24204-02-02/en



## 2.5.4 Removing the support plates

Make sure that the following prerequisite is met:

- The support cylinders **19** are in transport position.



---

### Note

- ▶ The support plates **11** are positioned for transport on the central ballast **4**!
- ▶ The weight of the support plate is 50 kg !
- ▶ For safety reasons, disassemble the support plates **11** always with two persons!

- 
- ▶ Remove the safety locking pin **13** at point **P5** and unpin the pin **14**, see illustration **12**.
  - ▶ Pull out the retainer **15** from the ball head **16**, see illustration **12**.



---

### Note

- ▶ Retract the support cylinder with the BTT-E, the BTT and the TE1, see section „Positioning the support cylinders in transport position“!

- 
- ▶ Retract the support cylinders.
  - ▶ Pull the retainer **15** again on the ball head **16**, see illustration **12**.
  - ▶ Insert the pin **14** at point **P5** and secure with safety locking pin **13**.
  - ▶ Place the support plate **11** in transport position on the central ballast.
  - ▶ Secure the support plate **11** in transport position with the transport belts **12**, see illustration **12**.
  - ▶ Remove all support plates.

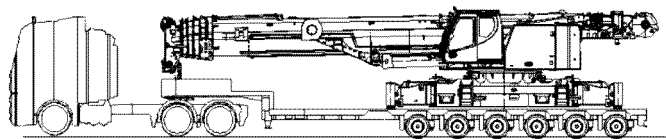
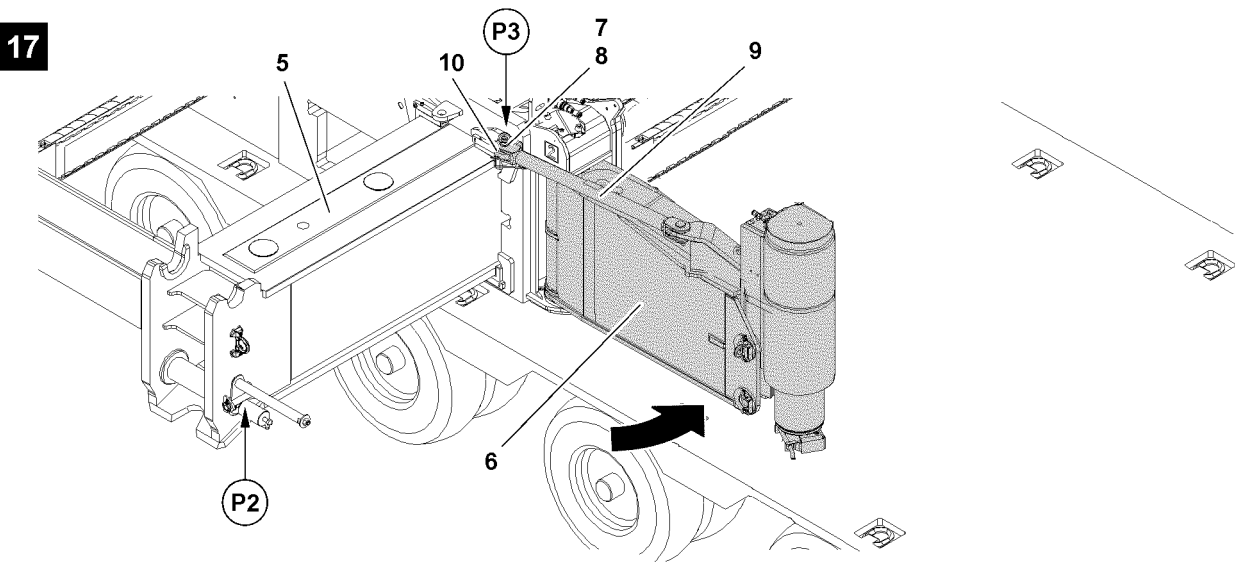
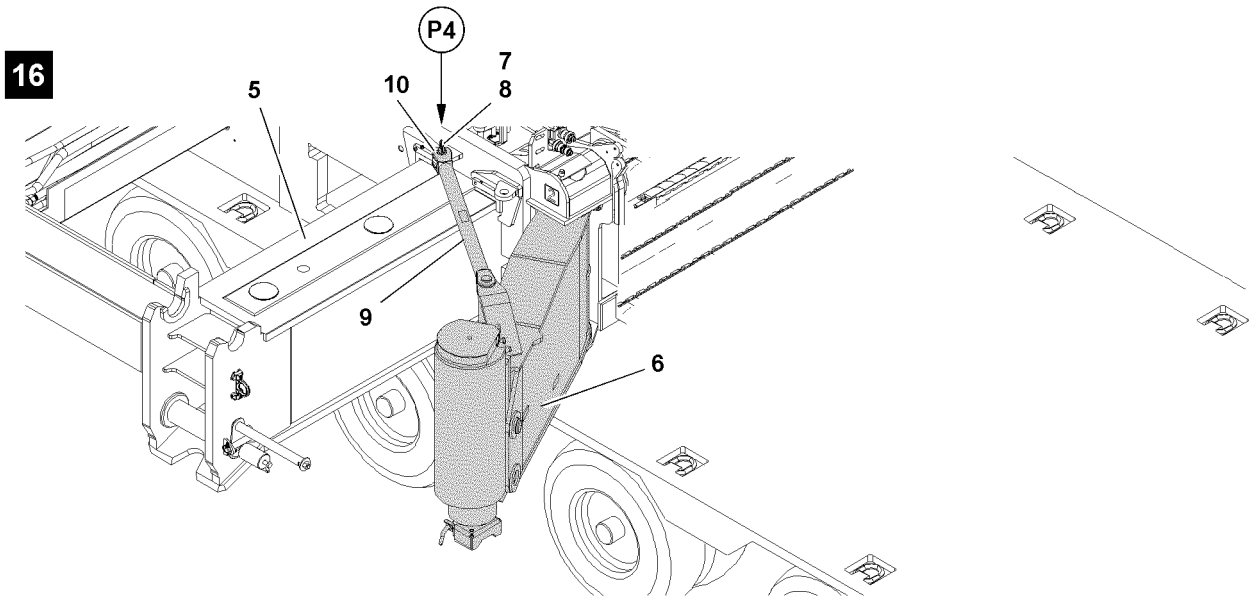


Fig.116887

LWE/LTR 1220-003/24204-02-02/en

## 2.5.5 Swinging the folding brackets in

Make sure that the following prerequisite is met:

- The support plates **11** are removed.



---

### **DANGER**

Danger of crushing!

- ▶ Make sure that no persons or objects are within the danger zone when swinging the folding brackets **6**!
- 
- ▶ Remove the spring retainer **7** at point **P4**, see illustration **16**.
  - ▶ Unpin the pin **8** at point **P4**, see illustration **16**.
  - ▶ Remove the rod **9** from the connection.

### **Result:**

- The folding bracket **6** is released.
- ▶ Swing the folding bracket **6** in until the connection fork **10** of the rod can be pinned at point **P3**.

When the bores align at point **P3**:

- ▶ Insert the pin **8** at point **P3**, see illustration **17**.
- ▶ Insert the spring retainer **7** at point **P3**, see illustration **17**.

### **Result:**

- The folding bracket **6** is secured.
- ▶ Swing all folding brackets in.

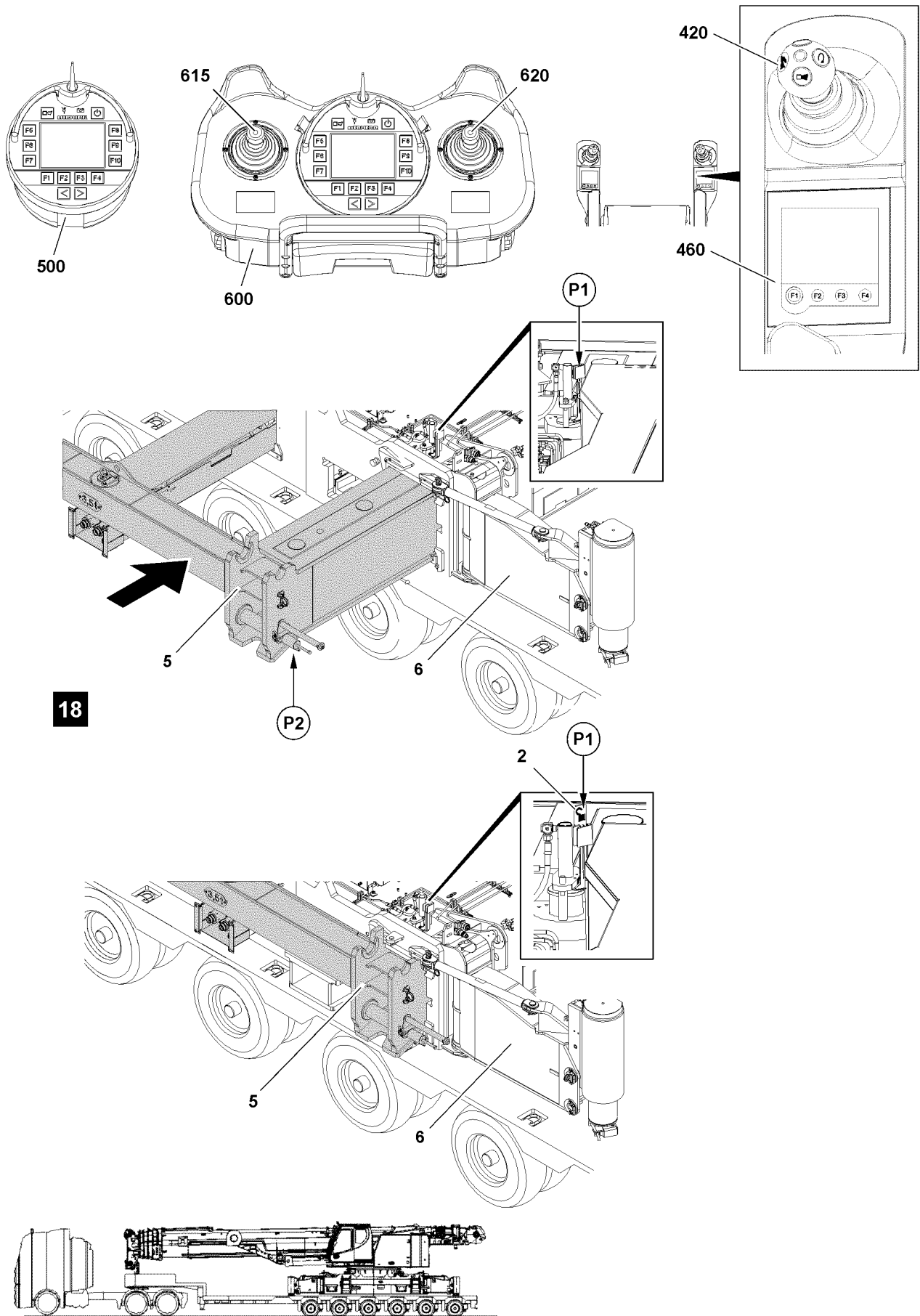


Fig.116892

## 2.6 Retracting the cross carriers



### WARNING

Danger of crushing!

- ▶ Make sure that no persons are between the crane and the cross carrier during the entire retraction procedure!

### NOTICE

Damage to the pin pulling device!

If the folding brackets **6** are not swung in before retracting the cross carrier, then the pin pulling device will be damaged at point **P2** when retracting the cross carrier!

- ▶ Make sure that the folding brackets **6** are swung into transport position before retracting the cross carrier **5**!



### Note

- ▶ The extension conditions of the cross carrier is displayed as percentage on the display on the Bluetooth™ Terminal (BTT), the radio remote control (BTT-E) and on the LICCON monitor!
- ▶ The cross carriers are only pinned on extension conditions of 0 %; 50 %; 100 %.
- ▶ The pin points of the cross carriers are marked in percentages with tags on the cross carriers.

Make sure that the following prerequisites are met:

- No personnel is within the danger zone.
- The folding brackets are swung in.

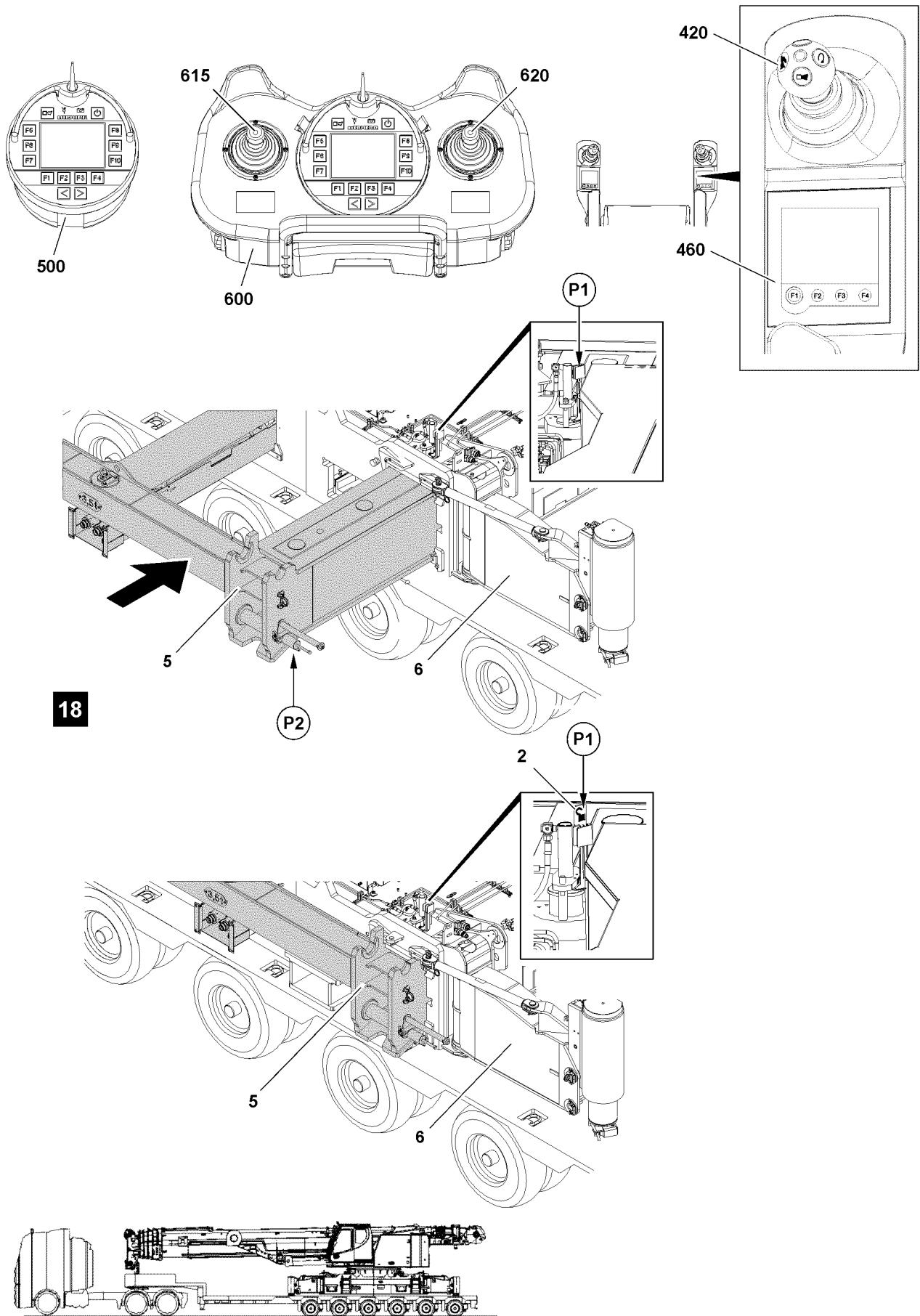


Fig.116892

LWE/LTR 1220-003/24204-02-02/en

## 2.6.1 Retracting the cross carrier with the BlueTooth™ Terminal

Make sure that the following prerequisite is met:

- On the display of the BTT, the menu overview is visible.

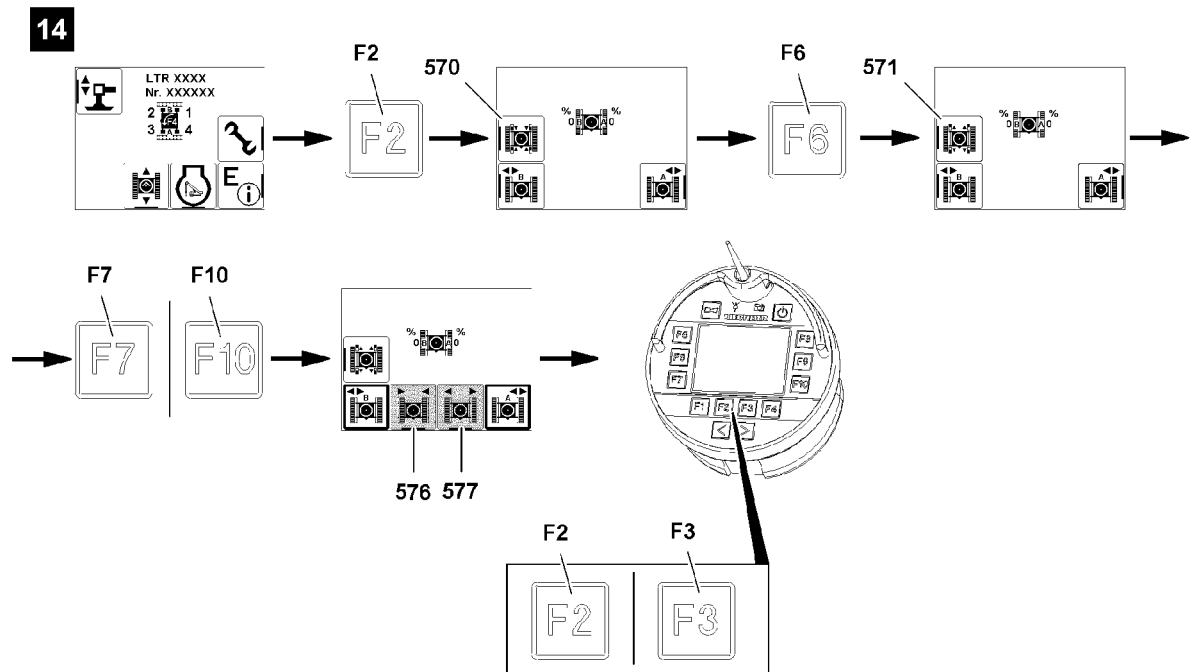


Fig. 116896

### Unpinning the cross carrier

- ▶ Call up the „Crawler travel gear“ menu: Press the function key **F2**, see illustration 14.

#### Result:

- Functions „Track width adjustment“ are visible.

When icon „Pin the cross carrier“ **570** is visible:

- ▶ Activate „Unpin the cross carrier“: Press the function key **F6**.

#### Result:

- Icon „Unpin the cross carrier“ **571** appears.

### Selecting the cross carrier

Before you retract or extend the cross carrier, select one of the cross carriers or both cross carriers:

- **F7** Function key
- **F10** Function key

In this and the following sections is described how both cross carriers are retracted together. Alternatively you can also select and retract the cross carriers individually.

Depending on which cross carriers are selected, different icons for „retract crawler carrier“ and „extend crawler carrier“ appear, see Crane operating instructions, chapter 5.31.

- ▶ Select both cross carriers: Press function key **F7** and function key **F10**, see illustration 14.

#### Result:

- Icon „Extend crawler carrier“ **577** is visible.
- Icon „Retract crawler carrier“ **576** is visible.

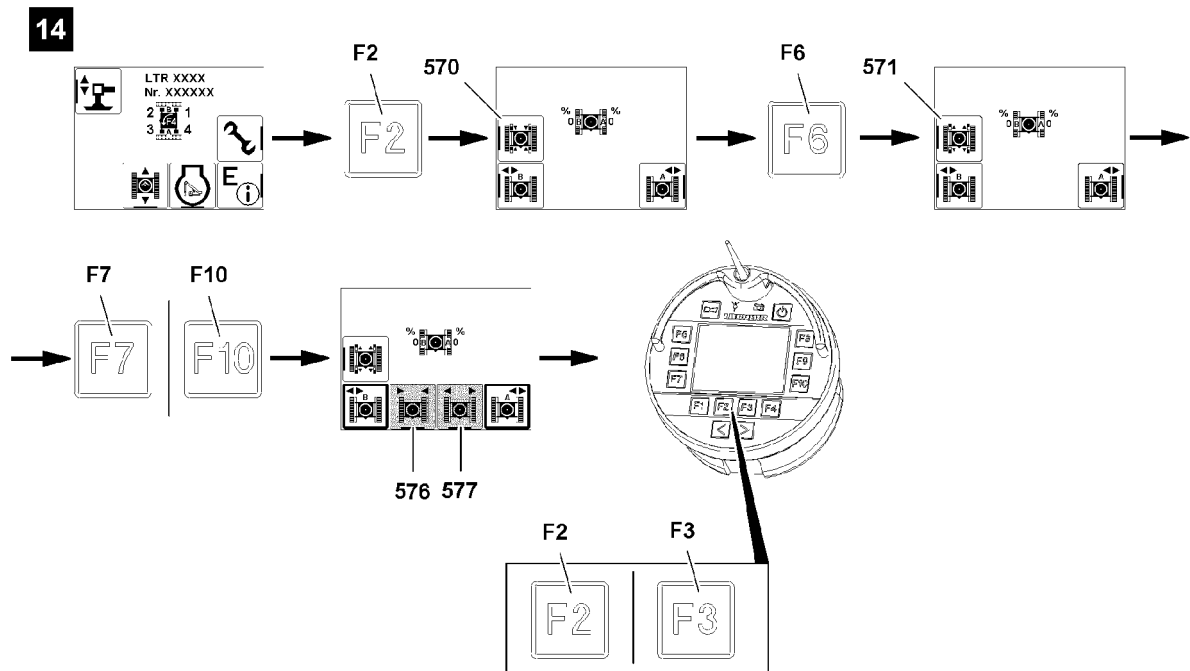


Fig. 116896

### Retracting the cross carriers

To unpin the cross carriers on points **P1**, you have to retract or extend the cross carriers, see illustration 18.

You can check on points **P1** if the pins are completely pinned or unpinned:

- The pins are unpinned: Tags **2** are visible.
- The pins are pinned: Tags **2** are **not** visible.



### WARNING

Crushing danger due to movement of cross carriers!

- ▶ Make sure that no personnel is within the danger zone of the cross carriers during „track width adjustment“.
- ▶ Differentiation of the cross carriers, see Crane operating instructions, chapter 5.31.

When „extending the cross carrier“:

- ▶ Press the function key **F3**.

When „retracting the cross carrier“:

- ▶ Press the function key **F2**.

### Result:

- The pins are unpinned.

### Problem remedy

Pins are not unpinned!

The pin is stuck: The position of the cross carriers prevents the pins from unpinning.

- ▶ Extend and retract the cross carriers again: Press the function keys until the pins are completely unpinned.

- ▶ Make sure that the pins are completely unpinned on points **P1**, see illustration 18.

### Result:

- The pins are unpinned.



- The cross carriers retract.

### **Pinning the cross carriers**

Before the cross carriers reach the 0% extension status:

- ▶ Activate „Pin the cross carrier“: Press the function key **F6**.

#### **Result:**

- Icon „pin the cross carrier“ **570** is visible.
- The pins are pinned.

---

### **Problem remedy**

The pins are not pinned!

The pin is stuck: The position of the cross carriers prevents the pins from pinning.

- ▶ Extend and retract the cross carriers again: Press the function keys until the pins are completely pinned.

- 
- ▶ Make sure that the pins are completely pinned on points **P1**, see illustration **18**.

#### **Result:**

- The pins are pinned.
- The cross carriers are retracted and secured at 0 %.

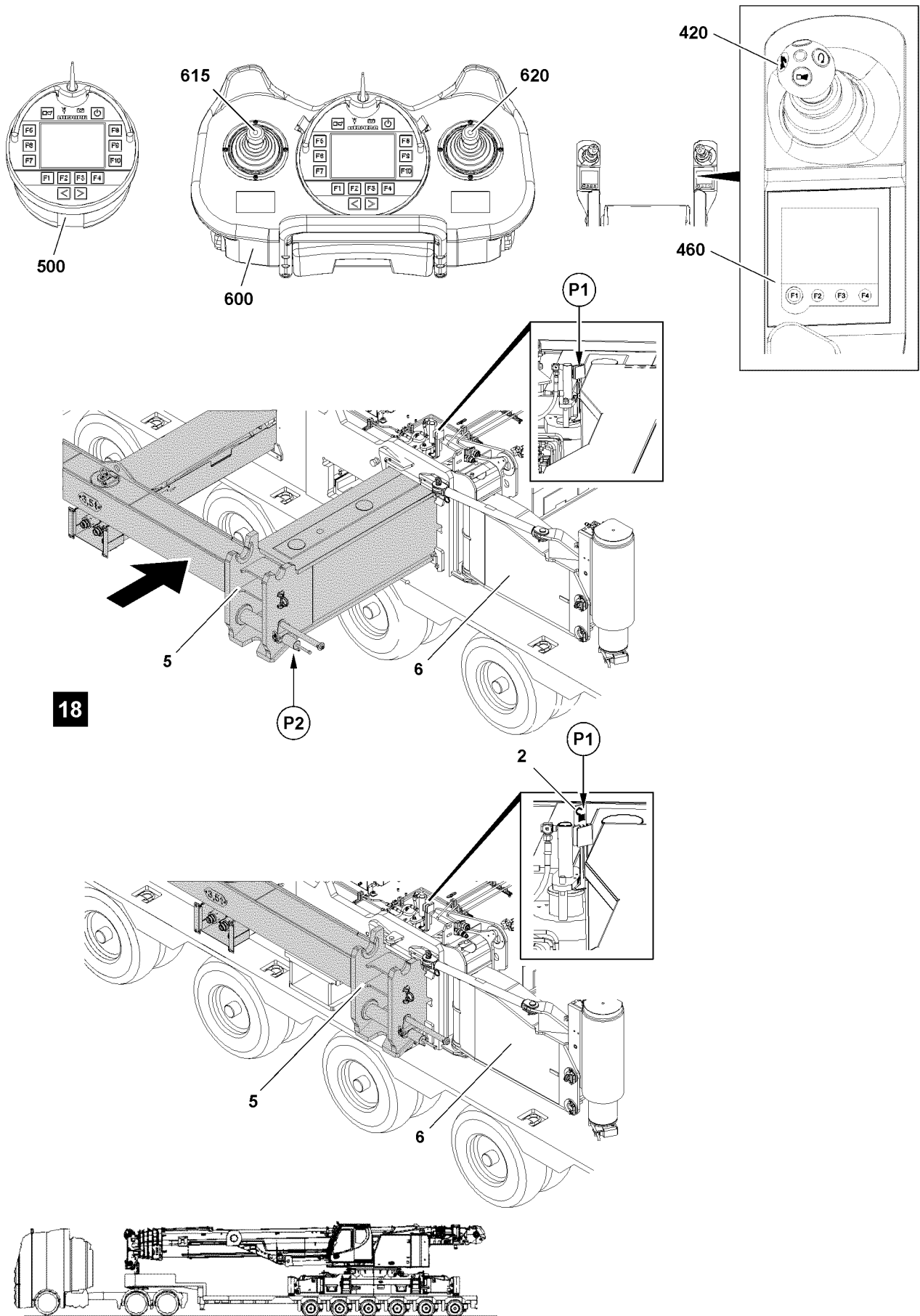


Fig.116892

LWE/LTR 1220-003/24204-02-02/en

## 2.6.2 Extending the cross carriers from the crane operator's cab

Make sure that the following prerequisite is met:

- On the TE1 the „Master switch configuration“ menu is visible.

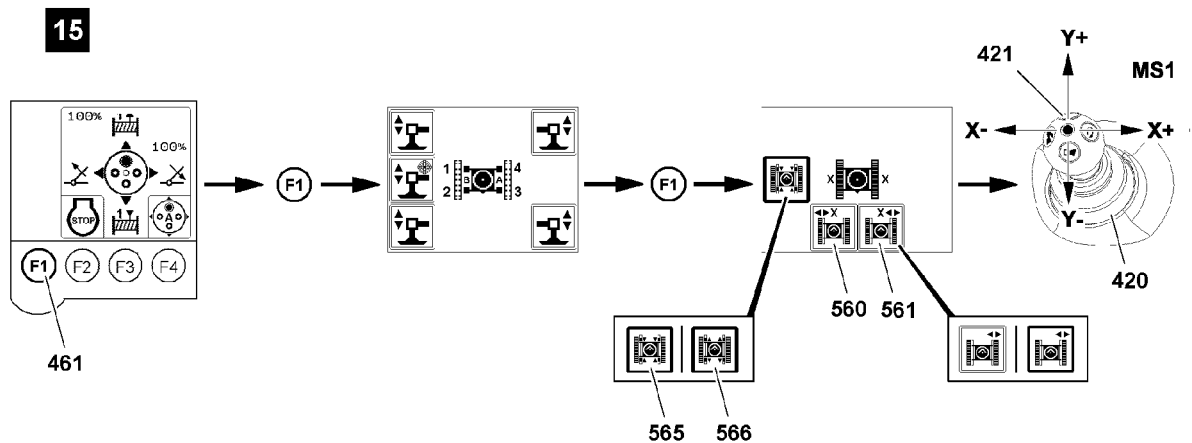


Fig.116897

### Unpinning the cross carrier

- ▶ Press the function key F1 **461**, see illustration **15**.

#### Result:

- The „Support“ menu appears.

- ▶ Press function key F1 **461**.

#### Result:

- The „Track width adjustment“ menu appears.

When icon **565** „Pin the cross carrier“ is visible:

- ▶ Activate „Unpin the cross carrier“: Select the icon **565** („touch“).

#### Result:

- Icon „unpin cross carrier“ **566** is visible.

### Selecting the cross carrier

Before you retract or extend the cross carrier, select one of the cross carriers or both cross carriers:

- **560** Icon
- **561** Icon

In this and the following sections is described how both cross carriers are retracted together. Alternatively you can also select and retract the cross carriers individually.

- ▶ Pay attention to cross carrier assignment.
- ▶ Select both cross carriers: Select the icon **560** and icon **561** („touch“).

#### Result:

- Selected icons with filled out frames: Cross carriers are selected.

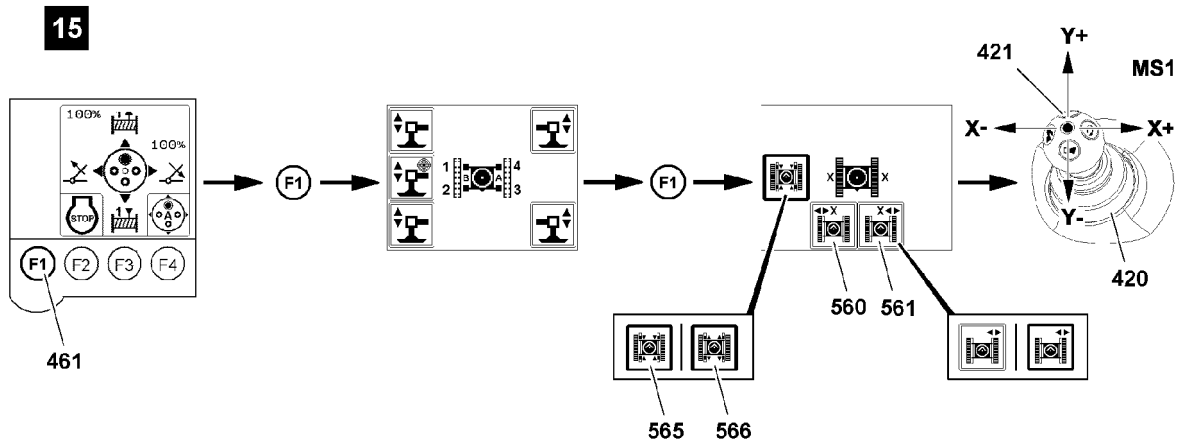


Fig.116897

### Retracting the cross carriers

To unpin the cross carriers on points **P1**, you have to retract or extend the cross carriers, see illustration **18**:

You can check on points **P1** if the pins are completely pinned or unpinned:

- The pins are unpinned: Tags **2** are visible.
- The pins are pinned: Tags **2** are **not** visible.



### WARNING

Crushing danger due to movement of cross carriers!

- ▶ Make sure that no personnel is within the danger zone of the cross carriers during „track width adjustment“.
- ▶ Differentiation of the cross carriers, see Crane operating instructions, chapter 4.01.

To initiate a movement, you have to release master switch MS1 **420** with the button **421**.

- ▶ Press the button **421** and hold.

When „extending the cross carrier“:

- ▶ Move master switch MS1 **420** in direction X+.

When „retracting the cross carrier“:

- ▶ Move master switch MS1 **420** in direction X-.

### Result:

- The pins are unpinned.

### Problem remedy

Pins are not unpinned!

The pin is stuck: The position of the cross carriers prevents the pins from unpinning.

- ▶ Extend and retract the cross carriers again: Move master switch MS1 **420** in direction X+ or X- until the pins are completely unpinned.

- ▶ Make sure that the pins are completely unpinned on points **P1**, see illustration **18**.

### Result:

- The pins are unpinned.
- The cross carriers retract.

### Pinning the cross carriers

Before the cross carrier reaches the 0% extension status:

- ▶ Activate „Pin the cross carrier“: Select icon **566** („touch“), see illustration **15**.

**Result:**

- Icon **565** „pin cross carrier“ is visible.
  - The pins are pinned.
- 

**Problem remedy**

The pins are not pinned!

The pin is stuck: The position of the cross carriers prevents the pins from pinning.

- ▶ Extend and retract the cross carriers again: Move master switch MS1 **420** in direction X+ or X- until the pins are completely pinned.
- 

- ▶ Make sure that the pins are completely pinned on points **P1**, see illustration **18**.

**Result:**

- The pins are pinned.
- The cross carriers are retracted and secured at 0 %.

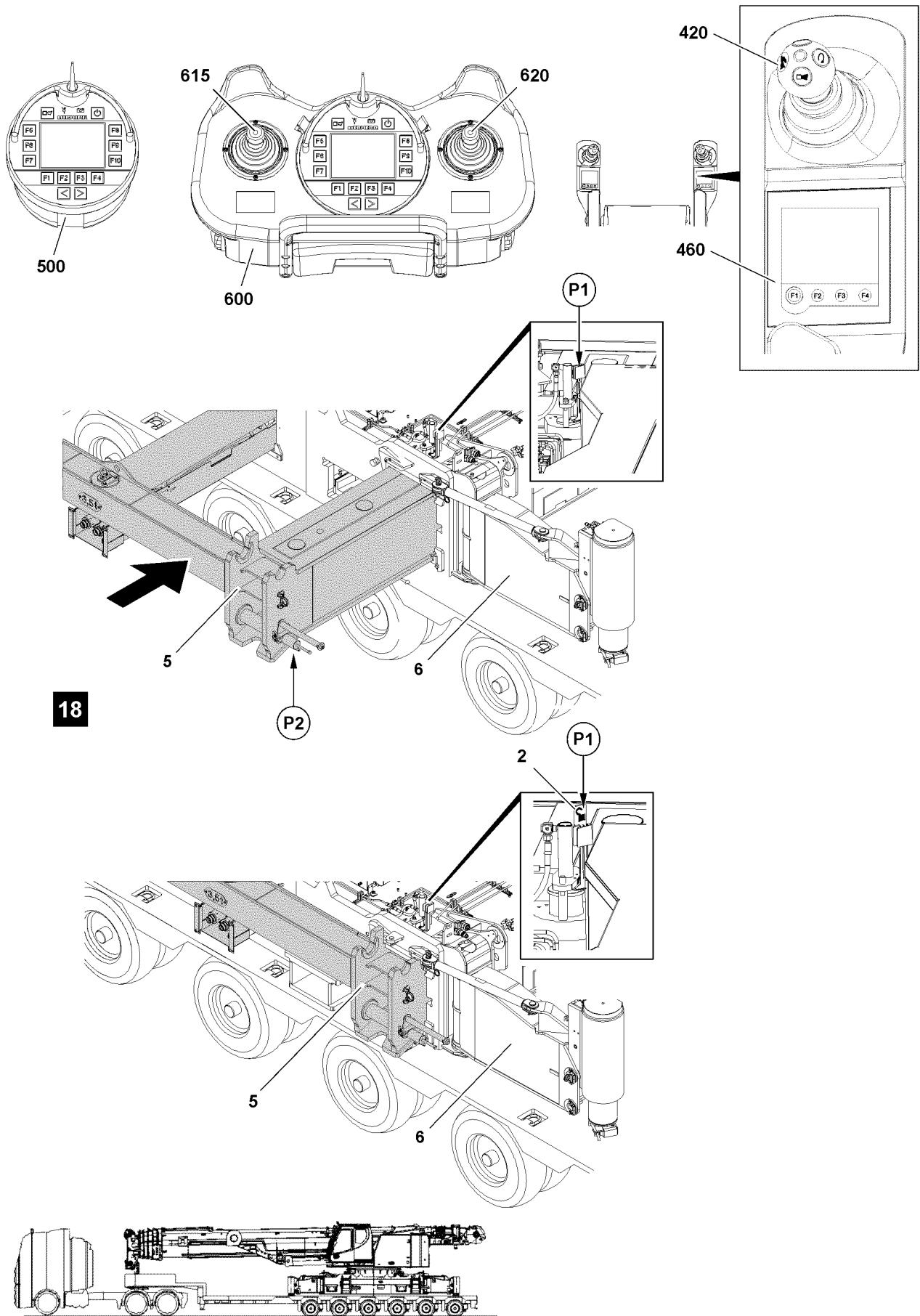


Fig.116892

LWE/LTR 1220-003/24204-02-02/en

### 2.6.3 Retracting the cross carriers with the radio remote control\*

Make sure that the following prerequisite is met:

- On the display of the BTT-E, the menu overview is visible.

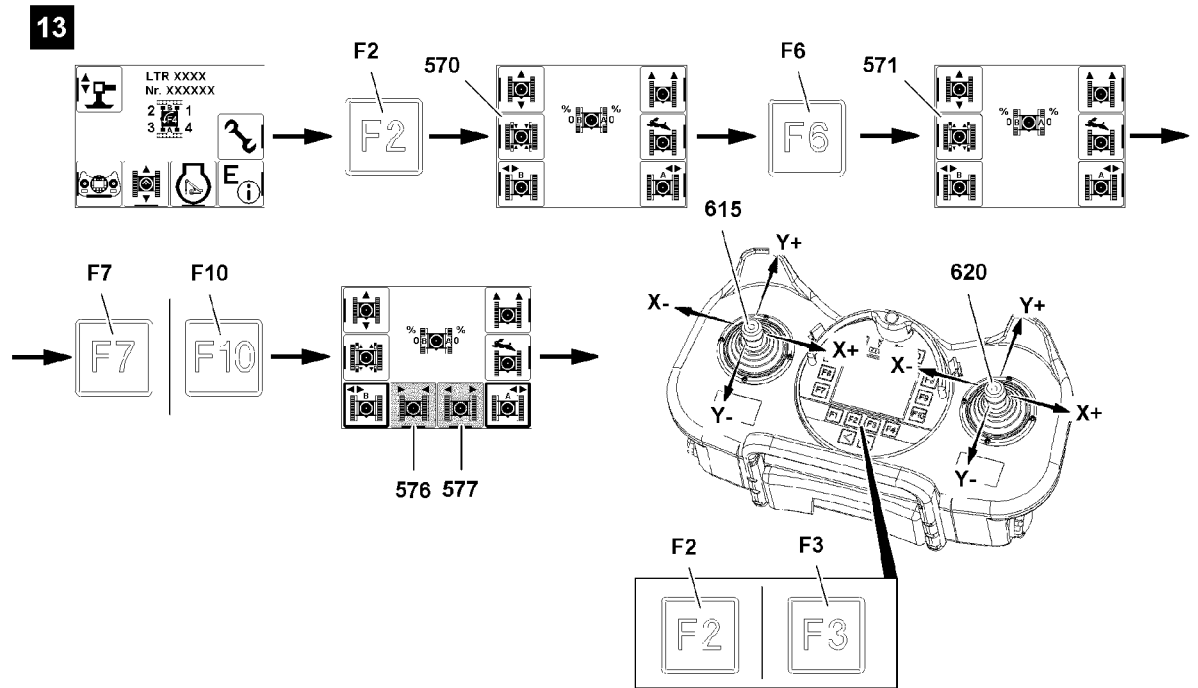


Fig. 116893

#### Unpinning the cross carrier

- ▶ Call up the „Crawler travel gear“ menu: Press the function key **F2**, see illustration 13.

#### Result:

- Functions „Track width adjustment“ are visible.

When icon „Pin the cross carrier“ **570** is visible:

- ▶ Activate „Unpin the cross carrier“: Press the function key **F6**.

#### Result:

- Icon „Unpin the cross carrier“ **571** appears.

#### Selecting the cross carrier

Before you retract or extend the cross carrier, select one of the cross carriers or both cross carriers:

- **F7** Function key
- **F10** Function key

In this and the following sections is described how both cross carriers are retracted together. Alternatively you can also select and retract the cross carriers individually.

Depending on which cross carriers are selected, different icons for „retract crawler carrier“ and „extend crawler carrier“ appear, see Crane operating instructions, chapter 6.08.

- ▶ Select both cross carriers: Press function key **F7** and function key **F10**, see illustration 13.

#### Result:

- Icon „Extend crawler carrier“ **577** is visible.
- Icon „Retract crawler carrier“ **576** is visible.

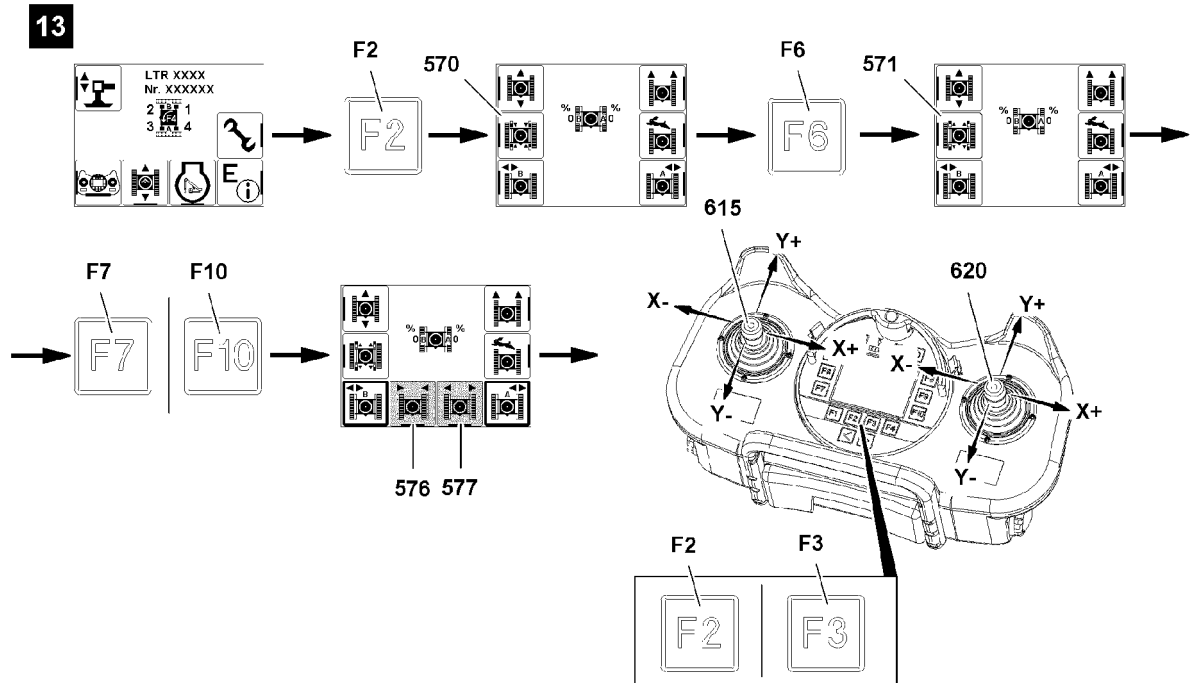


Fig. 116893

### Retracting the cross carriers

To unpin the cross carriers on points **P1**, you have extend the cross carriers, see illustration **18**.

You can check on points **P1** if the pins are completely pinned or unpinned:

- The pins are unpinned: Tags **2** are visible.
- The pins are pinned: Tags **2** are **not** visible.



### WARNING

Crushing danger due to movement of cross carriers!

- ▶ Make sure that no personnel is within the danger zone of the cross carriers during „track width adjustment“.
- ▶ Differentiation of the cross carriers, see Crane operating instructions, chapter 6.08.

When both cross carriers are selected, then the operation is assigned to the following manual control levers on the BTT-E:

- Manual control lever **615** or manual control lever **620**

When „extending the cross carrier“:

- ▶ Deflect the manual control lever in direction X+.
- or
- Press the function key **F3**.

When „retracting the cross carrier“:

- ▶ Deflect the manual control lever in direction X-.
- or
- Press the function key **F2**.

### Result:

- The pins are unpinned.



---

**Problem remedy**

Pins are not unpinned!

The pin is stuck: The position of the cross carriers prevents the pins from unpinning.

- ▶ Extend and retract the cross carriers again: Deflect the manual control levers on the BTT-E in direction X+ or X- or press function keys until the pins are completely unpinned.

- 
- ▶ Make sure that the pins are completely unpinned on points **P1**, see illustration **18**.

**Result:**

- The pins are unpinned.
- The cross carriers retract.

**Pinning the cross carriers**

Before the cross carriers reach the 0% extension status:

- ▶ Activate „Pin the cross carrier“: Press the function key **F6**.

**Result:**

- Icon „pin the cross carrier“ **570** is visible.
- The pins are pinned.

---

**Problem remedy**

The pins are not pinned!

The pin is stuck: The position of the cross carriers prevents the pins from pinning.

- ▶ Extend and retract the cross carriers again: Deflect the manual control levers on the BTT-E in direction X+ or X- or press function keys until the pins are completely pinned.

- 
- ▶ Make sure that the pins are completely pinned on points **P1**, see illustration **18**.

**Result:**

- The pins are pinned.
- The cross carriers are retracted and secured at 0 %.

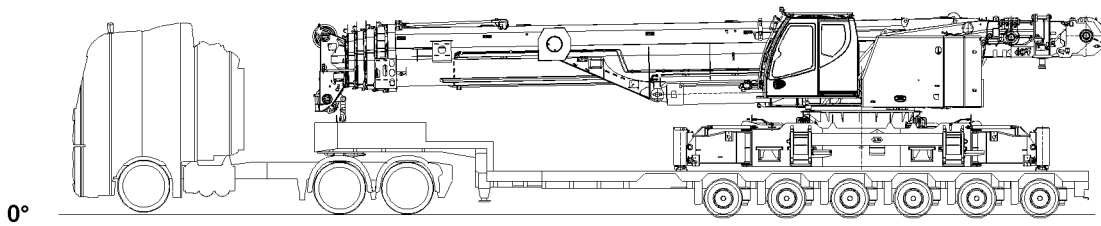


Fig.116888

## 2.7 Rigging the crane on the transport vehicle

Make sure that the following prerequisites are met:

- The folding brackets are pinned in transport position.
  - The cross carriers are retracted in transport position.
  - The crane has been placed on the transport vehicle.
- ▶ Lock the crane superstructure with the crane chassis.



### Note

- ▶ The telescopic boom must be supported on the transport vehicle to ensure the stability of the crane!

- 
- ▶ Luff the telescopic boom down and place it on the support.
- ▶ Fasten the hook block to the crawler center section and lightly tension the hoist rope.



### WARNING

Falling crane if insufficiently secured!

- ▶ The crane must be rigged and secured sufficiently to survive a strong braking maneuver!
- 
- ▶ Rig and secure the crane properly on the transport vehicle, see Crane operating instructions, chapter 3.80.

---

Empty page!

LWE/LTR 1220-003/24204-02-02/en

## 3.01.20 Assembling the cross carrier on the crawler center section

1	Component description	3
2	Disassembly of cross carrier with bracket	5
3	Assembly of cross carrier with bracket	8
4	Disassembly Cross carrier with installed extension cylinder	11
5	Assembly Cross carrier with installed extension cylinder	14

*Fig.195219*

LWE/LTR 1220-003/24204-02-02/en

# 1 Component description

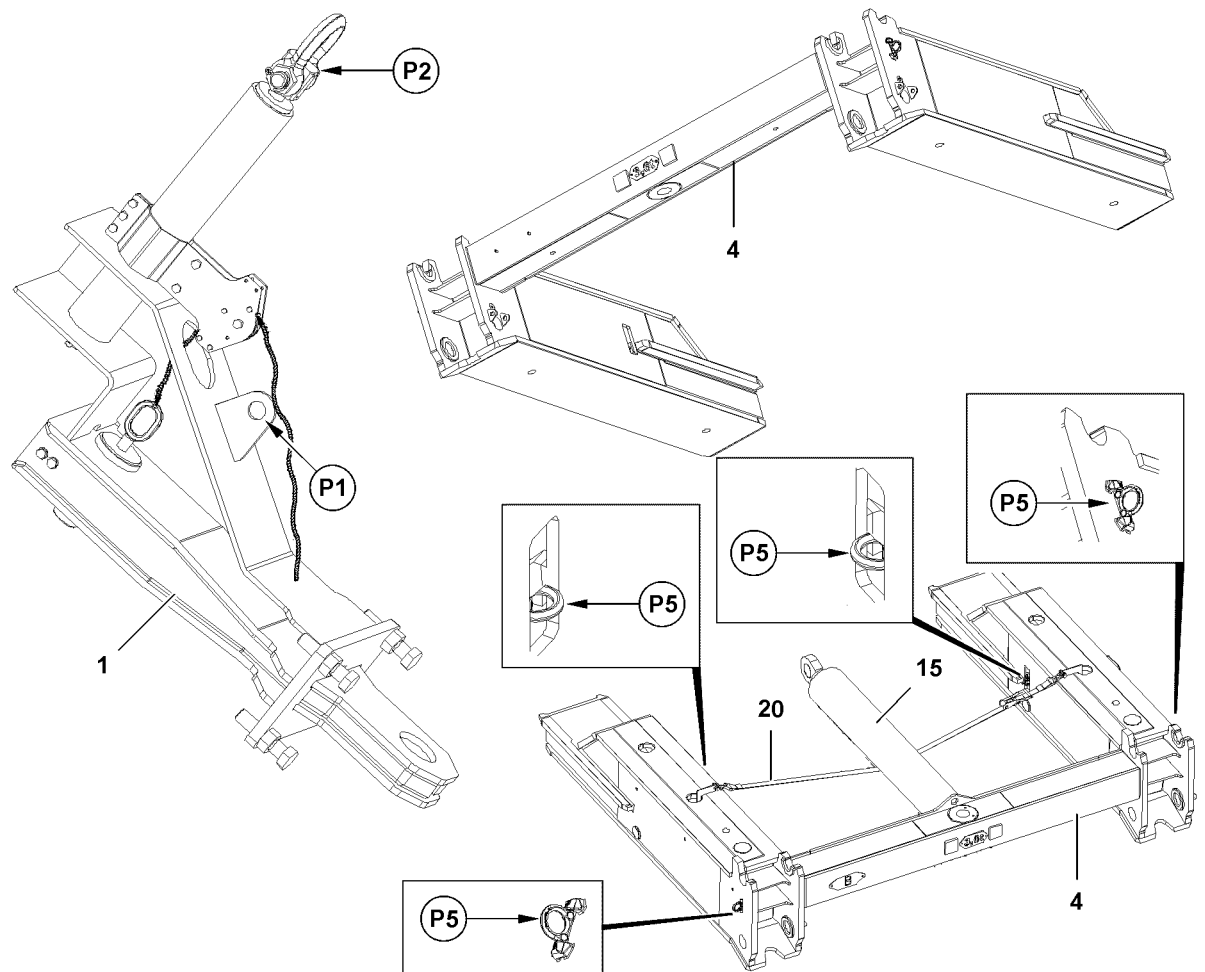


Fig.119526

With the bracket **1**, the cross carriers **4** can be disassembled or assembled without auxiliary crane.

With the tension belt **20**, the cross carriers **4** with extension cylinder **15** can be disassembled or assembled without auxiliary crane.

## 1.1 Weight

Description	Weight
Assembly bracket crawler carrier	0.2 t
Cross carrier	3.6 t
Cross carrier with extension cylinder	4.2 t

## 1.2 Fastening points

Description	Load
Fastening point P1 (center of gravity bracket)	0.5 t
Fastening point P2 (center of gravity cross carrier / bracket)	4.0 t
Fastening points P5 (cross carrier / extension cylinder)	4.2 t

To lift the bracket **1** a fastening point **P1** is installed.

For the assembly / disassembly of the cross carriers **4** with bracket **1** the fastening point **P2** is installed.

For the assembly / disassembly of the cross carriers **4** with bracket **15** the fastening point **P5** is installed.



### Note

- ▶ For the assembly and disassembly of the cross carriers **2** the fastening point **P2** for the bracket **1** must be used.
- ▶ For the assembly and disassembly of the cross carriers **4** with extension cylinders **15** the fastening points **P5** must be used.



## 2 Disassembly of cross carrier with bracket

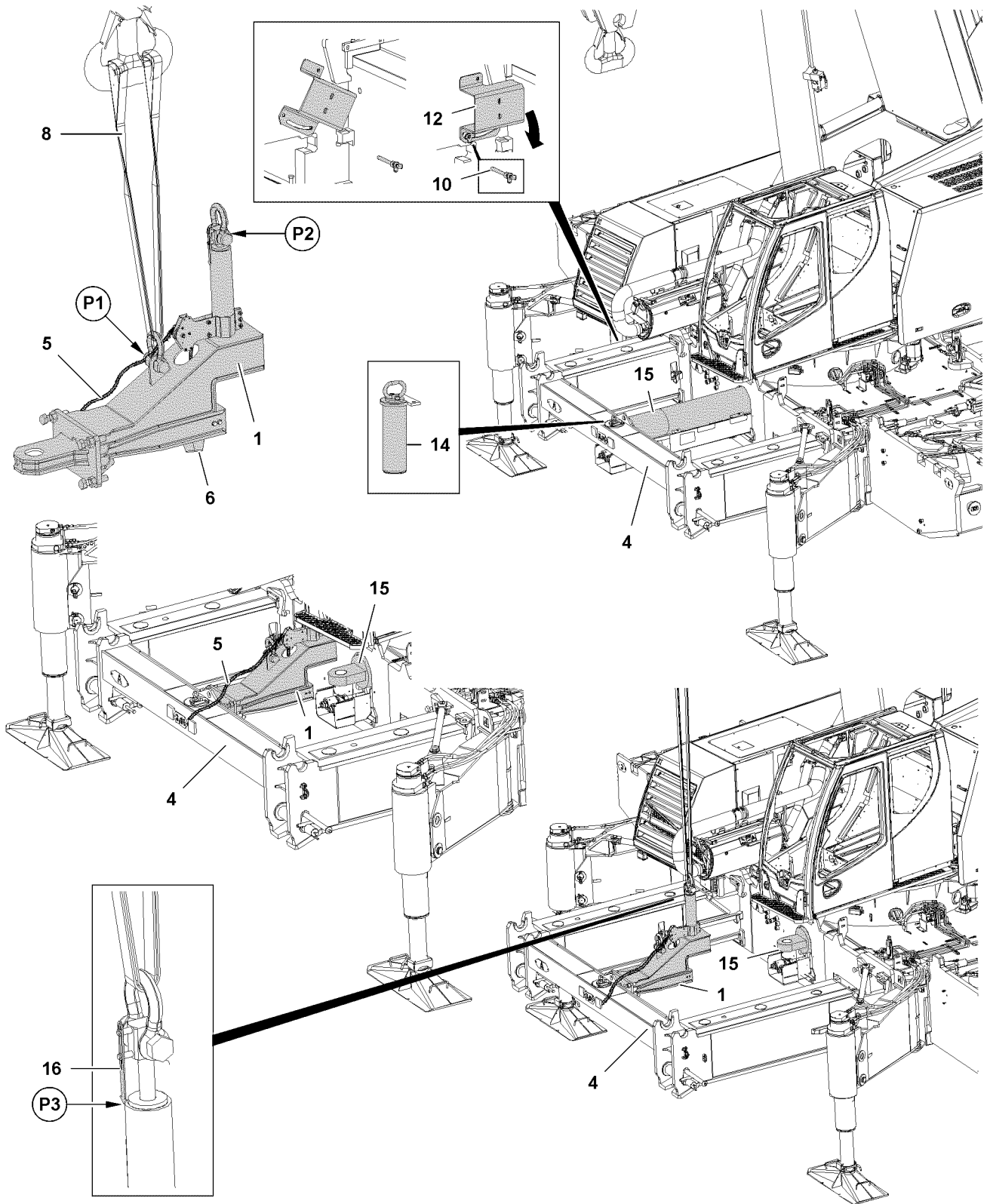


Fig. 119527

LWE/LTR 1220-003/24204-02-02/en

**WARNING**

Danger of falling!

During assembly and disassembly, personnel must be secured with appropriate aids to prevent them from falling! If this is not observed, assembly personnel could fall and suffer fatal injuries!

- ▶ All work aloft, where there is a danger of falling must be carried out with suitable aids!
- ▶ If fall arrest equipment is available, then it must be used, see Crane operating instructions, chapter 2.06!
- ▶ If aids are not available and work cannot be carried out from the ground, then the assembly personnel must secure themselves with the supplied fall arrest system to prevent falling, see Crane operating instructions, chapter 2.04!
- ▶ The supplied fall arrest system must be fastened on the fastening and hook points as well as on the retaining ropes. For safety points, see Crane operating instructions, chapter 2.06!
- ▶ Only step on the aids, ladders and catwalks with clean shoes!
- ▶ Keep aids, ladders and catwalks free of heavy dirt, snow and ice!

**WARNING**

The crane can topple over!

At assembly / disassembly of the crawler carriers, if the values of the load chart are not adhered to, the crane can topple over at assembly / disassembly!

Personnel can be severely injured or killed!

This could result in high property damage!

- ▶ Observe and adhere to the values in the load chart for assembly / disassembly of the crawler carrier.

Make sure that the following prerequisites are met:

- The crane is properly supported and horizontally aligned.
- The central ballast 20.0 t is completely installed.
- The cross carriers are fully moved out and pinned.
- The crawler carriers are removed.
- The LICCON overload protection is set:
  - Support base 4.4 m on supports
  - Central ballast 20 t
  - Counterweight 0 t
  - Without auxiliary boom / accessory
  - Slewing range

## 2.1 Removing the cross carrier

- ▶ Unpin the ball locking pin **10** and swing the sensor **12** for the track width monitoring into assembly position.
- ▶ Insert the ball locking pin **10** in assembly position.
- ▶ Open the screws and unpin the pins **14**.
- ▶ Move the extension cylinder **15** in completely.

**Note**

- ▶ For a detailed description of the actuation of the extension cylinders with the Bluetooth™ Terminal (BTT) refer to the Crane operating instructions, chapter 5.31.

- ▶ Fasten the bracket **1** on point **P1** on the crane.

**DANGER**

Danger of fatal accident if the bracket falls down!

- ▶ Detach the crane only after the bracket **1** is pinned with the cross carrier **4**!
- ▶ Lift the bracket **1** and pin with the cross carrier **4**.
- ▶ Insert and secure pin **14**.

**WARNING**

Crushing danger due to movement of extension cylinder!

- ▶ Make sure that no personnel is within the danger zone of the cross carriers when moving the extension cylinder out.
  - ▶ With the auxiliary rope **5** unpin the pin **6**.
- 
- ▶ Pull the auxiliary rope **5** and unpin the pin **6**.

**Note**

▶ For a detailed description of the actuation of the extension cylinders with the Bluetooth™ Terminal (BTT) refer to the Crane operating instructions, chapter 5.31.

- ▶ Move the extension cylinder **15** out and connect with bracket **1**.
- ▶ Release the auxiliary rope **5** and insert the pin **6**.
- ▶ Unhook the fastening rope **8** of the bracket **1** at point **P1** and fasten at point **P2**.
- ▶ Tension the fastening rope **8** of the bracket **1** until the tip of the arrow **16** with the collar is at the same height as point **P3**.

**WARNING**

Crushing danger due to movement of cross carriers!

- ▶ Make sure that no personnel is within the danger zone of the cross carriers during „track width adjustment“.

**Note**

▶ For a detailed description of the actuation of the extension cylinders with the Bluetooth™ Terminal (BTT) refer to the Crane operating instructions, chapter 5.31.

- ▶ Unpin the cross carrier **4** and slide out with the extension cylinder **15** all the way.

When the cross carrier **4** is suspended freely:

- ▶ Unpin the pin **6** with the auxiliary rope **5**.
- ▶ Move the extension cylinder **15** in completely.
- ▶ Place the cross carrier **4** on the transport vehicle.
- ▶ Unhook the fastening rope **8** of the bracket **1** at point **P2** and fasten at point **P1**.
- ▶ Unpin the pin **14** on the cross carrier **4**.
- ▶ Lift the bracket **1**.

### 3 Assembly of cross carrier with bracket

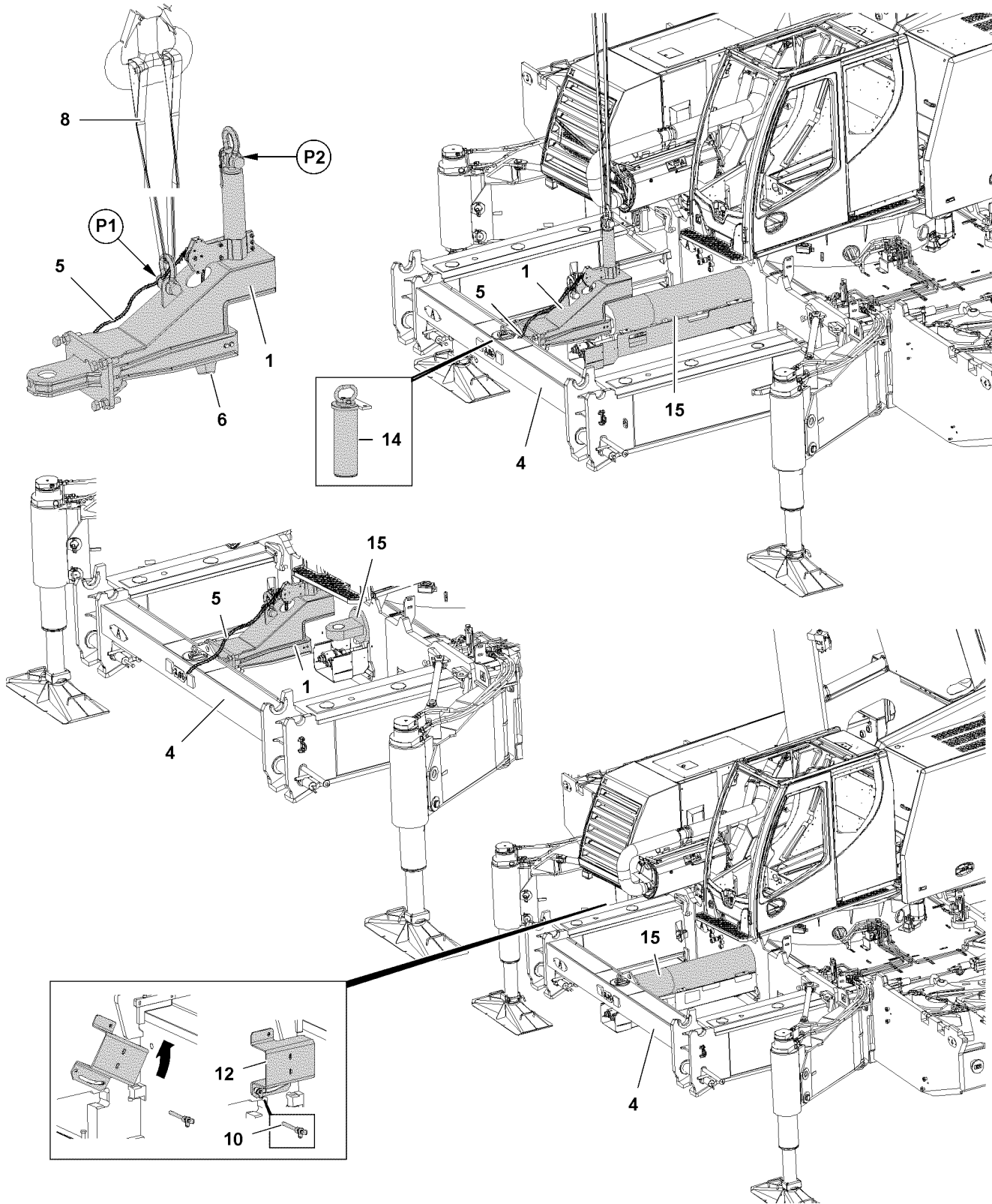


Fig. 119528

LWE/LTR 1220-003/24204-02-02/en

**WARNING**

Danger of falling!

During assembly and disassembly, personnel must be secured with appropriate aids to prevent them from falling! If this is not observed, assembly personnel could fall and suffer fatal injuries!

- ▶ All work aloft, where there is a danger of falling must be carried out with suitable aids!
- ▶ If fall arrest equipment is available, then it must be used, see Crane operating instructions, chapter 2.06!
- ▶ If aids are not available and work cannot be carried out from the ground, then the assembly personnel must secure themselves with the supplied fall arrest system to prevent falling, see Crane operating instructions, chapter 2.04!
- ▶ The fall arrest system must be fastened on the fastening and hook points as well as on the safety ropes. For safety points, see Crane operating instructions, chapter 2.06!
- ▶ Only step on the aids, ladders and catwalks with clean shoes!
- ▶ Keep aids, ladders and catwalks free of heavy dirt, snow and ice!

Make sure that the following prerequisites are met:

- The crane is properly supported and horizontally aligned.
- The cross carriers are fully moved out and pinned.
- The central ballast 20.0 t is completely installed.
- The crawler carriers are removed.
- The LICCON overload protection is set:
  - Support base 4.4 m on supports
  - Central ballast 20 t
  - Counterweight 0 t
  - Without auxiliary boom / accessory
  - Slewing range

### 3.1 Installing the cross carrier

- ▶ Unpin the pin **14** on the cross carrier **4**.
- ▶ Fasten the bracket **1** on point **P1** on the crane.
- ▶ Lift the bracket **1** and pin with the cross carrier **4**.
- ▶ Insert and secure pin **14**.
- ▶ Unhook the fastening rope **8** of the bracket **1** at point **P1** and fasten at point **P2**.

**WARNING**

Crushing danger due to movement of extension cylinder!

- ▶ Make sure that no personnel is within the danger zone of the cross carriers when moving the extension cylinder out.
- ▶ Move the extension cylinder **15** out completely.

**Note**

▶ For a detailed description of the actuation of the extension cylinders with the Bluetooth™ Terminal (BTT) refer to the Crane operating instructions, chapter 5.31.

- ▶ Lift the cross carrier **4** with the bracket **1**.
- ▶ Pin the bracket **1** with the cross carrier **4** with the extension cylinder **15**.
- ▶ Pull the auxiliary rope **5**.
- ▶ Release the auxiliary rope **5** and insert the pin **6**.

**DANGER**

Danger of fatal accident if the bracket falls down!

- ▶ Detach the crane only after the bracket **1** is pinned with the cross carrier **4**!
- ▶ Slide the cross carrier **4** into the crane chassis and move the extension cylinder **15** in.

**Note**

- ▶ For a detailed description of the actuation of the extension cylinders with the Bluetooth™ Terminal (BTT) refer to the Crane operating instructions, chapter 5.31.

- ▶ Move the extension cylinder **15** in.
- ▶ Unhook the fastening rope **8** of the bracket **1** at point **P2** and fasten at point **P1**.

**WARNING**

Crushing danger due to movement of extension cylinder!

- ▶ Make sure that no personnel is within the danger zone of the cross carriers when moving the extension cylinder out.
- ▶ With the auxiliary rope **5** unpin the pin **6**.
- ▶ Pull the auxiliary rope **5** and unpin the pin **6**.

**Note**

- ▶ For a detailed description of the actuation of the extension cylinders with the Bluetooth™ Terminal (BTT) refer to the Crane operating instructions, chapter 5.31.

- ▶ Move the extension cylinder **15** in completely.
- ▶ Open the screws and unpin the pins **14**.
- ▶ Lift the bracket **1** and place down.
- ▶ Unpin the ball locking pin **10** and swing the sensor **12** for the track width monitoring into operating position.
- ▶ Insert the ball locking pin **10** in operating position.

# 4 Disassembly Cross carrier with installed extension cylinder

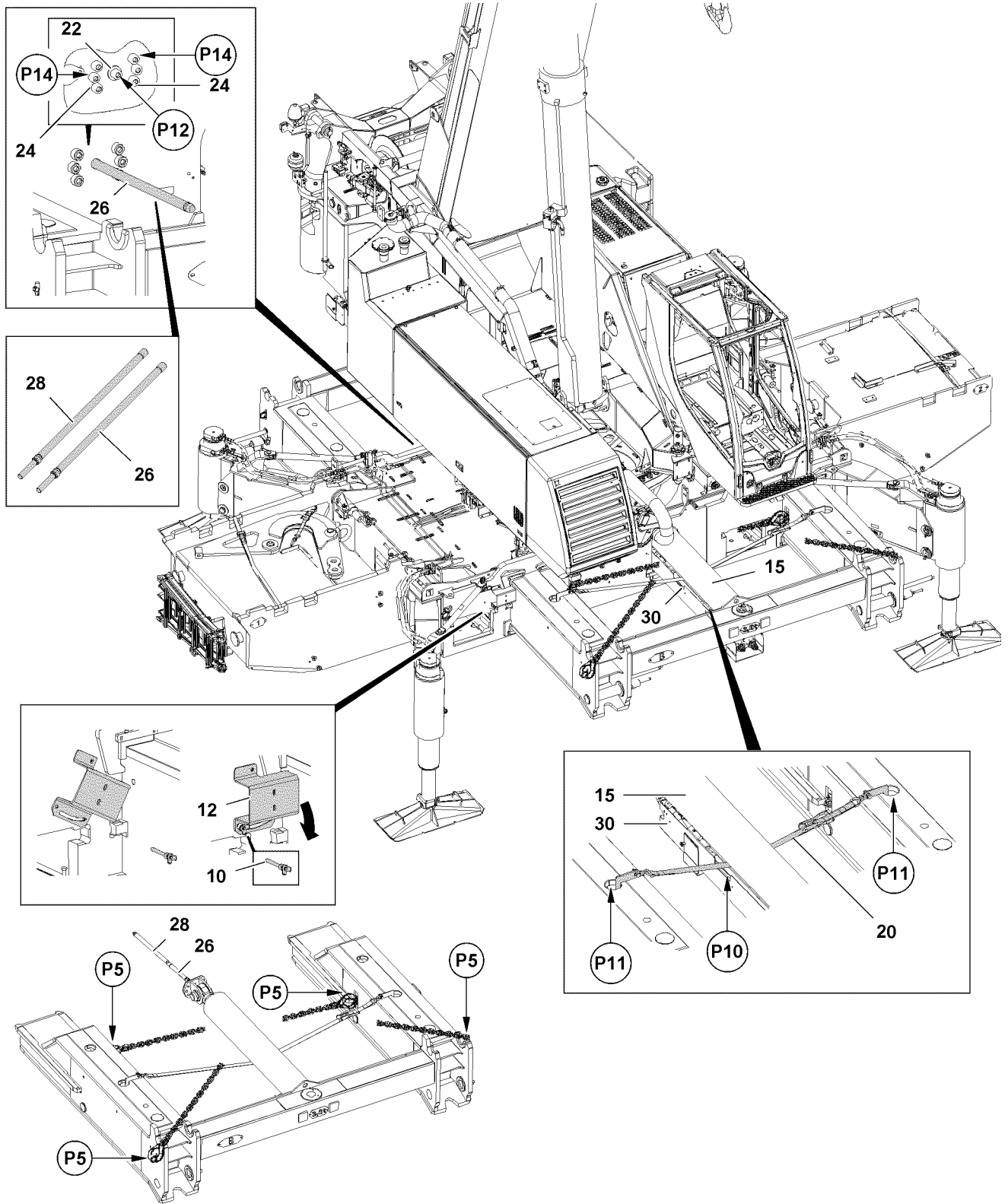


Fig.119529

LWE/LTR 1220-003/24204-02-02/en

**WARNING**

Danger of falling!

During assembly and disassembly, personnel must be secured with appropriate aids to prevent them from falling! If this is not observed, assembly personnel could fall and suffer fatal injuries!

- ▶ All work aloft, where there is a danger of falling must be carried out with suitable aids!
- ▶ If fall arrest equipment is available, then it must be used, see Crane operating instructions, chapter 2.06!
- ▶ If aids are not available and work cannot be carried out from the ground, then the assembly personnel must secure themselves with the supplied fall arrest system to prevent falling, see Crane operating instructions, chapter 2.04!
- ▶ The supplied fall arrest system must be fastened on the fastening and hook points as well as on the retaining ropes. For safety points, see Crane operating instructions, chapter 2.06!
- ▶ Only step on the aids, ladders and catwalks with clean shoes!
- ▶ Keep aids, ladders and catwalks free of heavy dirt, snow and ice!

**WARNING**

The crane can topple over!

At assembly / disassembly of the crawler carriers, if the values of the load chart are not adhered to, the crane can topple over at assembly / disassembly!

Personnel can be severely injured or killed!

This could result in high property damage!

- ▶ Observe and adhere to the values in the load chart for assembly / disassembly of the crawler carrier.

Make sure that the following prerequisites are met:

- The crane is properly supported and horizontally aligned.
- The central ballast 20.0 t is completely installed.
- The cross carriers are fully moved out and pinned.
- The crawler carriers are removed.
- The LICCON overload protection is set:
  - Support base 4.4 m on supports
  - Central ballast 0 t
  - Counterweight 0 t
  - Without auxiliary boom / accessory
  - Slewing range

## 4.1 Disassembling the cross carrier with installed extension cylinder

- ▶ Unpin the ball locking pin **10** and swing the sensor **12** for the track width monitoring into assembly position.
- ▶ Insert the ball locking pin **10** in assembly position.
- ▶ Pull the tension belt **20** through under the extension cylinder **15** at point **P10**.
- ▶ Hook the tension belt **20** at point **P11**.
- ▶ Tension the tension belt **20** until the tension belt **20** is touching on the extension cylinder **15**.
- ▶ Fasten the cross carrier **4** with installed extension cylinder **15** on points **P5** on the crane.
- ▶ Lightly tighten the hoist rope.

**DANGER**

Mortal danger if the cross carrier with installed extension cylinder falls down!

- ▶ Detach the crane only after the cross carrier **4** with extension cylinder has been safely placed down!
- ▶ Release and remove the screw **22** on position **P12**.
- ▶ Screw the threaded rod **26** in at position **P12**.
- ▶ Release and remove all screws **24**.
- ▶ Move the extension cylinder **15** in until the threaded rod **28** can be screwed in.



**Note**

- ▶ For a detailed description of the actuation of the extension cylinders with the Bluetooth™ Terminal (BTT) refer to the Crane operating instructions, chapter 5.31.

- ▶ Screw the threaded rod **28** in.
- ▶ Move the extension cylinder **15** in completely.

The engine must be turned off before connecting and disconnecting hydraulic lines.

- ▶ Remove the cylinder guard **30** and place it in the crawler center section.
- ▶ Release the hydraulic connection for the extension cylinder **15**.
- ▶ Unpin the cross carrier **4**.

**Note**

- ▶ For a detailed description of the actuation of the extension cylinders with the Bluetooth™ Terminal (BTT) refer to the Crane operating instructions, chapter 5.31.

- ▶ Pull the cross carrier **4** with the extension cylinder **15** from the guide and place down.
- ▶ Remove the threaded rod **26** and threaded rod **28**.
- ▶ Unhook the fastening chain on the cross carrier **4**.

# 5 Assembly Cross carrier with installed extension cylinder

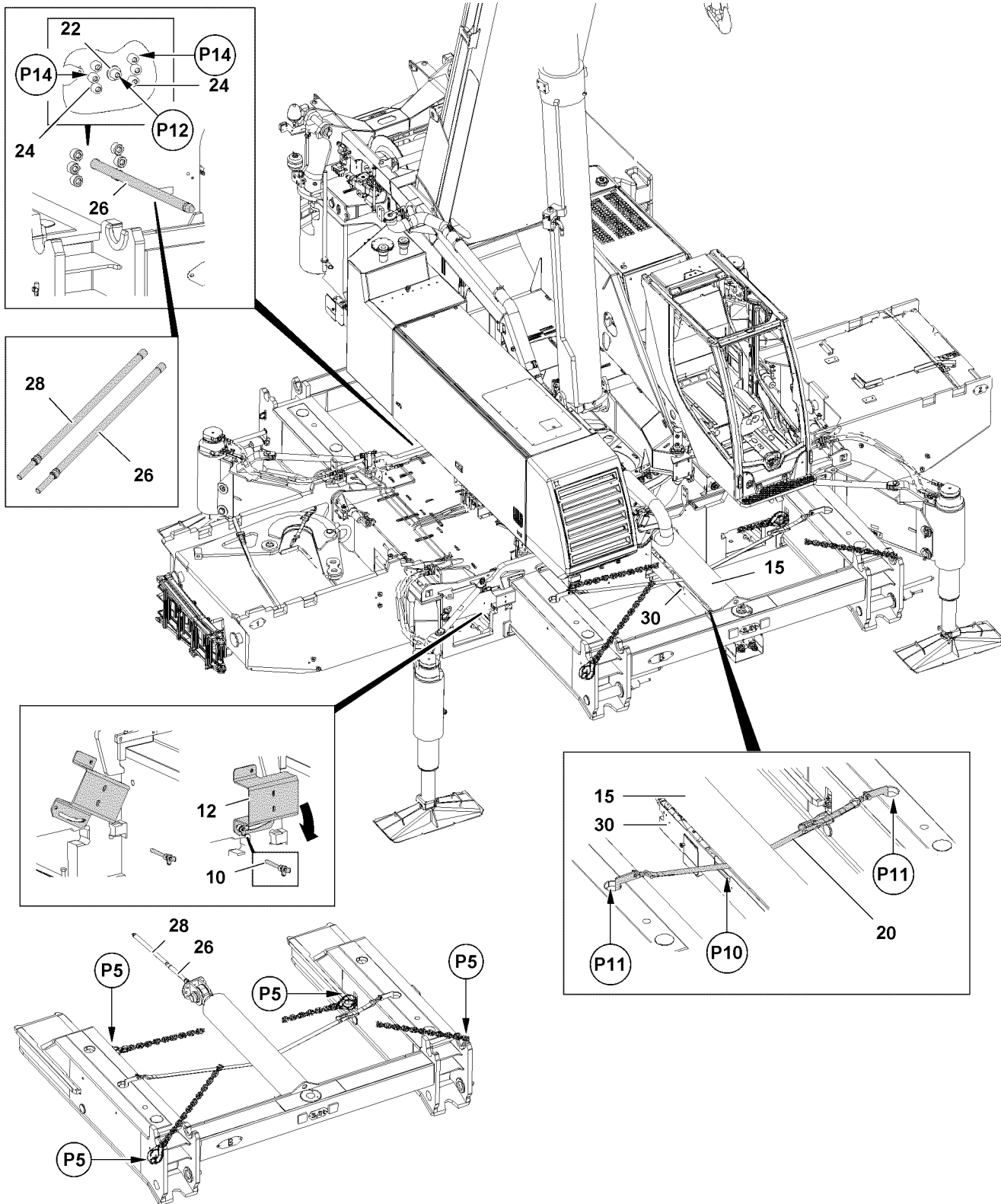


Fig.119529

LWE/LTR 1220-003/24204-02-02/en

**WARNING**

Danger of falling!

During assembly and disassembly, personnel must be secured with appropriate aids to prevent them from falling! If this is not observed, assembly personnel could fall and suffer fatal injuries!

- ▶ All work aloft, where there is a danger of falling must be carried out with suitable aids!
- ▶ If fall arrest equipment is available, then it must be used, see Crane operating instructions, chapter 2.06!
- ▶ If aids are not available and work cannot be carried out from the ground, then the assembly personnel must secure themselves with the supplied fall arrest system to prevent falling, see Crane operating instructions, chapter 2.04!
- ▶ The supplied fall arrest system must be fastened on the fastening and hook points as well as on the retaining ropes. For safety points, see Crane operating instructions, chapter 2.06!
- ▶ Only step on the aids, ladders and catwalks with clean shoes!
- ▶ Keep aids, ladders and catwalks free of heavy dirt, snow and ice!

**WARNING**

The crane can topple over!

At assembly / disassembly of the crawler carriers, if the values of the load chart are not adhered to, the crane can topple over at assembly / disassembly!

Personnel can be severely injured or killed!

This could result in high property damage!

- ▶ Observe and adhere to the values in the load chart for assembly / disassembly of the crawler carrier.

Make sure that the following prerequisites are met:

- The crane is properly supported and horizontally aligned.
- The central ballast 20.0 t is completely installed.
- The cross carriers are fully moved out and pinned.
- The crawler carriers are removed.
- The LICCON overload protection is set:
  - Support base 4.4 m on supports
  - Central ballast 0 t
  - Counterweight 0 t
  - Without auxiliary boom / accessory
  - Slewing range

## 5.1 Assembling the cross carrier with installed extension cylinder

- ▶ Install the threaded rod **26** and threaded rod **28**.
- ▶ Fasten the cross carrier **4** with installed extension cylinder **15** on points **P5** on the crane.

**NOTICE**

Damage of threaded rods!

- ▶ Carefully move the threaded rods in bore **P30**.
- ▶ Slide the cross carrier **4** with extension cylinder **15** and threaded rods carefully into the guides.
- ▶ Pin the cross carrier **4** at „wide“ track.

**Note**

- ▶ **For a detailed description of the actuation of the extension cylinders with the Bluetooth™ Terminal (BTT) refer to the Crane operating instructions, chapter 5.31.**

- ▶ Unhook the fastening chain on the cross carrier **4**.

The engine must be turned off before connecting and disconnecting hydraulic lines.

- ▶ Connect the hydraulic connection for the extension cylinder **15**.
- ▶ Release the tension belt **20**, unhook on point **P11** and remove.
- ▶ Remove the cylinder guard **30** from the crawler center section and install.

- ▶ Move the extension cylinder **15** out carefully.



---

**Note**

- ▶ **For a detailed description of the actuation of the extension cylinders with the Bluetooth™ Terminal (BTT) refer to the Crane operating instructions, chapter 5.31.**
- 

When the threaded rod **28** is completely visible on position **P12**:

- ▶ Remove the threaded rod **28**.
- ▶ Move the extension cylinder **15** out carefully.
- ▶ Install all screws **24** at position **P14**.
- ▶ Remove the threaded rod **26** at position **P12**.
- ▶ Install all screw **22** at position **P12**.
- ▶ Unpin the ball locking pin **10** and swing the sensor **12** for the track width monitoring into operating position.
- ▶ Insert the ball locking pin **10** in operating position.

## 3.03 Central ballast

1	Central ballast combinations	3
2	Central ballast during start up	3
3	Assembling the central ballast	5
4	Disassembling the central ballast	17

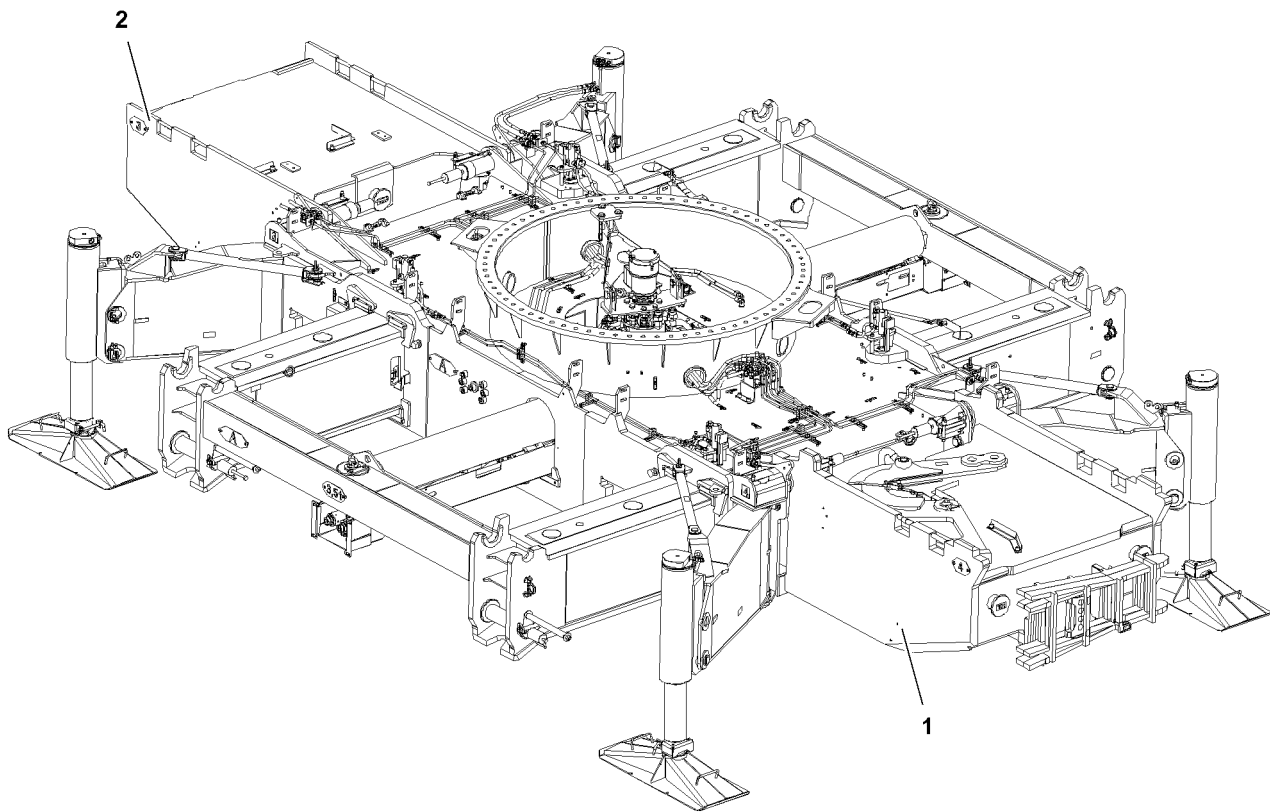


Fig.117547

LWE/LTR 1220-003/24204-02-02/en

# 1 Central ballast combinations

The central ballast is composed of:

- 1 Central ballast block, rear
- 2 Central ballast block, front



## WARNING

The crane can topple over!

The crane can topple over if another central ballast combination is used than specified in the charts!  
Personnel can be severely injured or killed!

- ▶ For crane operation, only use central ballast combinations that are specified in the following charts!

Central ballast	Composition	Individual weight
0.0 t	Without central ballast	0.0 t

Central ballast	Composition	Individual weight
20.0 t	Central ballast block, front <b>2</b>	10.0 t
	Central ballast block, rear <b>1</b>	10.0 t

# 2 Central ballast during start up

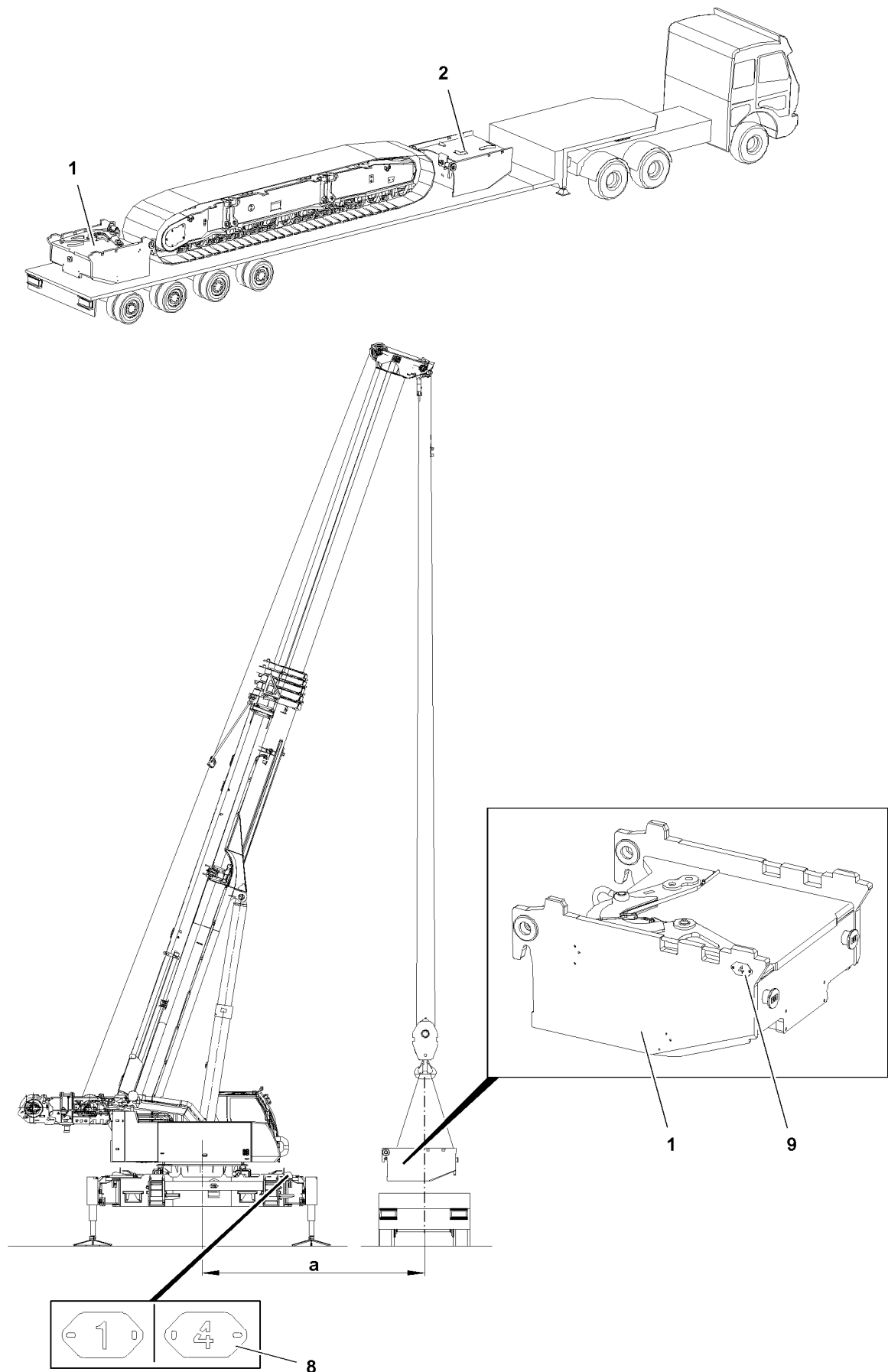


## WARNING

Falling central ballast!

If the central ballast blocks are not properly installed, they can fall down and cause severe accidents!  
Personnel can be severely injured or killed!

- ▶ Before start up, make sure that the central ballast block **1** and central ballast block **2** are installed properly!



LWE/LTR 1220-003/24204-02-02/en

Fig.117541



## 3 Assembling the central ballast



### WARNING

Danger of falling!

During assembly and disassembly, assembly personnel must be secured with appropriate aids to prevent them from falling! If this is not observed, assembly personnel could fall and suffer life-threatening or fatal injuries!

- ▶ Any work, where there is a danger of falling must be carried out with suitable aids (for example lifting platform, scaffolding, ladder, auxiliary crane).
- ▶ If the work can neither be carried out with such aids nor from the ground, then assembly personnel must secure themselves with approved fall arrest systems to avoid falling, see chapter 2.04 of the operating instructions!
- ▶ If railings are present on the crane components, then they must be brought into the corresponding position and secured for assembly / disassembly work!
- ▶ Only step on aids and fall protection equipment with clean shoes!
- ▶ Keep aids and fall protection equipment clean and free from snow and ice!
- ▶ During all assembly and disassembly work, maintenance work and inspections, travel or crane operation is prohibited!



### WARNING

Danger of impact / crushing!

When installing / removing crane components with the auxiliary crane, crane components can start to swing back and forth!

When lifting / lowering and positioning crane components, there is an increased danger of impacts / crushing!

Personnel can be caught and thereby injured or killed!

- ▶ Make sure that personnel cannot be caught by crane components!
- ▶ When working in danger zones: Use aids to protect limbs!
- ▶ Guide crane components with suitable aids to minimize oscillation!



### WARNING

Falling crane components!

During assembly, crane components can fall down!

Personnel can be severely injured or killed!

- ▶ Make sure that no persons or objects are within the danger zone!



### WARNING

The crane can topple over!

If the central ballast is assembled / disassembled, the set up configuration of the crane changes.

If changes are made to the central ballast, no central ballast may be taken into account as set up configuration of the crane when doing so.

- ▶ Make sure that the LICCON overload protection is set to a set up configuration without central ballast when making changes to the central ballast.
- ▶ Observe and adhere to the values in the load chart for assembly of the central ballast.
- ▶ Lift or take down the central ballast block at a permissible distance **a**, see the load chart.



### Note

- ▶ When the crane is **not** supported: Support the crane, see the Crane operating instructions, chapter 3.01.

Make sure that the following prerequisites are met:

- The crane is horizontally aligned.
- The crane is positioned on a level and load-bearing surface.
- The crane is supported on base 6.0 m x 4.4 m.
- Support cylinders are extended.

- The LICCON overload protection has been adjusted according to the set up configuration and the load chart.
- The crane is operational.

The equipment has the following set up configuration:

- Support base 6.0 m x 4.4 m
- Central ballast 0 t
- Counterweight 0 t
- Maximum 3-pulley hook block (smaller than / equal to 70.6 t load) reeved in
- When auxiliary boom is available on the crane:  
The auxiliary boom is assembled in the transport position on the telescopic boom

If a hook block is reeved in that is larger than the 3-pulley hook block (greater than 70.6 t load), the auxiliary boom on the telescopic boom must be disassembled.

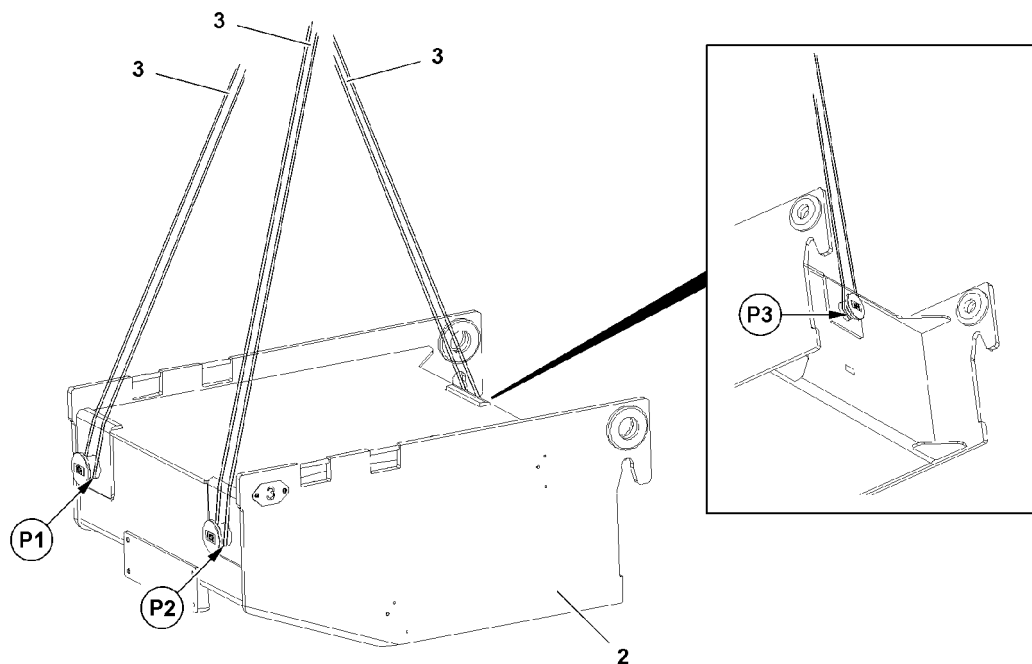


Fig.117543: Central ballast block fastening points

### 3.1 Checking the central ballast blocks



#### WARNING

Damaged central ballast block!

If a damaged / dirty central ballast block is used, then tight seating and operational safety are no longer ensured!

- ▶ Do not use a damaged central ballast block!
  - ▶ Replace / repair a damaged central ballast block!
  - ▶ Clean the fastening points of the central ballast before assembly!
- 
- ▶ Before assembly / disassembly of the central ballast blocks, carry out a visual inspection for damage or foreign matter.

## 3.2 Fastening the central ballast blocks



### WARNING

Improperly fastened central ballast block!

An improperly fastened central ballast block can slip and fall down when lifting or swinging it! Personnel can be severely injured or killed!

- ▶ Before lifting, make sure that the central ballast block is properly fastened!
- ▶ Use only approved and suitable fastening equipment **3**!
- ▶ Always keep sufficient distance from the suspended central ballast block!
- ▶ Standing under a raised central ballast block is **prohibited**!
- ▶ Carefully initiate all crane movements with attached central ballast block extremely sensitively and initiate slow down with utmost caution!



### WARNING

Swinging central ballast block!

If the fastening equipment is not positioned in the center over the fastening points of the central ballast block **2**, then the central ballast block **2** can start to swing after lifting and fall down!

This could result in serious accidents!

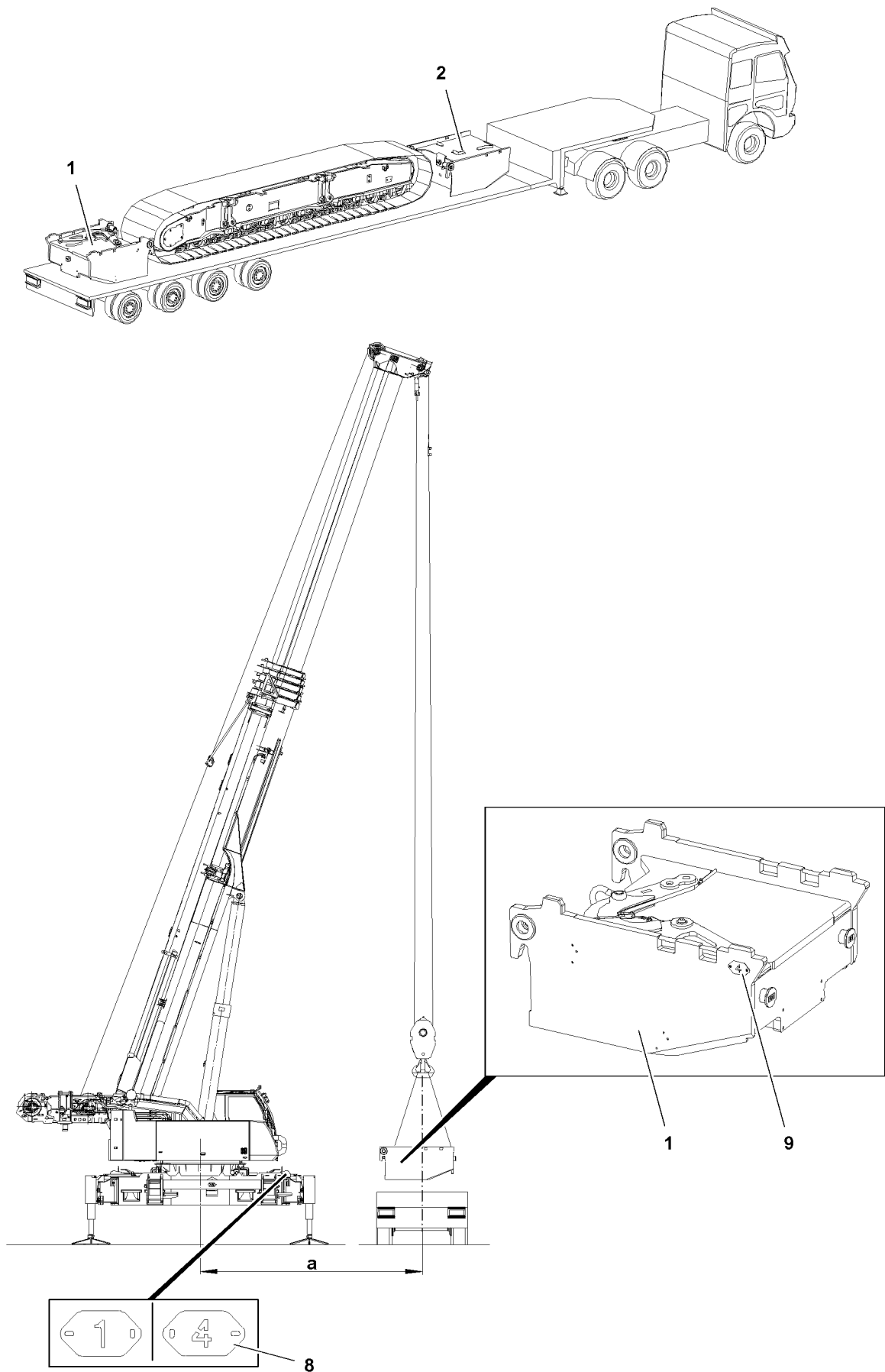
Personnel can be severely injured or killed!

- ▶ Make sure that the fastening equipment **3** is centered over the fastening points of the central ballast block **2** when fastening!



### Note

- ▶ The central ballast blocks are marked with numbers.
  - ▶ Make sure that the numbers on the central ballast block match the numbers on the pin points on the crawler center section.
- ▶ Fasten the central ballast block **2** in point **P1**, point **P2** and point **P3**, see illustration.



LWE/LTR 1220-003/24204-02-02/en

Fig.117541

### 3.3 Assembling the central ballast block on the rear



#### Note

- ▶ The „rear“ of the central ballast block and the crawler center section is marked with the number **1** and number **4**.
- ▶ The numbers on the central ballast block **1** and crawler center section **5** must be identical upon assembly.
- ▶ Positions of numbers, see tag **8** and tag **9**.

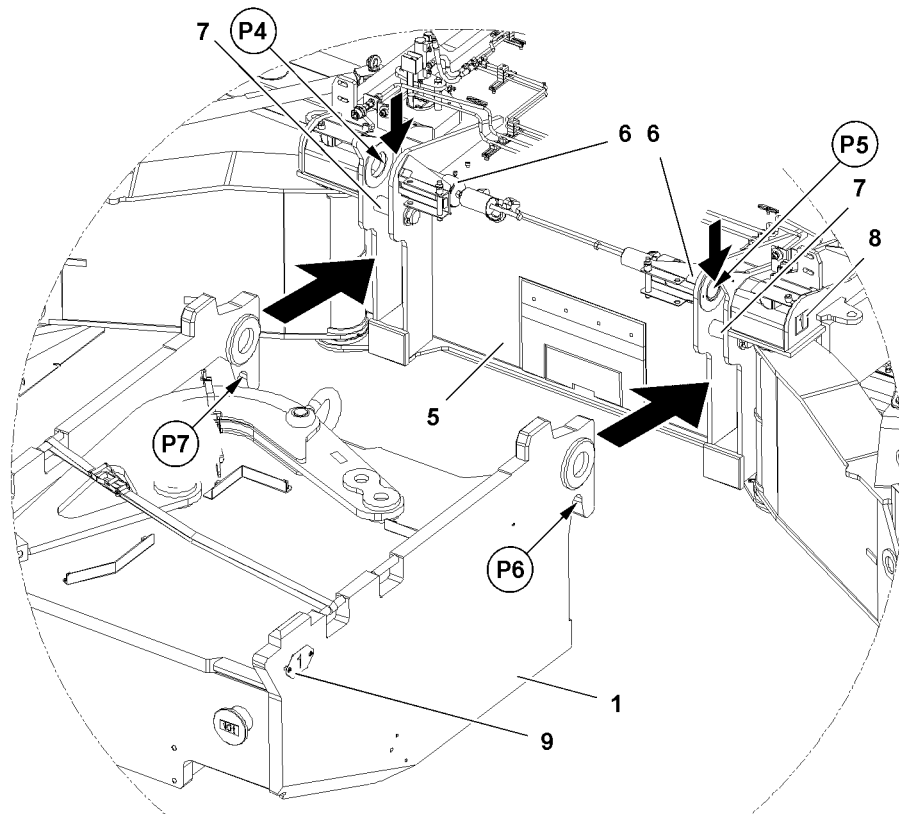


Fig.117545: Central ballast block, rear: Connection and pin points

- ▶ Make sure that the numbers on the central ballast block match the numbers on the pin points on the crawler center section.
- ▶ Fasten the central ballast block **1**.
- ▶ Lift the central ballast block **1**, pay attention to the load momentum indicator.
- ▶ Make sure that the pins **6** in point **P4** and point **P5** are unpinned.
- ▶ Swing the central ballast block **1** in and connect to point **P6** and point **P7** from the top on pin **7**.
- ▶ Lower the central ballast block **1** until the pin bores in point **P4** and point **P5** align.

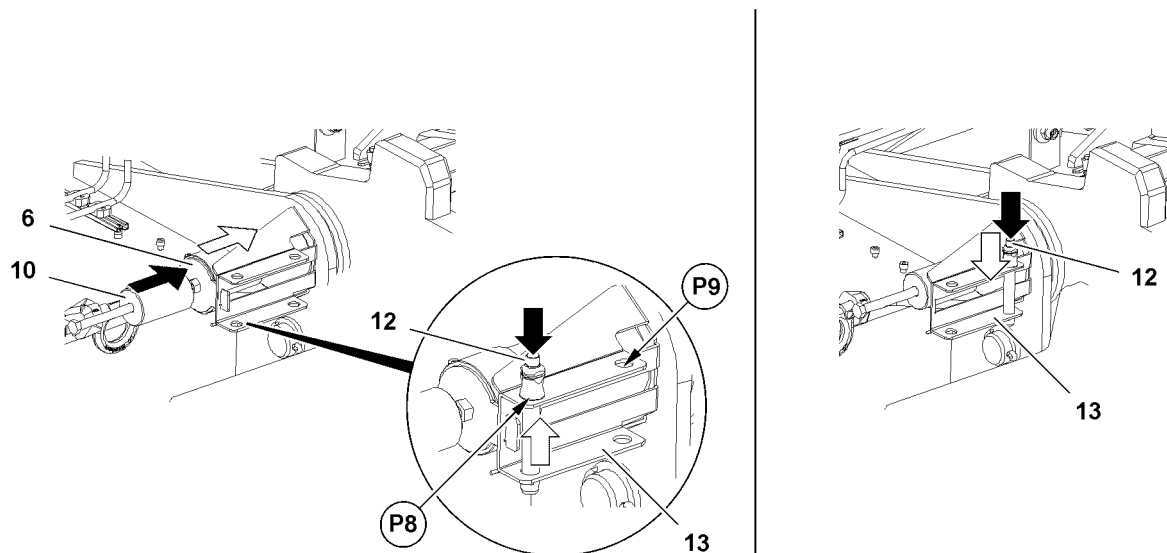
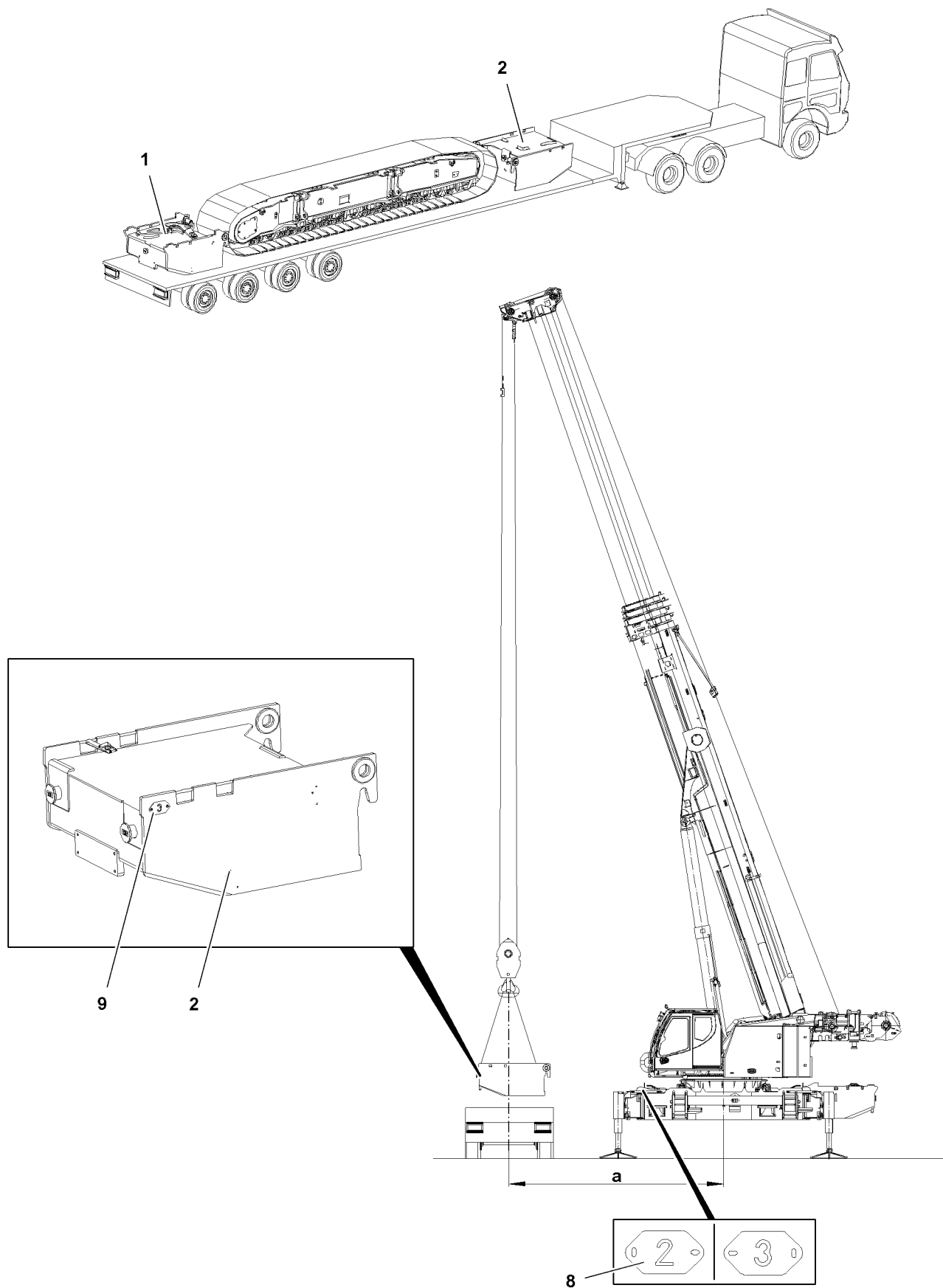


Fig.117546: Releasing, pinning and securing the pin

- ▶ Release the pin **6**: Actuate the ball locking pin **12** and unpin from the retainer **13** in point **P8**.
- ▶ Insert the pin **6**: Insert the pin **6** with the mechanical pin pulling device **10** to the stop.
- ▶ Secure the pin **6**: Actuate the ball locking pin **12** and insert in point **P9** in the retainer **13**.
- ▶ Remove the fastening equipment.

Empty page!

LWE/LTR 1220-003/24204-02-02/en



LWE/LTR 1220-003/24204-02-02/en

Fig.117544



### 3.4 Assembling the central ballast block on the front



#### Note

- ▶ The „front“ on the central ballast block **2** and on the crawler center section is marked with the number **2** and number **3**.
  - ▶ The numbers on the central ballast block **2** and crawler center section **5** must be identical upon assembly.
  - ▶ Positions of numbers, see tag **8** and tag **9**.
- 
- ▶ Fasten the central ballast block **2**.
  - ▶ Lift the central ballast block **2**, pay attention to the load momentum indicator.
  - ▶ Make sure that the pins are unpinned in the pin points on the crawler center section.
  - ▶ Connect the central ballast block **2** in the same way on the crawler center section as described in section „Assembling the central ballast block on the rear“.
  - ▶ Lower the crawler center section until the pin bores align.

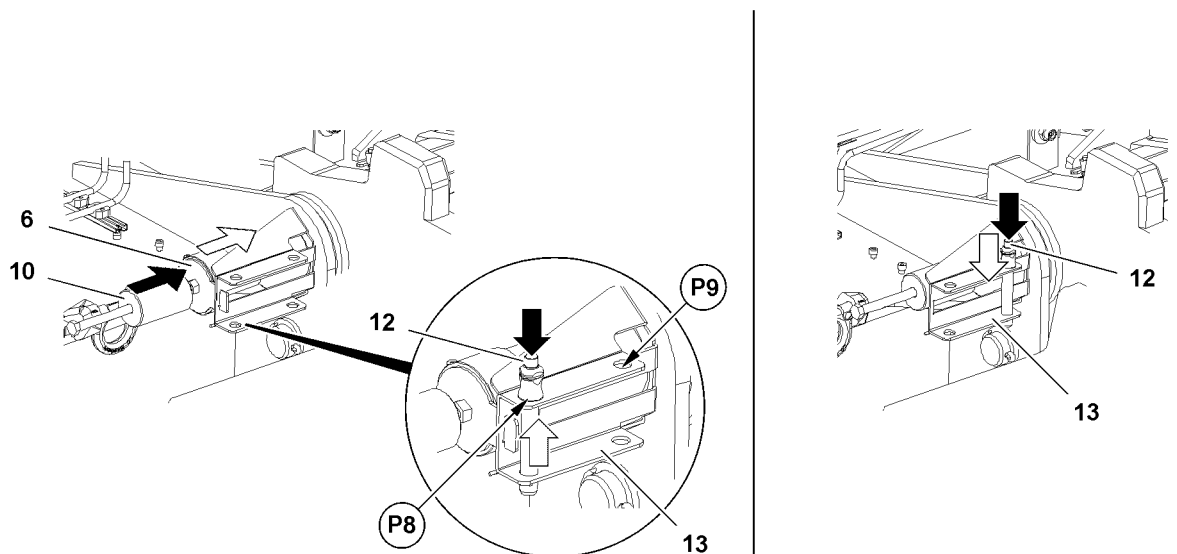


Fig.117546: Releasing, pinning and securing the pin

- ▶ Release the pin **6**: Actuate the ball locking pin **12** and unpin in point **P8** from the retainer **13**.
- ▶ Insert the pin **6**: Insert the pin **6** with the mechanical pin pulling device **10** to the stop.
- ▶ Secure the pin **6**: Actuate the ball locking pin **12** and insert in point **P9** in the retainer **13**.
- ▶ Remove the fastening equipment.

#### Result:

- The central ballast blocks are assembled.

### 3.5 Establishing an electrical connection for ballast monitoring\*

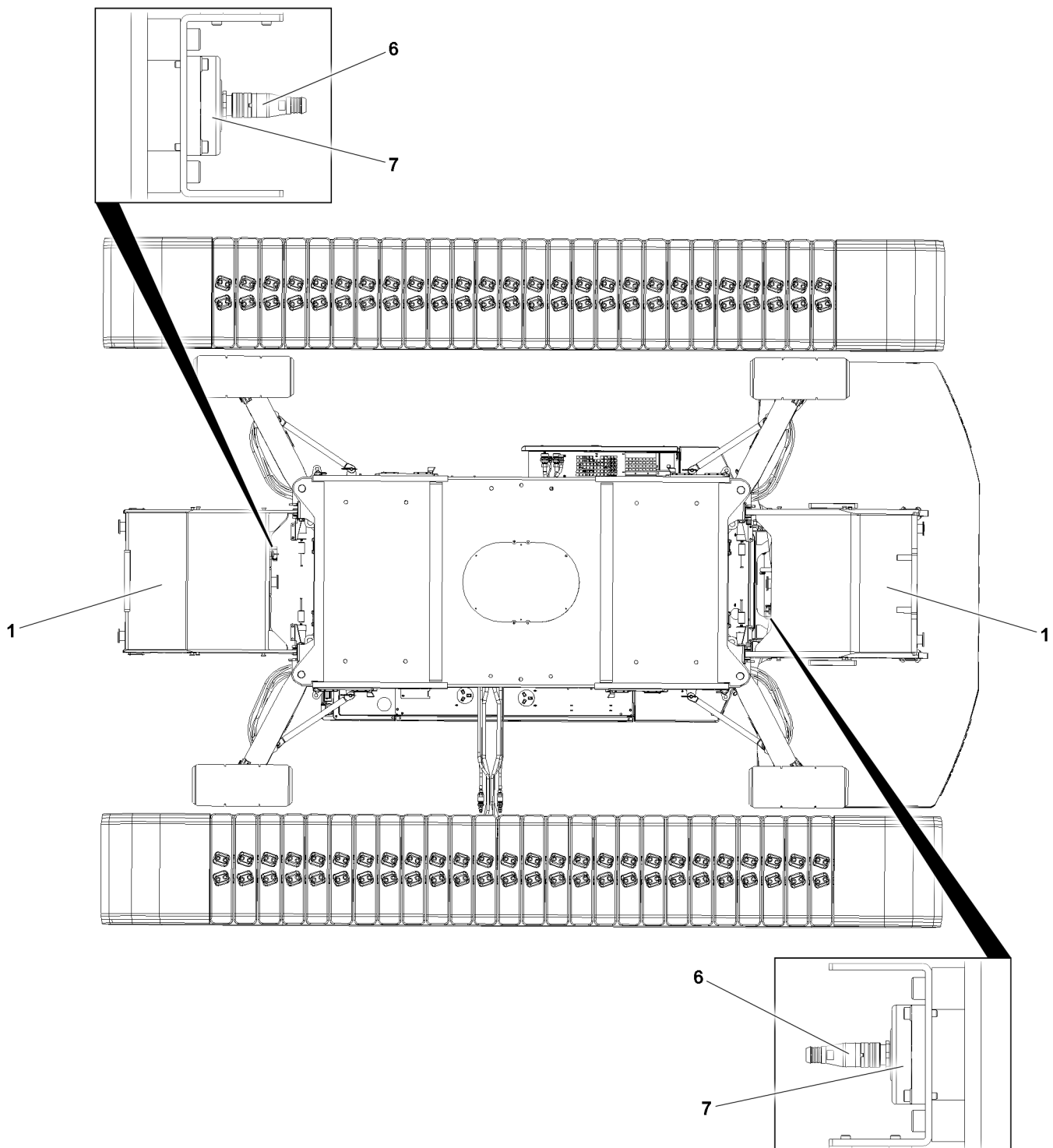


Fig.157762: Ballast monitoring

**WARNING**

No electrical connection established to the central ballast block **1**!

If central ballast blocks **1** are assembled on the crane and an electrical connection is not established, the central ballast blocks **1** will not be detected by ballast monitoring\*.

- ▶ When the respective central ballast block **1** is assembled: Insert the plug **6** in the socket **7** on the respective central ballast block **1**.

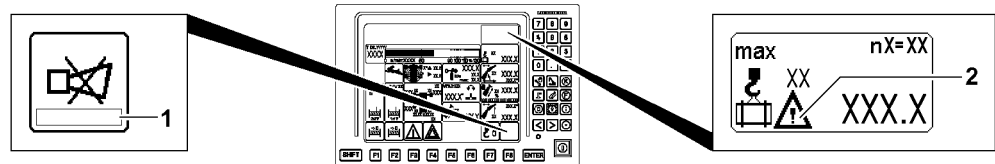


Fig.147403: Ballast monitoring error message not recognized display

- ▶ Insert the plug **6** in the socket **7** on the respective central ballast block **1**.
- ▶ Set the set up configuration for crane operation with central ballast on the LICCON overload protection.

**Result:**

- The electrical connection for ballast monitoring is established.
- The new counterweight is detected, an error message is displayed on the LICCON monitor.
- ▶ Perform the ballasting procedure **after** establishing the electrical connections, see chapter 4.07.

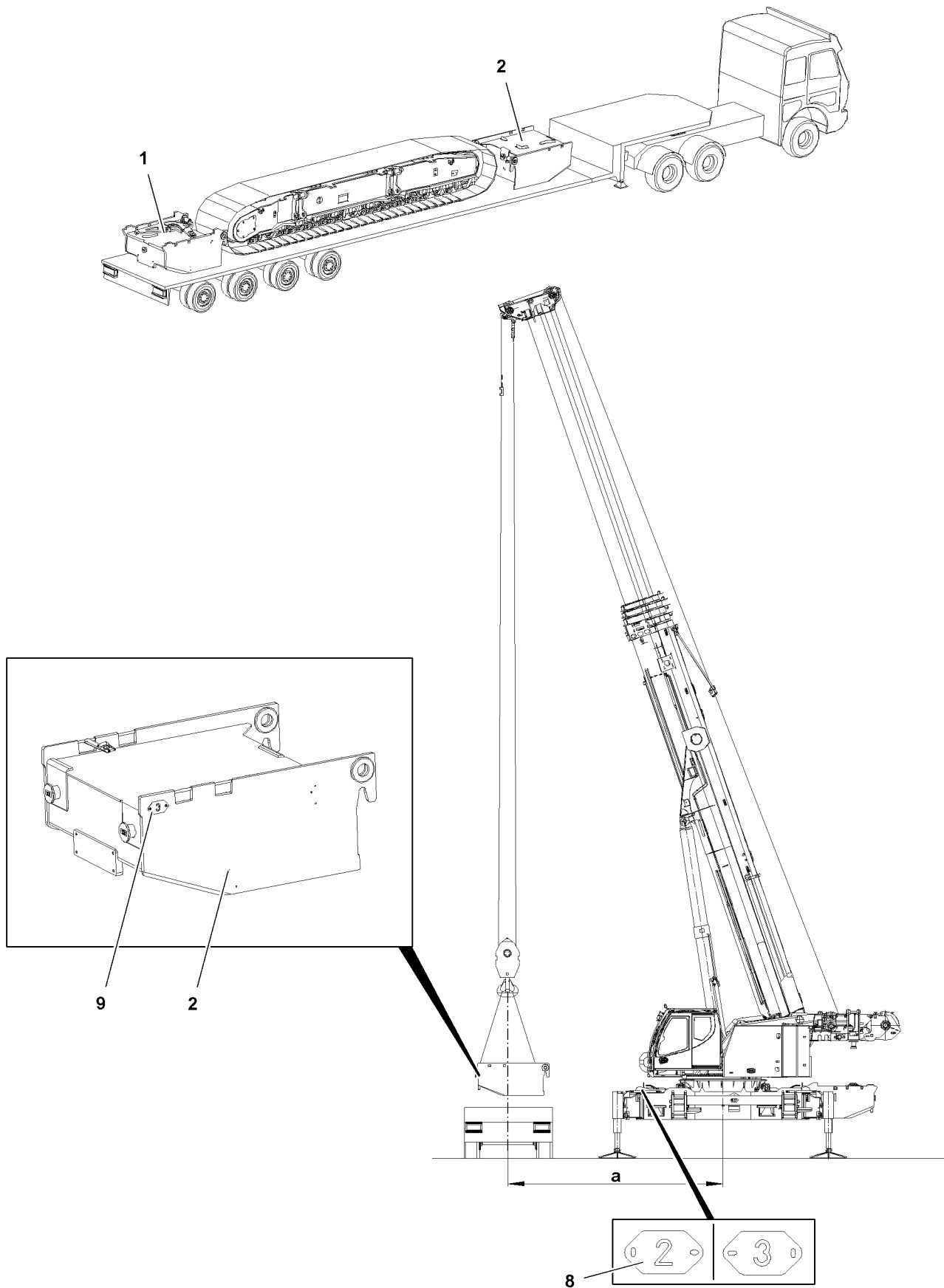
**Note**

- ▶ For a detailed description of ballast monitoring\*, see Chapter 4.07.

## 3.6 Assembling the crawler carrier

**Note**

- ▶ Assemble the crawler carrier, see the Crane operating instructions, chapter 3.01.



LWE/LTR 1220-003/24204-02-02/en

Fig.117544

## 4 Disassembling the central ballast



### WARNING

Danger of falling!

During assembly and disassembly, assembly personnel must be secured with appropriate aids to prevent them from falling! If this is not observed, assembly personnel could fall and suffer life-threatening or fatal injuries!

- ▶ Any work, where there is a danger of falling must be carried out with suitable aids (for example lifting platform, scaffolding, ladder, auxiliary crane).
- ▶ If the work can neither be carried out with such aids nor from the ground, then assembly personnel must secure themselves with approved fall arrest systems to avoid falling, see chapter 2.04 of the operating instructions!
- ▶ If railings are present on the crane components, then they must be brought into the corresponding position and secured for assembly / disassembly work!
- ▶ Only step on aids and fall protection equipment with clean shoes!
- ▶ Keep aids and fall protection equipment clean and free from snow and ice!
- ▶ During all assembly and disassembly work, maintenance work and inspections, travel or crane operation is prohibited!



### WARNING

Danger of impact / crushing!

When installing / removing crane components with the auxiliary crane, crane components can start to swing back and forth!

When lifting / lowering and positioning crane components, there is an increased danger of impacts / crushing!

Personnel can be caught and thereby injured or killed!

- ▶ Make sure that personnel cannot be caught by crane components!
- ▶ When working in danger zones: Use aids to protect limbs!
- ▶ Guide crane components with suitable aids to minimize oscillation!



### WARNING

Falling crane components!

During assembly, crane components can fall down!

Personnel can be severely injured or killed!

- ▶ Make sure that no persons or objects are within the danger zone!



### WARNING

The crane can topple over!

If the central ballast is assembled / disassembled, the set up configuration of the crane changes.

If changes are made to the central ballast, no central ballast may be taken into account as set up configuration of the crane when doing so.

- ▶ Make sure that the LICCON overload protection is set to a set up configuration without central ballast when making changes to the central ballast.
- ▶ Observe and adhere to the values in the load chart for assembly of the central ballast.
- ▶ Lift or take down the central ballast block at a permissible distance **a**, see the load chart.



### Note

- ▶ When the crawler carriers are **not** disassembled: Disassemble the crawler carrier, see the Crane operating instructions, chapter 3.01.

Make sure that the following prerequisites are met:

- The crawler carriers are disassembled.
- The crane is horizontally aligned.
- The crane is positioned on a level and load-bearing surface.
- The crane is supported on base 6.0 m x 4.4 m.
- Support cylinders are extended.

- The LICCON overload protection has been adjusted according to the set up configuration and the load chart.
- The crane is operational.

The equipment has the following set up configuration:

- Support base 6.0 m x 4.4 m
- Central ballast 0 t
- Counterweight 0 t
- Maximum 3-pulley hook block (smaller than / equal to 70.6 t load) reeved in
- When auxiliary boom is available on the crane:  
The auxiliary boom is assembled in the transport position on the telescopic boom

If a hook block is reeved in that is larger than the 3-pulley hook block (greater than 70.6 t load), the auxiliary boom on the telescopic boom must be disassembled.

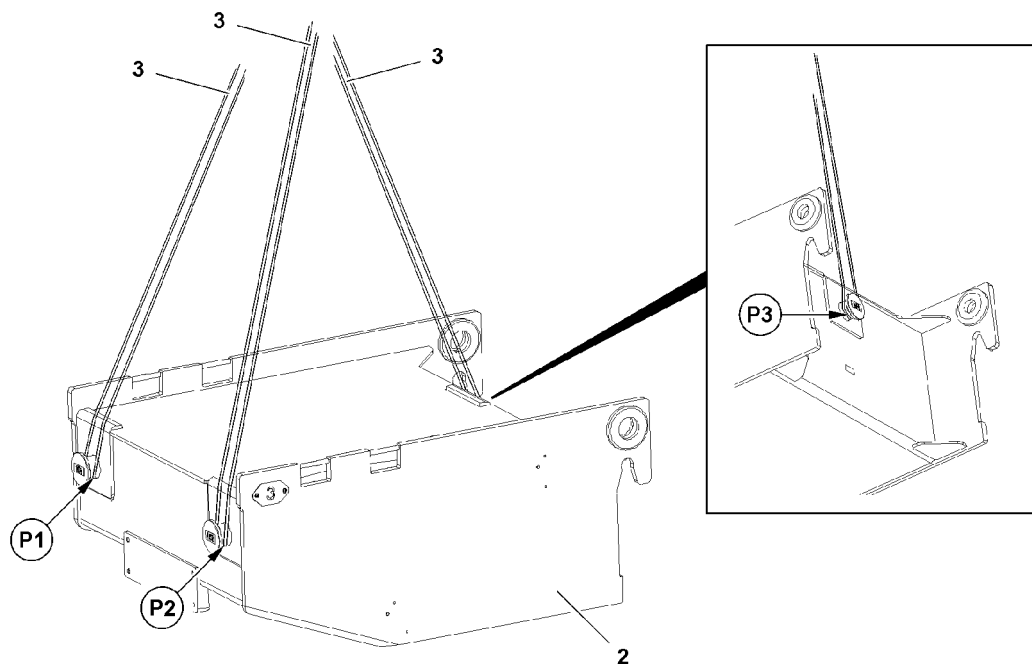


Fig.117543: Central ballast block fastening points

## 4.1 Fastening the central ballast blocks



### WARNING

Improperly fastened central ballast block!

An improperly fastened central ballast block can slip and fall down when lifting or swinging it! Personnel can be severely injured or killed!

- ▶ Before lifting, make sure that the central ballast block is properly fastened!
- ▶ Use only approved and suitable fastening equipment **3**!
- ▶ Always keep sufficient distance from the suspended central ballast block!
- ▶ Standing under a raised central ballast block is **prohibited**!
- ▶ Carefully initiate all crane movements with attached central ballast block extremely sensitively and initiate slow down with utmost caution!

**WARNING**

Swinging central ballast block!

If the fastening equipment is not positioned in the center over the fastening points of the central ballast block **2**, then the central ballast block **2** can start to swing after lifting and fall down!

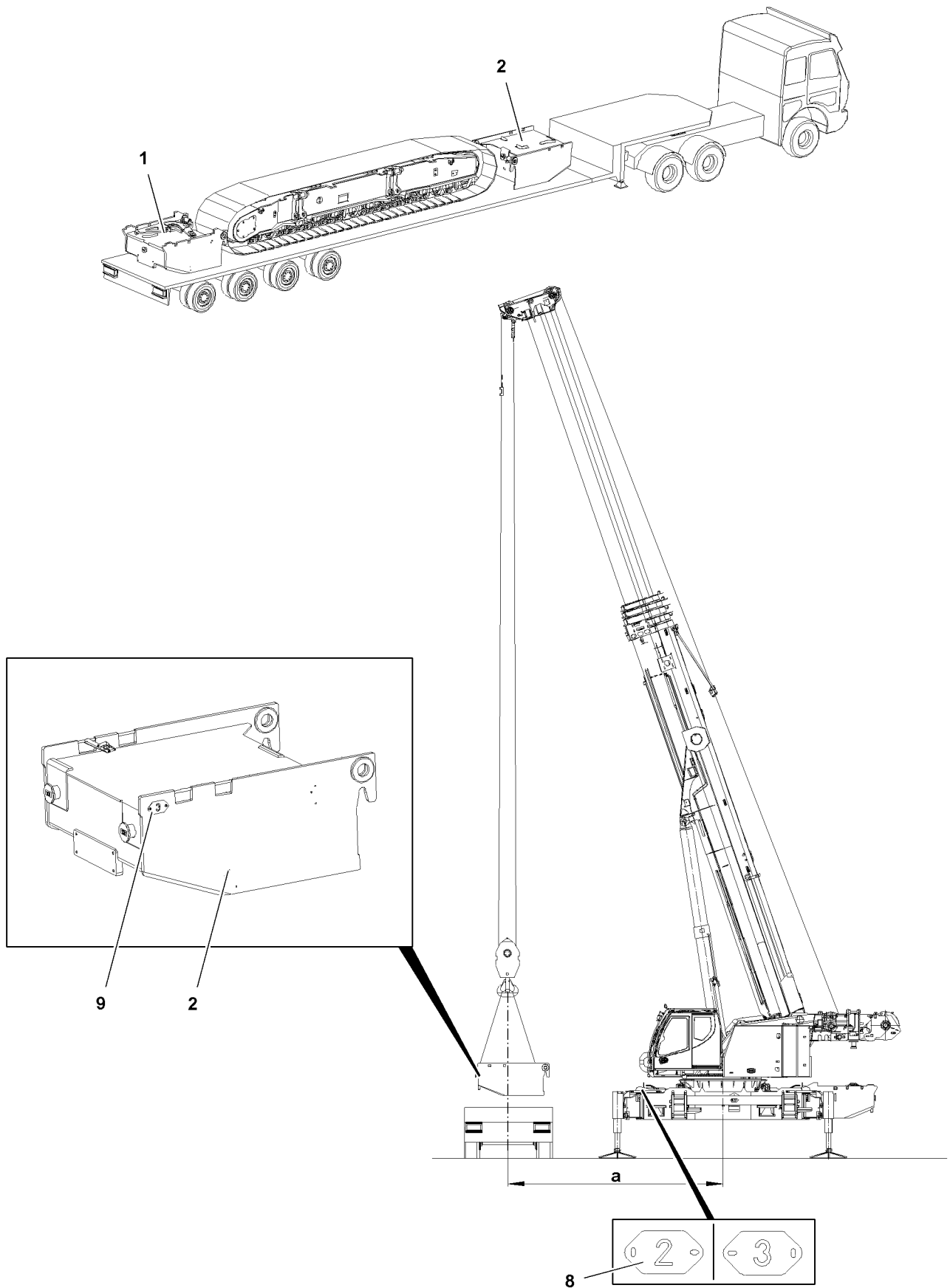
This could result in serious accidents!

Personnel can be severely injured or killed!

- ▶ Make sure that the fastening equipment **3** is centered over the fastening points of the central ballast block **2** when fastening!

**Note**

- ▶ The central ballast blocks are marked with numbers.
  - ▶ Make sure that the numbers on the central ballast block match the numbers on the pin points on the crawler center section.
- 
- ▶ Fasten the central ballast block **2** in point **P1**, point **P2** and point **P3**, see illustration.



LWE/LTR 1220-003/24204-02-02/en

Fig.117544



## 4.2 Disassembling the central ballast block on the front



### Note

- ▶ The „front“ on the central ballast block and on the crawler center section is marked with the number **2** and number **3**.
  - ▶ Positions of numbers, see tag **8** and tag **9**.
- 
- ▶ Fasten the central ballast block **2**.
  - ▶ Lift the central ballast block **2** until the fastening equipment is tensioned.

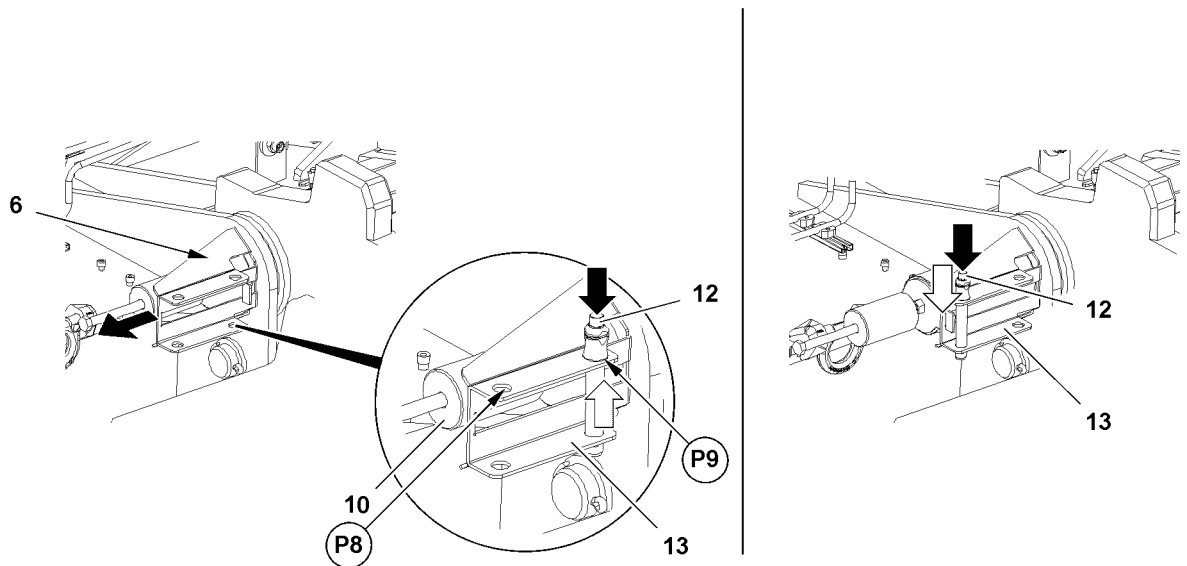


Fig.117549: Releasing, unpinning and securing the pin

- ▶ Release the pin **6**: Actuate the ball locking pin **12** and unpin in point **P9** from the retainer **13**.
- ▶ Unpin the pin **6**: Unpin the pin **6** with the mechanical pin pulling device **10**.
- ▶ Secure the pin **6**: Actuate the ball locking pin **12** and insert in point **P8** in the retainer **13**.

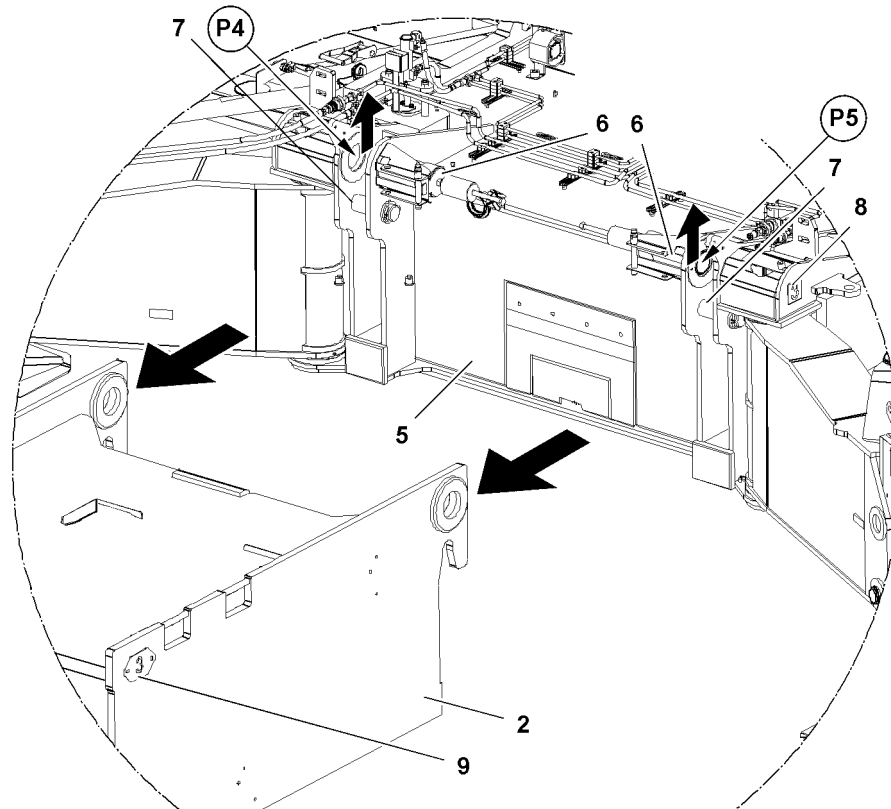


Fig.117822: Central ballast block, rear: Connection and unpinning points

- ▶ Make sure that the pins **6** in point **P4** and point **P5** are unpinned.
- ▶ Lift the central ballast block **2** until the central ballast block **2** is completely detached from the pin **7**.
- ▶ Swing the central ballast block **2** out and take it down on the transport vehicle.
- ▶ Remove the fastening equipment.

Empty page!

LWE/LTR 1220-003/24204-02-02/en

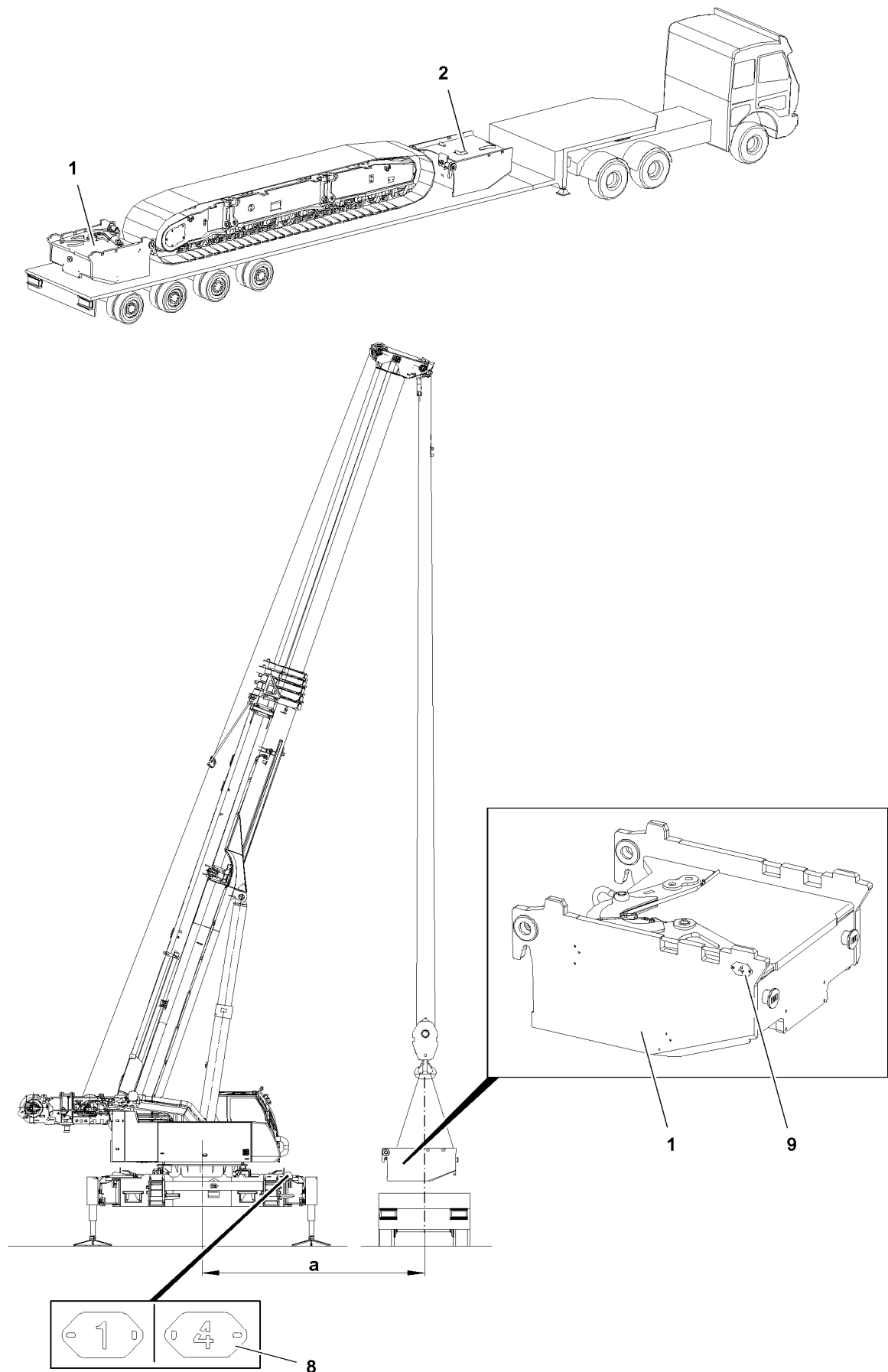


Fig.117541

LWE/LTR 1220-003/24204-02-02/en

### 4.3 Disassembling the central ballast block on the rear



#### Note

- ▶ The „rear“ of the central ballast block and the crawler center section is marked with the number **1** and number **4**.
- ▶ Positions of numbers, see tag **8** and tag **9**.

- ▶ Fasten the central ballast block **1**.
- ▶ Lift the central ballast block **1** until the fastening equipment is tensioned.

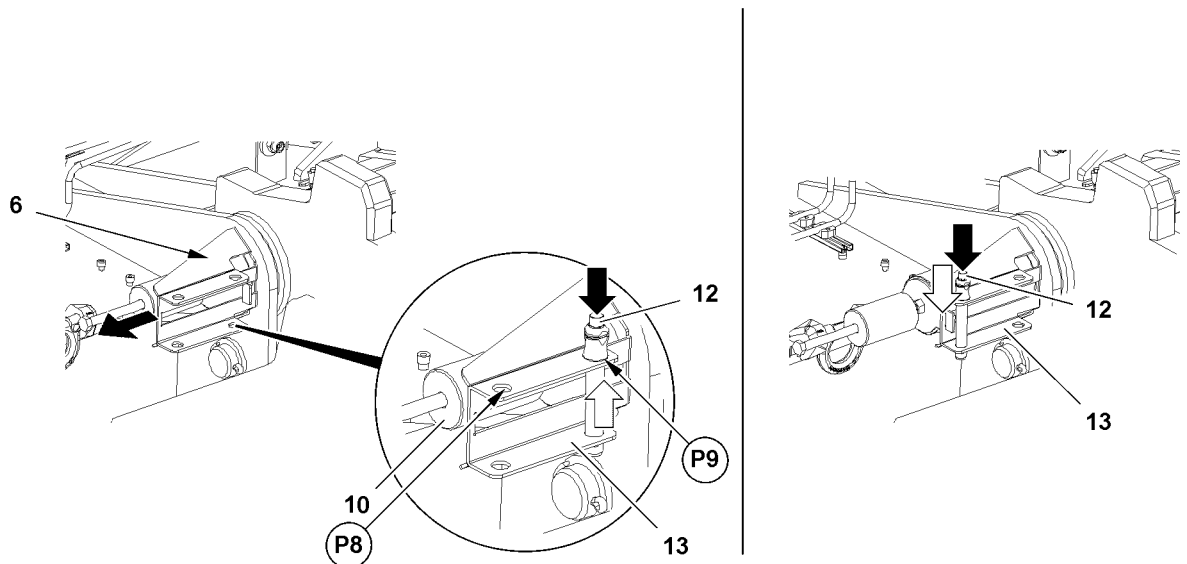


Fig.117549: Releasing, unpinning and securing the pin

- ▶ Release the pin **6**: Actuate the ball locking pin **12** and unpin in point **P9** from the retainer **13**.
- ▶ Unpin the pin **6**: Unpin the pin **6** with the mechanical pin pulling device **10**.
- ▶ Secure the pin **6**: Actuate the ball locking pin **12** and insert in point **P8** in the retainer **13**.
- ▶ Make sure that the pins on the pinning devices are unpinned.
- ▶ Detach the central ballast block in the same way on the crawler center section as described in section „Disassembling the central ballast block on the front“.
- ▶ Lift the central ballast block and detach it from the crawler center section.
- ▶ Swing the central ballast block out and take it down on the transport vehicle.
- ▶ Remove the fastening equipment.

#### Result:

- The central ballast blocks are disassembled.

### 4.4 Loading the crane onto the transport vehicle



#### Note

- ▶ Load the crane on the transport vehicle, see the Crane operating instructions, chapter 3.01.

---

Empty page!

LWE/LTR 1220-003/24204-02-02/en

## 3.80 Crane and crane component transport

1	Safety	2
2	Crane	3
3	Crawler carrier	9
4	Dimensions and weights	10
5	Unloading and loading with the auxiliary crane	13
6	Unloading without an auxiliary crane	16
7	Loading without an auxiliary crane	31
8	Rigging	42
9	Securing	43

# 1 Safety

Observe and adhere to the transport safety instructions. See chapter 2.04.

## 1.1 Forms of transport

Observe and adhere to the specifications for the respective form of transport:

- Road transport
- Rail transport
- Ship transport
- Air transport

## 1.2 Transport company

The transport company is responsible for fulfilling the following prerequisites:

- Loading on the transport vehicle must be positioned taking into consideration the applicable permissible axle loads in the respective countries.
- Suitable rigging devices are provided.
- The transport location is even, level in horizontal direction and of sufficient load bearing capacity.
- A guide is present.

## 1.3 Rigging plans

Observe and adhere to the rigging plans, see rigging plans.



### WARNING

Rigging plans **not** observed!

The mobile crane can roll off or topple over.

Death, severe bodily injuries, property damage.

- ▶ Fasten the tension belts or tension chains on rigging points according to the rigging plan.
- ▶ Adhere to the angles, radii and tension surfaces according to the rigging plan.

## 1.4 Rigging points



### WARNING

Impermissible use of the rigging points and rigging eyehooks!

The rigging points and rigging eyehooks can fail. The crane or components can fall from the transport vehicle.

Death, severe bodily injuries, property damage.

- ▶ Use the rigging eyehooks only for rigging the crane or components.
- ▶ Do **not** use the rigging eyehooks to lift the crane or components.
- ▶ Do **not** use the rigging eyehooks to lift loads.
- ▶ Observe and adhere to the maximum permissible rigging forces.
- ▶ Make sure that rigging eyehooks of the transport vehicle correspond at least to the load carrying capacity of the rigging device.

## 1.5 Transport vehicle

Observe and adhere to the following notes for safe transport:

- Use a suitable transport vehicle.
- Establish the greatest possible frictional coefficient to the transport surface: Clean the wheels before transporting.
- The loading surface must be free of snow, ice, grease and be well-swept.



## 1.6 Rigging device

Observe and adhere to the following notes for safe transport:

- Use a rigging device with a sufficient load capacity.
- Use the rigging belts and rigging chains in application of the respectively valid regulations for loading and load retention.

## 1.7 Substructure

To avoid accidents, observe the following notes regarding anti-slip mats:


- Comply with the minimum friction value, minimum load bearing capacity and minimum thickness of the anti-slip mats.
- Replace the anti-slip mats when one of the following criteria is fulfilled:
  - Permanent deformation or pressure marks
  - Cracks
  - Abrasion on the surface
  - Broken out material area
  - Swollen areas
  - Damage due to contact with aggressive materials
  - Brittleness
  - Function-impairing contaminants

To avoid accidents, observe the following notes regarding wood:

- Wood with a minimum quality of „spruce“ is to be used.

# 2 Crane

## 2.1 Rigging plans

Position in the rigging plan	Rigging point	Permissible rigging force
X	With RUD eyehook	13400 daN
Y	With RUD eyehook	8000 daN
1	No RUD eyehook	10000 daN
	Area where rigging is permissible	

*Rigging point, properties*

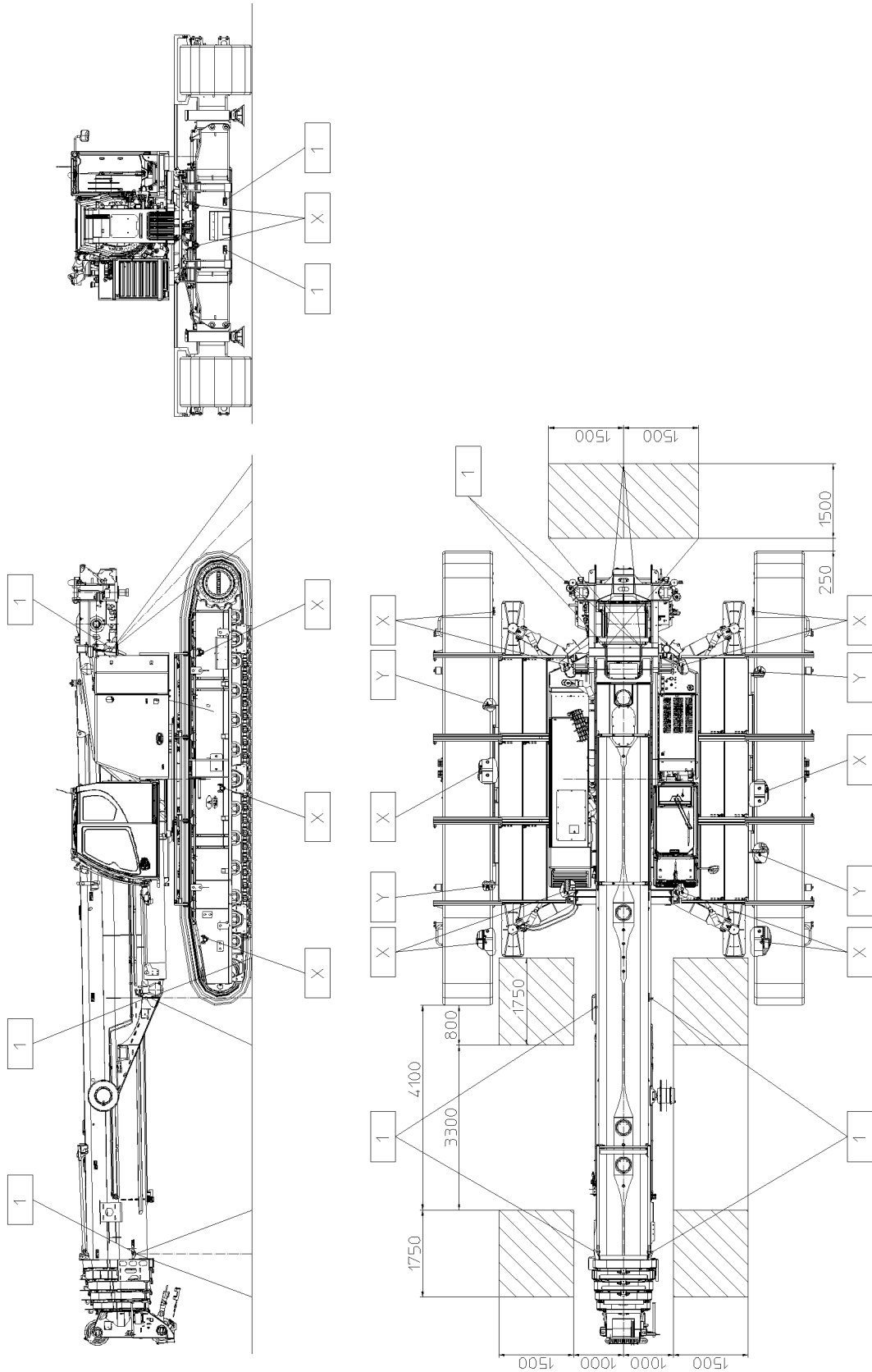


Fig.128350: Crane rigging plan

LWE/LTR 1220-003/24204-02-02/en

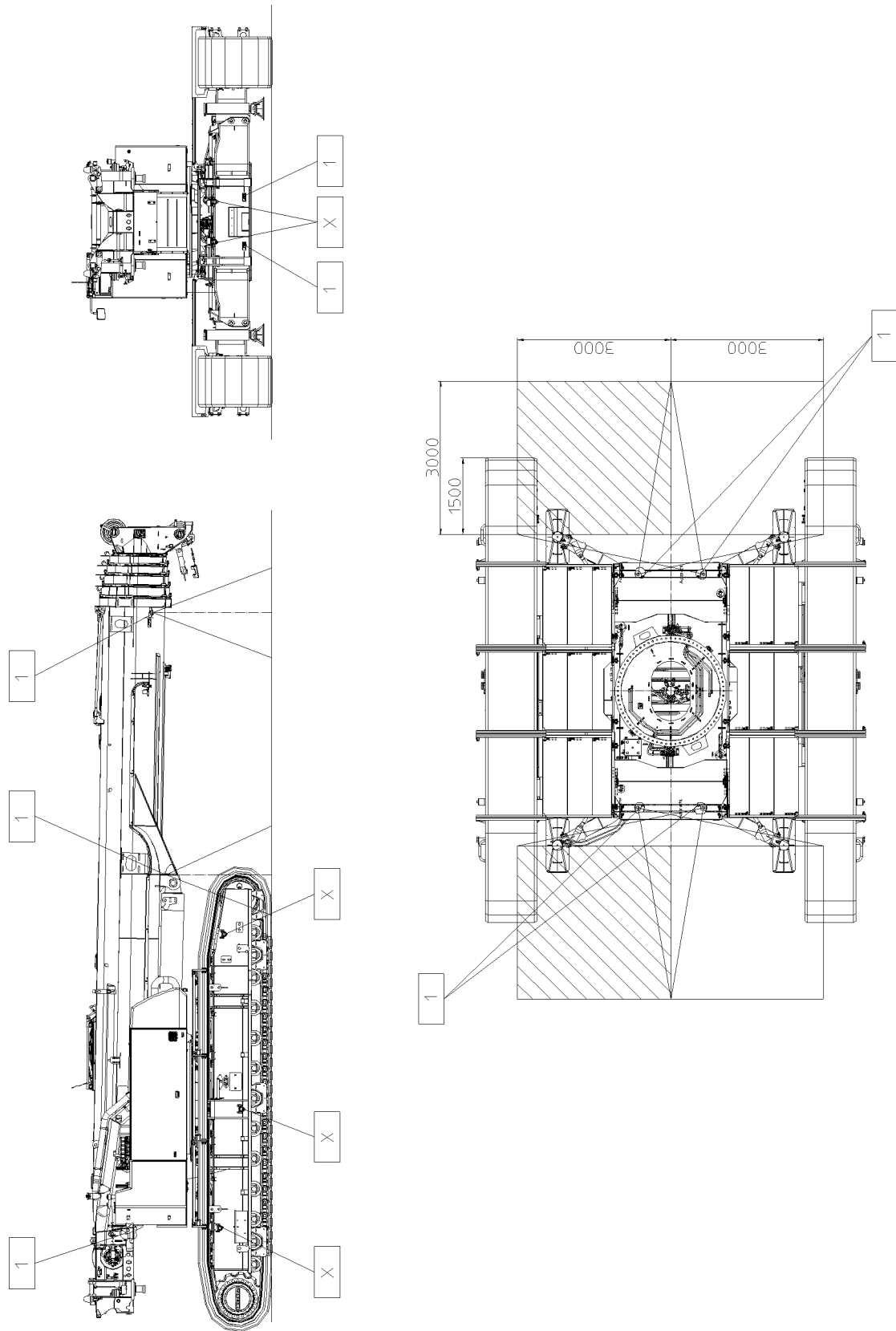


Fig.128349: Crane rigging plan

LWE/LTR 1220-003/24204-02-02/en

## 2.2 Basic machine

Position in the rigging plan	Rigging point	Permissible rigging force
X	With RUD eyehook	13400 daN
1	No RUD eyehook	10000 daN

*Rigging point, properties*

LWE/LTR 1220-003/24204-02-02/en

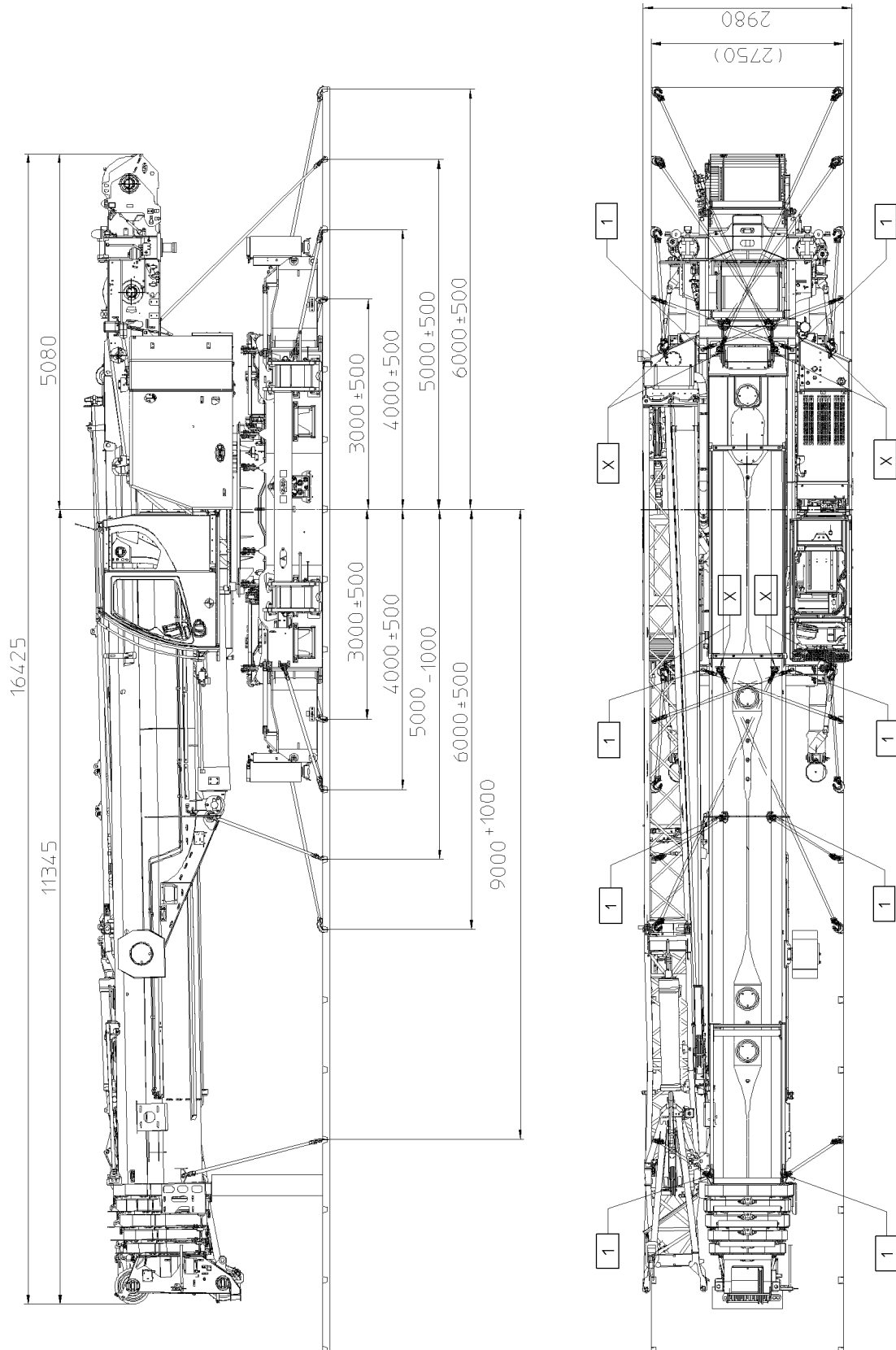


Fig.127116: Basic unit rigging plan

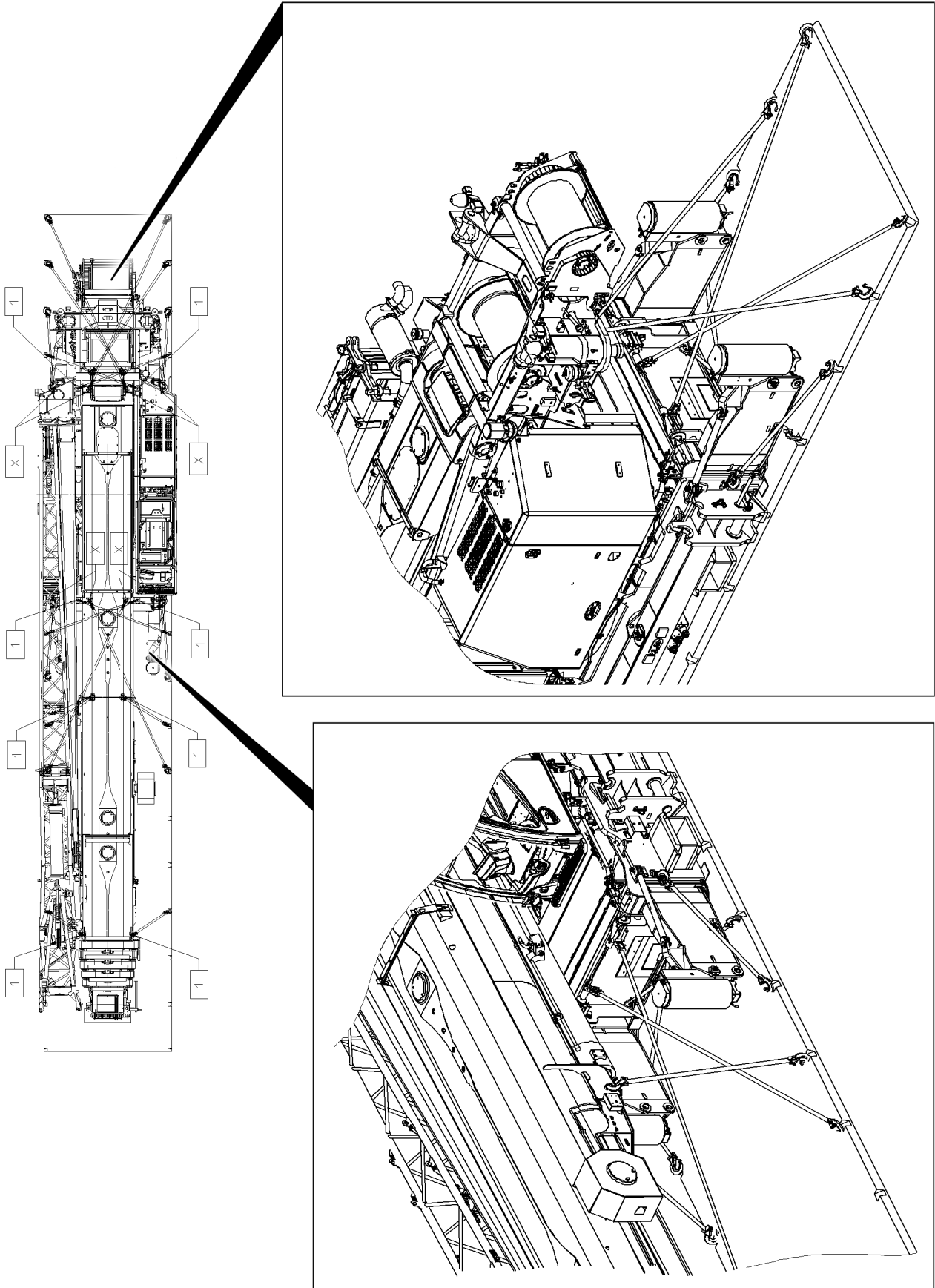


Fig.128348: Basic unit rigging plan

LWE/LTR 1220-003/24204-02-02/en

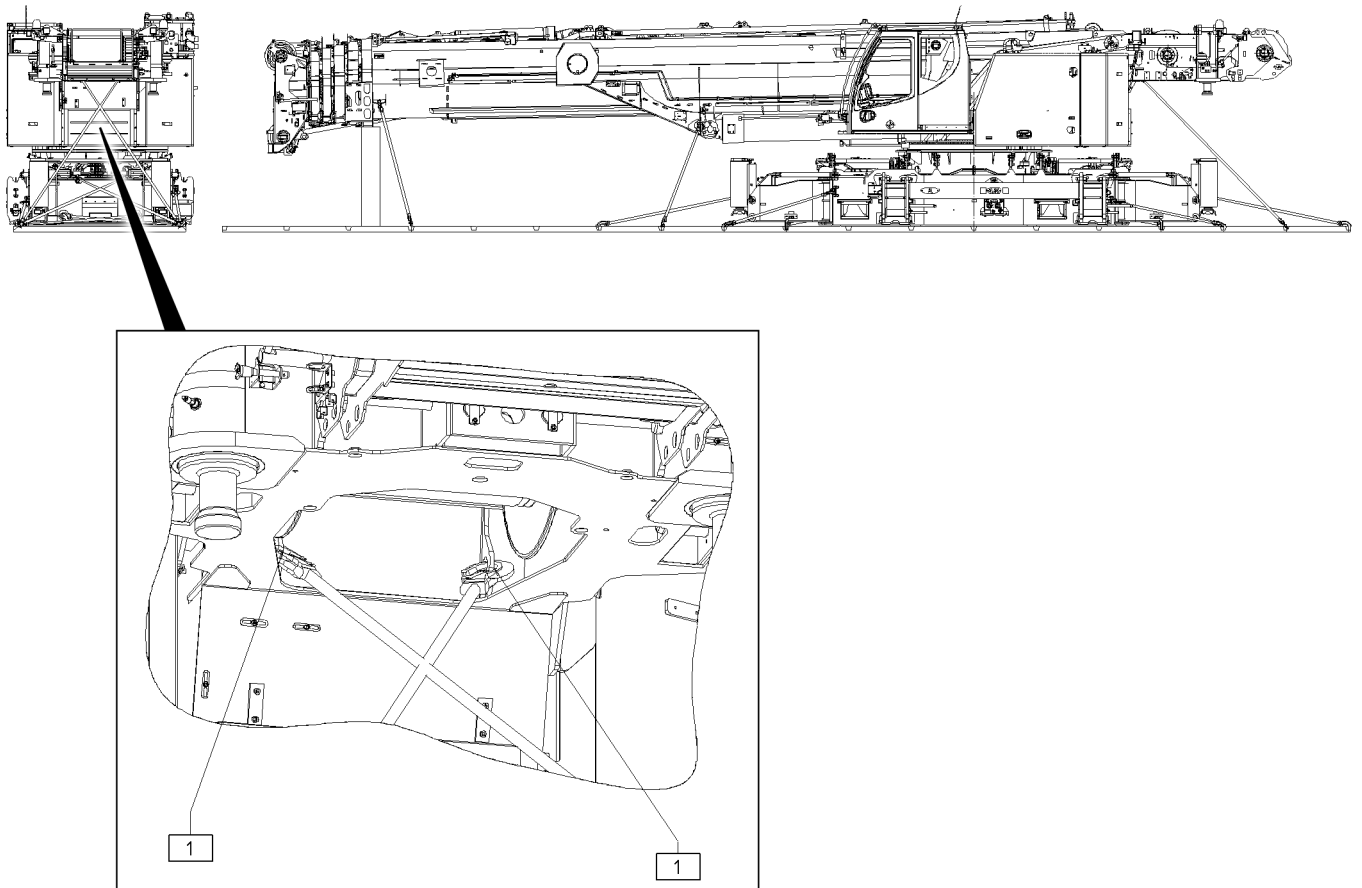


Fig.128351: Basic unit rigging plan

### 3 Crawler carrier

#### 3.1 Rigging plans

Position in the rigging plan	Rigging point	Permissible rigging force
X	With RUD eyehook	13400 daN

Rigging point, properties

LWE/LTR 1220-003/24204-02-02/en

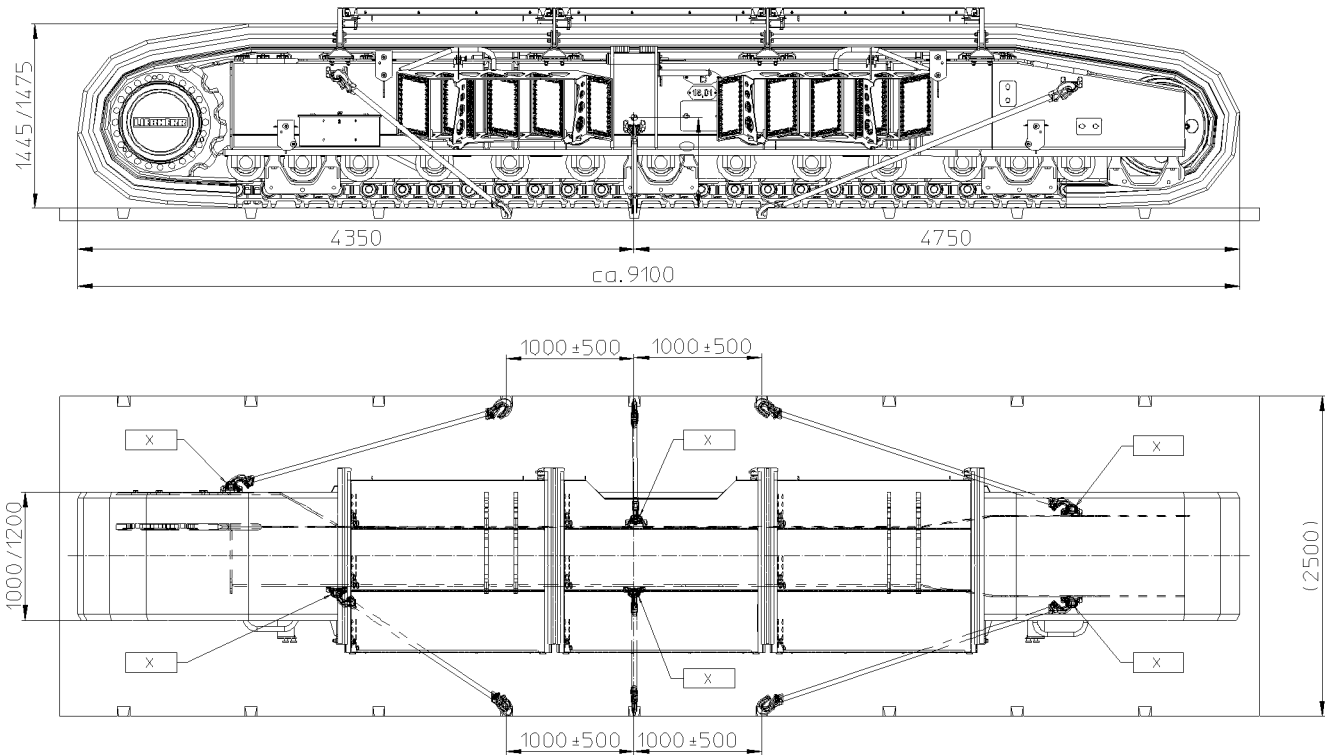


Fig.128116: Crawler carrier rigging plan

## 4 Dimensions and weights

### 4.1 Road transport

Observe the permissible axle loads of the respective country.  
Crane and crane component transport, see rigging plans.

#### 4.1.1 Basic machine

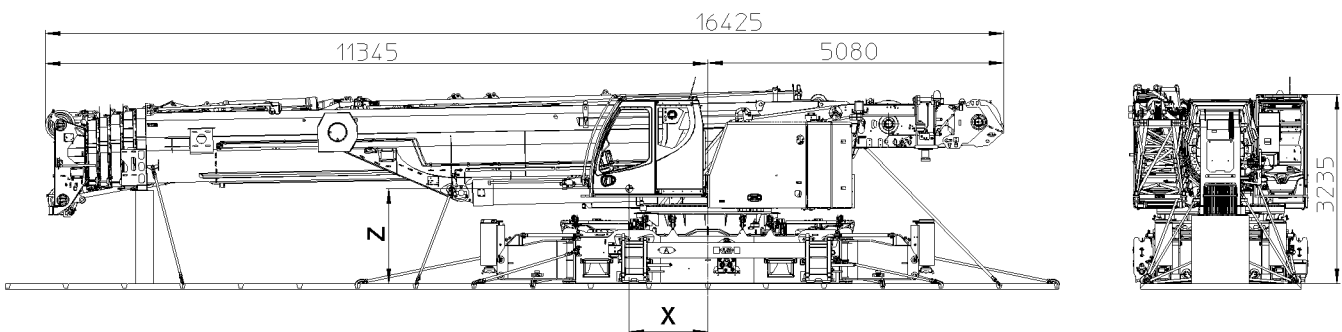


Fig.128347: Basic unit center of gravity

**Z** Dimensions, see chart      **X** Dimensions, see chart

LWE/LTR 1220-003/24204-02-02/en



Cross carrier	Auxiliary hoist gear Winch 2	Double folding jib		Single folding jib		Weight	Dimension X	Dimension Y
		Hydraulic	Mechanical	Hydraulic	Mechanical			
x	x	x	—	—	—	60.2 t	1340 mm	1620 mm
x	x	—	x	—	—	59.9 t	1310 mm	1610 mm
x	x	—	—	x	—	59.5 t	1330 mm	1610 mm
x	x	—	—	—	x	59.2 t	1300 mm	1600 mm
x	x	—	—	—	—	57.6 t	1160 mm	1570 mm
x	—	x	—	—	—	58.5 t	1510 mm	1590 mm
x	—	—	x	—	—	58.2 t	1480 mm	1580 mm
x	—	—	—	x	—	57.8 t	1500 mm	1570 mm
x	—	—	—	—	x	57.5 t	1470 mm	1570 mm
x	—	—	—	—	—	55.9 t	1340 mm	1530 mm
—	x	x	—	—	—	52.9 t	1520 mm	1790 mm
—	x	—	x	—	—	52.6 t	1490 mm	1780 mm
—	x	—	—	x	—	52.3 t	1510 mm	1770 mm
—	x	—	—	—	x	52.0 t	1480 mm	1770 mm
—	x	—	—	—	—	50.3 t	1330 mm	1740 mm
—	—	x	—	—	—	51.2 t	1730 mm	1750 mm
—	—	—	x	—	—	50.9 t	1700 mm	1750 mm
—	—	—	—	x	—	50.6 t	1720 mm	1740 mm
—	—	—	—	—	x	50.3 t	1680 mm	1730 mm
—	—	—	—	—	—	48.6 t	1540 mm	1700 mm

*Total weight and center of gravity dimensions depending on the set up configuration*

## 4.2 Rail transport

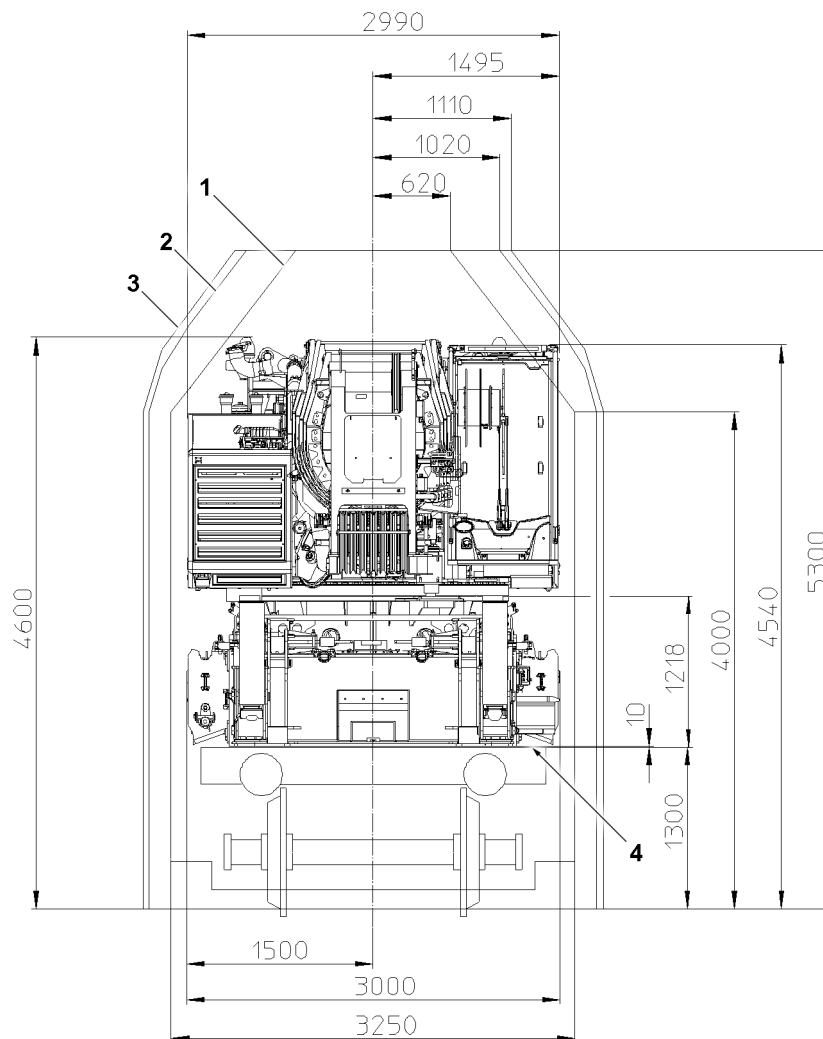


Fig.128344: Loading dimension, rail transport

- |          |                                     |          |                       |
|----------|-------------------------------------|----------|-----------------------|
| <b>1</b> | Normal loading dimension of the RZB | <b>3</b> | Loading oversize LÜ-3 |
| <b>2</b> | Loading oversize LÜ-2               | <b>4</b> | Slip-resistant mat    |

The reachable loading dimension is LÜ-2.

In order to reach the loading oversize **LÜ-2**, disassemble the following component groups:

- Crawler carrier
- Hydraulic support, 2-stage
- Climate control system
- Engine preheating
- Central ballast, counterweight
- Storage box
- Support plates
- Hoist gear 2
- Folding jib
- Pin pulling device
- Hook block

The following component groups are assembled on the crane for loading oversize **LÜ-2**:

- Cross carrier
- Hydraulic support, 2-stage
- Climate control system

- Engine preheating

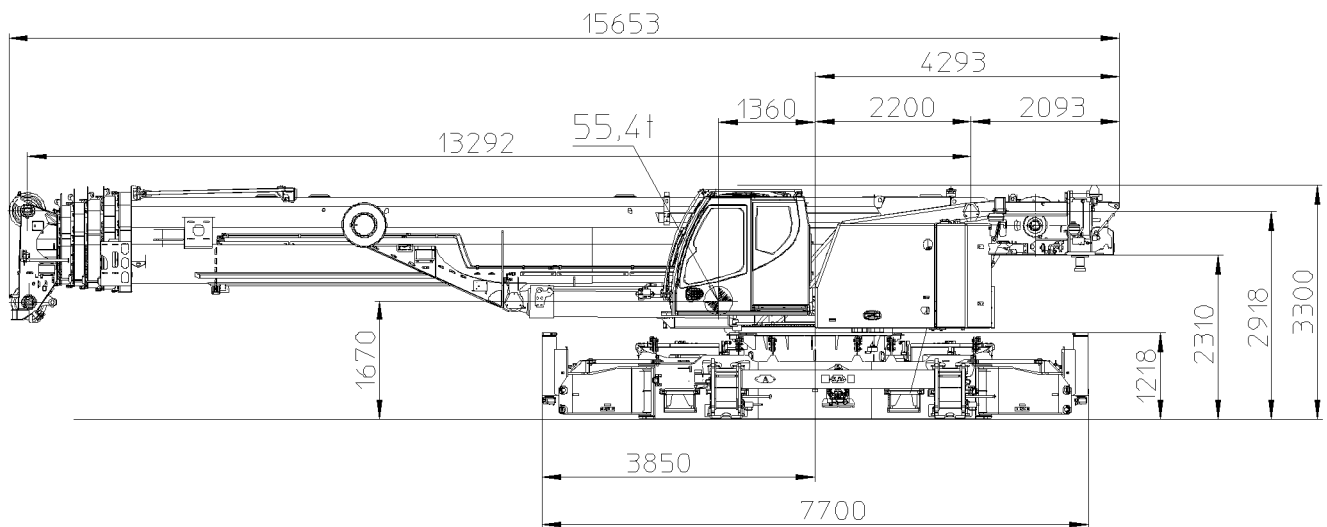


Fig.128343: Dimensions and centre of gravity, rail transport

Component	Weight
Crane with cross carrier, hydraulic support, 2-stage, air conditioning system, engine preheating	55.4 t

Weight for LÜ-2 configuration

## 5 Unloading and loading with the auxiliary crane

The complete machine can be unloaded or loaded with two auxiliary cranes or with one auxiliary crane and a cross beam.

## 5.1 Complete machine with crawler carrier

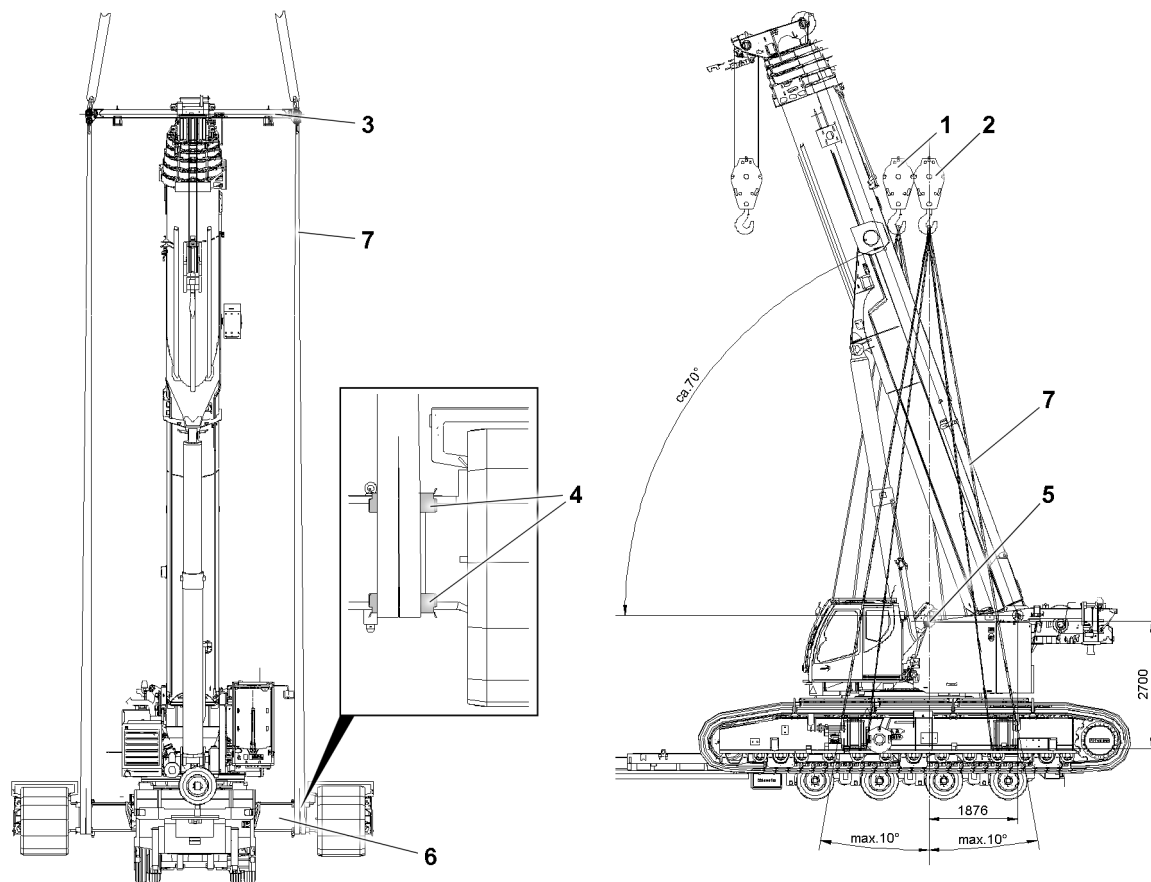


Fig.151575: Complete machine with crawler carrier

- |   |                   |   |                     |
|---|-------------------|---|---------------------|
| 1 | Auxiliary crane 1 | 5 | Center of gravity   |
| 2 | Auxiliary crane 2 | 6 | Cross carrier       |
| 3 | Cross beam        | 7 | Fastening equipment |
| 4 | Edge protection   |   |                     |

Component	Weight
Crane with crawler carrier	91.4 t

### Crane weight with crawler carrier

Make sure that the following prerequisites are met:

- The center of gravity is in the middle.
- The cross carriers are pinned at a wide gauge.
- ▶ Attach the edge protection **4** on the cross carrier **6**.
- ▶ Fasten the fastening equipment **7** on the left and right to the cross carrier **6**.
- ▶ Tension the strands of the fastening equipment **7** and check that the edge protection **4** is fit properly.
- ▶ Lift the complete machine and unload it from the transport vehicle.  
or  
Lift the complete machine and load it onto the transport vehicle.

## 5.2 Complete machine without crawler carrier

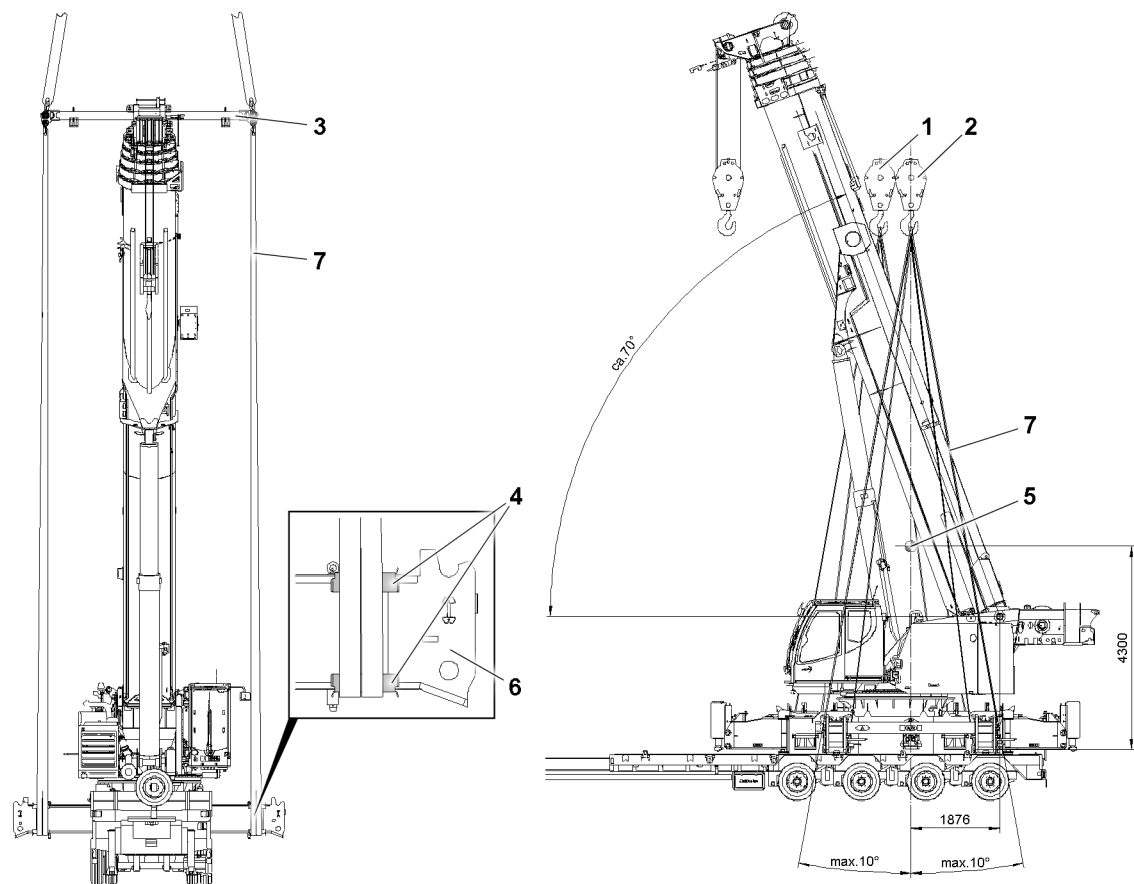


Fig.151574: Complete machine without crawler carrier

- |   |                   |   |                     |
|---|-------------------|---|---------------------|
| 1 | Auxiliary crane 1 | 5 | Center of gravity   |
| 2 | Auxiliary crane 2 | 6 | Cross carrier       |
| 3 | Cross beam        | 7 | Fastening equipment |
| 4 | Edge protection   |   |                     |

Component	Weight
Crane without crawler carrier	55.3 t

### Crane weight without crawler carrier

Make sure that the following prerequisites are met:

- The center of gravity is in the middle.
  - The cross carriers are pinned at a wide gauge.
  - The crawler carriers have been removed.
- ▶ Attach the edge protection **4** on the cross carrier **6**.
  - ▶ Fasten the fastening equipment **7** on the left and right to the cross carrier **6**.
  - ▶ Tension the strands of the fastening equipment **7** and check that the edge protection **4** is fit properly.
  - ▶ Lift the complete machine and unload it from the transport vehicle.
- or**
- ▶ Lift the complete machine and load it onto the transport vehicle.

## 6 Unloading without an auxiliary crane

This chapter describes how the crane is supported in order to remove the transport vehicle.



### DANGER

Crane movement in **unsupported** status!

If the crane superstructure is turned or the boom erected, then the crane can tip over. Death, severe bodily injuries, property damage.

When the crane is laying on the transport vehicle:

- ▶ Do **not** turn the crane superstructure.

When the crane is laying on the transport vehicle:

- ▶ Do **not** erect the boom.
- ▶ Before carrying out crane movements, support the crane with the assembly support and align it horizontally.
- ▶ Adhere to the sequence of the assembly steps in this chapter.



### WARNING

Danger of falling!

During assembly / disassembly, inspection and maintenance work, assembly personnel must be secured with appropriate aids to prevent them from falling! If this is not observed, assembly personnel could fall and be killed or seriously injured!

- ▶ The assembly personnel must always move carefully and anticipatory on the crane, the crane components or lattice sections!
- ▶ All work at a height, when there is a danger of falling, must be carried out with suitable aids!
- ▶ If fall protection equipment is available, then it must be used!
- ▶ If aids are not available and work cannot be carried out from the ground, then assembly personnel must secure themselves with the permissible fall arrest system to prevent falling, see Crane operating instructions, chapter 2.04!
- ▶ The fall arrest system must be attached on the fastening and hook points as well as to the safety ropes!
- ▶ Only step on the aids, ladders and catwalks with clean shoes!
- ▶ Keep aids, ladders and catwalks free of heavy dirt, snow and ice!



### WARNING

Danger of impact / crushing!

When installing / removing crane components with the auxiliary crane, crane components can start to swing back and forth!

When lifting / lowering and positioning crane components, there is an increased danger of impacts / crushing!

Personnel can be caught and thereby injured or killed!

- ▶ Make sure that personnel cannot be caught by components!
- ▶ When working in danger zones: Use aids to protect limbs!
- ▶ Guide components with suitable aids to minimize oscillation!



### WARNING

Improper substructure!

The crane can sink into the ground and topple over.

Death, severe bodily injuries, property damage.

- ▶ Make sure that the substructure takes on the crane weight safely.
- ▶ Use stable materials such as wood, steel plates or concrete slabs of a suitable size for the substructure, depending on the ground conditions.

Make sure that the following prerequisites are met:

- The crawler carriers are removed.

Assemble and disassemble the crawler carrier, see the Crane operating instructions, chapter 3.01.

## 6.1 Removing the rigging device

- ▶ Remove the rigging device.

## 6.2 Extending the cross carrier with the BTT

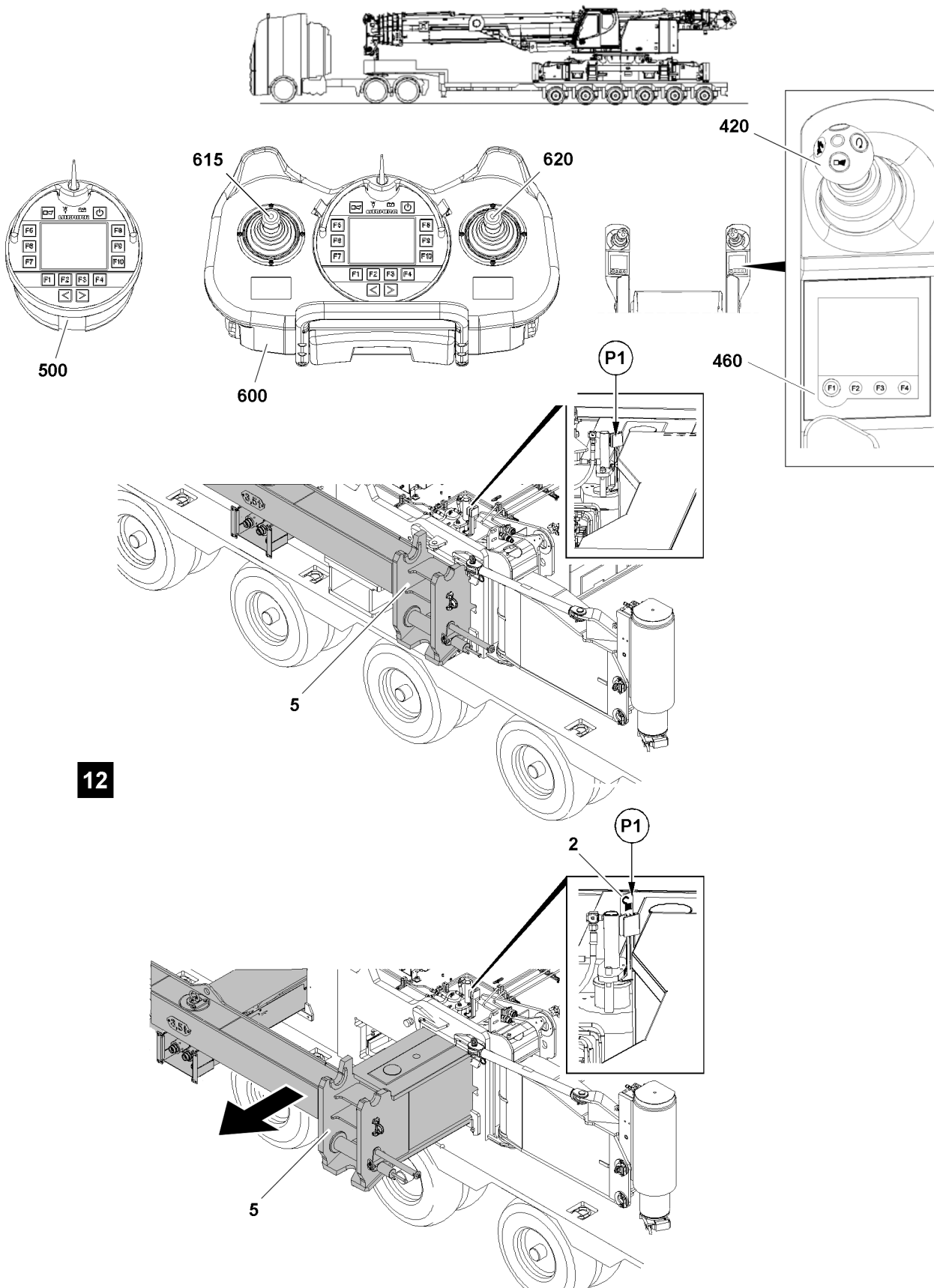


Fig.128117

LWE/LTR 1220-003/24204-02-02/en



Observe and comply with the following notes:

- The extension condition of the cross carrier is displayed as a percentage on the BTT display.
- The extension conditions of the cross carriers / crawler carriers are specified in the load chart.
- The pin points of the cross carriers are marked in percentages with tags on the cross carriers.
- Only pin the cross carriers on extension conditions of 0 %; 50 %; 100 %.
- When the transport vehicle is changed: Only pin the cross carriers on extension conditions of 0 %; 50 %.

Make sure that the following prerequisites are met:

- No personnel is within the danger zone.
- The menu overview is shown on the BTT display.

### 6.2.1 Activating „Unpin the cross carrier“

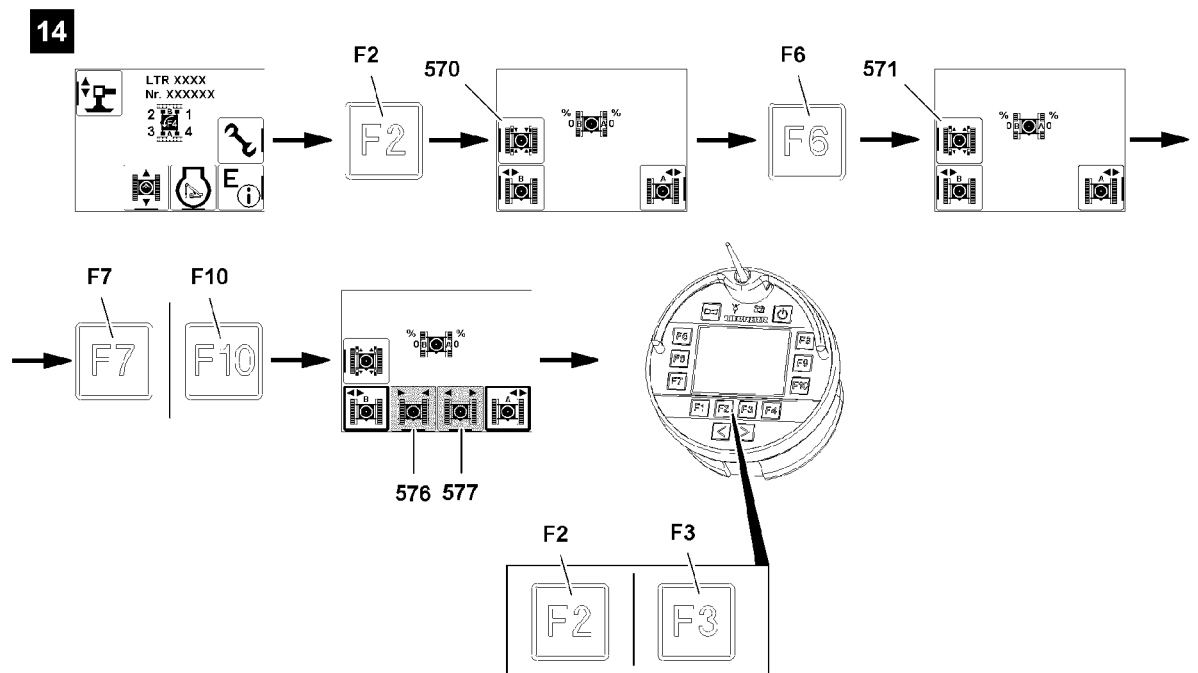


Fig. 116896

- ▶ Call up the „Crawler travel gear“ menu: Press the function key **F2**, see illustration 14.

**Result:**

- Functions „Track width adjustment“ are visible.

When icon „Pin the cross carrier“ **570** is visible:

- ▶ Activate „Unpin the cross carrier“: Press the function key **F6**.

**Result:**

- Icon „Unpin the cross carrier“ **571** appears.

### 6.2.2 Selecting the cross carrier

Before you retract or extend the cross carrier, select one of the cross carriers or both cross carriers:

- **F7** Function key
- **F10** Function key

This and the following sections describe how both cross carriers are extended together. Alternatively you can also select and extend the cross carriers individually.

Depending on which cross carriers are selected, different icons for „retract crawler carrier“ and „extend crawler carrier“ appear, see Crane operating instructions, chapter 5.31.

- ▶ Select both cross carriers: Press function key **F7** and function key **F10**, see illustration **14**.

**Result:**

- Icon „Retract crawler carrier“ **576** is visible.
- Icon „Extend crawler carrier“ **577** is visible.

### 6.2.3 Extending the cross carriers

To unpin the cross carriers on points **P1**, you have extend the cross carriers, see illustration **12**.

You can check on points **P1** if the pins are completely pinned or unpinned:

- The pins are unpinned: Tags **2** are visible.
- The pins are pinned: Tags **2** are **not** visible.




---

**WARNING**

Adjustment of the cross carriers!  
Crushing of people and body parts.

- ▶ Make sure that no personnel is within the danger zone of the cross carriers during „track width adjustment“.
  - ▶ Differentiation of the cross carriers, see Crane operating instructions, chapter 5.31.
- 

Before extending the cross carrier, observe the section „Pinning the cross carriers“.

#### Retracting the cross carriers

When the cross carrier must be retracted:

- ▶ Press the function key **F2**.

**Result:**

- The cross carriers retract.

#### Extending the cross carriers

- ▶ Press the function key **F3**.

**Result:**

- The pins are unpinned.
- 

#### Problem remedy

Pins are not unpinned!

The pin is stuck: The position of the cross carriers prevents the pins from unpinning.

- ▶ Extend and retract the cross carriers again: Press the function keys until the pins are completely unpinned.
- 

- ▶ Make sure that the pins are completely unpinned on points **P1**, see illustration **12**.

**Result:**

- The cross carriers extend.

### 6.2.4 Pinning the cross carriers

Before the cross carriers reach the 50 % extension condition:

- ▶ Activate „Pin the cross carrier“: Press the function key **F6**.

**Result:**

- Icon „pin the cross carrier“ **570** is visible.
- The pins are pinned.

---

**Problem remedy**

The pins are not pinned!

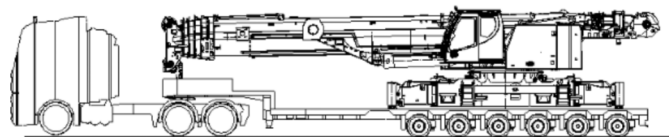
The pin is stuck: The position of the cross carriers prevents the pins from pinning.

- ▶ Extend and retract the cross carriers again: Press the function keys until the pins are completely pinned.
- 
- ▶ Make sure that the pins are completely pinned on points **P1**, see illustration **12**.

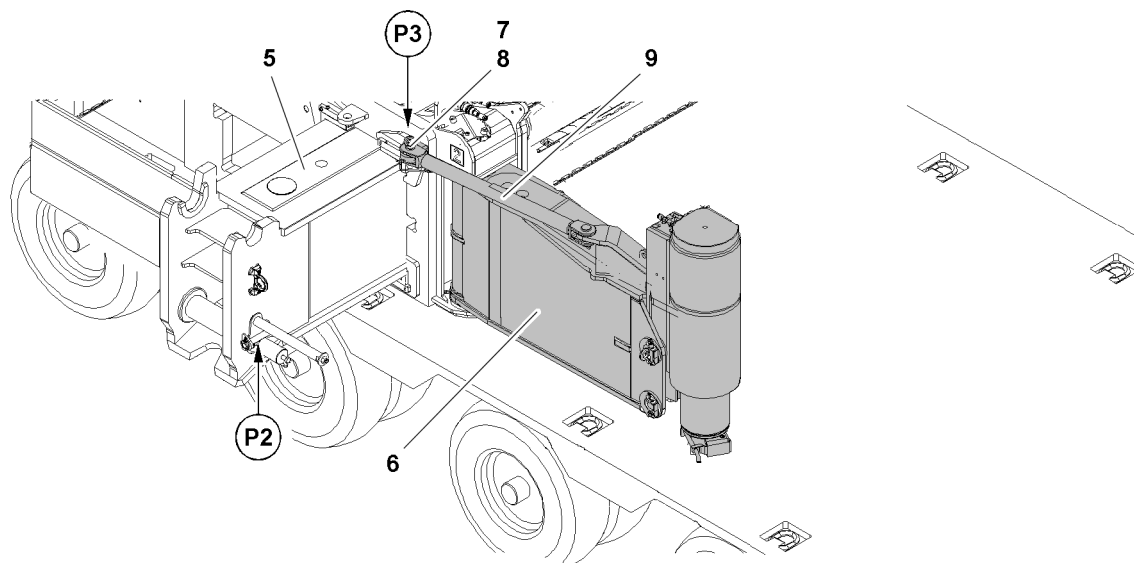
**Result:**

- The pins are pinned.
- The cross carriers are extended and secured at 50 %.

### 6.3 Swinging the folding brackets out



20



21

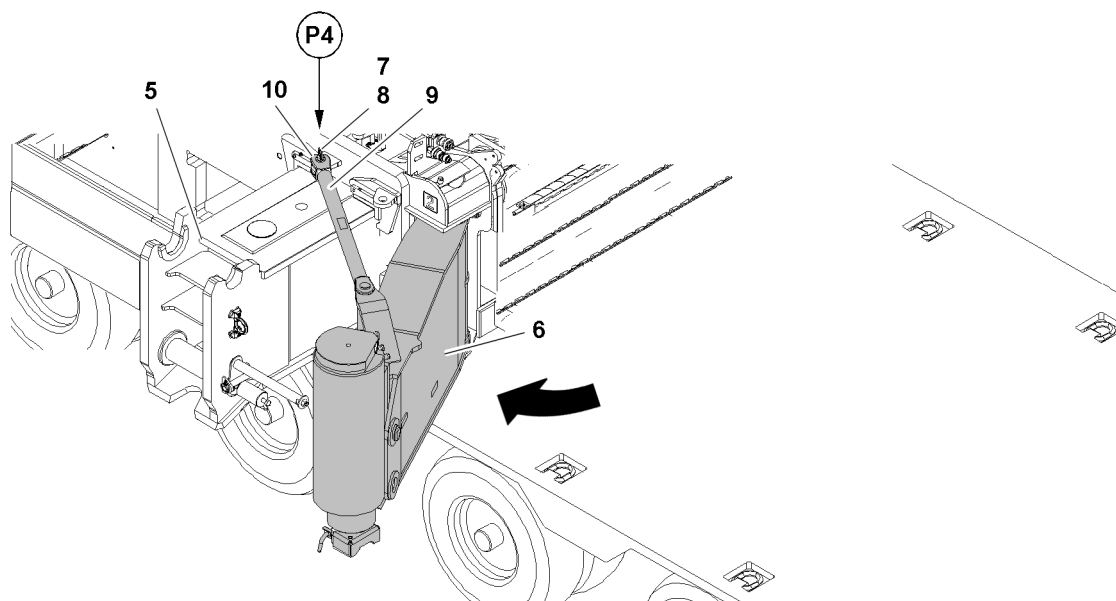


Fig.128118

Make sure that the following prerequisites are met:

- Both cross carriers **5** are 50 % extended and pinned.

---

**NOTICE**

Damage to the pin pulling device!

If the cross carriers **5** are not extended when swinging the folding brackets **6**, then the pin pulling devices will be damaged at point **P2** when swinging the folding brackets!

- ▶ Make sure that the cross carriers **5** are extended before swinging the folding brackets **6**!
- ▶ Make sure that no persons or objects are within the danger zone when swinging the folding brackets **6**!

- 
- ▶ Remove the spring retainer **7** at point **P3**, see illustration **20**.
  - ▶ Unpin the pin **8** at point **P3**, see illustration **20**.
  - ▶ Remove the rod **9** from the connection.

**Result:**

- The folding bracket **6** is released.
- ▶ Swing the folding bracket **6** out until the connection fork **10** of the rod can be pinned at point **P4**, see illustration **21**.

When the bores align at point **P4**:

- ▶ Insert the pin **8** at point **P4**, see illustration **21**.
- ▶ Insert the spring retainer **7** at point **P4**, see illustration **21**.

**Result:**

- The folding bracket **6** is secured.
- ▶ Swinging all folding brackets out

### 6.4 Assembling the support plates

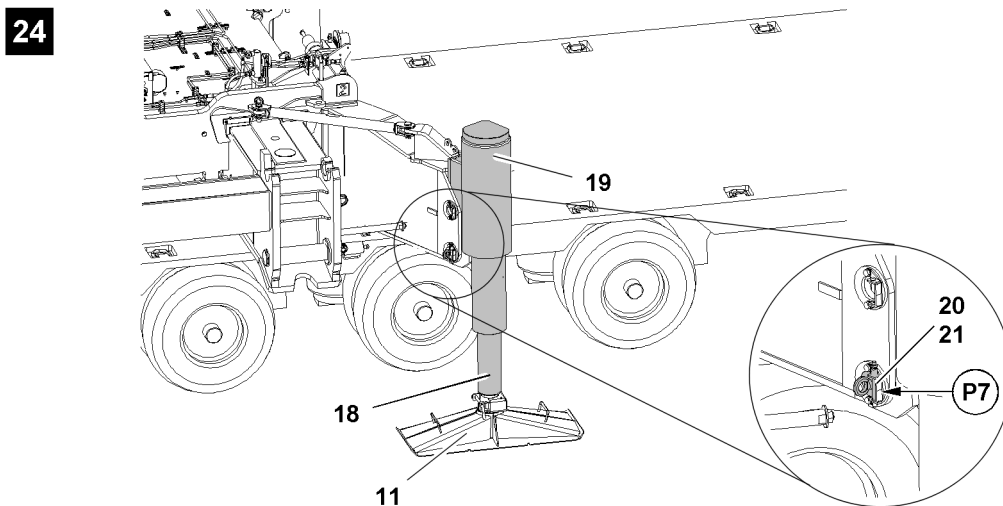
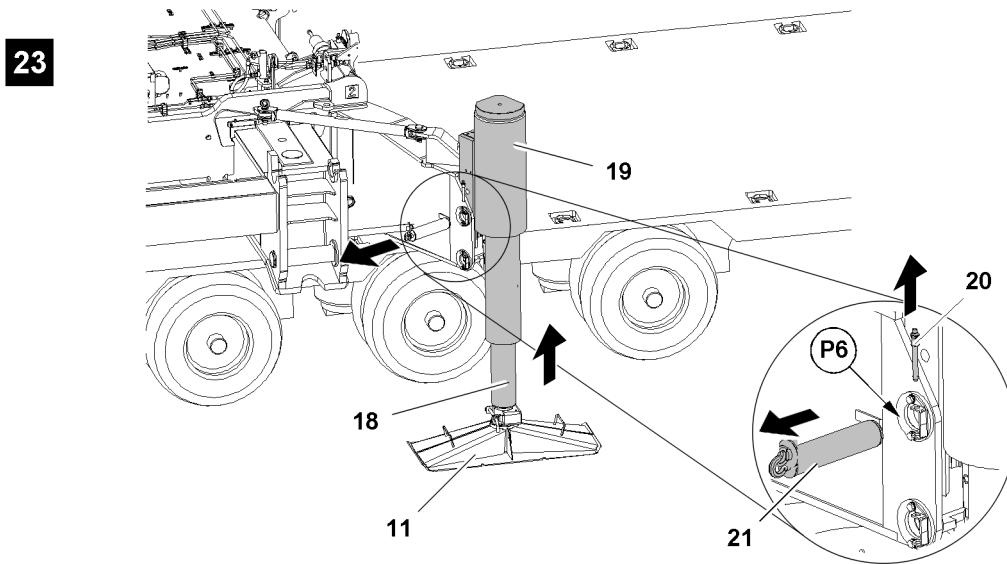
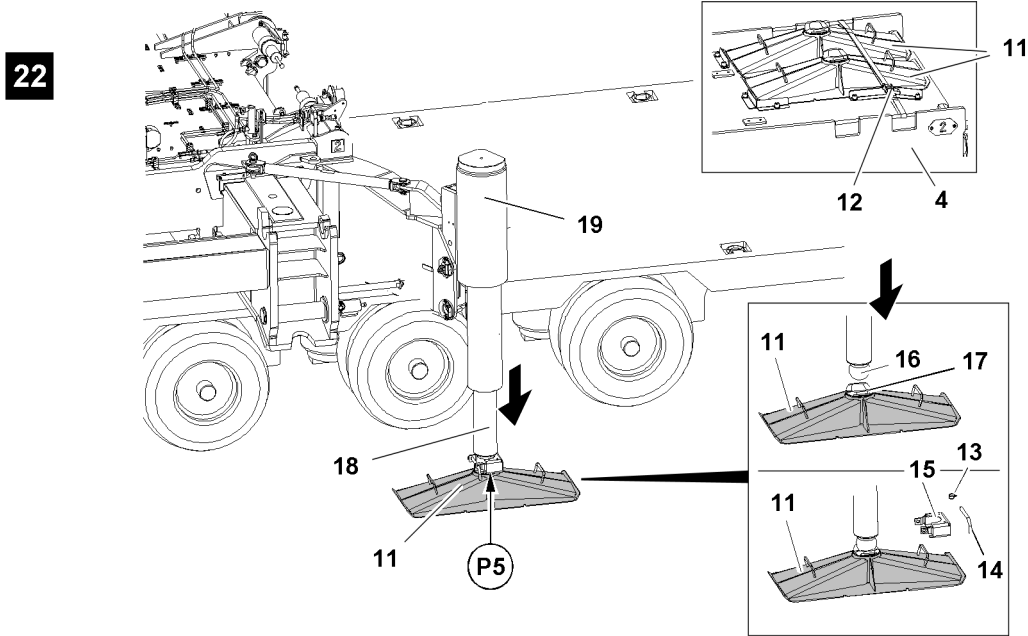


Fig.128119

LWE/LTR 1220-003/24204-02-02/en

### 6.4.1 Preparing the support plates for assembly



#### Note

- ▶ The support plates **11** are positioned for transport on the central ballast **4!**
- ▶ The weight of the support plate is 50 kg !
- ▶ For safety reasons, assemble the support plates **11** always with two persons!

- ▶ Remove the transport belts **12**, see illustration **22**.
- ▶ Remove the support plates **11** from the transport receptacle.



#### DANGER

Support plates **not** properly supported!

The crane can topple over. Death, severe bodily injuries, property damage.

- ▶ Make sure that the support plates are positioned on load bearing and horizontal ground.
  - ▶ Only use suitable materials for the substructure.
  - ▶ Place the substructures in the center under the support plates.
  - ▶ Support all support plates **11** with the same materials.
  - ▶ Observe the track width of the flat bed trailer: The supports may **not** project into the driving track.
- ▶ Place stable materials such as wood, steel plates or concrete slabs of a suitable size under the support plates **11**, depending on the ground conditions.
  - ▶ Place the support plates **11** under the support cylinder **19** and align them lengthwise to the transport vehicle.
  - ▶ Remove the safety locking pin **13** at point **P5** and unpin the connector **14**, see illustration **22**.
  - ▶ Pull out the retainer **15** from the ball head **16**, see illustration **22**.

### 6.4.2 Extending / retracting the piston rod with the BTT

#### Selecting the support cylinder

Make sure that the following prerequisite is met:

- The menu overview is shown on the BTT display.

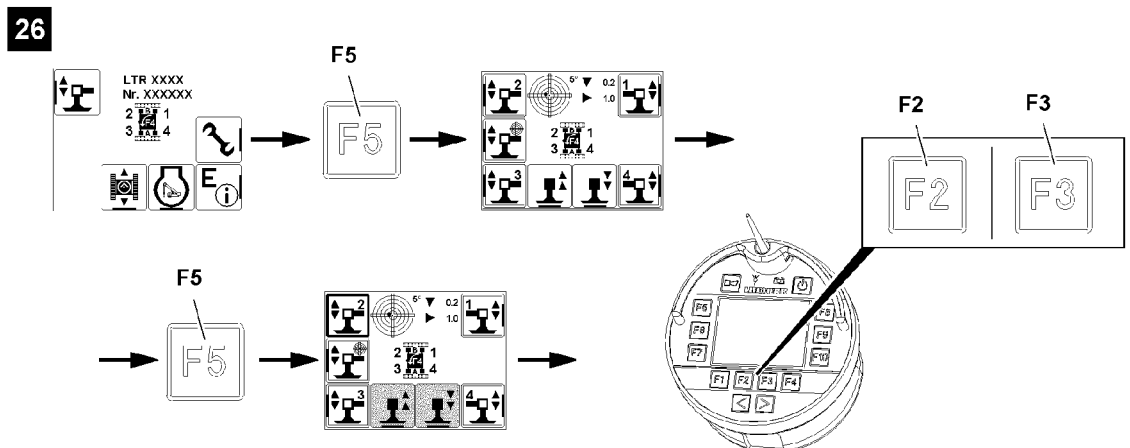


Fig. 116899

- ▶ Press the function key **F5**, see illustration **26**.

#### Result:

- The „Support“ menu is visible.

The support cylinders are marked with numbers depending on the alignment of the BTT.

Support cylinders are selected with function keys:

- **F5** Function key
- **F7** Function key
- **F8** Function key
- **F10** Function key

► Select the support cylinder: Press the function key.

**Result:**

- Selected icons are visible with filled out frames: Support cylinders are selected.
- Support cylinders are ready for extension and retraction.

**Retracting the support cylinders**

When the support cylinder must be retracted:

► Press the function key **F2**.

**Result:**

- Piston rod **18** retracts.

**Extending the support cylinders**

When the support cylinder must be extended:

► Press the function key **F3**.

**Result:**

- Piston rod **18** extends.



### 6.5 Positioning the support cylinders in operating position

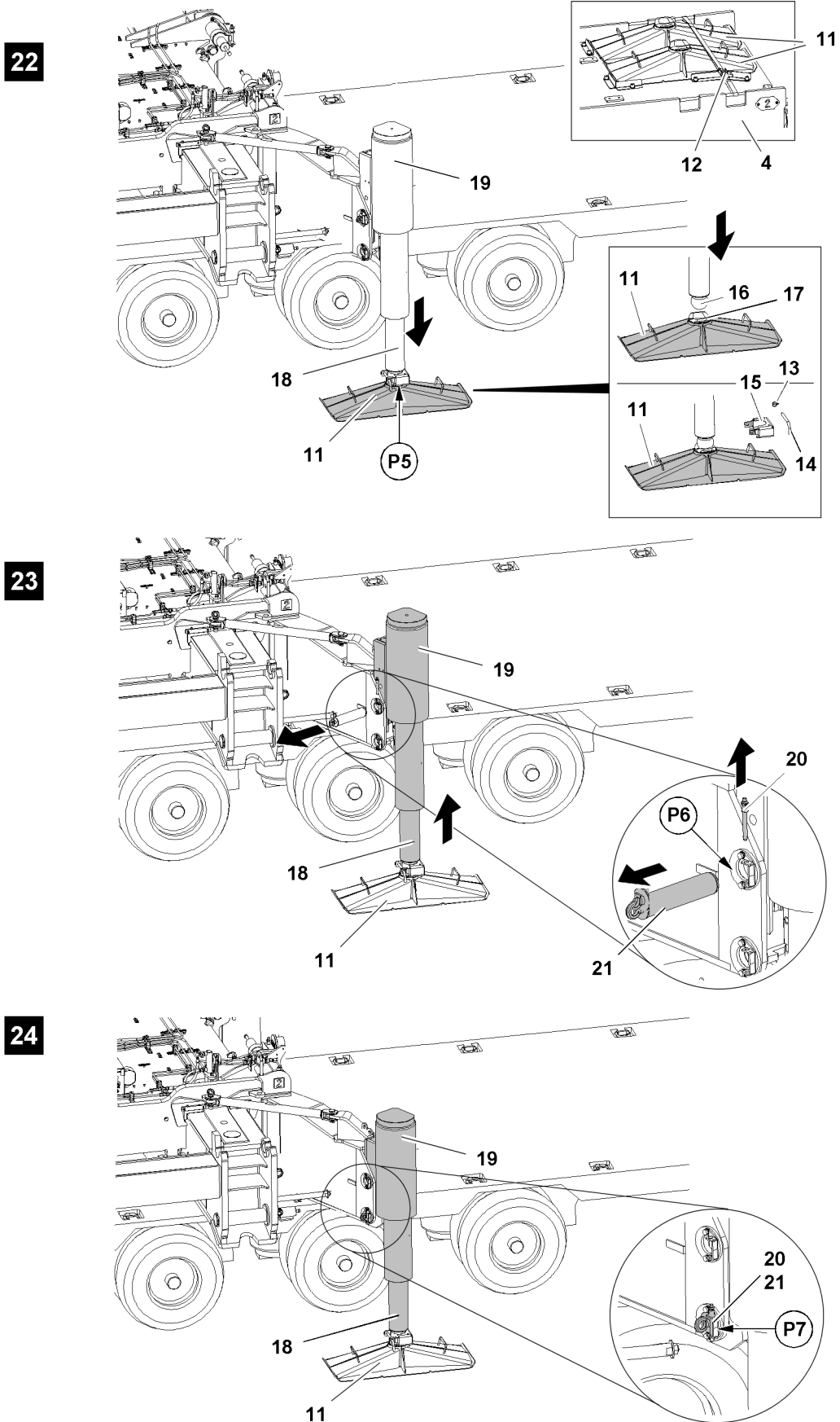


Fig.128119

LWE/LTR 1220-003/24204-02-02/en

Make sure that the following prerequisites are met:

- All support plates **11** are pinned on support cylinders **19** and secured.
- The support cylinders **19** are extended to the ground.

### 6.5.1 Unpinning the support cylinders

- ▶ Release the pin **21**: Unpin locking ball pin **20**, see illustration **23**.
- ▶ Unpin the pin **21** at point **P6**, see illustration **23**.

### 6.5.2 Retracting the support cylinders

Retract the support cylinder with the BTT, see section „Extending / retracting the piston rod with the BTT“.

- ▶ Retract the piston rod **18** until the pin bores align at point **P7**, see illustration **24**.

### 6.5.3 Pinning the support cylinders

When the bores align at point **P7**:

- ▶ Insert the pin **21** at point **P7**, see illustration **24**.
- ▶ Secure the pin **21**: Insert the ball locking pin **20**.

**Result:**

- The support cylinder **19** is pinned and secured in operating position.
- ▶ Position and secure all support cylinders in the operating position.

## 6.6 Luffing the telescopic boom up

The telescopic boom must be luffed up to the point that the transport vehicle can be driven out under the crane.

- ▶ Luff up the telescopic boom a few degrees.
- ▶ Remove the substructure.

## 6.7 Supporting the crane with the BTT

The crane can be supported manually or automatically.

With manual support, the support cylinders can be extended individually or all four simultaneously.



### WARNING

Folding brackets incompletely assembled!

The assembly support is **not** monitored by the control.

The crane can topple over. Death, severe bodily injuries, property damage.

- ▶ The crane operator must check the assembly support before further assembly steps.
- ▶ Make sure that all folding brackets are swung and secured with rods.
- ▶ Make sure that all support plates are supported.



### WARNING

The crane is **not** horizontally aligned!

The crane can tip and topple over.

Death, severe bodily injuries, property damage.

- ▶ Align the crane horizontally.

**WARNING**

Impermissible crane alignment! Support plates without ground contact!  
Automatic support, the crane can topple over.  
Death, severe bodily injuries, property damage.

- ▶ Make sure that the alignment is within the permitted tolerance.
- ▶ Make sure that all four support plates have contact with the ground.

**WARNING**

Load chart values not adhered to!  
Crane can topple over.

Death, severe bodily injuries, property damage.

- ▶ Observe and adhere to the values in the load chart when supporting.

Make sure that the following prerequisites are met:

- No personnel is within the danger zone.
- The engine is running.
- All folding brackets are folded out.
- All support cylinders are extended.
- All support plates are supported.
- The LICCON overload protection is set:
  - Support base 4.4 m on supports
  - Central ballast 0 t
  - Counterweight 0 t
  - Without auxiliary boom / accessories
  - Slewing range
- The menu overview is shown on the BTT display.

### 6.7.1 Selecting the support automatic

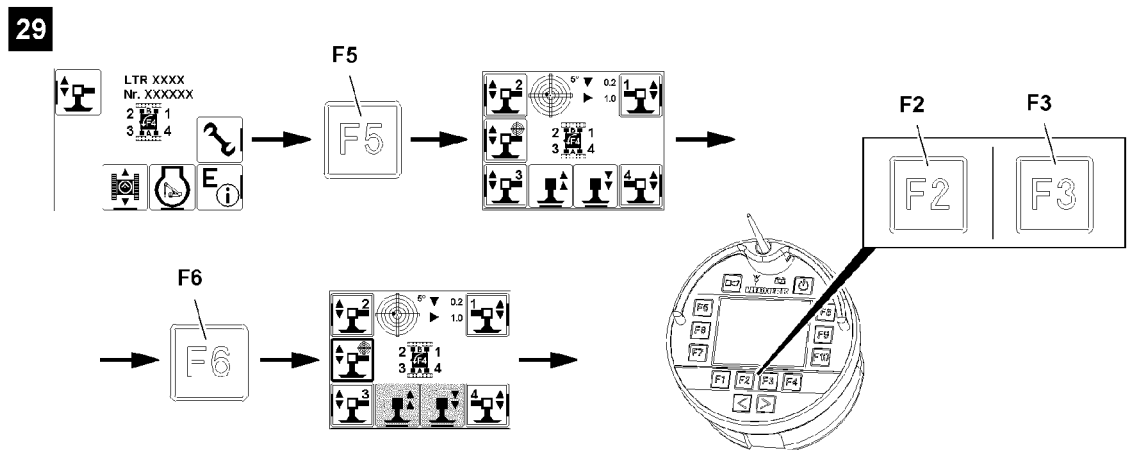


Fig. 116904

- ▶ Press the function key **F5**, see illustration 29.

**Result:**

- The „Support“ menu is visible.

The support cylinders are marked with numbers depending on the alignment of the radio remote control.

The support automatic extends or retracts all support cylinders simultaneously and levels the crane during the support procedure automatically.

- ▶ Select the support automatic: Press the function key **F6**.

**Result:**

- Selected icon is visible with filled out frame: The support automatic is selected.
- Support cylinders are ready for extension and retraction.

### 6.7.2 Retracting the support cylinders

When the crane must be lowered:

- ▶ Press the function key **F2**.

**Result:**

- The support cylinders **19** retract simultaneously.
- The crane is horizontally aligned.

### 6.7.3 Extending the support cylinders

When the crane must be lifted:

- ▶ Press the function key **F3**.

**Result:**

- The support cylinders **19** extend simultaneously.
- The crane is horizontally aligned.

## 6.8 Supporting the crane

Make sure that the following prerequisites are met:

- The crawler carriers have been removed.
- The counterweight is removed.
- The central ballast has been removed.
- The telescopic boom is luffed up a few degrees.



**WARNING**

Lifting the crane!

Increased danger of accidents due to collision.

Death, severe bodily injuries, property damage.

- ▶ Make sure that **no** persons or objects are within the danger zone.

Extend the support cylinder with BTT, see section „Supporting the crane with the BTT“.

- ▶ Support the crane until the transport vehicle can drive out from under the crane.

## 6.9 Driving the transport vehicle out

Make sure that the following prerequisite is met:

- The crane is horizontally aligned.
- The crane is supported high enough so that the transport vehicle can drive out from under the crane.



**WARNING**

Scraping of the support cylinder when driving out the transport vehicle!

Collision. The crane can topple over.

- ▶ Drive out the transport vehicle only with a guide.
- ▶ Make sure that the guide is constantly in acoustic and visual contact with the transport vehicle operator.
- ▶ Make sure that the transport vehicle does not scrape on a support cylinder when extending it.

- ▶ Drive the transport vehicle out from under the crane.

## 7 Loading without an auxiliary crane

This chapter describes how the crane is supported in order to lower the crane onto the transport vehicle.

Assemble and disassemble the crawler carrier, see the Crane operating instructions, chapter 3.01.

Make sure that the following prerequisites are met:

- The crawler carriers are removed.
- The crane superstructure is locked with the crane chassis.

### 7.1 Retracting the transport vehicle

Make sure that the following prerequisite is met:

- The crane is supported at a sufficient height to enable the transport vehicle to drive under the crane.
- The telescopic boom is luffed up a few degrees so that the transport vehicle can drive under the crane.



#### WARNING

Scraping of the support cylinder when retracting the transport vehicle!  
Collision. The crane can topple over.

- ▶ Drive in the transport vehicle only with a guide.
  - ▶ Make sure that the guide is constantly in acoustic and visual contact with the transport vehicle operator.
  - ▶ Make sure that the transport vehicle does not scrape on a support cylinder when retracting it.
- 
- ▶ Retract the transport vehicle and align it parallel to the crane.

### 7.2 Supporting the crane with the BTT

The crane can be supported manually or automatically.

With manual support, the support cylinders can be extended individually or all four simultaneously.



#### WARNING

Folding brackets incompletely assembled!  
The assembly support is **not** monitored by the control.  
The crane can topple over. Death, severe bodily injuries, property damage.

- ▶ The crane operator must check the assembly support before further assembly steps.
  - ▶ Make sure that all folding brackets are swung and secured with rods.
  - ▶ Make sure that all support plates are supported.
- 



#### WARNING

The crane is **not** horizontally aligned!  
The crane can tip and topple over.  
Death, severe bodily injuries, property damage.

- ▶ Align the crane horizontally.
- 



#### WARNING

Impermissible crane alignment! Support plates without ground contact!  
Automatic support, the crane can topple over.  
Death, severe bodily injuries, property damage.

- ▶ Make sure that the alignment is within the permitted tolerance.
  - ▶ Make sure that all four support plates have contact with the ground.
-

**WARNING**

Load chart values not adhered to!

Crane can topple over.

Death, severe bodily injuries, property damage.

- ▶ Observe and adhere to the values in the load chart when supporting.

Make sure that the following prerequisites are met:

- No personnel is within the danger zone.
- The engine is running.
- All folding brackets are folded out.
- All support cylinders are extended.
- All support plates are supported.
- The LICCON overload protection is set:
  - Support base 4.4 m on supports
  - Central ballast 0 t
  - Counterweight 0 t
  - Without auxiliary boom / accessories
  - Slewing range
- The menu overview is shown on the BTT display.

## 7.2.1 Selecting the support automatic

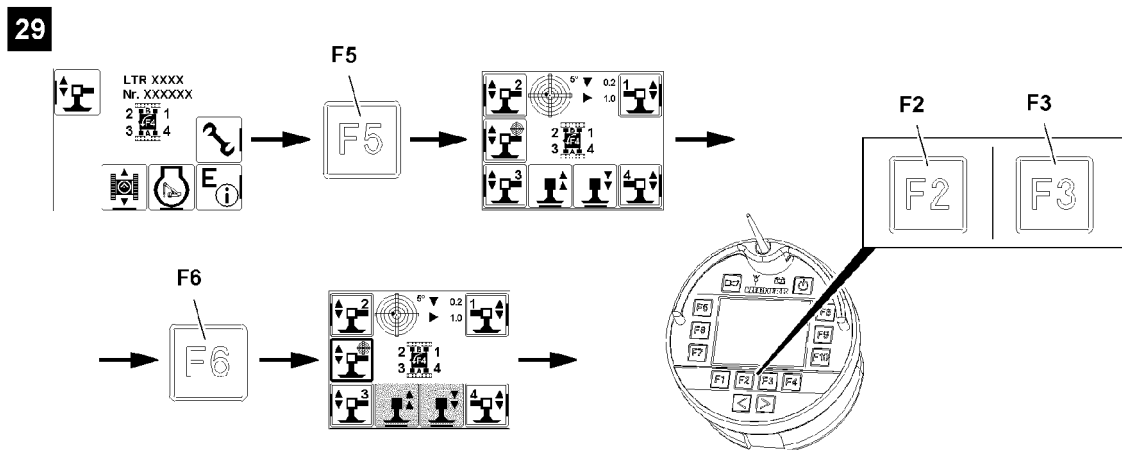


Fig.116904

- ▶ Press the function key **F5**, see illustration 29.

**Result:**

- The „Support“ menu is visible.

The support cylinders are marked with numbers depending on the alignment of the radio remote control.

The support automatic extends or retracts all support cylinders simultaneously and levels the crane during the support procedure automatically.

- ▶ Select the support automatic: Press the function key **F6**.

**Result:**

- Selected icon is visible with filled out frame: The support automatic is selected.
- Support cylinders are ready for extension and retraction.

## 7.2.2 Retracting the support cylinders

When the support cylinder must be retracted:

- ▶ Press the function key **F2**.

**Result:**

- The support cylinders **19** retract simultaneously.
- The crane is horizontally aligned.

## 7.2.3 Extending the support cylinders

When the support cylinder must be extended:

- ▶ Press the function key **F3**.

**Result:**

- The support cylinders **19** extend simultaneously.
- The crane is horizontally aligned.

## 7.3 Lowering the crane

Make sure that the following prerequisites are met:

- The transport vehicle is driven in and aligned.
- The substructures are placed on the transport vehicle.
- The anti-slip mats are placed near the false edges on the crawler center section of the crane on the transport vehicle.



---

### WARNING

Lower the crane!

Increased danger of accident due to crushing.

Death, severe bodily injuries.

- ▶ Make sure that there are **no** persons in the danger zone.
- 

Retract the support cylinder with BTT, see section „Supporting the crane with the BTT“.

- ▶ Lower the crane on the transport vehicle.

### 7.4 Positioning the support cylinders in transport position

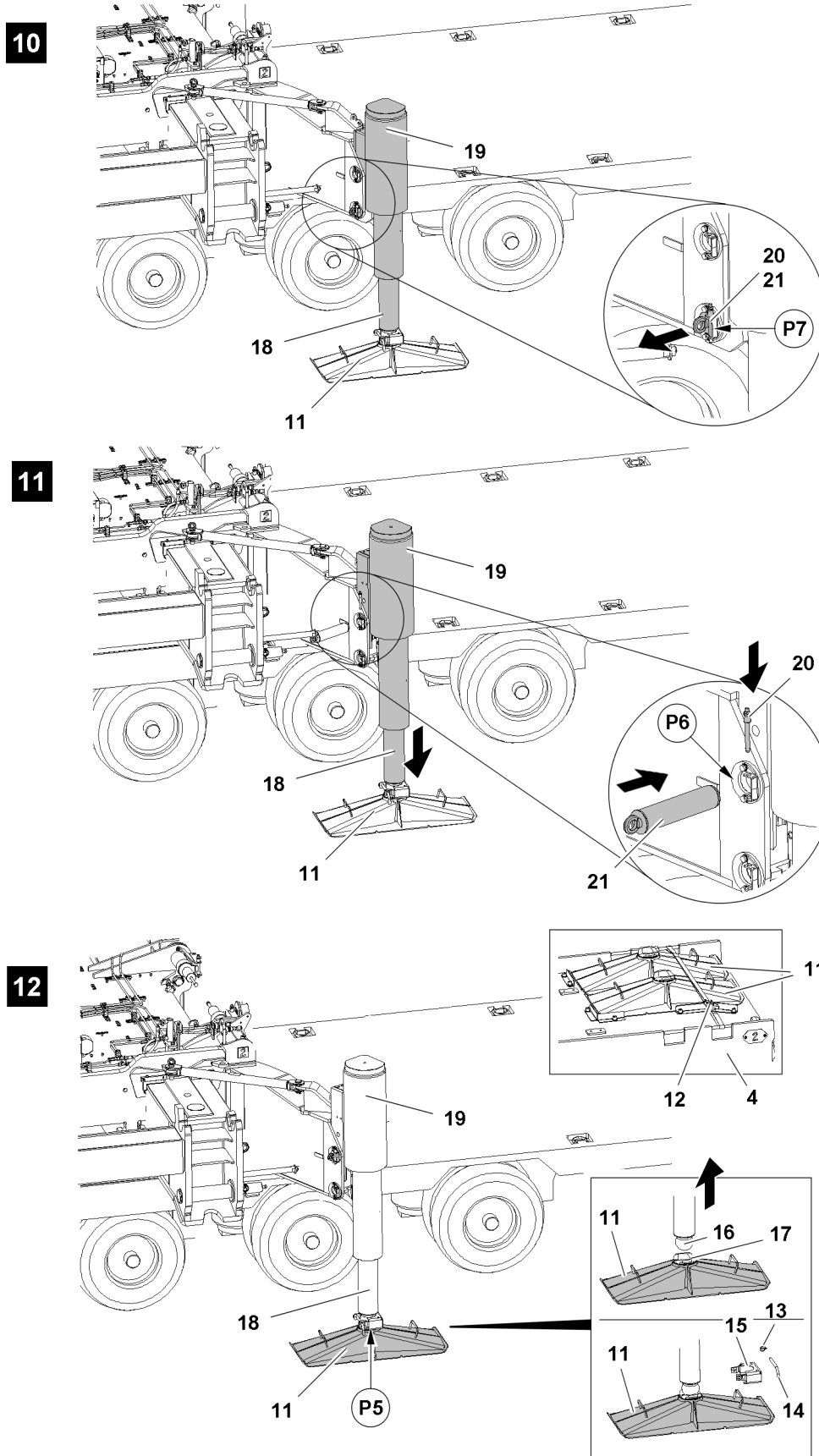


Fig.128340

LWE/LTR 1220-003/24204-02-02/en



Make sure that the following prerequisite is met:

- The crane is laying completely on the transport vehicle.

### 7.4.1 Unpinning the support cylinders

- ▶ Release the pin **21**: Unpin the ball locking pin **20** on point **P7**, see illustration **10**.
- ▶ Unpin the pin **21**.

### 7.4.2 Extending / retracting the piston rod with the BTT

#### Selecting the support cylinder

Make sure that the following prerequisite is met:

- The menu overview is shown on the BTT display.

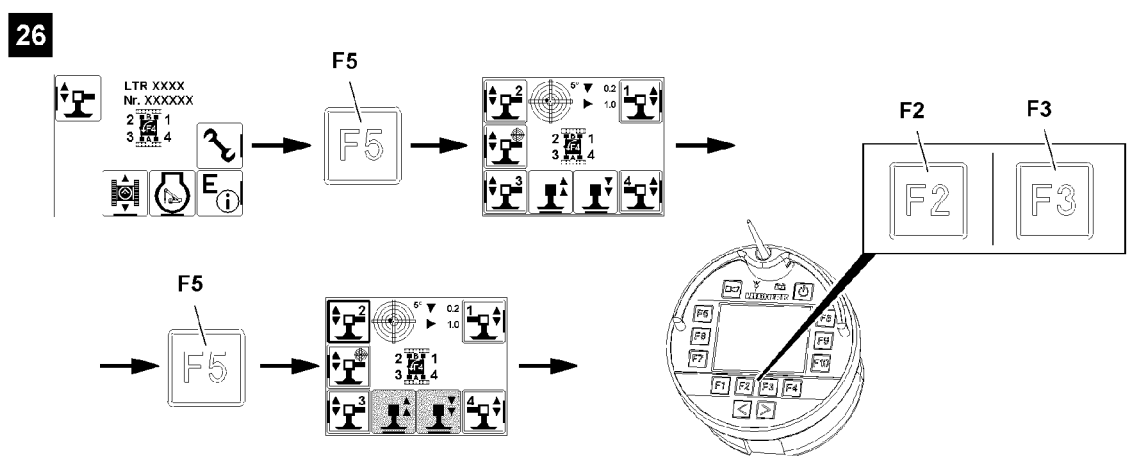


Fig.116899

- ▶ Press the function key **F5**, see illustration **26**.

#### Result:

- The „Support“ menu is visible.

The support cylinders are marked with numbers depending on the alignment of the BTT.

Support cylinders are selected with function keys:

- **F5** Function key
- **F7** Function key
- **F8** Function key
- **F10** Function key

- ▶ Select the support cylinder: Press the function key.

#### Result:

- Selected icons are visible with filled out frames: Support cylinders are selected.
- Support cylinders are ready for extension and retraction.

#### Retracting the support cylinders

When the support cylinder must be retracted:

- ▶ Press the function key **F2**.

#### Result:

- Piston rod **18** retracts.

### Extending the support cylinders

When the support cylinder must be extended:

- ▶ Press the function key **F3**.

**Result:**

- Piston rod **18** extends.

### 7.4.3 Pinning the support cylinders

Make sure that the following prerequisites are met:

- The pin bores align on point **P6**, see illustration **11**.
- ▶ Insert the pin **21** on point **P6**, see illustration **11**.
- ▶ Secure the pin **21**: Pin the ball locking pin **20** on point **P7**, see illustration **10**.

## 7.5 Removing the support plates

Make sure that the following prerequisite is met:

- The support cylinders **19** are in the transport position.



#### Note

- ▶ The support plates **11** are positioned for transport on the central ballast **4**.
- ▶ The weight of the support plate is 50 kg.
- ▶ The support plates **11** must always be disassembled by two persons.

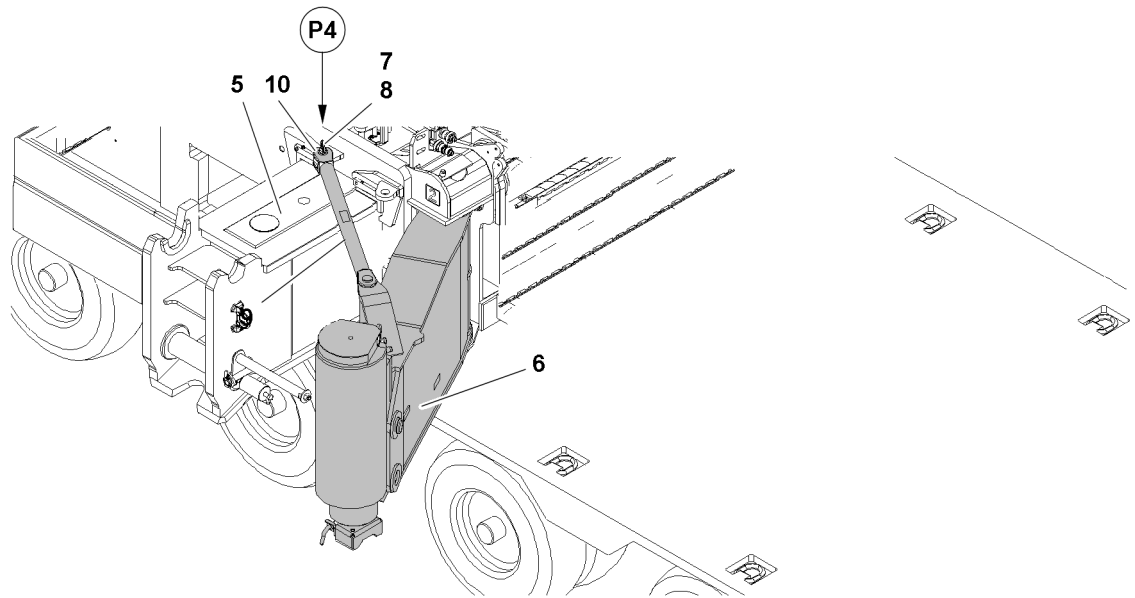
- ▶ Remove the safety locking pin **13** at point **P5** and unpin the connector **14**, see illustration **12**.
- ▶ Pull out the retainer **15** from the ball head **16**, see illustration **12**.

Retract the support cylinder with the BTT, see section „Extending / retracting the piston rod with the BTT“.

- ▶ Retract the support cylinders.
- ▶ Pull the retainer **15** again on the ball head **16**, see illustration **12**.
- ▶ Insert the connector **14** at point **P5** and secure with safety locking pin **13**.
- ▶ Take the support plate **11** down in transport position on the central ballast.
- ▶ Secure the support plate **11** in the transport position with the transport belts **12**, see illustration **12**.
- ▶ Remove all support plates.

## 7.6 Swinging the folding brackets in

**16**



**17**

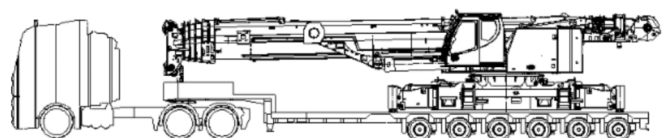
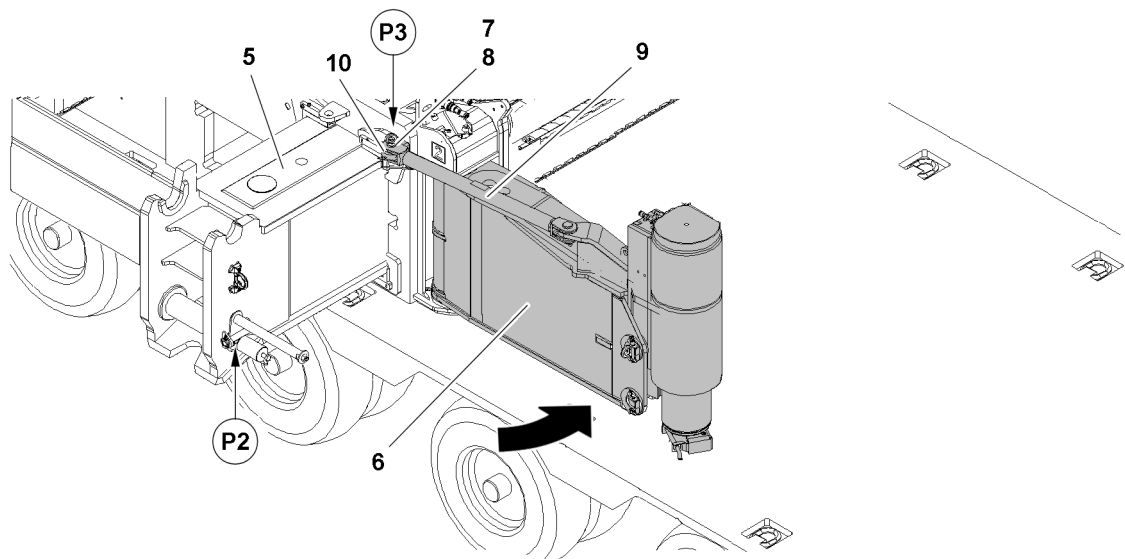


Fig. 128341

Make sure that the following prerequisite is met:

- The support plates 11 are removed.

**DANGER**

Danger of crushing!

- ▶ Make sure that no persons or objects are within the danger zone when swinging the folding brackets **6**!
- 
- ▶ Remove the spring retainer **7** at point **P4**, see illustration **16**.
  - ▶ Unpin the pin **8** at point **P4**, see illustration **16**.
  - ▶ Remove the rod **9** from the connection.

**Result:**

- The folding bracket **6** is released.
- ▶ Swing the folding bracket **6** in until the connection fork **10** of the rod can be pinned at point **P3**.

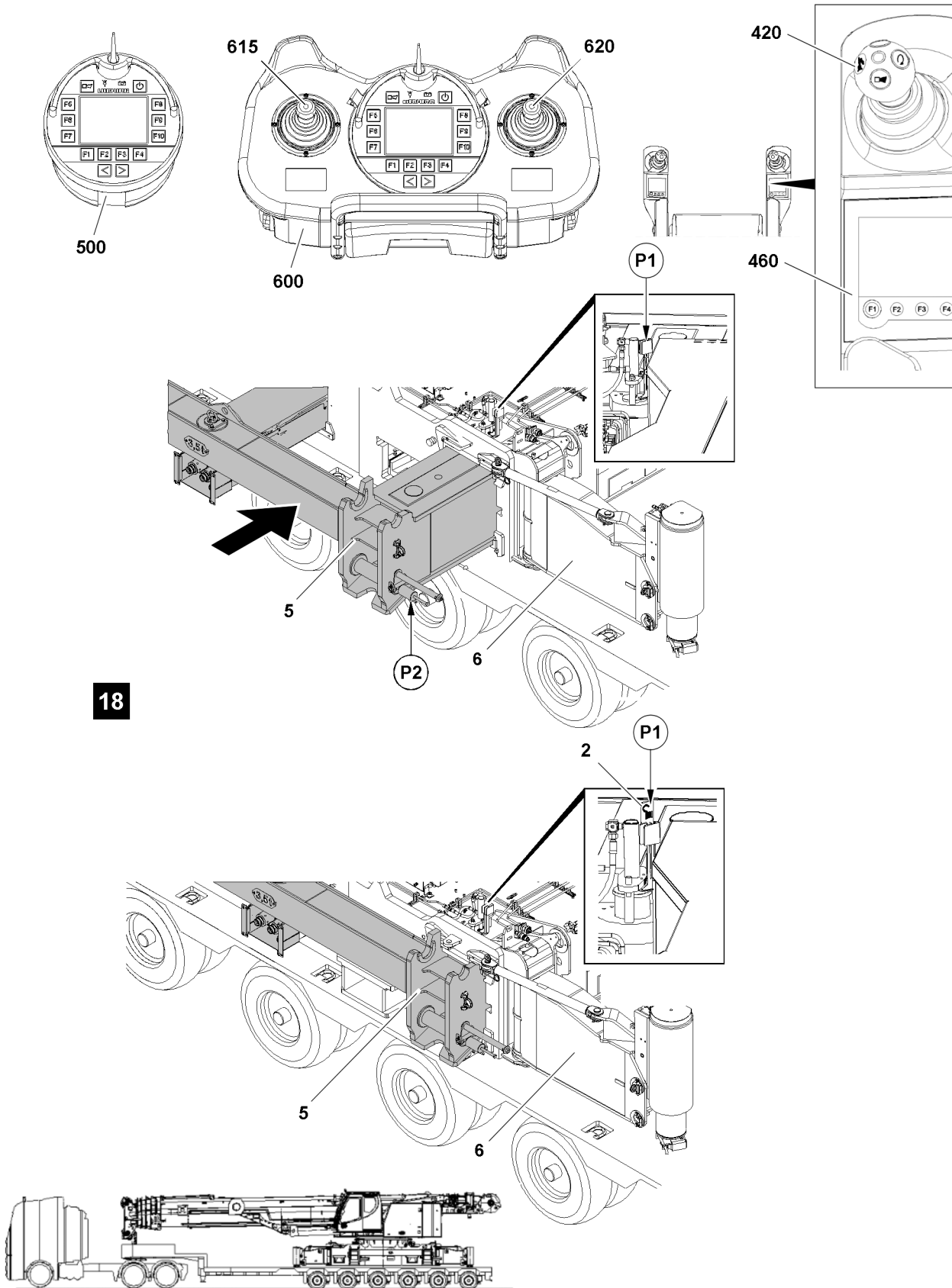
When the bores align at point **P3**:

- ▶ Insert the pin **8** at point **P3**, see illustration **17**.
- ▶ Insert the spring retainer **7** at point **P3**, see illustration **17**.

**Result:**

- The folding bracket **6** is secured.
- ▶ Swing all folding brackets in.

### 7.7 Retracting the cross carrier with the BTT



LWE/LTR 1220-003/24204-02-02/en

Fig.128342

**WARNING**

The cross carriers retract!  
Personnel can be crushed.

- ▶ Make sure that no persons are between the crane and the cross carrier during the entire retraction procedure.

**NOTICE**

Damage to the pin pulling device!

If the folding brackets **6** are not swung in before retracting the cross carrier, then the pin pulling device will be damaged at point **P2** when retracting the cross carrier!

- ▶ Make sure that the folding brackets **6** are swung into transport position before retracting the cross carrier **5**!

**Note**

- ▶ The extension condition of the cross carrier is displayed as a percentage on the BTT display!
- ▶ The cross carriers are only pinned in extension conditions of 0 %; 50 %; 100 %.
- ▶ The pin points of the cross carriers are marked in percentages with tags on the cross carriers.

Make sure that the following prerequisites are met:

- No personnel is within the danger zone.
- The folding brackets are swung in.
- The menu overview is shown on the BTT display.

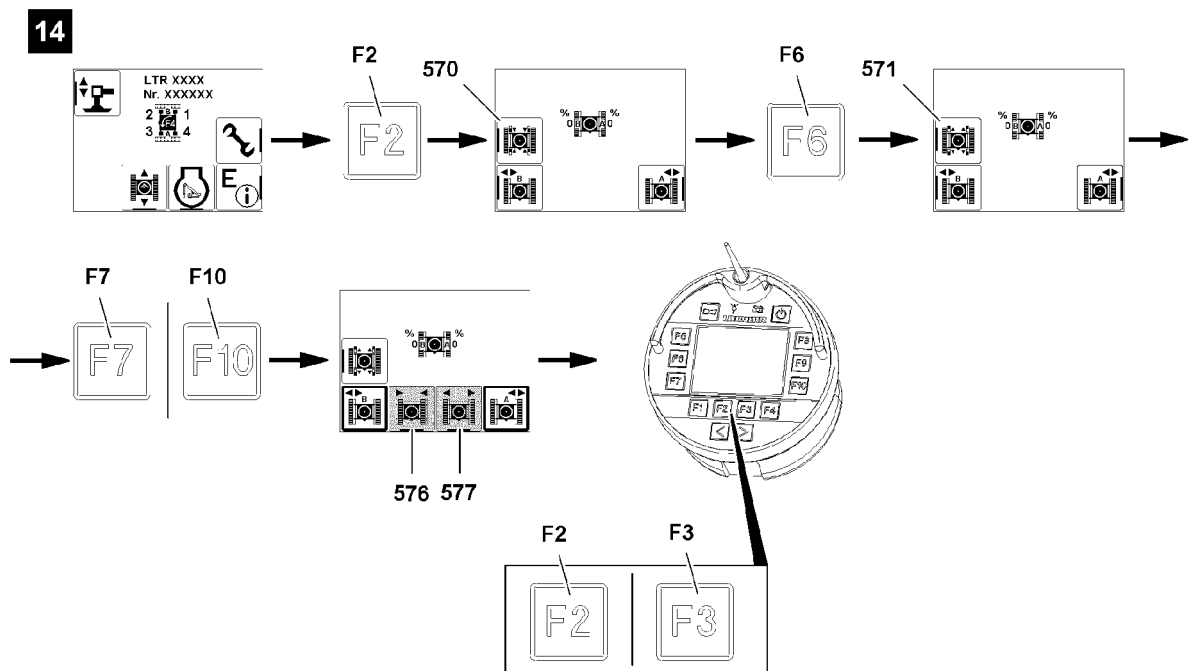
**7.7.1 Unpinning the cross carrier**

Fig.116896

- ▶ Call up the „Crawler travel gear“ menu: Press the function key **F2**, see illustration **14**.

**Result:**

- Functions „Track width adjustment“ are visible.

When icon „Pin the cross carrier“ **570** is visible:

- ▶ Activate „Unpin the cross carrier“: Press the function key **F6**.

**Result:**

- Icon „Unpin the cross carrier“ **571** appears.

**7.7.2 Selecting the cross carrier**

Before you retract or extend the cross carrier, select one of the cross carriers or both cross carriers:

- **F7** Function key
- **F10** Function key

This and the following sections describe how both cross carriers are retracted together. Alternatively you can also select and retract the cross carriers individually.

Depending on which cross carriers are selected, different icons for „retract crawler carrier“ and „extend crawler carrier“ appear, see Crane operating instructions, chapter 5.31.

- ▶ Select both cross carriers: Press function key **F7** and function key **F10**, see illustration **14**.

**Result:**

- Icon „Extend crawler carrier“ **577** is visible.
- Icon „Retract crawler carrier“ **576** is visible.

**7.7.3 Retracting the cross carriers**

To unpin the cross carriers on points **P1**, you have to retract or extend the cross carriers, see illustration **18**.

You can check on points **P1** if the pins are completely pinned or unpinned:

- The pins are unpinned: Tags **2** are visible.
- The pins are pinned: Tags **2** are **not** visible.

**WARNING**

Crushing danger due to movement of cross carriers!

- ▶ Make sure that no personnel is within the danger zone of the cross carriers during „track width adjustment“.
- ▶ Differentiation of the cross carriers, see Crane operating instructions, chapter 5.31

When „extending the cross carrier“:

- ▶ Press the function key **F3**.

When „retracting the cross carrier“:

- ▶ Press the function key **F2**.

**Result:**

- The pins are unpinned.

**Problem remedy**

Pins are not unpinned!

The pin is stuck: The position of the cross carriers prevents the pins from unpinning.

- ▶ Extend and retract the cross carriers again: Press the function keys until the pins are completely unpinned.

- ▶ Make sure that the pins are completely unpinned on points **P1**, see illustration **18**.

**Result:**

- The pins are unpinned.
- The cross carriers retract.

**7.7.4 Pinning the cross carriers**

Before the cross carriers reach the 0 % extension condition:

- ▶ Activate „Pin the cross carrier“: Press the function key **F6**.

**Result:**

- Icon „pin the cross carrier“ **570** is visible.
- The pins are pinned.

**Problem remedy**

The pins are not pinned!

The pin is stuck: The position of the cross carriers prevents the pins from pinning.

- ▶ Extend and retract the cross carriers again: Press the function keys until the pins are completely pinned.

- ▶ Make sure that the pins are completely pinned on points **P1**, see illustration **18**.

**Result:**

- The pins are pinned.
- The cross carriers are retracted and secured at 0 %.

## 7.8 Luffing the telescopic boom down

- ▶ Position the substructure for the telescopic boom.
- ▶ Luff the telescopic boom down and take it down on the substructure.

## 8 Rigging

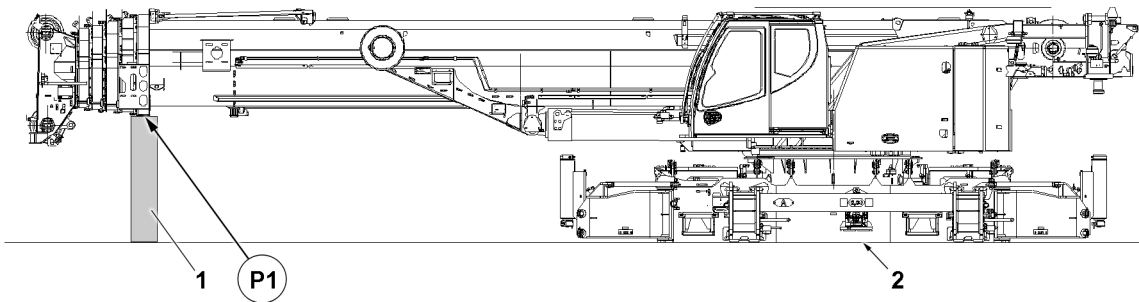


Fig.128345: Substructure telescopic boom, transport

<b>P1</b> Position for the telescopic boom substructure	<b>1</b> Substructure	<b>2</b> Slip-resistant mat
---	-----------------------	-----------------------------

**WARNING**

Telescopic boom **not** supported!

The crane's stability is endangered.

- ▶ The telescopic boom is properly supported.
- ▶ Support the crane's placement surface with anti-slip mats.

**WARNING**

Insufficient retainer!

The crane can fall off the transport vehicle in the case of sharp brake maneuvers. Death, severe bodily injuries, property damage.

- ▶ Sufficiently rig and secure the crane.



Make sure that the following prerequisites are met:

- There are anti-slip mats between the placement surfaces of the crane and the loading surface, d= 10 mm.
- The central ballast has been removed.
- The counterweight is disassembled.
- The hook block is disassembled.
- The crane superstructure is locked with the crane chassis.
- The folding brackets are pinned in the transport position.
- The cross carriers are retracted in the transport position.
- The telescopic boom is luffed down and taken down in point **P1** onto the substructure.



#### WARNING

Retainer insufficient!

The crane can fall off the transport vehicle in the case of sharp brake maneuvers.

Death, severe bodily injuries, property damage.

- ▶ Properly rig and secure the crane.



#### WARNING

Impermissible rigging!

The rigging points and rigging device can fail. The crane or loads can fall down.

Death, severe bodily injuries, property damage.

- ▶ Fasten tension belts or tension chains only on the permissible rigging points and rigging eyehooks, see rigging plans.
- ▶ When rigging, observe the angles, radii and tension surfaces, see rigging plans.

The rigging points are marked with a sign, see the signage plan and the Crane operating instructions, chapter 2.05.

- ▶ Secure the crane and crane components with tension belts or tension chains on the rigging points.
- ▶ Secure the telescopic boom with tension belts or tension chains by observing the marked tension areas on the rigging points.
- ▶ Attach the tension belts or tension chains on the transport vehicle.

## 9 Securing

The crane must be secured against unauthorized use.

Make sure that the following prerequisites are met:

- The crane is properly rigged on the transport vehicle.
- ▶ Close all cover doors.
- ▶ Turn off the engine and pull out the ignition key.

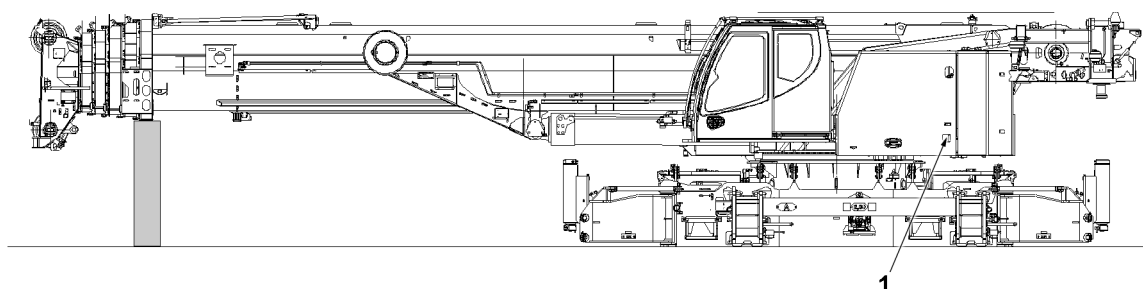


Fig.128353: Battery master switch

### 1 Battery master switch

When a battery master switch is present:

- ▶ Turn off the battery master switch **1** and remove the switch cams. Take down the switch cam in the crane cab.
- ▶ Lock the crane cab.

---

## 4 Operation of crane superstructure

LWE/LTR 1220-003/24204-02-02/en

---

LWE/LTR 1220-003/24204-02-02/en

## 4.01 Operating and monitoring instruments on the crane superstructure

1	Operating and control instruments	3
2	Operating elements on the control panels	11
3	Roof instrument panel operating elements	39
4	Side panel	40
5	Control elements	41
6	Climate control	41
7	Operating elements on the operating and control unit (BKE)	46

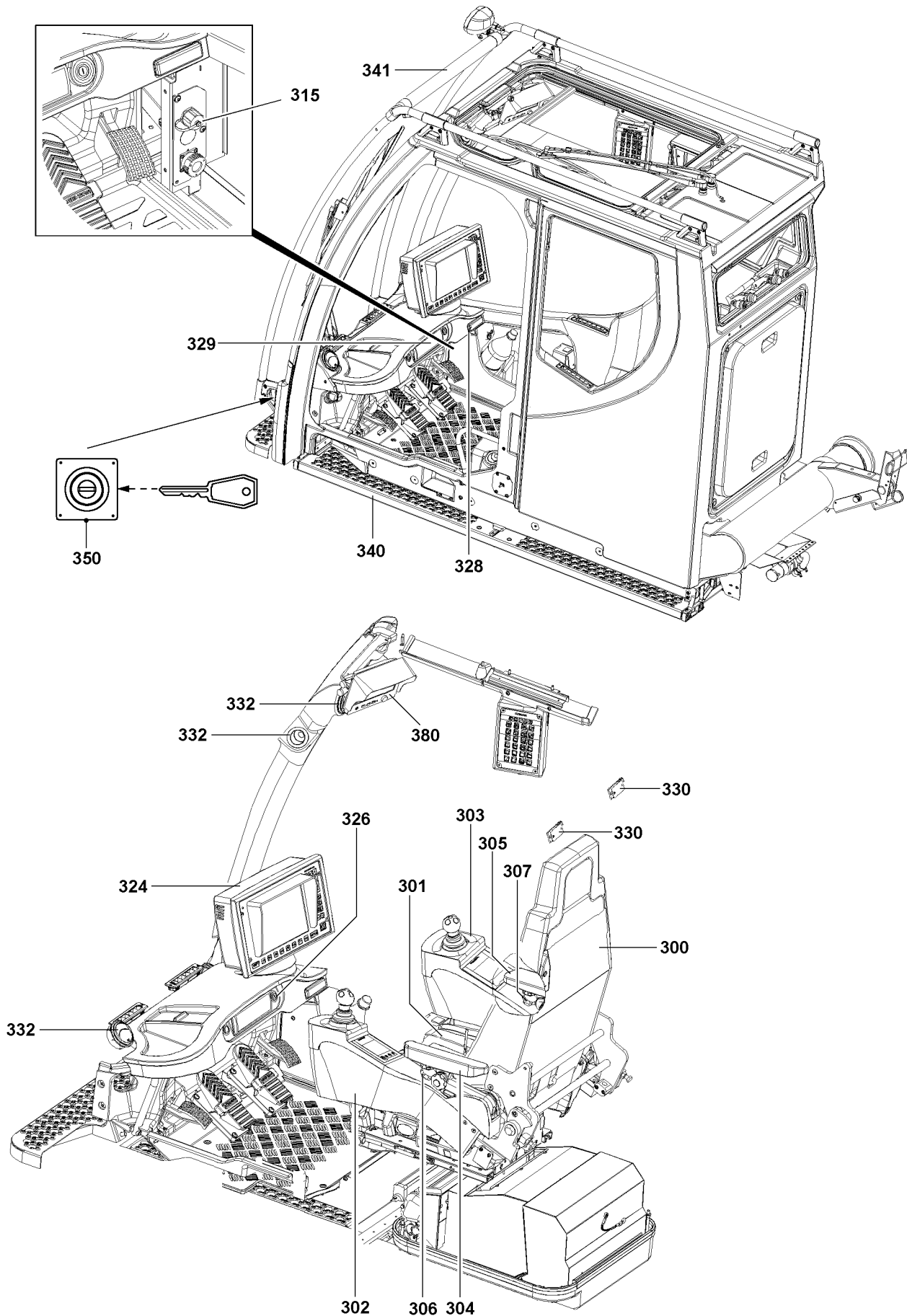


Fig.123704

LWE/LTR 1220-003/24204-02-02/en

# 1 Operating and control instruments

## 1.1 Operating elements on the control platform

- 300** Crane operator's seat
- 301** Seat contact button
- 302** Left console
  - Master switch 2 (MS2)
  - Touch display
- 303** Right console
  - Master switch 1 (MS1)
  - Touch display
- 304** Left armrest
- 305** Right armrest
- 306** Left notch lever
- 307** Right notch lever

### 1.1.1 Operating elements for seat adjustment



---

**Note**

- ▶ For a detailed description of the seat adjustment controls, see Crane operating instructions, chapter 4.03.
-

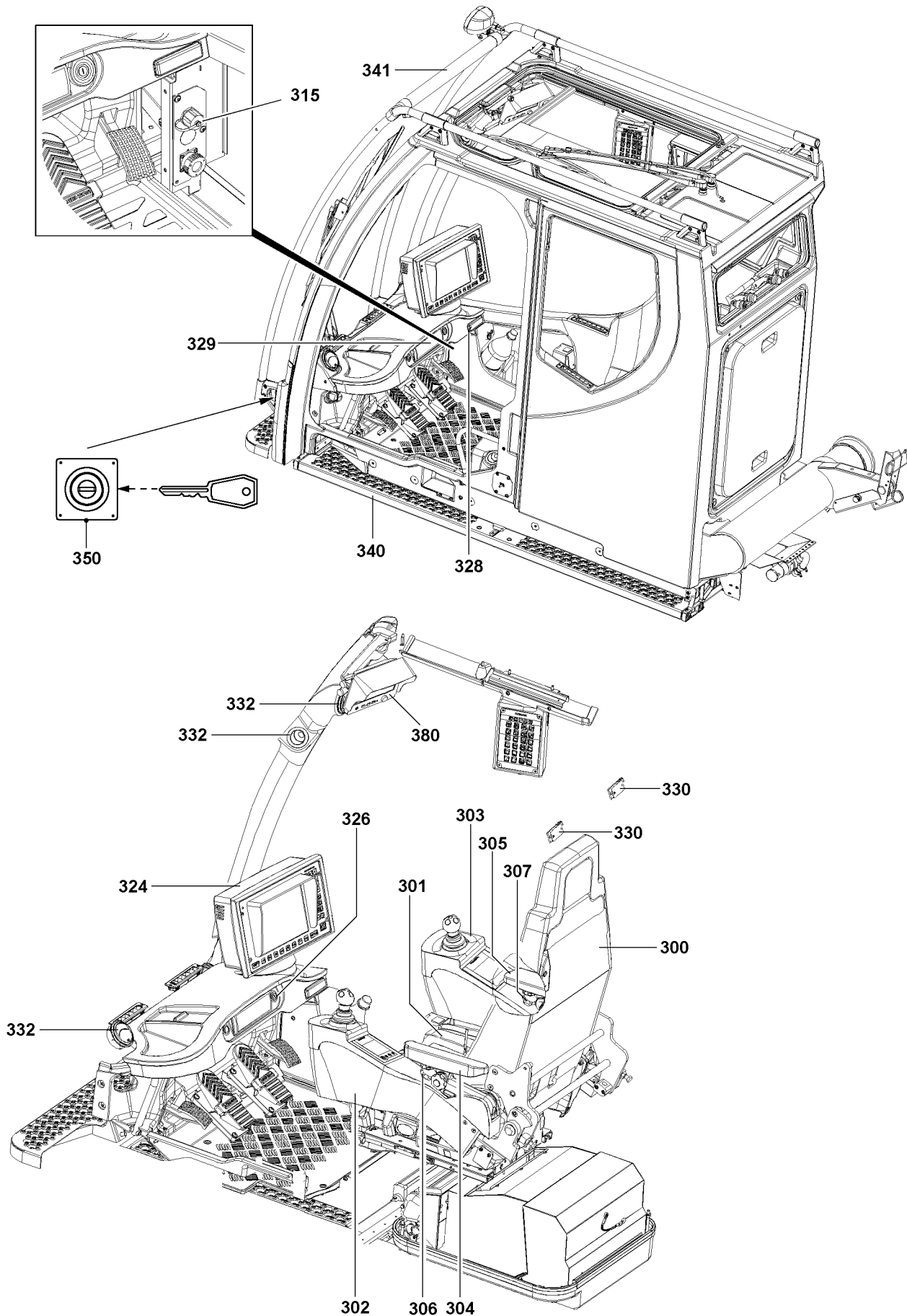


Fig.123704

LWE/LTR 1220-003/24204-02-02/en



## 1.2 Operating elements, General

- 324 LICCON monitor
  - Display of crane data required for **Crane operation**, see Crane operating instructions, chapter 4.02
- 380 TFT monitor
  - Camera monitoring
- 326 Ignition switch
  - Position:**
    - 0 = Ignition key can be pulled out
    - 1 = Ignition on
    - 2 = Start the engine
- 315 Ethernet interface
- 327 Cigarette lighter
- 328 Drink holder
- 329 Radio
- 330 LED interior lights
  - Located above the crane operator's seat
  - Dimmable
- 332 Outlet nozzles
  - For heater / ventilation / Climate control system\*
- 333 Reservoir
  - Window washer fluid
- 340 Step
  - **Note:**  
Refer to section „Operating elements on the operating and control unit (BKE)“.
- 341 Warning light rod
  - LICCON utilization display:
    - Green:  
„**Safe range**“
    - Yellow:  
Above a utilization of 90 %, the „**Safe range**“ is exceeded.
    - Red:  
Above a utilization of 100 %, the „**DANGER ZONE**“ is reached!  
**Note:**  
Once 100 % utilization is reached, the red warning light lights up and an „**LMB-Stop**“ occurs.
- 350 EMERGENCY STOP switch
  - Crane operator's cab (external)

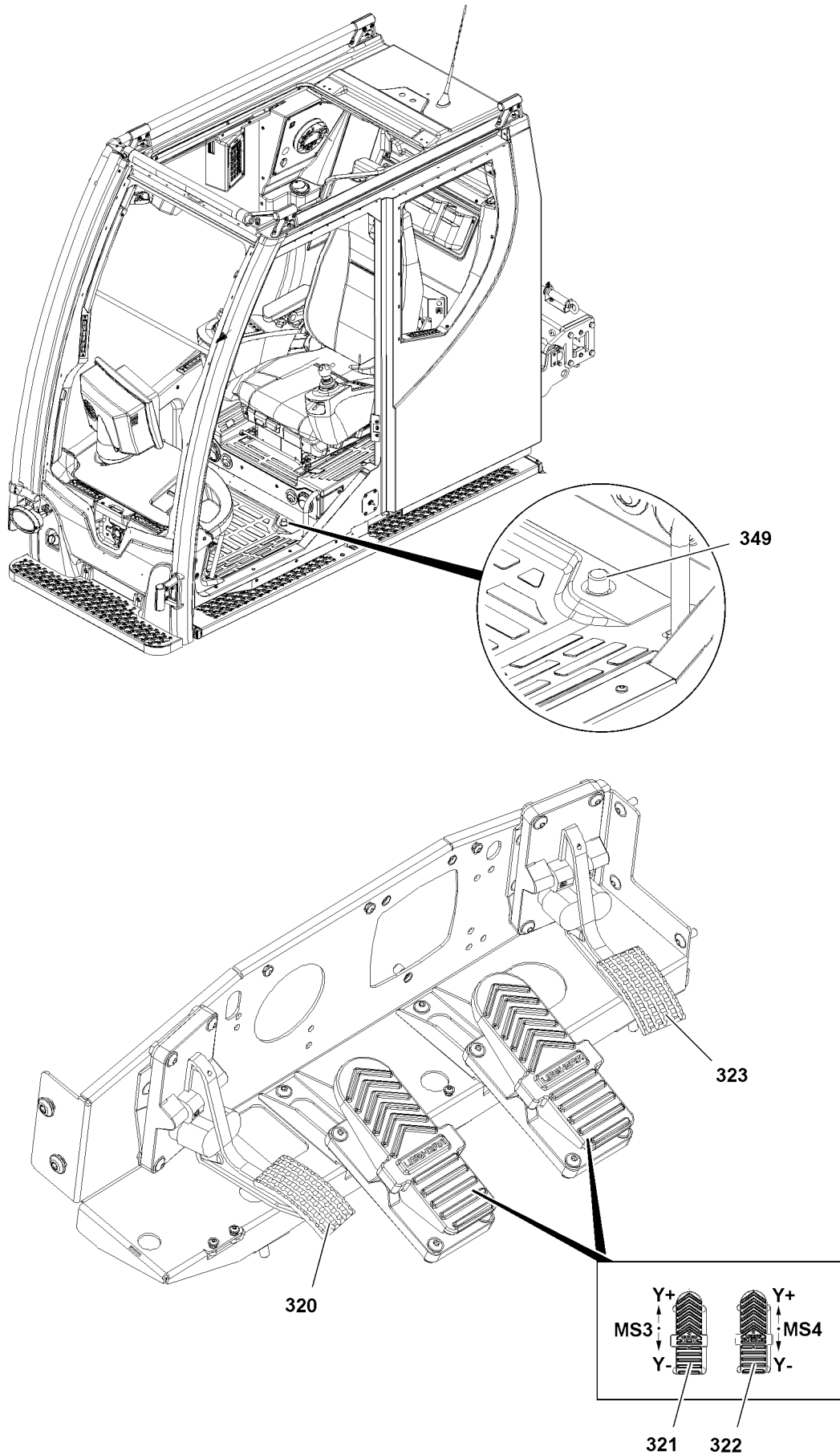


Fig.117626

LWE/LTR 1220-003/24204-02-02/en

## 1.3 Pedal operating elements

### 320 Pedal

- Slewing gear brake

### 321 Left foot rocker (MS 3)

#### **Drive the left crawler:**

Move the foot rocker **321** in direction Y+ (forward): The left crawler drives forward.

Move the foot rocker **321** in direction Y- (backward): The left crawler drives backward.

#### **Telescoping\*:**

Move the foot rocker **321** in direction Y+ (forward): The telescopic boom is telescoped out.

Move the foot rocker **321** in direction Y- (backward): The telescopic boom is telescoped in.

### 322 Right foot rocker (MS 4)

#### **Drive the right crawler:**

Move the foot rocker **322** in direction Y+ (forward): The right crawler drives forward.

Move the foot rocker **322** in direction Y- (backward): The right crawler drives backward.

### 323 Pedal

- Engine regulation

### 349 Foot button

- Slewing gear change over to freewheeling

## 1.4 LMB emergency operation operating elements

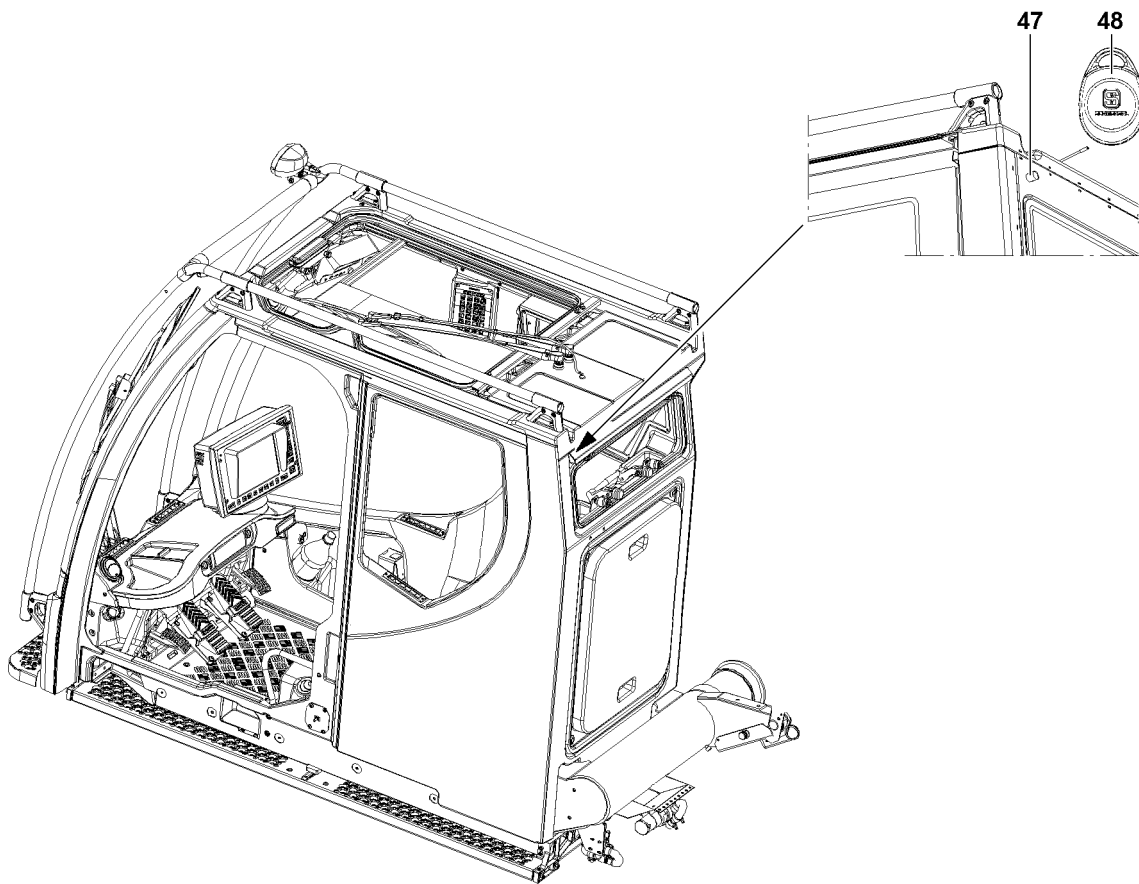


Fig.123716: LMB emergency operation operating elements



### WARNING

Increased danger of accident during emergency operation of the LICCON overload protection!  
In emergency operation, the crane movements are no longer monitored by the LICCON overload protection!

- ▶ If emergency operation of the LICCON overload protection is required, observe Crane operating instructions, chapter 7.15!
- ▶ The emergency operation may only be activated by persons who are aware of the consequences of their actions!
- ▶ A shut-off by the LICCON overload protection may not be circumvented by the emergency operation!
- ▶ If normal „crane operation“ is possible, then the emergency operation may not be activated!
- ▶ All crane movements must be carried out with extreme caution and anticipatorily!

### 1.4.1 LMB emergency operation for crane control „EN 13000:2010 active“

Applies only apply for cranes with crane control „EN 13000:2010 active“.

The emergency operation for the LICCON overload protection is activated by the sensor **47** via the transponder **48**.

**47** Sensor

**48** Transponder

Empty page!

LWE/LTR 1220-003/24204-02-02/en

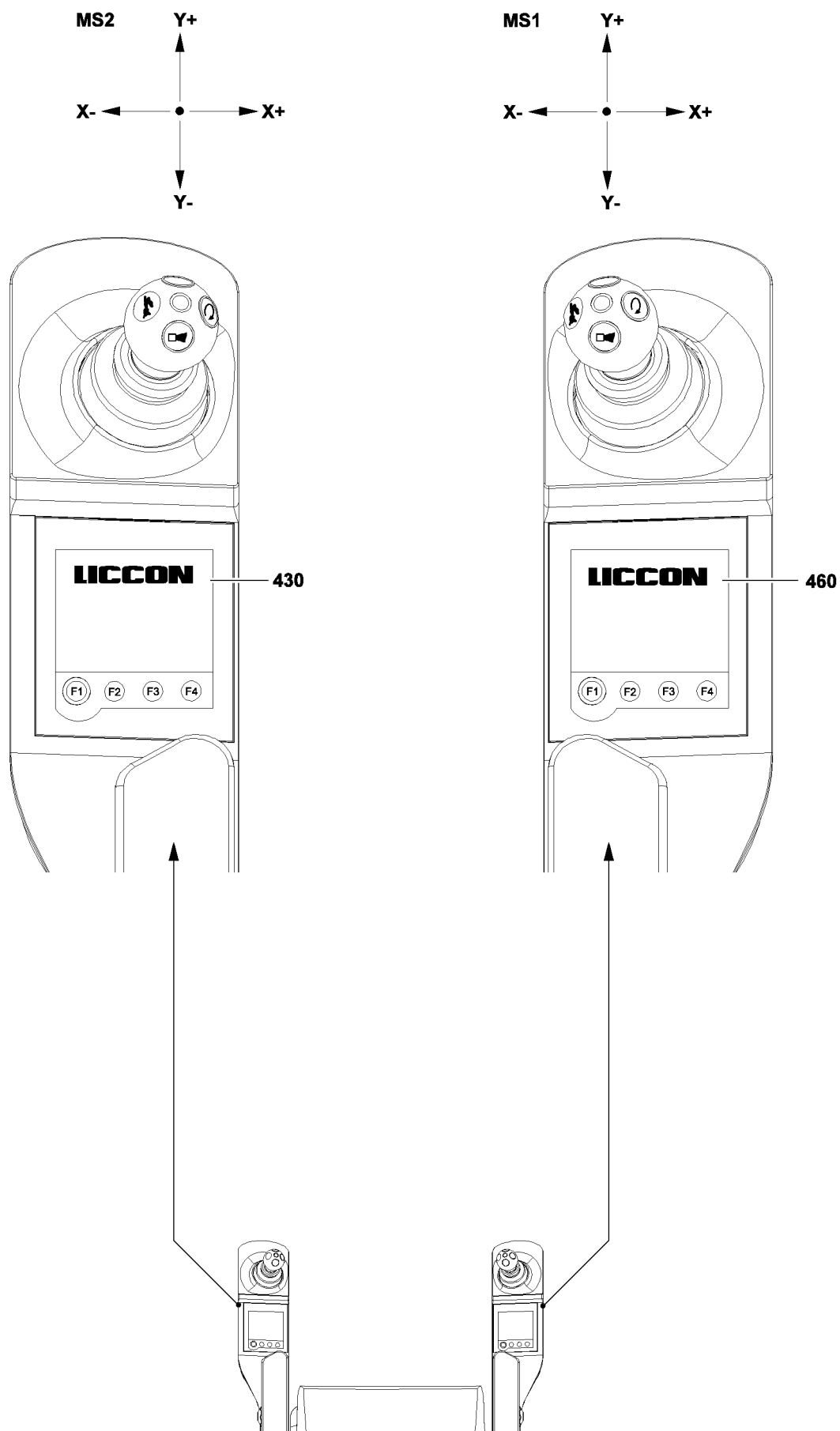


Fig.105575

LWE/LTR 1220-003/24204-02-02/en

## 2 Operating elements on the control panels

### 2.1 The touch displays

The touch displays are combined display and operating elements. The touch displays are operated using the function key line „F1“ to „F4“ and by direct „touch“ (fingertip) on the corresponding display icons.



#### Note

- ▶ The illustrations or icons on the touch displays are only examples.
- ▶ They may differ from the crane!
- ▶ If the function key **F1** is continuously pressed, the system shifts continuously between the existing menu points.

The left touch display **430** and the right touch display **460** can be used to call up various menus. Various crane functions can be selected or preselected, turned on or off, or directly activated in these menus.



#### Note

- ▶ In low temperatures it is possible that the touch displays initially change to the menu items delayed and that the touch functions remain deactivated for that time.
- ▶ Wait a few minutes after ignition „ON“ until the menu items are shown on the touch display.

#### F Function keys

- The function of individual function keys depends on the menu and can vary, depending on the menu selected. Therefore the individual menus will now be described in more detail. The icons on the touch display above the function key line with a single border indicate the functions that will be triggered by activating the function keys below them.

#### 460 Right touch display

- „Master switch configuration“ menu
- „Support“ menu
- „Track width adjustment“ menu

#### 430 Left touch display

- „Master switch configuration“ menu
- „Floodlight“ menu
- Menu „Climate control settings“
- „Hydraulic oil preheating / telescopic boom disassembly“ menu

#### 2.1.1 Starting up the LICCON Computer system and the touch displays

After turn on and correct boot up of the LICCON computer system, a static crane screen appears briefly on the left touch display **430** and the right touch display **460**. From here the system automatically switches to the master switch assignment for the relevant master switch, MS1 (right) or MS2 (left).

The touch display always displays the master switch assignment that was set or „active“ before the LICCON computer system was shut off.

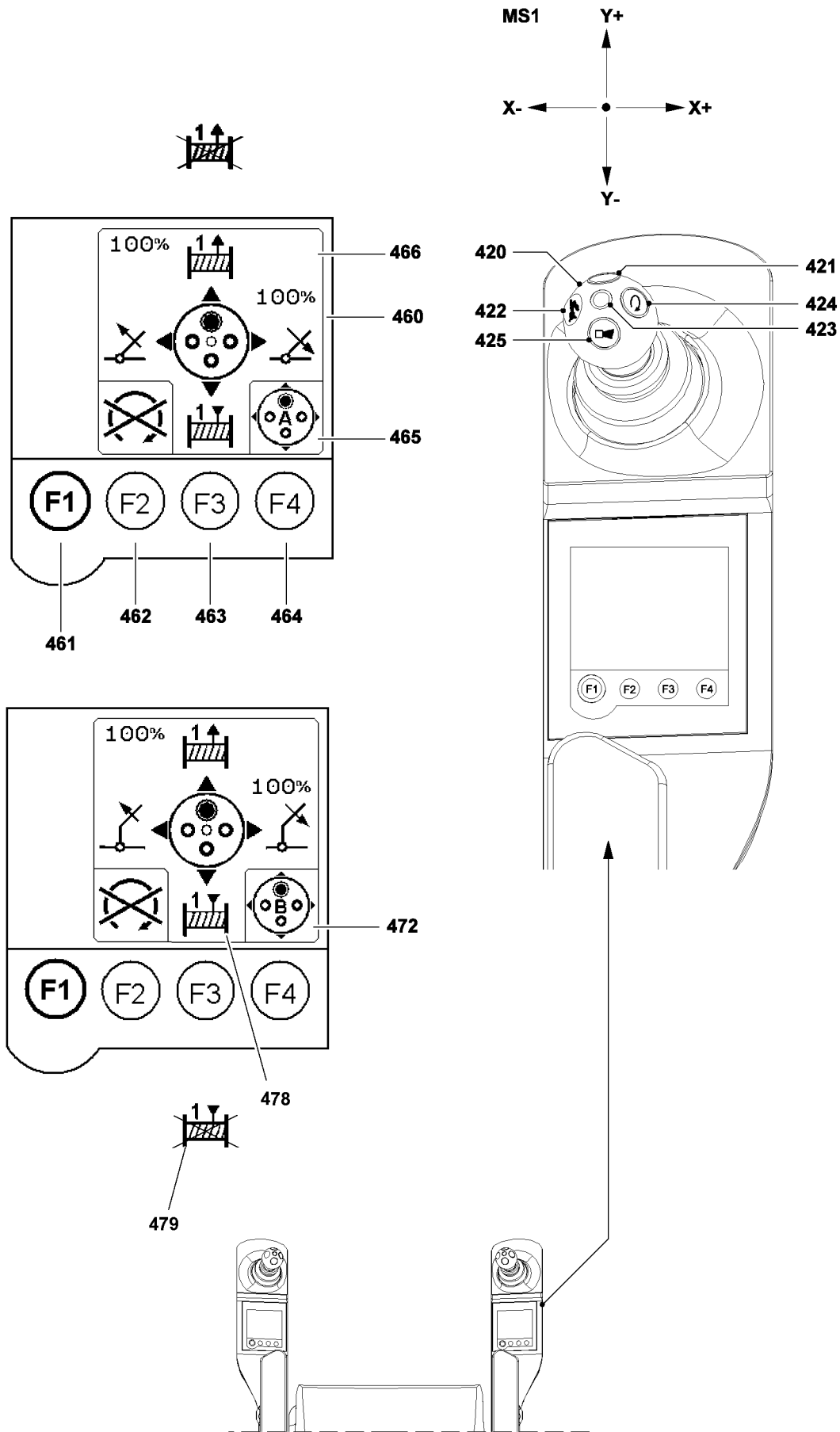


Fig.123705



## 2.2 Master switch assignment for machines with one winch

### 2.2.1 The „Master switch configuration“ menu (right touch display)

#### The function key line

**461** Function key F1

- Switch to the next menu

**462** Function key F2

- Engine STOP

**463** Function key F3

- Winch changeover - Winch 1  
Activate / deactivate the winch

**Conditions:**

Neutral position master switch 1 **420** (MS1) right

**Danger of accident!**

**Never** activate / deactivate winch 1 while a crane movement is being actuated.

The winch status (winch activated / deactivated) can be seen on the touch display:

- **478** Winch 1 released
- **479** Winch 1 blocked

**464** Function key F4

- Change master switch assignment from „A“ to „B“

**Conditions:**

Neutral position master switch 1 **420** (MS1) right

An operating mode or set up configuration with auxiliary boom must be set and confirmed on the LICCON computer system.

**Note**

If no set up configuration with auxiliary boom has been set and confirmed, the „luffing auxiliary boom“ master switch assignment is **not** available.

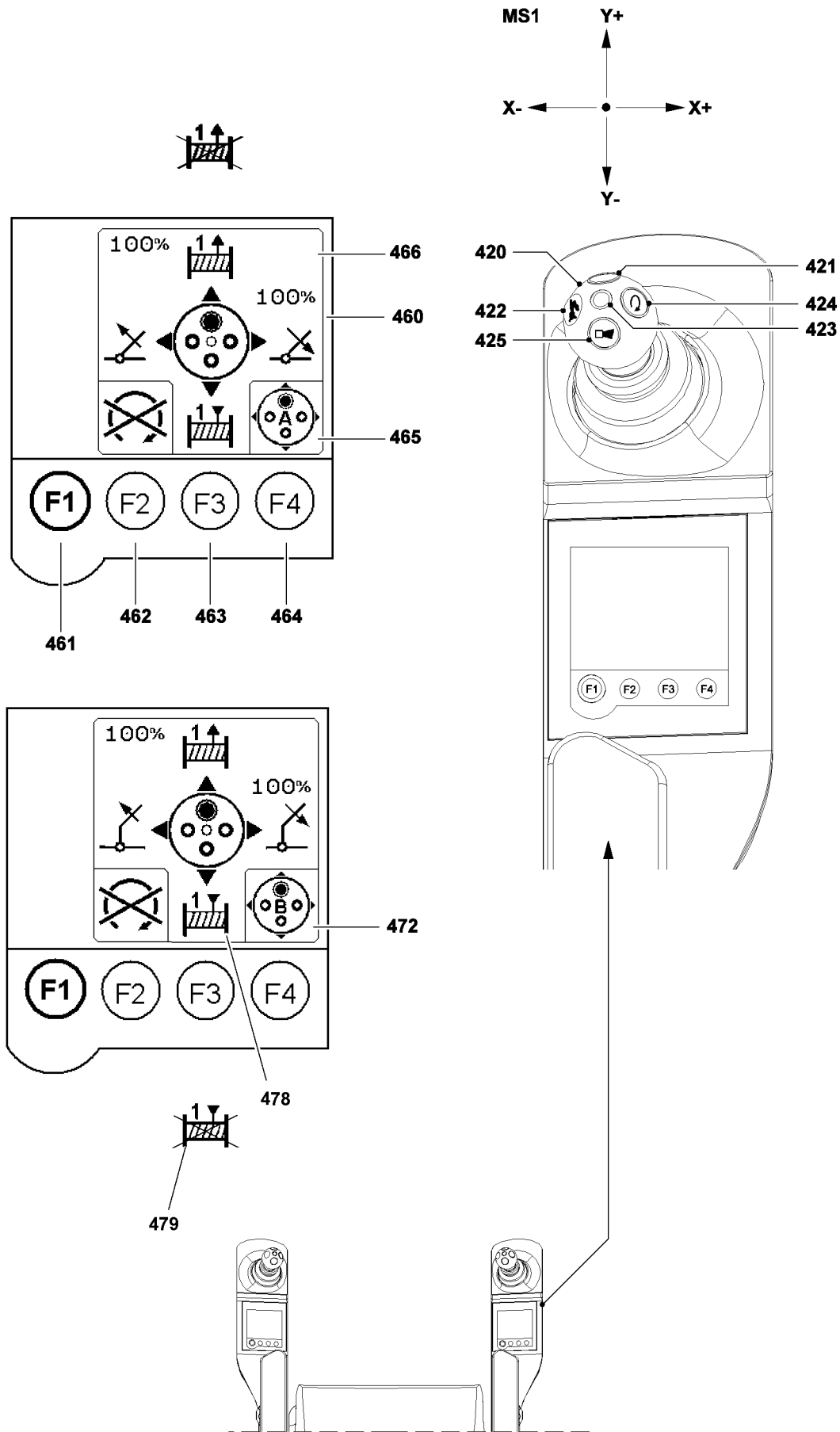


Fig.123705

**Right master switch assignment****420** Right master switch (MS 1)**Hoist gear 1:**

- Move the master switch **420** in direction Y+ (forward): Winch 1 spools out and the load is lowered
- Move the master switch **420** in direction Y- (backward): Winch 1 spools up and the load is raised

**Telescopic boom luffing gear:** Master switch assignment „A“ **465** is active:

- Move the master switch **420** in direction X+ (toward the right): Luff the telescopic boom down
- Move the master switch **420** in direction X- (toward the left): Luff the telescopic boom up

**Luffing the auxiliary boom\*:** Master switch assignment „B“ **472** is active:

- Move the master switch **420** in direction X+ (toward the right): Luff the auxiliary boom down
- Move the master switch **420** in direction X- (toward the left): Luff the auxiliary boom up

**421** Button

- Bypass of the seat contact button. **Or** if the seat contact button is actuated: Activation of the vibration sensor **423**

**422** Button

- Activation of rapid gear for the hoist gear(s) and luffing up

**423** Vibration sensor

- Winch turn sensor, (vibrator) winch 1

**424** Button

- Lock the engine regulation of superstructure engine

**Note:**

Pressing the button **424** will lock the engine regulation in the current position.

**425** Button

- Horn

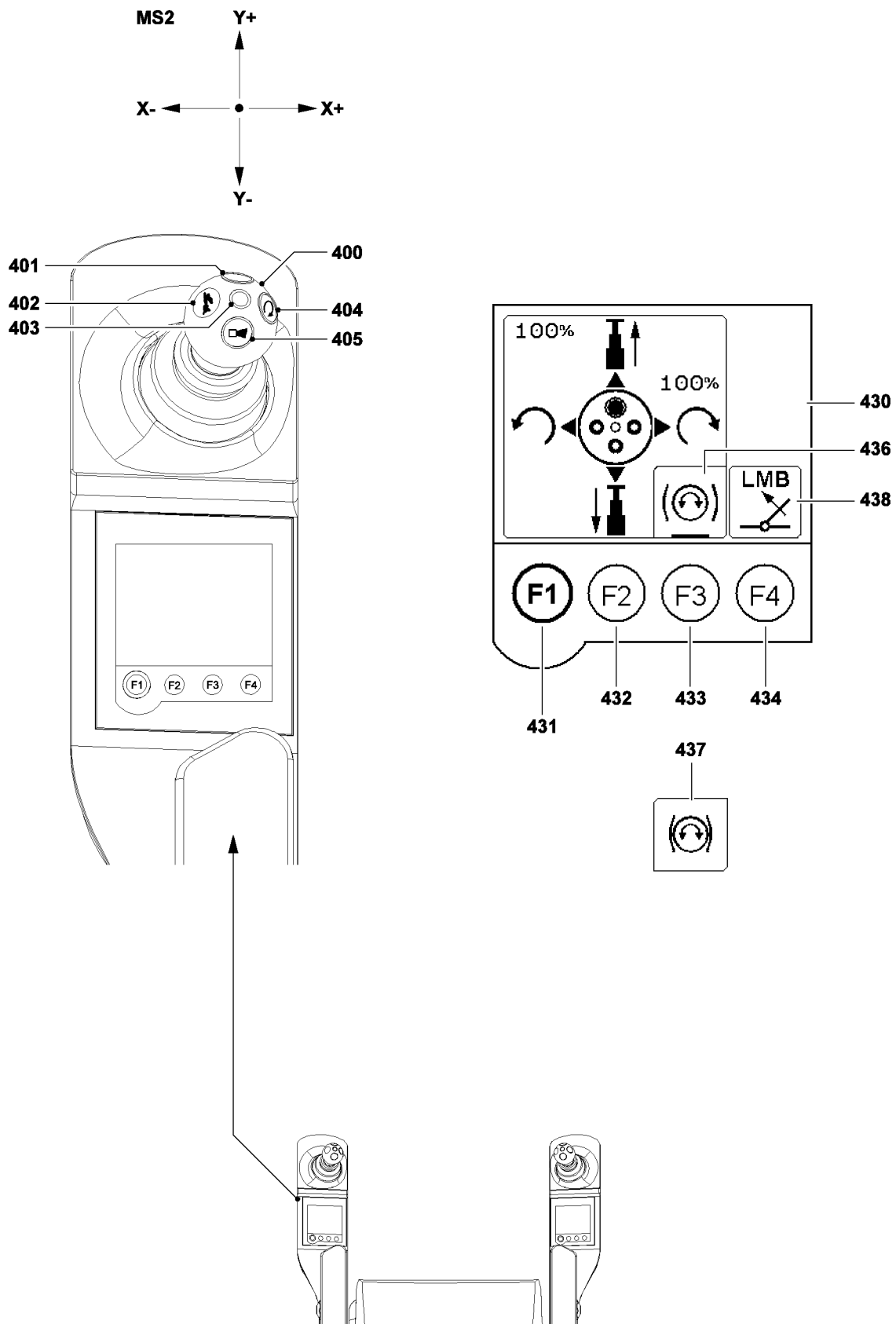


Fig.152504

## 2.2.2 The „Master switch configuration“ menu (left touch display)

### The function key line

- 431** Function key F1
  - Switch to the next menu
- 432** Function key F2
  - **No** function
- 433** Function key F3
  - Apply / release slewing gear brake
    - **436** Slewing gear brake released
    - **437** Slewing gear brake applied
- 434** Function key F4 (touching)
  - Exceeding the overload protection (icon **438**), is used to luff in with suspended load  
**Danger:**  
**The exceedance may only be carried out if the overload was caused by luffing down at freely suspended load and the crane operator is absolutely certain that luffing up the load will take it out of the overload range.**

### Left master switch assignment:

- 400** Left master switch (MS 2)
  - Telescoping gear**
    - Move the master switch **400** in direction Y+ (forward): Telescope out.
    - Move the master switch **400** in direction Y- (backward): Telescope in.
  - Slewing gear:**
    - Move the master switch **400** in direction X+ (toward the right): The crane superstructure turns to the right.
    - Move the master switch **400** in direction X- (toward the left): The crane superstructure turns to the left.
- 401** Button
  - Bypass of the seat contact button. **Or** if the seat contact button is actuated: Activation of the vibration sensor **403**
- 402** Button
  - Switching of the rapid gear for winch(es) and luffing up
- 403** Vibration sensor
  - Winch turn sensor, (vibrator) winch 1 or winch 2 **or** turn sensor, (vibrator) slewing gear
- 404** Button
  - Lock the engine regulation of superstructure engine  
**Note:**  
 Pressing the button **404** will lock the engine regulation in the current position.
    - The idling speed can be increased up to the maximum rpm.
      - Can be „overridden“ with the engine regulation (gas pedal)
      - At continued actuation of the engine regulation (gas pedal), the current rpm is taken over
      - By pressing the button **404** with the engine regulation (gas pedal) **not actuated**, the manual throttle is cancelled
      - At locked engine rpm, a „+“ appears in the „dynamic utilization bar display“ (crane operation)
- 405** Button
  - Horn

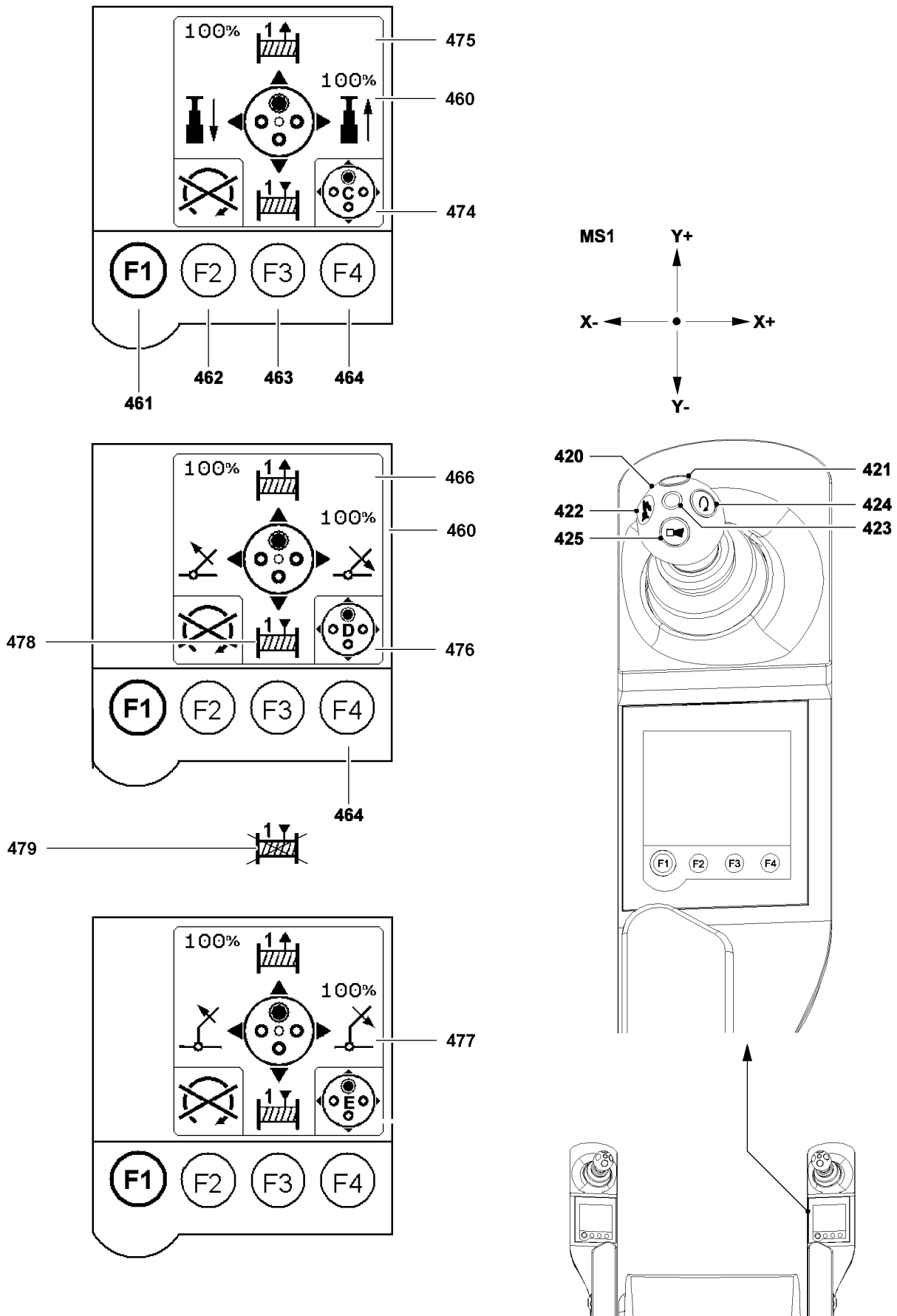


Fig.123707

LWE/LTR 1220-003/24204-02-02/en

## 2.3 Master switch assignment for machines with two winches



### Note

Change of master switch assignment!

The assignment of the master switches to the respective units on the crane can change, depending on the set up configuration and winch application!

► **Check the assignment before actuating the master switch on the TE!**



### Note

► For the master switch assignment „A“ and „B“ refer to section „Master switch assignment for machines with one winch“.

### 2.3.1 The „Master switch configuration“ menu (right touch display)

#### The function key line

#### 461 Function key F1

- Switch to the next menu

#### 462 Function key F2

- Engine STOP

#### Note:

After „Engine STOP“, the engine can be restarted by turning the ignition switch to „position 2“, also see Crane operating instructions, chapter 4.02.

#### 463 Function key F3

- Winch changeover - Winch 1  
Activate / deactivate the winch

#### Conditions:

Neutral position master switch 1 **420** (MS1) right

Crane driving speed = 0 km/h

#### Danger of accident!

**Never** activate / deactivate winch 1 while a crane movement is being actuated.

#### Note:

The winch status (winch activated / deactivated) can be seen on the touch display:

- **478** Winch 1 released
- **479** Winch 1 blocked

#### 464 Function key F4

- Change master switch assignment from „C“ to „D“ or „E“.

#### Conditions:

Neutral position master switch 1 **420** (MS1) right

For master switch assignment **E**, an operating mode or set up configuration with auxiliary boom must be selected and confirmed on the LICCON computer system.

#### Note

If no set up configuration with auxiliary boom has been set and confirmed, the „luffing auxiliary boom“ master switch assignment is **not** available.

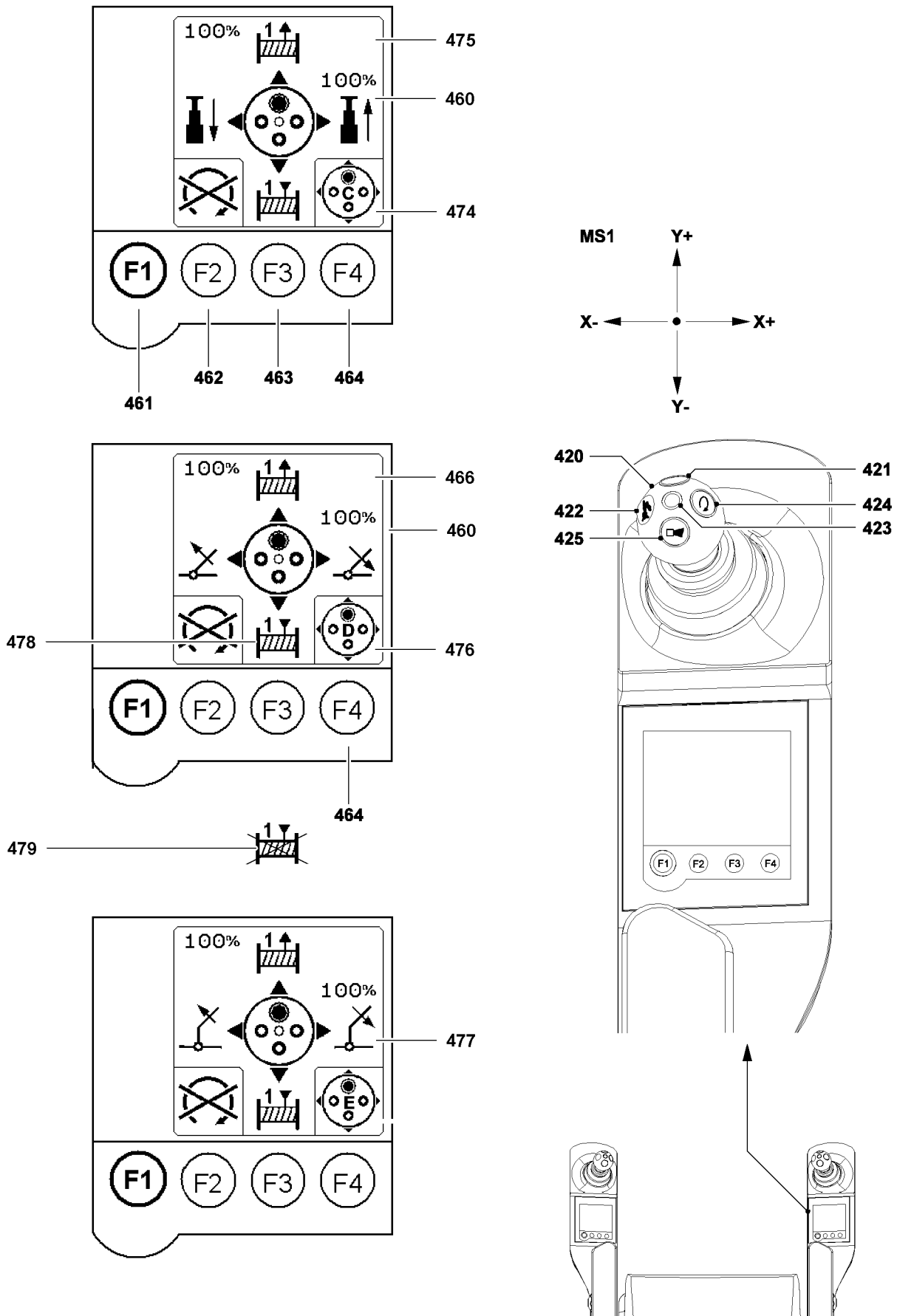


Fig.123707

LWE/LTR 1220-003/24204-02-02/en



## Touch functions in the Travel operation and master switch configuration menu



### Note

- ▶ To switch between the master switch configurations for one and two winch systems, press function key „F4“ **464** for longer than 3 s (continuous actuation) in the „Travel operation and master switch configuration“ menu on the right touch display.
- ▶ When the changeover has taken place, a short acoustic signal is heard.

### Right master switch assignment

#### 420 Right master switch (MS 1)

##### Hoist gear 1:

- Move the master switch **420** in direction Y+ (forward): Winch 1 spools out and the load is lowered
- Move the master switch **420** in direction Y- (backward): Winch 1 spools up and the load is raised

##### Telescoping gear: Master switch assignment „C“ **474** is active:

- Move the master switch **420** in direction X+ (toward the right): Telescope the telescopic boom out
- Move the master switch **420** in direction X- (toward the left): Telescoping the telescopic boom in

##### Telescopic boom luffing gear: Master switch assignment „D“ **476** is active:

- Move the master switch **420** in direction X+ (toward the right): Luff the telescopic boom down
- Move the master switch **420** in direction X- (toward the left): Luff the telescopic boom up

##### Luffing the auxiliary boom\*: Master switch assignment „E“ **477** is active:

- Move the master switch **420** in direction X+ (toward the right): Luff the auxiliary boom down
- Move the master switch **420** in direction X- (toward the left): Luff the auxiliary boom up

#### 421 Button

- Bypass of the seat contact button. **Or** if the seat contact button is actuated: Activation of the vibration sensor **423**

#### 422 Button

- Activation of rapid gear for the hoist gear(s) and luffing up

#### 423 Vibration sensor

- Winch turn sensor, (vibrator) winch 1

#### 424 Button

- Lock the engine regulation of superstructure engine

##### Note:

Pressing the button **424** will lock the engine regulation in the current position.

#### 425 Button

- Horn

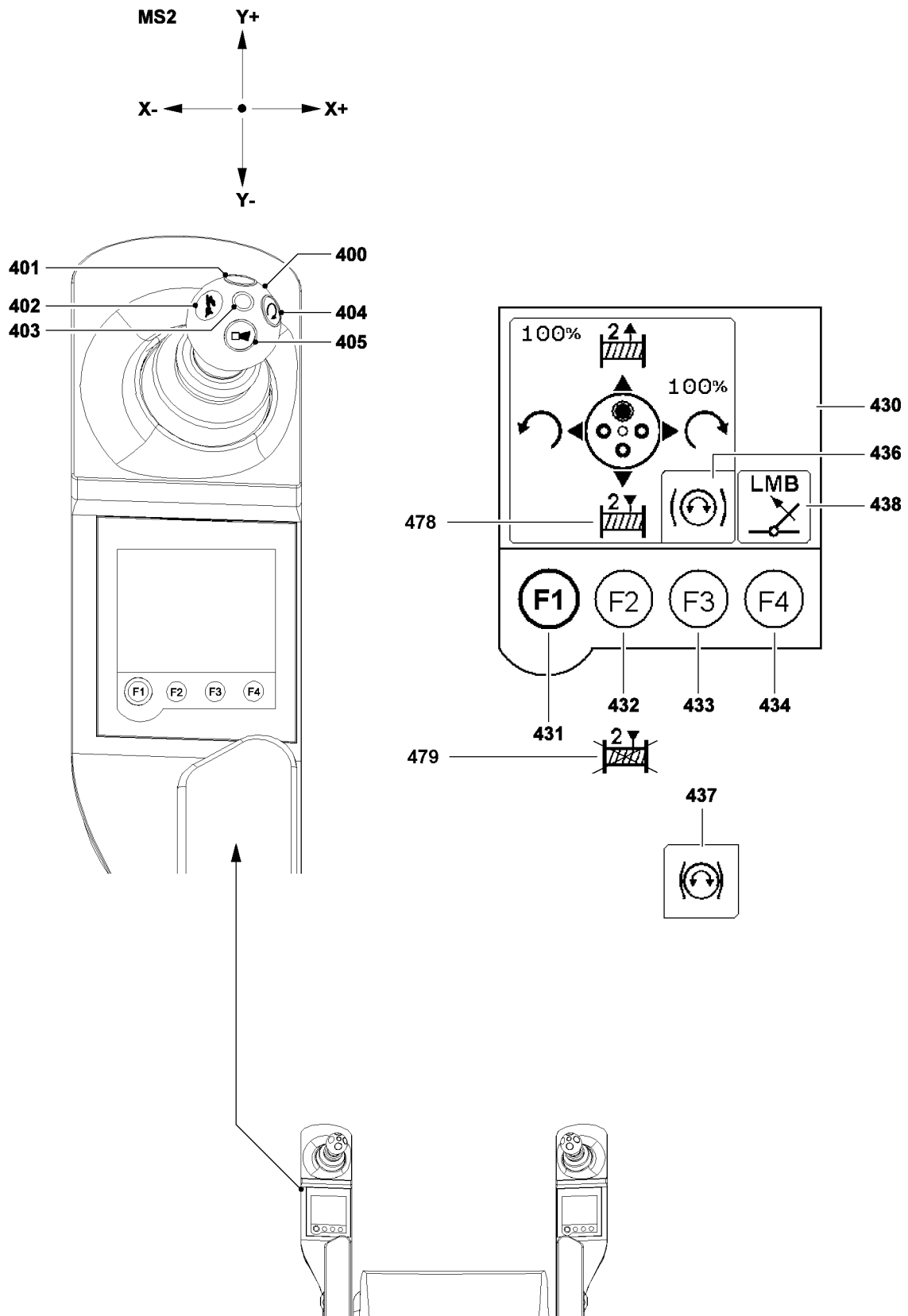


Fig. 152505

## 2.3.2 The „Master switch configuration“ menu (left touch display)

### The function key line

- 431** Function key F1
- Switch to the *Climate control* menu
- 432** Function key F2
- Winch changeover - Winch 2  
Activate / deactivate the winch
- Conditions:**  
Neutral position master switch 2 **400** (MS2) right  
Crane driving speed = 0 km/h
- Danger of accident!**  
**Never** activate / deactivate winch 2 while a crane movement is being actuated.
- Note:**  
The winch status (winch activated / deactivated) can be seen on the touch display:
- **478** Winch 2 released
  - **479** Winch 2 blocked
- 433** Function key F3
- Open / close slewing gear brake (with freely rotating slewing gear)
  - **436** Slewing gear brake released
  - **437** Slewing gear brake applied
- 434** Function key F4 (touching)
- Exceeding the overload protection (icon **438**), is used to luff in with suspended load
- Danger:**  
**The exceedance may only be carried out if the overload was caused by luffing down at freely suspended load and the crane operator is absolutely certain that luffing up the load will take it out of the overload range.**

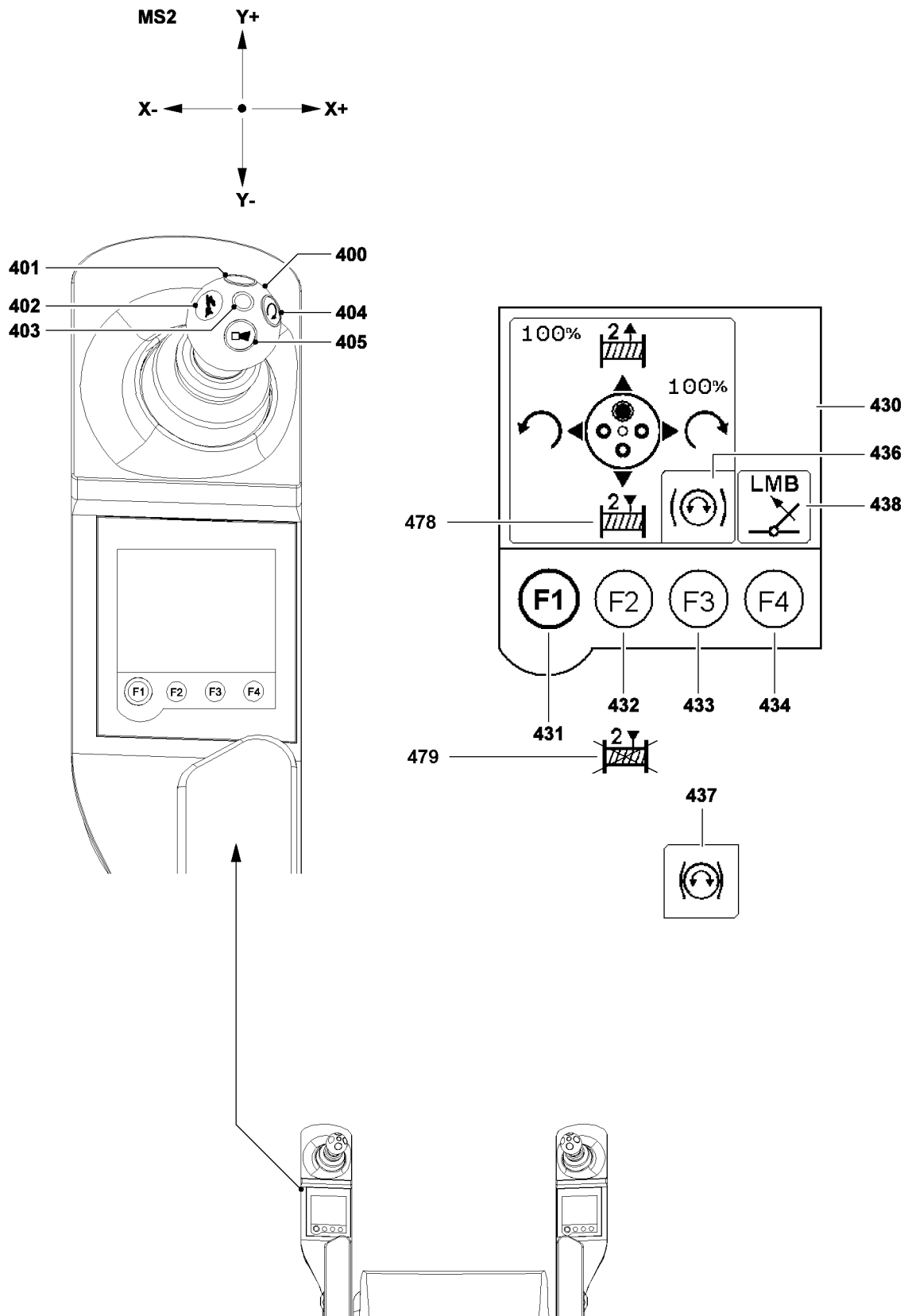


Fig.152505

**Left master switch assignment:****400** Left master switch (MS 2)**Hoist gear 2:**

- Move the master switch **400** in direction Y+ (forward): Winch 2 spools out and the load is lowered
- Move the master switch **400** in direction Y- (backward): Winch 2 spools up and the load is raised

**Slewing gear:**

- Move the master switch **400** in direction X+ (toward the right): Slewing gear turns to the right
- Move the master switch **400** in direction X- (toward the left): Slewing gear turns to the left

**401** Button

- Bypass of the seat contact button. **Or** if the seat contact button is actuated: Activation of the vibration sensor **403**

**402** Button

- Switching of the rapid gear for winch(es) and luffing up

**403** Vibration sensor

- Winch turn sensor, (vibrator) winch 1 or winch 2 **or** turn sensor, (vibrator) slewing gear

**404** Button

- Lock the engine regulation of superstructure engine

**Note:**

Pressing the button **404** will lock the engine regulation in the current position.  
The idling speed can be increased up to the maximum rpm.

- Can be „overridden“ with the engine regulation (gas pedal)
- At continued actuation of the engine regulation (gas pedal), the current rpm is taken over
- By pressing the button **404** with the engine regulation (gas pedal) **not actuated**, the manual throttle is cancelled
- If the engine rpm is locked, the „dynamic engine rpm display“ (travel operation) and the „dynamic load utilization bar display“ (crane operation) contain a „+“

**405** Button

- Horn

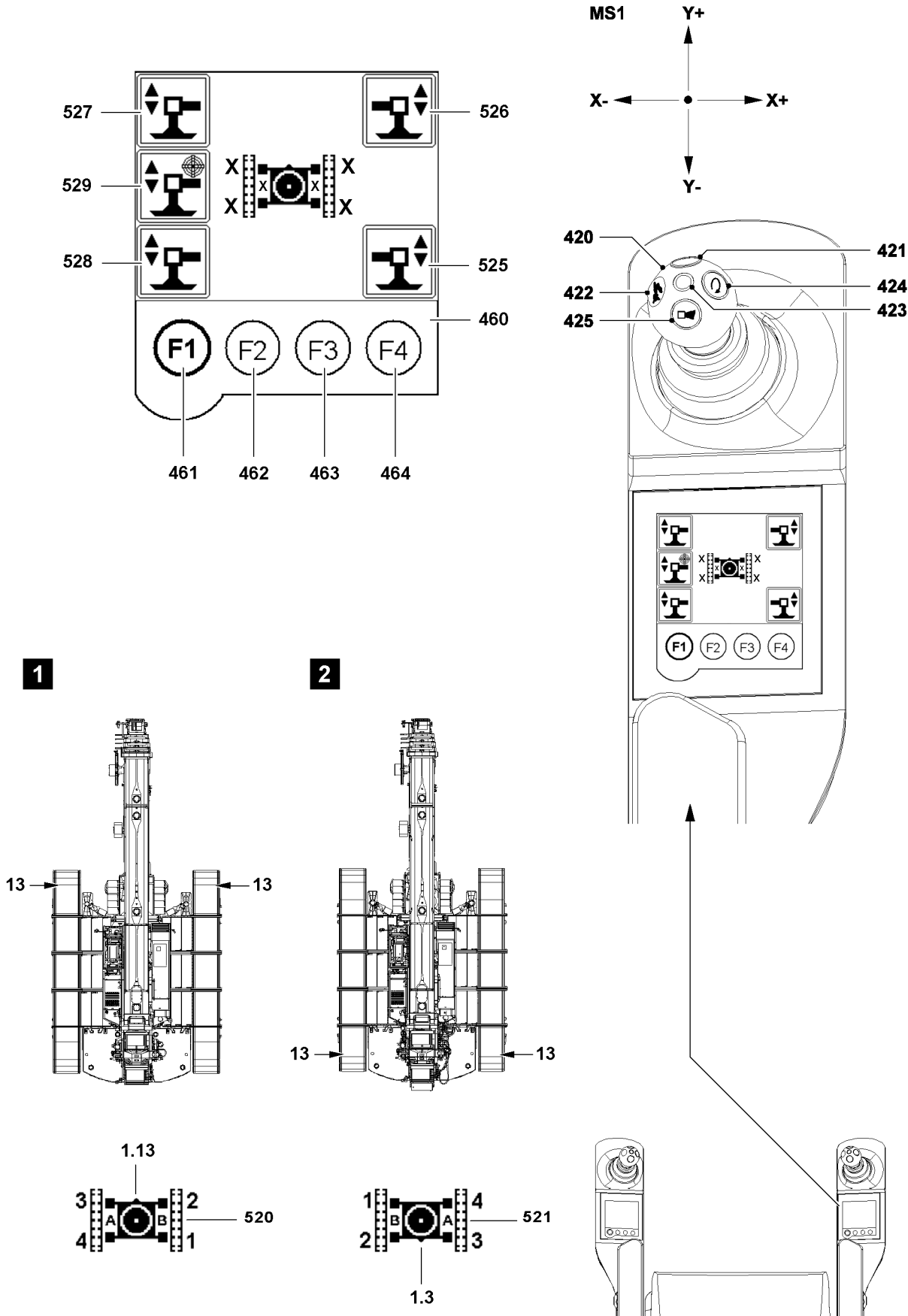


Fig.152438

LWE/LTR 1220-003/24204-02-02/en

## 2.4 The menus (operating functions)

### 2.4.1 The „Support“ menu (right touch display)



#### Note

Assignment of working direction, support cylinder and crawler carrier!

Illustration 1 and illustration 2 show the assignment.

- ▶ The rear and front on the crawler travel gear can be determined by the chain tension device **13** (chain tension side). The chain tension device **13** is on the front on the crawler travel gear.
- ▶ In the „Support“ menu the assignment of the support cylinders and the crawler carriers on the touch display depends on the working direction of the crane. If the working direction of the crane is changed by turning the turntable from working direction „forward“ to working direction „backward“, then the crane icon **520** changes to crane icon **521** - or vice versa.
- ▶ Crane icon **520**, turntable turned „to the front“: The triangle **1.3** shows the front of the crane chassis; assignment of the support cylinders and the crawler carriers as seen by the crane operator in the crane operator's cab.
- ▶ Crane icon **521**, turntable turned „to the rear“: The triangle **1.3** shows the front of the crane chassis; assignment of the support cylinders and the crawler carriers as seen by the crane operator in the crane operator's cab.

#### The function key line

- 461** Function key F1
  - Switch to the next menu
- 462** Function key F2
  - **No** function
- 463** Function key F3
  - **No** function
- 464** Function key F4
  - **No** function

#### Touch functions in the Support menu

- 525** Support cylinder
  - Select support
- 526** Support cylinder
  - Select support
- 527** Support cylinder
  - Select support
- 528** Support cylinder
  - Select support
- 529** Automatic support
  - Select automatic mode

#### Right master switch assignment

- 420** Right master switch (MS 1)

#### Manual support:

- Move the master switch **420** in direction Y+ (forward): The selected support cylinders extend.
- Move the master switch **420** in direction Y- (backward): The selected support cylinders retract.

#### Automatic support:

- Move the master switch **420** in direction Y+ (to the right): The support cylinders extend (the crane is raised) until the crane is aligned horizontally.
- Move the master switch **420** in direction Y- (to the left): The support cylinders retract (the crane is lowered) until the crane is aligned horizontally.

- 421** Button
  - Release of master switch **420**, to retract / extend the support cylinders

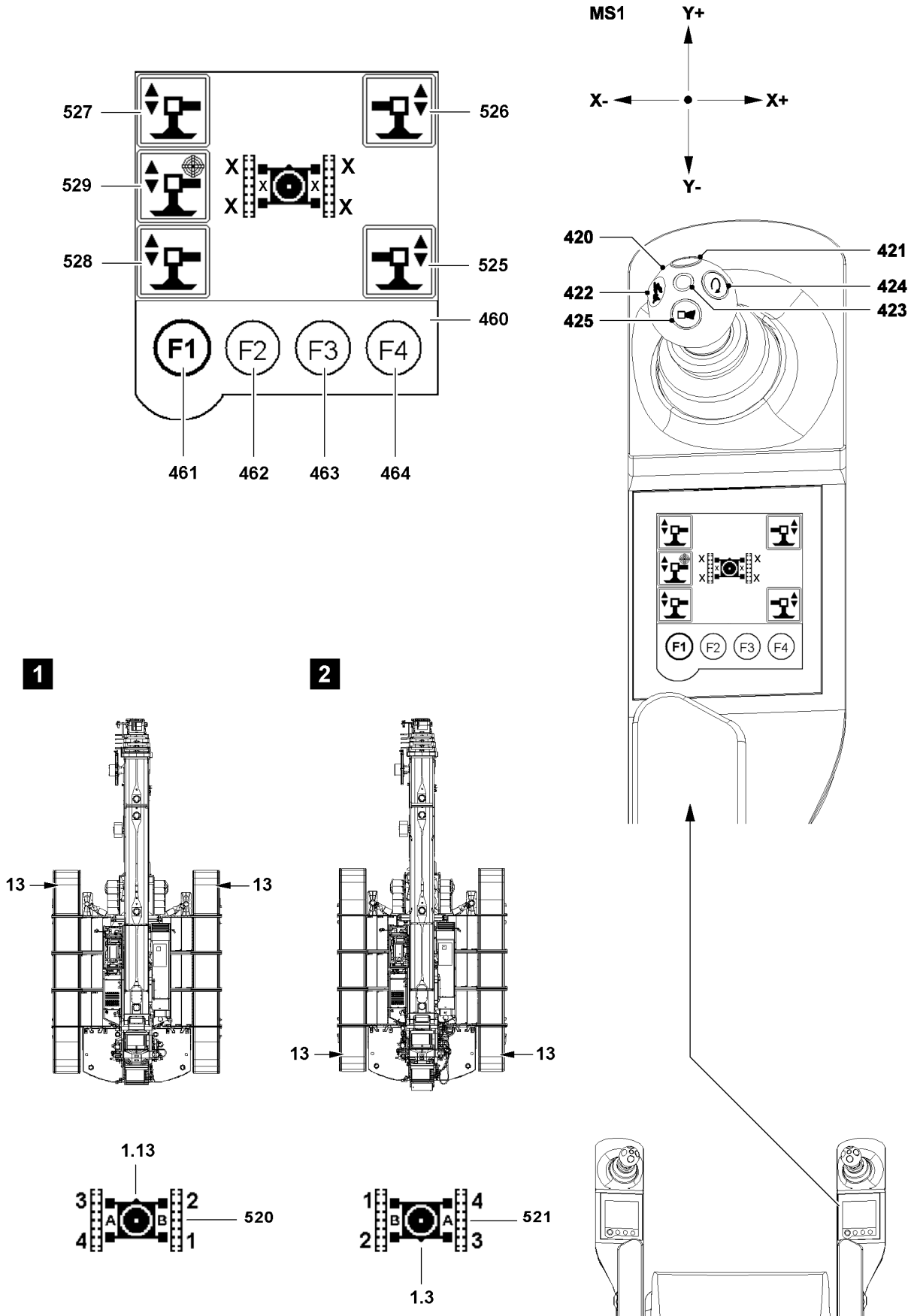


Fig.152438

LWE/LTR 1220-003/24204-02-02/en



### Support cylinder

In the „Support“ menu, the following functions depend on the deflection of the master switch:

- Extension / retraction speed of the support cylinders
- Manual support
- Automatic support

Two extension / retraction speeds of the support cylinders are available:

Master switch deflection < 80 % = slow

Master switch deflection ≥ 80 % = fast



#### Note

- ▶ Release support movement: Press the button **421** (bypass seat contact) and hold it.
  - ▶ Retract or extend the support cylinders: Deflect the master switch (MS1) **420** in direction Y+ or Y-.
- 



#### Note

If the master switch deflection is changed from Y+ or Y- to X+ or X- when the selected support cylinders are being retracted or extended, the current movement is shut off.

- ▶ Move the right master switch (MS1) **420** to the neutral position.
  - ▶ Now you can extend / retract the support cylinders to the required position with the master switch.
- 

### Supporting manually

0 -4 supports can be selected on the touch-display („touch“) simultaneously and „extended / retracted“ with the master switch (MS1). When a support cylinder is selected, the automatic support **529** selection is cancelled.



#### Note

- ▶ The extension / retraction of the support cylinders is „coupled“ with the Y+ and Y- deflection direction of the right master switch (MS1) **420**.
  - ▶ Moving the MS1 in direction Y+ extends the support cylinder / support cylinders.
  - ▶ Moving the MS1 in direction Y- retracts the support cylinder / support cylinders.
-

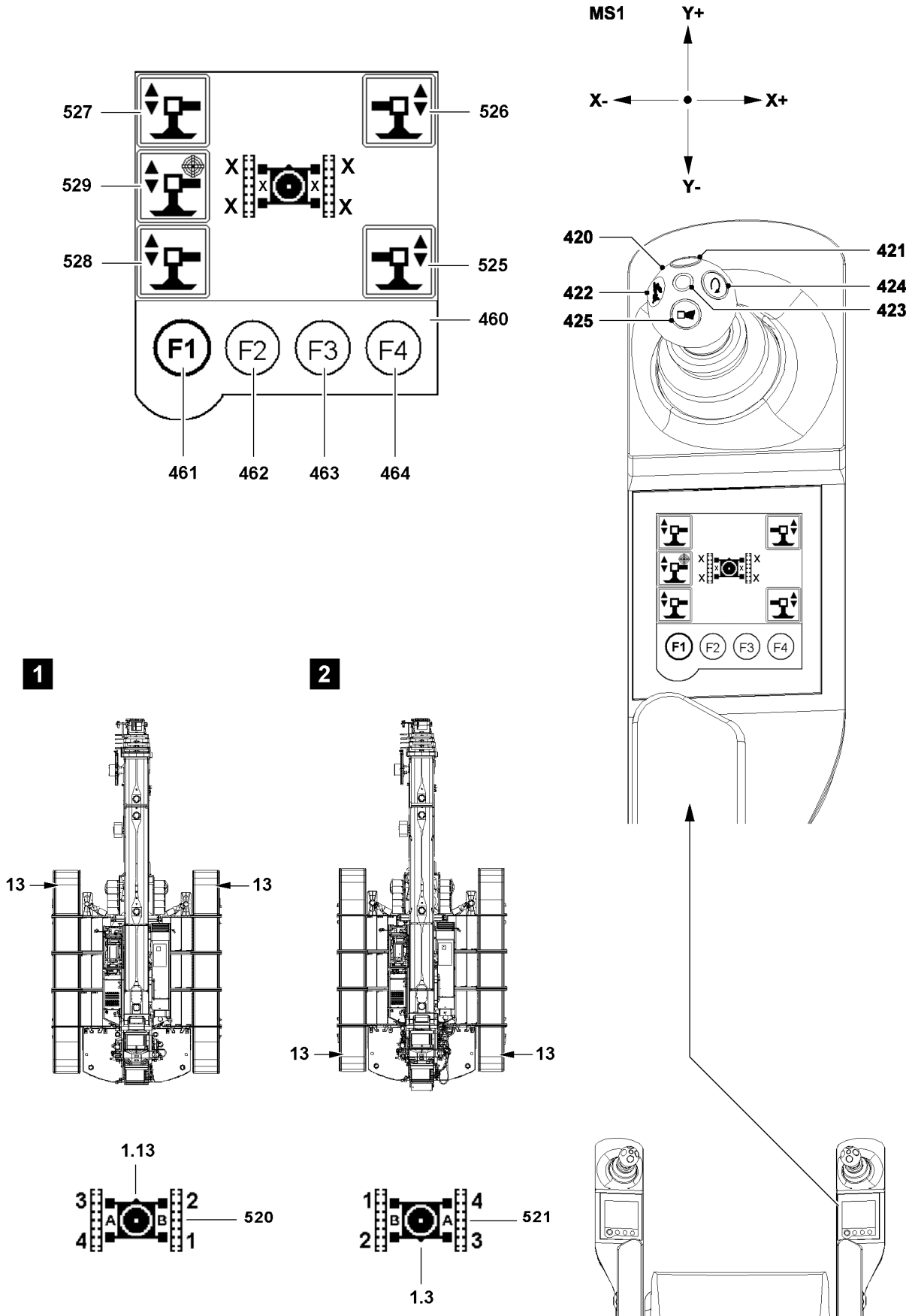


Fig.152438

LWE/LTR 1220-003/24204-02-02/en

### Automatic support

By selecting („touch“) the automatic support **529** cancels all manual support function selections.



---

#### Note

- ▶ The extension / retraction of the support cylinders is „coupled“ to the Y+ and Y- deflection direction of the master switch (MS1) **420**.
  - ▶ Moving the MS1 in direction Y+ levels the crane by extending the support cylinders.
  - ▶ Moving the MS1 in direction Y- levels the crane by retracting the support cylinders.
- 

If the automatic support **529** has been selected, the support function is carried out via the master switch deflection. The automatic support function automatically levels the crane during the support procedure.

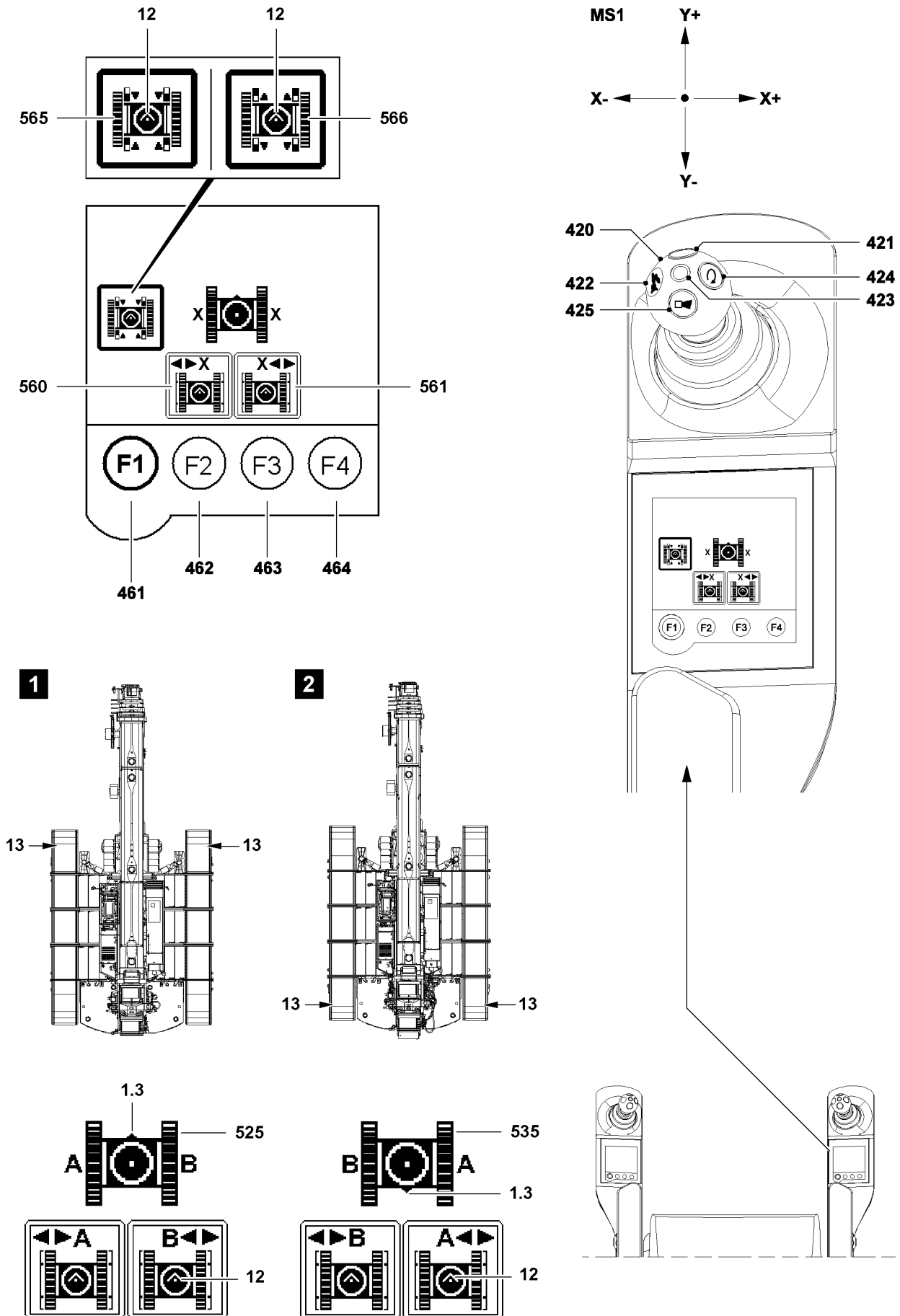


Fig.117634

LWE/LTR 1220-003/24204-02-02/en

## 2.4.2 The „Track width adjustment“ menu (right touch display)

In the „Track width adjustment“ menu, the crane driver has the possibility to extend the track width of the crawlers to a larger track width or retract them to a smaller track width.



### Note

Assignment of working direction and crawler carrier!

Illustration 1 and illustration 2 show the assignment.

- ▶ The rear and front on the crawler travel gear can be determined by the chain tension device **13** (chain tension side). The chain tension device **13** is on the front on the crawler travel gear.
- ▶ In the „Track width adjustment“ menu the assignment of the crawler carriers on the touch display depends on the working direction of the crane. If the working direction of the crane is changed by turning the turntable from working direction „forward“ to working direction „backward“, then the crane icon **525** changes to crane icon **535** - or vice versa.
- ▶ The arrow **12** shows the direction of view of the crane operator in the crane operator's cab: icon **560**, icon **561**, icon **565** and icon **566**.
- ▶ Crane icon **525**, turntable turned „to the front“: The triangle **1.3** shows the front on the crane chassis; assignment of the crawler carriers as seen by the crane operator in the crane operator's cab.
- ▶ Crane icon **535**, turntable turned „to the rear“: The triangle **1.3** shows the front on the crane chassis; assignment of the crawler carriers as seen by the crane operator in the crane operator's cab.

### The function key line

- 461** Function key F1
  - Switch to the next menu
- 462** Function key F2
  - No function
- 463** Function key F3
  - No function
- 464** Function key F4
  - No function

### Touch functions in the Track width adjustment menu

- 565** „Pin“ the track width adjustment
  - Icon **565** selected: Pinning the cross carriers
  - Note:**  
If the icon **565** is selected („touch“), then the Icon **566** appears.
- 566** „Unpin“ the track width adjustment
  - Icon **566** selected: Unpinning the cross carrier
  - Note:**  
When changing to the „Track width adjustment“ menu after system start, then the icon **565** is automatically selected.  
When changing to the „Track width adjustment“ menu during operation, then the last active icon is selected.
- 560** „Left“ track
  - Select / deselect the „left“ track
- 561** „Right“ track
  - Select / deselect the „right“ track

### Right master switch assignment

- 420** Right master switch (MS 1)
  - Move the master switch **420** in direction X+ (toward the right): The selected crawler carriers extend.
  - Move the master switch **420** in direction X- (toward the left): The selected crawler carriers retract.
- 421** Button
  - Release of the master switch **420** to retract / extend the crawler carriers.

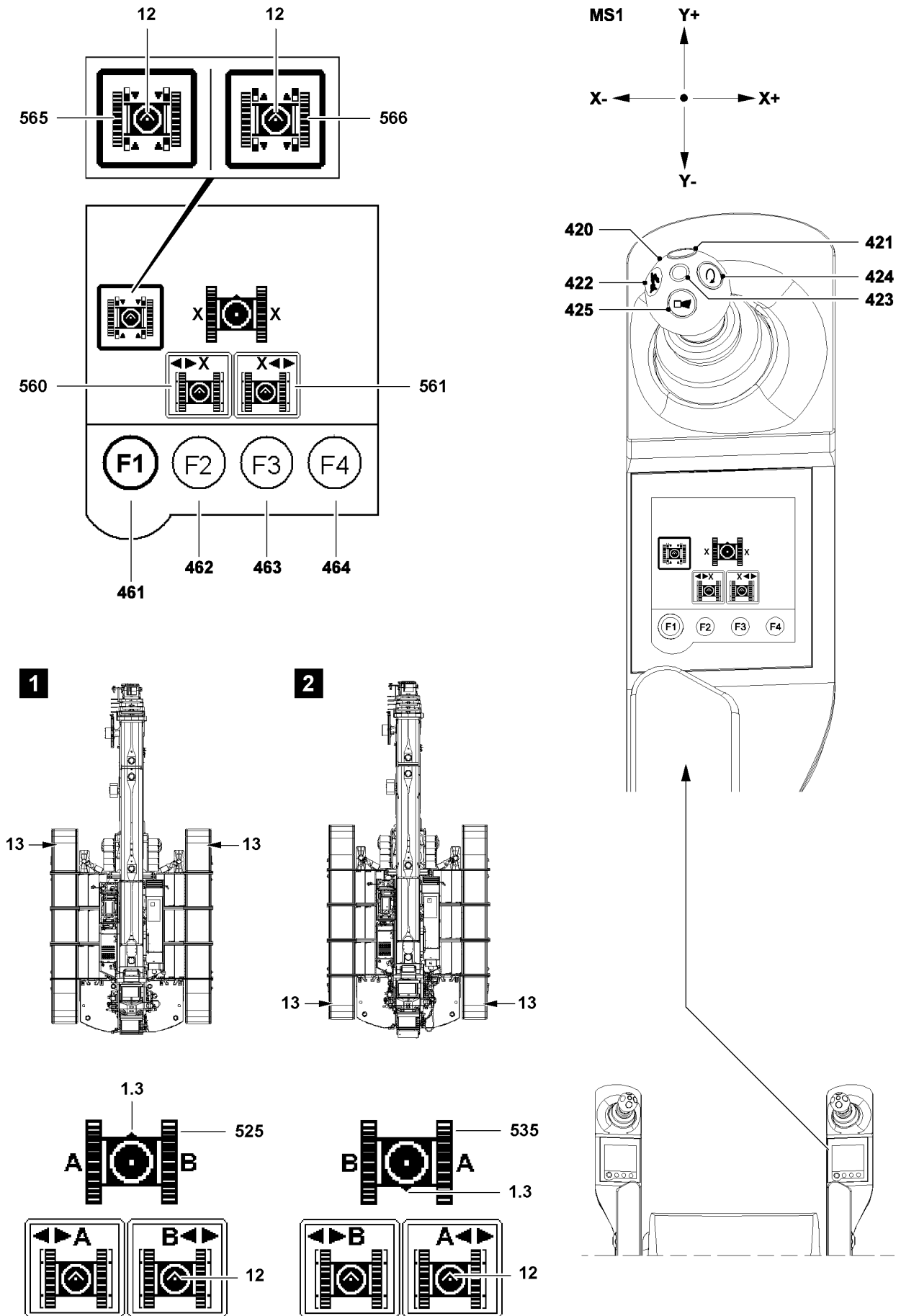


Fig.117634

LWE/LTR 1220-003/24204-02-02/en

### Pinning / unpinning the cross carriers



#### Note

- ▶ The cross carriers are only pinned in extension conditions of 0 %; 50 %; 100 %.
- ▶ Asymmetric track width adjustment is reached by pinning in extension conditions of 0 % and 100 %, see the Crane operating instructions, chapter 4.03.50

To automatically pin the cross carriers, you have to „pin“ the track adjustment, touch function **565** before the pin points at 0 % or 50 % or 100 % are reached.

To be able to extend the crawler carriers, you have to select „unpin“ the track adjustment, touch function **566**.

The cross carrier is automatically unpinned as soon as a crawler carrier is extended / retracted.

### Extending / retracting the crawler carrier



#### Note

- ▶ The „left“ or „right“ track or the „left“ and „right“ track can be selected on the touch display and can be extended or retracted with the master switch 1 **420**.
- ▶ The extension / retraction of the crawlers is „coupled“ with the X+ and X- deflection direction of master switch (MS1) **420**.
- ▶ Release support movement: Press the button **421** (bypass seat contact) and hold it.
- ▶ Retract or extend the crawler carriers: Deflect the master switch (MS1) **420** in direction X+ or X-.



#### Note

- ▶ Adjustment of track width, see the Crane operating instructions, chapter 4.03.50.

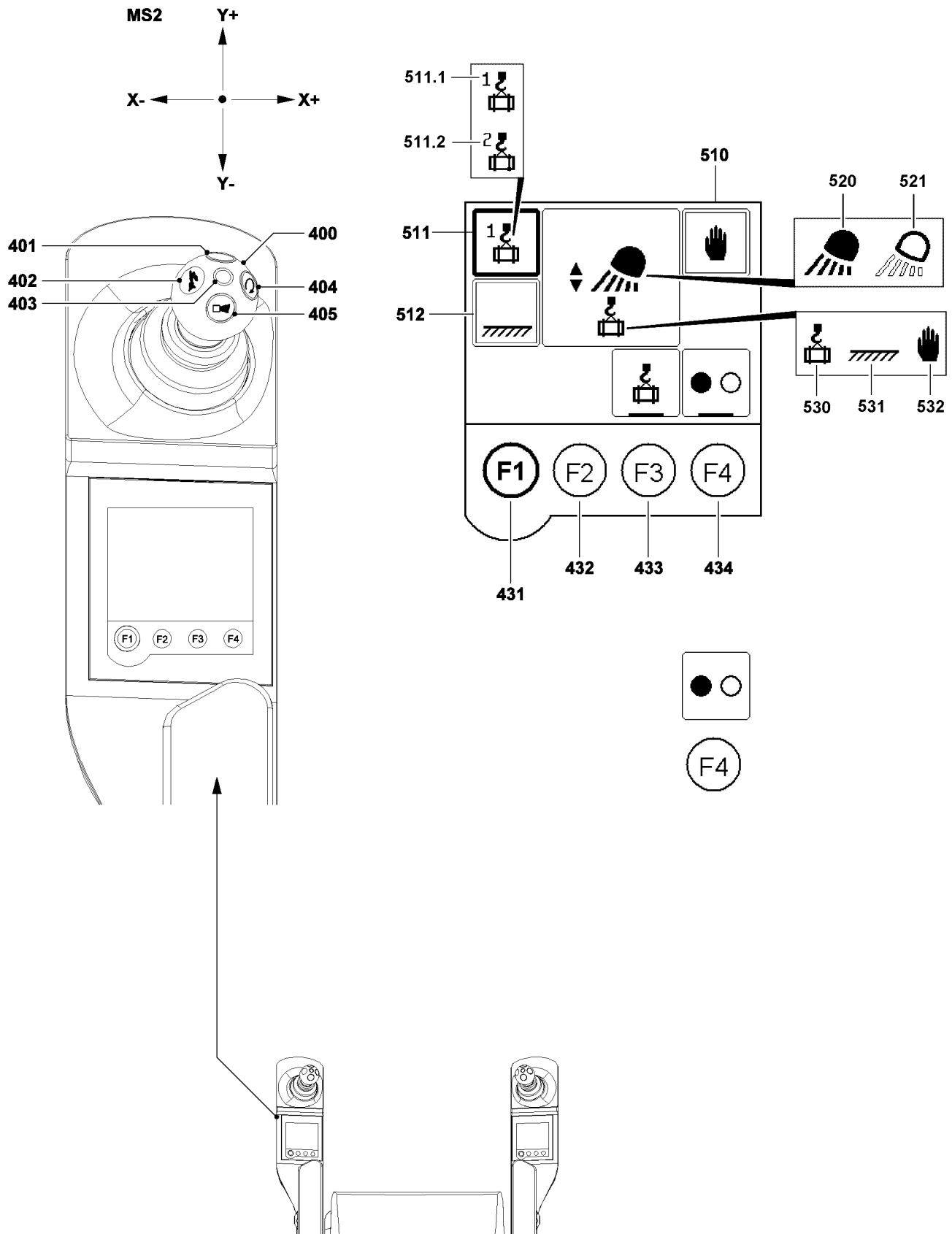


Fig.121279

LWE/LTR 1220-003/24204-02-02/en



### 2.4.3 The „floodlight“ menu\* (left touch display)

In the floodlight „menu“\*, the crane driver has the opportunity to manually align the floodlights to suit the current load or the planned working range. In crane operation, the previously aligned floodlight changes its position according to the movement direction of the load (load-following) or the working range (fixed to working range).



#### Note

- ▶ The floodlight menu\* is only available if the floodlight is installed and connected.
- ▶ „Touching“ the desired floodlight function does not directly activate this function, instead it only **selects the function**.
- ▶ Only if a floodlight function has been selected, can function key F4 **434** be used to turn it on or off.

#### The function key line

- 431** Function key F1
  - Switch to the next menu
- 432** Function key F2
  - **No** function
- 433** Function key F3
  - Load position preselection for 2-hook operation
    - When selecting the main boom, the icon **511.1** appears
    - When selecting the auxiliary jib, the icon **511.2** appears
- 434** Function key F4
  - Turn the floodlight on / off

#### Touch functions

- 510** Floodlight
  - Select „Manually“
- 511** Floodlight
  - Select „Load following“
- 512** Floodlight
  - Select „Fixed to working range“

#### Icons

- 520** Floodlight
  - Turned on
- 521** Floodlight
  - Turned off
- 530** Floodlight
  - „Load following“ selected
- 531** Floodlight
  - „Fixed to working range“ selected
- 531** Floodlight
  - „Manually“ selected



#### Note

- ▶ Before the required operating mode of the floodlight is selected, the „starting position“ of the floodlight must be manually selected in „Floodlight manual“ operating mode by moving the Master switch 2 **400** (MS2) left in direction Y+ or Y-.

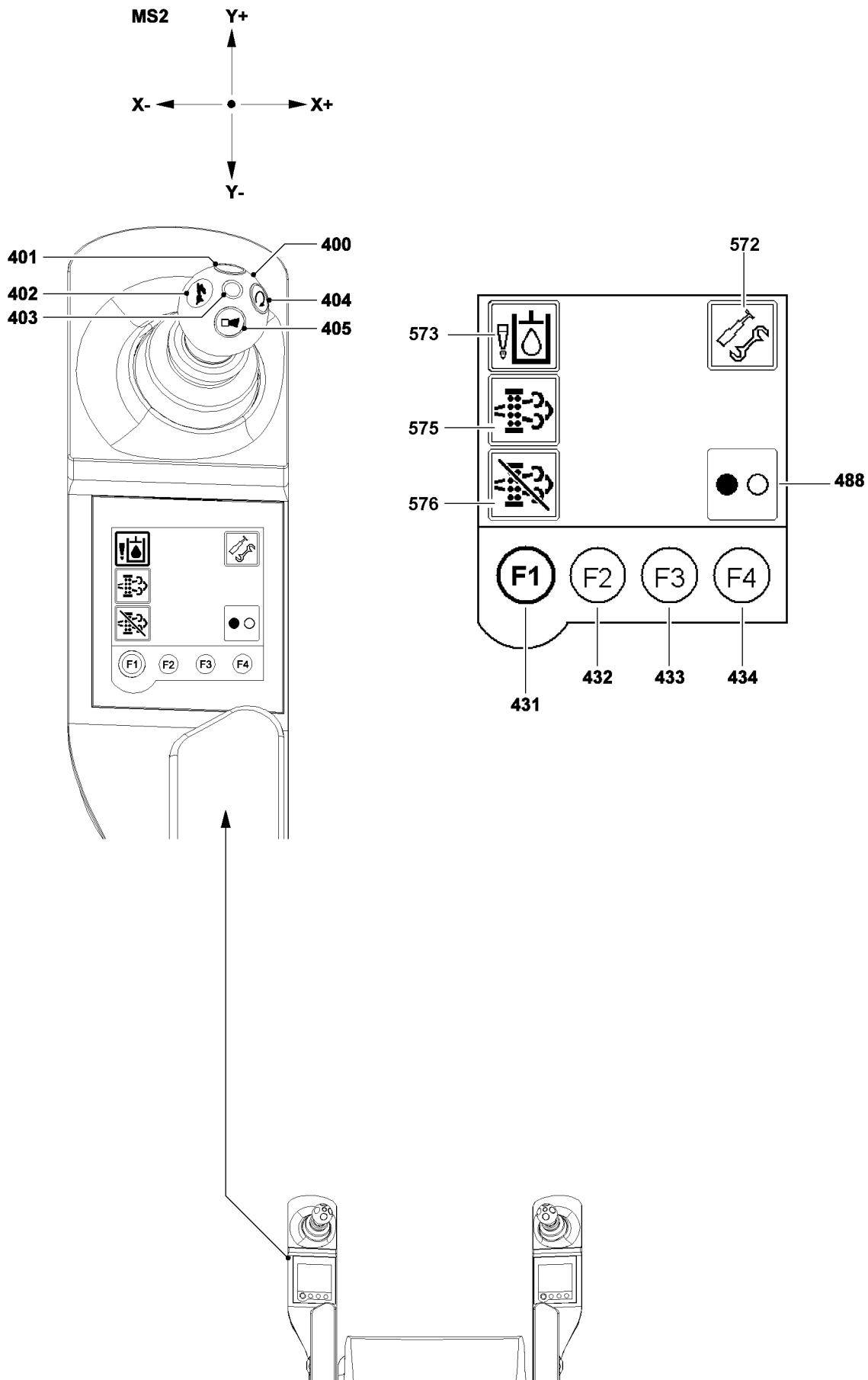


Fig.152539

LWE/LTR 1220-003/24204-02-02/en

## 2.4.4 The „Hydraulic oil preheating / telescopic boom disassembly“ menu\* (left touch display)

### The function key line

- 431** Function key F1
  - Switch to the next menu
- 432** Function key F2
  - **No** function
- 433** Function key F3
  - **No** function
- 434** Function key F4
  - Turn the hydraulic oil preheating on / off
  - Turn telescopic boom disassembly on / off

### Touch functions

- 572** Telescopic boom disassembly
  - Select / deselect telescopic boom disassembly
- 573** Hydraulic oil preheating
  - Select / deselect hydraulic oil preheating
- 575** Triggering diesel particle filter (DPF) regeneration
  - Select / deselect triggering diesel particle filter (DPF) regeneration
- 576** Disabling diesel particle filter (DPF) regeneration
  - Select / deselect disabling diesel particle filter (DPF) regeneration
- 488** Changeover ON / OFF
  - Changeover ON / OFF is made by pressing **F4**
  - Can only be applied to the selected or preselected functions.

## 3 Roof instrument panel operating elements

### 3.1 Operating elements, General

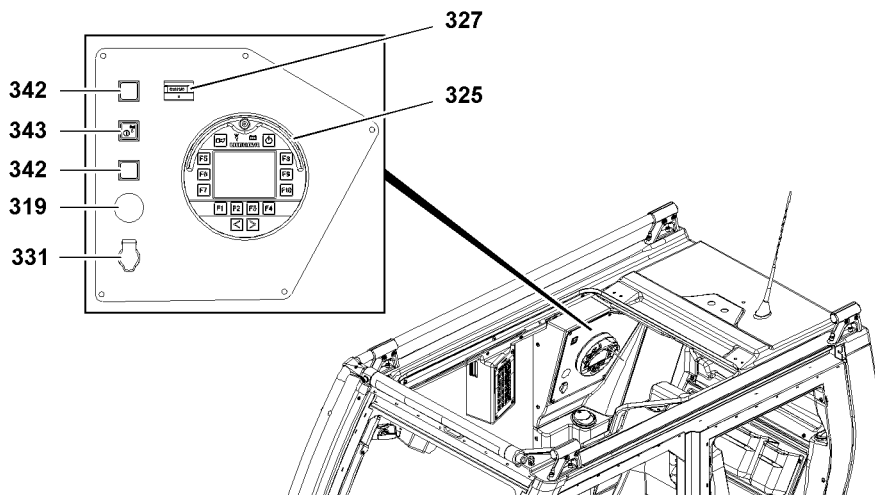


Fig.154848: Instrument panel Roof

- 319** Integrated socket 12 V
- 331** Integrated socket 24 V
- 327** Travel gear operating hour meter\*
- 343** Turn the remote diagnostics module (GSM module) on

**342** Dummy cover

**325** Charging cradle

BTT

**Note:**

For a detailed description of the BTT, see the Crane operating instructions, chapter 5.31.

## 4 Side panel

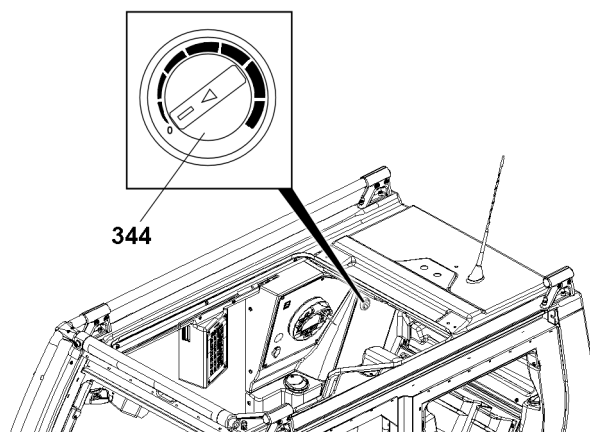


Fig.152429: Side panel

### 4.1 Air heater\*

For description of the air heater\*, see the documentation from the manufacturer.



#### WARNING

Danger of explosion!  
Death. Severe bodily injuries. Property damage.

- For the maintenance and safety instructions for the air heater\*, see the documentation from the manufacturer.

Position	Designation	Function	LED	Description
344	Air heater* rotary switch	On	Lights up	Turn the rotary switch to the right
		Off	Off	Turn the rotary switch to the left
		Error	Blinks	Error / problem

Side console rotary switch

## 5 Control elements

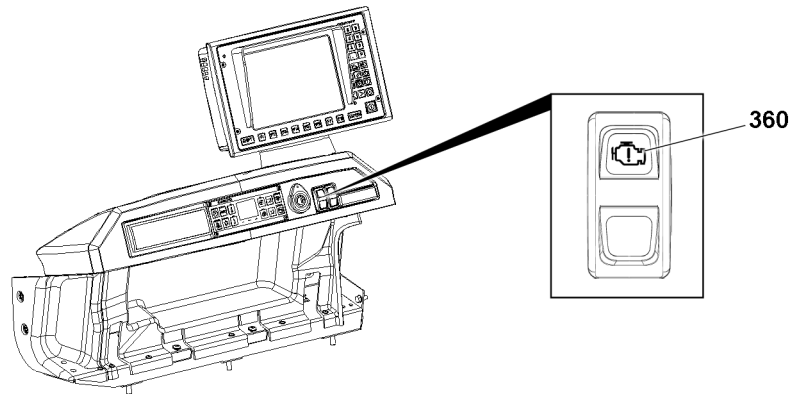



Fig.152590: Engine stop request

360 Engine stop request

Position	Indicator light	LED condition	Description
360	 Engine stop request	Red blinking	Remedy the error

## 6 Climate control

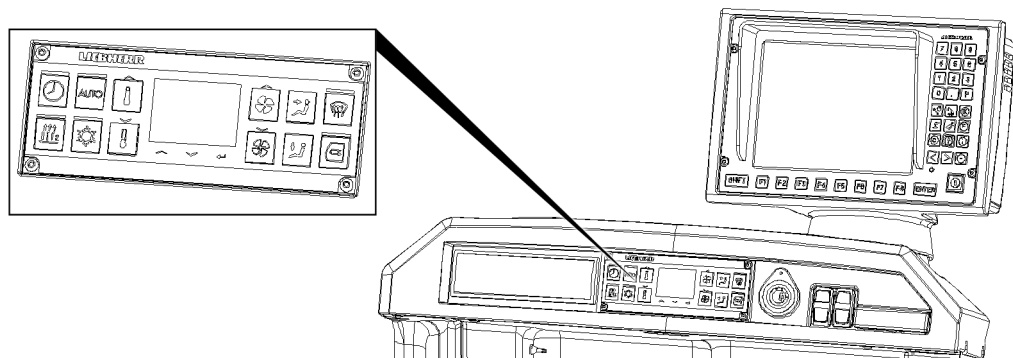














Fig.147625: Climate control

## 6.1 Climate control button

Position	Icon	Designation	Description
1		Button	Timer
2		Button	Automatic operation
3		Button	Crane cab auxiliary heater / engine preheating*
4		Button	Climate control system*
5		Button	Increase temperature
6		Button	Decrease temperature
7		Button	Increase blower stage
8		Button	Decrease blower stage
9		Button	Air distribution for head area

Position	Icon	Designation	Description
10		Button	Air distribution for floorboard area
11		Button	Defrost front window
12		Button	Recirculating air

Climate control button

## 6.2 Display\*

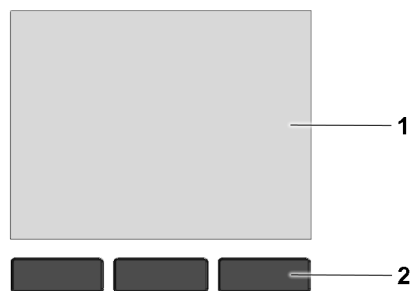


Fig.145596: Display with buttons


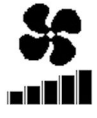
1 Display

2 Set the timer button, select crane cab auxiliary heater / engine preheating\*

## 6.3 Displays

### 6.3.1 Fan stage

This section describes the fan stage icons. Each bar in the icon represents a switch level. Five switch levels are available.



Position	Icon	Description
1		Fan turned off
2		Fan turned on (1 to 5 switch levels)

Fan stage

LWE/LTR 1220-003/24204-02-02/en

### 6.3.2 Air distribution for head area



This section describes the head area air distribution icons. Each bar in the icon represents a switch level. Six switch levels are available.

Position	Icon	Description
1		Head area air distribution turned off
2		Head area air distribution turned on (1 to 6 switch levels)

*Head area*

### 6.3.3 Air distribution for floorboard area

This section describes the floorboard area air distribution icons. Each bar in the icon represents a switch level. Six switch levels are available.

Position	Icon	Description
1		Floorboard area air distribution turned off
2		Floorboard area air distribution turned on (1 to 6 switch levels)

*Floorboard area*

### 6.3.4 Temperature display

The temperature display can be shown in [°C] or [°F].

**25°C**

*Fig.145906: Temperature display*

### 6.3.5 Time

**07:00**

*Fig.145107: Time*

### 6.3.6 Timer




MO  
FR **07:00 00:30**

*Fig.145907: Timer*



### 6.3.7 Auxiliary heater / engine preheating\*

This section describes the auxiliary heater / engine preheating\* icons.

Position	Icon	Description
1		Crane cab auxiliary heater
2		Crane cab auxiliary heater engine preheating*
3		Engine preheating*

*Auxiliary heater / engine preheating\**

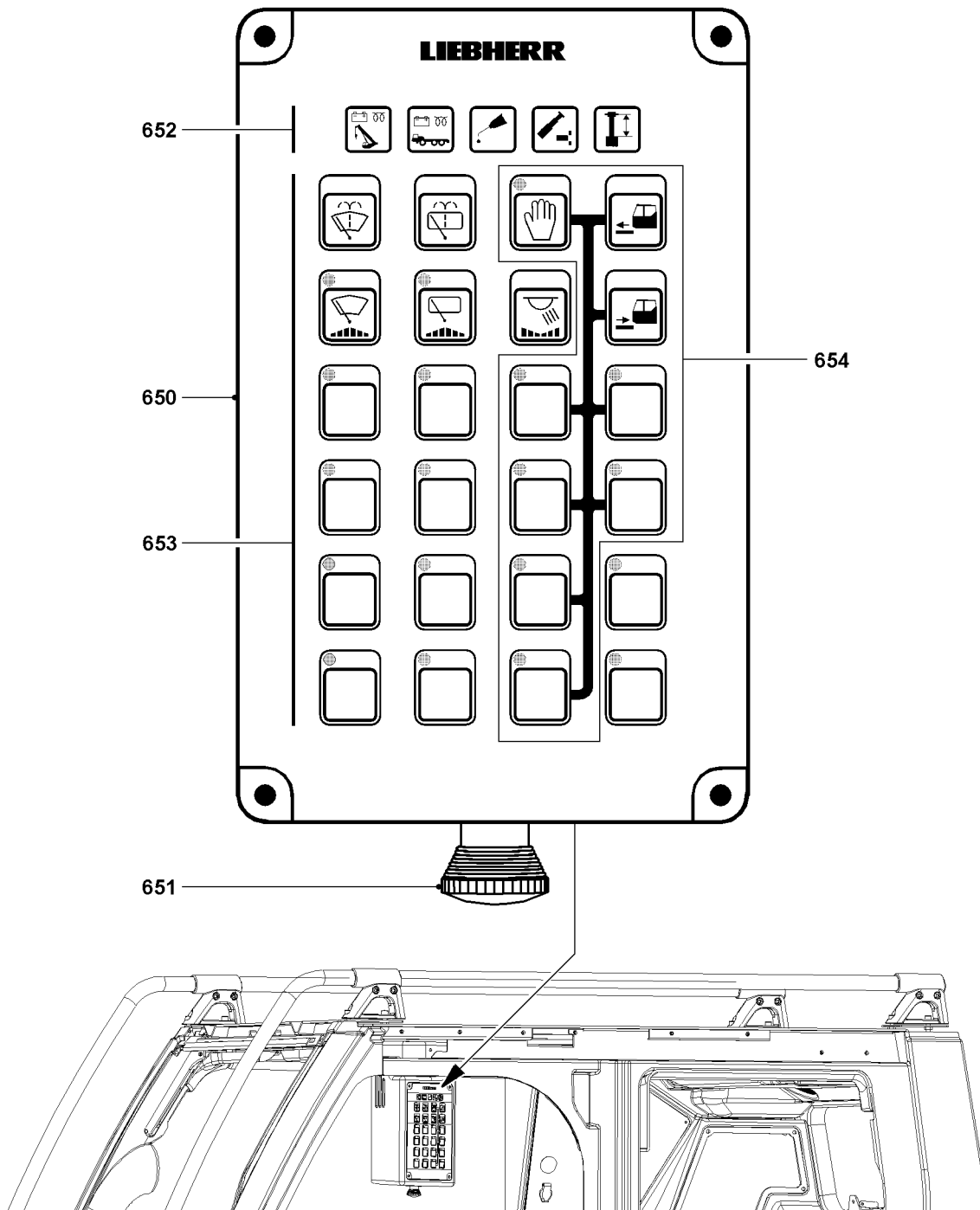


Fig.117632

## 7 Operating elements on the operating and control unit (BKE)

### 7.1 Operating console








#### Note

► The indicator lights as well as the operating buttons are described in detail in the following sections.

- 650** Operating console
  - Housing with indicator lights and buttons
- 651** EMERGENCY OFF switch\*
  - Impact switch
- 652** Indicator lights on the BKE
- 653** Operating buttons on the BKE
  - Standard assignment
- 654** Operating buttons on the BKE for release actuations
  - Standard assignment

## 7.2 Indicator lights on the BKE „652“





Position	Indicator light	LED condition	Description
660	 Superstructure engine monitoring	Yellow:	Engine preheating active
		Yellow blinking (slow)	Engine ready to start
		Yellow blinking (fast)	Engine preheating Error / problem
		Off:	Engine is running (after engine has been started)
		Red:	The engine is running, the alternator does not charge
661	 Engine monitoring chassis	<b>Note:</b> Indicator light <b>not</b> assigned!	
662	 Central lubrication	Yellow + red (orange)	Functional readiness (shown after engine start for 1.5 s)
		Yellow:	Lubrication active
		Red:	Error / problem
		Off:	Central lubrication not active
663	 Pinning tele / cylinder	Yellow	Unpin cylinder
		Green	Tele unpinned
664	 Cylinder in position	Yellow	Gripper in position





## 7.3 Operating buttons on the BKE „653“










### Note


- ▶ With the LEDs in the operating buttons, the operating conditions and problems can be recognized quickly and reliably by the crane driver.

Position	Key	Function	LED	Description
670	 Front window washer system	„On“	–	Clean the window: By pressing and holding the „Front“ or „Roof“ button
				<b>Note:</b> After releasing the „Front“ or „Roof“ button, three additional wipe movements are carried out before the wiper blades return to their original position.
671	 Window washer system Roof	„Off“	–	By releasing the „Front“ or „Roof“ button
672	 Front window wiper			<b>Note:</b> There are three different wipe stages.
673	 Window wiper, roof			<ol style="list-style-type: none"> <li>1. Wiper „On“: Continuous operation</li> <li>2. Intermittent 1: Wipe with long pauses</li> <li>3. Intermittent 2: Wipe with short pauses</li> <li>4. Wiper „Off“</li> </ol> <p>Every time the „Front“ or „Roof“ button is pressed, the wipe stages change incrementally</p>
		„On“	Lights up	By pressing the „Front“ or „Roof“ button
		„Off“	Off	<p>By pressing the „Front“ or „Roof“ button longer than one second until a „beep“ sounds</p> <p><b>or</b></p> <p>By pressing the „Front“ or „Roof“ button until the LED is off</p> <p><b>or</b></p> <p>Ignition „Off“</p>

Position	Key	Function	LED	Description
674	 Interior light cab	<b>Note:</b> The interior lighting can also be turned on when the ignition is „Off“, by pressing the button longer than 1 s.		
		„On“ (100 %)	–	By opening the door  <b>or</b> By pressing the button
		Dim	–	There are three different dimmer stages: 1. 75 % 2. 50 % 3. 25 % 4. „Interior light Off“  When the interior light is turned on: Each time the button is pressed, the brightness is reduced incrementally.
		„Off“	–	By pressing the button for longer than one second  <b>or</b> By pressing the button until the lighting turns „Off“  <b>or</b> If the following conditions are present simultaneously for longer than 30 s: - The driver's seat is not occupied - The door is closed - The engine is „Off“
679	 Airplane warning	<b>Note:</b> The airplane warning can also be actuated when the ignition is „Off“, by pressing the button longer than 1 s.		
		„Off“	Off	By pressing the button
		„On“	Lights up	By pressing the button
680	 Crawler operation	„On“	Blinks	Error / problem
		„Off“	Off	By pressing the button
		„On“	Lights up	Crawler operation is turned on.
681	 Rapid gear „crawlers“	„On“	Blinks	Error / problem
		„Off“	Off	By pressing the button
		„On“	Lights up	Rapid gear for crawler operation is turned on
		„On“	Blinks	Error / problem

LWE/LTR 1220-003/24204-02-02/en

Position	Key	Function	LED	Description
682	 Floodlight on front of turntable	„Off“	Off	By pressing the button
		„On“	Lights up	By pressing the button
		„On“	Blinks	Error / problem
683	 Floodlight on rear of turntable	„Off“	Off	By pressing the button
		„On“	Lights up	By pressing the button
		„On“	Blinks	Error / problem
684	 Floodlight on turntable side	„Off“	Off	Button <b>not</b> assigned, <b>no function!</b>
		„On“	Lights up	Button <b>not</b> assigned, <b>no function!</b>
		„On“	Blinks	Error / problem
685	 Telescopic boom head floodlight	„Off“	Off	By pressing the button
		„On“	Lights up	By pressing the button
		„On“	Blinks	Error / problem
686	 Low beam	„Off“	Off	By pressing the button
		„On“	Lights up	Button <b>not</b> assigned, <b>no function!</b>
		„On“	Blinks	Transmission error to chassis
687	 Parking light	„Off“	Off	By pressing the button
		„On“	Lights up	Button <b>not</b> assigned, <b>no function!</b>
		„On“	Blinks	Transmission error to chassis
688	 Floodlight camera*	„Off“	Off	By pressing the button
		„On“	Lights up	By pressing the button
		„On“	Blinks	Error / problem





Position	Key	Function	LED	Description
695	 Crawler „Parallel control“	„Off“	Off	By pressing the button
		„On“	Lights up	Parallel control for crawler operation is turned on
		„On“	Blinks	Error / problem

## 7.4 Operating buttons on the BKE for release actuations „654“








### Note

- ▶ The following functions require the activation of the „release button“.
- ▶ The „release button“ is active for 30 s. If an operating button is pressed during this time, the release time is reset to 30 s. The release stops after 30 s.
- ▶ A function is triggered by activation of the „release button“ and then pressing the corresponding operating button.
- ▶ For the listed key combinations, hold the corresponding operating button until the desired end position is reached.

Position	Key combination	Function	LED	Function
675	 Release button	<b>Note:</b> After pressing the release button, the functions, which require a release can be activated. The release is indicated if the green LED on the release button lights up.		
		„On“	Lights up	Press the release button
		„Off“	Off	By pressing the button <b>or</b> as long as no button is pressed, which requires a release: Automatically after 30 s
676	 Extend the step	„On“		Activate „release button“ and press „Extend step“ button
677	 Retract the step	„On“		Activate „release button“ and press „Retract step“ button
688	 Unpin the turntable lock	„Off“	Off	Function inactive
		„On“	Blinks slowly	The unpinning procedure „runs“
		„On“	Blinks fast	Error / problem
		„On“	Lights up	The „top“ end position has been reached, an acoustic signal will sound when the end position is reached

LWE/LTR 1220-003/24204-02-02/en

Position	Key combination	Function	LED	Function
689	 Pin the turntable lock	„Off“	Off	Function inactive
		„On“	Blinks slowly	The pinning procedure „is running“
		„On“	Blinks fast	Error / problem
		„On“	Lights up	The „bottom“ end position has been reached, an acoustic signal will sound when the end position is reached
690	 Lift the counterweight	„Off“	Off	Function inactive
		„On“	Blinks slowly	The counterweight is raised
		„On“	Blinks fast	Error / problem
		„On“	Lights up	The „top“ end position has been reached, an acoustic signal will sound when the end position is reached
691	 Lower the counterweight	„Off“	Off	Function inactive
		„On“	Blinks slowly	The counterweight is lowered
		„On“	Blinks fast	Error / problem
		„On“	Lights up	The „bottom“ end position has been reached, an acoustic signal will sound when the end position is reached
692	 Tilting the cab upward	„Off“	Off	Function inactive
		„On“	Blinks	Error / problem
		„On“	Lights up	The cab is raised
693	 Tilting the cab downward	„Off“	Off	Function inactive
		„On“	Blinks	Error / problem
		„On“	Lights up	The cab is lowered



## 4.02 LICCON computer system

1	General	2
2	System start of the LICCON computer system	4
3	Operating elements of the LICCON computer system	5
4	The set up program	7
5	Crane operation program	15
6	The Telescoping program	65
7	The working range limitation program*	74
8	Speed reduction master switch	78
9	Setting the operating mode of the slewing gear	82
10	Track width monitoring without shut-off of crane movement	84
11	Track width monitoring with shut off of crane movement*	85
12	ECO-Mode	88
13	Power-save mode and Stand-by mode in the LICCON computer system	94

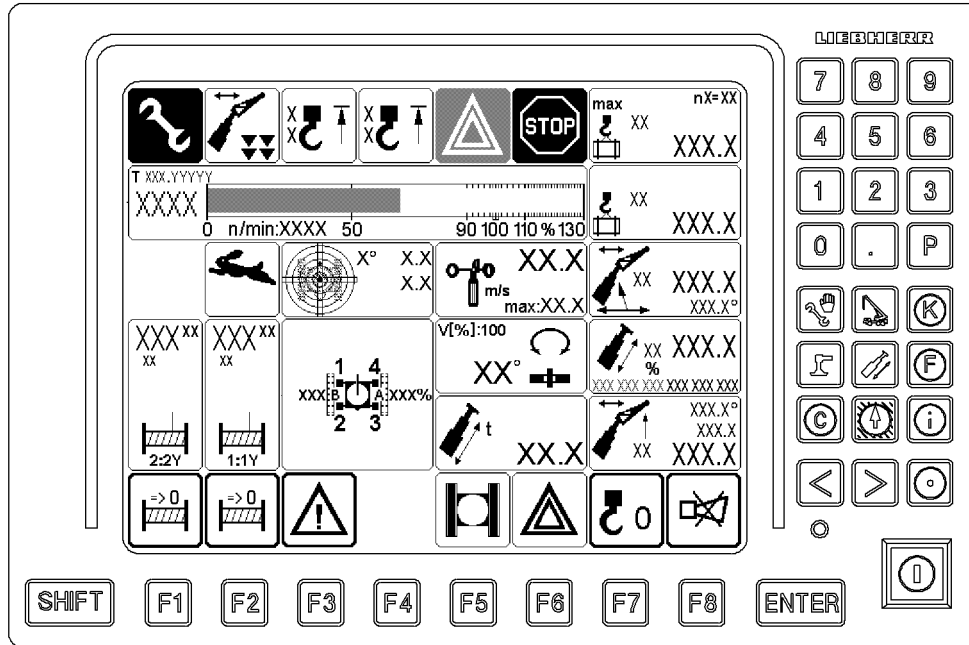


Fig. 122533: Exemplary illustration of displays in a LICCON computer system program

## 1 General



### Note

- ▶ The illustrations and monitor illustrations in this chapter are only examples.
- ▶ The numerical values in the individual icons and charts do not have to necessarily match the crane exactly.
- ▶ Numbers and letters can be replaced by place holders.
- ▶ The display and assignment of the icons can deviate, depending on the set up configuration, operating status and configuration of the crane.
- ▶ In addition, many of the illustrations show the maximum configuration of the LICCON monitor with icons.
- ▶ In crane operation, an identical display will **not** appear on the LICCON monitor.

The LICCON computer system is a computer system for controlling and monitoring mobile and crawler cranes. In addition to the use of overload protection and load capacity display there are a number of application programs that can be used for controlling and monitoring the crane movements.

**The electrical and electronic components are linked via data bus transmission technology (Liebherr System Bus = LSB).**

### 1.1 Overload protection

The overload protection includes limiters and displays (for example load bearing capacity displays), which also alert to danger conditions via acoustic and optical warning signals.

The computer controlled part of the overload protection is called the LICCON overload protection. The LICCON overload protection is set by entering the set up configuration in the LICCON computer system.

The LICCON overload protection works, among others, on the principle of comparing the current and actual load with the maximum load according to the load chart and reeving.

### 1.1.1 Acoustic and optical warning signals

The crane is equipped with acoustical and optical warning device to warn crane operator, auxiliary personnel and any person nearby.

Overview of acoustic / optical warnings, see Crane operating instructions, chapter 4.20.

### 1.1.2 Actual load

The actual load is determined by recording changing dimensions, the set up configuration and situational influences.

The **load on the crane** results from the load momentum, boom momentum as well as environmental and mechanical influences. The occurring moments and forces are measured and processed by the LICCON computer system.

The **load momentum** results from load and boom radius. The load includes load, fastening equipment and hook block / load hook. The boom radius is calculated with aid of the angle sensor information (boom angle) and the length of the boom system. This also takes into account the boom flexation due to its own weight and the weight of the load.

The **boom momentum** is calculated from the length of the boom system, the crane data (boom weights) and angle sensor information (boom angle).

**Environmental and mechanical influences** are recorded, determined and taken into account individually.

### 1.1.3 Maximum load according to load chart and reeving

The crane data such as load charts (also called load capacity charts), boom weights and geometry data are stored in the central data memory of the LICCON computer system.

The *maximum load according to the load chart and reeving* is constantly determined, based on the load charts, for the set up configuration, the calculated boom radius and additional influences.

### 1.1.4 Comparison

The actual load and the *maximum load according to the load chart and reeving* are compared. When they approach the specified limit, an advance warning is issued by the overload protection. If this limit is exceeded, the overload protection turns the load moment increasing crane movements off.

## 1.2 Error messages

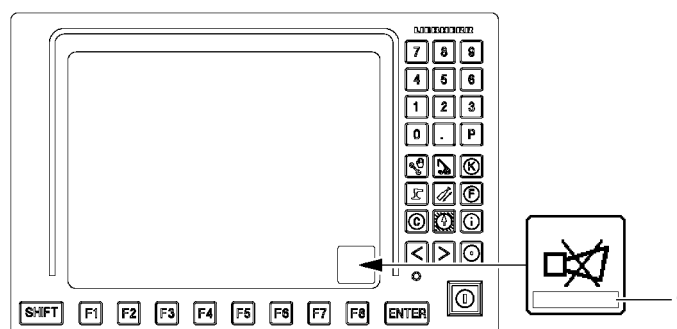


Fig.121805: Display location Error message

The LICCON computer system monitors the crane permanently for operating and system errors.

If an operating error or system error occurs, an error code is generated and issued as an error message. Error messages **1** appear on a fixed display location in the *horn* icon of the LICCON monitor.

**Note**

- ▶ Always pay attention to error messages 1.
- ▶ For procedure in case of error messages, see Diagnostics manual and the respective chapter in the Crane operating instructions.

## 2 System start of the LICCON computer system

There are two operating modes for the LICCON computer system:

- The LICCON computer system in normal mode (crane engine turned on).
- The LICCON computer system in stand-by mode (crane engine turned off).

Starting in normal mode:

- System start of LICCON computer system in connection with a started crane engine.

Starting in stand-by mode:

- See section „Power-Save and Stand-by mode in the LICCON computer system“

### 2.1 LICCON monitor at system start

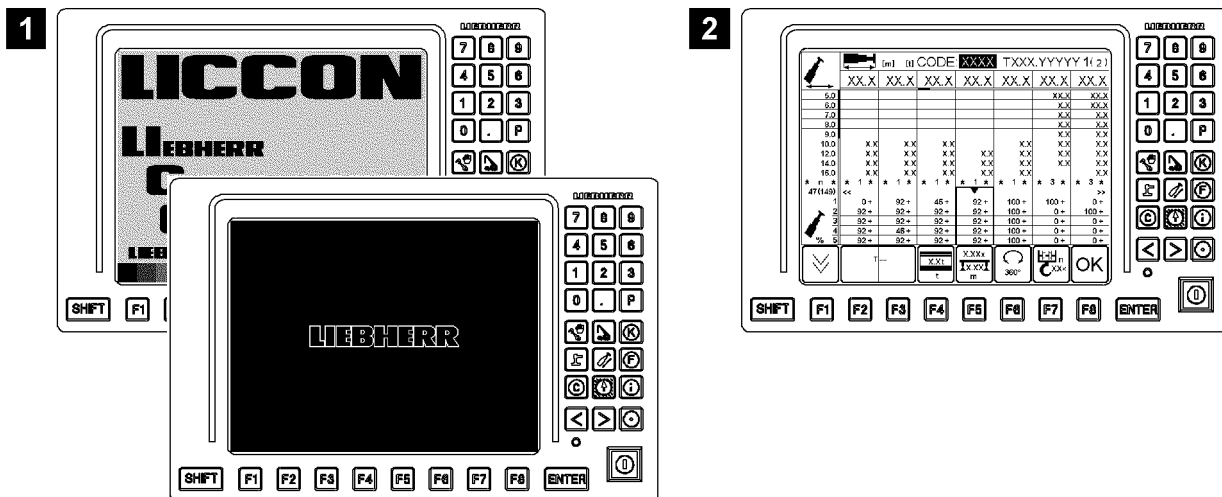


Fig.156208: Self test / set up screen after completed self test

At the beginning of the self test, the start screen appears, see sample illustration 1.

When the last set up configuration that was set appears (see example illustration 2), then system start on the LICCON monitor is completed.

**Note**

Error during the system start of the LICCON computer system.

If an error is detected during the system start, an error message appears on the LICCON monitor .

- ▶ Consult Liebherr Service if an error occurs during system start.

The existing set up configuration or a newly entered set up configuration must be confirmed, see section „The set up program“. Subsequently one can work with the other programs.

### 3 Operating elements of the LICCON computer system

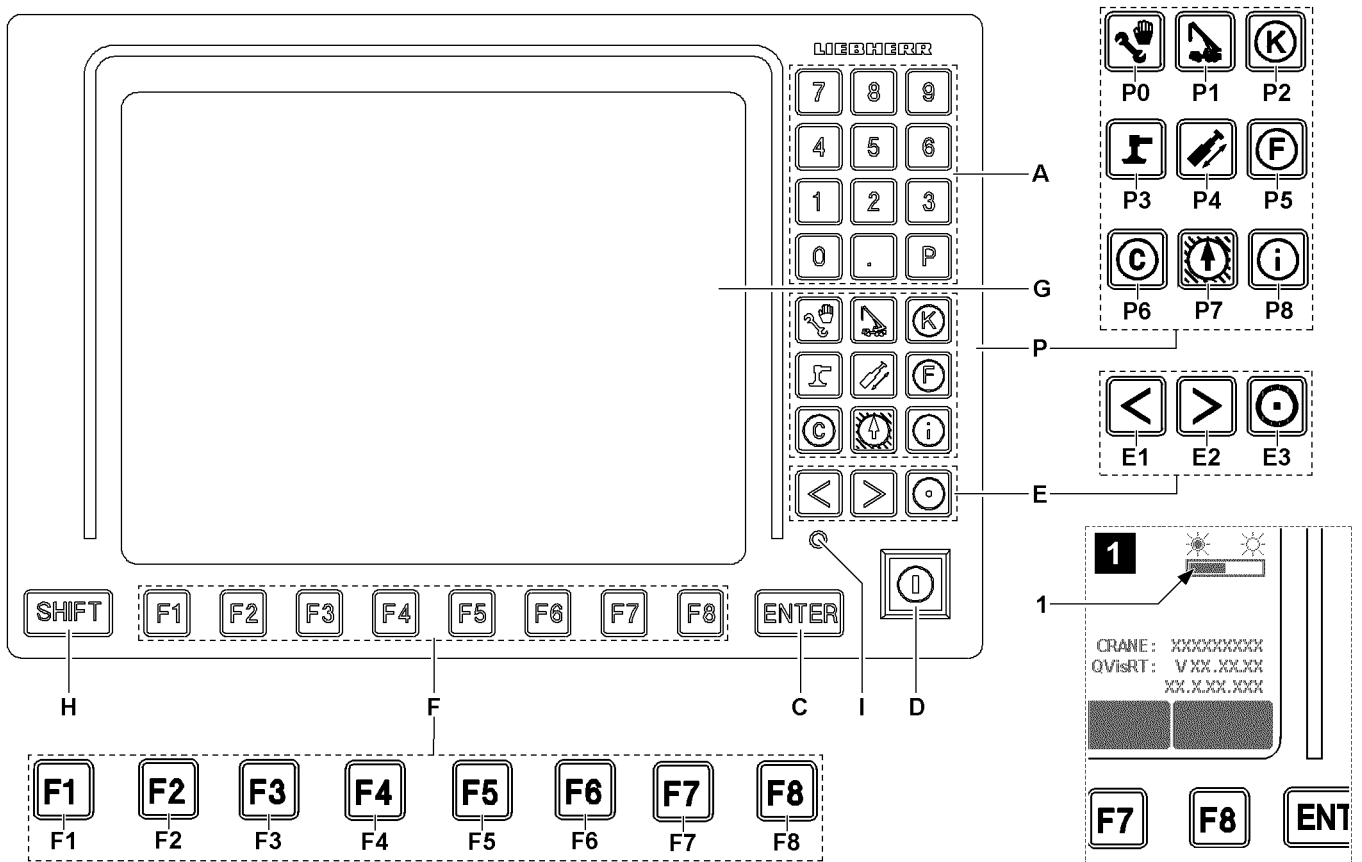


Fig.121803: LICCON computer system operating elements

- A** Keypad
  - Function is program dependent
- P** Program keys
  - Selection of the individual LICCON programs
- P0** Set up
  - Call up the Set up program
- P1** Crane operation
  - Call up the crane operation program
- P2** -
  - Program key not assigned.
- P3** -
  - Program key not assigned.
- P4** Telescoping
  - Call up the Telescoping program
  - Note:** Only for crane types with the TELEMATIK telescoping system.
- P5** Job planner\*
  - Call up the Job Planner\* program
  - Note:** Only available for certain crane types.
- P6** -
  - Program key not assigned.
- P7** Working range limitation\*
  - Call up the Working range limitation\* program
- P8** BSE test system
  - Call up the BSE test system program

- **Note:** For a description of the BSE test system program, see the Diagnostics manual.

#### C ENTER key

- Confirmation of changes in the running program

#### D Set up key

Has the following function only in certain programs:

- Zero position (not actuated):  
Normal operation.
- Touching:  
Special functions LICCON overload protection released, see section „Special functions LICCON overload protection“  
Special function TELEMATIK Emergency operation\* released, see section „Special function TELEMATIK emergency operation“

#### E Special function keys

- Functions of the special function keys are program-dependent and are further explained in the description of the individual LICCON programs.
- **Monitor brightness adjustment:**
  - Press **E3** (hold down) and **E1**: 6-stage night design.
  - Press **E3** (hold down) and **E2**: Brightness setting in 7 stages  
The brightness adjustment can be made from all available programs (for example: Set up, Crane operation).



#### Note

Automatic brightness adjustment of the LICCON monitor

The brightness of the LICCON monitor can be matched to the existing light conditions automatically or manually.

The current brightness setting of the LICCON monitor can be seen via the bar display **1** on the starting screen of the BSE test system program (illustration 1)

- ▶ Press the button BSE test system **P8** to call up the BSE test system program.
- ▶ With the *medium brightness* brightness setting the automatic brightness adjustment is **activated**.
- ▶ In brightness setting *lowest brightness* the automatic brightness adjustment is **inactive**.
- ▶ In brightness setting *highest brightness* the automatic brightness adjustment is **inactive**.

#### F Function keys

- The function keys should always be viewed in conjunction with the function key icon line displayed on the display **G**.

#### G Display

- In the display appears a program-dependent operating screen

#### H SHIFT key

- Second-level key assignments, for example Supervisory function

#### I LED display

- Indicator light for the supply voltage of the monitor

## 4 The set up program

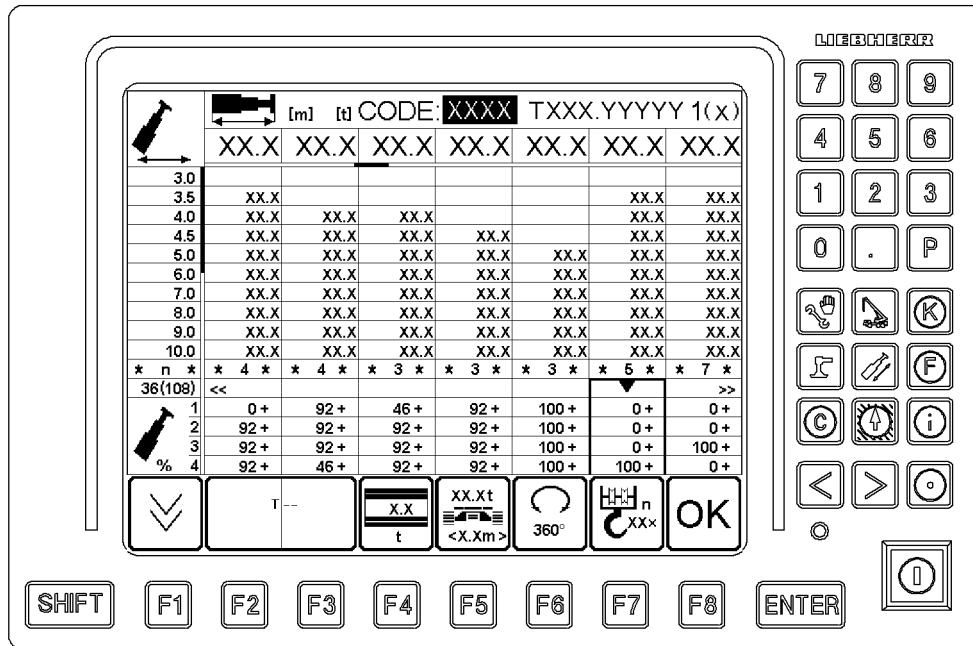


Fig.122537: Exemplary illustration of display in the Set up program

After turning the LICCON computer system on and after correct boot up, the Set up program appears automatically.



**Note**

Adjustment and display of set up configuration and reeving.

- ▶ Normally, after booting up the LICCON computer system, the most recently used set up configuration and the reeving used at that time will be automatically set and displayed.

You can see the programmed load charts in the Set up program.

You can set the desired operating mode and the desired set up configuration for the crane in the Configuration program to be able to operate the crane.

### 4.1 Setting the operating mode and set up configuration

The crane operator can select the operating mode and the set up configuration using the function keys or by entering a short code.

#### 4.1.1 Setting the operating mode and set up configuration via the function keys

The function keys are explained in section „Function key line (Set up)“ in this chapter.

- ▶ Select the respective function keys.
- ▶ Press the **ENTER** key to confirm and accept the settings.

**Result:**

- The data of the selected load chart can be viewed.

#### 4.1.2 Setting the operating mode and set up configuration with the short code

The function keys are explained in section „Function key line (Set up)“ in this chapter.

- ▶ Enter the short code with the keypad on the LICCON monitor.
- ▶ Press the **ENTER** key to confirm and accept the settings.

LWE/LTR 1220-003/24204-02-02/en

**Result:**

- The data of the selected load chart can be viewed.

## 4.2 Display areas in the Set up program

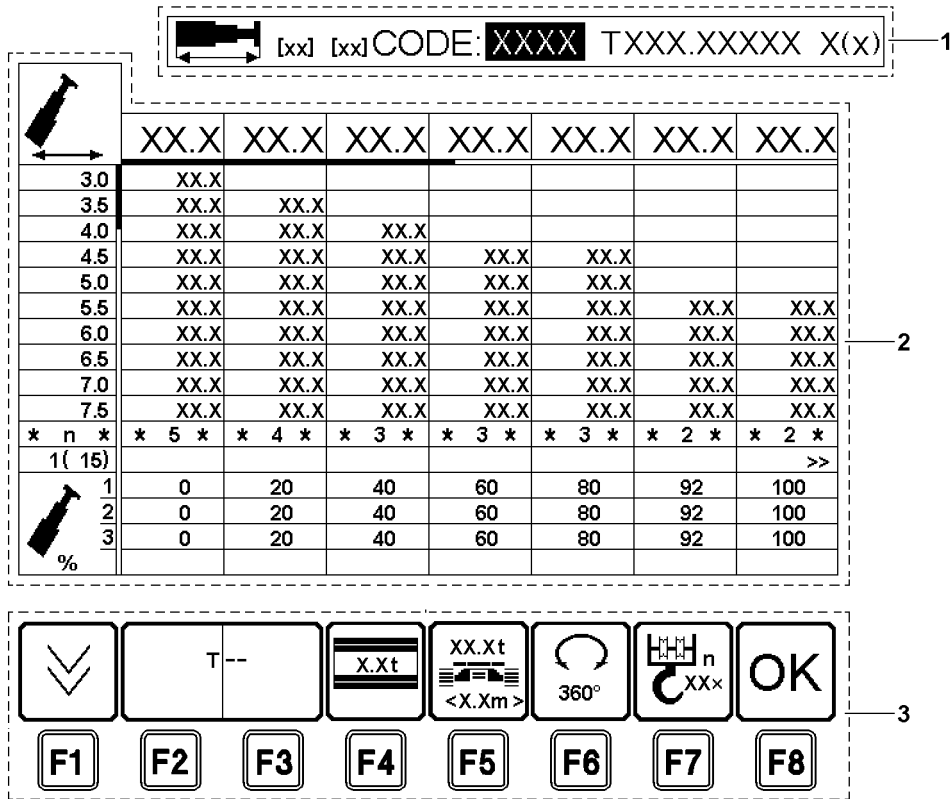


Fig.122534: Display areas in the Set up program

The monitor is divided into three areas in the set up program:

- 1 General information line
- 2 Display area of load chart values
- 3 Function key line (set up)

### 4.2.1 General information line

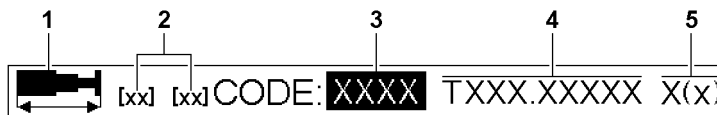


Fig.121819: General information line

- 1 Telescopic boom length icon
  - **Note:** The icon is identical for all operating modes.
- 2 Abbreviations
  - For the programmed length units (LE) and weight units (GE)  
Possible length units are [m] and [ft]  
Possible weight units are [t] and [lbs]
- 3 4-digit short code
  - Stands next to the word **CODE**



- Each short code uniquely identifies a crane set up configuration. The valid set up configuration and their associated short code numbers for the crane can be found in the load chart manual of the crane.
- If, via the function key line:
  - An invalid set up configuration is selected, then the „CODE 0000“ is shown in white on a red background.
  - A valid set up configuration is selected, then the short code is shown in white on a blue background. The values are entered into the load value field only after pressing the **ENTER** key.
- 4 Organization number
  - For internal Liebherr load chart administration
- 5 Page counter
  - The number of the displayed page of this load chart is located in front of the parenthesis
  - The total number of pages in this load chart is in parentheses

### 4.2.2 Display areas of load chart values

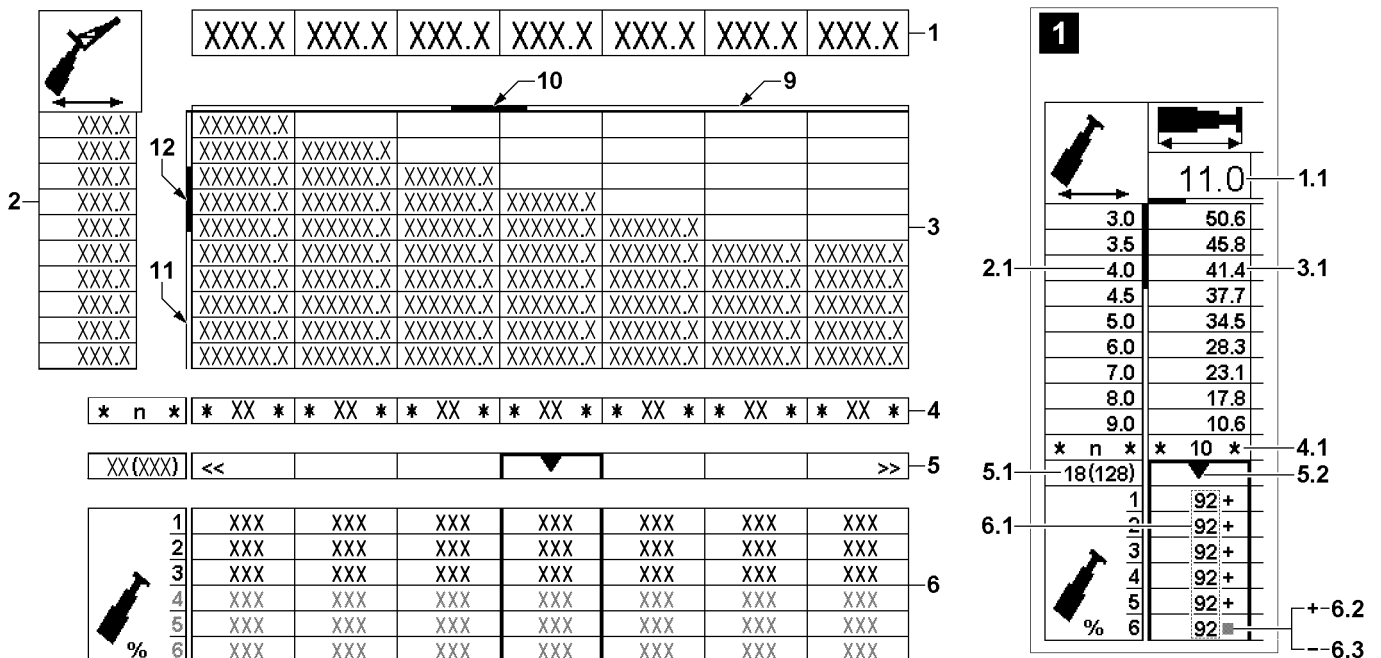


Fig.121820: Display areas of load chart values

- 1 Telescopic boom lengths
  - In [m] or [ft]
  - Maximum of 7 columns per display page
  - Displayed as the horizontal axis of the load value field
- 2 Boom radius icon
  - Operating mode dependent
  - In [m] or [ft]
  - Maximum 10 lines of radius values
  - Displayed as the vertical axis of the load value field
- 3 Load value field
  - Columns under the telescopic boom lengths and in the lines to the right of the radius values
  - Load values depending on boom length and boom radius
- 4 Hoist rope reeving number
  - \* n \*

LWE/LTR 1220-003/24204-02-02/en

n = Reeving number of the hoist rope between the boom head and hook block, in order to be able to lift the maximum load in the corresponding load chart column

**Note:** If an exclamation mark („!“) is next to the reeving number, then an auxiliary device is required for at least one load value in the column, see Crane operating instructions, chapter 4.06 / 4.15.

#### 5 Special displays line

- If a load chart consists of more than seven columns, it cannot be fully displayed because of the size of the monitor. In that case, marking arrows in the first or the seventh field indicate that there are additional columns to the left or right of the displayed chart. Press the button **E1** or button **E2** to switch to the left or right.

As supporting information, the currently selected column number and the number of columns in the chart are shown, for example 18(128) means the 18th of 128 columns.

#### 6 Extension condition of telescopic sections

- In percent [%]
- In the first column is a boom icon  
Next to that are the lines for the extension condition of the telescopic sections. The number in the icon column describes the respective telescopic section. The value in the boom length column displays the extension condition of the telescope in percentages, which must be maintained for the corresponding boom length.
- **Only for crane types with the TELEMATIK telescoping system:**  
The status indicator „-“ next to the percentage extension status value means that the telescope can be telescoped to the percentage extension condition value under load (according to the load chart).  
The status indicator „+“ next to the percentage extension condition values means that the telescope must be pinned.

#### 9 Horizontal orientation display

- The horizontal orientation display **9** shows the crane driver by the display element **10** (color red), where he is in the load chart in a horizontal direction.

**Note:** If the display element **10** in the horizontal orientation display **9** is displayed on the left edge, then it is in the first column of page 1 in the load chart of the set operating mode.

#### 11 Vertical orientation display

- The vertical orientation display **11** shows the crane driver by the display element **12** (color red), where he is in the load chart in a vertical direction.

**Note:** If the display element **12** in the vertical orientation display **11** is displayed at the top, then it is in the first row of the maximum number of available rows in the load chart of the set operating mode.



#### Note

Example illustration 1:

- ▶ Column for Telescopic boom length **1.1** for 11.0 m is selected.
- ▶ With a boom radius **2.1** of 4.0 m a maximum load **3.1** of 41.4 t is possible. Reeving **4.1** of n=10 is required for this.
- ▶ As column number **5.1** column 18 of 128 available columns is called up.
- ▶ All telescopes require for that the extension condition **6.1** of 92 %.

Only for crane types with the TELEMATIK telescoping system:

- ▶ If the status display **6.2** „+“ appears behind the value for the extension condition **6.1**, then the telescope must be pinned.
- ▶ If the status display **6.3** „-“ appears behind the value for the extension condition **6.1**, then the telescope does not have to be pinned.

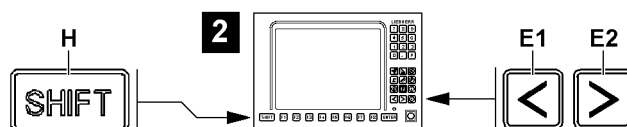


Fig.121821: Paging within the load chart columns

**Note**

Paging within the load chart columns, illustration 2

- ▶ By pressing the special function key **E1** or special function key **E2** once, page by one load chart column to the left or right.
- ▶ By pressing special function key **E1** or special function key **E2** twice in quick succession, you can browse left or right by seven load chart columns (equals the display area of the LICCON monitor).
- ▶ Press the **SHIFT** button **H** (hold down) and the special function key **E1**: Jump to the first column in the load chart.
- ▶ Press the **SHIFT** button **H** (hold down) and the special function key **E2**: Jump to last column in load chart.

### 4.2.3 Function key line (Set up)

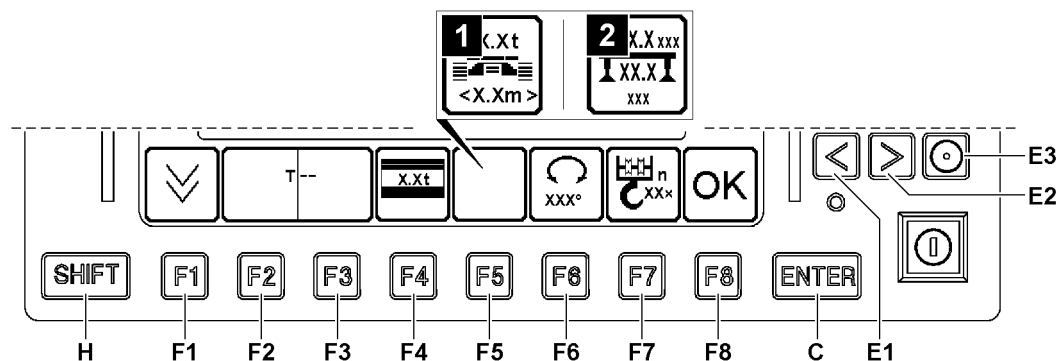


Fig.122535: Function key line in the Set up program

The function key line consists of function keys **F1** to **F8** and the icon line above them. The function keys correspond to the various function key icons above them.

Various functions are indicated by the function key icons, or they may refer to changes of operating mode and crane set up configuration.

Depending on the crane type and set up configuration, fewer function key icons may be present.

Not all function keys have icons / functions assigned to them. This depends on the program selection.

Pressing a function key can change the appearance of the icon above, its meaning, or its textual content.

**Note**

- ▶ By simultaneously pressing the special function key **E3** and the function key **F3** it is possible to switch by groups through the accessories. This allows quicker access to the operating mode required for crane application.
- ▶ See also description „**E3** and **F3**“ as well as „**E3** and **SHIFT** and **F3**“.

#### **F1** Vertical paging

- Depending on the size of the monitor, up to 10 load chart lines can be displayed at once. If a chart consists of more than 10 lines, then the display is spread over several pages.
- Press the button to show the next page of the load chart - the page counter counts up one page.
- The function key icons always show the functions that are activated by pressing a button.
- The function is called up after pressing a button. In addition, the icon above it can change its display, its meaning or its text.

#### **SHIFT** and **F1**

- Press the button to show the previous page of the load chart - the page counter counts down one page.

**F2** Main geometry status

- Options for setting the different main geometry conditions of the crane (if available). The types are described by abbreviations and length data in the icon.

**Example:** „T“ for Telescopic boom

**SHIFT** and **F2**

- Previous main geometry condition (if present)

**F3** Accessories

- Options for selecting the different accessory geometry conditions of the crane (if available). The types are described using abbreviations, angle and length data in the icon.

**Example:** „TK“ for Crane operation with mechanically adjustable folding jib

- **Note:** Pressing the function key **F2** and / or the function key **F3** deletes all operating mode and configuration dependent data from the monitor and sets the short code in the general information line to a new value. The „CODE 0000“ is displayed in white on a red background if the entered set up configuration for function keys **F4**, **F5** and / or **F6** does not exist or has not been programmed. For the existing set up configuration, the short code, more than 0, appears in white on a blue background.

• **Operating mode dependent data:**

- Icons
- Length units and weight units
- Load chart organization number
- Telescopic boom lengths
- Percentage extension condition of telescopic sections, with status indicator if applicable

• **Set up dependent data:**

- Radius values in length units
- Load values in weight units

**SHIFT** and **F3**

- Previous accessory geometry condition

**E3** and **F3**

- Select the accessories in groups forward („K\*“, „HK\*“) by pressing key combination **E3** (hold down) and then pressing function key **F3**

**Note:** After actuation, the first accessory configuration for the next accessory group is set.

**E3** and **SHIFT** and **F3**

- By pressing the key combination **E3** and **SHIFT** (hold down both) and then pressing the function key **F3**, the accessories can be selected in groups in reverse („HK\*“, „K\*“).

**Note:** After actuation, the first accessory configuration for the previous accessory group is set.

**F4** Counterweight

- Adjustment option for the current counterweight, which must be on the superstructure in order to achieve the values in the current chart. When pressing a key, the following icon appears with additional text in the counterweight icon.

- In addition only for crane types with an adjustable counterweight radius:

Adjustment option for the corresponding counterweight radius that must be set on the superstructure in order to reach the value in the current chart. When pressing a key, the following icon appears with additional text in the counterweight icon.

**SHIFT** and **F4**

- Set the previous counterweight

**F5** Crane chassis set up configuration

- When working with the present load chart, then the set up configuration of the crane chassis must match.

- Crawler travel gear, illustration 1: Setting possibility for the extension status of the cross carriers, the track width of the crawler and the current central ballast.

- Support (only for crane types with extra load charts on support), illustration 2: Setting possibility for the support width and the current central ballast.

**SHIFT** and **F5**

- Previous crane chassis set up configuration

**F6** Superstructure slewing range

- Adjustment option for slewing range

**Example:**

- 360° slewing range: Unlimited turning is possible.
- 0° slewing range: Toward the rear (locked).

**SHIFT and F6**

- Set the previous slewing range

**F7** Hoist rope reeving

- Adjustment possibility for the number of hoist rope strands, which are reeved to reach a certain load carrying capacity on the boom.

The displayed number of hoist rope strands (reeving) in the icon will be increased by one with every keystroke, up to a fixed maximum value for the respective operating mode. After that the counter restarts from a fixed minimum value.

If the set value is still within the minimum and maximum values when switching to another operating mode within that range, it remains valid. Otherwise it will be set to the minimum value for the new operating mode.

**Note:** For certain operating modes, for example THKH the hoist rope reeving is specified and cannot be otherwise set.

**SHIFT and F7**

- Reduce the reeving number by 1

**WARNING**

Danger of accident due to incorrectly entered set up configuration!

The following prerequisites must be met before pressing the function key **OK F8**:

- ▶ The configuration mode setting must be completed, i.e. a valid short code is displayed and load capacity values are in the chart field.
- ▶ The external conditions for this set up configuration, if specified, must be fulfilled (e.g. locking the superstructure, hoist rope reeving).
- ▶ The crawler carriers must be extended to the track width specified in the selected load chart.
- ▶ If these prerequisites are met, then the **OK** function key **F8** confirms that the selected set up configuration and the selected reeving are correct and transfers the parameters to the Crane operation program.

**F8** OK function key

- Accept the selected set up configuration and automatic change over in the operating screen.

**Note:** Make sure that after switching to the operating screen, the selected set up configuration (short code) and the hoist rope reeving(s) have been accepted correctly.

If the active set up configuration is to be changed:

- The utilization bar must be blue.
- The crane may not be utilized too much (20 % utilization or less, load not heavier than 0.5 t)

## 4.2.4 Control elements in the set up program

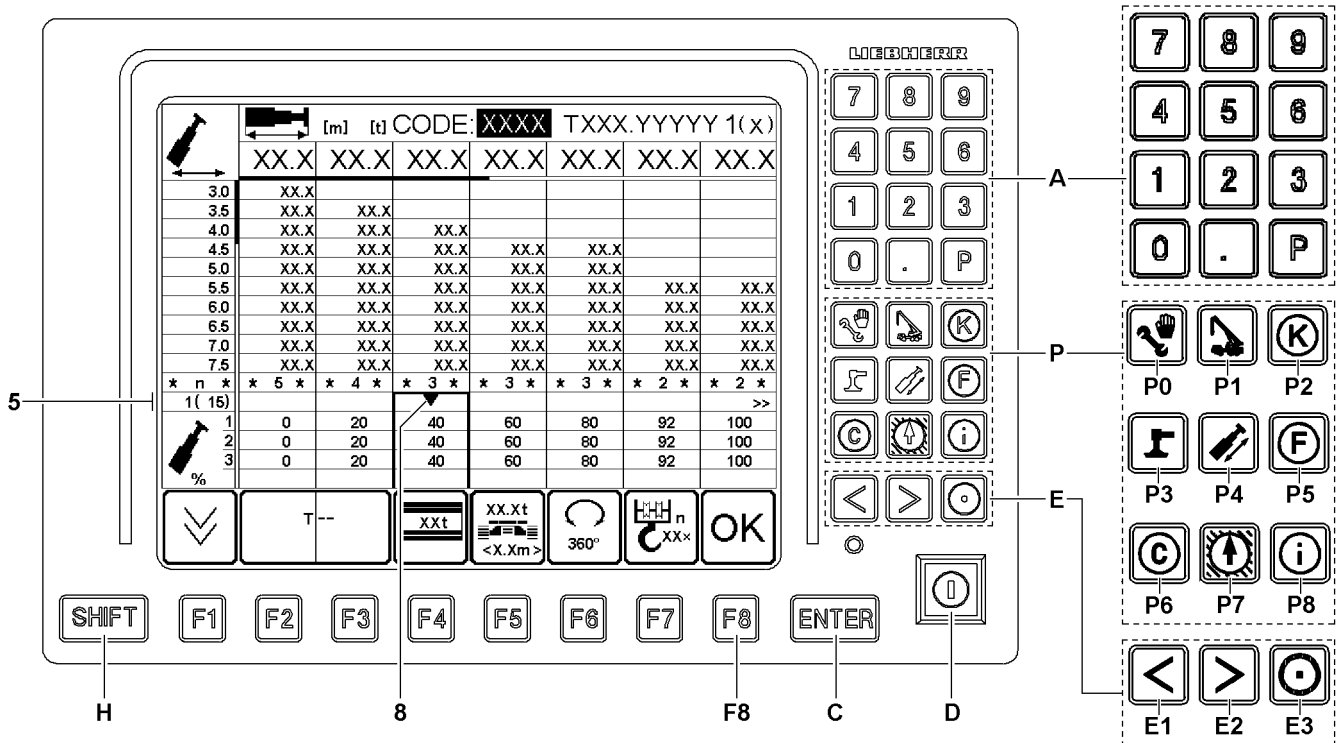


Fig.122536: Control elements in the set up program

### A Numeric keypad

- The keys **0** to **9** on the keypad can be used to enter the short code directly into the LICCON monitor. During entry, the short code is displayed in green.
- The key **P** and the key **.** have no function in the Set up program.
- Note:** Pressing the keypad deletes all operating mode and set up configuration dependent data from the display.

### P Program keys

- Selection among the individual programs. The settings in the set up program are discarded and the set up configuration and reeving, which were last confirmed with the function key **OK F8** are continued to be used.

### C ENTER key

- Confirmation of input both for short codes and for any change in the set up configuration using the function keys.
  - ENTER** after entering the short code searches for the short code in the programmed load charts. If the relevant load chart has been programmed, it is displayed in full. If the relevant load chart has **not** been programmed, the short code is displayed in white on a red background and an acoustic signal from the LICCON monitor is heard.
  - ENTER** after a changing the operating mode using the function key **F2** and / or the function key **F3** displays the load chart (if the chart exists) plus the short code on the LICCON monitor.
  - ENTER** after a change in the set up configuration using the function key **F4**, the function key **F5** and the function key **F6**, displays the load chart (if the chart exists) plus the short code on the LICCON monitor.
- Note:** If no load chart is defined or available for the changed operating mode, then, after pressing the **ENTER** key, the first available set up configuration in this operating mode with the appropriate load chart and short code will be displayed in the set up screen.

### D Set up key

- Has no function in the set up program

**E Horizontal paging**

- The key **E1** and key **E2** only have a function if this is indicated in the line *special displays 5*.

If a load chart consists of more than 7 columns, the first display of the set up configuration only shows columns the first seven columns in this line.

- With the key **E1**, the cursor **8** can be moved to the left.
- With the key **E2**, the cursor **8** can be moved to the right.

The double arrow at the right edge of the line points to additional columns in either direction. If the cursor **8** (movement mark) is moved to an edge marked with arrows, then, for example, when pressing the key **E2** again, the chart columns are moved by 3 columns to the left.

- **Note:** By pressing key **E1** or key **E2** twice in quick succession, you can page to the left or right by 7 load chart columns (equals the display area of the LICCON monitor).

**H SHIFT key**

- **SHIFT** (hold down) and **E1**: Jump to the first column in the load chart.
- **SHIFT** (hold down) and **E2**: Jump to last column in load chart.

## 5 Crane operation program

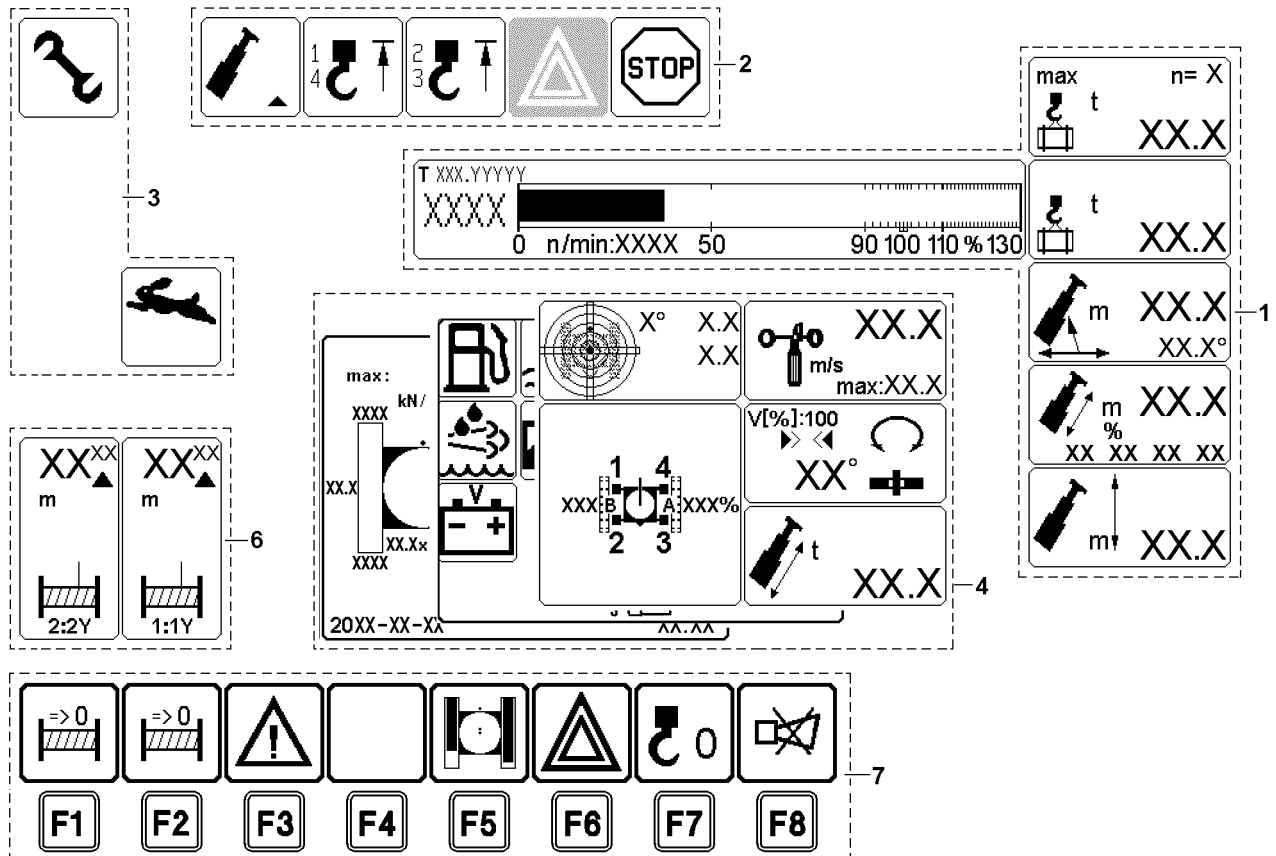


Fig.122528: Exemplary illustration of displays in the Crane operation program

The Crane operation LICCON program assists the crane driver by clearly displaying the data needed for crane operation on the monitor. An acoustic signal accompanies all critical displays. Depending on the equipment, a range of other icons may also be turned on as additional displays, either as required by the crane operator or automatically in the event of a problem.

It also alerts the crane operator to imminent overload conditions. In the event of overload and many error conditions, which could be hazardous, the system shuts off.

LWE/LTR 1220-003/24204-02-02/en

The monitor is divided into seven areas in the Crane operation program:

- 1 Crane geometry and load information
- 2 Alarm functions
- 3 Special functions
- 4 Monitoring functions
  - Monitoring functions during crane operation
  - Monitoring the surface pressure and center of gravity
  - Monitored auxiliary functions
- 6 Winch display
- 7 Function key line (crane operation)



#### Note

- ▶ The monitor illustrations in this chapter are only examples. The display values in the individual icons and charts do not have to necessarily match the crane exactly. The configuration of the LICCON monitor with icons is only descriptive.
- ▶ An identical icon display will **not** appear during crane operation.

## 5.1 Crane geometry and load information

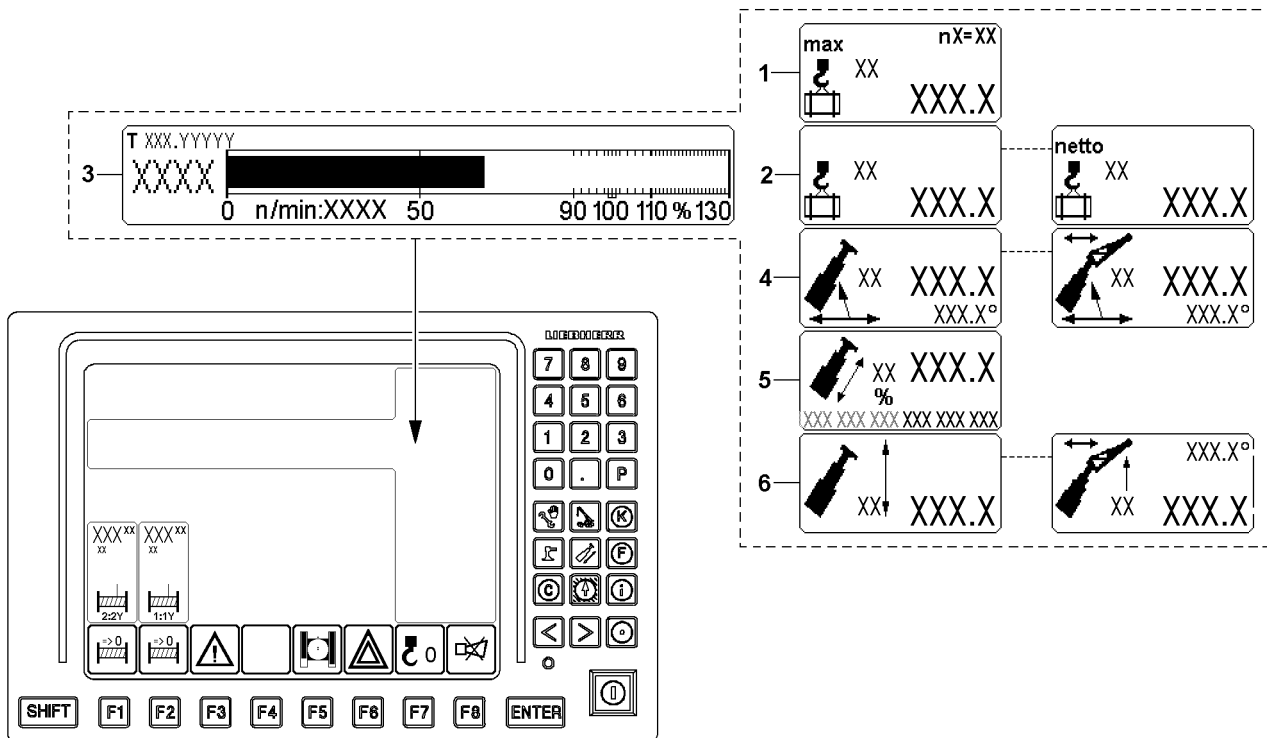


Fig.123733: Crane geometry and load information



#### Note

- ▶ The crane illustrations in this section are only examples and are generalized.
- ▶ They may differ from the crane type and equipment.

The information regarding crane geometry and load involves six icons:

- 1 Maximum load
- 2 Actual load / net load
  - **Note:** The actual load display can be changed over to the net load display.
- 3 Utilization bar diagram



- 4 Boom radius
  - **Note:** For crane types with auxiliary boom\* the illustration of the icon can change depending on the set up configuration.
- 5 Boom length
- 6 Pulley head height
  - **Note:** For crane types with auxiliary boom\* the illustration of the icon can change depending on the set up configuration.



**Note**

- ▶ A question mark („?“) is shown instead of values when no load chart value can be accessed.  
Example: The crane is not in the range of the load chart.
- ▶ A question mark („?“) is shown instead of values if the value cannot be calculated / determined.  
Example: A sensor error can be present - pay attention to the error messages.

**5.1.1 Maximum load**

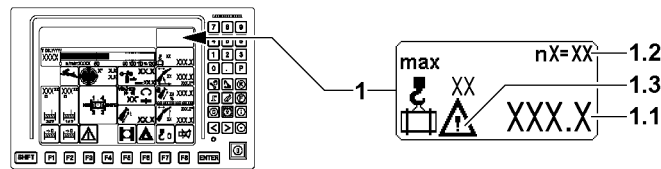


Fig.122529: Display Maximum load

- 1 Maximum load icon
  - With text for measurement unit
- 1.1 Maximum load
  - Maximum load according to load chart
  - In [t] or [lbs]
- 1.2 Reeving
  - Reeving according to settings from the Set up program
- 1.3 Warning icon
  - When the warning icon 1.3 appears:
    - Check the displays / display values on the LICCON monitor
    - Pay attention to error messages



**WARNING**

Danger of accident!

- ▶ If the warning icon 1.3 appears on the LICCON monitor, crane operation is prohibited.
- ▶ Pay attention to the error message: Call up the BSE-Test system and evaluate the error message, see the Diagnostics manual.
- ▶ Initiate measures to counteract the warning message and to put the crane in a safe operating condition.

**5.1.2 Actual load (current load) / net load**

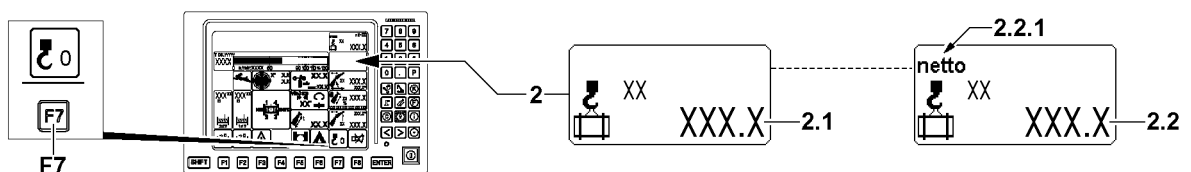


Fig.122530: Display Actual load / net load

- 2 Actual load / net load icon
  - With text for MU [t] or [lbs]

LWE/LTR 1220-003/24204-02-02/en

### 2.1 Actual load display

- Actual load display = load in [t] or [lbs] that is currently suspended from the boom
- Display of the calculated total load including the weights of the load carrying, load taking on and / or fastening equipment.

### 2.2 Net load

- Net load display = the actual load display 2.1 can be changed at any time to net load 2.2 (tared) by pressing the function key **F7**.
- After pressing the function key **F7** the display value is set to zero and the word net 2.2.1 is shown.
- As long as net load is set, the icon above the function key **F7** is shown in red.
- If the taring is cancelled, the word net 2.2.1 disappears from the icon and the gross load value is displayed.

The change to net load is cancelled by each of the following actions:

- By pressing the function key **F7** again.
- By telescoping the boom by more than three LE (LE= 1 decimeter or 1/10 ft).
- By luffing by more than  $\pm 4^\circ$ .
- **Note:** This makes it possible to eliminate the weights of the load handling, load taking on and / or fastening equipment in the display value. The maximum load is not increased / adjusted.



### WARNING

Incorrectly determined weight of the load!

Due to operating errors or tolerances, deviations can occur for the displayed values in the *Actual load / net load* icon 2.

- ▶ The actual load display / net load display is no calibrated weighing device.
- ▶ Always observe the actual weight of the load in connection with the load charts and the set up configuration of the crane.

## 5.1.3 Utilization bar diagram (dynamic utilization bar display)

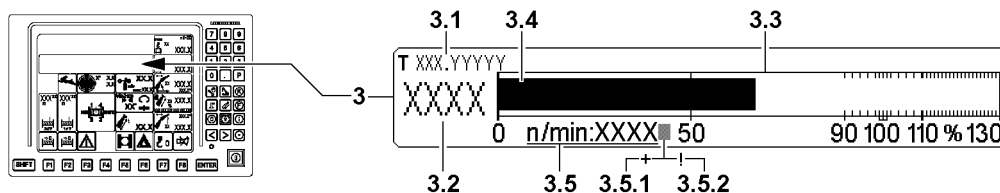


Fig.122531: Utilization bar diagram

#### 3 Bar diagram of utilization icon

##### 3.1 Chart names

- Note to the set chart name (chart number) with associated operating mode

##### 3.2 Short code

- Identifies the selected set up configuration

##### 3.3 Utilization scale

- Marking from a utilization of 90 % <sup>1)</sup>: **Advance warning**
- Marking at a utilization of 100 % <sup>1)</sup>: **STOP shut-off**
- **Note:** 1) Factory settings, observe section „Setting the limit values for the load torque limiter for advance warning and shut-off“

##### 3.4 Crane utilization bar

- Current utilization of crane according to load chart and reeving
- Displayed as bar diagram
- Appears in blue, green, yellow and red, depending on the situation
- Utilization bar 3.4 blue: Utilization in permissible range, set up change of crane in this utilization is permissible
- Utilization bar 3.4 green: Utilization in permissible range

- Utilization bar 3.4 yellow: **Advance warning!** Utilization just before impermissible range
- Utilization bar 3.4 red: **Warning!** Utilization in impermissible range

Utilization of crane according to load chart and reeving	
Current utilization of the crane	Actual load
	= $\frac{\text{Actual load}}{\text{Maximum load}}$



**Note**

- ▶ The set up configuration of the crane may only be changed if the utilization bar 3.4 is blue or if there is no load on the hook (load hook / hook block).

**3.5 Engine rpm**

- In revolutions per minute [rpm]
- **NOTICE:** If the display is in red, an error is present.
- **Note:** Question marks („?“) instead of a numeric value appear if there is an error in the rpm recording. Then the rpm specified by the control for the diesel engine is set for the output regulation of the drives. The rpm specified by the control is shown blinking. An error message is issued.

**3.5.1 Engine rpm lock**

- The engine rpm can be locked on the master switch. If the engine rpm has been locked, the „+“ sign appears behind the rpm display.

**3.5.2 ECO-Mode engine rpm limitation**

- The engine rpm can be limited in ECO-Mode, see section „ECO-Mode“. If the engine rpm is limited, the „!“ character appears behind the rpm display.

**5.1.4 Boom radius**

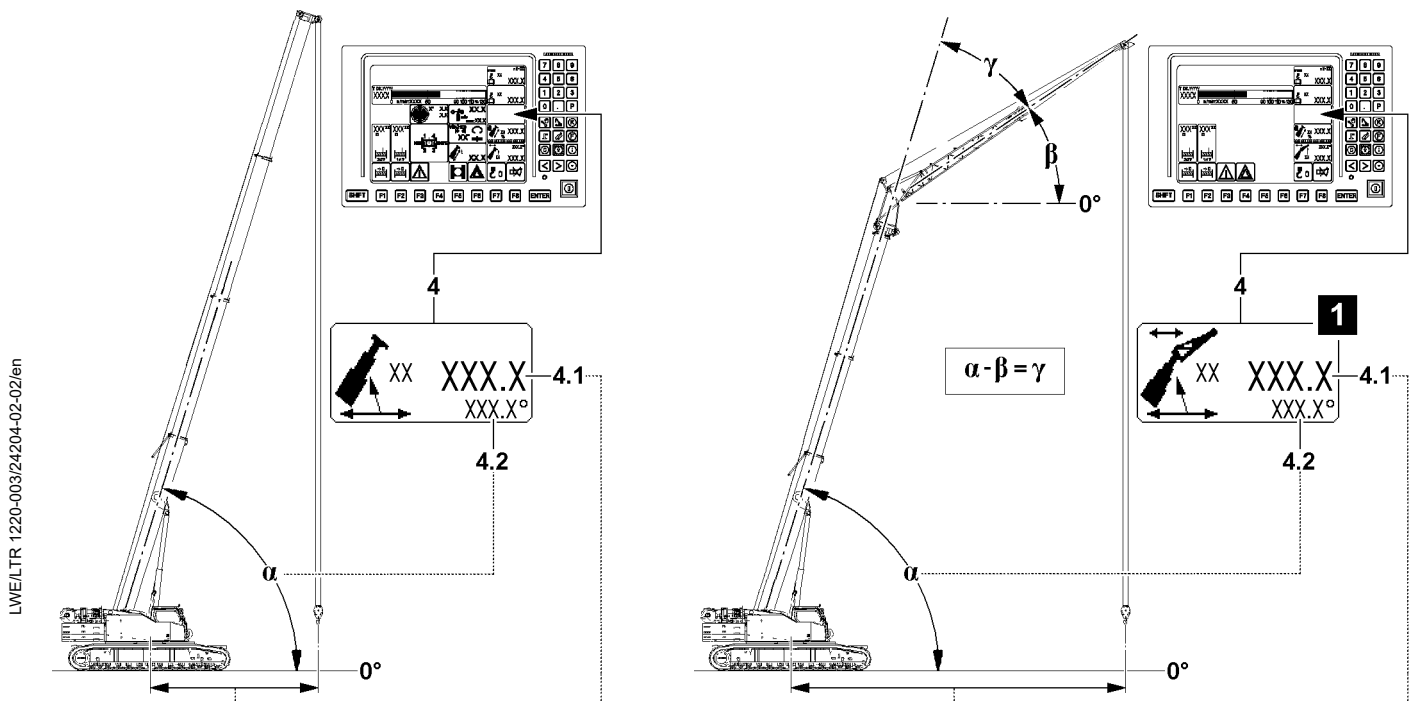


Fig.122526: Boom radius display

LWE/TR 1220-003/24204-02-02/en

**Note**

- For crane types with an auxiliary boom\*, the illustration of the icon can change depending on the set up configuration, see example illustration 1.

**4 Boom radius icon****4.1 Boom radius**

- In [m] or [ft]

Denotes the horizontal distance of the load hook from the rotation axis of the crane superstructure. This also takes into account the boom flexation due to its own weight and the suspended weight of the load.

**4.2 Main boom angle**

- In [°]
- Displayed is the angle of the main boom to the horizontal (angle  $\alpha$ )

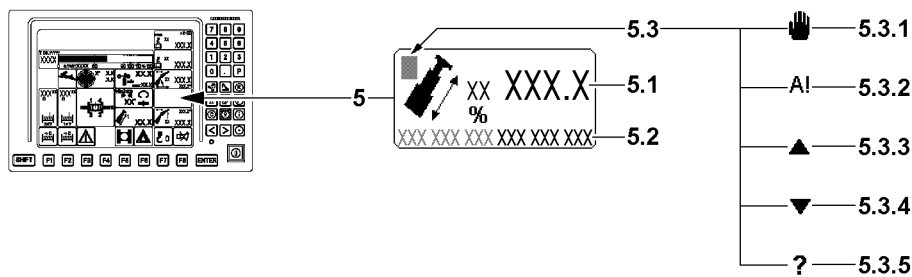
**5.1.5 Main boom length**

Fig.122532: Main boom length display

**5 Main boom length icon****5.1 Length of the main boom**

- In [m] or [ft]

**5.2 Extension conditions of individual telescopic sections**

- In [%]
- The extension conditions of telescope 1, telescope 2 etc. are shown from the left to the right.

**Note:** Depending on the crane type, up to seven extension conditions can be displayed

**5.3 TELEMATIK**

- **Note:** Only for crane types with the TELEMATIK telescoping system
- **5.3.1** Manual telescoping active
- **5.3.2** Preselected telescoping target reached
- **5.3.3** Up arrow: Telescope out request
- **5.3.4** Down arrow: Telescope in request
- **5.3.5** Error in system, observe error message

**Note**

- In the icon *boom length* **5** all required information is shown to allow an experienced crane operator to telescope the telescopic boom to the desired length.
- For a detailed description for telescoping, see Chapter 4.05.

### 5.1.6 Pulley head height

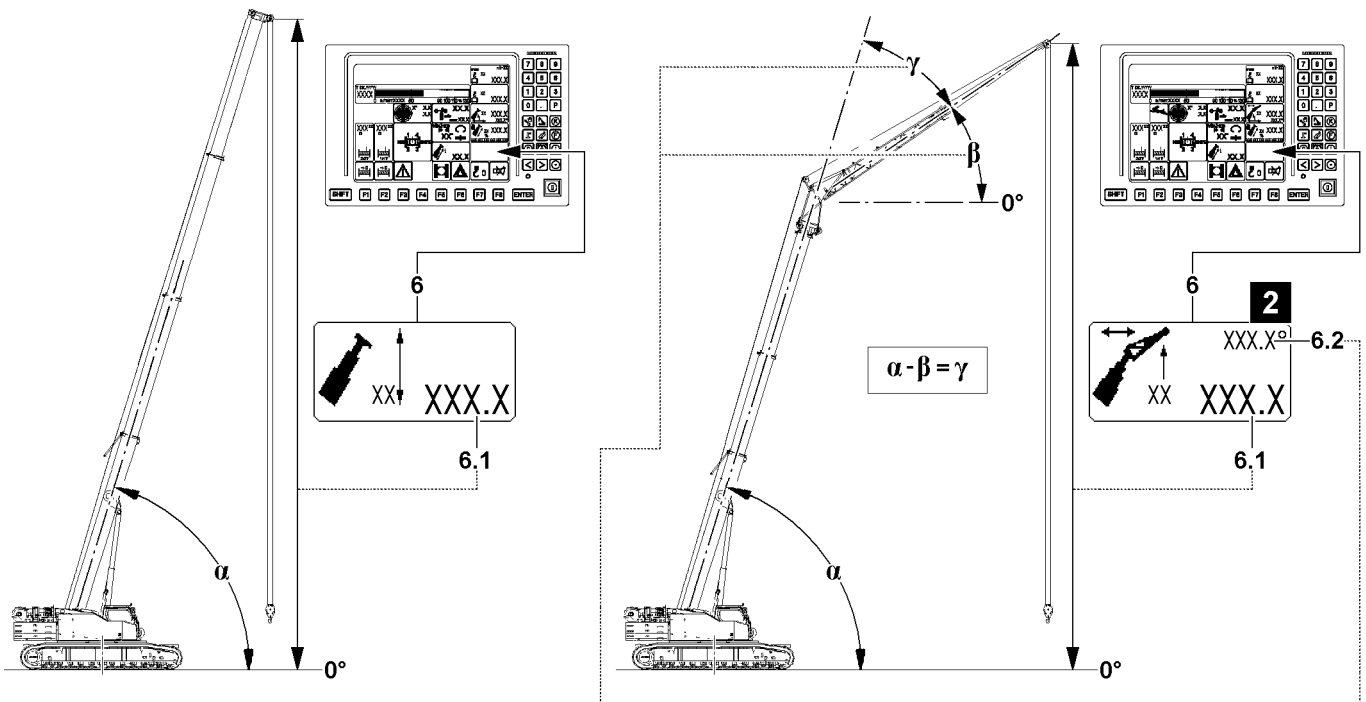


Fig.122527: Pulley head height display



**Note**

- ▶ For crane types with an auxiliary boom\*, the illustration of the icon can change depending on the set up configuration, see example illustration 2.

**6 Pulley head height icon**

**6.1 Pulley head height**

- In [m] or [ft]
- Identifies the vertical distance from the crane base to the selected pulley head axle, for which the displayed maximum load applies

**6.2 Auxiliary boom / accessory angle**

- In [°]



**Note**

- ▶ Depending on the set up configuration and the load chart, a differentiation is made between an absolute angle display or a relative angle display. Position of angle, see example Illustration 2.

**β Auxiliary boom / accessory absolute angle**

- The angle of the auxiliary boom / accessory to the horizontal in [°]
- Display absolute angle: For operating modes with load chart for specified angles of the main boom.

or

**γ Relative angle auxiliary boom / accessory**

- Angle between the main boom and the auxiliary boom / accessory in [°]
- Display relative angle: For operating modes with load chart for specified angles of the auxiliary boom / accessory.

LWE/LTR 1220-003/24204-02-02/en

## 5.2 Alarm functions

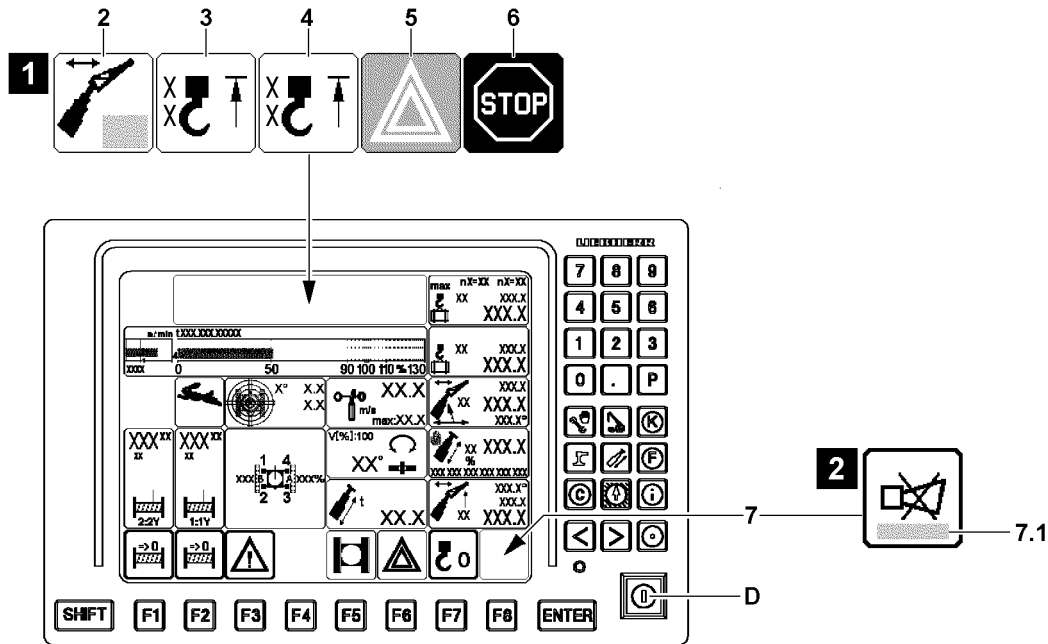


Fig.123723: Exemplary illustration of alarm functions

### NOTICE

Triggered alarm function!

If an alarm function is triggered (for example an advance warning occurrence or shut off of crane movement), the cause must be determined.

- ▶ Always pay attention to triggered alarm functions.

The limit ranges of the crane movements are monitored. When the limit ranges are reached, the crane operator is warned by the alarm functions.

The alarm functions are shown by the LICCON monitor via:

- Icons, shown optically, see illustration 1.
- A warning sound is acoustically reported.

If a warning occurs, an error message 7.1 is issued in the *horn* icon 7, see illustration 2.

The alarm functions include:

- 2 Boom limitation
  - See section „Boom limitations“
- 3 Hoist limit switch
  - Hoist limit switch of first load position
  - See section „Hoist limit switch“
- 4 Hoist limit switch
  - Hoist limit switch of second load position\*
  - See section „Hoist limit switch“
- 5 Occurrence of an advance warning
  - See section „Occurrence of advance warning“
- 6 Shut off the crane movement
  - See section „Shut off the crane movement“

as well as

- 7 Acoustic warnings
  - See section „Acoustic warnings on the LICCON monitor“

### 5.2.1 Boom limitations

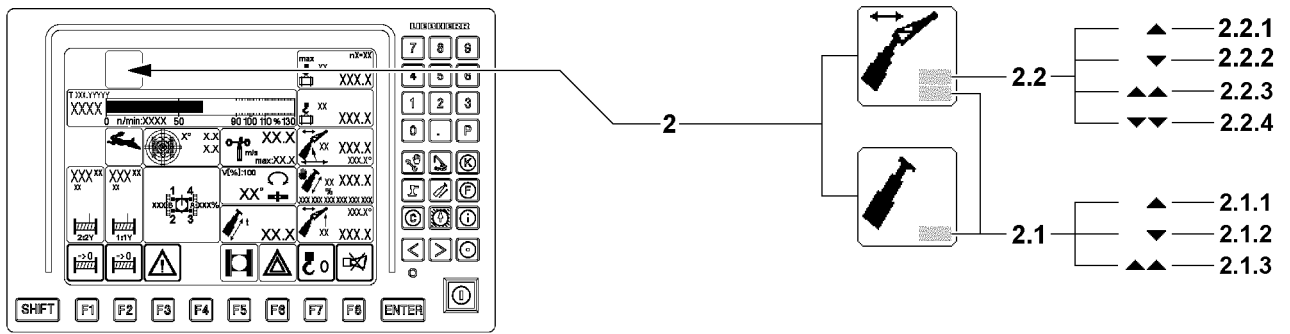


Fig.123724: Exemplary illustration of boom limitations

#### Limit signs main boom



**Note**

- ▶ The *Boom limitation* icon **2** can change in different operating modes, but it is shown always in the same position on the LICCON monitor.
- ▶ The field **2.1** refers to the main boom.
- ▶ The field **2.2** refers to the auxiliary boom / accessory.

**2.1 Boom limitation Main boom icon**

- The luffing range of the main boom is limited both upward and downward.
- This icon appears if an end position determined by the load chart is reached when luffing the boom or when luffing the boom is disabled by a proximity switch.

Position	Icon	Description
2.1.1	▲	The shut-off <i>Luffing up the main boom</i> is made by running against the upper load chart limit. <b>Note:</b> Luffing down the main boom is still possible.
2.1.2	▼	The <i>Luffing down the main boom</i> shut-off is made by running against the lower load chart limit. <b>Note:</b> Luffing up the main boom is still possible.



**WARNING**

Alarm function deactivated!

When the set up key **D** is actuated, there is no shut-off of crane movement via position **2.1.1** and position **2.1.2**.

- ▶ Observe chapter 4.20.

Position	Icon	Description
2.1.3	▲▲	The shut-off <i>Luffing up the main boom</i> is made by triggering the proximity switch (boom steep). <b>Note:</b> Luffing down the main boom is still possible.

LWE/LTR 1220-003/24204-02-02/en

**Limit sign auxiliary boom / accessory**



**Note**

- ▶ The *Boom limitation* icon **2** can change in different operating modes, but it is shown always in the same position on the LICCON monitor.
- ▶ The field **2.1** refers to the main boom limitation sign.
- ▶ The field **2.2** refers to the limitation signs auxiliary boom / accessory.

**2.2 Auxiliary boom / accessory boom limitation icon**

- The luffing range of the auxiliary boom / accessory is limited both upward and downward.
- This icon appears if an end position determined by the load chart is reached when luffing the auxiliary boom / accessory or when luffing is disabled by a limit switch.

Position	Icon	Description
2.2.1	▲	The <i>Luffing up the auxiliary boom / accessory</i> shut-off is triggered by running against the upper load chart limit. <b>Note:</b> Luffing down the auxiliary boom / accessories remains possible.
2.2.2	▼	The <i>Luffing down the auxiliary boom / accessory</i> shut-off is triggered by running against the lower load chart limit. <b>Note:</b> Luffing up the auxiliary boom / accessories remains possible.



**WARNING**

Alarm function deactivated!

When the set up key **D** is actuated, there is no shut-off of crane movement via position **2.2.1** and position **2.2.2**.

- ▶ Observe chapter 4.20.

Position	Icon	Description
2.2.3	▲▲	The <i>Luffing up the auxiliary boom / accessory</i> shut-off was triggered by reaching a proximity switch ( <i>Jib on top block</i> or <i>Jib on top flap</i> ). <b>Note:</b> Luffing down the auxiliary boom / accessories remains possible.
2.2.4	▼▼	The <i>Luffing down the auxiliary boom / accessory</i> shut-off is triggered by running against one of the block limit switches ( <i>jib bottom</i> ). <b>Note:</b> Luffing up the auxiliary boom / accessories remains possible.

**Failure of sensor / limit switch**

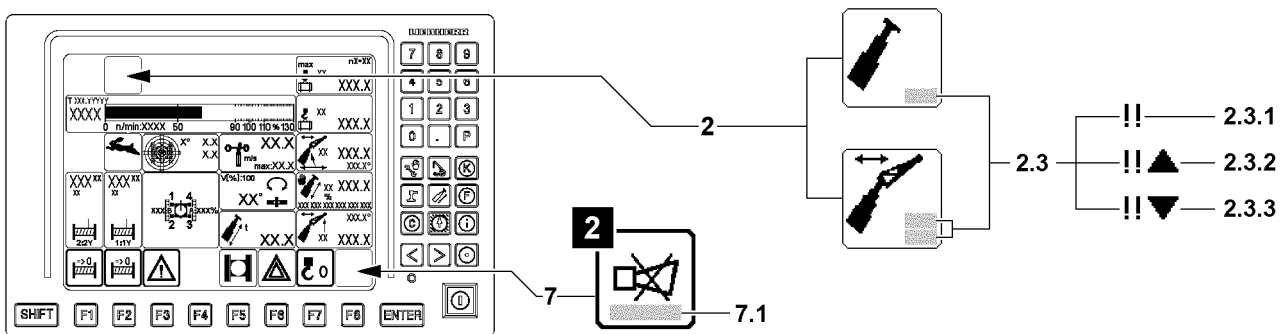


Fig.123725: Exemplary illustration of failure of sensor / limit switch

LWE/LTR 1220-003/24204-02-02/en



**NOTICE**

Failure of sensor / limit switch!

Depending on the classification of the sensor / limit switch, the crane can continue to be operated with limitation or is shut off by the control.

An error message 7.1 is issued in the *Horn* icon 7, see illustration 2.

The error message shows defective sensors / limit switches, see Diagnostics manual.

- ▶ The error must be remedied immediately.
- ▶ Crane movements after a failure of a sensor / limit switch must be carried out anticipatorily and with extreme caution.

Position	Icon	Description
2.3.1	!!	On the auxiliary boom / accessory, at least one associated sensor / limit switch is defective / missing. If an alarm function occurs at the same time, then the icon can be shown differently, see position 2.3.1, position 2.3.2 or position 2.3.3.
2.3.2	!!▲	
2.3.3	!!▼	<b>Note:</b> Not every failure of a sensor / limit switch on the boom is shown in the <i>Boom limitation</i> icon 2. Observe the error message in the <i>Horn</i> icon 7.



**Note**

- ▶ Depending on the classification of the sensor / limit switch, the respective crane movement is shut off in case of a failure and **cannot be bypassed**. An emergency operating mode may be required for subsequent steps.
- ▶ When deflecting the master switch, an operating error message is issued in the *Horn* icon 7. The operating error message shows defective sensors / limit switches.
- ▶ If the error cannot be remedied by yourself, contact Liebherr Service.

**5.2.2 Hoist limit switch**

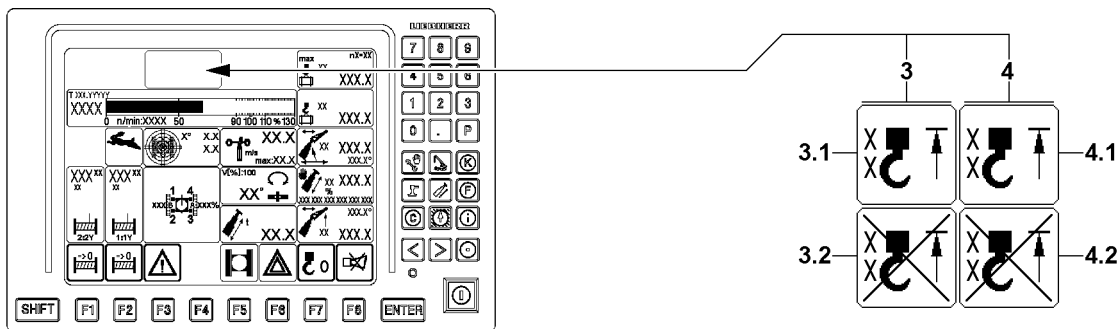


Fig.123726: Exemplary illustration of hoist limit switch triggered / bypassed

In order to prevent the crane from being operated without hoist limit switches (HES), the minimum hoist limit switch configuration is continuously monitored to ensure it is present. If a hoist limit switch required for a particular operating mode is not plugged in, therefore not active on the LSB bus system, corresponding crane movements can be disabled and an operating error message is also issued.

The identification of the triggered hoist limit switch HES1 to HES6 appears in the respective icon.

**3 Hoist top icon**

- *Hoist top* icon 3 for the first load position

**Note:** Appears only when a hoist limit switch is active for the first load position on the LSB bus system.

LWE/LTR 1220-003/24204-02-02/en

### 3.1 Hoist top triggered icon

- The *Hoist top triggered* icon 3.1 appears when:
  - The hook block is pulled against the hoist limit switch.
  - The minimum weight on the hoist limit switch is not attached (for example on a taken down boom).
  - The hoist limit switch is not active, although it must be present on the bus.
  - The hoist limit switch has an internal error.
- Note:** Spool up hoist winches is turned off.  
Additional crane movements can be turned off.

### 3.2 Hoist top bypassed icon

- The *hoist top bypassed* icon 3.2 appears if the hoist limit switch is bypassed, see section „Special functions“.

### 4 Hoist top icon

- Hoist top icon 4* for the second load position  
**Note:** Appears only when a hoist limit switch is active for the second load position on the LSB bus system.

### 4.1 Hoist top triggered icon

- The *Hoist top triggered* icon 4.1 appears when:
  - The hook block is pulled against the hoist limit switch.
  - The minimum weight on the hoist limit switch is not attached (for example on a taken down boom).
  - The hoist limit switch is not active, although it must be present on the bus.
  - The hoist limit switch has an internal error.
- Note:** Spool up hoist winches is turned off.  
Additional crane movements can be turned off.

### 4.2 Hoist top bypassed icon

- The *hoist top bypassed* icon 4.2 appears if the hoist limit switch is bypassed, see section „Special functions“.

## 5.2.3 Occurrence of an advance warning

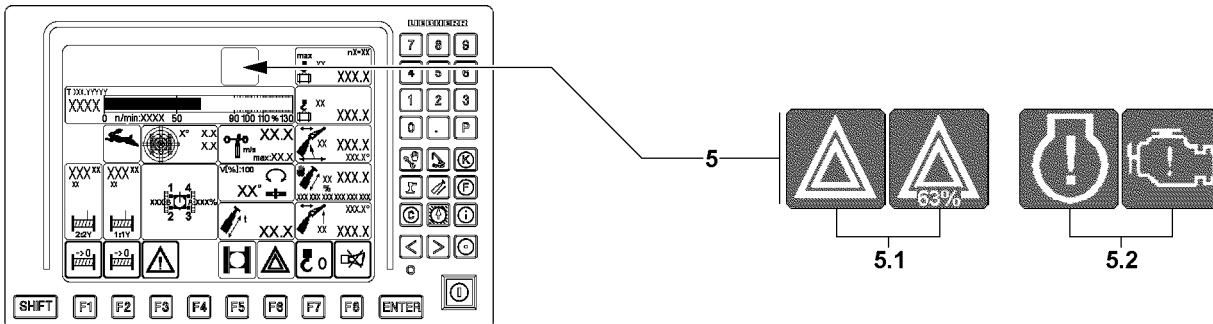


Fig.152664: Exemplary illustration of possible advance warnings

### 5 Advance warning icon

#### 5.1 Advance warning

- The current utilization of the crane results from the actual load and the maximum load.
- The *Advance warning* icon appears if:
  - The current utilization of the crane exceeds the limit programmed for the advance warning (standard value **90 percent**).
  - or**
  - The current utilization of the crane exceeds the limit set for the advance warning (sample value 63 percent).

#### 5.2 Engine monitoring advance warning

- an advance warning for one or more monitoring functions in the engine monitoring occurs  
**or**

- a load reduction is triggered by the exhaust aftertreatment (only for engines with an SCR system for exhaust aftertreatment)
- **NOTICE:** If the Advance warning engine monitoring **5.2** appears, the monitoring functions must be checked.
- **Note:** Only for certain crane types.



### WARNING

Non-observance of advance warnings!

If advance warnings are not observed, then this can result in a sudden shut-off of the crane movement.

A sudden shut off of the crane movement can result in high stress and strain for crane and load. High stress and strain for crane and load can cause accidents.

- ▶ Operate the crane in such a way that there is no shut off of crane movements by the crane control.
- ▶ Pay attention to advance warnings and approach a possible shut off of crane movements extremely cautiously.

### NOTICE

Shut off engine monitoring!

Outside of the crane operation program, the engine monitoring is turned off.

When the engine monitoring is turned off, problems and warning occurrences are not recognized. This could result in crane failure.

- ▶ If work is not carried out in the crane operation program, then turn the crane engine off and operate the LICCON computer system in stand-by mode, see section „Power-Save mode and Stand-by mode on the LICCON computer system“.
- ▶ If work has to be carried out for a longer period outside of the Crane operation program, with the crane engine running, then switch regularly to the engine monitoring screen.

## 5.2.4 Shutting off the crane movement

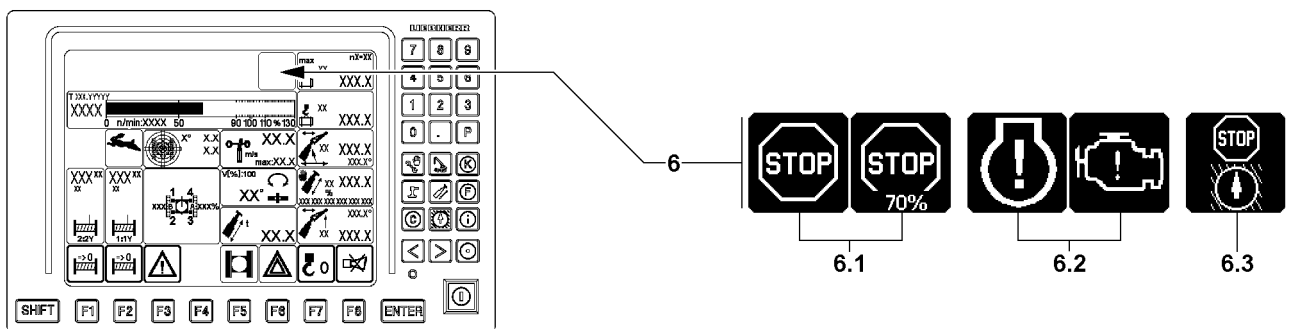


Fig.152665: Exemplary illustration of possible shut-offs

### 6 STOP icon

#### 6.1 LMB-STOP icon

- The *LMB-STOP* icon appears when the crane movement is turned off by the overload protection.

Possible causes:

- **Utilization of the crane:**

- The *LMB-STOP* icon appears when the current utilization of the crane exceeds the programmed limit for the overload protection (Standard 100 percent).

or

The *LMB-STOP* icon appears when the current utilization of the crane exceeds the limit set for the overload protection (Standard 70 percent).

- **Sensor error:** The *LMB-STOP* icon appears when a sensor which is required to monitor the load chart has an error (*LMB-STOP* is actuated).
- **No load chart:** The *LMB-STOP* icon appears if no load chart is available (*LMB-STOP* is triggered).

**WARNING**

Crane movements at *LMB-STOP*!

If the *LMB-STOP* icon **6.1** appears, not all crane movements are necessarily turned off. In certain circumstances, load moment decreasing crane movements are still possible.

- ▶ Always determine the exact cause for the *LMB-STOP* **6.1** first.
- ▶ Carry out any crane movements which are still possible with extreme caution.

**6.2 Engine STOP**

- The *Engine-STOP* icon appears if:
  - A STOP event takes place in engine monitoring.
- or**
- a load reduction is triggered by the exhaust aftertreatment (only for engines with an SCR system for exhaust aftertreatment)

**6.3 Working range STOP**

- Appears if a STOP event takes place in the working range limitation
- **Note:** Appears only on crane types with Working range limitation\*

**WARNING**

Shut off of the crane movement!

A sudden shut off of the crane movement can result in high stress and strain for crane and load. High stress and strain for crane and load can cause accidents.

- ▶ Operate the crane in such a way if possible that there is no shut off of crane movements by the crane control.
- ▶ Monitor the display instruments constantly.
- ▶ If not otherwise possible, approach a possible shut off of crane movements with extreme caution.

**NOTICE**

Shut off engine monitoring!

Outside of the crane operation program, the engine monitoring is turned off.

When the engine monitoring is turned off, problems and warning occurrences are not recognized. This could result in crane failure.

- ▶ If work is not carried out in the crane operation program, then turn the crane engine off and operate the LICCON computer system in stand-by mode, see section „Power-Save mode and Stand-by mode on the LICCON computer system“.
- ▶ If work has to be carried out for a longer period outside of the Crane operation program, with the crane engine running, then switch regularly to the engine monitoring screen.

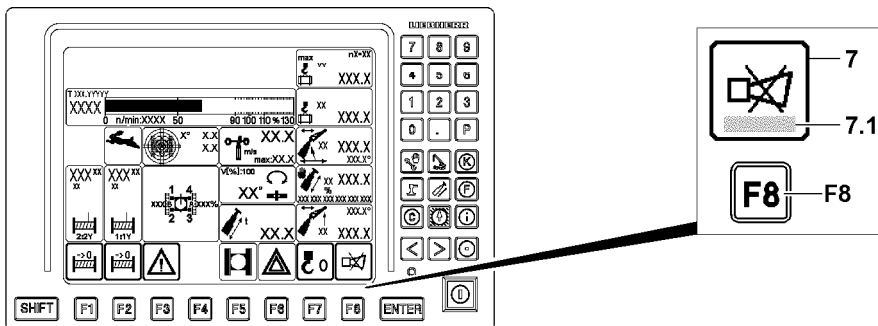
**5.2.5 Acoustic warnings on the LICCON monitor**

Fig.123729: Acoustic warnings on the LICCON monitor

Acoustic warnings on the LICCON monitor are indicated by a warning sound.

The warning sound is divided into two categories:

- Warning sound *Horn* is a beeping sound of a duration of approximately 0.5 seconds, which is repeated in a second cycle.

- Warning sound *Short horn* is a beeping sound of a duration of approximately 0.1 seconds, which is repeated in a second cycle.

#### 7 Horn icon

- When the *horn* icon is shown on the LICCON monitor, any acoustic signals which will occur can be shut off by pressing the function key **F8**.
- If an error message is shown in the *Horn* icon 7 in field 7.1, then the present error can be determined through it. Pressing the function key **F8** twice automatically changes to the error determination screen of the BSE test system. The error is displayed in documentary form.

#### Horn warning sound

1. Sounds in addition to the visual display of an error message in field 7.1 in case of operational errors are found, which lead to a shut-off of a crane movement.

Operational errors are:

- Overload
  - Boom outside of the angle / boom radius range of the load chart
  - Extension condition of telescopes not in accordance with the load chart
2. In case of application errors with error number (LICCON-Error-Code - LEC). For example sensor errors, which occur due to insufficient sensor signals or a defective sensor.

The following sensors are monitored:

- Length sensors
- Angle sensor
- Pressure sensor
- Pull test brackets (force test boxes)
- Inductive sensors
- Hoist limit switch
- Wind sensor
- Battery voltage

#### Short horn warning sound

Sounds in addition to the visual display of error messages without an error number and that do not lead directly to crane movement shut-off by the LICCON overload protection

Monitored error messages are:

- Maximum permissible wind speed exceeded (only with an activated wind sensor\*)
- Support force exceeded / fallen below (only in activated support force monitoring\*)
- Crane utilization value for advance warning (90 %) reached or exceeded

#### Priority acoustic signal

- The warning sound *Horn* has higher priority than the *Short horn* warning sound, which means the *Horn* warning sound takes preference over the *Short horn* warning sound.

#### Turning the warning sound off

- The warning sound can be turned off by pressing the function key **F8**.
- The *Horn* warning sound as well as the *Short horn* warning sound immediately become active again if a new error occurs.

## 5.3 Special functions

With the special functions the special cases for the operation of the LICCON overload protection (special cases for the overload protection EN 13000:2010) can be operated, see Crane operating instructions, chapter 4.20.

### 5.3.1 Special functions LICCON overload protection

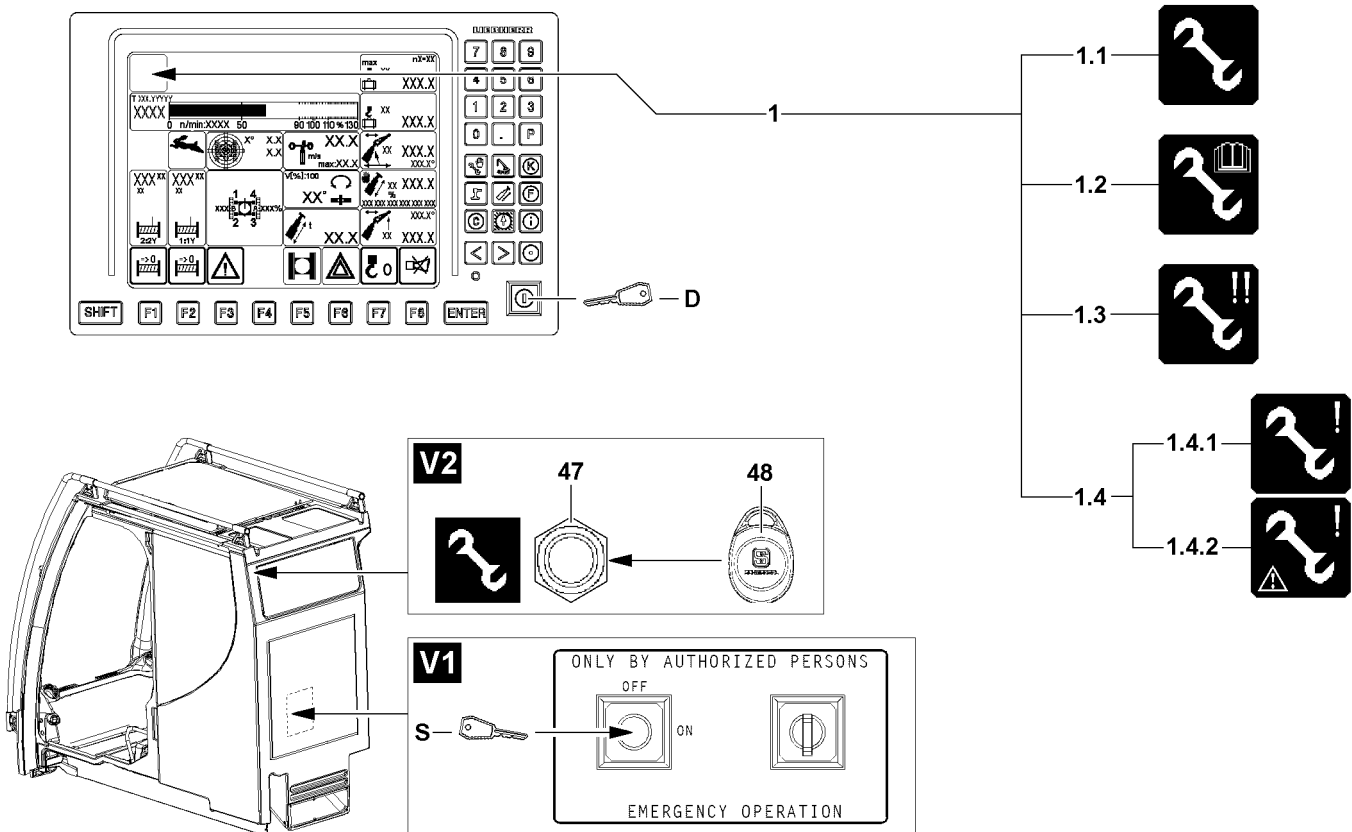


Fig. 123730: Exemplary illustration of the displays for special functions of the LICCON overload protection with operating elements

If the shut off limits of the LICCON overload protection are exceeded, the LICCON overload protection shuts the crane movements off.

These shut off limits can be exceeded by the set up key **D** in the *right touching* position. To do so, chapter 4.20 in the Crane operating instructions must be observed.



#### WARNING

Danger of accident due to the *Exceedance of shut-off limits of the LICCON overload protection* function!

If the shut off limits of the LICCON overload protection are exceeded, there is no additional protection against crane overload.

Due to erroneous operation or deliberate misuse, the crane could collapse, the boom can break off or the crane can topple over.

Personnel can be severely injured or killed.

- ▶ The function *Exceedance of shut off limits of the LICCON overload protection* is only permissible in emergencies and for assembly purposes.
- ▶ The set up key **D** may only be actuated when the specifications of the crane documentation in this regard are adhered to.
- ▶ The set up key **D** may only be actuated by persons who are aware of the effects of their acts regarding the function *Exceedance of shut off limits of the LICCON overload protection*.
- ▶ The *Exceedance of shut off limits of the LICCON overload protection* function requires the presence of an authorized person and must be performed with utmost caution.
- ▶ Crane operation with the *Exceedance of shut-off limits of the LICCON overload protection* function activated is prohibited.

**Note**

Double function set up key

If the crane control *EN 13000:2010 not active* is programmed, the shut offs are deactivated by the LICCON overload protection when the set up key **D** is pressed.

- ▶ If the crane control *EN 13000:2010 not active* is programmed, when actuating the set up key **D**, the function *Emergency operation LICCON overload protection* is automatically also released.

Before pressing the set up key **D** make sure that:

- Conditions and specifications to use the set up key **D** are known to the crane operator, were understood and adhered to, see also Crane operating instructions, chapter 4.20.

**Note**

- ▶ The various *Assembly* icons **1** are shown on the same position in the LICCON monitor, depending on the situation. Two icons **1** variations cannot appear simultaneously.

**Note**

- ▶ The actuation of the set up key **D** is recorded in the data logger.
- ▶ The actuation of the key button **S** is recorded in the data logger.
- ▶ The application of the transponder **48** on the sensor **47** is recorded in the data logger.

**Exceeding the shut off limits of the LICCON overload protection****1.1 Assembly**

- The icon appears when a special case for operation of the LICCON overload protection was activated, for example the shut off limits of the LICCON overload protection were bypassed by the set up key **D**.

**No load chart is available****1.2 Assembly - no load chart**

- The icon appears when the shut off limits of the LICCON overload protection are bypassed via the set up key **D** and no load chart is available.
- The crane may solely be operated according to the specifications in the crane documentation.
- **Note:** By actuating the set up key **D**, all erection / take down procedures can be carried out within the erection / take down charts, for which no load charts are available!

**Emergency operation LICCON overload protection (EN 13000:2010 active)****WARNING**

Increased danger of accident during emergency operation of the LICCON overload protection!

In emergency operation, the crane movements are no longer monitored by the LICCON overload protection.

- ▶ The emergency operation may only be activated by persons who are aware of the consequences of their actions.
- ▶ A shut-off by the LICCON overload protection may not be circumvented by the emergency operation.
- ▶ If normal crane operation is possible, then the emergency operation may not be activated.
- ▶ All crane movements must be carried out with extreme caution and anticipatorily.

**1.3 Emergency operation activated**

- The icon appears:
  - when the emergency operation of the LICCON overload protection is activated via the key button **S** or by actuation of the transponder **48** on the sensor **47**.

**Note**

Activating emergency operation

- ▶ If emergency operation of the LICCON overload protection is activated via the key button **S** or by actuation of the transponder **48** on the sensor **47** depends on the crane type. Observe the Crane operating instructions, chapter 4.01.

### LICCON overload protection emergency operation (EN 13000:2010 not active)

**Note**

If the crane control *EN 13000:2010 not active* is programmed, then the function *Emergency operation of the LICCON overload protection* is activated by the set up key **D**.

- ▶ If the emergency operation LICCON overload protection is needed, press the set up key **D**.

#### 1.3 LMB emergency operation 1.3 activated

- The icon appears:
  - when the LMB emergency operation is activated via the set up key **D**.
  - **Note:** Depending on the reason for the LMB emergency operation, the icon for no load chart available **1.2** can also appear.

### Additional emergency operating modes

**WARNING**

Improper crane operation!

If one of the icons for additional emergency operating modes **1.4** appears, then there is a high danger of accident due to erroneous operation of the crane.

Safety equipment could be deactivated.

Personnel can be killed or injured.

This could result in property damage.

- ▶ Deactivate additional operating modes **1.4** again or contact Liebherr Service and coordinate further procedure.

#### 1.4 Additional emergency operating modes

- Icon **1.4.1** or icon **1.4.2** appears if additional emergency operating modes were activated.

## 5.3.2 Bypass of hoist limit switch

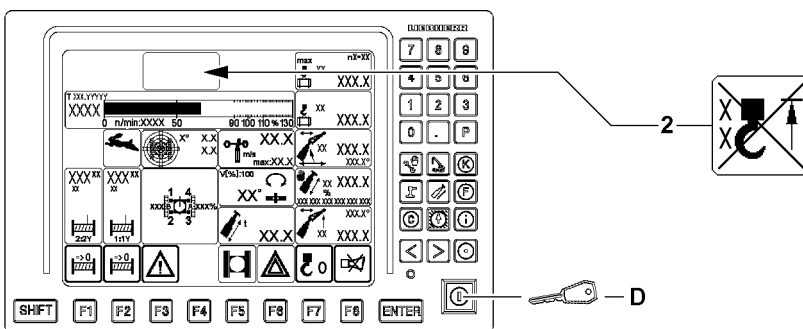


Fig.123731: Bypass of hoist limit switch

If the hook block touches the hoist limit switch weight during upward movement, the hoist limit switch is activated. The *Spool up winches*, *Luff telescopic boom down* and *Telescope telescopic boom out* crane movements are shut off. This shut-off can be bypassed by the set up key **D** in the *right touching* position. To do so, chapter 4.20 in the Crane operating instructions must be observed.

#### 2 Hoist top bypassed icon

- The icon appears when the hoist limit switch is bypassed by pressing the set up key **D**.



**Note:** All hoist limit switches are always bypassed together.

### 5.3.3 Rapid gear

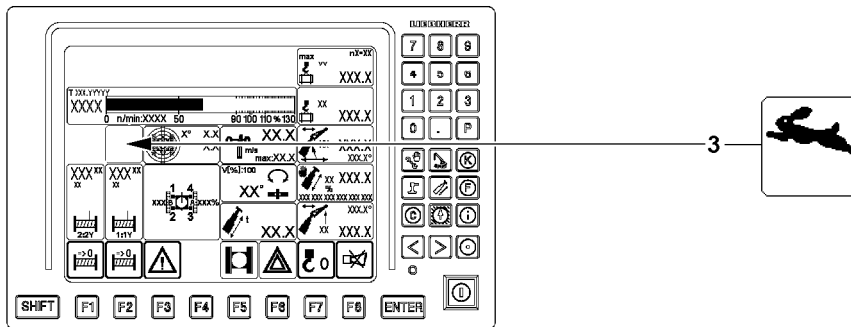


Fig.123732: Rapid gear turned on

**3 Rapid gear icon**

- The icon appears if the rapid gear is enabled during a crane movement
- This is possible, for example, for the following crane movements:
  - Lift / lower hoist gears
  - Luff the boom up

### 5.4 Crane operation monitoring functions

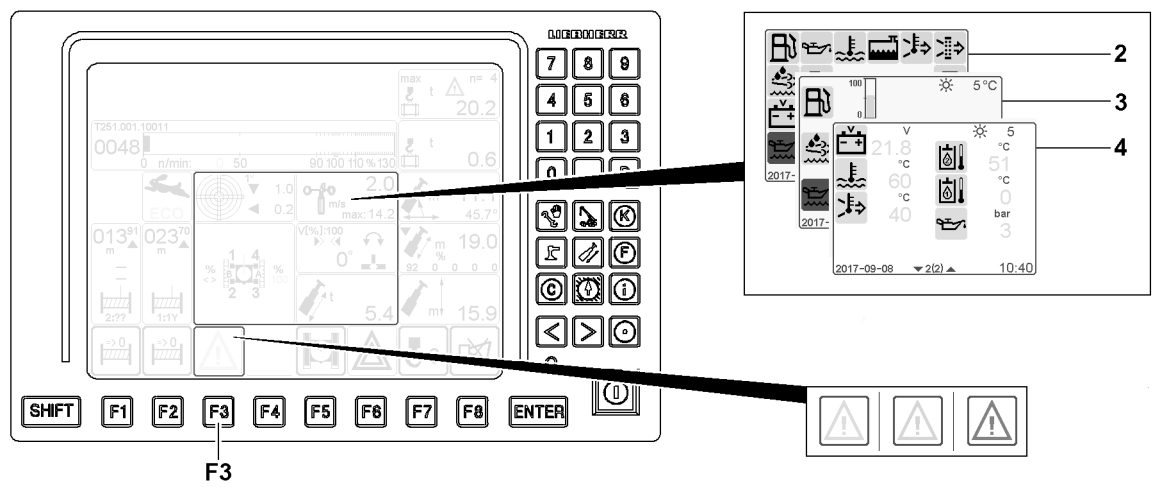


Fig.152672: Crane operation monitoring functions

The crane operation monitoring functions include the following displays:

- **2** Monitoring function icons
- **3** Fill level individual control displays
- **4** Actual value displays individual control displays

The monitoring functions are always active and can be displayed in the monitoring field, if necessary. Due to the color of the icon over the function key **F3** the crane operator is automatically alerted in case of a warning occurrence.

Meaning of the color of the warning icon over the function key **F3**:

- Warning icon green: All monitoring functions are ok.
- Warning icon yellow: Advance warning for one or several monitoring functions.
- Warning icon red: Warning for one or several monitoring functions.

LWE/LTR 1220-003/24204-02-02/en

**NOTICE**

Danger of severe crane engine damage!

If the monitoring functions report a problem and / or warning occurrence, then you must react immediately and remedy the problem.

- ▶ React to problems and / or warning occurrences immediately and remedy the problem.
- ▶ If necessary, stop crane operation and turn the crane engine off.

**NOTICE**

Shut off engine monitoring!

Outside of the crane operation program, the monitoring functions are turned off.

When the engine monitoring is turned off, problems and warning occurrences are not recognized. This could result in crane failure.

- ▶ If work is not carried out in the crane operation program, then turn the crane engine off and operate the LICCON computer system in stand-by mode, see section „Power-Save mode and Stand-by mode on the LICCON computer system“.
- ▶ If work has to be carried out for a longer period outside of the crane operation program, with the crane engine running, then switch continuously to the engine monitoring screen and check the display values.
- ▶ Register changes in the display values mindfully and proceed anticipatorily, for example, refuel in time.

### 5.4.1 Order of the displays in the crane operation monitoring functions

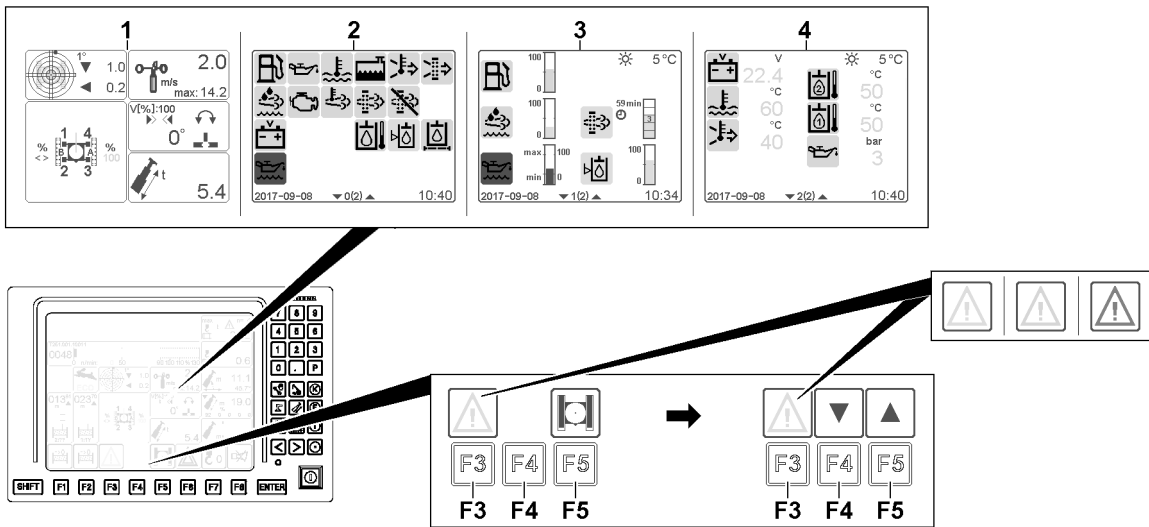


Fig.152674: Displays in the crane operation monitoring functions

The order of the displays in the crane operation monitoring functions depends is specified by the LICCON computer system according to the current situation.

- By pressing the function key **F3**, the monitored auxiliary functions **1** are masked, the crane operation monitoring functions are displayed. The function assignments of the function keys **F4-F5** change.
- By pressing the function key **F4** and function key **F5**, it is possible to switch between the following displays:
  - **2** Monitoring function icons
  - **3** Fill level individual control displays
  - **4** Actual value displays individual control displays
- By pressing the function key **F3** again, the crane operation monitoring functions are masked again. The monitored auxiliary functions **1** are displayed again.

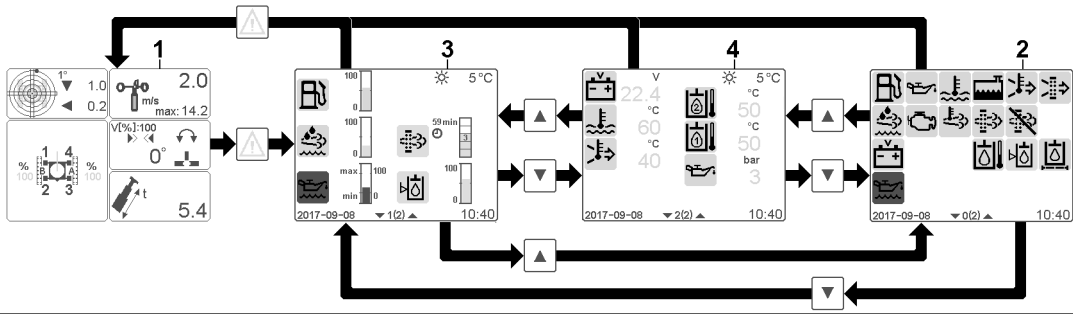


Fig.156232: Example for the order of the displays, when the warning icon over function key F3 is green

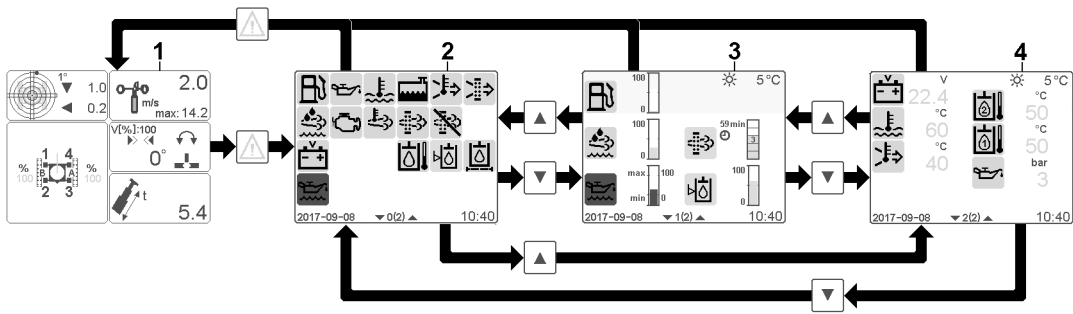


Fig.156236: Example for the order of the displays, when the warning icon over function key F3 is yellow

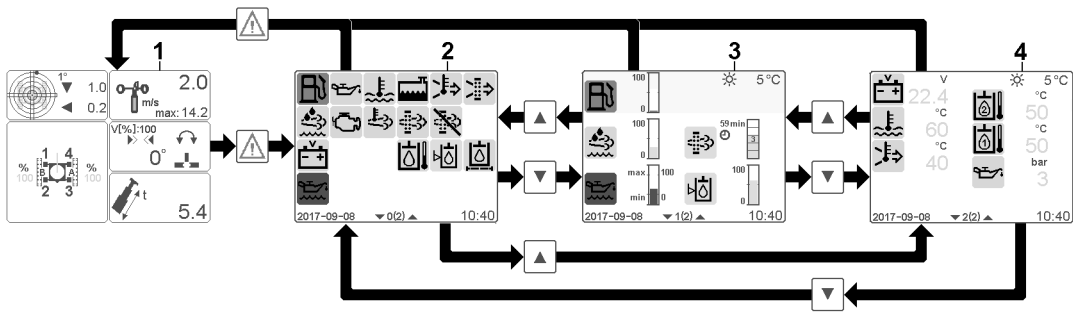


Fig.156240: Example for the order of the displays, when the warning icon over function key F3 is red

► Press the function keys in the corresponding order.

## 5.4.2 Calling up / masking the crane operation monitoring functions

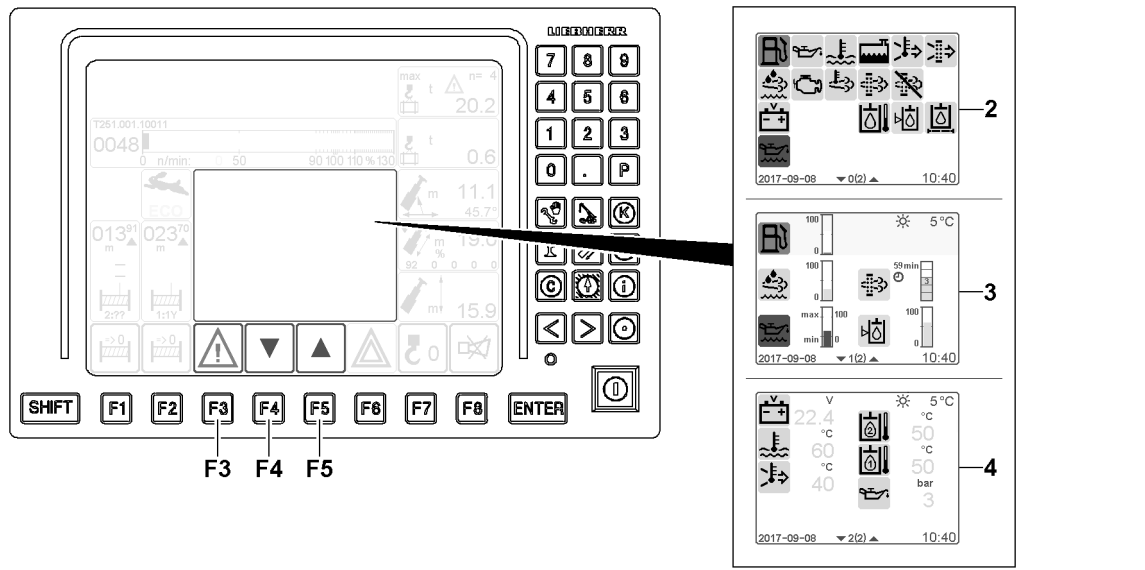


Fig.152682: Example for the Fuel reserve low / depleted warning event

If a warning event occurs on one or on several monitoring functions, then this is indicated by the color of the warning icon over the function key **F3**. The warning icon is displayed statically and in the color of the monitoring function that triggered the warning event.

Example for the fuel reserve low / depleted warning event:

- The icon above the function key **F3** is red
- In the monitoring functions icon **2**, the *fuel reserve* icon appears in red
- In the *fill level* individual control displays **3**, the *fuel reserve* icon appears in red and the assigned bar graph shows an empty fill level.
- The *actual value displays* individual control displays **4** do not provide any further information regarding this warning event.

To call up / mask the crane operation monitoring functions:

- ▶ Press the function keys in the corresponding order, see section „Order of the displays in the crane operation monitoring functions“

**Result:**

- By pressing the function key **F4** and function key **F5**, it is possible to switch between the displays.
- By pressing the function key **F3** again, the crane operation monitoring functions can be immediately masked again.
- For a description of the monitoring function icons **2**, see the following section „Overview of icons for monitoring functions“.
- Description of the *fill level* individual control displays **3**, see the following section „Overview of the individual control displays“.
- Description of the *actual value displays* individual control displays **4**, see the following section „Overview of individual control displays“.

### 5.4.3 Overview of icons for monitoring functions

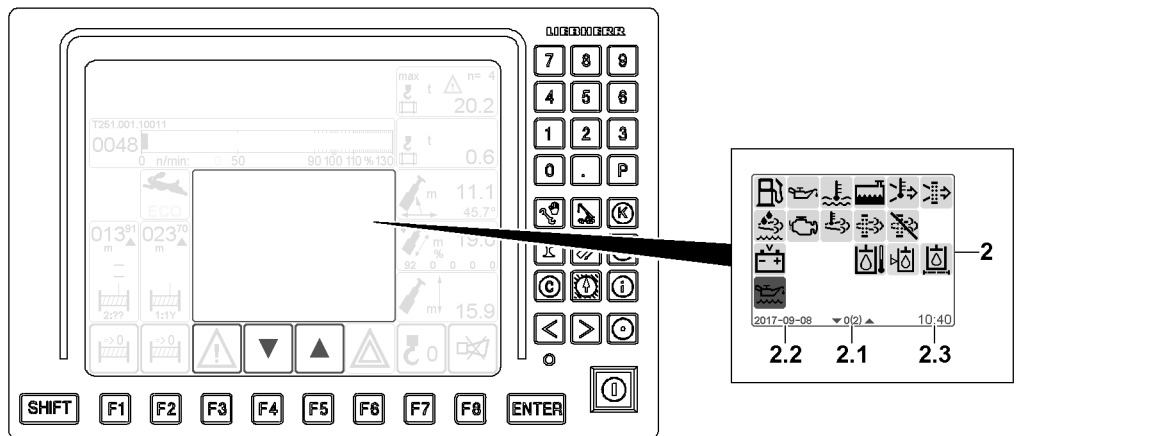


Fig.152684: Monitoring function icons

– 2 Monitoring function icons


- In addition to the monitoring function icons, the following appears:
  - 2.1 Page counter
  - 2.2 Date
  - 2.3 Time




**Note**

The scope of the monitoring function icons 2 depends on the crane type and crane configuration.

- ▶ Not all crane types have all listed monitoring functions.

	<b>Fuel reserve</b>
Green:	Fuel reserve sufficient
Yellow:	Fuel reserve is short
Red:	Fuel reserve low / depleted / system error <b>NOTICE!</b> Add fuel immediately / Immediately bring the crane to a standstill, turn the crane engine off and remedy the problem. Pay attention to the error message.

	<b>Engine oil pressure</b>
Green:	Engine oil pressure OK (engine on)
Red:	Engine oil pressure too low (engine on) / system error <b>NOTICE!</b> Immediately bring the crane to a standstill, turn the engine off and remedy the problem. Pay attention to the error message.

LWE/LTR 1220-003/24204-02-02/en



### Coolant temperature

Green:	Coolant temperature OK
Red:	Coolant temperature too high / system error <b>NOTICE!</b> Immediately bring the crane to a standstill, turn the engine off and remedy the problem. Pay attention to the error message.



### Coolant level

Green:	Coolant level OK
Red:	Coolant level too low / system error <b>NOTICE!</b> Immediately bring the crane to a standstill, turn the engine off and remedy the problem. Pay attention to the error message.




### Charge air temperature

Green:	Charge air temperature OK
Red:	Charge air temperature too high / system error <b>NOTICE!</b> Immediately bring the crane to a standstill, turn the engine off and remedy the problem. Pay attention to the error message.




### Air filter Engine

Green:	Air intake opening / air filter OK (engine on)
Yellow	Air intake opening / Air filter dirty (engine on) / system error <b>NOTICE!</b> Immediately bring the crane to a standstill, turn the engine off and remedy the problem. Pay attention to the error message.

 <b>Urea tank / exhaust aftertreatment <sup>1)</sup></b>	
Green:	Urea reserve sufficient
Yellow:	The urea reserve is low or erroneous function of exhaust aftertreatment <sup>2)</sup> <b>Advance warning!</b> Add urea or remedy the erroneous function of the exhaust aftertreatment. Pay attention to the error message.
Red:	Urea level too low / depleted or erroneous function of exhaust aftertreatment system <sup>2)</sup> / system error <b>NOTICE!</b> Add urea or remedy the erroneous function of the exhaust aftertreatment / immediately bring the crane to a standstill, turn the engine off and remedy the problem. Pay attention to the error message.


1) Applies only for engines with the SCR system.

2) Under some circumstances a power reduction or start block of the engine is triggered. The type and scope of a power reduction or start block of the engine depends on the respectively valid national / regional regulations and the vehicle configuration.

 <b>Exhaust aftertreatment <sup>1)</sup></b>	
Green:	Exhaust aftertreatment OK
Yellow / red:	Urea level too low / depleted or erroneous function of exhaust aftertreatment system <sup>2)</sup> / system error <b>NOTICE!</b> Add urea or remedy the erroneous function of the exhaust aftertreatment. Under some circumstances a power reduction or start block of the engine <sup>2)</sup> is triggered, pay attention to the error message.


1) Applies only for engines with the SCR system.

2) Under some circumstances a power reduction or start block of the engine is triggered. The type and scope of a power reduction or start block of the engine depends on the respectively valid national / regional regulations and the vehicle configuration.


 <b>Exhaust gas temperature <sup>4)</sup></b>	
Green:	Normal exhaust gas temperature
Yellow	High exhaust gas temperature, diesel particle filter regeneration is carried out <b>Note:</b> Engine noise may change slightly during regeneration. After generation is complete, the icon turns green again.

4) Only for engines with a diesel particle filter (DPF).


LWE/LTR 1220-003/24204-02-02/en


 <b>Diesel particle filter<sup>4)</sup></b>	
Green:	Diesel particle filter <sup>4)</sup> OK
Yellow:	Diesel particle filter <sup>4)</sup> reports an advance warning <b>Note:</b> Call up the individual control displays and check the load condition of the diesel particle filter <sup>4)</sup> . Pay attention to the error message.
Red:	Diesel particle filter <sup>4)</sup> reports a warning / problem <b>NOTICE!</b> Call up the individual control displays and check the load condition of the diesel particle filter <sup>4)</sup> . Remedy the problem. Pay attention to the error message.


4) Only for engines with a diesel particle filter (DPF).

 <b>Disabling diesel particle filter regeneration<sup>4)</sup></b>	
Green:	Automatic regeneration of the diesel particle filter is not disabled
Yellow:	Automatic regeneration of the diesel particle filter is disabled <b>NOTICE!</b> If automatic regeneration of the diesel particle filter is disabled for too long, damage can occur to the crane engine and the exhaust gas system


4) Only for engines with a diesel particle filter (DPF).


 <b>Battery voltage</b>	
Green:	Battery voltage OK
Red:	Overvoltage or undervoltage in on-board power supply / system error <b>NOTICE!:</b> Immediately bring the crane to a standstill, turn the engine off and remedy the problem. Pay attention to the error message.


 <b>Torque converter temperature</b>	
Green:	Torque converter temperature OK
Red:	Torque converter temperature not OK / system error <b>NOTICE!:</b> Immediately bring the crane to a standstill, turn the engine off and remedy the problem. Pay attention to the error message.

 <b>Hydraulic oil temperature</b>	
Green:	Hydraulic oil temperature OK
Red:	Hydraulic oil temperature too high / system error <b>NOTICE!:</b> Immediately bring the crane to a standstill, turn the engine off and remedy the problem. Pay attention to the error message.





 <b>Transmission / torque converter</b>	
Green:	Transmission and torque converter OK
Yellow / red:	Problem in transmission or torque converter / system error <b>NOTICE!</b> Immediately bring the crane to a standstill, turn the engine off and remedy the problem. Pay attention to the error message.

 <b>Transmission temperature</b>	
Green:	Transmission temperature OK
Red:	Transmission temperature not OK / system error <b>NOTICE!</b> Immediately bring the crane to a standstill, turn the engine off and remedy the problem. Pay attention to the error message.


 <b>Hydraulic oil level<sup>3)</sup></b>	
Green:	Hydraulic oil level OK
Yellow / red:	Hydraulic oil level too low / error / system error <b>NOTICE!</b> Immediately bring the crane to a standstill, turn the engine off and remedy the problem. Pay attention to the error message.

3) Only for certain crane types.

 <b>Leak oil filter</b>	
Green:	Leak oil filter OK (engine on)
Red:	Leak oil filter dirty (engine on) / system error <b>NOTICE!</b> Immediately bring the crane to a standstill, turn the engine off and remedy the problem. Pay attention to the error message.

 <b>Engine oil level</b>	
Blue	The engine oil level can not be checked here on the display, call up the individual indicator light

LWE/LTR 1220-003/24204-02-02/en

 <b>Charge control display (alternator) <sup>5)</sup></b>	
Green:	Charge control OK (engine on)
Red:	Charge control has a problem (engine on) / system error <b>NOTICE!:</b> Immediately bring the crane to a standstill, turn the engine off and remedy the problem. Pay attention to the error message.

5) Alternatively, the charge control display is located on the BKE, see the Crane operating instructions, chapter 4.01.

## 5.4.4 Overview of the individual control displays

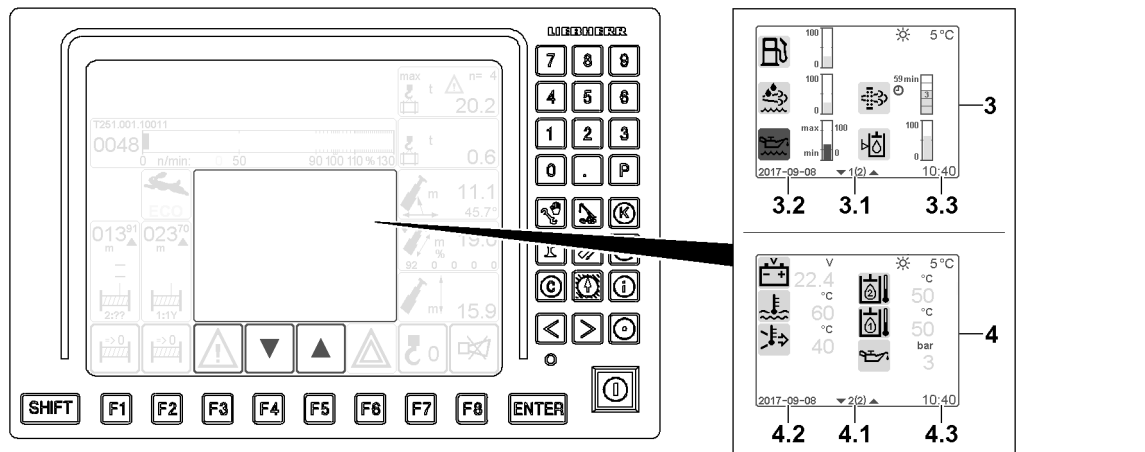


Fig.152686: Overview of the individual control displays

- **3** Fill level individual control displays
  - The following also appears:
    - **3.1** Page counter
    - **3.2** Date
    - **3.3** Time
- **4** Actual value displays individual control displays
  - The following also appears:
    - **4.1** Page counter
    - **4.2** Date
    - **4.3** Time



### Note

- ▶ For some monitoring functions, detailed individual control displays can be displayed.
- ▶ The display values in the depicted individual indicator displays are examples.

### Fuel reserve individual control display

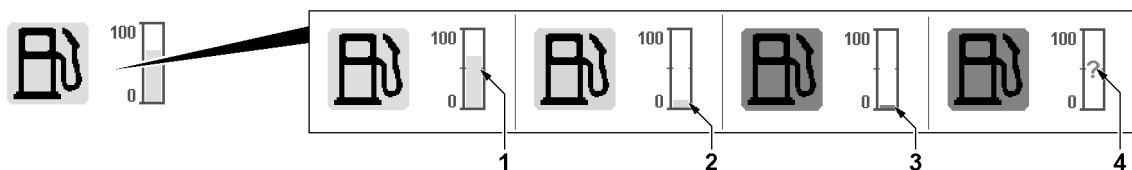


Fig.148375: Fuel reserve, bar graph

- Icon and bar **1** green: Fuel reserve sufficient

- Icon and bar **2** yellow: Fuel reserve is short
- Icon and bar **3** red: Fuel reserve low / depleted
- Icon and question mark **4** red: System error, the fill level cannot be determined

**NOTICE!** Add fuel immediately before it is depleted / Immediately bring the crane to a standstill, turn the crane engine off and remedy the problem. Pay attention to the error message.

The exact fill level can be read on the scale of the bar chart:

- Scale value 100: The tank is completely full
- Scale value 0: The tank is completely empty

#### Urea tank individual control displays

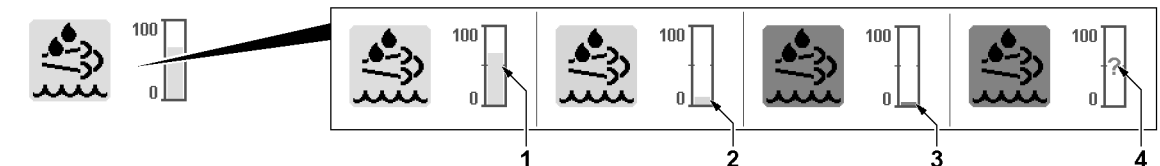


Fig.148377: Urea reserve, bar graph

- Icon and bar **1** green: Urea reserve sufficient
- Icon and bar **2** yellow: Urea reserve is short
- Icon and bar **3** red: Urea reserve low / depleted
- Icon and question mark **4** red: System error, the fill level cannot be determined, erroneous function of the exhaust aftertreatment

**NOTICE!** Add urea immediately before it is depleted / Immediately bring the crane to a standstill, turn the crane engine off and remedy the problem. Pay attention to the error message.

The exact fill level can be read on the scale of the bar chart:

- Scale value 100: The tank is completely full
- Scale value 0: The tank is completely empty

#### Engine oil level individual control display

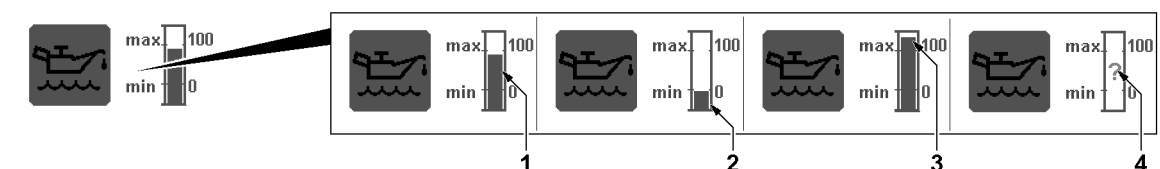


Fig.148379: Engine oil level, bar graph

- Icon and bar **1** blue, bar height between 0 and 100: Normal engine oil level
  - Icon and bar **2** blue, bar height below 0: Engine oil underfilled
  - Icon and bar **3** blue, bar height above 100: Engine oil overfilled
  - Icon blue and question mark **4** red: faulty measurement value, fill level cannot be determined
- Note:** When the engine is running an erroneous test value appears, to check the engine oil level align the crane horizontally and turn the engine off.

**NOTICE!:** Do not start the engine if the engine oil is underfilled or overfilled. Remedy the problem and observe the error message.

The exact fill level can be read on the scale of the bar chart:

- Scale value 100: Engine oil fill level upper limit
- Scale value 0: Engine oil fill level lower limit

### Diesel particle filter individual control display

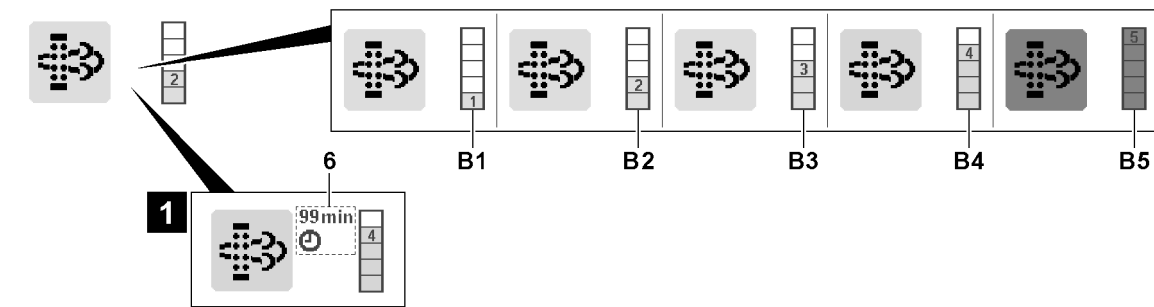


Fig.152688: Diesel particle filter load condition, bar graph

- **B1** Load condition 1 (green)
  - Load condition OK, diesel particle filter minimally loaded
- **B2** Load condition 2 (green)
  - Load condition OK, diesel particle filter lightly loaded
- **B3** Load condition 3 (green)
  - Load condition OK, diesel particle filter half loaded
- **B4** Load condition 4 (yellow)
  - Load condition increased, diesel particle filter strongly loaded
- **B5** Load condition 5 (red)
  - Load condition critical, diesel particle filter with maximum load
- **6** Regeneration time
  - This appears only when regeneration at a standstill of the diesel particle filter has started, see illustration 1
  - The remaining time (regeneration time) of regeneration at a standstill of the diesel particle filter is displayed continuously.
  - **Note:** Start regeneration at a standstill of the diesel particle filter, see the Crane operating instructions, chapter 4.03.

If load condition 4 **B4** appears, Liebherr-Werk Ehingen GmbH recommends carrying out regeneration at a standstill as soon as possible (during the work day).

If load condition 5 **B5** appears and regeneration at a standstill is no longer possible:

- Stop engine operation.
- Contact Customer Service at Liebherr-Werk Ehingen GmbH.



#### Note

Load condition 5 **B5**

- ▶ The engine torque is reduced to protect the engine against damage.

### Hydraulic oil level individual control display

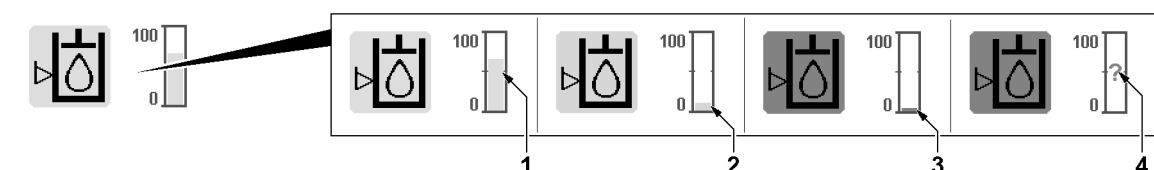


Fig.152690: Hydraulic oil level, bar graph

- Icon and bar **1** green: Hydraulic oil level OK
- Icon and bar **2** yellow: Hydraulic oil level low
- Icon and bar **3** red: Hydraulic oil level too low
- Icon and question mark **4** red: System error, the hydraulic oil level cannot be determined

**NOTICE!** Stop crane operation if the hydraulic oil level is too low. Remedy the problem and observe the error message.

The exact fill level can be read on the scale of the bar chart:

- Scale value 100: The tank is completely full
- Scale value 0: The tank is completely empty

#### Battery voltage individual control display



Fig.148382: Battery voltage icon, display value and unit of measure

Icon and display value

- Green: Battery voltage OK
- Red: Overvoltage or undervoltage in on-board power supply / system error

**NOTICE!** Immediately bring the crane to a standstill, turn the crane engine off and remedy the problem. Pay attention to the error message.

#### Coolant temperature individual control display



Fig.148383: Coolant temperature icon, display value and unit of measure

Icon and display value

- Green: Coolant temperature OK
- Red: Charge air temperature too high / system error

**NOTICE!** Immediately bring the crane to a standstill, turn the crane engine off and remedy the problem. Pay attention to the error message.

#### Charge air temperature individual control display



Fig.148384: Charge air temperature icon, display value and measuring unit

Icon and display value

- Green: Charge air temperature OK
- Red: Charge air temperature too high / system error

**NOTICE!** Immediately bring the crane to a standstill, turn the crane engine off and remedy the problem. Pay attention to the error message.

#### Individual control display of the transmission temperature



Fig.148385: Transmission temperature icon, display value and unit of measure

Icon and display value

- Green: Transmission temperature OK
- Red: Transmission temperature not OK

**NOTICE!** Immediately bring the crane to a standstill, turn the crane engine off and remedy the problem. Pay attention to the error message.

### Hydraulic oil temperature individual control display



Fig.156249: Hydraulic oil temperature icon, display value and measuring unit

Icon and display value

- Green: Hydraulic oil temperature OK
- Red: Hydraulic oil temperature too high

**NOTICE!** Immediately bring the crane to a standstill, turn the crane engine off and remedy the problem. Pay attention to the error message.

### Individual control display of the hydraulic oil temperature, hydraulic circuit 1



Fig.148386: Hydraulic oil temperature, hydraulic circuit 1 icon, display value and unit of measure

Icon and display value

- Green: Hydraulic temperature in hydraulic circuit 1 OK
- Red: Hydraulic temperature in hydraulic circuit 1 too high

**NOTICE!** Immediately bring the crane to a standstill, turn the crane engine off and remedy the problem. Pay attention to the error message.

### Individual control display of the hydraulic oil temperature, hydraulic circuit 2



Fig.148387: Hydraulic oil temperature, hydraulic circuit 2 icon, display value and unit of measure

Icon and display value

- Green: Hydraulic temperature in hydraulic circuit 2 OK
- Red: Hydraulic temperature in hydraulic circuit 2 too high

**NOTICE!** Immediately bring the crane to a standstill, turn the crane engine off and remedy the problem. Pay attention to the error message.

### Engine oil pressure individual control display



Fig.148388: Engine oil pressure, display value and unit of measure

Icon and display value

- Green: Engine oil pressure OK
- Red: Engine oil pressure too low

**NOTICE!** Immediately bring the crane to a standstill, turn the crane engine off and remedy the problem. Pay attention to the error message.

**Individual control display of the torque converter temperature**



Fig.148389: Torque converter temperature icon, display value and unit of measure

Icon and display value

- Green: Torque converter temperature OK
- Red: Torque converter temperature not OK

**NOTICE!** Immediately bring the crane to a standstill, turn the crane engine off and remedy the problem. Pay attention to the error message.

**5.5 Monitoring the surface pressure and center of gravity**

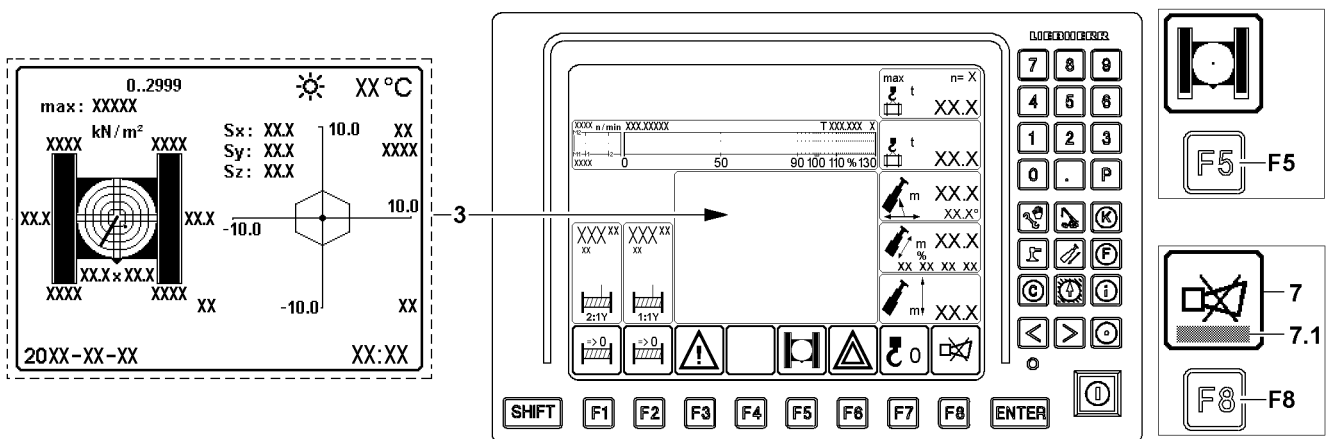


Fig.122538: Exemplary illustration of monitoring of surface pressure and center of gravity



**WARNING**

The crane can topple over!

When the programmed limit values are reached in the monitoring of surface pressure and center of gravity, there is no automatic shut-off of crane movements.

The displayed values are calculated and are informative. Calculated values are below the tolerances and unpredictable influences, for example crane control, surrounding and environmental influences. Due to the resulting tolerance field of the values, the monitoring of surface pressure and center of gravity may not be used to determine the limit values of the crane.

If this is disregarded, then the crane can topple over.

Personnel can be severely injured or killed.

- ▶ Do not use the displayed values to determine the limit values of the crane and to utilize the crane to its tipping limit or until it sinks in.
- ▶ Make sure that all values are within the programmed limit values.



**WARNING**

Increased surface pressure!

The calculation of the values for the display of the surface pressure in the LICCON monitor are based on ideal assumptions.

- ▶ Side deformations of the boom system due to wind, incline position and elastic resilience of the steel structure are not taken into account but they can lead to an increase of the surface pressure.

LWE/LTR 1220-003/24204-02-02/en

**WARNING**

Shifting of the center of gravity!

The calculation of the values for the display of the center of gravity in the LICCON monitor are based on ideal assumptions.

- ▶ Side deformations of the boom system due to wind, incline position and elastic resilience of the steel structure are not taken into account but they can lead to a shifting of the center of gravity.

**WARNING**

The crane can topple over!

If the permissible incline of the crane is exceeded, the crane can topple over.

- ▶ Do not exceed the permissible incline from the load chart.
- ▶ Do not exceed the permissible incline for driving the crane, see Crane operating instructions, chapter 4.10.

The monitoring of surface pressure and center of gravity **3** is always active and can be displayed in the monitoring field, if necessary. Due to the color of the icon over the function key **F5** the crane driver is automatically alerted in case of a warning event.

The monitoring field has its fixed position on the LICCON monitor and can be hidden or assigned with other functions.

By pressing the function key **F5**, the surface pressure and center of gravity monitoring **3** is displayed in the monitoring field.

**Note**

Turned off monitoring of surface pressure and center of gravity.

- ▶ Outside of the crane operation program, the monitoring of surface pressure and center of gravity is turned off.
- ▶ When the monitoring of surface pressure and center of gravity is turned off, warning events are not recognized.

Warning icon color key above the function key **F5**

- Blue warning icon: Monitoring the surface pressure and center of gravity is ok.
- Crawler carrier in warning icon red: Warning for monitoring of surface pressure and center of gravity.

If a warning occurs, an error message **7.1** is displayed in the *Horn* icon **7**.

The error message **7.1** includes an acoustic signal through the LICCON monitor and an error description.

Press the function key **F8** once: The acoustic signal is turned off.

Press the function key **F8** twice: The error description for the error message **7.1** which occurred last is called up.

**3** *Monitoring of surface pressure and center of gravity display*

- The values are calculated depending on the set up configuration of the crane and the load.



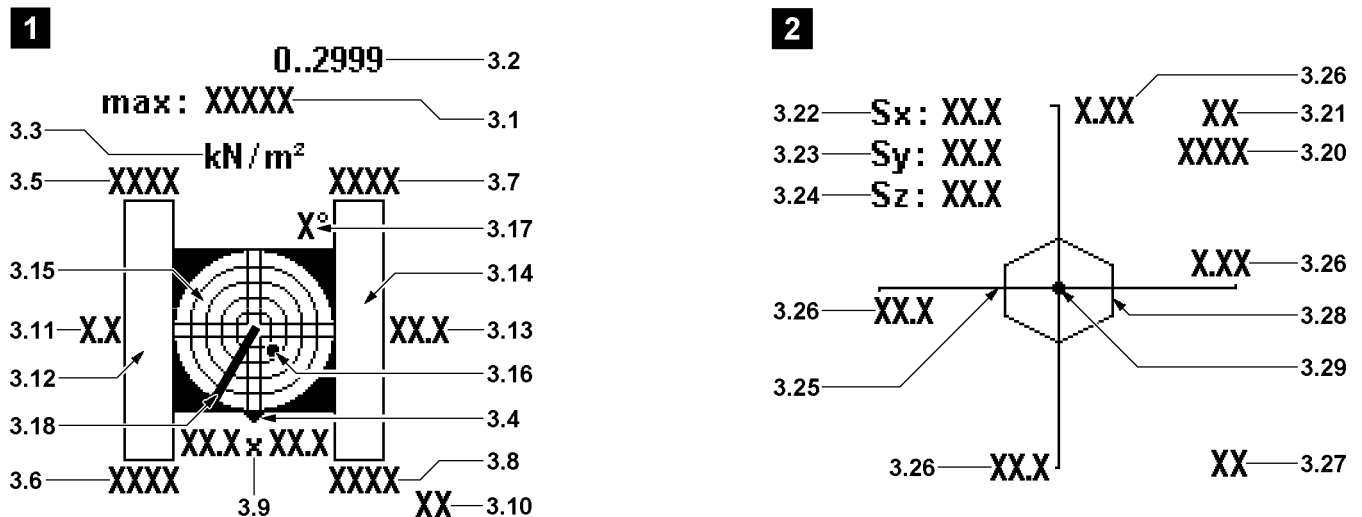


Fig.122539: Exemplary illustration of the surface pressure and center of gravity display

**Surface pressure icon display, illustration 1:**

- 3.1 Permissible surface pressure
  - The value is entered by the crane operator via the keypad.
- 3.2 Input area
  - Input area for the permissible surface pressure 3.1.
- 3.3 Measuring unit for surface pressure
  - Measuring unit for the pressure data in the *Surface pressure* icon (illustration 1).
- 3.4 Direction specification
  - The triangle symbolizes where the front of the crawler travel gear is in the illustration.
  - **Note:** The front of the track is always on the side where the chain tension devices for the crawler carriers are located.
- 3.5 Surface pressure
  - Calculated actual value of surface pressure on the crawler travel gear, left rear.
- 3.6 Surface pressure
  - Calculated actual value of surface pressure on the crawler travel gear, left front.
- 3.7 Surface pressure
  - Calculated actual value of surface pressure on the crawler travel gear, right rear.
- 3.8 Surface pressure
  - Calculated actual value of surface pressure on the crawler travel gear, right front.
- 3.9 Track width / support base
  - Display of equipped track width / support base
- 3.10 Length data measuring unit
  - Measuring unit for the measuring data in the *surface pressure* icon
- 3.11 Placement surface
  - Calculated placement surface of crawler carrier right as value.
- 3.12 Placement surface
  - Calculated placement surface of crawler carrier right as graphic.
- 3.13 Placement surface
  - Calculated placement surface of crawler carrier left as value.
- 3.14 Placement surface
  - Calculated placement surface of crawler carrier left as graphic.
- 3.15 Incline indicator
  - The graphic display is in the form of a spirit level, with a moving dot 3.16 representing the air bubble.
  - **Note:** Incline display with number values, see section „Monitored auxiliary functions“.
- 3.16 Point
  - The center of the dot 4.2 shows the incline.

- 3.17 Display resolution
  - This value describes the resolution of the graphic view. The resolution is matched automatically to the inclination
- 3.18 Boom direction
  - Current boom direction of the crane, in reference to the displayed icon.

**Center of gravity icon display, illustration 2:**

- 3.20 Weight data
  - Calculated total weight of the crane including load.
- 3.21 Weight unit
  - Weight unit for the weight data 3.20 in the *center of gravity* icon (illustration 2).
- 3.22 Center of gravity position
  - Calculated center of gravity position in direction „Sx“
- 3.23 Center of gravity position
  - Calculated center of gravity position in direction „Sy“
- 3.24 Center of gravity position
  - Calculated center of gravity position in direction „Sz“
- 3.25 Axis of coordinates
  - The axis of coordinates 3.25 is aligned according to the direction of the *surface pressure* icon (illustration 1) centered to the slewing ring on the placement surface of the crane.
- 3.26 Scale value
  - Scale value on the axis of coordinates 3.25
- 3.27 Measuring unit
  - Measuring unit in the *center of gravity* (illustration 2)
- 3.28 Core area
  - Calculated core area of the crane according to the set up configuration, load and ground conditions.
  - **Note:** The core area is an important reference point for the center of gravity of the crane.
- 3.29 Center of gravity Sx/Sy
  - Calculated center of gravity displayed graphically in direction Sx/Sy
  - **Note:** The actual position is in direct relation to the values center of gravity position 3.22 and center of gravity position 3.23



**Note**

Additional display values in the Display *Monitoring of surface pressure and center of gravity 3*

- Date, time and outside temperature are also displayed.

## 5.6 Monitored auxiliary functions

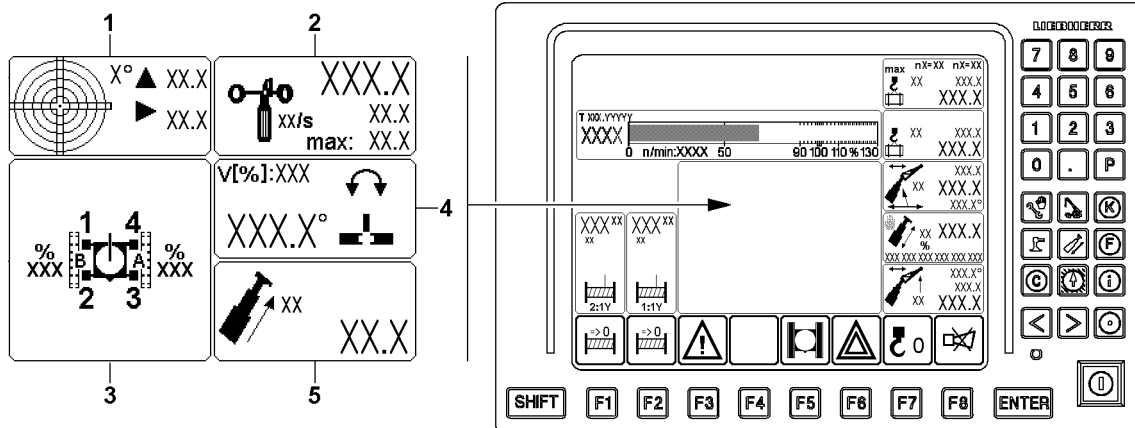


Fig.122521: Exemplary illustration of monitored auxiliary functions

There are several monitored auxiliary functions, which can be displayed when needed or automatically.

The monitoring of all auxiliary functions is always active during normal crane operation, only the icons may be hidden. The icons of the monitored auxiliary functions have their fixed place on the LICCON monitor.

Using the function key **F4**, you can show the icons for the monitored auxiliary functions.

Auxiliary functions:

- 1 Crane incline
- 2 Wind speed
- 3 Crawler travel gear
- 4 Slewing range
- 5 Telescopic load

The display changes depending if the monitored auxiliary functions are turned on or off:

### Monitored auxiliary functions turned off:

- No error:  
Icons are not shown.
- Error in one function:  
Icon with error message is shown.

### Monitored auxiliary functions turned on:

- Optional icons (customer request) are displayed permanently.

## 5.6.1 Crane incline

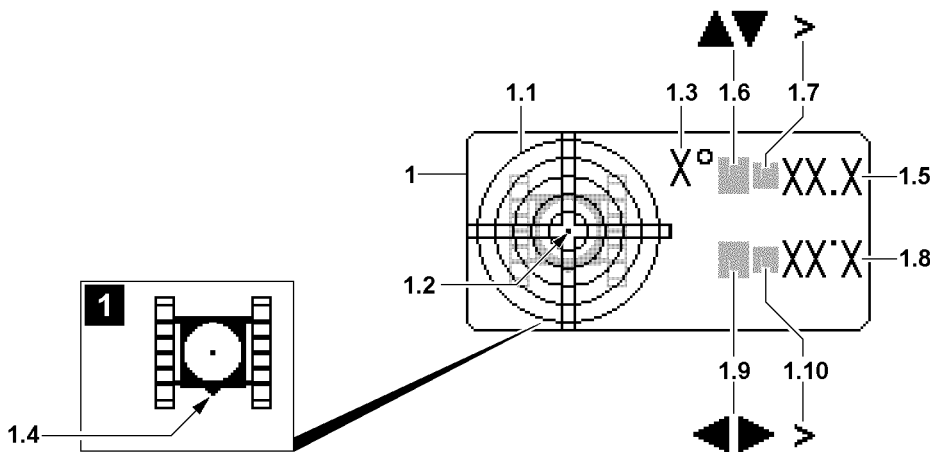


Fig.122522: Display Crane incline



### WARNING

The crane can topple over!

If the permissible incline from the load chart is exceeded, the crane can topple over.

The *larger than* icon shows that the crane is inclined further than can be shown.

The exact incline can then not be read.

- ▶ Do not exceed the permissible incline from the load chart.

#### 1 Incline icon

- Display of the inclination of the crane to the horizontal in the longitudinal and lateral direction. The display is graphic as well as numeric.
- The display is divided in a graphic section and a numeric section.
- The direction notes refer to the crawler travel gear.

#### Graphic part:

##### 1.1 Graphic display

- The graphic display is in the form of a spirit level, with a moving dot **1.2** representing the air bubble.

##### 1.2 Point

- The dot **1.2** shows the incline position.

##### 1.3 Display resolution

- This value describes the resolution of the graphic view. The resolution is matched automatically to the inclination

##### 1.4 Crawler travel gear front side

- To the graphic view **1.1** the overhead view of the imitated crawler travel gear is provided, see illustration **1**. The position of the front side of the crawler travel gear **1.4** provides the orientation aid in the sight gauge.

#### Numeric part:

##### 1.5 Longitudinal direction

- Incline of crane in the longitudinal direction in [°].

##### 1.6 Direction arrow

- The direction arrow shows the direction of the incline

##### 1.7 Display range exceeded

- If the *larger than* icon appears, then the display range is exceeded.
- **Note:** The crane is inclined further than can be shown.

##### 1.8 Lateral direction

- Incline of crane in lateral direction in [°]

##### 1.9 Direction arrow

- The direction arrow shows the direction of the incline

### 1.10 Display range exceeded

- If the *larger than* icon appears, then the display range is exceeded.
- **Note:** The crane is inclined further than can be shown.



#### Note

Orientation of the crane in *Incline* icon 1.

- ▶ Observe the position of the front side of the crawler travel gear **1.4**: The chain tension devices of the crawler carriers are located on the front side of the crawler travel gear.

## 5.6.2 Wind speed

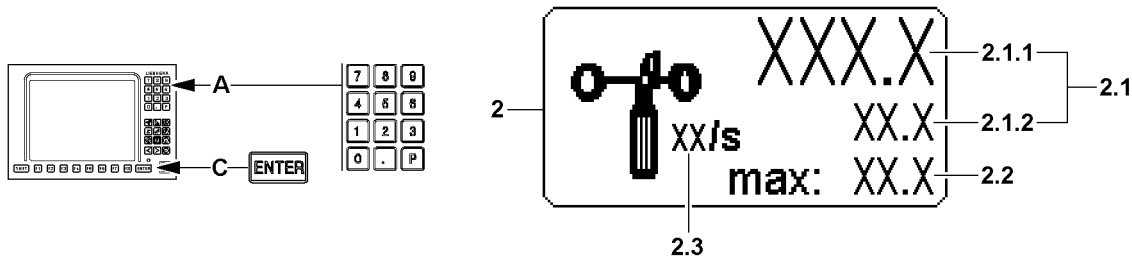


Fig.122523: Wind speed display



#### WARNING

Wind speed too high!

If the maximum permissible wind speed is exceeded with an erected boom system, there is a danger of accident.

Dangerous situations can arise, such as oscillating load or shaking crane.

The crane can topple over, personnel can be severely injured or killed.

- ▶ **The crane movements will not be shut-off.**
- ▶ The boom system must be taken down in time before exceeding the maximum permissible wind speed of the crane.



#### WARNING

Crane operation without wind speed display value!

If question marks („?“) appear in the *wind speed* icon 2 instead of display values, then a wind sensor which must be present is missing or there is an error in the wind sensor.

- ▶ Before starting to work with the crane, make sure that all wind sensors which must be present are present and functioning.
- ▶ Remedy the error immediately.
- ▶ If an error cannot be remedied, then it must be ensured that the wind speed is monitored otherwise.

### 2 Wind speed icon

#### 2.1 Current wind speed icon

- **Note:** If a wind sensor is connected, then the wind speed appears at **2.1.1**.  
If two wind sensors are connected (example: Crane operation with auxiliary boom / accessory), then a second wind speed appears additionally at **2.1.2**.
- **2.1.1** current wind speed WG1
- **2.1.2** current wind speed WG2



#### Note

- ▶ If several wind sensors are connected, the installation location of the wind sensor determines the corresponding display in the *Wind speed* icon 2.
- ▶ The priority depends on the installation location of the wind sensor, from outside (auxiliary boom / accessory) to inside (main boom). The wind speed for the outside wind sensor is shown independent from the inside wind sensor.

### 2.2 Maximum permissible wind speed

- The value depends on the operating mode and the set up configuration.
- If the current wind speed value exceeds the displayed maximum value, the maximum value starts to blink and an acoustic warning sounds.



#### Note

- ▶ If access to a load chart is not possible, then the maximum value starts to blink and an acoustic warning sounds.

### 2.3 Measuring unit icon

- [m/s] or [ft/s]
- On some crane types additionally:  
[km/h] or [mph]\*

### Reducing the maximum permissible wind speed\*



#### Note

- ▶ This function is not available for all crane types.

The value for the maximum permissible wind speed **2.2** can possibly be reduced.

Ensure that the following prerequisite is met:

- The *Wind speed icon 2* is shown.

#### Reduce the wind speed:

1. Press the **ENTER** key **C**.
2. As soon as the value for the maximum permissible wind speed **2.2** is highlighted in blue, enter the new value via the keypad **A**.
3. Press the **ENTER C** key again. The changed value for the maximum permissible wind speed **2.2** is shown in red.

#### Cancel reduce the wind speed:

1. Press the **ENTER** key **C**.
2. As soon as the value for the maximum permissible wind speed **2.2** is highlighted in blue, enter 0 (zero) as the new value via the keypad **A**.
3. Press the **ENTER C** key again. The original value from the load chart is taken over again.



#### Note

- ▶ If you try to enter a value for the maximum permissible wind speed **2.2** which is too high, then the highest possible value is taken over.

### 5.6.3 Crawler travel gear

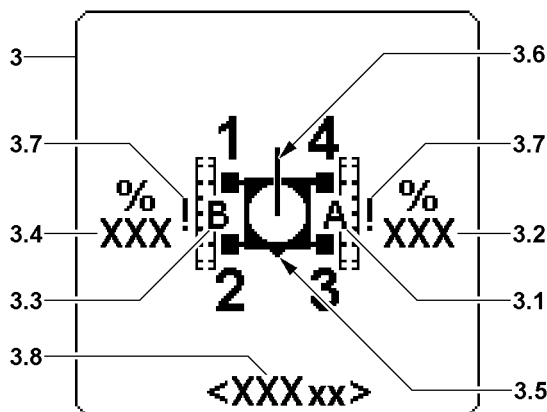


Fig.122520: Crawler travel gear display

#### 3 Crawler travel gear icon

- 3.1 Crawler carrier A
  - Marked crawler carrier A in the icon
- 3.2 Extension condition A
  - Extension condition of crawler carrier A in percent
- 3.3 Crawler carrier B
  - Marked crawler carrier B in the icon
- 3.4 Extension condition B
  - Extension condition of crawler carrier B in percent
- 3.5 Front on crawler travel gear
  - Shows where the front side of the crawler travel gear is in the icon.
- 3.6 Telescopic boom alignment
  - The bar shows the direction of the telescopic boom in reference to the crawler travel gear.
  - In the example, the telescopic boom extends to the rear past the crawler travel gear.
- 3.7 Exclamation mark
  - Appears if the track width monitoring is bypassed.
- 3.8 Track width / support base\*
  - **Note:** Only present for certain crane types
  - Display of equipped track width / support base
  - In [m] or [ft]



#### Note

- ▶ The large numbers 1 - 4 correspond to the numbering on the crawler travel gear.
- ▶ The letters A and B correspond to the signs on the crawler carriers.

### 5.6.4 Slewing range

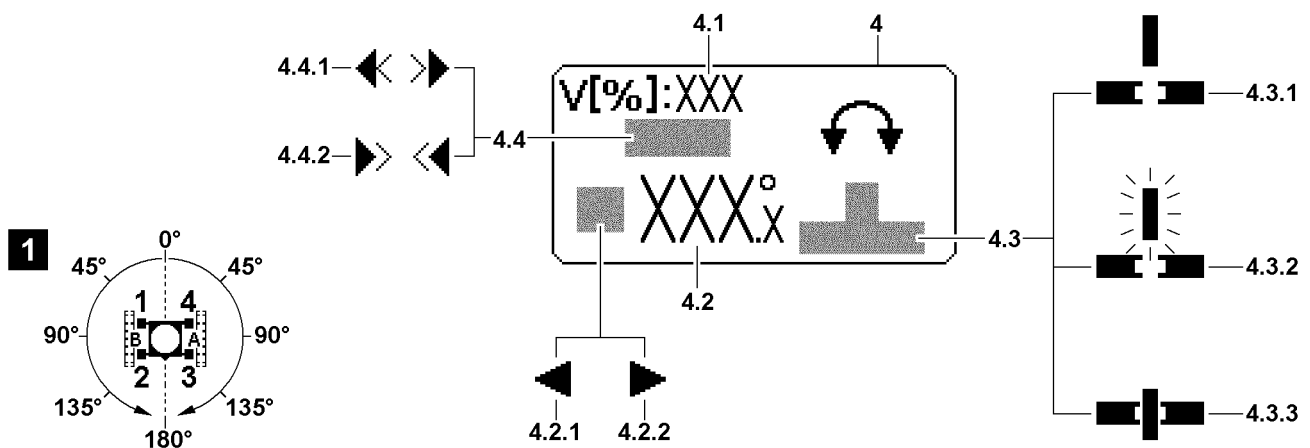


Fig.152693: Display Slewing range

#### 4 Slewing range icon



#### WARNING

Danger of accident due to excessive slewing speed!

- ▶ Make the preselection of the maximum slewing speed according to the specifications in the load chart manual, see section „Speed reduction master switch“.
- ▶ The following applies: The longer the boom and / or the greater the load, the lower the maximum slewing speed must be.
- ▶ **Never** deflect the master switch for the slewing gear to the stop with a long boom and / or great load.

#### 4.1 Maximum slewing speed

- Maximum slewing speed V in [%]

- Marks the set maximum slewing speed of the slewing gear at fully deflected master switch.  
100 % correspond to the largest possible slewing speed of the slewing gear.  
This value can be infinitely preselected, see section „Speed reduction master switch“.

#### 4.2 Slewing angle

- Slewing angle of the superstructure in relation to the working direction to the rear (0 [°]) increases on both sides to the maximum value of 180°, see illustration 1
- The direction arrow in front of the value shows the direction of rotation of the superstructure.
- **4.2.1** (Left arrow): The superstructure is turned to the left from the zero point.
- **4.2.2** (Right arrow): The superstructure is turned to the right from the zero point.

#### 4.3 Turntable pinning

- Current status of turntable pinning between turntable and crane travel gear

##### 4.3.1 The lock is unpinned and static **4.3.1**

- Locking pin on top: Turntable unpinned

##### 4.3.2 Lock is unpinned and blinking

- Locking pin in intermediate position: Error

##### 4.3.3 Lock is pinned and static

- Locking pin on the bottom, turntable pinned



#### Note

- ▶ The turntable pinning is controlled with the operating and control unit (BKE), see chapter 4.01.

#### 4.4 Operating mode of the slewing gear\*

- **Note:** Only present for certain crane types:

The operating mode of the slewing gear can only be set for crane types that are not equipped with a foot button\* for the freewheeling of the slewing gear. For a description of the foot button\* for the freewheeling of the slewing gear, see the Crane operating instructions, chapter 4.01 and 4.05.

##### 4.4.1 Flexible slewing gear *freely rotating*

##### 4.4.2 Flexible slewing gear *fixed*



#### Note

- ▶ To set the operating mode of the slewing gear, see section „Setting the operating mode of the slewing gear“.
- ▶ In certain situations the operating mode of the slewing gear can be specified by the crane control. If this is the case, the setting via the crane control is used, even if a deviating settings is set by the crane operator.

### 5.6.5 Telescopic load

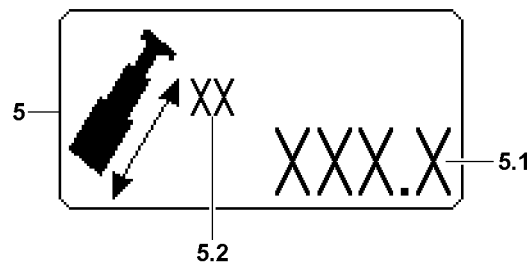


Fig.122525: Telescopic load display

#### 5 Telescopic load icon

- The maximum load with which the boom can be telescoped is shown in the icon.



**5.1 Telescopic load**

- The maximum load with which the boom can be telescoped.
- If the current load on the hook is higher (display value in icon *Actual load* is higher), then the value is shown blinking.



**Note**

- ▶ The *Telescopic load* icon **5** is automatically displayed with a blinking value, when the telescopic load **5.1** is smaller than the display value in the actual load display.
- ▶ The *Telescopic load* icon **5** cannot be masked as long as the telescopic load **5.1** is smaller than the display value in the actual load display.

**5.2 Weight unit**

- Weight unit of telescopic load
- In [t] or [kips]



**WARNING**

Danger of accident if the telescopic load is exceeded!  
 Exceeding the telescopic load does not shut off crane movements.

- ▶ Do not exceed the telescopic load.

**5.7 Winch display**

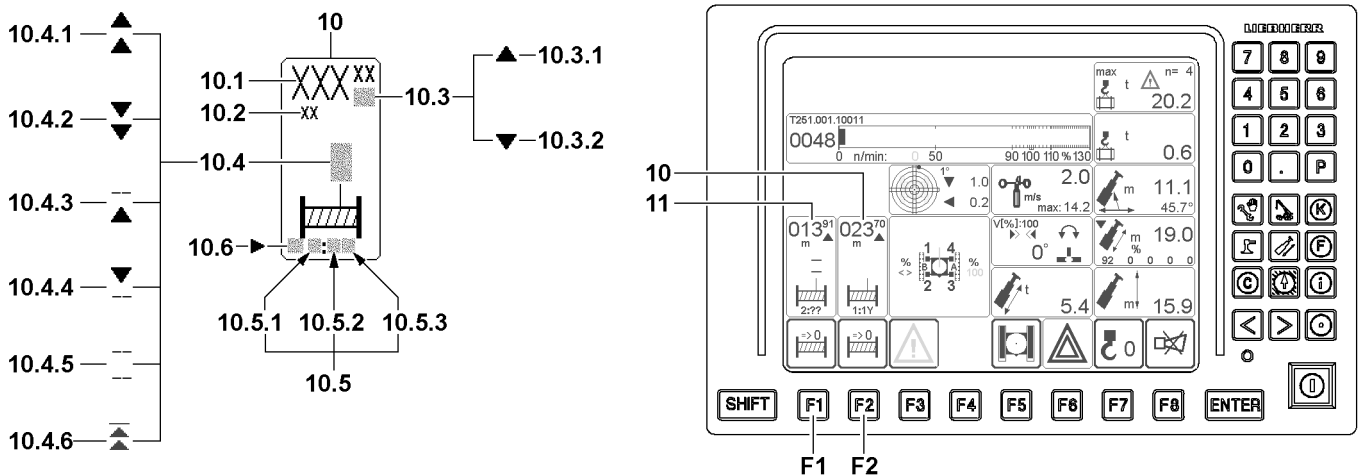


Fig.152696: Display for winch 1 and winch 2

The displays for winch 1 and winch 2 have a fixed space on the LICCON monitor.

The current position of each winch can be set as zero point:

- Hoist winch: The completed hook path is calculated with the reeving set in the Set up program. A prerequisite for a correct display is that the value entered matches the entered reeving and the actual number of rope strands between the boom head and the hook block.
- Control winch: Rope length of winch spooled out / up

**F1** Function key

- Above the function key **F1** appears the icon *Reset winch display*. Pressing on the button sets the display of the rope measurement to zero. Path measurement starts here.

**F2** Function key

- Above the function key **F2** appears the icon *Reset winch display*. Pressing on the button sets the display of the rope measurement to zero. Path measurement starts here.

**10** Winch 1

- Icon for winch 1 (WI)

**11** Winch 2

- Icon for winch 2 (WII)

LWE/LTR 1220-003/24204-02-02/en

**Note**

- ▶ The displays for winch 1 and winch 2 are identical and are explained on one icon element.

**10.1** Rope measurement

- In [m] or [ft], see Measuring unit **10.2**  
From a zero point to be determined
- As hoist winch with the reeving set in the Set up program: completed hook path. A prerequisite for a correct display is that the reeving value entered equals the actual number of rope strands between the boom head and the hook block.
- The positions before the decimal point are displayed with a maximum of three large digits. The digits after the decimal point are displayed with small digits.

**Note**

Display area winch displays.

- ▶ The *rope measurement 10.1* display has only three positions before the comma, any positions before that are cut off. The crane operator must evaluate for himself if, for example 200 m rope are spooled up on a winch or 1200 m. **The display in both cases would be identical with 200 m.**
- ▶ The hook path calculation only works accurately if the load is suspended freely and is not luffed or telescoped during the lifting procedure. Not taken into account are flexation and rope expansion.
- ▶ The length display (hook path display) is only correct when the winch is calibrated.

**10.2** Measuring unit

- Measuring unit of hook path display: [m] or [ft]

**10.3** Direction of hook movement

- The arrows on the length value show the direction of the hook movement in relation to the zero point
- **10.3.1** (Up arrow:): Hook moves upward from the zero point
- **10.3.2** (Down arrow): Hook moves downward from the zero point

**10.4** Winch status display

- There are five winch condition icons, all blinking
- **Note:** If no winch status icon appears, the activated winch is inactive and is neither spooled up nor spooled out.

**10.4.1** Spool out

- Winch is spooled out

**10.4.2** Spool up

- Winch is spooled up

**10.4.3** Spooled out

- Additional spooling out of the winch is blocked

**10.4.4** Spooled up

- Additional spooling up of the winch is blocked

**10.4.5** Winch deactivated

- Winch is deactivated or unplugged
- **Note:** Winch cannot be controlled.

**10.4.6** Winch turned off in emergency

- Spooling out of the winch is blocked
- Pay attention to the error message

**10.5** Master switch assignment

- **10.5.1** First digit
  - First digit: Winch number, every winch icon is permanently assigned to a winch
- **10.5.2** Second digit
  - Master switch number, according to the assigned master switch
  - ? : No master switch assigned
- **10.5.3** Letter
  - Actuation direction of the master switch, see illustration
  - ? : No actuation direction assigned

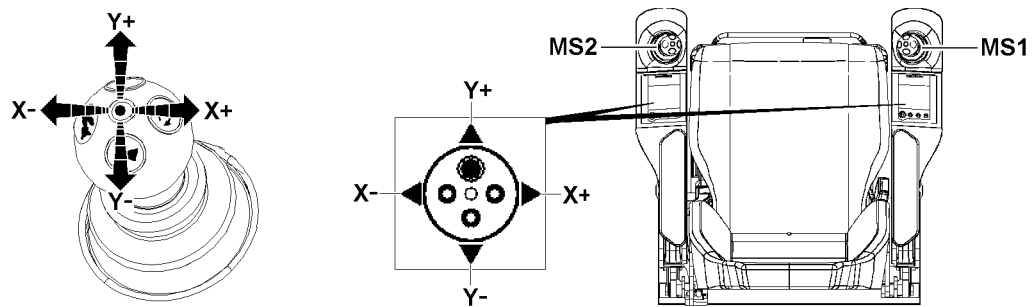


Fig.122441: Actuation directions Master switch

**MS1** Master switch 1

**MS2** Master switch 2

**X+** To the right

**X-** To the left

**Y+** To the front

**Y-** To the rear

#### 10.6 Vibration sensor

- If the vibration sensor for a winch is added on the master switch, then an arrow appears in this winch icon for the added vibration sensor.
- **Note:** The vibration sensor is added at the first actuated crane function.

## 5.8 Function key line (crane operation)

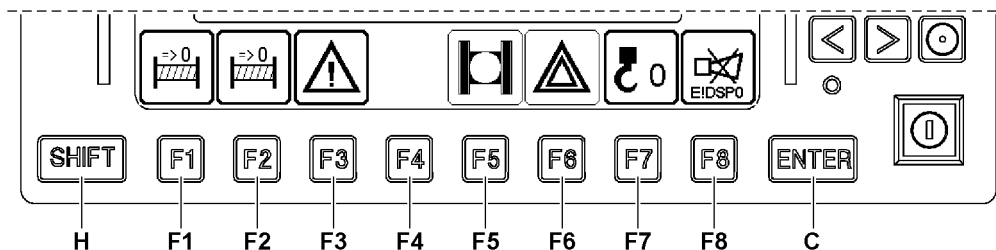


Fig.122540: Function key line in the Crane operation program

The function key line consists of function keys **F1** to **F8** and the icon line above them. The function keys correspond to the various function key icons above them.

The function key icons may trigger a function or they change their appearance upon the push of a key (function keys) and thereby their definition.

Depending on the crane type and set up configuration, fewer function key icons may be present.

Not all function keys have icons or functions assigned to them. This depends on the program selection.

Pressing a function key can change the appearance of the icon above, its meaning, or its textual content.

#### **F1** Function key

- Set the current hook position as the zero point for the Winch 2\* hook path display.
- Pressing the function key **F1** causes the *Reset winch display* icon to appear, i.e. the winch 2\* hook path display in the winch icon above is set to „000.00“ when the key is pressed. Path measurement starts here.

#### **F2** Function key

- Set the current hook position as the zero point for the Winch 1 hook path display.
- Pressing the function key **F2** causes the *Reset winch display* icon to appear, i.e. the winch 1 hook path display in the winch icon above is set to „000.00“ when the key is pressed. Path measurement starts here.

#### **F3** Function key

- Displaying monitoring functions during crane operation
- Using the function key **F3**, the *monitoring functions in crane operation* displays can be displayed.



**Note**

- ▶ The monitoring functions in crane operation are always active; however, they can be hidden.
- ▶ If a warning event occurs, there is an acoustic warning (horn) and the *monitoring function in crane operation* displays are displayed on the LICCON monitor, even if they were previously hidden.

- F4** Function key
  - Not assigned
- F5** Function key
  - Display or hide surface pressure and center of gravity monitoring
  - Using the function key **F5**, the monitoring of the surface pressure and center of gravity can be displayed or hidden.
- F6** Function key
  - Fading monitored auxiliary functions in or out
  - The function key **F6** can be used to display or hide all monitored auxiliary functions in the crane.
- F7** Function key
  - Taring Actual load display: The actual load display can be changed at any time to net load (tare) by pressing the function key **F7**.
  - As long as net load is set, the icon above the function key **F7** is shown in red.
  - For a detailed description of the actual load display, see section „Information regarding crane geometry and load“.
  - The change to net load is cancelled by each of the following actions:
    1. By pressing the function key **F7** again.
    2. By telescoping the boom by more than 3 LE (dm or 1/10 ft.).
    3. By luffing by more than  $\pm 4^\circ$ .
- F8** Function key
  - Shut-off of acoustic warning / error diagnostics
  - For a detailed description of acoustic warnings on the LICCON monitor, see section „Acoustic warnings on LICCON monitor“

### 5.9 Operating elements in the Crane operation program

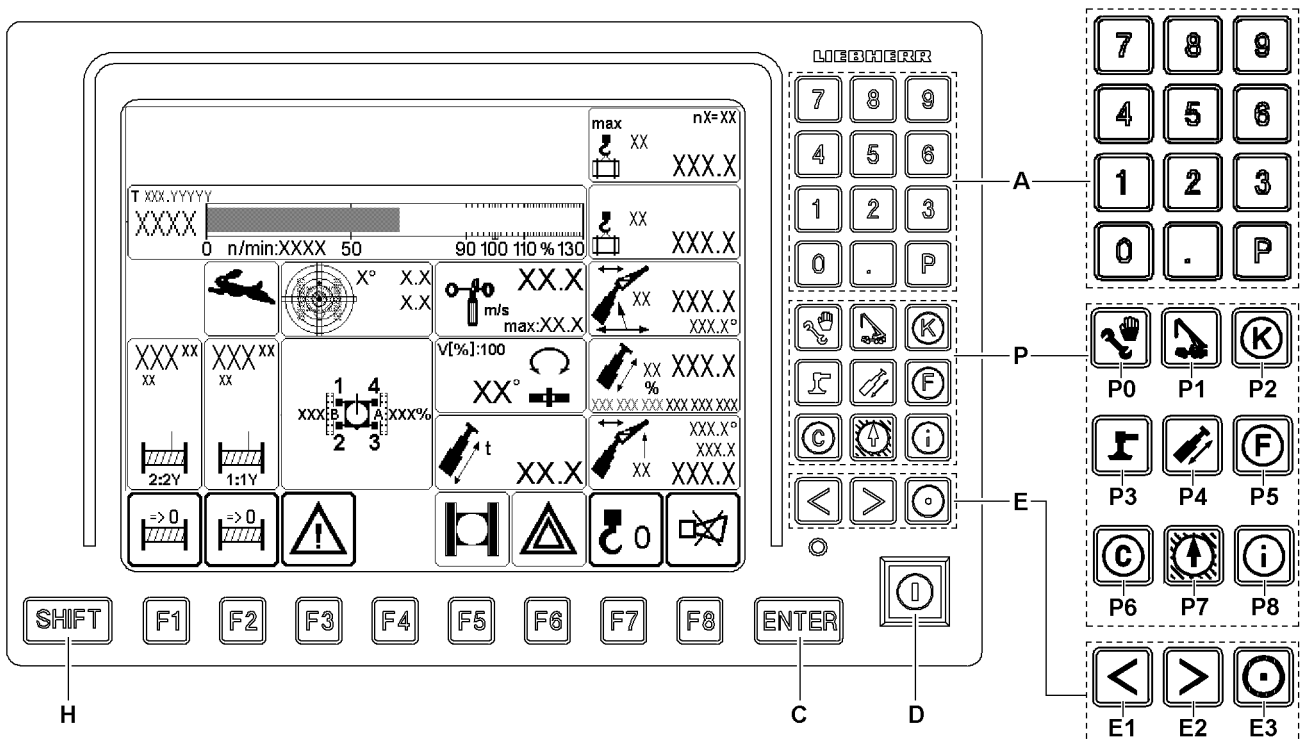


Fig.122541: Operating elements in the Crane operation program

The following functions are assigned to the other operating elements of the display and operating unit of the LICCON computer system in the Crane operation program.

- A** Numeric keypad
  - For entry of numeric values (if required)
- P** Program keys
  - The program keys are used to select individual programs. The program specific peculiarities must be observed, see respective sections of programs in this chapter.
    - Note:** Some programs can only be called up with the program key when no functions are activated via the set up key **D** at the same time.
- C** **ENTER** key
  - For confirmation of entry (if required)
- D** Set up key
  - Zero position (not actuated):  
Normal operation.
  - Touching:  
Special functions LICCON overload protection released, see section „Special functions LICCON overload protection“
- E** Special function keys
  - Monitor brightness adjustment (see section „Operating elements of the LICCON computer system“)



**Note**

- ▶ Additional functions of the special function keys **E** are program-dependent and are further explained in the description of the individual LICCON programs.

- H** **SHIFT** key
  - Second level key assignments

### 5.10 Setting the limit values for the load torque limiter for advance warning and shut-off

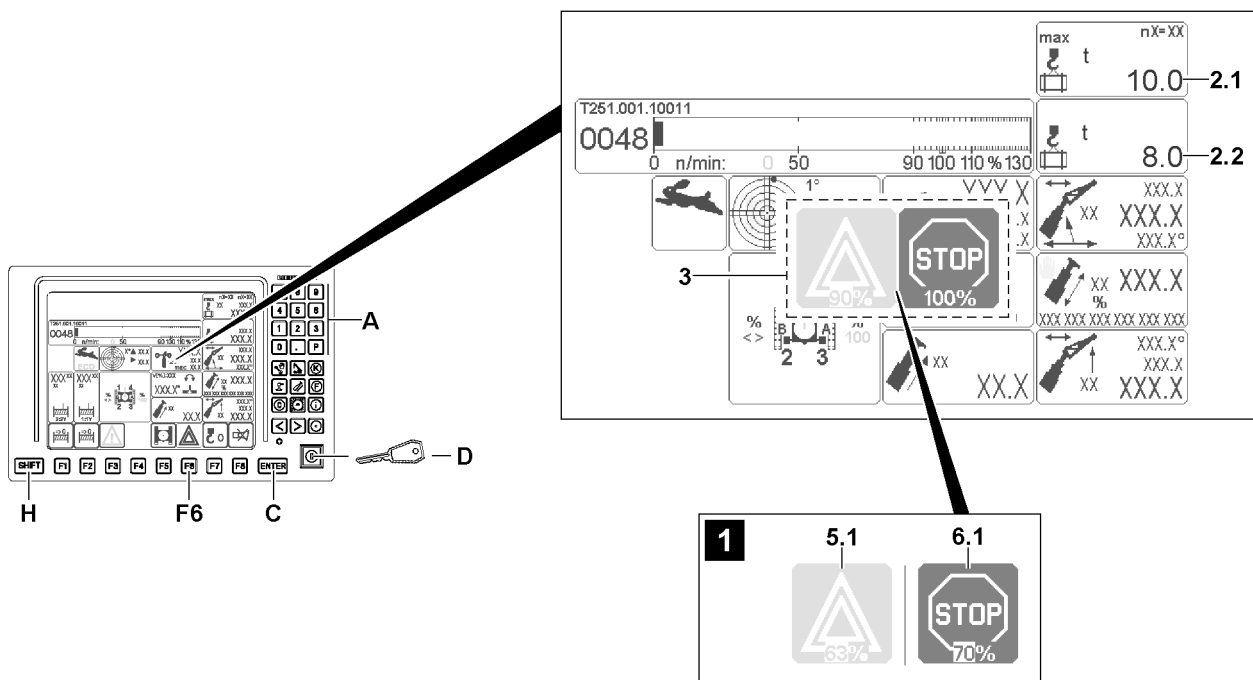


Fig.152692: Setting the limit values for the load torque limiter for advance warning and shut-off

LWE/LTR 1220-003/24204-02-02/en

The crane driver can reduce the factory set limit values of the load torque limiter for advance warning and shut-off.

Factory settings:

- The *advance warning* limit value is 90%
- The *shut-off* limit value is 100%

If the limit values for the load torque limiter for advance warning and shut-off are reduced:

- the displayed maximum load **2.1** cannot be lifted without exceeding the shut-off limits of the LICCON overload protection
- the crane movements are shut off earlier by the crane control



### WARNING

Crane possibilities additionally limited!

If the *shut-off* limit value is reduced, the crane possibilities are additionally reduced.

The maximum load **2.1** can only be lifted by exceeding the shut-off limits of the LICCON overload protection.

The maximum boom radius of the crane can be reduced.

For crane operation on a variable support, the slewing range can be significantly limited.

- ▶ Select the *shut-off* limit value such that crane operation is possible without exceeding the shut off limits of the LICCON overload protection.
- ▶ Before exceeding the shut off limits of the LICCON overload protection, it is recommended to reset the factory set *shut-off* limit value.
- ▶ When transferring the crane to another crane operator: Inform the following crane operator about the changed limit value of the load torque limiter for advance warning and shut-off.



### Note

- ▶ In order to not limit crane performance, it is advisable to only reduce the *advance warning* limit value.



### Note

Crane control EN13000:2010 active

Exceeding the shut off limits of the LICCON overload protection.

- ▶ By pressing the set up key **D** the *shut-off* limit value can be exceeded only 1/10.
- ▶ Example: If the *shut-off* limit value is set to 70%, the set up key **D** can be used to exceed crane utilization to maximum 77%.
- ▶ In order to bypass the *shut-off* limit value beyond that, the emergency operation LICCON overload protection must be activated.



### Note

Crane control EN13000:2010 not active

Exceeding the shut off limits of the LICCON overload protection.

- ▶ By pressing the set up key **D** the *shut-off* limit value is bypassed.

Ensure that the following prerequisite is met:

- The *shut-off* limit value is selected such that crane operation is possible without exceeding the shut-off limits of the LICCON overload protection.

## 5.10.1 Displaying the set limit values

- ▶ Press the SHIFT key **H** and function key **F6** at the same time.

**Result:**

- The settings window **3** opens.
- The *advance warning* limit value can be read on the *advance warning* setting icon **5.1**.
- The *shut-off* limit value can be read on the *STOP* settings icon **6.1**.

Close the settings window **3**:

- ▶ Press the SHIFT key **H** and function key **F6** at the same time.
- or
- Wait for ten seconds.

### 5.10.2 Setting the limit value



#### Note

If you try to set a limit value that is too high, the highest possible value is taken over.  
If you try to set a limit value that is too low, the lowest possible value is taken over.  
The difference between the limit values is at least 1/10 of the <sup>shut-off</sup> limit value.

- ▶ Select the <sup>advance warning</sup> limit value between 18 and 90.
- ▶ Select the <sup>shut-off</sup> limit value between 20 and 100.

- ▶ Press the SHIFT key **H** and function key **F6** at the same time.

#### Result:

- The settings window **3** opens.
- The <sup>advance warning</sup> limit value is highlighted in white in the *advance warning* settings icon **5.1** and can be set, see illustration **1**.



#### Note

- ▶ It is possible to switch between the adjustable limit values by pressing the Enter key **C**.

Set a new <sup>advance warning</sup> limit value:

- ▶ Enter the required <sup>advance warning</sup> limit value (for example 63) using the keys (0 to 9) on the keypad **A**.

#### Result:

- The new <sup>advance warning</sup> limit value is displayed on the *advance warning* setting icon **5.1**.

#### Problem remedy

The set <sup>advance warning</sup> limit value is always rejected?

The difference between the limit values must be at least 1/10 of the <sup>shut-off</sup> limit value. If the <sup>advance warning</sup> limit value is increased, the <sup>shut-off</sup> limit value must be correspondingly high.

- ▶ First increase the <sup>shut-off</sup> limit value.

- ▶ Press the Enter key **C** until the <sup>shut-off</sup> limit value is highlighted in white in the *STOP* settings icon **6.1**, see illustration **1**.

Set a new <sup>shut-off</sup> limit value:

- ▶ Enter the required <sup>shut-off</sup> limit value (for example 70) using the keys (0 to 9) on the keypad **A**.

#### Result:

- The new <sup>shut-off</sup> limit value is displayed on the *STOP* setting icon **6.1**.

End the settings:

- ▶ Press the SHIFT key **H** and function key **F6** at the same time.
- or
- Wait for ten seconds.

#### Result:

- The settings window **3** closes.
- The limit values are set.

**Example 1: Occurrence of an advance warning with reduced <sup>advance warning</sup> limit value**

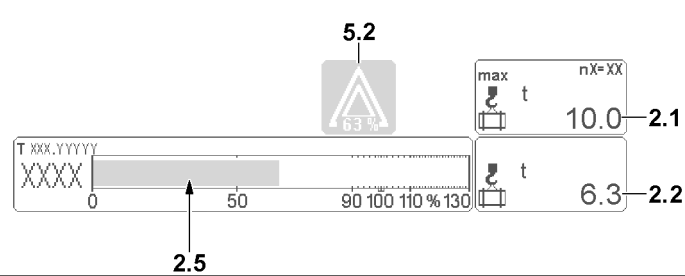


Fig.148397: Advance warning limit value set to 63%, crane utilization 63%

- The actual load value 2.2 reaches 63% of the maximum load value 2.1
- Utilization bar 2.5 turns yellow
- The advance warning icon 5.2 appears with the set advance warning limit value (in the example, 63%)

#### Example 2: Occurrence of a shut-off with reduced shut-off limit value

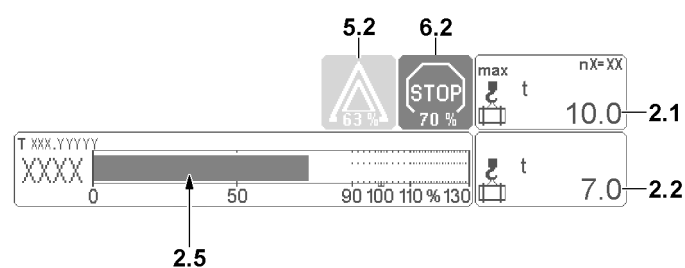


Fig.148398: Shut-off limit value set to 70%, crane utilization 70%

- The actual load value 2.2 reaches 70% of the maximum load value 2.1
- Utilization bar 2.5 turns red
- The advance warning icon 5.2 appears with the set advance warning limit value (in the example, 63%)
- The STOP icon 6.2 appears with the set shut-off limit value (in the example, 70%)
- Load moment increasing crane movements are shut off
- When transferring the crane to another crane operator: Inform the following crane operator about the changed limit value of the load torque limiter for advance warning and shut-off.



## 6 The Telescoping program

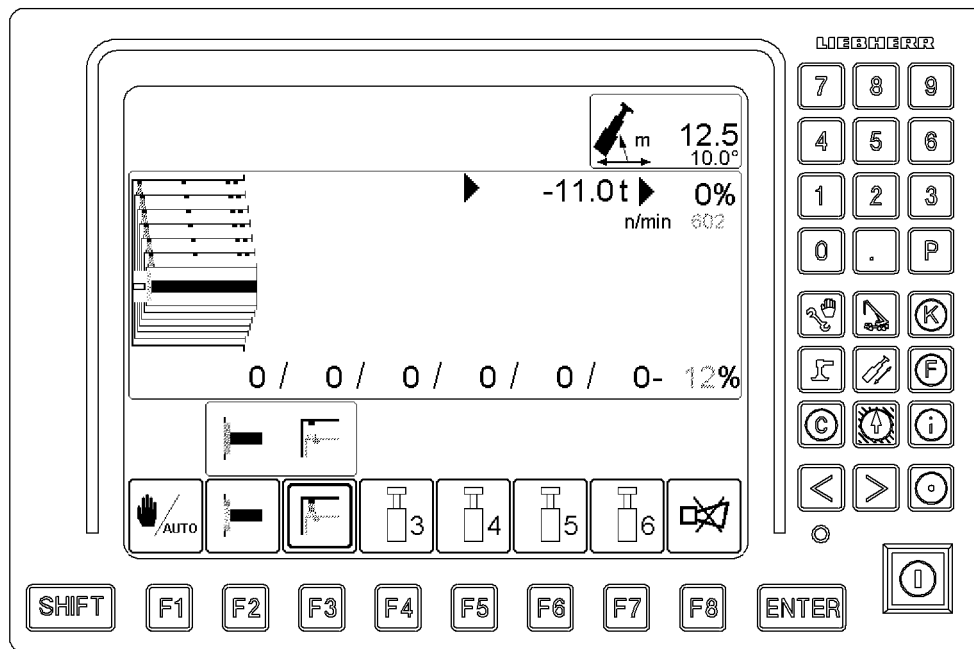


Fig.122469: Exemplary illustration of displays in the Telescoping program



### Note

- ▶ Only for crane types with the TELEMATIK telescoping system.

## 6.1 Display areas in the Telescoping program

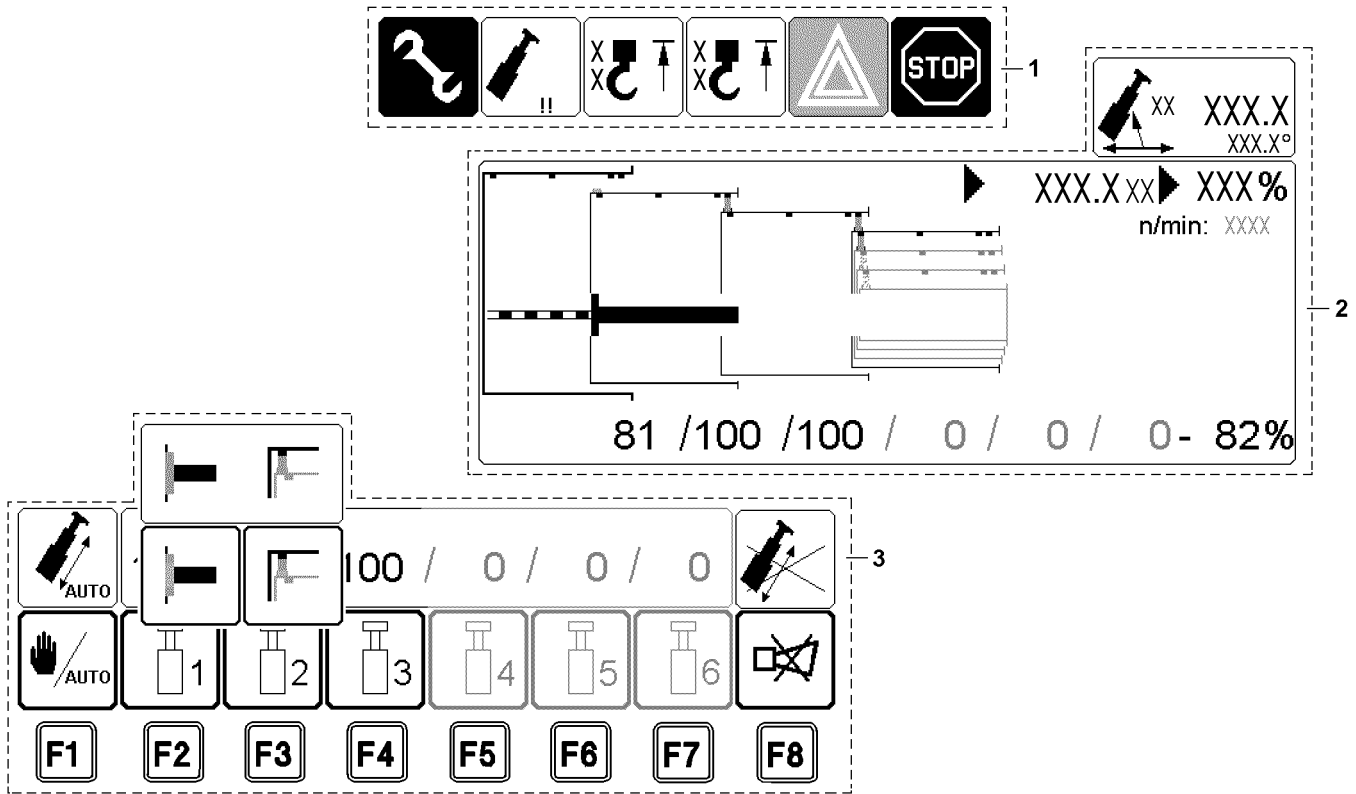


Fig.152701: Display areas in the Telescoping program

In the Telescoping program, the following areas are shown:

- 1 Alarm functions
- 2 Telescoping screen
- 3 Function key line



### Note

- For a detailed description of the alarm functions 1, see section „The Crane operation program“.

The telescoping screen 2 shows the crane operator in a dynamic view:

- The pin condition of the telescopic boom.
- The position of the individual telescopes to each other.
- The extension condition of telescoping cylinder.

The function key line 3 consists of function keys F1 to F8 and the icon line above them:

- The function keys correspond to the various function key icons above them.
- The function key icons always show the functions that are activated by pressing a button.
- The function is called up after pressing a button. In addition, the icon above it can change its display, its meaning or its text.
- Not all function keys must have assigned icons. This depends on the active program selection.



### Note

- For a detailed description for the telescoping procedure, see Chapter 4.05.
- In the *Boom length* icon of the crane operating screen, information about the telescoping procedure is also shown, see section „The Crane operation program“.

## 6.2 Starting the Telescoping program

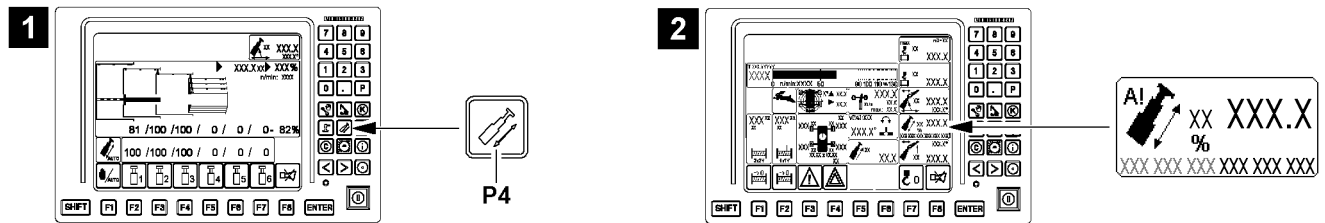


Fig.122462: Starting the Telescoping program

- ▶ Press the program key **P4**, see illustration 1.

or

Automatic start from the Crane operation program: When the telescoping target is reached (illustration 2) deflect the respective master switch in direction telescope in / telescope out.

## 6.3 Operating interface

### 6.3.1 Alarm functions

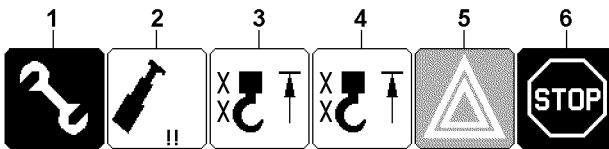


Fig.152702: Operating interface: Alarm functions

For a detailed description of the alarm functions 1, see section „The Crane operation program“.

#### 1 Assembly

- The icon appears if:
  - A special case was activated upon operation of the LICCON overload protection, see section „LICCON overload protection special functions“
  - TELEMATIK emergency operation was activated (only for certain crane types)

#### 2 Boom limitation

- The icon appears when a boom system limitation occurred

#### 3 Hoist top icon

- The icon appears when the hoist limit switch for the first load position was triggered.
- The icon appears crossed out when the concerned hoist limit switch is bypassed.

#### 4 Hoist top icon

- The icon appears when the hoist limit switch for the second load position was triggered.
- The icon appears crossed out when the concerned hoist limit switch is bypassed

#### 5 Advance warning icon

- The icon appears when an advance warning was triggered.

#### 6 STOP icon

- The icon appears when the crane movements were turned off by the LICCON computer system.

## 6.3.2 Telescoping screen

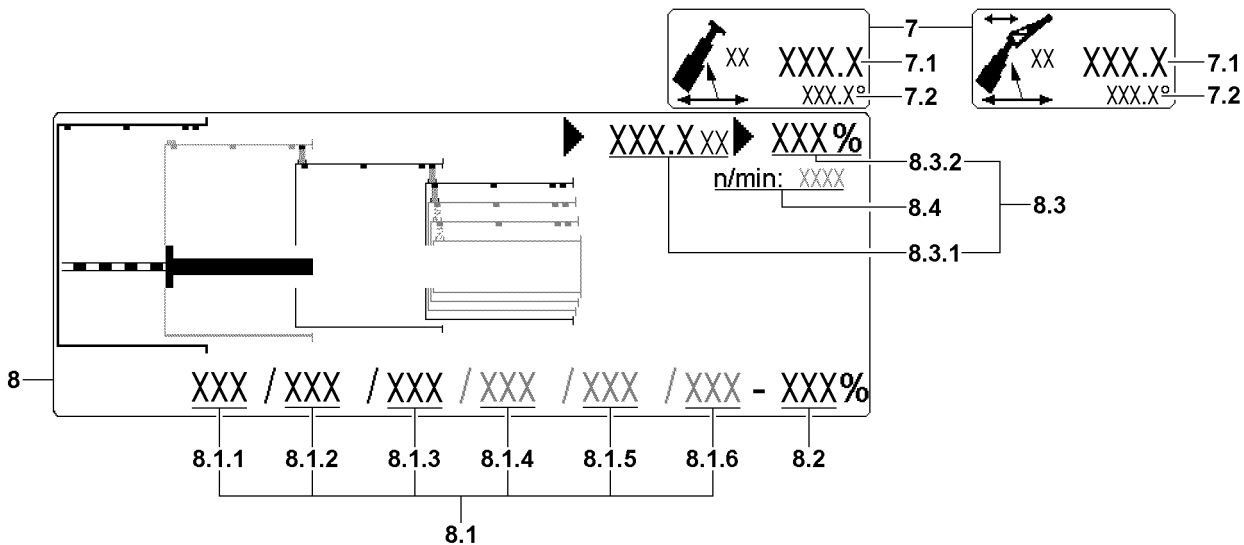


Fig.122464: Operating interface: Telescoping screen upper screen area

- 7 Boom radius icon
- 7.1 Boom radius
  - Boom radius of the crane
  - In [m] or [ft]
- 7.2 Main boom angle
  - In [°]
- 8 View of the telescopic boom
  - Stylized illustration of the telescopic boom
  - **Note:** The illustration refers to a telescopic boom with six telescopeable slide-in modules, for crane types with other telescopic booms the illustration is adjusted.
- 8.1 Extension condition of telescopes
  - Current extension condition of the telescopes
  - In [%]
  - 8.1.1 Telescope 1 (T1)
  - 8.1.2 Telescope 2 (T2)
  - 8.1.3 Telescope 3 (T3)
  - 8.1.4 Telescope 4 (T4)
  - **Note:** Only for crane types with corresponding telescopic boom.
  - 8.1.5 Telescope 5 (T5)
  - **Note:** Only for crane types with corresponding telescopic boom.
  - 8.1.6 Telescope 6 (T6)
  - **Note:** Only for crane types with corresponding telescopic boom.
- 8.2 Extension condition of telescoping cylinder
  - Current extension condition of telescoping cylinder
  - In [%]

### NOTICE

Damage to hydraulic pumps!

If the telescoping cylinder is not telescoped in before turning the superstructure engine off, then the hydraulic pumps can be damaged. This applies especially at low temperatures.

- ▶ Before turning the superstructure engine off, set the extension condition of the telescoping cylinder 8.2 to between 0 % and 15 %, see Crane operating instructions, chapter 4.05.

- 8.3 Load display
  - Display of actual load and utilization of crane in percentages

**8.3.1 Actual load**

- Current load
- In [t] or [lbs]

**8.3.2 Crane utilization**

- Current utilization of the crane
- In [%]

**8.3.3 Utilization bar**

- **Note:** Only present for certain crane types.
- Utilization bar blue / green: Utilization in permissible range
- Utilization bar yellow:  
**Advance warning!** - Utilization just before impermissible range
- Utilization bar red:  
**Warning!** - Utilization in impermissible range

**8.4 Engine rpm**

- In revolutions per minute
- When the engine rpm is locked, a „+“ is displayed behind the rpm value.
- When the engine rpm is limited, a „!“ is displayed behind the rpm value (see eco mode).

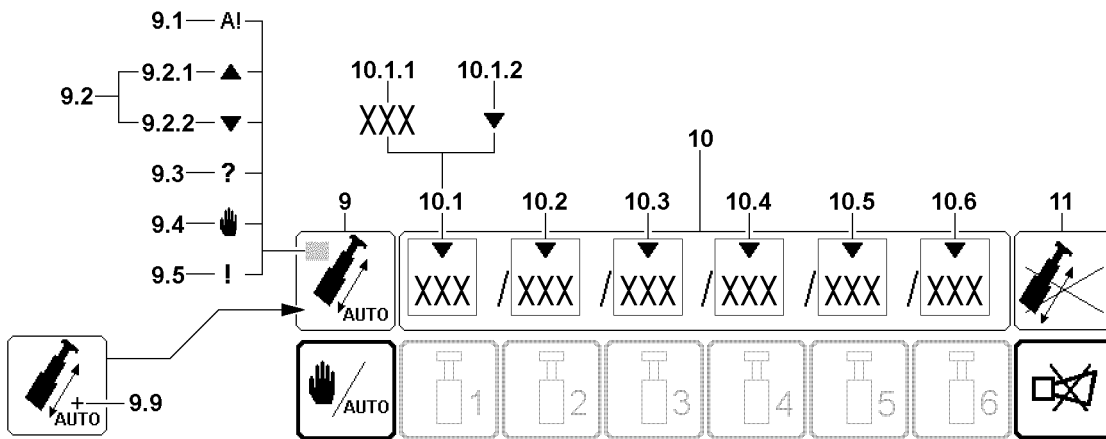


Fig.152703: Operating interface: Telescoping screen lower screen area

**9 TELEMATIK**

- Icon appears only in automatic operation telescoping
- **9.1** Preselected telescoping target reached
- **9.2** Direction specification telescoping
- **9.2.1** Up arrow: Telescope out request
- **9.2.2** Down arrow: Telescope in request
- **9.3** Error in system, observe error message
- **9.4** Manual telescoping
- **9.5** TELEMATIK emergency operation control  
**Note:** Only for certain crane types.
- **9.9** Telescoping with automatic carrying along of auxiliary boom / accessory  
**Note:** Only for certain crane types.

**10 Telescoping targets**

- Selected telescoping targets of telescopes

**10.1 Telescope 1 target selection**

- **Note:** Valid as an example for all target selections for telescopes.
- **10.1.1** Telescoping target Telescope
- **10.1.2** Notification arrow: As a warning in the event of incorrect operation, target already reached or enter new target.

**10.2 Telescope 2 target selection**

**10.3 Telescope 3 target selection**

**10.4 Telescope 4 target selection**

LWE/LTR 1220-003/24204-02-02/en

**Note:** Only for crane types with corresponding telescopic boom.

#### 10.5 Telescope 5 target selection

**Note:** Only for crane types with corresponding telescopic boom.

#### 10.6 Telescope 6 target selection

**Note:** Only for crane types with corresponding telescopic boom.

#### 11 Telescoping procedure disabled

- Disabling further telescoping procedure due to expected exceeding of maximum load in uninned condition
- **Note:** See section “Monitored auxiliary functions”.

## 6.4 The function key line (Telescoping program)

### 6.4.1 Function key line: Telescoping automatic operation

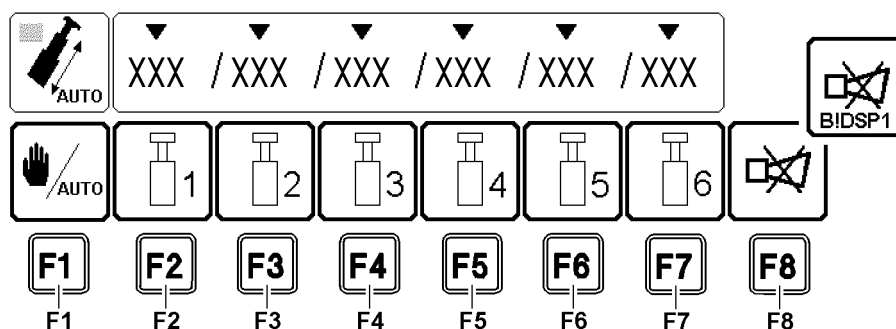


Fig.122466: Function key line in Telescoping program, automatic operation telescoping

#### F1 Function key

Change over between:

- Telescoping automatic operation
- Telescoping automatic operation with carrying lattice jib along
- **Note:** Only for certain crane types
- Manual telescoping

#### F2 Function key

- Telescope 1 target selection

#### F3 Function key

- Telescope 2 target selection

#### F4 Function key

- Telescope 3 target selection

#### F5 Function key

- Telescope 4 target selection

**Note:** Only for crane types with telescope 4

#### F6 Function key

- Telescope 5 target selection

**Note:** Only for crane types with telescope 5

#### F7 Function key

- Telescope 6 target selection

**Note:** Only for crane types with telescope 6

#### F8 Function key

- Possibly shut off of acoustic warning and calling up of error messages:
  - Press the function key **F8** once: The acoustic signal is turned off.
  - Press the function key **F8** twice: The error description for the error message which occurred last is called up.
- **Note:** A new error turns the acoustic warning on again.

## 6.4.2 Function key line: Manual telescoping

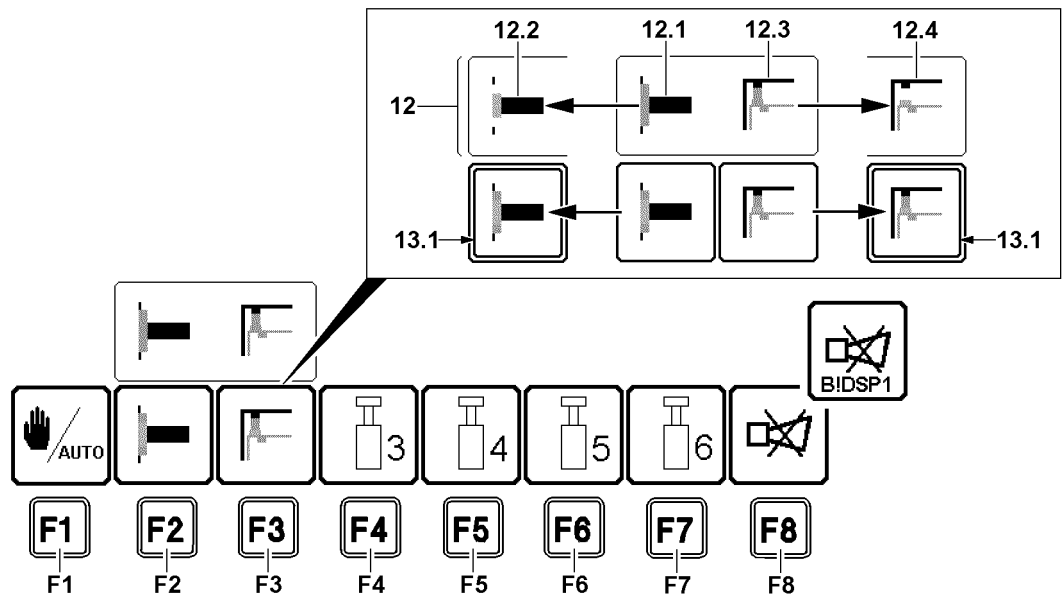


Fig.122467: Function key line in Telescoping program, manual telescoping

### F1 Function key

Change over between:

- Manual telescoping
- Telescoping automatic operation
- Telescoping automatic operation with carrying lattice jib along

**Note:** Only for certain crane types.

### F2 Function key

- Telescoping cylinder unpinned / pinned

**Note:** If the function is activated by pressing the function key **F2** then a red frame **13.1** appears

### F3 Function key

- Telescopic pinning unpinned / pinned

**Note:** If the function is activated by pressing the function key **F3** then a red frame **13.1** appears

### F4 Function key

- No function in manual telescoping

### F5 Function key

- No function in manual telescoping

### F6 Function key

- No function in manual telescoping

### F7 Function key

- No function in manual telescoping

### F8 Function key

- Possibly shut off of acoustic warning and calling up of error messages:
  - Press the function key **F8** once: The acoustic signal is turned off.
  - Press the function key **F8** twice: The error description for the error message which occurred last is called up.
- **Note:** A new error turns the acoustic warning on again.

### 12 Manual telescoping status icons

Active process is shown in icon:

- **12.1** Telescoping cylinder pinned
- **12.2** Telescoping cylinder unpinned
- **12.3** Telescopic pinning pinned

- 12.4 Telescopic pinning unpinning

## 6.5 TELEMATIK emergency operation special function

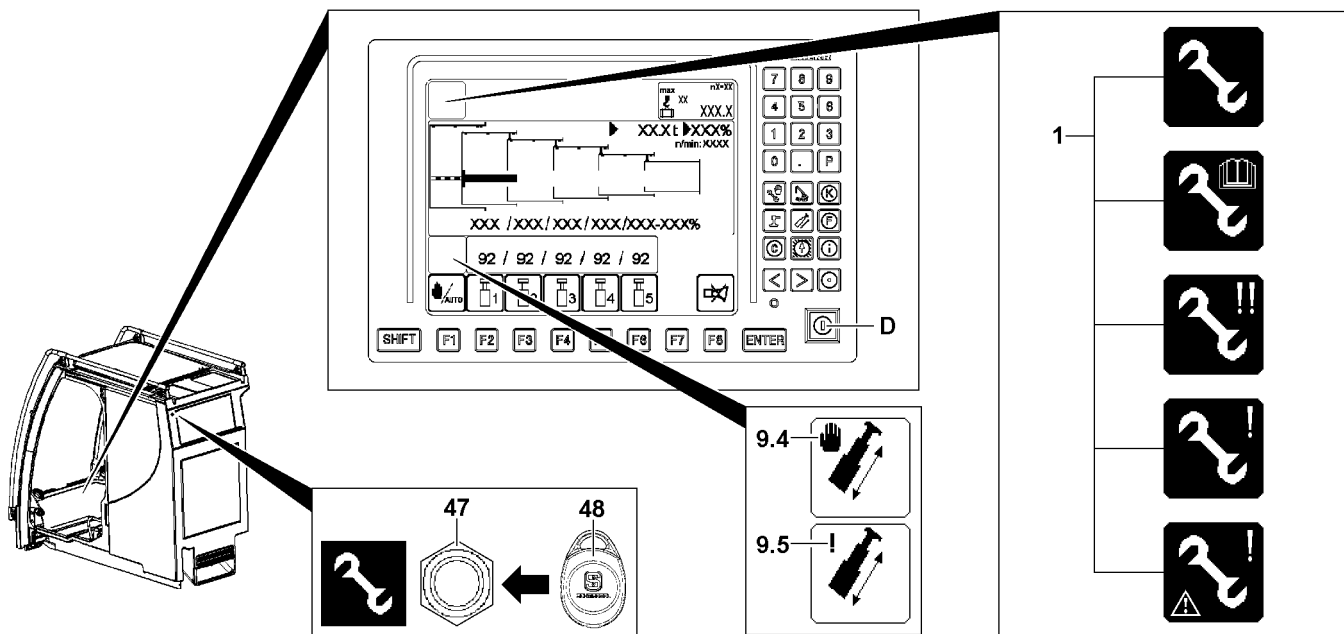


Fig.148666: TELEMATIK Emergency operation\* special function



### Note

- Only for certain crane types.



### WARNING

Shut off safety equipment!

In TELEMATIK emergency operation the LICCON overload protection is totally deactivated.

The crane movements are no longer monitored by the LICCON overload protection.

Due to erroneous operation or deliberate misuse, the crane could collapse, the boom can break off or the crane can topple over.

Personnel can be severely injured or killed.

- The emergency operation may only be activated by persons who are aware of the consequences of their actions.
- A shut-off by the LICCON overload protection may not be circumvented by the emergency operation.
- If normal crane operation is possible, then the emergency operation may not be activated.
- All crane movements must be carried out with extreme caution and anticipatorily.

In TELEMATIK emergency operation the opening of the tele pin is ensured.

The following shut offs are bypassed:

- Retract / extend telescoping cylinder is made possible with placed cylinder pin.
- Maximum push out length of telescoping cylinder reached (extend cylinder possible).
- Collision with folding jib (telescoping out is made possible).

Make sure that the following prerequisites are met:

- An error in the TELEMATIK system is present.
- The Telescoping program is called up.
- Manual telescoping is called up.

### 6.5.1 TELEMATIK emergency operation (EN 13000:2010 not active)

Activate TELEMATIK emergency operation:



- ▶ Press the set up button **D**.

**Result:**

- Special function TELEMATIK emergency operation is activated.
- One of the assembly icons **1** appears.
- The Control TELEMATIK emergency operation icon **9.5** appears.

**Note**

When the set up key **D** was actuated:

- ▶ If no crane movement occurs, then the special function TELEMATIK emergency operation is deactivated after ten seconds.
- ▶ The actuation of the set up key **D** is recorded in the data logger.

**Turn TELEMATIK emergency operation off:**

- ▶ Press the set up key **D** again.

**Result:**

- The TELEMATIK emergency operation special function is turned off.
- The Control TELEMATIK emergency operation icon **9.5** turns off.

## 6.5.2 TELEMATIK emergency operation (EN 13000:2010 active)

**Activate TELEMATIK emergency operation:**

- ▶ Place the transponder **48** on the sensor **47**.

**Result:**

- Special function TELEMATIK emergency operation is activated.
- One of the assembly icons **1** appears.
- The Control TELEMATIK emergency operation icon **9.5** appears.

**Note**

When the transponder **48** was placed on the sensor **47**:

- ▶ If no crane movement occurs, then the special function TELEMATIK emergency operation is deactivated after thirty minutes.
- ▶ The application of the transponder **48** on the sensor **47** is recorded in the data logger.

**Turn TELEMATIK emergency operation off:**

- ▶ Place the transponder **48** on the sensor **47**.

**Result:**

- The TELEMATIK emergency operation special function is turned off.
- The Control TELEMATIK emergency operation icon **9.5** turns off.

## 7 The working range limitation program\*

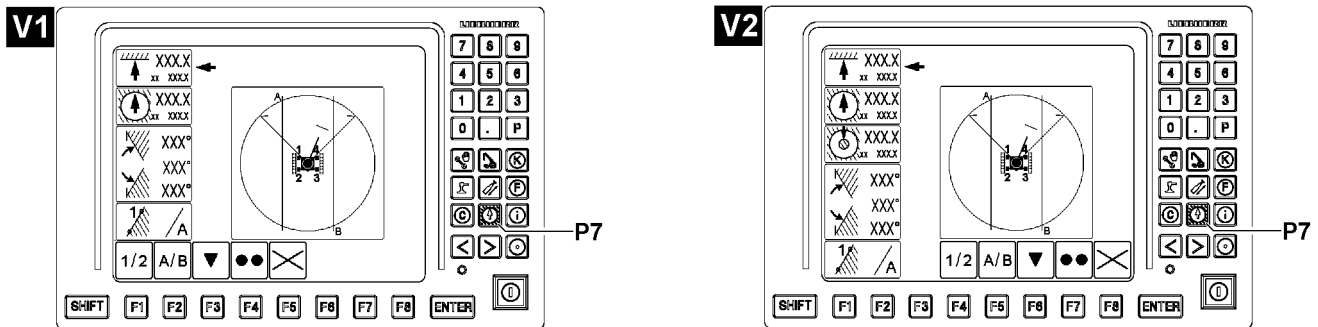


Fig.122542: Exemplary illustration of operating interfaces in the Working range limitation program

On the operating interface two variations are available of the Working range limitation program:

- V1 Variation
- V2 Variation



### Note

- ▶ For a detailed description of Working range limitation program, see Operating instructions for Working range limitation.

### 7.1 Calling up the Working range limitation program

The working range limitation program runs in the background, crane movements are only shut off when the respective icon for the limitation is active (not crossed out).

- ▶ Press the program key **P7**.

## 7.2 Operating interface Working range limitation program

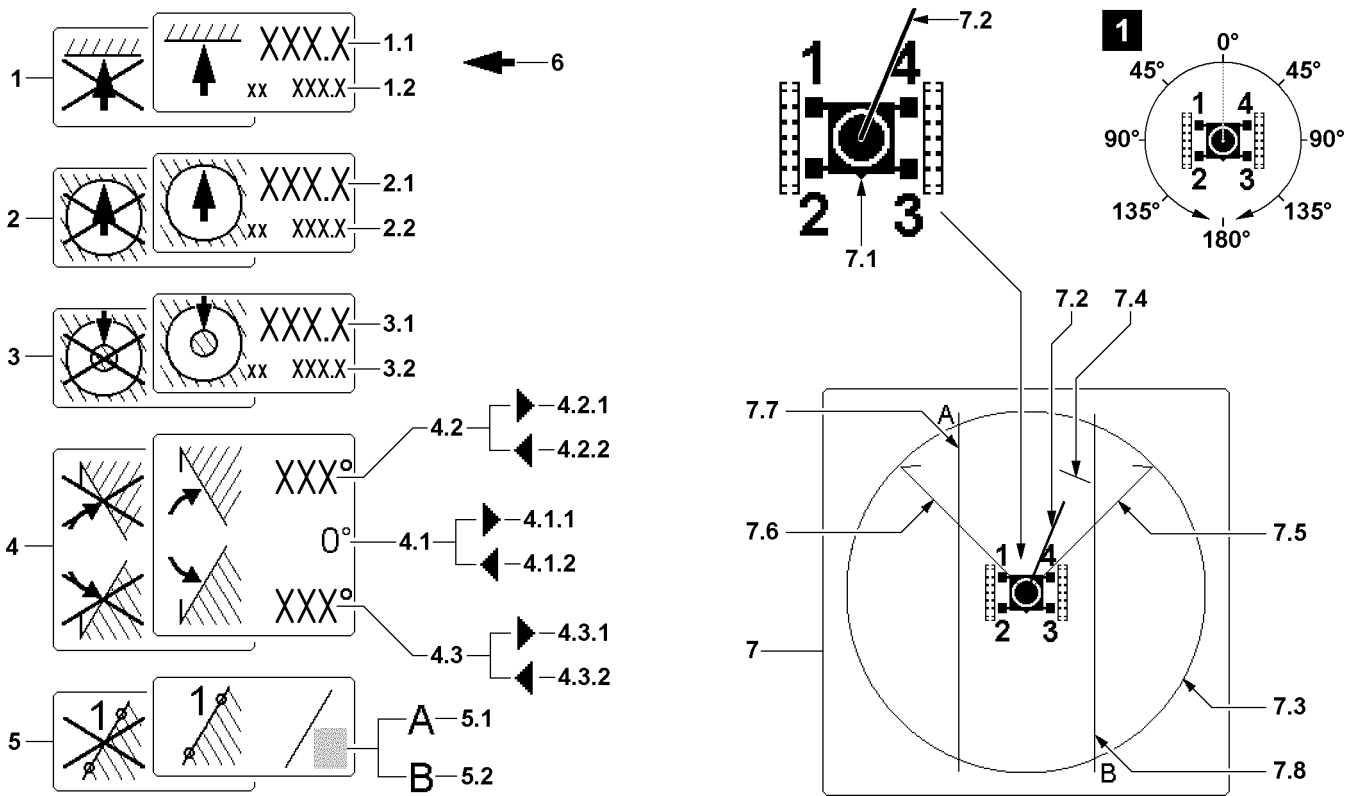


Fig.122543: Operating interface Working range limitation program



**Note**

► The limit function icons are shown crossed out if they are inactive.

- 1 Pulley head height
  - Limitation of pulley head height
  - Limits the height of the load pulley to a predetermined dimension
- 1.1 Limit value
  - The limitation is made by reaching the limit value of the pulley head height
- 1.2 Actual value
  - Current pulley head height
- 2 Working radius<sub>max</sub>
  - Limitation of maximum working radius (maximum boom radius)
  - Limits the working radius of the load hook to a predetermined upper limit
- 2.1 Limit value
  - The limitation is made by reaching the limit value for the maximum working radius
- 2.2 Actual value
  - Current working radius
- 3 Working radius<sub>min</sub>
  - **Note:** Only present for certain crane types.
  - Limitation of minimum working radius (minimum boom radius)
  - Limits the working radius of the load hook to a predetermined lower limit
- 3.1 Limit value
  - The limitation is made by reaching the limit value for the minimum working radius
- 3.2 Actual value
  - Current working radius
- 4 Turning limitation
  - Limitation of slewing range

LWE/LTR 1220-003/24204-02-02/en

- Limits the slewing range of the turntable to a predetermined angle range.
- Each consists of one right limit angle **4.2** and one left limit angle **4.3**.

#### 4.1 Slewing angle

- Current slewing angle of the turntable
- Main working direction of the crane = slewing angle 0°  
The slewing angle 0° is displayed when the turntable points exactly to the rear
- The slewing angle increases on both sides up to 180° when the turntable is turned.  
When turning past 180°, the display changes sides and the slewing angle starts to decrease (for scale see illustration 1).
- Arrow to the right **4.1.1**: Range *Turntable turned to the right*
- Arrow to the left **4.1.2**: Range *Turntable turned to the left*

#### 4.2 Right limit angle

- The limitation is made by reaching this right limit angle
- Arrow to the right **4.2.1**: Limit angle is in range *Turntable turned to the right*
- Arrow to the left **4.2.2**: Limit angle is in range *Turntable turned to the left*

#### 4.3 Left limit angle

- The limitation is made by reaching this left limit angle
- Arrow to the right **4.3.1**: Limit angle is in range *Turntable turned to the right*
- Arrow to the left **4.3.2**: Limit angle is in range *Turntable turned to the left*

#### 5 Edge limitation

- Limitation of freely selectable edges (limitations)
- Consists of up to two edges („edge A **5.1**“ and „edge B **5.2**“), which do not have to run through the center of the slewing ring.



#### Note

- ▶ Due to the edge limitation it is possible to determine the working range limits, which allow turning 360° compared to the slewing angle limitation. If necessary, the boom radius must be shorted for turning.

#### 6 Function selector

- To select the limitation functions (Position **1** to **5**)

#### 7 Graphic display

- Graphic display of programmed working range limits viewed from above.  
The crawler travel gear is shown in the center.
- The triangle **7.1** shows where the front is on the crawler travel gear.
- The green bar **7.2** shows the current direction and boom radius of the boom. The longer the green bar, the larger the boom radius of the crane.

#### 7.3 Crane working radius

- Graphic illustration of the maximum working radius (maximum boom radius) of the crane under ideal conditions.
- **Note**: Setting cannot be changed in the program.

#### 7.4 Working radius<sub>max</sub>

- Graphic illustration of maximum working radius (maximum boom radius).
- Based on the limit value **2.1** from *Working radius<sub>max</sub>* icon **2**
- **Note**: If the green bar **7.2** crosses the red line of the working radius<sub>max</sub> **7.4**, a shut-off occurs.

#### 7.5 Right limit angle

- Graphic illustration of the right limit angle.
- Based on the limit angle right **4.2** from *Turning limit* icon **4**
- **Note**: If the green bar **7.2** and the orange line of the limit angle right **7.5** are superimposed, a shut-off occurs.

#### 7.6 Left limit angle

- Graphic illustration of the left limit angle.
- Based on the limit angle left **4.3** from *Turning limit* icon **4**
- **Note**: If the green bar **7.2** and the red line of the limit angle left **7.6** are superimposed, a shut-off occurs.

### 7.7 Edge A

- Graphic illustration *Edge A*
- Based on edge A 5.1 from the *edge limitation icon 5*
- **Note:** If the green bar 7.2 crosses the red line of the edge A 7.7, a shut-off occurs.

### 7.8 Edge B

- Graphic illustration *Edge B*
- Based on the edge B 5.2 from *Edge limitation icon 5*
- **Note:** If the green bar 7.2 crosses the orange line of the edge B 7.8, a shut-off occurs.

## 7.3 Function key line (working range limitation)

### 7.3.1 Function key line (working range limitation) for variation V1

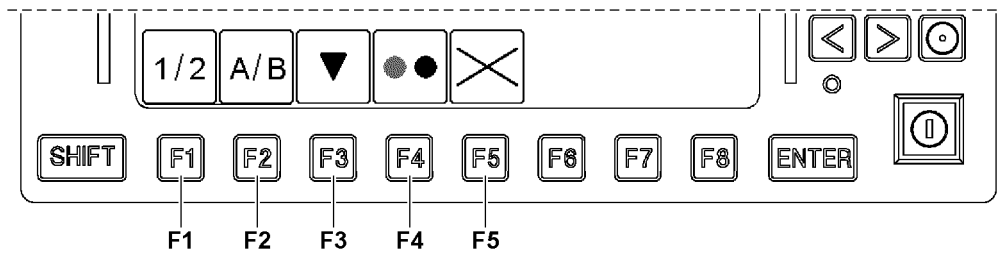


Fig.122437: Function key line in Working range limitation program, variation V1

#### F1 Function key

- Selection of point 1 or 2 of selected edge A (red) or B (orange)

#### F2 Function key

- Selection of edge A (red) or B (orange) that is being programmed

#### F3 Function key

- The function selector is moved down by one limit function

#### F4 Function key

- ON / OFF

The limit function selected with the function selector changes its status. If previously active, it will now be inactive when the function key **F4** is pressed, and vice versa. An inactive limit function is identified by a crossed out icon. If the function selector shows a slewing limit to the left or the right, then both limits will always be switched.

**Note:** For the edge limit, only the preselected edge will be switched. The edge that is not displayed can be active or inactive at the same time.



#### Note

- ▶ Limit functions can only be added via the function key **F4** when the boom is in the respective permissible range.

#### F5 Function key

- All limit functions become inactive

### 7.3.2 Function key line (working range limitation) for variation V2

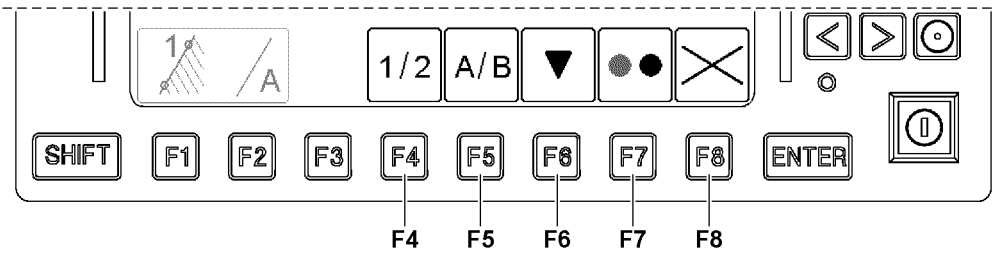


Fig.122436: Function key line in Working range limitation program, variation V2

- F4** Function key
- Selection of point 1 or 2 of selected edge A (red) or B (orange)
- F5** Function key
- Selection of edge A (red) or B (orange) that is being programmed
- F6** Function key
- The function selector is moved down by one limit function
- F7** Function key
- ON / OFF

The limit function selected with the function selector changes its status. If previously active, it will now be inactive when the function key **F7** is pressed, and vice versa. An inactive limit function is identified by a crossed out icon. If the function selector shows a slewing limit to the left or the right, then both limits will always be switched.

**Note:** For the edge limit, only the preselected edge will be switched. The edge that is not displayed can be active or inactive at the same time.



#### Note

- ▶ Limit functions can only be added via the function key **F7** when the boom is in the respective permissible range.

- F8** Function key
- All limit functions become inactive

## 7.4 Occurrence of a shut-off in the working range limitation

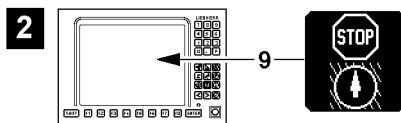


Fig.122438: Occurrence of a shut-off in the working range limitation

If the programmed working range limitation is actuated, then this status is shown in the crane operating screen by a **STOP** icon **9**, see illustration **2**.

## 8 Speed reduction master switch

The speed reduction of master switches is made in the settings window. The speeds of the displayed crane movements / crane functions can be limited steplessly to the desired value.

Speed reduction of master switches is the speed of the crane function reduced to the speed set in the settings window.

**WARNING**

Danger of accident!

- ▶ Make the preselection of the slewing speed according to the specifications in the load chart manual.
- ▶ The following applies: The longer the boom and / or the greater the load, the lower the set maximum slewing speed must be.
- ▶ **Never** deflect the master switch for the slewing gear to the stop with a long boom and / or great load.

**WARNING**

Deactivated speed reduction of master switches!

When the rapid gear is engaged, the speed reductions of the master switches can be ineffective / limited.

Too high a crane speed can cause accidents.

- ▶ Turn the rapid gear off when a speed reduction of the master switches is necessary.

## 8.1 Operating elements at speed reduction of master switches

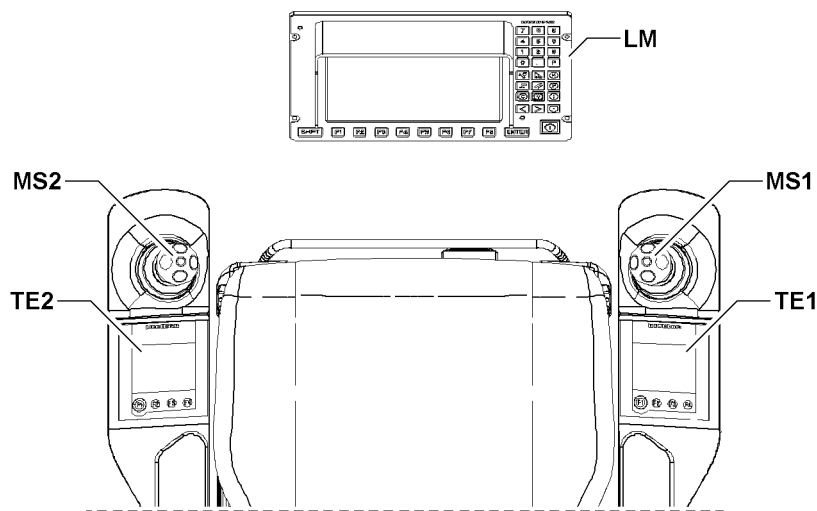


Fig.122445: Operating elements at speed reduction of master switches

**LM** LICCON monitor

**MS1** Master switch 1

**TE1** Touch display 1

**MS2** Master switch 2

**TE2** Touch display 2

## 8.2 Operating interface in the settings window for speed reduction of master switches

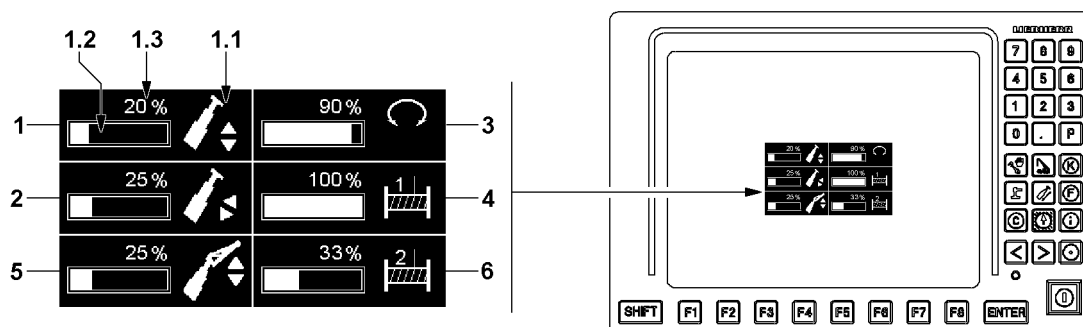


Fig.122446: Operating interface in the settings window for speed reduction of master switches



### Note

- The structure of the individual settings windows is always the same. The structure is explained via the first settings window (luffing).

#### 1 Luffing 1 settings window

##### 1.1 Assignment icon

- Icon of assigned crane movement / crane function

##### 1.2 Bar display

- Graphic illustration of current speed reduction

##### 1.3 Display value

- Numeric display of the current speed reduction in [%]

#### 2 Telescoping 2 settings window

#### 3 Slewing gear 3 settings window

#### 4 Winch 1 4 settings window

- **Note:** Appears only when the winch is active.

#### 5 Settings window Auxiliary boom 5

- Display field for auxiliary boom

- **Note:** Appears only when an auxiliary boom is installed and entered in the Set up program.

#### 6 Winch 2 settings window

- Display field for winch 2

- **Note:** Appears only if winch 2 is installed and active.



## 8.3 Editing the speed reduction

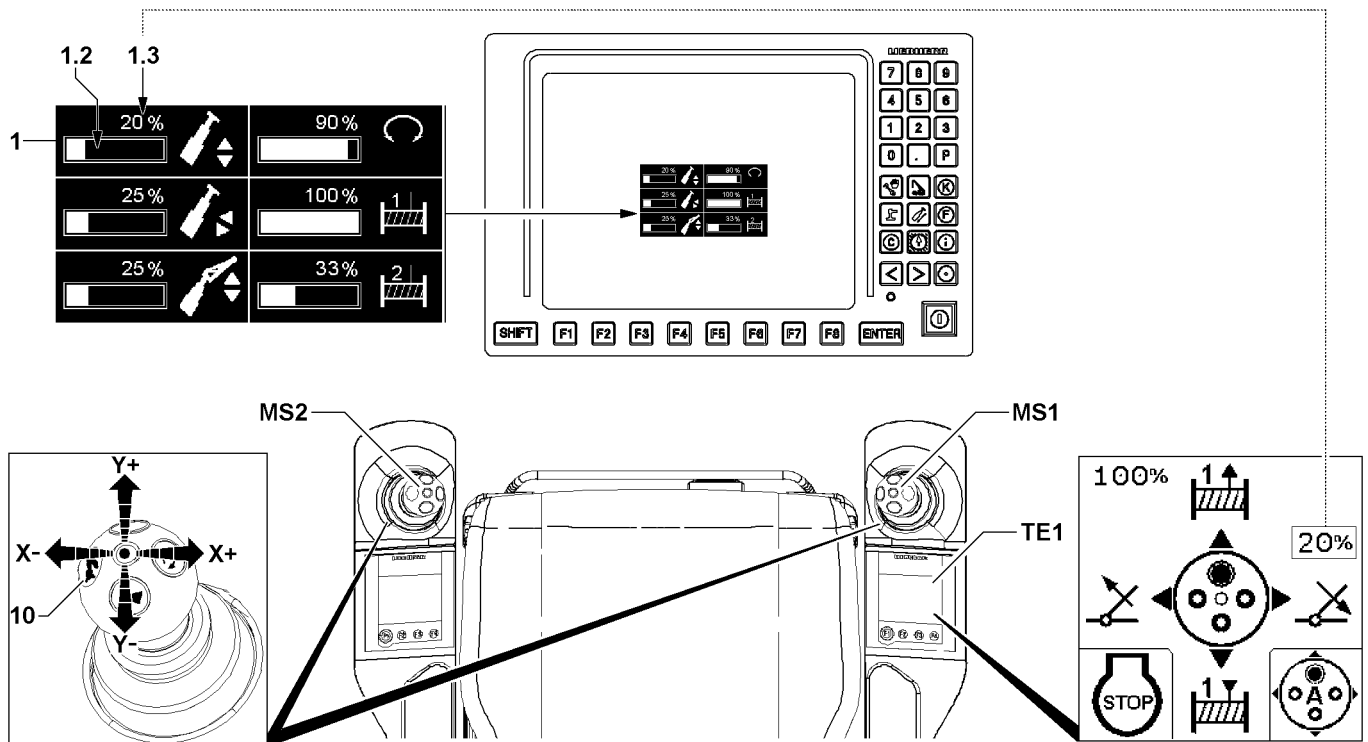


Fig.122447: Example of editing the speed reduction

The procedure in the settings window *Speed reduction master switch* is identical for all crane functions.

Using the example Setting crane movement *Luffing*, the individual steps are explained.



### Note

Only the settings for the displayed crane movements / crane functions can be carried out.

- ▶ If necessary, activate required crane movements / crane functions before calling up the settings windows.

### 8.3.1 Displaying the settings window

- ▶ Press the button **10** on master switch **MS1** or master switch **MS2** for at least two seconds.

#### Result:

- The settings window for the speed reduction of the master switches is shown.



### Note

The settings window is automatically hidden after ten seconds if during that time there is no access to the speed reduction of a crane function.

- ▶ Continue in time with the next steps.

### 8.3.2 Procedure

The speed reduction is always set via the master switch which controls the crane movement.



### Note

- ▶ If the master switch is deflected lightly, the value is slowly increased / reduced.
- ▶ If the master switch is deflected strongly, the value is quickly increased / reduced.

**Example:** Set the *Luffing* crane movement. The crane movement is carried out via the master switch **MS1**.

Reducing the value of the speed reduction:

- ▶ Move the master switch **MS1** in direction X- (to the left).

**Result:**

- The bar in the bar display **1.2** gets shorter.
- The display value **1.3** is reduced.
- The speed for crane movement *luffing* is set to the new display value **1.3**.
- The new display value for the crane movement *luffing* is shown in the touch display **TE1**.

Increasing the value of the speed reduction:

- ▶ Move the master switch **MS1** in direction X+ (to the right).

**Result:**

- The bar on the bar display **1.2** becomes longer.
- The display value **1.3** is increased.
- The speed for crane movement *luffing* is set to the new display value **1.3**.
- The new display value for the crane movement *luffing* is shown in the touch display **TE1**.

### 8.3.3 Closing the settings window

Make sure that the following prerequisite is met:

- All speed reductions are set.
- ▶ Press the button **10** on master switch **MS1** or master switch **MS2** for at least two seconds.  
**or**  
Wait ten seconds without further steps.

**Result:**

- The settings window for the speed reduction of the master switches closes.

## 9 Setting the operating mode of the slewing gear

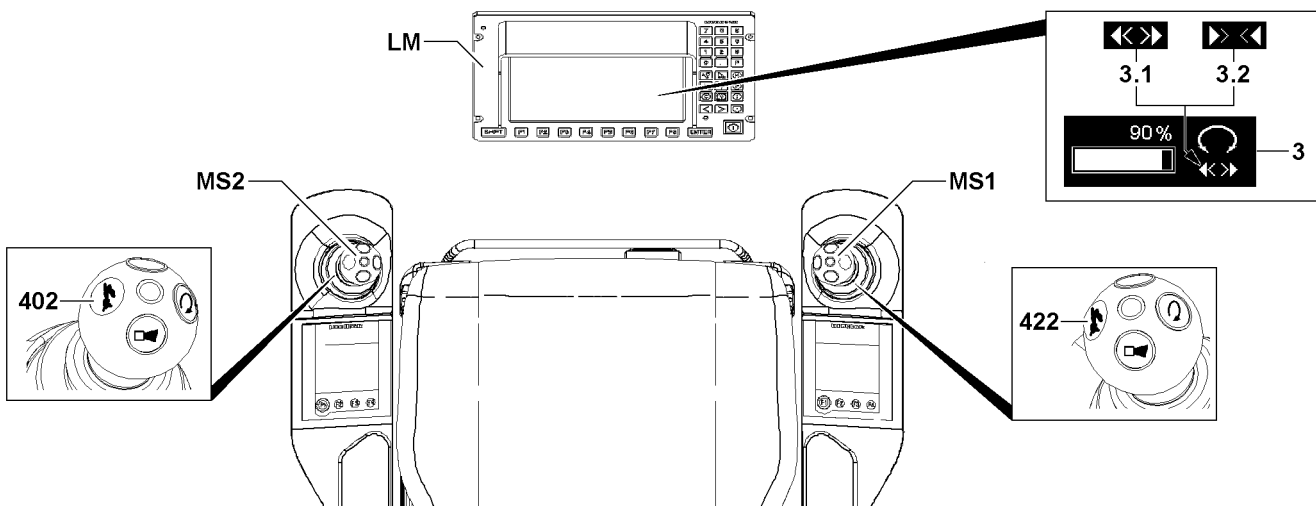


Fig.123810

**Note**

- ▶ Only for certain crane types.
- ▶ The operating mode of the slewing gear can only be set for crane types that are not equipped with a foot button\* for the freewheeling of the slewing gear. For a description of the foot button\* for the freewheeling of the slewing gear, see the Crane operating instructions, chapter 4.01 and 4.05.

## 9.1 Icons for setting the slewing gear operating mode

- 3 *Slewing gear* settings window
  - 3.1 Slewing gear freely rotating
    - Flexible slewing gear freely rotating / coasting switched
  - 3.2 Slewing gear fixed
    - Flexible slewing gear fixed switched

## 9.2 Setting the operating elements for operating mode of the slewing gear

- MS1** Master switch 1
- MS2** Master switch 2
- 402** *Rapid gear* button
  - Button Rapid gear on MS2
- 422** *Rapid gear* button
  - Button Rapid gear on MS1
- LM** LICCON monitor

## 9.3 Carrying the setting out

- ▶ Press the *rapid gear* button **422** on master switch 1 **MS1** for longer than 2 seconds.  
or
- ▶ Press the *rapid gear* button **402** on master switch 2 **MS2** for longer than 2 seconds.

**Result:**

- The settings window is displayed.

**Note**

- ▶ The settings window is automatically hidden after 10 s when no setting is made within this time.
- ▶ Press button *Rapid gear* **402** on master switch 2 **MS2**.

**Result:**

The status of the slewing gear changes between:

- **3.1** Slewing gear freely rotating
- **3.2** Slewing gear fixed

**Note**

- ▶ In certain situations the operating mode of the slewing gear is specified by the crane control. If this is the case, the setting via the crane control is used, even if a deviating settings is set by the crane operator.

## 10 Track width monitoring without shut-off of crane movement

The track width monitoring monitors the extension conditions of the crawler carriers. The measured extension conditions are compared hereby with the specifications in the set load chart.

If the extension conditions of a crawler carrier are wrong or in case of a defect in the monitoring system, track width monitoring issues an optical and acoustic warning. Track width monitoring does **not** shut the crane movements off.

Make sure that the following prerequisites are met:

- The crawler carriers are extended to the width required for crane operation.
- The crawler carriers are pinned and secured.
- The extension conditions for crawler carriers (support base), load chart and settings in the Set up program match.
- The crane operation screen is displayed.

### 10.1 Crawler carrier in an incorrect position

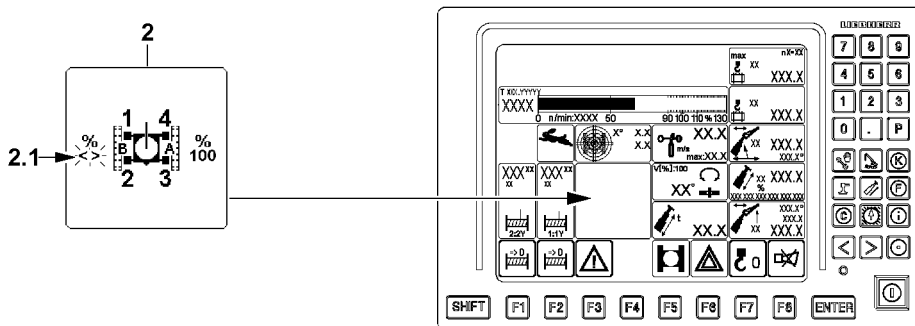


Fig.122544: Crawler carrier in an incorrect position

Example of a crawler carrier in an incorrect position:

- In the *Crawler travel gear icon 2* either:
  - the incorrect extension condition **2.1** is shown blinking in red
  - or
  - the *intermediate position sign <>* appears blinking red
- A signal tone sounds.



#### WARNING

Crawler carrier in an incorrect position!  
Toppling crane, death, property damage.

- ▶ Prior to crane operation, set the crawler carrier in the correct position according to the load chart.

## 10.2 Defect during track width monitoring

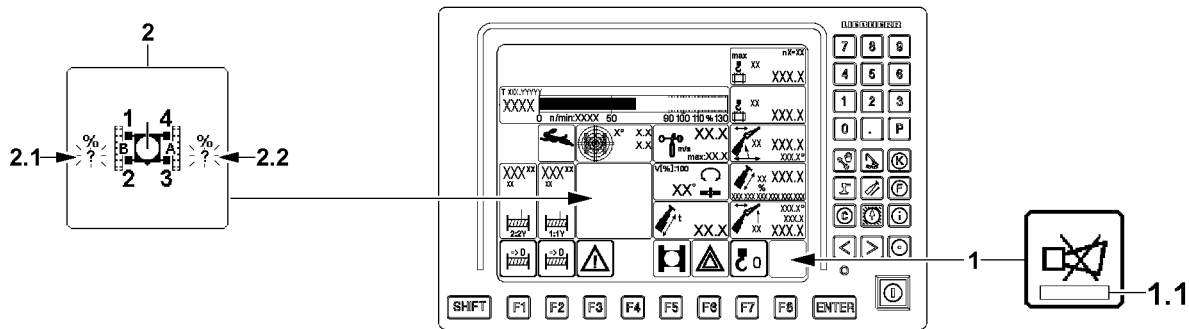


Fig.122545: Defect during track width monitoring

Example for a defect in the monitoring system for track width monitoring:

- An error message 1.1 is displayed in the *Horn* icon 1.
- Red blinking question marks appear in the *crawler travel gear* icon 2 instead of the values for the extension condition 2.1 / extension condition 2.2.
- A signal tone sounds.



### WARNING

Defect in the monitoring system for track width monitoring!  
Toppling crane, death, property damage.

- ▶ Before crane operation, fix the track width monitoring.

## 11 Track width monitoring with shut off of crane movement\*

The track width monitoring monitors the extension conditions of the crawler carriers. The measured extension conditions are compared hereby with the specifications in the set load chart.

Optionally, track width monitoring can be equipped with a shut off function. In cases of an incorrect extension condition of the crawler carriers or a defect in the track width monitoring, track width monitoring turns selected crane movements off.

The shut-off of the crane movement can be bypassed. When track width monitoring is bypassed, the crane driver bears the sole responsibility for the correct extension condition of the crawler carriers (support base) of the crane.

Make sure that the following prerequisites are met:

- The crawler carriers are extended to the width required for crane operation.
- The crawler carriers are pinned and secured.
- The extension condition (support base), load chart and settings in the Set up program match.
- The crane operation screen is displayed.

## 11.1 Crawler carrier in an incorrect position

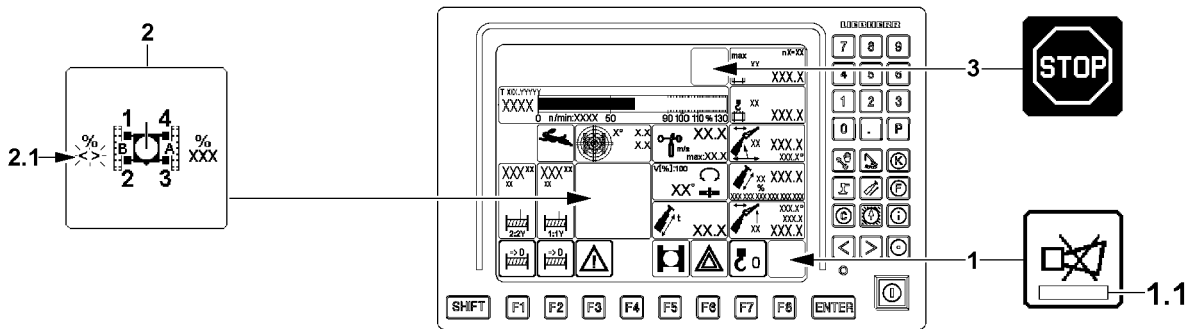


Fig.122546: Crawler carrier in an incorrect position

Example of a crawler carrier in an incorrect position:

- As soon as a crane movement is actuated, an error message 1.1 appears in the *Horn* icon 1.
- In the *Crawler travel gear* icon 2:
  - the incorrect extension condition 2.1 is shown blinking in red
  - or
  - the *intermediate position* sign <> appears blinking red
- A signal tone sounds.
- The *LMB-STOP* icon 3 appears.



### WARNING

Crawler carrier in an incorrect position!  
Toppling crane, death, property damage.

- ▶ Prior to crane operation, set the crawler carrier in the correct position according to the load chart.

## 11.2 Defect during track width monitoring

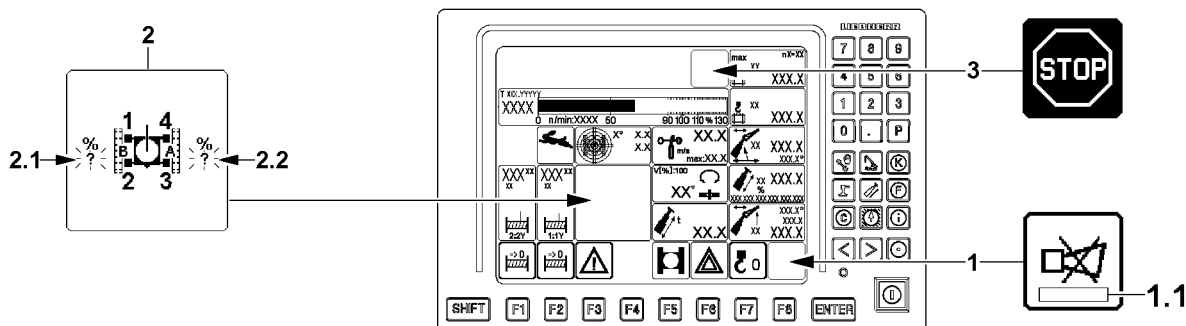


Fig.122547: Defect during track width monitoring

Example for a defect in the monitoring system for track width monitoring:

- An error message 1.1 is displayed in the *Horn* icon 1.
- Red blinking question marks appear in the *crawler travel gear* icon 2 instead of the values for the extension condition 2.1 / extension condition 2.2.
- A signal tone sounds.
- The *LMB-STOP* icon 3 appears.



### WARNING

Defect in the monitoring system for track width monitoring!  
Toppling crane, death, property damage.

- ▶ Before crane operation, fix the track width monitoring.

### 11.3 Bypassing track width monitoring



**WARNING**

Erroneous operation with bypassed track width monitoring!  
Toppling crane, death, property damage.

- ▶ Before crane operation, fix the track width monitoring.
- ▶ Before crane operation, set the crawler carriers in the correct position according to the load chart.

A defect in track width monitoring causes an **LMB-STOP 3**, selected crane movements are turned off.  
To be able to carry out crane movements in case of a defect in track width monitoring, track width monitoring can be bypassed.

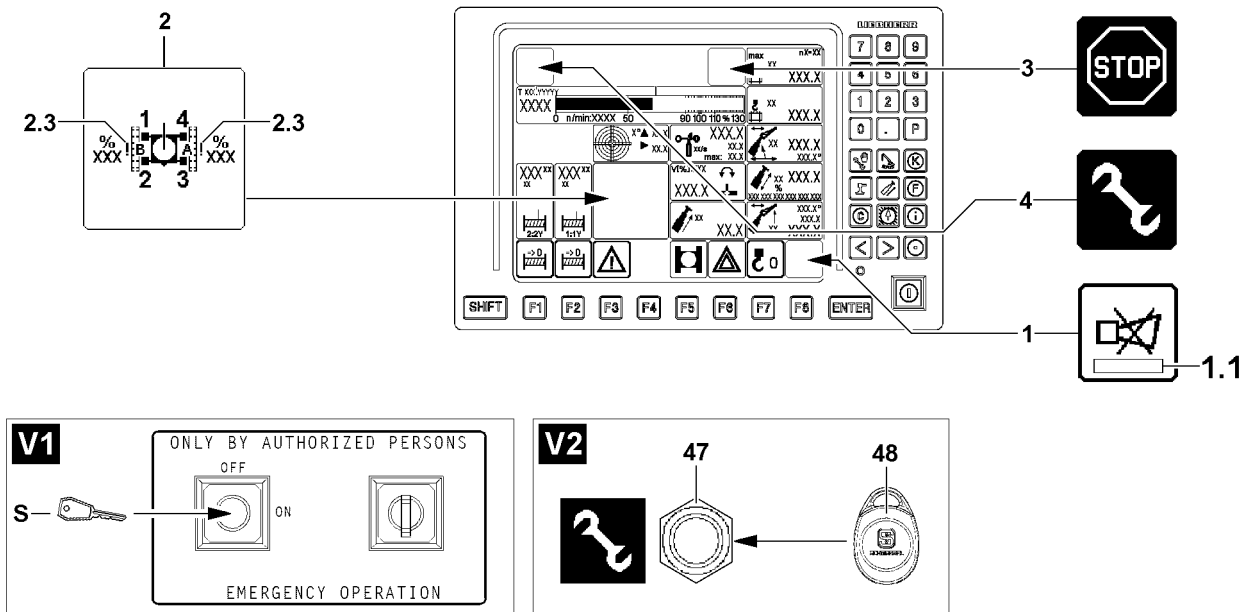


Fig.123721: Bypass track width monitoring on the crane with EN 13000:2010 active

On cranes with *EN 13000:2010 active* the crane driver has 30 minutes time after activation of the bypass to initiate a crane movement. After 30 minutes, the bypass is deactivated. To initiate another crane movement after that period of time, the bypass must be activated again.



**Note**

- ▶ Depending on the crane type, either the key button **S** (variation **V1**) or a sensor **47** with transponder **48** (variation **V2**) are present on the crane, see Crane operating instructions, chapter 4.01.

On cranes with *EN 13000:2010 active*:

- ▶ Activate the sensor **47** by actuating it with the transponder **48**.
- or

If no sensor **47** is installed on the crane:

Actuate the key button **S**.

**Result:**

- The *Crawler travel gear* icon **2** contains two exclamation marks **2.3**.
- The *Assembly* icon **4** appears.
- Crane movements with a reduced speed are possible.
- Track width monitoring is bypassed.

LWE/LTR 1220-003/24204-02-02/en

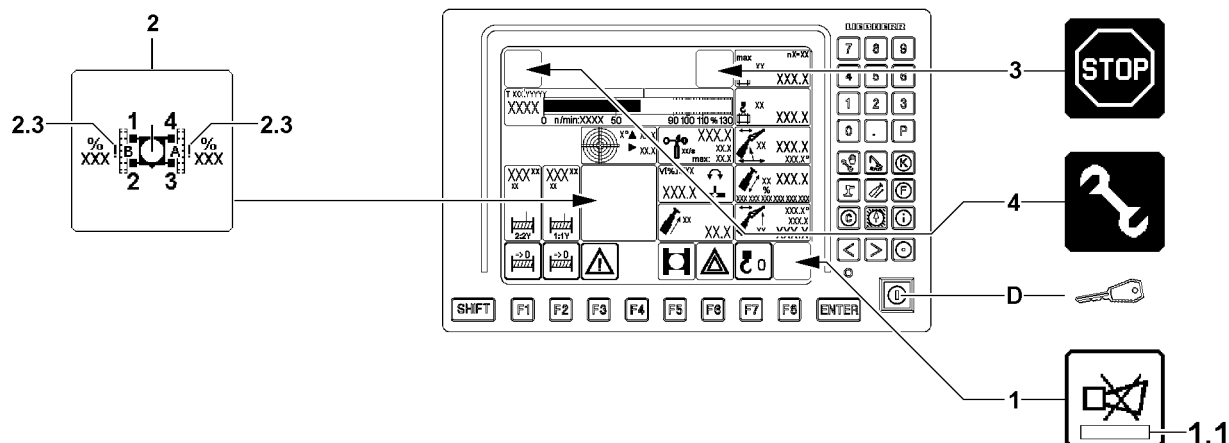


Fig.123722: Bypass track width monitoring on the crane with EN 13000:2010 not active

On cranes with *EN 13000:2010 not active* the crane driver has 10 seconds time after activation of the bypass to initiate a crane movement. After 10 seconds, the bypass is deactivated. To initiate another crane movement after that period of time, the bypass must be activated again.

On cranes with *EN 13000:2010 not active*:

- ▶ Press the set up button **D**.

**Result:**

- The *Crawler travel gear* icon **2** contains two *exclamation marks* **2.3**.
- The *Assembly* icon **4** appears.
- Track width monitoring is bypassed.

## 12 ECO-Mode



**Note**

- ▶ Only present for certain crane types.

In ECO mode, the optimum engine rpm is calculated for the respective crane movement and the engine is regulated accordingly. Fuel consumption and noise emission are reduced.



## 12.1 Operating elements in ECO-Mode

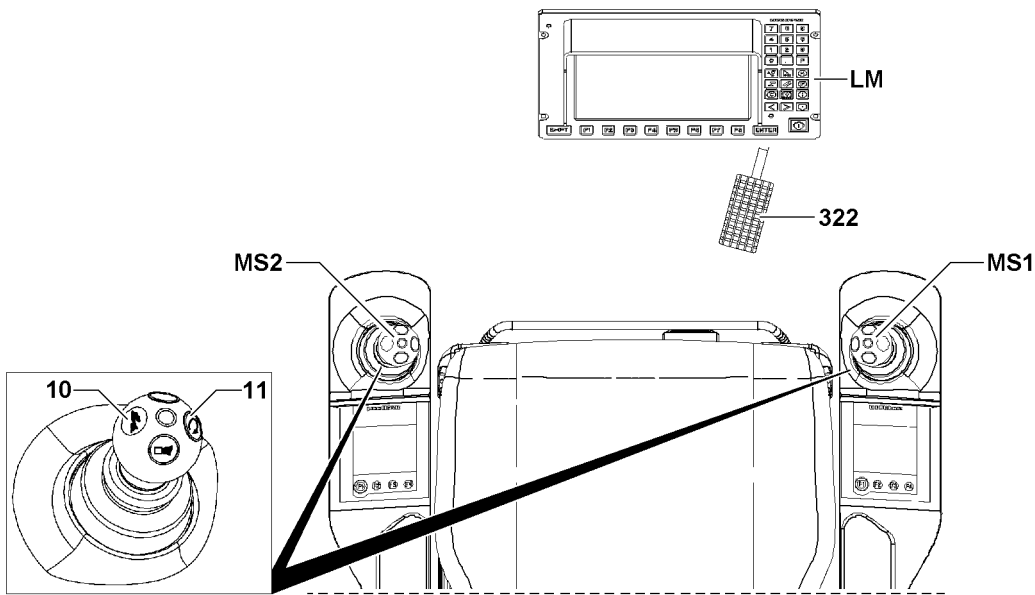


Fig.122450: Operating elements in ECO-Mode

- MS1** Master switch 1
  - Rapid gear **10** button
  - Rpm lock **11** button
- MS2** Master switch 2
  - Rapid gear **10** button
  - Rpm lock **11** button
- 322** Engine regulation
- LM** LICCON monitor

## 12.2 Operating interface in ECO-Mode

### 12.2.1 Displays ECO-Mode in settings window

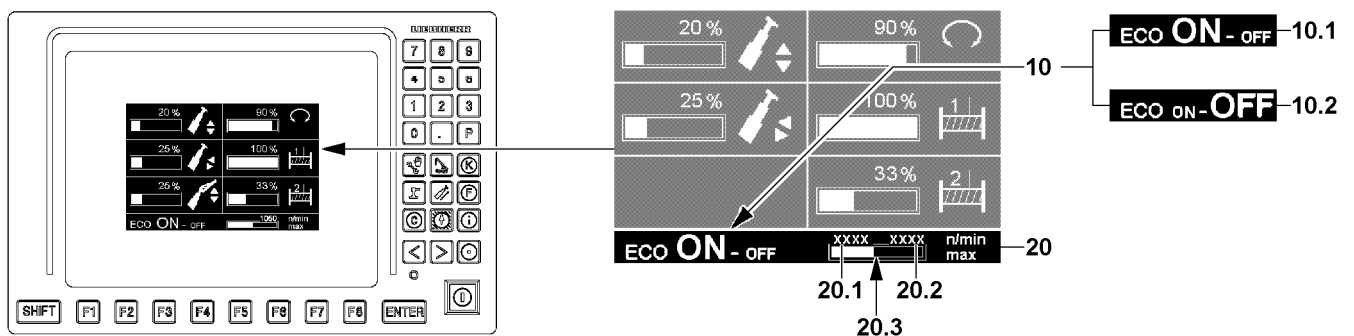


Fig.122449: Displays ECO-Mode in settings window

- 10** ECO-Mode status
- 10.1** ECO-Mode ON
  - ECO-Mode is turned on
- 10.2** ECO-Mode OFF
  - ECO-Mode is turned off
- 20** ECO-Mode rpm settings
  - Information for current rpm settings

LWE/LTR 1220-003/24204-02-02/en

- 20.1** Setting rpm
  - Appears only when actuating engine regulation
- 20.2** Highest rpm
  - Maximum possible rpm of crane engine in ECO-Mode
- 20.3** Bar diagram
  - The bar diagram shows the ratio of the setting rpm **20.1** to the highest rpm **20.2**

## 12.2.2 ECO-Mode in crane operating screen displays

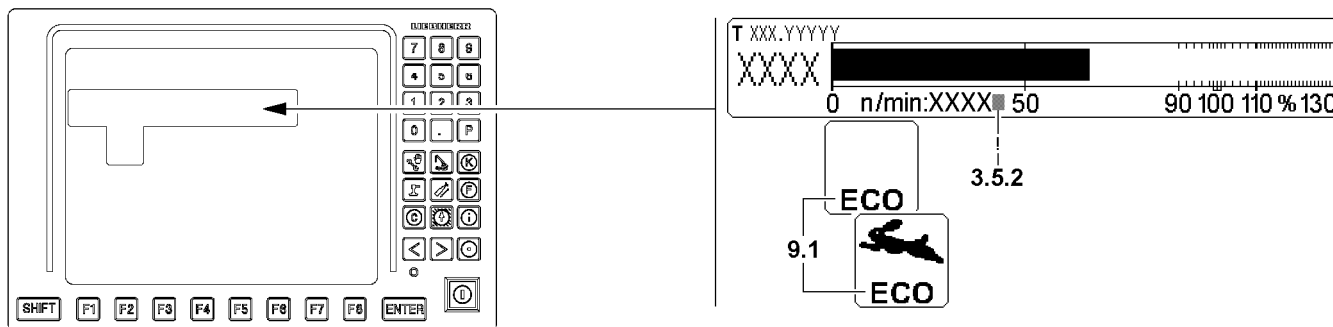


Fig.122451: ECO-Mode in crane operating screen displays

### 9.1 Status display

- The status display is made in the *Rapid gear* icon:
  - The word ECO is *green*: ECO-Mode is turned on and active.
  - The word ECO is *yellow*: ECO mode is turned on but inactive
  - No ECO word shown: ECO-Mode is turned off

### 3.5.2 Rpm limited

- If the „!“ appears behind the rpm display, then the engine rpm is limited in ECO mode

## 12.3 Operating ECOMode

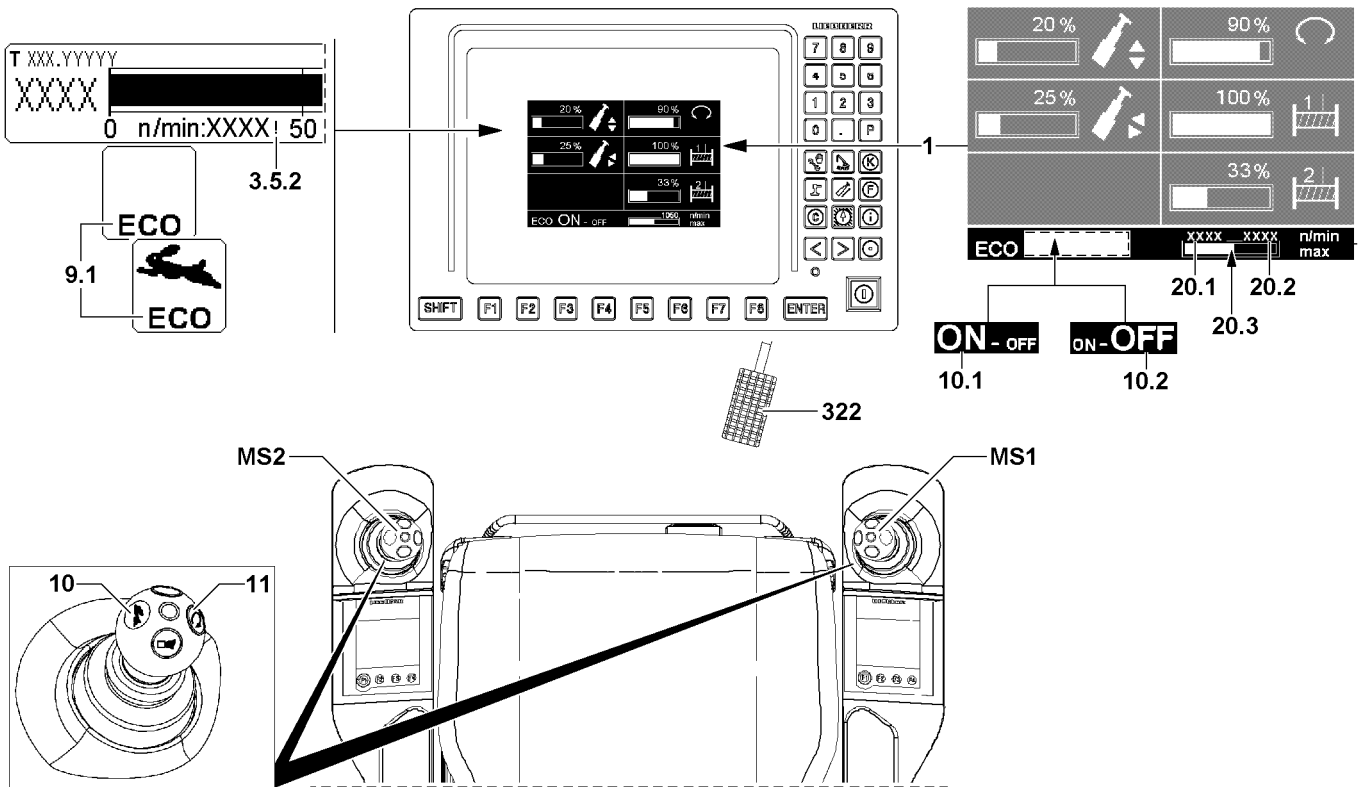


Fig.156266: Example of illustration Operating ECO-Mode

### 12.3.1 Displaying the settings window



**Note**

The setting window can be called up from every program in which the crane can be controlled.

If the settings window cannot be called up from the currently selected program:

- ▶ Select a program from which the crane can be controlled using the master switches, for example the *crane operation* program.
- ▶ Press the rapid gear **10** button on the master switch **MS1** or master switch **MS2** for at least two seconds.

**Result:**

- The settings window **1** is displayed.



**Note**

The settings window **1** is turned off again after ten seconds if no subsequent step is carried out within this time frame.

- ▶ Continue in time with the next steps.

### 12.3.2 Turning ECO-Mode on

Make sure that the following prerequisites are met:

- The settings window **1** is shown.
- The engine regulation **322** is not actuated.
- The master switches are not actuated.
- No auxiliary user is activated.
- The radio remote control is not activated.
- The engine regulation **322** is not actuated.

- ▶ Press the rpm lock **11** button on the master switch **MS1** or master switch **MS2**.

**Result:**

- ECO-Mode **ON 10.1** appears in the settings window.
- ECO-Mode is turned on and active.
- As soon as the settings window **1** is masked, the status display **9.1** appears in green



**Note**

- ▶ When master switch **MS1** and master switch **MS2** are in the neutral position, then engine rpm is automatically reduced when ECO mode is turned on.
- ▶ If master switch **MS1** or master switch **MS2** is deflected or an auxiliary user is added, then the engine rpm is automatically adjusted when ECO-Mode is turned on.
- ▶ The engine rpm can be increased by actuating the engine regulation **322** when ECO-Mode is turned on. ECO mode is then still turned on but inactive - the status display **9.1** appears in yellow.
- ▶ As long as the status display **9.1** is yellow, there is no adjustment of the engine rpm for the respective crane movement.
- ▶ In the following additional cases, the status display **9.1** also appears in yellow: Rpm lock active, idling speed is automatically reduced, rpm is specified with the radio remote control.

### 12.3.3 Limiting engine rpm in ECO-Mode

Make sure that the following prerequisites are met:

- The settings window **1** is shown.
- ECO-Mode is turned on.
- ▶ Activate the engine regulation **322**.

**Result:**

- The learning mode is activated:
- The setting rpm **20.1** is displayed and the bar diagram **20.3** appears in purple for the duration of the procedure
- The degree of actuation of the engine regulation **322** changes the value for the setting rpm **20.1**.
- ▶ Actuate the engine regulation **322** until the desired setting rpm **20.1** is reached.
- ▶ Press the rpm lock **11** button on the master switch **MS1** or master switch **MS2**.

**Result:**

- The setting rpm **20.1** is taken over as the highest rpm **20.2**.
- ▶ Do no longer actuate the engine regulation **322**.

**Result:**

- The learning mode is deactivated.
- The setting rpm **20.1** is hidden and the bar diagram **20.3** appears in white again



**Note**

Limited engine rpm

- ▶ In the operating screen, behind the display of the engine rpm appears the icon **3.5.2** (exclamation mark), when the ECO-Mode with limited engine rpm is turned on.
- ▶ To reset the maximum engine rpm, the maximum setting rpm **20.1** must be set during the setting procedure and taken over as described.

### 12.3.4 Turning ECO-Mode off

Make sure that the following prerequisite is met:

- ECO-Mode is turned on.
- ▶ Press the rapid gear **10** button on the master switch **MS1** or master switch **MS2** for at least two seconds.

**Result:**

- The settings window **1** is displayed.

As long as the settings window is displayed:

- ▶ Press the rpm lock **11** button on the master switch **MS1** or master switch **MS2**.

**Result:**

- ECO-Mode **OFF 10.2** appears in the settings window
- ECO-Mode is turned off
- ▶ Press the rapid gear **10** button on the master switch **MS1** or master switch **MS2** for at least two seconds.  
**or**  
Wait ten seconds without further steps.

**Result:**

- The settings window is hidden.
- The status display **9.1** no longer appears.

### 12.3.5 ECO-Mode inactive

Various tasks cause ECO-Mode to become inactive. In this case, the ECO mode is not turned off, just remains in stand-by operation.

- ▶ For example, actuating the engine regulation **322** or turning on an auxiliary user.

**Result:**

- ECO-Mode is inactive
- The status display **9.1** appears in yellow.

Remedy the reason for inactivity:

- ▶ For example, stop actuating the engine regulation **322** or turn off an auxiliary user.

**Result:**

- ECO-Mode is active again.
- The status display **9.1** appears in green.

# 13 Power-save mode and Stand-by mode in the LICCON computer system

## 13.1 Power-Save mode

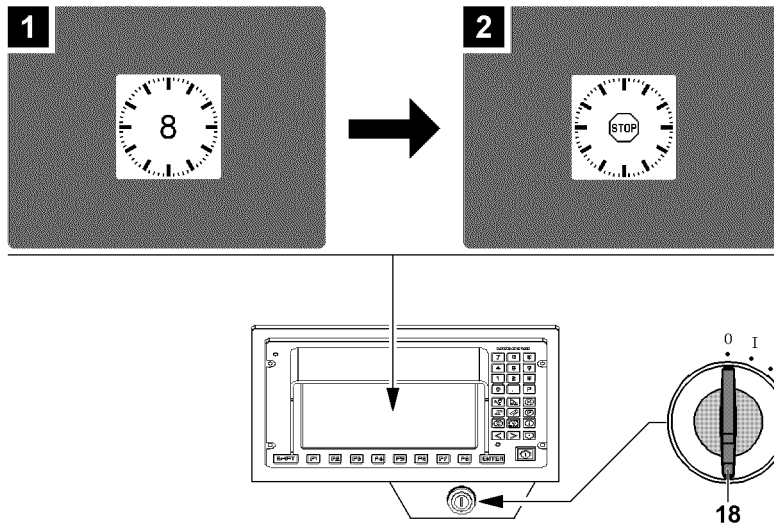


Fig.122440: Power-Save mode

If the crane engine - by turning the ignition switch **18** - is turned off to position 0 (ignition **OFF**), the LICCON computer system changes to the Power-Save mode.

The Power-Save mode enables the crane driver - within eight seconds of turning the ignition off - to start the crane engine again without having to start the LICCON computer system again.

If the crane engine is not restarted within eight seconds, then the LICCON computer system shuts off completely.



### Note

- ▶ In the Power-Save mode, no crane movements are possible.

### Procedure of Power-Save mode

- ▶ Turn the ignition switch **18** to position 0 (ignition **OFF**).

### Result:

- The crane engine is turned off.
- The Power-Save mode is active.
- The clock with remaining run time of the Power-Save mode (approx. eight seconds) appears, illustration 1.



### Note

- ▶ After completion of the remaining run time, a clock appears briefly with an integrated **STOP** icon (illustration 2), which displays the complete shut-off of the LICCON computer system.

- The clock with an integrated **STOP** icon appears for a few seconds, illustration 2.
- All processes on the LICCON computer system are stopped.
- The LICCON computer system turns off completely.

### Press any key in Power-save mode once



### Note

- ▶ Pressing a button in Power-Save mode once shortens the run time to five seconds.

- ▶ Press any key.

**Result:**

- The remaining run time is shortened to five seconds.

**Press any key twice in Power-save mode**

- ▶ Press any key twice in succession.

**Result:**

- The remaining run time is set to zero.
- The clock with an integrated *STOP* icon appears for a few seconds, illustration 2.
- All processes on the LICCON computer system are stopped.
- The LICCON computer system is turned off completely, the LICCON monitor does not display anything.

## 13.2 Stand-by mode

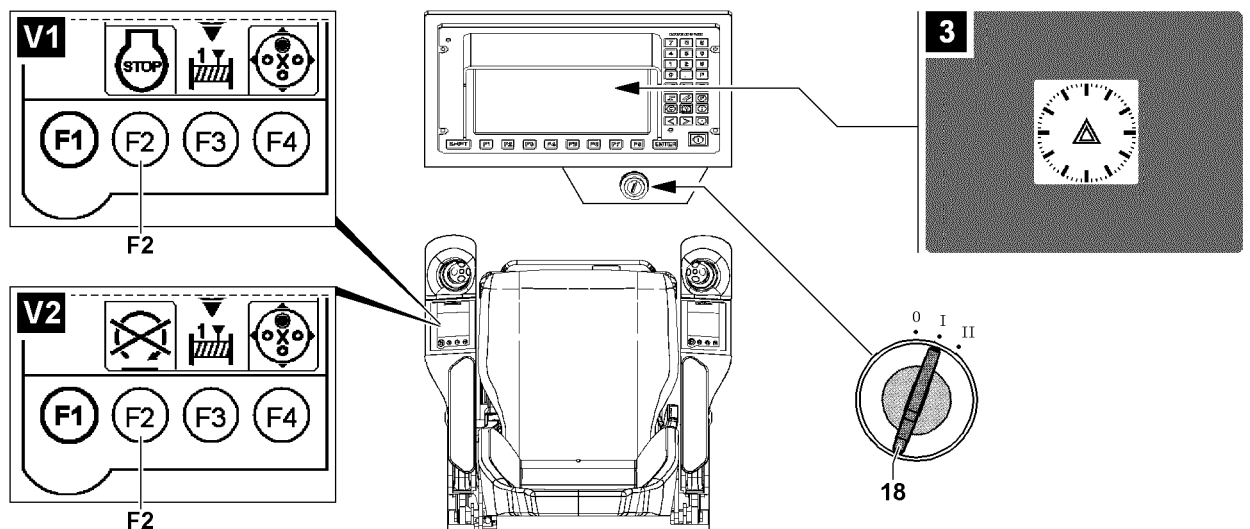


Fig.122439: Stand-by mode

After pressing the engine *STOP* button **F2** (depending on the crane type variation **V1** or variation **V2**) - the crane engine is turned off - on the LICCON monitor, the operating interface of the most recently active application program continues to be displayed for an additional ten minutes.

After these ten minutes are over, the Stand-by mode is reached. The Stand-by mode is displayed on the screen by the *Stand-by clock with warning icon* (illustration 3) on the LICCON monitor and by a repeated acoustic signal (rhythmic horn).



**Note**

- ▶ In the Stand-by mode, no crane movements are possible.

**Initiate the Stand-by mode in the LICCON computer system:**

- ▶ Press the engine *STOP* button **F2**.
- ▶ Leave the ignition key **18** in position „I“.

**Result:**

- The crane engine is turned off.
- The operating interface of the last active application program is shown further.
- The ten minute time frame starts to run down.
- ▶ Within the ten minute time frame, press **any key**.

**Result:**

- The ten minute time frame is reset and starts to run down again.
- ▶ Within the ten minute time frame, press **no key**.

**Result:**

- After the time is over, the **Stand-by mode** is reached.
- The display area on the LICCON monitor turns black.
- The stand-by clock with a warning icon is shown, illustration **3**.
- Every half a minute a repeating acoustic signal from the LICCON monitor sounds.

**Note**

- ▶ The Stand-by mode does not lead to any automatic shut-off of the LICCON computer system.
- 

**Turn the LICCON computer system off from the Stand-by mode**

- ▶ Turn the ignition switch to position 0.

**Result:**

- The Power-Save mode becomes active for eight seconds, then the LICCON computer system is turned off by itself.



## 4.03 Start up and shut down of crane

1	Inspections	2
2	Monitoring functions	5
3	Diesel particle filter (DPF)*	6
4	<i>Exhaust system</i> cleaning procedure	11
5	Crane driver's seat Version 1	12
6	Crane driver's seat Version 2	17
7	Control platform	19
8	Step	21
9	Crane cab	23
10	Hydraulic oil preheating*	26
11	LICCON computer system	27
12	Disengaging / engaging the coupling control on the pump distributor gear	30
13	Starting the engine	32
14	Turning the engine off	33
15	Indicator lights	35
16	Window wiper / window washer system	35
17	Hook block	36

# 1 Inspections

The illustrations in this chapter are examples and may differ from the crane.

Various inspections must be carried out prior to crane start-up.

The inspection and maintenance of the components of the crane superstructure are described in chapter 7.05.

The inspection and maintenance of the components of the crane chassis are described in chapter 7.04.

The fill quantities of the components are listed in the Service fill. Additionally observe and adhere to the instructions in chapter 7.06 and chapter 7.07.



## WARNING

Defective function of the crane!

Defects on components, missing quantities or dirty filters affect the operating safety of the crane.

If a defect is found in a component:

- ▶ Rectify the defect.

If an incorrect quantity is found:

- ▶ Replenish or reduce the quantity to the normal level.

If a very dirty filter is found:

- ▶ Clean or replace the filter.



## WARNING

Hot surfaces of components!

Severe burns.

- ▶ Let any components to be serviced or inspected cool off.
- ▶ Keep a sufficient distance from hot components.



## WARNING

Emergency devices not operational!

Death, severe bodily injuries, property damage.

- ▶ Check emergency devices for accessibility and operational readiness.
- ▶ Open or remove anti-theft device!



## WARNING

Operating fluids not suitable for ambient temperature!

Death, severe bodily injuries, property damage.

- ▶ Adjust the operating fluids in time to the ambient temperatures.

Make sure that the following prerequisites are met:

- The engine is off.
- The respective components are at ambient temperature.

## 1.1 Engine

- ▶ For crane types without an electric engine oil level display, the oil level can be checked on the dipstick.

## 1.2 Hydraulic tank

- ▶ Check the oil level on the sight gauge.
- ▶ Check the filter.

## 1.3 Coolant



### WARNING

The cooling system is pressurized!  
When the coolant reservoir is opened, hot coolant can escape explosively.  
Severe scalding.

When the engine is warm:

- ▶ Do **not** open the cover of the coolant reservoir.
  - ▶ To protect face, hands and arms from hot steam of hot coolant, cover the cap with a large rag when opening.
- 
- ▶ Check the coolant level.

## 1.4 Central lubrication system

- ▶ Check the grease level on the grease tank.

## 1.5 Window washer fluid



### Note

- ▶ The window cleaning fluid must be adapted to the prevalent ambient temperatures.
- 
- ▶ Check the level of the window washer fluid.

## 1.6 Displaying the lubricants, operating fluids and fill levels on the LIC-CON monitor

Replenish lubricants and operating fluids in time.

Regenerate the diesel particle filter\* in time

Make sure that the following prerequisites are met:

- The ignition switch in the crane cab is in position „I“.
- The engine is turned off.
- The LICCON computer system is in the „Crane operation“ program.

### 1.6.1 Displaying the fuel reserve

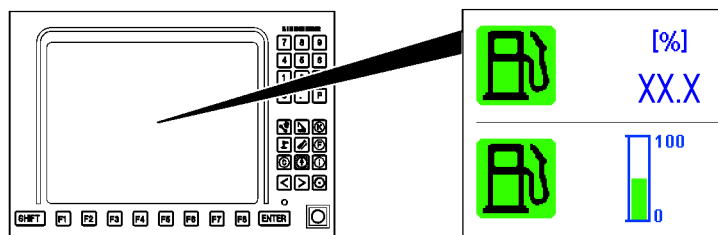


Fig.147669: Fuel reserve display - both variations



### Note

If the fuel tank has run dry, then the fuel system must be bled!

- ▶ Refuel in time.

Depending on the crane type, the fuel reserve is displayed as a percentage value or a bar graph.

- ▶ Call up the monitoring functions, see chapter 4.02.
- ▶ Check the fuel reserve.

## 1.6.2 Displaying the urea reserve

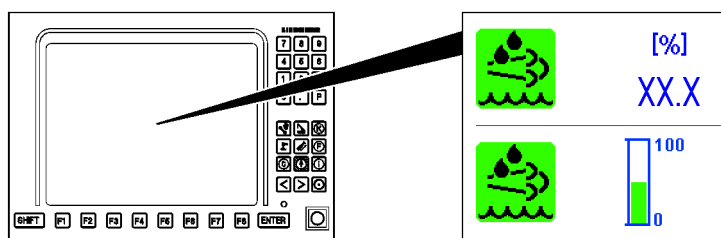


Fig.147670: Urea reserve display - both variations



### Note

- ▶ Valid only for engines that are equipped with an exhaust aftertreatment with SCR system.

Depending on the crane type, the urea reserve is displayed as a percentage value or a bar graph.

- ▶ Call up the monitoring functions, see chapter 4.02.
- ▶ Check the urea reserve.

## 1.6.3 Displaying the engine oil level

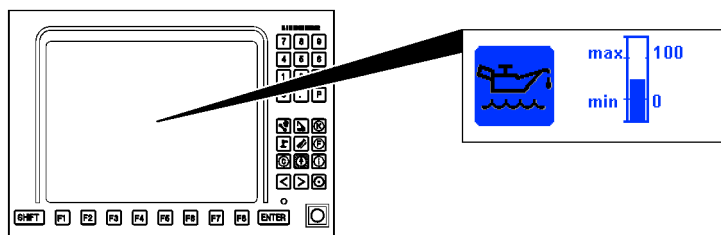


Fig.147671: Engine oil level display, example for engine oil level between min and max

The engine oil level is displayed as a bar graph.

Explanation of the bar graph:

- Under *min*: Engine oil level too low
- Between *min* and *max*: Engine oil level OK
- Over *max*: Engine oil level overfilled



### Note

- ▶ The engine oil level can only be displayed when the engine is turned off.

- ▶ Call up the monitoring functions, see chapter 4.02.

Before starting the engine:

- ▶ Check the engine oil level.

## 1.6.4 Displaying the diesel particle filter load condition (DPF)

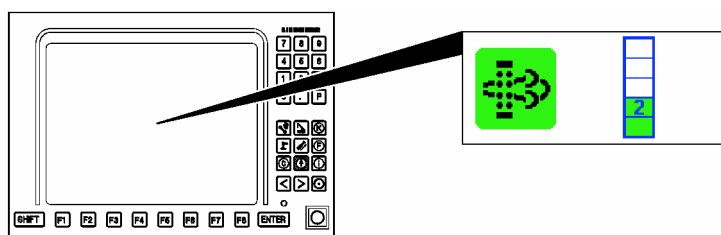


Fig.152660: Diesel particle filter load condition, example for load condition 2 (green)

**Note**

- ▶ Applies only for engines with a diesel particle filter (DPF).

The load condition of the diesel particle filter is displayed as a bar graph.

Explanation of the bar graph:

- Load condition 1 (green): Load condition OK, diesel particle filter minimally loaded
  - Load condition 2 (green): Load condition OK, diesel particle filter lightly loaded
  - Load condition 3 (green): Load condition OK, diesel particle filter half loaded
  - Load condition 4 (yellow): Load condition increased, diesel particle filter strongly loaded
  - Load condition 5 (red): Load condition critical, diesel particle filter with maximum load
- Note:** Prompt need for action required regarding the load condition of the diesel particle filter.
- Note:** Immediate need for action required regarding the load condition of the diesel particle filter.
- ▶ Call up the monitoring functions, see chapter 4.02.

Before starting the engine:

- ▶ Check the diesel particle filter load condition.

## 1.7 Crane condition

**WARNING**

Impermissible crane condition!

Death, severe bodily injuries, property damage.

- ▶ Observe and adhere to the following prerequisites.

Make sure that the following prerequisites are met:

- All safety equipment is functioning.
- The crane is positioned on a level and load-bearing surface.
- The crane is supported and horizontally aligned.
- The gear ring of the slewing ring connection is clean and greased.
- The air supply for the oil cooler and the water cooler is clear.
- All covers are closed and locked.
- No persons or objects are within the danger zone of the crane.
- The cable drum, rope drum and limit switches are free of snow and ice.
- There are no loose parts on the boom and crane.

## 2 Monitoring functions

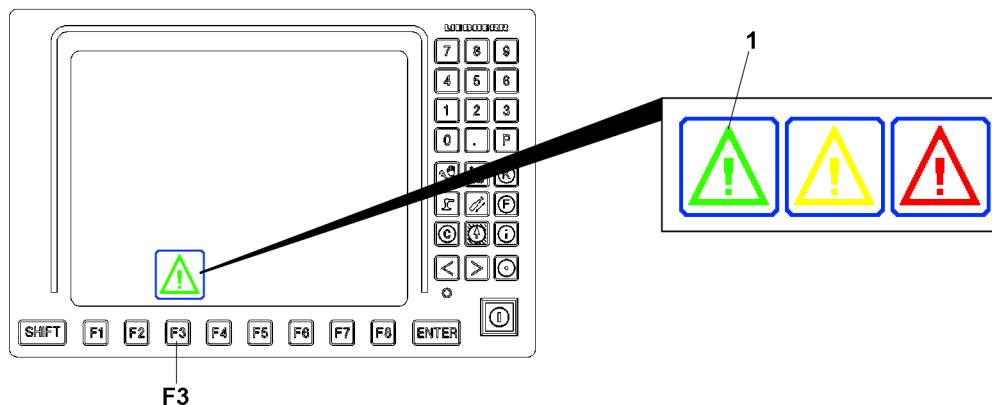


Fig.147668: Monitoring function warning icon

The monitoring functions are described in detail in chapter 4.02.

The crane components and operating conditions are monitored in the LICCON computer system. The warning icon **1** above the function key **F3** is displayed in green when all monitoring functions are ok. If a control value reached a limit range, or if there is a malfunction or warning, the warning icon **1** above the function key **F3** is displayed in yellow or red.

#### NOTICE

The warning icon **1** is displayed in yellow or red - malfunction / warning!  
Damage to components.

- ▶ End crane movement.
- ▶ Turn the engine off.
- ▶ Remedy the cause of the error.
- ▶ Observe and adhere to the instructions in chapter 4.02.

## 3 Diesel particle filter (DPF)\*



#### Note

- ▶ Applies only for engines with a diesel particle filter (DPF).

### 3.1 Calling up the diesel particle filter load condition

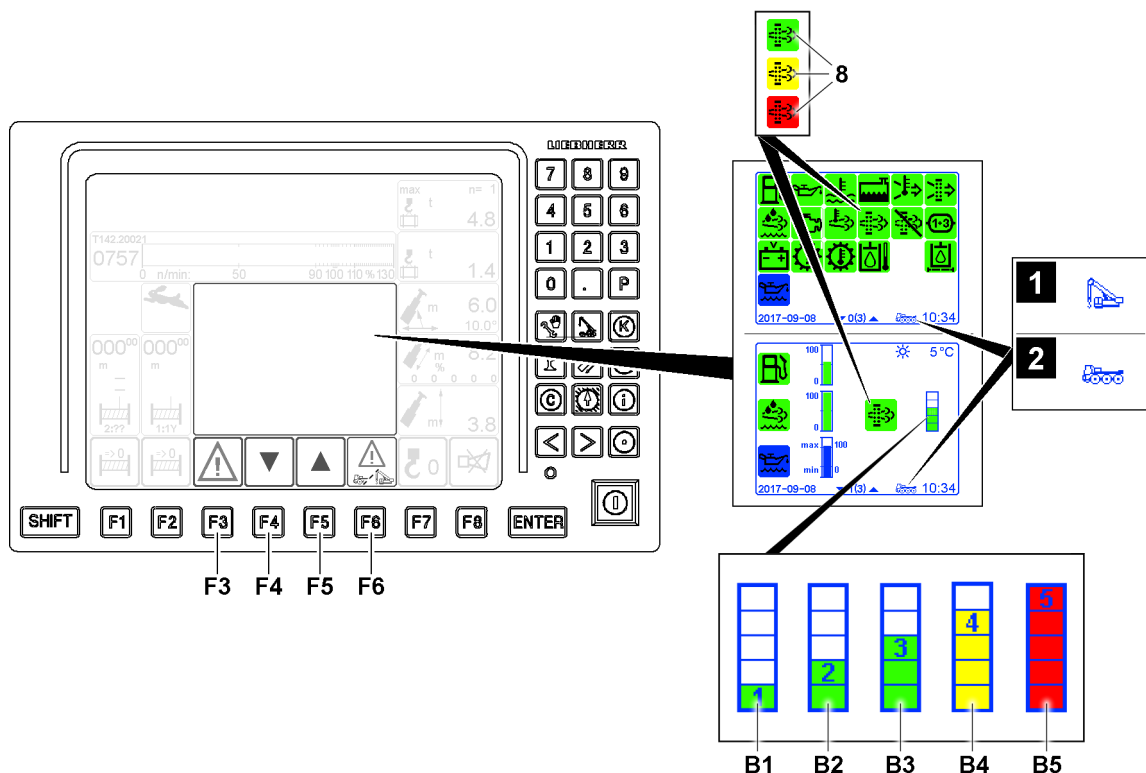


Fig.151825: Calling up the diesel particle filter load condition

Make sure that the following prerequisites are met:

- The ignition is turned on.
- The *Crane operation* program is active.

- ▶ Press the function key **F3**.

#### Result:

- The monitoring functions / individual control displays are displayed on the LICCON monitor, see illustration 1.

In the case of crane types with a separate engine for the crane chassis and crane superstructure, observe the following:

- Illustration 1: *Crane superstructure assignment* icon
  - The monitoring functions / individual control displays are assigned to the crane superstructure
- Illustration 2: *Crane chassis assignment* icon
  - The monitoring functions / individual control displays are assigned to the crane chassis



#### Note

- ▶ By pressing the function key **F4** / function key **F5**, it is possible to switch between the monitoring functions / individual control displays.

When the crane chassis ignition is turned on:

- ▶ By pressing the function key **F6**, it is possible to switch between the monitoring functions / individual control displays of the crane superstructure and the crane chassis.

There are five load conditions for the diesel particle filter.

Read the load condition on the LICCON monitor:

- Load condition 1 **B1** (green): Load condition OK, diesel particle filter minimally loaded
- Load condition 2 **B2** (green): Load condition OK, diesel particle filter lightly loaded
- Load condition 3 **B3** (green): Load condition OK, diesel particle filter half loaded
- Load condition 4 **B4** (yellow): Load condition increased, diesel particle filter strongly loaded
- Load condition 5 **B5** (red): Load condition critical, diesel particle filter with maximum load

If the icon **8** appears / blinks yellow or red, the load condition must be checked immediately.

Observe the error messages and have it evaluated in the BSE test system.

If the load condition 4 **B4** icon appears, Liebherr-Werk Ehingen GmbH recommends carrying out a regeneration at a standstill as soon as possible (during the work day).

If the load condition 5 **B5** icon appears and regeneration at a standstill is no longer possible:

- ▶ Stop engine operation.
- ▶ Contact Customer Service at Liebherr-Werk Ehingen GmbH.



#### Note

Load condition 5 **B5**

- ▶ The engine torque is reduced to protect the engine against damage.

## 3.2 Automatic regeneration of the diesel particle filter

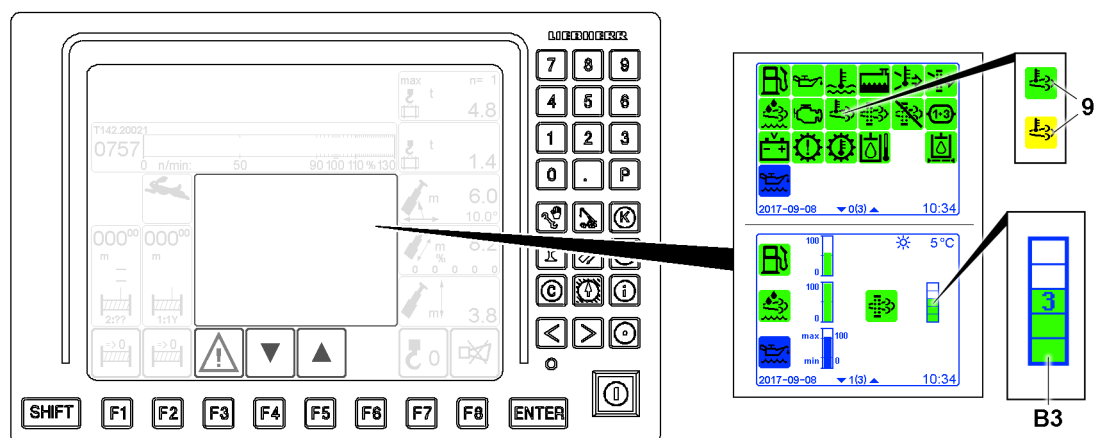


Fig.152143: Displays during automatic regeneration of the diesel particle filter

From load condition 3 **B3**, automatic regeneration is carried out automatically during engine operation. This means no limitations for crane operation. Engine noise may change slightly during regeneration.

Regeneration is triggered when the ambient conditions (load profile) of the engine permit regeneration. The engine must be operated for at least one hour to complete regeneration.

While the diesel particle filter is being regenerated, the icon **9** in the crane operation monitoring functions turns yellow. When generation is complete, the icon **9** turns green.

### 3.3 Disabling automatic regeneration of the diesel particle filter

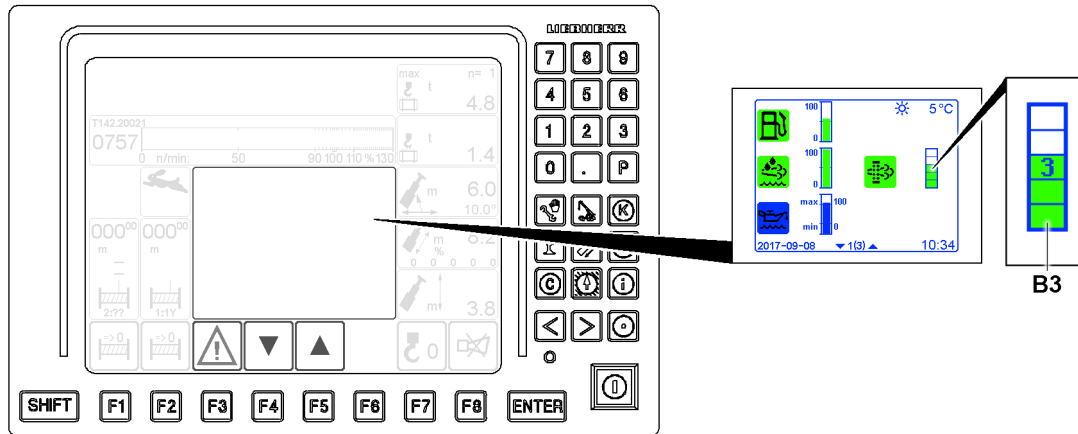


Fig.151823: Displays for load condition 3

From load condition 3 **B3**, automatic regeneration is carried out automatically during engine operation.

If needed, automatic regeneration can be:

- disabled as a precaution
- interrupted and disabled while it is being carried out

Make sure that the following prerequisites are met:

- The crane is at a standstill.
- The monitoring functions are displayed on the LICCON monitor.

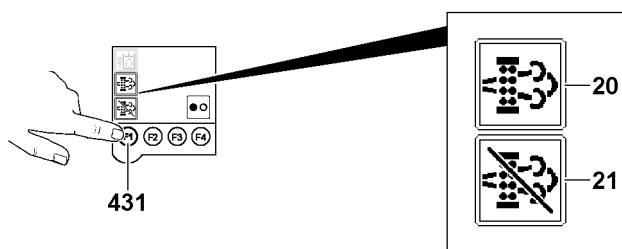


Fig.151820: Diesel particle filter regeneration / disabling diesel particle filter regeneration at a standstill icons

- ▶ Press the F1 key **431** on the left touch display (TE2) until the *Diesel particle filter regeneration at a standstill* **20** icon and *Disable diesel particle filter regeneration at a standstill* icons **21** are displayed, see illustration.

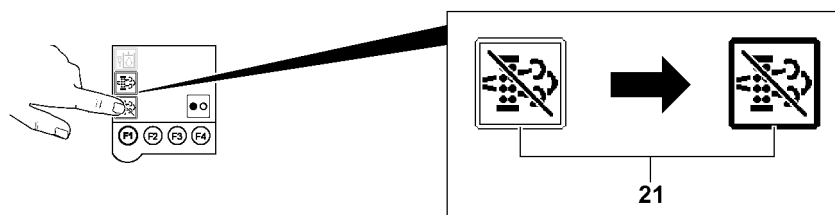


Fig.151821: Selecting disabling regeneration at a standstill of the diesel particle filter

- ▶ Tap the *disable diesel particle filter regeneration at a standstill* icon **21** to select it.



**Result:**

- The frame of the Symbol *disable diesel particle filter regeneration at a standstill* icon **21** is displayed in bold.
- Disabling automatic regeneration of the diesel particle filter is selected.

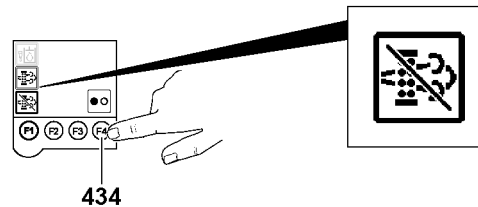


Fig.152573: Activating disabling regeneration at a standstill of the diesel particle filter

- ▶ Press the F4 key **434**.

**Result:**

- Automatic regeneration of the diesel particle filter is disabled.

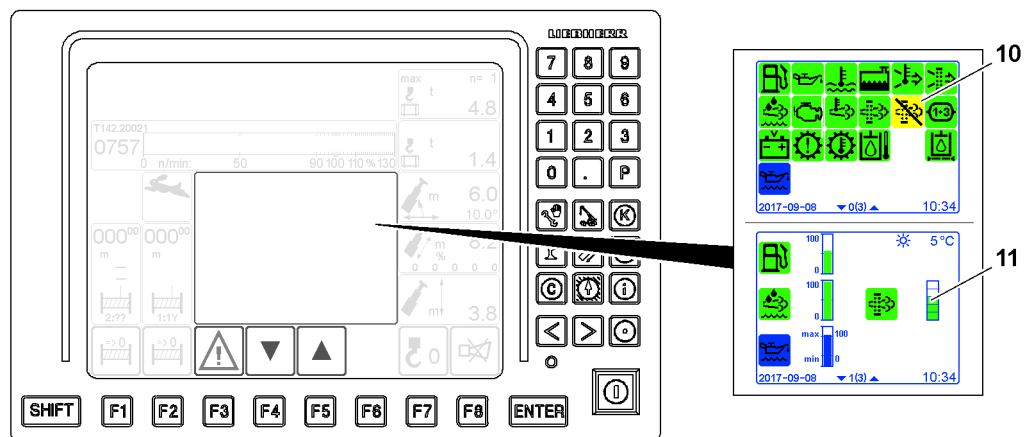


Fig.151824: Displays during disabling automatic regeneration of the diesel particle filter

As long as the automatic regeneration of the diesel particle filter is disabled, the *disable diesel particle filter regeneration at a standstill* icon **10** appears yellow.

If automatic regeneration of the diesel particle filter is disabled:

- ▶ Monitor the *load condition* display **11**. As soon as the load condition becomes critical (yellow), Liebherr-Werk Ehingen GmbH recommends carrying out a regeneration at a standstill as soon as possible (during the work day).

### 3.4 Regenerating at a standstill of the diesel particle filter

**DANGER**

Regeneration of the diesel particle filter\*!  
High exhaust gas temperature. Danger of fire.

- ▶ In an environment with a fire hazard, disable or stop active regeneration.

**Note**

High temperatures at the exhaust outlet!

- ▶ Only if necessary: Carry out regeneration at a standstill.

Regeneration at a standstill of the diesel particle filter must be initiated on touch display 2. Regeneration at a standstill can be carried out at the earliest from load condition 2 and at the latest by load condition 4.

**NOTICE**

Engine stop during regeneration at a standstill!

Interrupting the regeneration at a standstill by stopping the engine destroys the diesel particle filter (DPF).

- ▶ Do **not** interrupt regeneration at a standstill by stopping the engine.

**Note**

- ▶ Do **not** carry out any crane operation or travel operation during regeneration at a standstill!

Make sure that the following prerequisites are met:

- The crane is at a standstill.
- The load condition of the diesel particle filter is displayed on the LICCON monitor.
- Load condition 2, load condition 3 or load condition 4 is reached.

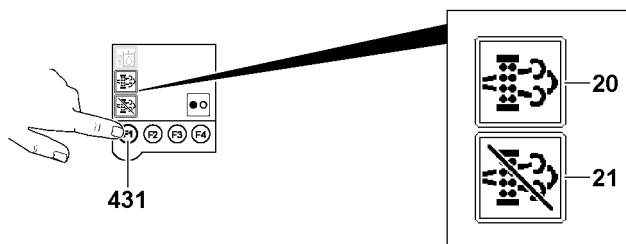


Fig.151820: Diesel particle filter regeneration / disabling diesel particle filter regeneration at a standstill icons

- ▶ Press the F1 key **431** on the left touch display (TE2) until the *Diesel particle filter regeneration at a standstill* **20** icon and *Disable diesel particle filter regeneration at a standstill* icons **21** are displayed, see illustration.

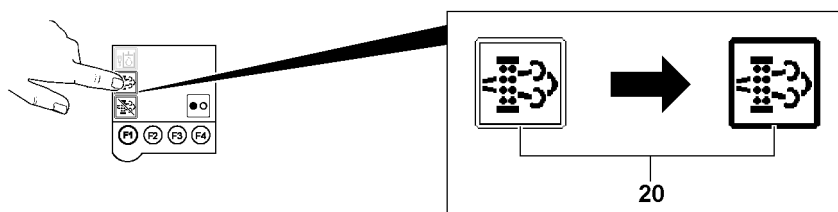


Fig.151822: Selecting regeneration at a standstill of the diesel particle filter

- ▶ Tap the *diesel particle filter regeneration at a standstill* icon **20** to select it.

**Result:**

- The frame of the Symbol *diesel particle filter regeneration at a standstill* icon **20** is displayed in bold.
- Regeneration at a standstill of the diesel particle filter is selected.

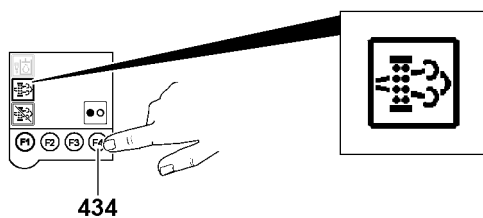


Fig.151826: Activating regeneration at a standstill of the diesel particle filter

- ▶ Press the F4 key **434**.

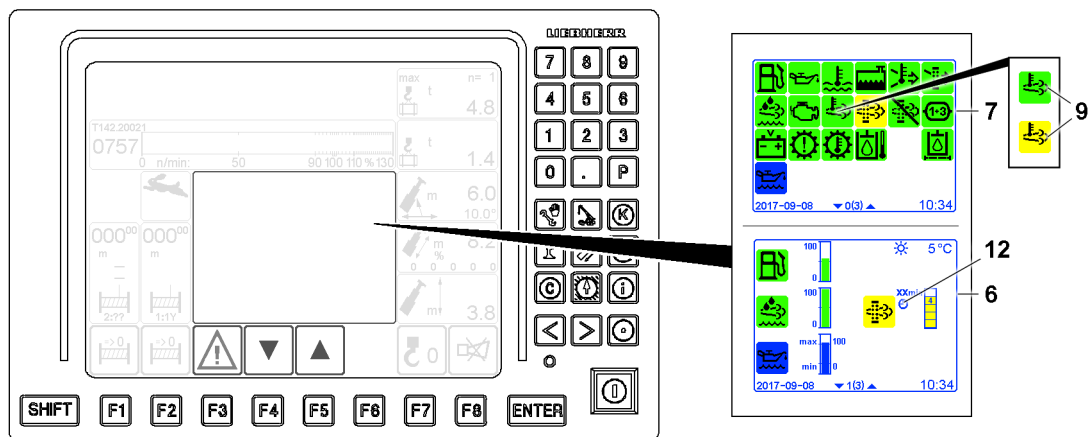
**Result:**

Fig.152142: Example of carrying out the regeneration at a standstill of the diesel particle filter with load condition **B4**

- Regeneration at a standstill of the diesel particle filter has started.
  - The crane operation monitoring functions **7** icon **9** turns yellow.
  - The remaining regeneration time **12** is displayed on the individual control displays **6**.
- ▶ Wait until the regeneration time **12** elapses.

**Result:**

- The icon **9** turns green.
- After successful regeneration, a permissible load condition is reached.

## 4 Exhaust system cleaning procedure

The automatic cleaning procedure for the *exhaust system* prevents damaging the exhaust system.

Prior to the *exhaust system* cleaning procedure, the engine rpm is increased for 10 to 20 minutes by the crane control. A message **1** is displayed.

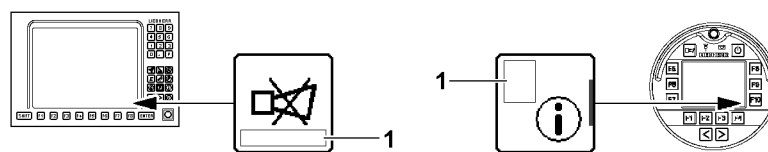


Fig.154108: Note regarding the message **1** in the display field

If the engine is turned off during the cleaning procedure, the cleaning procedure restarts the next time the engine is started.

**NOTICE**

*Exhaust system* cleaning procedure active!  
Hot exhaust system. Property damage.

If the *exhaust system* cleaning procedure active message is displayed:

- ▶ Do **not** turn the engine off.

If the *exhaust system* cleaning procedure active message disappears:

- ▶ The engine can be turned off.

## 5 Crane driver's seat Version 1

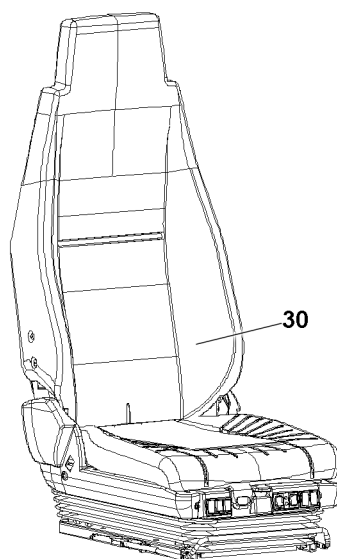


Fig.147578: Adjusting the crane driver's seat

The crane driver's seat **30** can be adjusted to suit any body size.



### WARNING

Sudden backward movement of the crane driver's seat when the crane cab is tilted!  
Danger of crushing.

- ▶ Adjust the seat position only when the crane cab is in the horizontal position.

### 5.1 Horizontal adjustment

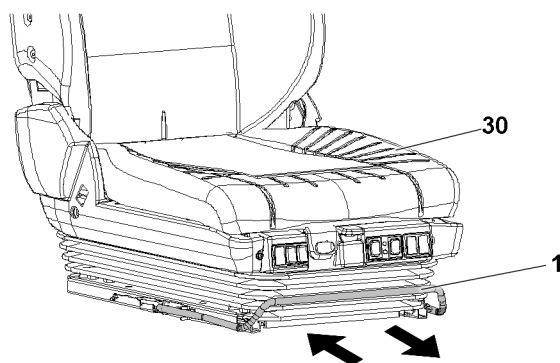


Fig.147579: Adjusting the crane driver's seat horizontally

- ▶ Pull the lever **1** up.
- ▶ Push the crane driver's seat **30** forward / backward.
- ▶ Engage the lever **1**.

#### Result:

- The crane driver's seat **30** is horizontally adjusted.

## 5.2 Backrest adjustment

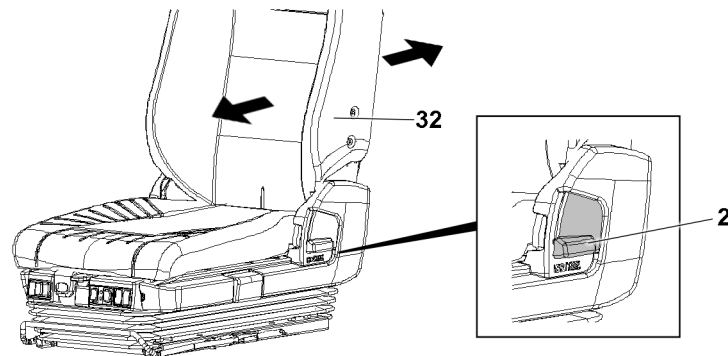


Fig.147580: Adjusting the backrest

- ▶ Pull the lever 2 up completely.
- ▶ Bring the backrest 32 into the desired position using body weight.
- ▶ Engage the lever 2.

**Result:**

- The desired backrest position is adjusted.

## 5.3 Integrated pneumatic system (IPS)

The „Integrated pneumatic system“ (IPS) makes it possible to optimally adapt the backrest contour to the body.

### 5.3.1 „Lower“ lumbar area support

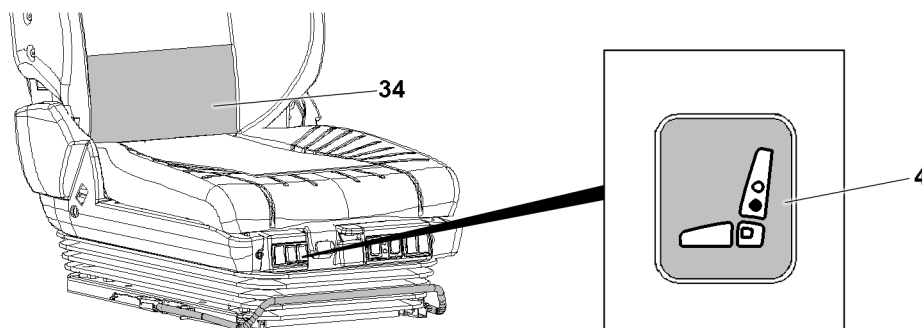


Fig.147581: Lower lumbar area support

- ▶ Press the button 4.

**Result:**

- The air chamber 34 for the „lower lumbar area support“ is inflated.

- ▶ Press the button 4.

**Result:**

- The air chamber 34 for the „lower lumbar area support“ is deflated.

### 5.3.2 „Upper“ lumbar area support

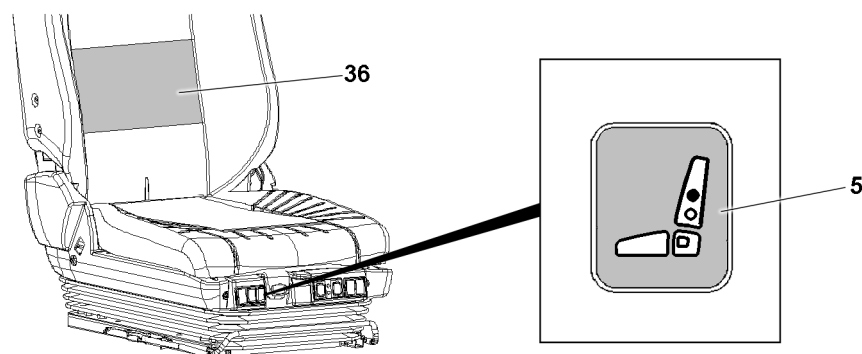


Fig.147582: Upper lumbar area support

- ▶ Press the button **5** forward.

**Result:**

- The air chamber **36** for the „upper lumbar area support“ is inflated.

- ▶ Press the button **5** backward.

**Result:**

- The air chamber **36** for the „upper lumbar area support“ is deflated.

### 5.4 Incline adjustment

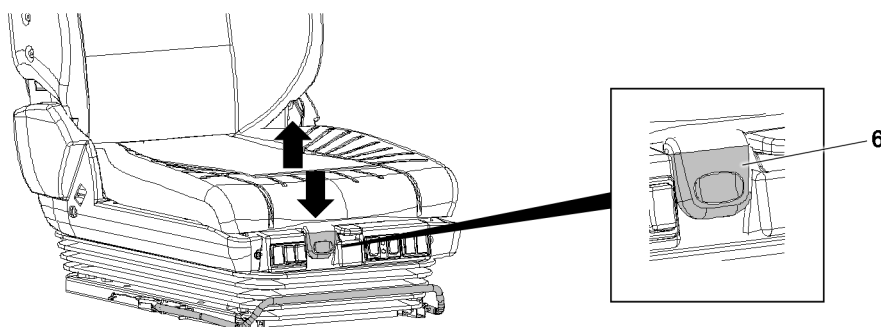


Fig.147583: Incline adjustment

- ▶ Pull the lever **6** up.
- ▶ Adjust the seat incline by inflating or releasing the front of the seat cushion.
- ▶ Engage the lever **6**.

**Result:**

- The incline adjustment has been set.

## 5.5 Seat cushion adjustment

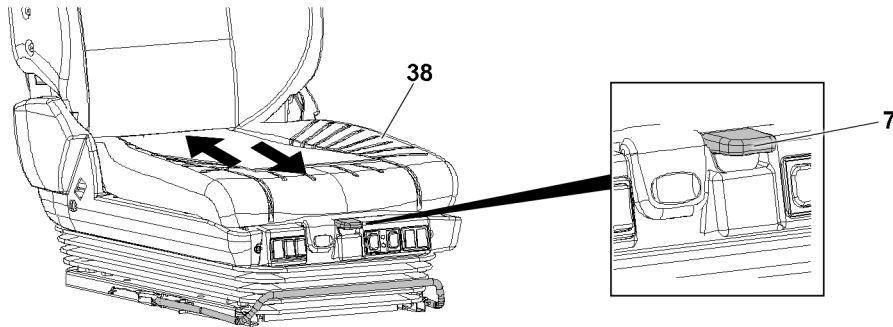


Fig.147584: Adjusting the seat cushion

- ▶ Pull the lever 7 up.
- ▶ Push the seat cushion 38 forward / backward.
- ▶ Engage the lever 7.

**Result:**

- The seat cushion 38 is adjusted.

## 5.6 Height adjustment

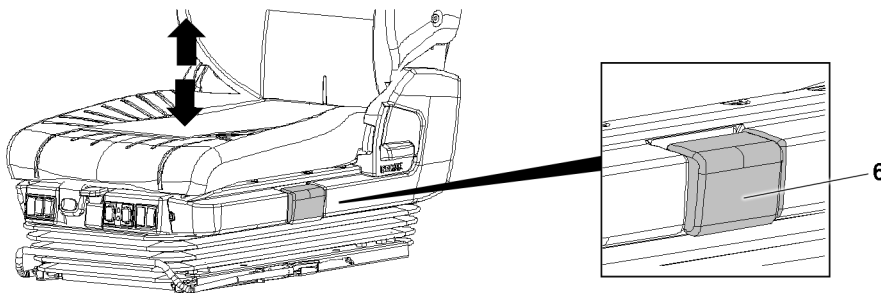


Fig.147585: Adjusting the seat height

---

**NOTICE**

Crane driver's seat adjusted too low!  
No seat suspension is available.

- ▶ Before starting to work: Adjust the crane driver's seat so that there is headroom and the pedals can be pressed down fully.

- 
- ▶ Adjust the seat height: Pull or press the handle 6.
  - ▶ Release the handle 6.

**Result:**

- The desired seat height is adjusted.

## 5.7 Heater / climate control

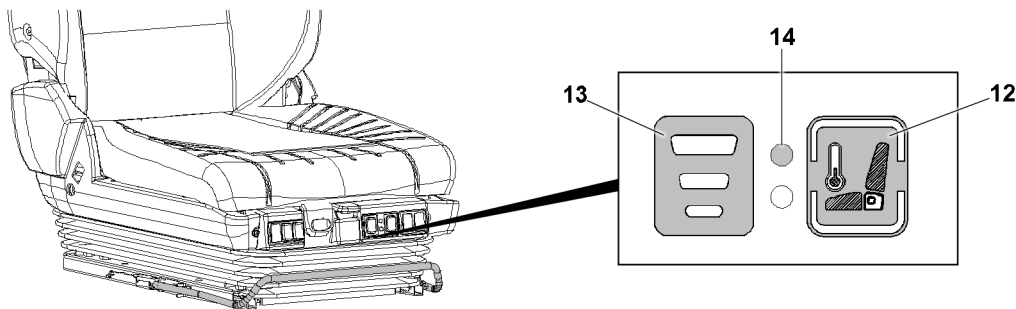


Fig.147586: Heater / climate control

### NOTICE

Anomalous use of the heater / climate control!  
Overheating, damage to the seat.

- ▶ Do **not** dry wet clothing.
- ▶ Do **not** place objects such as clothing, cushions, bags on the seat.
- ▶ Do **not** use seat covers on the seat.
- ▶ If the seat is not occupied, use of the heater / climate control is prohibited.



### WARNING

Continuous operation of the climate control!  
Undercooling.

- ▶ Avoid the continuous operation of the climate control.

### 5.7.1 Heater / climate control

The button **12** has three switch positions.

Switch position neutral (center position): No function, switch position „OFF“.

Switch position up: Heater turned on.

Switch position down: Fan on.

- ▶ Button **12** in the „OFF“ switch position.

#### Result:

- The heater / climate control is turned off.

- ▶ Push the button **12** upward.

#### Result:

- Heater turned on.

- ▶ Press the button **12** downward.

#### Result:

- Fan on.

### 5.7.2 Heater / fan stages

The button **13** has three switch stages. The switch levels can be selected from low to high.

- ▶ Select the switch level: Press the button **13**.

#### Result:

- The heater / fan stage is set.

### 5.7.3 Heater / climate control indicator light

If the red indicator light **14** blinks, a problem is displayed.



- ▶ The red indicator light **14** blinks: Switch the button **12** to the neutral switch position (center position).

**Result:**

- The heater / climate control is turned off.
- ▶ Remedy the problem.

## 6 Crane driver's seat Version 2

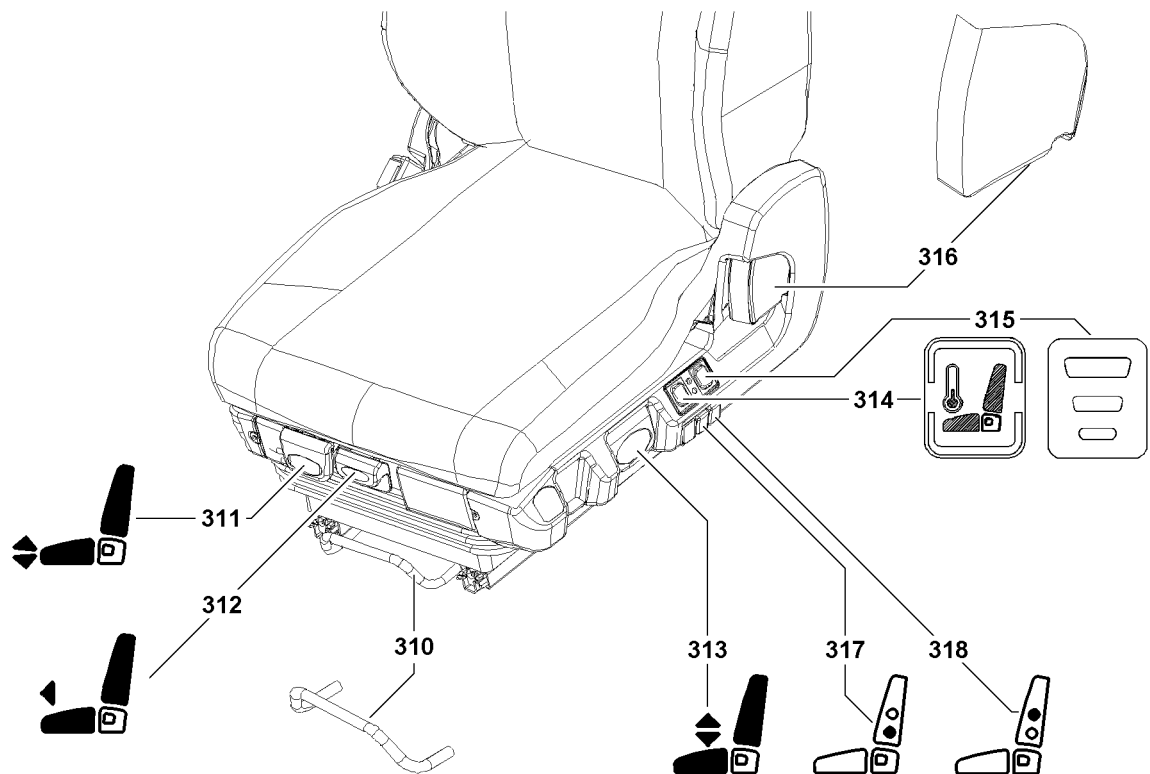


Fig.122070: Crane driver's seat

### 6.1 Horizontal adjustment

**WARNING**

Sudden backward movement of the crane driver's seat when the crane cab is tilted!  
Danger of crushing.

- ▶ Adjust the seat position only when the crane cab is in the horizontal position.

- ▶ Pull the lever **310** up.
- ▶ Position the seat.
- ▶ Engage the lever **310**.

**Result:**

- The horizontal adjustment is adjusted.

### 6.2 Incline adjustment

- ▶ Pull the lever **311** up.
- ▶ Adjust the seat incline by inflating or releasing the front of the seat cushion.
- ▶ Engage the lever **311**.

**Result:**

- The incline adjustment is adjusted.

### 6.3 Seat cushion adjustment

- ▶ Pull the lever **312** up.
- ▶ Push the seat cushion forward / backward.
- ▶ Engage the lever **312**.

**Result:**

- The seat cushion is adjusted.

### 6.4 Height adjustment

- ▶ Pull or press the lever **313**.
- ▶ Adjust the desired seat height.
- ▶ Engage the lever **313**.

**Result:**

- The seat height is adjusted.

### 6.5 Seat heater / seat climate control\*

- ▶ Set the switch **314** upward.

**Result:**

- Seat cushion and backrest heater turned on. The seat cushion and backrest heater are thermostatically controlled.
- ▶ Set the switch **314** to neutral (middle position).

**Result:**

- Seat heater / seat climate control turned off.
- ▶ Set the switch **314** downward.

**Result:**

- Seat cushion and backrest climate control turned on.

### 6.6 Fan\*

**Note:** The fan is only available in conjunction with the seat heater / climate control\*.

- ▶ Operate the lever **315**.
- ▶ Adjust the fan stage.

**Result:**

- The fan stage is adjusted.

### 6.7 Backrest adjustment

- ▶ Pull the lever **316** up.
- ▶ Bring the backrest into the desired position using body weight.
- ▶ Engage the lever **316**.

**Result:**

- Backrest adjustment set.

### 6.8 Upper lumbar area support\*

- ▶ Operate the lever **317**.
- ▶ Until the desired support is adjusted: Inflate or vent the air chamber in the „upper lumbar area support“.

**Result:**

- Upper lumbar area support adjusted.

**6.9 Side support\***

- ▶ Operate the lever **318**.
- ▶ Until the desired support is adjusted: Inflate or vent the air chamber in the „side support“.

**Result:**

- The side support is adjusted.

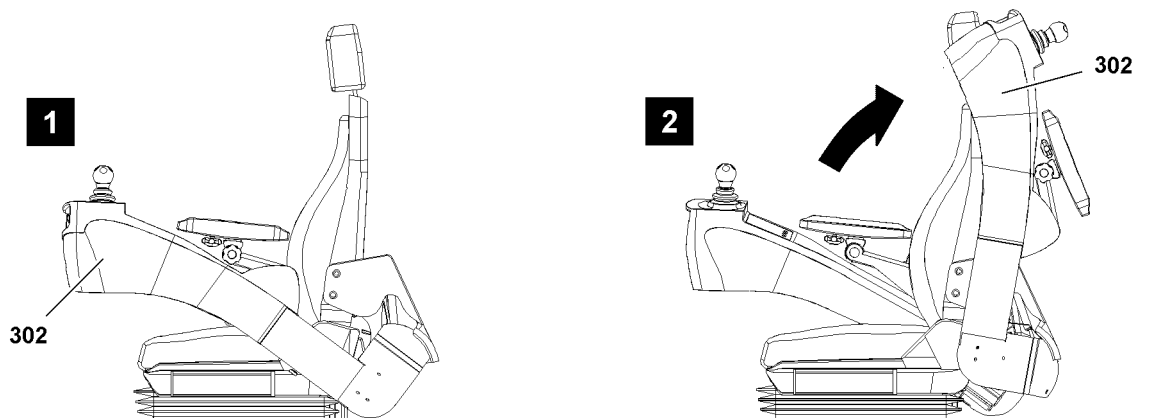
**7 Control platform****7.1 Folding the control helm**

Fig.122071: Folding the control helm

The control helm **302** can be folded up or down.

- Operating position: Control helm **302** is folded down, illustration **1**
- Entry / exit position: Control helm **302** is folded up, illustration **2**

**WARNING**

Sudden fold down of control helm!  
Danger of crushing.

After entering and exiting:

- ▶ Fold the control helm **302** down.

Before entering and exiting:

- ▶ Fold the control helm **302** up.

## 7.2 Adjusting the control helm

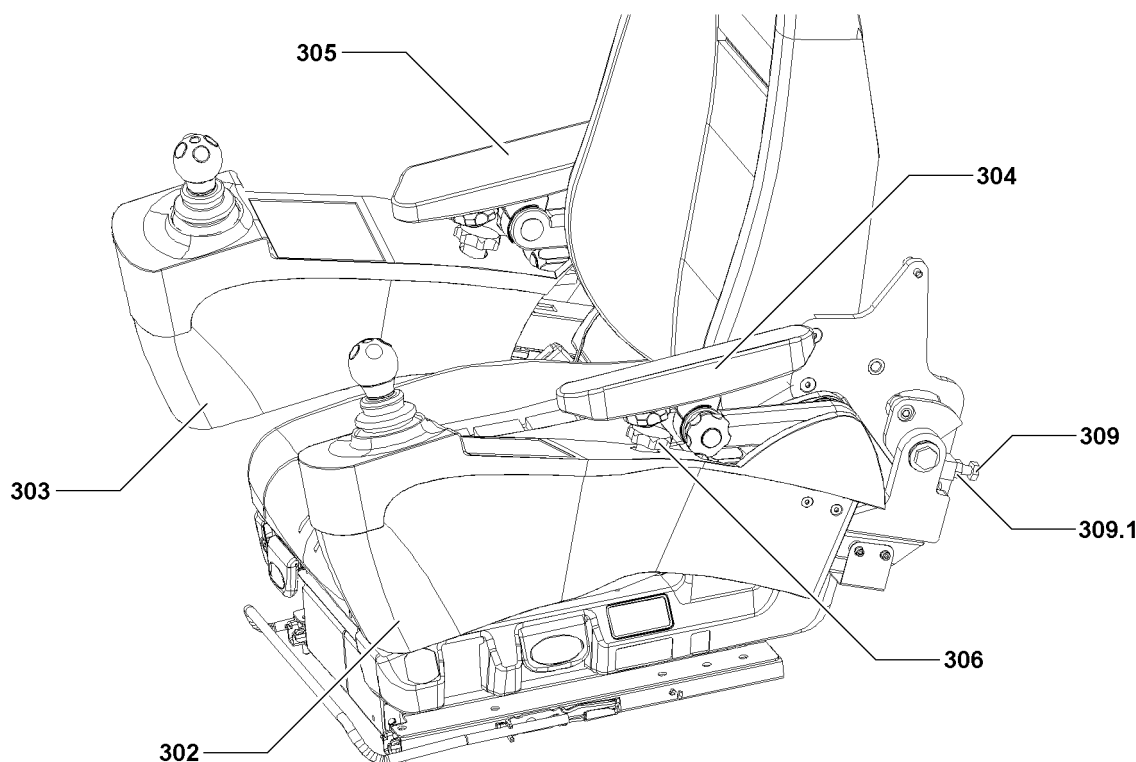


Fig.122072: Adjusting the control helm

The control helms can be adjusted individually to suit. Every crane operator can set his work place optimally to his body size.

The control helms can be adjusted to suit the crane driver as described for the left control helm **302**. The adjustment of the right control helm **303** functions the same way.

### Adjust the incline

- ▶ Release the nut **309.1**.

Until the control helm **302** has reached the desired incline:

- ▶ Turn the stop screw **309**.
- ▶ Secure the stop screw **309** with the nut **309.1**.

### Move horizontally.

- ▶ Fold the armrest **304** up.
- ▶ Pull the locking pin **306**.
- ▶ Set the horizontal position by sliding the control helm **302**.
- ▶ Release the locking pin **306** and let it engage.
- ▶ Fold the armrest **304** down.

## 7.3 Armrests

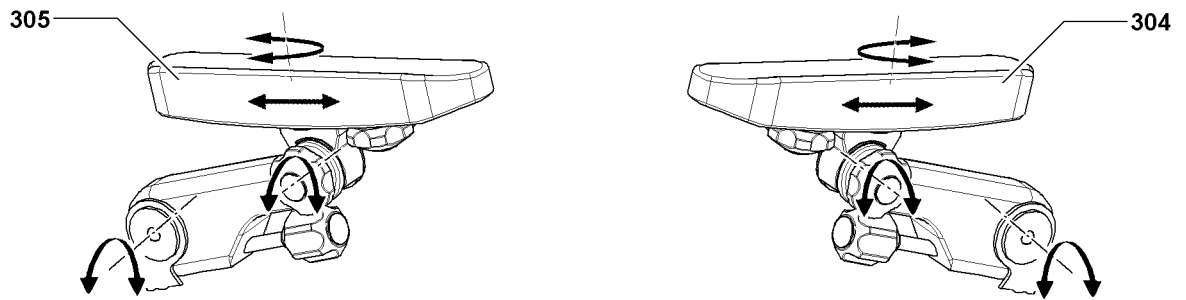


Fig.122073: Armrests

By releasing the adjustment screws, the armrests can be adjusted individually. To operate the master switches comfortably, set the armrests to the size of the crane driver.

- ▶ Release the adjustment screws.
- ▶ Adjust the left armrest **304** and right armrest **305**.
- ▶ Close the adjustment screws.

## 8 Step

The step is only present on certain crane types.

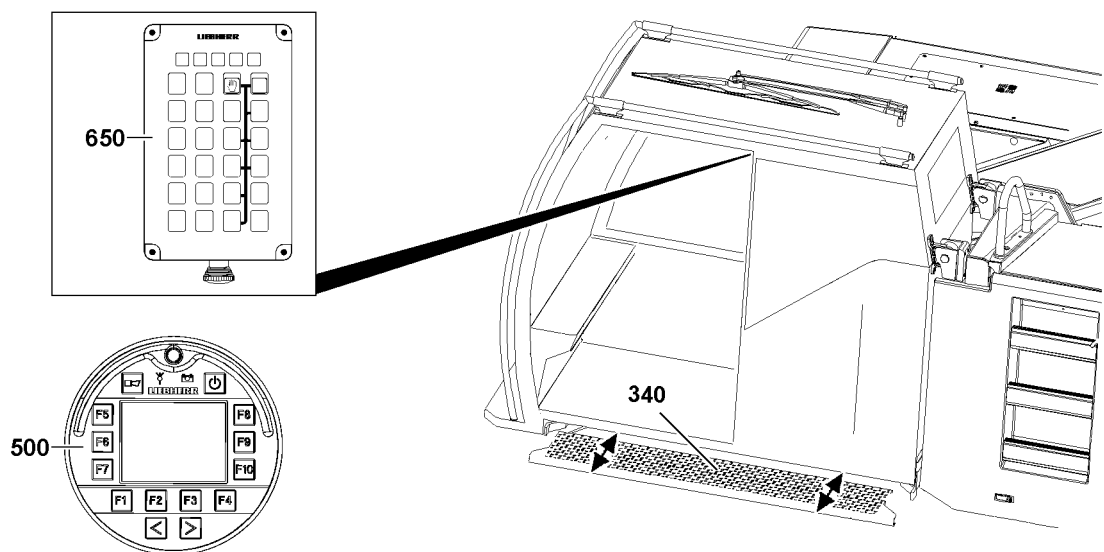


Fig.152551: Operating the step with BKE / BTT

To be able to get into the crane cab easier, the step **340** can be extended / retracted.



### WARNING

Step **340** **not** fully retracted or extended!  
Danger of falling, death, severe bodily injuries.

- ▶ Retract or extend the step completely!

Only when the step is extended completely:

- ▶ Step on the step.

**WARNING**

Personnel can be caught by the step!  
Personnel can fall, death, severe bodily injuries.

- ▶ When extending and retracting the steps, make sure that there are no persons within the extension range.

**WARNING**

Danger of collision!  
The step **340** protrudes over the crane contour.

- ▶ Before driving the crane, retract the step completely.

There are up to two ways to operate the step **340**:

Operating the step from the crane cab

- There are operating buttons on the BKE **650**.

Operating the step with the BTT **500**

- **Note: Operating the step with the BTT is only possible on certain crane types.**
- The step can be operated from the *Crane superstructure assembly function* menu.

## 8.1 Operating the step from the crane cab

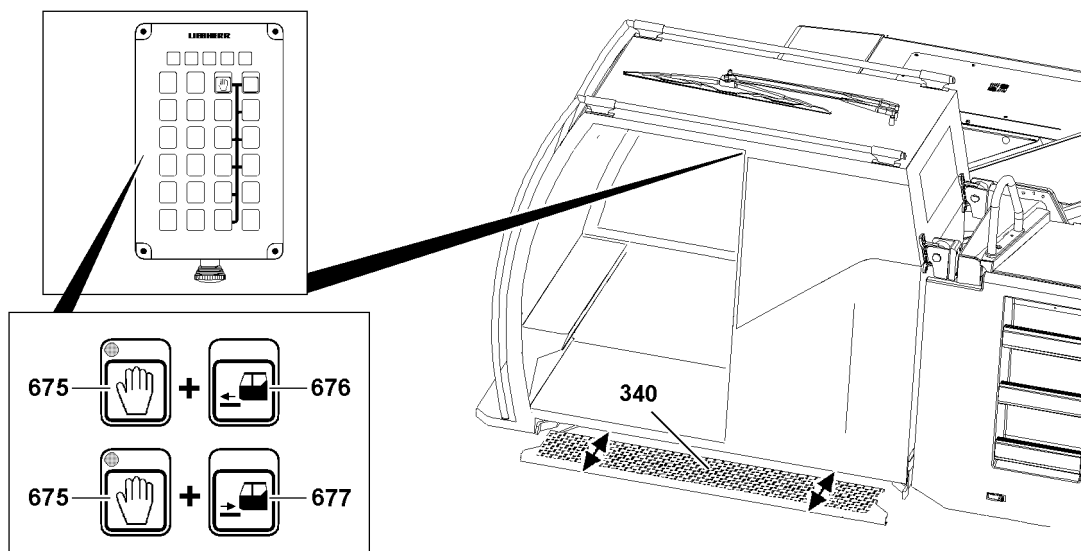


Fig.152552: Operating the step from the crane cab

Make sure that the following prerequisite is met:

- The crane superstructure ignition is turned on.

### Extend the step:

- ▶ Press the button **675** and the button **676**.

### Result:

- The step **340** is extended.

### Retract the step:

- ▶ Press the button **675** and the button **677**.

### Result:

- The step **340** is retracted.

## 9 Crane cab

### 9.1 Tilting the crane cab

**Tilting the crane cab is only possible on certain crane types.**

To give the crane driver a better field of vision, the crane cab can be tilted upwards.

When you have finished working with the crane, always set the crane cab to horizontal position.



#### WARNING

Persons on step with inclined crane operator's cab!  
Danger of falling, death, severe bodily injuries.

Before stepping on the step:

- ▶ Align the crane cab horizontally.
- ▶ Do not step on the step when the crane cab is tilted!



#### WARNING

Door suddenly moves back when the crane cab is inclined!  
Crushing of hands.

- ▶ Set the crane cab in the horizontal position, then open the door!



#### WARNING

Persons under the crane cab!  
Danger of crushing.

- ▶ Make sure that there are no persons below the crane cab.

Make sure that the following prerequisite is met:

- The engine is running.

#### 9.1.1 Tilting the crane cab upward

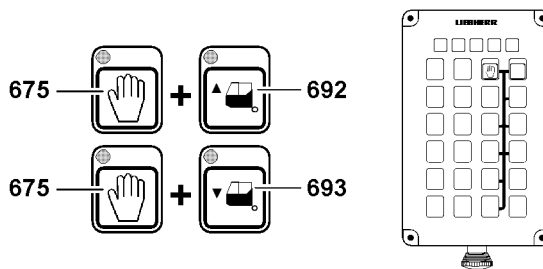


Fig.152550: Tilting the crane cab

- ▶ Press the button **675** and the button **692**.

**Result:**

- The crane cab swings up.

## 9.1.2 Aligning the crane cab horizontally

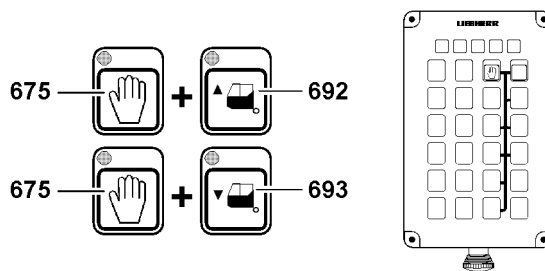


Fig.152550: Tilting the crane cab

- ▶ Press the button **675** and the button **693**.

### Result:

- The crane cab swings downward.

## 9.2 Windows



### WARNING

Danger of crushing!

- ▶ When closing the front or roof window, do **not** crush hands.

### NOTICE

Property damage!

Before driving the crane:

- ▶ Close windows and door!

### 9.2.1 Opening / closing the front window of the crane cab

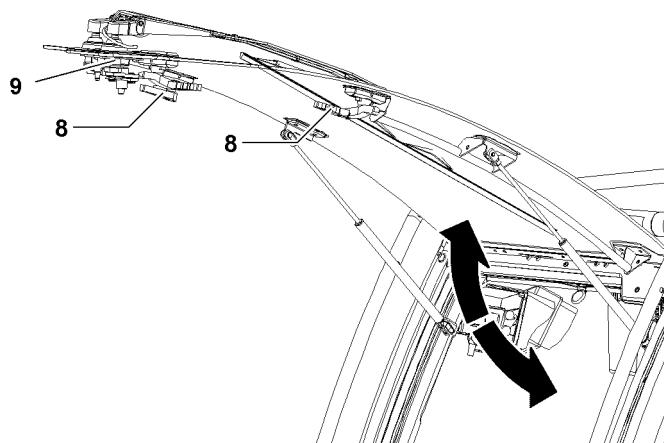


Fig.116425: Opening / closing the front window

A nitrogen gas cylinder provides help to lift the front window.

#### Open the front window:

- ▶ Unlock the turn handle **8** and turn handle **9** on both sides.
- ▶ Open the front window.

#### Close the front window:

- ▶ Pull the front window closed.
- ▶ Lock the turn handle **8** and turn handle **9** on both sides.



## 9.2.2 Opening / closing the roof window

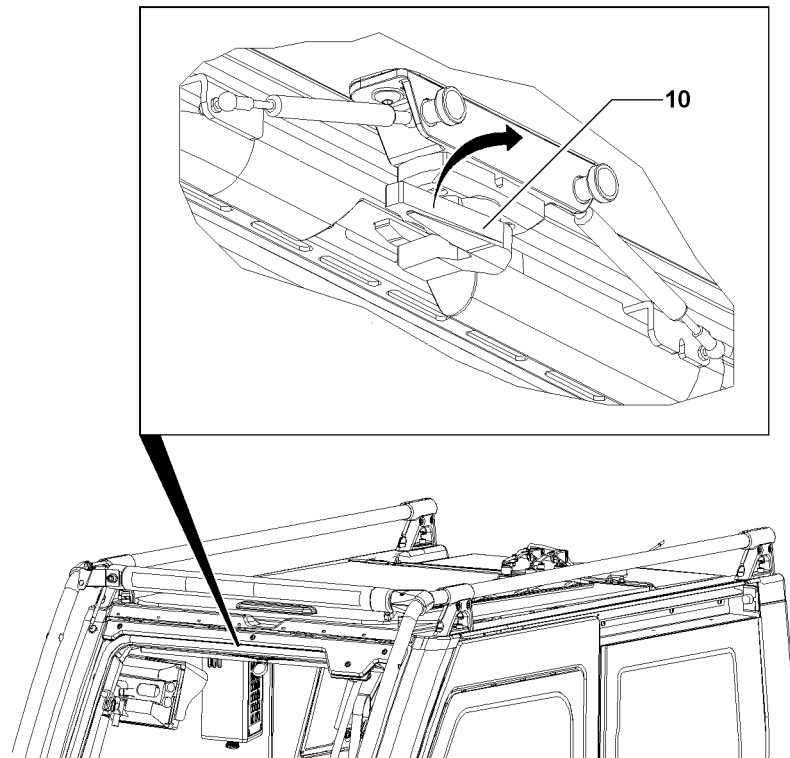


Fig.116426: Opening / closing the roof window

Use the rotary handle **10** to open / close the roof window.

### Open the roof window:

- ▶ Release the rotary handle **10** and press the roof window up.

### Close the roof window:

- ▶ Pull the roof window closed and lock with the rotary handle **10**.

## 9.3 Horn

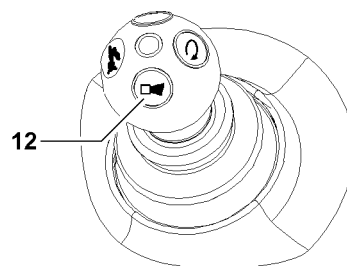


Fig.115322: Horn

If the horn is used outside of danger situations, then the horn can lose its warning effect.

**WARNING**

Improper use of horn!  
Loss of signal effect.

When the horn is checked:

- ▶ Announce it to all persons who are present.

When the horn test is completed:

- ▶ Announce it to all persons who are present.
- ▶ Do **not** actuate the horn wrongly.

Before starting to crane work, check that the horn is functioning.

- ▶ Press the button **12** on the master switch.

**Result:**

- The horn sounds.

**Problem remedy**

The horn does not sound?  
The horn is defective.

- ▶ Repair the horn before starting to work with the crane.

## 9.4 Climate control

Climatizing the crane cab is described in chapter 6.02.

- ▶ Climatize the crane cab.

# 10 Hydraulic oil preheating\*

The hydraulic oil can be preheated with the Hydraulic oil preheating\*.

**Note**

- ▶ At low ambient temperatures, preheat the hydraulic oil.

From a hydraulic oil temperature above 25 °C:

- ▶ Do **not** turn the hydraulic oil preheating\* on.

Make sure that the following prerequisite is met:

- The engine is running.

## 10.1 Displaying the hydraulic oil temperature

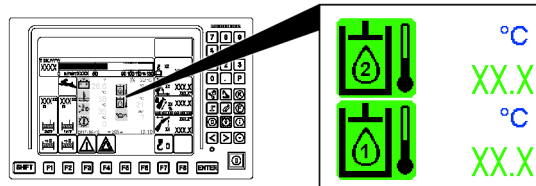


Fig.147667: Hydraulic oil temperature

The current hydraulic oil temperature can be displayed on the LICCON monitor.

- ▶ Call up the monitoring functions, see chapter 4.02.
- ▶ Check the hydraulic oil temperature.

## 10.2 Turning the hydraulic oil preheating\* on

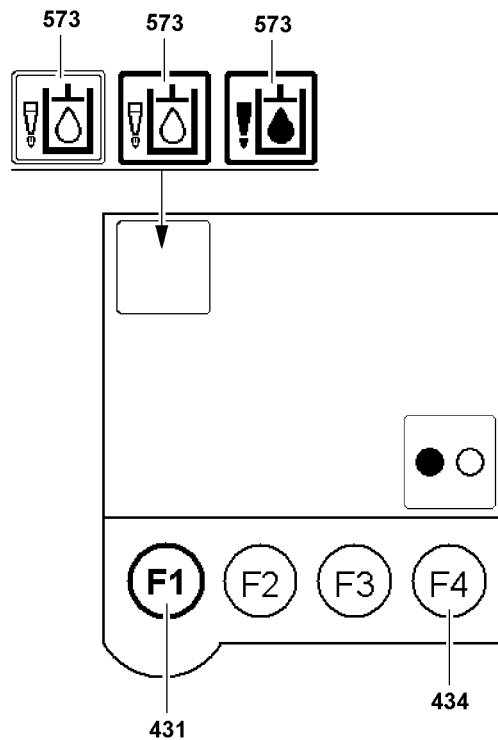


Fig.122075: Turning the hydraulic oil preheating\* on



### Note

When the Hydraulic oil preheating\* is turned on, various crane movements are turned off.

▶ If necessary, turn the Hydraulic oil preheating\* off.

- ▶ Press the function key **431** on the left touch display until the *Auxiliary supply* menu appears.
- ▶ Select the function Hydraulic oil preheating **573** by „touch“.

### Result:

– The icon Hydraulic oil preheating **573** is bordered in black.

- ▶ Press the function key **434**.

### Result:

- The hydraulic oil preheating is turned on.
- The icon Hydraulic oil preheating **573** is filled.

When the hydraulic oil has reached operating temperature:

- ▶ Press the function key **434** again.

### Result:

- The hydraulic oil preheating is turned off.
- The Hydraulic oil preheating **573** icon is **not** filled.

To preheat the hydraulic components:

- ▶ Actuate all hydraulic crane functions without a load for 15 minutes.

## 11 LICCON computer system

The LICCON computer system is described in chapter 4.02.

LICCON computer system operating modes:

- LICCON computer system in stand-by mode (engine turned off)
- LICCON computer system in normal mode (engine turned on)

## 11.1 System start

After turning the ignition on, the LICCON computer system boots up and carries out a self test.

- ▶ Do not actuate any operating elements during system start.

### Problem remedy

System start is aborted?

Operating element was actuated.

After an abort at system start:

- ▶ Turn off the engine and the ignition.
- ▶ Start the ignition and engine again.

- ▶ Wait for the boot up phase.

### Result:

- Set up screen appears on the LICCON monitor.
- The last set up configuration is shown.

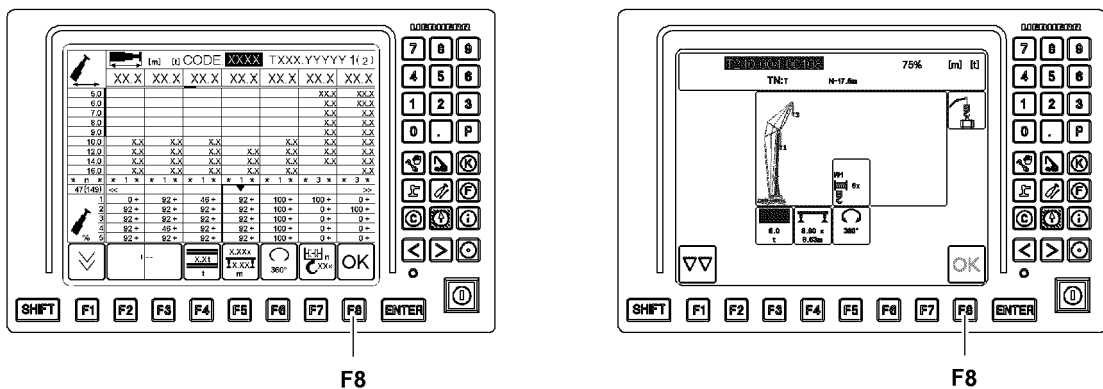


Fig.122082

- ▶ Check the set up configuration.

When entries and settings do not match the set up configuration of the crane:

- ▶ Enter the correct entries and settings.

### Problem remedy

Does an error message appear on the LICCON monitor?

- ▶ Turn off the engine and the ignition.
- ▶ Start the ignition and engine again.

When an error message appears again:

- ▶ Contact Customer Service at Liebherr-Werk Ehingen.

## 11.2 Accepting the set up configuration

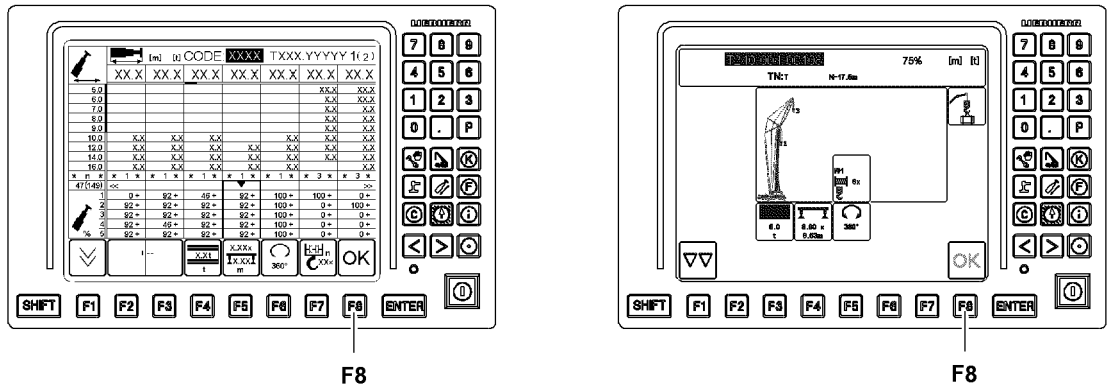


Fig.122082

Make sure that the following prerequisite is met:

- The entries and settings in the set up program match the actual set up configuration of the crane.

When the entries and settings in the Set up program are correct:

- ▶ Press the function key **F8**.

**Result:**

- The entries and settings are taken over and the *Set up* program is ended.
- The *Crane operation* program is called up.

## 11.3 Changing the set up configuration

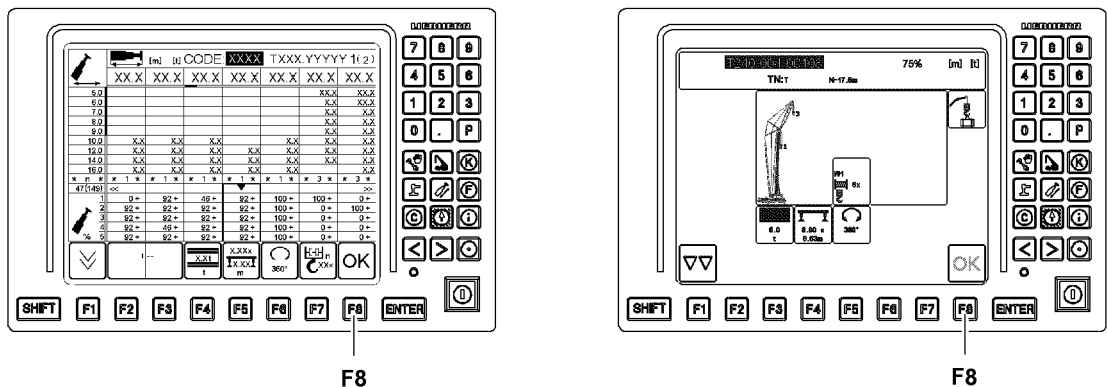


Fig.122082

The entries and settings can be changed in the Set up program.

Changing the entries and settings in the *Set up* program is described in chapter 4.02.

Make sure that the following prerequisite is met:

- The *Set up* program is called up in the LICCON computer system.

- ▶ Enter the correct entries and settings.

When the entries and settings in the *Set up* program are correct:

- ▶ Press the function key **F8**.

**Result:**

- The entries and settings are taken over and the *Set up* program is ended.

- The *Crane operation* program is called up.

## 12 Disengaging / engaging the coupling control on the pump distributor gear

The coupling control is only present on certain crane types.

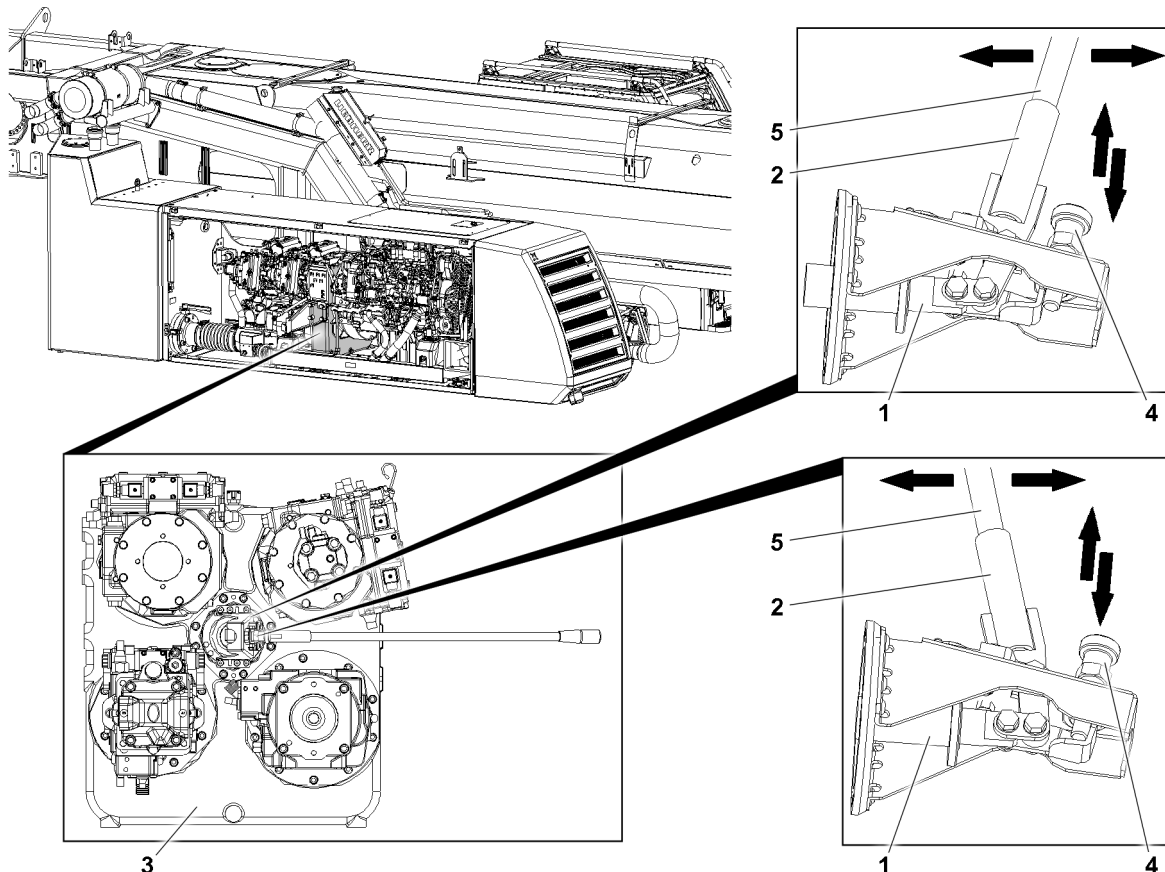


Fig.152556: Disengaging / engaging the coupling control



### Note

- ▶ In high altitude application and at low ambient temperatures it may be necessary to disengage the coupling control **1** of the pump distributor gear **3** before starting the engine.
- ▶ The cold start behavior of the engine is thereby improved.

### NOTICE

Danger of damaging the engine!

When the coupling control **1** is disengaged and the engine temperature is not constantly monitored, the engine can overheat.

This could result in significant property damage.

- ▶ Monitor the engine temperature constantly while the engine is running.
- ▶ Make sure that the engine does not overheat.
- ▶ If there is any doubt, turn the engine off.

## 12.1 Disengage the coupling control

Make sure that the following prerequisites are met:

- The engine is turned off.
- The coupling control is engaged.
- ▶ Take the lever extension **5** from park position.
- ▶ Set the lever extension **5** on the linkage **2**.
- ▶ Release and turn the locking pin **4**.
- ▶ Actuate the linkage **2** with the lever extension **5** to the stop.

**Result:**

- The coupling control **1** is disengaged.
- The pumps on the pump distributor gear **3** are **not** driven at engine start.
- ▶ Secure the coupling control **1**: Engage the locking pin **4**.
- ▶ Remove the lever extension **5** and store it in park position.



### WARNING

Danger of accident due to rotating parts!

- ▶ Make sure that there are no persons within the danger zone of the engine.
- ▶ Start the engine, see section „Starting the engine“.

**Result:**

- ▷ The engine is warmed up.

## 12.2 Engaging the coupling control

### NOTICE

Property damage on the pump distributor gear!

- ▶ Make sure that the coupling control **1** is engaged when the engine is at a standstill.

Make sure that the following prerequisites are met:

- The engine is turned off.
- The coupling control is disengaged.

When the engine has reached operating temperature:

- ▶ Turn the engine off.

When the engine has come to a complete standstill:

- ▶ Release and turn the locking pin **4**.
- ▶ Engage the coupling control **1** with the lever extension **5**.

### Problem remedy

The coupling control **1** cannot be engaged on the pump distributor gear **3**?

- ▶ Start the engine for a short time and turn it off again until the coupling control **1** can be engaged.

When the coupling control **1** is completely engaged:

- ▶ Secure the coupling control **1**: Engage the locking pin **4**.
- ▶ Remove the lever extension **5** and store it in park position.

**Result:**

- At engine start, the hydraulic pumps on the pump distributor gear **3** are driven.

## 13 Starting the engine

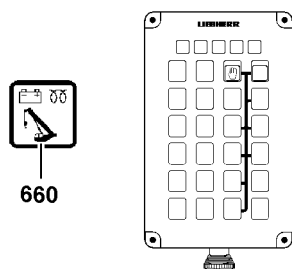


Fig.152522: Indicator light

### NOTICE

Increased wear on the engine!  
Engine damage.

Solely when the indicator light **660** blinks yellow:

- ▶ Start the engine.
- ▶ Do not put a full load on the engine until the operating temperature is reached.

Make sure that the following prerequisites are met:

- The transmission is in the neutral position „N“.
- The ignition in the chassis is turned off.

### 13.1 Starting procedure

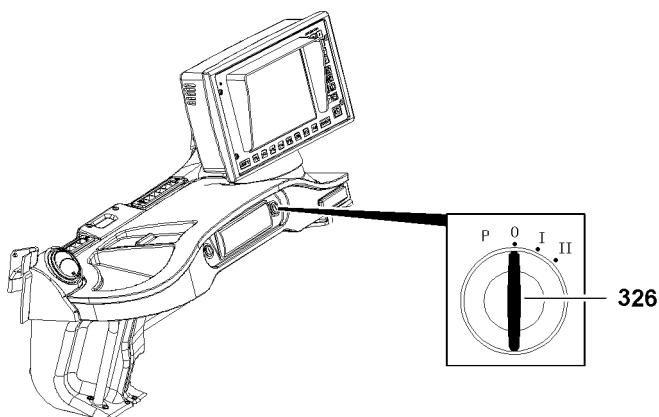


Fig.122259: Starting the engine

- ▶ Turn the ignition switch **326** to position „I“.

#### Result:

- The indicator light **660** lights up yellow.

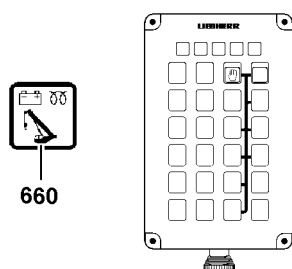


Fig.152522: Indicator light



When the indicator light **660** blinks yellow, the engine is ready to start:

- ▶ Turn the ignition switch **326** to position „II“.

**Result:**

- The engine starts.

---

**NOTICE**

The engine does not start after three start attempts!

The starter motor can be damaged after more than three start attempts.

- ▶ Interrupt the starting procedure.
- 

Before a new start attempt:

- ▶ Observe a break of 20 minutes.

## 13.2 For an ambient temperature above -18 °C

- ▶ Start the engine.

---

**Problem remedy**

The engine does not start after a maximum of 30 seconds?

- ▶ Wait for 30 seconds.

The starter motor can be operated three times for 30 seconds per starting procedure, with a 30 second break in between.

- ▶ Start the engine again.
- 

## 13.3 For ambient temperatures of -18 °C and lower

- ▶ Start the engine.

---

**Problem remedy**

The engine does not start after a maximum of 30 seconds?

- ▶ Wait for 120 seconds.

The starter motor can be operated three times for 30 seconds per starting procedure, with a 120 second break in between.

- ▶ Start the engine again.
- 

## 13.4 Maintaining the battery charge

The capacity of the battery is significantly reduced at low temperatures.

When the engine is turned off:

- ▶ Store that batteries in a heated area, if possible.

# 14 Turning the engine off

---

**NOTICE**

Engine with malfunction!

Engine damage.

- ▶ In case of malfunction, turn the engine off immediately.
- 

Malfunctions are:

- Dropping or significantly fluctuating oil pressure
- Reducing power without changing the gas pedal
- Reducing rpm without changing the gas pedal
- Significant smoke development
- Increasing coolant temperature
- Abnormal engine noises

**NOTICE**

Increased engine wear!

If the crane has been operated at full engine output or if the coolant temperature is above 95 °C:

- ▶ Allow the engine to run without load at idling speed for 1 to 2 minutes.

## 14.1 Turning off procedure

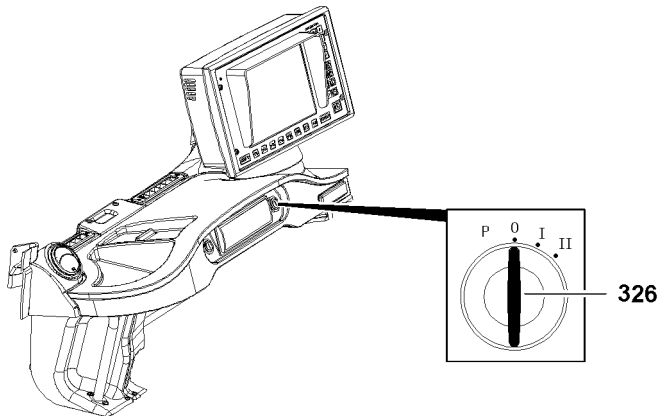


Fig.122259: Turning the engine off

- ▶ Turn the ignition switch **326** back to the stop.
- ▶ Pull the ignition switch **326** out and store it.

## 14.2 Turning the engine off with the engine stop button

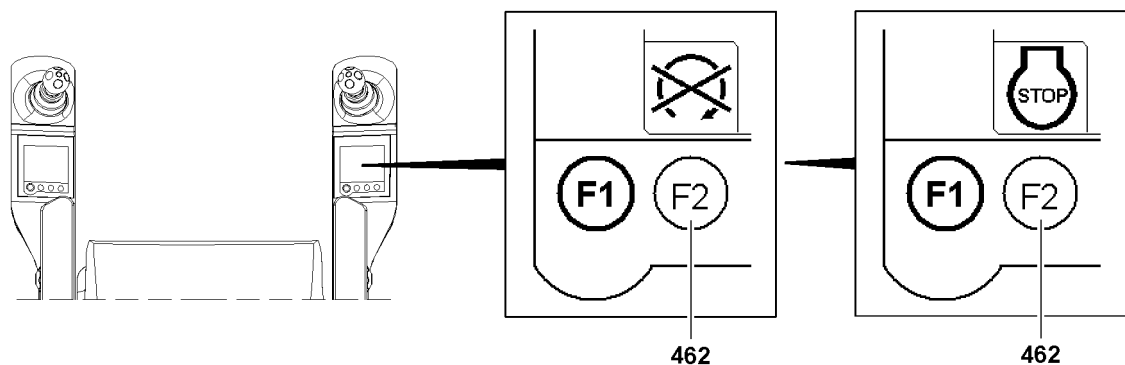


Fig.116432: Turning the engine off with the engine stop button

- ▶ Press the function key **462** on the right touch display and turn the engine off.

## 14.3 Turning off the engine in case of danger

The EMERGENCY STOP switches are described in chapter 4.04.

**NOTICE**

Incorrect use of the EMERGENCY STOP switches!

Oscillation of load.

Increased wear of crane components.

- ▶ Actuate the EMERGENCY STOP switch only in emergency situations.

If an emergency situation occurs:

- ▶ Actuate the EMERGENCY STOP switch.

**Result:**

- The crane is turned off.

## 15 Indicator lights

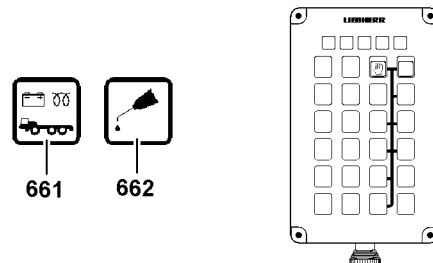


Fig.152526: Indicator lights

The indicator lights are described in detail in chapter 4.01.

When an indicator light lights up red, then an erroneous function or warning is present.

---

### NOTICE

Erroneous function / warning!

Damage to components.

- ▶ End crane movement.
  - ▶ Turn the engine off.
  - ▶ Remedy the cause of the error.
- 

## 16 Window wiper / window washer system

The window wiper / window washer system on the front and roof window can be operated via the function buttons on the Operating and control unit (BKE). Each window has a button assigned to it.

### 16.1 Turning the window wiper on

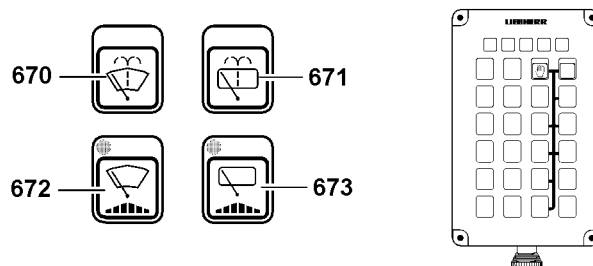


Fig.152525: Button

There are three different wipe stages.

Pressing the button **672** or button **673** (less than 0.5 seconds) reduces the wiper speed incrementally.

Wipe speeds:

1. Continuous operation
2. Short interval
3. Long interval
4. Wiper off

When the wipe stage *Wiper off* is reached, a signal sounds.

To turn the window wiper on the front window on:

- ▶ Press the button **672** until the desired wipe stage is reached.

To turn the window wiper on the roof window on:

- ▶ Press the button **673** until the desired wipe stage is reached.

## 16.2 Turning the window wiper off

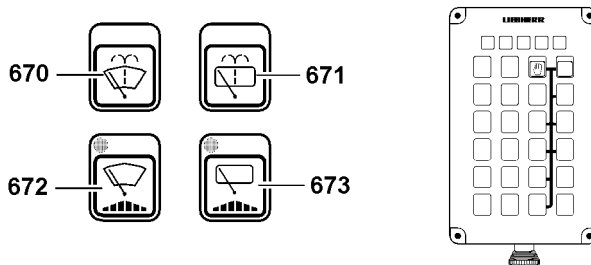


Fig.152525: Button

- ▶ Press the button **672** or button **673** for at least one second.  
or

Until a signal sounds:

- Press the button **672** or button **673**.

## 16.3 Window washer system

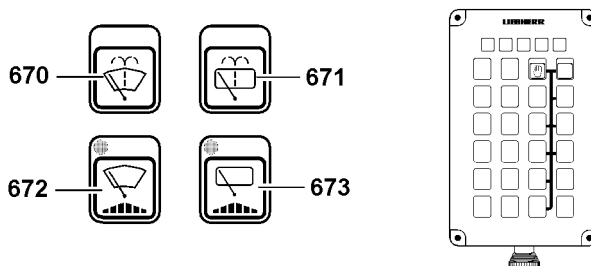


Fig.152525: Button

The window washer system runs as long as the button **670** or button **671** are pressed.

After pressing the button **670** or button **671** momentarily, three wipe movements are made.

To turn the window washer system on the front window on:

- ▶ Press the button **670**.

To turn the window washer system on the roof window on:

- ▶ Press the button **671**.

# 17 Hook block

**Connecting / disconnecting the hook block is only possible for certain crane types.**

Depending on the travel condition, a hook block or only a rope lock can be carried along. Detaching and attaching functions accordingly. Observe and adhere to the travel conditions in chapter 3.04.

The connecting and disconnecting procedure is described using the BTT. Alternatively, crane movements can be controlled with the help of a guide from the crane cab.

## 17.1 Switching on crane control from the crane superstructure

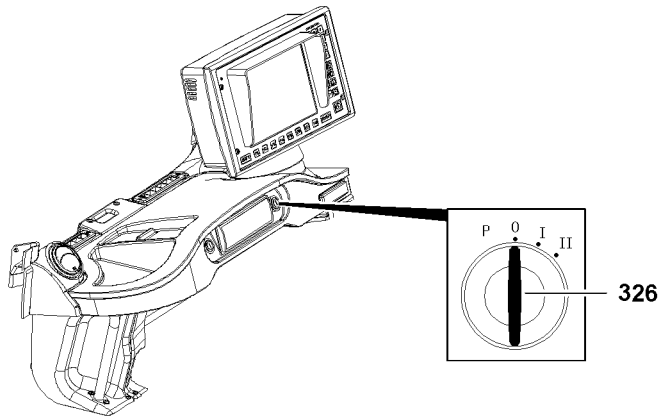


Fig.122259: Crane superstructure ignition

- ▶ Turn on the ignition in the crane superstructure: Turn the ignition switch **326** to position „II“.

**Result:**

- The engine starts.
- The LICCON computer system starts.
- ▶ As soon as the set up program is displayed on the LICCON monitor: Enter a valid set up configuration and confirm.

**Result:**

- The crane control is turned on from the crane superstructure.

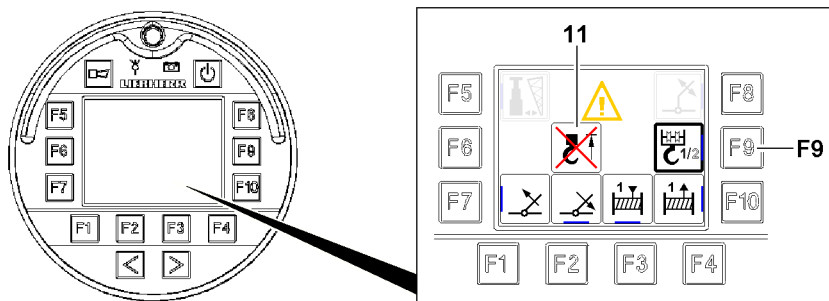


Fig.149645: Crane superstructure ignition

- ▶ Call up the *Crane superstructure assembly function* menu on the BTT.
- ▶ Press the function key **F9**: Select operating the hook block on the BTT.

**Result:**

- If the *hoist limit switch bypassed* icon **11** appears, the hoist limit switch is bypassed.

## 17.2 Disconnecting the hook block

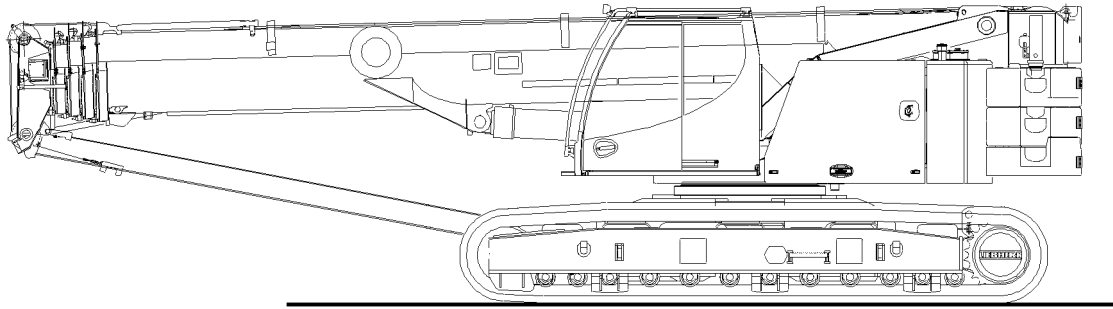


Fig.152559: Hook block attached

Select a location where the danger zone can be seen safely and well visibly.



### WARNING

Sudden swinging of hook block!  
 Danger of crushing!  
 ► Select a safe location.

Make sure that the following prerequisites are met:

- The crane is horizontally aligned.
- The crane superstructure is pinned forward with the crane chassis.
- The telescopic boom is telescoped in all the way and pinned.
- No load is hanging on the hook.
- The crane control is switched on for BTT operation.
- The *Crane superstructure assembly function* menu is selected on the BTT.

When assembling the hook block with BTT, the hoist limit switch is bypassed up to a boom angle of 10°.

### NOTICE

Hoist limit switch bypassed!  
 Collision Hook block with pulley head.  
 ► Do not pull the hook block against the pulley head.

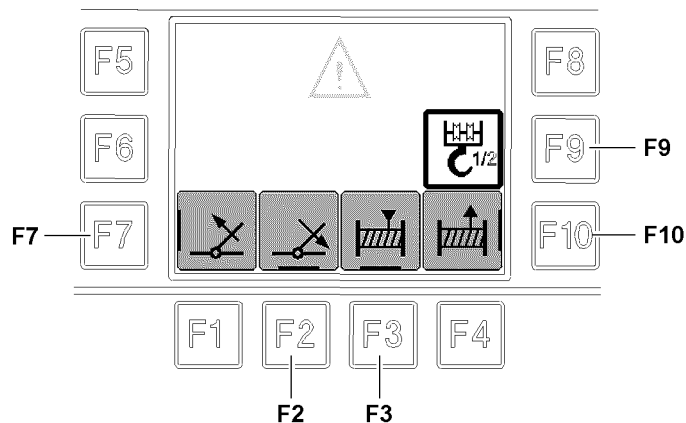


Fig.121578: Crane superstructure assembly function menu

► Press the function key **F9** and select the reeved in hoist winch.

### Result:

- Icons for hook block assembly are displayed.
- Hoist limit switch is bypassed.

The function key **F2**, function key **F3**, function key **F7** and function key **F10** have two speed stages.

For example, if the function key **F10** is actuated lightly, the hoist rope is spooled out at reduced speed (70 % speed). If the function key **F10** is actuated harder, the hoist rope is spooled out quickly (100 % speed).

- ▶ Press the function key **F10** and spool the hoist rope out slightly.

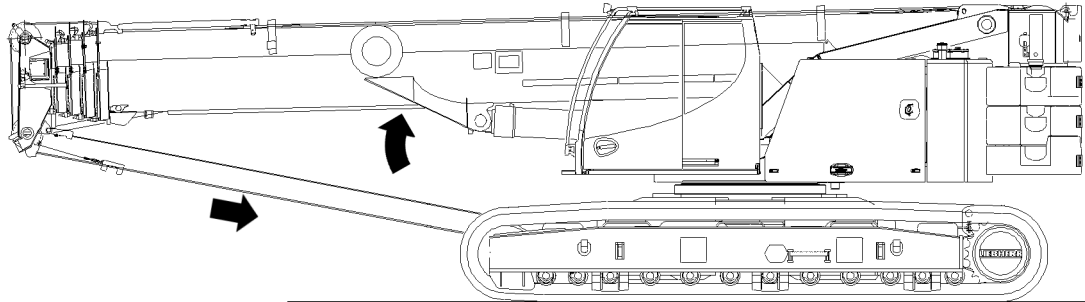


Fig.152557: Disconnecting the hook block

---

#### NOTICE

Collision Hook block with driver's cab!

Property damage.

- ▶ Monitor the position of the hook block.

Before the hook block collides:

- ▶ Match the hoist rope length.

---

Until the hook block can be disconnected:

- ▶ Continue to spool the hoist rope out and **simultaneously** luff the telescopic boom up via the function key **F7**.
- ▶ Disconnect the hook block from the transport retainer.

## 17.3 Attaching the hook block

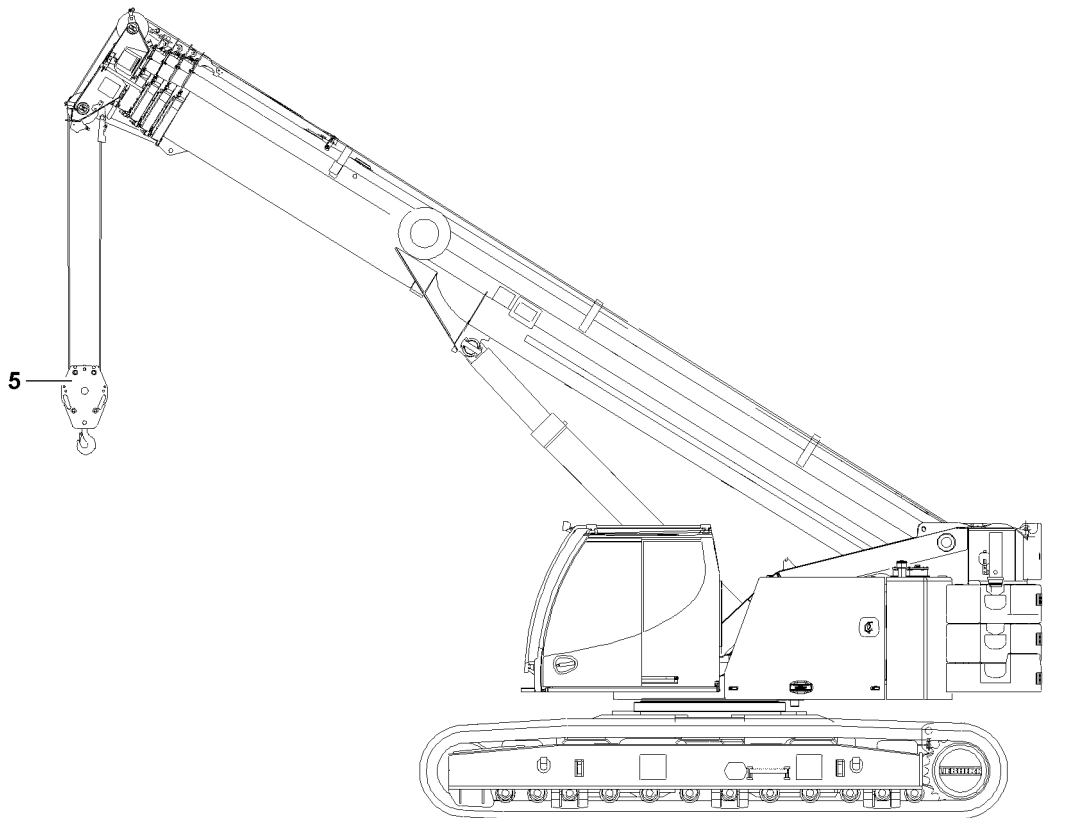


Fig.152558: Hook block detached

For transport, the hook block **5** must be connected in the transport retainer.

Select a location where the danger zone can be seen safely and well visibly.



### WARNING

Sudden swinging of hook block!  
Danger of crushing!

- ▶ Select a safe location.

Make sure that the following prerequisites are met:

- The crane is horizontally aligned.
- The crane superstructure is pinned forward with the crane chassis.
- The telescopic boom is telescoped in all the way and pinned.
- The telescopic boom is luffed up so that the hook block **5** can be connected to the eyehook on the crane chassis.
- No load is hanging on the hook.
- The central ballast is disassembled.
- The crane control is switched on for BTT operation.
- The *Crane superstructure assembly function* menu is selected on the BTT.

When assembling the hook block with BTT, the hoist limit switch is bypassed up to a boom angle of 10°.

### NOTICE

Hoist limit switch bypassed!  
Collision Hook block with pulley head.

- ▶ Do not pull the hook block **5** against the pulley head.



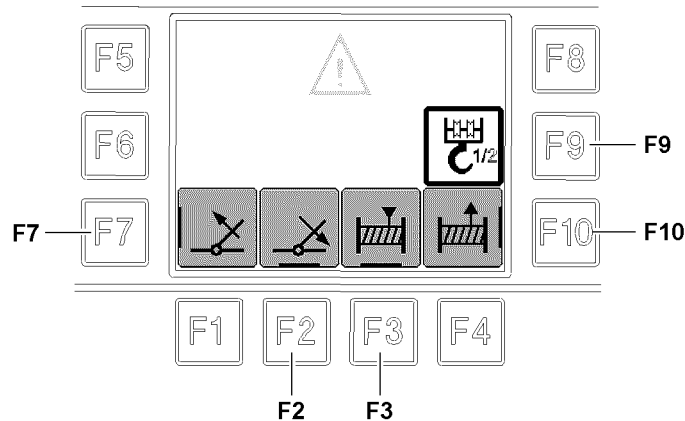


Fig.121578: Crane superstructure assembly function menu

- ▶ Press the function key **F9** and select the reeved in hoist winch.

**Result:**

- Icons for hook block assembly are displayed.
- Hoist limit switch is bypassed.

The function key **F2**, function key **F3**, function key **F7** and function key **F10** have two speed stages.

For example, if the function key **F10** is actuated lightly, the hoist rope is spooled out at reduced speed (70 % speed). If the function key **F10** is actuated harder, the hoist rope is spooled out quickly (100 % speed).

---

**NOTICE**

Collision Hook block with driver's cab!  
Property damage.

- ▶ Monitor the position of the hook block.

Before the hook block collides:

- ▶ Match the hoist rope length.

---

Until the hook block **5** can be detached comfortably:

- ▶ Luff the telescopic boom up via the function key **F7** and **simultaneously** spool the hoist rope out via the function key **F10**.
- ▶ Attach the hook block **5** to the fastening point.

If the hoist rope is tensioned too much, then the rope pulleys, trailer coupling or hoist rope can be damaged.

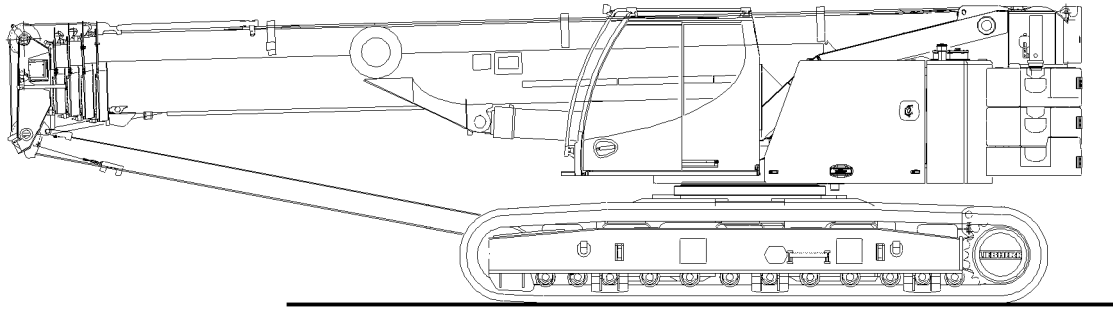
If the hoist rope is not tensioned enough, then the driver's cab can be damaged.

---

**NOTICE**

The hoist rope is incorrectly tensioned!  
Property damage!

- ▶ Tighten the hoist rope properly.
-



*Fig.152559: Hook block attached*

Until the telescopic boom is taken down in the receptacle and the hoist rope is properly tensioned:

- ▶ Luff the telescopic boom down using the function key **F2** and **simultaneously** spool the hoist rope up using the function key **F3**.

## 4.03.50 Adjustment of the track width

1	Track widths and extension conditions	2
2	Track width set up configuration	2
3	Prior to track width adjustment	4
4	Variation A: Track width adjustment with the superstructure turned, one-side	6
5	Variation B: Track width adjustment without counterweight	10
6	Variation C: Adjusting the track width while driving	12
7	Track width adjustment operation	18

# 1 Track widths and extension conditions

The extension conditions of the cross carriers or crawler carriers are specified in the load chart.

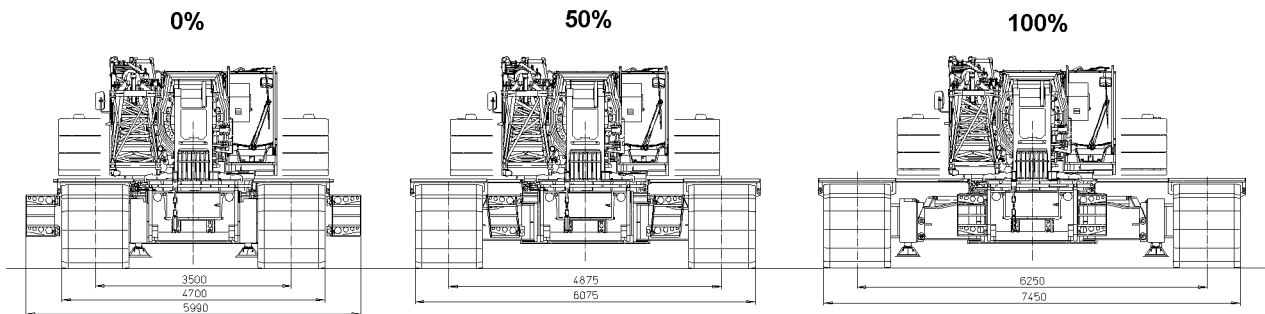


Fig.116890: Track width adjustment: Symmetric extension conditions of cross carriers

Asymmetric extension condition: One crawler carrier is retracted, one crawler carrier is completely extended (wide).

Track width	Track width on LICCON monitor	Extension conditions BTT or LICCON monitor	
		Crawler carrier A	Crawler carrier B
Retracted	3.5 m	0 %	0 %
Reduced	4.9 m	50 %	50 %
Wide	6.3 m	100 %	100 %
Asymmetrical	4.9 m	0 %	100 %
		100 %	0 %

Definition of track width and display of extension conditions

## 2 Track width set up configuration



### WARNING

The crane can topple over!

The retracted or asymmetrical track reduces the stability of the crawler crane. Due to operational errors during crane operation or driving, the crawler crane can topple over and fatally injure personnel.

- ▶ Crane operation and „driving the crawler with load“ is permitted for a retracted or asymmetrical track width, if **extra load charts** are programmed for this case.
- ▶ Crane operation and „driving the crawler with load“ is strictly prohibited for a retracted or asymmetrical track width, if **no extra load charts are programmed for this case**.

The charts with track widths that must be set in the LICCON computer system differ based on the track width adjustment:

- Symmetric track width adjustment
- Asymmetric track width adjustment

## 2.1 Symmetric track width adjustment

Initial track width		Target track width		Adjustment in Set up program	
Retracted	3.5 m	Reduced	4.9 m	Retracted track set up configuration	3.5 m
0 %	11.0 ft	50 %	16.0 ft		11.0 ft
Retracted	3.5 m	Wide	6.3 m	Retracted track set up configuration	3.5 m
0 %	11.0 ft	100 %	21.0 ft		11.0 ft
Reduced	4.9 m	Wide	6.3 m	Reduced track set up configuration	4.9 m
50 %	16.0 ft	100 %	21.0 ft		16.0 ft
Reduced	4.9 m	Retracted	3.5 m	Retracted track set up configuration	3.5 m
50 %	16.0 ft	0 %	11.0 ft		11.0 ft
Wide	6.3 m	Reduced	4.9 m	Reduced track set up configuration	4.9 m
100 %	21.0 ft	50 %	16.0 ft		16.0 ft
Wide	6.3 m	Retracted	3.5 m	Retracted track set up configuration	3.5 m
100 %	21.0 ft	0 %	11.0 ft		11.0 ft

*Track width in the LICCON computer system for symmetric track adjustment*

## 2.2 Asymmetric track width adjustment

Initial track width		Target track width		Adjustment in Set up program	
Crawler carrier A retracted	3.5 m	Crawler carrier B extended	4.90 m	Retracted track set up configuration	3.5 m
Crawler carrier B retracted					
0 %	11.0 ft	100 %	16.0 ft		11.0 ft
Crawler carrier B retracted	3.5 m	Crawler carrier A extended	4.9 m	Retracted track set up configuration	3.5 m
Crawler carrier A retracted					
0 %	11.0 ft	100 %	16.0 ft		11.0 ft

*Track width in the LICCON computer system for asymmetric track adjustment*

## 3 Prior to track width adjustment

### 3.1 Safety instructions



#### WARNING

Track adjustment with supported crane!

Overload of the crane structures. Death, severe bodily injuries, property damage.

- ▶ Do **not** support the crane with the equipment in place with the assembly support.
- ▶ Only use the assembly support for the assembly of the crawler carrier and for loading and unloading the crane.



#### WARNING

Adjustment of the track width!

Death, severe bodily injuries, property damage.

When adjusting the track, the crawler carrier always moves with the lesser ground contact.

It is possible that the other crawler carrier is pushed away instead when extending a crawler carrier.

This can double the space requirement on one side.

Persons and objects standing too close can be caught by the crawler carrier.

In case of insufficient ground condition and ground contact, the crane can topple over.

- ▶ To extend the crawler on both sides, plan for the double sliding range as space requirement.
- ▶ In the adjustment range the ground condition and ground contact must be sufficient.

#### NOTICE

Cross carriers are **not** sufficiently greased!

Corrosion.

- ▶ Clean and grease the gliding surfaces of the cross carrier. See chapter 7.02 for the maintenance intervals. For the lubricants, see Service fill.

### 3.2 Steps and folding brackets

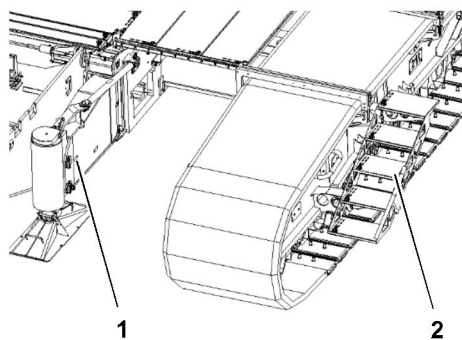


Fig.149062: Crawler travel gear: Steps, folding brackets

#### NOTICE

The steps **2** are assembled on the central ballast!

Damage to the steps.

When the steps **2** are assembled on the central ballast:

- ▶ Before changing the crane track width from wide to reduced or from wide to narrow: Assemble the steps **2** on the crawler carrier, see chapter 2.07.

**NOTICE**

Do **not** swing in the folding brackets **1** before reducing the track width!  
Damage to the cross carriers when retracting.

- ▶ Swing in and pin the folding brackets **1** before reducing the track width, see chapter 3.01.

### 3.3 Cross carrier pinning cylinder

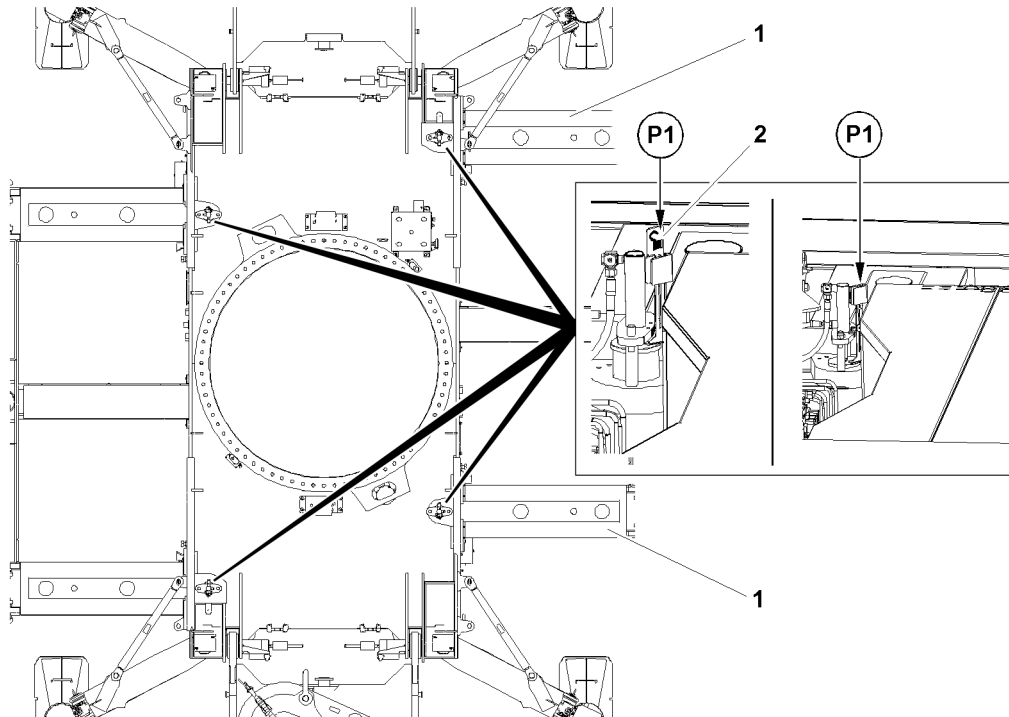


Fig.148528: Pinning the cross carriers, view from above: Position of the pinning devices

**1** Cross carrier

**2** Sign: Cross carrier unpinned

The cross carriers can only be pinned in extension conditions of 0 %; 50 %; 100 %.

You can check in positions **P1** if the pins are completely pinned or unpinned:

- The pins are unpinned: Tags **2** are visible.
- The pins are pinned: Tags **2** are **not** visible.

### 3.4 Front crawler travel gear, definition

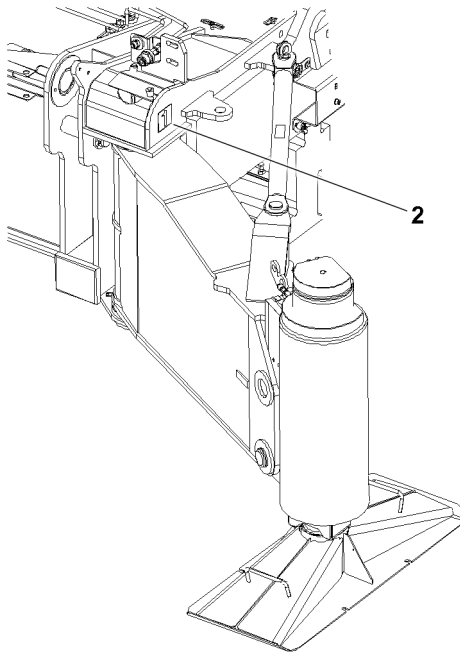


Fig.149068: Sign on the crawler center section, example position 1

The location of the chain tension device (chain tension side) helps determine where the rear and front of the crawler travel gear are. The chain tension devices are on the front on the crawler travel gear.

The chain tension devices are located at the ends of the crawler carrier, which lie on the sides of position 2 and position 3, see the sign 2 on the crawler center section.

## 4 Variation A: Track width adjustment with the superstructure turned, one-side



### Note

- For the adjustment of the track width, Liebherr-Werk Ehingen GmbH recommends turning the superstructure and to push in or pull out each crawler carrier individually.

### 4.1 Setting the set up configuration



### WARNING

Load chart **not** adhered to!  
The crane can topple over.

- Select the 360° track width load chart in accordance with section „Track width set up configuration“, in consideration of the set up configuration and the inclination of the ground.



Make sure that the following prerequisites are met:

- The crane is standing on the crawlers.
- The central ballast is assembled.
- All loads and load handling equipment have been taken down.
- The telescopic boom is telescoped in all the way.
- The ground is sufficiently level and has a sufficient load bearing capacity over the entire adjustment range.
- The crawlers may **not** sink into the ground.
- The ground is free of obstacles, such as rock edges or rising ground over the entire adjustment range.
- The ground has a permissible inclination, see the load chart.
- The counterweight is assembled or disassembled according to the specifications of the load chart.
- The equipment is assembled or disassembled according to the specifications of the load chart.
- The steps are assembled on the crawler carrier.
- The folding brackets are swung in and pinned.

The smaller of both track widths, initial track width and target track width, must be set in the LICCON computer system, see section „Track width set up configuration“.

- ▶ Set the track width and 360° slewing range in the LICCON computer system.
- ▶ Make sure that the remaining set up configuration is set up according to the load chart and set in the LICCON computer system.

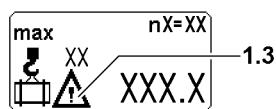


Fig. 152437: Load display on the LICCON monitor: The load is **not** valid

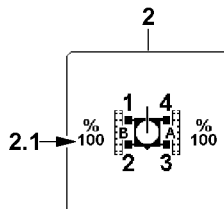


Fig. 152440: Crawler travel gear icon on the LICCON monitor: Crawler carrier in an incorrect position

If the actual extension condition deviates from the track width that is set in the LICCON computer system, an optical and acoustic warning is issued:

- The warning icon **1.3** is visible on the load display: The load is **not** valid.
- The extension condition **2.1** blinks red in the crawler travel gear **2** icon.

- ▶ Confirm the set up configuration.

### Problem remedy

An optical and acoustic warning is issued!

The actual extension condition deviates from the track width set in the LICCON computer system.

- ▶ Adjust the track width until the target track width is obtained.
- ▶ Follow the additional instructions, see section „Setting the crawler carrier to the target track width“.

## 4.2 Setting the crawler carrier to the target track width

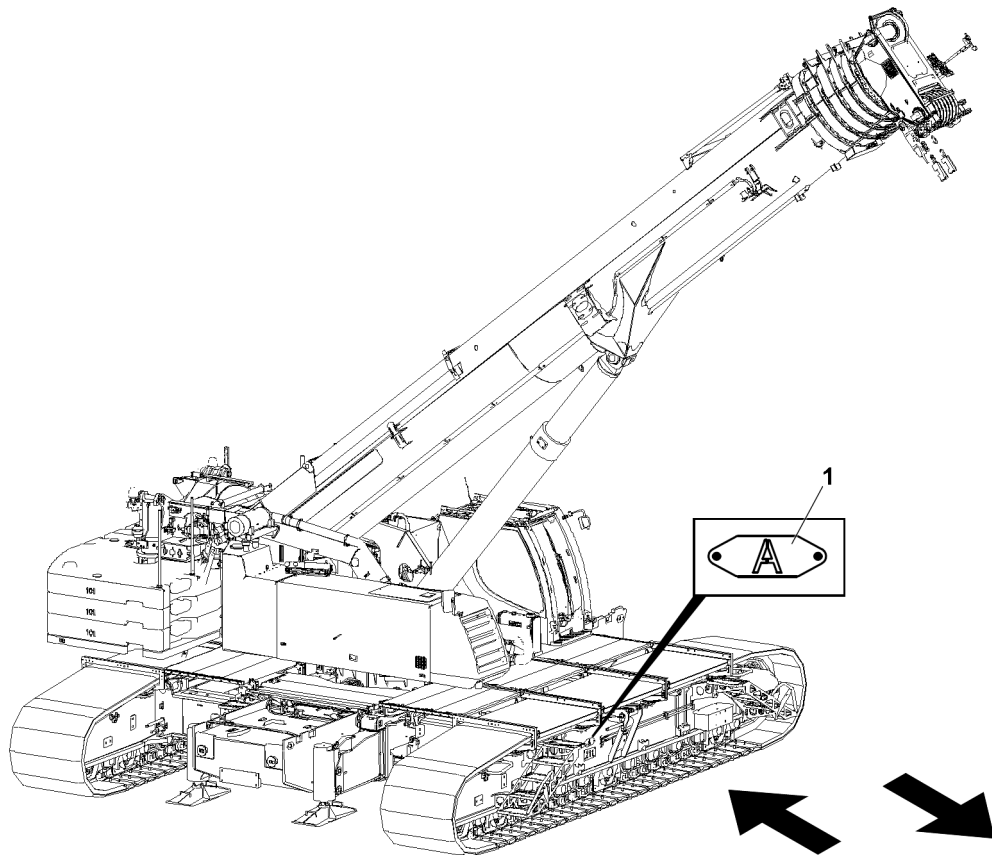


Fig.118946: Shifting of the center of gravity

- 1 Sign: Designation, example crawler carrier **A**

A crawler carrier is relieved when the center of gravity of the crane is shifted.

The center of gravity of the crane is shifted by means of a combination of movements:

- Luffing the boom up
- Turning the crane superstructure

The crane's center of gravity is displayed on the LICCON monitor. Monitoring of surface pressure and center of gravity, see chapter 4.02.

Make sure that the following prerequisites are met:

- The set up configuration is set in the LICCON computer system, track width in accordance with section „Track width set up configuration“.

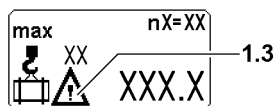


Fig.152437: Load display on the LICCON monitor: The load is **not** valid

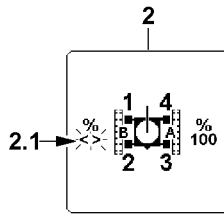


Fig.152436: Crawler travel gear icon on the LICCON monitor: Crawler carrier in an incorrect position

An optical and acoustic warning is issued while a cross carrier moves between the pin positions:

- The warning icon **1.3** is visible on the load display: The load is **not** valid.
- The *intermediate position* **2.1** flashes red in the crawler travel gear **2** icon.

See section „Track width adjustment operation“ for how to extend or retract the crawler carrier.

A description is provided below as an example of how crawler carrier **A** and crawler carrier **B** are adjusted in succession.



### WARNING

Load chart **not** adhered to!

The crane can topple over. Death, severe bodily injury, property damage.

- ▶ For turning the crane superstructure, select the 360° track width load chart in accordance with section „Track width set up configuration“, in consideration of the set up configuration and the inclination of the ground.
- ▶ Only turn the crane superstructure according to the information in the load chart.
- ▶ Do **not** change the set up configuration that was set until the target track width of both crawler carriers is reached.



### WARNING

Obstacles when luffing up and turning!

Death, severe bodily injuries, property damage.

- ▶ Make sure that there are no obstacles within 360° of the slewing range of the crane.
- ▶ Make sure that the telescoped in boom **cannot** collide with obstacles when luffing it up.
- ▶ Until the steepest permissible position is reached: Luff the telescopic boom up.
- ▶ Turn the crane superstructure until the crane superstructure is turned 90° to the side and the counterweight is located over crawler carrier **B**.
- ▶ Until the target track width is reached: Extend or retract crawler carrier **A**.



### WARNING

Turning the crane superstructure with an impermissible set up configuration!

The crane can topple over. Death, severe bodily injuries, property damage.

- ▶ Before turning the crane superstructure: Make sure that the extension condition of crawler carrier **A** and the target track width are identical.
- ▶ Turn the crane superstructure until the crane superstructure is turned 90° to the other side and the counterweight is located over crawler carrier **B**.
- ▶ Until the target track width is reached: Extend or retract crawler carrier **B**.

If the target track width is reached and the track width set in the LICCON computer system deviates from the target track width:

- ▶ Set the target track width in the LICCON computer system and confirm.

## 5 Variation B: Track width adjustment without counterweight

This section refers exclusively to the adjustment of the track width while the crane is **not** driving and the crawler carrier is pushed out or is retracted. It is easier to adjust the track width if less counterweight is assembled.

Take down the counterweight with the crane, see the Crane operating instructions, chapter 4.07.

### 5.1 Setting the set up configuration



#### WARNING

Load chart **not** adhered to!  
The crane can topple over.

- ▶ Select the 0° track width load chart in accordance with section „Track width set up configuration“, in consideration of the set up configuration and the inclination of the ground.
- ▶ Lock the crane superstructure with the crane chassis in the driving direction, see the load chart specification.

Make sure that the following prerequisites are met:

- The crane is standing on the crawlers.
- The central ballast is assembled.
- All loads and load handling equipment have been taken down.
- The telescopic boom is telescoped in all the way.
- The ground is sufficiently level and has a sufficient load bearing capacity over the entire adjustment range.
- The crawlers may **not** sink into the ground.
- The ground is free of obstacles, such as rock edges or rising ground over the entire adjustment range.
- The ground has a permissible inclination, see the load chart.
- The counterweight is disassembled.
- The equipment is assembled or disassembled according to the specifications of the load chart.
- The crane superstructure is locked with the crane chassis in the driving direction.
- The steps are assembled on the crawler carrier.
- The folding brackets are swung in and pinned.

The smaller of both track widths, initial track width and target track width, must be set in the LICCON computer system, see section „Track width set up configuration“.

- ▶ Set the track width and 0° slewing range in the LICCON computer system.
- ▶ Make sure that the remaining set up configuration is set up according to the load chart and set in the LICCON computer system.

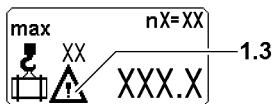


Fig.152437: Load display on the LICCON monitor: The load is **not** valid

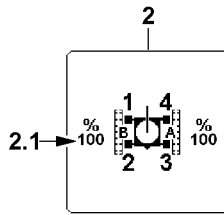


Fig.152440: Crawler travel gear icon on the LICCON monitor: Crawler carrier in an incorrect position

If the actual extension condition deviates from the track width that is set in the LICCON computer system, an optical and acoustic warning is issued:

- The warning icon **1.3** is visible on the load display: The load is **not** valid.
- The extension condition **2.1** blinks red in the crawler travel gear **2** icon.

▶ Confirm the set up configuration.

### Problem remedy

An optical and acoustic warning is issued!

The actual extension condition deviates from the track width set in the LICCON computer system.

- ▶ Adjust the track width until the target track width is obtained.
- ▶ Follow the additional instructions, see section „Setting the crawler carrier to the target track width“.

## 5.2 Setting the crawler carrier to the target track width

The crane's center of gravity is displayed on the LICCON monitor. Monitoring of surface pressure and center of gravity, see chapter 4.02.

- ▶ Luff the telescopic boom up until the crane's center of gravity is located in the center.

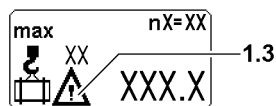


Fig.152437: Load display on the LICCON monitor: The load is **not** valid

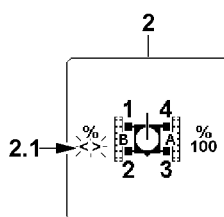


Fig.152436: Crawler travel gear icon on the LICCON monitor: Crawler carrier in an incorrect position

An optical and acoustic warning is issued while a cross carrier moves between the pin positions:

- The warning icon **1.3** is visible on the load display: The load is **not** valid.
- The *intermediate position* **2.1** flashes red in the crawler travel gear **2** icon.

▶ Adjust the track width, see section „Track width adjustment operation“.

If the target track width is reached and the track width set in the LICCON computer system deviates from the target track width:

- ▶ Set the target track width in the LICCON computer system and confirm.

## 6 Variation C: Adjusting the track width while driving

This section refers exclusively to the adjustment of the track width while the crane is driving and the crawler carrier is extended or retracted.

Driving from the crane cab, without adjusting the track width, see chapter 4.10.

It is easier to adjust the track width if less counterweight is assembled. Take down the counterweight with the crane, see the Crane operating instructions, chapter 4.07.

Limitations for operating the track adjustment while driving:

- It is **not** possible to adjust the track width with the BTT and radio remote control while driving.
- It is only possible to adjust the track width while driving using the right touch display in the crane cab.

### 6.1 Prerequisites for adjusting the track width while driving

When driving the crane (crawler operation) the conditions of the travel route are the deciding factor.

For driving the crane, there are **no** separately programmed charts available for „driving with the equipment in place“.

In the case of ground inclination within the range of a valid load chart, it is possible to adjust track width while driving **without** a load.



#### WARNING

Driving the crane!

The crane can topple over. Death, severe bodily injuries, property damage.

- ▶ Only drive the crane **without** a load on the hook.
- ▶ Comply with the maximum permissible ground inclinations according to the load chart.
- ▶ Comply with the maximum permissible wind speeds in the load charts.
- ▶ Comply with the permissible surface pressures for the travel route.



#### WARNING

The following specifications, instructions and prerequisites are **not** observed!

Danger of toppling or overloading the crane. Death, severe bodily injuries, property damage.

- ▶ The crane operator is responsible for adhering to all specifications, instructions and prerequisites in the crane documentation.
- ▶ The crane operator may **not** drive the crane if not all specifications, instructions and prerequisites in the crane documentation can be adhered to.
- ▶ The crane operator is responsible for the correct and complete entry of data in the LICCON computer system.
- ▶ Initiate all driving movements (starting out, steering, acceleration, deceleration, stopping etc.) sensitively, smoothly, with utmost caution and at the lowest speed.
- ▶ Depending on the situation, additional observers, who are acoustically or visually in contact with the crane operator (for example by radio or sight), may have to support the crane operator with shared responsibility.

### 6.1.1 Travel route



#### WARNING

The following specifications, instructions and prerequisites are **not** observed!

Danger of toppling or overloading the crane. Death, severe bodily injuries, property damage.

- ▶ The transfer from the horizontal to an uphill slope and from an uphill slope to the horizontal must be made evenly, i.e.: There may be no edges that can cause the crane to topple over. Any inclination changes must be made continuously.
- ▶ If the travel route **cannot** safely absorb the surface pressure, then measures must be taken to be able to safely transfer the forces to the ground.
- ▶ If measures were taken to transfer the forces to the ground, then they must be checked by an expert before starting to drive for proper execution and sufficient supportability.
- ▶ An insufficient ground condition can cause accidents, for example the crane can slide away to the side and as a result get into an impermissible incline position.

Make sure that the following prerequisites are met:

- Before starting to drive, the travel route was determined.
- Before starting to drive, the condition of the ground has been checked.
- The entire travel route can safely absorb the surface pressure.
- All inclinations occurring on the travel route can be driven safely by the crane.
- The entire travel route is free of obstacles.
- The friction coefficient between crawler travel gear and ground is sufficiently large to absorb the occurring drive forces or to exclude that the crane slips away in an incline position.
- Possible environmental influences for driving the crane (among others precipitation and wind) were taken into account for the travel route.
- The travel route was selected and prepared in such a way that the boom system can be taken down at any time.
- Select the travel route in such a way that no steering movements are required, if possible.
- The entire travel route is secured as a danger zone.
- The travel route has been selected in such a way that it is possible to maintain a sufficient distance from local facilities (power lines, etc.).



#### Note

- ▶ For a detailed description of the LICCON job planner on the crane\*, see the LICCON Job planner operating instructions.
- ▶ For a detailed description of the LICCON job planner computer program, see the separate description.

## 6.1.2 Optimizing measures for the travel route

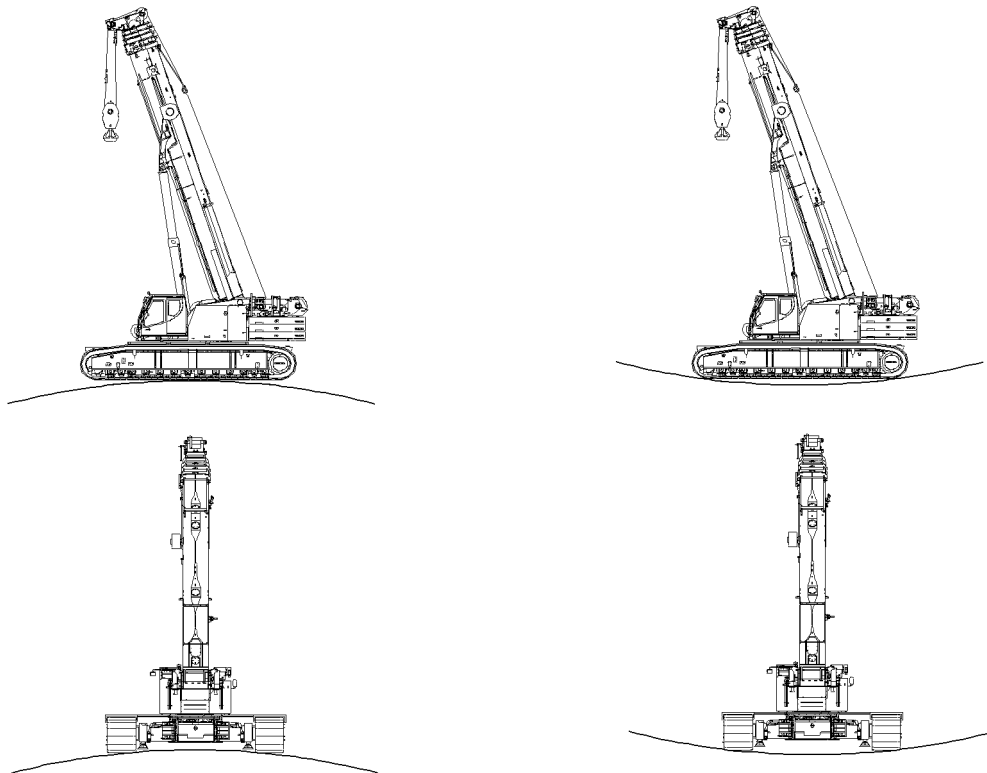


Fig. 117927: Depressions, crests, track grooves and other uneven areas of the travel route cause localized pressure on the crawler travel gear

### NOTICE

Damage to the crawler travel gear!

Continuous localized pressure on the crawler travel gear causes increased wear. Continuous increased wear can cause damage to the crawler travel gear.

- ▶ Set up the travel routes in such a way that the crawler travel gear is not subjected to continuous localized pressure.
- ▶ For extended travel operation shorten the maintenance intervals.

Through the following configuration features of the travel route, wear on the crawler travel gear can be minimized:

- Shapings of the travel route (such as depressions, crests, track grooves) have been eliminated via suitable measures.
- Select the travel route in such a way that **no** steering movements are required, if possible.

## 6.1.3 Calculating the required length of transfers on uphill and downhill slopes

Observe and comply with the notes, see chapter 4.10

## 6.1.4 Maximum permissible temperatures on the travel gear

Observe and comply with the notes, see chapter 4.10

## 6.1.5 Use of insertion plates into the track chains

Observe and comply with the notes, see chapter 4.10



## 6.2 Displays for center of gravity, surface pressure and incline on the LICCON monitor



### WARNING

Danger of accident due to deviating set up configuration!

If the actual set up configuration of the crane deviates from the entries and settings in the Set up program, then the overload protection is not correctly set.

An incorrectly set overload protection calculates the actual load incorrectly and transmits faulty display values.

The crane can be overloaded without noticing it and topple over or collapse as a result.

Death, severe bodily injuries, property damage.

- ▶ The entries and settings in the set up program must match the actual set up configuration of the crane.
- ▶ Adjust the track width while the crane is driving only **without** a load on the hook.

Make sure that the following prerequisites are met:

- The actual set up configuration of the crane matches the entries and settings in the set up program.
- The assignment of the crane to the displays on the LICCON monitor is clear.
- All displays function perfectly.



### Note

- ▶ For a detailed description of the displays on the LICCON monitor, see the Crane operating instructions, chapter 4.02.
- ▶ For a detailed description of the safety equipment, see Crane operating instructions, chapter 4.04.

Observe and comply with the notes, see chapter 4.10:

- Display for the center of gravity on the LICCON monitor
- Display for surface pressure and inclination on the LICCON monitor
- Display for inclination on the LICCON monitor

## 6.3 Preparing for crane driving

Observe and comply with the notes, see chapter 4.10:

- Distribution of the surface pressure
- Suitable distribution of the surface pressure

## 6.4 Crawler crane in crawler operation



### WARNING

The crane can topple over!

If the permissible incline of the crane is exceeded, the crane can topple over.

In impermissible inclines, the LICCON computer system does **not** turn the travel operation off.

The crane driver carries the sole responsibility for possible risks or dangers when working with impermissible inclines.

- ▶ Do not exceed the permissible incline from the load chart.
- ▶ Do not exceed the permissible incline for driving the crane.
- ▶ While driving the crane, monitor the displays for center of gravity, surface pressure and inclination on the LICCON monitor constantly.

Make sure that the following prerequisites are met:

- The set up configuration of the crane has been entered correctly in the LICCON computer system.
- The displays for inclination, surface pressure and center of gravity are shown.
- There are no persons or objects in the danger zone.

Observe and comply with the following notes, see chapter 4.10:

- Operating elements for the crawler operation
- Assignment of the crane superstructure to the travel direction
- Turning crawler operating modes on and off

- Driving the crawler crane in normal travel
- Driving the crawler crane in parallel travel

## 6.5 Adjusting the track width while driving



### WARNING

The crane can topple over!

If the following conditions are **not** observed, the crane can topple over. Personnel can be severely injured or killed.

- ▶ The ground must be sufficiently level and within the range of the permissible inclination.
- ▶ The ground must be able to safely absorb the maximum occurring surface pressure.



### WARNING

The crane can topple over!

If the permissible inclinations of the load charts are exceeded when driving the crane, then the crane can topple over or be overloaded.

If the permissible wind speeds of the load charts are exceeded when driving, then the crane can topple over or be overloaded.

Personnel can be severely injured or killed.

- ▶ If the inclinations are too large then driving the crane is prohibited.
- ▶ If the wind speeds are too high then driving the crane is prohibited.

Permissible inclinations	
Overall inclination	See load charts

Permissible wind speeds	
Wind speed	See load charts



### WARNING

Driving the crane with an active LMB-Stop!

If the crane is driven with an active LMB-Stop, then the crane can topple over or be overloaded.

- ▶ Drive the crane only when no LMB-Stop is active.

Make sure that the following prerequisite is met:

- **No** LMB stop (shut-off due to load torque limitation) is active.

### 6.5.1 Setting the set up configuration



### WARNING

Load chart **not** adhered to!

The crane can topple over.

- ▶ Select the 0° track width load chart in accordance with section „Track width set up configuration“, in consideration of the set up configuration and the inclination of the ground.
- ▶ Lock the crane superstructure with the crane chassis in the driving direction, see the load chart specification.

Make sure that the following prerequisites are met:

- The crane is standing on the crawlers.
- The central ballast is assembled.
- All loads and load handling equipment have been taken down.
- The telescopic boom is telescoped in all the way.
- The ground is sufficiently level and has a sufficient load bearing capacity over the entire adjustment range.
- The crawlers may **not** sink into the ground.
- The ground is free of obstacles, such as rock edges or rising ground over the entire adjustment range.
- The counterweight is assembled or disassembled according to the specifications of the load chart.
- The equipment is assembled or disassembled according to the specifications of the load chart.
- The crane superstructure is locked with the crane chassis in the driving direction.
- The steps are assembled on the crawler carrier.
- The folding brackets are swung in and pinned.

The smaller of both track widths, initial track width and target track width, must be set in the LICCON computer system, see section „Track width set up configuration“.

- ▶ Set the track width and 0° slewing range in the LICCON computer system.
- ▶ Make sure that the remaining set up configuration is set up according to the load chart and set in the LICCON computer system.

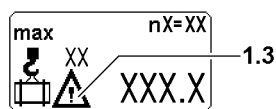


Fig. 152437: Load display on the LICCON monitor: The load is **not** valid

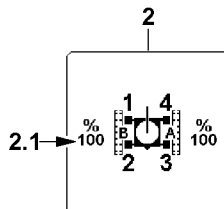


Fig. 152440: Crawler travel gear icon on the LICCON monitor: Crawler carrier in an incorrect position

If the actual extension condition deviates from the track width that is set in the LICCON computer system, an optical and acoustic warning is issued:

- The warning icon **1.3** is visible on the load display: The load is **not** valid.
- The extension condition **2.1** blinks red in the crawler travel gear **2** icon.

- ▶ Confirm the set up configuration.

#### Problem remedy

An optical and acoustic warning is issued!

The actual extension condition deviates from the track width set in the LICCON computer system.

- ▶ Adjust the track width until the target track width is obtained.
- ▶ Follow the additional instructions, see section „Setting the crawler carrier to the target track width“.

## 6.5.2 Setting the crawler carrier to the target track width

Make sure that the following prerequisites are met:

- **No** personnel or obstacles are within the danger zone.
- **No** loose objects are located on the crane.
- The central ballast and counterweight are properly assembled and secured.
- The hook block is secured to prevent it from swinging back and forth.
- The crane is in a set up configuration permitted for travel operation.

### NOTICE

Steering movements while adjusting the track width!

Overload of the travel gear. Property damage.

- ▶ Select the travel route in such a way that **no** steering movements are required.
- ▶ Adjust the track width when the crane drives forward.

- ▶ Drive the crane straight forward.

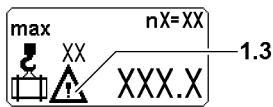


Fig.152437: Load display on the LICCON monitor: The load is **not** valid

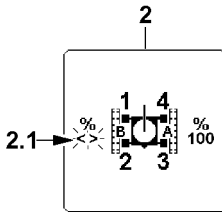


Fig.152436: Crawler travel gear icon on the LICCON monitor: Crawler carrier in an incorrect position

An optical and acoustic warning is issued while a cross carrier moves between the pin positions:

- The warning icon **1.3** is visible on the load display: The load is **not** valid.
- The *intermediate position* **2.1** flashes red in the crawler travel gear **2** icon.

When the crane is driving straight forward:

- ▶ Adjust the track width from the crane cab, see section „Track width adjustment operation“.

If the target track width is reached and the track width set in the LICCON computer system deviates from the target track width:

- ▶ Set the target track width in the LICCON computer system and confirm.

## 7 Track width adjustment operation

The track width can be adjusted with the following control units:

- Touch display in the crane cab
- BTT
- Radio remote control

### 7.1 Adjusting the track width from the crane cab

This section describes the adjustment of the track width with:

- Master switch MS1 and right touch display in the crane cab

### 7.1.1 Assignment of working direction and crawler carrier

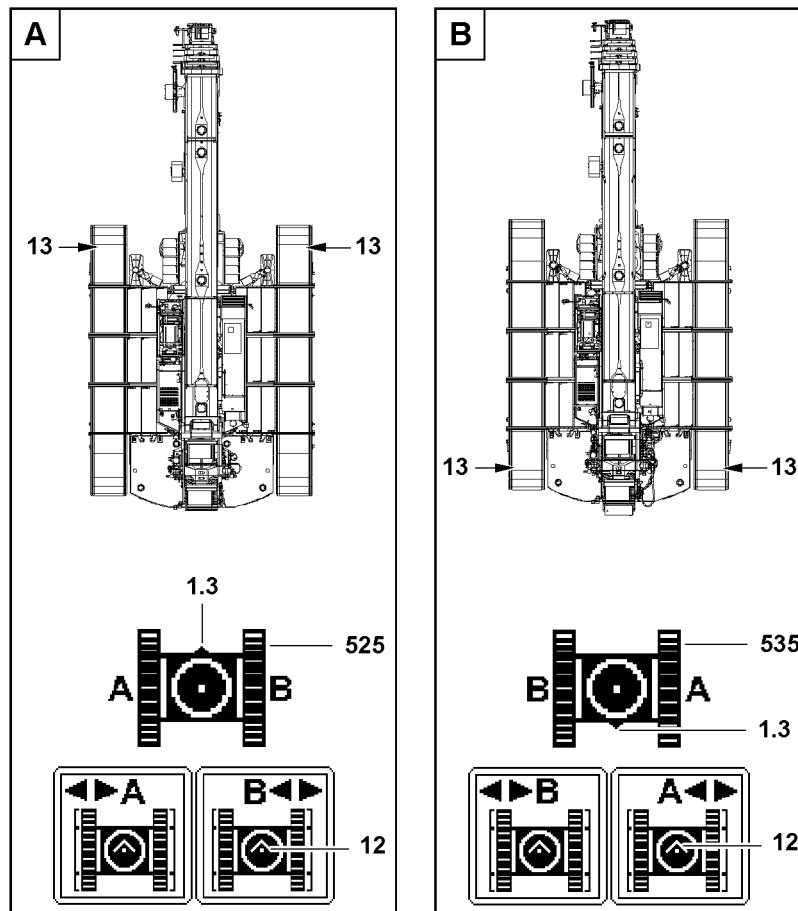


Fig.148519: Touch display: Assignment of working direction and crawler carrier

Variation **A**: Working direction „to the front“

Variation **B**: Working direction „to the rear“

Observe the notes for the assignment of working direction and crawler carrier:

- The chain tension devices **13** are on the front on the crawler travel gear. See section „Front crawler travel gear, definition“.
- In the „Crawler travel gear“ menu the assignment of the crawler carriers on the touch display depends on the working direction of the crane. If the working direction of the crane is changed by turning the turntable from working direction „to the front“ to working direction „to the rear“, then the crane icon **525** changes to crane icon **535** - or vice versa.
- The arrow **12** shows the direction of view of the crane operator in the crane cab.
- Crane icon **525**, turntable turned „to the front“: The triangle **1.3** shows the front on the crane chassis; assignment of the crawler carriers as seen by the crane operator in the crane cab.
- Crane icon **535**, turntable turned „to the rear“: The triangle **1.3** shows the front on the crane chassis; assignment of the crawler carriers as seen by the crane operator in the crane cab.

### 7.1.2 Selecting / deselecting icons on the touch display

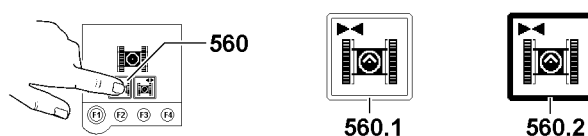


Fig.114229: Touch display: Selecting icons

Touch functions are identified by the double border (empty frame) of the touch display icons. The function is selected / deselected with the press of a finger („touch“) on the icon.

Example with the „Left track“ icon **560**:

- „Left track“ icon **560.1**: Left track deselected (not active), double border (empty frame) is visible.
- „Left track“ icon **560.2**: Left track selected (active), double border is filled (frame filled).

### 7.1.3 Activating the *Unpin the cross carrier* icon

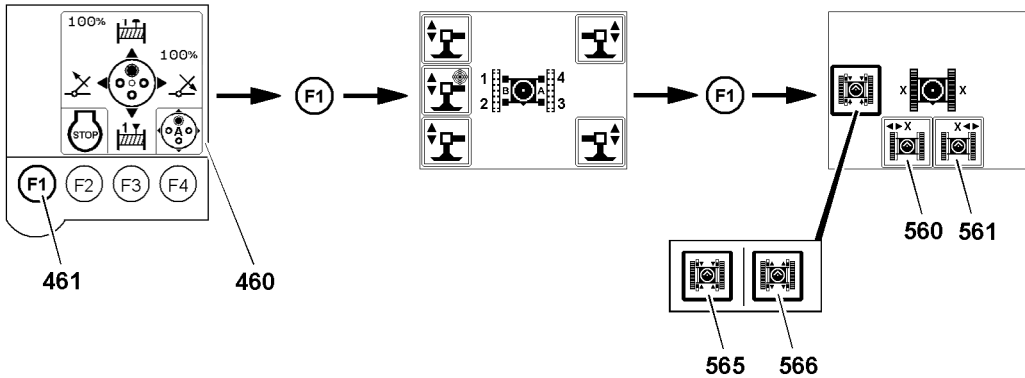


Fig.147003: Right touch display: Activating the *Unpin the cross carrier* icon

Make sure that the following prerequisite is met:

- The „master switch configuration“ menu is visible on the right touch display **460**.

► Press the F1 function key **461**.

**Result:**

- The „Support“ menu appears.

► Press the F1 function key **461**.

**Result:**

- The „Track width adjustment“ menu appears.

When the icon **565** „pin the cross carrier“ is visible:

► Activate „Unpin the cross carrier“: Select the icon **565** („touch“).

**Result:**

- The „unpin cross carrier“ icon **566** is visible.

### 7.1.4 Selecting the crawler carrier

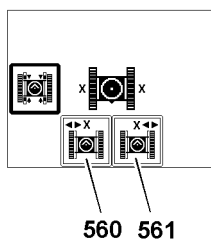


Fig.148525: Right touch display: Selecting the crawler carrier

Before the crawler carrier can be retracted or extended, the crawler carrier must be selected:

- **560** Icon
- **561** Icon

Both crawler carriers can be selected and therefore moved at the same time.

- Pay attention to crawler carrier assignment.
- Select the crawler carrier to be extended or retracted: Select the icon („touch“).

**Result:**

- The selected icon is visible with a filled out frame.

**7.1.5 Extending / retracting the crawler carrier**

The extension condition of the cross carrier is displayed as a percentage on the LICCON monitor.

When the crawler carriers are retracted or extended, the crawler carriers are unpinned.

**WARNING**

Adjustment of the crawler carriers!

Danger of crushing.

- ▶ Make sure that **no** personnel is within the danger zone of the crawler carriers during „track width adjustment“.

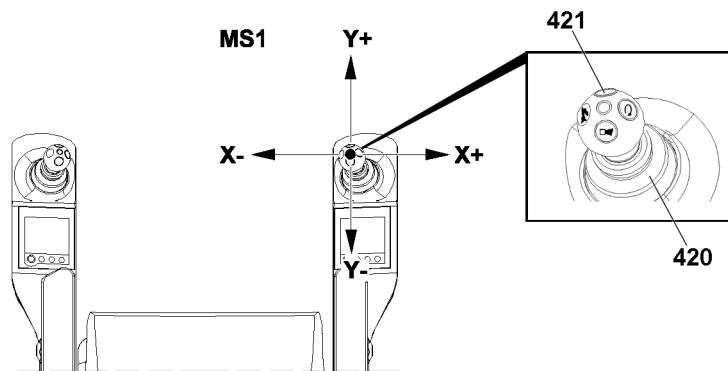


Fig.148523: Master switch MS1

Master switch MS1 **420** must be released with the button **421**.

- ▶ Press the button **421** and hold.

When „extending the crawler carrier“:

- ▶ Move master switch MS1 **420** in direction X+.

When „retracting the crawler carrier“:

- ▶ Move master switch MS1 **420** in direction X-.

**Result:**

- The pins on the cross carrier lock are unpinned.

**Problem remedy**

Pins are **not** unpinned!

The pin is stuck: The position of the cross carrier prevents the pins from unpinning.

- ▶ Extend and retract the cross carriers again: Move master switch MS1 in direction X+ or X- until the pins are completely unpinned.

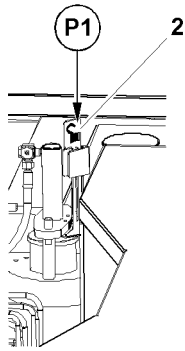


Fig.148530: Sign: Cross carrier unpinned

- ▶ Make sure that the sign **2** displays that the pins are completely unpinned.

**Result:**

- The crawler carrier extends or retracts.

### 7.1.6 Pinning the cross carriers

The cross carriers are only pinned in extension conditions of 0 %; 50 %; 100 %.

The pin points of the cross carriers are marked in percentages with tags on the cross carriers.

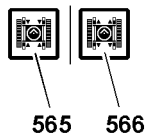


Fig.148524: Right touch display: Pinning the cross carriers

Before the cross carrier reaches one of the extension conditions of 0 %, 50 %, 100 %:

- ▶ Activate „Pin the cross carrier“: Select the icon **566** („touch“).

**Result:**

- The icon **565** „pin the cross carrier“ is visible.
- The pins are pinned.

#### Problem remedy

The pins are **not** pinned!

The pin is stuck: The position of the cross carrier prevents the pins from pinning.

- ▶ Extend and retract the cross carriers again: Move master switch MS1 in direction X+ or X- until the pins are completely pinned.

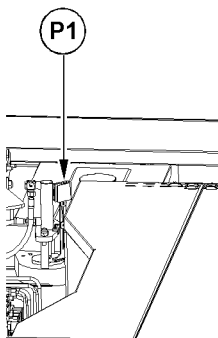


Fig.148529: Cross carriers pinned



- ▶ Make sure that the signs in positions **P1** are **not** visible.

**Result:**

- The pins are pinned.

## 7.2 Adjusting the track width with the BTT

**Note**

- ▶ When actuating the individual functions, the 2-hand keypad on the rear of the BTT must be pressed simultaneously.

### 7.2.1 Assignment of working direction and crawler carrier

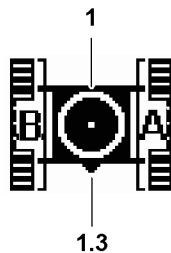


Fig.117819: BTT: Assignment of working direction and crawler carrier

Observe the notes for the assignment of working direction and crawler carrier:

- The chain tension devices are on the front on the crawler travel gear. See section „Front crawler travel gear, definition“.
- The illustration of the crane icon **1** is **independent** of the working direction. The triangle **1.3** shows the front of crane chassis.
- Crawler carrier **B** is in the „front“ right direction of view.
- Crawler carrier **A** is in the „front“ left direction of view.

Make sure that the following prerequisites are met:

- The menu overview is visible on the BTT display.
- The radio remote control is aligned with the crane, see chapter 5.31.

### 7.2.2 Activating the *Unpin the cross carrier* icon

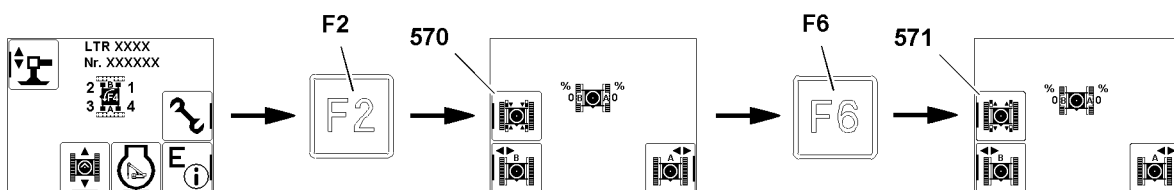


Fig.149064: BTT: Activating the *Unpin the cross carrier* icon

- ▶ Open the „Crawler travel gear“ menu: Press the function key **F2**.

**Result:**

- The „Track width adjustment“ functions are visible.

When the icon „pin the cross carrier“ **570** is visible:

- ▶ Activate „Unpin the cross carrier“: Press the function key **F6**.

**Result:**

- Icon „Unpin the cross carrier“ **571** appears.

### 7.2.3 Selecting the crawler carrier

The extension condition of the cross carrier is displayed as a percentage on the BTT display. Icon reference in the crawler travel gear menu in BTT, see chapter 5.31.

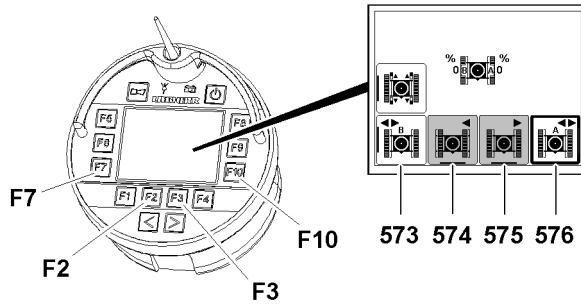


Fig.148527: BTT: Crawler carrier A is selected

Selection and deselection of the crawler carrier with function keys:

- Crawler carrier **B**: Function key **F7**
- Crawler carrier **A**: Function key **F10**

Both crawler carriers can be selected and therefore moved at the same time.

- ▶ Select the crawler carrier to be retracted or extended.

**Result:**

If crawler carrier **A** is selected, for example:

- The icon **576** is visible with a filled out frame.
- The „retract crawler carrier“ icon **574** is visible on the function key **F2**.
- The „extend crawler carrier“ icon **575** is visible on the function key **F3**.

### 7.2.4 Extending / retracting the crawler carrier

When the crawler carriers are retracted or extended, the crawler carriers are unpinned.



**WARNING**

Adjustment of the crawler carriers!  
Danger of crushing.

- ▶ Make sure that no personnel is within the danger zone of the crawler carriers during „track width adjustment“.

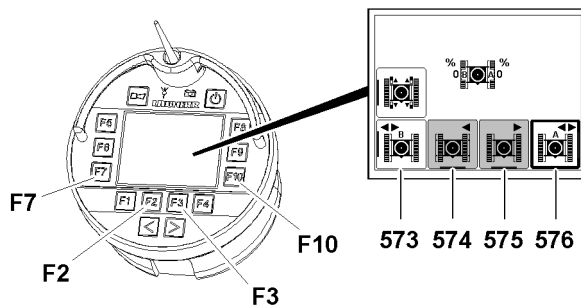


Fig.148527: BTT: Extending / retracting the crawler carrier

- ▶ Extend the crawler carrier: Press the function key **F3**.
- ▶ Retract the crawler carrier: Press the function key **F2**.

**Result:**

- The pins on the cross carrier lock are unpinned.

**Problem remedy**

Pins are **not** unpinned!

The pin is stuck: The position of the cross carrier prevents the pins from unpinning.

- ▶ Extend and retract the cross carriers again: Press the function keys until the pins are completely unpinned.

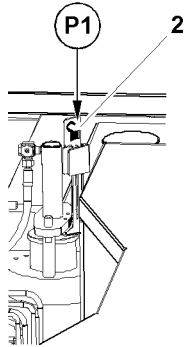


Fig.148530: Sign: Cross carrier unpinned

- ▶ Make sure that the sign **2** displays that the pins are completely unpinned.

**Result:**

- The crawler carrier extends or retracts.

**7.2.5 Pinning the cross carriers**

The cross carriers are only pinned in extension conditions of 0 %; 50 %; 100 %.

The pin points of the cross carriers are marked in percentages with tags on the cross carriers.

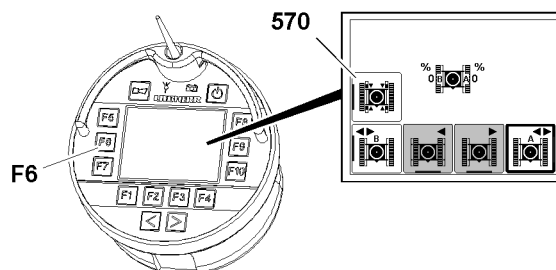


Fig.149063: BTT: Pinning the cross carriers

Before the cross carrier reaches one of the extension conditions of 0 %, 50 %, 100 %:

- ▶ Activate „Pin the cross carrier“: Press the function key **F6**.

**Result:**

- The icon „pin the cross carrier“ **570** is visible.
- The pins are pinned.

**Problem remedy**

The pins are **not** pinned!

The pin is stuck: The position of the cross carrier prevents the pins from pinning.

- ▶ Extend and retract the cross carriers again: Press the function keys until the pins are completely pinned.

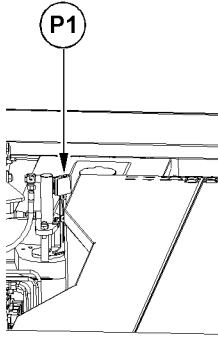


Fig.148529: Cross carriers pinned

- Make sure that the signs in positions **P1** are not visible.

**Result:**

- The pins are pinned.

## 7.3 Adjusting the track width with the radio remote control\*

### 7.3.1 Assignment of working direction and crawler carrier

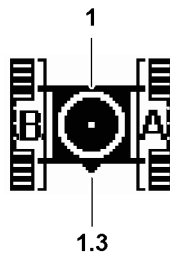


Fig.117819: Radio remote control: Assignment of working direction and crawler carrier

Observe the notes for the assignment of working direction and crawler carrier:

- The chain tension devices are on the front on the crawler travel gear. See section „Front crawler travel gear, definition“.
- The illustration of the crane icon **1** is **independent** of the working direction. The triangle **1.3** shows the front of crane chassis.
- Crawler carrier **B** is in the „front“ right direction of view.
- Crawler carrier **A** is in the „front“ left direction of view.

Make sure that the following prerequisites are met:

- The menu overview is visible on the radio remote control display.
- The radio remote control is aligned with the crane, see the radio remote control operating instructions.

### 7.3.2 Activating the *Unpin the cross carrier* icon

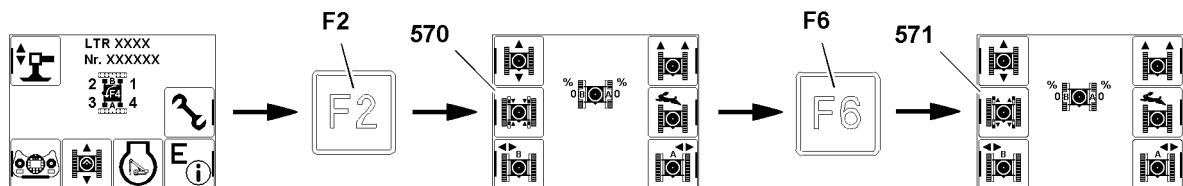


Fig.149067: Radio remote control: Activating the *Unpin the cross carrier* icon

- ▶ Open the „Crawler travel gear“ menu: Press the function key **F2**.

**Result:**

- The „Track width adjustment“ functions are visible.

When the icon „pin the cross carrier“ **570** is visible:

- ▶ Activate „Unpin the cross carrier“: Press the function key **F6**.

**Result:**

- Icon „Unpin the cross carrier“ **571** appears.

### 7.3.3 Selecting the crawler carrier

The extension condition of the cross carrier is displayed as a percentage on the BTT display.

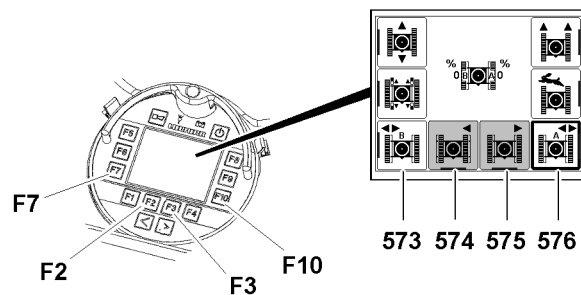


Fig.149074: Radio remote control: Crawler carrier A is selected

Selection and deselection of the crawler carrier with function keys:

- Crawler carrier **B**: Function key **F7**
- Crawler carrier **A**: Function key **F10**

Both crawler carriers can be selected and therefore moved at the same time.

- ▶ Select the crawler carrier to be retracted or extended.

**Result:**

If crawler carrier **A** is selected, for example:

- The icon **576** is visible with a filled out frame.
- The „retract crawler carrier“ icon **574** is visible on the function key **F2**.
- The „extend crawler carrier“ icon **575** is visible on the function key **F3**.

### 7.3.4 Extending / retracting the crawler carrier

Icon reference in the crawler travel gear menu in the radio remote control, see the radio remote control operating instructions.

When the crawler carriers are retracted or extended, the crawler carriers are unpinned.



**WARNING**

Adjustment of the crawler carriers!

Danger of crushing.

- ▶ Make sure that no personnel is within the danger zone of the crawler carriers during „track width adjustment“.

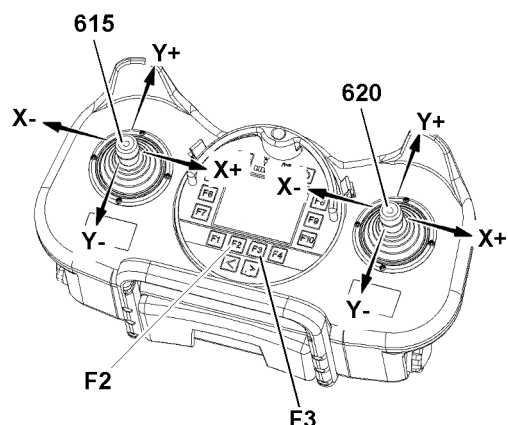


Fig.149066: Radio remote control: Extending / retracting the crawler carrier

Manual control lever	Crawler carrier A	Crawler carrier B
Position	620	615
„Extend“ direction of movement	X+	X-
„Retract“ direction of movement	X-	X+

Allocation of the manual control lever directions of movement to the crawler carriers

When „extending the crawler carrier“:

- ▶ Deflect the manual control lever.
- or
- Press the function key **F3**.

When „retracting the crawler carrier“:

- ▶ Deflect the manual control lever.
- or
- Press the function key **F2**.

#### Result:

- The pins on the cross carrier lock are unpinned.

#### Problem remedy

Pins are **not** unpinned!

The pin is stuck: The position of the cross carrier prevents the pins from unpinning.

- ▶ Extend and retract the cross carriers again: Deflect the manual control levers on the radio remote control in direction X+ or X- or press function keys until the pins are completely unpinned.

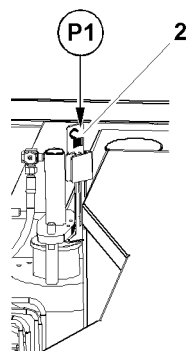


Fig.148530: Sign: Cross carrier unpinned

- ▶ Make sure that the sign **2** displays that the pins are completely unpinned.

**Result:**

- The crawler carrier extends or retracts.

**7.3.5 Pinning the cross carriers**

The cross carriers are only pinned in extension conditions of 0 %; 50 %; 100 %.

The pin points of the cross carriers are marked in percentages with tags on the cross carriers.

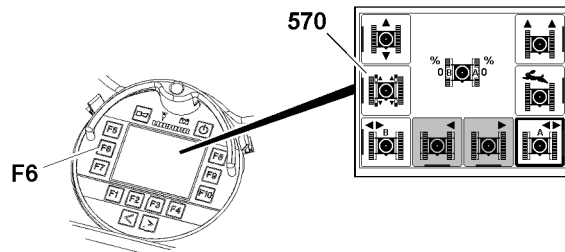


Fig.149075: Radio remote control: Pinning the cross carriers

Before the cross carrier reaches one of the extension conditions of 0 %, 50 %, 100 %:

- ▶ Activate „Pin the cross carrier“: Press the function key **F6**.

**Result:**

- The icon „pin the cross carrier“ **570** is visible.
- The pins are pinned.

**Problem remedy**

The pins are **not** pinned!

The pin is stuck: The position of the cross carrier prevents the pins from pinning.

- ▶ Extend and retract the cross carriers again: Deflect the manual control levers on the radio remote control in direction X+ or X- or press function keys until the pins are completely unpinned.

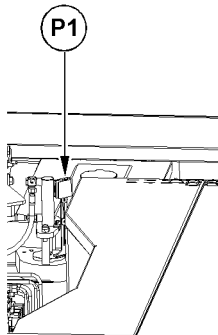


Fig.148529: Cross carriers pinned

- ▶ Make sure that the signs in positions **P1** are not visible.

**Result:**

- The pins are pinned.

---

Empty page!

LWE/LTR 1220-003/24204-02-02/en



## 4.04 Safety equipment

1	General	3
2	Crane geometry quick test	3
3	Overload protection quick test	3
4	LICCON computer system	3
5	Safety equipment on the crane	9

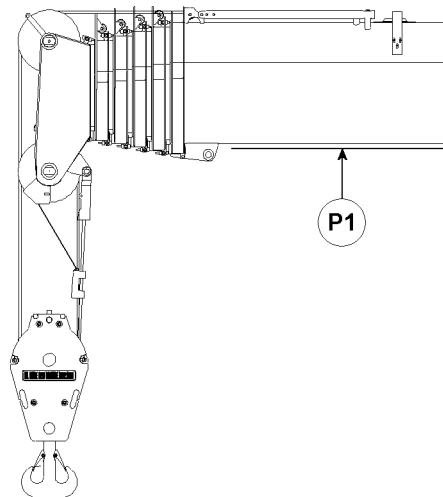
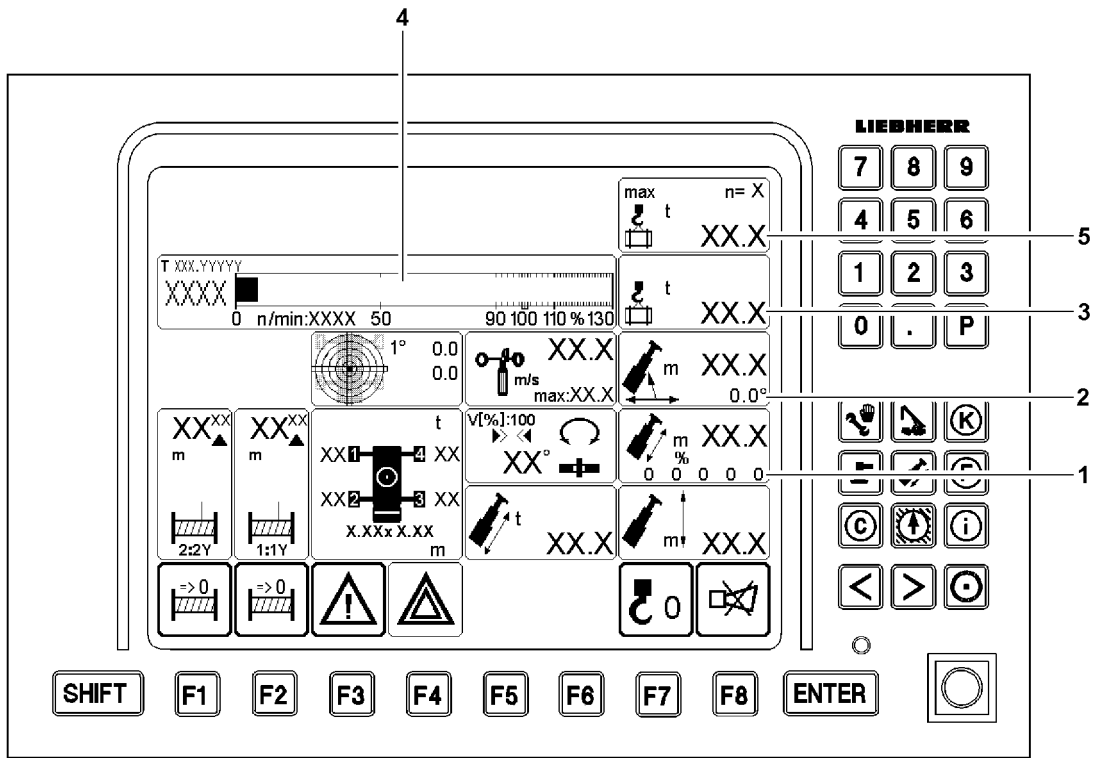


Fig.112697

# 1 General

The crane operator is obligated before every crane operation to ensure that the warning and safety equipment are functioning.



## WARNING

Danger of accident due to defective warning and safety equipment!

If the crane is operated with defective warning and safety equipment, then there is a danger of accident!

Personnel can be killed or seriously injured!

This could result in property damage!

- ▶ Make sure that all warning and safety equipment is functioning.
- ▶ Make sure that the overload protection is functioning.

## 2 Crane geometry quick test

Make sure that the following prerequisites are met:

- The crane is properly supported and horizontally aligned.
- No load on the hook.



## Note

- ▶ The horizontal alignment of the telescopic boom can be checked with a spirit level in point **P1**.

When the telescopic boom is telescoped in all the way and horizontally aligned, the LICCON computer system must show the following:

- Telescope extension condition **1** display: all values to 0 %
- Telescopic boom angle **2** display: 0°

## 3 Overload protection quick test

Lift a known weight completely, such as the hook block or a counterweight plate and then set it down.

Make sure that the following prerequisite is met:

- The crane is properly supported and horizontally aligned.

The respective displayed values must be plausible:

- **3** Actual load display
- Utilization bar **4** (ratio of the actual load display **3** value to the maximum load **5** value)

## 4 LICCON computer system

The LICCON computer system is a system for controlling and monitoring mobile cranes. In addition to the LICCON overload protection (Load torque limiter = LMB), there are a number of application programs that can be used for controlling and monitoring the crane movements. For a detailed description see the Crane operating instructions, chapter 4.02 and chapter 4.20.

### 4.1 LICCON overload protection

The LICCON overload protection is programmed to **shut off** the crane movements if the permissible load moment is exceeded (LMB-STOP).

The LICCON overload protection may not be used as an operational shut-off device for crane movements of any kind.

An overload protection cannot detect all occurring conditions by itself. Careful and diligent crane operation by the crane operator is important.

The basis for the calculation of the utilization of the crane are:

- The current data and values recorded by the crane control.
- The set up configuration entered by the crane operator.

Direct influence has, for example:

- Failure of a test device (for example: length sensor, angle sensor, pressure sensor).
- A set up configuration incorrectly entered by the crane operator.
- Environmental influences not considered (such as wind influence, ground with insufficient load bearing capability).
- Assembly and operating errors.



### WARNING

Danger of accident due to assembly and operating errors!

Due to assembly and operating errors it is possible that the overload protection is not effective or shut-off is delayed!

A set up configuration that deviates from the load chart cannot be detected by the overload protection!

Environmental influences that are not considered cannot be detected by the overload protection!

Dangerous situations and accidents can result!

Personnel can be killed or seriously injured!

This could result in property damage!

- ▶ Always assemble and operate the crane carefully!



### WARNING

Operational utilization of the overload protection!

If the LICCON overload protection is utilized as an operational shut-off device for crane movements, then there is a danger of accident!

For example, crane movements can be shut off abruptly or uncontrolled!

The behaviour of the load and crane cannot be predicted in such a case!

Personnel can be killed or seriously injured!

This could result in property damage!

- ▶ Do not use the LICCON overload protection as an operational shut-off device for crane movements!



### WARNING

Lifting of unknown loads!

The presence of the overload protection does not relieve the crane operator of his obligation for care and attention!

The crane may not be operated only according to the displays of the LICCON overload protection!

Lifting of loads with unknown weight and unknown properties can lead to accidents!

Personnel can be killed or seriously injured!

This could result in property damage!

- ▶ Before lifting a load, its weight and properties must be known to the crane operator!
- ▶ The crane operator must check with the load chart if the crane is able to carry out the work safely!

The LICCON computer system detects various values, which result in optical and acoustical warnings if exceeded:

Within the crane operator's cab:

- Acoustic warning „Horn / short horn“ on the LICCON monitor
- Optical warning „blinking value / display“ on the LICCON monitor

Outside the crane operator's cab:

- Acoustic warning via the horn on the turntable
- Optical warning via the warning light on the turntable

All warnings, even those that do not lead to an immediate shut-off must be noted by the crane operator and personnel within the danger zone.

The overload protection can **not** detect (examples of cases):

- The hooking of the load or the load handling equipment
- Excessive retarding forces
- Loads falling onto the rope
- Angular pull
- Driving the crane on ground with large slope
- Collapsing ground

#### 4.1.1 Failure of the overload protection



##### **WARNING**

Crane operation without overload protection!

If the LICCON overload protection is no longer functioning properly because of one or more errors, then there is a danger of accident if crane operation is continued!

Due to operation of the crane with failed LICCON overload protection, the crane can be overloaded and collapse!

Personnel can be killed or seriously injured!

This could result in property damage!

- ▶ Crane operation without overload protection is prohibited!
- ▶ Do not restart crane operation again until the overload protection is functioning again!

A failed overload protection:

- Must be repaired before the crane can be operated again.
- May only be bypassed in emergency cases or emergency situations.

## 4.2 Bypassing the overload protection

The overload protection can be bypassed in case of:

- Failure of the overload protection
- In an emergency situation (according to EN 13000:2010)

### 4.2.1 Bypassing the overload protection: Failure of the overload protection



##### **Note**

- ▶ Does **not** apply for cranes with CE-mark and configuration according to EN 13000:2010!

To bring the crane to a safe condition after failure of a component required for the overload protection, it may be necessary to bypass the overload protection.



##### **WARNING**

Bypassed overload protection!

If the overload protection is bypassed, crane movements are no longer monitored!

The crane can be overloaded and collapse!

Personnel can be killed or seriously injured!

This could result in property damage!

- ▶ Only carry out crane movements within the range of the load chart as well as the erection / take-down charts!

### 4.2.2 Bypassing the overload protection: Failure of overload protection (according to EN 13000:2010)

To bring the crane to a safe condition after failure of a component required for the overload protection, it may be necessary to bypass the overload protection.

With the specification that:

- The bypass is automatically reset at engine stop.
- The bypass is automatically reset after no later than 30 minutes.
- The bypass of the overload protection limits the working speed to no more than maximum 15 %.

**WARNING**

Bypassed overload protection!

If the overload protection is bypassed, crane movements are no longer monitored!

The crane can be overloaded and collapse!

Personnel can be killed or seriously injured!

This could result in property damage!

- ▶ Only carry out crane movements within the range of the load chart as well as the erection / take-down charts!

### 4.2.3 Bypassing the overload protection: Emergency situation (according to EN 13000:2010)

In an emergency situation, it may be necessary to bypass the overload protection.

With the specification that:

- The bypass is automatically reset at engine stop.
- The bypass is automatically reset after no later than 30 minutes.
- The bypass of the overload protection limits the working speed to no more than maximum 15 %.

**DANGER**

Overload of crane!

After a bypass of the overload protection, the crane movements are no longer shut off in case of a danger of overload of the crane!

An overload of the crane can result in severe damage or collapse!

Personnel can be killed or seriously injured!

This could result in property damage!

- ▶ Do not subject the crane to such a load that it collapses!
- ▶ Clear and secure the danger zone of the crane!

**Note**

- ▶ Location of the bypass device, see the Crane operating instructions, chapter 4.01 and chapter 4.02.

Empty page!

LWE/LTR 1220-003/24204-02-02/en

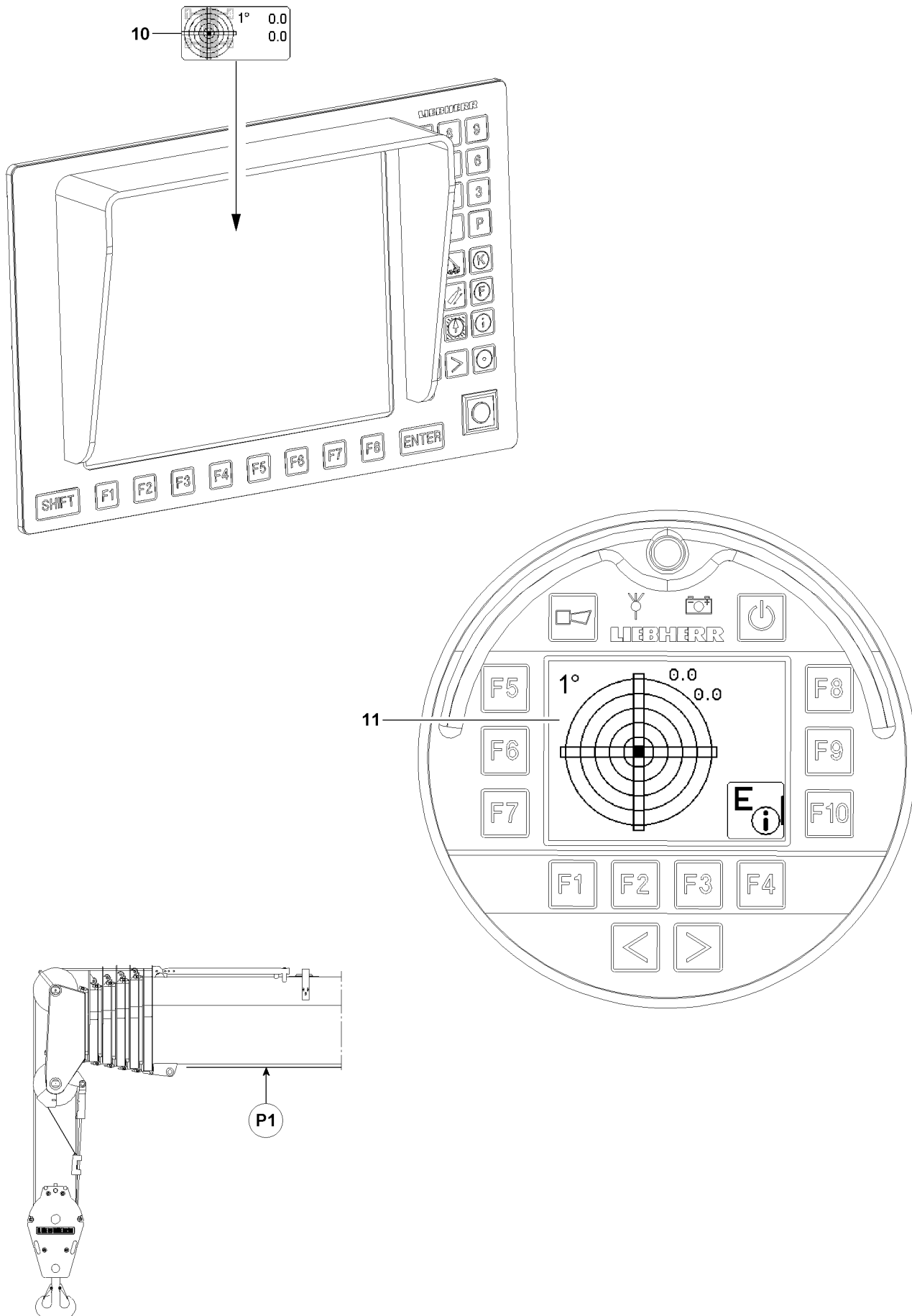


Fig.112699

LWE/LTR 1220-003/24204-02-02/en



## 5 Safety equipment on the crane

### 5.1 Leveling instruments

To ensure the working safety of the crane, the crane must be aligned horizontally on level ground with a sufficient load bearing capacity. Alignment of the crane, see the Crane operating instructions, chapter 3.05.

The current values are displayed continuously in the leveling instruments, see the Crane operating instructions, chapter 4.02 and chapter 5.31.



#### **WARNING**

Defective leveling instruments!

If the leveling instruments are defective, there is a danger that the crane is not horizontally aligned. The crane can topple over.

Death, severe bodily injuries, property damage.

- ▶ Fix or replace the defective leveling instruments.
- ▶ Align the crane horizontally to 0.0° during the support procedure.

#### 5.1.1 Leveling instruments in the LICCON monitor

The incline of the crane is shown in the Incline icon **10** graphically as well as numerically, see the Crane operating instructions, chapter 3.05 and 4.02.

#### 5.1.2 Leveling instrument in the BTT

The incline of the crane is shown in the Incline display menu **11** graphically as well as numerically, see the Crane operating instructions, chapter 3.05 and 5.31.

#### 5.1.3 Leveling instrument quick test

Make sure that the following prerequisites are met:

- The crane is properly supported and horizontally aligned.
- No load on the hook.

For a horizontally aligned crane:

- The telescopic boom must be aligned horizontally at telescopic boom angle 0° over the entire slewing range of the turntable.



#### **Note**

- ▶ The horizontal alignment of the telescopic boom can be checked with a spirit level in point **P1**.

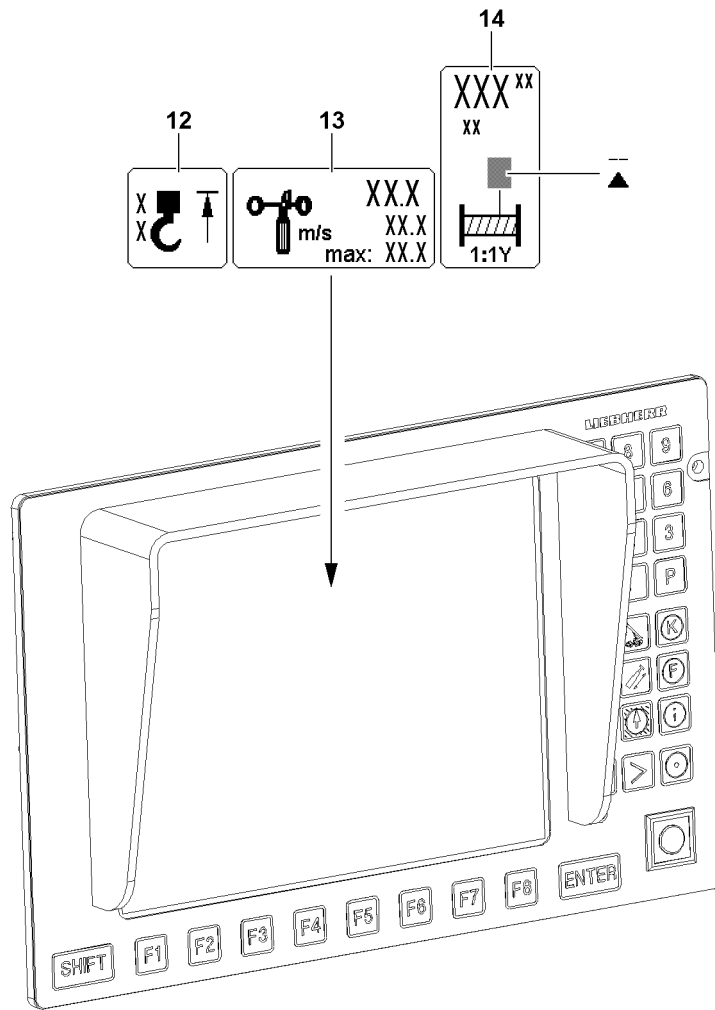


Fig.112700

LWE/LTR 1220-003/24204-02-02/en

## 5.2 Acoustic and optical warning devices



### Note

- ▶ Overview of acoustic and optical warnings, see the Crane operating instructions, chapter 4.20.
- 
- The acoustic and optical warning devices must be functioning and operational.
  - Take care of any possible detriments in function, such as snow on the warning lights.

## 5.3 „Hoist top“ hoist limit switch

The hoist limit switch is intended to prevent the hook block from running against the boom head.

Before every crane application, the function of the hoist limit switch must be checked by running up against the switch weight with the hook block.

For installation purposes and in emergency cases, the hoist limit switch can be bypassed, see the Crane operating instructions, chapter 4.20.



### WARNING

Falling load and property damage!

If the hoist limit switch is defective, there is danger that the hook block or the load hook is pulled against the pulley head!

Falling load and property damage can result!

Personnel can be severely injured or killed!

- ▶ Crane operation without or with a defective hoist limit switch is prohibited!
- ▶ Repair or replace a defective hoist limit switch!

The hoist limit switch must actuate when the hoist limit switch weight is lifted by the load hook / hook block:

- When the hoist limit switch is actuated, the „Hoist top“ icon **12** appears on the operating screen. The „Spool up winch“, „Luff telescopic boom down“ and „Telescope the telescopic boom out“ crane movements are shut off.

### 5.3.1 Hoist limit switch quick test

When the hoist limit switch weight is lifted:

- The „Hoist top“ icon **12** must appear on the operating screen.
- The actuated crane movement must be shut off.

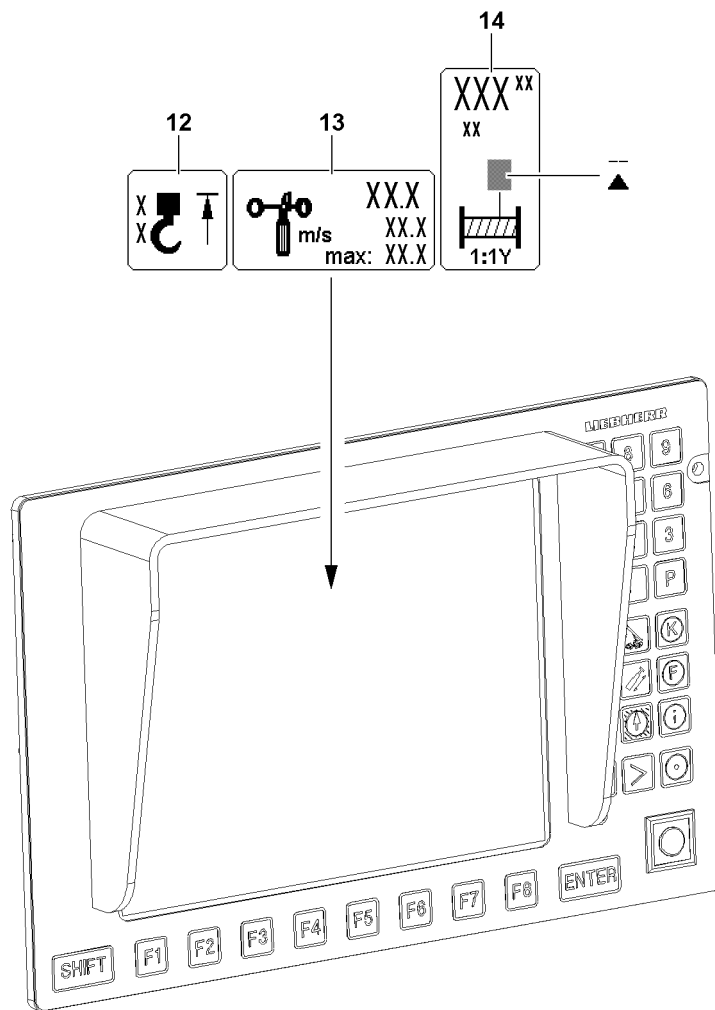


Fig.112700

LWE/LTR 1220-003/24204-02-02/en

## 5.4 Wind speed sensor

The wind warning by the wind speed sensor appears on the operating screen of the LICCON computer system.



### WARNING

The crane can topple over!

If the crane is operated with a defective wind speed sensor, then there is the danger that excessively high wind speeds are not recognized!

The crane can topple over!

Personnel can be killed or seriously injured!

This could result in property damage!

- ▶ Crane operation with a defective wind speed sensor is prohibited!
- ▶ Repair / replace a defective wind speed sensor!

If wind occurs, then the wind speed sensor must report its speed:

- If the actual wind speed value exceeds the displayed maximum value, the value in the „Wind speed“ icon **13** starts to blink and the „Short horn“ acoustic alarm sounds on the LICCON monitor. But there is **no shut-off** of crane movements.

### 5.4.1 Wind speed sensor quick test

When blowing in the cups:

- The wind speed sensor must start to move.
- An actual value must be displayed in the „Wind speed“ icon **13**.

## 5.5 Winch spooled out limit switch

The winch speed sensor is adjusted in the factory. If used properly, the winch turn sensor will not need readjustment.



### Note

Minimum rope coils on the shut off point!

- ▶ For the winches, a minimum of 4 rope coils are set on the winch speed sensor.



### WARNING

The load can fall off!

If the winch speed sensor does not turn off when four minimum rope coils are reached, then there is the danger that the rope lock is pulled out and the load falls down when the rope is spooled out further!

Falling load can cause the crane to sway and / or topple over!

Personnel can be severely injured or killed!

This could result in property damage!

- ▶ Crane operation with an incorrectly or non-adjusted winch is strictly prohibited!
- ▶ If the winch falls below the four minimum rope coils, have the winch speed sensor readjusted by **Liebherr Service!**

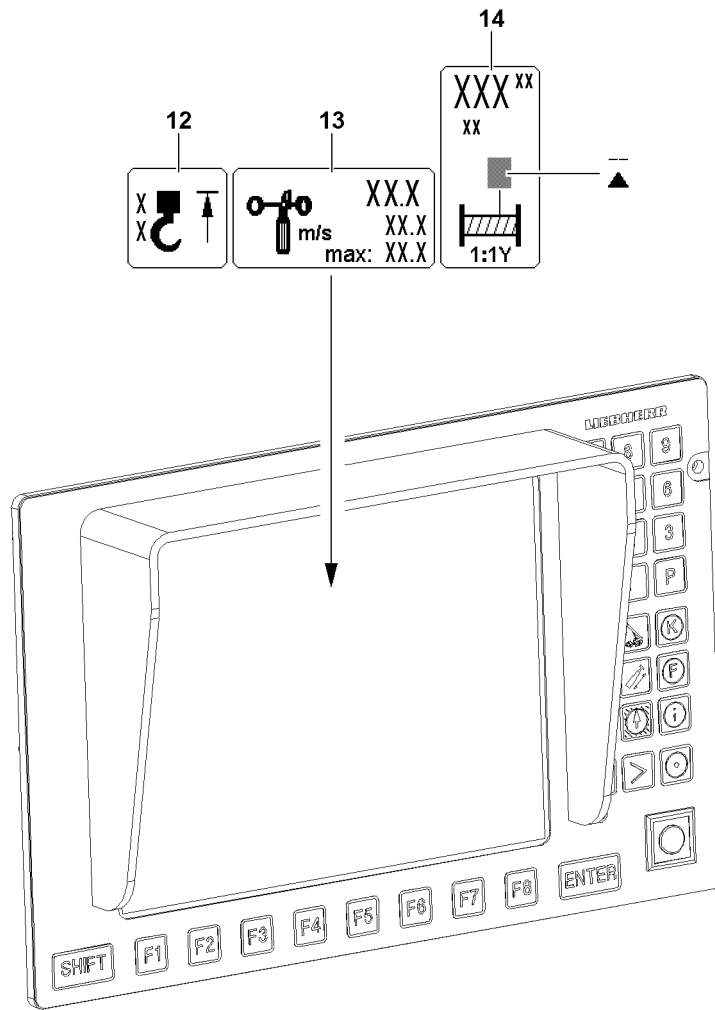


Fig.112700

LWE/LTR 1220-003/24204-02-02/en

**WARNING**

The load can fall off!

If the rope is not spooled up or out properly, then the adjustment of the winch speed sensor is changed!

If the adjustment of the winch speed sensor has changed, there is danger that the minimum rope coils are fallen below!

The load can fall down!

Falling load can cause the crane to sway and / or topple over!

Personnel can be severely injured or killed!

This could result in property damage!

- ▶ **Never** pull the end of rope underneath the winch by spooling up the rope winch!
- ▶ **Never** pull the rope from the „stationary“ winch!
- ▶ If you suspect that the winch speed sensor adjustment has changed: Check the shut-off without a load on the hook!

The limit switch Winch spooled out must shut off when the minimum rope coils for the winch are reached:

- When the minimum rope coil for the winch is reached, then the „Winch spooled out“ display appears in the winch icon **14**. The „spool winch out“ crane movement is shut off.

### 5.5.1 Winch limit switch quick test

When the minimum rope coil is reached:

- The „Winch spooled out“ display must appear in the winch icon **14**.
- The „spool winch out“ crane movement must be shut off.

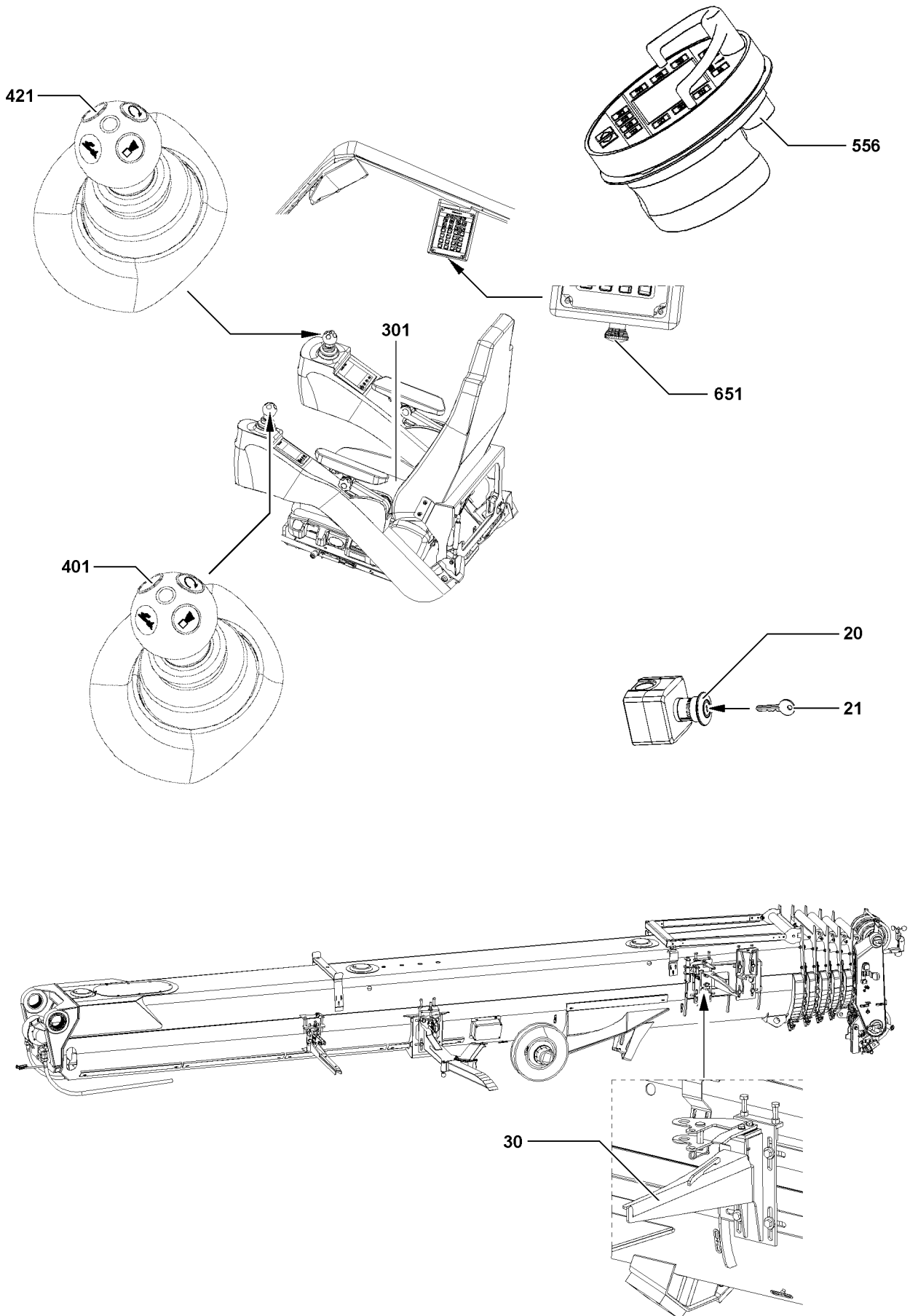


Fig.112698

LWE/LTR 1220-003/24204-02-02/en



## 5.6 EMERGENCY STOP switch / EMERGENCY OFF switch

If an EMERGENCY STOP switch / EMERGENCY OFF switch is actuated, then every carried out movement can be stopped immediately.



### WARNING

Defective EMERGENCY STOP switch / EMERGENCY OFF switch!

If the crane is operated with a defective EMERGENCY STOP switch / EMERGENCY OFF switch, then the movement cannot be stopped by actuating the EMERGENCY STOP switch.

This could result in accidents.

Personnel can be killed or seriously injured.

This could result in property damage.

- ▶ Crane operation with a defective EMERGENCY STOP switch / EMERGENCY OFF switch is prohibited.
- ▶ Repair or replace a defective EMERGENCY STOP switch / EMERGENCY OFF switch.

### NOTICE

Operational actuation of the EMERGENCY STOP switch / EMERGENCY OFF switch!

Actuation of the EMERGENCY STOP switch / EMERGENCY OFF switch causes the crane movement to shut off abruptly.

Abrupt shut off of the crane movement can cause the load to swing.

Crane components are strongly loaded due to the abrupt shut-off of the crane movement.

- ▶ Do not use the EMERGENCY STOP switch / EMERGENCY OFF switch operationally.
- ▶ Use the EMERGENCY STOP switch / EMERGENCY OFF switch only in emergency situations.

The EMERGENCY STOP switch / EMERGENCY OFF switch is available in three versions:

- After actuating a version switch\* **20**, the release is only obtained by an authorized person with a key **21** and subsequently by briefly turning the ignition „Off - On“.
- After actuation of the switch **651**, the release is obtained by turning and unlocking the knob and subsequently by briefly turning the ignition „Off - On“.
- After actuation of the switch **556**, the release is obtained by turning and unlocking the knob and subsequently by briefly turning the ignition „Off - On“.



### Note

- ▶ The switch **556** on the BTT is only activated when working with the BTT.

### 5.6.1 EMERGENCY STOP switch / EMERGENCY OFF switch quick test

After actuation of the EMERGENCY STOP switch / EMERGENCY OFF switch:

- The crane movements must be shut off.
- No crane movements must be possible until the release was issued by turning and unlocking the knob and then by briefly turning the ignition „Off - On“.

## 5.7 Control release

The control release can be made via three switches:

- **301** Seat contact button
- Master switch MS1 button **401** (right control panel)
- Master switch MS2 button **421** (left control panel)

The seat contact button **301** shuts down the crane control as soon as the crane operator gets up from the seat.

This prevents unintended crane movements by accidentally touching the master switch, for example when getting in or out of the cab.

The button **401** and button **421** bypass the seat contact button **301** if it becomes necessary for the operator to work standing up.

## 5.8 Catch bar



### Note

- ▶ Only for cranes with a folding jib.

The catch bar **30** on the telescopic boom pivot section is mechanical safety equipment!



### WARNING

Danger of fatal injury due to falling folding jib!

Due to incorrectly installed, damaged or non-existing catch bar **30** on the telescopic boom pivot section, the folding jib can fall down - in case of an installation error!

Personnel can be hit and killed or seriously injured!

This could result in property damage!

- ▶ Before folding jib assembly make sure that the catch bar **30** has been installed properly on the telescopic boom pivot section and that it is not damaged!
- ▶ The catch bar **30** is mechanical safety equipment. For that reason, it is prohibited to change the catch bar **30** and its installation in any way!

## 5.9 Hydraulic safety valves

A differentiation is made between three types:

- Pressure limiting valves
  - Prevent pipe and hose bursts due to excessive pressure.
- Shut off valves
  - Control and secure the luffing cylinder and the support cylinders.
- Check valves
  - Control and secure the flow direction.

## 5.10 Limit switch Boom system



### WARNING

Danger of toppling or destroying the crane!

If the crane movement is stopped by the block limit switches, then the load forces cannot be absorbed and calculated by the control!

The crane can be overloaded and topple over!

Personnel can be hit and killed or seriously injured!

This could result in property damage!

- ▶ Do **not** use the hoist limit switch as an operational shut off device!
- ▶ Do not actuate the block limit switches!

## 5.11 Telescopic boom limit switch

On the telescopic boom, the limit switches monitor the „steepest position“ and the „lowest position“.

## 5.12 Luffing accessories limit switch



### Note

- ▶ Only for cranes with luffing accessories.

For operation with luffing accessories (for example a luffing lattice jib), limit switches monitor the „steepest position“ and the „lowest position“.

## 5.13 Gravity actuated relapse retainer

**Note**

- ▶ Only for cranes with luffing accessories.

The gravity actuated relapse retainer (oscillation guard / flap / relapse support) prevent the luffing accessory from tipping to the rear in the „steepest position“.

**WARNING**

The crane can topple over!

If the gravity actuated relapse retainer (oscillation guard / flap / relapse support) is hard to move, then it will no longer function!

Shut-off and limit functions can be disabled!

The crane can be overloaded and topple over!

Personnel can be killed or seriously injured!

This could result in property damage!

- ▶ Before erecting the crane, check the relapse retainer for easy movement!
- ▶ Crane operation with a hard to move relapse retainer is prohibited!

---

Empty page!

LWE/LTR 1220-003/24204-02-02/en

## 4.05 Crane operation

1	Description	2
2	Safety instructions	2
3	Prerequisites for crane operation	3
4	Master switch	3
5	Pinning the crane superstructure	9
6	Master switch assignment	10
7	Luffing	11
8	Lifting / lowering	13
9	Turning	17
10	Telescoping	22

# 1 Description

With the crane various crane movements can be carried out. Through these crane movements, the load can be taken up, positioned and placed down exactly.

The following crane movements are possible:

- Luffing
- Lifting / lowering
- Turning
- Telescoping

The crane movements are described in the following sections.

## 2 Safety instructions



### WARNING

Operating condition on crane is **not** safe!  
Crane can topple over, death, severe property damage in crane.

Only when the crane is in a safe operating condition:

- ▶ Start crane operation.

Solely when all safety equipment is functioning:

- ▶ Start crane operation.

The safety equipment is described in the Crane operating instructions, chapter 2.04.

Additional notes and danger notes for crane operation are described in Crane operating instructions, chapter 2.04 and chapter 4.08.



### Note

- ▶ Observe and adhere to the data in Crane operating instructions, chapter 2.04 and chapter 4.08.



### WARNING

The crane can topple over!

The retracted track width reduces the stability of the crawler crane. Due to operational errors during crane operation or driving, the crawler crane can topple over and fatally injure personnel.

- ▶ Crane operation and „driving the crawler with load“ is permitted for a retracted or asymmetrical track width, if **extra load charts** are programmed for this case.
- ▶ Crane operation and „driving the crawler with load“ is strictly prohibited for a retracted or asymmetrical track width, if **no extra load charts are programmed for this case**.



### WARNING

Personnel in the danger zone!

Crushing danger, death, severe bodily injuries.

- ▶ Monitor the danger zone.
- ▶ Make sure that there is **no** personnel in the danger zone.
- ▶ Before initiating a crane movement, give a warning signal (horn).



### WARNING

Obstacle in working range!

Property damage on crane and on obstacle.

- ▶ Monitor the working range.
- ▶ Make sure that there are **no** obstacles within the working area of the crane and the crane components.

The crane movements have a direct effect on the hoist rope.

**NOTICE**

Collision of the hook block with the boom head!

- ▶ Equalize the crane movements by spooling the hoist winch.

The crane driver must evaluate constantly if the displayed values shown on the LICCON monitor can be correct. The crane driver may not rely blindly on the LICCON computer system but must think for himself and must recognize a possibly occurring error or overload condition.

**WARNING**

Error on the LICCON monitor display!

Death, severe bodily injury, property damage.

- ▶ Monitor the displays in LICCON monitor.
- ▶ Monitor the utilization conditions and forces.
- ▶ Observe and adhere to the data in the Crane operating instructions, chapter 4.02.

## 3 Prerequisites for crane operation

Make sure that the following prerequisites are met:

- The ground is able to carry the weight of the crane and the load handling equipment.
- The ground has a permissible inclination, see the load chart.
- The counterweight is installed and secured according to the data in the load chart.
- The hook block is correctly reeved in according to the reeving plan.
- The step at the entry to the crane cab is moved out.
- The engine is running.
- The set up configuration has been entered in the LICCON computer system. All displays are within a permissible range.
- All safety equipment has been set according to the data in the load chart.
- **No** persons are in the danger zone.
- **No** obstacles are in the working range.

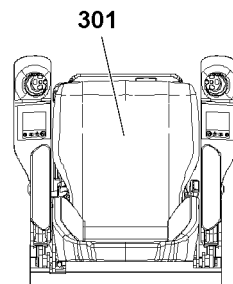


Fig.124225: Seat contact button

To release a crane movement, the seat contact button **301** must be actuated. As soon as the crane driver sits down on the crane seat, the seat contact button **301** is actuated.

- ▶ Sit down on the driver's seat and actuate the seat contact button **301**.

**Result:**

- Crane movements can be carried out.

## 4 Master switch

Master switch **MS1** and master switch **MS2** each have four buttons and a vibration sensor. The buttons on the master switch **MS1** and master switch **MS2** have the same functions.

The following functions can be regulated with the buttons:

- Vibration sensor
- Warning signal
- Bypassing the seat contact button
- Rapid gear
- Engine rpm lock

## 4.1 Giving a warning signal



Fig.124226: Giving a warning signal

- ▶ Press the button **425** on the master switch **MS1**.
- or
- ▶ Press the button **405** on the master switch **MS2**.

**Result:**

- Warning signal (horn) sounds.

## 4.2 Bypassing the seat contact button

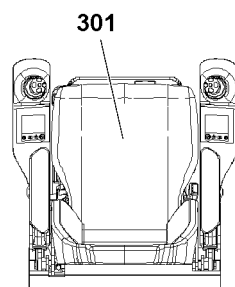


Fig.124225: Seat contact button

If the crane driver must work while standing, the seat contact button **301** must be bypassed.

Make sure that the following prerequisite is met:

- The seat contact button **301** is **not** actuated.



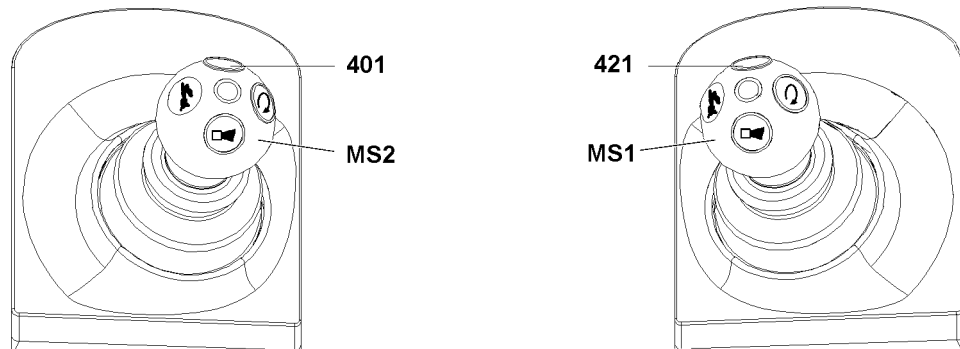


Fig.124227: Bypassing the seat contact button

- ▶ Press the button **421** on the master switch **MS1**.
- or
- Press the button **401** on the master switch **MS2**.

**Result:**

- The seat contact button **301** is bypassed.
- Crane movements can be carried out.

### 4.3 Turning the vibration sensor on / off

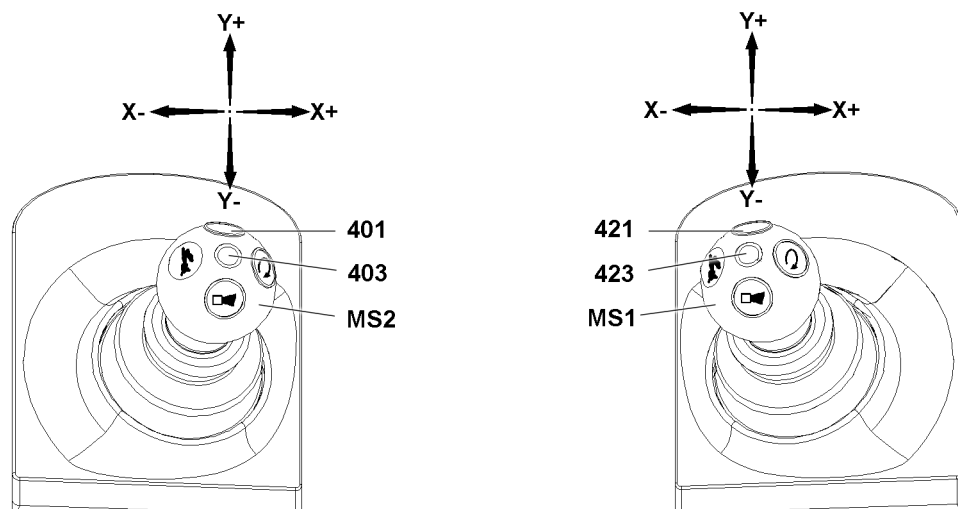


Fig.125241: Vibration sensor

By engaging the vibration sensor, a crane movement can be detected through the vibration of the master switch. The vibration sensor is only actuated when the movement is carried out. The further the master switch is deflected, the faster cycles the vibration sensor.

The vibration sensor can only be assigned to one deflection axis (X-axis or Y-axis). To activate the vibration sensor for the other deflection axis, the vibration sensor must be turned off first. Then the vibration sensor can be assigned to the other deflection axis.

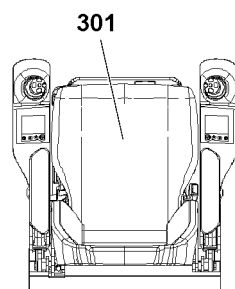


Fig.124225: Seat contact button

The vibration sensor can only be engaged when the seat contact button **301** is actuated.

Make sure that the following prerequisite is met:

- The seat contact button **301** is actuated.

### 4.3.1 Winch 1

- ▶ Press the button **421**.

**Result:**

- Vibration sensor **423** is turned on.
- ▶ Deflect the master switch **MS1** in Y-axis.

**Result:**

- Vibration sensor winch 1 is activated.

If the vibration sensor is to be turned off:

- ▶ Press the button **421** again.

**Result:**

- Vibration sensor **423** is turned off.

### 4.3.2 Winch 2 or slewing gear

- ▶ Press the button **401**.

**Result:**

- Vibration sensor **403** is turned on.
- ▶ Deflect the master switch **MS2** in Y-axis.

**Result:**

- Vibration sensor winch 2 is activated.

- ▶ Deflect the master switch **MS2** in X-axis.

**Result:**

- Vibration sensor slewing gear is activated.

If the vibration sensor is to be turned off:

- ▶ Press the button **401** again.

**Result:**

- Vibration sensor **403** is turned off.

## 4.4 Rapid gear

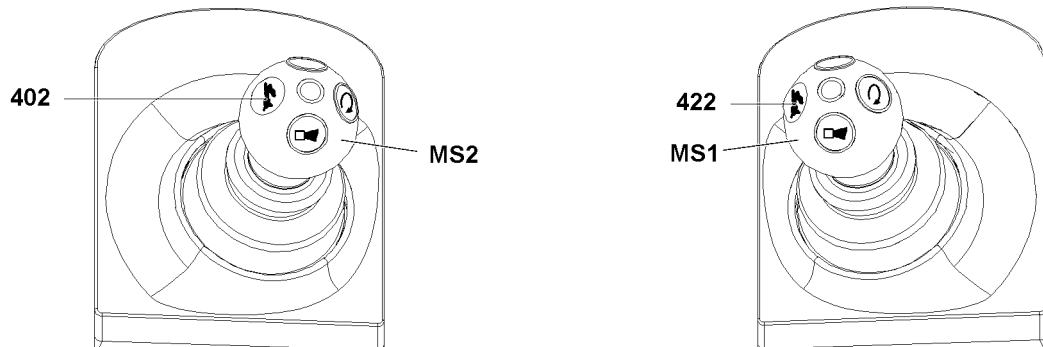


Fig.124229: Rapid gear

Using the button **402** or the button **422** will increase the speed of the crane movement for luffing, telescoping and lifting / lowering.



### WARNING

Rapid gear engaged at 1-strand to 3-strand reeving!  
Load can oscillate.

If the crane is loaded to more than 50 % of its maximum permitted load carrying capacity for the respective boom radius:

- ▶ Do **not** engage the rapid gear.

If a crane movement has reached its maximum speed based on the current utilization, then no speed increase is possible by engaging the rapid gear.

If several crane movements are actuated at the same time in active rapid gear, then the speed of a crane movement can be reduced.

We recommend not to engage the rapid gear, or to turn the rapid gear off, if any interference impacts the individual crane movements among one another.

### 4.4.1 Engaging the rapid gear

- ▶ Press the button **422** on the master switch **MS1**.  
or  
Press the button **402** on the master switch **MS2**.

**Result:**

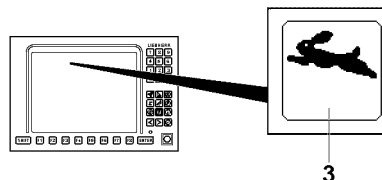


Fig.124536: Rapid gear icon 3

- Rapid gear is engaged.
- The Rapid gear **3** icon appears on the LICCON monitor.

### 4.4.2 Turning the rapid gear off

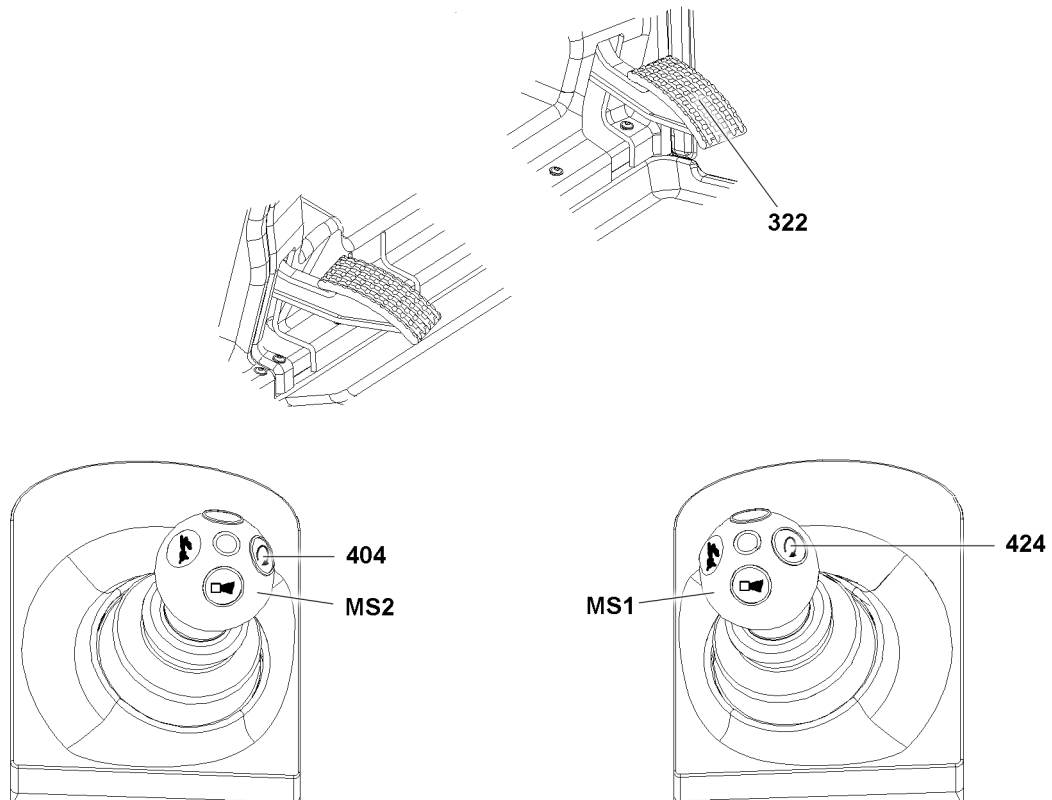
When the rapid gear is turned on:

- ▶ Press the button **422** on the master switch **MS1**.  
or  
Press the button **402** on the master switch **MS2**.

**Result:**

- Rapid gear is turned off.
- The Rapid gear **3** icon turns off in the LICCON monitor.

## 4.5 Engine rpm

*Fig.124230: Engine rpm*

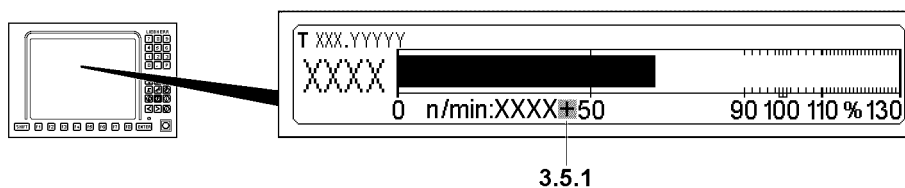
Locking the engine rpm relieves the crane operator if he must work for an extended period with constant rpm. Every permissible engine rpm can be locked.

Make sure that the following prerequisite is met:

- The engine is running.

### 4.5.1 Locking the engine rpm

- ▶ Until the desired engine rpm is reached: Actuate the engine regulation (gas pedal) **322**.
- ▶ Press the button **404** on the master switch **MS1**.  
or  
Press the button **424** on the master switch **MS2**.

**Result:***Fig.124537: „+“ symbol 3.5.1*

- The engine rpm is locked.
- The „+“ symbol **3.5.1** appears behind the rpm display in the LICCON monitor.

The locked engine rpm can be overridden with the engine regulation (gas pedal) **322**. By pressing the button **404** or the button **424** the new engine rpm can be taken over.

- ▶ When necessary, change the engine rpm.

### 4.5.2 Releasing the engine rpm lock

Make sure that the following prerequisite is met:

- The engine regulation (gas pedal) **322** is **not** actuated.
- ▶ Press the button **404**.
- or**
- Press the button **424**.

**Result:**

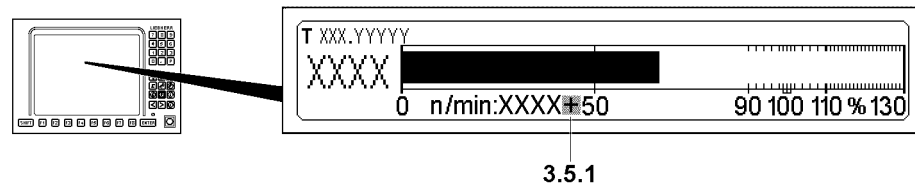


Fig.124537: „+“ symbol 3.5.1

- The engine rpm lock is released.
- The „+“ symbol 3.5.1 turns off.

## 5 Pinning the crane superstructure

The crane superstructure must be pinned in certain operating conditions with the crane chassis.

In the following situations, the crane superstructure must be pinned with the crane chassis:

- Driving the crane vehicle
- Driving with the equipment in place
- Ballasting the counterweight
- Load charts, where the crane superstructure must be locked with the crane chassis.

The crane superstructure can be pinned in 0° position or in 180° position.

### 5.1 Pinning the crane superstructure

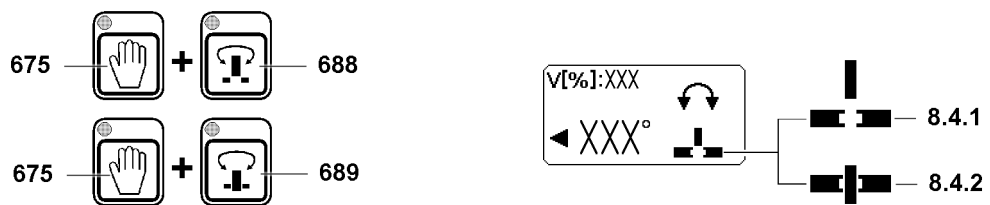


Fig.124538: Pinning the crane superstructure

Make sure that the following prerequisite is met:

- The crane superstructure is in a 0° position or 180° position.
- ▶ Activate the release button **675** by pressing it.
- ▶ Until the LED lights statically on the button **689** and an acoustic signal sounds: Press the button **689**.

**Result:**

- The crane superstructure is pinned with the crane chassis.
- The „Crane superstructure pinned“ icon **8.4.1** appears in the LICCON monitor.

LWE/LTR 1220-003/24204-02-02/en

## 5.2 Unpinning the crane superstructure

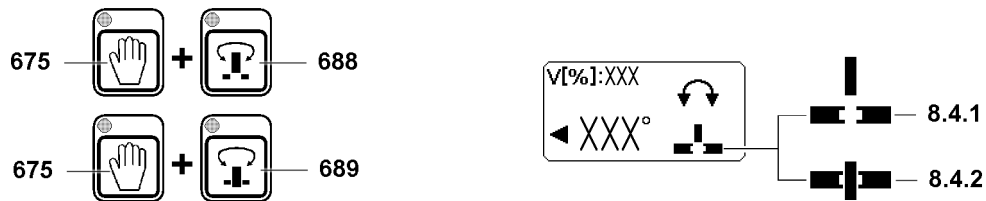


Fig.124538: Unpinning the crane superstructure

Make sure that the following prerequisite is met:

- The crane superstructure is pinned.
- ▶ Activate the release button **675** by pressing it.
- ▶ Until the LED lights statically on the button **688** and an acoustic signal sounds: Press the button **688**.

**Result:**

- The crane superstructure is unpinned.
- The „Crane superstructure unpinned“ icon **8.4.2** appears in the LICCON monitor.

## 6 Master switch assignment

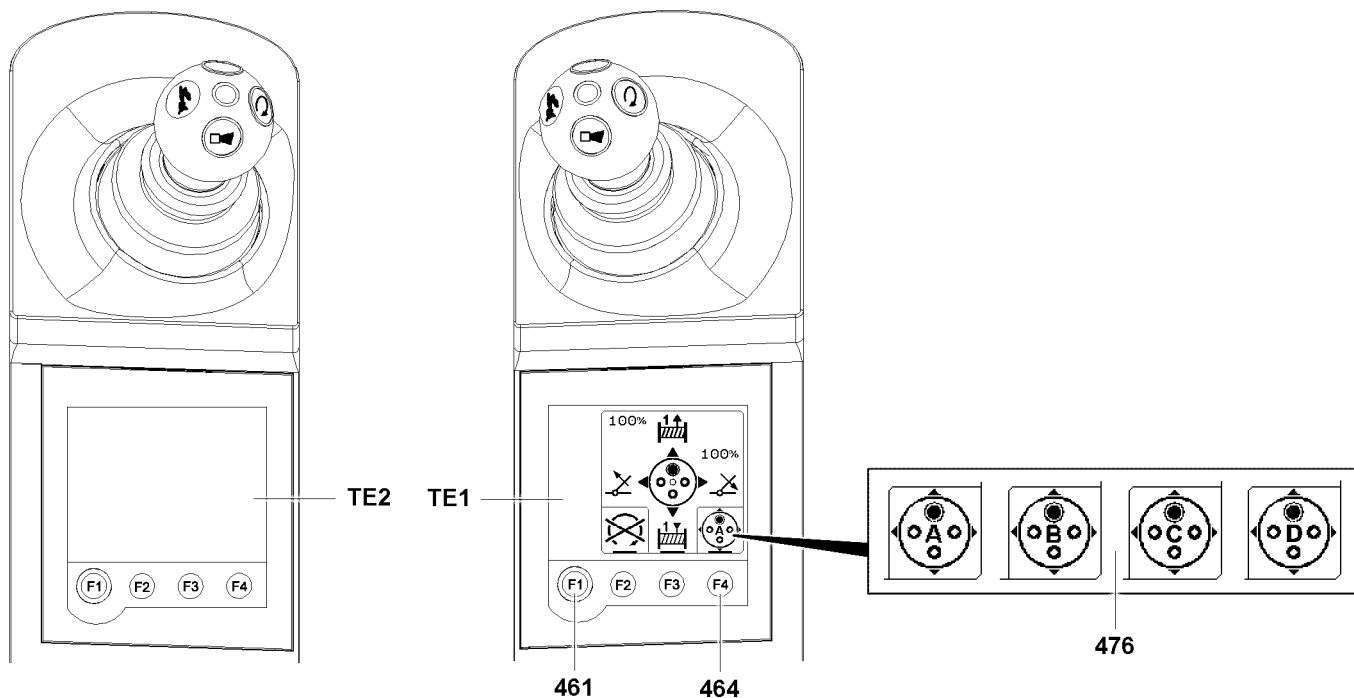


Fig.124539: Master switch assignment

Before starting crane operation, the master switch assignment must be matched to the set up configuration of the crane. The various master switch assignments are displayed with code letters **476**, for example **A, B, C, D...** on the touch display **TE1**.

The touch display **TE1** and touch display **TE2** are described in the Crane operating instructions, chapter 4.01.



### Note

- ▶ Observe and adhere to the data in operating instructions, chapter 4.01.

## 6.1 Changing the master switch assignment

Make sure that the following prerequisites are met:

- Both master switches are in the neutral position.
- ▶ Until the „Master switch assignment“ menu appears: Press the F1 key **461** on the touch display **TE1**.
- ▶ Until the required master switch assignment is active: Press the F4 key **464**.

**Result:**

- The active master switch assignment is displayed on the touch display **TE1** and on the touch display **TE2**.

## 7 Luffing

The speed of the luffing movement is controlled by:

- Deflection of the master switch.
- Actuation of the engine regulation (gas pedal).
- Rapid gear engaged / turned off.



### WARNING

Lift the load by luffing up the boom!  
The crane can topple over, death, property damage.

When the LICCON overload protection turns off when lifting a load:

- ▶ Do **not** lift the load by luffing up.
- ▶ Lift the load solely with the hoist gear.

### 7.1 Luffing the telescopic boom

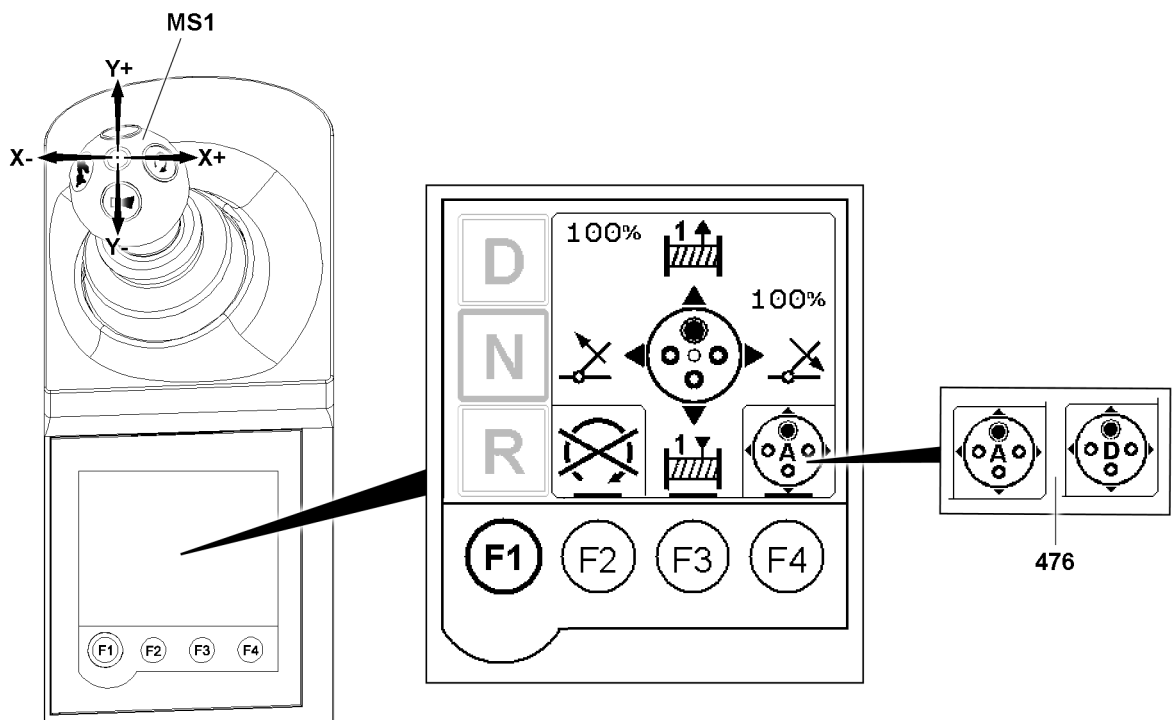


Fig. 124540: Luffing the telescopic boom

Depending on the set up configuration of the crane, various master switch assignments are available to luff the telescopic boom.

Depending on the set up configuration, not all master switch assignments are always available.  
The telescopic boom is luffed with master switch **MS1** in direction of the X-axis.

### NOTICE

Fully telescoped out telescopic boom luffed down to block position!  
Telescopic boom can collide with cover plates.

When the telescopic boom is completely telescoped out:

- ▶ Do **not** luff the telescopic boom down to block position.

Make sure that the following prerequisites are met:

- If the crane is equipped with one winch:  
Master switch assignment **476 A** is active.
- If the crane is equipped with two winches:  
Master switch assignment **476 A** or **D** is active.
- ▶ Deflect the master switch **MS1** in direction X-.

### Result:

- The telescopic boom is luffed up.
- ▶ Deflect the master switch **MS1** in direction X+.

### Result:

- Telescopic boom is luffed down.

## 7.2 Luffing the hydraulic auxiliary boom\*

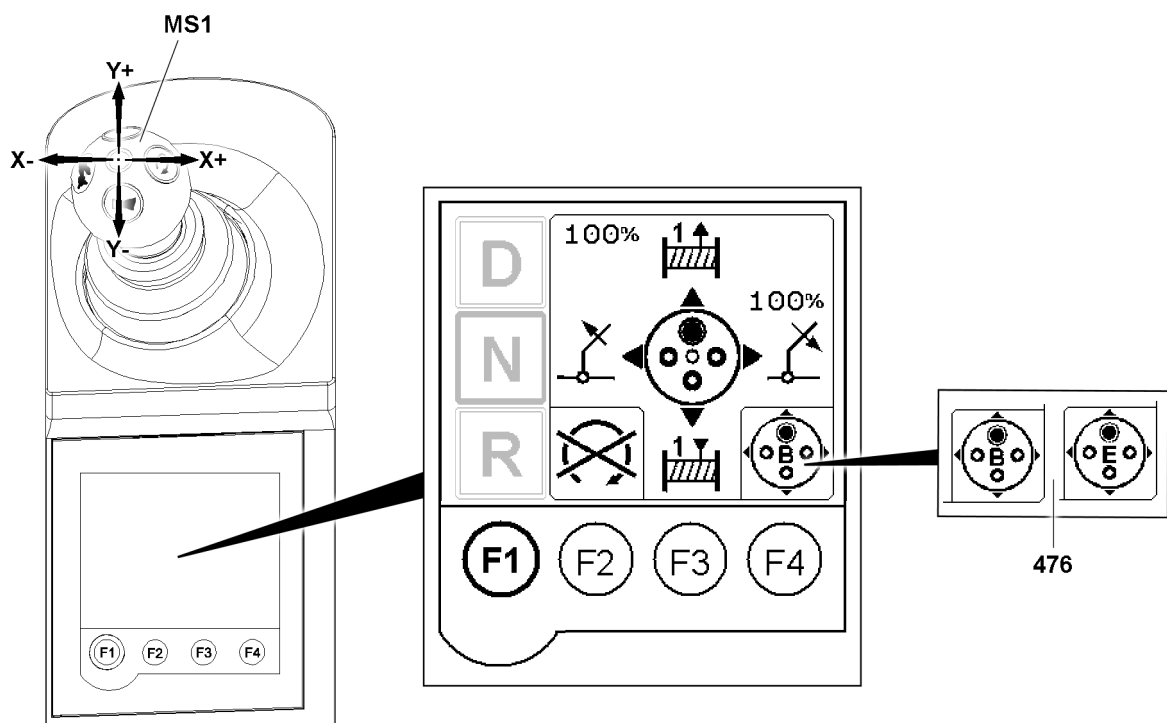


Fig.124541: Luffing the hydraulic auxiliary boom\*

**Luffing the hydraulic auxiliary boom\* is only possible for certain crane types.**

Depending on the set up configuration of the crane, various master switch assignments are available to luff the hydraulic auxiliary boom\*.

Depending on the set up configuration, not all master switch assignments are always available.

The hydraulic auxiliary boom\* is luffed with master switch **MS1** in direction of the X-axis.



Make sure that the following prerequisites are met:

- The set up configuration with hydraulic auxiliary boom is set on the LICCON computer system.
- If the crane is equipped with one winch:  
Master switch assignment **476 B** is active.
- If the crane is equipped with two winches:  
Master switch assignment **476 B** or **E** is active.

- ▶ Deflect the master switch **MS1** in direction X-.

**Result:**

- Hydraulic auxiliary boom\* is luffed up.

- ▶ Deflect the master switch **MS1** in direction X+.

**Result:**

- Hydraulic auxiliary boom\* is luffed down.

## 8 Lifting / lowering

The lifting / lowering speed is controlled by:

- Deflection of the master switch.
- Actuation of the engine regulation (gas pedal).
- Rapid gear engaged / turned off.

### NOTICE

Slack rope formation!

The hoist rope can be damaged.

- ▶ Do not allow slack rope formation.

### 8.1 Activating / deactivating winch 1

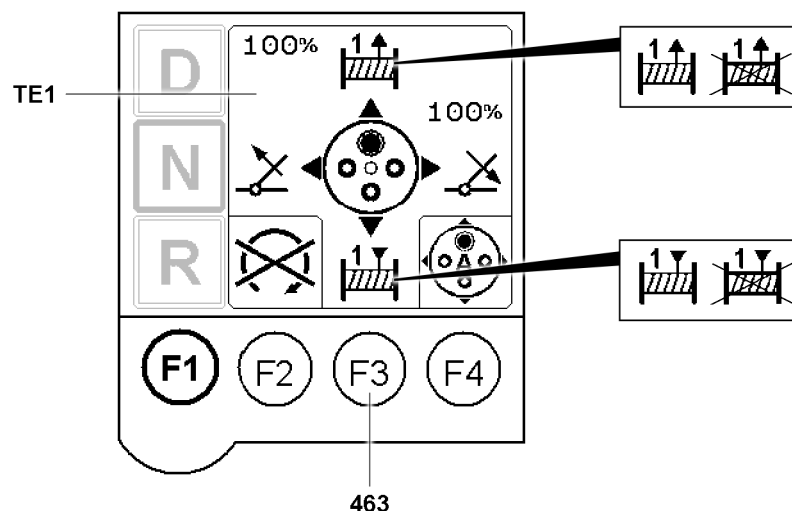


Fig. 124542: Activating / deactivating winch 1

Winch 1 can be activated or deactivated with the F3 key **463**.

Make sure that the following prerequisite is met:

- Winch 1 is not actuated.

If winch 1 is deactivated:

- ▶ Press the F3 key **463** on the touch display **TE1** for 3 seconds.

**Result:**

- Winch 1 is activated.
- Winch 1 icon is no longer shown crossed out.

When winch 1 is activated:

- ▶ Press the F3 key **463** on the touch display **TE1** for 3 seconds.

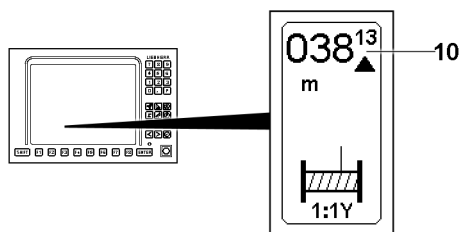
**Result:**

- Winch 1 is deactivated.
- Winch 1 icon is shown crossed out.

## 8.2 Lifting / lowering with winch 1

Depending on the set up configuration of the crane, there are various master switch assignments for lifting / lowering with winch 1.

Depending on the set up configuration, not all master switch assignments are always available.



*Fig.124546: Icon 10*

As soon as winch 1 turns, this is shown in the icon **10**.

The lifting and lowering movements are controlled with the master switch **MS1** in direction of the Y-axis.

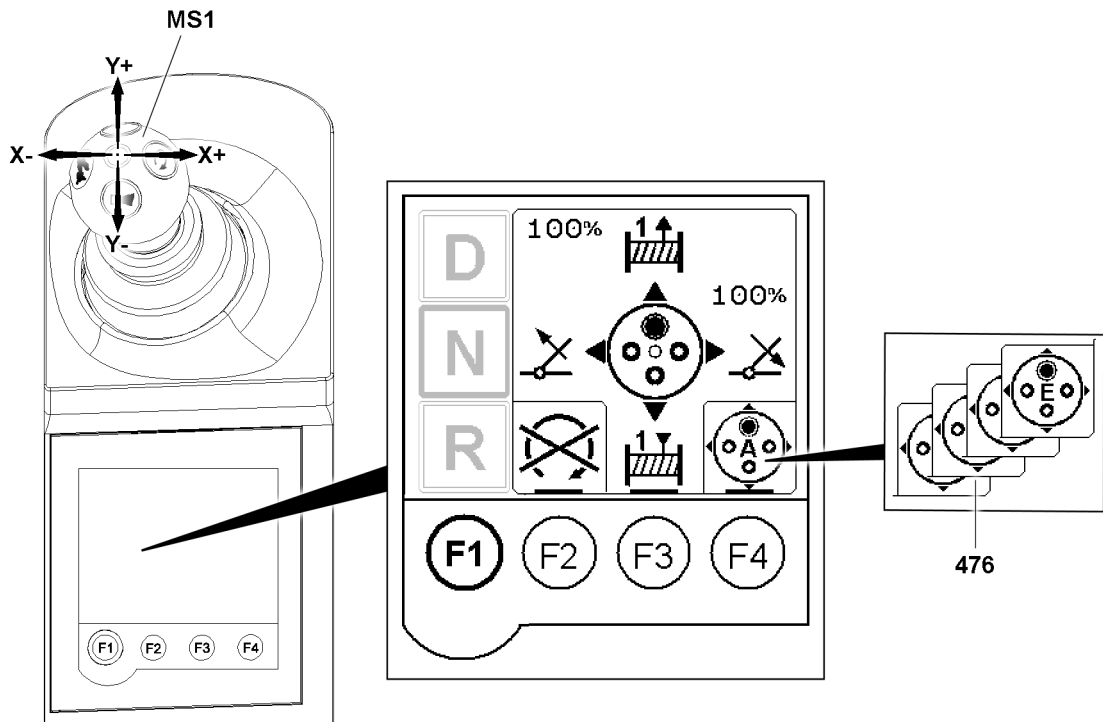


Fig.151535: Lifting / lowering with winch 1

Make sure that the following prerequisites are met:

- If the crane is equipped with one winch:  
Master switch assignment **476 A** or **B** is active.
- If the crane is equipped with two winches:  
Master switch assignment **476 A, B, C, D** or **E** is active.

- ▶ Deflect the master switch **MS1** in direction Y+.

**Result:**

- Winch 1 spools out and the load is lowered.

- ▶ Deflect the master switch **MS1** in direction Y-.

**Result:**

- Winch 1 spools up and the load is lifted.

### 8.3 Activating / deactivating winch 2\*

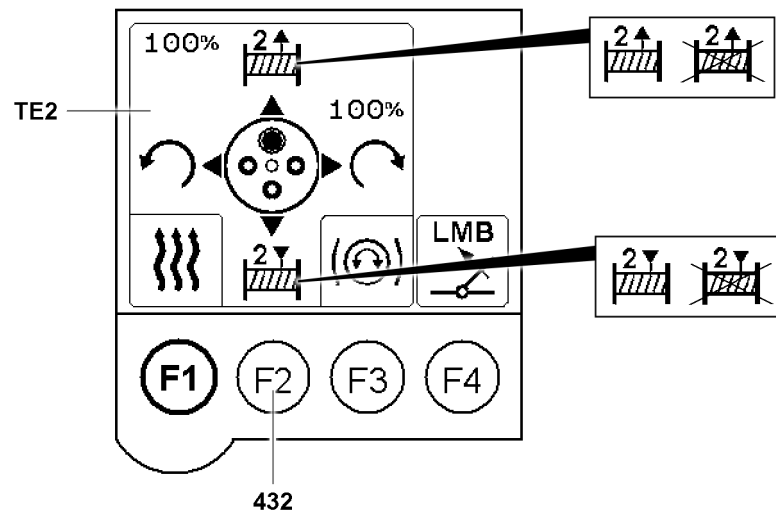


Fig.124544: Activating / deactivating winch 2\*

Winch 2 can be activated or deactivated with the F2 key **432**.

Make sure that the following prerequisite is met:

- Winch 2 is not actuated.

If winch 2 is deactivated:

- ▶ Press the F2 key **432** on the touch display **TE2** for 3 seconds.

**Result:**

- Winch 2 is activated.
- Winch 2 icon is no longer shown crossed out.

When winch 2 is activated:

- ▶ Press the F2 key **432** on the touch display **TE2** for 3 seconds.

**Result:**

- Winch 2 is deactivated.
- Winch 2 icon is shown crossed out.

### 8.4 Lifting / lowering with winch 2\*

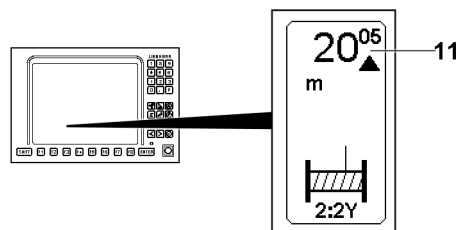


Fig.124547: Icon 11

As soon as winch 2\* turns, this is shown in the icon **11**.

The lifting and lowering movements are controlled with the master switch **MS2** in direction of the Y-axis.

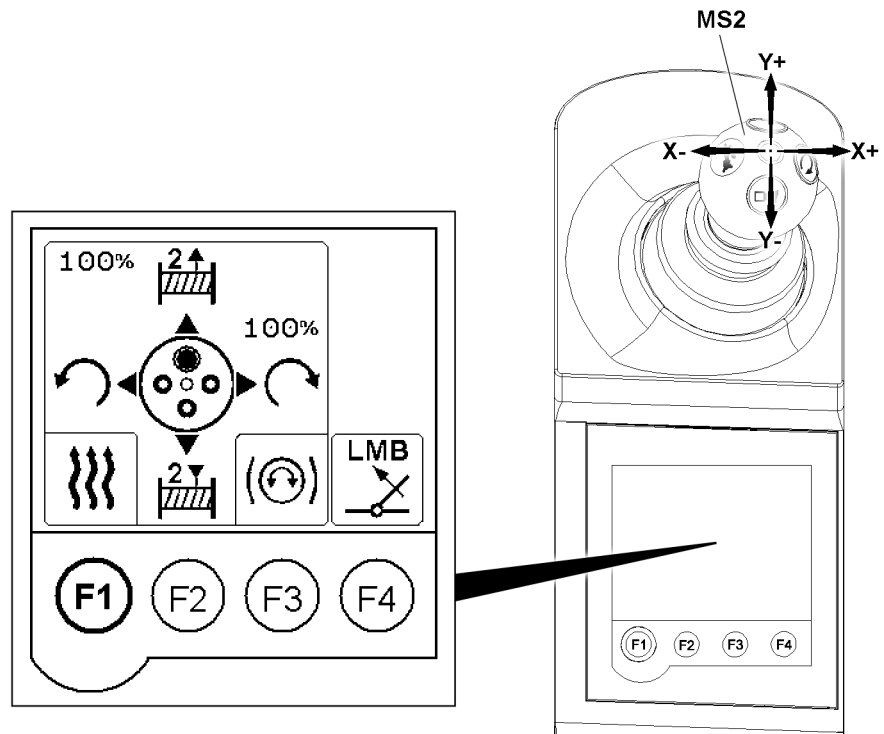


Fig.124545: Lifting / lowering with winch 2\*

- ▶ Deflect the master switch **MS2** in direction Y+.

**Result:**

- Winch 2 spools out and the load is lowered.

- ▶ Deflect the master switch **MS2** in direction Y-.

**Result:**

- Winch 2 spools up and the load is lifted.

## 9 Turning

The speed of the turning movement is controlled by:

- Deflection of the master switch.
- Actuation of the engine regulation (gas pedal).



**WARNING**

Persons in the slewing range!  
Crushing danger, death, severe bodily injuries.

- ▶ Monitor the slewing range.
- ▶ Make sure that there are **no** persons within the slewing range.
- ▶ Before initiating a turning movement, give a warning signal (horn).



**WARNING**

Obstacle in the slewing range!  
Property damage on crane and on obstacle.

- ▶ Make sure that there are **no** obstacles within the turning range of the crane and the crane components.

## 9.1 Monitoring the turning range

On certain crane types, one or two mirrors are installed on the right side of the turntable. This makes it easier to view the turning range.

- ▶ Monitor the turning range.

### Problem remedy

Can the turning range **not** be viewed using the mirror?

- ▶ Until the turning range can be viewed using the mirror: Bend your upper body or tilt the crane cab.

## 9.2 Maximum slewing speed

The load chart manual lists the maximum slewing speeds in percentages.

The setting of the maximum slewing speed is described in the Crane operating instructions, chapter 4.02.



### Note

- ▶ For a longer boom and larger load, turn the crane superstructure at a slower speed.



### WARNING

Slewing speed set too high!

The crane can topple over, death, property damage.

- ▶ Observe and adhere to the slewing speeds which are specified in the load chart manual and the crane documentation.
  - ▶ Do **not** exceed the maximum permissible slewing speeds.
  - ▶ Initiate and brake a turning movement extremely sensitively.
- 
- ▶ Determine the maximum slewing speed and set it on the LICCON overload protection.

## 9.3 Slewing gear brake

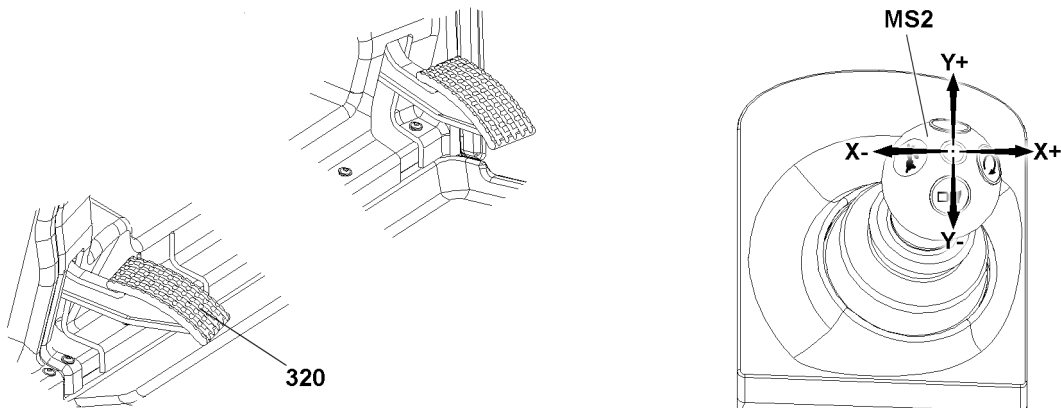


Fig.125210: Slewing gear brake

The slewing gear brake cannot brake the full turning momentum.

### NOTICE

Incorrect use of the slewing gear brake!

The slewing gear and the roller ring connection can be damaged.

- ▶ Use the pedal **320** only at minimum slewing speeds.
- ▶ Do not brake the turning movement of the crane by moving the master switch **MS2** back to the neutral position and / or by simultaneously applying the pedal **320**.

Use the pedal **320** only for the following situations:

- Starting the slewing movement with a strong side wind

- Stopping the slewing movement with a strong side wind

### 9.3.1 Starting the slewing movement with a strong side wind

If the crane must be turned against the wind with a strong side wind, then the crane superstructure can turn in the opposite the direction due to insufficient drive torque.

- ▶ Actuate the pedal **320** and deflect the master switch **MS2** into the desired turning direction.
- ▶ Slowly release the pedal **320** until the superstructure turns in the desired turning direction.

### 9.3.2 Stopping the slewing movement with a strong side wind

- ▶ Slow down the crane with master switch **MS2** to minimum slewing speed.
- ▶ Apply the pedal **320** carefully, until the crane has come to a standstill at the desired position.

## 9.4 Parking brake slewing gear

As long as the *parking brake of the slewing gear* is released, the crane superstructure can turn by itself due to wind or incline position.



### WARNING

Crane superstructure turns without actuated turning movement!

- ▶ Apply the *parking brake slewing gear*.

With **released** parking brake, the parking brake is released permanently. Regardless if the slewing gear is actuated with the master switch **MS2**. This prevents a sudden stop.

If the parking brake is **applied**, the parking brake is released as soon as the master switch **MS2** is deflected. The parking brake is applied again as soon as the master switch **MS2** is moved to the neutral position and the slewing gear is no longer actuated.

The parking brake can **not** be released if:

- The working range limitation is active.
- A load chart with limited slewing range is selected.
- Variable support is selected.

### 9.4.1 Releasing the parking brake

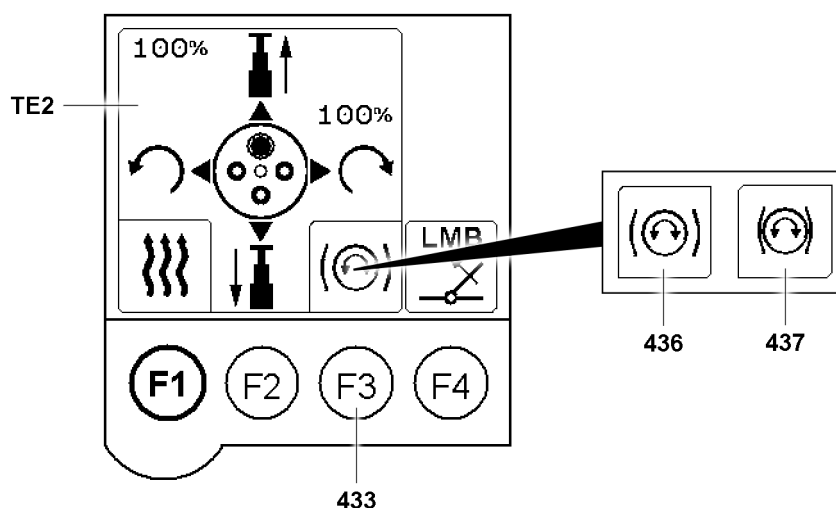


Fig. 124550: Releasing the parking brake

Make sure that the following prerequisites are met:

- The parking brake is applied.
- The icon **437** is shown on the touch display **TE2**.

- ▶ Press the F3 key **433**.

**Result:**

- The parking brake is released.
- The Icon **436** appears on the touch display **TE2**.

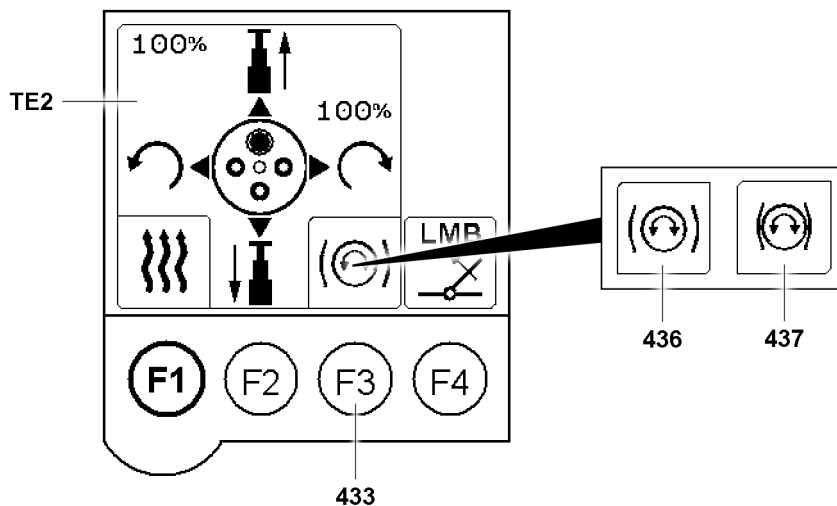
**9.4.2 Applying the parking brake**

Fig.124550: Applying the parking brake

Make sure that the following prerequisites are met:

- The crane superstructure is **not** turning.
- The parking brake is released.
- The icon **436** is shown on the touch display **TE2**.

► Press the F3 key **433**.

**or**

Turn the engine off.

**or**

Do **not** actuate the seat contact button or the bypass button for the seat contact button.

**Result:**

- The parking brake is applied.
- The Icon **437** appears on the touch display **TE2**.



## 9.5 Switching the slewing gear to freewheeling

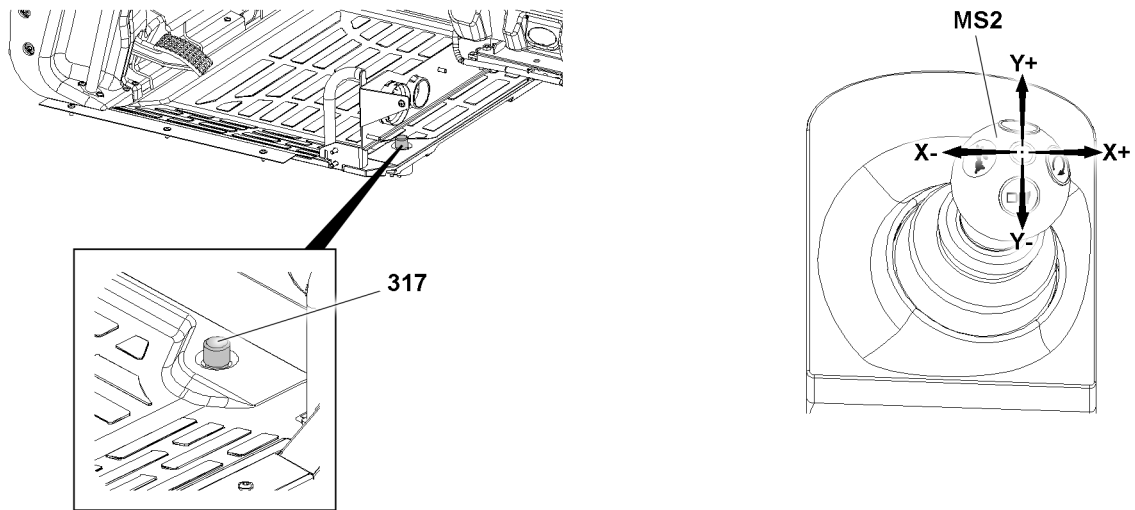


Fig.125211: Switching the slewing gear to freewheeling

In order to position the boom over the load more easily, the slewing gear can be switched to freewheeling.

As long as slewing gear is switched to freewheeling, the crane superstructure can turn in an uncontrolled manner due to wind or incline position.



### WARNING

Crane superstructure turns without actuated turning movement!

Only when independent slewing movements are excluded:

- ▶ Switch the slewing gear to freewheeling.

The slewing gear **cannot** be switched to freewheeling if:

- A load chart with limited slewing range is selected.
- The working range limitation is active.
- Variable support is selected.
- Radio operation is active.

The activation of the freewheel and actuation of the slewing movement via the master switch **MS2** are mutually exclusive. When the master switch **MS2** is deflected, the slewing gear cannot be switched to freewheeling via the foot button **317**. When the foot button **317** is actuated, no turning movement is possible.

Make sure that the following prerequisite is met:

- The master switch **MS2** is not deflected.

- ▶ Press the foot button **317**.

### Result:

- The slewing gear is switched to freewheeling.

## 9.6 Turning the crane superstructure

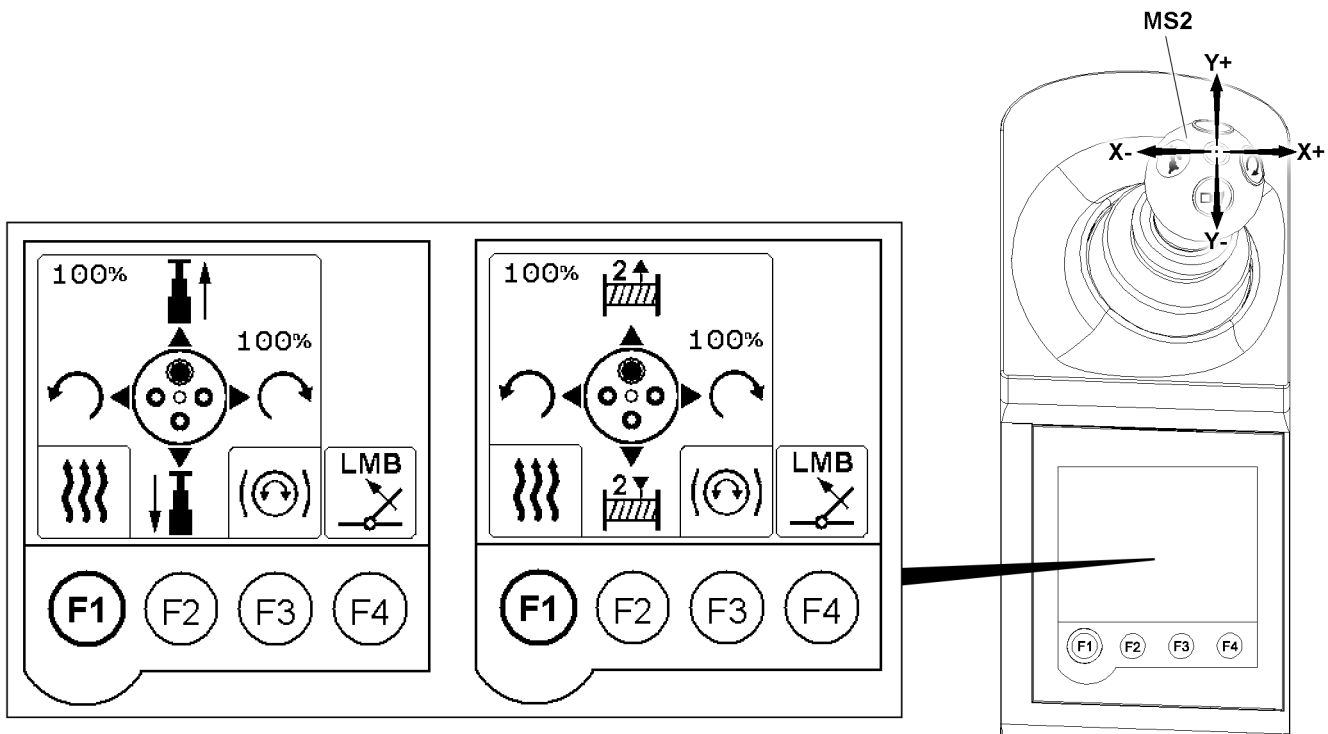


Fig.124548: Turning the crane superstructure

Depending on the set up configuration of the crane, various master switch assignments are available to turn the crane superstructure.

Depending on the set up configuration, not all master switch assignments are always available.

The crane superstructure is turned with the master switch **MS2** in direction of the X-axis.

Make sure that the following prerequisites are met:

- Master switch assignment Turning the crane superstructure is active.
- Crane superstructure **not** pinned with the crane chassis.

► Deflect the master switch **MS2** in direction X+.

**Result:**

- The crane superstructure turns to the right.

► Deflect the master switch **MS2** in direction X-.

**Result:**

- The crane superstructure turns to the left.

## 10 Telescoping

### 10.1 Safety

If the case of problems with the Telematik system, crane operation must be stopped immediately and the customer service at Liebherr-Werk Ehingen GmbH must be contacted.

If operation must be continued due to an emergency situation, this may only be carried out by persons who are aware of the effects of their acts in compliance with all necessary safety precautions.

**WARNING**

Telematik system problem!

The telescopic boom can telescope in by itself.

- ▶ First telescope in all the way the telescope locked in the telescoping cylinder.
- ▶ If the telescoping cylinder is extended and locked in a telescope: Never release the cylinder pinning in the case of a problem.
- ▶ Continue working with the Telematik system only after the error has been rectified.

The speed of the telescoping movement is controlled by:

- Deflection of the master switch.
- Actuation of the engine regulation (gas pedal).
- Rapid gear engaged / turned off.

Telescoping has a direct effect on the hoist rope.

**NOTICE**

Collision of the hook block with the boom head!

- ▶ The movement of the hook block when telescoping by spooling the hoist winch.

Telescoping the telescopic boom under load is determined by the friction of the bearing shoes and the existing tension lengths of the telescopes.

**NOTICE**

Damage to the telescopic boom when telescoping under load!

When telescoping under load:

- ▶ Do **not** exceed the load shown on the LICCON monitor.
- ▶ We recommend: Telescope the telescopic boom out without a load and then pick up the load.

In case of an overlap of unfavorable ancillary conditions the telescopic boom can swing up during telescoping.

In case of increased friction between the telescopic sections, an excessive elastic system-dependent pretension of the push out mechanism occurs. Due to this elastic pretension of the push out mechanism, a „stick-slip effect“ can be created, which then leads to the upswing of the telescopic boom.

These swing movements can be created due to the elasticity of the crane, especially when working in 90° position or 270° position.

**NOTICE**

Upswing of telescopic boom when telescoping „stick-slip effect“!

- ▶ Before crane operation, lubricate the boom glide bearings sufficiently.

When the telescopic boom swings up:

- ▶ Stop the telescoping movement.
- ▶ Wait until the telescopic boom swings no longer.
- ▶ Continue telescoping.

When telescoping out, then it can happen that the individual telescopes get pulled apart due to friction and the bore play of the pinning.

When telescoping in or luffing up, the telescopes can retract suddenly. This is system inherent and is not a sign of an erroneous function.

**NOTICE**

Friction and bore play in pinning!

Telescopic boom can retract jerkily.

- ▶ Prevent oscillation of the load.

If a load is set down, it can cause the telescopes to telescope out suddenly due to a compressed oil column in the telescoping cylinder.

**WARNING**

The oil column in the telescoping cylinder is relieved after a telescoped load is set down!  
The telescopic boom can telescope out by itself.

- ▶ When setting down the load: Telescope the telescopic boom in briefly or luff up briefly.

If the telescopic boom is telescoped out and a load is lifted after a delay, the oil column that cooled down in the meantime in the telescoping cylinder could cause the telescopic boom to telescope in suddenly.

**WARNING**

Telescoping the telescopic boom out and lifting a load with a delay!  
The telescopic boom can telescope in suddenly.

- ▶ Before lifting a load: Telescope the telescopic boom out slightly.

In the case of a large boom radius and heavy pinned loads, the telescopic boom can sag considerably. If the telescoping cylinder is retracted or extended with a pinned telescope, the telescoping cylinder can collide with components of the telescope.

**NOTICE**

Considerable telescopic boom sagging. The telescoping cylinder is retracted or extended with a pinned telescope!

The telescoping cylinder can collide with components of the telescope.

- ▶ If the telescopic boom is sagging considerably, do **not** retract or extend the telescoping cylinder.
- ▶ Set down the load. Then move the telescoping cylinder.

In the case of sun exposure on one side, the telescopic boom can deform considerably on one side. If the telescoping cylinder is retracted or extended with a pinned telescope, the telescoping cylinder can collide with components of the telescope.

**NOTICE**

The telescopic boom distorts too much on the side. The telescoping cylinder is retracted or extended with a pinned telescope!

The telescoping cylinder can collide with components of the telescope.

- ▶ If the telescopic boom is deformed considerably on the side, do **not** retract or extend the telescoping cylinder.
- ▶ Until both sides of the boom are heated up equally: Turn the crane superstructure.
- ▶ Then move the telescoping cylinder.

**WARNING**

Do **not** take the crane out of service with the telescopic boom pinned!  
The telescopic boom can retract by itself.

- ▶ Cranes with a Telematik system may only be taken out of service with the telescopic boom pinned.

Make sure that the following prerequisites are met before telescoping:

- The mobile crane is supported and horizontally aligned.
- The telescopic boom is **not** sagging considerably.
- The telescopic boom is **not** deformed on one side due to sun exposure.
- There is **no** strong side wind.

## 10.2 Telescoping with master switch MS2

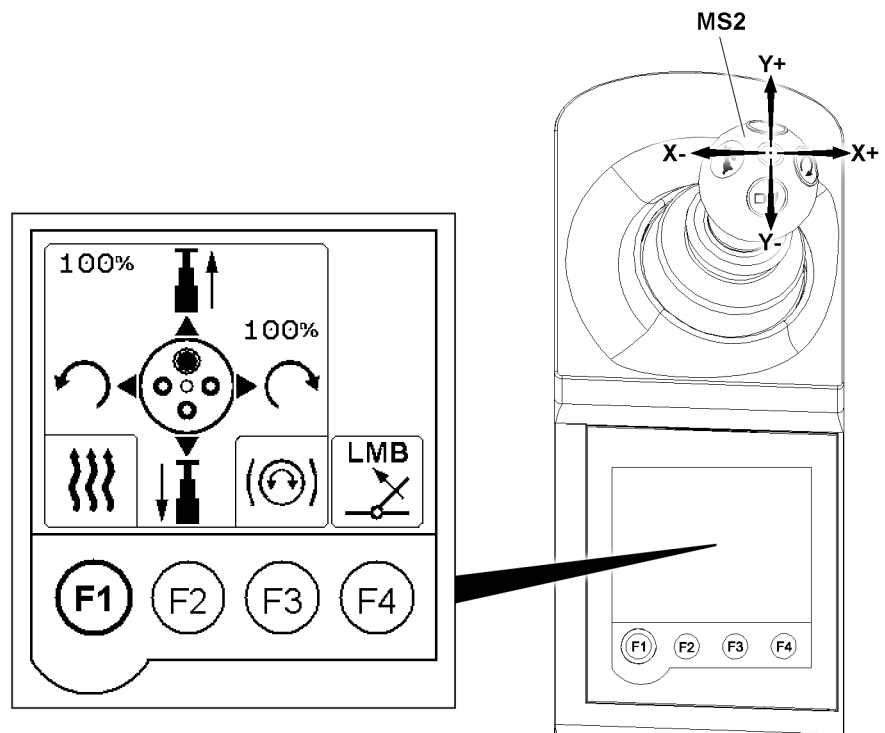


Fig.124554: Telescoping with cranes with one hoist gear

The telescopic boom on cranes with one hoist gear is telescoped with the master switch **MS2** in direction of the Y-axis.

- ▶ Move the master switch **MS2** in direction Y+.

**Result:**

- The telescopic boom is telescoped out.

- ▶ Move the master switch **MS2** in direction Y-.

**Result:**

- The telescopic boom is telescoped in.

## 10.3 Telescoping with master switch MS1

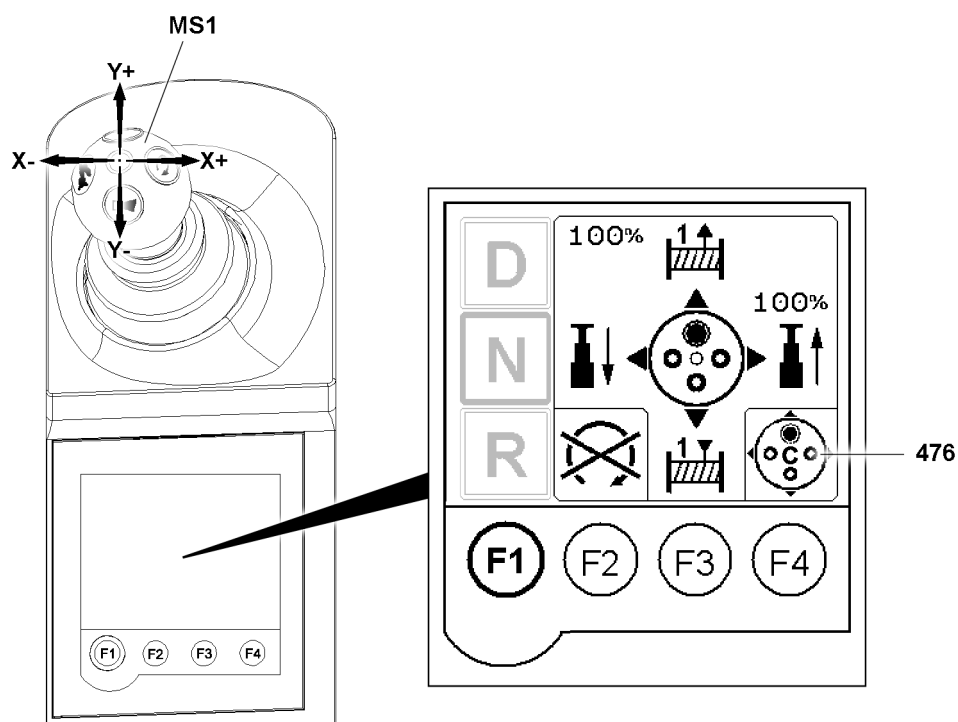


Fig.124555: Telescoping with cranes with two hoist gears

The telescopic boom on cranes with two hoist gears is telescoped with master switch **MS1** in direction of the X-axis.

Make sure that the following prerequisites are met:

- If the crane is equipped with two winches:  
Master switch assignment **476 C** is active.

► Move the master switch **MS1** in direction X+.

**Result:**

- The telescopic boom is telescoped out.

► Move the master switch **MS1** in direction X-.

**Result:**

- The telescopic boom is telescoped in.

## 10.4 Telescoping with master switch MSY

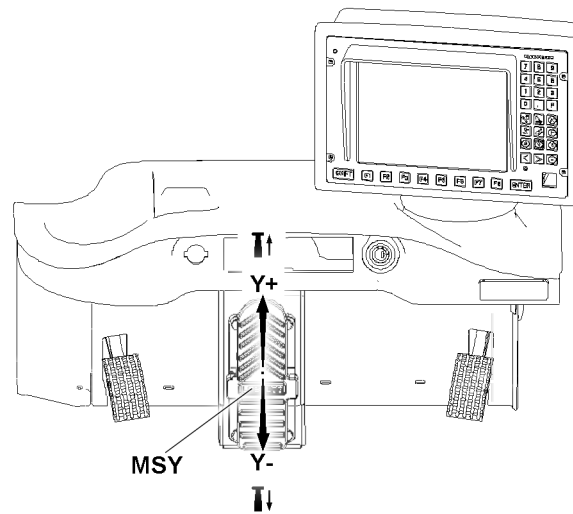


Fig.144223: Telescoping with foot rocker



### Note

- ▶ The master switch **MSY** is only available for certain cranes.

The telescopic boom on cranes with a foot rocker is telescoped in direction of the Y-axis.

- ▶ Move the master switch **MSY** in direction Y+.

### Result:

- The telescopic boom is telescoped out.

- ▶ Move the master switch **MSY** in direction Y-.

### Result:

- The telescopic boom is telescoped in.

## 10.5 Telematik system

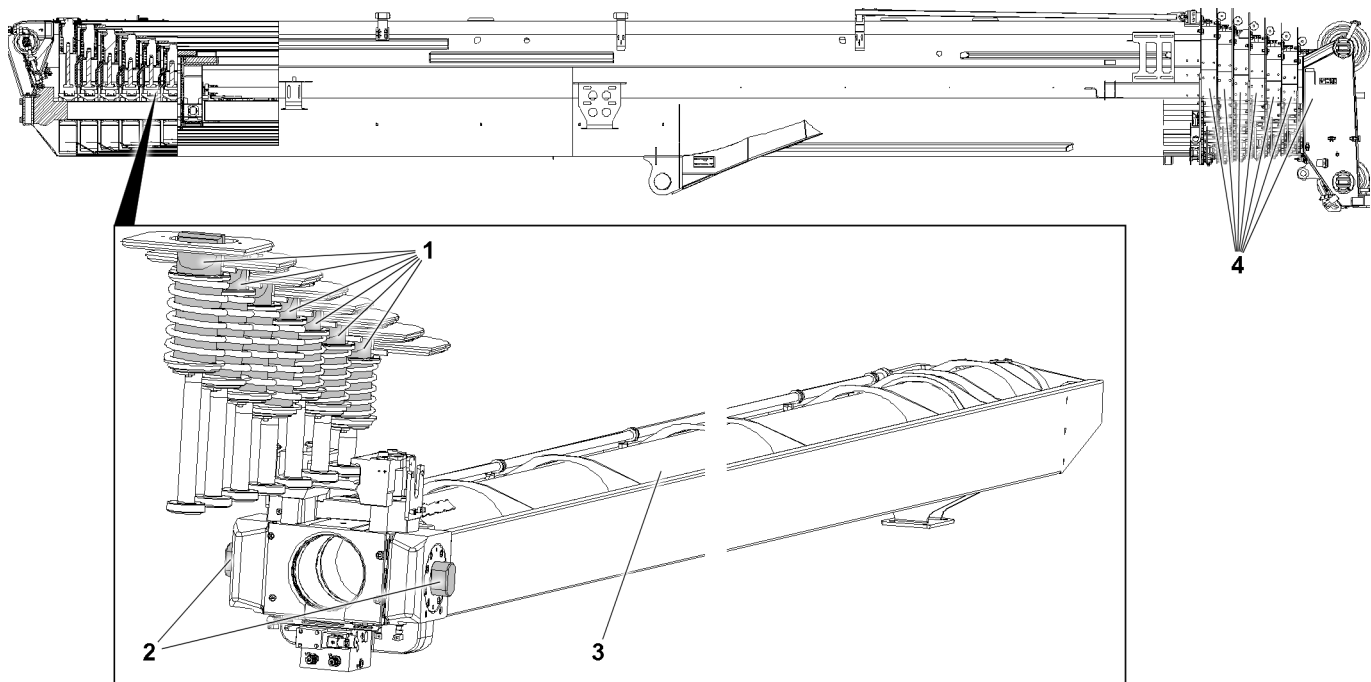


Fig.151521: Telematik system

- |   |                    |   |                      |
|---|--------------------|---|----------------------|
| 1 | Telescopic pinning | 3 | Telescoping cylinder |
| 2 | Cylinder pinning   | 4 | Telescopes           |

The illustration is exemplary. The structure of the telescopic boom depends on the crane type.

The cylinder pinning **2** and telescopic pinning **1** are mechanically interlinked, which means a telescopic section can only be unpinning when the cylinder pinning **2** is locked simultaneously with this telescopic section.

In the LICCON telescoping screen the crane operator can see, in dynamic graphics, the pinning state of the telescopic boom, the position of the individual telescopes **4** in relation to each other and the extension condition of the telescoping cylinder **3**.

Due to the automatic telescoping procedure, the crane operator can telescope the telescopic boom easily. He does not have to deal with pinning and unpinning the telescoping cylinder **3** or the telescopes **4**. The LICCON Telescope control thus simplifies telescoping. The crane driver only has to enter the desired telescoping target into the system.

The control decides the sequence in which the individual telescopes **4** will be moved in order to achieve the desired end state. After specifying the desired telescoping target, all telescoping movements are automatically carried out.

The following procedures are carried out by the system:

- Locking and unlocking of the telescoping cylinder **3**.
- Pinning and unpinning of the telescopes **4**.
- Sequence of telescopes **4**.

The telescoping movement is only carried out as long as the master switch is deflected.

The master switch determines the direction and the speed of the telescoping movement. In this way the crane operator has continuous control over the crane.

The direction of the cylinder movement is set by the LICCON computer system.

If the telescopic boom is telescoped out, whereby currently unreachable telescopes **4** must be moved, then they must first be telescoped in until the last telescope **4** to be moved is reached. In this case telescope in first for telescoping out.



The LICCON computer system displays the direction in which the next telescoping must be done. The master switch must also be pressed in correspondence of this direction setting. In this way the connection between the direction of movement of the appropriate master switch and the telescope 4 continues.

## 10.6 Selecting the telescoping target

The telescoping target can be selected in two programs:

- Set up program
- Telescoping program

### 10.6.1 Selecting the telescoping target in the Set up program

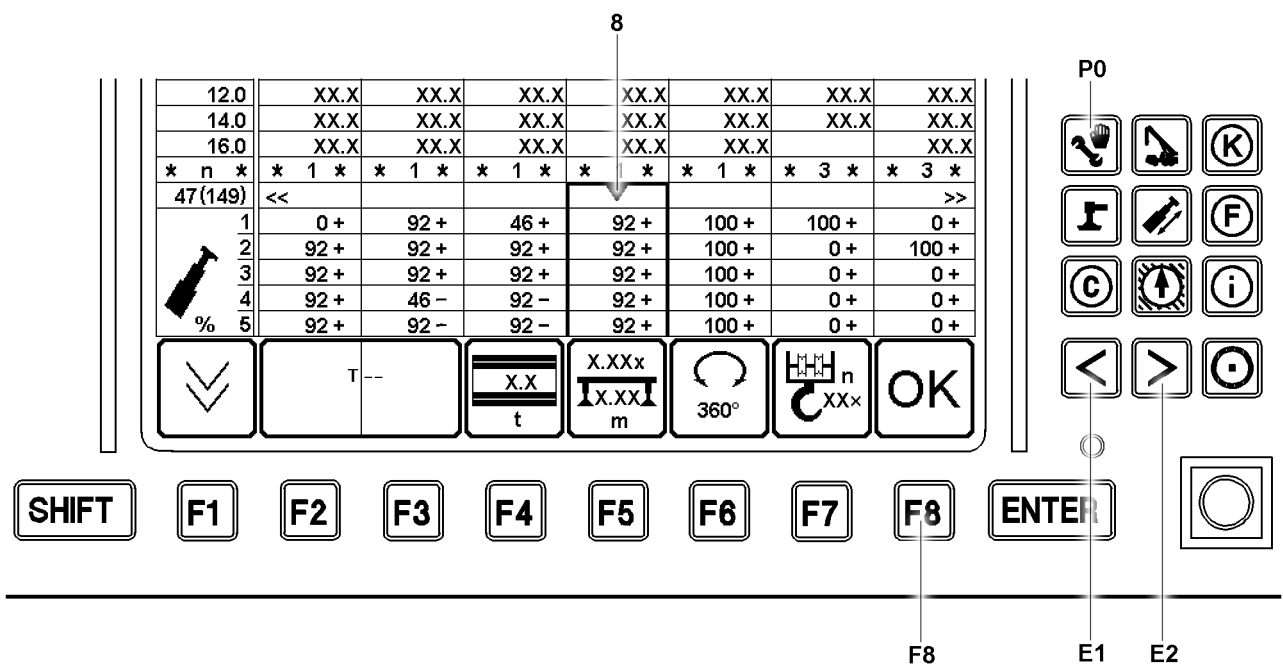


Fig.124556: Selecting the telescoping target in the Set up program

The *Set up program* is described in the Crane operating instructions, chapter 4.02.

- ▶ Press the program key **P0**.

**Result:**

- The *Set up* program is called up in the LICCON monitor.

The required telescopic boom length can be selected with the arrow key **E1** and the arrow key **E2**. To do so, the cursor **8** must be moved to the column with the required telescopic boom length.

If the cursor **8** touches an edge marked with arrows, then the next movement in this direction will display the next load chart column(s).

The status indicator ( $\pm$ ) next to the extension condition means:

- „+“ Telescopic section must be pinned.
- „-“ Telescopic section must **not** be pinned.

- ▶ With the arrow key **E1** and arrow key **E2** move the marker **5.2** to the column with the required telescopic boom length.
- ▶ Press the function key **F8**.

**Result:**

- Set up configuration is taken over.
- The LICCON overload protection changes into the *Crane operation* program.

- ▶ Check the set up configuration in the *Crane operation* program.

## 10.6.2 Selecting the telescoping target with the Telescoping program

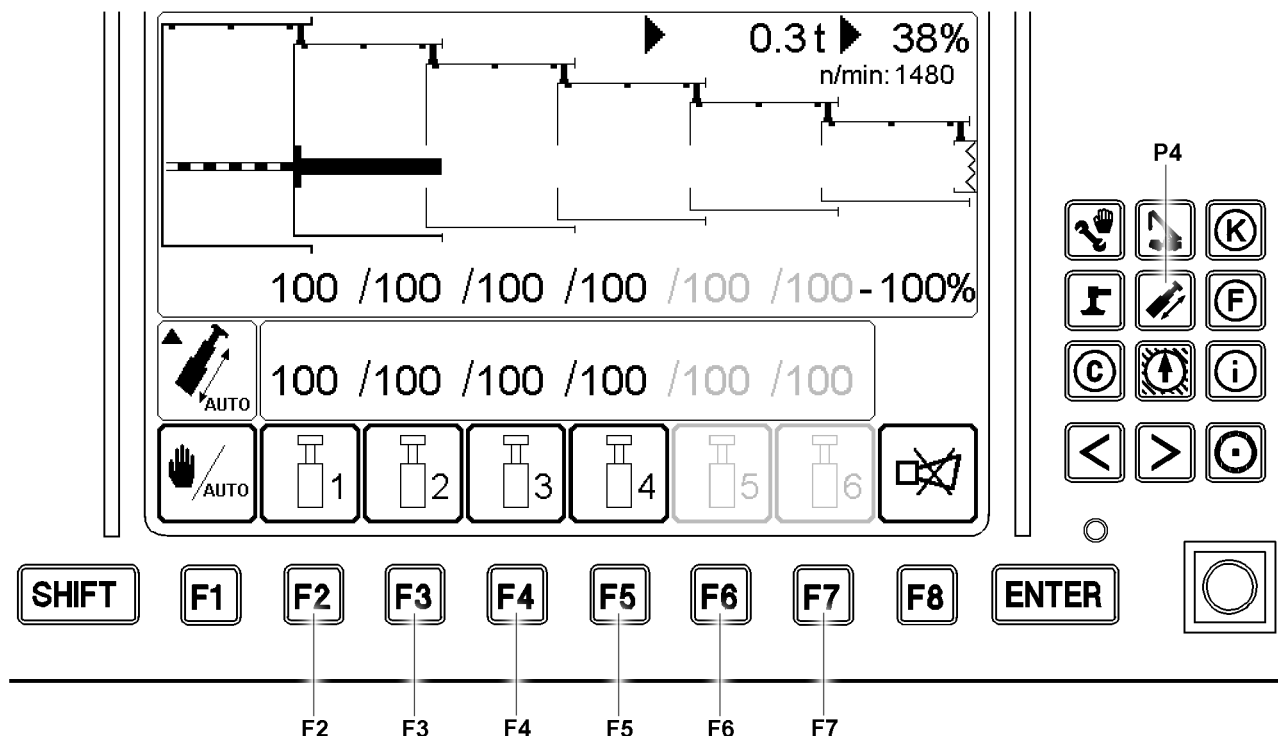


Fig.124557: Selecting the telescoping target with the Telescoping program

The *Telescoping program* is described in the Crane operating instructions, chapter 4.02.

- ▶ Press the program key **P4**.

**Result:**

- The *Telescoping program* is called up in the LICCON monitor.

The telescoping target is selected by pressing the function key several times. After every key press, the desired extension condition for the associated telescope changes to the next percentage value.

In contrast to the set up screen, the telescoping length is displayed immediately as a target as soon as the function key is pressed. No confirmation is required, as the assigned function keys do not have any other functions.

- ▶ Press the function key **F2**.

**Result:**

- On telescope 1 appears: 0 %, 46 %, 92 %, or 100 %.

- ▶ Press the function key **F3**.

**Result:**

- On telescope 2 appears: 0 %, 46 %, 92 %, or 100 %.

- ▶ Press the function key **F4**.

**Result:**

- On telescope 3 appears: 0 %, 46 %, 92 %, or 100 %.

- ▶ Press the function key **F5**.

**Result:**

- On telescope 4 appears: 0 %, 46 %, 92 %, or 100 %.

**Telescope 5 is only present on certain crane types.**

- ▶ Press the function key **F6**.

**Result:**

- On telescope 5 appears: 0 %, 46 %, 92 %, or 100 %.

**Telescope 6 is only present on certain crane types.**

- ▶ Press the function key **F7**.

**Result:**

- On telescope 6 appears: 0 %, 46 %, 92 %, or 100 %.

## 10.7 Telescoping to the telescoping target

The telescoping target can be telescoped in two programs:

- Crane operation program
- Telescoping program

### 10.7.1 Telescoping in the Crane operation program

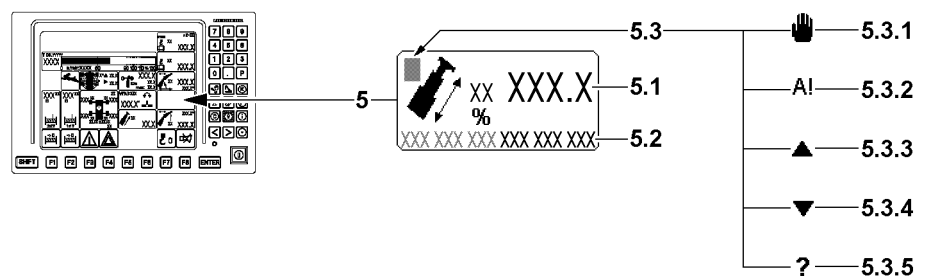


Fig.121831: Telescoping in the Crane operation program

The *Crane operation program* is described in the Crane operating instructions, chapter 4.02.

The crane driver receives information about the direction in which the master switch must be moved from the arrows in the icon **5**.

If the master switch is moved against the specified direction, the telescope remains stationary. The specified direction remains visible as an error criterion.

If the crane driver tries to continue to telescope when the telescoping target is reached, then the system switches from the *Crane operation program* into the *Telescoping program*. If the master switch is still being deflected, then the markings on the set telescoping target blink. This means that the telescoping target has been reached.

Make sure that the following prerequisite is met:

- The *Crane operation program* is active.

If the arrow **5.3.3** appears in the icon **5**:

- ▶ Telescope the telescopic boom out.

If the arrow **5.3.4** appears in the icon **5**:

- ▶ Telescope the telescopic boom in.

Once the telescoping target is reached, icon **A!** **5.3.2** appears.

When the icon **A!** **5.3.2** appears:

- ▶ End the telescoping operation.

## 10.7.2 Telescoping in the Telescoping program

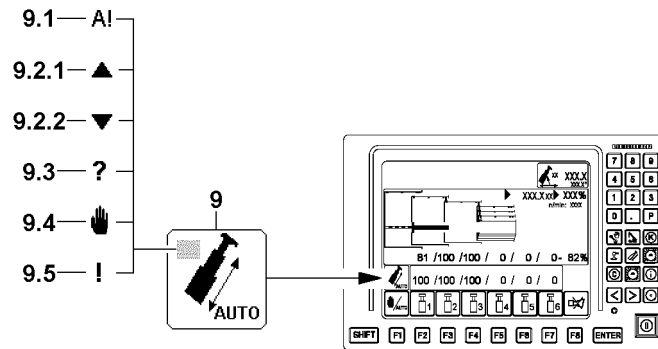


Fig.124558: Telescoping in the Telescoping program

The *Telescoping program* is described in the Crane operating instructions, chapter 4.02.

The crane driver receives information about the direction in which the master switch must be moved from the arrows in the icon **9**.

If the master switch is moved against the specified direction, the telescope remains stationary. The specified direction remains visible as an error criterion.

If the set telescoping target is reached, then the markings on the set telescoping target blink. This means that the telescoping target has been reached.

Make sure that the following prerequisite is met:

- The *Telescoping program* is active.

If the arrow **9.2.1** appears in the icon **9**:

- ▶ Telescope the telescopic boom out.

If the arrow **9.2.2** appears in the icon **9**:

- ▶ Telescope the telescopic boom in.

Once the telescoping target is reached, icon AI **9.1** appears.

When the icon AI **9.1** appears:

- ▶ End the telescoping operation.

## 10.8 Telescoping the telescopic boom manually

Manual telescoping is regarded as an exception mode, as automatic mode makes it possible to reach any chosen extension condition.

During manual telescoping, pinning and unpinning of the telescoping cylinder and telescoping must be carried out manually.

The marking on the telescoping screen will indicate in which telescope the pinning equipment of the telescoping cylinder is currently located.

The proximity to a telescope pin bore can be seen on the telescoping screen to an accuracy of 1 %.

The crane driver must be familiar with all functions of the extension system. The crane driver is responsible for damage to the telescoping system or the boom system.

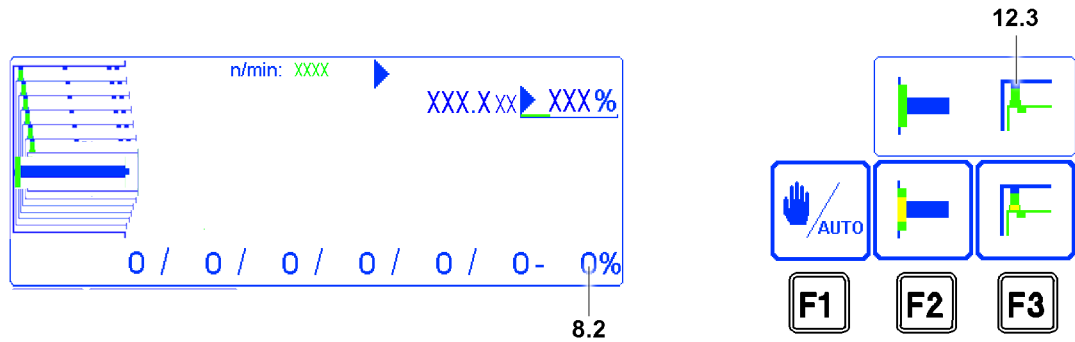


Fig.145144: Extension conditions

**NOTICE**

The pinning procedure cannot be completed! The pin in icon 12.3 is yellow.  
 The pin position must be searched for.  
 The telescopic boom can be damaged.

- ▶ Approach the pin points slowly and carefully.
- ▶ Complete the manual telescoping procedure and pin the telescope. The pin in icon 12.3 must be green.

**NOTICE**

After ending the telescoping procedure: The telescopic boom is **not** tensioned!  
 The telescopic boom can be damaged.

When the telescoping procedure is completed and the telescope is pinned:

- ▶ Tension the telescopic boom: Actuate the telescoping cylinder for 8 seconds with maximum master switch deflection to telescoping in. During this period of time, the extension condition of the telescoping cylinder 8.2 may **not** change.

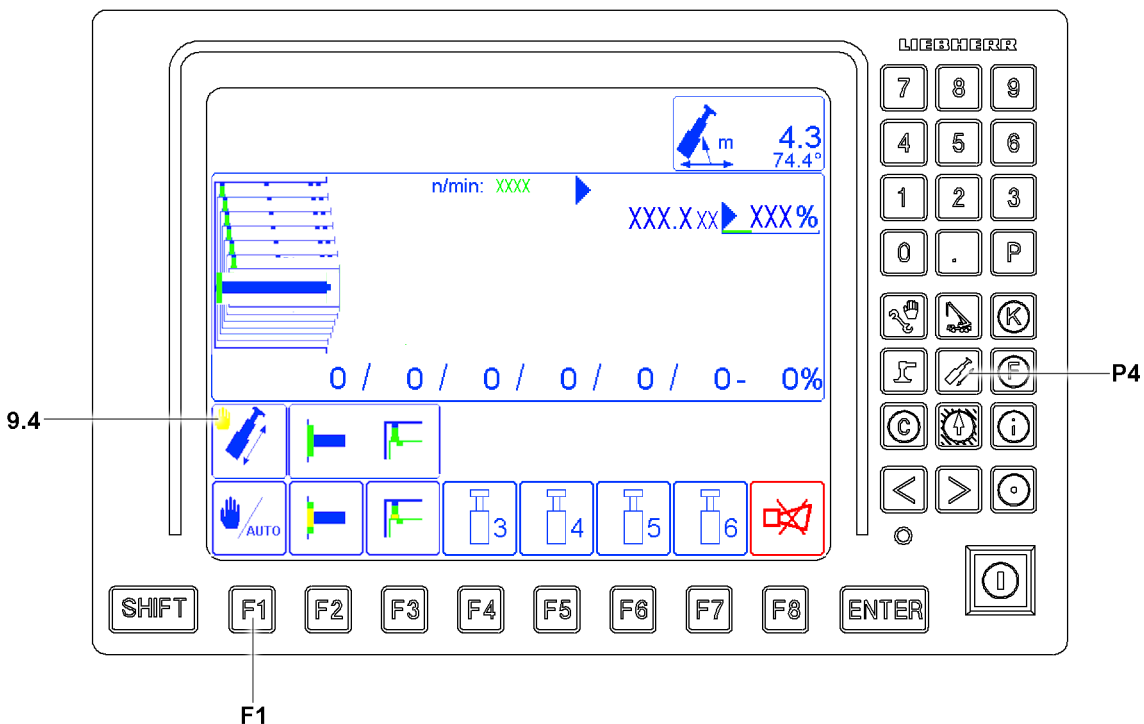


Fig.124559: Activating manual telescoping

- ▶ Press the program key P4.

**Result:**

- The *Telescoping program* is called up.
- ▶ Until manual telescoping is active: Press the function key **F1**.

**Result:**

- The icon **9.4** is displayed.

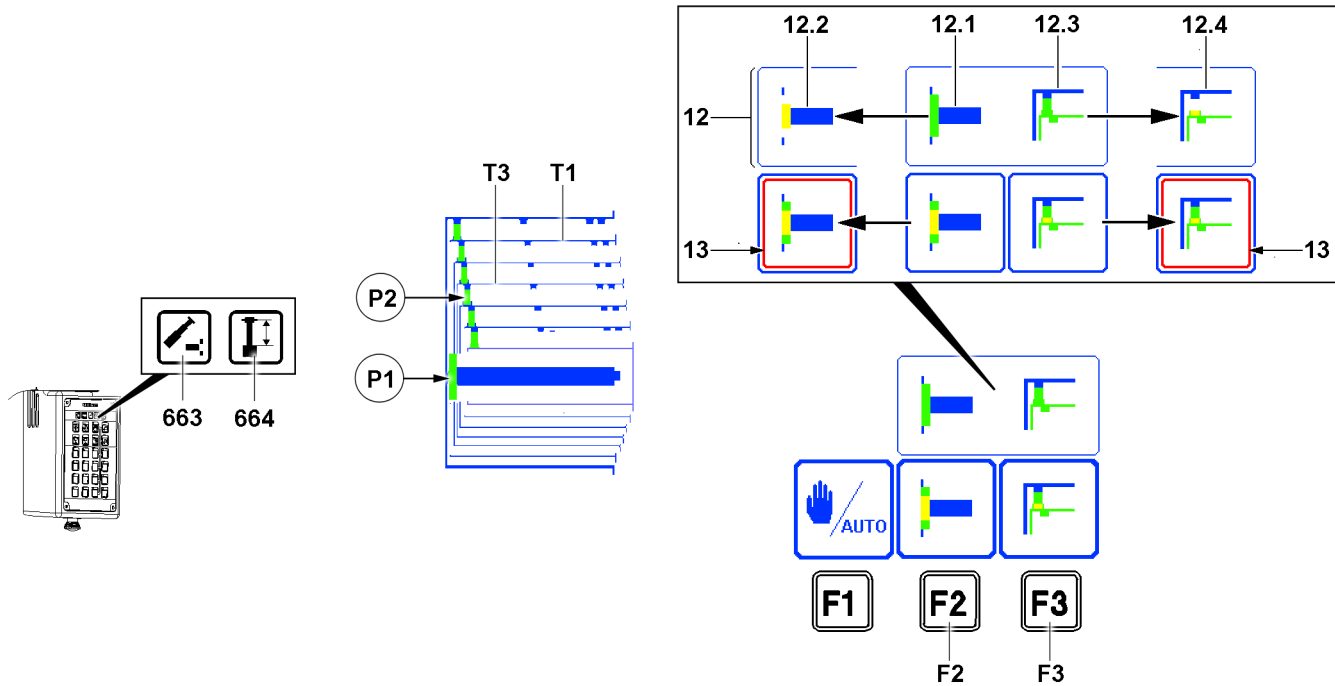


Fig.145141: Telescoping the telescopic boom manually

In this description it is assumed that all telescopes are telescoped in and the telescope **T1** is selected and pinned.

**Example:** The telescope **T3** should be telescoped out and pinned.

- Manual telescoping is activated.
- Telescoping cylinder is pinned. The cylinder pinning in the icon **12.1** is green.
- The telescope **T1** is pinned. Pin in icon **12.3** is green.
- ▶ Press the function key **F2**.

**Result:**

- The icon with a red frame **13** appears above the function key **F2**.
- Telescoping cylinder will be unpinned. The cylinder pinning in the icon **12.2** turns yellow.
- Display of the cylinder pinning in position **P1** turns yellow.
- The indicator light **663** lights up yellow.
- ▶ Until the telescope **T3** appears green on the LICCON monitor and the indicator light **664** lights up yellow: Extend the telescoping cylinder.
- ▶ Press the function key **F2**.

**Result:**

- The telescoping cylinder is pinned on the telescope **T3** and the cylinder pinning in the icon **12.1** turns green.
- Display of the cylinder pinning in position **P1** turns green.

**Problem remedy**

Display of the cylinder pinning in position **P1** is yellow?

Telescoping cylinder **not** audibly pinned.

Cylinder pinning is not in position. Pinning is stuck.

- ▶ Until the display of the cylinder pinning in position **P1** is green: Carefully extend and retract the telescoping cylinder.

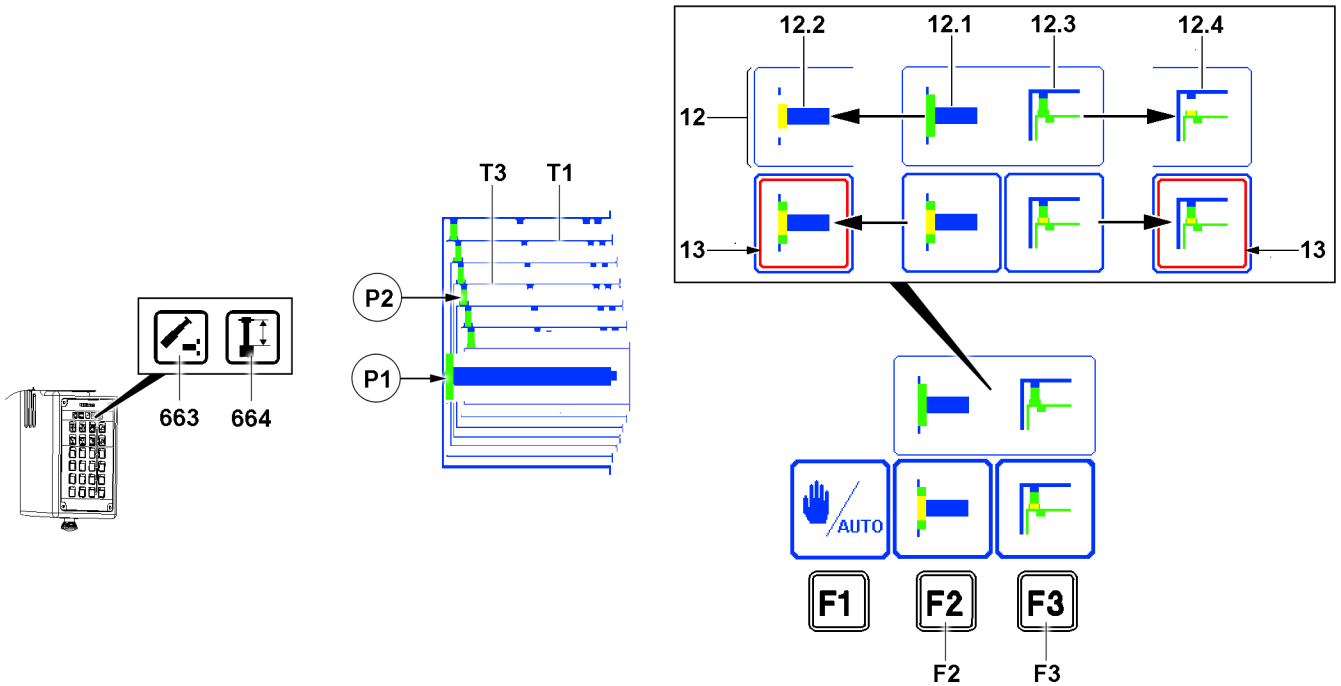


Fig.145141: Telescoping the telescopic boom manually

- ▶ Press the function key **F3**.

**Result:**

- The icon with a red frame **13** appears above the function key **F3**.
- The telescope **T3** is unpinned. Pin in icon **12.4** turns yellow.
- The indicator light **663** lights up green.

**Problem remedy**

Pin in position **P2** is extended and yellow?

The pin is stuck.

- ▶ Until the pin in icon **12.3** is moved in and is yellow: Carefully extend and retract the telescoping cylinder.

**NOTICE**

The telescope is **not** pinned!

Damage to the telescopic boom pinning.

- ▶ Pin the telescoping cylinder in the specified pin points.
- ▶ The telescopic boom pinning must pin audibly.

LWE/LTR 1220-003/24204-02-02/en

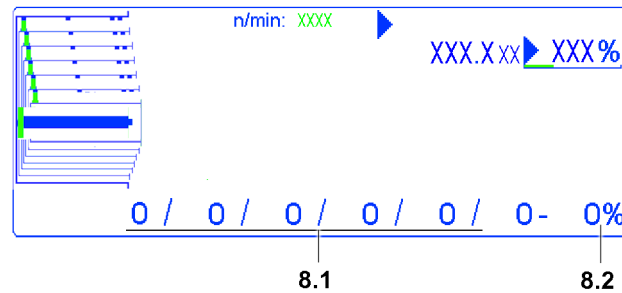


Fig.124561: Extension conditions

Display Extension status of telescopes **8.1** ascending from left to right in percentages. Beginning with Telescope **T1**. Pin points are at 0 %, 46 %, 92 % and 100 %.

Display Extension condition Telescoping cylinder **8.2** in percentages.

Pin points can also be accessed via the graphic illustration in the LICCON monitor.

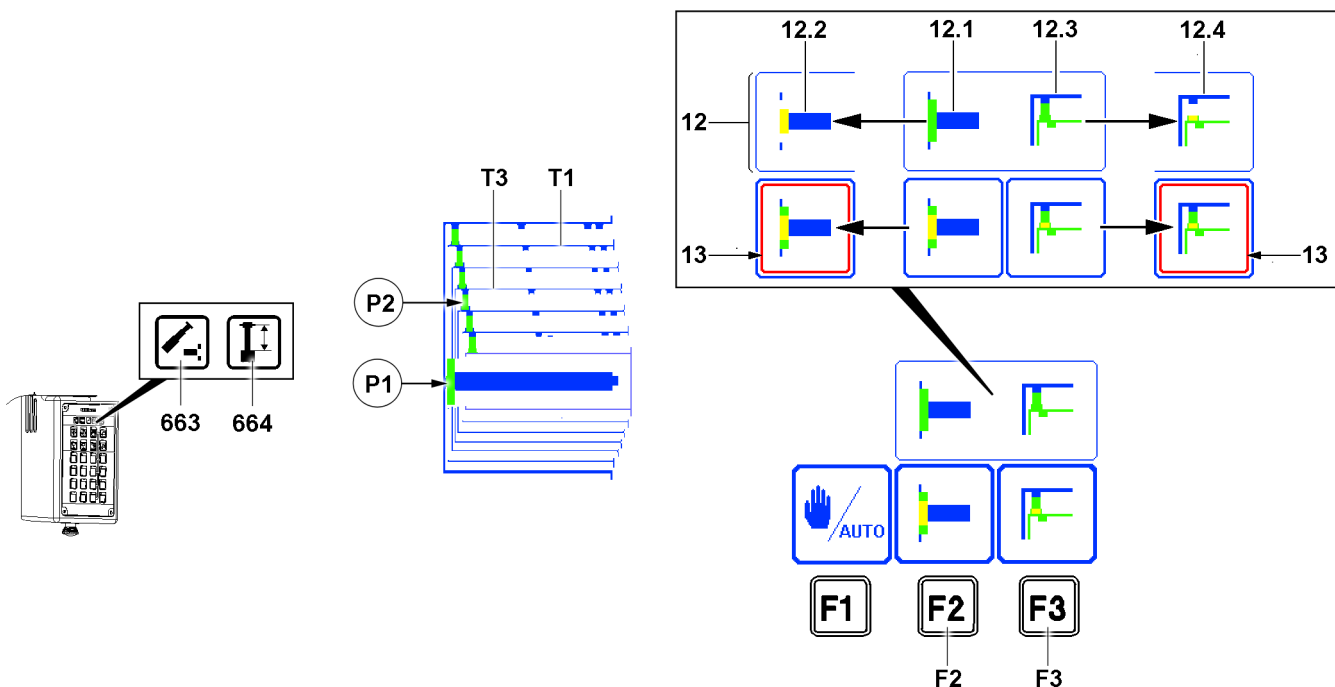


Fig.145141: Telescoping the telescopic boom manually

Apply telescopic pinning exclusively to an area of 2% in front of or after the pin point.

For example, this means that at the 46% pin point:

- When telescoping out, apply telescopic pinning in the 44% area.
- When telescoping in, apply telescopic pinning in the 48% area.

- ▶ Telescope the telescope **T3** out to an area of 2% in front of the pin point.
- ▶ Press the function key **F3**.

**Result:**

- The telescopic pinning is applied.
- ▶ Telescope the telescope **T3** out to the pin point.

**Result:**

- Telescope 3 is pinned.
- The pin in the icon **12.3** turns green.



**Problem remedy**

Pin in position **P2** is extended and yellow?

Pin is next to the pin point.

- ▶ Until the pin on position **P2** is moved out and green: Carefully extend and retract the telescoping cylinder.

**Note**

- ▶ Adhere to the sequence during telescoping.

**Example:** Telescope telescope 3 and telescope 4 out: Telescope telescope 4 out first and then telescope 3. Telescope out in descending order.

**Example:** Telescope telescope 3 and telescope 4 in: Telescope telescope 3 in first and then telescope 4. Telescope in in ascending order.

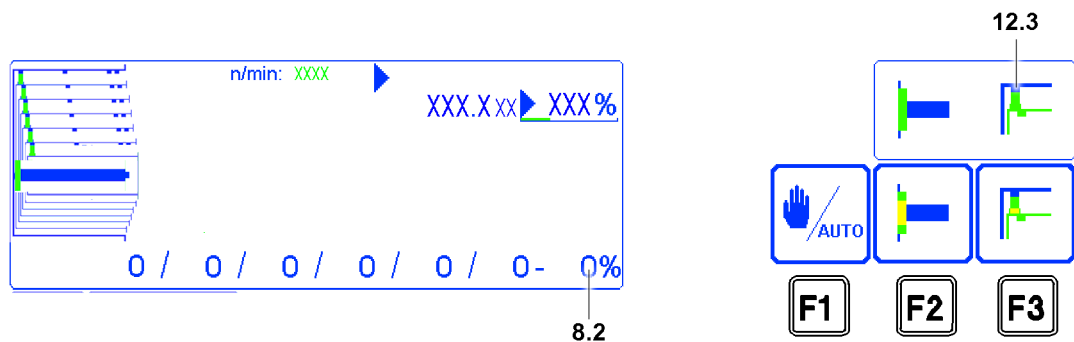


Fig.145144: Extension conditions

**NOTICE**

The pinning procedure cannot be completed! The pin in icon **12.3** is yellow.

The pin position must be searched for.

The telescopic boom can be damaged.

- ▶ Approach the pin points slowly and carefully.
- ▶ Complete the manual telescoping procedure and pin the telescope. The pin in icon **12.3** must be green.

**NOTICE**

After ending the telescoping procedure: The telescopic boom is **not** tensioned!

The telescopic boom can be damaged.

When the telescoping procedure is completed and the telescope is pinned:

- ▶ Tension the telescopic boom: Actuate the telescoping cylinder for 8 seconds with maximum master switch deflection to telescoping in. During this period of time, the extension condition of the telescoping cylinder **8.2** may **not** change.
- ▶ Telescope the remaining telescopes as described.

## 10.9 Telescoping under load

If the crane is equipped with telescopic load charts, then loads can also be telescoped.

Telescoping under load is possible when:

- The „Telescoping under load“ load charts are available.
- The bearing shoes are sufficiently greased.

	1	46 -	92 -	0 +	0 -	46 -	92 -	0 +	0 +	0 +	0 +	0 -	46 -	92 -	0 +
	2	46 +	46 +	92 -	92 +	92 +	92 +	0 +	0 -	46 -	92 -	92 +	92 +	92 +	0 +
	3	46 +	46 +	46 +	46 +	46 +	46 +	92 -	92 +	92 +	92 +	92 +	92 +	92 +	0 +
	4	46 +	46 +	46 +	46 +	46 +	46 +	46 +	46 +	46 +	46 +	46 +	46 +	46 +	92 -
	5	46 +	46 +	46 +	46 +	46 +	46 +	46 +	46 +	46 +	46 +	46 +	46 +	46 +	46 +
	% 6	46 +	46 +	46 +	46 +	46 +	46 +	46 +	46 +	46 +	46 +	46 +	46 +	46 +	46 +

Fig.145142: Set up 1 load chart

	%	1	0+	0+	46-	92-	0+	0+	0+	0+	0+	0+	0+	0+
	%	2	46-	92-	92+	92+	0+	0+	0+	0+	0+	0+	0+	0+
	%	3	92+	92+	92+	92+	0+	0+	0+	0+	0+	0+	0+	46-
	%	4	92+	92+	92+	92+	0+	0+	0+	0+	46-	92-	100-	100+
	%	5	92+	92+	92+	92+	0+	46-	92-	100-	100+	100+	100+	100+
	%	6	92+	92+	92+	92+	100-	100+	100+	100+	100+	100+	100+	100+
	n	EST1	3x	3x	3x	2x	7x	8x	6x	5x	5x	4x	4x	3x

Fig.145143: Set up 2 load chart

The extension conditions of the individual telescopes are indicated as a percentage in the load chart. A „-“ sign next to the percentage value means that the corresponding telescopic section can be telescoped to the extension condition percentage under load (according to the load chart).

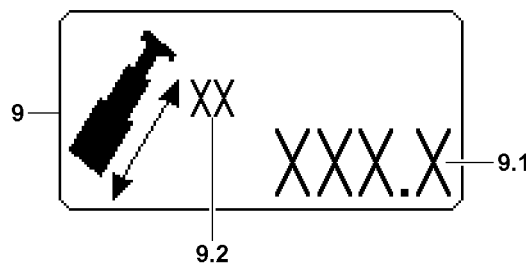


Fig.122430: Telescopic load

The maximum load that the telescopic boom can telescope can be read on the LICCON overload protection in the „telescopic load“ icon **9.1**.

The „Telescopic load“ icon **9.1** is displayed with a blinking value, when the telescopic load is smaller than the display value on the ACTUAL load display. In manual telescoping operation, the „telescopic load“ icon **9.1** is displayed continuously with a flashing value. In automatic operation, the „telescopic load“ icon **9.1** is only displayed with a flashing value if telescoping target is not reached.

Telescoping under load is possible in two ways:

- Telescoping in automatic operation
- Telescoping in automatic operation and manual operation

### 10.9.1 Telescoping in automatic operation

Telescoping in automatic operation under load has the disadvantage that the telescoping target must always be reselected.

- ▶ Select telescoping in automatic operation.
- ▶ Telescoping under load in automatic operation to the telescoping target.

## 10.9.2 Telescoping in automatic operation and manual operation

The pinning of the telescoping cylinder and the telescope is carried out in automatic operation. The subsequent telescoping of the boom under load takes place in manual operation.

**Example:** The telescopic boom is telescoped to telescope condition 0/**46**/92/92/92/92 and should be telescoped out under load to telescope condition 0/**92**/92/92/92/92.

- ▶ In automatic operation, pin the telescoping cylinder in telescope 2 and telescope out telescope 2 approx. 5 percent.
- ▶ Select manual telescoping.
- ▶ Telescope telescope 4 under load to telescoping target 0/**92**/92/92/92/92.

---

Empty page!

LWE/LTR 1220-003/24204-02-02/en

## 4.06 Rope reeving

1	Wire ropes and rope end connections	2
2	Hoist rope lug*	3
3	Moveable back pulley*	6
4	Hoist rope	7
5	Hook block	14
6	Load hook	18
7	Two-part hoist limit switch weight	20
8	One-part hoist limit switch weight	23
9	Wedge lock	26
10	Auxiliary pulley*	28
11	Rope reeving	29

# 1 Wire ropes and rope end connections

## 1.1 Wire ropes

**Rotation-resistant** or **twisting** ropes are used for crane operation. Check if a **rotating resistant** or a **non-rotating** rope is required for the application. The selected type of rope then requires the corresponding rope end connections, see chapter 8.04.



### Note

- ▶ Correct choice and use of the wire rope and the rope end connections are a decisive precondition for proper and accident-free crane operation.



### DANGER

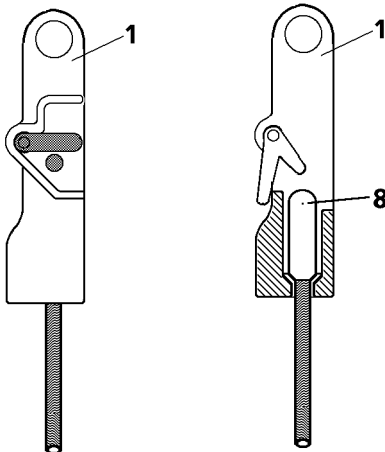
Incorrect rope type!

Death, severe bodily injury, property damage.

- ▶ **Never** use rotation-resistant ropes with a rotating rope end connection.
- ▶ **Never** install a twist compensator / swivel.

## 1.2 Rope end connections

**1**



**2**

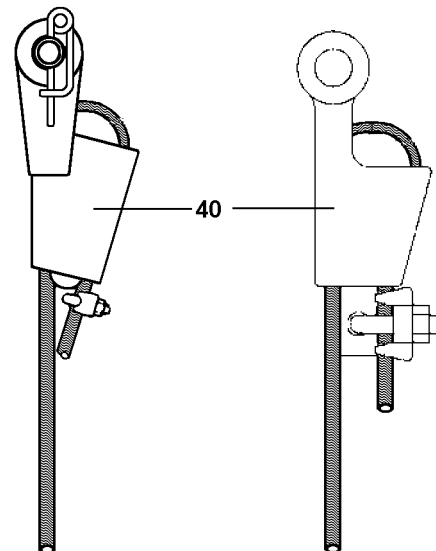


Fig.122724: Rope end connections

Rope end connections are grouped into:

- Rope end connection with locking clamp **8** or locking cast sleeve **8**  
For that, use a rope lock **1**, see illustration **1**
- Rope end connection **without** locking clamp **8** or locking cast sleeve **8**  
For that, use a wedge lock **40**, see illustration **2**



### Note

- ▶ The locking clamp **8** is pressed on the rope.
- ▶ The locking cast sleeve **8** is cast with the rope.

## 2 Hoist rope lug\*

If a hoist rope lug **30** is installed on the telescopic boom, then the hoist rope **31** is guided through the hoist rope lug **30**. Depending on the operating mode, the hoist rope **31** must be reeved through the hoist rope lug **30** or over the hoist rope lug **30**.

On the LTM 1400/1 and LTM 1400-7.1 the hoist rope **31** must be reeved on the hoist rope lug **30** according to chapter 4.06.10.

---

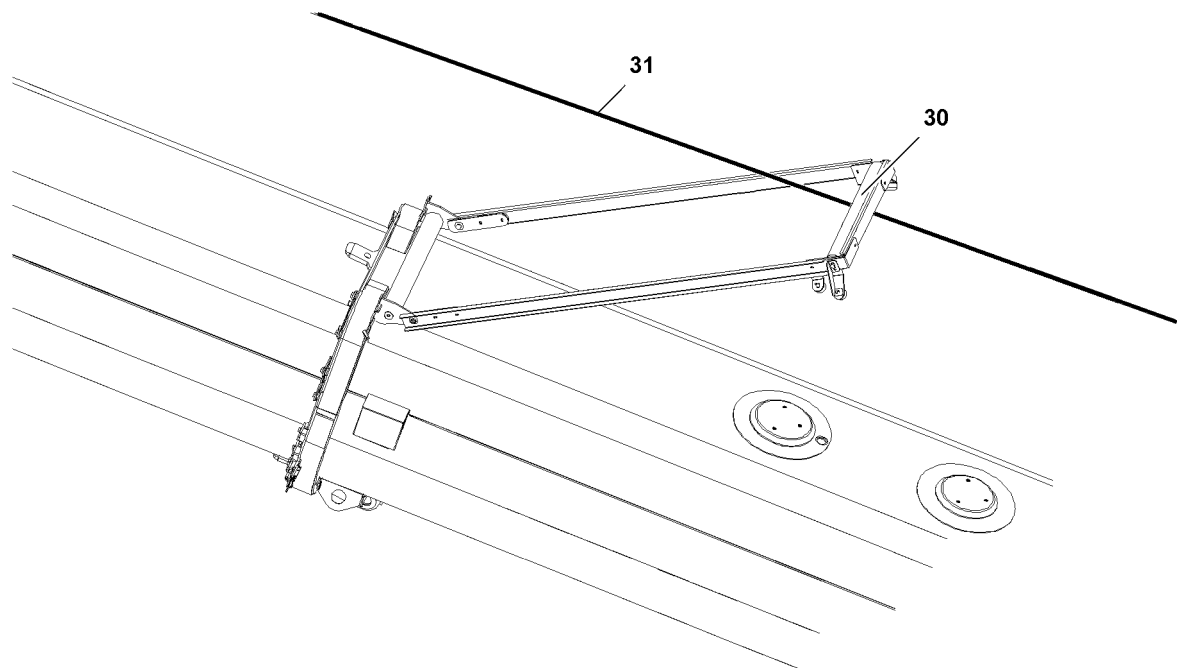
### NOTICE

Incorrect reeving!  
Damage to the hoist rope.

On the LTM 1400/1 and LTM 1400-7.1:

- ▶ Reeve the hoist rope **31** on the hoist rope lug **30** according to chapter 4.06.10.
- 

### 2.1 Hoist rope guide for telescopic boom operation



*Fig.121112: Hoist rope routing under the hoist rope lug **30***

When a hoist rope lug is installed on the telescopic boom:

- ▶ Reeve the hoist rope **31** under the hoist rope lug **30**.

## 2.2 Hoist rope routing Folding jib / fixed lattice jib

### 2.2.1 Hoist rope routing with one hoist rope

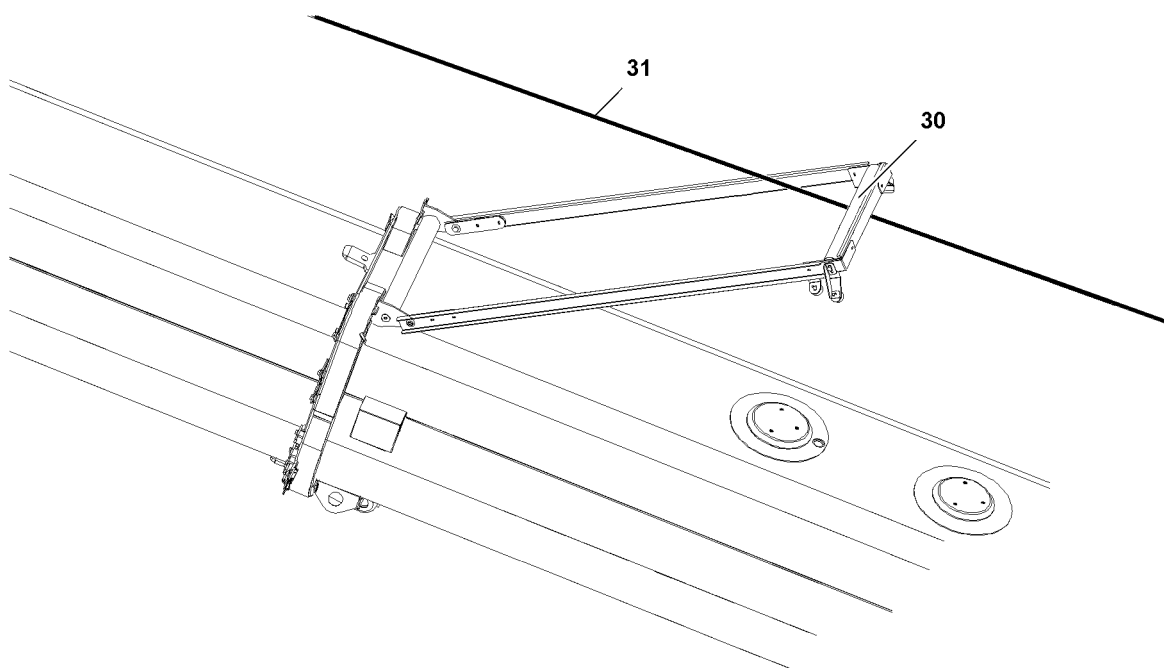


Fig.122742: Hoist rope routing under the hoist rope lug 30

When a hoist rope lug is installed on the telescopic boom:

- Reeve the hoist rope 31 under the hoist rope lug 30.

### 2.2.2 Hoist rope routing with two hoist ropes

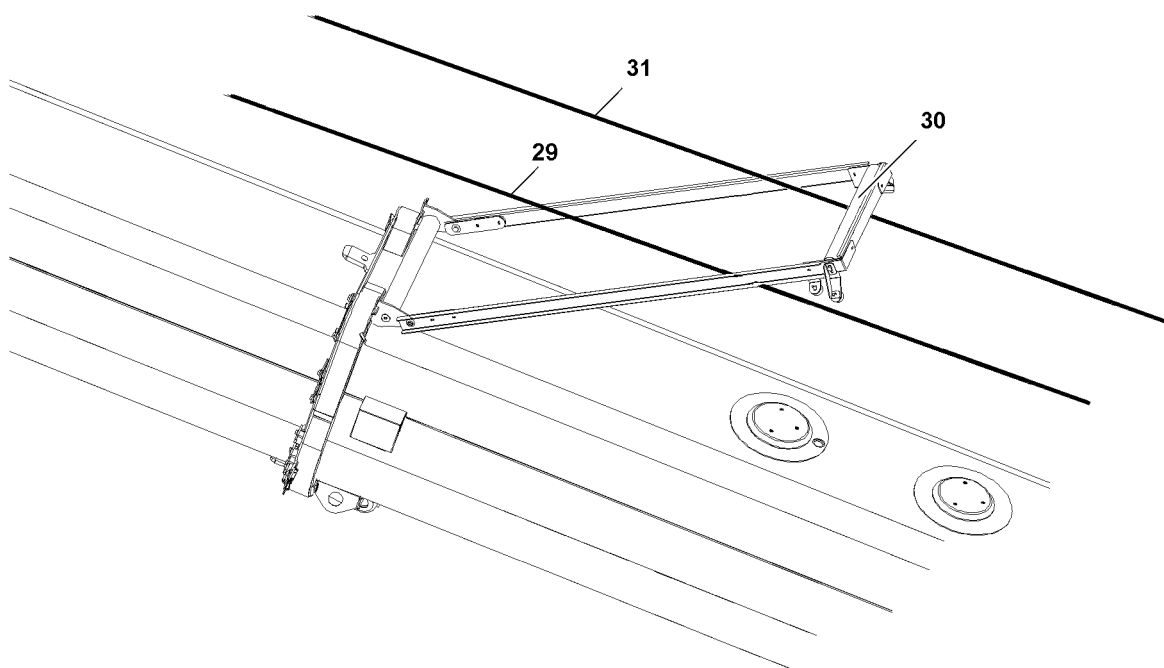


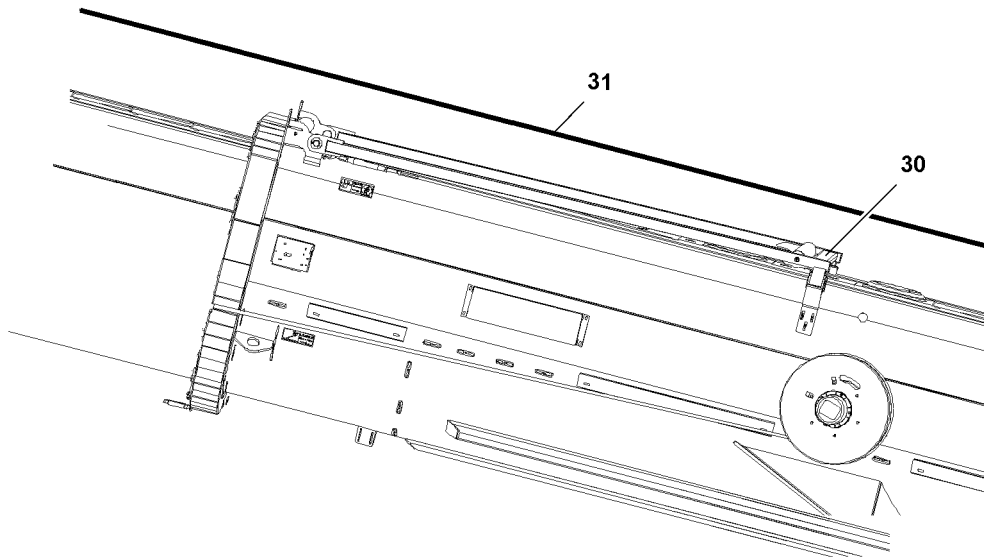
Fig.122743: Hoist rope routing under the hoist rope lug 30



When a hoist rope lug is installed on the telescopic boom:

- ▶ Reeve the hoist rope **29** and hoist rope **31** under the hoist rope lug **30**.

## 2.3 Hoist rope routing for operation with luffing lattice jib



*Fig.121113: Hoist rope routing over the hoist rope lug 30*

For operation with luffing lattice jib:

- ▶ Reeve the hoist rope **31** over the hoist rope lug **30**.

### 3 Moveable back pulley\*

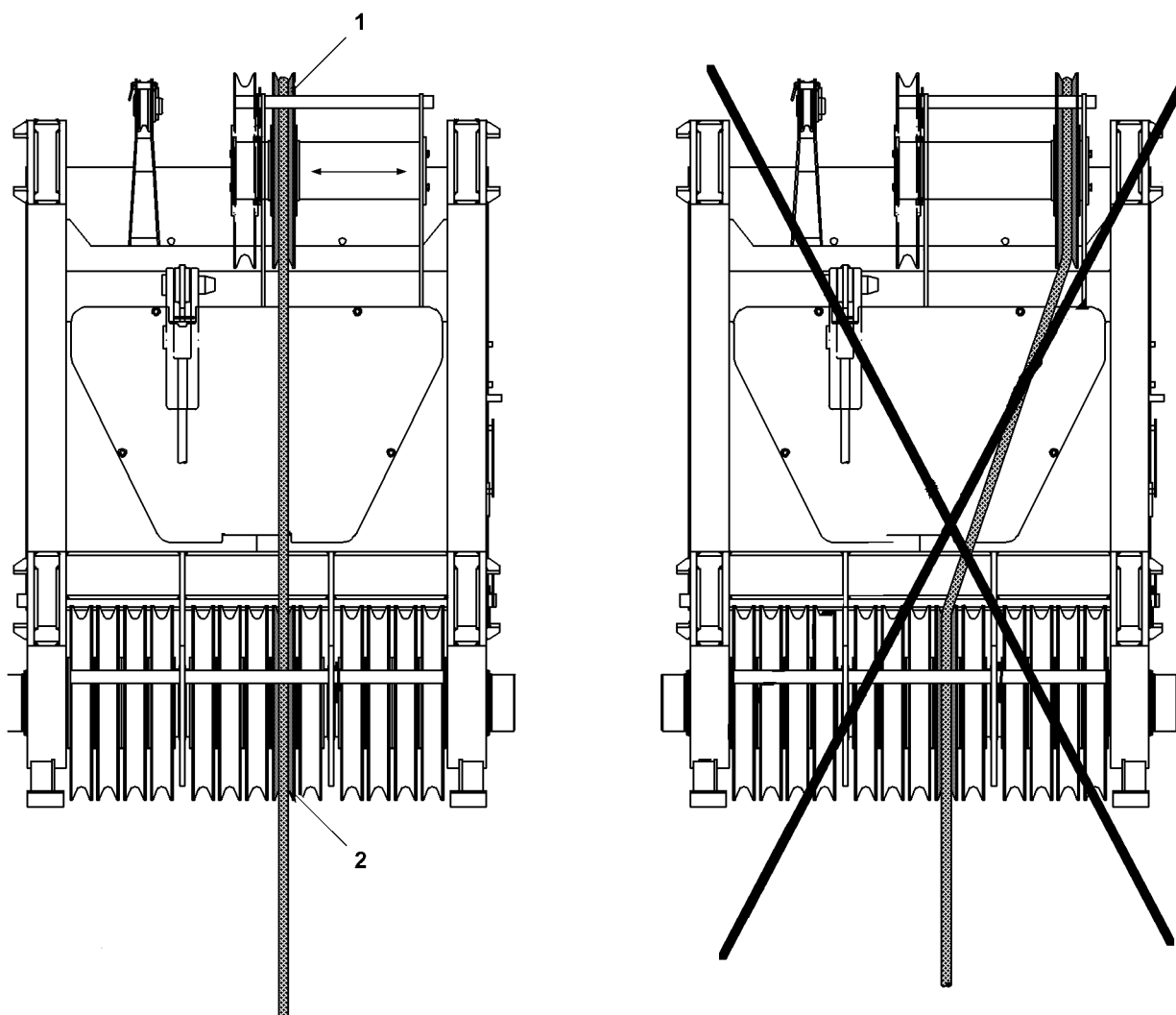


Fig.122732: Boom head with moveable back pulley

If a moveable back pulley 1 is installed on the crane, then it must be aligned before reeving.

#### 3.1 Aligning the moveable back pulley

##### NOTICE

Angular pull of hoist rope!  
Damage of moveable back pulley.

- ▶ Move the moveable back pulley 1 on the side in such a way that the moveable back pulley 1 aligns to the run-in pulley 2.
- ▶ Align the moveable back pulley 1 to the run-in pulley 2.

## 4 Hoist rope



### WARNING

Slipping during assembly work!

Danger of falling.

Death, severe injury, property damage.

- ▶ The telescopic boom may only be accessed if assembly personnel is protected with suitable safety measures to prevent them from falling and an assembly winch is used for rope reeving.
- ▶ If safety ropes are present on the telescopic boom, then assembly personnel must hook themselves with the supplied fall arrest system on the safety ropes of the telescopic boom on the left and right with both snap hooks and secure themselves against falling.
- ▶ Without appropriate safety measures, it is **strictly** prohibited to step on the telescopic boom.
- ▶ If railings are present for the crane, then they must be brought into the corresponding position and secured for assembly / disassembly.
- ▶ Carry out all assembly work from a safe location.
- ▶ Observe the assembly specifications in chapter 5.01.

Make sure that the following prerequisites are met:

- The crane is properly supported and horizontally aligned.
- The counterweight is installed according to the load chart.
- The LICCON overload protection has been set according to the load chart.
- The telescopic boom is telescoped in all the way.
- The telescopic boom has been swung to the rear or the side.
- The telescopic boom is luffed down to the 0° position.

### 4.1 Reeving in the hoist rope with the auxiliary reeving rope

- ▶ Only use the provided fall arrest system and protective equipment.



### WARNING

Ladder **not** properly secured!

The ladder can topple over. Personnel can be fatally injured.

- ▶ Secure the ladder on the hoist gear and on the telescopic boom so that it cannot fall over.

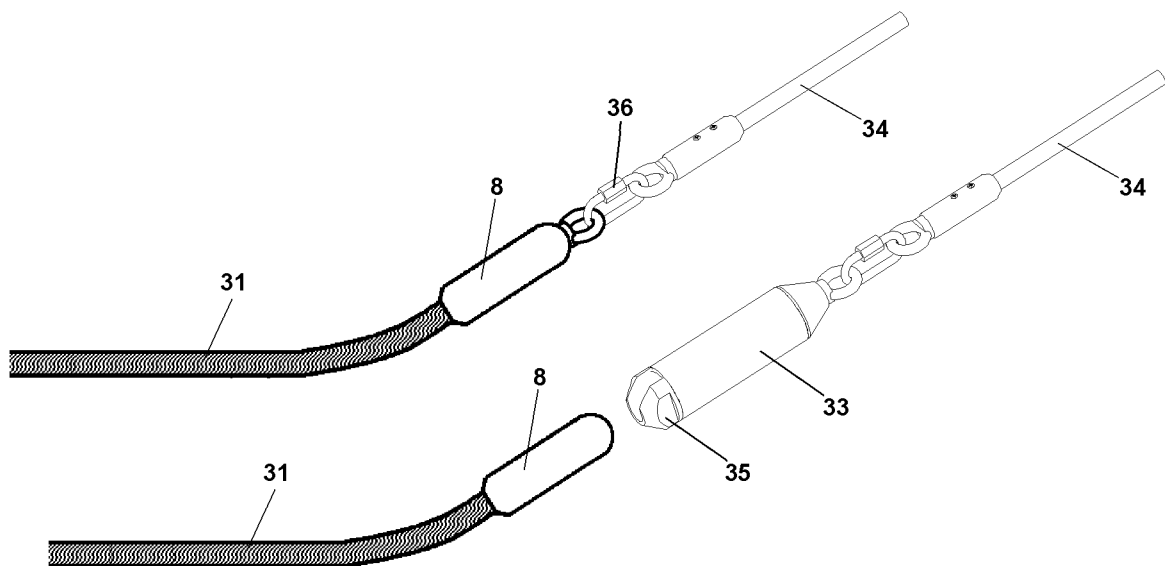


Fig.146776: Auxiliary reeving rope 34

If **no** railing is installed on the crane superstructure:

- ▶ Set up the ladder on the hoist gear in a stable manner and secure.

If a railing is installed on the crane superstructure:

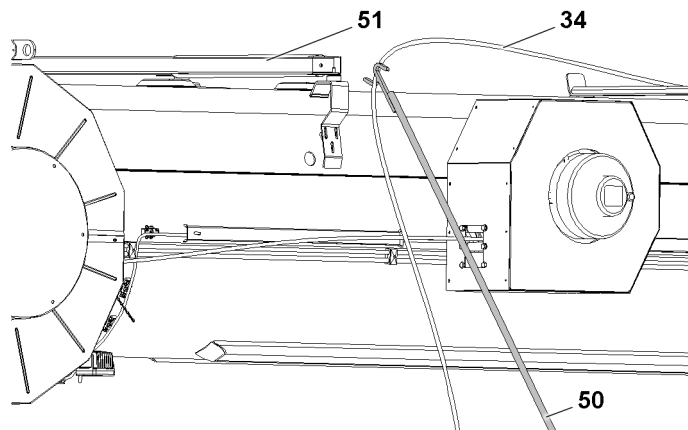
- ▶ Place the railing on the crane superstructure in the assembly / disassembly position, see chapter 2.06.
- ▶ Secure assembly personnel to prevent them from falling: Hook the assembly personnel with fall arrest system on the respective fastening points.

When **one** intake sleeve **33** is installed on the auxiliary reeving rope **34**:

- ▶ Connect the auxiliary reeving rope **34** with the hoist rope **31**: Slide the intake sleeve **33** onto the locking clamp **8** and close off with the sleeve plug **35**.

When **no** intake sleeve **33** is installed on the auxiliary reeving rope **34**:

- ▶ Connect the auxiliary reeving rope **34** with the hoist rope **31**: Open the chain lock **36**, connect it with the eyehook of the lock clamp **8** and close the chain lock **36**.



*Fig.157599: Guiding the auxiliary rope with the assembly rod*

- ▶ Throw the auxiliary reeving rope **34** to the front.
- ▶ Route the auxiliary reeving rope **34** with assembly rod **50** to the hoist rope lug **51**.
- ▶ Guide the auxiliary reeving rope **34** through below the hoist rope lug **51**. See section „Hoist rope guide for telescopic boom operation“.
- ▶ Set up the ladder on the telescopic boom in a stable manner and secure.
- ▶ Secure assembly personnel to prevent them from falling: Hook the assembly personnel with fall arrest system on the respective fastening points.

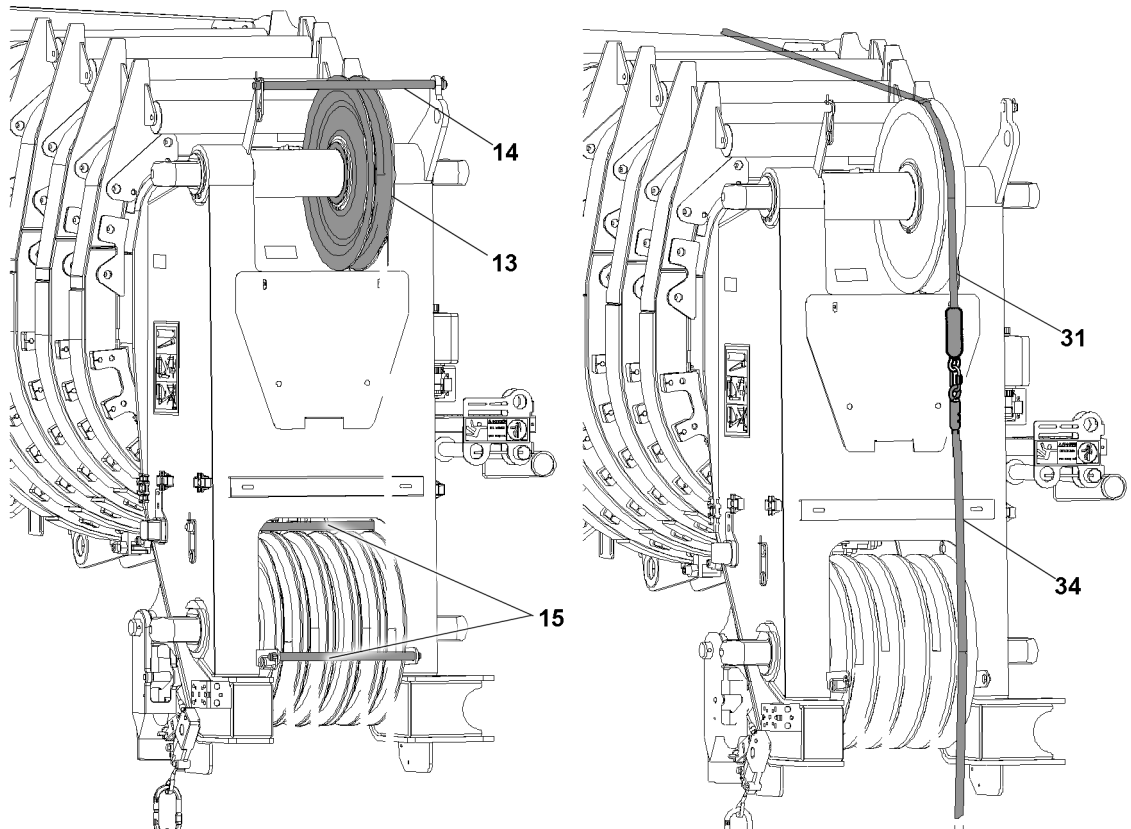


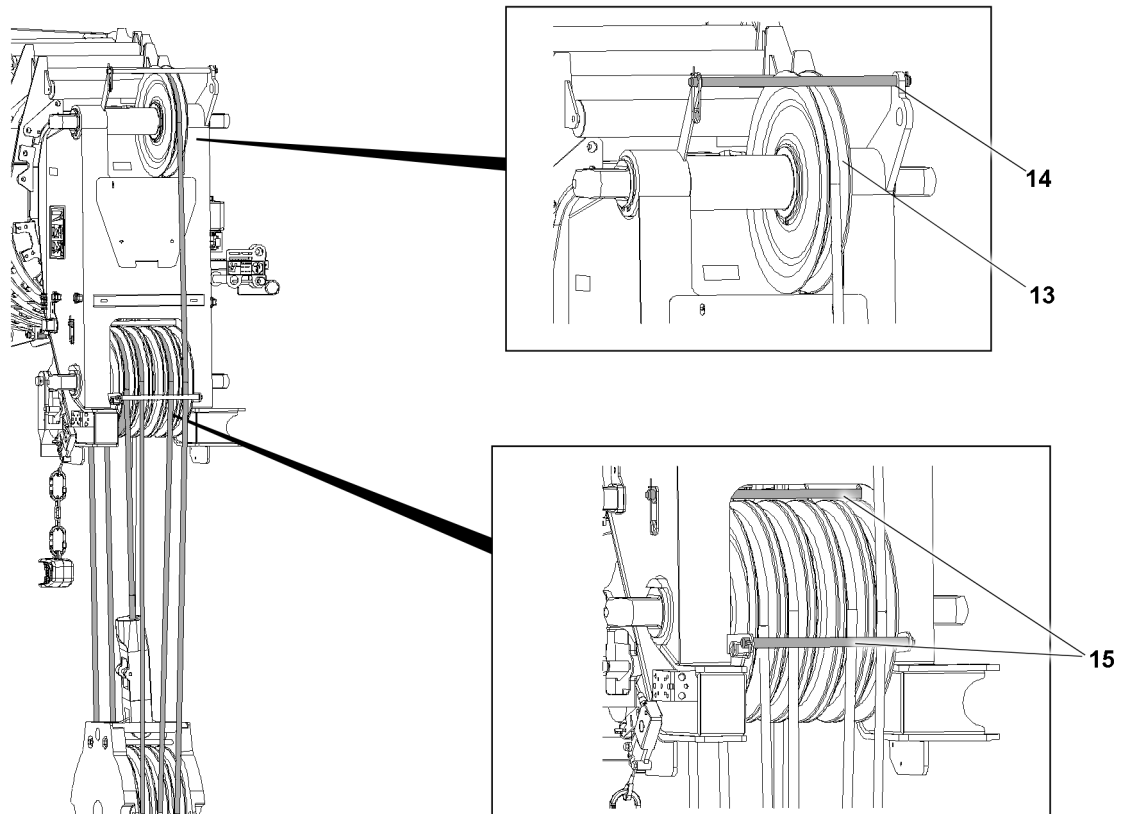
Fig.146777: Reeving in the hoist rope with the auxiliary reeving rope

- ▶ Remove the rope retaining pipe **14** and rope retaining pipe **15** on the pulley head.
- ▶ Place the auxiliary reeving rope **34** over the upper rope pulley **13**.

#### NOTICE

Hoist rope tension too low!  
Slack rope formation.

- ▶ Do not permit slack rope on the hoist winch.
- ▶ Spool out the winch slowly and pull the auxiliary reeving rope **34** with the hoist rope **31** over the upper rope pulley **13**.
- ▶ Remove the auxiliary reeving rope **34** from the hoist rope **31**.



*Fig.146781: Reeving in the hoist rope 31*

- ▶ Reeve in the hoist rope **31** in the hook block.
- ▶ Pin and secure the rope retaining pipe **14** and the rope retaining pipe **15** on the pulley head.

## 4.2 Reeving in the hoist rope with the assembly winch\*

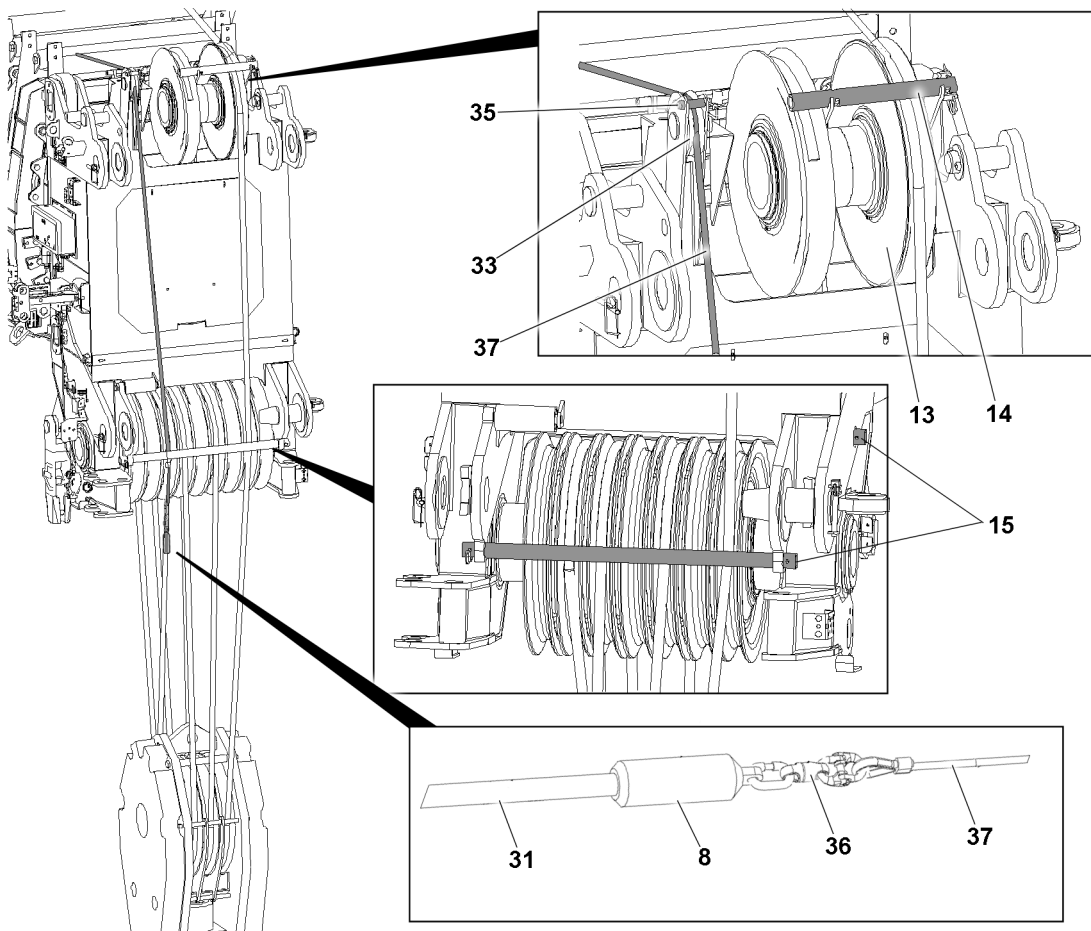


Fig.146778: Reeving in the hoist rope with the assembly winch\*

- ▶ Wear the approved fall arrest system and protective equipment.



### WARNING

Ladder **not** properly secured!

The ladder can topple over. Personnel can be fatally injured.

- ▶ Secure the ladder on the telescopic boom so that it cannot fall over.

If **no** railing is installed on the crane superstructure:

- ▶ Set up the ladder on the hoist gear in a stable manner and secure.
- ▶ Place the railing on the crane superstructure in the assembly / disassembly position, see chapter 2.06.
- ▶ Switch the assembly winch to freewheeling.
- ▶ Pull the auxiliary rope **37** forward to the change over pulley **33**.
- ▶ Set up the ladder on the telescopic boom in a stable manner and secure.
- ▶ Secure assembly personnel to prevent them from falling: Hook the assembly personnel with fall arrest system on the respective fastening points.
- ▶ Release and unpin the rope retaining pipe **35**, the rope retaining pipe **14** and the rope retaining pipe **15**.
- ▶ Place the auxiliary rope **37** over the change over pulley **33**.
- ▶ Pin the rope retaining pipe **35** and secure.
- ▶ Connect the auxiliary rope **37** with the auxiliary reeving rope (hemp rope).
- ▶ Reeve in the auxiliary rope **37** in the reverse direction between the hook block and the pulley head.
- ▶ Bring the auxiliary rope **37** with the auxiliary reeving rope (hemp rope) upward over the rope pulley **13**.
- ▶ Release the auxiliary reeving rope (hemp rope) from the auxiliary rope **37**.

- ▶ Pull the auxiliary rope **37** to the rear to the hoist winch.
- ▶ Connect the auxiliary rope **37** with the hoist rope **31**: Open the connecting link **36**, connect it with the eyehook of the lock clamp **8** and close the connecting link **36**.
- ▶ Turn the freewheeling off on the assembly winch.

---

#### NOTICE

Hoist rope tension too low!

Slack rope formation.

- ▶ Do not permit slack rope on the hoist winch and the assembly winch.

- 
- ▶ Reeve in the hoist rope **31**: Spool the hoist rope **31** from the hoist winch and simultaneously spool up the auxiliary rope **37** on the assembly winch.

When the hoist rope **31** is reeved in with the on the hook block:

- ▶ Stop the hoist winch and the assembly winch.
- ▶ Remove the rope retaining pipe **35**.
- ▶ Release the auxiliary rope **37** from the hoist rope **31** and spool up.
- ▶ Spool the auxiliary rope **37** on the assembly winch and secure.
- ▶ Pin and secure the rope retaining pipe **35**, the rope retaining pipe **14** and the rope retaining pipe **15**.

### 4.3 Reeving the hoist rope out

Make sure that the following prerequisites are met:

- The hoist rope **31** is reeved out of the hook block.
- ▶ Only use the provided fall arrest system and protective equipment.



#### WARNING

Ladder **not** properly secured!

The ladder can topple over. Personnel can be fatally injured.

- ▶ Secure the ladder on the hoist gear and on the telescopic boom so that it cannot fall over.
- ▶ Set up the ladder on the telescopic boom in a stable manner and secure.
- ▶ Remove the rope retaining pipe **14** and rope retaining pipe **15** on the pulley head.
- ▶ Reeve out the hoist rope **31** on the hook block.

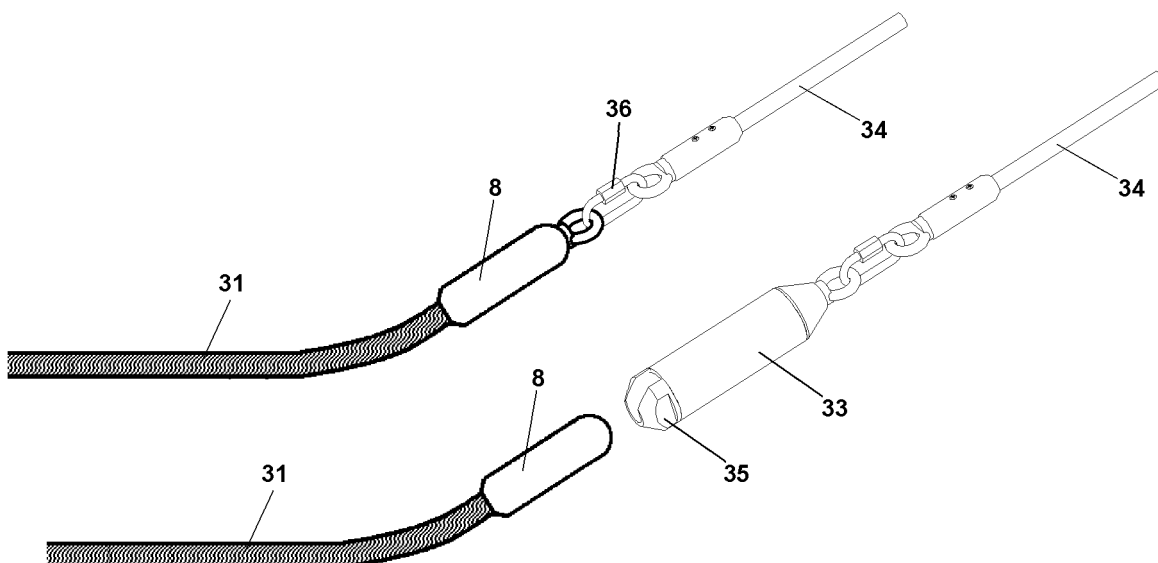


Fig.146776: Auxiliary reeving rope **34**



When **one** intake sleeve **33** is installed on the auxiliary reeving rope **34**:

- ▶ Connect the auxiliary reeving rope **34** with the hoist rope **31**: Slide the intake sleeve **33** onto the locking clamp **8** and close off with the sleeve plug **35**.

When **no** intake sleeve **33** is installed on the auxiliary reeving rope **34**:

- ▶ Connect the auxiliary reeving rope **34** with the hoist rope **31**: Open the chain lock **36**, connect it with the eyehook of the lock clamp **8** and close the chain lock **36**.

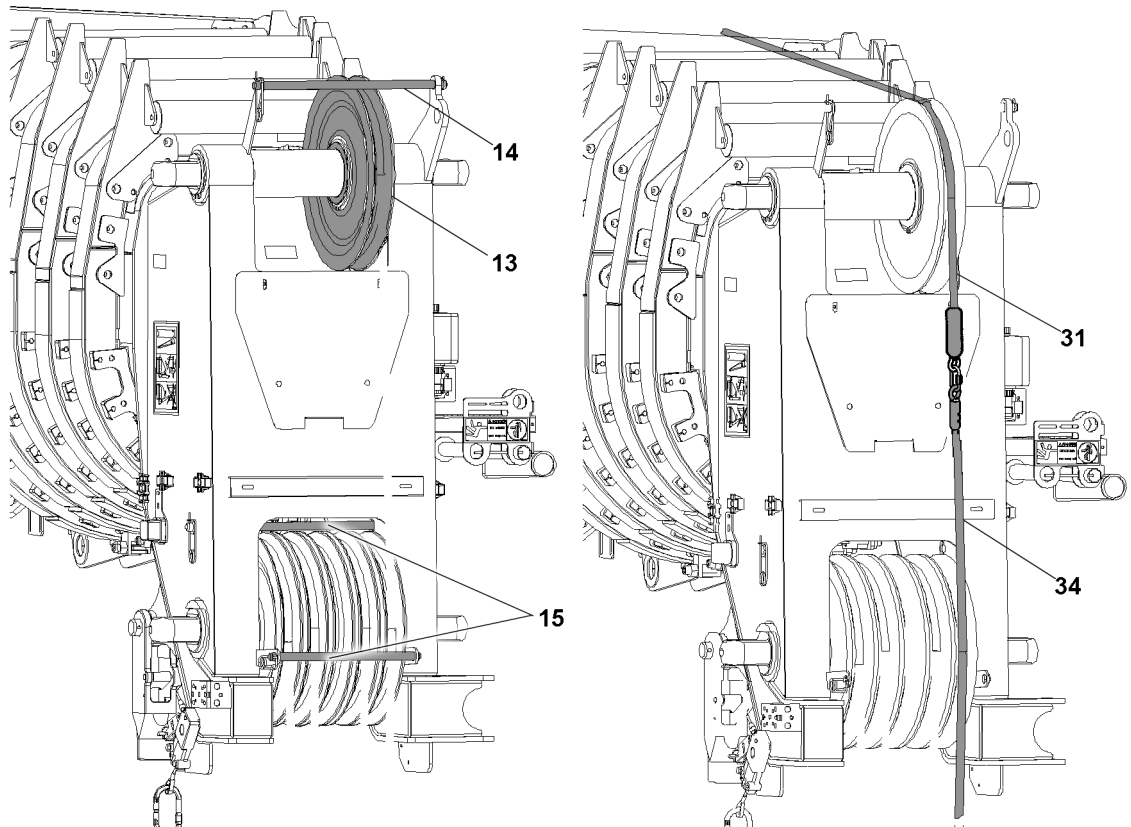


Fig.146777: Reeving out the hoist rope with the auxiliary reeving rope



#### WARNING

Danger of crushing due to rotating rope pulleys!

Arms and legs can be caught and crushed or severed between the rope pulley and the rope due to rotating rope pulleys.

- ▶ It is prohibited to touch the hoist ropes or the rope pulleys during operation.
- ▶ Adhere to the safety distance to ropes and rotating rope pulleys.

#### NOTICE

Hoist rope tension too low!

Slack rope formation.

- ▶ Do not permit slack rope on the hoist winch.

- ▶ Spool up the winch slowly and tension the hoist rope **31** with the auxiliary reeving rope **34**.
- ▶ When the hoist rope **31** is spooled up: Stop the winch movement.
- ▶ Pin and secure the rope retaining pipe **14** and the rope retaining pipe **15** on the pulley head.

If **no** railing is installed on the crane superstructure:

- ▶ Set up the ladder on the hoist gear in a stable manner and secure.

If a railing is installed on the crane superstructure:

- ▶ Place the railing on the crane superstructure in the assembly / disassembly position, see chapter 2.06.

- ▶ Secure assembly personnel to prevent them from falling: Hook the assembly personnel with fall arrest system on the respective fastening points.
- ▶ Remove the auxiliary reeving rope **34** from the hoist rope **31**.
- ▶ Fasten the hoist rope **31** to the hoist winch.

## 5 Hook block

### 5.1 Reeving the hook block in

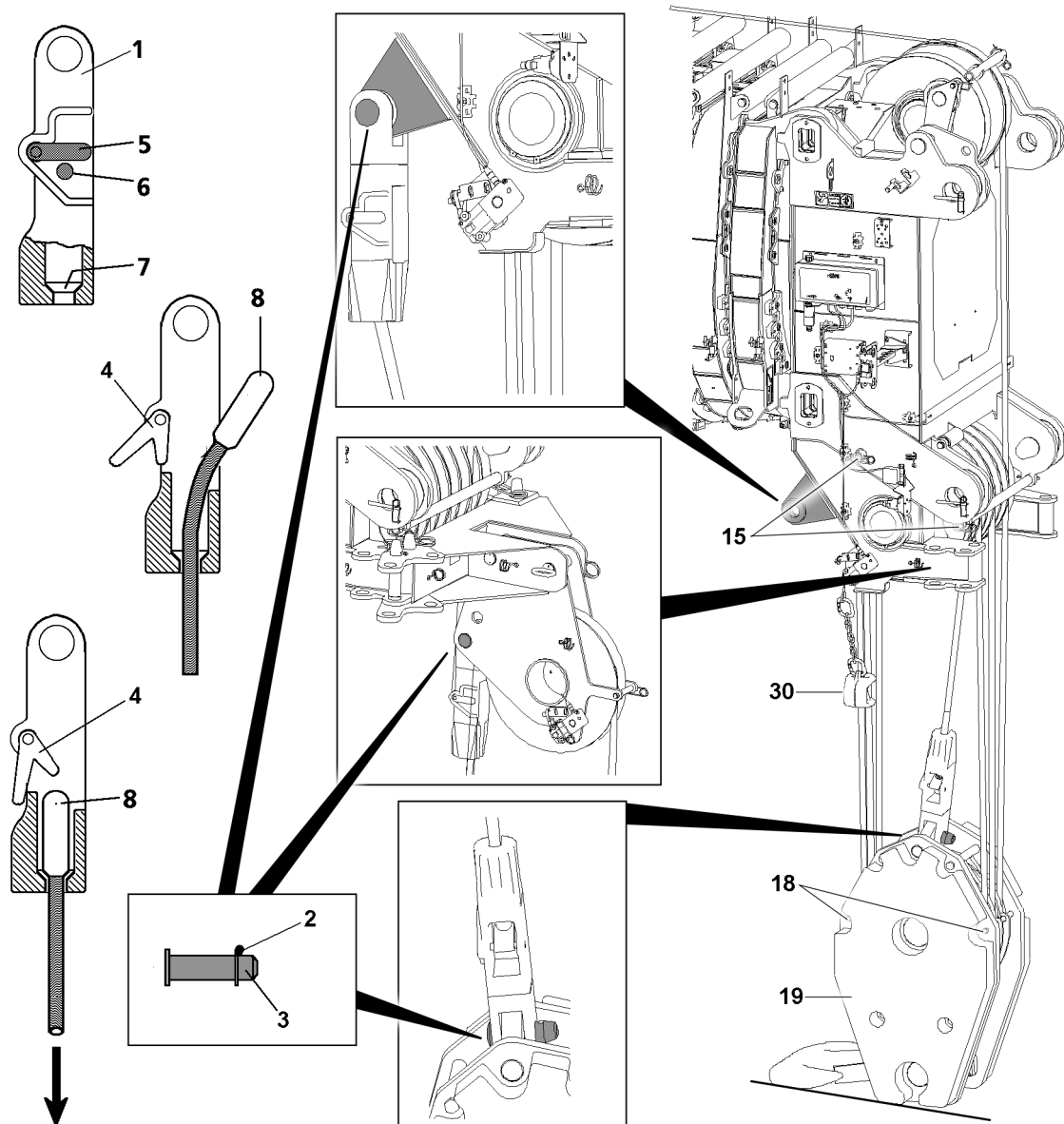


Fig.146779: Reeving the hook block in

To reeve in the hook block, also observe and adhere to the section „Reeving in the hoist rope“.

### 5.1.1 Preparing the hook block

Make sure that the following prerequisites are met:

- The crane is horizontally aligned.
- The required hook block is located below the boom head.
- The hook block is positioned securely on the ground.
- The boom is luffed down to the point where the boom head is above the hook block.
- An assistant is present to guide the hoist rope.

---

#### NOTICE

Hook block incorrectly reeved!

Damage to the hoist rope.

- ▶ Carry out the reeving of the hoist rope according to the reeving plan.
  - ▶ Select the rope fixed point on the hook block in such a way that the last strand runs parallel to the remaining rope strands, as much as possible.
- 
- ▶ Release and unpin both rope retaining pipes **18** on the hook block **19**.




---

#### WARNING

Slipping during assembly work!

Danger of falling.

Death, severe injury, property damage.

- ▶ The telescopic boom may only be accessed if assembly personnel is protected with suitable safety measures to prevent them from falling.
  - ▶ If safety ropes are present on the telescopic boom, then assembly personnel must hook themselves with the supplied fall arrest system on the safety ropes of the telescopic boom on the left and right with both snap hooks and secure themselves against falling.
  - ▶ Without appropriate safety measures, it is **strictly** prohibited to step on the telescopic boom.
  - ▶ If railings are present for the crane, then they must be brought into the corresponding position and secured for assembly / disassembly.
  - ▶ Carry out all assembly work from a safe location.
  - ▶ Observe the assembly specifications in chapter 5.01.
- 
- ▶ Reeve in the hook block **19**.
  - ▶ Insert the rope retaining pipes **18** again and secure.

### 5.1.2 Hooking the hoist rope on the rope lock

The attachment of the hoist rope with the locking clamp **8** or the locking cast sleeve **8** is identical.

---

#### NOTICE

Hoist rope is incorrectly installed!

Damage to the hoist rope.

- ▶ Always insert the pins **3** from „inside to outside“ and secure from the outside.
- 
- ▶ The rope lock **1** must be pinned in either at the pulley head or on the hook block and secured with the retaining element **2**, depending on reeving.
  - ▶ On the rope lock **1**, push the retaining element pin **6** in.
  - ▶ Swing the lever **5** „down“ and hold it in this position.

#### Result:

- The locking pawl **4** is swung „downwards“.
- ▶ Attach the rope end with the locking clamp **8** in the rope lock **1** and pull „down“ firmly (in direction of the arrow), until the locking clamp **8** is touching in the cone **7**.

**WARNING**

Locking clamp is incorrectly installed!  
Death, severe injuries, property damage.

- ▶ The locking clamp **8** must touch on the cone **7** after hanging it into the rope lock **1** and must be secured by the locking pawl **4**.

- ▶ Release the lever **5**.

**Result:**

- The lever **5** returns to the initial position and is locked by the retaining element pin **6**.
- ▶ Check the rope retainer. Perform a visual inspection.
- ▶ Attach the hoist limit switch weight **30**.

## 5.2 Reeving the hook block out

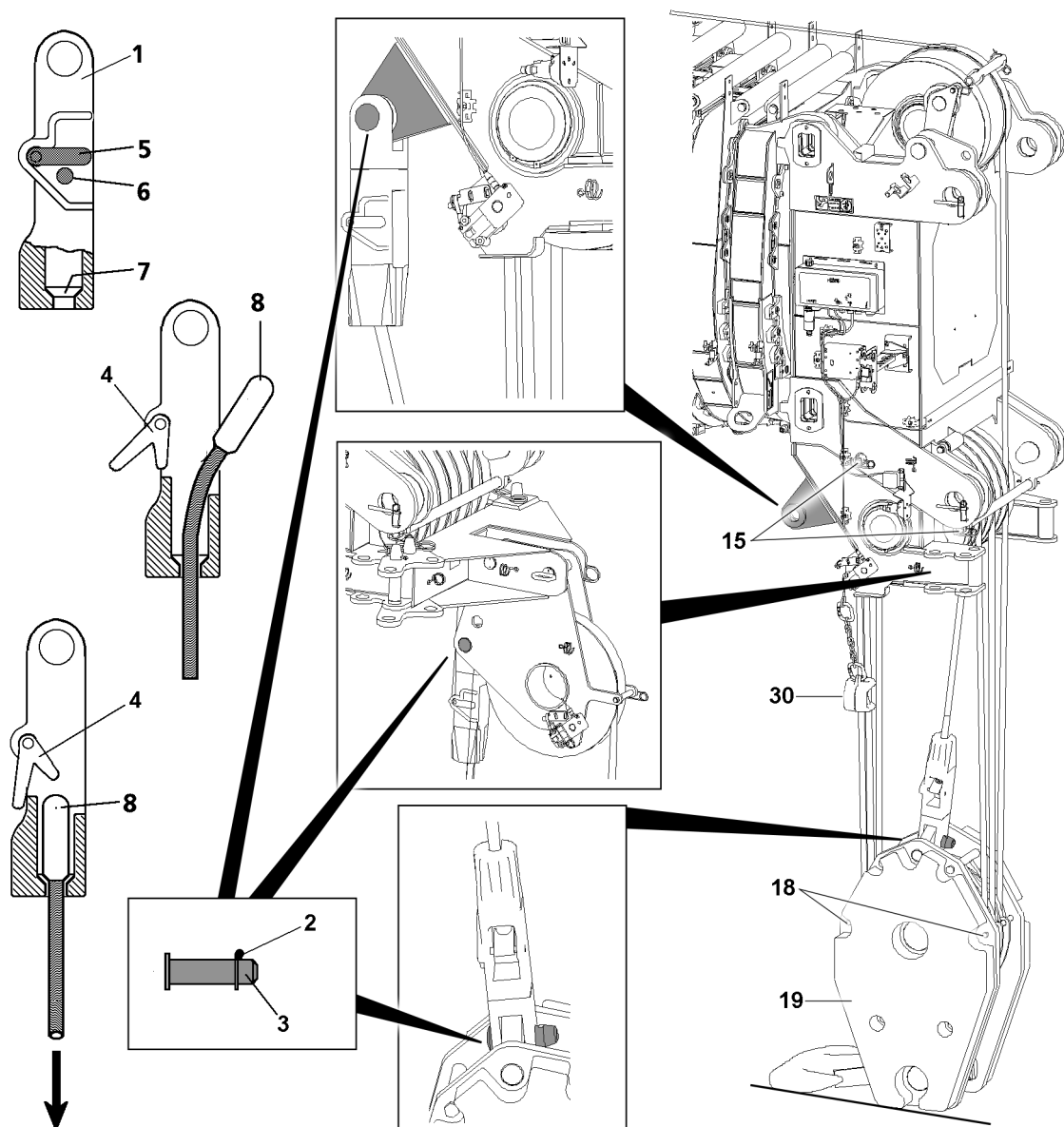


Fig.146779: Reeving the hook block out

Make sure that the following prerequisites are met:

- The crane is properly supported and horizontally aligned.
- The counterweight is installed according to the load chart.
- The LICCON overload protection has been set according to the load chart.
- The telescopic boom is telescoped in all the way.
- The telescopic boom has been swung to the rear or the side.
- The telescopic boom is luffed down to the 0° position.
- The ground is level and of sufficient load carrying capacity.



---

**WARNING**

Crushing of hands!

When reeving out the hook block **19**, it can topple over.

Death, severe injury, property damage.

- ▶ Use the handles in the safe area of the hook block **19**.
- ▶ Make sure the hook block **19** is safely positioned.

- 
- ▶ Lower the hook block **19** and place it on the ground.
  - ▶ Remove the hoist limit switch weight **30**.
  - ▶ On the rope lock **1**, push the retaining element pin **6** in.
  - ▶ Swing the lever **5** „down“ and hold it in this position.

**Result:**

- The locking pawl **4** is swung downwards.
- The locking clamp **8** is released.
  
- ▶ Push the hoist rope up and detach the locking clamp **8**.
- ▶ Release and unpin the rope retaining pipe **15** on the pulley head.
- ▶ Release and unpin the rope retaining pipes **18** on the hook block **19**.
- ▶ Reeve out the hoist rope from the hook block **19**.
- ▶ Insert the rope retaining pipes **18** again and secure.

## 6 Load hook

### 6.1 Assembling the load hook

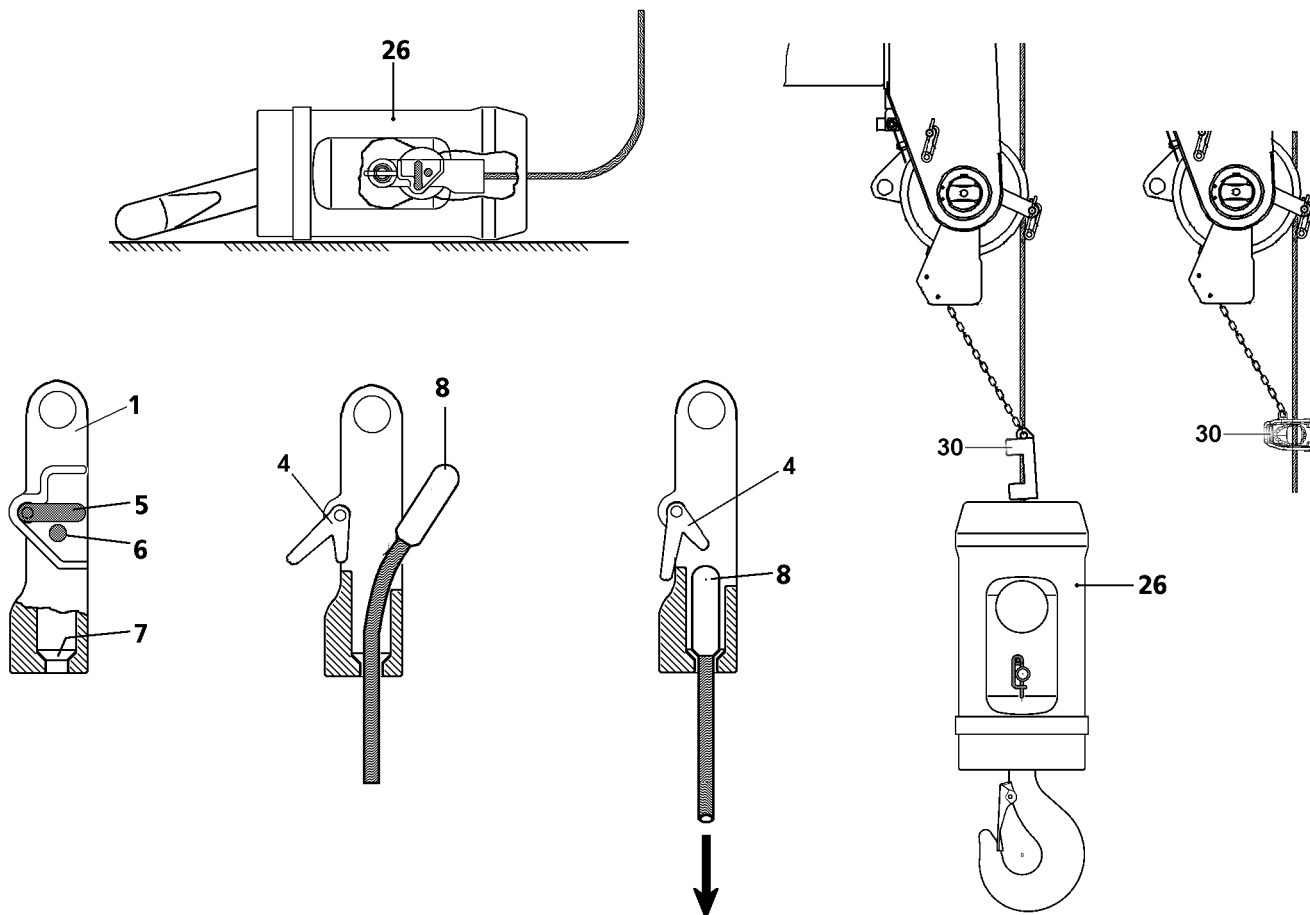


Fig.127730: Assembling the load hook

Make sure that the following prerequisites are met:

- The crane is horizontally aligned.
- The hoist rope is reeved in on the boom head.
- The required load hook lies below the boom head.
- The boom is luffed down to the point where the boom head is above the load hook.
- An assistant is present to guide the hoist rope.

- ▶ On the rope lock **1**, push the retaining element pin **6** in.
- ▶ Swing the lever **5** „down“ and hold it in this position.

**Result:**

- The locking pawl **4** is swung „downwards“.
- ▶ Attach the rope end with the locking clamp **8** in the rope lock and pull „down“ firmly (in direction of the arrow), until the locking clamp **8** is touching in the cone **7**.



#### WARNING

Locking clamp is incorrectly fastened!  
Damage to locking clamp.

Death, severe injuries, property damage

- ▶ The locking clamp **8** must touch on the cone **7** after hanging it into the rope lock **1** and must be secured by the locking pawl **4**.

- ▶ Release the lever **5**.

**Result:**

- The lever **5** returns back to the initial position and is locked by the retaining element pin **6**.
- ▶ Pin the rope lock **1** in the load hook **26** and secure with the retaining element.
- ▶ Check the rope retainer. Perform a visual inspection.
- ▶ Attach the hoist limit switch weight **30**.

## 6.2 Disassembling the load hook

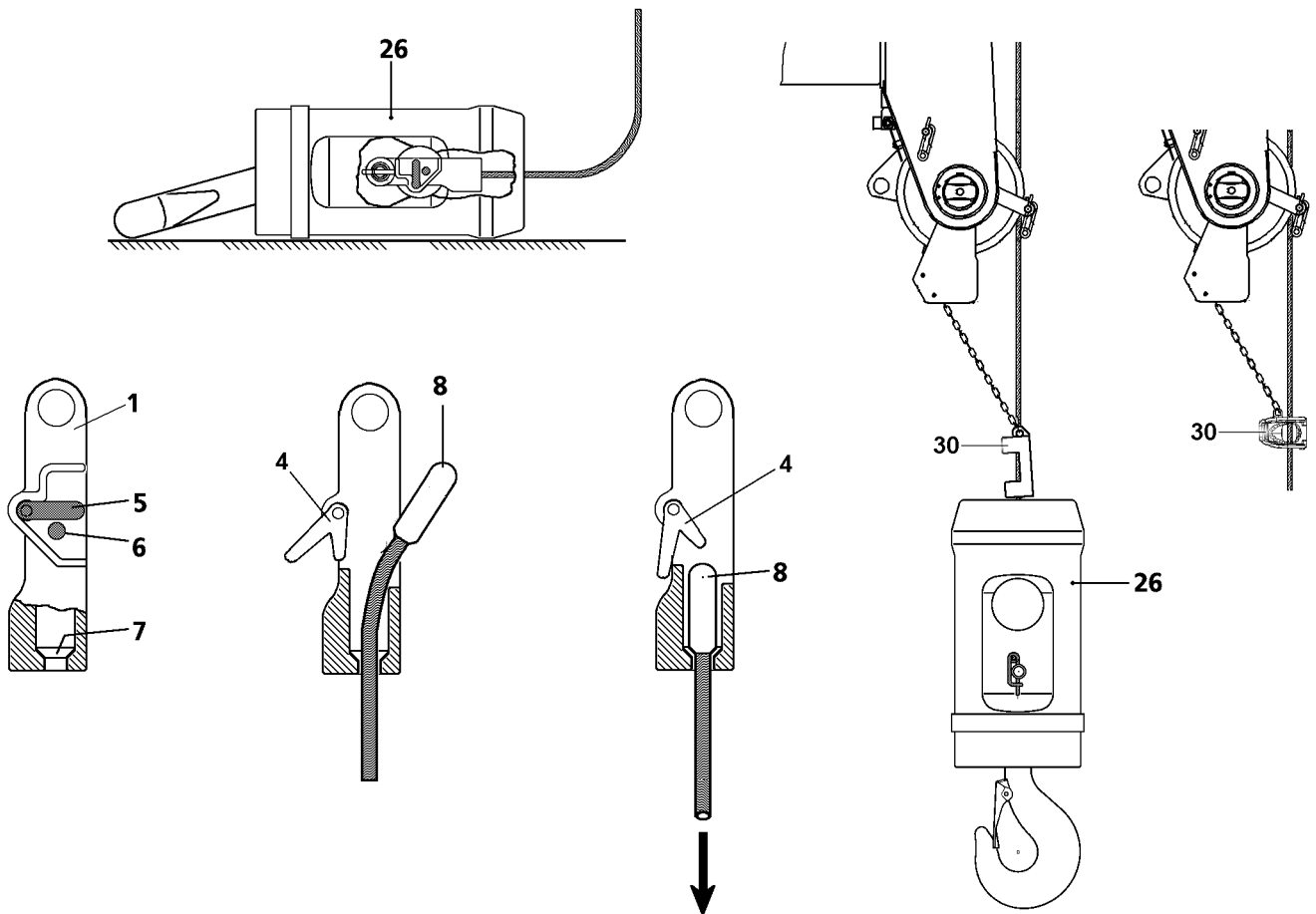


Fig.127730: Disassembling the load hook

Make sure that the following prerequisites are met:

- The crane is properly supported and horizontally aligned.
- The counterweight is installed according to the load chart.
- The LICCON overload protection has been set according to the load chart.
- The telescopic boom is telescoped in all the way.
- The telescopic boom has been swung to the rear or the side.
- The telescopic boom is luffed down to the 0° position.
- The ground is level and of sufficient load carrying capacity.

- ▶ Take the load hook **26** down on the ground.
- ▶ Remove the hoist limit switch weight **30**.
- ▶ Push the retaining element pin **6** into the rope lock **1**, swing the lever **5** sideways and hold it in this position.

**Result:**

- The locking pawl **4** is moved to the side and the locking clamp **8** is released.
- ▶ Push the hoist rope in the direction of the load hook and detach the locking clamp **8**.

- Unpin the rope lock **1** on the load hook **26** and remove.

## 7 Two-part hoist limit switch weight

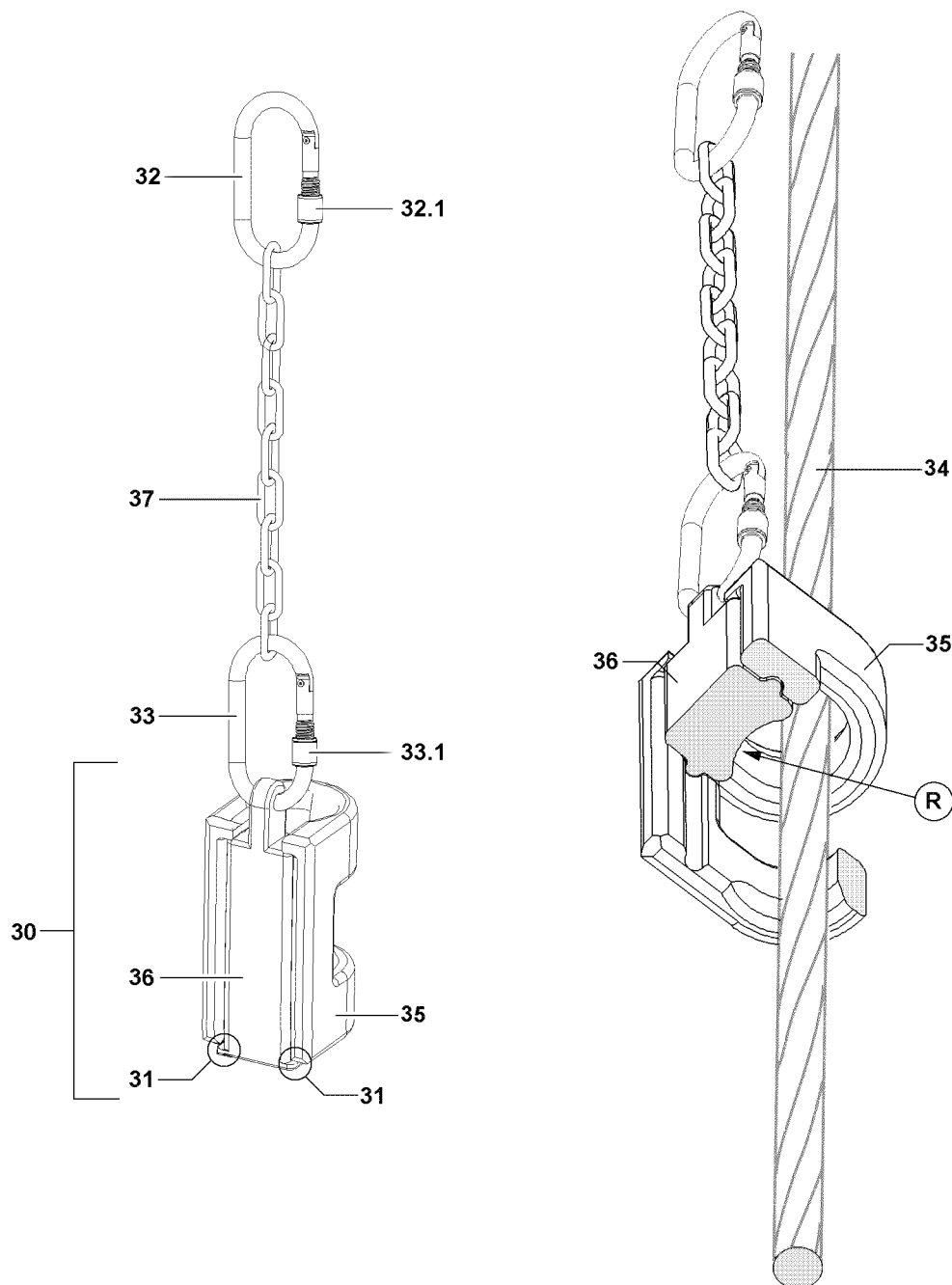


Fig.156691: Two-part hoist limit switch weight

The two-part hoist limit switch weight is only available on certain crane types.

The hoist limit switch weight is hung on the hoist limit switch. By hanging the hoist limit switch weight **30** on the hoist limit switch, the *Spool winch up* crane movement is released. As soon as the hoist limit switch weight **30** is lifted, the hoist limit switch switches off the *Spool winch up* crane movement.

The following parts are required:

- **30** Hoist limit switch weight



- **32** Upper carabiner
- **33** Lower carabiner
- **37** Chain

The hoist limit switch weight **30** consists of two parts, which are pushed into each other:

- The weight **35**
- The carrier section **36**



#### WARNING

Incorrect parts installed!

The crane movement is **not** switched off or is switched off too late.

Death, severe bodily injuries, property damage.

- ▶ Do **not** replace the hoist limit switch weight **30**, carabiner and chain **37** with other parts.

The chain **37** must be attached with its full length during crane operation and may not be shortened.



#### WARNING

Chain **37** shortened!

The crane movement is **not** switched off or is switched off too late.

Death, severe bodily injuries, property damage.

- ▶ Do **not** shorten the chain **37**.

## 7.1 Attaching the hoist limit switch weight



#### WARNING

Hoist limit switch weight is incorrectly installed!

The hoist limit switch weight can fall down. Death, severe injuries.

- ▶ When detaching or attaching the hoist limit switch weight **30** make sure that the weight **35** and the carrier section **36** do not fall down.
- ▶ Make sure that the curvature **R** of the carrier section **36** points to the hoist rope **34**.
- ▶ Make sure that the noses **31** of the carrier section **36** is placed on the weight **35**.



#### WARNING

Knurled nut installed closing upward!

The carabiner could loosen up itself by itself. The hoist limit switch weight **30** can fall down.

Death or severe bodily injuries.

- ▶ **Assemble the knurled nut closing downward.**

- ▶ Hang the chain **37** with the upper carabiner **32** on the hoist limit switch.
- ▶ Secure the upper carabiner **32** with the knurled nut **32.1**.

The attachment of the hoist limit switch weight **30** depends on the position of the rope fixed point.

#### Rope fixed point on the pulley head:

- In the event of multiple hoist rope reeving, the hoist limit switch weight **30** must always be laid around the „stationary rope strand“, in other words around the rope strand that leads directly to the cable lock.

#### Rope fixed point on the hook block:

- The hoist limit switch weight **30** is laid around the outer strand that has the least angular pull, i.e. the one with the smallest angle between the hanging hoist limit switch weight and the hoist rope.
  - ▶ Release and unscrew the knurled nut **33.1** on the lower carabiner **33**.
  - ▶ Push the weight **35** with one hand on the hoist rope **34** and hold.
  - ▶ With the other hand, guide the carrier section **36** behind the hoist rope **34** and under the weight **35**. The curvature **R** of the carrier section **36** must point to the hoist rope **34**.
  - ▶ Push the weight **35** on the carrier section **36**.
  - ▶ Connect the hoist limit switch weight **30** with the carrier section **36** in the lower carabiner **33**.
  - ▶ Secure the lower carabiner **33** with the knurled nut **33.1**.

## 7.2 Removing the hoist limit switch weight

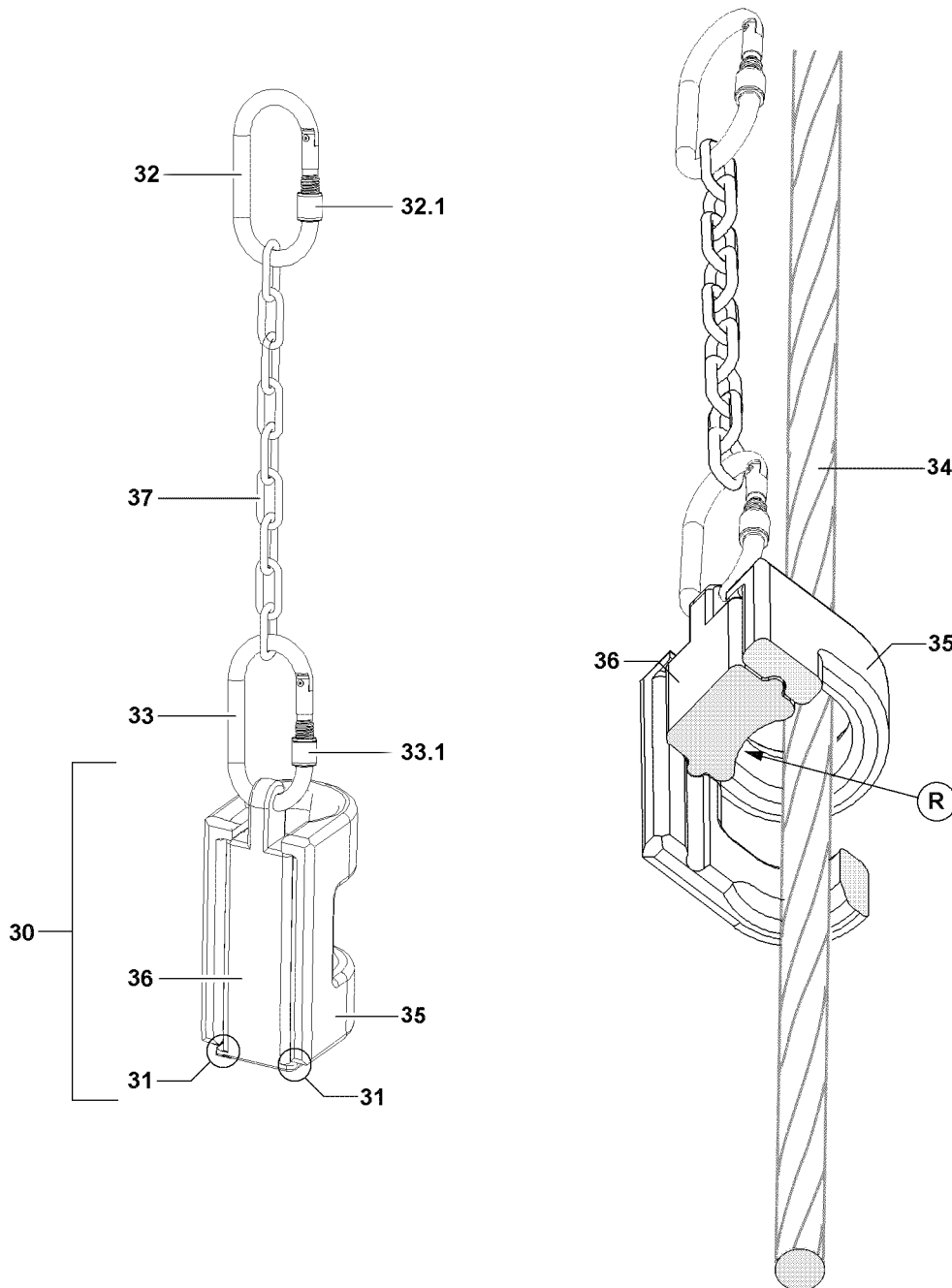


Fig.156691: Details Hoist limit switch weight



### WARNING

Hoist limit switch weight is incorrectly installed!  
The hoist limit switch weight can fall down. Death, severe injuries.

- ▶ When detaching or attaching the hoist limit switch weight **30** make sure that the weight **35** and the carrier section **36** do not fall down.
  - ▶ It is prohibited to remain in the danger zone.
- 
- ▶ Release and unscrew the knurled nut **33.1** on the lower carabiner **33**.
  - ▶ Detach the hoist limit switch weight **30** from the lower carabiner **33**.
  - ▶ Hold the weight **35** with one hand and with the other hand, push the carrier section **36** out of the weight **35**.

- ▶ Remove the chain **37** with the upper carabiner **32** on the hoist limit switch.
- ▶ Store the weight **35**, carrier section **36** and chain **37** with the carabiner safely.

## 8 One-part hoist limit switch weight

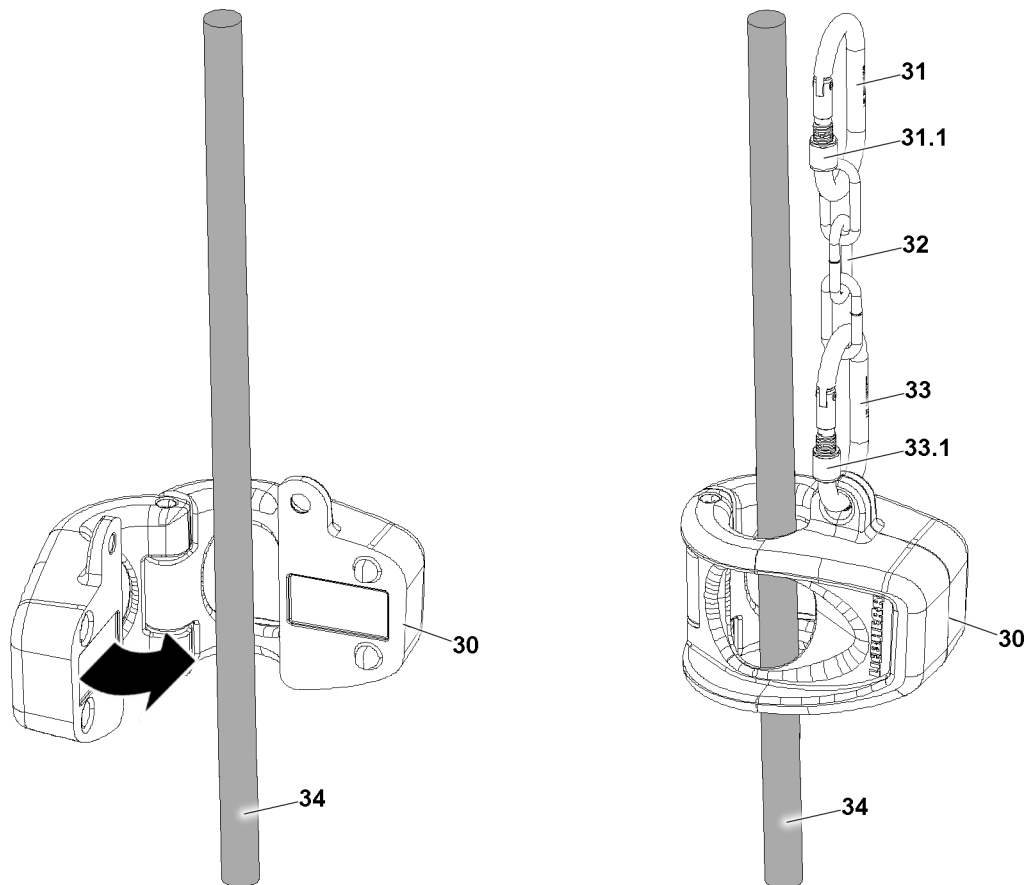


Fig.127727: Hoist limit switch weight

The one-part hoist limit switch weight is only available on certain crane types.

The hoist limit switch weight is hung on the hoist limit switch. By hanging the hoist limit switch weight **30** on the hoist limit switch, the crane movement *Spool winch up* is released. As soon as the hoist limit switch weight **30** is lifted, the hoist limit switch switches off the *Spool winch up* crane movement.

The following parts are required:

- **30** Hoist limit switch weight
- **31** Upper carabiner
- **32** Chain
- **33** Lower carabiner



### WARNING

Incorrect parts installed!

The crane movement is **not** switched off or is switched off too late.  
Death, severe bodily injuries, property damage.

- ▶ Do **not** replace the hoist limit switch weight **30**, carabiner and chain **32** with other parts.

The chain **32** must be attached with its full length during crane operation and may not be shortened.

**WARNING**

Chain **32** shortened!

The crane movement is **not** switched off or is switched off too late.  
Death, severe bodily injuries, property damage.

- ▶ Do **not** shorten the chain **32**.

## 8.1 Attaching the hoist limit switch weight

**WARNING**

Hoist limit switch weight is incorrectly installed!

The hoist limit switch weight can fall down.  
Death or severe bodily injuries.

- ▶ Makes sure that the hoist limit switch weight **30**, carabiner and chain **32** do not scrape against the hoist rope **34** after assembly.
- ▶ Do **not** let the hoist limit switch weight **30** fall down.

**WARNING**

Knurled nut installed closing upward!

The carabiner could loosen up itself by itself. The hoist limit switch weight **30** can fall down.  
Death or severe bodily injuries.

- ▶ **Assemble the knurled nut closing downward.**

- ▶ Hang the chain **32** with the upper carabiner **31** on the hoist limit switch.
- ▶ Secure the upper carabiner **31** with the knurled nut **31.1**.

The attachment of the hoist limit switch weight **30** depends on the position of the rope fixed point.

**Rope fixed point on the pulley head:**

- In the event of multiple hoist rope reeving, the hoist limit switch weight **30** must always be laid around the „stationary rope strand“, in other words around the rope strand that leads directly to the cable lock.

**Rope fixed point on the hook block:**

- The hoist limit switch weight **30** is laid around the outer strand that has the least angular pull, i.e. the one with the smallest angle between the hanging hoist limit switch weight **30** and the hoist rope **34**.
- ▶ Place the hoist limit switch weight **30** around the hoist rope **34**.
- ▶ Close the hoist limit switch weight **30**.
- ▶ Hang the chain **32** with the lower carabiner **33** on the hoist limit switch weight **30**.
- ▶ Secure the lower carabiner **33** with the knurled nut **33.1**.

**Result:**

- The hoist limit switch weight **30** is assembled and secured.

## 8.2 Removing the hoist limit switch weight

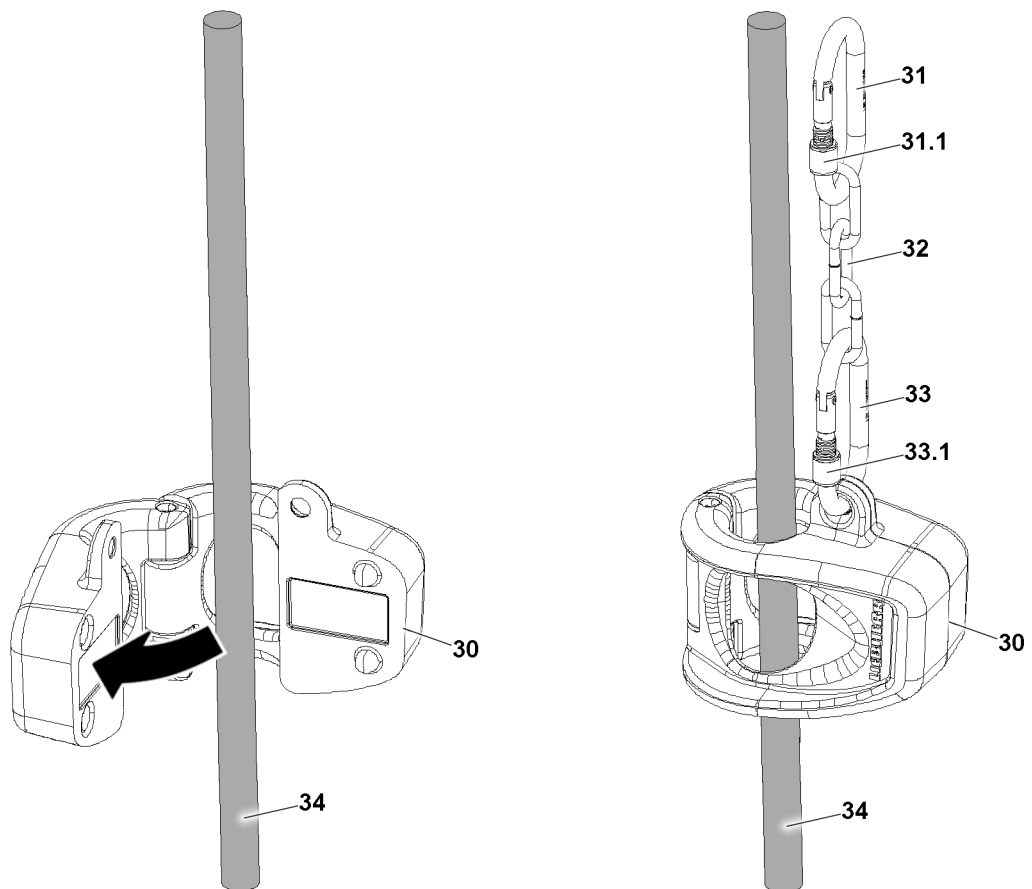


Fig.127728: Removing the hoist limit switch weight



### WARNING

Hoist limit switch weight **not** secured during disassembly!  
The hoist limit switch weight can fall down.

▶ Do **not** let the hoist limit switch weight **30** fall down during disassembly.

- ▶ Release and unscrew the knurled nut **33.1** on the lower carabiner **33**.
- ▶ Hold the hoist limit switch weight **30** with one hand and with the other hand, hang the lower carabiner **33** on the hoist limit switch weight **30**.
- ▶ Remove the chain **32** with the upper carabiner **31** on the hoist limit switch.
- ▶ Store the hoist limit switch weight **30**, chain **32** with the carabiner **31** and carabiner **33** safely.

## 9 Wedge lock

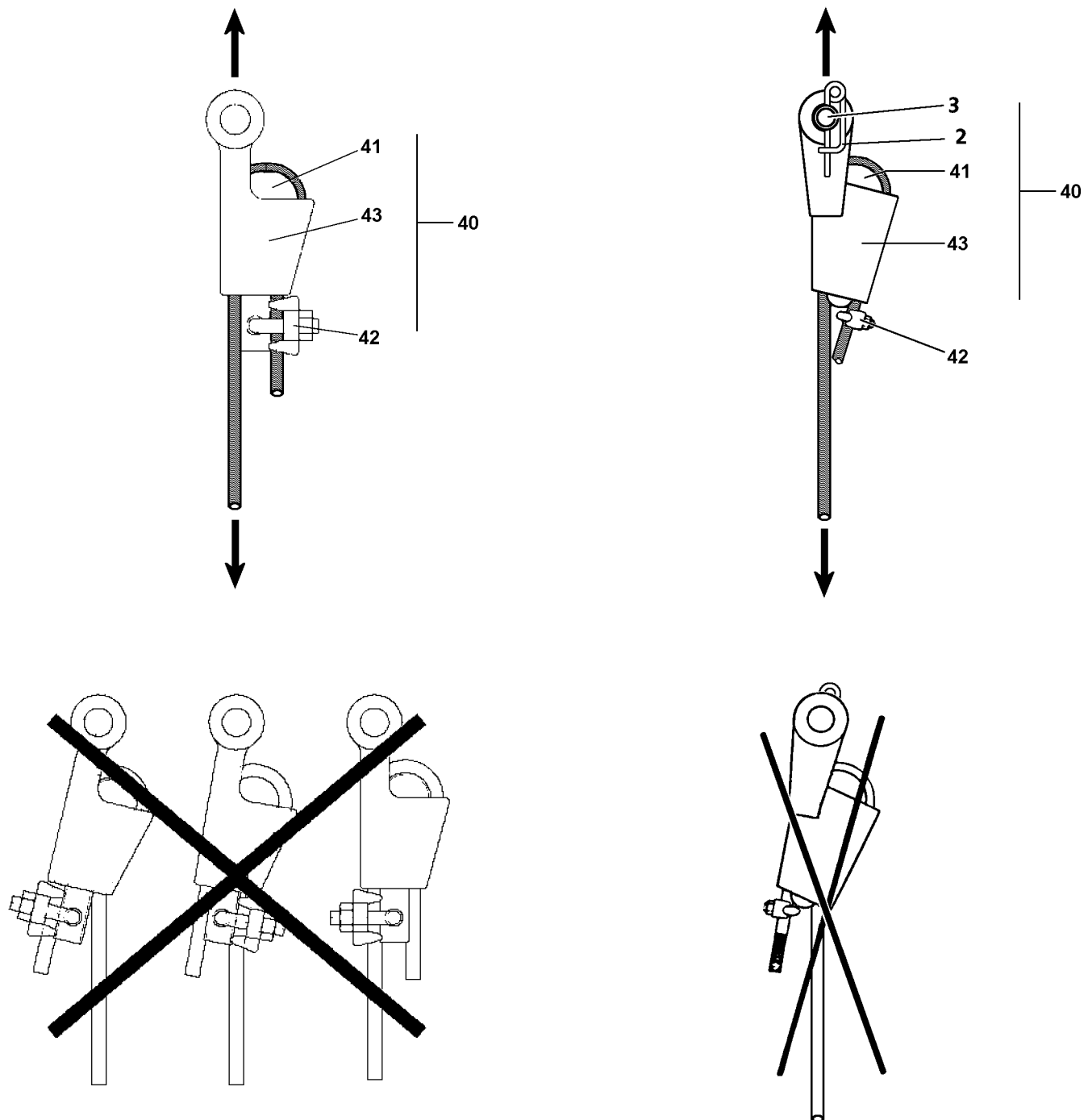


Fig.122729: Wedge lock

Liebherr-Werk Ehingen GmbH does not have any safety concerns regarding the use of a cotter as a replacement for the lock. However, when using a cotter in connection with rotation-resistant hoist ropes, they do not have some of the positive characteristics of the lock, which can lead to a reduced service life of the rope.



### Note

Continuous use of cotters with rotation-resistant hoist ropes!  
The service life of the rope can be reduced.

- ▶ Continuous use of cotters with rotation-resistant hoist ropes is **not** recommended.

Make sure that the following prerequisites are met:

- The locking clamp or locking cast sleeve is cut off on the hoist rope.
- The hook block or the load hook is ready for assembly.

## 9.1 Installing the wedge lock



### WARNING

Wedge lock is incorrectly installed!

Hook block or load can fall down. Death, severe injuries, property damage.

- ▶ Use only a wedge lock **40** approved by Liebherr-Werk Ehingen.
  - ▶ Install the wedge lock **40** correctly.
  - ▶ Place the hoist rope with the wedge **41** into the housing **43** in such a way that the rope strand runs in the pull axle of the wedge lock **40**.
  - ▶ The dead end of the rope must be secured by the wire rope clamp **42** to prevent it from being pulled through.
- 
- ▶ Take a matching wedge lock **40**.
  - ▶ Insert the hoist rope with the wedge **41** in the housing **43**.
  - ▶ If possible, assemble the wire rope clamp **42** through the wedge **41** on the dead end of the rope.

### NOTICE

Damage to the hoist rope!

If the pin **3** has been assembled incorrectly, the hoist rope may rub against the pin **3** or on the retaining element **2**.

- ▶ Always insert the pins **3** from „inside to outside“ and secure from the outside.
- 
- ▶ Pin and secure the wedge lock **40** on the fixed point of the pulley head or on the fixed point of the hook block or on the load hook, depending on the reeving plan.

## 9.2 Removing the wedge lock

- ▶ Unpin the wedge lock **40** on the fixed point.
- ▶ Remove the wire rope clamp **42** and pull the hoist rope with the wedge from the housing.
- ▶ Store the wedge lock **40**.

## 10 Auxiliary pulley\*

### 10.1 Crane operation with auxiliary pulley\*

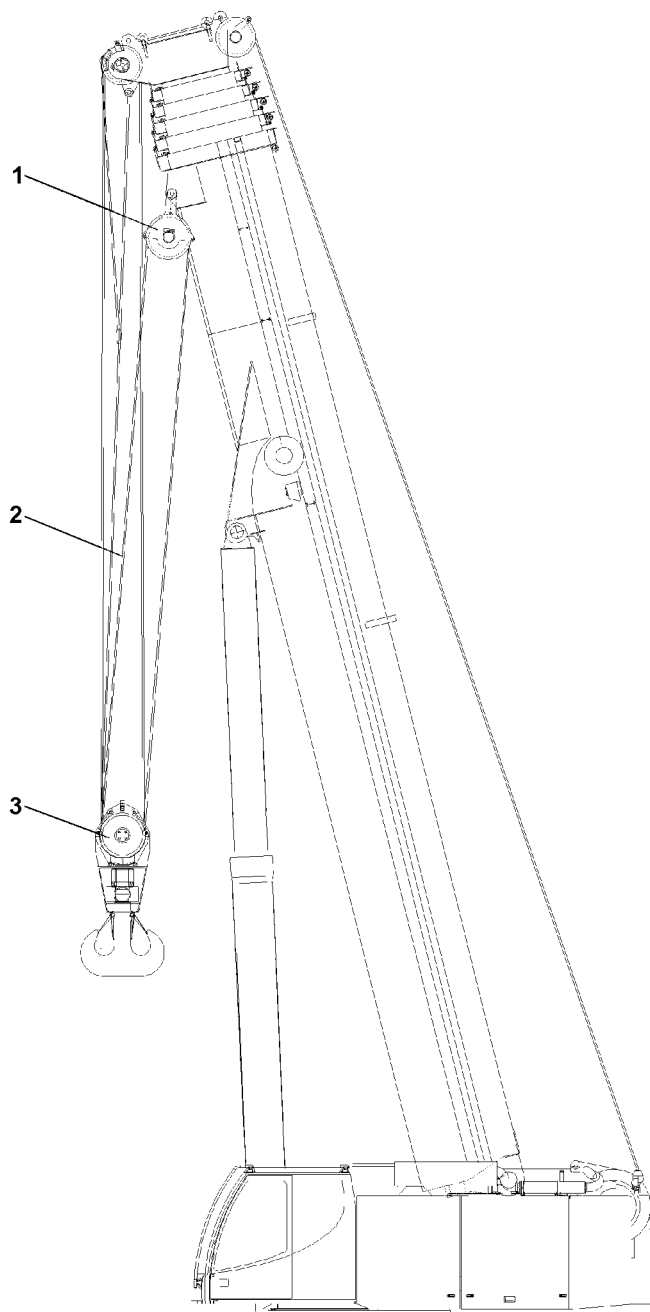


Fig.122730: Telescopic boom with auxiliary pulley 1

Make sure that the following prerequisites are met:

- The TY-guying has been disassembled (if present).
- The floodlights on the telescopic boom have been disassembled.



#### Note

- ▶ For crane operation with auxiliary pulley 1 on the telescopic boom, move only to the radius ranges, which are present in the load chart.



---

**NOTICE**

Hoist limit switch chain too short!

Damage of hook block, auxiliary pulley or hoist rope.

- ▶ Before crane operation with auxiliary pulley **1**, assemble the longer hoist limit switch chain.
  - ▶ Before crane operation with auxiliary pulley **1**, remove the rope protection pipes on the hook block **3**.
  - ▶ When the hook block **3** is on the ground, ensure that the hoist rope **2** remains in the pulleys.
  - ▶ For crane operation with auxiliary pulley **1**, do **not** telescope the telescopic boom out and run only the radii ranges, which are specified in the load chart.
- 
- ▶ Carry out crane operation with auxiliary pulley **1** carefully.

## 11 Rope reeving



---

**Note**

- ▶ Observe and adhere to the separate reeving plans.
-

---

Empty page!

LWE/LTR 1220-003/24204-02-02/en

## 4.07 Counterweight

1	Overview of counterweight	3
2	Counterweight combinations	5
3	Fastening the counterweight plates and receptacle plate	7
4	Assembling the counterweight	11
5	Ballast monitoring	21
6	Counterweight error message	24
7	Disassembling the counterweight	27
8	Bluetooth Terminal (BTT) operating element	37

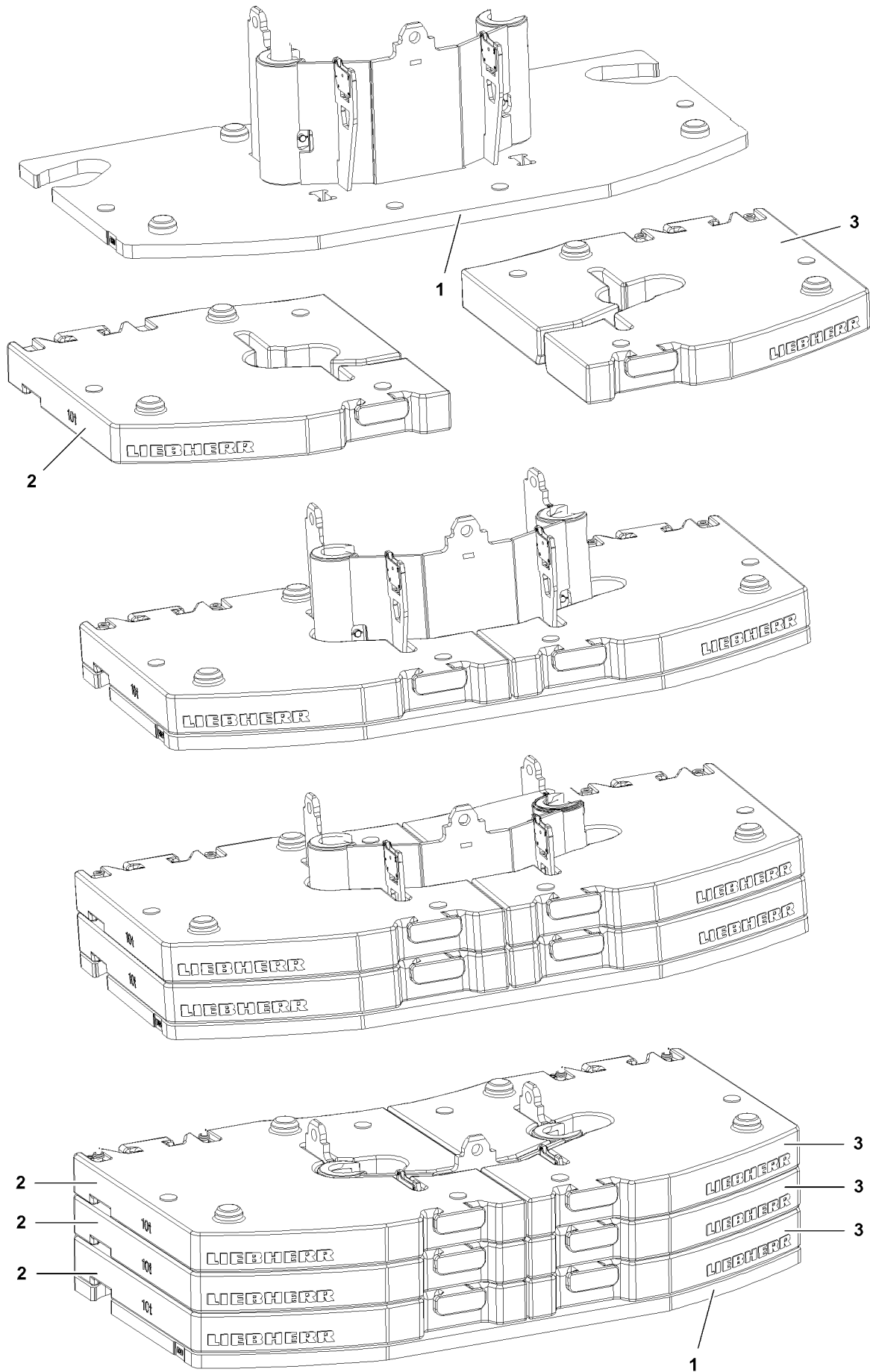


Fig.117323

LWE/LTR 1220-003/24204-02-02/en

# 1 Overview of counterweight

The counterweight consists of:

- **1** Receptacle plate
- **2** Counterweight plate
- **3** Counterweight plate



## Note

- ▶ The counterweight plates are marked with their respective own weights.
  - ▶ There are three identical counterweight plates **2**.
  - ▶ There are three identical counterweight plates **3**.
-

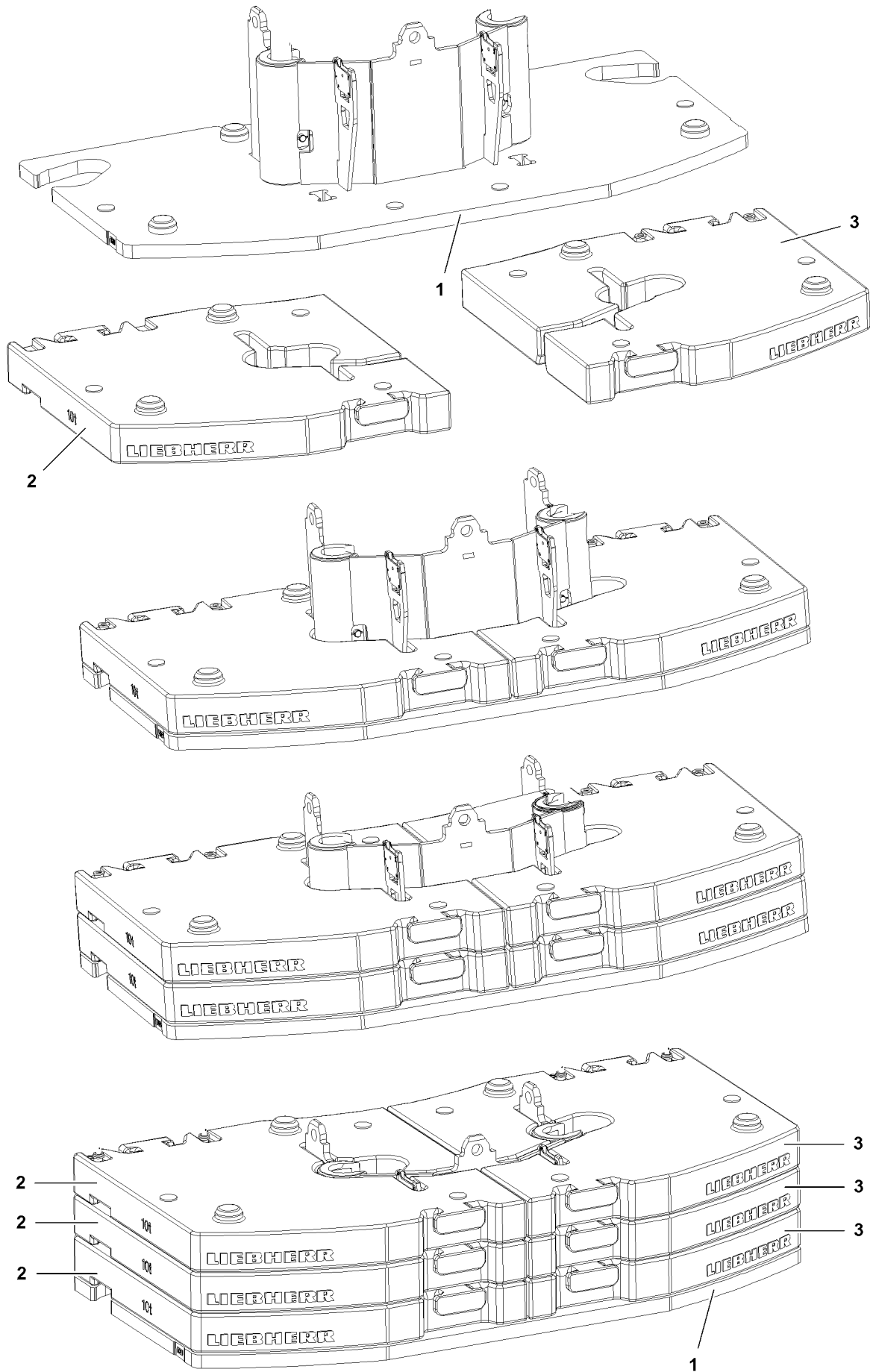


Fig.117323

LWE/LTR 1220-003/24204-02-02/en

## 2 Counterweight combinations



### WARNING

The crane can topple over!

If any other counterweight combination than the one noted in the charts is used, the crane can topple over!

► Counterweight combinations specified in the following charts must be used!

Counterweight	Composition	Individual weight
0.0 t	No receptacle plate, no counterweight	0.0 t

Counterweight	Composition	Individual weight
10.0 t	Receptacle plate 1	10.0 t

Counterweight	Composition	Individual weight
30.0 t	Receptacle plate 1	10.0 t
	1 x counterweight plate 2	10.0 t
	1 x counterweight plate 3	10.0 t

Counterweight	Composition	Individual weight
50.0 t	Receptacle plate 1	10.0 t
	2 x counterweight plate 2	10.0 t
	2 x counterweight plate 3	10.0 t

Counterweight	Composition	Individual weight
70.0 t	Receptacle plate 1	10.0 t
	3 x counterweight plate 2	10.0 t
	3 x counterweight plate 3	10.0 t

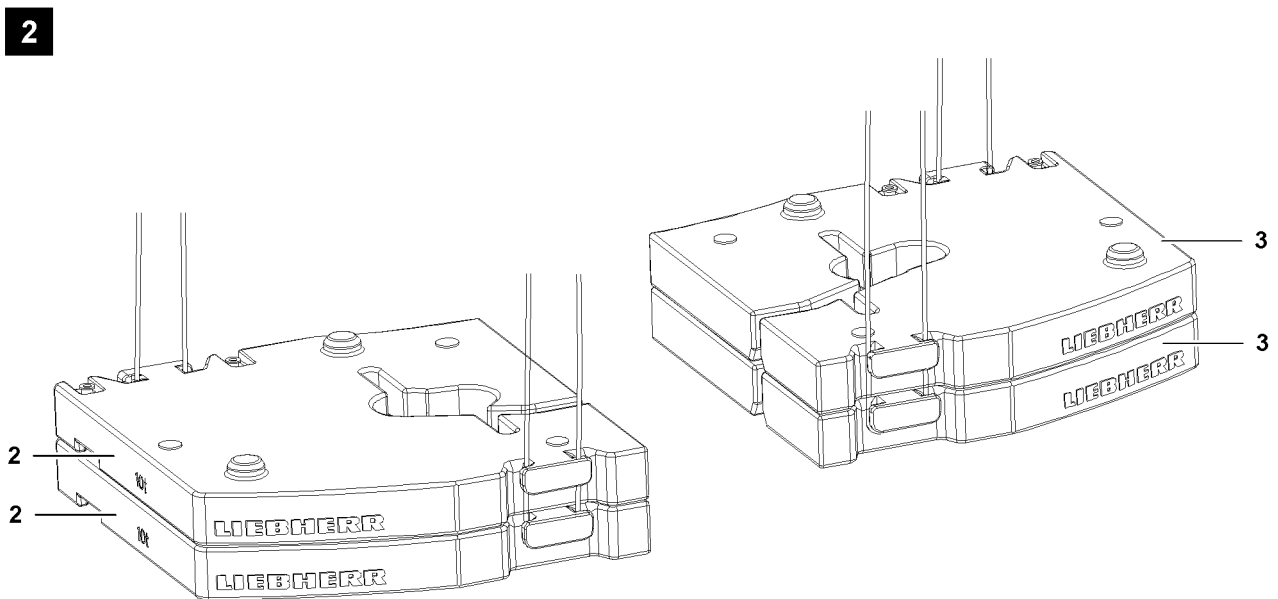
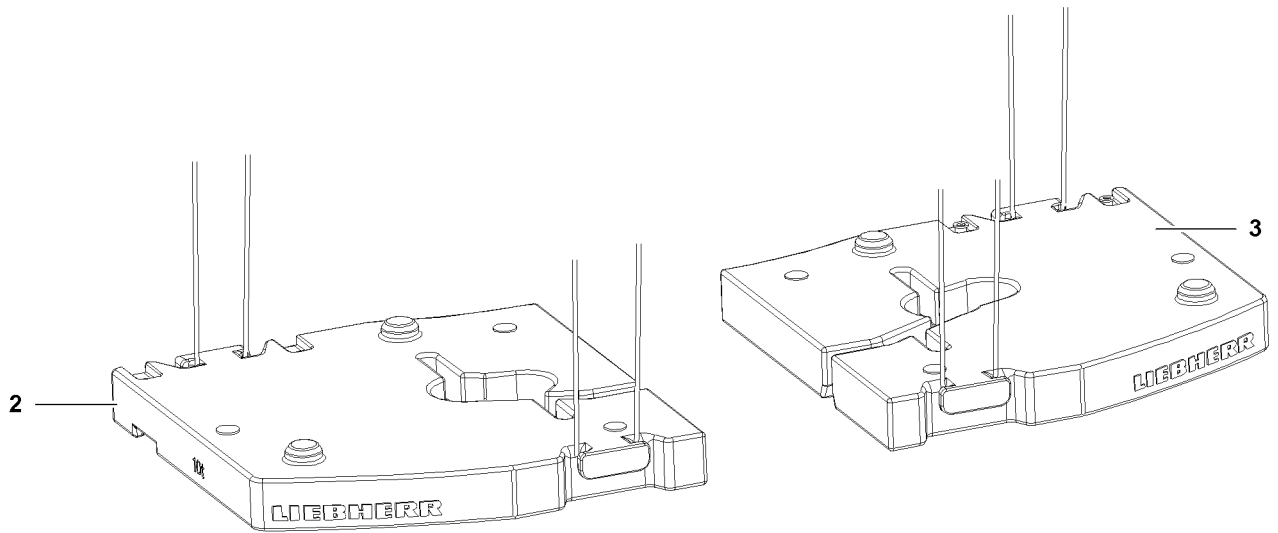
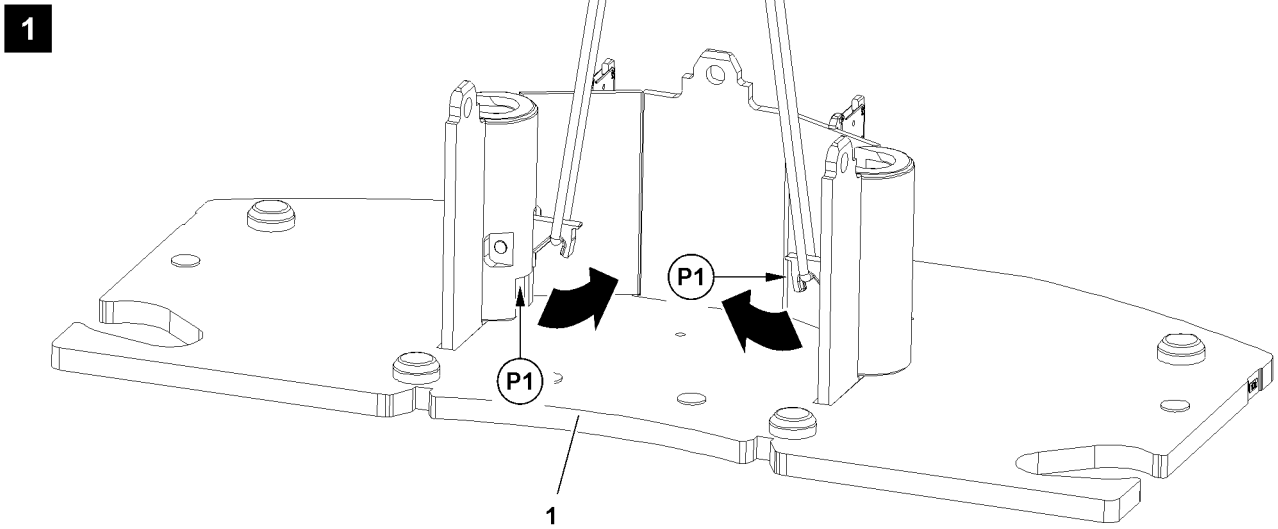


Fig.117324

LWE/LTR 1220-003/24204-02-02/en



## 3 Fastening the counterweight plates and receptacle plate



### WARNING

Improperly fastened crane components!

Improperly fastened crane components can slip and fall down when lifting or swinging them.

Personnel can be severely injured or killed.

- ▶ Before lifting, make sure that the crane components are properly fastened.
- ▶ Use only approved and suitable fastening equipment.
- ▶ Always keep a sufficient distance from suspended crane components.
- ▶ Standing under raised crane components is **prohibited**.
- ▶ Carefully initiate all crane movements with attached crane components extremely sensitively and initiate slow down with utmost caution.

### 3.1 Fastening the counterweight plate

Fold the fastening points out in point **P1**.

Fasten the receptacle plate to the fastening points, see illustration 1.

### 3.2 Fastening the counterweight plates



### WARNING

Property damage due to overload!

- ▶ Lift a maximum of two form-fit stacked counterweight plates as an assembly.

Fasten the counterweight plates to the fastening points, see illustration 2.

3

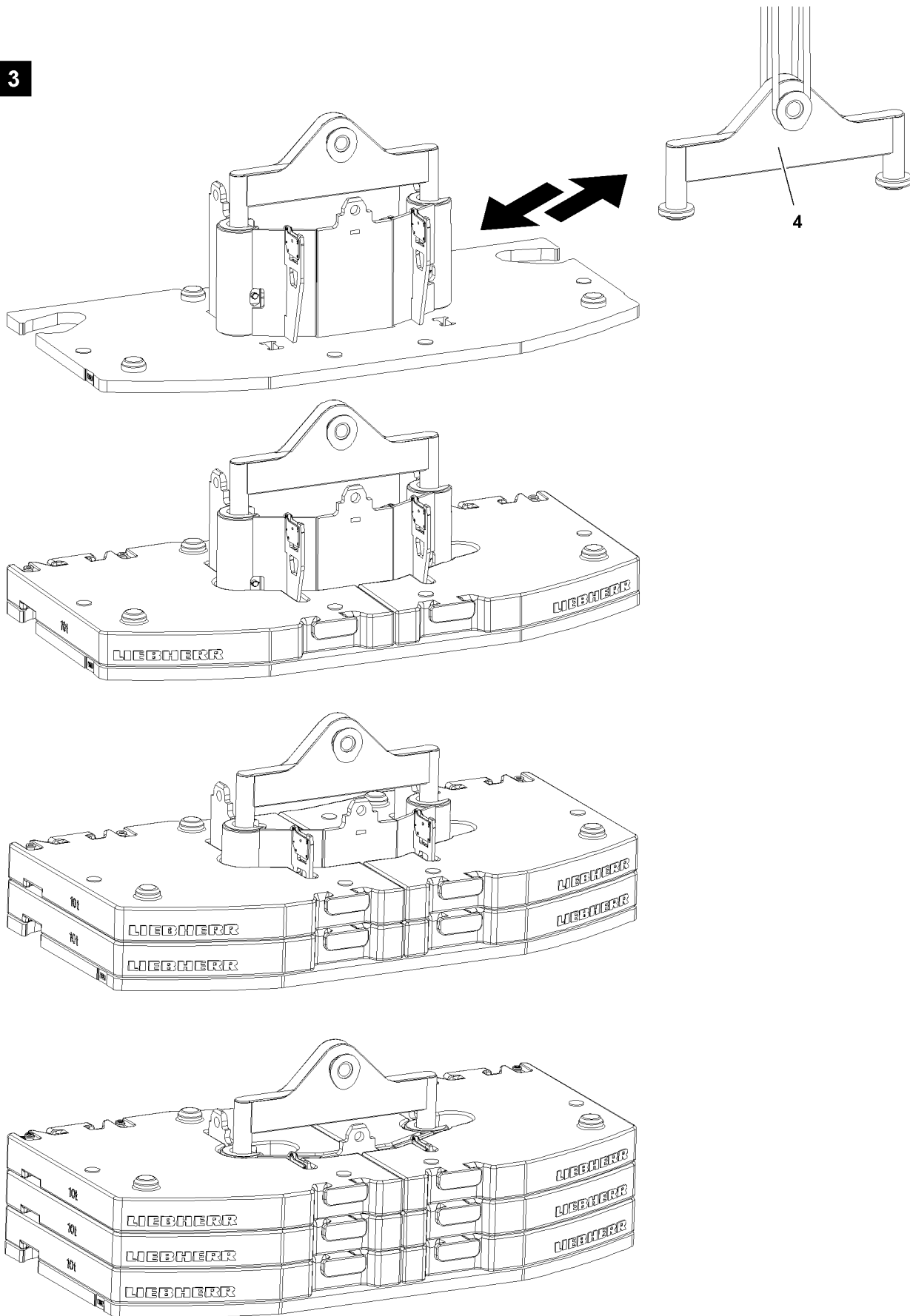


Fig.117325

LWE/LTR 1220-003/24204-02-02/en

### 3.3 Fastening the counterweight with a cross beam

**Note**

- ▶ The counterweight receptacle can be fastened as an assembly with the cross beam **4**, see illustration **3**.

**WARNING**

Improperly fastened crane components!

Improperly fastened crane components can slip and fall down when lifting or swinging them!

Personnel can be severely injured or killed!

- ▶ Before lifting, make sure that the crane components are properly fastened!
- ▶ Use only approved and suitable fastening equipment!
- ▶ Always keep a sufficient distance from suspended crane components!
- ▶ Standing under raised crane components is **prohibited!**
- ▶ Carefully initiate all crane movements with attached crane components extremely sensitively and initiate slow down with utmost caution!
- ▶ Lift only form-fit and symmetrically stacked counterweight plates as an assembly!

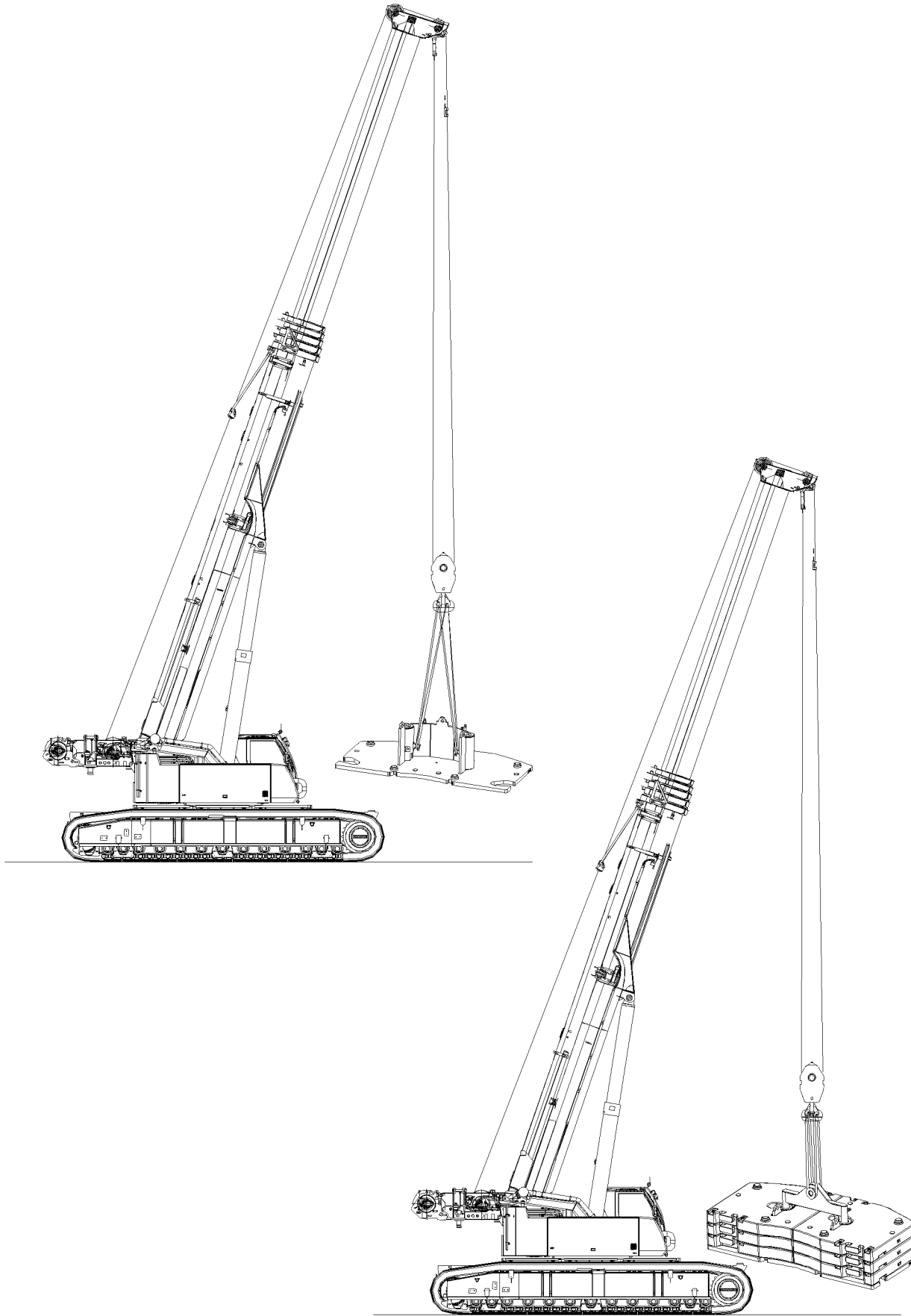


Fig.117329

LWE/LTR 1220-003/24204-02-02/en

## 4 Assembling the counterweight



### WARNING

Danger of falling!

During assembly and disassembly, assembly personnel must be secured with appropriate aids to prevent them from falling! If this is not observed, assembly personnel could fall and suffer life-threatening or fatal injuries!

- ▶ Any work, where there is a danger of falling, must be carried out with suitable aids (for example: lifting platforms, scaffoldings, ladders, auxiliary crane)!
- ▶ If the work cannot be carried out with such aids nor from the ground, then the assembly personnel must secure themselves with approved fall arrest systems to avoid falling, see chapter 2.04!
- ▶ If railings are present on the crane components, then they must be brought into the corresponding position and secured for assembly / disassembly work!
- ▶ Only step on aids and fall protection equipment with clean shoes!
- ▶ Keep aids and fall protection equipment clean and free from snow and ice!
- ▶ During all assembly and disassembly work, maintenance work and inspections, travel or crane operation is prohibited!



### WARNING

Danger of accident!

During assembly or disassembly of the counterweight, personnel can be injured or killed!

Objects can be damaged!

- ▶ During the assembly or disassembly of the counterweight, no personnel may remain within the danger zone!
- ▶ During the assembly or disassembly of the counterweight, no objects may remain within the danger zone!



### WARNING

Damaged counterweight!

If a damaged / dirty counterweight is used, then the tight seating and the operational safety are no longer ensured.

- ▶ Do not use a damaged counterweight.
- ▶ Replace / repair a damaged counterweight.
- ▶ Clean a dirty counterweight.
- ▶ Keep the placement / installation surfaces of the counterweight clean.



### WARNING

Falling counterweight!

If the counterweight is not properly ballasted / installed, then it can fall down and cause severe accidents.

Personnel can be severely injured or killed.

- ▶ Before start up, make sure that the counterweight is properly ballasted / installed.

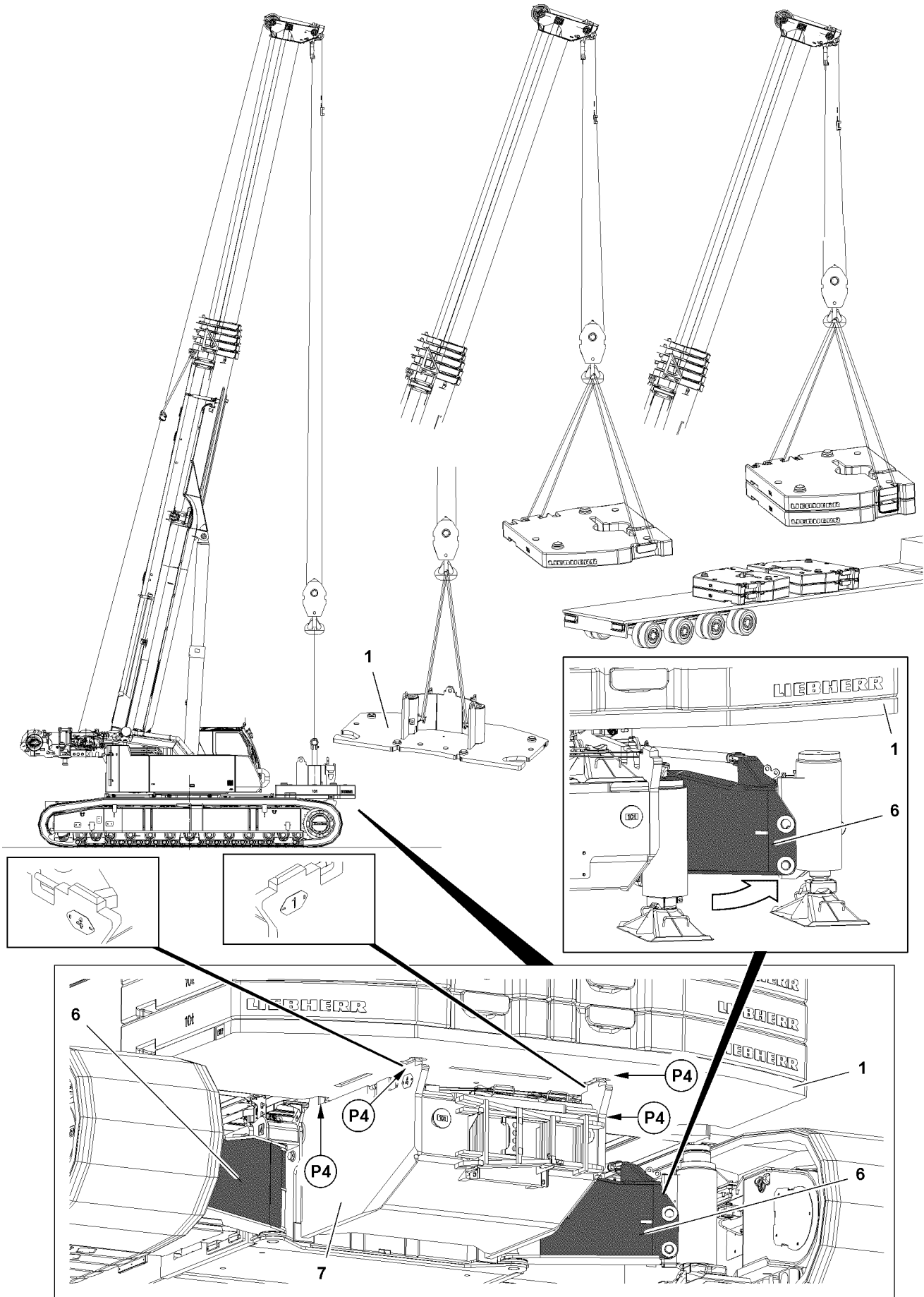


Fig.117326

## 4.1 Taking the counterweight down with the crane

Make sure that the following prerequisites are met:

- The crane is positioned on a level and load-bearing surface.
- The crane is horizontally aligned.
- The central ballast blocks **7** are installed on the front and rear, see chapter 3.03.
- The crane with installed crawler carriers is operational as assembly crane.
- The support cylinders are completely retracted.
- The transport vehicle with the counterweight plates is in the immediate vicinity of the crane.
- No support plates and the assembly device are taken down on the central ballast.
- The fall protection equipment is installed.
- The LICCON overload protection is set:
  - Crawler operation with track width
  - Central ballast 20 t
  - Counterweight 0 t
  - Without auxiliary boom / accessories
  - Slewing range

The receptacle plate acts as a carrier plate for the counterweight plates and must always be taken down onto the central ballast first.

### 4.1.1 Taking the receptacle plate down on the central ballast



#### **DANGER**

Danger of fatal accident due to toppling of the crane!

If the counterweight is not taken down on the central ballast block 1/4 **7**, the crane will topple over.

- ▶ Make sure that the receptacle plate and the counterweight plates are taken down on the central ballast block 1/4 **7**.

#### **NOTICE**

Damage of receptacle plate due to collision!

If the support cylinders are pinned in the uppermost position, then the support cylinders can collide with the base plate.

- ▶ Swing both folding beam brackets **6** out and secure.
- ▶ Fasten the receptacle plate **1** with fastening ropes to the crane.
- ▶ Take the receptacle plate down in the centerings **P4** of the central ballast block 1/4 **7**.

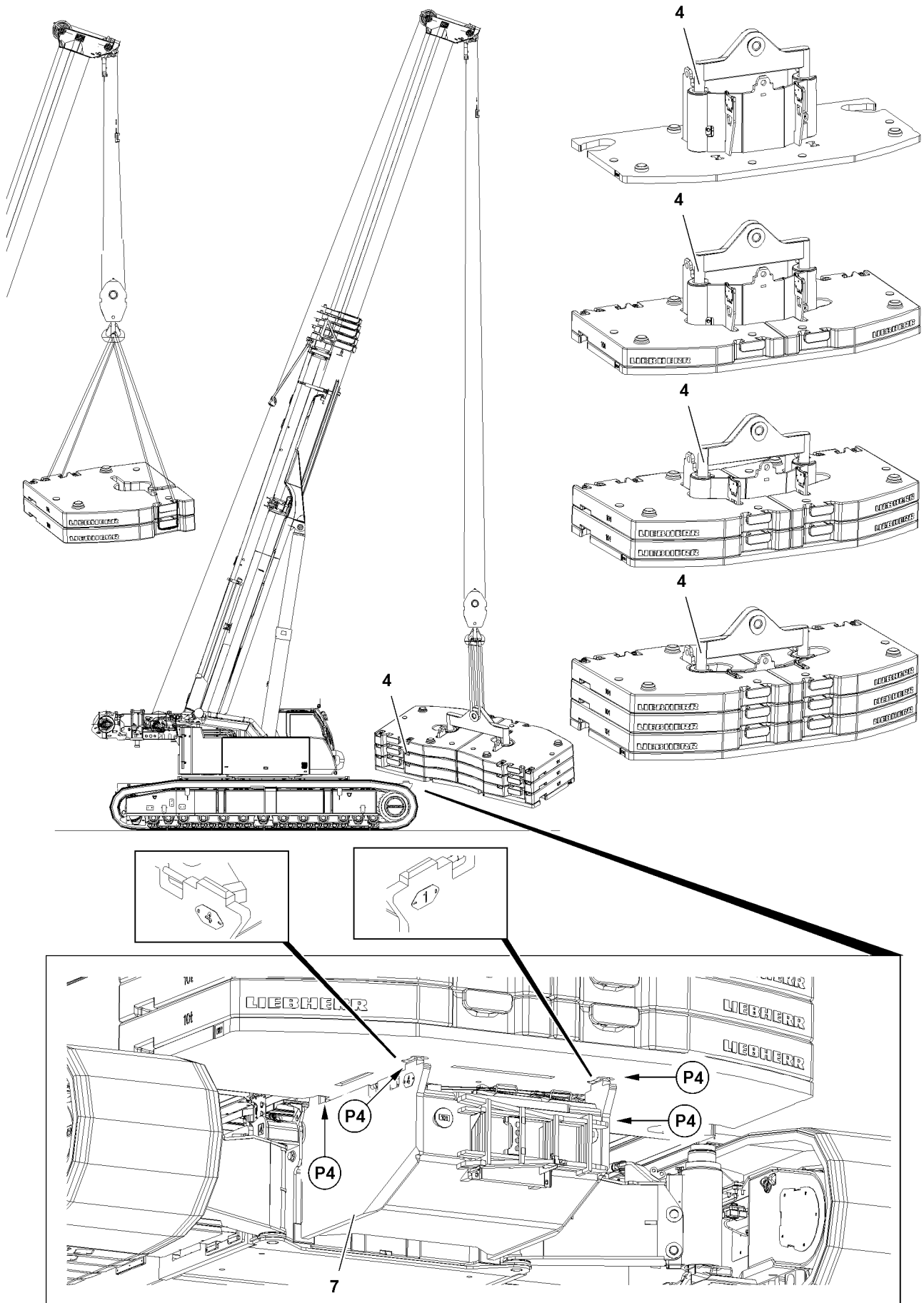


Fig.117331

LWE/LTR 1220-003/24204-02-02/en



### 4.1.2 Taking the counterweight plates down on the central ballast



#### WARNING

Property damage due to overload!

- ▶ Lift a maximum of two form-fit stacked counterweight plates as an assembly.



#### WARNING

The crane can topple over!

If the counterweights are taken down asymmetrically on the receptacle plate **1** or if the counterweight is installed asymmetrically, then the crane can topple over and kill personnel!

- ▶ Take the counterweights down alternately on the left and right on the receptacle plate only up to a difference of 10 t.
  - ▶ Attach the counterweight symmetrically.
- 
- ▶ Fasten the counterweight plates to the crane.
  - ▶ Take the counterweight plates down to match on the centering cone of the counterweight receptacle.

### 4.2 Taking the counterweight down as an assembly with the cross beam on the central ballast



#### WARNING

Toppling crane if asymmetrically assembled!

- ▶ Install the counterweight symmetrically.

#### NOTICE

Damage of receptacle plate due to collision!

If the support cylinders are pinned in the uppermost position, then the support cylinders can collide with the base plate.

- ▶ Swing both folding beam brackets **6** out and secure.
- 
- ▶ Fasten the counterweight with the cross beam **4** to the crane.
  - ▶ Take the counterweight down with the cross beam **4** in the centering **P4** of the central ballast.

### 4.3 Assembling hoist gear 2\*

When hoist gear 2 is to be installed, see chapter 5.09.

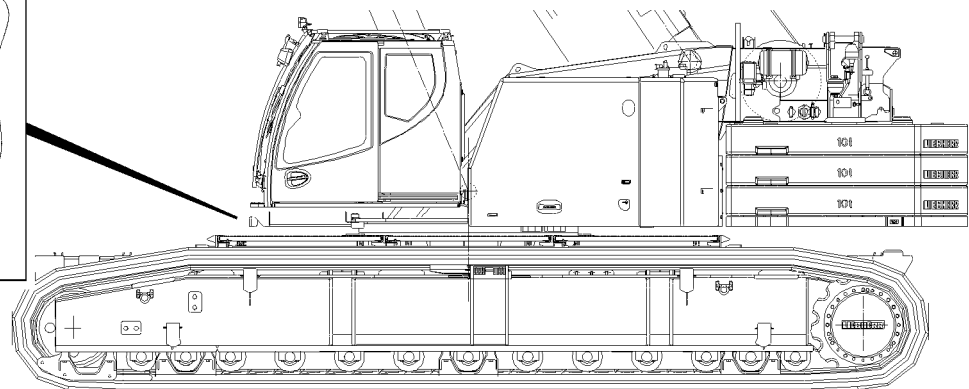
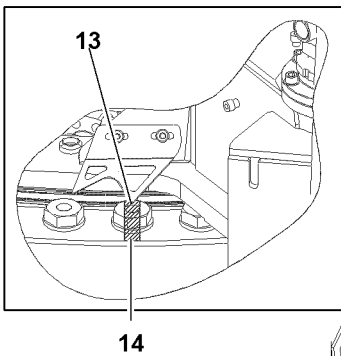
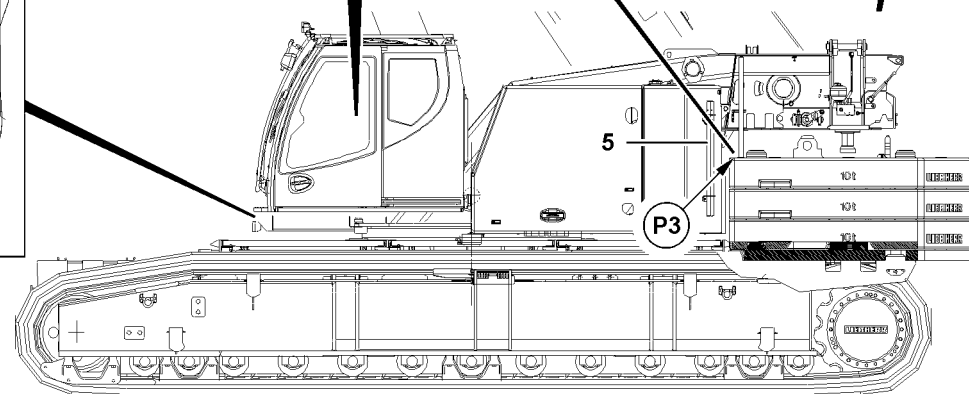
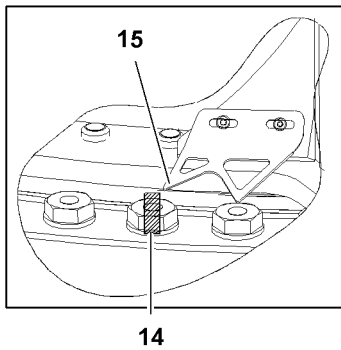
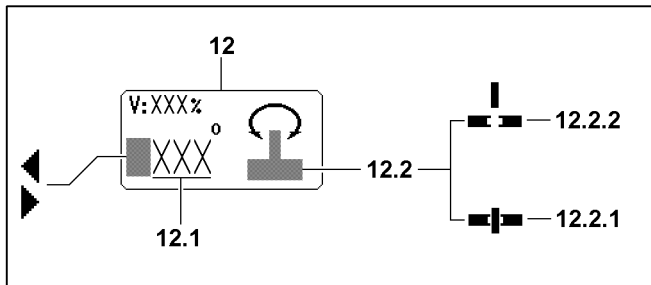
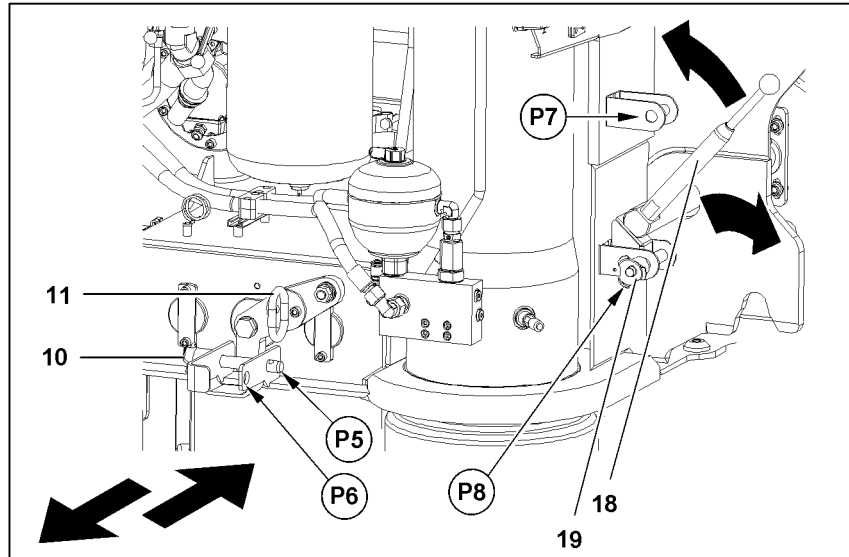
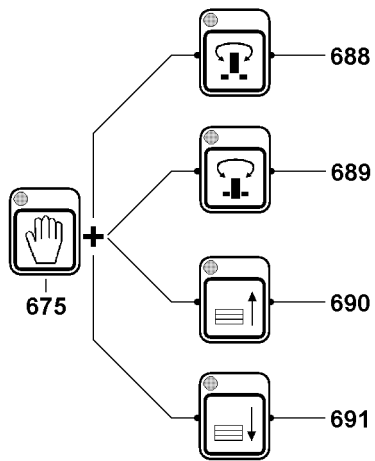


Fig.117327

LWE/LTR 1220-003/24204-02-02/en

## 4.4 Picking up the counterweight with the ballasting device

### 4.4.1 Unpinning the ballasting device

#### NOTICE

Damage to the ballasting device!

If the ballasting device is not unpinned before extending the ballast cylinders, then the ballasting device can be damaged!

▶ Unpin the ballasting device before extending the ballast cylinders!

- ▶ Release the grip pins: Unpin the ball locking pin **10**.
- ▶ Unpin the grip pin **11** to the stop.
- ▶ Secure the grip pins **11**: Insert the ball locking pin **10** in position **P6**.
- ▶ Release the hand lever **18**: Unpin the ball locking pin **19** in point **P7**.
- ▶ Swing the hand lever **18** downwards.
- ▶ Insert the ball locking pin **19** in the park position **P8**.

### 4.4.2 Ballasting the counterweight plates



#### WARNING

Danger of accident!

- ▶ As long as the crane superstructure is **not** locked, no movement (lift / lower counterweight) may be carried out!



#### WARNING

Ballast cylinders not retracted!

If the ballast cylinders are not fully retracted, they can collide with the counterweight when the crane superstructure is turned and cause significant property damage to the crane. The counterweight can fall down and hit personnel!

Personnel can be severely injured or killed!

- ▶ Make sure that the ballast cylinders are fully retracted before turning the crane superstructure!

The crane operating screen is called up on the LICCON monitor:

- ▶ Turn the crane superstructure to the right until the small pointer **15** on the slewing ring aligns with the marked screw **14**, see illustration **1**.
- The ballast cylinders are now located over the intake openings of the counterweight.
- The LICCON monitor displays a value **12.1** from 176° to 177° in the slewing range icon **12**.

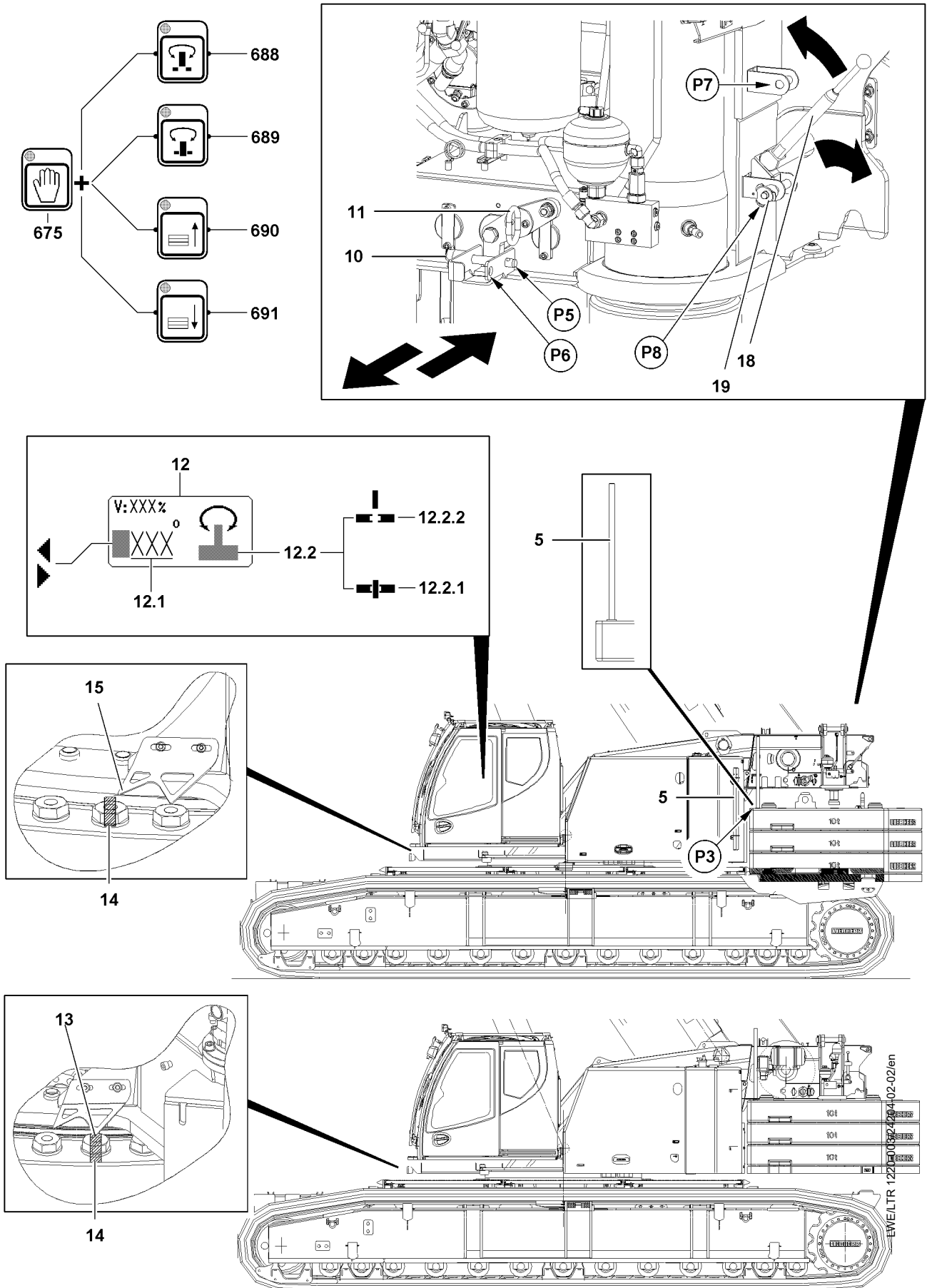


Fig.117327

**Note**

- ▶ Use the release button **675** to control the functions that require a release. The release button **675** is deactivated 30 s after an operating button is last pressed on the BKE.
- ▶ Activate the release button **675** and then press the button **689**.

**Result:**

- The LED on button **689** blinks as the turntable is pinned.
- During the pinning procedure, the pin in the „Turntable locked“ icon **12.2.1** blinks.
- As soon as the crane superstructure is locked with the crane chassis, the „Turntable locked“ icon **12.2.1** appears static and the LED on button **689** lights up (static).

When the pinning procedure of the turntable lock has been completed:

- ▶ Release the button **689**.
- ▶ Press the button **691**.

**Result:**

- When the ballast cylinders are extended completely, the LED on button **691** lights up static.

When the ballast cylinders are fully extended:

- ▶ Release the button **691**.
- ▶ Press the button **688**.

**Result:**

- The LED on the button **688** blinks during the turntable unpinning procedure.
- During the unpinning procedure, the pin in the „Turntable released“ icon **12.2.2** blinks.
- As soon as the crane superstructure is released, the „Turntable released“ icon **12.2.2** appears static and the LED on button **689** lights up (static).

When the unpinning procedure of the turntable lock has been completed:

- ▶ Release the button **688**.
- ▶ Turn the crane superstructure carefully to the right until the large pointer **13** on the slewing ring aligns with the marked screw **14** (180° angle position), illustration **2**.

**Result:**

- The ballast cylinders are now retracted into the receptacle studs of the counterweight.
- The Slewing range icon **12** on the LICCON monitor displays the value **12.1** 180°.

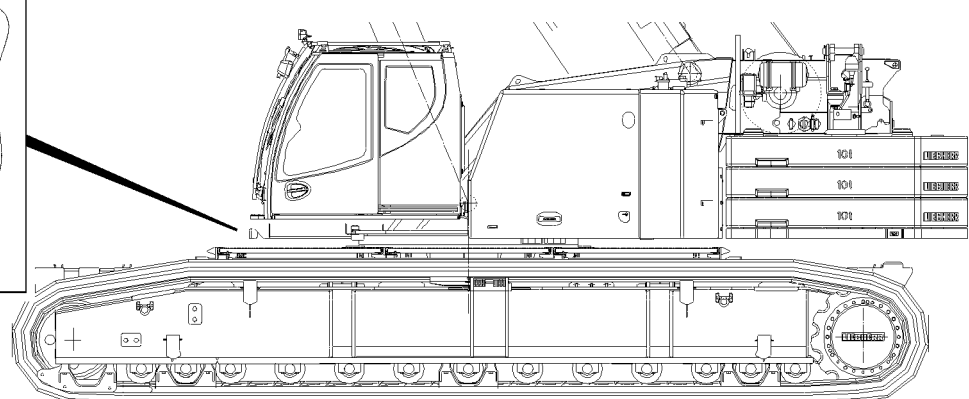
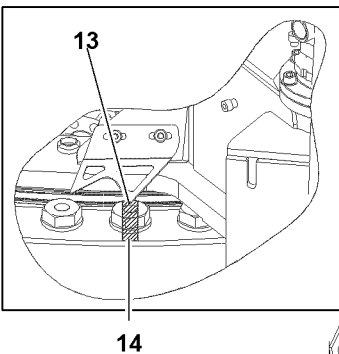
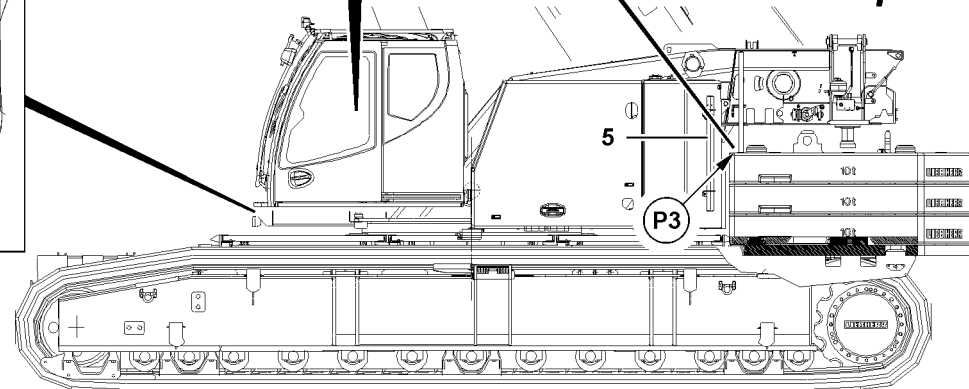
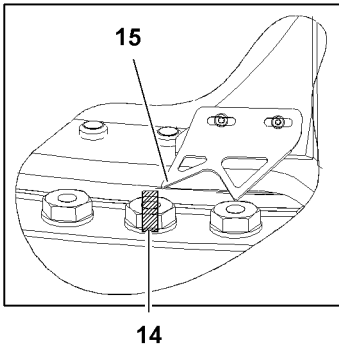
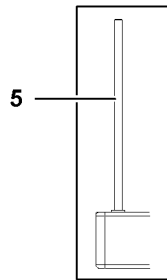
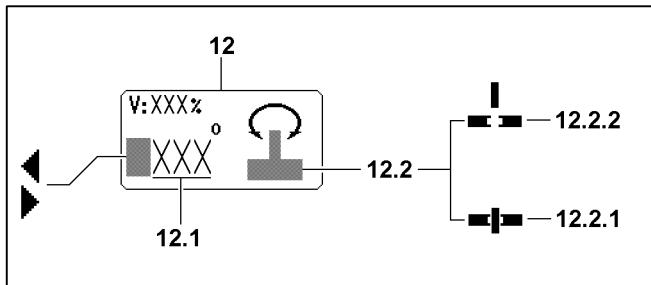
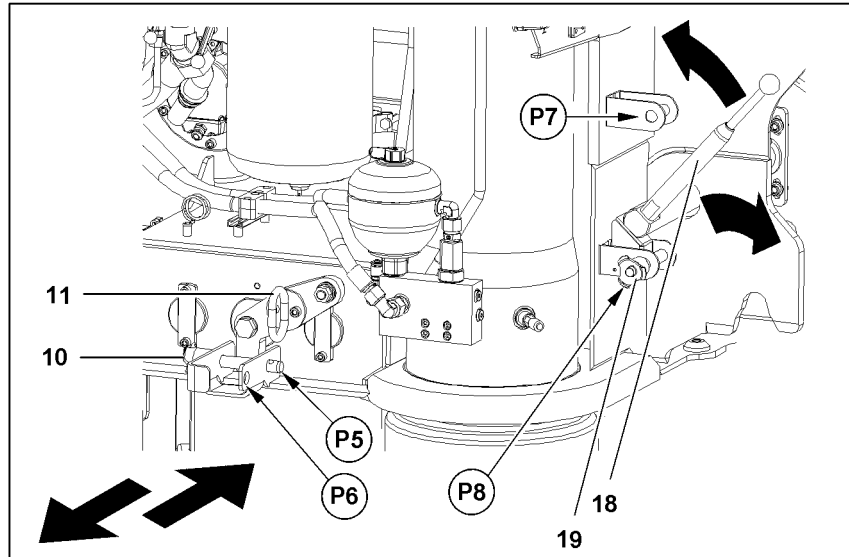
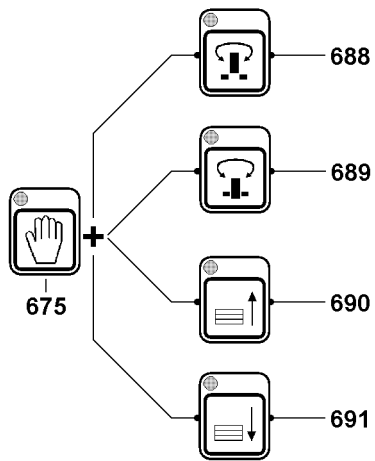


Fig.117327

LWE/LTR 1220-003/24204-02-02/en

- ▶ Press the button **689**.

**Result:**

- The LED on button **689** blinks as the turntable is pinned.
- During the pinning procedure, the pin in the „Turntable locked“ icon **12.2.1** blinks.
- As soon as the crane superstructure is locked with the crane chassis, the „Turntable locked“ icon **12.2.1** appears static and the LED on button **689** lights up (static).

When the pinning procedure of the turntable lock has been completed:

- ▶ Release the button **689**.
- ▶ Press the button **690**.

**Result:**

- The ballast cylinders are retracted and the counterweight is raised.

Once the ballast cylinders are completely retracted and the counterweight is fully lifted:

- ▶ Release the button **690**.

### 4.4.3 Pinning the ballasting device



**WARNING**

Falling counterweight!

If the ballasting device is not pinned when the counterweight is installed, then the counterweight can loosen up! The counterweight can fall down and cause severe accidents!

Personnel can be severely injured or killed!

- ▶ Pin the ballasting device with the counterweight!
- 
- ▶ Take the retaining pipe **5** out of the park position and pin on both sides in the counterweight plate in position **P3**.
  - ▶ Release the grip pins: **10** Unpin the ball locking pin **10**.
  - ▶ Pin the grip pin **11**.
  - ▶ Secure the grip pins **11**: Insert the ball locking pin **10** in position **P5**.
  - ▶ Unpin the ball locking pin **19** in the park position **P8**.
  - ▶ Swing the hand lever **18** upward.
  - ▶ Secure the hand lever **18**: Insert the ball locking pin **19** in point **P7**.
  - ▶ Unpin the retaining pipe **5** and pin it in the park position.

### 4.4.4 Releasing the turntable lock

- ▶ Press the button **688**.

**Result:**

- The LED on the button **688** blinks during the turntable unpinning procedure.
- During the unpinning procedure, the pin in the „Turntable released“ icon **12.2.2** blinks.
- As soon as the crane superstructure is released, the „Turntable released“ icon **12.2.2** appears static and the LED on button **688** lights up (static).

## 5 Ballast monitoring

When ballast monitoring is **activated** on the crane, the installed counterweight is recognized and compared with the counterweight settings in the set up program.

When ballast monitoring is **not activated** on the crane, the crane operator must independently compare the installed counterweight with the counterweight settings in the set up program.

**WARNING**

Change to the counterweight!

If the counterweight is changed without updating the counterweight settings in the set up program, the crane can topple over and fatally injure personnel!

- ▶ Changes to the counterweight without updating the counterweight settings in the set up program are prohibited.
- ▶ Ballast monitoring does not automatically update incorrect counterweight settings in the set up program.

A differentiation is made between the following procedures with ballast monitoring:

- **Detecting the counterweight with a pressure sensor in the ballast cylinders**  
Through ballasting (retracting the ballast cylinders), the counterweight is determined via the pressure sensor and compared with the set up counterweight.  
The weighing result is deleted when the ballast cylinders are fully extended.
- **Detecting the counterweight with sensors on the counterweight plates**  
By plugging the plug into the sensors, the counterweight is determined and compared with the set up counterweight. Observe and comply with section „Establishing an electrical connection for ballast monitoring“.
- **Detecting the swing angle with sensors on the turntable\***  
With certain types of cranes, the swing angle is detected by means of sensors and compared with the set up counterweight radius.

**Note**

Use of winch 2\*

- ▶ The electrical connection to winch 2\* must be established, see chapter 5.09.

## 5.1 Establishing the electrical connection for ballast monitoring to the central ballast blocks

**WARNING**

No electrical connection established to the central ballast blocks!

If central ballast blocks are assembled on the crane and an electrical connection is not established, the central ballast blocks will not be detected by ballast monitoring\*.

- ▶ Establish the electrical connection for ballast monitoring to the central ballast blocks, see chapter 3.03.

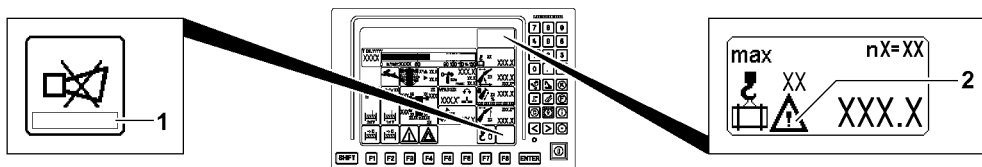


Fig.147403: Ballast monitoring error message not recognized display

- ▶ Take the counterweight down onto the counterweight receptacle.
- ▶ Establish the electrical connections to the central ballast blocks, see chapter 3.03.
- ▶ Perform the ballasting procedure **after** establishing the electrical connections.



## 5.2 Ballast weighing via the ballasting procedure



### WARNING

The wrong counterweight is set in the LICCON overload protection!  
The crane can topple over, death, property damage.

- ▶ Changes to the counterweight without updating the counterweight settings in the set up program are prohibited.
- ▶ Ballast monitoring does not automatically update incorrect counterweight settings in the set up program.
- ▶ Weigh the ballast only after completely installing the counterweight.

Make sure that the following prerequisites are met:

- Electrical connections to the central ballast blocks are established.
- Only on crane types with swingable counterweight plates\*: The counterweight radius is set correctly.



### Note

- ▶ To correctly weigh the ballast, the ballast cylinders must be fully extended and relieved. To relieve the ballast cylinders, the counterweight plates that are lifted by the ballast cylinders are taken down on the counterweight receptacle.

- ▶ Perform ballast weighing.
- ▶ Extend the ballast cylinders fully until an acoustical signal sounds.

### Result:

- The counterweight plates are taken down on the counterweight receptacle.



### Note

- ▶ If the ballast cylinder retraction is interrupted, the counterweight is not weighed. The weighing procedure must be repeated.

- ▶ Retract the ballast cylinders fully until an acoustical signal sounds.

### Result:

- The counterweight is detected and compared with the counterweight settings in the set up program.

### Problem remedy

The error message does not turn off?

The error message is displayed on the LICCON monitor.

- ▶ Check if the set up configuration that is set matches the counterweight installed on the crane.
- ▶ Check if all electrical connections for ballast monitoring are established.

- ▶ Perform ballast weighing again.

### Result:

- The error message on the LICCON monitor turns off.

## 6 Counterweight error message

Only for crane types with ballast monitoring\* / counterweight radius monitoring\*.

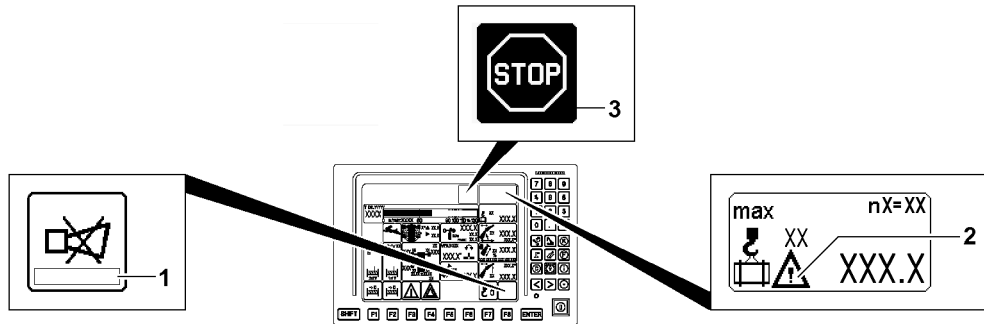


Fig.149635: Counterweight error message display

If the ballast monitoring\* / counterweight radius monitoring\* reports an error, a corresponding error message 1 and / or the warning icon 2 or icon 3 is displayed on the LICCON monitor.



### Note

The ballast monitoring\* provides no feedback if the correct counterweight is measured / detected. The counterweight radius monitoring\* provides no feedback if the correct counterweight radius is measured / detected.

- ▶ If no error is detected, no message appears.

### Examples for the reason of an error message

<b>1. Example</b>	<p>Error message during set up, for example when the counterweight or hoist gear 2 is installed / removed / changed.</p> <p>For crane types with ballast monitoring shut-off*, the shut-off acts on the selected crane movements. The retracting and extending of the ballast cylinders are not shut off.</p> <p>For crane types with an adjustable counterweight radius, there may be an overlap with further shut-offs if the correct counterweight radius is not yet set.</p> <p><b>Next steps:</b> Set and accept the target counterweight in the set up program. After acceptance, there may be a new error message.</p> <p>Properly install the counterweight / hoist gear 2. Normally, the last ballast weighing will be discarded. A new error message may be issued.</p> <p>In the case of crane types with an adjustable counterweight radius, set the correct counterweight radius.</p> <p>Perform ballast weighing again.</p>
-------------------	---

Examples for the reason of an error message	
<b>2. Example</b>	<p>Error message during crane operation / error message after ballast weighing.</p> <p>For crane types with ballast monitoring shut-off*, the shut-off acts on the selected crane movements. The retracting and extending of the ballast cylinders are not shut off.</p> <p>In the case of crane types with an adjustable counterweight radius, crane movements will be shut off if the correct counterweight radius is not detected.</p>
	<p><b>Next steps:</b> Compare the settings from the Set up program with the installed counterweight. Make sure that all counterweight plates and hoist gear 2 or, if applicable, the replacement weight are correctly installed and connected.</p> <p>In the case of crane types with an adjustable counterweight radius, set the correct counterweight radius.</p> <p>Perform ballast weighing again.</p>
	<p><b>Note 1:</b> If the ballast weighing of the checked counterweights leads to a new error message, there may be an error within ballast monitoring.</p> <p>If an error is detected within ballast monitoring in crane types with ballast monitoring shut-off*, certain crane movements may only be possible in emergency operation or with the overload protection bypassed. A special case during operation of the LICCON overload protection has occurred, observe the Crane operating instructions, chapter 4.20.</p>
	<p><b>Note 2:</b> If the error message / shut-off regarding the counterweight radius continues, there may be an error regarding the monitoring or recording of the counterweight radius.</p> <p>If an error is detected, certain crane movements may only be possible in emergency operation or with the overload protection bypassed. A special case during operation of the LICCON overload protection has occurred, observe the Crane operating instructions, chapter 4.20.</p>

LWE/LTR 1220-003/24204-02-02/en

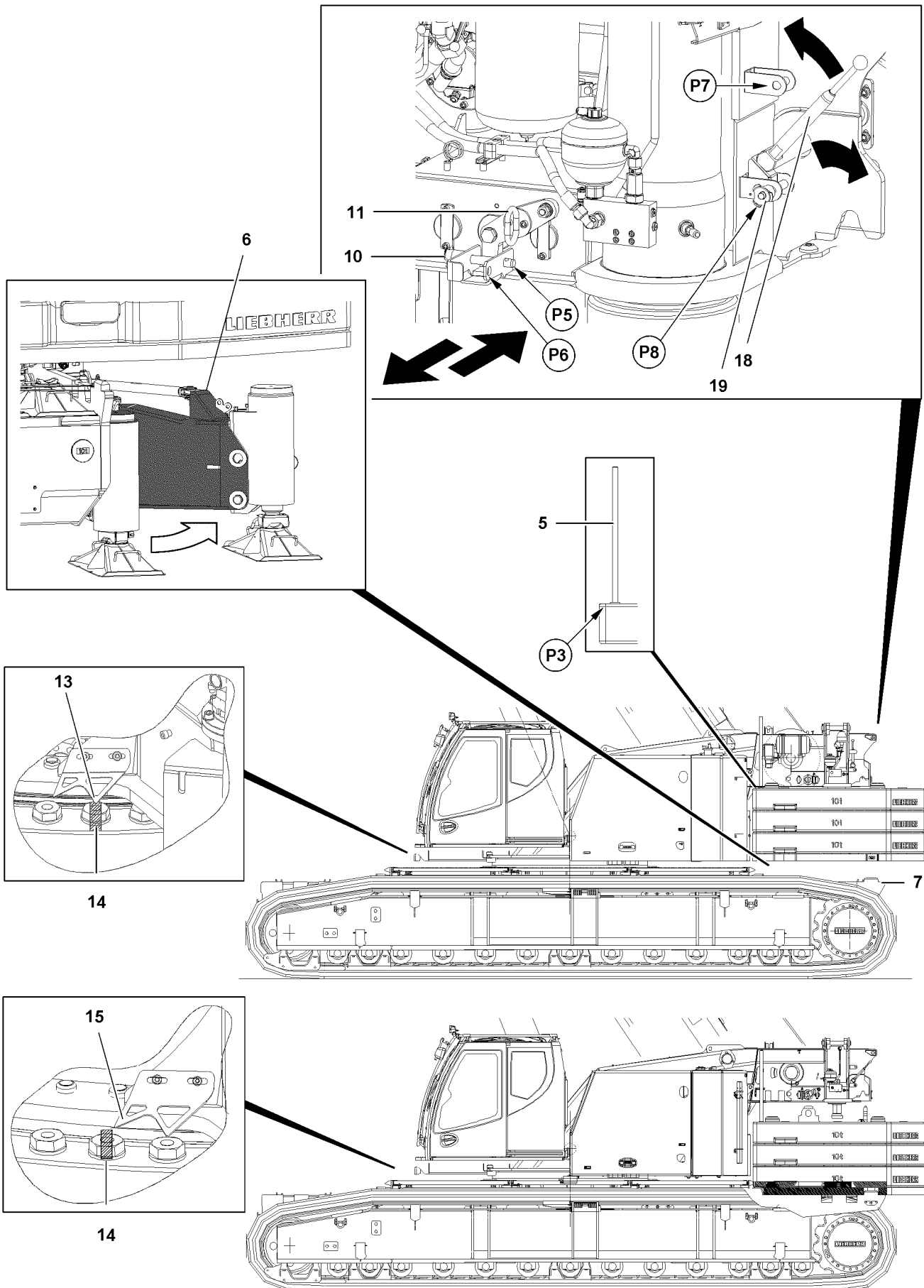


Fig.117355

LWE/LTR 1220-003/24204-02-02/en

## 7 Disassembling the counterweight

---



### WARNING

Danger of falling!

During assembly and disassembly, assembly personnel must be secured with appropriate aids to prevent them from falling! If this is not observed, assembly personnel could fall and suffer life-threatening or fatal injuries!

- ▶ Any work, where there is a danger of falling, must be carried out with suitable aids (for example: lifting platforms, scaffoldings, ladders, auxiliary crane)!
  - ▶ If the work cannot be carried out with such aids nor from the ground, then the assembly personnel must secure themselves with approved fall arrest systems to avoid falling, see chapter 2.04!
  - ▶ If railings are present on the crane components, then they must be brought into the corresponding position and secured for assembly / disassembly work!
  - ▶ Only step on aids and fall protection equipment with clean shoes!
  - ▶ Keep aids and fall protection equipment clean and free from snow and ice!
  - ▶ During all assembly and disassembly work, maintenance work and inspections, travel or crane operation is prohibited!
- 



### WARNING

Danger of accident!

During assembly or disassembly of the counterweight, personnel can be injured or killed!

Objects can be damaged!

- ▶ During the assembly or disassembly of the counterweight, no personnel may remain within the danger zone!
  - ▶ During the assembly or disassembly of the counterweight, no objects may remain within the danger zone!
- 

### 7.1 Removing hoist gear 2\*

When hoist gear 2 is to be disassembled, see chapter 5.09.

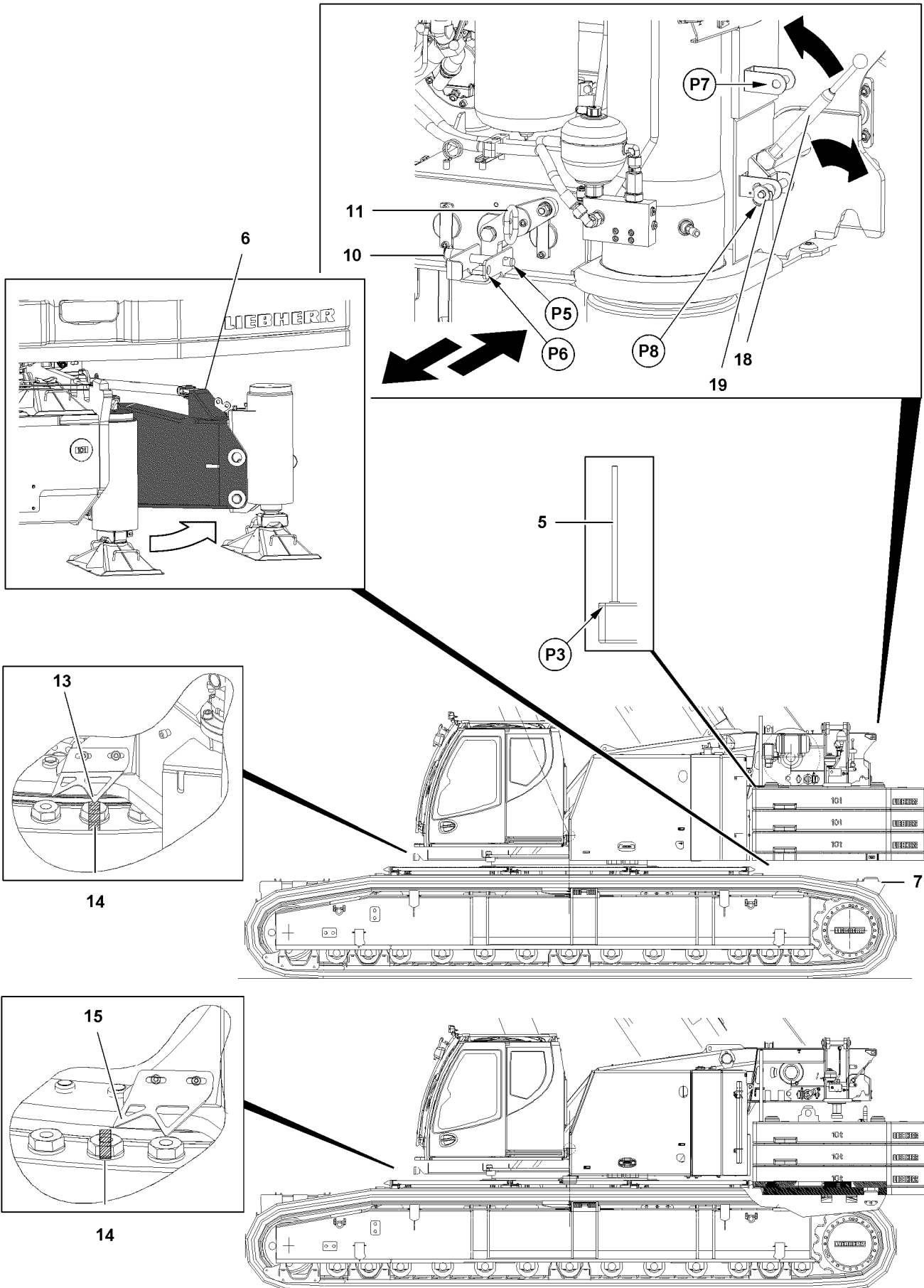


Fig.117355

LWE/LTR 1220-003/24204-02-02/en

## 7.2 Setting down the counterweight with the ballasting device

Make sure that the following prerequisites are met:

- The crane is positioned on a level and load-bearing surface.
- The crane is horizontally aligned.
- The central ballast blocks **7** are installed on the front and rear, see chapter 3.03.
- The crane with installed crawler carriers is operational as assembly crane.
- The support cylinders are completely retracted.
- The transport vehicle for the counterweight plates is in the immediate vicinity of the crane.
- No support plates and the assembly device are taken down on the central ballast.
- The fall protection equipment is installed.
- The LICCON overload protection has been set according to the load chart and the set up configuration.
  - Crawler operation with track width
  - Central ballast 20 t
  - Counterweight 0 t
  - Without auxiliary boom / accessories
  - Slewing range

---

### NOTICE

Damage of receptacle plate due to collision!

If the support cylinders are pinned in the uppermost position, then the support cylinders can collide with the base plate.

- ▶ Swing both folding beam brackets **6** out and secure.
- 

### 7.2.1 Unpinning the ballasting device

Make sure that the following prerequisites are met:

- The large pointer **13** on the slewing ring aligns with the marked screw **14** (180° angle position).

---

### NOTICE

Damage to the ballasting device!

If the ballasting device is not unpinned before extending the ballast cylinders, then the ballasting device can be damaged!

- ▶ Unpin the ballasting device before extending the ballast cylinders.
- 
- ▶ Take the retaining pipe **5** out of the park position and pin on both sides in the counterweight plate in position **P3**.
  - ▶ Release the grip pins: Unpin the ball locking pin **10**.
  - ▶ Unpin the grip pin **11** to the stop.
  - ▶ Secure the grip pins **11**: Insert the ball locking pin **10** in position **P6**.
  - ▶ Release the hand lever **18**: Unpin the ball locking pin **19** in point **P7**.
  - ▶ Swing the hand lever **18** downwards.
  - ▶ Insert the ball locking pin **19** in the park position **P8**.
  - ▶ Unpin the retaining pipe **5** and pin it in the park position.

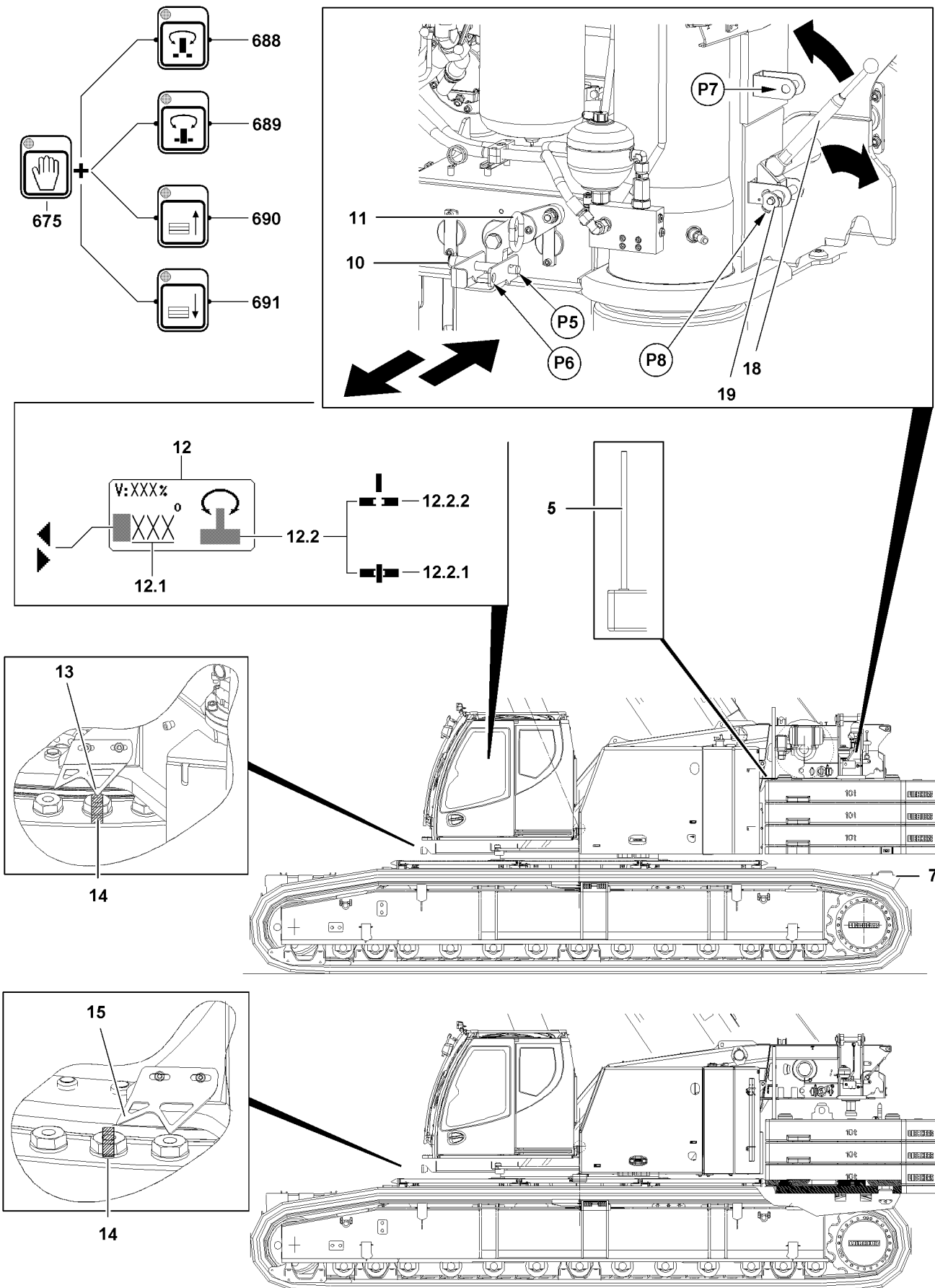


Fig.117328

LWE/LTR 1220-003/24204-02-02/en



## 7.2.2 Taking the counterweight plates down on the central ballast



### Note

- ▶ Use the release button **675** to control the functions that require a release. The release button **675** is deactivated 30 s after an operating button is last pressed on the BKE.

- ▶ Activate the release button **675** and then press the button **689**.

### Result:

- The LED on button **689** blinks as the turntable is pinned.
- During the pinning procedure, the pin in the „Turntable locked“ icon **12.2.1** blinks.
- As soon as the crane superstructure is locked with the crane chassis, the „Turntable locked“ icon **12.2.1** appears static and the LED on button **689** lights up (static).

When the pinning procedure of the turntable lock has been completed:

- ▶ Release the button **689**.
- ▶ Press the button **691**.

### Result:

- The counterweight is lowered on the counterweight receptacle.
- When the ballast cylinders are extended completely, the LED on button **691** lights up static.

When the ballast cylinders are completely extended and the counterweight is completely taken down on the counterweight receptacle:

- ▶ Release the button **691**.
- ▶ Press the button **688**.

### Result:

- The LED on the button **688** blinks during the turntable unpinning procedure.
- During the unpinning procedure, the pin in the „Turntable released“ icon **12.2.2** blinks.
- As soon as the crane superstructure is released, the „Turntable released“ icon **12.2.2** appears static and the LED on button **688** lights up (static).

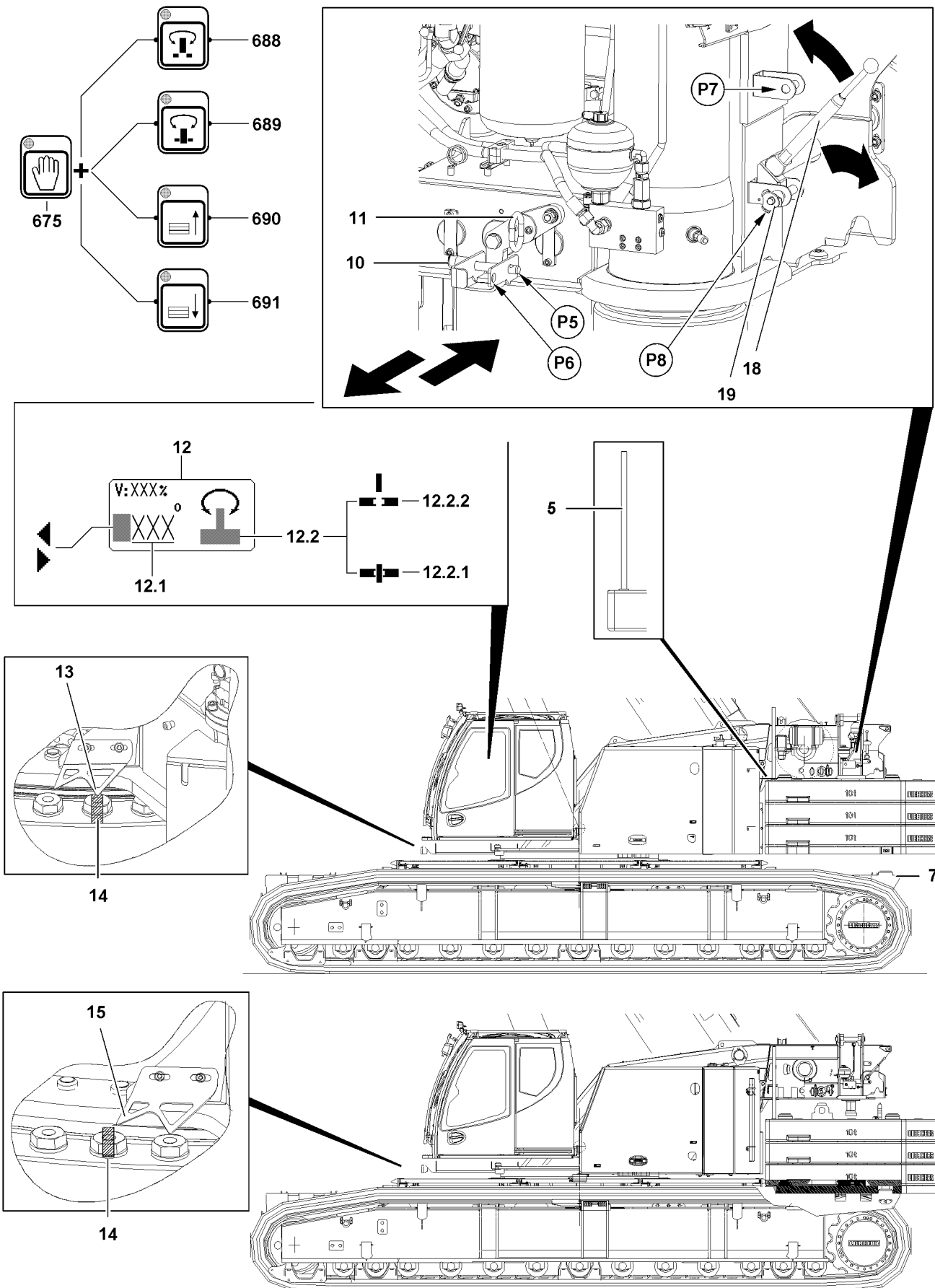


Fig.117328

LWE/LTR 1220-003/24204-02-02/en

When the unpinning procedure of the turntable lock has been completed:

- ▶ Release the button **688**.
- ▶ Turn the crane superstructure until the small pointer **15** on the slewing ring aligns with the marked screw **14**, illustration **1**.

**Result:**

- The ballast cylinders are now extended from the receptacle studs of the counterweight.
- The LICCON monitor displays a value **12.1** of 176° to 177° in the turning rage icon **12**.
- ▶ Press the button **689**.

**Result:**

- The LED on button **689** blinks as the turntable is pinned.
- During the pinning procedure, the pin in the „Turntable locked“ icon **12.2.1** blinks.
- As soon as the crane superstructure is locked with the crane chassis, the „Turntable locked“ icon **12.2.1** appears static and the LED on button **689** lights up (static).

When the pinning procedure of the turntable lock has been completed:

- ▶ Release the button **689**.
- ▶ Press the button **690**.

**Result:**

- The ballast cylinders are retracted.

### 7.2.3 Releasing the turntable lock

- ▶ Press the button **688**.

**Result:**

- The LED on the button **688** blinks during the turntable unpinning procedure.
- During the unpinning procedure, the pin in the „Turntable released“ icon **12.2.2** blinks.
- As soon as the crane superstructure is released, the „Turntable released“ icon **12.2.2** appears static and the LED on button **688** lights up (static).

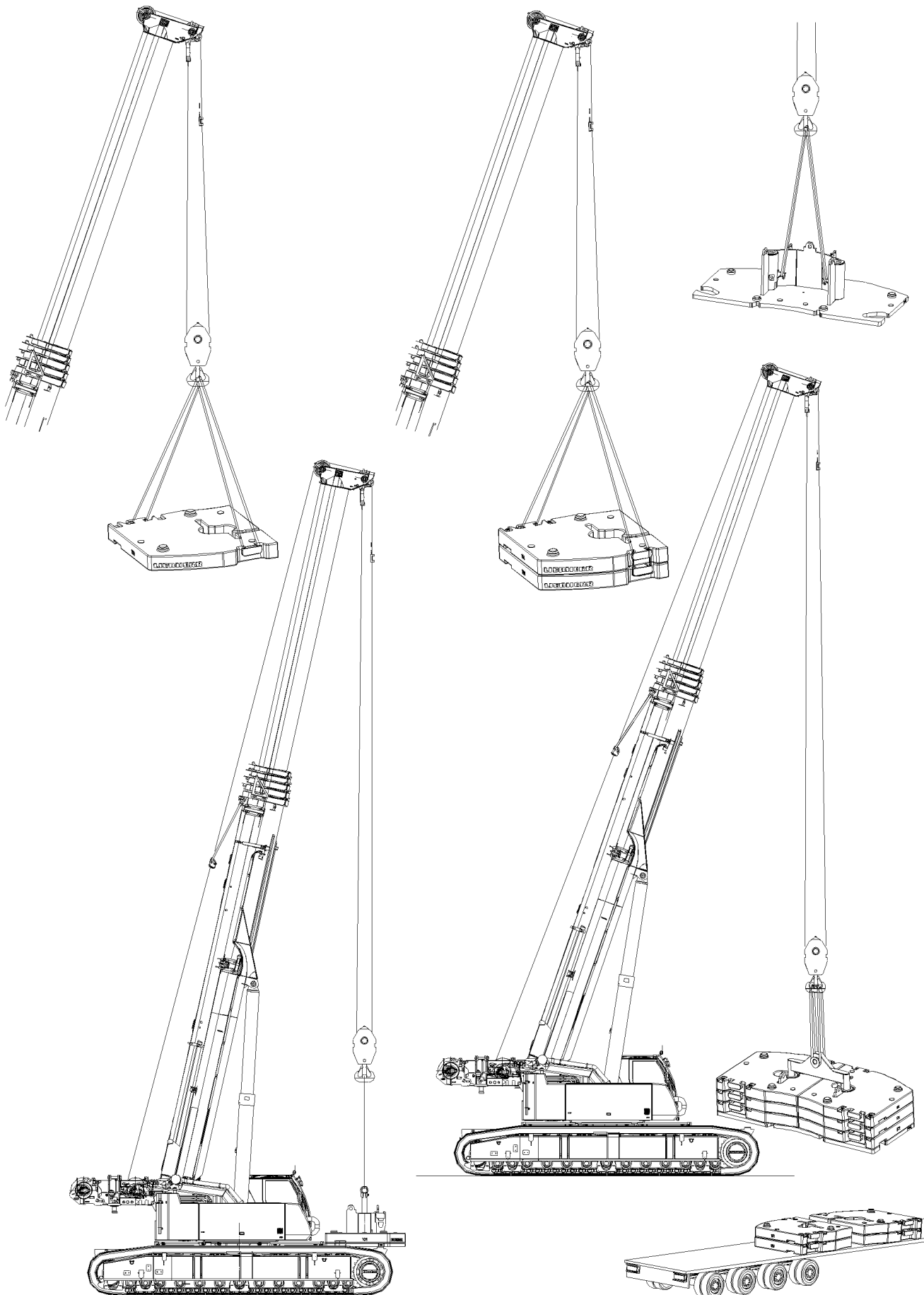


Fig.117332

LWE/LTR 1220-003/24204-02-02/en

## 7.3 Lifting the counterweight from the central ballast



### WARNING

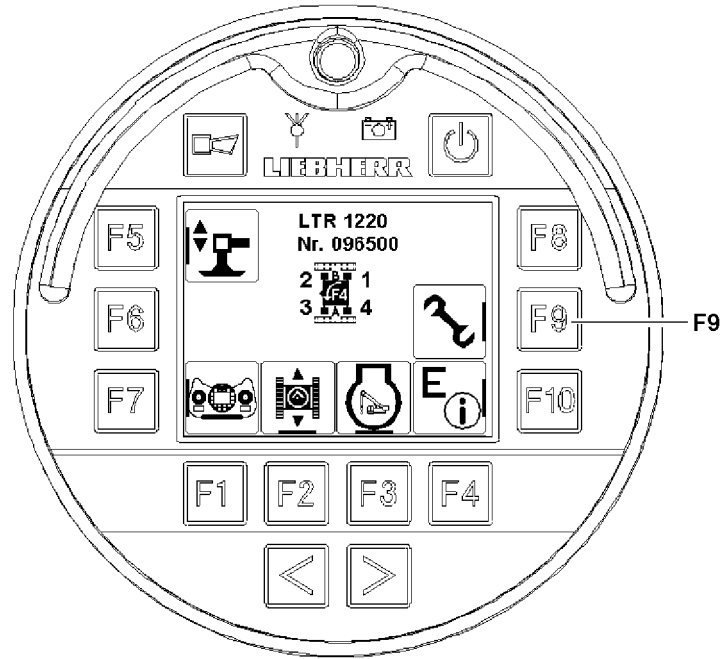
Danger of accident due to toppling crane!

The boom lengths and boom radii specified in the load chart may not be exceeded. If this is not observed, there is a danger of accident as the crane can topple over!

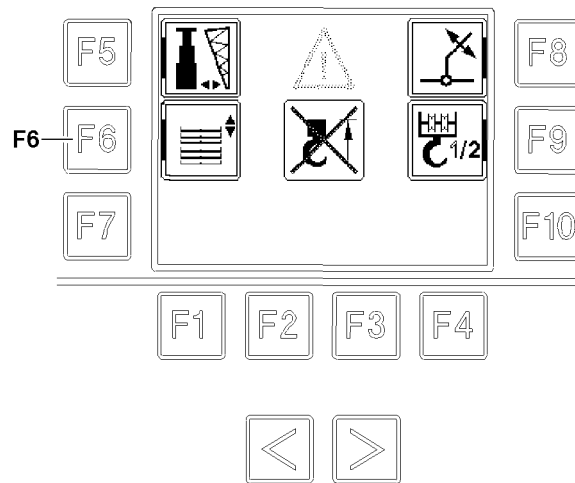
Personnel can be severely injured or killed!

- ▶ The boom lengths and boom radii noted in the load chart must be strictly observed!
- ▶ Fasten the counterweight to the crane.
- ▶ Take the counterweight down individually or as an assembly with the cross beam onto the transport vehicle.

1



2



3

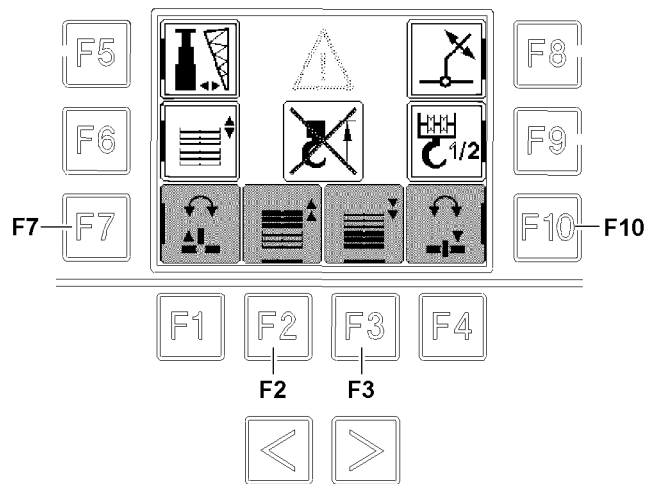


Fig.117334

LWE/LTR 1220-003/24204-02-02/en

## 8 Bluetooth Terminal (BTT) operating element

The turntable lock and the ballast cylinders can be controlled with the BTT.

Make sure that the following prerequisites are met:

- The BTT is turned on.
- The start menu is set, see illustration 1.

### 8.1 Pinning the turntable with the BTT

- ▶ Press the function key **F9**.

**Result:**

- The BTT displays the „Menu overview“, see illustration 2.

- ▶ Press the function key **F6**.

**Result:**

- The BTT displays the „Menu overview“, see illustration 3.

- ▶ Press the function key **F10**, see illustration 3.

**Result:**

- The turntable lock is pinned.

- ▶ Press the function key **F7**, see illustration 3.

**Result:**

- The turntable lock is unpinned.

### 8.2 Retracting / extending the ballast cylinder with the BTT

- ▶ Press the function key **F9**.

**Result:**

- The BTT displays the „Menu overview“, see illustration 2.

- ▶ Press the function key **F6**.

**Result:**

- The BTT displays the „Menu overview“, see illustration 3.

- ▶ Press the function key **F2**, see illustration 3.

**Result:**

- The ballast cylinders are retracted.

- ▶ Press the function key **F3**, see illustration 3.

**Result:**

- The ballast cylinders are extended.

---

Empty page!

LWE/LTR 1220-003/24204-02-02/en



## 4.08 Working with a load

1	Safety instructions	3
2	Checks before starting to work with the crane	4
3	Telescoping crane movement	5
4	Taking on a load	7
5	Load weighing and load display	13
6	Crane operation	18
7	Ram work or pulling sheet piles	19
8	Crane rope pretension	20

*Fig.195219*

LWE/LTR 1220-003/24204-02-02/en

# 1 Safety instructions

In addition, observe the general technical safety instructions in chapter 2.04.

In steep boom positions for which no loads are specified in the load charts, there is a danger of tipping to the rear to the counterweight side.

The danger of tipping to the rear exists especially in case of:

- Crane operation on tires
- Supported, with retracted sliding beams
- Reduced support base



## WARNING

Crane operation in steep boom positions for which no loads are specified in the load charts!

The crane can tip to the rear and fatally injure personnel.

- ▶ Comply with the boom radius specified in the load chart.
- ▶ Crane operation outside the permissible set up configurations, boom radii and slewing ranges according to the load chart is prohibited.



## WARNING

Incorrect reeving number set up!

If the reeving number on the pulley head is less than the reeving number set on the LICCON computer system, it can result in an overload of the hoist rope.

The hoist rope can rip. The load can fall down and fatally injure personnel.

- ▶ Comply with the reeving numbers specified in the load chart for maximum loads.
- ▶ Make sure that the reeving on the pulley head and the reeving set on the LICCON computer system match.

The minimum rope coils must remain on the rope winches. The number of minimum rope coils depends on if the rope winch is equipped with a cam limit switch or a winch speed sensor.



## WARNING

Minimum rope coils fallen below!

The rope will be ripped out. The load falls down.

Personnel can be killed.

- ▶ Make sure that the minimum rope coils remain on the rope winch.
- ▶ Observe and comply with the number of the minimum rope coils in chapter 5.01.



## WARNING

Lift the load by luffing up!

The crane can topple over and fatally injure personnel.

- ▶ Lift the load with the hoist gear.

Always comply with the maximum loads specified in the load chart.

The weight of the hook block according the load chart must be taken into account. Subtract the weight of the hook block from the load chart value. The minimum hook block weight must be determined according to the reeving number and the data in the load charts.

For the stroke, use the hook block which is suited best for the existing set up configuration in connection with the load chart.

Initiate all crane movements carefully. Also brake the crane movements carefully. That way you can avoid a swinging or pendulum motion in the suspended load.

## 2 Checks before starting to work with the crane

Before starting work with the crane, the crane operator must carry out a further inspection to satisfy himself about the crane's operational safety:

- Check that the crane is properly supported and level.
- Check that the set up configuration set in the control matches the actual set up configuration.
- Check that all values in the load chart that apply to the current equipment configuration have been entered and met.
- Ensure that there are no people or objects within the danger zone of the crane.



### WARNING

Persons in the slewing range!  
Crushing danger, death, severe bodily injuries.

- ▶ Monitor the slewing range.
- ▶ Make sure that there are **no** persons within the slewing range.
- ▶ Block off the slewing range if necessary.



### WARNING

Obstacle in the slewing range!  
Property damage on crane and on obstacle.

- ▶ Make sure that there are **no** obstacles within the turning range of the crane and the crane components.

### 2.1 Visual check for damage



### WARNING

Danger of accident!

If the crane is operated despite existing defects, personnel can be severely injured or killed.

- ▶ In the event of deficiencies which threaten operational safety, stop crane operation immediately.

The following deficiencies threaten the crane's operational safety:

- Damage to load-bearing parts of the crane design, such as booms, supports etc.
- Failure of the hoist gear brake and consequent slipping of the load
- Functional failures in the crane control system
- Functional defects in the indicator and warning lights
- Damage to the hoist ropes
- Safety defects in the safety equipment
- Leaks on safety relevant components of the crane hydraulic

Inform the appropriate supervisor about the deficiencies on the crane and also inform your relief when crane operators are changed.

### 2.2 Operating with telescopic boom and auxiliary boom

When operating with a telescopic boom and auxiliary boom in the 0° position and with a steep luffed up telescopic boom, the hook blocks can collide with the telescopic boom or the auxiliary boom.

**NOTICE**

Operation with the telescopic boom and auxiliary boom in the 0° position and steep luffed up telescopic boom!

The hook block can collide with the telescopic boom or auxiliary boom.

- ▶ Make sure that the hook block is always at a sufficient distance from the crane structure.

Before collision of the hook block with the telescopic boom or the auxiliary boom:

- ▶ Stop spooling up the winch or end luffing up the boom.

With a hydraulic auxiliary boom:

- ▶ Increase the freedom of movement of the hook block with respect to the auxiliary boom by luffing down the auxiliary boom.

## 2.3 Telescopic boom distortion because of sunshine on one side

A temperature difference occurs between the side facing the sun and the side facing away from the sun for cranes with telescopic booms. This causes telescopic boom side distortion, which can reduce the load bearing capacity of the telescopic boom.

For example, a temperature difference between the two boom sides of 30 °C and a boom length of 60 m results in a length difference caused by the temperature difference between the two sides of the telescopic boom of approximately 22 mm. With narrow boom parts, this causes the profiles to bend sideways.

If the maximum load is being utilized during operation with a telescopic boom extension such as a fixed lattice jib, luffing lattice jib or folding jib, then it must be ensured through a visual inspection before picking up the load that the boom is not showing signs of side deformation due to one-sided sun exposure.

**WARNING**

Danger of accident due to component overload!

If the telescopic boom has become distorted because of one-sided sunlight, this can cause component overload and therefore accidents.

- ▶ Turn the crane so that both sides of the boom are heated up equally, eliminating side deformation due to temperature difference.

## 3 Telescoping crane movement

If the telescopic boom is telescoped with the jib boom or telescopic boom extension, before the telescoping procedure, ensure that:

- The crane is properly supported and horizontally aligned.
- The telescopic boom is evenly warmed up by solar radiation.
- There is no strong side wind.

**WARNING**

Damage to the telescopic boom or the hoist rope!

If these 3 factors are not adhered to, damage of the telescopic boom or the hoist rope can occur and lead to accidents.

- ▶ Support the crane properly and align it horizontally.
- ▶ Keep both sides of the boom at about the same temperature.
- ▶ Telescope only to the permissible wind speed according to the load chart.
- ▶ If the actual wind speed is higher than the permissible wind speed noted on the load chart, telescoping is prohibited.

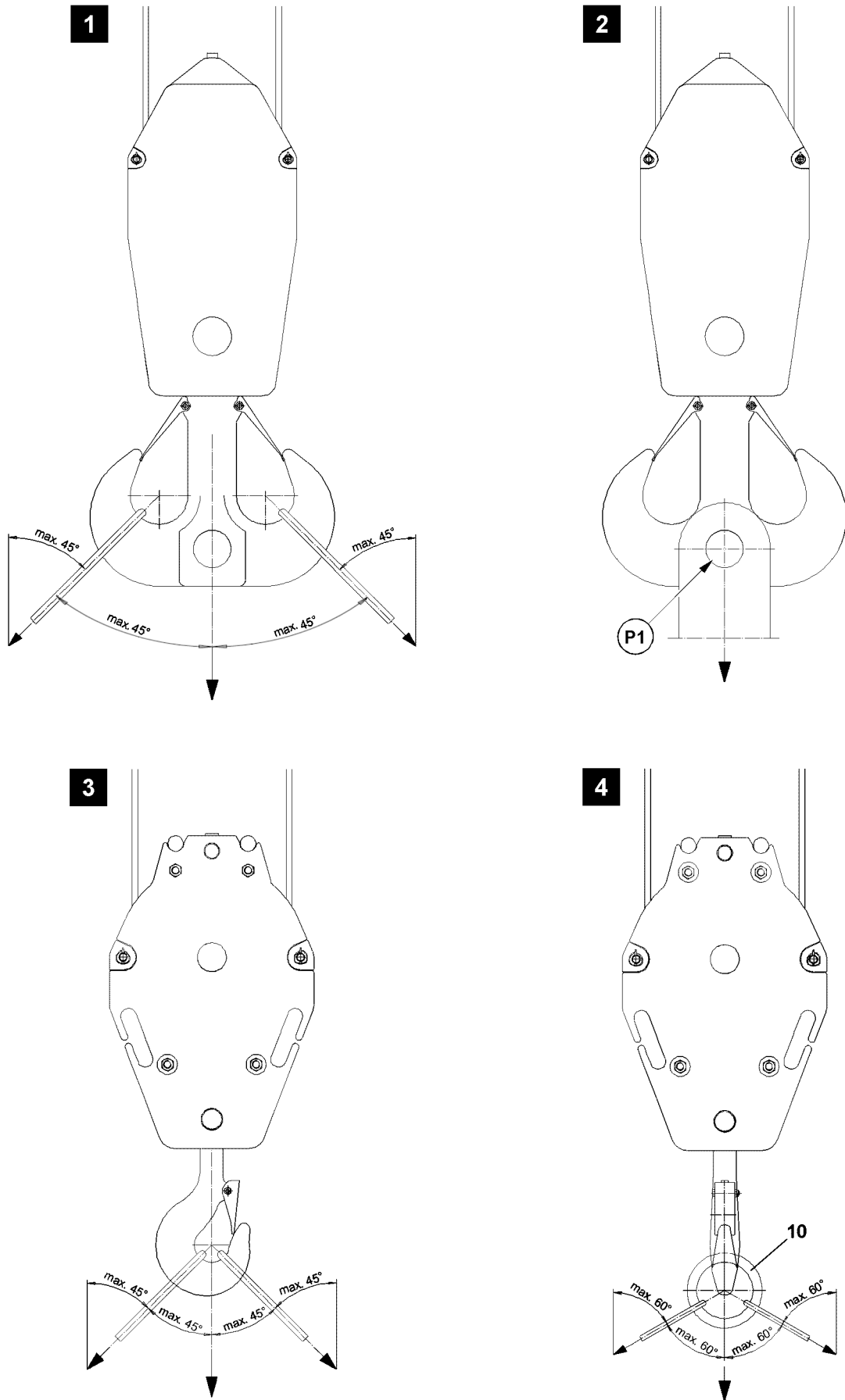


Fig.145147

LWE/LTR 1220-003/24204-02-02/en

## 4 Taking on a load

The crane must always be operated in such a way that its load-bearing parts are not destroyed or damaged and its stability is ensured.

Make sure that the following prerequisites are met:

- The crane is supported and horizontally aligned.
- The LICCON overload protection has been set according to the load chart and the set up configuration.
- The LICCON overload protection is active.
- In the case of cranes with central ballast: The central ballast is installed according to the load chart.
- The counterweight is installed according to the load chart.
- In the case of cranes with derrick ballast: The derrick ballast is installed according to the load chart.
- The hook block or the load hook is correctly reeved.

### 4.1 Fastening the load



#### WARNING

Load can be ripped off!

If impermissible fastening and / or load handling equipment is used when taking on a load on the centric bore on the double hook at point **P1** (illustration 2), then the double hook as well as the hook block can be damaged.

The load can rip off and fall down.

Personnel can be severely injured or killed.

- ▶ Lift the load via the centric bore on the double hook (point **P1**): For the technical requirements and the technical design of the fastening and / or load handling equipment contact the hook block manufacturer.



#### WARNING

The crane can topple over!

If the following conditions are not met, the crane can topple over.

Personnel can be severely injured or killed.

This could result in significant property damage.

- ▶ Pay attention to the own weight of the load handling equipment.
- ▶ Pay attention to the load bearing capacity of the load handling equipment.
- ▶ The maximum permissible incline of the strands fastened on the single or double hook in the hook jaws is 45°. See illustration 1 and illustration 3.

If necessary for the single hook:

- ▶ Use fastening equipment with a suspension link **10**. The maximum permissible incline in this case is 60°. See illustration 4.
- ▶ Load a single and double hook symmetrically. A maximum deviation of  $\pm 3^\circ$  from the direction of the center of gravity is permissible.

If necessary:

- ▶ Use cross beam or two cranes for taking on the load.

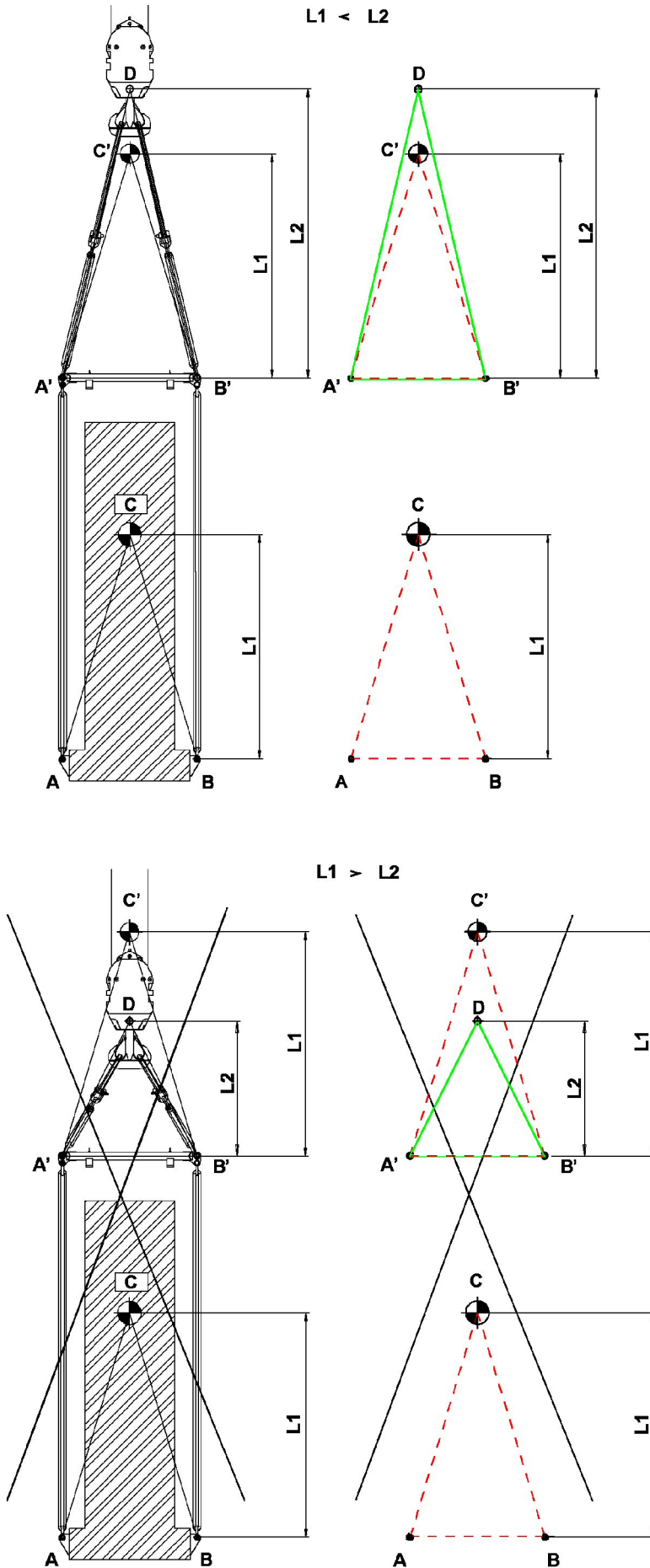


Fig.116274

LWE/LTR 1220-003/24204-02-02/en



## 4.2 Taking on a load with cross beam

Cross beam are load handling equipment between crane hook and load.

The distance of the center of gravity **L1** is the vertical dimension from the fastening point of the load to the center of gravity of the load.

The cross beam height **L2** is the vertical dimension from the point of rotation of the crane hook to the next lower linkage point of the cross bar.



### WARNING

Tipping of load to the side!

If fastening ropes are used which are too short, so that the load center of gravity is above the fastening point, then there is a danger of the load tipping to the side.

Personnel can be severely injured or killed.

- ▶ The load center of gravity must be below the crane hook.
- ▶ The distance of the center of gravity **L1** must be smaller than the cross beam height **L2** ( $L1 < L2$ ).
- ▶ The triangle **A'B'C'** must be within the triangle **A'B'D**.

## 4.3 Transporting the hook block



### WARNING

Danger of accident!

If a hook block is fastened incorrectly for transport, personnel can be injured.

- ▶ Fasten the hook block for transport on the fixed point in the center.
- ▶ Fastening the complete hook block on the auxiliary weights is prohibited.
- ▶ When setting down, secure the hook block against falling over.
- ▶ Prevent the load hook from rolling away.

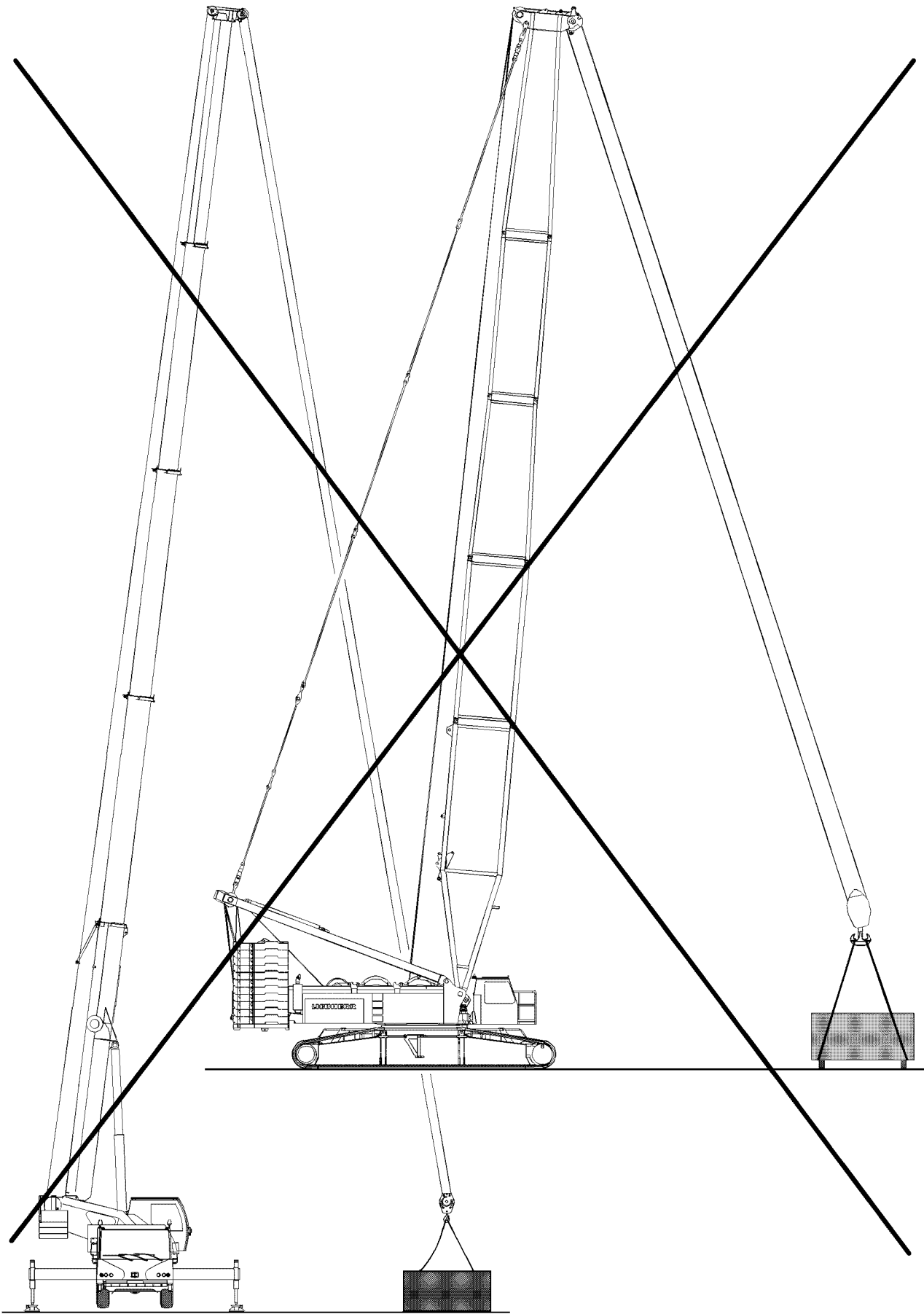


Fig.102716

LWE/LTR 1220-003/24204-02-02/en

## 4.4 Lifting the load



### WARNING

Danger of crushing for people in the load zone!

If personnel is located between the load to be lifted and a possible interfering edge (such as a wall of a building or similar) when the load is lifted, personnel can be severely injured or killed.

- ▶ Before lifting the load it must be ensured that there are no persons within the danger zone.
- ▶ It is prohibited to remain in the danger zone.
- ▶ It is prohibited for anyone to be under the load. Maintain a safe distance.
- ▶ Swinging the load is prohibited.
- ▶ Exercise extreme caution when lifting a load.



### WARNING

The crane can topple over!

If an attempt to lift a load over the hoist gear causes the LICCON overload protection to turn off, then the load may not be lifted by luffing up the boom. This causes overload or toppling the crane. Personnel can be severely injured or killed.

- ▶ Do not lift the load by luffing up the boom off the ground.



### Note

When using the assembly winch\* observe the following:

- ▶ Use the assembly winch\* only for assembly and not for lifting loads.
- ▶ Lifting of loads with the auxiliary winch is prohibited.

If the fastening rope is manually attached by an assistant to the load to be lifted:

- Make sure that the assistant's hands are not crushed by the tightened ropes between the load and the fastening rope.
- Make sure that the assistant's body parts (hands, legs etc.) are not crushed by a swaying movement of the load during lifting.

## 4.5 Angular pull



### WARNING

The crane can topple over!

Angular pulling can destroy the crane or cause it to topple over.

Personnel can be severely injured or killed.

- ▶ Fasten (hang) the hook block always vertically over the center of gravity of the load to be lifted.
- ▶ Do not use the slewing gear to pull and set up loads.
- ▶ When lifting, compensate for boom deflection.
- ▶ Angular pull is prohibited.

The crane is designed only to lift loads vertically. During angular pulling, regardless of whether this is done in the same direction as the boom or laterally, horizontal forces are generated from the load in addition to the vertical forces, for which the boom is not designed.

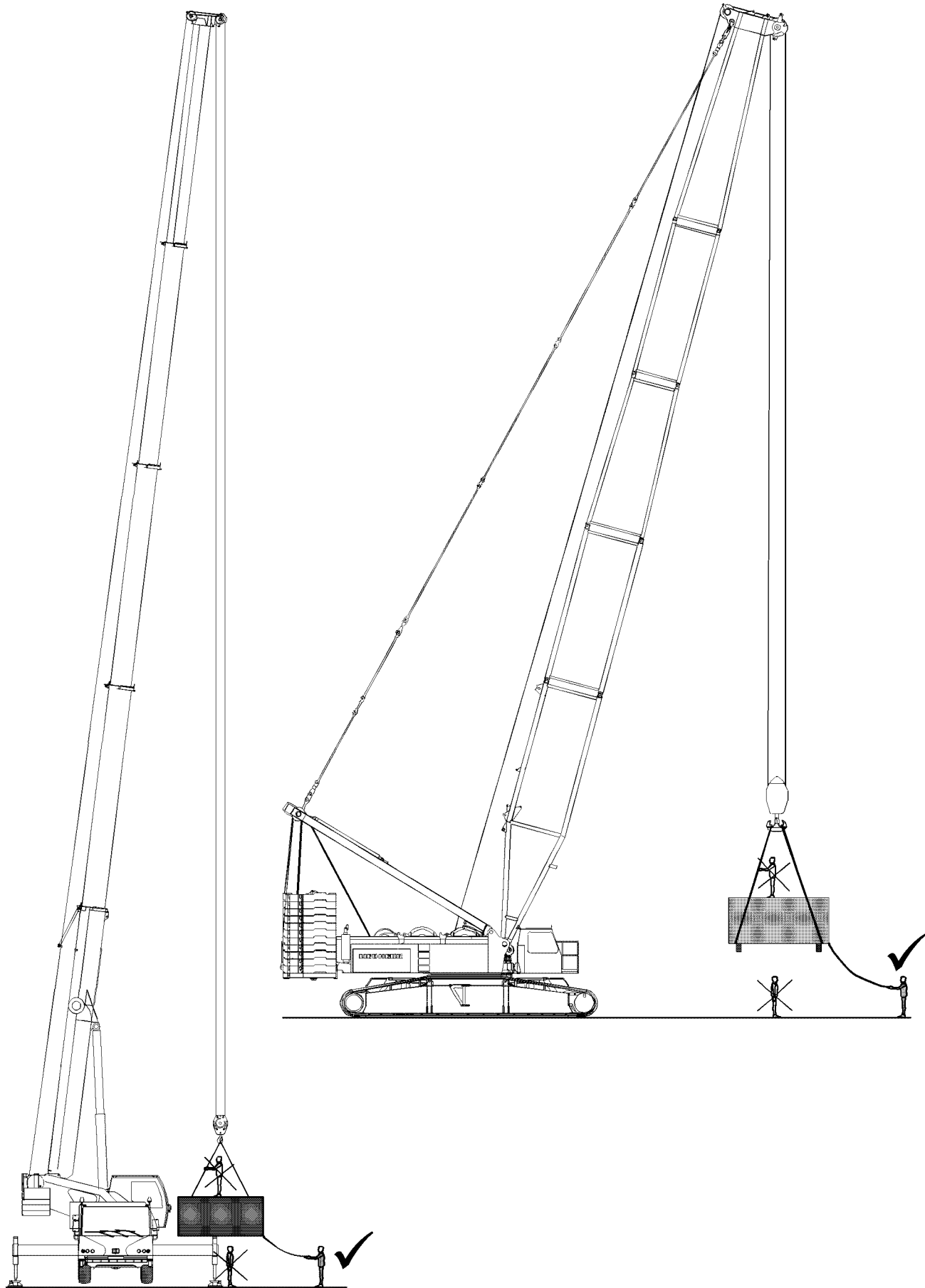


Fig.102717

LWE/LTR 1220-003/24204-02-02/en

## 4.6 Breaking away fixed loads



### WARNING

The crane can topple over!

Ripping stuck loads free can destroy the crane or cause it to topple over.

Personnel can be severely injured or killed.

► Ripping stuck loads free is prohibited.

## 5 Load weighing and load display

Load weighing and load display are described based on the example of a crane with a telescopic boom. The situation is the same for a crane with a telescopic boom and lattice mast boom.

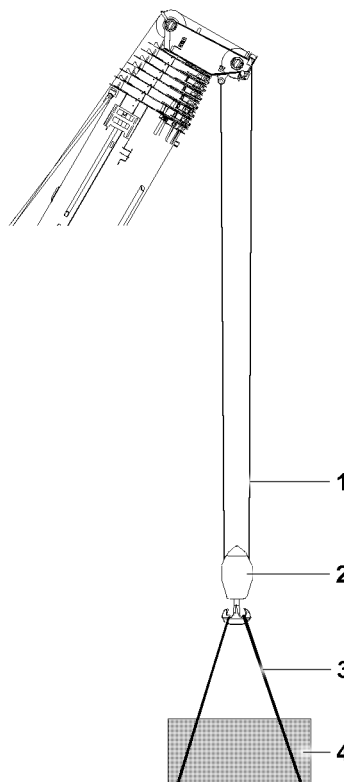


Fig.157473

- |   |                  |   |                           |
|---|------------------|---|---------------------------|
| 1 | Hoist rope       | 3 | Fastening equipment 0.5 t |
| 2 | Hook block 1.5 t | 4 | Actual load capacity 48 t |

The loads indicated in the load chart take the weight of the hoist rope into account.

The weight of the hook block and the weights of the fastening equipment must be subtracted from the load indicated in the load chart and are displayed as a load

Calculation of the actual load capacity of the crane	Load
Maximum permissible load according to the load chart	50 t
Hook block weight	- 1.5 t
Fastening equipment weight	- 0.5 t
Actual load capacity	= 48 t

LWE/LTR 1220-003/24204-02-02/en

The weight of the actual load capacity (the component being lifted) may be not exceed **48 t** in this example.

## 5.1 Load weighing

Make sure that the following prerequisites are met:

- The angle sensors are functioning.
- The incline sensors are functioning.
- The turn sensor in the turntable is functioning.
- The pressure sensors are functioning.
- The length sensors are functioning.
- The pull sensors are functioning.



---

### WARNING

The sensor is defective.  
Load display and load weighing are not exact.  
An error message is displayed.  
► Stop crane operation. Replace the sensor.

---

### 5.1.1 Possible weighing errors

Exact sensor signals are required for precise load weighing.

Since all sensor values are always within a certain tolerance, a weighing error can occur.

The weighing error is increasingly larger if:

- The reeving is small.
- The boom, on which the load is suspended, is short.
- The boom, on which the load is suspended, is steep.



---

### WARNING

Weighing error!  
The crane can be overloaded.  
► Plan and carry out the crane operation very carefully.

---

### 5.1.2 Adjusting the reeving

The number of reevings must be correctly set on the LICCON overload protection. If the reevings are higher than what is considered in the load chart, either the max load for LICCON 2 cranes are reduced or the actual load for LICCON 1 cranes is increased for the crane.

## 5.2 Actual load display

### 5.2.1 Hoist rope length

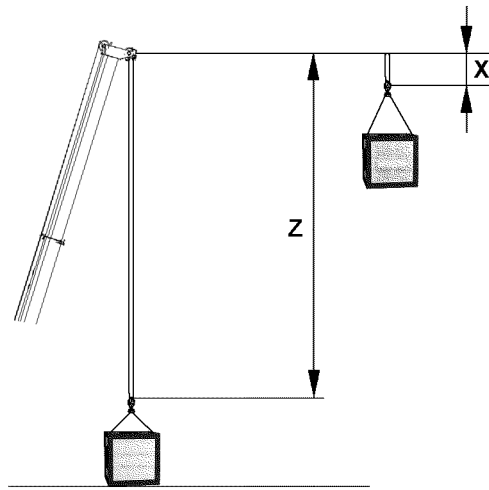


Fig.157474

**Z** Hoist rope length

**X** Hoist rope length

For the calculation of the displayed actual load, the hoist rope weight of the hoist rope length **Z** is deducted from the total load.

In that case, the number of the reevings set on the LICCON overload protection are taken into account, but no more than the nominal reeving.

If the load is raised far above the ground, (hoist rope length **X**), then the actual load display is smaller by the hoist rope weight of the load to the ground.





### 5.2.3 Lowering the load

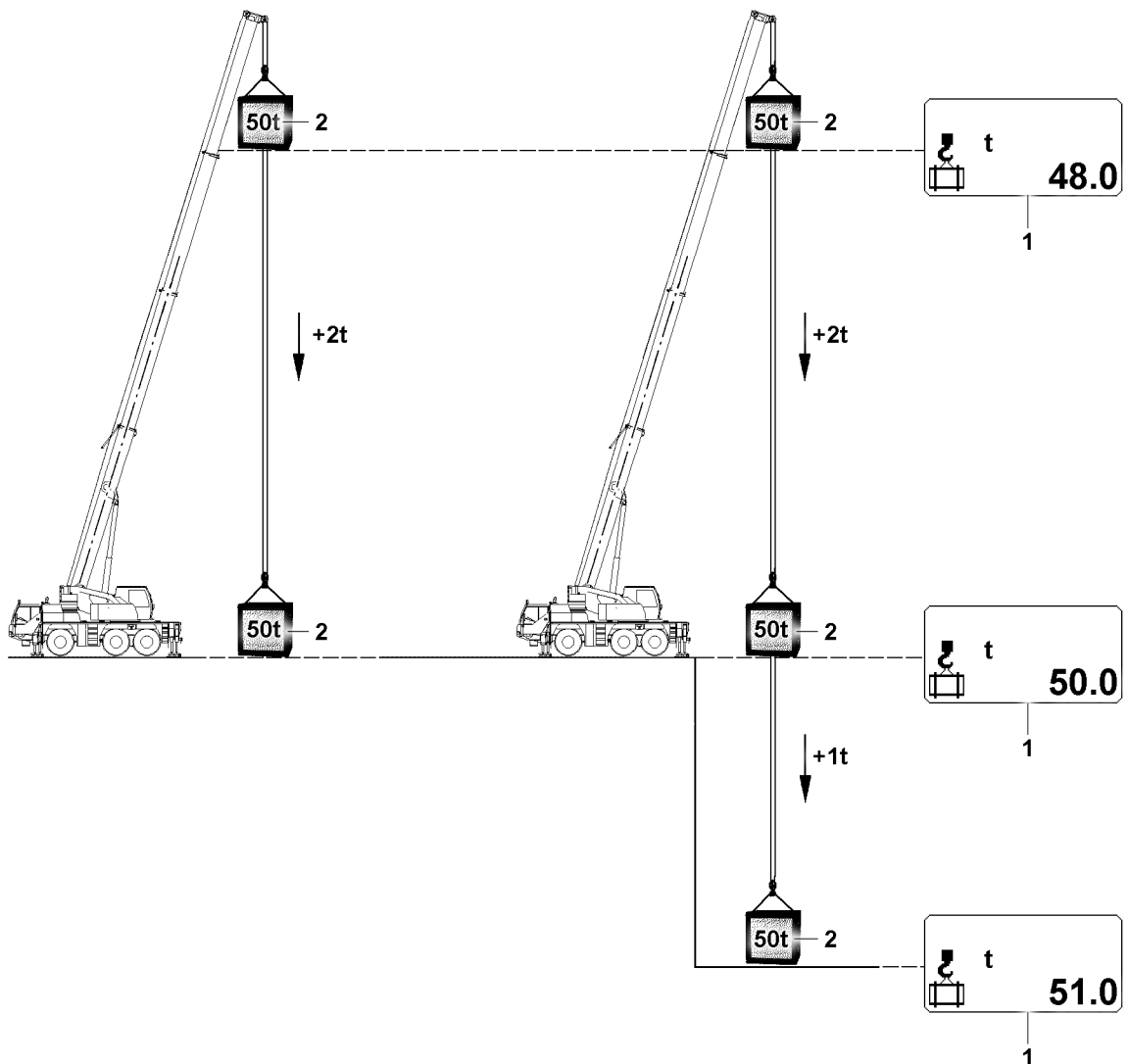


Fig.157502: Lowering the load

- 1 Actual load display
- 2 Load

The load consists of:

- Hook block
- Fastening equipment
- Actual load capacity (the component that is lifted)

When a load **2** with 100 percent utilization is picked up and then lowered, the weight of the hoist rope is calculated as the load and displayed. The utilization is then higher than 100%.



**DANGER**

When the load is lowered, the higher percentage of the hoist rope weight is **not** observed! The crane is overloaded. Death, property damage

When a load **2** is lowered:

- ▶ When taking on a load, do **not** utilize the crane 100%.
- ▶ During job planning, add the higher percentage of the hoist rope weight to the load **2**.

When lowering the load **2**, make sure that the actual load display **1** is correct and the crane overload is also displayed in the utilization bar, but the lowering movement is not shut off. In the case of an LMB overload, all crane movements are shut off, which would increase the danger of overload, however

LWE/LTR 1220-003/24/204-02-02/en

load **2** lowering remains possible because the control assumes that the overload takes place due to lifting the load **2**.

However, the crane can also be overloaded by lowering the load **2**, especially in case of high reevings with a large hoist rope weight on the pulley head. The crane driver must observe this, so that he can relieve the crane by careful lifting again in this special case, even though the lifting and not the lowering of the load **2** is automatically shut off.

## 6 Crane operation

The maximum load capacity of the crane is not just limited by the stability, but in many cases a load-bearing component breaks when the crane is overloaded **before** the crane topples over. Components that are susceptible to buckling such as the telescopic boom may fail suddenly **without showing signs of distortion beforehand** if the crane is overloaded.



### WARNING

Danger of accidents for cranes with luffing cylinders!

When the luffing cylinder is in the block position, the overload protection is not functioning.

- ▶ Crane operation at block position of luffing cylinders is prohibited.

### 6.1 General

A suspended load must always be kept under control. A fundamental requirement for this is the safe and delicate control of the crane's functions.



### WARNING

Danger of accident due to swaying loads!

A swaying load can damage the crane and cause it to topple.

- ▶ All crane movements must be executed slowly and delicately.
- ▶ Initiate all crane movements slowly.
- ▶ Apply the brakes slowly in all crane movements.
- ▶ Crane operation with swaying load is prohibited.

### NOTICE

Damage of rope pulleys!

- ▶ Place down hook blocks, booms, folding jibs, jib booms and boom noses in such a way that the rope pulleys do not lie on the ground and are damaged.

### 6.2 Guiding the load

The use of guide ropes is recommended to help the crane operator manage the load more precisely and to prevent the load from swaying. This will prevent undesirable movements of the load and consequent damage.

### 6.3 Danger of crushing



### WARNING

Danger of fatal injury!

Extreme caution is needed when lowering a load. Danger of fatal injury exists for personnel in the immediate area of the load being lowered.

Personnel can be severely injured or killed.

- ▶ Standing under a suspended loads is strictly prohibited.
- ▶ Observe the danger of tipping when setting down the load. For example, small support surfaces or unsuitable ground.

## 6.4 Danger of falling



### WARNING

Danger of fatal injury!

If persons are on the suspended load, then they can fall down and be severely injured or killed.

- ▶ Remaining on a suspended load is strictly prohibited.
- ▶ Remaining on or within crane components (for example: At assembly of boom sections, lattice sections) which are moved during lifting, lowering, turning or closing procedures is strictly prohibited.

## 6.5 Working in the vicinity of electricity transmission lines

If there are electricity transmission lines in the immediate vicinity of the building site, then the electrical transmission lines must be turned off by qualified electricians. If this is not possible, the danger area must be covered over or cordoned off.



### WARNING

Danger of current transfer!

If electricity transmission lines are not shut off nor covered nor blocked off, then there is an increased danger of accident due to current transfer.

- ▶ For rated voltages up to 500 kV AC: Adhere to a safety distance of 8 m.

If the crane becomes electrified despite having taken all necessary precautions, proceed as follows:

- ▶ Remain calm.S
- ▶ Do not leave the crane cab.
- ▶ Warn people outside: Stay in place and do not touch the crane.
- ▶ Move the crane away from the danger zone.

## 7 Ram work or pulling sheet piles

The cranes from Liebherr Werk Ehingen GmbH have been designed to lift loads. When working with a free-riding vibrating unit for ramming and pulling operations, vibrations may be transmitted to the load bearing steel structure even if a vibration damper is used. This vibration can cause premature fatigue of the material and therefore cracks in the supporting steel structure. Furthermore, the components can loosen and fall down due to the vibrations. This work should only be performed on the mobile crane in exceptional situations or when the use of machines built specially for this work is not possible.

Before performing this work, a risk assessment must be carried out that concerns the particular risks when driving and pulling the sheet piles and handling them.

Following higher loads on the crane, shorter inspection intervals for the mobile crane and the hook block must be defined by an authorized inspector. Before and after performing the work on the free-riding jogging unit, the crane, hook block and fastening equipment as well as the vibrating unit must be inspected for damage.

The free-riding vibrating unit must be equipped with vibration dampers. Rigid connections for this equipment to the crane are prohibited!

The following vibrating unit and vibration damper combinations are permissible:

- Free-riding vibrating unit with integrated vibration dampers.
- Free-riding jogging unit combined with a vibration damper designed for this equipment.

Specifications for working with the free-riding vibrator:

- Slack rope and angular pull on the hoist rope are prohibited.
- The vibrator may only be switched on if the vibrator is connected correctly with the ramming element and the ramming element is lying flush on the ground or is partially in the ground.
- Starting or stopping the vibrating unit must take place with an eccentric moment of zero (no vibrator vibration), in order to avoid peak vibration amplitudes and resonances due to the possibility of running through the natural frequency band of the vibrator. Only after reaching the nominal speed and

the operating pressure of the unit may the eccentric moment be set to the desired value or amplitude.

---

#### NOTICE

**No vibration dampers used!**

The boom or the crane can be damaged.

- ▶ Use ramming equipment and pulling equipment with vibration dampers.
  - ▶ The ramming equipment and pulling equipment may **not** pass on vibrations to the boom.
- 

When pulling sheet piles, the maximum permissible pull force must be limited to 50% of the load chart value for the corresponding crane boom radius. The utilization of the hook block load may not exceed 50%.



#### Note

- ▶ When pulling sheet piles, **only** work in main boom operation or telescopic boom operation.
  - ▶ Do **not** use operating modes with a Derrick, auxiliary boom or boom extensions.
- 

#### NOTICE

Maximum permissible pull force exceeded when pulling sheet piles!

The boom or the crane can be damaged.

- ▶ Limit the maximum permissible pull force to 50% of the load chart value for the corresponding crane boom radius.
  - ▶ Additionally check the pull force by measuring it.
  - ▶ Do not limit the maximum pull force of the crane **exclusively** by means of the overload protection.
- 

#### NOTICE

Hook block load utilization exceeded when pulling sheet piles!

The hook blocks or the crane can be damaged.

- ▶ Limit the utilization of the hook block load to maximum 50%.
- 

Liebherr Werk Ehingen GmbH shall not be held liable for damage caused to the machine, to the used ramming and pulling equipment, on the piling element or in the surroundings (for example adjacent buildings) due to the installation and use of the free-riding vibrator.

## 8 Crane rope pretension

Damage that can occur with multi layer spooling:

- Abrasion
  - Broken wires and loop formation
  - Flattenings, deformations
- 

#### NOTICE

Crane rope pretension too low!

Loosely coiled rope layers.

Rope damage. Reduced service life of the crane rope.

Cutting of the crane rope into the lower rope layers. The load can not be lowered any further.

- ▶ To maximize the service life of the crane rope, carry out the measures in the following sections.
- 



#### Note

- ▶ Liebherr recommends to shorten crane ropes with damage in the cross over area of the coils, in order to lengthen the service life. Shortening the crane rope, see Crane operating instructions, chapter 7.05.50.
-

## 8.1 Working with a high rope pull

If multiple lifts are performed with a high rope pull, loosen the lower rope layers that are rarely or never spooled out.

---

### NOTICE

Loosely spooled out rope layers!

Rope damage.

Upper rope layers with a high rope pull deform the lower rope layers in the cross over area of the crane rope.

Spooling deformed rope sections over rope pulleys reduces the service life of the crane rope.

- ▶ Place a shorter crane rope.

When the lower rope layers are **not** used during repeat work:

- ▶ Increase the pretension of the lower rope layers: Spool out the entire rope length and then spool back up with the highest rope pull possible. See section „Increasing the hoist rope pretension“.
- 

### 8.1.1 Placing a shorter crane rope



#### Note

- ▶ Liebherr recommends using the entire rope length.
- 

Unused rope sections cause the loosening of the lower rope layers.

When only a part of the crane rope length is used for a longer period of time:

- ▶ Place a shorter crane rope.

### 8.1.2 Reducing rope unwinding

#### Telescopic boom

When telescoping out less, then the smallest amount of fixed coiled up crane rope is spooled out.

- ▶ Telescope out as little as possible.

#### Picking up the fastening equipment

If the fastening equipment with a flat boom system must be picked up, then the smallest possible amount of crane rope is spooled up loose.

- ▶ Establish a flat boom system: Telescope out or luff up the boom.
- ▶ Pick up the fastening equipment.

### 8.1.3 Restoring hoist rope pretension

#### Brief description

If a multi-pulley hook block is reeved, then the entire hoist rope length can be spooled out from the rope drum.

- ▶ Spool the hoist rope out until three safety coils.
- ▶ Create 10 % maximum strand pull: Attach the load.

While the hoist rope is spooled up:

- Hold the load just off the ground.
- In the permissible range of the load chart of the relevant set up configuration: Increase the load radius by luffing down.
- ▶ Spool the hoist rope up.

### Description using the example LR 1600-2, SL3F

This section explains the procedure with the help of the set up configuration for LR 1600-2 with boom system SL3F.

The crane-specific parameters ensure that rope is spooled out until four rope coils and as many rope coils with pretension as possible can be spooled up.

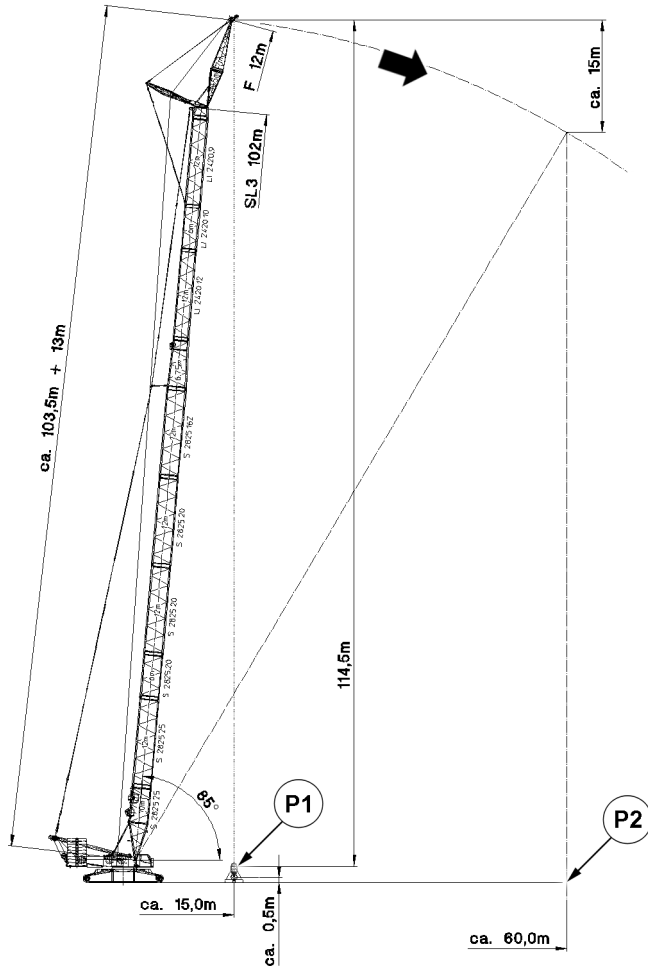


Fig.127131: LR 1600-2, SL3F: Spooling up hoist rope with pretension

Boom radius	Load	10 % of maximum strand pull
60 m	14.4 t	1.8 t

Load example: LR 1600-2, SL3 102, F12, according to the load chart

Hoist rope for this example:

- Hoist rope with a length of 1050 m

Hook block for this example:

- Hook block 200 DM, 5-pulley, reeved 8 times
- The weight of the hook block with ten auxiliary weights is 7.0 t

Make sure that the following prerequisites are met when hanging the load:

- Load is hung as short as possible.
- For a boom radius of 15.0 m, the hoist rope can be spooled out on the winch until four coils.

To reach sufficient rope pull, another load must be hung in addition to the hook block.

The additional load of 7.4 t is calculated from the difference between the load 14.4 t and the weight of the hook block 7.0 t.

- ▶ Fasten the load with 7.4 t.
- ▶ Until the load is 0.5 m above the ground: Lift the load.
- ▶ Set the boom system to boom radius 15.0 m.
- ▶ Spool the hoist rope out.

**Result:**

- In position **P1** there are 9 m of hoist rope (four coils) on the hoist winch:

Spoiled out rope section	Length
8-way reeving, distance of ground to the F-jib with boom radius 15 m	8 x 114.5 m = 916.0 m
Winch to FA-frame	103.5 m
F-head	13.0 m
Rope pulleys	7.5 m
Total of spoiled out hoist rope	1040.0 m

*Rope lengths in position P1*

While the hoist rope is spooled up:

- Hold the load just off the ground.
- In the permissible range of the load chart of the relevant set up configuration: Increase the load radius by luffing down.
- ▶ Until a boom radius of 60.0 m is reached: Spool up the hoist rope and luff down the boom at the same time.
- ▶ Set down the load.

**Result:**

- The pretension of the first and second position of the rope coils is restored.
- In position **P2** there are 130 m of hoist rope (23 coils) on the hoist winch:

Spoiled up rope section	Length
Four coils initial situation	9 m
8-way reeving, F-jib height difference with boom radius 60 m	8 x 15 m = 120 m
Total of spoiled up hoist rope	130 m

*Rope lengths in position P2*

- ▶ Make sure that the hoist rope on the winch remains pretensioned: Reeve out the hook block and reeve in with slower reeving. See Reeving plan.

## 8.2 Picking up and lowering overhead loads

The load is picked up overhead in the following application examples:

- Repowering wind power plants
- Disassembly of slewing tower cranes

**NOTICE**

Load picked up overhead with loosely coiled rope layers!

The rope pull increases when the load is picked up. The rope coils in the lower rope layers move laterally and are compressed. The hoist rope can cut into the lower rope layers.

- ▶ Spool up the hoist rope without a load only with rope pretension.

**NOTICE**

Load lowered with cut in rope layers!

The hoist rope is pulled jerkily from the lower rope layers. Vibrations are introduced into the crane system.

Cut in hoist rope clamped between the lower rope layers. The load can **not** be lowered any further.

- ▶ To prevent the cutting in of the hoist rope, carry out the measures in the following sections.

## 8.2.1 Increasing the reeving number

**NOTICE**

Higher reeving number than indicated on the load chart!

Slack rope formation.

The crane load drops due to additional weight from the rope strands and hook block.

If a higher reeving number is not considered in the set up configuration, the load display on the LIC-CON monitor no longer corresponds.

- ▶ Redetermine the hook block weight according to the load chart manual and adjust if necessary.
- ▶ Check if the crane load is sufficient for higher reeving.
- ▶ After telescoping out, check if the hook block can still reach the desired position for putting down the load.

A higher reeving number reduces the rope pull. A lower rope pull prevents the cutting in of the hoist rope in the lower rope layers.

- ▶ Select the highest reeving number possible for the hoist rope.

## 8.2.2 Increasing the hook block weight

**NOTICE**

Lift the hook block without a load!

The hoist rope is spooled up with a low rope pull. The rope layers are spooled up loose on the rope pulley.

- ▶ Increase the rope pull: Increase the hook block weight.

A higher hook block weight increases the rope pull.

- ▶ Increase the hook block weight.

If the crane load is sufficient:

- ▶ Attach an auxiliary weight between the load and hook block.

## 8.2.3 Pretensioning the hoist rope with pretensioning ballast with two hook operation

The pretensioning ballast is **not** included in the Liebherr delivery scope.

**NOTICE**

Lift the hook block without a load!

The hoist rope is spooled up with a low rope pull. The rope layers are spooled up loose on the rope drum.

- ▶ Pretension the hoist rope with pretensioning ballast with two hook operation.

Make sure that the following prerequisites are met:

- The crane is equipped for two hook operation.
- The pretensioning ballast is present.

Properties of the pretensioning ballast:

- Developed by Liebherr.
- The weight is 4 t.
- Special tow coupling



- ▶ Fasten the pretensioning ballast on the main hook and on the auxiliary hook.

The pretensioning ballast is lifted with the main hook, the auxiliary hook is carried along without a load.

- ▶ Lift the pretensioning ballast.

When the main hook has reached the required height:

- ▶ Stop the main hook.

After the load is completely transferred to the auxiliary hook, the main hook fastening ropes release automatically.

- ▶ Lift the auxiliary hook until the pretensioning ballast hangs completely on the auxiliary hook.

When the main hook fastening ropes have released:

- ▶ Lower the pretensioning ballast with the auxiliary hook and place it on the ground.

**Result:**

- The full load is present on the main hook.

---

Empty page!

LWE/LTR 1220-003/24204-02-02/en

## 4.10 Driving from the crane cab

1	Prerequisites for driving the crane (crawler operation)	2
2	Displays for center of gravity, surface pressure and incline on the LICCON monitor	6
3	Preparing for crane driving	13
4	Driving the crane: Load chart available	15
5	Driving the crane: No load chart is available	17
6	Crawler crane in crawler operation	20

# 1 Prerequisites for driving the crane (crawler operation)

For driving the crane (crawler operation) the conditions of the travel route are the deciding factor.

- For **ground inclinations within the area of a valid load chart Driving with load** is possible at a slow speed. The ground must be sufficiently level and capable of supporting the load. The supplements to the load charts for driving the crane must be observed.
- For **ground inclinations outside the area of a valid load chart Driving without load** is possible at a slow speed up to certain inclination ranges. The ground must be sufficiently level and capable of supporting the load.

Driving the crane: Load chart available:

- Valid and regular load chart available
- With load on the hook
- Without load on the hook

Driving the crane: No load chart is available:

- Only without load on the hook
- With specifications and limitations for the set up configuration of the crane



## WARNING

The crane can topple over!

If the permissible inclinations of the crane are exceeded, the crane can topple over.

If the permissible surface pressures of the travel route are exceeded, the crane can topple over.

Personnel can be severely injured or killed.

- ▶ Do not exceed the permissible inclinations of the crane.
- ▶ Do not exceed the permissible surface pressures for the travel route.



## WARNING

The crane can topple over!

If the following specifications, instructions and prerequisites are not observed, then the crane can topple over or be overloaded.

Personnel can be severely injured or killed.

- ▶ The crane operator is responsible for adhering to all specifications, instructions and prerequisites in the crane documentation.
- ▶ The crane operator may not drive the crane if not all specifications, instructions and prerequisites in the crane documentation can be adhered to.
- ▶ The crane operator is responsible for the correct and complete entry of data in the LICCON computer system.
- ▶ All drive movements (starting, steering, acceleration, deceleration, stopping etc.) must be initiated sensitively, smoothly, with utmost caution and at the lowest speed.
- ▶ Depending on the situation, additional observers, who are acoustically or visually in contact with the crane operator (for example by radio or sight), may have to support the crane operator with shared responsibility.

Make sure that the following prerequisites are met:

- No personnel or obstacles are within the danger zone.
- The crane is in an operational condition.
- The crane is in a set up configuration permitted for travel operation.
- The installed ballast (central ballast and counterweight) is properly installed and secured.
- There are no loose objects on the crane.

## 1.1 Travel route



### WARNING

The crane can topple over!

If the following specifications, instructions and prerequisites are not observed, then the crane can topple over or be overloaded.

Personnel can be severely injured or killed.

- ▶ The transition from the horizontal to an uphill slope and from an uphill slope to the horizontal must be made evenly, i.e.: There may be no edges that can cause the crane to topple over. Any inclination changes must be made continuously.
- ▶ If the travel route cannot safely absorb the surface pressure, then measures must be taken to be able to safely transfer the forces to the ground.
- ▶ If measures were taken to transfer the forces to the ground, then they must be checked by an expert before starting to drive for proper execution and sufficient supportability.
- ▶ An insufficient ground condition can cause accidents, for example the crane can slide away to the side and as a result get into an impermissible incline position.

Make sure that the following prerequisites are met:

- Before starting to drive, the travel route was determined.
- Before starting to drive, the condition of the ground has been checked.
- The entire travel route can safely absorb the surface pressure.
- All inclinations occurring on the travel route can be driven safely by the crane.
- The entire travel route is free of obstacles.
- The friction coefficient between the track and ground is sufficiently large to absorb the occurring drive forces or to prevent the crane from slipping away in an incline position.
- Possible environmental influences for driving the crane (including precipitation and wind) were taken into account for the travel route.
- The travel route was selected and prepared in such a way that the boom system can be taken down at any time.
- Select the travel route in such a way that no steering movements are required, if possible.
- With a load on the hook: setting down the load is possible at any time.
- The entire travel route is secured as a danger zone.
- The travel route has been selected in such a way that a sufficient distance to local facilities (among others power lines) can be retained.

For ground outside the range of a valid load chart, the following applies additionally:

- Before starting to drive, the travel route was checked in connection with the actual set up configuration of the crane on the LICCON job planner.
- Before starting to drive, the optimum positions for the boom system were determined to obtain as even a surface pressure as possible - the LICCON job planner can be used for this purpose.



### Note

- ▶ For a detailed description of the LICCON job planner on the crane\*, see the LICCON Job planner operating instructions.
- ▶ For a detailed description of the LICCON job planner computer program, see the separate description.

### 1.1.1 Optimizing measures for the travel route

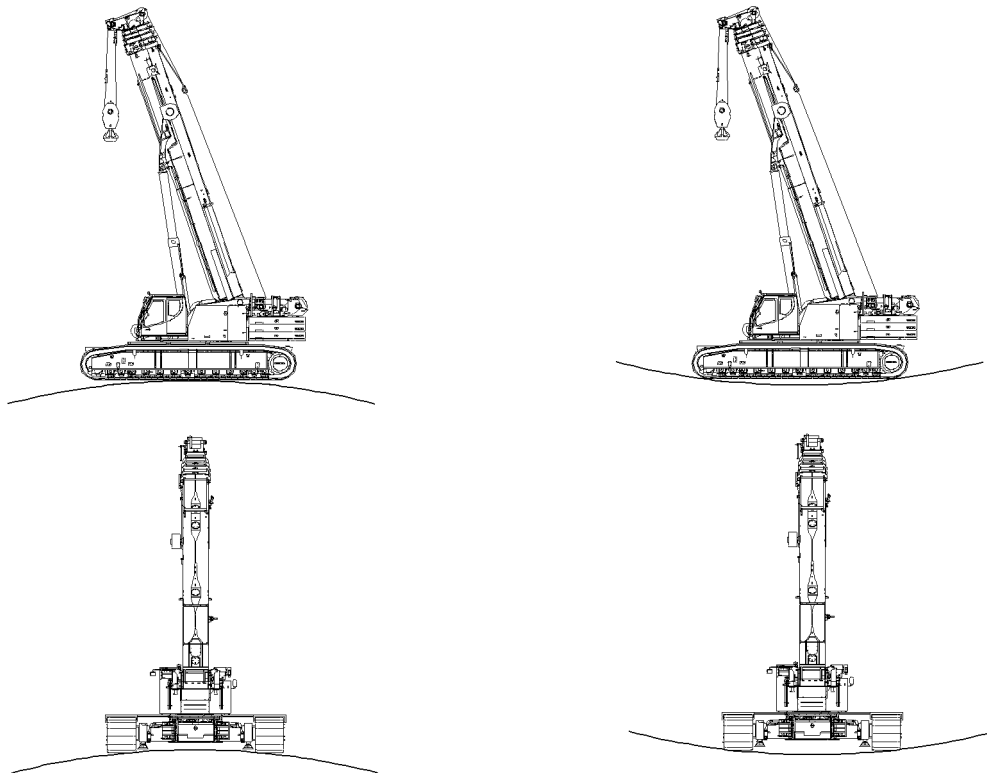


Fig. 117927: Depressions, crests, track grooves and other uneven areas of the travel route cause localized pressure on the crawler travel gear

---

#### NOTICE

Damage to the crawler travel gear!

Continuous localized pressure on the crawler travel gear causes increased wear. Continuous increased wear can cause damage to the crawler travel gear.

- ▶ Set up the travel routes in such a way that the crawler travel gear is not subjected to continuous localized pressure.
  - ▶ For extended travel operation shorten the maintenance intervals.
- 

Through the following configuration features of the travel route, wear on the crawler travel gear can be minimized:

- Deformations in the travel route (such as depressions, crests, track grooves) have been eliminated via suitable measures.
- Select the travel route in such a way that few steering movements are required.

## 1.2 Calculating the required length of transitions on uphill / downhill slopes

The required length  $L$  for transfers results from the existing uphill angle  $\alpha$  and the length of the crawlers  $LC$ .

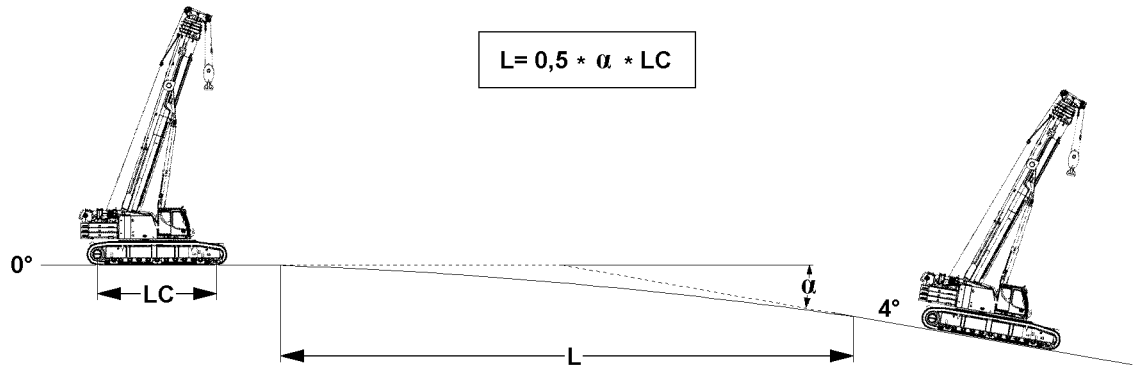


Fig.121101: The illustration is an example

Abbreviation	Description
L	Required length of transfers
$\alpha$	Angle rising / falling inclines in degrees
LC	Length of crawlers between drive wheels / steering wheels

### 1.2.1 Calculation example

Given:

$\alpha = 4^\circ$

LC = 8.0 m (use only the actual value of the crane!)

Wanted:

L = ?

Calculation formula						
L	=	0.5	*	$\alpha$	*	LC
L	=	0.5	*	4	*	8.0 m
L	=	16.0 m				

### 1.3 Travel gear / hydraulic motors / track rollers

**NOTICE**

Damage to the travel gear, hydraulic motors and track rollers!

On longer travel routes and / or when driving uphill / downhill, the travel gears, hydraulic motors and / or track rollers can be overheated and damaged.

- ▶ Make sure that the travel gears - before driving the crane - have the maximum fill level.
- ▶ With suitable measuring devices make sure that the maximum permissible temperature of the travel gears, hydraulic motors and / or track rollers in travel operation over longer distances is below 90 °C. For a short time (**maximum** 10 minutes), the temperature may increase to a value between 90 °C and 100 °C.
- ▶ As soon as the maximum permissible temperature in one position is exceeded, take a break from driving for cooling down.
- ▶ The crane operator is responsible for any damage to travel gears, hydraulic motors and / or track rollers.

LWE/LTR 1220-003/24/204-02-02/en

When the maximum permissible temperature range on a travel gear and / or hydraulic motor is reached:

- ▶ Take a break until the temperature on travel gear(s), hydraulic motor(s) and / or track rollers had dropped considerably.

Maximum permissible temperature range on travel gear(s) / hydraulic motor(s)		
	to 90 °C	between 90 °C and 100 °C
Duration of exposure	Continuous	Not longer than 10 minutes

When the temperature of all travel gears / hydraulic motors has dropped below 90 °C:

- ▶ Travel operation is permissible again.

## 1.4 Using insertion plates in the crawler chains

If insertion plates are used in the crawler chains:

- The ground can be protected against damage.
- It is possible that the friction coefficient between the track and the ground changes.



### WARNING

If the friction coefficient is too low between the track and the ground then there is a danger of accident! In unfavorable ground characteristics, such as snow or ice, the friction coefficient between the track and the ground is reduced.

The drive forces can no longer be absorbed.

The crane can slide off.

- ▶ Use insertion plates only when a sufficient friction coefficient between the track with insertion plates and the ground is ensured.

## 2 Displays for center of gravity, surface pressure and incline on the LICCON monitor



### WARNING

Danger of accident due to deviating set up configuration!

If the actual set up configuration of the crane deviates from the entries and settings in the Set up program, then the overload protection is not correctly set.

An incorrectly set overload protection calculates the actual load incorrectly and transmits faulty display values.

The crane can be overloaded without noticing it and topple over or collapse as a result.

Personnel can be severely injured or killed.

- ▶ The entries and settings in the set up program must match the actual set up configuration of the crane.



### WARNING

Incorrect display values!

If the display values do not increase correspondingly when lifting known weights, an erroneous display value may be present.

If the crane is operated with erroneous display values, then the crane can be overloaded.

This could result in serious accidents.

- ▶ When lifting the hook block off the ground check if the display value for the actual load increases correspondingly.
- ▶ When lifting the load off the ground check if the display value for the actual load increases correspondingly.



Make sure that the following prerequisites are met:

- The actual set up configuration of the crane matches the entries and settings in the set up program.
- The assignment of the crane to the displays on the LICCON monitor is clear.
- All displays function perfectly.



**Note**

- ▶ For a detailed description of the displays on the LICCON monitor, see the Crane operating instructions, chapter 4.02.
- ▶ For a detailed description of the safety equipment, see Crane operating instructions, chapter 4.04.

## 2.1 Center of gravity display on the LICCON monitor



**WARNING**

Shifting of the center of gravity!

The calculation of the values for the display of the center of gravity in the LICCON monitor are based on ideal assumptions.

- ▶ Side deformations of the boom system due to wind, inclined position and elastic resilience of the steel structure are not taken into account but they can lead to a shifting of the center of gravity.

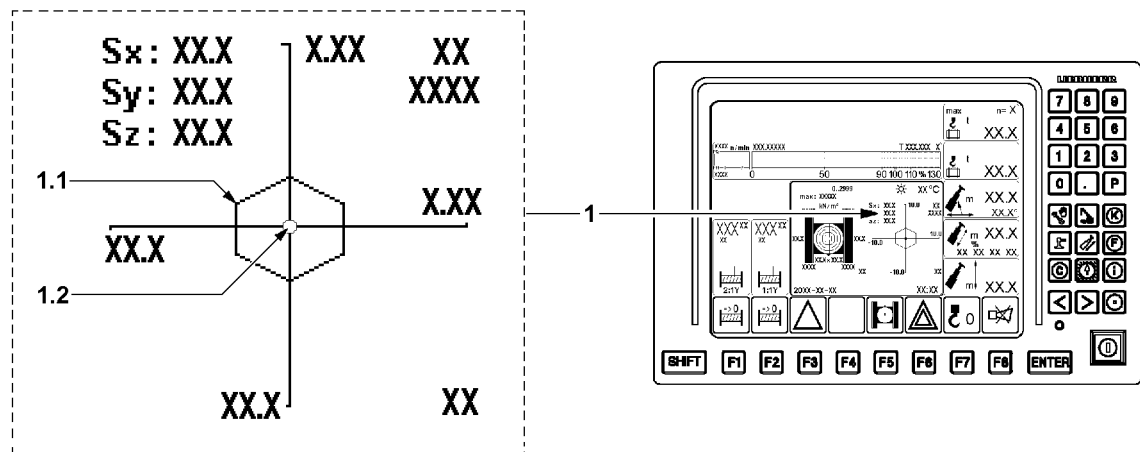


Fig.117916

Center of gravity 1 display	
Position	Name
1.1	Core area
1.2	Center of gravity



**WARNING**

The center of gravity of the crane is outside the core area!

If the center of gravity 1.2 of the crane is outside the core area 1.1, then the crane can topple over. Personnel can be severely injured or killed.

- ▶ To drive the crane, the center of gravity 1.2 must always be within the core area 1.1.
- ▶ If the center of gravity 1.2 is outside of the core area 1.1, then it is prohibited to drive the crane.

The following specifications and instructions must be observed:

- By luffing the boom system up and down, the position of the center of gravity 1.2 must be corrected in such a way that the overall center of gravity remains within the core area 1.1.

## 2.2 Display for surface pressure and inclination on the LICCON monitor



### WARNING

Increased surface pressure!

The calculation of the values for the display of the surface pressure in the LICCON monitor are based on ideal assumptions.

- ▶ Side deformations of the boom system due to wind, inclined position and elastic resilience of the steel structure are not taken into account but they can lead to an increase of the surface pressure.

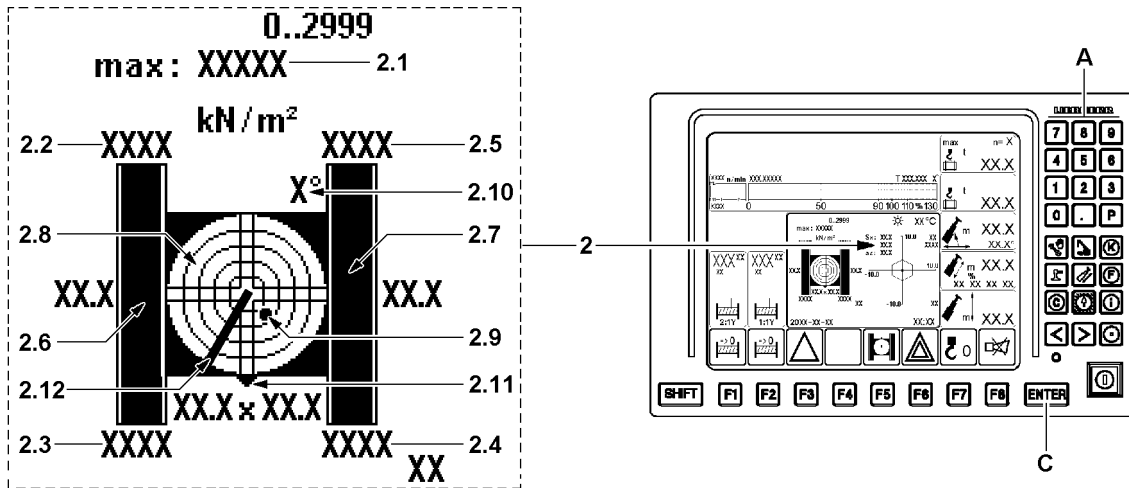


Fig.117917

Display Surface pressure 2	
Position	Name
2.1	Maximum surface pressure
2.2	Surface pressure right rear
2.3	Surface pressure right front
2.4	Surface pressure left front
2.5	Surface pressure left rear
2.6	Right crawler placement surface
2.7	Left crawler placement surface
2.8	Incline indicator <sup>1)</sup>
2.9	Point
2.10	Display resolution <sup>2)</sup>
2.11	„Front side of crawler carrier <sup>(3)</sup> marker
2.12	Boom direction <sup>4)</sup>

1) The graphic display is in the form of a spirit level with a moving dot 2.9 representing the air bubble.

2) This value describes the resolution of the graphic view. The resolution is matched automatically to the inclination

3) The front of the track is always on the side where the chain tension devices for the crawler carriers are located.

4) Current boom direction in reference to the displayed icon.

**WARNING**

Surface pressure too high!

If the maximum surface pressure is exceeded, the crane can topple over.

Personnel can be severely injured or killed.

- ▶ Do not exceed the maximum surface pressure.
- ▶ The value entered in the LICCON computer system for the maximum surface pressure **2.1** must match the actual conditions of the travel route.

**WARNING**

The crane can topple over!

If the permissible incline of the crane is exceeded, the crane can topple over.

- ▶ Do not exceed the permissible incline from the load chart.
- ▶ Do not exceed the permissible inclination for driving the crane, see the following sections.

**Note**

- ▶ The placement surface of the crawler is graphically shown in the display of the surface pressure.
- ▶ If the resulting surface pressure can be distributed so that the maximum surface pressure of the travel route is not exceeded **and** the resulting forces can be transferred safely into the ground, then the stability of the crane is ensured.
- ▶ Incline indicator **2.8** with number values, see section „Display of incline in LICCON monitor“.

The following specifications and instructions must be observed:

- The maximum surface pressure that may be reached must be entered as the maximum surface pressure **2.1**.
- By luffing the boom system up and down, the resulting surface pressure must be distributed in such a way that the maximum surface pressure of the travel route is not exceeded.
- The inclinations that are reached on the travel route are known and are taken into account.
- As soon as the crane shows the tendency that the permissible incline could be exceeded, the load must be set down. If necessary, driving the crane must be interrupted.

### 2.2.1 Entering the maximum permissible surface pressure

Make sure that the following prerequisites are met:

- The *Crane operation* program is called up.
- The maximum permissible surface pressure of the travel route is known.

- ▶ Press the enter key **C**.

**Result:**

- The value for the maximum surface pressure **2.1** can be changed.
- ▶ Enter the value for the maximum permissible surface pressure via the keypad **A**.
- ▶ Press the enter key **C**.

**Result:**

- The new value for the maximum surface pressure **2.1** appears.
- ▶ Check the value for the maximum permissible surface pressure.

### 2.3 Display for the inclination on the LICCON monitor

The display of the incline is additional shown at the monitored auxiliary functions.

There is the display of the incline of the crane to the horizontal in the longitudinal and lateral direction. The display is graphic as well as numeric.

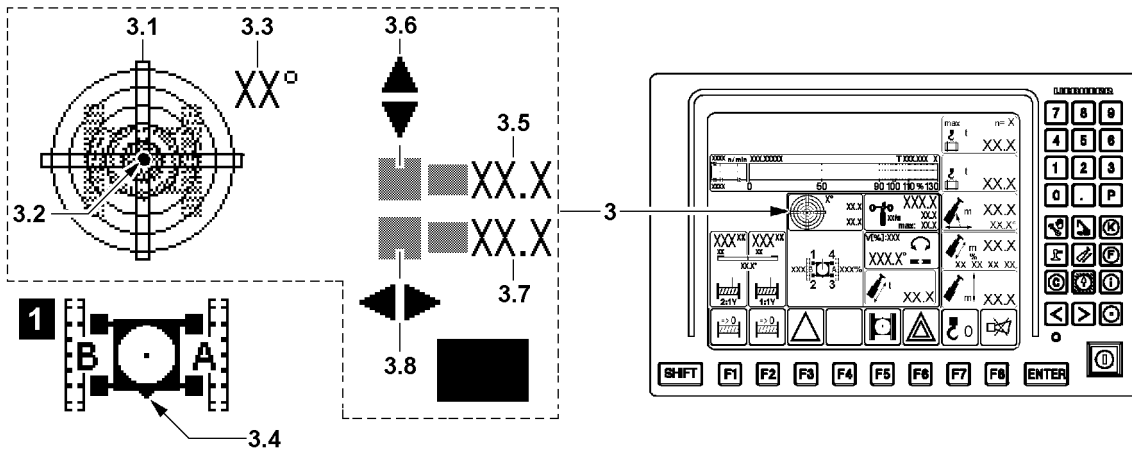


Fig.117918

Incline 3 display	
Position	Name
3.1	Sight gauge
3.2	Bubble
3.3	Display resolution
3.4	Front side of crawler carrier <sup>1)</sup> marker
3.5	Incline in longitudinal direction
3.6	Incline direction
3.7	Incline in lateral direction
3.8	Incline direction

1) The track is highlighted in the sight gauge 3.1 as an orientation aid. The front side of the crawler travel gear 3.4 is in the display below, see detail 1. The front of the track is always on the side where the chain tension devices for the crawler carriers are located.



**WARNING**

The crane can topple over!

If the permissible incline of the crane is exceeded, the crane can topple over.

- ▶ Do not exceed the permissible incline from the load chart.
- ▶ Do not exceed the permissible inclination for driving the crane, see the following sections.

The following specifications and instructions must be observed:

- The inclinations that are reached on the travel route are known and are taken into account.
- As soon as the crane shows the tendency that the permissible incline could be exceeded, the load must be set down.

Empty page!

LWE/LTR 1220-003/24204-02-02/en

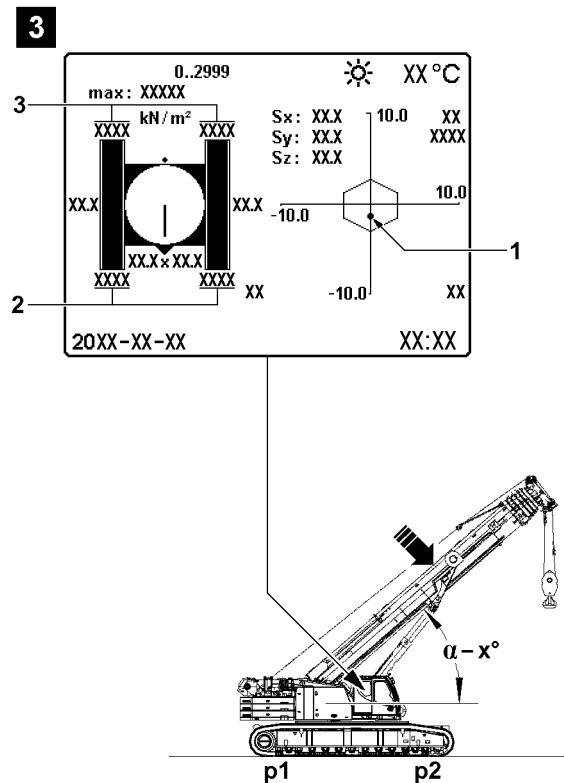
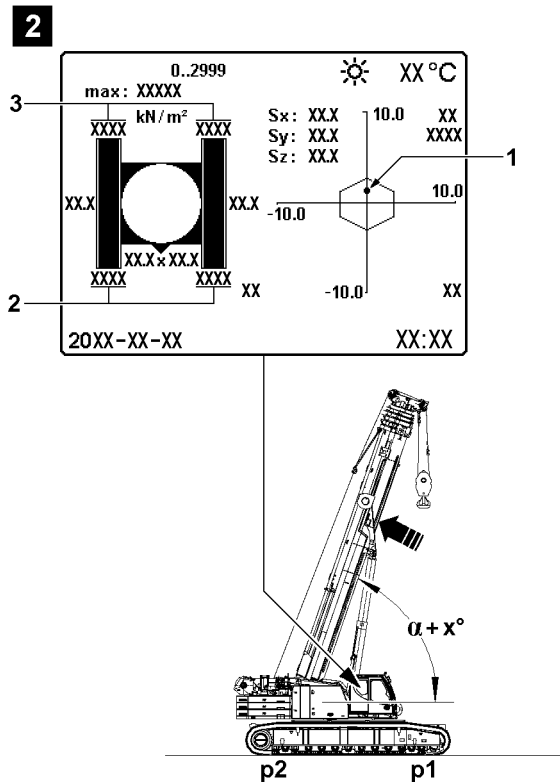
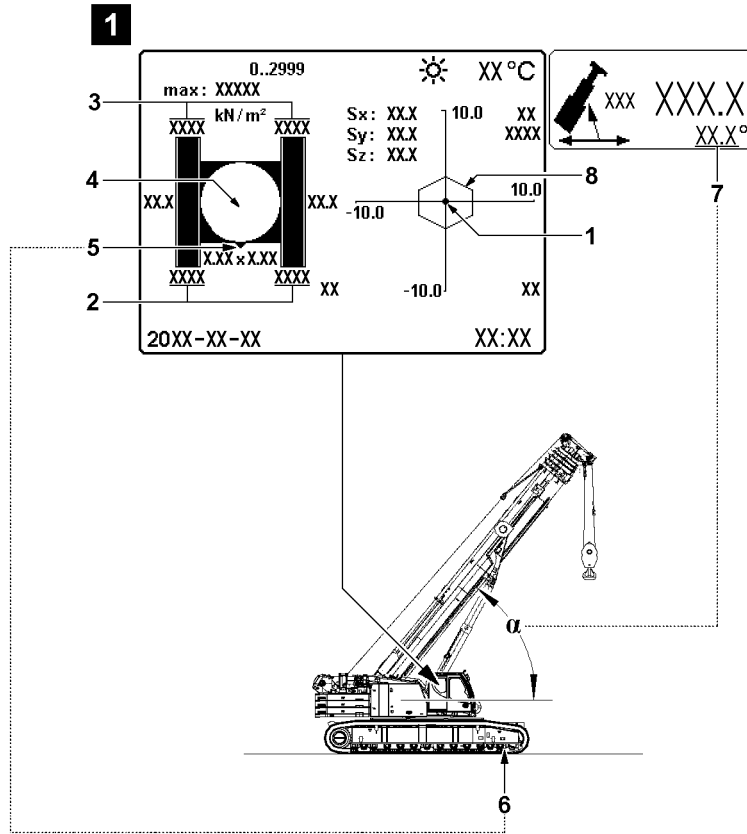


Fig.121102

## 3 Preparing for crane driving

### 3.1 Distribution of the surface pressure

While driving, pay attention in all driving conditions to the ratio of the surface pressure between the front and the rear sides of both crawlers.

In the following examples it is assumed that the crawler travel gear and the turntable are oriented to the front.

Distribution of the surface pressure	
Position	Name
1	Center of gravity
2	Surface pressure on the front
3	Surface pressure on the rear
4	Incline indicator <sup>1)</sup>
5	„Front side of crawler carrier“ <sup>(2)</sup> marker
6	Crawler carrier chain tension device
7	Main boom angle display
8	Core area
$\alpha$	Main boom angle

1) The angle display always refers to the crawler travel gear. As an orientation aid, the front side of the crawler travel gear **5** is optically highlighted.

2) The side where the chain tension device for the crawler carriers is located is always at the front on the track.

Before driving the crane is it required to position the boom in such a way that a suitable distribution of surface pressure for driving is obtained.

#### 3.1.1 Examples for the distribution of surface pressure

The center of gravity **1** is in the center, illustration **1**

- The surface pressure on the front **2** is the same as the surface pressure on the rear **3**.

The center of gravity **1** is in the rear, illustration **2**

- The boom was luffed up.
- The surface pressure on the rear **3** is higher.

The center of gravity **1** is in the front, illustration **3**

- The boom was luffed down.
- The surface pressure on the front **2** is higher.

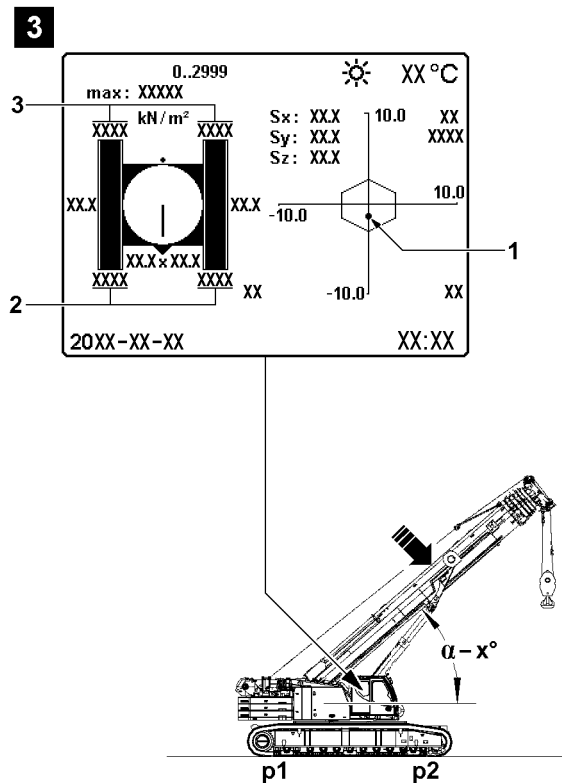
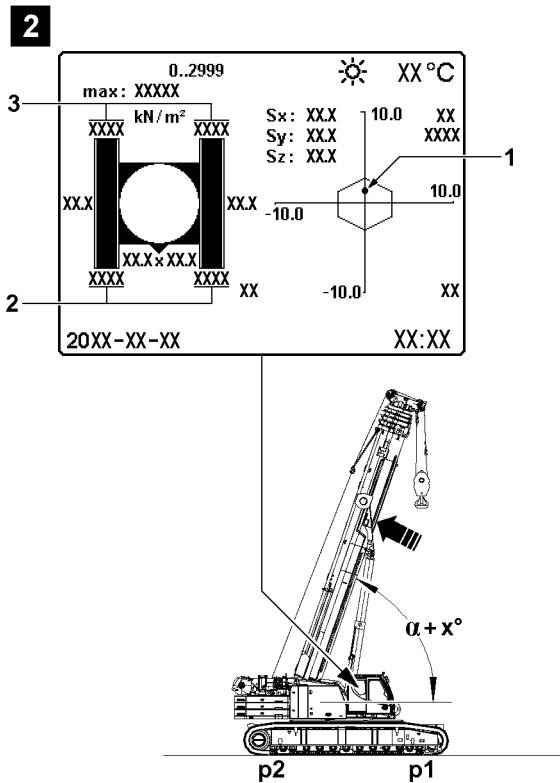
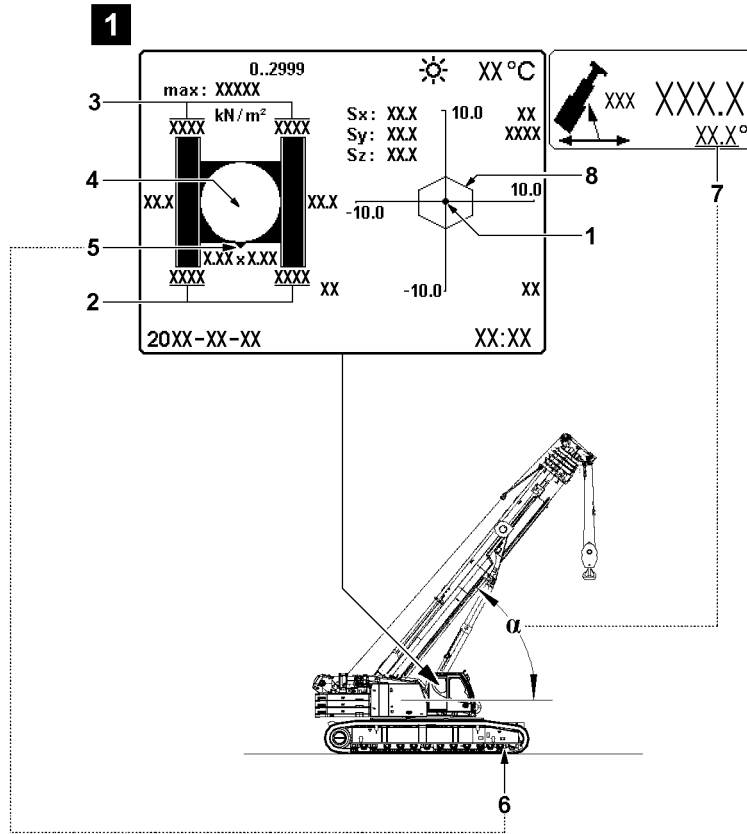


Fig.121102



## 3.2 Suitable distribution of the surface pressure

For the suitable distribution of the surface pressure, the following applies:

- p1 = Surface pressure on the side of the crawler travel gear with the lower load
- p2 = Surface pressure on the side of the crawler travel gear with the higher load

Distribution of surface pressure p1 to p2			
p1	/	p2	= Should be greater than 0.3

In case of unfavorable distribution of surface pressure it is required to position the boom system in such a way that a suitable distribution of the surface pressure is reached for driving.

- ▶ The turntable should be turned while at a standstill: The boom system should be luffed in such a way that the crawlers are subjected to a load as evenly as possible.
- ▶ Driving uphill: The boom system should be luffed in such a way that the side of the crawler travel gear which has less of a load is on the rear.
- ▶ Driving downhill: The boom system should be luffed in such a way that the side of the crawler travel gear which has less of a load is on the front.

## 3.3 Steering ability



### Note

High load on the crane

When driving the crane, steering movements cause a high load on the crane travel gear.

- ▶ If possible, do not make any steering movements with a load on the hook.
- ▶ Select the travel route in such a way that no steering movements are required.
- ▶ If not otherwise possible, before initiating a steering movement, set down the load.

The steering ability depends on the following factors:

- Friction conditions under the chains
- Evenness of the ground:
  - Steering is not possible if the track is only making contact with the ground in the front and rear.
- Load bearing capacity of the ground:
  - If the crawler travel gear sinks into the ground, then the steering ability is significantly restricted.
- Position of the total center of gravity:
  - If the total center of gravity - taking the suspended load into account - is at the center of the crane, then steering is hard or not possible at all.

Steering ability can be improved by:

- Placing metal sheeting, scattered sand or gravel, slight application of water.
- By taking the load bearing capacity of the ground and the position of the center of gravity into account: Changing the center of gravity.

## 4 Driving the crane: Load chart available



### WARNING

The crane can topple over!

If the following conditions are not observed, the crane can topple over.

Personnel can be severely injured or killed.

- ▶ The ground must be sufficiently level and within the range of the permissible inclination.
- ▶ The ground must be able to safely absorb the maximum occurring surface pressure.

**WARNING**

The crane can topple over!

If the permissible inclinations of the load charts are exceeded when driving the crane, then the crane can topple over or be overloaded.

If the permissible wind speeds of the load charts are exceeded when driving, then the crane can topple over or be overloaded.

Personnel can be severely injured or killed.

- ▶ If the inclinations are too large then driving the crane is prohibited.
- ▶ If the wind speeds are too high then driving the crane is prohibited.

Permissible inclinations	
Overall inclination	See load charts

Permissible wind speeds	
Wind speed	See load charts

Driving with a load is possible under specifications of the load chart:

- The permissible inclinations from the load charts apply for driving.
- Take the maximum permissible wind speeds from the load charts.
- Take the maximum permissible driving speed from the following sections.

**WARNING**

Driving the crane with an active LMB stop!

If the crane is driven with an active LMB-Stop, then the crane can topple over or be overloaded.

- ▶ Drive the crane only when no LMB-Stop is active.

Make sure that the following prerequisite is met:

- No LMB stop (shut-off due to load momentum limitation) is active.

## 4.1 Driving with a load on the hook

**WARNING**

The crane can topple over!

If the load on the hook collides with the crane, the ground or obstacles when driving, then the crane can be damaged and topple over.

Personnel can be severely injured or killed.

- ▶ Make sure that the load does not collide with anything when driving.

**WARNING**

Danger of accident!

If the suspended load starts to swing, then the crane operator can lose control of the crane.

If the following prerequisites are not observed, the crane can topple over.

This could result in serious accidents.

- ▶ Do not exceed the maximum permissible driving speed.
- ▶ Avoid jerky driving movements.
- ▶ The attached load must be secured to prevent it from swinging. If oscillating movements should occur, set the load down on the ground as fast as possible. Observe the limit values of the load moment display while doing so.

Make sure that the following prerequisites are met:

- The permissible inclinations from the load charts are adhered to.
- The maximum permissible wind speeds from the load charts are adhered to.
- The travel speed may **not** exceed 0.1 m/s or 0.36 km/h.
- The attached load hangs freely.
- The attached load must be secured to prevent it from swinging up / back and forth.
- Keep the attached load close to the ground.
- Keep the attached load with a small boom radius.
- The boom length is reduced as much as the load case permits.

## 4.2 Driving without a load on the hook

Make sure that the following prerequisites are met:

- The crane is driving according to the inclinations from the load charts.
- Take the maximum permissible wind speeds from the load charts.
- The maximum travel speed is matched to the local conditions.
- The hook block is secured to prevent it from swinging back and forth.
- The boom is telescoped in as far as possible.

# 5 Driving the crane: No load chart is available



### WARNING

The crane can topple over!

If the following note is not observed, the crane can topple over.  
Personnel can be severely injured or killed.

- ▶ Driving uphill and downhill must always be anticipatory, with utmost caution and at the slowest speed.
- ▶ Drive at a right angle at the beginning of uphill and downhill inclines (for example ramps), so that both crawler carriers evenly drive into the uphill or downhill incline.
- ▶ It is prohibited to let the crane tip over an edge.



### WARNING

The crane can topple over!

If the permissible incline of the crane is exceeded, the crane can topple over.

- ▶ Do not exceed the permissible incline for driving the crane.



### WARNING

The crane can topple over!

If the crane is driven outside the load chart with a load, accidents can occur.

The crane can topple over or be overloaded.

Personnel can be severely injured or killed.

- ▶ Driving the crane with a load outside the load chart is prohibited.

Make sure that the following prerequisites are met:

- There is no load on the hook.
- The boom is telescoped in as far as possible.
- The oil level of the crane engine is at the maximum fill level.
- The travel speed may **not** exceed 0.1 m/s or 0.36 km/h.
- The turntable is aligned and pinned parallel to the track, 0° or 180° position.
- The track is moved out and locked in the largest track width.
- The permissible lateral incline when driving without a load is adhered to.
- The permissible longitudinal inclination when driving without a load is adhered to.

Permissible incline		
Longitudinal incline less than / equal to 25°	at	Lateral incline less than / equal to 1°
Longitudinal incline less than / equal to 10°	at	Lateral incline less than / equal to 4°

## 5.1 Driving uphill / downhill



### WARNING

The crane can topple over!

If the following notes are not observed, the crane can topple over.

Personnel can be severely injured or killed.

- ▶ The deciding factor for driving on inclines is the exact knowledge of the operational conditions at the job site.
- ▶ Specifications, instructions and prerequisites in this chapter must be adhered to.
- ▶ Driving uphill / downhill must always be anticipatory, with utmost caution and at the slowest speed.
- ▶ Uphill / downhill inclines must be driven in the direction of the dip, never angularly to the incline.



### WARNING

The crane can topple over!

If the crane is driven with a load on uphill / downhill inclines, the crane can topple over.

If the crane is turned on uphill / downhill inclines, the crane can topple over.

If the angle of the boom system is not matched to the incline when driving the crane on inclines, then the crane can topple over.

- ▶ Match the angle of the boom system to the incline.
- ▶ Do not turn the crane on uphill / downhill inclines.
- ▶ Driving uphill with a load is prohibited.



### WARNING

The crane can topple over!

If the turntable is not parallel to the crawler travel gear when driving the crane on uphill or downhill inclines, then the crawler crane can topple over or be overloaded.

- ▶ For downhill inclines outside the load charts, make sure that the turntable is aligned parallel to the track (0° or 180° position) and pinned before moving the crawler crane.

Make sure that the following prerequisites are met:

- The turntable is aligned and pinned parallel to the track, 0° or 180° position.
- The track is moved out and locked in the largest track width.

There are two different possibilities for driving crawler cranes on uphill / downhill slopes:

- By adjusting the angle of the boom system.
- Without adjusting the angle of the boom system.

### 5.1.1 Maximum climbing ability

The maximum climbing ability of the crawler crane is limited by the following criteria:

- The location of the center of gravity for the complete crawler crane
- The friction coefficient between the road and track pads
- The transition between the horizontal and the uphill slope

### 5.1.2 Driving uphill / downhill by adjusting the angle of the boom system



**WARNING**

The crane can topple over!

If the limit values for the center of gravity and the surface pressure are exceeded, then the crane can topple over or be overloaded.

- ▶ Driving without display values for the center of gravity and the surface pressure is only permissible when the center of gravity and the surface pressure are otherwise monitored and ensured.



**Note**

Driving without display values for center of gravity and surface pressure!

- ▶ On level ground, set the optimum angle of the boom system regarding the center of gravity and the surface pressure.
- ▶ When driving into an uphill incline, during the transition between the horizontal into the incline, the original angle of the boom system must be changed continuously in such a way that the same angle ratio always remains between the boom system and the horizontal. This angle must be retained in the uphill incline.
- ▶ When driving out from an uphill incline, at the transition from incline to the horizontal, change the angle of the boom system continuously so that the same angle ratio is always retained.
- ▶ As a rule, the center of gravity and the surface pressure of the crane must be taken into account.

Make sure that the following prerequisites are met:

- On level ground, set the optimum angle of the boom system regarding the center of gravity and the surface pressure.
- If the telescopic boom must be telescoped out to do so, then in flattest boom position possible.
- On uphill / downhill inclines, as soon as the value of the displays for the center of gravity and the surface pressure become more unfavorable, match the boom angle in the permissible range.

#### Positive longitudinal incline



**Note**

- ▶ When driving on positive longitudinal inclinations (uphill), the main boom must usually be luffed down.

Status	Transition	Boom angle
Driving horizontally	To the uphill incline	match
Driving on the uphill incline		
Driving on the uphill incline	To the horizontal	match
Driving horizontally		

#### Negative longitudinal inclination



**Note**

- ▶ When driving on negative longitudinal inclinations (downhill), the main boom must usually be luffed up.

Status	Transition	Boom angle
Driving horizontally	To downhill	match
Driving downhill		
Driving downhill	To the horizontal	match
Driving horizontally		

LWE/LTR 1220-003/24204-02-02/en

### 5.1.3 Prerequisites for driving uphill / downhill without adjusting the angle of the boom system

The following specifications and instructions must be observed:

- Make sure that with the selected position of the boom system, the center of gravity and the surface pressure are within the permissible range. Possibly telescope the telescopic boom out in a flat position.



#### WARNING

The crane can topple over!

If the limit values for the center of gravity and the surface pressure are exceeded, then the crane can topple over or be overloaded.

Personnel can be severely injured or killed.

- ▶ Before driving onto uphill and downhill slopes, check the change of the center of gravity and the surface pressure and ensure that it is permissible.
- ▶ Before driving the crane, determine if the crane may drive on the intended route without adjusting the boom system.
- ▶ If the intended uphill / downhill slope cannot be driven without adjusting the angle of the boom system, then the boom angle must be adjusted to be able to drive on the uphill / downhill slope.

Make sure that the following prerequisites are met:

- With the selected position of the boom system, the center of gravity and the surface pressure is within the permissible range.
- If the telescopic boom must be telescoped out to do so, then in flattest boom position possible.

## 6 Crawler crane in crawler operation



#### WARNING

The crane can topple over!

The worn track reduces the stability of the crawler crane. Due to operational errors during crane operation or driving, the crawler crane can topple over and fatally injure personnel.

- ▶ Crane operation and „driving with a load on the hook“ is permitted for a retracted or asymmetric track if **extra load charts** are programmed for this case.
- ▶ Crane operation and „driving with a load on the hook“ is permitted for a retracted or asymmetric track if **no extra load charts are programmed for this case** is strictly prohibited.



#### WARNING

The crane can topple over!

If the permissible incline of the crane is exceeded, the crane can topple over.

In impermissible inclines, the LICCON computer system does **not** turn the travel operation off.

The crane driver carries the sole responsibility for possible risks or dangers when working with impermissible inclines.

- ▶ Do not exceed the permissible incline from the load chart.
- ▶ Do not exceed the permissible incline for driving the crane.
- ▶ While driving the crane, monitor the displays for center of gravity, surface pressure and inclination on the LICCON monitor constantly.

Make sure that the following prerequisites are met:

- The set up configuration of the crane has been entered correctly in the LICCON computer system.
- The displays for inclination, surface pressure and center of gravity are shown.
- There are no persons or objects in the danger zone.

Empty page!

LWE/LTR 1220-003/24204-02-02/en

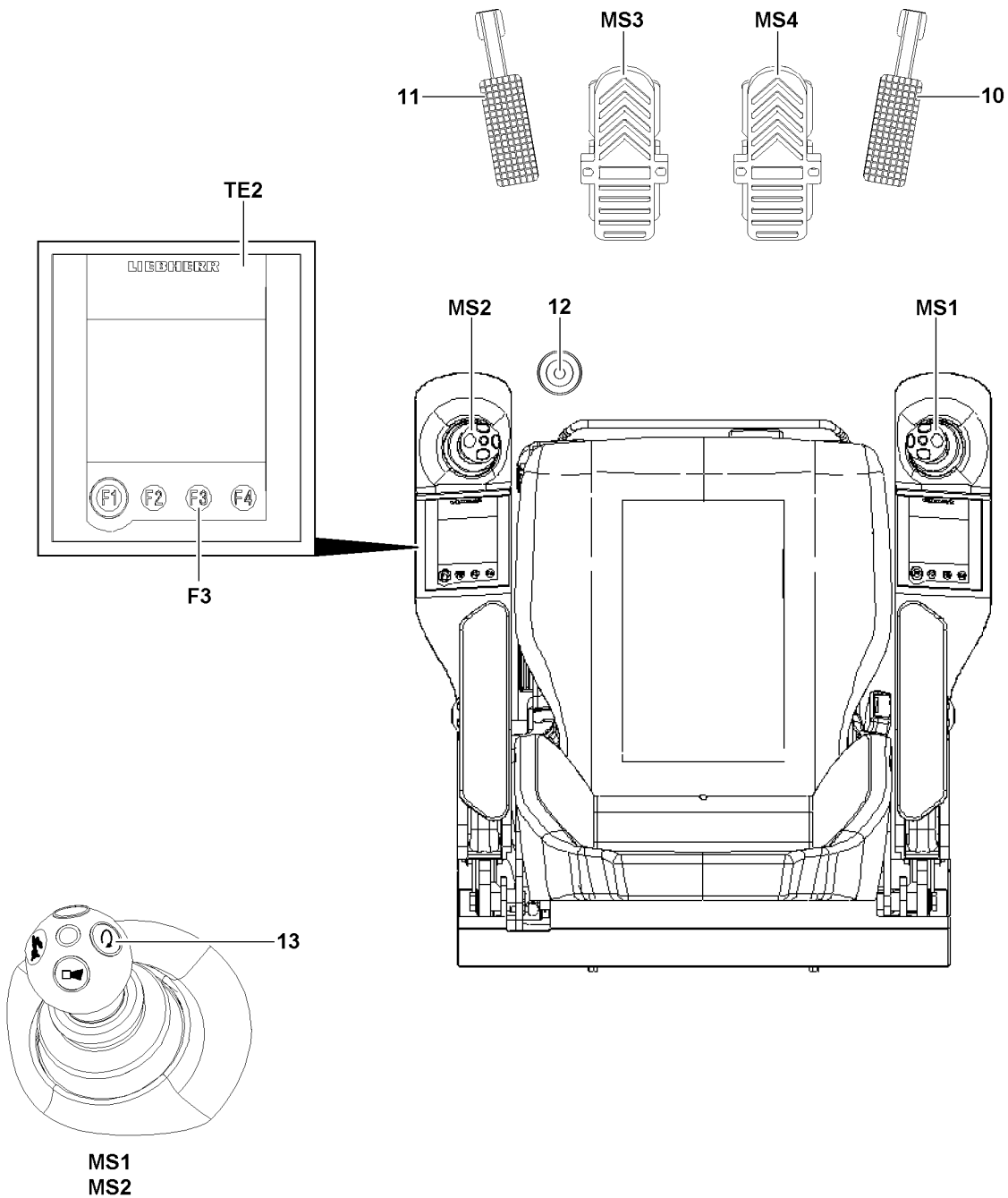


Fig.117921



## 6.1 Operating elements for the crawler operation



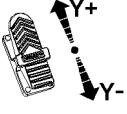
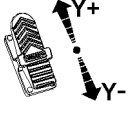
**Note**

Variable low idle rpm (only present on certain crane types)

- ▶ If no hydraulic power is required, the engine rpm is automatically reduced to approx. 600 rpm. If hydraulic power is required, the engine rpm is automatically increased to at least 850 rpm.

### 6.1.1 Pedal carrier

- **10** Pedal for engine regulation
- **11** Slewing gear brake pedal
- **12** Foot button for freewheeling slewing gear
  - **Note:** The foot button for freewheeling slewing gear **12** is only available on certain crane types.
- **MS3** Foot rocker
- **MS4** Foot rocker

Crawler operating mode	Pedal carrier	
	 Foot rocker <b>MS3</b>	 Foot rocker <b>MS4</b>
<b>Normal travel</b>	Left crawler forward / backward: <b>MS3</b> direction <b>Y+ / Y-</b>	Right crawler forward / backward: <b>MS4</b> direction <b>Y+ / Y-</b>
<b>Parallel travel</b>	Steer both crawlers: <b>MS3</b> direction <b>Y+ / Y-</b>	Forward / backward both crawlers: <b>MS4</b> direction <b>Y+ / Y-</b>

### 6.1.2 Engine regulation

The rpm of the crane engine is controlled with the engine regulation pedal **10**. For crawler operation, a certain rpm can be locked in, see the Crane operating instructions, chapter 4.05.

- ▶ Lock the current rpm of the crane engine: Press the button **13** on master switch **MS1** or master switch **MS2**.

**Result:**

- A „+“ appears on the LICCON monitor behind the rpm display.
- The current rpm of the crane engine is locked.
- The rpm can be increased further via the engine regulation pedal **10**.

- ▶ Release the rpm lock: Press the button **13** on master switch **MS1** or master switch **MS2** again.

**Result:**

- The „+“ behind the rpm display turns off.

LWE/LTR 1220-003/24204-02-02/en

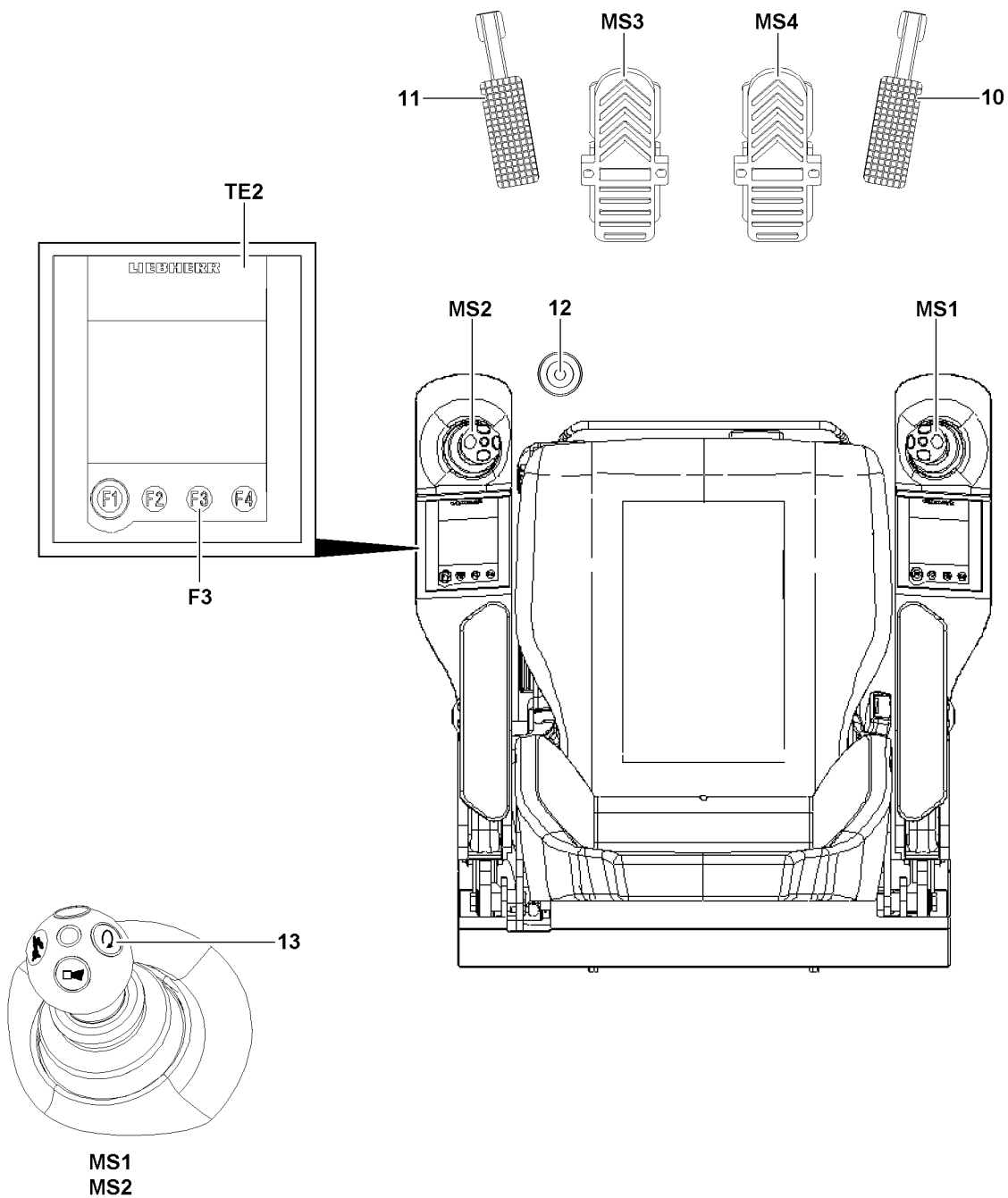


Fig.117921

LWE/LTR 1220-003/24204-02-02/en

### 6.1.3 Slewing gear brake

Slewing gear brake operating elements:



- **11** Slewing gear brake pedal
  - **12** Foot button for freewheeling slewing gear
    - Note: The foot button for freewheeling slewing gear **12** is only available on certain crane types.
  - Key **F3**: Slewing gear brake in TE2 (parking brake)
- ▶ Regulate the slewing gear brake steplessly: Press down the slewing gear brake pedal **11**.

**Result:**

- The slewing gear brake is regulated according to the pedal position: The further the pedal is pressed down, the stronger the slewing gear brake brakes.
- ▶ Adding the freewheeling for the slewing gear (only on crane types with respective foot button): Actuate the foot button for freewheeling the slewing gear **12**.

**Result:**

- Freewheeling the slewing gear is engaged as long as the foot button for freewheeling the slewing gear **12** is pressed down.

Icon	Assignment TE2 main menu: Slewing gear
	Nominal status slewing gear brake released, icon remains even when the slewing gear brake is applied with the slewing gear brake pedal <b>11</b>
	Nominal status slewing gear applied, icon remains even when the slewing gear brake is automatically released by the control

- ▶ Apply the slewing gear brake (parking brake): Press the button **F3** on touch display 2 **TE2**.

**Result:**

- The „Slewing gear brake applied“ icon appears.
- ▶ Release the slewing gear brake (parking brake): Press the button **F3** on touch display 2 **TE2** again.

**Result:**

- The „slewing gear brake released“ icon appears.

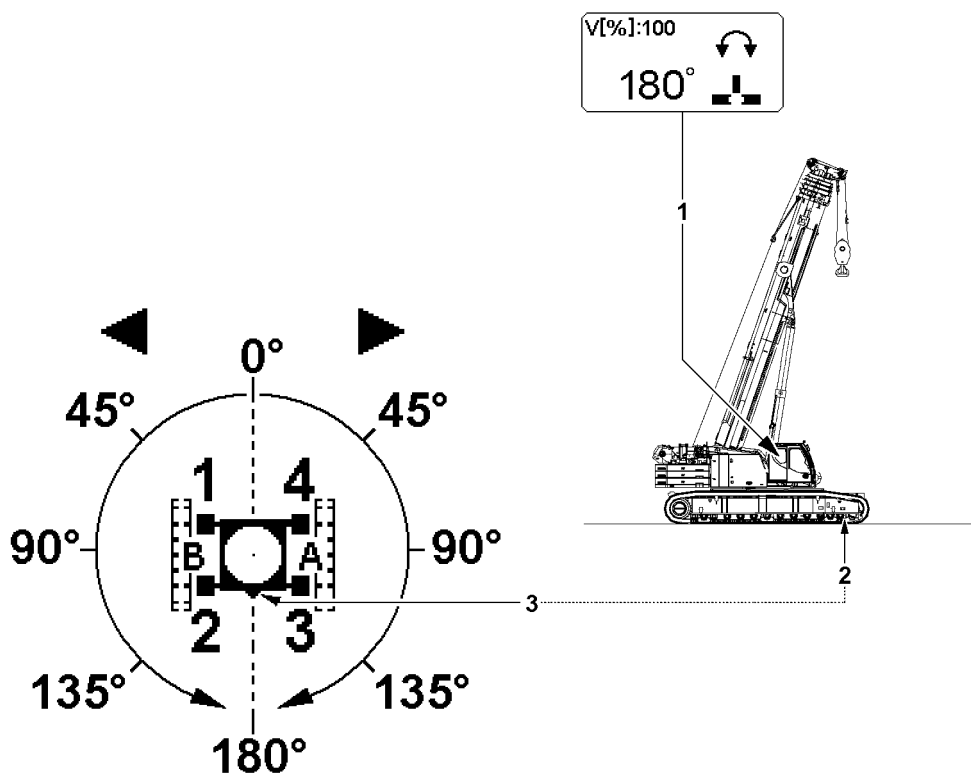


Fig.117923

LWE/LTR 1220-003/24204-02-02/en

## 6.2 Assignment of the crane superstructure to the travel direction

The travel direction of the crane is continuously assigned to the position of the crane superstructure.

The position of the crane superstructure with respect to the crawler travel gear can be read with one glance on the slewing range icon **1**:

- At display value 180° in slewing range icon **1** the crane superstructure is exactly in the „forward“ position, see illustration.
- **Note:** The front on the crawler travel gear is always on the side where the chain tension device **2** for the crawler carriers is located. In the LICCON view of the crawler travel gear, the front side is marked by a directional triangle **3**.
- With display value 0° in the slewing range icon **1** the crane superstructure is exactly in position „to the rear“.
- The apex for the assignment of the crane superstructure is at display value 90° in the slewing range icon **1**. At display values from 0° to 90° the crane superstructure is positioned „to the rear“. At display values from 90° to 180° the crane superstructure is positioned „to the front“.
- If the crane superstructure is swung over / under the display value 90° in the slewing range icon **1**, then the running direction of the crawler carriers changes to actuation direction of the foot rockers. The change happens only when the foot rockers are in position 0 (not actuated).
- If the crane superstructure is swung while driving over / under the display value 90° in the slewing range icon **1**, then the running direction of the crawler carriers and therefore the travel direction remains until the respective foot rocker is „returned“ to the zero position.  
The new assignment of the travel direction becomes only active after the foot rockers are next time in position 0 (not actuated).



### WARNING

Change of travel direction after turning the crane superstructure!

If the crane superstructure is swung while driving over / under the display value 90° in the slewing range icon **1**, then the running direction of the crawler carriers only remains until the respective foot rocker is „returned“ to the zero position. If the foot rocker is actuated again in the same direction, the crane is driven in the opposite direction.

- ▶ When performing turning movements of the crane superstructure in connection with driving the crane, pay attention to the assignment of the crane superstructure to the travel direction.
- ▶ After turning the crane superstructure, check the travel route in both directions for persons and obstacles. Initiate travel movements with utmost caution.

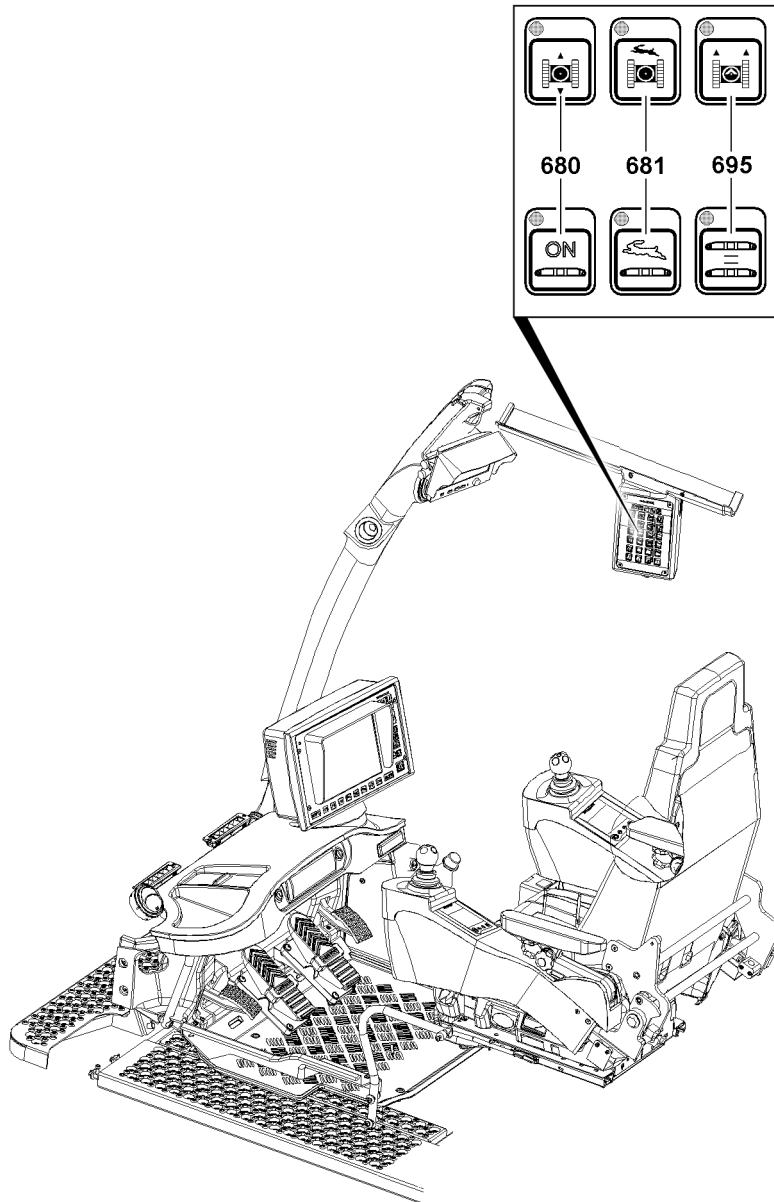


Fig.155682

LWE/LTR 1220-003/24204-02-02/en

### 6.3 Turning crawler operating modes on / off

The crawler crane can be driven with various crawler operating modes:

- Normal travel crawler operation.
  - Classic crawler operation, every crawler is controlled via a separate foot pedal.
- Parallel travel crawler operation
  - The steering movement is controlled by a separate foot pedal.
  - The travel direction is controlled by a separate foot pedal

To obtain a higher travel speed, the rapid gear can be activated.

#### 6.3.1 Turning normal travel crawler operation on / off

Normal travel crawler operation is the prerequisite to drive the crane and must generally be activated.

- ▶ Press the operating button **680**.

**Result:**

- The LED on the operating button **680 lights up**.  
Normal travel crawler operation is activated.

If the normal travel crawler operation is to be turned off:

- ▶ Press the operating button **680** again.

**Result:**

- The LED on the operating button **680 does not light up**.  
The crawler operation is turned off, the crane can no longer be driven.

#### 6.3.2 Turning parallel travel crawler operation on / off

Make sure that the following prerequisites are met:

- Normal travel crawler operation is activated.
- The tracks are at a standstill.

- ▶ Press the operating button **695**.

**Result:**

- The LED on the operating button **695 lights up**.  
The parallel travel crawler operation is turned on.

If the parallel travel crawler operation is to be turned off:

- ▶ Press the operating button **695** again.

**Result:**

- The LED on the operating button **695 does not light up**.  
Parallel travel is turned off, normal travel crawler operation remains on.

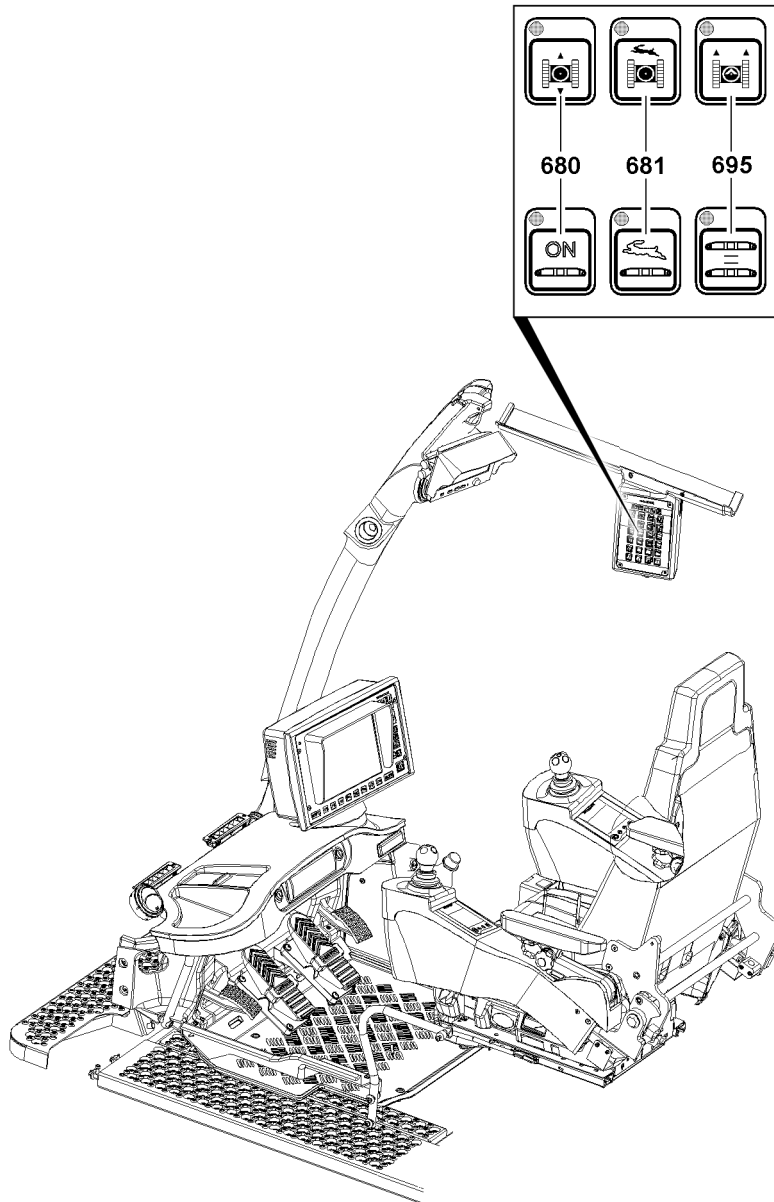


Fig.155682



### 6.3.3 Turning the rapid gear on / off



#### WARNING

The crane can topple over!

If the crane is driven in rapid gear with a load, then the crane can topple over. Personnel can be severely injured or killed.

- ▶ Observe the permissible highest speeds for driving the crawler crane.

Make sure that the following prerequisite is met:

- Normal travel crawler operation is activated
- or**
- the parallel travel crawler operation is turned on.

- ▶ Press the operating button **681**.

#### Result:

- The LED on the operating button **681 lights up**.  
The rapid gear is turned on, no higher travel speeds can be obtained.

If the rapid gear is to be turned off:

- ▶ Press the operating button **681** again.

#### Result:

- The LED on the operating button **681 does not light up**.  
The rapid gear is turned off, the normal travel crawler operation or parallel travel crawler operation remains activated.

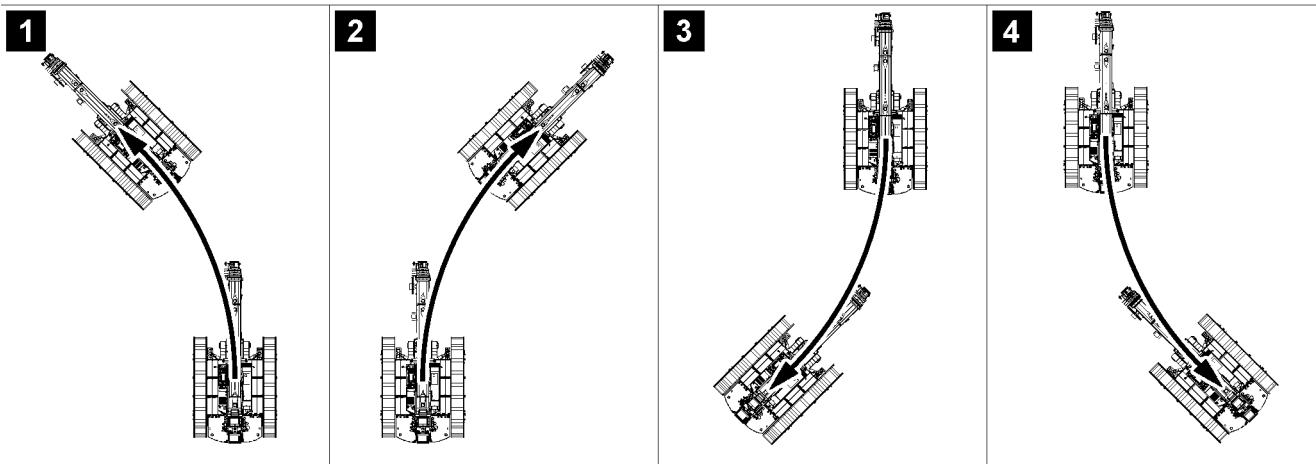
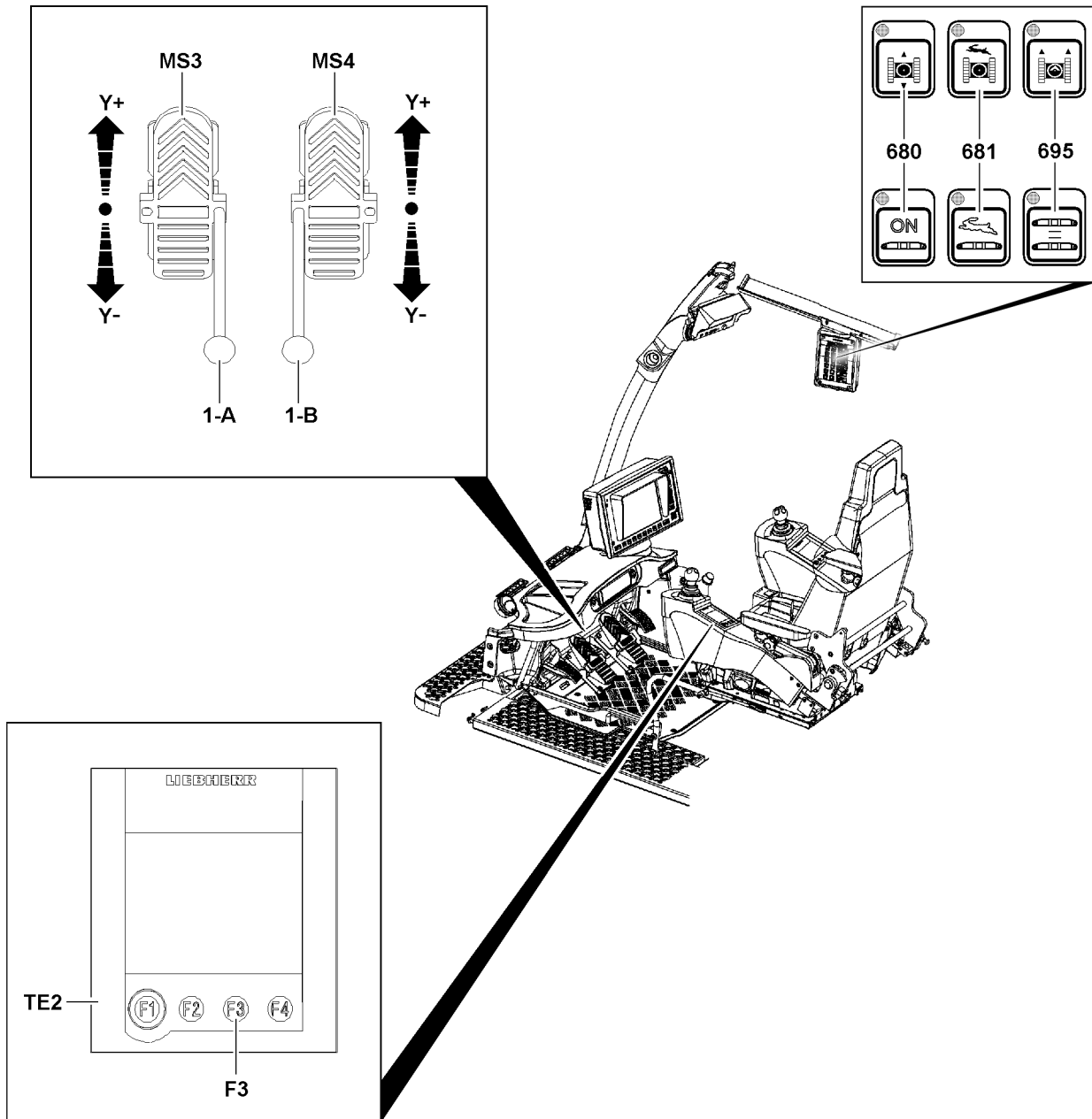


Fig.155683

LWE/LTR 1220-003/24204-02-02/en

## 6.4 Driving the crawler crane in normal travel

### NOTICE

Increased wear on the crawler travel gear!

When steering in small radii, high friction forces are created that lead to increased wear.

- ▶ If possible, always drive in curves with large radii.
- ▶ Avoid turning over a stationary track, if possible.
- ▶ Avoid turning on the spot, if possible.

Make sure that the following prerequisites are met:

- A travel direction change may only be done from the standstill.
- The desired rpm of the crane engine is set.
- Normal travel crawler operation is selected.



### Note

- ▶ The special hand lever **1-A** and hand lever **1-B** can be inserted into the foot rockers. These hand levers **1-A** and hand levers **1-B** are used for delicate driving maneuvers.
- ▶ Hand lever **1-A** and hand lever **1-B** are placed in the transport retainer on the left of the crane operator's seat.
- ▶ The technical version of the hand lever **1-A** and the hand lever **1-B** is completely identical. The differentiation of the two hand levers refers only in their assignment to the corresponding foot rockers in the assembled (connected) condition.

### 6.4.1 Driving forward

- ▶ Deflect the left foot rocker **MS3** and the right foot rocker **MS4** synchronously to the front (direction **Y+**).

#### Result:

- The crane drives forward.

### 6.4.2 Driving in reverse

- ▶ Deflect the left foot rocker **MS3** and the right foot rocker **MS4** synchronously to the rear (direction **Y-**).

#### Result:

- The crane drives backward.

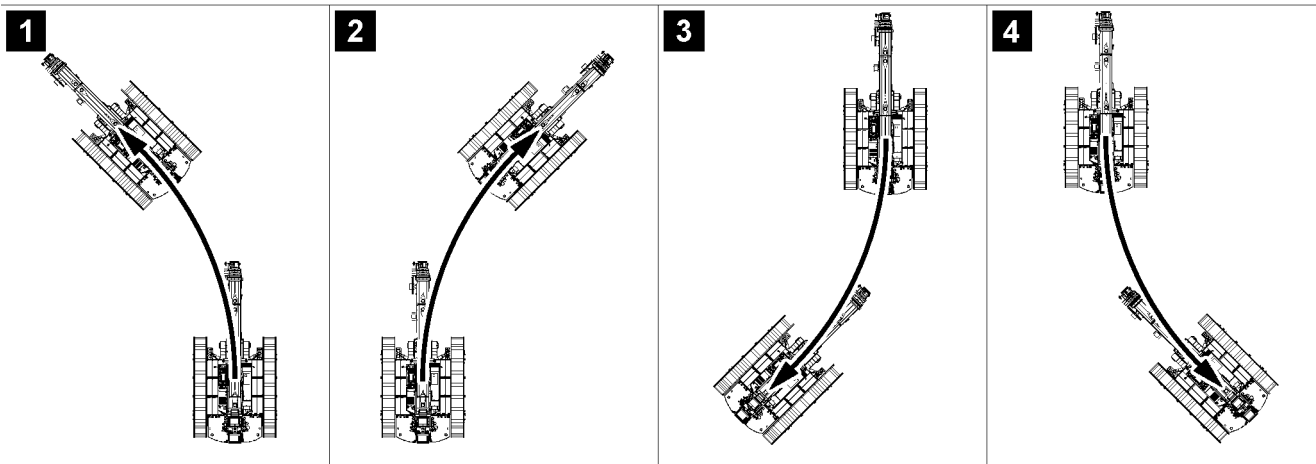
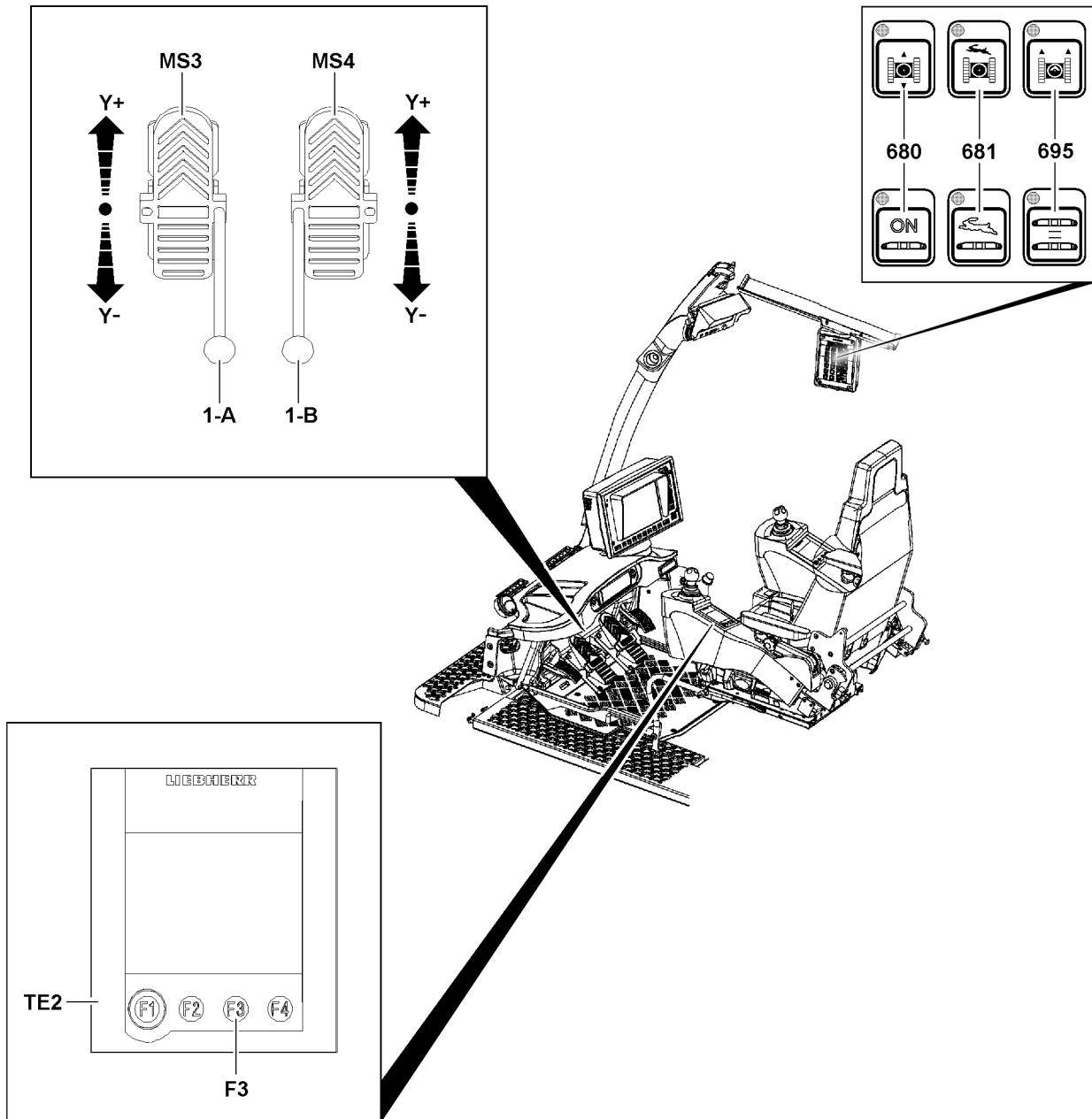


Fig.155683

LWE/LTR 1220-003/24204-02-02/en

### 6.4.3 Driving in curves forward to the left

See illustration 1.

- ▶ Actuate the left foot rocker **MS3** reduced to the front (direction **Y+**) and the right foot rocker **MS4** stronger to the front (direction **Y+**).

**Result:**

- The crane drives a forward curve to the left.

### 6.4.4 Driving in curves forward to the right

See illustration 2.

- ▶ Actuate the left foot rocker **MS3** stronger to the front (direction **Y+**) and the right foot rocker **MS4** reduced to the front (direction **Y+**).

**Result:**

- The crane drives a forward curve to the right.

### 6.4.5 Driving in curves in reverse to the left

See illustration 3.

- ▶ Actuate the left foot rocker **MS3** reduced to the rear (direction **Y-**) and the right foot rocker **MS4** stronger to the rear (direction **Y-**).

**Result:**

- The crane drives a reverse curve to the left.

### 6.4.6 Driving in curves in reverse to the right

See illustration 4.

- ▶ Actuate the left foot rocker **MS3** stronger to the rear (direction **Y-**) and the right foot rocker **MS4** reduced to the rear (direction **Y-**).

**Result:**

- The crane drives a reverse curve to the right.

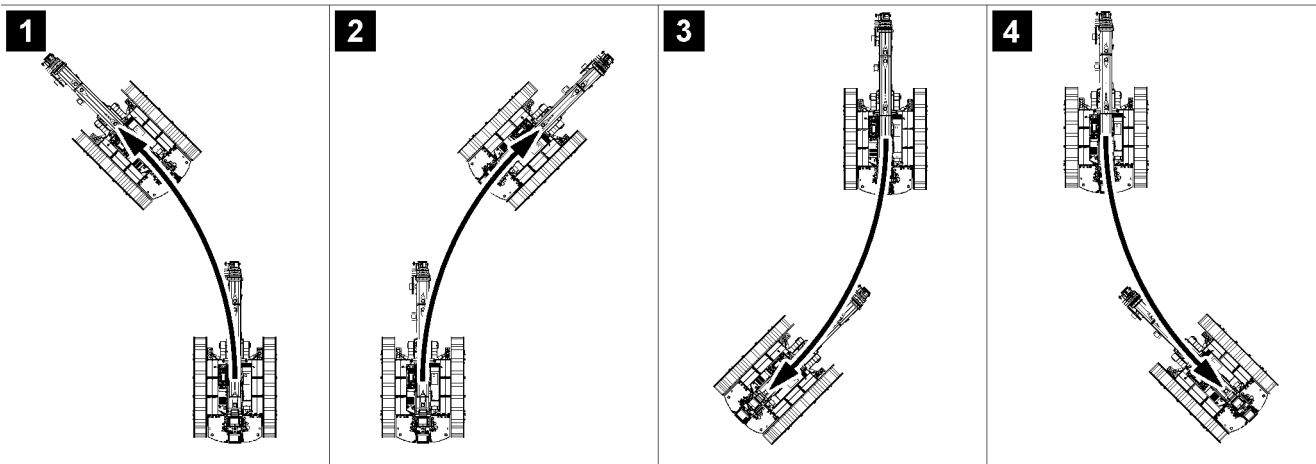
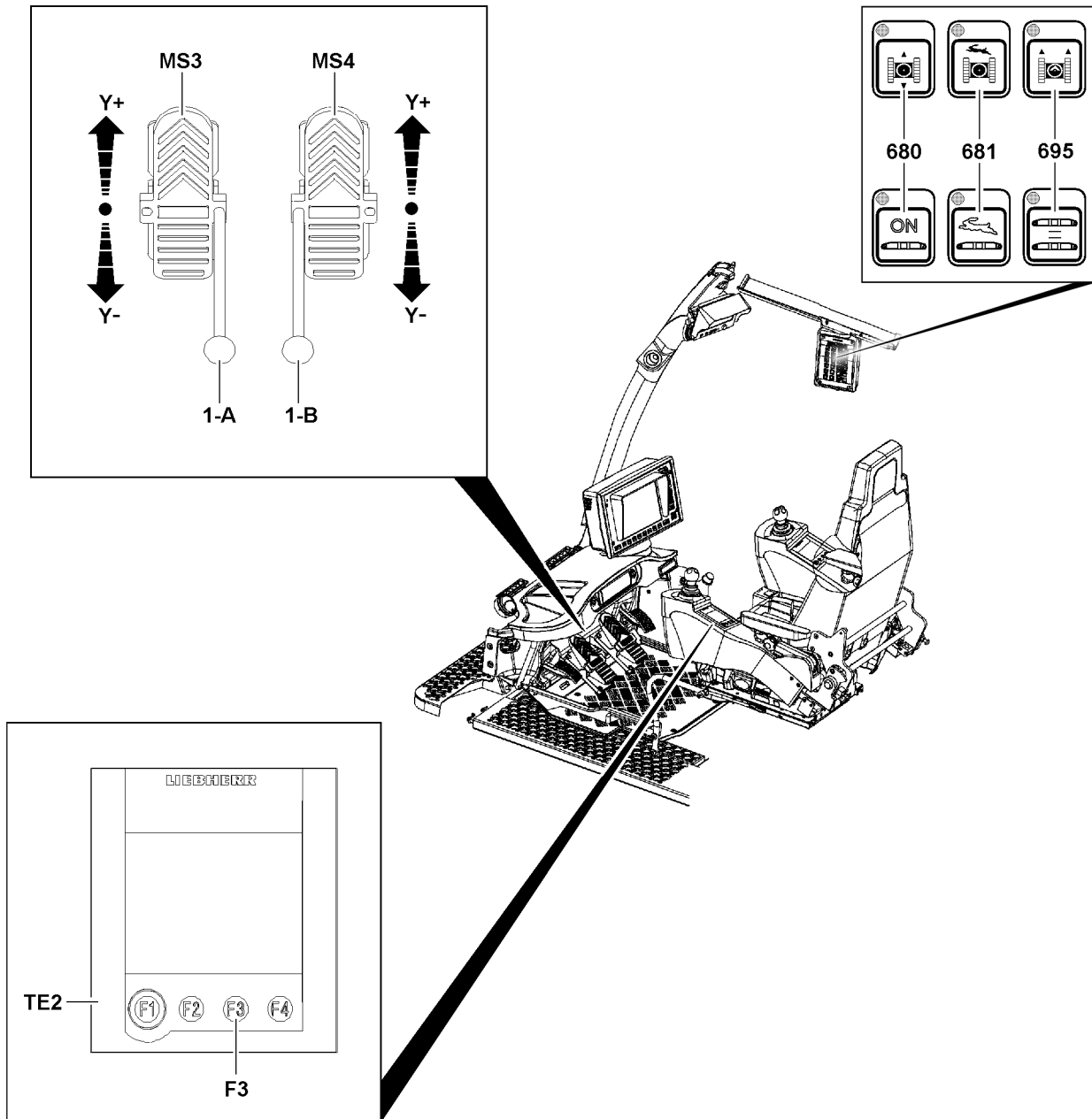


Fig.155683

LWE/LTR 1220-003/24204-02-02/en

### 6.4.7 Turning forward to the left

- ▶ Actuate the right foot rocker **MS4** forward (direction **Y+**).

**Result:**

- The crane is turned forward to the left.

### 6.4.8 Turning forward to the right

- ▶ Actuate the left foot rocker **MS3** forward (direction **Y+**).

**Result:**

- The crane is turned forward to the right.

### 6.4.9 Turning backward to the left

- ▶ Actuate the right foot rocker **MS4** backward (direction **Y-**).

**Result:**

- The crane is turned backward to the left.

### 6.4.10 Turning backward to the right

- ▶ Actuate the left foot rocker **MS3** backward (direction **Y-**).

**Result:**

- The crane is turned backward to the right.

### 6.4.11 Turning on the spot to the left (counterclockwise direction)

- ▶ Actuate the left foot rocker **MS3** to the rear (direction **Y-**) and the right foot rocker **MS4** to the front (direction **Y+**).

**Result:**

- The crane is turned to the left.

### 6.4.12 Turning on the spot to the right (clockwise)

- ▶ Actuate the left foot rocker **MS3** to the front (direction **Y+**) and the right foot rocker **MS4** to the rear (direction **Y-**).

**Result:**

- The crane is turned to the right.

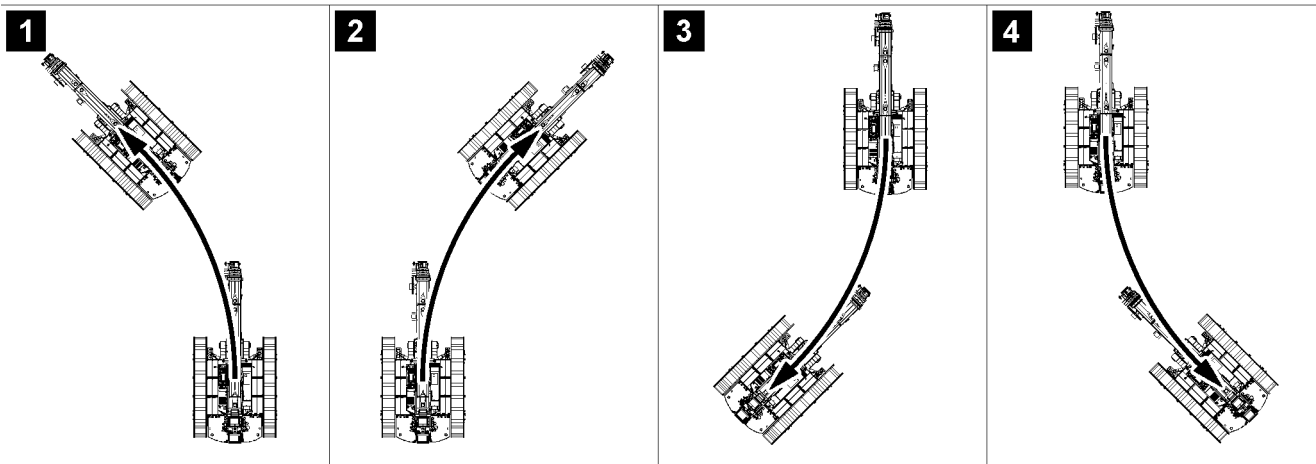
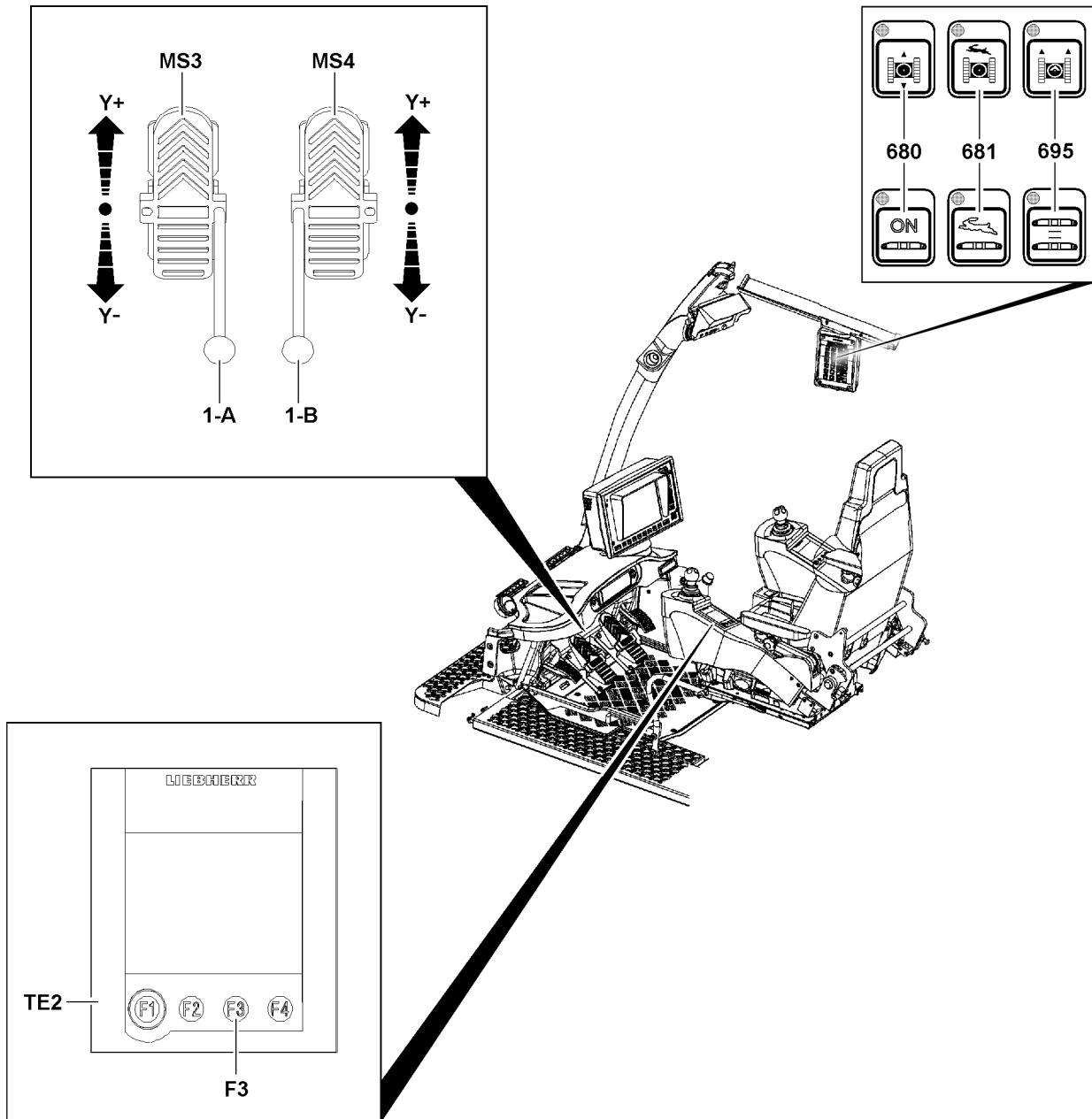


Fig.155683

LWE/LTR 1220-003/24204-02-02/en



## 6.5 Driving the crawler crane in parallel travel

### NOTICE

Increased wear on the crawler travel gear!

When steering in small radii, high friction forces are created that lead to increased wear.

- ▶ If possible, always drive in curves with large radii.
- ▶ Avoid turning over a stationary track, if possible.

Make sure that the following prerequisites are met:

- The desired rpm of the crane engine is set.
- The parallel travel crawler operation is selected.



### Note

- ▶ The special hand lever **1-A** and hand lever **1-B** can be inserted into the foot rockers. These hand levers **1-A** and hand levers **1-B** are used for delicate driving maneuvers. The operation is identical to that for the foot rockers.
- ▶ Hand lever **1-A** and hand lever **1-B** are placed in the transport retainer on the left of the crane operator's seat.
- ▶ The technical version of the hand lever **1-A** and the hand lever **1-B** is completely identical. The differentiation of the two hand levers refers only in their assignment to the corresponding foot rockers in the assembled (connected) condition.

Turning the crawler travel gear on the spot is not possible in parallel travel.

### 6.5.1 Driving forward

- ▶ Deflect the right foot rocker **MS4** forward (direction **Y+**).

#### Result:

- The crane drives forward.



### Note

- ▶ The further the foot rockers are actuated forward (direction **Y+**) the higher the speed.

### 6.5.2 Driving in reverse

- ▶ Deflect the right foot rocker **MS4** backward (direction **Y-**).

#### Result:

- The crane drives backward.



### Note

- ▶ The further the foot rockers are actuated forward (direction **Y+**) the higher the speed.

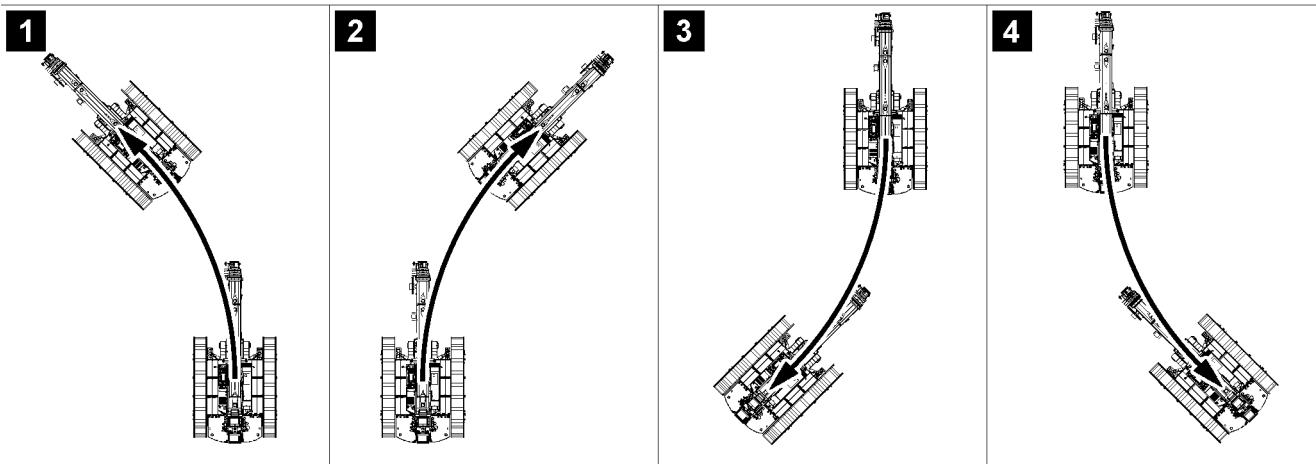
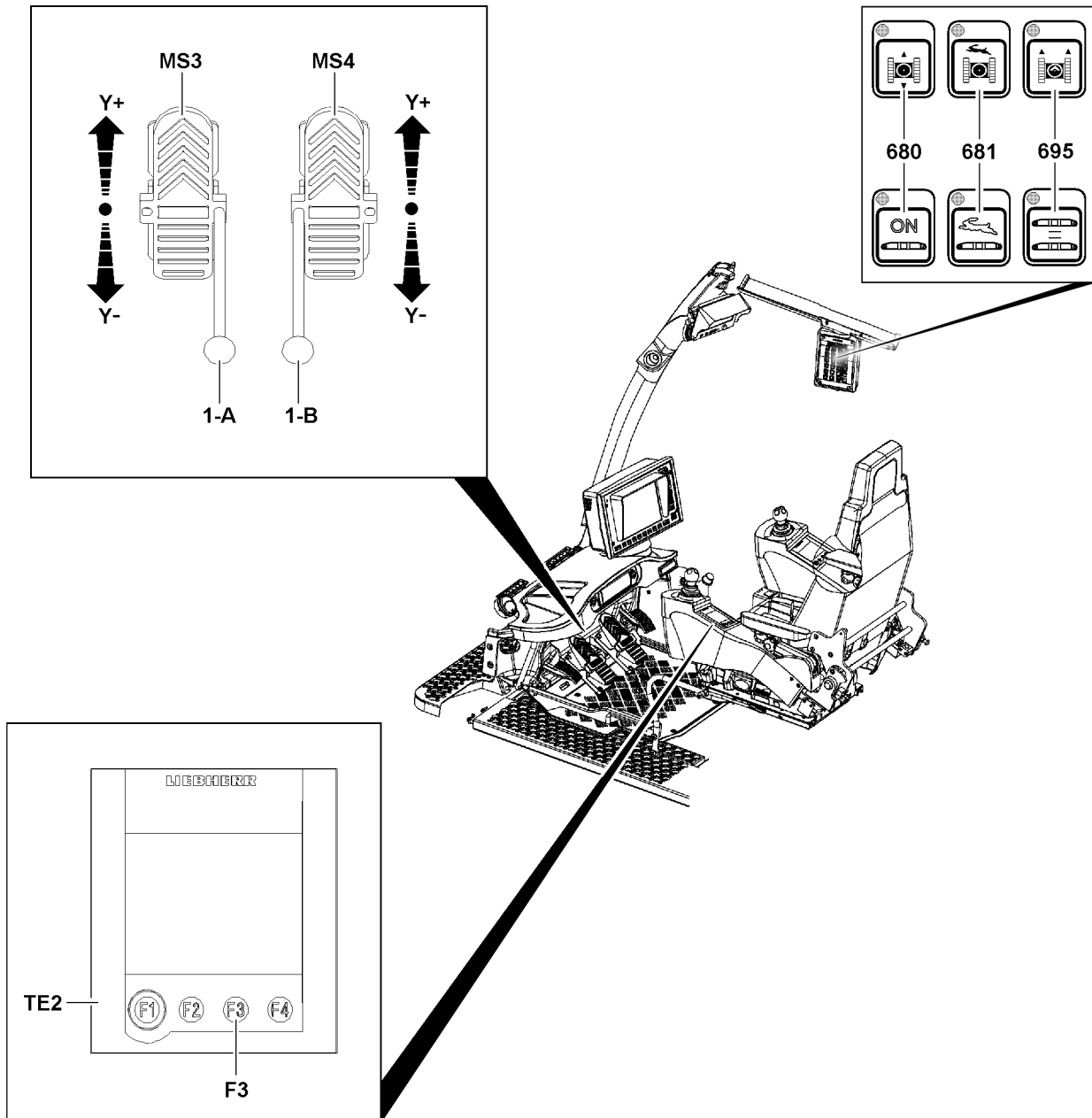


Fig.155683

LWE/LTR 1220-003/24204-02-02/en

### 6.5.3 Driving in curves forward to the left

See illustration 1.

- ▶ Actuate the left foot rocker **MS3** reduced to the rear (direction **Y-**) and the right foot rocker **MS4** to the front (direction **Y+**).

**Result:**

- The crane drives a forward curve to the left.



**Note**

- ▶ The further the right foot rocker **MS4** is actuated forward (direction **Y+**) the higher the speed of driving a curve.
  - ▶ If the left foot rocker **MS3** is pushed fully to the rear (direction **Y-**), the left crawler stops.
- 

### 6.5.4 Driving in curves forward to the right

See illustration 2.

- ▶ Actuate the left foot rocker **MS3** reduced to the front (direction **Y+**) and the right foot rocker **MS4** to the front (direction **Y+**).

**Result:**

- The crane drives a forward curve to the right.



**Note**

- ▶ The further the right foot rocker **MS4** is actuated forward (direction **Y+**) the higher the speed of driving a curve.
  - ▶ If the left foot rocker **MS3** is pushed fully to the front (direction **Y+**), the right crawler stops.
- 

### 6.5.5 Driving in curves in reverse to the left

See illustration 3.

- ▶ Actuate the left foot rocker **MS3** reduced to the rear (direction **Y-**) and the right foot rocker **MS4** to the rear (direction **Y-**).

**Result:**

- The crane drives a reverse curve to the left.



**Note**

- ▶ The further the right foot rocker **MS4** is actuated backward (direction **Y-**) the higher the speed of driving a curve.
  - ▶ If the left foot rocker **MS3** is pushed fully to the rear (direction **Y-**), the left crawler stops.
-

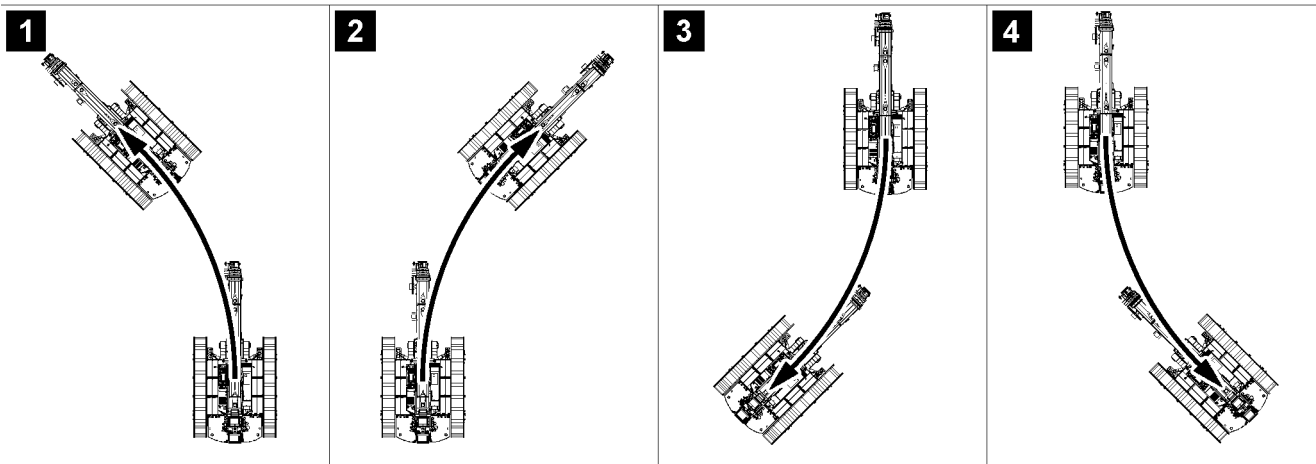
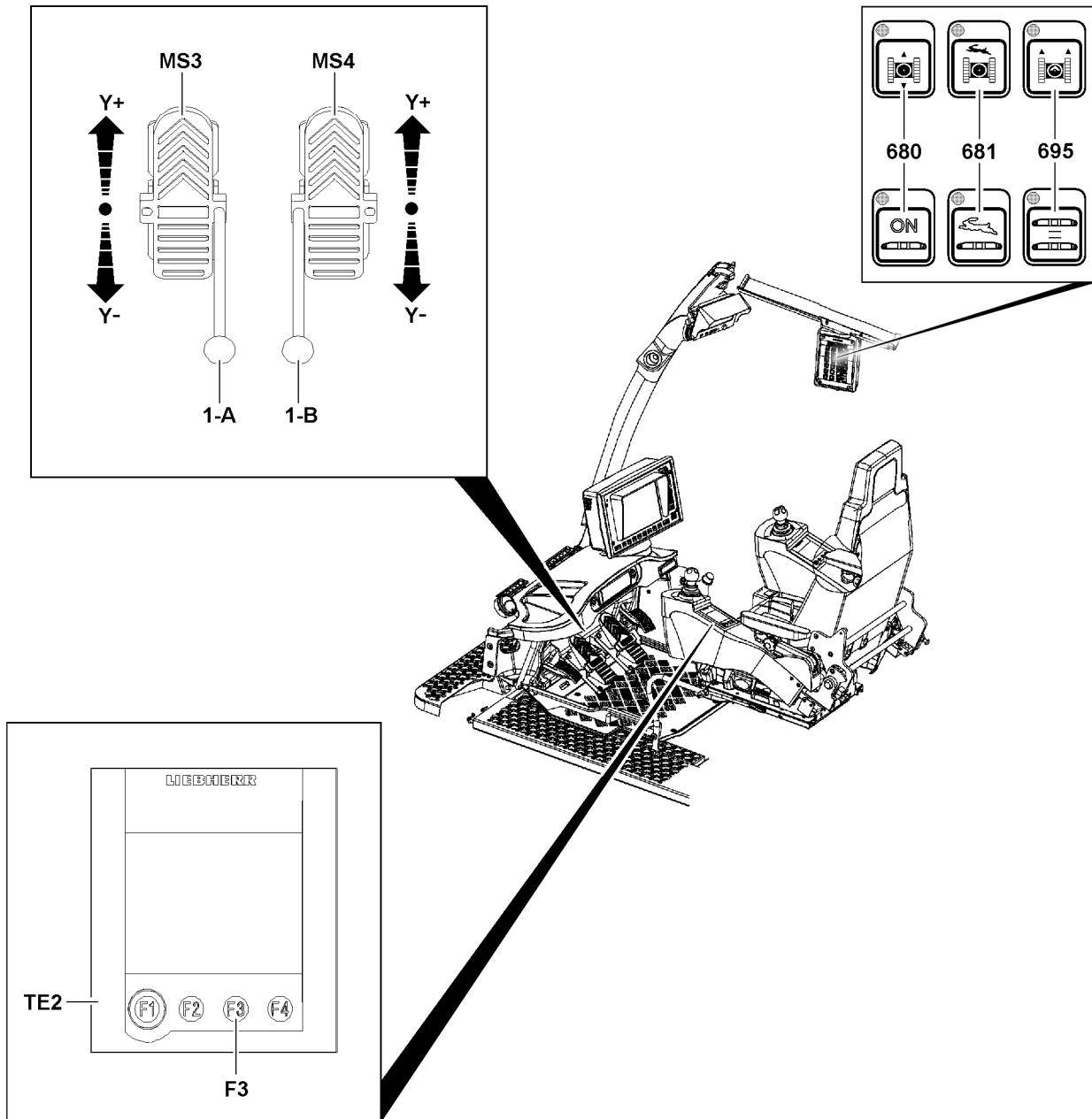


Fig.155683

LWE/LTR 1220-003/24204-02-02/en

### 6.5.6 Driving in curves in reverse to the right

See illustration 4.

- ▶ Actuate the left foot rocker **MS3** reduced to the front (direction **Y+**) and the right foot rocker **MS4** to the rear (direction **Y-**).

**Result:**

- The crane drives a reverse curve to the right.



**Note**

- ▶ The further the right foot rocker **MS4** is actuated backward (direction **Y-**) the higher the speed of driving a curve.
  - ▶ If the left foot rocker **MS3** is pushed fully to the front (direction **Y+**), the right crawler stops.
- 

### 6.5.7 Turning forward to the left

- ▶ Push through and hold the left foot rocker **MS3** fully to the rear (direction **Y-**).
- ▶ Actuate the right foot rocker **MS4** forward (direction **Y+**).

**Result:**

- The crane is turned forward to the left.



**Note**

- ▶ The further the right foot rocker **MS4** is actuated forward (direction **Y+**) the higher the speed of the turning movement.
- 

### 6.5.8 Turning forward to the right

- ▶ Push through and hold the left foot rocker **MS3** fully to the front (direction **Y+**).
- ▶ Actuate the right foot rocker **MS4** forward (direction **Y+**).

**Result:**

- The crane is turned forward to the right.



**Note**

- ▶ The further the right foot rocker **MS4** is actuated forward (direction **Y+**) the higher the speed of the turning movement.
-

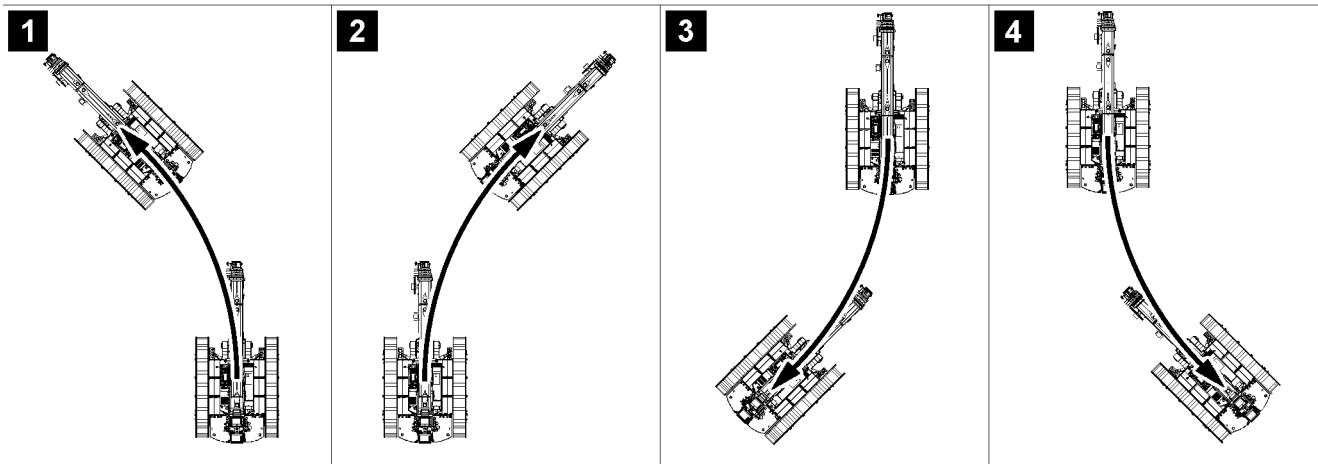
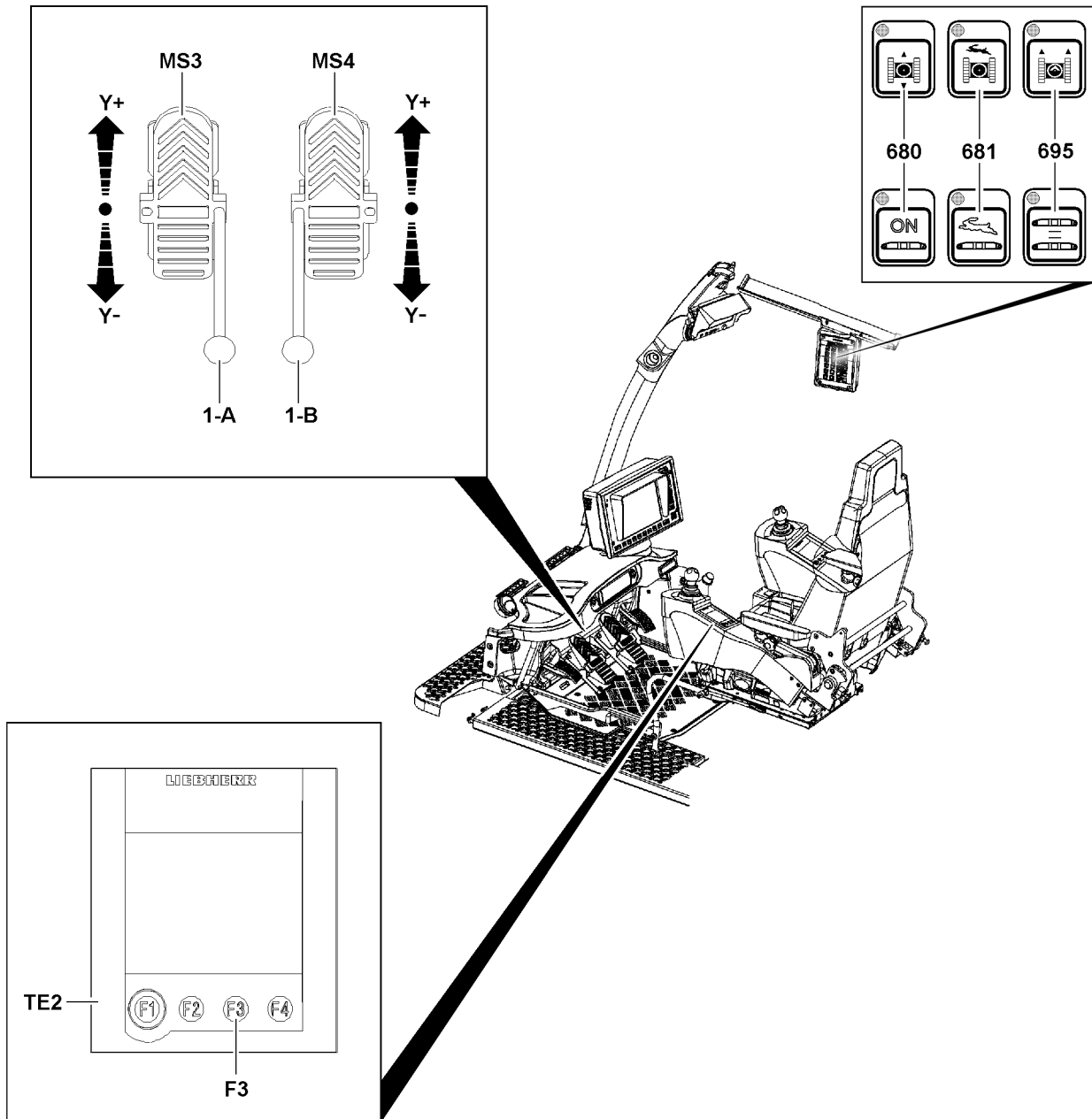


Fig.155683

LWE/LTR 1220-003/24204-02-02/en

### 6.5.9 Turning backward to the left

- ▶ Push through and hold the left foot rocker **MS3** fully to the rear (direction **Y-**).
- ▶ Actuate the right foot rocker **MS4** backward (direction **Y-**).

**Result:**

- The crane is turned backward to the left.



**Note**

- ▶ The further the right foot rocker **MS4** is actuated backward (direction **Y-**) the higher the speed of the turning movement.
- 

### 6.5.10 Turning backward to the right

- ▶ Push through and hold the left foot rocker **MS3** fully to the front (direction **Y+**).
- ▶ Actuate the right foot rocker **MS4** backward (direction **Y-**).

**Result:**

- The crane is turned backward to the right.



**Note**

- ▶ The further the right foot rocker **MS4** is actuated backward (direction **Y-**) the higher the speed of the turning movement.
-

---

Empty page!

LWE/LTR 1220-003/24204-02-02/en



## 4.12 Two hook operation

1	Auxiliary boom	3
2	Hook operation	7
3	Two hook operation monitored / Two hook operation not monitored	10
4	Safety instructions	11
5	Boom nose on telescopic boom	13
6	Auxiliary jib on the telescopic boom	14
7	Folding jib	15
8	Strong lattice jib	17
9	Fixed lattice jib	18
10	Boom nose on the fixed lattice jib	19
11	Auxiliary jib on the fixed lattice jib	21
12	Luffing lattice jib	22
13	Boom nose on the luffing lattice jib	23
14	Auxiliary jib on the luffing lattice jib	24
15	Lifting a joint load	26

*Fig.195219*

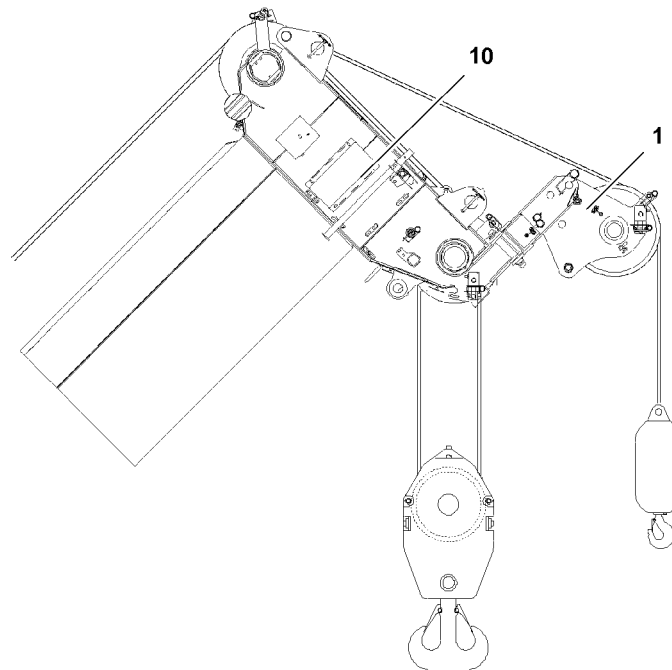
LWE/LTR 1220-003/24204-02-02/en

# 1 Auxiliary boom

A distinction is made between the following auxiliary booms:

- Boom nose on telescopic boom
- Boom nose on lattice jib
- Auxiliary jib
- Folding jib
- Strong lattice jib
- Fixed lattice jib
- Luffing lattice jib

## 1.1 Boom nose on telescopic boom



*Fig.120451: Boom nose 1 on telescopic boom*

- Short auxiliary boom as bracket
- Is assembled on the telescopic boom head **10**
- No proprietary load charts available
- Abbreviation: **M**

## 1.2 Boom nose on lattice jib

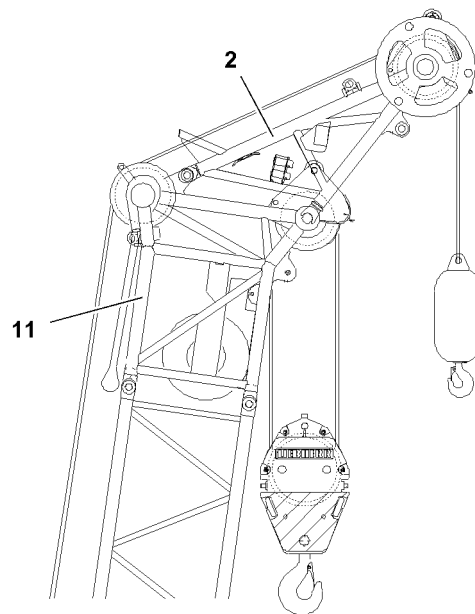


Fig.120452: Boom nose 2 on lattice jib

- Auxiliary boom as lattice structure
- Is assembled on the N-head 11
- No proprietary load charts available
- Abbreviation: **M**

## 1.3 Auxiliary jib

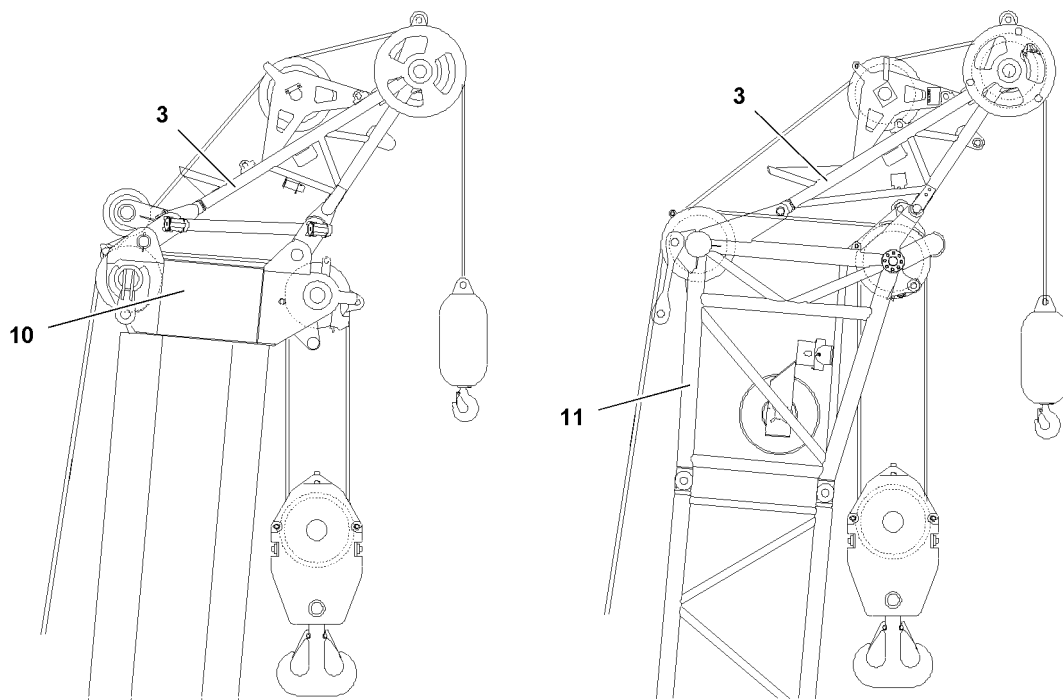
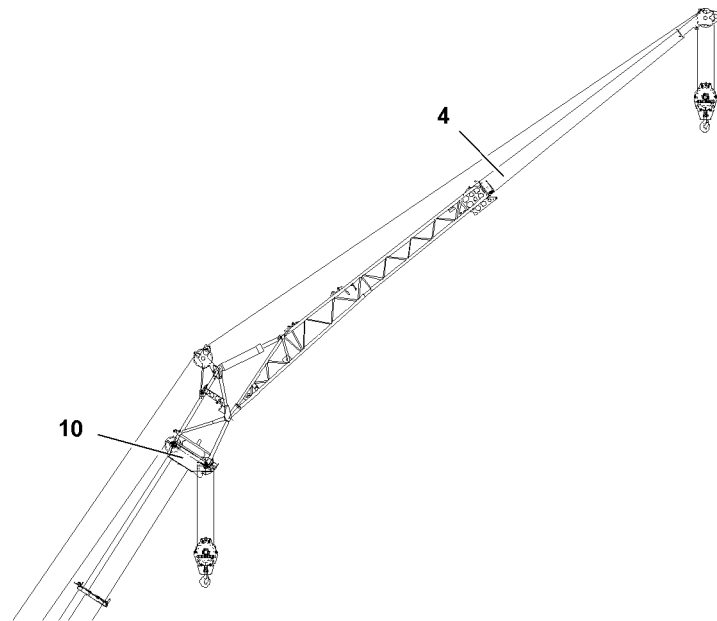


Fig.120453: Auxiliary jib 3

- Short auxiliary boom as lattice structure
- Is installed on the telescopic boom head 10 or N-head 11
- Proprietary load charts available

- Abbreviation: **H**

## 1.4 Folding jib



*Fig. 120454: Folding jib 4*

- Auxiliary boom as lattice or sheet metal structure
- Is assembled on the telescopic boom head **10**
- Proprietary load charts available
- Abbreviation: **K**

The following folding jib variations are possible:

- Special folding jib
- Single folding jib
- Double folding jib
- 3-part single folding jib
- 3-part double folding jib
- 4-part single folding jib
- 4-part double folding jib

## 1.5 Strong lattice jib

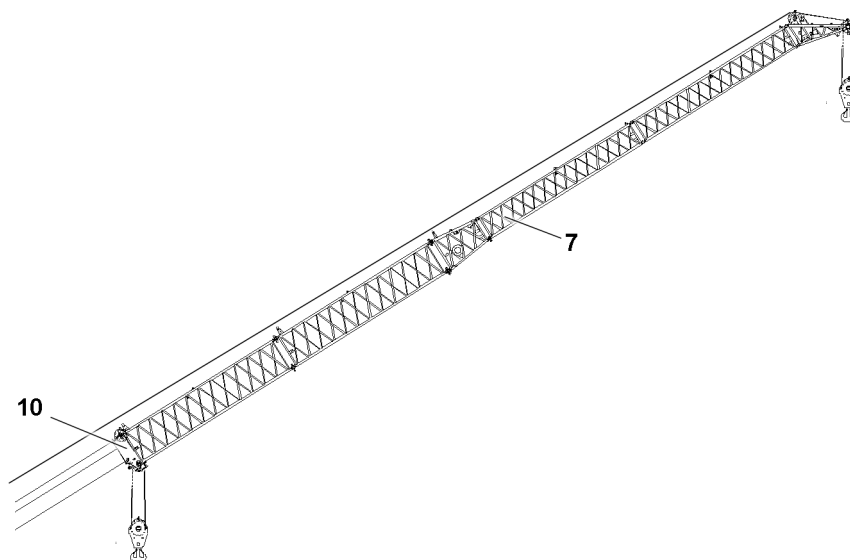


Fig.126099: Strong lattice jib 7

- Auxiliary boom in lattice structure
- Is assembled on the telescopic boom head **10**
- Proprietary load charts available
- Abbreviation: **S**

## 1.6 Fixed lattice jib

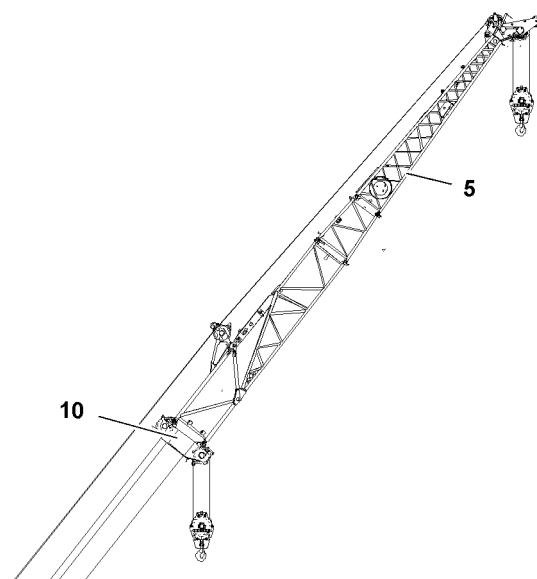


Fig.120455: Fixed lattice jib 5

- Auxiliary boom in lattice structure
- Is assembled on the telescopic boom head **10**
- Proprietary load charts available
- Abbreviation: **F**

## 1.7 Luffing lattice jib

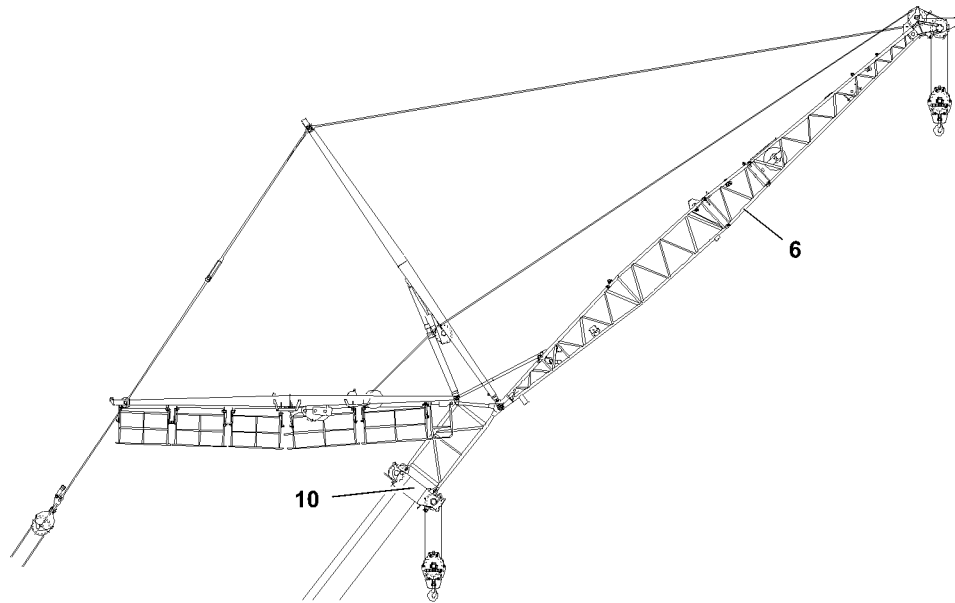


Fig.120456: Luffing lattice jib 6

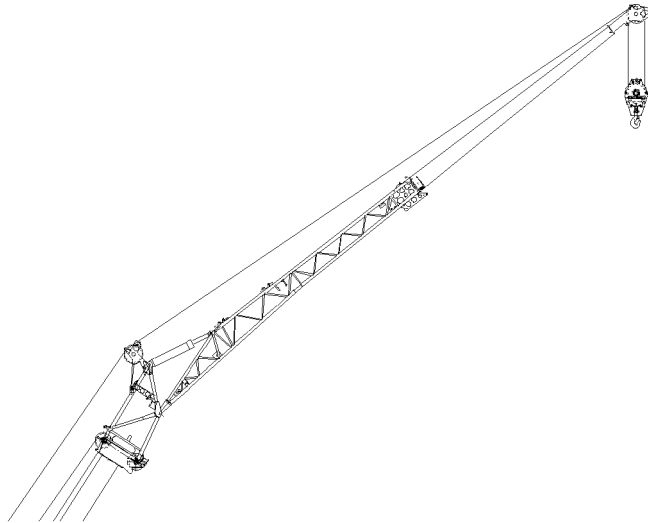
- Auxiliary boom as lattice structure with guying
- Is assembled on the telescopic boom head **10**
- Proprietary load charts available
- Abbreviation: **N**

## 2 Hook operation

A distinction is made between the following hook operating modes:

- Single hook operation
- Two hook operation
- Three hook operation
- Hook operation depending on the load

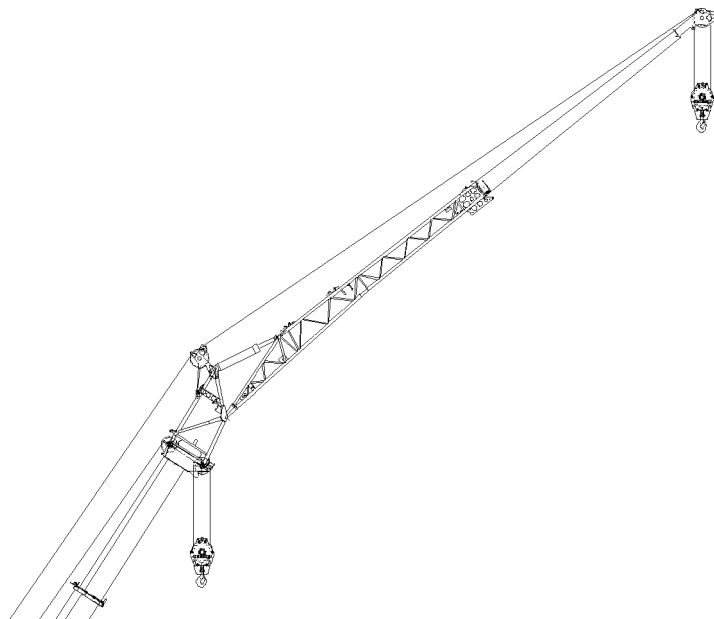
## 2.1 Single hook operation



*Fig.120458: Single hook operation*

**One hook is reeved on the boom.**

## 2.2 Two hook operation



*Fig.120459: Two hook operation*

**Two hooks are reeved on the booms. Number of loads and type of crane operation are not taken into account.**



## 2.3 Three hook operation

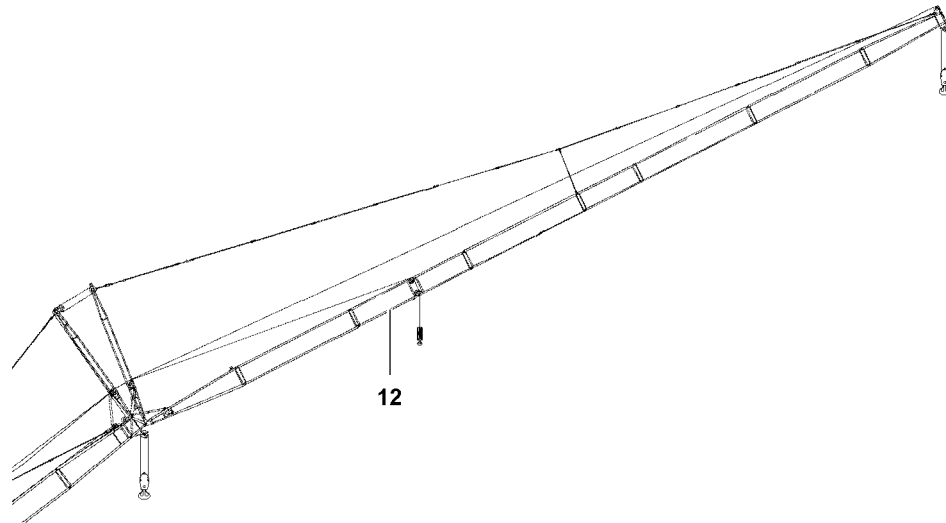


Fig.120457: Three hook operation

Three hooks are reeved on the booms. Number of loads and type of crane operation are not taken into account.



### Note

► Three hook operation is **not** possible on telescopic cranes.

## 2.4 Hook operation depending on the load

The following hook operating modes are differentiated depending on the load:

- Two hook operation on joint load
- Two hook operation on individual loads

### 2.4.1 Two hook operation on joint load

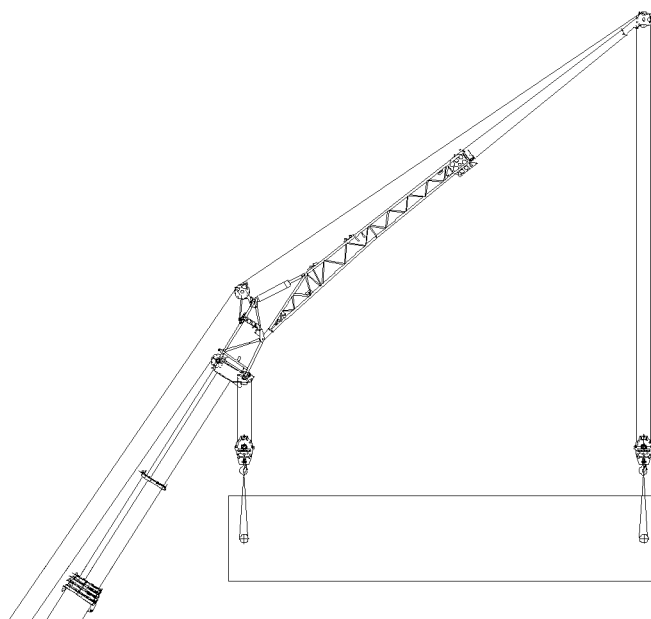


Fig.120460: Two hook operation on joint load

A joint load hangs on two hooks.

## 2.4.2 Two hook operation on individual loads

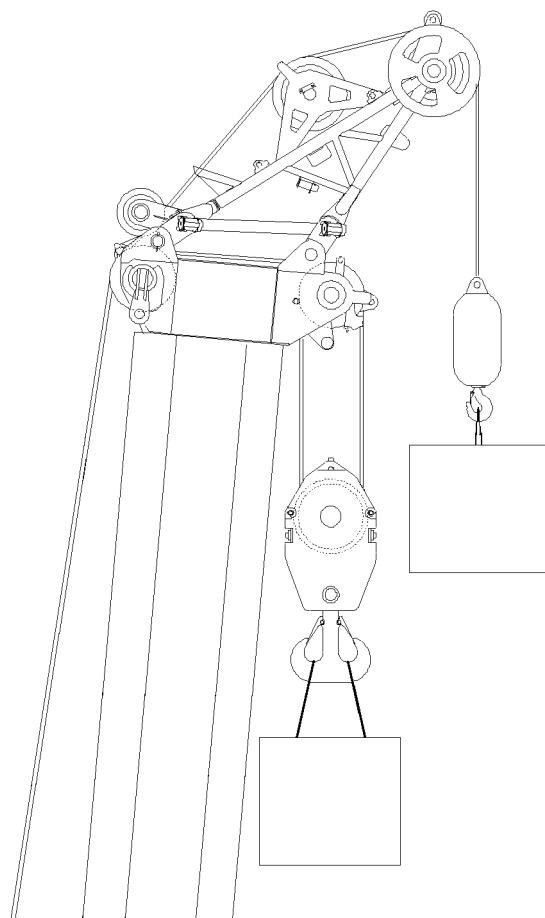


Fig.121508: Two hook operation on individual loads

Individual loads hang on individual hooks.

## 3 Two hook operation monitored / Two hook operation not monitored

The following is differentiated for two hook operation:

- Two hook operation monitored  
Two hook operation on joint load and on individual loads is monitored by the LICCON overload protection
- Two hook operation **not** monitored  
Two hook operation on joint load and on individual loads is **not** monitored by the LICCON overload protection

### 3.1 Two hook operation monitored

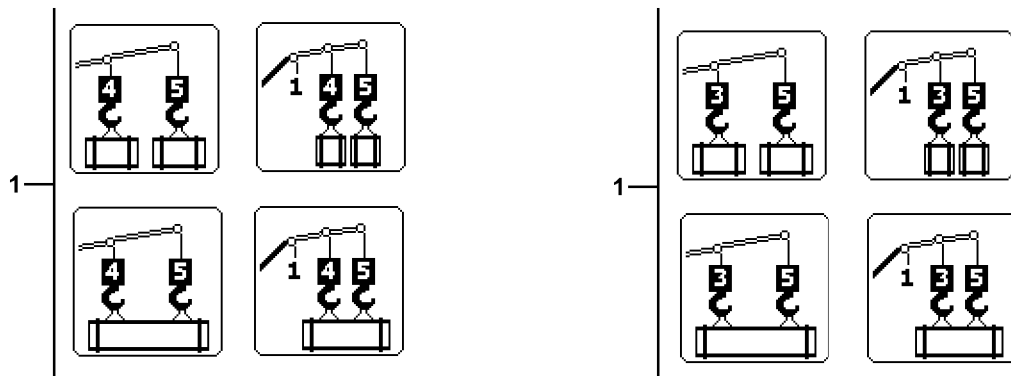


Fig.121109: Two hook operation monitored icons 1

For crane types, which are equipped with monitored two hook operation, the two hook operation can be selected in the Set up program. The monitored two hook operation is displayed by the two selectable icons 1.

### 3.2 Two hook operation not monitored

If two hook operation can **not** be selected in the Set up program, then two hook operation is **not** monitored.

## 4 Safety instructions



#### WARNING

Danger of accident if „two hook operation is **not** monitored“!

If „two hook operation is **not** monitored“ and both hooks are subjected to a load, then the boom can be overloaded when luffing down.

When both hooks are subjected to a load and are **not** monitored:

- ▶ Do not luff the boom down.



#### WARNING

Overload of crane!

Death, severe injuries, property damage.

- ▶ Only set up permissible hook operations.
- ▶ Lift and lower the load vertically.

When a hook is reeved on the telescopic boom:

- ▶ Do **not** carry out two hook operation with TY-guying and an eccentric or spacer.



#### WARNING

Overload of crane!

Death, severe injuries, property damage.

**If no load chart is available:**

- ▶ **Make sure that the total weight of the load(s) is less than / equal to the maximum permissible load of the auxiliary boom.**
- ▶ Two hook operation with load(s) heavier than the maximum permissible load of the auxiliary boom is prohibited.

**WARNING**

Overload of crane due to imprecise radius and load display!  
When no load chart is available, then the radius and load display is not exact.  
Toppling crane, death, property damage.

- ▶ Move the crane within the permissible utilization range.

**WARNING**

Incorrect reeving for two hook operation!

Overload of crane, death, property damage.

- ▶ Reeve in an auxiliary boom head smaller than / equal to the main boom head.
- ▶ Set the LICCON overload protection to reeving on the auxiliary boom head.

**WARNING**

Incorrect distance of fastening points!

Overload of crane, death, property damage.

For two hook operation on joint load:

- ▶ Place the fastening points according to the horizontal distance of both hooks.

**WARNING**

Danger of collision for two hook operation on joint load!

Falling load, death, property damage.

- ▶ Lift the load no higher than to the height of the main boom head.

**NOTICE**

Hoist rope of incorrect winch is reeved!

The hoist rope can drag and be damaged.

- ▶ Reeve in the hoist rope of winch 1 on the main boom head.
- ▶ Reeve in the hoist rope of winch 2 on the auxiliary boom head.

**Note**

Erection and take down charts not observed!

The boom system cannot be erected.

When erection and take-down charts are present:

- ▶ Observe and adhere to the Erection and take down charts.
- ▶ Only set up permissible operating modes.

Add the following weights to the load:

- Hook block on main boom head
- Hook block (load hook) on auxiliary boom head
- Fastening equipment

## 5 Boom nose on telescopic boom

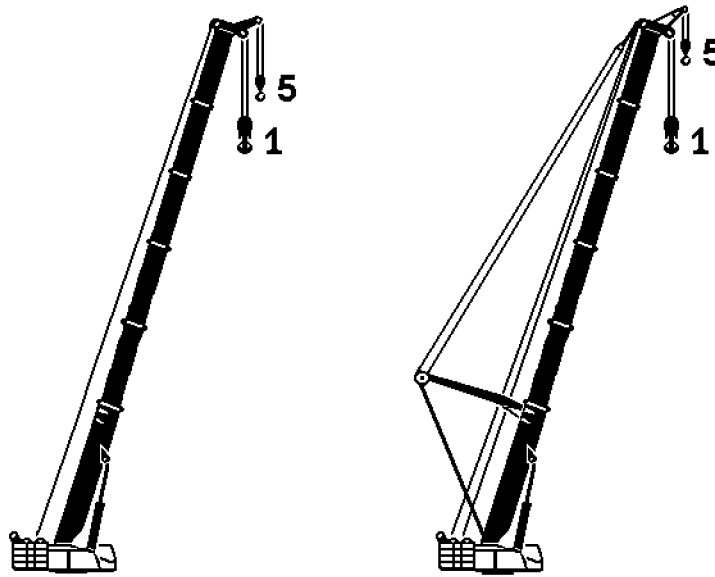


Fig.120462: Boom nose on telescopic boom



### WARNING

Impermissible operating conditions!  
Overload of crane, death, property damage.

- ▶ Only set up permissible hook operations.
- ▶ Set up of **non-permissible** hook operations is prohibited.

Hook	Illustration	Permissible hook operations for boom nose on telescopic boom
[5]		<b>Single hook operation:</b> Hook 5 is reeved in on the <b>boom nose</b> . Load is fastened on hook 5. <b>WARNING!</b> Radius and load display is not exact.
[1]		<b>Single hook operation:</b> Hook 1 is reeved in on the <b>telescopic boom</b> . Load is fastened on hook 1. <b>WARNING!</b> Load display is not exact.
1 [5]		<b>Two hook operation:</b> Hook 1 is reeved in on the <b>telescopic boom</b> . Hook 5 is reeved in on the <b>boom nose</b> . Load is fastened on hook 5. <b>WARNING!</b> Radius and load display is not exact.
[1] 5		<b>Two hook operation:</b> Hook 1 is reeved in on the <b>telescopic boom</b> . Hook 5 is reeved in on the <b>boom nose</b> . Load is fastened on hook 1. <b>WARNING!</b> Load display is not exact.

### 5.1 Setting up for boom nose on telescopic boom

- ▶ Reeve in a boom nose smaller than / equal to the telescopic boom head.

When a load is fastened on hook 5 (boom nose):

- ▶ Set the LICCON overload protection to the reeving on the boom nose.

For the two hook operation boom nose on telescopic boom no special load charts are available.

- ▶ Set the **telescopic boom** operating mode on the LICCON overload protection.

## 6 Auxiliary jib on the telescopic boom

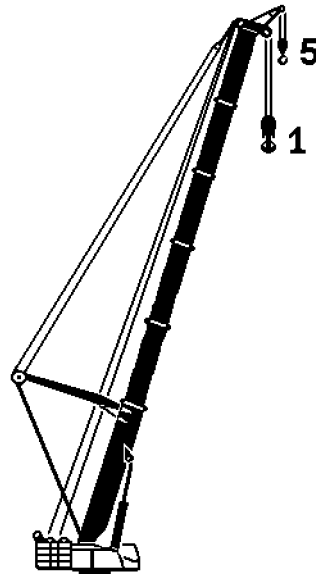


Fig.120467: Auxiliary jib on the telescopic boom



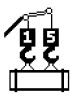
### WARNING

Impermissible operating conditions!

Overload of crane, death, property damage.

- ▶ Only set up permissible hook operations.
- ▶ Set up of **non-permissible** hook operations is prohibited.

Hook	Illustration	Permissible hook operations for the auxiliary jib on the telescopic boom
[5]		<b>Single hook operation:</b> Hook 5 is reeved in on the <b>auxiliary jib</b> . Load is fastened on hook 5.
[1]		<b>Single hook operation:</b> Hook 1 is reeved in on the <b>telescopic boom</b> . Load is fastened on hook 1. <b>WARNING!</b> During <b>non-monitored</b> two hook operation: Radius and load display is not exact.
1 [5]		<b>Two hook operation:</b> Hook 1 is reeved in on the <b>telescopic boom</b> . Hook 5 is reeved in on the <b>auxiliary jib</b> . Load is fastened on hook 5. <b>WARNING!</b> During <b>non-monitored</b> two hook operation: Load display is not exact.
[1] 5		<b>Two hook operation:</b> Hook 1 is reeved in on the <b>telescopic boom</b> . Hook 5 is reeved in on the <b>auxiliary jib</b> . Load is fastened on hook 1. <b>WARNING!</b> During <b>non-monitored</b> two hook operation: Radius and load display is not exact.
[1] [5]		<b>Two hook operation:</b> Hook 1 is reeved in on the <b>telescopic boom</b> . Hook 5 is reeved in on the <b>auxiliary jib</b> . First load is fastened on hook 1. Second load is fastened on hook 5. <b>WARNING!</b> Permissible solely for monitored two hook operation.

Hook	Illustration	Permissible hook operations for the auxiliary jib on the telescopic boom
[1 5]		<p><b>Two hook operation:</b> Hook 1 is reeved in on the <b>telescopic boom</b>. Hook 5 is reeved in on the <b>auxiliary jib</b>. A joint load is fastened on hook 1 and hook 5.</p> <p><b>WARNING!</b> Permissible solely for monitored two hook operation.</p> <p><b>WARNING!</b> Make sure that the weight of the load is smaller than / equal to the maximum permissible load of the auxiliary jib.</p>

## 6.1 Setting up for the auxiliary jib on the telescopic boom



### WARNING

Impermissible operating conditions!  
Overload of crane, death, property damage.

Only if the required load chart is available:

- ▶ Set up hook operation.
- 
- ▶ Reeve in a auxiliary jib smaller than / equal to the telescopic boom head.
  - ▶ Set the LICCON overload protection to the reeving on the auxiliary jib.
  - ▶ Set the **auxiliary jib** operating mode on the LICCON overload protection.

## 7 Folding jib

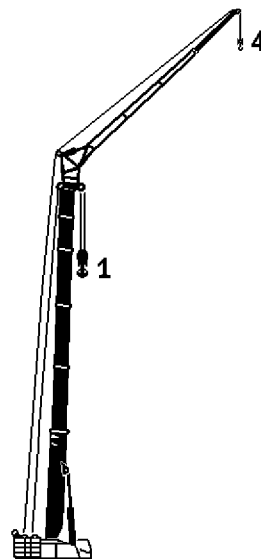


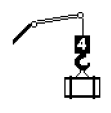
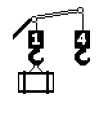
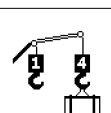
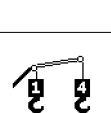
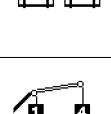
Fig.120468: Folding jib



### WARNING

Impermissible operating conditions!  
Overload of crane, death, property damage.

- ▶ Only set up permissible hook operations.
- ▶ Set up of **non-permissible** hook operations is prohibited.

Hook	Illustration	Permissible hook operations for folding jib
[4]		<b>Single hook operation:</b> Hook 4 is reeved in on the <b>folding jib</b> . Load is fastened on hook 4.
[1] 4		<b>Two hook operation:</b> Hook 1 is reeved in on the <b>telescopic boom</b> . Hook 4 is reeved in on the <b>folding jib</b> . Load is fastened on hook 1. <b>WARNING!</b> During <b>non-monitored</b> two hook operation: Radius and load display is not exact.
1 [4]		<b>Two hook operation:</b> Hook 1 is reeved in on the <b>telescopic boom</b> . Hook 4 is reeved in on the <b>folding jib</b> . Load is fastened on hook 4. <b>WARNING!</b> During <b>non-monitored</b> two hook operation: Load display is not exact.
[1] [4]		<b>Two hook operation:</b> Hook 1 is reeved in on the <b>telescopic boom</b> . Hook 4 is reeved in on the <b>folding jib</b> . First load is fastened on hook 1. Second load is fastened on hook 4. <b>WARNING!</b> Permissible solely for monitored two hook operation.
[1 4]		<b>Two hook operation:</b> Hook 1 is reeved in on the <b>telescopic boom</b> . Hook 4 is reeved in on the <b>folding jib</b> . A joint load is fastened on hook 1 and hook 4. <b>WARNING!</b> During <b>non-monitored</b> two hook operation: Radius and load display is not exact. <b>WARNING!</b> Make sure that the weight of the load is smaller than / equal to the maximum permissible load of the folding jib.

## 7.1 Setting up for operation with folding jib



### WARNING

Impermissible operating conditions!  
Overload of crane, death, property damage.

Only if the required load chart is available:

- ▶ Set up hook operation.
- 
- ▶ Reeve in a folding jib smaller than / equal to the telescopic boom head.
  - ▶ Set the LICCON overload protection to the reeving on the folding jib.
  - ▶ Set **folding jib** operating mode on the LICCON overload protection.



## 8 Strong lattice jib

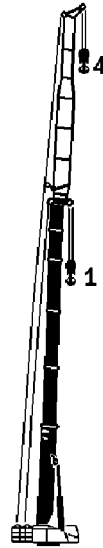


Fig.126100: Strong lattice jib



### WARNING

Impermissible operating conditions!  
Overload of crane, death, property damage.

- ▶ Only set up permissible hook operations.
- ▶ Set up of **non-permissible** hook operations is prohibited.

Hook	Illustration	Permissible hook operations for strong lattice jib
[4]		<b>Single hook operation:</b> Hook 4 is reeved on the <b>strong lattice jib</b> . Load is fastened on hook 4.
[1] 4		<b>Two hook operation:</b> Hook 1 is reeved in on the <b>telescopic boom</b> . Hook 4 is reeved on the <b>strong lattice jib</b> . Load is fastened on hook 1. <b>WARNING!</b> Radius and load display is not exact. <b>WARNING! Not permissible for TY-operation.</b>
1 [4]		<b>Two hook operation:</b> Hook 1 is reeved in on the <b>telescopic boom</b> . Hook 4 is reeved on the <b>strong lattice jib</b> . Load is fastened on hook 4. <b>WARNING!</b> Load display is not exact. <b>WARNING! Not permissible for TY-operation.</b>
[1 4]		<b>Two hook operation:</b> Hook 1 is reeved in on the <b>telescopic boom</b> . Hook 4 is reeved on the <b>strong lattice jib</b> . A joint load is fastened on hook 1 and hook 4. <b>WARNING!</b> Radius and load display is not exact. <b>WARNING!</b> Make sure that the weight of the load is smaller than / equal to the maximum permissible load of the fixed lattice jib. <b>WARNING! Not permissible for TY-operation.</b>

LWE/LTR 1220-003/242004-02-02/en

## 8.1 Setting up for operation with a strong lattice jib



### WARNING

Impermissible operating conditions!  
Overload of crane, death, property damage.

Only if the required load chart is available:

- ▶ Set up hook operation.
- 
- ▶ Reeve in a strong lattice jib smaller than / equal to the telescopic boom head.
  - ▶ Set the LICCON overload protection to the reeving on the strong lattice jib.
  - ▶ Set the **strong lattice jib** operating mode on the LICCON overload protection.

## 9 Fixed lattice jib

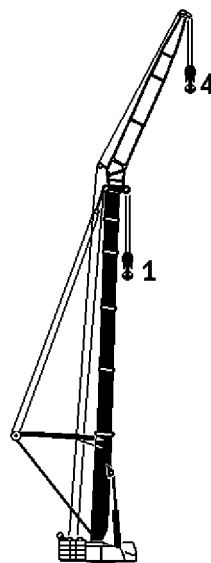




Fig.120473: Fixed lattice jib





### WARNING

Impermissible operating conditions!  
Overload of crane, death, property damage.

- ▶ Only set up permissible hook operations.
- ▶ Set up of **non-permissible** hook operations is prohibited.

Hook	Illustration	Permissible hook operations for fixed lattice jib
[4]		<b>Single hook operation:</b> Hook 4 is reeved in on the <b>fixed lattice jib</b> . Load is fastened on hook 4.
[1] 4		<b>Two hook operation:</b> Hook 1 is reeved in on the <b>telescopic boom</b> . Hook 4 is reeved in on the <b>fixed lattice jib</b> . Load is fastened on hook 1. <b>WARNING!</b> Radius and load display is not exact. <b>WARNING!</b> Not permissible for TY-operation

Hook	Illustration	Permissible hook operations for fixed lattice jib
1 [4]		<p><b>Two hook operation:</b> Hook 1 is reeved in on the <b>telescopic boom</b>. Hook 4 is reeved in on the <b>fixed lattice jib</b>. Load is fastened on hook 4.</p> <p><b>WARNING!</b> Load display is not exact.</p> <p><b>WARNING!</b> Not permissible for TY-operation.</p>
[1 4]		<p><b>Two hook operation:</b> Hook 1 is reeved in on the <b>telescopic boom</b>. Hook 4 is reeved in on the <b>fixed lattice jib</b>. A joint load is fastened on hook 1 and hook 4.</p> <p><b>WARNING!</b> Radius and load display is not exact.</p> <p><b>WARNING!</b> Make sure that the weight of the load is smaller than / equal to the maximum permissible load of the fixed lattice jib.</p> <p><b>WARNING!</b> Not permissible for TY-operation.</p>

## 9.1 Setting up for operation with a fixed lattice jib



### WARNING

Impermissible operating conditions!  
Overload of crane, death, property damage.

Only if the required load chart is available:

- ▶ Set up hook operation.
- 
- ▶ Reeve in a fixed lattice jib smaller than / equal to the telescopic boom head.
  - ▶ Set the LICCON overload protection to the reeving on the fixed lattice jib.
  - ▶ Set the **fixed lattice jib** operating mode on the LICCON overload protection.

## 10 Boom nose on the fixed lattice jib

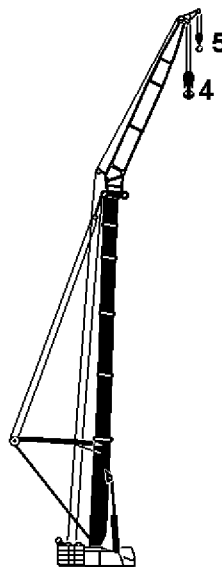


Fig.120474: Boom nose on the fixed lattice jib

**WARNING**

Impermissible operating conditions!

Overload of crane, death, property damage.

- ▶ Only set up permissible hook operations.
- ▶ Set up of **non-permissible** hook operations is prohibited.

Hook	Illustration	Permissible hook operations for the boom nose on the fixed lattice jib
[5]		<p><b>Single hook operation:</b> Hook 5 is reeved in on the <b>boom nose</b>. Load is fastened on hook 5.</p> <p><b>WARNING!</b> Radius and load display is not exact.</p>
[4]		<p><b>Single hook operation:</b> Hook 4 is reeved in on the <b>fixed lattice jib</b>. Load is fastened on hook 4.</p> <p><b>WARNING!</b> Load display is not exact.</p> <p><b>WARNING! Not permissible</b> for LTM 11200-9.1 and LTR 11200 in NZFM operation.</p>
4 [5]		<p><b>Two hook operation:</b> Hook 4 is reeved in on the <b>fixed lattice jib</b>. Hook 5 is reeved in on the <b>boom nose</b>. Load is fastened on hook 5.</p> <p><b>WARNING!</b> Radius and load display is not exact.</p> <p><b>WARNING! Not permissible</b> for LTM 11200-9.1 and LTR 11200 in NZFM operation.</p>
[4] 5		<p><b>Two hook operation:</b> Hook 4 is reeved in on the <b>fixed lattice jib</b>. Hook 5 is reeved in on the <b>boom nose</b>. Load is fastened on hook 4.</p> <p><b>WARNING!</b> Load display is not exact.</p> <p><b>WARNING! Not permissible</b> for LTM 11200-9.1 and LTR 11200 in NZFM operation.</p>
[4 5]		<p><b>Two hook operation:</b> Hook 4 is reeved in on the <b>fixed lattice jib</b>. Hook 5 is reeved in on the <b>boom nose</b>. A joint load is fastened on hook 4 and hook 5.</p> <p><b>WARNING!</b> Radius and load display is not exact.</p> <p><b>WARNING!</b> Make sure that the weight of the load is smaller than / equal to the maximum permissible load bearing capacity of the boom nose.</p> <p><b>WARNING! Not permissible</b> for LTM 11200-9.1 and LTR 11200 in NZFM operation.</p>

## 10.1 Setting up for operation with a boom nose on the fixed lattice jib

- ▶ Reeve in a boom nose smaller than / equal to the N-head.

When a load is fastened on hook 5 (boom nose):

- ▶ Set the LICCON overload protection to the reeving on the boom nose.
- ▶ Set the **fixed lattice jib** operating mode on the LICCON overload protection.

# 11 Auxiliary jib on the fixed lattice jib

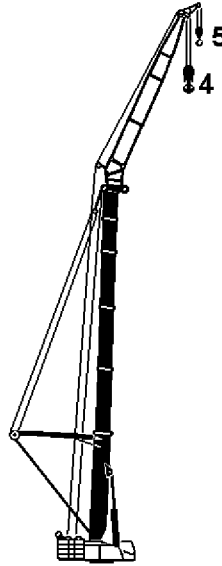


Fig.120474: Auxiliary jib on the fixed lattice jib

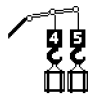
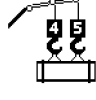


**WARNING**

Impermissible operating conditions!  
 Overload of crane, death, property damage.  
 ► Only set up permissible hook operations.  
 ► Set up of **non-permissible** hook operations is prohibited.

Hook	Illustration	Permissible hook operations for the auxiliary jib on the fixed lattice jib
[5]		<b>Single hook operation:</b> Hook 5 is reeved in on the <b>auxiliary jib</b> . Load is fastened on hook 5.
[4]		<b>Single hook operation:</b> Hook 4 is reeved in on the <b>fixed lattice jib</b> . Load is fastened on hook 4.  <b>WARNING!</b> During <b>non-monitored</b> two hook operation: Radius and load display is not exact.  <b>WARNING! Not permissible</b> for LTM 11200-9.1 and LTR 11200 in NZFM operation.
4 [5]		<b>Two hook operation:</b> Hook 4 is reeved in on the <b>fixed lattice jib</b> . Hook 5 is reeved in on the <b>auxiliary jib</b> . Load is fastened on hook 5.  <b>WARNING!</b> During <b>non-monitored</b> two hook operation: Load display is not exact.  <b>WARNING! Not permissible</b> for LTM 11200-9.1 and LTR 11200 in NZFM operation.
[4] 5		<b>Two hook operation:</b> Hook 4 is reeved in on the <b>fixed lattice jib</b> . Hook 5 is reeved in on the <b>auxiliary jib</b> . Load is fastened on hook 4.  <b>WARNING!</b> During <b>non-monitored</b> two hook operation: Radius and load display is not exact.  <b>WARNING! Not permissible</b> for LTM 11200-9.1 and LTR 11200 in NZFM operation.

LWE/LTR 1220-003/24204-02-02/en

Hook	Illustration	Permissible hook operations for the auxiliary jib on the fixed lattice jib
[4] [5]		<p><b>Two hook operation:</b> Hook 4 is reeved in on the <b>fixed lattice jib</b>. Hook 5 is reeved in on the <b>auxiliary jib</b>. First load is fastened on hook 4. Second load is fastened on hook 5</p> <p><b>WARNING!</b> Permissible solely for monitored two hook operation.</p> <p><b>WARNING! Not permissible</b> for LTM 11200-9.1 and LTR 11200 in NZFM operation.</p>
[4 5]		<p><b>Two hook operation:</b> Hook 4 is reeved in on the <b>fixed lattice jib</b>. Hook 5 is reeved in on the <b>auxiliary jib</b>. A joint load is fastened on hook 4 and hook 5.</p> <p><b>WARNING!</b> During <b>non-monitored</b> two hook operation: Radius and load display is not exact.</p> <p><b>WARNING!</b> Make sure that the weight of the load is smaller than / equal to the maximum permissible load of the auxiliary jib.</p> <p><b>WARNING! Not permissible</b> for LTM 11200-9.1 and LTR 11200 in NZFM operation.</p>

## 11.1 Setting up for operation with an auxiliary jib on the fixed lattice jib



### WARNING

Impermissible operating conditions!  
Overload of crane, death, property damage.

Only if the required load chart is available:

- ▶ Set up hook operation.
- 
- ▶ Reeve in an auxiliary jib smaller than / equal to the N-head.
  - ▶ Set the LICCON overload protection to the reeving on the auxiliary jib.
  - ▶ Set the **auxiliary jib** operating mode on the LICCON overload protection.

## 12 Luffing lattice jib

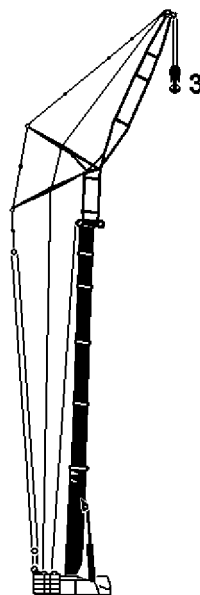



Fig.120700: Luffing lattice jib

**WARNING**

Impermissible operating conditions!  
Overload of crane, death, property damage.

- ▶ Only set up permissible hook operations.
- ▶ Set up of **non-permissible** hook operations is prohibited.

Hook	Illustration	Permissible hook operations for luffing lattice jib
[3]		<b>Single hook operation:</b> Hook 3 is reeved in on the <b>luffing lattice jib</b> . Load is fastened on hook 3.

## 12.1 Setting up for operation with the luffing lattice jib

**WARNING**

Impermissible operating conditions!  
Overload of crane, death, property damage.

Only if the required load chart is available:

- ▶ Set up hook operation.
- ▶ Set the LICCON overload protection to reeving on the luffing lattice jib.
- ▶ Set the **luffing lattice jib** operating mode on the LICCON overload protection.

## 13 Boom nose on the luffing lattice jib

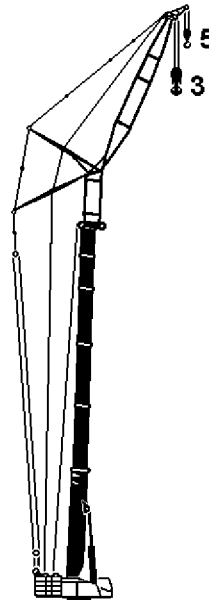
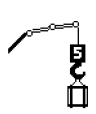
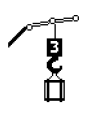
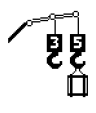
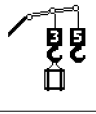
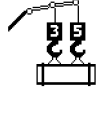


Fig.120702: Boom nose on the luffing lattice jib

**WARNING**

Impermissible operating conditions!  
Overload of crane, death, property damage.

- ▶ Only set up permissible hook operations.
- ▶ Set up of **non-permissible** hook operations is prohibited.

Hook	Illustration	Permissible hook operations for the boom nose on the luffing lattice jib
[5]		<b>Single hook operation:</b> Hook 5 is reeved in on the <b>boom nose</b> . Load is fastened on hook 5. <b>WARNING!</b> Radius and load display is not exact.
[3]		<b>Single hook operation:</b> Hook 3 is reeved in on the <b>luffing lattice jib</b> . Load is fastened on hook 3. <b>WARNING!</b> Load display is not exact.
3 [5]		<b>Two hook operation:</b> Hook 3 is reeved in on the <b>luffing lattice jib</b> . Hook 5 is reeved in on the <b>boom nose</b> . Load is fastened on hook 5. <b>WARNING!</b> Radius and load display is not exact.
[3] 5		<b>Two hook operation:</b> Hook 3 is reeved in on the <b>luffing lattice jib</b> . Hook 5 is reeved in on the <b>boom nose</b> . Load is fastened on hook 3. <b>WARNING!</b> Load display is not exact.
[3 5]		<b>Two hook operation:</b> Hook 3 is reeved in on the <b>luffing lattice jib</b> . Hook 5 is reeved in on the <b>boom nose</b> . A joint load is fastened on hook 3 and hook 5. <b>WARNING!</b> Radius and load display is not exact. <b>WARNING!</b> Make sure that the weight of the load is smaller than / equal to the maximum permissible load bearing capacity of the boom nose.

### 13.1 Setting up for operation with a boom nose on the luffing lattice jib

- ▶ Reeve in a boom nose smaller than / equal to the N-head.

When a load is fastened on hook 5 (boom nose):

- ▶ Set the LICCON overload protection to the reeving on the boom nose.
- ▶ Set the **luffing lattice jib** operating mode on the LICCON overload protection.

## 14 Auxiliary jib on the luffing lattice jib

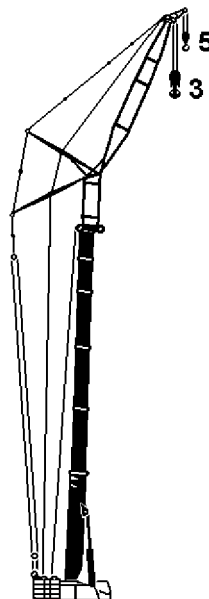


Fig.120702: Auxiliary jib on the luffing lattice jib



**WARNING**

Impermissible operating conditions!  
Overload of crane, death, property damage.

- ▶ Only set up permissible hook operations.
- ▶ Set up of **non-permissible** hook operations is prohibited.

Hook	Illustration	Permissible hook operations for the auxiliary jib on the luffing lattice jib
[5]		<b>Single hook operation:</b> Hook 5 is reeved in on the <b>auxiliary jib</b> . Load is fastened on hook 5.
[3]		<b>Single hook operation:</b> Hook 3 is reeved in on the <b>luffing lattice jib</b> . Load is fastened on hook 3. <b>WARNING!</b> During <b>non-monitored</b> two hook operation: Radius and load display is not exact. <b>WARNING!</b> Not permissible for LTM 1750-9.1 in TYV23EN operation.
3 [5]		<b>Two hook operation:</b> Hook 3 is reeved in on the <b>luffing lattice jib</b> . Hook 5 is reeved in on the <b>auxiliary jib</b> . Load is fastened on hook 5. <b>WARNING!</b> During <b>non-monitored</b> two hook operation: Load display is not exact. <b>WARNING!</b> Not permissible for LTM 1750-9.1 in TYV23EN operation.
[3] 5		<b>Two hook operation:</b> Hook 3 is reeved in on the <b>luffing lattice jib</b> . Hook 5 is reeved in on the <b>auxiliary jib</b> . Load is fastened on hook 3. <b>WARNING!</b> During <b>non-monitored</b> two hook operation: Radius and load display is not exact. <b>WARNING!</b> Not permissible for LTM 1750-9.1 in TYV23EN operation.
[3] [5]		<b>Two hook operation:</b> Hook 3 is reeved in on the <b>luffing lattice jib</b> . Hook 5 is reeved in on the <b>auxiliary jib</b> . First load is fastened on hook 3. Second load is fastened on hook 5. <b>WARNING!</b> Permissible solely for monitored two hook operation. <b>WARNING!</b> Not permissible for LTM 1750-9.1 in TYV23EN operation.
[3 5]		<b>Two hook operation:</b> Hook 3 is reeved in on the <b>luffing lattice jib</b> . Hook 5 is reeved in on the <b>auxiliary jib</b> . A joint load is fastened on hook 3 and hook 5. <b>WARNING!</b> During <b>non-monitored</b> two hook operation: Radius and load display is not exact. <b>WARNING!</b> Make sure that the weight of the load is smaller than / equal to the maximum permissible load of the auxiliary jib. <b>WARNING!</b> Not permissible for LTM 1750-9.1 in TYV23EN operation.

## 14.1 Setting up for operation with an auxiliary jib on the luffing lattice jib

**WARNING**

Impermissible operating conditions!  
Overload of crane, death, property damage.

Only if the required load chart is available:

- ▶ Set up hook operation.
- ▶ Reeve in an auxiliary jib smaller than / equal to the N-head.

- ▶ Set the LICCON overload protection to the reeving on the auxiliary jib.
- ▶ Set the **auxiliary jib** operating mode on the LICCON overload protection.

## 15 Lifting a joint load

### 15.1 Lifting a joint load solely with the auxiliary boom

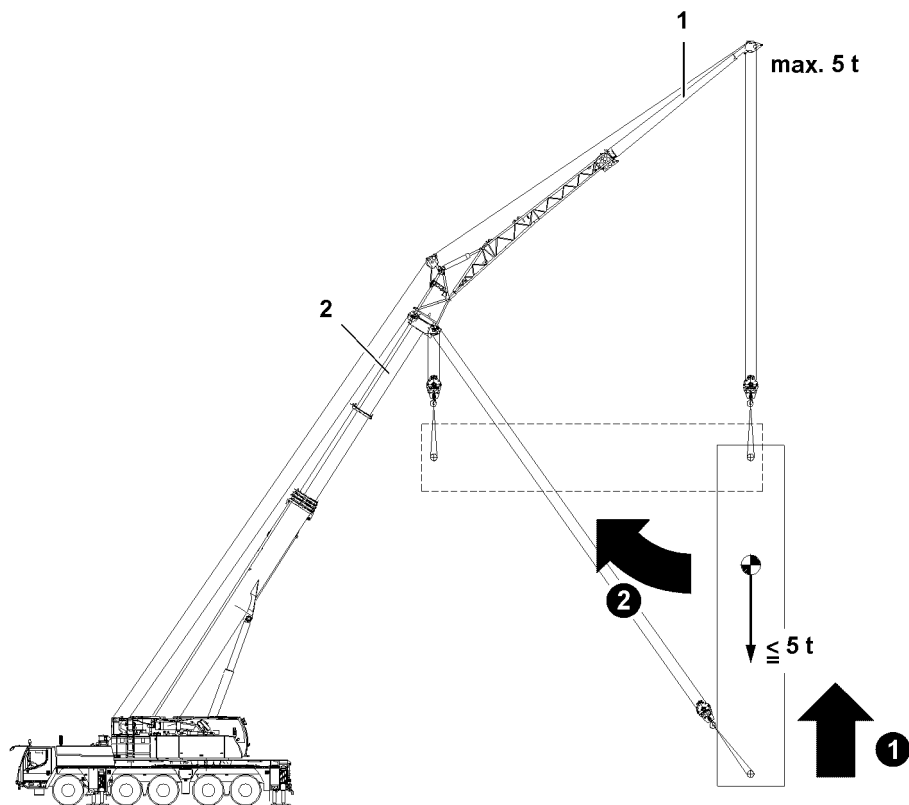


Fig.120710: Lifting the load with the auxiliary boom 1 to 100 %

If the weight or the center of gravity of the load is not exactly known, then the load must first be lifted with the auxiliary boom 1 to 100 %.

Make sure that the following prerequisite is met:

- The weight of the load is less than / equal to the maximum permissible load of the auxiliary boom 1.



#### WARNING

Incorrect lifting of the load!  
Toppling crane, death, property damage.

- ▶ Lift the load with the auxiliary boom 1 to 100 %.

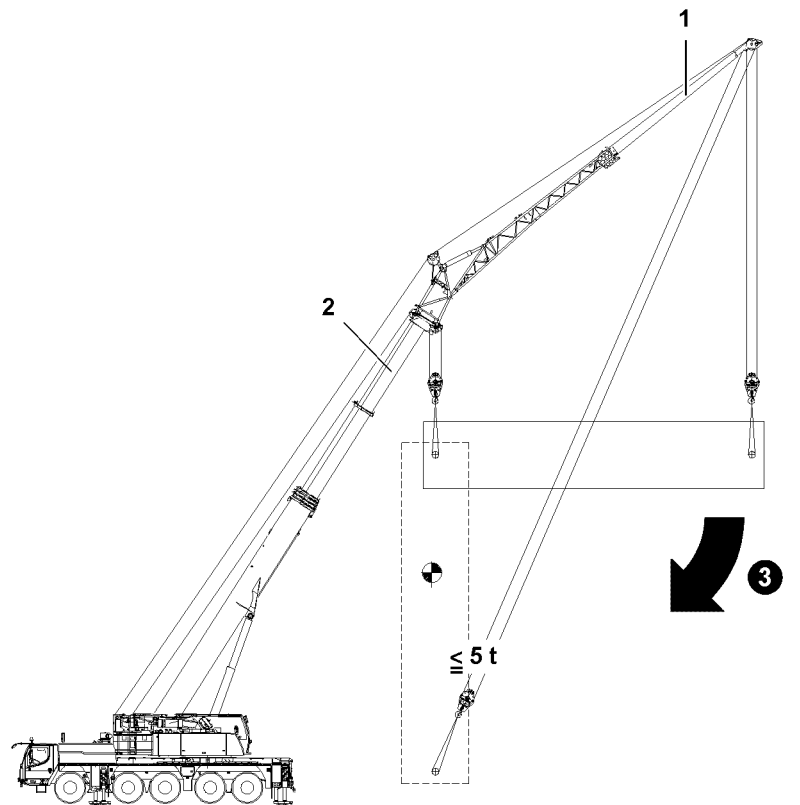


Fig.120711: Taking on the load with the main boom 2

In „two hook operation“ angular pull is only permissible in the boom direction with raised load.

---

**NOTICE**

Rubbing hoist ropes!

- ▶ Make sure that the hoist ropes do not rub on the rope retaining pipes of the rope pulleys during angular pull.

- 
- ▶ Take on the load with the main boom 2.

## 15.2 Lifting a joint load with two booms

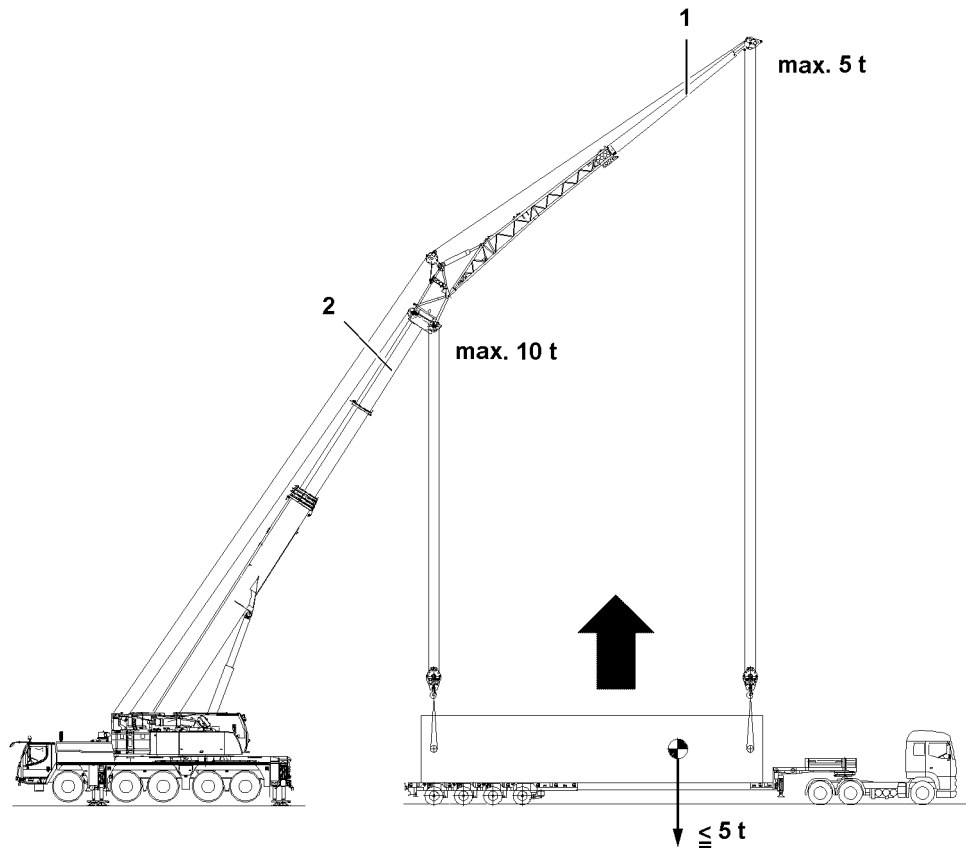


Fig.120712: Lifting the load with the main boom 2 and auxiliary boom 1

Make sure that the following prerequisite is met:

- The weight of the load is less than / equal to the maximum permissible load of the auxiliary boom 1.



### WARNING

Overload of crane!  
Death, severe injuries, property damage.

- ▶ Make sure that the weight and the center of gravity of the load is known exactly.

In „two hook operation“ angular pull is only permissible in the boom direction with raised load.

### NOTICE

Rubbing hoist ropes!

- ▶ Make sure that the hoist ropes do not rub on the rope retaining pipes of the rope pulleys during angular pull.

- ▶ Lift the load with the main boom 2 and auxiliary boom 1.

## 4.20 Procedure for shut-off of crane movement

1	General	3
2	Instructions for resuming crane movement	19

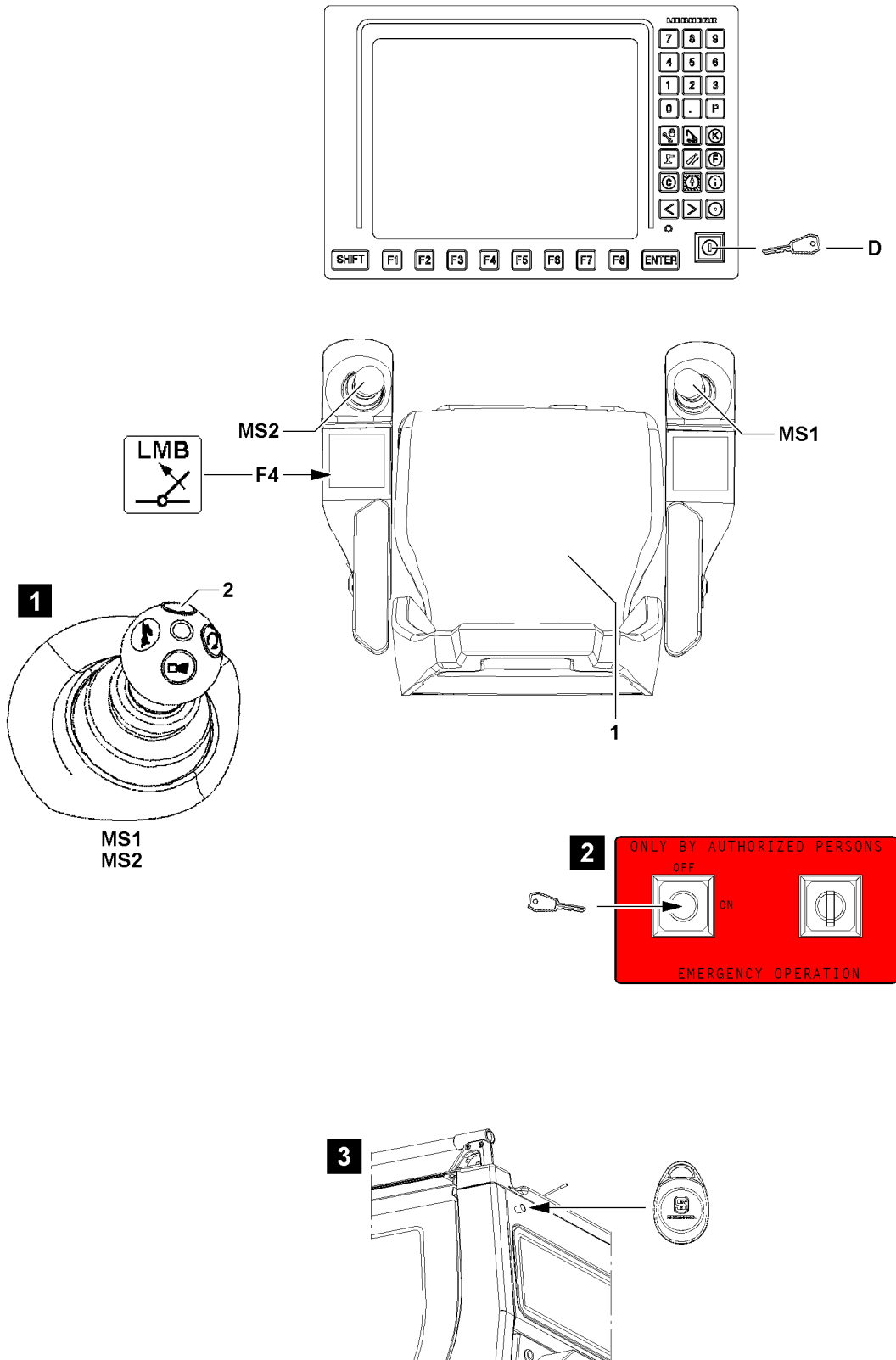


Fig.117245

# 1 General



## WARNING

Limits of LICCON computer system!

The LICCON computer system cannot reduce the danger of accident in case of unsuitable or careless operation nor overcome physical limits.

The LICCON computer system cannot take misjudgments / erroneous operation into account.

- ▶ Safe crane operation / assembly operation and crane application is the sole responsibility of the crane operator and operating personnel.
- ▶ Always adapt crane operation / assembly operation and crane application to the operating conditions.



## Note

- ▶ The monitor illustrations in this chapter are only examples.
- ▶ The numerical values in the individual icons and charts do not have to necessarily match the crane exactly.
- ▶ Numbers and letters can be replaced by place holders.
- ▶ The display and assignment of the icons can deviate, depending on the set up configuration, operating status and configuration of the crane.
- ▶ In addition, many of the illustrations show the maximum configuration of the LICCON monitor with icons.
- ▶ In crane operation, an identical display will **not** appear on the LICCON monitor.



## Note

- ▶ Load hook and hook block are generally also described as hooks.

## 1.1 Operating elements for special cases for operation of the LICCON overload protection

Within the crane operator's cab, two buttons are installed as operating elements for „Special cases for operation of the LICCON overload protection“:

- Button **F4** on the left control panel
- The set up key **D** on LICCON monitor 0

Depending on the crane configuration, an additional operating element can be installed outside the crane operator's cab for „Special cases for operation of the LICCON overload protection“:

- LMB-emergency operation key switch in the control cabinet, see illustration **2**.
- or**
- LMB-emergency operation transponder / sensor on the rear of the crane cab, see illustration **3**

If a crane movement is to be carried out with master switch **MS1** or master switch **MS2**, then at least one of the following buttons must be actuated:

- **1** Seat contact button
  - Is actuated by sitting properly on the seat.
- **2** Button
  - To bypass the seat contact button **1**, to be able to work while standing up, if necessary.

## 1.2 Special cases for operation of the LICCON overload protection

When special cases for operation of the LICCON overload protection occur, then the functionality of the LICCON overload protection intervenes.

**WARNING**

Intervention of the functionality of the LICCON overload protection!

If the functionality of the LICCON overload protection intervenes by pressing the button **F4**, set up button **D** or by activation of the LMB-emergency operation, then the LICCON overload protection is entirely deactivated, bypassed or limited.

It is possible to exceed several shut-off limits of the LICCON overload protection simultaneously or one after the other.

It is possible to carry out crane movements that are not monitored by the LICCON overload protection. Without the LICCON overload protection, no additional protection against overload of the crane via the crane control is present.

- ▶ When accessing the functionality of the LICCON overload protection, take into account that the LICCON overload protection is deactivated totally or is limited.
- ▶ Only access the functionality of the LICCON overload protection according to the specifications in the operating instructions.

**Possible limitation in the crane control:**

- During certain „Special cases at operation of the LICCON overload protection“, the working speed of the crane is significantly reduced.
- During certain „Special cases at operation of the LICCON overload protection“, the possibility to control the crane is limited in time.
- During certain „Special cases at operation of the LICCON overload protection“, the individual display instruments show no values.

**1.2.1 Special operating conditions**

If a special operating condition occurs, such as self-blocking of overload protection („Deadlock“), pressing button **F4** or set up key **D** can provide a remedy.

By pressing the key **F4** you can:

- Luff in with suspended load, after the boom radius range of the load chart is left

By pressing the set up key **D**, the function „Exceeding the shut-off limits of the LICCON overload protection“ is activated. This makes it possible:

- To exceed the maximum permissible load moment
- To exceed the maximum value of the F-load display in crane operation.
- To enable individual, limited crane movements after LMB STOP

**Note**

- ▶ Depending on the crane configuration, exceeding the maximum permissible load moment is limited to 110 %.

**1.2.2 Assembly / disassembly procedures**

By pressing the set up key **D** you can:

- Bypass the LICCON overload protection to carry out erection / take down procedures and assembly procedures.
- Bypass hoist top shut-off (erection / take down procedures and assembly procedures).

**Note**

- ▶ For assembly / disassembly procedures, depending on the circumstances there may not be any display values or they may be significantly reduced.
- ▶ The display of the required display values or determination of required values is ensured when proceeding correctly.



### 1.2.3 Failure of components



#### WARNING

Erroneous operation of the crane!

If the LICCON overload protection turns the crane movement off due to failure of components, then the exact cause for the shut-off must be determined.

After a failure of components, no normal operating condition can be reached. No normal crane operation is possible.

- ▶ Procedure, see separate chapter for Diagnostics and Maintenance.
- ▶ Resume normal crane operation only when the cause for the shut-off has been remedied and the crane control is fully functioning.

Depending on the crane configuration, a shut-off due to „failure of components“ can be bypassed by:

- Activating the LMB-emergency operation:
  - LMB-emergency operation key switch in the control cabinet
  - or
  - LMB-emergency operation transponder / sensor on the rear of the crane cab

**or**

- The set up key **D** on the LICCON monitor

The activated function includes the following:

- Allows crane movements in case of failure of components, for example sensors which are required for monitoring by the LICCON overload protection.



#### Note

- ▶ Installation location of the operating elements, see Chapter 4.01

### 1.2.4 Emergency situations



#### WARNING

Overload of crane!

If the LICCON overload protection is bypassed, then the LICCON overload protection is entirely deactivated.

If the LICCON overload protection is bypassed, there is no further protection against crane overload. There is no longer a load torque limiter.

If the LICCON overload protection is bypassed, the crane can be overloaded readily.

Overloading the crane can lead to accidents.

During accidents, personnel could be killed or seriously injured.

- ▶ If the LICCON overload protection is bypassed, take into account that the LICCON overload protection is entirely deactivated.
- ▶ If the LICCON overload protection is bypassed, the crane operator assumes the full responsibility for his actions.

Depending on the crane configuration, the LICCON overload protection can be bypassed as follows:

- Activating the LMB-emergency operation:
  - LMB-emergency operation key switch in the control cabinet
  - or
  - LMB-emergency operation transponder / sensor on the rear of the crane cab

**or**

- The set up key **D** on the LICCON monitor

The activated function includes the following:

- Allowing crane movements in emergency situations without monitoring by the LICCON overload protection

**Note**

- ▶ Installation location of the operating elements, see Chapter 4.01
- ▶ For the procedure, see Crane operating instructions, chapter 4.04.

### 1.3 Operating condition of crane

A „**normal operating condition**“ can only be reached if all of the following statements apply:

- The crane is in a proper condition.
- The crane is set up according to the specifications in the Operating instructions.
- The set up configuration of the crane has been entered correctly in the LICCON computer system.
- The crane is in the range of a valid load chart.
- The crane utilization is in the range of 0 % to 100 %.
- The F-load display is in the permissible range.
- All required displays in the LICCON monitors provide the correct display values.
- All required display instruments are functioning.
- The local conditions meet the specifications for crane application.

The „**operating condition is not normal**“, among others, if one or more of the following statements apply:

- The crane has defects that compromise operational safety.
- The crane is not set up according to the specifications in the operating instructions.
- The set up configuration of the crane deviates from the entries in the LICCON computer system.
- The limit values from the load charts are exceeded.
- The maximum permissible load moment is exceeded.
- The hoist top shut-off is bypassed.
- The limit values from the F-load display are exceeded.
- Required displays in the LICCON monitors provide no correct display values.
- Required display instruments are not functioning.
- The functionality of the LICCON overload protection has intervened by pressing the button **F4**, set up button **D**.
- When LMB emergency operation is activated.
- Crane movements are carried out without a functioning overload protection.
- Crane movements are carried out outside of the load charts.
- A special case at operation of the LICCON overload protection has occurred.

Empty page!

LWE/LTR 1220-003/24204-02-02/en

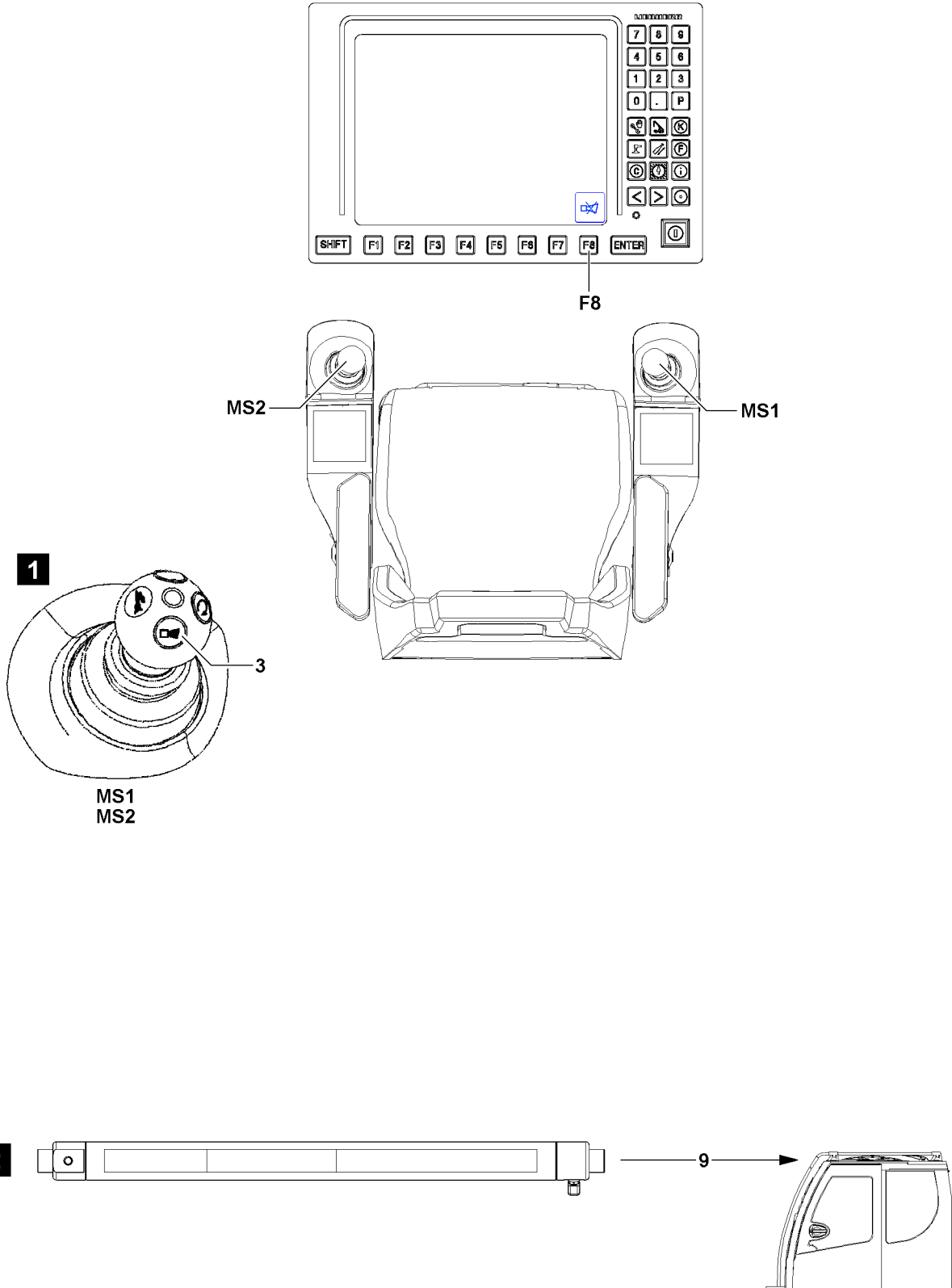


Fig.117246

LWE/LTR 1220-003/24204-02-02/en

## 1.4 Overview of acoustic / optical warnings

- Via the signal sounds of the LICCON monitor, the acoustic warnings are issued to the crane operator.
- The acoustic warnings are issued to the surrounding crane area via a horn on the turntable.
- Via warning icons in display instruments, the optical warnings are issued to the crane operator.
- Via the LMB-warning lights, optical warnings are issued to the area surrounding the crane.
- The acoustic warnings within the crane operator's cab are shut off by pressing the key **F8** on the corresponding LICCON monitor.
- The shut-off of the acoustical warnings outside the crane operator's cab is made by pressing the button **3** (signal horn / horn, illustration 1) on master switch **MS1** or master switch **MS2**.

### 1.4.1 General notes regarding the acoustic / optical warnings to the surrounding crane area



#### WARNING

Disregard of acoustic or optical warnings!

If persons in the crane surrounding area are not informed about the meaning of acoustic / optical warnings of the crane, then there is a danger of accidents.

- ▶ Only persons who have been informed about how to proceed correctly according to the acoustic / optical warnings may be in the area surrounding the crane.

In reference to the horn on the turntable, the following applies:

- An intermittent sound is heard: A special case in the operation of the LICCON overload protection has occurred or the overload protection has turned the crane movement off.

In reference to the three color light **9**, (illustration **2**) the following applies:

- The three color light **9** lights up green: The crane is in normal operating condition.
- The three color light **9** lights up yellow: The crane is still in normal operating condition, an advance warning for upcoming shut-off exists.
- The three color light **9** lights up red: The crane movement was turned off by the overload protection.
- The three color light **9** blinks yellow: A special case at operation of the LICCON overload protection has occurred.
- The three color light **9** blinks red: A special case at operation of the LICCON overload protection has occurred.

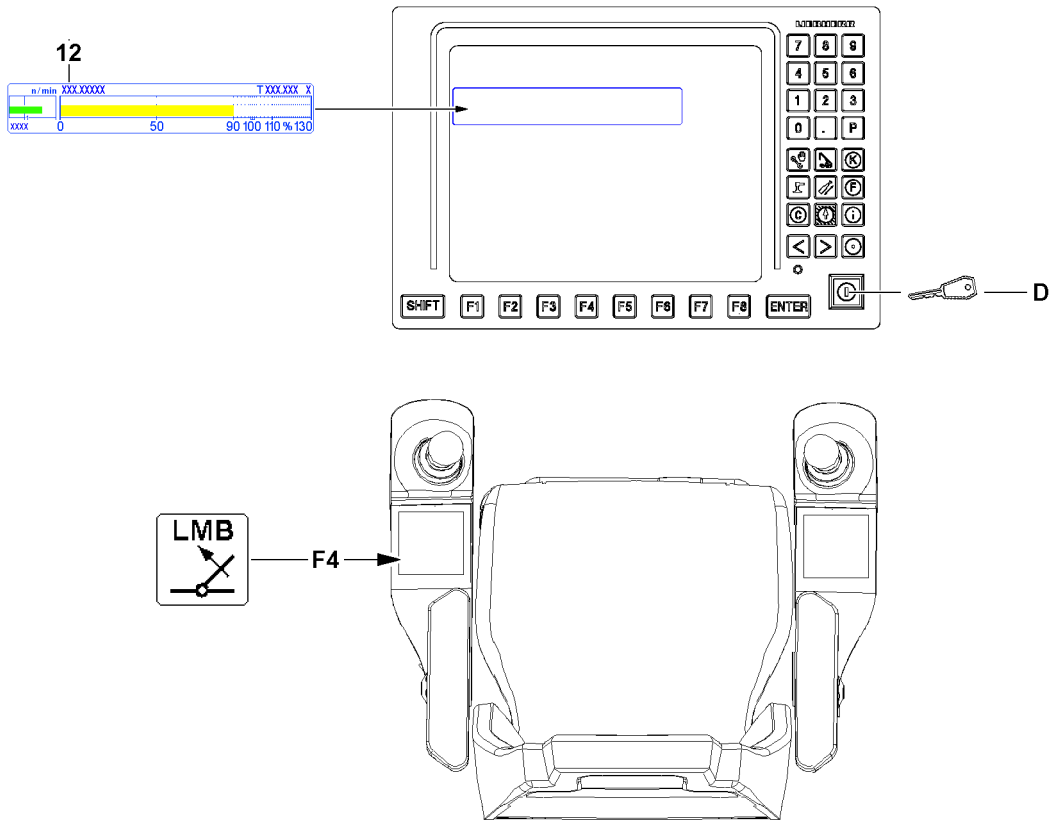


Fig.117247

LWE/LTR 1220-003/24204-02-02/en

## 1.4.2 Description of acoustic / visual warnings

The occurrence of acoustic / optical warnings in crane operation is explained via sample situations. The situation numbers from the chart „Overview of possible situations“ is valid for the following charts in this chapter:

- Acoustic / visual warnings on the LICCON monitor
- LMB warning lights
- Horn on the turntable



### Note

- ▶ The percentage values in the „Overview of possible situations“ refers to the crane utilization according to the display in the bar diagram for utilization **12**.

<b>Overview of possible situations</b>	
<b>Situation number</b>	<b>Sample description of the situation</b>
<b>Situation 001</b>	Normal operating condition with crane utilization of 0 % to 100 %.
<b>Situation 003</b>	The crane movement was turned off due to a crane utilization above 100 % - LMB-STOP was triggered
<b>Situation 004</b>	The crane movement was turned off even though the crane utilization is below 100 % - LMB-STOP was triggered
<b>Situation 005</b>	The crane movement „luffing in with suspended load“ is carried out at a crane utilization above 100 % with the button <b>F4</b>
<b>Situation 006</b>	Failure of LICCON overload protection components
<b>Situation 010</b>	The shut off limits of the LICCON overload protection are deactivated / exceeded with the set up key <b>D</b>
<b>Situation 011</b>	An actuated hoist limit switch (hoist top shut-off) is bypassed with the set up key <b>D</b>
<b>Situation 020</b>	The assembly operation was activated with the set up key <b>D</b> to erect / take down the boom system No load chart is available.

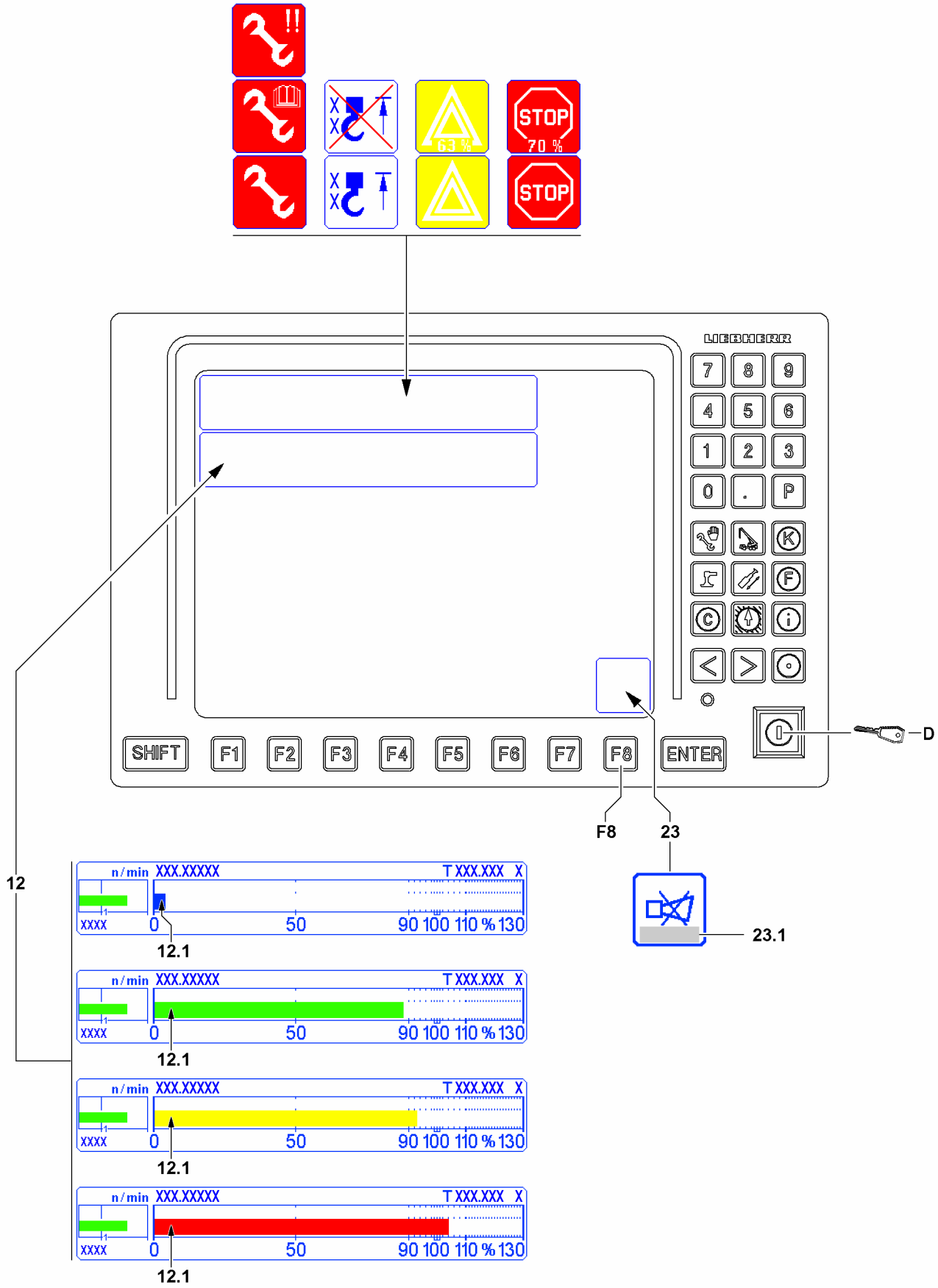


Fig.148653

LWE/LTR 1220-003/24204-02-02/en



### 1.4.3 Acoustic / visual warnings within the crane operator's cab



#### Note

The percentage values refer to the crane utilization according to the display in the bar diagram for utilization **12**.

If the limit values for the load torque limiter for advance warning and shut-off are set otherwise by the crane driver, the percentage values are correspondingly lower. See the Crane operating instructions, chapter 4.02.

- ▶ Up to utilization of 20%, the utilization bar **12.1** is blue, when the actual load is simultaneously lower than 0.5 t.
- ▶ Up to utilization of 90 %, the utilization bar **12.1** is green. In the case of very low utilization, the utilization bar **12.1** is also blue.
- ▶ Above utilization of 90% to 100 %, the utilization bar **12.1** is yellow.
- ▶ Above utilization of 100 %, the utilization bar **12.1** is red.



#### WARNING

Erroneous operation of the crane!

- ▶ In relation with acoustic / optical warnings in the horn **23** icon, pay attention to the notes regarding error messages **23.1**.



#### Note

- ▶ For a more detailed description of the situations according to the situation numbers, see chart „Overview of possible situations“

Acoustic / visual warnings on the LICCON monitor							
Situation <sup>4)</sup>	Acoustic warning		Visual warning LICCON monitor				
	Horn short <sup>2)</sup>	Horn long <sup>2)</sup>	Warning signs		Special signs		
<b>Situation 001</b>	Above 90 % <sup>5)</sup>	-	Above 90 % <sup>5)</sup>	-	-	-	-
<b>Situation 003</b>	Above 90 % <sup>5)</sup>	Above 101 % <sup>5)</sup>	Above 90 % <sup>5)</sup>	Above 101 % <sup>5)</sup>	-	-	-
<b>Situation 004</b>	-	Always	-	Always	-	-	-
<b>Situation 005</b>	-	Above 101 % <sup>5)</sup>	Above 101 % <sup>5)</sup>	Above 101 % <sup>5)</sup>			
<b>Situation 006</b>				Always	Always <sup>3)</sup>		
<b>Situation 010</b>	Above 90 % <sup>5)</sup>	Above 101 % <sup>5)</sup>	Above 90 % <sup>5)</sup>	Above 101 % <sup>5)</sup>	Always	-	-
<b>Situation 011<sup>1)</sup></b>	-	Always	-	-	-	-	Always
<b>Situation 020</b>	-	Always	-	-	-	Always	-

<sup>1)</sup> Is in part superseded by other warnings

<sup>2)</sup> Can be turned off immediately on the LICCON monitor with the function key **F8**

<sup>3)</sup> Depending on the crane configuration, a variant of this icon appears, see the Crane operating instructions, chapter 4.02

<sup>4)</sup> Description of individual situations, see chart „Overview of possible situations“.

<sup>5)</sup> If the limit values for the load torque limiter for advance warning and shut-off are set otherwise by the crane driver, this value can be lower. See the Crane operating instructions, chapter 4.02.

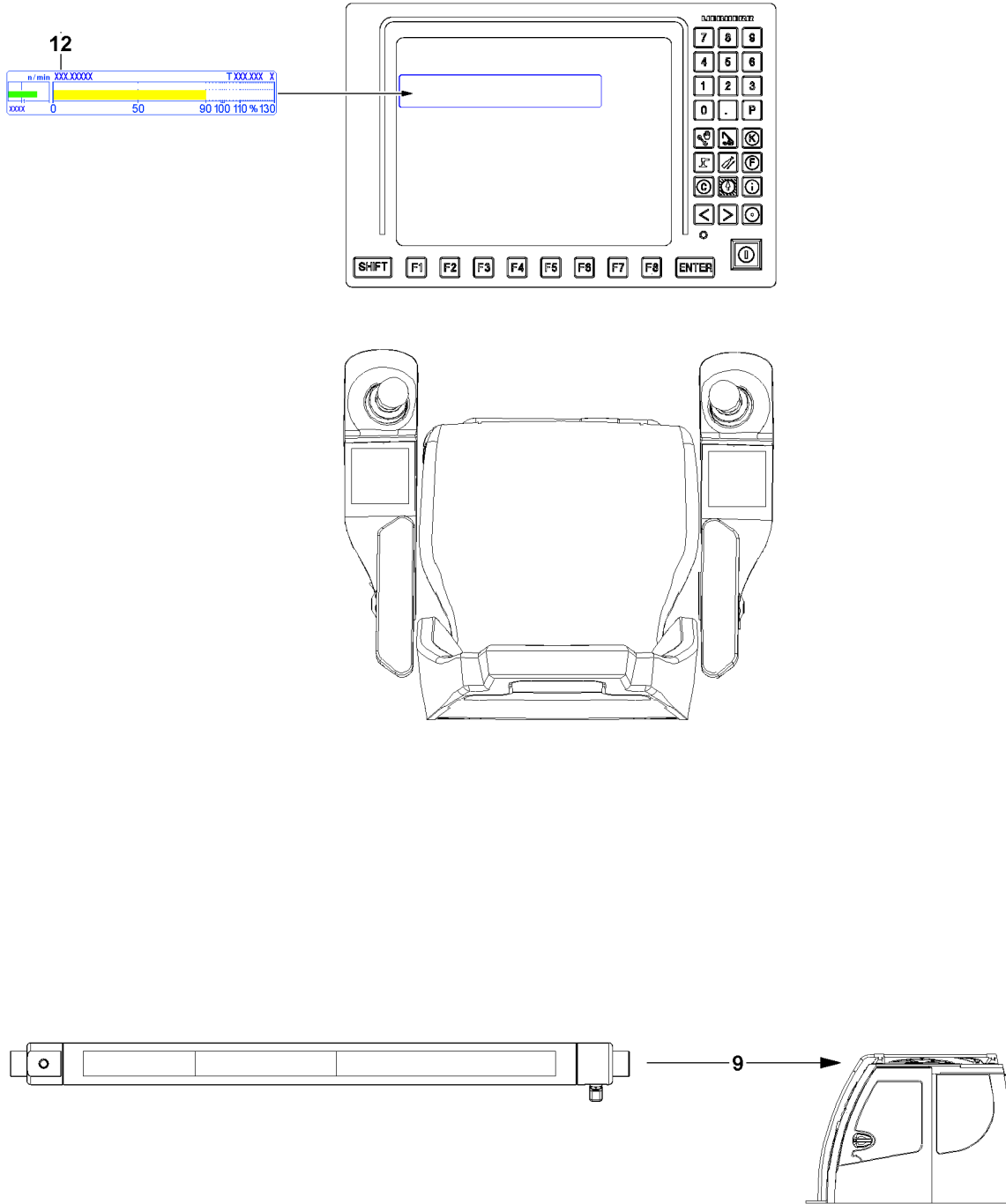


Fig.117249

### 1.4.4 Acoustic / visual warnings outside the crane operator's cab



#### Note

- ▶ For description of the situations assigned to the situation numbers, see chart „Overview of possible situations“
- ▶ The percentage values refer to the crane utilization according to the display in the bar diagram for utilization **12**.

LMB warning lights				
Situation number	At utilization of crane	Three color light 9		
		Green	Yellow	Red
Situation 001	0 % to 89 %	Lights up		
	90 % to 100 %		Lights up	
Situation 003	Above 101 %			Lights up
Situation 004	Always			Lights up
Situation 005	Above 101 %			Blinks
Situation 006	Always			Blinks
Situation 010 <sup>6)</sup>	0 % to 89 %	Lights up		
	90 % to 100 %		Lights up	
	101 % to 110 %		Blinks	
	Above 111 %			Lights up
Situation 010	0 % to 89 %	Lights up		
	90 % to 100 %		Lights up	
	Above 101 %			Blinks
Situation 011 <sup>1)</sup>	Always		Blinks	
Situation 020	No display value		Blinks	

<sup>1)</sup> Is in part superseded by other warnings

<sup>6)</sup> Cranes according to EN13000:2010

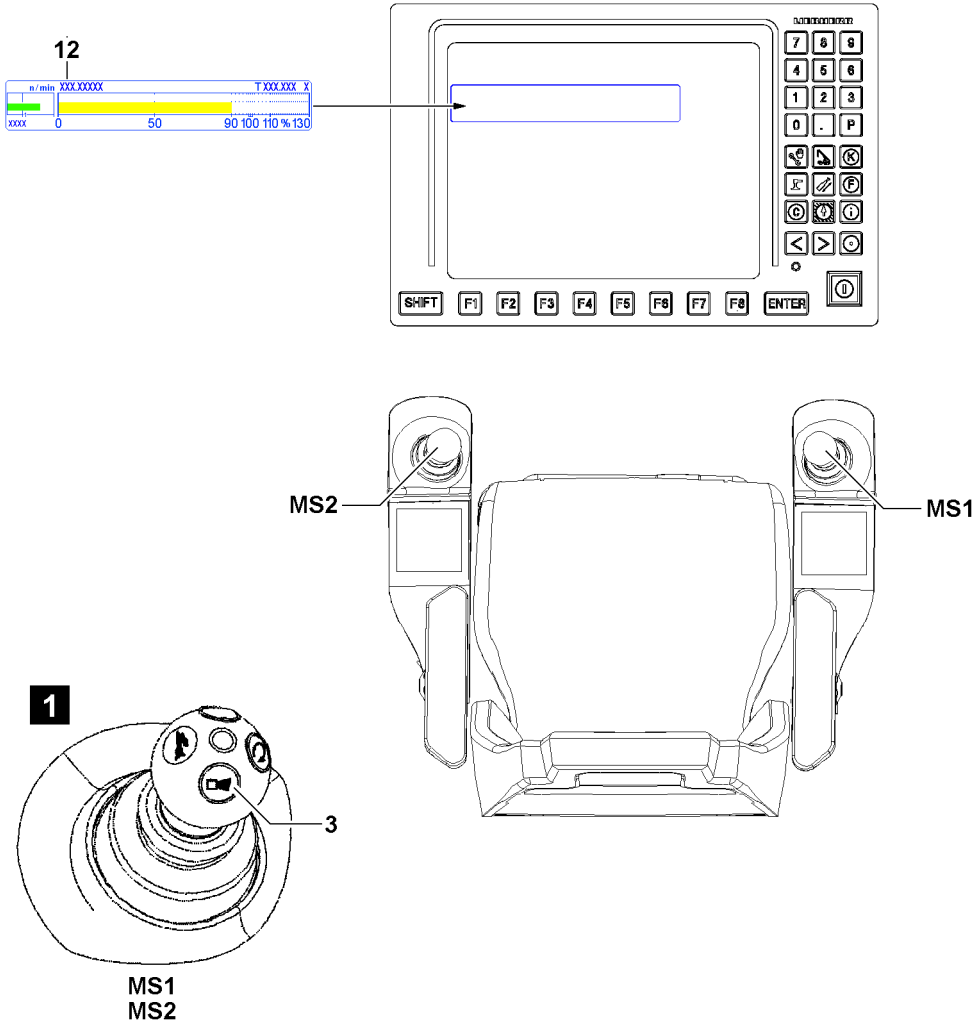


Fig.117250

**Note**

- ▶ For description of the situations assigned to the situation numbers, see chart „Overview of possible situations“
- ▶ The percentage values refer to the crane utilization according to the display in the bar diagram for utilization **12**.

The shut-off of the acoustical warnings outside the crane operator's cab is made by pressing the button **3** (signal horn / horn, illustration **1**) on master switch **MS1** or master switch **MS2**. The signal shut-off is effective no earlier than after five seconds.

Signal turntable		
Situation number	At utilization of crane	Signal type
<b>Situation 001</b>	0 % to 89 %	-
<b>Situation 002</b>	90 % to 100 %	-
<b>Situation 003</b>	Above 101 %	Intermittent sound, can be shut off after five seconds
<b>Situation 004</b>	Always	-
<b>Situation 005</b>	Above 101 %	Intermittent sound, can be shut off after five seconds
<b>Situation 006</b>	Always	Intermittent sound
<b>Situation 010</b>	Above 111 %	Intermittent sound, can be shut off after five seconds
<b>Situation 011<sup>1)</sup></b>	Always	Intermittent sound, can be shut off after five seconds
<b>Situation 020</b>	No display value	-

<sup>1)</sup> Is in part superseded by other warnings

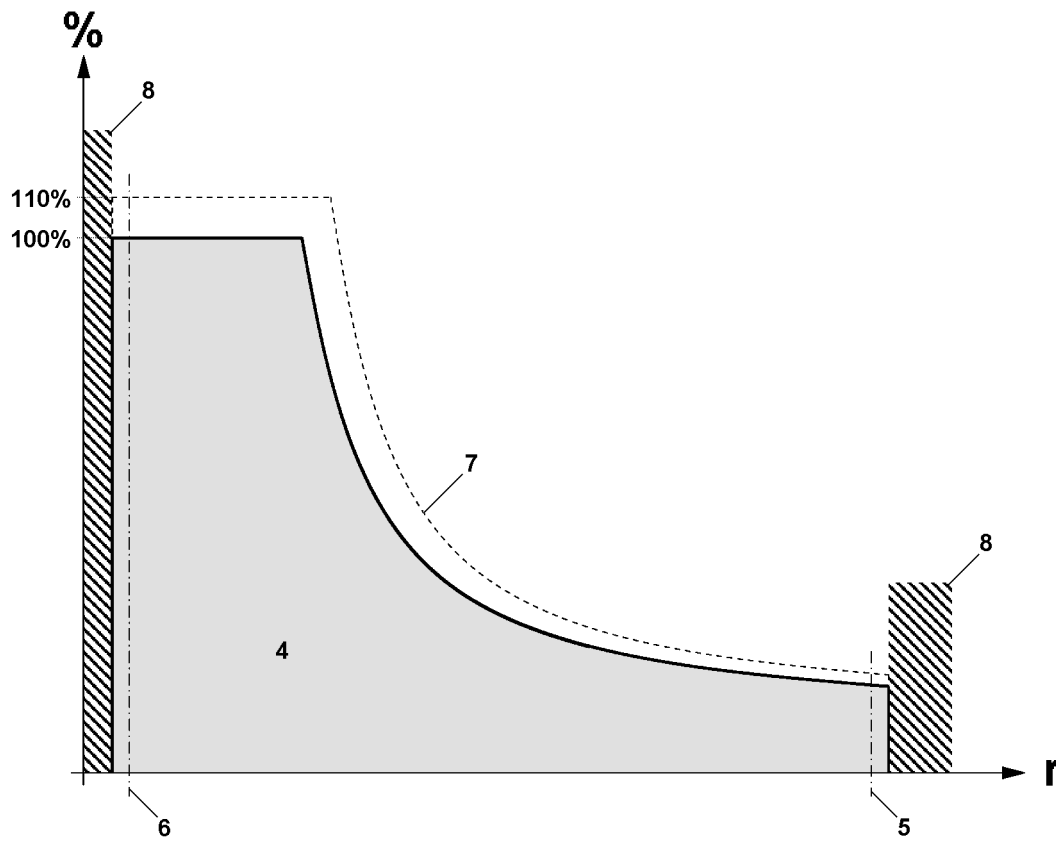


Fig.115265

LWE/LTR 1220-003/24204-02-02/en

## 2 Instructions for resuming crane movement



### WARNING

Danger of accident!

If the following points are not observed, personnel can be severely injured or killed.

- ▶ The crane operator bears the sole and full responsibility for the adherence to measures to be taken in case of shut-off of crane movement.

### 2.1 Overview Load chart

Sample overview of a load chart

Axle	Description
r	Boom radius (working radius)
%	Utilization of the crane in percentages

Position	Description
4	Range „Load chart available“
5	Lower limit angle load chart <sup>1)</sup>
6	Upper limit angle load chart <sup>2)</sup>
7	Curve utilization 110 %
8	Range „No load chart available“

<sup>1)</sup> Maximum boom radius of the boom within the load chart reached, the boom is located within the load chart in the flattest position

<sup>2)</sup> Minimum boom radius of the boom within the load chart reached, the boom is located within the load chart in the steepest position

### 2.2 Shut-off of crane movement

The LICCON overload protection carries out the following shut-offs if a limit value is exceeded during crane operation:

- Shut-off of overload
- Luffing the telescopic boom up / down shut-off
- Luffing the auxiliary boom / accessory up / down shut-off
- Telescoping the telescopic boom out shut-off (limit length)
- Telescoping the telescopic boom in shut-off
- Spooling the winch up / out shut-off
- Hoist top shut-off
- Crane movement with danger of tipping to the rear shut-off
- Maximum value F-load display shut-off
- Telescoping cylinder (pressure too high) shut-off
- Shut-off due to error message

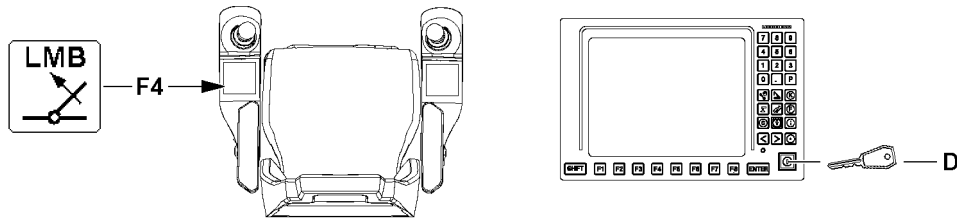


Fig.117251

**WARNING**

Erroneous operation of the crane!

If the LICCON overload protection turns the crane movement off, then the exact cause for the shut-off must be determined first.

- ▶ Determine the cause for the shut-off and remedy it if possible without pressing the key **F4** „Luffing in with suspended load“ or the set up key **D**.
- ▶ If it is not possible to reset the crane movement causing the shut-off, see section „Procedure for special cases at operation of the LICCON overload protection“.

### 2.2.1 Shut-off of overload

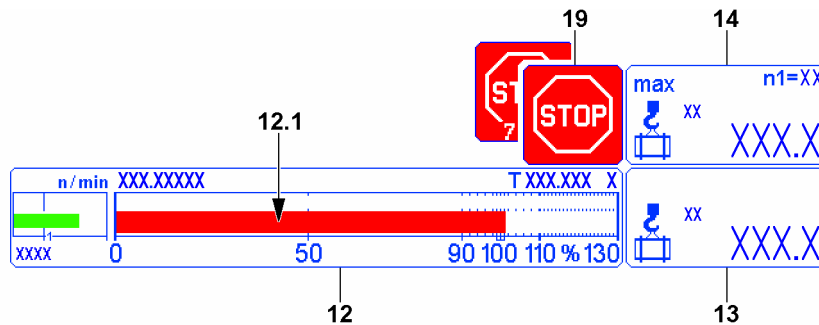


Fig.148656

In the bar diagram utilization **12** the utilization bar **12.1** exceeds the 100 % mark. The LICCON overload protection has turned off the crane movement, the LMB-STOP icon **19** appears. The actual load **13** has exceeded the maximum load **14**.

**Note**

The crane and load may be swaying.

If possible:

- ▶ Wait until the crane and load came to a complete standstill.

**Note**

Limit values for the load torque limiter for advance warning and shut-off reduced

If the limit values for the load torque limiter for advance warning and shut-off are reduced by the crane operator, shut-off takes place earlier according to the set value.

- ▶ Observe the settings of the limit values for the load torque limiter for advance warning and shut-off, see the crane operating instructions, chapter 4.02.

When the utilization bar diagram **12** levels off at less than or equal to 100 %:

- ▶ Carry out crane movements in such a way that no repeated shut-off by the LICCON overload protection occurs.

When the utilization bar diagram **12** levels off at more than 100 %:

- ▶ Check if there are permissible tasks, which positively influence the utilization of the crane.

When necessary and possible:

- ▶ Set down the load.





**Note**

It is possible that the following tasks can positively influence the utilization of the crane:

- ▶ Set down and reduce the load.
- ▶ Reduce the boom radius.
- ▶ Set down the load and reconfigure the crane to obtain higher load chart values.
- ▶ Set down the load and reduce the boom radius by changing over the crane.

- ▶ Carry out permissible tasks that reduce the utilization of the crane.

**Problem remedy**

Crane operation is limited because the maximum load **14** is seemingly too low or reached too soon?

- ▶ Make sure that the load bearing capacity of the crane is sufficient for the upcoming crane application.
- ▶ Make sure that a valid set up configuration has been entered in the LICCON computer system.
- ▶ Make sure that the crane is assembled according to the specifications in the Operating instructions.
- ▶ Make sure that the actual set up configuration and the entered set up status of the crane match.
- ▶ Make sure that all attachment parts and guy rods on the boom system, which are not needed, have been removed (weight).
- ▶ Make sure that the boom system is free of snow and ice (weight).
- ▶ Make sure that the environmental influences (for example wind influence) onto the crane are not too great.
- ▶ Contact Liebherr Service.

When the shut-off cannot be remedied despite the observance of all points listed here:

- ▶ Change to section „Procedure for special cases at operation of the LICCON overload protection“.

**2.2.2 Luffing the telescopic boom up / down shut-off**



**Note**

- ▶ The illustration of the icon **15** depends on the set up configuration of the crane.

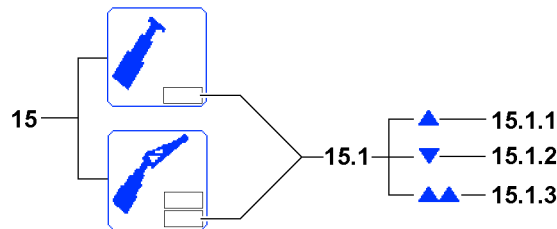


Fig.117253

In the icon **15** the arrow **15.1.1** or arrow **15.1.2** blinks and the LICCON overload protection has shut off the crane movement.

„Luffing the telescopic boom up“ (arrow **15.1.1**) or „Luffing the telescopic boom down“ (arrow **15.1.2**) was shut off because the upper / lower limit angle of the selected load chart was exceeded or fallen below.

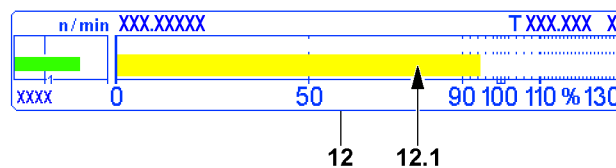


Fig.117254

LWE/LTR 1220-003/24204-02-02/en

**Note**

- ▶ If the utilization of the crane approaches 100 % (in the utilization bar diagram **12** the utilization bar **12.1** is just before 100 %) and the maximum load according to the load chart (falling load capacity) drops when continuing to luff up the boom, then the arrow **15.1.1** also appears and the „Luffing the telescopic boom up“ crane movement is turned off.

If the double arrow **15.1.3** appears, then:

- **either** it was luffed up to a limit switch or the limit switch has turned off the „Luffing the telescopic boom up“ crane movement
- **or** there is an error on one of the „Telescopic boom top“ limit switches

The arrow **15.1.1** appears and the „luffing the telescopic boom up“ crane movement is turned off:

- ▶ Luff the telescopic boom down.

**Result:**

- Crane operation is possible again.

The arrow **15.1.2** appears and the „luffing the telescopic boom down“ crane movement is turned off:

- ▶ Luff the telescopic boom up.

**Result:**

- Crane operation is possible again.

The double arrow **15.1.3** appears and the „Luffing the telescopic boom up“ crane movement is turned off:

- ▶ Luff the telescopic boom down.

**Result:**

- Crane operation is possible again.

**Problem remedy**

The double arrow **15.1.3** appears continuously?

If a double arrow **15.1.3** appears without having luffed the telescopic boom up to a limit switch, then there may be an error in the limit switches / sensors.

- ▶ Check if there is an error message from the LICCON computer system, see section „Shut-off due to error message“.
- ▶ If yes: Remedy the error immediately.

**WARNING**

Limited warning functions!

If one of the double version limit switches / sensors is not OK and the crane is continued to be operated, then the warning functions of the LICCON overload protection are limited.

- ▶ The crane can only be operated in an emergency after failure of a double limit switch.
- ▶ Carry out crane movements in such a way that no repeated shut-off by the LICCON overload protection occurs.

**2.2.3 Luffing the auxiliary boom / accessory up / down shut-off****Note**

- ▶ Only in operating modes with auxiliary boom / accessory
- ▶ The illustration of the icon **15** depends on the set up configuration of the crane.
- ▶ The designation „auxiliary boom / accessory“ comprises all boom types that are installed luffable / adjustable on the telescopic boom.

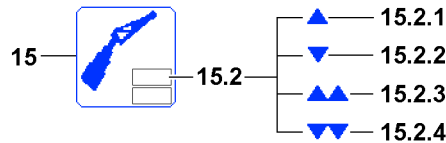


Fig.117255

The arrow **15.2.1** or arrow **15.2.2** blinks in the icon **15** (upper field) and the LICCON overload protection has shut off the crane movement.

„Luffing the auxiliary boom / accessory up“ (arrow **15.2.1**) or „Luffing the auxiliary boom / accessory down“ (arrow **15.2.2**) was shut off because the upper / lower limit angle of the selected load chart was exceeded or fallen below.

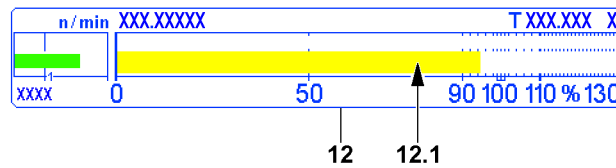


Fig.117254



### Note

- ▶ If the utilization of the crane approaches 100 % (in the utilization bar diagram **12** the utilization bar **12.1** is just before 100 %) and the maximum load according to the load chart (falling load capacity) drops when continuing to luff up the boom, then the arrow **15.2.1** also appears and the „Luffing the auxiliary boom / accessories up“ crane movement is turned off.

If the double arrow **15.2.3** appears, then:

- **either** it was luffed up to a limit switch or the limit switch has turned off the crane movement „Luffing the auxiliary boom / accessory up“
- **or** the mechanical relapse support has turned off the crane movement „Luffing the auxiliary boom / accessory up“
- **or** there is an error on one of the „Auxiliary boom / accessory top“ limit switches

If the double arrow **15.2.4** appears, then:

- **either** it was luffed down to a limit switch „Auxiliary boom / accessory bottom“ and the limit switch has turned off the crane movement „Luffing the auxiliary boom / accessory up“
- **or** there is an error on one of the „Auxiliary boom / accessory bottom“ limit switches

The arrow **15.2.1** appears and the crane movement „Luffing the auxiliary boom / accessory up“ was turned off:

- ▶ Luff the auxiliary boom / accessory down.

### Result:

- Crane operation is possible again.

The arrow **15.2.2** appears and the crane movement „Luffing the auxiliary boom / accessory down“ was turned off:

- ▶ Luff the auxiliary boom / accessory up.

### Result:

- Crane operation is possible again.

The double arrow **15.2.3** appears and the crane movement „Luffing the auxiliary boom / accessory up“ was turned off:

- ▶ Luff the auxiliary boom / accessory down.

### Result:

- Crane operation is possible again.

**Problem remedy**

The double arrow **15.2.3** appears continuously?

If a double arrow **15.2.3** appears without having luffed up to a limit switch, then there may be an error in the „Auxiliary boom / accessory top“ limit switches.

- ▶ Check if there is an error message from the LICCON computer system, see section „Shut-off due to error message“.
- ▶ If yes: Remedy the error immediately.

The double arrow **15.2.4** appears and the crane movement „Luffing the auxiliary boom / accessory down“ was turned off:

- ▶ Luff the auxiliary boom / accessory up.

**Result:**

- Crane operation is possible again.

**Problem remedy**

The double arrow **15.2.4** appears continuously?

If a double arrow **15.2.4** appears without having luffed down to a limit switch, then there may be an error in the limit switches / sensors.

- ▶ Check if there is an error message from the LICCON computer system, see the Diagnostics manual.
- ▶ If yes: Remedy the error immediately.

**WARNING**

Limited warning functions!

If one of the double version limit switches / sensors is not OK and the crane is continued to be operated, then the warning functions of the LICCON overload protection are limited.

- ▶ The crane can only be operated in an emergency after failure of a double limit switch / sensor.
- ▶ Carry out crane movements in such a way that no repeated shut-off by the LICCON overload protection occurs.

**2.2.4 Telescoping the telescopic boom out shut-off (limit length)**

Fig. 117258

An error message appears in the „Horn“ icon, illustration **1**. An acoustical signal sounds, the LICCON overload protection has interrupted the „Telescoping the telescopic boom out“ crane movement. Depending on the crane type, the double arrow in the icon **16** will also blink.

The „Telescoping the telescopic boom out“ crane movement was shut off because the **limit length** of the selected load chart has been exceeded.

- ▶ Telescope the telescopic boom in.

**Result:**

- Crane operation is possible again.

## 2.2.5 Telescoping the telescopic boom in shut-off

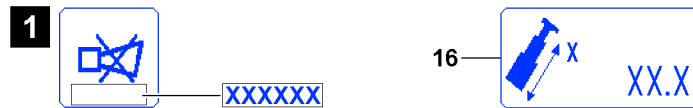


Fig.117258

An error message appears in the „Horn“ icon, illustration 1. An acoustical signal sounds, the LICCON overload protection has interrupted the „Telescoping the telescopic boom in“ crane movement. Depending on the crane type, the double arrow in the icon 16 will also blink.

The „Telescoping the telescopic boom in“ crane movement was shut off because the **limit length** of the selected load chart has been fallen below.

- ▶ Telescope the telescopic boom out.

**Result:**

- Crane operation is possible again.

## 2.2.6 Spooling the winch up / out shut-off

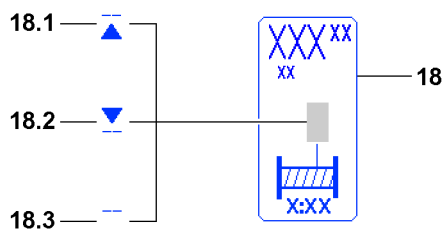


Fig.117256

The line / arrow 18.1, arrow / line 18.2 or line / line 18.3 appears in the icon 18 and the LICCON overload protection has shut off the crane movement.

„Spooling the winch out“ (line / arrow 18.1) or „Spooling the winch up“ (arrow / line 18.2) was shut off because the upper / lower limit value of the rope for the selected winch was exceeded or fallen below.

If the line / line 18.3 appears blinking in the icon 18, then the concerned winch is deactivated.

The line / arrow 18.1 appears and the „Spooling the winch out“ crane movement turns off:

- ▶ Spool the winch up.

**Result:**

- Crane operation is possible again.

The arrow / line 18.2 appears and the crane movement „Spooling the winch up“ was turned off:

- ▶ Spool the winch out.

**Result:**

- Crane operation is possible again.

The line / line 18.3 appears and the winch is deactivated:

- ▶ Activate the winch, see chapter 4.02.

**Result:**

- Crane operation is possible again.

### 2.2.7 Hoist top shut-off

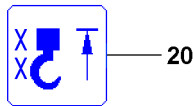


Fig.115281

The „hoist top“ 20 icon appears on the LICCON monitor and the LICCON overload protection has turned off crane movement.

Spooling the hoist winch up was turned off because the hook (hook block / load hook) has touched a hoist limit switch weight during the upward movement and the concerned hoist limit switch was triggered.



**WARNING**

Property damage / falling load!

- ▶ After shut-off spool hoist winch up (hoist top), for every further crane movement, the distance between the hook (hook block / load hook) and the boom head must be checked.



**Note**

- ▶ After a hoist top shut-off occurs, further crane movements, which affect the length of the hoist rope are also shut-off.

- ▶ Spool the hoist winch out.

**Result:**

- Crane operation is possible again.

### 2.2.8 Crane movement with danger of tipping to the rear shut-off



**Note**

- ▶ Applies only for cranes with support force monitoring\*.



**WARNING**

Danger of tipping backward!

When reaching the programmed minimum / maximum support force limits there is **no** automatic shut-off of crane movements.

**Exception:** When the two supports with the lowest forces are in the boom direction, then some crane movements which increase the „danger of tipping to the rear“ significantly are turned off.

- ▶ If there is a „danger of tipping to the rear“, luff the boom down carefully or telescope out until the support limit forces are again within the minimum / maximum values.

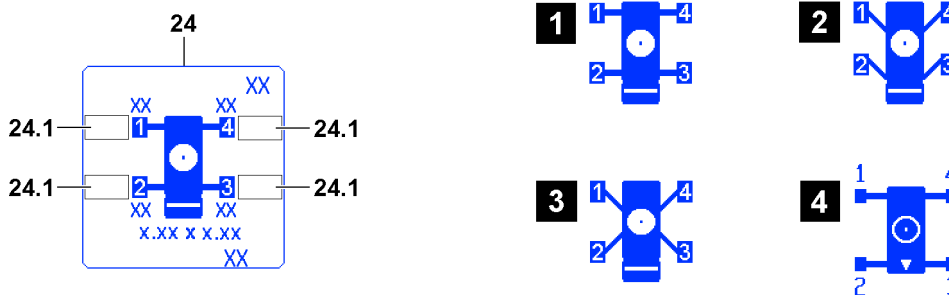


Fig.117257

LWE/LTR 1220-003/24204-02-02/en

The icon **24** (depending on the crane similarly to illustration **1** to illustration **4**) is shown on the LICCON monitor with blinking values in the fields **24.1** of the supports with the lowest forces. An acoustical signal sounds and the LICCON overload protection has shut off the crane movement.

Crane movements that increase the „danger of tipping to the rear“ significantly are turned off.

- ▶ Luff the boom down carefully until the support limit forces are again within the minimum / maximum values and no value in the fields **24.1** blinks any longer.

**Result:**

- Crane operation is possible again.



**Note**

Possibilities to counteract the tipping danger to the rear:

- ▶ Luff the boom down.
- ▶ Telescope the boom out.
- ▶ Reduce the counterweight.

## 2.2.9 Maximum value F-load display shut-off



**Note**

- ▶ Applies only for certain crane types with respective display on the second LICCON monitor.

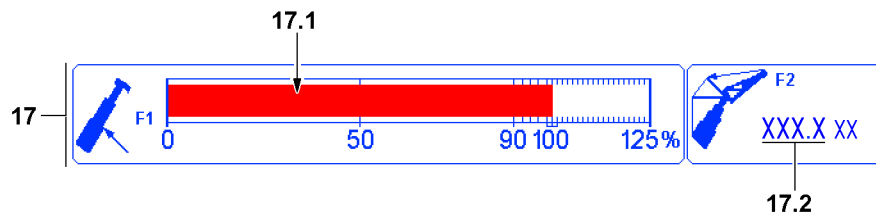


Fig.117259

- F1-utilization bar **17.1** = Test point F1 (luffing cylinder pressure display)
- F2-actual value **17.2** = Test point F2 (force of guying auxiliary boom / accessories)

**Note:** Appears only for a corresponding boom system

In the F-load display **17** the F1-utilization bar **17.1** exceeds the 100 % mark and the LICCON overload protection has shut off the crane movement.  $F1_{actual}$  has exceeded  $F1_{max}$ .

All subsequent movements, which lead to a deterioration of the force ratios on the test point F1, are shut off.

- ▶ Reverse any crane movement that has caused the shut-off.
- or**
- Initiate an alternative crane movement that improves the force ration on test point F1.

**Result:**

- Crane operation is possible again.
- ▶ Carry out crane movements in such a way that no repeated shut-off by the LICCON overload protection occurs.

**Problem remedy**

The crane operation is limited because the  $F1_{max}$  apparently is reached too early?

- ▶ Make sure that a valid set up configuration has been entered in the LICCON computer system.
- ▶ Make sure that the crane is assembled according to the specifications in the Operating instructions.
- ▶ Make sure that the actual set up configuration and the entered set up status of the crane match.
- ▶ Make sure that all attachment parts and guy rods on the boom system, which are not needed, have been removed (weight).
- ▶ Make sure that the boom system is free of snow and ice (weight).
- ▶ Make sure that the wind influence on the crane is not too great.

If no irregularities can be found:

- ▶ Contact Liebherr Service.

When the shut-off cannot be remedied despite the observance of all points listed here:

- ▶ Change to section „Procedure for special cases at operation of the LICCON overload protection“.

**2.2.10 Telescoping cylinder (pressure too high) shut-off****Note**

- ▶ Applies only for certain crane types with respective display on the second LICCON monitor.

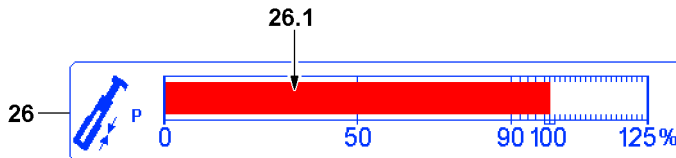


Fig.117260

In the icon **26** (telescoping cylinder pressure) the utilization bar **26.1** reaches the 100 % mark and the LICCON overload protection has shut off the crane movement.

All further movements, which directly lead to an increase of the telescoping cylinder pressure, are shut off.

- ▶ Lower the telescoping cylinder pressure by lowering the load.  
**or**  
Initiate an alternative crane movement that lowers the telescoping cylinder pressure.

**Result:**

- Crane operation is possible again.

During assembly operation:

Make sure that the specifications in the erection / take-down charts are observed.

- ▶ Check that the specifications are observed.

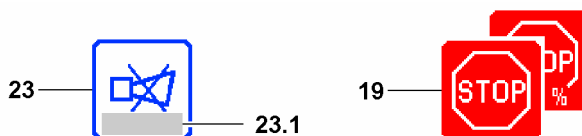
**2.2.11 Shut-off due to error message**

Fig.148297: Shut-off due to error message

In the icon **23** appears an error message, the icon **19** appears in the LICCON monitor and the LICCON overload protection has turned off crane movement.



- ▶ Determine the existing error with the help of the error message from the error field **23.1** in icon **23**, see Diagnostics manual.
- ▶ Rectify the error.

If the error cannot be remedied:

- ▶ Contact Liebherr Service.

---

**Problem remedy**

The erection of the crane, for example after assembly at a new job site or with another set up configuration, is not possible due to an error message?

- ▶ Evaluate the error message.
- ▶ Make sure that all electrical connections are established correctly.
- ▶ Check if all sensors are connected properly.
- ▶ Check if all end plugs (dust caps with integrated electric) have been connected properly.

**Note**

If there is a defect in an involved sensor (LMB), then the crane can no longer be operated in normal operating condition.

- ▶ Fix / replace the sensor, contact Liebherr Service if necessary.
-

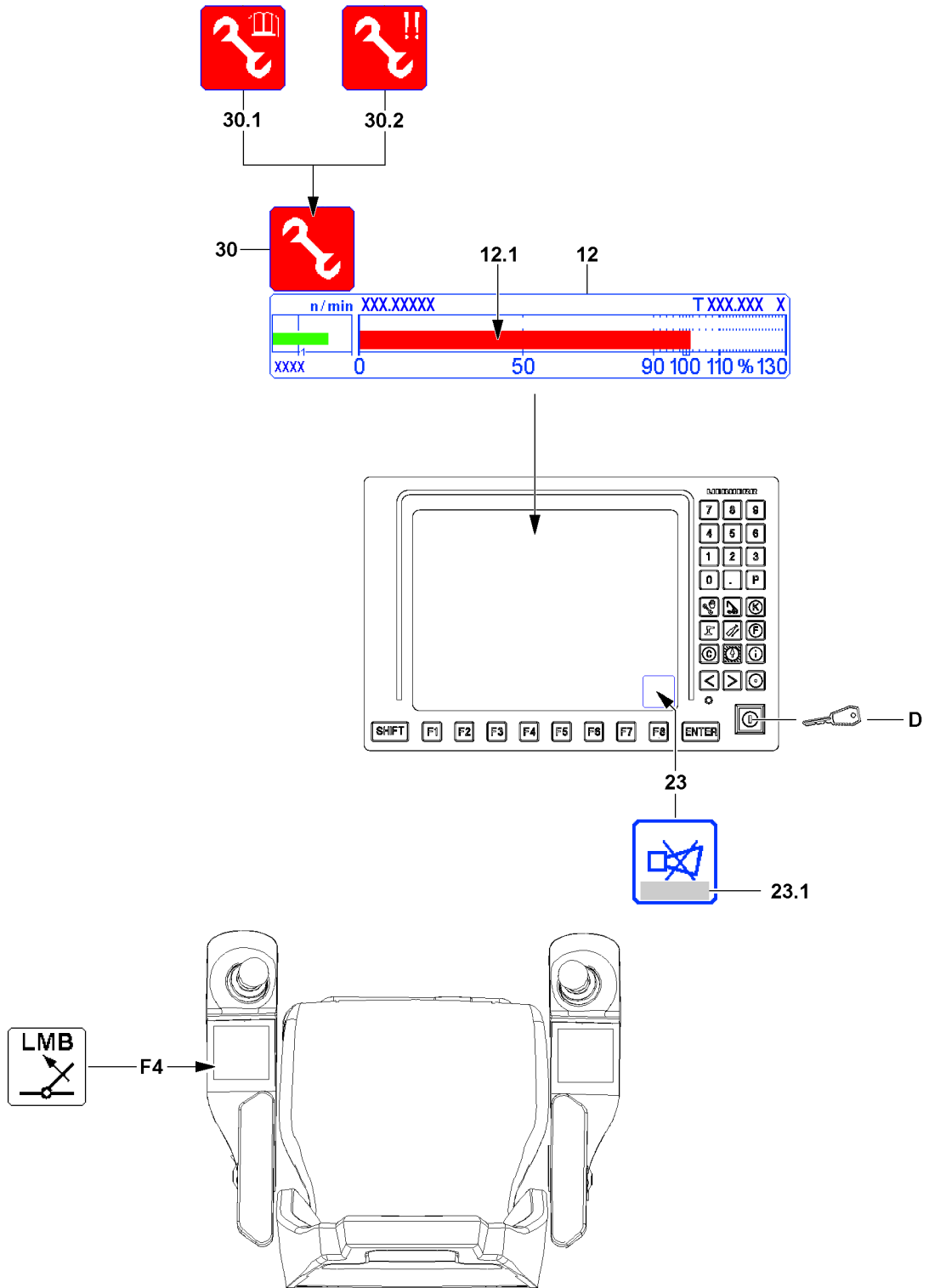


Fig.117261

LWE/LTR 1220-003/24204-02-02/en

## 2.3 Procedure for special cases at operation of the LICCON overload protection

Within the crane operator's cab, the following operating elements available for Special cases at operation of the LICCON overload protection:

- Button **F4** on the left control panel
- Set up key **D** on the right LICCON monitor

By pressing button **F4** and set up key **D** the functionality of the LICCON overload protection is accessed. If the set up key **D** is actuated, the assembly icon **30** appears in the LICCON monitor 0.

The assembly icon **30** appears, depending on the situation, also as:

- Assembly icon **30.1** - no load chart / assembly condition / sensor defect
- Assembly icon **30.2** - emergency operation (also with only one exclamation mark)

Error messages **23.1** also appear in the horn icon **23**:

- Observe and evaluate the error messages **23.1**, see also the Diagnostics manual.



### WARNING

Risk of overloading and toppling of the crane!

If the functionality of the LICCON overload protection intervenes without knowing the exact cause for the shut-off, then the crane can be overloaded and topple over.

Personnel can be severely injured or killed.

- ▶ Before accessing the functionality of the LICCON overload protection, determine the exact cause for the shut-off.
- ▶ Observe and evaluate the error messages **23.1**.



### WARNING

Intervention of the functionality of the LICCON overload protection!

When accessing the functionality of the LICCON overload protection, the LICCON overload protection is deactivated totally or limited.

It is possible to exceed several shut-off limits of the LICCON overload protection simultaneously or one after the other.

It is possible to carry out crane movements that are not monitored by the LICCON overload protection. Without the LICCON overload protection, no additional protection against overload of the crane via the crane control is present.

- ▶ When accessing the functionality of the LICCON overload protection, take into account that the LICCON overload protection is deactivated totally or is limited.
- ▶ Only access the functionality of the LICCON overload protection according to the specifications in the operating instructions.
- ▶ Outside of the load charts, the data in the erection / take-down charts is binding.



### WARNING

Leaving the load chart!

If the set up key **D** is actuated, it is possible that the crane leaves the range of the load charts.

Without a load chart, various display values are no longer displayed on the crane operating screen.

A load on the hook can no longer be monitored by the LICCON overload protection.

Severe accidents due to crane overload can result.

Personnel can be severely injured or killed.

- ▶ Do not leave the range of the load charts.

**WARNING**

Danger of accident due to incorrect procedure!

Due to erroneous operation or deliberate misuse, the crane could collapse, the boom can break off or the crane can topple over.

Button **F4** „Luffing in at suspended load“ and set up key **D** may only be actuated when it is ensured that without their actuation no normal operating status (see section „operating status of the crane“) can be reached.

- ▶ Actuate the set up key **D** only when no normal operating status can be reached with the button **F4** „Luffing in with suspended load“.
- ▶ The set up key **D** may only be actuated by persons who are aware of the effects of their acts regarding the intervention of the functionality of the LICCON overload protection.
- ▶ Intervention of the functionality of the LICCON overload protection requires the presence of an authorized person and must be performed with utmost caution.
- ▶ Accessing the functionality of the LICCON overload protection is prohibited in normal crane operation.

**WARNING**

Expanded working / danger zone of the crane!

Due to an access the functionality of the LICCON overload protection it is possible that the working / danger zone of the crane is significantly expanded.

If these circumstances are not observed, collisions and accidents can occur.

Personnel can be severely injured or killed.

- ▶ During a special case at operation of the LICCON overload protection take an expanded working / danger zone of the crane into account and monitor it.

**WARNING**

Overload of crane!

Luffing in / pulling in of a load standing on the ground is not permissible.

When picking up a load by luffing the boom up, the crane can be overloaded.

This could result in serious accidents.

- ▶ Taking on load by luffing up the boom is prohibited.
- ▶ Pick up a load only with the hoist gear.

**WARNING**

Self-blocking of the overload protection (Deadlock)

After activation of the „exceeding the shut-off limits of the LICCON overload protection“ function, if no crane movements that lead immediately to a normal operating status (see section „operating status of the crane“) are initiated, then the overload protection can be self-blocked (Deadlock).

In the case of a self-blocked overload protection, it is no longer possible to control the crane.

- ▶ After activation of the function „exceeding the shut-off limits of the LICCON overload protection“ initiate crane movements that lead immediately to a normal operating condition (see section „operating condition of the crane“).

**Possible limitation in the crane control during certain „Special cases for operation of the LICCON overload protection“:**

- During certain „Special cases for operation of the LICCON overload protection“ the shut-off limits of the overload protection can be exceeded to maximum 110 % by pressing the set up key **D**
- During certain „Special cases at operation of the LICCON overload protection“, the working speed of the crane is significantly reduced.
- During certain „Special cases at operation of the LICCON overload protection“, the possibility to control the crane is limited in time.
- During certain „Special cases at operation of the LICCON overload protection“, the individual display instruments show no values.

**Note**

Depending on the number of load positions, the display in the utilization bar diagram **12** changes for certain crane types.

- ▶ If an additional utilization bar appears next to the utilization bar **12.1**, then the description applies accordingly.
- ▶ For a detailed description of the utilization bar diagram **12**, see chapter 4.02.

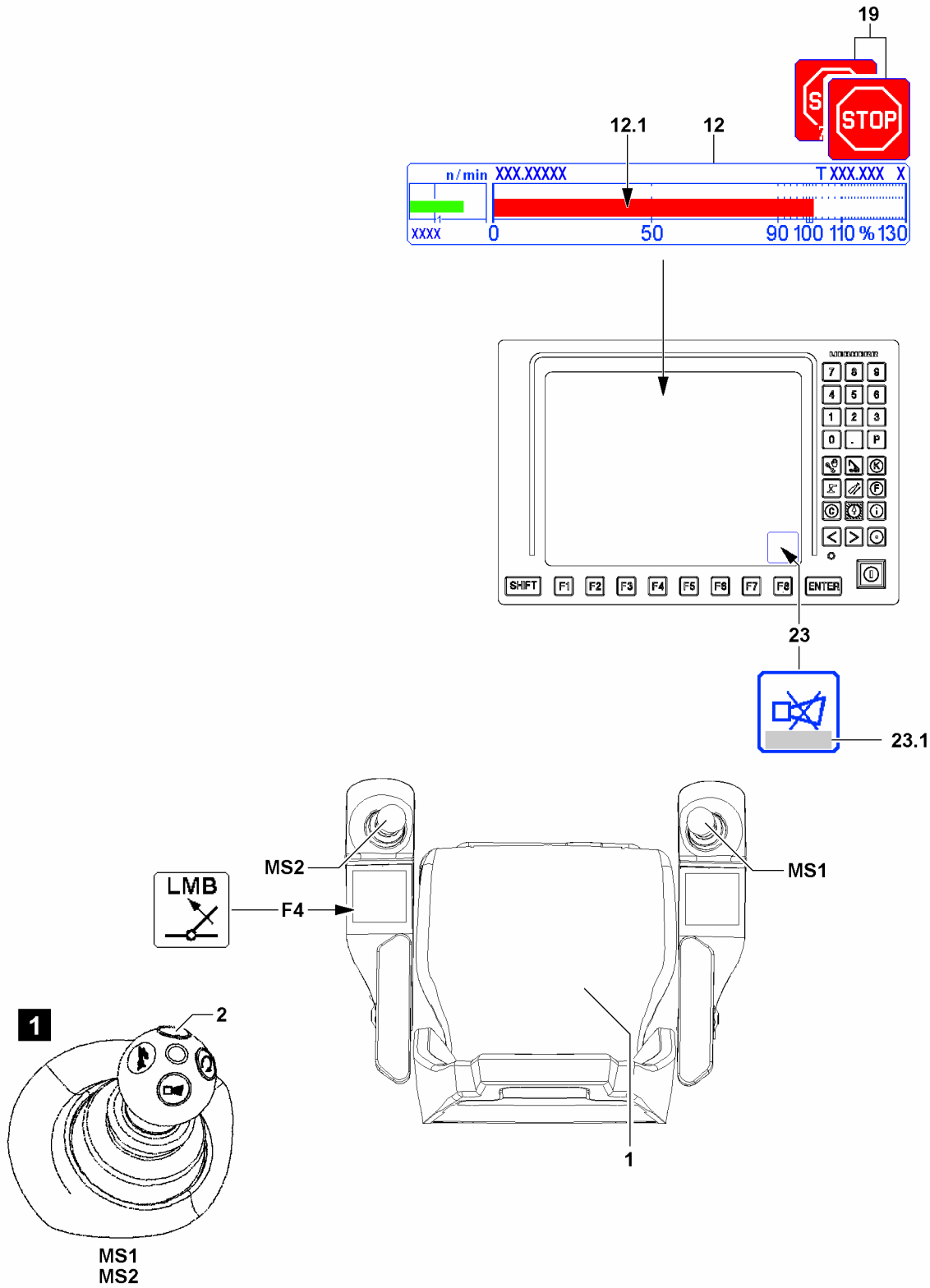


Fig.148660

LWE/LTR 1220-003/24204-02-02/en

### 2.3.1 Luffing in with a suspended load

If the maximum permissible load torque is exceeded, the LICCON overload protection turns off all crane movements that increase the load torque.

In the bar diagram utilization **12** (load moment display) the utilization bar **12.1** is red (shut-off limit value exceeded) and the LICCON monitor displays the icon **19**.



#### Note

Limit values for the load torque limiter for advance warning and shut-off reduced

If the limit values for the load torque limiter for advance warning and shut-off are reduced by the crane operator, shut-off takes place earlier according to the set value.

- ▶ Observe the settings of the limit values for the load torque limiter for advance warning and shut-off, see the crane operating instructions, chapter 4.02.

This shut-off limit can be exceeded by actuating the button **F4** „Luffing in with suspended load“.

Make sure that the following prerequisites are met:

- The load hangs freely.
- The load hook / hook block and boom system have no ground contact.
- Either the seat contact button **1** or one of the buttons **2** (illustration **1**) of the master switches (MS1, MS2) is actuated.



#### Note

If the load is reduced by luffing up or the values in the utilization bar diagram **12** are exceeded too much, then the „Luffing in with suspended load“ button **F4** is possibly not functioning.

- ▶ Pay attention to notes regarding error messages **23.1** occurring in the horn **23** icon.
- ▶ For the procedure when the „Luffing in with suspended load“ button **F4** is not functioning, see section „Exceedance of maximum permissible load moment“.

- ▶ Press the „luffing in with suspended load“ button **F4** and hold it.

#### Result:

- The LICCON overload protection is inactive.
- ▶ Luff the load in.

The „Luffing in with suspended load“ function is deactivated:

- When the „luffing in with suspended load“ button **F4** is not longer actuated.
- When neither the seat contact button **1** nor one of the buttons **2** of the master switches (MS1, MS2) is actuated.

The „Luffing in with a suspended load“ function is deactivated:

- The LICCON overload protection is active.
- ▶ Carry out crane movements in such a way that no repeated shut-off by the LICCON overload protection occurs.

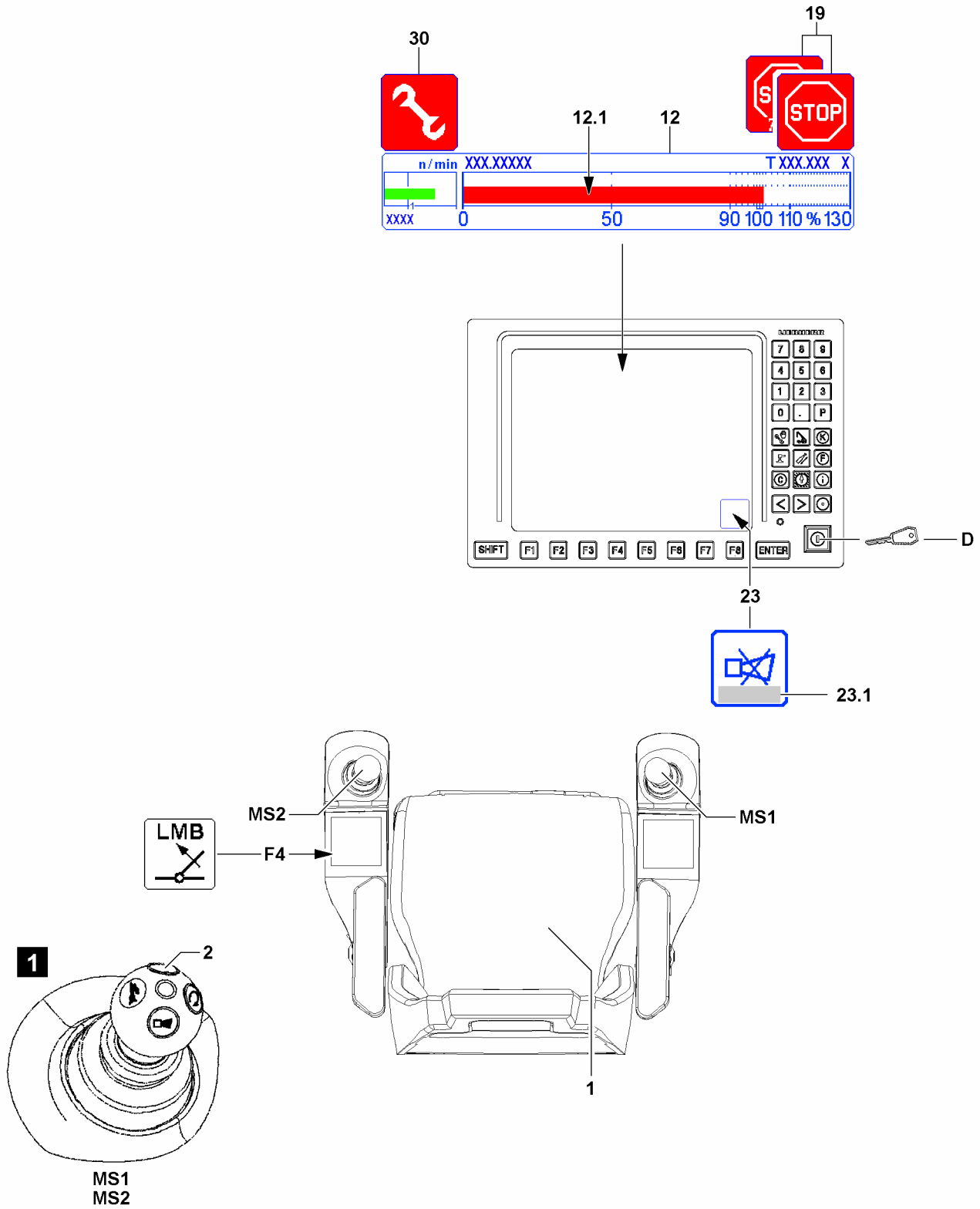


Fig.148661

LWE/LTR 1220-003/24204-02-02/en



### 2.3.2 To exceed the maximum permissible load moment

If the maximum permissible load torque is exceeded, the LICCON overload protection turns off all crane movements that increase the load torque.

In the bar diagram utilization **12** (load moment display) the utilization bar **12.1** is red (shut-off limit value exceeded) and the LICCON monitor displays the icon **19**.



#### Note

Limit values for the load torque limiter for advance warning and shut-off reduced

If the limit values for the load torque limiter for advance warning and shut-off are reduced by the crane operator, shut-off takes place earlier according to the set value.

- ▶ Observe the settings of the limit values for the load torque limiter for advance warning and shut-off, see the crane operating instructions, chapter 4.02.

This limit value can be exceeded via the set up key **D** in the „right touching“ position.



#### WARNING

Shut off safety device!

If the function „Exceedance of shut-off limits of LICCON overload protection“ is activated by actuating the set up key **D** then it is possible to exceed the maximum permissible load torque.

- ▶ All notes regarding the „Special cases at operation of LICCON overload protection“ must be observed.

The set up key **D** on the LICCON monitor has two positions:

- Operating position (not actuated): Crane is in normal operation.
- Position to right (touching): The function „Exceedance of shut-off limits of the LICCON overload protection“ is activated, the assembly icon **30** appears in the LICCON monitor.

Make sure that the following prerequisites are met:

- With the „Luffing in with suspended load“ button **F4**, a normal operating condition (utilization below 100 % and no active shut-off) cannot be reached.
- All master switches are in the zero position (not deflected).
- Either the seat contact button **1** or one of the buttons **2** (illustration **1**) of the master switches (MS1, MS2) is actuated.
- The crane is in the range of a load chart.



#### Note

If the values in the bar diagram utilization **12** are exceeded too far, then the functionality of the set up key **D** may be disabled.

- ▶ Pay attention to notes regarding error messages **23.1** occurring in the horn **23** icon.

- ▶ Turn the set up key **D** to the right (touching).

#### Result:

- The LICCON overload protection is inactive.
- The assembly icon **30** appears on the LICCON monitor.

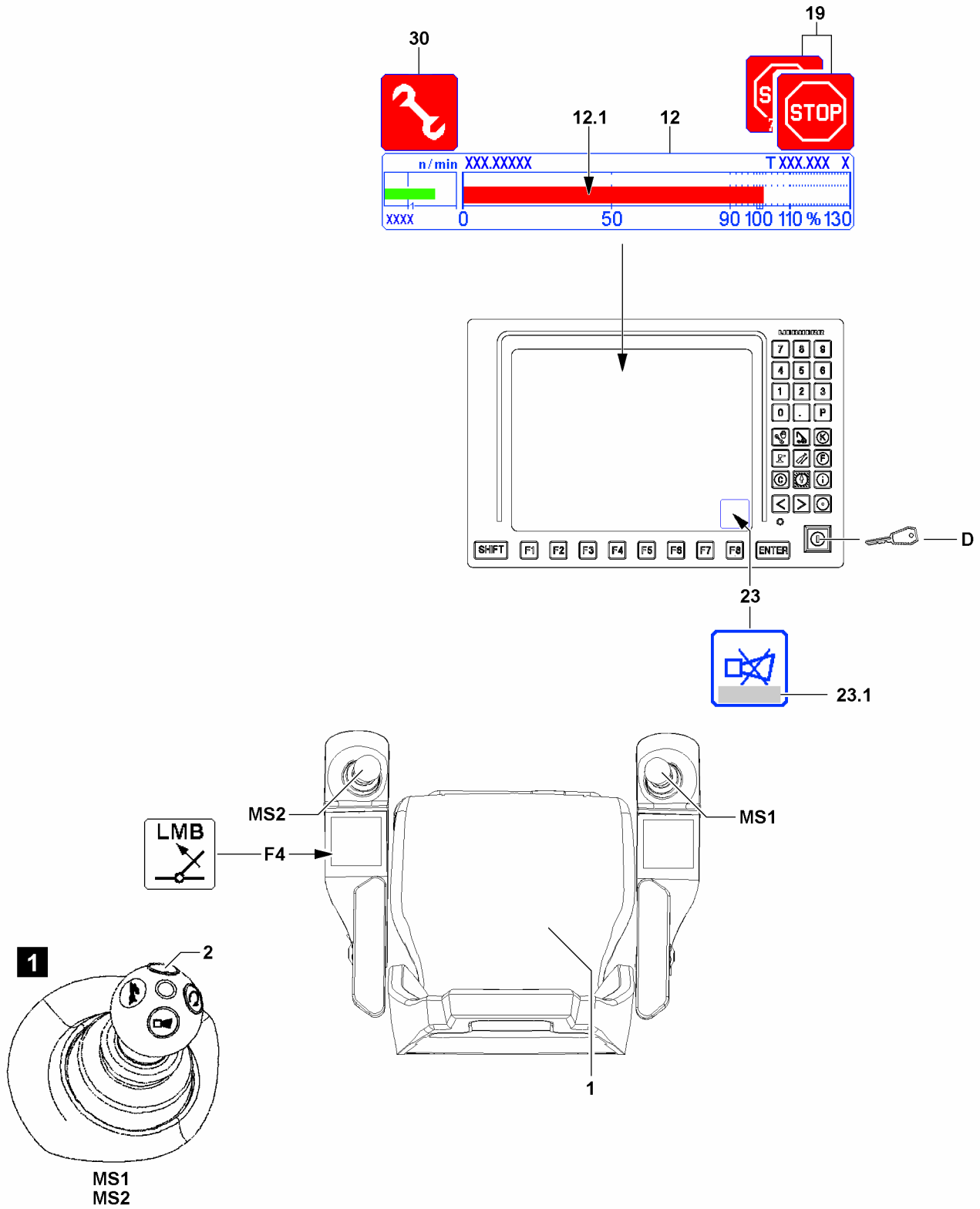


Fig.148661

LWE/LTR 1220-003/24204-02-02/en

- ▶ Initiate crane movements which lead immediately to a normal operating condition (see section „operating condition of the crane“).

The „Exceedance of shut-off limits of LICCON overload protection“ function turns off immediately also:

- If the set up key **D** is actuated again.
- If all master switches are in neutral position for 10 seconds.
- When neither the seat contact button **1** nor one of the buttons **2** of the master switches (MS1, MS2) is actuated.
- When a hoist top shut-off occurs.



---

**Note**

- ▶ The function „Exceedance of shut-off limits of the LICCON overload protection“ is only turned off when the assembly icon **30** in the LICCON monitor turns off.
- ▶ If the „Exceedance of shut off limits of the LICCON overload protection“ function does not turn off after pressing the set up key **D** once, then press the set up key **D** again until the assembly icon **30** on the LICCON monitor turns off.

---

The „Exceedance of shut-off limits of the LICCON overload protection“ function has / was shut off:

- The assembly icon **30** in the LICCON monitor turns off.
- The working speed is possibly reduced until all master switches are in the zero position at the same time.
- ▶ Make sure that the assembly icon **30** no longer appears on the LICCON monitor.
- ▶ Carry out crane movements in such a way that no repeated shut-off by the LICCON overload protection occurs.

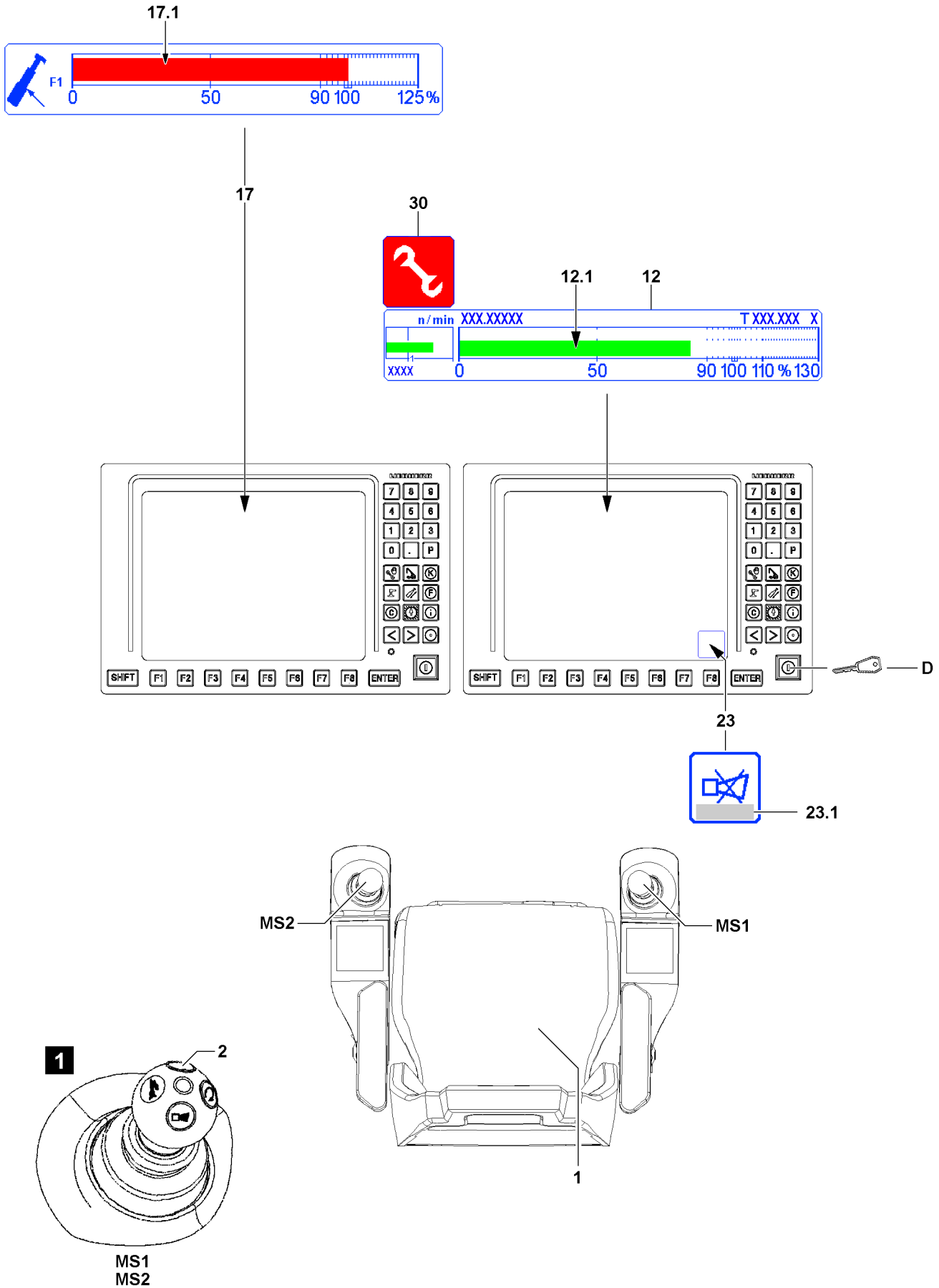


Fig.117264

LWE/LTR 1220-003/24204-02-02/en

### 2.3.3 To exceed the maximum value of the F-load display in crane operation.



#### Note

- ▶ Applies only for certain crane types with respective display on the second LICCON monitor.



#### WARNING

Shut off safety device!

If the maximum value of the F-load display is exceeded by pressing the set up key **D**, then the function „Exceedance of shut-off limits of the LICCON overload protection“ is automatically activated. Thus there is no shut-off if the maximum permissible load moment is exceeded.

- ▶ All notes regarding the „Special cases at operation of LICCON overload protection“ must be observed.
- ▶ The utilization bar **12.1** of the bar diagram utilization **12** must be observed.
- ▶ The F1-utilization bar **17.1** of the F-load display **17** must be observed.



#### Note

- ▶ See also section „Maximum values of F-load display reached“.

On the F1-load display **17**, the utilization bar<sub>actual</sub> **17.1** exceeds the 100 % mark and the LICCON overload protection has shut off the crane movement.  $F1_{actual}$  has exceeded the  $F1_{max}$  value.

All other movements that lead to a decline of the force ratio in the F-load display **17** are turned off.



#### Note

If the values in the F-load display **17** or in the utilization bar diagram **12** are outside the permissible range, then the functionality of the set up key **D** may be disabled.

- ▶ Pay attention to notes regarding error messages **23.1** occurring in the horn **23** icon.

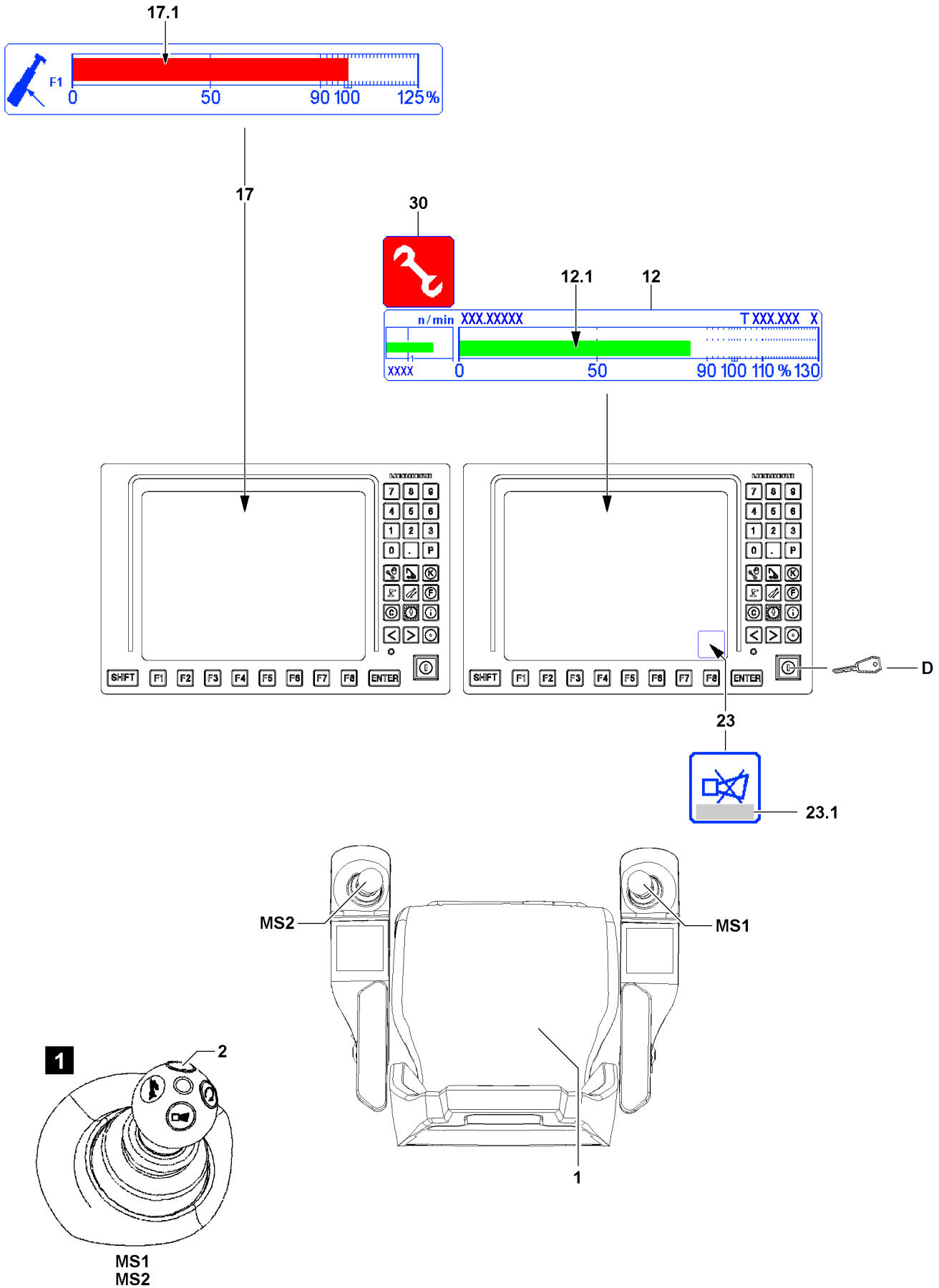


Fig.117264

LWE/LTR 1220-003/24204-02-02/en

Make sure that the following prerequisites are met:

- All master switches are in the zero position (not deflected).
- Either the seat contact button **1** or one of the buttons **2** (illustration **1**) of the master switches (MS1, MS2) is actuated.
- The crane is in the range of a load chart.
- ▶ Turn the set up key **D** to the right (touching).

**Result:**

- The function „Exceedance of shut-off limits of the LICCON overload protection“ is activated. As a result the maximum value of the F-load display can be exceeded.
- The assembly icon **30** appears.
- $F_{1_{\max}}$  can be exceeded.
- ▶ Initiate crane movements which lead immediately to a normal operating condition (see section „operating condition of the crane“).

The „Exceedance of shut-off limits of LICCON overload protection“ function turns off immediately also:

- If the set up key **D** is actuated again.
- If all master switches are in neutral position for 10 seconds (with load chart available).
- When neither the seat contact button **1** nor one of the buttons **2** of the master switches (MS1, MS2) is actuated.
- When a hoist top shut-off occurs.



**Note**

- ▶ The function „Exceedance of shut-off limits of the LICCON overload protection“ is only turned off when the assembly icon **30** in the LICCON monitor turns off.
- ▶ If the „Exceedance of shut off limits of the LICCON overload protection“ function does not turn off after pressing the set up key **D** once, then press the set up key **D** again until the assembly icon **30** on the LICCON monitor turns off.

The „Exceedance of shut-off limits of the LICCON overload protection“ function has / was shut off:

- The assembly icon **30** in the LICCON monitor turns off.
- The working speed is possibly reduced until all master switches are in the zero position at the same time.
- ▶ Make sure that the assembly icon **30** no longer appears on the LICCON monitor.
- ▶ Carry out crane movements in such a way that no repeated shut-off by the LICCON overload protection occurs.

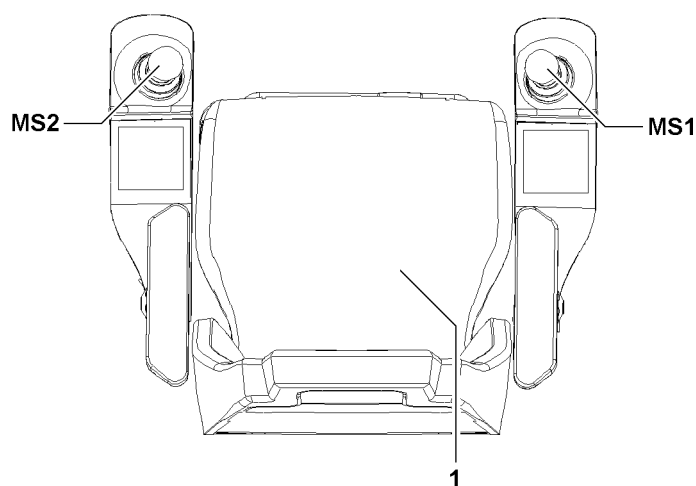
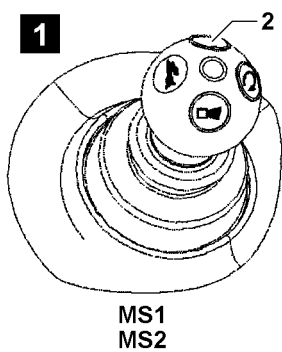
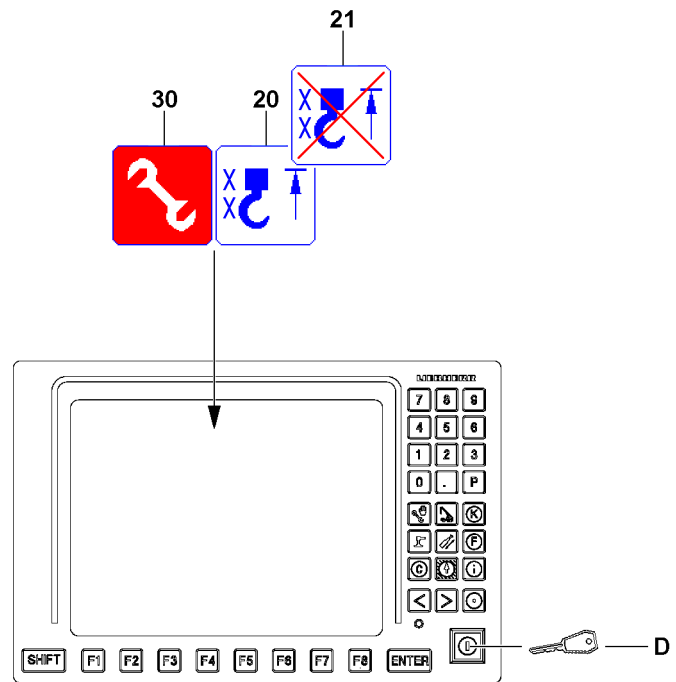


Fig.117265

LWE/LTR 1220-003/24204-02-02/en



## 2.4 Bypassing the hoist top shut-off



### WARNING

Improper use of the function „Bypass of hoist top shut-off“!

- ▶ The function „Bypass of hoist top shut-off“ may never be used to increase the lifting height during crane operation.



### WARNING

Property damage and falling load!

If the function „Bypass of hoist top shut-off“ is activated, there is the danger that the hook (hook block / load hook) is pulled against the pulley head.

This danger exists especially when the hoist winch is continued to be spooled up and for crane movements that have an influence on the hoist rope, for example luffing the telescopic boom or the auxiliary boom / accessory.

Property damage and falling load can result.

Personnel can be severely injured or killed.

- ▶ The „Bypass of hoist top shut-off“ function is only possible if the crane operator is able to determine otherwise that there is a sufficient distance between hook block / load hook and boom head.
- ▶ Carry out all crane movements with utmost caution.



### Note

- ▶ A bypass of the hoist top shut off is only possible in some circumstances when the shut-off has already occurred due to a triggered hoist limit switch.
- ▶ For assembly purposes or in emergency cases, if the activation of the function „Bypass of hoist top shut-off“ **and** activation of the function „Exceedance of shut-off limits of the LICCON overload protection“ is necessary, then the set up key **D** must be actuated until the icon **21** and assembly icon **30** appear.

Spooling the hoist winch up was turned off because the hook (hook block / load hook) has touched a hoist limit switch weight during the upward movement and the concerned hoist limit switch was triggered.

Make sure that the following prerequisites are met:

- A hoist top shut-off has occurred, the hoist top icon **20** appears on the LICCON monitor.
- Either the seat contact button **1** or one of the buttons **2** (illustration **1**) of the master switches (MS1, MS2) is actuated.
- All master switches are in the zero position (not deflected).

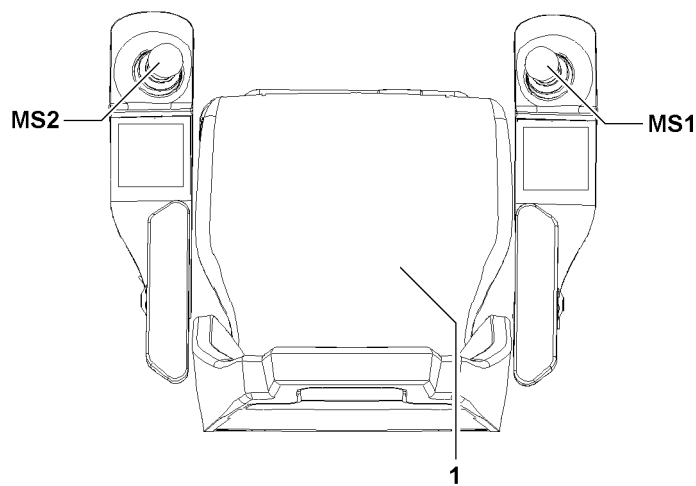
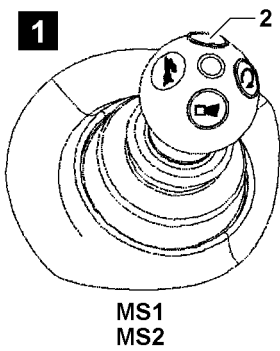
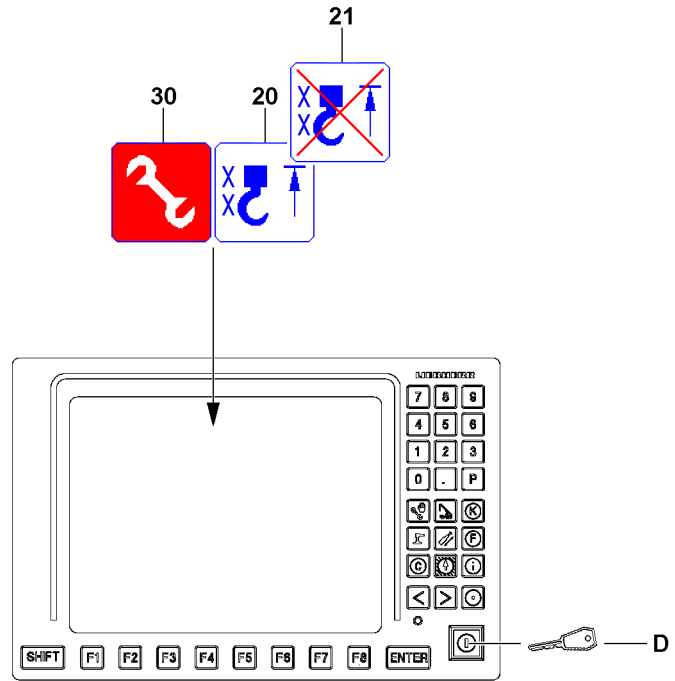


Fig.117265

LWE/LTR 1220-003/24204-02-02/en

- To bypass the hoist top shut-off, a combined actuation of the set up key **D** and at least one master switch (MS1, MS2) is required.
- ▶ Turn the set up key **D** to the right (touching).

**Result:**

- The assembly icon **30** (assembly operation) appears on the LICCON monitor.
- The hoist top icon **20** on the LICCON monitor changes to the icon **21**.

**Note**

- ▶ Depending on the situation, it may be possible that the bypass of the hoist top shut-off only remains active as long as the master switch (MS1, MS2) is deflected.

Within 10 seconds, if the master switch (MS1, MS2) to lift the hoist gear is deflected, the hoist limit switches are bypassed.

- ▶ Carry out a crane movement with utmost caution and by taking the safety guidelines into account.

The function „Bypass of the hoist top shut-off“ turns off:

- If the set up key **D** is actuated again.
- When no master switch (MS1, MS2) is deflected for 10 seconds.
- When neither the seat contact button **1** nor one of the buttons **2** of the master switches (MS1, MS2) is actuated.
- If there is no longer a shut-off of a hoist limit switch.

The function „Bypass of the hoist top shut-off“ has / was turned off:

- The assembly icon **30** (assembly operation) in the LICCON monitor turns off.
- The icon **21** on the LICCON monitor turns off.
- ▶ Make sure that the assembly icon or the assembly icon **30** (assembly operation) as well as the icon **21** no longer appear on the LICCON monitor.
- ▶ Carry out the crane movements in such a way that no repeated hoist top shut-off occurs.

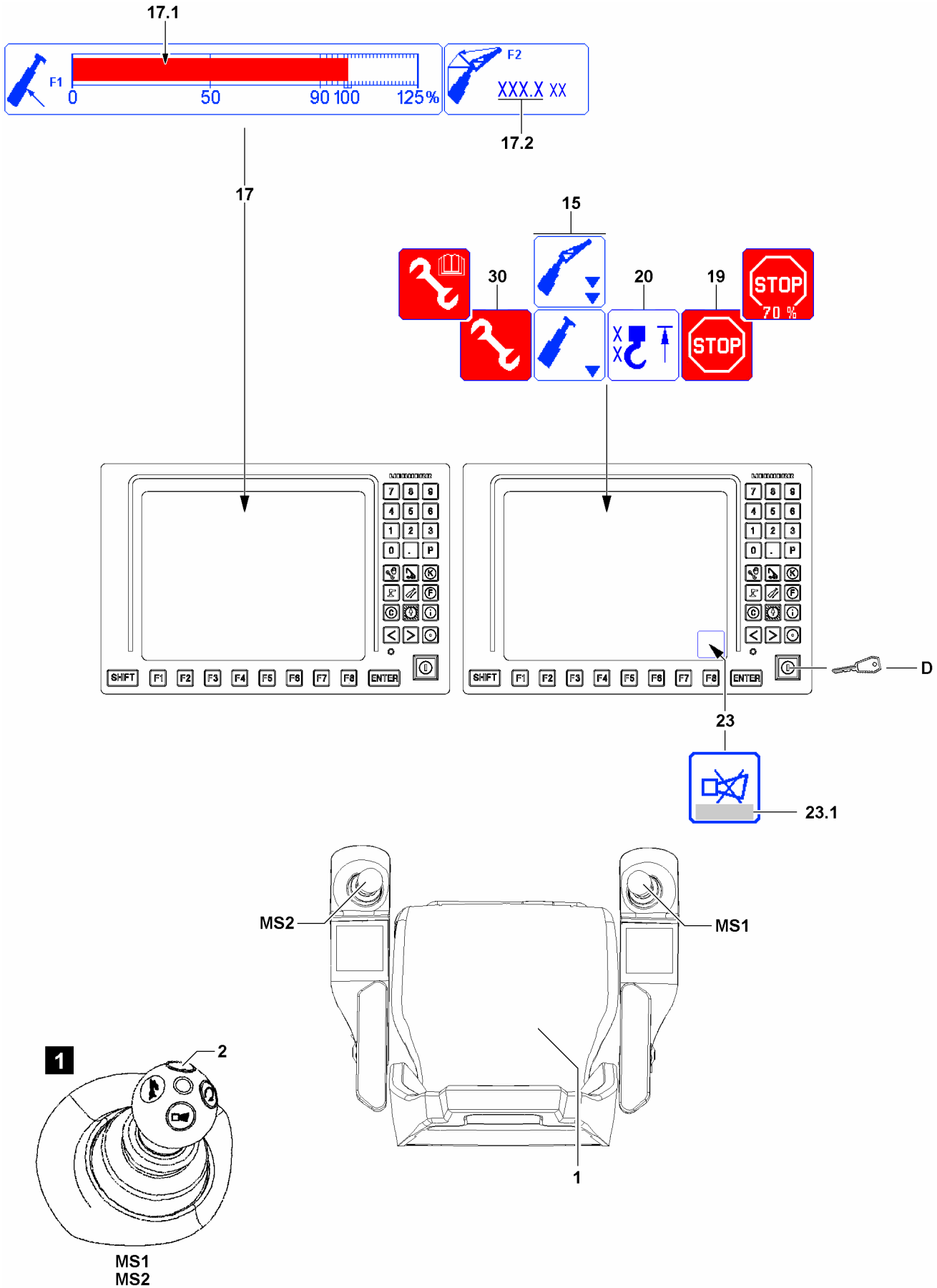


Fig.148662

LWE/LTR 1220-003/24204-02-02/en

## 2.5 Carrying out the erection / take down procedures

To carry out the erection / take down procedures and assembly procedures, the LICCON overload protection can be bypassed with the set up key **D**.



### Note

- ▶ If the crane is in the „No load chart available“ range, then there is a shut-off of the crane control by the LICCON overload protection. The icon **19** appears on the LICCON monitor.
- ▶ By pressing the set up key **D** all erection / take down procedures and assembly procedures can be carried out according to the specifications in the Operating instructions.



### WARNING

Danger of accident during erection / take down procedures!

If the specifications of the Operating instructions are not observed, the crane can collapse, the boom can break off or the crane can topple over.

Personnel can be severely injured or killed.

- ▶ Make sure to adhere to all specifications in the Operating instructions.
- ▶ Press the set up key **D** only when the set up configuration has been entered correctly in the LICCON computer system and matches the actual situation.

### Additional information for cranes with an F-load display:

- F1-load display  
Luffing cylinder pressure display
- F2-load display  
Force of guying Auxiliary boom / accessory

#### Note:

Appears only for corresponding boom system



### Note

The permissible maximum value corresponds to 100 % in the bar display.

- ▶ The F1-utilization bar **17.1** shows the relationship  $F1_{\text{actual}}$  to  $F1_{\text{max}}$ .
- ▶ F2-load display, the F2 value<sub>actual</sub> **17.2** is only shown. .
- ▶ When leaving the „load chart available“ range, the display of the assembly icon **30** changes.
- ▶ Pay attention to error messages **23.1**.

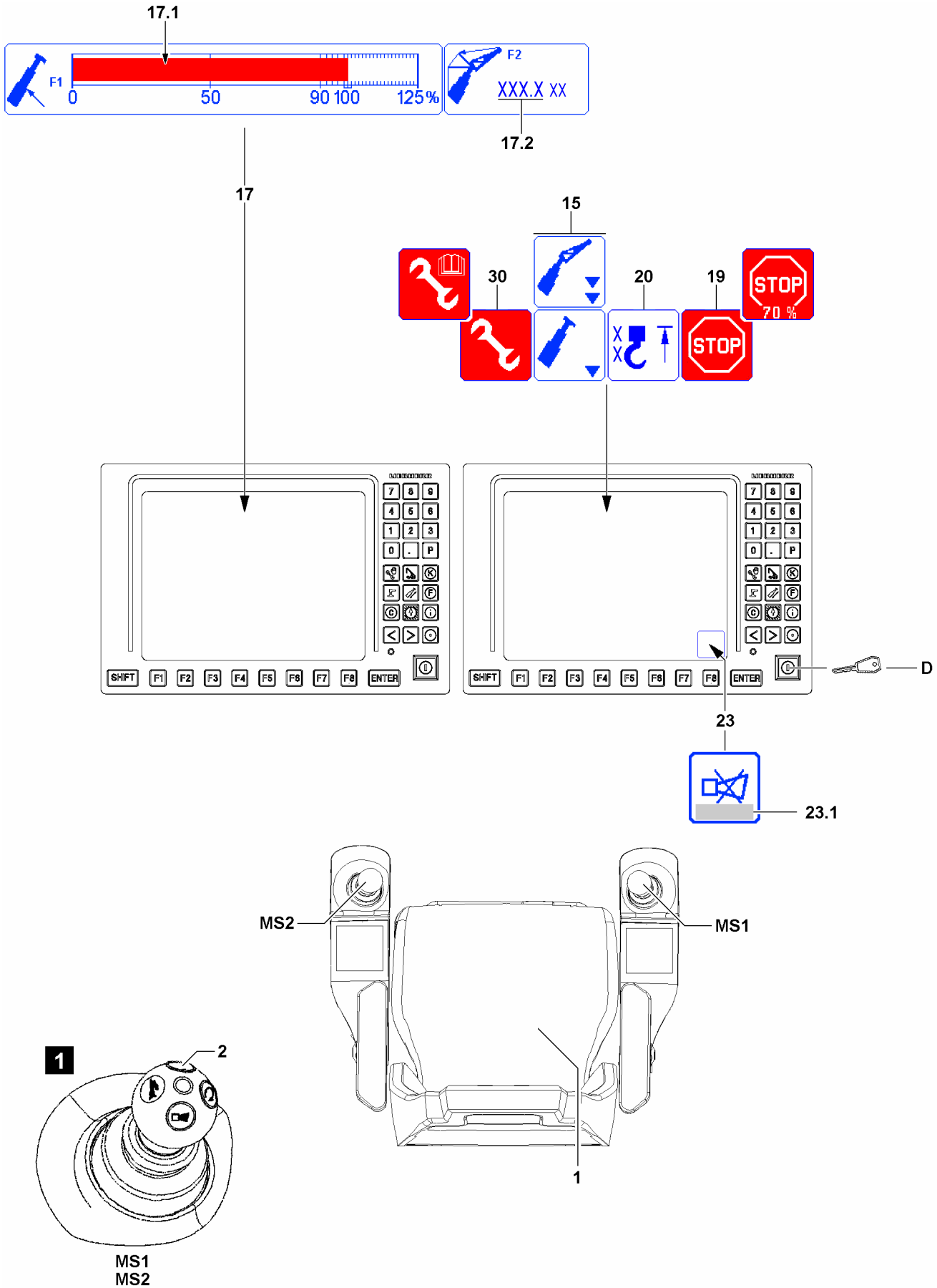


Fig.148662

LWE/LTR 1220-003/24204-02-02/en

## 2.5.1 Carrying out erection procedures

Make sure that the following prerequisites are met:

- The set up configuration corresponds to the specifications in the Operating instructions.
- The set up configuration has been entered correctly in the LICCON computer system.
- All master switches are in the zero position (not deflected).
- Either the seat contact button **1** or one of the buttons **2** (illustration **1**) of the master switches (MS1, MS2) is actuated.



### Note

- ▶ Depending on the situation, the hoist top shut-off (icon **20** appears) must be bypassed at the same time.
- ▶ Depending on the situation, one of the icons **15** appears, because a limit angle load chart is reached.

- ▶ Turn the set up key **D** to the right (touching).

### Result:

- The assembly icon **30** appears.
- The erection procedure can be carried out.

### Problem remedy

The functionality of the set up key **D** is disabled by the crane control?

- ▶ Pay attention to notes regarding error messages **23.1** occurring in the horn **23** icon.
- ▶ Check the electrical connections.
- ▶ Check if all sensors or dummy plugs with integrated electrics have been connected properly.

- ▶ Luff the boom system according to the specifications of the Operating instructions.
- ▶ Observe the F-load display **17**, all values must be within the permissible range.

### Problem remedy

The erection / take down procedure cannot be carried out due to exceeding of the maximum values?

- ▶ See section „Maximum values of F-load display reached“.

The „Bypass of the LICCON overload protection“ via the set up key **D** turns off:

- If the set up key **D** is actuated again.
- When an range with existing load chart is reached (erection procedure).
- If all master switches are in the neutral position for 10 seconds (with „load chart available“).
- When neither the seat contact button **1** nor one of the buttons **2** of the master switches (MS1, MS2) is actuated.

The „Exceedance of shut-off limits of the LICCON overload protection“ function has / was shut off:

- The assembly icon **30** in the LICCON monitor turns off.
- ▶ After completion of the erection / take down procedures, make sure that the assembly icon **30** no longer appears in the LICCON monitor.

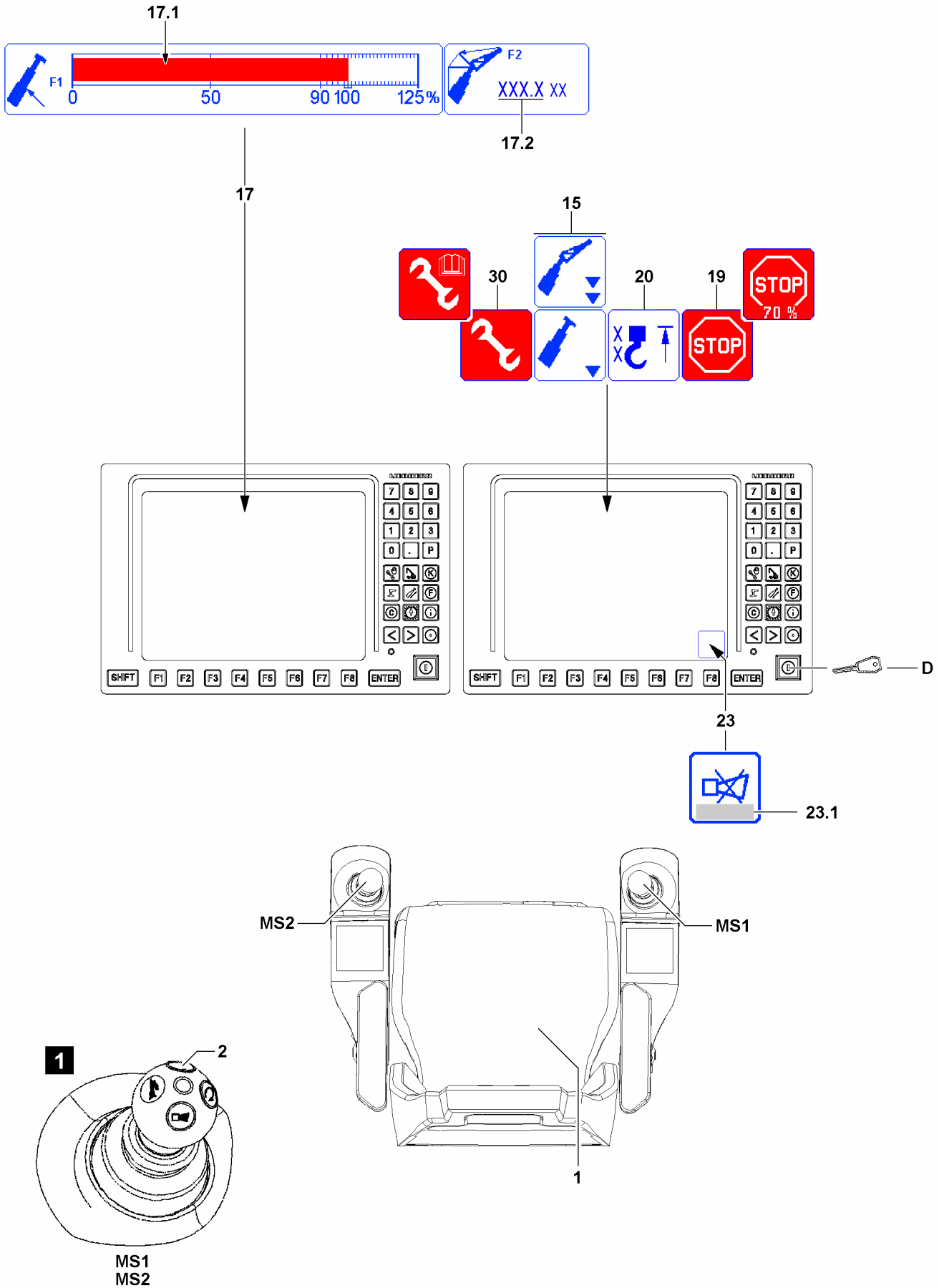


Fig.148662

LWE/LTR 1220-003/24204-02-02/en



## 2.5.2 Carrying out take down procedures



### WARNING

Danger of accidents when taking the boom system down!

When the luffing the telescopic boom / auxiliary boom / accessory down shut-off is bypassed, then the LICCON overload protection as a whole is deactivated, bypassed or limited.

The telescopic boom and / or auxiliary boom / accessory can be luffed from the range of the load chart.

In case of deviations from the specifications of the Operating instructions, severe accidents can be the result.

Personnel can be severely injured or killed.

- ▶ Always proceed according to the specifications of the Operating instructions.
- ▶ Carry out all crane movements with utmost caution.

Make sure that the following prerequisites are met:

- One of the icons **15** appears (limit angle load chart reached) and the LICCON overload protection has shut off the crane movement.
- Either the seat contact button **1** or one of the buttons **2** (illustration **1**) of the master switches are actuated.
- All master switches are in the zero position (not deflected).
- There is no load on the hook (hook block / load hook).
- If necessary, the hook (hook block / load hook) is placed on the ground.
- The set up configuration corresponds to the specifications in the Operating instructions.
- The set up configuration has been entered correctly in the LICCON computer system.



### Note

- ▶ When leaving the „load chart available“ range, the appearance of the assembly icon **30** changes.

- ▶ Turn the set up key **D** to the right (touching).

### Result:

- The assembly icon **30** appears on the LICCON monitor.
- The take down procedure can be carried out.
- ▶ Take the boom system down according to the specifications of the Operating instructions.
- ▶ Observe the F-load display **17**, all values must be within the permissible range.

### Problem remedy

The erection / take down procedure cannot be carried out due to exceeding of the maximum values?

- ▶ See section „Maximum values of F-load display reached“.

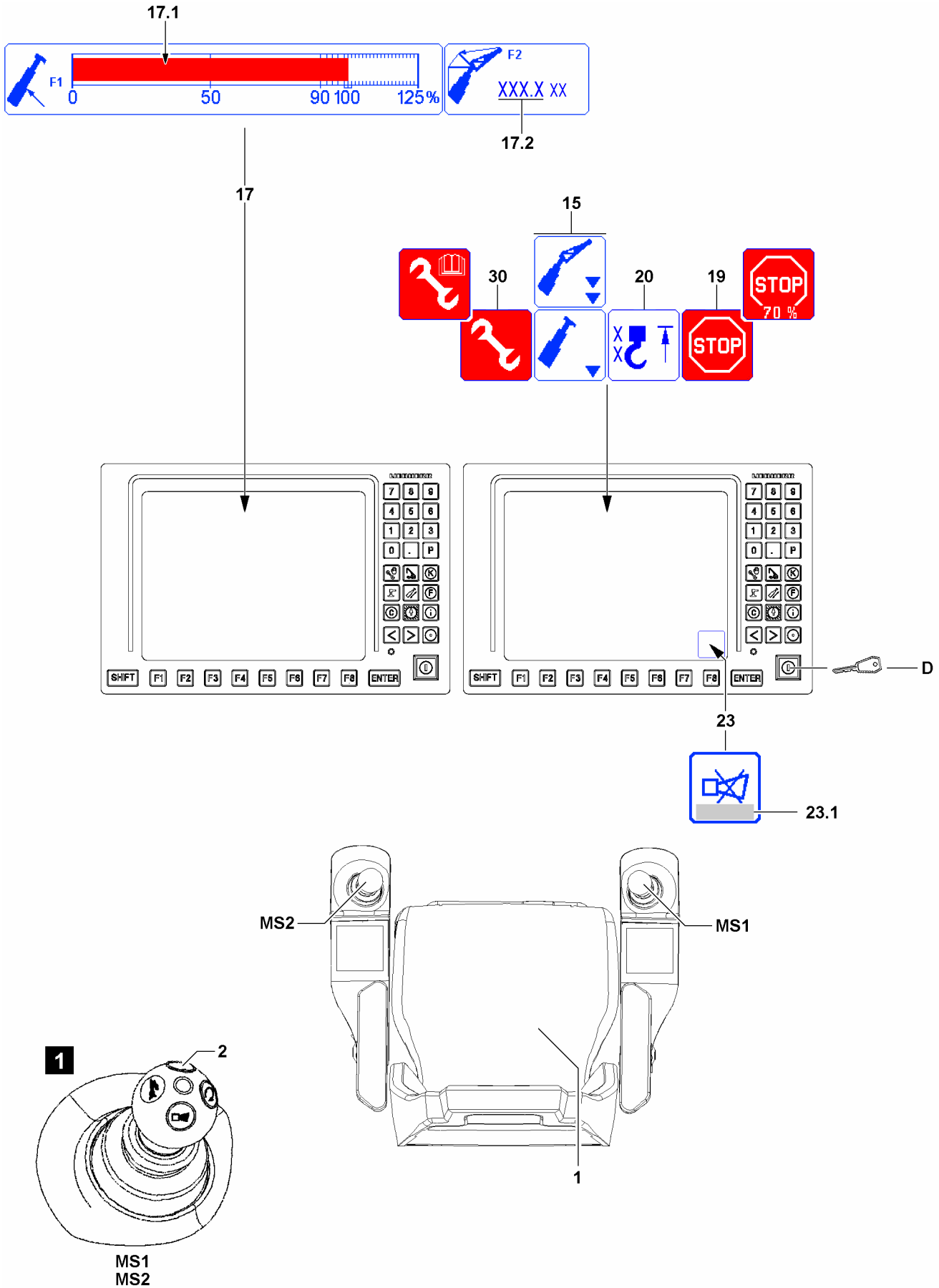


Fig.148662

LWE/LTR 1220-003/24204-02-02/en

**Note**

- ▶ Depending on the situation, the hoist top shut-off (icon **20** appears) must be bypassed at the same time.

The „Bypass of the LICCON overload protection“ via the set up key **D** turns off:

- If the set up key **D** is actuated again.
- When neither the seat contact button **1** nor one of the buttons **2** of the master switches (MS1, MS2) is actuated.
- When an area with an existing load chart is reached.

The bypass of the LICCON overload protection is / was turned off:

- The assembly icon **30** in the LICCON monitor turns off.
- ▶ Make sure that the assembly icon **30** no longer appears on the LICCON monitor.

### 2.5.3 Carrying out the assembly procedures

**WARNING**

Danger of accident during assembly procedures!

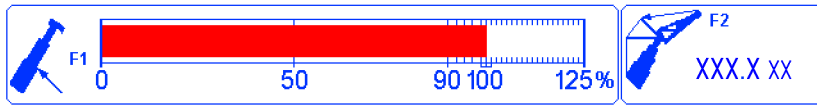
In case of deviations from the specifications of the Operating instructions for the assembly procedures, severe accidents can result.

Personnel can be severely injured or killed.

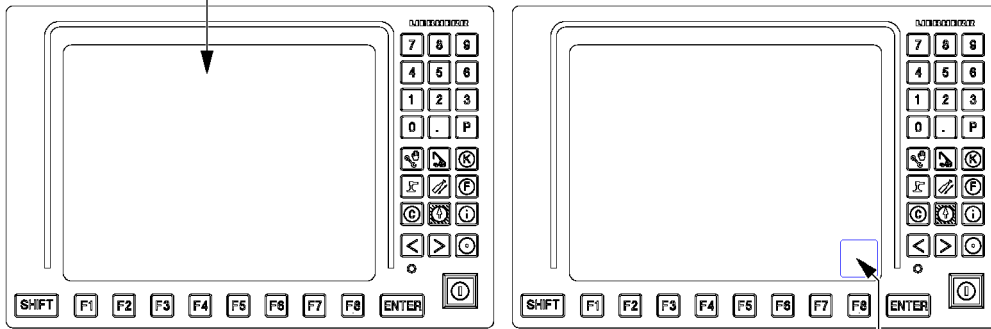
- ▶ Always proceed according to the specifications of the Operating instructions.
- ▶ **If you cannot proceed according to the Operating instructions, contact Liebherr Service before carrying out any subsequent steps and agree on the procedure.**

Make sure that the following prerequisites are met:

- The set up configuration corresponds to the specifications in the Operating instructions.
- The set up configuration has been entered correctly in the LICCON computer system.
- ▶ Actuate the set up key **D** according to the specifications of the Operating instructions.



17



23



23.1

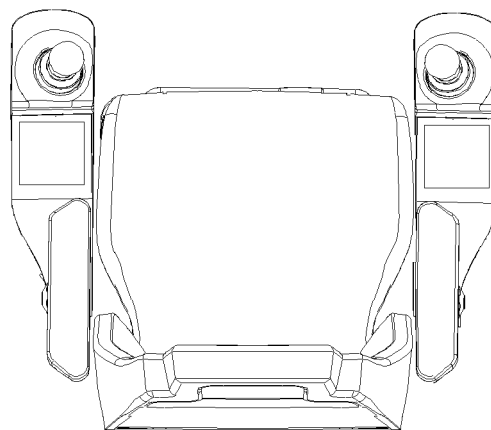


Fig.117267

## 2.6 Maximum values of F-load display reached



### Note

- ▶ The display and assignment of the F-load display **17** can deviate depending on the set up configuration, operating status and configuration of the crane, see chapter 4.02.

The maximum values were reached on the F-load display **17**.

Make sure that the following prerequisites are met:

- The crane is assembled according to the specifications in the Operating instructions.
  - A valid set up configuration has been entered in the LICCON computer system (Set up program).
  - The actual set up configuration has been entered in the LICCON computer system (Set up program).
  - The hook block or the load hook is correctly installed and reeved in.
  - All attachment parts and guy rods on the boom system, which are not needed, have been removed (weight).
  - The boom system is free of snow and ice (weight).
  - The wind influence on the crane is not too great.
  - The local conditions (terrain incline) are in the permissible range.
  - Possible notes regarding error messages **23.1** occurring in the horn **23** icon were observed.
- ▶ Check if a crane movement was initiated that leads to an improvement of the force ratio in the F-load display **17**.



### Note

In the permissible framework of specifications of the Operating instructions, a positive influence of the force ratio in the F-load display **17** can be reached by:

- ▶ Erection of the telescopic boom: Carrying the hook (hook block / load hook) along.
- ▶ In difficult local conditions (terrain incline): Support the placed down boom system to obtain more favorable angle conditions.
- ▶ In difficult local conditions (terrain incline): Support the placed down boom system to reduce flexation.

---

Empty page!

LWE/LTR 1220-003/24204-02-02/en

---

## 5 Equipment

LWE/LTR 1220-003/24204-02-02/en

---

LWE/LTR 1220-003/24204-02-02/en



## 5.01 Technical safety instructions for assembly and disassembly

1	Equipment	2
2	Rope pulleys	2
3	Ropes	2
4	Fiber guy ropes	3
5	Control measures before crane operation	4
6	Relapse cylinders	6
7	Pneumatic springs	6
8	Manual rope winches	7
9	Weights	7
10	Guy rods	8
11	Auxiliary guying	9
12	Bypassing the overload protection	9
13	Bypassing the hoist top shut-off	11
14	Pin connections	12
15	Retaining elements	14
16	Assembling / disassembling	22
17	Erecting / taking-down	67
18	Walking on a boom component	71

# 1 Equipment

## 1.1 Checking the steel structures

All components part of the crane's delivery scope must be checked regularly together with the crane.

If equipment or components are assembled that are part of the delivery scope of another crane: Prior to first time use, check load bearing crane structures, especially steel structures, see chapter 8.01.

## 1.2 Checking the labeling



### WARNING

Labeling **not** legible or **not** present!

Components, especially guy rods, can be mixed up.

Death, severe bodily injuries, property damage.

- ▶ Do **not** continue to use the components, especially the guy rods.

## 2 Rope pulleys



### WARNING

Danger of crushing due to rotating rope pulleys!

Arms and legs can be caught and crushed or severed between the rope pulley and the rope due to rotating rope pulleys.

- ▶ It is prohibited to touch the ropes or rope pulleys during operation.
- ▶ Adhere to the safety distance to ropes and rotating rope pulleys.

## 3 Ropes



### WARNING

Danger of accident!

- ▶ The ropes must be checked by an expert before assembly and checks must be performed at regular intervals in order to detect possible damage or wear and tear at an early stage. See chapter 8.04.

The ropes must be taken down immediately if any of the following damage is detected:

- Breakage of a strand
- Wire breaks
- Broken wire nests
- Reduction in the rope diameter by 10 % or more of the nominal size
- Rope deformations

### 3.1 Placing the hoist rope or the control rope

In order to guarantee safety and operating characteristics, only original Liebherr replacement parts or parts approved by Liebherr may be used.

#### NOTICE

Damage to the hoist rope or the control rope!

If a hoist rope or control rope is placed with worn rope pulleys, damage can occur.

- ▶ Before placing a rope, check the rope pulleys. See chapter 8.01.
- ▶ Replace worn or damaged rope pulleys.

## 3.2 Minimum rope coils

### NOTICE

If the following notes are not observed, the cam limit switch / winch speed sensor must be readjusted!

- ▶ When the hoist rope is spooled up, the end of the hoist rope must remain in front of the winch and may not be pulled over the winch.
- ▶ Pull the hoist rope end never under the winch by spooling the winch up.
- ▶ Pull the hoist rope never off from the „stationary“ winch.
- ▶ The winch speed sensor must also be readjusted, if it is determined during operation or when changing the hoist rope that the winch does not shut off when the minimum rope coils are reached.

### 3.2.1 Cranes with cam limit switch

The cam limit switch is adjusted at the factory that it turns off before the minimum rope coils are reached (three hoist rope coils on the winch).



#### WARNING

Danger of accident due to falling load!

If the following instructions are not observed, the hoist rope end attachment may be torn out, causing the load to topple.

- ▶ If a new hoist rope is used, the cam limit switch must be reset.
- ▶ The cam limit switch must be adjusted so that it turns off when only 3 hoist rope coils remain on the winch.

### 3.2.2 Cranes with winch speed sensor

The winch speed sensor is adjusted at the factory that it turns off before the minimum rope coils are reached (four hoist rope coils on the winch). If used properly, the winch turn sensor will not need readjustment.



#### WARNING

Danger of accident due to falling load!

If the following instructions are not observed, the hoist rope end attachment may be torn out, causing the load to topple.

- ▶ If a new hoist rope is placed, the winch speed sensor must be checked.
- ▶ The winch speed sensor must be set to turn off when only 4 hoist rope coils remain on the winch.

## 4 Fiber guy ropes



#### Note

- ▶ Depending on the crane type and equipment, the fiber guy ropes have different diameters and lengths as boom guying and as auxiliary guying.
- ▶ Fiber guy ropes are subjected to high loads and therefore must be checked regularly.



#### WARNING

Load can be ripped off!

Death, severe bodily injuries, property damage.

- ▶ The ropes must be checked by an expert before assembly and checks must be performed at regular intervals in order to detect possible damage or wear and tear at an early stage. See chapter 8.16.
- ▶ Notes regarding the proper transport of the fiber guy ropes, see chapter 2.04.

## 5 Control measures before crane operation



### WARNING

The crane can topple over!

If the following control measures and the crane-specific additional controls are not carried out before crane operation or if they are not carried out sufficiently, then accidents can occur.

The crane can topple over, be overloaded or damaged.

Loose parts, aids or ice can fall down from the boom or the crane superstructure.

Death, severe bodily injuries, property damage.

- ▶ Crane operation with safety equipment that is **not** functioning correctly is strictly prohibited.
- ▶ Start crane operation only after all safety equipment have been checked and are functioning correctly.
- ▶ Start crane operation only if the overload protection has been set according to the data in the load chart.
- ▶ Start crane operation only if the crane is properly supported and horizontally aligned.
- ▶ Only start crane operation after making sure that there are not loose parts on the boom, crane superstructure or crane chassis.
- ▶ Only start crane operation after making sure that there is no snow, frost or ice on the boom.
- ▶ Only start crane operation after making sure that all specifications, crane conditions and / or properties that are checked and required during the extensive control measures and additional controls have also been completely fulfilled.



### WARNING

Interruption of crane operation!

If the following specifications for interruption of crane operation are not observed, accidents can occur.

- ▶ If the crane operator leaves the crane cab even if for just a short time, the crane must be secured to prevent unauthorized access.
- ▶ Before starting to work again with the crane, the crane operator is obligated to check the operating mode settings and to reset them, if necessary.



Fig.113437: Control displays

Make sure that the following prerequisites are met:

- The overload protection is not bypassed.
- No assembly operation is activated.

### 5.1 General controls before crane operation

- Make sure that no visible damage is present on the crane.
- Make sure that there are no loose parts on the boom, crane chassis and crane superstructure.
- Make sure that all hoist and control ropes are free of snow, frost and ice.
- Make sure that the boom system is free of snow, frost and ice.
- Make sure that exposed rope pulleys are free of snow, frost and ice.
- Make sure that the cable / rope drums as well as the limit switches are free of snow and ice.
- Make sure that the cylinders are free of ice.
- Make sure that the gear ring of the slewing ring connection is clean and greased.
- Make sure that the air supply to the oil and water cooler is clear.
- Make sure that steps, ladders and platforms are in the correct position for crane operation.
- Make sure that all tool boxes, compartments, coverings, covers and cabinet doors are closed.
- Make sure that no persons or objects are within the danger zone of the crane.
- Make sure that the crane is standing on level, load bearing ground.
- Make sure that the crane is sufficiently supported depending on the load case and the ground conditions.

- Make sure that there is a sufficient safety distance to excavations and slopes.
- Make sure that no obstacles are within the working range of the crane, which obstruct the required crane movements.
- Make sure that the crane has sufficient distance to live power lines.
- Make sure that the LICCON overload protection is set according to the data in the load chart.
- Make sure that the overload protection is set according to the actual set up configuration of the crane.
- Make sure that the electrical connections, the connector plug, the pull relief, the cables and the protective insulation function. Replace missing or defective parts.
- Make sure that the cable routings on the electrical connections are seated tightly. If necessary, tighten loose screw connections.
- Make sure that the existing safety equipment is functioning.
- Make sure that the overload protection is functioning.
- Make sure that the hoist limit switches are functioning.
- Make sure that the limit switch boom „steepest position“ is functioning.
- Make sure that the wind speed sensor easily moves and is functioning.

## 5.2 Additional controls for cranes with crane support

- Make sure that the folding / sliding beams are secured with pins to prevent them from sliding.
- Make sure that the support plates are secured in the operating position.
- Make sure that the crane is properly supported.
- Make sure that the crane is horizontally aligned.
- Make sure that the axle suspension is blocked (mobile crane).
- Make sure that the tires have no contact to the ground (mobile crane).
- Make sure that the track chains are secured to prevent them from sagging (crawler crane).

## 5.3 Additional controls for cranes on tires on the front and supported on the rear

- Make sure that the rear folding / sliding beams are secured with pins to prevent them from sliding.
- Make sure that the rear support plates are secured in the operating position.
- Make sure that the crane is properly supported on the rear.
- Make sure that the axle pressure compensation is correctly switched.
- Make sure that the axle suspension is blocked.
- Make sure that the tires of the rear axle group have no contact with the ground.
- Make sure that a sufficient tire pressure is present in the tires.
- Make sure that the ground for the front axle group is sufficiently level and has a sufficient load bearing capacity.

## 5.4 Additional controls for cranes supported on the front and on tires on the rear

- Make sure that the front folding / sliding beams are secured with pins to prevent them from sliding.
- Make sure that the front support plates are secured in the operating position.
- Make sure that the crane is properly supported on the front.
- Make sure that the axle pressure compensation is correctly switched.
- Make sure that the axle suspension is blocked.
- Make sure that the tires of the front axle group have no contact with the ground.
- Make sure that a sufficient tire pressure is present in the tires.
- Make sure that the ground for the rear axle group is sufficiently level and has a sufficient load bearing capacity.

## 5.5 Additional controls for freestanding crane operation (on tires)

- Make sure that all prerequisites for freestanding crane operation are met.
- Make sure that sufficient tire pressure is in all tires for crane operation on tires.

- Make sure that the ground is sufficiently level for crane operation on tires and has a sufficient load bearing capacity.

## 5.6 Additional controls for cranes with a derrick boom

- Make sure that the shut-off via the limit switch - derrick is functioning.
- Make sure that the entire slewing range of the suspended ballast / ballast trailer is free of personnel and obstacles.

## 5.7 Additional controls for cranes with luffing auxiliary boom / accessories

- Make sure that the shut-off via the limit switch luffing auxiliary boom / accessories „steepest position“ is functioning.
- Make sure that the shut-off via the limit switch luffing auxiliary boom / accessories „lowest position“ is functioning.
- Make sure that the shut-off via the limit switch flap in „steepest position“ position is functioning.
- Make sure that the pendulum of the mechanical relapse retainer moves easily over the entire slewing range and is functioning.

## 5.8 Additional controls for certain crawler cranes

For existing crawler assembly key button:

- Make sure that the crawler assembly key button is turned off.

# 6 Relapse cylinders

## 6.1 Block position of the relapse cylinders when setting down the load

### NOTICE

Damage to the boom or the relapse cylinders!

If the block position of the relapse cylinders is triggered by the boom or the derrick with attached, freely suspended load, then there is a danger of damaging the boom or the relapse cylinders when setting the load on the ground. By setting down the load, the crane is relieved, and this movement causes the boom system to move to the rear.

There is no shut-off of the hoist gear lowering function.

- ▶ Actuate the opposite direction of movement which caused the block position and eliminate the block position.

# 7 Pneumatic springs

Pneumatic springs are installed on various crane components to simplify the assembly of these components.

**WARNING**

Danger of crushing!

Defective pneumatic springs no longer provide the supporting properties on the movable components. Components can fall down.

Death, severe bodily injuries, property damage.

- ▶ Always check pneumatic springs for damage before actuating the corresponding components.
- ▶ Do not use components with defective pneumatic springs. Replace defective pneumatic springs immediately.
- ▶ Make sure that no persons or objects are in the movement range of the moving components which is supported by the pneumatic spring.
- ▶ It is strictly prohibited to remain or place any objects in the movement or other danger zone of the moving crane components which are supported by the pneumatic spring.

## 8 Manual rope winches

Manual rope winches are installed on various components to simplify the assembly or disassembly of these components.

**WARNING**

Danger of crushing!

Defective manual rope winches no longer provide the supporting action on the movable components. Components can fall down.

Death, severe bodily injuries, property damage.

- ▶ Always check manual rope winches for external and functional damage before actuating the respective components.
- ▶ Check the rope of the manual rope winch for damage.
- ▶ At least two rope coils must always remain on the rope drum.
- ▶ Do not use components with defective manual rope winches. Replace defective manual rope winches.
- ▶ It is strictly prohibited for personnel or objects to remain within the movement range of the components, which are supported by the manual rope winch.
- ▶ It is prohibited for personnel or objects to remain within the danger zone of the moving components.

## 9 Weights

**Note**

- ▶ The weight of each component is specified in the chapter 1.03 or the respective chapter in the Crane operating instructions or is stated on the tag attached to the corresponding component.
- ▶ If components are pushed into one another (for example the boom intermediate sections) or folded together (for example the folding jib), then the total weight is given by the sum of the individual components.

**NOTICE**

False estimation of weights

- ▶ Contact the Service department at **Liebherr-Werk Ehingen GmbH** if the weight of the respective component is not stated on the tag or in the Crane operating instructions.
- ▶ Use an auxiliary crane with sufficient load carrying capacity including judicious reserve.

## 10 Guy rods



### WARNING

The boom can break off!

The arrangement of the guy rods for the boom or boom systems is stipulated in the rod plan. If the arrangement of the guy rods according to the rod plan is not observed, the crane can collapse, the boom can break off or the crane can topple over.

Death, severe bodily injuries, property damage.

- ▶ Always carry out the arrangement of the guy rods according to the rod plan.
- ▶ If an auxiliary guying is required for a certain boom length, then it must always be installed according to the rod plan on the position defined in the rod plan.



### WARNING

Unutilized guy rods on boom!

If guy rods are on the lattice sections which are not used for operation, then there is a danger of accident.

Unused guy rods can loosen up and fall down.

Death, severe bodily injuries, property damage.

The load chart is invalid.

The load display of the LICCON computer system shows an incorrect value.

The weight of the boom is too heavy for erection.

- ▶ Disassemble and remove the guy rods that are not needed on the transport retainers before erecting the boom.



### Note

- ▶ Inspection and maintenance of guy rods, see chapter 8.15.
- ▶ In reference to the guy rods, observe section „Erection / take-down“.

### 10.1 Guy rods for telescopic cranes with luffing lattice jib

This section applies only to cranes with a telescopic boom and luffing lattice jib.

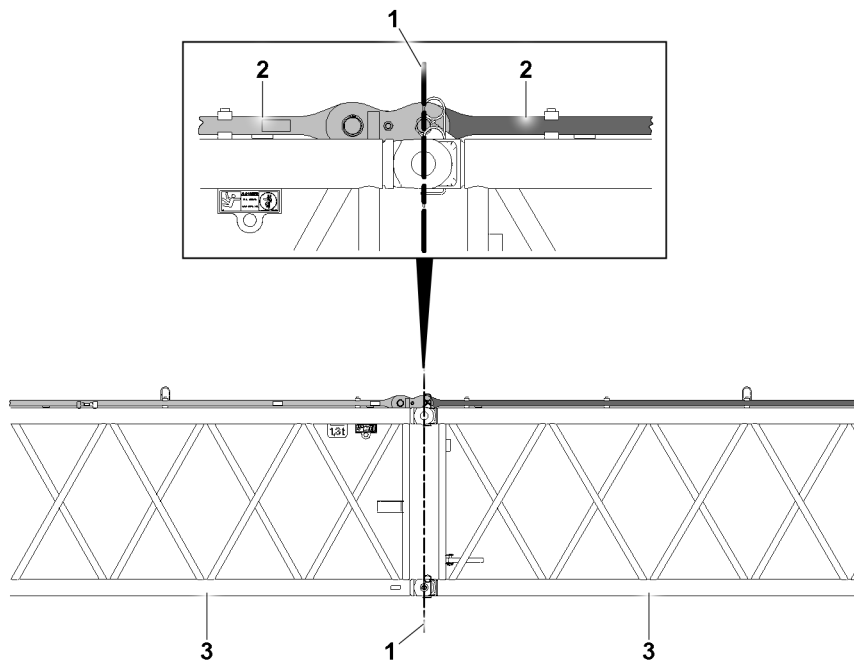


Fig.152299: Lattice section pin level

1 Pin level

2 Guy rods

3 Lattice section



If guy rods **2** are assembled, then close the guy rods **2** in the pin level **1** of the lattice sections **3**. In this way it can be determined if the correct guy rods **2** are assembled.

To completely check the guying, the requirements of the **rod plan**, the **assembly drawings** and the **operating instructions** must be observed.

## 11 Auxiliary guying

The auxiliary guying is of significant importance for safe crane operation.

The auxiliary guying is a deciding factor in relieving the boom, or the boom system during erection and take-down as well as during crane operation.



### WARNING

The crane can topple over!

If the auxiliary guying is not installed or not installed on the position specified in the rod plan, then the crane can collapse, the boom can break off or the crane can topple over.

- ▶ If an auxiliary guying is specified in the rod plan for the required boom length, then it must be installed on the respective position.
- ▶ Make sure that the auxiliary guying is always completely installed and that all pins are properly pinned and secured.

## 12 Bypassing the overload protection



Fig. 113438: Bypassing the overload protection

- Illustration 1: LICCON monitor (only certain crane types).
- Illustration 2: „Assembly“ indicator light on the crane cab instrument panel (only certain crane types).

The overload protection is considered bypassed for:

- All types of assembly operations.
- All types of exceeded shut off limits of the overload protection.
- All types of emergency operation.
- All types of crane operation with deactivated or defective sensors and limit switches.
- All types of deviation from specified set up configuration of the crane.

**DANGER**

Increased danger of accident due to bypass of the overload protection!

Proper and destined use of the crane is ensured due to the construction of the overload protection system and observance of the information in the Crane operating instructions. All **sensibly foreseeable erroneous operations** of the crane have been taken into consideration.

Impermissible crane operation with bypassed overload protection – with the aim of increasing the maximum load bearing capacity of the crane above the rated value in the load chart or of extending the designated working range of the crane – does not constitute a **reasonably foreseeable erroneous operation**, rather **deliberate improper use with high danger of accident**.

The possible risks and consequences of such improper use are detailed in the Crane operating instructions.

Such deliberate improper use can neither be prevented by means of the structural design nor by means of information in the Crane operating instructions.

- ▶ Bypass the overload protection only according to the Crane operating instructions.
- ▶ Exceed the shut off limits of the overload protection only according to the Crane operating instructions.
- ▶ Any other use of the crane with bypassed overload protection than that described in the Crane operating instructions is prohibited.

If the maximum permissible load moment is exceeded, the overload protection turns all load moment increasing crane movements off.

This shut-off can be bypassed or exceeded various ways, for example:

- Exceeding the shut off limits (utilization more than 100 % or leaving the load chart).
- Activating an assembly operation.
- Activating an emergency operation.

The displays of the LICCON overload protection remain functioning when all associated sensors and limit switches are active and a load chart is available.

**WARNING**

Increased danger of accident due to bypass of the overload protection!

If the overload protection is bypassed, there is no longer any protection against crane overload.

In the event of improper use, the crane could collapse, the boom can break off or the crane can topple over.

Death, severe bodily injuries, property damage.

This could result in significant property damage.

- ▶ It is only permitted to bypass the overload protection for assembly or in emergencies.
- ▶ The bypass of the overload protection may only be carried out by persons who are aware of the effects of their acts.
- ▶ Bypassing the overload protection requires the presence of a person authorized by the crane operator and must be performed with utmost caution.
- ▶ Crane operation is strictly prohibited when the overload protection is bypassed.

## 12.1 Bypassing the LICCON overload protection

**Note**

- ▶ Applies only for cranes with LICCON overload protection.

Depending on the crane version, one or more operating elements are available to bypass the overload protection:

- Button in the control panel.
- Key button on the LICCON monitor.
- Key button in the instrument panel.
- Key button in the control cabinet.
- Sensor for transponder on the crane cab.

The functions of the operating elements are described in chapter 4.20.

- ▶ Actuate the respective operating element.

**Result:**

- The LICCON overload protection is bypassed / inactive.
- The „Assembly“ icon appears on the LICCON monitor.
- Depending on the circumstances, acoustic and / or optical warning signals (blinkers, flashing lights, bells and horns) sound.

If the LICCON overload protection is to be reactivated:

- ▶ No longer actuate the respective operating element or reset.

**Result:**

- The LICCON overload protection is active.
- The „Assembly“ icon no longer appears on the LICCON monitor.
- The acoustic and / or optical warning signals which were triggered by the bypass are turned off again.

## 12.2 Bypassing the PAT overload protection

**Note**

- ▶ Applies only for cranes with PAT overload protection.
- ▶ Actuate the bypass key button and turn the PAT overload protection off.

**Result:**

- The PAT overload protection is bypassed / inactive.
- ▶ Actuate the bypass key button and turn the PAT overload protection on.

**Result:**

- The PAT overload protection is active.

## 13 Bypassing the hoist top shut-off

**Note**

- ▶ Applies only for cranes with hoist limit switch.

If the hook block touches the hoist limit switch weight during upward movement, the hoist limit switch is activated. The „Spool up winches“, „Luff boom down“ and „Telescope the telescopic boom out“ crane movements are turned off. The shut-off can be bypassed.

**WARNING**

Danger of accident due to bypass of hoist top shut-off!

When bypassing the hoist top shut-off, there is a danger that the hook block may be pulled against the pulley head when continuing to lift or luffing down the boom. This may damage the pulleys and cause the loads to fall.

- ▶ The bypass of the hoist top shut-off in crane operation with a load may only be carried out by a person authorized by the crane operator with the aid of a „Guide“. The guide must be in direct contact with the crane operator and must continually monitor the distance between the hook block and the boom head.
- ▶ Carry out all crane movements with maximum caution and minimum speed.

## 14 Pin connections



### WARNING

Pin connections **not** lubricated!

If pins or pin connections are not properly greased or lubricated before assembly, then they can corrode.

The pins can be stuck in the pin bores and be damaged.

During the unpinning procedure, the pins can suddenly release.

Death, severe bodily injuries, property damage.

- ▶ Make sure that all pins, which are not supplied with grease via the central lubrication system are sufficiently greased before assembly.
- ▶ Make sure that all lube points, which are equipped with a grease fitting, are properly greased at assembly and according to the respective interval specification.
- ▶ Never insert or unpin pins by force.



### WARNING

Pin **not** secured to prevent it from loosening up by itself!

The pin connection could loosen up suddenly.

Death, severe bodily injuries, property damage.

- ▶ Secure all pins with retaining elements against loosening up by itself.



### WARNING

Distorted pin!

Angular pull or excessive or low hoisting force of the auxiliary crane may result in distortion of the pins.

Distorted parts can suddenly fly off when the pins are unpinned.

Death, severe bodily injuries, property damage.

- ▶ When the pins are unpinned, the lifting force of the auxiliary crane must be adapted to the weight of the components being lifted.
- ▶ Do **not** unpin difficult to remove pins by force.
- ▶ Remedy the cause of the tension.

### 14.1 Pinning the collar pin

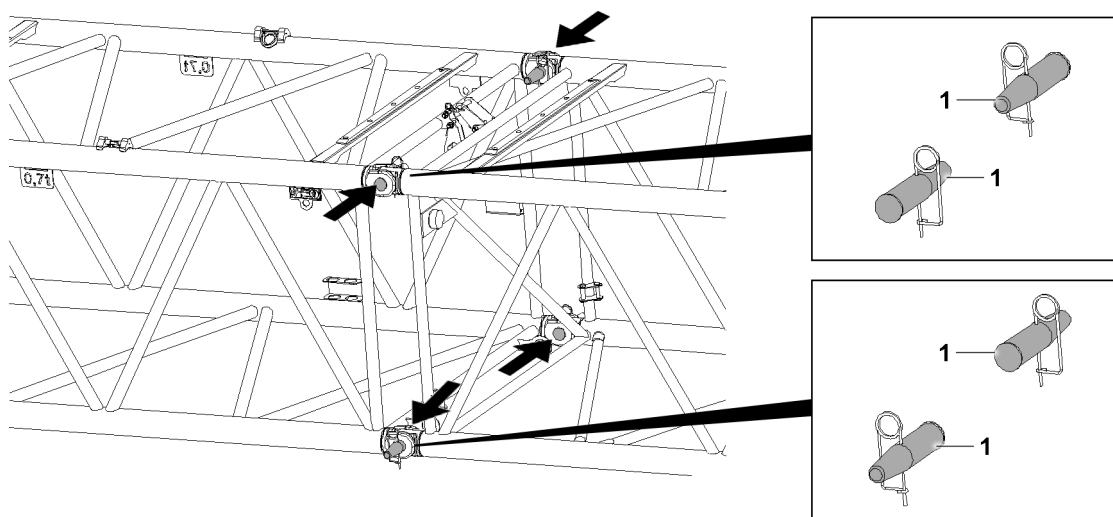


Fig.143114: Pinning the collar pin

**WARNING**

The collar pin is incorrectly pinned!  
Death, severe bodily injuries, property damage.

- ▶ Insert or unpin both pins on the same horizontal level, i.e. **left and right**.
- ▶ Pin the upper collar pin **1** from the **outside to the inside** and unpin from the **inside to the outside**.
- ▶ Pin the lower collar pin **1** from the **inside to the outside** and unpin from the **outside to inside**.

## 14.2 Assembling the double cone pins horizontally

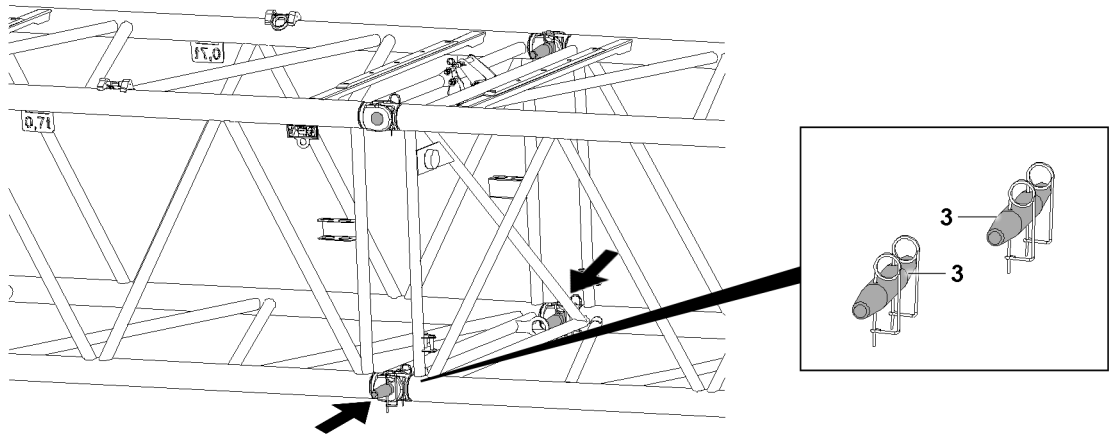


Fig.143115: Pinning the double cone pins horizontally

**WARNING**

Double cone pins incorrectly pinned!  
Death, severe bodily injuries, property damage.

- ▶ Insert or unpin both pins on the same horizontal level, i.e. **left and right**.
- ▶ Pin and unpin the horizontally installable double cone pin **3** from the **outside to the inside**.

## 14.3 Assembling the double cone pins vertically

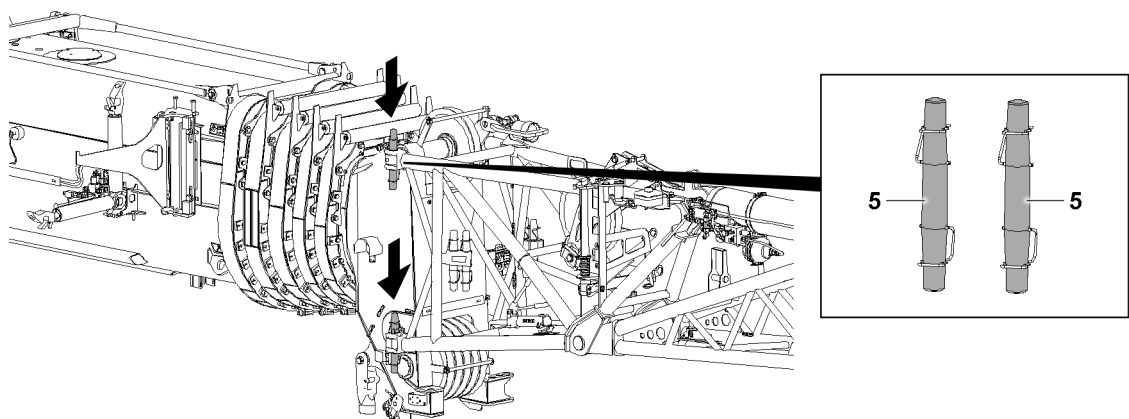


Fig.143116: Assembling the double cone pins vertically

**WARNING**

Double cone pins incorrectly pinned!  
Death, severe bodily injuries, property damage.

- ▶ Pin and unpin the vertically installable double cone pins **5** from the **top to the bottom**.

## 14.4 Impact protection

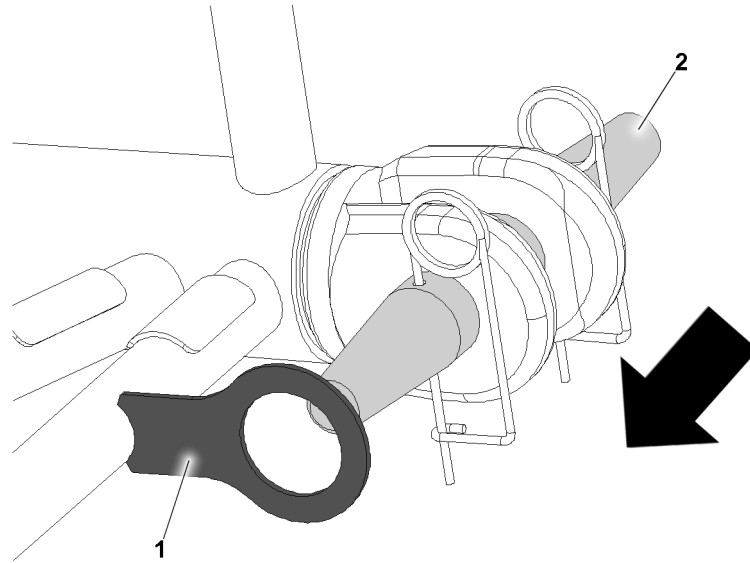


Fig.148194: Lattice section impact protection

Impact protection 1 is installed on certain lattice sections. The impact protection 1 should prevent the pins from being unpinned from the **inside to the outside**.

If impact protection 1 is installed:

- ▶ Only use double cone pins 2.
- ▶ Only pin and unpin the double cone pins 2 from the **outside to the inside**.

## 15 Retaining elements

### 15.1 Checking the retaining elements

Retaining elements are used to secure the pins. Due to mechanical damage / distortion, the function of the retaining elements can be compromised. In addition, the spring force of the retaining elements can be reduced significantly. Do **not** re-use retaining elements if there is insufficient spring force. The pin retainer must be secured with a correctly **functioning** retaining element.



#### WARNING

Mechanical damage or deformation of the retaining element!

The retaining elements can fail.

The pin can unpin by itself.

Death, severe bodily injury, property damage.

- ▶ Use exclusively functioning retaining elements in a proper condition.
- ▶ Replace defective retaining elements.

## 15.2 Overview of the retaining elements

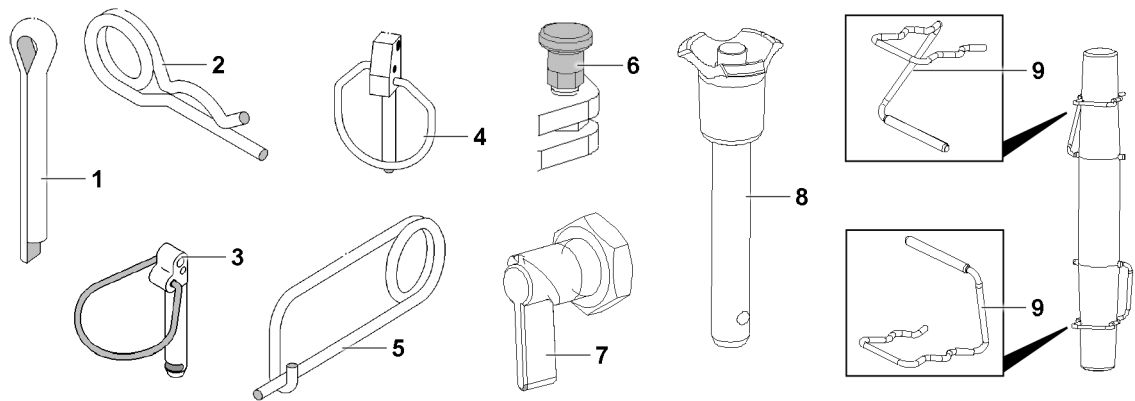


Fig.143102: Retaining elements

- |   |                    |   |                  |
|---|--------------------|---|------------------|
| 1 | Split pin          | 6 | Detent pin       |
| 2 | Cotter pin         | 7 | Latch            |
| 3 | Safety locking pin | 8 | Ball locking pin |
| 4 | Linch pin          | 9 | Retaining clip   |
| 5 | Spring retainer    |   |                  |

## 15.3 Split pin

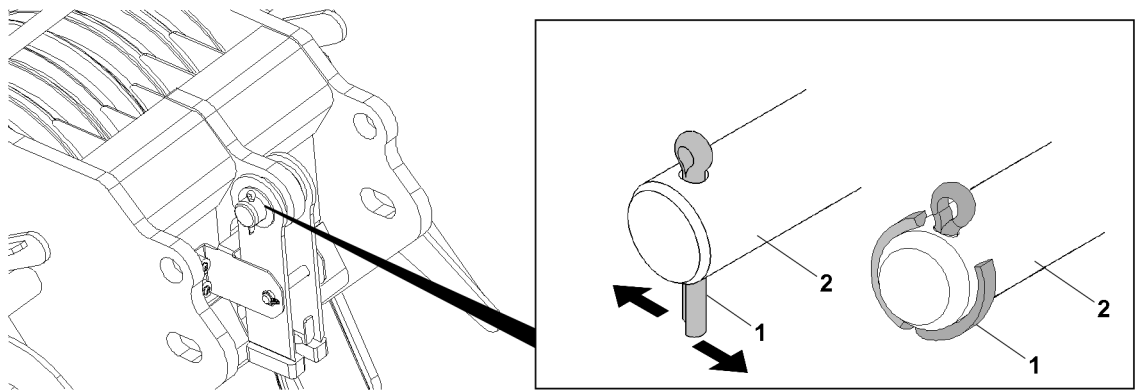


Fig.143105: Split pin

- |   |           |   |     |
|---|-----------|---|-----|
| 1 | Split pin | 2 | Pin |
|---|-----------|---|-----|



### WARNING

Multiple use of a split pin 1!  
The split pin 1 can break.

- ▶ Assemble the split pin 1 only once.
- ▶ Use a correctly sized split pin 1.

- ▶ Secure the pin 2: Insert the split pin 1.
- ▶ Bend the end of the split pin 1 toward the outside.

### Problem remedy

Split pin 1 defective!

- ▶ Replace the split pin 1.

## 15.4 Cotter pin

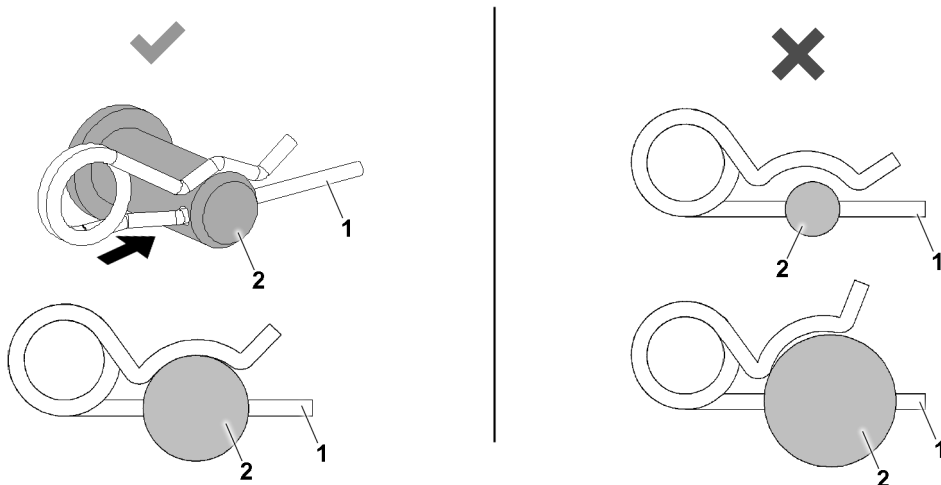


Fig.143106: Cotter pin, correct and incorrect dimensions

1 Cotter pin

2 Pin



### WARNING

Improper dimensions of the cotter pin 1!  
The cotter pin 1 can loosen up by itself.

- ▶ Use a correctly sized cotter pin 1.
- ▶ Secure the pin 2: Insert the cotter pin 1.

### Problem remedy

Spring tension is too low?  
The cotter pin 1 is defective.  
▶ Replace the cotter pin 1.

## 15.5 Safety locking pin

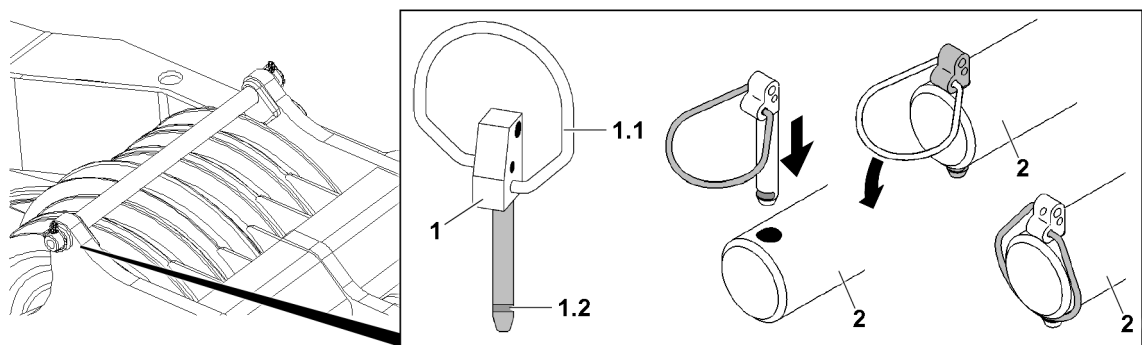


Fig.143103: Safety locking pin

1 Safety locking pin

1.2 Groove

1.1 Spring clip

2 Pin

Increased effort is necessary for opening the safety locking pin 1.



### WARNING

Spring clip 1.1 not engaged!  
The safety locking pin 1 can loosen up by itself.

- ▶ Engage the spring clip 1.1 completely in the groove 1.2.



- ▶ Secure the pin **2**: Insert the safety locking pin **1**.
- ▶ Close the spring clip **1.1** and engage it completely in the groove **1.2**.

**Problem remedy**

The spring clip **1.1** does **not** engage completely?

Tension of the spring clip **1.1** is too low.

- ▶ Replace the safety locking pin **1**.

## 15.6 Linch pin

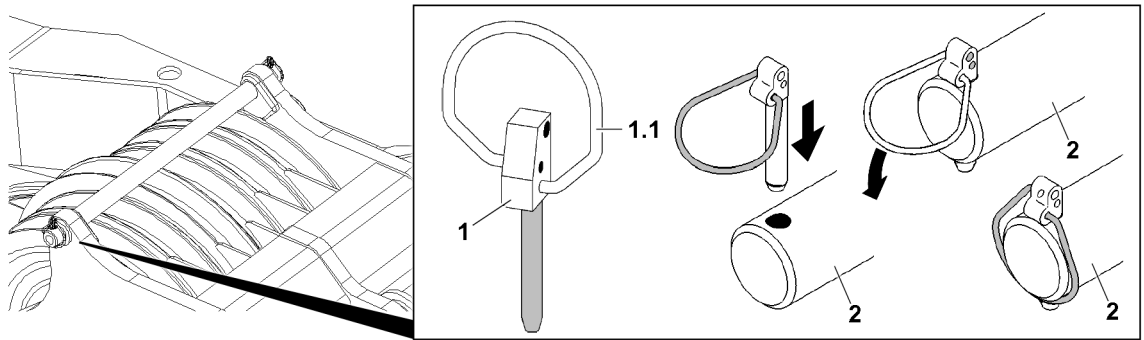


Fig.143104: Linch pin

**1** Safety locking pin

**2** Pin

**1.1** Spring clip

**WARNING**

The linch pin **1** is **not** completely closed!

The locking pin **1** can loosen up by itself.

- ▶ Close the spring clip **1.1** completely.
- ▶ Secure the pin **2**: Insert the locking pin **1**.
- ▶ Close the spring clip **1.1** completely.

**Problem remedy**

The spring clip **1.1** does not close completely?

Tension of the spring clip **1.1** is too low.

- ▶ Replace the locking pin **1**.

## 15.7 Spring retainer

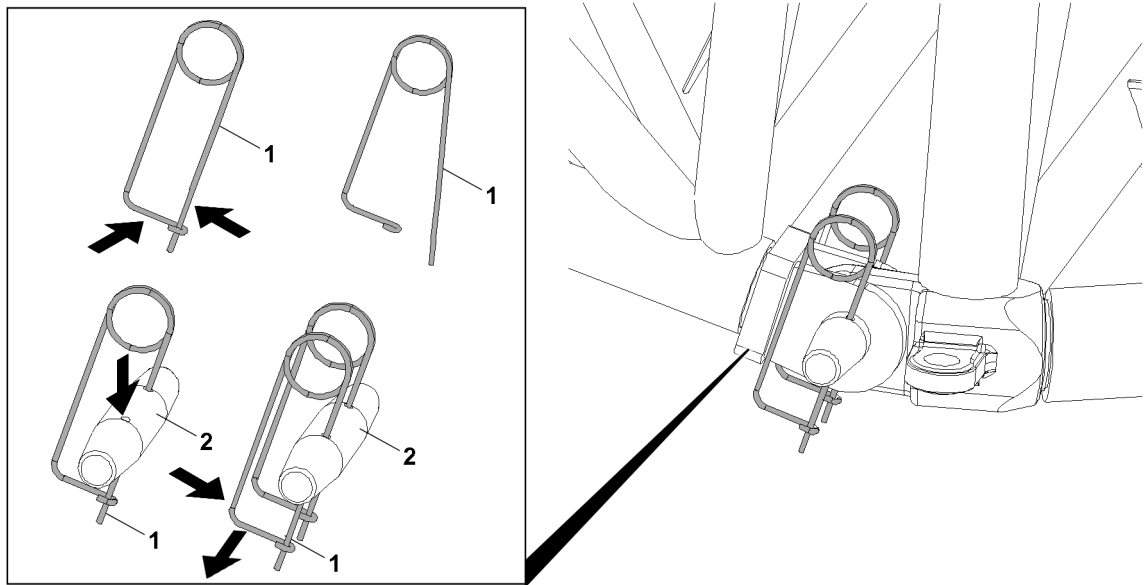


Fig.143108: Spring retainer

1 Spring retainer



### WARNING

The spring retainer 1 is **not** closed!  
The spring retainer 1 can loosen up by itself.

- ▶ Close the spring retainer 1.
- ▶ Secure the pin 2: Insert the spring retainer 1.
- ▶ Close the spring retainer 1.

### Problem remedy

Spring tension is too low?  
The spring retainer 1 is defective.

- ▶ Replace the spring retainer 1.

## 15.8 Detent pin

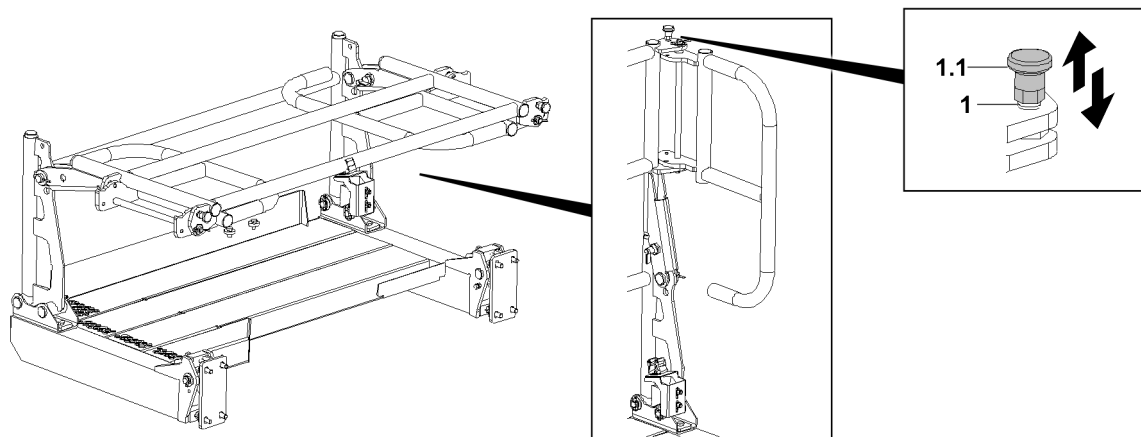


Fig.143110: Detent pin

1 Detent pin

1.1 Handle

**WARNING**

The handle **1.1** is **not** locked!  
The detent pin **1** can loosen up by itself.  
▶ Lock the detent pin **1**.

▶ Pull the handle **1.1**.

**Result:**

- The detent pin **1** is unlocked.
- ▶ Insert the detent pin **1**: Release the handle **1.1**.

**Result:**

- The detent pin **1** is pinned.

**Problem remedy**

The handle **1.1** cannot be pulled.  
The detent pin **1** is defective.  
▶ Replace the detent pin **1**.

## 15.9 Latch

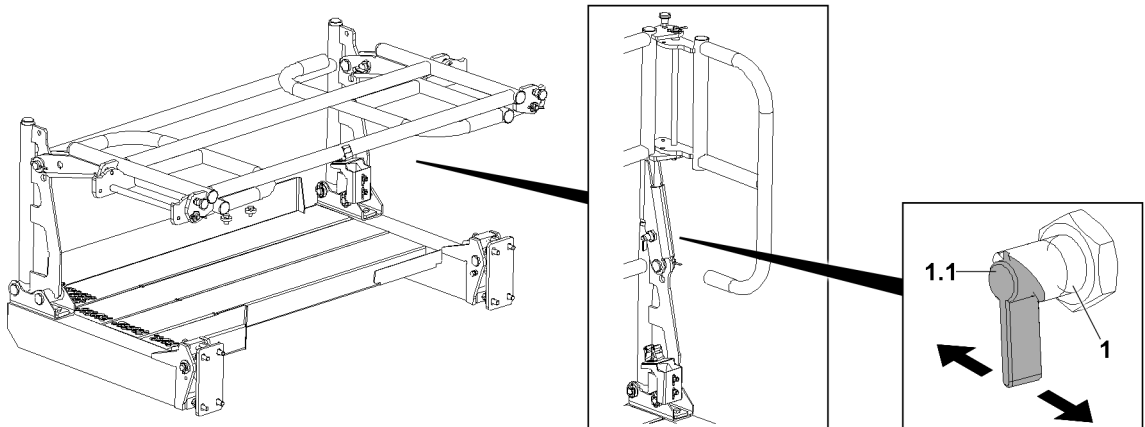


Fig.143111: Latch

**1** Latch

**1.1** Lever

**WARNING**

The latch **1** is **not** locked!  
The latch **1** can loosen up by itself.  
▶ Lock the latch **1**.

▶ Operate the lever **1.1**.

**Result:**

- The latch **1** is unlocked.
- ▶ Pin the latch **1**: Release the lever **1.1** and swing the railing until the latch is pinned.

**Problem remedy**

The lever **1.1** cannot be actuated?  
The latch **1** is defective.  
▶ Replace the latch **1**.

## 15.10 Ball locking pin

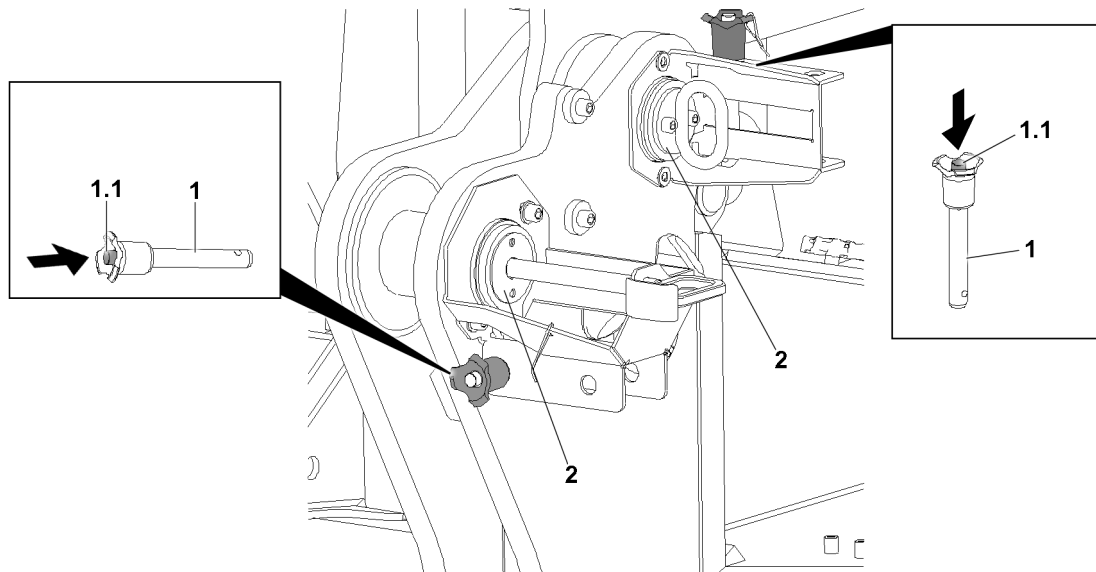


Fig.143109: Ball locking pin

- 1 Ball locking pin  
 1.1 Press button  
 2 Pin



### WARNING

The ball locking pin **1** is **not** locked!  
 The ball locking pin **1** can loosen up by itself.

- ▶ Lock the ball locking pin **1**.
- ▶ Secure the pin **2**: Actuate the press button **1.1**.

### Result:

- The ball locking pin **1** is unlocked.
- ▶ Pin the ball locking pin **1** and release the press button **1.1**.

### Result:

- The ball locking pin **1** is pinned and secured.

### Problem remedy

The press button **1.1** cannot be actuated?

The ball locking pin **1** is defective.

- ▶ Replace the ball locking pin **1**.

## 15.11 Retaining clips

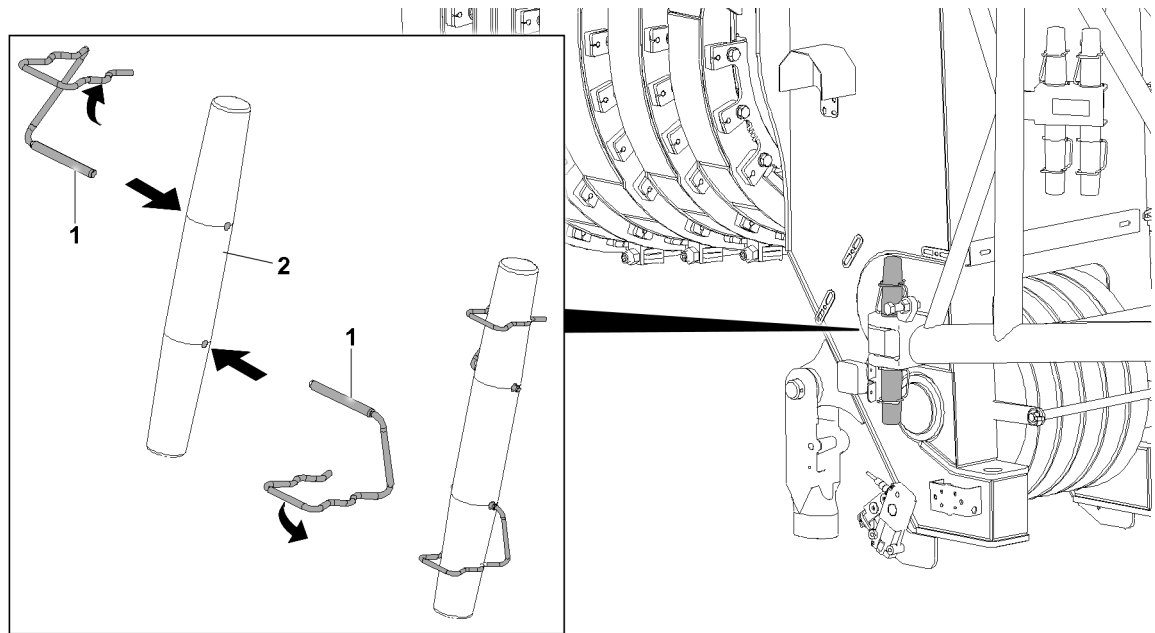


Fig.143107: Retaining clips 1

1 Retaining clip

2 Pin



### WARNING

Incorrect retaining element!  
Shearing off of the retaining element.

- ▶ To secure the folding jib pinning: Use retaining clips 1.
- ▶ The use of other retaining elements is **prohibited**.



### WARNING

Retaining clip **not** engaged!  
The retaining clip 1 can loosen up by itself.

- ▶ Engage the retaining clip 1.
- ▶ Secure the pin 2: Insert the retaining clip 1.
- ▶ Engage the retaining clip 1.

### Problem remedy

Retaining clip 1 defective?  
The spring force of the retaining clip 1 is too low.

- ▶ Replace the retaining clip 1.

## 16 Assembling / disassembling



### WARNING

Danger of fatal injury due to incorrect assembly or disassembly!

The assembly / disassembly of lattice sections and / or components may never be performed by untrained personnel.

An erroneous assembly / disassembly of lattice sections and / or components can cause damage on load carrying crane structures.

Crane components can fail due to improper assembly / disassembly.

Death, severe bodily injuries, property damage.

- ▶ Make sure that the assembly / disassembly of lattice sections and / or components is carried out only by authorized and trained expert personnel.
- ▶ Make sure that the fastening equipment on lattice sections and / or components is always fastened properly.
- ▶ Make sure that lattice sections and / or components are always properly pinned and secured at assembly.
- ▶ For assembly / disassembly of individual components, also observe the chapters relating to those components.
- ▶ The boom combinations must be assembled according to the separately supplied rod plans.
- ▶ All components which must be transported separately must be transported with suitable auxiliary cranes and fastening equipment near ground level.



### WARNING

Failure of auxiliary winch!

▶ Only use the auxiliary winch (assembly or reeving winch) for assembly and not to lift loads.

▶ Lifting of loads with the auxiliary winch is prohibited.



### WARNING

Danger of impact / crushing!

When installing / removing crane components with the auxiliary crane, crane components can start to swing back and forth.

When lifting / lowering and positioning crane components, there is an increased danger of impacts / crushing.

Death, severe bodily injuries, property damage.

- ▶ Make sure that personnel cannot be caught by components.
- ▶ Make sure that the crane is horizontally aligned.
- ▶ When working in danger zones: Use aids to protect limbs.
- ▶ Guide components with suitable aids to minimize oscillation.
- ▶ During assembly / disassembly no one may be in the dangerous area around or underneath the suspended components before the load has been secured.

Part of the category „Aids for working at a height“ are, for example:

- Lifting platforms
- Scaffolding
- Auxiliary cranes
- Ladders

**WARNING**

Danger of falling!

During assembly / disassembly, inspection and maintenance work, assembly personnel must be secured with appropriate aids to prevent them from falling.

Death, severe bodily injuries, property damage.

- ▶ All work at a height, when there is a danger of falling, must be carried out with suitable aids.
- ▶ If aids are not available and work cannot be carried out from the ground, then assembly personnel must secure themselves with the supplied fall arrest system to prevent falling, see chapter 2.04.
- ▶ If fall protection equipment is available, then it must be used, see chapter 2.06.
- ▶ When lifting, lowering, swinging crane parts in and out, no persons may remain in the danger zone.
- ▶ When closing or opening boom systems during boom assembly or boom disassembly, no persons may remain on the boom system or in the danger zone.
- ▶ If railings are present on the components, then they must be brought into the corresponding position and secured for assembly / disassembly work.
- ▶ Only step on the aids, ladders and catwalks with clean shoes.
- ▶ Keep aids, ladders and catwalks free of heavy dirt, snow, frost and ice.
- ▶ During all assembly and disassembly work, maintenance work and inspections, travel or crane operation is prohibited.
- ▶ Remaining on a suspended load is prohibited.
- ▶ Stepping and walking on crane components and lattice sections, which have an incline of more than 20° is prohibited.
- ▶ For all assembly work, the crane driver of the main crane must be in voice contact with the crane driver / crane drivers of the auxiliary crane / auxiliary cranes.
- ▶ For all assembly work, the crane driver of the main crane must be in voice contact with the assembly personnel.
- ▶ For assembly tasks, the crane driver may only initiate crane movements when the responsible guide has explicitly released the movement.

**DANGER**

The components can fall down!

If the corresponding component is disengaged from the auxiliary crane before the corresponding component is pinned, then the corresponding component can fall down.

Death, severe bodily injuries, property damage.

- ▶ Do not disengage the auxiliary crane and the fastening equipment until the respective component is pinned and secured.

**WARNING**

The components can fall down!

If the corresponding component is unpinned without being secured by an auxiliary crane, the corresponding component can fall down.

Death, severe bodily injuries, property damage.

- ▶ Do not unpin the components until they are secured by an auxiliary crane.

**WARNING**

Falling components and tools!

Whenever working at a height, for example on the crane or on an aerial platform, components or tools can fall down.

Death, severe bodily injuries, property damage.

- ▶ Make sure that the danger zone under the work area is blocked off and marked and that no personnel is located within it.

## 16.1 Assembly drawings



### WARNING

Use of assembly drawings!

Due to sole use of assembly drawings, dangerous situations can arise up to toppling of the crane. Death, severe bodily injuries, property damage.

- ▶ Assembly drawings should only be considered to be **additional** and **supplementary** information.
- ▶ The respective chapters in the crane operating instructions are decisive for the assembly and disassembly of crane structures, lattice sections or crane components.
- ▶ The detailed information and danger notes in the respective chapters must be observed.

## 16.2 Guiding crane structures, lattice sections or crane components



### WARNING

Danger due to oscillating load!

During the assembly of crane structures, lattice sections or crane components with the auxiliary crane, they can start to swing back and forth.

Death, severe bodily injuries, property damage.

- ▶ To guide and position crane structures, lattice sections or crane components always use a guide rope.
- ▶ Make sure that there are no persons or obstacles within the danger zone.
- ▶ Make sure that the guide rope is long enough.

## 16.3 Assembling / disassembling of electrical lines



### WARNING

The crane can topple over!

If mechanical crane components, which have electrical connections are not immediately electrically connected after assembly then the limit switches and / or electrical sensors are not functioning.

Safety relevant shut offs are not recognized by the LICCON computer system.

Any errors or safety relevant messages which might occur are not shown on the LICCON computer system.

Death, severe bodily injuries, property damage.

- ▶ Make sure that the electrical connections are made immediately after installation of the respective crane components on the crane.
- ▶ Make sure that the procedure to make the electrical connections to the boom end sections in the respective assembly and set up chapters are observed.

### NOTICE

Danger of damage to the electrical connections!

If the following measures are not adhered to, the electrical connections can be damaged.

- ▶ Do not plug in the plug connection or unplug them under tension.
- ▶ Do not pinch or crush electrical connections.

When pulling the cable out:

- ▶ Hold the plug and not the cable. Do not pull on the cable to release the plug connection.
- ▶ Relieve the electrical connections in operating condition.
- ▶ In case of defective or faulty electrical lines, contact Customer Service at Liebherr-Werk Ehingen GmbH.



**WARNING**

Malfunction if dummy plugs are not installed!

If the dummy plugs on the non-required electrical connections are not installed, then malfunctions or functional limitations can occur on the crane.

- ▶ Make sure that all non-required electrical connections, which have a dummy plug, are closed off with dummy plugs.
- ▶ Pay attention to the electrical wiring diagram.

**NOTICE**

Property damage due to dirt and / or corrosion!

The plug connections are only protected when plugged in. If the plug connections are not plugged in, then the contact surfaces can corrode.

This could result in malfunctions.

- ▶ Always plug or screw the plug connections together properly.
- ▶ Keep plug connections clean and dry. Clean contact surfaces provide the best signal transfer.
- ▶ Close off the plug connections that are not used with dust caps.

- ▶ Establish the electrical connections to the installed crane components properly.
- ▶ As a rule, close off on-required electrical connections (for example of accessories which are not installed) with the respective dummy plugs.
- ▶ Properly close off electrical connections, which have no dummy plugs, with the corresponding protective dust or cover caps.

If a pull relief for the cable drum is present:

- ▶ Connect the pull relief in the fixed point and relieve the plug connection from the pull strain.

After installing the plug connections:

- ▶ Check all plug connections for proper connection.

If a plug connection is not properly connected:

- ▶ Plug or screw the plug connection together properly.

After removing the plug connections:

- ▶ Protect the electrical connections with protective dust or cover caps or place them in intended storage retainers.
- ▶ After unplugging the electrical plug connections, install the dummy plugs, see Electrical wiring diagram.

If locking brackets are present:

- ▶ Close the locking bracket.

## 16.4 Assembling / disassembling of hydraulic lines

When connecting and releasing hydraulic lines with quick couplings, make sure that the coupling procedure is carried out correctly.

**WARNING**

Danger of accident due to loss of pressure or leakage!

Incorrectly coupled or self-loosening quick couplings (particularly return lines) can result in serious accidents due to component failure.

Death, severe bodily injuries, property damage.

- ▶ Check the quick couplings after assembly for correct connection.
- ▶ Make sure that the sleeve and plug are bolted with the knurled nut after assembly.

**WARNING**

Pressure in the hydraulic lines!

If the pressure supply is not interrupted before releasing the hydraulic lines, the hydraulic oil can escape with high pressure.

Death, severe bodily injuries, property damage.

- ▶ Release the pressure in the hydraulic system before releasing. Interrupt the pressure supply and wait for a short time.
- 
- ▶ Release the pressure in the hydraulic system before connecting or disconnecting: Turn the engine off and wait for a short time.
  - ▶ Connect the coupling components (sleeve and connector) and screw together with the knurled nut.
  - ▶ Tighten the hydraulic coupling by hand. Turn the knurled nut until it reaches a tangible, fixed stop position.

## 16.5 Bypassing at crawler assembly / disassembly

**Note**

- ▶ Applies only for cranes with crawler assembly key button.

**WARNING**

High danger of accident in case of actuated crawler assembly key button!

If the crawler assembly key button is actuated, the overload protection is bypassed. No shut-off at overload will occur in assembly operation nor in crane operation.

In the event of misuse, the crane can topple over.

Death, severe bodily injuries, property damage.

- ▶ The crawler assembly key button may only be actuated for assembly tasks.
- ▶ All other usage of the crawler assembly key button other than as described in the operating instructions is prohibited.
- ▶ Crane operation with the crawler assembly key button enabled is strictly prohibited.

### 16.5.1 Activating the bypass at crawler assembly and crawler disassembly

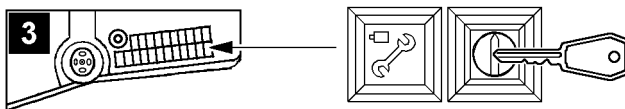


Fig.113441: Activating the bypass

- Illustration 3: Crawler assembly key button and *Crawler assembly* indicator light with *Crawler assembly off* touch function

- ▶ Actuate the crawler assembly key button.

**Result:**

- The LICCON overload protection is inactive.
- The indicator light *Crawler assembly* lights up.

### 16.5.2 Deactivating the bypass at crawler assembly and crawler disassembly

Make sure that the following prerequisites are met:

- The LICCON overload protection is bypassed / inactive and the „Bypass at assembly and disassembly“ is activated.
- The *crawler assembly* indicator light illuminates.

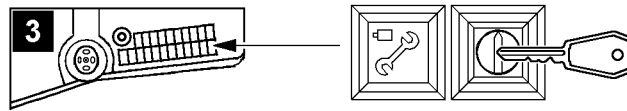


Fig. 113441: Deactivating the bypass

If the bypass at crawler assembly is to be turned off:

- ▶ Turn the crawler assembly off by pressing the off button *Crawler assembly off*.

**Result:**

- The indicator light in the button *Crawler assembly* turns off.

## 16.6 Bypassing at assembly / disassembly

Depending on the crane version, the „Bypass at assembly and disassembly“ is activated by:

- The set up button (key button) on the LICCON monitor.
- The assembly key button in the instrument panel.



### Note

- ▶ Applies only for cranes with LICCON overload protection.
- ▶ Indicator light *Assembly* is only present in the instrument panel for certain crane types.



### WARNING

High danger of accident at crane operation with activated „Bypass at assembly and disassembly“! At activated „Bypass at assembly and disassembly“ the overload protection and possibly bypassed hoist limit switches.

In the event of improper use, the crane could collapse, the boom can break off or the crane can topple over.

Death, severe bodily injuries, property damage.

- ▶ The activation of the „Bypass at assembly and disassembly“ is only permissible for assembly and disassembly purposes.
- ▶ All other usage of the „Bypass at assembly and disassembly“ other than as described in the operating instructions is prohibited.
- ▶ The „Bypass at assembly and disassembly“ may only be activated by persons who are aware of the consequences of a bypass.
- ▶ Crane operation with activated „Bypass at assembly and disassembly“ is strictly prohibited.
- ▶ The „Bypass at assembly and disassembly“ must be deactivated immediately after assembly and disassembly work.
- ▶ The crane operator or a person authorized by him must make sure that no misuse of the bypass device is possible (remove the key and store it safely, if necessary).

### 16.6.1 Activating the bypass at assembly and disassembly



Fig. 113438: Activating the bypass at assembly and disassembly

- Illustration 1: LICCON monitor (only certain crane types).
- Illustration 2: „Assembly“ indicator light on the crane cab instrument panel (only certain crane types).
- ▶ Actuate the respective operating element.

**Result:**

- The LICCON overload protection is bypassed / inactive and the „Bypass at assembly and disassembly“ is activated.
- The „Assembly“ icon appears in the LICCON monitor and / or the indicator light „Assembly“ in the instrument panel lights up.
- Depending on the circumstances, acoustic and / or optical warning signals (blinkers, flashing lights, bells and horns) sound.

**16.6.2 Bypassing at assembly and disassembly**

Fig.113437: Bypassing at assembly and disassembly

- ▶ No longer actuate the respective operating element or reset.

**Result:**

- The LICCON overload protection is active and the „Bypass at assembly and disassembly“ is deactivated.
- The „Assembly“ icon turns off in the LICCON monitor and / or the indicator light „Assembly“ in the instrument panel no longer lights up.
- The acoustic and / or optical warning signals which were triggered by the bypass are turned off again.

**16.7 Actuation of winch and / or crane movements during assembly / disassembly****Note**

- ▶ The winches and / or crane movements can be controlled from the crane cab or, depending on the crane set up configuration, with the Bluetooth™ Terminal (BTT) or the radio remote control\*.
- ▶ Observe the chapter 4.05, chapter 5.31 and chapter 6.08.

**WARNING**

Uncoordinated procedure for assembly tasks!  
Death, severe bodily injuries, property damage.

- ▶ Before starting the assembly tasks, define the course of action and agree on all steps with all involved personnel.
- ▶ Monitor all steps and continuously check the course of action.
- ▶ In the case of unforeseen events, stop the course of action and agree on the new situation with all involved personnel.
- ▶ Make sure that winches and / or crane movements are only controlled by people who are aware of the effects on the crane and / or boom system as well as the connected dangers.
- ▶ Make sure that no persons, objects or obstacles are within the danger zone of the crane.
- ▶ Prewarn persons within the surrounding area of the crane, for example via a horn signal.
- ▶ Perform all winch and / or crane movements anticipatorily and at a low speed.

## 16.8 Assembling / disassembling the counterweight

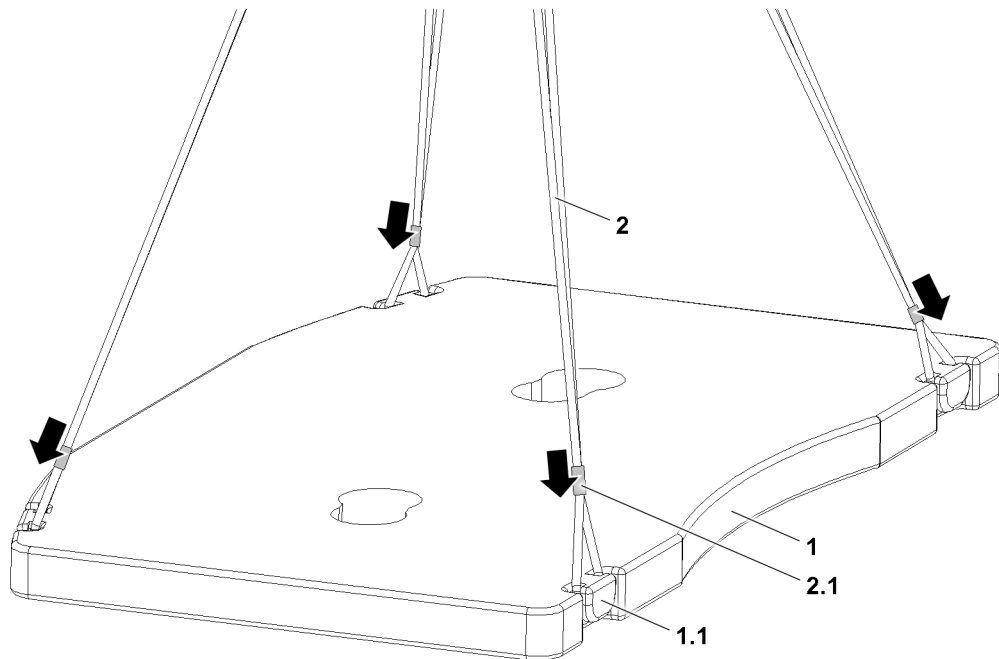


Fig.152587: Grommets and cable laid fastening rope

### 16.8.1 Grommets and cable laid fastening rope

Use the supplied fastening ropes **2** only for set up work on the crane.

The fastening ropes **2** are marked with the maximum load bearing capacity.



#### WARNING

Fastening ropes used incorrectly!

The fastening ropes can fail. The load can fall down.

- ▶ Do **not** exceed the load bearing capacity or the fastening ropes **2** when lifting the counterweight.
- ▶ **Never** fasten the fastening ropes **2** to the red marked impact points.
- ▶ **Never** cross or twist the fastening ropes **2**.

Depending on the structural form of the counterweight **1**, use two, three or four fastening ropes **2**.

- ▶ Lay the fastening rope **2** around the bitts **1.1** of the counterweight **1** to be lifted.
- ▶ Until the fastening ropes **2** are positioned firmly on the fastening points: Push the mobile ferrules **2.1** in the direction of the fastening point of the counterweight **1**.

## 16.9 Assembling / disassembling the booms



#### WARNING

The crane can topple over!

Angular pull can overload the crane.

Overload can cause destruction of the crane or cause it to topple over.

Death, severe bodily injuries, property damage.

- ▶ The hook block must always be attached (hooked) vertically over the center of gravity of the load to be lifted.
- ▶ Angular pull is prohibited

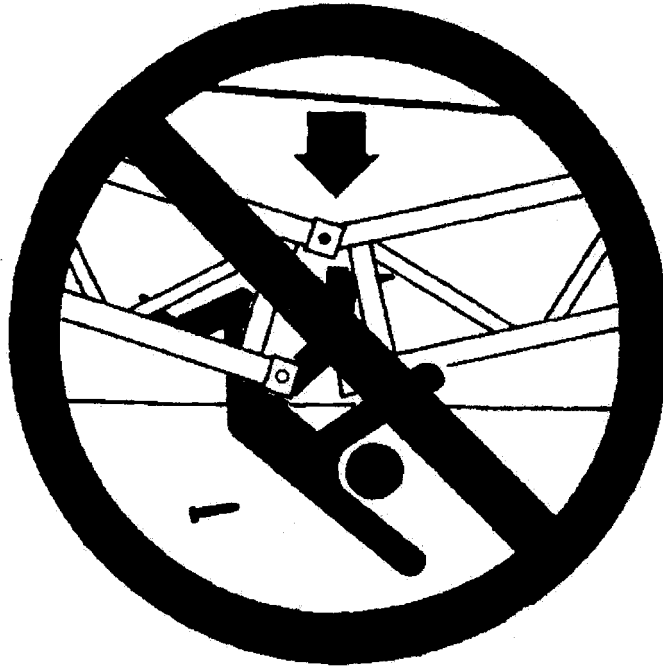


Fig.113444: Danger of accident during assembly / disassembly



#### WARNING

Danger of accident at assembly / disassembly of booms!

When you disassemble unsecured or unsupported booms, they can fall down.

Death, severe bodily injuries, property damage.

- ▶ Never unpin the pins under unsecured or unsupported booms.
- ▶ Never unpin the connector pins on unsecured or unsupported booms.
- ▶ Do not stand under the booms or within the complete danger zone during the pinning and unpinning procedure of the booms.
- ▶ Secure the pins in the bearing points and in the racks.
- ▶ The railing must be horizontal during the assembly and disassembly of the booms.
- ▶ Do not lean the ladder against the component being disassembled.

Make sure that the following prerequisites are met for the closing assembly:

- If parts of the equipment (for example lattice sections) are not in contact with the ground during assembly / disassembly, then they must be supported with suitable, stable materials.
- Take down the parts of the equipment with rope pulleys in such a way that the rope pulleys are not damaged.
- During disassembly make sure that the auxiliary crane can lift the load vertically.
- Have an auxiliary crane with sufficient load bearing capacity available to be able to hold the load at the corresponding radius.

## 16.10 Fastening positions for assembly / disassembly of the lattice jib



#### WARNING

Danger of fatal accidents due falling components!

The maximum permissible tensile load on the fastening eye is engraved on the fastening eye.

The maximum permissible fastening load of the respective components can differ to the maximum permissible tensile load of the fastening eye.

Components can be damaged at overload and fall down during lifting.

- ▶ Observe the maximum permissible fastening load according to the operating instructions and the tags on the components.
- ▶ Fasten the lattice jib only according to the following descriptions.
- ▶ Do not overload the components.

### 16.10.1 Closing the end section

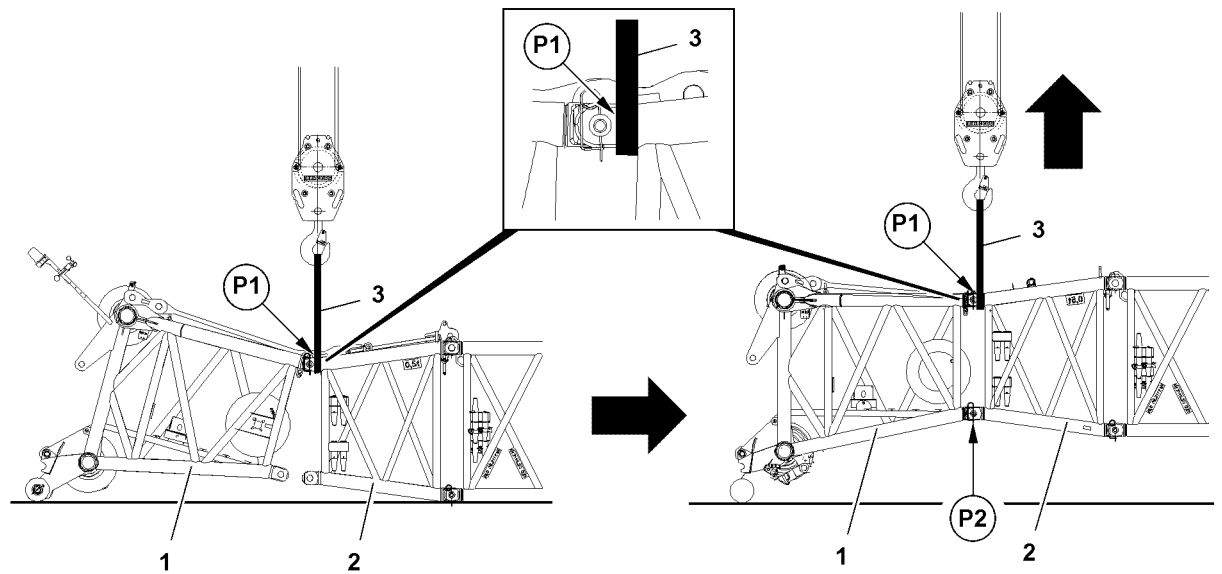


Fig.117840: Closing the end section

For closing the end section, observe the following:

- Use textile type fastening equipment **3**.
- Loop the textile type fastening equipment **3** on the left and right around on the pin points.

Before fastening:

- ▶ Check the position of the spring retainers and correct, if necessary.
- ▶ Fasten the textile type fastening equipment **3** on the upper pin points **P1** between the end section **1** and the pinned components **2**.
- ▶ Lift the lattice jib until the lower pin points **P2** align between the end section **1** and components **2**.
- ▶ Pin the end section **1** and components **2** on the lower pin points **P2** on the left and right.

After pinning:

- ▶ Remove the textile type fastening equipment **3**.

### 16.10.2 Taking the lattice jib down into the roller cart



#### Note

- ▶ The following illustrations are examples and may not match your crane exactly.

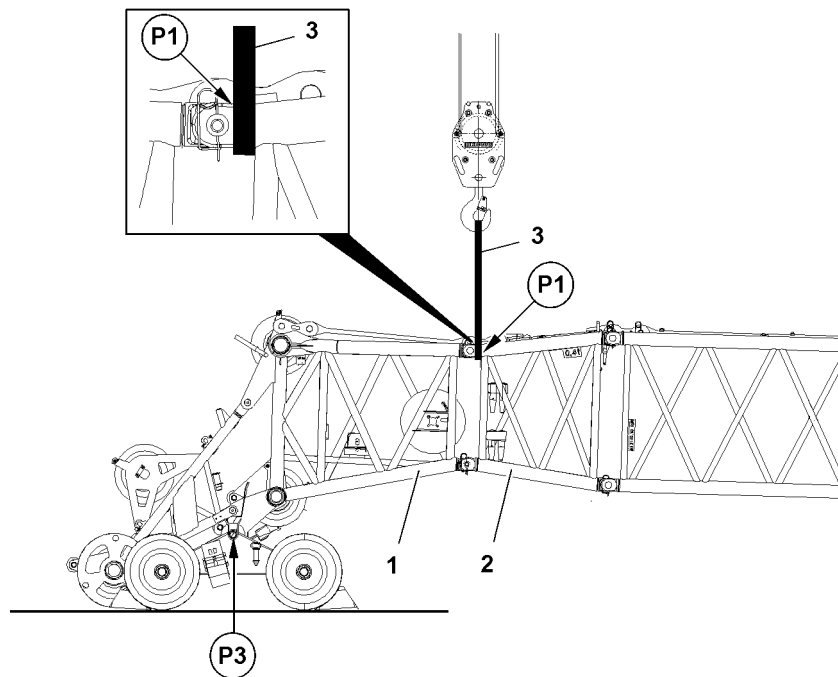


Fig.117842: Taking the lattice jib down into the roller cart (telescopic crane with lattice jib)

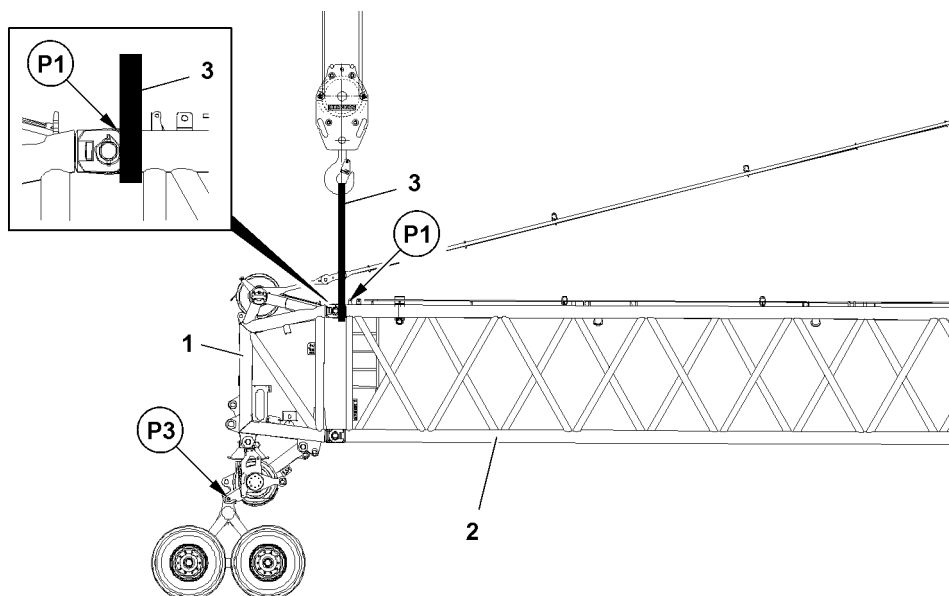


Fig.121550: Taking the lattice jib down into the roller cart (crane with lattice mast)

When taking it down into the roller cart, observe the following:

- The end section 1 is completely assembled.
- Use textile type fastening equipment 3.
- Loop the textile type fastening equipment 3 on the left and right around on the pin points.

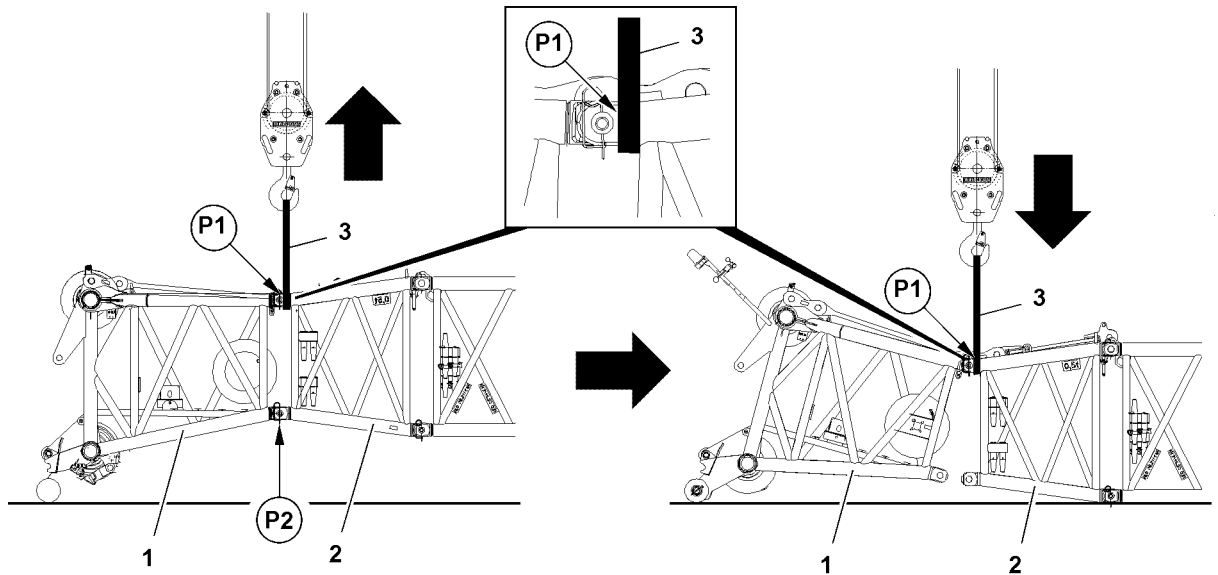
Before fastening:

- ▶ Check the position of the spring retainers and correct, if necessary.
- ▶ Fasten the textile type fastening equipment 3 on the upper pin points P1 between the end section 1 and the pinned components 2.
- ▶ Lift the lattice jib and take it down in the roller cart 4.
- ▶ Pin the end section 1 with the roller cart 4 on the pin points P3 on the left and right.
- ▶ Remove the textile type fastening equipment 3.



**Note**

- ▶ The disassembly and removal of the pulley cart **4** is handled accordingly.

**16.10.3 Opening the end section**

*Fig.117841: Opening the end section*

For opening the end section, observe the following:

- The roller cart is disassembled and removed.
- Use textile type fastening equipment **3**.
- Loop the textile type fastening equipment **3** on the left and right around on the pin points.

Before fastening:

- ▶ Check the position of the spring retainers and correct, if necessary.
- ▶ Fasten the textile type fastening equipment **3** on the upper pin points **P1** between the end section **1** and the pinned components **2**.
- ▶ Lift the lattice jib and relieve the pins on the lower pin points **P2**.
- ▶ Unpin the end section **1** and components **2** on the lower pin points **P2** on the left and right.
- ▶ Take the lattice jib down onto the ground.
- ▶ Remove the textile type fastening equipment **3**.

### 16.10.4 Holding the luffing lattice jib

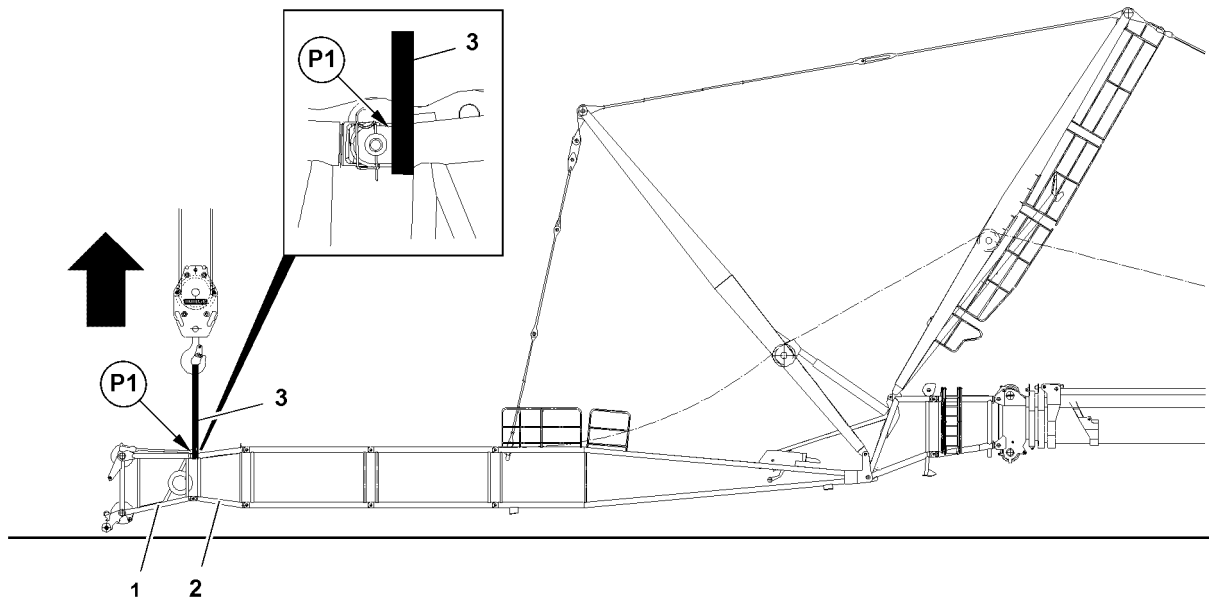


Fig. 117843: Holding the luffing lattice jib

To be able to install or remove the guy rods and "flying assembly", the luffing lattice jib must be held on the upper pin points **P1**.

When holding the luffing lattice jib, observe the following:

- The lattice jib has been completely assembled.
- Use textile type fastening equipment **3**.
- Loop the textile type fastening equipment **3** on the left and right around on the pin points.

Before fastening:

- ▶ Check the position of the spring retainers and correct, if necessary.
- ▶ Fasten the textile type fastening equipment **3** on the upper pin points **P1** between the end section **1** and the pinned components **2**.
- ▶ Lift the lattice jib and install the guy rods.

When the guy rods are installed:

- ▶ Remove the textile type fastening equipment **3**.



#### Note

- ▶ The removal of the guy rods is handled accordingly.

### 16.10.5 Assembling the fixed lattice jib on the TF-adapter



#### WARNING

Mortal danger if the lattice jib tilts over!

Due to unfavorable center of gravity, only certain lattice jib lengths can be installed / removed as an assembled lattice jib.

If a lattice jib length cannot be installed / removed as an assembled lattice jib, then they must be installed / removed individually in flying mode.

- ▶ Check if the respective lattice jib length can be installed / removed as an assembled lattice jib. See charts in chapter 5.01.10.

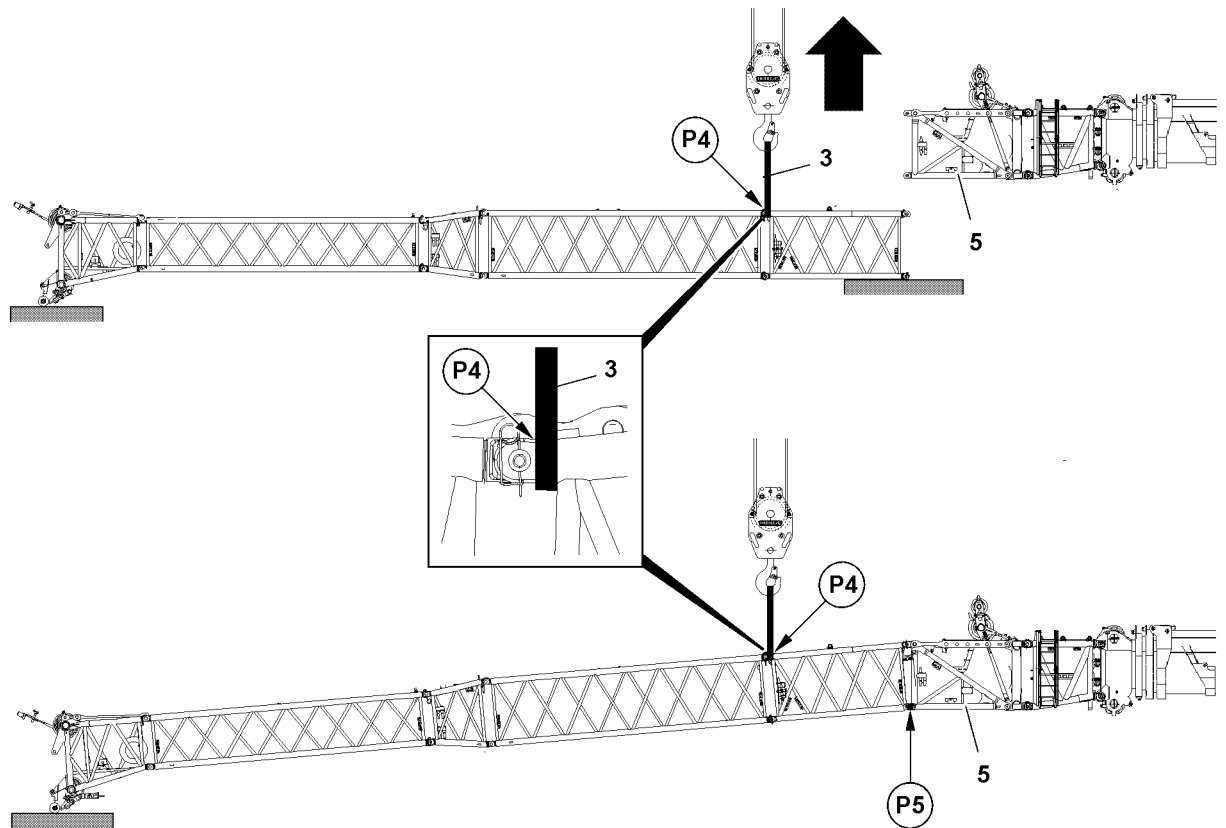


Fig.117844: Assembling the lattice jib on the TF-adapter

For installation on the TF-adapter, observe the following:

- The lattice jib has been assembled.
- The TF-adapter **5** is assembled.
- Use textile type fastening equipment **3**.
- Loop the textile type fastening equipment **3** on the left and right around on the pin points.

Before fastening:

- ▶ Check the position of the spring retainers and correct, if necessary.

Fasten between the lattice sections, which are installed directly on the TF-adapter.

- ▶ Fasten the textile type fastening equipment **3** on the upper pin points **P4**.
- ▶ Lift the lattice jib and affix on the lower pin point **P5** on the TF-adapter **5**.
- ▶ Pin the lattice jib on the lower pin point **P5** with the TF-adapter **5**.

After pinning:

- ▶ Remove the textile type fastening equipment **3**.



### WARNING

Mortal danger if the lattice jib tilts over!

- ▶ Make sure to always observe the permissible lattice jib length at disassembly.
- ▶ Disassemble accordingly.

### 16.10.6 Closing the fixed lattice jib

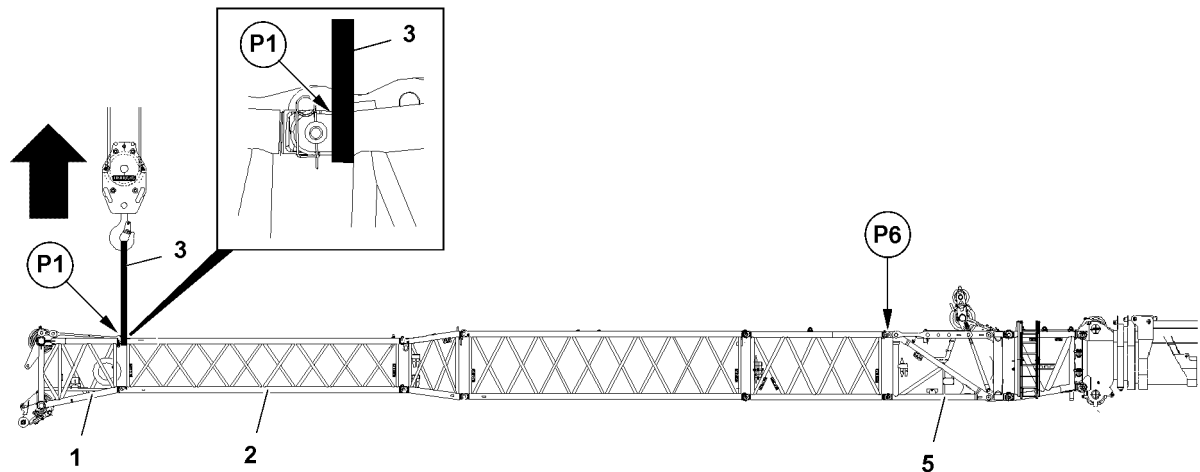


Fig.117850: Closing the lattice jib

For installation on the TF-adapter, observe the following:

- The lattice jib is pinned on the lower pin points of the TF-adapter 5.
- Use textile type fastening equipment 3.
- Loop the textile type fastening equipment 3 on the left and right around on the pin points.

Before fastening:

- ▶ Check the position of the spring retainers and correct, if necessary.
- ▶ Fasten the textile type fastening equipment 3 on the upper pin points P1 between the end section 1 and the pinned components 2.
- ▶ Lift the lattice jib and affix on the upper pin point P6 on the TF-adapter 5.
- ▶ Pin the lattice jib on the upper pin point P6 with the TF-adapter 5.

After pinning:

- ▶ Remove the textile type fastening equipment 3.



#### Note

- ▶ Disassemble accordingly.

### 16.10.7 Angle adjustment on the fixed lattice jib with mechanical adjustment

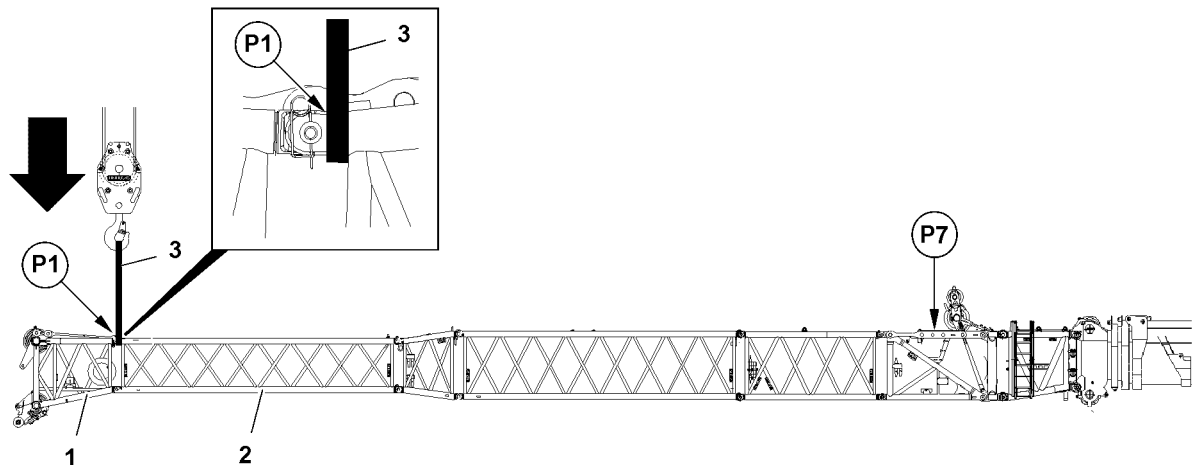


Fig.117851: Angle adjustment on the fixed lattice jib

For the angle adjustment on the fixed lattice jib, observe the following:

- The lattice jib has been completely assembled.
- Use textile type fastening equipment 3.
- Loop the textile type fastening equipment 3 on the left and right around on the pin points.

Before fastening:

- ▶ Check the position of the spring retainers and correct, if necessary.
- ▶ Fasten the textile type fastening equipment 3 on the upper pin points P1 between the end section 1 and the pinned components 2.
- ▶ Lift the lattice jib and relieve the pins on the angle adjustment P7.
- ▶ Unpin the angle adjustment P7, see chapter 5.03.
- ▶ Set and pin a New angle on the angle adjustment P7, see chapter 5.03.
- ▶ Lower the lattice jib.

After lowering:

- ▶ Remove the textile type fastening equipment 3.

### 16.10.8 Loading the preassembled lattice jib

For loading the lattice jib, observe the following:

- The lattice jib has been preassembled.
- Use textile type fastening equipment.
- Loop the textile type fastening equipment on the left and right around on the pin points.

Before fastening:

- ▶ Check the position of the spring retainers and correct, if necessary.
- ▶ Fasten the preassembled lattice jib according to the fastening points, chapter 5.03.

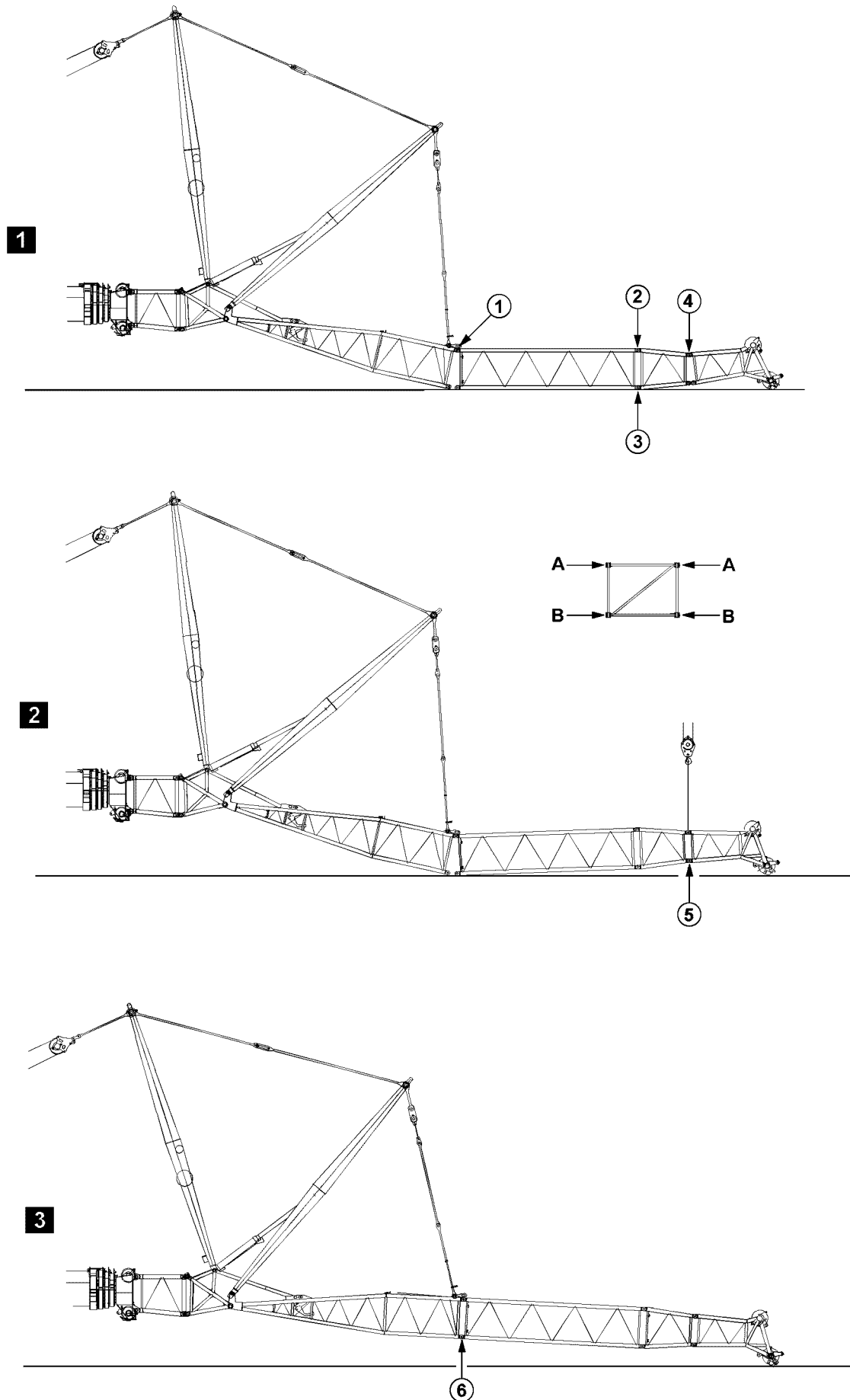


Fig.197718: Example of cranes with a telescopic boom

## 16.11 Assembling / disassembling the lattice sections on telescopic cranes with a luffing lattice jib

### 16.11.1 Assembling the lattice sections on a luffing lattice jib

The illustrations serve as examples. The illustrations may differ depending on the crane.



---

#### WARNING

Danger of fatal injury when assembling auxiliary booms!

If the pins are not pinned in the given sequence, then lattice sections may suddenly fold down or fall down.

Death, severe bodily injuries, property damage.

▶ Pins must be pinned in the order specified.

---

- ▶ Pin and secure pins at both sides (level **A**) at point **1**, illustration **1**.
- ▶ Pin and secure pins at both sides (level **A**) at point **2**, illustration **1**.
- ▶ Pin and secure pins at both sides (level **B**) at point **3**, illustration **1**.
- ▶ Pin and secure pins at both sides (level **A**) at point **4**, illustration **1**.
- ▶ Close the end section with the auxiliary crane, illustration **2**.
- ▶ Pin and secure pins at both sides (level **B**) at point **5**, illustration **2**.
- ▶ Lift the lattice sections, illustration **3**.
- ▶ Pin and secure pins at both sides (level **B**) at point **6**, illustration **3**.

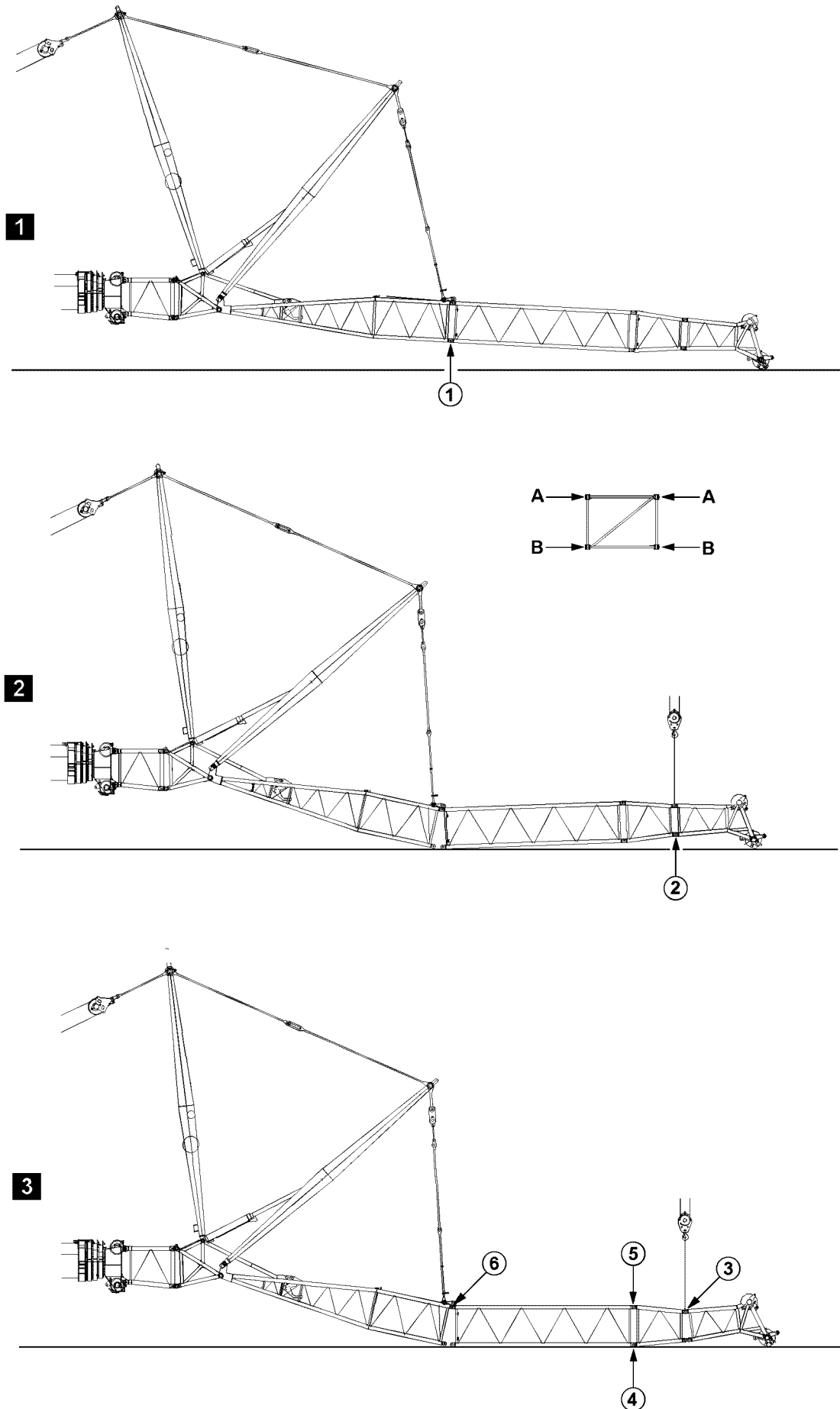


Fig.197719: Example of cranes with a telescopic boom

LWE/LTR 1220-003/24204-02-02/en



### 16.11.2 Disassembling the lattice sections on a luffing lattice jib

The illustrations serve as examples. The illustrations may differ depending on the crane.



---

#### WARNING

Danger of fatal injury when disassembling auxiliary booms!

If the pins are not unpinned in the given sequence, then lattice sections may suddenly fold down or fall down.

Death, severe bodily injuries, property damage.

▶ Pins must be unpinned in the specified order.

---

- ▶ Luff the boom down until the end section touches the ground slightly, illustration 1.
- ▶ Guy the boom with NA-frame I, illustration 1.
- ▶ Release and unpin the pins on both sides (level **B**) at point 1, illustration 1.
- ▶ Open the boom with the NA-frame I and completely take down the boom, illustration 2.
- ▶ Lift the end section with the auxiliary crane, illustration 2.
- ▶ Release and unpin the pins on both sides (level **B**) at point 2, illustration 2.
- ▶ Release and unpin the pins on both sides (level **A**) at point 3, illustration 3.
- ▶ Release and unpin the pins on both sides (level **B**) at point 4, illustration 3.
- ▶ Release and unpin the pins on both sides (level **A**) at point 5, illustration 3.
- ▶ Release and unpin the pins on both sides (level **A**) at point 6, illustration 3.

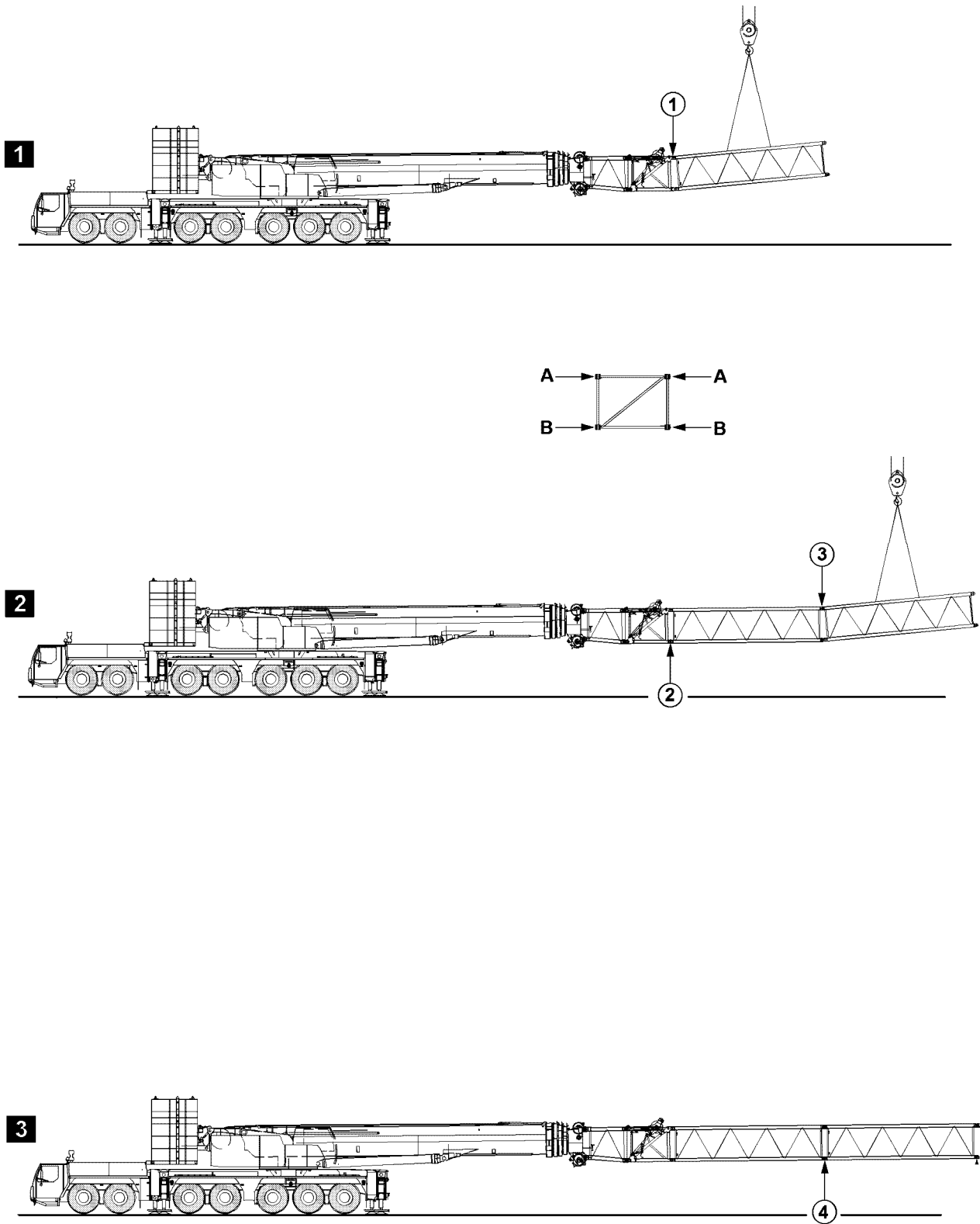


Fig.197705: Example of cranes with a telescopic boom

## 16.12 Assembling / disassembling the lattice sections on telescopic cranes with an auxiliary boom, with an auxiliary crane

### 16.12.1 Assembling the lattice sections on an auxiliary boom with an auxiliary crane

The illustrations serve as examples. The illustrations may differ depending on the crane.



---

#### WARNING

Danger of fatal injury when assembling auxiliary booms!

If the pins are not pinned in the given sequence, then lattice sections may suddenly fold down or fall down.

Death, severe bodily injuries, property damage.

▶ Pins must be pinned in the order specified.

---

- ▶ Pin and secure pins at both sides (level **A**) at point **1**, illustration **1**.
- ▶ Pin and secure pins at both sides (level **B**) at point **2**, illustration **2**.
- ▶ Pin and secure pins at both sides (level **A**) at point **3**, illustration **2**.
- ▶ Pin and secure pins at both sides (level **B**) at point **4**, illustration **3**.

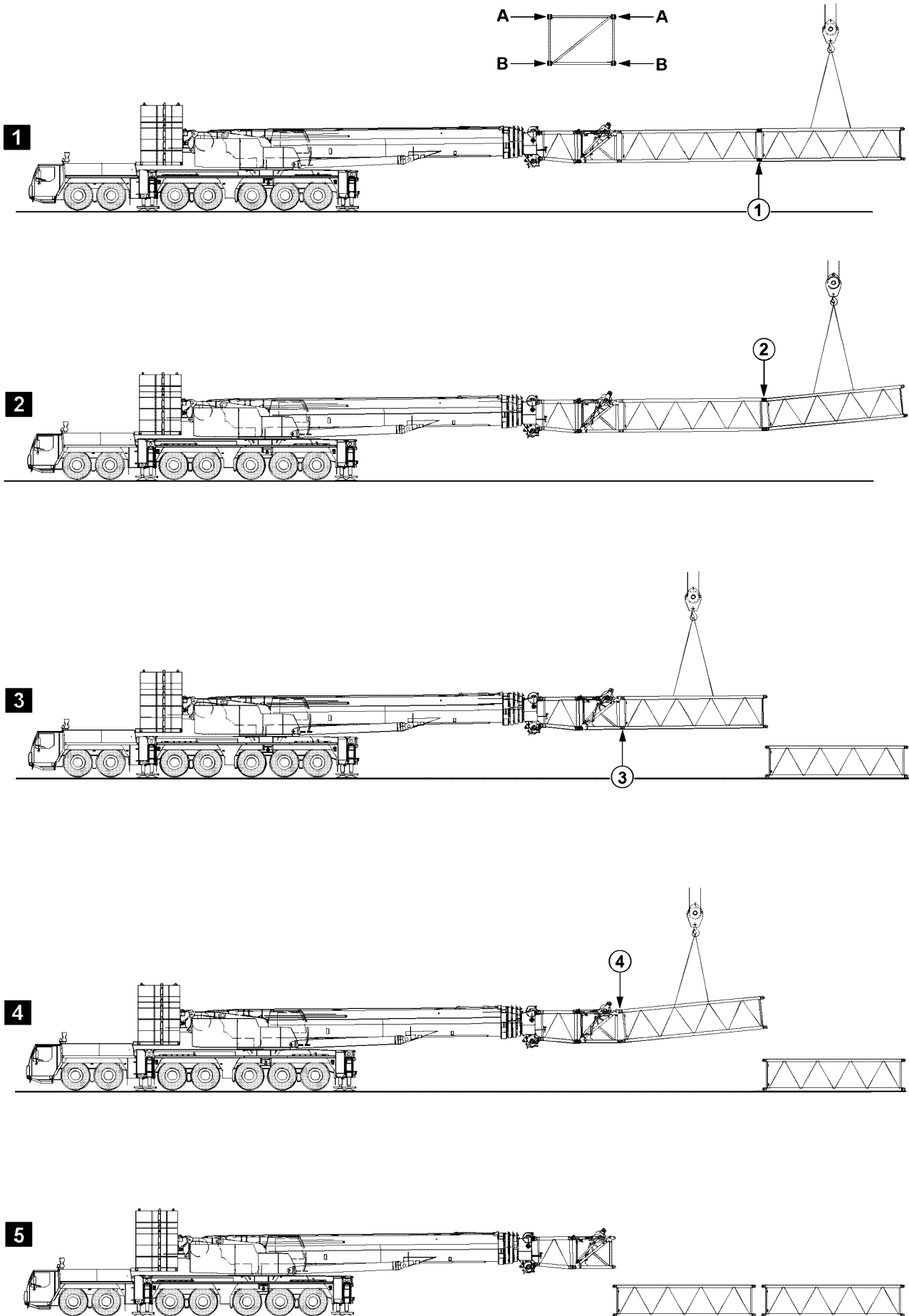


Fig.105510: Example of cranes with a telescopic boom

LWE/LTR 1220-003/24204-02-02/en

## 16.12.2 Disassembling the lattice sections on an auxiliary boom with an auxiliary crane

The illustrations serve as examples. The illustrations may differ depending on the crane.



---

### WARNING

Danger of fatal injury when disassembling auxiliary booms!

If the pins are not unpinned in the given sequence, then lattice sections may suddenly fold down or fall down.

Death, severe bodily injuries, property damage.

▶ Pins must be unpinned in the specified order.

---

- ▶ Release and unpin the pins on both sides (level **B**) at point **1**, illustration **1**.
- ▶ Release and unpin the pins on both sides (level **A**) at point **2**, illustration **2**.
- ▶ Release and unpin the pins on both sides (level **B**) at point **3**, illustration **3**.
- ▶ Release and unpin the pins on both sides (level **A**) at point **4**, illustration **4**.

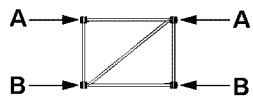
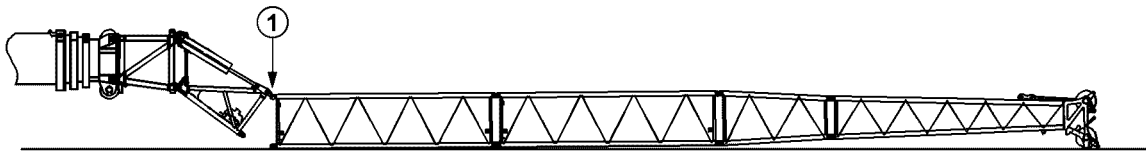
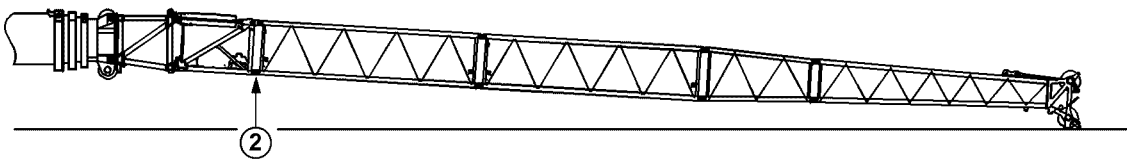
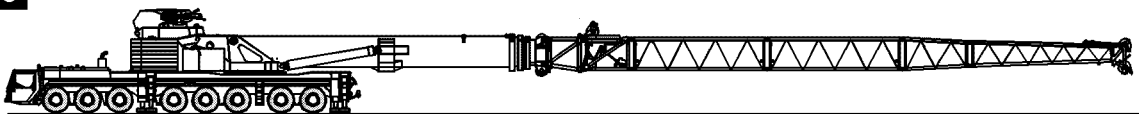
**1****2****3**

Fig.197712: Example of cranes with a telescopic boom

## 16.13 Assembling / disassembling the lattice sections on telescopic cranes with an auxiliary boom, without an auxiliary crane

### 16.13.1 Assembling the lattice sections on an auxiliary boom without an auxiliary crane

The illustrations serve as examples. The illustrations may differ depending on the crane.



---

#### WARNING

Danger of fatal injury when assembling auxiliary booms!

If the pins are not pinned in the given sequence, then lattice sections may suddenly fold down or fall down.

Death, severe bodily injuries, property damage.

- ▶ Pins must be pinned in the order specified.
- 

For cranes with hydraulic angle adjustment and self-supporting auxiliary boom, the assembly / disassembly of additional lattice sections may be performed using the crane itself.

In order to do so, proceed as follows.

- ▶ Assemble the lattice sections to the required length.
- ▶ Pin and secure pins at both sides (level **A**) at point **1**, illustration **1**.
- ▶ Close the auxiliary boom until the pins can be pinned at point **2**, illustration **2**.
- ▶ Pin and secure pins at both sides (level **B**) at point **2**, illustration **2**.

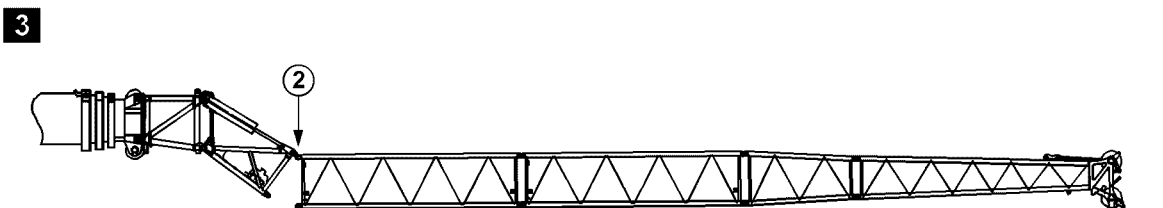
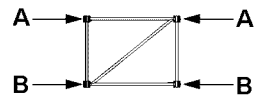
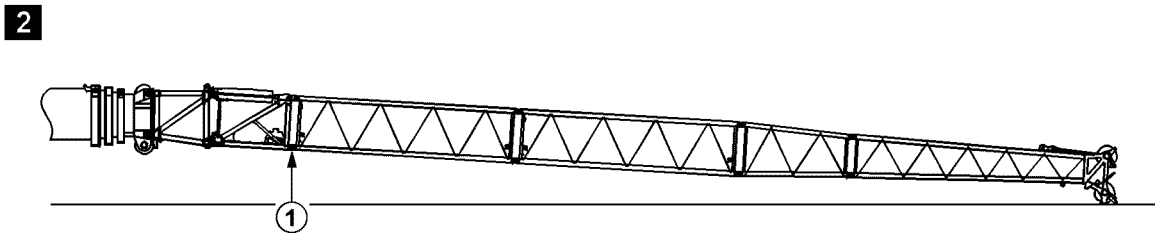
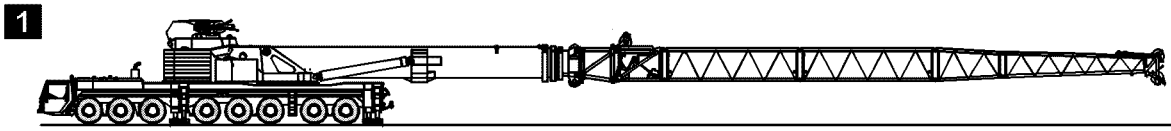


Fig.197713: Example of cranes with a telescopic boom



### 16.13.2 Disassembling the lattice sections on an auxiliary boom without an auxiliary crane

The illustrations serve as examples. The illustrations may differ depending on the crane.



#### WARNING

Danger of fatal injury when disassembling auxiliary booms!

If the pins are not unpinned in the given sequence, then lattice sections may suddenly fold down or fall down.

Death, severe bodily injuries, property damage.

- ▶ Pins must be unpinned in the specified order.

For cranes with hydraulic angle adjustment and self-supporting auxiliary boom, the assembly / disassembly of additional lattice sections may be performed using the crane itself.

In order to do so, proceed as follows.

#### NOTICE

Damage of hydraulic cylinders on the TF-adapter!

- ▶ As soon as the lattice jib is placed, stop the luff down movement.
- ▶ It is prohibited to set down the fixed lattice jib „hard“.

- ▶ Luff the main boom down until the end section touches the ground slightly, illustration 2.

If it is not possible to luff down that far:

- ▶ Adjust the TF-adapter until the end section touches the ground slightly, illustration 2.
- ▶ Release and unpin the pins on both sides (level **B**) at point 1, illustration 2.

#### NOTICE

Damage of hydraulic cylinders on the TF-adapter.

- ▶ As soon as the lattice jib is placed, stop the opening movement.

- ▶ Open the auxiliary boom until the lattice sections to be removed are laying completely on the ground, illustration 3.
- ▶ Release and unpin the pins on both sides (level **A**) at point 2, illustration 3.
- ▶ Completely remove the auxiliary boom.

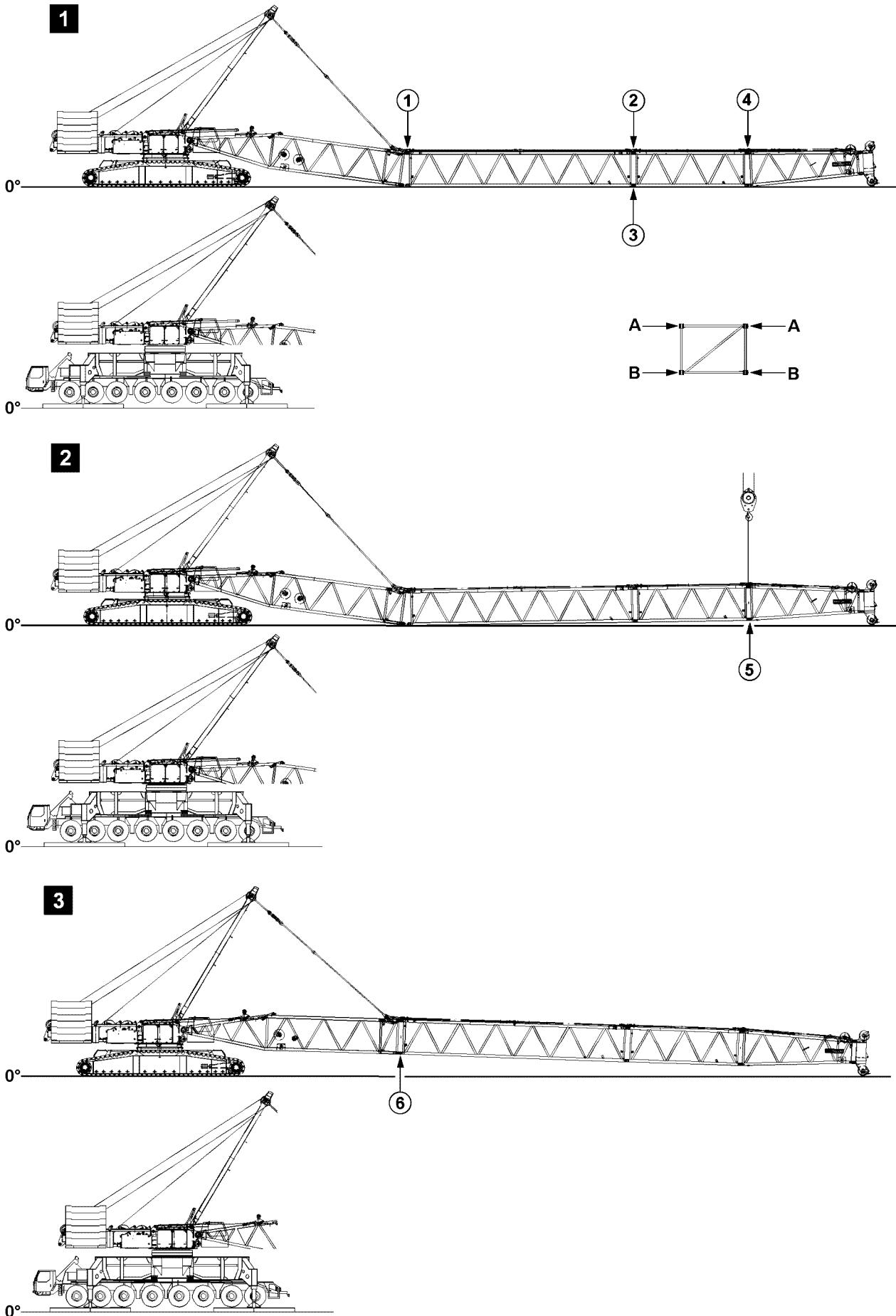


Fig.121633: Example of cranes with a lattice mast boom

LWE/LTR 1220-003/24204-02-02/en

## 16.14 Assembling / disassembling of lattice sections for lattice mast cranes

### 16.14.1 Assembling lattice sections

The illustrations serve as examples. The illustrations may differ depending on the crane.



---

#### WARNING

Danger of fatal injury when assembling booms!

If the pins are not pinned in the given sequence, then lattice sections may suddenly fold down or fall down.

Death, severe bodily injuries, property damage.

▶ Pins must be pinned in the order specified.

---

- ▶ Pin and secure pins at both sides (level **A**) at point **1**, illustration **1**.
- ▶ Pin and secure pins at both sides (level **A**) at point **2**, illustration **1**.
- ▶ Pin and secure pins at both sides (level **B**) at point **3**, illustration **1**.
- ▶ Pin and secure pins at both sides (level **A**) at point **4**, illustration **1**.
- ▶ Lift the end section with the auxiliary crane, illustration **2**.
- ▶ Pin and secure pins at both sides (level **B**) at point **5**, illustration **2**.
- ▶ Close the boom system with the SA-frame, illustration **3**.
- ▶ Pin and secure pins at both sides (level **B**) at point **6**, illustration **3**.

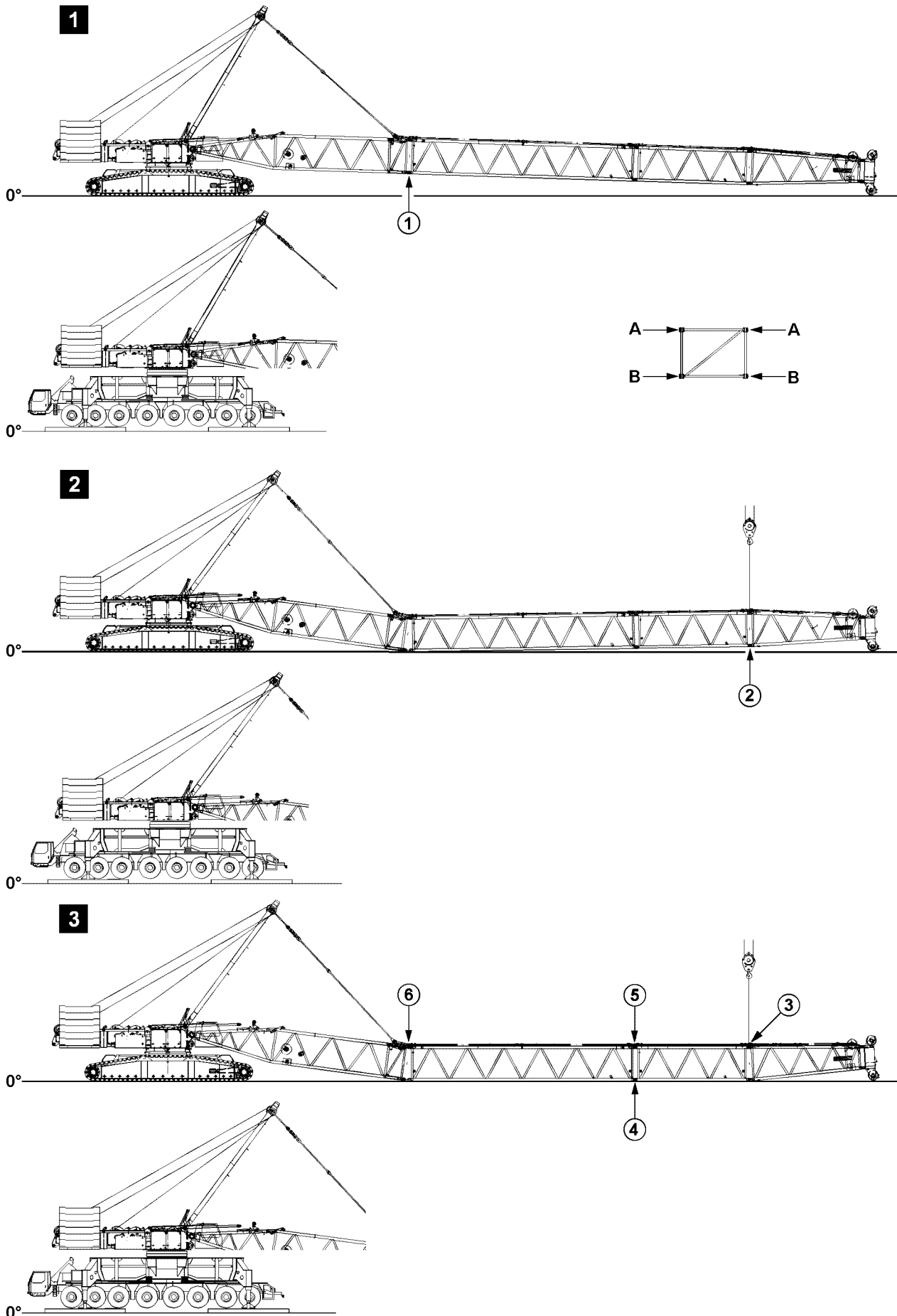


Fig.121634: Example of cranes with a lattice mast boom

LWE/LTR 1220-003/24204-02-02/en

## 16.14.2 Disassembling lattice sections

The illustrations serve as examples. The illustrations may differ depending on the crane.



### WARNING

Danger of fatal injury when disassembling booms!

If the pins are not unpinned in the given sequence, then lattice sections may suddenly fold down or fall down.

Death, severe bodily injuries, property damage.

- ▶ Make sure that the SA-frame guying is tensioned before the pins are unpinned in point **1**, see illustration **1**.
  - ▶ Pins must be unpinned in the specified order.
- 
- ▶ Luff the boom down until the end section touches the ground slightly, illustration **1**.
  - ▶ Guy the boom with SA-frame, illustration **1**.
  - ▶ Release and unpin the pins on both sides (level **B**) at point **1**, illustration **1**.
  - ▶ Open the boom system with the SA-frame, illustration **2**.
  - ▶ Take the lattice sections down completely, illustration **2**.
  - ▶ Lift the end section with the auxiliary crane, illustration **2**.
  - ▶ Release and unpin the pins on both sides (level **B**) at point **2**, illustration **2**.
  - ▶ Release and unpin the pins on both sides (level **A**) at point **3**, illustration **3**.
  - ▶ Release and unpin the pins on both sides (level **B**) at point **4**, illustration **3**.
  - ▶ Release and unpin the pins on both sides (level **A**) at point **5**, illustration **3**.
  - ▶ Release and unpin the pins on both sides (level **A**) at point **6**, illustration **3**.

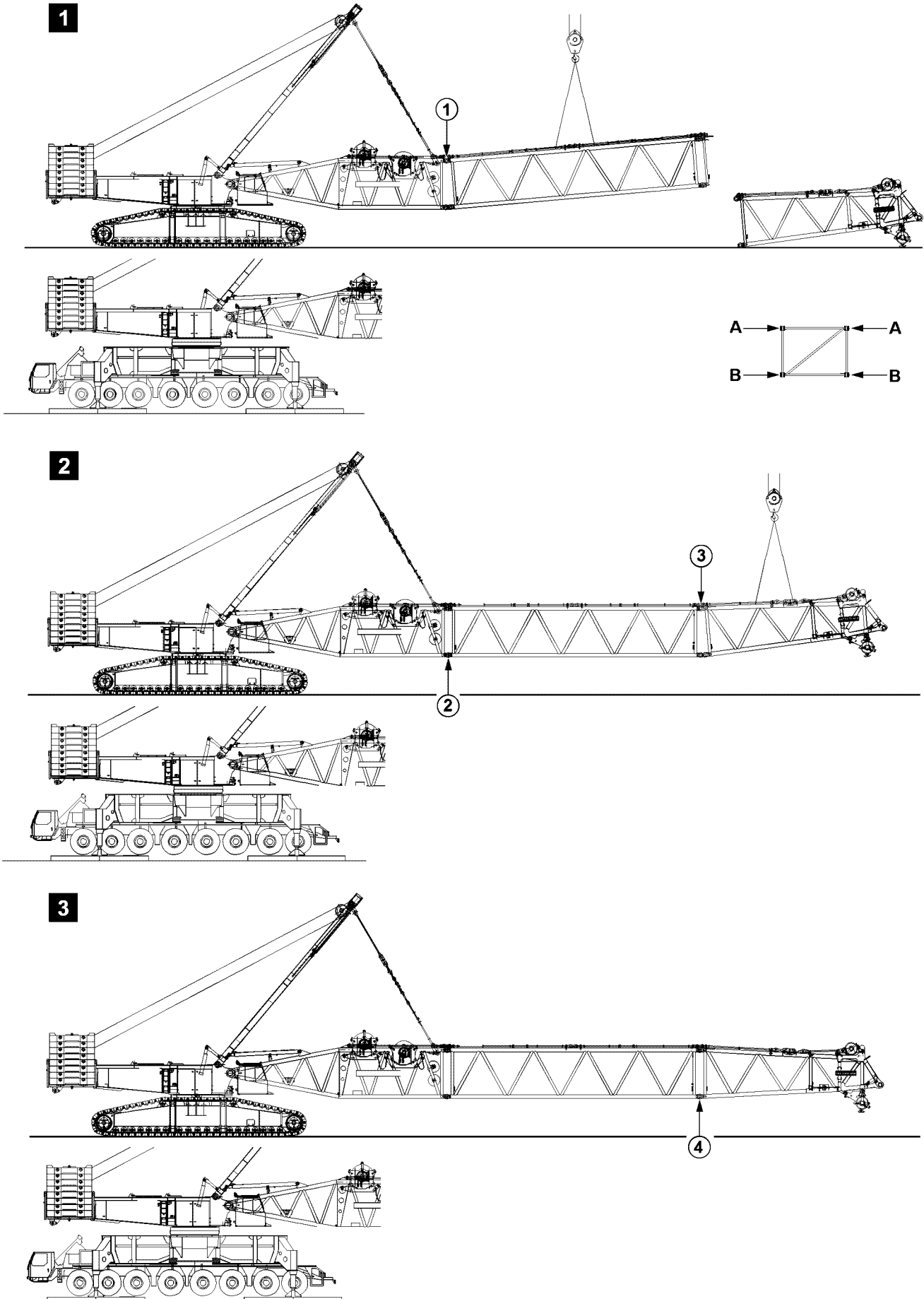


Fig.198182: Example of cranes with a lattice mast boom

LWE/LTR 1220-003/24204-02-02/en

## 16.15 Flying assembly / disassembly of lattice sections

### 16.15.1 Flying assembly of lattice sections

The illustrations serve as examples. The illustrations may differ depending on the crane.



---

#### **WARNING**

Danger of fatal injury when assembling booms!

If the pins are not pinned in the given sequence, then lattice sections may suddenly fold down or fall down.

Death, severe bodily injuries, property damage.

▶ Pins must be pinned in the order specified.

---

- ▶ Pin and secure pins at both sides (level **A**) at point **1**, illustration **1**.
- ▶ Pin and secure pins at both sides (level **B**) at point **2**, illustration **2**.
- ▶ Pin and secure pins at both sides (level **A**) at point **3**, illustration **2**.
- ▶ Pin and secure pins at both sides (level **B**) at point **4**, illustration **3**.

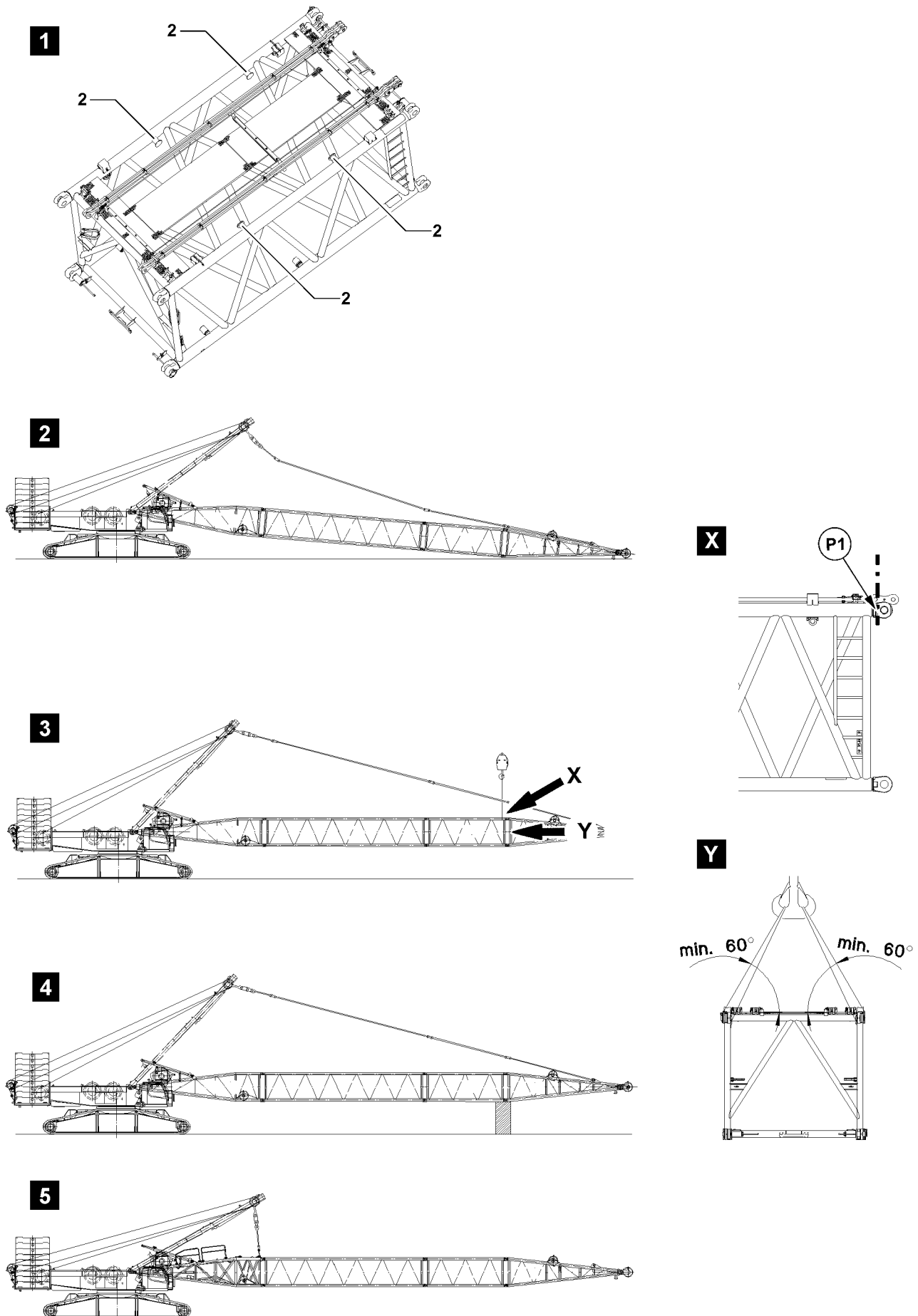


Fig.111448: Guying the pivot section with the SA-frame

LWE/LTR 1220-003/24204-02-02/en



## 16.15.2 Flying disassembly of lattice sections

The illustrations serve as examples. The illustrations may differ depending on the crane.

The flying disassembly of lattice sections can be used on:

- Derrick boom
- Main boom

Make sure that the following prerequisite is met:

- Before guying the pivot section, secure the boom properly to prevent it from falling down.

### Guying the pivot section in flying mode with the SA-frame

There are three ways to change the guying point for flying disassembly:

- Take down the boom on the ground.
  - Secure the boom with the auxiliary crane.
  - Support the boom.
- ▶ Take down the boom on the ground, see illustration 2.  
or



#### WARNING

Lattice section incorrectly attached!

If the fastening equipment is attached on the bits **2** when securing the boom, then the bits will be overloaded. The lattice section will be damaged.

The boom can fall down.

Death, severe bodily injuries, property damage.

If an auxiliary crane is used to secure the boom for flying disassembly:

- ▶ Do **not** fasten the lattice section on the bits **2**, see illustration 1.
- ▶ Attach the fastening equipment in the area of point **P1** on both sides on the lattice section, see detail **X**.
- ▶ Make sure that the long fastening equipment is used, so that the angle between the cross section of the lattice section and guyed fastening equipment is at least 60°, see detail **Y**.

Secure the boom with the auxiliary crane, see illustration 3.

or



#### WARNING

Falling boom!

If the boom is not properly and securely supported from below, then the boom can fall down.

- ▶ Support the boom properly and safely with suitable material.

Support the boom, see illustration 4.

#### Result:

- The guy rods can be disassembled.
- ▶ Take down, secure and disassemble the guy rods.
- ▶ Pin and secure the guy rods SA-frame on the pivot section.
- ▶ Tighten the guy rods SA-frame until the boom is in horizontal position.

#### Result:

- Pivot section is guyed in flying mode with the SA-frame, see illustration 5.
- The lattice sections can be disassembled in flying mode.

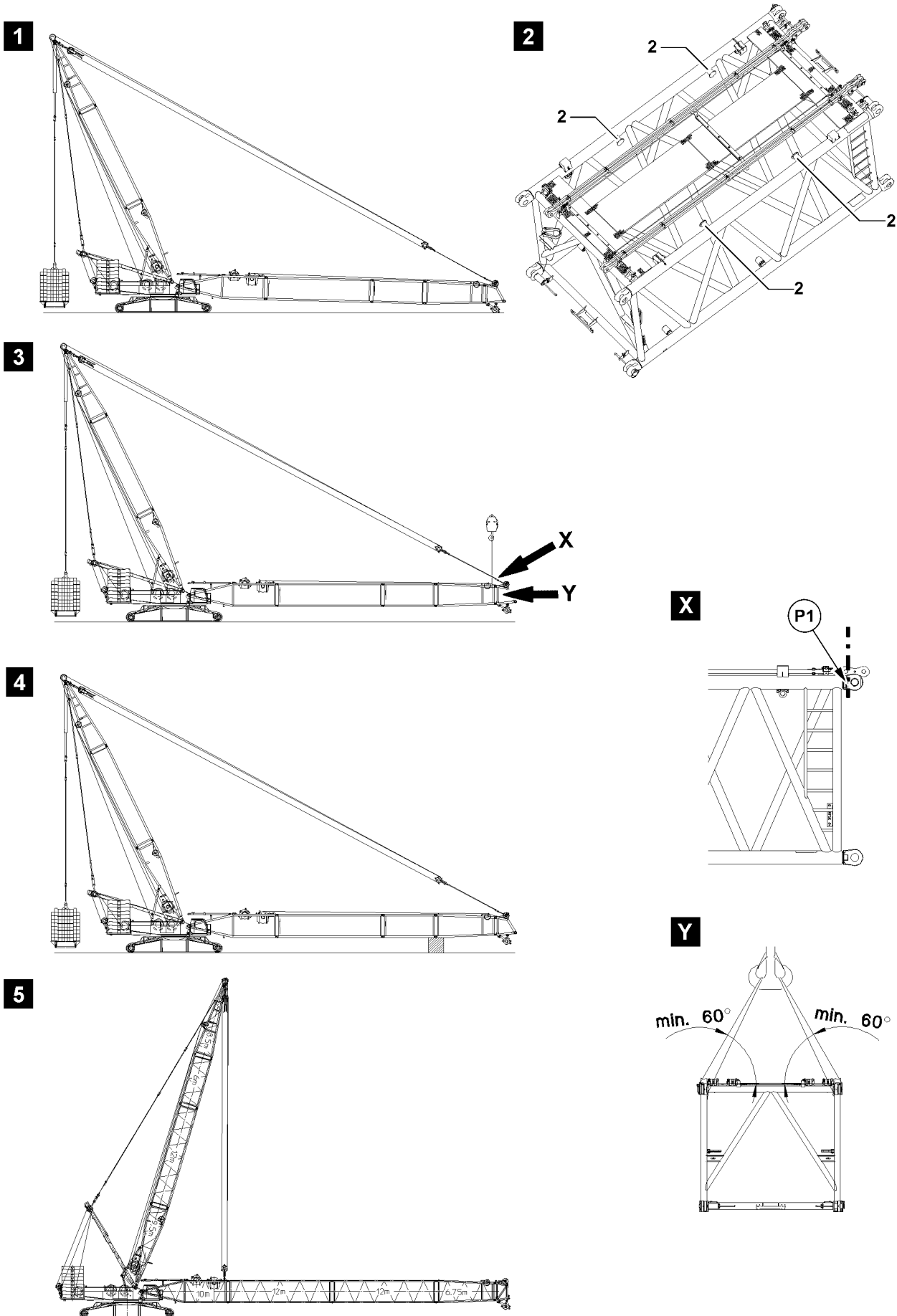


Fig.111449: Guying the pivot section with the derrick boom

LWE/LTR 1220-003/24204-02-02/en

### Guying the pivot section in flying mode with the derrick boom

There are three ways to change the guying point for flying disassembly:

- Take down the boom on the ground.
  - Secure the boom with the auxiliary crane.
  - Support the boom.
- ▶ Take down the boom on the ground, see illustration 1.  
or



#### WARNING

Lattice section incorrectly attached!

If the fastening equipment is attached on the bitts **2** when securing the boom, then the bitts will be overloaded. The lattice section will be damaged.

The boom can fall down.

Death, severe bodily injuries, property damage.

If the auxiliary crane is used to secure the boom for flying disassembly:

- ▶ Do **not** fasten the lattice section on the bitts **2**, see illustration 2.
- ▶ Attach the fastening equipment in the area of point **P1** on both sides on the lattice section, see detail **X**.
- ▶ Make sure that the long fastening equipment is used, so that the angle between the cross section of the lattice section and guyed fastening equipment is at least 60°, see detail **Y**.

Secure the boom with the auxiliary crane, see illustration 3.

or



#### WARNING

Falling boom!

If the boom is not properly supported from below, then the boom can fall down.

- ▶ Support the boom properly and safely with suitable material.

Support the boom, see illustration 4.

#### Result:

- The guy rods can be disassembled.
- ▶ Take down, secure and disassemble the guy rods.
- ▶ Pin and secure the luffing pulley block on the pivot section.
- ▶ Tighten the control rope until the boom is in horizontal position.

#### Result:

- Pivot section is guyed in flying mode with the derrick boom, see illustration 5.
- The lattice sections can be disassembled in flying mode.

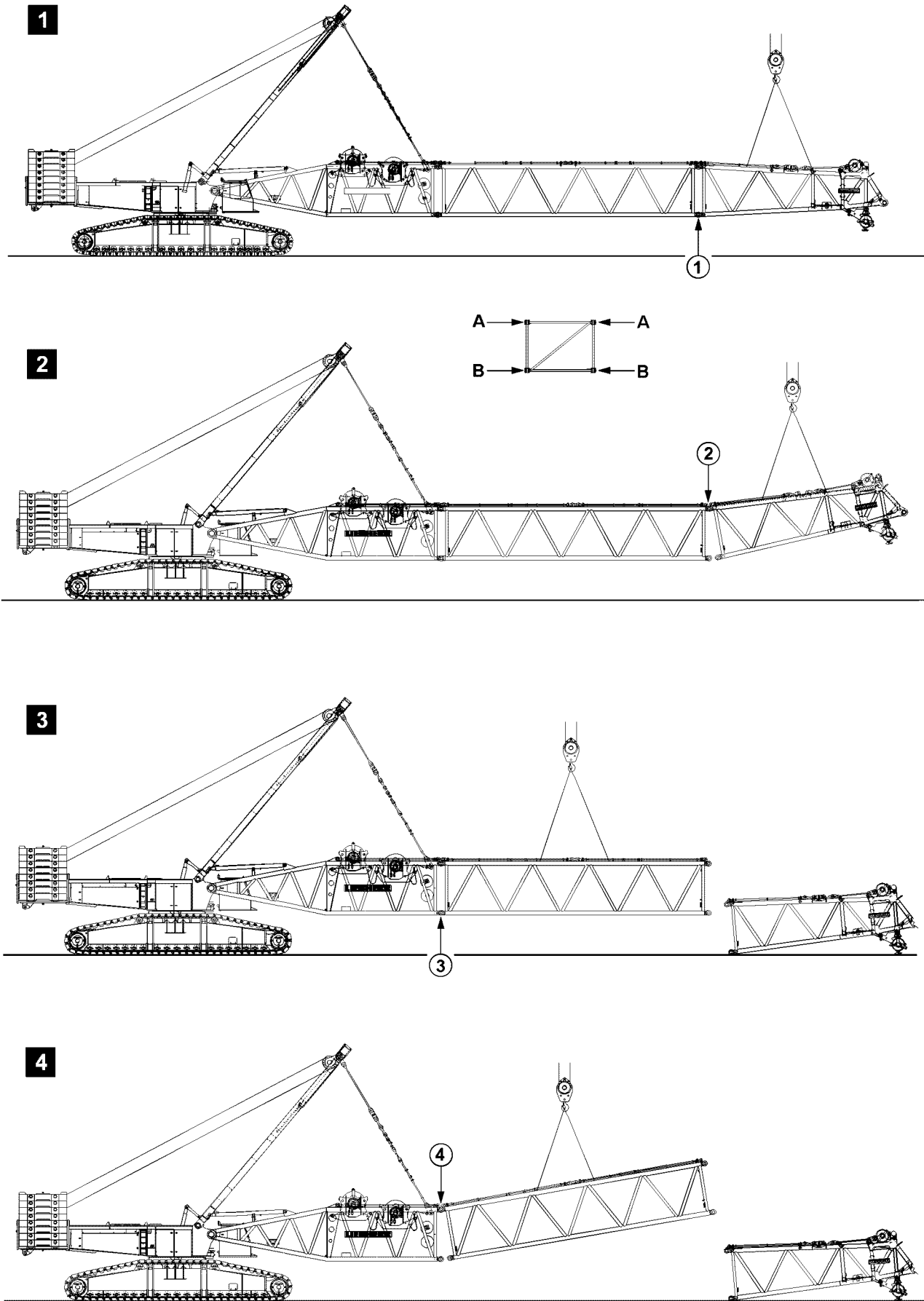


Fig.105511: Example of cranes with a lattice mast boom

LWE/LTR 1220-003/24204-02-02/en

### Unpinning the lattice components



#### WARNING

Danger of fatal injury when disassembling booms!

If the pins are not unpinned in the given sequence, then lattice sections may suddenly fold down or fall down.

Death, severe bodily injuries, property damage.

▶ Pins must be unpinned in the specified order.

- ▶ Release and unpin the pins on both sides (level **B**) at point **1**, illustration 1.
- ▶ Release and unpin the pins on both sides (level **A**) at point **2**, illustration 2.
- ▶ Release and unpin the pins on both sides (level **B**) at point **3**, illustration 3.
- ▶ Release and unpin the pins on both sides (level **A**) at point **4**, illustration 4.

## 16.16 Assembling / disassembling of boom systems for supporting on ascending terrain (assembly / disassembly schematic)



#### Note

- ▶ The following assembly steps are simplified and are examples and may not match your crane exactly.



#### WARNING

Danger of fatal injury when assembling / disassembling booms!

If the pins are not pinned / unpinned in the specified sequence, then lattice sections may suddenly fold down or fall down.

Death, severe bodily injuries, property damage.

- ▶ Pin / unpin pins in the specified sequence, see section „Assembly of lattice sections“.
- ▶ Observe all safety technical notes in section „Assembly / disassembly“.
- ▶ Make sure that there is no personnel in the danger zone.



#### WARNING

Horizontal movement of the boom!

- ▶ Make sure that there is no personnel in the danger zone.

### 16.16.1 Assembling the boom systems on ascending terrain

Make sure that the following prerequisites are met:

- An auxiliary crane with sufficient load bearing capacity is available.

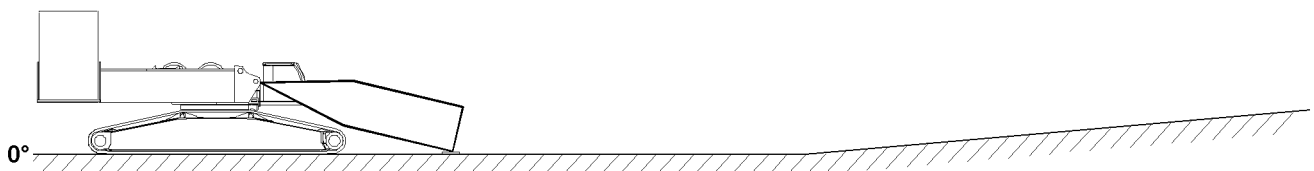


Fig. 121635: Boom - pivot section installed on the turntable and taken down on the ground

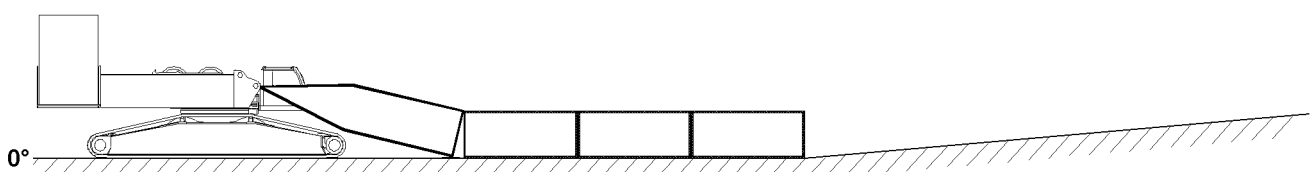


Fig. 121636: Boom - intermediate sections installed on the boom - pivot section and taken down on the ground

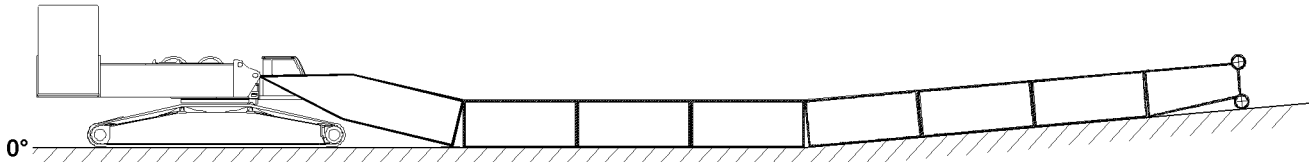


Fig.121637: Boom - intermediate sections installed and taken down on ascending terrain

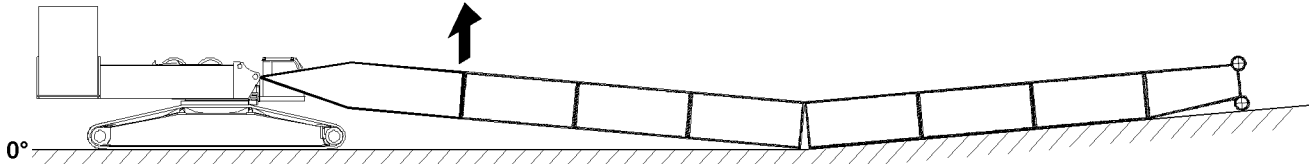


Fig.121638: Lifting and close the boom system in the area of the boom - pivot section

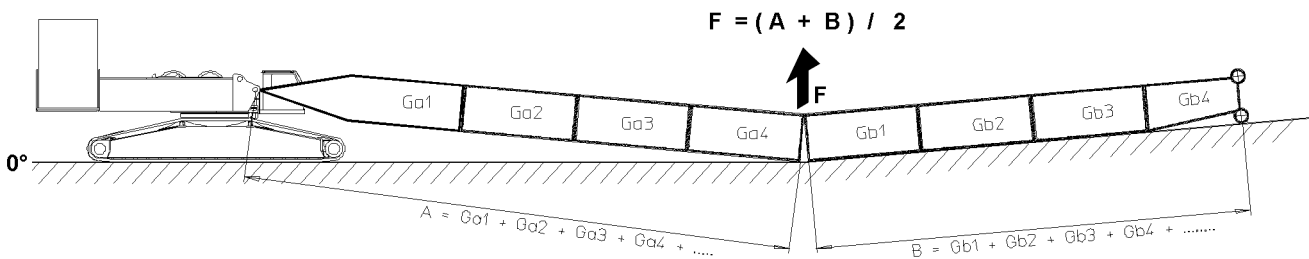


Fig.145512: Calculation of force for the closing procedure of the boom system



**Note**

- ▶ The abbreviations Ga1, Ga2, ... and Gb1, Gb2, ... are for the weights of the individual lattice sections.
- ▶ The weights of the lattice sections are noted on the welded on weight tags on the lattice sections.

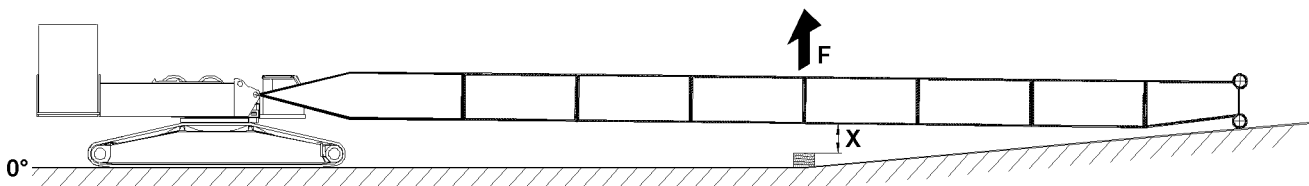


Fig.121639: Lifting and close the boom system // Support the boom system



**Note**

- ▶ The height of the substructure or the dimension X is noted on the respective boom assembly chapter, see chapter 5.38 or chapter 5.39.
- ▶ If the dimension X is not available in chapter 5.38 or chapter 5.39, see the separately supplied drawing „Support assembly drawing“.
- ▶ Support the boom system properly after the closing procedure.

### 16.16.2 Disassembling boom systems on ascending terrain

Make sure that the following prerequisites are met:

- An auxiliary crane with sufficient load bearing capacity is available.

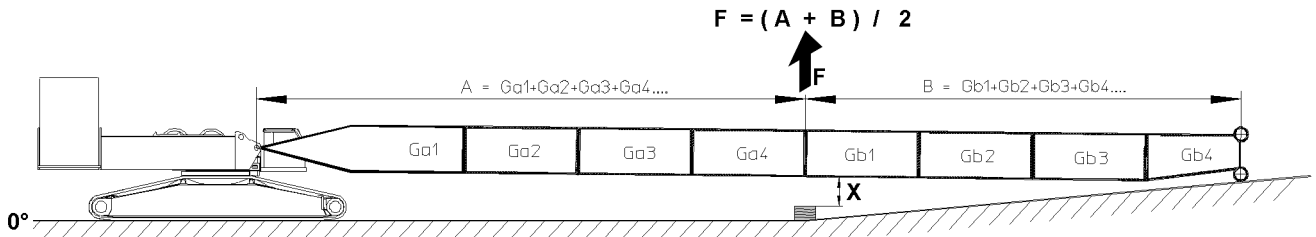


Fig. 145513: Calculation of force for opening the boom system // Lift the boom system // Remove the substructure // Open the boom system



**Note**

- ▶ The abbreviations Ga1, Ga2, ... and Gb1, Gb2, ... are for the weights of the individual lattice sections.
- ▶ The weights of the lattice sections are noted on the welded on weight tags on the lattice sections.

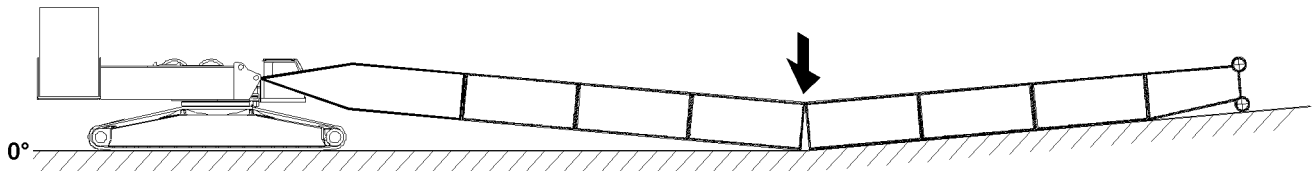


Fig. 121657: Taking the boom system down

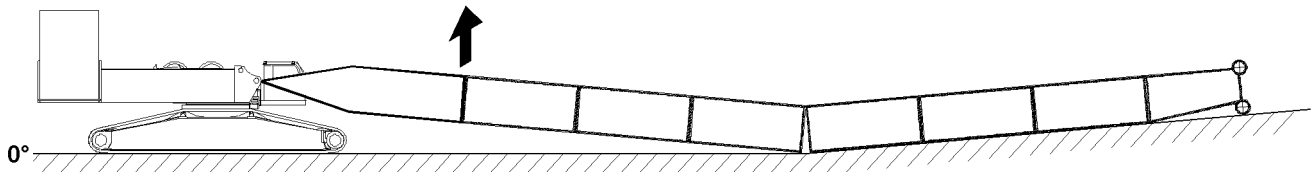


Fig. 121652: Lifting and opening the boom system

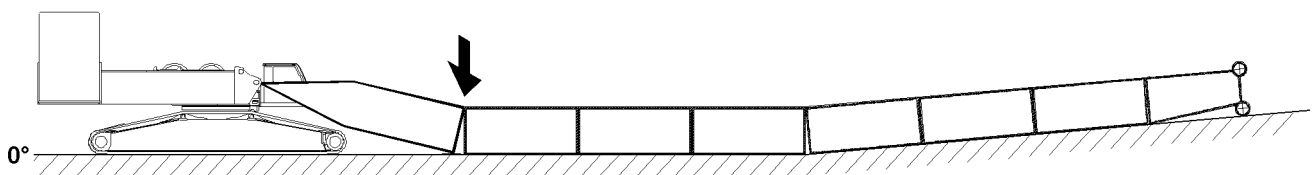


Fig. 121653: Taking the boom system down

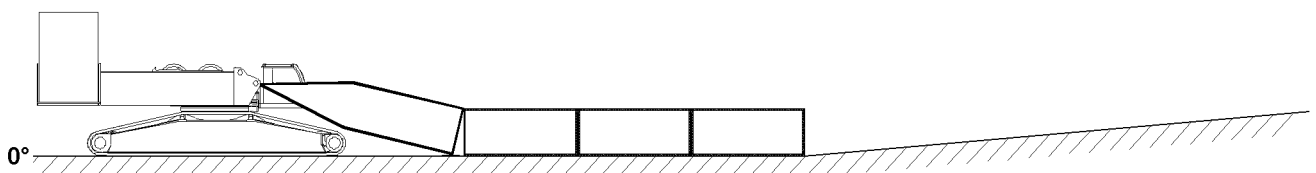


Fig. 121636: Disassembling and removing the boom - intermediate sections with the end section

LWE/LTR 1220-003/24204-02-02/en



Fig. 121635: Disassembling and removing the boom - intermediate sections to the boom - pivot section

- ▶ Disassemble and remove the boom - pivot section.

## 16.17 Assembling / disassembling of boom systems for supporting on descending terrain (assembly / disassembly schematic)



### Note

- ▶ The following assembly steps are simplified and are examples and may not match your crane exactly.



### WARNING

Danger of fatal injury when assembling / disassembling booms!

If the pins are not pinned / unpinned in the specified sequence, then lattice sections may suddenly fold down or fall down.

Death, severe bodily injuries, property damage.

- ▶ Pin / unpin pins in the specified sequence, see section „Assembly of lattice sections“.
- ▶ Observe all safety technical notes in section „Assembly / disassembly“.
- ▶ Make sure that there is no personnel in the danger zone.

### 16.17.1 Assembling the boom systems on descending terrain

Make sure that the following prerequisites are met:

- The lattice sections are properly assembled.
- An auxiliary crane with sufficient load bearing capacity is available.

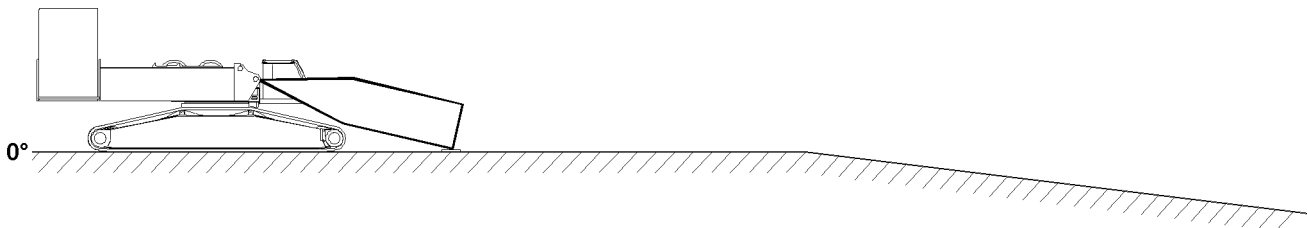


Fig. 121640: Boom - pivot section installed on the turntable and taken down on the ground

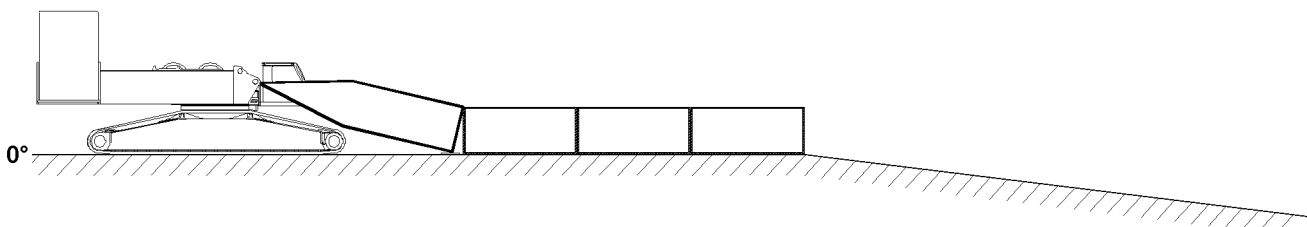


Fig. 121641: Boom - intermediate sections installed on the boom - pivot section and taken down on the ground



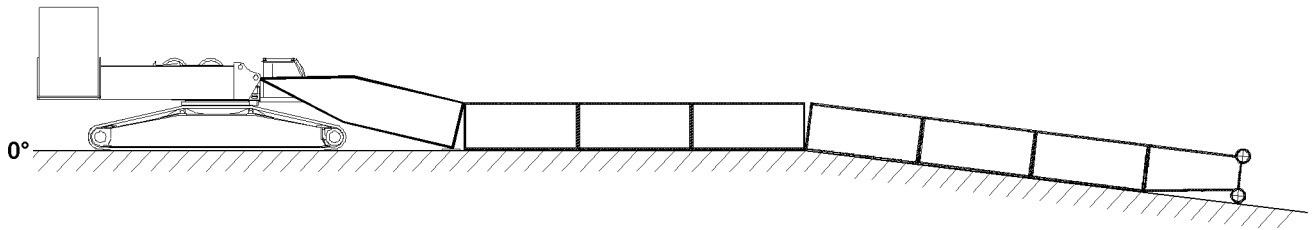


Fig.121642: Boom - intermediate sections installed and taken down on descending terrain

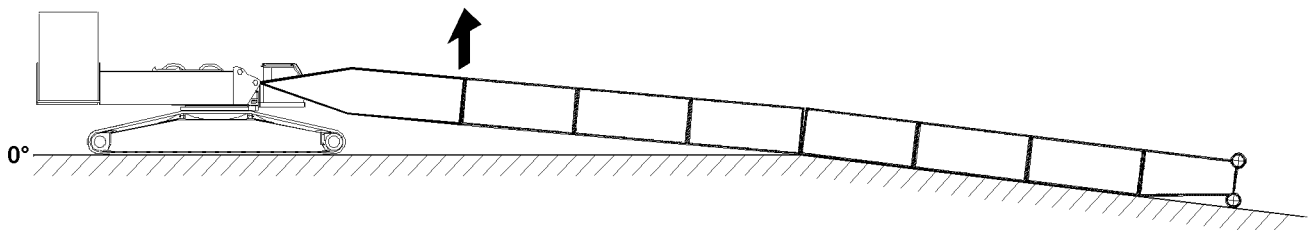


Fig.121643: Lifting and close the boom system in the area of the boom - pivot section

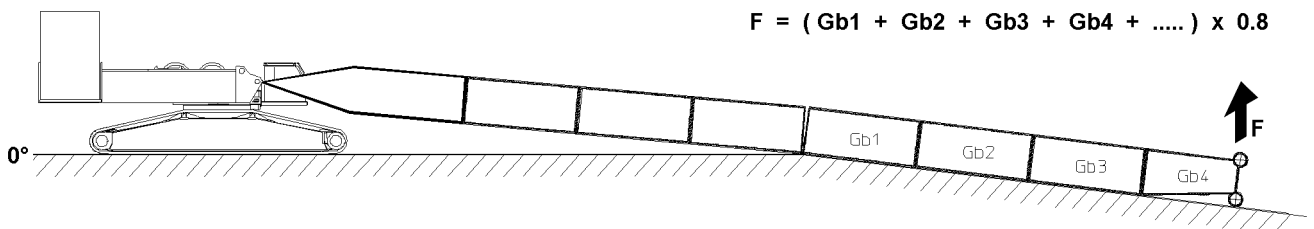


Fig.145514: Calculation of force for the closing procedure of the boom system



**Note**

- ▶ The abbreviations Gb1, Gb2, ... are for the weights of the individual lattice sections.
- ▶ The weights of the lattice sections are noted on the welded on weight tags on the lattice sections.

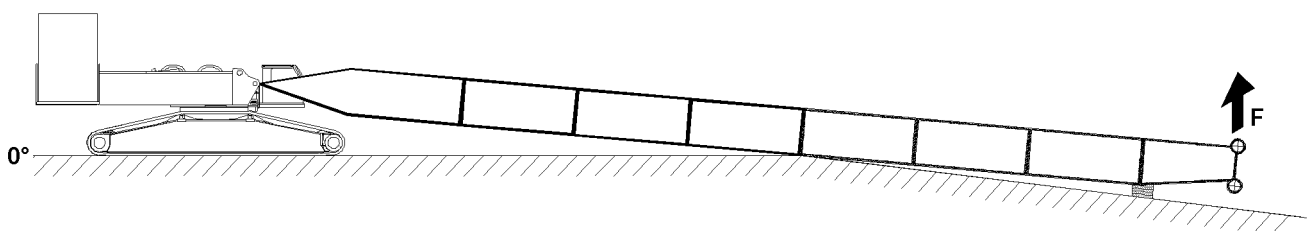


Fig.121644: Lifting and close the boom system // Support the boom system



**Note**

- ▶ The height of the substructure depends on the lay of the terrain and the resulting incline of the boom system.
- ▶ Support the boom system properly after the closing procedure.

### 16.17.2 Disassembling boom systems on descending terrain

Make sure that the following prerequisite is met:

- An auxiliary crane with sufficient load bearing capacity is available.

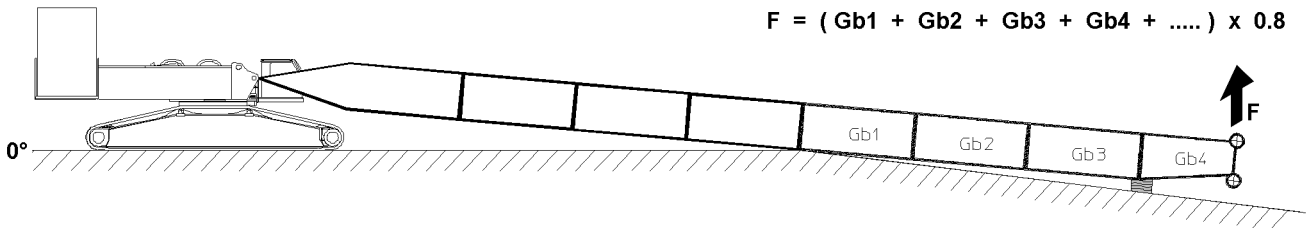


Fig.145515: Calculation of force for opening the boom system // Lift the boom system // Remove the substructure // Open the boom system



**Note**

- ▶ The abbreviations Gb1, Gb2, ... are for the weights of the individual lattice sections.
- ▶ The weights of the lattice sections are noted on the welded on weight tags on the lattice sections.

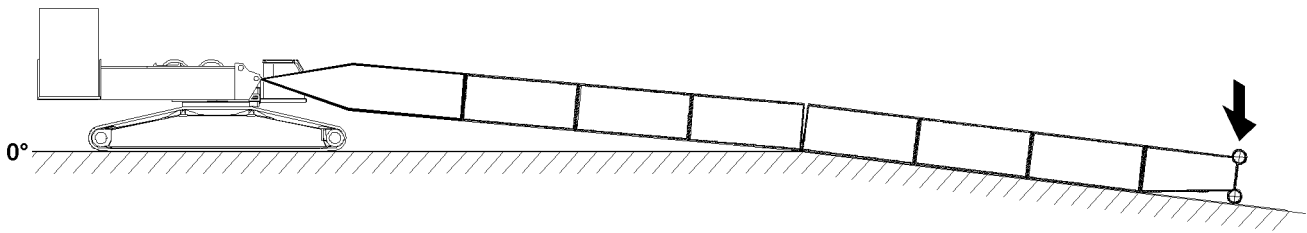


Fig.121658: Taking the boom system down

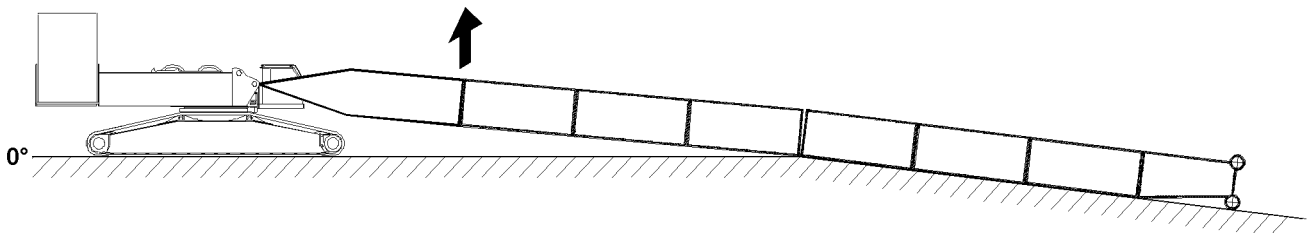


Fig.121655: Lifting and opening the boom system

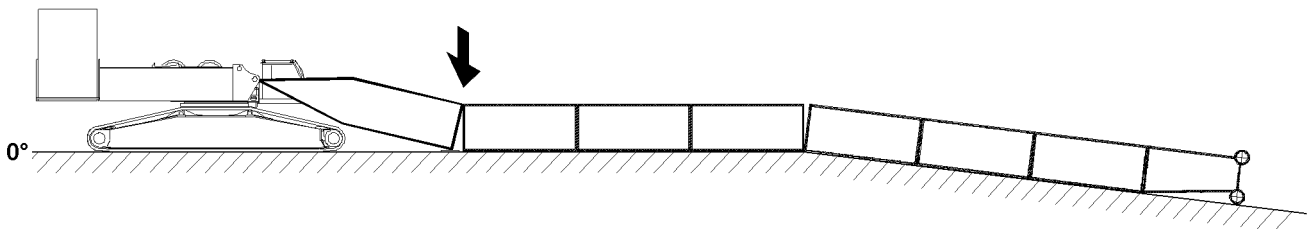


Fig.121656: Taking the boom system down

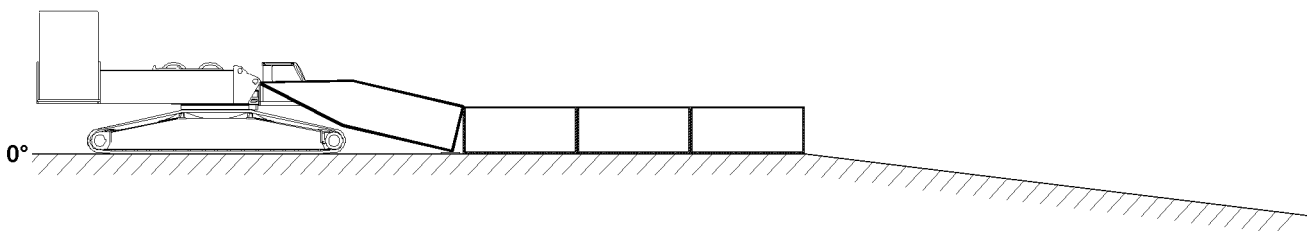


Fig.121641: Disassembling and removing the boom - intermediate sections with the end section

LWE/LTR 1220-003/24204-02-02/en

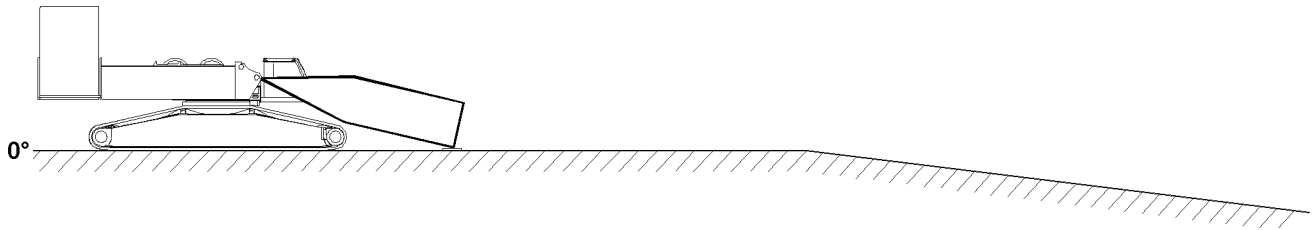


Fig.121640: Disassembling and removing the boom - intermediate sections to the boom - pivot section

- ▶ Disassemble and remove the boom - pivot section.

## 17 Erecting / taking-down



### WARNING

The crane can topple over!

Due to an unforeseen occurrence, for example: Sudden strong wind or storm can lead to dangerous operating situations, up to toppling the crane.

Death, severe bodily injuries, property damage.

- ▶ The boom must be able to be taken down at any time with its current equipment, observe the erection and take-down charts. Observe the job planner.
- ▶ The counterweights and / or ballasts required for this must always be in direct vicinity of the crane.
- ▶ The crane operator must ensure that the required counterweight and / or the required ballast is carried along when driving the crane with the equipment in place and that the boom can be placed down at any time.



### WARNING

Danger of fatal injury!

- ▶ Incorrectly installed or non-functioning limit switches as well as falling parts (pins, cotter pins, ice etc.) can cause accidents.

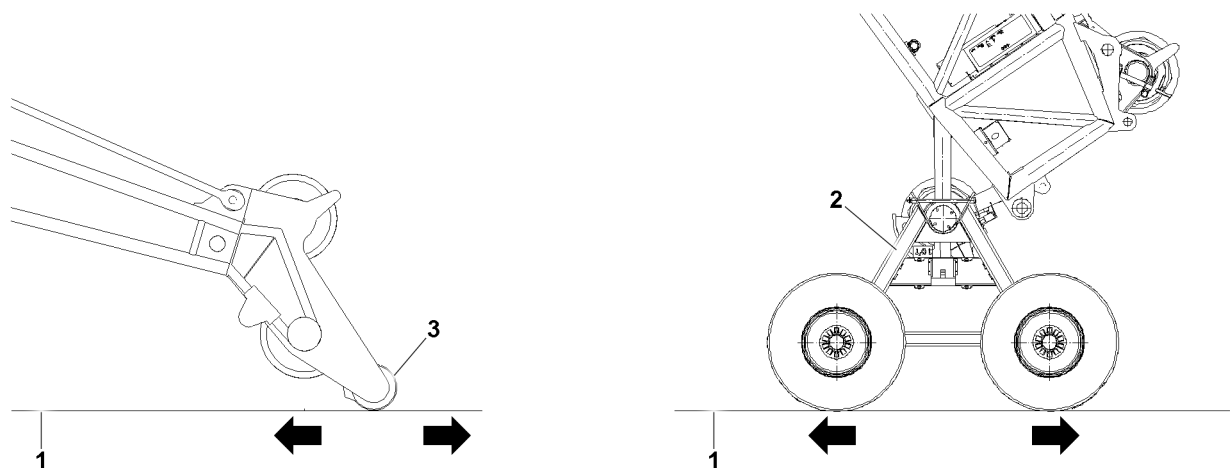


Fig.152357: Roller cart road or lattice head track roller

- |      |             |                           |
|------|-------------|---------------------------|
| 1    | 2           | 3                         |
| Road | Roller cart | Lattice head track roller |

When erecting or taking down with the aid of a roller cart **2** or a lattice head track roller **3**, make sure that the following prerequisites are met:

- The road **1** is level.
- The road **1** is of sufficient load bearing capacity.
- The road **1** is free of obstacles.
- The road **1** is free of persons.

## 17.1 Erecting / taking down with mobile cranes

Make sure that the following prerequisites are met:

- The crane is properly supported.
  - The crane is horizontally aligned.
  - The counterweight has been installed on the turntable according to the load chart or the erection / take down charts.
  - In the case of cranes with derrick ballast: The derrick ballast (suspended ballast or ballast trailer ballast) is installed according to the load chart or the erection / take down charts.
  - For cranes with a telescopic boom: The telescopic boom is telescoped in all the way.
  - The boom has been installed according to the load chart and the Crane operating instructions.
  - The hoist rope has been correctly placed in the rope pulleys and prevented from jumping out with the rope retaining pins.
  - All limit switches have been correctly assembled and are fully operational.
  - All pin connections are secured.
  - No persons in the danger zone.
  - No loose parts on the boom or the auxiliary boom.
  - The exposed rope pulleys are free of snow and ice.
  - The boom and its components (limit switches, cable drums, airplane warning light, wind speed sensor etc.) must be kept free of ice and snow.
- Check if all prerequisites have been met.

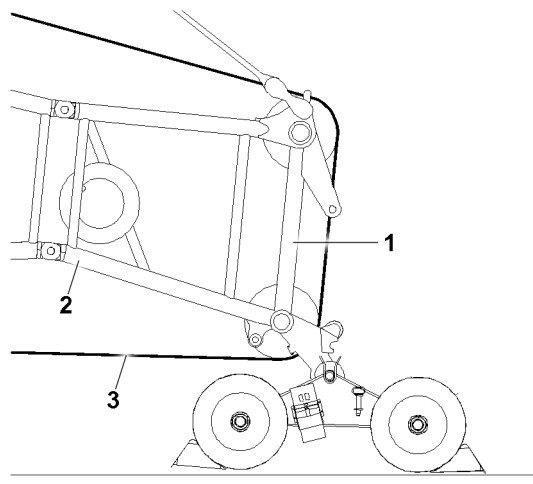


Fig.152358: Securing the hoist rope on the head of the lattice jib

When the luffing lattice jib is erected or taken down **angled**, then the hoist rope must be secured **prior to reeving in** or **after reeving out** the hook block.

Before the hook block is reeved in or after the hook block is reeved out, it is possible that the hoist rope is pulled out of the head of the lattice jib. Therefore the hoist rope must be secured by a hemp rope.



### WARNING

Hoist rope not secured!

The hoist rope can run back in the direction of the hoist winch after reeving out or reeving in the hook block.

► Secure the hoist rope with the hemp rope.

► Fasten the hemp rope with Prusik knots to the hoist rope **3**.

► Fasten the hemp rope with the other end on the corner bar pipe **2** of the head **1** of the lattice jib with tie knots.

## 17.2 Erecting / taking down with crawler cranes

Make sure that the following prerequisites are met:

- Comply with the maximum permissible incline of the crane specified in the load chart manual.
  - For cranes with a support: The crane is properly supported.
  - For cranes with a support: The crane is horizontally aligned.
  - The counterweight has been installed on the turntable according to the load chart.
  - The central ballast is installed according to the load chart.
  - The counterweight is installed according to the load chart or the erection / take down charts.
  - In the case of cranes with derrick ballast: The derrick ballast (suspended ballast or ballast trailer ballast) is installed according to the load chart or the erection / take down charts.
  - For cranes with a telescopic boom: The telescopic boom is telescoped in all the way.
  - The boom has been installed according to the load chart and the Crane operating instructions.
  - The hoist rope has been correctly placed in the rope pulleys and prevented from jumping out with the rope retaining pins.
  - All limit switches have been correctly assembled and are fully operational.
  - All pin connections are secured.
  - No persons in the danger zone.
  - No loose parts on the boom or the auxiliary boom.
  - The exposed rope pulleys are free of snow and ice.
  - The boom and its components (limit switches, cable drums, airplane warning light, wind speed sensor etc.) must be kept free of ice and snow.
- ▶ Check if all prerequisites have been met.

## 17.3 Rigging the guy rods on lattice booms on placed down boom system



### WARNING

Danger of fatal injury due to damaged guy rods!

If the boom system is placed on the ground or a load bearing substructure in strong wind or longer downtime, the guy rods can be damaged due to wind influence on the boom guying. This wind influenced oscillations can lead to fatigue on the guy rods.

As a result, the guy rods could break or rip off under load - for example when erecting the boom system or in crane operation. The boom system can therefore fall uncontrolled forward onto the ground. Death, severe bodily injuries, property damage.

- ▶ Make sure that the guy rods are taken down completely on the lattice sections and relieved when the boom systems are taken down on the ground.
- ▶ Make sure that freely suspended guy rods are rigged on the lattice boom.
- ▶ Make sure that the upper pulley block is rigged on the lattice boom in Derrick operating modes.
- ▶ Make sure, that the guying on the luffing lattice jib is removed on lattice mast cranes.
- ▶ Make sure that the guy rods are inspected before resuming crane operation and that no damage or cracks are present.
- ▶ Make sure that the maintenance intervals of the guy rods are adhered to.



### Note

- ▶ In case of strong wind or longer downtimes of the crane, the boom system must be placed on the ground or on a load bearing substructure.
- ▶ The guying must be relieved and the guy rods must be placed on the transport receptacles.
- ▶ The following illustrations are examples and may not match your crane exactly.

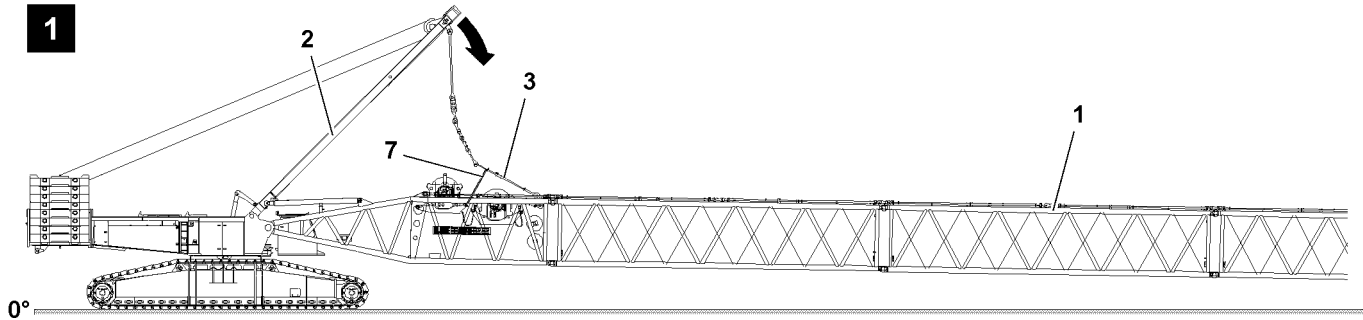


Fig.120722: Guying placed in transport receptacle and SA-frame guying relieved

- ▶ Take the guy rods down on the lattice sections 1: Luff the SA-frame 2 down to the front until the guying is placed completely in the transport receptacles on the lattice sections and the SA-frame guying 3 is relieved, see illustration 1.
- ▶ To minimize side oscillation of the SA-frame guying 3 due to wind influence: Rig the SA-frame guying 3 with suitable rigging straps / ropes 7 against the boom, see illustration 1.

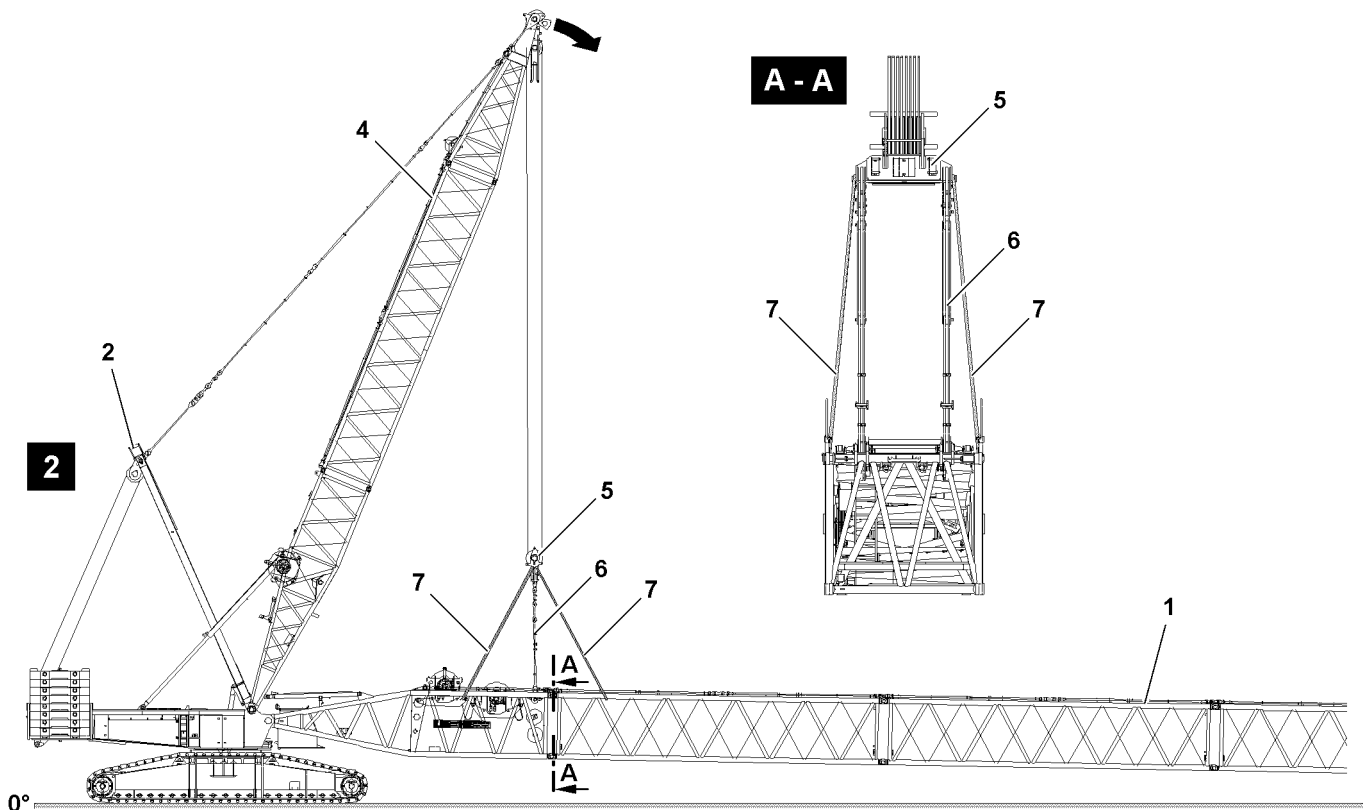


Fig.120771: Guying placed in transport receptacle and upper pulley block rigged against the boom

- ▶ Take the boom system down and - if present - release the derrick guying to the derrick ballast.
- ▶ Take the guy rods down on the lattice sections 1: Luff the D-boom 4 down to the front until the main boom guying is placed completely in the transport receptacles on the lattice sections and the upper pulley block 5 is positioned over the S-pivot section, see illustration 2.
- ▶ To minimize side oscillation of the upper pulley block 5 due to wind influence: Rig the upper pulley block 5 with suitable rigging straps / ropes 7 against the boom, see illustration 2.

**For lattice mast cranes with luffing lattice jib the following applies:**

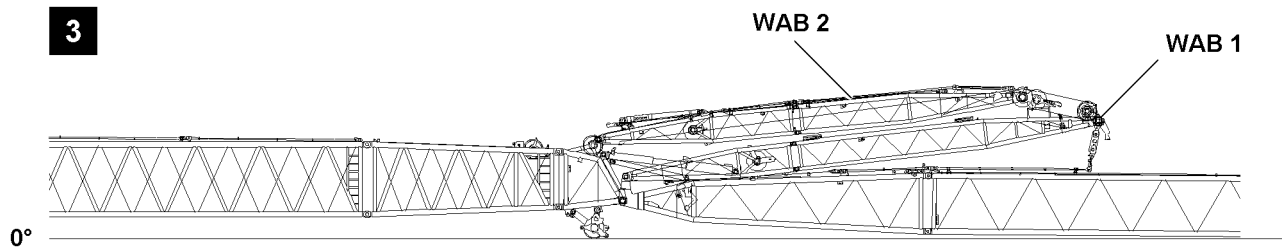


Fig.120821: Guying in transport receptacle(s) and WA-frames placed down to the front (example crane with lattice mast)



### WARNING

Danger of accident when removing the W-guying!

When taking down and removing the guying dangerous situations can arise.

- ▶ Make sure that the danger notes in the respective chapter of the Crane operating instructions are observed.
- ▶ Remove the guy rods on the luffing lattice jib and take them down into the transport receptacles.
- ▶ Take the WA-frames (WA-frame 1 **WAB 1** and WA-frame 2 **WAB 2**) down to the front.

**For telescopic cranes with luffing lattice jib the following applies:**

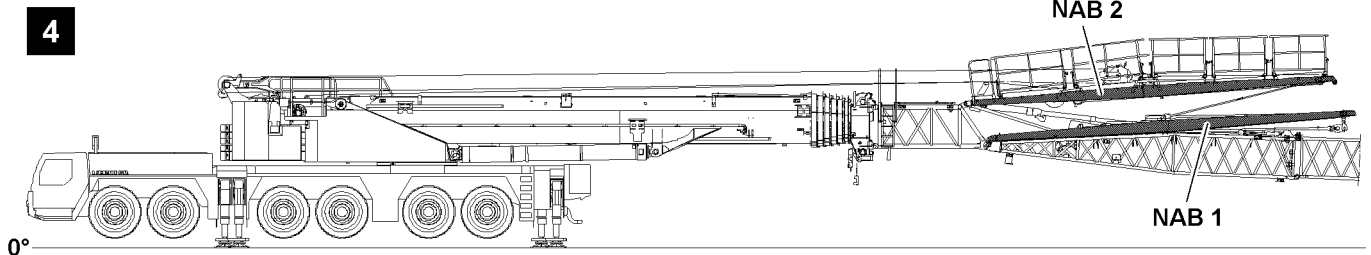


Fig.121261: Guying in transport receptacle(s) and NA-frames placed down to the front (example telescopic crane)



### WARNING

Danger of accident when taking the NA-frames down!

When taking the guy rods as well as the NA-frames down dangerous situations can arise.

- ▶ Make sure that the danger notes in the respective chapter of the Crane operating instructions are observed.
- ▶ Spool the jib control winch out and take the NA-frames down to the front so that the guy rods are relieved.

## 18 Walking on a boom component



### WARNING

Falling from the boom component!

Death, severe bodily injuries.

- ▶ Before working on a boom component, personnel must wear an approved fall arrest system and protective equipment.

**WARNING**

Falling from the boom component!

Operating personnel falling from a boom component due to tripping on objects.

Death, severe bodily injuries.

- ▶ Make sure that there are no objects on the boom component when walking on it.

**WARNING**

Overload of the grating!

Operating personnel falling from the boom component grating if the grating is overloaded due to an impermissible number of personnel.

The grating for the boom components is permitted for the weight of only two people.

Death, severe bodily injuries.

- ▶ Make sure that only the permissible number of personnel can walk on the grating at the same time.

**WARNING**

Impermissible work position for the hydraulic aggregate!

If a hydraulic aggregate is placed on boom components or crane components for assembly purposes, this can cause accident situations.

Operating personnel can fall down from the grating of the boom component if the grating is overloaded by the hydraulic aggregate positioned on it.

The grating for the boom components is permitted for the weight of only two people.

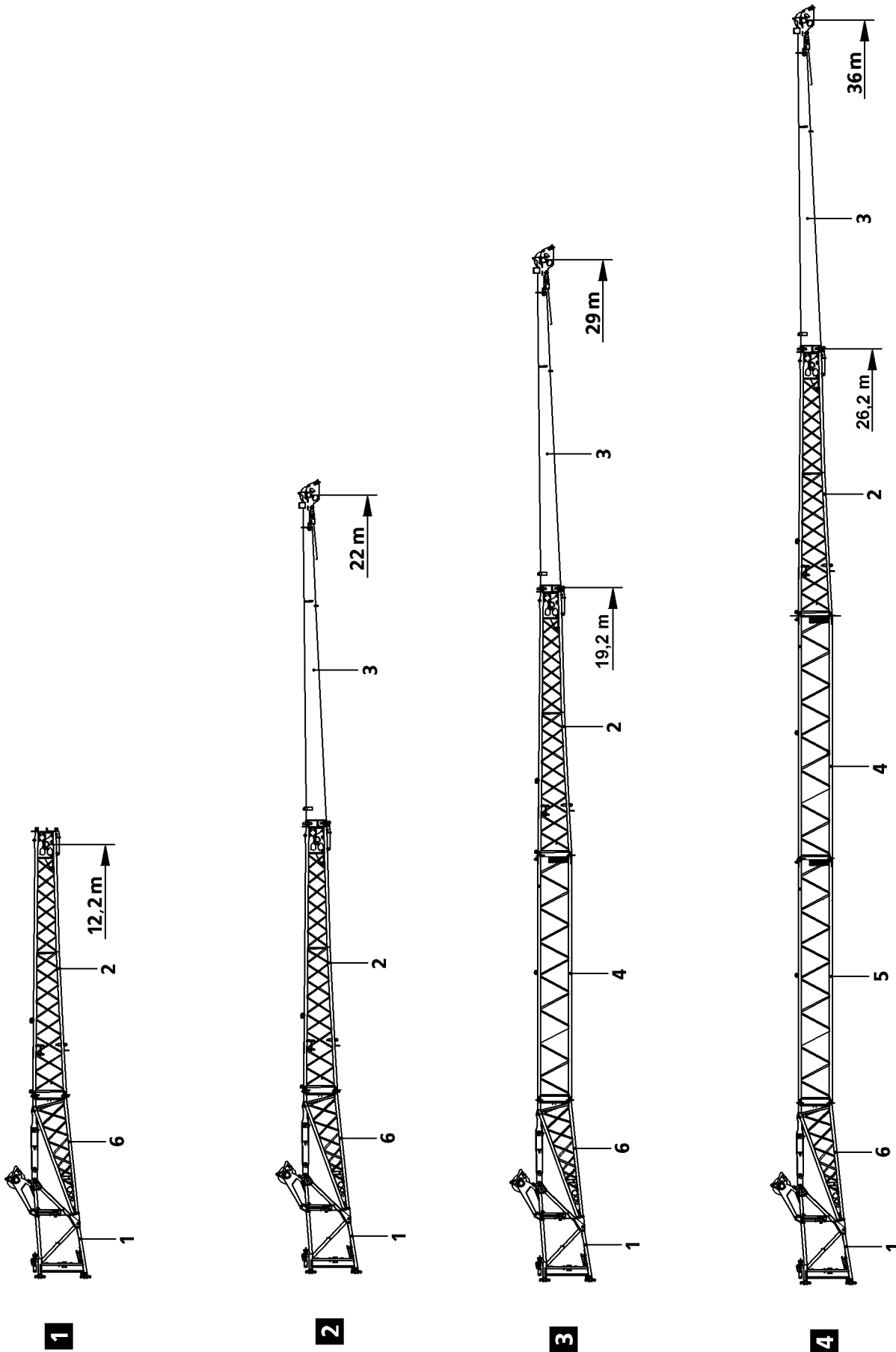
Death, severe bodily injuries, property damage.

- ▶ Make sure that a hydraulic aggregate is never placed on boom components or crane components.
- ▶ The hydraulic aggregate may only be operated on the ground.



## 5.02 Folding jib - TK

1	General	3
2	Assembling the folding jib	13
3	Reeving the hoist rope in	43
4	Changing over the mechanical folding jib from 0° to 22.5° or 45°	45
5	Hydraulic connections	57
6	Electrical connections	63
7	Erecting	73
8	Adjusting the folding jib angle hydraulically*	75
9	Changing over the mechanical folding jib from 22.5° or 45° to 0°	77
10	Reeving the hoist rope out	85
11	Disassembling the folding jib	87



LWE/LTR 1220-003/24204-02-02/en

Fig.192122

# 1 General

This crane may be equipped with a hydraulic or mechanical folding jib. The folding jib with „mechanical angle adjustment“ may be assembled as a straight (0 °) extension or below an angle of 22.5 ° or 45 ° to the telescopic boom. The folding jib with „hydraulic angle adjustment“ may be luffed under load from 0 ° to 45 °. The folding jib is folded onto the telescopic boom and mechanically secured for on-road driving.



## DANGER

Danger of accident when driving with the folding jib!

- ▶ Before on-road driving, the folding jib must always be brought into the transport position and mechanically secured.
- ▶ Make sure that the folding jib is properly secured before moving the crane on public roads.

## 1.1 Folding jib variations

The following folding jib variations are possible:

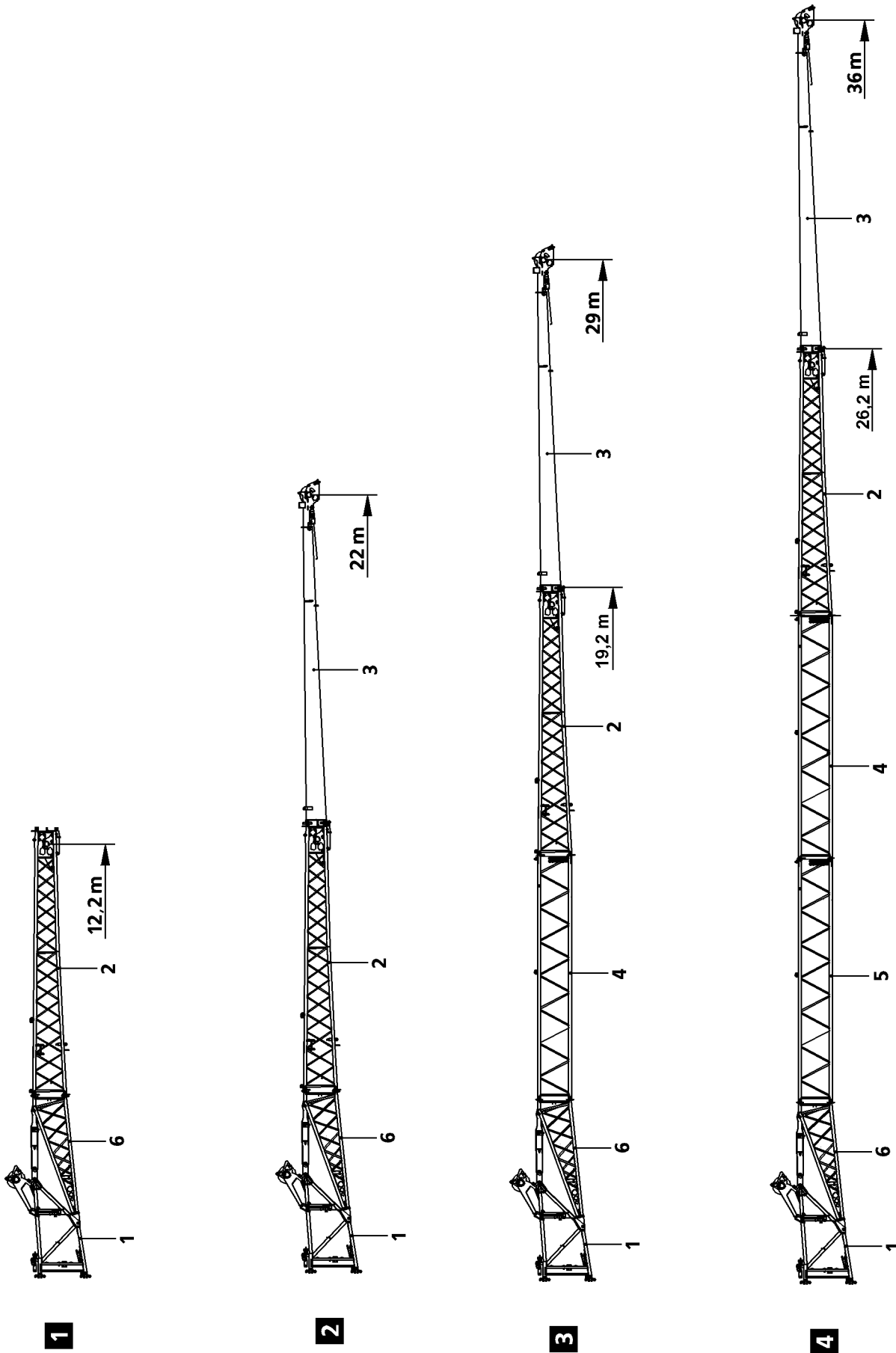
- Single folding jib with „mechanical angle adjustment“
- Single folding jib with „hydraulic angle adjustment“
- Double folding jib with „mechanical angle adjustment“
- Double folding jib with „hydraulic angle adjustment“
- 3-piece folding jib with „mechanical angle adjustment“
- 3-piece folding jib with „hydraulic angle adjustment“
- 4-piece folding jib with „mechanical angle adjustment“
- 4-piece folding jib with „hydraulic angle adjustment“

### 1.1.1 Single folding jib, see illustration 1

Position	Designation	Length
1	Adapter	1.5 m
2	Reducer	7.55 m
6	Pivot section	3.65 m
Length of the single folding jib		12.7 m

### 1.1.2 Double folding jib, see illustration 2

Position	Designation	Length
1	Adapter	1.5 m
2	Reducer	7.55 m
3	End section	9.3 m
6	Pivot section	3.65 m
Length of double folding jib		22.0 m



LWE/LTR 1220-003/24204-02-02/en

Fig.192122

**1.1.3 3-piece folding jib, see illustration 3**

Position	Designation	Length
1	Adapter	1.5 m
2	Reducer	7.55 m
3	End section	9.3 m
4	Folding jib extension	7 m
6	Pivot section	3.65 m
Length of 3-piece folding jib		29 m

**1.1.4 4-piece folding jib, see illustration 4**

Position	Designation	Length
1	Adapter	1.5 m
2	Reducer	7.55 m
3	End section	9.3 m
4	Folding jib extension	7 m
5	Folding jib extension	7 m
6	Pivot section	3.65 m
Length of 4-piece folding jib		36 m

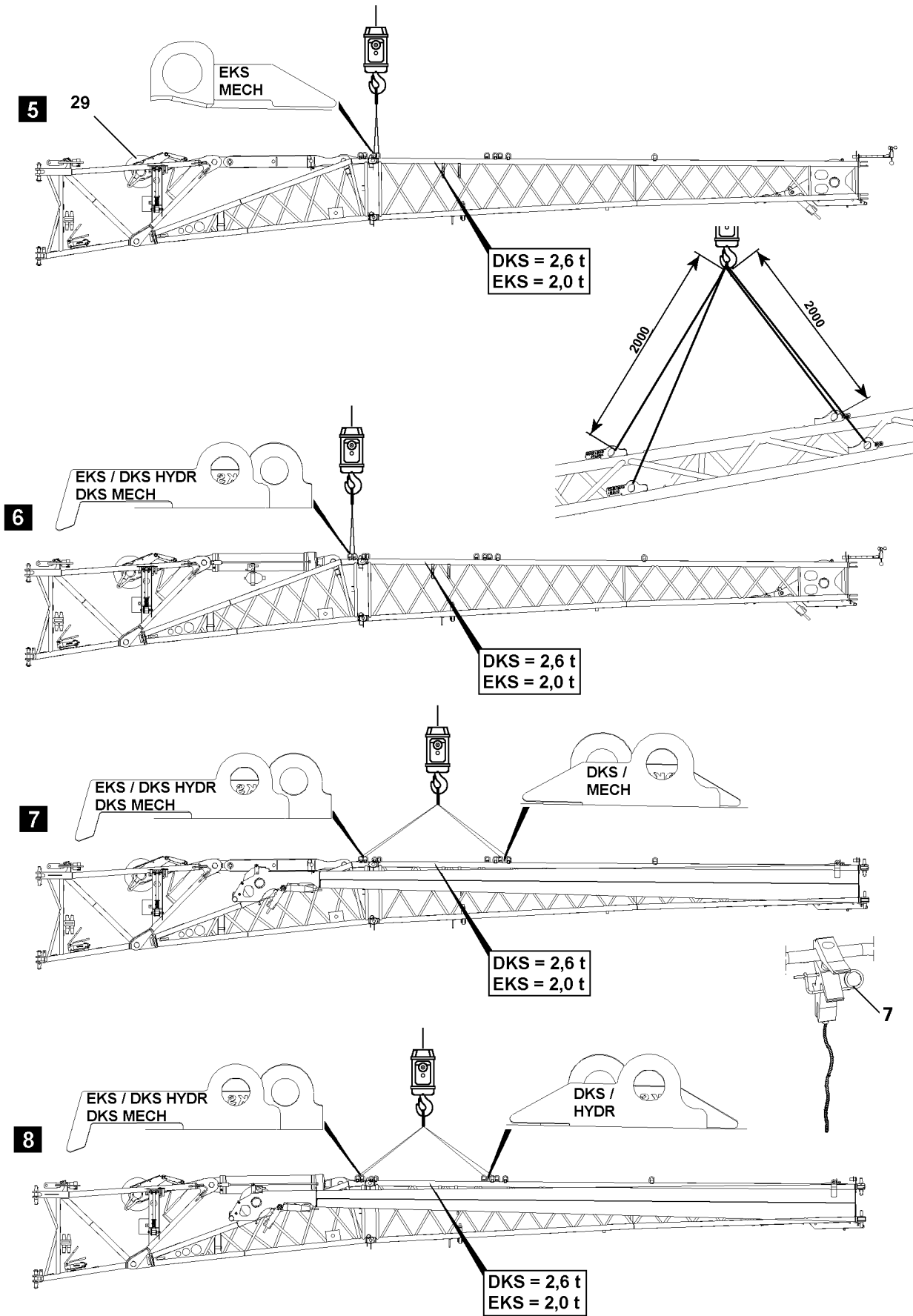


Fig.117343

LWE/LTR 1220-003/24204-02-02/en

## 1.2 Fastening points „folding jib complete“

If the folding jib is carried along separately with a transport vehicle, then fastening points are installed for the assembly and disassembly of the folding jib. The transportation methods vary in terms of single or double folding jib and / or „mechanical angle adjustment“ or „hydraulic angle adjustment“.

The appropriate fastening eyes are marked with tags.

Make sure that the following prerequisites are met:

- The single folding jib or the double folding jib is pinned and secured in the 0° position.
- The rope guide pulley **29** is pinned and secured in the transport position.
- The end section is pinned with the pivot section in folded in position and secured with spring retainer **7**.



### DANGER

Danger of accident due to incorrect fastening!

Life-threatening situations can arise if the folding jib is improperly or incorrectly fastened!

- ▶ The folding jib is to be fastened according to the fastening points shown on the signs.
- ▶ The appropriate fastening eyes / fastening points are marked with tags.
- ▶ Attaching the single folding jib or the double folding jib on non-intended points or on any arbitrary location is **prohibited**.
- ▶ When attaching the double folding jib, the end section **3** must be folded in, locked and the spring retainer **7** must be secured.

### NOTICE

Damage of fastening points due to fastening equipment that is too short!

- ▶ Use fastening equipment with a strand length of at least 2000 mm each.



### WARNING

Attachment parts assembled!

Center of gravity changed, the folding jib can tip over.

Death, severe bodily injuries, property damage.

- ▶ Remove all installation parts before fastening the folding jib.

Attachment parts are for example:

- Camera
- Flashing beacon
- Wind speed sensor

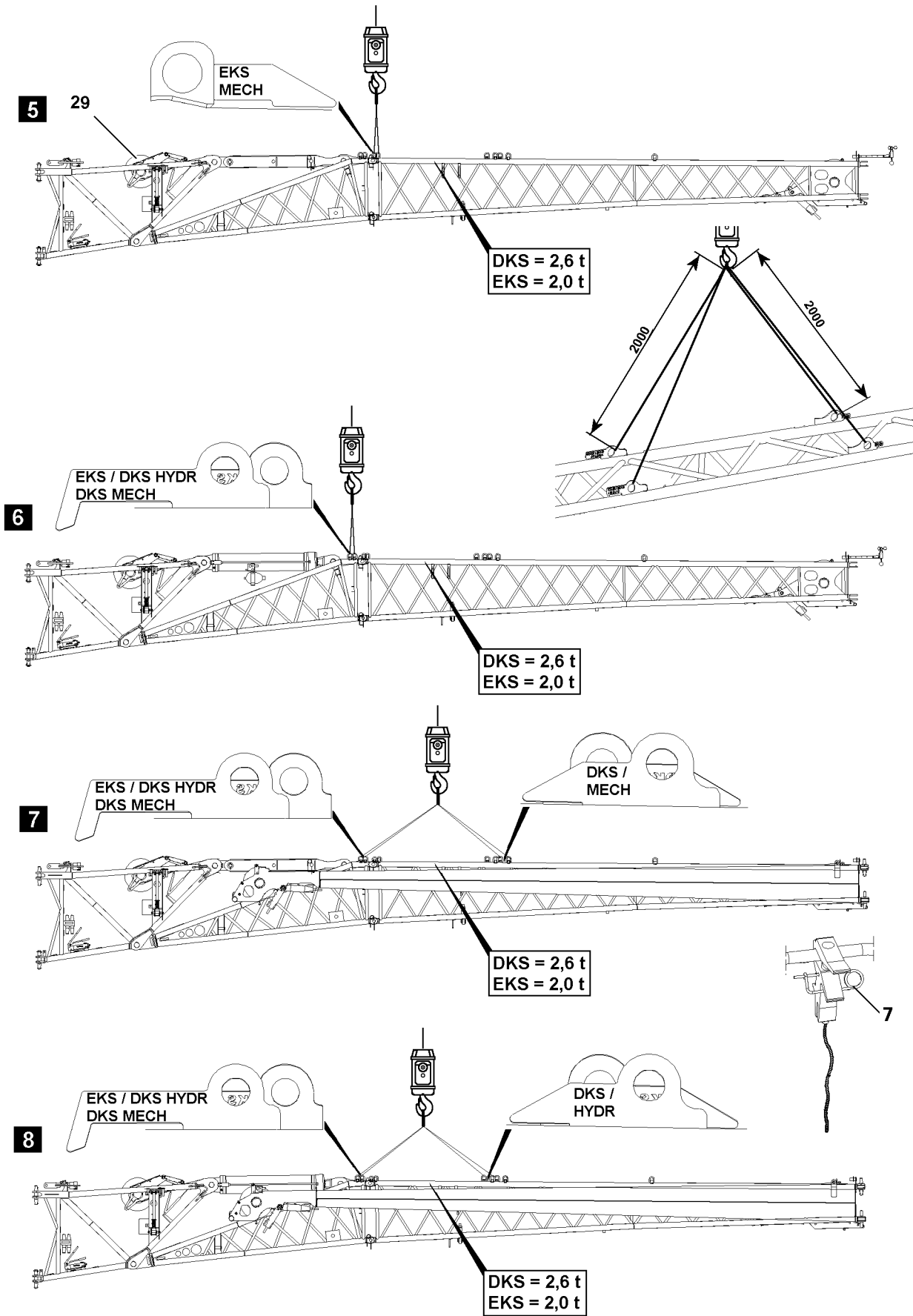


Fig.117343

LWE/LTR 1220-003/24204-02-02/en



**1.2.1 Single folding jib, see illustration 5**

Single folding jib with „mechanical angle adjustment“.

Name	Abbreviation	Weight
Mechanical	MECH	2.0 t
Single folding jib	EKS	

**1.2.2 Single folding jib, see illustration 6**

Single folding jib with „hydraulic angle adjustment“.

Name	Abbreviation	Weight
Hydraulic	HYDR	2.0 t
Single folding jib	EKS	

**1.2.3 Double folding jib, see illustration 7**

Double folding jib with „mechanical angle adjustment“.

Name	Abbreviation	Weight
Mechanical	MECH	2.6 t
Double folding jib	DKS	

**1.2.4 Double folding jib, see illustration 8**

Double folding jib with „hydraulic angle adjustment“.

Name	Abbreviation	Weight
Hydraulic	HYDR	2.6 t
Double folding jib	DKS	

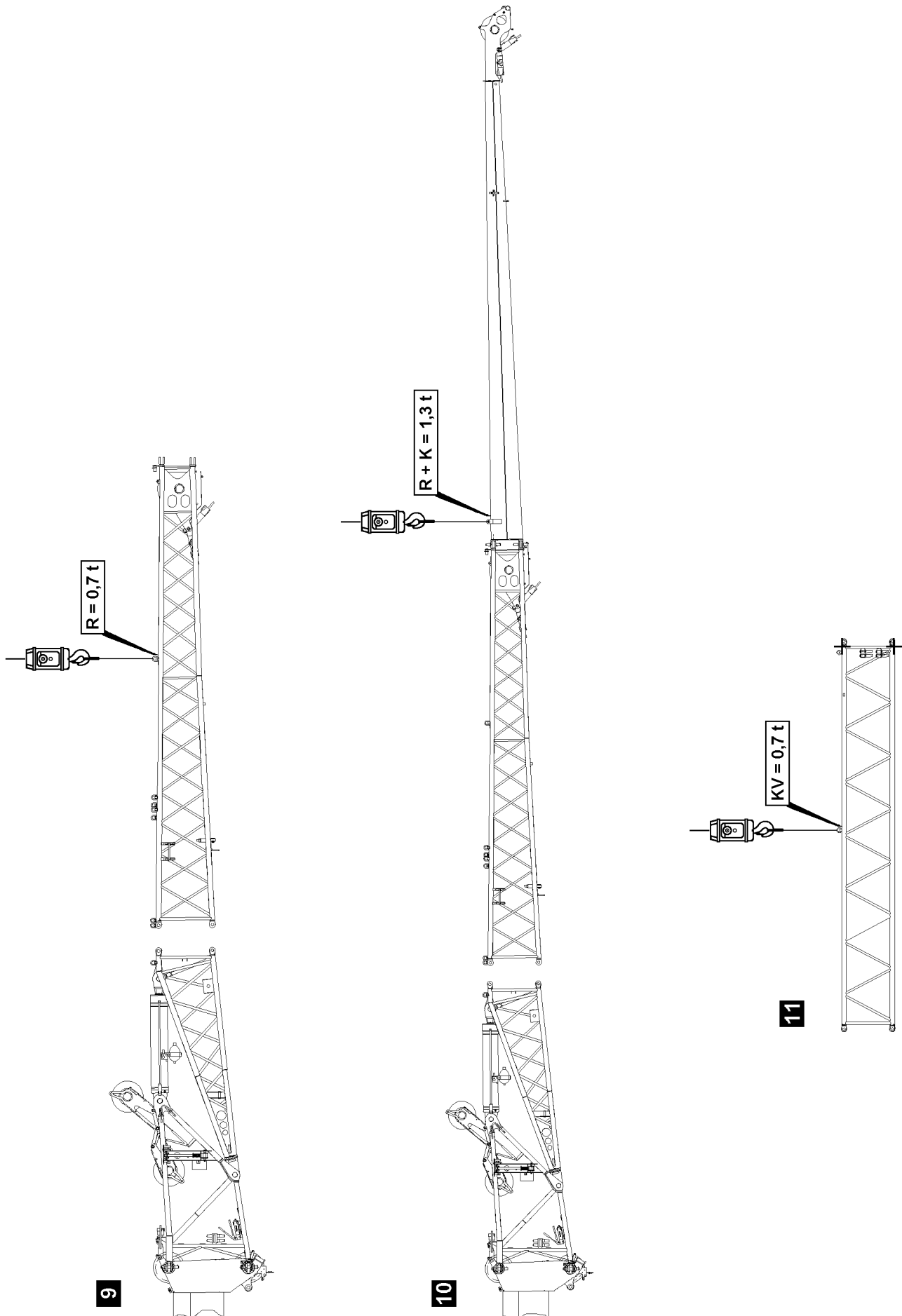


Fig.196429

### 1.3 Fastening points „separated folding jib“

To install or remove the 3 or 4 piece folding jib, various fastening eyes are installed on the folding jib.  
The appropriate fastening eyes are marked with tags.

#### 1.3.1 Single folding jib, see illustration 9

Name	Abbreviation	Weight
Reducer	R	0.7 t

#### 1.3.2 Double folding jib, see illustration 10

Name	Abbreviation	Weight
Reducer with end section	R + K	1.3 t

#### 1.3.3 Folding jib extension, see illustration 11

Name	Abbreviation	Weight
Folding jib extension	KV	0.7 t

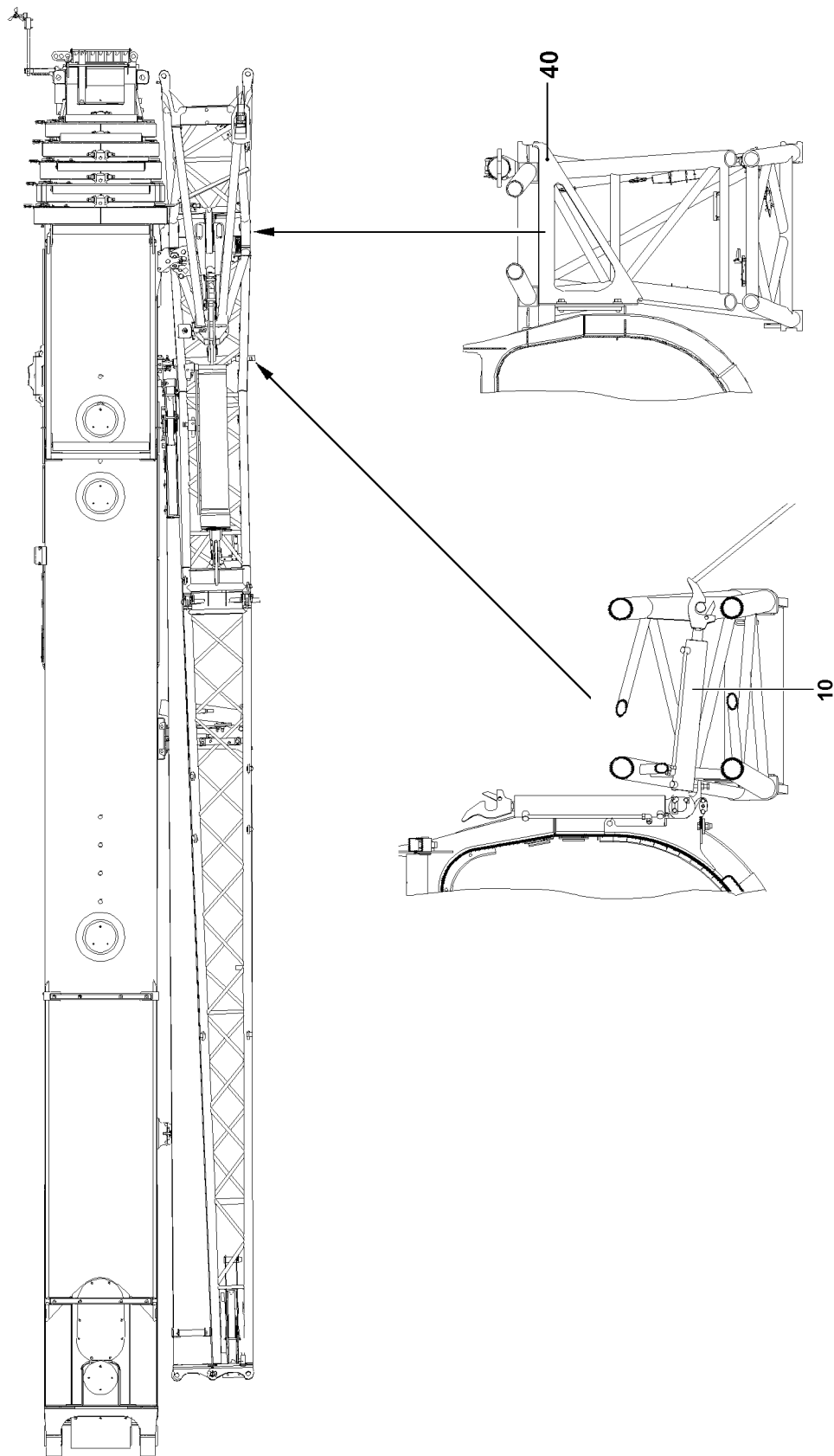


Fig.103445

## 2 Assembling the folding jib

For tele operation, the swing cylinder **10** can be folded up, if necessary.

### 2.1 General



#### DANGER

Danger of fatal injury due to falling folding jib!

As a result of improperly assembled, damaged or non-existing catch bar **40** on the telescopic boom pivot section, the folding jib – due to an assembly error – can fall down and cause fatal injuries.

- ▶ Before the folding jib assembly, make sure that the catch bar **40** is properly mounted on the telescopic boom pivot section and that it is not damaged.
- ▶ The catch bar **40** is mechanical safety equipment. For that reason, it is prohibited to change the catch bar **40** in any way.
- ▶ Standing under the folding jib during the swing procedure is prohibited.
- ▶ Standing in the slewing range as well as in the folding range of the folding jib is prohibited.
- ▶ The folding jib must be secured by an auxiliary rope during the swinging process.



#### WARNING

Danger of falling!

During assembly and disassembly, assembly personnel must be secured with appropriate aids to prevent them from falling! If this is not observed, assembly personnel could fall and suffer fatal injuries!

- ▶ All work at a height, when there is a danger of falling, must be carried out with suitable aids.
- ▶ If fall protection equipment is available, then it must be used, see the Crane operating instructions, chapter 2.06.
- ▶ If aids are not available and work cannot be carried out from the ground, then assembly personnel must secure themselves with the supplied fall arrest system to prevent falling, see the Crane operating instructions, chapter 2.04.
- ▶ The supplied fall arrest system must be fastened to the fastening and hook points. For safety points, see Crane operating instructions, chapter 2.06.
- ▶ Only step on the aids, ladders and catwalks with clean shoes.
- ▶ Keep aids, ladders and catwalks free of heavy dirt, snow and ice.
- ▶ It is prohibited to walk on the telescopic boom.

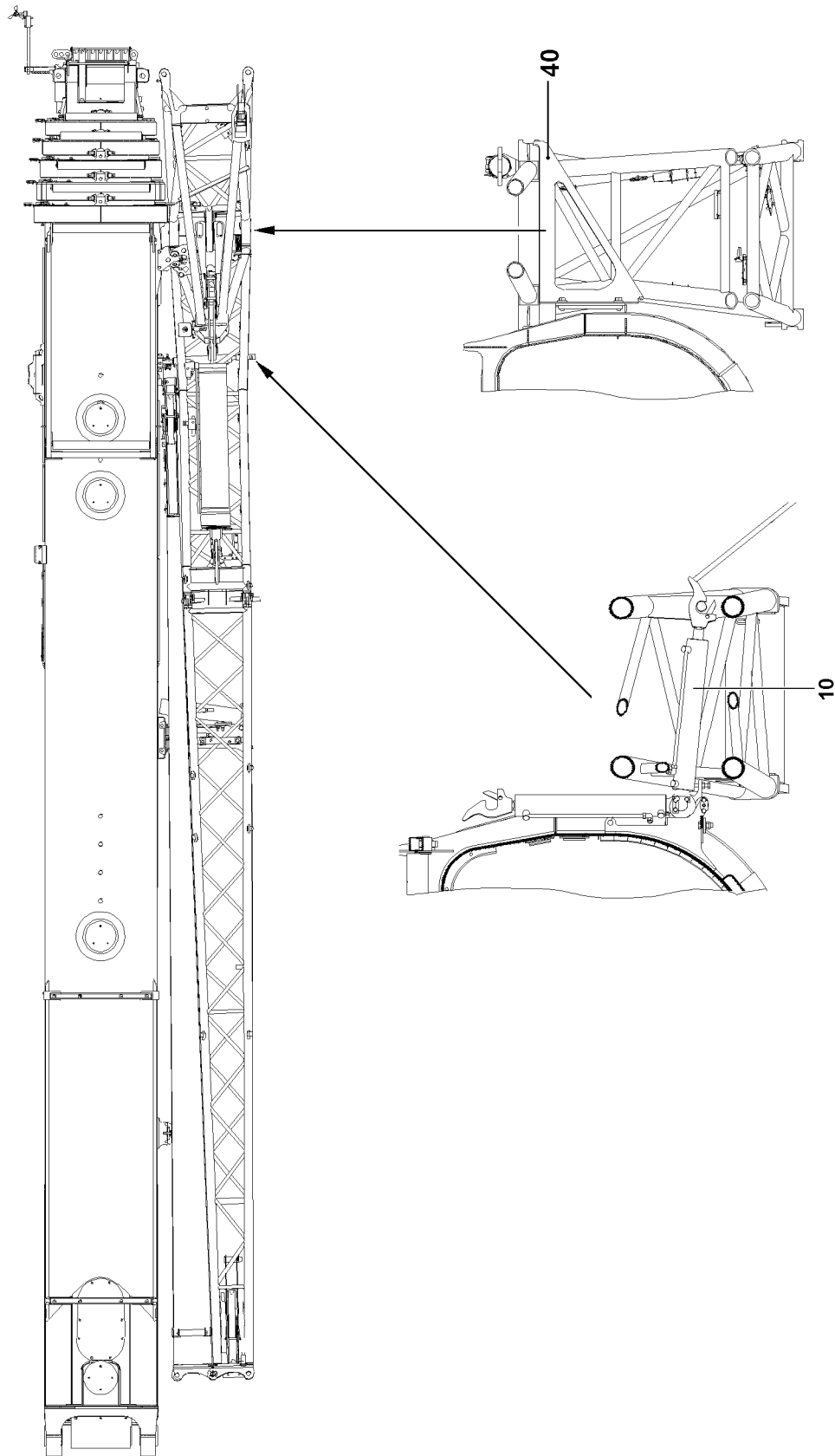


Fig.103445

### 2.1.1 Prerequisite for assembly

Make sure that the following prerequisites are met:

- The crane is properly supported and horizontally aligned.
- The counterweight has been installed on the turntable according to the load chart.
- The telescopic boom is telescoped in all the way.
- The folding jib has been attached for transport to the telescopic boom pivot section.

### 2.1.2 Prerequisites for operation with crane LTM 1220

Make sure that the following prerequisite is met:

- The telescopic boom has been luffed down to the rear or to the side in the 0° position.



---

**DANGER**

Danger of accident if the folding jib swings out by itself when it is unpinned!

If the telescopic boom is not in the 0° position, there is a danger of accidents if the folding jib swings out by itself when it is unpinned.

- ▶ Move the telescopic boom to the 0° position.
- 

### 2.1.3 Prerequisites for operation with crane LTR 1220

Make sure that the following prerequisite is met:

- The telescopic boom is luffed up to the rear or to the side to 1°.



---

**DANGER**

Danger of accident if the folding jib swings out by itself when it is unpinned!

If the telescopic boom is not in the 1° position, there is a danger of accidents if the folding jib swings out by itself when it is unpinned.

- ▶ Move the telescopic boom to the 1° position.
-

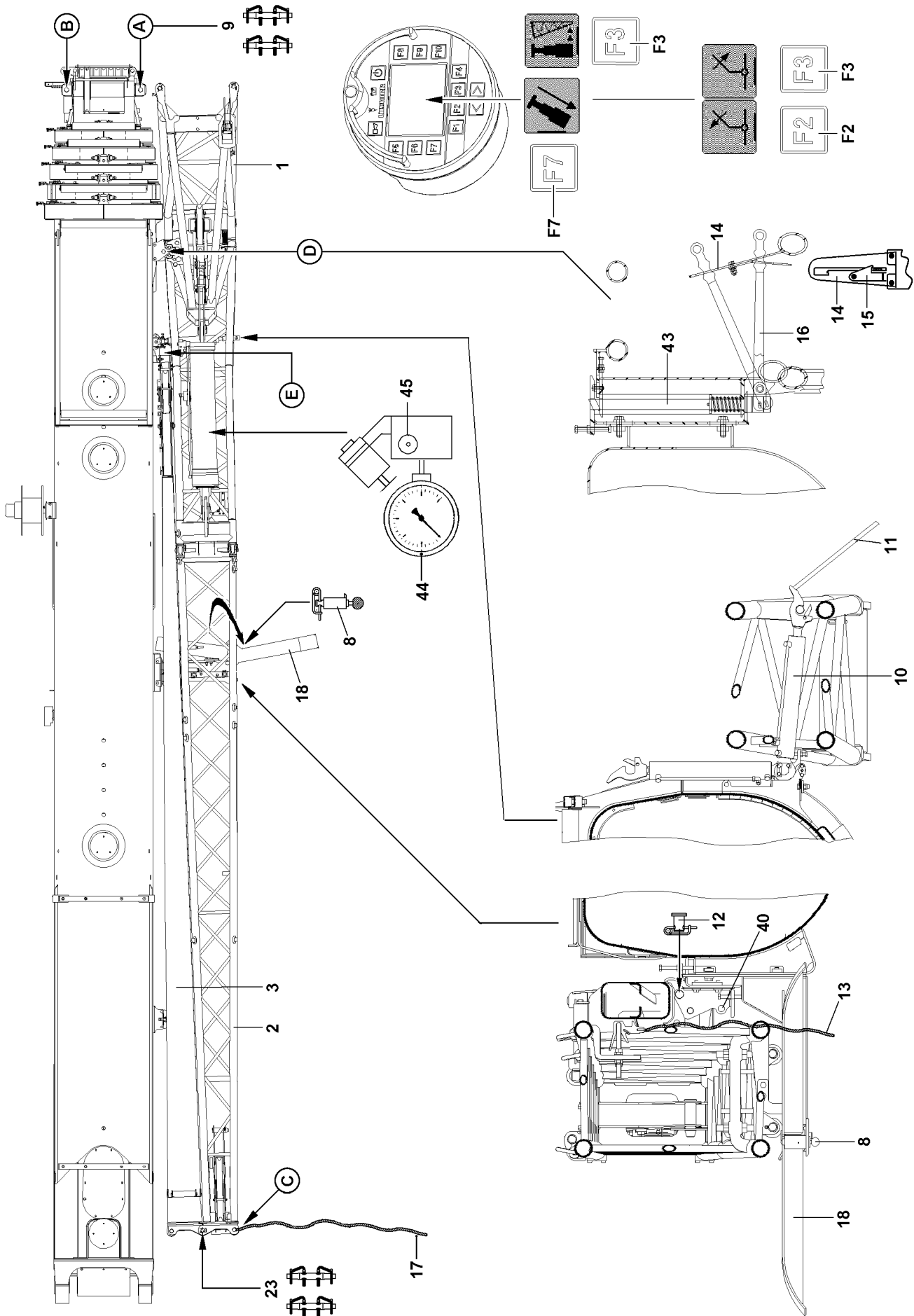


Fig.118027



## 2.2 Reeving out the hoist rope on the telescopic boom head

In order to speed up subsequent reeving in of the hoist rope after assembling the folding jib, the hook block can be taken down at a distance from the crane that corresponds approximately to the subsequent distance of the telescoped in telescopic boom **with** the assembled folding jib.

- ▶ Telescope the telescopic boom out to the respective length.
- ▶ Place the hook block on the ground.
- ▶ Disengage the hoist rope on the rope fixed point.
- ▶ For safety reasons, remove the hoist limit switch weight and the chain.



### Note

- ▶ The hoist limit switch must be pulled mechanically and the operating rope must be attached to the telescopic boom head with the snap hook when operating the folding jib.
- ▶ The telescopic boom can remain reeved in, if the hoist rope of winch 2 is used for the folding jib operation.

- ▶ Remove the rope retaining pipes on the pulley head and on the back pulley.
- ▶ Telescope the telescopic boom in all the way again.

## 2.3 Important check before swinging out the hydraulic folding jibs (TNZK operation)



### DANGER

Danger of fatal injury if the folding jib inadvertently folds down!

When using hydraulic folding jibs (TNZK operation), before swinging the folding jib out, check if a pressure of 60 bar is shown on the pressure gauge **44**. If the pressure on the pressure gauge **44** is too low, fatal accidents can occur if the folding jib folds down by itself!

- ▶ It is **expressly prohibited** to swing out the folding jib with less than 60 bar on the pressure gauge **44**.

The restrictor **45** may only be operated during maintenance operations.

If the pressure gauge **44** shows pressure that is too low:

- ▶ Connect the hydraulic line.
- ▶ Luff the folding jib up with the master switch until a pressure of at least 60 bar is shown on the pressure gauge **44**.

**or**

On the Bluetooth Terminal (BTT) call up the „Lift / lower the folding jib“ menu.

- ▶ Press the key **F2** until a pressure of at least 60 bar is shown on the pressure gauge **44**, see the Crane operating instructions, chapter 5.31.

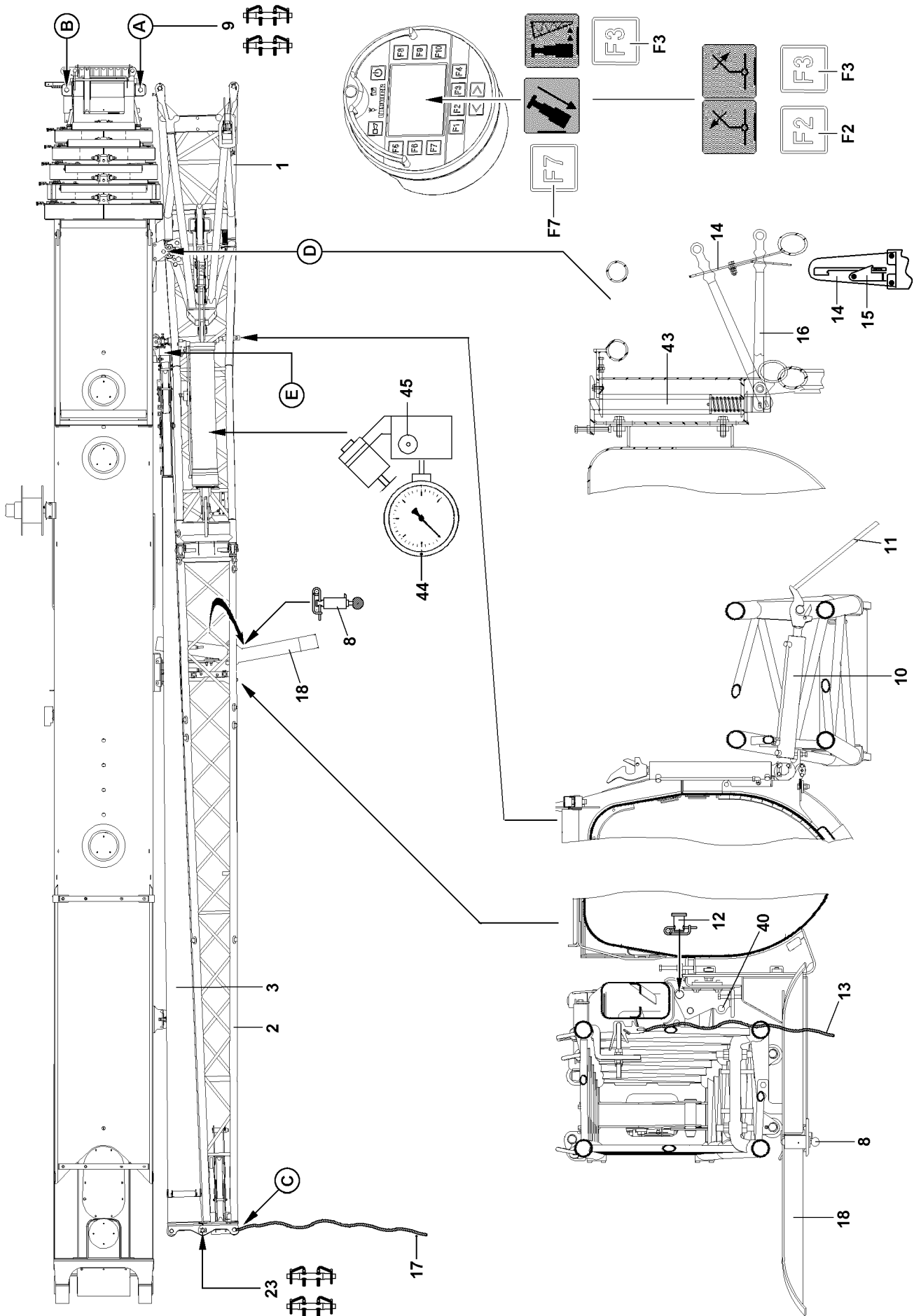


Fig.118027

## 2.4 Assembling the single folding jib carried on the crane

The end section **3** that is not required remains pinned to the telescopic boom during single folding jib operation.



### DANGER

Danger of fatal injuries due to toppling end section!

During operation with the single folding jib, the end section **3** may not be unpinned from the telescopic boom. Otherwise, there is a danger of accidents if the end section **3** falls down.

- ▶ Do not unpin the end section **3** on the telescopic boom.

### 2.4.1 Assembly procedure, part 1

When swinging the folding jib support **18** in and out, ensure that the spring pin **8** is unlocked with one hand and that the folding jib support **18** is moved overhead with the other hand.

- ▶ Release and unpin the spring pin **8**
- ▶ Swing the folding jib support **18** out until the spring pin **8** locks again.

For a „hydraulic folding jib“ (TNZK operation), the hydraulic line must be uncoupled before swinging the folding jib out.

If a hydraulic folding jib is carried along:

- ▶ Uncouple the hydraulic line on point **E**.
- ▶ Attach the auxiliary rope **17** in point **C**.

If a double folding jib is carried along:

- ▶ Release and unpin the pin **23**.

If a double folding jib is carried along:

- ▶ Pull the nylon rope **13** and loosen the lock between the end section **3** and the reducer **2**.
- ▶ Start the crane engine.
- ▶ Press the function key **F3** on the BTT and swing out the folding jib with swing cylinder until it can be pinned in point **A**.

### Problem remedy

If the pin bores on point **A** do not align, the telescopic boom can be tensioned with the function key **F7**:

- ▶ Take the telescopic boom down and telescope all telescopes in all the way.
- ▶ Pin telescope 5.



### WARNING

Danger of severe crushing!

For the „Tension the telescopic boom“ function, all telescopic sections are pulled together, which can lead to severe crushing injuries of fingers.

- ▶ As long as the „Tension telescopic boom“ function is carried out, it is prohibited for any personnel to remain in the push out range of the telescopic sections.

- ▶ Press the function key **F7** on the BTT.

### Result:

- All telescopic sections are pulled together.

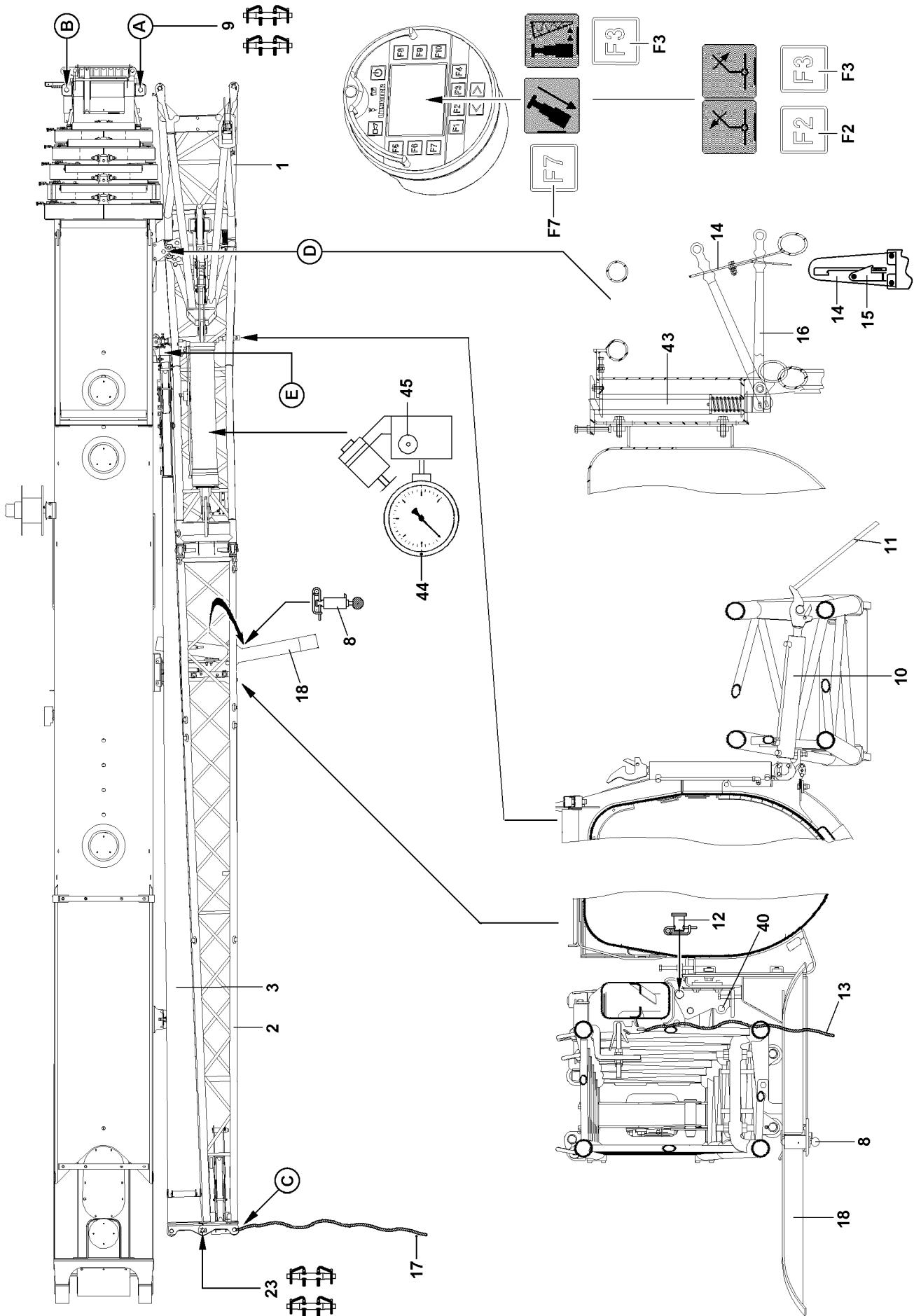


Fig.118027

**Note**

- ▶ Bluetooth Terminal (BTT), see Crane operating instructions, chapter 5.31 section,,. The Assembly functions menu on the BTT“.
- 
- ▶ Insert the pins **9** on the top and at the bottom in point **A** and secure.

**DANGER**

Danger of fatal injury due to falling folding jib!

The special retaining clips must be used to secure the pins **9**. The use of cotter pins or spring retainers on the pins **9** is not permitted. The folding jib may only be unlocked at point **D**, when the pins **9** are pinned and secured at the top and bottom at point **A**.

- ▶ Pin and secure the pins **9** in point **A** at the top and bottom.
- 
- ▶ Swing the retaining bracket **15** with the assembly rod **11** to the side.
  - ▶ Press the lever **16** with the assembly rod **11** upward and latch it into the link **14**.
  - ▶ Press the function key **F3** on the BTT and swing the folding jib with the swing cylinder all the way out.
  - ▶ Unlock the swing cylinder **10** with the assembly rod **11**.

**DANGER**

Danger of fatal injury due to falling folding jib!

The folding jib could fall down due to an assembly error.

- ▶ Standing under the folding jib during the swing procedure is prohibited.
  - ▶ Standing in the slewing range as well as in the folding range of the folding jib is prohibited.
- 
- ▶ Swing the reducer **2** with the auxiliary rope **17** 180° until it can be pinned on the top and at the bottom in the point **B**.

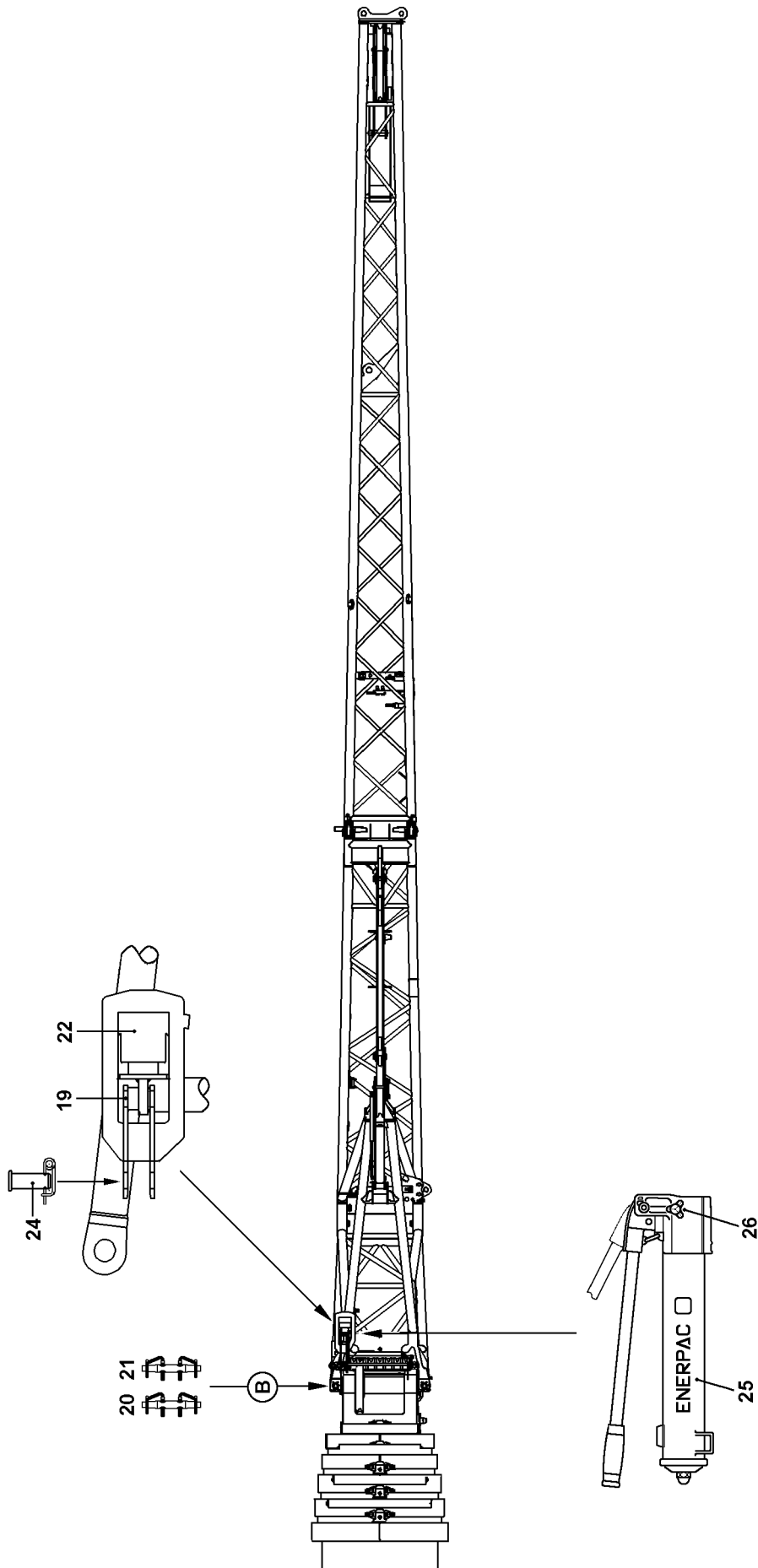


Fig.196431

LWE/LTR 1220-003/24204-02-02/en

## 2.4.2 Assembly procedure, part 2



### DANGER

Danger of accident!

- ▶ The use of spring pins or retaining springs is prohibited on pins **20** and pins **21**.
- ▶ To secure the pin **20** and the pin **21**, use the special retaining clips.

- ▶ Pin and secure the pin **20** on the bottom at point **B**.

In order to be able to pin on top on point **B**, the hydraulic / mechanical assembly aid **22** must be used.

- ▶ Release the pin **24** and unpin from the bore **19**.
- ▶ Pin and secure the assembly aid **22** to the towing bracket with the pin **24**.
- ▶ Close the knob **26**.
- ▶ Extend the hydraulic cylinder of the assembly aid **22** by operating the hand pump **25** until the bore at the opening of the folding jib is aligned with the one on the telescopic boom.
- ▶ Pin and secure the pin **21** on the top in point **B**.
- ▶ Open the knob **26**.

### Result:

- The hydraulic cylinder of the assembly aid **22** returns to the starting position and the pin **24** is released.

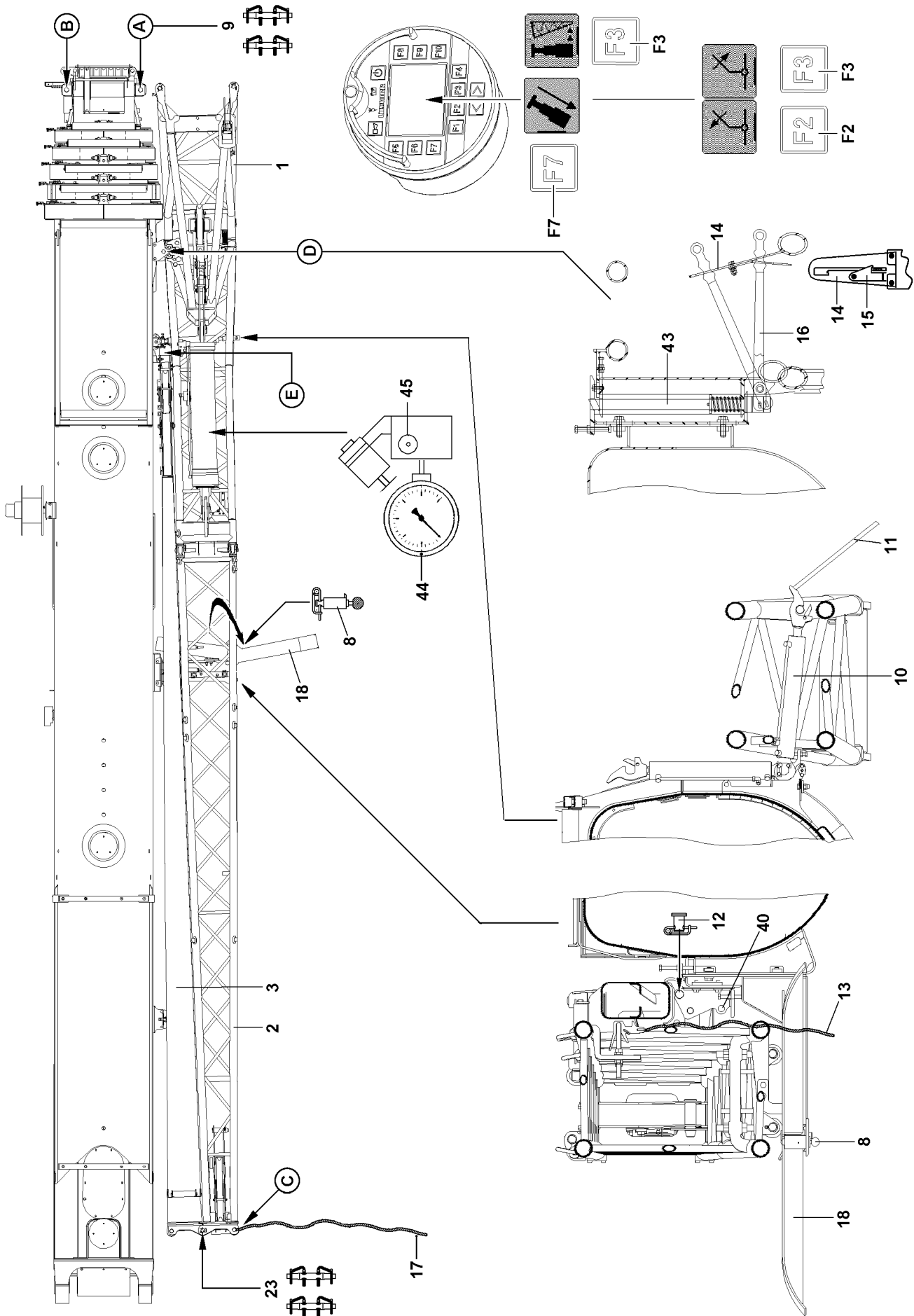


Fig.118027

LWE/LTR 1220-003/24204-02-02/en



## 2.5 Assembling the double folding jib carried on the crane

### 2.5.1 Assembling the reducer, part 1

When swinging the folding jib support **18** in and out, ensure that the spring pin **8** is unlocked with one hand and that the folding jib support **18** is moved overhead with the other hand.

- ▶ Release and unpin the spring pin **8**
- ▶ Swing the folding jib support **18** out until the spring pin **8** locks again.

For a „hydraulic folding jib“ (TNZK operation), the hydraulic line must be uncoupled before swinging the folding jib out.

If a hydraulic folding jib is carried along:

- ▶ Uncouple the hydraulic line on point **E**.
- ▶ Attach the auxiliary rope **17** in point **C**.
- ▶ Release and unpin the pin **12** and insert it into the bore **40**.
- ▶ Press the function key **F3** on the BTT and swing out the folding jib with swing cylinder until it can be pinned in point **A**.

---

#### Problem remedy

If the pin bores on point **A** do not align, the telescopic boom can be tensioned with the function key **F7**:

- ▶ Take the telescopic boom down and telescope all telescopes in all the way.
  - ▶ Pin telescope 5.
- 



#### WARNING

Danger of severe crushing!

For the „Tension the telescopic boom“ function, all telescopic sections are pulled together, which can lead to severe crushing injuries of fingers.

- ▶ As long as the „Tension telescopic boom“ function is carried out, it is prohibited for any personnel to remain in the push out range of the telescopic sections.
- 
- ▶ Press the function key **F7** on the BTT.

#### Result:

- All telescopic sections are pulled together.
- 



#### Note

- ▶ Bluetooth Terminal (BTT), see Crane operating instructions, chapter 5.31 section. The „Assembly functions menu on the BTT“.
-

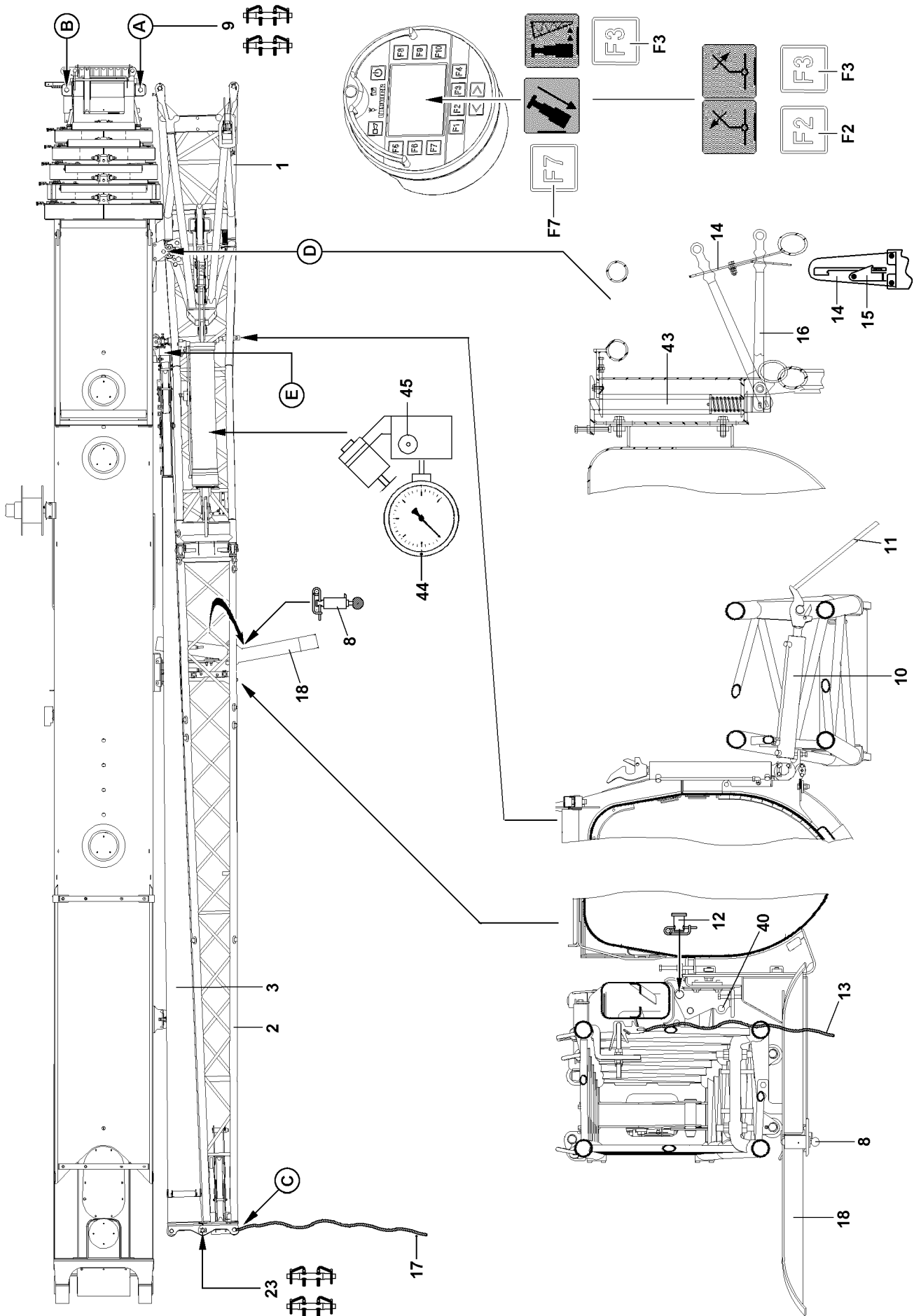


Fig.118027

- ▶ Insert the pins **9** on the top and at the bottom in point **A** and secure.

**DANGER**

Danger of fatal injury due to falling folding jib!

The special retaining clips must be used to secure the pins **9**. The use of cotter pins or spring retainers on the pins **9** is not permitted. The folding jib may only be unlocked at point **D**, when the pins **9** are pinned and secured at the top and bottom at point **A**.

- ▶ Pin and secure the pins **9** in point **A** at the top and bottom.
- 
- ▶ Swing the retaining bracket **15** with the assembly rod **11** to the side.
  - ▶ Press the lever **16** with the assembly rod **11** upward and latch it into the link **14**.
  - ▶ Press the function key **F3** on the BTT and swing the folding jib with the swing cylinder all the way out.
  - ▶ Unlock the swing cylinder **10** with the assembly rod **11**.

**DANGER**

Danger of fatal injury due to falling folding jib!

The folding jib could fall down due to an assembly error.

- ▶ Standing under the folding jib during the swing procedure is prohibited.
  - ▶ Standing in the slewing range as well as in the folding range of the folding jib is prohibited.
- 
- ▶ Swing the reducer **2** with the auxiliary rope **17** 180° until it can be pinned on the top and at the bottom in the point **B**.

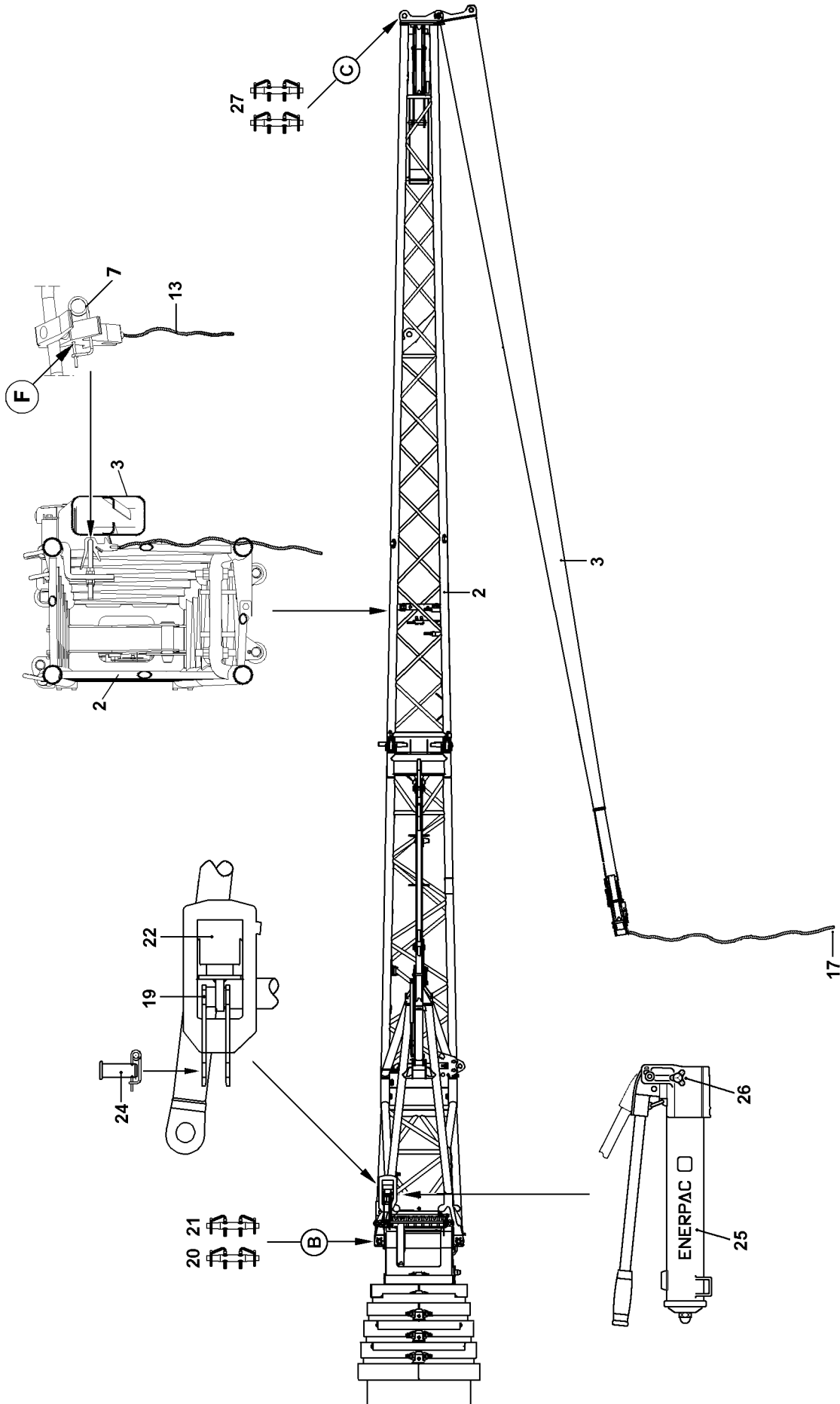


Fig.103448

LWE/LTR 1220-003/24204-02-02/en

## 2.5.2 Assembling the reducer, part 2



### DANGER

Danger of accident!

- ▶ The use of spring pins or retaining springs is prohibited on pins **20** and pins **21**.
- ▶ To secure the pin **20** and the pin **21**, use the special retaining clips.

- ▶ Pin and secure the pin **20** on the bottom at point **B**.

In order to be able to pin on top on point **B**, the hydraulic / mechanical assembly aid **22** must be used.

- ▶ Release the pin **24** and unpin from the bore **19**.
- ▶ Pin and secure the assembly aid **22** to the towing bracket with the pin **24**.
- ▶ Close the knob **26**.
- ▶ Extend the hydraulic cylinder of the assembly aid **22** by operating the hand pump **25** until the bores are aligned at the opening of the folding jib and the telescopic boom.
- ▶ Pin and secure the pin **21** on the top in point **B**.
- ▶ Open the knob **26**.

### Result:

- The hydraulic cylinder of the assembly aid **22** returns to the starting position and the pin **24** is released.

## 2.5.3 Assembling the end section

- ▶ Remove the auxiliary rope **17** in point **C** and attach to the end section **3**.



### CAUTION

The folding jib can swing out inadvertently!

The folding jib may swing out inadvertently while releasing the lock.

In order to prevent the folding jib from swinging out by itself:

- ▶ Hold the folding jib with the auxiliary rope.

- ▶ Remove the spring retainer **7** in point **F**.
- ▶ Pull the nylon rope **13** and loosen the lock between the end section **3** and the reducer **2**.
- ▶ Swing the end section **3** forward 180° until it can be pinned in point **C**.



### DANGER

Danger of fatal injury due to falling folding jib!

The folding jib could fall down due to an assembly error.

- ▶ Standing under the folding jib during the swing procedure is prohibited.
- ▶ Standing in the slewing range as well as in the folding range of the folding jib is prohibited.
- ▶ The use of spring pins or retaining springs is prohibited on pins **27**.
- ▶ Use the special retaining clips to secure the pins **27**.

- ▶ Insert the pins **27** at the top and bottom and secure with retaining clips.
- ▶ Remove the auxiliary rope.

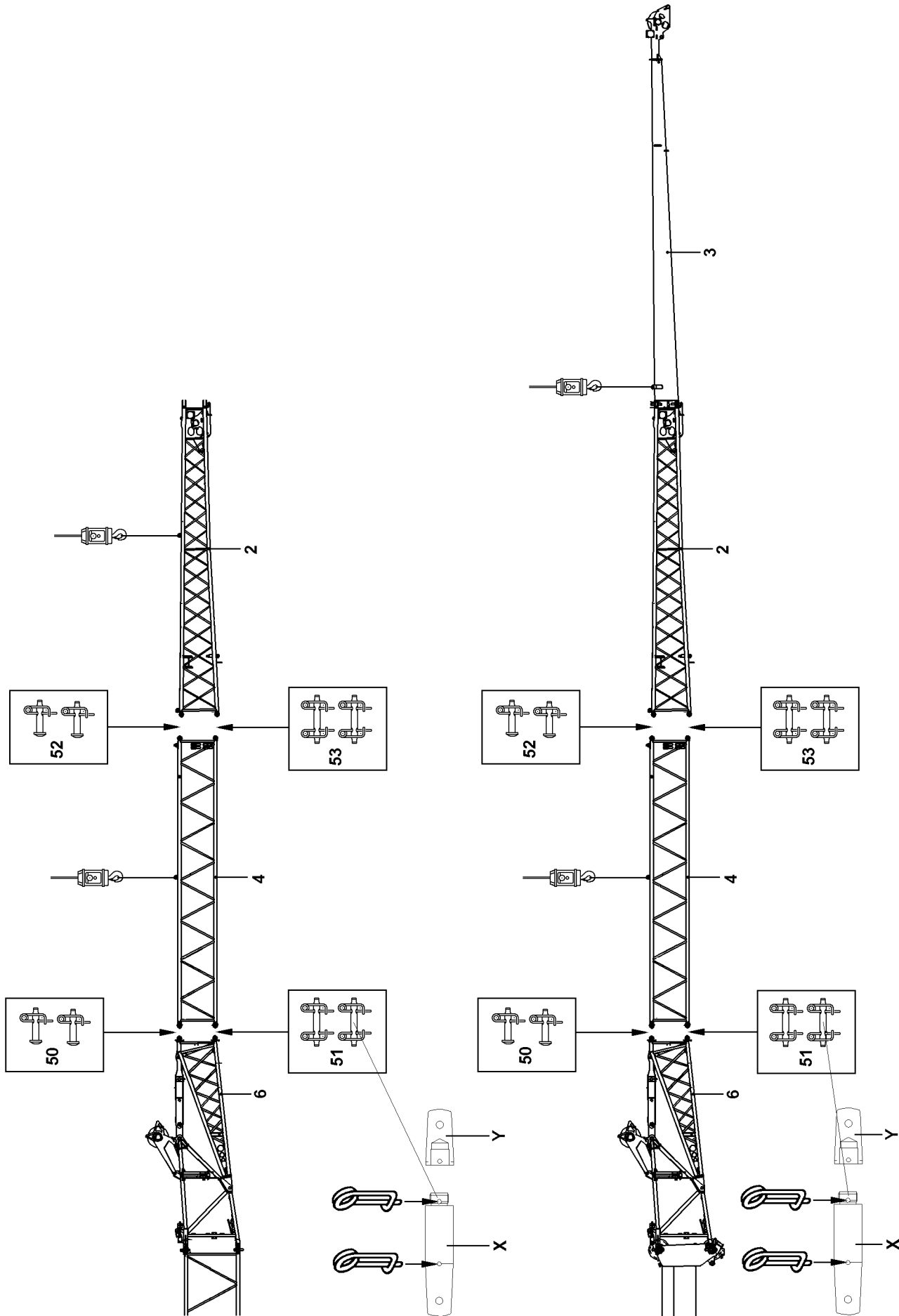


Fig.197289

## 2.6 Assembling the 3-piece folding jib

The 3-piece folding jib is a folding jib that has been extended with a folding jib extension **4**.

Make sure that the following prerequisites are met:

- The folding jib is attached on the telescopic boom or on the telescopic boom extension.
- An auxiliary crane with an adequate load-bearing capacity is available.



### DANGER

Danger of accident when assembling / disassembling the 3-piece folding jib!

If the following conditions are not met, personnel can be fatally injured during assembly / disassembly.

- ▶ When knocking out the pins, no one may remain under the folding jib.
  - ▶ Pin and unpin the pins in the specified sequence.
  - ▶ Fasten the auxiliary crane in such a way that no angular pull occurs.
- 
- ▶ Attach the reducer section **2** to the auxiliary crane and tighten the fastening rope slightly.
  - or**
  - ▶ Attach the reducer section **2** with the end section **3** to the auxiliary crane and tighten the fastening rope slightly.



### DANGER

Danger of accident due to distorted pins!

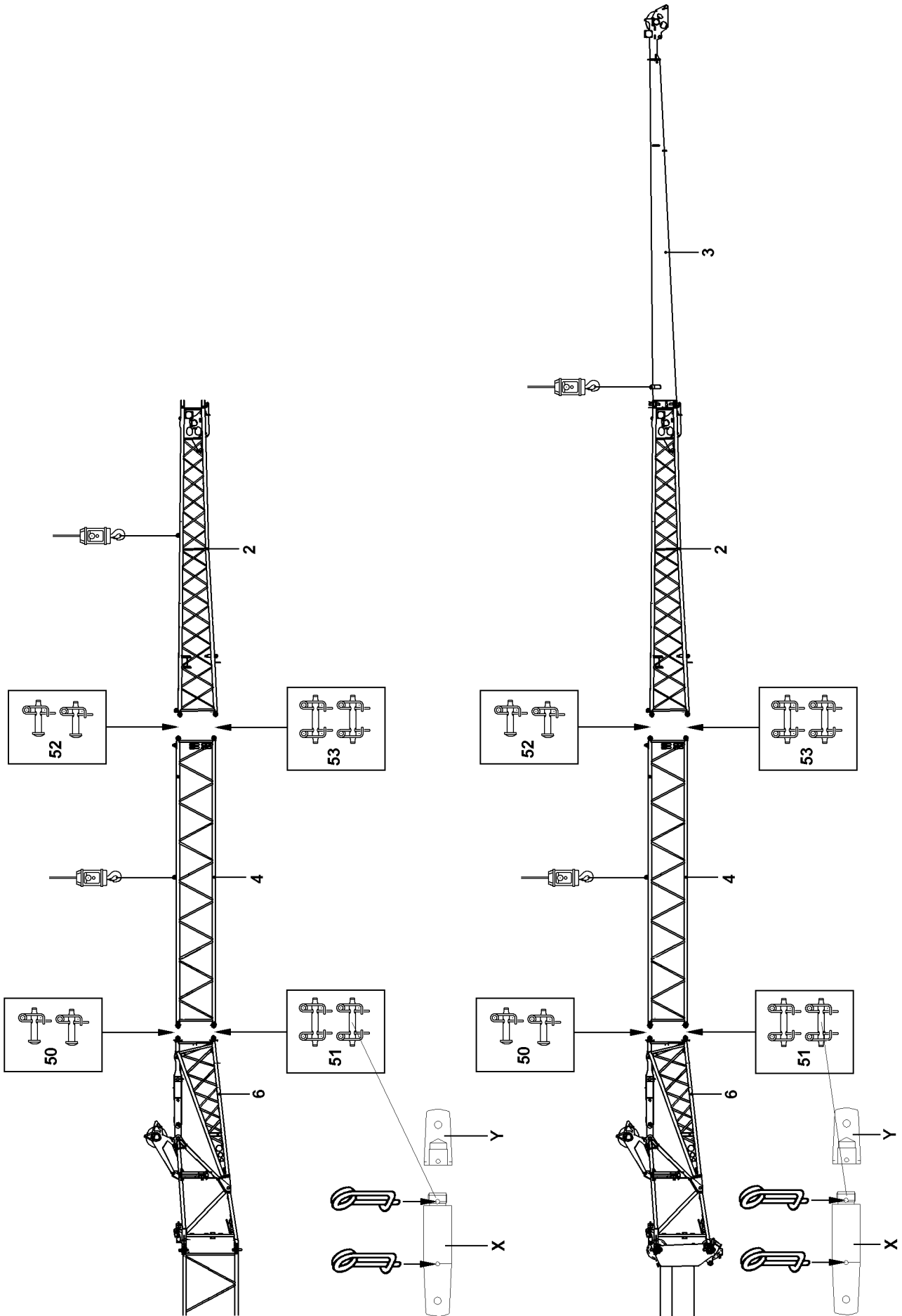
Angular pull or excessive / low hoisting force of the auxiliary crane may result in distortion of the pins. Distorted parts can suddenly fly off when the pins are unpinned.

- ▶ When the pins are unpinned, the „lifting force“ of the auxiliary crane must be adapted to the „weight“ of the parts being lifted.
  - ▶ Do **not** unpin difficult to remove pins by force.
  - ▶ Remedy the cause of the tension.
- 
- ▶ Release and unpin the pins **50** on both sides.



### Note

- ▶ Before unpinning and pinning the pins **X**, screw on or unscrew the extension **Y** accordingly. Then secure the pins **X** on both sides with spring retainers. Before starting to travel, the extension **Y** must be removed again, and the pins **X** must be secured on both sides with the spring retainers.
- 
- ▶ Release the pins **51** on both sides and unpin from the outside to the inside.
  - ▶ Take the reducer **2** down.
  - or**
  - ▶ Take the reducer **2** down with the end section **3**.



LWE/LTR 1220-003/24204-02-02/en

Fig.197289



- ▶ Fasten the folding jib extension **4** to the auxiliary crane and insert into the fork heads on the pivot section **6**.
- ▶ Pin the folding jib extension **4** with the pivot section **6**: Pin the pins **50** on both sides from the outside to the inside and secure.
- ▶ Pin the pins **51** on both sides from the outside to the inside and secure.
- ▶ Attach the reducer section **2** to the auxiliary crane and insert into the fork heads on the folding jib extension **4**.  
**or**  
Attach the reducer section **2** with the end section **3** on the auxiliary crane and insert into the fork heads on the folding jib extension **4**.
- ▶ Pin the reducer **2** with the folding jib extension **4**: Pin the pins **52** on both sides from the outside to the inside and secure.
- ▶ Pin the pins **53** on both sides from the outside to the inside and secure.

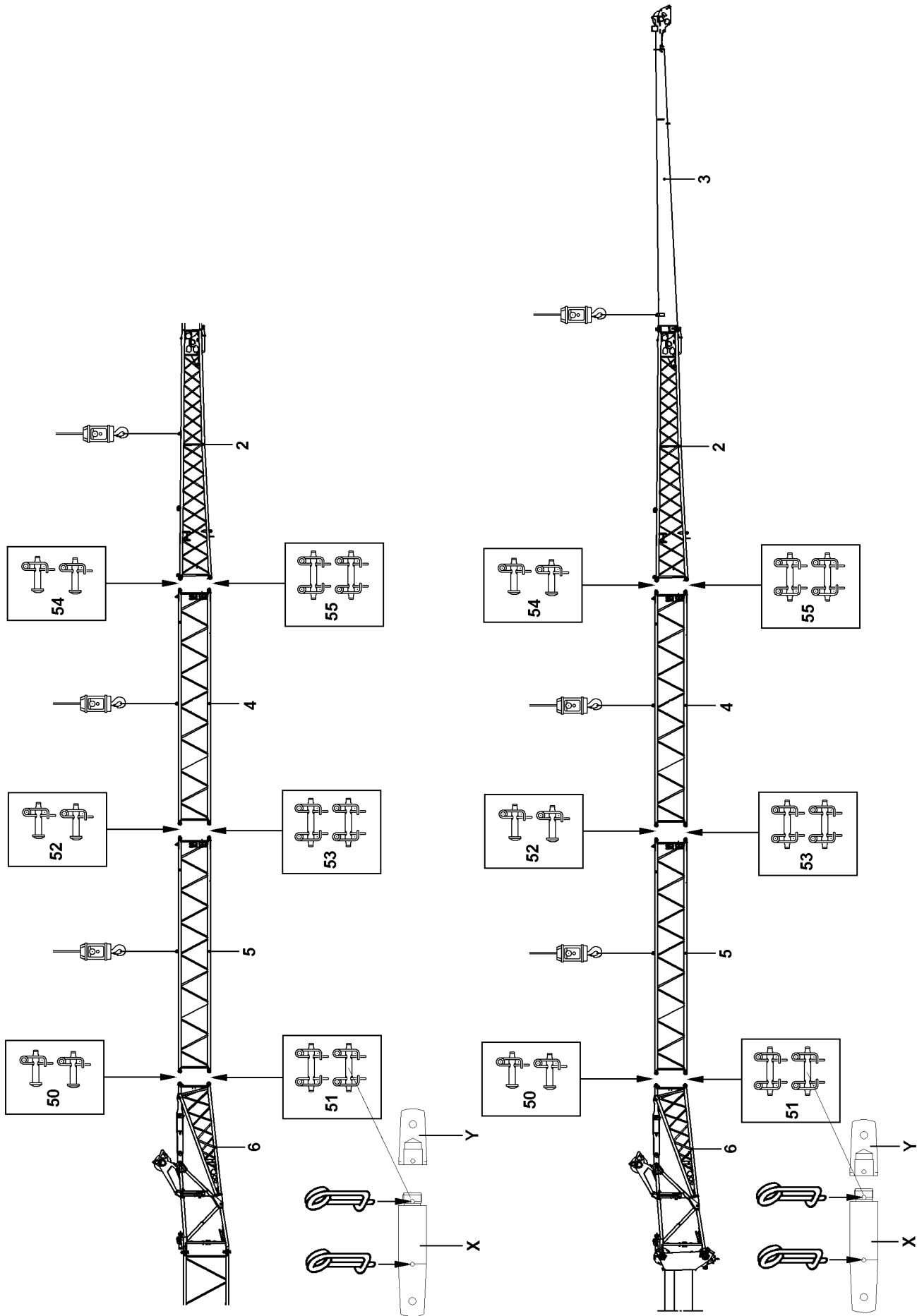


Fig.197290

LWE/LTR 1220-003/24204-02-02/en

## 2.7 Assembling the 4-piece folding jib

The 4-piece folding jib is a folding jib that has been extended with a folding jib extension **4** and a folding jib extension **5**.

Make sure that the following prerequisites are met:

- The folding jib is attached on the telescopic boom or on the telescopic boom extension.
- An auxiliary crane with an adequate load-bearing capacity is available.



### DANGER

Danger of accident when assembling / disassembling the 4-piece folding jib!

If the following conditions are not met, personnel can be fatally injured during assembly / disassembly.

- ▶ When knocking out the pins, no one may remain under the folding jib.
  - ▶ Pin and unpin the pins in the specified sequence.
  - ▶ Attach fastening ropes in such a way that no angular pull occurs.
- 
- ▶ Attach the reducer section **2** to the auxiliary crane and tighten the fastening rope slightly.
  - or**
  - ▶ Attach the reducer section **2** with the end section **3** to the auxiliary crane and tighten the fastening rope slightly.



### DANGER

Danger of accident due to distorted pins!

Angular pull or excessive / low hoisting force of the auxiliary crane may result in distortion of the pins. Distorted parts can suddenly fly off when the pins are unpinned.

- ▶ When the pins are unpinned, the „lifting force“ of the auxiliary crane must be adapted to the „weight“ of the parts being lifted.
  - ▶ Do **not** unpin difficult to remove pins by force.
  - ▶ Remedy the cause of the tension.
- 
- ▶ Release and unpin the pins **50** on both sides.
  - ▶ Release the pins **51** on both sides and unpin from the outside to the inside.
  - ▶ Take the reducer **2** down.
  - or**
  - ▶ Take the reducer **2** down with the end section **3**.
  - ▶ Fasten the folding jib extension **5** to the auxiliary crane and insert into the fork heads on the pivot section **6**.
  - ▶ Pin the folding jib extension **5** with the pivot section **6**: Pin the pins **50** on both sides from the outside to the inside and secure.



### Note

- ▶ Before unpinning and pinning the pins **X**, screw on or unscrew the extension **Y** accordingly. Then secure the pins **X** on both sides with spring retainers. Before starting to travel, the extension **Y** must be removed again, and the pins **X** must be secured on both sides with the spring retainers.

- ▶ Pin the pins **51** on both sides from the outside to the inside and secure.

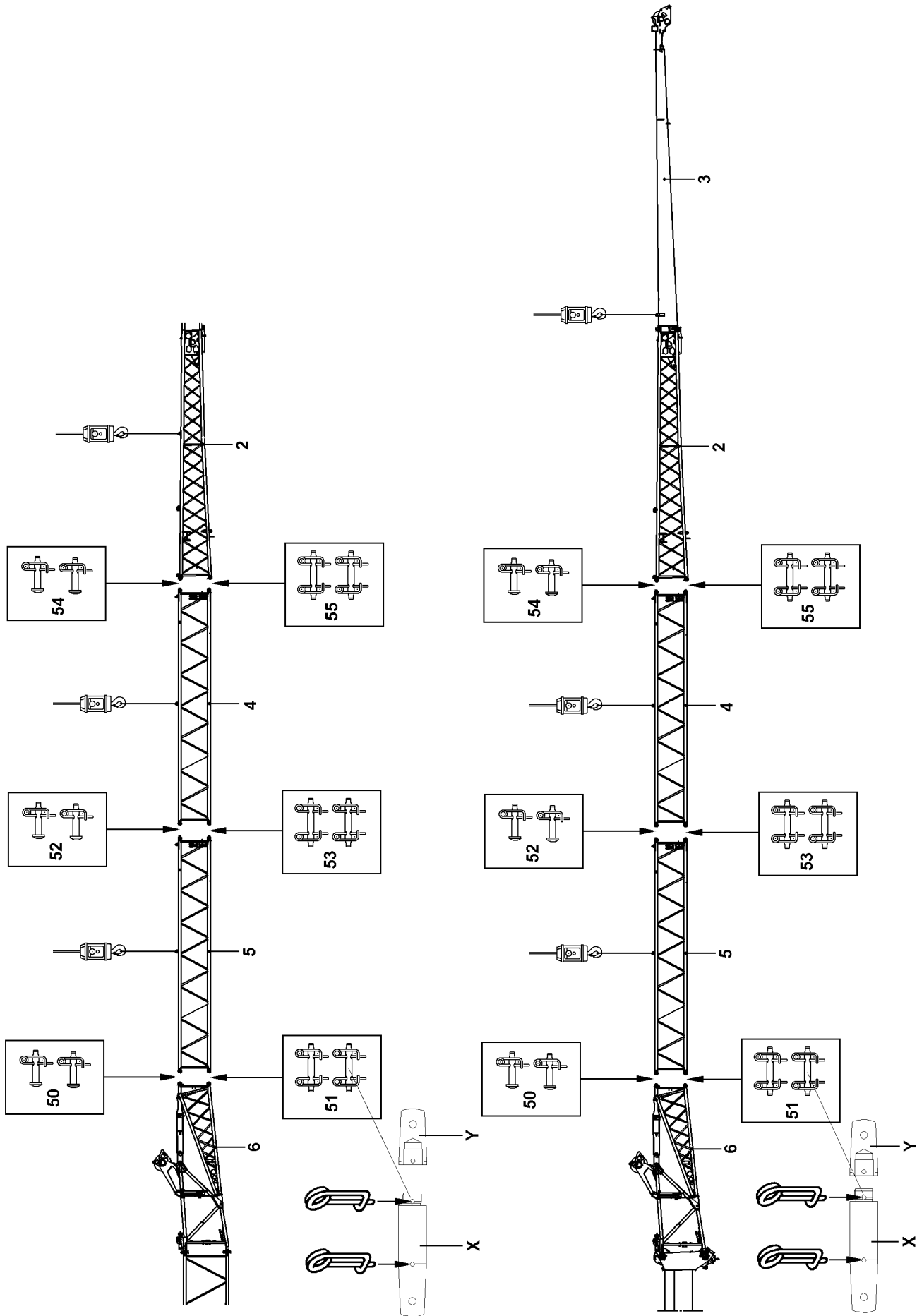


Fig.197290

LWE/LTR 1220-003/24204-02-02/en

- ▶ Attach folding jib extension **4** to the auxiliary crane and insert into the fork heads on the folding jib extension **5**.
- ▶ Pin the folding jib extension **4** with the folding jib extension **5**: Pin the pins **52** on both sides from the outside to the inside and secure.
- ▶ Pin the pins **53** on both sides from the outside to the inside and secure.
- ▶ Attach the reducer section **2** to the auxiliary crane and insert into the fork heads on the folding jib extension **4**.  
**or**  
Attach the reducer section **2** with the end section **3** on the auxiliary crane and insert into the fork heads on the folding jib extension **4**.
- ▶ Pin the reducer **2** with the folding jib extension **4**: Pin the pins **54** on both sides from the outside to the inside and secure.
- ▶ Pin the pins **55** on both sides from the outside to the inside and secure.

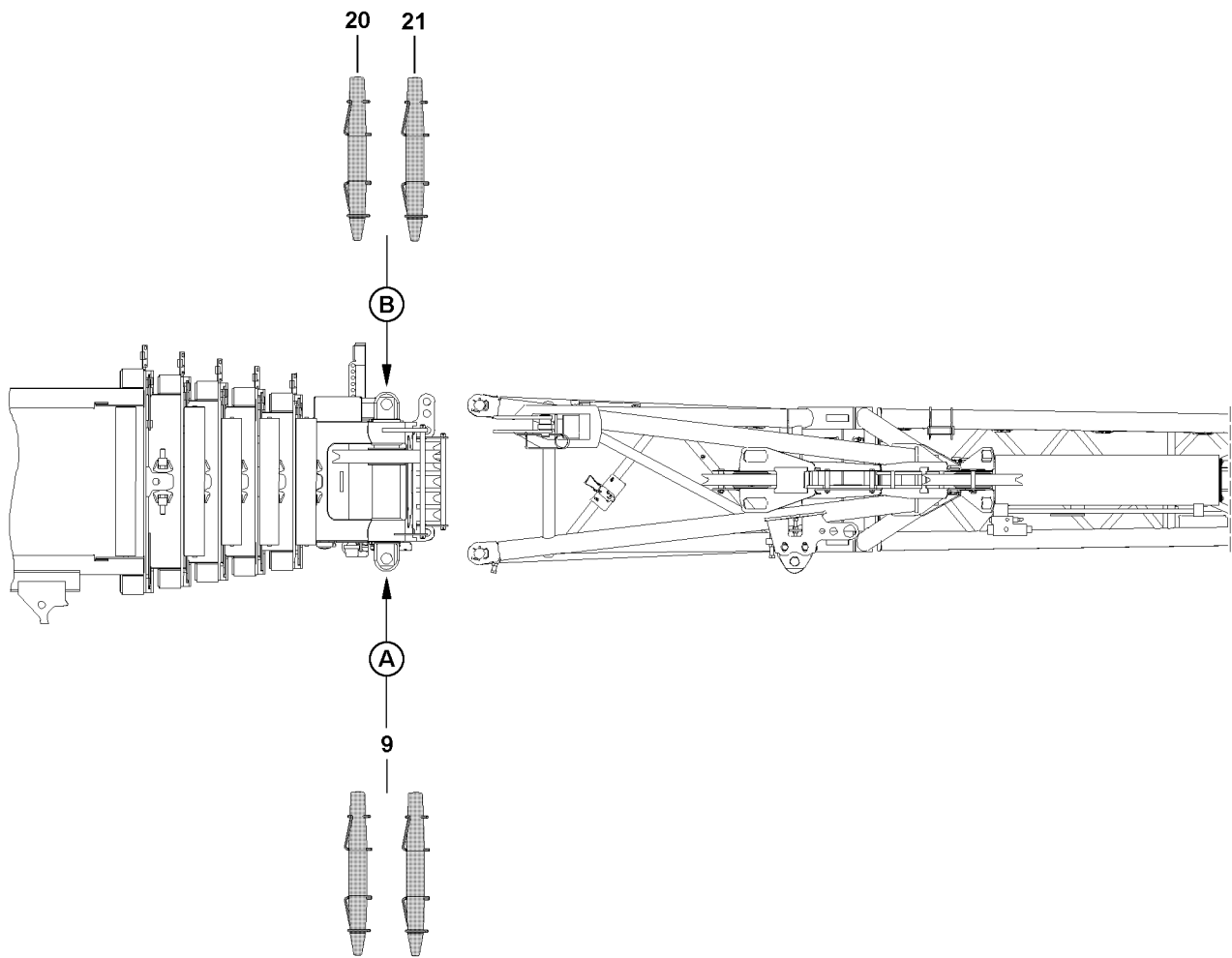


Fig.103446

## 2.8 Assembling the separately transported folding jib on the crane

### 2.8.1 Assembling the separately transported folding jib for crane operating position

For a description of the fastening points, see the section „Fastening points“.



#### DANGER

Danger of accident due to incorrect fastening!

Life-threatening situations can arise if the folding jib is improperly or incorrectly fastened!

- ▶ The folding jib is to be fastened according to the fastening points shown on the signs.
- ▶ The appropriate fastening eyes / fastening points are marked with tags.
- ▶ Attaching the single folding jib or the double folding jib on non-intended points or on any arbitrary location is **prohibited**.
- ▶ When fastening the double folding jib, the end section must be folded in, locked and the spring retainer must be secured.



#### CAUTION

Damage to the fastening points!

If the fastening equipment is too short, then the fastening points on the folding jibs can be damaged!

- ▶ To attach the folding jibs, fastening equipment with a strand length of at least 2000 mm each must be used.
- ▶ Fasten the auxiliary crane to the respective fastening points of the folding jib.
- ▶ Lift the folding jib with the auxiliary crane and insert it into the pin points on the telescopic boom.



#### DANGER

Danger of accident!

- ▶ The use of cotter pins or spring retainers is prohibited on pins **9**, pins **20** and pins **21**.
- ▶ Use the special retaining clips to secure pins **9**, pins **20** and pins **21**.
- ▶ Pin the folding jib with the telescopic boom:
- ▶ Insert and secure the pin **9** at the top in point **A**.
- ▶ Insert and secure the pin **20** at the top in point **B**.
- ▶ Insert and secure the pin **9** at the bottom at point **A**.
- ▶ Insert and secure the pin **21** at the bottom at point **B**.
- ▶ For the further assembly of the double folding jib, see section „Assembling the end section“.

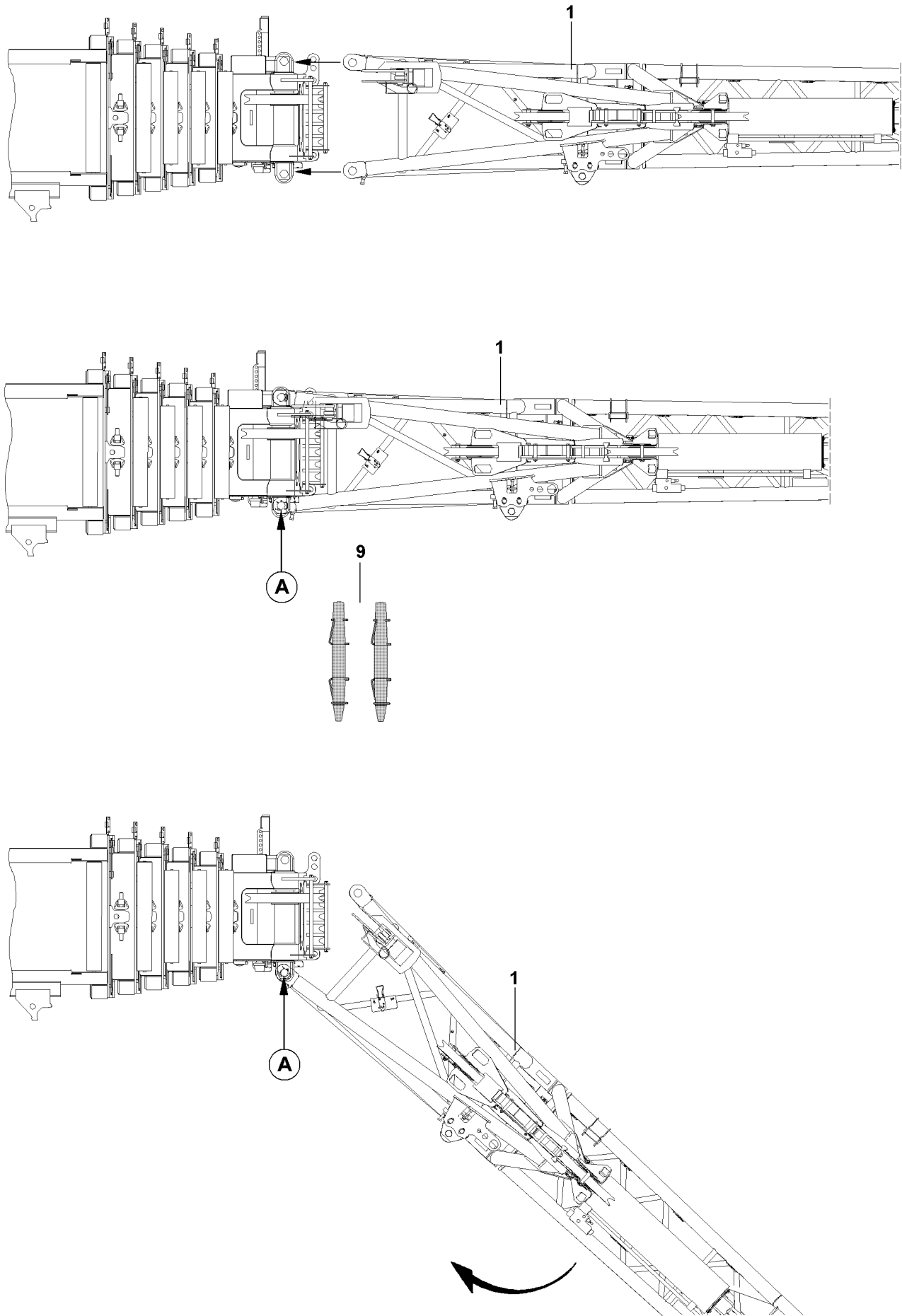


Fig.103447



## 2.8.2 Assembling the separately transported folding jib for the transport position

An auxiliary crane must be available for the assembly of the separate folding jib 1.

Make sure that the following prerequisites are met:

- The crane is properly supported and horizontally aligned.
- The telescopic boom is telescoped in all the way.
- The telescopic boom is in travel direction in the 0° position.



### DANGER

Danger of accident from involuntary swinging out of the folding jib when removing the fastening equipment!

If the telescopic boom is not in 0° position, a danger of accident exists due to involuntary swinging out of the folding jib when the fastening equipment is removed.

- ▶ Move the telescopic boom to the 0° position.
- ▶ Attach the auxiliary crane to corresponding fastening points on folding jib, see section „Fastening points“.



### CAUTION

Danger of property damage!

If the following notes are not observed, the folding jib can move uncontrolled and as a result, damage can occur in the area of the telescopic boom and the driver's cab.

- ▶ Carry out auxiliary crane movements only with utmost caution and the least possible acceleration.
- ▶ The folding jib must be secured with an auxiliary rope during the assembly procedure.
- ▶ Lift the folding jib with the auxiliary crane and guide it into pin points on the telescopic boom head.



### DANGER

Danger of accident!

- ▶ The use of cotter pins or spring retainers on the pins 9 is prohibited.
- ▶ Use the special retaining clips to secure the pins 9.
- ▶ Pin the folding jib with the telescopic boom:
- ▶ Pin and secure the pins 9 on top and on the bottom at point A.



### DANGER

Danger of fatal injury due to falling folding jib!

If the folding jib is improperly pinned on the telescopic boom, life threatening or even fatal injuries can occur.

- ▶ Before removing the auxiliary crane, make sure that the folding jib is pinned and secured in point A on the top and bottom.
- ▶ Remove the auxiliary crane.



### Note

- ▶ For further procedure to fold the folding jib onto the telescopic boom or in transport position, refer to section „Disassembling the folding jib“.

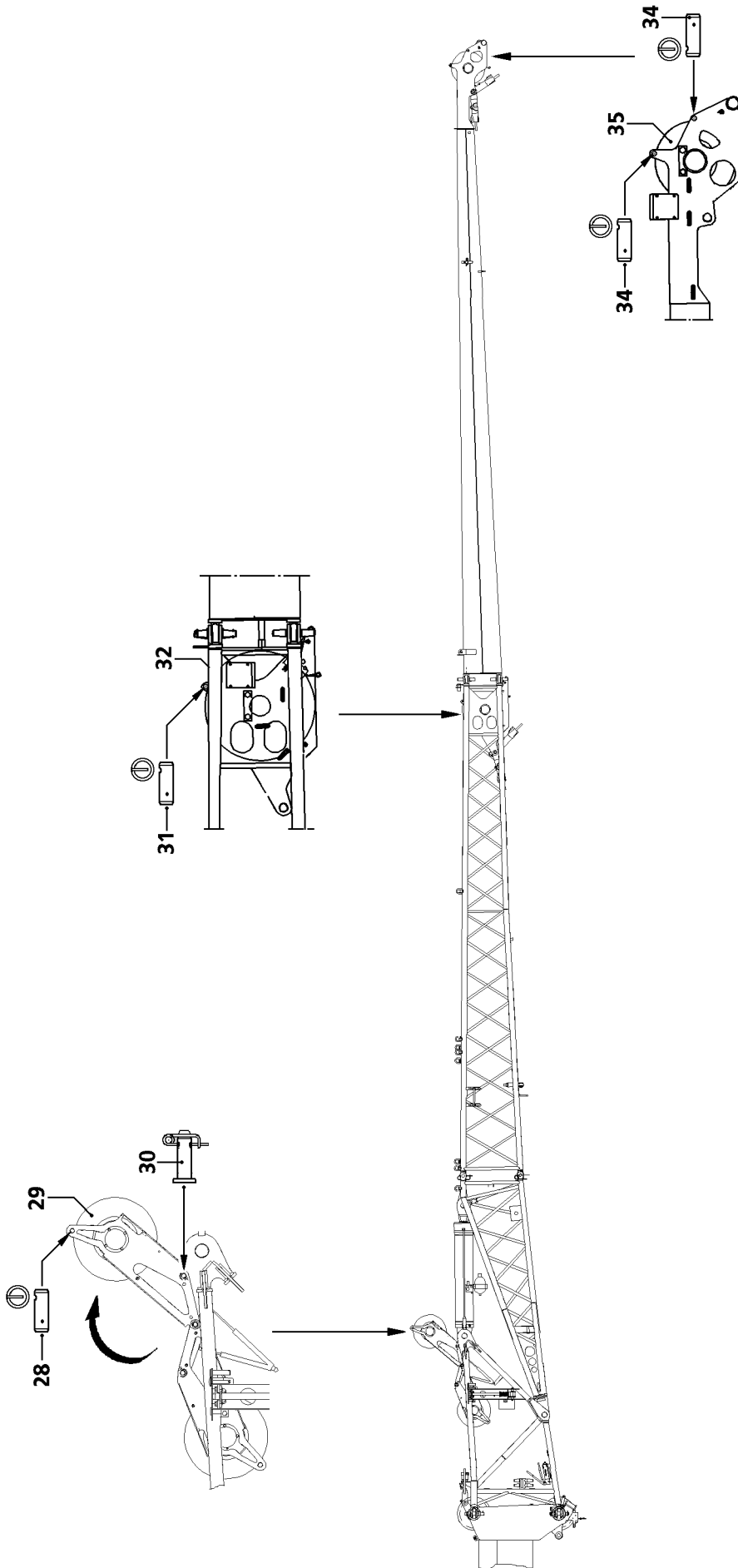


Fig.196435

## 3 Reeving the hoist rope in



### DANGER

Danger of sliding off the folding jib!

When stepping on the folding jib, for example to reeve the hoist rope in or out, there is a danger of slipping and falling from the folding jib.

- ▶ Do not step on the folding jib.

### 3.1 Swinging the rope guide pulley into the operating position

- ▶ Release and unpin the pin **30**.
- ▶ Swing the rope guide pulley **29** into the operating position.
- ▶ Pin the rope guide pulley **29** in the operating position: Insert and secure the pin **30**.

### 3.2 Reeving the hoist rope in

#### NOTICE

Damage to the hoist rope or the rope retaining pins!

If the hoist rope is reeved via hoist gear 2 at operation with single or double folding jib in 0°-position, then the hoist rope can lift off from the rope guide pulley **29** and scrape on the rope retaining pins!

The hoist rope, rope retaining pin **28**, rope retaining pin **31** or rope retaining pin **34** can be damaged!

- ▶ Reeving the hoist rope via the hoist gear 2 at operation with the single or double folding jib in 0°-position is prohibited.
- ▶ At operation with the single or double folding jib in 0°-position, reeve the hoist rope only via hoist gear 1.

- ▶ Release and unpin the rope retaining pin **28** and rope retaining pin **31**.

For operation with a double folding jib, 3-piece folding jib or 4-piece folding jib:

- ▶ Release and unpin the rope retaining pins **34**.
- ▶ Place the hoist rope over the rope guide pulley **29** and over the end pulley **32** at 12.2 m or over the end pulley **35** at 22 m.
- ▶ Insert the rope retaining pin again and secure with locking pins.

#### NOTICE

Damage to the hoist rope!

If the rope retaining pin **31** is inserted during operation with the double folding jib, the 3-piece folding jib or the 4-piece folding jib, then the slack hoist rope can scrape against the rope retaining pin **31** and be damaged.

- ▶ Do **not** insert the rope retaining pins **31** for double folding jib, 3-piece folding jib or 4-piece folding jib operation.
- ▶ Install the load hook on the hoist rope.  
**or**  
Reeve in the hoist rope on the hook block.
- ▶ Attach the hoist limit switch weight.

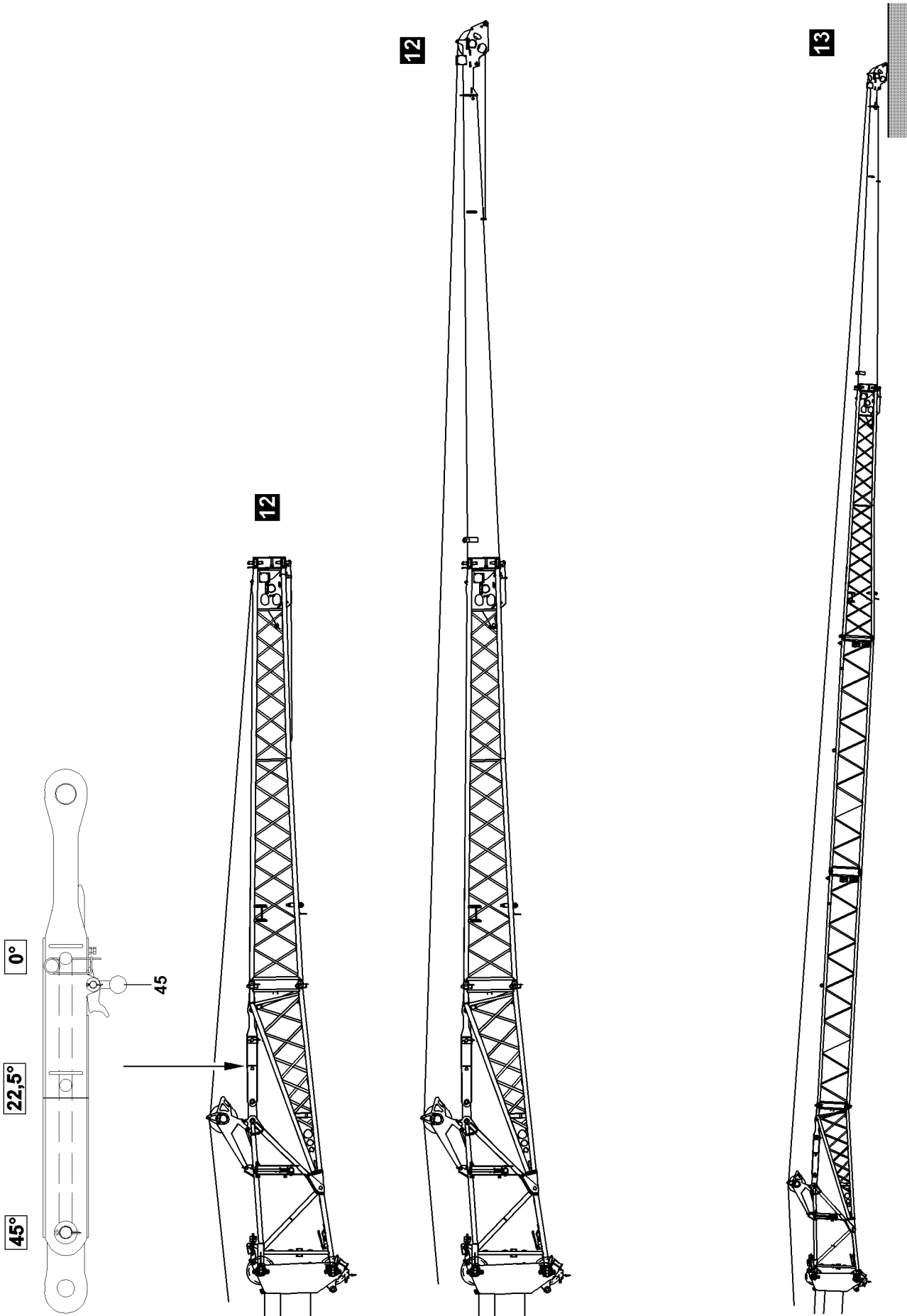


Fig.114341

LWE/LTR 1220-003/24204-02-02/en

## 4 Changing over the mechanical folding jib from 0° to 22.5° or 45°

---



### DANGER

Danger of fatal injury!

If the following danger notes are not observed, fatal injuries can occur during assembly and change over work on the folding jib.

- ▶ No persons may remain within the danger zone of the crane.
- 

There are two ways of changing the mechanical folding jib to 22.5° or 45°:

1. Changing the double folding jib with the hoist rope, see illustration **12**.  
Only permitted for operation with the single folding jib and double folding jib.
  2. Changing the folding jib by supporting, see illustration **13**.
- 



### DANGER

Danger of accident due to stiff oscillation guard!

If the oscillation guard **45** is stiff, safe crane operation with the folding jib is **not** ensured.

- ▶ Before crane operation with folding jib, check the oscillation guard **45** for easy movement.
  - ▶ Crane operation with folding jib with a stiff oscillation guard **45** is prohibited.
-

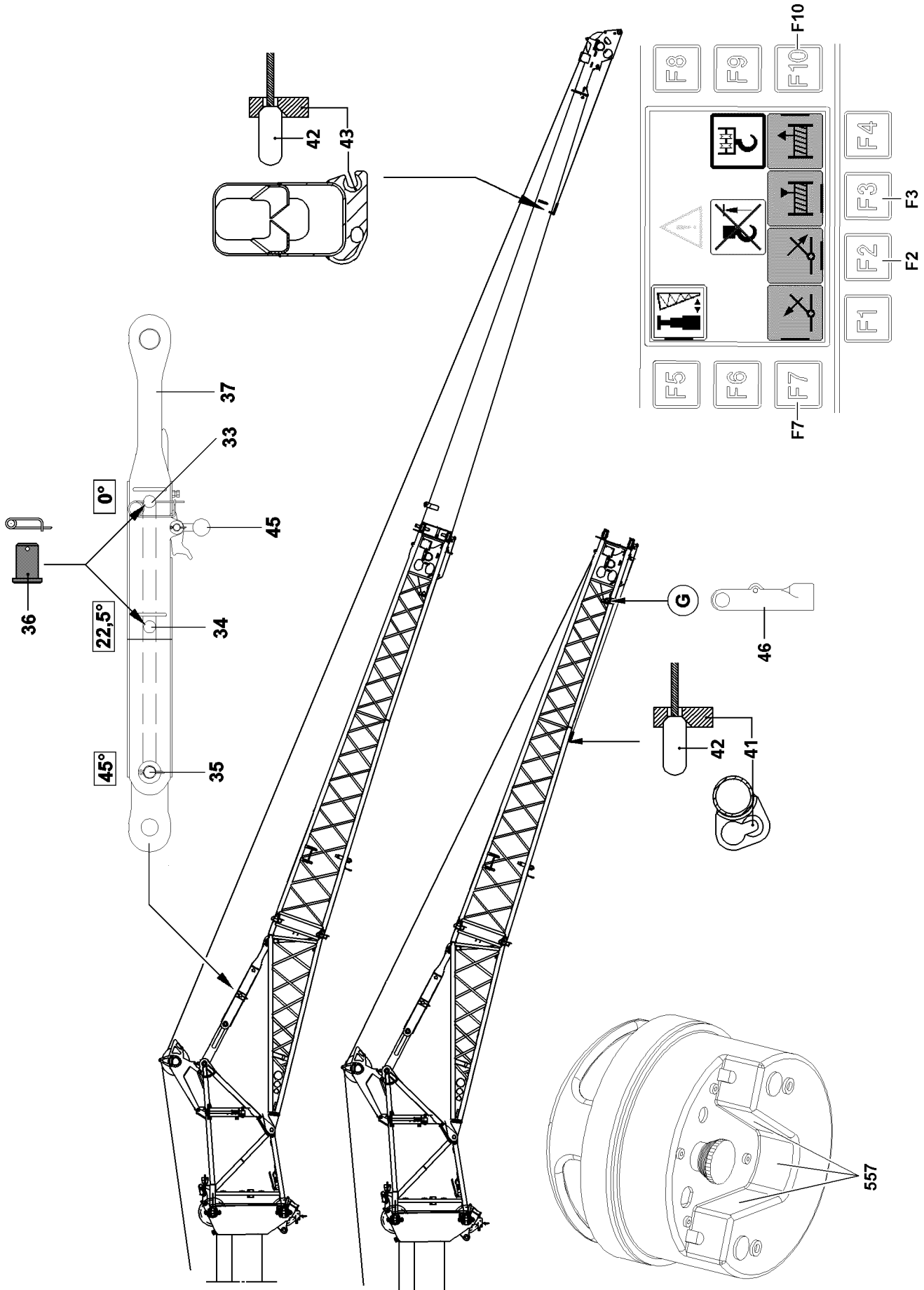


Fig.114342

## 4.1 Changing the folding jib with the hoist rope



### WARNING

Danger of fatal injury at angle installation with the BTT!

Due to jerky movements during angle installation of the folding jib with the hoist rope, the boom can swing up together with the folding jib. This can cause the folding jib to fold down uncontrolled! Personnel can be severely injured or killed!

- ▶ Make sure that there are no persons within the danger zone of the folding jib.
- ▶ Actuate all movements carefully with the BTT.

### 4.1.1 Preparatory work

Make sure that the following prerequisites are met:

- The telescopic boom is luffed down and telescoped in all the way.
- The counterweight has been installed on the turntable according to the load chart.
- The folding jib is attached as a straight extension in the 0° position.
- The telescopic boom has been luffed to the rear or the side.
- The hoist rope is detached from the rope lock.
- The rope lock has been removed.
- The hoist limit switch weight has been removed.
- The master switches have **not** been operated.
- The hook block or the load hook is reeved out.



### WARNING

Danger of accident!

- ▶ When adjusting the folding jib angle with the hoist rope, it is **explicitly prohibited** to telescope the telescopic boom out / in or to luff the telescopic boom up / down.
- ▶ If this is not observed, crane components of the folding jib as well as the hoist rope will be overloaded and damaged.



### CAUTION

Damage to the hoist rope!

The hoist rope can be damaged by the rope lock **46**.

- ▶ Remove the rope lock **46** on point **G**.

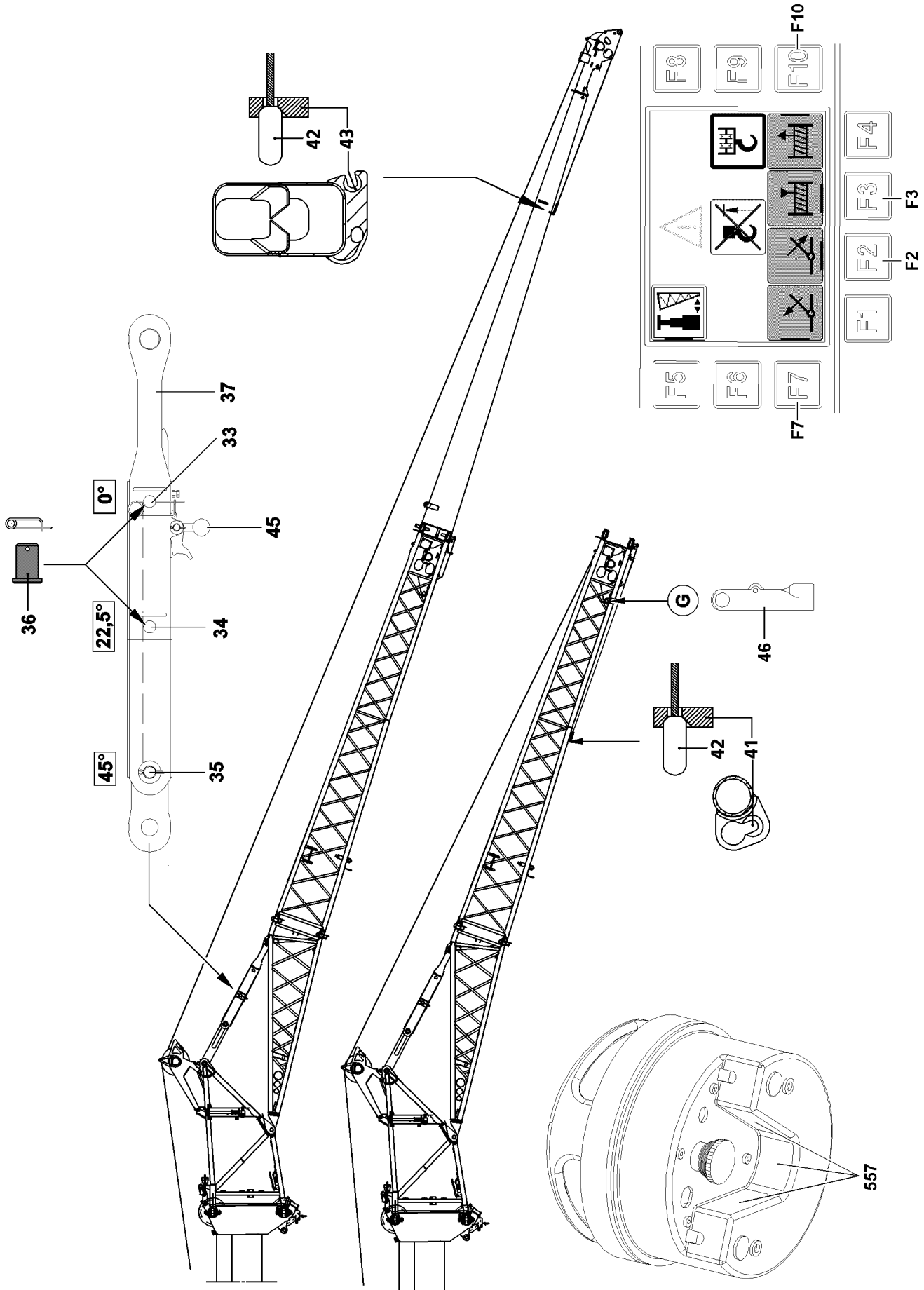


Fig.114342

LWE/LTR 1220-003/24204-02-02/en



For operation with a double folding jib

- ▶ Guide the locking clamp **42** into the assembly fixed point **43**.
- or

For operation with a single folding jib:

- ▶ Guide the locking clamp **42** into the assembly fixed point **41**.
- ▶ Press the set up key on the LICCON monitor.

**Note**

- ▶ When changing the folding jib with the BTT, the hoist limit switch is bypassed.
- ▶ BTT, see the Crane operating instructions, chapter 5.31.

- 
- ▶ Tighten the hoist rope by **carefully deflecting** the appropriate manual control lever.
- or
- ▶ Tighten the hoist rope by actuating the 2-hand keypad **557** and the function key **F3**.

**Note**

- ▶ Hold the pulley head of the folding jib approx. 1 m above the ground.
-

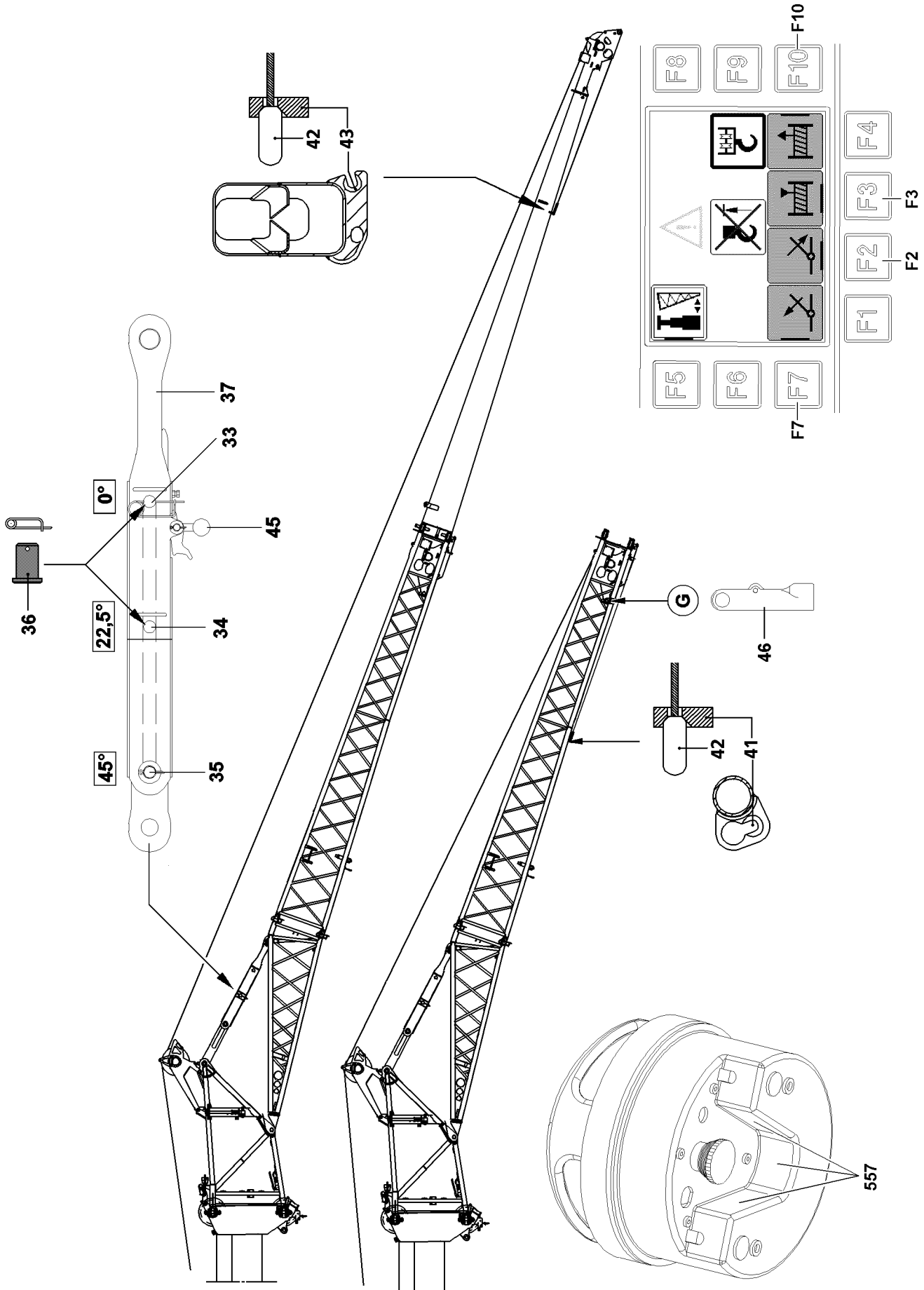


Fig.114342

## 4.1.2 Changing the angle with the hoist rope

You can operate the folding jib at three different angles. The required angle is set with the pin **36**. In the „Basic setting“, immediately after assembling the folding jib, the folding jib is in the 0° position.



### DANGER

Danger of fatal injury!

Danger of fatal injury if the folding jib suddenly „folds downward“!

- ▶ Make sure that there are no persons within the danger zone of the folding jib.
- ▶ **Before unpinning** the pins **36**, ensure that the hoist rope is taut and that the folding jib is held by the hoist rope.
- ▶ Unpinning the retaining pin **35** in the 45° pin bores is **prohibited**.

### Angle setting 22.5°

- ▶ Release the pin **36** and unpin from the 0° bore **33**.
- ▶ Insert the pin **36** into the 22.5° bore **34** and secure.

### Angle setting 45°

- ▶ Release the pin **36** and unpin from the 0° bore **33**.
- ▶ Insert the pin **36** into the pin receptacle and secure.

### Positioning the folding jib

Make sure that the pin **36** is properly inserted and secured for the required angle setting.

### NOTICE

Danger of property damage!

- ▶ When using the hoist rope to adjust the angle from 0° to 22.5° or 45°, it must be ensured that no slack rope forms when simultaneously luffing the telescopic boom up and spooling the hoist rope out when the corresponding end position is reached.
- ▶ Spool the hoist rope out by carefully deflecting the corresponding master switch and simultaneously luffing the telescopic boom up.  
**or**  
Spool out the hoist rope by actuating the 2-hand keypad **557** and the function key **F10** on the BTT. At the same time, luff the telescopic boom up slowly and carefully by pressing the function key **F7**.

### Result:

- The pull bracket **37** places itself against the respective pin in the selected angle setting.
- The folding jib is held by the pin **36**.



### Note

- ▶ BTT, see the Crane operating instructions, chapter 5.31.
- ▶ Release the locking clamp from the assembly fixed point.
- ▶ Install the rope lock **46** on point **G**.

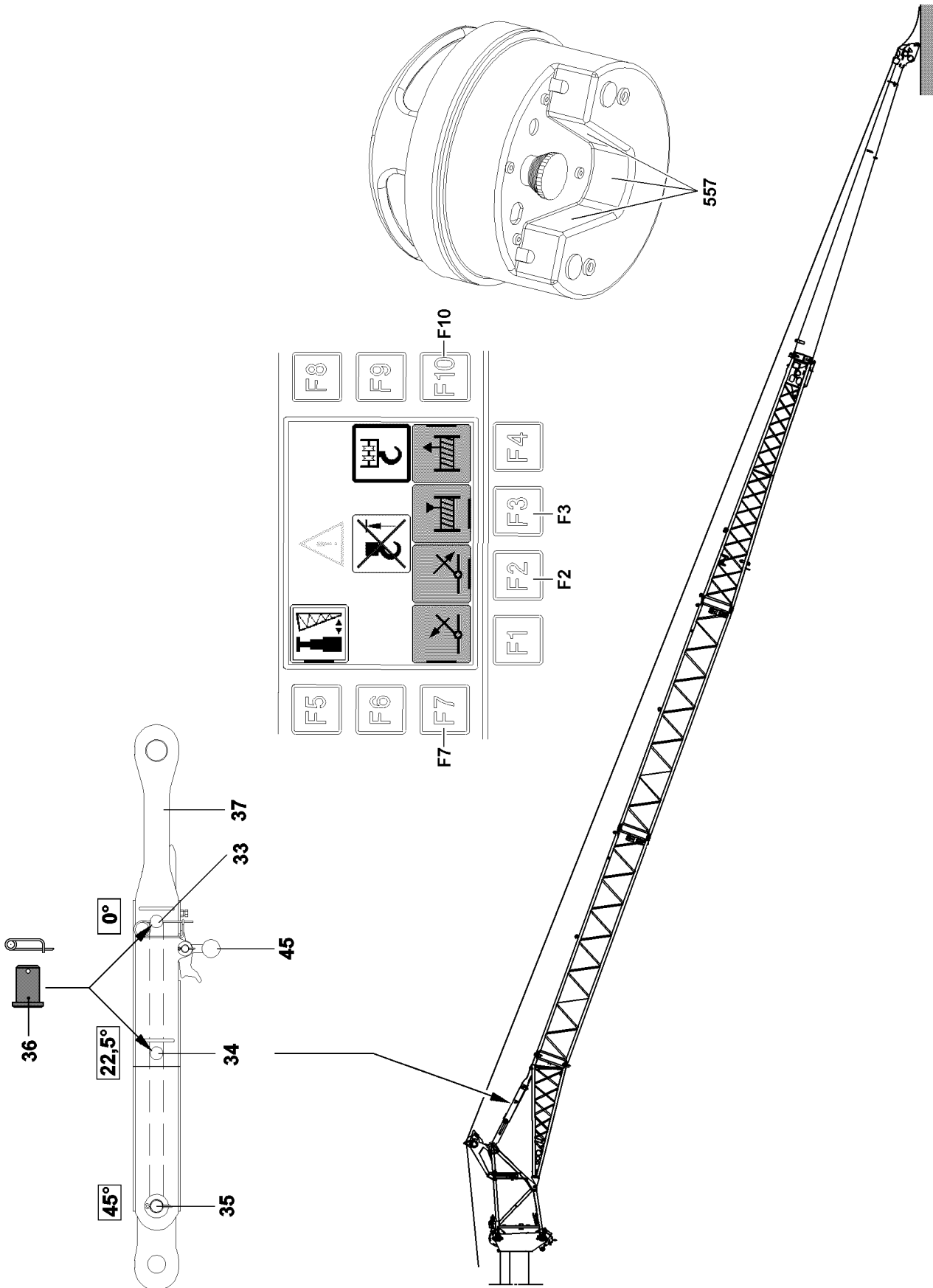


Fig.114343

## 4.2 Changing the folding jib by supporting it

### 4.2.1 Preparatory work



#### Note

- ▶ The folding jib can lie on the ground or must be properly supported, if necessary.



#### CAUTION

Danger of property damage!

- ▶ When taking down the folding jib, make sure that the folding jib is **not** taken down on the rope pulley. The folding jib can be damaged.
  - ▶ Make sure that the hoist rope is **not** damaged.
- 
- ▶ Completely luff down the telescopic boom until the folding jib lies on the ground.

### 4.2.2 Changing the angle with the folding jib supported

The folding jib can be operated in three different angles. The required angle is set with the pin **36**. In the „Basic setting“ - immediately after assembling the folding jib - the folding jib is in the 0° position.



#### DANGER

Danger of fatal injury!

Danger of fatal injury if the folding jib suddenly „folds downward“!

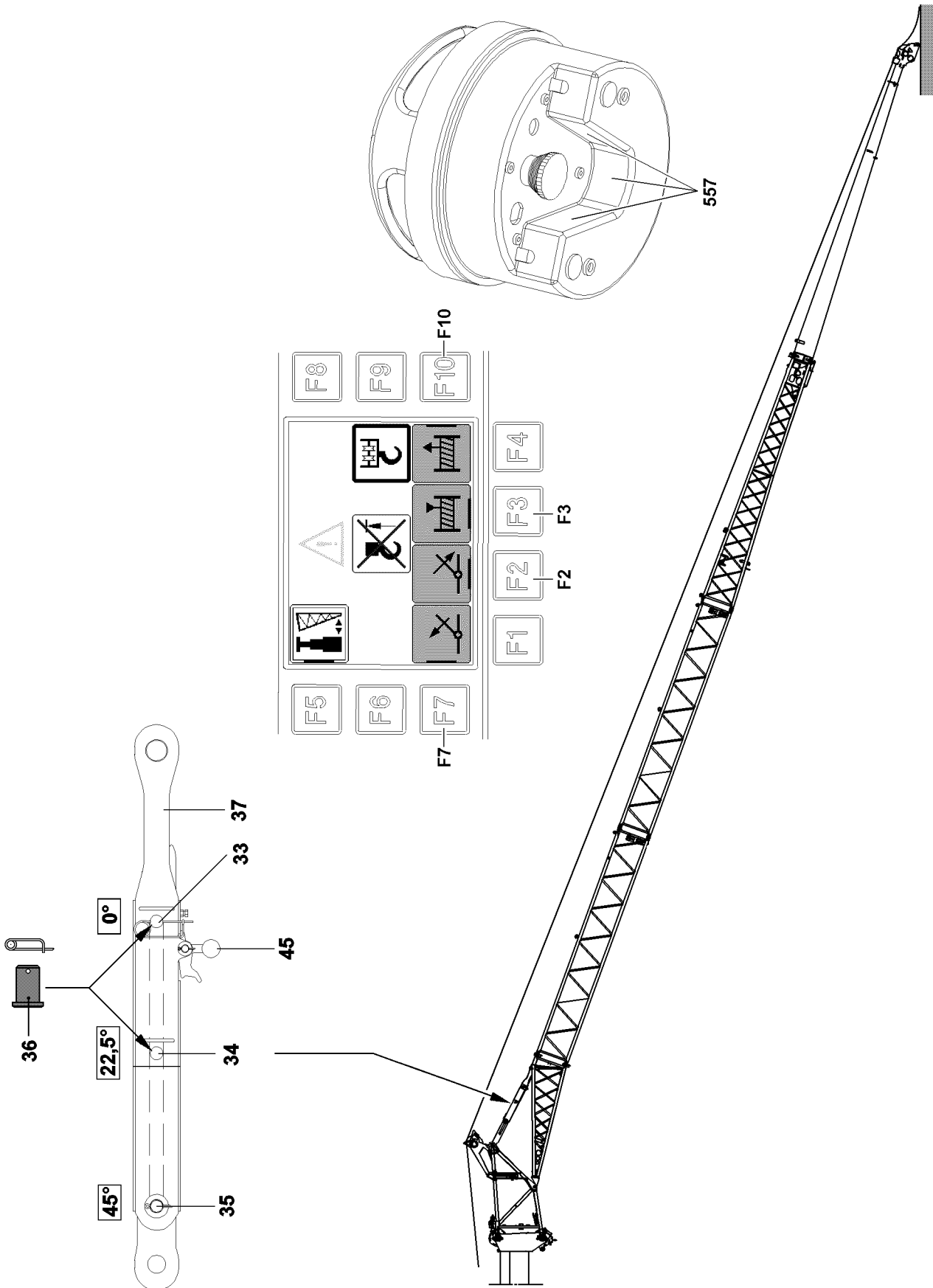
- ▶ Make sure that there are no persons within the danger zone of the folding jib.
- ▶ **Before unpinning** the pins **36**, make sure that the folding jib is lying on the ground or on a proper and secure substructure.
- ▶ Unpinning the retaining pin **35** in the 40° pin bores is **prohibited**.

#### Angle setting 22.5°

- ▶ Release the pin **36** and unpin from the 0° bore **33**.
- ▶ Insert the pin **36** into the 22.5° bore **34** and secure.

#### Angle setting 45°

- ▶ Release the pin **36** and unpin from the 0° bore **33**.
- ▶ Insert the pin **36** into the pin receptacle and secure.



LWE/LTR 1220-003/24204-02-02/en

Fig.114343

## Positioning the folding jib

---



### WARNING

Danger of fatal injury at angle installation with the BTT!

- ▶ Actuate all movements carefully with the BTT.
  - ▶ Make sure that there are no persons within the danger zone of the folding jib.
- 



### Note

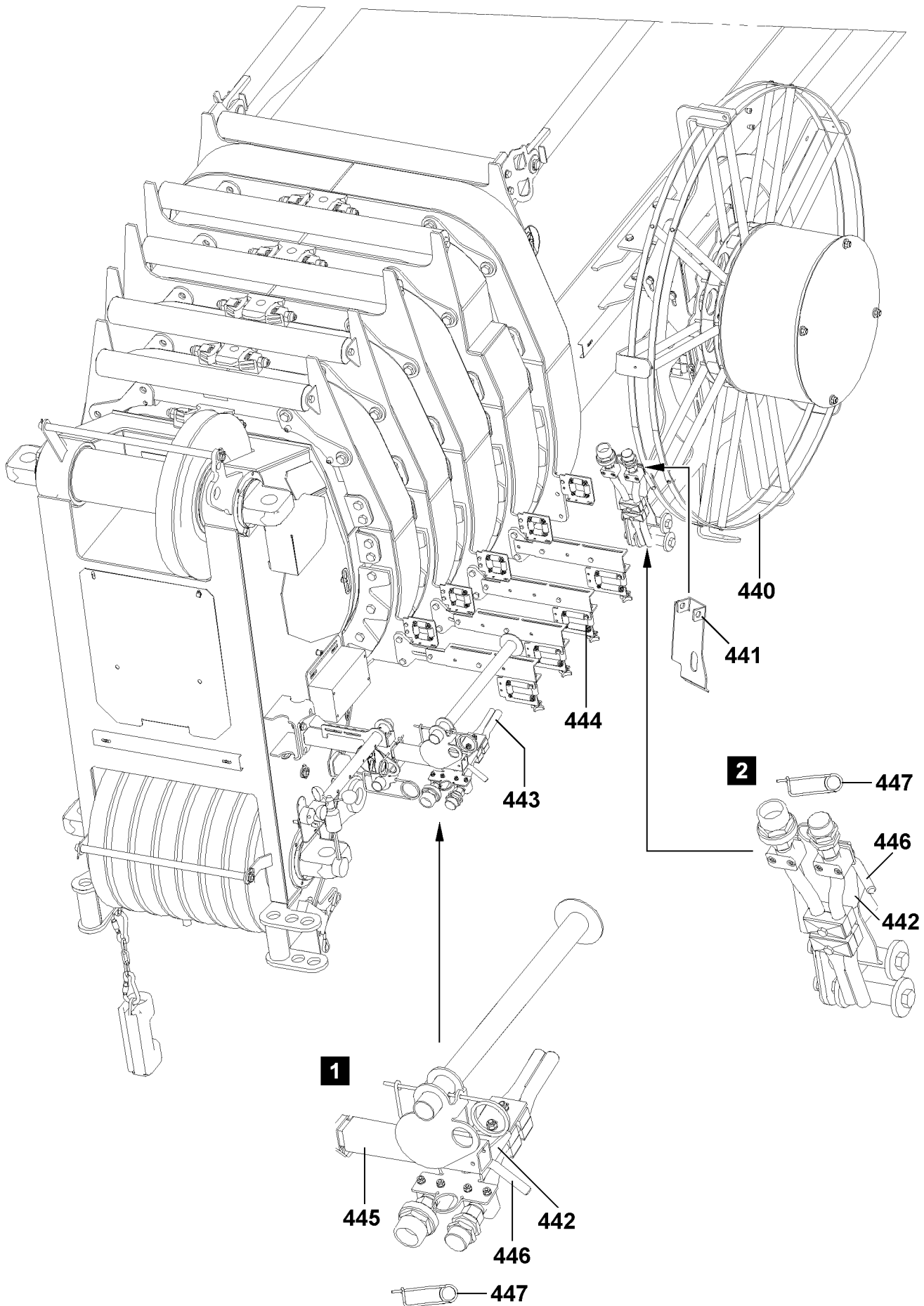
- ▶ When changing the folding jib with the BTT, the hoist limit switch is bypassed.
  - ▶ BTT, see the Crane operating instructions, chapter 5.31.
- 

Make sure that the pin **36** is properly inserted and secured for the required angle setting.

- ▶ Spool the hoist rope out by deflecting the corresponding manual control lever and at the same time luff up the telescopic boom slowly and carefully.
- or**
- Luff the telescopic boom up slowly and carefully by actuating the 2-hand keypad **557** and the function key **F7** on the BTT.

### Result:

- The pull bracket **37** places itself against the respective pin in the selected angle setting.
  - The folding jib is held by the respective pin.
- ▶ Assemble the hoist limit switch weight and chain.
  - ▶ Attach the hoist limit switch weight on the hoist rope.



LWE/LTR 1220-003/24204-02-02/en

Fig.114339



## 5 Hydraulic connections

### 5.1 Establishing the hydraulic connections

A hydraulic connection to the folding jib only has to be established for hydraulic angle adjustment (TNZK operation). Hydraulic lines cannot be incorrectly connected due to the different diameters of the hydraulic connections.

For operation with a hydraulic folding jib:

- ▶ Establish the hydraulic connections.

After operation with a hydraulic folding jib:

- ▶ Protect the connections from contamination.

### 5.2 Installing the hose couplings in the operating or neutral position

The hydraulic supply to the folding jib is made via the hydraulic hose drum **440** on the telescopic boom. For extended telescopic boom operation, the bracket **442** should be installed in the retainer **441** in the „neutral position“.

This avoids having to spool the hydraulic hoses up and out unnecessarily.



#### CAUTION

Danger of accident due to rebounding hydraulic hoses!

The hydraulic hoses are under spring tension. If the removed bracket **442** is released, it snaps back against the hydraulic hose drum **440** due to the spring force. This can cause injury to assembly personnel or damage the hydraulic hose drum **440**.

- ▶ Do not allow the removed bracket **442** to snap back.
- ▶ Hold the removed bracket **442** and then reinstall it.

#### 5.2.1 Assembling the hose couplings in operating position (illustration 1)

- ▶ Unpin the bracket **442** with the hydraulic couplings from the retainer **441**.
- ▶ Place the two-fold hydraulic hose **443** in the guides **444**.
- ▶ Install the bracket **442** with hydraulic couplings in the retainer **445** on the telescopic boom head, to do so, insert the pin **446** and secure with spring retainer **447**, see illustration 1.
- ▶ Secure the hydraulic hose **443** in the guides **444**.

#### 5.2.2 Assembling the hose couplings in resting position (illustration 2)

- ▶ Release the hydraulic hose **443** in the guides **444**.
- ▶ Remove the bracket **442** with the hydraulic couplings from the retainer **445** on the boom head, to do so, release and unpin the pin **446**, see illustration 1.
- ▶ Remove the two-fold hydraulic hose **443** from the guides **444**.
- ▶ Install the bracket **442** with hydraulic couplings in the retainer **441** on the hydraulic hose drum **440**, to do so, insert the pin **446** and secure with spring retainer **447**, see illustration 2.

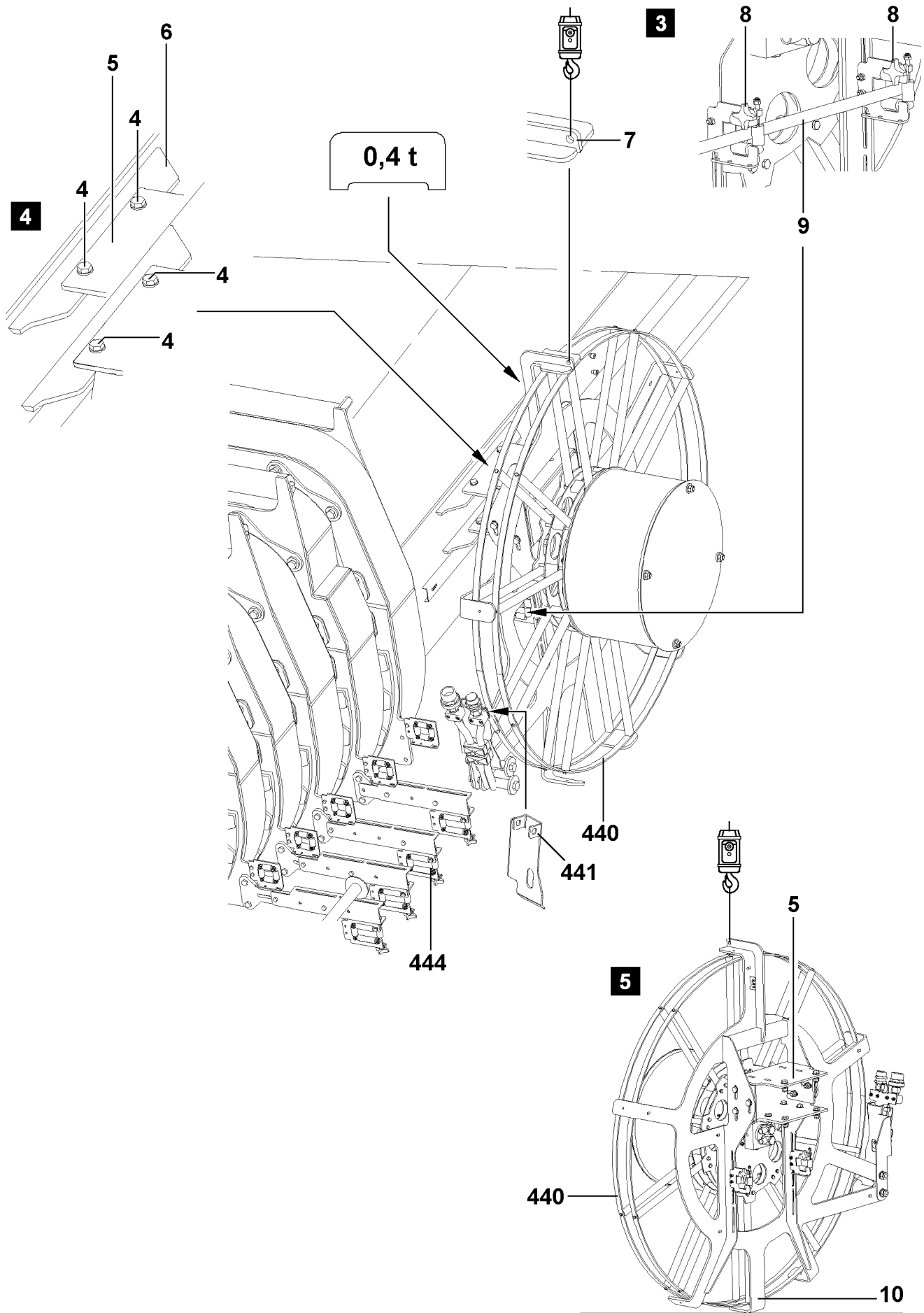


Fig.107186

## 5.3 Disassembling the hydraulic hose drum



### WARNING

Danger of falling!

During assembly and disassembly of the hydraulic hose drum **440**, personnel must be secured with appropriate fall arrest aids to prevent them from falling. If this is not observed, assembly personnel could fall and be killed or seriously injured!

- ▶ All work at a height, when there is a danger of falling, must be carried out with suitable aids.
- ▶ If fall protection equipment is available, then it must be used, see the Crane operating instructions, chapter 2.06.
- ▶ If aids are not available and work cannot be carried out from the ground, then assembly personnel must secure themselves with the supplied fall arrest system to prevent falling, see the Crane operating instructions, chapter 2.04.
- ▶ The supplied fall arrest system must be fastened to the fastening and hook points. For safety points, see Crane operating instructions, chapter 2.06.
- ▶ Only step on the aids, ladders and catwalks with clean shoes.
- ▶ Keep aids, ladders and catwalks free of heavy dirt, snow and ice.
- ▶ It is prohibited to walk on the telescopic boom.



### WARNING

Danger of fatal injuries due to toppling hose drum!

- ▶ In case of an assembly / disassembly error, the hydraulic hose drum **440** can fall down.
- ▶ It is prohibited for anyone to remain under the hydraulic hose drum **440** during assembly or disassembly.

Make sure that the following prerequisites are met:

- The telescopic boom is luffed down, telescoped in and swung 90° to the side **or** to the rear.
- The hydraulic connections of the hose couplings to the folding jib are released and the hose couplings are installed in resting position, see section „Assembling the hose couplings in resting position“.
- An auxiliary crane with suitable fastening equipment is available for disassembling the hydraulic hose drum **440**.
- ▶ Attach the auxiliary crane with fastening equipment on the suspension lug **7** of the hydraulic hose drum **440** and secure, see illustration **3**.
- ▶ Release the cross handles **8** from the pulley sections and remove the cable **9**, see illustration **3**.



### WARNING

Danger of burning due to hot oil!

When releasing hydraulic connections, hot oil can emerge!

- ▶ When releasing hydraulic connections, it is imperative to use suitable work gloves.

- ▶ Release all hydraulic connections from the telescopic boom to the hydraulic hose drum **440**.
- ▶ Remove all **four** hex head screws **4** from the retainer **5** and bracket **6**, see illustration **4**.
- ▶ Lift the hydraulic hose drum **440** with the auxiliary crane and remove.



### WARNING

Danger of crushed limbs!

When taking the hydraulic hose drum **440** down, limbs can be crushed!

- ▶ Take the hydraulic hose drum **440** down especially carefully.
- ▶ Place the hydraulic hose drum **440** on the center spoke **10** on level ground, see illustration **5**.
- ▶ Take the hydraulic hose drum **440** down slowly on the retainer **5**, see illustration **5**.

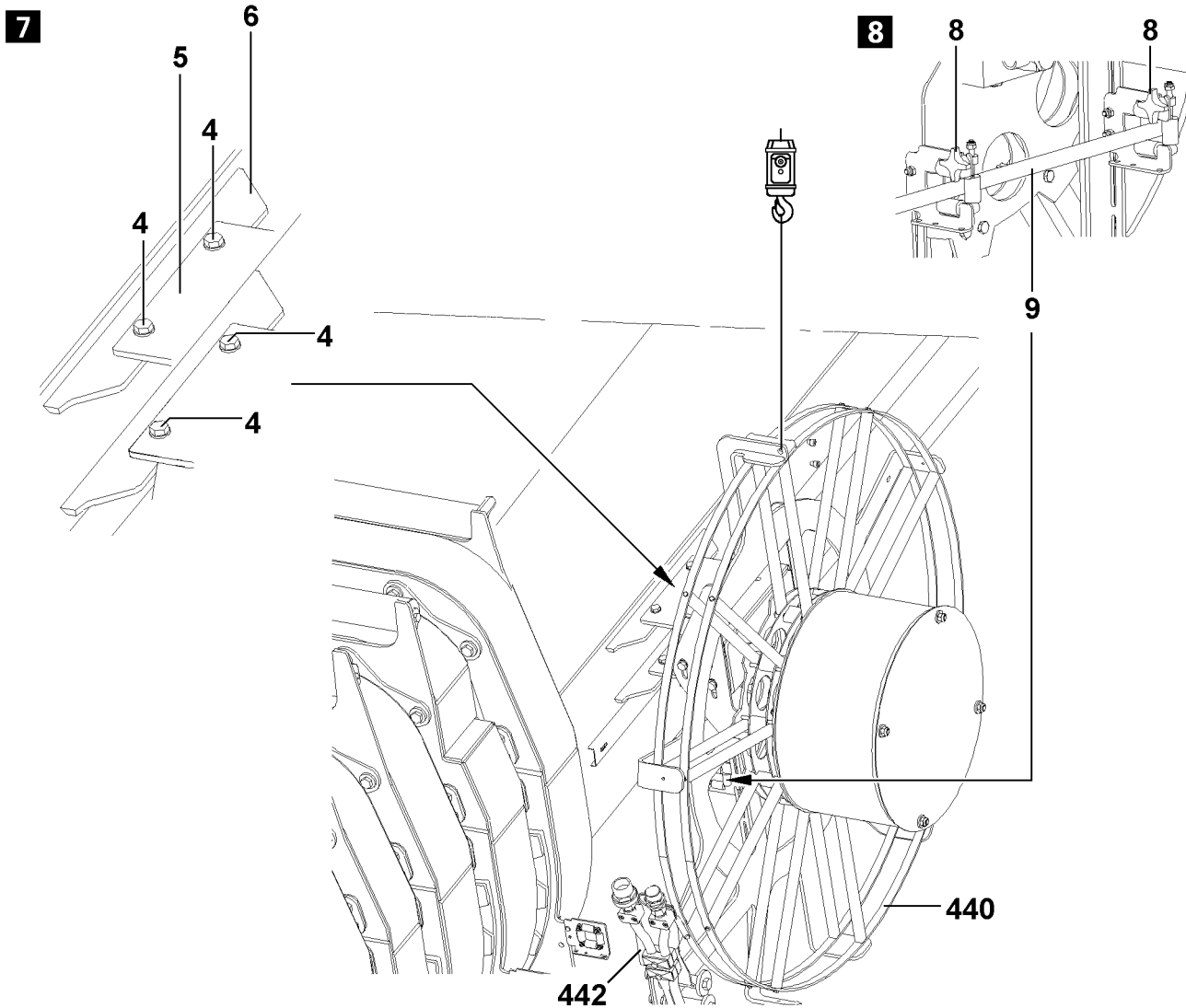
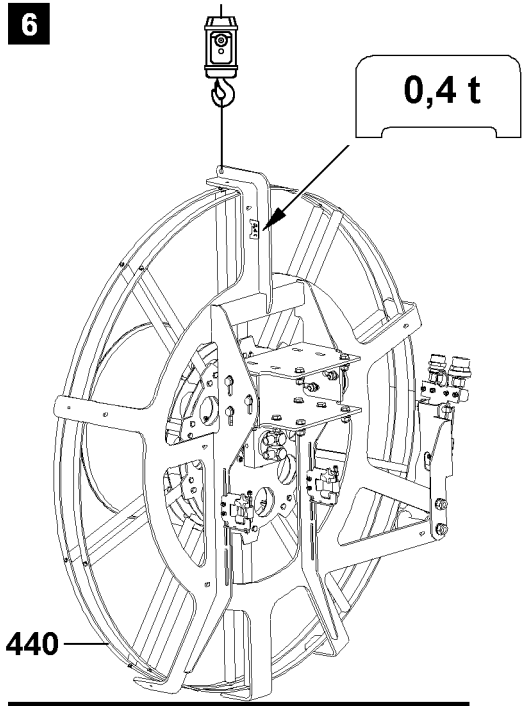


Fig.107270

## 5.4 Installing the hydraulic hose drum



### WARNING

Danger of falling!

During assembly and disassembly of the hydraulic hose drum **440**, personnel must be secured with appropriate fall arrest aids to prevent them from falling. If this is not observed, assembly personnel could fall and be killed or seriously injured!

- ▶ All work at a height, when there is a danger of falling, must be carried out with suitable aids.
- ▶ If fall protection equipment is available, then it must be used, see the Crane operating instructions, chapter 2.06.
- ▶ If aids are not available and work cannot be carried out from the ground, then assembly personnel must secure themselves with the supplied fall arrest system to prevent falling, see the Crane operating instructions, chapter 2.04.
- ▶ The supplied fall arrest system must be fastened to the fastening and hook points. For safety points, see Crane operating instructions, chapter 2.06.
- ▶ Only step on the aids, ladders and catwalks with clean shoes.
- ▶ Keep aids, ladders and catwalks free of heavy dirt, snow and ice.
- ▶ It is prohibited to walk on the telescopic boom.



### WARNING

Danger of fatal injuries due to toppling hose drum!

- ▶ Due to an assembly / disassembly error, the hydraulic hose drum **440** can fall down.
- ▶ It is prohibited for anyone to remain under the hydraulic hose drum **440** during assembly or disassembly.

Make sure that the following prerequisites are met:

- The telescopic boom is luffed down, telescoped in and swung 90° to the side **or** to the rear.
- An auxiliary crane with suitable fastening equipment is available for disassembling the hydraulic hose drum **440**.
- ▶ Attach the auxiliary crane to the suspension lug **7** of the hydraulic hose drum **440** with suitable fastening equipment and secure, see illustration **6**.
- ▶ Lift the hydraulic hose drum **440** with the auxiliary crane and fasten on the telescopic boom, see illustration **7**.



### WARNING

Danger of crushed limbs!

When installing the hydraulic hose drum **440** on the telescopic boom, limbs can be crushed!

- ▶ Be especially careful upon assembly of the hydraulic hose drum **440**.
- ▶ Screw the retainer **5** on the bracket **6** with all **four** hex head screws **4** and **new self-locking nuts**, see illustration **7**.
- ▶ Guide the cable **9** into the pulley sections and attach the cross handles **8** tightly, see illustration **8**.
- ▶ Establish all hydraulic connections from the telescopic boom to the hydraulic hose drum **440**.
- ▶ Remove the auxiliary crane.
- ▶ Install the bracket **442** with hose couplings in operating position, if needed, see section „Installing the hose couplings in operating position“.

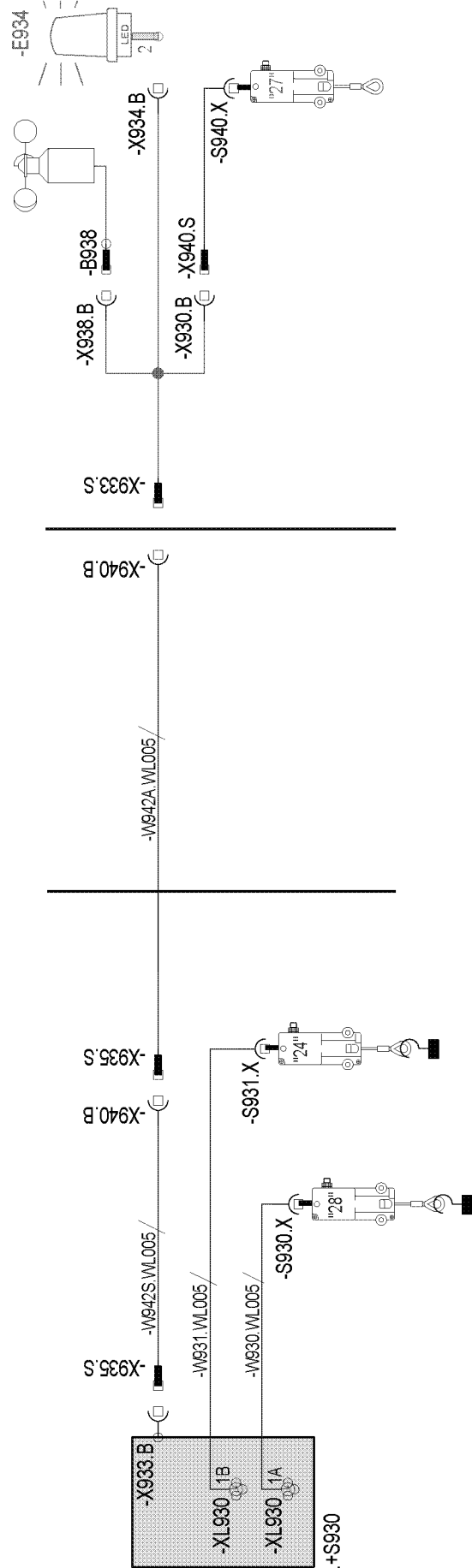
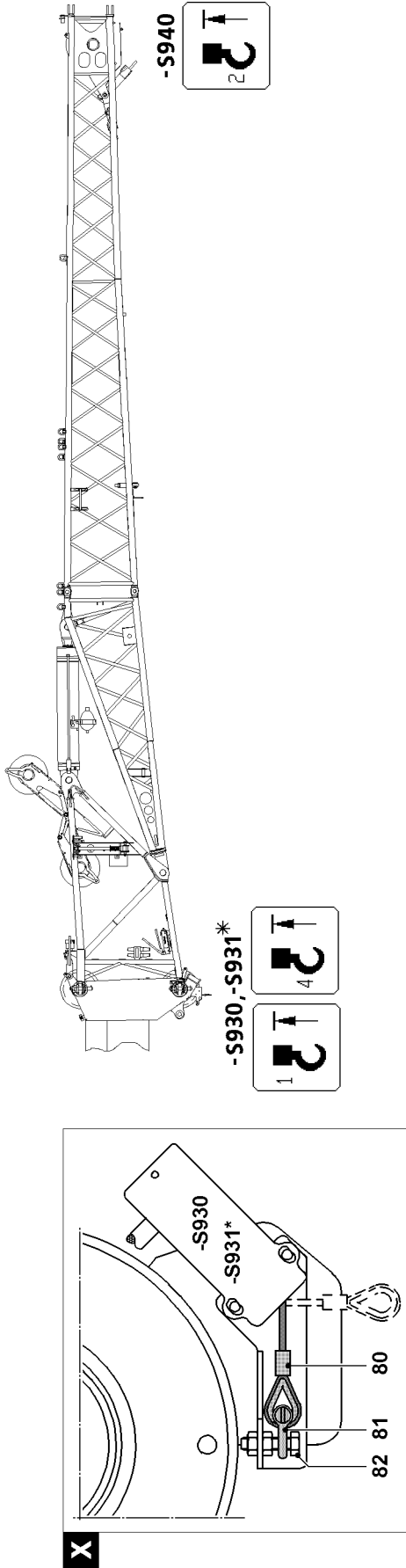


Fig.115025

## 6 Electrical connections

### 6.1 Mechanically actuating the hoist limit switch, illustration X

If you are working in „Single hook operation“ with the installed folding jib, the hoist limit switch **-S930** and hoist limit switch\* **-S931** which is not required must be actuated manually.

- ▶ Disassemble the hoist limit switch weight and chain.
- ▶ Pull the hoist limit switch rope **80** and attach to the fixed point **82** with the shackle **81**.

### 6.2 Establishing the electrical connections on the single folding jib

#### 6.2.1 Establishing the electrical connection to the hoist limit switch



##### Note

- ▶ In single hook operation, only the hoist limit switch **-S940** on the single folding jib is active. The hoist limit switch **-S930** and the hoist limit switch\* **-S931** must be mechanically actuated, see illustration X.
- ▶ In two hook operation, the hoist limit switch **-S940** on the single folding jib and the hoist limit switch **-S930** on the telescopic boom are active. The hoist limit switch\* **-S931** must be mechanically actuated, see illustration X.

- ▶ Plug the cable **W942** with the plug **-X935.S** into the terminal box **-S930**.
- ▶ Plug the cable **W942** with the plug **-X935.S** into the socket **-X940.B**.



##### Note

- ▶ To be able to establish the electrical connection to the hoist limit switch **-S940**, the Y-adapter must be plugged in the socket **-X940.B** with the plug **-X933.S**.
- ▶ Plug the Y-adapter with the plug **-X933.S** into the socket **-X940.B**.
- ▶ Plug the Y-adapter with the plug **-X940.S** into the socket **-X930.B**.
- ▶ Plug in the hoist limit switch **-S940**.

#### 6.2.2 Establishing the electrical connection to the LED continuous light\* or flashing beacon\*



##### Note

- ▶ To be able to establish the electrical connection to the LED continuous light and the flashing beacon, the Y-adapter on the cable must be plugged in the socket **-X940.B** with the plug **X933.S**.
- ▶ Plug the LED continuous light or flashing beacon in the socket **-X934.B**.

#### 6.2.3 Establishing the electrical connection to the wind speed sensor\*



##### Note

- ▶ To be able to establish the electrical connection to the wind speed sensor, the Y-adapter with the plug **X933.S** must be plugged in the socket **-X940.B**.
- ▶ Plug the wind speed sensor in the socket **-X938.B**.



##### Note

- ▶ After the folding jib operation, protect the electrical connections from contamination with caps.

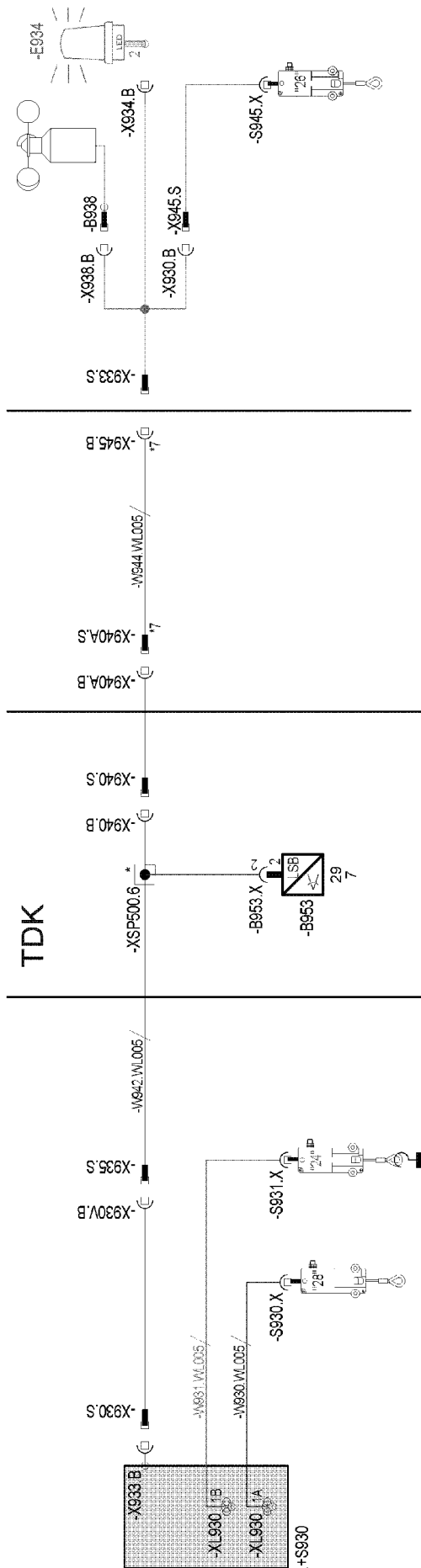
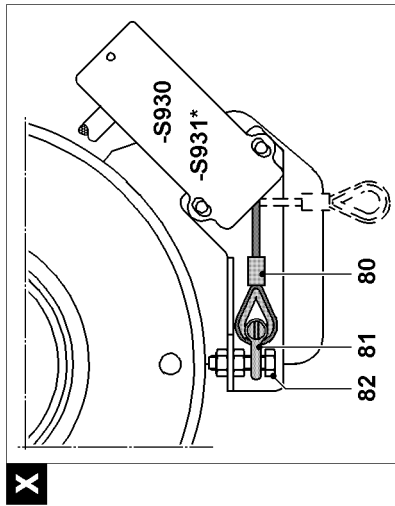
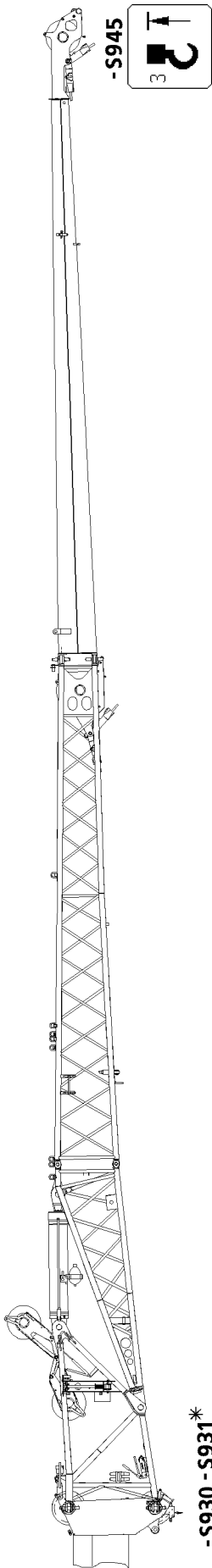


Fig.115026

LWE/LTR 1220-003/24204-02-02/en



## 6.3 Establishing the electrical connections on the double folding jib

### 6.3.1 Establishing the electrical connection to the hoist limit switch



#### Note

- ▶ Only the hoist limit switch **-S945** on the double folding jib is active during single hook operation. The hoist limit switch **-S940** on the single folding jib must be unplugged. The hoist limit switch **-S930** and the hoist limit switch\* **-S931** must be mechanically actuated, see illustration **X**.
- ▶ In two hook operation, the hoist limit switch **-S945** on the double folding jib and the hoist limit switch **-S930** on the telescopic boom are active. The hoist limit switch **-S940** must be unplugged and the hoist limit switch\* **-S931** must be mechanically actuated, see illustration **X**.

- ▶ Plug the cable with the plug **-X930.S** into the terminal box **-S930**.
- ▶ Plug the cable **W942** with the plug **-X935.S** into the socket **-X930V.B**.
- ▶ Plug the cable with the plug **-X940.S** into the socket **-X940.B**.
- ▶ Plug the cable with the plug **-X940.AS** into the socket **-X945.A.B**.
- ▶ Plug the Y-adapter with the plug **X933.S** in the socket **-X945.B**
- ▶ Plug in the hoist limit switch **-S945**.

### 6.3.2 Establishing the electrical connection to the LED continuous light\* or flashing beacon\*



#### Note

- ▶ To be able to establish the electrical connection to the LED continuous light and the flashing beacon, the Y-adapter on the cable must be plugged in the socket **-X945.B** with the plug **X933.S**.
- ▶ Plug the LED continuous light or flashing beacon in the socket **-X934.B**.

### 6.3.3 Establishing the electrical connection to the wind speed sensor\*



#### Note

- ▶ To be able to establish the electrical connection to the wind speed sensor, the Y-adapter with the plug **X933.S** must be plugged in the socket **-X945.B**.
- ▶ Plug the wind speed sensor in the socket **-X938.B**.

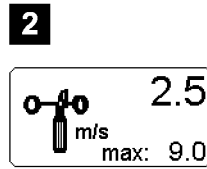
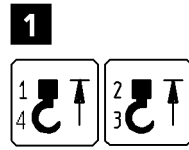


Fig.105574

LWE/LTR 1220-003/24204-02-02/en

## 6.4 Function check

Make sure that the following prerequisites are met:

- All electrical connections have been established.
- The crane engine is running.
- The appropriate folding jib operating mode is set on the LICCON monitor.

### 6.4.1 Hoist limit switch

- ▶ Actuate all active hoist limit switches manually.

**Result:**

- The corresponding symbol element „Hoist top“ appears on the LICCON monitor.
- The hoist winch turns off in the lift direction, see illustration 1.



**Note**

The respective „Hoist top“ icon element does not appear on the monitor when manually actuating the hoist limit switch?

Is „spool winch up“ and „luff telescopic boom down“ blocked?

The jib boom is not compatible with the LICCON overload protection!

- ▶ Contact the nearest **Liebherr customer service center** or **Liebherr-Werk Ehingen**.
- 



**Note**

- ▶ When replacing or changing a hoist limit switch (HES), the corresponding hoist limit switch must have the correct bus address and the correct software version in order to be detected again by the bus system (LSB).
-

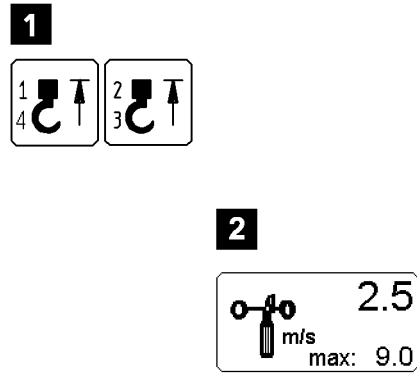


Fig.105574

LWE/LTR 1220-003/24204-02-02/en

## 6.4.2 Function check

Make sure that the following prerequisites are met:

- All electrical connections have been established.
- The crane engine is running.
- The appropriate folding jib operating mode is set on the LICCON monitor.

### Hoist limit switch

- ▶ Actuate all active hoist limit switches manually.

#### Result:

- The corresponding symbol element „Hoist top“ appears on the LICCON monitor.
- The hoist winch turns off in the lift direction, see illustration 1.



#### Note

The respective „Hoist top“ icon element does not appear on the monitor when manually actuating the hoist limit switch?

Is „spool winch up“ and „luff telescopic boom down“ blocked?

The jib boom is not compatible with the LICCON overload protection!

- ▶ Contact the nearest **Liebherr customer service center** or **Liebherr-Werk Ehingen**.
- 



#### Note

- ▶ When replacing or changing a hoist limit switch (HES), the corresponding hoist limit switch must have the correct bus address and the correct software version in order to be detected again by the bus system (LSB).
- 

### Wind sensor



#### WARNING

Danger of accident due to toppling crane!

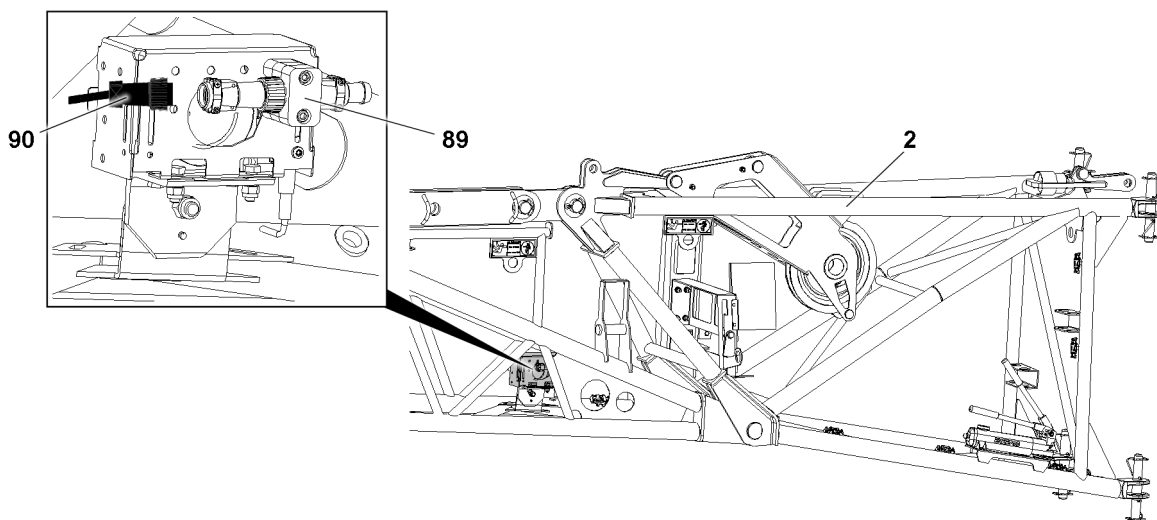
The wind speed can no longer be determined when attaching a defective wind sensor.

- ▶ Check the function of the wind sensor every time it is installed.
- 

- ▶ Manually actuate the wind sensor.

#### Result:

- The „Wind speed“ icon, see illustration 2, appears on the LICCON monitor.

**Angle sensor\***

*Fig.153550: Folding jib with angle sensor\**

Depending on the version, an angle sensor **89** is attached to the folding jib **2**.

Make sure that the following prerequisites are met:

- All electrical connections have been established.
- The LICCON computer system is running.
- If an angle sensor **89** is installed on the folding jib **2**: The cable plug **90** is inserted in the angle sensor **89**.

Folding jib with angle sensor

Observe the display on the LICCON monitor.

**Problem remedy**

Is the error message displayed on the LICCON monitor?

The angle sensor **89** is not detected by the crane.

- ▶ Unplug the cable plug **90** from the angle sensor **89**.

Folding jib without angle sensor

Observe the display on the LICCON monitor.

**Problem remedy**

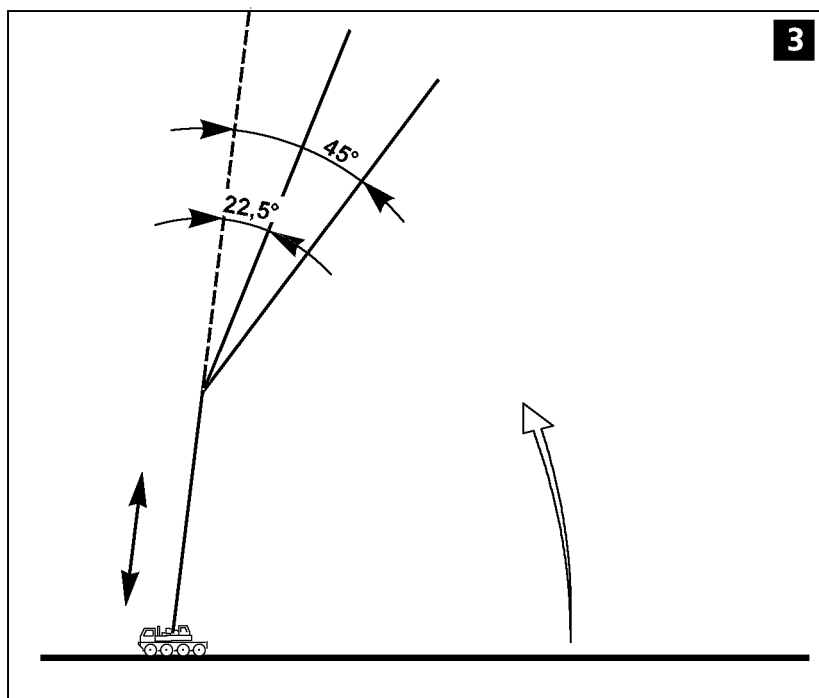
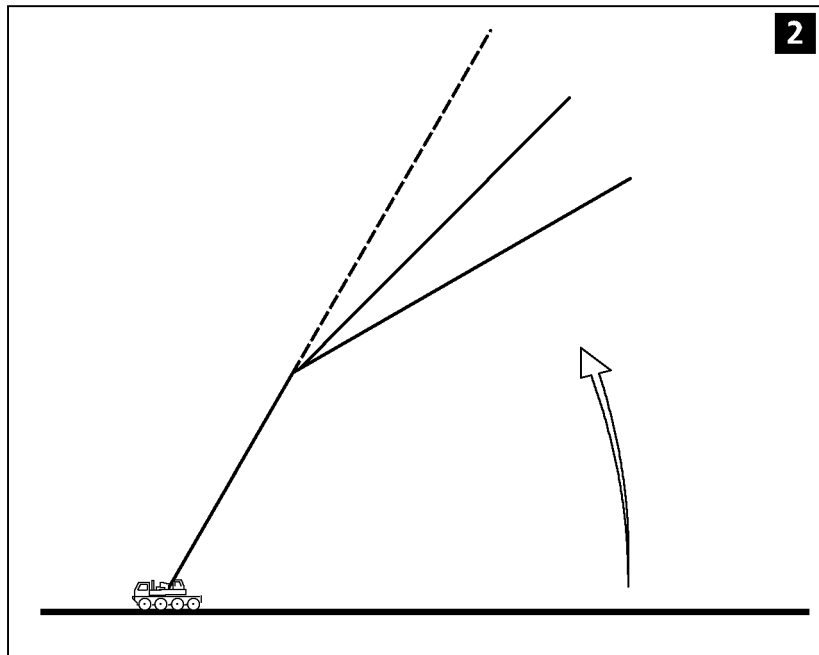
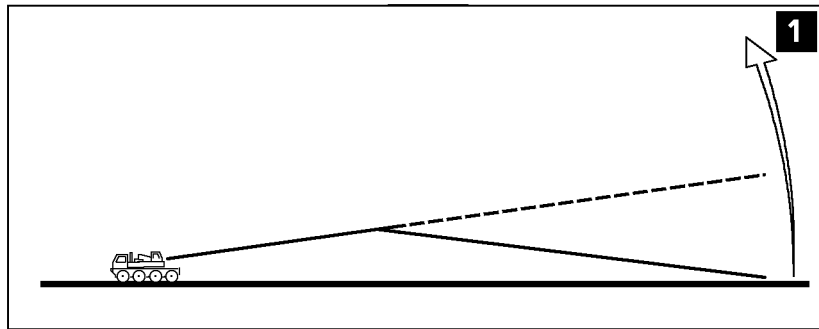
Is the error message displayed on the LICCON monitor?

The angle sensor **89** is required by the crane.

- ▶ Contact Liebherr Service and have the angle sensor **89** installed.

Empty page!

LWE/LTR 1220-003/24204-02-02/en



LWE/LTR 1220-003/24204-02-02/en

Fig.196442



## 7 Erecting

### 7.1 Preparatory work

Make sure that the following prerequisites are met:

- The crane is properly supported and horizontally aligned.
- The counterweight has been installed on the turntable according to the load chart.
- The telescopic boom is telescoped in all the way.
- The folding jib has been assembled according to the load chart and the operating instructions.
- All limit switches have been correctly installed and are fully functioning.
- All pin connections have been secured.
- The hoist rope has been correctly placed in the rope pulleys and prevented from jumping out with the rope retaining pins.
- There are no „foreign objects“ on the telescopic boom and the folding jib.
- The telescopic boom, the folding jib and its components (such as: Limit switch, airplane warning light, wind speed sensor) must be free of snow and ice in winter.



#### **DANGER**

Danger of accident!

Incorrectly installed or non-functioning limits switches as well as falling parts (such as: pins, cotter pins, ice) can cause accidents!

- ▶ Install all limit switches, pins and cotter pins properly.
- ▶ Check if all prerequisites have been met.

### 7.2 Erection procedure



#### **DANGER**

Danger of accident due to toppling of the crane!

The boom radii specified in the load chart may not be exceeded or fallen below, even if there is no load on the hook! If this regulation is not observed, the crane can topple over.

- ▶ Compare and check the settings on the LICCON computer system with the actual set up configuration.

Adjustment of the LICCON overload protection, refer to the Crane operating instructions, chapter 4.02.

- ▶ Set and confirm the LICCON overload protection according to the required set up configuration.
- ▶ Luff the telescopic boom up with the folding jib attached until the LICCON signals the release.
- ▶ Telescope the telescopic boom out to the values specified in the load chart.

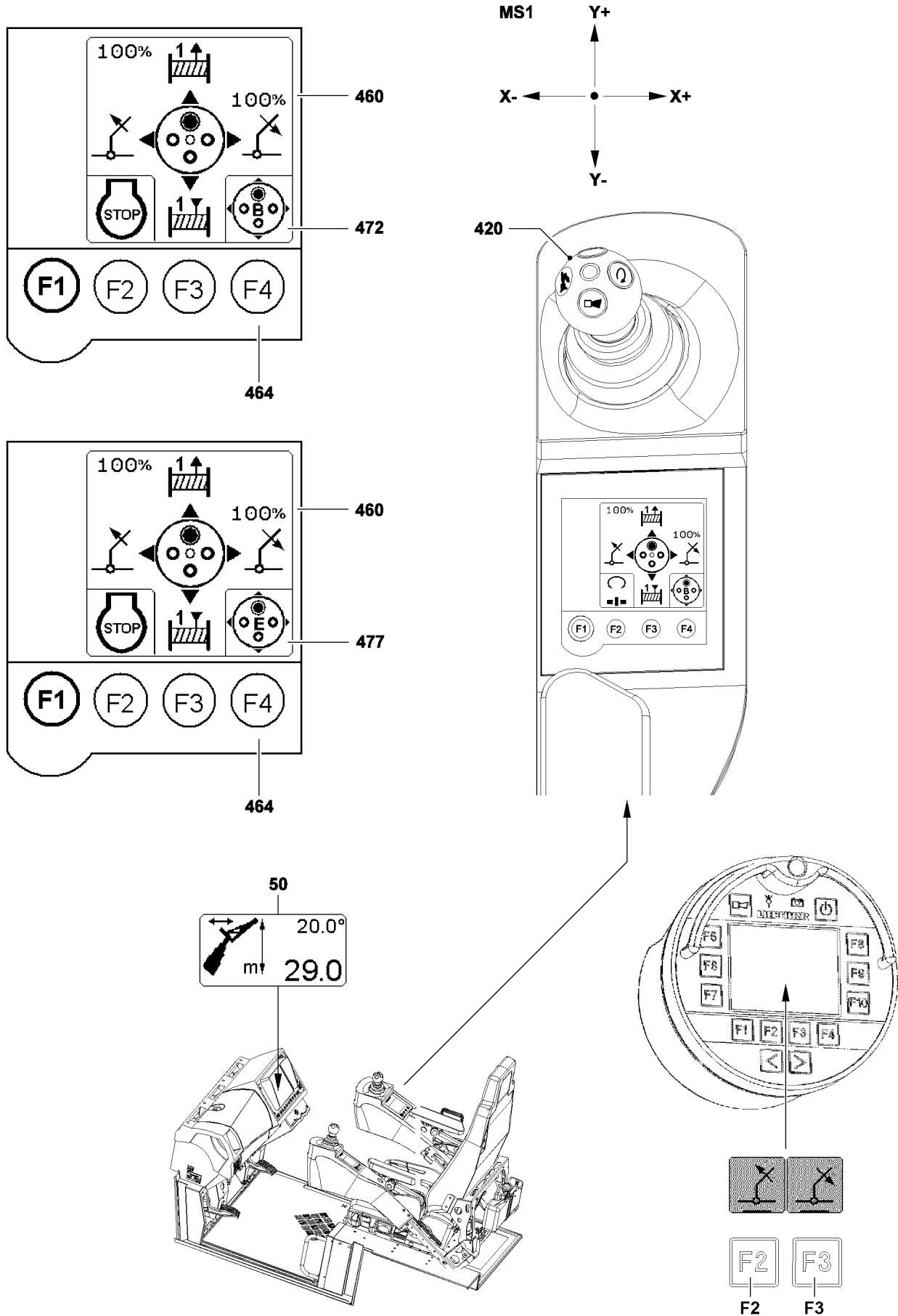


Fig.118512

LWE/LTR 1220-003/24204-02-02/en

## 8 Adjusting the folding jib angle hydraulically\*

### 8.1 Folding jib with hydraulic\* angle adjustment

The adjustment range of the folding jib lies between 0° and 40° to the telescopic boom. It is possible to luff the hydraulically adjustable folding jib under load.



#### **DANGER**

Danger of accident due to toppling crane!

The crane may topple if the maximum load is exceeded.

- ▶ The information in the load charts must be adhered to.
- ▶ The load charts for the hydraulically adjustable folding jib are only valid for angles of 0°, 20° and 40°.
- ▶ For the adjustment angles between the nominal angles of 0°, 20° and 40°, the maximum load will be determined by the LICCON computer system shown on the LICCON monitor.

Make sure that the following prerequisites are met:

- All hydraulic connections have been made.
- All electrical connections have been made.
- The crane engine is running.
- The operating mode **TNZK** has been set and confirmed on the LICCON computer system.

#### 8.1.1 Angle indicator for the folding jib

The folding jib angle **50** is shown on the LICCON monitor as the relative angle between the telescopic boom pulley head and the folding jib.

#### 8.1.2 Luffing with „hydraulic angle adjustment“

Make sure that the following prerequisites are met:

- The right touch display **460** appears in the „Travel operation + Master switch configuration“ menu.
- The master switch assignment „B“ **472** is active (for devices with one winch).
- The master switch assignment „E“ **477** is active (for devices with two winches).

The folding jib angle adjustment can be made with a load.

If the folding jib is to be luffed down:

- ▶ Deflect the master switch **420** to the right in direction X+.

#### **Result:**

- The hydraulic folding jib is luffed down.

If the folding jib is to be luffed up:

- ▶ Deflect the master switch **420** to the left in direction X-.

#### **Result:**

- The hydraulic folding jib is luffed up.



#### **Note**

- ▶ Alternatively, hydraulic angle adjustment is possible with the BTT.
- ▶ The hydraulic folding jib can be luffed up with the function key **F2** or luffed down with the function key **F3**, see chapter 5.31 Section. The „Assembly functions menu on the BTT“.

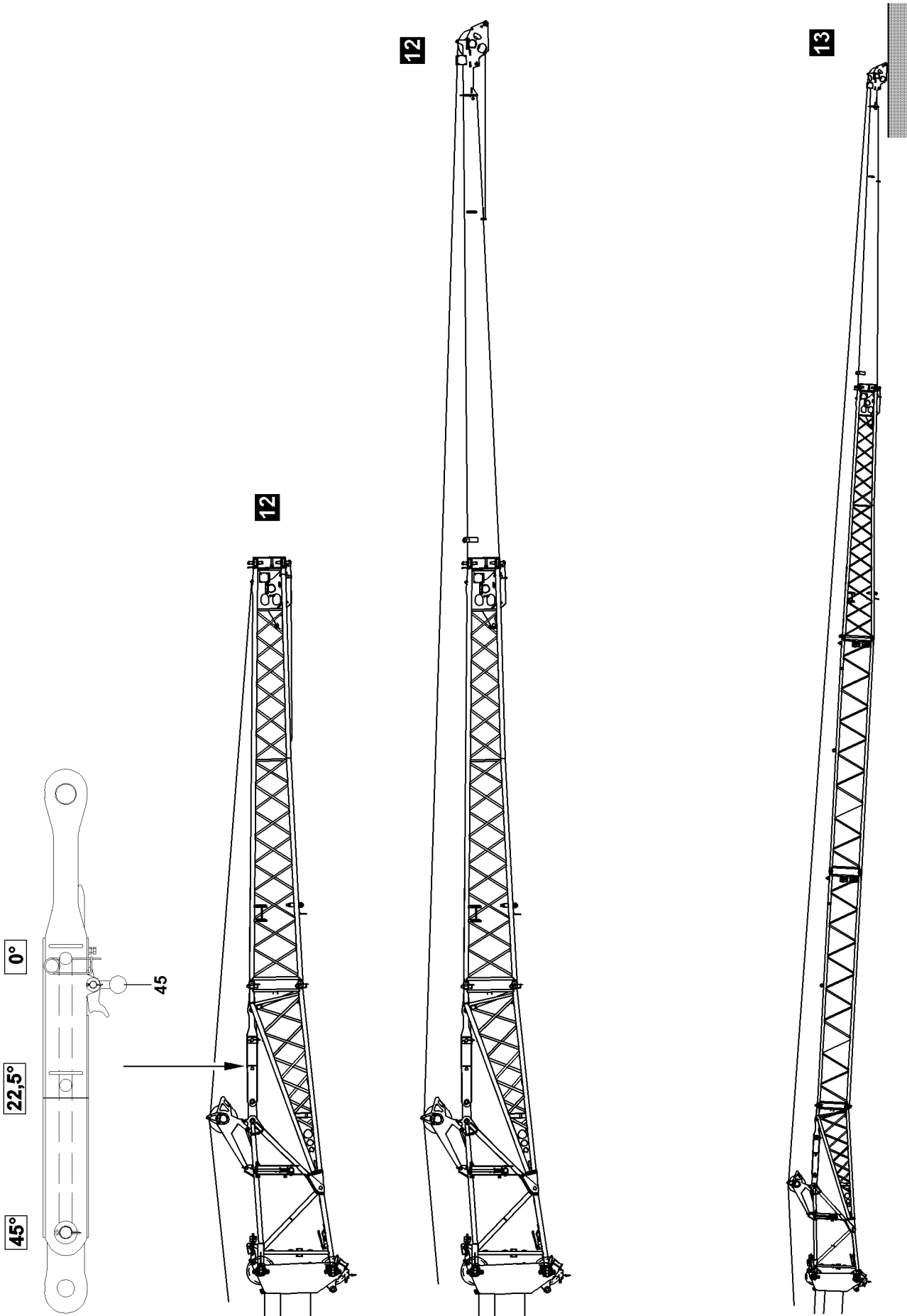


Fig.114341

LWE/LTR 1220-003/24204-02-02/en

## 9 Changing over the mechanical folding jib from 22.5° or 45° to 0°



### DANGER

Danger of fatal injury!

If the following danger notes are not observed, fatal injuries can occur during assembly and change over work on the folding jib.

- ▶ No persons may remain within the danger zone of the crane.

There are two ways of changing the mechanical folding jib to 0°:

1. Changing the folding jib with the hoist rope, see illustration 12.  
Only permitted for operation with the single folding jib and double folding jib.
2. Changing the folding jib by supporting it from below, see illustration 13.

### 9.1 Changing the folding jib with the hoist rope



### WARNING

Danger of fatal injury at angle installation with the BTT!

Due to jerky movements during angle installation of the folding jib with the hoist rope, the boom can swing up together with the folding jib. This can cause the folding jib to fold down uncontrolled! Personnel can be severely injured or killed.

- ▶ Actuate all movements carefully with the BTT.
- ▶ Make sure that there are no persons within the danger zone of the folding jib.



### Note

- ▶ When changing the folding jib with the BTT, the hoist limit switch is bypassed.
- ▶ BTT, see the Crane operating instructions, chapter 5.31.

Make sure that the following prerequisites are met:

- The crane is properly supported and horizontally aligned.
- The counterweight has been installed on the turntable according to the load chart.
- The telescopic boom is telescoped in all the way.
- The folding jib is installed at an angle of 22.5° or 45°.
- The telescopic boom has been luffed to the rear or the side.

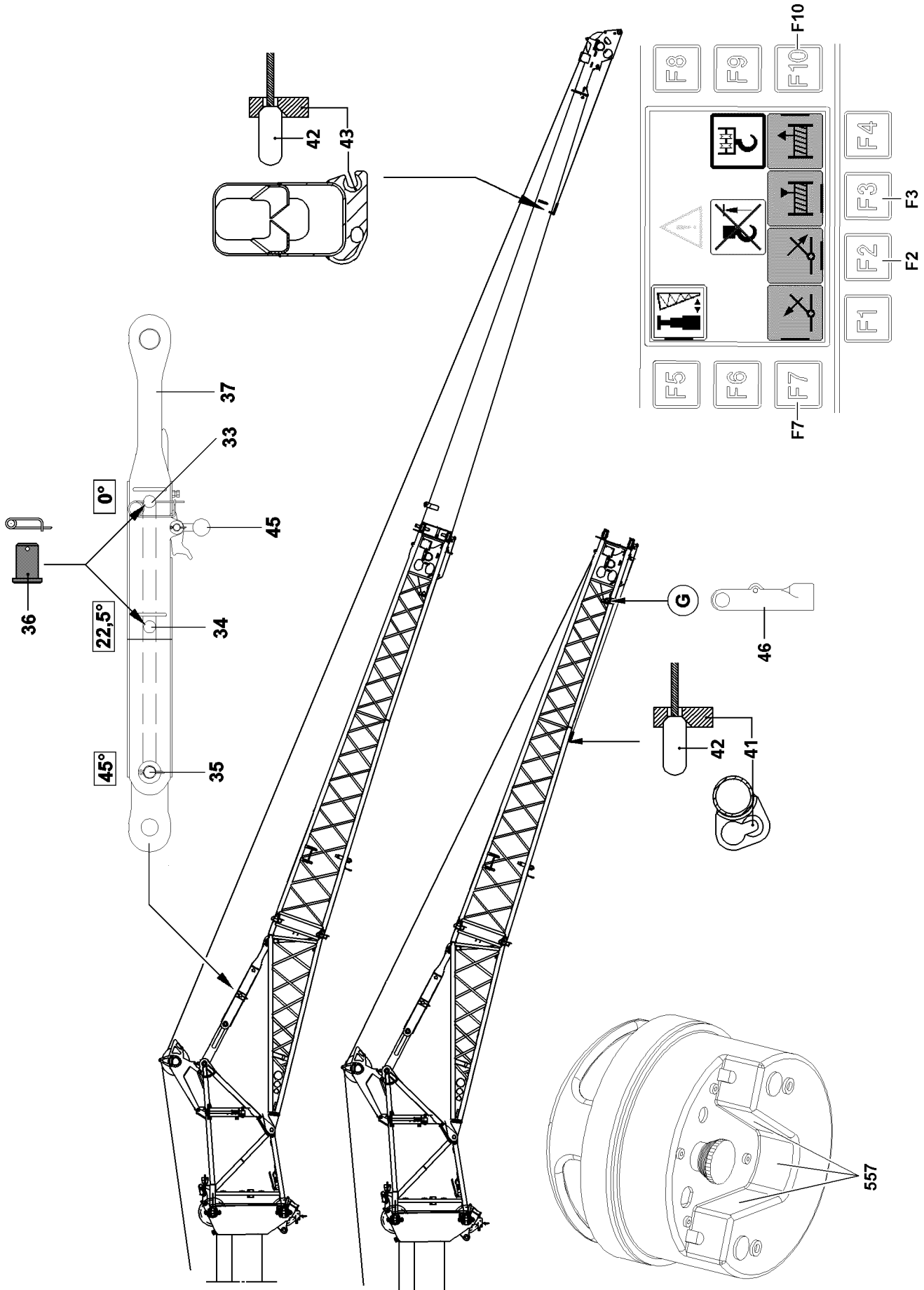


Fig.114342

### 9.1.1 Preparatory work

- ▶ Luff the telescopic boom down until the hook block can be reeved out on the end section of the folding jib.
- ▶ Reeve out the hoist rope on the hook block.
- ▶ Disassemble the hoist limit switch weight.



---

#### CAUTION

Damage to the folding jib and the hoist rope!

If the telescopic boom is telescoped out or luffed down as long as the hoist rope is tightened on the assembly fixed point, the hoist rope can rip and the folding jib can be damaged.

- ▶ Do not telescope out or luff down the telescopic boom with the hoist rope attached on the assembly fixed point.
- 

For operation with a double folding jib:

- ▶ Guide the locking clamp **42** into the assembly fixed point **43**.
- or**

For operation with a single folding jib:

Guide the locking clamp **42** into the assembly fixed point **41**.

- ▶ Tighten the hoist rope by **carefully deflecting** the appropriate manual control lever.
- or**

Tighten the hoist rope by actuating the 2-hand keypad **557** and the function key **F3**.

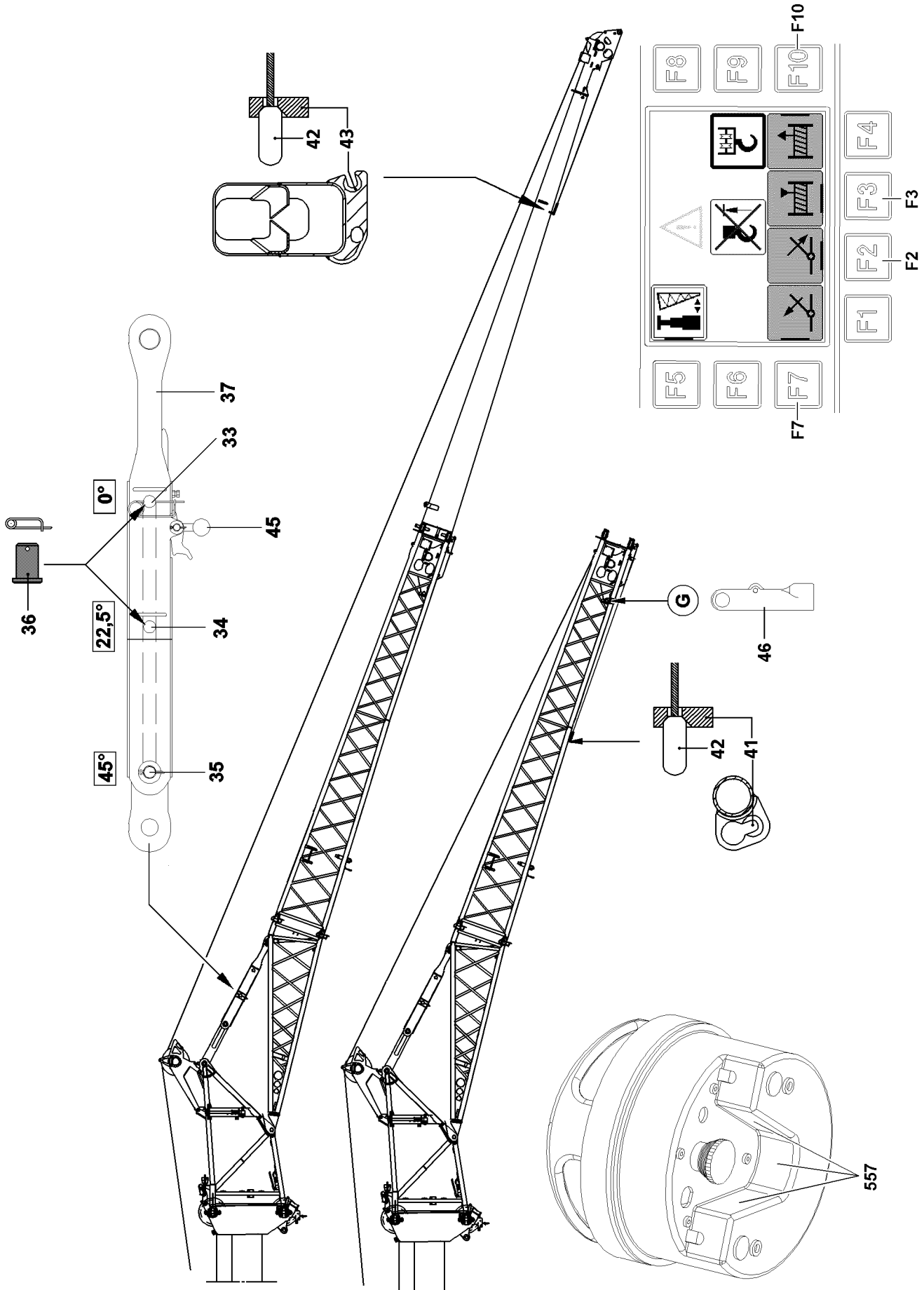


Fig.114342



## 9.1.2 Changing the angle with the hoist rope



### CAUTION

Danger of damage to the folding jib and the hoist rope!

- ▶ As soon as the folding jib has reached the 0° position (stop at pull bracket), the „Lifting“ and „Luffing“ movement must be stopped immediately.
- 
- ▶ Luff the telescopic boom down and simultaneously spool up the hoist rope so that the pivot section of the folding jib is always kept at the same height, approx. 1.0 m - 1.5 m , above the ground until the 0° position (stop on pull bracket) has been reached.
- or**
- Luff the telescopic boom down via the BTT by actuating the 2-hand keypad **557** and the function key **F2**. Spool up the hoist rope simultaneously with the function key **F3** so that the pivot section of the folding jib is always held at the same height, approx. 1.0 m to 1.5 m above the ground until the 0 ° position „Stop on pull bracket“ is reached.



### DANGER

Danger of fatal injury!

Danger of fatal injury if the folding jib suddenly „folds downward“!

- ▶ Make sure that there are no persons within the danger zone of the folding jib.
  - ▶ **Before unpinning** the pins **36**, ensure that the hoist rope is taut and that the folding jib is actually held by the hoist rope.
  - ▶ Unpinning the retaining pin **35** in the 45° pin bores is **prohibited**.
- 
- ▶ Release the pins **36** and unpin from the 22.5° bore **34** **or** remove from the transport retainer.
  - ▶ Insert the pin **36** into the 0° bore **33** and secure.
  - ▶ Disengage the hoist rope on the assembly fixed point.
  - ▶ Install the rope lock **46** on point **G**.

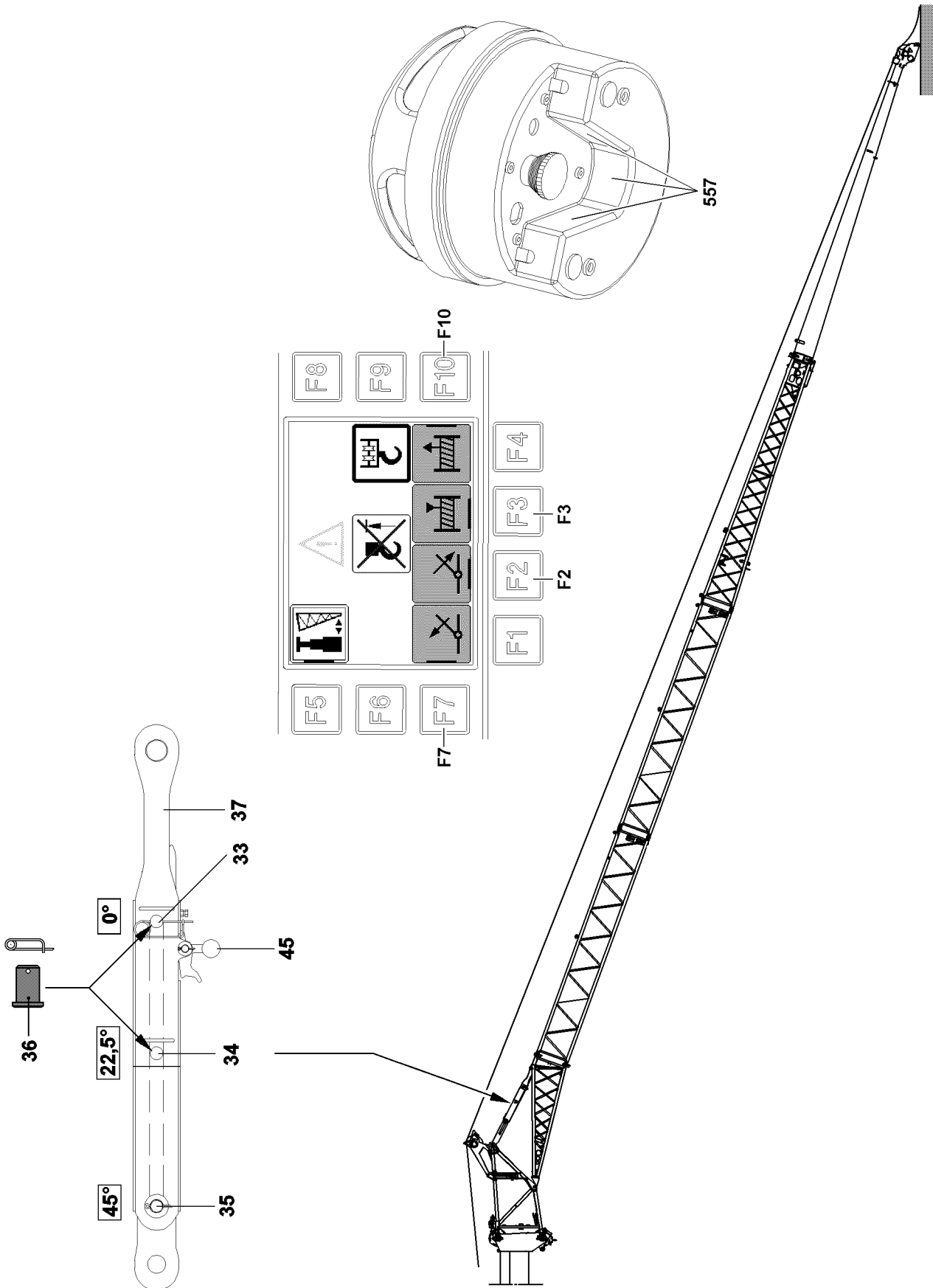


Fig.114343

## 9.2 Changing the folding jib by supporting it



### WARNING

Danger of fatal injury at angle installation with the BTT!

- ▶ Actuate all movements carefully with the BTT.
- ▶ Make sure that there are no persons within the danger zone of the folding jib.



### Note

- ▶ When changing the folding jib with the BTT, the hoist limit switch is bypassed.
- ▶ Luff the telescopic boom completely down via the master switch until the hook block can be reeved out.
- ▶ Remove the lock and the hoist limit switch weight.



### CAUTION

Danger of property damage!

- ▶ When taking down the folding jib, make sure that the folding jib is **not** taken down on the rope pulley. The folding jib can be damaged.
- ▶ Make sure that the hoist rope is **not** damaged.
- ▶ Make sure that the ground is level and solid, so that the folding jib does not sink into the ground when luffing it down.
- ▶ Completely luff down the telescopic boom until the folding jib lies on the ground.  
**or**  
Luff the telescopic boom down all the way by actuating the 2-Hand key field **557** and the function key **F2** on the BTT until the folding jib is laying on the ground.
- ▶ Continue to luff down the telescopic boom carefully until the 0° position (stop at pull bracket) is reached.



### DANGER

Danger of fatal injury!

Danger of fatal injury if the folding jib suddenly „folds downward“!

- ▶ No persons may remain within the danger zone of the crane.
- ▶ Make sure **before unpinning** the pin **36**, that the folding jib is lying on the ground or on a proper and secure substructure.
- ▶ Unpinning the retaining pin **35** in the 45° pin bores is **prohibited**.
- ▶ Release the pin **36** and unpin from the 22.5° bore **34** **or** remove from the transport retainer.
- ▶ Insert the pin **36** into the 0° bore **33** and secure.

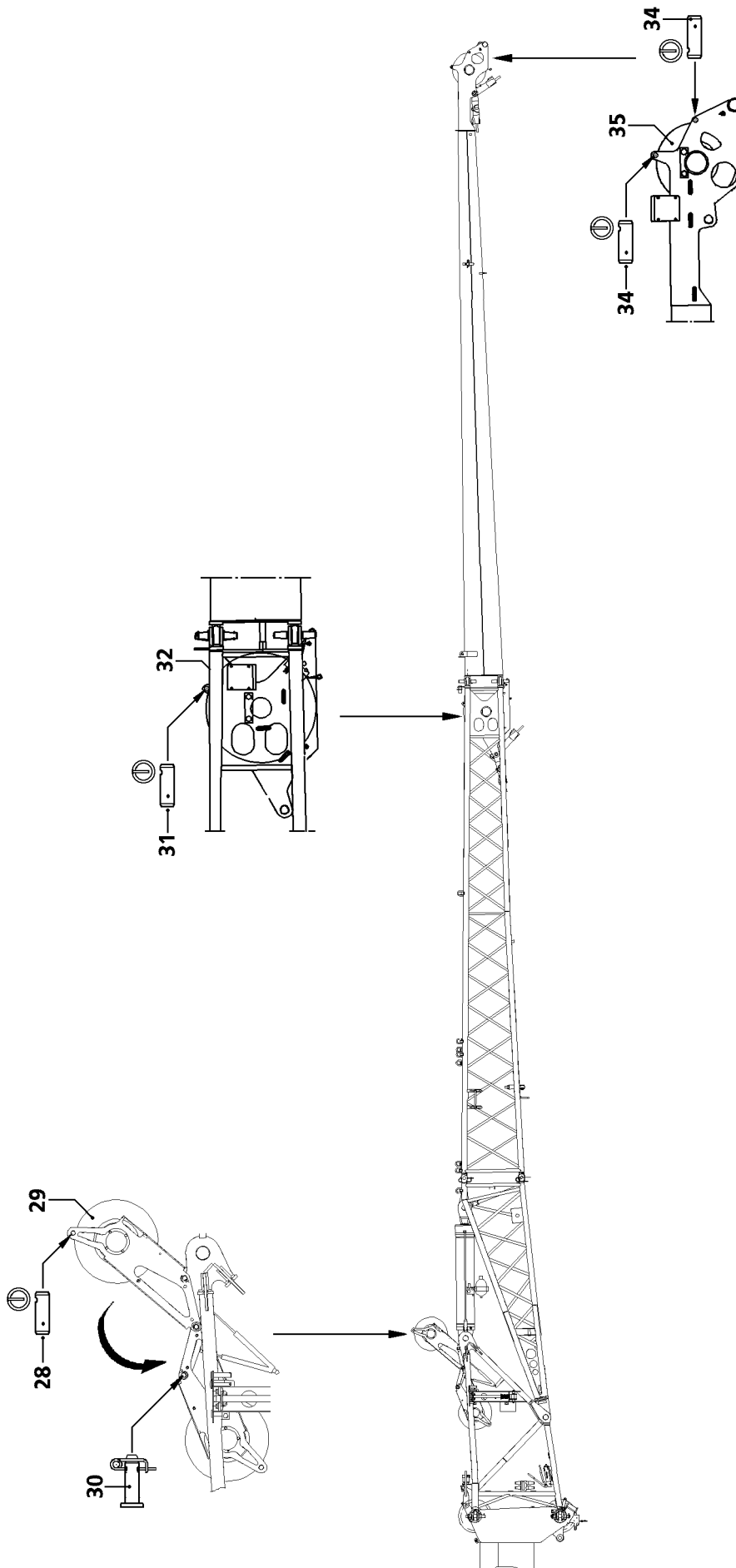


Fig.196444

LWE/LTR 1220-003/24204-02-02/en

## 10 Reeving the hoist rope out



### DANGER

Danger of falling from the folding jib!

When stepping on the folding jib, for example to reeve the hoist rope in or out, there is a risk of slipping and falling from the folding jib.

- ▶ Do not step on the folding jib.

Make sure that the following prerequisites are met:

- The telescopic boom is telescoped in.
- The hook block / load hook has been taken down onto the ground.
- The hoist rope is detached from the rope fixed point.
- The hoist limit switch weight and the chain have been disassembled.

### 10.1 Unpinning / pinning the rope retaining pin

- ▶ Release and unpin the rope retaining pin **28** and rope retaining pin **31**.

For operation with a double folding jib, 3-piece folding jib or 4-piece folding jib:

- ▶ Release and unpin the rope retaining pin **34**.
- ▶ Spool the hoist rope up.
- ▶ Reinsert the rope retaining pin **28**, rope retaining pin **31** and rope retaining pin **34** and secure with locking pins.

### 10.2 Swinging the rope guide pulley into the transport position

- ▶ Release and unpin the pin **30**.
- ▶ Swing the rope guide pulley **29** into the transport position.
- ▶ Pin the rope guide pulley **29** in the transport position: Insert and secure the pin **30**.

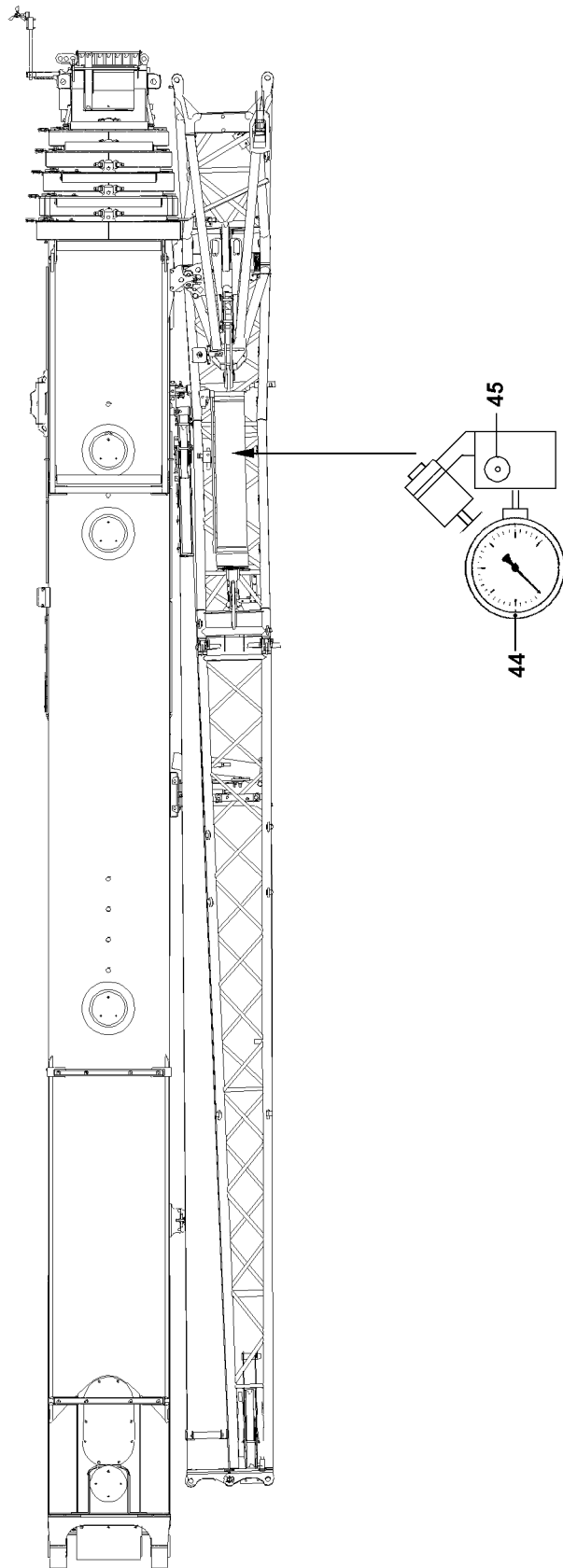


Fig.103452

# 11 Disassembling the folding jib

## 11.1 General



### **DANGER**

Danger of fatal injury due to falling folding jib!

The folding jib could fall down due to a disassembly error.

- ▶ Standing under the folding jib during the swing procedure is prohibited.
- ▶ Standing in the slewing range as well as in the folding range of the folding jib is prohibited.
- ▶ The folding jib must be secured by an auxiliary rope during the swinging process.



### **WARNING**

Danger of falling!

During assembly and disassembly, assembly personnel must be secured with appropriate aids to prevent them from falling! If this is not observed, assembly personnel could fall and suffer fatal injuries!

- ▶ All work at a height, when there is a danger of falling, must be carried out with suitable aids.
- ▶ If fall protection equipment is available, then it must be used, see the Crane operating instructions, chapter 2.06.
- ▶ If aids are not available and work cannot be carried out from the ground, then assembly personnel must secure themselves with the supplied fall arrest system to prevent falling, see the Crane operating instructions, chapter 2.04.
- ▶ The supplied fall arrest system must be fastened to the fastening and hook points. For safety points, see Crane operating instructions, chapter 2.06.
- ▶ Only step on the aids, ladders and catwalks with clean shoes.
- ▶ Keep aids, ladders and catwalks free of heavy dirt, snow and ice.
- ▶ It is prohibited to walk on the telescopic boom.

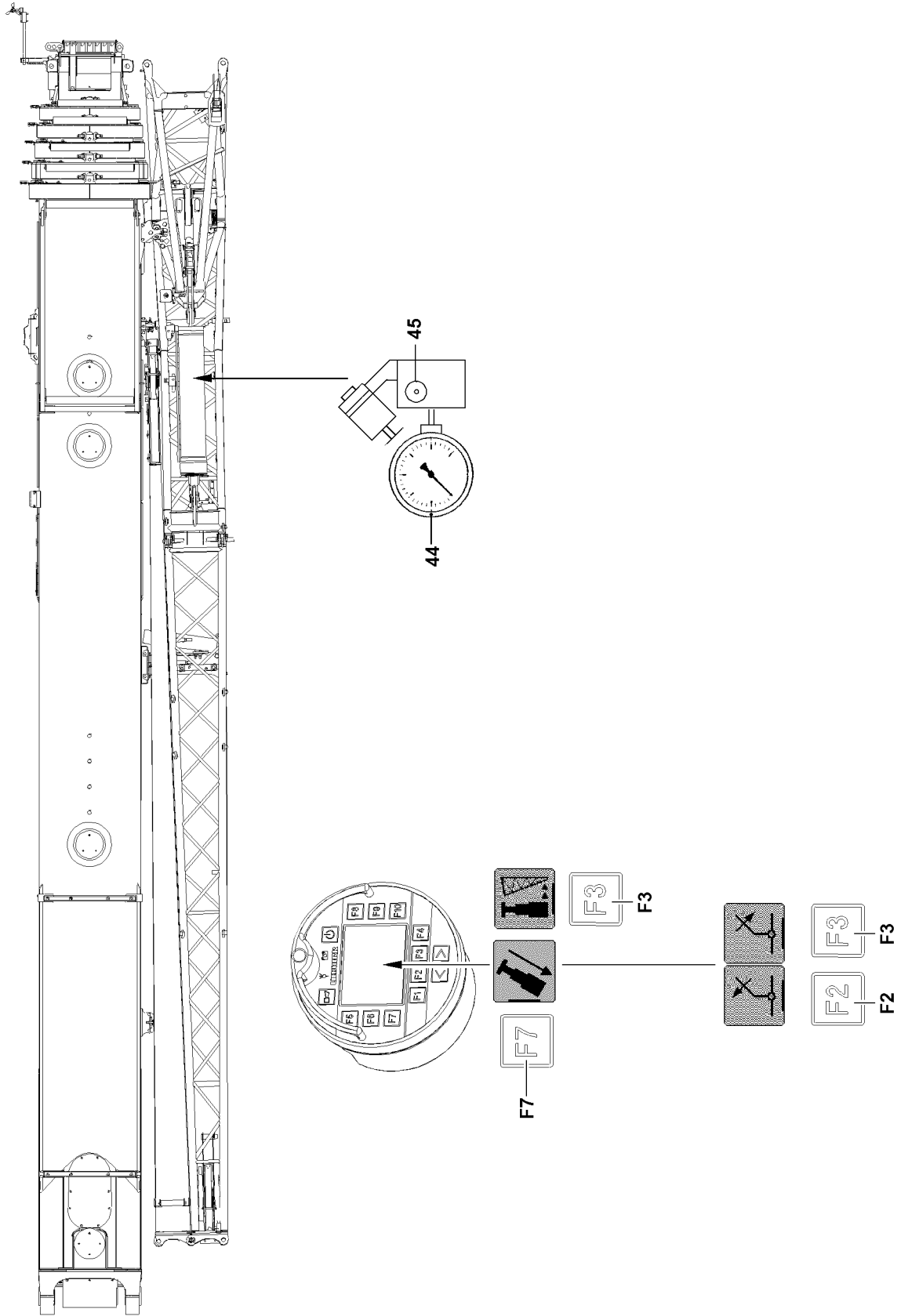


Fig.118028



## 11.2 Preparatory work before swinging in hydraulic folding jibs



### DANGER

Danger of fatal injury if the folding jib inadvertently folds down!

When using hydraulic folding jibs (TNZK operation), prior to swinging in the folding jib, check if a pressure of at least 200 bar is shown on the pressure gauge **44**. If the pressure on the pressure gauge **44** is too low, fatal accidents can occur if the folding jib folds down by itself!

- ▶ It is **expressly prohibited** to swing in the folding jib with less than 200 bar on the pressure gauge **44**.

Prior to swinging in the hydraulic folding jib\*, the folding jib must be completely luffed up and held in the end position for approximately 15 seconds. This causes the hydraulic reservoir to fill.

If the oil pressure on the pressure gauge **44** is below 200 bar

- ▶ Luff the folding jib completely up with the master switch and move it to end position.

**or**

On the Bluetooth Terminal (BTT) call up the „Lift / lower the folding jib“ menu.

- ▶ Press the key **F2** until a pressure of at least 200 bar is shown on the pressure gauge **44**, see the Crane operating instructions, chapter 5.31.

### Result:

- The pressure gauge **44** then must show 200 bar to 250 bar.

## 11.3 Prerequisite for disassembly

Make sure that the following prerequisites are met:

- The crane is properly supported and horizontally aligned.
- The counterweight has been installed on the turntable according to the load chart.
- The telescopic boom is telescoped in all the way.
- The folding jib is in the 0° position.
- The electrical / hydraulic connections on the folding jib have been released.
- The rope guide pulley has been folded from the operating position into the transport position.



### DANGER

Danger of accident if the folding jib swings out by itself when it is unpinned!

If the telescopic boom is not in the 0° position, there is a danger of accidents if the folding jib swings out by itself when it is unpinned.

- ▶ Move the telescopic boom to the 0° position.

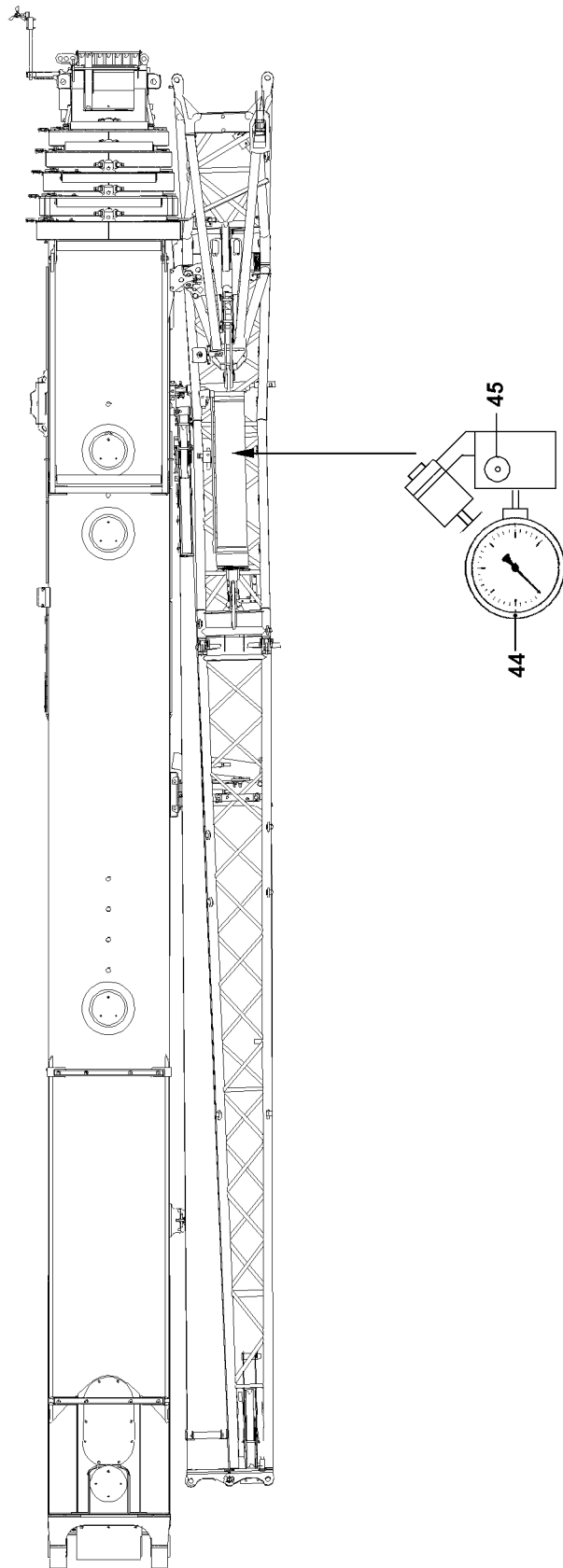


Fig.103452

## 11.4 Prerequisites for operation with crane LTM 1220

Ensure that the following prerequisites are met:

- The telescopic boom has been luffed down to the rear or to the side in the 0° position.



---

### **DANGER**

Danger of accident if the folding jib swings out by itself when it is unpinned!

If the telescopic boom is not in the 0° position, there is a danger of accidents if the folding jib swings out by itself when it is unpinned.

- ▶ Move the telescopic boom to the 0° position.
- 

## 11.5 Prerequisites for operation with crane LTR 1220

Ensure that the following prerequisites are met:

- The telescopic boom is luffed up to the rear or to the side to 1°.



---

### **Note**

- ▶ If the telescopic boom is not luffed up 1°, then the folding jib cannot be installed.
-

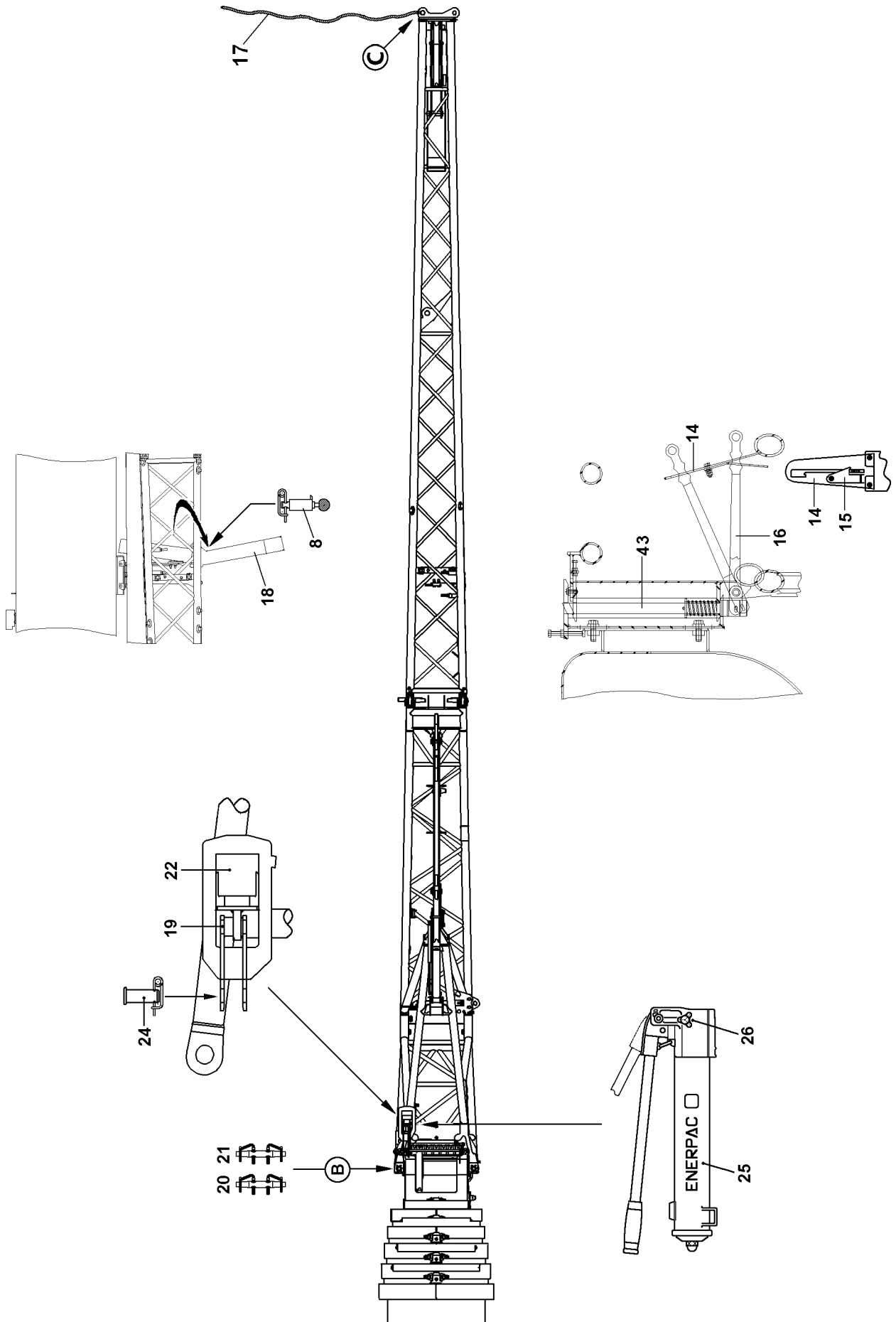


Fig.196445

## 11.6 Disassembling the single folding jib carried on the crane, part 1

- ▶ Disengage the lever **16** with the assembly rod from the link **14** and pull downward.
- ▶ Attach the auxiliary rope **17** in point **C**.

When swinging the folding jib support **18** in and out, ensure that the spring pin **8** is unlocked with one hand and that the folding jib support **18** is moved overhead with the other hand.

- ▶ Release and unpin the spring pin **8**.
- ▶ Swing out the folding jib support **18** until the spring pin **8** engages again.

In order to unpin on the top in point **B**, the hydraulic / mechanical assembly aid **22** must be used.

- ▶ Close the knob **26** on the hand pump **25**.
- ▶ Extend the hydraulic cylinder of the assembly aid **22** by operating the hand pump **25** until the pin **21** can be unpinned.
- ▶ Release and unpin the pin **21** on top.
- ▶ Open the knob **26** on the hand pump **25**.

### Result:

- The hydraulic cylinder of the assembly aid **22** returns to the starting position.
- ▶ Unpin the pins **24** and insert into bore **19** and secure.



### DANGER

The folding jib can swing out inadvertently!

When removing the pin **20**, the folding jib can swing out inadvertently.

In order to prevent the folding jib from swinging out by itself:

- ▶ Hold the folding jib with the auxiliary rope.
  - ▶ Do not lean the ladder against the folding jib.
- 
- ▶ Release the pin **20** on the bottom and unpin.

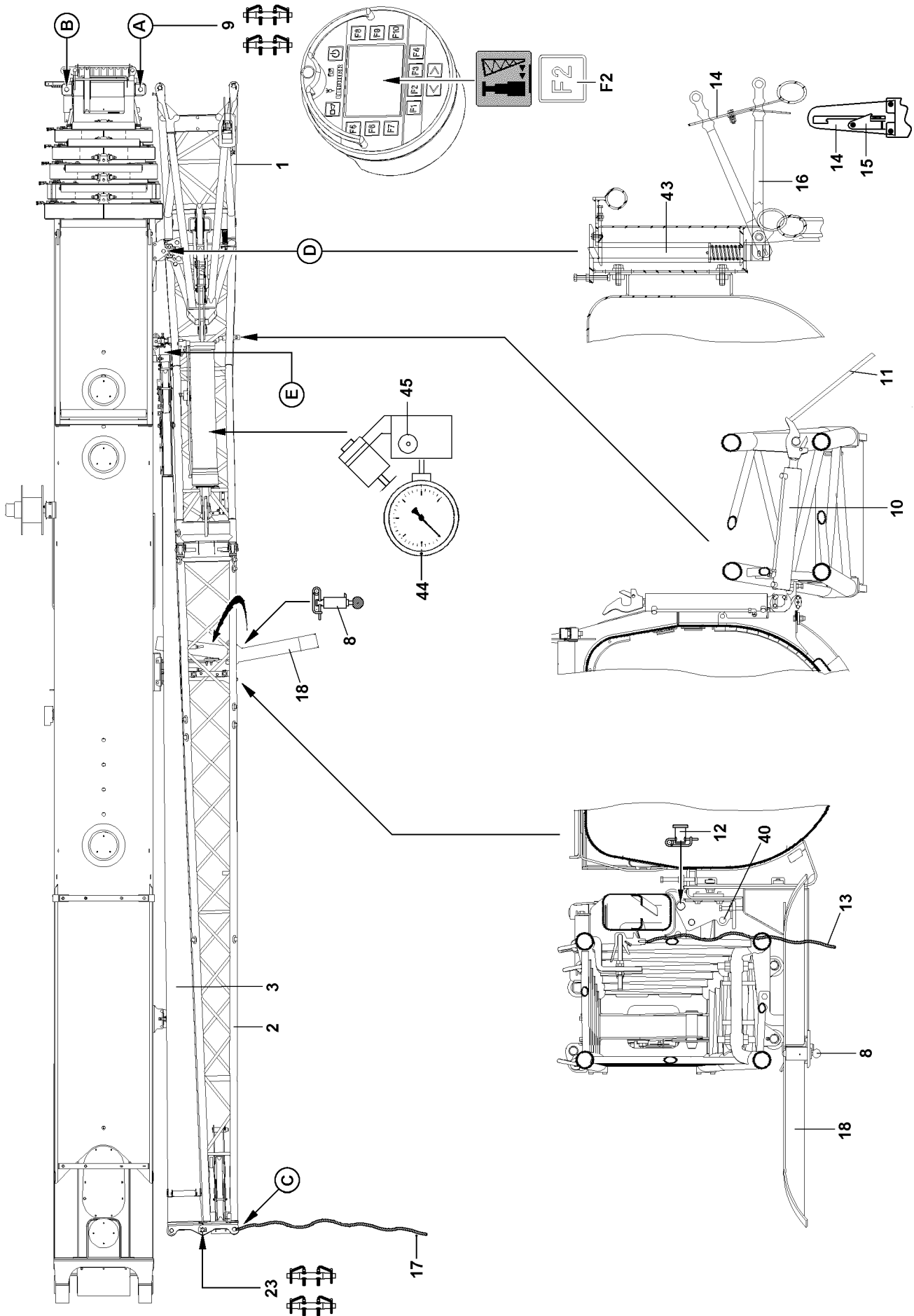


Fig.114340

## 11.7 Disassembling the single folding jib carried on the crane, part 2



### DANGER

Danger of fatal injury due to falling folding jib!

The folding jib could fall down due to a disassembly error.

- ▶ Standing under the folding jib during the swing procedure is prohibited.
- ▶ Standing in the slewing range as well as in the folding range of the folding jib is prohibited.

- ▶ Swing the folding jib back until the swing cylinder **10** is locked with the folding jib.
- ▶ Start the crane engine.
- ▶ Press the function key **F2** on the BTT and swing in the folding jib with the swing cylinder until the lock **43** engages audibly.
- ▶ Check if the lock **43** is engaged properly.



### DANGER

Danger of fatal injury when unpinning the pins **9**!

If the pins **9** are unpinned before the lock **43** has engaged, then the folding jib will fall down and possibly cause fatal injury to the assembly personnel.

- ▶ The pins **9** may not be unpinned until the lock **43** has engaged and the hand lever **16** has been secured with the retaining bracket **15**.
- ▶ Secure the hand lever **16** with the retaining bracket **15**.
- ▶ Release the pin **9** at point **A**, unpin and insert it into the transport retainer.
- ▶ Press the function key **F2** on the BTT and swing the folding jib with swing cylinder in all the way.

### Result:

- When carrying the double folding jib along, the reducer section **2** is locked with the end section **3**.

If a double folding jib is carried along:

- ▶ Insert and secure the pin **23**.

When swinging the folding jib support **18** in and out, ensure that the spring pin **8** is unlocked with one hand and that the folding jib support **18** is moved overhead with the other hand.

- ▶ Unpin the spring pin **8** and swing in the folding jib support **18** until the spring pin **8** engages.
- ▶ Secure the spring pin **8**.

If a hydraulic folding jib is carried along:

- ▶ Connect the hydraulic line to the hydraulic cylinder at the point **E**.
- ▶ Remove the auxiliary rope **17**.

On „Hydraulic folding jibs“, an overflow tank is installed on the hydraulic cylinder. The overflow tank must be emptied when it is full. Even when the folding jib is not carried along on the crane.

For operation with a hydraulic folding jib:

- ▶ Empty the overflow tank on the hydraulic cylinder.

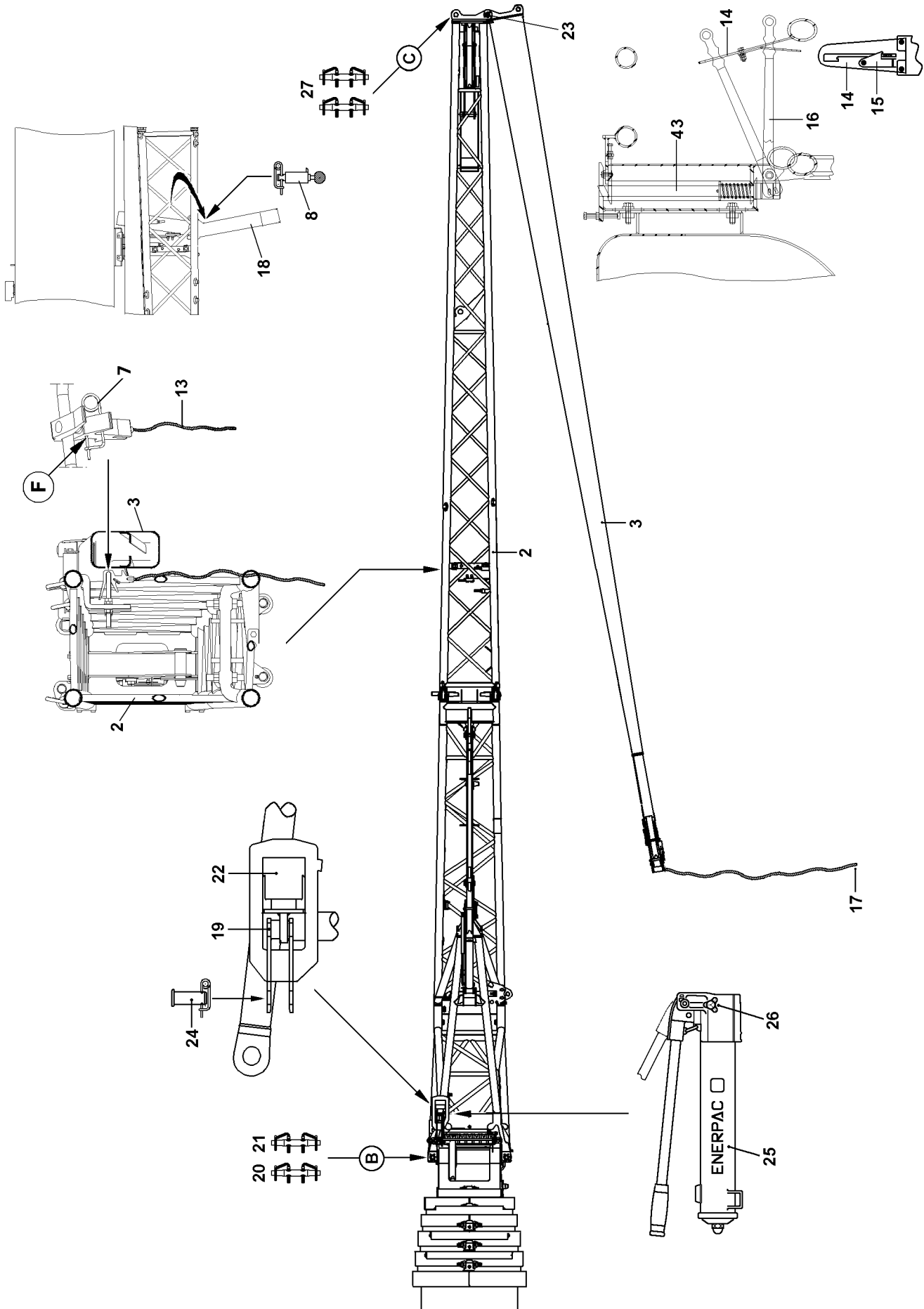


Fig.103449

LWE/LTR 1220-003/24204-02-02/en



## 11.8 Disassembling the double folding jib carried on the crane

### 11.8.1 Disassembling the end section

- ▶ Attach the auxiliary rope **17** to the end section.



#### **DANGER**

The folding jib can swing out inadvertently!  
When removing the pin **27**, the folding jib can swing out inadvertently.

In order to prevent the folding jib from swinging out by itself:

- ▶ Hold the folding jib with the auxiliary rope.
- ▶ Do not lean the ladder against the folding jib.

- ▶ Release and unpin the pin **27**.



#### **DANGER**

Danger of fatal injury due to falling folding jib!  
The folding jib could fall down due to a disassembly error.

- ▶ Standing under the folding jib during the swing procedure is prohibited.
- ▶ Standing in the slewing range as well as in the folding range of the folding jib is prohibited.
- ▶ The pins **23** must remain pinned.

- ▶ Swing in the end section **3** and then lock with the reducer section **2**.



#### **DANGER**

The end section can swing out inadvertently!  
To prevent the lock between the end section **3** and the pivot section **2** from opening inadvertently, the spring retainer **7** must also be inserted on point **F**.

- ▶ Insert the spring retainer **7** on point **F**.
- ▶ Check if the end section **3** and the reducer section **2** are properly locked.
- ▶ Remove the auxiliary rope **17** from the end section **3** and attach on point **C**.
- ▶ Disengage the lever **16** with the assembly rod from the link **14** and pull downward.

When swinging the folding jib support **18** in and out, ensure that the spring pin **8** is unlocked with one hand and that the folding jib support **18** is moved overhead with the other hand.

- ▶ Release and unpin the spring pin **8**.
- ▶ Swing out the extension of the folding jib support **18** until the spring pin **9** engages again.

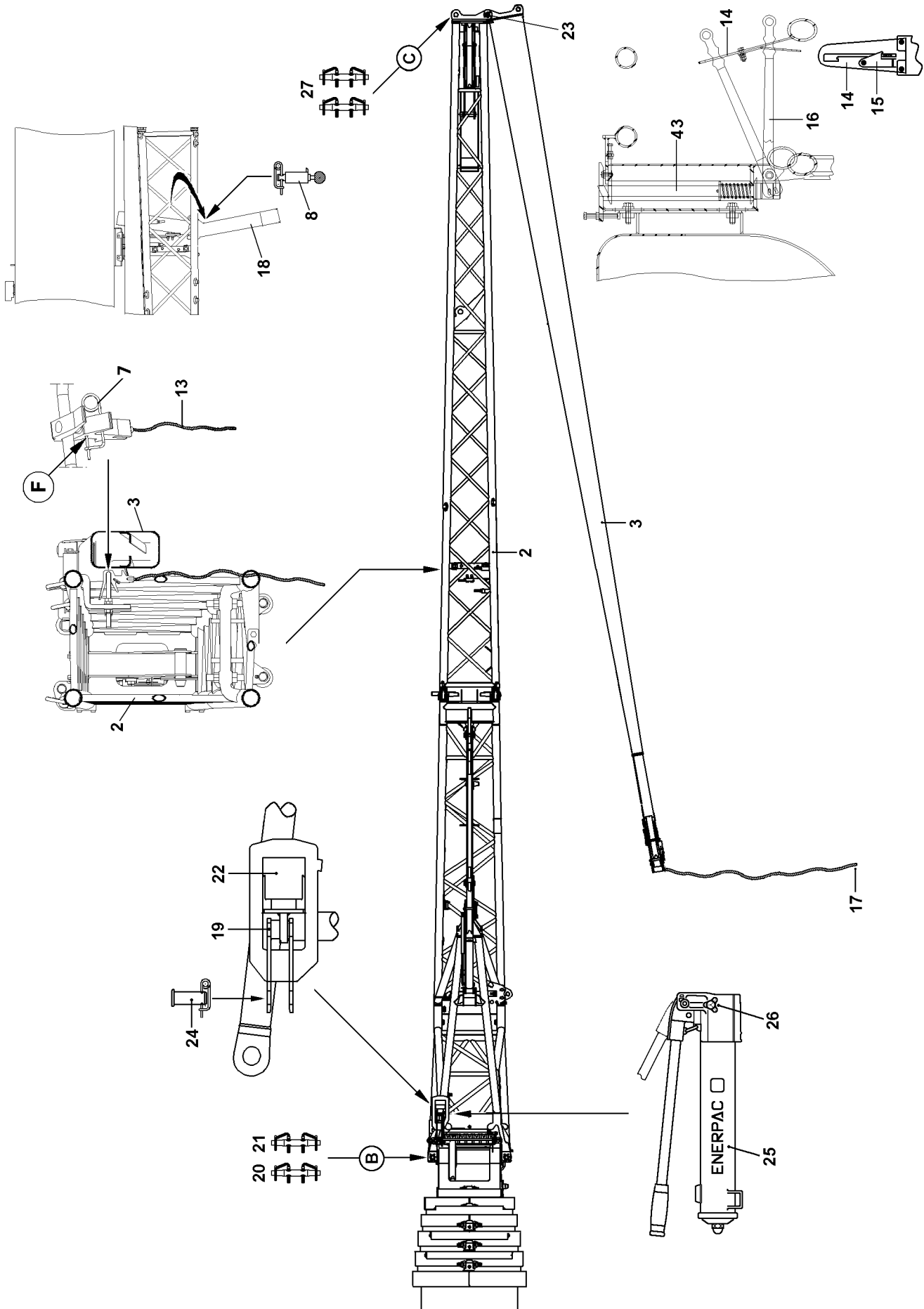


Fig.103449

### 11.8.2 Disassembling the reducer, part 1

In order to unpin on the top in point **B**, the hydraulic / mechanical assembly aid **22** must be used.

- ▶ Close the knob **26** on the hand pump **25**.
- ▶ Extend the hydraulic cylinder of the assembly aid **22** by operating the hand pump **25** until the pin **21** can be unpinned.
- ▶ Release and unpin the pin **21** on top.
- ▶ Open the knob **26** on the hand pump **25**.

**Result:**

- The hydraulic cylinder of the assembly aid **22** returns to the starting position.
- ▶ Unpin the pins **24** and insert into bore **19** and secure.



**CAUTION**

The folding jib can swing out inadvertently!  
When removing the pin **20**, the folding jib can swing out inadvertently.

In order to prevent the folding jib from swinging out by itself:

- ▶ Hold the folding jib with the auxiliary rope.
  - ▶ Do not lean the ladder against the folding jib.
- 
- ▶ Release the pin **20** on the bottom and unpin.

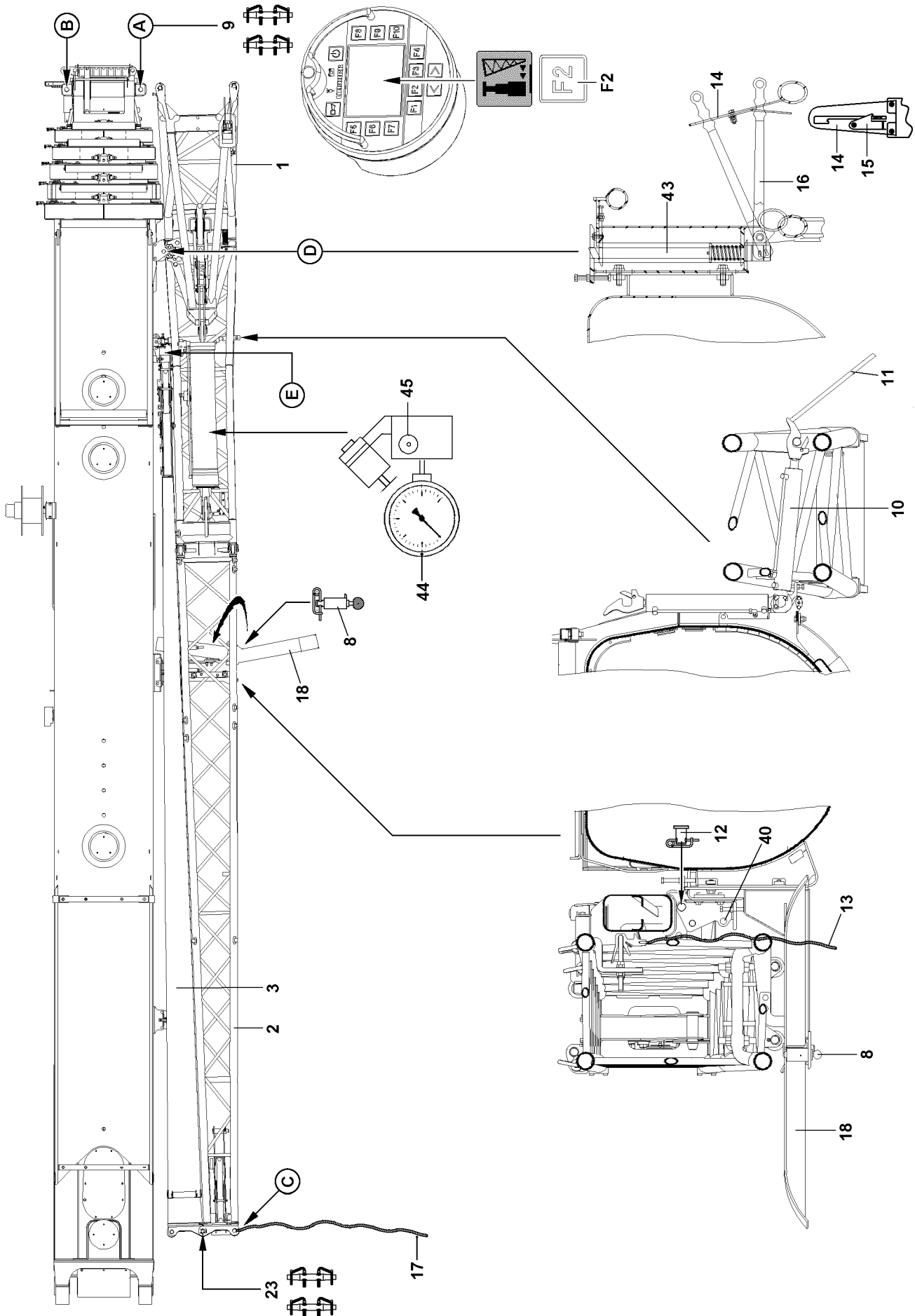


Fig.114340

### 11.8.3 Disassembling the reducer, part 2



#### DANGER

Danger of fatal injury due to falling folding jib!

The folding jib could fall down due to a disassembly error.

- ▶ Standing under the folding jib during the swing procedure is prohibited.
- ▶ Standing in the slewing range as well as in the folding range of the folding jib is prohibited.

- 
- ▶ Swing the folding jib back until the swing cylinder **10** is locked with the folding jib.
  - ▶ Start the crane engine.
  - ▶ Press the function key **F2** on the BTT and swing in the folding jib with the swing cylinder until the lock **43** engages audibly.
  - ▶ Check if the lock **43** is engaged properly.



#### DANGER

Danger of fatal injury when unpinning the pins **9**!

If the pins **9** are unpinned before the lock **43** has engaged, then the folding jib will fall down and possibly cause fatal injury to the assembly personnel.

- ▶ The pins **9** may not be unpinned until the lock **43** has engaged and the hand lever **16** has been secured with the retaining bracket **15**.
- 
- ▶ Secure the hand lever **16** with the retaining bracket **15**.
  - ▶ Release the pin **9** at point **A**, unpin and insert it into the transport retainer.
  - ▶ Press the function key **F2** on the BTT and swing the folding jib with swing cylinder in all the way.
  - ▶ Pin the folding jib with the folding jib retainer: Insert and secure the pin **12**.

Unpin the spring pin **8** and swing in the folding jib support **18** until the spring pin **8** engages.

- ▶ Unpin the spring pin **8** and swing in the folding jib support **18** until the spring pin **8** engages.
- ▶ Secure the spring pin **8**.

If a hydraulic folding jib is carried along:

- ▶ Connect the hydraulic line to the hydraulic cylinder at the point **E**.
- ▶ Remove the auxiliary rope **17**.

On „Hydraulic folding jibs“, an overflow tank is installed on the hydraulic cylinder. The overflow tank must be emptied when it is full. Even when the folding jib is not carried along on the crane.

For operation with a hydraulic folding jib:

- ▶ Empty the overflow tank on the hydraulic cylinder.

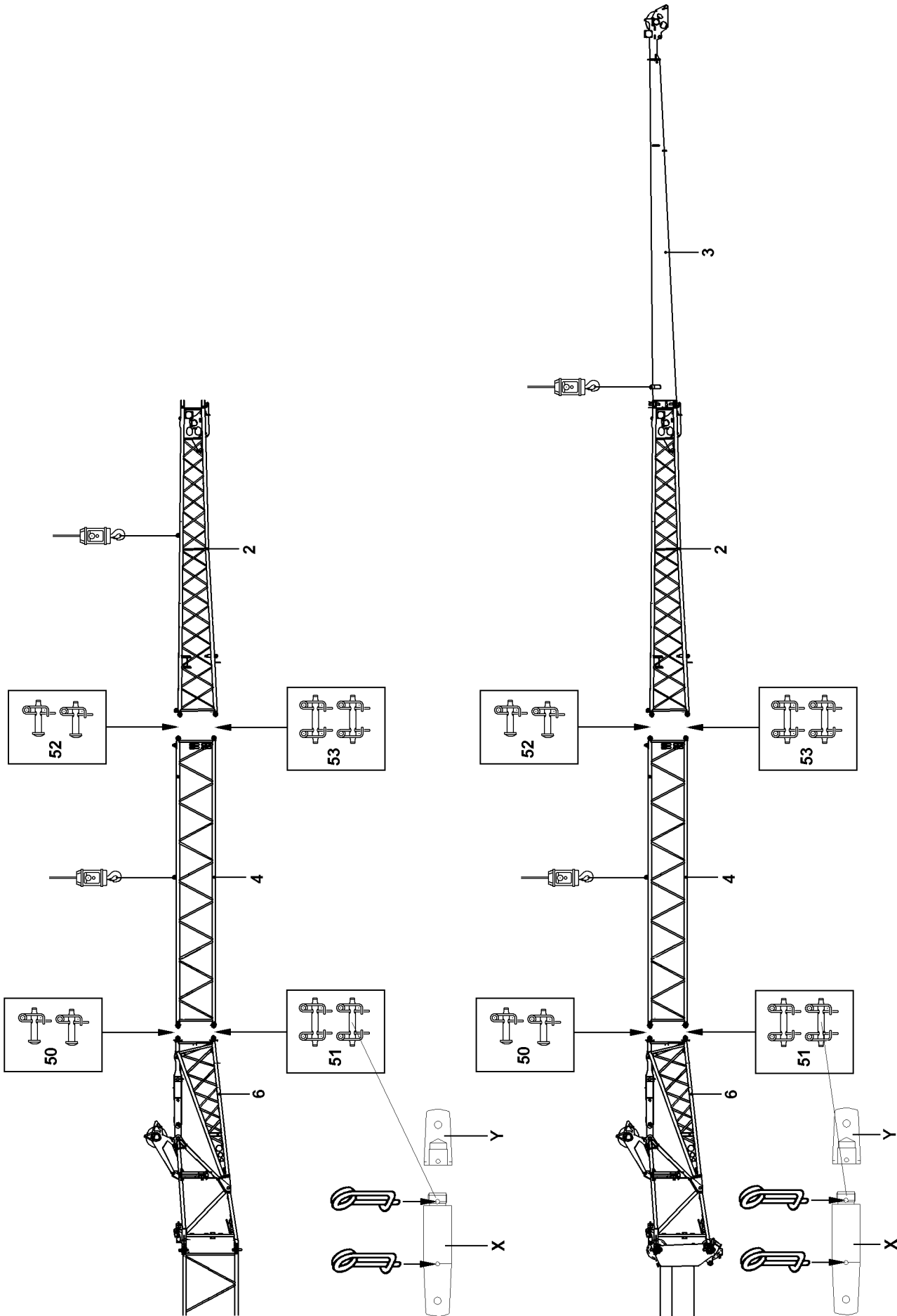


Fig.197289

## 11.9 Disassembling the 3-piece folding jib



### DANGER

Danger of accident when assembling / disassembling the 3-piece folding jib!

If the following conditions are not met, personnel can be fatally injured during assembly / disassembly.

- ▶ When knocking out the pins, no one may remain under the folding jib.
- ▶ Pin and unpin the pins in the specified sequence.
- ▶ Fasten the auxiliary crane in such a way that no angular pull occurs.
- ▶ Do not remove the folding jib until it has been secured with the auxiliary crane to prevent it from falling.
- ▶ Do not lean the ladder against the folding jib.

- 
- ▶ Attach the reducer section **2** to the auxiliary crane and tighten the fastening rope slightly.

**or**

Attach the reducer section **2** with the end section **3** to the auxiliary crane and tighten the fastening rope slightly.



### DANGER

Danger of accident due to distorted pins!

Angular pull or excessive / low hoisting force of the auxiliary crane may result in distortion of the pins. Distorted parts can suddenly fly off when the pins are unpinned.

- ▶ When the pins are unpinned, the „lifting force“ of the auxiliary crane must be adapted to the „weight“ of the parts being lifted.
- ▶ Do **not** unpin difficult to remove pins by force.
- ▶ Remedy the cause of the tension.

- 
- ▶ Release and unpin the pins **52** on both sides.
  - ▶ Take the pins **52** down into the transport retainer.
  - ▶ Release the pins **53** on both sides and unpin from the outside to the inside.
  - ▶ Take the pins **53** down into the transport retainer.
  - ▶ Take the reducer **2** down.

**or**

Take the reducer **2** down with the end section **3**.

- ▶ Attach folding jib extension **4** to the auxiliary crane and tighten the cables lightly.
- ▶ Release and unpin the pins **50** on both sides.
- ▶ Take the pins **50** down into the transport retainer.



### Note

- ▶ Before unpinning and pinning the pins **X**, screw on or unscrew the extension **Y** accordingly. Then secure the pins **X** on both sides with spring retainers. Before starting to travel, the extension **Y** must be removed again, and the pins **X** must be secured on both sides with the spring retainers.

- 
- ▶ Release the pins **51** on both sides and unpin from the outside to the inside.

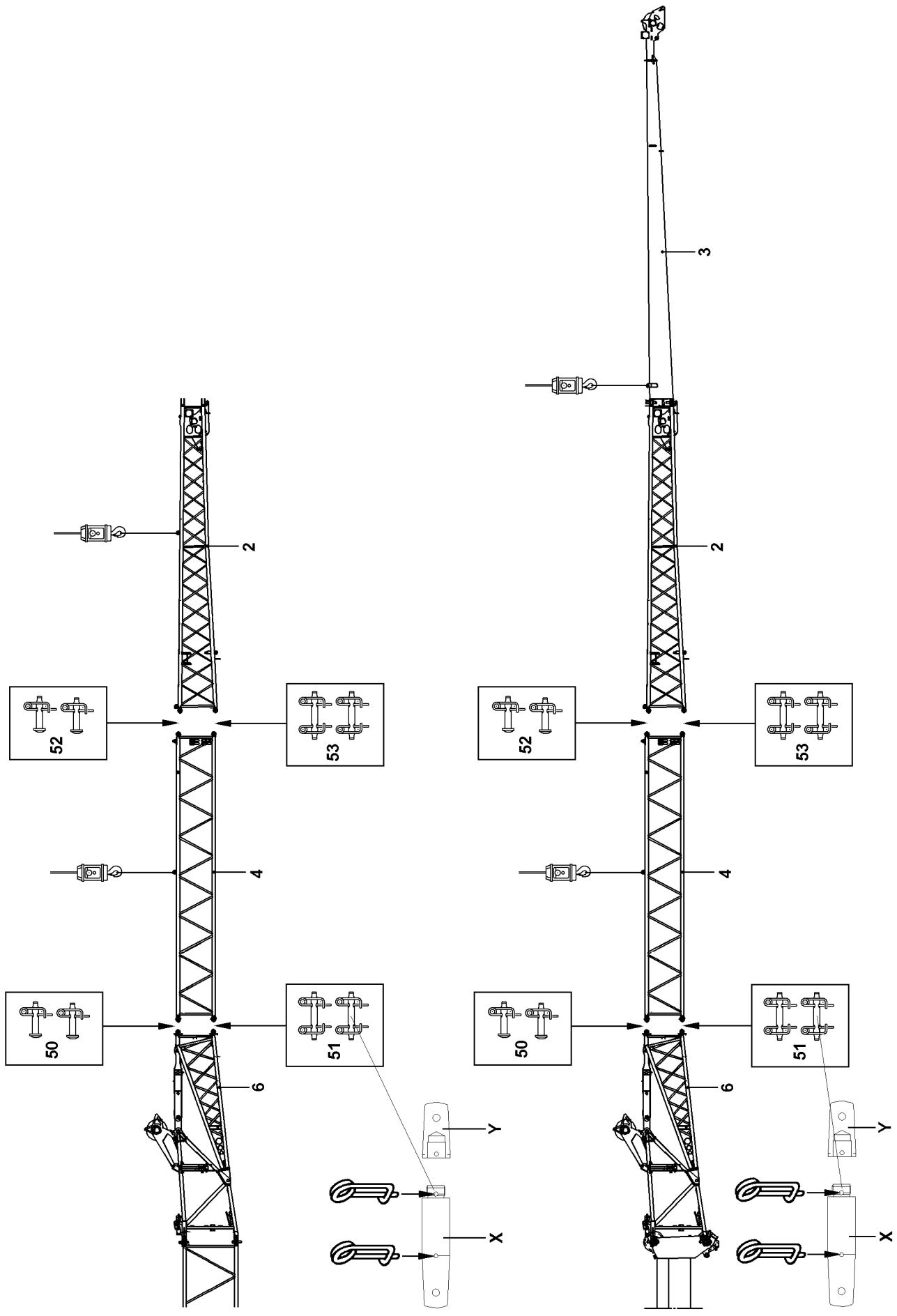


Fig.197289



- ▶ Take the pins **51** down into the transport retainer.
  - ▶ Take down the folding jib extension **4**.
  - ▶ Hang the reducer section **2** on the auxiliary crane and guide into the fork heads on the pivot section **6**.
- or**
- Hang the reducer section **2** with the end section **3** on the auxiliary crane and guide into the fork heads on the pivot section **6**.
- ▶ Pin the reducer **2** to the pivot section **6**: Pin the pins **50** on both sides from the outside to the inside and secure.
  - ▶ Pin the pins **51** on both sides from the outside to the inside and secure.

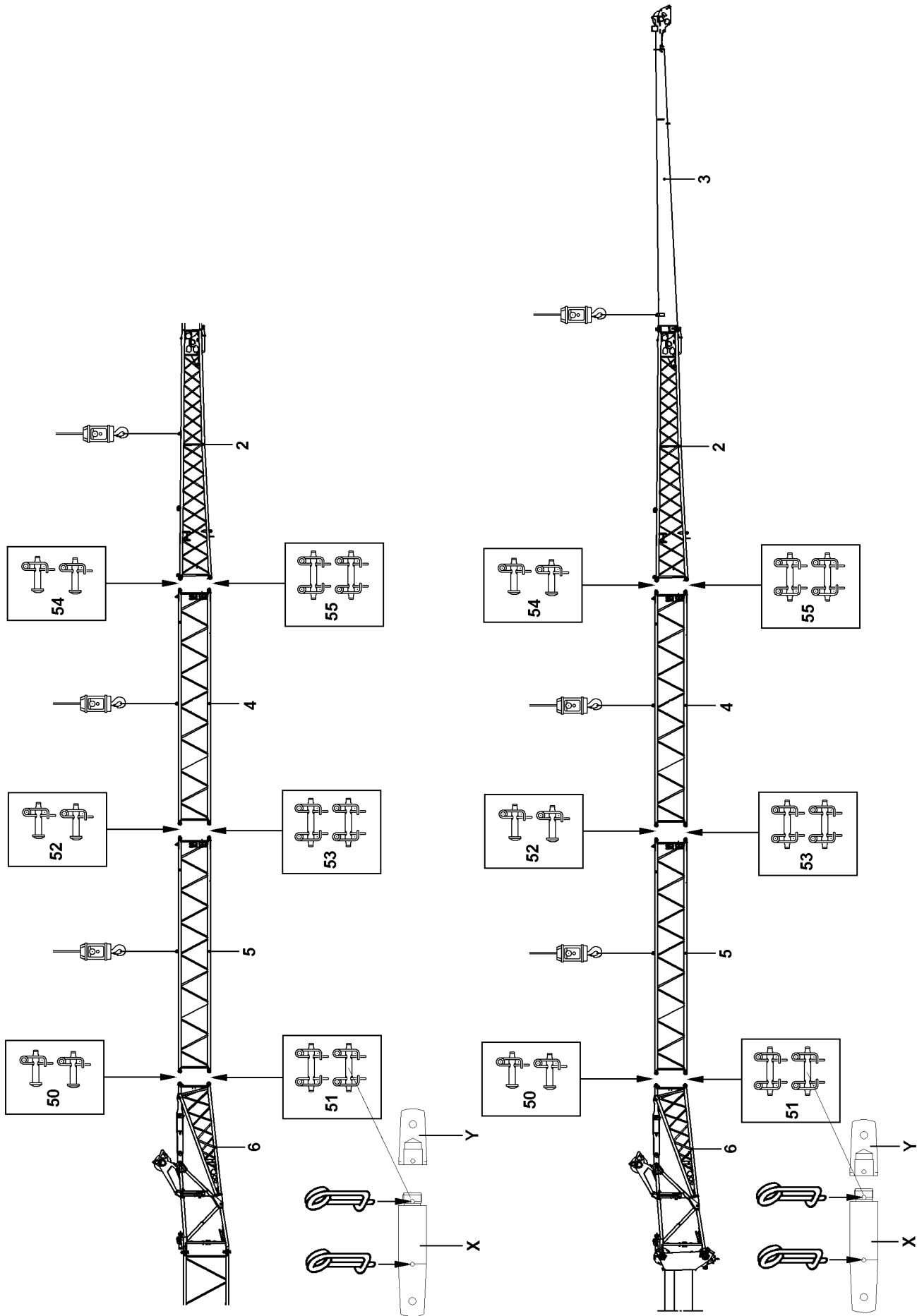


Fig.197290

LWE/LTR 1220-003/24204-02-02/en

## 11.10 Disassembling the 4-piece folding jib



### DANGER

Danger of accident when assembling / disassembling the 4-piece folding jib!

If the following conditions are not met, personnel can be fatally injured during assembly / disassembly.

- ▶ When knocking out the pins, no one may remain under the folding jib.
- ▶ Pin and unpin the pins in the specified sequence.
- ▶ Attach fastening ropes in such a way that no angular pull occurs.
- ▶ Do not remove the folding jib until it has been secured with the auxiliary crane to prevent it from falling.
- ▶ Do not lean the ladder against the folding jib.

- 
- ▶ Attach the reducer section **2** to the auxiliary crane and tighten the fastening rope slightly.

**or**

Attach the reducer section **2** with the end section **3** to the auxiliary crane and tighten the fastening rope slightly.



### DANGER

Danger of accident due to distorted pins!

Angular pull or excessive / low hoisting force of the auxiliary crane may result in distortion of the pins. Distorted parts can suddenly fly off when the pins are unpinned.

- ▶ When the pins are unpinned, the „lifting force“ of the auxiliary crane must be adapted to the „weight“ of the parts being lifted.
- ▶ Do **not** unpin difficult to remove pins by force.
- ▶ Remedy the cause of the tension.

- 
- ▶ Release and unpin the pins **54** on both sides.
  - ▶ Release the pins **55** on both sides and unpin from the outside to the inside.
  - ▶ Take the pins **54** down and the pins **55** in the transport retainer.
  - ▶ Take the reducer **2** down.

**or**

Take the reducer **2** down with the end section **3**.

- ▶ Attach the folding jib extension **4** to the auxiliary crane and tighten the fastening rope lightly.
- ▶ Release and unpin the pins **52** on both sides.
- ▶ Release the pins **53** on both sides and unpin from the outside to the inside.
- ▶ Take down the folding jib extension **4**.
- ▶ Take the pins **52** down and the pins **53** in the transport retainer.
- ▶ Attach the folding jib extension **5** to the auxiliary crane and tighten the fastening rope lightly.

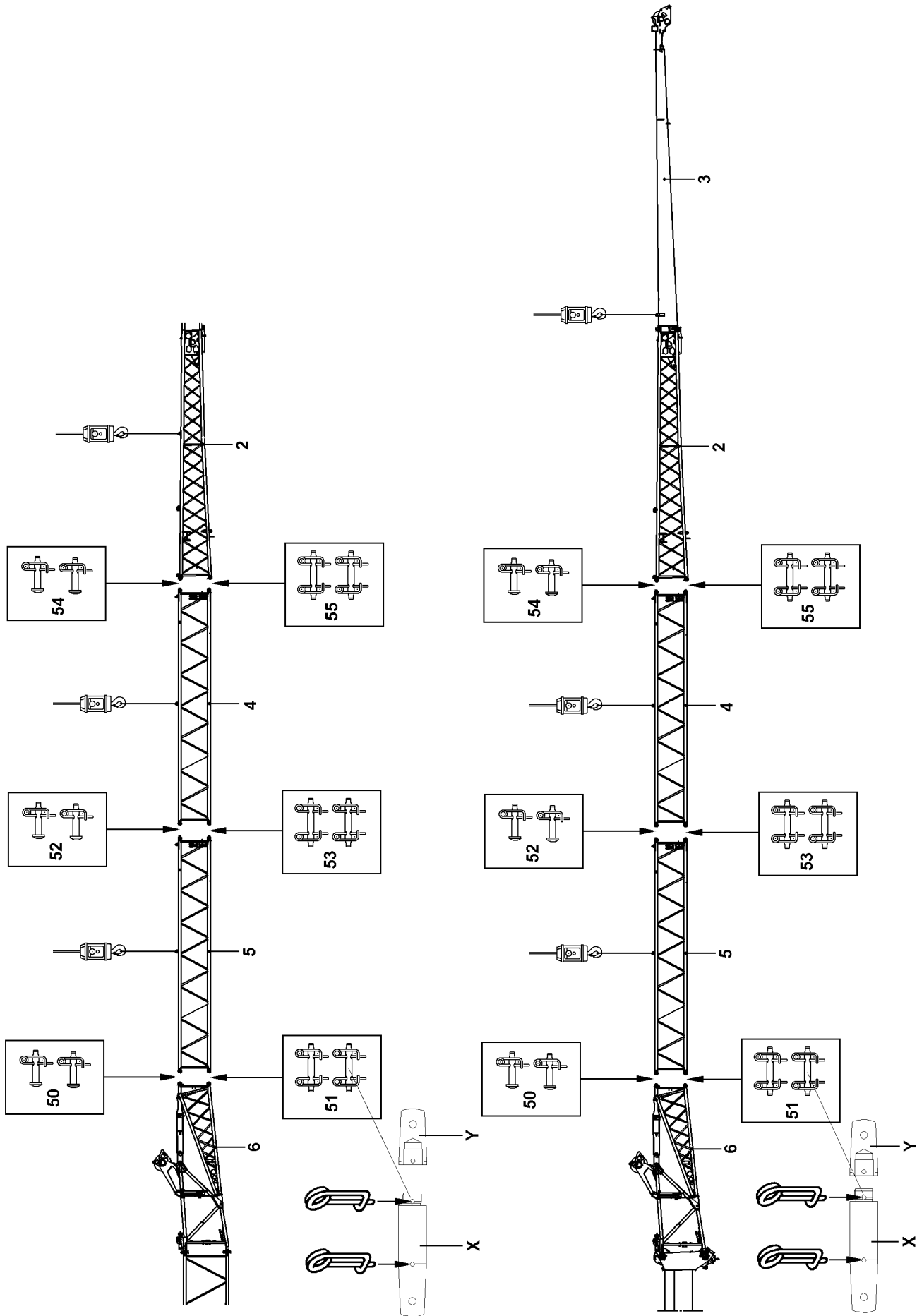


Fig.197290

LWE/LTR 1220-003/24204-02-02/en

- ▶ Release and unpin the pins **50** on both sides.



---

**Note**

- ▶ Before unpinning and pinning the pins **X**, screw on or unscrew the extension **Y** accordingly. Then secure the pins **X** on both sides with spring retainers. Before starting to travel, the extension **Y** must be removed again, and the pins **X** must be secured on both sides with the spring retainers.
- 
- ▶ Release the pins **51** on both sides and unpin from the outside to the inside.
  - ▶ Take down the folding jib extension **5**.
  - ▶ Hang the reducer section **2** on the auxiliary crane and guide into the fork heads on the pivot section **6**.
- or**
- Hang the reducer section **2** with the end section **3** on the auxiliary crane and guide into the fork heads on the pivot section **6**.
- ▶ Pin the reducer **2** to the pivot section **6**: Pin the pins **50** on both sides from the outside to the inside and secure.
  - ▶ Pin the pins **51** on both sides from the outside to the inside and secure.

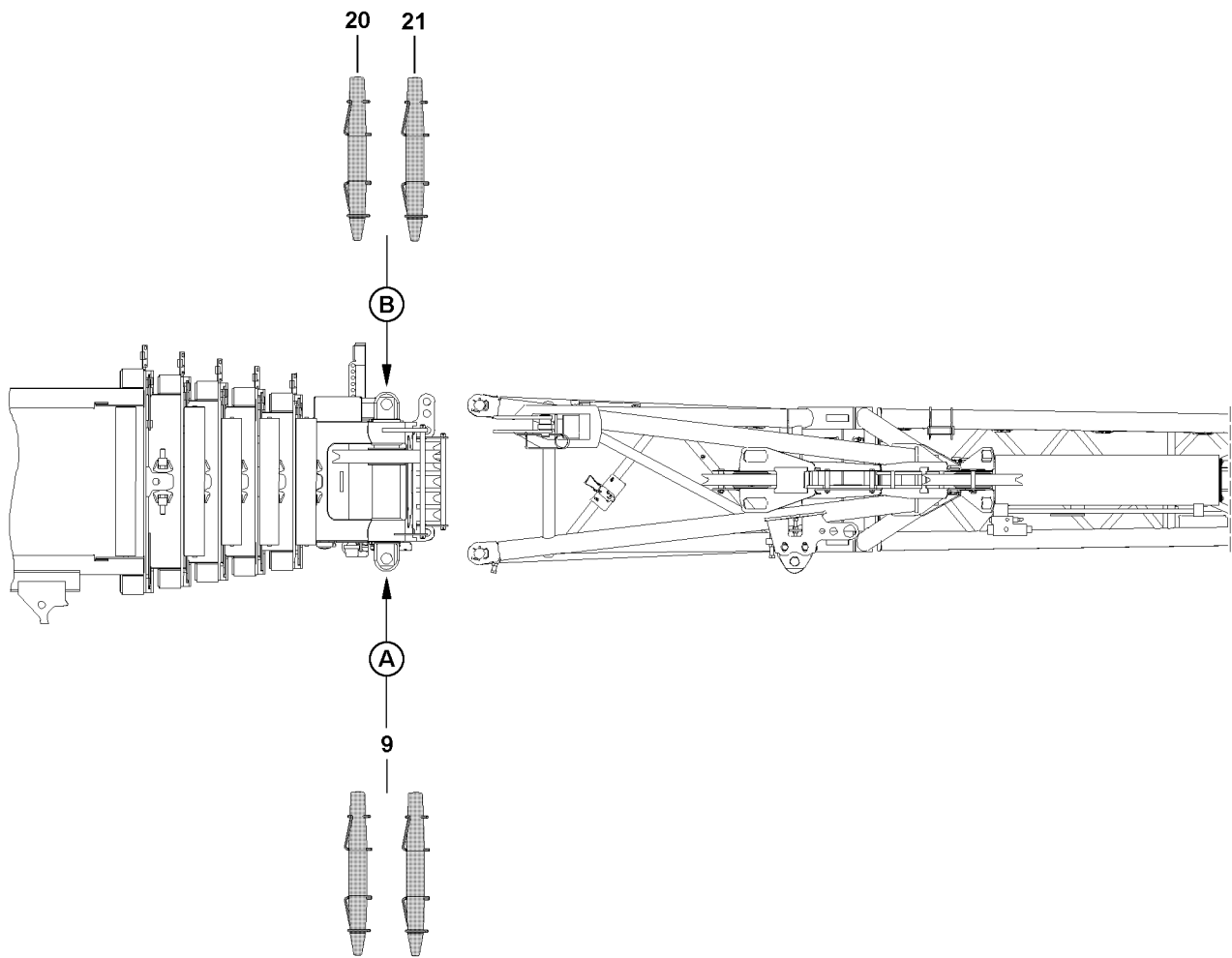


Fig.103446

## 11.11 Disassembling the separately transported folding jib

Make sure that the following prerequisite is met:

- The end section is locked with the reducer.  
See section „Disassembling the end section“.

For description of the respective fastening points, see section „Folding jib fastening points, complete“.



### DANGER

Danger of accident due to incorrect fastening!

Life-threatening situations can arise if the folding jib is improperly or incorrectly fastened!

- ▶ The folding jib is to be fastened according to the fastening points shown on the signs.
- ▶ The appropriate fastening eyes / fastening points are marked with tags.
- ▶ Attaching the single folding jib or the double folding jib on non-intended points or on any arbitrary location is **prohibited**.
- ▶ When attaching the double folding jib, the end section must be folded in, locked and secured.



### CAUTION

Damage to the fastening points!

If the fastening equipment is too short, then the fastening points on the folding jibs can be damaged!

- ▶ To attach the folding jibs, fastening equipment with a strand length of at least 2000 mm each must be used.
- ▶ Fasten the auxiliary crane to the respective fastening points of the folding jib.



### DANGER

Danger of accident when disassembling the folding jib!

If the following conditions are not met, then the assembly personnel can be fatally injured during disassembly.

- ▶ When knocking out the pins, no one may remain under the folding jib.
- ▶ Fasten the auxiliary crane so that no angular pull occurs.
- ▶ Only lift a weight with the auxiliary crane that corresponds to the weight of the folding jib that is being removed.
- ▶ The folding jib can suddenly release due to tension.
- ▶ Do not remove the folding jib until it has been secured with the auxiliary crane to prevent it from falling.
- ▶ Do not lean the ladder against the folding jib.
- ▶ Tighten the fastening ropes until the folding jib is secured to prevent it from falling.
- ▶ Unpin the folding jib from the telescopic boom:
- ▶ Release the pin **9** on top in point **A** and unpin.
- ▶ Release the pin **20** on top in point **B** and unpin.
- ▶ Release the pin **9** on the bottom in point **A** and unpin.
- ▶ Release the pin **21** on the bottom in point **B** and unpin.
- ▶ Take the folding jib down onto the transport vehicle.

On hydraulic folding jibs, an overflow tank is installed on the hydraulic cylinder. The overflow tank must be emptied when it is full. Even if the folding jib is not transported on the crane.

For operation with a hydraulic folding jib:

- ▶ Empty the overflow tank on the hydraulic cylinder.

---

Empty page!

LWE/LTR 1220-003/24204-02-02/en



## 5.09 Hoist gear 2

1	Component overview	3
2	Fastening points	3
3	Assembling winch 2 without the auxiliary crane	5
4	Assembling winch 2 with the auxiliary crane	11
5	Disassembling winch 2 without the auxiliary crane	13
6	Disassembling winch 2 with the auxiliary crane	19

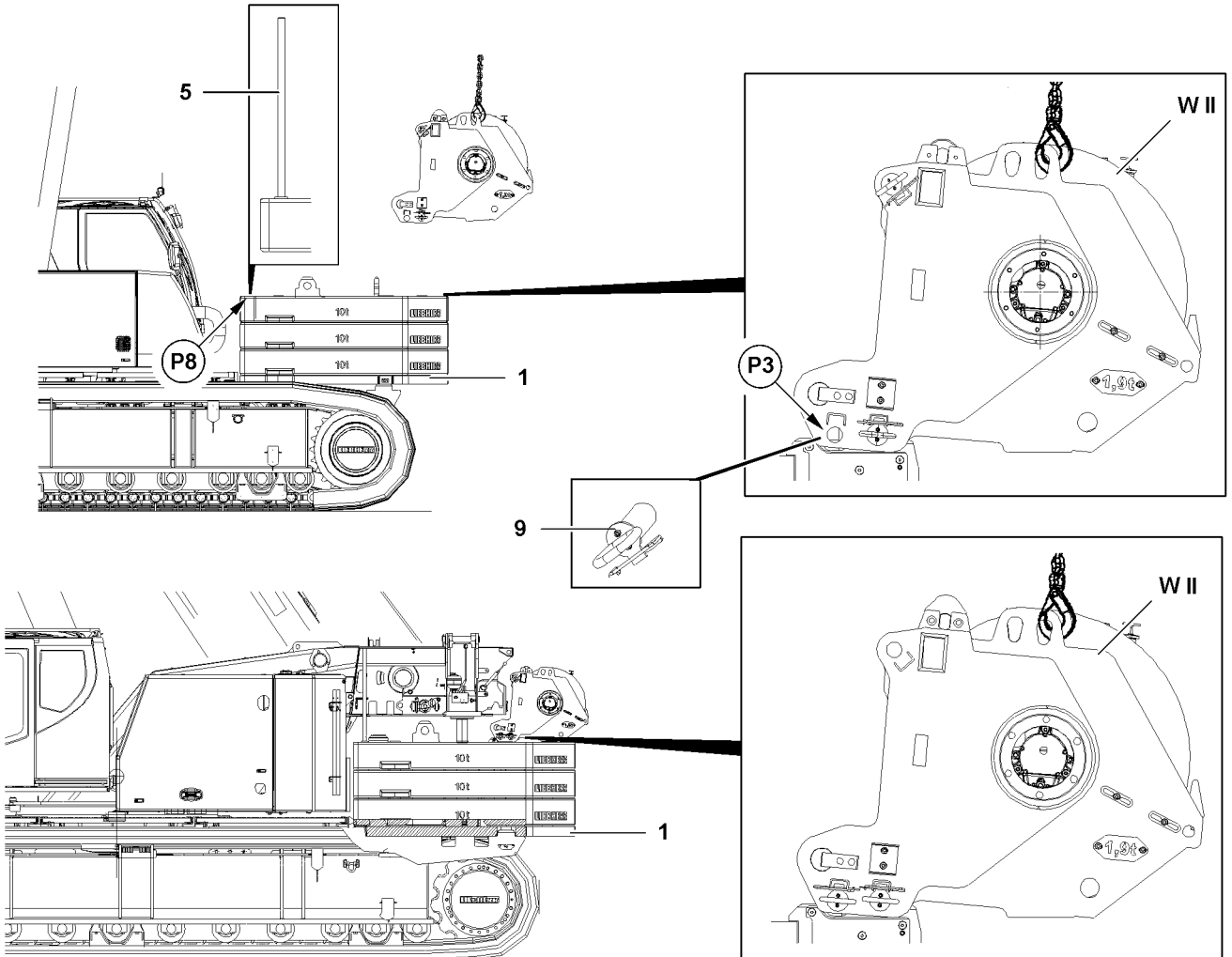
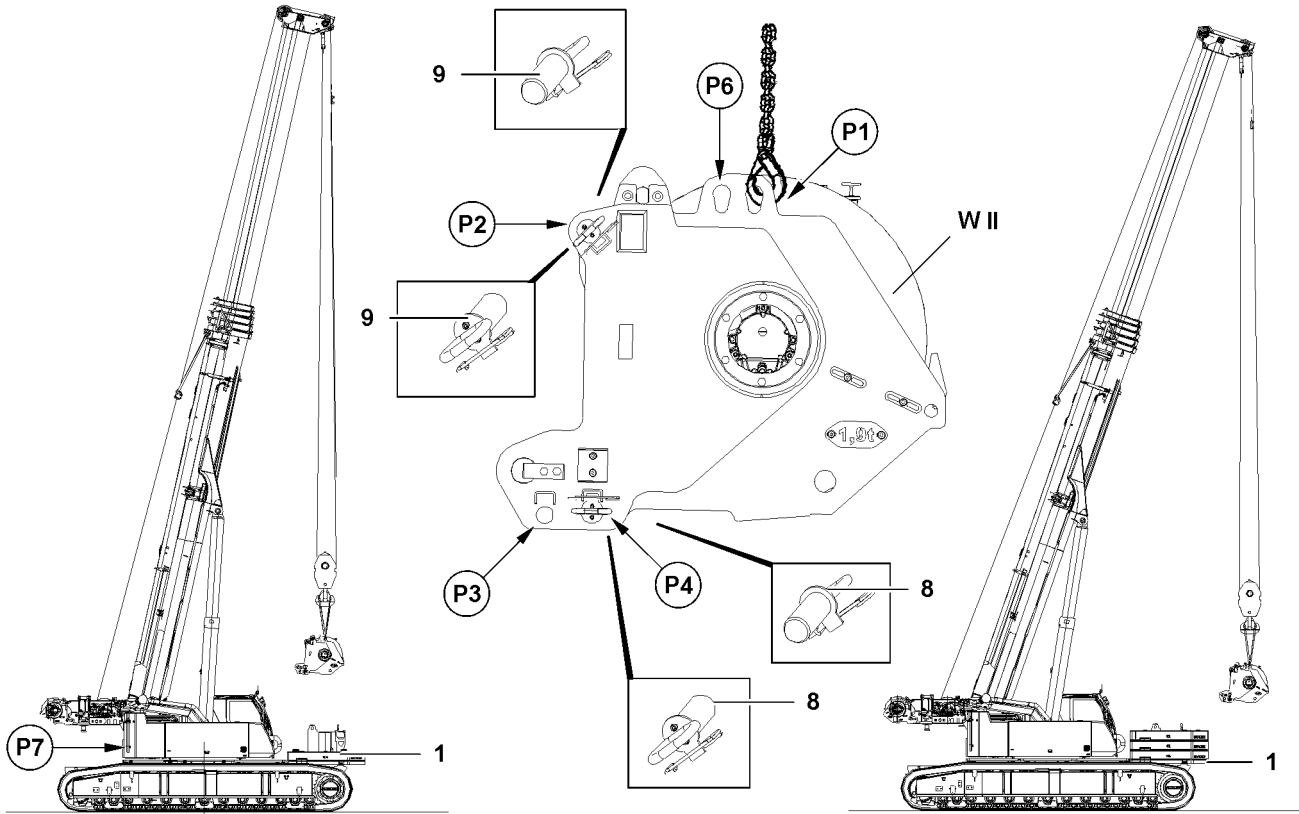


Fig.117356

LWE/LTR 1220-003/24204-02-02/en

# 1 Component overview

Winch 2 dimensions and weights **WII**, see chapter 1.03.

## 2 Fastening points

Fastening points	
<b>P1</b>	Winch 2: Assembly, disassembly without auxiliary crane
<b>P6</b>	Winch 2: Assembly, disassembly with auxiliary crane

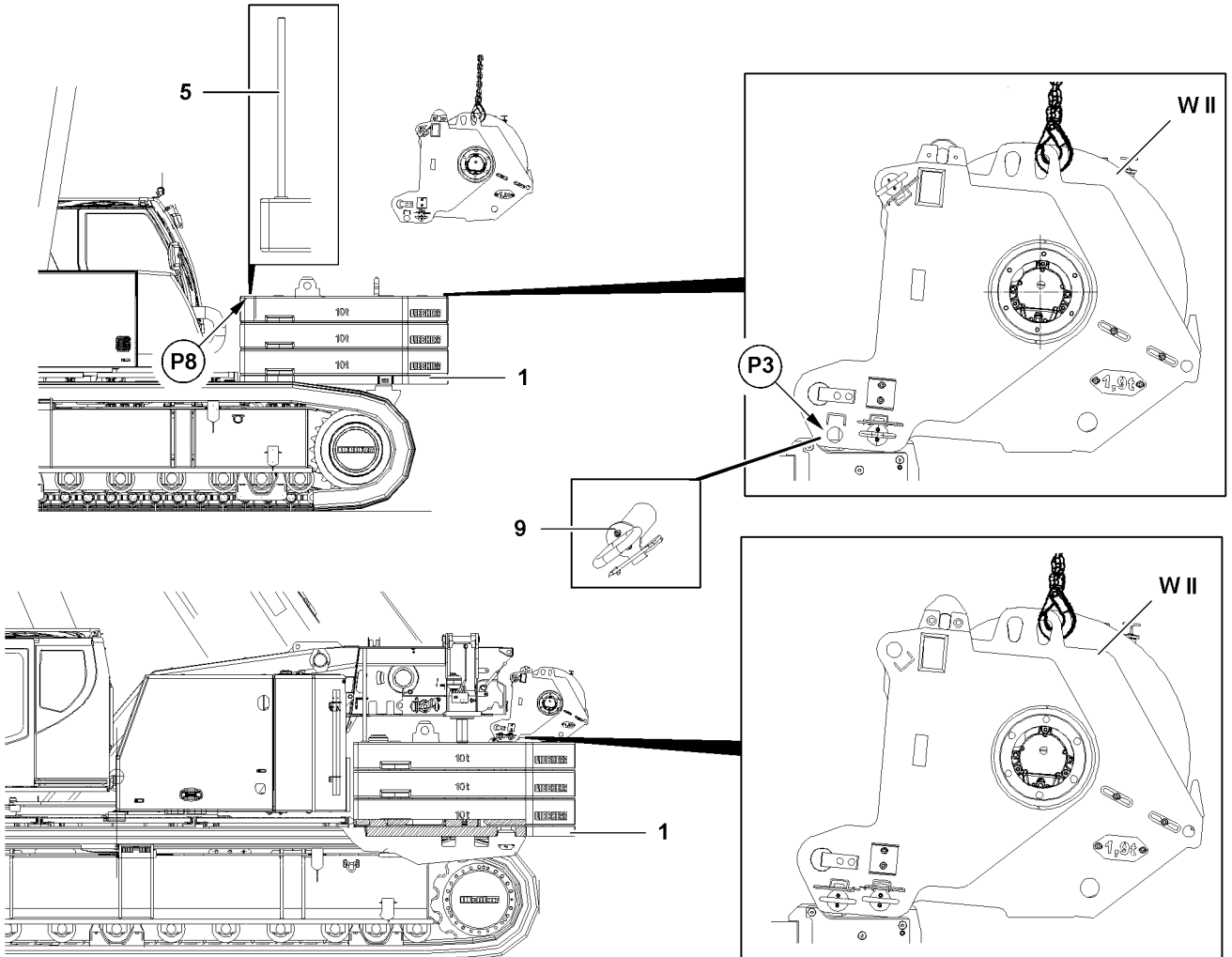
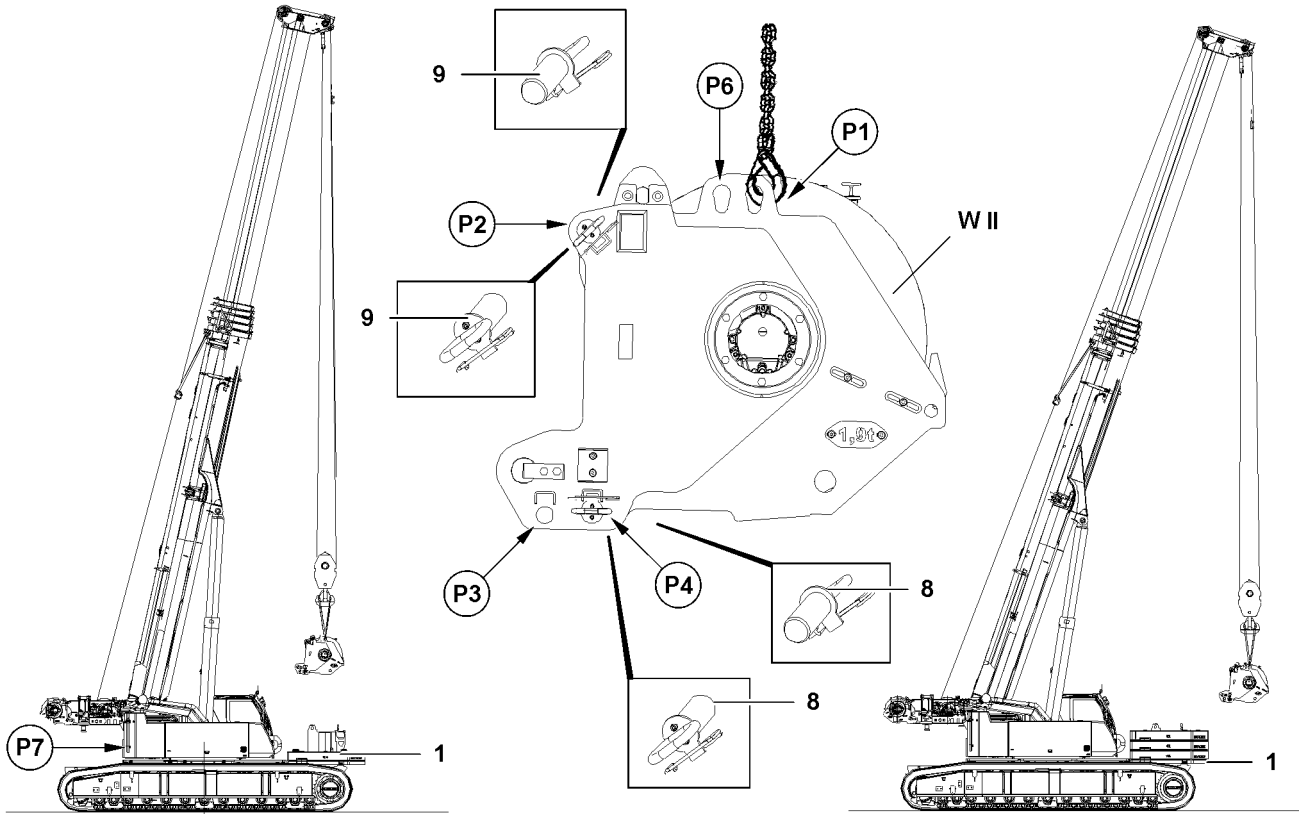


Fig.117356

LWE/LTR 1220-003/24204-02-02/en

## 3 Assembling winch 2 without the auxiliary crane

Take the receptacle plate or the counterweight down on the central ballast block, see chapter 4.07.

Make sure that the following prerequisites are met:

- The pin **8** is pinned and secured on both sides in position **P4**.
- The crane is horizontally aligned.
- The receptacle plate, with or without the permissible counterweight, has been taken down on the „rear“ central ballast block.
- The counterweight is not ballasted.
- The LICCON overload protection is set:
  - Crawler operation with track width
  - Central ballast 2 0 t
  - Counterweight 0 t
  - Without auxiliary boom / accessories
  - Slewing range

### 3.1 Assembling winch 2\*

- ▶ Fasten winch 2 **WII** on both sides to the eyehooks **P1** on the crane.
- ▶ Release the pin **9** on both sides in position **P2** and unpin.
- ▶ Set winch 2 **WII** on the receptacle plate **1**.



#### DANGER

Winch 2 can fall down!

When winch 2 **WII** is released from the crane before winch 2 **WII** is pinned with the receptacle plate **1**, then winch 2 **WII** can fall down.

Personnel can be severely injured or killed.

- ▶ Do not disengage the crane until winch 2 **WII** has been pinned with the receptacle plate **1** and secured.
- 
- ▶ Insert the pin **9** on both sides into the receptacle plate **1** in position **P3** and secure.
  - ▶ Detach winch 2 **WII** from the crane.
  - ▶ Swing the crane superstructure, extend the ballast cylinder and swing into the receptacle of the counterweight, see the Crane operating instructions, chapter 4.07.
  - ▶ Take the retaining pipe **5** out of the park position **P7** and pin on both sides in the counterweight plate in position **P8**.

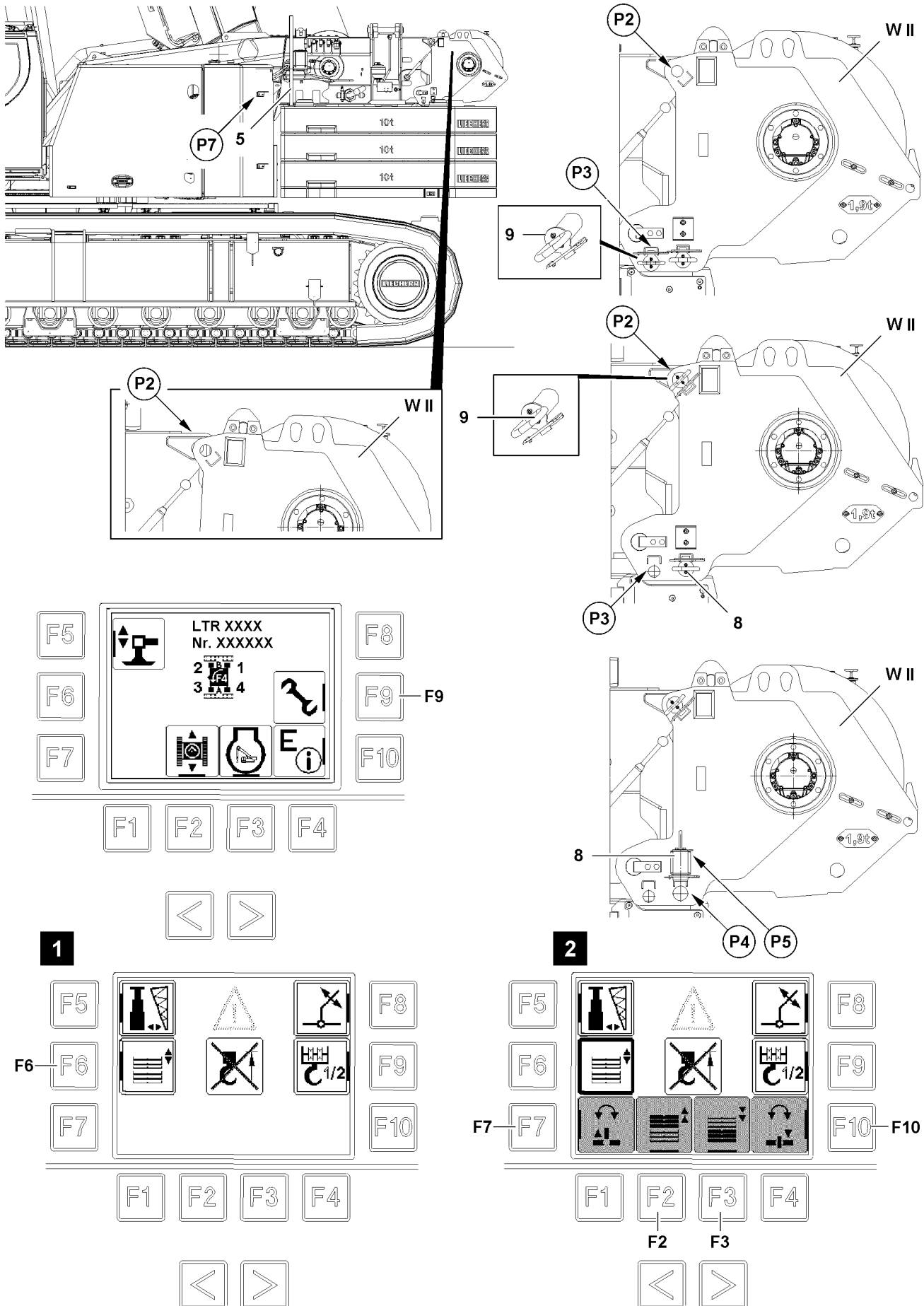


Fig.117357

LWE/LTR 1220-003/24204-02-02/en

- ▶ Press the function key **F9** on the BTT.

**Result:**

- The „Ballast cylinder“ menu appears, see illustration 1.

- ▶ Press the function key **F6** on the BTT.

**Result:**

- The „Ballast cylinder“ menu is active, see illustration 2.

- ▶ Retract the ballast cylinder completely with function key **F2**.

**WARNING**

Winch 2 can fall down!

If the pins **9** are unpinned before the ballast cylinders are fully retracted, then the winch can fall down.

- ▶ Make sure that the ballast cylinders are fully retracted.

When the ballast cylinders are fully retracted:

- ▶ Unpin the pin **9** on both sides in position **P3**.
- ▶ Insert the pin **9** on both sides in the bores in position **P2** and secure with spring retainers.
- ▶ Press the function key **F3**, relieve the ballast cylinder.

**DANGER**

Damage to winch 2!

If the pins **8** are not removed after assembly, then the winch or the ballast cylinders can be damaged.

- ▶ Release and unpin the pin **8**.

- ▶ Release the pin **8** on both sides in position **P4** and unpin.
- ▶ Insert the pin **8** on both sides in park position **P5** and secure.
- ▶ Unpin the retaining pipe **5** and insert it in park position **P7**.
- ▶ Retract the ballast cylinder completely with function key **F2**.

### 3.2 Establishing the electrical connection to winch 2

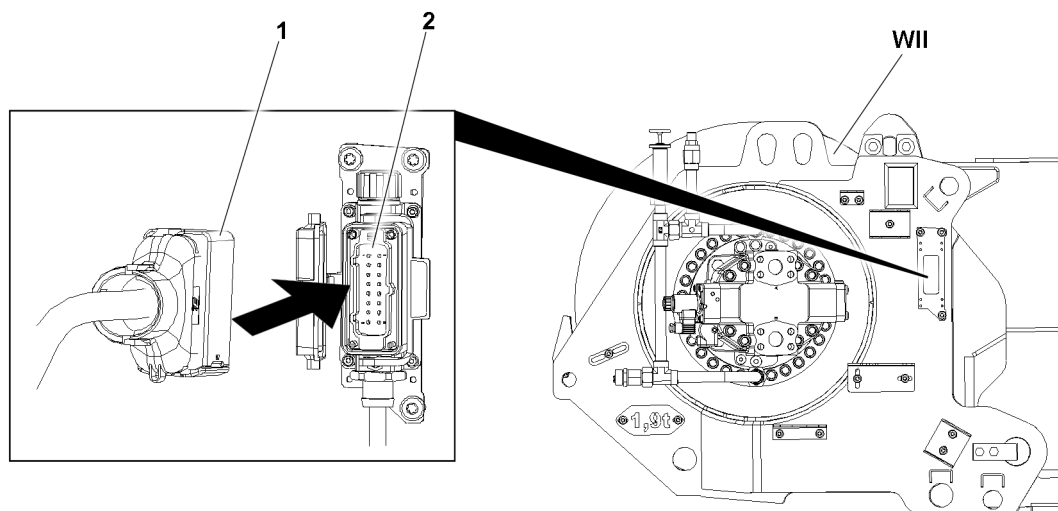


Fig.157763: Establishing the electrical connection

**WARNING**

Weighing error due to ballast monitoring\*

If winch 2 **WII** is assembled on the crane and no electrical connection is established, winch 2 **WII** is not detected by ballast monitoring\*.

- ▶ When winch 2 **WII** is assembled: Insert the plug 1 into the socket 2 of winch 2 **WII**.

If the crane is equipped with ballast monitoring\*, winch 2 **WII** is weighed during assembly of winch 2 **WII** and the simultaneous ballasting of the counterweight.

After establishing the electrical connection for winch 2 **WII**, the previous weighing of the counterweight is deleted by the ballast monitoring\*. An error message is displayed on the LICCON monitor, see chapter 4.07.

- ▶ Insert the plug 1 into the socket 2 of winch 2 **WII**.

**Result:**

- The last calculated weighing result is deleted.
- The error message is displayed on the LICCON monitor.

**WARNING**

The wrong counterweight is set in the LICCON overload protection!

The crane can topple over, death, property damage.

- ▶ Changes to the counterweight without updating the counterweight settings in the set up program are prohibited.
- ▶ Ballast monitoring does not automatically update incorrect counterweight settings in the set up program.
- ▶ Weigh the ballast only after assembling winch 2 and after completely installing the counterweight.
- ▶ Check if the set up configuration that is set matches the installed counterweight.

- ▶ Weigh the ballast, see chapter 4.07.

**Result:**

- The current counterweight is detected and compared with the counterweight settings in the set up program.
- The error message on the LICCON monitor turns off.

### 3.3 Connecting the supply lines

- ▶ Establish the supply line for the central lubrication system.

The engine must be turned off before connecting and disconnecting the hydraulic lines.

The different diameters of the hydraulic lines prevent incorrect coupling.

- ▶ Establish the hydraulic connection for winch 2 **WII**.
- ▶ Unpin the retaining pipe 5 and insert it in park position.



Empty page!

LWE/LTR 1220-003/24204-02-02/en

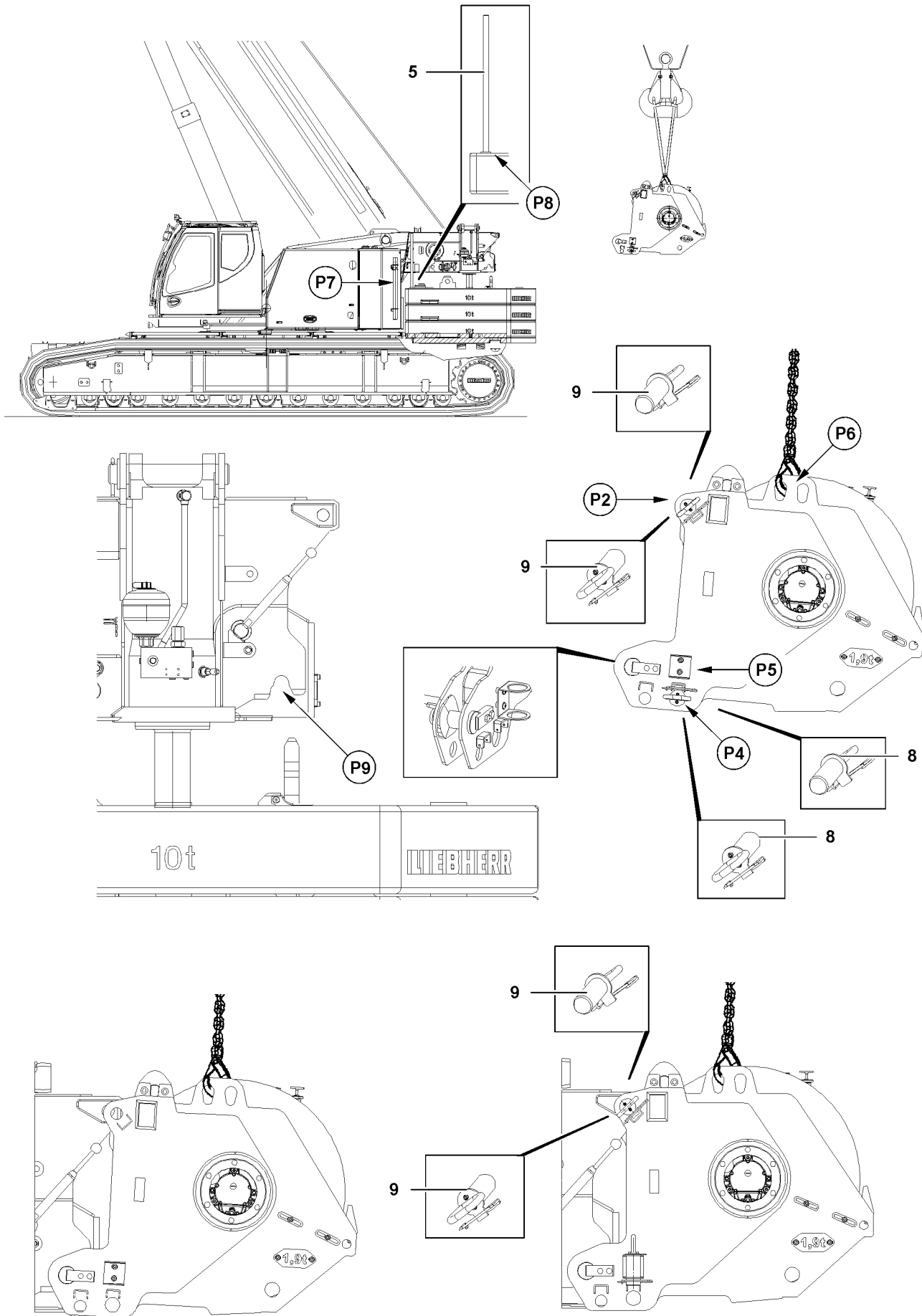


Fig.117360

LWE/LTR 1220-003/24204-02-02/en

## 4 Assembling winch 2 with the auxiliary crane

Take the receptacle plate or the counterweight down on the central ballast block, see chapter 4.07.

Make sure that the following prerequisites are met:

- The crane is horizontally aligned.
- An auxiliary crane is available.
- The pins **8** are unpinned on both sides and pinned in park position **P5** and secured.
- The permissible counterweight has been taken down on the central ballast.

### 4.1 Assembling winch 2\*

- ▶ Fasten winch 2 **WII** on both sides to the eyehooks **P6** on the auxiliary crane.
- ▶ Take the retaining pipe **5** out of the park position and pin on both sides in the counterweight plate in position **P8**.
- ▶ Winch 2 **WII** with auxiliary crane in assembly position.
- ▶ Retract winch 2 **WII** into the receptacle **P9**.
- ▶ Lift winch 2 **WII** until the pin bores of winch 2 **WII** align with the pin bores on the turntable.
- ▶ Pin the turntable with winch 2 **WII**: Insert the pin **9** on both sides in position **P2**.
- ▶ Secure the pin **9** with spring retainers.



#### **DANGER**

Danger of accident if winch 2 falls down!

- ▶ Do not remove the fastening equipment until winch 2 **WII** has been properly pinned and secured in position **P2**!
- ▶ Unhook winch 2 **WII** from the auxiliary crane.

### 4.2 Connecting the supply lines

- ▶ Establish the electrical connection for winch 2 **WII**.
- ▶ Establish the supply line for the central lubrication system.

The engine must be turned off before connecting and disconnecting the hydraulic lines.

The different diameters of the hydraulic lines prevent incorrect coupling.

- ▶ Establish the hydraulic connection for winch 2 **WII**.
- ▶ Unpin the retaining pipe **5** and pin it in the park position **P7**.

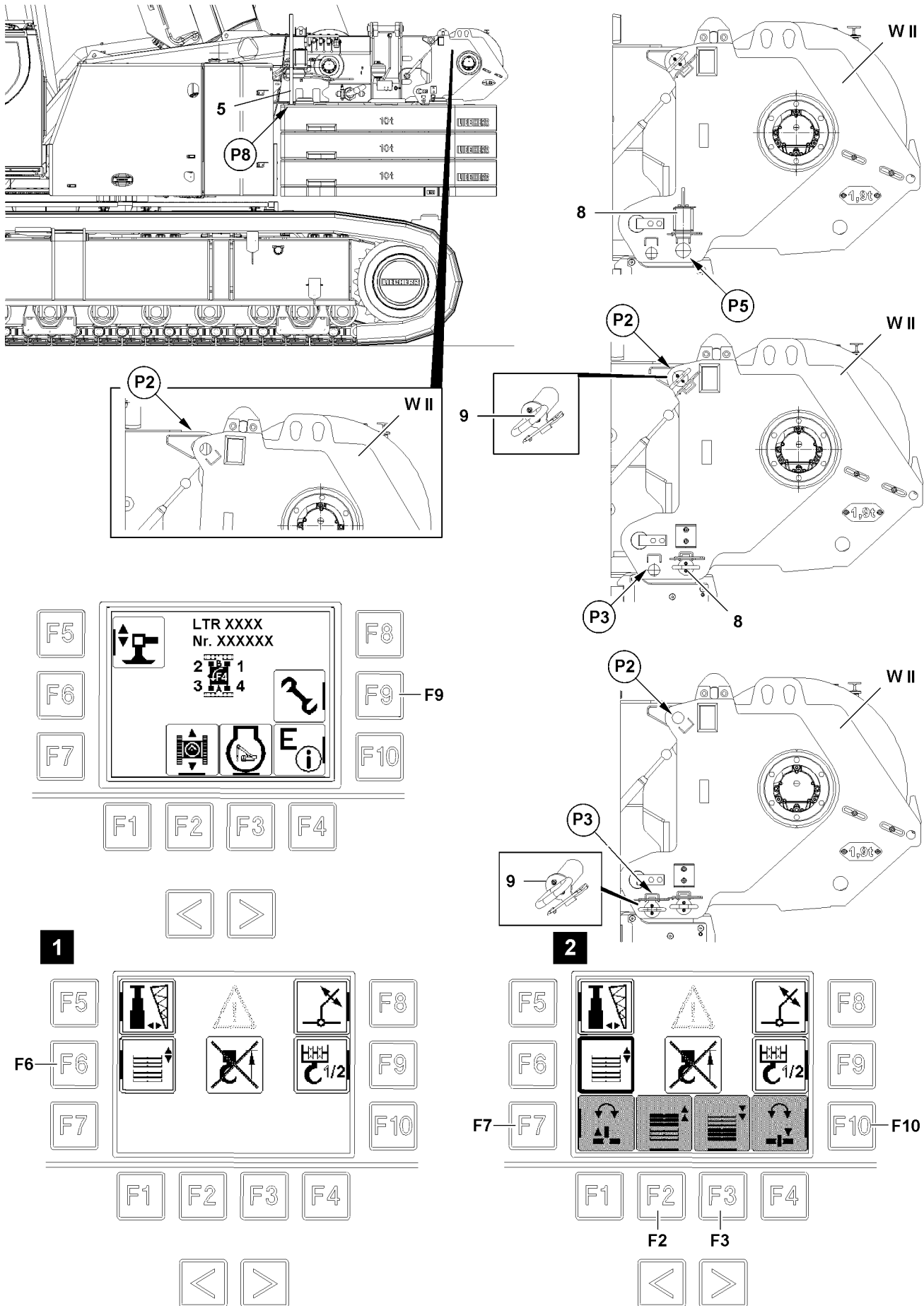


Fig.117358

LWE/LTR 1220-003/24204-02-02/en

## 5 Disassembling winch 2 without the auxiliary crane

Take the receptacle plate or the counterweight down on the central ballast block, see chapter 4.07.

Make sure that the following prerequisites are met:

- The pin **8** is pinned and secured in position **P5**.
- The crane is horizontally aligned.
- The receptacle plate, with or without the permissible counterweight, has been taken down on the „rear“ central ballast block.
- The hoist rope is spooled up and secured.
- The LICCON overload protection is set:
  - Crawler operation with track width
  - Central ballast 2 0 t
  - Counterweight 0 t
  - Without auxiliary boom / accessories
  - Slewing range

### 5.1 Releasing the supply lines

The engine must be turned off before connecting and disconnecting the hydraulic lines.

- ▶ Release the hydraulic connection for winch 2.
- ▶ Release the electrical connection for winch 2.
- ▶ Release the supply line for the central lubrication system.
- ▶ Secure the supply lines in the transport retainers.

### 5.2 Disassembling winch 2

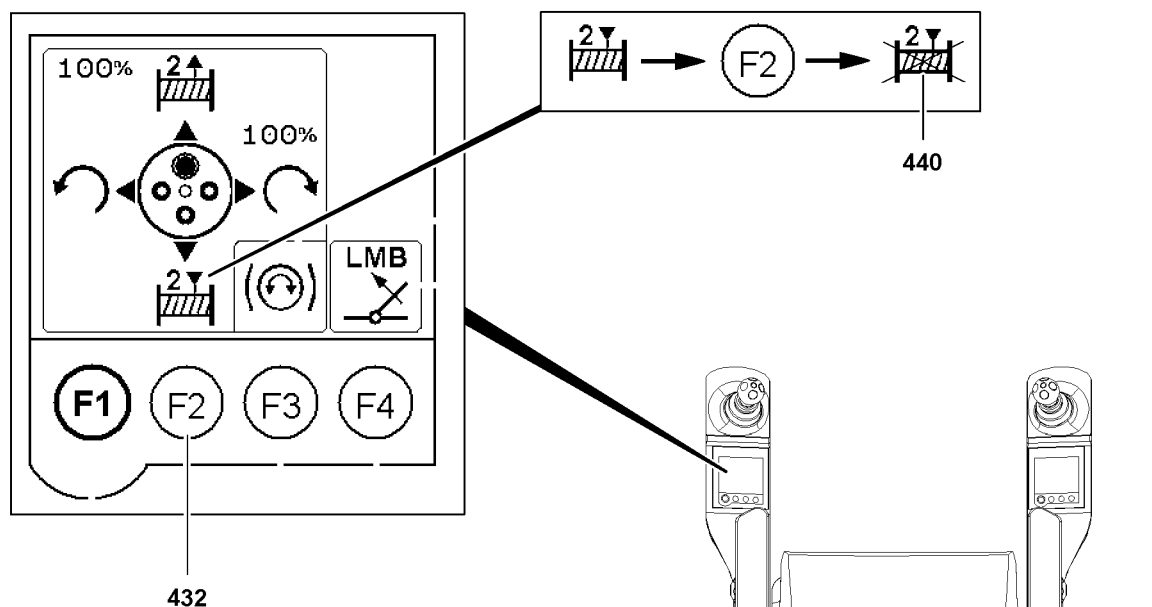


Fig. 118093

- ▶ Block winch 2 **WII** on the left touch display by pressing function key **F2 432**.

**Result:**

- The icon **440** is visible.
- ▶ Swing the crane superstructure, extend the ballast cylinder and swing into the receptacle of the counterweight, see the Crane operating instructions, chapter 4.07.
- ▶ Press the function key **F9** on the BTT.

**Result:**

- The „Ballast cylinder“ menu appears, see illustration 1.
- ▶ Press the function key **F6** on the BTT.

**Result:**

- The „Ballast cylinder“ menu is active, see illustration 2.
- ▶ Retract the ballast cylinder completely with function key **F2**.
- ▶ Take the retaining pipe **5** out of the park position and pin on both sides in the counterweight plate in position **P8**.

**WARNING**

Winch 2 can fall down!

If the pins **9** are unpinned before the ballast cylinders are fully retracted, then the winch can fall down.

- ▶ Make sure that the ballast cylinders are fully retracted.

When the ballast cylinders are fully retracted:

- ▶ Unpin the pin **9** on both sides in position **P2**.
- ▶ Insert the pin **9** on both sides in the bores in position **P3** and secure with spring retainers.
- ▶ Press the function key **F3** on the BTT.

**Result:**

- The ballast cylinders are extended, the counterweight plates are taken down with winch 2 **WII** on the crane chassis.

Empty page!

LWE/LTR 1220-003/24204-02-02/en

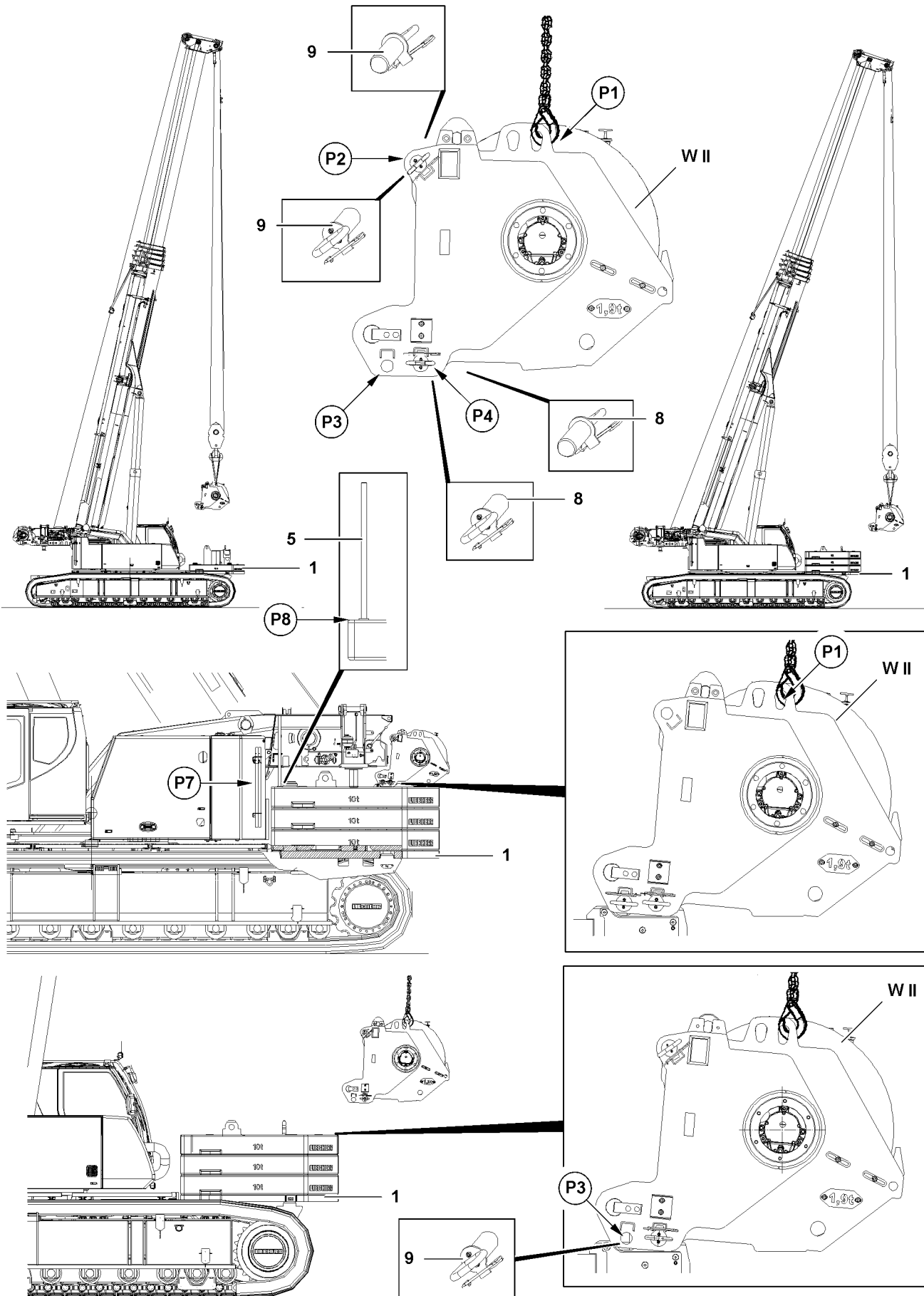


Fig.117359

LWE/LTR 1220-003/24204-02-02/en



**DANGER**

Winch 2 can fall down!

If the pin **9** in position **P3** is unpinned before the winch is fastened and secured on the crane, then winch 2 **WII** can fall down.

Personnel can be severely injured or killed.

- ▶ Fasten winch 2 **WII** to the crane.
- 
- ▶ Fasten winch 2 **WII** to the eyehooks **P1** on the crane.
  - ▶ Release the pin **9** on both sides in position **P3** and unpin.
  - ▶ Insert the pin **9** on both sides in winch 2 **WII** in position **P2** and secure.
  - ▶ Unpin the retaining pipe **5** and insert it in park position **P7**.
  - ▶ Lift winch 2 **WII** from the counterweight and set it on the transport vehicle.

**Note**

- ▶ If winch 2 **WII** has been removed, the master switch assignment must be switched from a „two-winch system“ to a „one-winch system“, see the Crane operating instructions, chapter 4.01.

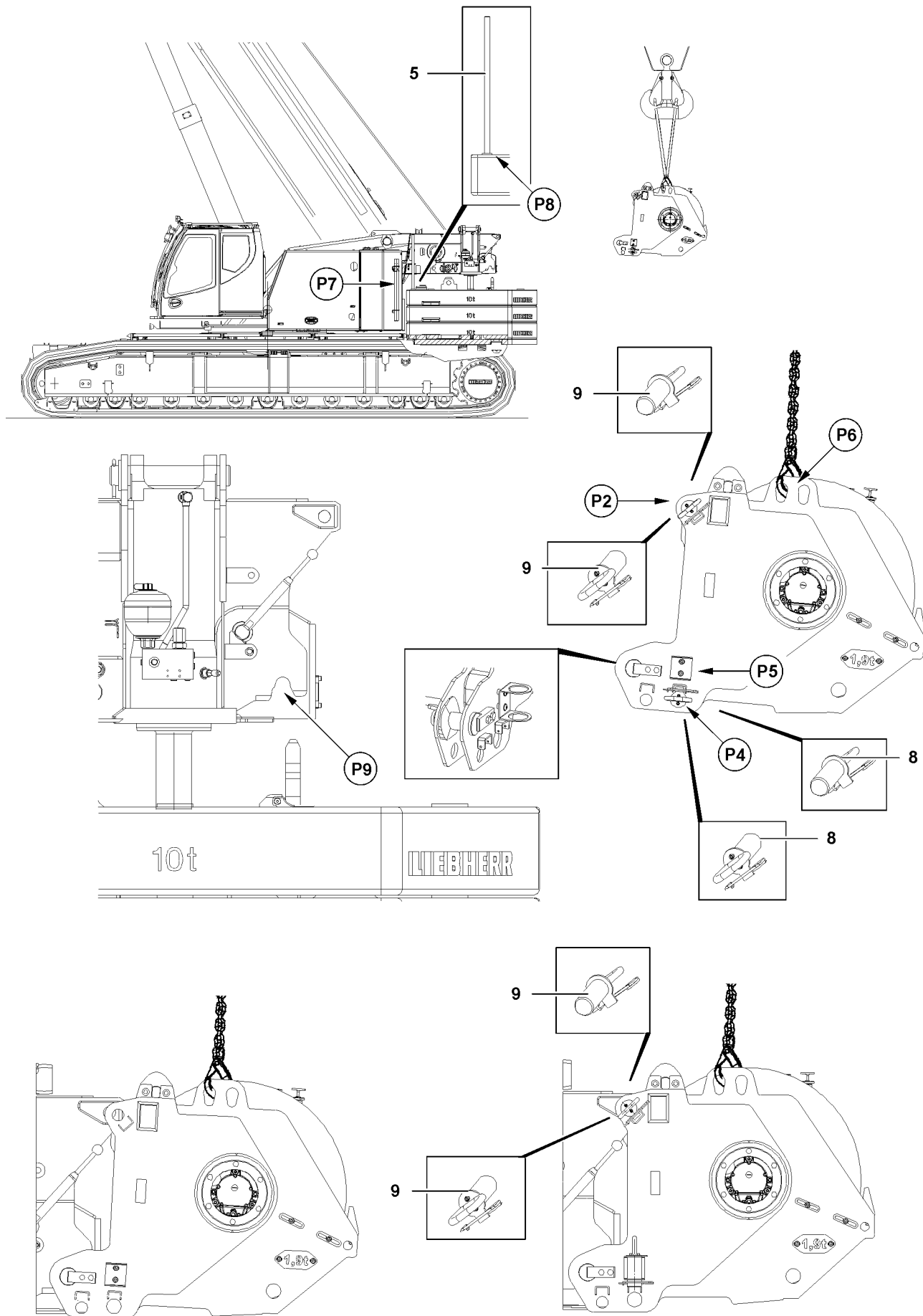


Fig.117360

LWE/LTR 1220-003/24204-02-02/en

## 6 Disassembling winch 2 with the auxiliary crane

Take the receptacle plate or the counterweight down on the central ballast block, see chapter 4.07.

Make sure that the following prerequisites are met:

- The crane is horizontally aligned.
- An auxiliary crane is available.
- The hoist rope is spooled up and secured.
- The permissible counterweight has been taken down on the central ballast.

### 6.1 Releasing the supply lines

#### 6.1.1 Releasing the supply lines

The engine must be turned off before connecting and disconnecting the hydraulic lines.

- ▶ Release the hydraulic connection for winch 2.
- ▶ Release the electrical connection for winch 2.
- ▶ Release the supply line for the central lubrication system.
- ▶ Secure the supply lines in the transport retainers.

### 6.2 Disassembling winch 2\*

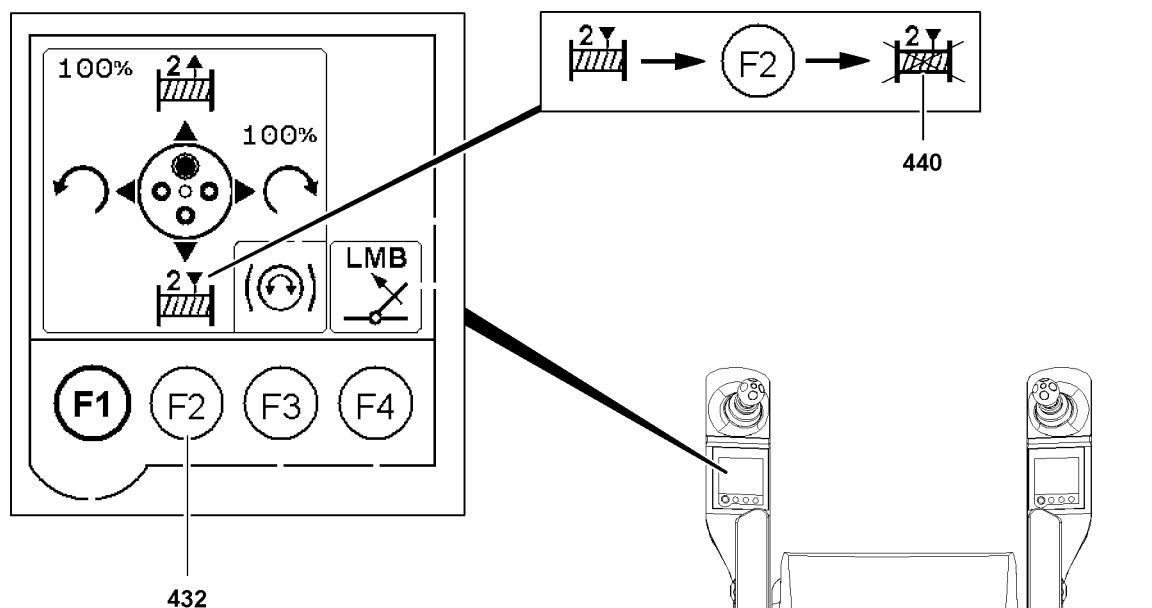


Fig. 118093

- ▶ Block winch 2 **WII** on the left touch display by pressing function key F2 **432**.

#### Result:

- The icon **440** is visible.
- ▶ Take the retaining pipe **5** out of the park position **P7** and pin on both sides in the counterweight plate in position **P8**.
- ▶ Fasten the auxiliary crane to the eyehooks **P6** on both sides.
- ▶ Tension the hoist rope of the auxiliary crane slightly.



#### DANGER

Danger of accident if winch 2 falls down!

- ▶ Do not unpin the pin **9** until winch 2 **WII** has been secured with the auxiliary crane.

- ▶ Release and unpin the pin **9**.
- ▶ Take winch 2 **WII** down on the transport vehicle.
- ▶ Unpin the retaining pipe **5** and pin it in the park position **P7**.

**Note**

- ▶ If winch 2 **WII** has been removed, the master switch assignment must be switched from a „two-winch system“ to a „one-winch system“, see the Crane operating instructions, chapter 4.01.
-

## 5.10 Boom nose - telescopic boom

1	General	3
2	Assembly	5
3	Disassembly	11

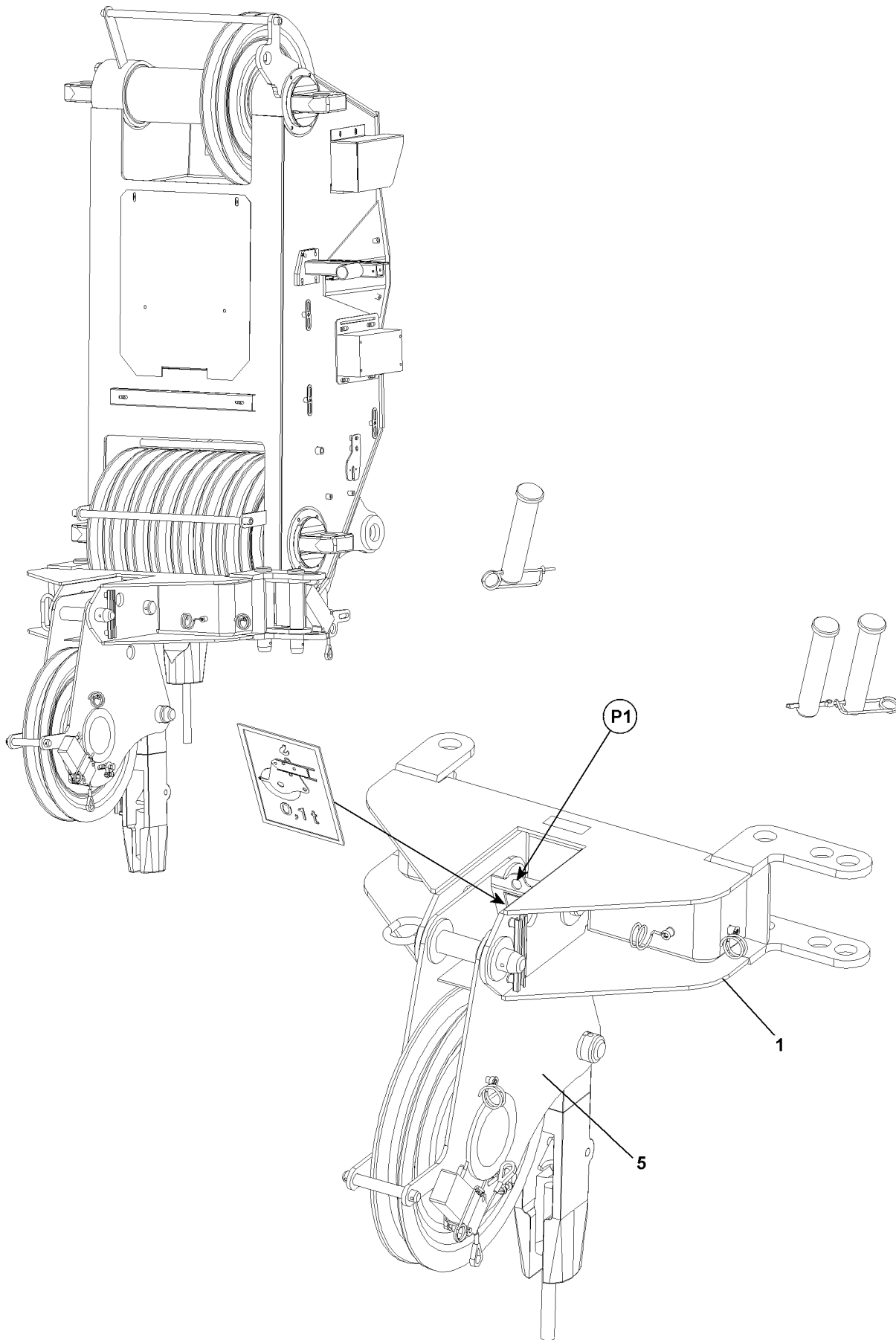


Fig.114100

LWE/LTR 1220-003/24204-02-02/en

# 1 General

Operation with the boom nose **1** is set up for rapid lifting via the boom nose **1**, whereby the hook block can remain reeved on the telescopic boom.

Position	Description	Weight
1	Boom nose	0.1 t



## Note

Load charts

- ▶ No special load charts are available for operation with boom nose **1**. The boom nose is generally run in the telescopic boom operating mode. However, the load is reduced by the weight of the boom nose and the lifting and fastening equipment that is used.

## 1.1 Fastening point

A fastening point **P1** is installed on the boom nose **1**.

The fastening point **P1** is marked with a tag.



## WARNING

Danger of accident!

Life-threatening situations can arise if the boom nose **1** is improperly or incorrectly attached!

- ▶ At assembly / disassembly, fasten the boom nose **1** properly on the fastening point **P1**!

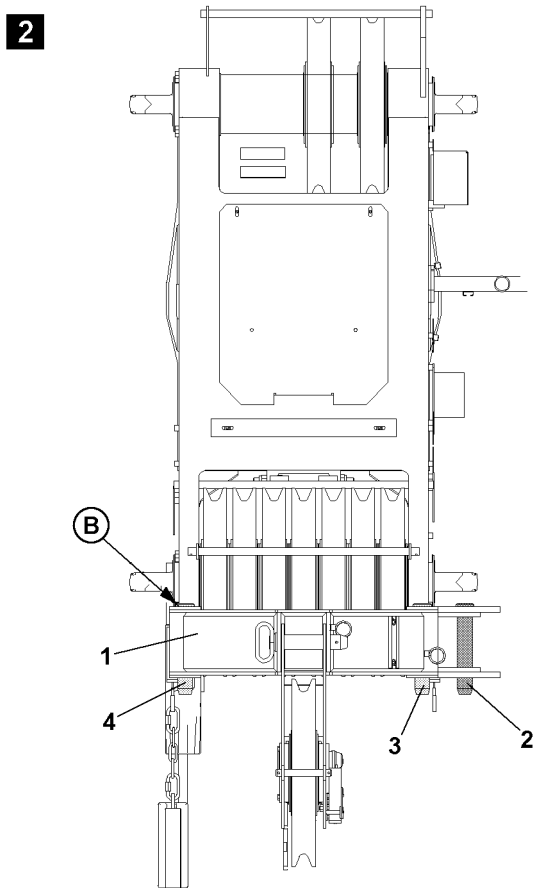
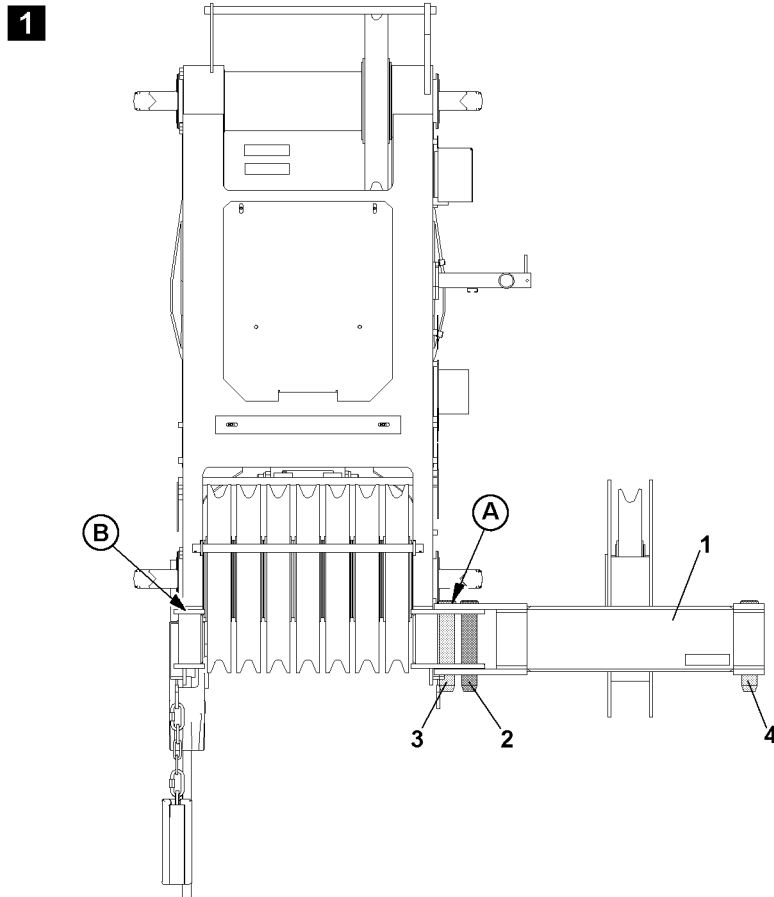


Fig.196449

LWE/LTR 1220-003/24204-02-02/en



## 2 Assembly

### 2.1 Installing the boom nose on the telescopic boom



#### WARNING

Danger of crushing!

During assembly, hands can be crushed due to swing movements of the boom nose **1**!

- ▶ Make sure that the boom nose **1** is not swinging back and forth during installation!

- ▶ Attach the boom nose **1** on the auxiliary crane.



#### DANGER

The boom nose can fall down!

If the boom nose **1** is unhooked from the auxiliary crane before the boom nose **1** is pinned, then the boom nose **1** can fall down and kill or severely injure personnel!

- ▶ Do not detach the auxiliary crane until the boom nose **1** is properly installed and secured!

- ▶ Install the boom nose on the telescopic boom: Insert the swing pin **2** and secure with spring retainer.
- ▶ Detach the auxiliary crane.

### 2.2 Swinging the boom nose into operating position, illustrations 1 and 2



#### DANGER

Danger of accident if the boom nose falls down!

If the swing pin **2** is unpinned, the boom nose will fall down.

- ▶ Never unpin the swing pin **2**!

- ▶ Release the pin **3** and the pin **4** and unpin.



#### CAUTION

Danger of crushing fingers!

Fingers could be crushed between the telescopic boom and the boom nose when the boom nose is swivelled.

- ▶ Do not put fingers between the boom nose and the telescopic boom!

- ▶ Swing the boom nose **1** by 180 ° until the pin **4** can be inserted on point **B**.
- ▶ Pin and secure the pin **4**.
- ▶ Pin and secure the pin **3**.

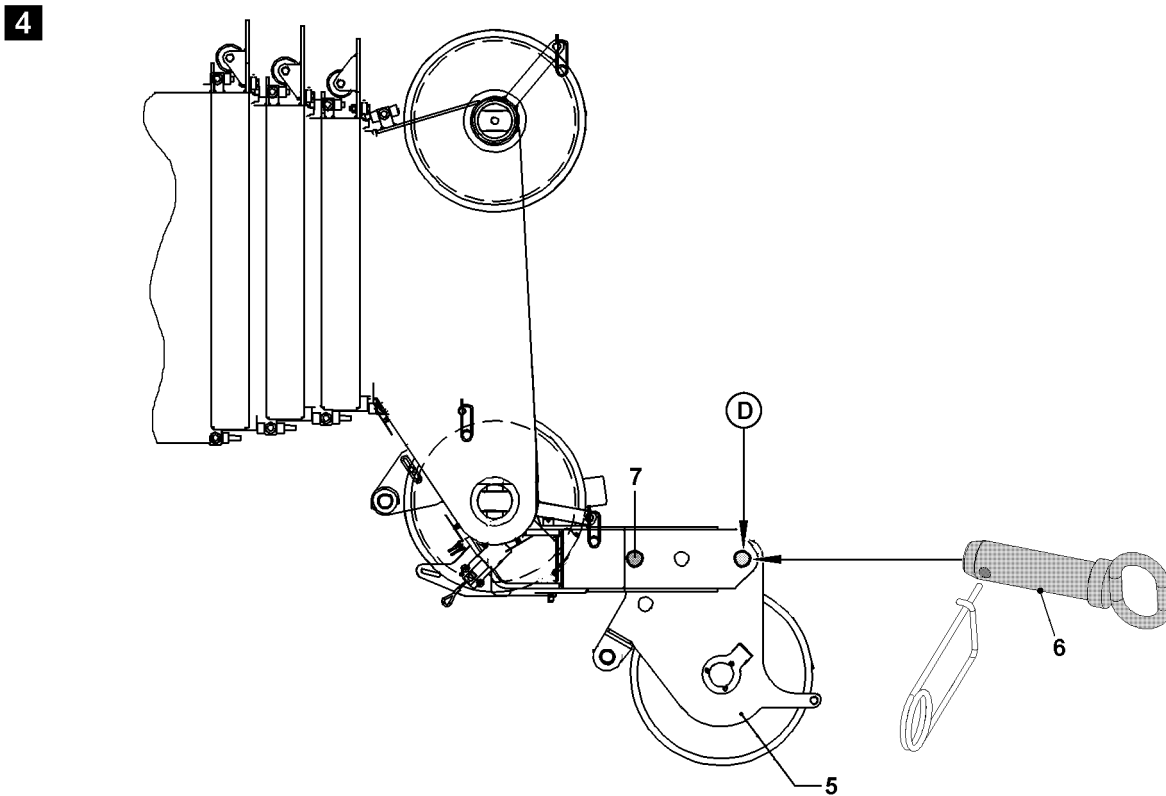
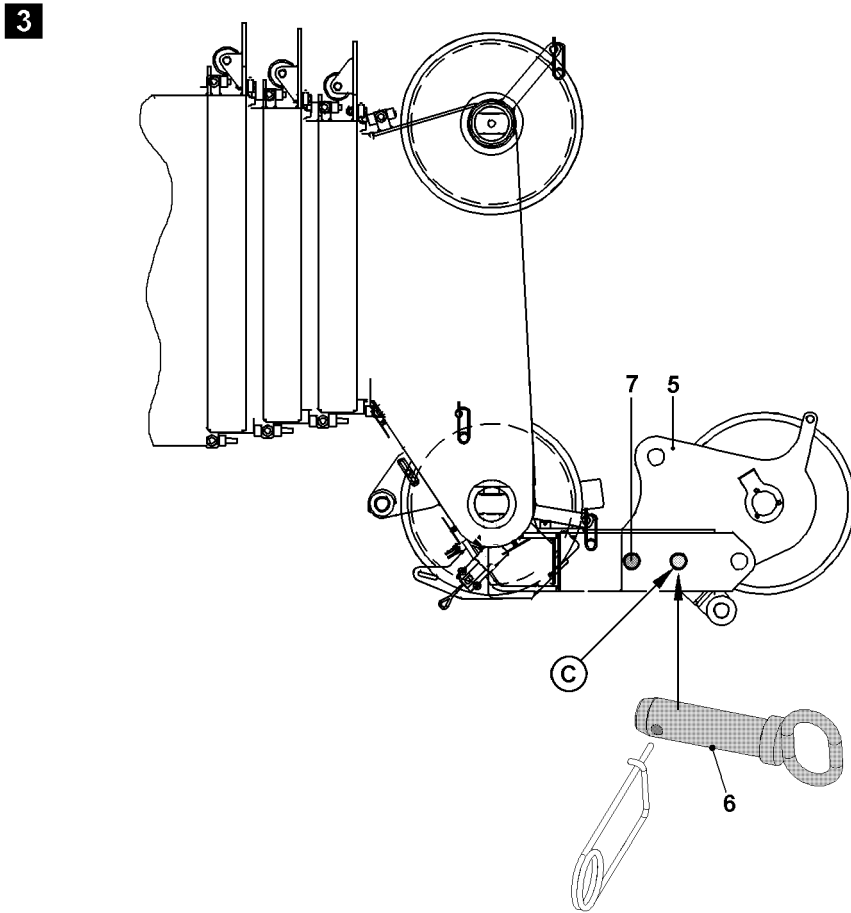


Fig.196450

## 2.3 Folding the boom nose into operating position, illustrations 3 and 4



### WARNING

Damage of boom nose!

If the boom nose is not folded into operating position, the boom nose can be overloaded!

- ▶ Fold the boom nose into operating position!



### DANGER

Danger of accident if the boom nose falls down!

If the swing pin 7 is unpinned, the boom nose will fall down.

- ▶ Never unpin the swing pin 7!
- ▶ Release the pin 6 on point C and unpin.



### CAUTION

Danger of crushing fingers!

Fingers can be crushed when the boom nose is folded.

- ▶ Do not crush your fingers when the rope pulley 5 folds down!
- ▶ Fold the rope pulley 5 down until it can be pinned at point D.
- ▶ Pin and secure the pin 6.

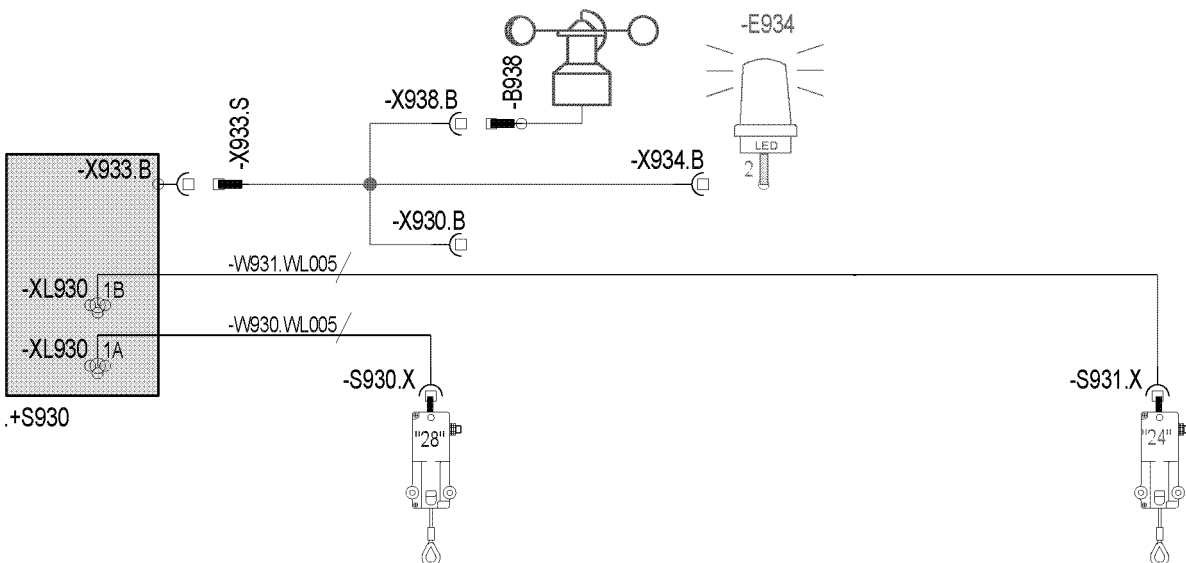
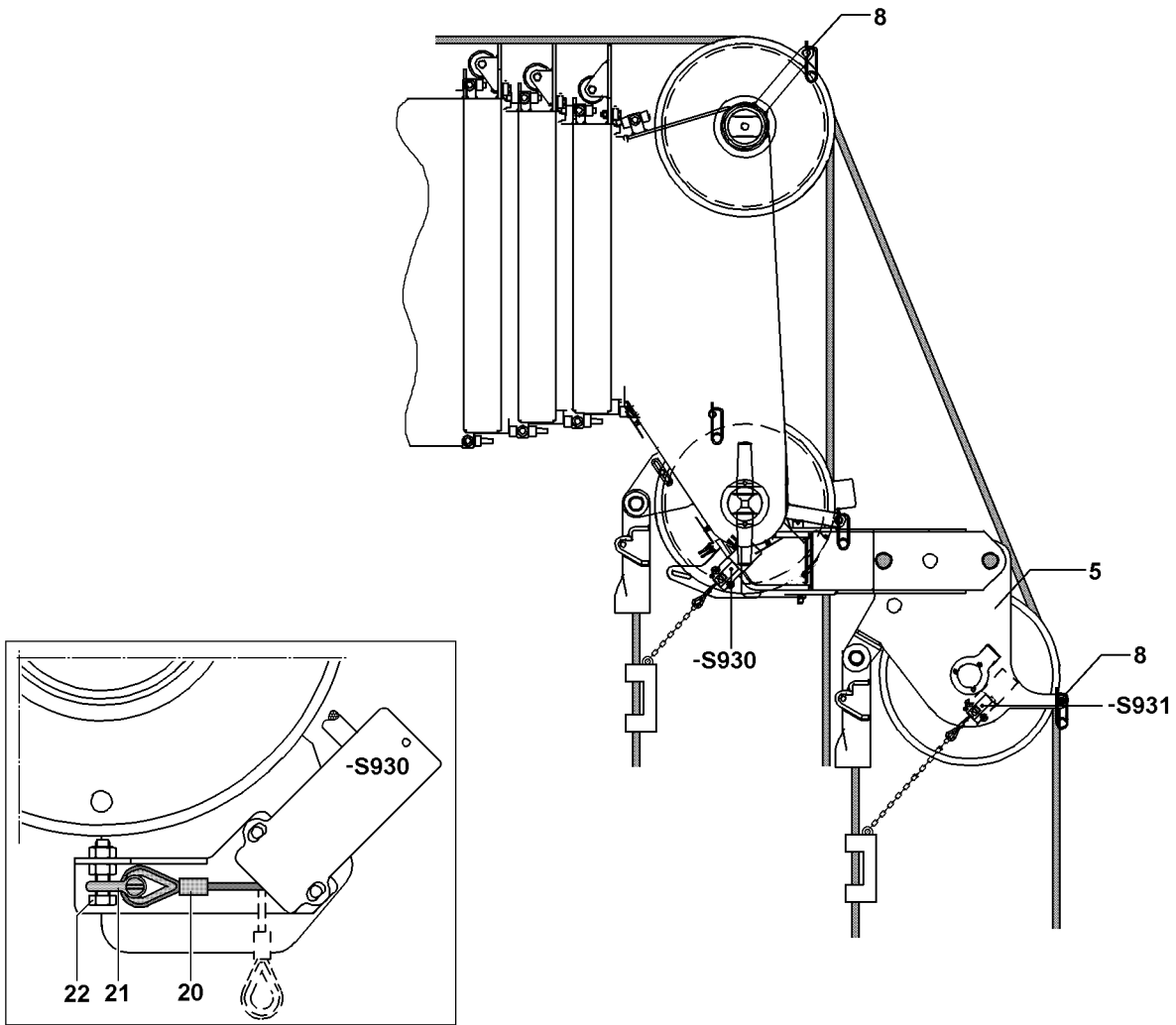


Fig.114102

## 2.4 Reeving in the hoist rope

Can be reeved in a maximum of 2 times on the boom nose.

- ▶ Release and unpin the rope retaining pipes **8**.
- ▶ Place the hoist rope over the end pulley on the telescopic boom and over the rope pulley **5**.
- ▶ Pin the rope retaining pipes **8** and secure.
- ▶ Reeve in the load hook or hook block.
- ▶ Attach the hoist limit switch weight.

## 2.5 Hoist limit switch

The hoist limit switch **-S930**, the airplane warning light\* and the wind sensor\* remain attached on the telescopic boom head.

If the hoist limit switch **-S931** is attached to the telescopic boom:

- ▶ Remove the hoist limit switch **-S931** from the telescopic boom and assemble to the boom nose.

## 2.6 Single hook operation

If you are working in „single hook mode“, the hoist limit switch **-S930** that is not required must be operated manually.

- ▶ Remove the hoist limit switch weight and chain.
- ▶ Pull the hoist limit switch rope **20** and attach to the fixed point **22** with the shackle **21**.
- ▶ Actuate the hoist limit switch **-S930** mechanically.

## 2.7 Two hook operation

During two hook operation the hoist limit switch **-S930** on the telescopic boom and the hoist limit switch **-S931** on the boom nose are active!

## 2.8 Function check

The function check **must** be performed by the operator before lifting a load.

The following checks must be performed.

- ▶ Check that the hoist limit switch, wind sensor\* and airplane warning light\* connections are properly connected.
- ▶ Check wind sensor\* operation on LICCON monitor.
- ▶ Check the function of the airplane warning light\*.

Check the movement of hoist limit switches. The following steps are required to perform these checks.

- ▶ Actuate the hoist limit switch manually.
- ▶ Check that „Hoist top“ icon is displayed on LICCON monitor for main boom or boom nose.
- ▶ Check that hoist winch switches off correctly.

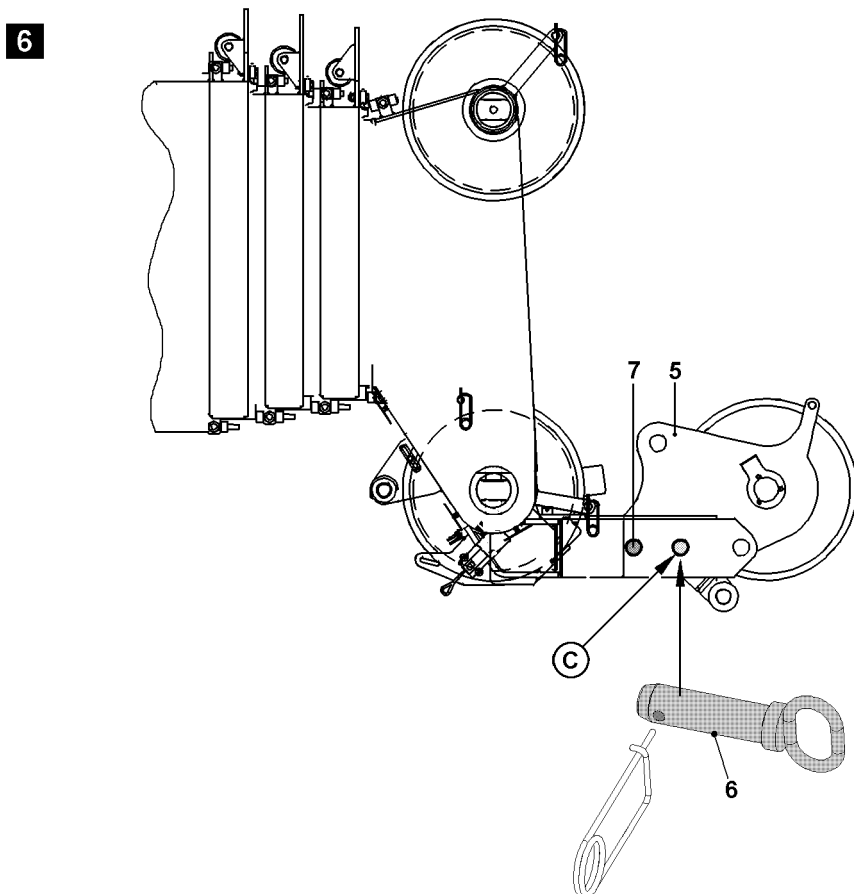
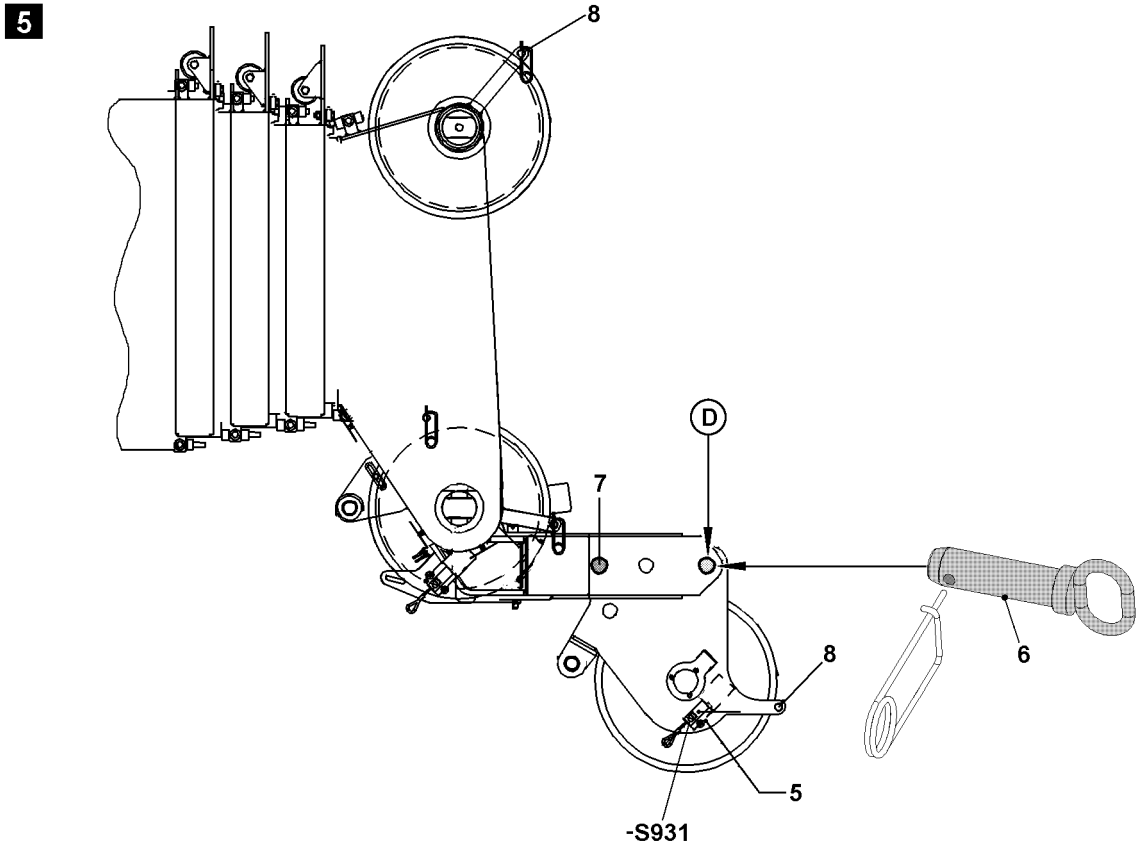


Fig.196452

## 3 Disassembly

### 3.1 Folding the boom nose into transport position, illustrations 5 and 6

- ▶ Remove the hoist limit switch weight.
- ▶ Reeve out the load hook / hook block to boom nose.
- ▶ Release and unpin the rope retaining pipes **8**.

Do not pull hoist rope beneath the winch when reeling in.

- ▶ Spool the hoist rope up.



#### Note

- ▶ During operation **without** the boom nose, you must use the hoist limit switch **-S931** as an additional hoist limit switch for the telescopic boom **or** mechanically pull the hoist limit switch **-S931** and attach it to the rope fixed position with a shackle.



#### DANGER

Danger of accident if the boom nose falls down!  
If the swing pin **7** is unpinned, the boom nose will fall down.

- ▶ Never unpin the swing pin **7**!
- ▶ Release the pin **6** on point **D** and unpin.

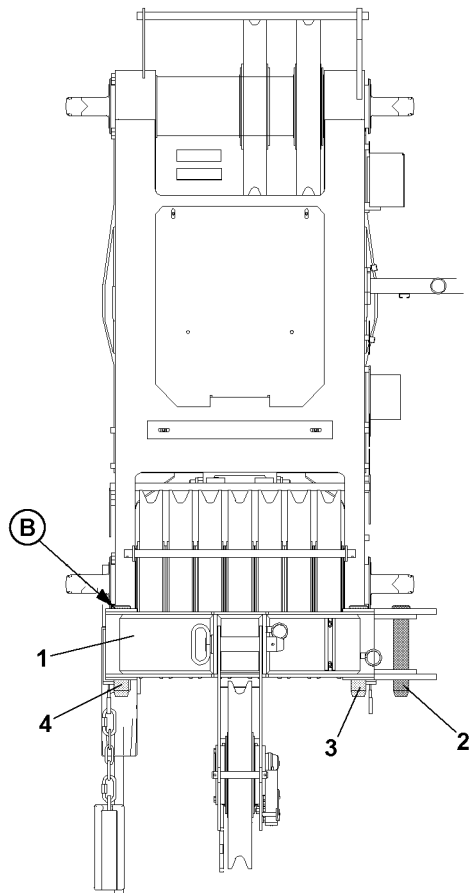


#### CAUTION

Danger of crushing fingers!  
Fingers can be crushed when the boom nose is folded.

- ▶ Do not crush your fingers when the rope pulley **5** folds up!
- ▶ Move the rope pulley **5** up until it can be pinned at the point **C**.
- ▶ Pin and secure the pin **6**.

**7**



**8**

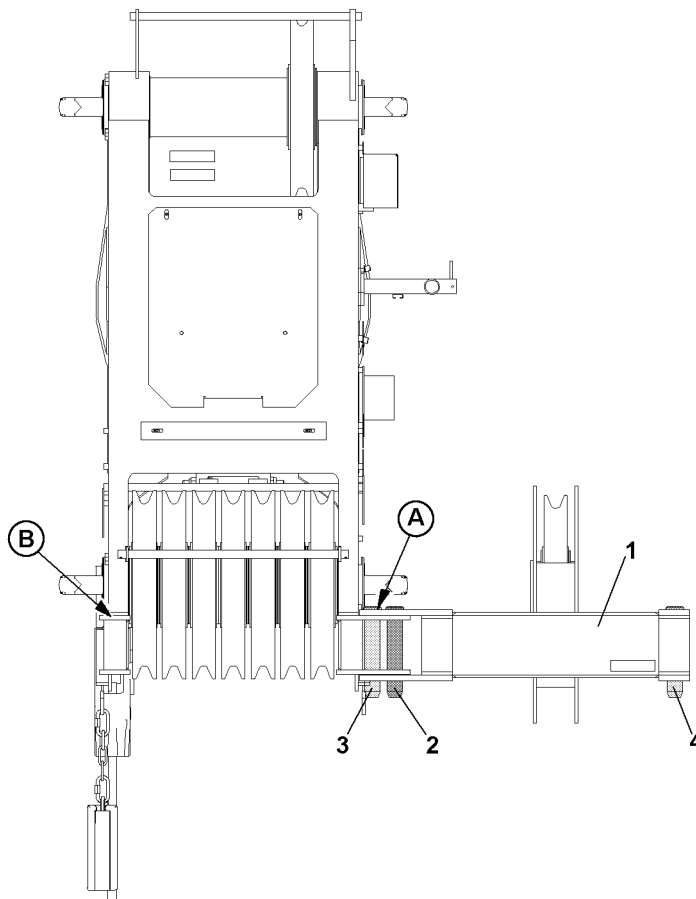


Fig.196453

LWE/LTR 1220-003/24204-02-02/en



## 3.2 Swinging the boom nose into transport position, illustrations 7 and 8



---

### DANGER

Danger of accident if the boom nose falls down!  
If the swing pin **2** is unpinned, the boom nose will fall down.

- ▶ Never unpin the swing pin **2**!
- 
- ▶ Release and unpin the pin **4**.



---

### CAUTION

Danger of crushing fingers!  
Fingers could be crushed between the telescopic boom and the boom nose when the boom nose is swivelled.

- ▶ Do not put fingers between the boom nose and the telescopic boom!
- 
- ▶ Swing the boom nose **1** by 180 ° until the pin **3** can be inserted on point **A**.
  - ▶ Insert and secure pin **3**.
  - ▶ Pin the pin **4** on the boom nose and secure.

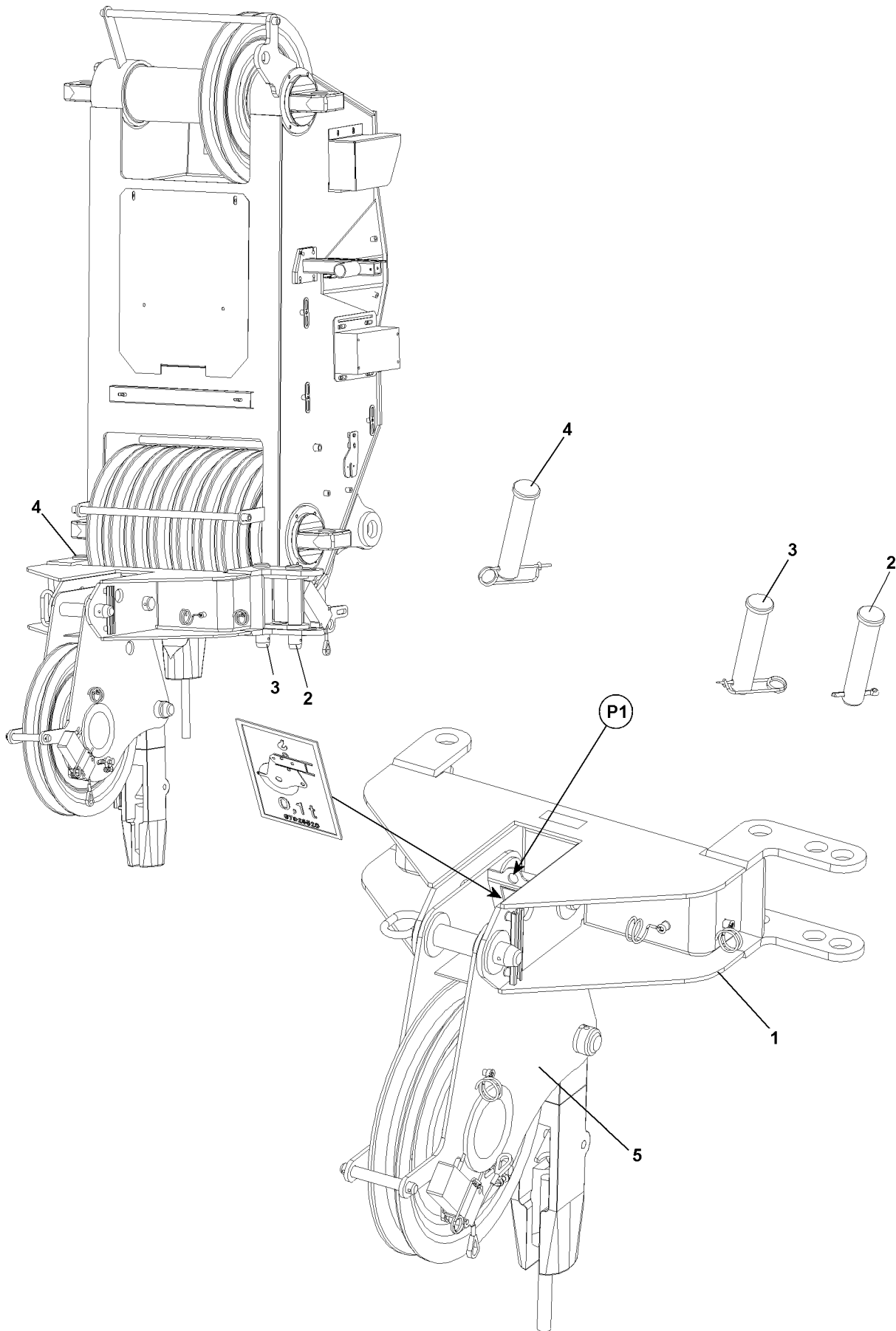


Fig.114101

LWE/LTR 1220-003/24204-02-02/en

### 3.3 Removing the boom nose on the telescopic boom

Make sure that the following prerequisite is met:

- The boom nose is folded into operating position.



---

**DANGER**

Danger of accident if the boom nose falls down!

If the swing pin **2** is unpinned before the boom nose **1** is secured with the auxiliary crane, then the boom nose **1** can fall down and kill or severely injure personnel!

- ▶ Unpin the swing pin **2** only when the boom nose is secured with the auxiliary crane!

- ▶ Attach the auxiliary crane on the boom nose **1**.



---

**WARNING**

Danger of crushing!

During disassembly, hands can be crushed due to swing movements of the boom nose **1**!

- ▶ Make sure that the boom nose **1** is not swinging back and forth during removal!

---

Remove the boom nose **1**:

- ▶ Release and unpin the pin **3**.
- ▶ Release and unpin the pin **4**.
- ▶ Release and unpin the swing pin **2**.
- ▶ Place the boom nose onto the transport vehicle.
- ▶ Detach the auxiliary crane.

---

Empty page!

LWE/LTR 1220-003/24204-02-02/en

## 5.12 Jib boom

1	General	3
2	Assembling the jib boom	5
3	Erecting	25
4	Reeving the hoist rope out	27
5	Disassembling the jib boom	29

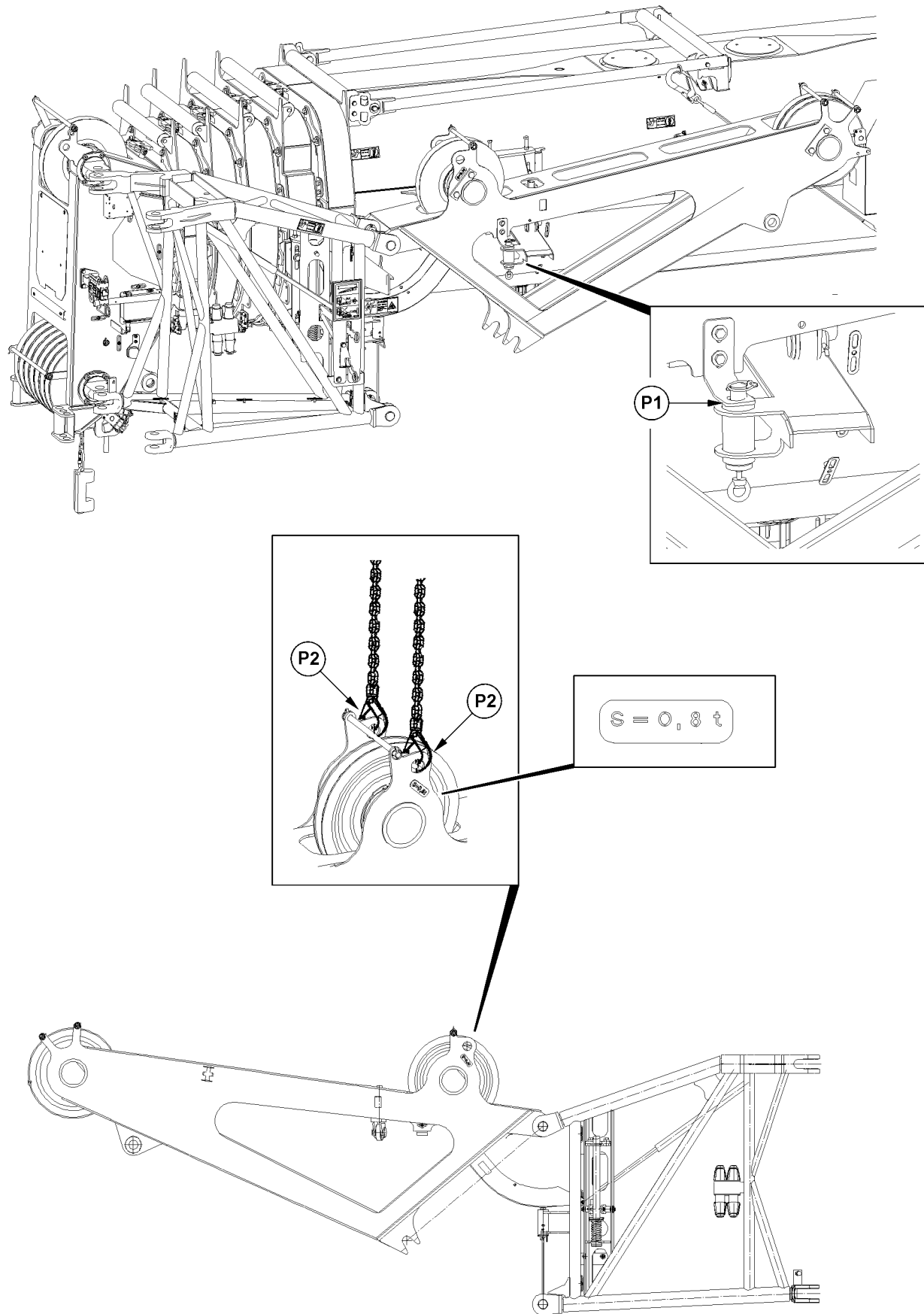


Fig.117354

LWE/LTR 1220-003/24204-02-02/en

# 1 General



## DANGER

Danger of accident when transporting the crane with the jib boom!

- ▶ Before transporting the crane, the jib boom must always be brought into transport position and mechanically secured in point **P1**.
- ▶ Make sure that the jib boom is properly secured in point **P1** before transporting the crane on public roads.



## Note

- ▶ **Load reduction!** With the hook block reeved to the telescopic boom, loads in jib boom operating modes are reduced by the weight of the reeved-in hook block.

## 1.1 Component overview

Position	Designation	Length	Weight
1	Pivot section	3.4 m	0.8 t
2	End section		

## 1.2 Fastening point



## DANGER

Danger of accident due to incorrect fastening!

Life-threatening situations can arise due to improper or incorrect fastening of the jib boom!

- ▶ Fasten the jib boom according to the fastening point **P2** shown on the tag.
- ▶ The appropriate fastening eyes / fastening points are marked with tags.
- ▶ Fastening the jib boom to non-intended points or to any arbitrary location is **prohibited**.

Name	Abbreviation
Jib boom	<b>S</b>

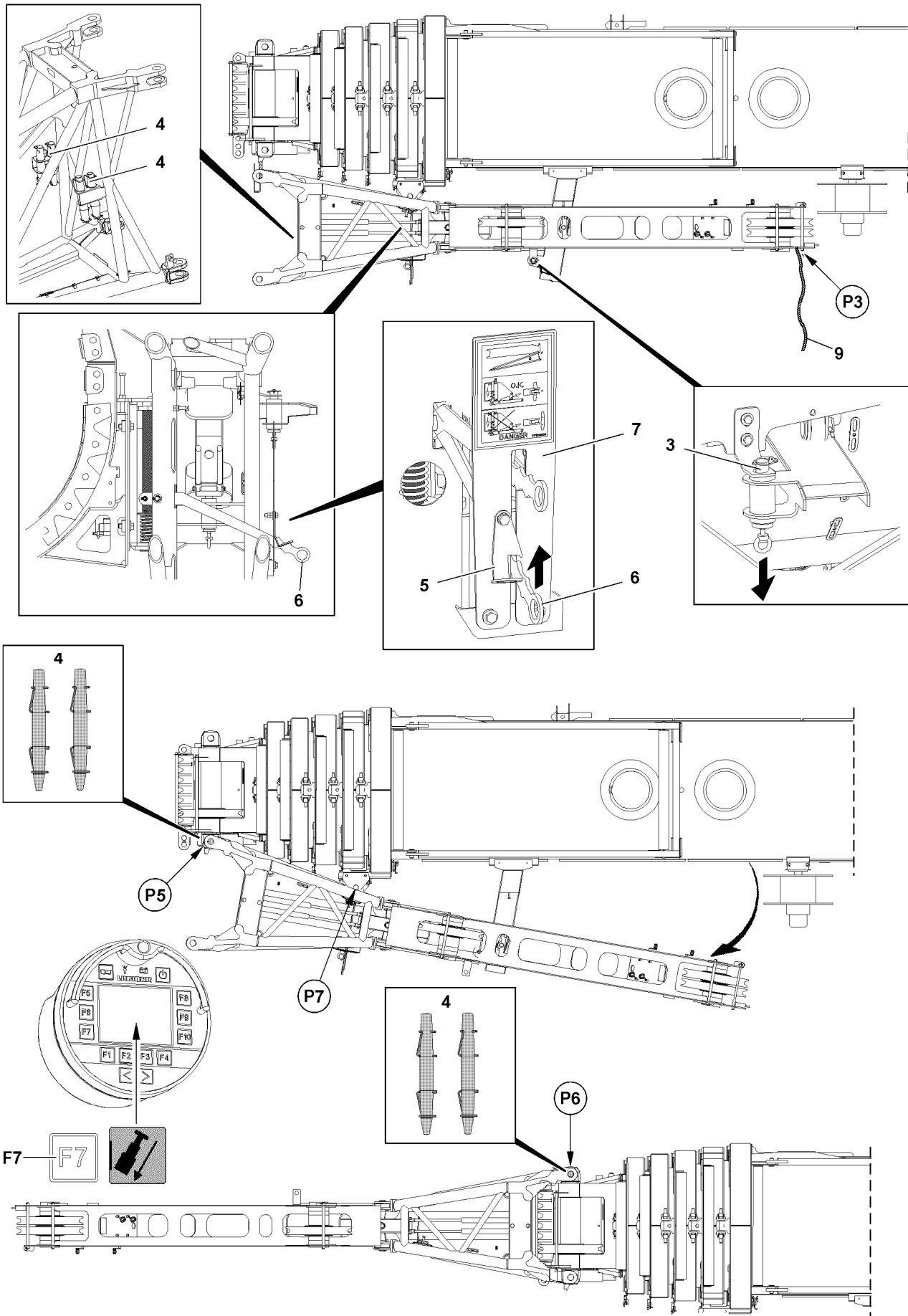


Fig.117349



## 2 Assembling the jib boom

### 2.1 General



#### **DANGER**

Danger of fatal injury due to falling jib boom!

The jib boom can fall down due to an assembly error.

- ▶ Standing under the jib boom during the swing operation is prohibited.
- ▶ It is prohibited for anyone to remain within the slewing range as well as the folding area of the jib boom.
- ▶ The jib boom must be secured by an auxiliary rope during the swing process.



#### **WARNING**

Danger of falling!

During assembly and disassembly, assembly personnel must be secured with appropriate aids to prevent them from falling! If this is not observed, assembly personnel could fall and suffer fatal injuries.

- ▶ All work at a height, when there is a danger of falling, must be carried out with suitable aids.
- ▶ If fall protection equipment is available, then it must be used, see the Crane operating instructions, chapter 2.06.
- ▶ If aids are not available and work cannot be carried out from the ground, then assembly personnel must secure themselves with the supplied fall arrest system to prevent falling, see the Crane operating instructions, chapter 2.04.
- ▶ The supplied fall arrest system must be fastened to the fastening and hook points. For safety points, see Crane operating instructions, chapter 2.06.
- ▶ Only step on the aids, ladders and catwalks with clean shoes.
- ▶ Keep aids, ladders and catwalks free of heavy dirt, snow and ice.
- ▶ Do not walk on the jib boom.

Make sure that the following prerequisites are met:

- The crane is horizontally aligned.
- The counterweight has been installed on the turntable according to the load chart.
- The telescopic boom is telescoped in all the way.
- The jib boom is attached on the telescopic boom pivot section for transport.
- The telescopic boom has been luffed up to the rear or the side in the 1° position.

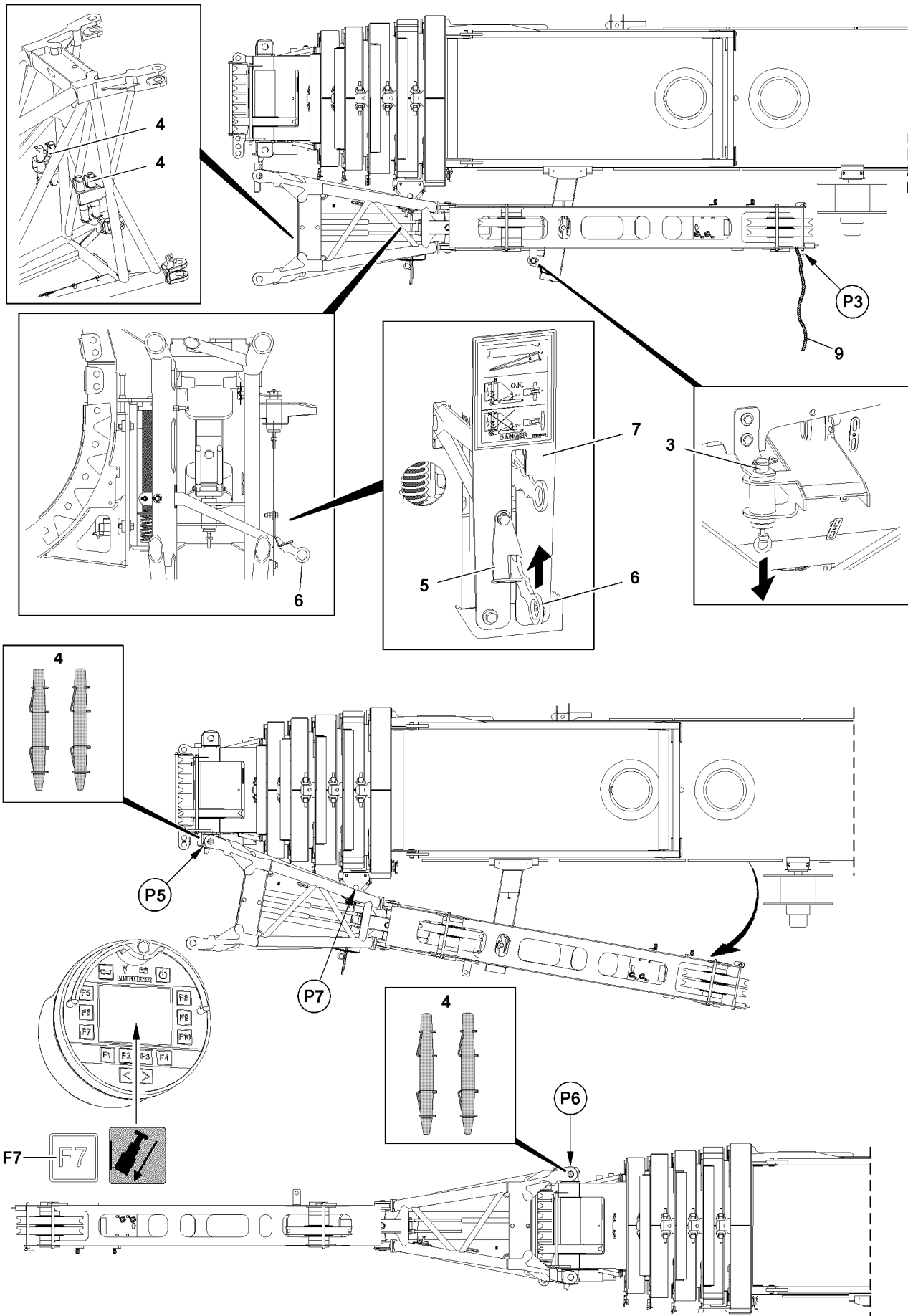


Fig.117349

## 2.2 Reeving out the hoist rope on the telescopic boom head

- ▶ Extend the telescopic boom to a length of approximately 4 m.
- ▶ Place the hook block on the ground.
- ▶ Disengage the hoist rope on the rope fixed point.
- ▶ For safety reasons, remove the hoist limit switch weight and the chain.



### Note

- ▶ The hoist limit switch must be pulled mechanically and the control rope must be attached to the telescopic boom head with the snap hook when operating the jib boom.
  - ▶ The telescopic boom may remain reeved in, if the hoist rope of winch 2 is used for auxiliary jib operation.
- 
- ▶ Remove the rope retaining pipes on the pulley head and on the back pulley.
  - ▶ Telescope the telescopic boom in all the way.

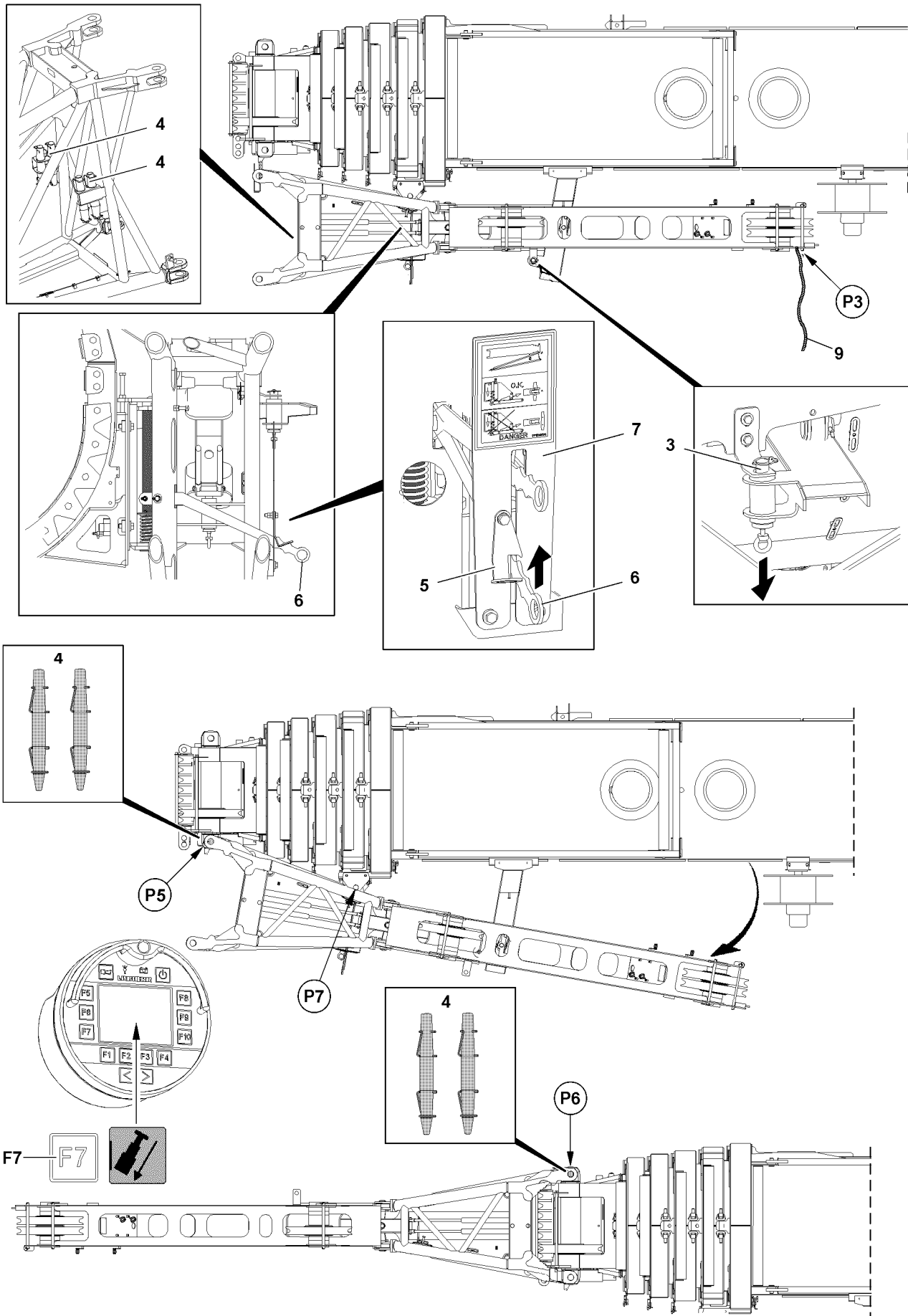


Fig.117349

## 2.3 Assembling the jib boom carried on the crane

### 2.3.1 Swinging the jib boom into the operating position

Make sure that the following prerequisite is met:

- The telescopic boom is luffed up to the rear or to the side to 1°.



#### WARNING

Danger of accident due to involuntary swinging out of the jib boom!

If the telescopic boom is not luffed up to 1°, then the jib boom may not be installed.

- ▶ Luff the telescopic boom up to 1°.

- ▶ Attach the auxiliary rope **9** to point **P3**.
- ▶ Release the spring pin **3**.
- ▶ Pull the spring pin **3**.
- ▶ Swing jib boom out until it can be pinned at point **P5**.

#### Problem remedy

If the pin bores on point **P5** do not align, the telescopic boom can be tensioned with the function key **F7** on the BTT in the „Assembly functions on the BTT“ menu:

- ▶ Start the crane engine.
- ▶ Pin telescope 5.



#### Note

- ▶ Bluetooth Terminal (BTT), see Crane operating instructions, chapter 5.31.



#### WARNING

Danger of severe crushing!

For the „Tension the telescopic boom“ function, all telescoping sections are pulled together, which can lead to severe crushing injuries of fingers.

- ▶ As long as the „Tension telescopic boom“ function is carried out, it is prohibited for any personnel to remain in the push out range of the telescopic sections!

- ▶ Press the function key **F7** on the BTT.

#### Result:

- All telescopic sections are pulled together.
- ▶ Insert the pins **4** at the top and bottom in point **P5** and secure.



#### DANGER

Danger of fatal injury due to falling jib boom!

The special retaining clips must be used to secure the pins **4**. The use of cotter pins or spring retainers on the pins **4** is not permitted.

The jib boom may only be released in point **P7** if the pins **4** are pinned and secured on top and bottom in point **P5**.

- ▶ Pin and secure the pins **4** in point **P5** at the top and bottom.

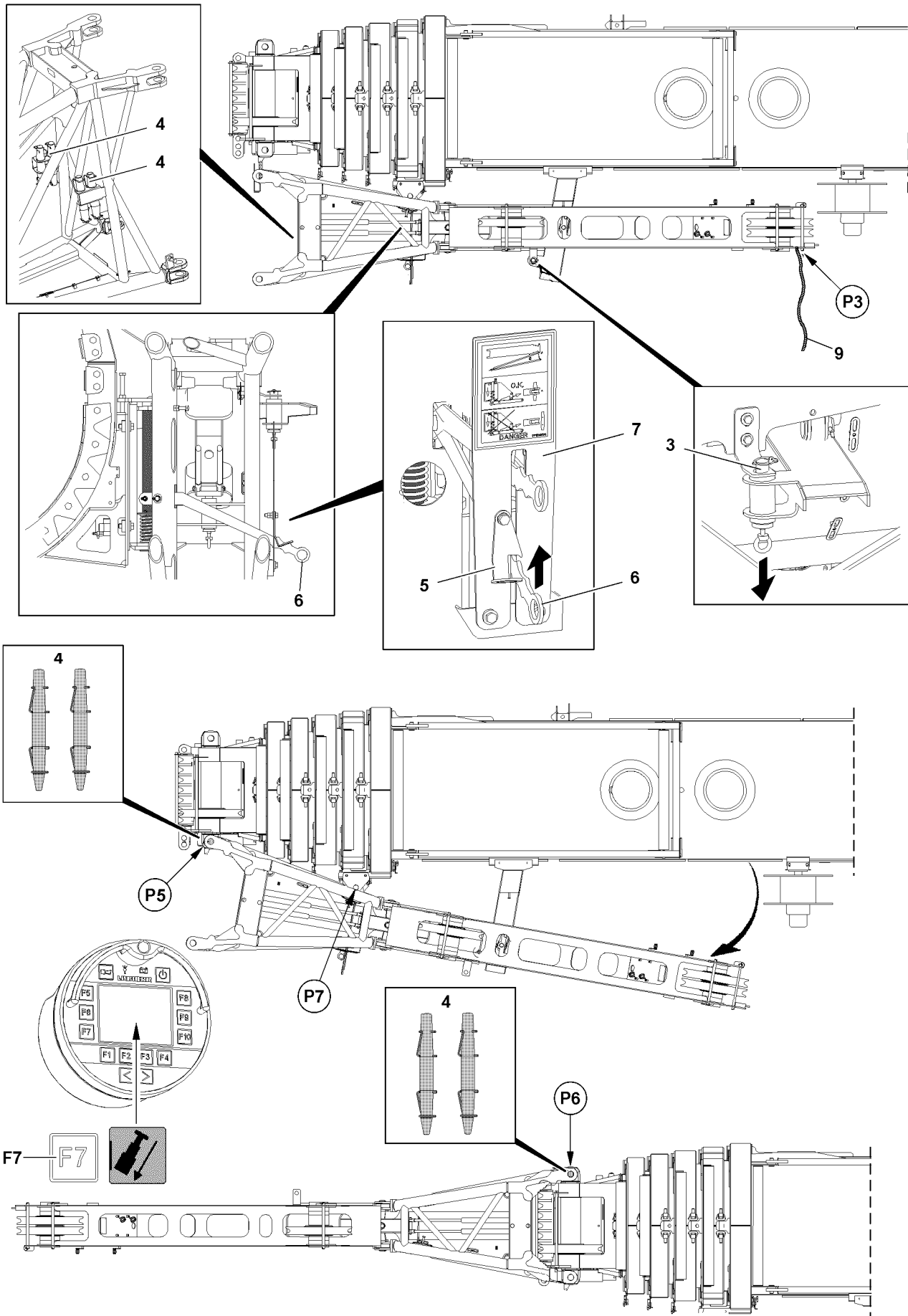


Fig.117349

LWE/LTR 1220-003/24204-02-02/en

- ▶ Swing the retaining bracket **5** with the assembly rod to the side.
- ▶ Press the lever **6** with the assembly rod upward and latch it into the link **7**.



---

**DANGER**

Danger of fatal injury due to falling jib boom!  
The jib boom can fall down due to an assembly error.

- ▶ Standing under the jib boom during the swing operation is prohibited.
  - ▶ Standing in the slewing range as well as the folding range of the jib boom is prohibited.
- 
- ▶ Swing the jib boom with the auxiliary rope **9** by 180 ° until it can be pinned at point **P6** on the top and bottom.



---

**DANGER**

Danger of fatal injury due to falling jib boom!

- ▶ Use the special retaining clips to secure the pins **4**.
  - ▶ The use of cotter pins or spring retainers on the pins **4** is prohibited.
- 
- ▶ Insert the pins **4** at the top and bottom in point **P6** and secure.
  - ▶ Remove the auxiliary rope **9**.

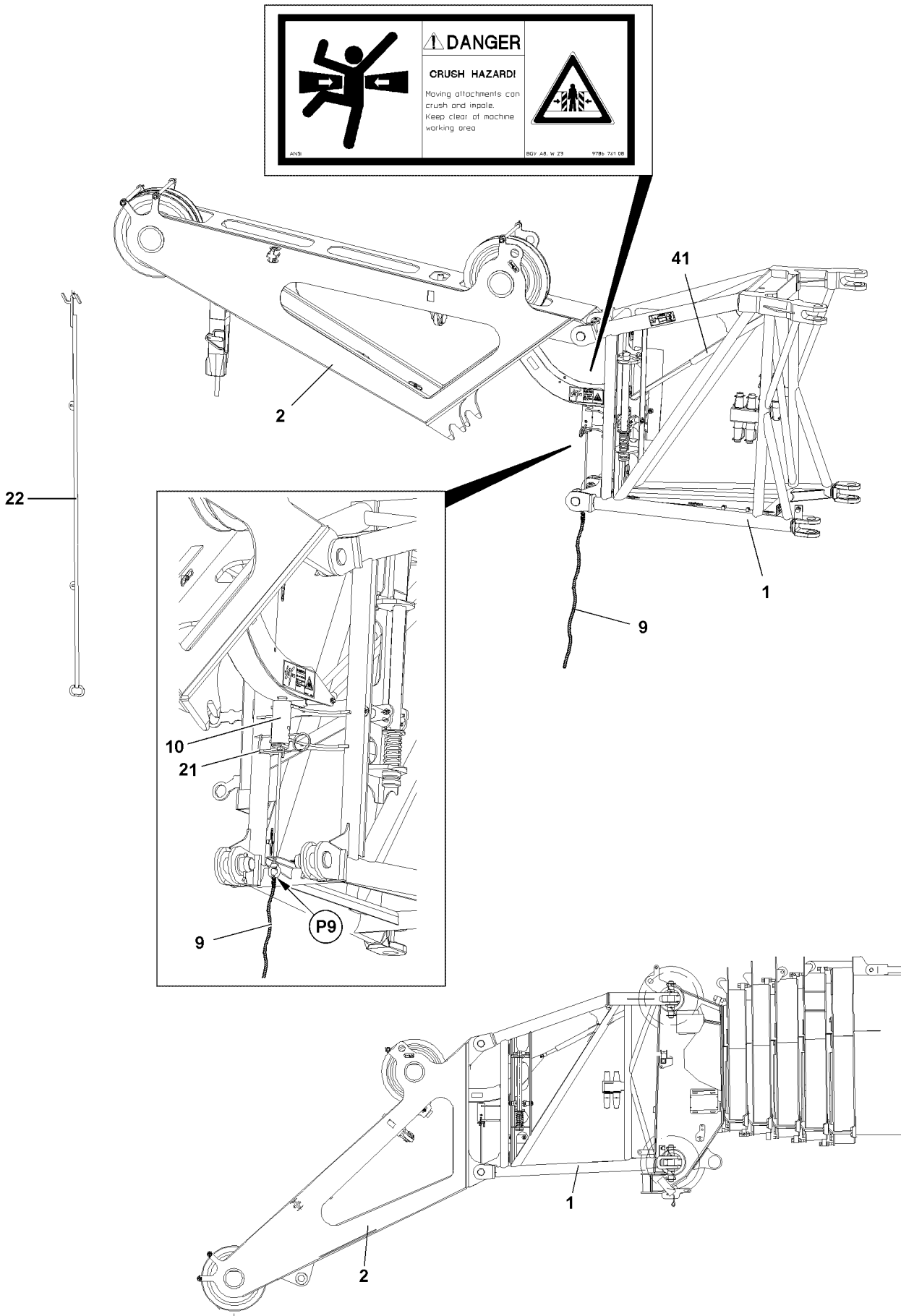


Fig.118506

LWE/LTR 1220-003/24204-02-02/en



### 2.3.2 Folding the end section into operating position



#### DANGER

Danger of fatal injury in case of a defective pneumatic spring!

Defective pneumatic springs **41** no longer provide the supporting action for the movable components on the jib boom.

If the pneumatic spring **41** is defective, the end section **2** can fall down and fatally or seriously injure personnel.

There is an increased danger of accident.

- ▶ Before unpinning the spring pin **10** and before actuation, check the pneumatic spring **41** for external damage.
- ▶ Do not use a jib boom with defective pneumatic spring **41**! Replace the defective pneumatic spring **41**.
- ▶ If the pneumatic spring **41** is defective, support the end section **2** from below or hang it on an auxiliary crane.
- ▶ It is strictly prohibited for personnel or objects to remain within the movement range between the end section **2** and the pivot section **1**.
- ▶ It is prohibited for personnel or objects to remain within the danger zone of the moving components.

- ▶ Attach the auxiliary rope **9** to point **P9**.



#### DANGER

Danger of accident!

Before unpinning the spring pins **10** it must be ensured that no persons or objects are in the danger zone, particularly between the end section **2** and the pivot section **1**.

- ▶ Unpin the spring pin **10** only if there are no persons or objects in the danger zone.

- ▶ Remove the retaining pin **21**.
- ▶ Hook the assembly rod **22** in the end section **2** and unpin the spring pin **10** with the auxiliary rope **9**.
- ▶ Fold the end section **2** down with the assembly rod **22** until the spring pin **10** engages.
- ▶ Secure the spring pin **10** with the retaining pin **21**.



#### DANGER

Danger of accident!

- ▶ Before operation with the jib boom can be started, the end section **2** must lie against the pivot section **1** and be pinned and secured with the spring pin **10**.

- ▶ Check if the jib boom has been pinned according to the operating instructions.
- ▶ Remove the auxiliary rope **9**.

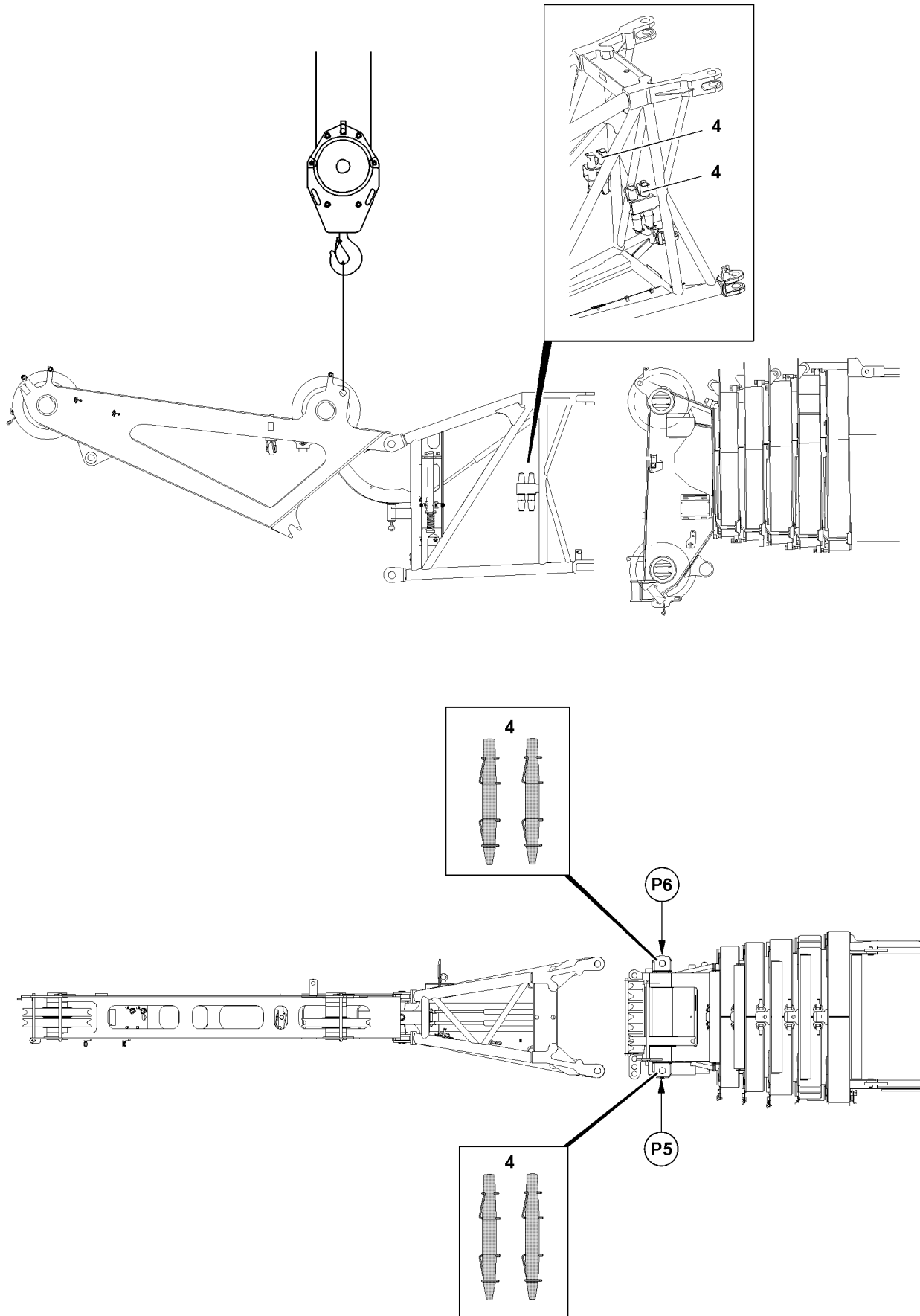


Fig.117350

LWE/LTR 1220-003/24204-02-02/en

## 2.4 Assembling the separately transported jib boom

Make sure that the following prerequisite is met:

- The telescopic boom is luffed up to the rear or to the side to 1°.



### DANGER

Danger of fatal injury due to falling jib boom!

The jib boom can fall down due to an assembly error.

- ▶ Do not allow anyone to stand beneath the jib boom during assembly!
- ▶ Attach jib boom at the fastening point and insert into pinning points of telescopic boom.



### DANGER

Danger of fatal injury due to falling jib boom!

- ▶ The use of cotter pins or spring retainers on the pins **4** is prohibited.
- ▶ To secure the pin **4** and the pin **8**, use the special retaining clips.

- ▶ Pin the jib boom with the telescopic boom:
- ▶ Pin and secure the pin **4** on top in point **P5** and point **P6**.
- ▶ Pin and secure the pin **4** on the bottom in point **P5** and point **P6**.
- ▶ For the rest of the assembly see section „Folding the end section into the operating position“.

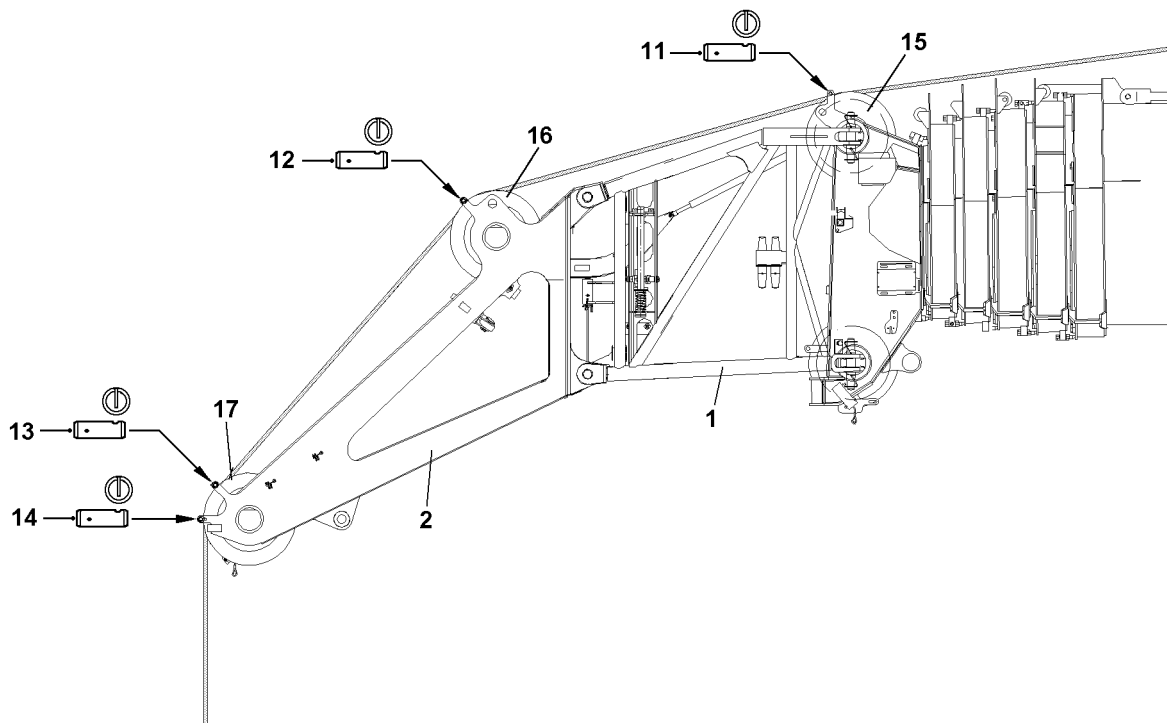


Fig.118508

## 2.5 Reeving the hoist rope in

---



### **DANGER**

Danger of falling from the jib boom!

When walking on the jib boom to reeve the hoist rope in or out, there is a risk of slipping and falling from the jib boom.

▶ Do not walk on the jib boom!

---

- ▶ Release and unpin the rope retaining pin **11**, rope retaining pin **12**, rope retaining pin **13** and rope retaining pin **14**.
  - ▶ Run hoist rope over rope guide pulley **15**, rope guide pulley **16** and rope guide pulley **17**.
  - ▶ Insert all rope retaining pins and secure with locking pins.
  - ▶ Reeve the hoist rope in. See chapter „4.06 Rope reeving“.
  - ▶ Attach the hoist limit switch weight.
- 



### **Note**

- ▶ For auxiliary jib operation with hook block reeved in on the telescopic boom, the weight of the hook block reeved in on the telescopic boom must be deducted from the load.
-

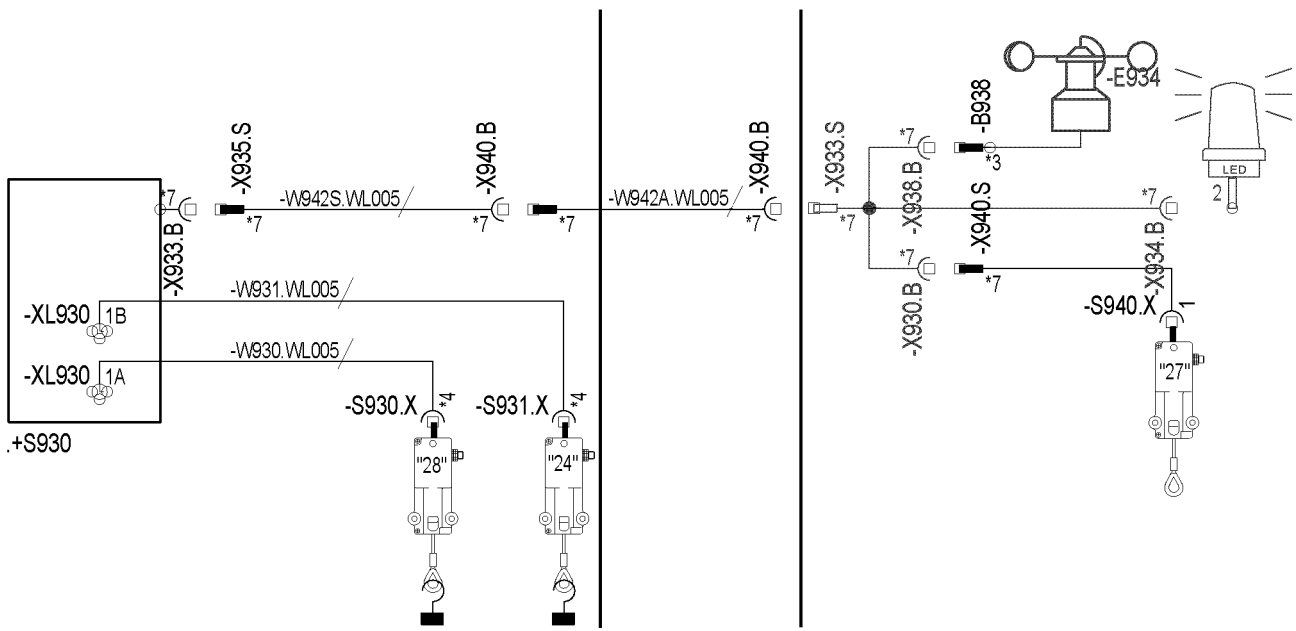
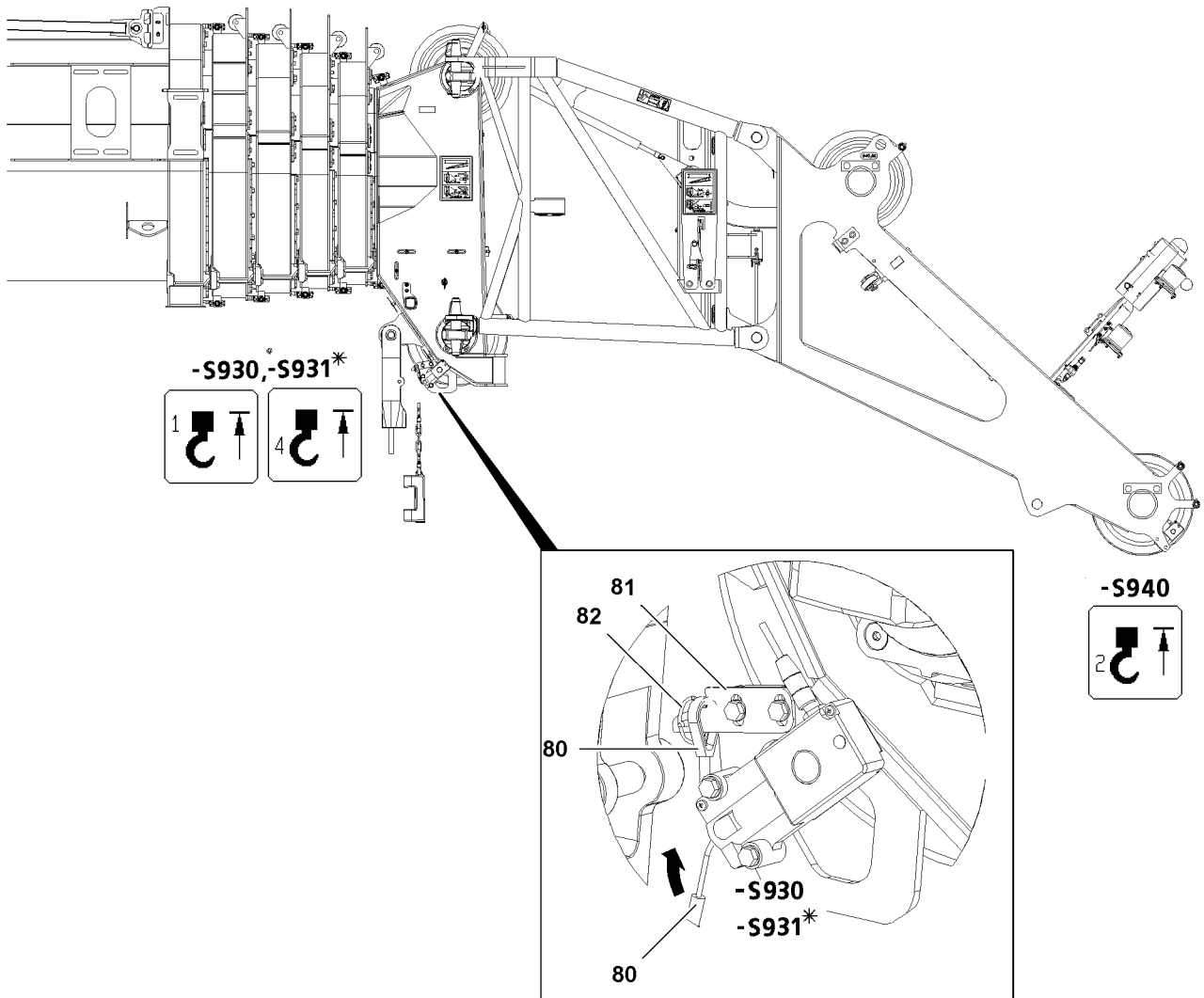


Fig.117351

LWE/LTR 1220-003/24204-02-02/en

## 2.6 Electrical connections on jib boom

### 2.6.1 Actuating the hoist limit switch mechanically, illustration 1

In jib boom operation in „single hook operation“, the hoist limit switch **-S930/-S931** which is not required must be actuated manually.

- ▶ Remove the hoist limit switch weight of the hoist limit switch **-S930.X** and hoist limit switch\* **-S931.X**.
- ▶ Pull the hoist limit switch rope **80**, hang it on the fixed point **81** and secure with the locking pin **82**.
- ▶ After jib boom operation, protect the electrical connections from contamination with caps.

### 2.6.2 Electrical connections

#### Single hook operation



#### Note

- ▶ Only the hoist limit switch **S940** on the jib boom is active during single hook operation.

- ▶ Actuate the hoist limit switch **-S930** mechanically.

If installed on the telescopic boom:

- ▶ Actuate the hoist limit switch\* **-S931** mechanically.
- ▶ Insert the cable **-W942.S** with cable plug **-X935.S** into the socket **-X933.B**.
- ▶ Plug the cable **-W942A** into the socket **-X940.B**.
- ▶ Plug the Y-adapter with the plug **-X933.S** into the socket **-X940.B**.
- ▶ Plug the Y-adapter with the plug **-X940.S** into the socket **-X930.B**.
- ▶ Plug in the hoist limit switch **-S940**.

#### Establishing the electrical connection to the LED continuous light\* or flashing beacon\*



#### Note

- ▶ To be able to establish the electrical connection to the LED continuous light and the flashing beacon, the Y-adapter on the cable must be plugged in the socket **-X940.B** with the plug **X933.S**.
- ▶ Plug the LED continuous light or flashing beacon in the socket **-X934.B**.

#### Establishing the electrical connection to the wind speed sensor\*



#### Note

- ▶ To be able to establish the electrical connection to the wind speed sensor, the Y-adapter with the plug **X933.S** must be plugged in the socket **-X940.B**.
- ▶ Plug the wind speed sensor in the socket **-X938.B**.



#### Note

- ▶ After the folding jib operation, protect the electrical connections from contamination with caps.

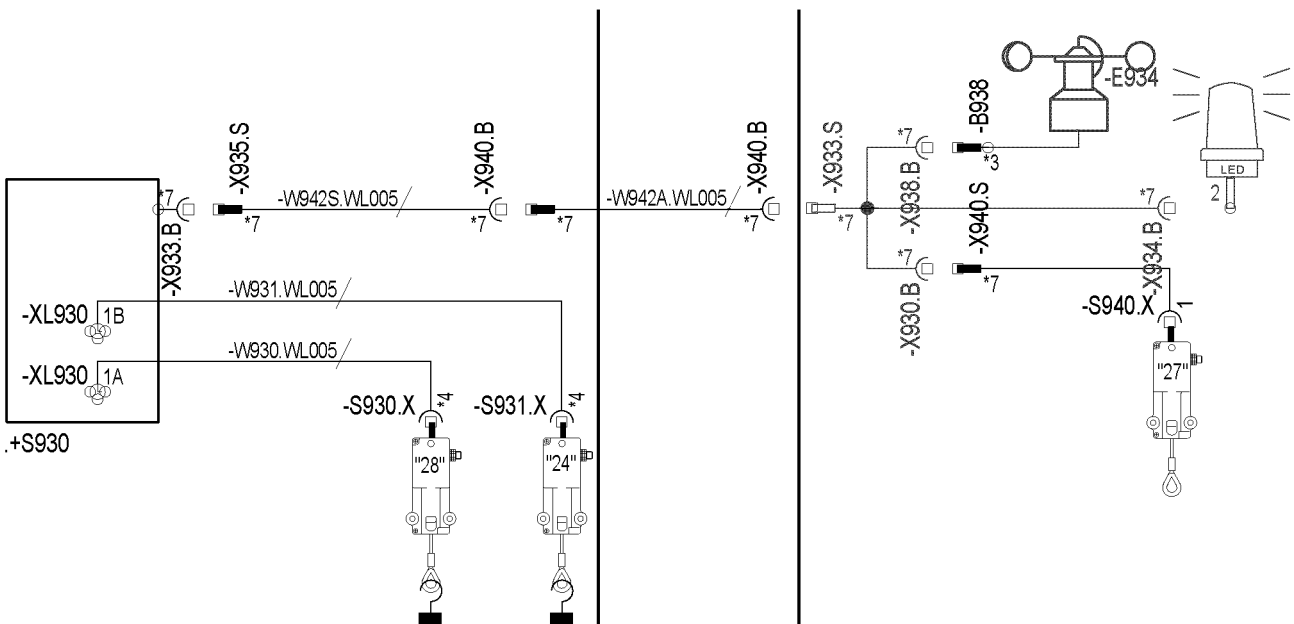
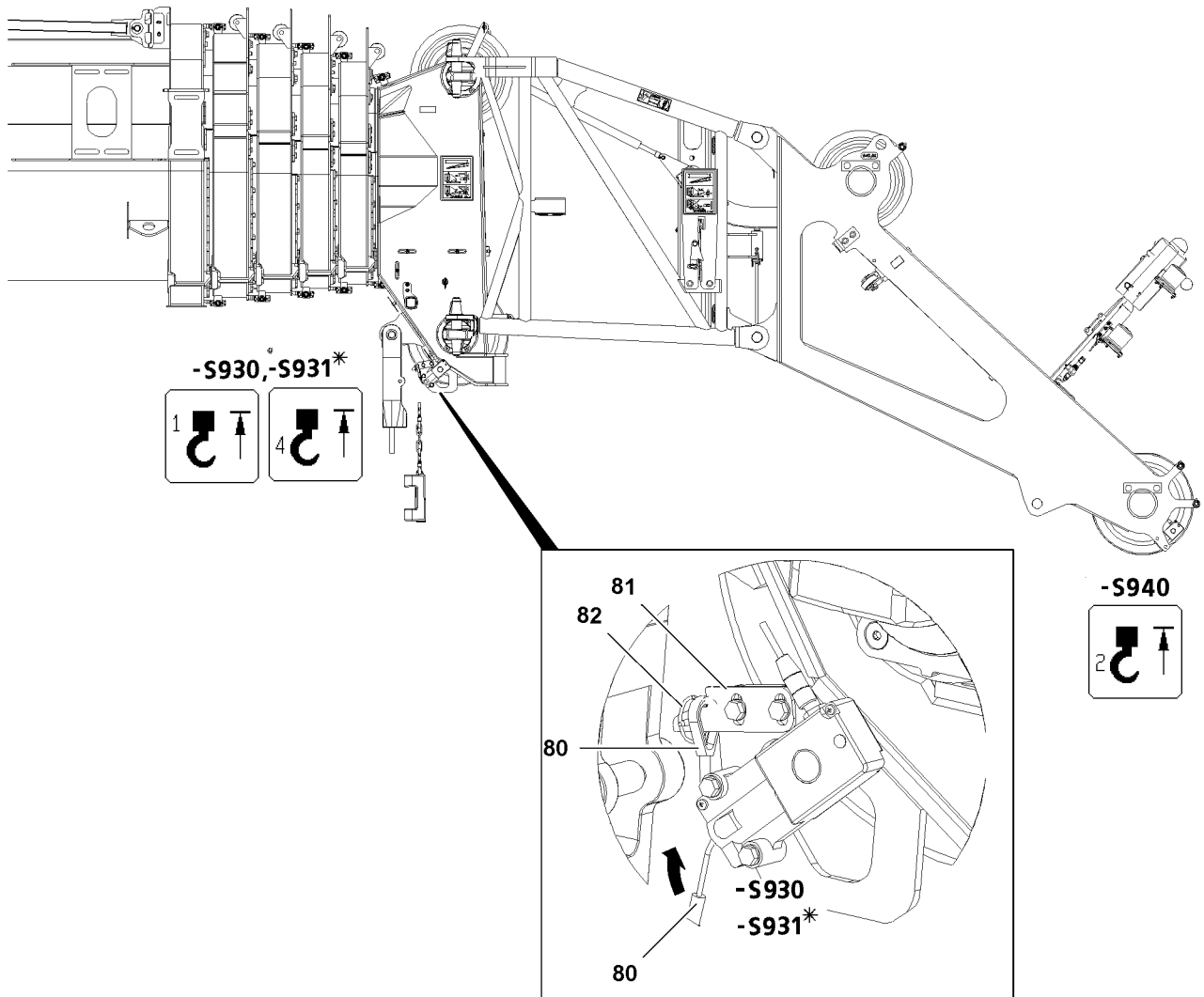


Fig.117351

LWE/LTR 1220-003/24204-02-02/en



## Two hook operation



### Note

- ▶ In two hook operation, the hoist limit switch **S930** on the telescopic boom and the hoist limit switch **S940** on the jib boom are active.

If installed on the telescopic boom:

- ▶ Actuate the hoist limit switch\* **-S931** mechanically.
- ▶ Insert the cable **-W942.S** with cable plug **-X935.S** into the socket **-X933.B**.
- ▶ Plug the cable **-W942A** into the socket **-X940.B**.
- ▶ Plug the Y-adapter with the plug **-X933.S** into the socket **-X940.B**.
- ▶ Plug the Y-adapter with the plug **-X940.S** into the socket **-X930.B**.
- ▶ Plug in the hoist limit switch **-S940**.

## Establishing the electrical connection to the LED continuous light\* or flashing beacon\*



### Note

- ▶ To be able to establish the electrical connection to the LED continuous light and the flashing beacon, the Y-adapter on the cable must be plugged in the socket **-X940.B** with the plug **X933.S**.
- ▶ Plug the LED continuous light or flashing beacon in the socket **-X934.B**.

## Establishing the electrical connection to the wind speed sensor\*



### Note

- ▶ To be able to establish the electrical connection to the wind speed sensor, the Y-adapter with the plug **X933.S** must be plugged in the socket **-X940.B**.
- ▶ Plug the wind speed sensor in the socket **-X938.B**.



### Note

- ▶ After the folding jib operation, protect the electrical connections from contamination with caps.

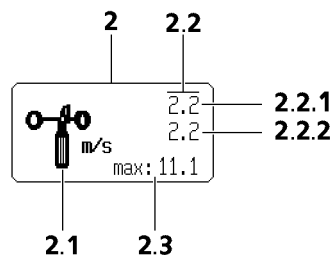
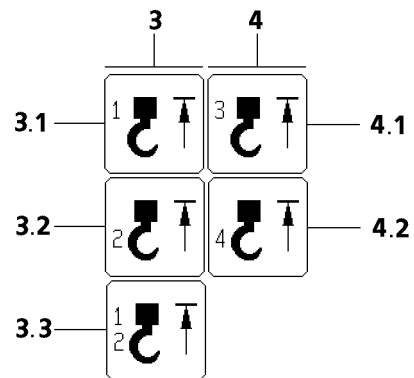


Fig.103473

### 2.6.3 Function check

Make sure that the following prerequisites are met:

- All electrical connections have been made.
- The LICCON computer system is running.

#### Wind sensor



#### CAUTION

Danger of accident due to toppling crane!

The wind speed can no longer be determined when attaching a defective wind sensor.

- ▶ Check the function of the wind sensor every time it is installed!

- ▶ Manually actuate the wind sensor.

#### Result:

- The „wind speed“ **2.2** icon element appears on the monitor.

#### Hoist limit switch

- ▶ Actuate all active hoist limit switches manually.

#### Result:

- The appropriate icon element „Hoist top“ appears on the monitor.
- The winch turns off.



#### Note

- ▶ When replacing or changing the hoist limit switch, the respective hoist limit switch must have the correct bus address and the correct software version in order to be detected by the bus system.

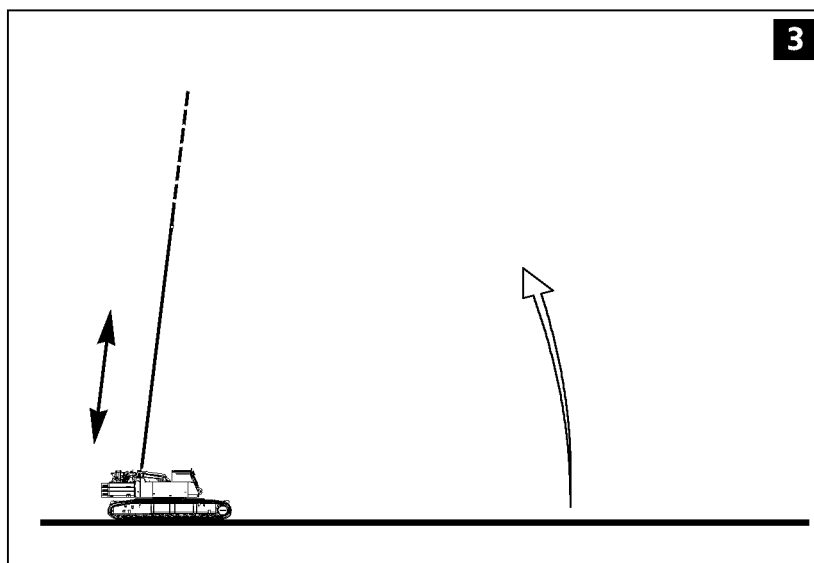
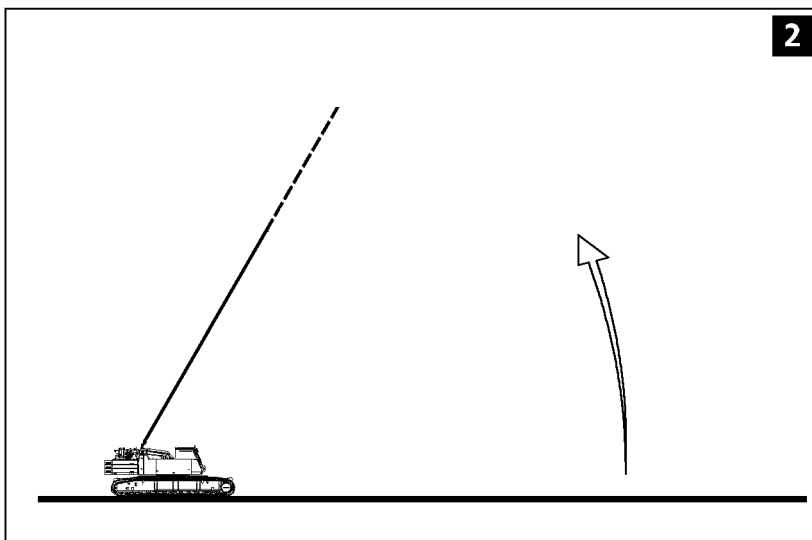
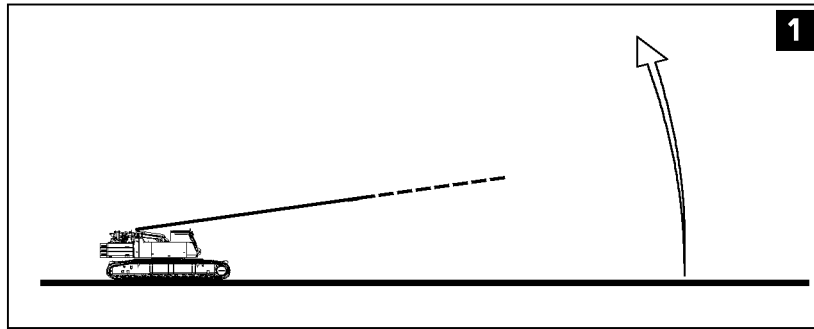


Fig.117352

## 3 Erecting

### 3.1 Preparatory work

Make sure that the following prerequisites are met:

- The track width is extended according to the load chart.
- The crane is horizontally aligned.
- The counterweight has been installed on the turntable according to the load chart.
- The telescopic boom is telescoped in all the way.
- The jib boom has been assembled according to the load chart and the operating instructions.
- The end section is folded and secured in operating position.
- All limit switches have been correctly installed and are fully functioning.
- All pin connections have been secured.
- The hoist rope has been correctly placed in the rope pulleys and prevented from jumping out with the rope retaining pins.
- There is no „debris“ on the telescopic boom and the jib boom.
- The telescopic boom, the jib boom and its components (such as: Limit switch, airplane warning light, wind speed sensor) must be free of snow and ice in winter.



#### **DANGER**

Danger of accident!

Incorrectly installed or non-functioning limits switches as well as falling parts (such as: pins, cotter pins, ice) can cause accidents.

- ▶ Install all limit switches, pins and cotter pins properly.
- ▶ Check if all prerequisites have been met.

### 3.2 Erection procedure



#### **DANGER**

Danger of accident due to toppling crane!

The boom radii specified in the load chart may not be exceeded or fallen below, even if there is no load on the hook! If this regulation is not observed, the crane can topple over.

- ▶ Compare and check the settings on the LICCON computer system with the actual set up configuration.

Adjustment of the LICCON overload protection, refer to the Crane operating instructions, chapter 4.02.

- ▶ Set and confirm the LICCON overload protection according to the required set up configuration.
- ▶ Luff the telescopic boom up with installed jib boom until the LICCON issues the release.
- ▶ Telescope the telescopic boom out to the values specified in the load chart.

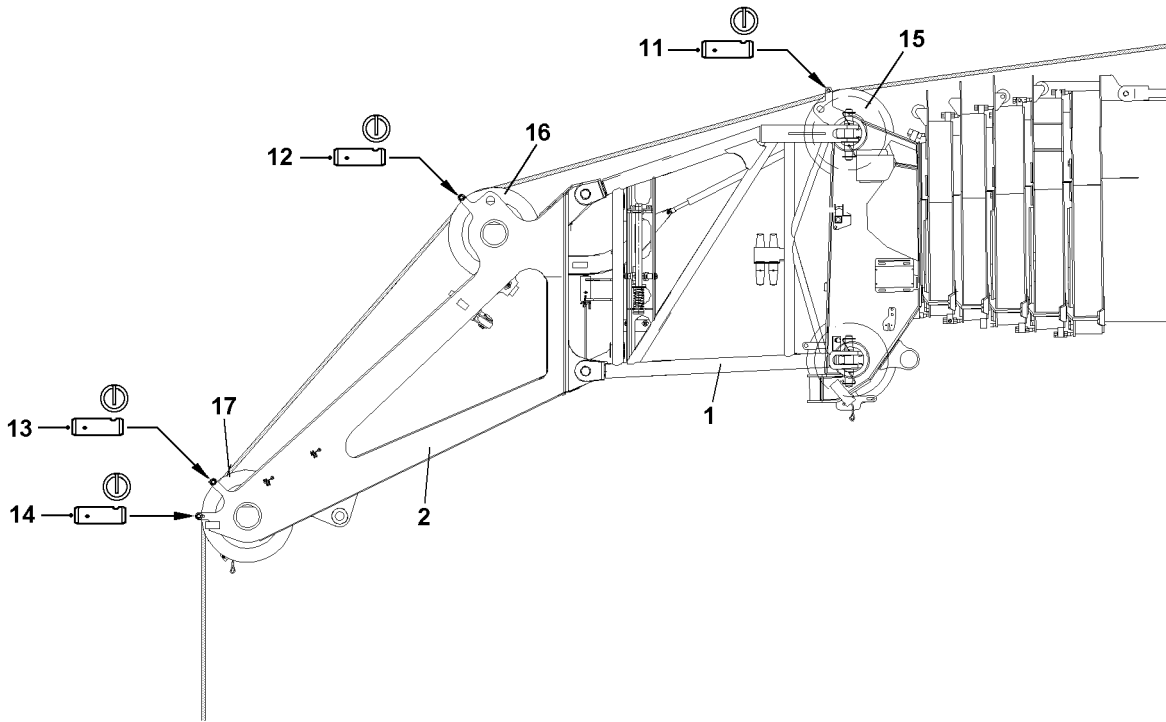


Fig.118508

LWE/LTR 1220-003/24204-02-02/en

## 4 Reeving the hoist rope out

---



### **DANGER**

Danger of falling from the jib boom!

When walking on the jib boom to reeve the hoist rope in or out, there is a risk of slipping and falling from the jib boom.

- ▶ Do not walk on the jib boom.
- 

### 4.1 Reeving the hoist rope out

Make sure that the following prerequisites are met:

- The telescopic boom is telescoped in all the way.
- The hook block / load hook has been taken down onto the ground.
- The hoist rope is detached from the rope fixed point.
- The hoist limit switch weight and the chain have been disassembled.
- ▶ Release and unpin the rope retaining pin **11**, rope retaining pin **12**, rope retaining pin **13** and rope retaining pin **14**.
- ▶ Spool the hoist rope up.
- ▶ Insert the rope retaining pin **11**, rope retaining pin **12**, rope retaining pin **13** and rope retaining pin **14** and secure with locking pins.

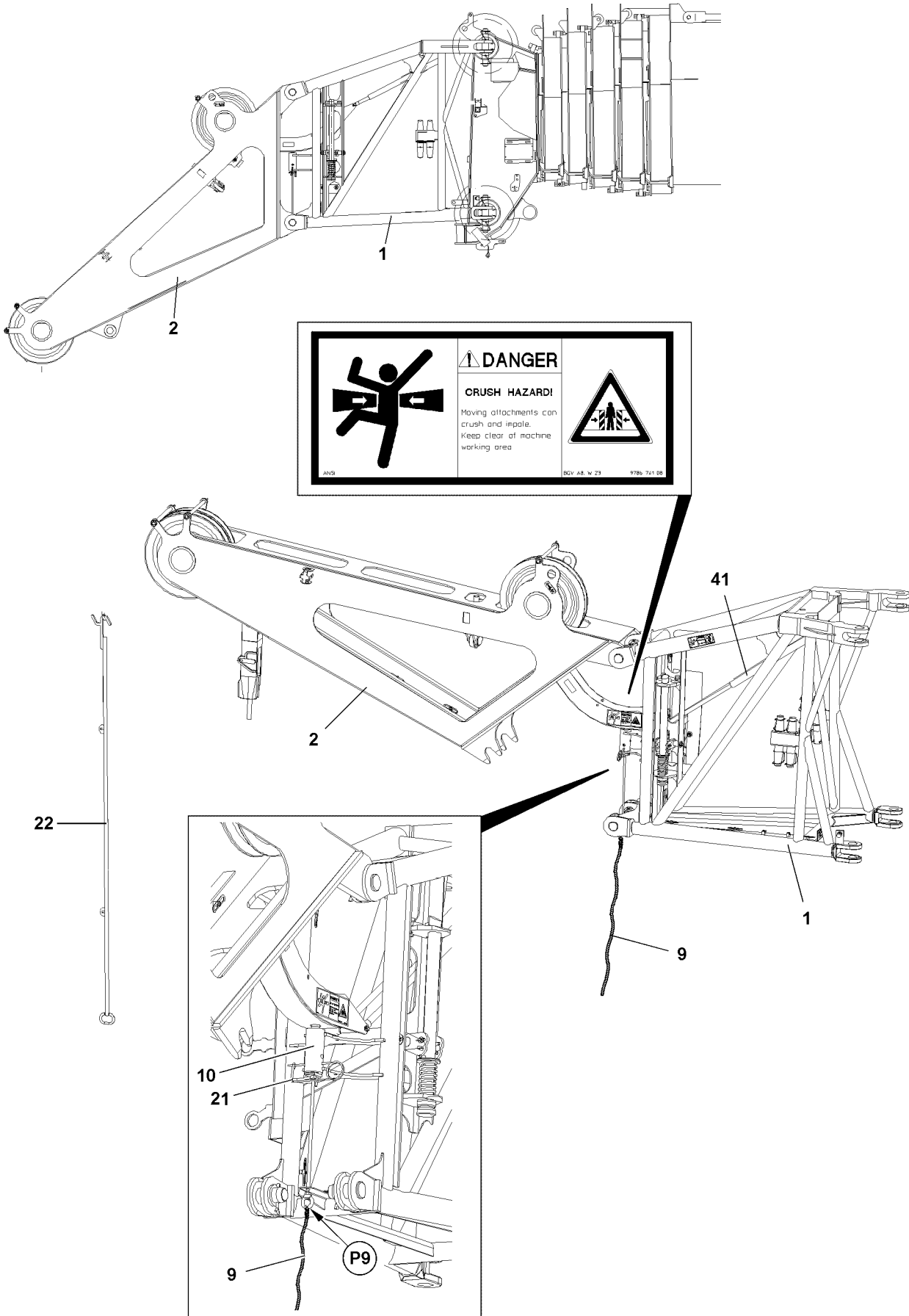


Fig.118507

LWE/LTR 1220-003/24204-02-02/en



## 5 Disassembling the jib boom

### 5.1 General



#### **DANGER**

Danger of fatal injury due to falling jib boom!

The jib boom can fall down due to a disassembly error.

- ▶ Standing under the jib boom during the swing operation is prohibited.
- ▶ It is prohibited for anyone to remain within the slewing range as well as the folding area of the jib boom.
- ▶ The jib boom must be secured by an auxiliary rope during the swing process.



#### **WARNING**

Danger of falling!

During assembly and disassembly, assembly personnel must be secured with appropriate aids to prevent them from falling! If this is not observed, assembly personnel could fall and suffer fatal injuries!

- ▶ All work at a height, when there is a danger of falling, must be carried out with suitable aids.
- ▶ If fall protection equipment is available, then it must be used, see the Crane operating instructions, chapter 2.06.
- ▶ If aids are not available and work cannot be carried out from the ground, then assembly personnel must secure themselves with the supplied fall arrest system to prevent falling, see the Crane operating instructions, chapter 2.04.
- ▶ The supplied fall arrest system must be fastened to the fastening and hook points. For safety points, see Crane operating instructions, chapter 2.06.
- ▶ Only step on the aids, ladders and catwalks with clean shoes.
- ▶ Keep aids, ladders and catwalks free of heavy dirt, snow and ice.
- ▶ Do not walk on the jib boom.

Make sure that the following prerequisites are met:

- The crane is horizontally aligned.
- The counterweight has been installed on the turntable according to the load chart.
- The telescopic boom is telescoped in all the way.
- The electrical connection of the jib boom has been disconnected.
- The telescopic boom has been luffed up to the rear or the side in the 1° position.

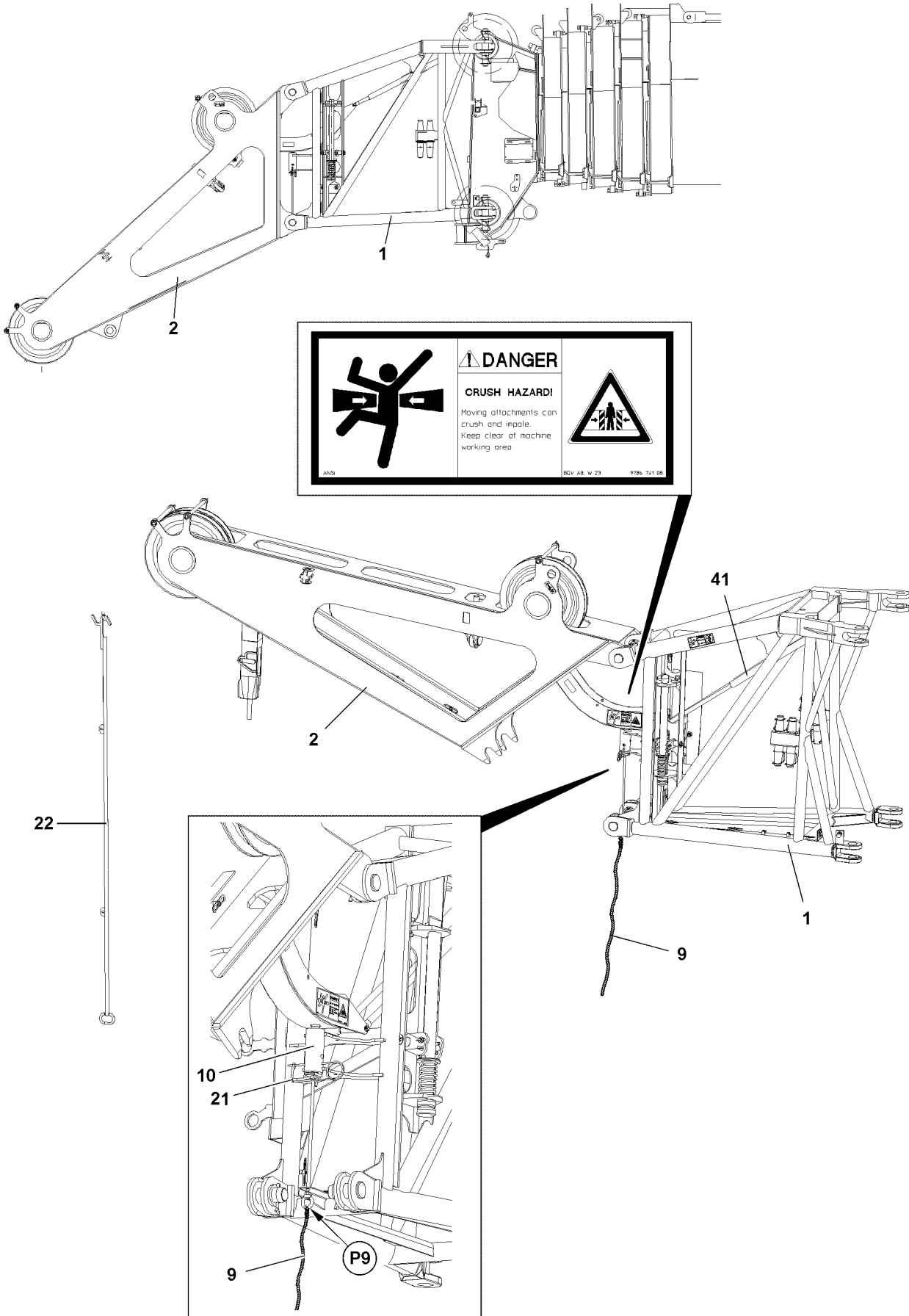


Fig.118507

LWE/LTR 1220-003/24204-02-02/en

## 5.2 Disassembling the jib boom carried on the crane

### 5.2.1 Folding the end section into the transport position



#### DANGER

Danger of fatal injury in case of a defective pneumatic spring!

Defective pneumatic springs **41** no longer provide the supporting action for the movable components on the jib boom.

If the pneumatic spring **41** is defective, the end section **2** can fall down and fatally or seriously injure personnel.

There is an increased danger of accident.

- ▶ Before unpinning the spring pin **10** and before actuation, check the pneumatic spring **41** for external damage.
- ▶ Do not use a jib boom with a defective pneumatic spring **41**. Replace the defective pneumatic spring **41**.
- ▶ If the pneumatic spring **41** is defective, support the end section **2** from below or hang it on an auxiliary crane.
- ▶ It is strictly prohibited for personnel or objects to remain within the movement range between the end section **2** and the pivot section **1**.
- ▶ It is prohibited for personnel or objects to remain within the danger zone of the moving components.

- 
- ▶ Check the pneumatic spring **41** for external damage.
  - ▶ Attach the auxiliary rope **9** to point **P9**.
  - ▶ Remove the retaining pin **21**.
  - ▶ Hook the assembly rod **22** in the end section **2** and unpin the spring pin **10** with the auxiliary rope **9**.
  - ▶ Fold the end section **2** up with the assembly rod **22** until the spring pin **10** engages.
  - ▶ Secure the spring pin **10** with the retaining pin **21**.



#### DANGER

Danger of accident!

- ▶ The spring pin **10** must be engaged and secured **before** the jib boom is swung into transport position.

- 
- ▶ Engage and secure the spring pin **10**.

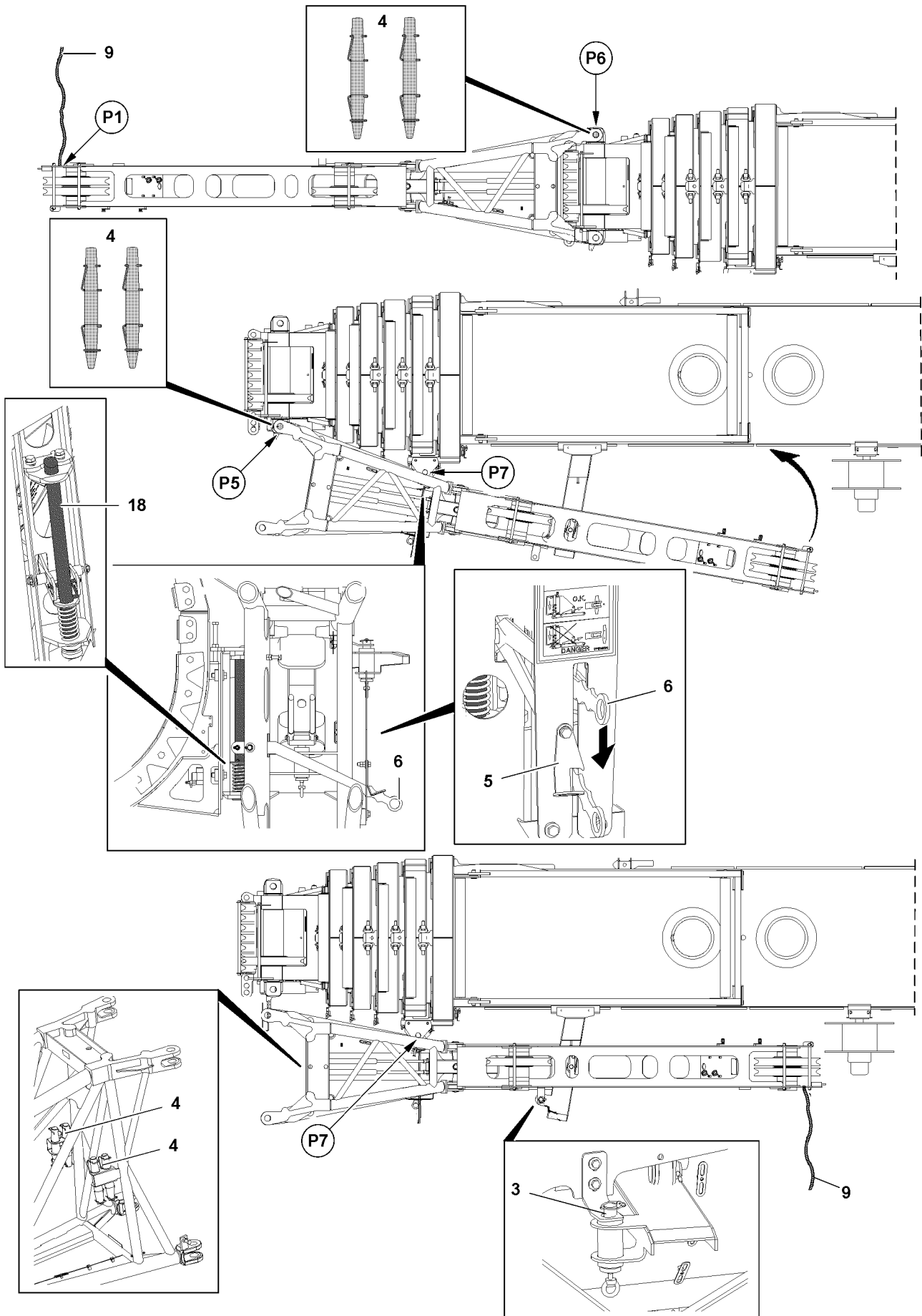


Fig.117353

LWE/LTR 1220-003/24204-02-02/en

## 5.2.2 Swinging the jib boom into the transport position

Make sure that the following prerequisite is met:

- The telescopic boom is luffed up to the rear or to the side to 1°.



### WARNING

Danger of accident due to involuntary swinging out of the jib boom!

If the telescopic boom is not luffed up to 1°, then the jib boom may not be disassembled.

- ▶ Luff the telescopic boom up to 1°.
- ▶ Attach the auxiliary rope **9** to point **P1**.



### DANGER

The jib boom can swing out inadvertently!

While unpinning the pin **4** in point **P6**, the jib boom can swing out inadvertently.

In order to prevent the jib boom from inadvertently swinging out:

- ▶ Hold the jib boom with the auxiliary rope.
- ▶ It is prohibited to lean the ladder against the jib boom.
- ▶ Release and unpin the pins **4** on the bottom and on top in point **P6**.
- ▶ Swing the safety bracket **5** to the side.
- ▶ Disengage the hand lever **6** with the assembly rod from the platform **7** and pull downward.
- ▶ Swing the jib boom in with the auxiliary rope **9** until the lock **18** audibly engages in point **P7**.
- ▶ Check if the lock **18** has engaged properly in point **P7**.
- ▶ Secure the hand lever **6** with the retaining bracket **5**.



### DANGER

Danger of fatal injury due to falling jib boom!

If the pins **4** are unpinned in point **P5** before the lock **18** has audibly engaged, then the jib boom will fall down and possibly fatally injure assembly personnel.

- ▶ The pins **4** may not be unpinned until the lock **18** has audibly engaged in point **P7** and the hand lever **6** has been secured with the safety bracket **5**.
- ▶ Release and unpin the pins **4** on the bottom and on top in point **P5**.
- ▶ Release and unpin the spring pin **3**.
- ▶ Swing the jib boom in until the spring pin **3** engages.
- ▶ Secure the spring pin **3**.
- ▶ Remove the auxiliary rope **9**.

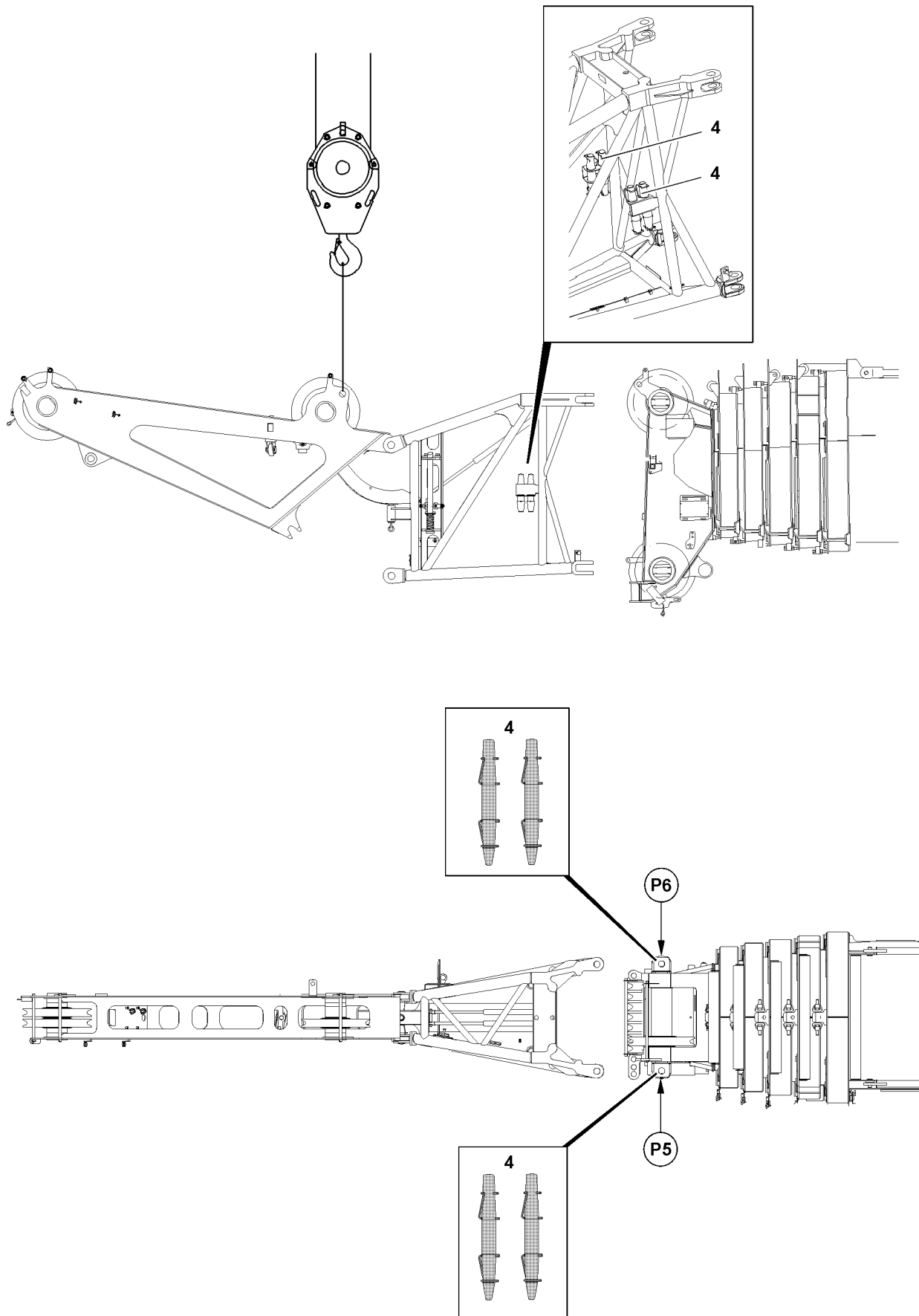


Fig.117350

LWE/LTR 1220-003/24204-02-02/en

### 5.3 Disassembling the separately transported auxiliary jib

Make sure that the following prerequisite is met:

- The telescopic boom is luffed up to the rear or to the side to 1°.
- ▶ Fasten the auxiliary crane to the fastening point of the jib boom.



#### **DANGER**

Danger of accident when disassembling the auxiliary jib!

If the following conditions are not met, then the assembly personnel can be fatally injured during disassembly.

- ▶ When knocking out the pins, no personnel may remain under the auxiliary jib!
  - ▶ Fasten the auxiliary crane so that no angular pull occurs.
  - ▶ Only lift as much weight with the jib crane which corresponds to the weight of the jib boom.
  - ▶ The jib boom can detach suddenly because of distortion.
  - ▶ Do not remove the jib boom until it has been secured with the auxiliary crane to prevent it from falling.
  - ▶ It is prohibited to lean the ladder against the jib boom.
- 
- ▶ Tighten the fastening ropes until the jib boom is secured to prevent it from falling.
  - ▶ Unpin the jib boom on the telescopic boom:
  - ▶ Release the pin **4** on the bottom in point **P5** and unpin.
  - ▶ Release the pin **4** on the bottom in point **P6** and unpin.
  - ▶ Release the pin **4** on top in point **P5** and unpin.
  - ▶ Release the pin **4** on top in point **P6** and unpin.
  - ▶ Insert and secure all pins **4** in the transport receptacle.
  - ▶ Take the jib boom down onto the transport vehicle.

---

Empty page!

LWE/LTR 1220-003/24204-02-02/en



## 5.19 Hook blocks

1	Procedure in case of slack rope	3
2	Hook block overview	5
3	Transporting the hook block / load hook	7
4	Installing the single blocks	9
5	Removing the single blocks	13

*Fig.195219*

LWE/LTR 1220-003/24204-02-02/en

# 1 Procedure in case of slack rope

## 1.1 Lowering the hook block if slack rope forms

If the hook block can no longer be lowered due to slack rope formation, then the following steps must be carried out.

### 1.1.1 Spooling up loose hoist rope

- ▶ Spool up loose hoist rope between the boom head and the winch carefully onto the winch.



---

**Note**

- ▶ A slight rope slack must remain between the boom head and the winch!
- 

### 1.1.2 Luffing the boom down

---

**NOTICE**

Risk of collision!

When luffing the boom down, the hoist rope length can shorten and pull the hook block against the boom head.

- ▶ Monitor the distance of the hook block to the boom head!
- 

- ▶ Luff the boom down carefully.

**Result:**

- The hoist rope between the boom head and the winch is tensioned.

### 1.1.3 Lowering the hook block

- ▶ Lower the hook block carefully with the hoist gear.

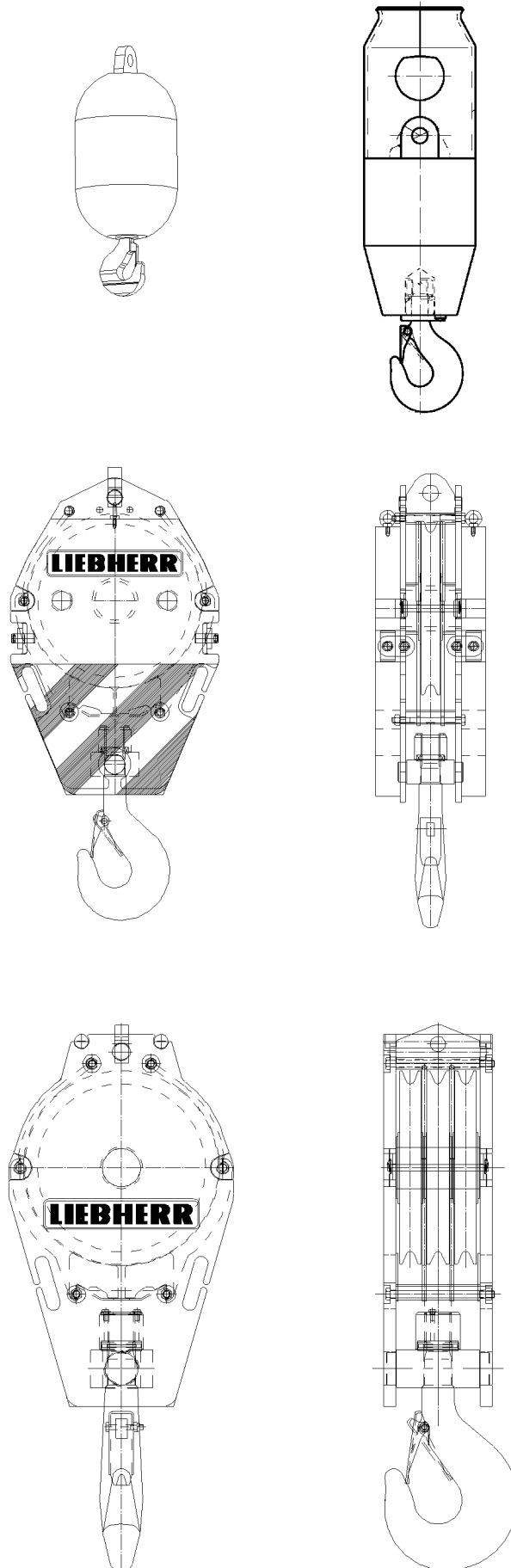


Fig.108963

LWE/LTR 1220-003/24204-02-02/en

## 2 Hook block overview

### 2.1 Handling of hook blocks



#### Note

- ▶ For the load hooks and hook blocks approved for this crane type refer to the separate load chart manual!
- ▶ The hook blocks shown in this chapter are only examples and can differ from your hook block in type and number of rope pulleys. The different assembly and disassembly procedures are therefore only an example of the description for a number of different hook blocks!



#### DANGER

Hook block weights!

If the data in the erection and take down charts as well as the load charts are not observed, dangerous situations up to toppling of the crane can occur!

Personnel can be severely injured or killed, in addition, high property damage can result!

- ▶ Observe the data in the erection and take down charts!
- ▶ The specifications in the load charts must be adhered to!
- ▶ The crane operator bears the sole and full responsibility for the adherence to the data in the erection and take down charts as well as the load charts!

Differently sized hook blocks can be used for various loads.

#### NOTICE

Rope damage due to insufficient hook block weight!

If the hook block weight is too low to tighten the hoist rope sufficiently, spooling problems may occur on the winches when lowering and lifting the hook block due to slack rope formation!

The hoist rope can be damaged!

- ▶ In order to prevent spooling problems on the winches, the hook block weight may be increased with auxiliary weights, if necessary!
- ▶ If problems develop in the assembly and set up conditions due to the weight increase of the hook block, auxiliary weights must be removed again!

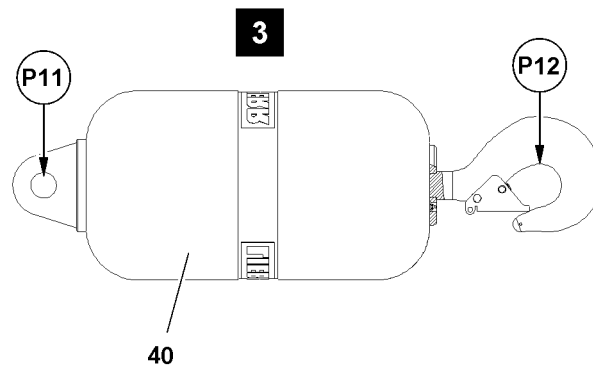
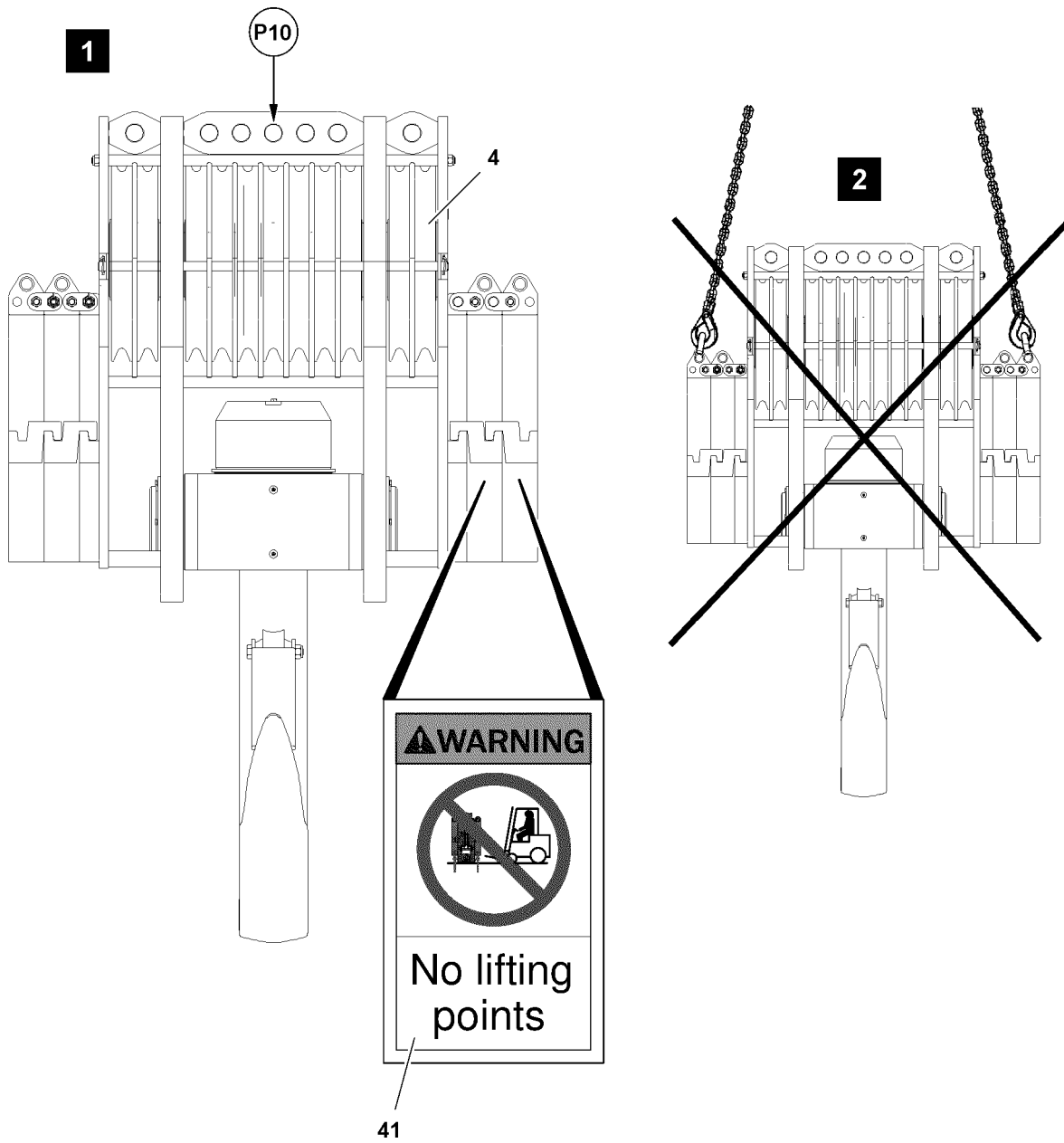


Fig.118076

LWE/LTR 1220-003/24204-02-02/en

## 3 Transporting the hook block / load hook

### 3.1 Transporting the hook block / load hook with the crane

**WARNING**

Falling hook block during transport!

If the hook block **4** is fastened incorrectly, then the fastening point can fail and the hook block **4** can fall down!

Personnel can be killed or seriously injured!

- ▶ Fasten the hook block **4** exclusively in the center on the fastening point **P10**, illustration 1.
- ▶ Do **not** fasten the hook block **4** on the auxiliary weights, illustration 2.

- ▶ Fasten the load hook **40** on the fastening point **P11** or on the hook **P12**, illustration 3.

### 3.2 Transporting the hook block / load hook with the forklift

**WARNING**

Falling hook block during transport!

If the hook block **4** is lifted with a forklift on the auxiliary weights, the auxiliary weights can fail and the hook block **4** can fall down! See sign **41**.

Personnel can be killed or seriously injured!

- ▶ Place the hook block **4** for transport on the EU-pallet.
- ▶ Do **not** lift the hook block **4** with a forklift on the auxiliary weights.

- ▶ Transport the hook block **4** with a EU-pallet.

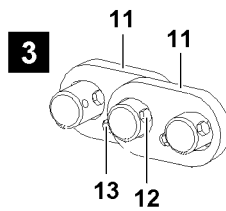
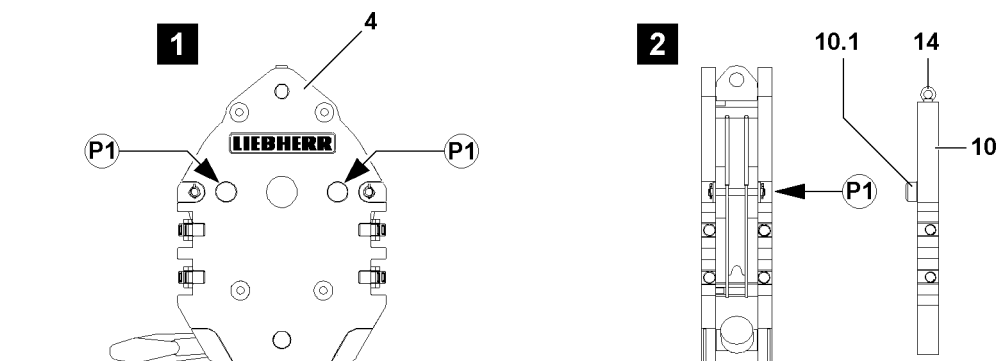


Fig.108965



## 4 Installing the single blocks

### 4.1 Installing the auxiliary weights



#### Note

- ▶ The own weight for each auxiliary weight is marked on the auxiliary weight!



#### WARNING

Toppling of hook block!

If the auxiliary weights are installed one-sided, the hook block can topple over!

Personnel can be severely injured or killed!

- ▶ The auxiliary weights may only be installed **individually** and alternately on the left and right on the hook block!
- ▶ When the required auxiliary weight is installed on the hook block, the difference between the left and right side may never be more than one auxiliary weight!
- ▶ Asymmetrical installation of auxiliary weights is prohibited!
- ▶ Do not exceed the maximum permissible own weight of the hook block! The maximum permissible own weight is engraved on ballastable hook blocks. See „Engraving WT max.“.

Make sure that the following prerequisite is met:

- The hook block is placed on the ground.



#### WARNING

Falling auxiliary weights!

If the auxiliary weights are not properly installed on the hook block, then they can fall down during installation or in crane operation!

Personnel can be severely injured or killed!

- ▶ Standing under a suspended auxiliary weight is prohibited!
- ▶ Make sure that the auxiliary weights are properly installed and secured!
- ▶ Crane operation with insufficiently secured auxiliary weights is prohibited!
- ▶ Attach the auxiliary weight **10** on the ring screw **14** on the auxiliary crane.



#### WARNING

Danger of crushing!

When swinging the auxiliary weights to the hook block, personnel can be severely injured or killed!

Fingers, hands and arms can be crushed or severed!

- ▶ It is prohibited for anyone to remain between the hook block and the auxiliary weight!
- ▶ Swing auxiliary weights in to the hook block with utmost caution and at the least possible speed!

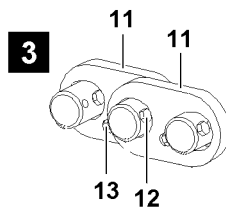
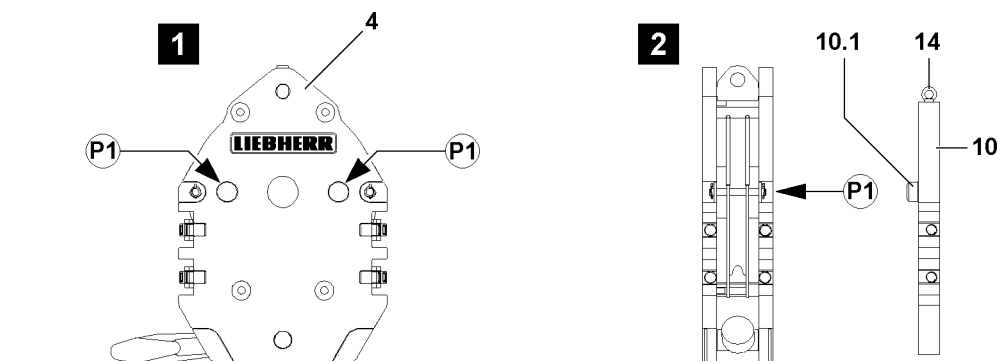


Fig.108965

- ▶ Align the auxiliary weight **10** on the hook block.
- ▶ Move the centering pin **10.1** of the auxiliary weight into the centering bores **P1** on the hook block.

**WARNING**

Falling auxiliary weights!

If all mounting brackets **11** are removed simultaneously on an unsecured auxiliary weight, then the auxiliary weight can fall down!

Personnel can be severely injured or killed!

- ▶ Never remove all mounting brackets **11** of an unsecured auxiliary weight at the same time!
- ▶ Always install or remove the mounting brackets **11** alternately!

- ▶ Install the mounting brackets **11** on the side and connect the hook block with the auxiliary weight **10**, illustration **3**.
- ▶ Secure the mounting brackets **11** with screws **12** and lock nuts **13**, illustration **3**.

**Note**

- ▶ Additional auxiliary weights must be connected with the mounting brackets **11**!

**WARNING**

Falling auxiliary weights!

The auxiliary weights can fall down by removing the auxiliary crane!

Personnel can be severely injured or killed!

- ▶ Remove the auxiliary crane only when it is ensured that the auxiliary weight **10** is properly secured with the mounting brackets **11**!

When the respective auxiliary weight is properly installed and secured:

- ▶ Remove the auxiliary crane.

## 4.2 Preparing the hook block for crane operation

**Note**

- ▶ The reeving of the hook blocks is described in chapter 4.06 of the Crane operating instructions!
- ▶ Observe the „permissible hook block weights“ in the erection and take down charts!
- ▶ Reeve the hoist rope according to the instructions in chapter 4.06 of the Crane operating instructions and the reeving plans!

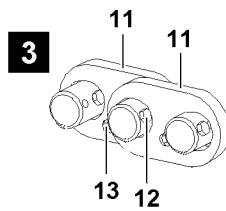
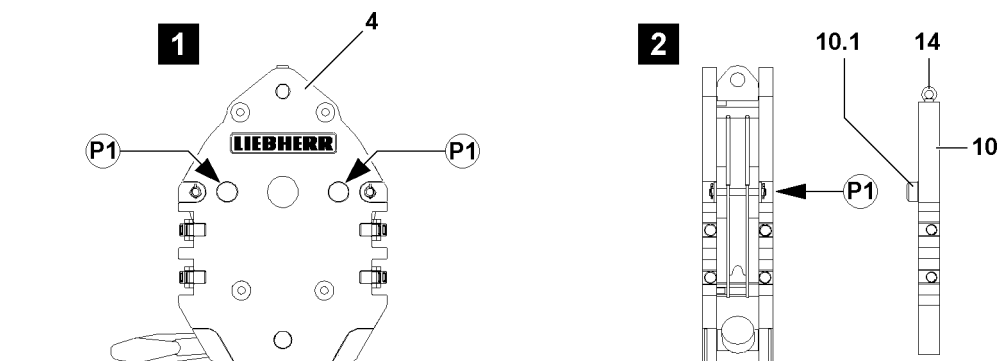


Fig.108965

## 5 Removing the single blocks

### 5.1 Preparing the hook block for removal



#### Note

- ▶ The unreeving of the hook blocks is described in chapter 4.06 of the Crane operating instructions!
- ▶ Observe the „permissible hook block weights“ in the erection and take down charts!

Make sure that the following prerequisites are met:

- The ground is sufficiently load bearing to take on the weight of the hook block and the auxiliary weights safely.
- The ground is level and horizontal.
- ▶ Lower the hook block completely to the ground.

When the hook block was placed down on the ground properly:

- ▶ Unreeve the hoist rope according to chapter 4.06 of the Crane operating instructions!

### 5.2 Removing the auxiliary weights



#### Note

- ▶ The own weight for each auxiliary weight is marked on the auxiliary weight!



#### WARNING

Toppling of hook block!

If the auxiliary weights are removed one-sided, the hook block can topple over!

Personnel can be severely injured or killed!

- ▶ The auxiliary weights may only be removed **individually** and alternately on the left and right on the hook block!
- ▶ The difference between the left and the right side at removal of the auxiliary weights may never be more than one auxiliary weight!
- ▶ Asymmetrical removal of auxiliary weights is prohibited!



#### WARNING

Falling auxiliary weights!

If the auxiliary weights on the pulley block are not properly removed, then they can fall down at removal!

Personnel can be severely injured or killed!

- ▶ Standing under a suspended auxiliary weight is prohibited!
- ▶ Attach the auxiliary weight **10** on the ring screw **14** on the auxiliary crane.
- ▶ Tension the fastening equipment carefully.

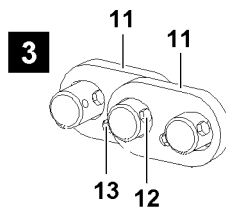
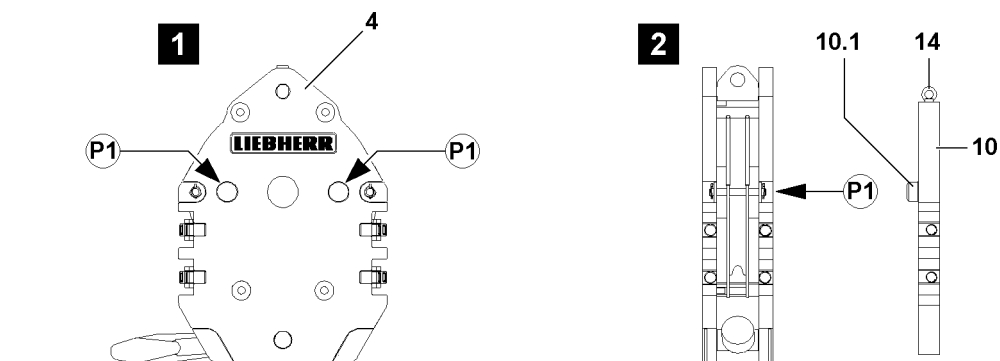


Fig.108965

**WARNING**

Oscillating auxiliary weights!

During the removal of the auxiliary weights, the auxiliary weights can start to swing back and forth!  
Personnel can be severely injured or killed!

- ▶ It is prohibited for anyone to remain in the danger zone!
- ▶ Make sure that the auxiliary weight which is being removed is properly attached on the auxiliary crane before releasing the mounting brackets!
- ▶ Angular pull is prohibited!

When the fastening equipment is tensioned on the auxiliary weight:

- ▶ Release the screw connection on the mounting brackets of the outermost auxiliary weight and remove the screws.

**WARNING**

Falling auxiliary weights!

If all mounting brackets **11** are removed simultaneously on an unsecured auxiliary weight, then the auxiliary weight can fall down!

Personnel can be severely injured or killed!

- ▶ Never remove all mounting brackets **11** of an unsecured auxiliary weight at the same time!
- ▶ Always install or remove the mounting brackets **11** alternately!

- ▶ Pull the mounting brackets **11** off to the side.

**WARNING**

Falling auxiliary weights!

If additional auxiliary weights which are being removed are released, then these auxiliary weights can fall down!

Personnel can be severely injured or killed!

- ▶ Make sure, before removing the outermost auxiliary weight, that the other auxiliary weights are secured with the mounting brackets **11**!

If additional mounting brackets **11** must be removed to release the outermost auxiliary weight:

- ▶ Reinstall the mounting brackets **11** again immediately, so that only the auxiliary weight which is being removed is released.
- ▶ Lift the auxiliary weight with the auxiliary crane from the hook block.
- ▶ Place the auxiliary weight onto the ground.
- ▶ Remove the auxiliary crane.
- ▶ Remove additional auxiliary weights as described above.

---

Empty page!

LWE/LTR 1220-003/24204-02-02/en



## 5.25 Telescopic boom extension

1	General	3
2	Assembly	5
3	Establishing the electrical / hydraulic connections	7
4	Erection	7
5	Disassembly	9

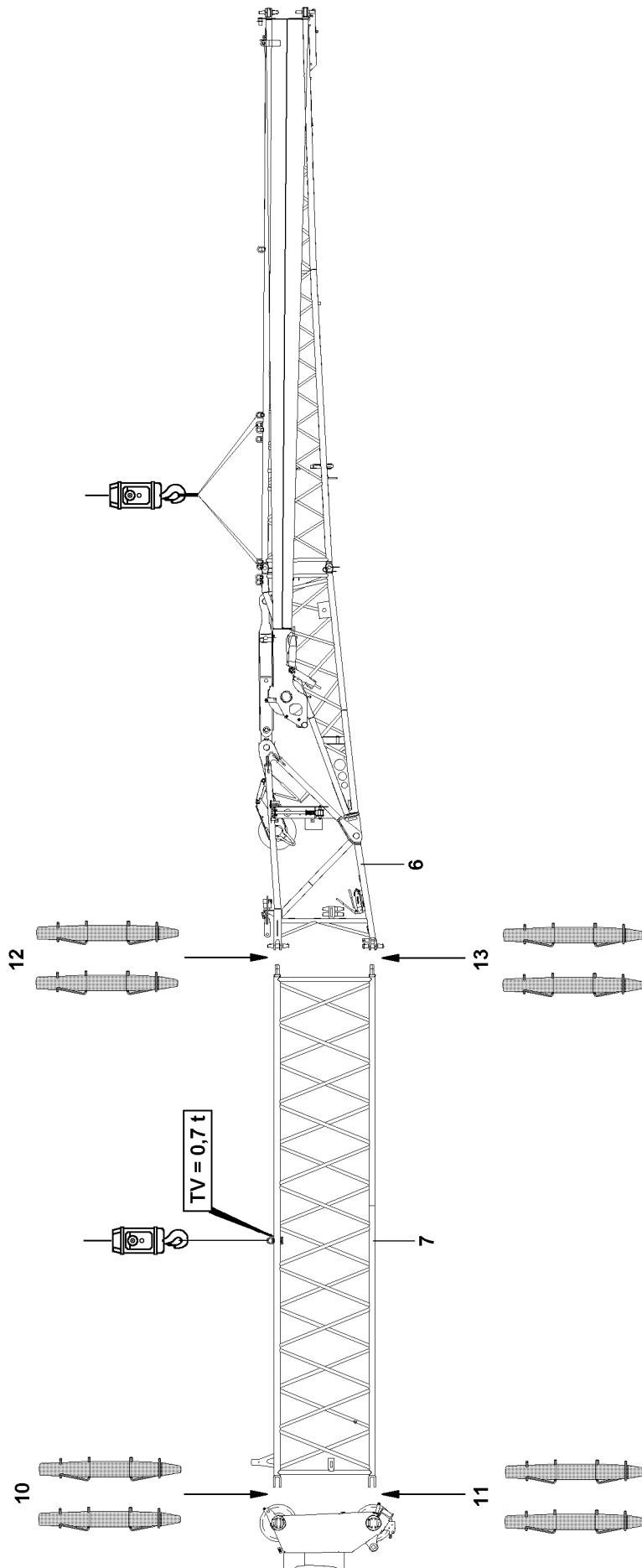


Fig.114346

LWE/LTR 1220-003/24204-02-02/en

# 1 General

In order to increase the lifting height on this crane, a 7 m long telescopic boom extension can be installed.



## DANGER

Danger of falling!

During assembly and disassembly, assembly personnel must be secured with appropriate aids to prevent them from falling. If this is not observed, assembly personnel could fall and suffer life-threatening injuries.

- ▶ Also refer to hazard warnings in the Crane operating instructions, chapter 5.01, section „Assembly / disassembly“.

## 1.1 Telescopic boom extension fastening points



## DANGER

Danger of accident due to incorrect attachment!

Life-threatening situations can arise if the telescopic boom extension is improperly or incorrectly attached!

- ▶ Attach the telescopic boom extension according to the fastening points shown on the signs!
- ▶ The appropriate fastening eye hooks / fastening points are marked with signs.
- ▶ Attaching the telescopic boom extension on non-intended points or on any arbitrary location is **prohibited!**



## CAUTION

Damage of fastening points!

If the fastening equipment is too short, then the fastening points on the telescopic boom extension can be damaged!

- ▶ To attach the telescopic boom extension, fastening equipment with a strand length of at least 2000 mm each must be used!

Description	Abbreviation	Weight
Telescopic boom extension	TV	0.7 t

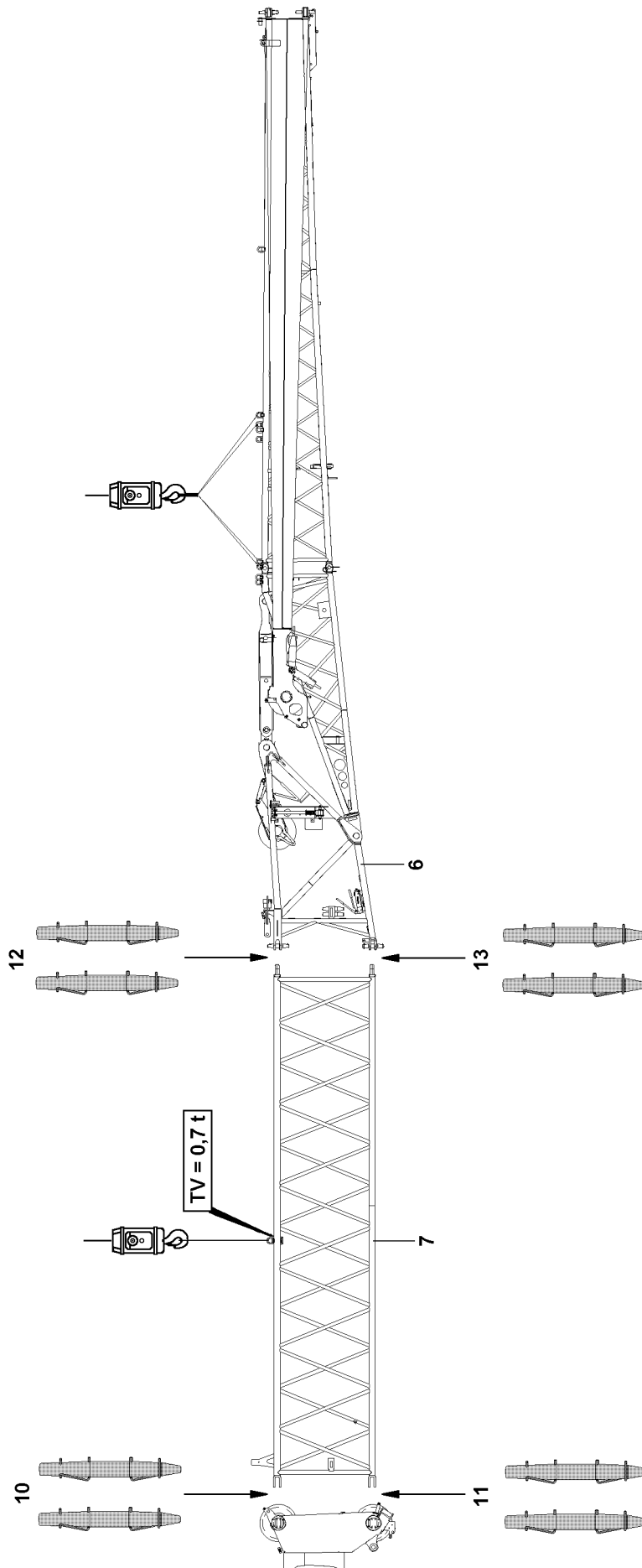


Fig.114346

LWE/LTR 1220-003/24204-02-02/en

## 2 Assembly



### DANGER

Danger of accident during the assembly / disassembly of the telescopic boom extension!

If the following conditions are not fulfilled, people may be fatally injured during assembly / disassembly.

- ▶ When knocking the pins out, no personnel may be underneath the telescopic boom extension!
- ▶ Unpin or insert the pins in the sequence specified in the operating instructions!
- ▶ Unpin or insert the pins from the top to the bottom!
- ▶ The use of cotter pins or spring retainers is prohibited on pins **10**, pins **11**, pins **12** and pins **13**!
- ▶ To secure the pins **10**, pins **11**, pins **12** and pins **13**, use the special retaining clips.
- ▶ Attach the auxiliary crane so that no diagonal pull occurs!

Make sure that the following prerequisites are met:

- The crane is properly supported and horizontally aligned.
- The counterweight has been installed on the turntable according to the load chart.
- The telescopic boom is fully telescoped in.
- The telescopic boom has been luffed down to the rear or the side in the 0° position.
- An auxiliary crane is on hand.

### 2.1 Assembly procedure

- ▶ Attach telescopic boom extension **7** to the auxiliary crane and insert into the fork heads at the telescopic boom.
- ▶ Pin the telescopic boom extension **7** with the telescopic boom: Insert the pins **10** on both sides from top to bottom and secure.
- ▶ Insert the pins **11** on both sides from top to bottom and secure.

For the fastening points of the folding jib, see chapter 5.02.

- ▶ Attach folding jib to the auxiliary crane and insert into the fork heads at the telescopic boom extension **7**.
- ▶ Pin the folding jib with the telescopic boom extension **7**: Insert the pins **12** on both sides from top to bottom and secure.
- ▶ Insert the pins **13** on both sides from top to bottom and secure.

For more information concerning folding jib assembly see chapter 5.02.

- ▶ Completely assemble the folding jib.

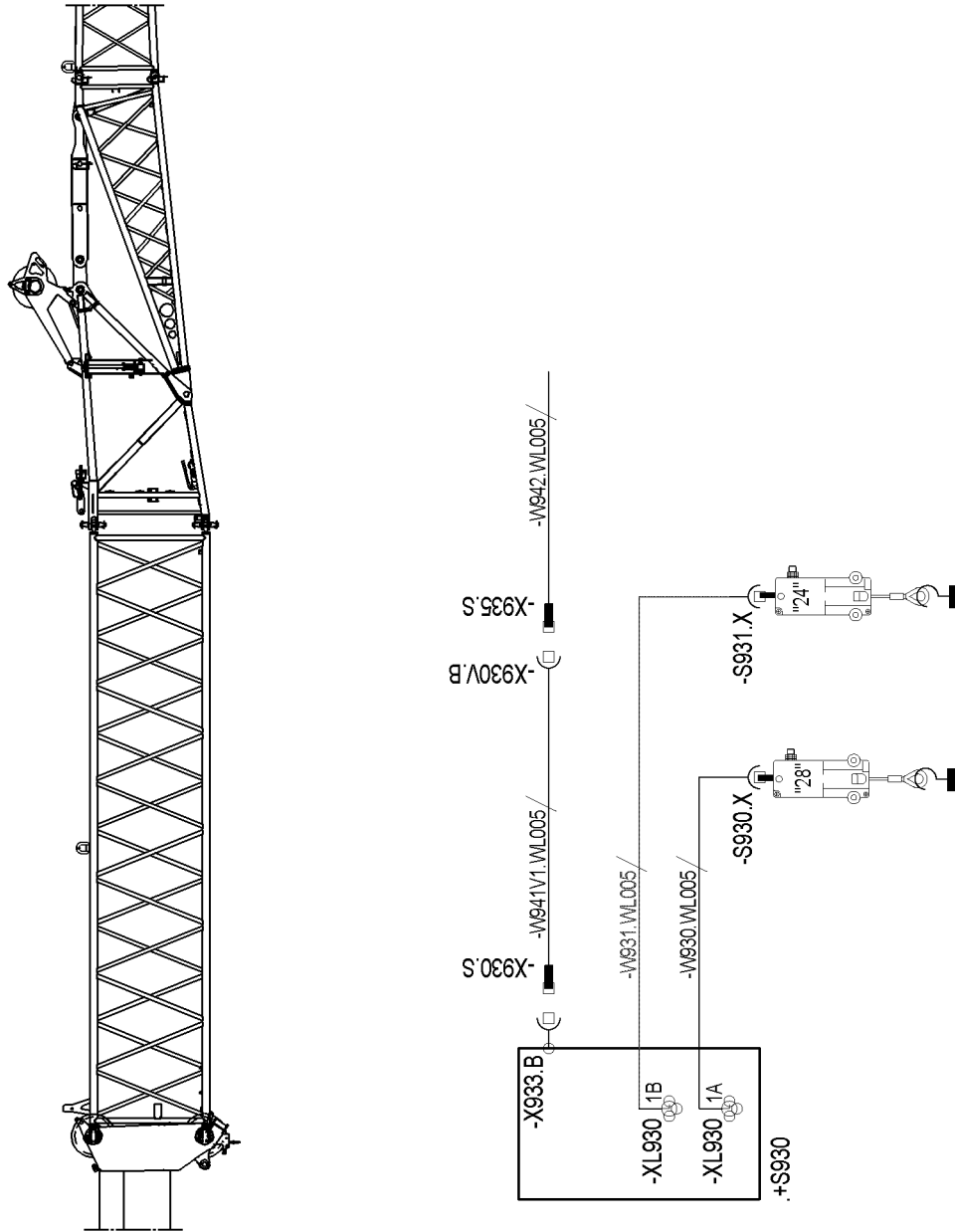


Fig.114347

## 3 Establishing the electrical / hydraulic connections

### 3.1 Establishing the hydraulic connection

A hydraulic connection to the folding jib must only be established for a hydraulic angle adjustment (TNZK operation). Hydraulic lines cannot be incorrectly connected due to the different diameters of the hydraulic connections.

For operation with a hydraulic folding jib:

- ▶ Establish the hydraulic connections.

After operation with a hydraulic folding jib:

- ▶ Protect the connections from contamination.

### 3.2 Establishing the electrical connection

- ▶ Insert the cable plug **-X930.S** into the socket **-X933B**.
- ▶ Insert the cable plug **-X935S** into the socket **-X930VB**.

For remaining electrical connections to the folding jib, see Crane operating instructions, Chapter 5.02.

- ▶ Establish the electrical connection for the folding jib.

## 4 Erection

Carry out the erection according to the Crane operating instructions, chapter 5.02.

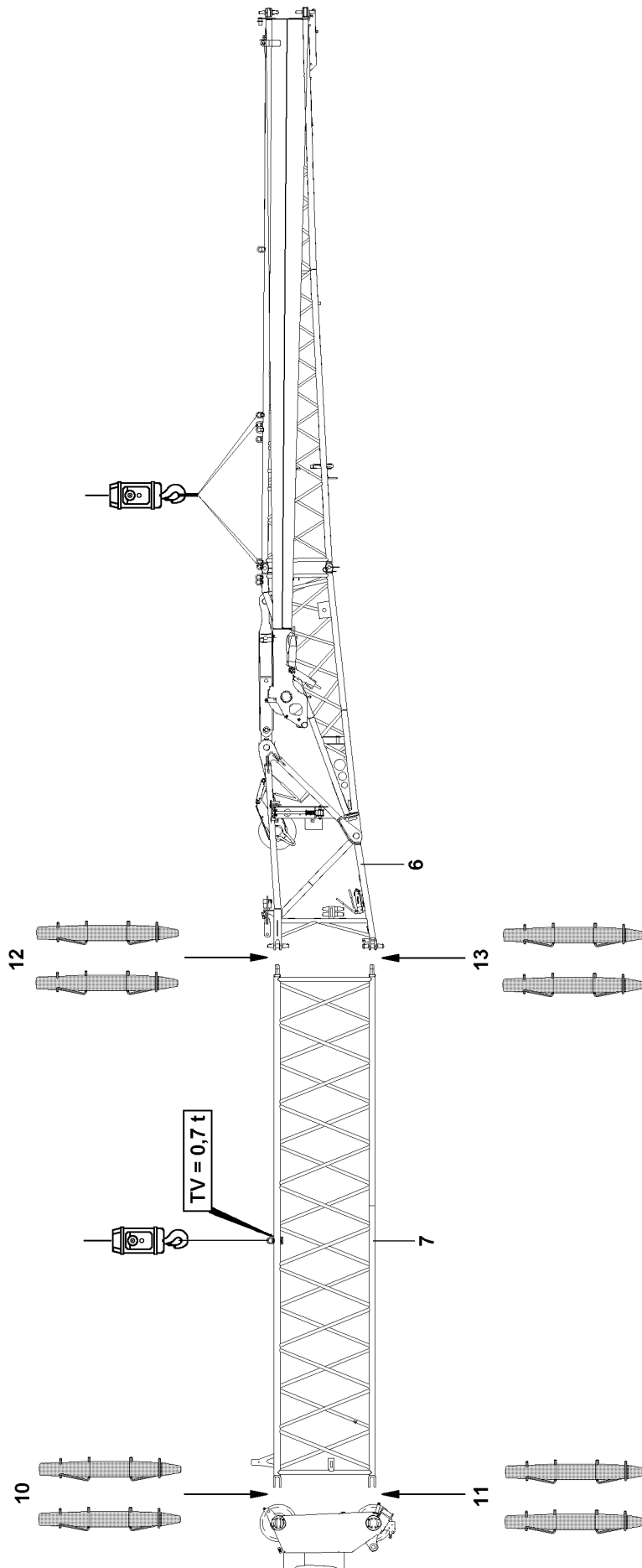


Fig.114346

LWE/LTR 1220-003/24204-02-02/en



## 5 Disassembly



### DANGER

Danger of accident during the assembly / disassembly of the telescopic boom extension!

If the following conditions are not fulfilled, people may be fatally injured during assembly / disassembly.

- ▶ When knocking the pins out, no personnel may be underneath the telescopic boom extension or the folding jib!
- ▶ Remove or insert the pins in the sequence specified in the operating instructions!
- ▶ Unpin or insert the pins from the top to the bottom!
- ▶ Attach the auxiliary crane so that no diagonal pull occurs!
- ▶ Only lift a weight with the auxiliary crane that corresponds to the weight of the folding jib or telescopic boom extension that is being removed!
- ▶ The folding jib or telescopic boom extension may detach suddenly because of distortion!
- ▶ Do not remove folding jib or telescopic boom extension until it has been secured with the auxiliary crane to prevent it from falling!
- ▶ Leaning the auxiliary ladder on the folding jib or the telescopic boom extension is prohibited if it is just being removed!



### DANGER

Danger of accident due to incorrect attachment!

Life-threatening situations can arise if the telescopic boom extension is improperly or incorrectly attached!

- ▶ Attach the telescopic boom extension according to the fastening points shown on the signs!
- ▶ The appropriate fastening eye hooks / fastening points are marked with signs.
- ▶ Attaching the telescopic boom extension on non-intended points or on any arbitrary location is **prohibited!**



### CAUTION

Damage of fastening points!

If the fastening equipment is too short, then the fastening points on the telescopic boom extension can be damaged!

- ▶ To attach the telescopic boom extension, fastening equipment with a strand length of at least 2000 mm each must be used!

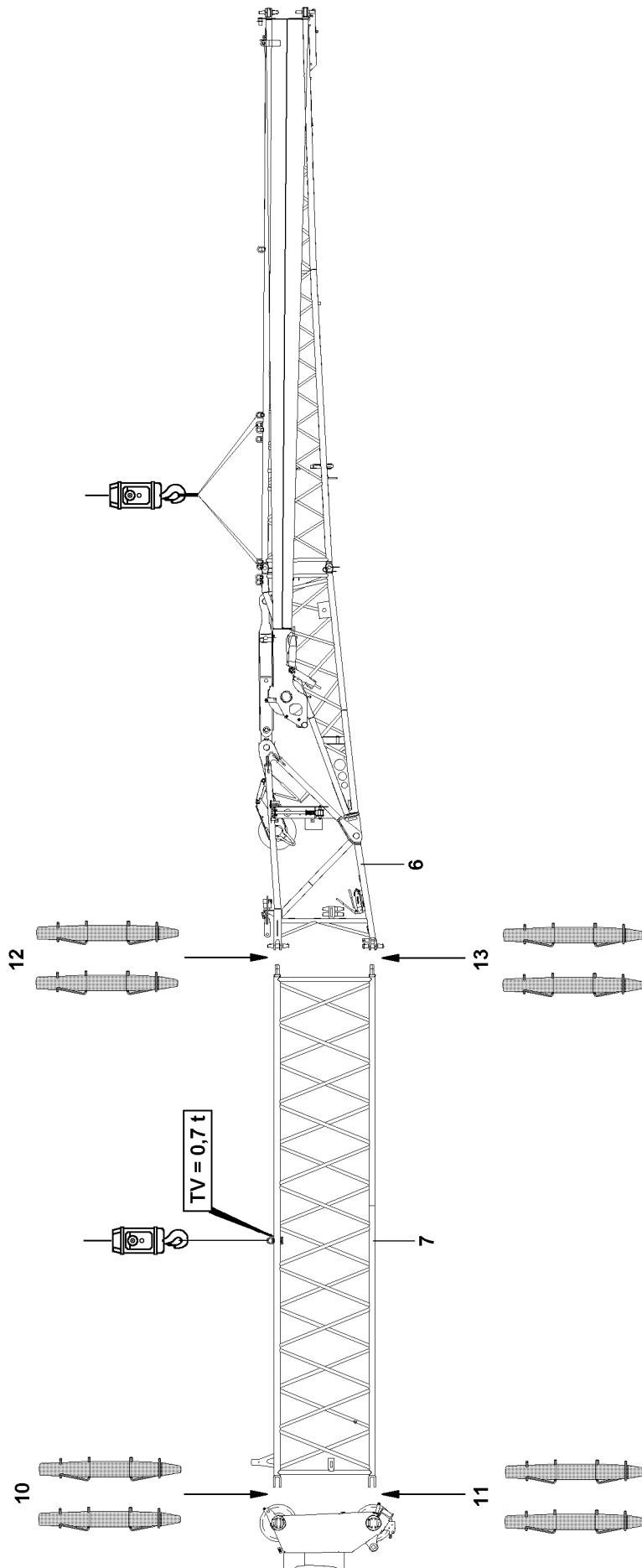


Fig.114346

LWE/LTR 1220-003/24204-02-02/en

## 5.1 Disassembly procedure

Make sure that the following prerequisites are met:

- The crane is properly supported and horizontally aligned.
- The telescopic boom is fully telescoped in.
- The telescopic boom has been luffed down to the rear or the side in the 0° position.
- The folding jib is in the 0° position.
- The end section, if it is carried along, is folded in and locked.
- The electrical and hydraulic lines have been disconnected.
- An auxiliary crane is on hand.



### Note

- ▶ Fastening points folding jib, see Crane operating instructions, chapter 5.02.

- ▶ Attach the fastening ropes on the folding jib and tighten until the folding jib is secured to prevent it from falling.
- ▶ Release pins **13** at both sides and unpin from top to bottom.
- ▶ Release pins **12** at both sides and unpin from top to bottom.
- ▶ Put down folding jib.
- ▶ Attach the fastening ropes on the telescopic boom extension **7** and tension until the telescopic boom extension **7** is secured to prevent it from falling down.
- ▶ Release pins **10** at both sides and unpin from top to bottom.
- ▶ Release pins **11** at both sides and unpin from top to bottom.
- ▶ Place the telescopic boom extension **7** down.

The following tasks are only necessary if the folding jib is to be driven along with the crane.

- ▶ Attach folding jib to the auxiliary crane and insert into the fork heads at the telescopic boom.
- ▶ Pin the folding jib to telescopic boom: Insert the pins **10** on both sides from top to bottom and secure.
- ▶ Insert the pins **11** on both sides from top to bottom and secure.

For the remaining disassembly of the folding jib, see Crane operating instructions, chapter 5.02.

- ▶ Completely disassemble the folding jib.

---

Empty page!

LWE/LTR 1220-003/24204-02-02/en

## 5.31 Bluetooth Terminal (BTT)

1	Display / operating element BTT	3
2	Start menu of the BTT	12
3	Settings and status displays on the BTT	17
4	Aligning the BTT with the crane	19
5	Crawler travel gear menu	21
6	Engine operation menu	29
7	Support menu	39
8	Assembly functions menu	49
9	Test system menu	67
10	BTT operation	69
11	Measures in case of problems	71

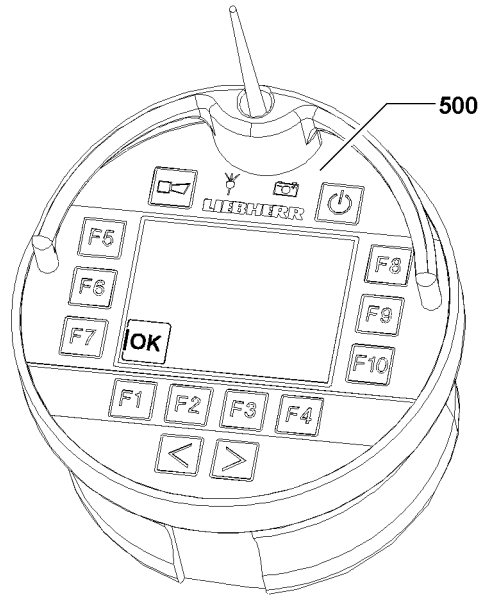


Fig.114221

# 1 Display / operating element BTT



## Note

- ▶ One of the described BTTs is used depending on the delivery condition of the crane.



## Note

- ▶ The Bluetooth Terminal is referred to as BTT in the description.
- ▶ The Bluetooth Basis is referred to as BTB in the description.

The BTT is a combined display / operating element for the crane. Selected crane movements can be carried out. The data exchange is made via the BTB on the crane. The data exchange can also be made wireless as well as via a connector cable.

The BTT is operated using function keys F1 - F10 and two changeover buttons



## Note

- ▶ The illustrations or icons on the screen display of the BTT are only examples.
- ▶ They may differ from the crane!

Via the BTT **500** you can call up various menus. Various crane functions can be selected or preselected, turned on or off, or directly activated in these menus.

The operation of the BTT **500** via the function keys and changeover buttons:

### Function keys

- The function of the function keys is menu dependent. For exact description, see the respective menu section.

### Changeover buttons

- The function of the changeover buttons is menu dependent. For exact description, see the respective menu section.

## NOTICE

Destruction of the BTT!

- ▶ Under no circumstances clean the BTT **500** with a jet of water or a steam cleaner.

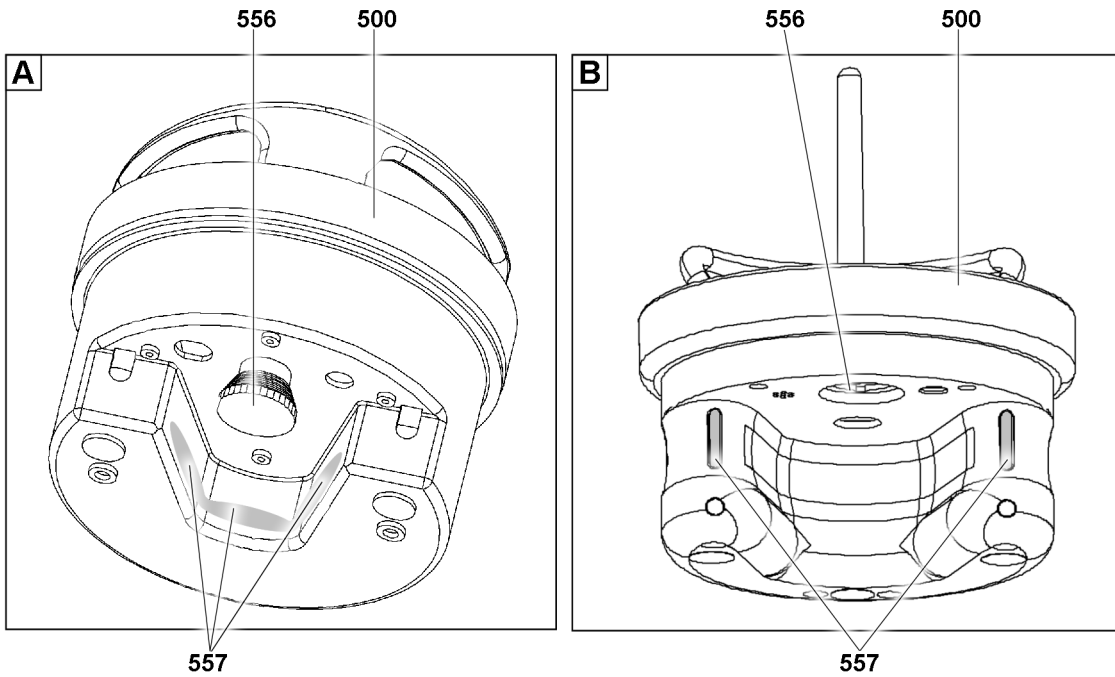
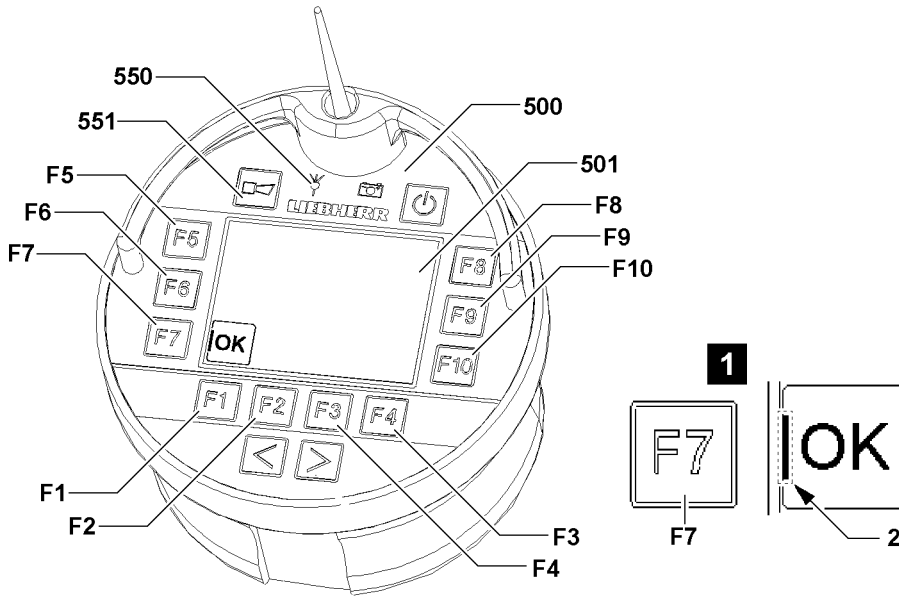


Fig. 146318

- A** 2-hand keypad: On the inner surface
- B** 2-hand keypad: Button on the front side of the curvature

LWE/LTR 1220-003/24204-02-02/en



## 1.1 Important information about the BTT

The following important information must be observed for operation with the BTT **500**:

- The machine number on the data tag of the crane cab must match the machine number on the BTT display **501**.
- It can only be turned on when the EMERGENCY STOP switch **556** on the rear of the BTT is **not** actuated.
- The rechargeable battery of the BTT is only charged if the EMERGENCY STOP switch **556** on the rear of the BTT is **not** actuated when plugging it into the charging module.
- When a function is selected via a function key, the corresponding icon is surrounded with a black border. In some case, additional icons are shown on the display.
- The operation of the BTT must be made with two hands for safety reasons, see section „Release of button block on the BTT“.
- During crane operation via the BTT **500**, the complete crane must be in the field of visibility of the operator.
- Before any movement, which is controlled via the BTT **500**, the horn **551** must be actuated.
- As soon as the reception of the radio signal deteriorates, the indicator light **550** lights up orange.
- The reach of the radio signal can fluctuate due to local conditions.
- If the radio contact between the BTT **500** and the BTB is interrupted or the EMERGENCY STOP switch **556** on the rear of the BTT **500** is actuated, the crane movement stops.
- Keep the BTT **500** and the charging module clean.
- Protect the BTT **500** from direct sun exposure.
- Protect the BTT **500** from dirt and moisture.



### Note

Function keys **F1** to **F10**

- ▶ Icons are assigned to the individual function keys. A small bar **2** marks the assigned button, see illustration 1: Example for function key **F7**.

## 1.2 Releasing the button block on the BTT

To prevent inadvertent crane operation, movements to be carried out on the BTT are secured by a button block. The 2-Hand keypad **557** can be activated by finger touch. The button block is removed.

After selecting a function, the actual movement (operation) is only released after activation of the 2-hand keypad **557**. Released icons are highlighted with the color **purple**.

If the icon is released and the respective function key is pressed, the movement is carried out.



### Note

- ▶ The actuation of the 2-hand keypad **557** is stored for 30 seconds. If no movement is actuated within these 30 seconds or if the 2-hand keypad **557** is actuated again, then the button block is activated and a signal tone sounds.

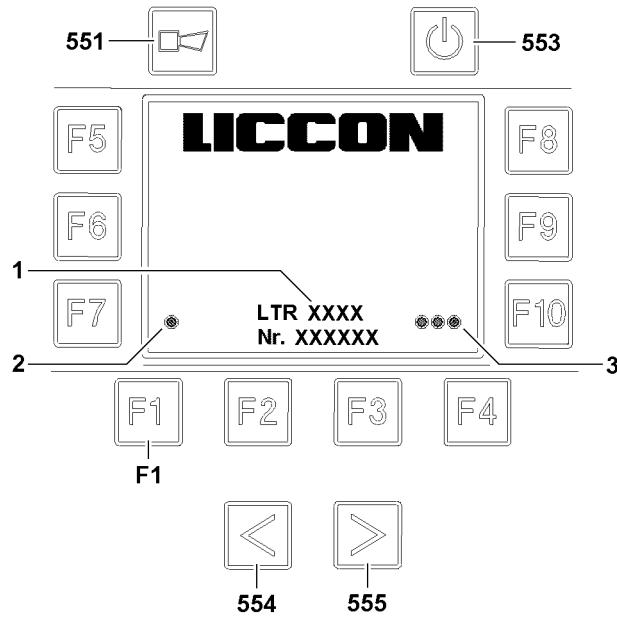


Fig.114223

## 1.3 Connecting the BTB and the BTT



### Note

- ▶ If crane type and crane number **2** do not match, a connection between BTB and BTT is not possible.

To be able to control the crane via the BTT a connection to the BTB must be established.

The connection is based on a pairing process and code comparison.

### 1.3.1 Pairing process

If the BTT is plugged into the charging module when the ignition is turned on, then a pairing process is carried out automatically with the BTB.

Carry out the pairing process by hand:

To do so, the turned on BTT must be plugged into the charging module. Various connecting parameters are compared and checked for a match via an infrared interface.

When the pairing process is completed successfully, the indicator light **1** lights up green.



### Note

- ▶ If the pairing process does not run successfully, contact your **Liebherr customer service center** or **Liebherr-Werk Ehingen!**

### 1.3.2 Code calibration

If the BTT is plugged into the charging module when the ignition is turned on, then the code calibration is made automatically.

Carry out the code calibration by hand:

One after the other, press the button **554**, then the button **555** and then the function key **F1**.

When the code calibration is completed successfully, all indicator lights **3** light up green.

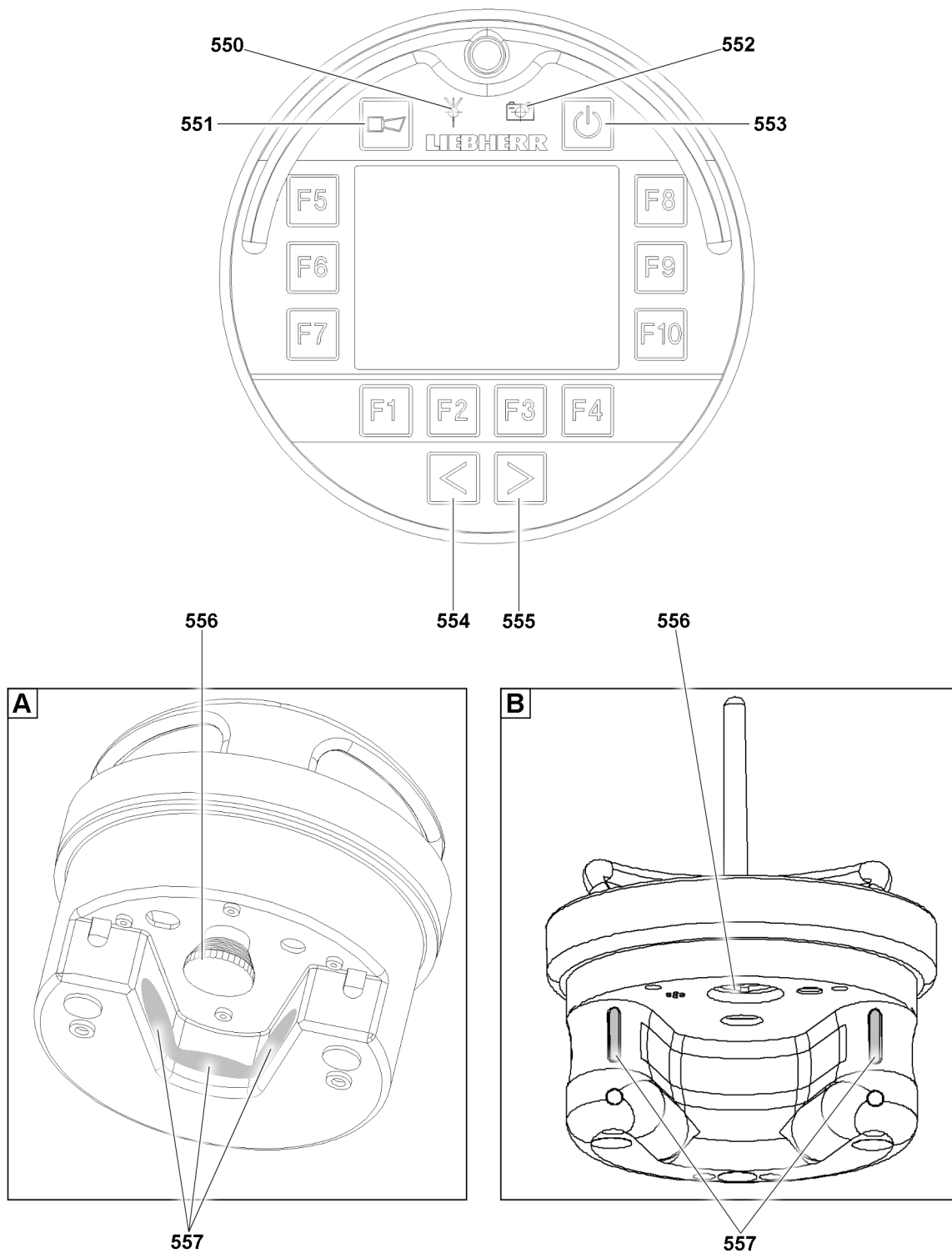


Fig.146316

- A** 2-hand keypad. On the inner surface
- B** 2-hand keypad: Button on the front side of the curvature

LWE/LTR 1220-003/24204-02-02/en

## 1.4 General information regarding the BTT

### 550 Indicator light

Transmission signal for BTT:

- Green: Transmission signal ok
- Yellow: Transmission signal about to be lost
- Red: Transmission signal not available

### 551 Button

- Operate the acoustic signal of the crane (horn)

### 552 Indicator light

Charge condition of the rechargeable battery on the BTT:

- Green: Rechargeable battery fully charged
- Yellow: Rechargeable battery almost discharged
- Red: Rechargeable battery discharged



#### Note

- ▶ To recharge the rechargeable battery, the BTT **500** must be plugged into the charging cradle.

### 553 Button

- ON / OFF button: Turn the BTT on / off
- ON / OFF button: End stand-by of the BTT

### 554 Button

- Changeover button (menu dependent)

### 555 Button

- Changeover button (menu dependent)

### 556 EMERGENCY STOP switch

- **Note:**  
The EMERGENCY STOP switch **556** is on the underside of the BTT.

### 557 2-hand keypad

- **Note:**  
The 2-hand keypad **557** must be actuated in order to be able to actuate a movement with the BTT.

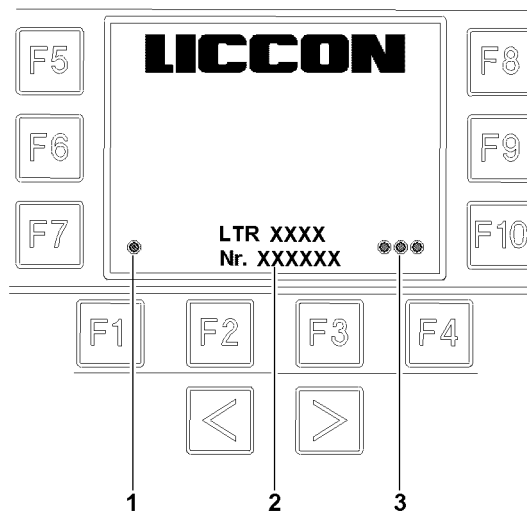
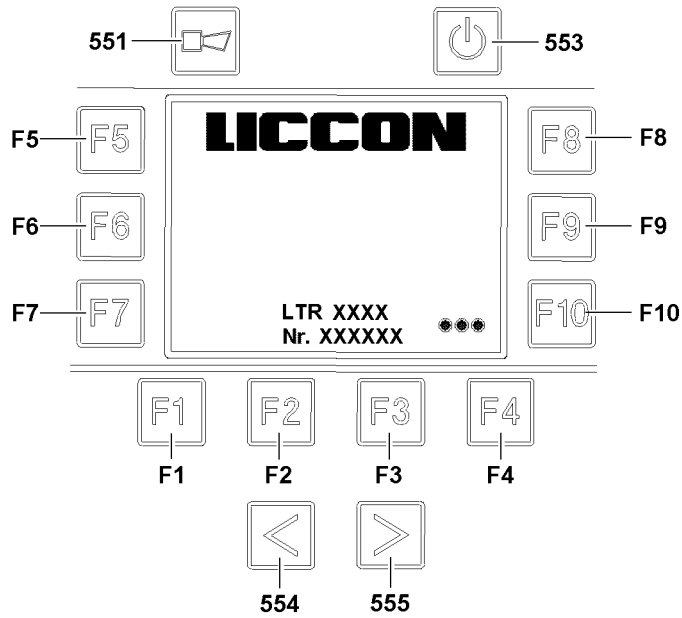


Fig.110317

## 1.5 Start screen BTT

### 1.5.1 Icon explanation Start screen BTT

#### 1 Indicator light

Status display connection to BTT receiver

- Yellow / red: not connected
- Yellow: Transmission signal being build up or severed
- Green / magenta: Connection prepared
- Green: Connection established
- Red: No connection between BTT and BTB

**Note:**

If necessary, the pairing process must be repeated, see section „Connecting the BTB and BTT“.

#### 2 Crane type and crane number

#### 3 Indicator lights

Status display Code entry:

- Green: Code entry OK
- Red: No code entered, code entry incorrect

#### **F1- F10** Function key

• **Note:**

Once the code has been successfully entered, press any function key **F1-F10** to switch back to the selection overview.

## 2 Start menu of the BTT

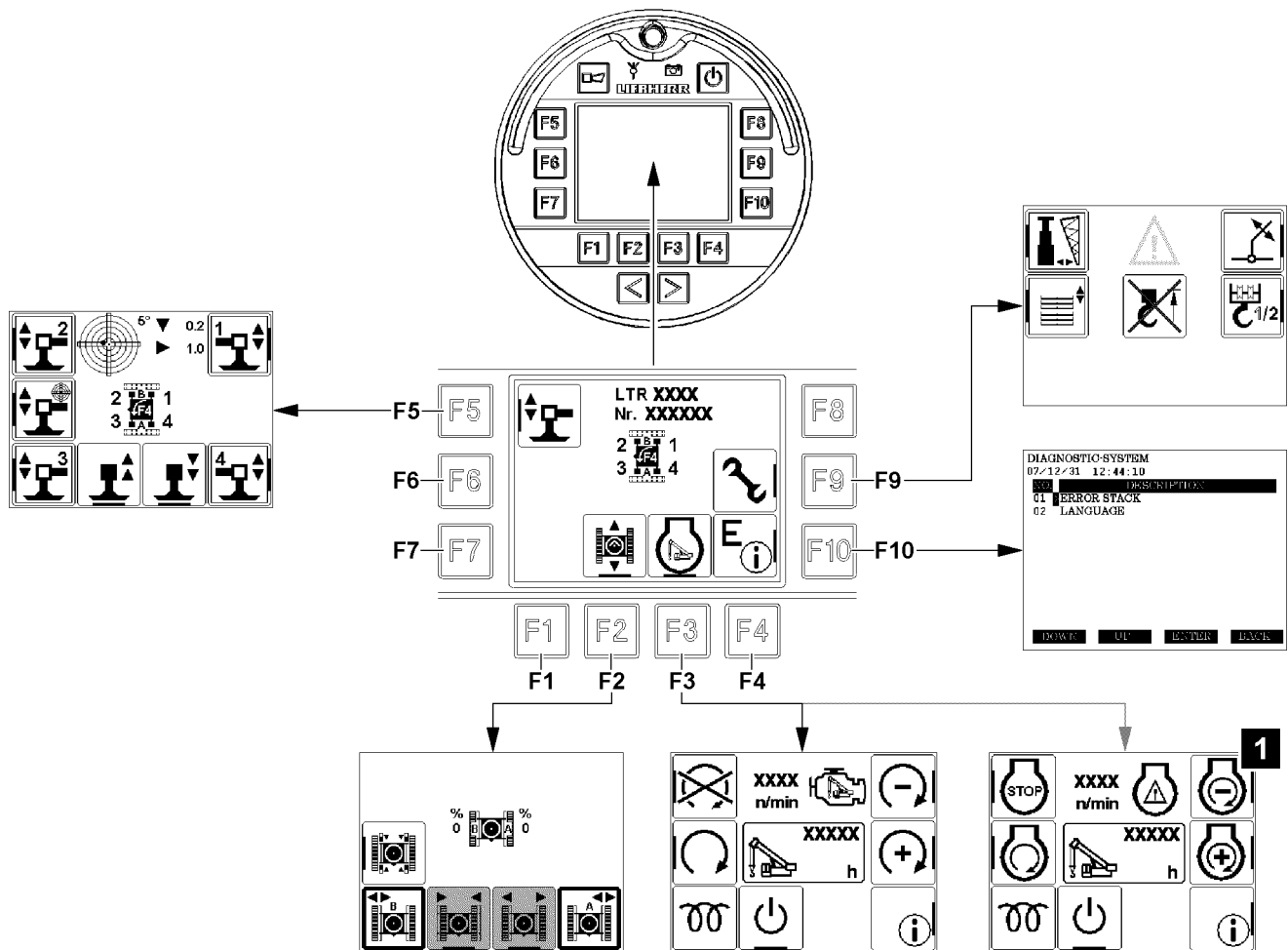


Fig.122497

F2	Crawler travel gear menu
>> F1	-back to the start menu-
>> F2	Retract the selected crawler carrier
>> F3	Extend the selected crawler carrier
>> F6	Unpin / pin the track width adjustment
>> F7	Selection / deselection of crawler carrier B
>> F10	Selection / deselection of crawler carrier A

F3	Engine operation <sup>1)</sup> menu
>> F1	-back to the start menu-
>> F2	Turn the crane superstructure ignition on / off <sup>2)</sup>
>> F5	Turn the engine off
>> F6	Turn the engine on



<b>F3</b>	<b>Engine operation <sup>1)</sup> menu</b>
>> <b>F8</b>	Decrease engine rpm
>> <b>F9</b>	Increase the engine rpm
>> <b>F10</b>	Call up the test system

1) Illustration of individual icons can vary, depending on the crane programming, see example illustration 1.

2) Function only available for certain crane types.

<b>F4</b>	<b>Turn off the disengageable acoustic warning signal</b>
<p><b>Note:</b> After an error message of the LICCON computer system the BTT issues an <i>acoustic warning signal</i>. Depending on the error message (for example operating error or system error), the warning signal can be turned off directly via the <b>F4</b> function key or it remains and additional steps are required.</p>	

<b>F5</b>	<b>Support menu</b>
>> <b>F1</b>	-back to the start menu-
>> <b>F2</b>	Retract selected support(s)
>> <b>F3</b>	Extend selected support(s)
>> <b>F5</b>	Select / deselect the support for a given crane position
>> <b>F6</b>	Selection / deselection of the automatic support <sup>2)</sup>
>> <b>F7</b>	Select / deselect the support for a given crane position
>> <b>F8</b>	Select / deselect the support for a given crane position
>> <b>F10</b>	Select / deselect the support for a given crane position

2) Function only available for certain crane types.

<b>F9</b>	<b>Crane superstructure assembly functions menu</b>
>> <b>F1</b>	-back to the start menu-
>> <b>F5</b>	Selection / deselection of assembling the hydraulic folding jib*
>> <b>F6</b>	Selection / deselection of the ballasting / turntable lock
>> <b>F8</b>	Selection / deselection of lifting / lowering the hydraulic folding jib*
>> <b>F9</b>	Selection / deselection of fastening the hook block
>>	<b>554</b> Control floodlight menu <sup>2)</sup>

2) Function only available for certain crane types.

<b>F9</b>	<b>Crane superstructure assembly functions menu</b>
>> <b>F1</b>	Back to the start menu
>> <b>F5</b>	Selection / deselection of assembling the folding jib / tensioning the telescopic boom
>> <b>F6</b>	Selection / deselection of the ballasting / turntable lock <sup>2)</sup>
>> <b>F8</b>	Selection / deselection of lifting / lowering the <i>hydraulic folding jib</i> <sup>2)</sup>
>> <b>F9</b>	Fasten the hook block

<b>F9</b>	<b>Crane superstructure assembly functions menu</b>
>> <b>554/555</b> <sup>4)</sup>	<i>Control floodlight</i> <sup>5)</sup> menu
	<i>Crane floodlight menu</i> <sup>5)</sup>
	Call up the <i>crane chassis engine operation</i> menu

4) Press the change over key **554** or change over key **555** until the next menu (if applicable) is displayed.

5) Only when the corresponding equipment is available.

<b>F10</b>	<b>Test system</b>
	<b>Note:</b> The test system can be called up at any time. If an error message of the LICCON computer system is present, then an error text can be viewed.

Empty page!

LWE/LTR 1220-003/24204-02-02/en

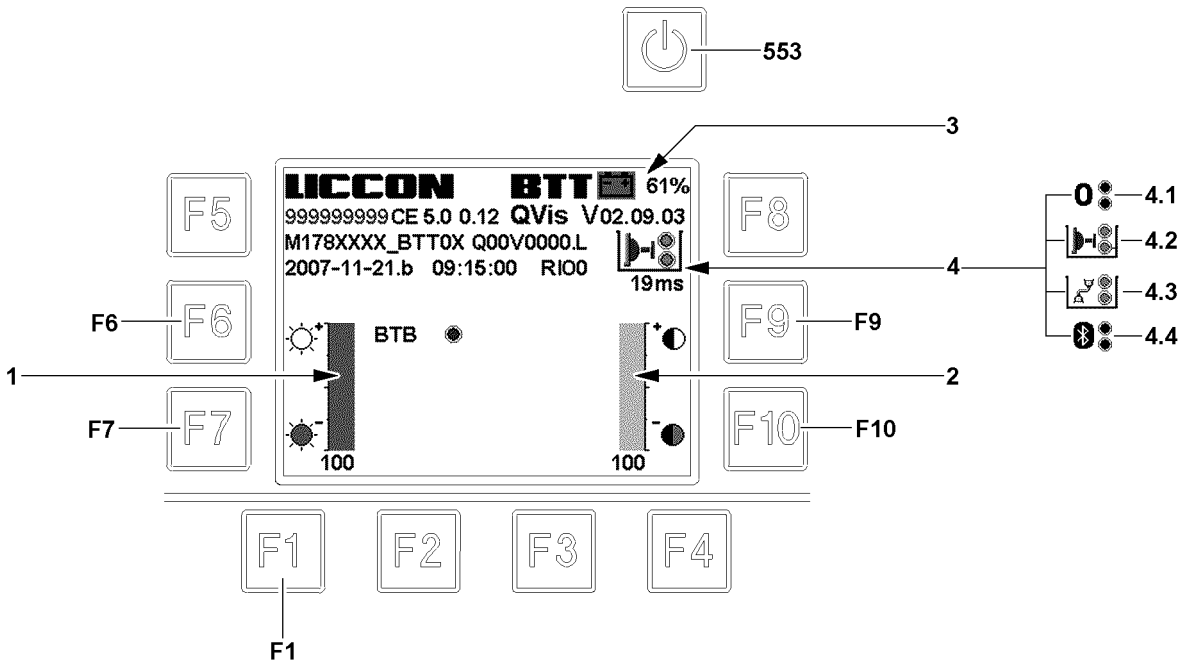


Fig.117976

## 3 Settings and status displays on the BTT

Settings can be made and status displays can be read on the BTT system screen.

### 3.1 Calling up / closing the system screen

Make sure that the following prerequisite is met:

- The start menu is displayed.
- ▶ Select the system screen: Press the button **553** momentarily until the system screen appears (max. 1 second).



#### Note

- ▶ When the button **553** is pressed too long, the BTT turns off.
- ▶ To switch back to the start menu: Press the function key **F1**.

### 3.2 Adjusting the brightness level of the BTT display

The current setting stage for brightness can be read on the bar diagram 1.

- ▶ BTT display brighter: Press the function key **F6**.
- ▶ BTT display darker: Press the function key **F7**.

### 3.3 Adjusting the contrast of the BTT display



#### Note

- ▶ Only available for certain crane types.

The current setting stage for the contrast can be read on the bar diagram 2.

- ▶ BTT display more contrast: Press the function key **F9**.
- ▶ BTT display less contrast: Press the function key **F10**.

### 3.4 Determining the exact charge condition of the rechargeable battery

The exact charge condition of the rechargeable battery can be read on the charge condition display 3.

- ▶ Read the charge condition, if necessary recharge the BTT by inserting it in the charging bay.

### 3.5 Checking the connection type

The connection type can be read on the connection type display 4.

- ▶ Read the connection type.

#### Result:

- **4.1** No connection
- Infrared **4.2** (only in the charging bay)
- **4.3** Cable
- **4.4** Bluetooth

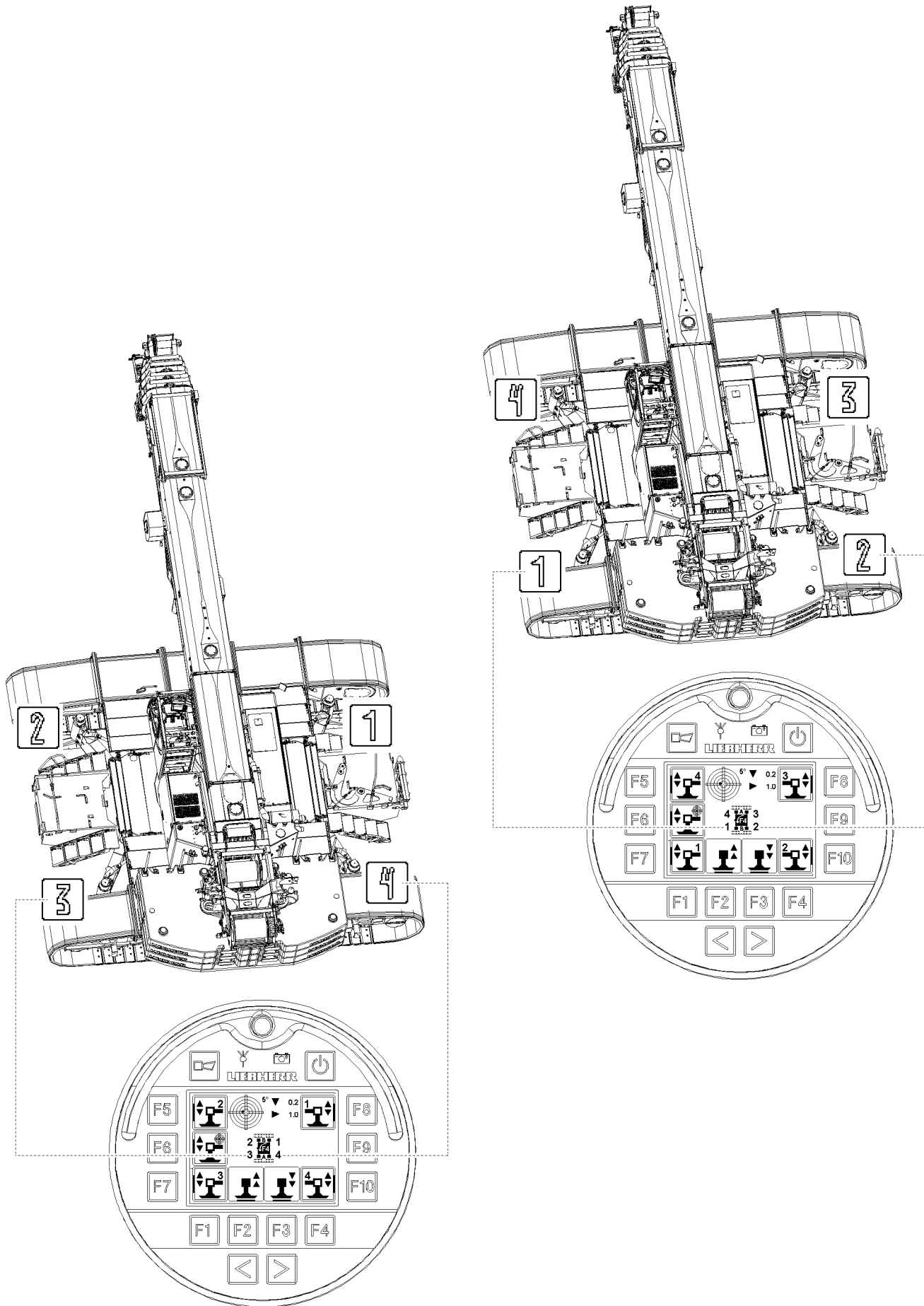


Fig.117814

LWE/LTR 1220-003/24204-02-02/en

## 4 Aligning the BTT with the crane

If „F4“ and two rotation arrows appear within the crane icon on the BTT display, then the location of the operator with the BTT must be aligned with the crane.

- The determining factor for the alignment of the BTT is the crane chassis.
- A selection can be made between two alignments:
  - Illustration 1:
    - Operator is standing on the side of support 3 and support 4 (crawler carrier A).
    - In the crane icon on the BTT display, the supports with number 3 and number 4 are at the bottom.
  - Illustration 2:
    - Operator is standing on the side of support 1 and support 2 (crawler carrier B).
    - In the crane icon on the BTT display, the supports with number 1 and number 2 are at the bottom.



---

### WARNING

Danger of accident if the operator is incorrectly aligned with the crane!

If the operator is not correctly aligned with the crane, then the working range / danger zone cannot be viewed completely.

Personnel can be severely injured or killed!

- ▶ The crane icon on the BTT display and the actual alignment of the operator with the crane must match!
- 

### F4 Function key

- When „F4“ and two rotation arrows appear in the crane icon:  
Press the function key **F4** to turn the crane icon in 180° increments.

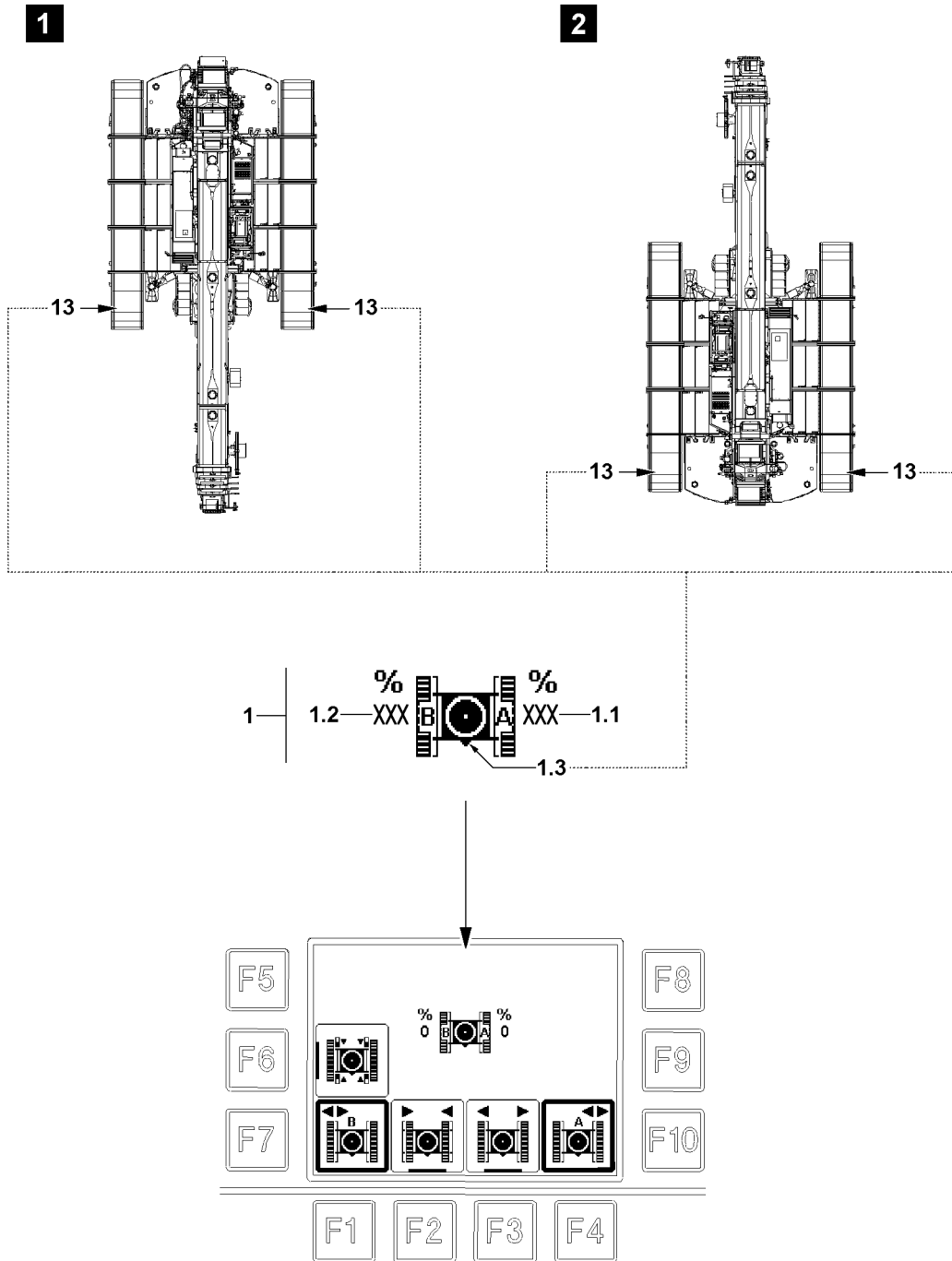


Fig.117969



## 5 Crawler travel gear menu

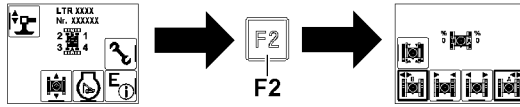


Fig.119845



### Note

Change from the start menu to the crawler travel gear menu:

- ▶ Press the function key **F2**.

Functions in the „Crawler travel gear“ menu:

- Extending / retracting the crawler carrier

In the crawler travel gear menu, the display of the crane icon **1** cannot be adjusted:

- The marker „front side of crawler travel gear“ **1.3** shows the position in the display of the front side of the crawler travel gear.
- The position of the crane superstructure is not relevant in the crawler travel gear menu, see example of illustration **1** and illustration **2**.
- The front and rear on the crawler travel gear can be determined by the chain tension devices **13** (chain tension side):
  - The chain tension devices **13** are always on the front of the crawler travel gear.
  - The chain tension devices **13** are on the side of support 2 and support 3.

### 5.1 Icon explanation in the crawler travel gear menu

#### 1 Track width display

- The crawler carriers are marked with letters.
- The extension conditions of the cross carriers are given in percentages.

#### 1.1 Crawler carrier A

- Extension condition of crawler carrier A in percent (%)
  - 0 % = Crawler carrier A is completely retracted
  - up to
  - 100 % = Crawler carrier A is completely extended

#### 1.2 Crawler carrier B

- Extension condition of crawler carrier B in percent (%)
  - 0 % = Crawler carrier B is completely retracted
  - up to
  - 100 % = Crawler carrier B is completely extended

#### 1.3 Front on the travel gear

- Shows where the front side of the crawler travel gear is in the icon.

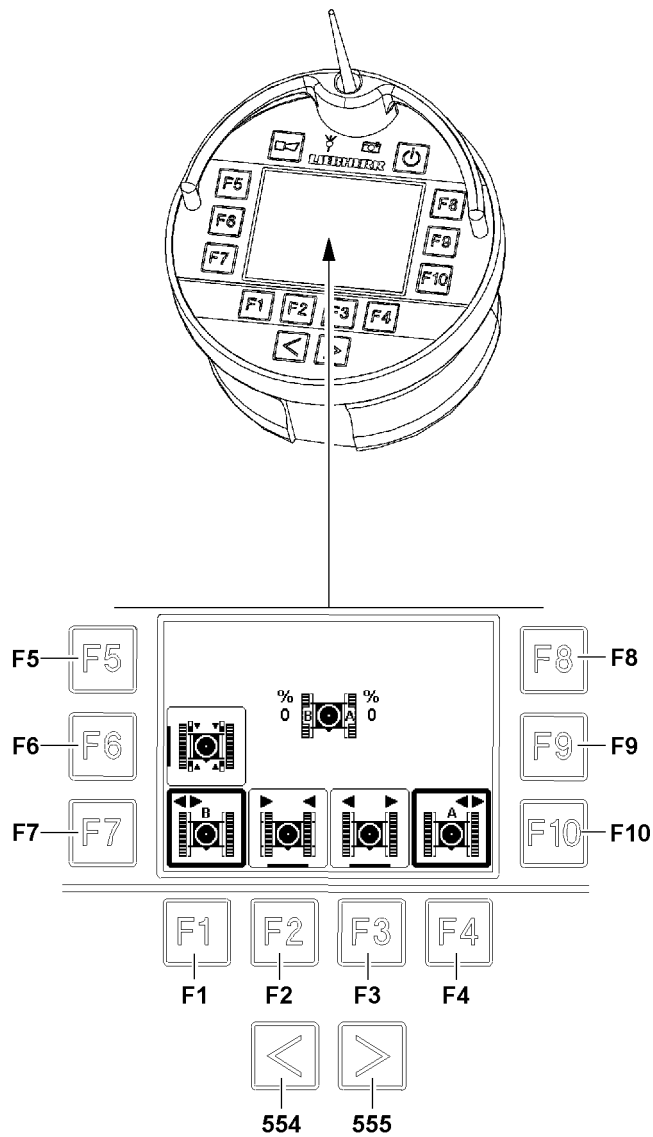


Fig.117971

## 5.2 Function keys in the crawler travel gear menu

- 554** Key
  - Switch to the engine operation menu
- 555** Key
  - Call up the radio remote control operating screen
- F1** Function key
  - Return to the start menu
- F2** Function key
  - Retract the selected crawler carrier
- F3** Function key
  - Extend the selected crawler carrier
- F4** Function key
  - -No function-
- F5** Function key
  - -No function-
- F6** Function key
  - Unpin / pin the track width adjustment
- F7** Function key
  - Selection / deselection of crawler carrier B
- F8** Function key
  - -No function-
- F9** Function key
  - -No function-
- F10** Function key
  - Selection / deselection of crawler carrier A

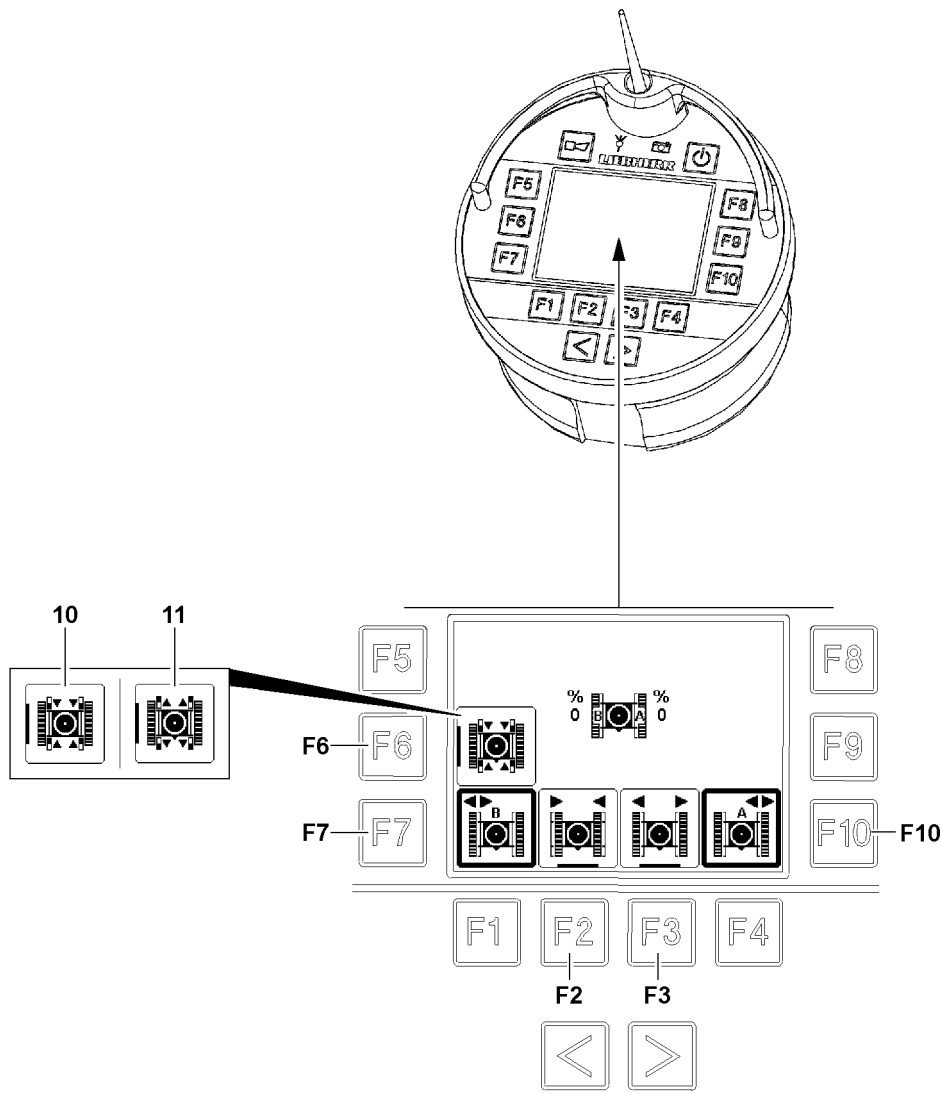


Fig.117972

### 5.3 Extending / retracting the crawler carrier

The crawler carriers can be selected and controlled individually or together.

To be able to extend / retract the crawler carriers, the cross carriers must be unpinned.

- **Selection / deselection of crawler carrier:**
  - Press function key **F7** for crawler carrier B
  - Press function key **F10** for crawler carrier A
    - **Result:** Selected crawler carriers are bordered in bold. The other crawler carrier can be selected / deselected as desired.
- **Unpin / pin the cross carriers:**
  - Press the function key **F6**.
    - Pin the cross carrier active: The icon **10** appears.  
As soon as the pin aligns with a pin point, the cross carriers are pinned. Pin points are at 0 %, 50 % or 100 % extension condition of crawler carriers.
    - Unpin the cross carriers active: The icon **11** appears.  
Unpin the pin from the pin point is actuated.
- **Control release:**
  - The control release is made by touching the 2-Hand keyboard in the rear of the BTT, see section „Release of button block on BTT“
  - After the control release is provided, the icons over the function key **F2** / function key **F3** are highlighted in purple.



#### Note

- ▶ To control the crawler carriers, a control release must be issued: The corresponding icons must be highlighted in purple.
-

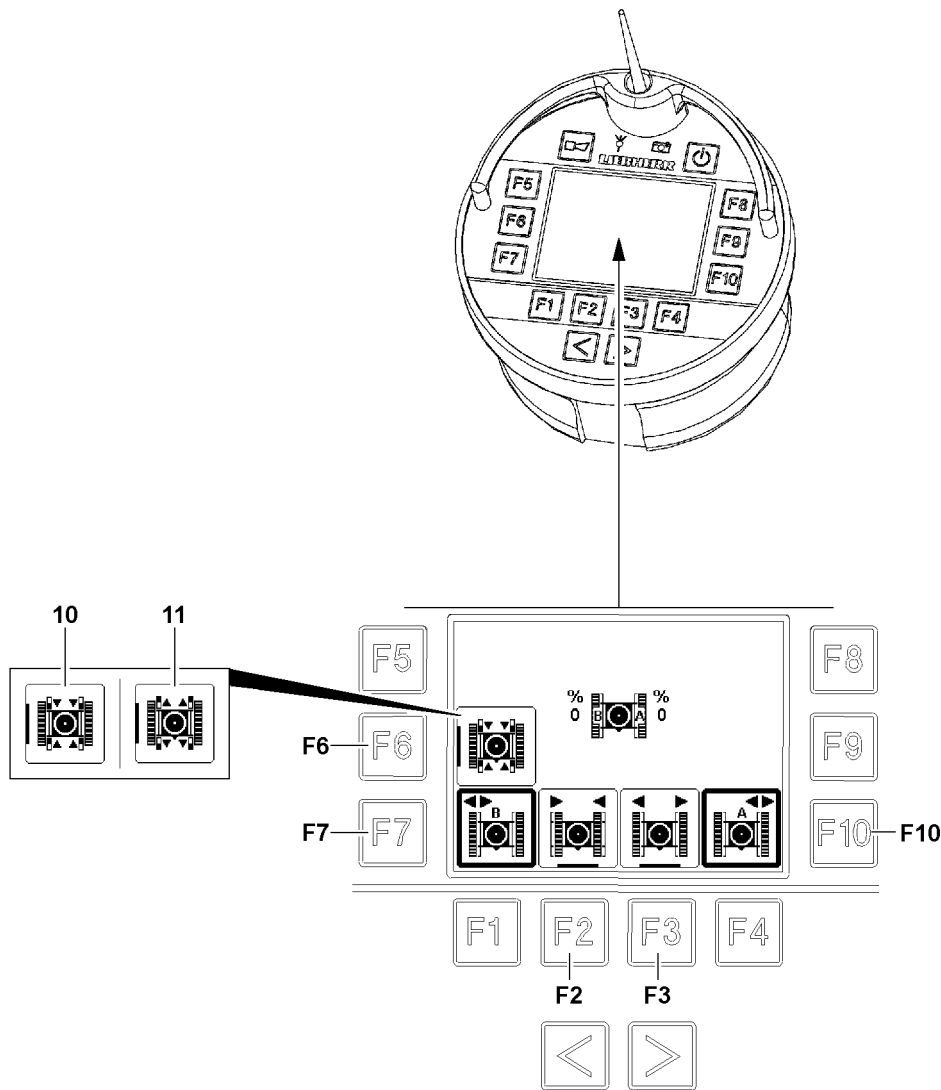


Fig.117972

- **Retract crawler carrier A:**  
Prerequisite: Icon **11** must appear, crawler carrier A is selected.
  - Press the function key **F2**.
- **Extend crawler carrier A:**  
Prerequisite: Icon **11** must appear, crawler carrier A is selected.
  - Press the function key **F3**.
- **Retract crawler carrier B:**  
Prerequisite: Icon **11** must appear, crawler carrier B is selected.
  - Press the function key **F2**.
- **Extend crawler carrier B:**  
Prerequisite: Icon **11** must appear, crawler carrier B is selected.
  - Press the function key **F3**.
- **Retract both crawler carriers in parallel:**  
Prerequisite: Icon **11** must appear, crawler carrier A and crawler carrier B are selected.
  - Press the function key **F2**.
- **Extend both crawler carriers in parallel:**  
Prerequisite: Icon **11** must appear, crawler carrier A and crawler carrier B are selected.
  - Press the function key **F3**.

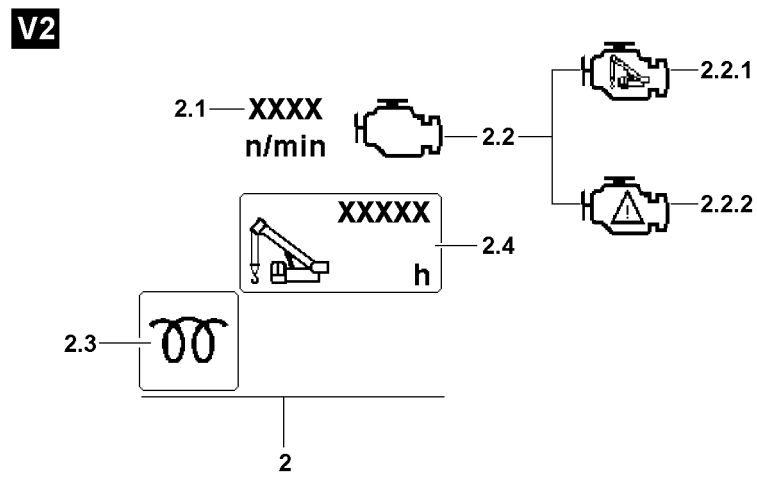
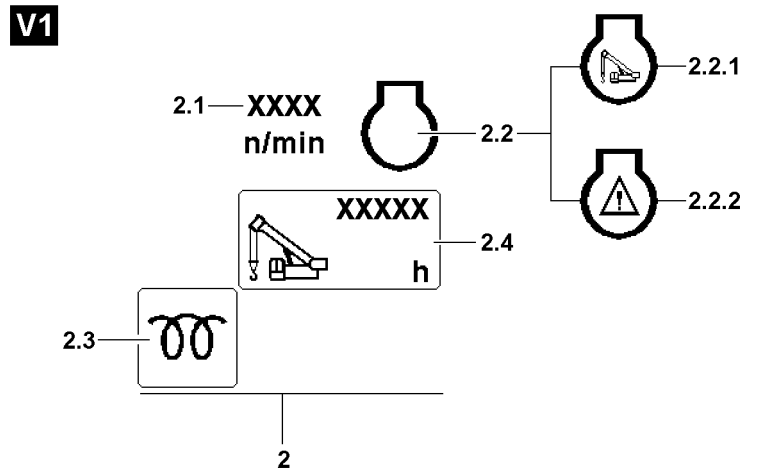


Fig.122498

LWE/LTR 1220-003/24204-02-02/en



## 6 Engine operation menu

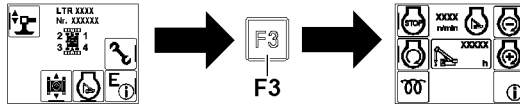


Fig.119846



### Note

Change from the start menu to the engine operation menu:

- ▶ Press the function key **F3**.



### Note

The depiction of the Engine operation icons **2** depends on the crane programming.

- ▶ Either the variation **V1** or variation **V2** icons appear.

### 6.1 Icon explanation in engine operation menu

- 2 Engine operation icons
  - 2.1 Engine rpm
    - Actual engine rpm
  - 2.2 Engine monitoring
    - If icon **2.2.1** appears, then there is no engine warning present.
    - If warning icon **2.2.2** appears, then an engine warning is present.
    - **NOTICE:**  
Call up engine monitoring functions and evaluate.
  - 2.3 Monitoring indicator
    - The monitoring indicator lights up green: The crane superstructure engine is ready to start
    - The monitoring indicator lights up yellow: Crane superstructure engine preheating is active
    - The monitoring indicator lights up red: The crane superstructure engine is not ready to start
  - 2.4 Operating hour meter
    - Operating hours of crane engine

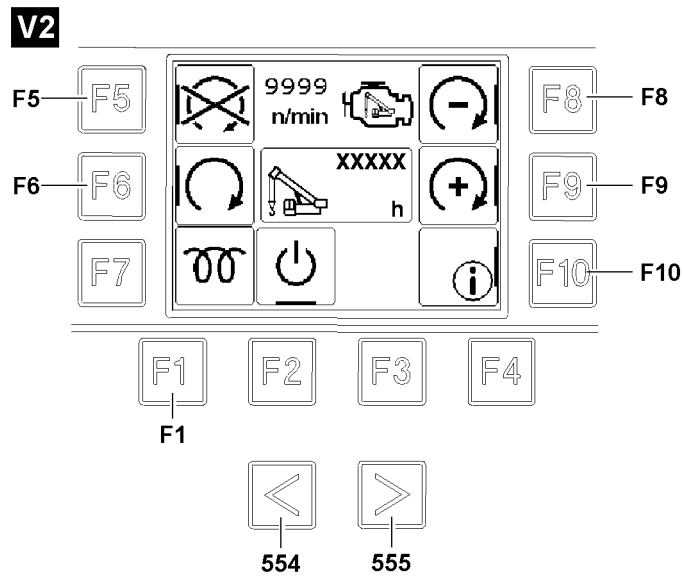
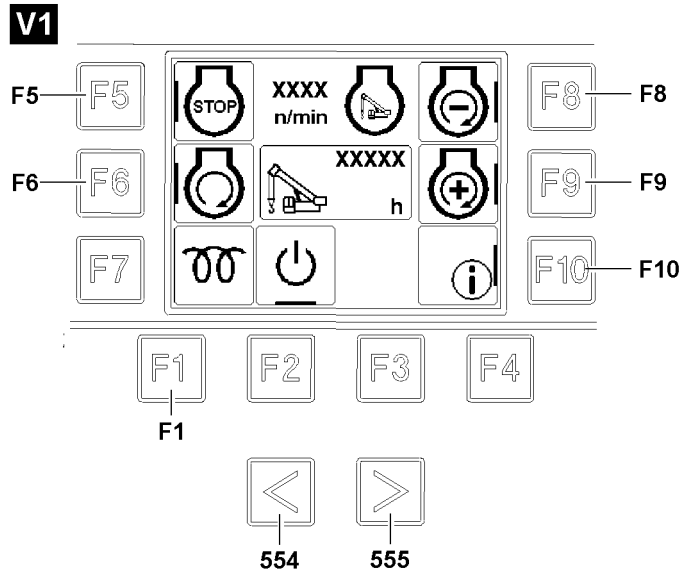


Fig.122499

## 6.2 The function keys



### Note

The depiction of the Engine operation icons depends on the crane programming.  
► Either the variation **V1** or variation **V2** icons appear.

- 554** Button
  - Call up engine monitoring functions
- 555** Button
  - Call up engine monitoring functions
- F1** Function key
  - Back to the start menu
- F2** Function key
  - Turn the crane chassis ignition on / off
  - **Note:** Appears only for certain crane types
- F5** Function key
  - Press momentarily (less than 0.5 seconds): Reset settings in the engine operation menu
  - Press long: Turn the engine off
  - **Note:** The control release must have been made by touching the 2-Hand keypad in the rear of the BTT, see section „Release of button block on BTT“.
- F6** Function key
  - Turn the engine on
- F8** Function key
  - Decrease engine rpm
  - **Note:** The control release must have been made by touching the 2-Hand keypad in the rear of the BTT, see section „Release of button block on BTT“.
- F9** Function key
  - Increase the engine rpm
  - **Note:** The control release must have been made by touching the 2-Hand keypad in the rear of the BTT, see section „Release of button block on BTT“.
- F10** Function key
  - Change to test system

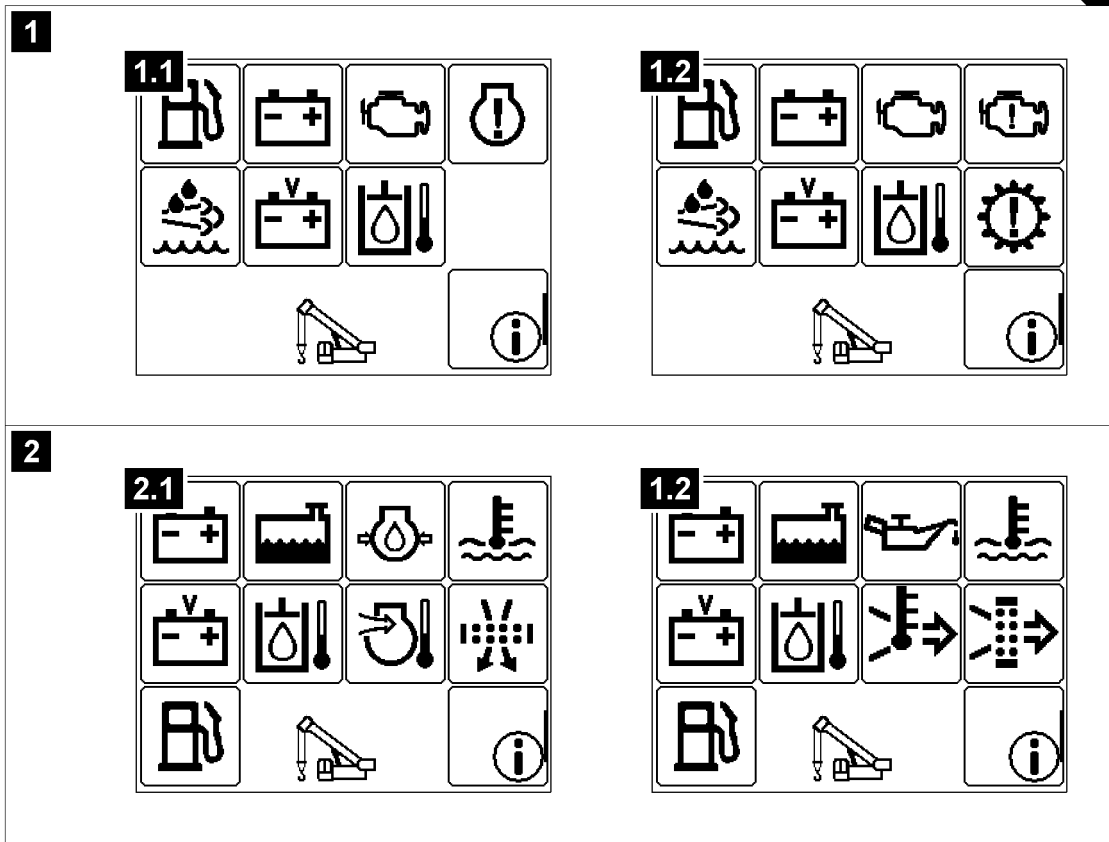
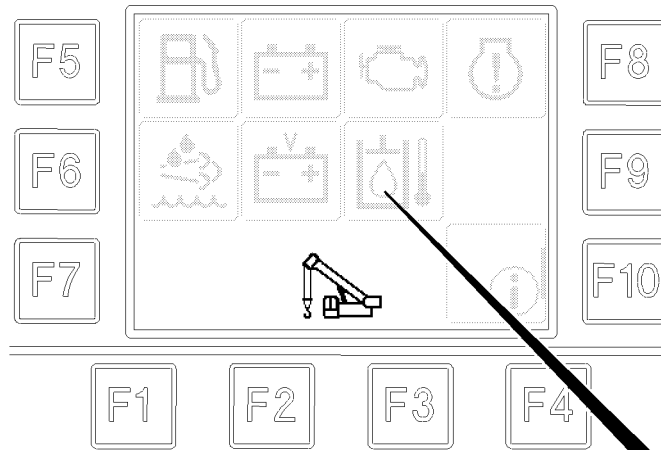


Fig.122500

LWE/LTR 1220-003/24204-02-02/en

### 6.3 Engine monitoring functions

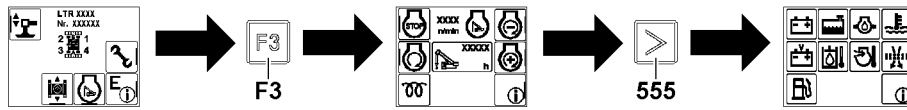


Fig.119847



**Note**

Change from the start menu to the engine monitoring functions:

- ▶ Press the function key **F3**.
- ▶ Press the function key **555**.



**Note**

- ▶ Engines **with SCR system** for exhaust aftertreatment - Display in BTT display, see illustrations 1. Depending on the crane programming, either the illustration 1.1 or illustration 1.2 icon appears.
- ▶ Engines **without SCR system** - Display on the BTT display, see illustrations 2. Depending on the crane programming, either the illustration 2.1 or illustration 2.2 icon appears.
- ▶ If a function is highlighted **green**, this function is operating correctly.
- ▶ If a function is highlighted **red** or **orange**, then there is a problem with this function.

**NOTICE**

Property damage!

Significant property damage can result if a problem is not immediately rectified!


- ▶ Remedy the problem immediately!




**Note**

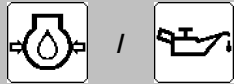
The scope of the monitoring functions depends on the crane type and crane configuration. The depiction of the icon depends on the crane programming. If two icons are depicted for one function, then only one of the two appears.

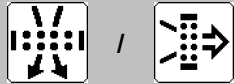
- ▶ Not all crane types have all listed monitoring functions.


	<b>Fuel reserve</b>
Green:	Fuel reserve sufficient
Yellow:	Fuel reserve is short
Red:	Fuel reserve low / depleted / system error <b>NOTICE!</b> Add fuel immediately / Immediately bring the crane to a standstill, turn the crane engine off and remedy the problem. Pay attention to the error message.


	<b>Coolant temperature</b>
Green:	Coolant temperature OK
Red:	Coolant temperature too high / system error <b>NOTICE!</b> Immediately bring the crane to a standstill, turn the engine off and remedy the problem. Pay attention to the error message.

LWE/LTR 1220-003/24204-02-02/en

	<b>Engine oil pressure</b>
Green:	Engine oil pressure OK (engine on)
Red:	Engine oil pressure too low (engine on) / system error <b>NOTICE!</b> Immediately bring the crane to a standstill, turn the engine off and remedy the problem. Pay attention to the error message.


	<b>Air filter Engine</b>
Green:	Air intake opening / air filter OK (engine on)
Yellow / red	Air intake opening / air filter dirty (engine on) / system error <b>NOTICE!</b> Immediately bring the crane to a standstill, turn the engine off and remedy the problem. Pay attention to the error message.


	<b>Charge control display (alternator)</b>
Green:	Charge control OK (engine on)
Red:	Charge control has a problem (engine on) / system error <b>NOTICE!</b> Immediately bring the crane to a standstill, turn the engine off and remedy the problem. Pay attention to the error message.


	<b>Urea tank / exhaust aftertreatment<sup>1)</sup></b>
Green:	Urea reserve sufficient
Yellow:	The urea reserve is low or erroneous function of exhaust aftertreatment <sup>2)</sup> <b>Advance warning!</b> Add urea or remedy the erroneous function of the exhaust aftertreatment. Pay attention to the error message.
Red:	Urea level too low / depleted or erroneous function of exhaust aftertreatment system <sup>2)</sup> / system error <b>NOTICE!</b> Add urea or remedy the erroneous function of the exhaust aftertreatment / immediately bring the crane to a standstill, turn the engine off and remedy the problem. Pay attention to the error message.


1) Applies only for engines with the SCR system.


2) Under some circumstances a power reduction or start block of the engine is triggered. The type and scope of a power reduction or start block of the engine depends on the respectively valid national / regional regulations and the vehicle configuration.


	Coolant level
Green:	Coolant level OK
Red:	Coolant level too low / system error <b>NOTICE!</b> Immediately bring the crane to a standstill, turn the engine off and remedy the problem. Pay attention to the error message.

	Charge air temperature
Green:	Charge air temperature OK
Red:	Charge air temperature too high / system error <b>NOTICE!</b> Immediately bring the crane to a standstill, turn the engine off and remedy the problem. Pay attention to the error message.


	Hydraulic oil temperature
Green:	Hydraulic oil temperature OK
Red:	Hydraulic oil temperature too high / system error <b>NOTICE!</b> Immediately bring the crane to a standstill, turn the engine off and remedy the problem. Pay attention to the error message.

	Hydraulic oil
Green:	Leak oil filter OK (engine on) and hydraulic oil temperature OK
Red:	Air filter dirty (engine on) and / or hydraulic oil temperature too high / system error <b>NOTICE!</b> Immediately bring the crane to a standstill, turn the engine off and remedy the problem. Pay attention to the error message.


	Battery voltage
Green:	Battery voltage OK
Red:	On-board power supply over / undervoltage / system error <b>NOTICE!</b> Immediately bring the crane to a standstill, turn the engine off and remedy the problem. Pay attention to the error message.

	Engine oil level <sup>3)</sup>
Green:	Engine oil level OK
Blue	The engine oil level can not be checked here on the display, call up the individual indicator light
Red:	Engine oil level not OK / System error <b>NOTICE!</b> Immediately bring the crane to a standstill, turn the engine off and remedy the problem. Call up individual indicator lights and adjust the engine oil according to the display - pay attention to error message.

3) Only for certain crane types.


	Hydraulic oil level <sup>3)</sup>
Green:	Hydraulic oil level OK
Red:	Hydraulic oil level too low / error / system error <b>NOTICE!</b> Immediately bring the crane to a standstill, turn the engine off and remedy the problem. Pay attention to the error message.

3) Only for certain crane types.


	Exhaust aftertreatment <sup>1)</sup>
Green:	Exhaust aftertreatment OK
Yellow / red:	Urea level too low / depleted or erroneous function of exhaust aftertreatment system <sup>2)</sup> / system error <b>NOTICE!</b> Add urea or remedy the erroneous function of the exhaust aftertreatment. Under some circumstances a power reduction or start block of the engine <sup>2)</sup> is triggered, pay attention to the error message.


1) Applies only for engines with the SCR system.

2) Under some circumstances a power reduction or start block of the engine is triggered. The type and scope of a power reduction or start block of the engine depends on the respectively valid national / regional regulations and the vehicle configuration.

	Collective warning
Green:	No warning messages present
Generally at yellow or red:	A warning is present / system error <b>NOTICE!</b> Determine the cause with the error message or in the LICCON monitor and observe the following description.
Yellow:	Air intake opening / Air filter dirty (engine on) / system error <b>NOTICE!</b> Immediately bring the crane to a standstill, turn the engine off and remedy the problem. Pay attention to the error message.
Red:	Engine oil pressure too low (engine on) / system error <b>NOTICE!</b> Immediately bring the crane to a standstill, turn the engine off and remedy the problem. Pay attention to the error message!



	Collective warning
Red:	Engine oil level too low or too high <b>NOTICE!</b> Call up the display for the engine oil level in the LICCON monitor and match the engine oil level according to the display. See the Crane operating instructions, chapter 4.02 Pay attention to the error message!
Red:	Coolant level too low / system error <b>NOTICE!</b> Immediately bring the crane to a standstill, turn the engine off and remedy the problem. Pay attention to the error message!
Red:	Coolant temperature too high / system error <b>NOTICE!</b> Immediately bring the crane to a standstill, turn the engine off and remedy the problem. Pay attention to the error message.
Red:	Charge air temperature too high / system error <b>NOTICE!</b> Immediately bring the crane to a standstill, turn the engine off and remedy the problem. Pay attention to the error message.

	Information field
B / E:	If a <i>B (operating error)</i> or <i>E (system error)</i> appears in the information field, then at least one error message is present. Call up and evaluate the error message by pressing function key F10 on the BTT, see also Diagnostics Manual.

**Note****Triggers power reduction or start block of the engine**

If the urea level is too low or if there is a malfunction in the exhaust aftertreatment, then a power reduction or starting block of the engine can be triggered.

The crane operation and travel operation can be limited or disabled.

- ▶ Replenish the Urea level in time.
- ▶ Remedy the faulty function of the exhaust aftertreatment immediately.
- ▶ Observe any valid national / regional regulations and the vehicle configuration.

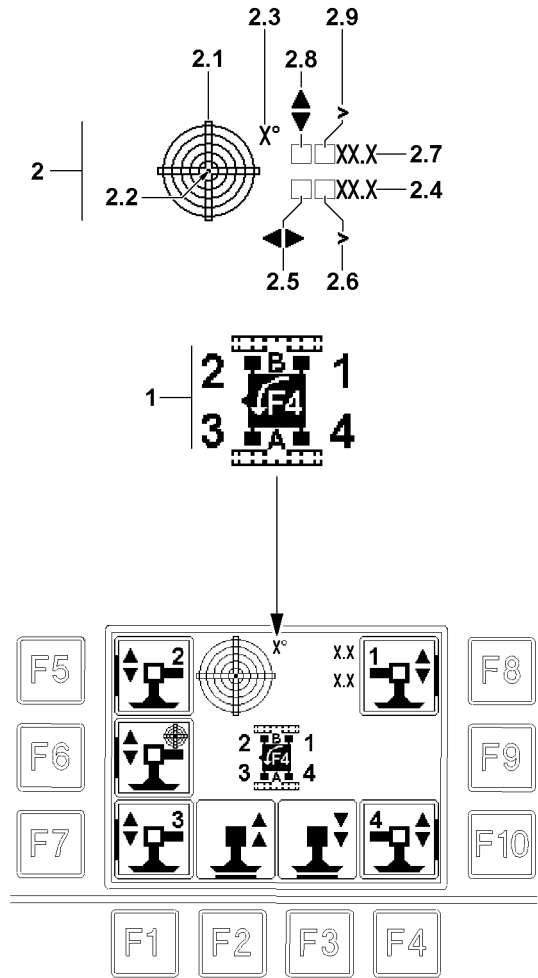


Fig.117930

## 7 Support menu



### WARNING

Danger of accident if the operator is incorrectly aligned with the crane!

If the operator is not correctly aligned with the crane, then the working range / danger zone cannot be viewed completely.

Personnel can be severely injured or killed!

- ▶ The crane icon on the BTT display must correspond to the actual position of the operator with respect to the crane, see section „Aligning the radio remote control with the crane“!

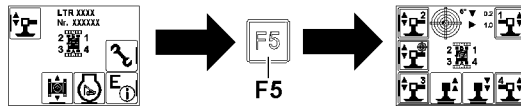


Fig.119848



### Note

Change from the start menu to the support menu:

- ▶ Press the function key **F5**.

In the Support menu, the operator can select between manual support and automatic support\* (only for certain crane types).

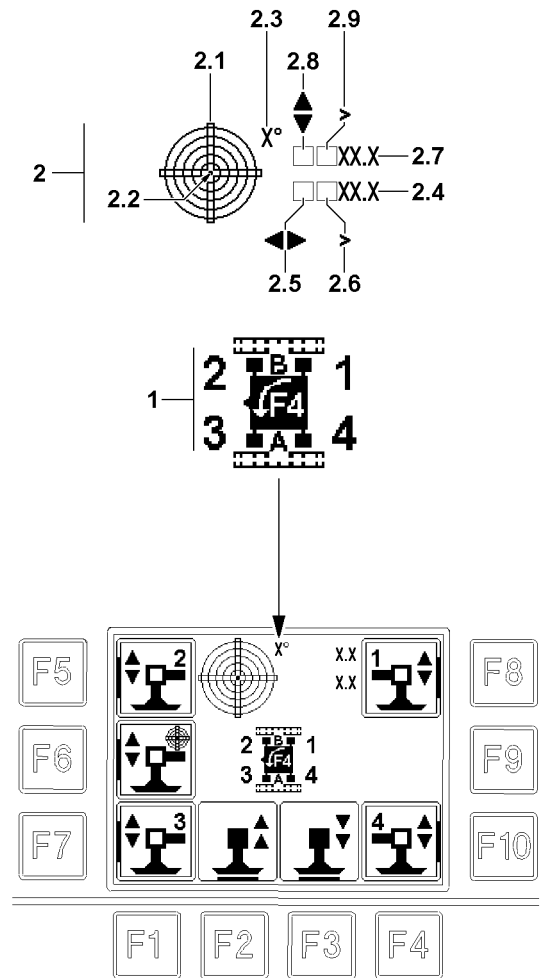


Fig.117930

## 7.1 Icon explanation in the support menu

### 1 Crane icon

- On the crane icon:
  - The crawler carriers are displayed with their identification letter.
  - The support cylinders are displayed with numbers.



### WARNING

The crane can topple over!

The „larger than symbol“ shows that the crane is inclined further than can be shown!

The exact incline can then not be read!

- ▶ Do not exceed the permissible incline of the crane!

### 2 „Incline“ icon

- Display of the inclination of the crane to the horizontal in the longitudinal and lateral direction. The display is graphic as well as numeric.
- The direction data refer to the orientation of the displayed crane icon

#### 2.1 Graphic display

- The graphic display has the form of a sight gauge. In it is a moving dot **2.2**, which represents the air bubble

#### 2.2 Point

- The center of the dot **2.2** shows the incline value

#### 2.3 Display resolution

- This value describes the resolution of the graphic view. The resolution is matched automatically to the inclination

#### 2.4 Longitudinal direction

- Incline of crane in the longitudinal direction in [°].

#### 2.5 Direction arrow

- The direction arrow shows the direction of the incline

#### 2.6 Display range exceeded

- If the „larger than icon“ appears, then the display range is exceeded
- **Note:**  
The crane is inclined further than can be shown!

#### 2.7 Lateral direction

- Incline of crane in lateral direction in [°]

#### 2.8 Direction arrow

- The direction arrow shows the direction of the incline

#### 2.9 Display range exceeded

- If the „larger than icon“ appears, then the display range is exceeded
- **Note:**  
The crane is inclined further than can be shown!

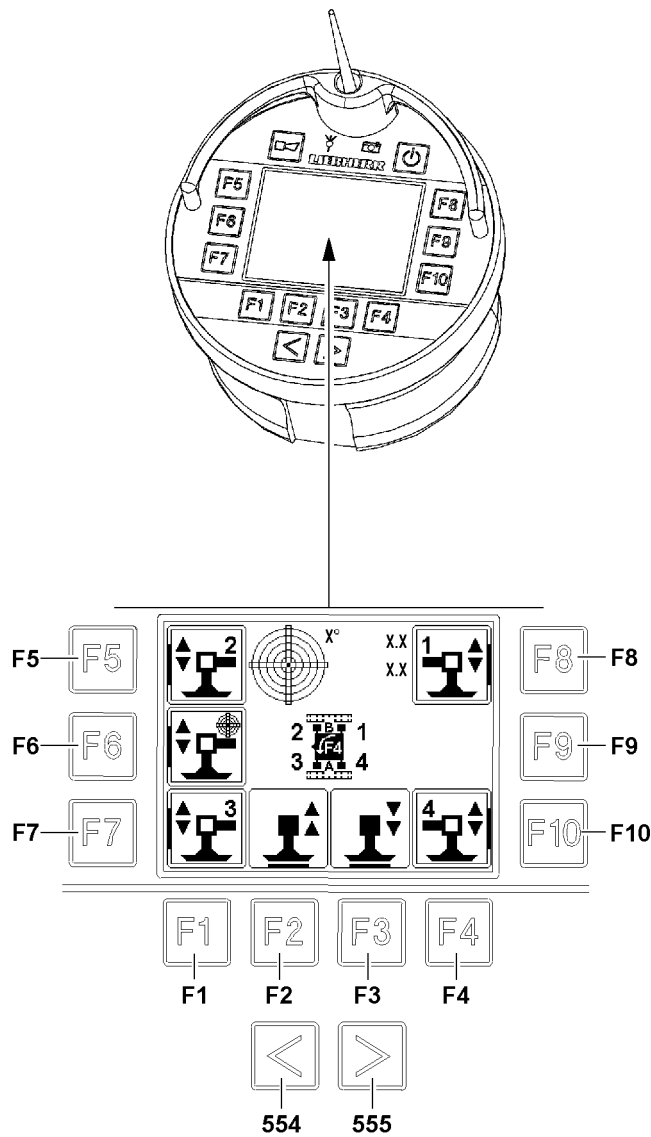


Fig.117973

## 7.2 Function keys in the support menu

- 554** Key
  - Switch to the engine operation menu
- 555** Key
  - Switch to the engine operation menu
- F1** Function key
  - Return to the start menu
- F2** Function key
  - Retract the selected support cylinder
  - **Note:** The control release must have been made by touching the 2-Hand keypad in the rear of the BTT, see section „Release of button block on BTT“.
- F3** Function key
  - Extend the selected support cylinder
  - **Note:** The control release must have been made by touching the 2-Hand keypad in the rear of the BTT, see section „Release of button block on BTT“.
- F4** Function key
  - Turn the crane icon in 180° increments
- F5** Function key
  - Select / deselect the support cylinders according to the crane position
- F6** Function key
  - Select / deselect automatic support\*
  - **Note:** The function support automatic\* is only available on certain crane types.
- F7** Function key
  - Select / deselect the support cylinders according to the crane position
- F8** Function key
  - Select / deselect the support cylinders according to the crane position
- F9** Function key
  - -No function-
- F10** Function key
  - Select / deselect the support cylinders according to the crane position

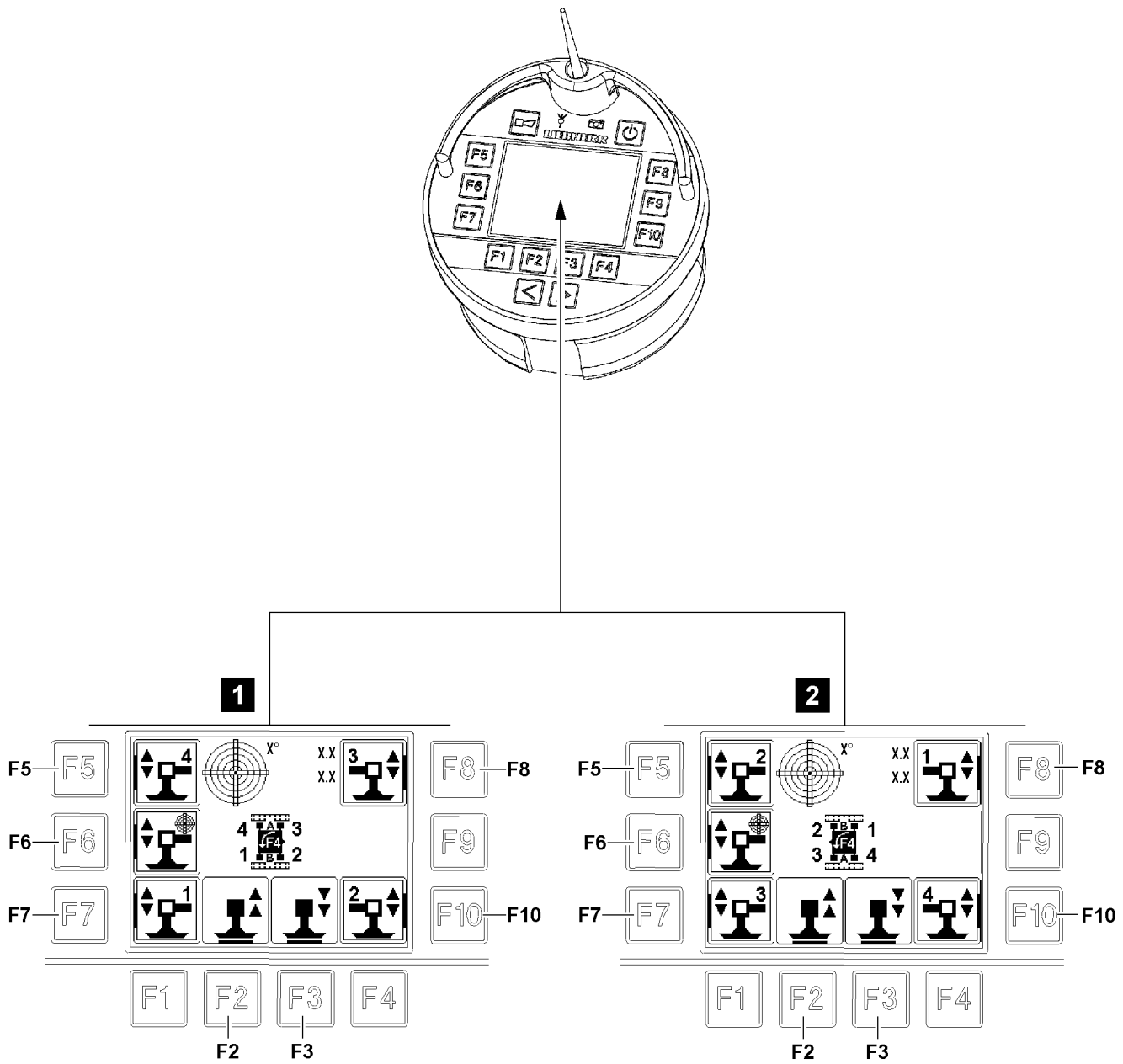


Fig.117974

LWE/LTR 1220-003/24204-02-02/en



## 7.3 Manual support

The supports can be selected and controlled individually or in groups. When a support cylinder is directly selected, then the automatic support selection is cancelled.

Make sure that the following prerequisite is met:

- The orientation of the operator to the crane has been set correctly, see section „Aligning the radio remote control with the crane“.

### Selection / deselection of the support cylinder:

- **Illustration 1:** The operator is standing to the side of crawler carrier B:
  - Actuate the function key **F5** for support cylinder 4.
  - Actuate the function key **F7** for support cylinder 1.
  - Actuate the function key **F8** for support cylinder 3.
  - Actuate the function key **F10** for support cylinder 2.
    - **Result:** Selected support cylinders are bordered in bold. Additional support cylinders can be selected / deselected as desired.
- **Illustration 2:** Operator is standing to the side of crawler carrier A:
  - Actuate the function key **F5** for support cylinder 2.
  - Actuate the function key **F7** for support cylinder 3.
  - Actuate the function key **F8** for support cylinder 1.
  - Actuate the function key **F10** for support cylinder 4.
    - **Result:** Selected support cylinders are bordered in bold. Additional support cylinders can be selected / deselected as desired.
- **Control release:**
  - The control release is made by touching the 2-Hand keyboard in the rear of the BTT, see section „Release of button block on BTT“
  - After the control release is provided, the icons over the function key **F2** / function key **F3** are highlighted in purple.



### Note

- ▶ To control the support cylinders, a control release must be issued: The corresponding icons must be highlighted in purple.

- **Retract the support cylinder:**
  - Press the function key **F2**.
- **Extend the support cylinder:**
  - Press the function key **F3**.

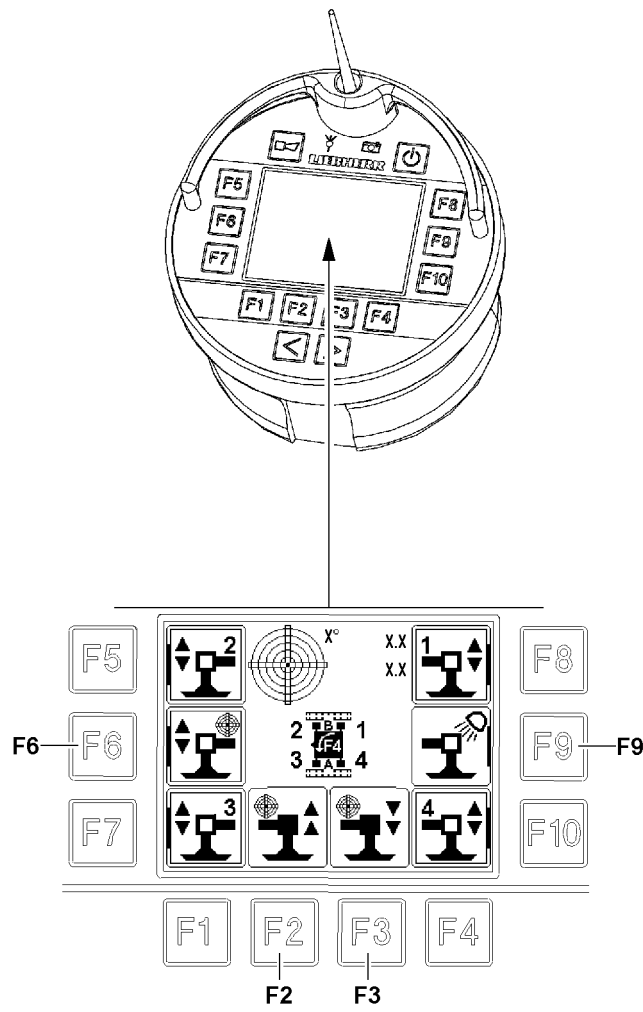


Fig.118947

## 7.4 Automatic support\*



### Note

- ▶ The function support automatic\* is only available on certain crane types.

The automatic support function automatically levels the crane during the support procedure.

At selection of the automatic support, an existing individual selection of the support cylinders will be deleted.

Make sure that the following prerequisite is met:

- The orientation of the operator to the crane has been set correctly, see section „Aligning the radio remote control with the crane“.
- **Automatic support selection:**
  - Press the function key **F6**.
    - **Result:** When the automatic support is selected, the icon is surrounded with a bold border. When subsequently individual support cylinders are selected / deselected, the automatic support is deselected.
- **Control release:**
  - The control release is made by touching the 2-Hand keyboard in the rear of the BTT, see section „Release of button block on BTT“
  - After the control release is provided, the icons over the function key **F2** / function key **F3** are highlighted in purple.



### Note

- ▶ To control the support cylinders, a control release must be issued: The corresponding icons must be highlighted in purple.

- **Levelling the crane by retracting the support cylinder:**
  - Press the function key **F2**.
- **Levelling the crane by extending the support cylinders:**
  - Press the function key **F3**.

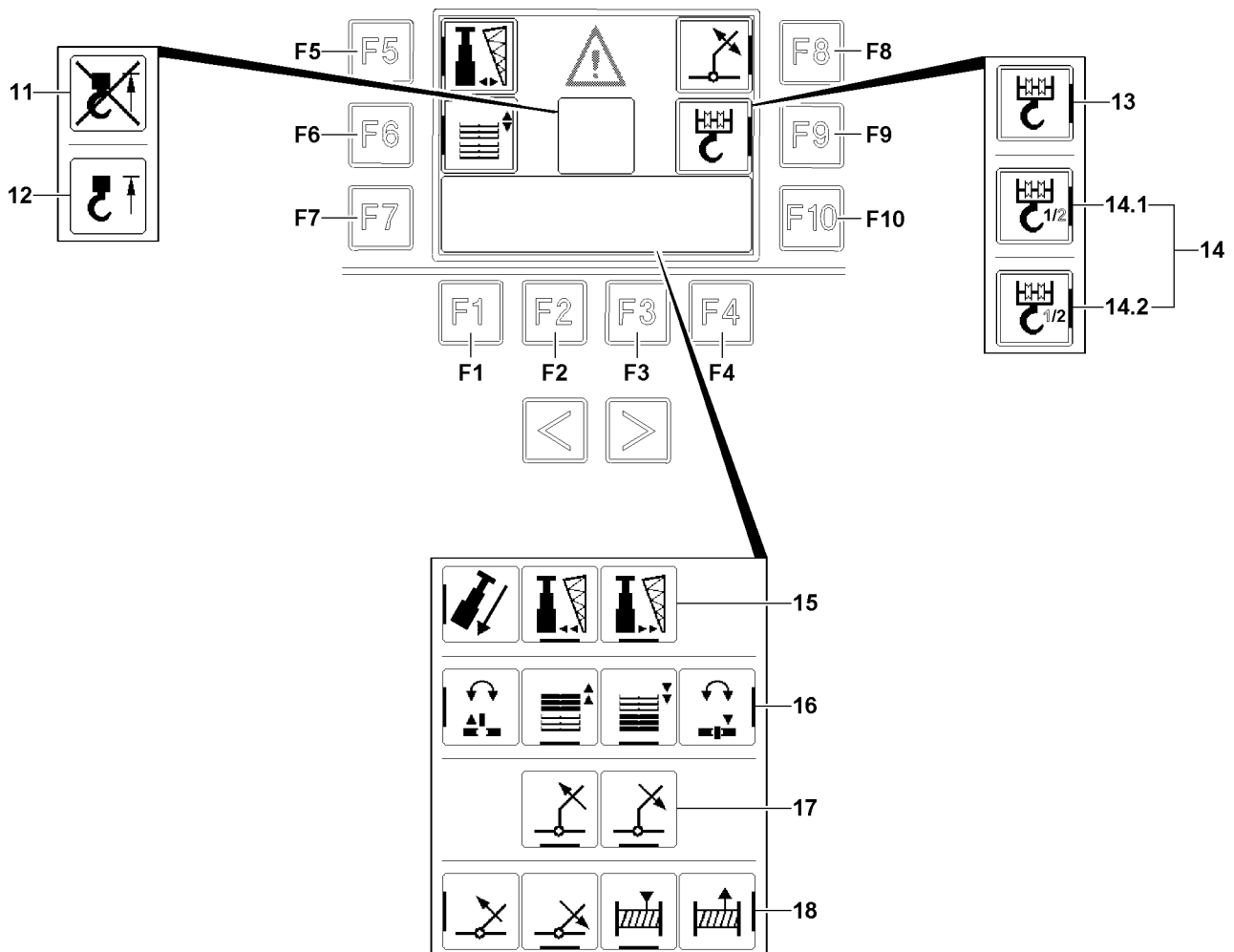


Fig.117950

## 8 Assembly functions menu

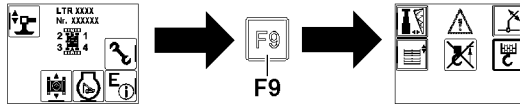


Fig.119849



### Note

Change from the start menu to the assembly function menu:

- ▶ Press the function key **F9**.



### Note

- ▶ The function key **F5** and the function key **F9** in the assembly functions menu remain active only as long as the telescopic boom is telescoped in all the way.

### 8.1 Icon explanation in assembly function menu

- 11** Hoist top bypassed
  - Appears when the hoist top limit switch is automatically bypassed by the control.
- 12** Hoist top triggered
  - Appears when the hoist top limit switch is triggered.
- 13** Single hoist gear
  - Icon appears when only one hoist winch is activated.
- 14** Two hoist gears
  - Icon appears if two hoist winches are activated
  - The icon **14.1** appears: Hoist gear 1 selected
  - The icon **14.2** appears: Hoist gear 2\* selected

### 8.2 The function keys in the assembly functions menu

- 554** Key
  - Press until the following menu is displayed (if available):
    - *Control floodlight menu / Crane floodlight menu / Crane chassis engine operation*
- 555** Key
  - Press until the following menu is displayed (if available):
    - *Control floodlight menu / Crane floodlight menu / Crane chassis engine operation*
- F1** Function key
  - Back to the start menu
- F2** Function key
  - Operate the assembly function according to the selection:
    - The operating icons **15** appear: Swing the folding jib in
    - The operating icons **16** appear: Lift the counterweight / retract the ballast cylinders
    - The operating icons **17** appear: Lift the hydraulic folding jib
    - The operating icons **18** appear: Luff the telescopic boom down
- F3** Function key
  - Operate the assembly function according to the selection:
    - The operating icons **15** appear: Swing the folding jib out
    - The operating icons **16** appear: Lower the counterweight / extend the ballast cylinders
    - The operating icons **17** appear: Lower the hydraulic folding jib
    - The operating icons **18** appear: Spool the hoist winch up
- F5** Function key
  - Selection / deselection of assembling the hydraulic folding jib\*
  - After selection, the operating icons **15** appear additionally

- Function is only active when the telescopic boom is telescoped in all the way.

**F6** Function key

- Selection / deselection of the ballasting / turntable lock
- After selection, the operating icons **16** appear additionally

**F7** Function key

- Operate the assembly function according to the selection:
  - The operating icons **15** appear: Tension the telescopic boom
  - The operating icons **16** appear: Unpin the turntable lock
  - The operating icons **18** appear: Luff the telescopic boom up
- **Note:** Applies only when an icon appears to the right next to the function key.

**F8** Function key

- Selection / deselection of lifting / lowering the hydraulic folding jib\*
- After selection, the operating icons **17** appear additionally

**F9** Function key

- Selection / deselection of fastening the hook block
- After selection, the operating icons **18** appear additionally
- Function is only active when the telescopic boom is telescoped in all the way.

**F10** Function key

- Operate the assembly function according to the selection:
  - The operating icons **16** appear: Pin the turntable lock
  - The operating icons **18** appear: Spool the hoist winch out
- **Note:** Applies only when an icon appears to the left next to the function key.

Empty page!

LWE/LTR 1220-003/24204-02-02/en

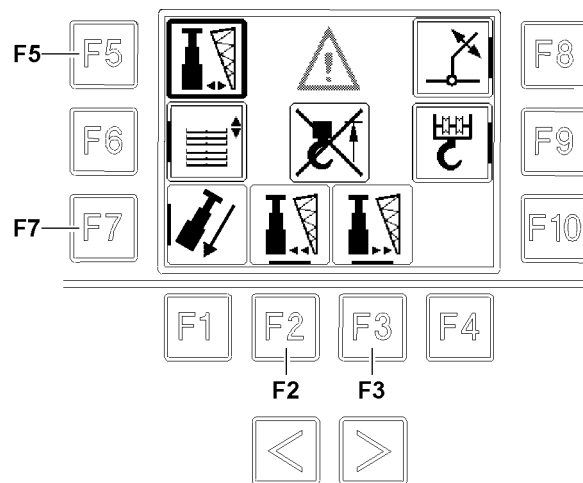


Fig.117953



### 8.3 Assembling the hydraulic folding jib\*

In order to be able to assemble the hydraulic folding jib\* on the boom head, it must be swung out over a cylinder.

To be able to pin the hydraulic folding jib\* on the boom head, it can be possible that the pin bores do not align. The telescopic boom must then be tensioned, in doing so the telescopic sections are pulled together.

Make sure that the following prerequisites are met:

- The telescopic boom is telescoped in all the way.
- The boom angle is less than 5°.



#### WARNING

Danger of crushing!

For the Tension the telescopic boom function, all telescopic sections are pulled together. Limbs or other body parts can be caught and crushed.

- ▶ As long as the function „tension the telescopic boom“ is carried out, keep sufficient distance to the push area of the telescopic sections!

#### – Selection / deselection of assembling the hydraulic folding jib\*:

- Press the function key **F5**.
  - **Result:** When the selection has been made, the border on the icon on the right of function key **F5** is bold. The icons over the function key **F2** / function key **F3** and next to the function key **F7** appear.

#### – Control release:

- The control release is made by touching the 2-Hand keyboard in the rear of the BTT, see section „Release of button block on BTT“
- After provided control release, the icons over the function key **F2** / function key **F3** and next to function key **F7** are highlighted in purple.



#### Note

- ▶ To control the functions, a control release must be issued: The corresponding icons must be highlighted in purple.

#### – Swing the hydraulic folding jib\* out:

- Press the function key **F3**.

#### – Swing the hydraulic folding jib\* in:

- Press the function key **F2**.

#### – Tension the telescopic boom:

- Press the function key **F7**.

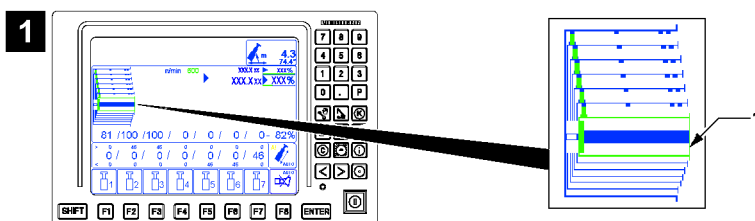


Fig.154557: Example: Telescoping cylinder pinned with the innermost telescope 1



#### Note

- ▶ To be able to tension the telescopic boom completely, the telescoping cylinder must be pinned with the innermost telescope, see example illustration 1.

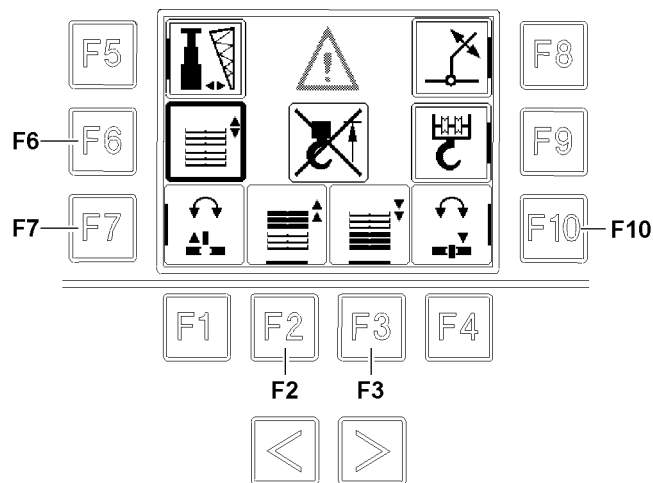


Fig.117954

## 8.4 Ballasting / turntable lock

Ballasting is performed using the ballast cylinders. By pinning the turntable lock, the crane superstructure is prevented from turning. By pinning the turntable lock on the respective location, a collision of the ballast cylinder with the counterweight can be eliminated. The turntable can be pinned on the intake point of the counterweight plates and on the lifting point of the receptacle plate, see Crane operating instructions, chapter 4.07.

- **Selection / deselection of the ballasting / turntable lock:**
  - Press the function key **F6**.
    - **Result:** When the selection has been made, the border on the icon on the right of function key **F6** is bold. The icons over the function key **F2** / function key **F3** and next to the function key **F7** / function key **F10** appear.
- **Control release:**
  - The control release is made by touching the 2-Hand keyboard in the rear of the BTT, see section „Release of button block on BTT“
  - After the control release is provided, the icons over the function key **F2** / function key **F3** and next to function key **F7** / function key **F10** are highlighted in purple.



### Note

- ▶ To control the functions, a control release must be issued: The corresponding icons must be highlighted in purple.

- **Lift the counterweight / retract the ballast cylinders:**
  - Press the function key **F2**.
- **Lower the counterweight / extend the ballast cylinders:**
  - Press the function key **F3**.
- **Unpin the turntable lock:**
  - Press the function key **F7**.
- **Pin the turntable lock:**
  - Press the function key **F10**.

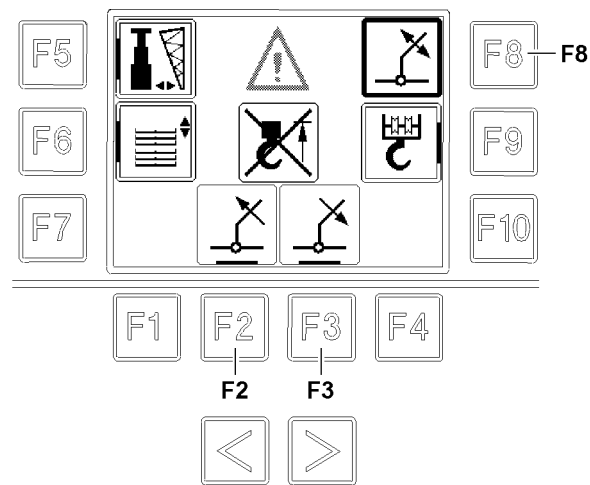


Fig.117955

## 8.5 Lifting / lowering the hydraulic folding jib\*

The hydraulic folding jib\* can be lifted / lowered for assembly, see the Crane operating instructions, chapter 5.02.

- **Selection / deselection of lifting / lowering the hydraulic folding jib\*:**
  - Press the function key **F8**.
    - **Result:** When the selection has been made, the border on the icon on the left of function key **F8** is in bold. The icons over the function key **F2** / function key **F3** appear.
- **Control release:**
  - The control release is made by touching the 2-Hand keyboard in the rear of the BTT, see section „Release of button block on BTT“
  - After the control release is provided, the icons over the function key **F2** / function key **F3** are highlighted in purple.



### Note

- ▶ To control the functions, a control release must be issued: The corresponding icons must be highlighted in purple.
- 

- **Lift the hydraulic folding jib\*:**
  - Press the function key **F2**.
- **Lower the hydraulic folding jib\*:**
  - Press the function key **F3**.

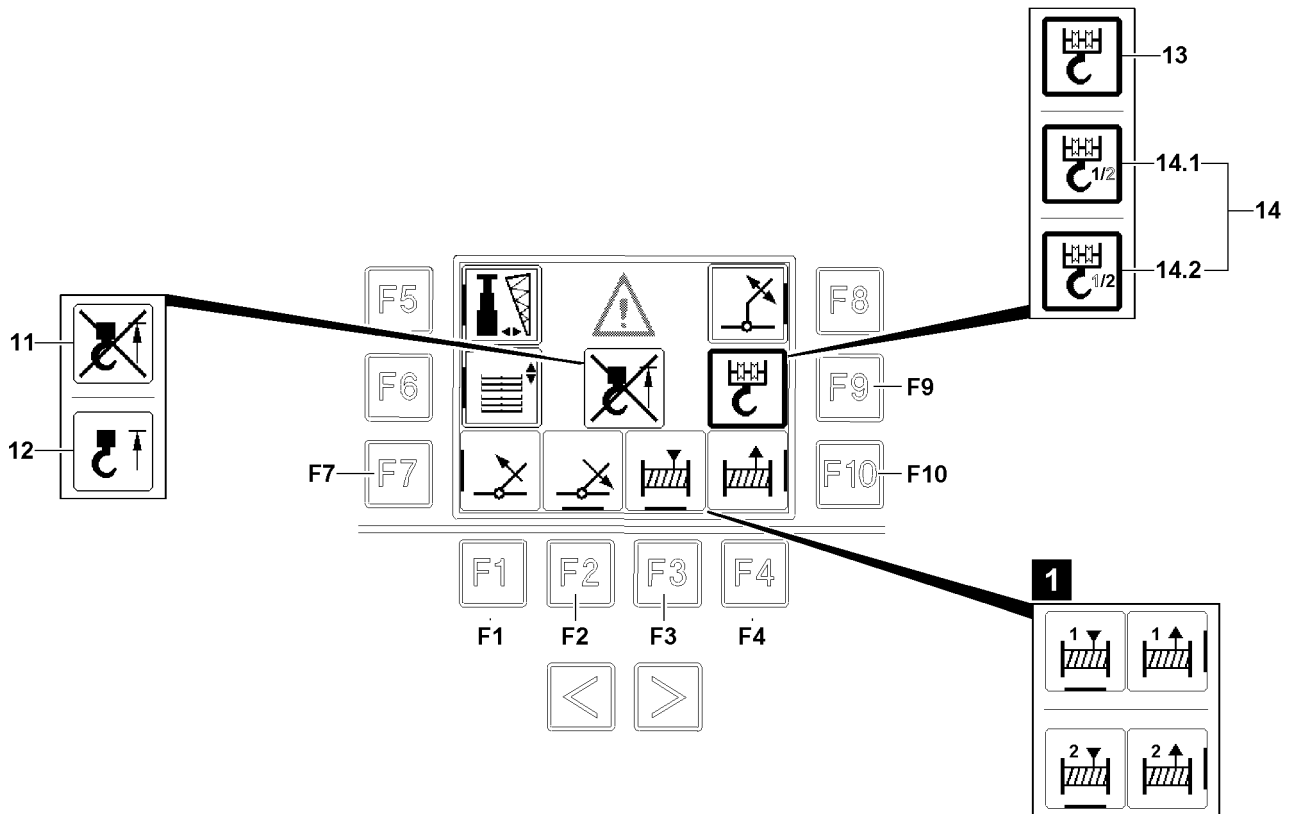


Fig.117951

## 8.6 Fastening the hook block

---

### NOTICE

Incorrect hoist winch selected!

If the incorrect hoist winch is selected, the crane can be damaged.

- ▶ When two hoist winches are active, select the correct hoist winch for the hook block.
- 

### 8.6.1 Selecting the hoist winch

When the hoist winches **14** icon appears, a hoist winch must be selected first. The selection is only possible via the operating elements in the crane operator's cab! To do so, the winch that should not be driven must be blocked.

- The hoist winch **14.1** icon is displayed: Hoist winch 1 (winch 1) is active.
- The hoist winch **14.2** icon is displayed: Hoist winch 2 (winch 2) is active.

Make sure that the following prerequisite is met:

- The hoist winches **14** icon appears in the BTT display.

- **Selection of the hoist winch:**

- Release the respective winch, see Crane operating instructions, chapter 4.05.

- **Result:** The number for the active hoist winch is displayed in bold.

In the icons for the control appears the number of the active hoist winch, see illustration 1.

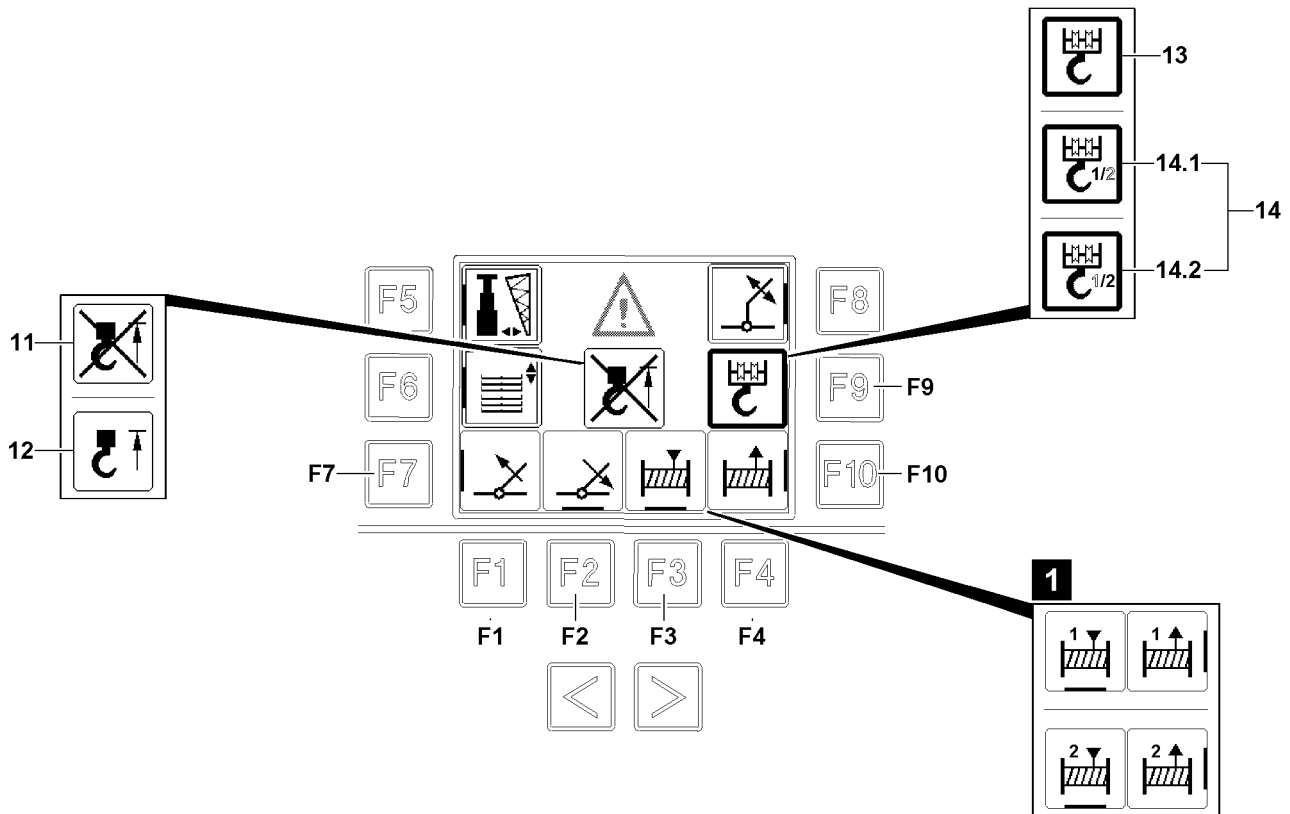


Fig.117951



## 8.6.2 Detaching / attaching the hook block on the fastening point

Detaching / attaching the hook block on the fastening point is described in chapter 4.03.

- **11** Hoist top limit switch bypassed  
Is displayed when the hoist top limit switch is automatically bypassed by the control.
- **12** Hoist top limit switch triggered  
Is displayed when the hoist top limit switch is triggered, crane movements are limited.
- **Hoist winch / hook block selection:**
  - Press the function key **F9**.
    - **Result:** When the selection has been made, the border on the icon on the left of function key **F9** is in bold. The icons over the function key **F2** / function key **F3** and next to the function key **F7** / function key **F10** appear.
- **Control release:**
  - The control release is made by touching the 2-Hand keyboard in the rear of the BTT, see section „Release of button block on BTT“
  - After the control release is provided, the icons over the function key **F2** / function key **F3** and next to function key **F7** / function key **F10** are highlighted in purple.



### Note

- ▶ To control the functions, a control release must be issued: The corresponding icons must be highlighted in purple.



### Note

- ▶ The function key **F2**, function key **F3**, function key **F7** and function key **F10** have 2 speed stages. For example, if the function key **F10** is actuated lightly, the hoist rope is spooled out slowly. If the function key **F10** is actuated harder, the hoist rope is spooled out quickly.

### Spool the hoist winch up:

- Press the function key **F3**.

### Spool the hoist winch out:

- Press the function key **F10**.

### Luff the telescopic boom down:

- Press the function key **F2**.

### Luff the telescopic boom up:

- Press the function key **F7**.

## 8.7 Control floodlight menu

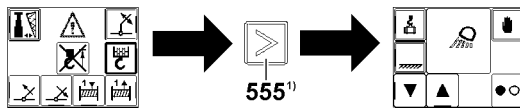


Fig.154558: Switching from crane superstructure assembly functions menu to the Control floodlight menu

- 1) Press the change over key **555** until the *Control floodlight* menu is displayed.



### Note

- ▶ Only with corresponding crane equipment.

The *Fasten the hook block* function can be used to call up the *Floodlight control* menu.

### 8.7.1 Icons in the Control floodlight\* menu

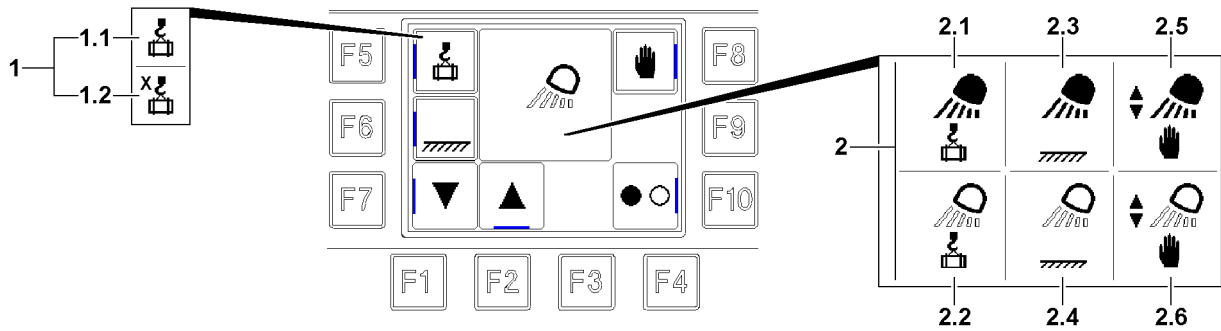


Fig.155568: Icon explanation for the Controlling floodlight\* menu

- 1 Load following icon
  - 1.1 Load following hook block / load position
  - 1.2 Load following is set in case of two hook blocks / load positions; selected hook block / load position is displayed in the icon

**Note:** Only for crane types with corresponding equipment.
- 2 Floodlight icon
  - 2.1 Working floodlight turned on and set to load following
  - 2.2 Working floodlight turned off and set to load following
  - 2.3 Working floodlight turned on and set to illuminate work area
  - 2.4 Working floodlight turned off and set to illuminate work area
  - 2.5 Working floodlight turned on and set to manual control
  - 2.6 Working floodlight turned off and set to manual control

### 8.7.2 Control floodlight menu function keys

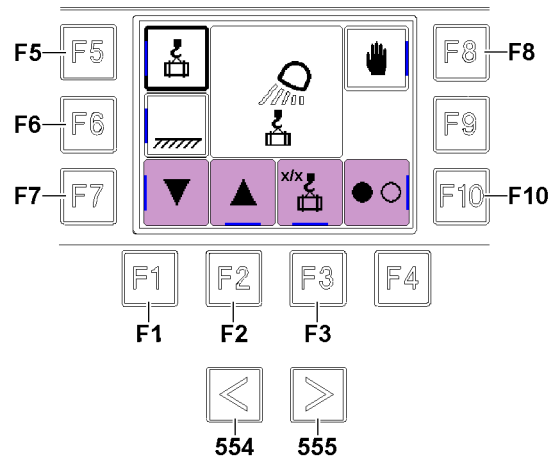


Fig.155569: Control floodlight menu function keys

- 554** Change over key
  - Press until the following menu is displayed (if available):
    - Crane floodlight menu / Crane superstructure engine operation menu / Crane superstructure assembly functions menu
- 555** Change over key
  - Press until the following menu is displayed (if available):
    - Crane floodlight menu / Crane superstructure engine operation menu / Crane superstructure assembly functions menu
- F1** Function key
  - Back to the start menu

- F2** Function key
  - Swing working floodlight up manually
- F3** Function key
  - Load following with two hook blocks / load positions: switch between the hook blocks / load positions
  - Possible hook blocks / load positions are displayed in the icon
  - Note:** Only for crane types with corresponding equipment.
- F5** Function key
  - Automatic floodlight control operation: Select load following
- F6** Function key
  - Automatic floodlight control operation: Select illuminate work area
- F7** Function key
  - Swing working floodlight down manually
- F8** Function key
  - Select working floodlight manual control operation
- F10** Function key
  - Turn the floodlight on / off

### 8.7.3 Control floodlight\*

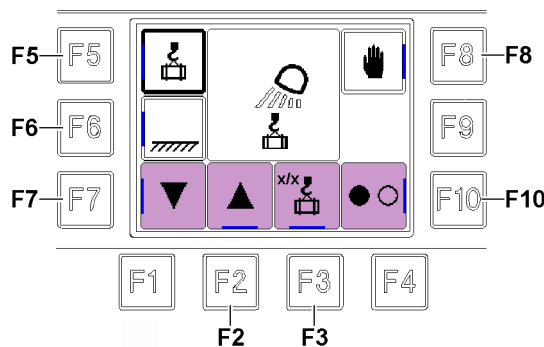


Fig.155571: Control floodlight\*

- **Turn the floodlight on / off:**
  - Press the function key **F10**.
  - Result:** The floodlight is turned on / off.
- **With two active hoist gears, switch between the hoist gears / load positions:**
  - Press the function key **F3**.
  - Result:** The floodlight swings to the selected hook block / load position.
- **Automatic floodlight control operation: Select load following:**
  - Press the function key **F5**.
  - Result:** The floodlight is automatically controlled according to the movement of the load.
    - Adjust the floodlight up / forward:
      - Press the function key **F2**.
    - Adjust the floodlight down / backward:
      - Press the function key **F7**.
- **Automatic floodlight control operation: Select illuminate work area:**
  - Press the function key **F6**.
  - Result:** The floodlight is automatically controlled according to the location of the work area.
    - Adjust the floodlight up / forward:
      - Press the function key **F2**.
    - Adjust the floodlight down / backward:
      - Press the function key **F7**.

- **Manual floodlight control operation:**
  - Swing the floodlight up / forward:
    - Press the function key **F2**.
  - Swing the floodlight down / backward:
    - Press the function key **F7**.

## 8.8 Crane floodlight menu

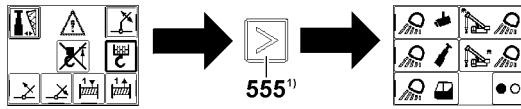


Fig.154559: Switching from crane superstructure assembly functions menu to the Crane floodlight menu

1) Press the change over key **555** until the *Crane floodlight* menu is displayed.



### Note

- ▶ Only with corresponding crane equipment.

The *fasten the hook block* function can be used to call up the *Crane floodlight* menu.

In the *crane floodlight* menu, up to five different crane floodlights can be turned on / turned off individually or together.

### 8.8.1 Icons in the crane floodlight menu

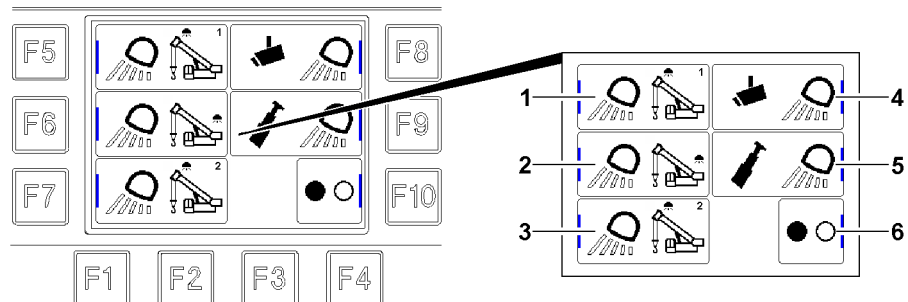


Fig.144539: Icons in the crane floodlight menu

- 1 Front turntable floodlight 1 icon
- 2 Rear turntable floodlight icon
- 3 Front turntable floodlight 2 icon
- 4 Crane monitoring floodlight icon
- 5 Pivot section floodlight icon
- 6 All floodlights on / off icon

## 8.8.2 Function keys in the *Crane floodlight* menu

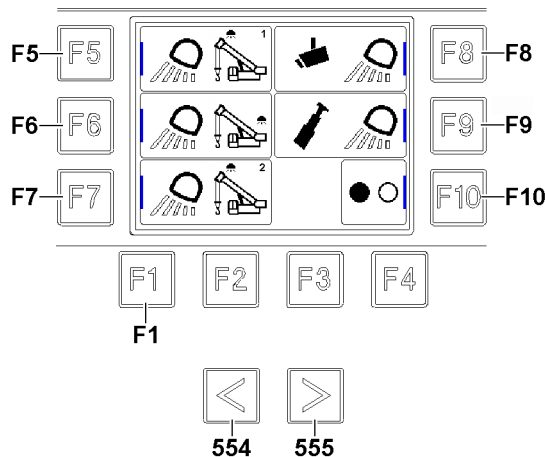


Fig.144540: Crane floodlight menu function keys

- 554** Change over key
- Press until the following menu is displayed (if available):
    - *Control floodlight* menu / *Crane superstructure engine operation* menu / *Crane superstructure assembly functions* menu
- 555** Change over key
- Press until the following menu is displayed (if available):
    - *Control floodlight* menu / *Crane superstructure engine operation* menu / *Crane superstructure assembly functions* menu
- F1** Function key
- Back to the start menu
- F5** Function key
- Turn *Floodlight 1 turntable front* on / off
- F6** Function key
- Turn *Floodlight turntable rear* on / off
- F7** Function key
- Turn *Floodlight 2 turntable front* on / off
- F8** Function key
- Turn *Floodlight camera monitoring* on / off
- F9** Function key
- Turn *Floodlight pivot section* on / off
- F10** Function key
- Turn all floodlights on / off

## 8.8.3 Turning the Floodlight\* on / off

- **Turn the floodlight on / off individually:**
  - Press the respective function key **F5-F9**.  
**Result:** The floodlight is turned on / off alternately.
- **Turn all floodlights on / off together:**
  - Press the function key **F10**.  
**Result:** All floodlights are turned on / turned off alternately together.

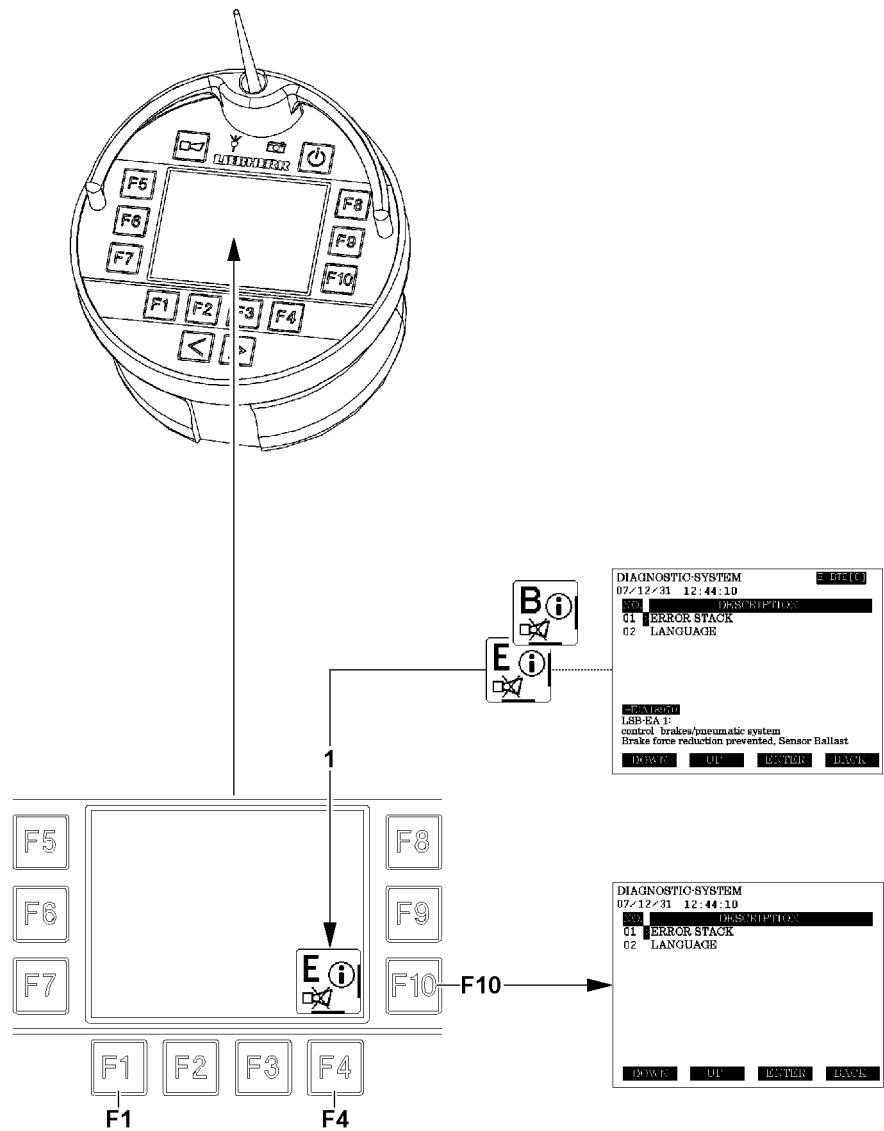


Fig.117975

LWE/LTR 1220-003/24204-02-02/en

## 9 Test system menu

If an error message is issued for the LICCON control:

- a „B“ or „E“ is shown in the information field 1, see illustration
- an acoustic warning signal of the radio remote control is issued

### 9.1 Function keys in the „Test system“ menu

**F1** Function key

- Return to selection overview

**F4** Function key

- When a note for an error message appears and a horn is shown in the information field 1:  
Press 1x: acoustic warning signal of the radio remote control, which can be shut off, is shut off in the case of operating / system errors  
Press 2x: Call up the test system

**F10** Function key

- Call up the test system

### 9.2 Operating the test system

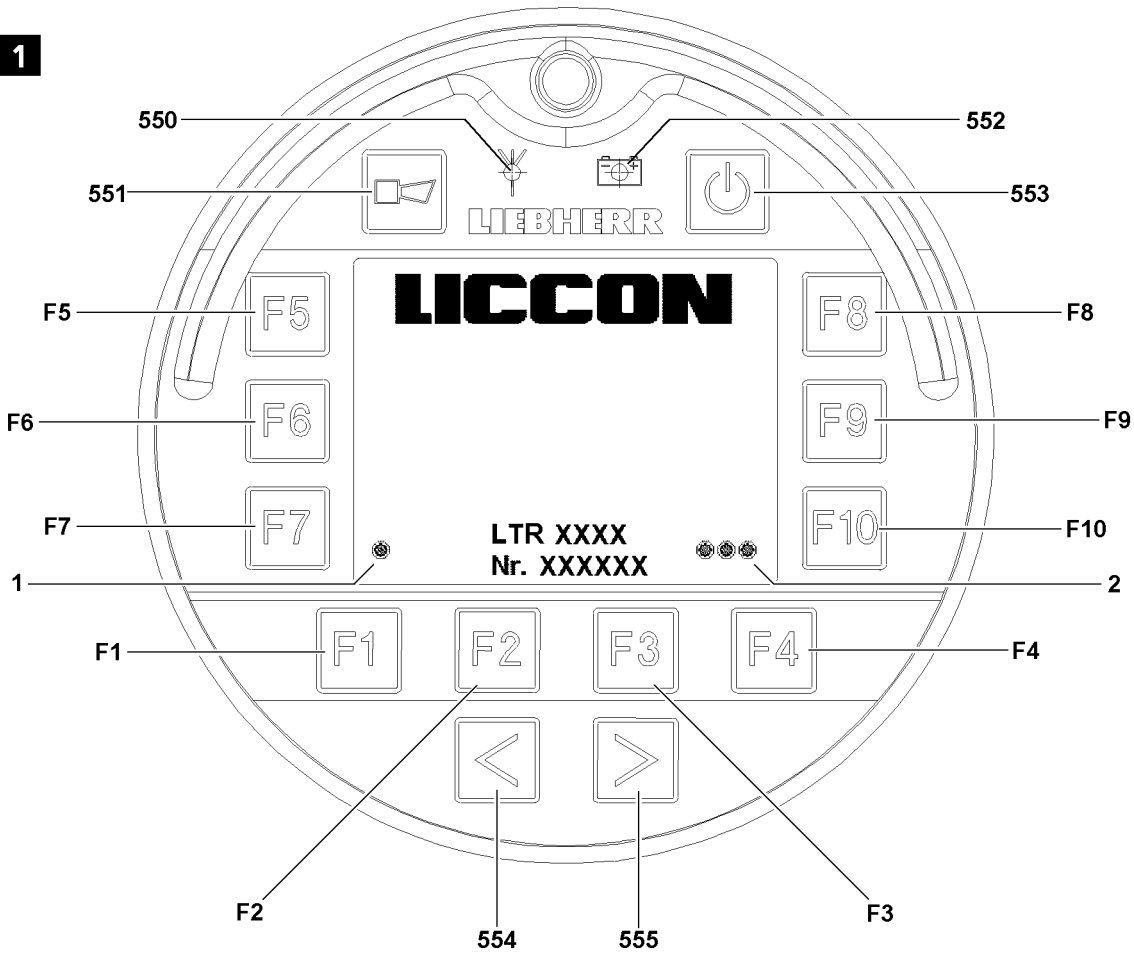
- **Turn the acoustic warning signal off:**
  - Press the function key **F4**.
    - **Result:** The disengageable acoustic warning signal of the radio remote control is shut off in the case of an operating / system error.
- **Call up the test system:**
  - Press the function key **F4** again.  
or
  - Press the function key **F10**.
    - **Result:** Start page of test system is called up.
- **Close the test system:**
  - Press the function key **F1**.



#### Note

- ▶ For a detailed description of the test system, see the Diagnostics Manual.

**1**



**2**

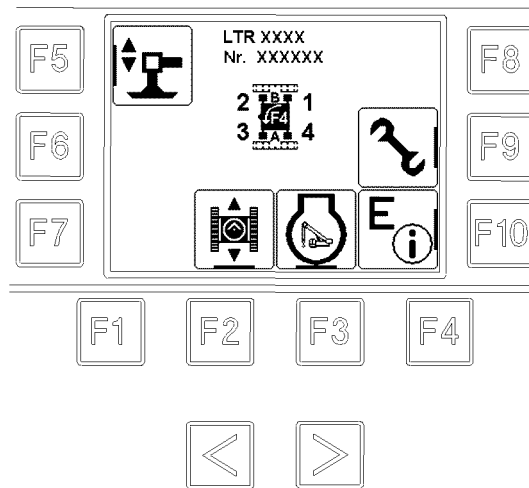


Fig.117808

LWE/LTR 1220-003/24204-02-02/en



## 10 BTT operation

There are two ways to turn the BTT:

- Turning the BTT on using the ignition switch
- Turning the BTT on using the ON / OFF button

### 10.1 Turning the BTT on using the ignition switch

Make sure that the following prerequisite is met:

- The BTT is in the charging cradle.
- ▶ Turn the ignition for the crane engine on: Actuate the ignition switch, see Crane operating instructions, chapter 4.01.

**Result:**

- The BTT turns itself on.
- After completion of the starting procedure, the indicator light **550** and indicator light **552** light up green, see illustration 1.
- The starting screen is shown before the display for „Menu overview“ changes, see illustration 2.

### 10.2 Turning the BTT on using the ON / OFF button

Make sure that the following prerequisite is met:

- The BTT is pulled off the charging cradle
- ▶ Turn the ignition for the crane engine on: Actuate the ignition switch, see Crane operating instructions, chapter 4.01.
- ▶ Turn the BTT on: Press the button **553** (ON / OFF button).

**Result:**

- The BTT turns itself on.
- The indicator light **550** and indicator light **552** light up in orange.
- The start screen is displayed, see illustration 1.
- ▶ Enter the code: Press button **554**, then button **555** and then function key **F1**.

**Result:**

- The indicator light **550** and indicator light **552** light up in green.
- The indicator light **1** and indicator light **2** turn on green.
- The connection between the BTT and the receiver is established.

- ▶ Press any function key.

**Result:**

- The BTT displays the „Menu overview“, see illustration 2.
- ▶ Select the menu with the appropriate function key, see the relevant technical chapter.

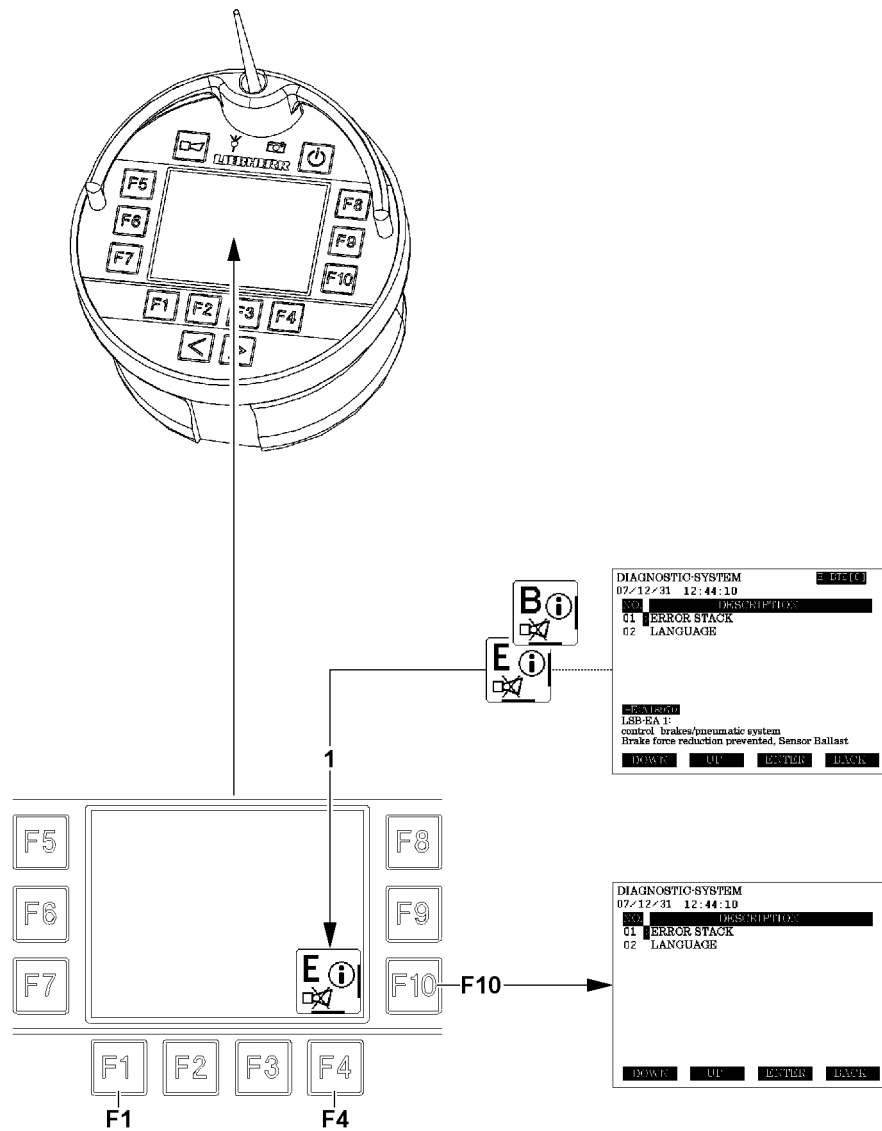


Fig.117975

# 11 Measures in case of problems

## 11.1 Did an error message appear?

If an event occurs that leads to the display of an error message, a „B“ or „E“ is shown in the icon 1, see illustration.



### WARNING

Danger of accident!

If the displayed errors in the icon 1 are ignored, there is a danger of accidents!

- ▶ Take the crane out of operation and remedy the cause of the error!
- ▶ Do not put the crane back into operation before the cause of the error has been remedied!

- ▶ Press the function key **F4**.

### Result:

- The disengageable acoustic warning signal of the radio remote control is shut off in the case of an operating / system error.

- ▶ Press the function key **F10**.

### Result:

- The „Test system“ program (error determination screen) is called up.



### Note

- ▶ To be able to find the cause of the problem, the error or errors must be read on the error determination screen / error stack of the BTT **500**, see the Diagnostics manual.

Close the „Test system“ program (error determination screen):

- ▶ Press the function key **F1**.

### Result:

- The „Test system“ program (error determination screen) is closed.

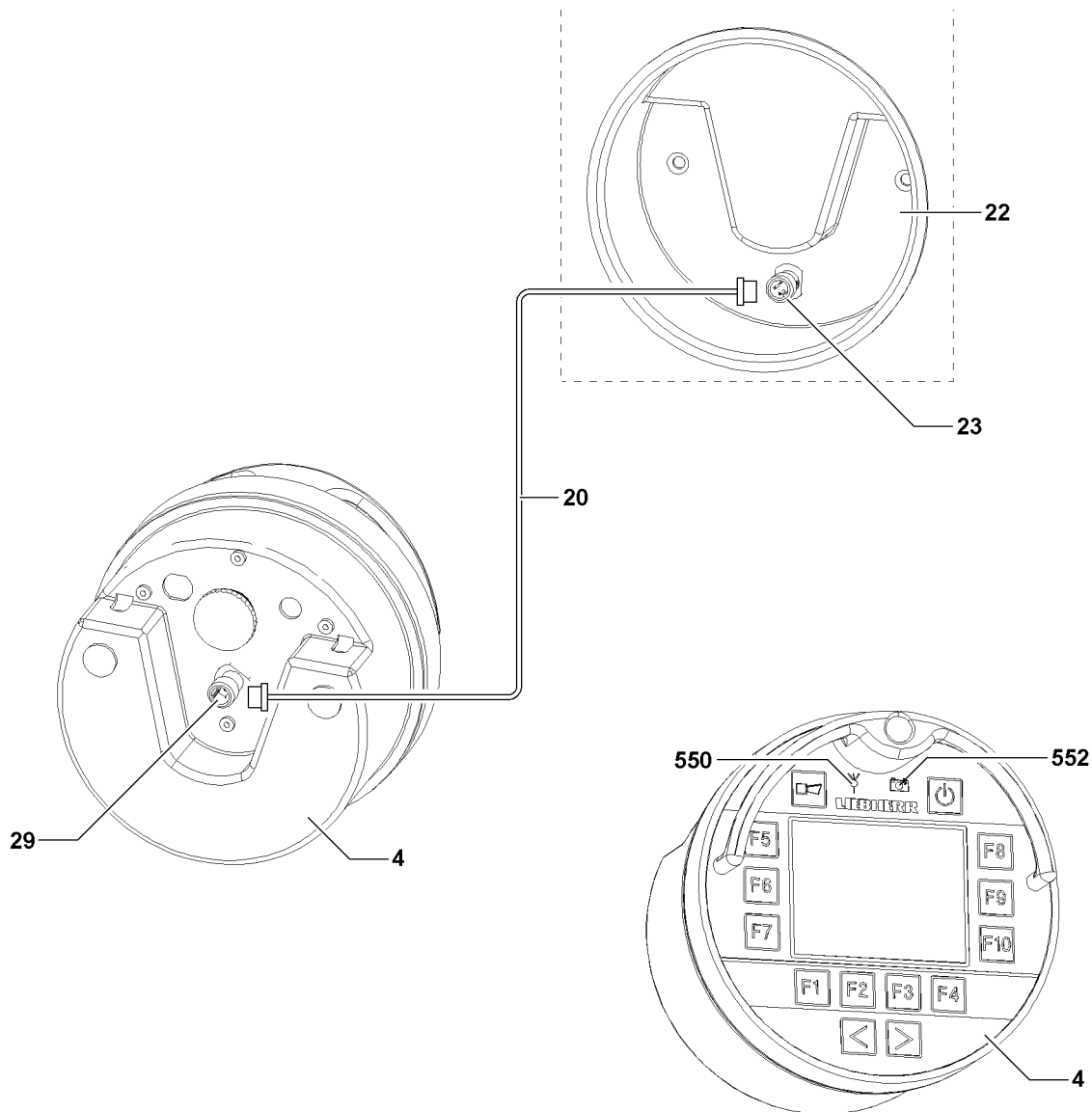


Fig.112952

## 11.2 The displays remain dark?



### Note

- ▶ The charge condition indicator light **552** shows the charge condition.
- ▶ Indicator light Transmission signal **550** shows the quality of the radio contact connection.

When the indicator light charge condition **552** does not light up or lights up red:

- ▶ Plug the BTT **4** into the charging module **22**.

When the LED **552** does not light up even though the BTT **4** is in the charging module **22** or the BTT **4** can not be turned on:

- ▶ Contact Liebherr Service to determine the cause of the problem and further procedure.

## 11.3 Is the radio connection faulty?

If the radio contact connection to the BTT **4** is faulty or interrupted (Indicator light Transmission signal **550** lights up red), then it can be bypassed with line **20**.

The radio connection to the BTT 4 can become faulty or interrupted through the following occurrences:

- By interference signals from a nearby radio tower.
- The radio module on the BTT 4 or on the BTB is defective.
- The rechargeable battery in the BTT 4 is discharged.
- Due to bad selection of the placement location by the operator.

### 11.3.1 Bypassing the radio connection

Make sure that the following prerequisites are met:

- The line 20 to bypass the radio communication has been removed from the control cabinet of the crane cab.
- The BTT 4 has been removed from the charging module 22 and is turned on.
- The caps on the plug connection 23 and the plug connection 29 have been removed.
- ▶ Screw the line 20 on the charging module 22 onto the plug connection 23.
- ▶ Screw the line 20 on the BTT 4 onto the plug connection 29.

**Result:**

- The radio communication is bypassed.



**Note**

If the BTT 4 does not turn on, even though the line 20 is connected with the charging module 22, then the rechargeable battery may be defective!

- ▶ Contact Liebherr Service to determine the cause of the problem and further procedure.
-

---

Empty page!

LWE/LTR 1220-003/24204-02-02/en

## 5.70 Camera

1	Safety instructions	3
2	Swinging the transmitter and receiver into the operating position	4
3	Bringing the camera to the assembly height	5
4	Bringing the cable drum to the assembly height	5
5	Assembling the camera on the telescopic boom	6
6	Assembling the cable drum on the telescopic boom	8
7	Assembling the cable drum on the auxiliary boom	9
8	Assembling the cable drum on the fixed jib	10
9	Assembling the cable drum on the luffing lattice jib	10
10	Assembling the camera on the auxiliary boom	10
11	Assembling the camera on the fixed jib	14
12	Assembling the camera on the luffing lattice jib	18
13	Establishing the electrical connections	22
14	Checking the electrical connections	33
15	Disconnecting the electrical connections	33
16	Swinging the transmitter and receiver into the transport position	33
17	Disassembling the camera	34
18	Disassembling the cable drum	35
19	Transporting the camera	36

*Fig.195219*

LWE/LTR 1220-003/24204-02-02/en



# 1 Safety instructions



## WARNING

Boom / equipment fastened with attachment parts!

The boom / equipment can tip over.

Death, severe bodily injuries, property damage.

- ▶ Before the boom / equipment is fastened: Make sure that all attachment parts have been removed.

## NOTICE

Boom / equipment is installed / removed with attachment parts!

The attachment parts can be damaged.

- ▶ **After** the hook block or the load hook is installed: Install the attachment parts.
- ▶ **Before** the hook block or the load hook is removed: Remove the attachment parts.



## WARNING

Attachment parts in the field of vision of the crane driver!

Death, severe bodily injury, property damage.

- ▶ Before the crane is driven: Make sure that all attachment parts have been removed or are in the park position.

Attachment parts are for example:

- Camera
- Cable drum
- Flashing beacon
- Wind speed sensor
- Hoist limit switch weight with chain



## WARNING

Assembly personnel **not** secured with suitable aids to prevent them from falling!

Assembly personnel can fall, death, severe bodily injuries.

- ▶ Carry out all overhead work, where there is a danger of falling with suitable aids.

When fall protection equipment is available:

- ▶ Use the fall protection equipment.

When there are railings on the crane components:

- ▶ Move the railings to the assembly / disassembly position and secure.

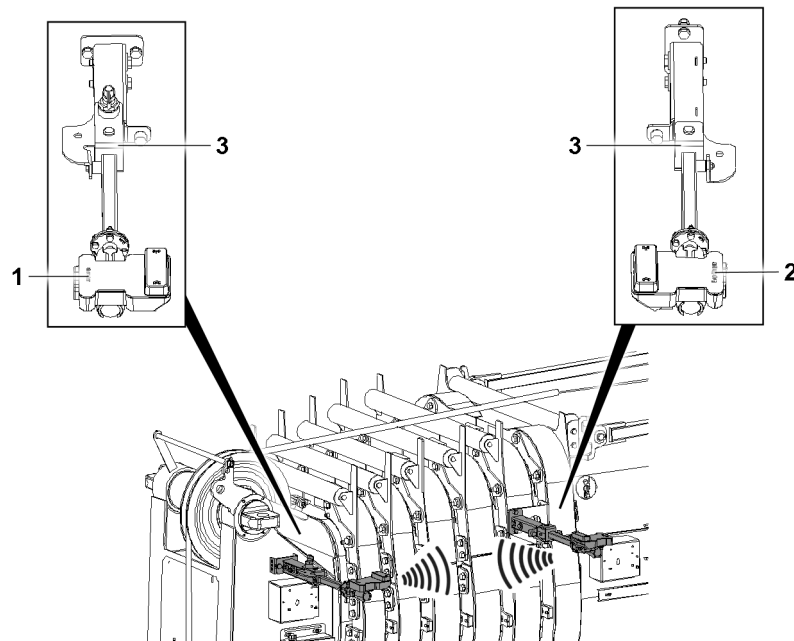
If aids are **not** available and work **cannot** be carried out on the ground:

- ▶ Secure assembly personnel with the supplied fall arrest system to prevent falling.
- ▶ Attach the supplied fall arrest system on the fastening and hook points as well as on the safety ropes.
- ▶ Only step on the aids, ladders and catwalks with clean shoes.
- ▶ Keep aids, ladders and catwalks free of heavy dirt, snow, frost and ice.

The illustrations in this chapter are an example. The installation of the camera is described as an example. The attached retainers are located at times in other positions than as shown.

Carry out the assembly of the camera depending on the crane structure.

## 2 Swinging the transmitter and receiver into the operating position



*Fig.145629: Retainer on the telescopic boom*

- |   |             |   |          |
|---|-------------|---|----------|
| 1 | Transmitter | 3 | Retainer |
| 2 | Receiver    |   |          |

Before a radio connection can be established, the holder for the transmitter and receiver must be swung into the operating position.

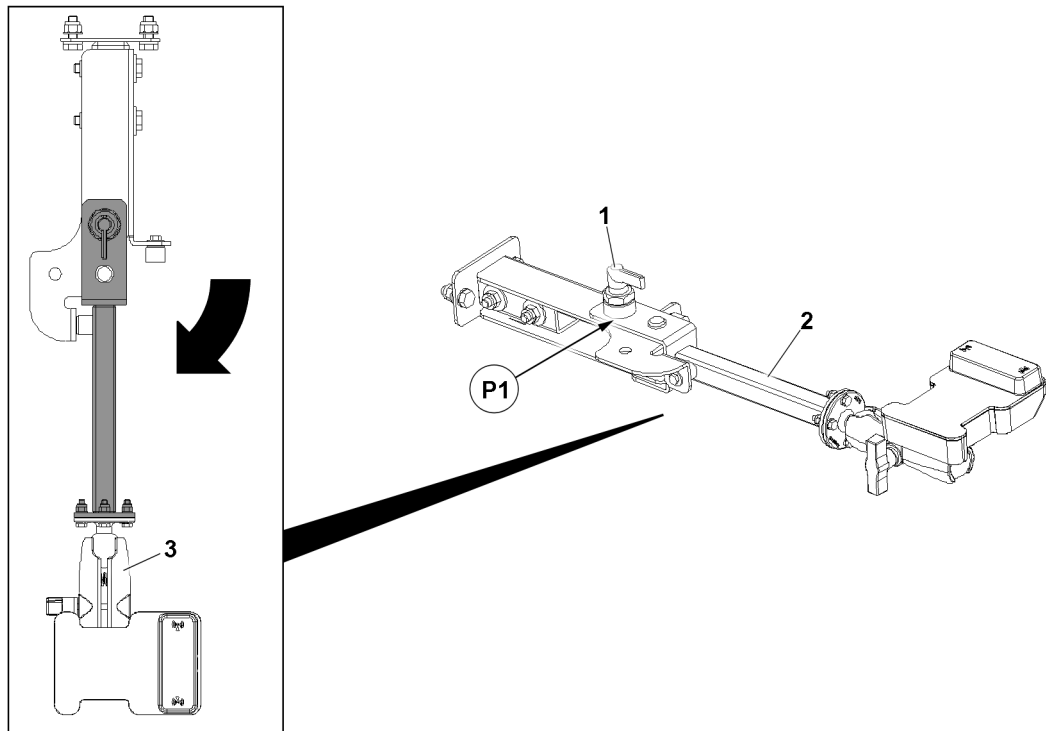


Fig.145661: Holder operating position

- |   |                   |   |                 |
|---|-------------------|---|-----------------|
| 1 | Retaining element | 3 | Connecting link |
| 2 | Swing arm         |   |                 |

- ▶ Release the retaining element 1.
- ▶ Until the retaining element 1 can be pinned in position P1: Swing the swing arm 2 in the direction of the arrow.
- ▶ Pin the retaining element 1 in position P1.
- ▶ Align the connecting link 3 vertically with the swing arm 2.

### 3 Bringing the camera to the assembly height

If a second person is not present during assembly and a ladder is used, then the camera must be brought to the assembly height as described:

- ▶ Fasten the auxiliary rope to the camera.
- ▶ Climb onto the ladder and at the same time carry along the auxiliary rope relieved.
- ▶ Until the camera is at the assembly height: Pull the auxiliary rope up.

### 4 Bringing the cable drum to the assembly height

If a second person is not present during assembly and a ladder is used, then the cable drum must be brought to the assembly height as described:

- ▶ Fasten the auxiliary rope to the cable drum.
- ▶ Climb onto the ladder and at the same time carry along the auxiliary rope relieved.
- ▶ Until the cable drum is at the assembly height: Pull the auxiliary rope up.

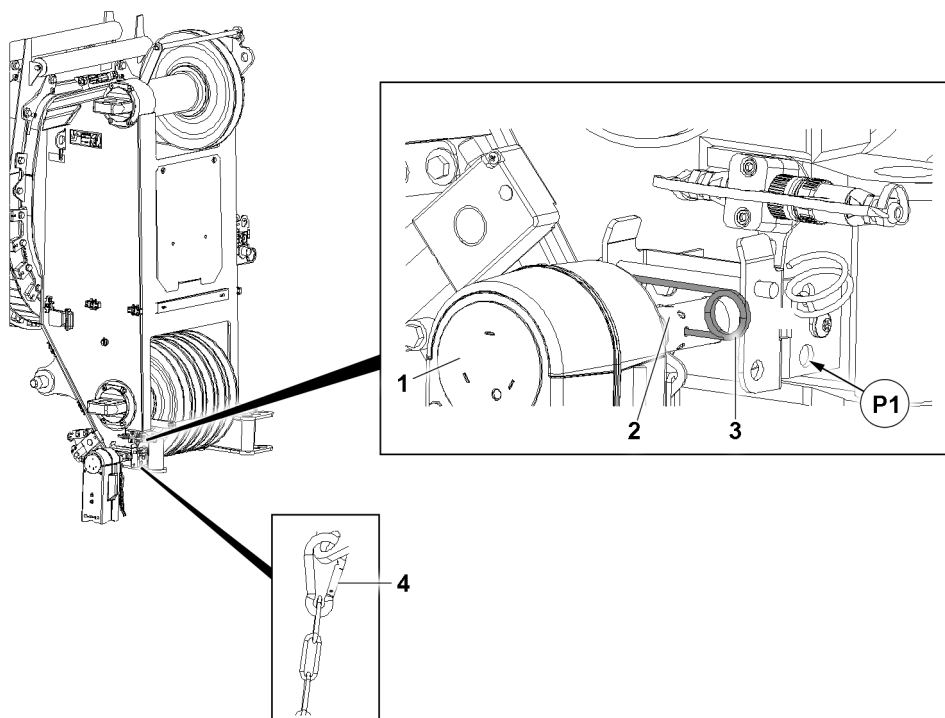
## 5 Assembling the camera on the telescopic boom

Make sure that the following prerequisites are met:

- The telescopic boom is luffed down to the 0° position.
- The telescopic boom is telescoped in all the way.

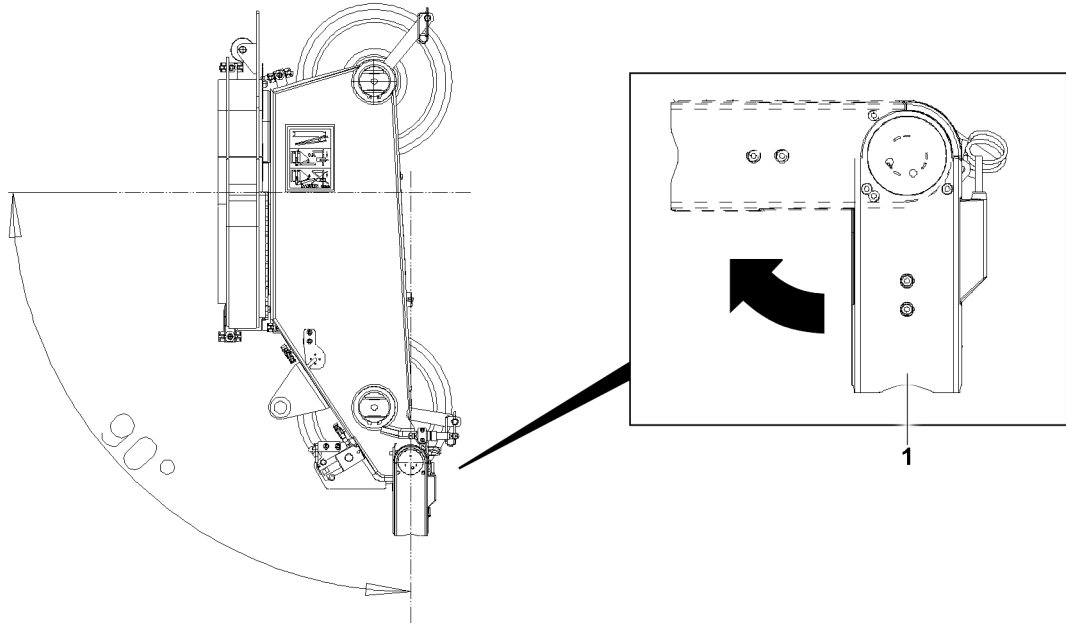
If possible, to reduce the working height:

- ▶ Luff the telescopic boom down all the way.



*Fig.128377: Camera installed on the telescopic boom*

- ▶ Insert the camera **1** in the retainer **2**.
- ▶ Secure the camera **1**: Install the retainer **3**.
- ▶ Attach the camera retaining chain **4** in position **P1**.

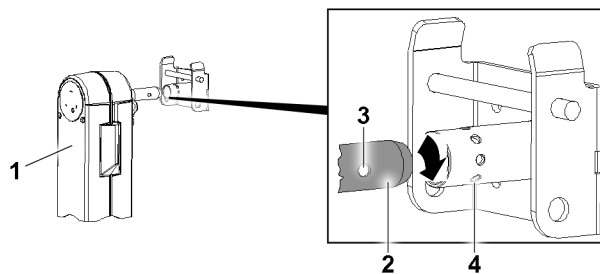


*Fig.128406: Telescopic boom camera slewing range*

The camera changes its angle automatically so that it is aligned vertically, gravity related. The swing angle is limited by design.

To ensure that the camera can align with the hook depending on the boom position, a certain swing angle must be possible.

- ▶ Make sure that the camera **1** has a swing angle of **90°** with respect to the vertical position to the boom.



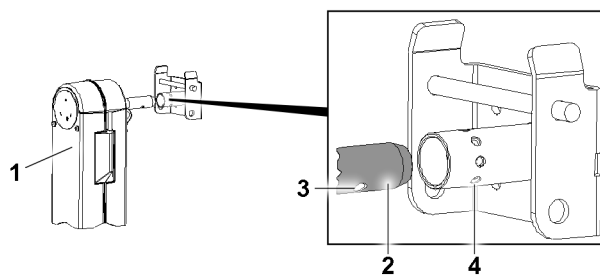
*Fig.128404: Assemble the camera turned.*

If the **90°** swing angle is not reached:

- ▶ Disassemble the camera **1**.
- ▶ Until the bore **3** and bore **4** are concentrically aligned: Turn the pin **2** in direction of the arrow.

**Result:**

- The bore **3** and bore **4** are concentrically aligned.



*Fig.128399: The bores are concentric.*

LWE/LTR 1220-003/24204-02-02/en

- ▶ Install the camera **1** as described in this section.
- ▶ Make sure that the camera **1** has a swing angle of **90°** with respect to the vertical position to the boom.

## 6 Assembling the cable drum on the telescopic boom

When all of the following requirements are fulfilled, the cable drum must be installed on the telescopic boom:

- The camera is installed on the auxiliary boom.

Make sure that the following prerequisite is met:

- The telescopic boom is telescoped in all the way.

In the following special cases, the cable drum must **not** be installed on the telescopic boom, as the cable drum on the telescopic boom is not used. A cable holding device is installed instead on the auxiliary boom.

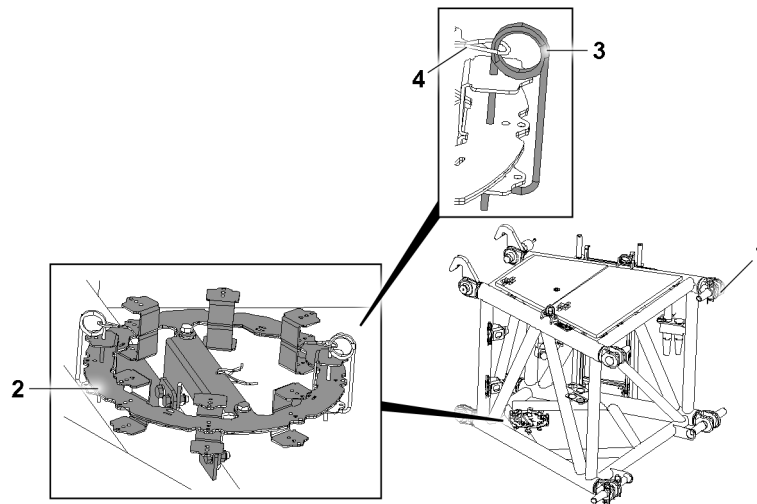


Fig.128407: Cable holding device on the TN/TF-adapter

- |   |                      |   |             |
|---|----------------------|---|-------------|
| 1 | TN/TF-adapter        | 3 | Retainer    |
| 2 | Cable holding device | 4 | Safety rope |

Crane type	Configuration
LTM 1350-6.1	TN/TF-adapter with cable holding device

*Special cases, do not assemble the cable drum on the telescopic boom*

If possible, to reduce the working height:

- ▶ Luff the telescopic boom down all the way.

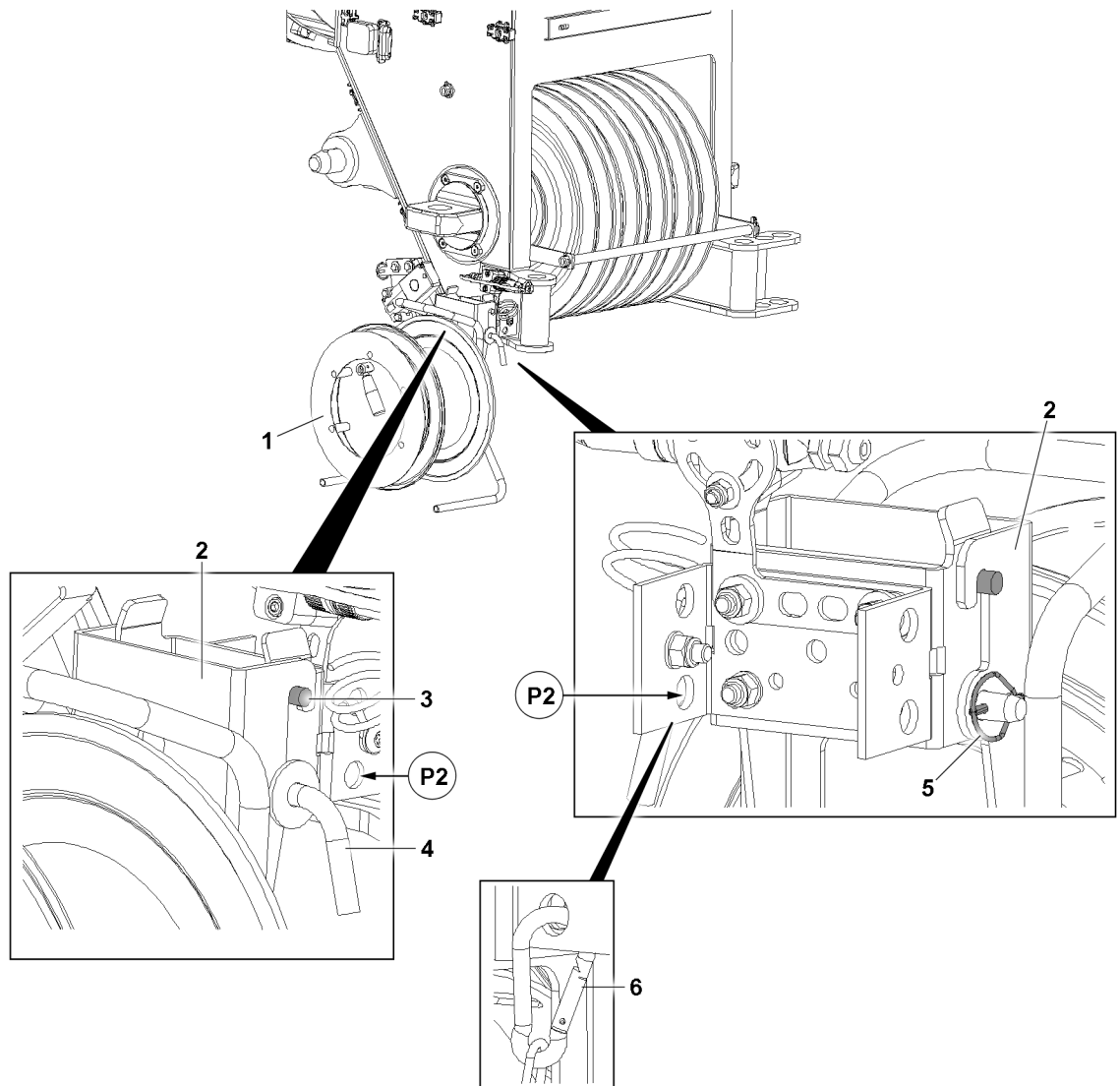


Fig.128379: Cable drum on the telescopic boom

- ▶ Attach the cable drum 1 with the retainer 2 on the pin 3.
- ▶ Secure the cable drum 1: Insert the pin 4.
- ▶ Secure the pin 4: Install the retainer 5.
- ▶ Attach the retaining chain 6 of the cable drum 1 in position P2.

## 7 Assembling the cable drum on the auxiliary boom

When all of the following requirements are fulfilled, the cable drum must be assembled on the auxiliary boom:

- The camera is installed on the auxiliary boom.
- The fixed routed cable for the camera is installed in the luffing range of the auxiliary boom.

Make sure that the following prerequisite is met:

- The telescopic boom is telescoped in all the way.

In the following special cases, the cable drum must **not** be installed.

Crane type	Configuration
LTM 1500-8.1	Equipment with a jib boom

*Special cases, do not assemble the cable drum*

If possible, to reduce the working height:

- ▶ Luff the auxiliary boom down as far as possible.

The cable drum is installed on the auxiliary boom using the same procedure used to install it on the telescopic boom.

- ▶ Install the cable drum. See section „Assembling the cable drum on the telescopic boom“.

## 8 Assembling the cable drum on the fixed jib

When all of the following requirements are fulfilled, the cable drum must be assembled on the auxiliary boom:

- The camera is installed on the auxiliary boom.
- The fixed routed cable for the camera is installed in the luffing range of the auxiliary boom.

Make sure that the following prerequisite is met:

- The telescopic boom is telescoped in all the way.

If possible, to reduce the working height:

- ▶ Luff the auxiliary boom down as far as possible.

The cable drum is installed on the auxiliary boom using the same procedure used to install it on the telescopic boom.

- ▶ Install the cable drum. See section „Assembling the cable drum on the telescopic boom“.

## 9 Assembling the cable drum on the luffing lattice jib

When all of the following requirements are fulfilled, the cable drum must be assembled on the auxiliary boom:

- The camera is installed on the auxiliary boom.
- The fixed routed cable for the camera is installed in the luffing range of the auxiliary boom.

Make sure that the following prerequisite is met:

- In the case of assembly by closing the lattice jib: The N-pivot section and N-head are still open on the ground.
- For flying assembly: The telescopic boom is in the 0° position.
- The telescopic boom is telescoped in all the way.

The cable drum is installed on the auxiliary boom using the same procedure used to install it on the telescopic boom.

- ▶ Install the cable drum. See section „Assembling the cable drum on the telescopic boom“.

## 10 Assembling the camera on the auxiliary boom

Depending on the available equipment, the camera can be installed in different positions.



Possible positions on the auxiliary boom are shown below as an example.

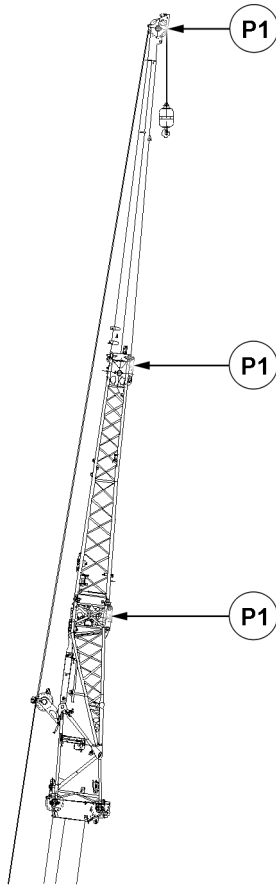


Fig.159546: Camera installation positions

**1** Illustration: folding jib

**P1** Camera installation position

Make sure that the following prerequisites are met:

- The telescopic boom is luffed down to the 0° position **or** if possible, the telescopic boom is luffed down completely.
- Luff the auxiliary boom down as far as possible.
- The telescopic boom is telescoped in all the way.

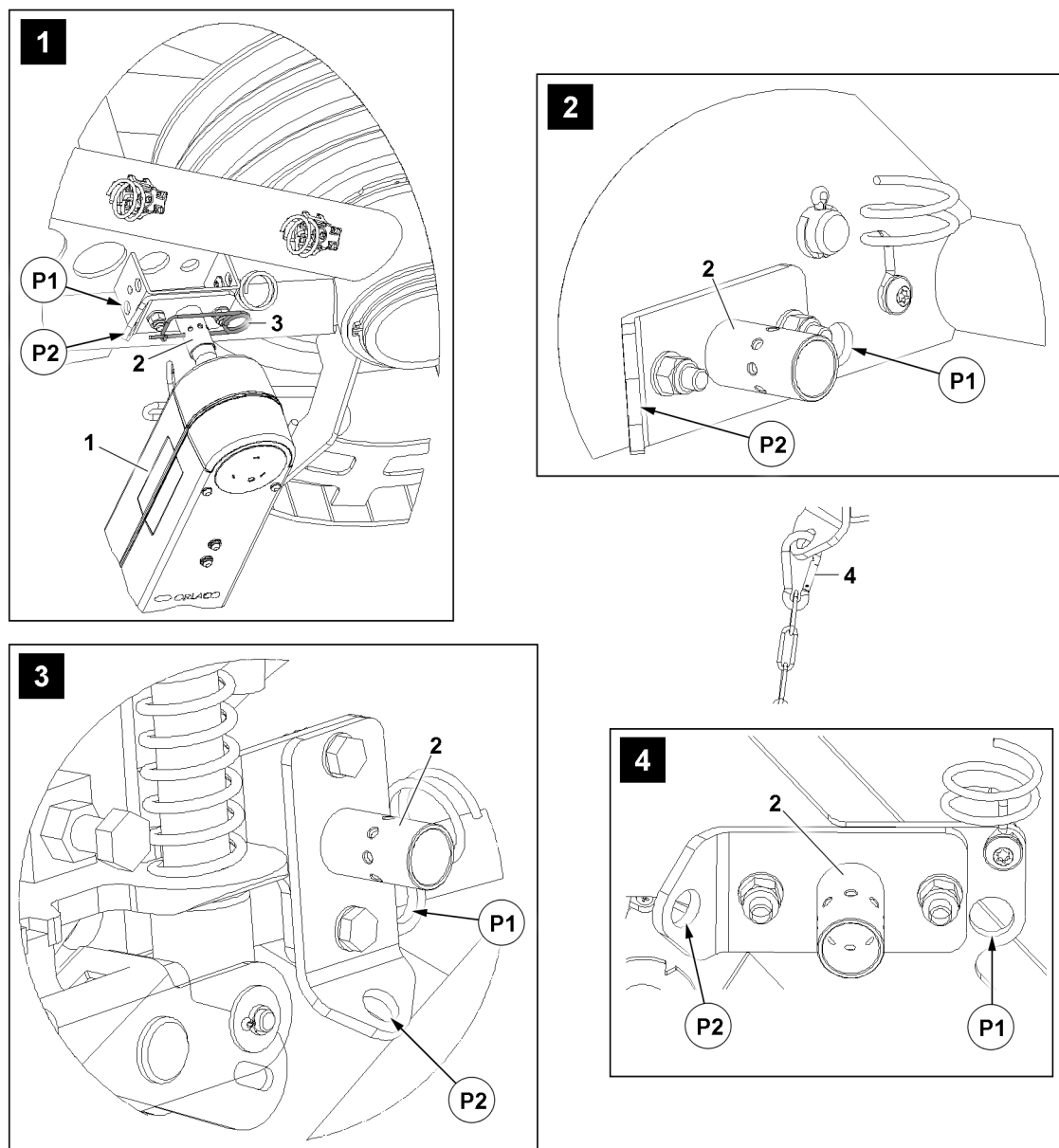


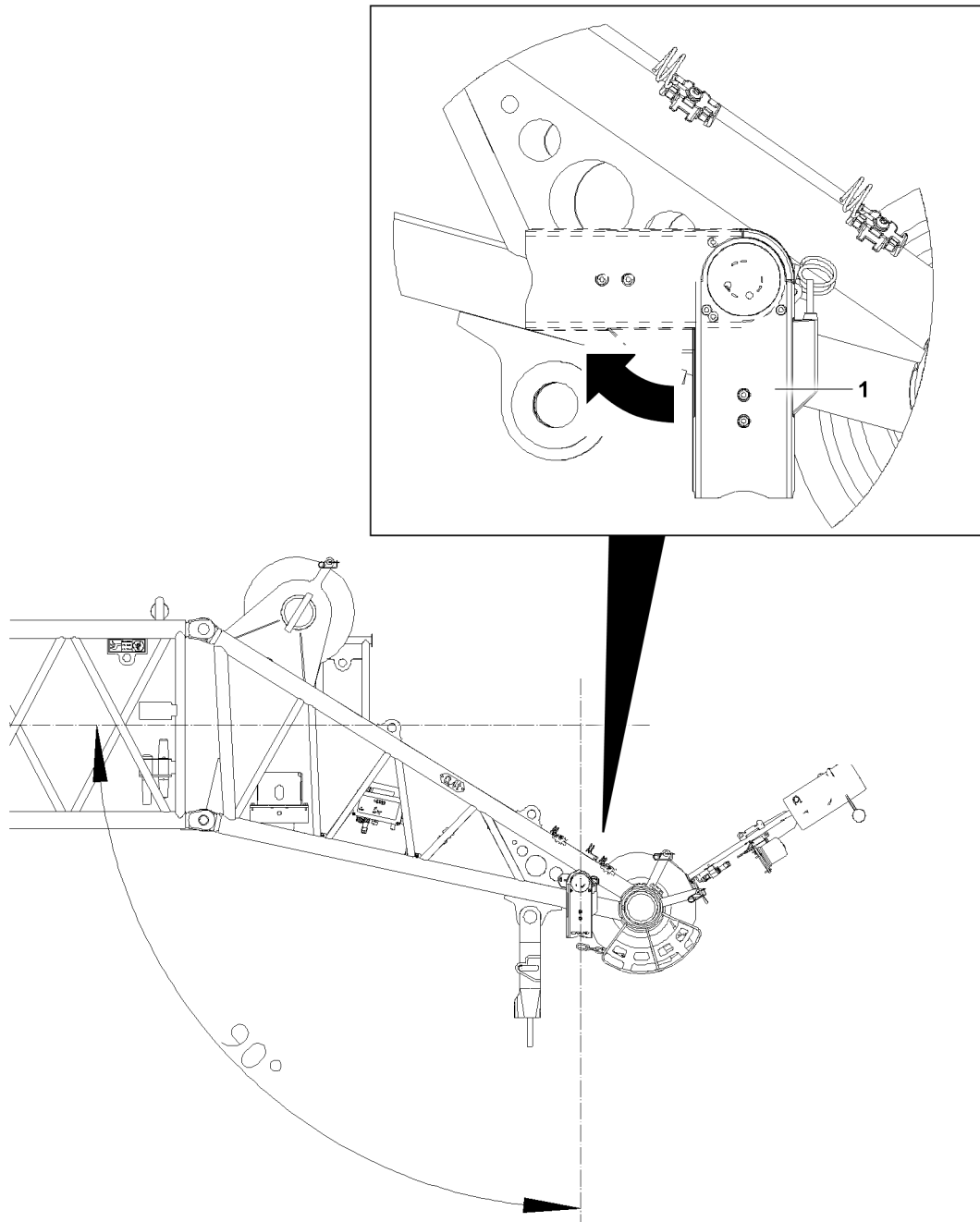
Fig.128375

Illustration 1 to illustration 4 show different variants of the retainer 2. The procedure for installing the camera 1 is the same for all variants.

- ▶ Insert the camera 1 in the retainer 2.
- ▶ Secure the camera 1: Install the retainer 3.
- ▶ Attach the camera retaining chain 4 in position P1.

The longer cable of the cable drum must be secured by the pull relief installed on the cable.

- ▶ Fit the pull relief cable in position P2.



*Fig.128376: Auxiliary boom camera slewing range*

The camera changes its angle automatically so that it is aligned vertically, gravity related. The swing angle is limited by design.

To ensure that the camera can align with the hook depending on the boom position, a certain swing angle must be possible.

- ▶ Make sure that the camera **1** has a swing angle of **90°** with respect to the vertical position to the boom.

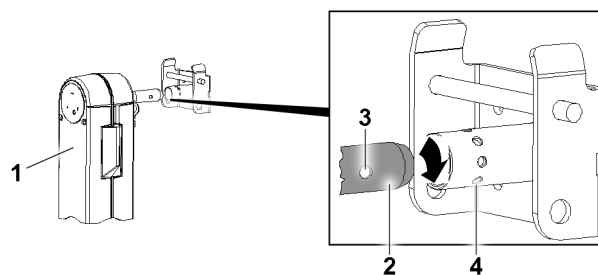


Fig.128404: Assemble the camera turned.

If the  $90^\circ$  swing angle is not reached:

- ▶ Disassemble the camera 1.
- ▶ Until the bore 3 and bore 4 are concentrically aligned: Turn the pin 2 in direction of the arrow.

**Result:**

- The bore 3 and bore 4 are concentrically aligned.

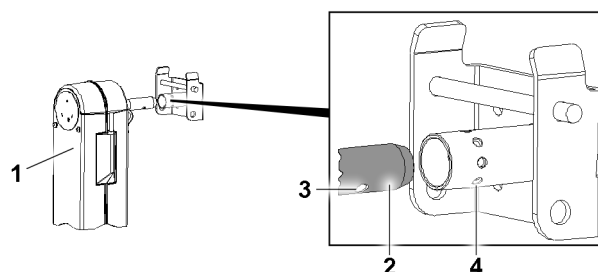


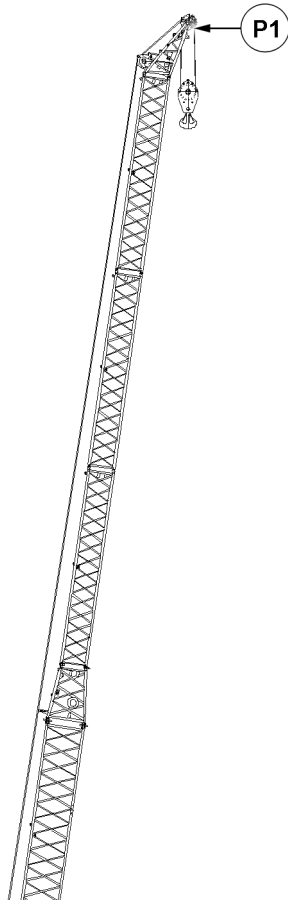
Fig.128399: The bores are concentric.

- ▶ Install the camera 1 as described in this section.
- ▶ Make sure that the camera 1 has a swing angle of  $90^\circ$  with respect to the vertical position to the boom.

## 11 Assembling the camera on the fixed jib

Depending on the available equipment, the camera can be installed in different positions.

A possible position on the fixed jib is shown below as an example.



*Fig.159544: Camera installation positions*

**P1** Camera installation position

Make sure that the following prerequisites are met:

- The telescopic boom is luffed down to the 0° position **or** if possible, the telescopic boom is luffed down completely.
- Luff the auxiliary boom down as far as possible.
- The cable drum(s) for the camera is / are assembled.
- The electrical connections are established to the camera position.
- The head of the fixed jib is **no** longer in the roller cart.
- The telescopic boom is telescoped in all the way.

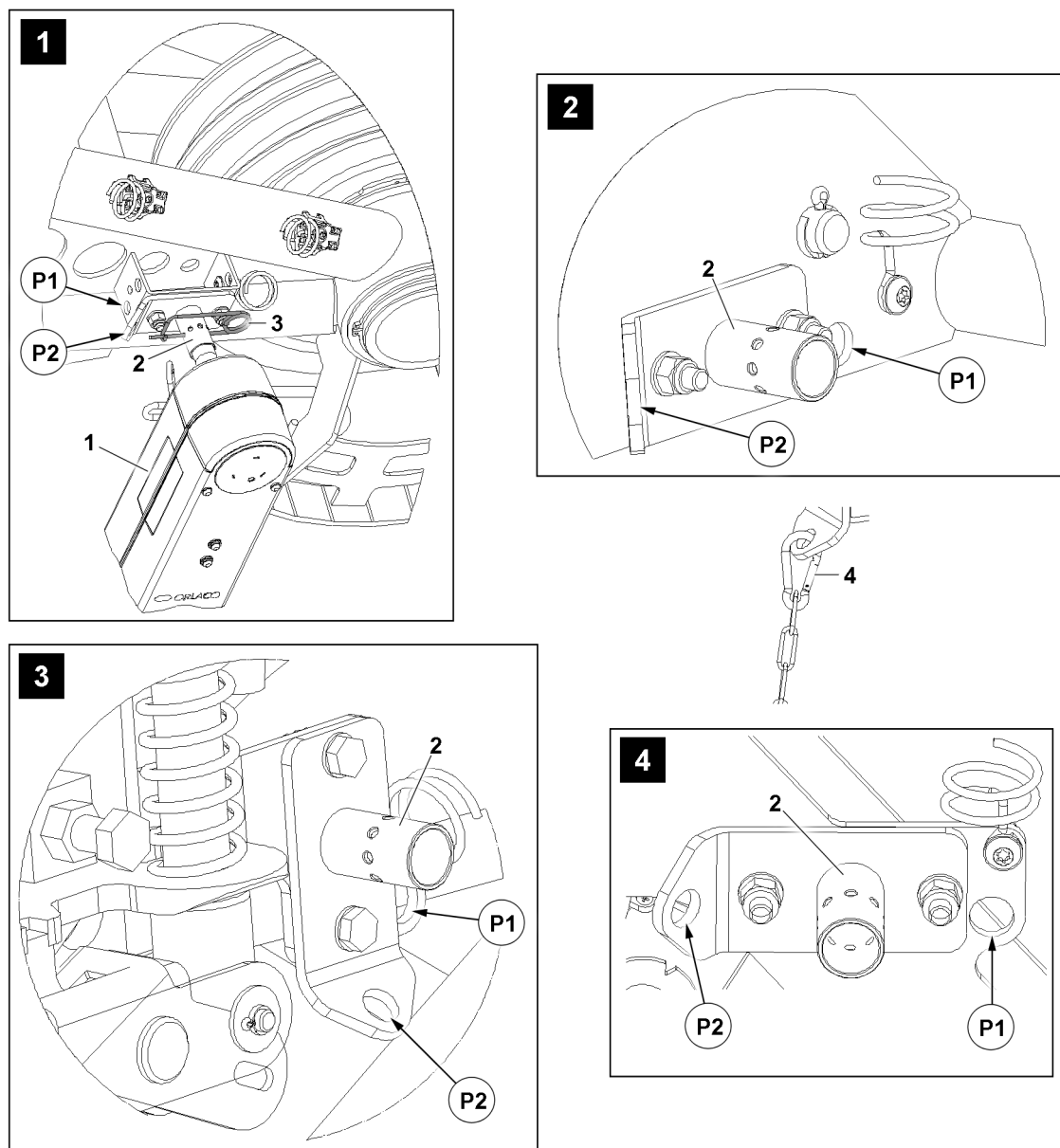


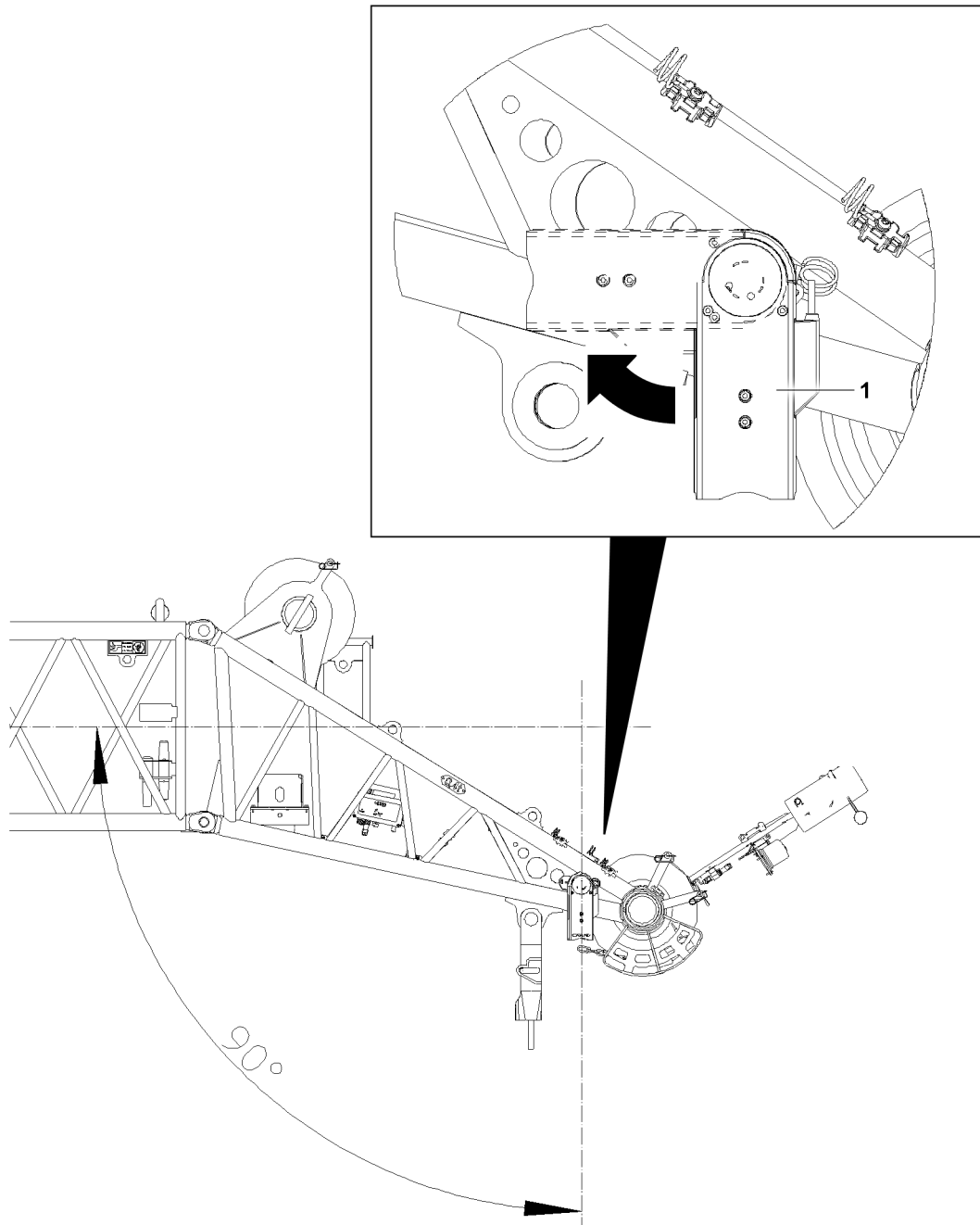
Fig.128375

Illustration 1 to illustration 4 show different variants of the retainer 2. The procedure for installing the camera 1 is the same for all variants.

- ▶ Insert the camera 1 in the retainer 2.
- ▶ Secure the camera 1: Install the retainer 3.
- ▶ Attach the camera retaining chain 4 in position P1.

The longer cable of the cable drum must be secured by the pull relief installed on the cable.

- ▶ Fit the pull relief cable in position P2.



*Fig.128376: Auxiliary boom camera slewing range*

The camera changes its angle automatically so that it is aligned vertically, gravity related. The swing angle is limited by design.

To ensure that the camera can align with the hook depending on the boom position, a certain swing angle must be possible.

- ▶ Make sure that the camera **1** has a swing angle of **90°** with respect to the vertical position to the boom.

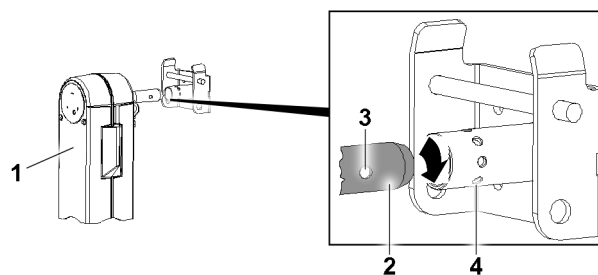


Fig.128404: Assemble the camera turned.

If the  $90^\circ$  swing angle is not reached:

- ▶ Disassemble the camera 1.
- ▶ Until the bore 3 and bore 4 are concentrically aligned: Turn the pin 2 in direction of the arrow.

**Result:**

- The bore 3 and bore 4 are concentrically aligned.

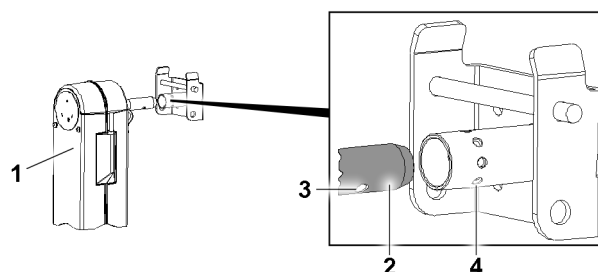


Fig.128399: The bores are concentric.

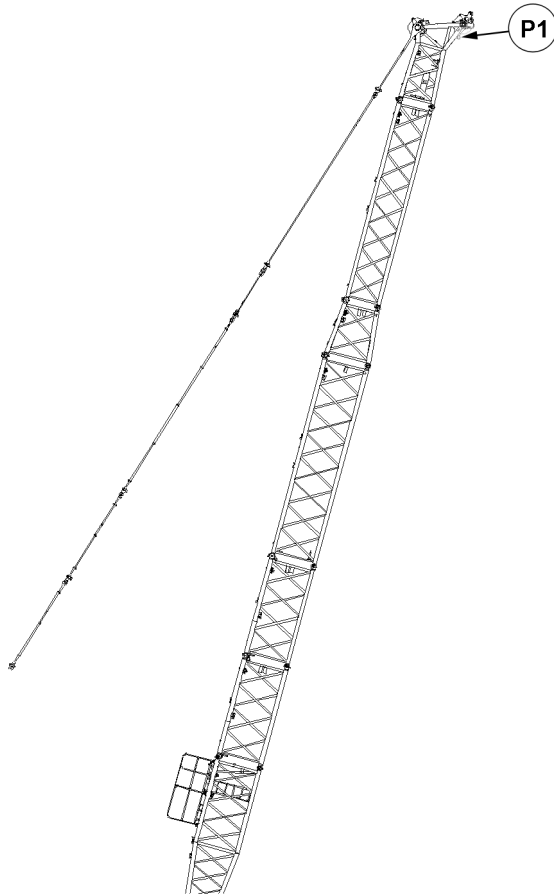
- ▶ Install the camera 1 as described in this section.
- ▶ Make sure that the camera 1 has a swing angle of  $90^\circ$  with respect to the vertical position to the boom.

## 12 Assembling the camera on the luffing lattice jib

Depending on the available equipment, the camera can be installed in different positions.

A possible position on the luffing lattice jib is shown below as an example.





*Fig.159545: Camera installation positions*

**P1** Camera installation position

Make sure that the following prerequisites are met:

- The telescopic boom is luffed down to the 0° position.
- The cable drum(s) is / are assembled.
- The electrical connections are established to the camera position.
- The luffing lattice jib is in the same position in which the hook block was reeved in. See chapter 5.04.

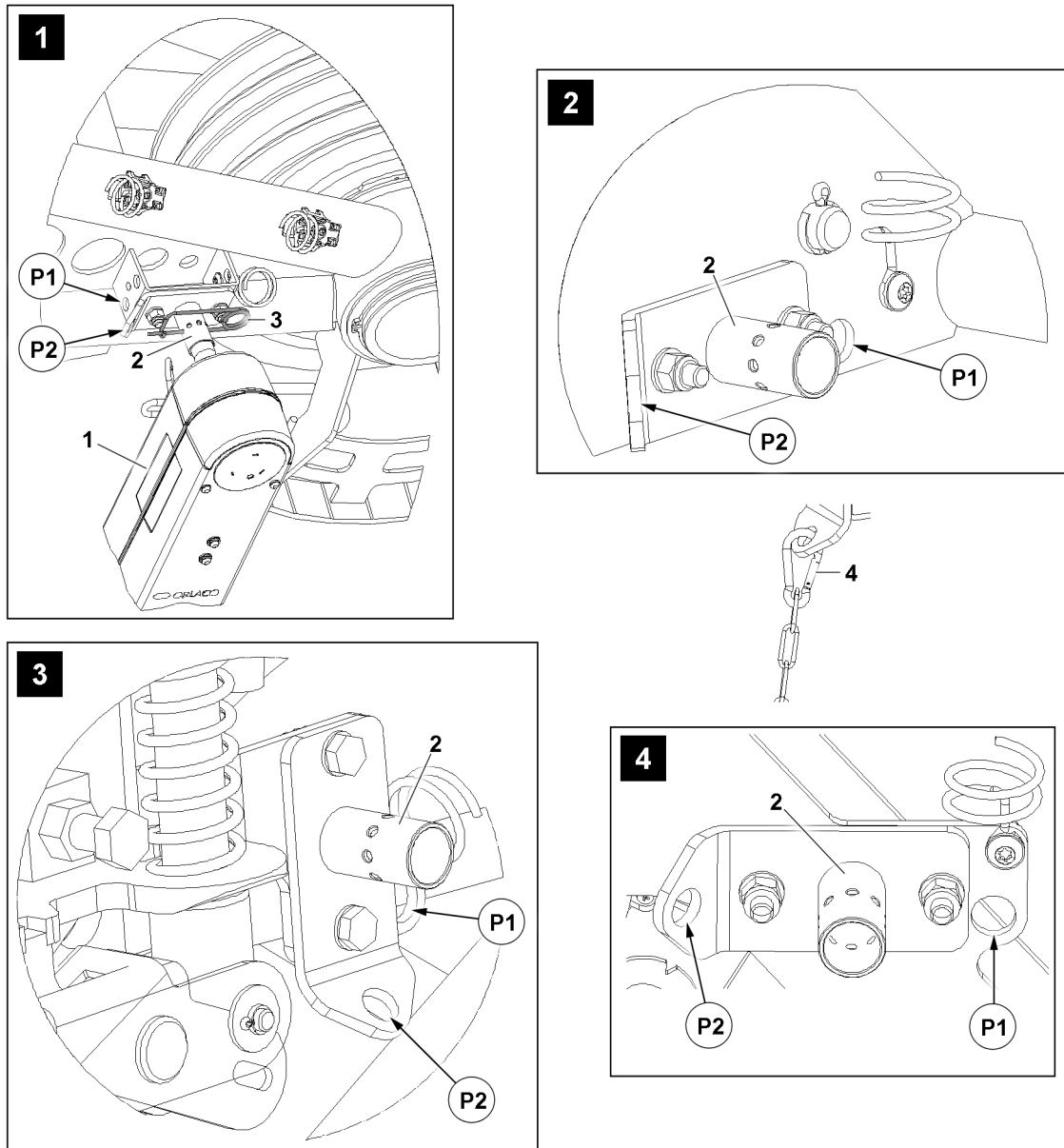


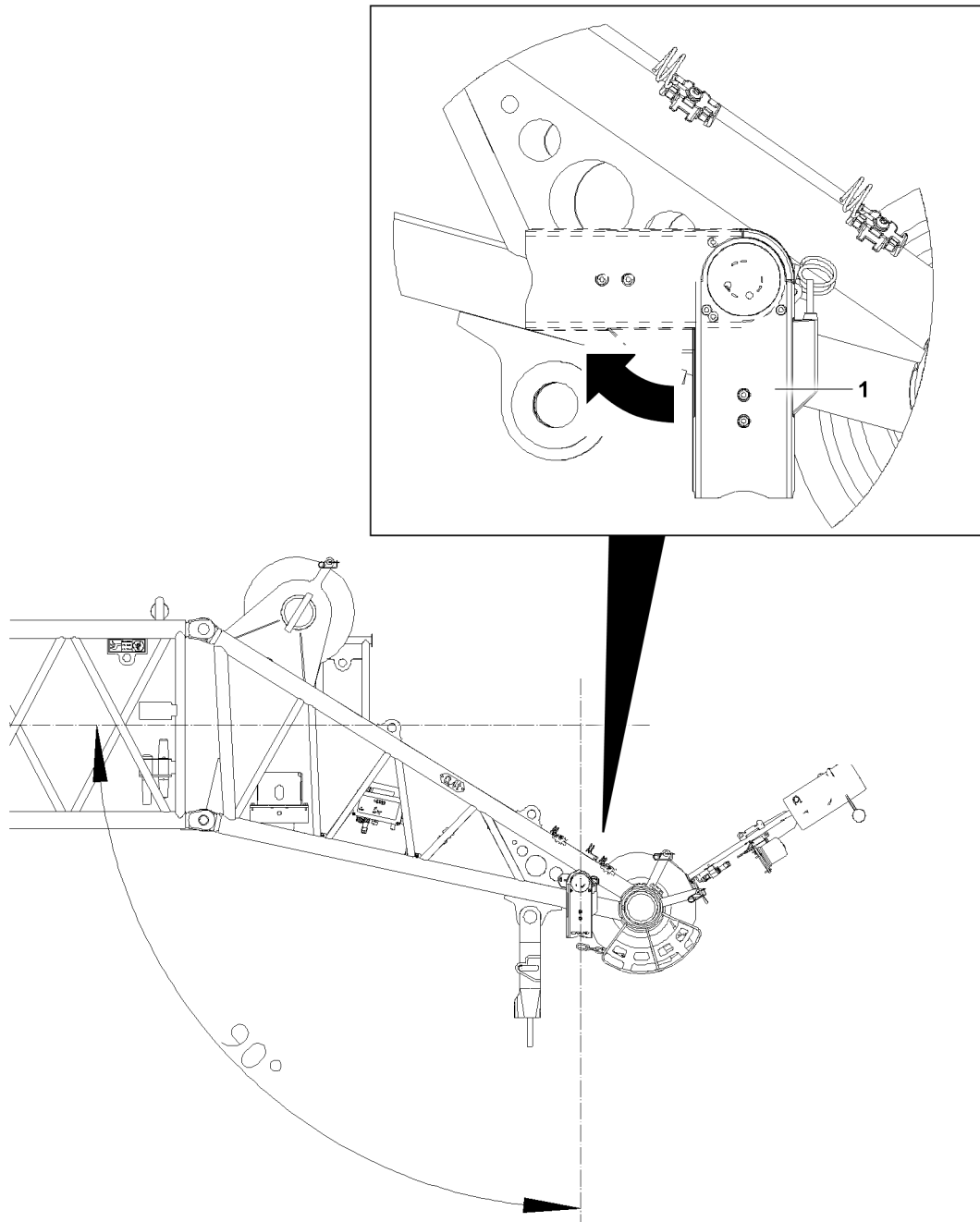
Fig.128375

Illustration 1 to illustration 4 show different variants of the retainer 2. The procedure for installing the camera 1 is the same for all variants.

- ▶ Insert the camera 1 in the retainer 2.
- ▶ Secure the camera 1: Install the retainer 3.
- ▶ Attach the camera retaining chain 4 in position P1.

The longer cable of the cable drum must be secured by the pull relief installed on the cable.

- ▶ Fit the pull relief cable in position P2.



*Fig.128376: Auxiliary boom camera slewing range*

The camera changes its angle automatically so that it is aligned vertically, gravity related. The swing angle is limited by design.

To ensure that the camera can align with the hook depending on the boom position, a certain swing angle must be possible.

- ▶ Make sure that the camera **1** has a swing angle of **90°** with respect to the vertical position to the boom.

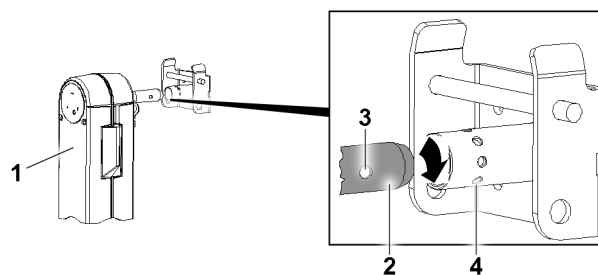


Fig.128404: Assemble the camera turned.

If the  $90^\circ$  swing angle is not reached:

- ▶ Disassemble the camera 1.
- ▶ Until the bore 3 and bore 4 are concentrically aligned: Turn the pin 2 in direction of the arrow.

**Result:**

- The bore 3 and bore 4 are concentrically aligned.

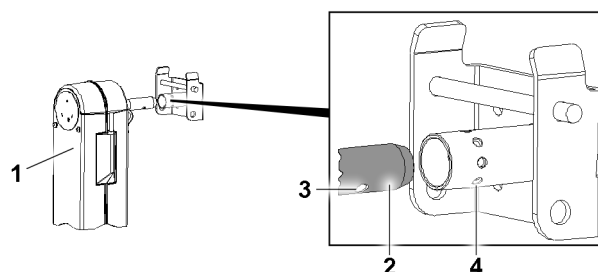


Fig.128399: The bores are concentric.

- ▶ Install the camera 1 as described in this section.
- ▶ Make sure that the camera 1 has a swing angle of  $90^\circ$  with respect to the vertical position to the boom.

## 13 Establishing the electrical connections

The electrical connections are established differently depending on the equipment.

There are the following variants:

- Camera on the telescopic boom
- Camera on the auxiliary boom - one cable drum
- Camera on the auxiliary boom - two cable drums
- Camera on the auxiliary boom - one cable drum and one cable holding device

### 13.1 Camera on the telescopic boom



**Note**

- ▶ This section is only relevant if the camera is assembled on the telescopic boom.

Make sure that the following prerequisites are met:

- The camera is assembled on the telescopic boom.

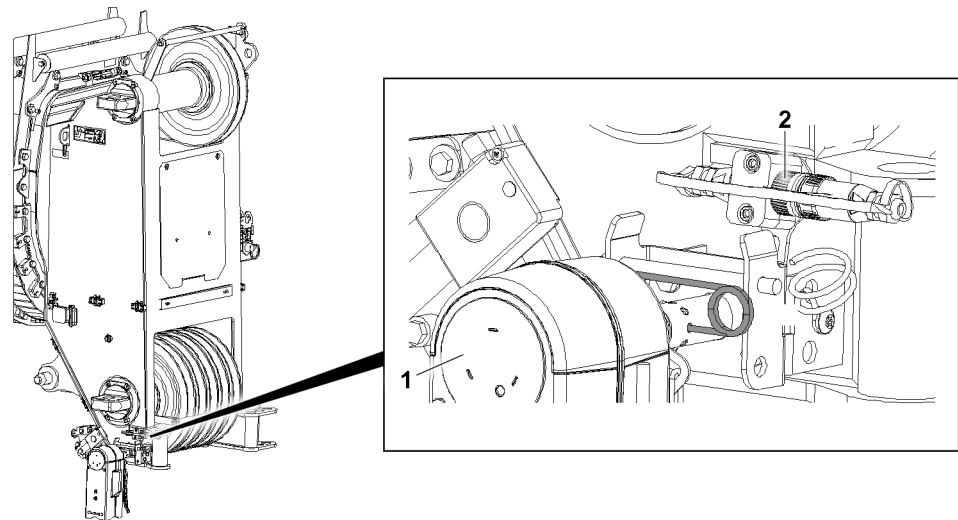


Fig.128383: Establishing the electrical connection on the telescopic boom

- ▶ Insert the cable from the camera 1 in the socket 2.
- ▶ Make sure that the socket 2 is connected with the transmitter to the telescopic boom head.

## 13.2 Camera on the auxiliary boom - one cable drum



### Note

- ▶ This section is only relevant if the camera is installed on the auxiliary boom **and one** cable drum is used.

Make sure that the following prerequisites are met:

- The camera is installed on the auxiliary boom.
- The cable drum is assembled on the telescopic boom.

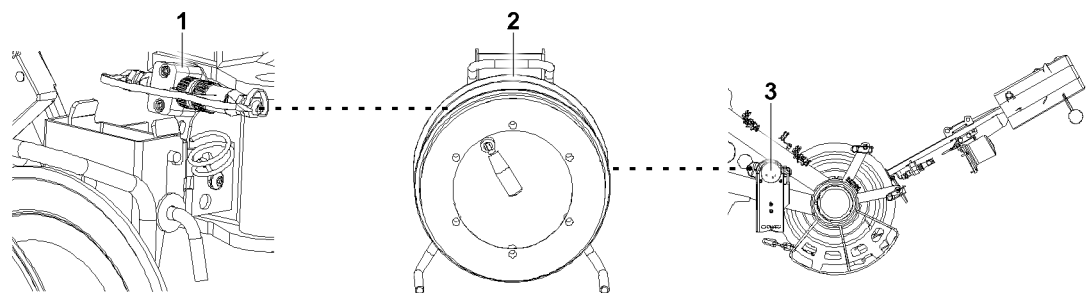


Fig.128380: Establishing the electrical connection to the camera on the auxiliary boom

- ▶ Connect the longer cable from the cable drum 2 with the camera 3 to the auxiliary boom.
- ▶ Insert the shorter cable from the cable drum 2 in the socket 1 on the telescopic boom.
- ▶ Make sure that the socket 1 is connected with the transmitter to the telescopic boom head.

## 13.3 Camera on the auxiliary boom - two cable drums



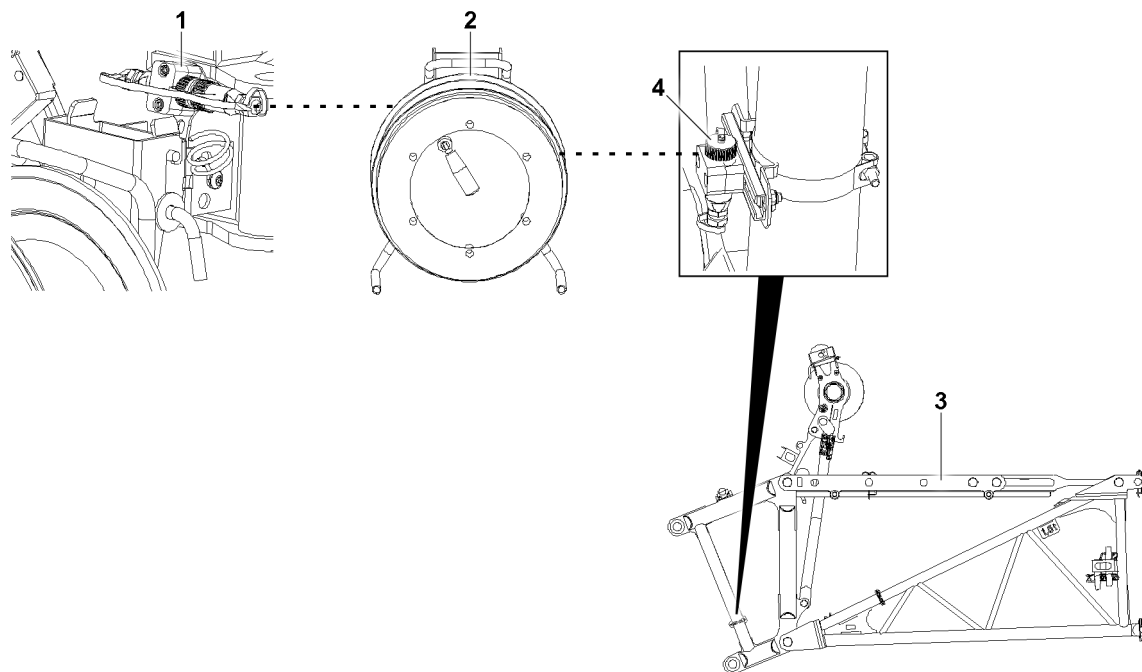
### Note

- ▶ This section is only relevant if the camera is installed on the auxiliary boom **and two** cable drums are used.

Make sure that the following prerequisites are met:

- The camera is installed on the auxiliary boom.
- The cable drum is assembled on the telescopic boom.
- The cable drum is installed on the auxiliary boom head.

The establishment of the electrical connection is explained below using an example of a configuration with a TF adapter. All equipment with fixed routed cable is connected using the same procedure.



*Fig.128400: Establishing the electrical connection, with two cable drums, to the camera on the auxiliary boom*

- ▶ Connect the longer cable from the cable drum **2** with the socket **4** to the TF adapter **3**.
- ▶ Insert the shorter cable from the cable drum **2** in the socket **1** on the telescopic boom.
- ▶ Make sure that the socket **1** is connected with the transmitter to the telescopic boom head.

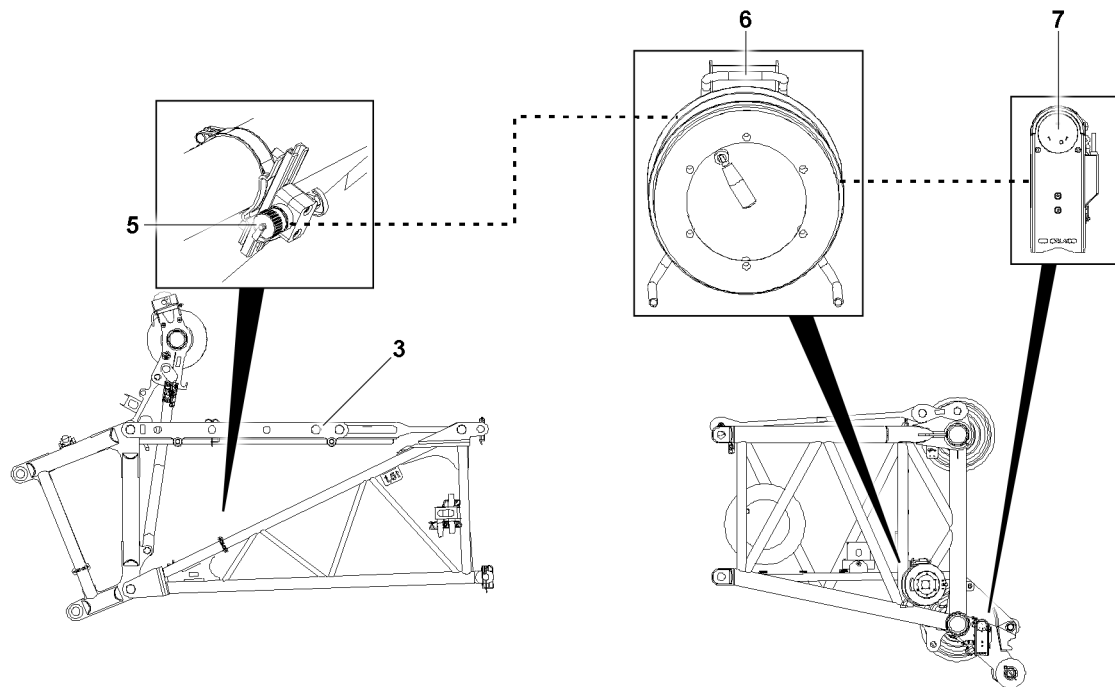


Fig.128401: Establishing the electrical connection, with two cable drums, to the camera on the auxiliary boom

- ▶ Connect the longer cable from the cable drum 6 with the socket 5 to the TF adapter 3.
- ▶ Connect the shorter cable from the cable drum 6 with the camera 7 to the boom head.

### 13.4 Camera on the auxiliary boom - one cable drum and one cable holding device



#### Note

- ▶ This section is only relevant if the camera is installed on the auxiliary boom **and one** cable drum **and one** cable holding device are used.

Make sure that the following prerequisites are met:

- The camera is installed on the auxiliary boom.
- The cable holding device is installed on the auxiliary boom.
- The cable drum is installed on the auxiliary boom head.

The electrical connection is made using the same procedure as the variant „Camera on the auxiliary boom - two cable drums“. The cable drum on the telescopic boom is not used. The cable holding device is used instead on the auxiliary boom.

- ▶ Establish the electrical connections, see section „Camera on the auxiliary boom - two cable drums“.

### 13.5 Auxiliary boom luffing range

The boom angle changes depending on crane operation. This also changes the required cable length.

#### NOTICE

Cable length too short!

The cable tears, property damage.

- ▶ Make sure that enough cable length is available for the luffing movement of the boom.

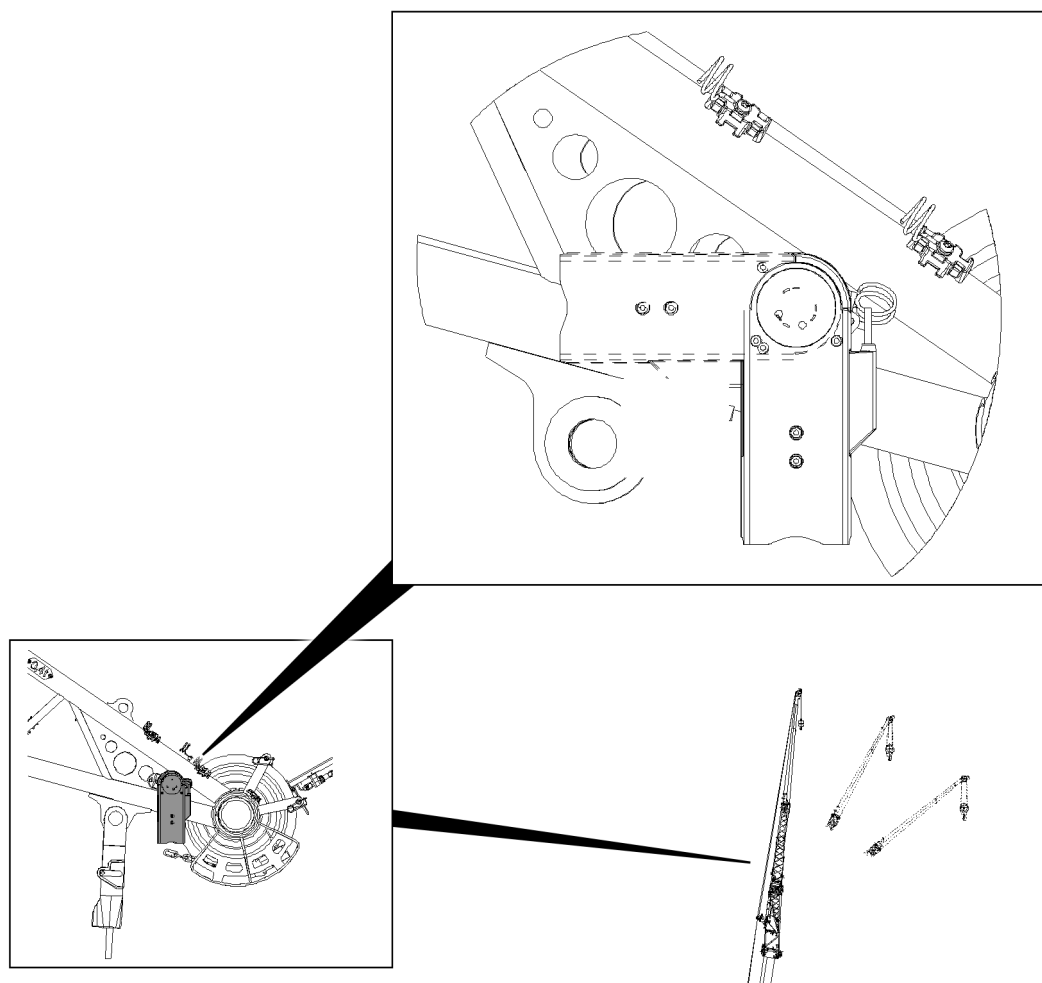


Fig.128402: Boom luffing range and camera slewing range

When the boom angle is changed, also the position of the camera **1** changes. Therefore, there must be enough cable length available for the swinging movement of the camera **1**.

- ▶ Make sure that enough cable length is available for the swinging movement of the camera **1**.

## 13.6 Securing the cable

### NOTICE

Cable in the luffing range of the auxiliary boom!  
The cable tears, property damage.

- ▶ Make sure that the cable for the camera and cable drum is not in the luffing range of the auxiliary boom.

### NOTICE

Cable in the working range of other components!  
The cable tears, property damage.

- ▶ Make sure that the cable for the camera and cable drum is not in the working range of other components.

Other components are, for example:

- Hoist rope



- Rope pulleys

### 13.6.1 Cable drum

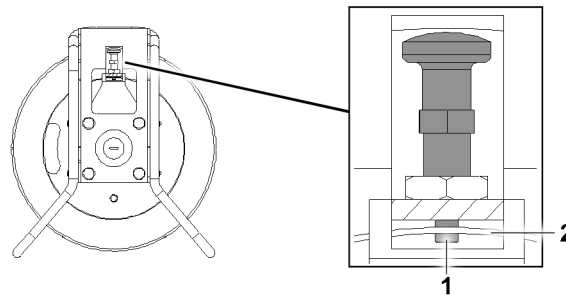
- ▶ Feed the longer cable through the struts on the auxiliary boom.

The longer cable of the cable drum must be secured by the pull relief installed on the cable.

If the longer cable is connected with the camera:

- ▶ Install the pull relief cable on the attached retainer.  
or

If the longer cable is connected with the fixed routed cable on the auxiliary boom:  
Secure the pull relief cable on the grating.



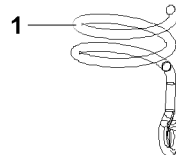
*Fig.128381: Locking the cable drum*

To ensure that the cable drum 1 does not rotate inadvertently, the cable drum 2 must be locked.

- ▶ Insert the pin 1.

**Result:**

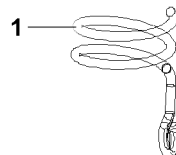
- The longer cable is secured.



*Fig.128403: Cable retainer*

- ▶ Attach the shorter cable to the cable retainer 1.

### 13.6.2 Camera



*Fig.128403: Cable retainer*

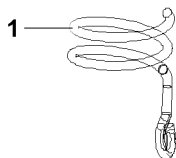
- ▶ Attach the cable to the cable retainer 1.

### 13.6.3 Cable holding device

- ▶ Feed the longer cable through the struts on the auxiliary boom.

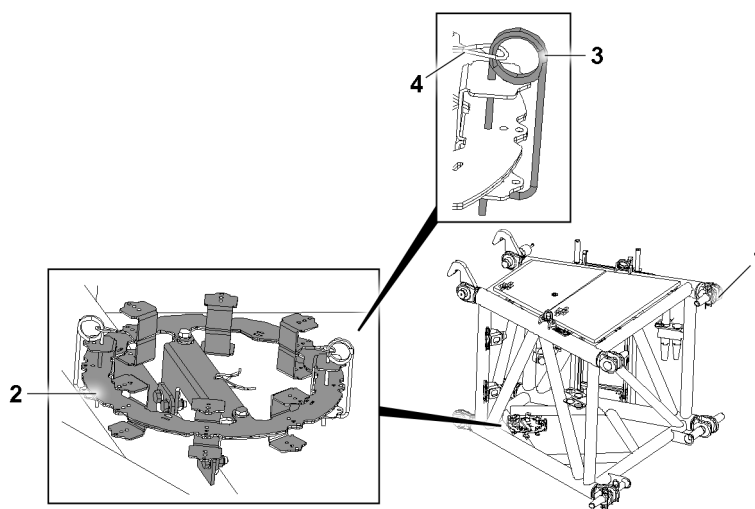
The longer cable of the cable holding device must be secured by the pull relief installed on the cable.

- If the longer cable is connected with the fixed routed cable on the auxiliary boom:
- ▶ Secure the pull relief cable on the grating.



*Fig.128403: Cable retainer*

- ▶ Attach the shorter cable to the cable retainer 1.



*Fig.128407: Cable holding device on the TN/TF-adaptor*

- ▶ Secure the cable to the cable holding device 2: Install all retainers 3.
- ▶ Make sure that all retainer ropes 4 are installed.

## 13.7 Radio connection

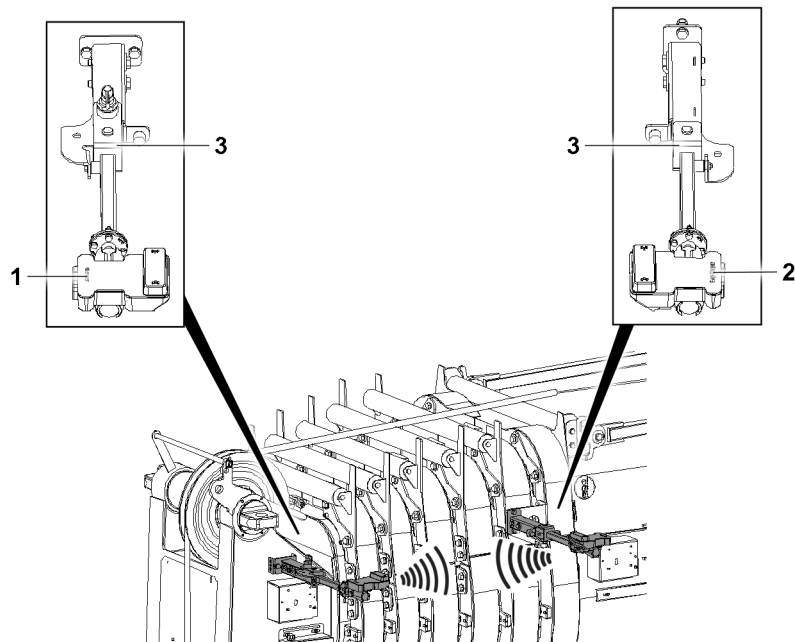


Fig.145629: Radio connection on the telescopic boom

- |   |             |   |          |
|---|-------------|---|----------|
| 1 | Transmitter | 3 | Retainer |
| 2 | Receiver    |   |          |

When the camera is used, a radio connection must be established between the transmitter **1** and the receiver **2**.



### Note

- ▶ The reach of the radio signal can fluctuate due to local conditions.

### 13.7.1 Alpha - $\alpha$ angle

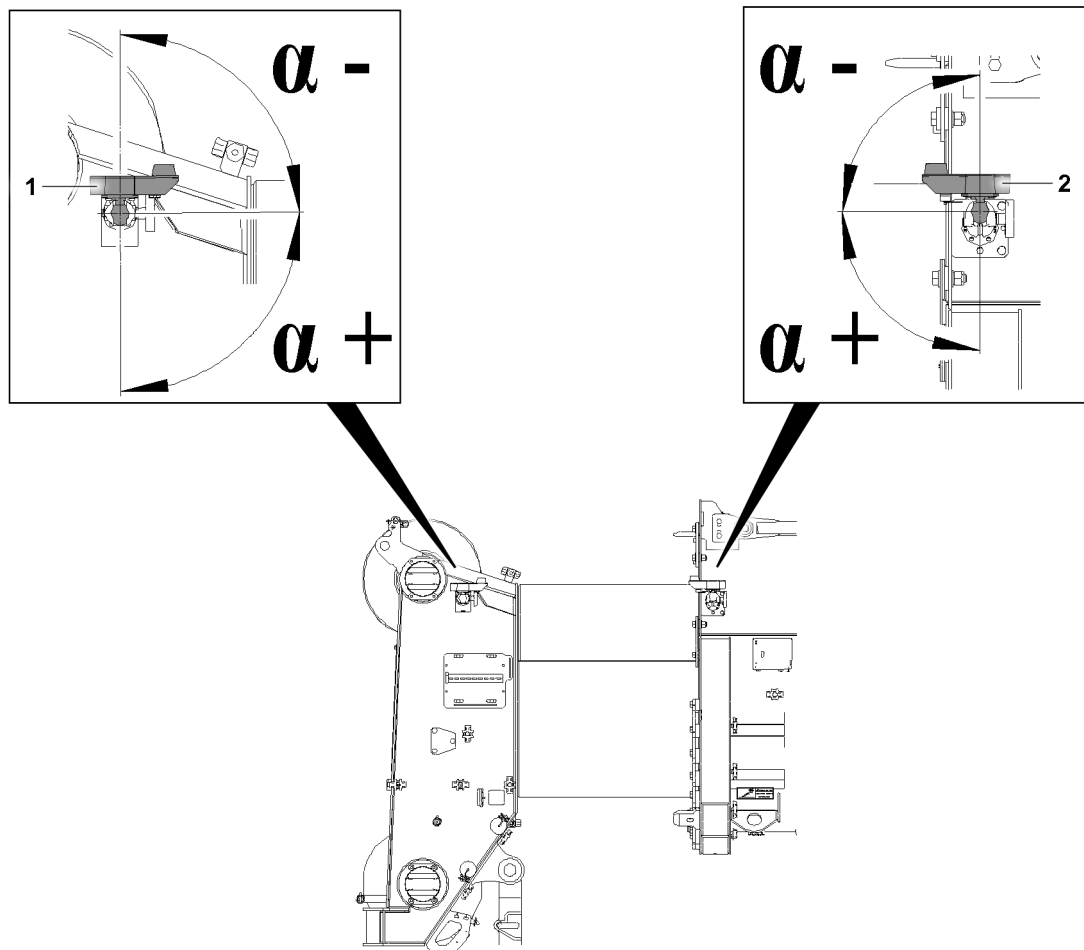


Fig.128420: Alpha  $\alpha$  angle

1 Transmitter

2 Receiver

### 13.7.2 Beta - $\beta$ angle

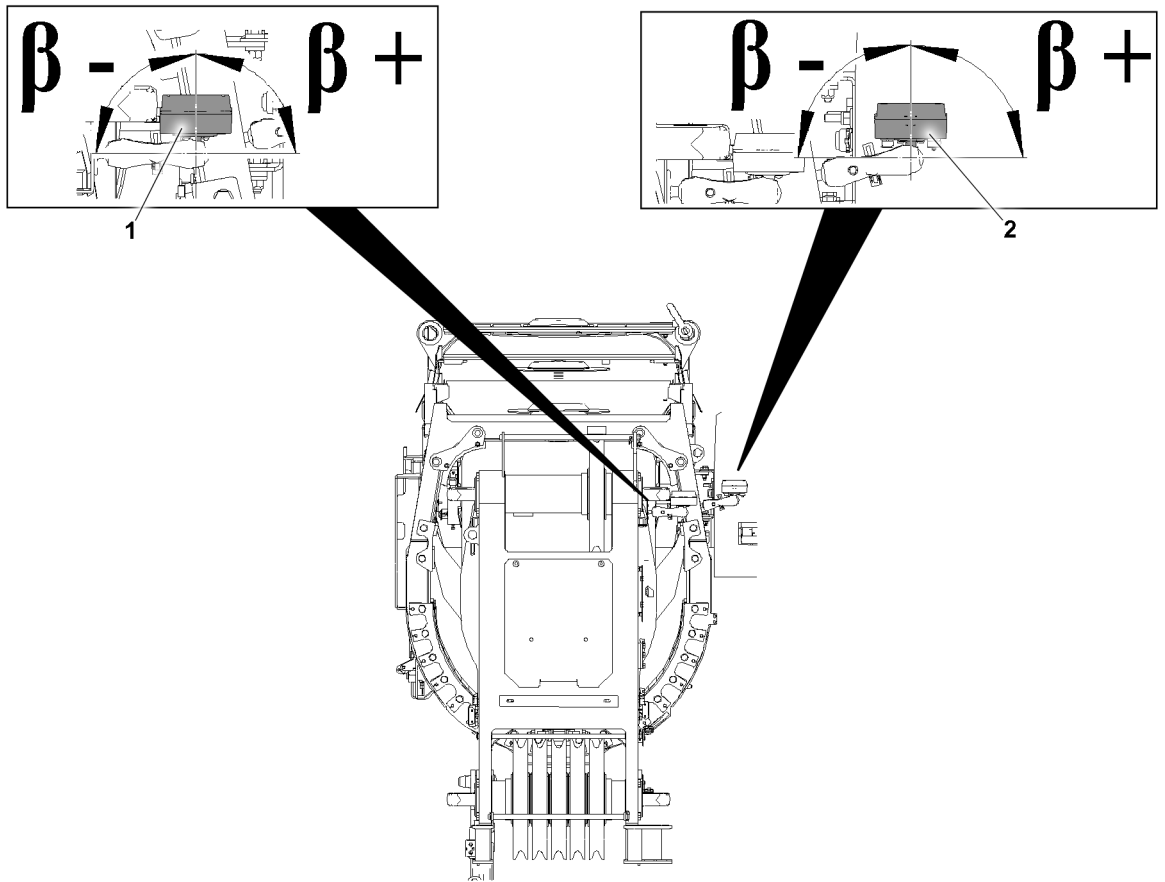


Fig.128421: Beta  $\beta$  angle

1 Transmitter

2 Receiver

LWE/LTR 1220-003/24204-02-02/en

### 13.7.3 Gamma - $\gamma$ angle

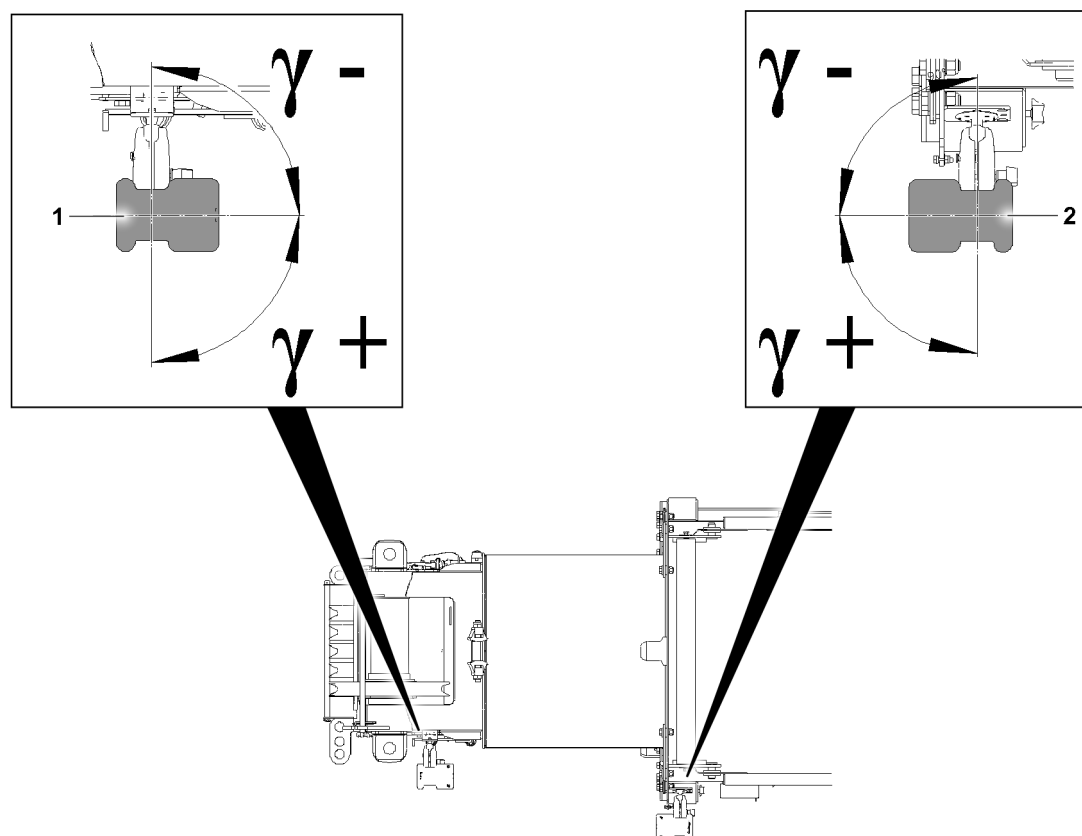


Fig.128422: Gamma  $\gamma$  angle

1 Transmitter

2 Receiver

### 13.7.4 Angle guide values

The rough angle values for the transmitter 1 and receiver 2 are provided below.

Crane type	Transmitter			Receiver		
	Alpha $\alpha$	Beta $\beta$	Gamma $\gamma$	Alpha $\alpha$	Beta $\beta$	Gamma $\gamma$
LTM 1090-4.2	-15°	+90°	0°	+15°	+90°	+5°
LTM 1160-5.2	+5°	+90°	0°	+5°	+90°	0°
LTM 1200-5.1	+10°	0°	0°	+5°	0°	0°
LTM 1230-5.1	0°	0°	0°	0°	0°	0°
LTM 1300-6.2	0°	+45°	+5°	0°	+45°	+5°
LTM 1350-6.1	0°	0°	0°	0°	0°	0°
LTM 1450-8.1	0°	0°	0°	0°	0°	0°
LTM 1500-8.1	+5°	+90°	0°	+5°	+90°	0°
LTM 1650-8.1	0°	+95°	0°	0°	+85°	0°
LTR 1220	+10°	0°	+5°	0°	0°	0°

Transmitter / receiver angle guide values

The Beta  $\beta$  angle must be set as the first angle. If the Beta  $\beta$  angle is not set as the first angle, the guide values are no longer correct.

- ▶ Set the Beta  $\beta$  angle.
- ▶ Set the Alpha  $\alpha$  angle.
- ▶ Set the Gamma  $\gamma$  angle.
- ▶ Align the transmitter **1** and the receiver **2** so a radio connection is established.

## 14 Checking the electrical connections

- ▶ Make sure that the camera image is displayed on the monitor.

## 15 Disconnecting the electrical connections

When the electrical connections are separated, protective caps must be installed to protect the electrical connections from damage.

When a protective cap is available:

- ▶ Install the protective cap.

## 16 Swinging the transmitter and receiver into the transport position

Before the crane may be driven on public roads, the holder must be swung into the transport position.

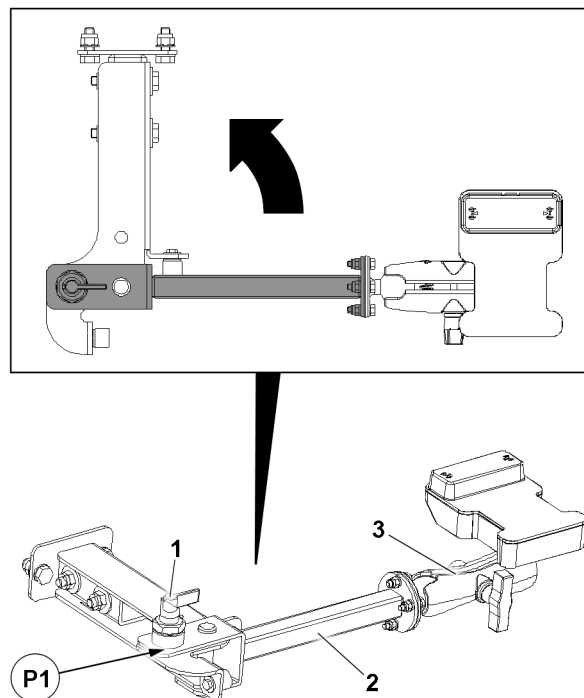


Fig.145662: Holder transport position

- |  |  |
|--|--|
| <ul style="list-style-type: none"> <li><b>1</b> Retaining element</li> <li><b>2</b> Swing arm</li> </ul> | <ul style="list-style-type: none"> <li><b>3</b> Connecting link</li> </ul> |
|--|--|

**NOTICE**

Crane parts in the area of the transport position!  
The transmitter or receiver can collide with crane parts and be damaged.

If there are crane parts in the area of the transport position:

- ▶ Until the transmitter and receiver cannot come into contact with other crane parts: Release and align the connecting link **3**.
- 
- ▶ Release the retaining element **1**.
  - ▶ Until the retaining element **1** can be pinned in position **P1**: Swing the swing arm **2** in the direction of the arrow.
  - ▶ Pin the retaining element **1** in position **P1**.

## 17 Disassembling the camera

The disassembly of the camera is described as an example.

Make sure that the following prerequisites are met:

- When the camera is assembled on the telescopic boom:
  - The telescopic boom is luffed down as far as possible. At least in the 0° position.
  - The telescopic boom is telescoped in all the way.
- When the camera is assembled on the auxiliary boom:
  - The telescopic boom is luffed down as far as possible. At least in the 0° position.
  - Luff the auxiliary boom down as far as possible. At least in the 0° position.
  - The telescopic boom is telescoped in all the way.
- When the camera is assembled on the luffing lattice jib:
  - The luffing lattice jib is in the same position in which the hook block was reeved out. See chapter 5.04.

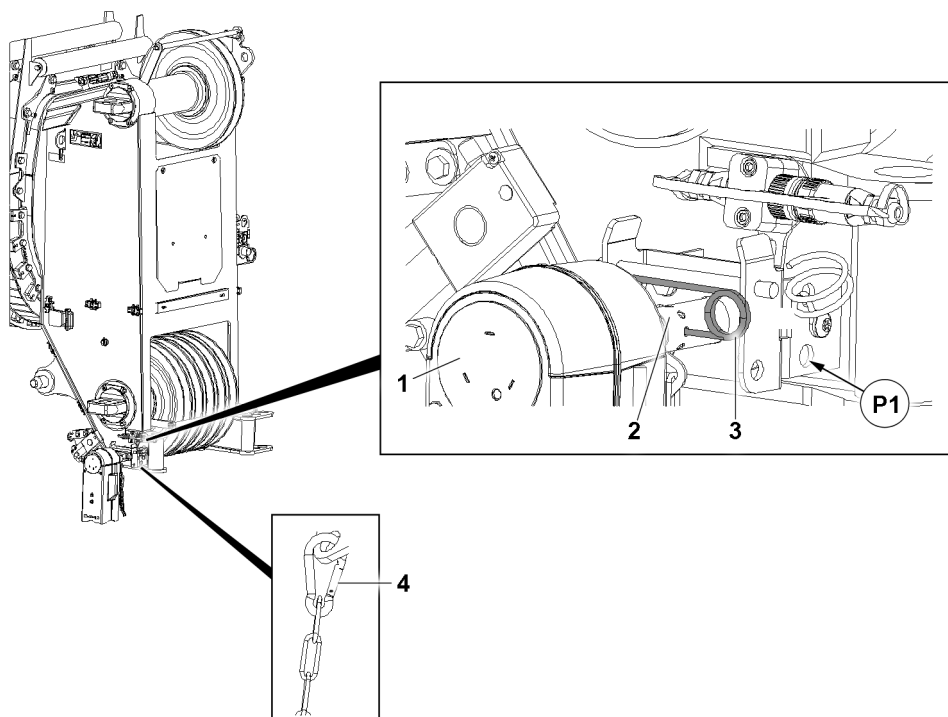


Fig.128377: Camera installed on the telescopic boom

- ▶ Disconnect the electrical connections to the camera.

When assembly personnel is alone on the ladder:

- ▶ Fasten the auxiliary rope to the camera.



- ▶ Detach the safety chain **4** for the camera in position **P1**.
- ▶ Release the camera **1**: Disassemble the retainer **3**.
- ▶ Pull the camera **1** out from the retainer **2**.
- ▶ Lower the camera **1** to the ground using the auxiliary rope.

## 18 Disassembling the cable drum

Make sure that the following prerequisites are met:

- The telescopic boom is completely disassembled.
- When the cable drum is assembled on the telescopic boom:
  - The telescopic boom is luffed down as far as possible. At least in the 0° position.
- When the cable drum is assembled on the auxiliary boom:
  - The telescopic boom is luffed down as far as possible. At least in the 0° position.
  - Luff the auxiliary boom down as far as possible. At least in the 0° position.
- When the cable drum is assembled on the luffing lattice jib and disassembly by opening the lattice jib on the ground:
  - The N-pivot section is unpinned from the first lattice section and is lying on the ground.
  - The N-head is unpinned from the first lattice section and is lying in the roller cart or on the ground.
- When the cable drum is assembled on the luffing lattice jib and flying disassembly of the lattice jib:
  - The telescopic boom is in the 0° position.

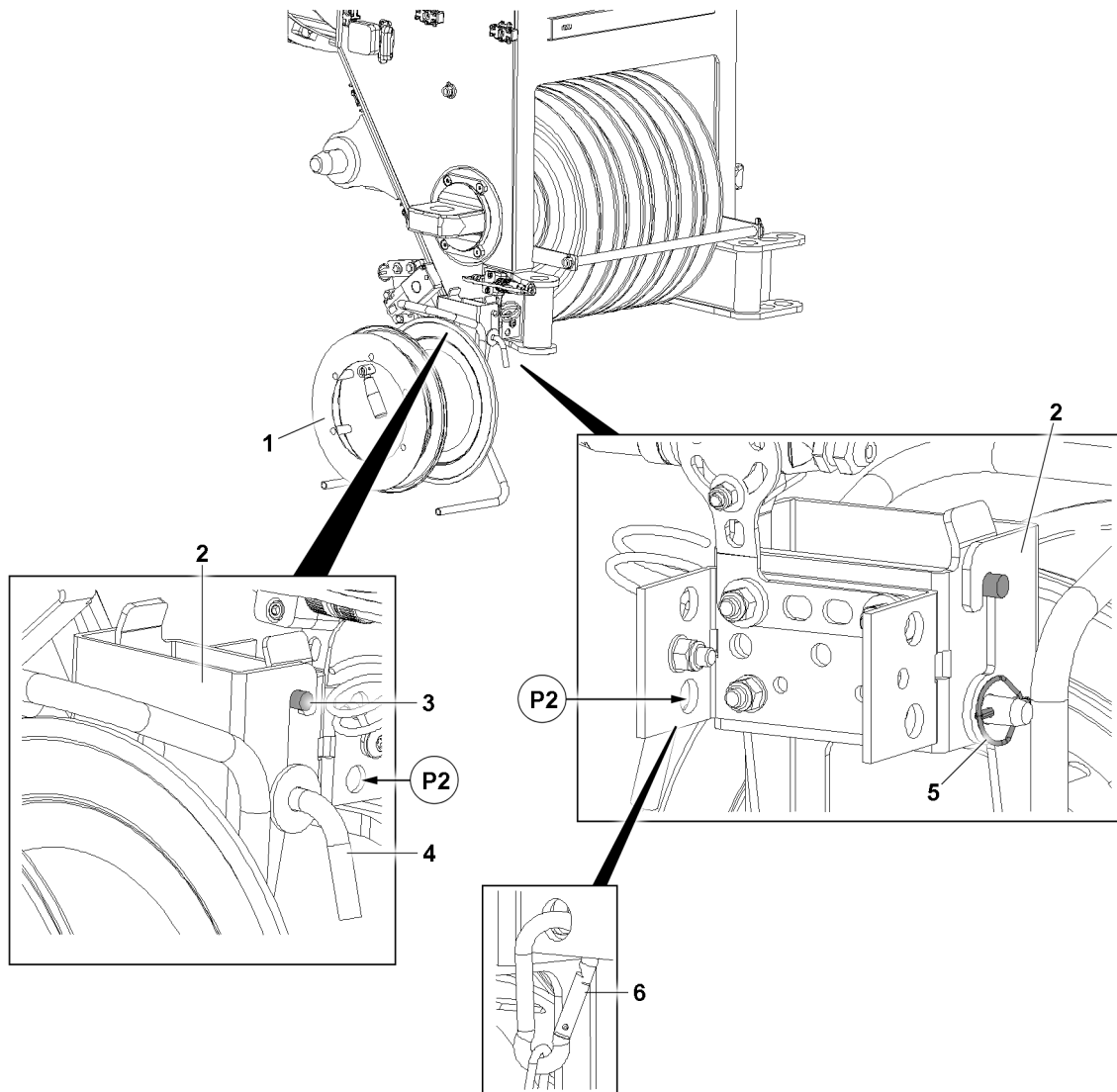


Fig.128379: Cable drum on the telescopic boom

- ▶ Disconnect the electrical connection for the cable drum.

When assembly personnel is alone on the ladder:

- ▶ Fasten the auxiliary rope to the cable drum.
- ▶ Detach the retaining chain **6** of the cable drum **1** in position **P2**.
- ▶ Release the pin **4**: Disassemble the retainer **5**.
- ▶ Release the cable drum **1**: Unpin the pin **4**.
- ▶ Detach the cable drum **1** from the pin **3**.
- ▶ Lower the cable drum **1** to the ground using the auxiliary rope.

## 19 Transporting the camera

To prevent the camera from being damaged, the camera must be protected by the supplied case.

- ▶ Disconnect the electrical connections to the camera.
- ▶ Disassemble the camera.
- ▶ Store the camera in the supplied case and transport it.

## 5.75 Wind speed sensor / airplane warning light

1	Safety	3
2	Description	3
3	Disassembling the wind speed sensor in the transport position	4
4	Installing the wind speed sensor	4
5	Electrical connection	12
6	Disassembling the wind speed sensor	12
7	Assembling the wind speed sensor in the transport position	14
8	Transporting the wind speed sensor	15

*Fig.195219*

LWE/LTR 1220-003/24204-02-02/en

# 1 Safety

Observe the safety instructions prior to assembly / disassembly.

- General safety information: See chapter 2.04.
- Information regarding personal protective equipment: See chapter 2.04.
- Information regarding the use of ladders: See chapter 2.04.




---

## WARNING

Attachment parts in the field of vision of the crane driver!  
Death, severe bodily injury, property damage.

- ▶ Before the crane is driven: Make sure that all attachment parts have been removed or are in the transport position.
- 

## NOTICE

The boom and the auxiliary boom are assembled or disassembled with the attachment parts!  
The attachment parts can be damaged.

- ▶ **After** the hook block or the load hook is installed: Assemble the attachment parts.
  - ▶ **Exception:** Assembly on the N-assembly unit. In this case, the wind speed sensor is fit immediately after assembly of the N-assembly unit.
  - ▶ **Before** the hook block or the load hook is removed: Remove the attachment parts.
- 

Attachment parts are for example:

- Camera
- Airplane warning light
- Wind speed sensor
- Hoist limit switch weight with chain

The illustrations in this chapter are an example. The installation of the wind speed sensor is described as an example. The attached retainers are located at times in other positions than as shown.

The assembly of the wind speed sensor is carried out depending on the crane structure.

# 2 Description

The assembly and disassembly of the wind speed sensor and the airplane warning light are identical and are explained based on the wind speed sensor.

During transport and when driving on public roads, the wind speed sensor is assembled on a retainer in the transport position.

During crane operation, the wind speed sensor is assembled in the highest point of the boom.

The wind speed sensor installed on the boom measures the wind speed at boom jib and shows the current wind speed on the LICCON monitor in the crane cab.

### 3 Disassembling the wind speed sensor in the transport position

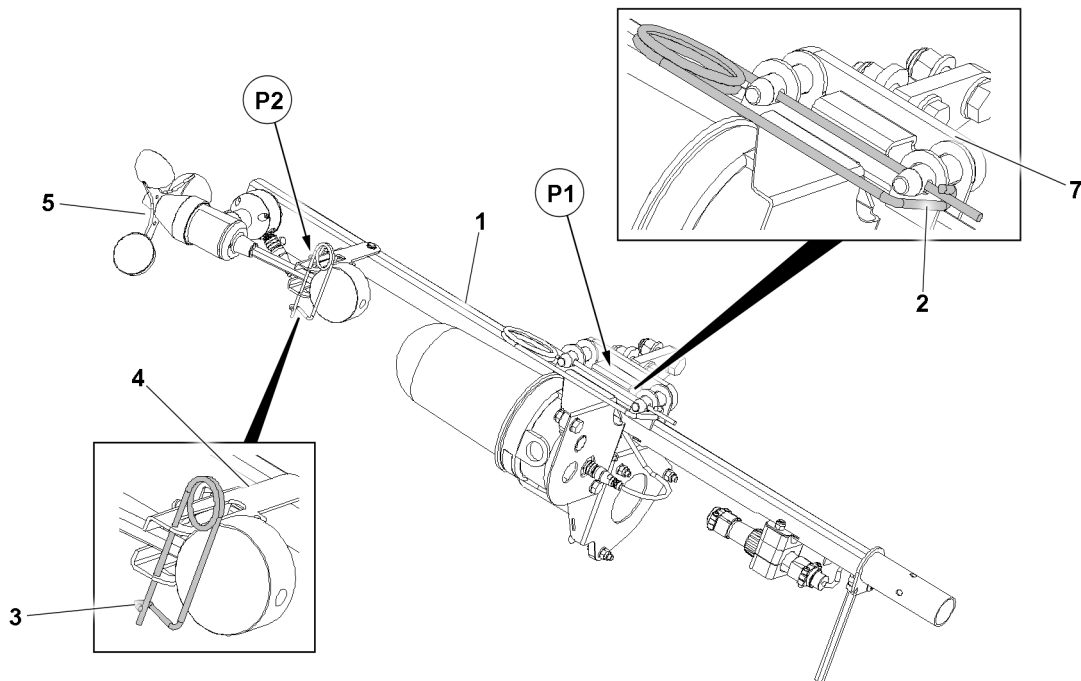


Fig.149020: Wind speed sensor in the transport position

Make sure that the following prerequisites are met:

- The telescopic boom is luffed down to the 0° position.
- ▶ Remove the protective cover and store it for later use.
- ▶ Remove the retaining element 2 in position P1 from the retainer 7 on the telescopic boom.
- ▶ Carefully remove the retainer 1 with attachment parts.
- ▶ Store the retaining element 2 safely for assembly on the telescopic boom head or auxiliary boom.

### 4 Installing the wind speed sensor

Depending on the available equipment, the wind speed sensor can be assembled in different positions.

Possible positions on the telescopic boom and the auxiliary boom are shown below as an example.

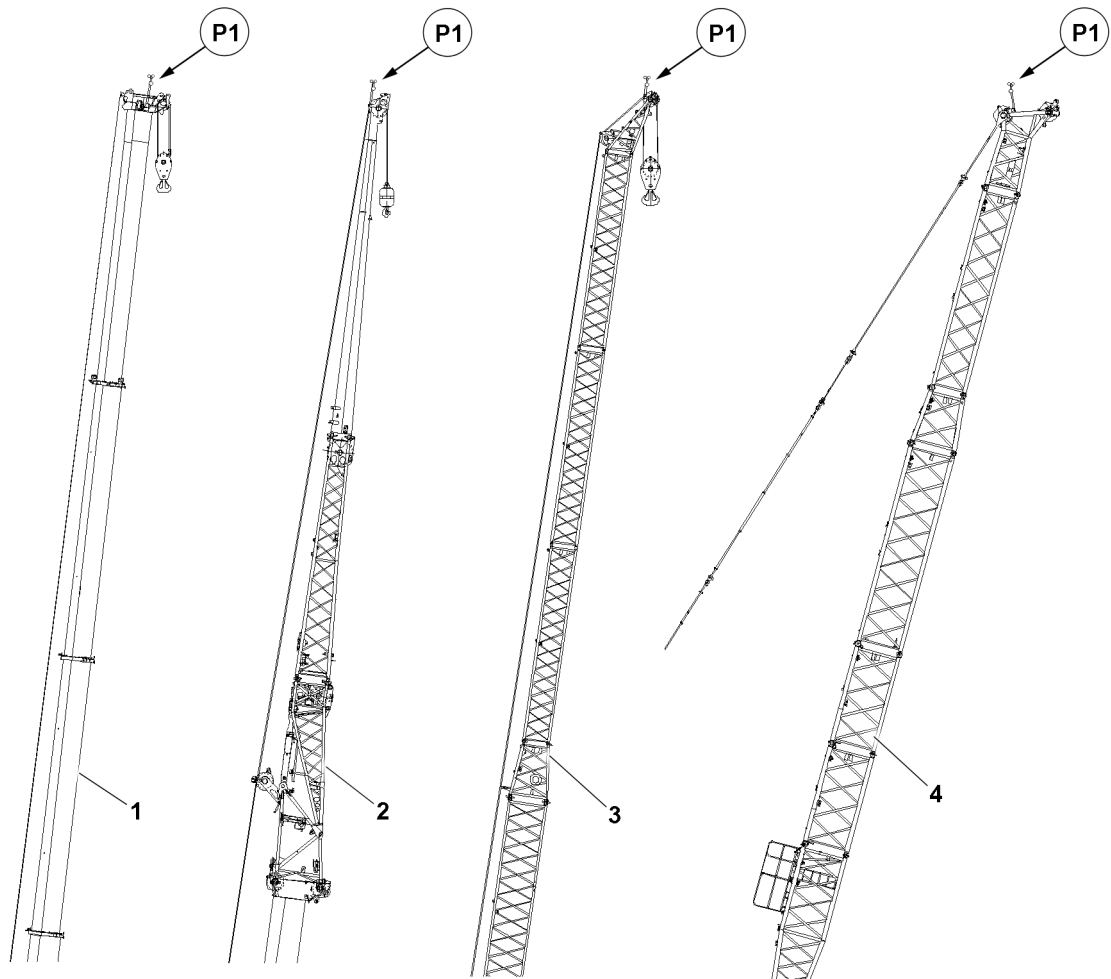


Fig.149022: Possible assembly positions

- |   |  |
|---|--|
| <ul style="list-style-type: none"> <li><b>1</b> Telescopic boom</li> <li><b>2</b> Folding jib</li> <li><b>3</b> Fixed lattice jib or sharp lattice jib</li> </ul> | <ul style="list-style-type: none"> <li><b>4</b> Luffing lattice jib</li> <li><b>P1</b> Wind speed sensor position</li> </ul> |
|---|--|

LWE/LTR 1220-003/24204-02-02/en

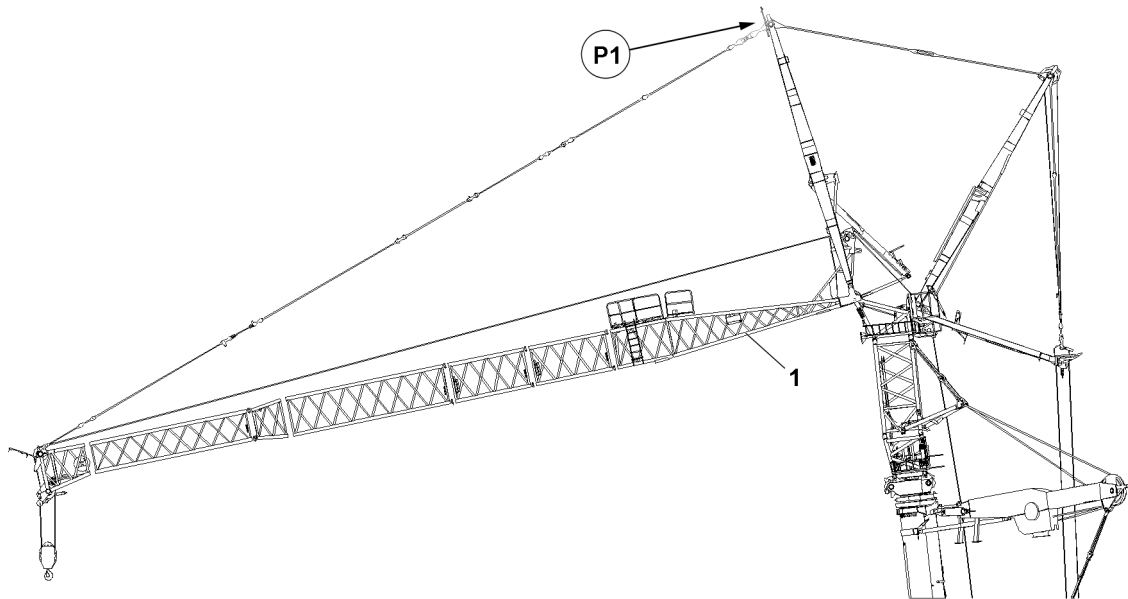


Fig.159771: Assembly on the N-assembly unit.

1 N-assembly unit

P1 Wind speed sensor position

## 4.1 Assembly position

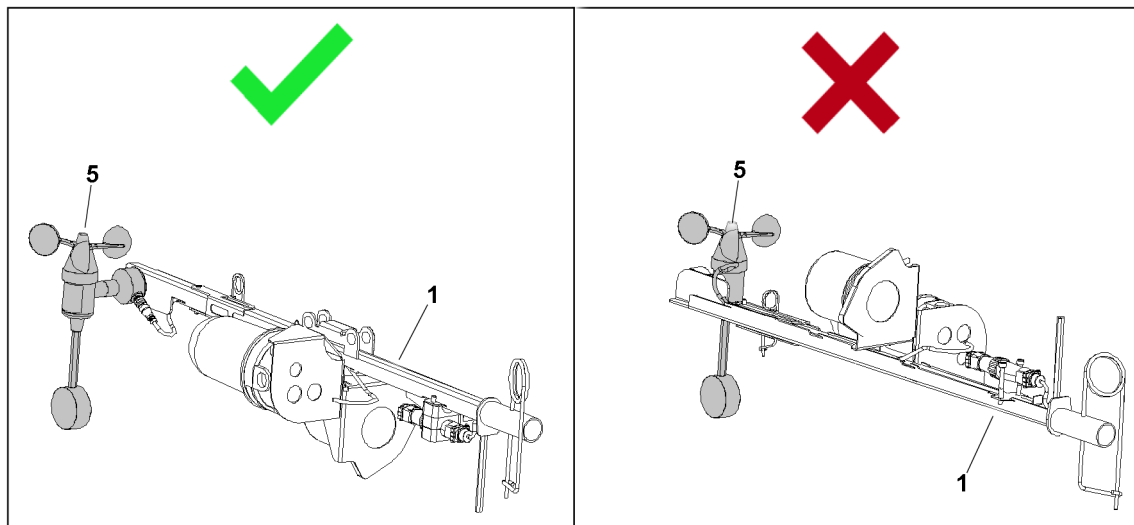


Fig.149030: Assembly position of the wind speed sensor



### WARNING

Wind speed sensor incorrectly assembled!

The wind speed will not be correctly recorded and incorrect values will be transmitted.

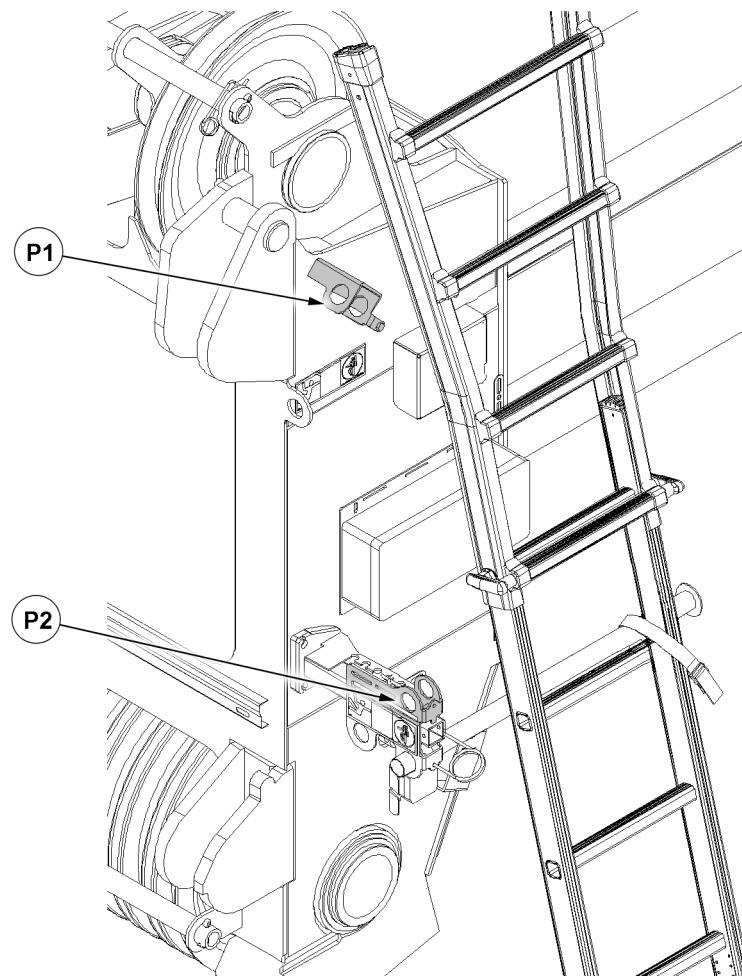
Failure of the equipment, death, severe bodily injuries, property damage.

▶ Assemble the wind speed sensor correctly.

▶ Assemble the retainer 1 such that the wind speed sensor 5 is on the left hand side of the retainer 1.



## 4.2 Assembly on the telescopic boom



*Fig.149023: Assembling the wind speed sensor on the telescopic boom*

The retainer **P1** is only present on certain crane types!

For cranes with two retainers on the telescopic boom:

- Assemble the wind speed sensor on the retainer **P1**.

For cranes with one retainer on the telescopic boom:

- Assemble the wind speed sensor on the retainer **P2**.

Make sure that the following prerequisites are met:

- The telescopic boom is luffed down to the 0° position.

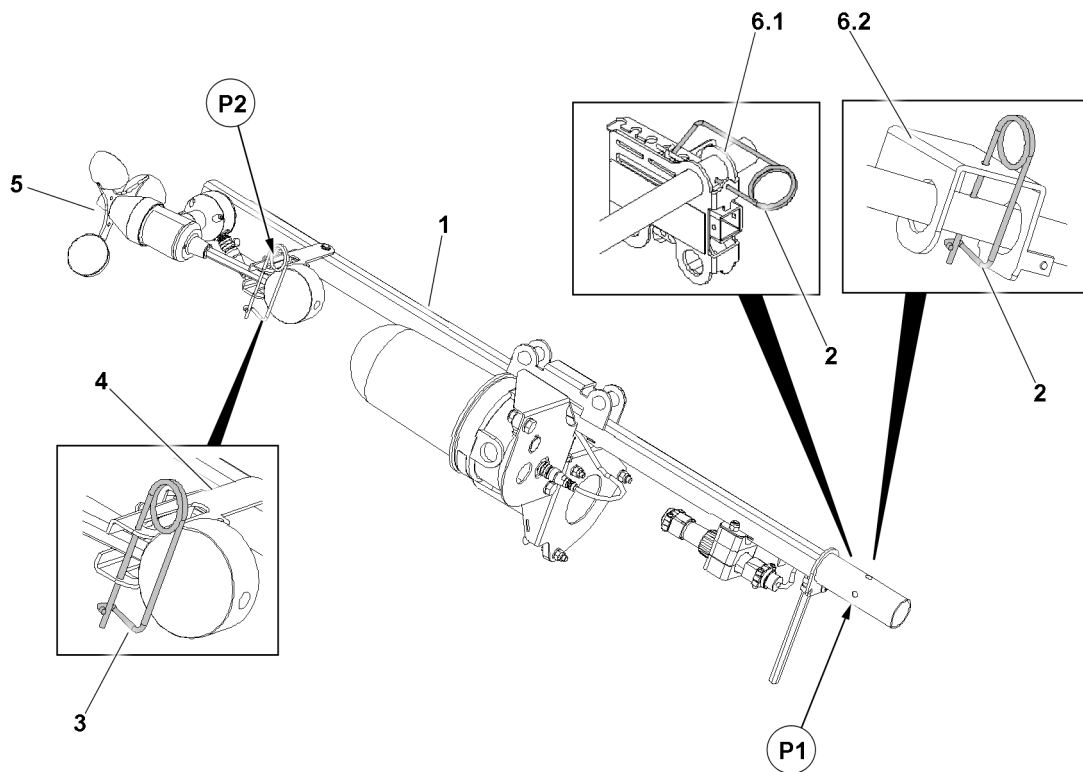
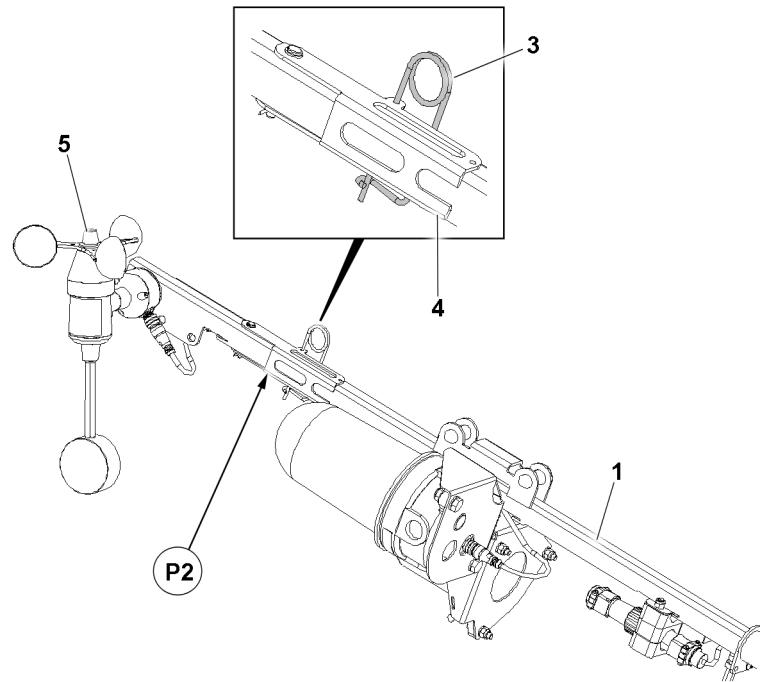


Fig.149024: Assembling the wind speed sensor on the telescopic boom

- ▶ Insert the retainer **1** of the wind speed sensor in the retainer **6.1** or retainer **6.2** on the telescopic boom.
- ▶ Secure the retainer **1** with the retaining element **2** in position **P1**. Pay attention to the correct assembly position: See section „Assembly position“.
- ▶ Remove the retaining element **3** from the transport position in position **P2**.

**Result:**

- The wind speed sensor **5** swings back and forth until the weight is located vertically below it.



*Fig.149025: Locking the transport retainer*

- ▶ Fold the transport retainer 4 back to the retainer 1.
- ▶ Secure the transport retainer 4 with the retaining element 3 in position P2.
- ▶ Establish the electrical connections: See the section „Establishing the electrical connections“.

### 4.3 Assembly on the auxiliary boom

Always assemble the wind speed sensor in the highest point of the auxiliary boom.

Make sure that the following prerequisites are met:

- The telescopic boom is luffed down to the 0° position.
- The auxiliary boom is in the 0° position.

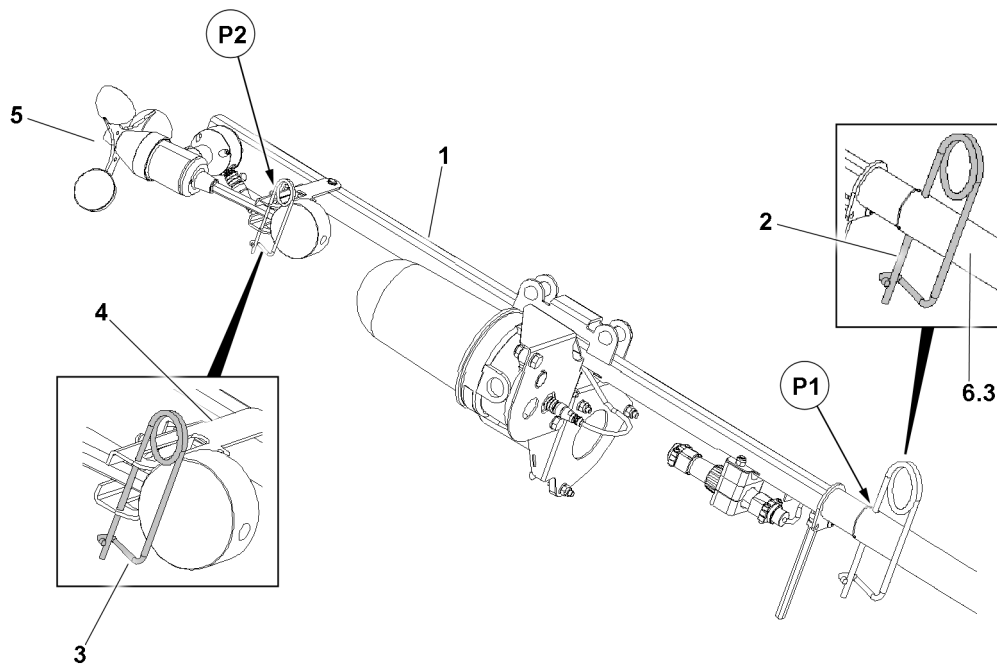


Fig.149026: Assembling the wind speed sensor on the auxiliary boom

- ▶ Insert the retainer **1** of the wind speed sensor in the retainer **6.3** on the auxiliary boom.
- ▶ Secure the retainer **1** with the retaining element **2** in position **P1**. Pay attention to the correct assembly position: See section „Assembly position“.
- ▶ Remove the retaining element **3** out of position **P2**.

**Result:**

- The wind speed sensor **5** swings back and forth until the weight is located vertically below it.

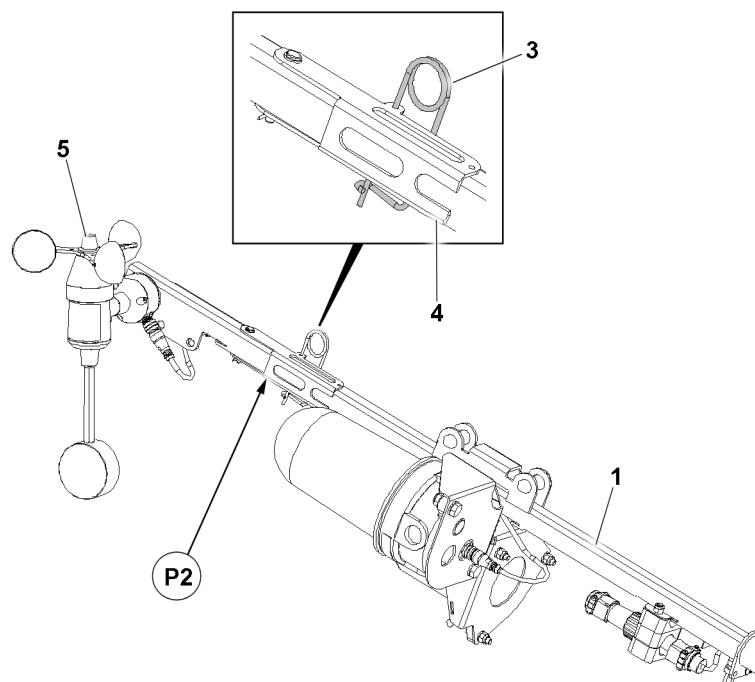


Fig.149025: Securing the transport retainer

- ▶ Fold the transport retainer **4** back to the retainer **1**.
- ▶ Secure the transport retainer **4** with the retaining element **3** in position **P2**.
- ▶ Establish the electrical connections: See the section „Establishing the electrical connections“.

#### 4.4 Assembly on the N-assembly unit.

This type of assembly is only possible for certain crane types.

Make sure that the following prerequisites are met:

- The N-assembly unit is assembled on the boom.
- NA-frame 2 is taken down (or not set up).

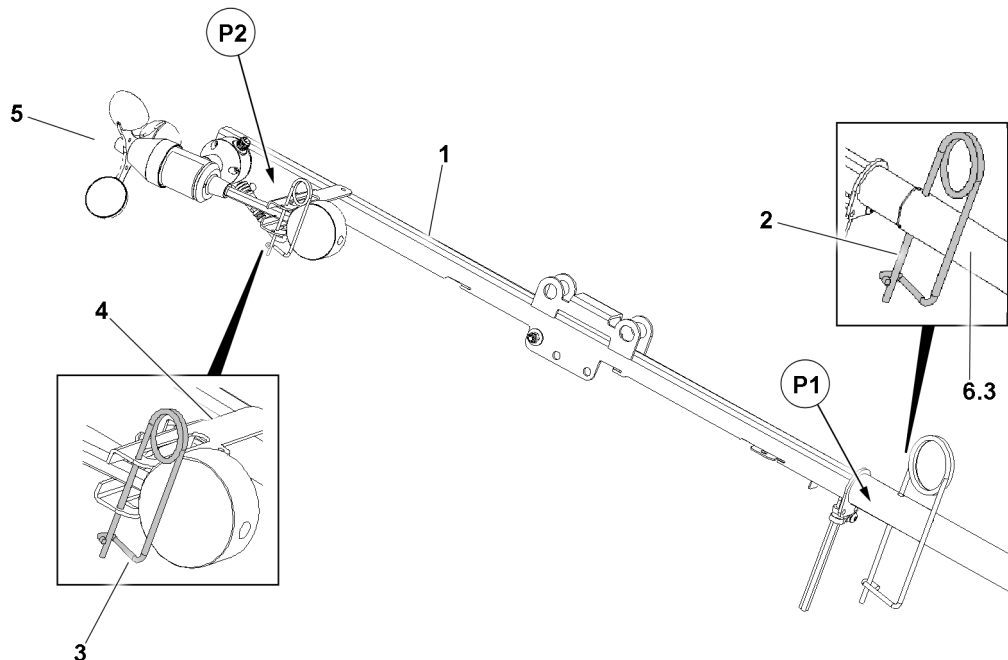


Fig.159773: Assembling the wind speed sensor on the N-assembly unit

- ▶ Insert the retainer **1** of the wind speed sensor in the retainer **6.3** on the N-assembly unit.
- ▶ Secure the retainer **1** with the retaining element **2** in position **P1**. Pay attention to the correct assembly position: See section „Assembly position“.
- ▶ Remove the retaining element **3** out of position **P2**.

#### Result:

- The wind speed sensor **5** swings back and forth until the weight is located vertically below it.

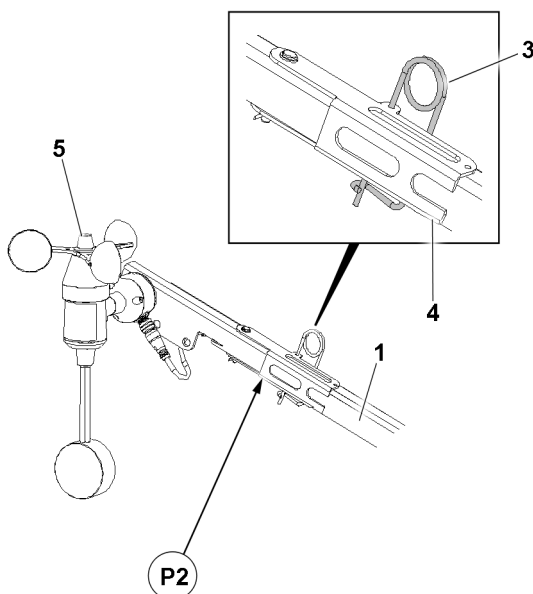


Fig.159774: Securing the transport retainer

- ▶ Fold the transport retainer **4** back to the retainer **1**.
- ▶ Secure the transport retainer **4** with the retaining element **3** in position **P2**.
- ▶ Establish the electrical connections: See the section „Establishing the electrical connections“.

## 4.5 Checking the wind speed sensor

The function of the wind speed sensor must be checked each time before erecting the boom.

Check the wind speed sensor for easy movement and proper function:

- ▶ Manually operate the cup anemometer of the wind speed sensor.
- ▶ Replace a defective wind speed sensor immediately.

# 5 Electrical connection

## 5.1 Establishing the electrical connection

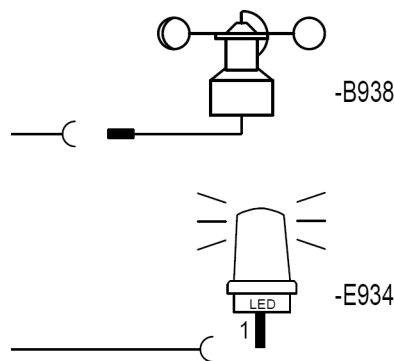


Fig.149031: Electrical connection

The establishment of the electrical connections is described based on an example.

The specifications in the supplied electric wiring diagram are applicable for the connection.

- ▶ Plug the wind speed sensor **-B938** into the socket.
- ▶ Plug the airplane warning light\* **-E934** into the socket.

## 5.2 Checking the electrical connections

- ▶ Check that the plug connections of the wind speed sensor and the airplane warning light\* have been connected correctly.
- ▶ Check the function of the wind speed sensor on the LICCON monitor.
- ▶ Check the function of the airplane warning light\*.

# 6 Disassembling the wind speed sensor

Make sure that the following prerequisites are met:

- The telescopic boom is luffed down to the 0° position.
- The auxiliary boom is in the 0° position.

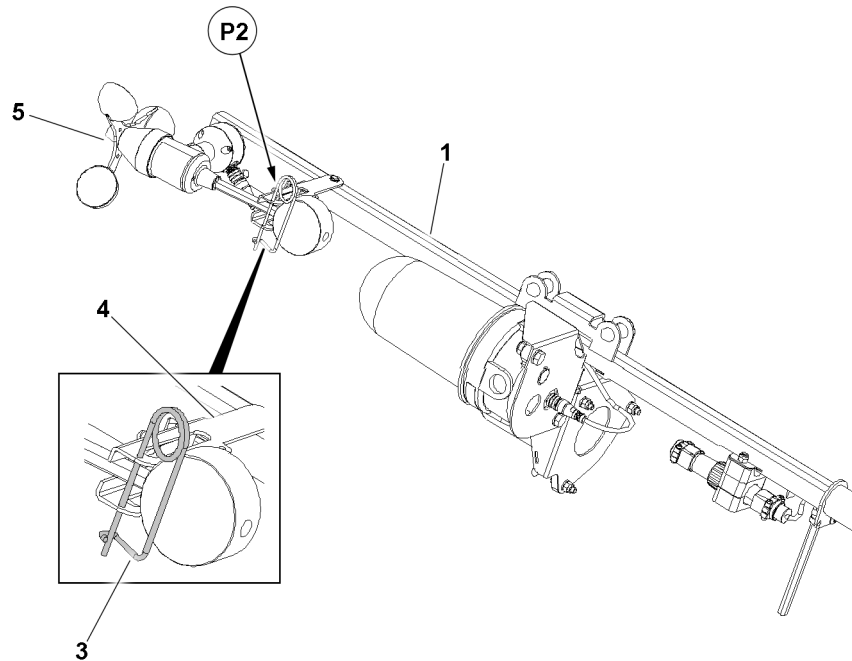


Fig.149028: Securing the wind speed sensor in the transport position

- ▶ Disconnect the electrical connection.
- ▶ Release the transport retainer 4 and fold it out.
- ▶ Swing the wind speed sensor 5 upward and lock the weight in position P2 in the transport retainer 4.
- ▶ Secure the wind speed sensor 5 with the retaining element 3.

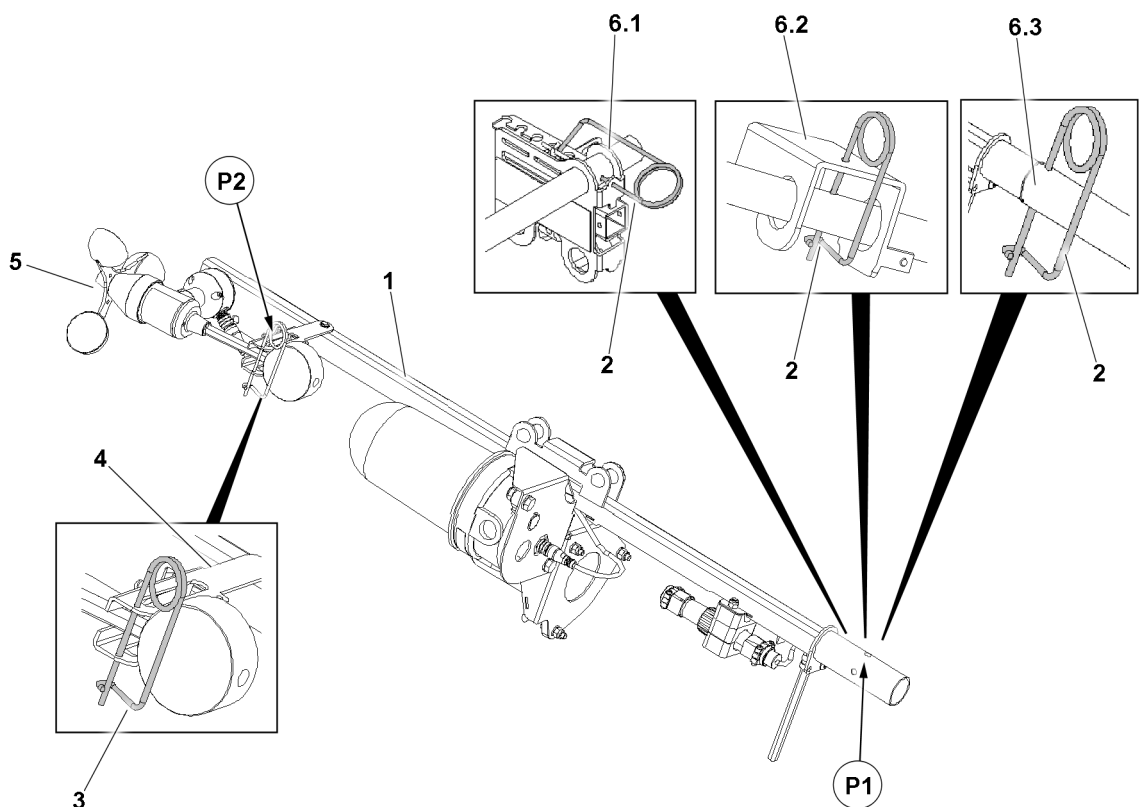


Fig.149027: Disassembling the retainer

- ▶ Remove the retaining element **2** from the retainer **6.1**, retainer **6.2** or retainer **6.3** and store it.
- ▶ Carefully remove the retainer **1** with attachment parts.

## 7 Assembling the wind speed sensor in the transport position

Before the crane may be driven or transported on public roads, the wind speed sensor **5** and the retainer **1** must be assembled in transport position.

### 7.1 Securing the wind speed sensor in the transport position

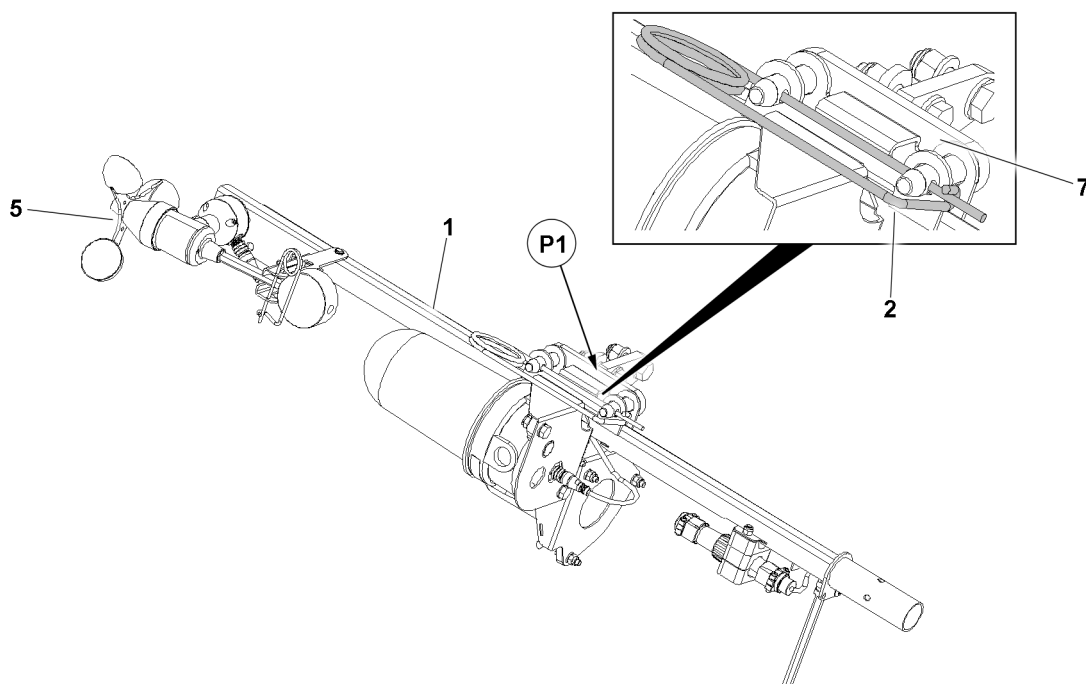


Fig.149029: Securing the wind speed sensor in the transport position

- ▶ Assemble the retainer **1** with the wind speed sensor **5** in position **P1**.
- ▶ Secure the retainer **1** with the retaining element **2** on the retainer **7**.



## 7.2 Transport position on the N-assembly unit.

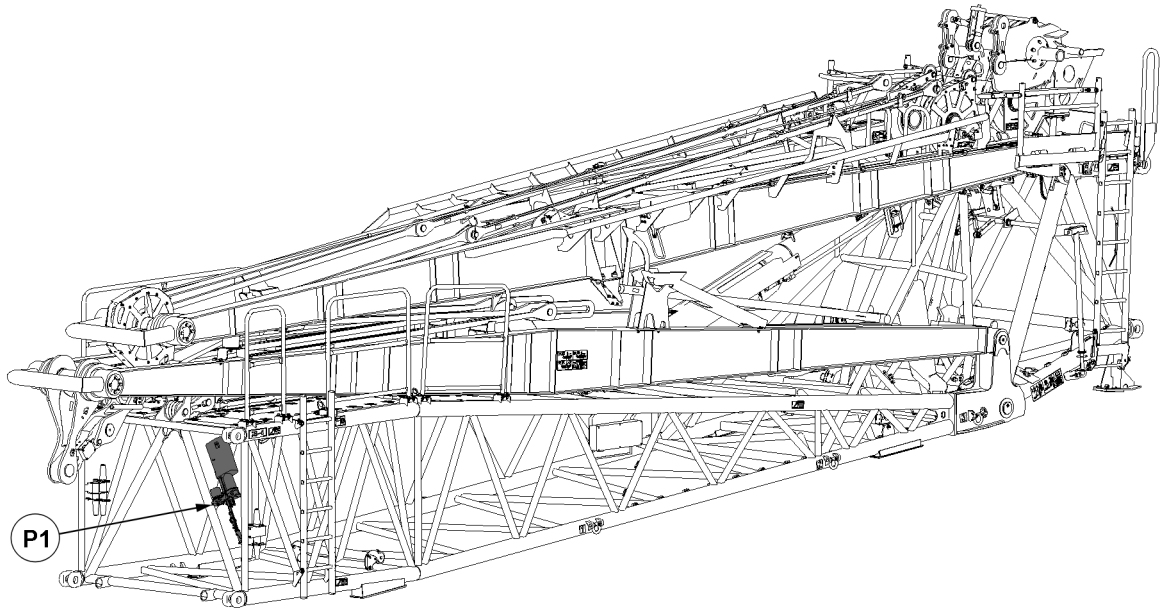


Fig.159772: Transport position on the N-assembly unit.

1 N-assembly unit

P1 Wind speed sensor transport position

## 8 Transporting the wind speed sensor

To prevent the wind speed sensor from being damaged, the wind speed sensor must be protected when driving and during transport.

- Fasten the supplied protective cover on the wind speed sensor.

---

Empty page!

LWE/LTR 1220-003/24204-02-02/en

## 5.80 Floodlight

1	Safety	2
2	Assembling the floodlight	2
3	Electrical connection	3
4	Disassembling the floodlight	4

# 1 Safety

Observe the safety instructions prior to assembly / disassembly of the floodlight.

- General safety information: See chapter 2.04.
- Information regarding personal protective equipment: See chapter 2.04.
- Information regarding the use of ladders: See chapter 2.04.

---

## NOTICE

Excessive width with installed floodlight!  
Impermissible vehicle condition.

If the mobile crane exceeds the permissible vehicle width with the floodlight assembled:

- ▶ Disassemble the floodlight before starting to travel.
- 

The illustrations in this chapter are an example. The installation of the floodlight is explained based on the example of a telescopic boom head. The attached retainers are located at times in other positions than as shown.

The assembly of the floodlight is carried out depending on the crane structure.

## 2 Assembling the floodlight

Depending on the available equipment, the floodlight can be assembled directly on the boom head or the pull relief for the hose drum.

### 2.1 Assembling the floodlight without pull relief

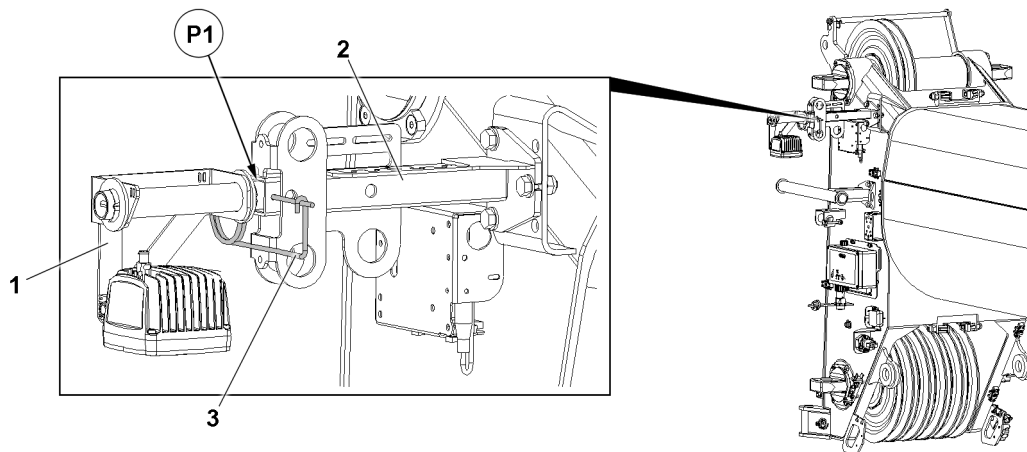


Fig.152468: Floodlight assembly

Make sure that the following prerequisites are met:

- The telescopic boom is luffed down to the 0° position.
- The pull relief for the hose drum is disassembled.
- ▶ Insert the floodlight 1 in position P1 in the retainer 2 on the telescopic boom.
- ▶ Secure the floodlight 1 with the retaining element 3.

#### Result:

- The floodlight 1 is assembled.

## 2.2 Assembling the floodlight with pull relief

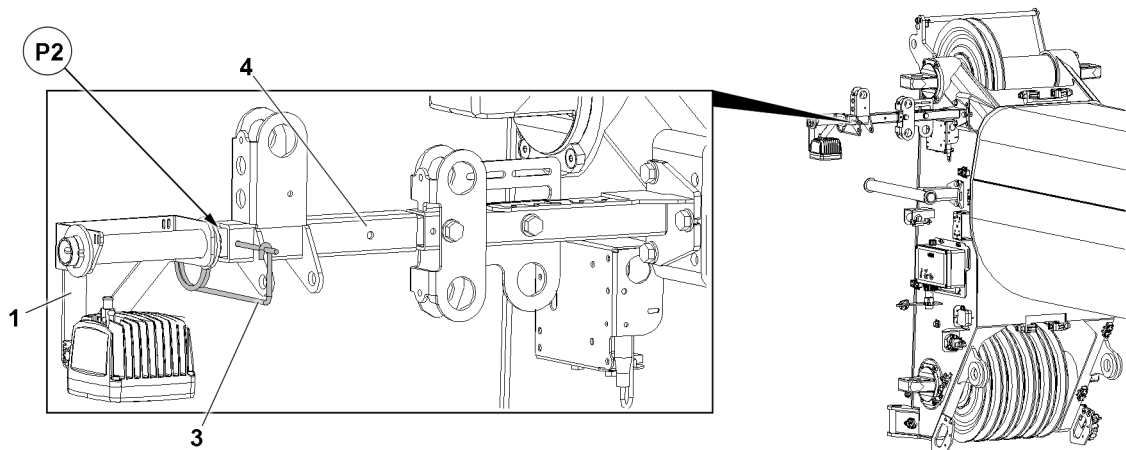


Fig.152469: Floodlight assembly on the pull relief

Make sure that the following prerequisites are met:

- The telescopic boom is luffed down to the 0° position.
- The pull relief 4 for the hose drum is assembled.
- ▶ Insert the floodlight 1 in position P2 in the pull relief 4 for the hose drum.
- ▶ Secure the floodlight 1 with the retaining element 3.

**Result:**

- The floodlight 1 is assembled.

## 3 Electrical connection

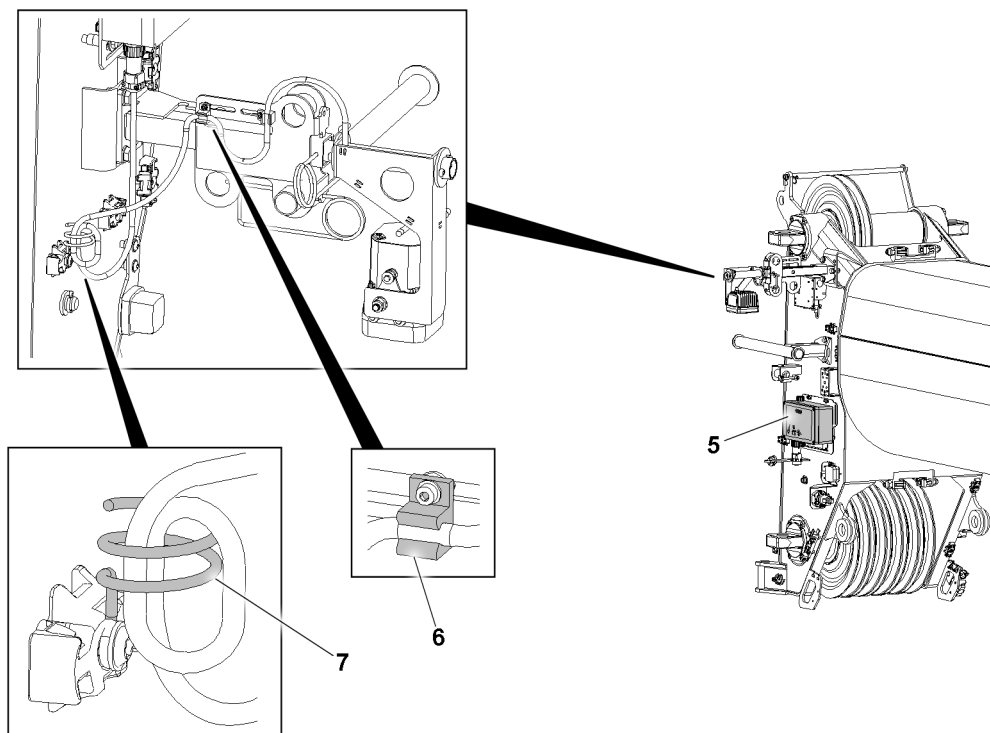


Fig.152471: Establishing the electrical connection

### 3.1 Establishing the electrical connection

The establishment of the electrical connection is described based on an example.

The specifications in the supplied Electric wiring diagram are applicable for the connection.

Make sure that the following prerequisites are met:

- The electrical connection has been carefully and clearly established.
- Secure the electrical connection with cable clips **6** and, if necessary, using a cable retainer **7**.
- ▶ Establish the electrical connection from the floodlight to the terminal box **5**.

### 3.2 Checking the electrical connections

- ▶ Check the function of the floodlight.

## 4 Disassembling the floodlight

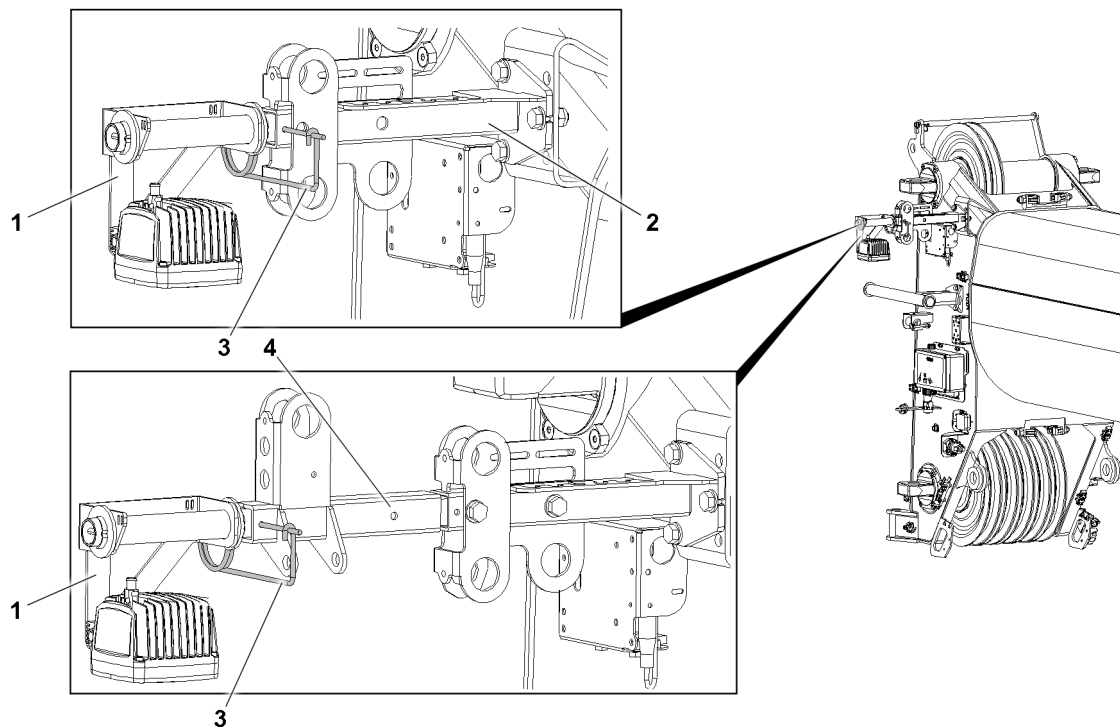


Fig.152470: Floodlight disassembly

Make sure that the following prerequisites are met:

- The telescopic boom is luffed down to the 0° position.
- The floodlight is assembled.
- ▶ Disconnect the electrical connection.
- ▶ Release the floodlight **1**: Remove the retaining element **3** and set it aside.
- ▶ Remove the floodlight **1** from the retainer **2** or the pull relief **4**.

---

## 6 Auxiliary equipment

---

LWE/LTR 1220-003/24204-02-02/en



## 6.02 Crane operator's cab heater / engine preheating / air conditioning system

1	Climate control systems	3
2	Safety instructions	3
3	Climate control	4
4	Air distribution	12
5	Defrosting the window	13
6	Air supply	14
7	Operating the timer	14
8	Air heater*	16
9	Checking the fill level of the fuel container*	17

*Fig.195219*

LWE/LTR 1220-003/24204-02-02/en

# 1 Climate control systems

The climate control system consists of multiple components:

- Crane superstructure auxiliary heater for the climate control of the crane cab
- Crane superstructure climate control system\* for the climate control of the crane cab



## Note

- ▶ The coolant circuit of the crane engine does not have any influence on crane cab heating.
- ▶ Engine preheating\* is controlled via the climate control system of the driver's cab, see the Crane operating instructions, chapter 6.01.

## 1.1 Operating instructions

The climate control system is only operational when the crane engine is running.

The auxiliary heater is operational independently of the crane engine.

It is not possible to heat the crane cab without switching on the auxiliary heater.

Cooling of the crane cab is possible in a limited manner only without the climate control system switched on.

Keep the air intake and the air filter of the climate control system free of:

- Ice
- Snow
- Contaminants
- Objects

For efficient climate control, close the windows and door of the crane cab.

# 2 Safety instructions

Observe the country specific regulations for the operation of climate control systems.



## WARNING

Danger of accident due to bad visibility!

A window that is fogged up, icy or dirty impedes the view of the crane operator.

- ▶ Only drive / operate the crane with good visibility through the windows.



## WARNING

Danger of poisoning and suffocation in enclosed areas!

- ▶ Do **not** operate the auxiliary heater in closed rooms.



## WARNING

Danger of poisoning and suffocation!

After turning the auxiliary heater off, there is an after-run phase.

During the after-run phase, exhaust gases are still emitted.

- ▶ Ensure sufficient ventilation.

For example, there is a danger of explosion and fires in the following locations:

- Gas stations and refueling facilities.
- Locations where vapors, gases or dust can form.
- Locations with easily flammable materials or fluids.



## WARNING

Danger of explosion and fires!

- ▶ Do **not** operate the auxiliary heater if there is a danger of explosion or fires.

Signs of a defective auxiliary heater:

- Significant smoke development
- Unusual combustion noise
- Fuel odor

---

#### NOTICE

Auxiliary heater defective!

- ▶ Turn the auxiliary heater off.
  - ▶ Take the auxiliary heater out of operation: Shut off the power supply to the auxiliary heater.
  - ▶ Before turning it on again: Have the auxiliary heater checked by authorized and trained service personnel.
- 

#### NOTICE

Damage to the climate control systems!

- ▶ Adjust the operating fluids in time to the ambient temperatures.
- ▶ Comply with the maintenance intervals, see chapter 7.02.

Repair work on the climate control systems:

- ▶ Contact Customer Service at Liebherr-Werk Echingen and coordinate the procedure.
- 

#### NOTICE

Deep discharge of the battery!

When the crane engine is turned off, operating the auxiliary heater can discharge the batteries. A long-term programmed turn on time for the auxiliary heater can discharge the batteries.

- ▶ Make sure that the battery charge is sufficient.
- 

## 3 Climate control

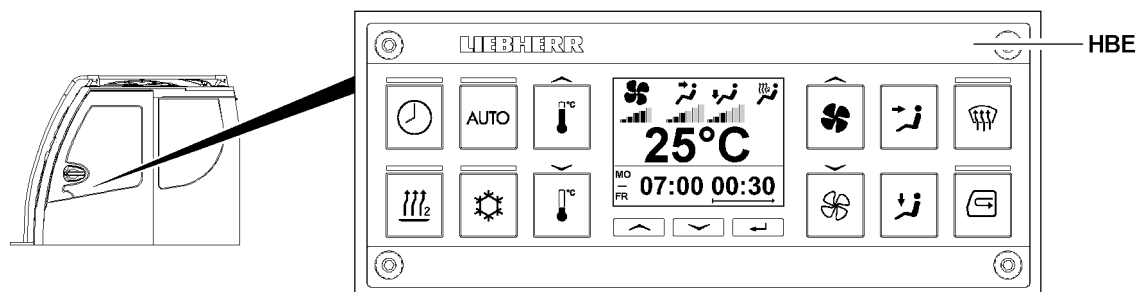


Fig.145971: Heater control unit

The climate control of the crane cab is controlled using the heater control unit **HBE**.

The climate control in the crane cab can:

- Be automatically regulated in automatic operation.
- Be manually regulated in manual operation.

### 3.1 Heater control unit operating elements

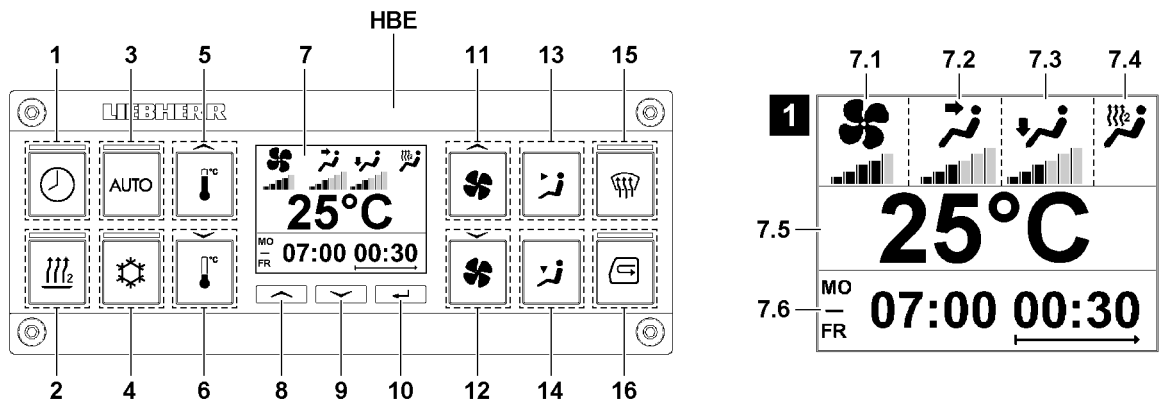


Fig.145959: Heater control unit operating elements

- 1 **Timer key**
  - Setting the timer for auxiliary heater and turning it on / off
  - The LED lights up: The timer for the auxiliary heater is turned on
- 2 **Auxiliary heater key**
  - Control the auxiliary heater:
    - Turn the auxiliary heater on
    - Turn the auxiliary heater off
  - The LED lights up: The auxiliary heater is turned on
- 3 **Automatic operation key**
  - Switching between automatic operation and manual operation
  - The LED lights up: Automatic operation is turned on, automatic control of heater settings
  - LED off: Manual operation is turned on, manual adjustment of the heater settings
- 4 **Climate control system key**
  - Control the climate control system:
    - Turn the climate control system on
    - Turn the climate control system off
  - The LED lights up: The auxiliary heater is turned on / ready to operate
  - Note: In automatic operation, the luminous LED signals that the climate control system is ready for operation and can be switched on / off as required using the control.
- 5 **Increase temperature key**
- 6 **Decrease temperature key**
- 7 **Display**

Display of the current settings, see illustration 1:

  - 7.1 Fan stage
  - 7.2 Head area air distribution
  - 7.3 Foot area air distribution
  - 7.4 Heat distribution
  - 7.5 Temperature
  - 7.6 Setting the time
- 8 **Up selection key**
- 9 **Down selection key**
- 10 **Confirm entry key**
- 11 **Increase fan stage key**
- 12 **Decrease fan stage key**
- 13 **Head area air distribution key**
  - Increase air distribution in the head area
  - Note: Each key press decreases at the same time the air distribution to the foot area

- 14 Foot area air distribution key**
- Increase air distribution in the foot area
  - Note: Each key press decreases at the same time the air distribution to the head area
- 15 Defrost window key**
- Defrost window function on / off
  - The LED lights up: The defrost window function is turned on
- 16 Recirculating air key**
- Recirculating air on / off
  - The LED lights up: Recirculating air is turned on

## 3.2 Turning the heater control unit on and off

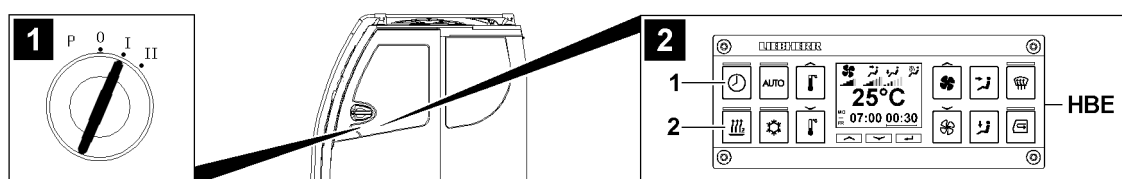


Fig.145978: Turning the heater control unit on and off

The heater control unit is turned on and ready to operate:

- With ignition turned on
- After being turned on manually with the ignition turned off



### Note

At very low temperatures, the display of the heater control unit **HBE** may not display anything initially.

- ▶ When turning on the heater control unit **HBE**, wait until the display can be read.

### 3.2.1 Turning the heater control unit on and off via the ignition

- ▶ Turn the heater control unit on: Turn on the ignition with the ignition switch, see illustration 1.

#### Result:

- The heater control unit turns on.

- ▶ Turn the heater control unit off: Turning the ignition off with the ignition switch.

#### Result:

- The heater control unit turns off after a short time.

### 3.2.2 Turning the heater control unit on and off manually

See illustration 2:

Make sure that the following prerequisites are met:

- The ignition is off.

#### Turning the heater control unit on

- ▶ Press the *timer* button **1** until the heater control unit turns on.  
or  
Press the *auxiliary heater* button **2** until the heater control unit turns on.

#### Turning the heater control unit off

The heater control unit cannot be turned off directly. To increase operating safety, there are partially automated processes for turning off the heater control unit.

**Note**

- ▶ As long as the auxiliary heater is operating, the heater control unit will not turn off.
- ▶ When the auxiliary heater is turned off, the heater control unit turns off automatically after a short period of time.

When the auxiliary heater is turned off:

- ▶ Do not press any button on the heater control unit for at least ten seconds.

**Result:**

- The heater control unit turns off after a short time.

When the auxiliary heater is still operating:

- ▶ The separate turning off of the heater control unit is not necessary and also not possible.

**Result:**

- As soon as the auxiliary heater is turned off by the automatic control, also the heater control unit turns off automatically after a short period of time.

When the auxiliary heater is still operating, but should be turned off:

- ▶ See section „Turning the auxiliary heater on and off“.

**Result:**

- As soon as the auxiliary heater is turned off, the heater control unit turns off automatically after a short period of time.

### 3.3 Switching between automatic operation and manual operation

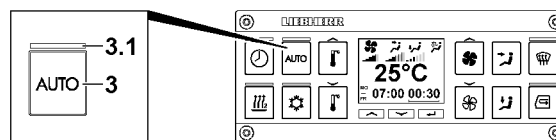


Fig.145964: Switching between automatic operation and manual operation

#### 3.3.1 Turning on automatic operation

Make sure that the following prerequisites are met:

- The LED **3.1** is off.
- ▶ Press the *automatic operation* key **3**.

**Result:**

- The LED **3.1** lights up: The automatic operation is turned on.
- The heater settings are automatically adjusted.

**Note**

In automatic operation:

- ▶ If the heater settings are changed extensively by hand, the climate control switches to manual operation.

#### 3.3.2 Turning manual operation on

Make sure that the following prerequisites are met:

- The LED **3.1** lights up.
- ▶ Press the *automatic operation* key **3**.

**Result:**

- The LED **3.1** turns off: Manual operation is turned on.
- The heater settings must be adjusted manually.

### 3.4 Automatic operation

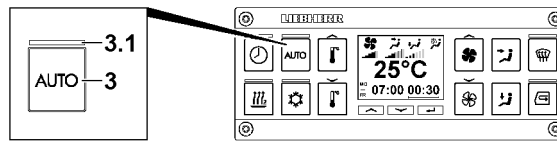


Fig.145964: Automatic operation - the LED 3.1 is on

Automatic operation is only turned on when the LED 3.1 over the *automatic operation* key 3 lights up. Automatic operation automatically regulates the climate control to reach the set temperature and keep it constant.

The following settings are automatically adjusted:

- Warm air supply
- Fan stage
- Air supply
- Auxiliary heater
- Climate control system

**Note:** The crane engine must be running to operate the climate control system.

#### 3.4.1 Adjusting the temperature

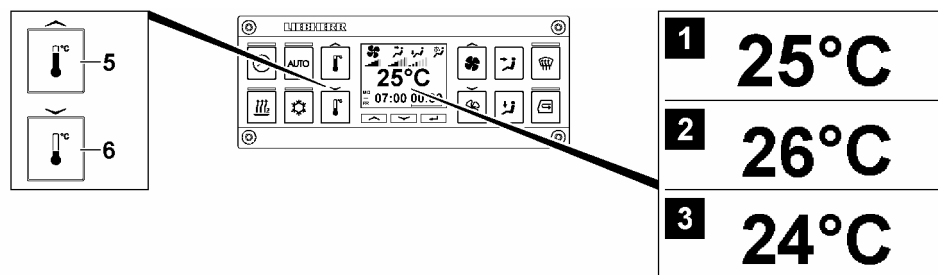


Fig.145967: Adjusting the temperature

The target temperature of 25°C is used as the initial setting, see illustration 1.

To increase the temperature:

- ▶ Press the *increase temperature* key 5.

**Result:**

- The set value increases, see illustration 2.

To decrease the temperature setting:

- ▶ Press the *decrease temperature* key 6.

**Result:**

- The set value decreases, see illustration 3.

#### Problem remedy

Is the cooling capacity of the climate control system insufficient?

The recirculated air filter, fresh air filter or condenser could be dirty.

- ▶ Check the filter for impurities. If necessary, clean or replace.
- ▶ Check the condenser for impurities and clean, if necessary.

When all these measures do not help:

- ▶ Contact the Service Dept. at Liebherr-Werk Ehingen.



## 3.5 Manual operation

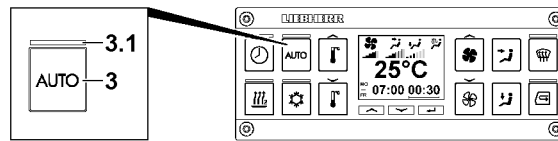


Fig.145964: Manual operation - the LED 3.1 is off

Manual operation is only turned on when the LED 3.1 over the *automatic operation* key 3 does not light up.

In manual operation all settings must be carried out manually.

### 3.5.1 Turning the auxiliary heater on and off

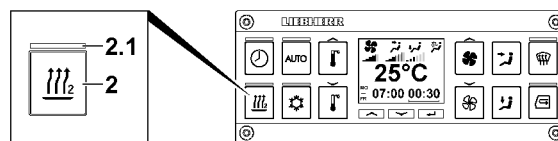


Fig.145963: Turning the auxiliary heater on and off



#### Note

Protection against auxiliary heater overheating

- ▶ If the temperature of the heat carrier is too high, the auxiliary heater turns off automatically.

#### Turning the auxiliary heater on



#### Note

- ▶ If the ignition is turned off while the auxiliary heater is turned on, the auxiliary heater continues to run with an automatic shut off delay for up to 30 minutes.
- ▶ If the ignition is turned on while the auxiliary heater is turned off, the auxiliary heater runs for 30 minutes.
- ▶ If the auxiliary heater must be turned on at a certain time when the ignition is turned off, the timer must be programmed, see section „Operating the timer“.

Make sure that the following prerequisites are met:

- The LED 2.1 is off.
- Sufficient fuel for the auxiliary heater has been added.
- With the auxiliary heater turned on, sufficient ventilation is ensured.
- With the auxiliary heater turned on, the crane is located in an area where operation of the auxiliary heater is permitted.

- ▶ Press the *auxiliary heater* key 2.

#### Result:

- The LED 2.1 lights up: The auxiliary heater is turned on.

#### Turning the auxiliary heater off

Make sure that the following prerequisites are met:

- The LED 2.1 lights up.
- ▶ Press the *auxiliary heater* key 2.

#### Result:

- The LED 2.1 turns off: The auxiliary heater is turned off.

### 3.5.2 Turning the climate control system on and off

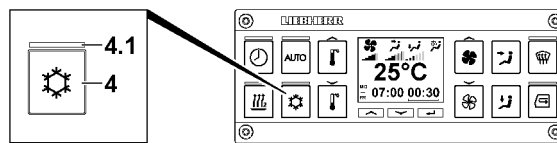


Fig.145965: Turning the climate control system on and off

The climate control system functions only when the crane engine is running.

The climate control system is responsible for cooling and the dehumidification of the air in the crane cab.

The humidity is reduced considerably when the climate control system is switched on. This counteracts the fogging up of the windows.

The maximum cooling output is reached when:

- The air supply is switched to recirculating air.
- The fan stage is set to maximum output.
- The temperature stage is set to the lowest value.
- All outlet nozzles in the crane cab are open.
- The door and windows of the crane cab are closed.



#### Note

Protection against condenser freezing

- ▶ If the outside temperature is too low, the climate control system turns off automatically.

#### Turning the climate control system on

Make sure that the following prerequisites are met:

- The crane engine is running.
- The LED 4.1 is off.
- ▶ Press the *climate control system* key 4.

#### Result:

- The LED 4.1 lights up: The climate control system is turned on.

#### Problem remedy

Is the cooling capacity of the climate control system insufficient?

The recirculated air filter, fresh air filter or condenser could be dirty.

- ▶ Check the filter for impurities. If necessary, clean or replace.
- ▶ Check the condenser for impurities and clean, if necessary.

When all these measures do not help:

- ▶ Contact the Service Dept. at Liebherr-Werk Ehingen.

#### Turning the climate control system off

Make sure that the following prerequisites are met:

- The LED 4.1 lights up.
- ▶ Press the *climate control system* key 4.

#### Result:

- The LED 4.1 turns off: The climate control system is turned off.

### 3.5.3 Adjusting the temperature

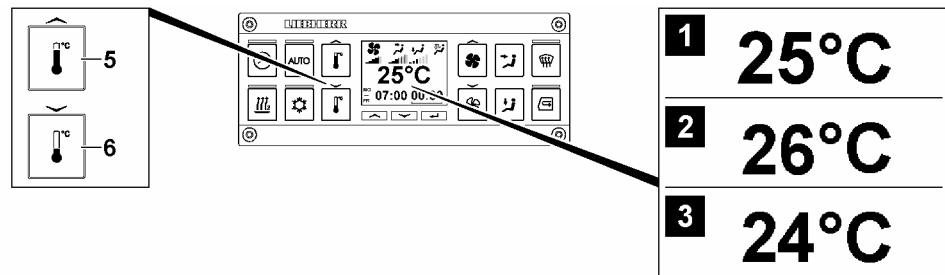


Fig.145967: Adjusting the temperature

Make sure that the following prerequisites are met:

- Turn the auxiliary heater on to heat the crane cab.
- Turn the climate control system on to cool the crane cab.

The target temperature of 25°C is used as the initial setting, see illustration 1.

To increase the temperature:

- ▶ Press the *increase temperature* key 5.

**Result:**

- The set value increases, see illustration 2.

To decrease the temperature setting:

- ▶ Press the *decrease temperature* key 6.

**Result:**

- The set value decreases, see illustration 3.

### 3.5.4 Adjusting the fan stage

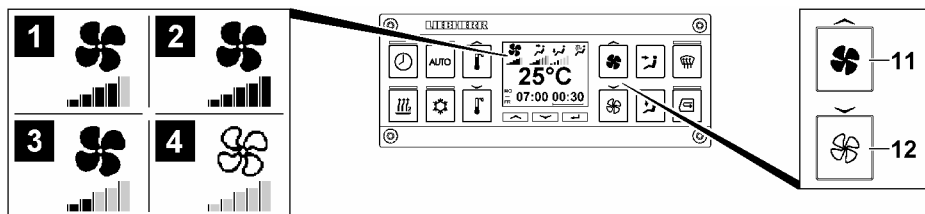


Fig.145969: Adjusting the fan stage in manual operation

Fan stage *four* is used as the initial setting, see illustration 1.

To increase the fan stage:

- ▶ Press the *increase fan stage* key 11.

**Result:**

- Fan stage *five* is displayed, see illustration 2.

To decrease the fan stage:

- ▶ Press the *decrease fan stage* key 12.

**Result:**

- Fan stage *three* is displayed, see illustration 3.



**Note**

- ▶ When the fan is switched off, the fan icon is displayed not filled out, see illustration 4.

## 4 Air distribution

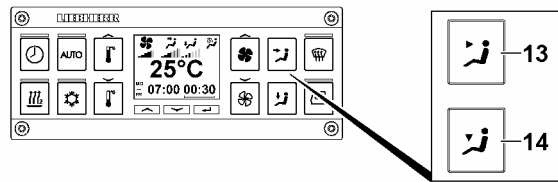


Fig.145974: Air distribution

- **13** Head area air distribution key
  - Increase air distribution in the head area
  - Note: Each key press decreases at the same time the air distribution to the foot area
- **14** Foot area air distribution key
  - Increase air distribution in the foot area
  - Note: Each key press decreases at the same time the air distribution to the head area

### 4.1 Increasing air distribution in the head area

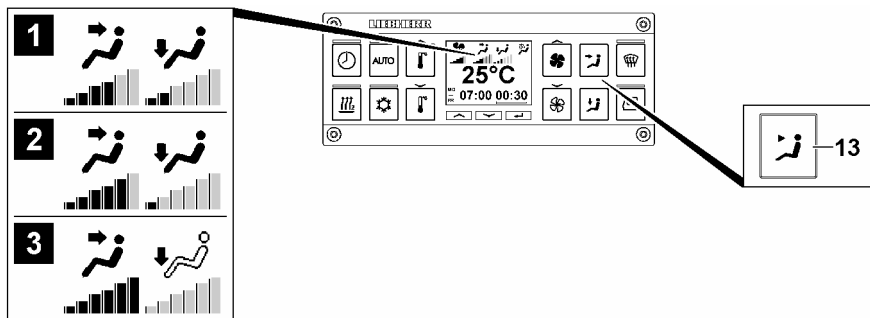


Fig.145968: Increasing air distribution in the head area

Level *four* in the head area is used as the initial setting, see illustration 1.

To increase the level in the head area:

- ▶ Press the *Head area air distribution* key **13**.

#### Result:

- Level *five* is displayed in the head area, see illustration 2.
- The level in the foot area is decreased accordingly.



#### Note

At the highest level in the head area, the air distribution to the foot area is turned off.

- ▶ When the air distribution to the foot area is turned off, the icon is displayed not filled out, see illustration 3.

## 4.2 Increasing air distribution in the foot area

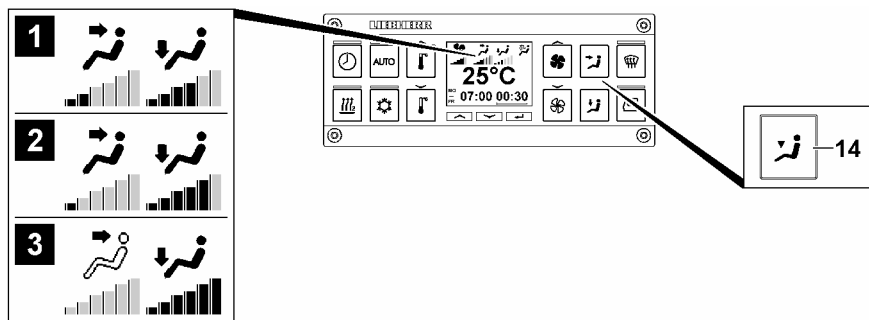


Fig.145972: Increasing air distribution in the foot area

Level *four* in the foot area is used as the initial setting, see illustration 1.

To increase the level in the foot area:

- ▶ Press the *Foot area air distribution* key 14.

### Result:

- Level *five* is displayed in the foot area, see illustration 2.
- The level in the head area is decreased accordingly.



### Note

At the highest level in the foot area, the air distribution to the head area is turned off.

- ▶ When the air distribution to the head area is turned off, the icon is displayed not filled out, see illustration 3.

## 5 Defrosting the window

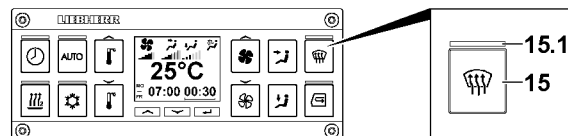


Fig.145973: Turning the defrost window function on / off

### 5.1 Turning the *defrost window* function on

Make sure that the following prerequisites are met:

- The outlet nozzles in the A-pillars and instrument panel are open and directed evenly towards the front window.
- The LED 15.1 is off.

- ▶ Press the *defrost window* key 15.

### Result:

- The LED 15.1 lights up: The *defrost window* function is turned on.

### 5.2 Turning the *defrost window* function off

Make sure that the following prerequisites are met:

- The LED 15.1 lights up.

- ▶ Press the *defrost window* key 15.

**Result:**

- The LED 15.1 turns off: The *defrost window* function is turned off.

## 6 Air supply

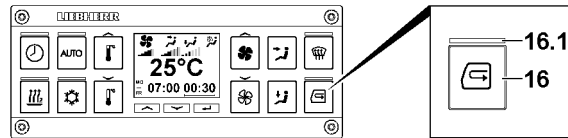


Fig.145970: Air supply

When recirculating air is turned on, the air is circulated in the crane cab.

When recirculating air is turned off, fresh air is introduced from the outside.

### 6.1 Turning recirculating air on

Make sure that the following prerequisites are met:

- The LED 16.1 is off.
- ▶ Press the *recirculating air* key 16.

**Result:**

- The LED 16.1 lights up: Recirculating air is turned on.

### 6.2 Turning recirculating air off

Make sure that the following prerequisites are met:

- The LED 16.1 lights up.
- ▶ Press the *recirculating air* key 16.

**Result:**

- The LED 16.1 turns off: Recirculating air is turned off.

## 7 Operating the timer

The auxiliary heater can be turned on at any time using the timer.

**WARNING**

Danger of suffocation and explosion!

Only when the auxiliary heater is turned on if sufficient ventilation is ensured and no danger of explosion exists:

- ▶ Activate the timer.

**Note**

- ▶ Pay attention to a sufficient fuel reserve for the auxiliary heater. See the section „Checking the fill level of the fuel container“.
- ▶ Add fuel, see chapter 7.05.

### 7.1 Programming the timer

The following applies when the timer for the auxiliary heater turns on:

- The fan stage is generally set to 30 %.

- The previously set air supply and air distribution is taken over.
- Operation of the auxiliary heater ends after the set time. Automatic start does not take place after another 7 days.

Make sure that the following prerequisites are met:

- At the programmed start time for the timer, the ignition is turned off.
- Sufficient fuel for the auxiliary heater has been added.
- With the auxiliary heater turned on, sufficient ventilation is ensured.
- With the auxiliary heater turned on, the crane is located in an area where operation of the auxiliary heater is permitted.

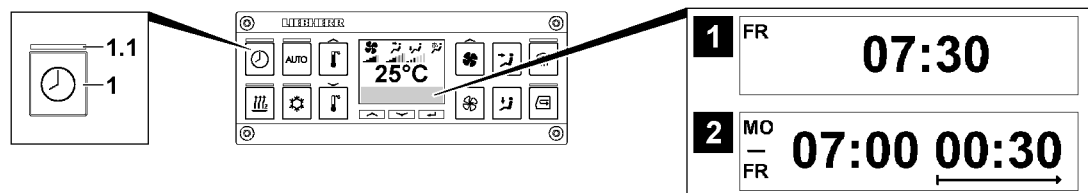


Fig.145976: Timer turned on / off

- When the timer is turned off, the system time appears on the display, see illustration 1. The system time includes the day of the week and time. The system time is the determining factor for the timer.
- When the timer is turned on, the *start time and running time* appears on the display, see illustration 2. The start time includes the day of the week / day of the week and time.

If the LED 1.1 does not light up:

- ▶ Press the *timer* key 1.

**Result:**

- The LED 1.1 lights up: The timer is turned on.
- The *start time and running time* display appears, see illustration 2.

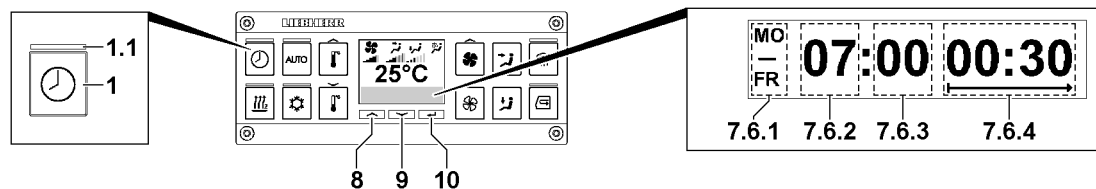


Fig.145977: Programming the timer

If the LED 1.1 lights up:

- ▶ Press the *timer* key 1 for approx. three seconds.

**Result:**

- The turn on day 7.6.1 blinks.

The following can be set as the turn on day 7.6.1:

- Single day of the week
- Daily from Monday to Friday
- Daily from Monday to Sunday

When the turn on day 7.6.1 blinks:

- ▶ Set the turn on day 7.6.1: Press the *up selection* key 8 or the *down selection* key 9. If the key is pressed longer, it is increased / decreased automatically.
- ▶ Accept the turn on day 7.6.1: Press the *confirm entry* key 10.

**Result:**

- The turn on day 7.6.1 is set.
- The turn on timehour 7.6.2 blinks.

When the turn on time *hour* **7.6.2** blinks:

- ▶ Set the turn on time *hour* **7.6.2**: Press the *up selection* key **8** or the *down selection* key **9**. If the key is pressed longer, it is increased / decreased automatically.
- ▶ Accept the turn on time *hour* **7.6.2**: Press the *confirm entry* key **10**.

**Result:**

- The turn on time *hour* **7.6.2** is set.
- The turn on time *minute* **7.6.3** blinks.

When the turn on time *minute* **7.6.3** blinks:

- ▶ Set the turn on time *minute* **7.6.3**: Press the *up selection* key **8** or the *down selection* key **9**. If the key is pressed longer, it is increased / decreased automatically.
- ▶ Accept the turn on time *minute* **7.6.3**: Press the *confirm entry* key **10**.

**Result:**

- The turn on time *minute* **7.6.3** is set.
- The turn on duration **7.6.4** blinks.

When the turn on duration **7.6.4** blinks:

- ▶ Set the turn on duration **7.6.4**: Press the *up selection* key **8** or the *down selection* key **9**. If the key is pressed longer, it is increased / decreased automatically.
- ▶ Accept the turn on duration **7.6.4**: Press the *confirm entry* key **10**.

**Result:**

- The turn on duration **7.6.4** is set.

Ending timer programming:

- ▶ Press the *confirm entry* key **10**



#### Note

- ▶ In the case of cranes with engine preheating, the heat distribution must then be checked / set, see section „Setting the auxiliary heater heat distribution“.
- ▶ After programming the timer, the set heat distribution will be displayed briefly.
- ▶ When the ignition is turned off and the auxiliary heater is not activated, the heat distribution is displayed permanently.

## 8 Air heater\*

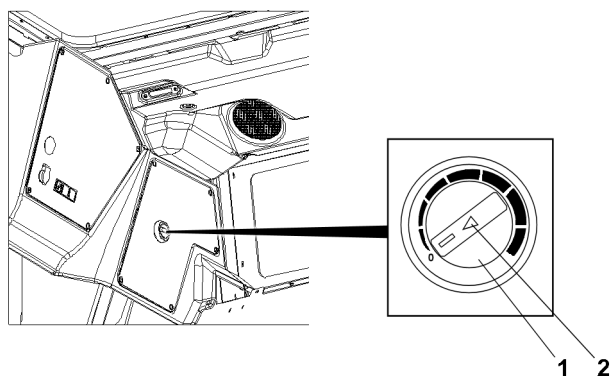


Fig.152187: Air heater\*

### 8.1 Turning the air heater\* on

For description of the air heater\*, see the documentation from the manufacturer.



- ▶ Turn the rotary switch **1** to the desired temperature.

**Result:**

- The LED **2** lights up: The *heating* function is turned on.

## 8.2 Turning the air heater\* off

- ▶ Set the rotary switch **1** to „0“.

**Result:**

- The LED **2** turns off: The *heating* function is turned off.

## 9 Checking the fill level of the fuel container\*

The position and refueling of the fuel tank is described in the maintenance guidelines.

- ▶ Make sure that before operating the auxiliary heater enough fuel is available.

If fuel must be added:

- ▶ Only use permissible fuel.

---

Empty page!

LWE/LTR 1220-003/24204-02-02/en

## 6.05 Emergency take down

1 Emergency control

---

3

LWE/LTR 1220-003/24204-02-02/en

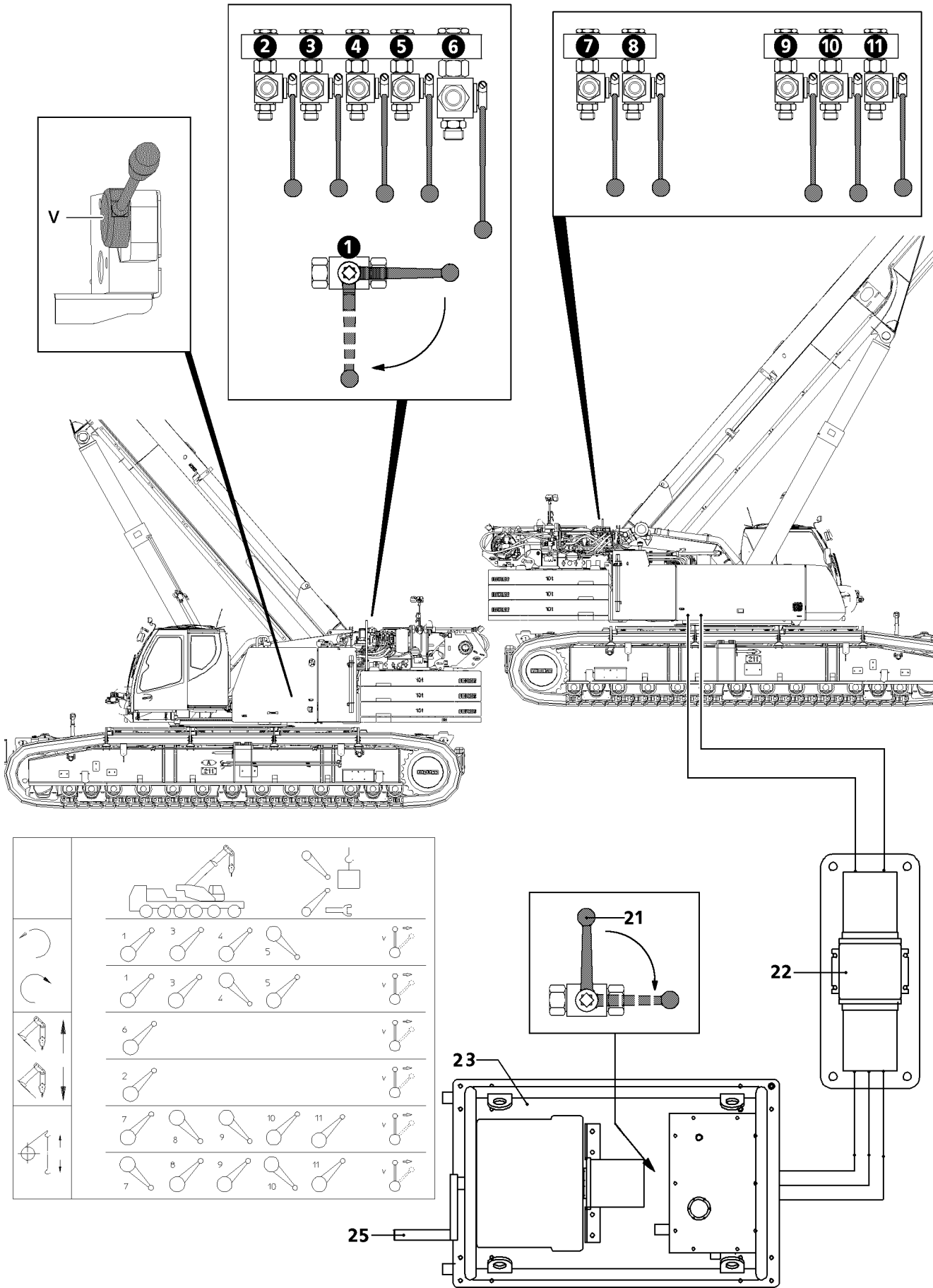


Fig.118014

# 1 Emergency control

To be able to take down the crane in case of failure of the crane hydraulic, the crane electrical system or the crane engine, ball valves and a hand lever **V** are installed on the superstructure. Via the ball valves, the corresponding crane movement can be preselected and carried out by deflecting the hand lever **V**.

## 1.1 General



### **DANGER**

Increased danger of accident during emergency operation!

The crane movements are no longer monitored by LICCON in emergency operation.

- ▶ Emergency operation and particularly luffing down of the telescopic boom may only be carried out in accordance with the information in the load chart.
  - ▶ If possible, set down the load first.
- 
- For normal „crane operation“, turn the ball valves downward.
  - For „emergency operations“, turn the respective ball valves (see following section and emergency operation sign on the crane superstructure) upward.
  - Several movements cannot be carried out at the same time.
  - All crane movements must be carried out with extreme caution and slowly.
  - The ball valves must always be switched over completely into the corresponding switch position.

## 1.2 Ball valve positions during emergency operation

### 1.2.1 Turning the turntable to the left

- ▶ Switch ball valve **1**, ball valve **3** and ball valve **4** upwards.
- ▶ Move the ball valve **5** downward.

### 1.2.2 Turning the turntable to the right

- ▶ Move the ball valve **1**, ball valve **3** and ball valve **5** upwards.
- ▶ Move the ball valve **4** downward.

### 1.2.3 Luff the telescopic boom up

- ▶ Move the ball valve **6** upward.

### 1.2.4 Luff the telescopic boom down

- ▶ Move the ball valve **2** upward.

### 1.2.5 Raising the hoist gear

- ▶ Move the ball valve **7**, ball valve **10** and ball valve **11** upwards.
- ▶ Switch ball valve **8** and ball valve **9** downwards.

### 1.2.6 Lowering the hoist gear

- ▶ Move the ball valve **8**, ball valve **9** and ball valve **11** upwards.
- ▶ Switch ball valve **7** and ball valve **10** downwards.

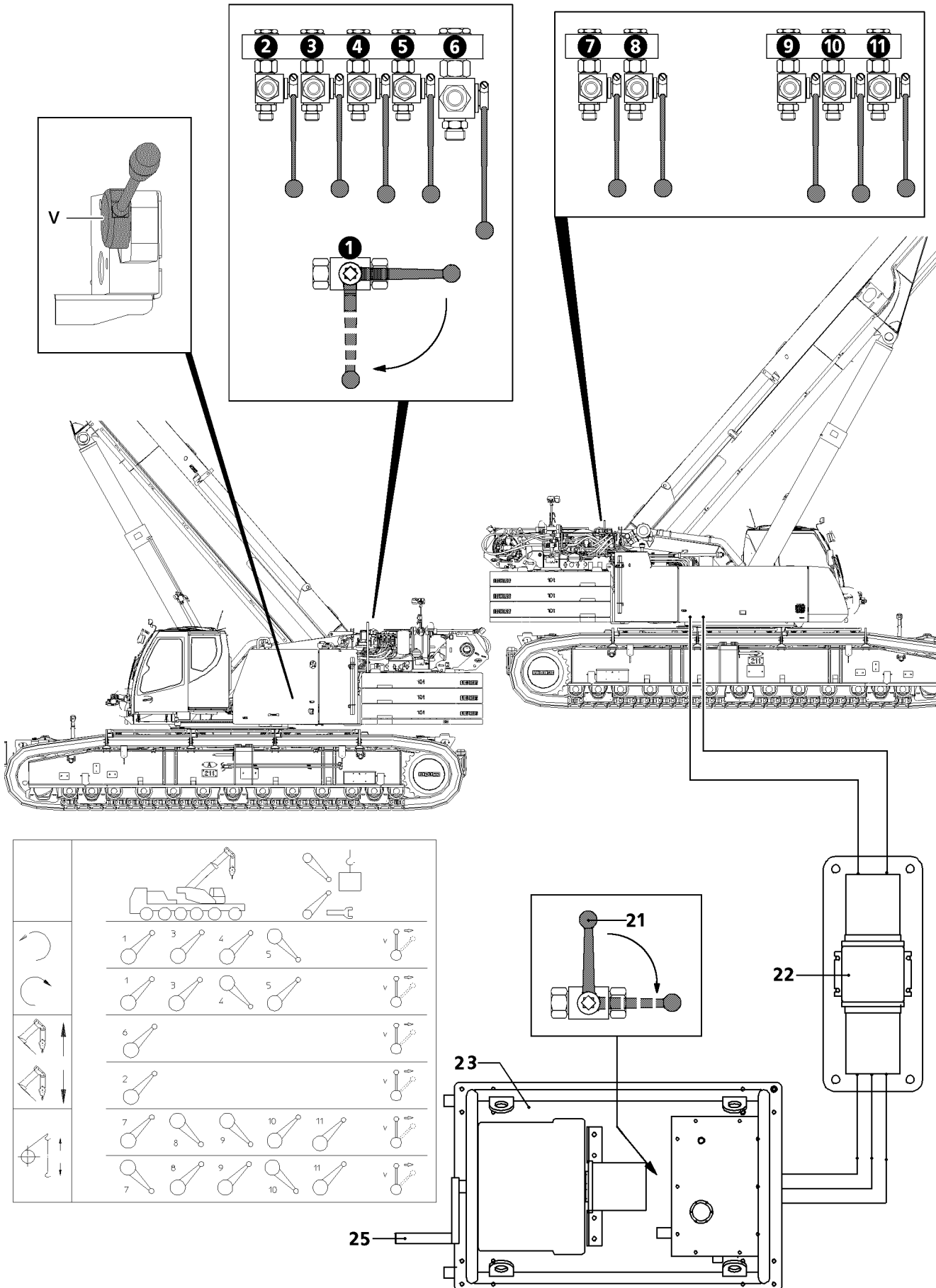


Fig.118014

LWE/LTR 1220-003/24204-02-02/en

## 1.3 Emergency operation with emergency operation unit

In cranes with one motor the superstructure can be supplied with power with the aid of the emergency operation unit **23** and a hydraulic transformer **22**.

### 1.3.1 Preparing the crane for emergency operation

- ▶ Remove the dummy plugs on the hydraulic connections.

The different diameters of the hydraulic lines prevent incorrect piping.

- ▶ Establish the hydraulic connections from the emergency operation aggregate **23** to the transformer **22**.
- ▶ Make the hydraulic connections between the transformer **22** and the superstructure and the chassis.

### 1.3.2 Emergency operation unit

- ▶ Start the emergency operation unit **23**.
- ▶ Move the ball valve **21** to emergency operation.



#### Note

- ▶ The engine rpm can be adjusted using a separate rpm regulator on the emergency operation unit **23**.

### 1.3.3 Emergency control

- ▶ Preselect ball valves (1 -11) for the respective crane movement, see previous section or the emergency operation tag on the crane superstructure.

The deflection of the hand lever **V** determines the speed of the respective crane movement.

- ▶ Move the hand lever **V** and carry out the respective crane movement carefully.

### 1.3.4 Completing emergency control



#### DANGER

Danger of accident!

- ▶ After „emergency operation“, always change the ball valves over to „crane operation“.
- ▶ Change all ball valves to „crane operation“.
- ▶ Turn the emergency operation unit **13** off and close the ball valve **21**.
- ▶ Disconnect the hydraulic lines and screw in dummy plugs.

---

Empty page!

LWE/LTR 1220-003/24204-02-02/en



---

## 7 Maintenance and service

LWE/LTR 1220-003/24204-02-02/en

---

LWE/LTR 1220-003/24204-02-02/en

## 7.01 Maintenance and service - General

1	Safety	2
2	Warranty and coverage	7
3	Liebherr Customer Service	7
4	Taking an oil sample	8
5	Taking care of the crane	8
6	Storage	14
7	Recommendation for safe disposal	15

# 1 Safety



## WARNING

Maintenance instructions **not** adhered to!

Death, severe injury, increased wear and failure of components.

- ▶ Observe the following listed safety instructions and the generally applicable safety rules.
- ▶ Adhere to the maintenance intervals.
- ▶ Carry out only applicable maintenance tasks.
- ▶ Repair and maintenance tasks are to be carried out carefully.
- ▶ For aggregates and components: Follow the operating instructions of the manufacturer.

## 1.1 Personnel



## WARNING

Personnel requirements **not** adhered to!

**Improper** maintenance. Death, severe bodily injuries, property damage.

- ▶ Adhere to the areas of responsibility and personnel requirements.
- ▶ Comply with the personnel requirements within the scope of the respective maintenance tasks.
- ▶ Have the repair tasks performed exclusively by authorized and trained service personnel.
- ▶ Make sure that only authorized persons are in the danger zone.

The operator commissions maintenance personnel and authorized and trained service personnel according to the maintenance and inspection schedule.

### 1.1.1 Maintenance technician

The maintenance technician has the following responsibilities:

- The maintenance technician is responsible for the crane maintenance assigned to him according to the maintenance and inspection schedule and to guarantee safe and satisfactory operation. Maintenance personnel carries out all required maintenance work in compliance with the manufacturer's maintenance and inspection schedule and within the framework of a systematic procedure for creating a safe working environment.
- The maintenance technician shall have read and understood the operating instructions and the maintenance instructions.
- The maintenance technician wears the personal protective equipment necessary for the respective work procedure in accordance with the operating instructions and national regulations.
- The maintenance technician shall not make any alterations or repairs to the crane that exceed his technical knowledge (welding, for example) without consulting with the manufacturer and receiving written approval.
- The maintenance technician uses only original spare parts from Liebherr-Werk Ehingen GmbH.
- The maintenance technician contacts his supervisors when the information in the operating instructions or maintenance instructions is not sufficient.

### 1.1.2 Authorized and trained service technician

The service technician has the following responsibilities:

- He is responsible for carrying out the assigned crane maintenance and repairs to guarantee safe and satisfactory operation. The technician carries out all required maintenance work in compliance with the manufacturer's maintenance and inspection schedule and within the framework of a systematic procedure for creating a safe working environment.
- The technician wears the personal protective equipment necessary for the respective work procedure in accordance with the operating instructions and national regulations.
- The technician only carries out work for which he was authorized and trained to carry out by Liebherr-Werk Ehingen GmbH or a Liebherr service point.

## 1.2 Description of intervals and tasks



### Note

- ▶ Fill quantities and designations of service fluids and lubricants are specified in the Service fill.

The maintenance intervals and scope of maintenance are described in several chapters.

#### For crane maintenance, observe the following chapters:

- Crane operating instructions, chapter 7.02: Maintenance intervals - Crane chassis <sup>1)</sup>
- Crane operating instructions, chapter 7.02.50: Maintenance intervals Ballast trailer\*<sup>1)</sup>
- Crane operating instructions, chapter 7.03: Maintenance intervals - Crane superstructure <sup>1)</sup>
- Crane operating instructions, chapter 7.03.50: Maintenance intervals - Crane boom <sup>1)</sup>
- Crane operating instructions, chapter 7.04: Maintenance instructions - Crane chassis <sup>2)</sup>
- Crane operating instructions, chapter 7.04.50: Ballast trailer maintenance instructions <sup>2)</sup>
- Crane operating instructions, chapter 7.05: Maintenance instructions - Crane superstructure <sup>2)</sup>
- Crane operating instructions, chapter 7.05.50: Crane boom maintenance instructions <sup>2)</sup>
- Crane operating instructions, chapter 7.06: Fill quantities, lubrication plan
- Crane operating instructions, chapter 7.07: Service fluids and lubricants

<sup>1)</sup> These chapters contain a list of maintenance intervals for all maintenance tasks.

<sup>2)</sup> For aggregates, observe and adhere additionally to the instructions of the manufacturer.

## 1.3 Maintenance intervals

Use the following rules for interval determination:

- Carry out maintenance and inspection tasks on the crane chassis after reaching the specified driven mileage, operating hours or calendar intervals. The interval that occurs first is the deciding factor.
- Carry out maintenance and inspection tasks on the crane superstructure after reaching the specified operating hours or calendar intervals. The interval that occurs first is the deciding factor.
- The maintenance intervals complement each other. If a higher interval is coming up, then carry out the tasks according to the lower interval also.

## 1.4 Securing against start up



### WARNING

Impermissible travel or crane operation during maintenance or repair tasks!

Death, severe injury, severe property damage.

- ▶ Make sure that travel and crane operation is not possible during maintenance and repair tasks.
- ▶ Show clearly with signs that maintenance or repair tasks are being carried out on the mobile crane.
- ▶ Use signs which show without a doubt that it travel operation and crane operation are prohibited.
- ▶ Adhere to the national regulations regarding tagging on mobile crane and signs.
- ▶ Turn the engine on the crane superstructure and the crane chassis off.
- ▶ Apply the „parking brake crane chassis“.

If possible:

- ▶ Lock the driver's cab and the crane cab.
- ▶ Hand the ignition key from the crane superstructure and the crane chassis to an authorized person.

## 1.5 Securing against falls



### WARNING

Personnel is **not** secured against falls!

During maintenance tasks on the crane superstructure or boom, personnel must be secured with appropriate safety measures to prevent them from falling. If this is **not** observed, working personnel can fall and be killed or severely injured.

- ▶ For all tasks on the crane where there is a danger of falling, take suitable safety measures.
- ▶ The crane superstructure or the boom may **not** be accessed without suitable aids.
- ▶ Suitable aids are, for example: Lifting platforms, scaffoldings, ladders, assembly platforms, auxiliary crane.
- ▶ If railings are present on the crane superstructure, then they must be swung into operating position and secured for all tasks. See the Crane operating instructions, chapter 2.06.
- ▶ Only step on such aids with clean shoes.
- ▶ Keep aids clean, free of snow and ice.
- ▶ If tasks cannot be carried out using these aids or from the ground, then the maintenance personnel must be protected from falling using approved fall arrest systems. See the Crane operating instructions, chapter 2.04.
- ▶ It is prohibited to step on the driver's cab or cab roof and specially marked surfaces. See the Crane operating instructions, chapter 2.05



### WARNING

Dirty slip-resistant mats!

Fall

- ▶ Keep slip-resistant mats clean and free of snow and ice!
- ▶ Only step on slip-resistant mats with clean shoes!
- ▶ Replace or renew missing or damaged slip-resistant mats!

## 1.6 Preventing fires



### WARNING

Excess fuel, excess oil in engine compartment during operation!

Death, severe injury, fire damage.

- ▶ Check the diesel engine after repairs and Service tasks but also in regular intervals for leaking oil and fuel.
- ▶ Fix the leaks. Replace damaged components.
- ▶ Do **not** spill service fluids.



### WARNING

Disregard of general safety regulations during tasks on the fuel system or on the electrical system!

Severe burns, fire damage.

- ▶ Disconnect the battery from the power supply.
- ▶ Do **not** smoke.
- ▶ Do **not** work near open flames.
- ▶ Keep a functioning fire extinguisher ready.

**WARNING**

Sound insulation mats are contaminated with fuel, engine oil, gear oil, hydraulic oil or solvents!  
The sound insulation mats can ignite. Severe burns, fire damage.

- ▶ Remove any polluted sound insulation mats **immediately** and **replace immediately** with **Original Liebherr spare parts**.

If there are sound insulation mats in the chassis near the starter:

- ▶ **Immediately remove** any sound insulation mats located in an area of 0.5 m around the starter and **do not replace them**

If there are sound insulation mats in the superstructure in the engine compartment flap:

- ▶ **Immediately remove** the sound insulation mats and **do not replace them**.
- ▶ Also observe and adhere to the section „Sound insulation mats“.

## 1.7 Protecting against burns

**WARNING**

Hot surfaces!  
Severe burns.

- ▶ Let any components to be maintained or inspected cool off.
- ▶ Let hot components cool off.
- ▶ Avoid contact with hands and skin.
- ▶ Wear personal protective equipment and suitable protective gloves.

**WARNING**

Hot service fluids!  
Severe burns.

- ▶ Let hot service fluids cool off.
- ▶ Avoid contact with hands, skin and eyes.
- ▶ Wear safety goggles.
- ▶ Wear personal protective equipment and suitable protective gloves.

**WARNING**

Electric short circuit!  
Severe burns.

- ▶ Prevent short circuits in the electrical system, especially on the battery.
- ▶ Replace or change missing or defective protective insulation.

## 1.8 Protecting from scalding

**WARNING**

The cooling system is pressurized!  
When the coolant reservoir is opened, hot coolant can escape explosively.  
Severe scalding.

When the engine is warm:

- ▶ Do **not** open the cover of the coolant reservoir.
- ▶ To protect face, hands and arms from hot steam of hot coolant, cover the cap with a large rag when opening.

## 1.9 Rotating parts



### WARNING

Rotating parts, ignition system on running engine!  
The cooler fan can turn on suddenly.  
Death, severe injury.

- ▶ Proceed especially careful.
- ▶ Do **not** reach into rotating parts.
- ▶ Never reach into the cooler fan when the engine is hot.

## 1.10 Using permissible service fluids

### NOTICE

Impermissible service fluid added!  
Destruction of components. Failure of the crane.

- ▶ Only add the service fluid that is specified on the sign on the respective service fluid container.
- ▶ Keep the service fluid absolutely pure.

## 1.11 Protecting against the hazards of service fluids



### WARNING

Contact with service fluids!  
Health risk.

- ▶ Make sure that personnel are aware of first aid measures.
- ▶ Use personal protective equipment depending on the service fluid.
- ▶ Observe and adhere to the safety data sheets of the service fluid manufacturer.



### WARNING

Impermissible handling of service fluids!  
Environmental risk.

- ▶ Make sure that the service fluids are **not** released in the environment.
- ▶ Immediately collect spilled service fluids using suitable material.
- ▶ Observe and adhere to the safety data sheets of the service fluid manufacturer.

## 1.12 Replacing damaged crane components



### WARNING

Damaged crane components **not** replaced!  
Death, severe injury, failure of components.

- ▶ Service the crane components according to the data in the maintenance intervals, the maintenance guidelines and the chart for service fluids and lubricants.
- ▶ Replace damaged crane components immediately.

## 1.13 After replacement of components

Type of oil, see data tag and supplied „Service fill“.

The following instructions must be observed when replacing components such as the engine, transmission or axle:



**WARNING**

Maintenance of a replaced component **not** carried out!

- ▶ Before start up, be sure to refill with the correct type of oil to the center of the minimum / maximum mark.
- ▶ Carry out first maintenance. See chapter „Maintenance intervals“.
- ▶ Adhere to regular maintenance intervals.
- ▶ Follow the break-in instructions. See the Crane operating instructions, chapter 2.02.

## 1.14 Tire size

When changing certain tire sizes, the mobile crane must be modified.

Contact Liebherr customer service to change the following tire sizes:

- From 385/95 R 25 to 445/95 R 25
- From 385/95 R 25 to 525/80 R 25
- From 445/95 R 25 to 385/95 R 25
- From 525/80 R 25 to 385/95 R 25

## 2 Warranty and coverage

**NOTICE**

Maintenance intervals and maintenance guidelines **not** adhered to, impermissible lubricants used!  
Damage, failure of crane components.

The warranty for the respective crane component is voided.

- ▶ Service the crane components according to the data in the maintenance intervals, the maintenance guidelines and the chart for service fluids and lubricants.

**NOTICE**

Use of **non**-original Liebherr spare parts and **non**-original Liebherr service fluids!

In the event that replacement parts are used that are **not** original Liebherr replacement parts and **not** original Liebherr service fluids and lubricants, Liebherr-Werk Ehingen GmbH excludes all liability for system functionality as well as for the parts.

- ▶ Use only original Liebherr spare parts.

**Note**

- ▶ Original Liebherr replacement parts have been tested for crane operation and may be used without risking safety.

The buyer is entitled to warranty or coverage only:

- When only original Liebherr spare parts are used.
- When Liebherr service fluids and Liebherr lubricants are used for the Liebherr crane.

## 3 Liebherr Customer Service

Liebherr mobile cranes, whether truck-mounted, mobile or crawler cranes - are technically advanced products, which prove their worth daily even under tough conditions.

The high technical standards of these cranes provide functional security, resistance to failure and ease of maintenance.

Liebherr is continuously developing the drive and control components. The combination of well proven units and modern manufacturing methods produces cranes that are safe to operate and easy to maintain.

Several hundred cranes are built every year for the international market, supported by international service.

Liebherr's „After Sales Service“ plays an important role at Liebherr in ensuring operational readiness and high crane availability.

With Liebherr, Service begins when the crane is handed over. Your crane operators will be professionally trained in line with their level of knowledge and we devote much time to this.

We also train your workshop staff in all crane-specific matters, because we know that they can deal with more than just minor repairs themselves. Often there are specialists who can quickly and reliably carry out crane repairs.

We have special service advisers available who will solve any problems you may have. This phone contact saves time and money. You should take advantage of it as soon as possible.

Our service technicians are specialists with years of experience, who can be deployed from local support points. Naturally these experts have specialized knowledge and special tools.

But before you call these specialists, it is worth making use of the facilities for getting advice mentioned above.

## 4 Taking an oil sample



### Note

- ▶ Liebherr recommends taking oil samples for the gears, engines and hydraulic system in regular intervals.
- ▶ Based on the trend analysis of the oil analysis results, changes can be determined in the lubricity of the oil and increased component wear.



### WARNING

Tasks on components and operating fluids at operating temperature!

Burns.

- ▶ Carry out all tasks with utmost caution.
- ▶ Wear protective clothing.

Make sure that the following prerequisites are met:

- Oil has a normal operating temperature.
- ▶ Always take oil in the same location.
- ▶ Take oil always according to the same method.
- ▶ Do **not** take oil right after an oil change.
- ▶ Do **not** take oil immediately after larger amounts of oil have been added.



### Note

Recommendation:

- ▶ Fill oil into original laboratory sample containers.
- ▶ Fill oil exclusively in a clean and dry sample container.

## 5 Taking care of the crane

### 5.1 Washing the crane

In order to ensure a consistent surface quality, the crane must be washed regularly. See the maintenance intervals, chapter 7.02, chapter 7.03, chapter 7.03.50. Clean the crane in particular after contact with highly corrosive materials or highly adherent contaminants.

Highly adherent contaminants are:

- Residual road salt
- Oils, grease and fuel
- Insect remains
- Rust film
- Tar splashes, concrete splatter

Check the crane for corrosion and paint damage. See the maintenance intervals, chapter 7.02, chapter 7.03chapter 7.03.50. If detected, have corrosion and paint damage removed by authorized and trained service personnel.

---

#### NOTICE

Impermissible cleaning agent!

Damage to the surface.

- ▶ Do not use aggressive cleaning agents.
- ▶ Do not use scouring cleaning agents.
- ▶ Do not use a phosphate based cleaner.
- ▶ Do not solvents or cleaning agents that contain solvents.
- ▶ Only use cleaning agents with a pH value that is less than / equal to 12.
- ▶ Make sure that the cleaning agent and water ratio of 3% is not exceeded.
- ▶ Rinse with clear water (not salt water).

Make sure that the following prerequisites are met:

- The crane is switched off and secured against unauthorized start up.
- The crane has cooled down.
- The battery master switch is turned off.

### 5.1.1 High pressure cleaner

The water jet of a circular jet nozzle can cause damage to the tires or parts of the travel gear that cannot be seen exteriorly.

---

#### NOTICE

High pressure cleaner with circular jet nozzle used!

Damaged components could fail unexpectedly.

- ▶ Do not use a high pressure cleaner with a circular jet nozzle.
- ▶ Replace damaged components.



#### CAUTION

Hot steam and water pressure!

Burns.

- ▶ Wear personal protective equipment.

Do **not** expose the following components to a water jet:

- Inside of the driver's cab and cab
- Electric motor
- Electrical plug connections, line drums and power distributor
- Control units
- Transmitter
- Relay circuit boards and fuse circuit boards
- Hydraulic block
- Intake manifolds for combustion air
- Seals
- Bellows
- Gear shafts
- Retracted sliding beams
- Sealing lips on slewing ring connections
- Radial shaft sealing rings on winches
- Slewing gears

- Hoist rope, control rope, assembly rope
- Piston rods
- Slip-resistant mats
- Signs
- Overflow container on the equipment
- Generator
- Lighting
- Wind speed sensor / airplane warning light
- Bearing on the rope pulleys
- Carrier rollers
- Swivel joints
- Pin points
- Head camera inclusive of the transmitter and receiver unit
- Hand pump on the folding jib

The crane can be cleaned with the high pressure cleaner. The water pressure, minimum distance and water temperature are specified in the following chart:

Washing painted surfaces		
Water pressure	Minimum distance	Water temperature
maximum 150 bar	30 cm to 40 cm	60 °C

*Adjusting the high pressure cleaner*

Washing surfaces covered with film		
Water pressure	Minimum distance	Water temperature
maximum 150 bar	80 cm	60 °C

*Adjusting the high pressure cleaner*

Washing surfaces protected against corrosion with Carlofon 81		
Water pressure	Minimum distance	Water temperature
maximum 30 bar	30 cm to 40 cm	40 °C

*Adjusting the high pressure cleaner*

Clean electrical systems, cables, cable harnesses and sound insulation mats with low pressure.

- ▶ Before cleaning, cover all openings.
- ▶ Wash the crane and equipment with a high pressure cleaner.
- ▶ Lubricate the crane and equipment.



#### Note

Environmental pollution!

- ▶ Dispose of auxiliary and cleaning materials contaminated with oil according to national and international regulations and directives.
- ▶ Only direct cleaning water through the oil separator of the drainage system.

### 5.1.2 Exhaust system

#### NOTICE

Ingress of water, steam or cleaning substances into the AGN-module!

Sensors and electrics for the exhaust aftertreatment can be destroyed, the coating of the catalytic converter can be washed off.

- ▶ Before cleaning, let the AGN system cool down (surface temperature 50 °C).
- ▶ Before cleaning, cover all openings.
- ▶ Make sure that **no** fluids and **no** dirt gets into the tailpipe opening of the AGN module.
- ▶ During cleaning, maintain a sufficient distance from the tailpipe opening.

### 5.1.3 Sound insulation mats

#### NOTICE

Improper cleaning (tools or cleaning methods)!

Sound insulation mats can be destroyed or damaged.

- ▶ Remove severe contamination with suitable tools, for example with soft plastic scrapers.
- ▶ Do **not** use tools with sharp edges.
- ▶ Use high pressure cleaners **exclusively** with extreme caution and with a sufficient distance to the sound insulation mats and with low water pressure.
- ▶ Do **not** use solvents for cleaning.

If sound insulation mats are contaminated with fuel, engine oil, gear oil, hydraulic oil or solvents:

- ▶ Observe and adhere to the section „Preventing fires“.

### 5.1.4 Slip-resistant mats



#### WARNING

Heavily worn slip-resistant mats!

People can slip and fall down from the crane.

- ▶ Replace heavily worn slip-resistant mats.
  - ▶ Do **not** wax slip-resistant mats.
- 
- ▶ Before every access: Check the slip-resistant mats for slip resistance and cleanliness.
  - ▶ If dirty: Clean the slip-resistant mats with a brush with hard plastic bristles.
  - ▶ For cleaning the surfaces, use commercially available cleaners.
  - ▶ Flush with water.

### 5.1.5 Driver's cab and crane cab



#### Note

- ▶ The steering wheel, center console, instrument panel cover, floor covering and dirty upholstery in the driver's cab and the crane cab should only be cleaned with warm water mixed with dishwashing detergent.
- ▶ Keep the driver's cab and crane cab free from trash.

### 5.1.6 Ladders

- ▶ Remove any dirt on the ladders.
- ▶ Make sure that the grooves on the rungs are free of dirt.

## 5.2 Protecting the crane against corrosion

### NOTICE

Aggressive environmental conditions!  
Crane components can corrode and be damaged.  
▶ Protecting the crane against corrosion

The corrosion protection agent **Carlofon 81** must be reapplied regularly according to wear. See the maintenance intervals, chapter 7.02, chapter 7.03 chapter 7.03.50.

The corrosion protection agent **Metacorin 822** must be reapplied regularly according to wear on the mechanically machined, blank surfaces. See the maintenance intervals, chapter 7.02, chapter 7.03 chapter 7.03.50.

The corrosion protection agent **Liebherr Cylinder Protect** must be reapplied regularly on the chrome-plated piston rods. See the maintenance intervals, chapter 7.02, chapter 7.03 chapter 7.03.50.



### WARNING

Improper corrosion protection!  
Injury to the respiratory system, suffocation.  
▶ Wear a respirator mask.

### NOTICE

Improper corrosion protection!  
Damage to the crane.

- ▶ Make sure that crane corrosion protection is carried out only by authorized and trained service personnel.
- ▶ Make sure that the inspection and reconditioning intervals are not exceeded.

Make sure that the following prerequisites are met:

- A sufficient quantity of corrosion protection agent is available.
- Appropriate tools and aids are available.
- The crane is switched off and secured against unauthorized start up.
- The crane has cooled down.
- The battery master switch is turned off.
- Protective equipment is worn.

### 5.2.1 Crane

- ▶ Wash the crane thoroughly with a high pressure cleaner.
- ▶ Let the crane dry.

If corrosion or paint damage is found:

- ▶ Remove the corrosion and paint damage.

The following surfaces must be masked prior to corrosion protection:

- Walking surfaces and stepping surfaces
- Vents on brake valves and control valves
- Vents and drains on electrical equipment
- Mechanically machined, blank surfaces
- Piston rods



### WARNING

Walking surfaces and stepping surfaces **not** masked!  
Personnel can slip and fall down.

- ▶ Mask walking surfaces and stepping surfaces prior to corrosion protection.

- ▶ All surfaces that should **not** be corrosion protected should be masked.
- ▶ Protect the crane against corrosion with **Carlofon 81**.
- ▶ Remove the masking.

- ▶ Protect mechanically machined, blank surfaces against corrosion with **Metacorin 822**.
- ▶ Lubricate the crane.

### 5.2.2 Cylinders

If the chrome-plated piston rods are not retracted for a longer period of time, the chrome-plated piston rods must be protected against corrosion by applying **Liebherr Cylinder Protect**.

Application temperatures of **Liebherr Cylinder Protect**:

- Possible application temperatures: Between -20 °C and +45 °C.
- Optimal application temperatures: Between -10 °C and +30 °C.

Liebherr-Werk Ehingen GmbH recommends the first-time application of anti-corrosion agent, in the case of:

- Aggressive influences such as a high salt content in the ambient air:
  - After 24 hours without cylinder movement.
- Normal environmental conditions:
  - At least after 1 week without cylinder movement.



**Note**

- ▶ Only use **Liebherr Cylinder Protect** as corrosion protection for cylinders with chrome-plated piston rods.
- ▶ Do **not** apply corrosion protection to piston rods with NiL35 coating.

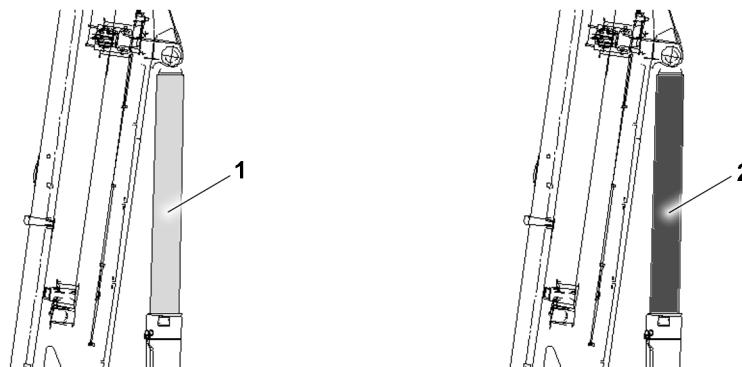


Fig. 156557: Piston rods

- |                            |                                 |
|----------------------------|---------------------------------|
| 1 Chrome-plated piston rod | 2 Piston rod with NiL35 coating |
|----------------------------|---------------------------------|

Piston rods with a NiL35 coating appear darker than chrome-plated piston rods and can therefore be optically differentiated.

Before applying the anti-corrosion agent, the surface of the piston rod must be carefully wiped off with a clean cloth. The surface must be free of visible dirt. The use of an additional cleaner is not required.

- ▶ Clean the surface of the piston rod.
- ▶ Shake the spray can well before use. Apply the anti-corrosion agent evenly on the piston rod.
- ▶ Until a sufficient protective film has formed on the piston rod: Wait approx. 30 to 60 minutes.

When the **Liebherr Cylinder Protect** must be reapplied:

- ▶ Clean the surface of the piston rod again.

The piston rod must **not** be cleaned again when putting the hydraulic cylinder back into service.

When the hydraulic cylinder is put back into operation:

- ▶ Remove the anti-corrosion agent from the scraper.

### 5.3 Protecting the crane against corrosion for storage



**Note**

- ▶ When storing the crane, contact the Service department at Liebherr-Werk Ehingen GmbH.

## 5.4 Protecting the crane against corrosion for shutdown



### Note

- ▶ Before shutting down the crane, contact the Service department at Liebherr-Werk Ehingen GmbH.

## 6 Storage

If the conditions in this section are observed, the crane can be stored as long as necessary.

### 6.1 Storage conditions

- ▶ Store the crane in a dry hall.

### 6.2 Decommissioning

Make sure that the following prerequisites are met:

- The crane is carefully washed.
- Corrosion and paint damage on the crane have been removed.
- Worn or damaged components have been replaced.

In the case of cranes with the battery master switch in the chassis and superstructure, both battery master switches must be turned off.

- ▶ Turn the battery master switch off.

In the case of cranes with a superstructure engine and a chassis engine, the batteries in the chassis and superstructure must be removed.

- ▶ Remove the batteries properly.

### 6.3 Maintenance

In the case of cranes with a fuel tank in the chassis and superstructure, both fuel tanks must be filled.

- ▶ Fill up the fuel tank completely.
- ▶ Apply approved lubricants in all lube points.
- ▶ Replace all operating fluids.
- ▶ Check the crane for leaking fluids.

If fluids are leaking from the crane:

- ▶ fix the leak.

In the case of cranes with a superstructure engine and a chassis engine, both engines must be started once a month.

- ▶ Start the engine once a month.

The specified maintenance interval must be observed even if the crane is in storage.

- ▶ Service the crane according to the maintenance interval.

### 6.4 Returning to service

#### NOTICE

Impermissible start up!

Damage to the crane.

- ▶ Make sure that the crane is supplied with approved lubricants.
- ▶ Make sure that the oil levels are correct.
- ▶ Only operate the crane in a perfect condition.



In the case of cranes with a superstructure engine and a chassis engine, the batteries must be installed in the chassis and superstructure.

- ▶ Install the batteries properly.
- ▶ Turn on the battery master switch.
- ▶ Put the crane in operation.

## 7 Recommendation for safe disposal

### 7.1 Service fluids and lubricants



#### WARNING

Service fluids and lubricants are dangerous waste products!

- ▶ Dispose of service fluids and lubricants separately.
- ▶ Service fluids and lubricants may **not** be disposed of in the ground, bodies of waters, wastewater systems, sewers or in the groundwater.
- ▶ Dispose of service fluids and lubricants in an environmentally safe manner.
- ▶ When disposing of service fluids and lubricants, observe and follow the applicable regulations of the responsible authorities.
- ▶ Observe and adhere to the safety data sheets of the service fluid manufacturer and the lubricant manufacturer.

Service fluids and lubricants are:

- Fuels
- Coolant
- Urea
- Engine oils, gear oils
- Hydraulic fluids
- Brake fluids
- Window washer concentrate
- Greases

### 7.2 Batteries



#### WARNING

Batteries contain harmful substances!

- ▶ Do **not** dispose of batteries in regular household trash.
- ▶ Collect batteries separately and send them for environmentally safe disposal.
- ▶ Leave batteries at a qualified workshop or at a licensed collection points for used batteries.

### 7.3 Prevention of improper machine use

After the end of its service life, the crane must be made unusable by cutting the load bearing crane structures, and in particular the steel structures. This can be done by means of flame cutting.

After the machine's service life has ended:

- ▶ Make the machine unusable.

### 7.4 Disposing of the machine

The crane owner is responsible for disposal.

- ▶ Separate the metals.

If the counterweights are made of concrete:

- ▶ Brake the steel parts out of the counterweight. Dispose of the concrete or recycle it.

Rope pulleys and bearing shoes in the boom are made out of PA6.

Due to the markings on the plastic parts, it is possible to dispose of them properly.

- ▶ Separate the plastic parts.
- ▶ Separate the remaining parts (for example, rubber, glass).
- ▶ Sort all parts.
- ▶ Take all parts to a licensed collection point for reusable materials and send them for recycling.

## 7.01.10 Service system

1	Description	2
2	Safety instructions	2
3	Calling up the service system	2
4	<i>Service system</i> operating interface	3
5	<i>Service system</i> function key line	6
6	Checking the maintenance status	6
7	Resetting the maintenance status	7

# 1 Description

The service system is only available for certain cranes.

The service system is a function of the BSE test system.

For further functions of the BSE test system, see the Diagnostics manual.

# 2 Safety instructions

Observe and comply with chapter 2.04, chapter 2.06, chapter 2.07.

Observe and comply with chapter 7.01.

## NOTICE

Maintenance intervals of the engine manufacturer **not** observed!

The engine could be damaged, property damage.

- ▶ Make sure that the maintenance intervals of the engine manufacturer are adhered to.
- ▶ Reset the performed maintenance intervals in the service system.

# 3 Calling up the service system

Make sure that the following prerequisite is met:

- The *Crane operation* program is visible on the LICCON monitor.

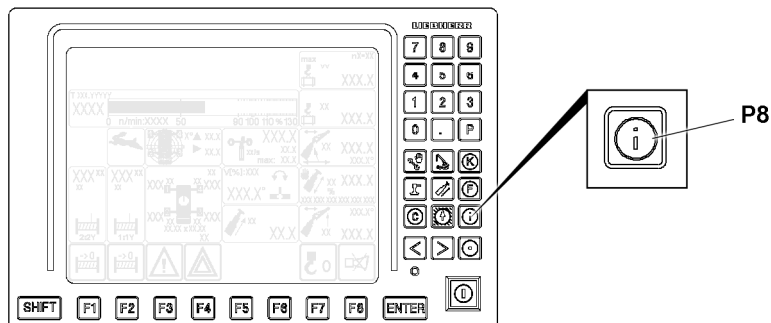


Fig.152484: Crane operation program

- ▶ Press the program key **P8**.

**Result:**

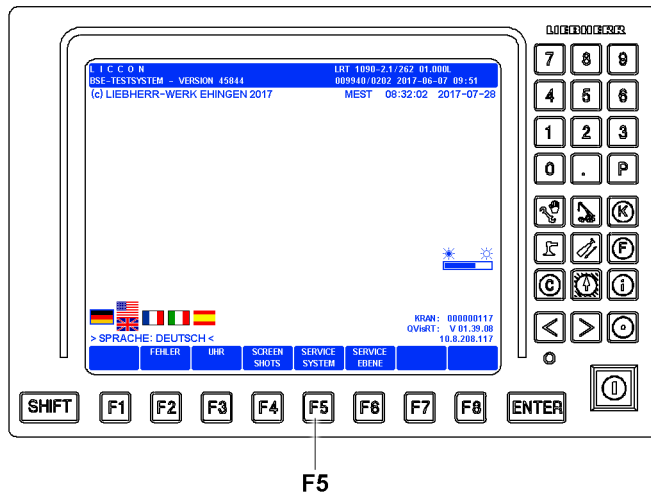


Fig.147628: BSE test system, start screen

– The BSE test system start screen is visible on the LICCON monitor.

▶ Press the function key **F5**.

**Result:**

– The service system operating interface is visible on the LICCON monitor.

## 4 Service system operating interface

### 4.1 Total operating hours

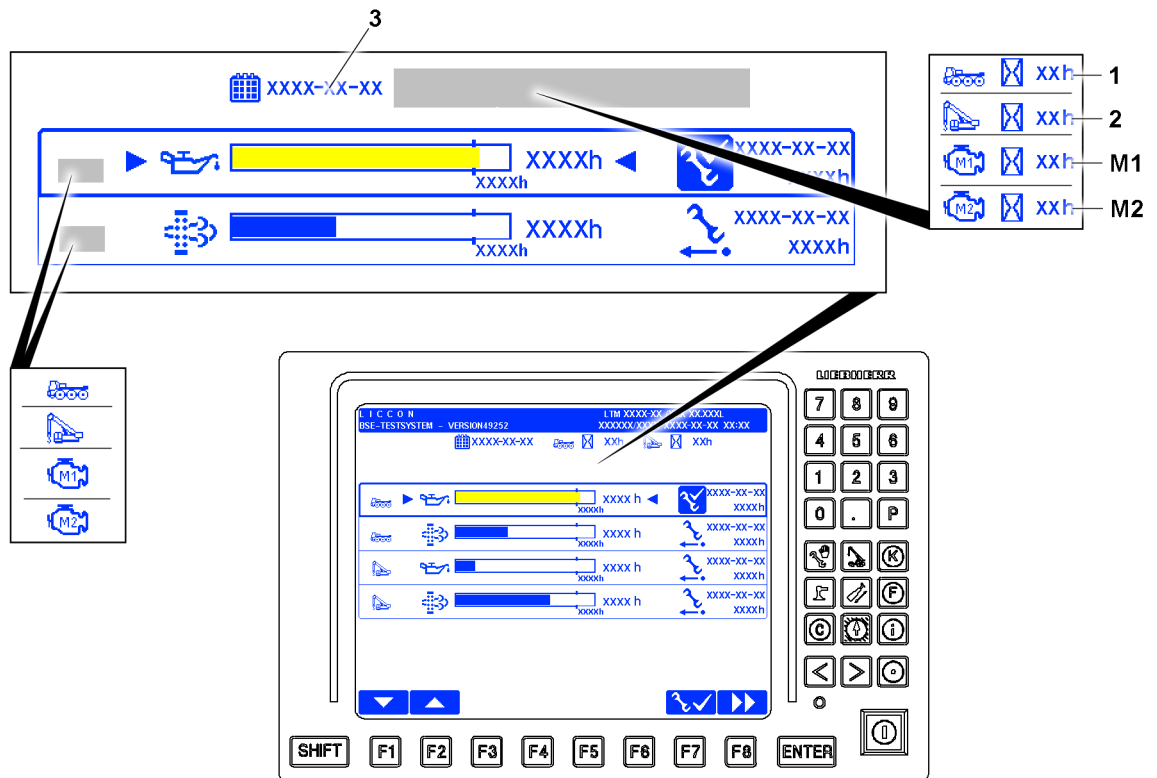


Fig.152481: Service system operating interface

LWE/LTR 1220-003/24204-02-02/en

Depending on the crane type, there are different displays for the total operating hours:

- 1 Crane chassis total operating hours
  - Only available for certain cranes.
- 2 Crane superstructure total operating hours
  - Only available for certain cranes.
- M1 Crane engine total operating hours (engine 1)
  - Only available for certain cranes.
- M2 Crane engine total operating hours (engine 2)
  - Only available for certain cranes.
- 3 Current date (year-month-day)

## 4.2 Maintenance status

When maintenance is due, the bar in the respective bar diagram turns yellow.

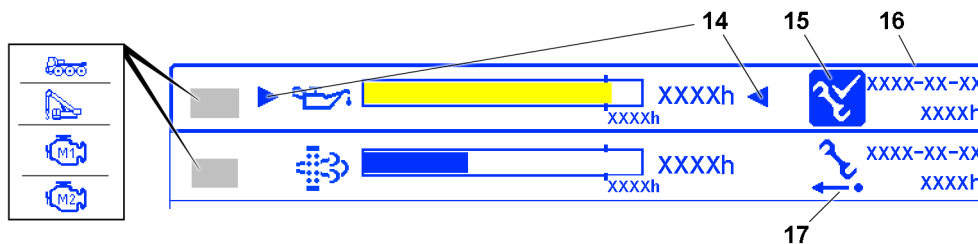


Fig.152482: Maintenance status, selected

The selected maintenance status is marked with the following elements:

- 14 Arrow
- 15 Selected maintenance status icon
- 16 Frame

The **unselected** maintenance status is marked with the following element:

- 17 Maintenance status not selected icon

## 4.3 Only available for a diesel engine: Determining the total operating hours for the diesel engine

Only for mobile cranes with a shared diesel engine for the crane chassis and crane superstructure.

Diesel engine <sup>1</sup> total operating hours (example)	
Crane chassis total operating hours 1	2680 h
+ crane superstructure total operating hours 2	+ 2260 h
<b>Total operating hours of the diesel engine</b>	<b>= 4940 h</b>

1) Only concerns cranes with a diesel engine and separate crane superstructure and crane chassis operating hour meter

- ▶ Add the crane chassis total operating hours 1 and the crane superstructure total operating hours 2.

## 4.4 Crane chassis diesel engine maintenance status



### Note

- ▶ Only available for certain cranes

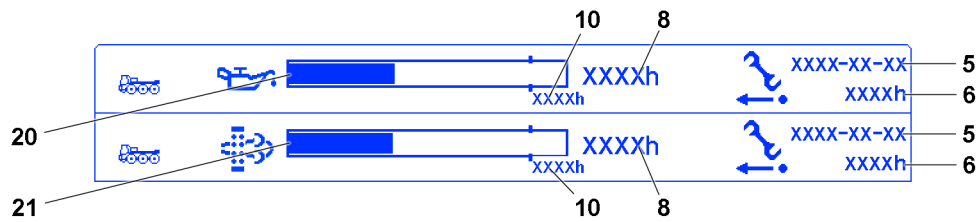


Fig.152554: Crane chassis diesel engine maintenance status

- |   |   |    |   |
|---|---|----|---|
| 5 | Date of last maintenance (year-month-day) | 10 | Maintenance interval in hours   |
| 6 | Interval hours at the last maintenance    | 20 | Engine oil maintenance status bar diagram (crane chassis diesel engine)             |
| 8 | Lapsed interval hours                     | 21 | Diesel particle filter maintenance status bar diagram (crane chassis diesel engine) |

### 4.5 Crane superstructure diesel engine maintenance status



**Note**

► Only available for certain cranes

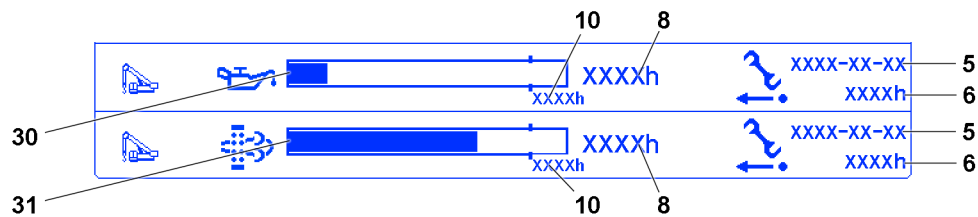


Fig.152555: Crane superstructure diesel engine maintenance status

- |   |   |    |  |
|---|---|----|--|
| 5 | Date of last maintenance (year-month-day) | 10 | Maintenance interval in hours  |
| 6 | Interval hours at the last maintenance    | 30 | Engine oil maintenance status bar diagram (crane superstructure diesel engine)             |
| 8 | Lapsed interval hours                     | 31 | Diesel particle filter maintenance status bar diagram (crane superstructure diesel engine) |

### 4.6 Crane engine maintenance status (engine 1)



**Note**

► Only available for certain cranes

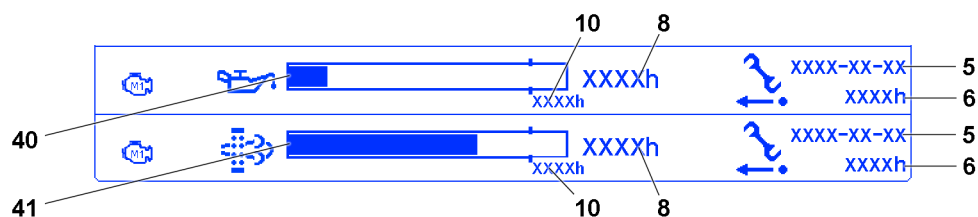


Fig.152589: Crane engine maintenance status

- |   |   |    |                               |
|---|---|----|-------------------------------|
| 5 | Date of last maintenance (year-month-day) | 10 | Maintenance interval in hours |
|---|---|----|-------------------------------|

For continuation of legend for illustrations, see next page

LWE/LTR 1220-003/24204-02-02/en

- |   |  |    |  |
|---|--|----|--|
| 6 | Interval hours at the last maintenance | 40 | Engine oil maintenance status bar diagram (engine 1)             |
| 8 | Lapsed interval hours                  | 41 | Diesel particle filter maintenance status bar diagram (engine 1) |

### 4.7 Crane engine maintenance status (engine 2)



**Note**

► Only available for certain cranes

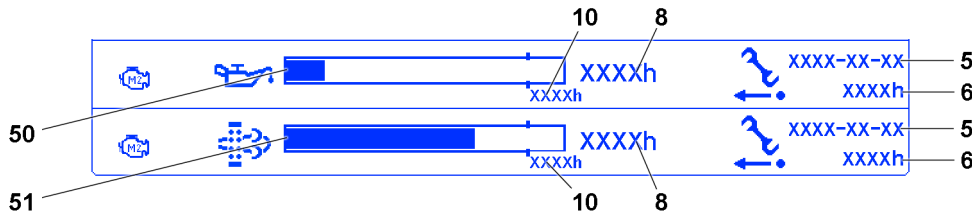


Fig.152588: Crane engine maintenance status

- |   |   |    |  |
|---|---|----|--|
| 5 | Date of last maintenance (year-month-day) | 10 | Maintenance interval in hours                                    |
| 6 | Interval hours at the last maintenance    | 50 | Engine oil maintenance status bar diagram (engine 2)             |
| 8 | Lapsed interval hours                     | 51 | Diesel particle filter maintenance status bar diagram (engine 2) |

## 5 Service system function key line

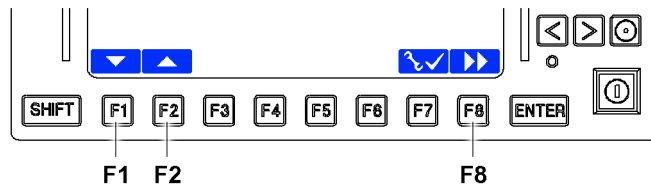


Fig.148511: Service system operating interface

The function key line consists of function keys **F1** to **F8** and the function key icon line above it.

- F1** Function key
  - Navigation in the *service system operating interface*: change downward
- F2** Function key
  - Navigation in the *service system operating interface*: change upward
- F8** Function key
  - Call up the *BSE test system* start screen.

## 6 Checking the maintenance status

When a bar diagram is displayed in yellow:

- Carry out the maintenance activities for the due maintenance interval.

When maintenance has been carried out completely:

- Reset the maintenance status for the due maintenance interval, see section „Resetting the maintenance status“.



## 7 Resetting the maintenance status

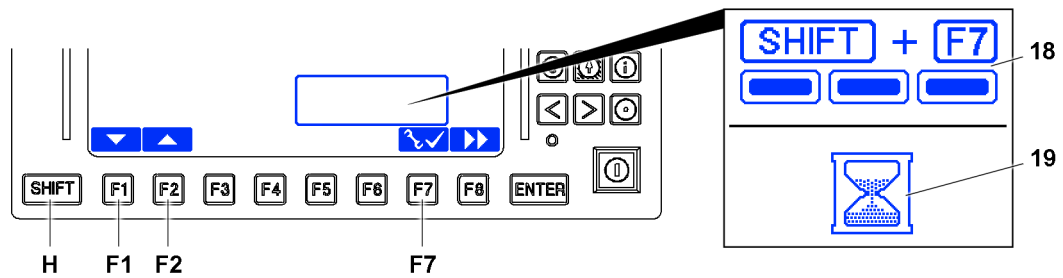


Fig.152483: Resetting the maintenance status

### 7.1 Resetting the engine oil maintenance status

Make sure that the following prerequisite is met:

- The diesel engine is turned off.

- ▶ Use the function key **F1** and function key **F2** to select the maintenance status that must be reset.

**Result:**

- The selected maintenance status is marked visually, see section „Maintenance status“.

- ▶ Press the SHIFT key **H** and function key **F7** simultaneously and hold.

**Result:**

- The display **18** is visible.

- ▶ Hold the SHIFT key **H** and the function key **F7** until the display **19** is displayed.

- ▶ Wait until the display **19** is hidden.

**Result:**

- The selected maintenance status is reset.
- The elapsed interval hours are taken over from the interval hours of the last maintenance.
- The date is updated.

### 7.2 Resetting the diesel particle filter maintenance status

Make sure that the following prerequisite is met:

- The diesel engine is turned off.

The maintenance interval for the diesel particle filter (DPF) can only be reset with a daily code.

The icon over the function key **F7** for resetting the maintenance interval for the diesel particle filter (DPF) appears only when entering the daily code.

- ▶ For registered customers: Call up the daily code at [www.myliebherr.com](http://www.myliebherr.com).

**or**

Request the daily code from Customer Service at Liebherr-Werk Ehingen GmbH.

- ▶ Enter the daily code on the service level in the *BSE test system*, see the Diagnostics manual.

- ▶ Use the function key **F1** and function key **F2** to select the maintenance status that must be reset.

**Result:**

- The maintenance status is marked visually, see section „Maintenance status“.

- ▶ Press the SHIFT key **H** and function key **F7** simultaneously and hold.

**Result:**

- The display **18** is visible.

- ▶ Hold the SHIFT key **H** and the function key **F7** until the display **19** is displayed.

- ▶ Wait until the display **19** is hidden.

**Result:**

- The selected maintenance status is reset.

- The elapsed interval hours are taken over from the interval hours of the last maintenance.
- The date is updated.

## 7.02 Maintenance intervals - Crawler chassis

1 Maintenance and inspection schedule

---

2

LWE/LTR 1220-003/24204-02-02/en

# 1 Maintenance and inspection schedule



## Note

- ▶ Carry out maintenance work after reaching the specified operating hours or calendar intervals. The interval that occurs first is the deciding factor.
- ▶ The maintenance intervals complement each other. If a higher interval is coming up, then carry out the work according to the lower interval also.
- ▶ The operating hour meter of the crawler travel gear is the determining factor for the operator hour intervals.
- ▶ The operating hour meter for the crawler travel gear is located in the instrument panel in the crane cab.

First maintenance after	Operating hour intervals			Calendar intervals			Work to be carried out	O.K.
	10 h	100 h	1000 h	Daily	Weekly	Annually		
<b>Safety systems</b>								<input type="checkbox"/>
						X	Personal protective equipment Follow the instructions of the manufacturer	
						X	Height rescue system Follow the instructions of the manufacturer	
<b>Fall protection equipment</b>								<input type="checkbox"/>
						X	Check protection points	
						X	Check safety ropes	
						X	Check the ladders for technically immaculate condition	
						X	Check railings, steps and pedestals for safe function	
						X	Check catwalks and open mesh flooring for safe function	
<b>Crane surface</b>								<input type="checkbox"/>
					X		Check accessible surfaces for cleanliness	
						X	Check accessible surfaces for completeness and slip resistance	
						X	Check labels for completeness and legibility	
<b>Rigging and fastening points</b>								<input type="checkbox"/>
				X <sup>1)</sup>			Visual inspection of the condition and mounts	
						X	Check for continued suitability by an authorized inspector, inspection expert	

LWE/LTR 1220-003/24204-02-02/en

First maintenance after	Operating hour intervals			Calendar intervals			Work to be carried out	O.K.
	10 h	100 h	1000 h	Daily	Weekly	Annually		
<b>Travel gear</b>								□
		500 h					Checking the oil level	
200 h			X			Every 4 years	Change the gear oil	
		500 h					Check the gear oil via oil analysis	
	X						Grease the sprocket bearing if it is not lubricated via the central lubrication system	
		X					Check the gear and hydraulic connections for leaks	
		X					Check the tightness of the mounting screws	
<b>Crawler carrier</b>								□
	X				X		Check the sprocket, idler and idler guides for wear	
	50 h				Every 4 weeks		Check the track rollers, carrier rollers, slide plates and guide blocks for wear Replace the components if necessary	
		X					Check that the carrier rollers, track rollers and idlers are tight If components are not tight, replace them	
				X			Chain tension cylinder: Have the pre-tension pressure of the nitrogen clamp checked by an authorized and trained service technician	
						X	Clean and grease the sliding surfaces of the grease rails on the sliding component	
					Every 4 weeks		Grease the connector pin between the crawler carrier and the cross carrier	
		X					Check the tightness of the mounting screws	
<b>Crawler chain</b>								□
		X					Check the track chain for damage	
	50 h				Every 4 weeks		Check the chain tension Tension if necessary	
	50 h				Every 4 weeks		Check the contact surfaces, gliding surfaces of the chain links, chain pitch, chain bushing and track pads for wear	
	50 h						Retighten the bolts on the track pads until the specified torque is reached	

LWE/LTR 1220-003/24204-02-02/en

First maintenance after	Operating hour intervals			Calendar intervals			Work to be carried out	O.K.
	10 h	100 h	1000 h	Daily	Weekly	Annually		
<b>Track adjustment</b>								<input type="checkbox"/>
	X				X		Clean and grease visible gliding surfaces	
	X				X		Check the hydraulic cylinder for tightness and tight seating	
	X				X		Check the hydraulic cylinder for the cross carrier lock for tightness and tight seating	
<b>Assembly support</b>								<input type="checkbox"/>
					X		Check the hydraulic cylinder for tightness and tight seating	
						X	Grease the bearing points of the support beams	
<b>Central lubrication system</b>								<input type="checkbox"/>
				X			Check the grease supply Add grease to the reservoir when the grease supply has dropped below 1/4 of the reservoir content	
		X					Check the function	
<b>Hydraulic hose lines</b>								<input type="checkbox"/>
				X			Check for leaks and damage	
						X	Check for a safe condition by an authorized inspector, inspection expert	
<b>Pin connections</b>								<input type="checkbox"/>
						Every 2 months <sup>2)</sup>	Check the retainer of the pin connections	
						Every 2 months <sup>2)</sup>	Check the pins and / or connector elements for damage, visual inspection	
						Every 2 months <sup>2)</sup>	Check the retaining elements for damage, visual inspection	
<b>Crane chassis</b>								<input type="checkbox"/>
					X <sup>3)</sup>		Wash the crane chassis	
						Every 6 months <sup>3)</sup>	Check the crane chassis for corrosion and paint damage	

LWE/LTR 1220-003/24204-02-02/en

First maintenance after	Operating hour intervals			Calendar intervals			Work to be carried out	O.K.
	10 h	100 h	1000 h	Daily	Weekly	Annually		
<b>Crane chassis, protected against corrosion</b>								□
						Every 6 months	Check the corrosion protection for wear, and if necessary reapply protection	
						Every 2 months	Check the corrosion protection on mechanically machined, blank surfaces for wear and reapply the corrosion protection if necessary	
						Every 3 months	Check the corrosion protection on the chrome-plated piston rods for wear, and if necessary reapply the corrosion protection	

- <sup>1)</sup> Before every start up  
<sup>2)</sup> For cranes used for a long period of time  
<sup>3)</sup> If possible: After every use of the crane

---

Empty page!

LWE/LTR 1220-003/24204-02-02/en



## 7.03 Maintenance intervals - Crane superstructure

1 Maintenance and inspection schedule

---

2

LWE/LTR 1220-003/24204-02-02/en

# 1 Maintenance and inspection schedule



## Note

- ▶ Carry out maintenance work after reaching the specified operating hours or calendar intervals. The interval which occurs first is the deciding factor!
- ▶ The maintenance intervals complement each other. If a higher interval is coming up, then carry out the work according to the lower interval also!

First maintenance after	Operating hour intervals			Calendar intervals			Work to be carried out	O.K.
	250 h	500 h	1000 h	Daily	Weekly	Annually		
<b>Safety systems</b>								<input type="checkbox"/>
						X	Personal protective equipment Follow the instructions of the manufacturer	<input type="checkbox"/>
						X	Height rescue system Follow the instructions of the manufacturer	
<b>Fall protection equipment</b>								<input type="checkbox"/>
						X	Check protection points	<input type="checkbox"/>
						X	Check safety ropes	
						X	Check the ladders for technically immaculate condition	
						X	Check railings, steps and pedestals for safe function	
						X	Check catwalks and open mesh flooring for safe function	
<b>Crane surface</b>								<input type="checkbox"/>
					X		Check accessible surfaces for cleanliness	<input type="checkbox"/>
						X	Check accessible surfaces for completeness and slip resistance	
						X	Check labels for completeness and legibility	
<b>Rigging and fastening points</b>								<input type="checkbox"/>
				X <sup>2)</sup>			Check condition and mounting	<input type="checkbox"/>
						X	Check for continued suitability by an authorized inspector, inspection expert	
<b>Load handling equipment and assembly aids</b>								<input type="checkbox"/>
				X <sup>2)</sup>			Check for cracks, damage, wear and distortion	<input type="checkbox"/>
						X	Check for continued suitability by an authorized inspector, inspection expert	

First maintenance after	Operating hour intervals			Calendar intervals			Work to be carried out	O.K.
	250 h	500 h	1000 h	Daily	Weekly	Annually		
<b>Fastening equipment and load securing devices</b>								□
				X <sup>2)</sup>			Observe and adhere to the manufacturer's instructions	
				X <sup>2)</sup>			Check the grommets and cable laid fastening rope for damage, operational safety, proper identification Take-down criteria, see chapter 8.01	
						X	Have the fastening equipment checked by an authorized person, authorized inspector	
<b>Fire extinguishing system</b>								□
						X	Carry out a visual inspection of the system For all other maintenance tasks, observe the instructions of the fire extinguisher manufacturer.	
						Every 5 years	Replace trigger elements and extinguisher tank.	

First maintenance after	Operating hour intervals			Calendar intervals			Work to be carried out	O.K.
	250 h	500 h	1000 h	Daily	Weekly	Annually		
<b>Diesel engine</b>								□
					X		Visual inspection (leaks, contamination, damage)	
				X			Checking the oil level in the crane cab	
		X					Checking the oil level with the dipstick	
			X <sup>14) 15)</sup>				Changing the engine oil, replacing the oil filter and oil separator filter insert	
Or when displayed in the service system: The interval and be reduced depending on the individual load duty cycle								
			X				Checking the ribbed V-belt	
			X				Checking the condition of the belt drive, replace if required	
			Every 5000 h			Every 5 years	Replacing the belt drive	
100 h			X				Checking the condition and fastening of the intake and exhaust system and checking for leaks	
			X				Checking the engine mount and diesel engine brackets for tight seating	
			Every 10000 h			X	Checking the heat flange	
			Every 10000 h				Replacing the heat flange	
			X				Checking the valve clearance	
			X				Checking the engine control unit mount, sensors, actuators, cable holders and plugs for damage	
<b>Fuel system</b>								□
					X		Checking the lubrication oil system and fuel system for leaks	
			X				Checking the condition and mounting of the fuel system	
100 h			X				Draining the sediments in the fuel tank	
					X		Checking fuel preliminary filter, drain water if necessary	
			X				Servicing the fuel preliminary filter	
			X				Replacing the fuel fine filter	

First maintenance after	Operating hour intervals			Calendar intervals			Work to be carried out	O.K.	
	250 h	500 h	1000 h	Daily	Weekly	Annually			
<b>Cooling system</b>								□	
				X			Checking the coolant level		
					X		Checking the cooling system for leaks		
			Every 6000 h			X	Checking the concentration of the anti-freeze in the coolant		
						Every 4 years	Changing the coolant		
<b>Exhaust system*</b>								□	
				X			Visual inspection: Check the exhaust system for leaks and damage		
			X				Checking the profile clamps		
			Every 5000 h				Replacing the diesel particle filter*		
			Or when displayed in the service system						
						X	Visual inspection: Checking the lines and electronic plug		
						X	Checking the filter strainer in the tank fitting of the urea tank, replace if necessary		
<b>Air filter system</b>								□	
					X		Cleaning the dust discharge valve		
						X <sup>13)</sup>	Replacing the dry air filter main element		
						X	Replacing the dry air filter safety element		
<b>Heating-air conditioning device</b>								□	
					Every 4 weeks		Operate the climate control system for 15 min and check the function		
						X	Replacing the filter insert		

First maintenance after	Operating hour intervals			Calendar intervals			Work to be carried out	O.K.
	250 h	500 h	1000 h	Daily	Weekly	Annually		
<b>Cab auxiliary heater*, Engine preheating auxiliary heater*</b>								□
				X			Check the fill level of the fuel container	
				X			Check the fill level in the expansion tank	
					Every 4 weeks <sup>8)</sup>		Operate the auxiliary heater for 15 min and check the function	
					X <sup>9)</sup>		Operate the auxiliary heater for 15 min and burn-off the burner	
						X <sup>12)</sup>	Have the water heater checked by an authorized and trained service technician	
						X <sup>12)</sup>	Have the air heater checked by an authorized and trained service technician	
						Every 2 years	Have the fluid in the heating system replaced by an authorized and trained service technician	
			3000 h				Have the burner of the heating system replaced by an authorized and trained service technician	
						Every 10 years	Have the heat exchanger of the heater replaced by an authorized and trained service technician	
<b>Slewing ring connection</b>								□
	X						Lubricate the gears	
						X <sup>1)</sup>	Lubricating the slewing ring connection	
					Every 6 months <sup>1)</sup>		Drain water on the water drain bores of the slewing ring connection (only LTM 11200-9.1, LTR 11200)	
250 h			1500 h			X	Check the tightness of the mounting screws	
						X	Checking the tilt play	

First maintenance after	Operating hour intervals			Calendar intervals			Work to be carried out	O.K.
	250 h	500 h	1000 h	Daily	Weekly	Annually		
<b>Winches</b>								
250 h			X			X	Check the tightness of the mounting screws	□
				X			Check for leaks	
					X <sup>6)</sup>		Check the oil level	
250 h			3000 h			Every 4 years	Change the gear oil	
			1500 h <sup>4)</sup>			X <sup>4)</sup>	Lubricate the space between V-ring / winch bearing (only for winches with a winch bearing that is lubricated with a grease fitting)	
			200 h			X	Check the condition of the tooth flanks; determining factor are the operating hours of the winch (only for winches with gear ring drive)	
						X	Check the remaining theoretical service life by an authorized inspector	
						Every 4 years	Check the remaining theoretical service life by an inspection expert	
<b>Winch brakes</b>								
				X			Check for leaks	□
						X	Check for correct function	
<b>Relapse supports</b>								
					Every 3 months <sup>5), 6)</sup>		Lubricating the bearings	□
X <sup>2), 6)</sup>							Check the oscillation guard for easy movement	
<b>Relapse cylinder</b>								
X <sup>2), 6)</sup>					X		Check for leaks	□
					Every 3 months <sup>5), 6)</sup>		Lubricating the bearings	
X <sup>2), 6)</sup>		X				X	Check pretension pressure (nitrogen)	
X <sup>2), 6)</sup>		X				X	Check the oil quantity	
<b>Pneumatic springs</b>								
X <sup>2), 5), 6)</sup>		X				X	Check for correct function	□

LWE/LTR 1220-003/24204-02-02/en

First maintenance after	Operating hour intervals			Calendar intervals			Work to be carried out	O.K.
	250 h	500 h	1000 h	Daily	Weekly	Annually		
<b>A-frame</b>								□
		X					Lubricate the bearing	
X <sup>2), 6)</sup>						X	Check the lever for the limit switch on the A-frame 3 for easy movement and reset of spring	
X <sup>2), 6)</sup>						X	Check the rods with guide rail on the A-frame 2 and A-frame 3 for easy movement and distortion	
<b>Counterweight frame</b>								□
						X	Check the cylinder stroke of the locking pin on the swinging arms (only LTM 1450-8.1)	
<b>Counterweight</b>								□
1000 km		or 10,000 km				X	Check tightening torque of mounting screws	
<b>Concrete ballast plates (ballast container) (only LR 13000)</b>								□
				X			Check for damage	
						Every 5 years	Check by licensing agency	
<b>Ballasting</b>								□
	X					X	Lubricating the bearings	
						X	Check the swing play (only LTM 11200-9.1)	
						X	Check the braid ropes (only LTM 11200-9.1)	
<b>Press on pulleys of rope winches</b>								□
	X					X	Grease guides	
<b>Rope pulleys</b>								□
					X <sup>5), 6)</sup>		Check groove base for cleanliness	
			X			X	Check for wear, damage, cracks and easy movement	
			3000 h			Every 3 years	Lubricate the bearings	
<b>Carrier rollers</b>								□
				X <sup>2)</sup>			Check for damage and distortion	
			X			X	Check for wear, damage and easy movement	
			X			X	Check the tightness of the mounting screws	



First maintenance after	Operating hour intervals			Calendar intervals			Work to be carried out	O.K.
	250 h	500 h	1000 h	Daily	Weekly	Annually		
<b>Crane cab</b>								□
				X			Check instruments for function	
				X			Check indicator lights for function	
						X	Replace the filter insert for switch cabinet ventilation	
				X			Check fluid level in expansion tank of engine regulation	
		X				X	Check the sliding or incline device for function	
		X				X	Lubricate the bearings of the sliding or incline device	
		X				X <sup>7)</sup>	Check the lift device (telescope arm) for function	
		X				X <sup>7)</sup>	Lubricate the bearings of the lift device and telescope arm	
<b>Window washing bays, camera washing bays</b>								□
				X			Check the fluid level in the reservoir for the washing bays	
<b>Overload protection</b>								□
				X			Check for correct function	
		X				X	Check length sensor for function	
		X				X	Check length sensor rope for damage	
<b>Remote diagnostics device</b>								□
						X	Check for correct function	
						X	Check the validity of the SIM card	
<b>Electrical system</b>								□
						X	Cable connections	
					Every 6 months <sup>3)</sup>		Service the batteries	
					Every 6 months <sup>3)</sup>		Empty the acid collection container	
						X <sup>5)</sup>	Replace the interior compartment filter of the switch cabinet ventilation	

First maintenance after	Operating hour intervals			Calendar intervals			Work to be carried out	O.K.
	250 h	500 h	1000 h	Daily	Weekly	Annually		
<b>Slewing gear</b>								
250 h			X			X	Check the tightness of the mounting screws	<input type="checkbox"/>
				X			Check for leaks	
					X		Check the oil level	
250 h			3000 h			Every 4 years	Change the gear oil	
<b>Slewing gear brakes</b>								
				X			Check for leaks	<input type="checkbox"/>
						X	Check for correct function	
<b>Turntable lock</b>								
		X				X	Grease	<input type="checkbox"/>
		X				X	Check for correct function	
<b>Bearings</b>								
						X	Checking the retaining elements	<input type="checkbox"/>
<b>Pin connections</b>								
					Every 2 months <sup>10)</sup>		Check the retainer of the pin connections	<input type="checkbox"/>
					Every 2 months <sup>10)</sup>		Check the pins and / or connector elements for damage, visual inspection	
					Every 2 months <sup>10)</sup>		Check the retaining elements for damage, visual inspection	
<b>Pump distributor gear</b>								
				X			Check for leaks	<input type="checkbox"/>
					X		Check the oil level	
500 h			1500 h			X	Change the gear oil	
<b>Crane drive miter gear</b>								
					X		Check for leaks	<input type="checkbox"/>
	X						Check mounting	
100 h			1500 h			X	Oil change	
<b>Hydraulic hose lines</b>								
				X			Check for leaks and damage	<input type="checkbox"/>
						X	Check for a safe condition by an authorized inspector, inspection expert	

First maintenance after	Operating hour intervals			Calendar intervals			Work to be carried out	O.K.
	250 h	500 h	1000 h	Daily	Weekly	Annually		
<b>Hydraulic system</b>								<input type="checkbox"/>
				X			Check the oil level	
					X		Check for leaks	
250 h		X				X	Replace the control pressure and replenishing pressure filter inserts	
250 h		X				X	Replace return filter inserts (only for cranes with open hydraulic circuit)	
250 h		X				X	Replace the bleeder and vent filter of hydraulic tank	
500 h			X			X	Check hydraulic oil, required degree of purity: 20/18/15 Take an oil sample and have it checked by the oil supplier	
<b>Hydraulic cylinder</b>								<input type="checkbox"/>
					X		Check for leaks	
					Every 3 months <small>5), 6)</small>		Lubricating the bearings	
<b>Hydraulic pressure accumulator (nitrogen)</b>								<input type="checkbox"/>
		X <sup>4)</sup>				X <sup>4)</sup>	Check pretension pressures	
<b>Hydraulic coupling system LIKUFIX</b>								<input type="checkbox"/>
				X <sup>2) 6)</sup>			Check for leaks, dirt and lubricate the guides	
<b>Compressed air system</b>								<input type="checkbox"/>
					X		Check for leaks	
					X		Check operating pressure	
					X		Check shut off pressure	
					X		Check operation of automatic drain valve	
						X	Replace air dryer granular cartridges	
						X	Clean air dryer preliminary filter	
<b>Central lubrication system</b>								<input type="checkbox"/>
					Every 6 months <small>1)</small>		Carrying out an intermediate lubrication	
		X					Check for correct function	
					X		Check the grease container fill level	
<b>Emergency control</b>								<input type="checkbox"/>
						X	Check for correct function	

First maintenance after	Operating hour intervals			Calendar intervals			Work to be carried out	O.K.
	250 h	500 h	1000 h	Daily	Weekly	Annually		
<b>Suspended ballast</b>								□
						X	Check the fall protection equipment	
						X	Check frame, suspension and guide section for distortion and cracks	
<b>Crane superstructure</b>								□
					X <sup>11)</sup>		Wash the crane superstructure	
						Every 6 months <sup>11)</sup>	Check the crane superstructure for corrosion and paint damage	
<b>Crane superstructure, protected against corrosion</b>								□
						Every 6 months	Check the corrosion protection for wear, and if necessary reapply protection	
						Every 2 months	Check the corrosion protection on mechanically machined, blank surfaces for wear and reapply the corrosion protection if necessary	
						Every 3 months	Check the corrosion protection on the chrome-plated piston rods for wear, and if necessary reapply the corrosion protection	

<sup>1)</sup> If the crane is not moved: every 3 months.

<sup>2)</sup> Before every start up: Perform a visual inspection.

<sup>3)</sup> In hot climate zones: every 3 months.

<sup>4)</sup> Observe maintenance instructions - crane superstructure, chapter 7.05.

<sup>5)</sup> And as necessary.

<sup>6)</sup> And during assembly.

<sup>7)</sup> In Great Britain: every 6 months.

<sup>8)</sup> Outside of the heating period.

<sup>9)</sup> During the heating period.

<sup>10)</sup> Also for cranes used for a long period of time.

<sup>11)</sup> Each time after the crane is used if possible.

<sup>12)</sup> Before and after every heating period.

<sup>13)</sup> Or if the maintenance display activates, or error message.

<sup>14)</sup> The interval is reduced in the case of alternative oil specifications, see the see separate engine manufacturer's operating instructions.

<sup>15)</sup> The interval depends on the sulphur content in the permissible fuel for the respective emissions level, see the see separate engine manufacturer's operating instructions.

## 7.03.50 Maintenance intervals - Crane boom

1 Maintenance and inspection schedule

---

2

LWE/LTR 1220-003/24204-02-02/en

# 1 Maintenance and inspection schedule



## Note

- ▶ Carry out maintenance work after reaching the specified operating hours or calendar intervals. The interval that occurs first is the deciding factor.
- ▶ The maintenance intervals complement each other. If a higher interval is coming up, then also carry out the work according to the lower interval.

First maintenance after	Operating hour intervals			Calendar intervals			Work to be carried out	O.K.
	250 h	500 h	1000 h	Daily	Weekly	Annually		
<b>Safety systems</b>								<input type="checkbox"/>
						X	Personal protective equipment Follow the instructions of the manufacturer	
						X	Height rescue system Follow the instructions of the manufacturer	
<b>Fall protection equipment</b>								<input type="checkbox"/>
						X	Check protection points	
						X	Check safety ropes	
						X	Check the ladders for technically immaculate condition	
						X	Check railings, steps and pedestals for safe function	
						X	Check catwalks and gratings for safe function	
<b>Crane boom surface</b>								<input type="checkbox"/>
					X		Check accessible surfaces for cleanliness	
						X	Check accessible surfaces for completeness and slip resistance	
						X	Check labels for completeness and legibility	
<b>Rigging and fastening points</b>								<input type="checkbox"/>
				X <sup>2)</sup>			Check the condition and mounting	
						X	Check for continued suitability by an authorized inspector, inspection expert	
<b>Load handling equipment and assembly aids</b>								<input type="checkbox"/>
				X <sup>2)</sup>			Check for cracks, damage, wear and distortion	
						X	Have continued suitability checked by an authorized inspector, inspection expert	

First maintenance after	Operating hour intervals			Calendar intervals			Work to be carried out	O.K.
	250 h	500 h	1000 h	Daily	Weekly	Annually		
<b>Fastening equipment and load securing devices</b>								
				X <sup>2)</sup>			Observe and adhere to the manufacturer's instructions	□
				X <sup>2)</sup>			Check the grommets and cable laid fastening rope for damage, operational safety, proper identification. Take-down criteria, see chapter 8.01	
						X	Have the fastening equipment checked by an authorized person, authorized inspector	
<b>Lattice sections</b>								
						X	Check cracks, damage and distortion	□
						X	Check protection points	
						X	Check safety ropes	
						X	Check railings and pedestals for safe function	
						X	Check catwalks and gratings for safe function	
X <sup>6)</sup>						X	Grease the lube points of lattice sections	
<b>Guy rods</b>								
						X	Check for cracks, damage and distortion by an authorized person	□
						Every 4 years	Check cracks, damage and distortion by an authorized inspector	
						X	Checking the retaining elements	
						X	Check labels for completeness and legibility	
X <sup>6)</sup>						X	Lubricate the lube points of guy rods	
<b>Fiber guy ropes</b>								
					Every 3 months <sup>7)</sup>		Check braid and intermediate layers for damage and distortion	□
					Every 3 months <sup>7)</sup>		Check rope end connections for cracks, damage and distortion	
					Every 3 months <sup>7)</sup>		Check rope grommet transitions for damage and distortion	

LWE/LTR 1220-003/24204-02-02/en

First maintenance after	Operating hour intervals			Calendar intervals			Work to be carried out	O.K.
	250 h	500 h	1000 h	Daily	Weekly	Annually		
<b>Pin connections</b>								
					Every 2 months <sup>9)</sup>		Check the retainer of the pin connections	□
					Every 2 months <sup>9)</sup>		Check the pins and / or connector elements for damage, visual inspection	
					Every 2 months <sup>9)</sup>		Check the retaining elements for damage, visual inspection	
<b>Relapse supports</b>								
					Every 3 months <sup>5), 6)</sup>		Lubricate the bearings	□
X <sup>2), 6)</sup>							Check the oscillation guard for easy movement	
<b>Relapse cylinder</b>								
X <sup>2), 6)</sup>					X		Check for leaks	□
					Every 3 months <sup>5), 6)</sup>		Lubricate the bearings	
X <sup>2), 6)</sup>		X				X	Check pretension pressure (nitrogen)	
X <sup>2), 6)</sup>		X				X	Check the oil quantity	
<b>Hydraulic hose lines</b>								
				X			Check for leaks and damage	□
						X	Have the safe condition checked by an authorized inspector, inspection expert	
<b>Hydraulic cylinder</b>								
					X		Check for leaks	□
					Every 3 months <sup>5) 6)</sup>		Lubricate the bearings	
<b>Hydraulic pressure accumulator (nitrogen)</b>								
		X <sup>4)</sup>				X <sup>4)</sup>	Check pretension pressures	□



First maintenance after	Operating hour intervals			Calendar intervals			Work to be carried out	O.K.
	250 h	500 h	1000 h	Daily	Weekly	Annually		
<b>Rope pulleys</b>								
				X			Remove snow and ice	□
					X <sup>2) 6)</sup>	X	Check the groove base for cleanliness	
			X			X	Perform a visual inspection: Damage and cracks, see chapter 8.01	
			X				Check the groove damager, see chapter 8.01	
			X				Function test: Check the bearing for easy movement	
			X			X	If the rope diameter is at least 25 mm: Lubricate the bearings	
<b>Carrier rollers</b>								
			X <sup>2) 6)</sup>			X	Perform a visual inspection: Wear, damage and cracks, see chapter 8.01	□
			X			X	Check the depth of the lead-in tracks, see chapter 8.01	
			X			X	Function test: Check the bearing for easy movement, see chapter 8.01	
			X			X	Check the tightness of the mounting screws (tightening torque)	
<b>Folding jib guide pulley</b>								
				X <sup>8)</sup>			Check for wear, damage and easy movement	□
<b>Telescopic boom with rope mechanism</b>								
						X	Check telescopic boom for distortions and cracks	□
	X					X <sup>5)</sup>	Grease the sliding surfaces of the telescopic boom bearing	
			X			X	Check change over pulleys of push out mechanics for damage and cracks	
	X					X <sup>5)</sup>	Grease the change over pulleys of push out mechanism	
	X					X	Check mounting screws on change over pulleys for tight seating	
						X	Check control rope: Pull-out ropes (braid ropes) and return ropes	
250 h		X					Check synchronization (telescope fastening point)	

LWE/LTR 1220-003/242004-02-02/en

First maintenance after	Operating hour intervals			Calendar intervals			Work to be carried out	O.K.
	250 h	500 h	1000 h	Daily	Weekly	Annually		
<b>Telematik telescopic boom system</b>								□
						X	Check telescopic boom system for distortion, damage and cracks	
						X	Check the hydraulic components for leaks and damage	
		X				X	Check telescoping cylinder for proper condition	
						X	Check pull knob retainer and mounting screws for tight seating	
						X	Check mounting screws of push out cylinder for tight seating	
						X	Check the cylinder pinning and telescopic boom pinning anti-rotation device	
		X				X	Check push out gripper for proper condition	
		X				X	Check the locking bores for proper condition	
		X				X	Check locking pins for easy movement and proper condition	
		X				X <sup>5)</sup>	Lubricate the locking pins	
		X				X	Check inner and outer sliding surfaces for proper condition	
						X <sup>5)</sup>	Lubricating the gliding surfaces	
						X <sup>5)</sup>	Grease the guide rails on the telescoping cylinder	
<b>Disconnect the telescopic boom</b>								□
						X	Check the threaded pin plugs for damage and if they are present (only LTM 1450-8.1 and LTM 1650-8.1)	

First maintenance after	Operating hour intervals			Calendar intervals			Work to be carried out	O.K.
	250 h	500 h	1000 h	Daily	Weekly	Annually		
<b>Telescopic boom guying</b>								□
						X	Check cracks, damage and distortion	
					Every 3 months <sup>5), 6)</sup>		Lubricate guy points on telescopic boom head on the grease nipples	
					Every 3 months <sup>5), 6)</sup>		Lubricate the TA/TY-guying on the grease fittings	
250 h		X				X	Check mounting screws of guy winch for tight seating	
				X			Check the guy winch for leaks	
					Every 6 months		Check the oil level on the guy winch	
			3000 h			Every 4 years	Replace gear oil of guy winch	
						X <sup>4)</sup>	Check the rope connection between the guy rope and the auxiliary rope (only LTM 1400-7.1)	
						X	Check braid ropes (only LTM 11200-9.1, LTR 11200)	
<b>Crane ropes</b>								□
				X			Check for damage and distortion	
					Monthly <sup>5)</sup>		Have expert personnel perform a check, grease	
						X	Have checked by an authorized expert	
						Every 4 years	Have checked by an authorized inspector	

First maintenance after	Operating hour intervals			Calendar intervals			Work to be carried out	O.K.
	250 h	500 h	1000 h	Daily	Weekly	Annually		
<b>Hook blocks</b>								<input type="checkbox"/>
				X <sup>3)</sup>			Have the load hook checked for distortion, cracks, wear, damage and corrosion by the crane operator	
			X			X	Check rope pulleys for distortion, wear, damage and cracks	
			3000 h			Every 3 years	Lubricate rope pulley bearings	
	100 h				Every 3 months <sup>5)</sup>		Lubricate pressure bearings	
	100 h				Every 3 months <sup>5)</sup>		Lubricate radial bushing	
	100 h				Every 3 months <sup>5)</sup>		Lubricate suspension of hook beam	
					Every 6 months <sup>5)</sup>		Replace batteries on incline sensor	
						X	Have the load hook checked for distortion, cracks, wear, damage and corrosion by an authorized person	
						Every 4 years	Have the load hook checked for distortion, cracks, wear, damage and corrosion by an authorized inspector	
						X	Have the retaining elements checked by an authorized person	
						Every 4 years	Have the retaining elements checked by an authorized person	
<b>Cross bar(fire trucks)</b>								<input type="checkbox"/>
						Every 6 months	Check the cross bar extension for ease of movement and grease	
<b>Boom and equipment</b>								<input type="checkbox"/>
					X <sup>10)</sup>		Wash the boom and equipment	
						Every 6 months <sup>10)</sup>	Check the boom and equipment for corrosion and paint damage	

First maintenance after	Operating hour intervals			Calendar intervals			Work to be carried out	O.K.
	250 h	500 h	1000 h	Daily	Weekly	Annually		
<b>Boom and equipment, protected against corrosion</b>								□
						Every 6 months	Check the corrosion protection for wear, and if necessary reapply protection	
						Every 2 months	Check the corrosion protection on mechanically machined, blank surfaces for wear and reapply the corrosion protection if necessary	
						Every 3 months	Check the corrosion protection on the chrome-plated piston rods for wear, and if necessary reapply the corrosion protection	

- <sup>2)</sup> before every start up: Perform a visual inspection
- <sup>3)</sup> before starting crane operation: Perform a visual inspection
- <sup>4)</sup> observe maintenance instructions - crane superstructure, chapter 7.05
- <sup>5)</sup> and as necessary
- <sup>6)</sup> and during assembly
- <sup>7)</sup> by authorized and trained expert personnel with boom taken down and before every erection procedure
- <sup>8)</sup> after operation with the folding jib and a negative operating angle
- <sup>9)</sup> also for cranes used for a long period of time
- <sup>10)</sup> each time after the crane is used if possible

LWE/LTR 1220-003/24204-02-02/en

---

Empty page!

LWE/LTR 1220-003/24204-02-02/en

## 7.04 Maintenance instructions - Crane chassis

1	Servicing the travel gear	3
2	Crawler travel gear	9
3	Servicing the central lubrication system of the crawler carrier	21
4	Hydraulic hose lines	27
5	Ladders	28

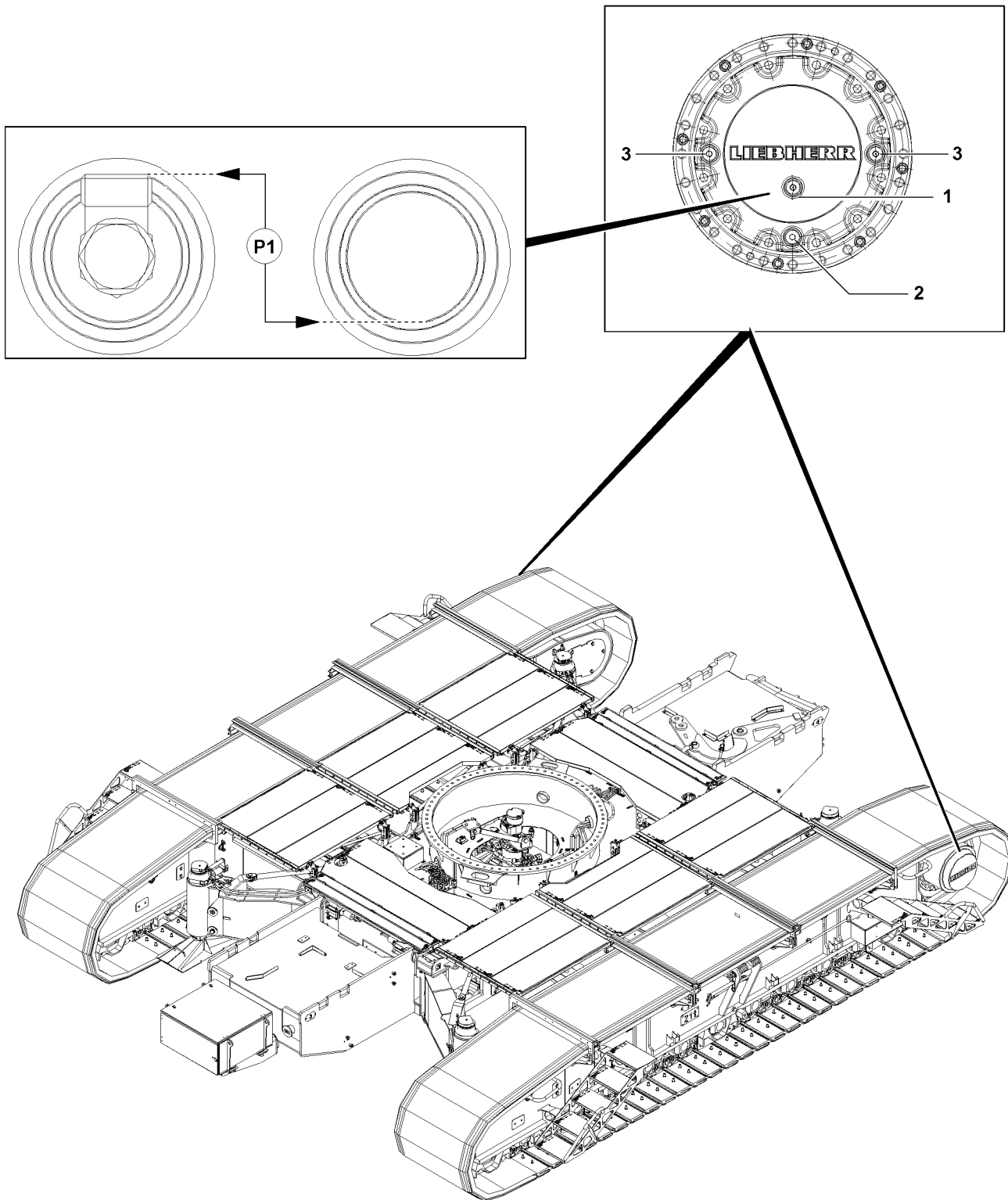


Fig.118012

LWE/LTR 1220-003/24204-02-02/en



# 1 Servicing the travel gear

**Note**

- ▶ Use only service items and lubricants according to the Service fill!
- ▶ Adhere to the maintenance intervals as specified in chapter 7.02 of the Crane operating instructions!

The travel gear consists of:

- Planetary gear

**WARNING**

Danger of burns during maintenance and inspection work!

Severe burns can result due to the travel gear and oils at operating temperatures!

- ▶ Avoid direct body contact to heated components and fluids!

**NOTICE**

Dirt in travel gear!

If any dirt gets into the inside of the travel gear, gear damage can occur!

- ▶ Make sure that no dirt gets into the inside of the travel gear during maintenance work!

The following maintenance ports are on the planetary gear:

- 1 Oil level plug, oil level port
- 2 Oil drain plug, oil drain port
- 3 Oil filler plug, oil filler port

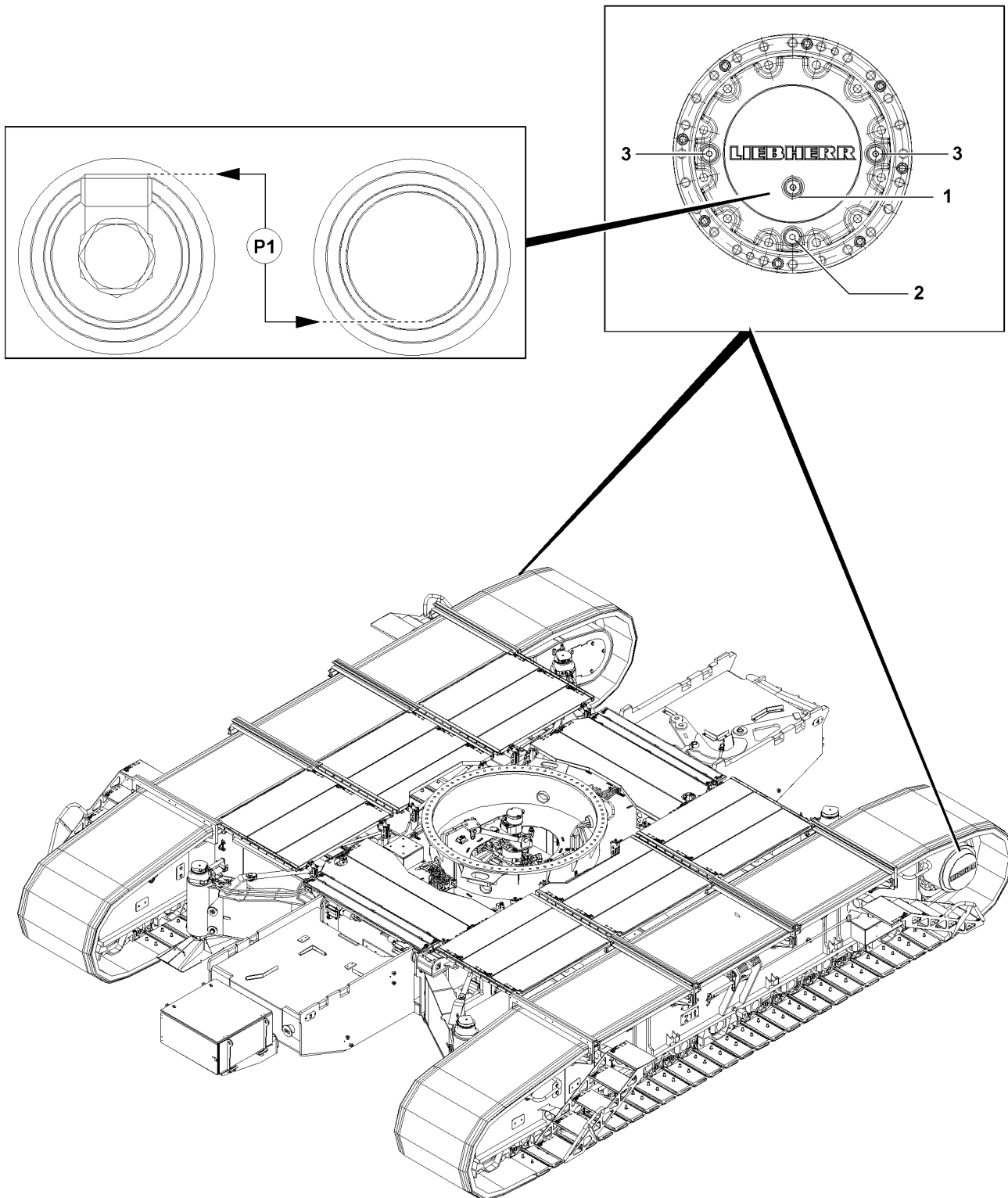


Fig.118012

LWE/LTR 1220-003/24204-02-02/en

## 1.1 Checking for leaks

- ▶ Check visually to ensure that the travel gears do not leak.

## 1.2 Checking the oil level

---

### NOTICE

Damage to the travel gear!

If seals are used repeatedly, it can result in loss of oil!

Due to loss of oil, the travel gears can wear significantly and / or be damaged!

- ▶ Use the seals on the maintenance ports only once!
- 

### NOTICE

Varying oil level in planetary gear!

Depending on the position of the gears in the planetary gear, the oil level can vary slightly upward!

When opening the oil level plug, oil can emerge despite correct fill quantity!

- ▶ The fill height must be at least on the height of the point **P1**!
  - ▶ If any oil emerged during the check, replace the same amount!
- 

Make sure that the following prerequisites are met:

- The crane is in horizontal position.
  - The travel gear is at a standstill.
- 



### Note

- ▶ To ensure a reliable oil level check, it must be ensured that the travel gears have been at a standstill for at least two minutes. This ensures that the oil has returned to the oil chamber completely!
- 
- ▶ Open the oil level port carefully.
- 

### NOTICE

Insufficient oil fill quantity!

If the oil level drops below the fill level on point **P1**, the travel gears can be damaged!

- ▶ Add gear oil until the oil level is again on the fill level on point **P1**!
- 

If gear oil must be added:

- ▶ Add oil on the oil filler port.
- ▶ If the oil level is on the fill level on point **P1**, then the oil level on the travel gear is OK.
- ▶ Close the maintenance ports tightly.

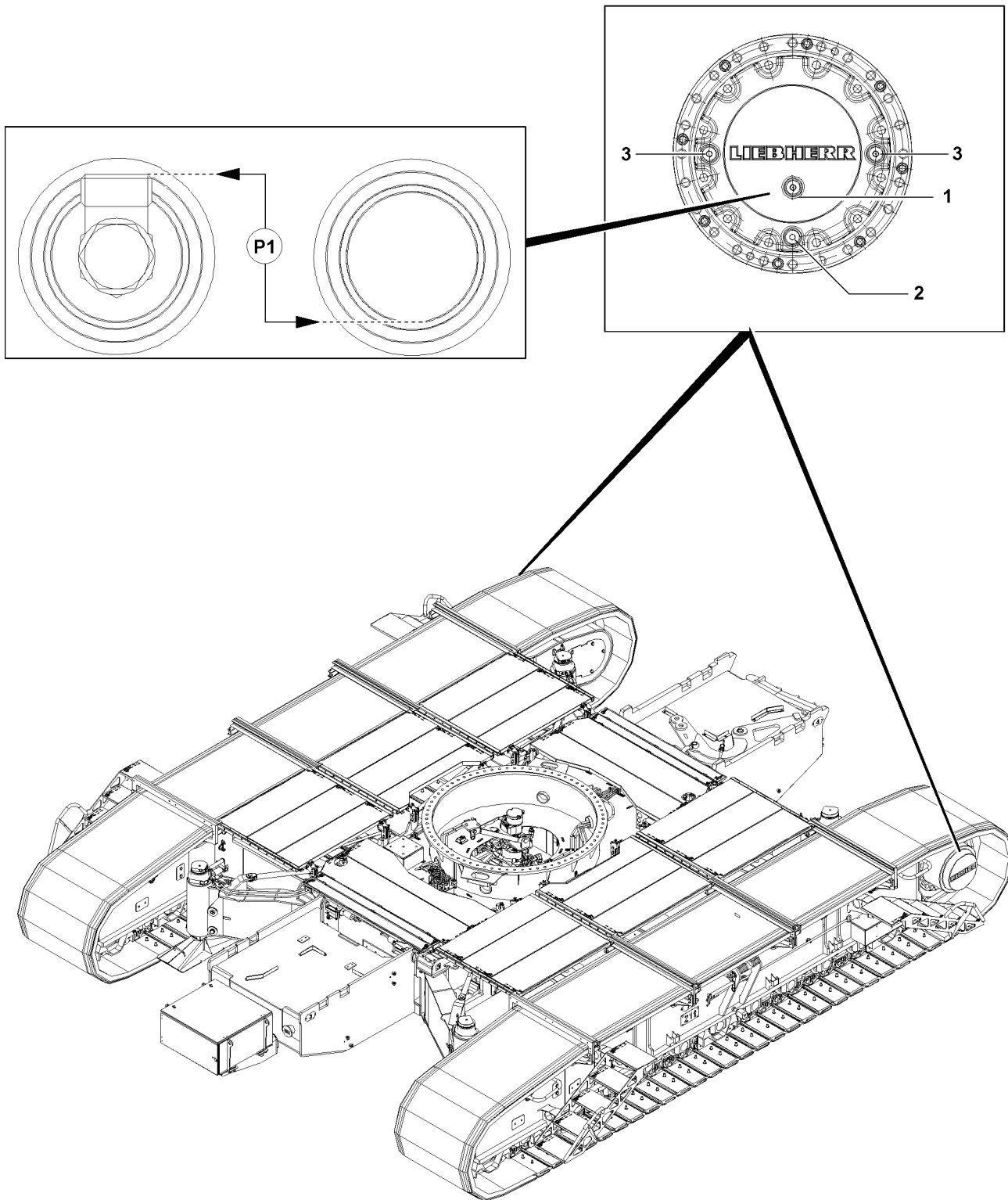


Fig.118012

LWE/LTR 1220-003/24204-02-02/en

## 1.3 Changing oil on the planetary gear

---

### NOTICE

Damage to the travel gear!

If seals are used repeatedly, it can result in loss of oil!

Due to loss of oil, the travel gears can wear significantly and / or be damaged!

- ▶ Use the seals on the maintenance ports only once!
- 

Make sure that the following prerequisites are met:

- The crane is in horizontal position.
  - The travel gear must be at a standstill.
  - The travel gear is at operating temperature.
  - A container to catch the used oil is available.
- 



### Note

- ▶ When selecting the container to catch the used oil, make sure that the container is sufficiently sized to be able to catch all the used oil!
  - ▶ For fill quantity of planetary gear, see Chapter 7.06 in the Crane operating instructions!
- 

- ▶ Remove the oil level plug **1**.
  - ▶ Remove the oil drain plug **2** and drain oil into a suitable container.
- 



### Note

- ▶ Empty the planetary gear completely!
- 

- ▶ Clean the oil drain plug **2** and the sealing surface.
- ▶ Close off the oil drain port **2** tightly.
- ▶ Add oil on an oil level plug **3** until it „stands“ at the height of the fill level **P1** of the oil level port **1** or until it starts to run over.
- ▶ Clean the sealing surfaces.
- ▶ Close off the oil level ports **1** tightly.
- ▶ Close off the oil fill plug **3** tightly.

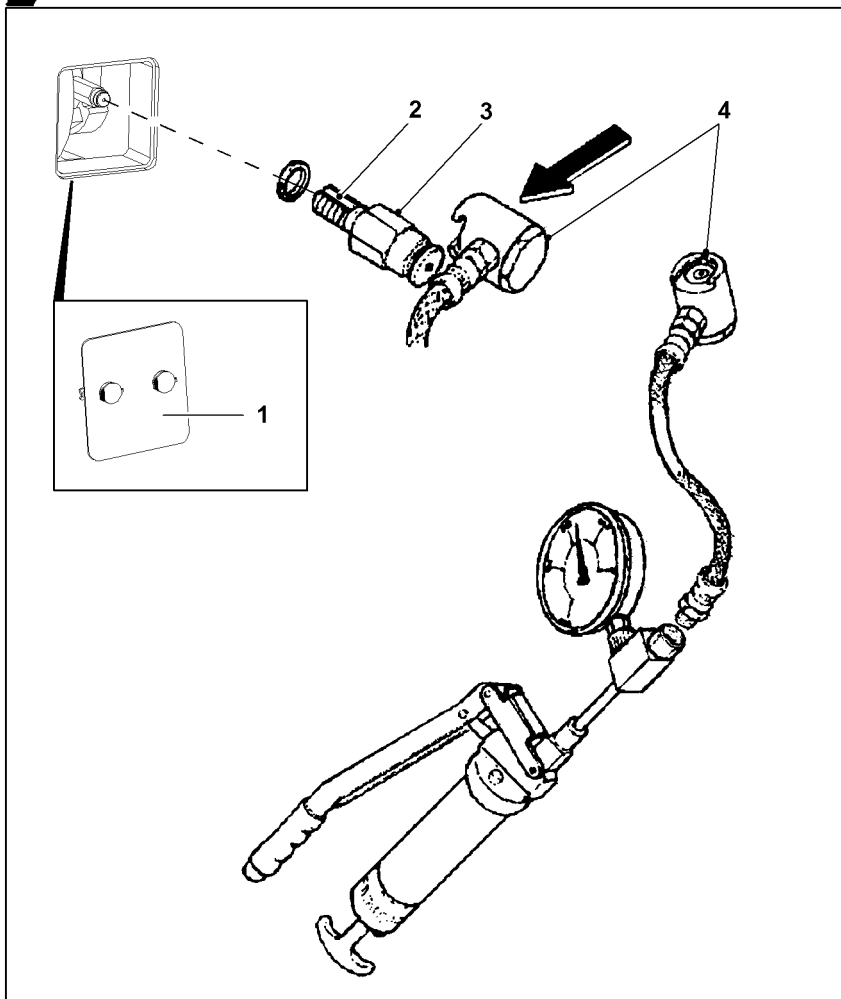
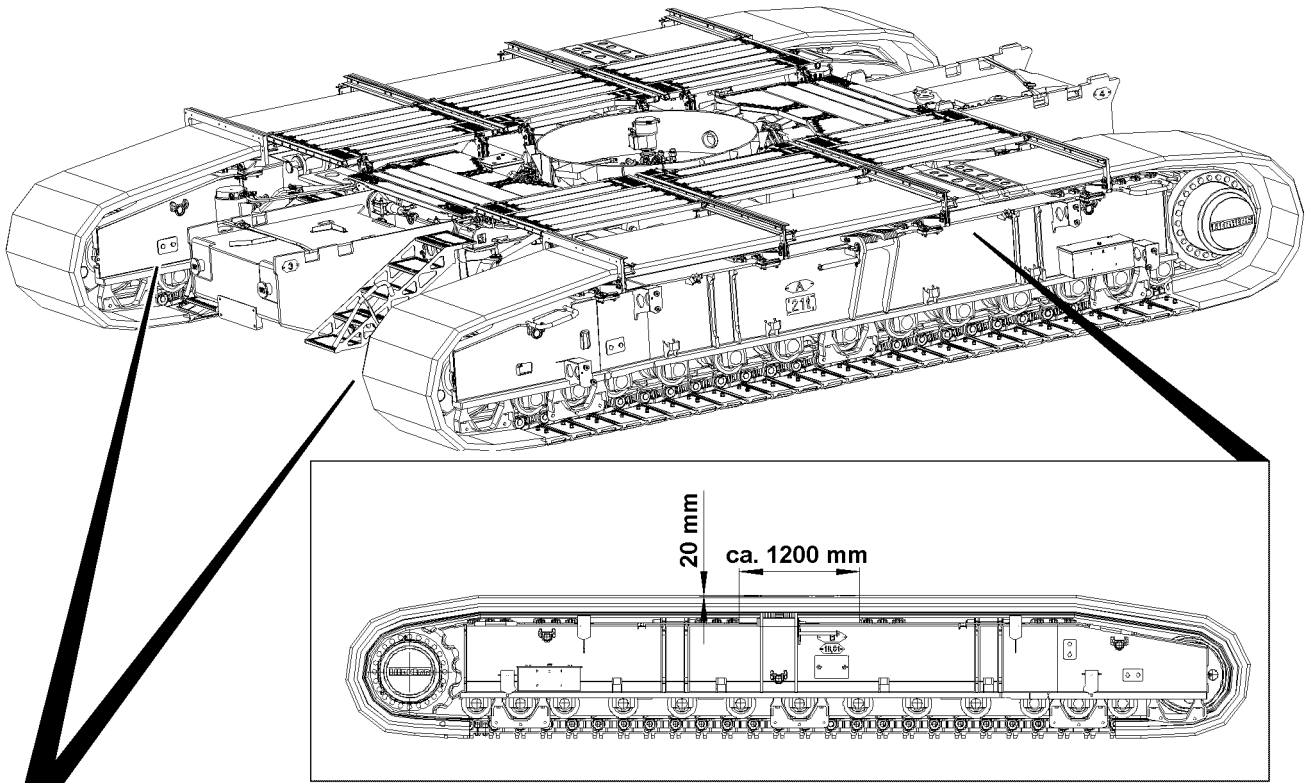


Fig.118013

LWE/LTR 1220-003/24204-02-02/en

## 2 Crawler travel gear

In crawler operation, the components of the track chain wear and must therefore be checked in specified intervals, see chapter 7.02 of the Crane operating instructions and replaced with new components, if necessary.

The track chains are tensioned with tension cylinders, which are extended with a manual grease gun.

To release the tension of the track chains, reduce the pressure in the tension cylinder.

### 2.1 Tensioning the track chain

---

#### NOTICE

Damage to the track chain!

If the chain tension is not checked within the specified maintenance intervals, the track chain or the steel structure of the crawler carrier can be damaged!

- ▶ Observe and adhere to the maintenance intervals as specified in chapter 7.02 of the Crane operating instructions!
  - ▶ Establish the permissible chain tension.
- 

#### NOTICE

Foreign matter in track chains!

Foreign matter in the track chains and on the travel drive can cause damage!

- ▶ Before tensioning the track chains, check the track chains and the travel drives for foreign particles, such as rocks, and clean them, if necessary!
- 

Make sure that the following prerequisites are met:

- The crane is in horizontal position.
- The manual grease gun with pressure gauge is on hand.

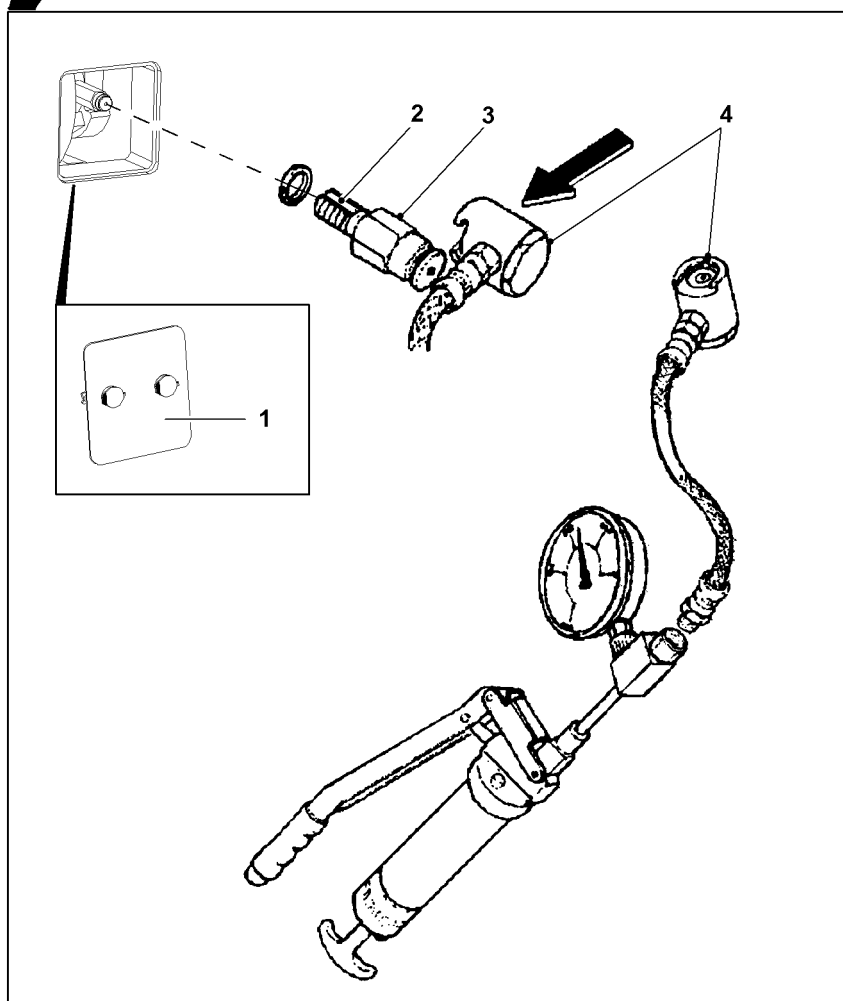
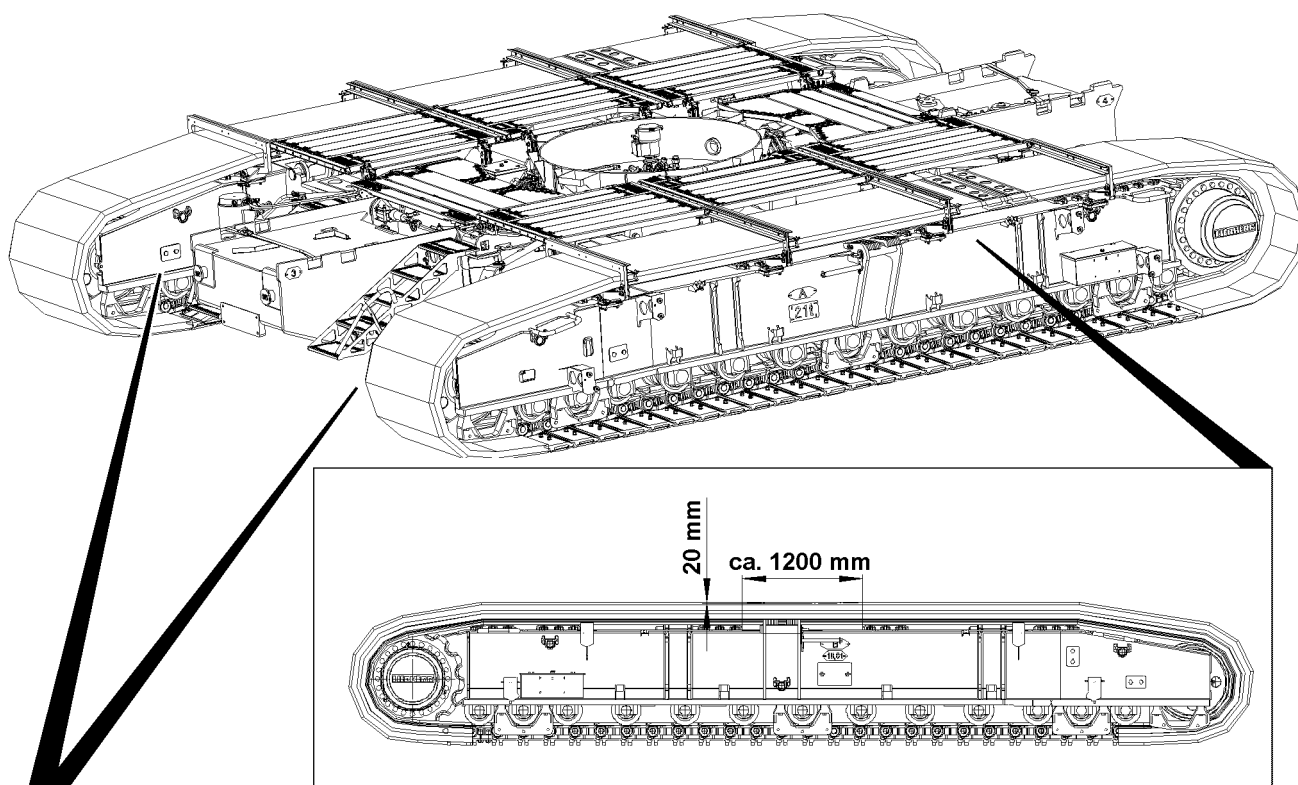


Fig.118013



### 2.1.1 Tensioning procedure

- ▶ Unscrew the cover **1** on the inside of the crawler carrier.
- ▶ Attach the hose **4** of the manual grease gun to the grease fitting **3** of the tension cylinder to the stop position (push).

---

#### NOTICE

Component wear due to **insufficient** chain tension!

- ▶ The track chain may have a sag of approx. 20 mm at a length section of 1200 mm.

- 
- ▶ Activate the manual grease gun until the pressure gauge shows a pressure of approx. **82 bar**.

#### Result:

- The track chain is tensioned.
- ▶ Remove the pressure hose **4** from the grease fitting.

---

#### Problem remedy

The pressure hose **4** does not detach from the grease fitting **3**?

The pressure in the pressure hose **4** is too high.

- ▶ Carefully loosen the pressure hose **4** on the manual grease gun, so that the pressure in the pressure hose is reduced.

- 
- ▶ Remove the pressure hose **4** from the grease fitting **3**.
  - ▶ Fasten the cover **1** tightly on the inside of the crawler carrier.
  - ▶ After the tensioning procedure, drive the track chain by about one track length straight ahead forwards and backwards.

#### Result:

- The tension in the lower chain area is relieved.



#### Note

- ▶ If necessary, repeat the tensioning procedure on the track chain.
-

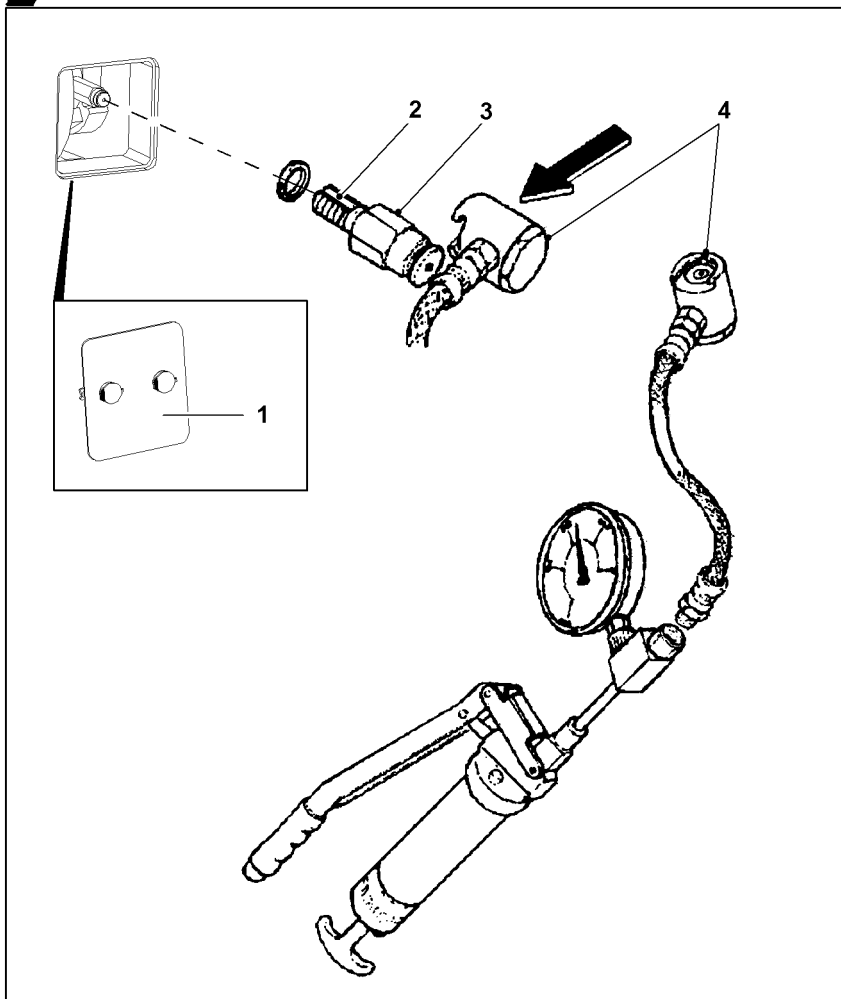
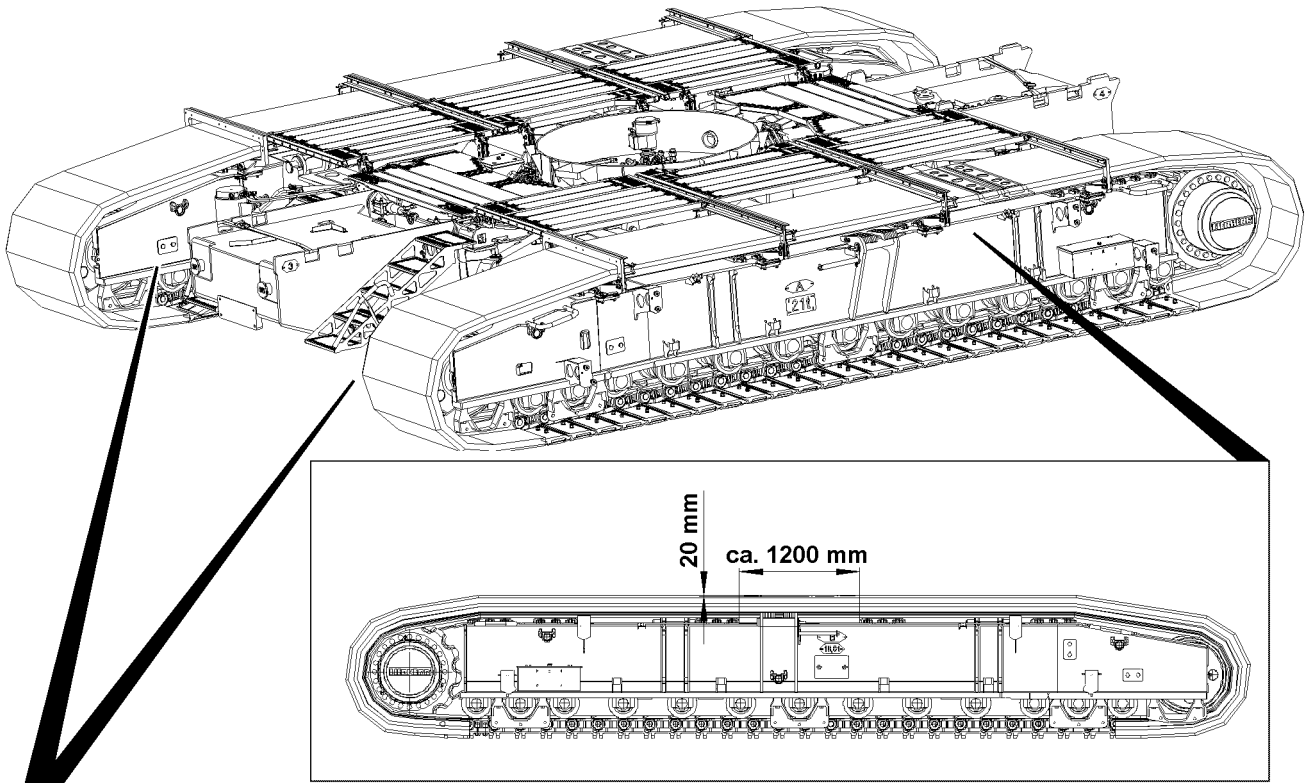


Fig.118013

LWE/LTR 1220-003/24204-02-02/en

## 2.2 Relieving the track chain

---

### NOTICE

Property damage due to high chain tension

- ▶ Establish the permissible chain tension.
- 



### WARNING

Danger of injury due to excess pressure!

Due to improper procedure when releasing the track chain, severe injuries to the face and especially the eyes can occur due to spraying grease.

- ▶ When releasing the grease fitting, do not look straight into the opening.
  - ▶ The following steps for the release procedure must be strictly adhered to.
- 

### 2.2.1 Release procedure

- ▶ Unscrew the cover **1** on the inside of the crawler carrier.
- ▶ Loosen the grease fitting **3** with extreme caution.
- ▶ Back the grease fitting **3** out carefully by 2 or 3 threads until grease can emerge from the groove **2**.
- ▶ Tighten the grease fitting **3** again.
- ▶ Fasten the cover **1** tightly on the inside of the crawler carrier.

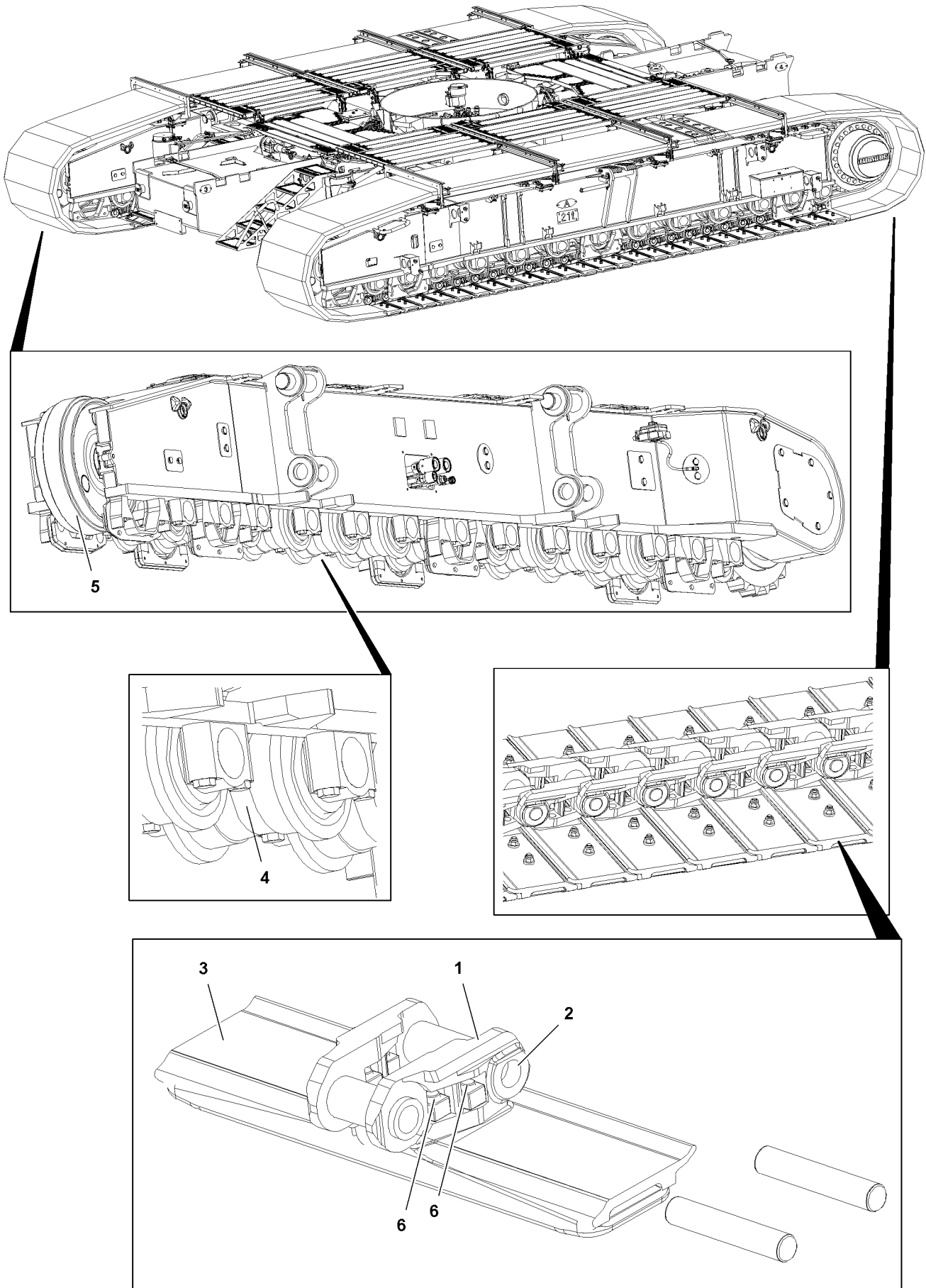


Fig.118030

LWE/LTR 1220-003/24204-02-02/en

## 2.3 Wear data for crawler travel gear



### WARNING

Track chain can be ripped off!

If the wear limit on the track pads, bolts or track rollers is exceeded, then the track chain can break off during crawler operation!

The crane can topple over and personnel can be severely injured or killed!

- ▶ Random inspections of the track pads, bolts and track rollers must be carried out within the specified intervals!
- ▶ During the random inspection of the track rollers, the first and last track roller on the crawler carrier must be included in the inspection!
- ▶ If a wear limit on the component is reached, then the component must be replaced or remachined!

### NOTICE

Significant wear of crawler travel gear!

If an individual track pad must be replaced, then it may not be replaced with a track pad which shows a much lower degree of wear!

Significant height differences between the individual track pads, see illustration, lead to an increased mechanical stress on the track pads and the track rollers of the crawler carrier!

- ▶ Replace a defective track pad with a track pad which shows a similar degree of wear!

### 2.3.1 Components

- 1 Chain link
- 2 Chain bushing
- 3 Track pad
- 4 Track roller
- 5 Idler
- 6 Track pad bolts

### 2.3.2 Chain link

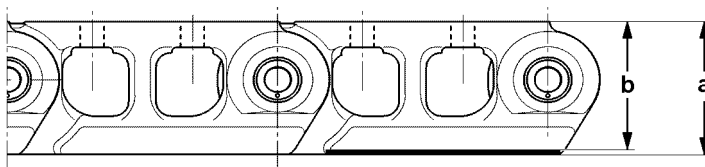


Fig.111492

Component	Dimensions	
	New	Wear limit
	a	b
Chain link	156 mm	144 mm

### 2.3.3 Chain pitch

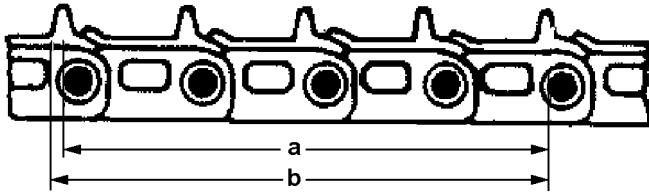


Fig.198807

Component	Dimensions	
	New	Wear limit
	a	b
Chain pitch	1041 mm	1062 mm

### 2.3.4 Chain bushing

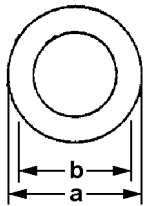


Fig.198808

Component	Dimensions	
	New	Wear limit
	a	b
Chain bushing	Diameter 85.62 mm	Diameter 81.4 mm

### 2.3.5 Track pad

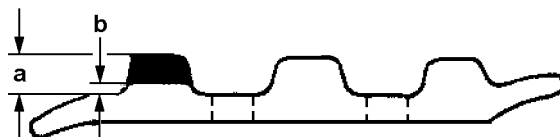


Fig.198809

Component	Dimensions	
	New	Wear limit
	a	b
Track pad	50 mm	15 mm

### 2.3.6 Track roller

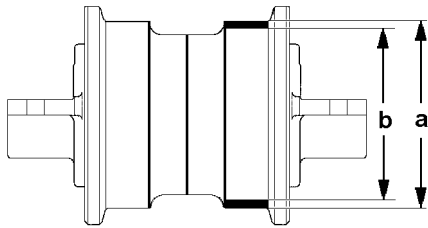


Fig.118517

Component	Dimensions	
	New	Wear limit
Track roller B9HD	a = Diameter 270 mm	b = Diameter 250 mm
Track roller B9HDS	a = Diameter 250 mm	b = Diameter 225 mm

### 2.3.7 Idler

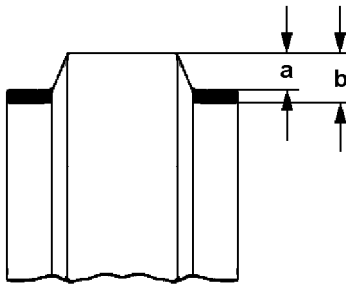


Fig.198812

Component	Dimensions	
	New	Wear limit
	a	b
Idler B9HD	22.5 mm	31.0 mm
Idler B9HDS	17.0 mm	30.0 mm

## 2.4 Installation of the track pads

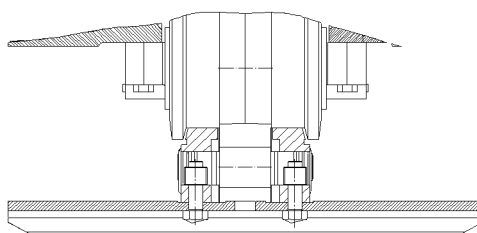


Fig.118970

The track pad bolts must be retightened after 50 operating hours.

For regular maintenance intervals for the track pad bolts refer to chapter 7.02 in the Crane operating instructions.

Track pad bolts	Tightening torque
1-1/8"	2210 Nm $\pm$ 110 Nm

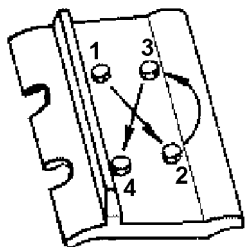


Fig.199143

- ▶ Retighten the bolts in the order shown on the illustration.



Empty page!

LWE/LTR 1220-003/24204-02-02/en

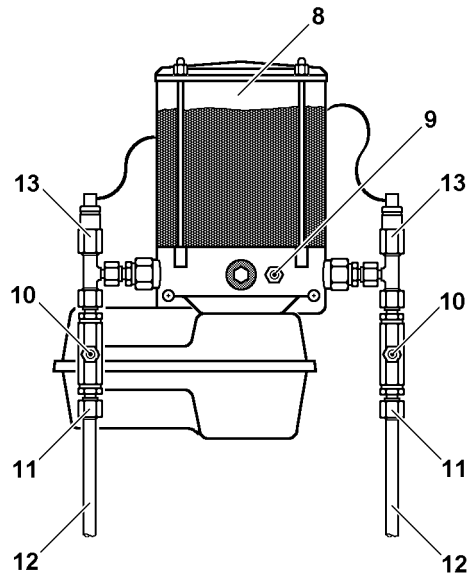


Fig.118029

## 3 Servicing the central lubrication system of the crawler carrier



### Note

- ▶ Use only service items and lubricants according to the Service fill.
- ▶ Adhere to the maintenance intervals as specified in chapter 7.02 of the Crane operating instructions.

If the crane is driven via the crawler travel gear, then the central lubrication system for the crawler carrier turns on automatically and supplies all grease points with the correct amount of grease.

### NOTICE

Insufficient lubrication!

The lubrication film is removed over time due to environmental influences!

Due to insufficient lubrication, the crawler carriers are exposed to significant wear and can be damaged!

- ▶ If the crawler carriers are not moved for a period of more than three months, then it must be lubricated every quarter, possibly with an external grease pump!



### Note

- ▶ When putting the crane back into service after an extended downtime, check the central lubrication system for function!
- ▶ When working on the central lubrication system, observe utmost cleanliness!
- ▶ Every crawler carrier has a separate grease pump with several lubrication circuits!
- ▶ Every lubrication circuit has its own main line **12**!

On the grease pump, see illustration, there are the following maintenance relevant components:

- 8** Grease container
- 9** Grease fitting
  - Filling the grease container
- 10** Grease fitting
  - Fill the lube lines
- 11** Main line connection
- 12** Main line
- 13** Pressure relief valve

### 3.1 Filling the grease container

### NOTICE

Insufficient lubrication!

In case of insufficient lubrication, the grease lubrication points can run dry!

This could result in high property damage!

- ▶ Fill the grease container **8** before it is completely empty!



### Note

- ▶ Do not deplete the grease container **8**!
- ▶ If the grease container **8** is empty, the central lubrication system must be bled!
- ▶ Fill the grease container **8** with an external grease pump via the grease fitting **9**.

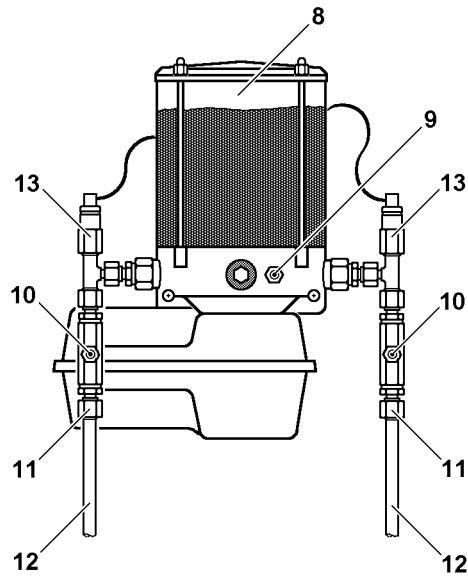


Fig.118029

LWE/LTR 1220-003/24204-02-02/en

## 3.2 Bleeding the central lubrication system

### NOTICE

Insufficient lubrication!

If there is air in the grease pump, lubrication points can run dry!

- ▶ Bleed the central lubrication system carefully!

The central lubrication system of the crawler travel gear can be bled two ways:

- By actuation of the grease pump by simulating the crawler operation.
- By separate actuation of the grease pump with the aid of the electric wiring diagram.

### 3.2.1 Bleeding by simulating crawler operation



#### WARNING

Crane can start to drive unintentionally!

If the foot rocker in the crane operator's cab or the manual control lever on the radio remote control console\* is moved too far while bleeding the grease pump, then the track chain can start to move!

The crane can start to drive and catch personnel!

Personnel can be severely injured or killed!

- ▶ Actuate the foot rocker carefully while bleeding the grease pump!
  - ▶ Watch the emergence of grease from the grease pump from a safe position!
- 
- ▶ Fill the grease container **8** with an external grease pump via the grease fitting **9**.
  - ▶ Fill the main lines **12** with an external grease pump via the grease fittings **10** until grease free of air bubbles emerges on all grease points.



#### Note

- ▶ Carry out the bleeding procedure individually for each main line connection **11**!
  - ▶ Every crawler carrier has a separate grease pump!
- 
- ▶ Unscrew the main line **12** from the main line connection **11**.
  - ▶ Start the crane engine.
  - ▶ Select crawler operation.
  - ▶ Actuate the foot rocker / manual control lever of the crawler carrier of the grease pump which is being bled only so far that the track chain does not start to move.
- Result:**
- The grease pump starts to supply.
  - The acoustic signal crawler operation sounds.
- ▶ Actuate the foot rocker / manual control lever only until grease free of air bubbles emerges on the main line connection **11**.
  - ▶ Connect the main line **12** again.
  - ▶ Actuate the foot rocker / manual control lever again until grease emerges again on at least one of the grease points in the bled lubrication circuit.

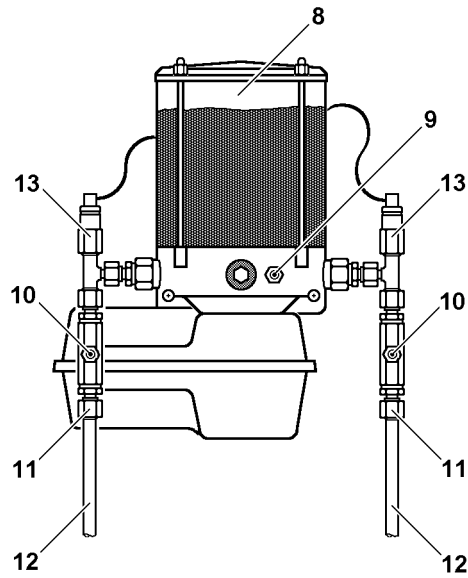


Fig.118029

LWE/LTR 1220-003/24204-02-02/en

### 3.2.2 Bleeding by separate actuation of the grease pump



#### Note

- ▶ Work on the electrical system of the crane may only be carried out by authorized and trained expert personnel!

Make sure that the following prerequisite is met:

- The separate electric wiring diagram of the crane is available.
- ▶ Fill the grease container **8** with an external grease pump via the grease fitting **9**.
- ▶ Fill the main lines **12** with an external grease pump via the grease fittings **10** until grease free of air bubbles emerges on all grease points.



#### Note

- ▶ The bleeding procedure must be carried out individually for each main line connection **11**!
- ▶ Every crawler carrier has a separate grease pump!

- ▶ Unscrew the main line **12** from the main line connection **11**.
- ▶ Actuate the grease pump separately, see crane electric wiring plan.

#### Result:

- The grease pump starts to supply.
- ▶ Actuate the grease pump until grease free of air bubbles emerges on the main line connection **11**.
- ▶ Connect the main line **12** again.
- ▶ Actuate the grease pump again until grease emerges again on at least one of the grease points in the bled lubrication circuit.

### 3.3 Bleeding repaired lubrication lines

#### NOTICE

Insufficient lubrication!

If there is air in the lube lines, lubrication points can run dry!

- ▶ If the lubrication lines are repaired or replaced, make sure that they are completely filled with grease!
- ▶ Fill lubrication lines completely with grease before installation.
- ▶ Check repaired lubrication lines for function and leaks.

### 3.4 Intermediate lubrication of crawler carriers

- ▶ Fill the main line **12** with an external grease pump via the grease fitting **10** until grease free of air bubbles emerges on all grease points.  
or  
Actuate the foot rocker / manual control lever in crawler operation until the grease pump starts to supply, but the track chain does not yet start to move. Continue actuation until grease emerges on all lube points.

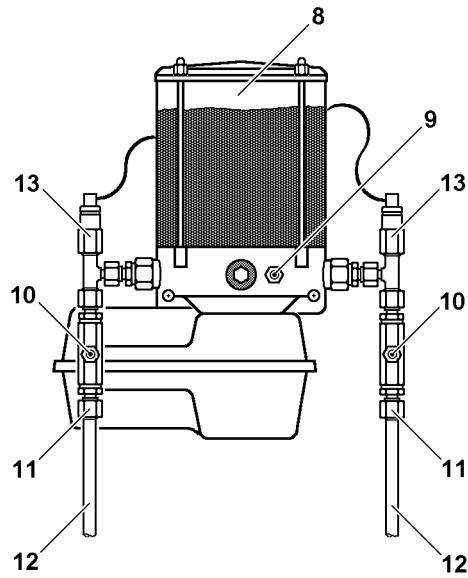


Fig.118029



### 3.5 Troubleshooting on the central lubrication system of the crawler carrier

Problem	Cause	Remedy
The grease pump does not work	Electrical line interrupted, grease pump defective	Fix or replace the electrical line, replace the grease pump
Grease pump operates, but does not deliver	Air cushion in delivery piston, minimum fill level fallen below, grease pump element defective	Bleed grease pump, fill reservoir, replace grease pump element
No grease collar on all lube points	Grease pump does not work, system blocked	See „Grease pump does not work“ or „Grease emerges via pressure relief valve“
No grease collar on several lube points	Supply lines to secondary distributors broken or leaking, screw connections leaking	Replace lines, tighten or replace screw connections
No grease collar on one lube point	Associated lube line broken or leaking, screw connection leaking	Replace line, tighten or replace screw fitting
Grease pump speed reduced	High system pressure, low ambient temperature	Check system / grease points, no damage: Lubricate manually once or twice in between <sup>1)</sup>
Grease emerges via pressure relief valve	System pressure too high, distributor blocked, system blocked, defective valve spring on pressure relief valve	Check system, replace distributor, repair blocked / seized bearing point, replace pressure relief valve

1) See section „Intermediate lubrication of crawler carriers“.

If a problem cannot be remedied, contact the Service Dept. at Liebherr-Werk Ehingen.

## 4 Hydraulic hose lines



### WARNING

Damaged and leaky hydraulic hose lines!  
Fire, accidents, death, severe injury, property damage.

If leaky areas are found during the visual inspection:

- ▶ Have these leaky areas inspected immediately by authorized and trained expert personnel and remedied.

If damage is found during the visual inspection:

- ▶ Have hydraulic hose lines checked by an **expert person for hydraulic hose lines**.



### Note

- ▶ For annual inspection of hydraulic hose lines and for definition of **expert person for hydraulic hose lines**, see Crane operating instructions, chapter 8.06.

Hydraulic hose lines must be inspected **once a year** by an **expert person for hydraulic hose lines**.

The system must be visually inspected **daily**.

The system must be visually inspected **before starting to work**.

## 4.1 Inspecting the hydraulic hose lines for damage

Hydraulic hose lines must be inspected by an **expert person for hydraulic hose lines** when one of the following defects is found:

- Damage on outer surface, such as chafe marks, cuts and cracks
- Brittleness due to aging of outer layer (cracks)
- Distortion, such as splitting of hose layers, bubbles, crushed areas, kinks, twists
- Damage or distortion of hose fixtures or hose fitting (seal is endangered)

▶ Inspect the hydraulic hose lines for damage.

If one of the listed defects is found:

- ▶ Have hydraulic hose lines checked by an **expert person for hydraulic hose lines**.
- ▶ Document conspicuous findings, decisions and replacements comprehensibly, see Crane operating instructions, chapter 8.06.

## 4.2 Inspecting the hydraulic hose lines for leaks

- ▶ Check the crane for escaped hydraulic oil.
- ▶ Check the ground under the crane for leaks.

When the hydraulic system leaks:

- ▶ Have these leaky areas inspected by authorized and trained expert personnel and remedied.

If one of the listed defects is found:

- ▶ Have hydraulic hose lines checked by an **expert person for hydraulic hose lines**.
- or**
- Contact Liebherr Service.
- ▶ Document conspicuous findings, decisions and replacements comprehensibly, see Crane operating instructions, chapter 8.06.

# 5 Ladders



### WARNING

Danger of falling!

If the following safety guidelines are **not** observed, personnel can fall down and be killed or severely injured.

- ▶ Observe and adhere to the installation and safety guidelines for ladders.
- ▶ Observe and adhere to the safety signs on the ladders.
- ▶ Install and secure the ladders properly.
- ▶ Do **not** use damaged ladders and replace them immediately.
- ▶ Repair the ladder exclusively through authorized service facilities.

## 5.1 Lubricating ladders

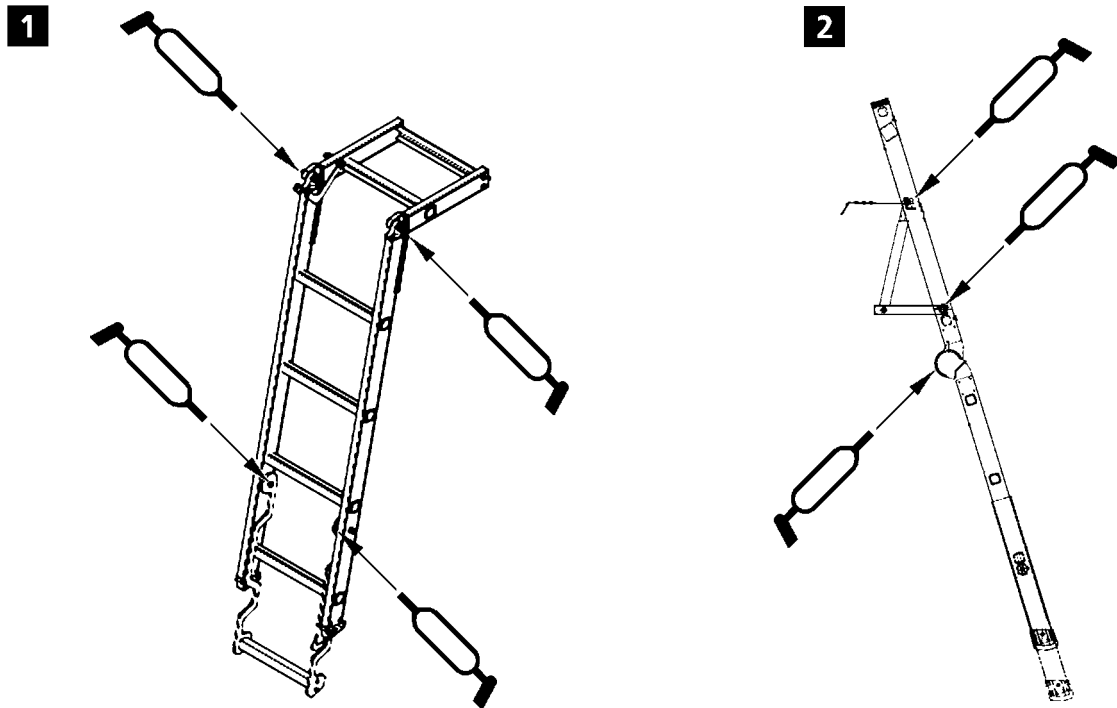


Fig.109766

- ▶ Grease joints and pivot points on the ladders regularly and check them for easy movement, see illustration 1 and illustration 2!
- ▶ Repairs and maintenance work on the ladder must be made by expert personnel.

---

Empty page!

LWE/LTR 1220-003/24204-02-02/en

## 7.05 Maintenance instructions - Crane superstructure

1	Safety	2
2	Diesel engine	2
3	Cooling system	5
4	Air filter system	10
5	Fuel system	12
6	Urea system*	21
7	Exhaust system*	24
8	Pump distributor gear	26
9	Central lubrication system	28
10	Slewing ring connection	32
11	Slewing gear(s)	34
12	Hoist gear(s)	39
13	Heating-air conditioning device	41
14	Cab auxiliary heater*	45
15	Engine preheating auxiliary heater*	49
16	Ventilation	52
17	Hydraulic system	53
18	Hydraulic hose lines	58
19	Compressed air system*	58
20	Electrical system	59
21	Ladders	63

# 1 Safety

Before performing maintenance activities, observe the safety notes:

- General safety information: See chapter 2.04.
- Information regarding personal protective equipment: See chapter 2.04.
- Information regarding ladders: See chapter 2.04.10.
- Information regarding fall protection equipment on the crane: See chapter 2.06.
- Information regarding accesses to the crane: See chapter 2.07.
- Information regarding maintenance and service: See chapter 7.01.

## 2 Diesel engine

### 2.1 Checking the oil level in the crane cab

Make sure that the following prerequisites are met:

- The crane is in a horizontal position.
- The diesel engine has been turned off for at least 30 minutes.
- The ignition is turned on.

#### NOTICE

**Impermissible** engine oil level!

Engine damage.

- ▶ Remedy the problem and observe the error message.
- ▶ Establish a permissible oil level.

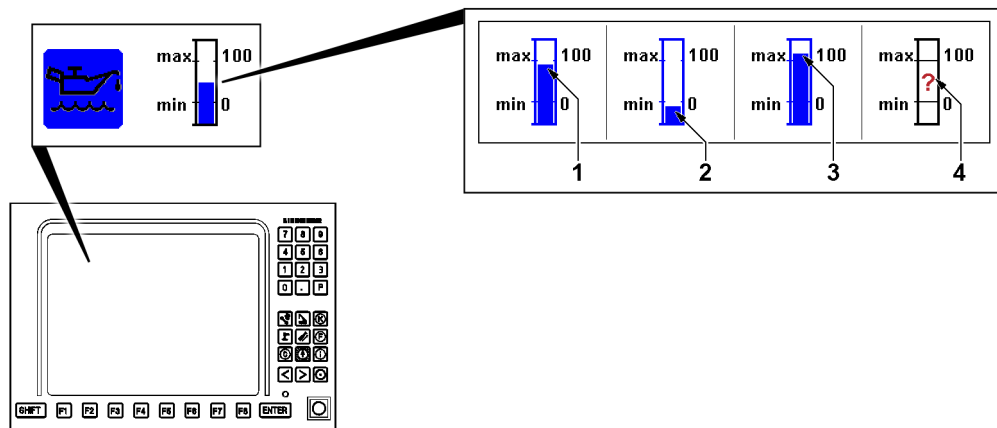


Fig.154714: Crane chassis engine oil level

- ▶ Call up the *Crane chassis engine display* menu.  
or  
Press the button **110**.

#### Result:

The engine oil level is shown on the BTT:

- At a normal level, the bar **1** reaches a display between 0 and 100.
- If underfilled, the bar **2** reaches a display under 0.
- If overfilled, the bar **3** reaches a display above 100.
- In case of an incorrect measurement, a question mark **4** (?) appears.

When the engine is running, a faulty measurement value appears. For the engine oil level check, make sure that the crane is aligned horizontally and that the diesel engine has been turned off for at least 30 min.

The oil level display must be between 0 and 100.

- ▶ Check the oil level, add engine oil if necessary.

---

#### Problem remedy

Is the oil level display above 100?

- ▶ Find the cause and remedy it.

If the cause cannot be remedied:

- ▶ Contact Customer Service at Liebherr-Werk Ehingen GmbH.
- 

#### Problem remedy

Excessive oil consumption or loss of oil?

- ▶ Find the cause and remedy it.

If the cause cannot be remedied:

- ▶ Contact Customer Service at Liebherr-Werk Ehingen GmbH.
- 

## 2.2 Checking the oil level with the dipstick

---

### NOTICE

**Impermissible** engine oil level!

Engine damage.

- ▶ Remedy the problem and observe the error message.
  - ▶ Establish a permissible oil level.
- 

### NOTICE

Mechanical stress!

Property damage.

- ▶ When working in the engine area, do **not** step on the fuel lines.
- 



### Note

Recommendation:

- ▶ Liebherr-Werk Ehingen GmbH recommends: Check the oil level or change the engine oil when the primary aggregate, the crane superstructure, is positioned on the transport vehicle.
- 

Make sure that the following prerequisites are met:

- The crane is in a horizontal position.
- The crane superstructure is aligned parallel to the crawler travel gear.
- The diesel engine has been turned off for at least 30 minutes. The ignition is off.
- The battery master switch is turned off.

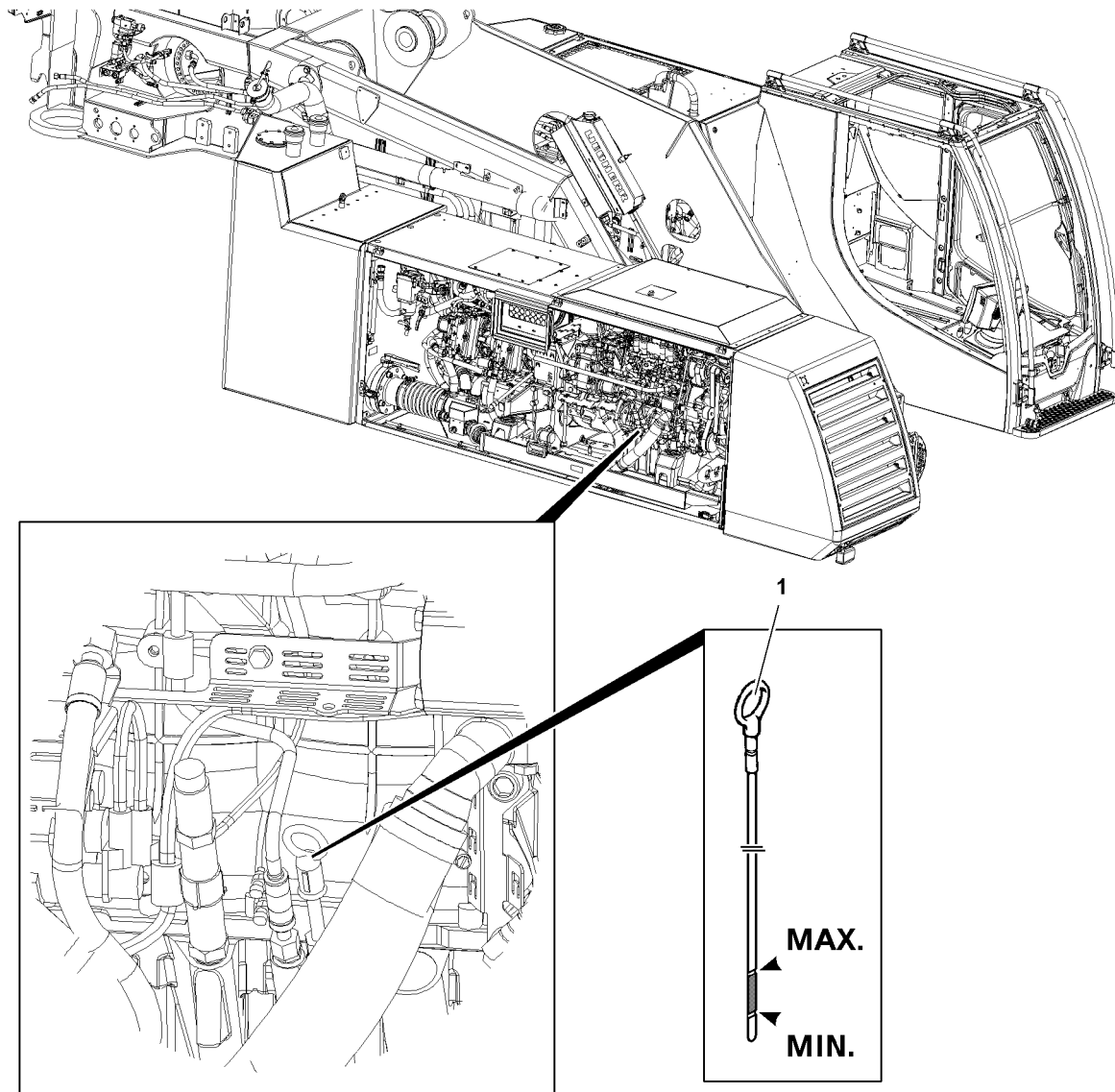


Fig.122553: Diesel engine dipstick

- ▶ Ascent and descent on the crawler carrier, observe the notes and instructions in chapter 2.07.
- ▶ Pull out the dipstick **1** and wipe it off.
- ▶ Insert the dipstick **1** and pull it out.

The engine oil must be visible between both marks on the dipstick **1**.

- ▶ Check the oil level.

When the oil level has dropped below the minimum mark:

- ▶ Add engine oil in the filler port until the oil level is visible between both marks on the dipstick.
- ▶ Insert the dipstick **1**.

#### Problem remedy

Is the oil level above the maximum mark?

- ▶ Find the cause and remedy it.

If the cause cannot be remedied:

- ▶ Contact Customer Service at Liebherr-Werk Ehingen GmbH.



**Problem remedy**

Excessive oil consumption or loss of oil?

- ▶ Find the cause and remedy it.

If the cause cannot be remedied:

- ▶ Contact Customer Service at Liebherr-Werk Ehingen GmbH.

**2.3 Checking the condition of the belt drive**

- ▶ Check the belt drive, see the separate engine manufacturer's operating instructions.

**2.4 Checking the heat flange**

- ▶ Check the heat flange, see the separate engine manufacturer's operating instructions.

**2.5 Replacing the heat flange**

- ▶ Replace the heat flange, see the separate engine manufacturer's operating instructions.

**2.6 Changing the engine oil**

Make sure that the following prerequisites are met:

- A drain hose for draining the engine oil is available, see the on-board tools.
- ▶ Change the engine oil, see the separate engine manufacturer's operating instructions.

**2.7 Replacing the oil filter**

- ▶ Replace the oil filter, see the separate engine manufacturer's operating instructions.

**2.8 Replacing the oil separator filter insert**

- ▶ Replace the oil separator filter insert, see the separate engine manufacturer's operating instructions.

**2.9 Checking the valve clearance**

- ▶ Check and set the valve clearance, see the separate engine manufacturer's operating instructions.

**3 Cooling system****WARNING**

Swallowing coolant, contact with coolant!

Poisoning when ingesting, eye damage and skin irritation at contact.

- ▶ Make sure that eyes, skin and clothing do **not** come in contact with coolant.
- ▶ Wear protective gloves and safety goggles.
- ▶ Do not swallow the coolant.

**First aid measures after contact with coolant:**

- If coolant was swallowed: Contact a physician immediately.
- When eyes came in contact with coolant: Flush eyes out with a lot of water and go to a physician, if necessary.
- If skin and clothing came into contact with coolant: Clean the skin and clothing immediately with water and soap.

**NOTICE**

Impermissible coolant!

Property damage.

- ▶ Do **not** mix different coolants.
- ▶ Do **not** thin Liebherr-Fertig-Mix (Liebherr Ready Made Mix).

When adding coolant:

- ▶ Use exclusively the same coolant with the same color.

Different coolants are differentiated by different colors.

Coolants contain corrosion inhibitor - antifreeze fluid.

### 3.1 Checking the coolant level

Make sure that the following prerequisites are met:

- The mobile crane is horizontal.
- The telescopic boom is luffed up.
- The diesel engine is cold.
- The battery master switch is turned off.

The coolant level is monitored electrically, see the display unit in the driver's cab.

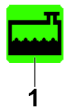


Fig.146632

When the *coolant level* icon **1** is red, then the coolant level is too low.

- ▶ Wait until the coolant has cooled off.

**DANGER**

Hot coolant vapor!

Scalding.

- ▶ Check the coolant level only when the diesel engine is cold.
- ▶ Wear protective gloves and safety goggles.

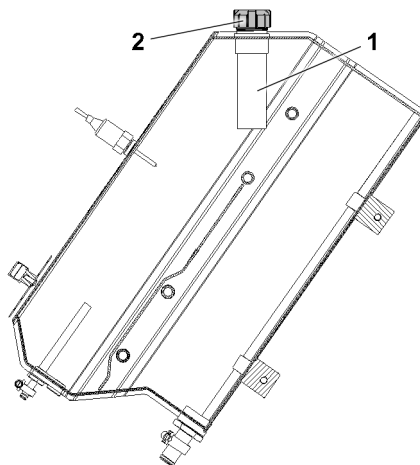


Fig.154112: Coolant expansion tank

- ▶ Release excess pressure: Turn the cover **2** on the filler neck of coolant expansion tank to the first notch.
- ▶ Remove the cover **2**.

The coolant must be filled up to the lower edge of the riser tube **1**.

Only add coolant only through the filler neck of the coolant expansion tank.

- ▶ Check the coolant level.

When the coolant level is too low:

- ▶ Add coolant to the lower edge of the riser tube 1.

### 3.2 Checking the concentration of the antifreeze in the coolant

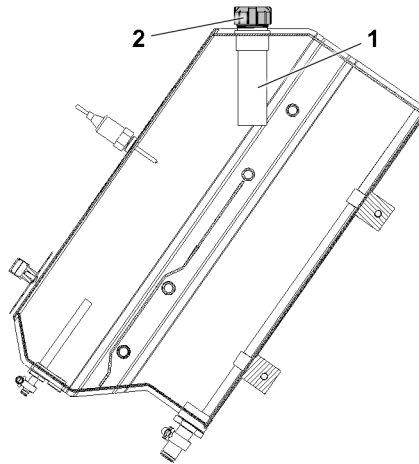


Fig.154112: Coolant expansion tank

Make sure that the following prerequisites are met:

- The mobile crane is horizontal.
- The telescopic boom is luffed up.
- The diesel engine is cold.
- The battery master switch is turned off.



#### **DANGER**

Hot coolant vapor!  
Scalding.

- ▶ Check the concentration of the antifreeze only when the diesel engine is cold.
- ▶ Wear protective gloves and safety goggles.
- ▶ Wait until the coolant has cooled off.

- ▶ Release excess pressure: Turn the cover 2 on the filler neck of coolant expansion tank to the first notch.
- ▶ Remove the cover 2.
- ▶ Remove the coolant specimen.

The concentration of the antifreeze must be between 50% and 60%.

- ▶ Check the concentration of the antifreeze.

If the concentration of the antifreeze is impermissible:

- ▶ Correct the concentration of the antifreeze, see the separate operating instructions of the engine manufacturer.
- ▶ Draining the coolant, see section „Changing the coolant“.

### 3.3 Changing the coolant



#### **Note**

When the coolant is changed:

- ▶ Empty the cooling system completely and flush it.

Make sure that the following prerequisites are met:

- The mobile crane is horizontal.
- The diesel engine is cold.
- The battery master switch is turned off.
- A container for coolant with sufficient capacity is on hand.
- Authorized and trained expert personnel replaces the coolant.

### 3.3.1 Draining the coolant

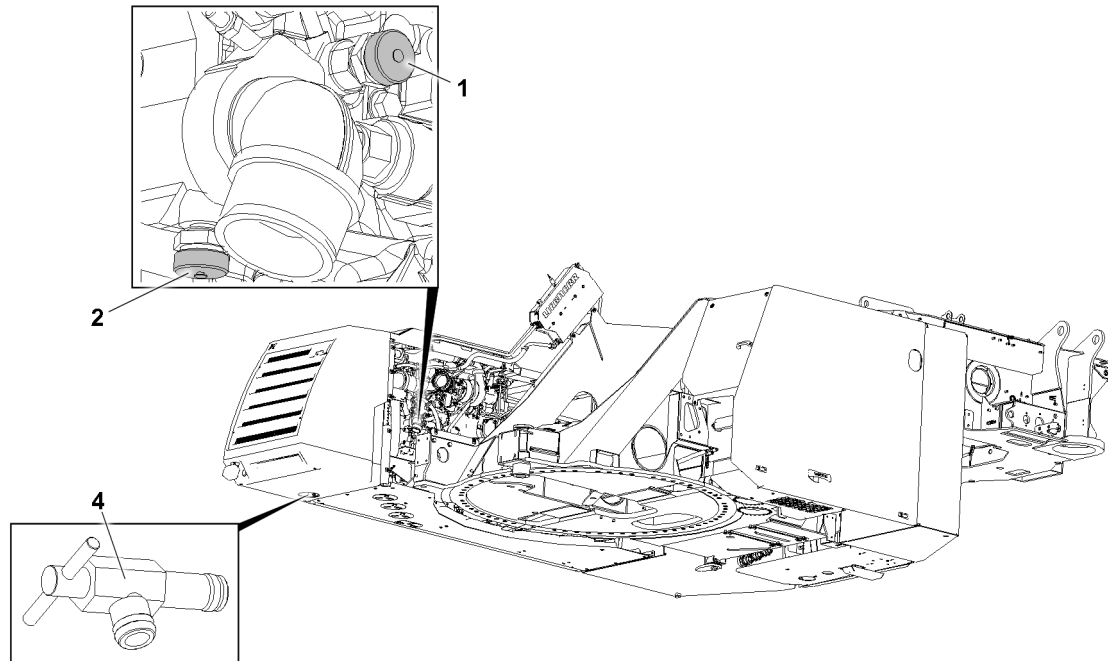


Fig.154847: Coolant draining positions

- |   |                      |
|---|----------------------|
| <p>1 Drain valve</p> <p>2 Drain valve</p> | <p>4 Drain valve</p> |
|---|----------------------|



#### DANGER

Hot coolant vapor!  
Scalding.

- ▶ Check the coolant level only when the Diesel engine is cold.
  - ▶ Wear protective gloves and safety goggles.
- 
- ▶ Turn the cap on the filler neck of coolant expansion tank to the first notch.
  - ▶ Remove the cap.
  - ▶ Collect the coolant: Position a container below the drain valve 4.
  - ▶ Drain the coolant: Open the drain valve 4 until the coolant has drained fully.
  - ▶ Close the drain valve 4.
  - ▶ Unscrew the protective caps from the drain valve 1 and bleeder valve 2.
  - ▶ Collect the coolant: Position a container under the drain valve 2.

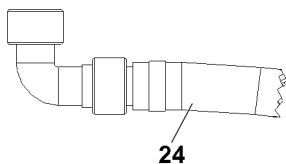


Fig.153600

- ▶ Connect the drain hose 24 to the drain valve 2 and drain the coolant fully.
- ▶ Screw the protective cap onto the drain valve 2.

- ▶ Collect the coolant: Position a container under the drain valve **1**.
- ▶ Connect the drain hose **24** to the drain valve **1** and drain the coolant fully.
- ▶ Screw the protective cap onto the drain valve **1**.

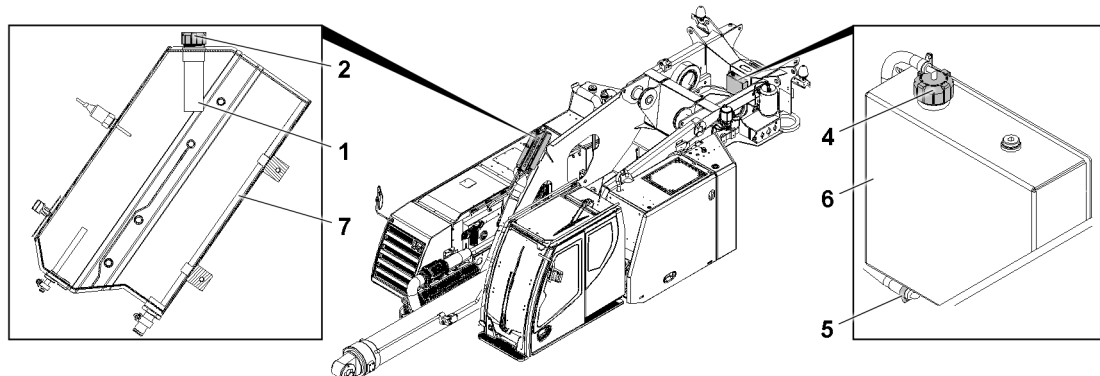


Fig.155742: Auxiliary coolant tank

- |          |                              |          |                        |
|----------|------------------------------|----------|------------------------|
| <b>1</b> | Riser tube                   | <b>5</b> | Hose clamp             |
| <b>2</b> | Coolant expansion tank cover | <b>6</b> | Auxiliary coolant tank |
| <b>4</b> | Auxiliary coolant tank cover | <b>7</b> | Coolant expansion tank |

- ▶ Open the cover **4** of the auxiliary coolant tank **6**.
- ▶ Release the hose clamp **5** from the coolant hose.
- ▶ Collect the coolant: Place a container below the Auxiliary coolant tank **6**.
- ▶ Pull the coolant hose out of the auxiliary coolant tank **6**.

When the coolant has been fully drained from the auxiliary coolant tank **6**:

- ▶ Attach the coolant hose to the auxiliary coolant tank **6**.
- ▶ Tighten the hose clamp **5**.

### 3.3.2 Filling up the coolant

Make sure that the following prerequisites are met:

- The coolant is fully drained.
- The drain valve and the bleeder valves are closed.
- Permissible coolant is available, see the service fill.
- The required quantity of coolant is available.

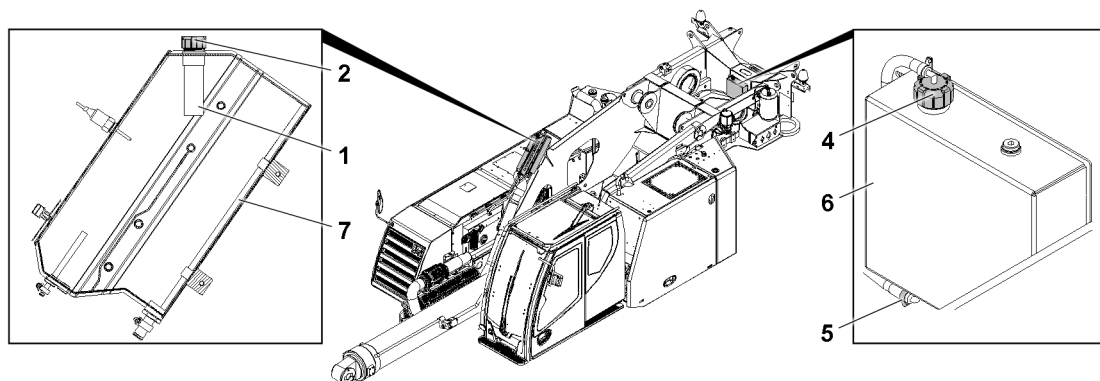


Fig.155742: Filling up the coolant

- |          |                              |          |                        |
|----------|------------------------------|----------|------------------------|
| <b>1</b> | Riser tube                   | <b>5</b> | Hose clamp             |
| <b>2</b> | Coolant expansion tank cover | <b>6</b> | Auxiliary coolant tank |
| <b>4</b> | Auxiliary coolant tank cover | <b>7</b> | Coolant expansion tank |

When the coolant is completely drained:

- ▶ Add coolant up to the lower edge of the riser tube **1** on the coolant expansion tank **7**.
- ▶ Position the cover **2** and close the coolant expansion tank **7**.

- ▶ Fill the auxiliary coolant tank **6** with 3 l coolant.
- ▶ Position the cover **4** and close the auxiliary coolant tank **6**.
- ▶ Start the diesel engine and let it warm up until the coolant temperature reaches at least 80 °C.
- ▶ Turn off the diesel engine and let it cool off.
- ▶ Check the coolant level, see section „Checking the coolant level in the expansion tank“.

## 4 Air filter system

### 4.1 Cleaning the dust discharge valve

#### NOTICE

The dust discharge valve is missing!

The service life of the air filter can be reduced.

- ▶ Operate the diesel engine only with the dust discharge valve.

Make sure that the following prerequisites are met:

- The crane is in a horizontal position.
- The diesel engine is turned off. The ignition is off.
- The battery master switch is turned off.

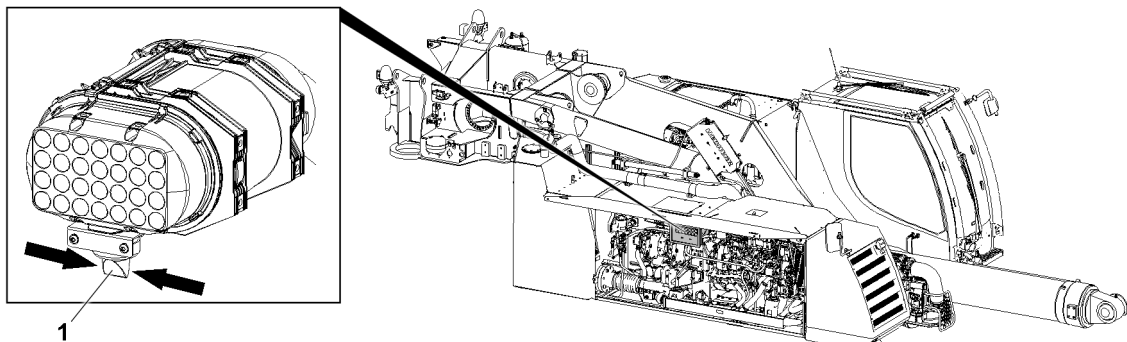


Fig.154849: Air filter

- ▶ Continue to compress the dust discharge valve **1** until the dust discharge valve **1** opens.

#### Result:

- Dust and deposits release from the dust discharge valve **1**.

#### Problem remedy

Dust and deposits do **not** release from the dust discharge valve **1**!

- ▶ Disassemble the dust discharge valve **1**: Remove the host clamp. Turn the dust discharge valve **1** and pull it out from below from the outlet pipe.

When the dust discharge valve **1** is disassembled:

- ▶ Clean the dust discharge valve **1** manually.

### 4.2 Replacing the dry air filter main element

Make sure that the following prerequisites are met:

- The crane is in a horizontal position.
- The diesel engine is turned off. The ignition is off.
- The battery master switch is turned off.

The dry air filter main element is monitored electrically see the display unit in the driver's cab.



3

Fig.146634

When the *air filter* icon **3** is yellow, then the air filter is dirty.

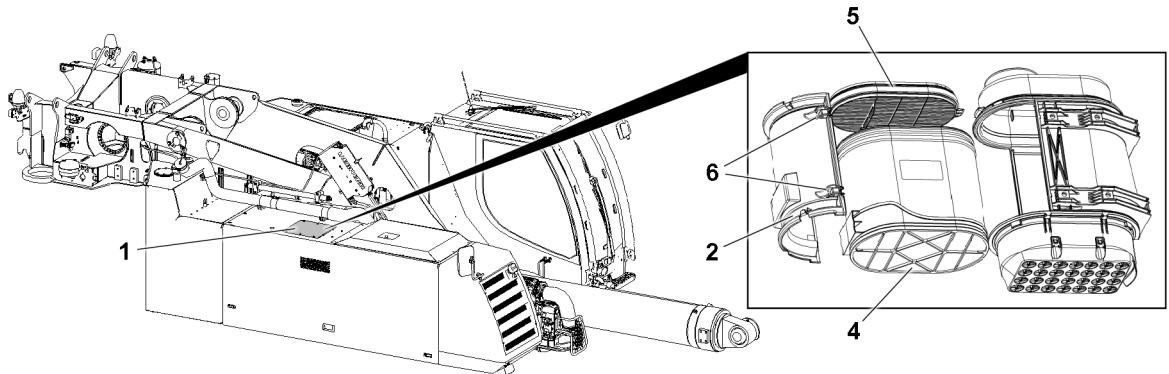


Fig.154850: Air filter elements

- |          |                             |          |                               |
|----------|-----------------------------|----------|-------------------------------|
| <b>1</b> | Safety panel                | <b>5</b> | Dry air filter safety element |
| <b>2</b> | Cover                       | <b>6</b> | Locks                         |
| <b>4</b> | Dry air filter main element |          |                               |

When the *air filter* icon **3** is yellow:

- ▶ Remove the safety panel **1**.
- ▶ Open the locks **6** and remove the cover **2**.
- ▶ Remove the dry air filter main element **4**.

When both filter elements are replaced:

- ▶ Replace the dry air filter safety element **5**.
- ▶ Replace the dry air filter main element **4**.
- ▶ Position the cover **2** and close the locks **6**.

### 4.3 Replacing the dry air filter safety element

Make sure that the following prerequisites are met:

- The crane is in a horizontal position.
- The diesel engine is turned off. The ignition is off.
- The battery master switch is turned off.

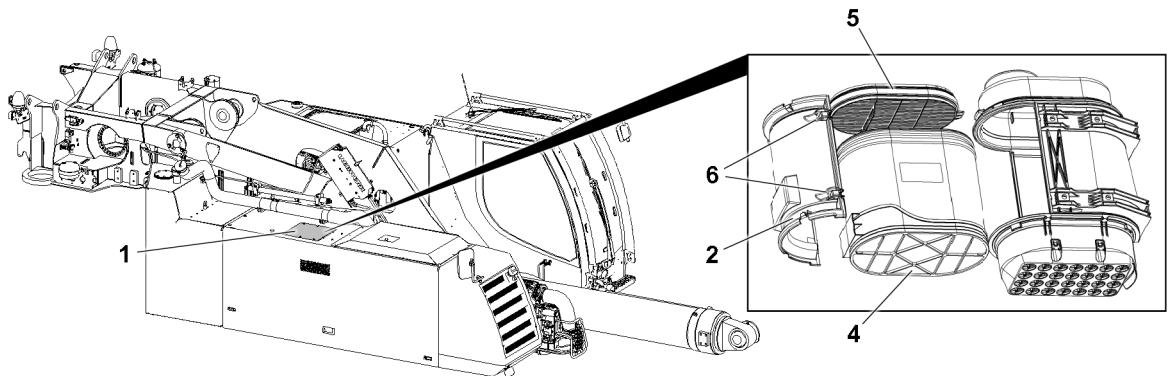


Fig.154850: Air filter elements

- |          |                             |          |                               |
|----------|-----------------------------|----------|-------------------------------|
| <b>1</b> | Safety panel                | <b>5</b> | Dry air filter safety element |
| <b>2</b> | Cover                       | <b>6</b> | Locks                         |
| <b>4</b> | Dry air filter main element |          |                               |

- ▶ Remove the safety panel **1**.
- ▶ Open the locks **6** and remove the cover **2**.
- ▶ Remove the dry air filter main element **4**.
- ▶ Replace the dry air filter safety element **5**.

When both filter elements are replaced:

- ▶ Replace the dry air filter main element **4**.
- ▶ Insert the dry air filter main element **4**.
- ▶ Position the cover **2** and close the locks **6**.

## 5 Fuel system



### WARNING

Smoking, fire, open light, electrical discharges!  
 Danger of fire: Diesel fuel is easily flammable.  
 Death, severe bodily injuries, property damage.

- ▶ Before the refueling procedure, turn the heating systems off, for example the auxiliary heater, flame start system.
- ▶ During refueling, forbid fire, open light and smoking.



### DANGER

Spilled fuel!  
 Danger of fire. Diesel fuel is easily flammable.

- ▶ Keep the engine area free of fuel.
- ▶ Absorb fuel with rags.
- ▶ Dry up spilled fuel.

### 5.1 Adding diesel fuel



### WARNING

Smoking, fire, open light, electrical discharges!  
 Danger of fire: Diesel fuel is easily flammable.  
 Death, severe bodily injuries, property damage.

- ▶ Before the refueling procedure, turn the heating systems off, for example the auxiliary heater, flame start system.
- ▶ During refueling, forbid fire, open light and smoking.



### DANGER

Spilled fuel!  
 Danger of fire. Diesel fuel is easily flammable.

- ▶ Keep the engine area free of fuel.
- ▶ Absorb fuel with rags.
- ▶ Dry up spilled fuel.



### WARNING

Contact with fuel!  
 Poisoning. Fuel is poisonous and hazardous to health.

- ▶ Do **not** allow fuel to come in contact with skin, eyes or clothing.
- ▶ Do **not** breathe in fuel vapors.
- ▶ Wear protective gloves and safety goggles.

#### First aid measures after contact with fuel:

- If fuel was swallowed: contact a physician immediately.
- In case of eye contact, flush out the eyes immediately and consult a physician if necessary.
- In the case of skin contact, clean affected skin areas with clear water.



**NOTICE**

Impermissible fuel!

Severe damage to the engine and fuel system.

- ▶ Make sure that the minimum requirement for fuel is fulfilled, see the separate operating instructions of the engine manufacturer.
- ▶ Do **not** mix fuels.

**NOTICE**

Dirt in the fuel system!

Damage to components. Increased wear and shorter service life of the components.

- ▶ Make sure that no dirt gets into the inside of the fuel system.

Make sure that the following prerequisites are met:

- The mobile crane is horizontal.
- The engine is turned off.
- The ignition is turned off.
- The heating systems are turned off, for example the auxiliary heater, flame start system.
- The battery master switch is turned off.
- The fuel nozzle holder is available, see the on-board tools.

When maintenance personnel can **not** reach the filler neck from the ground:

- Use the supplied ladder as a stepladder.
- ▶ Follow the notes and instructions, see chapter 2.04.10 and chapter 2.07.

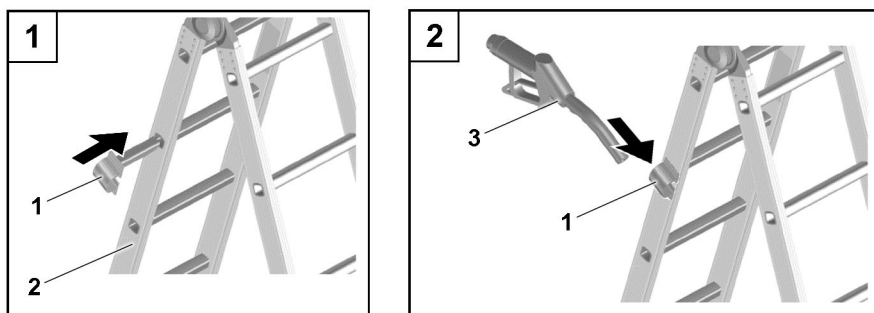


Fig.152445: Ladder with fuel nozzle holder

- ▶ Place the ladder **2** as a stepladder next to the mobile crane.
- ▶ Insert the fuel nozzle holder **1** to the stop in the ladder rung.

**WARNING**

Fuel nozzle **not** inserted deep enough!

Danger of fire: Escaping fuel, falling of the fuel nozzle.

- ▶ Insert the fuel nozzle as deep as possible into the fuel nozzle holder and in the filler neck.
- ▶ Insert the fuel nozzle **3** as deep as possible into the fuel nozzle holder **1** and secure it from falling down.
- ▶ Climb on the ladder **2**.

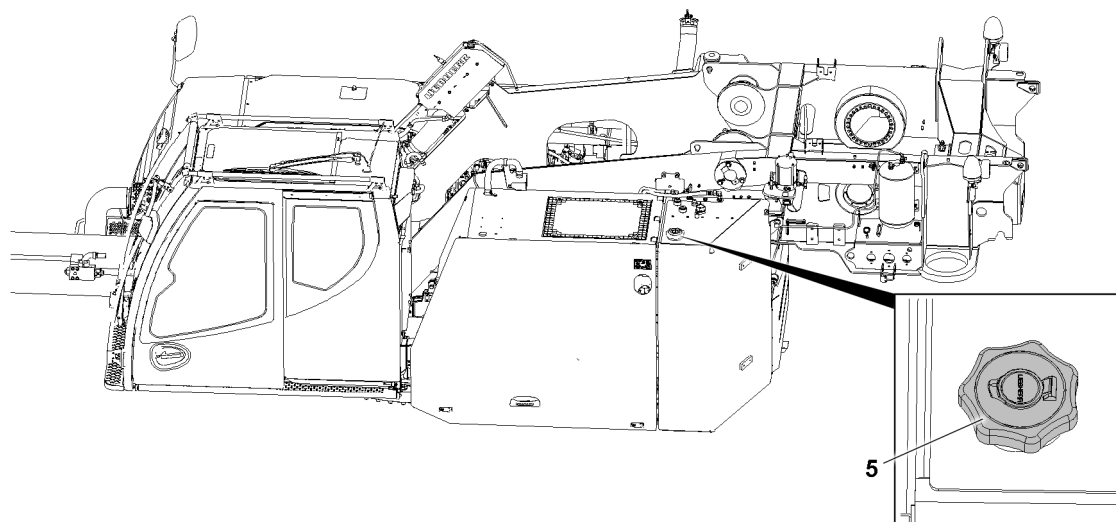


Fig.154851: Fuel tank

- ▶ Remove the cover **5**.
- ▶ Insert the fuel nozzle as deep as possible into the filler neck.
- ▶ Until the fuel nozzle turns off: Add diesel fuel.

When the refueling procedure is done:

- ▶ Remove the fuel nozzle **3** from the filler neck and insert it as deep as possible into the fuel nozzle holder **1** and secure it from falling down.



#### WARNING

The cover is **not** firmly closed!  
 Danger of fire: Escaping fuel.

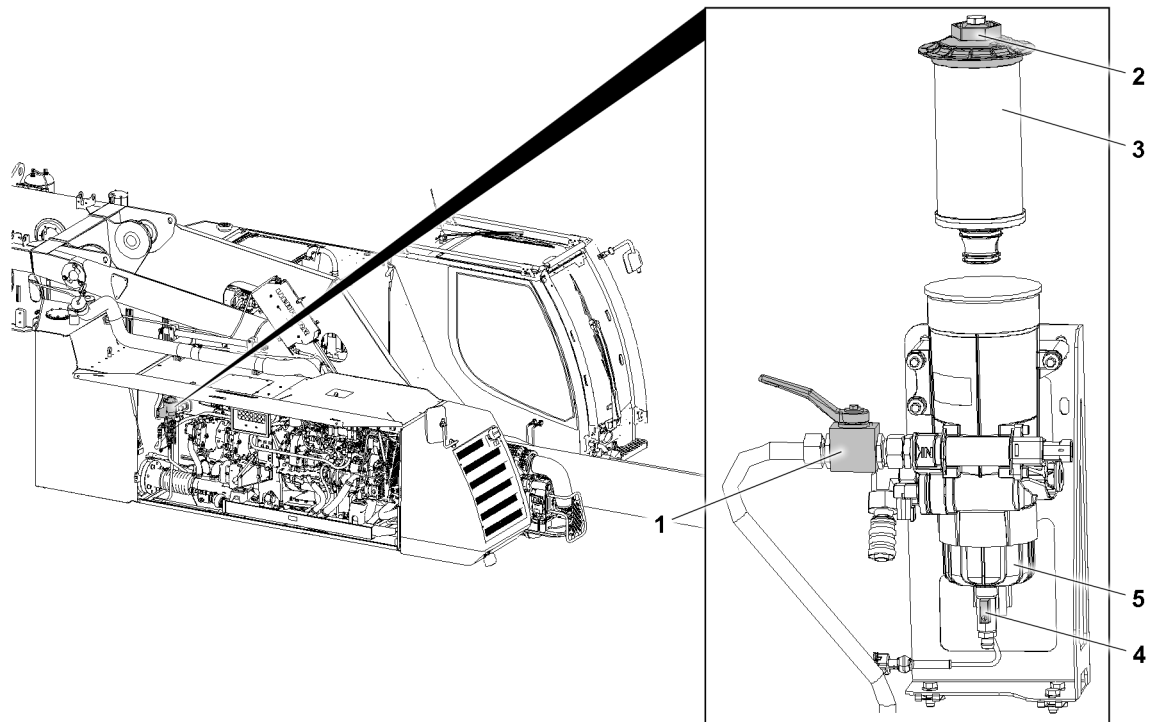
- ▶ Firmly close the cover **5**.
- 
- ▶ Firmly close the cover **5**.
  - ▶ Climb off the ladder.
  - ▶ Remove the fuel nozzle **3** from the fuel nozzle holder **1**.

#### Problem remedy

Was **impermissible** fuel added?

- ▶ Do **not** turn the ignition on.
- ▶ Have the fuel tank and fuel lines completely drained by authorized and trained expert personnel.

## 5.2 Checking the fuel preliminary filter



*Fig.154852: Fuel preliminary filter*

The fuel preliminary filter must be drained in the following situations:

- An error message is displayed.
- The diesel-water mixture is visible in the water manifold **5**.

When the prerequisites for draining the fuel preliminary filter are met:

- ▶ Follow the instructions in the section „Draining the fuel preliminary filter“.

### 5.3 Draining the fuel preliminary filter

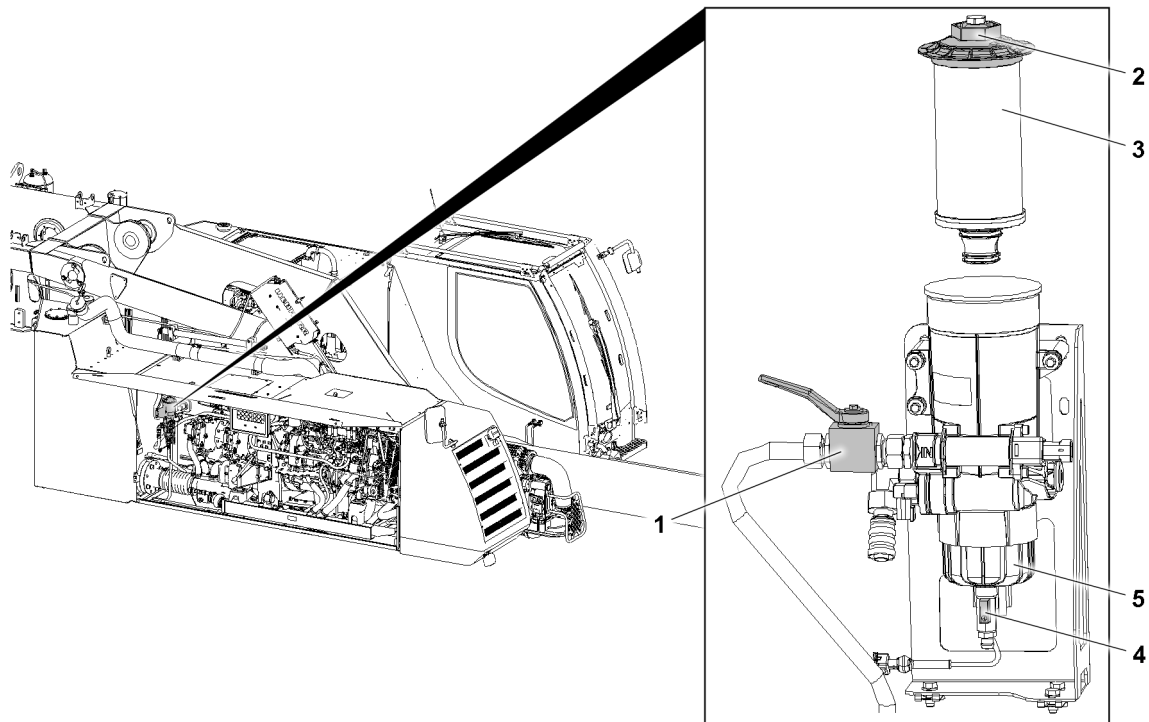


Fig.154852: Fuel preliminary filter

Make sure that the following prerequisites are met:

- The mobile crane is horizontal.
- The diesel engine has been turned off for at least 20 minutes. The ignition is off.
- The battery master switch is turned off.
- A container with sufficient capacity is on hand.



#### Note

Recommendation!

- ▶ Before draining the fuel preliminary filter:, place cleaning rags underneath it.

- ▶ Collect the diesel - water mixture: Position a container under the fuel preliminary filter.
- ▶ Drain the diesel - water mixture: Open the drain valve 4 until diesel fuel is visible in the water manifold 5.
- ▶ Close the drain valve 4.
- ▶ Remove the container and dispose of the fluid.
- ▶ Turn the ignition on and wait 1 minute.
- ▶ Start the diesel engine.

#### Problem remedy

Starting procedure remains unsuccessful after approx. 20 seconds?

- ▶ Turn the ignition off.
- ▶ Wait for 1 minute.
- ▶ Turn the ignition on and wait 1 minute.
- ▶ Start the diesel engine.

### 5.4 Servicing the fuel preliminary filter

Maintenance of the fuel preliminary filter consists of the following tasks:

- Take the fuel system out of service.
- Replace the filter insert.
- Clean the water manifold.

- Put the fuel system in operation.

### 5.4.1 Taking the fuel system out of service

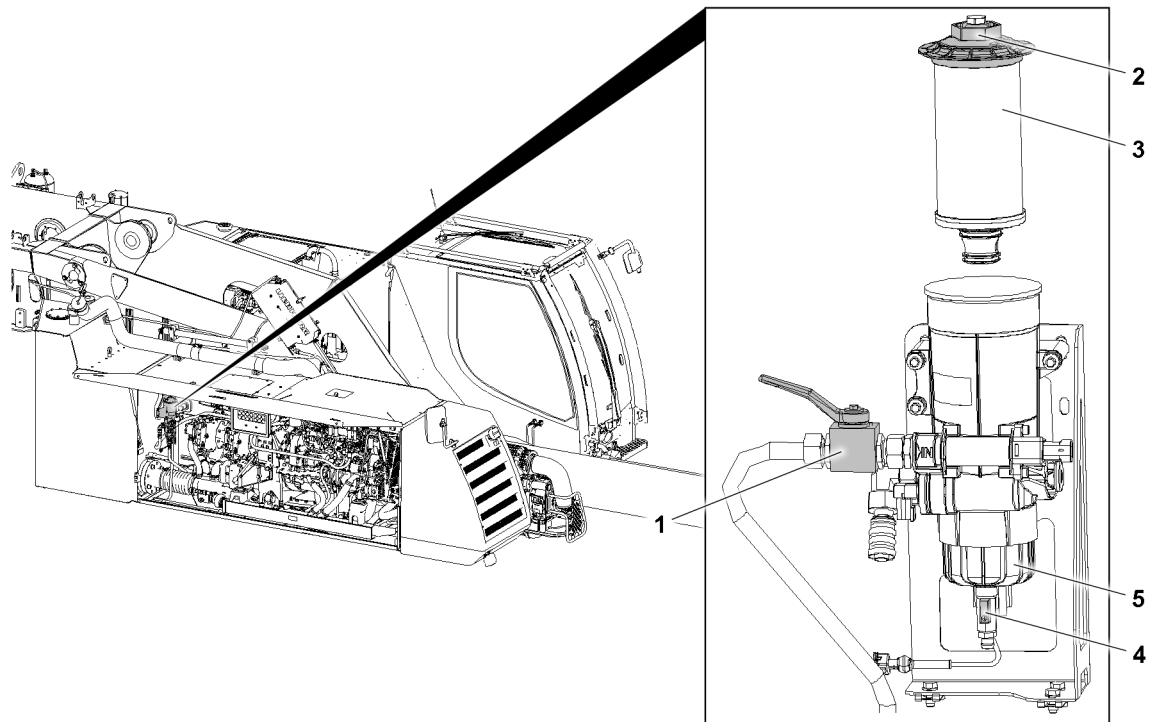


Fig.154852: Fuel preliminary filter

Make sure that the following prerequisites are met:

- The mobile crane is horizontal.
- The diesel engine has been turned off for at least 20 minutes. The ignition is off.
- The battery master switch is turned off.
- A container for diesel fuel with sufficient capacity is on hand.
- A new preliminary filter insert **3** is available.
- A new seal for the water manifold **5** is available.



#### Note

Recommendation!

- ▶ Prior to maintenance of the fuel preliminary filter, place cleaning rags underneath it.
- ▶ Turn off the diesel engine and turn off the ignition.
- ▶ The battery master switch is turned off.
- ▶ Collect the diesel fuel: Position a container under the fuel preliminary filter.
- ▶ Close the ball valve **1**.

## 5.4.2 Replacing the filter insert

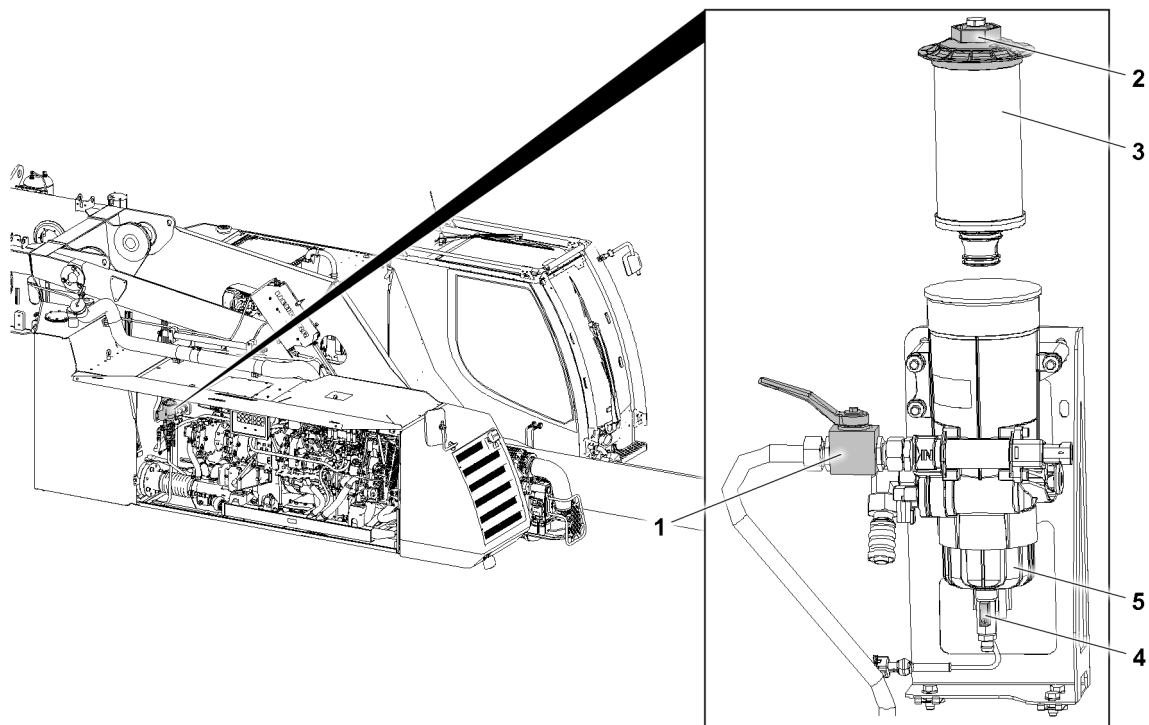


Fig.154852: Fuel preliminary filter

The filter insert **3** on the fuel preliminary filter is changed:

- According to the maintenance intervals.
- **Or** when an error message is shown.

Make sure that the following prerequisite is met:

- The fuel system is out of operation.
- The ball valve **1** is closed.

### NOTICE

Dirt!

Destruction of the Common Rail System.

- ▶ Make sure that **no** dirt gets into the inside of the preliminary filter insert **3**.
- ▶ Do **not** reuse a used preliminary filter insert.

- ▶ Unscrew the cover **2**.
- ▶ Take out the cover **2** with the filter insert **3** and remove the filter insert **3**.
- ▶ Properly insert a new preliminary filter insert **3**.
- ▶ Replace the o-ring.
- ▶ Wet the o-ring with fuel.
- ▶ Assemble the cover **2** with the preliminary filter insert **3** properly and tighten with tightening torque of 40 Nm.

### Problem remedy

Does the fuel preliminary filter insert need to be replaced regularly in short intervals?

Dirt entered the fuel tank during refueling.

- ▶ Drain the sediments, see section „Draining the sediments out of the fuel tank“.

### 5.4.3 Cleaning the water manifold

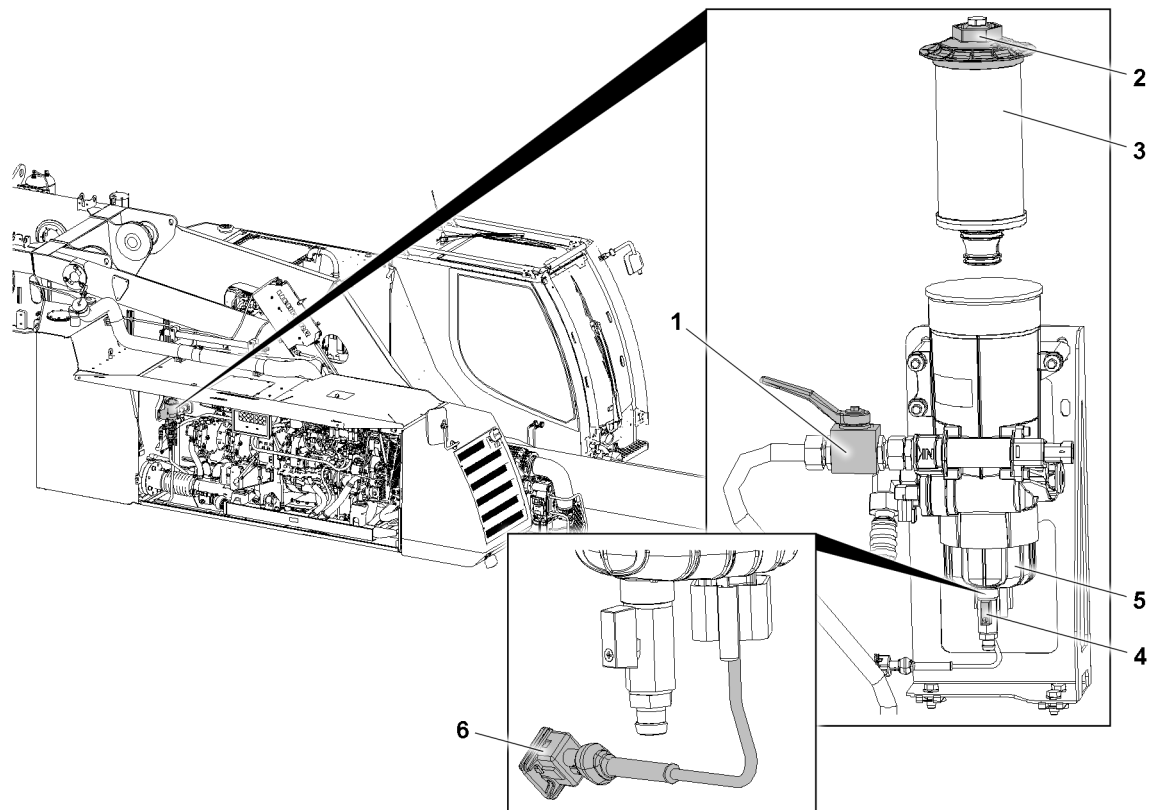


Fig.154853: Fuel preliminary filter

Make sure that the following prerequisites are met:

- The ball valve **1** is closed.
- A container with sufficient capacity has been positioned below the drain valve **4**.



#### WARNING

Manual opening of the fuel system!

Death, severe bodily injuries, destruction of the Common Rail System.

- ▶ Do **not** release or open the fuel lines and injection lines.
  - ▶ Maintain extreme cleanliness during all work.
- 
- ▶ Drain the diesel fuel: Open the drain valve **4** until the diesel fuel has drained fully.
  - ▶ Release the plug connection **6** of the water lever sensor.
  - ▶ Unscrew the water manifold **5**.
  - ▶ Clean the water manifold **5**.
  - ▶ Assemble a new seal on the water manifold **5** and wet it with diesel.
  - ▶ Tighten the water manifold **5** with maximum tightening torque of 5 Nm.
  - ▶ Close the drain valve **4**.

### 5.4.4 Putting the fuel system in operation

Make sure that the following prerequisites are met:

- The fuel preliminary filter insert is replaced.
  - The water manifold is clean.
  - The drain valve is closed.
- ▶ Open the ball valve **1**.
  - ▶ Remove the container and dispose of the fluid.

The fuel system is automatically bled when the ignition is turned on.

- ▶ Turn the ignition on and wait 1 minute.
- ▶ Start the diesel engine.

---

**Problem remedy**

Starting procedure remains unsuccessful after approx. 20 seconds?

- ▶ Turn the ignition off.
  - ▶ Wait for 1 minute.
  - ▶ Turn the ignition on and wait 1 minute.
  - ▶ Start the diesel engine.
- 

## 5.5 Replacing the fuel fine filter

The fuel system is automatically bled when the ignition is turned on.

- ▶ Change the fuel fine filter, see the separate engine manufacturer's operating instructions.

When the fuel fine filter has been replaced:

- ▶ Turn the ignition on and wait 1 minute.
  - ▶ Start the diesel engine.
- 

**Problem remedy**

Starting procedure remains unsuccessful after approx. 20 seconds?

- ▶ Turn the ignition off.
  - ▶ Wait for 1 minute.
  - ▶ Turn the ignition on and wait 1 minute.
  - ▶ Start the diesel engine.
- 

## 5.6 Draining the sediments in the fuel tank

Make sure that the following prerequisites are met:

- The mobile crane is horizontal.
- The parking brake is applied.
- The diesel engine has been turned off for at least 20 minutes. The ignition is off.
- The battery master switch is turned off.
- A container with sufficient capacity is on hand.

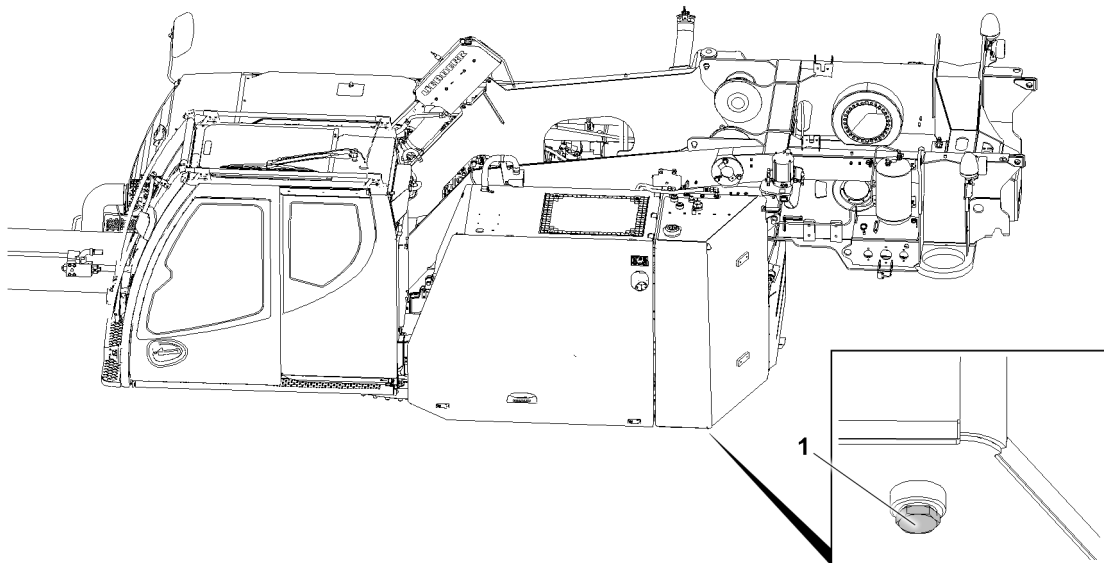


Fig.154854: Fuel tank, drain plugs

The drain plug has a cross hole. Fine sediments are flushed out through the cross hole.

- ▶ Collect the diesel fuel: Position a container under the fuel tank.
- ▶ Unscrew the drain plug 1 on the fuel tank until diesel fuel exits.



- ▶ Drain the sediment.
- ▶ Screw in the drain plug and tighten.

**Problem remedy**

Does the fuel preliminary filter insert still need to be replaced in short intervals?  
Coarse sediment is present in the fuel tank.

- ▶ The fuel tank must be cleaned: Contact Customer Service at Liebherr-Werk Ehingen.

## 6 Urea system\*

**Note**

- ▶ Applies only if an engine with exhaust aftertreatment, system SCR is installed.

**WARNING**

Contact with the urea solution!

Urea can cause skin irritation and eye injuries at contact.

- ▶ Do **not** allow the urea solution to come in contact with skin, eyes or clothing.
- ▶ Wear protective gloves and safety goggles.
- ▶ Do **not** swallow the urea.

**First aid measures after contact with the urea solution:**

- If the urea solution was swallowed: Flush the mouth immediately with a lot of water. Then drink a lot of water and consult a physician, if necessary.
- In case of eye contact, flush out the eyes immediately and consult a physician if necessary.
- Clean affected skin areas with clear water.

**WARNING**

Ammonia vapors!

If the cover of the urea tank is opened at high temperatures, ammonia vapors can emerge. Irritation of eyes and mucous membranes.

- ▶ Keep the urea tank closed at high temperatures.
- ▶ Do **not** breathe in ammonia vapors.

**NOTICE**

Admixing of special additives and diluting the urea solution!

The legally required emissions standards are not observed.

Destruction of the exhaust aftertreatment system.

- ▶ Do not mix or dilute the urea solution with special additives.
- ▶ Make sure that **no** dirt gets into the inside of the urea tank.
- ▶ Do not fill any operating materials in the urea tank.

### 6.1 Adding urea solution

Make sure that the following prerequisites are met:

- The mobile crane is horizontal.
- The diesel engine is turned off, the ignition is off.
- The heating systems are turned off, for example the auxiliary heater, flame start system.
- The battery master switch is turned off.

**NOTICE**

Spilled urea solution!

Affected surfaces can corrode.

- ▶ Rinse the affected surfaces immediately with lots of water.
- ▶ Do **not** overfill the container.
- ▶ Refuel using a fuel nozzle.

When maintenance personnel can **not** reach the filler neck from the ground:

- Use the supplied ladder as a stepladder.
- ▶ Follow the notes and instructions, see chapter 2.04.10 and chapter 2.07.

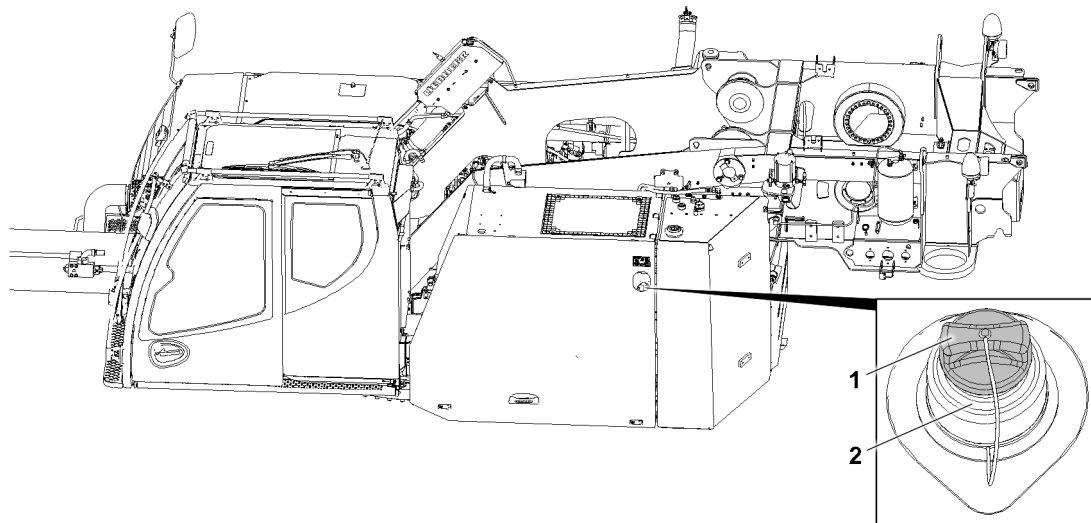


Fig.154855: Urea container, filler neck

1 Cover

2 Filler neck

- ▶ Remove the cover 1.



#### WARNING

Fuel nozzle **not** inserted deep enough!  
 Danger of fire: Escaping fuel, falling of the fuel nozzle.

- ▶ Insert the fuel nozzle as deep as possible into the fuel nozzle holder and in the filler neck.
- ▶ Insert the fuel nozzle as deep as possible into the filler neck 2.
- ▶ Refill urea.

When the refueling procedure is done:

- ▶ Remove the fuel nozzle from the filler neck 2.



#### WARNING

The cover is **not** firmly closed!  
 Danger of fire: Escaping fuel.

- ▶ Firmly close the cover 1.
- ▶ Firmly close the cover 1.

## 6.2 Replacing the filter strainer

#### NOTICE

Spilled urea solution!  
 Corrosion of affected surfaces.

- ▶ Rinse the affected surfaces immediately with lots of water.

#### NOTICE

Dirt in the urea tank!  
 Destruction of urea system.

- ▶ Make sure that **no** dirt gets into the inside of the urea tank.

If the filter strainer is dirty or damaged, the filter strainer must be cleaned or replaced.

Make sure that the following prerequisites are met:

- The mobile crane is horizontal.
- The diesel engine is turned off. The ignition is off.
- The heating systems are turned off, for example the auxiliary heater, flame start system.
- The battery master switch is turned off.

### Version 1

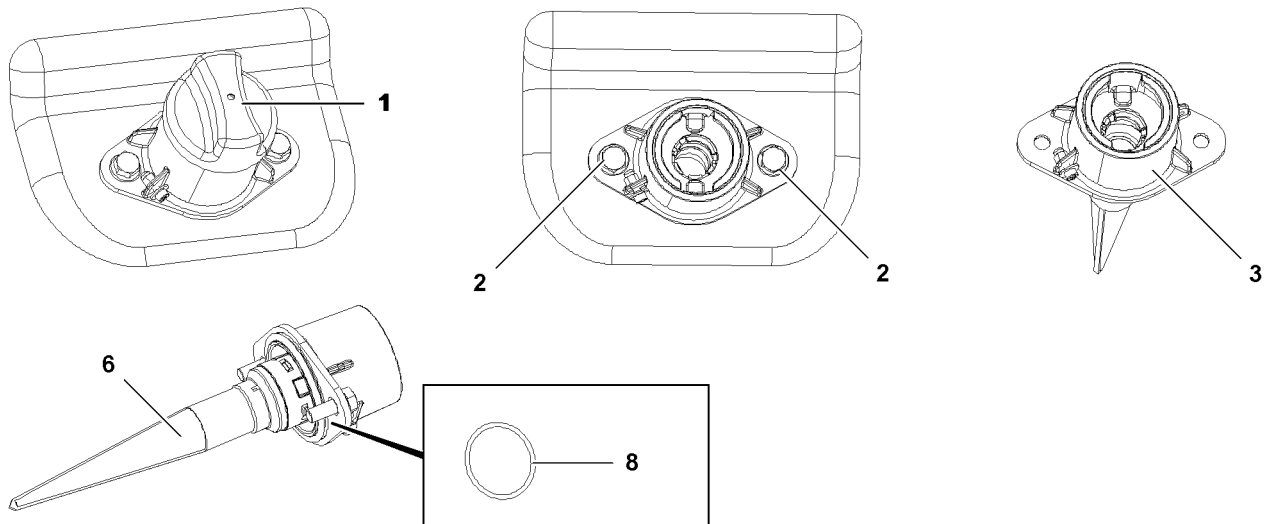


Fig.124111: Urea tank filter strainer

- ▶ Make sure that the version of the tank fitting **3** corresponds to the illustration.
- ▶ Remove the tank cover **1** of the urea tank.
- ▶ Back out the screws **2** and remove the tank fitting **3**.
- ▶ Clean the filter strainer **6** with water.

When the filter strainer **6** is damaged:

- ▶ Replace the filter strainer **6**.
- ▶ Check the seal **8** for damage.

When the seal **8** is damaged:

- ▶ Replace the seal **8**.
- ▶ Install the tank fitting **3** with the seal **8** and spacer properly.

---

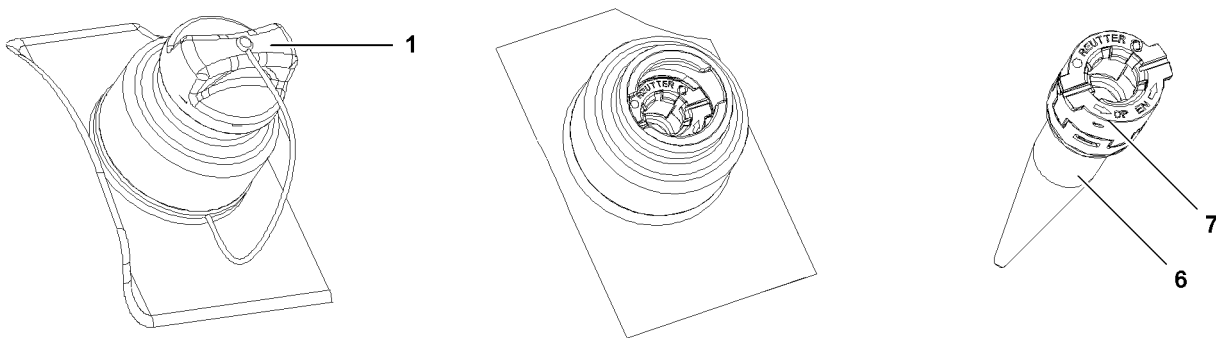
### NOTICE

Tightening torque too high!

Destruction of urea tank.

- ▶ Tighten the screws **2** with a maximum tightening torque of 8 Nm.
- 

- ▶ Properly screw in and tighten the screws **2**.
- ▶ Close the urea tank with the tank cover **1**.

**Version 2**

*Fig.124112: Urea tank filter strainer*

- ▶ Make sure that the version of the filter unit **7** corresponds to the illustration.
- ▶ Remove the tank cover **1** of the urea tank.
- ▶ Remove the filter unit **7**.
- ▶ Clean the filter strainer **6** with water.

When the filter strainer **6** is damaged:

- ▶ Replace the filter strainer **6**.
- ▶ Close the urea tank with the tank cover **1**.

## 7 Exhaust system\*

### 7.1 Checking the exhaust system for leaks and damage

- ▶ Check the exhaust gas aftertreatment component group for tightness and damage, see separate engine manufacturer's operating instructions.

### 7.2 Checking the profile clamps

- ▶ Check the profile clamps, see the separate engine manufacturer's operating instructions.

### 7.3 Replacing the diesel particle filter

#### 7.3.1 Changing the diesel particle filter (DPF / filter module) for cleaning

Make sure that the following prerequisites are met:

- Maintenance for the diesel particle filter (DPF / filter module) is due.
- ▶ Change the diesel particle filter (DPF / module), see the separate engine manufacturer's operating instructions.

#### 7.3.2 Ordering the diesel particle filter (DPF / filter module)

Registered customers can order the diesel particle filter on [www.myliebherr.com](http://www.myliebherr.com).

- ▶ Order a new replacement diesel particle filter (DPF / module), see the separate engine manufacturer's operating instructions.

### 7.3.3 Removing the diesel particle filter (DPF / filter module)

Make sure that the following prerequisite is met:

- The new replacement diesel particle filter (DPF / filter module) is available.
- The exhaust system has cooled down.
- ▶ Remove the diesel particle filter (DPF / module), see the separate engine manufacturer's operating instructions.

### 7.3.4 Packing the diesel particle filter (DPF / filter module) for transport

Make sure that the following prerequisites are met:

- The dirty diesel particle filter (DPF / filter module) has been removed.
- The dirty diesel particle filter (DPF / filter module) is not damaged.
- ▶ Pack the diesel particle filter (DPF / module) for transport, see the separate engine manufacturer's operating instructions.
- ▶ Send the diesel particle filter (DPF / module) to an authorized Liebherr service location for cleaning.

### 7.3.5 Installing the diesel particle filter (DPF / filter module) after cleaning

Make sure that the following prerequisites are met:

- The dirty diesel particle filter (DPF / filter module) has been removed.
- The new replacement diesel particle filter (DPF / filter module) is available.
- ▶ Install the diesel particle filter (DPF / module) after cleaning, see the separate engine manufacturer's operating instructions.

### 7.3.6 Resetting the maintenance interval for the diesel particle filter (DPF / filter module)

Make sure that the following prerequisite is met:

- The new replacement diesel particle filter (DPF / filter module) is installed.
- ▶ Reset the maintenance interval for the diesel particle filter (DPF / filter module), see chapter 7.01.10.

## 8 Pump distributor gear

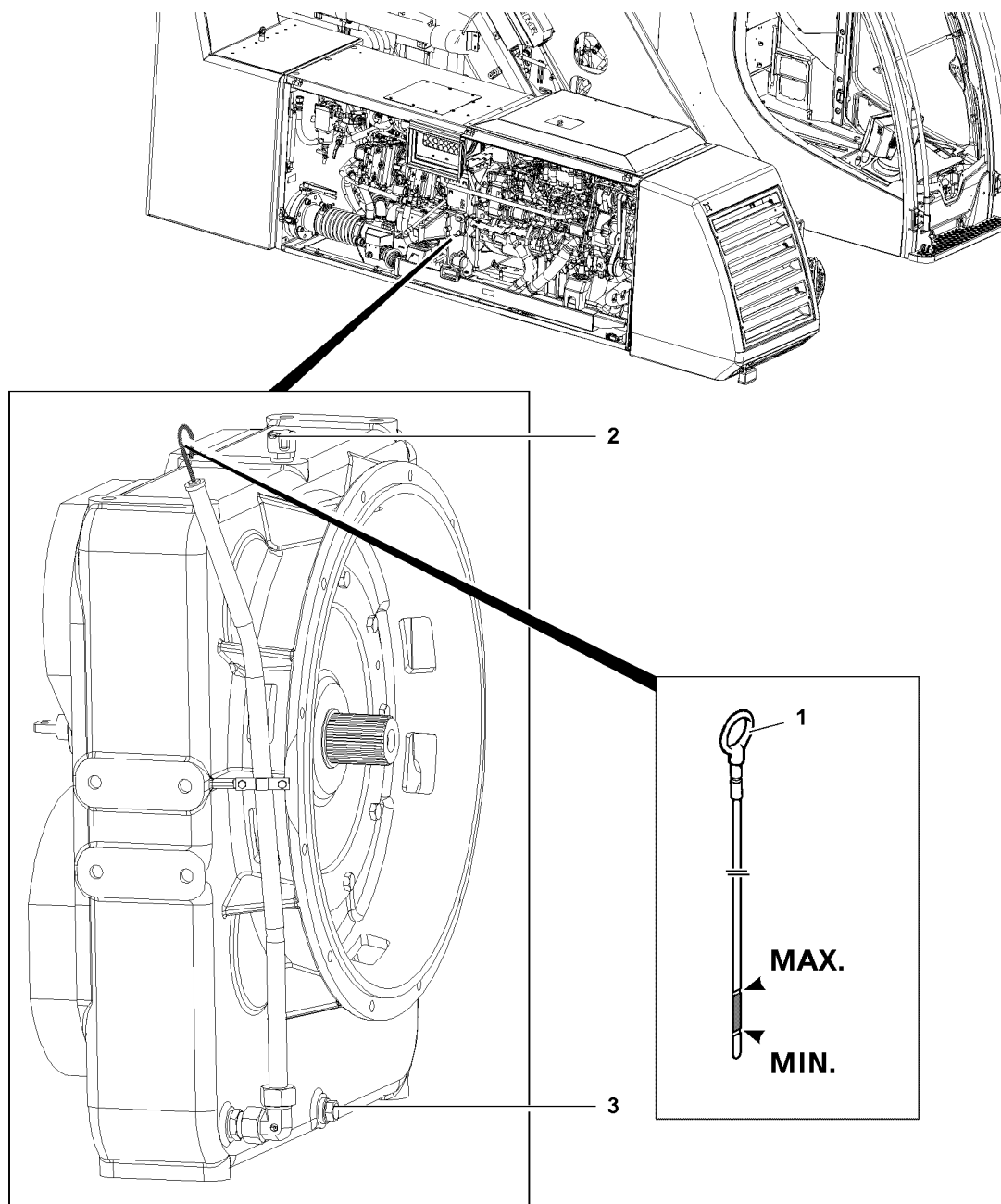


Fig.122559: Pump distributor gear

### NOTICE

Transmission damage due to lack of oil!

When the oil level has dropped below the minimum mark:

- ▶ Add gear oil in the filler bore until the oil level is visible between the minimum and maximum mark on the dipstick 1.

Maintain utmost cleanliness during all work to prevent any dirt from entering the gear.

Make sure that the following prerequisites are met:

- The crane is in a horizontal position.
- The gear is warm.

## 8.1 Checking the oil level

- ▶ Pull out the dipstick **1** and wipe it off.
- ▶ Insert the dipstick **1** and pull it out.

The oil level must be visible between the minimum and maximum mark on the dipstick **1**.

- ▶ Check the oil level.
- ▶ Insert the dipstick **1**.

---

### Problem remedy

Excessive oil consumption or loss of oil?

- ▶ Find the cause and remedy it.

If the cause cannot be remedied:

- ▶ Contact Liebherr Service.
- 

## 8.2 Changing the gear oil

Make sure that the following prerequisite is met:

- The gear oil is changed by authorized and trained expert personnel.

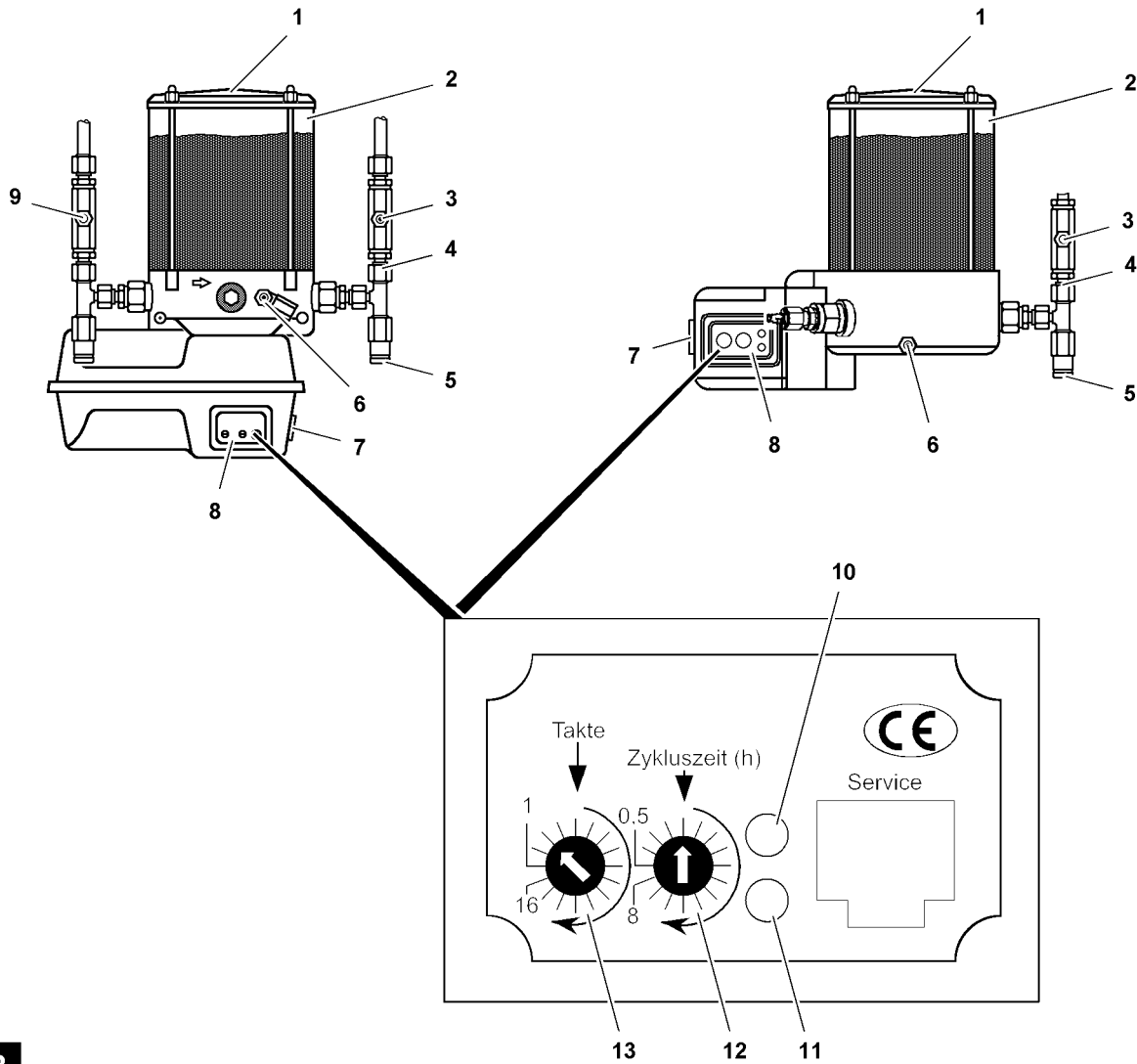
- ▶ Unscrew the filler plug **2**.
- ▶ Collect the gear oil: Position a container under the drain plug.
- ▶ Drain the gear oil: Unscrew the drain plug **3**.

When the gear oil is drained:

- ▶ Clean the drain plug **3** and sealing surface on the housing.
- ▶ Screw in the drain plug **3** with a new seal and tighten.
- ▶ Add gear oil on the filler bore until gear oil is visible between the minimum and maximum mark on the dipstick **1**.
- ▶ Screw in the filler plug **2** with new seal.
- ▶ Check the oil level.

## 9 Central lubrication system

**1**



**2**



Fig.118546: Central lubrication system

- |   |                        |   |                                 |    |                           |
|---|------------------------|---|---------------------------------|----|---------------------------|
| 1 | Cover Grease container | 6 | Grease fitting Grease container | 11 | LED green                 |
| 2 | Grease container       | 7 | Button                          | 12 | Latched switch cycle time |

For continuation of legend for illustrations, see next page



<b>3</b>	Lubrication line grease fitting	<b>8</b>	Control element	<b>13</b>	Latched switch lube cycles
<b>4</b>	Pump outlet	<b>9</b>	Lubrication line grease fitting	<b>662</b>	Crane cab button
<b>5</b>	Pressure relief valve	<b>10</b>	LED red		

## 9.1 Technical safety instructions



### WARNING

Non-observance of safety instructions!

Personnel can be harmed due to electrical, mechanical and chemical exposure.

Dangerous substances can be discharged and endanger the environment.

Property damage on the system can occur.

- ▶ Have maintenance and repair work carried out exclusively by authorized and trained expert personnel.
- ▶ Use exclusively original Liebherr spare parts.
- ▶ Remedy any errors, which affect safety immediately.

### NOTICE

Property damage if the crane has not been moved for longer than three months!

- ▶ Press the button **7** until lubricant emerges in all lube points.
- ▶ Repeat the respective crane movement several times.
- ▶ Carry out intermediate lubrications again.

### NOTICE

Property damage due to crane cleaning procedure!

- ▶ Cleaning is only permitted in washing bays.
- ▶ Carry out the cleaning procedure with a steam cleaner or high pressure cleaner at a minimum distance of 0.4 m.

When the crane is cleaned:

- ▶ Carry out intermediate lubrications manually with button **7** until lubricant emerges on all lube points.

## 9.2 Description of the function

The crane superstructure is equipped with a central lubrication system.

Types of central lubrication systems, see illustration 1.

The lube points in the bearings of the following components are automatically supplied with lubricant:

- Slewing ring connection
- Pivot section
- Luffing cylinder
- Winches

### 9.2.1 Displays on control element



#### Note

- ▶ In the crane cab, operating conditions and problems of the central lubrication system are shown on button **662**, see illustration 2.
- ▶ Problems, see section „Diagnostics“.
- ▶ Crane cab indicator lights, see chapter 4.01.

LED red 11	LED green 10	Operating condition
Lights up for 1.5 seconds	Lights up for 1.5 seconds	Operational readiness after ignition on
Off	Lights up	Lubrication is active (during lube cycles)

Status of LEDs on control element 8

### 9.2.2 Lubrication cycle



#### Note

The lubrication time and the cycle time are set in the factory!

- ▶ Do **not** change the settings.

**Cycle time:** Time from start of one lubrication to the start of another lubrication.

The cycle time is set with the latched switch **12**.

**Lube cycles:** Number of strokes, during which lubricant is supplied by the pump cylinder.

The number of lube pulses for a lubrication cycle is set with the latched switch **13**.

## 9.3 Checking the function

Make sure that the following prerequisite is met:

- The ignition is turned on.



#### Note

- ▶ When lubricant emerges on all lube points, then the central lubrication system functions error-free.
- ▶ Problems, see section „Diagnostics“.

- ▶ To check the function: Trigger several lube pulses.
- ▶ Trigger a lube pulse: Press the button **7** until lubricant emerges in all lube points.

## 9.4 Carrying out an intermediate lubrication

Manual intermediate lubrication is carried out, for example:

- If the crane has not been moved for longer than three months.
- After washing the crane.



#### Note

- ▶ When intermediate lubrication is carried out, the pump starts the lubrication cycle again. The lubrication cycle is reset.

Several lube pulses may be required until lubricant emerges on all lube points.

- ▶ Press the button **7** until lubricant emerges in all lube points.

## 9.5 Filling the grease container

### NOTICE

Property damage due to insufficient lubrication!

- ▶ Make sure that the grease container **2** is filled.
  - ▶ Make sure that all grease fittings are clean.
- 
- ▶ Fill the grease container **2** with a grease pump on the grease fitting **6**.

## 9.6 Bleeding the central lubrication system

If the grease container **2** is emptied, it may be necessary to bleed the central lubrication system.

- ▶ Fill the grease container **2** with a grease pump via the grease fitting **6**.
- ▶ Unscrew the main line from the pump outlet **4**.
- ▶ Trigger additional lubricating pulses until there are no more air bubbles in the emerging grease at the pump outlet **4**.
- ▶ Reconnect the main line.
- ▶ Carry out intermediate lubrication until lubricant emerges on all lube points.

## 9.7 Filling the lubrication lines

### NOTICE

Components running dry due to insufficient lubrication!

- ▶ After every repair on greased components, fill the lube lines with grease.
  - ▶ Make sure that all grease fittings are clean.
- 
- ▶ Fill lube lines with a grease pump on grease fitting **3** (and grease fitting **9**).  
or  
Carry out intermediate lubrication until lubricant emerges on all lube points.

## 9.8 Diagnostics and troubleshooting

### 9.8.1 Problem signals on control element



#### Note

- ▶ In the crane cab, operating conditions and problems of the central lubrication system are shown on button **662**, see illustration **2**.
- ▶ Crane cab indicator lights, see chapter 4.01.

Status LEDs		Cause	Remedy
LED red 10	LED green 11		
Blinks once in two seconds	Blinks once in two seconds	Cycle error	Fix the system; contact Liebherr Service
Blinks once a second	Off	CPU error, memory error	Fix the system; contact Liebherr Service
Lights up	Off	Grease level too low (depending on system type)	Filling the grease container

*Diagnostics for problem signals on control element 8*

### 9.8.2 Problems on central lubrication system

Lubrication system status	Cause	Remedy
Lubricant emerges via pressure relief valve <b>5</b>	The lubrication system is blocked	Fix the system; contact Liebherr Service
No lubricant emerges from the system	Grease container is empty <b>or</b> electric pump is defective	Fill grease container <b>or</b> fix system; contact Liebherr Service

*Diagnostics for problems on the central lubrication system*

### 9.8.3 Resetting a problem

- ▶ Press the button 7.

**Result:**

- Problem signal on control element turns off.

When a problem signal occurs again:

- ▶ Contact Liebherr Service.

## 10 Slewing ring connection



**WARNING**

Danger of crushing due to turning of crane superstructure!

- ▶ Work only when the crane superstructure is at a standstill.
- ▶ Do not crush your fingers during lubrication.

Make sure that the following prerequisites are met:

- The crane is in a horizontal position.
- The engine and the ignition are turned off.

### 10.1 Lubricating the slewing ring connection

To ensure the best possible corrosion protection, carry out the lubrication especially diligently:

- Before and after any winter breaks.
- Before and after longer breaks in operation.
- ▶ Lubricate the slewing ring connection.

If the crane has **not** been moved for longer than three months:

- ▶ Lubricate with an external lubrication pump every 3 months until lubricant emerges on the sealing lips. See section „Central lubrication system“.
- ▶ Repeat a crane movement several times and carry out the lubrication procedure again.

## 10.2 Lubricating the gear ring and the slewing gear pinion

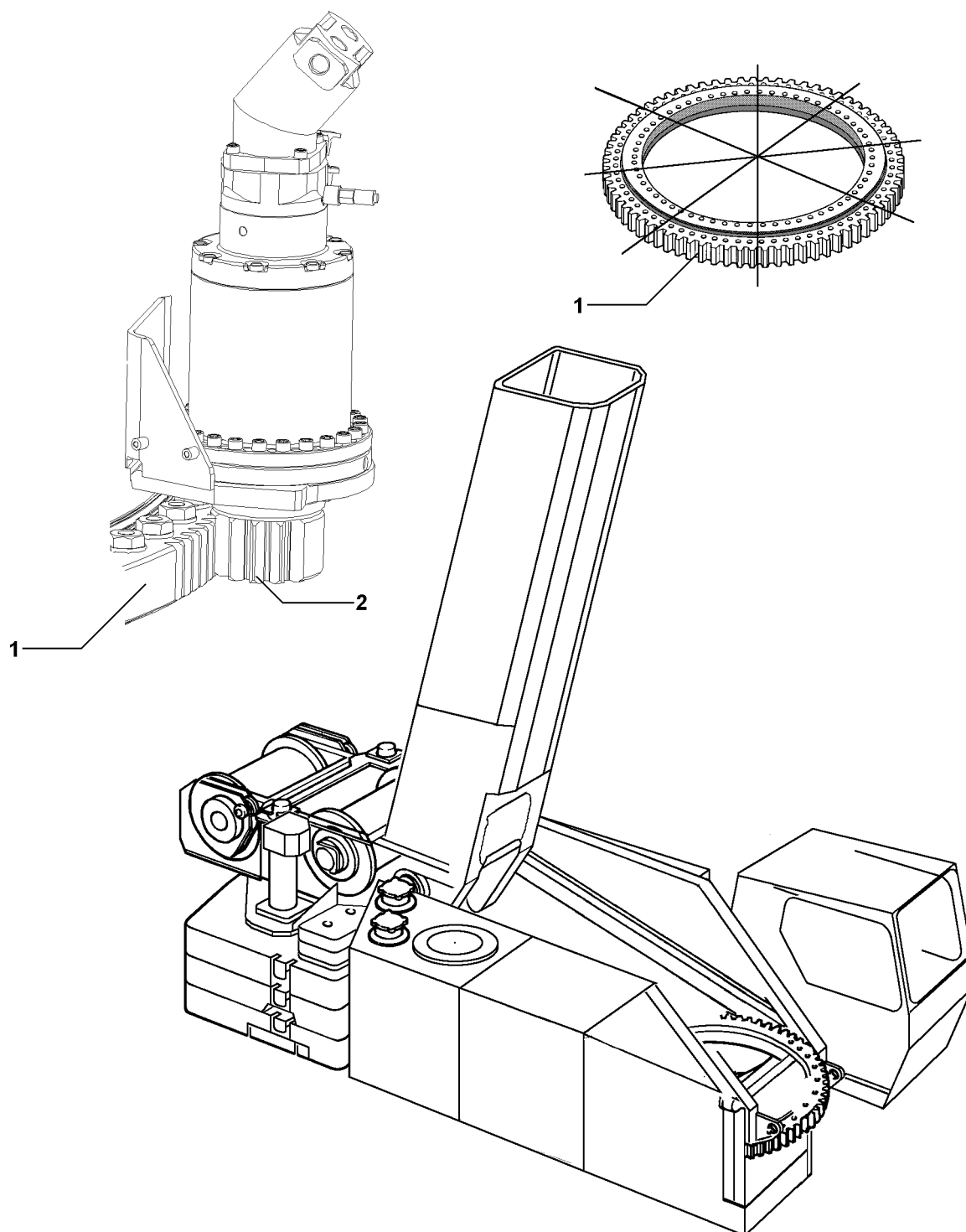


Fig.123717: Slewing gear

Before and after extended breaks in operation, grease the gear ring 1 and the slewing gear pinion 2 to ensure the best possible protection from corrosion.

- ▶ Grease the gear ring 1 and the slewing gear pinion 2 externally.

## 11 Slewing gear(s)



---

### WARNING

Uncontrolled load movement due to strong oil loss!  
Death, severe bodily injury, transmission damage.

- ▶ Contact Liebherr Service in the case of strong oil loss.
- 

### NOTICE

Insufficient oil!  
Transmission damage.

- ▶ Check the oil level and add gear oil if necessary.
- 

### NOTICE

Dirt inside the gear!  
Transmission damage. Increased wear and shorter service life of the components.

- ▶ Maintain extreme cleanliness during all work.
  - ▶ Make sure that **no** dirt gets inside the gear.
- 

Make sure that the following prerequisites are met:

- The crane is in a horizontal position.
- The gear is warm.

## 11.1 Checking the oil level

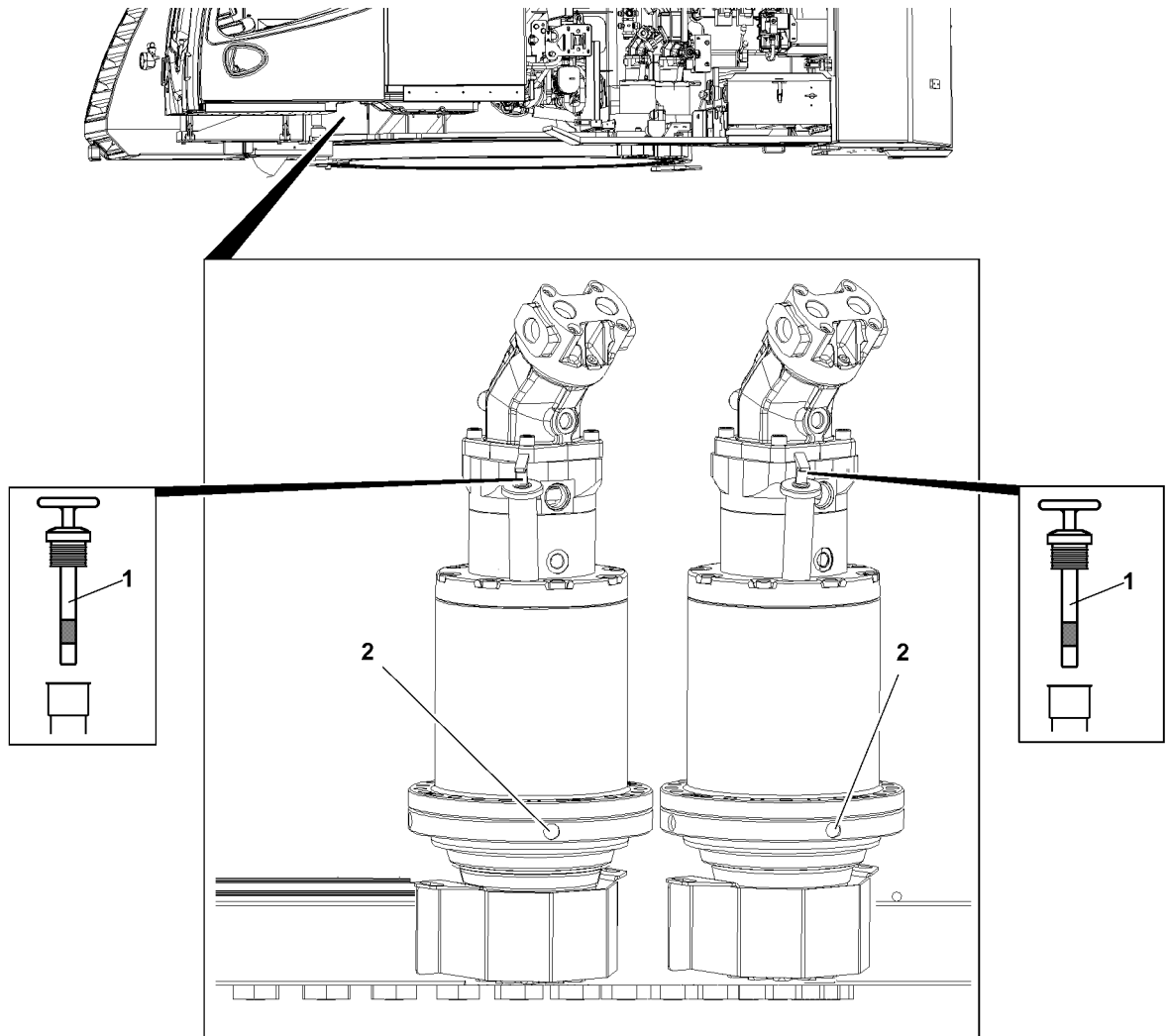


Fig.123718: Slewing gear

- ▶ Pull out the dipstick **1** and wipe it off.
- ▶ Insert the dipstick **1** and pull it out.

The oil level must be visible between the minimum and maximum mark on the dipstick **1**.

- ▶ Check the oil level.
- ▶ Insert the dipstick **1**.

### Problem remedy

Excessive oil consumption or loss of oil?

- ▶ Find the cause and remedy it.

If the cause cannot be remedied:

- ▶ Contact Liebherr Service.

## 11.2 Changing the gear oil

Make sure that the following prerequisite is met:

- The gear oil is changed by authorized and trained expert personnel.
- ▶ Pull out the dipstick **1**.
- ▶ Collect the gear oil: Position a container under the drain plug.

- ▶ Drain the gear oil: Unscrew the drain plug **2**.

When the gear oil is drained:

- ▶ Clean the drain plug **2** and sealing surface on the housing.
- ▶ Screw in the drain plug **2** with a new seal and tighten.
- ▶ Add gear oil on the filler bore until gear oil is visible between the minimum and maximum mark on the dipstick **1**.
- ▶ Insert the dipstick **1**.
- ▶ Check the oil level.



Empty page!

LWE/LTR 1220-003/24204-02-02/en

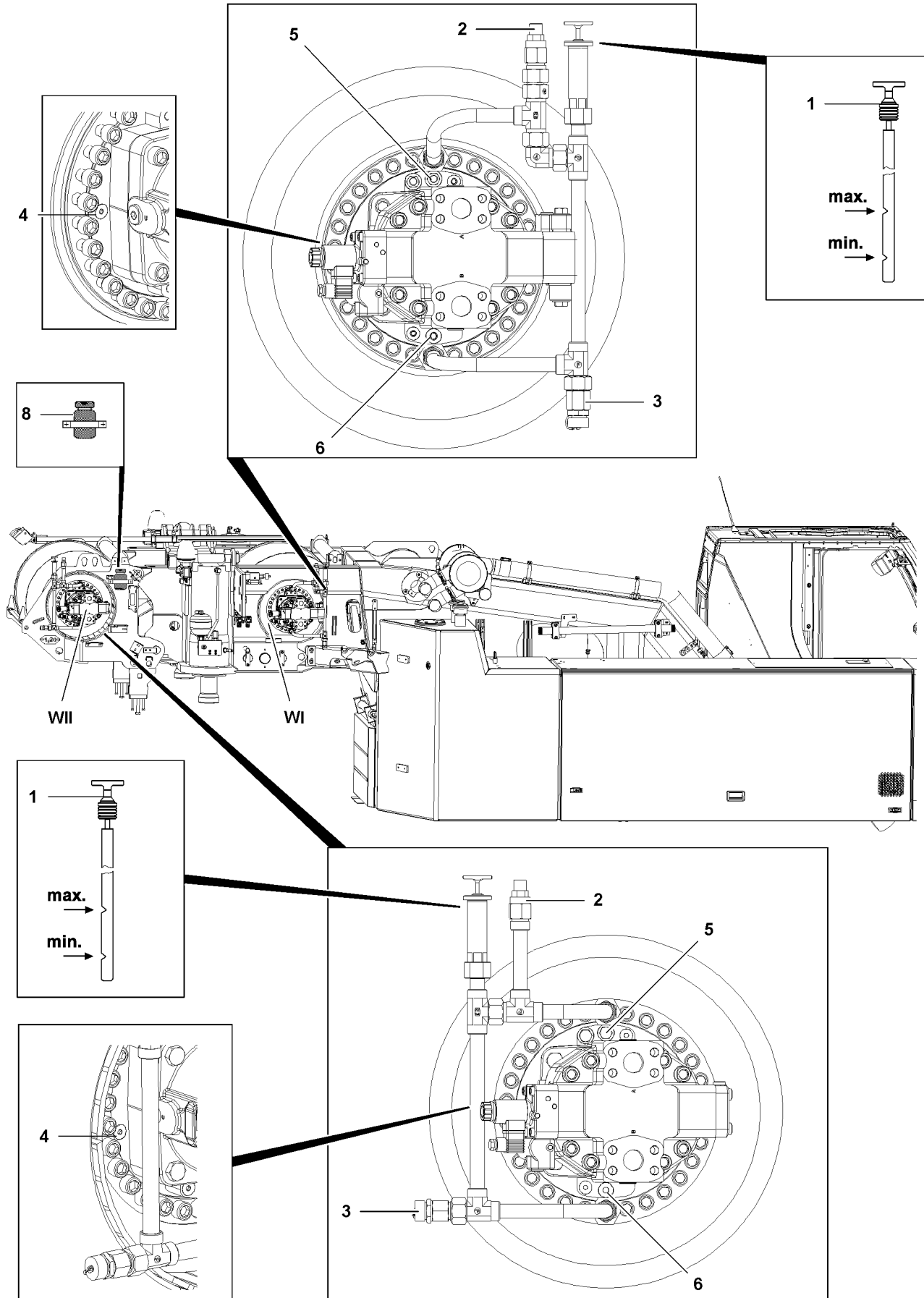


Fig.122797

LWE/LTR 1220-003/24204-02-02/en

## 12 Hoist gear(s)

The winch **WI** is the main hoist gear.

The winch\* **WII** is optional.



### WARNING

Uncontrolled load movement due to strong oil loss!

Death, severe bodily injury, transmission damage.

- ▶ Contact Liebherr Service in the case of strong oil loss.

### NOTICE

Insufficient oil!

Transmission damage.

- ▶ Check the oil level and add gear oil if necessary.

### NOTICE

Dirt inside the transmission!

Transmission damage. Increased wear and shorter service life of the components.

- ▶ Maintain extreme cleanliness during all work.
- ▶ Make sure that no dirt gets inside the gear.

Make sure that the following prerequisites are met:

- The crane is in a horizontal position.
- The hoist gear is at a standstill.

### 12.1 Hoist gear

Maintain utmost cleanliness during all work to prevent any dirt from entering the gear.

#### 12.1.1 Checking the oil level

- ▶ Remove and wipe off the dipstick **1**.
- ▶ Reinsert the dipstick **1** and pull it out again.

The oil level must be between the min. and max. marks on the dipstick **1**.

- ▶ Check the oil level.



### CAUTION

Gear damage due to incorrect oil level!

If the oil level has dropped below the minimum mark, add oil until the oil level is between the minimum and maximum marks. See Service fill.

- ▶ Add oil and check again.

- ▶ Reinsert the dipstick **1**.

#### 12.1.2 Changing the oil

- ▶ Unscrew the breather screw **2**.
- ▶ Unscrew the oil drain plug **2** with seal ring and drain oil into a suitable container.
- ▶ Screw in the oil drain plug **3** with a new seal ring and tighten.
- ▶ Unscrew the dipstick **1** to open the oil filler port.
- ▶ Add oil in the oil filler port.
- ▶ Screw in and tighten the breather screw **2**.
- ▶ Check the oil level as described above.

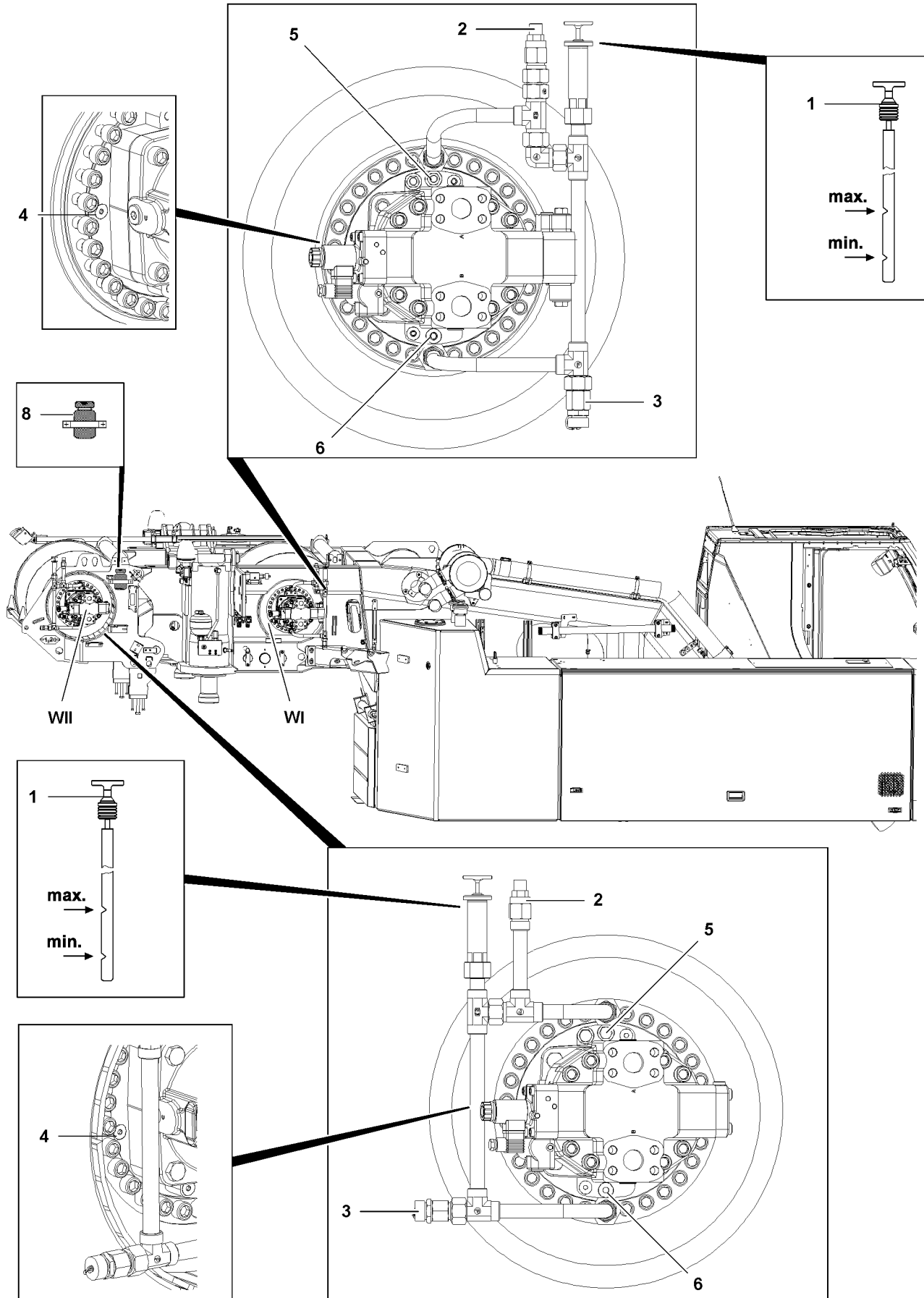


Fig.122797

LWE/LTR 1220-003/24204-02-02/en

## 12.2 Hoist gear brake

Maintain utmost cleanliness during all work to prevent any dirt from entering the gear.

### 12.2.1 Checking the oil level

- ▶ Remove the screw **4**.

The oil level must reach the edge of the bore.

- ▶ Perform a visual inspection.



#### CAUTION

Gear damage due to incorrect oil level!

- ▶ If the oil level has dropped, add oil up to the overflow of the oil filler port.

- ▶ Clean the sealing surfaces on the housing and on the screw.
- ▶ Reinstall the screw **4** and tighten.

### 12.2.2 Changing the oil

- ▶ Remove the oil filler plug **5** and clean the sealing surface.
- ▶ Unscrew the oil drain plug **6** with seal ring and drain oil into a suitable container.
- ▶ Clean the oil drain plug **6** and sealing surface on the housing.
- ▶ Screw in the oil drain plug **6** with a new seal ring and tighten.
- ▶ Add oil in the oil filler plug **5** until the oil starts to overflow on the opening **4**.
- ▶ Clean the oil filler plug **5** and screw it back in with a new seal ring and tighten.
- ▶ Check the oil level as described above.

## 12.3 Overflow container

### 12.3.1 Disposing of the oil

When the oil heats up in the hydro motor of the winch\* **WII**, the oil can enter the overflow container **4** via a check valve, but cannot flow back into the hydraulic system after cooling off.

Maintenance intervals - Crane superstructure, see chapter 7.03.

- ▶ Dispose of the oil in the overflow container **4** properly.

## 13 Heating-air conditioning device

### 13.1 Replacing the filter insert

The crane cab can be tilted upward for maintenance work.



#### WARNING

Remaining within the danger zone of the crane cab!  
Death, severe bodily injuries, property damage.

When the crane cab is inclined:

- ▶ Make sure that **no** persons or objects are located in the danger zone of the crane cab.
- ▶ Before stepping on the step: Align the crane cab horizontally.

#### 13.1.1 Tilting the crane cab upward

Make sure that the following prerequisite is met:

- The sliding door of the crane cab is open and pushed into the locking position.

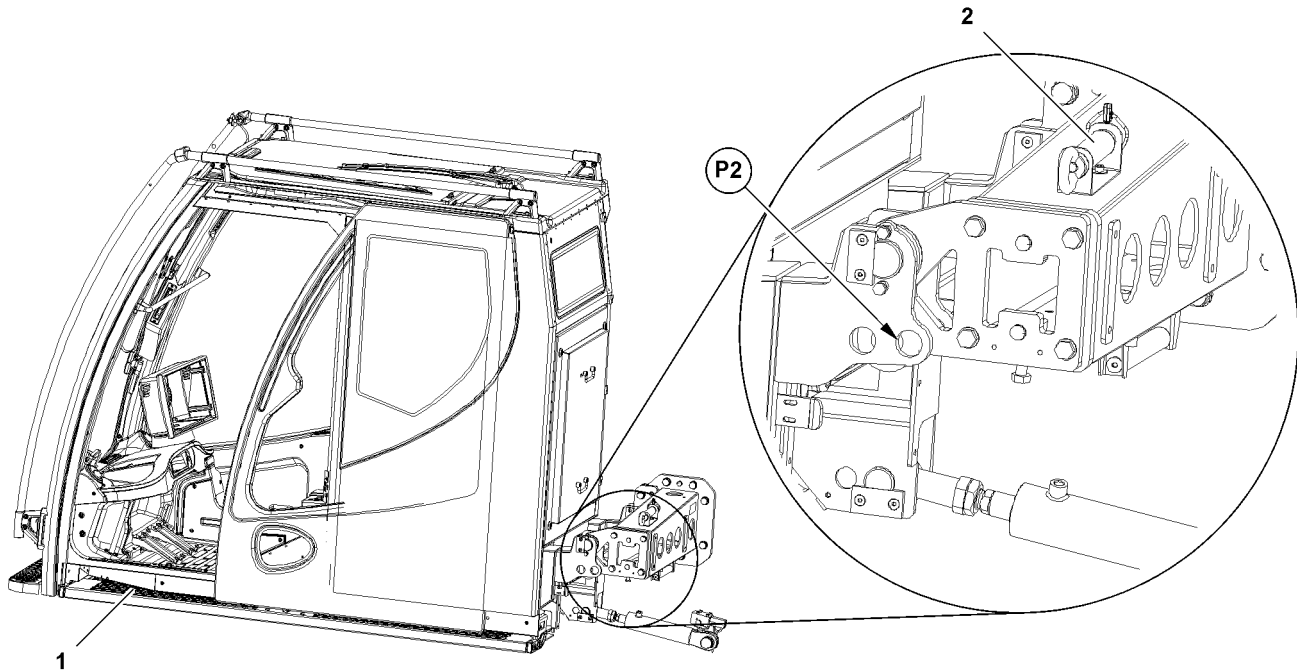


Fig. 123711

**WARNING**

Sliding door opening in an inclined position!

The sliding door can move back suddenly.

Hands can be crushed or injured.

When stepping on the step, persons can slip off.

- ▶ Before inclining the crane cab, open the sliding door of the crane cab and slide it into locking position.

When the crane cab is inclined:

- ▶ Do **not** step on the step **1**.
  - ▶ Leave the crane cab with a suitable aid, such as a working platform.
- 
- ▶ Until the retaining pin **2** can be pinned in point **P2**: Swing the crane cab upwards.
  - ▶ Turn the engine off and pull out the ignition key.

### 13.1.2 Securing the crane cab for maintenance work

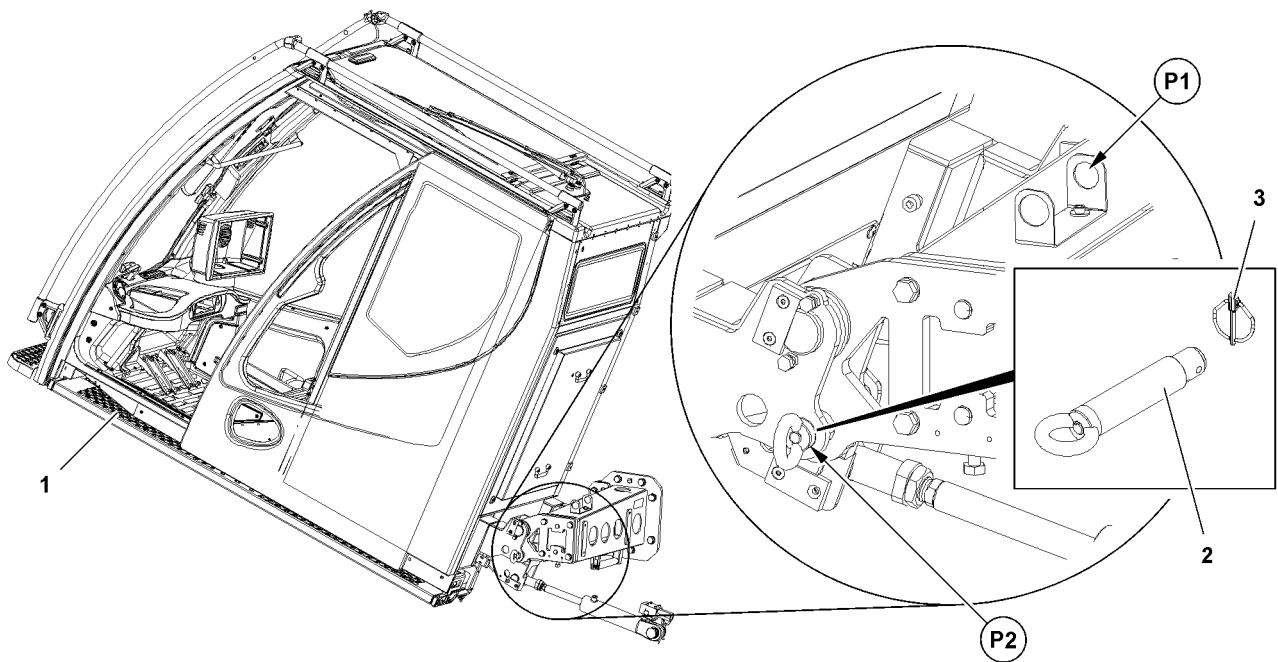


Fig. 123709



#### WARNING

**Non-secured** crane operator's cab!

The crane cab can swing down. Danger of crushing. Death, severe bodily injuries.

▶ Secure the crane cab with the retaining pin **2** to prevent it from swinging downward uncontrolled!

▶ Release the retaining pin **2** in point **P1**.

▶ Insert the retaining pin **2** in point **P2** and secure with the locking pin **3**.

#### Result:

– The crane cab is secured.

### 13.1.3 Replacing the filter insert



#### Note

▶ Change cycle, see chapter 7.03.

▶ The change cycle can change, depending on the area of application.

Make sure that the following prerequisites are met:

– The crane cab is secured.

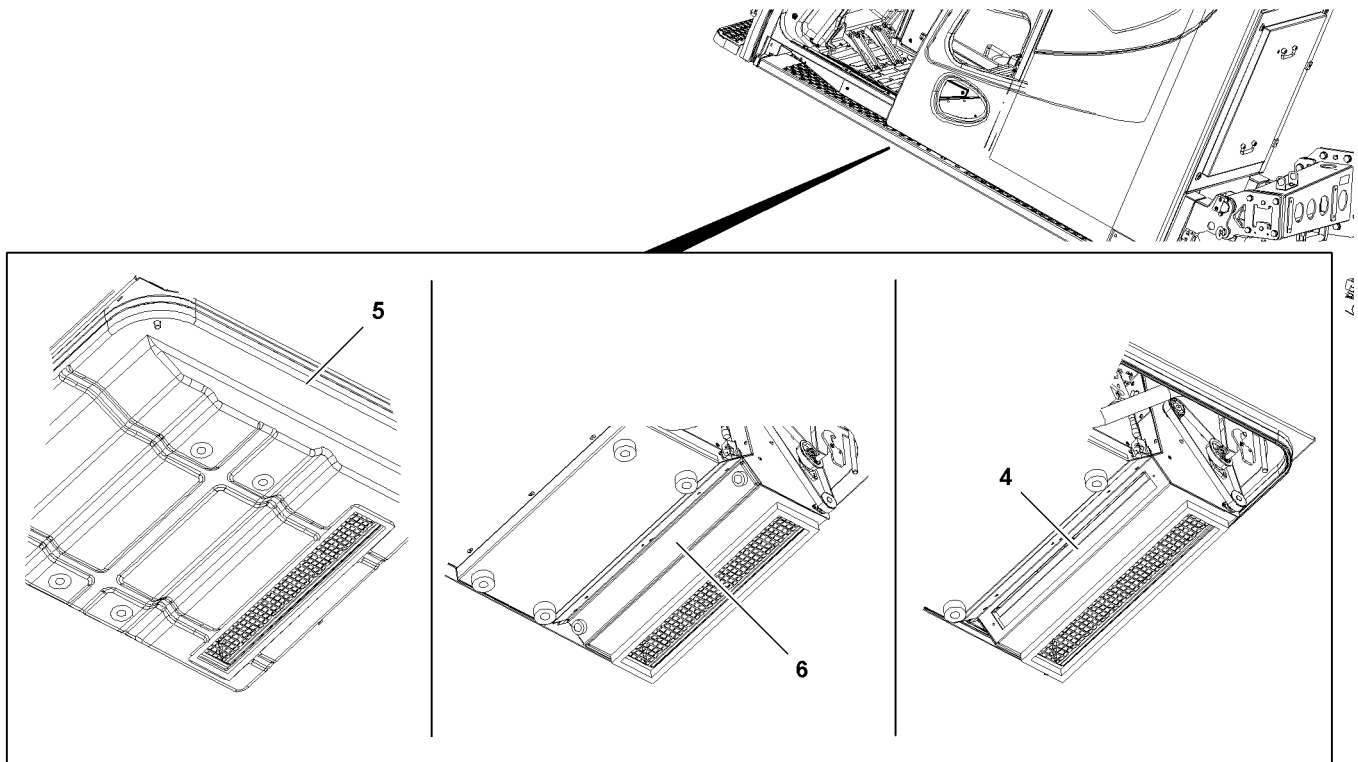


Fig. 123690

- ▶ Remove the housing **5** and the cover **6**.
- ▶ Remove the filter insert **4** and replace it.
- ▶ Install the cover **6** and housing **5**.

### 13.1.4 Releasing the crane cab

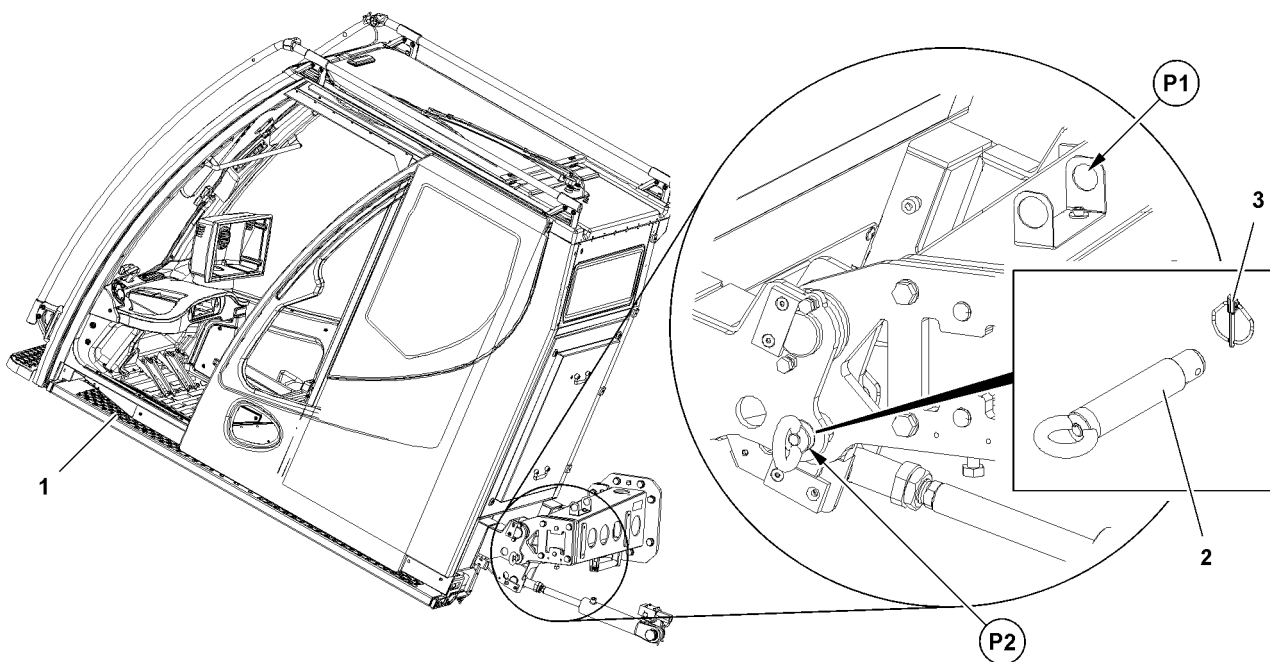


Fig. 123709

- ▶ Release the retaining pin **2** in point **P2** and unpin.



- ▶ Insert the retaining pin **2** in point **P1** and secure with the locking pin **3**.

**Result:**

- The crane cab is released.
- ▶ Align the crane cab horizontally.

## 14 Cab auxiliary heater\*

### 14.1 Checking the fill level of the fuel container

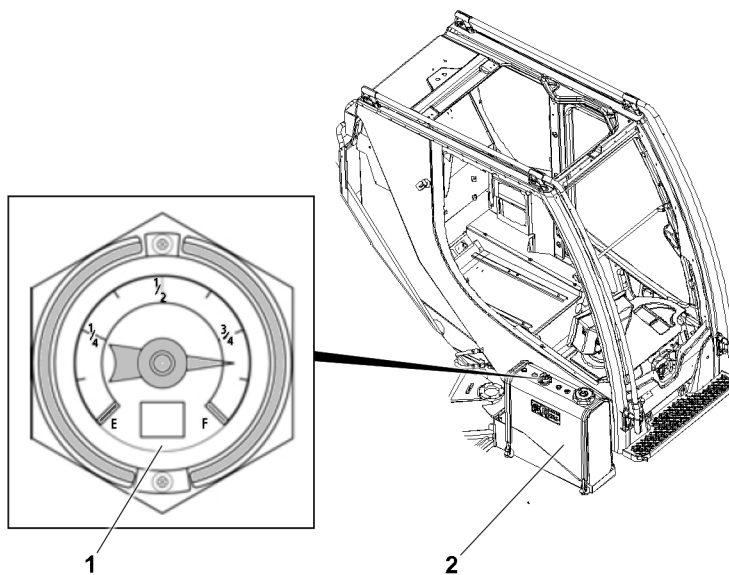


Fig.149086: Checking the fuel reserve

Make sure that the following prerequisites are met:

- The crane is in a horizontal position.

The fill level of the fuel container **2** is displayed by a level indicator **1**:

- Green mark F: The fuel container is full.
- Red mark E: The fuel container is empty.
- ▶ Check the fill level on the level indicator **1**.
- ▶ Add fuel in time before the fuel container is empty.
- ▶ Add fuel, see section „Adding fuel“.

### 14.2 Adding fuel

When the fuel is depleted:

- Under some circumstances, the fuel line must be bled.
- Contact Customer Service at Liebherr-Werk Ehingen and coordinate the procedure.



**WARNING**

Danger of fire!

Fuel is easily flammable and can cause fatal accidents in case of fire or open flames.  
High property damage.

- ▶ Before the refueling procedure, turn the heating systems off, for example the heater, flame start system.
- ▶ When adding fuel, preclude fire, open light and smoking.

**DANGER**

Danger of fires due to spilled fuel!

- ▶ Keep the heating area free of fuel.
- ▶ Absorb fuel with rags.
- ▶ Dry up spilled fuel.

**WARNING**

Poisoning due to fuel!

Fuel is poisonous and hazardous to health.

- ▶ Do **not** allow fuel to come into contact with skin, eyes or clothing.
- ▶ Do **not** breathe in fuel vapors.
- ▶ Keep children away from fuel.

**First aid measures after contact with fuel:**

- If fuel was swallowed: Contact a physician immediately.
- In case of eye contact, flush out the eyes immediately and consult a physician if necessary.
- Clean affected skin areas with clear water.

**NOTICE****Impermissible fuel!**

The auxiliary heater can be severely damaged.

- ▶ Only add permissible fuel, see the manufacturer's instructions.
- ▶ Select the fuel in relation to the weather and temperature conditions.

Make sure that the following prerequisites are met:

- The crane is in a horizontal position.
- The heater is turned off.
- The engine and the ignition are turned off.
- All railings and steps are swung into the assembly position, see chapter 2.06.

Access and climb up on the mobile crane, see chapter 2.07.

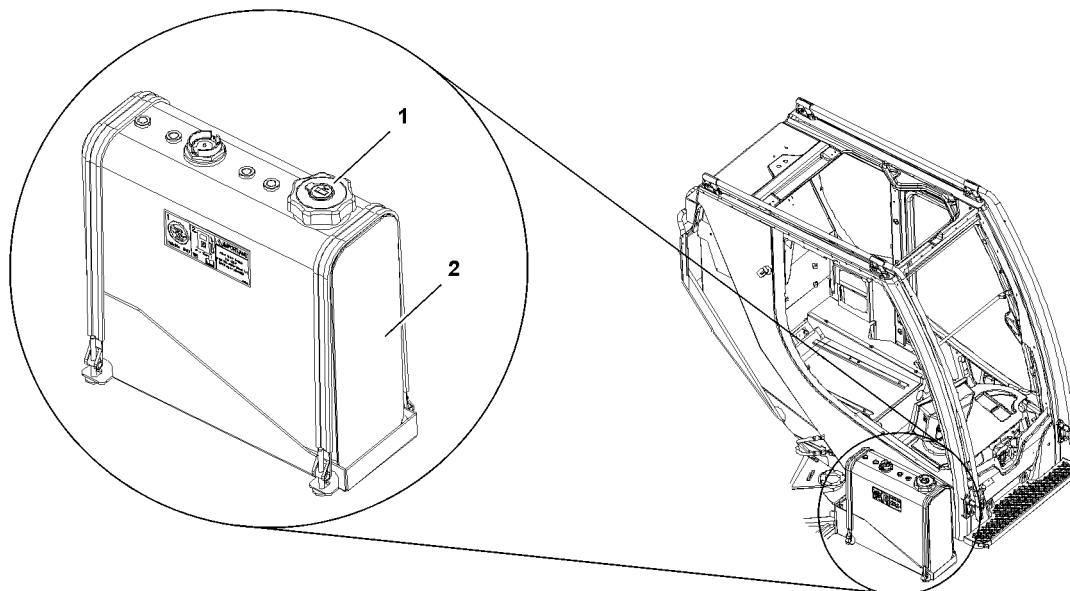


Fig.122551: Fuel container, auxiliary heater

- ▶ Open the fuel container **2**: Unscrew the cover **1**.
- ▶ Insert the fuel nozzle in the filler neck.
- ▶ Fill the fuel container **2** only to the point where the fuel nozzle shuts off: Add fuel.

After the refueling procedure:

- ▶ Take the fuel nozzle out of the filler neck.
- ▶ Close the fuel tank **2** with the cover **1**.

---

#### Problem remedy

Was **impermissible** fuel added?

- ▶ Do **not** turn the ignition on.
  - ▶ Have the fuel container and fuel lines completely drained by authorized and trained service personnel.
- 

### 14.3 Bleeding the fuel line

If the fuel ran out, then the fuel line may have to be bled.



#### Note

- ▶ Contact Customer Service at Liebherr-Werk Ehingen.
- 

### 14.4 Checking the function

Make sure that the following prerequisites are met:

- The air filters are not blocked.
  - Combustion air infiltration and exhaust emission of the heater are free of foreign particles.
  - If present: The pollen filter / dust filter of the heater are not blocked.
  - The heating circuit is bled.
  - The fuel line is bled.
  - The heating circuit is cold.
  - The LICCON computer system error memory does not contain any error messages regarding the auxiliary heater.
  - The crane engine is turned off.
- ▶ Turn on the auxiliary heater and run it for at least 15 min.

Wait a few minutes:

- ▶ Check the heat effect on the air vents of the vehicle.

### 14.5 Burning-off the burner

To prevent soot deposits in the burner of the auxiliary heater, free-burn the burner according to the maintenance interval. Burning off is used for the self-cleaning of the auxiliary heater burner.

Make sure that the following prerequisites are met:

- All outlet nozzles in the crane cab are open.
  - The crane cab door is open.
  - The interior temperature is set to the highest level.
  - The fan stage is set to the highest level.
  - The air supply is set to fresh air.
  - The heater is in manual operation.
- ▶ Operate the auxiliary heater at full load for at least 15 min.

### 14.6 Checking the water heater

Make sure that the following prerequisites are met:

- The heater and the heating circuit are cold.

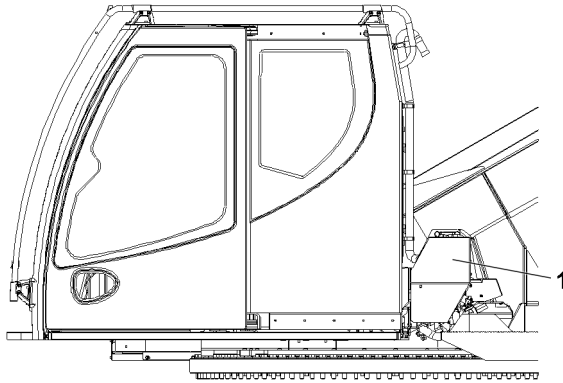


Fig.149080: Water heater, crane cab

- ▶ Remove the cover 1.
- ▶ Check the electrical connections for corrosion and tight seating.
- ▶ Check the exhaust line and combustion air line for damage and free passage.
- ▶ Check the hoses for leaks and cracks.
- ▶ Check the circulation pump for leaks.
- ▶ Check the coolant circuit and coolant pump for leaks and cracks.
- ▶ Check the fuel line and fuel filter for leaks and cracks.

When separately installed:

- ▶ Check the fuel filter for free passage.
- ▶ Replace the fuel filter.

The ratio of corrosion inhibitor - antifreeze in the heating circuit must be 50 % .

- ▶ Check the ratio of corrosion inhibitor / antifreeze in the heating circuit.

## 14.7 Checking the air heater\*

Make sure that the following prerequisites are met:

- The heater and the heating circuit are cold.

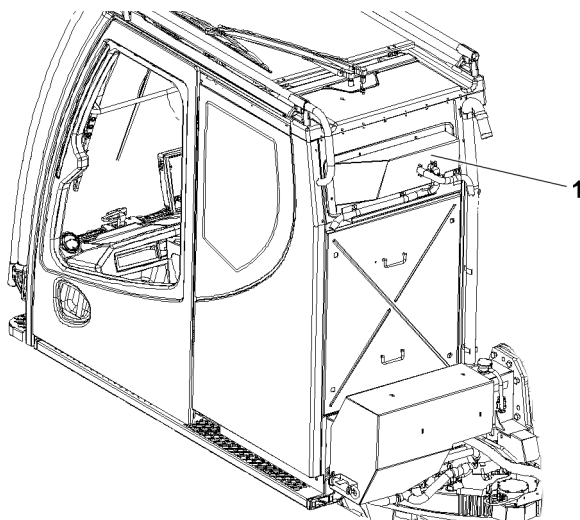


Fig.149082: Air heater, crane cab

1 Air heater

- ▶ Check the heated air inlet and heated air outlet for dirt and foreign bodies.
- ▶ Check the electrical connections for corrosion and tight seating.
- ▶ Check the exhaust line and combustion air line for damage and free passage.

- ▶ Check the fuel line for leaks and cracks.
- ▶ Replace the fuel filter.

## 15 Engine preheating auxiliary heater\*

### 15.1 Checking the fill level of the fuel container

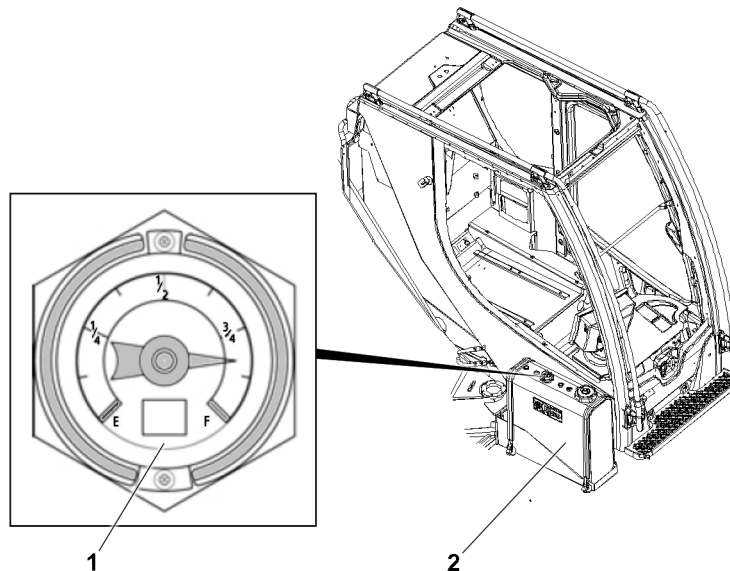


Fig.149086: Checking the fuel reserve

Make sure that the following prerequisites are met:

- The crane is in a horizontal position.

The fill level of the fuel container **2** is displayed by a level indicator **1**:

- Green mark F: The fuel container is full.
- Red mark E: The fuel container is empty.

- ▶ Check the fill level on the level indicator **1**.
- ▶ Add fuel in time before the fuel container is empty.
- ▶ Add fuel, see section „Adding fuel“.

### 15.2 Adding fuel

When the fuel is depleted:

- Under some circumstances, the fuel line must be bled.
- Contact Customer Service at Liebherr-Werk Ehingen and coordinate the procedure.



#### WARNING

Danger of fire!

Fuel is easily flammable and can cause fatal accidents in case of fire or open flames.

High property damage.

- ▶ Before the refueling procedure, turn the heating systems off, for example the heater, flame start system.
- ▶ When adding fuel, preclude fire, open light and smoking.

**DANGER**

Danger of fires due to spilled fuel!

- ▶ Keep the heating area free of fuel.
- ▶ Absorb fuel with rags.
- ▶ Dry up spilled fuel.

**WARNING**

Poisoning due to fuel!

Fuel is poisonous and hazardous to health.

- ▶ Do **not** allow fuel to come into contact with skin, eyes or clothing.
- ▶ Do **not** breathe in fuel vapors.
- ▶ Keep children away from fuel.

**First aid measures after contact with fuel:**

- If fuel was swallowed: Contact a physician immediately.
- In case of eye contact, flush out the eyes immediately and consult a physician if necessary.
- Clean affected skin areas with clear water.

**NOTICE****Impermissible fuel!**

The auxiliary heater can be severely damaged.

- ▶ Only add permissible fuel, see the manufacturer's instructions.
- ▶ Select the fuel in relation to the weather and temperature conditions.

Make sure that the following prerequisites are met:

- The crane is in a horizontal position.
- The heater is turned off.
- The engine and the ignition are turned off.
- All railings and steps are swung into the assembly position, see chapter 2.06.

Access and climb up on the mobile crane, see chapter 2.07.

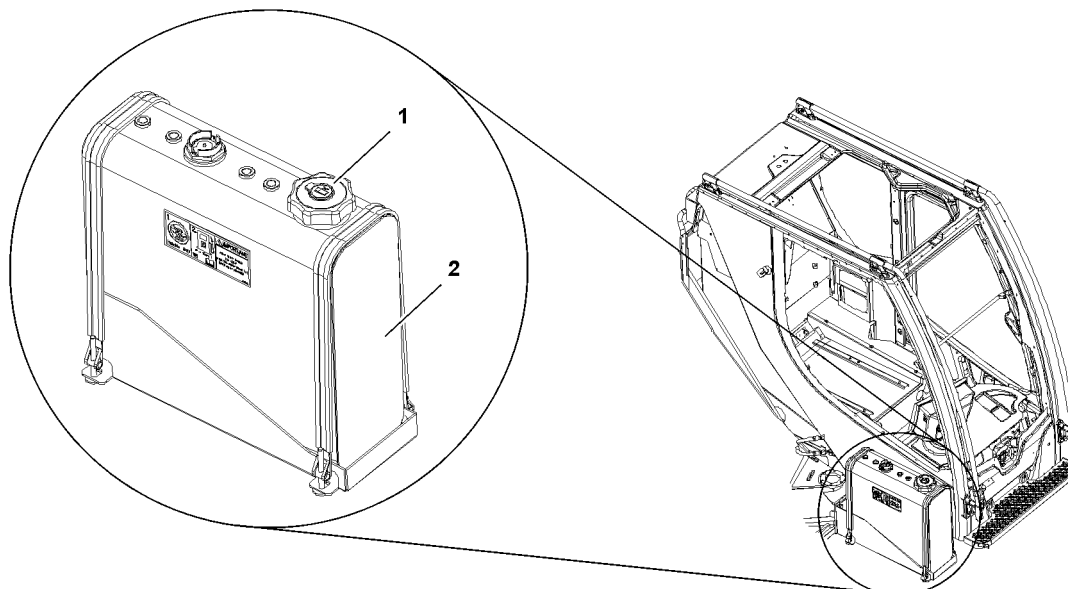


Fig.122551: Fuel container, auxiliary heater

- ▶ Open the fuel container **2**: Unscrew the cover **1**.
- ▶ Insert the fuel nozzle in the filler neck.
- ▶ Fill the fuel container **2** only to the point where the fuel nozzle shuts off: Add fuel.

After the refueling procedure:

- ▶ Take the fuel nozzle out of the filler neck.
- ▶ Close the fuel tank **2** with the cover **1**.

---

#### Problem remedy

Was **impermissible** fuel added?

- ▶ Do **not** turn the ignition on.
  - ▶ Have the fuel container and fuel lines completely drained by authorized and trained service personnel.
- 

### 15.3 Bleeding the fuel line

If the fuel ran out, then the fuel line may have to be bled.



#### Note

- ▶ Contact Customer Service at Liebherr-Werk Ehingen.
- 

### 15.4 Checking the function

Make sure that the following prerequisites are met:

- The air filters are not blocked.
  - Combustion air infiltration and exhaust emission of the heater are free of foreign particles.
  - If present: The pollen filter / dust filter of the heater are not blocked.
  - The heating circuit is bled.
  - The fuel line is bled.
  - The heating circuit is cold.
  - The LICCON computer system error memory does not contain any error messages regarding the auxiliary heater.
  - The crane engine is turned off.
- ▶ Turn on the auxiliary heater and run it for at least 15 min.

Wait a few minutes:

- ▶ Check the heat effect on the air vents of the vehicle.

### 15.5 Burning-off the burner

To prevent soot deposits in the burner of the auxiliary heater, free-burn the burner according to the maintenance interval. Burning off is used for the self-cleaning of the auxiliary heater burner.

Make sure that the following prerequisites are met:

- All outlet nozzles in the crane cab are open.
  - The crane cab door is open.
  - The interior temperature is set to the highest level.
  - The fan stage is set to the highest level.
  - The air supply is set to fresh air.
  - The heater is in manual operation.
- ▶ Operate the auxiliary heater at full load for at least 15 min.

### 15.6 Checking the water heater

Make sure that the following prerequisites are met:

- The heater and the heating circuit are cold.

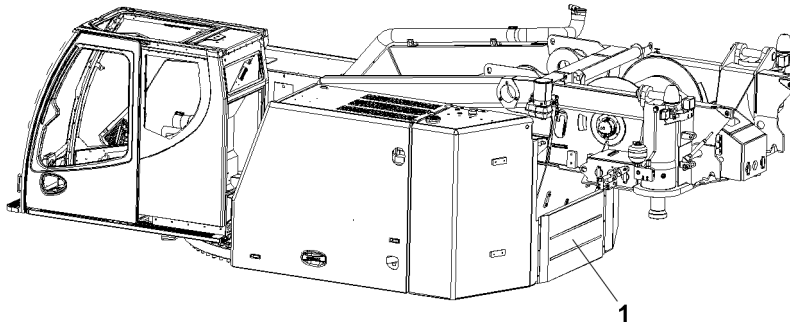


Fig.152441: Water heater, engine preheating

The water heater for engine preheating is located behind the cover **1**.

- ▶ Set down the counterweight with the ballasting device onto the central ballast, see chapter 4.07.
- ▶ Release the turntable lock.
- ▶ Make sure that the LICCON overload protection has been set according to the load chart and the set up configuration.
- ▶ Turn the crane superstructure until the cover **1** is accessible.
- ▶ Remove the cover **1**.
- ▶ Check the electrical connections for corrosion and tight seating.
- ▶ Check the exhaust line and combustion air line for damage and free passage.
- ▶ Check the hoses for leaks and cracks.
- ▶ Check the circulation pump for leaks.
- ▶ Check the coolant circuit and coolant pump for leaks and cracks.
- ▶ Check the fuel line and fuel filter for leaks and cracks.

When separately installed:

- ▶ Check the fuel filter for free passage.
- ▶ Replace the fuel filter.

The ratio of corrosion inhibitor - antifreeze in the heating circuit must be 50 % .

- ▶ Check the ratio of corrosion inhibitor / antifreeze in the heating circuit.

## 16 Ventilation

### 16.1 Replacing the filter

An interior filter for the ventilation of the control cabinet is located in the cab.

The filter must be replaced depending on the area of application and contamination.

The filter must be replaced at least once a year.



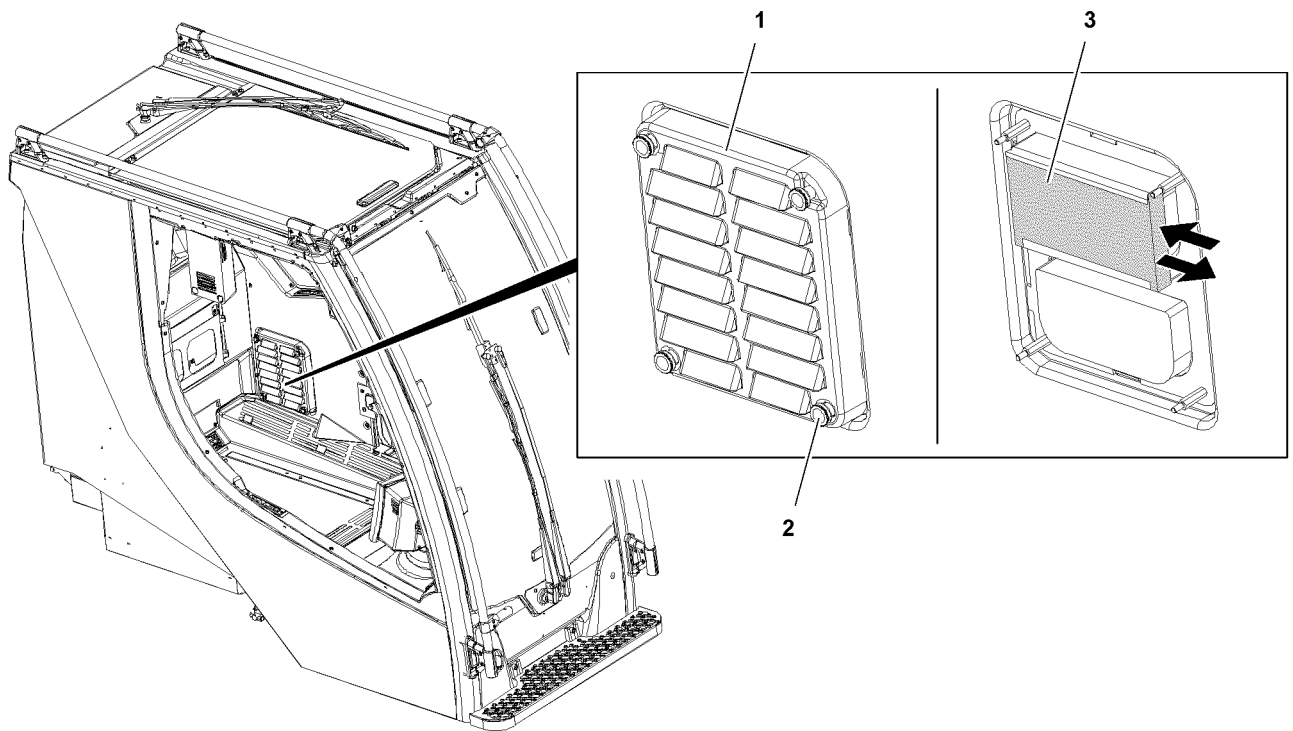


Fig.122791: Control cabinet ventilation

- ▶ Release and remove the knurled knobs 2.
- ▶ Remove the cover 1.
- ▶ Pull the filter 3 out.
- ▶ Slide in a new filter 3.
- ▶ Place the cover 1 and screw tight with knurled knobs 2.

## 17 Hydraulic system

### NOTICE

Dirt inside the hydraulic system!

Increased wear and shorter service life of the components.

- ▶ Extreme cleanliness must be maintained when adding oil.

### 17.1 Checking the oil level

Make sure that the following prerequisites are met:

- The crane is in a horizontal position.
- The luffing cylinder and the telescoping cylinder are fully retracted.

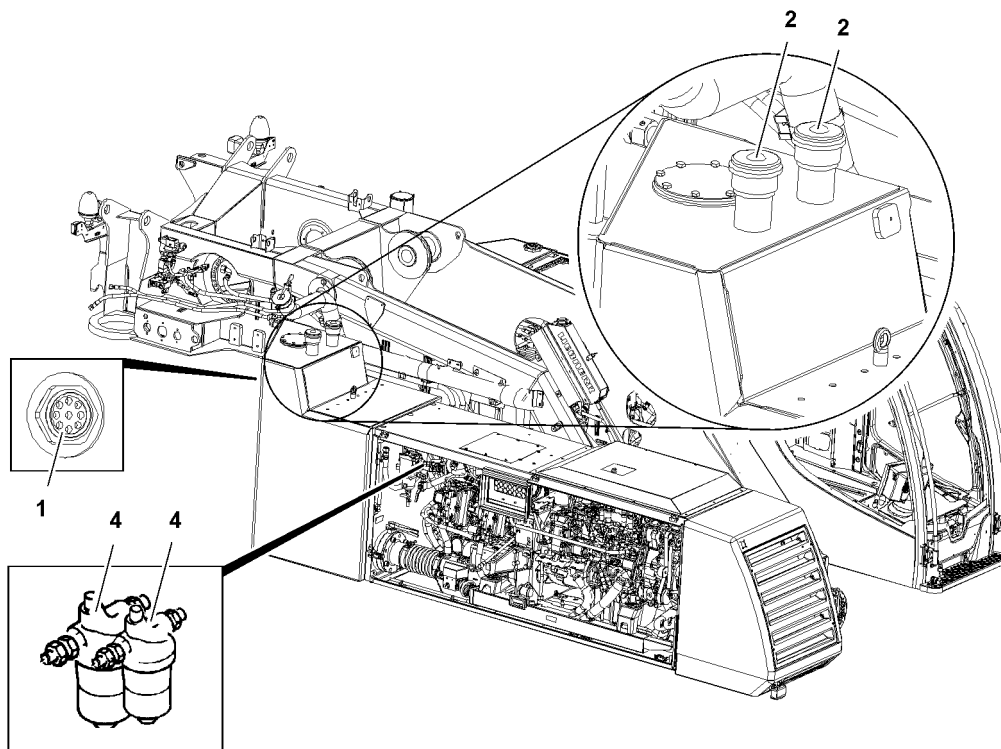


Fig.122788: Hydraulic oil tank

The oil level must be at 20 °C oil temperature in the center of the sight gauge **1**.

When the hydraulic temperature is lower than 20 °C:

- ▶ Warm up the hydraulic oil.

When the hydraulic temperature is higher than 20 °C:

- ▶ Let the hydraulic oil cool off.
- ▶ Retract all hydraulic cylinders completely, for example luffing cylinder, telescoping cylinder.

On cranes with level control:

- ▶ Lower the crane completely with the level control.

Extreme cleanliness must be maintained when adding hydraulic oil.

The oil level must be in the center of the sight gauge **1**.

- ▶ Check the oil level on the sight gauge **1**.

#### Problem remedy

**No hydraulic oil is visible in the sight gauge **1**?**

- ▶ Add hydraulic oil with a fine-meshed strainer via the return filter until the oil level is visible in the center of the sight gauge **1**.

#### Problem remedy

**Excessive oil consumption or loss of oil?**

- ▶ Find the cause and remedy it.

**If the cause cannot be remedied:**

- ▶ Contact Liebherr Service.

## 17.2 Checking the vent filter / breather filter

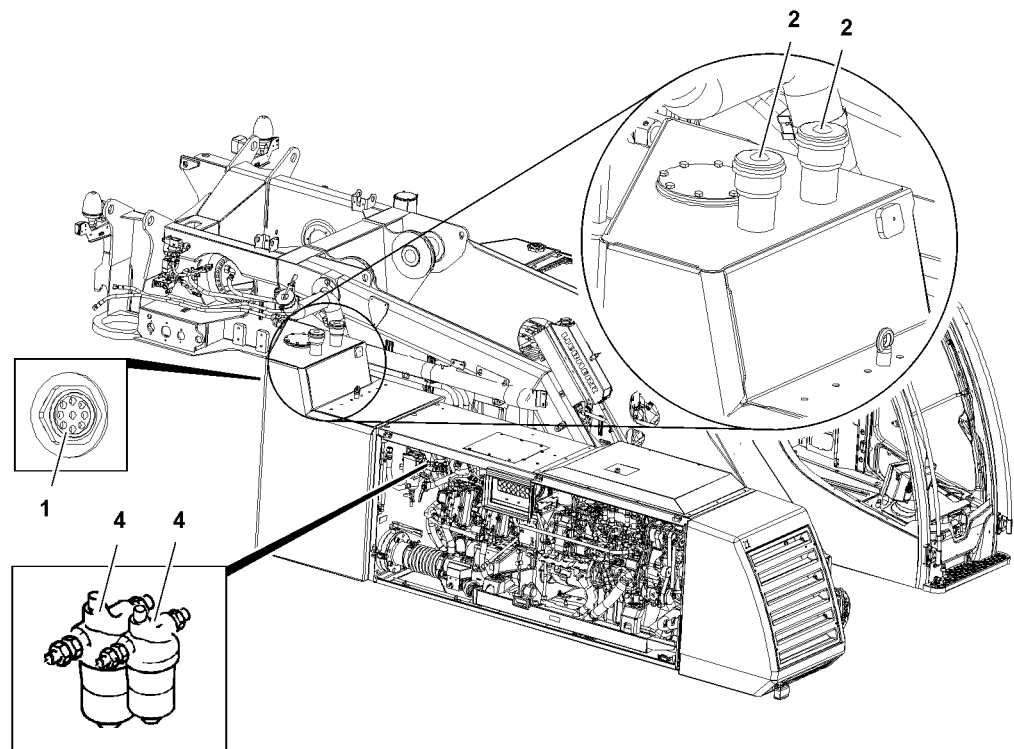


Fig.122788: Hydraulic oil tank

- ▶ Open the cover with the turn lock.
- ▶ Check the vent filter **2** for impurities (visual inspection).

When the vent filter **2** is very dirty:

- ▶ Replace the vent filter **2**.
- ▶ Close the cover with the turn lock.
- ▶ Start the diesel engine.
- ▶ Slowly run through all crane movements.
- ▶ Check the oil level and add hydraulic oil if necessary.

## 17.3 Checking and replacing the return filter

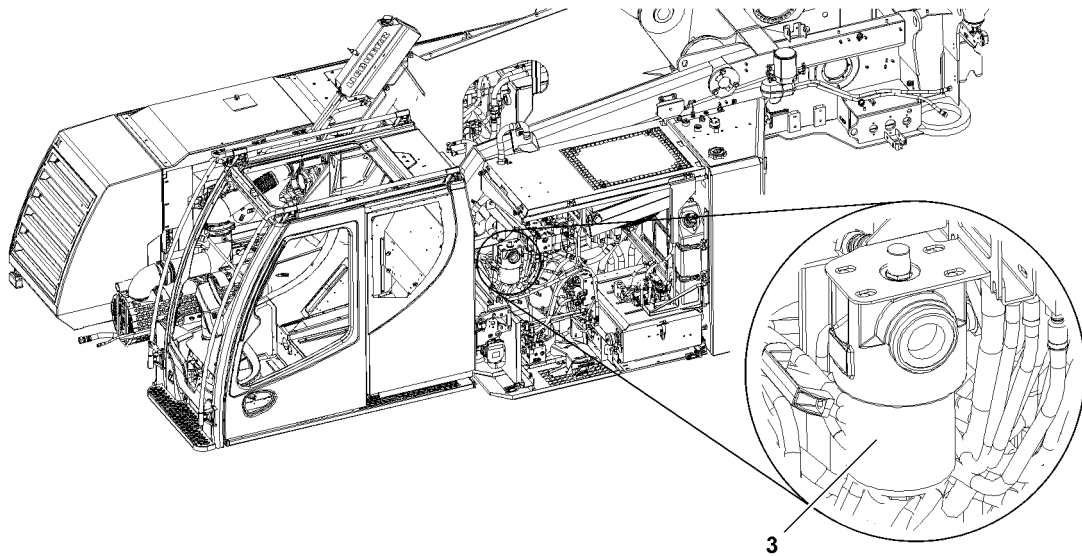


Fig.122789: Hydraulic system, return filter

One of the two return filters **3** is equipped with a maintenance indicator.

If the red mark is visible when the hydraulic oil is at operating temperature:

- ▶ Unscrew both filter covers.
- ▶ Unscrew the filter units.
- ▶ Clean the sealing surface on the covers.
- ▶ Install new filter units.
- ▶ Lubricate the rubber sealing rings in the covers with oil.
- ▶ Attach both filter covers and tighten them.
- ▶ Start the engine and check the filter for leaks.
- ▶ Check the oil level and add hydraulic oil if necessary.

## 17.4 Replacing the pressure filter elements

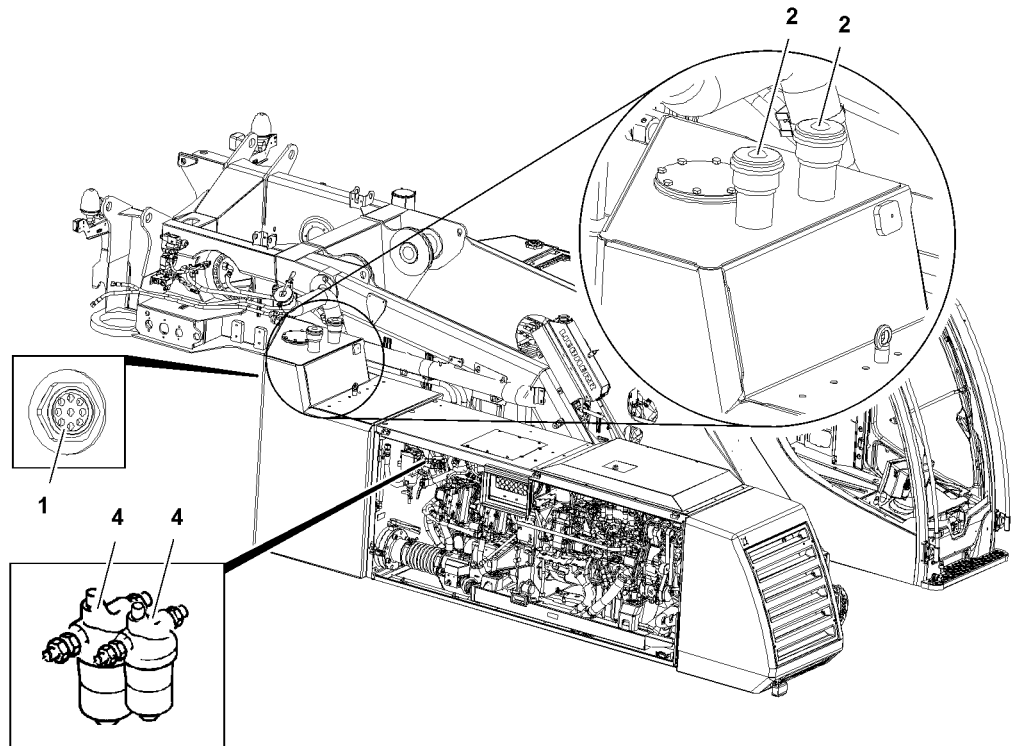


Fig.122788: Hydraulic oil tank

The pressure filters **4** are equipped with a maintenance indicator.

If the red bar is visible when the hydraulic oil is at operating temperature:

- ▶ Turn the diesel engine off.
- ▶ Release the filter element and catch escaping hydraulic oil in a container.
- ▶ Remove and dispose of the filter element.
- ▶ Clean the sealing surface on the filter bracket.
- ▶ Lubricate the rubber seal ring on the new filter element with oil.
- ▶ Screw on the new filter element and tighten it.
- ▶ Start the diesel engine and check for leaks.
- ▶ Slowly run through all crane movements.

### Result:

- The hydraulic system is bled.
- ▶ Check the oil level and add hydraulic oil if necessary.

## 17.5 Checking pretension pressure for the diaphragm reservoir

Various diaphragm reservoirs are installed in the hydraulic system.

The pretension pressures are specified in the hydraulic circuit diagram as well as on the individual diaphragm reservoirs.

The pretension pressure must be measured separately in each diaphragm reservoir.

Significantly fluctuating ambient temperatures occur:

- After transfer to countries with extremely warm or cold temperatures.
- In case of significant temperature differences between summer and winter.

**NOTICE**

Changes of pressures in diaphragm reservoirs due to significantly fluctuating ambient temperatures! Inadequate gas pretension may cause the reservoir diaphragms to be overstressed.

- ▶ Check the gas accumulator pressures and correct if necessary.

Make sure that the following prerequisite is met:

- The crane engine is turned off: The diaphragm reservoir is relieved on the fluid side.
- Authorized and trained expert personnel checks the pretension pressure of the diaphragm reservoir.

**DANGER**

Danger of explosion!

The pressure in the nitrogen cylinder must be less than the maximum permissible operating pressure of the accumulator or the pressure gauge. Otherwise install a pressure reducer between the cylinder and the filling device.

- ▶ Do **not** use air or oxygen to fill the diaphragm reservoir.

The pretension pressure in the hydraulic reservoirs must be checked by expert personnel with appropriate training and equipment.

In addition, the national regulations regarding pressurized container inspection must be observed and adhered to.

- ▶ Check the pretension pressure with a testing and filling device and correct, if necessary.

## 18 Hydraulic hose lines

**Note**

- ▶ See chapter 7.04.

## 19 Compressed air system\*

### 19.1 Replacing the granular cartridge of the air dryer

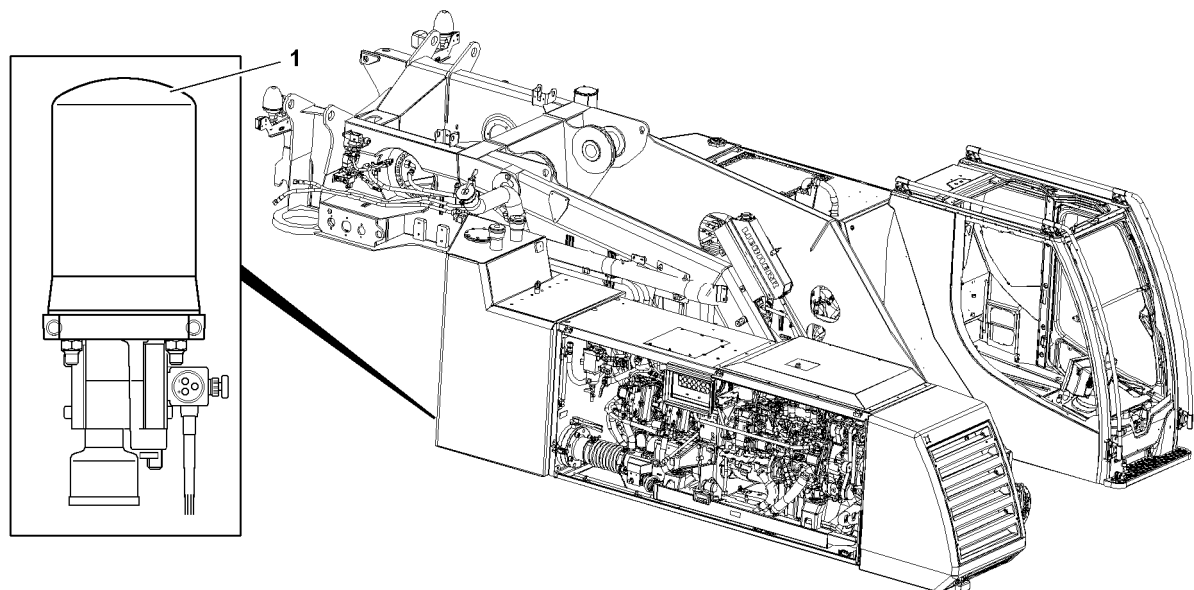


Fig.122790

LWE/LTR 1220-003/24204-02-02/en

The granular cartridge must be replaced annually.

The granular cartridge of the air dryer **1** is under spring tension.



#### WARNING

Uncontrolled release of the granular cartridge!

Severe injury, property damage.

- ▶ Replace the granular cartridge carefully and professionally.
- ▶ Replace the granular cartridge.

## 20 Electrical system

### 20.1 Bulbs and fuses

#### NOTICE

Property damage on the electrical system!

- ▶ Defective fuses may **not** be bypassed with wire or the like.
- ▶ Always replace defective fuses with fuses for the same current strength.
- ▶ Always replace defective bulbs with bulbs that have the same output.

When the same fuse or bulb becomes defective repeatedly:

- ▶ Check the electrical system.

### 20.2 Lines

- ▶ Make sure that all electrical lines are properly routed and fastened in their retainers.
- ▶ Fix any chafe marks or brittle areas in the insulation and coverings immediately.
- ▶ Any installation lines that are **not** in perfect condition must be immediately and professionally replaced.

### 20.3 Batteries

#### 20.3.1 Safety instructions



#### WARNING

Danger of accident due to discharged batteries!

- ▶ Plug in the cable of the external power supply on the Liebherr charger.
- ▶ Make sure that the batteries are charged while the crane is not in operation.



#### WARNING

Chemical burns due to battery acid!

Eye damage and skin irritation on contact.

- ▶ Make sure that eyes and skin do **not** come in contact with battery acid.
- ▶ Wear eye protection.
- ▶ Wear protective gloves.

When eyes came in contact with battery acid:

- ▶ Flush the eyes out immediately with clear water and consult a physician.

When skin came in contact with battery acid:




- ▶ Flush the skin immediately with water and consult a physician.

**Note**

- ▶ All safety signs on the batteries must be complete and always legible.
- ▶ Observe and adhere to the manufacturer's operating instructions.

Sign	Explanation
	Follow the guidelines on the battery, in the instruction manual and in the Crane operating instructions.
	Wear eye protection.
	Keep children away from acid and batteries.
	<b>Danger of explosion!</b> A highly explosive acoustic mixture is created when charging batteries.
	<b>Warning!</b> Fire, sparks, open light and smoking is prohibited. Avoid spark formation when handling cables and electrical devices. Avoid short circuits.
	<b>Danger of chemical burns!</b> Battery acid is very caustic, for that reason: Wear protective gloves and eye protection. Do <b>not</b> tilt the battery, acid can emerge from the vent openings.
	<b>First aid:</b> Flush splashed acid in the eye immediately for several minutes with clear water and consult a physician immediately. Neutralize splashed acid on skin or clothing immediately with an antacid or soap and flush with lots of water. When acid was ingested, contact a physician immediately.



Sign	Explanation
	<b>Warning!</b> Do <b>not</b> expose batteries unprotected to direct daylight. Discharged batteries can freeze. Store batteries frost free.
	<b>Disposal!</b> Dispose old batteries at a collection point. During transport, observe the guidelines of the manufacturer. Never dispose of old batteries in general trash.
	<b>Back to the manufacturer!</b> Used batteries with this sign are reusable assets. Send batteries for recycling. Old batteries, which are <b>not</b> recycled must be disposed of as hazardous waste under observation of all regulations.

### 20.3.2 Checking the batteries



#### DANGER

Mortal danger due to electric shock!

- ▶ When working on the electrical system of the crane, disconnect batteries from the electric circuits.
- ▶ Avoid spark formation caused by electrostatic charge.

When working on batteries:

- ▶ Wear a ground strap.
- ▶ Do **not** bring oil, grease, fuel or solvents into contact with the battery casting compound.

- ▶ Keep batteries dry and clean.
- ▶ Release dirty terminals, clean and grease them with an acid-free and acid-resistant grease.

#### NOTICE

Property damage due to excessively high or low acid level!

- ▶ Check the acid level in the battery only with a wooden stick or cardboard strip.
- ▶ Never check the acid level in the battery with metallic material.
- ▶ Adhere to the „minimum“ or „maximum“ acid level over the lead plates in the batteries according to the specifications of the battery manufacturer.

- ▶ Check the acid level in the batteries **every six months**.
- ▶ In summer and in hot climates, check it at least **every three months**.
- ▶ If necessary, add distilled water to the specified „max mark“.

An acid container is located in the battery box.

- ▶ Check the acid container.
- ▶ Fill the acid in the acid container into the battery.

The charge condition of a battery is determined by measuring the acid density.

Measure the acid density: The optimal acid temperature is + 20 °C.

When distilled water was added:

- ▶ Measure the acid density after 30 minutes.
- ▶ For the charge condition test, adhere to the specifications, see the following chart.

Acid density	Charge condition	Measure
in kg/l at +25 °C		
1.28/1.23*	Charged	—
1.20/1.16*	Semi-charged	Charge
1.12/1.08*	Discharged	Charge immediately

#### Specifications for the charge condition test

\* in tropical areas

Reduced battery performance requires greater power requirements.

- ▶ Charge batteries in time.
- ▶ Make sure that batteries are charged in the cold season.

### 20.3.3 Charging a battery with the Liebherr charger\*

The Liebherr charger is integrated in the crane electrical system.

Make sure that the following prerequisite is met:

- The ignition is turned off.

A socket for external power supply for the Liebherr charger is located on the crane.

- ▶ Plug in the cable of the external power supply on the socket.

### 20.3.4 Charging the battery with an external charger



#### WARNING

Danger of injuries!

- ▶ Do **not** place tools on batteries and keep out of open light.
- ▶ Eliminate spark formation caused by electrostatic charge.
- ▶ Work only in well ventilated rooms.
- ▶ Before working on batteries, wear a ground strap.
- ▶ Do **not** tilt or shake the batteries.

#### NOTICE

Property damage if charge voltage is more than 33 V !

- ▶ Make sure that the external charger delivers a charge voltage of maximum 33 V.

#### NOTICE

Loss of data due to disconnected battery!

When the battery is disconnected:

- ▶ Make sure that the temporary data memory is **not** needed.

#### Charging the battery when installed

Make sure that the following prerequisite is met:

- The ignition is turned off.
- ▶ Use an external charger with a charge voltage of maximum 33 V.
- ▶ Charge the battery professionally with an external charger.

#### Charging the battery while removed

#### NOTICE

Damage to alternator!

- ▶ Disconnect batteries solely if the Diesel engine has been turned off.

Make sure that the following prerequisite is met:

- The ignition is turned off.

Removing the batteries

- ▶ Use an external charger with a charge voltage of maximum 33 V.
- ▶ Disconnect the negative terminal first (ground cable), then the positive terminal.
- ▶ Disconnect the vent hose from the vent channels of the batteries.
- ▶ Remove the batteries.

Charging the batteries externally

---

#### NOTICE

Damage to batteries!

- ▶ Charge only with direct current: Maximum current: 1/10 of the battery capacity.
- 

Example for charging: To charge a battery with 170 Ah, the maximum charge current is 17.0 A.

- ▶ Thaw frozen batteries before charging.

When a plug is present:

- ▶ Before charging, remove all plugs.
- ▶ Check the acid level in the battery, see section „Maintaining the batteries“.
- ▶ Make sure that the battery is ventilated during the charging procedure (danger of oxyhydrogen explosion).
- ▶ Connect the battery to a charger (positive to positive and negative to negative).
- ▶ Turn on the battery charger after connecting the battery.

Stop charging immediately if:

- The acid temperature exceeds 55 °C (casing more than warm to the touch).
- The battery starts to give off gas.
- The electrolyte concentration or the charging voltage has **not** changed for 2 hours.
- ▶ Turn the battery charger off after charging, then remove the connector cables individually from the battery and battery charger.

Installing the batteries

- ▶ Check the acid level in the battery, see section „Checking the batteries“.
- ▶ Reinstall the batteries tightly in the vehicle.
- ▶ Connect the vent hose on the vent channels of the batteries.
- ▶ First connect positive terminal to battery, then negative terminal (ground lead).
- ▶ Check that the terminals are tightly seated (low transfer resistance).
- ▶ Grease the terminals and terminal posts with acid-free and acid-resistant grease (use corrosion protection even for modern maintenance-free batteries).

## 21 Ladders

### 21.1 Servicing the ladders




---

#### Note

- ▶ See chapter 7.04.
-

---

Empty page!

LWE/LTR 1220-003/24204-02-02/en

## 7.05.50 Maintenance instructions - Crane boom

1	Telescopic boom	2
2	Rope pulleys and guide pulleys	5
3	Crane ropes	6

# 1 Telescopic boom



## WARNING

Impermissible extension conditions!

The crane can topple over. Death, severe bodily injuries, property damage.

- ▶ For lubrication, adhere to the specified extension conditions of the telescopic boom.
- ▶ Do **not** telescope out more telescopes than specified.



## WARNING

Personnel in the danger zone!

Death, severe bodily injuries.

- ▶ Make sure that during telescoping **no** personnel remains within the danger zone of the telescopic boom.
- ▶ Lubricate the telescopic boom solely in resting status.



## WARNING

Telescoping the telescopic boom!

Shearing off of fingers.

- ▶ During telescoping, do **not** place your fingers in the maintenance port.



## Note

- ▶ For the gliding surfaces of the telescopic boom, use special grease as lubricant. See service fill and Crane operating instructions, chapter 7.07.

Make sure that the following prerequisites are met:

- Safety measures against falling have been made.
- Extend the crawler carriers to the **wide** track width.
- The central ballast of 20 t is installed.
- At least one counterweight of 10 t is installed on the turntable.
- **No** hook block is reeved in (reeving n=1).
- **No** auxiliary boom / accessory is installed.
- The hoist rope is spooled up and secured on the winch.
- The LICCON overload protection has been set according to the set up configuration.
- The telescopic boom is aligned in horizontal position to the rear (0°- main boom angle).
- The telescopic boom is telescoped in all the way.
- The *Telescoping* program is selected on the LICCON computer system, see the Crane operating instructions, chapter 4.05.



## Note

- ▶ The folding jib may remain on the side on the telescopic boom in the transport retainer.

## 1.1 Lubricating the outer gliding surfaces



## Note

Optimum lubrication result:

- ▶ To obtain an optimum lubrication result, let the sprayed on special grease cure four to eight hours before telescoping in.

To grease the outer gliding surfaces, every telescope can be telescoped out individually to 100 %.

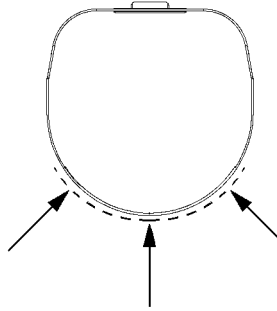


Fig.124866

- ▶ Telescope every telescope out individually to 100 % and spray special grease on the outer gliding surfaces.

## 1.2 Lubricating the inner gliding surfaces

Make sure that the following prerequisites are met:

- The telescopic boom is telescoped in all the way **0/0/0/0**.



---

### Note

- ▶ The inner gliding surfaces of the telescopes (plastic glide bearing plates) are lubricated via grease fittings.
  - ▶ The grease fittings can be accessed from the outside via maintenance ports on both sides of the pivot section and the telescopes.
-

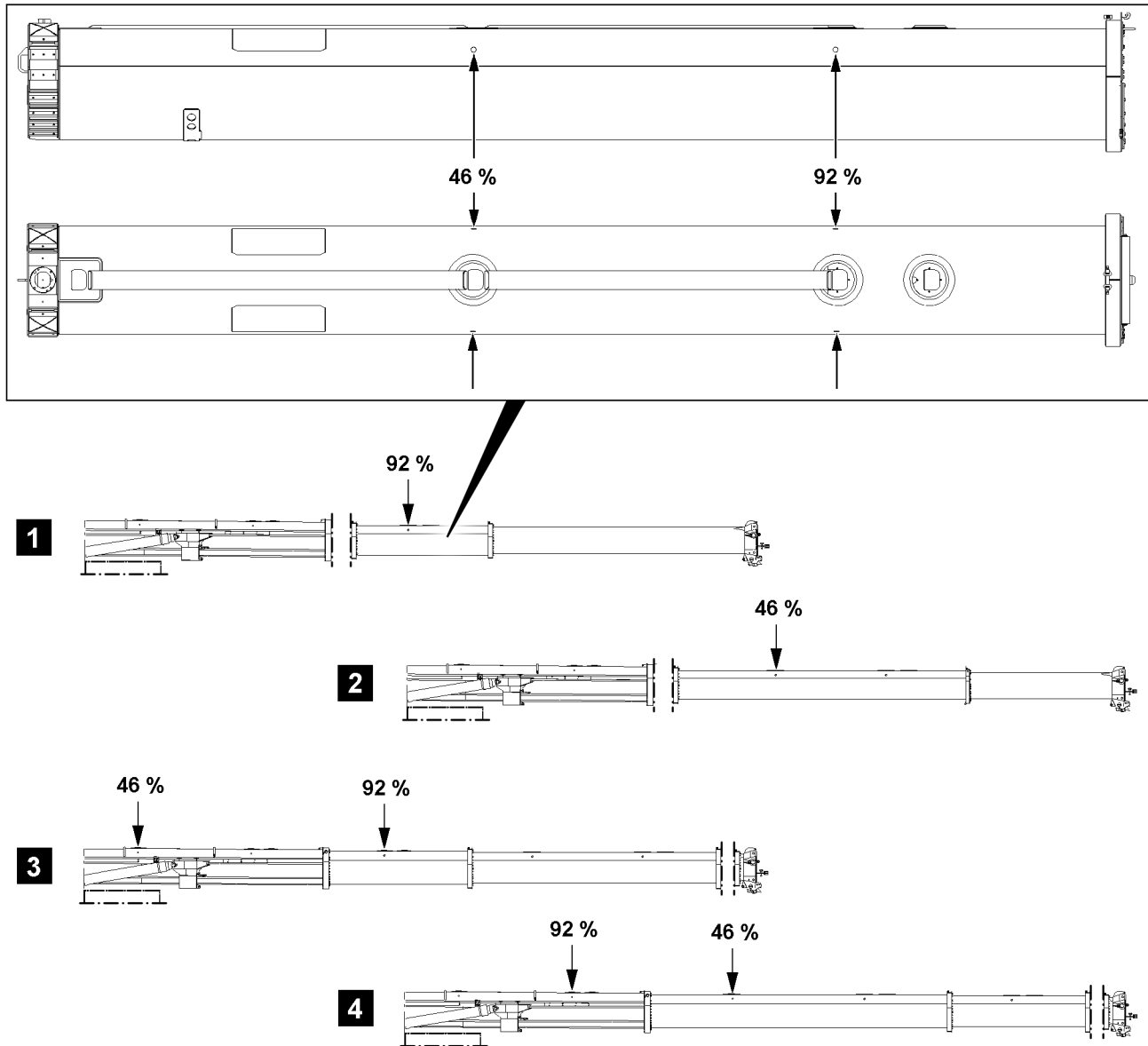


Fig.124863: Extension conditions and maintenance ports

Extension condition	Telescope	Maintenance port
0/0/0/46/92	4	92 %, see illustration 1
0/0/0/92/46	4	46 %, see illustration 2
0/0/46/92/0	3	92 %
0/0/92/46/0	3	46 %
0/46/92/0/0	2	92 %
0/92/46/0/0	2	46 %
46/92/0/0/0	1	46 % on pivot section, 92 % on telescope 1, see illustration 3
92/46/0/0/0	1	92 % on pivot section, 46 % on telescope 1, see illustration 4

LWE/LTR 1220-003/24204-02-02/en



- ▶ Telescope the telescopic boom one after the other to all extension conditions and lubricate the telescopes on the grease fittings.

### 1.3 Lubricating the locking pin

Make sure that the following prerequisites are met:

- The telescopic boom is telescoped to extension condition **92/46/0/0/0**.
- A lifting platform is on hand.

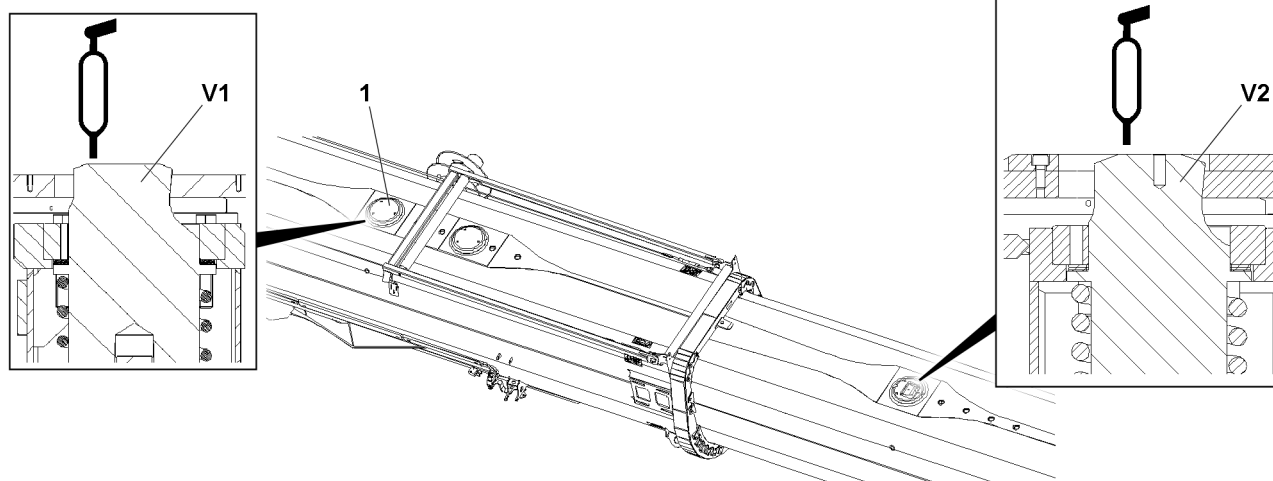


Fig.124867: Locking pins on telescopic boom

- ▶ Remove the cover **1** on the pivot section.
- ▶ Lubricate the locking pin **V1**.
- ▶ Assemble the cover **1**.

Extension condition	Locking pin
<b>92/46/0/0/0</b>	V2
<b>0/92/46/0/0</b>	V3
<b>0/0/92/46/0</b>	V4
<b>0/0/0/92/46</b>	V5

- ▶ Lubricate the locking pin **V2**.

The following steps must be carried out for every additional locking pin.

- ▶ Telescope the telescopic boom to the next extension condition.
- ▶ Lubricate the locking pin.

When all locking pins are lubricated:

- ▶ Telescope the telescopic boom in all the way and lock it.

## 2 Rope pulleys and guide pulleys

### 2.1 Checking for mechanical damage

Ropes can cause mechanical damage, such as stress marks.

- ▶ Check guide pulleys and rope pulleys for mechanical damage.
- ▶ Check the surface of the guide pulley and the groove of the rope pulley for smoothness.

The actual groove diameter must be larger than the actual rope diameter.

- ▶ Check the actual groove diameter of the rope pulley.

## 2.2 Checking bearings for easy movement

Stiff or blocked rope pulleys or compensation pulleys wear rapidly and unevenly and cause serious rope abrasion.

Ineffective compensation pulleys can lead to irregular rope tension.

- ▶ Check the rope pulleys for proper movement in their bearings.

When rope pulleys are **not** easily moveable in their bearings:

- ▶ Fix the bearings.

When the crane is at a standstill for a longer period of time:

- ▶ Turn the rope pulleys regularly.

## 2.3 Lubricating the bearings

Rope pulleys with a diameter of more than 25 mm can be lubricated.

### NOTICE

Lube pressure is too high!

When too much lubricant is introduced, then the lube pressure increases: Seal rings are pressed out.

- ▶ Meter the lube amount carefully.

- ▶ Turn the rope pulley and lubricate it.

# 3 Crane ropes

## 3.1 Personal protective equipment



### WARNING

Injury due to wires and skin irritation due to lubricant!

- ▶ When working with ropes, always wear work gloves.



### WARNING

Injuries if protective equipment is **not** worn!

- ▶ Wear hard hat, safety shoes and safety goggles.

## 3.2 Safe and problem-free operation



### WARNING

Wear, overload, incorrect use, damage, improper maintenance!

Failure of ropes. Death, severe injuries, property damage.

- ▶ Prevent failure of ropes: Observe and adhere to the following notes.

Carry out the following measures to ensure safe and problem-free rope operation:

- Service ropes and rope end connections regularly according to the maintenance intervals.
- Check ropes and rope end connections regularly according to the inspection intervals.
- When it is determined that the ropes should be withdrawn from service, do **not** continue to use them further.
- Exclude contact of rope with components except rope drive elements.
- Exclude contact of rope with structural parts, power lines or other objects within the surrounding area.

- Avoid corrosive and chemical surroundings.
- Avoid excessive soiling.
- Avoid excessive heat influence.
- Ensure proper condition of all elements of rope drive.
- Ensure proper spooling formation on the rope drum.
- Use the entire rope length of hoist ropes.
- Avoid slack rope formation on the drum.
- Do **not** bring outer twists into the rope.
- Avoid shock relief of the rope, such as sudden set down of the load.
- Avoid **non-permissible** angular pull, for example by pulling the load at an angle.

### 3.3 Temperature operating limits

Adhere the temperature operating limits for steel ropes. The determining factors are wire material, lubricant, rope end connections. See Manufacturer's specifications.

### 3.4 Qualification Maintenance personnel

Make sure that the following prerequisites are met:

- The maintenance personnel is trained and instructed in maintenance tasks.
- The maintenance personnel is assigned (authorized) for the maintenance by the crane operator.

### 3.5 Damage to the rope

**Rope removal criteria:** If severe damage reduces the operational safety, then the rope has reached the removal criteria.

This section provides an overview for possible damage to the rope. For clearer illustration, the distortions on the illustrations are exaggerated.

The displayed ropes show a condition, which is far above the removal criteria.

Damage to the rope causes uneven load distribution in the affected areas.

Damage to the rope is most often localized.

Typical examples for damage, which can be recognized during maintenance work:

- Broken strands
- Wire breaks
- Reduction of rope diameter
- Localized increase of rope diameter
- Corrosion
- Flattenings
- Corkscrew-like distortion
- Basket formation
- Protruding, distorted inlay or braiding
- Loop formation
- Kinking, rope loops (grommets) pulled closed
- Buckles
- Influence of heat or electrical voltage, such as arcing

Occurrence of removal criteria for individual criteria, see the Crane operating instructions, chapter 8.04.

#### 3.5.1 Broken strands

A strand consists of several individual wires.

When a complete braid is broken, then the rope must be taken down.

#### 3.5.2 Broken wire

Externally visible broken wires are the result of wear caused by operation.

Additional types of broken wires:

- Broken wire in the inside of the rope
- Broken wire in the strand valleys
- Broken wire on a rope connection

A broken wire does not endanger the safety of the rope.

### 3.5.3 Reduction of rope diameter

The rope diameter changes due to abrasion, settling and external influences.

Abrasion of cover wires of outer strands of rope due to frictional contact. Especially in those areas where ropes are in contact with the rope pulleys during start up or slow down of the load.

Wear is increased by lack of or incorrect lubrication and the effect of dust.

Abrasion reduces the tensile strength of steel ropes because the cross section of the steel is reduced.

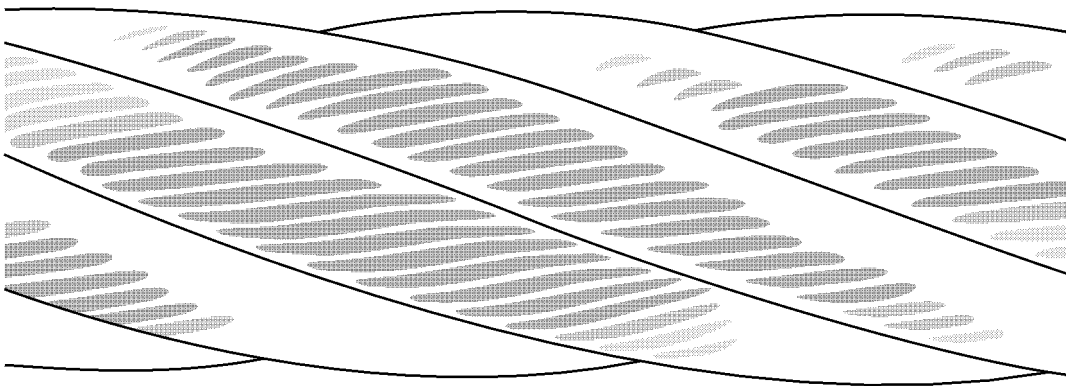


Fig.121001: External abrasion on the rope

When the rope diameter is reduced, the rope must be checked by **expert personnel for crane rope inspection**.

### 3.5.4 Localized increase of rope diameter

An increase, which occurs over a longer area of the rope can be caused by absorption of moisture in the fiber insert or due to corrosion in the inside of the rope.

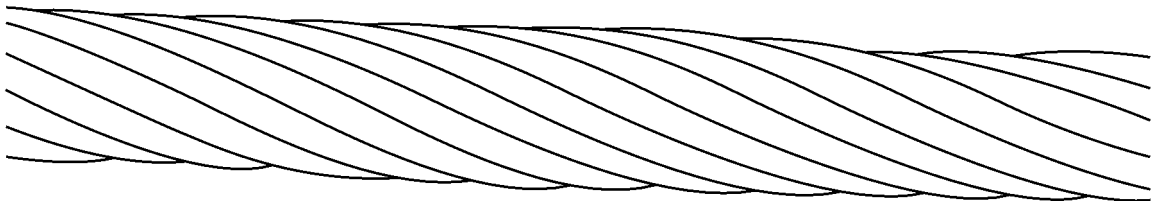


Fig.120992: Increase of rope diameter

When a localized increase of the rope diameter is present, then the rope must be checked by **expert personnel for crane rope inspection**.

### 3.5.5 Corrosion

Corrosion occurs due to insufficient lubrication, in maritime climates and in an atmosphere polluted by industrial fumes.

External corrosion is indicated by a rough wire surface. A superficial rust film can be wiped off.

Significant corrosion reduces the strength and elasticity of the rope due to the reduction of the rope diameter.

Inner corrosion is hard to detect.

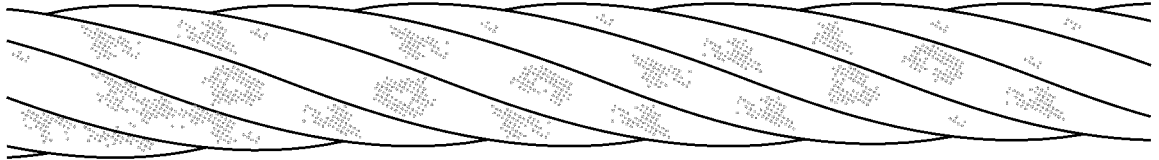


Fig.120994: External corrosion

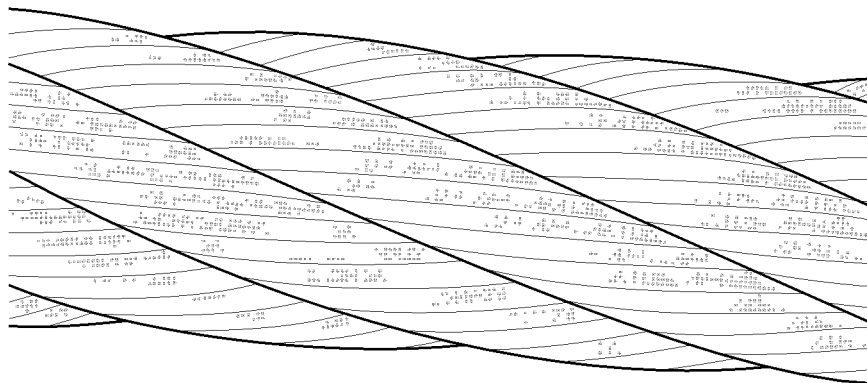


Fig.120995: Magnification of external corrosion for better depiction

When significant corrosion is present, the rope must be checked by **expert personnel for crane rope inspection**.

### 3.5.6 Flattening

Flattening occurs when the rope runs through the rope pulleys. In this area the rope wears quicker.

Corrosion occurs faster on retaining ropes and guy ropes.

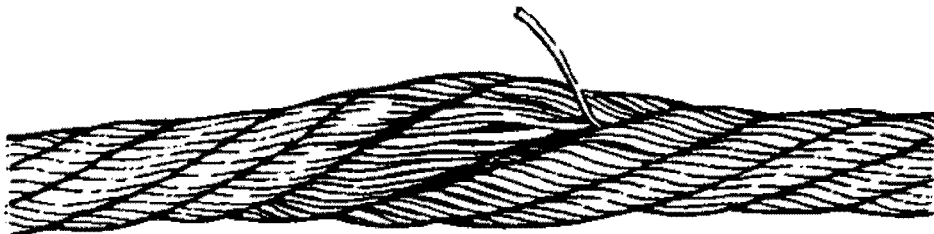
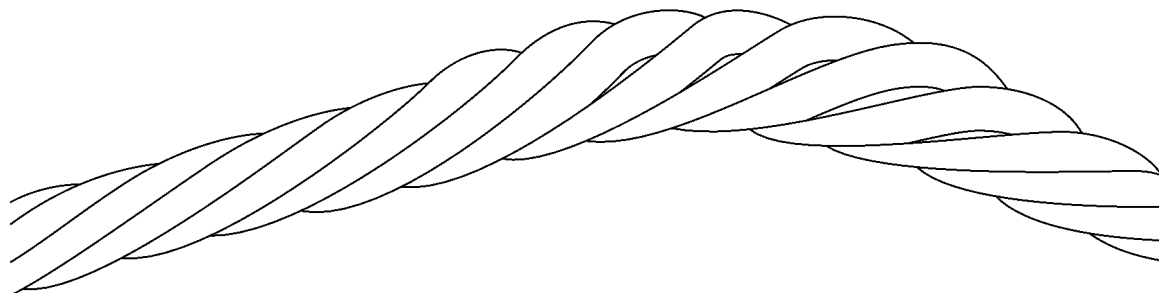


Fig.120997: Localized limited flattening, which leads to broken wires (single layer rope)



*Fig.120996: Flattenings on multi layer windings*

When flattening is present, the rope must be checked by **expert personnel for crane rope inspection**.

### 3.5.7 Corkscrew-like distortion

Distortion where the rope is in the form of a corkscrew along its longitudinal axis.

Corkscrew-like distortion causes rope wear, broken wires and bearing damage on rope pulleys.



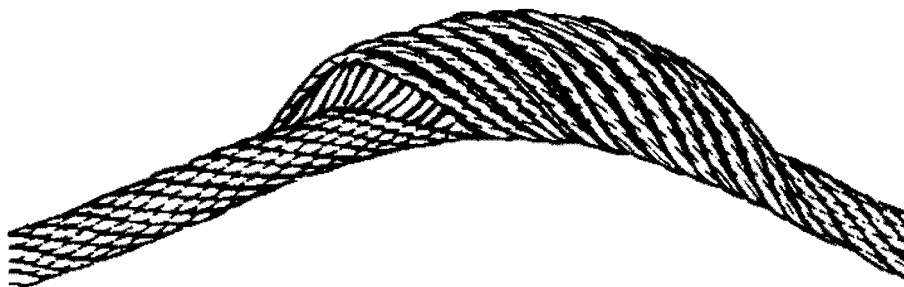
*Fig.120988: Corkscrew-like distortion*

When corkscrew-like distortion is present, the rope must be checked by **expert personnel for crane rope inspection**.

### 3.5.8 Basket formation

This distortion occurs due to different layers between the outer strand layers and the inside of the rope.

Causes for basket formation are high angular pull angles during the run over the rope pulleys and run-in rope pulleys. Even load distribution over the entire cross-section is not possible.



*Fig.120989: Basket formation*

When basket formation is present, then the rope must be taken down.

### 3.5.9 Protruding, distorted inlay, braiding

This distortion is a special form of basket formation: The insert or the core of the rope protrudes between the outer strands or an outer strand protrudes from the rope banding.

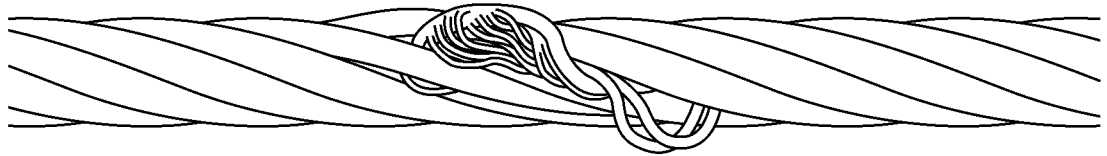


Fig.120990: Protrusion of an insert (rope single layer)



Fig.120991: Distorted or protruding strand

When the insert or a strand protrudes or is distorted, take the rope down. Have **expert personnel for crane rope inspection** check if the rope area with the distortion can be removed.

### 3.5.10 Loop formation

At loop formation individual wires protrude from the rope banding, when no broken wire ends can be seen.

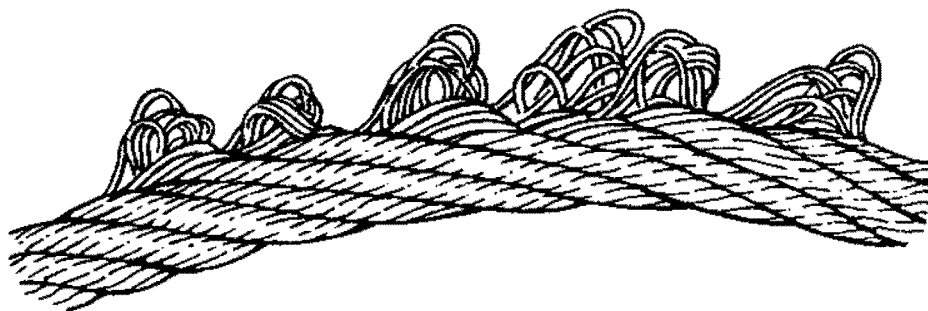


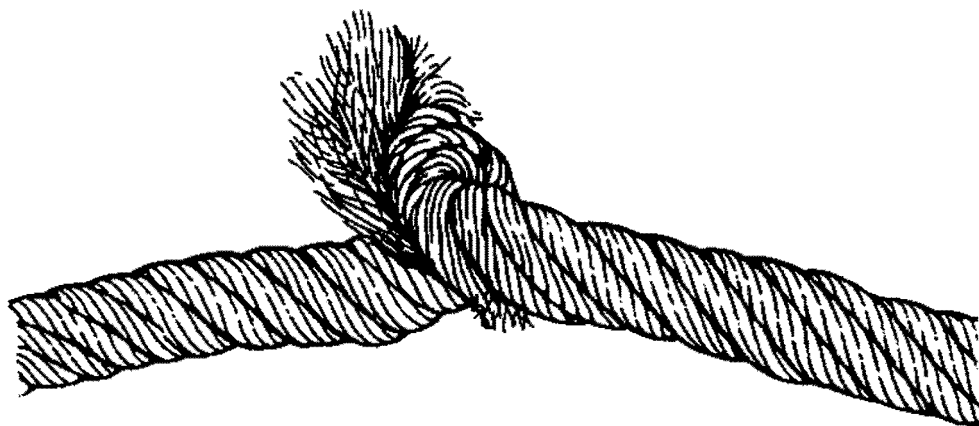
Fig.120993: Emergence of individual wires

When loop formation is present, take the rope down.

### 3.5.11 Kinking, rope loops (grommets) pulled closed

Deformation, where a loop has formed in the rope, without the possibility to rotate around its own axis during a load. The rope is subjected to significant wear.

The rope is deformed. The strength remains only in part.

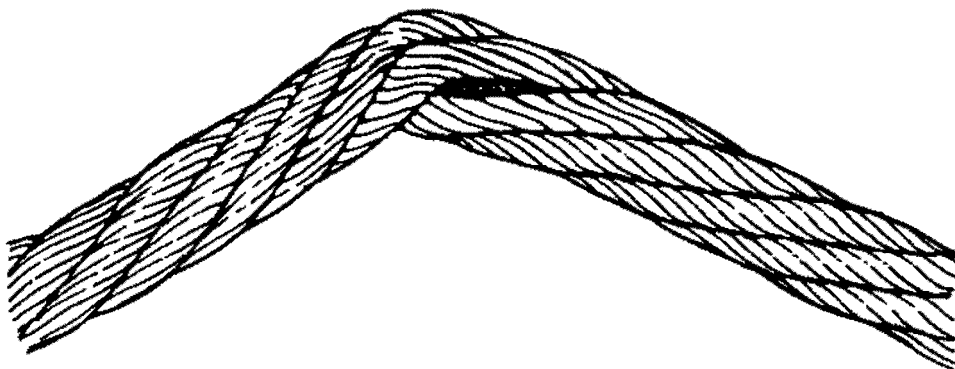


*Fig.120998: Severe kinking or knots*

When kinking or rope loops are present, take the rope down.

### 3.5.12 Buckles

Buckles are angular deformations. The rope was damaged due to external influences. Strong deformations of the rope cause stronger wear.



*Fig.120999: Severe buckle*

When buckles are present, take the rope down.

### 3.5.13 Effects of heat, arcs

Damage caused to the rope by welding work, for example.

Unusual heat impact is visible by tempering colors and loss of lubricant.

When heat impact has occurred on the rope, then the rope must be taken down.

## 3.6 Checking the ropes



### **WARNING**

Operation with damaged rope!  
Failure of rope. Death, severe injury, property damage.

When damage, wear and deformations are present:

- ▶ Have **expert personnel for crane rope inspection** determine if the rope has to be taken down.



The following sections describe the tasks for a **daily visual inspection**.

The crane operator can carry out a daily visual inspection if he is sufficiently trained in the tasks and considered to be able to do so.

### 3.6.1 Intervals

Intervals and situations where the daily visual inspection must be made:

- Daily, before starting to work
- In case of change of the reeving of the crane rope due to:
  - Transport
  - New reeving
  - Disassembly and assembly

### 3.6.2 Areas

The rope must be checked over the entire length.

The following areas must be checked with special care:

- Rope end connections
- Safety coils and fixed point on the winch

### 3.6.3 Documentation of rope condition

**Every visible change of the wire rope must be documented in the crane records.**

### 3.6.4 Checking the lubrication



#### WARNING

Missing lubrication!

Functional problems. Inner and outer corrosion.

- ▶ Lubricate the rope regularly.
- ▶ Make sure that the rope is lubricated all around.
- ▶ Select manual or automatic lubrication procedures.

The lubrication must be checked at least once a **month**.

When the rope shows signs of drying out:

- ▶ Lubricate the rope, see section „Lubricating the rope“.

### 3.6.5 Checking for wear and distortion

- ▶ Check all visible parts of the rope for wear and distortion.
- ▶ Check the rope end connections and fixed points especially carefully for wear, damage, cracks and distortion.
- ▶ Check pressed together rope end connection for slipping and traces on the rope.



#### Note

- ▶ The maximum permissible number for broken wires over a certain rope length may not be exceeded.
- ▶ Determine the maximum permissible number of broken wires, see the Crane operating instructions, chapter 8.04.

- ▶ Check the rope end connection and rope area near the rope end connection for broken wires.

When broken wires are present on the rope:

- ▶ Remove the broken wire, see section „Removing broken wires“.

When broken wires or damage is present on the rope end connection:

- ▶ Document visible changes of the rope condition.
- ▶ Have the rope checked by **expert personnel for crane rope inspection**.

When the rope can be shortened without reducing the operational safety:

- ▶ Shorten the rope, see section „Shortening the rope“.

### 3.6.6 Checking the rope drive for spooling problems

Lacking pretension of the rope on the winch can cause spooling problems in multi layer spooling.

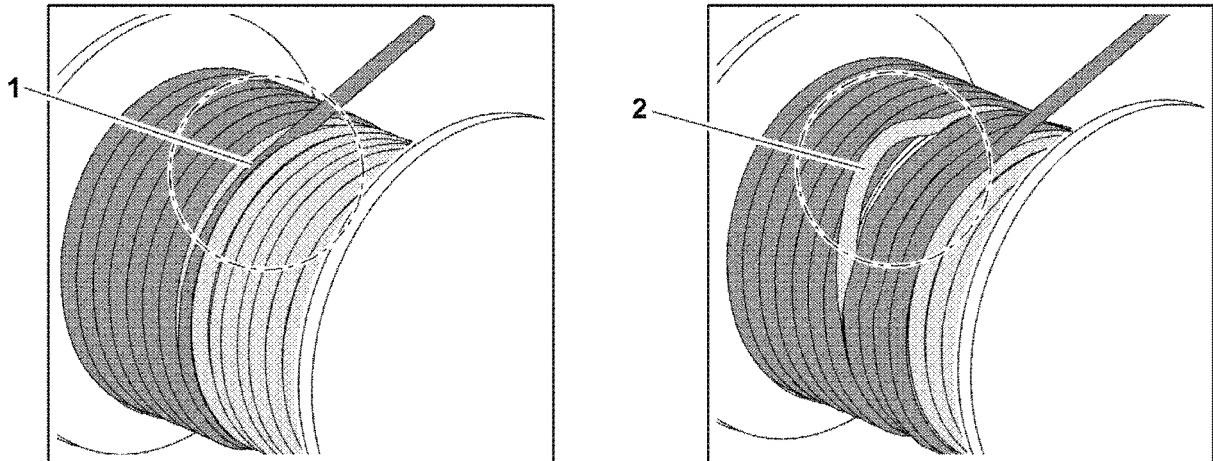


Fig.120967: Possible spooling problems on the rope winch

- 1 Cutting into the lower rope layers      2 Loop formation in the lower rope layers

- ▶ Check the spooling behavior of rope on the rope winch for cutting into the lower rope layers 1.
- ▶ Check the spooling behavior of rope on the rope winch for loop formation in the lower rope layers 2.

When spooling defects are found:

- ▶ Renew the pretension, see section „Renewing the pretension of hoist ropes“.
- ▶ Document visible changes of the rope condition.
- ▶ Have the rope checked by **expert personnel for crane rope inspection**.

### 3.6.7 Checking the position

- ▶ Check the correct position of the rope on the rope pulleys.

When the rope is **not** correctly laying on the rope pulley:

- ▶ Have the rope and rope pulley checked by **expert personnel for crane rope inspection**.

### 3.6.8 Checking for corrosion

A superficial „rust film“ can be wiped off.

- ▶ Do **not** clean the rope with solvents or cleaners.
- ▶ Clean the rope solely with a wire hand brush.
- ▶ Check rope for corrosion.

When the rope shows a rough surface:

- ▶ Document visible changes of the rope condition and have the rope checked by **expert personnel for crane rope inspection**.

If there is any uncertainty regarding the condition of the rope:

- ▶ Take the rope down or contact Liebherr Service.

### 3.6.9 Checking for flattenings

The rope is stressed more in the cross over area of the spooled up rope layers on the winch. The rope can be flattened as a result.

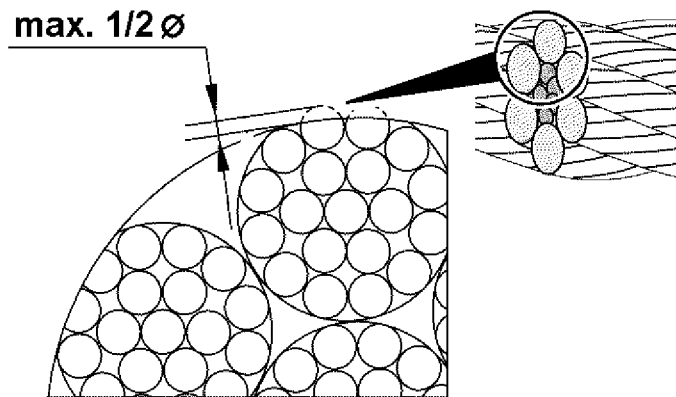


Fig.120966: Maximum flattening of wires on the outer strands

- ▶ Check the rope in the ascent zones of the rope spooling on the winch for flattenings.

When the outer braids are flattened more than half of the wire diameter:

- ▶ Document visible changes of the rope condition.
- ▶ Have the rope inspected by **expert personnel for crane rope inspection** or take the rope down.

When the rope can be shortened without reducing the operational safety:

- ▶ Shorten the rope on the rope drum fixed point, see section „Shortening the rope“.

### 3.7 Checking the control rope for distortions

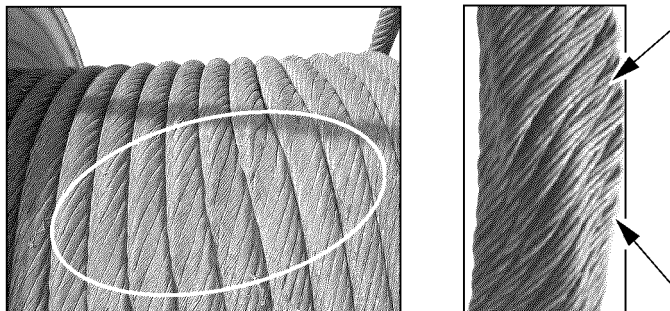


Fig.114002: Distortion on control ropes

- ▶ Check the first rope layer of the control winch for crushed areas and distortions.

When distortions are present:

- ▶ Have the rope checked by **expert personnel for crane rope inspection**.

### 3.8 Lubricating the rope



#### WARNING

Missing lubrication!  
Functional problems. Inner and outer corrosion.

- ▶ Lubricate the rope regularly.
- ▶ Make sure that the rope is lubricated all around.
- ▶ Select manual or automatic lubrication procedures.

#### NOTICE

Too much or incorrect lubricant!  
Excessive soiling. Wear on rope, on rope pulley and on winch. Recognition of take down criteria is impeded.

- ▶ Use lubricant, which is compatible with the rope and the original lubricant.

- ▶ Do **not** clean the rope with solvents or cleaners.
- ▶ Clean the rope solely with a wire hand brush.

Areas, which must be lubricated especially well are bending zones on winch and rope pulleys.

- ▶ Lubricate the rope.

### 3.9 Removing broken wires

#### NOTICE

Broken wires!

Damage of other components in crane operation, for example rope pulleys and compensation pulleys.

- ▶ Remove broken wires.

Make sure that the following prerequisites are met:

- Suitable pliers are on hand.

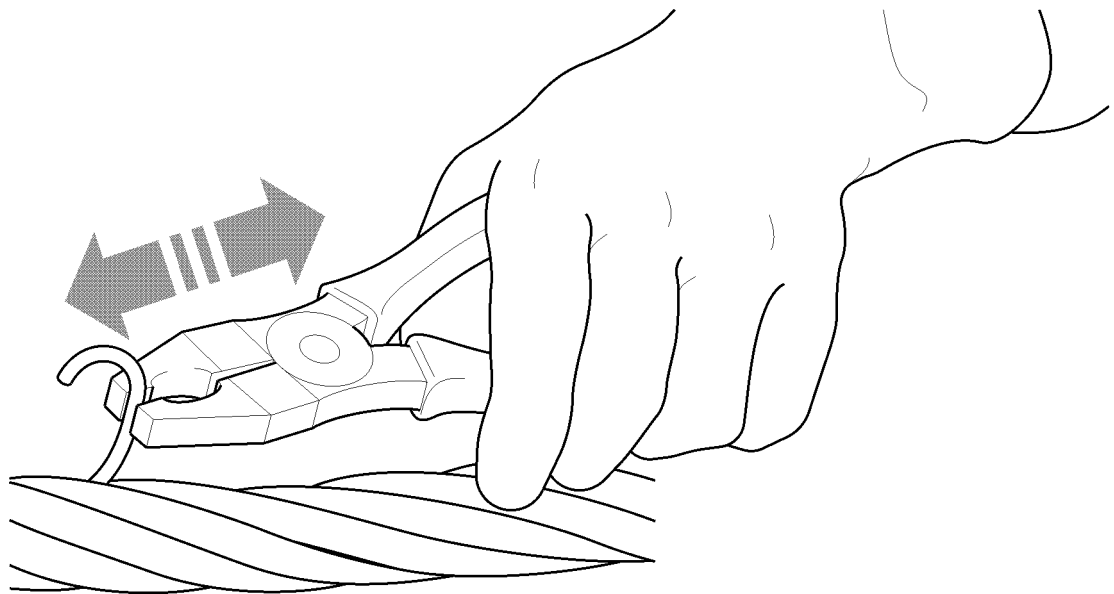


Fig.120979: Removing broken wire

- ▶ Grasp the wire on the upper end with pliers. Bend the wire back and forth until the wire breaks off in the braid valley.

The position of a broken wire is important for subsequent inspection. Individual broken wires are counted and are recorded later in the evaluation for withdrawal from service.

- ▶ Document the position of the broken wires in the crane record. Inspection checklist, see chapter 8.04.

### 3.10 Turning an extremely rotation-resistant hoist rope out



#### WARNING

Damage of rope due to incorrect procedure!

- ▶ Use extreme caution for the following procedures.
- ▶ Observe the following instructions exactly.

The cause for the turn-in of the hook block can have various reasons.

Check the crane for the following peculiarities:

- Scrub marks: Are hoist rope scrub marks present on the crane components? If scrub marks are present, check the hoist rope run and correct it.

- Rope pulleys: Did the groove diameter become too small?
  - Groove diameter dimensional stability must be present.
  - If this is not the case, the rope pulley must be replaced.
- Rope lubrication: Has the hoist rope been sufficiently lubricated? If the rope surface is dry, the hoist rope must be re-lubricated.

If the crane does not display other peculiarities, the hoist rope must be spun out.

The following sections describe two methods of how to spin out the hoist rope. The methods must be applied in the described sequence.

### 3.10.1 Spinning out with single strand reeving

- ▶ Reeve in the single strand hoist rope.
- ▶ Extend the boom to the maximal boom length and hook height.
- ▶ Lower hooks to approximately 1 m above the ground and allow the hoist rope to spin out.
- ▶ With an empty hook block, carry out one complete hoist cycle.
- ▶ Lower the hook again to approximately 1 m above the ground and allow the hoist rope to spin out again.
- ▶ Reeve in the number of strands of hoist rope carefully and spin free where the twisting of the hook block is largest.
- ▶ Distribute the spin out to the entire rope length: Run at least two entire hoist cycles at maximum boom length and hook height.



#### Note

When the hook block continues to turn in:

- ▶ Spin the rope out, see section „Spinning out by turning the hook block out“.

### 3.10.2 Spinning out by turning out the hook block

Make sure that the following prerequisites are met:

- The hook block is reeved with the number of strands where the twisting is the largest.
- ▶ Extend the boom completely and lower the hook block.
- ▶ Fasten a load of approximately 10 % of the nominal rope pull to the hook block.

Before lifting the load, a helper must turn the twisted hook block to a straight position by hand until the rope strands no longer touch each other.

- ▶ Continue to turn the hook block by one entire turn.

#### Result:

- The rope strands touch again.

#### NOTICE

The hook block turns back under load in a straight position!

When the hook block turns back in a straight position:

- ▶ Release the hook block.
- ▶ Hold the hook block in the prescribed position until the load lifts off the ground.
- ▶ Move the load until approximately 15 m before the uppermost hook position of the completely extended boom.
- ▶ Lower load and set it down.

### 3.11 Renewing the pretension of hoist ropes



#### WARNING

Lacking pretension of the rope on the winch!  
Excessive rope wear in the lower spooling layers, gap formation, rope cutting in.

When the lower rope layers on the winch are hardly used or **not**:

- ▶ Renew the pretension in the entire rope regularly.

Make sure that the following prerequisites are met:

- A reeving is selected where the entire rope length can be spooled.
- A clean spooling picture is visible when spooling on the drum.



#### Note

Recommendation!

- ▶ The rope application is the most economical when the entire rope length is utilized.

When only a part of the rope length is used for a longer period of time:

- ▶ Use a proportionally shorter rope.
- ▶ Spool the rope out until three safety coils.
- ▶ Spool the rope up with a rope tensile force of 10 % of the maximum rope tensile force.

### 3.12 Shortening the rope



#### WARNING

Distortions and mechanical damage!  
Operational safety significantly disturbed, uneven load distribution within the rope.  
▶ Have the manufacturer check if the distorted and damaged area can be severed.

Visible form changes often occur localized or in short rope sections.

When a safe operation of the rope is ensured, a distorted and damaged area can be severed.

To shorten the rope there are different prerequisites:

- Rope shows flattenings.
- Broken wires occur solely within the area of the rope end connection, the remaining rope is undamaged.



#### DANGER

Minimum number of remaining coils on the winch fallen below!  
Rope releases or rips off, falling load. Death, severe injury, property damage.

- ▶ Make sure, after shortening the rope that **at least three remaining coils** remain on the winch in all working positions of the crane.

Make sure that the following prerequisites are met:

- The rope was shortened by authorized and trained expert personnel.

**Multi layer spooling:** When the rope on the fixed point on the winch is shortened by half the winch diameter, then the service life of the rope increases significantly.

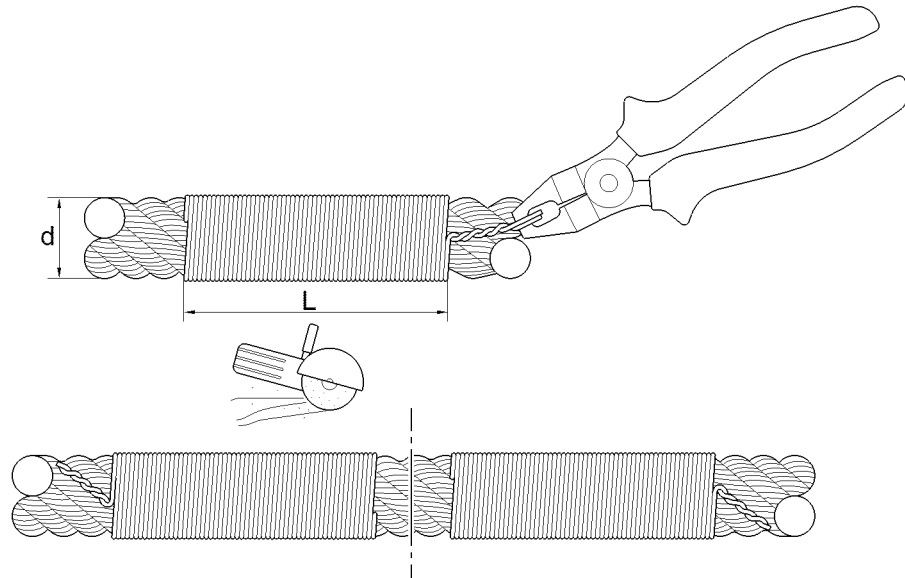


Fig.120972: Tying the rope before shortening it

**d** Rope nominal diameter                                      **L** Length of tie, at least 2d

The length of the tie **L** must be at least 2 times the nominal rope diameter (2d).

The shortening of the rope in this section applies to a single layer rope. On rotation-resistance, parallel roped ropes it may be necessary to tie several times to prevent the rope from jumping open when it is cut.

- ▶ Tie the rope on both sides with wire.
- ▶ Twist the end of the wire with the pliers to prevent them from releasing.



#### **WARNING**

Danger of injury due to flying sparks!

- ▶ Wear safety goggles and safety gloves.
- 
- ▶ Separate the rope vertically to the rope axis.
  - ▶ Fasten the end connections on the rope according to the manufacturer's instructions.
  - ▶ Remove the tie on both ends of the separation point from the rope.

---

Empty page!

LWE/LTR 1220-003/24204-02-02/en



## 7.06 Fill quantities, lubrication chart

1	Fill quantities	3
2	Lubrication schedule	4

*Fig.195219*

LWE/LTR 1220-003/24204-02-02/en

# 1 Fill quantities



## WARNING

Handling poisonous operating fluids and lubricants!  
Poisoning, severe health damage.

When operating fluids are to be used, stored and disposed of:

- ▶ Observe and follow the printed instructions on the original containers.
- ▶ Store operating fluids exclusively in the closed original container.
- ▶ Keep children away from operating fluids. Keep operating fluids away from children.
- ▶ Dispose of operating items and lubricants in an environmentally safe manner.

## NOTICE

Damage on aggregates due to impermissible additives!

- ▶ Make sure that **no** impermissible additives are added to the operating fluids.



## Note

- ▶ Fill quantities and descriptions of service items and lubricants are specified in the Service fill.
- ▶ Fill the crane chassis, crane superstructure and equipment with the respective operating fluids.
- ▶ The specified fill quantities (change quantities) are orientation values. The marks on the dipsticks, inspection ports and sight gauges are decisive for filling.
- ▶ The equipment depends on the purchased scope of delivery.

On mobile cranes with truck chassis:

- ▶ Observe the maintenance intervals and maintenance notes of the truck chassis manufacturer.

## NOTICE

Danger of property damage!

- ▶ Do **not** mix different oil products!
- ▶ Do **not** mix synthetic oils with mineral oils!
- ▶ Adhere to the data in the Service fill!

## 1.1 Diesel engine

- ▶ Check the engine oil. See Maintenance intervals and maintenance instructions.
- ▶ Adhere to the operating instructions of the engine manufacturer.

## 1.2 Coolant system

### NOTICE

Property damage due to impermissible coolant!

- ▶ Do **not** mix different coolant products.
- ▶ Do **not** thin Liebherr-Fertig-Mix (Liebherr Ready Made Mix).

When adding coolant:

- ▶ Use exclusively the same coolant.

Coolants contain corrosion inhibitor - antifreeze fluid.

Add coolant only on the filler neck. See Service fill.



### Note

If the coolant is changed:

- ▶ Contact the Service Dept. at Liebherr-Werk Ehingen GmbH for procedure.
- ▶ Empty the cooling system completely and flush.

In exceptional cases, the coolant can be supplemented with different coolants.

**Note**

Supplementing the coolant with different coolants:

- ▶ Contact the Service Dept. at Liebherr-Werk Ehingen GmbH for procedure.
- ▶ Check the coolant level. See Maintenance intervals and maintenance instructions.

### 1.3 Transmission

- ▶ Check the gear oil. See Maintenance intervals and maintenance instructions.

### 1.4 Hydraulic system

**Note**

- ▶ The oil level must be in the center of the hydraulic oil level sight gauge at 20 °C oil temperature.

At lower hydraulic oil temperature:

- ▶ Warm up the hydraulic oil.

At higher hydraulic oil temperature:

- ▶ Cool off the hydraulic oil.
- ▶ Retract all hydraulic cylinders completely, for example luffing cylinder, telescoping cylinder.

On vehicles with level regulation:

- ▶ Lower the vehicle completely with the level regulation.

- ▶ Check the hydraulic oil. See Maintenance intervals and maintenance instructions.

## 2 Lubrication schedule

**Note**

- ▶ Grease the crane chassis, crane superstructure and equipment with the respective lubricants. See Service fill.
- ▶ The equipment depends on the purchased scope of delivery.

On mobile cranes with truck chassis:

- ▶ Observe the maintenance intervals and maintenance notes of the truck chassis manufacturer.

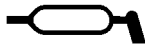


Fig.107729

**Note**

- ▶ Lube points are marked with a symbol.

## 7.07 Operating fluids and lubricants

1	Specified service fluids and lubricants for Liebherr cranes	3
---	---	---

---

*Fig.195219*

LWE/LTR 1220-003/24204-02-02/en

# 1 Specified service fluids and lubricants for Liebherr cranes

Information about the service fluids and lubricants that are approved for a mobile crane from Liebherr-Werk Ehingen GmbH can be found online at <https://lubricants.liebherr.com>.



## Note

► Observe and adhere to the specifications and notes in the safety data sheets.

No.	Crane components	Ambient temperature for driving and crane operation	
		-20 °C to +50 °C	-40 °C to +30 °C
1.1	Diesel engine with Exhaust aftertreatment	<b>LWE Id. No.: 11100934</b> <b>Liebherr Motoroil 5W-30 low ash</b> <b>or:</b> <b>LWE Id. No.: 10663796</b> <b>Liebherr Motoroil 10W-40 low ash</b> LH-00-ENG <sub>LA</sub> Observe the instructions of the engine manufacturer	<b>LWE Id. No.: 11100934</b> <b>Liebherr Motoroil 5W-30 low ash</b> <b>or:</b> <b>LWE Id. No.: 10663796</b> <b>Liebherr Motoroil 10W-40 low ash</b> LH-00-ENG <sub>LA</sub> Observe the instructions of the engine manufacturer <b>below -20 °C with pre-heating</b>
		<b>Note:</b> To improve the cold start ability of the diesel engine at an ambient temperature below -10 °C we recommend the use of Liebherr Motoroil 5W-30 low ash, <b>LWE Id. no.: 11100934</b>	
	Cummins B 6.7 with Exhaust aftertreatment	<b>LWE Id. No.: 10663796</b> <b>Liebherr Motoroil 10W-40 low ash</b> CES 20081 and 5W-40 <b>or</b> CES 20081 and 10W-40	CES 20081 and 0W-40
		<b>Note:</b> To improve the cold start ability of the Cummins diesel engine at an ambient temperature below -10°C, we recommend the use of engine oil according to CES 20081 and SAE viscosity grade 5W-40	
<b>Note:</b> For alternative oil specifications, see the separate engine manufacturer's operating instructions.			

No.	Crane components	Ambient temperature for driving and crane operation	
		-20 °C to +50 °C	-40 °C to +30 °C
1.2	Diesel engine <b>without</b> Exhaust aftertreatment	<b>LWE Id. No.: 10871536</b> <b>Liebherr Motoroil 5W-30</b> <b>or:</b> <b>LWE Id. No.: 861005308</b> <b>Liebherr Motoroil 10W-40</b> LH-00-ENG Observe the instructions of the engine manufacturer	<b>LWE Id. No.: 10871536</b> <b>Liebherr Motoroil 5W-30</b> <b>or:</b> <b>LWE Id. No.: 861005308</b> <b>Liebherr Motoroil 10W-40</b> LH-00-ENG Observe the instructions of the engine manufacturer <b>below -20 °C with pre-heating</b>
	<b>Note:</b> To improve the cold start ability of the diesel engine at an ambient temperature below -10 °C , we recommend the use of Liebherr Motoroil 5W-30, <b>LWE-Id no.: 10871536</b>		
	Cummins B 6.7 <b>without</b> Exhaust aftertreatment	<b>LWE Id. No.: 10663796</b> <b>Liebherr Motoroil 10W-40 low ash</b> CES 20078 and 5W-40 <b>or</b> CES 20078 and 10W-40	CES 20078 and 0W-40
<b>Note:</b> To improve the cold start ability of the Cummins diesel engine at an ambient temperature below -10°C, we recommend the use of engine oil according to CES 20081 and SAE viscosity grade 5W-40			
<b>Note:</b> For alternative oil specifications, see the separate engine manufacturer's operating instructions.			
2	Drive axle with differentials,  planetary gear and installed distributor gear	<b>LWE Id. No.: 861901008</b> <b>Liebherr Gear Hypoid 90 EP</b>  SAE 90 and API GL 5	<b>LWE Id. No.: 10425142</b> <b>Liebherr Syntogear Plus 75W-90</b>  SAE 75W-90 and API GL 5
3	Axle drive ZF DK-7	<b>LWE Id. No.: 861901008</b> <b>Liebherr Gear Hypoid 90 EP</b>  ZF TE-ML 05	<b>LWE Id. No.: 10425142</b> <b>Liebherr Syntogear Plus 75W-90</b>  ZF TE-ML 05
4.1	Vehicle distributor gear KESSLER  VG 1800, VG 2400, VG 2550, VG 2600, VG 2700, VG 3750, VG 3751  W 3750, W 3751	<b>LWE Id. No.: 861901008</b> <b>Liebherr Gear Hypoid 90 EP</b>  SAE 90 and API GL 5	<b>LWE Id. No.: 10425142</b> <b>Liebherr Syntogear Plus 75W-90</b>  SAE 75W-90 and API GL 5



No.	Crane components	Ambient temperature for driving and crane operation	
		-20 °C to +50 °C	-40 °C to +30 °C
4.2	Vehicle distributor gear with PTO for crane drive KESSLER VG 2700 with PTO VG 3751 with PTO	<b>LWE Id. No.: 10425142</b>  <b>Liebherr Syntogear Plus 75W-90</b> SAE 75W-90 and API GL 5	<b>LWE Id. No.: 10425142</b>  <b>Liebherr Syntogear Plus 75W-90</b> SAE 75W-90 and API GL 5
4.3	Vehicle distributor gear ZF Passau, STEYR PUCH  VG 1200, VG 1600, VG 2000, VG 3800	<b>LWE Id. No.: 861901008</b>  <b>Liebherr Gear Hypoid 90 EP</b>  ZF TE-ML 19	<b>LWE Id. No.: 10425142</b>  <b>Liebherr Syntogear Plus 75W-90</b>  ZF TE-ML 19
5	Miter gear for crane drive	<b>LWE Id. No.: 10425142</b>  <b>Liebherr Syntogear Plus 75W-90</b> SAE 75W-90 and API GL 5	<b>LWE Id. No.: 10425142</b>  <b>Liebherr Syntogear Plus 75W-90</b> SAE 75W-90 and API GL 5
6	Displacement gear (drop box) ZF Passau, STEYR PUCH	<b>LWE Id. No.: 861901008</b>  <b>Liebherr Gear Hypoid 90 EP</b>  ZF TE-ML 19	<b>LWE Id. No.: 10425142</b>  <b>Liebherr Syntogear Plus 75W-90</b>  ZF TE-ML 19
7.1	Pump distributor gear filled with <b>mineral</b> gear oil	<b>LWE Id. No.: 861901008</b>  <b>Liebherr Gear Hypoid 90 EP</b>  SAE 90 and API GL 5	<b>LWE Id. No.: 10425142</b>  <b>Liebherr Syntogear Plus 75W-90</b> SAE 75W-90 and API GL 5
7.2	Pump distributor gear filled with <b>synthetic</b> gear oil	<b>LWE Id. No.: 861901208</b>  <b>Liebherr Gear PG 220</b> CLP PG 220, DIN 51517-3 <b>WARNING: May not be mixed with other oils!</b>	<b>LWE Id. No.: 10664125</b>  <b>Liebherr Gear PG 150</b> CLP PG 150, DIN 51517-3 <b>WARNING: May not be mixed with other oils!</b>
7.3	Pump distributor gear LTC 1055-3.1	<b>LWE Id. No.: 10425142</b>  <b>Liebherr Syntogear Plus 75W-90</b> SAE 75W-90 and API GL 5	<b>LWE Id. No.: 10425142</b>  <b>Liebherr Syntogear Plus 75W-90</b> SAE 75W-90 and API GL 5
8.1	Powershift transmission ZF torque converter WG 120, WG 150, WG 180, WG 181, WG 200, WG 201	<b>LWE Id. No.: 861005308</b>  <b>Liebherr Motoroil 10W-40</b> ZF TE-ML 03	<b>LWE Id. No.: 861900608</b>  <b>Liebherr Hydraulic-Gear ATF</b> ZF TE-ML 03  <b>below -20 °C run until warm according to the operating instructions</b>

LWE/LTR 1220-003/24204-02-02/en

No.	Crane components	Ambient temperature for driving and crane operation	
		-20 °C to +50 °C	-40 °C to +30 °C
8.2	Powershift transmission ZF torque converter WG 251* ZF ERGOPOWER WG 210, WG 260, WG 310 * also for ambient temperatures above -10 °C	<b>LWE Id. No.: 861900608</b> <b>Liebherr Hydraulic-Gear ATF</b> ZF TE-ML 03	<b>LWE Id. No.: 861900608</b> <b>Liebherr Hydraulic-Gear ATF</b> ZF TE-ML 03  <b>below -20 °C</b> run until warm according to the operating in- structions
9	Powershift transmission CLARK	<b>LWE Id. No.: 861005308</b> <b>Liebherr Motoroil 10W-40</b> SAE 10W-40 and ACEA E4	<b>LWE Id. No.: 861900608</b> <b>Liebherr Hydraulic-Gear ATF</b> ATF Dexron II D and ALLI- SON C4  <b>below -20 °C</b> run until warm according to the operating in- structions
10	Displacement gear (drop box) ALLISON	<b>LWE Id. No.: 861005308</b> <b>Liebherr Motoroil 10W-40</b> SAE 10W-40 and API CF, ACEA E4	<b>LWE Id. No.: 861900608</b> <b>Liebherr Hydraulic-Gear ATF</b> ALLISON C4  <b>below -20 °C</b> run until warm according to the operating in- structions
11.1	Automatic transmission ALLISON CLBT 740, CLBT 750, CLBT 754, CLBT 755 HT 755, HD 4560	<b>LWE Id. No.: 861900608</b> <b>Liebherr Hydraulic-Gear ATF</b> ALLISON C4	<b>LWE Id. No.: 861903708</b> <b>CASTROL Transynd</b> ALLISON C4  <b>below -20 °C</b> run until warm according to the operating in- structions
11.2	Automatic transmission ZF	<b>LWE Id. No.: 861900608</b> <b>Liebherr Hydraulic-Gear ATF</b> ZF TE-ML 14	<b>LWE Id. No.: 861900608</b> <b>Liebherr Hydraulic-Gear ATF</b> ZF TE-ML 14  <b>below -20 °C</b> run until warm according to the operating in- structions
12.1	Automatic transmission ZF AS-Tronic ZF TC-Tronic (basic gear) ZF TC-Tronic HD (basic gear)	<b>LWE Id. No.: 10218305</b> <b>ZF-Ecofluid M</b> ZF TE-ML 02	<b>LWE Id. No.: 10218305</b> <b>ZF-Ecofluid M</b> ZF TE-ML 02  <b>below -20 °C</b> preheat the gear according to the operating in- structions

No.	Crane components	Ambient temperature for driving and crane operation	
		-20 °C to +50 °C	-40 °C to +30 °C
12.2	Automatic transmission ZF TraXon ZF TraXon Torque (basic gear)	<b>LWE Id. No.: 10218305</b> <b>ZF-Ecofluid M</b> ZF TE-ML 02	<b>LWE Id. No.: 10218305</b> <b>ZF-Ecofluid M</b> ZF TE-ML 02 <b>below -20 °C</b> preheat the gear according to the operating instructions
13.1	Torque converter coupling ZF TC HD	<b>LWE Id. No.: 10218305</b> <b>ZF-Ecofluid M</b> ZF TE-ML 02	<b>LWE Id. No.: 10218305</b> <b>ZF-Ecofluid M</b> ZF TE-ML 02 <b>below -20 °C</b> preheat the gear according to the operating instructions
13.2	Torque converter coupling ZF TC 2	<b>LWE Id. No.: 861900608</b> <b>Liebherr Hydraulic-Gear ATF</b> ZF TE-ML 14	<b>LWE Id. No.: 861900608</b> <b>Liebherr Hydraulic-Gear ATF</b> ZF TE-ML 14
14	Transmission ZF ECO-Split	<b>LWE Id. No.: 10218305</b> <b>ZF-Ecofluid M</b> ZF TE-ML 02	<b>LWE Id. No.: 10218305</b> <b>ZF-Ecofluid M</b> ZF TE-ML 02
15	Slewing gear	<b>LWE Id. No.: 861901208</b> <b>Liebherr Gear PG 220</b> CLP PG 220, DIN 51517-3 <b>WARNING: May not be mixed with other oils!</b>	<b>LWE Id. No.: 861901208</b> <b>Liebherr Gear PG 220</b> CLP PG 220, DIN 51517-3 <b>WARNING: May not be mixed with other oils!</b>
16.1	Rope winch	<b>LWE Id. No.: 861901208</b> <b>Liebherr Gear PG 220</b> CLP PG 220, DIN 51517-3 <b>WARNING: May not be mixed with other oils!</b>	<b>LWE Id. No.: 861901208</b> <b>Liebherr Gear PG 220</b> CLP PG 220, DIN 51517-3 <b>WARNING: May not be mixed with other oils!</b>
16.2	Rope winch (tooth flanks) LR 13000	<b>LWE Id. No.: 11000948</b> <b>Liebherr Universal grease 9900</b> KPF2N-25, DIN 51502	<b>LWE Id. No.: 11000948</b> <b>Liebherr Universal grease 9900</b> KPF2N-25, DIN 51502
17	Winch of Telescopic boom guying	<b>LWE Id. No.: 861901208</b> <b>Liebherr Gear PG 220</b> CLP PG 220, DIN 51517-3 <b>WARNING: May not be mixed with other oils!</b>	<b>LWE Id. No.: 861901208</b> <b>Liebherr Gear PG 220</b> CLP PG 220, DIN 51517-3 <b>WARNING: May not be mixed with other oils!</b>
18.1	Crane hydraulics Crane chassis and crane superstructure Observe exceptions, see 18.2	<b>LWE Id. No.: 861903508</b> <b>Liebherr Hydraulic 37</b>	<b>LWE Id. No.: 10293807</b> <b>Liebherr Hydraulic Plus Arctic</b>

LWE/LTR 1220-003/24204-02-02/en

No.	Crane components	Ambient temperature for driving and crane operation	
		-20 °C to +50 °C	-40 °C to +30 °C
18.2	Crane hydraulics Crane chassis and crane superstructure LTM 11200-9.1 LTR 11200 LR 13000, LR 11000, LR 1600/2, LR 1600/2-W LTC 1055-3.1	<b>LWE Id. No.: 10293807</b> <b>Liebherr Hydraulic Plus Arctic</b>	<b>LWE Id. No.: 10293807</b> <b>Liebherr Hydraulic Plus Arctic</b>
19	Brake system if hydraulically actuated	<b>LWE Id. No.: 861000108</b> <b>DOT 4</b> SAE J 1703e	<b>LWE Id. No.: 861000108</b> <b>DOT 4</b> SAE J 1703e
20	Clutch actuator	<b>LWE Id. No.: 861000108</b> <b>DOT 4</b> SAE J 1703e	<b>LWE Id. No.: 861000108</b> <b>DOT 4</b> SAE J 1703e
21	King pin bearing Gear shaft if <b>not</b> maintenance-free	<b>LWE Id. No.: 861301308</b> <b>Liebherr Special grease 9610 Plus</b> KP2K-20, DIN 51502	<b>LWE Id. No.: 10296825</b> <b>Liebherr Universal grease Arctic</b> KPFHC1N-60, DIN 51502
22.1	Glide and roller bearing roller bearing joint	<b>LWE Id. No.: 861301308</b> <b>Liebherr Special grease 9610 Plus</b> KP2K-20, DIN 51502	<b>LWE Id. No.: 10296825</b> <b>Liebherr Universal grease Arctic</b> KPFHC1N-60, DIN 51502
22.2	Rope pulley bearing	<b>LWE Id. No.: 10296825</b> <b>Liebherr Universal grease Arctic</b> KPFHC1N-60, DIN 51502	<b>LWE Id. No.: 10296825</b> <b>Liebherr Universal grease Arctic</b> KPFHC1N-60, DIN 51502
23	Central lubrication system	<b>LWE Id. No.: 861301308</b> <b>Liebherr Special grease 9610 Plus</b> KP2K-20, DIN 51502	<b>LWE Id. No.: 10296825</b> <b>Liebherr Universal grease Arctic</b> KPFHC1N-60, DIN 51502
24.1	Slewing ring connection Roller bearing	<b>LWE Id. No.: 861301308</b> <b>Liebherr Special grease 9610 Plus</b> KP2K-20, DIN 51502	<b>LWE Id. No.: 10296825</b> <b>Liebherr Universal grease Arctic</b> KPFHC1N-60, DIN 51502
24.2	Slewing ring connection LR 13000	<b>LWE Id. No.: 11000948</b> <b>Liebherr Universal grease 9900</b> KPF2N-25, DIN 51502	<b>LWE Id. No.: 10296825</b> <b>Liebherr Universal grease Arctic</b> KPFHC1N-60, DIN 51502

No.	Crane components	Ambient temperature for driving and crane operation	
		-20 °C to +50 °C	-40 °C to +30 °C
25.1	Support plate with equalization	<b>LWE Id. No.: 10877698</b> <b>Loctite LB 8104</b> Silicone oil base <b>WARNING: Do not use oils with another base!</b>	<b>LWE Id. No.: 10877698</b> <b>Loctite LB 8104</b> Silicone oil base <b>WARNING: Do not use oils with another base!</b>
25.2	Glide shoes for cab guidance on vehicle frame LTC 1045-3.1 LTC 1050-3.1	<b>LWE Id. No.: 861303608</b>  <b>Liebherr Telescope grease 9613 Plus</b> KP2K-30, DIN 51502	<b>LWE Id. No.: 861303608</b>  <b>Liebherr Telescope grease 9613 Plus</b> KP2K-30, DIN 51502
26	Sliding beam Plastic glide bearing Beam for track adjustment	<b>LWE Id. No.: 861303608</b>  <b>Liebherr Telescope grease 9613 Plus</b> KP2K-30, DIN 51502	<b>LWE Id. No.: 861303608</b>  <b>Liebherr Telescope grease 9613 Plus</b> KP2K-30, DIN 51502
27.1	Telescopic boom Plastic glide bearing Corner guide top	<b>LWE Id. No.: 861303608</b>  <b>Liebherr Telescope grease 9613 Plus</b> KP2K-30, DIN 51502	<b>LWE Id. No.: 861303608</b>  <b>Liebherr Telescope grease 9613 Plus</b> KP2K-30, DIN 51502
27.2	Telescopic boom Outer glide bearing Lower shell Inner glide bearing (only during assembly)	<b>LWE Id. No.: 861303308</b>  <b>Liebherr Special grease 1336</b> KP2K-30, DIN 51502 Spray grease	<b>LWE Id. No.: 861303308</b>  <b>Liebherr Special grease 1336</b> KP2K-30, DIN 51502 Spray grease
27.3	Telescopic boom LTC 1045-3.1 LTC 1050-3.1	<b>LWE Id. No.: 11651459</b>  <b>Bechem Berulub TCG 1 V</b>	<b>LWE Id. No.: 11651459</b>  <b>Bechem Berulub TCG 1 V</b>
27.4	Telescopic boom LTM 1050-3.1	<b>LWE Id. No.: 10878154</b>  <b>Liebherr Sliding Paste TB 1</b>	<b>LWE Id. No.: 10878154</b>  <b>Liebherr Sliding Paste TB 1</b>
28	Boom lock	<b>LWE Id. No.: 861301308</b>  <b>Liebherr Special grease 9610 Plus</b> KP2K-20, DIN 51502	<b>LWE Id. No.: 10296825</b>  <b>Liebherr Universal grease Arctic</b> KPFHC1N-60, DIN 51502
29	Guide rail on Telescoping cylinder	<b>LWE Id. No.: 861303308</b>  <b>Liebherr Special grease 1336</b> KP2K-30, DIN 51502 Spray grease	<b>LWE Id. No.: 861303308</b>  <b>Liebherr Special grease 1336</b> KP2K-30, DIN 51502 Spray grease

LWE/LTR 1220-003/24204-02-02/en

No.	Crane components	Ambient temperature for driving and crane operation	
		-20 °C to +50 °C	-40 °C to +30 °C
30	Gear ring rotary connection Slewing gear drive pinion	<b>LWE Id. No.: 861007708</b> <b>Liebherr RHS-Fluid</b> OGPF 0 S-20, DIN 51502	<b>LWE Id. No.: 861007708</b> <b>Liebherr RHS-Fluid</b> OGPF 0 S-20, DIN 51502
		<b>or</b> <b>LWE Id. No.: 861301508</b> <b>Liebherr gear protection RHY</b> OGPF 2 S-30, DIN 51502	<b>or</b> <b>LWE Id. No.: 861301508</b> <b>Liebherr gear protection RHY</b> OGPF 2 S-30, DIN 51502
31	Running rope	<b>LWE Id. No.: 10173371</b> <b>Liebherr WR-Lube SC</b> Adhesive grease	<b>LWE Id. No.: 10173371</b> <b>Liebherr WR-Lube SC</b> Adhesive grease
		<b>or</b> <b>LWE Id. No.: 10174262</b> <b>Liebherr WR-Lube SC</b> Adhesive grease	<b>or</b> <b>LWE Id. No.: 10174262</b> <b>Liebherr WR-Lube SC</b> Adhesive grease
32	Radiator fluid Diesel engine and heating system	<b>LWE Id. No.: 10871121</b> <b>Liebherr Antifreeze OS Mix</b> Pre-mixed corrosion inhibitor / antifreeze <b>WARNING: May not be diluted and / or mixed with other corrosion inhibitors / anti-freeze!</b>	<b>LWE Id. No.: 10871121</b> <b>Liebherr Antifreeze OS Mix</b> Pre-mixed corrosion inhibitor / antifreeze <b>WARNING: May not be diluted and / or mixed with other corrosion inhibitors / anti-freeze!</b>
33.1	Travel gears Crawler crane	see data tag	see data tag
33.2	Crawler crane with telescopic boom travel gear	see data tag	see data tag
34	Recovery winch	See the data tag and manufacturer's specifications	See the data tag and manufacturer's specifications
35	Recovery winch rope	See the manufacturer's specifications	See the manufacturer's specifications
36	Steering uncoupling LTC 1045-3.1 LTC 1050-3.1	<b>LWE Id. No.: 10800345</b> <b>Teflon Spray</b>	<b>LWE Id. No.: 10800345</b> <b>Teflon Spray</b>
37	Pin connections	<b>LWE Id. No.: 11000948</b> <b>Liebherr Universal grease 9900</b> KPF2N-25, DIN 51502	<b>LWE Id. No.: 11000948</b> <b>Liebherr Universal grease 9900</b> KPF2N-25, DIN 51502

---

## 8 Inspections of cranes

LWE/LTR 1220-003/24204-02-02/en

---

LWE/LTR 1220-003/24204-02-02/en



## 8.01 Periodic crane inspections

1	General information	2
2	Inspecting load bearing crane structures, especially steel structures	4
3	Inspecting the locking system of the telescopic boom	79
4	Inspection of the screws in the adjustment plates	81
5	Checking the safety ropes and anchor points	82
6	Inspecting the load handling equipment and assembly aids	84
7	Inspecting of fastening equipment	84
8	Inspecting the diaphragm reservoir	85
9	Inspecting the relapse cylinders	85
10	Inspecting the rope pulleys	86
11	Inspecting the carrier rollers	87
12	Inspecting the extension conditions of sliding beams	88
13	Inspecting the function of the overload protection	88
14	Inspecting the pin connections	89
15	Inspecting the slewing ring connection	89
16	Inspecting the mounting of the load bearing equipment	90
17	Inspecting the tele extension with eccentric, illustration 1	91
18	Inspecting the change over pulleys, illustration 2	92
19	Inspecting the oil and fuel tanks	92

# 1 General information

This crane was tested at the manufacturer's facilities prior to shipment in accordance with the valid ISO, FEM and DIN Standards and DGUV 52 (DGUV 309-001).

The safety level achieved during initial start up may not be attainable during operation.

Examples of the root cause of such deviations include; e.g., wear and tear, corrosion, effects of external forces, changes in the environment and changes to the mode of operation.

The operator is responsible for taking the necessary steps to ensure that the level of safety is maintained.

Periodic inspections are regulated nationally in the BetrSichV.

The crane operator is therefore obligated to have the crane inspected by an **authorized inspector**, at intervals depending on the operational conditions but at least once per year, from the first day of vehicle registration.

Certain conditions of use require however shorter inspection intervals or tests.

Conditions of use, the shorter inspection intervals or inspections between the regular inspections require:

- High utilization of the crane and / or a greater number of load cycles.
- Ramming work and pulling work, see chapter 4.08.
- Operation at low temperatures, see chapter 2.08.
- Lifting of personnel, see chapter 2.04.
- Situations during which the crane was exposed to sudden loads.

When equipment parts from other cranes are used: Make sure that the inspections and inspection intervals are observed also for the replaced equipment parts.

The operator specifies an authorized inspector and assigns him to perform the tests and maintenance required nationally and by Liebherr-Werk Ehingen GmbH to ensure further, safe and reliable crane operation:

- Carry out the inspection tasks required by Liebherr-Werk Ehingen GmbH.
- Additional national inspection intervals must be monitored by the crane operator.

Every 4 operating years, in the 13th Operating year and thereafter at least annually, from the first day of vehicle registration, the crane must be inspected by an **inspection expert**.

Periodic inspection are principally a visual inspection, where the inspector appraises the condition of the crane and its components.



## WARNING

There is danger of weakening the supporting components when major changes or repairs are made to the crane!

- ▶ In this case, the operator must have the crane reinspected by an inspection expert before putting it back in service!

In addition, all respective local and national regulations apply.

### Authorized inspector

Authorized inspectors are those persons who through their professional training, their professional experience and their recent professional activity have the necessary knowledge for the inspection of work equipment.

### Authorized inspector for pressure containers

Authorized inspectors for pressure containers are authorized inspectors who additionally:

- Have relevant technical professional training.
- Have at least one year of experience with the manufacture, assembly, operation or maintenance of the equipment or components to be inspected in accordance with BetrSichV.
- Keep their knowledge about pressure-related hazards up to date by participating in training or instruction, in particular with regard to the following topics:
  - Design and manufacturing processes

- Equipment and safeguarding concepts
- Assembly, installation and operation / use
- Intended use
- Risk assessment
- Inspections, inspection periods, inspection procedures including assessment of the results
- Relevant influences and damage symptoms found in practice

### Inspection expert

Inspection experts are authorized inspectors who also:

- Have completed training as an engineer or have equivalent knowledge and experience in the subject area with which their activities are involved.
- Have at least three years of experience in the design, construction, maintenance or inspection of cranes, of which at least half a year were involved in the inspection activities of an inspection expert.
- Possess sufficient knowledge of the relevant regulations and rules.
- Have the necessary facilities for inspection and documentation.
- Keep their professional knowledge up to date.

To ensure the high safety standard of the crane, it is recommended, no later than the 12th year, in the 20th year, in the 26th year and then every 4 years, to have the crane undergo a **general inspection** by an **inspection expert**. At that time, in addition to the usual scope of inspection, all load carrying parts of the crane - the complete steel structure with all welding seams as well as all components and connecting devices - are to be subjected to a complete visual inspection. The following procedural notes for repeat inspections are to be observed for that.

The purpose of the inspections is to avoid accidents by detecting deficiencies early on. Any deficiencies found by the inspector must be documented, corrected and subsequently reinspected.

For safe crane operation, important components must be inspected for their percentage of utilization or their reusability. Based on this inspection a statement can be made about the suitability of the components for further operation.

A number of important examples of items that are particularly important during the periodic crane inspections are listed below. We wish to advise that the **authorized inspectors** or **inspection experts** take sole responsibility for the crane inspections that they carry out.



### Note

- ▶ The inspection may not be solely limited to the following positions shown in the sample component illustrations. Rather the **entire** crane structure must be subjected to a careful inspection!

A checklist is provided in the Crane operating instructions, chapter 8.90, to assist the inspector during the periodic inspections of Liebherr mobile and crawler cranes.

If the inspector has any questions they should be directed through the Service Department of Liebherr-Werk Ehingen GmbH to the technical departments.



### WARNING

Danger of accident!

- ▶ Adhere to the following inspection guidelines and intervals.

## 2 Inspecting load bearing crane structures, especially steel structures

### 2.1 Basic principles and procedure



#### DANGER

Danger of fatal injury!

The crane structures, particularly steel constructions, have to be checked by an **authorized inspector** or **inspection expert** at least once a year. If this is not the case, they could fail and cause fatal injury or seriously damage the crane!

- ▶ Crane structures, particularly steel constructions must be checked by an **authorized inspector** or an **inspection expert** at least once a year!
- ▶ Shorten the inspection intervals when the crane is subjected to above-average load spectrums, for example during handling operation or frequently erecting long boom systems.
- ▶ When the crane was subjected to excessive operating loads; e.g., due to an unusual impact, the crane structure, especially the steel structures must be inspected immediately!

Crane structures, especially steel structures, such as booms, turntables, chassis, support equipment (e.g., sliding beams or folding outriggers) must be carefully inspected, at the very least during the annual recommended crane inspections. Inspect welding seams especially through an intensive visual inspection.

If paint damage with corrosion (rust) is found on load carrying parts of the crane structure, especially on telescopic booms, lattice booms, lattice jibs, pull rods etc., then the rust must be removed, primed and painted.

In the case of an electrolyte process, such as corrosion in combination with water, atomic hydrogen is created, which leads to hydrogen induced corrosion with resulting cracks in high tensile fine grain construction steel.

If disassembly and assembly work on the crane is required to carry out the inspections, then they must be carried out by taking the manufacturer's data into account or in coordination with the crane manufacturer.

We would like to point out that the framework of mobile cranes is designed for a limited number of stress work cycles. This also determines the utilization or service life of the framework. The service life is not determined solely by the number of stress cycles. It also depends on the loads (load spectrum) applied during the time in operation.

Liebherr mobile and crawler cranes are designed for specific characteristics and movements, such as constant deployment of drive forces, only occasional operation and load conditions according to EN 13000.

Liebherr mobile and crawler cranes are designed for assembly operation and, according to grouping in class A1 according to ISO 4301-1, they can only take on a limited number of work cycles ( $N = 63000$ ) with a collective class  $Q_1 = \text{light}$  ( $k_p = 0.125$ ).

Example of a load collective according to grouping in collective class  $Q_1 = \text{light}$  ( $k_p = 0.125$ ).

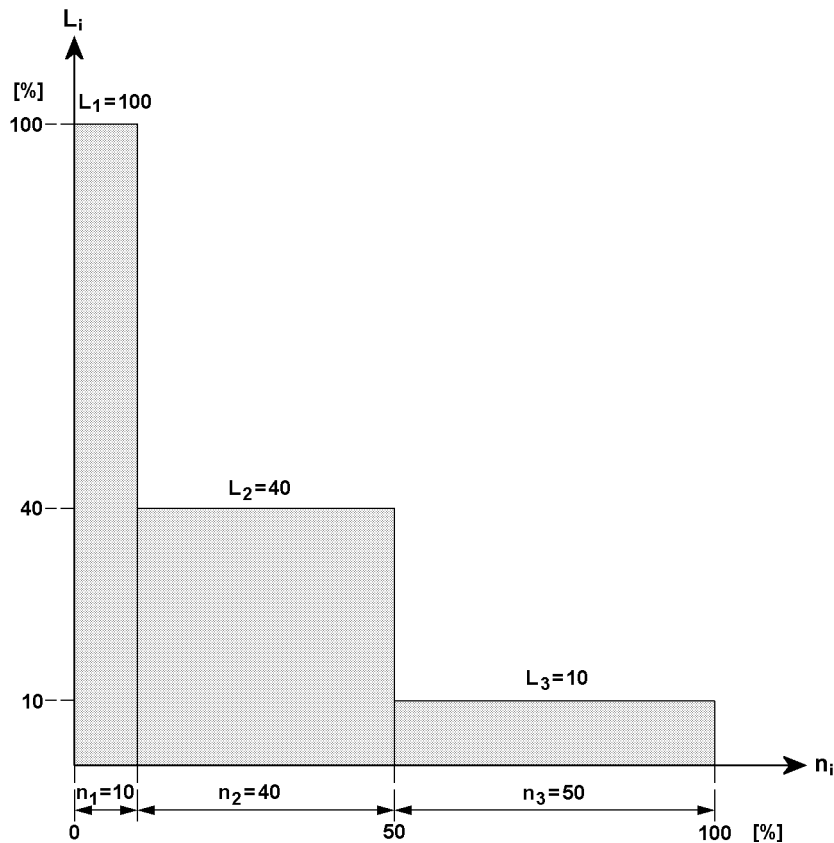


Fig.104716

**$L_i$ :** Load proportion in relation to maximum load [%]       **$n_i$ :** Load cycles in relation to maximum number [%]

**Note**

- ▶ The service life of Liebherr mobile and crawler cranes can be drastically reduced, for example when used in magnet, grapple or handling operations!
- ▶ Repeated inspection of crane structure, especially the steel structure and the welding seams must then be carried out in shorter intervals than specified.

For that reason, the steel structures and the welding joints must be subjected to a visual intensive inspection by the **authorized inspector** or **inspection expert** during the specified periodic inspections.

If any damage, such as cracks or suspicion of cracks, are apparent on any part of the steel structure, the total extent of the damage must be determined by qualified specialists using appropriate material testing methods, such as magnetic crack detection, ultrasound or x-rays. Thereafter, the qualified personnel must determine whether or not the damaged area can be repaired by welding or by other means.

The following diagrams are samples of the load-bearing welding structures. The welding joints or seams or steel structural zones that require inspection may be present more than once and in various forms. The joints or zones must be inspected all around at the locations identified by arrows.

**Note**

- ▶ The scope and extent of all inspections remain the sole responsibility of the inspectors!
- ▶ The scope and results of tests should be documented to permit reproducibility. This documentation forms part of the crane records and should be safely stored during the entire service life of the crane!
- ▶ The following diagrams are provided to assist the inspector. The illustrations are only examples and are not necessarily 100 % complete!

## 2.2 Repair welding

Defects such as cracks or permanent deformations on load-bearing steel components must be immediately reported to Customer Service at **Liebherr-Werk Ebingen GmbH**.

The defect must immediately be appraised by an inspection expert according to standard welding technology rules. The inspection expert must immediately ascertain if the crane can continue to be safely operated due to danger of accident until a repair welding is performed.

Repair welding may solely be made in consultation and under the guidance of Customer Service at **Liebherr-Werk Ebingen GmbH** by authorized and trained expert personnel.



---

### WARNING

Repair welding **not** according to regulations!  
Death, severe bodily injuries, property damage.

- ▶ Contact Customer Service at **Liebherr-Werk Ebingen GmbH**.
  - ▶ Coordinate the procedure for repair welding with **Liebherr-Werk Ebingen GmbH**.
- 



---

### Note

Exclusion of liability!

In the case of repair welding that were not carried out by personnel from **Liebherr-Werk Ebingen GmbH** or by authorized personnel from **Liebherr-Werk Ebingen GmbH**, **Liebherr-Werk Ebingen GmbH** excludes all liability for system functionality as well as for the parts.

- ▶ Have repair welding carried out solely by personnel of **Liebherr-Werk Ebingen GmbH** or by personnel authorized by **Liebherr-Werk Ebingen GmbH**.
-

## 2.3 Examples of test points

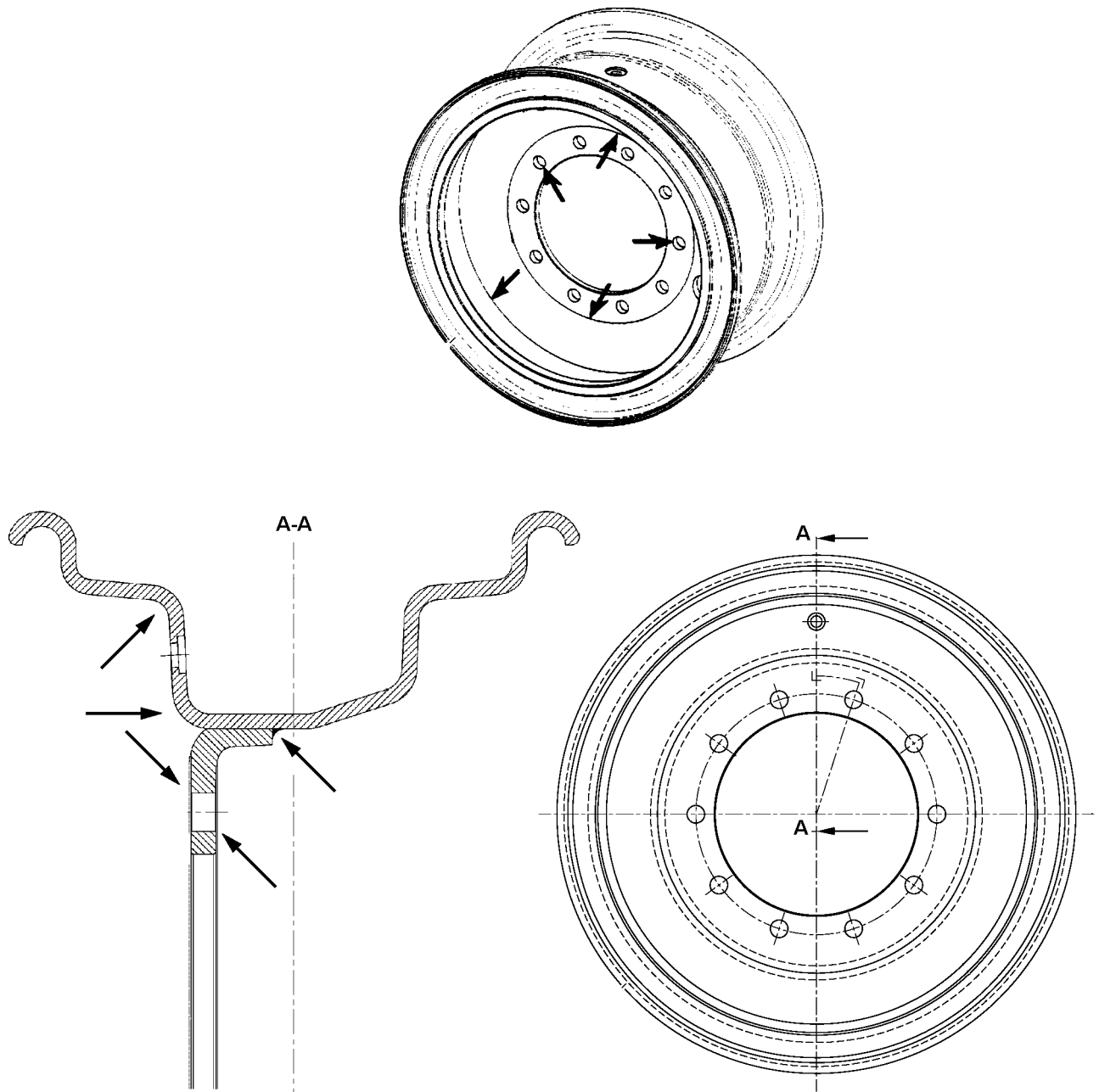


Fig.118052: Example of a 1-part disk wheel

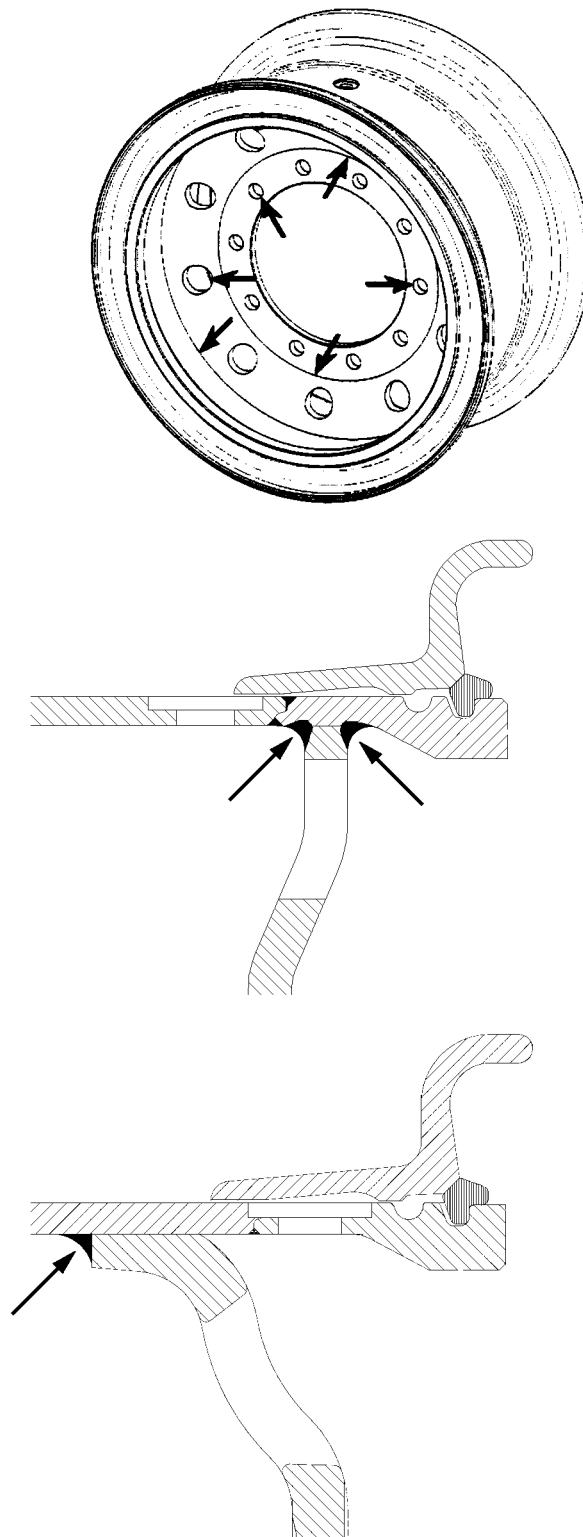
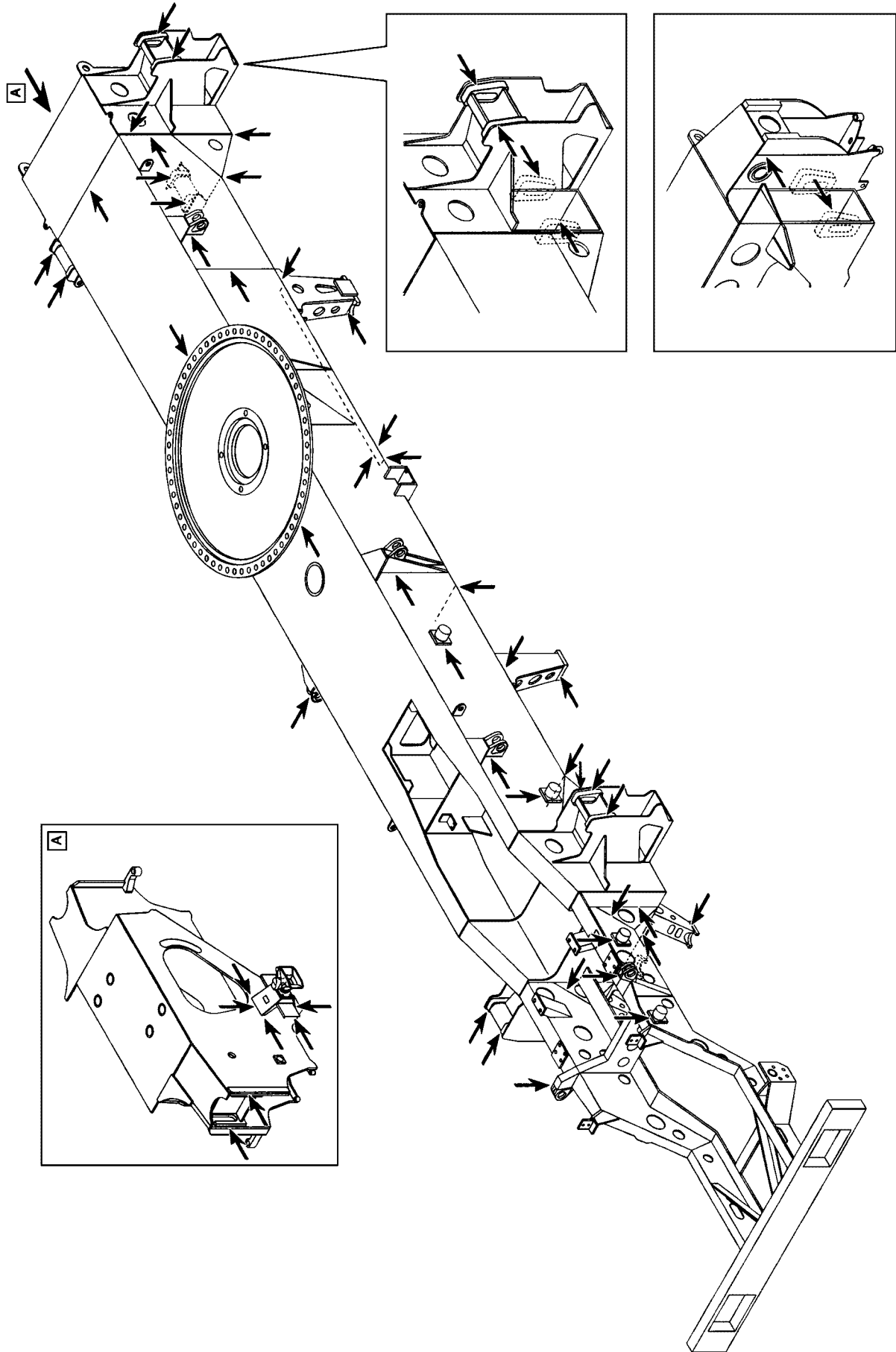


Fig.118053: Example of a 3-part disk wheel





LWE/LTR 1220-003/24204-02-02/en

Fig.185046: Example of a vehicle frame

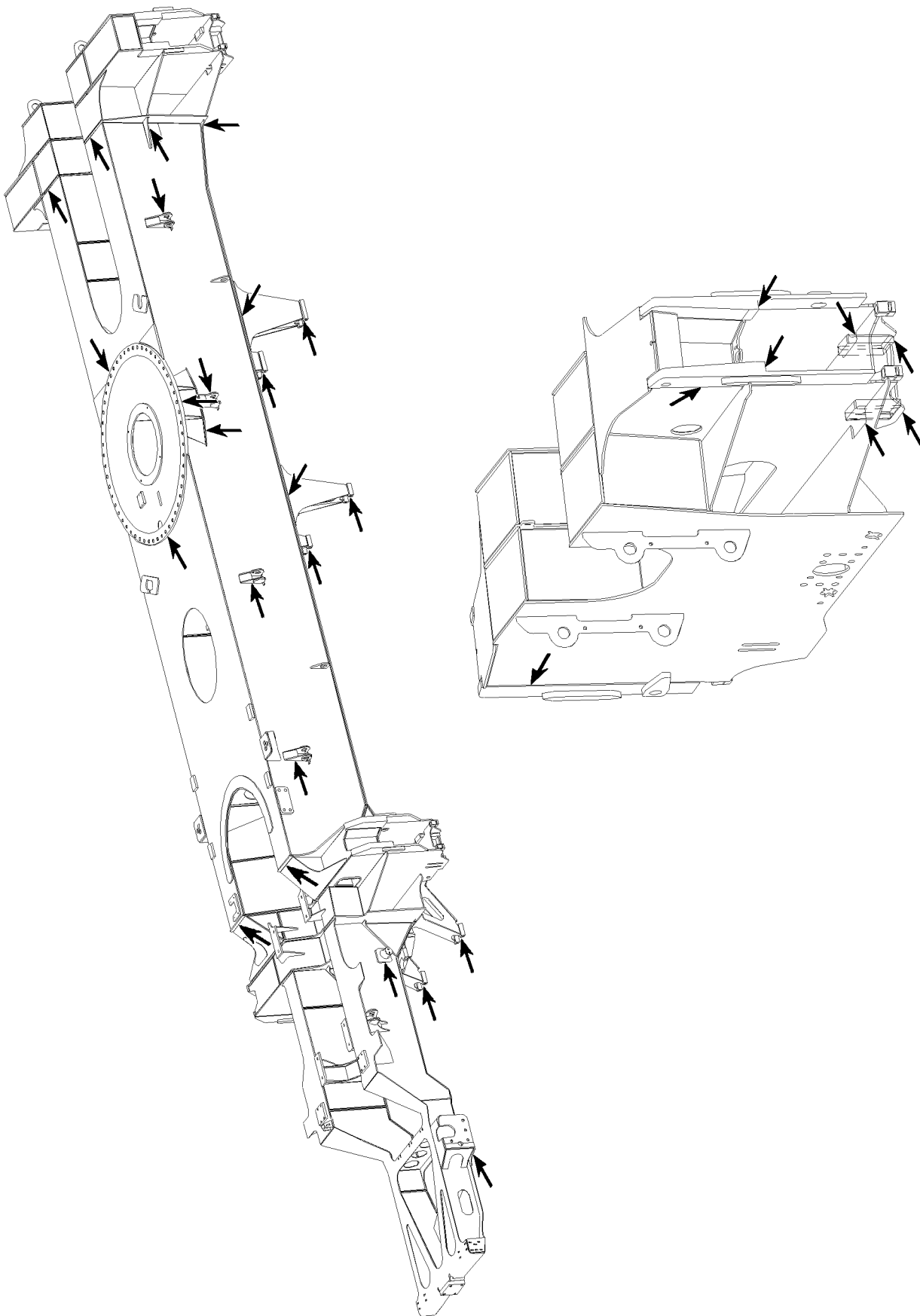
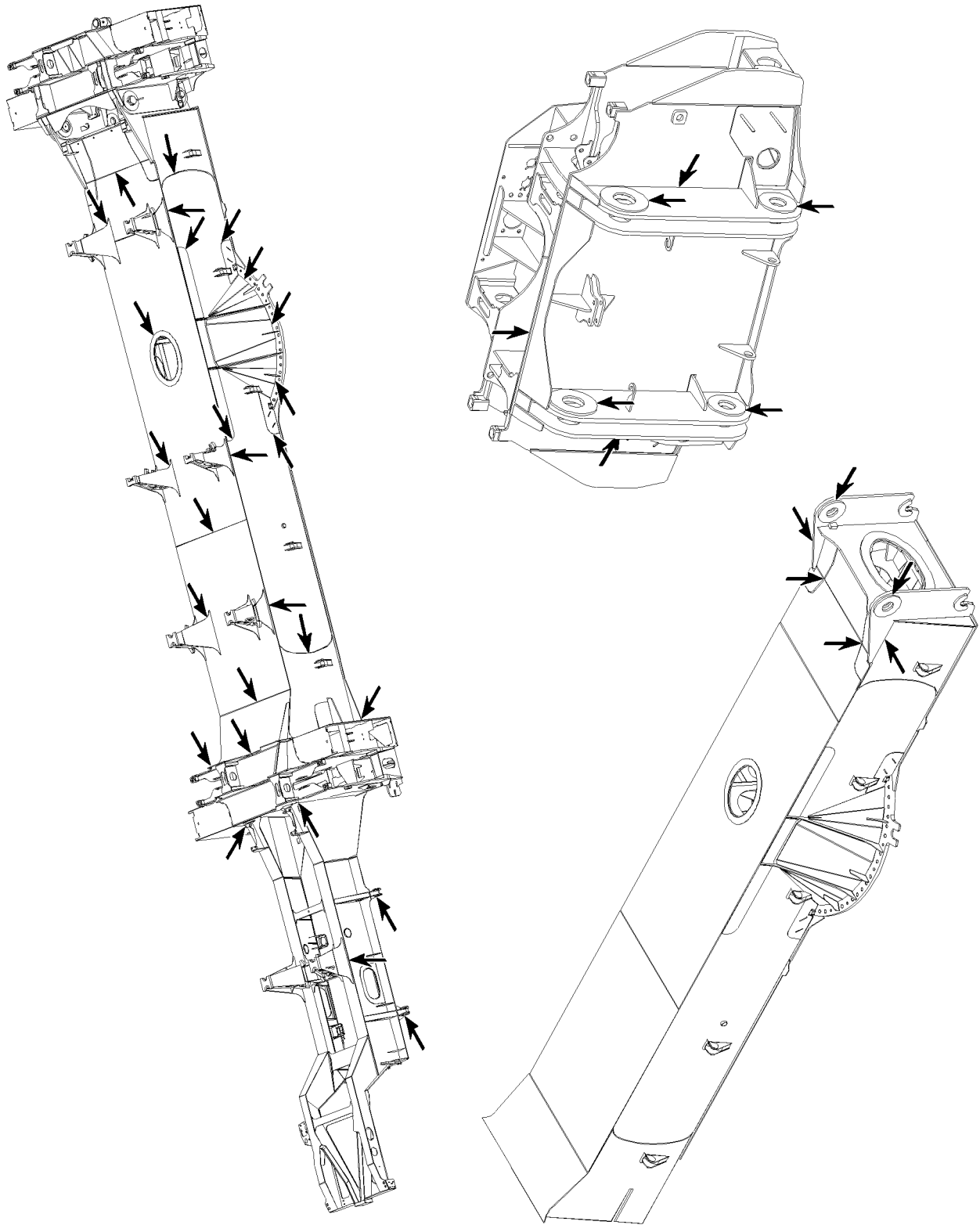


Fig.105702: Example of a vehicle frame



LWE/LTR 1220-003/24204-02-02/en

Fig.105719: Example of a vehicle frame

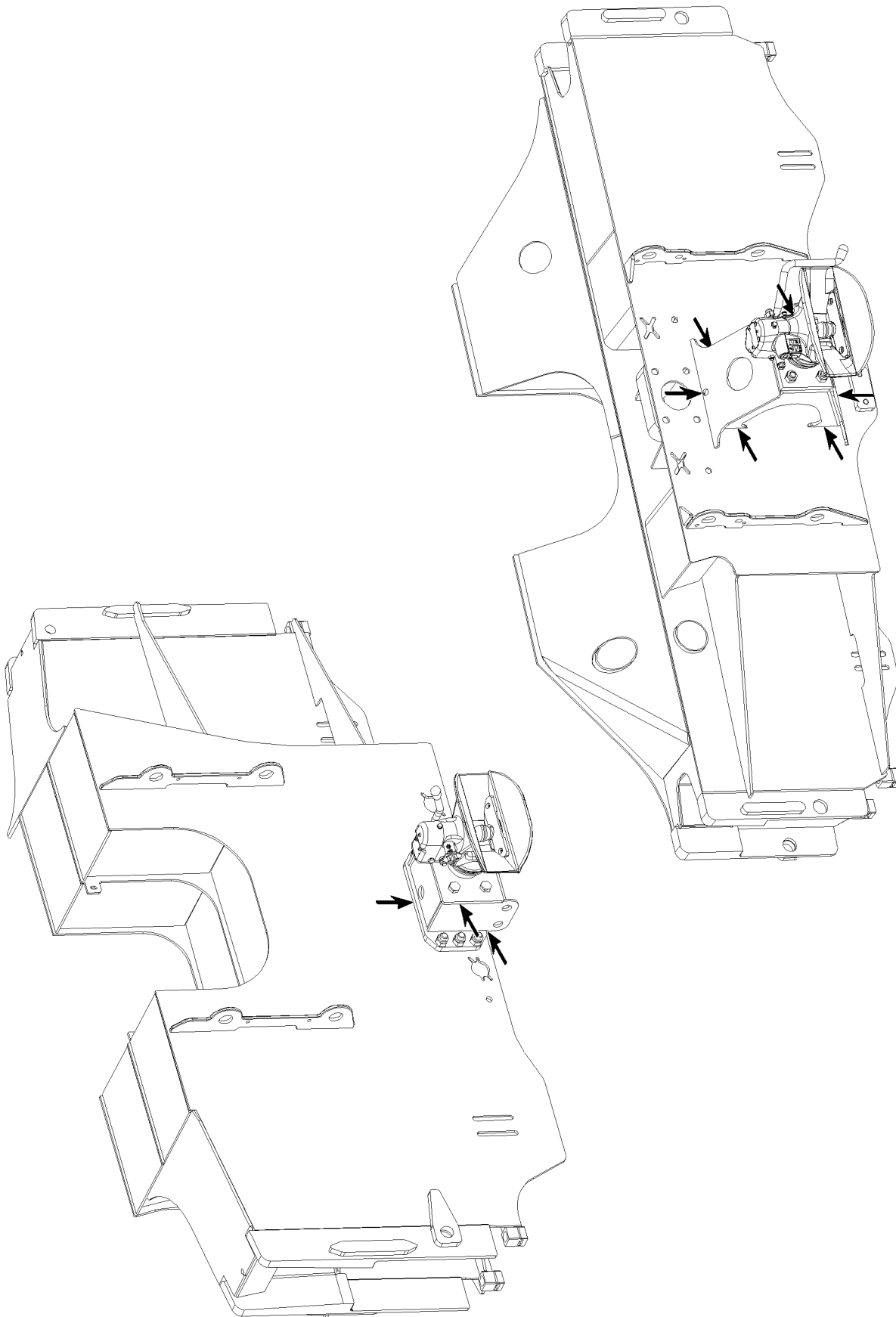
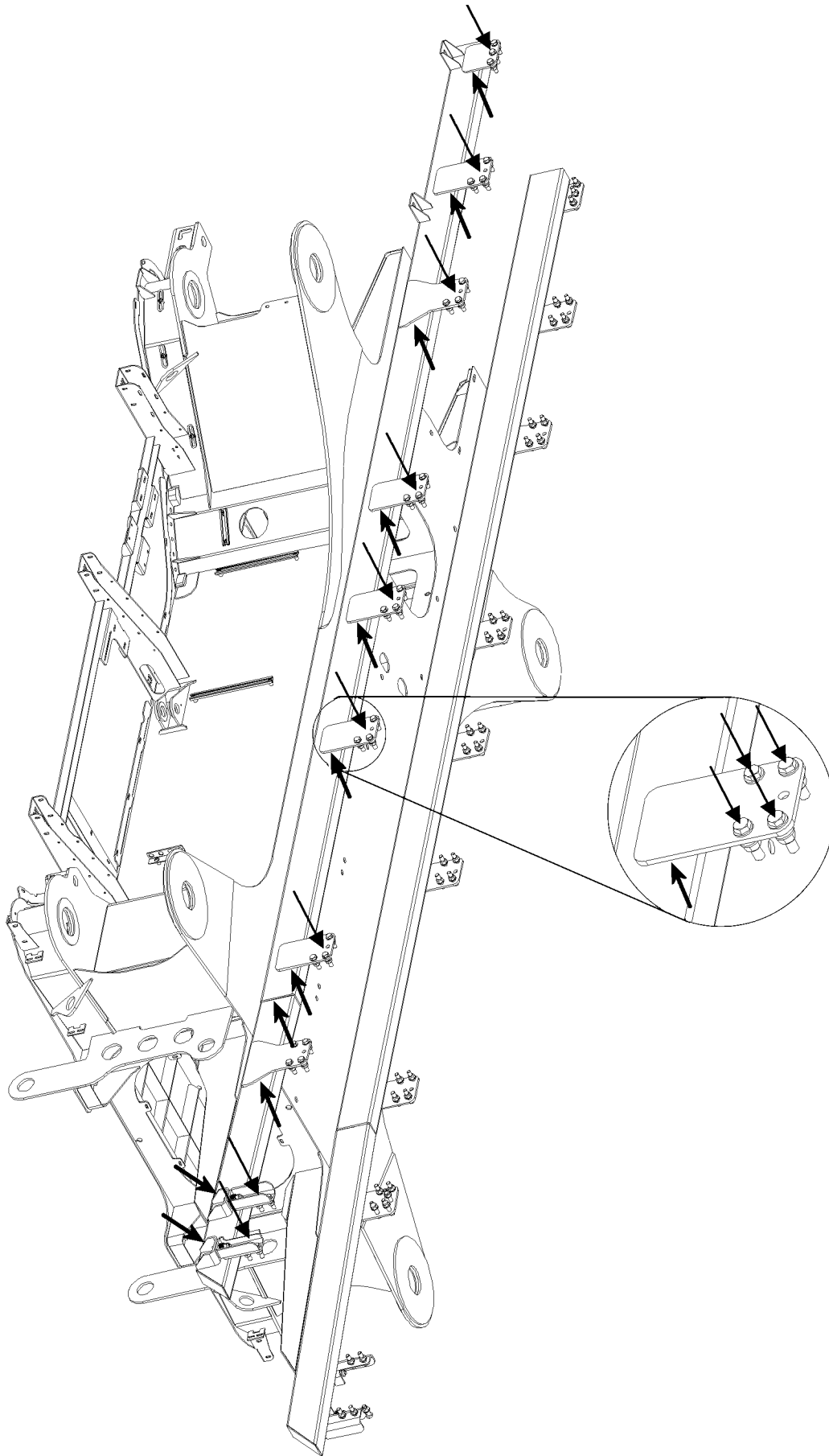


Fig.105687: Example of tow coupling

LWE/LTR 1220-003/24204-02-02/en



LWE/LTR 1220-003/24204-02-02/en

Fig.113940: Example of an intermediate frame

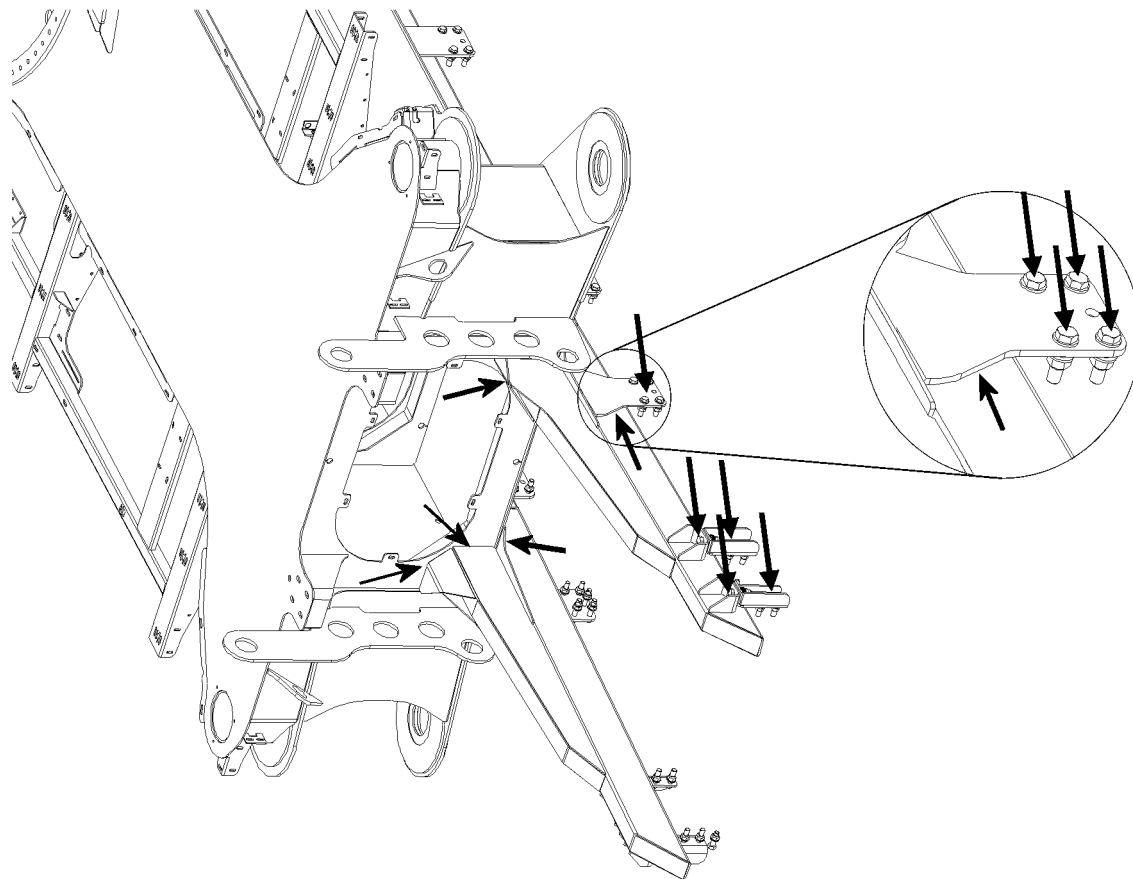
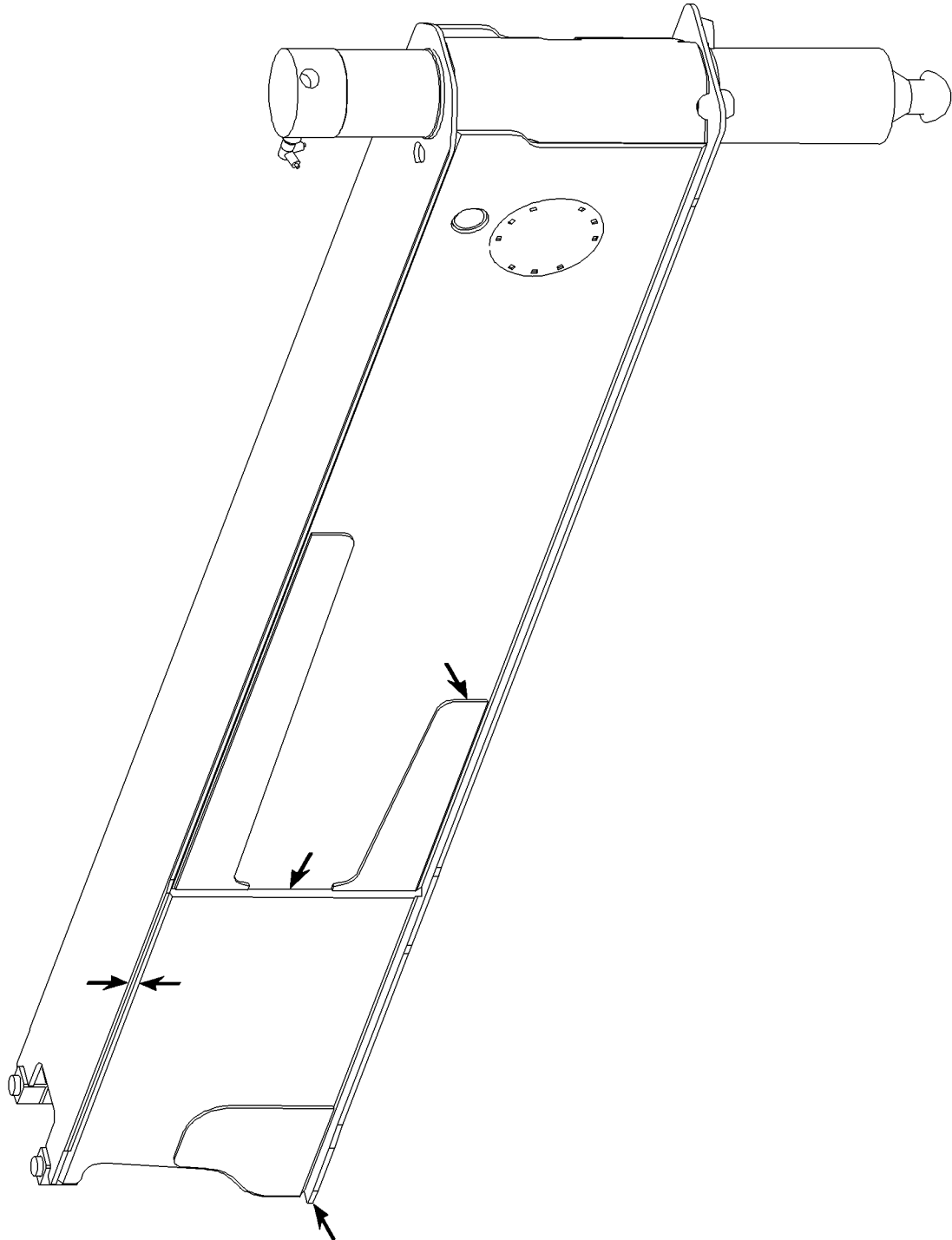


Fig.114000: Example of an intermediate frame

LWE/LTR 1220-003/24204-02-02/en



LWE/LTR 1220-003/24204-02-02/en

Fig.105698: Example of a sliding beam

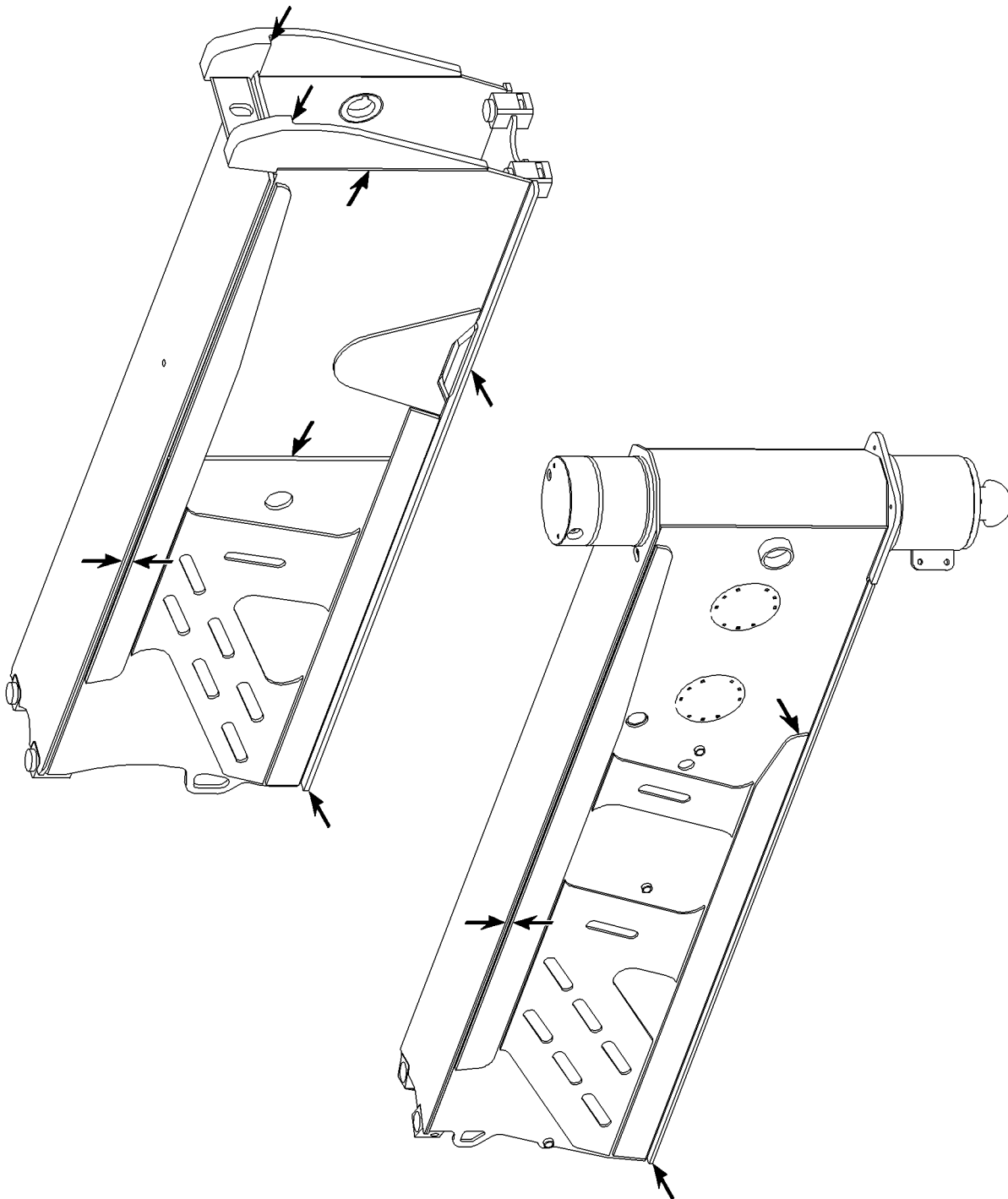
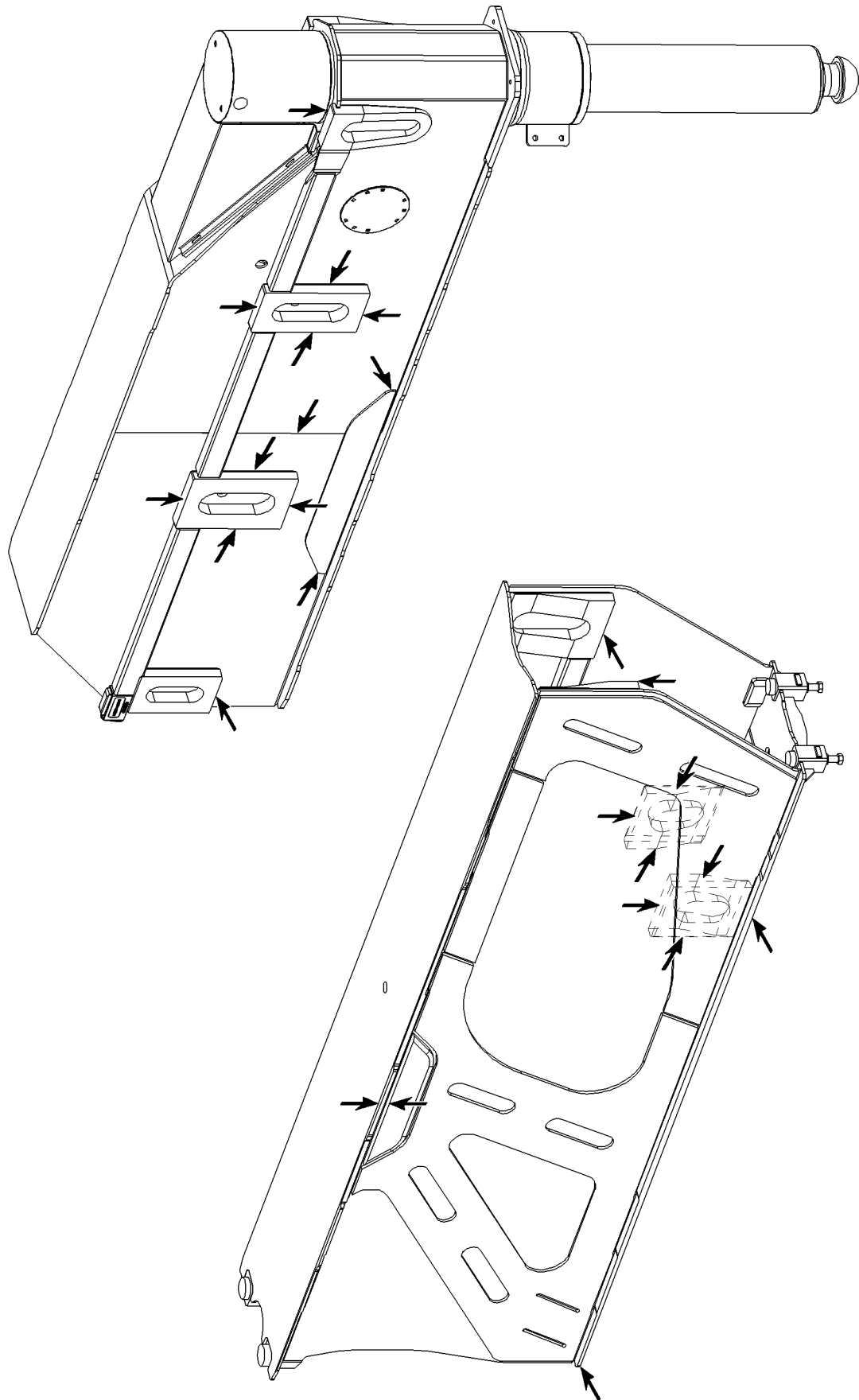


Fig.105717: Example of a sliding beam





LWE/LTR 1220-003/24204-02-02/en

Fig.105718: Example of a sliding beam

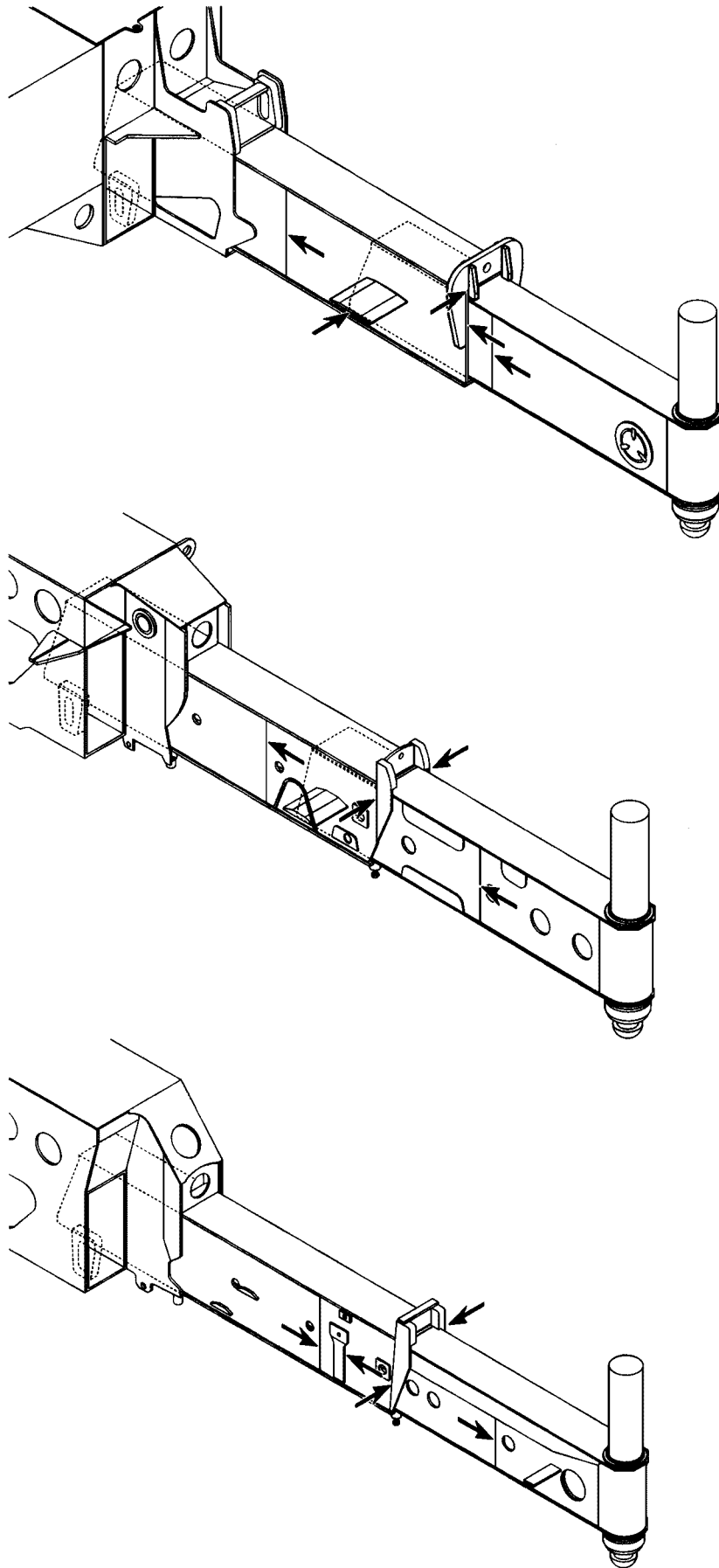
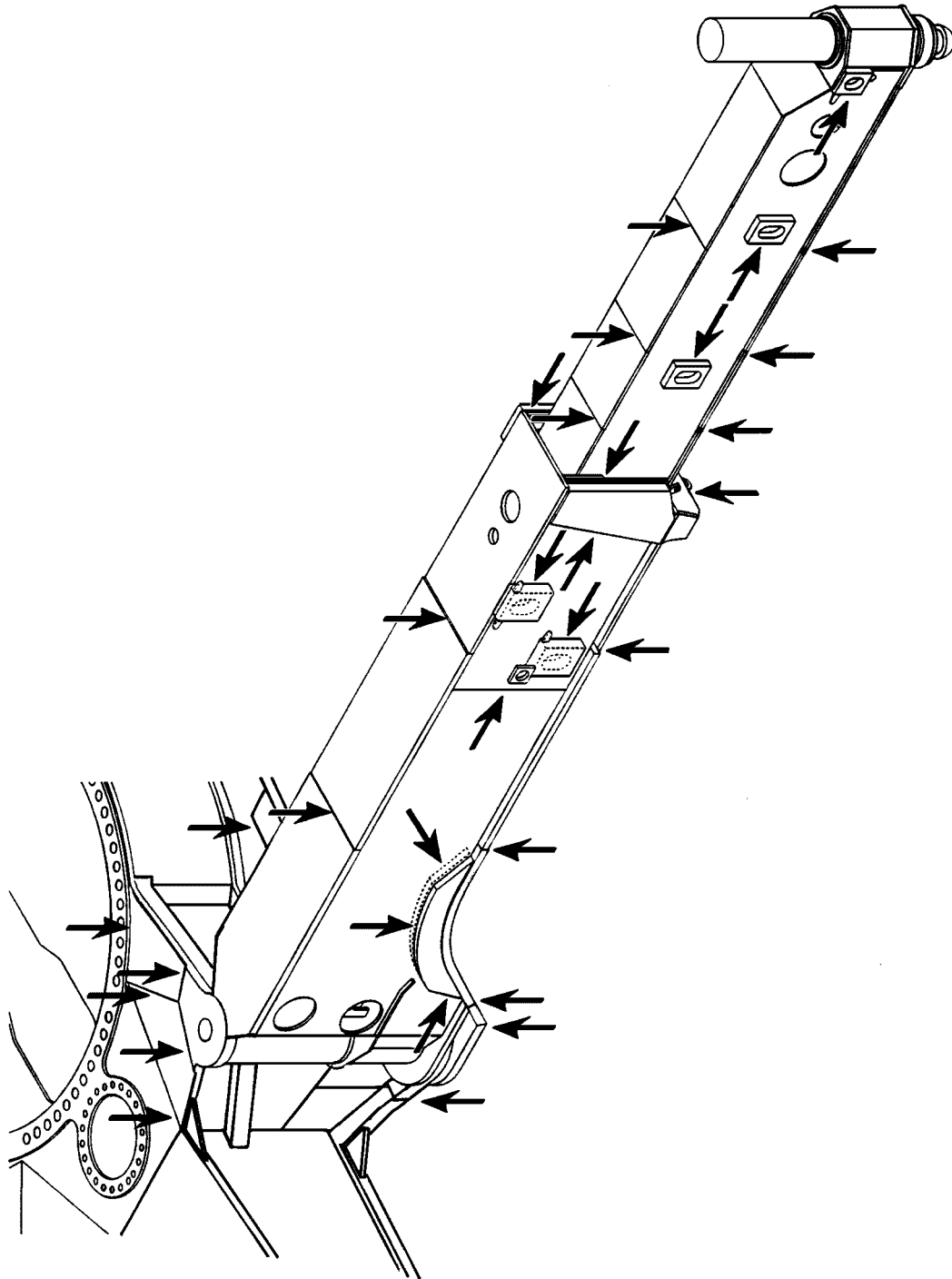


Fig.185047: Example of a sliding beam

LWE/LTR 1220-003/24204-02-02/en



LWE/LTR 1220-003/24204-02-02/en

Fig.185060: Example of a swinging sliding beam

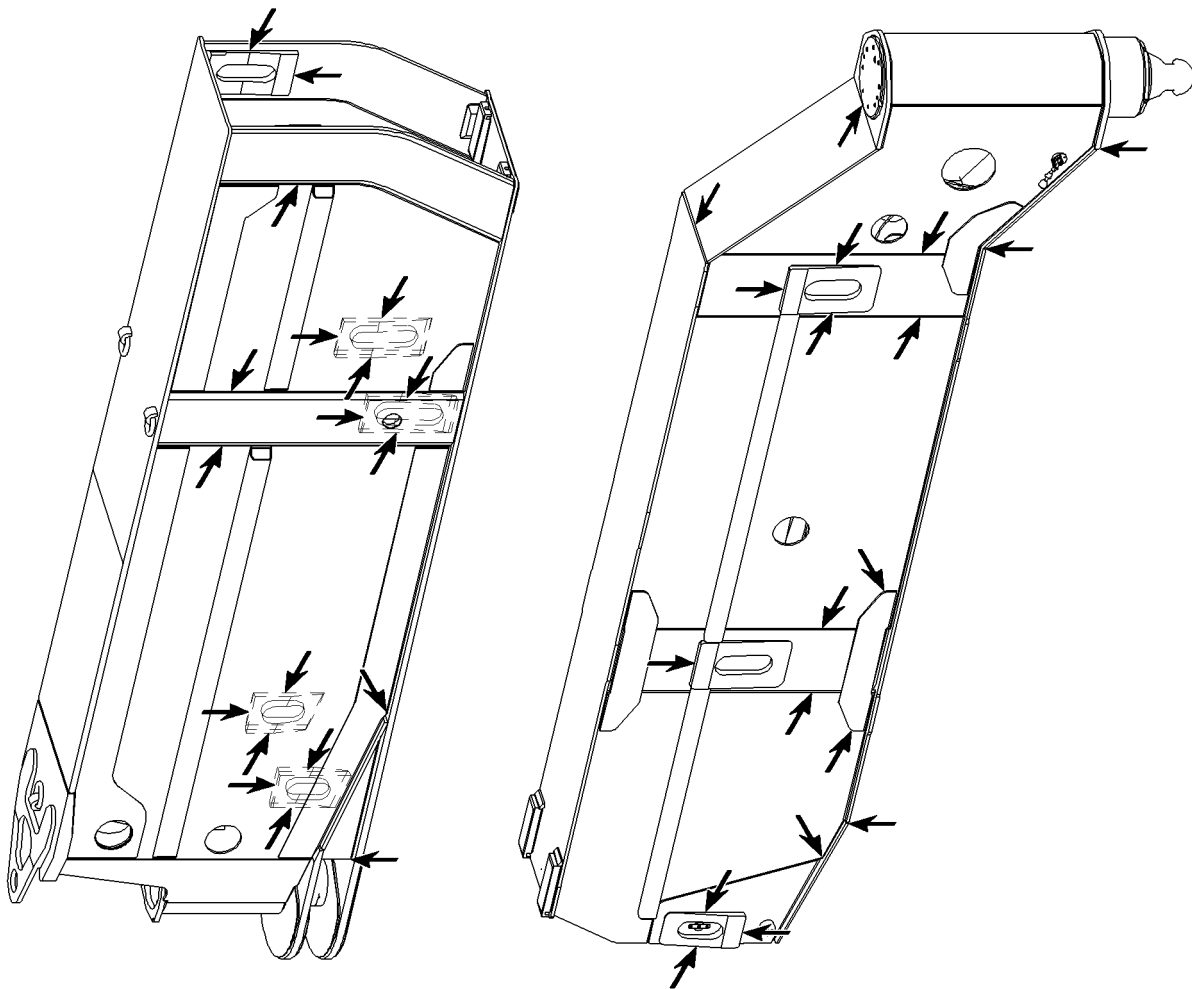
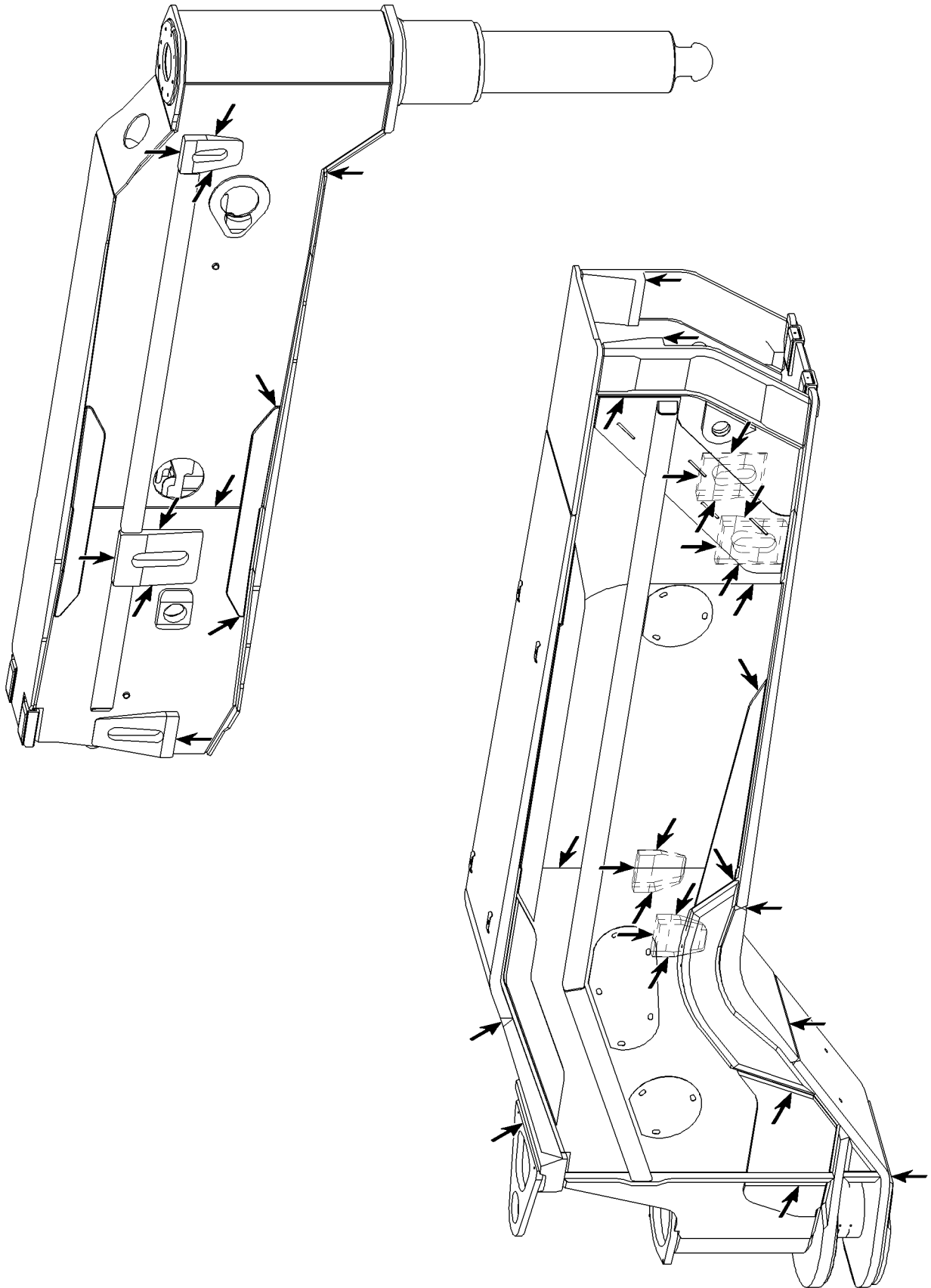


Fig.105690: Example of a swinging sliding beam



LWE/LTR 1220-003/24204-02-02/en

Fig.105704: Example of a swinging sliding beam

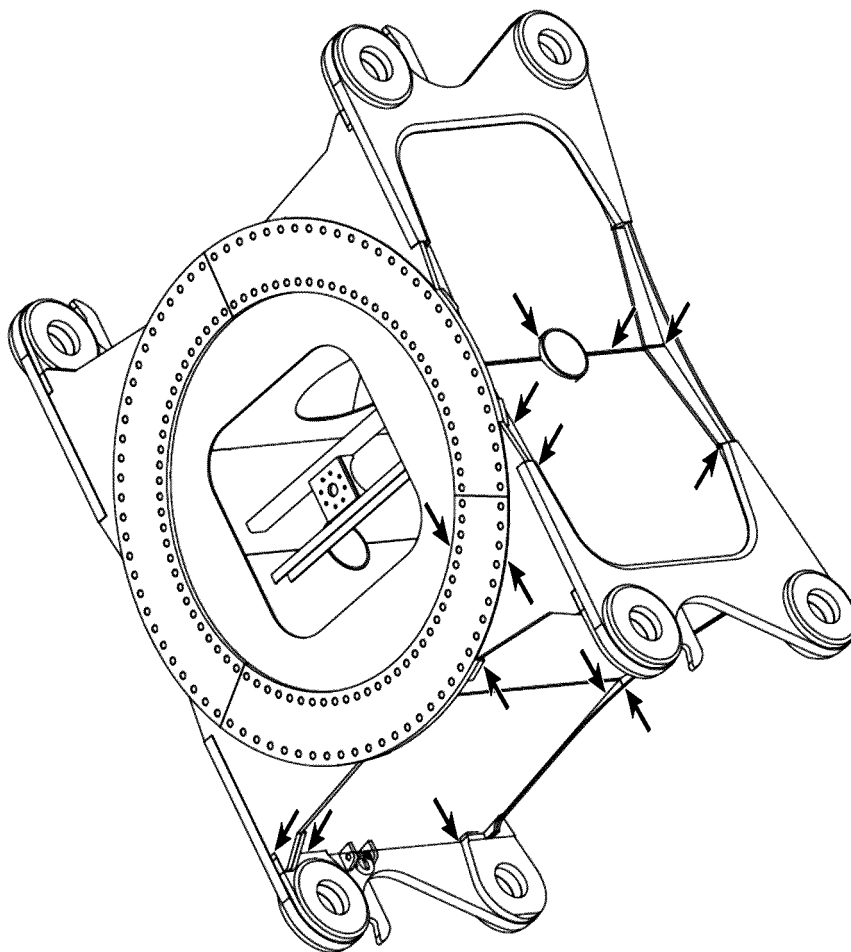
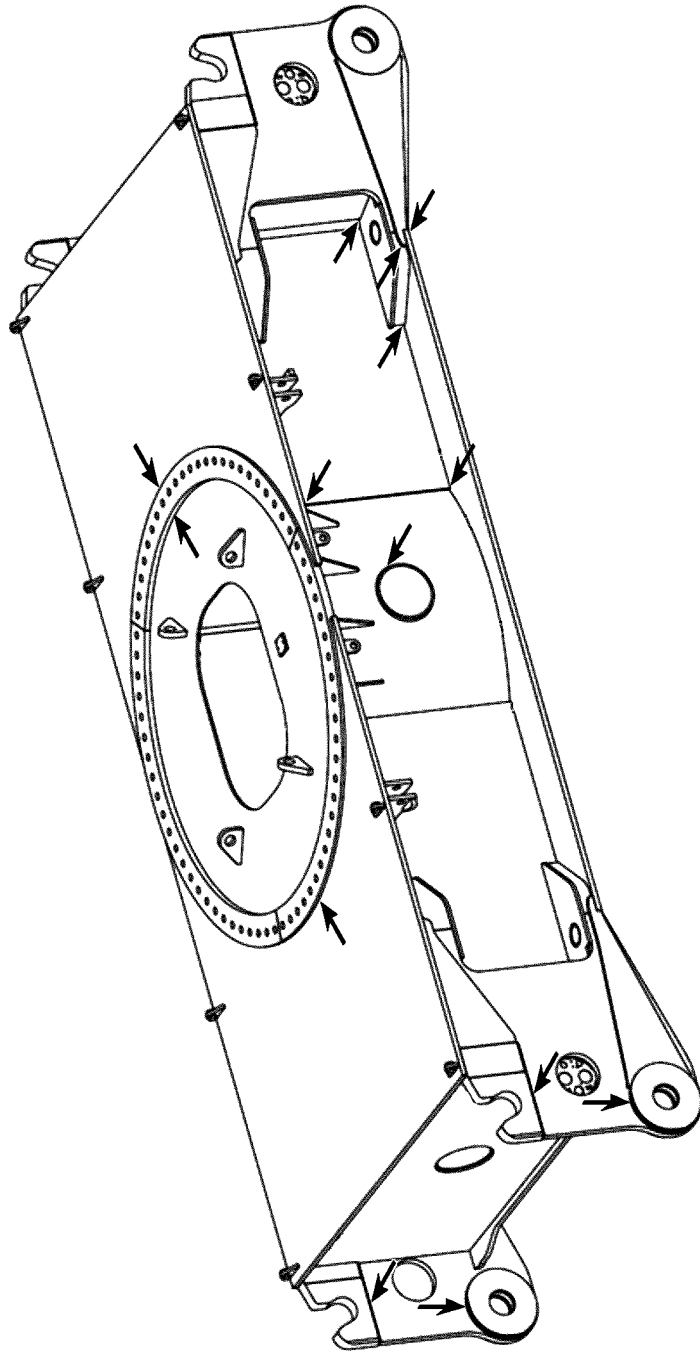


Fig.105725: Example of a crawler center section

LWE/LTR 1220-003/24204-02-02/en



LWE/LTR 1220-003/24204-02-02/en

Fig.105726: Example of a crawler center section

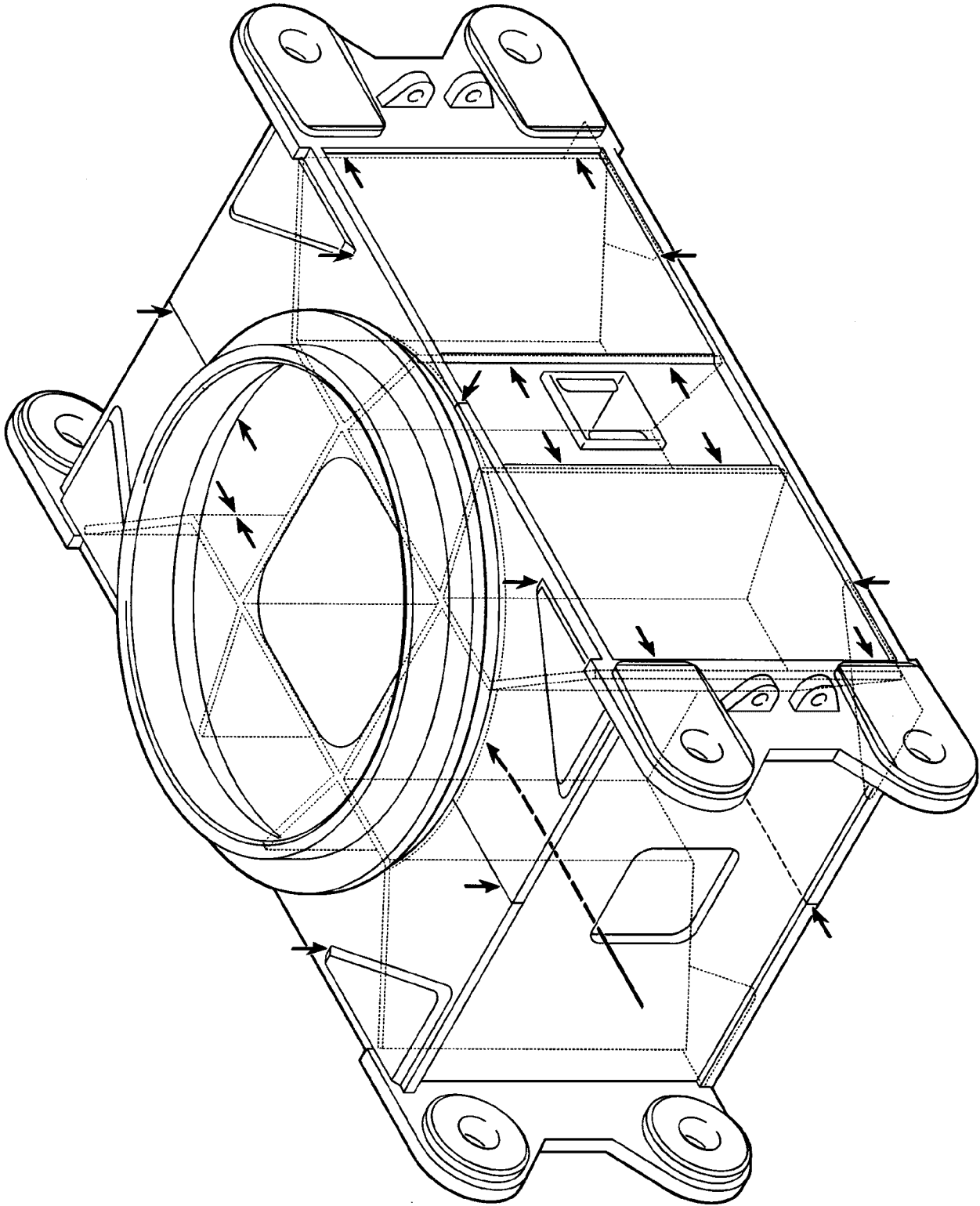
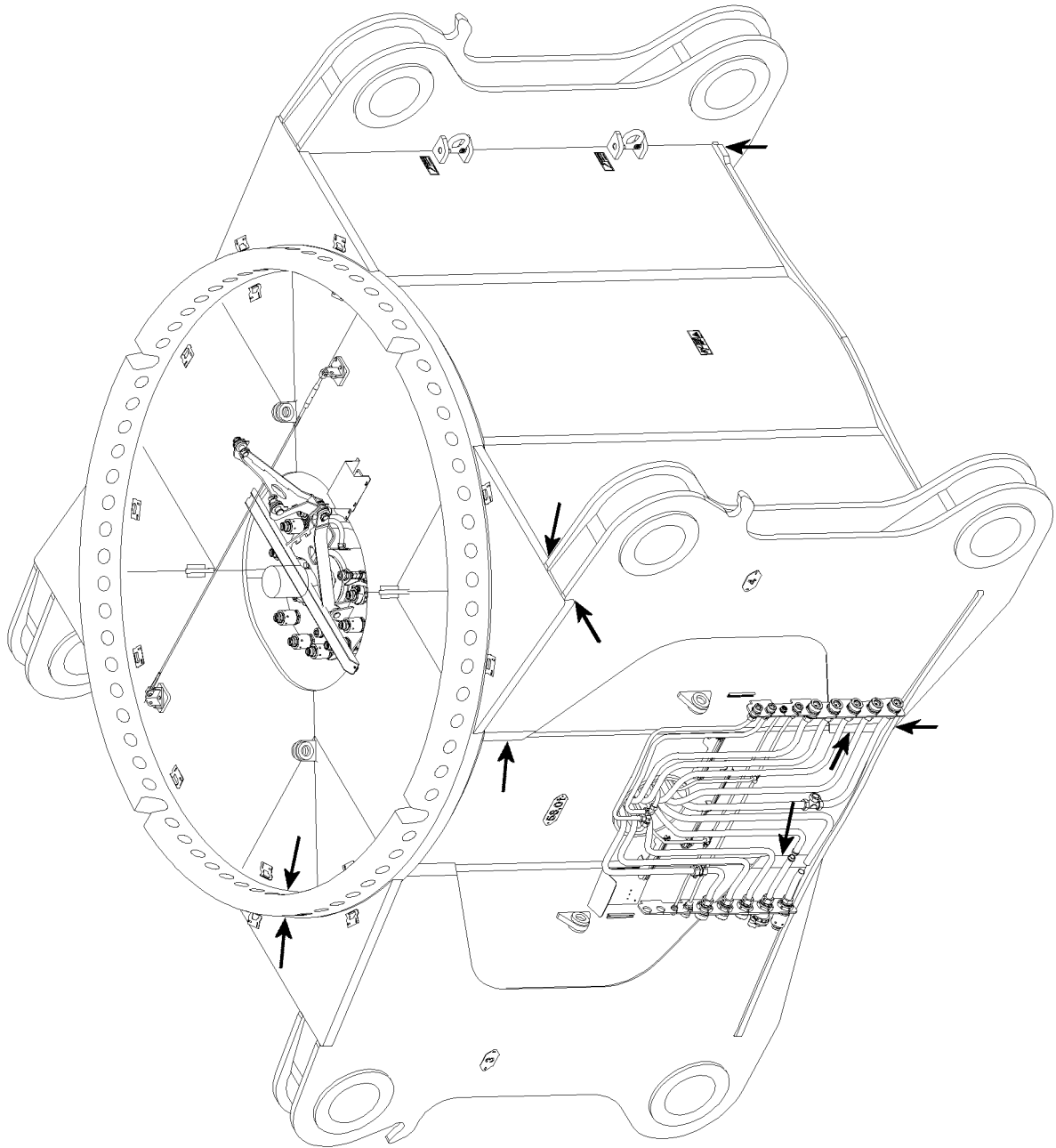


Fig.187347: Example of a crawler center section

LWE/LTR 1220-003/24204-02-02/en





LWE/LTR 1220-003/24204-02-02/en

Fig.115920: Example of a crawler center section

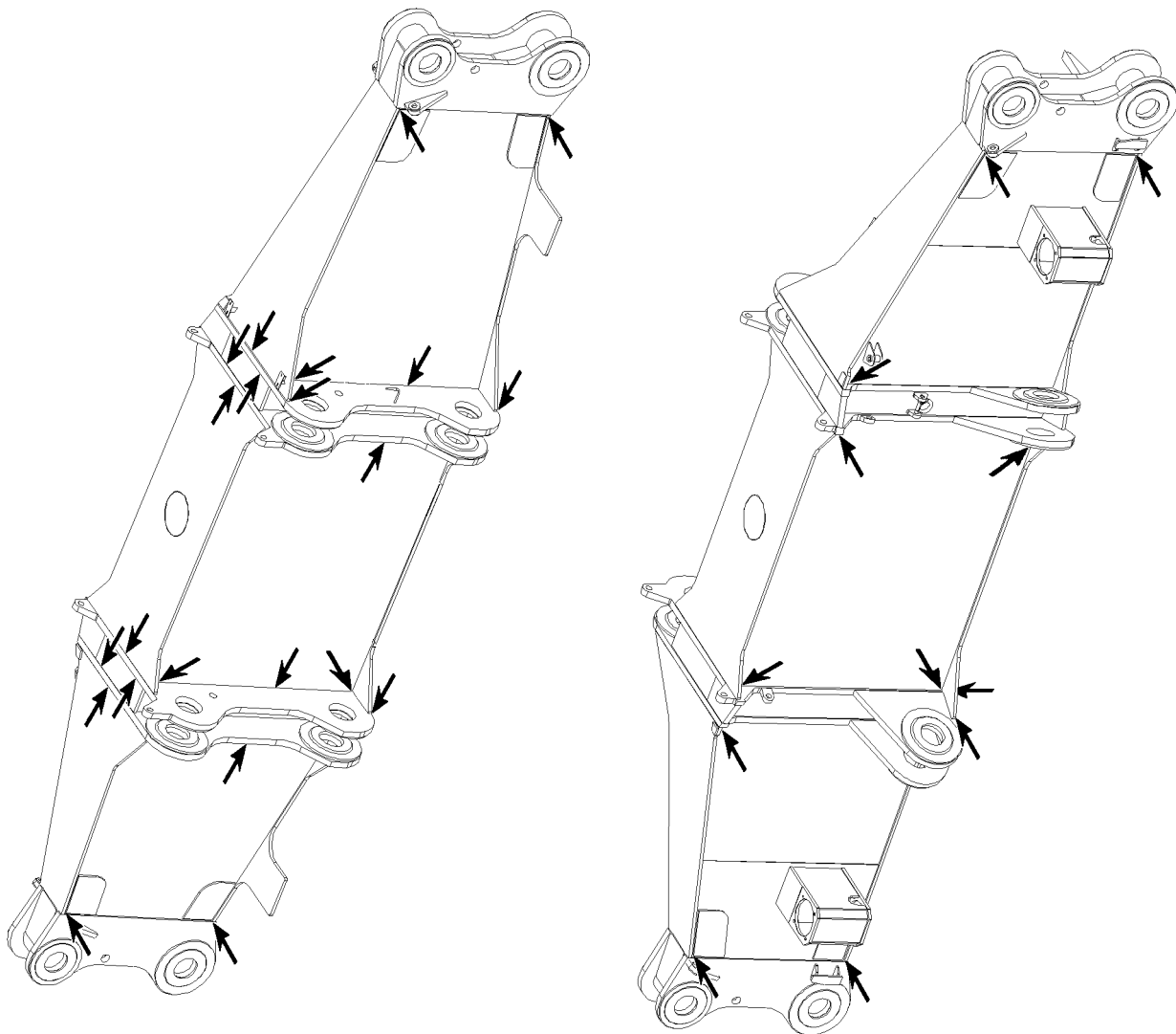
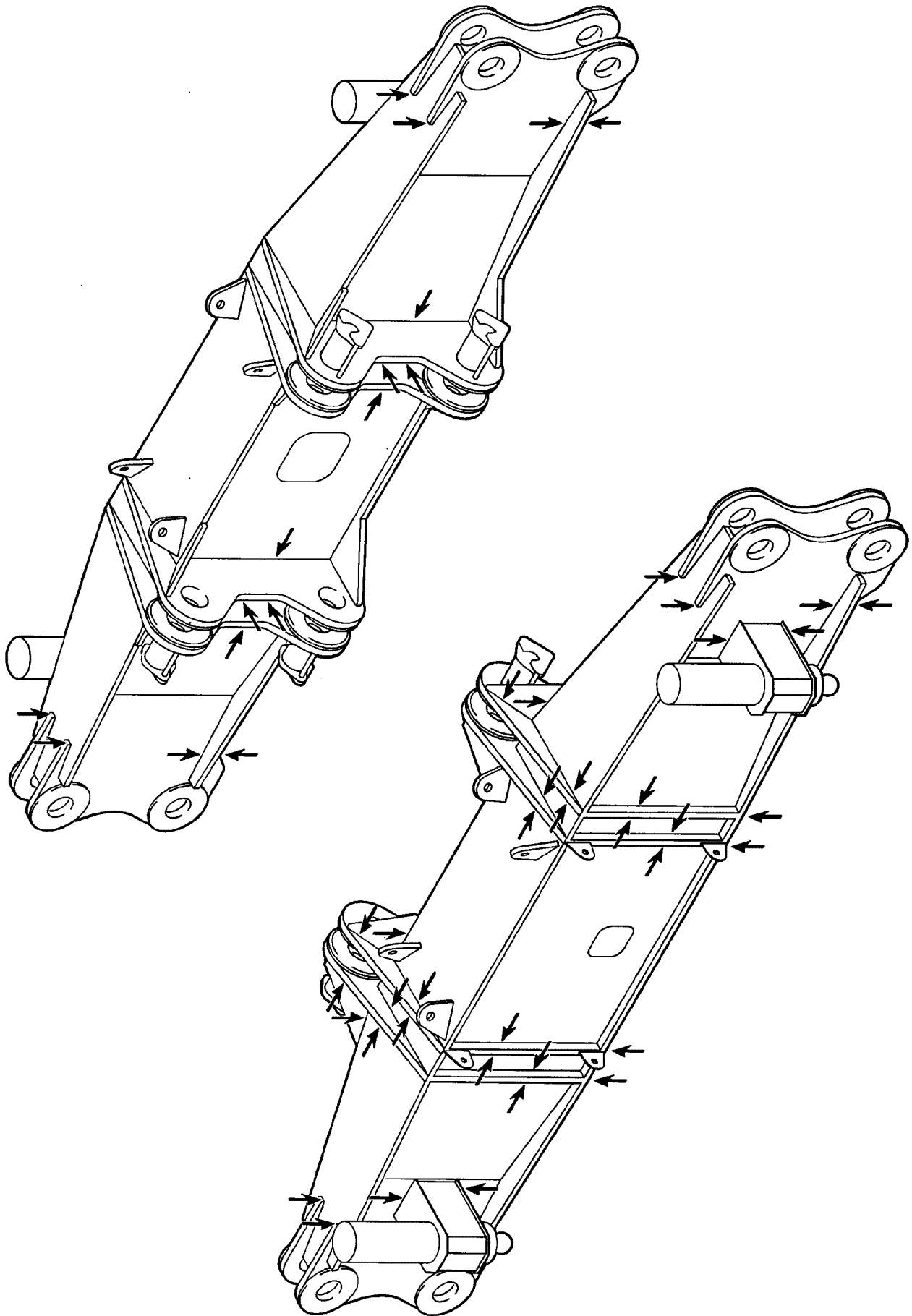


Fig.105727: Example of a cross carrier

LWE/LTR 1220-003/24204-02-02/en



LWE/LTR 1220-003/24204-02-02/en

Fig.187348: Example of a cross carrier

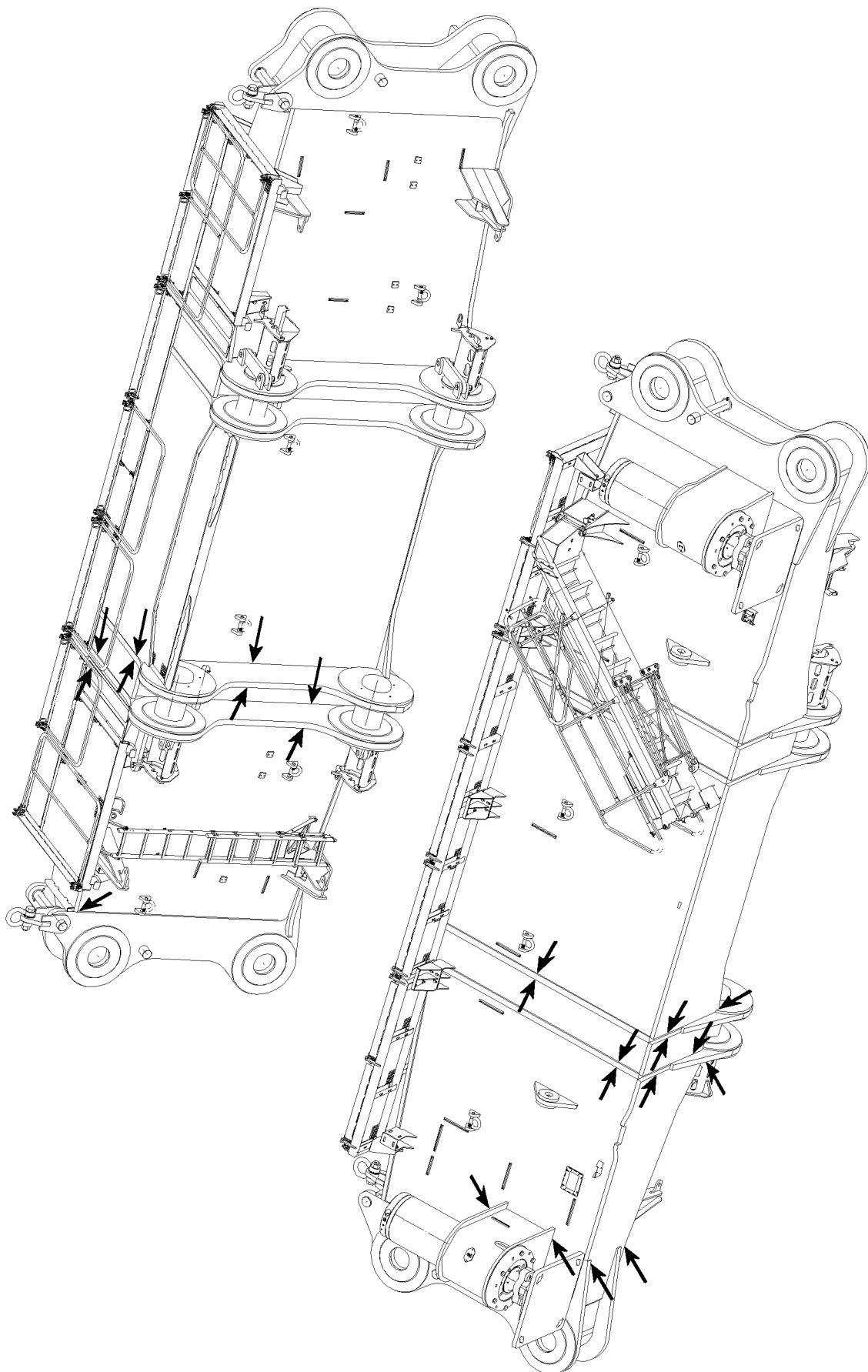
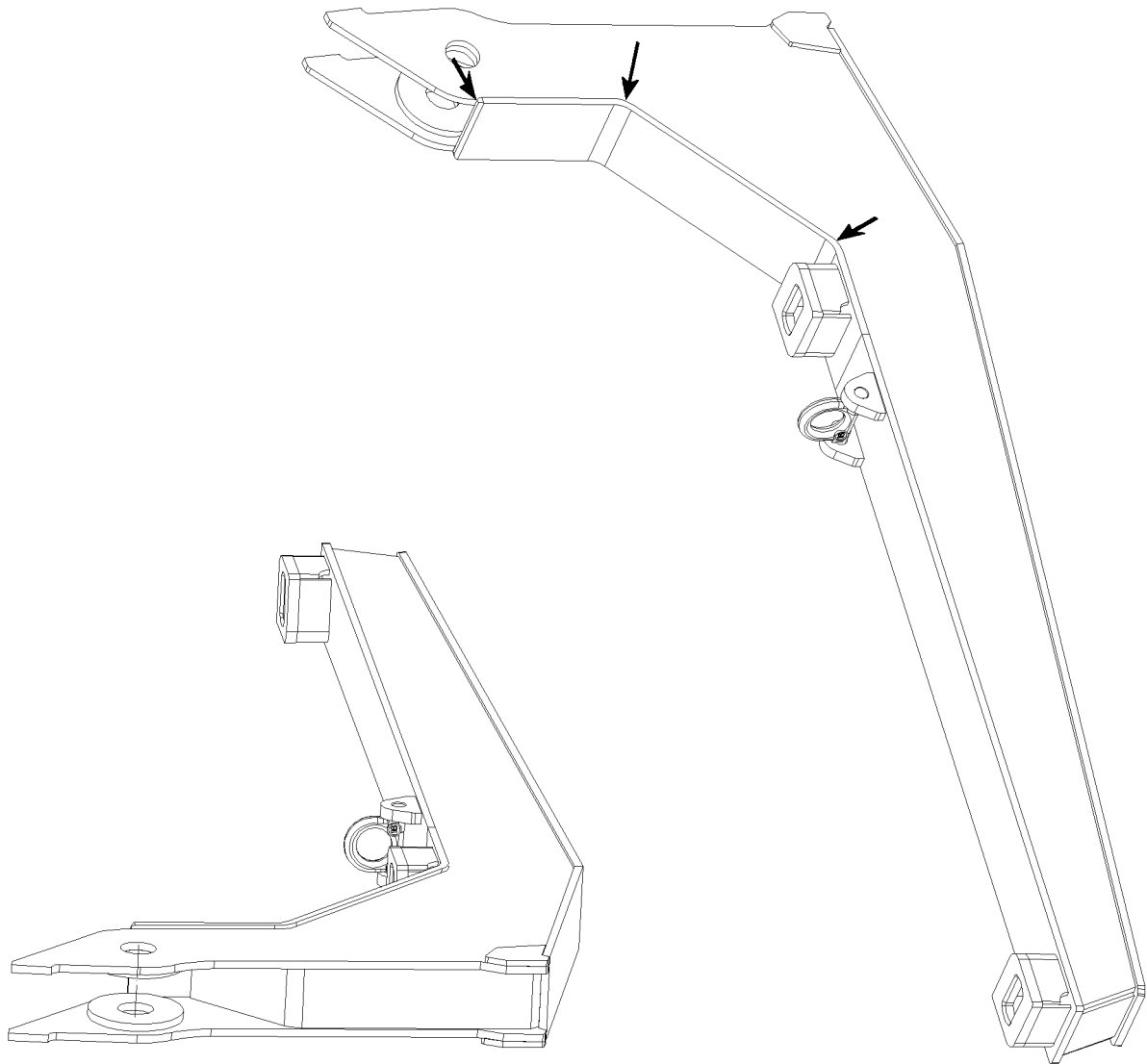


Fig.115921: Example of a cross carrier

LWE/LTR 1220-003/24204-02-02/en



LWE/LTR 1220-003/24204-02-02/en

Fig.115919: Example of carrier for central ballast

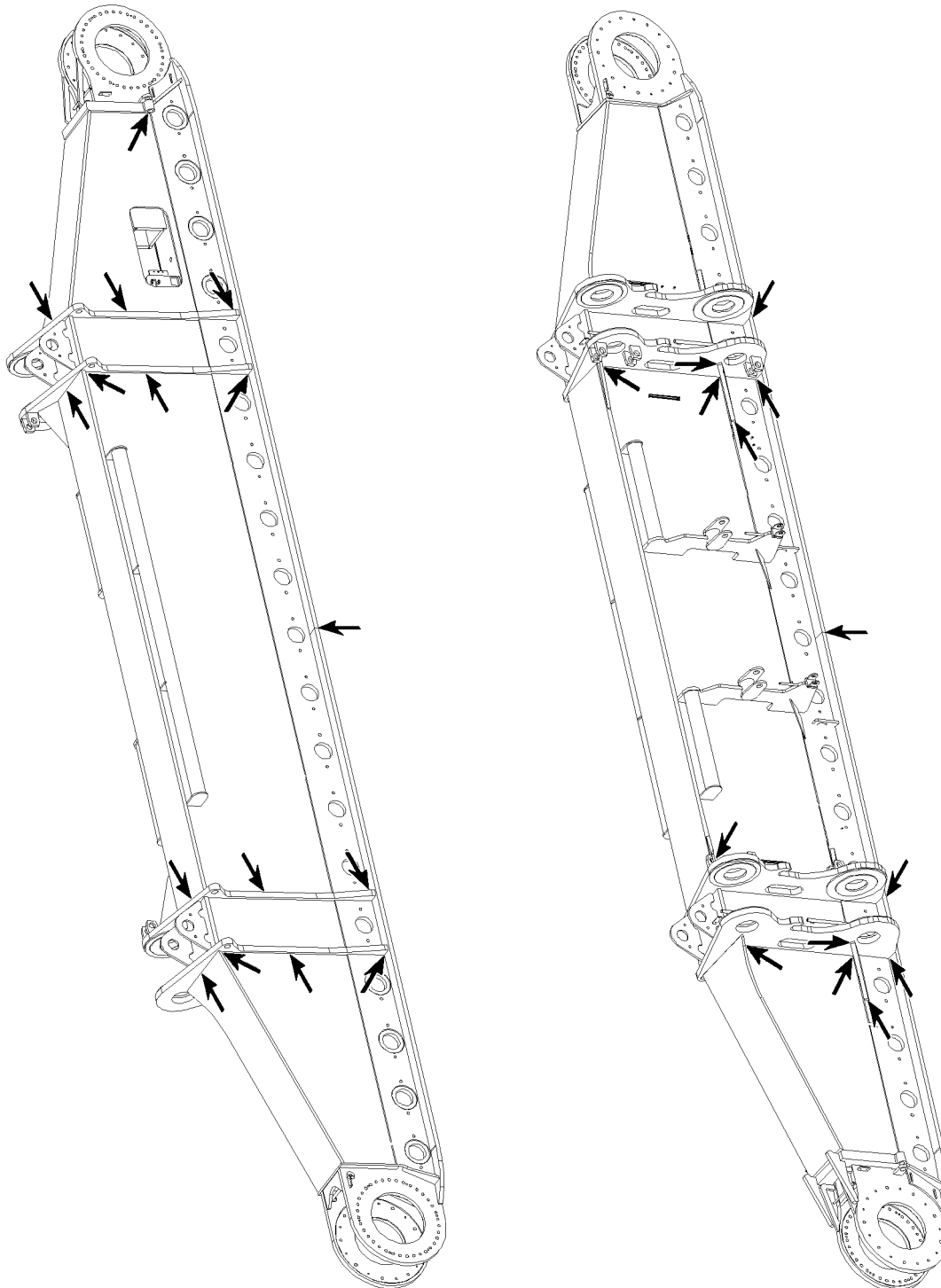
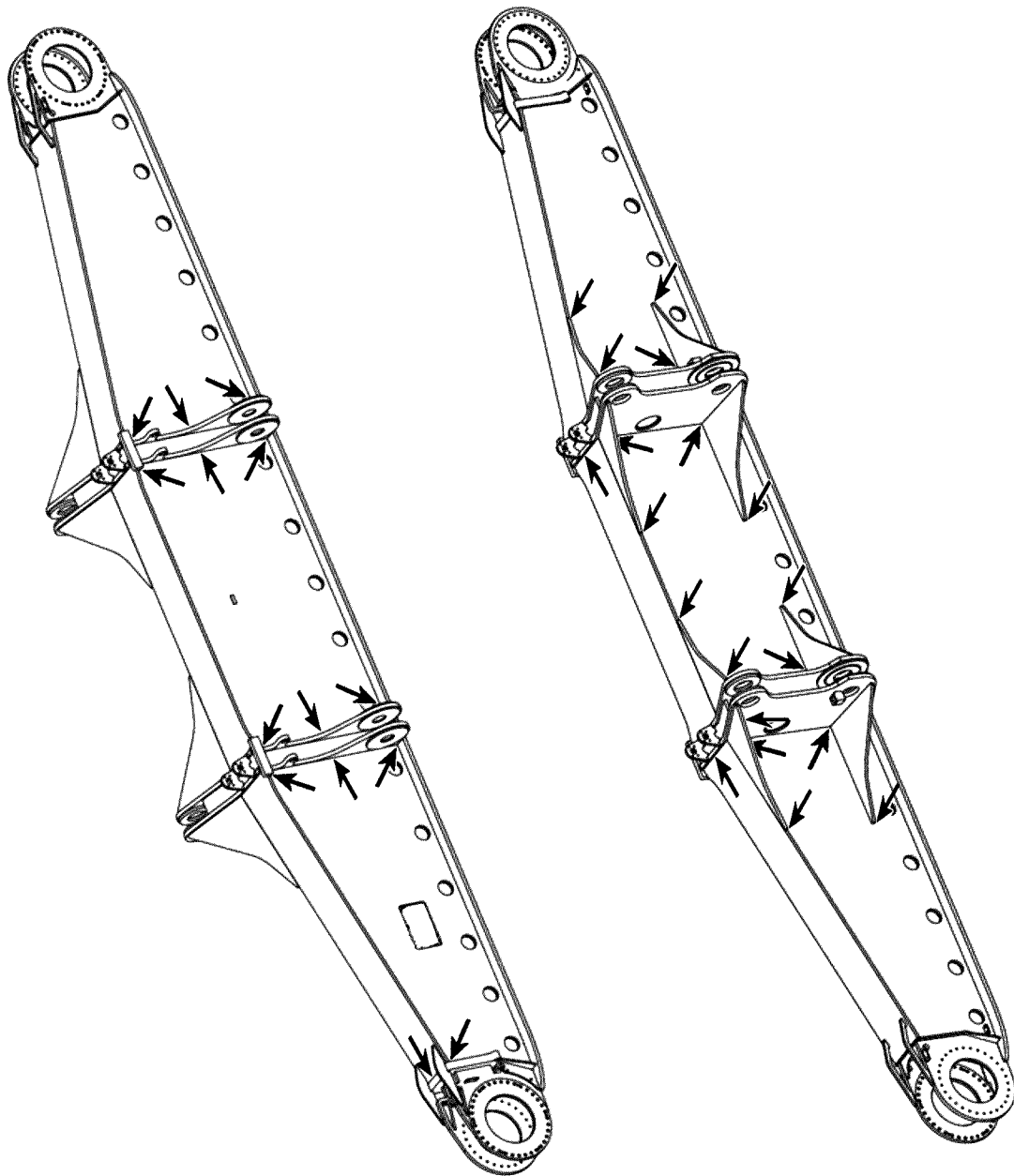


Fig.105728: Example of a crawler carrier



LWE/LTR 1220-003/24204-02-02/en

Fig.105729: Example of a crawler carrier

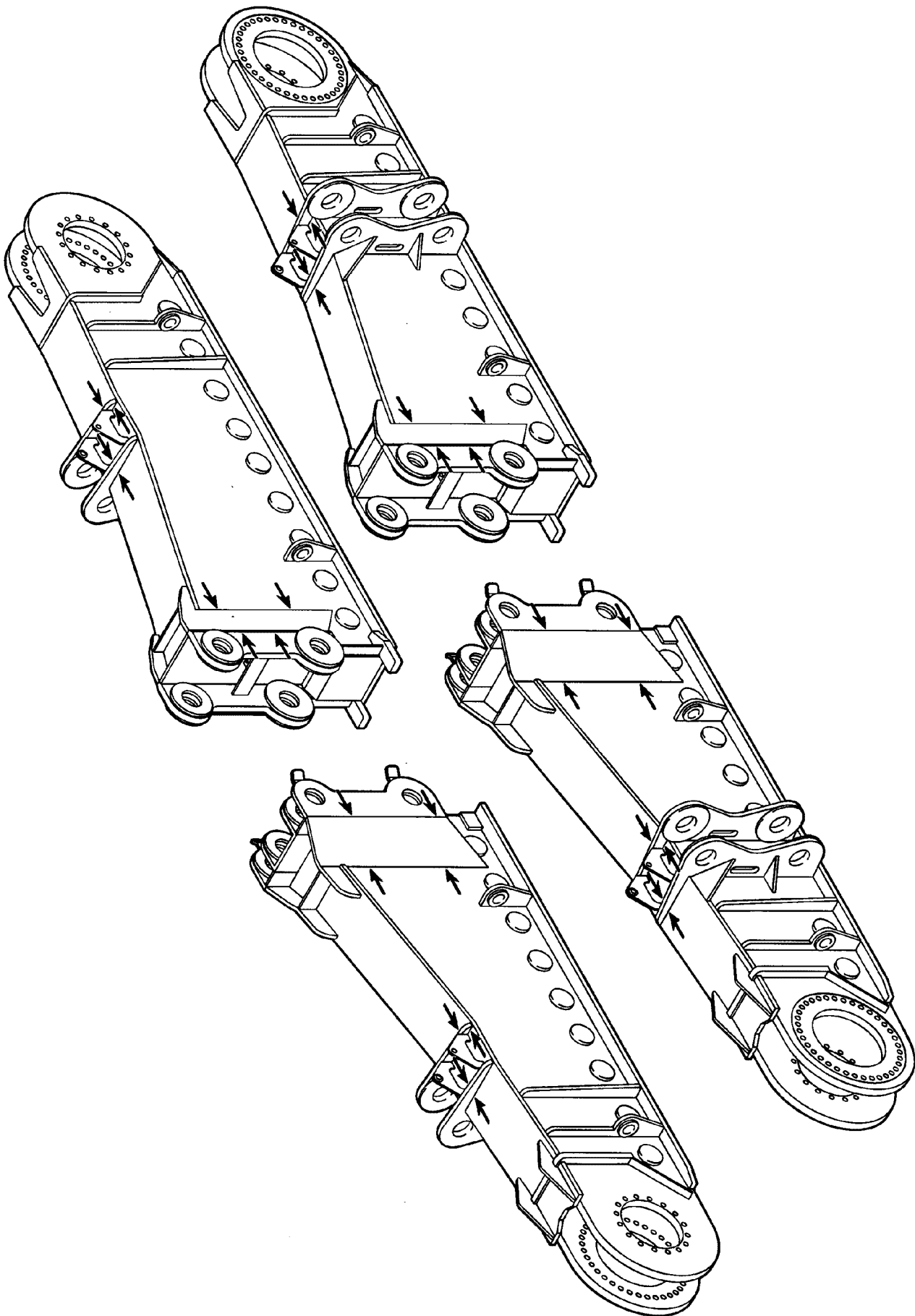
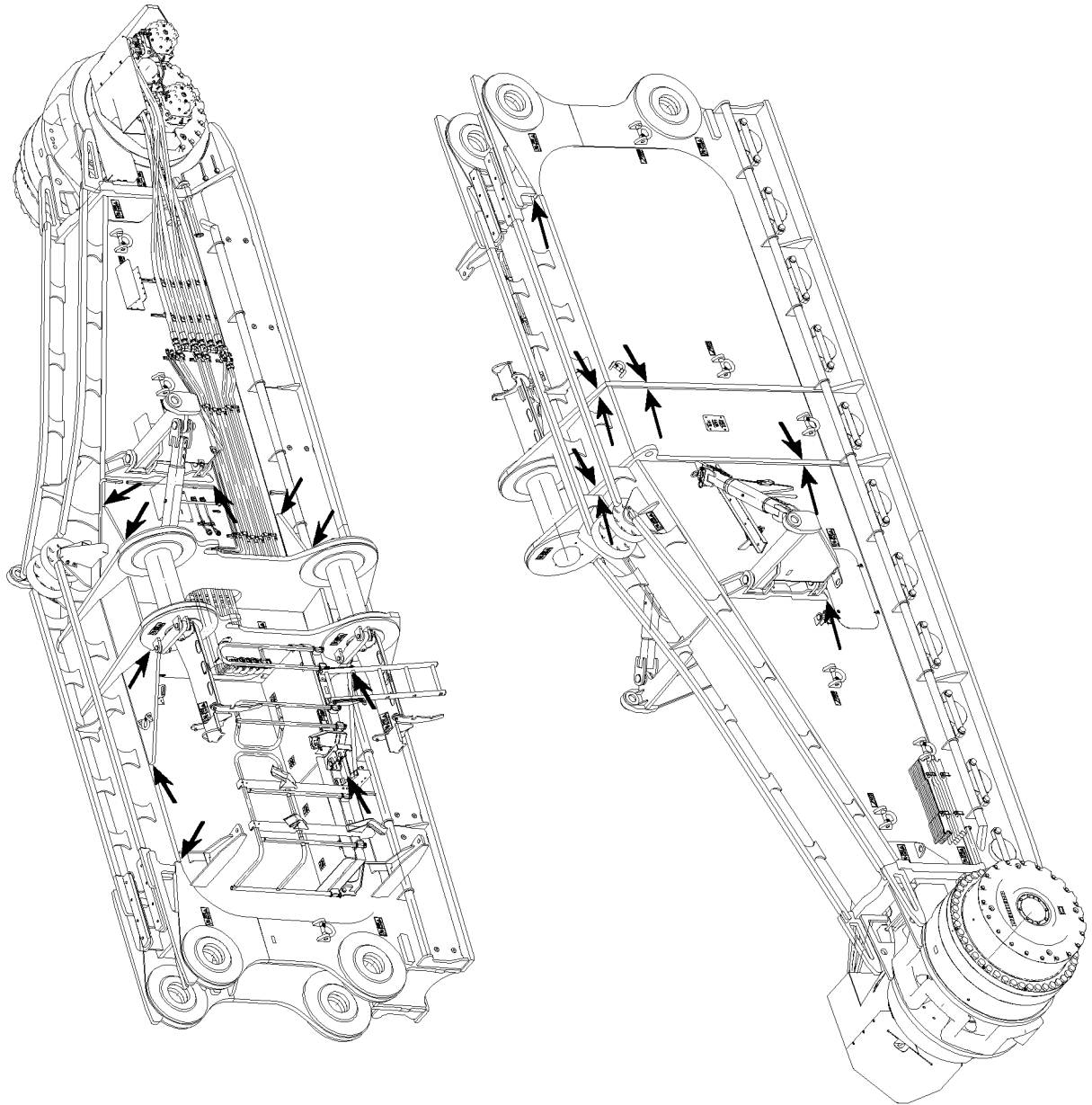


Fig.187349: Example of a crawler carrier

LWE/LTR 1220-003/24204-02-02/en





LWE/LTR 1220-003/24204-02-02/en

Fig.115917: Example of a crawler carrier

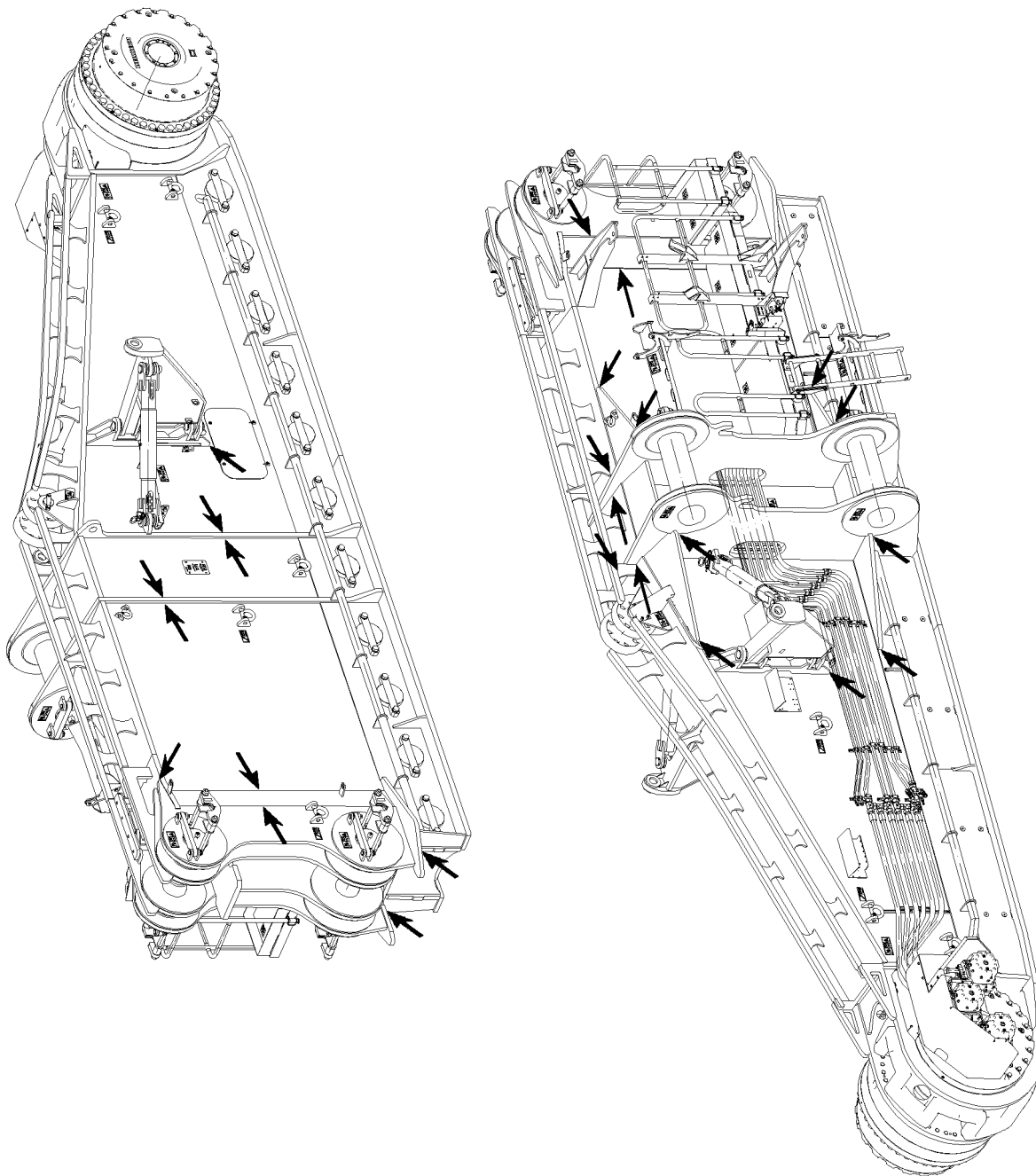
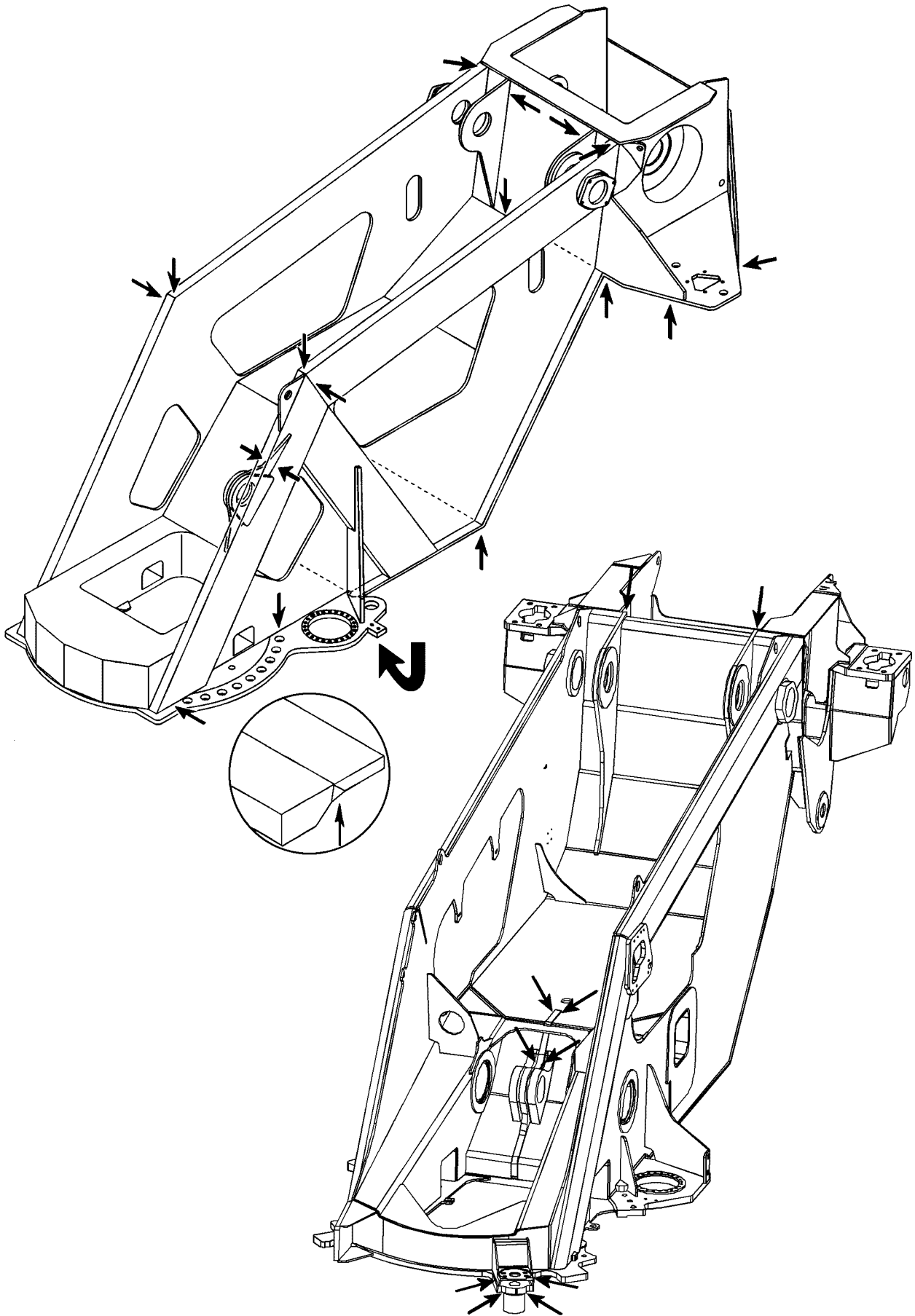


Fig.115918: Example of a crawler carrier

LWE/LTR 1220-003/24204-02-02/en



LWE/LTR 1220-003/24204-02-02/en

Fig.185048: Example of a turntable frame

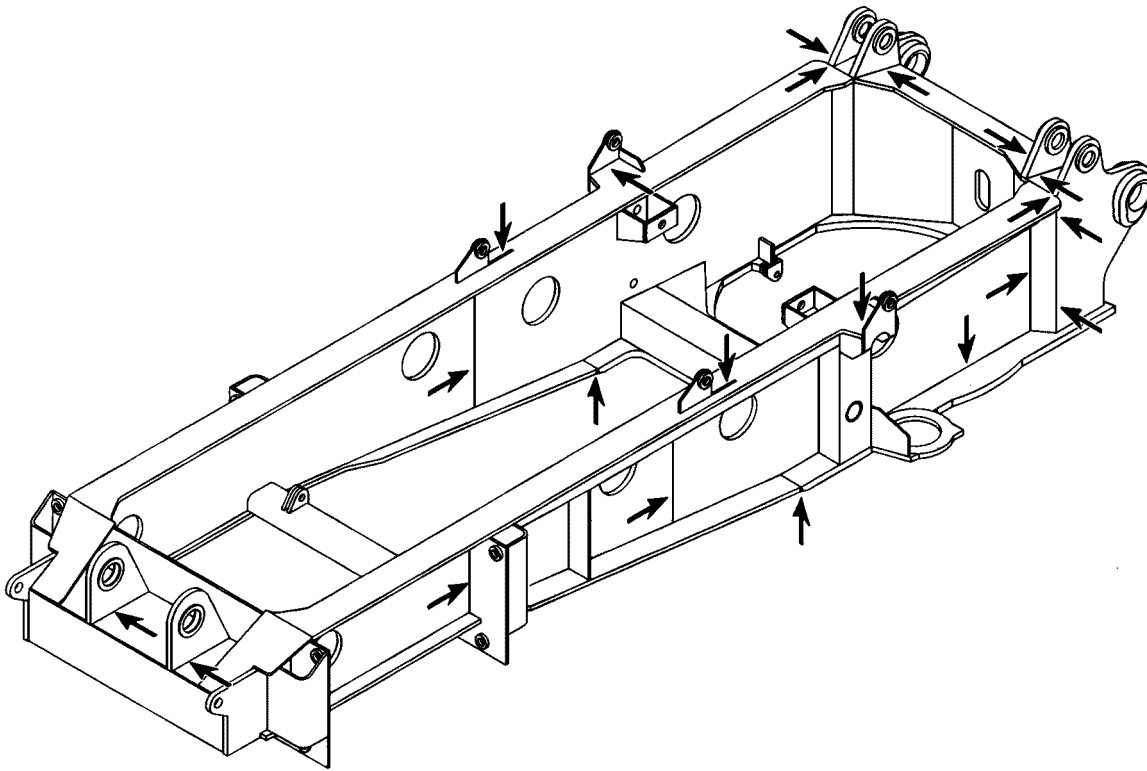


Fig.185049: Example of a turntable frame

LWE/LTR 1220-003/24204-02-02/en

LWE/LTR 1220-003/24204-02-02/en

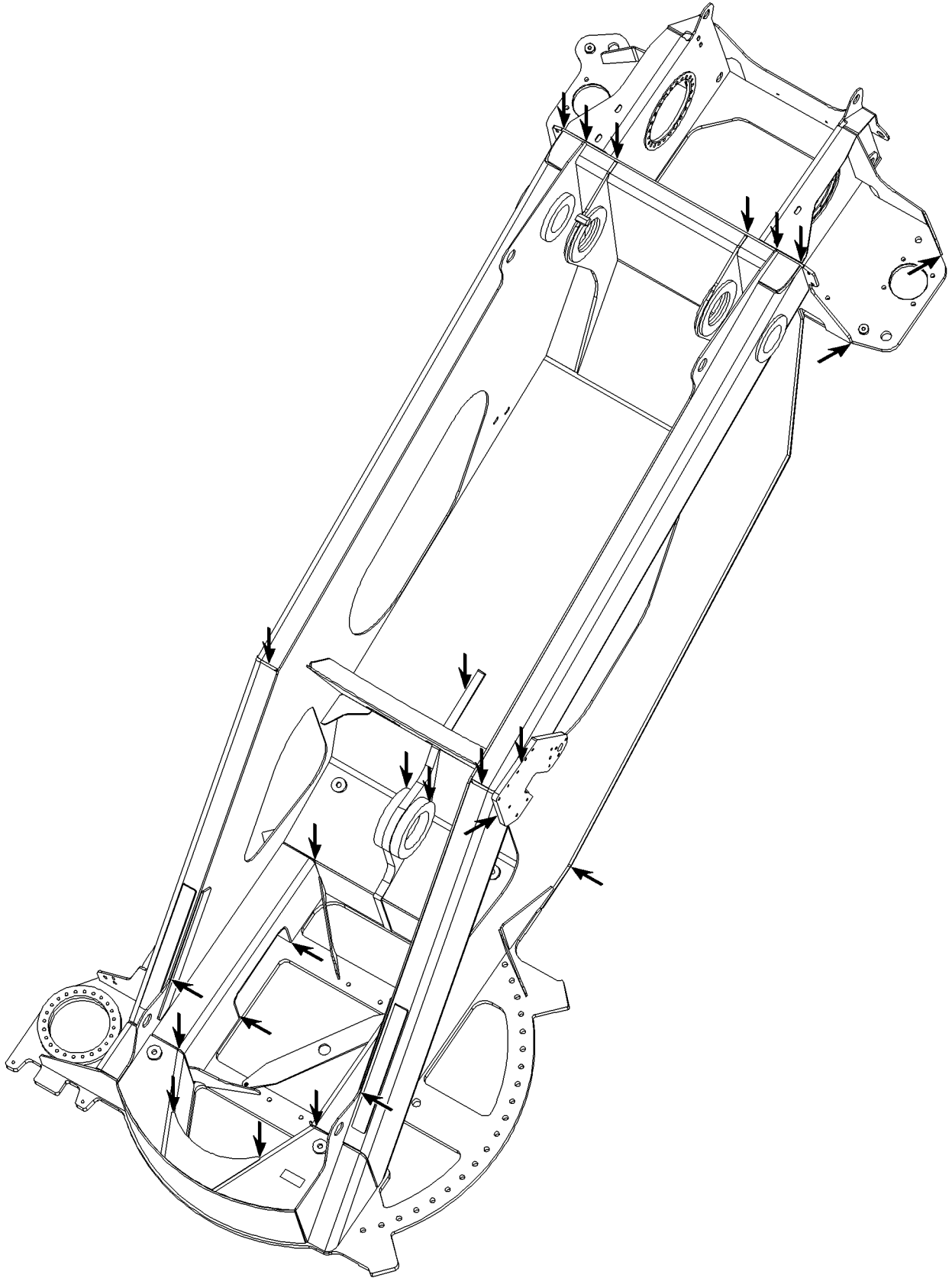


Fig.105700: Example of a turntable frame

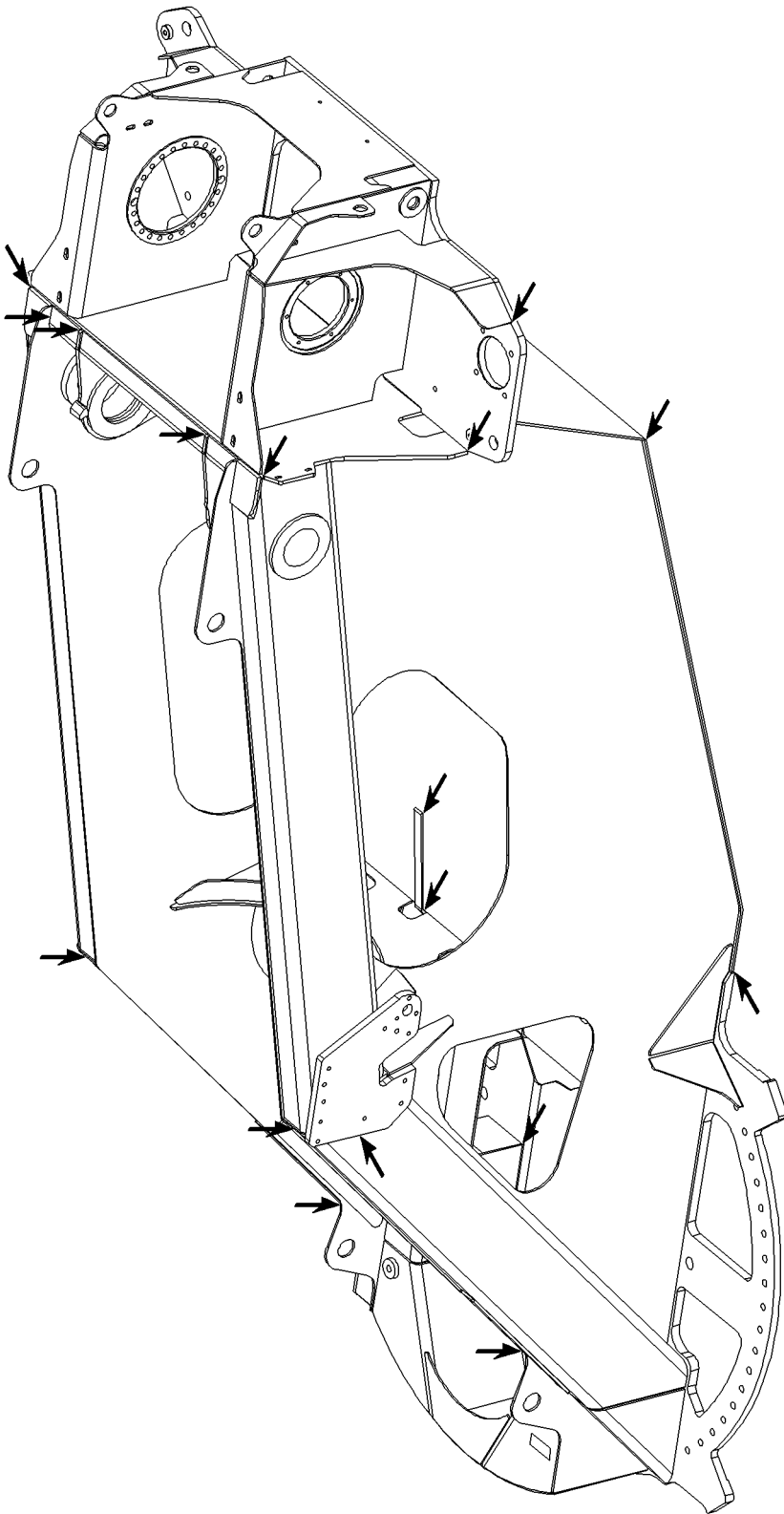
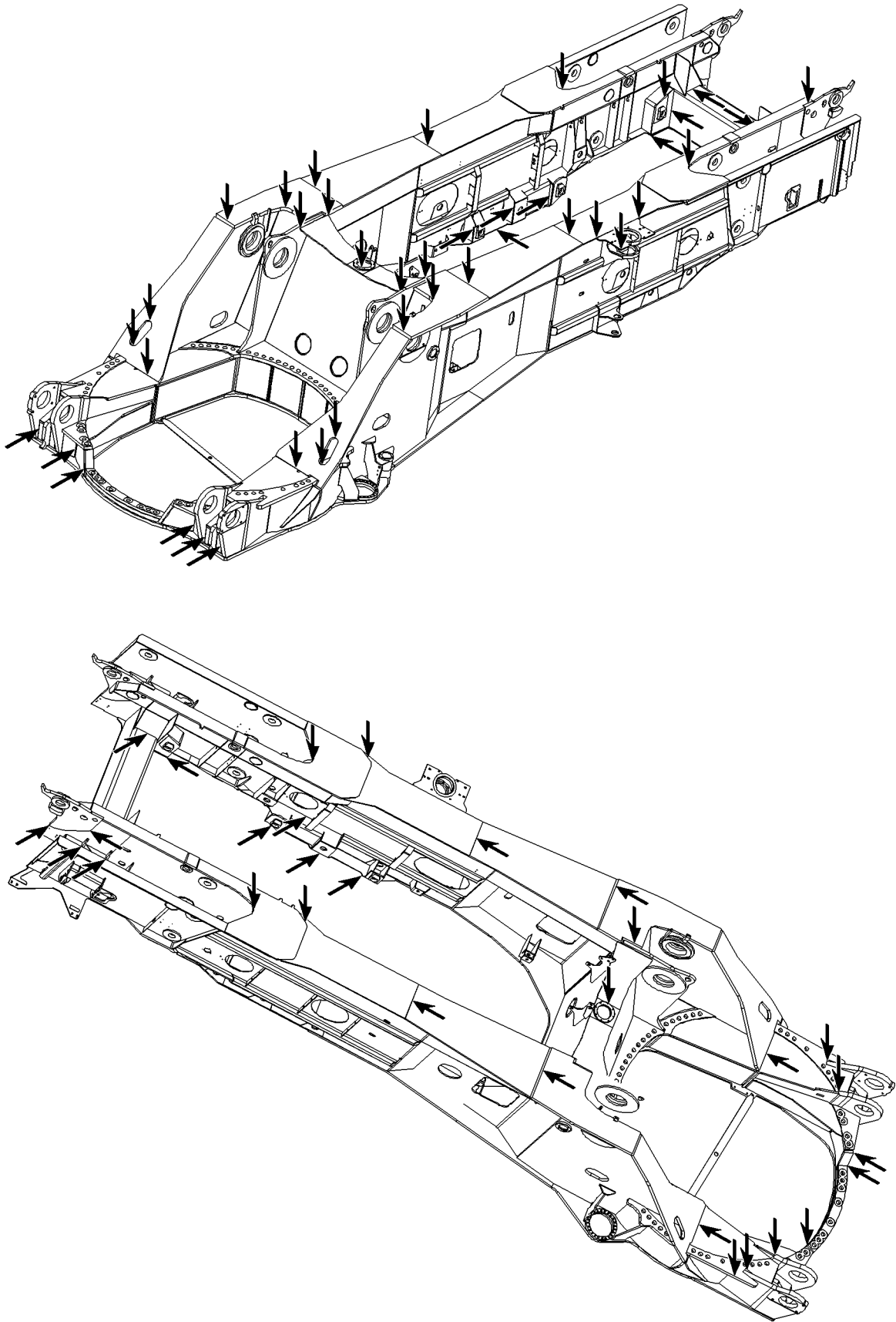


Fig.105701: Example of a turntable frame

LWE/LTR 1220-003/24204-02-02/en



LWE/LTR 1220-003/24204-02-02/en

Fig.105706: Example of a turntable frame

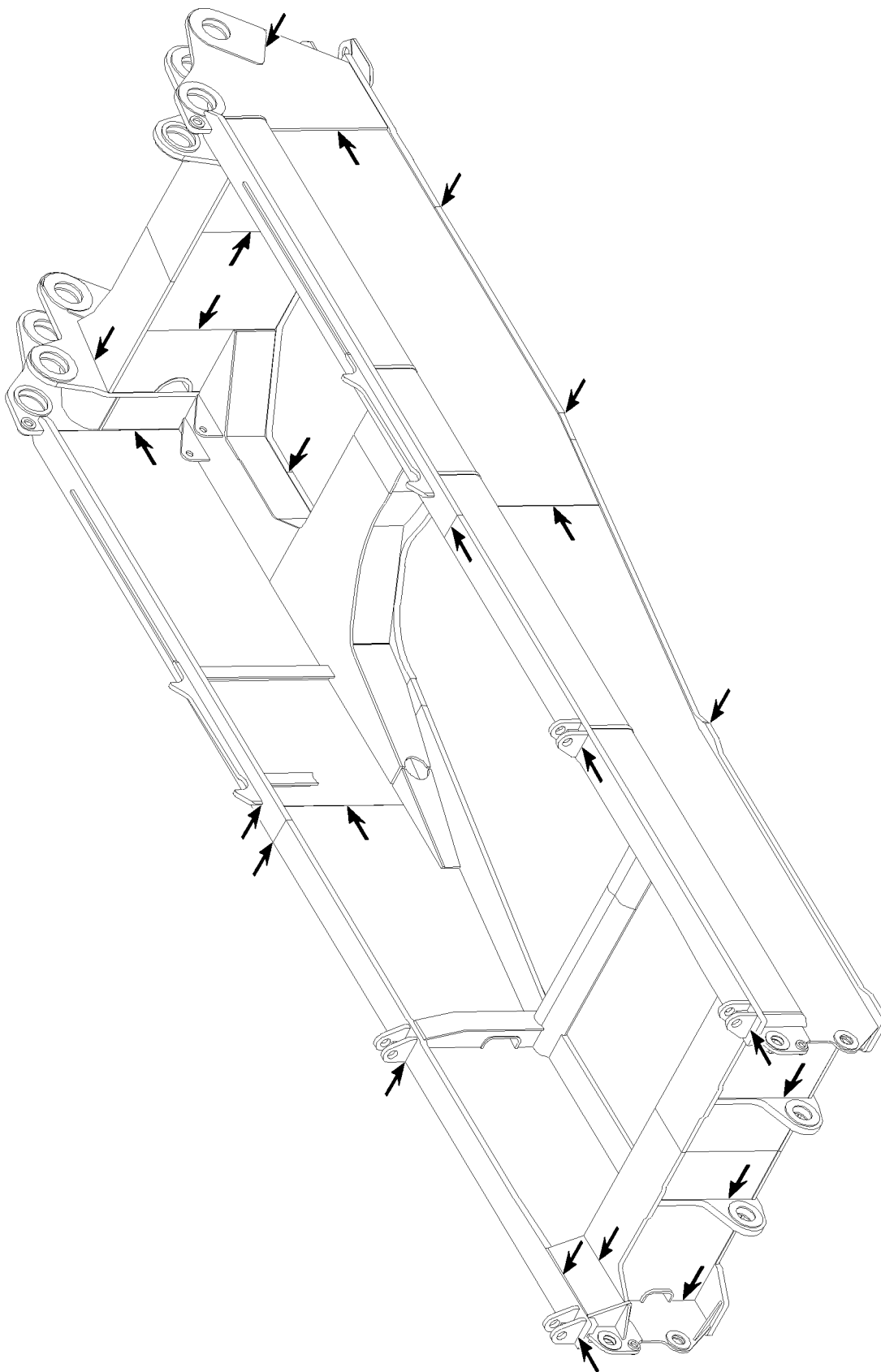
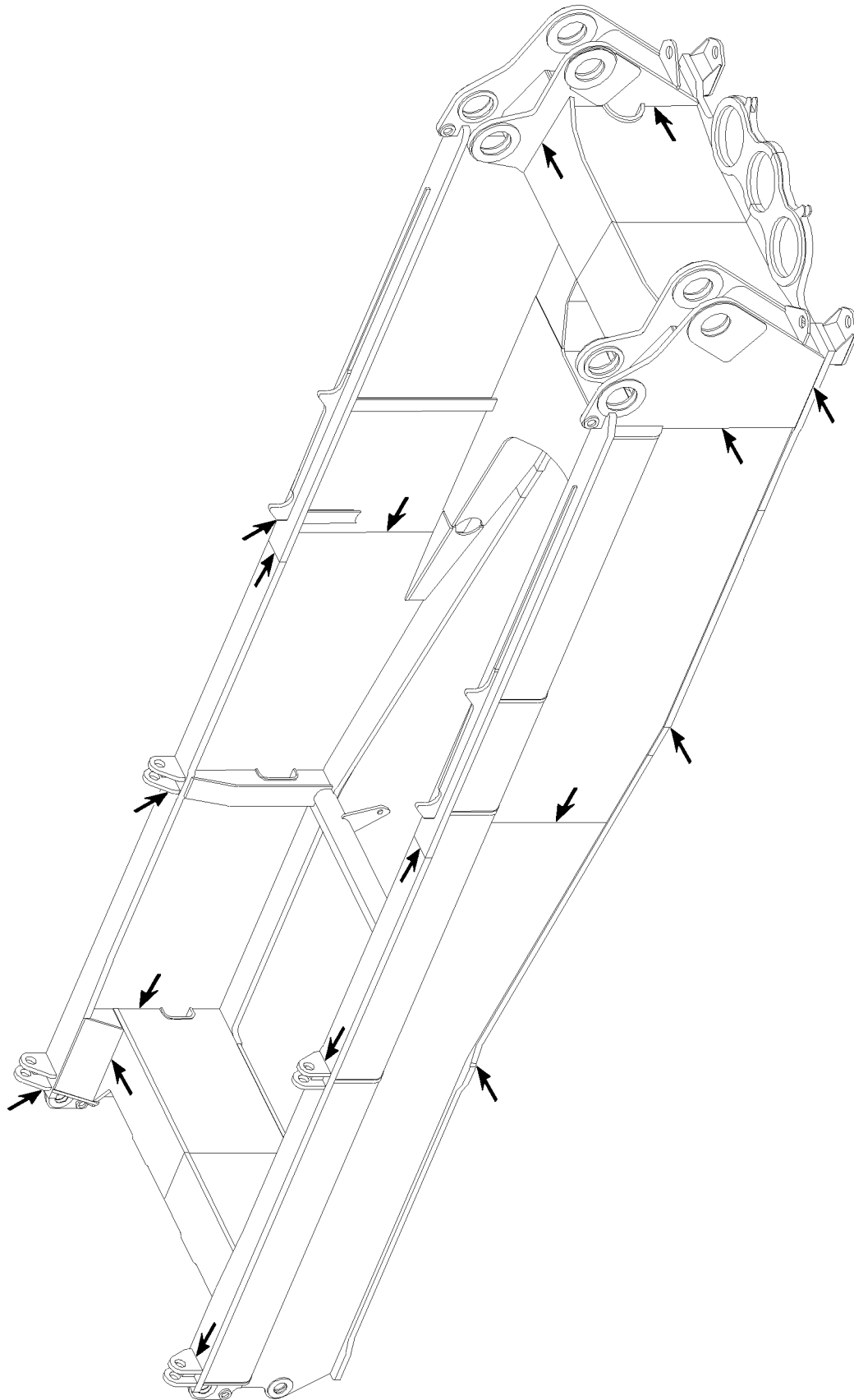


Fig.105694: Example of a turntable frame

LWE/LTR 1220-003/24204-02-02/en





LWE/LTR 1220-003/24204-02-02/en

Fig.105695: Example of a turntable frame

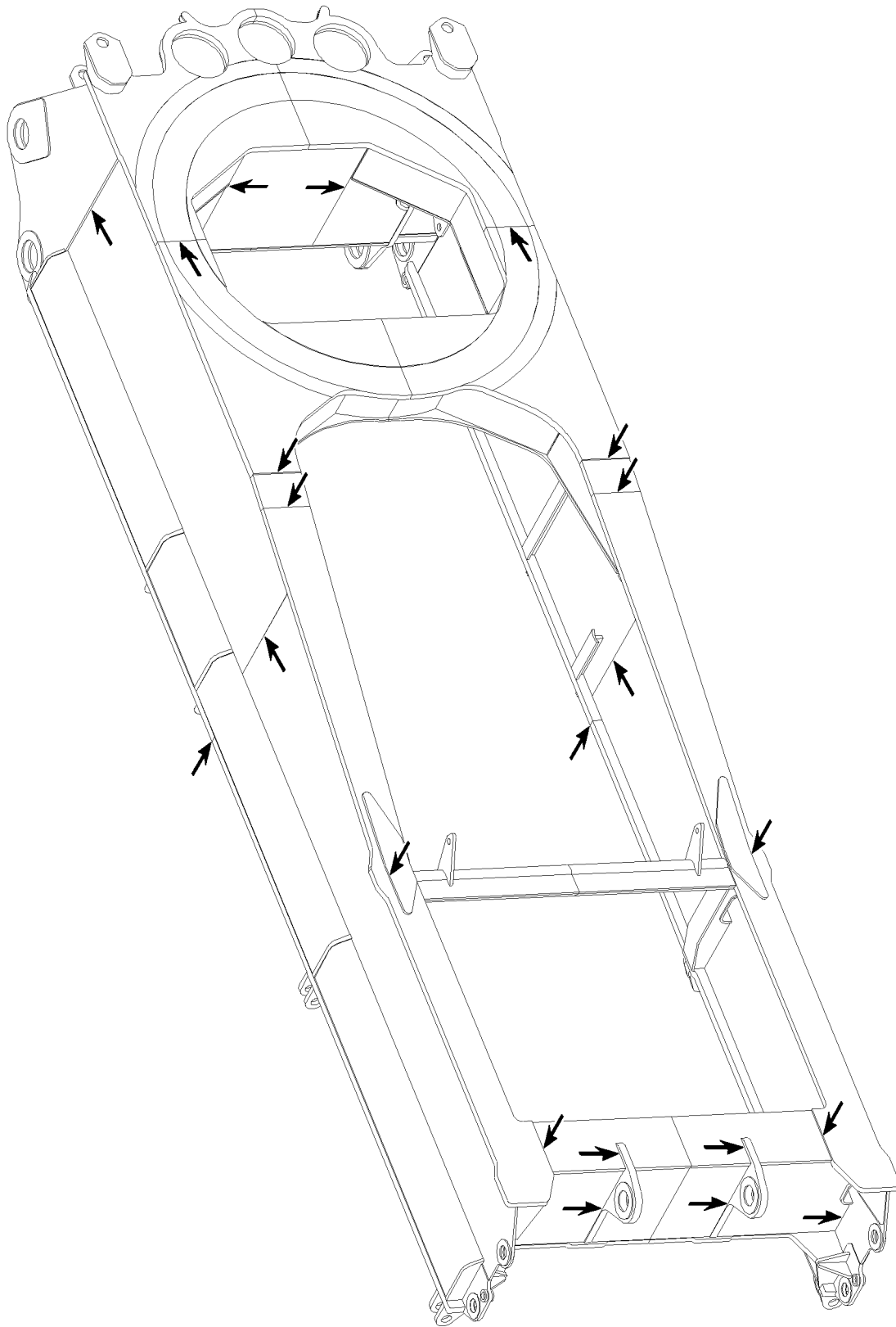
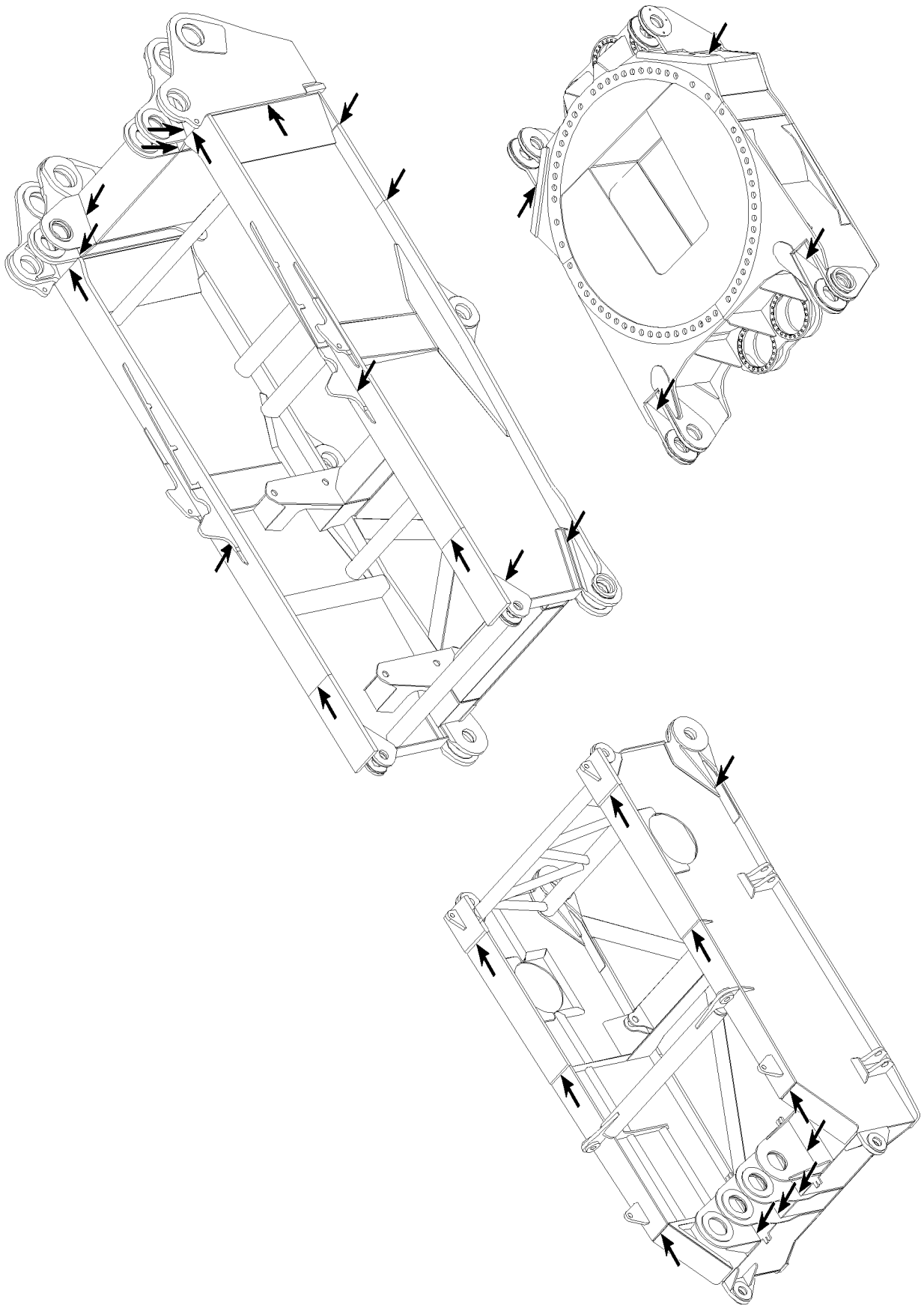


Fig.105696: Example of a turntable frame

LWE/LTR 1220-003/24204-02-02/en



LWE/LTR 1220-003/24204-02-02/en

Fig.105691: Example of a turntable frame

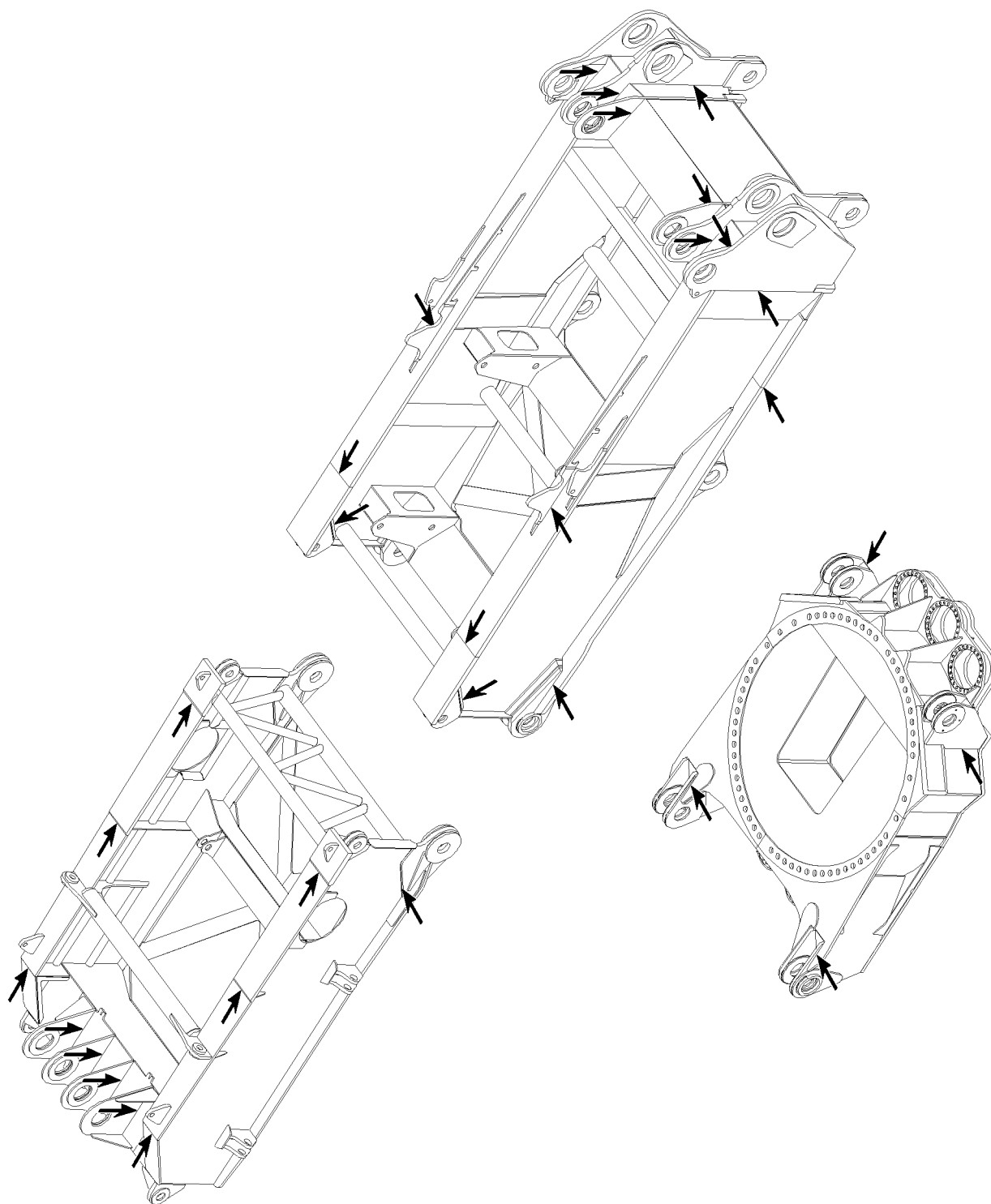
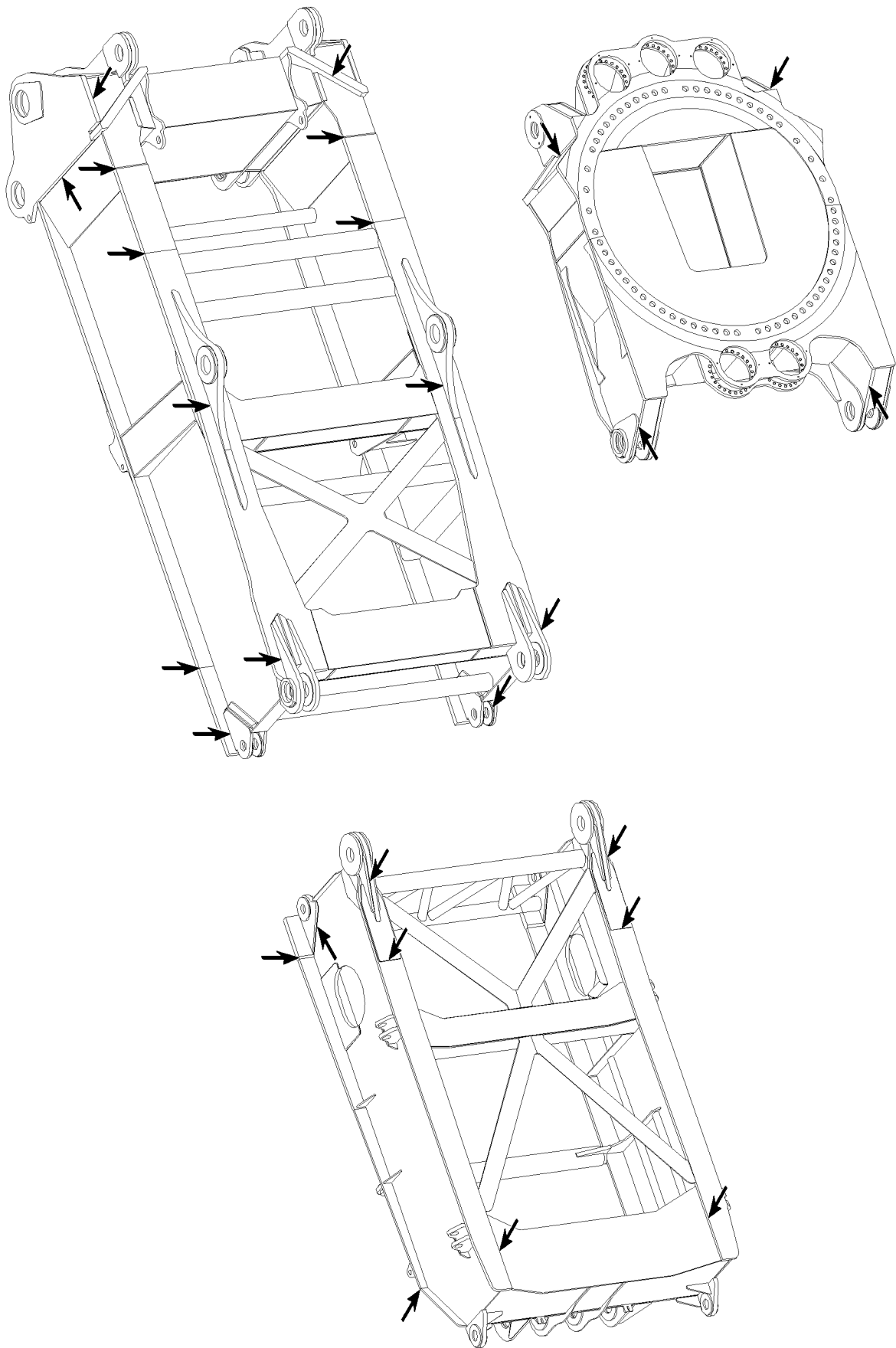


Fig.105692: Example of a turntable frame



LWE/LTR 1220-003/24204-02-02/en

Fig.105693: Example of a turntable frame

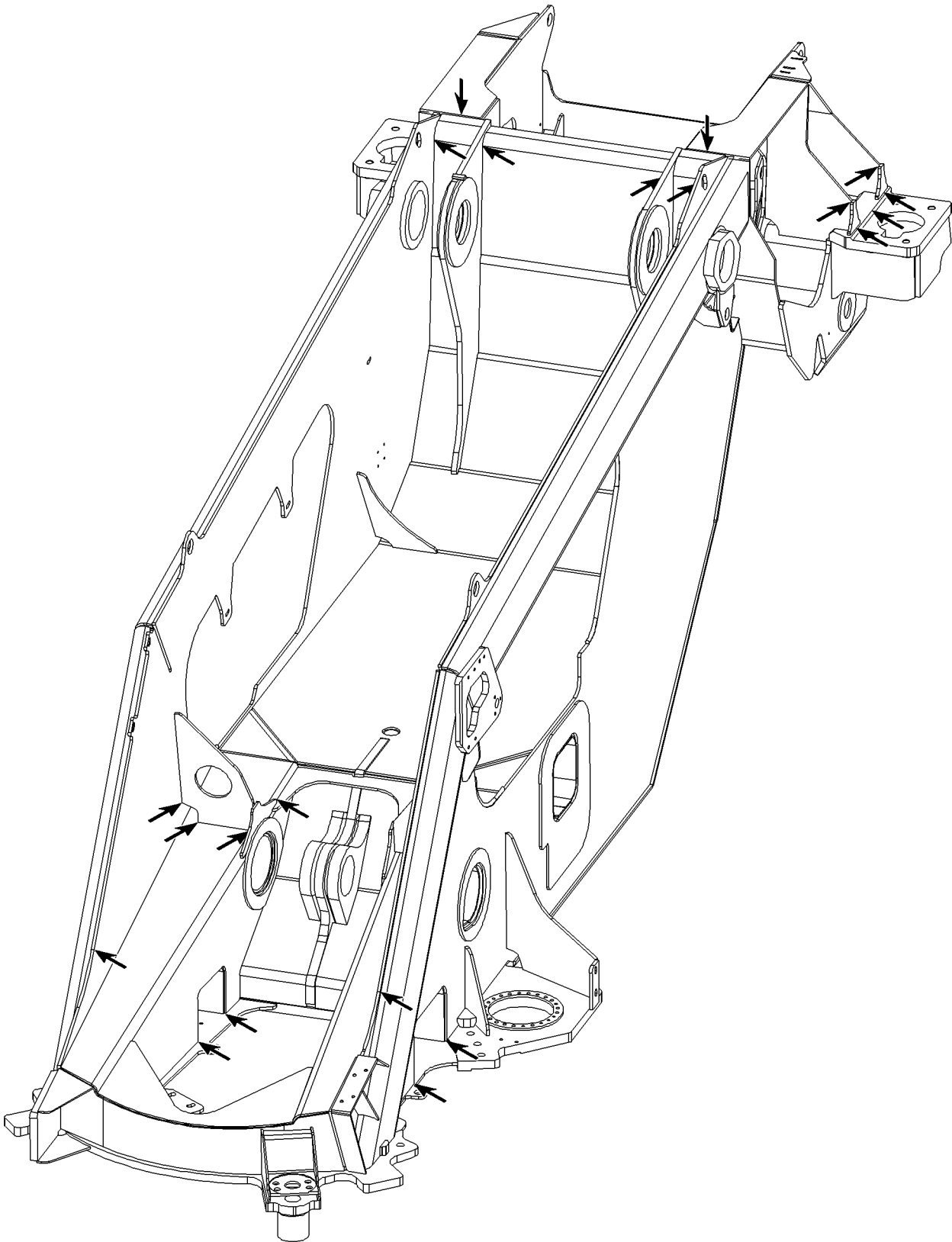
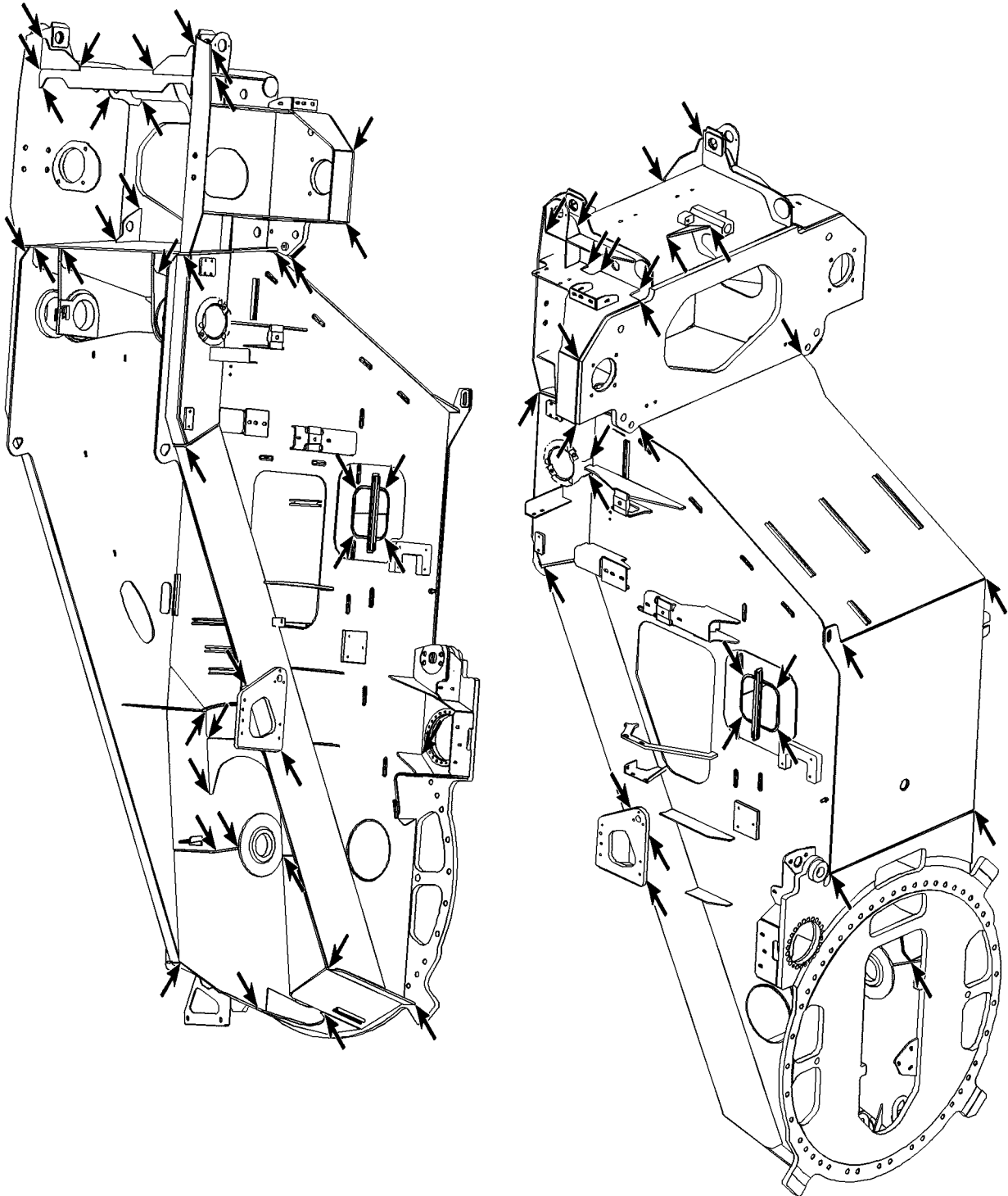


Fig.105722: Example of a turntable frame



LWE/LTR 1220-003/24204-02-02/en

Fig.105932: Example of a turntable frame

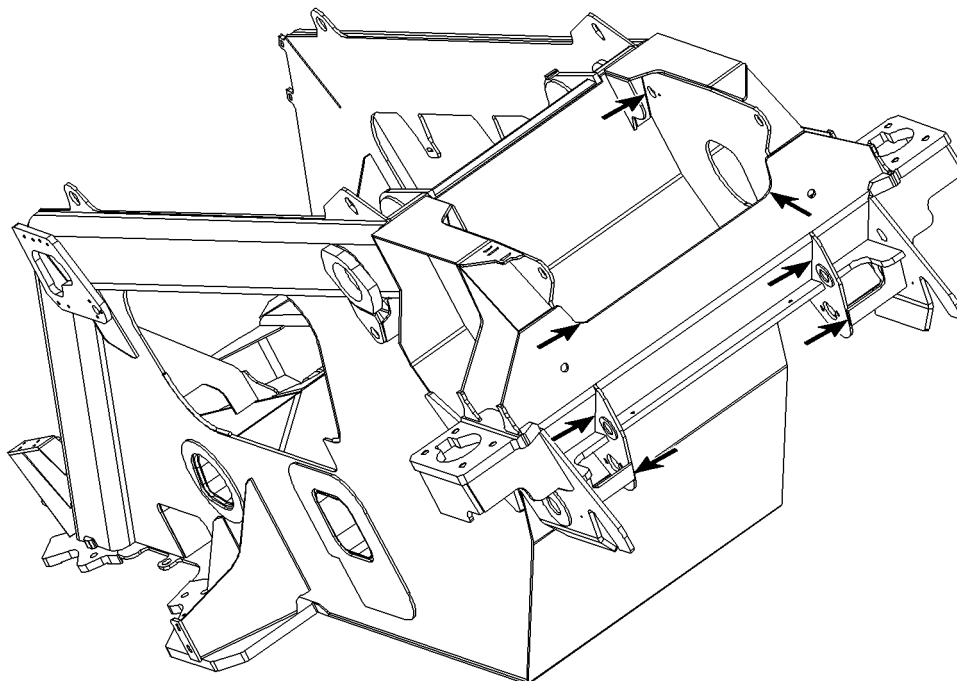
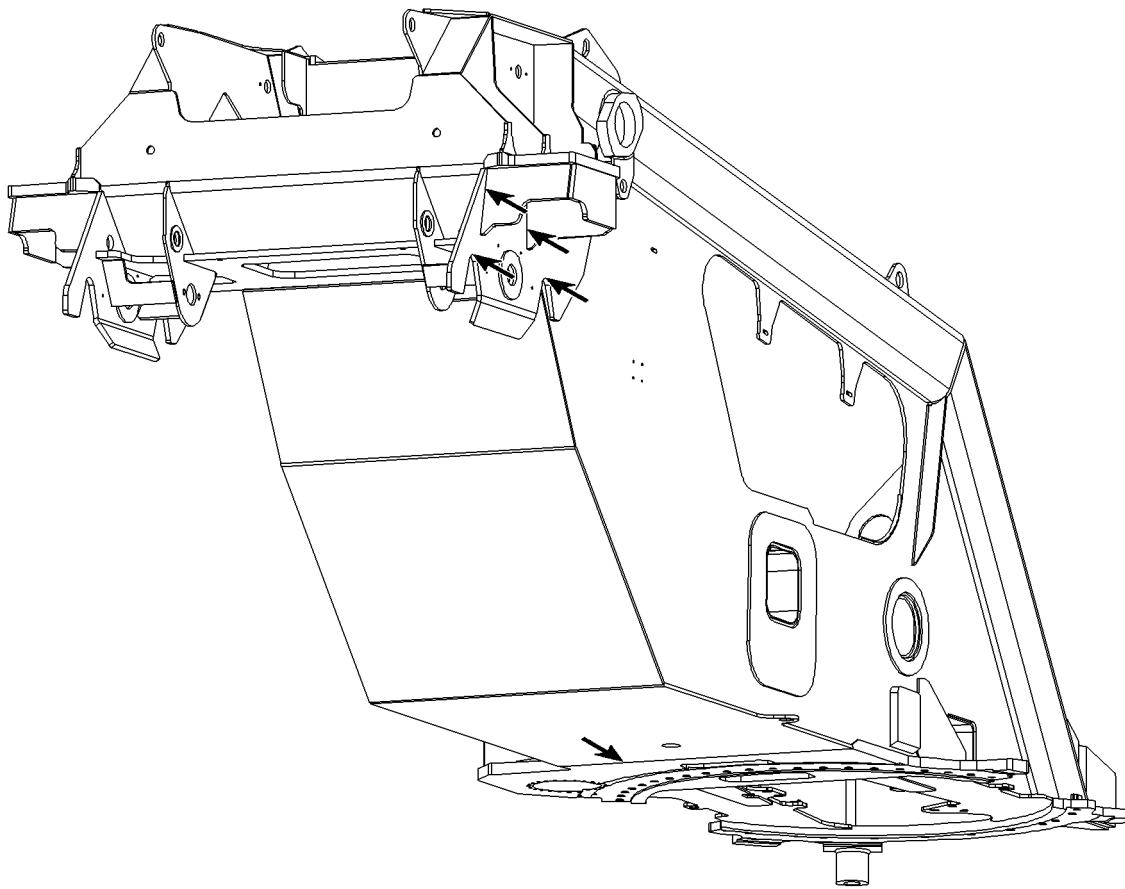
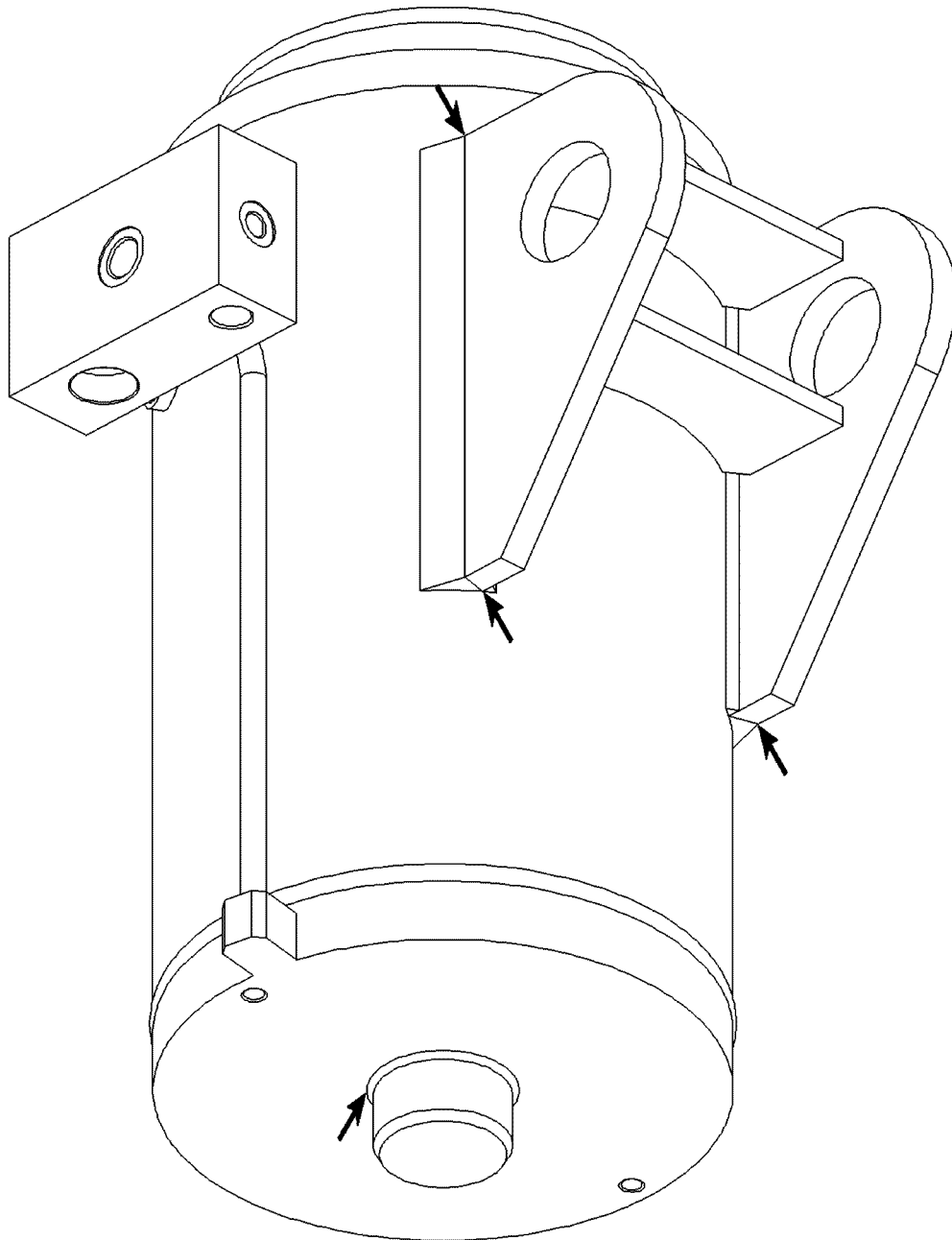


Fig.105723: Example of a turntable frame





LWE/LTR 1220-003/24204-02-02/en

Fig.105801: Example of a ballast cylinder

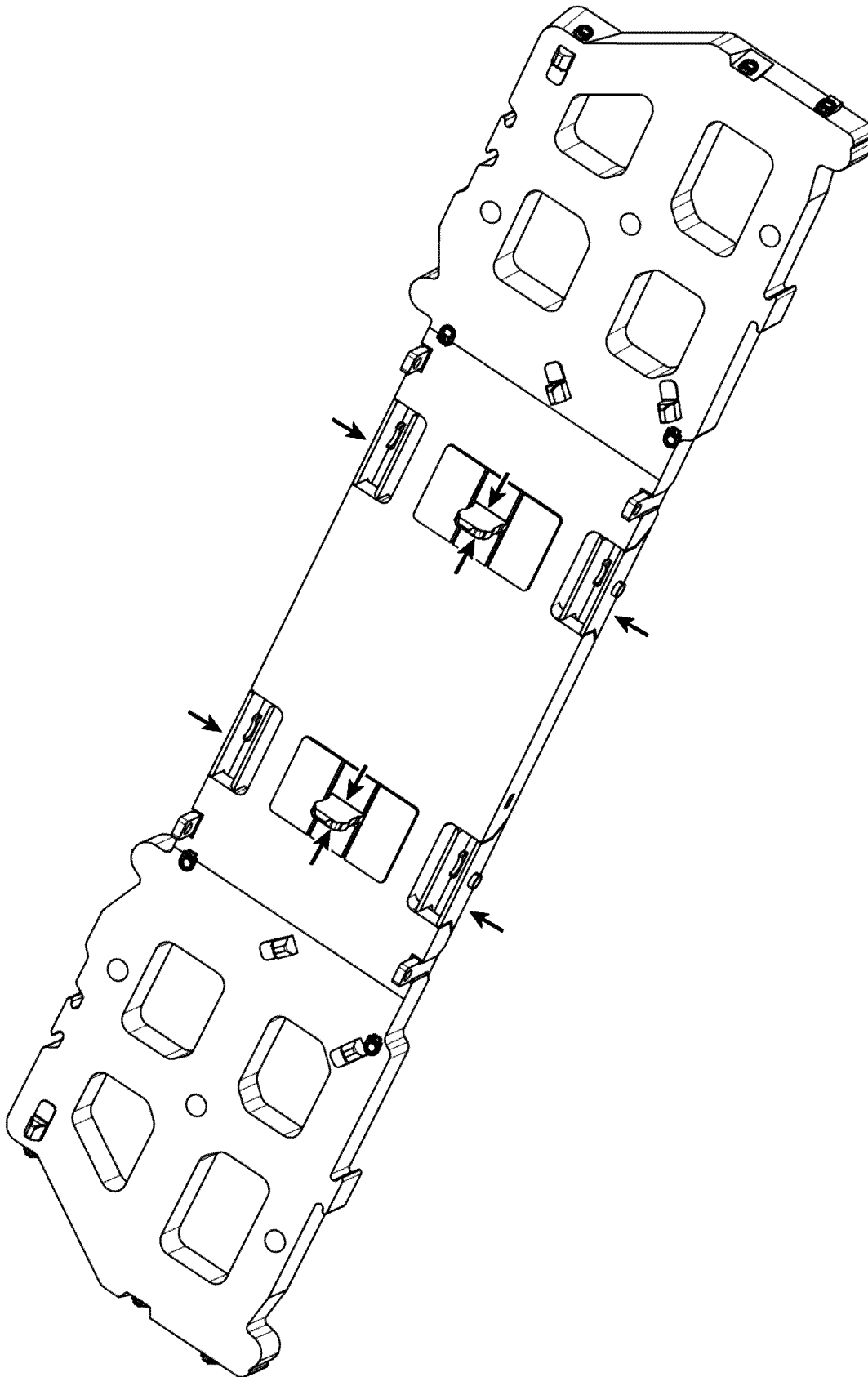
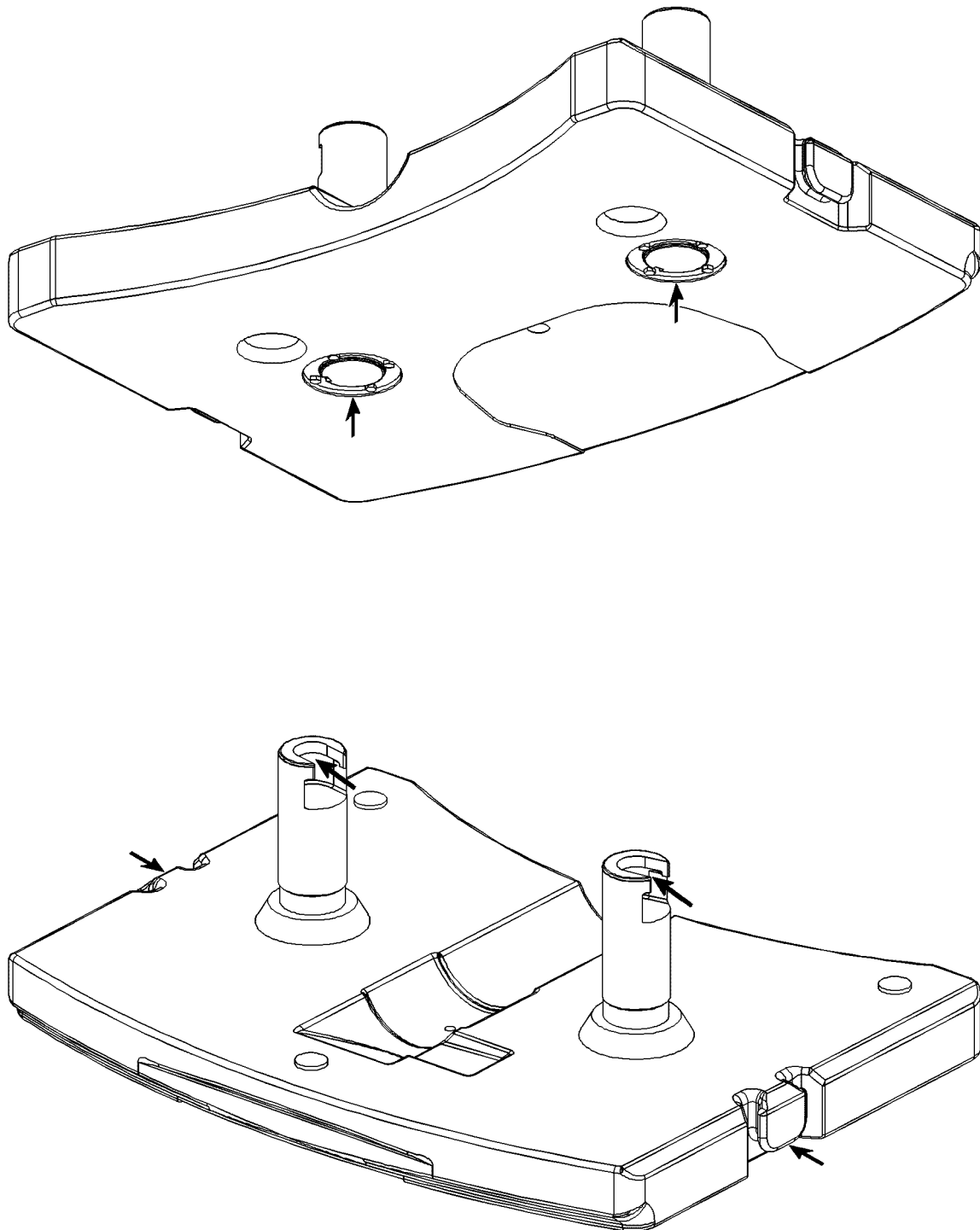


Fig.105705: Example of mounting plate

LWE/LTR 1220-003/24204-02-02/en



LWE/LTR 1220-003/24204-02-02/en

*Fig.105807: Example of base plate*

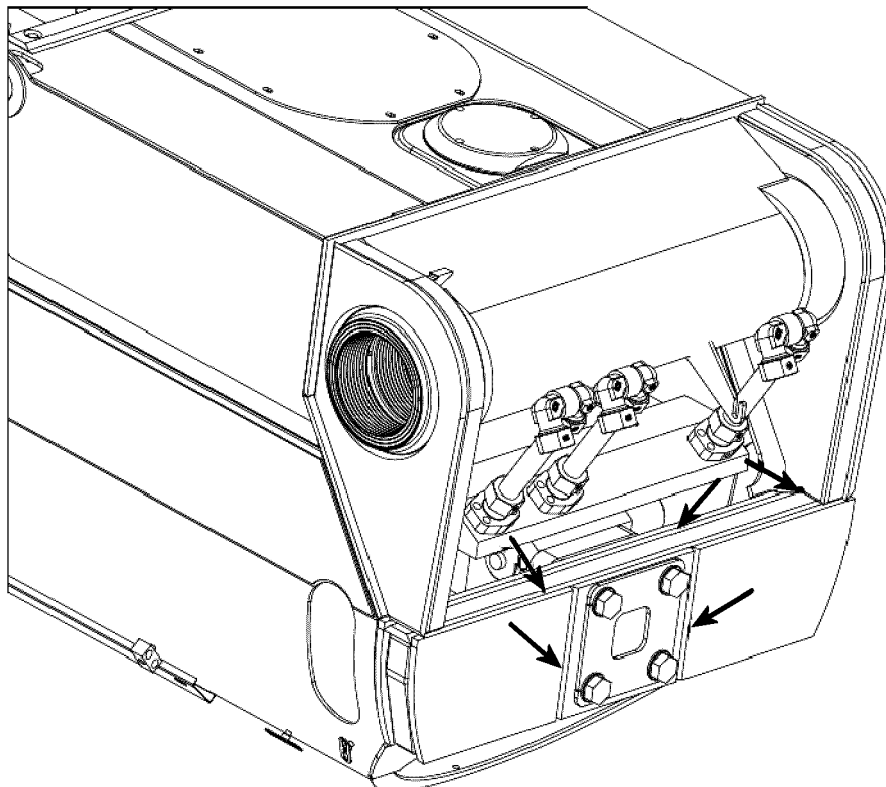
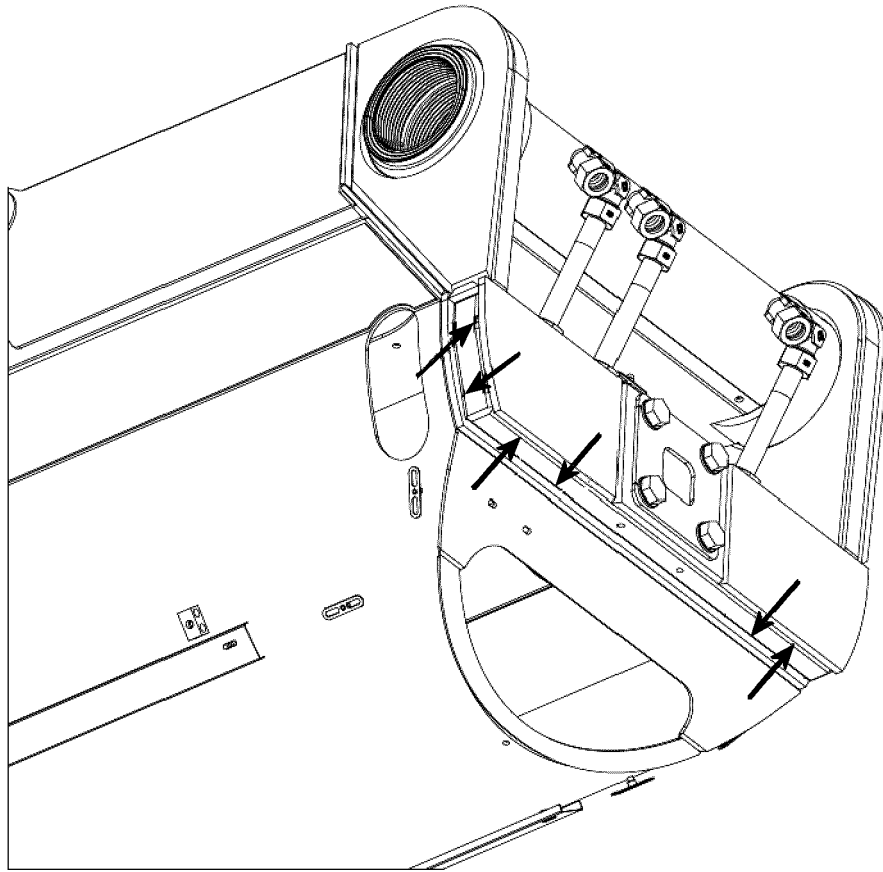
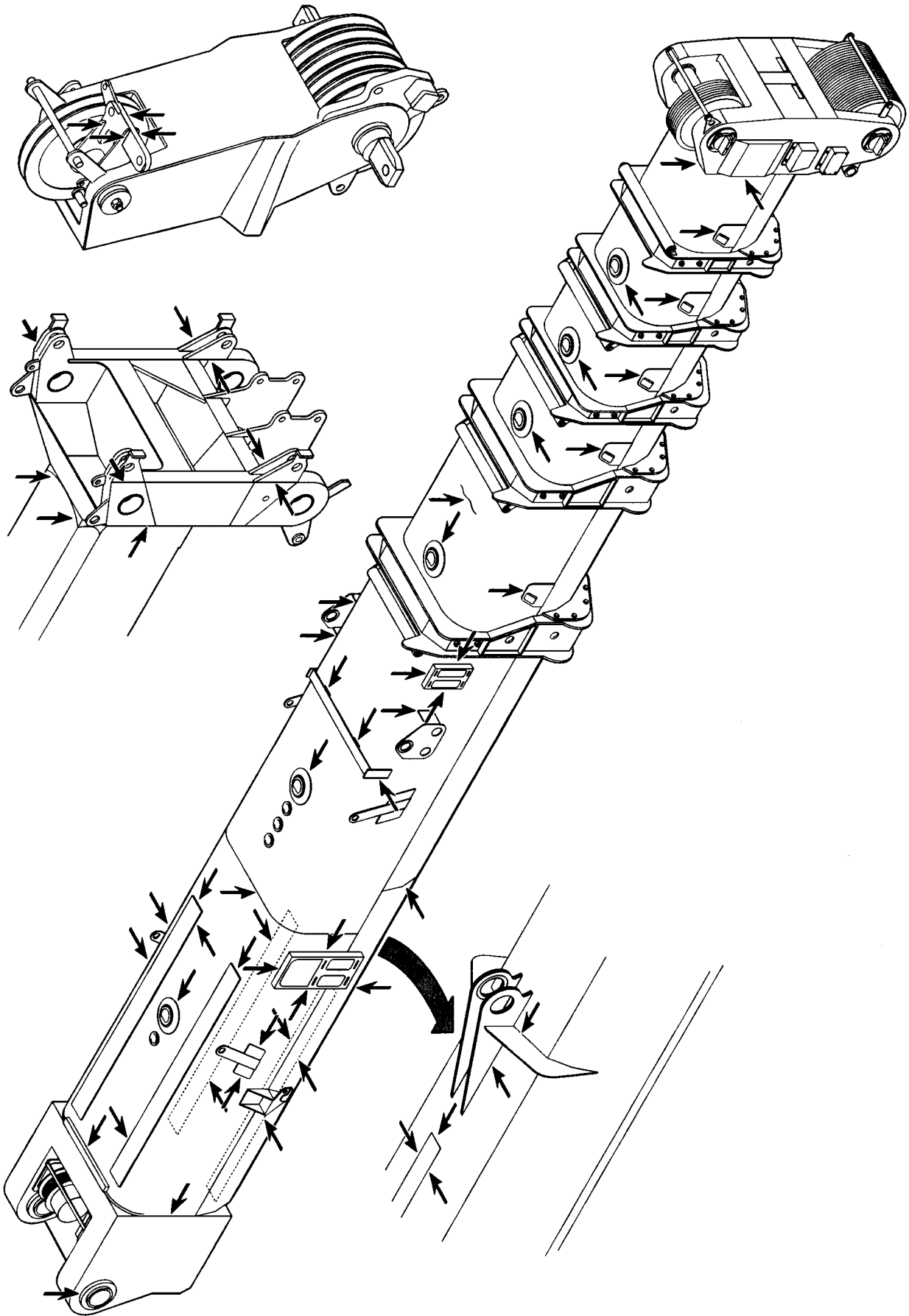


Fig.120273: Example of pivot section

LWE/LTR 1220-003/24204-02-02/en



LWE/LTR 1220-003/24204-02-02/en

Fig.185050: Example of a telescopic boom

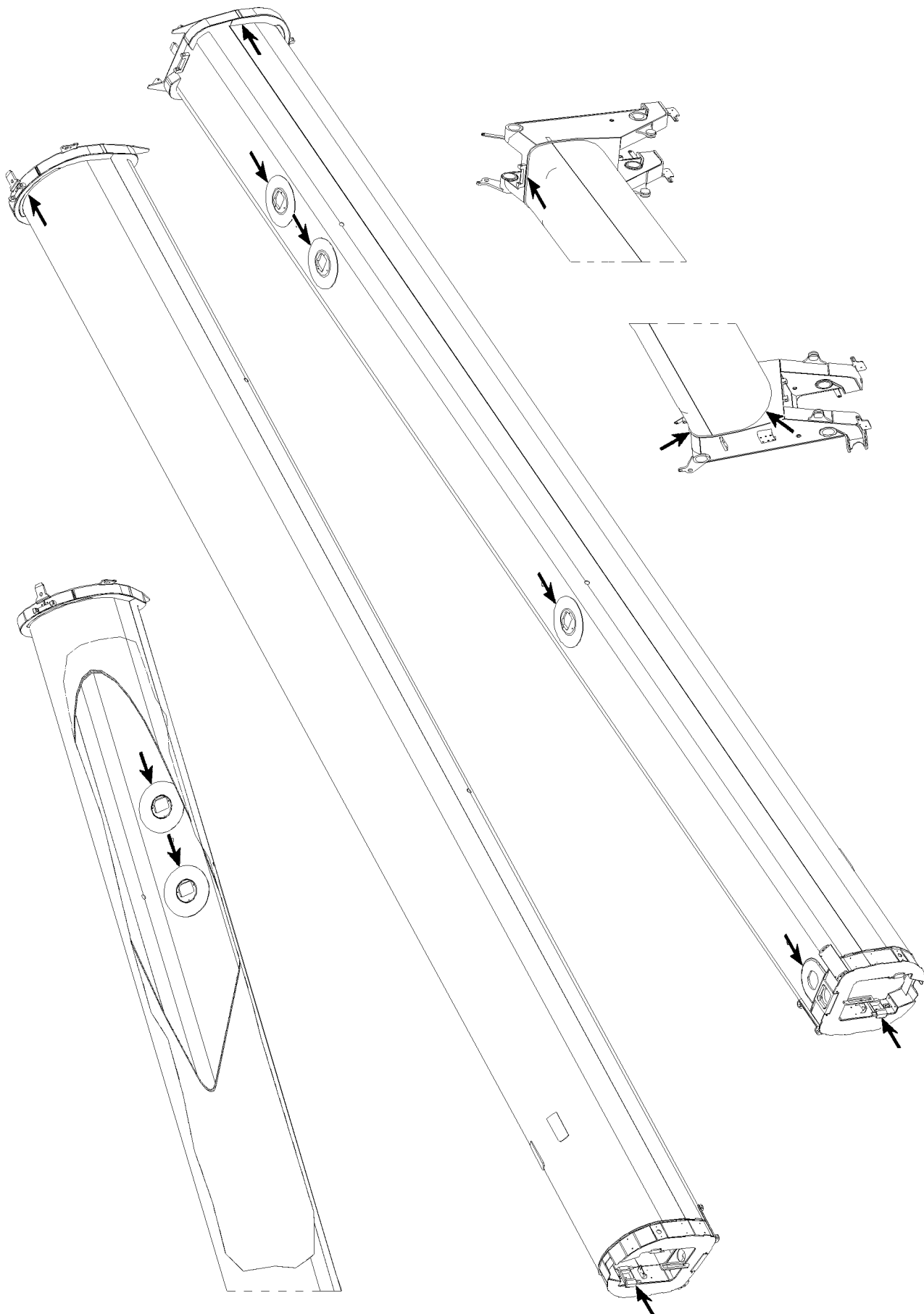
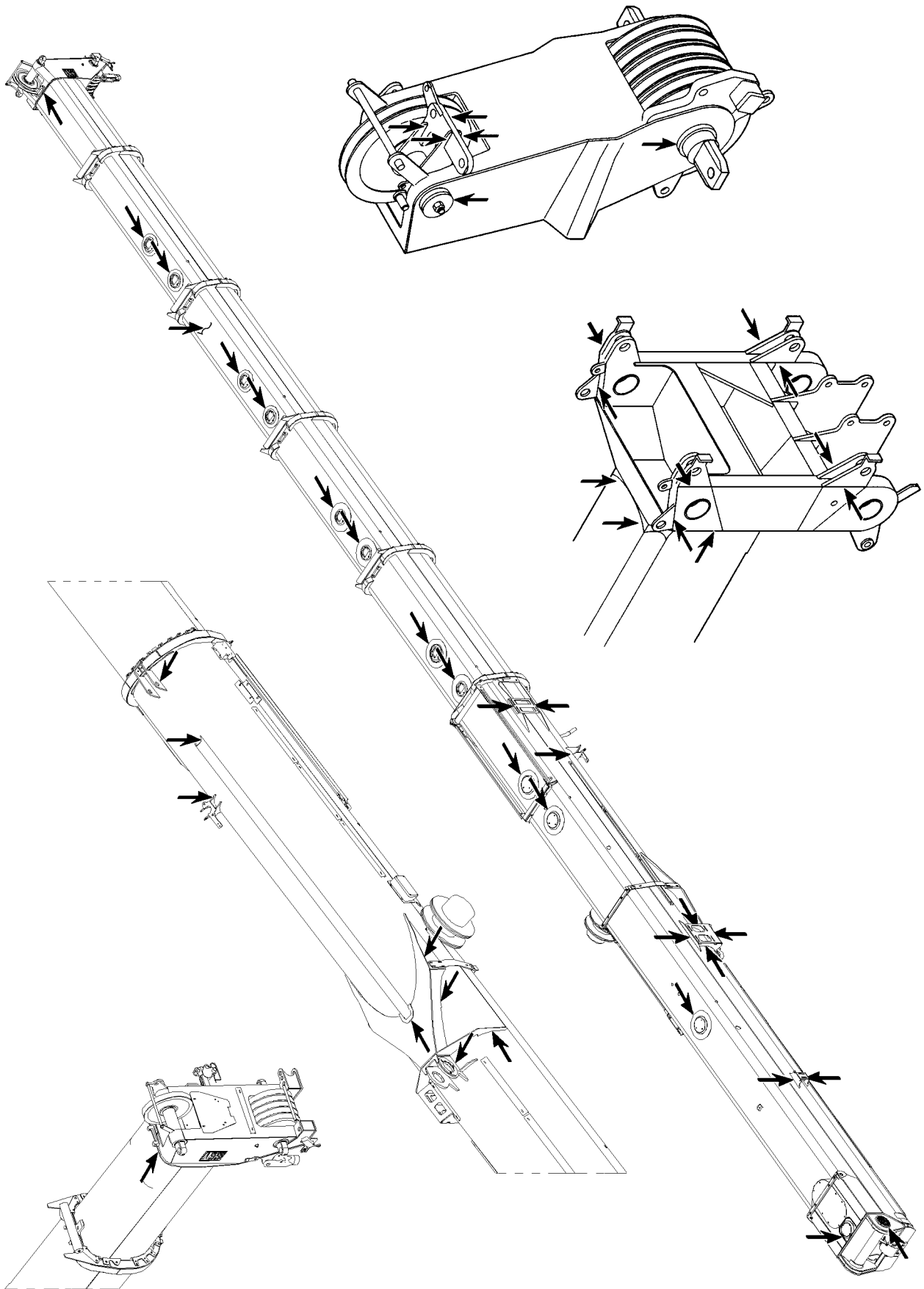


Fig.105710: Example of a telescopic boom

LWE/LTR 1220-003/24204-02-02/en



LWE/LTR 1220-003/24204-02-02/en

Fig.105711: Example of a telescopic boom

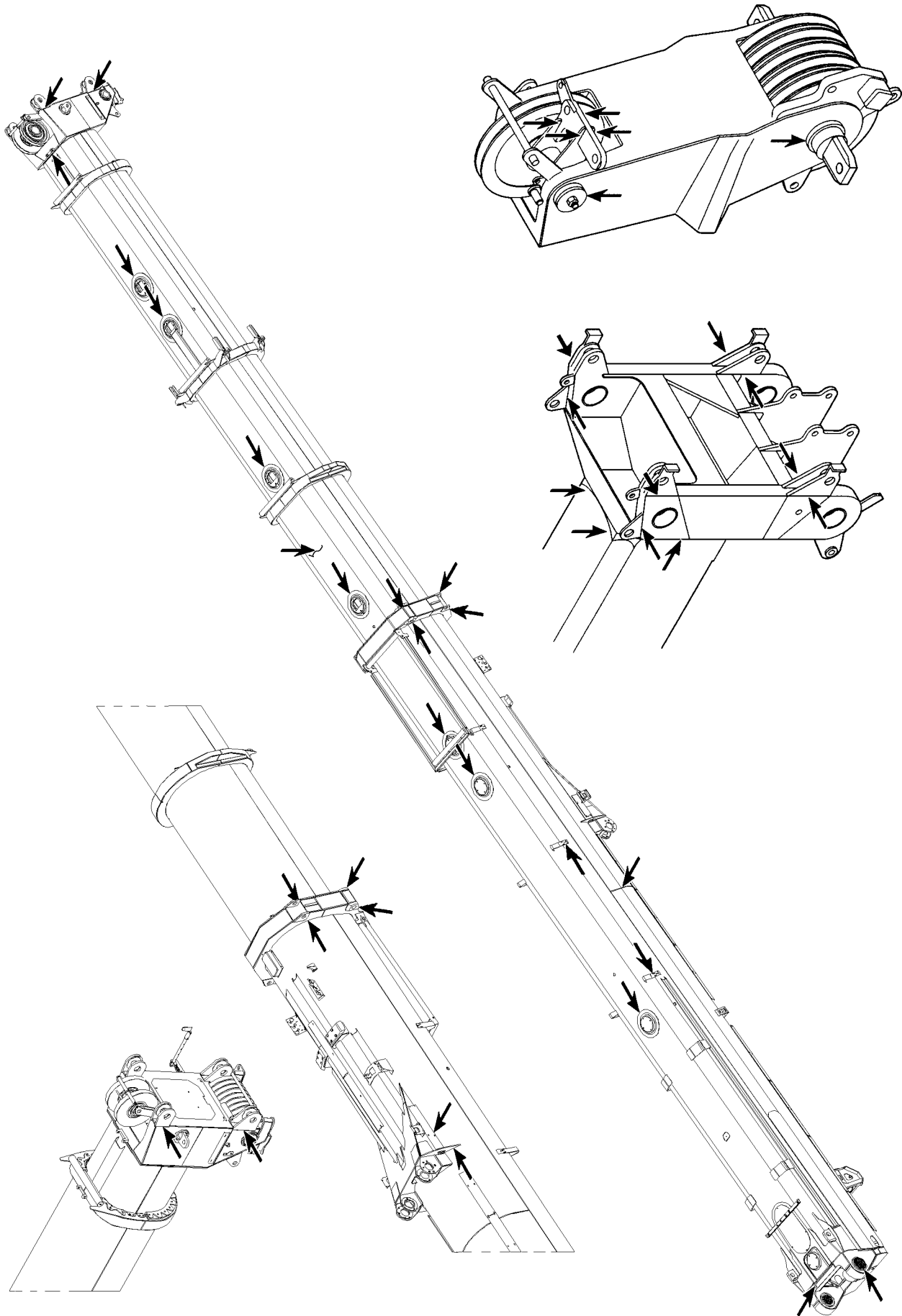
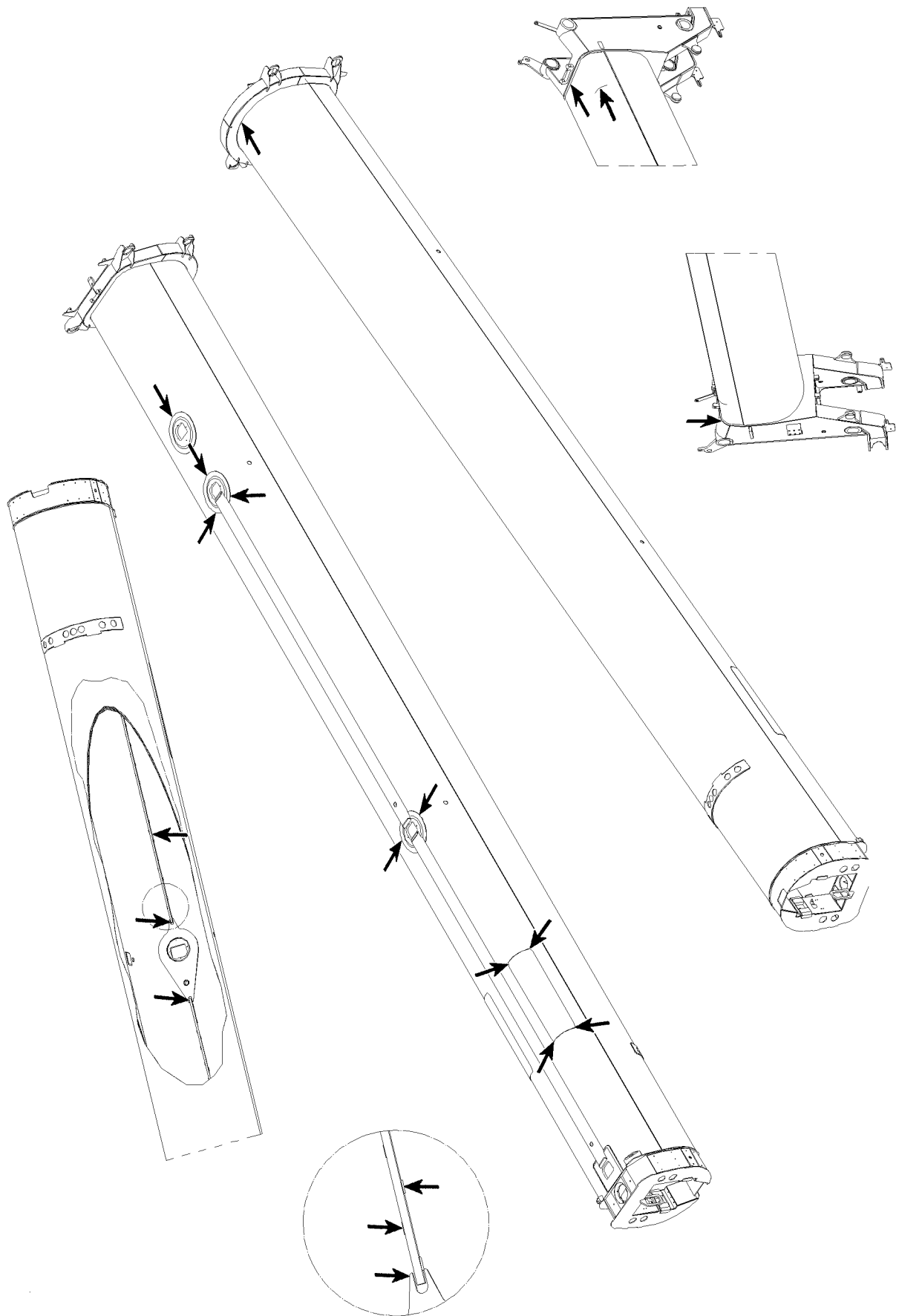


Fig.105720: Example of a telescopic boom

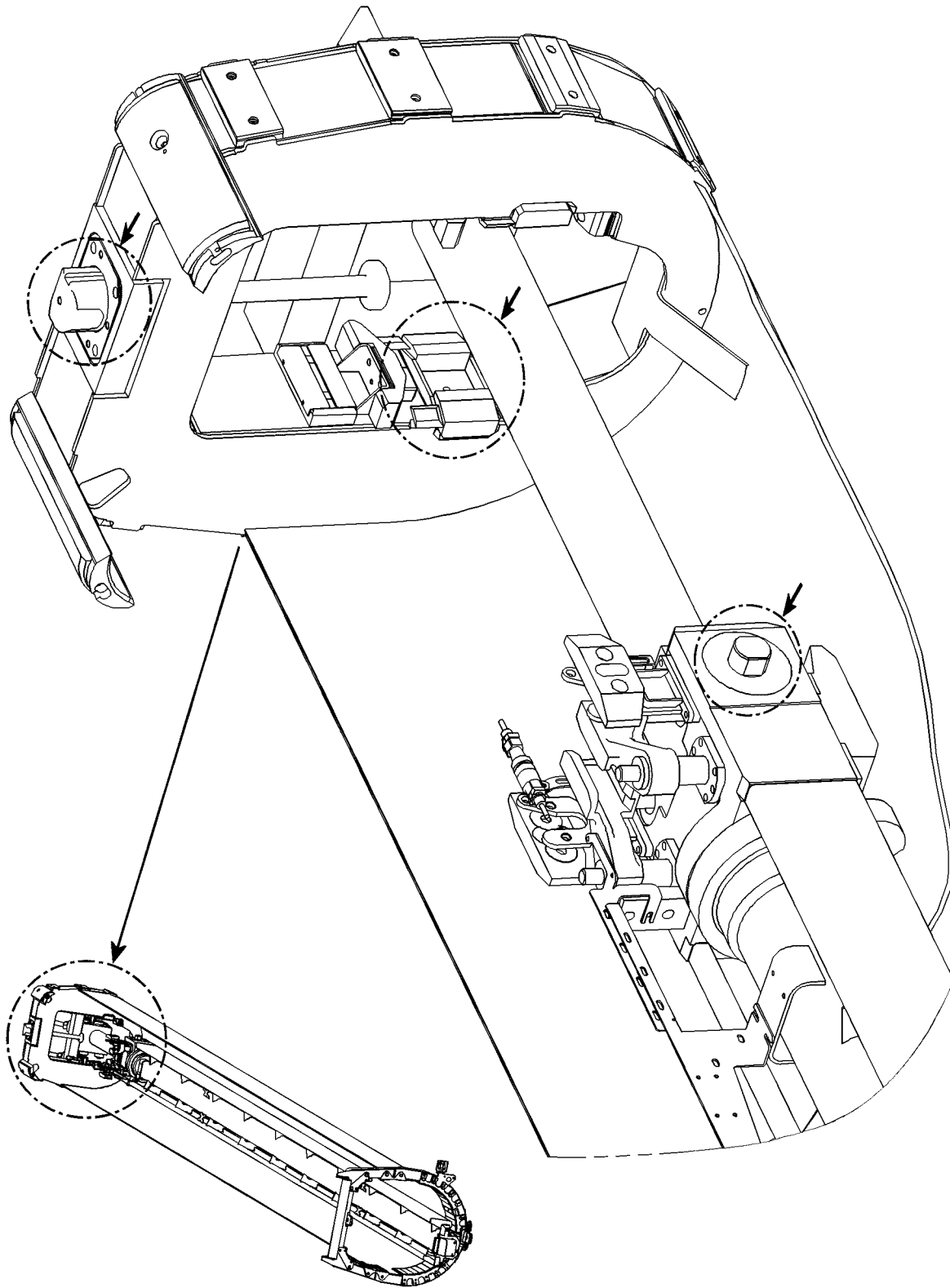
LWE/LTR 1220-003/24204-02-02/en





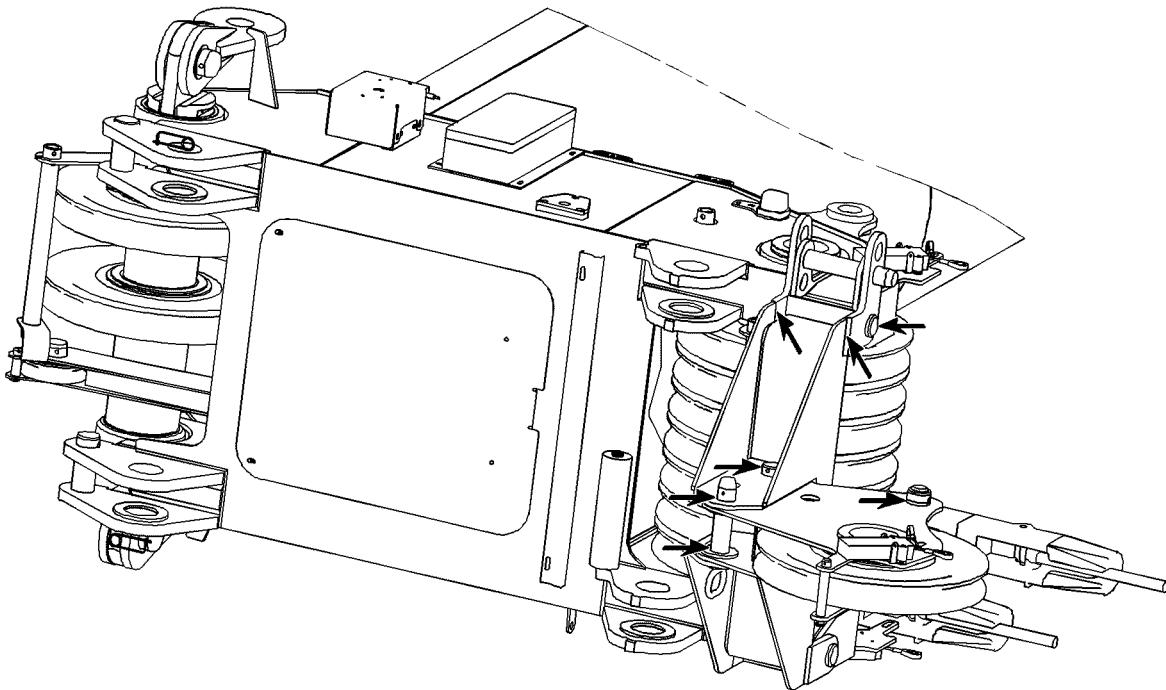
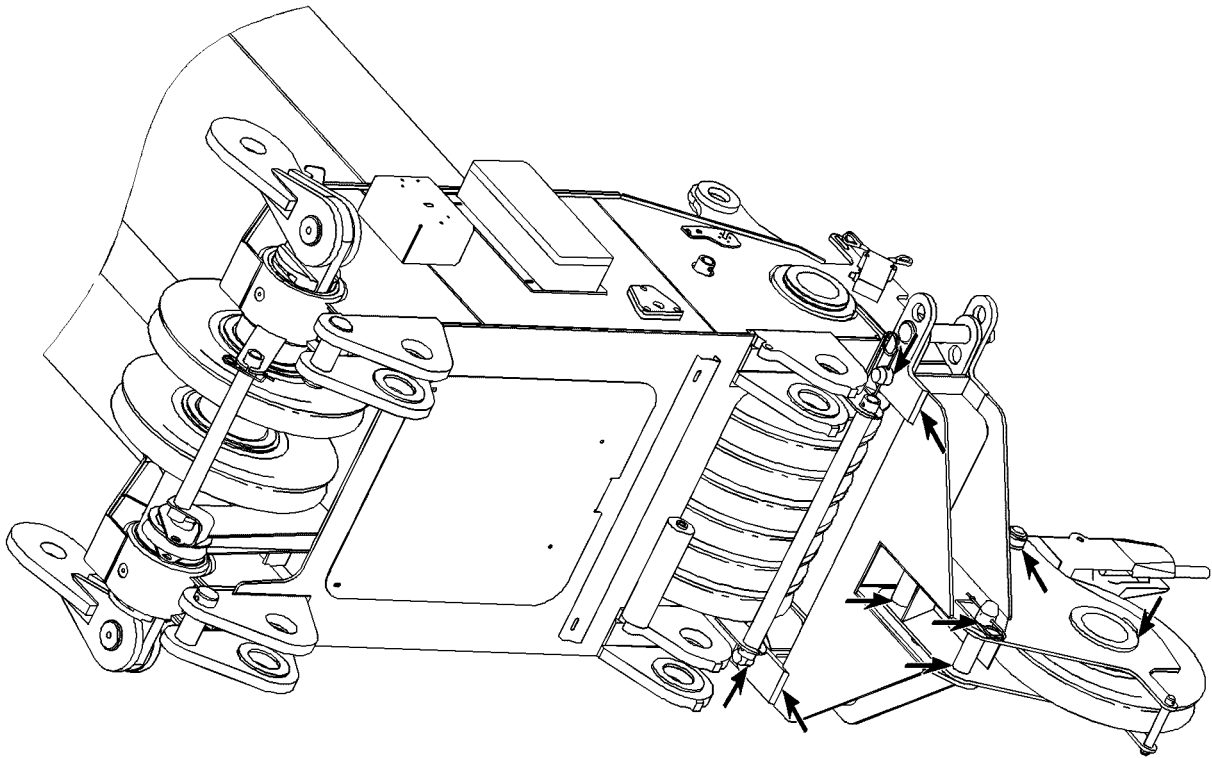
LWE/LTR 1220-003/24204-02-02/en

Fig.105721: Example of a telescopic boom



LWE/LTR 1220-003/24204-02-02/en

Fig.105891: Example of push out mechanics telescopic boom



LWE/LTR 1220-003/24204-02-02/en

Fig.105892: Example of boom nose

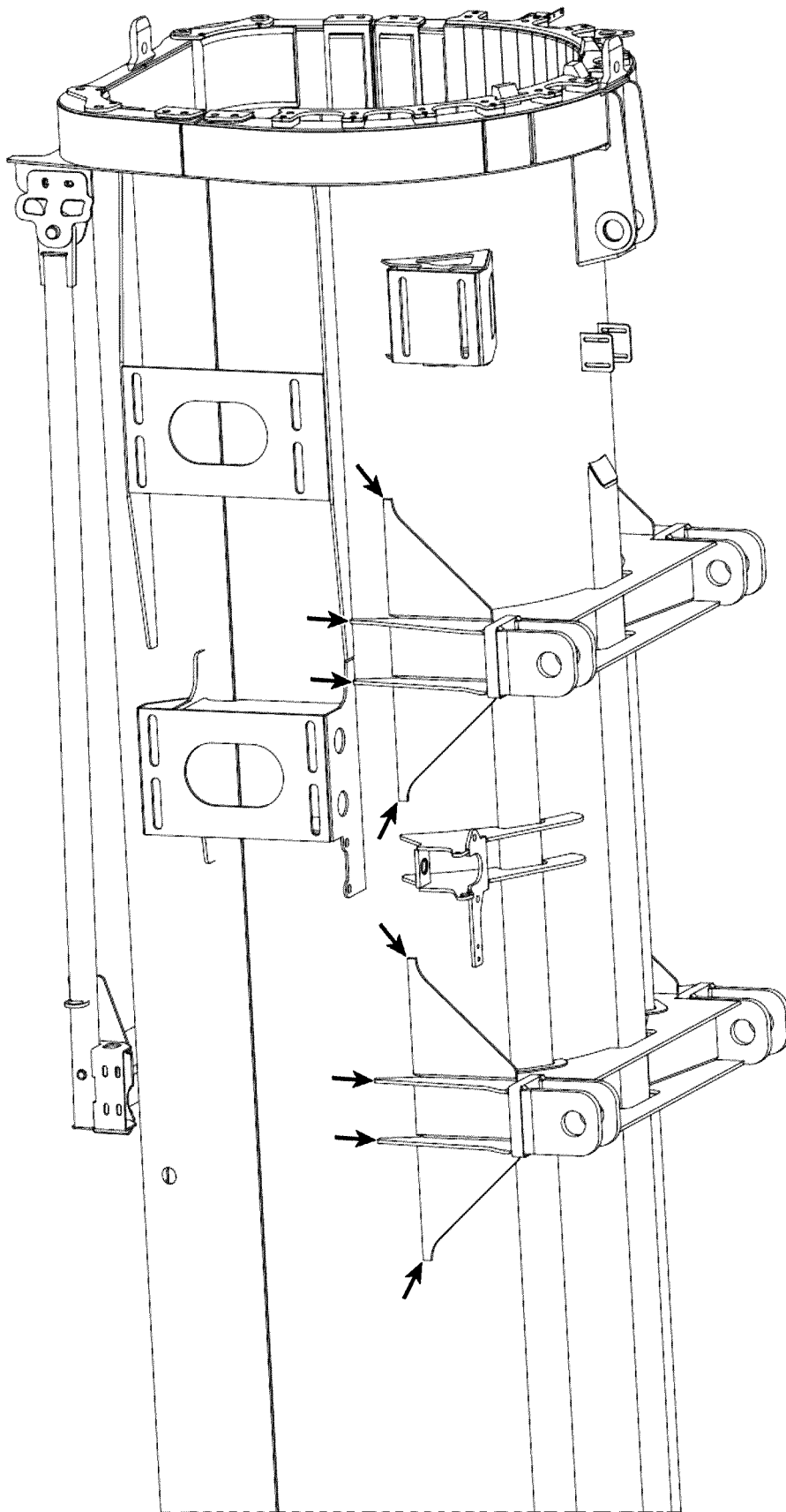
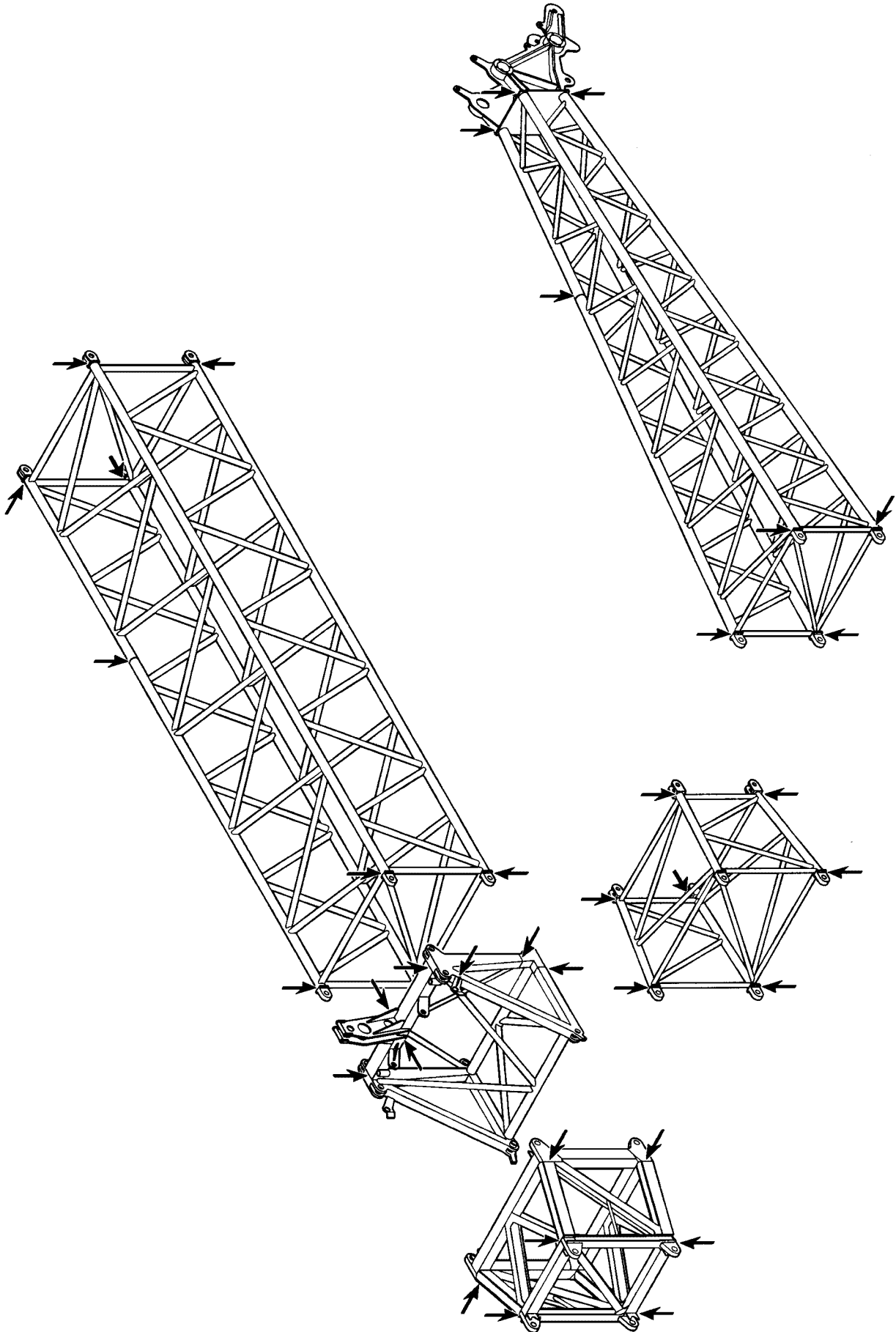


Fig.105689: Example of dolly console

LWE/LTR 1220-003/24204-02-02/en



LWE/LTR 1220-003/24204-02-02/en

Fig.185051: Example of lattice jib

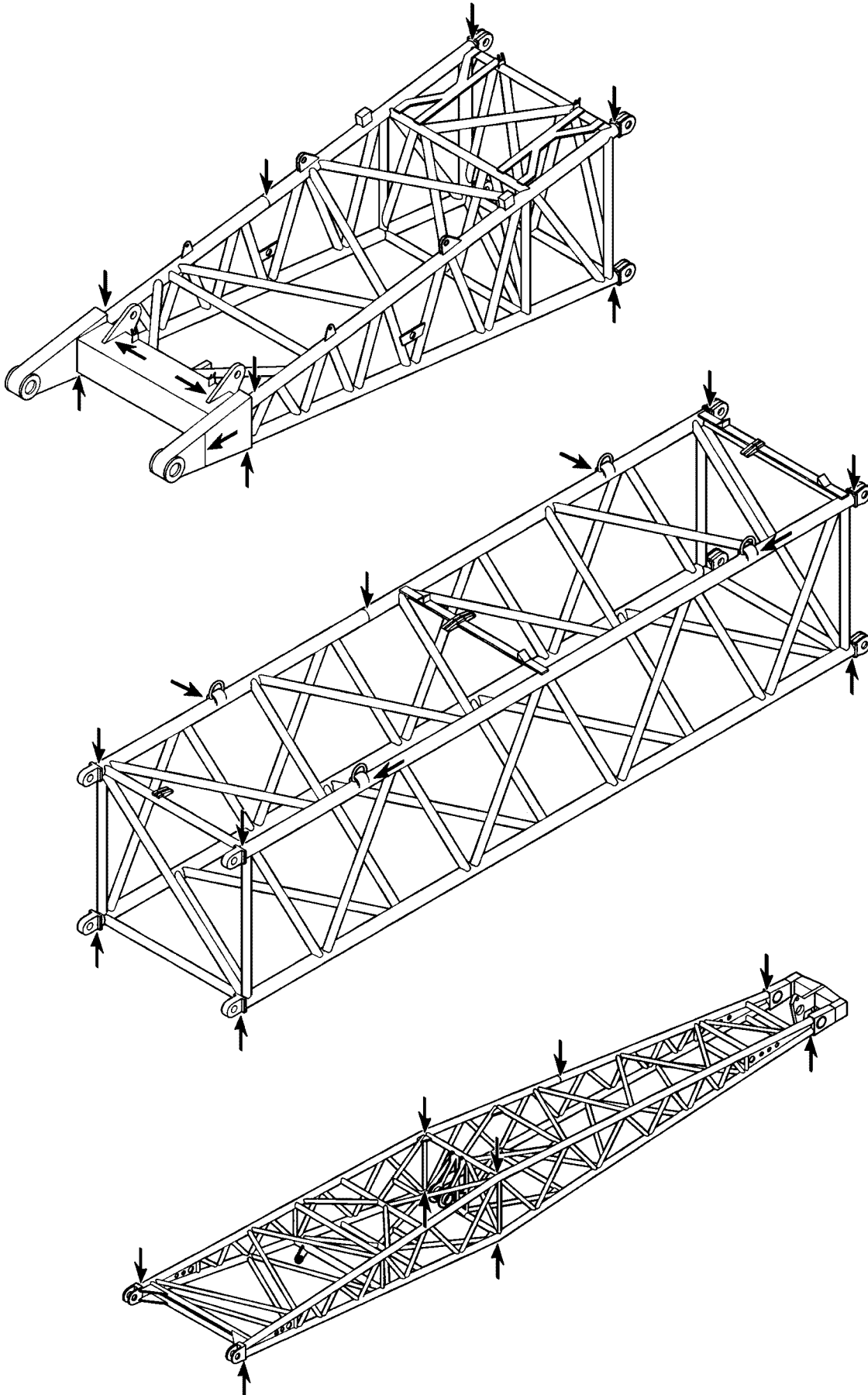
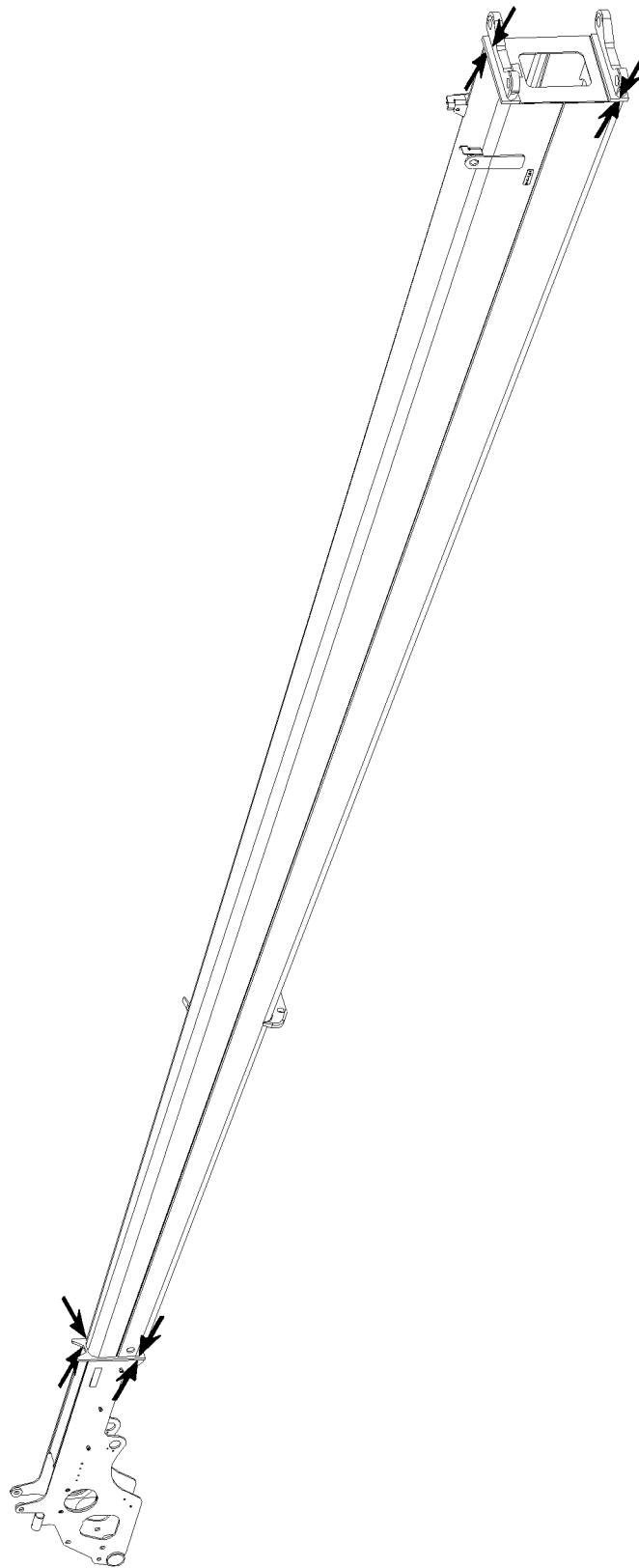


Fig.185052: Example of NA / WA-frame

LWE/LTR 1220-003/24204-02-02/en



LWE/LTR 1220-003/24204-02-02/en

Fig.105713: Example of an end section

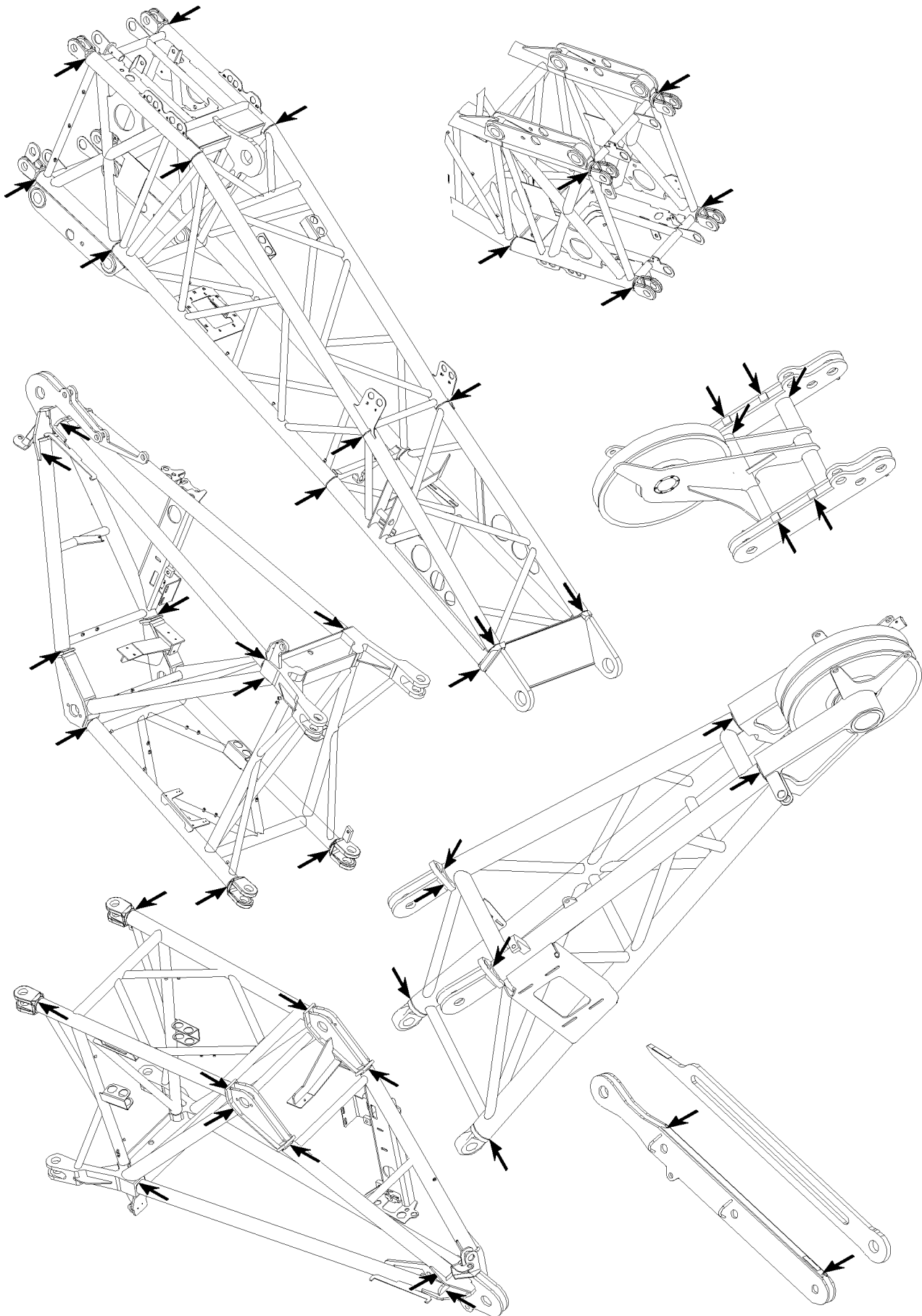
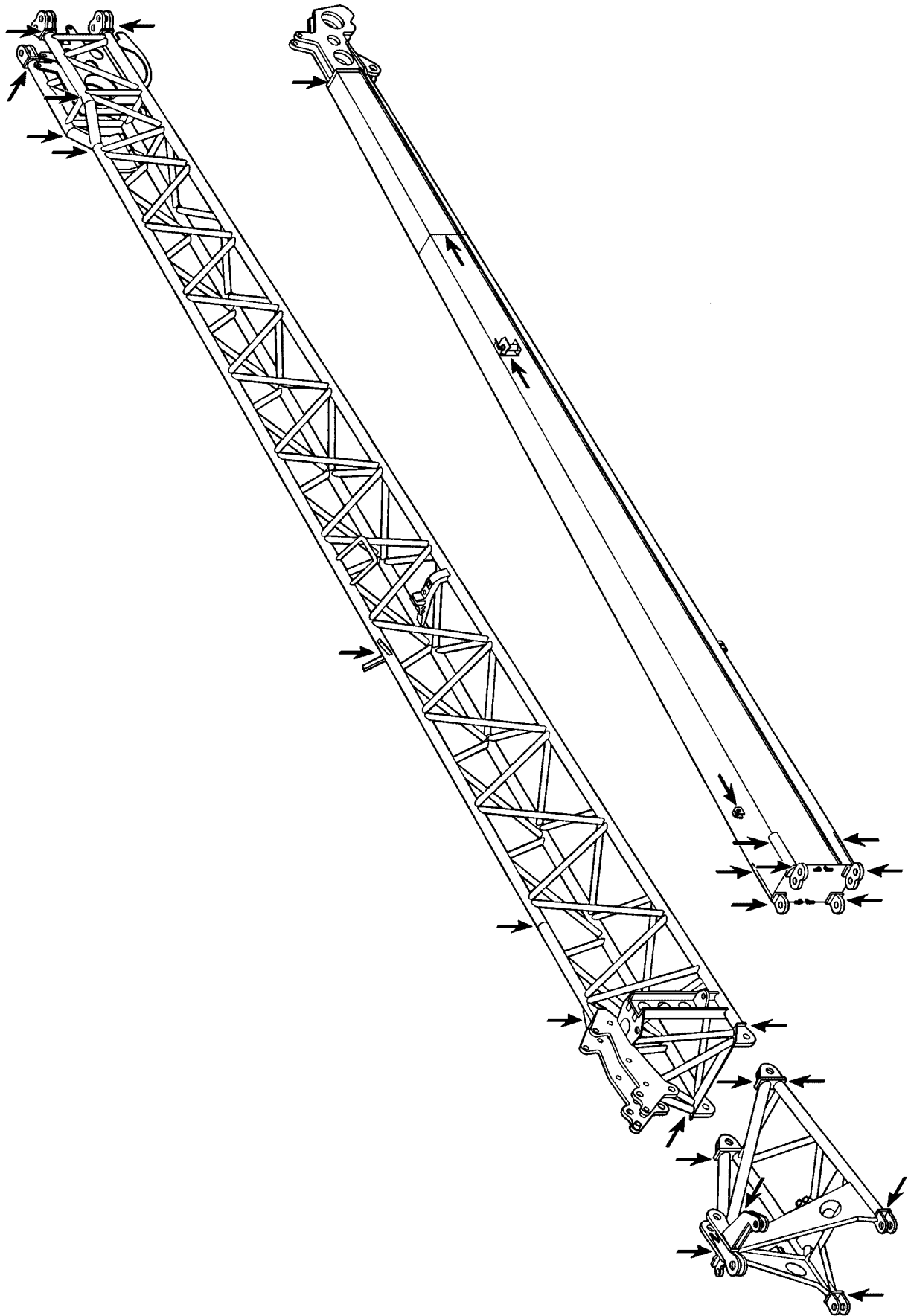


Fig.105836: Example of pivot section, adapter and boom nose

LWE/LTR 1220-003/24204-02-02/en





LWE/LTR 1220-003/24204-02-02/en

Fig.185058: Example of a folding jib

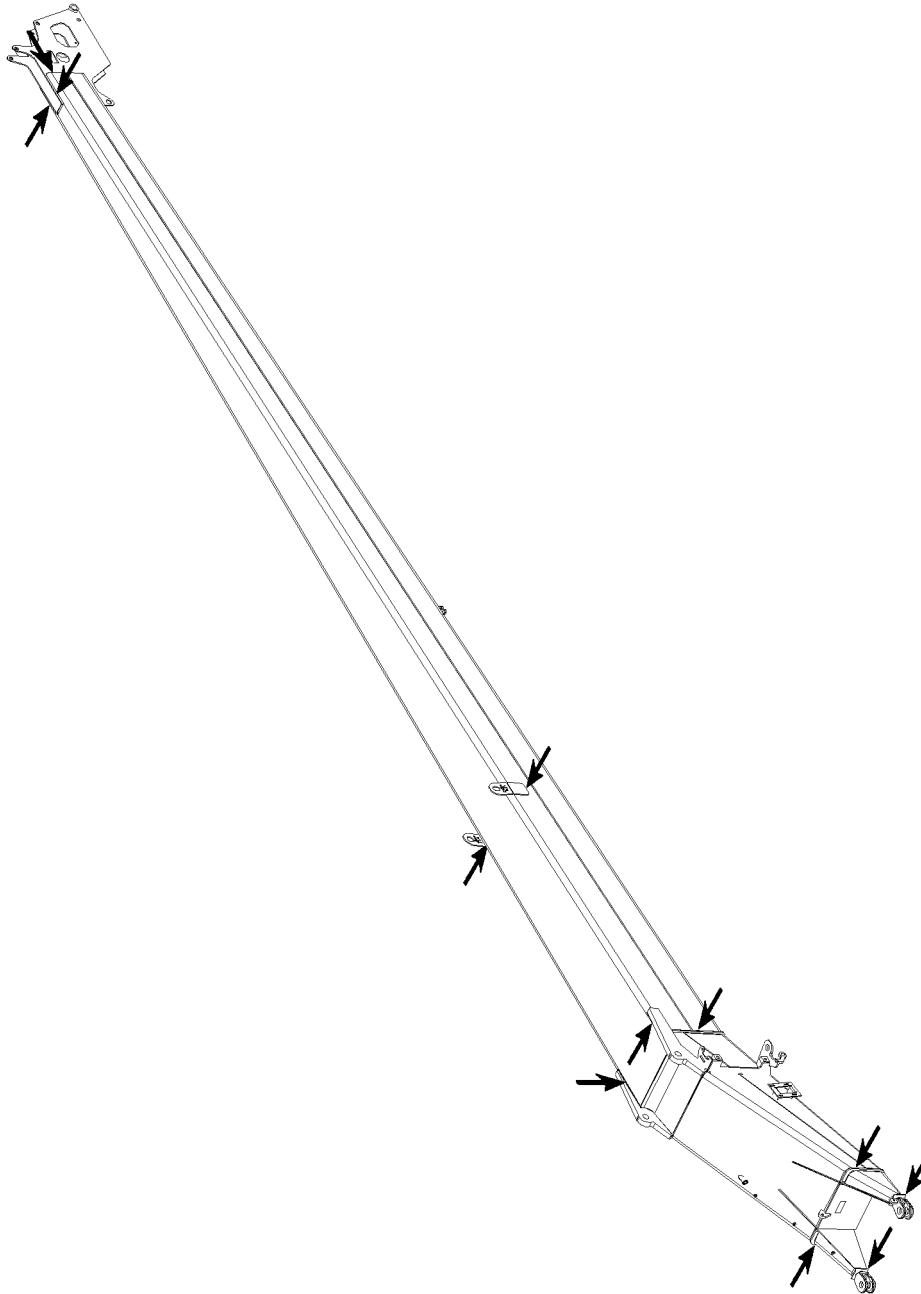
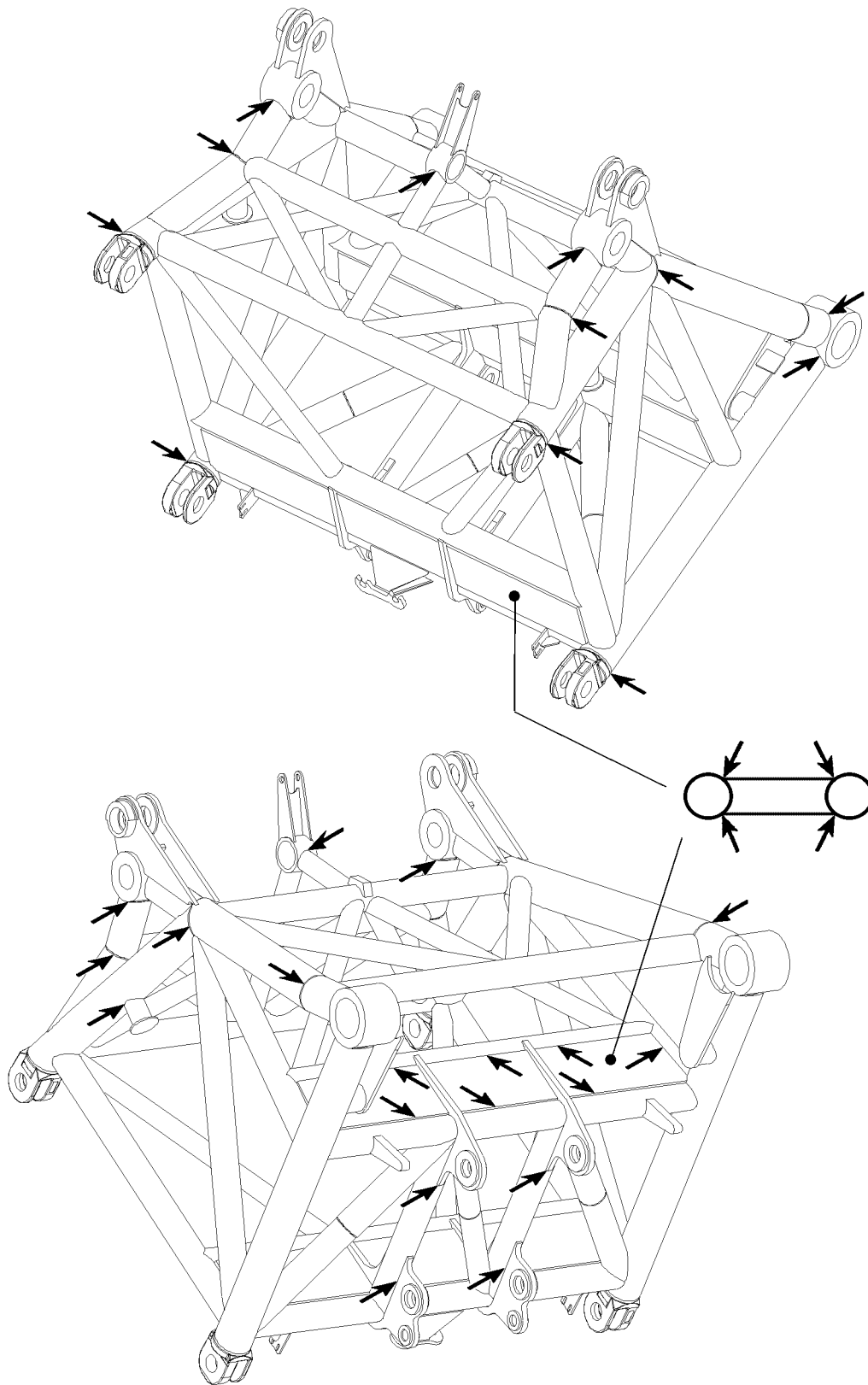


Fig.105697: Example of a folding jib

LWE/LTR 1220-003/24204-02-02/en



LWE/LTR 1220-003/24204-02-02/en

Fig.105732: Example of W-connector head

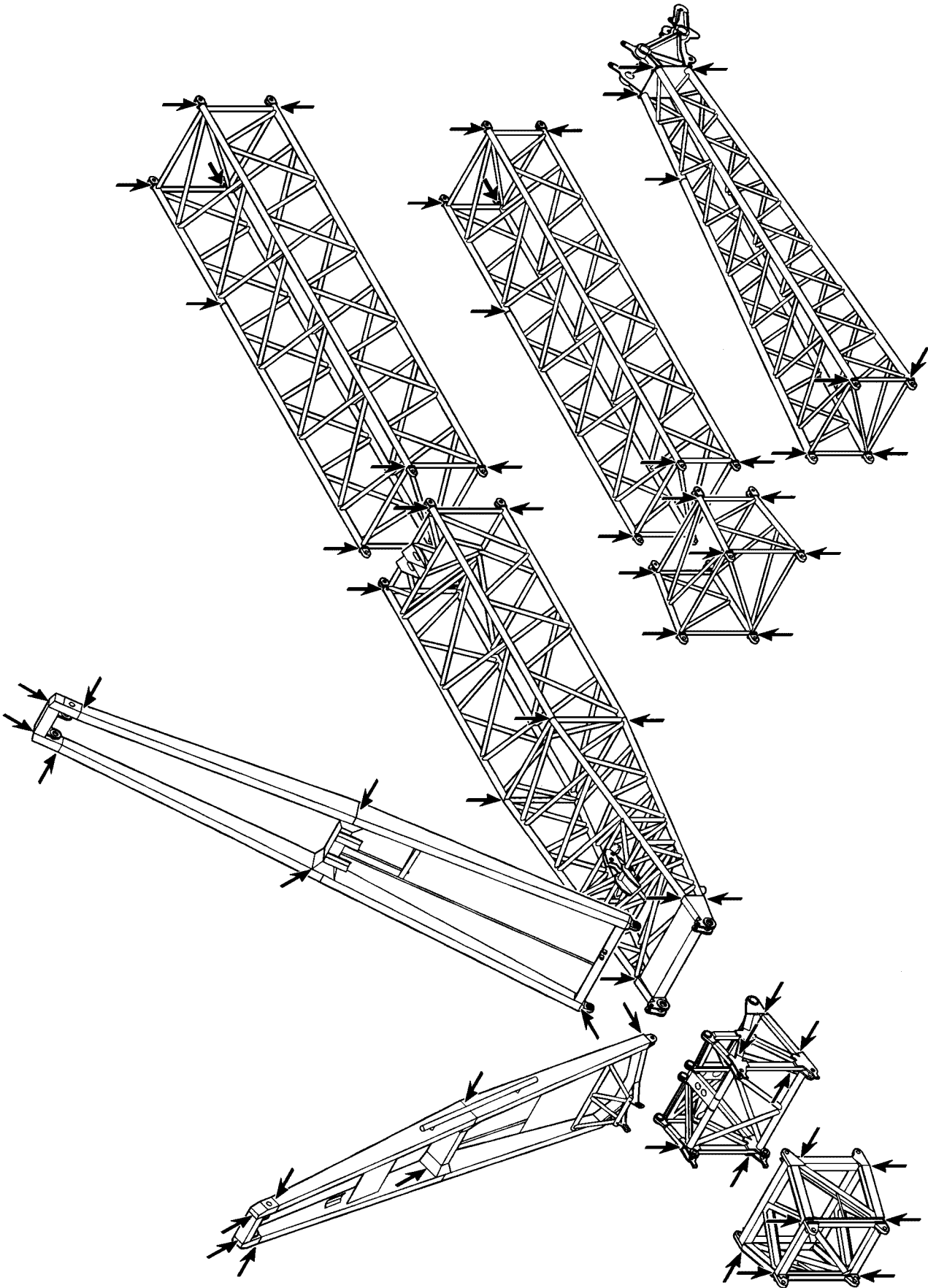
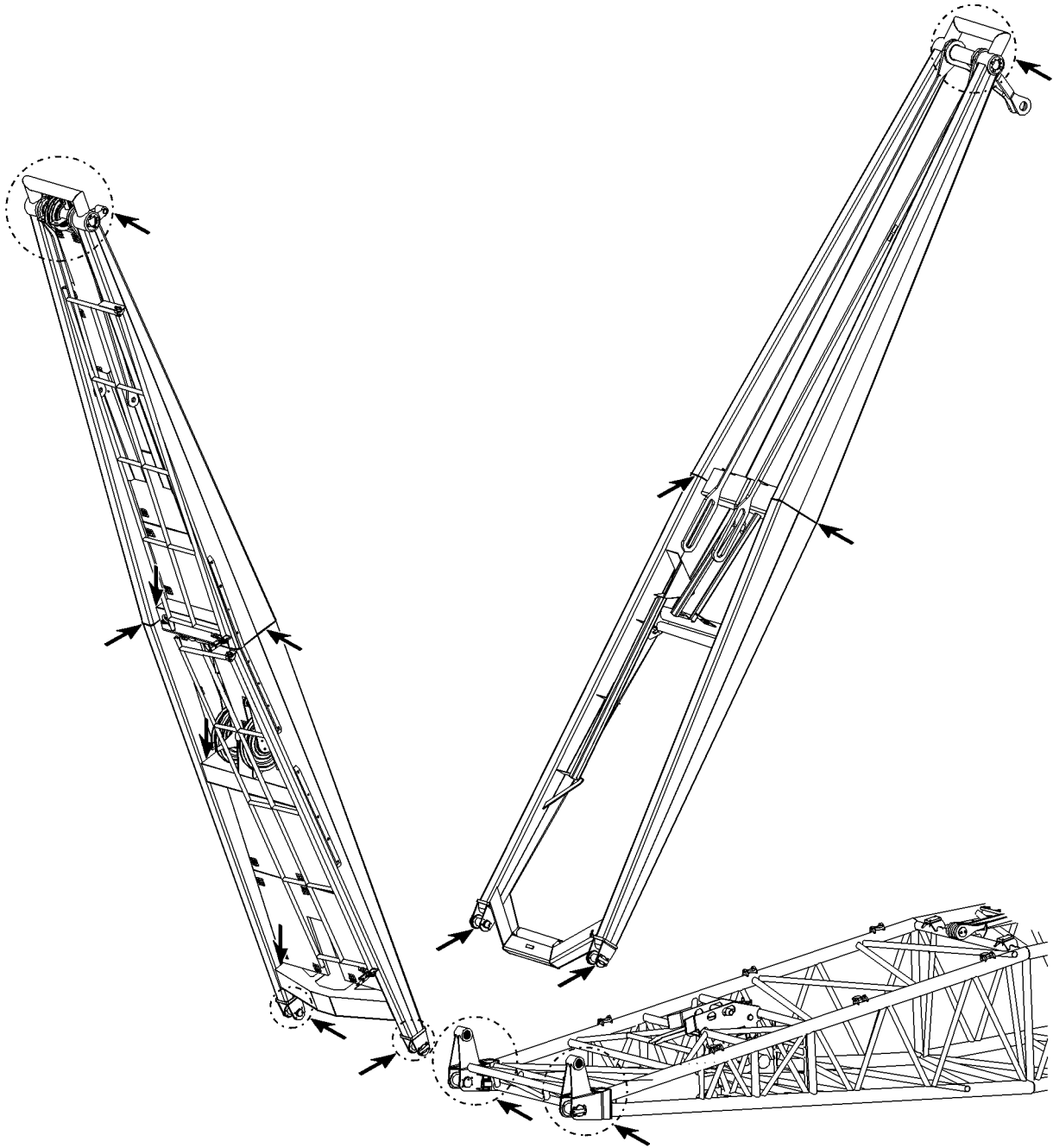


Fig.185053: Example of assembly unit with lattice jib

LWE/LTR 1220-003/24204-02-02/en



LWE/LTR 1220-003/24204-02-02/en

Fig.105838: Example of NA frames

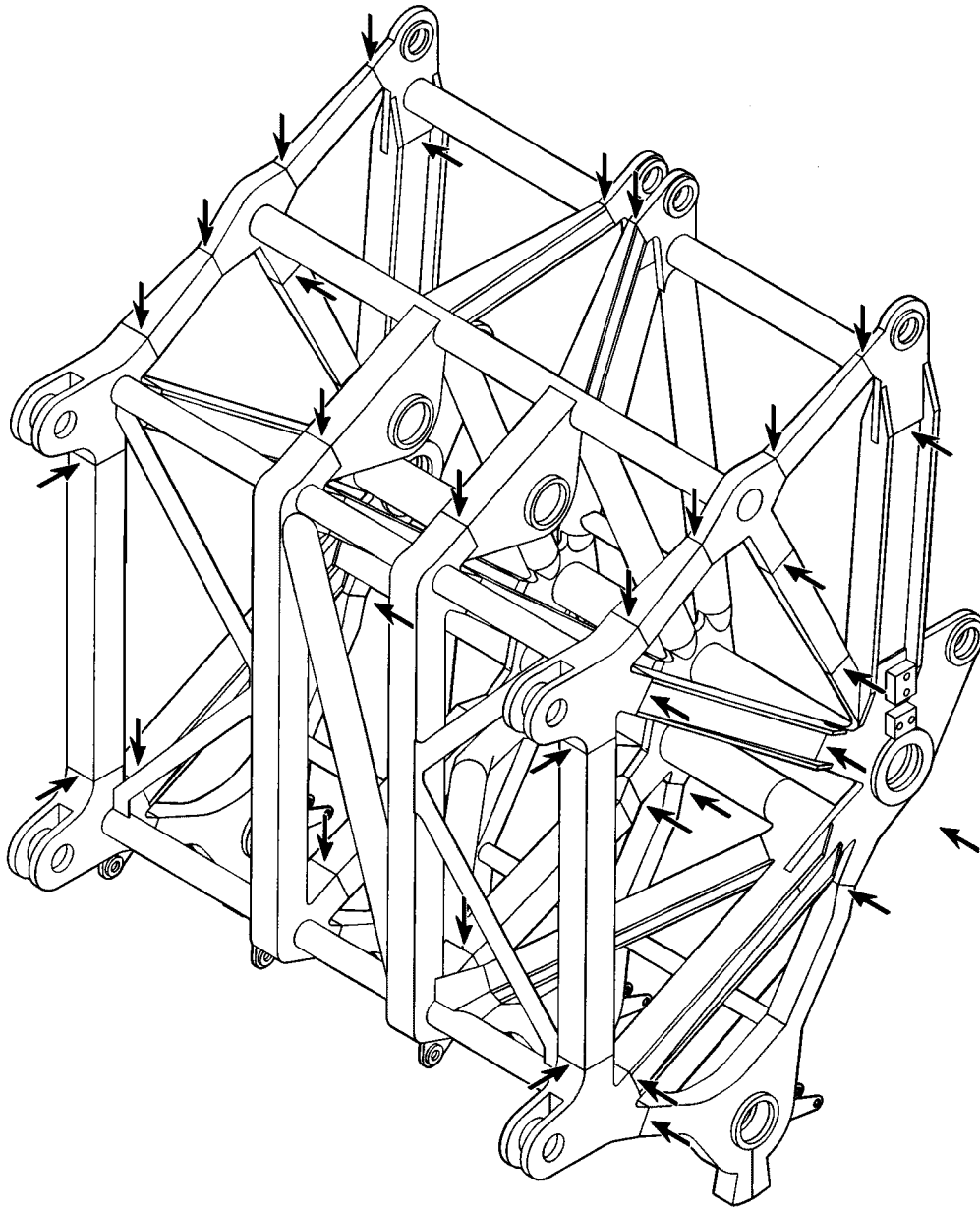
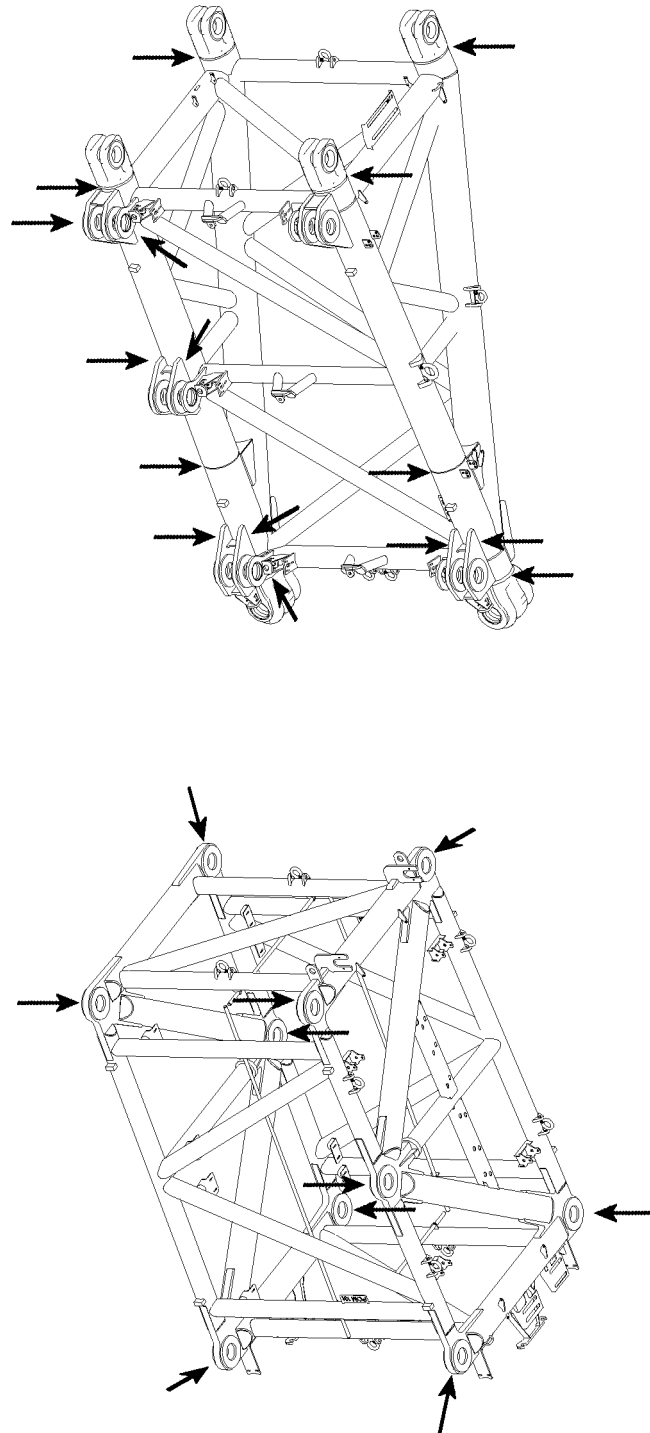


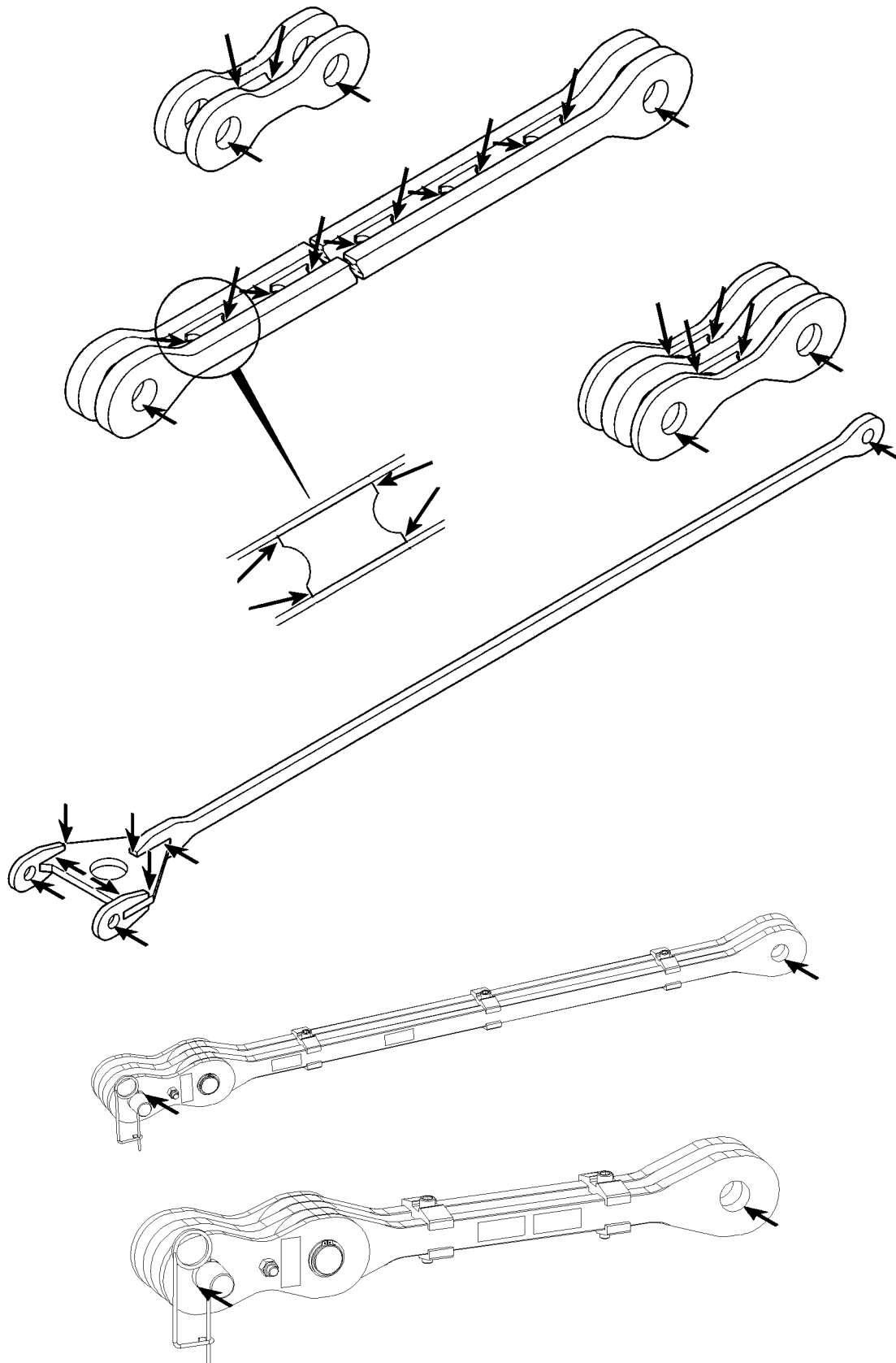
Fig.185054: Example of pulley head

LWE/LTR 1220-003/24204-02-02/en



LWE/LTR 1220-003/24204-02-02/en

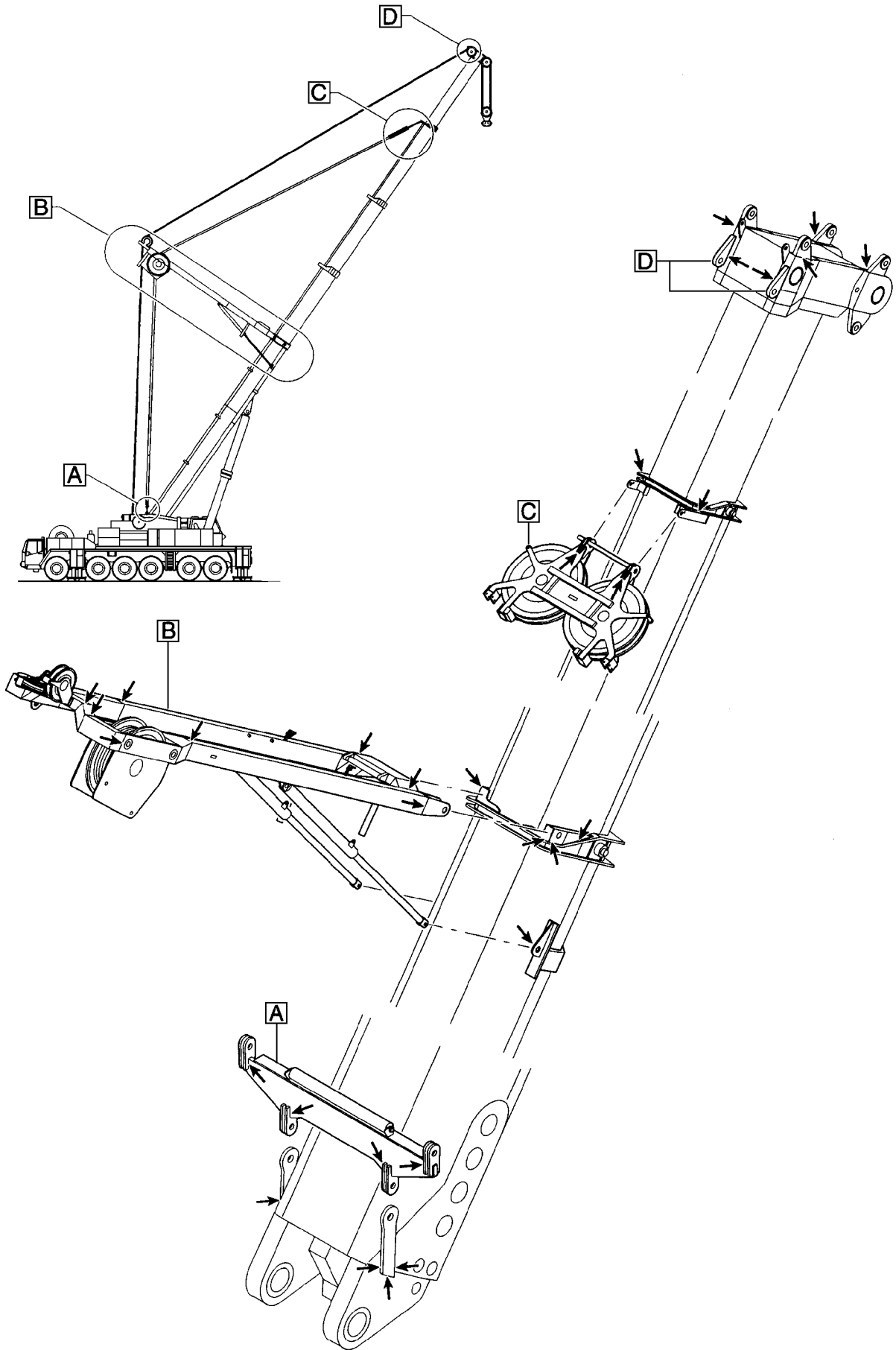
Fig.116609: Example of P-adapter



LWE/LTR 1220-003/24204-02-02/en

Fig.154111: Example of guy rods





LWE/LTR 1220-003/24204-02-02/en

Fig.185059: Example of TA-guying

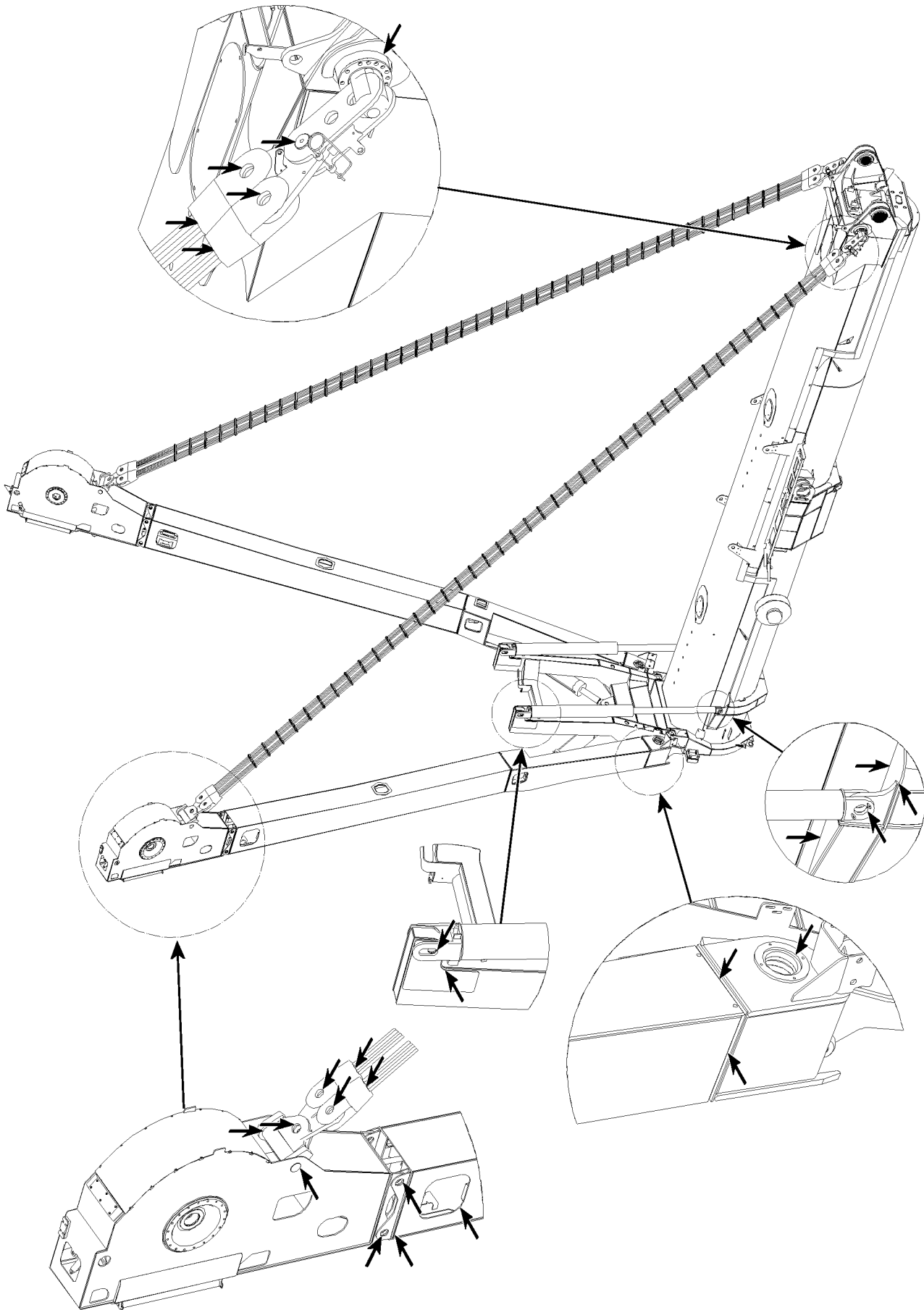
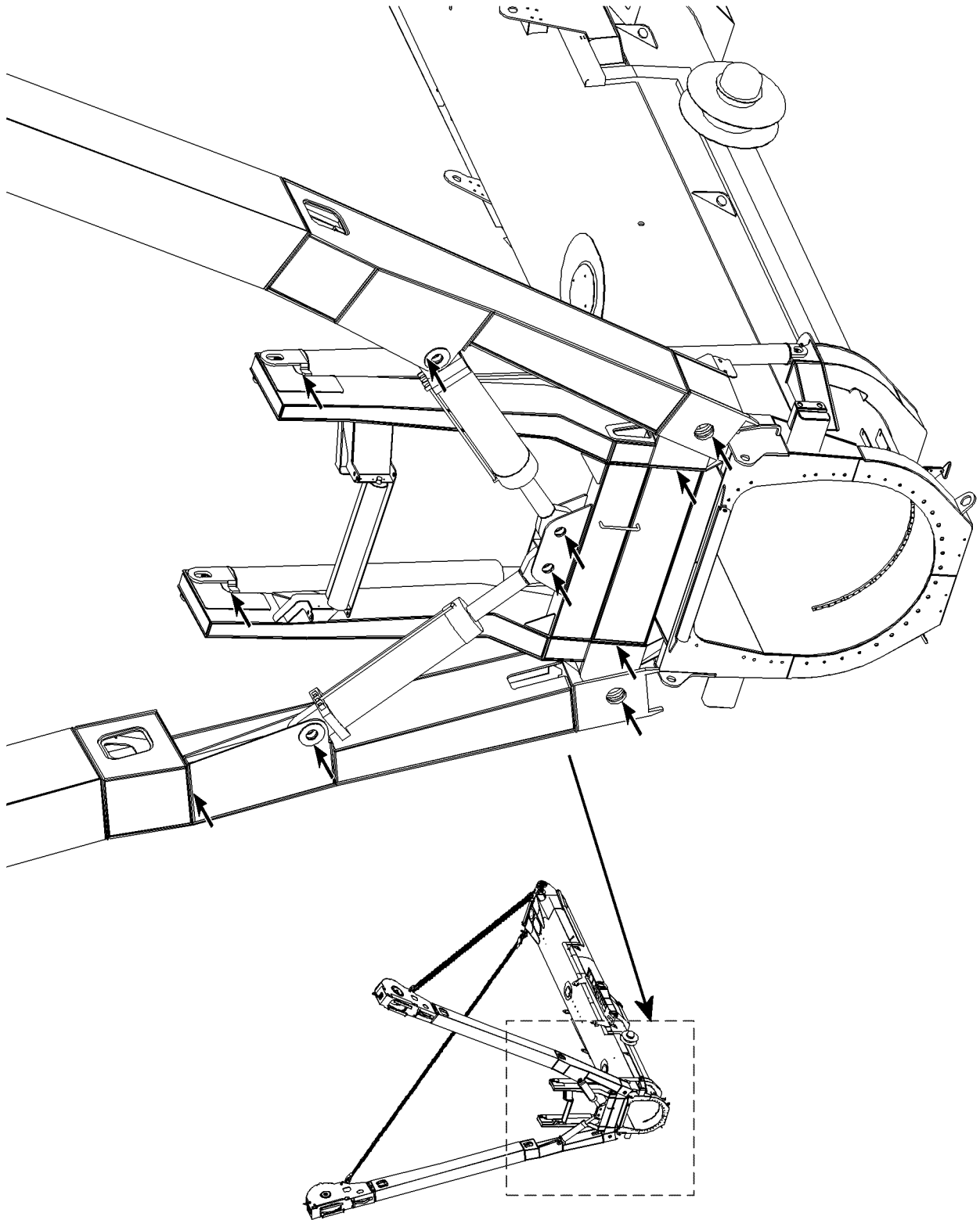


Fig.105707: Example of TY-guying

LWE/LTR 1220-003/24204-02-02/en



LWE/LTR 1220-003/24204-02-02/en

Fig.105708: Example of TY-guying

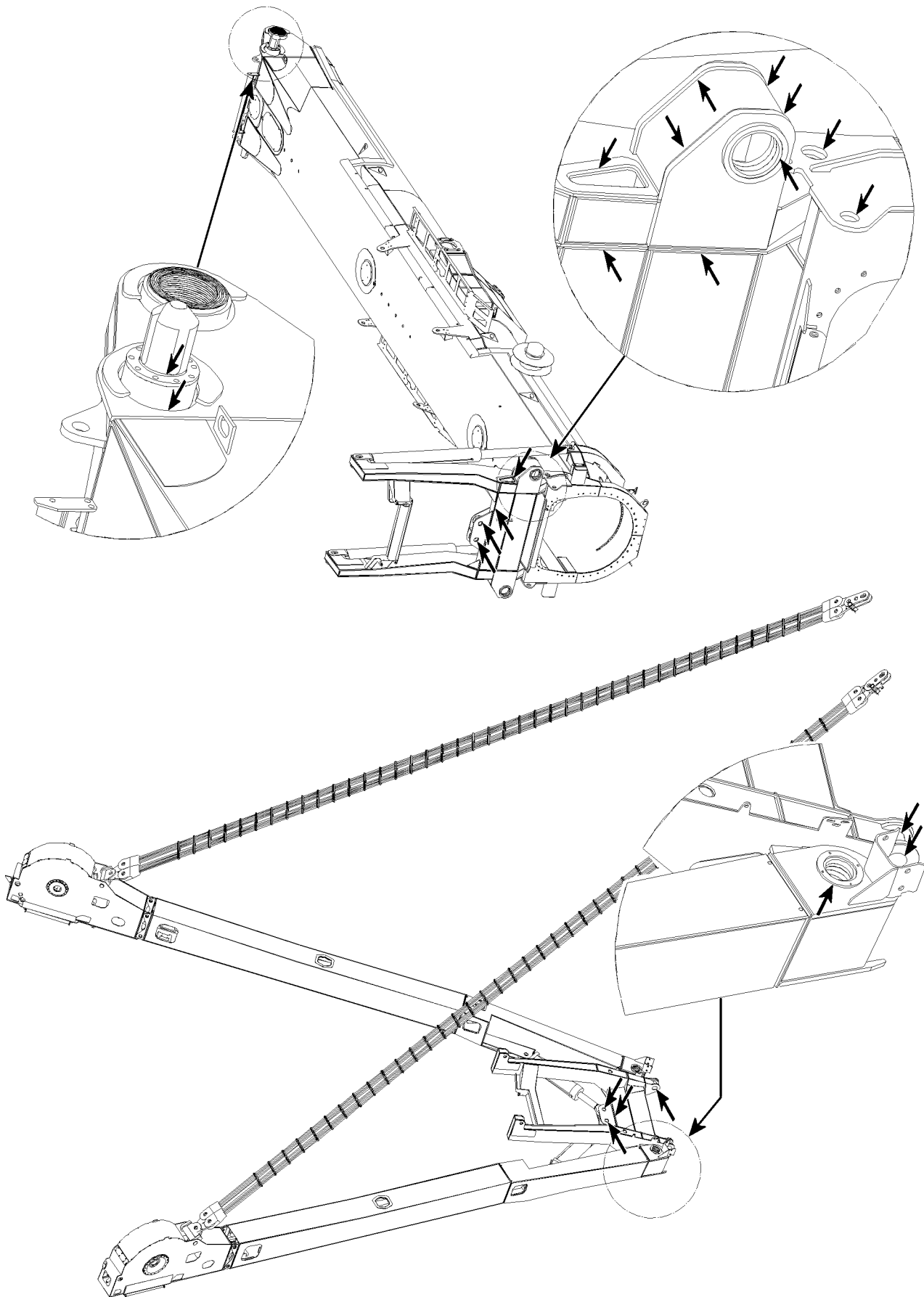


Fig.105709: Example of TY-guying

LWE/LTR 1220-003/24204-02-02/en

## 2.4 Rigging points and fastening points

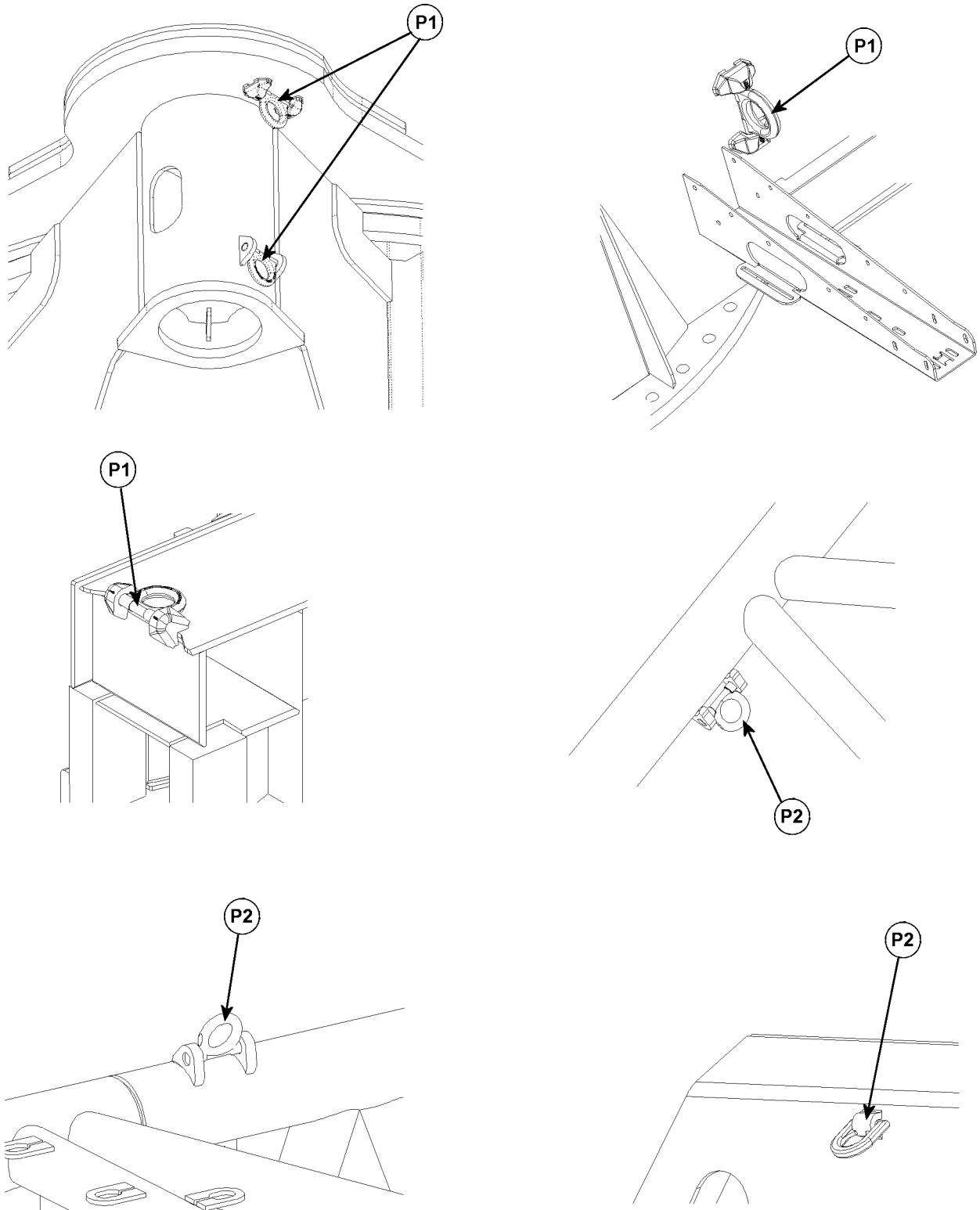


Fig.121160: Examples of rigging points and fastening points

**P1** Rigging points

**P2** Fastening points

LWE/LTR 1220-003/24204-02-02/en

**WARNING**

Unsafe rigging point or fastening point!

The mobile crane or component can rip free and fall down.

When a rigging point or fastening point is not safe for operation:

- ▶ Have the rigging point or fastening point replaced by authorized and trained expert personnel.
- ▶ Avoid damage on the rigging device due to a sharp-edged load.

Make sure that the following damage does **not** occur:

- Crushing points
- Shearing points
- Catch points
- Impact points

Inspection criteria:

- Completeness of the rigging point.
- Distortion of carrying parts.
- Mechanical damage such as severe nicks.
- Changes in diameter due to wear.
- Significant corrosion (pitting).
- Cracks on carrying parts.
- Cracks or other damage on the welding seam.

Check the rigging points **P1** and fastening points **P2** before every start up and at regular intervals.

## 2.5 Inspecting the lattice sections

**Note**

- ▶ The illustration is only an example and is valid for all lattice sections!
- ▶ Check all diagonal and frame pipe connections!
- ▶ Check all bores of the fork - finger connections!

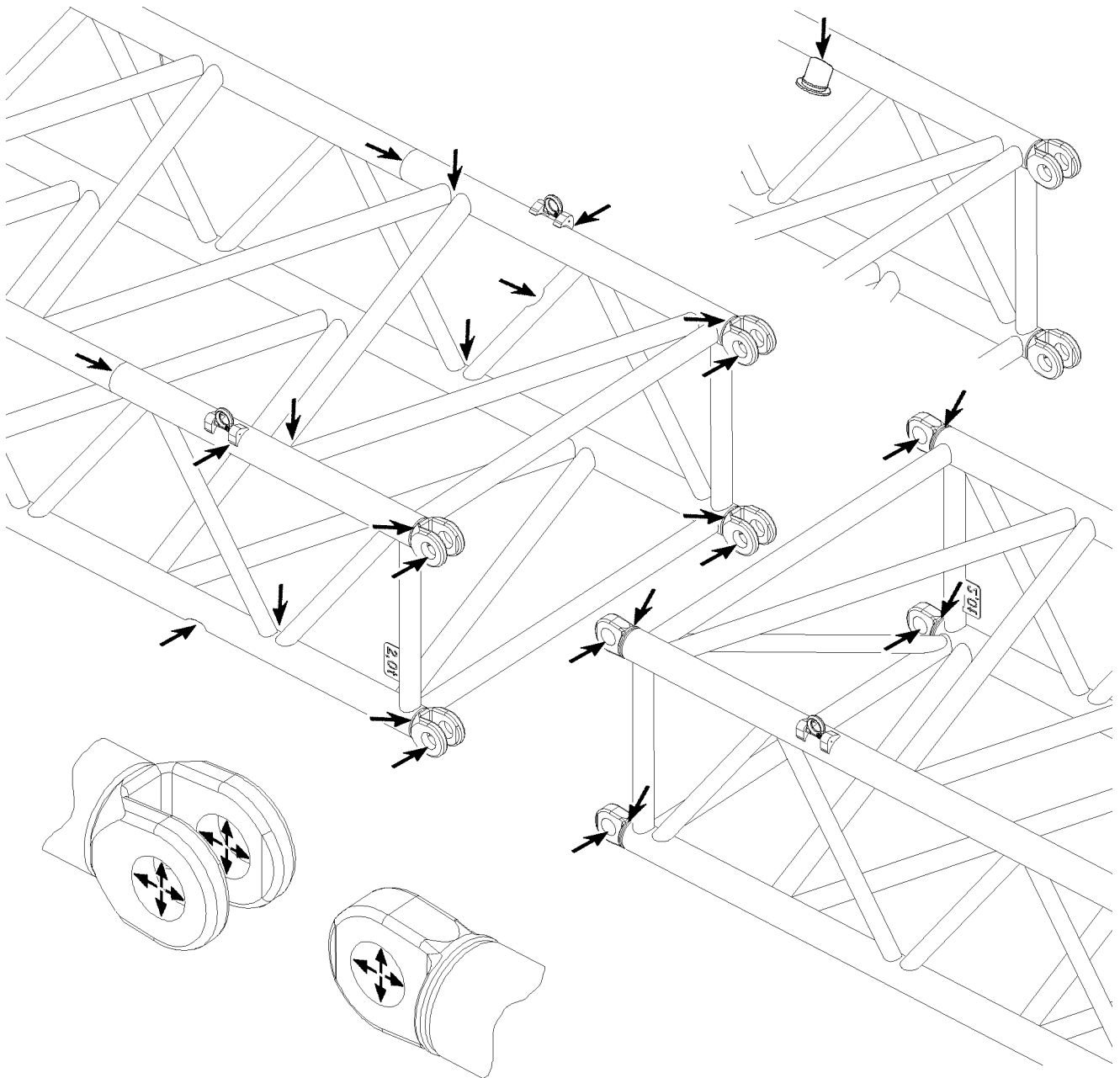


Fig.121023: Example of lattice sections

## 3 Inspecting the locking system of the telescopic boom

### 3.1 For cranes with pneumatic boom locking system

- For inspection of function, see chapter 8.11.
- For inspection of pin wear pattern, see chapter 8.11.
- For inspection of wear, see chapter 8.11.
- For inspection of safety control, see chapter 8.11.

### 3.2 For cranes with the Telematik telescopic boom system

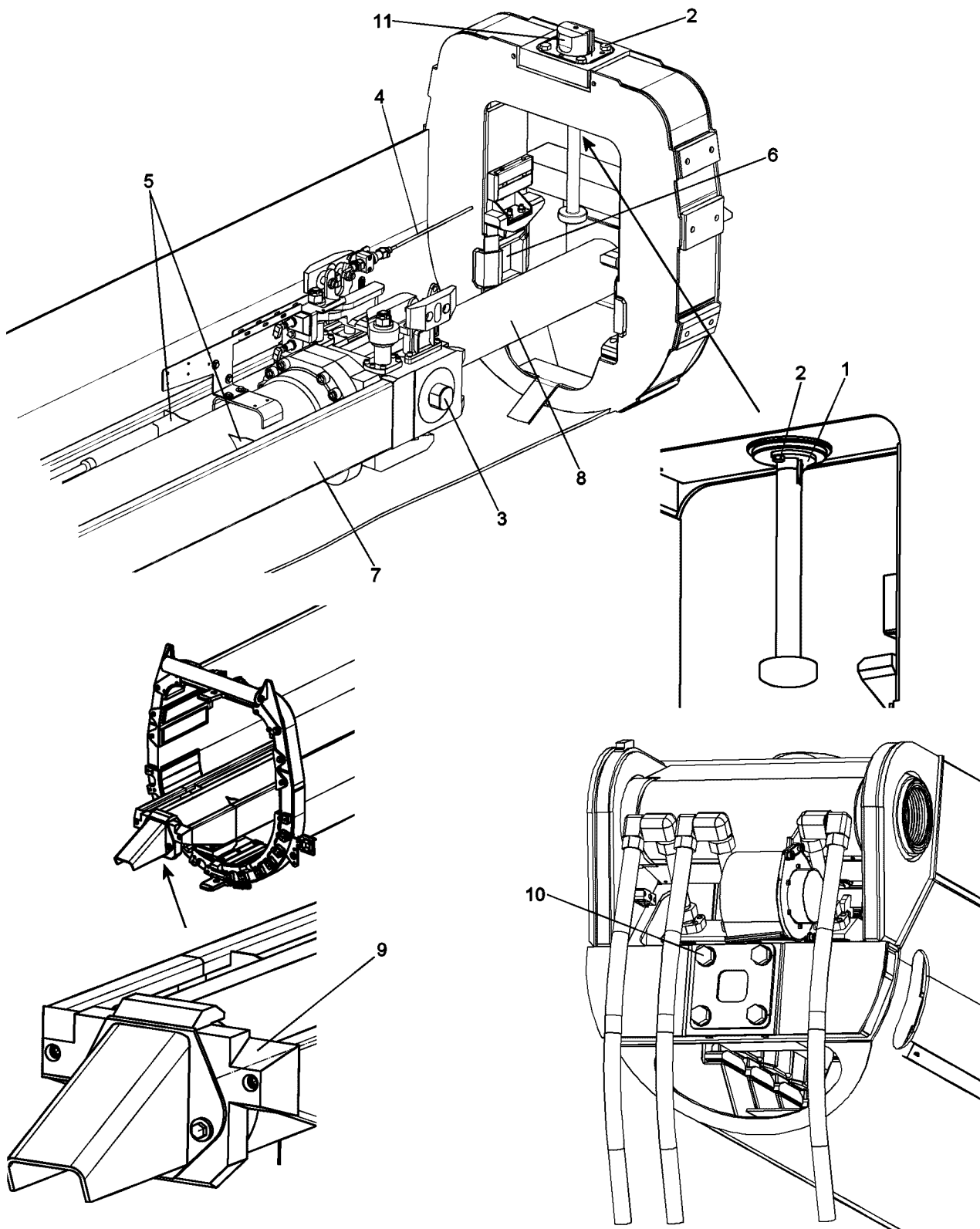


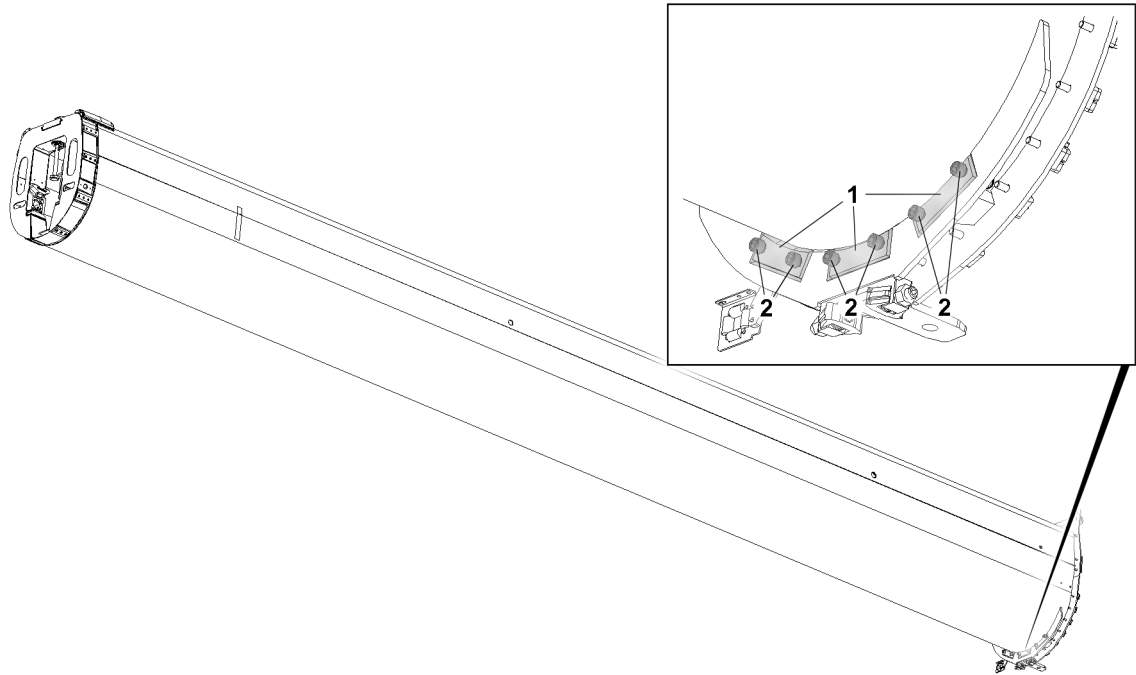
Fig.109286

- Inspection of the pull knob safety **1** and all mounting screws **2** for tight seating
- Inspection of twist guards for cylinder pinning **3** and telescopic boom pinning **11**
- Inspection of the length sensor rope **4** for damage
- Inspection of the cylinder barrel in the area of all welding seams **5** for crack formation
- Inspection of the locking pockets **6** for damage



- Grease the guide rail **7**
- In case of leakage: Inspection of the piston rod **8** for grooves
- Inspection of the wear pattern on the cylinder pinning **3** and the telescopic boom pinning **11**
- Inspection of guide rail **7** for distortion of contour
- Inspection of plastic guide **9** on the cylinder bottom for damage
- Inspection of all mounting screws **10** on the push out cylinder for tight seating

## 4 Inspection of the screws in the adjustment plates



*Fig.156447: Exemplary illustration of the adjustment plates on the telescope*

The adjustment plates **1** are **not** installed for all crane types.

Check that screws **2** in the adjustment plates **1** are firmly tightened according to the maintenance intervals.

## 5 Checking the safety ropes and anchor points

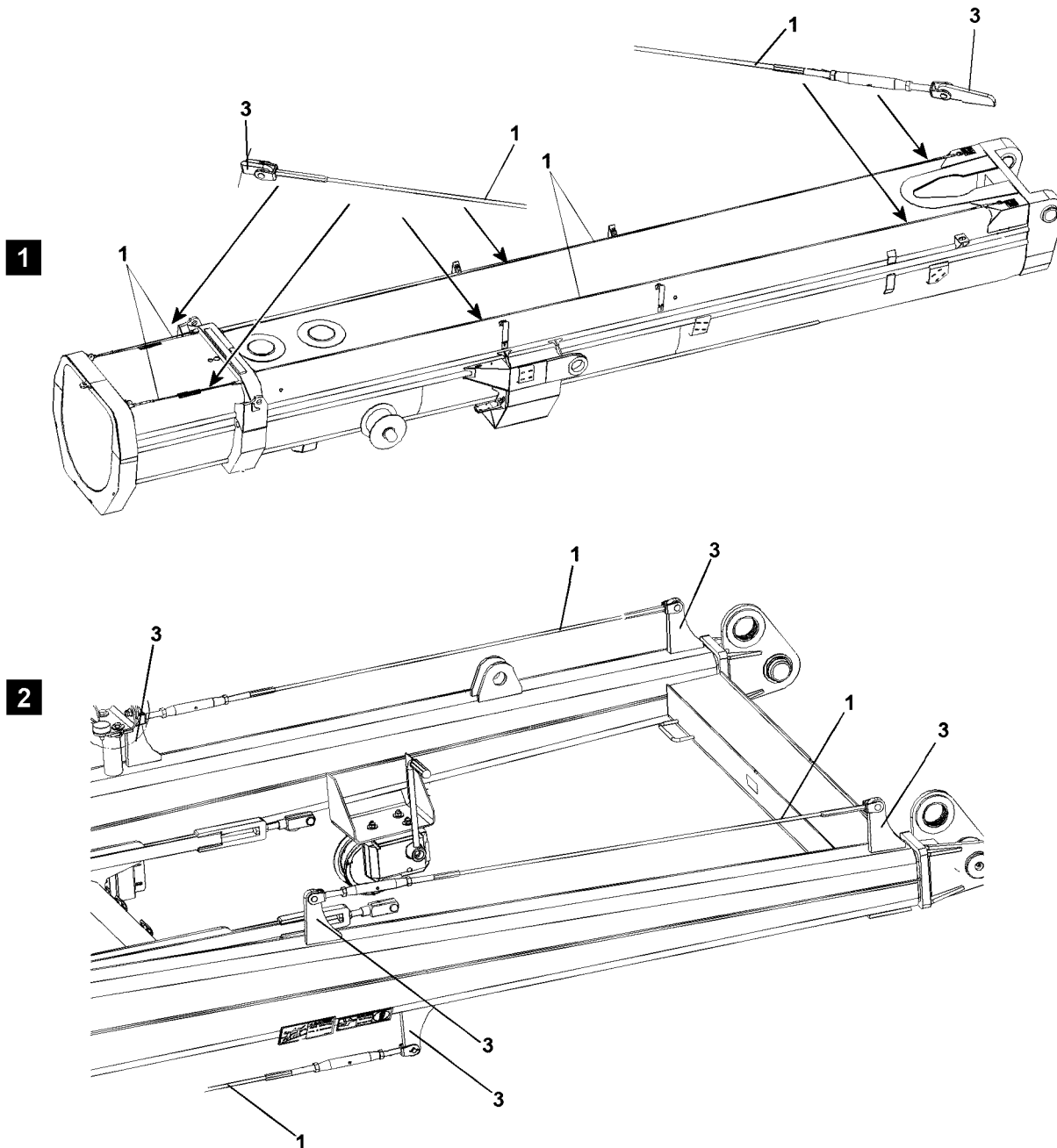


Fig.127130



### WARNING

Danger of falls due to damaged safety ropes or anchor points!

The safety ropes **1** and anchor points **3** must be checked **at least once a year** by an **authorized inspector** for safety and damage!

If any defects are found on the safety ropes **1** or anchor points **3** during the inspections, then the safety ropes **1** or anchor points **3** must be replaced immediately by authorized and trained specialists! If this is not observed, assembly personnel could be killed or fatally injured during a fall!

- ▶ The rope pretension on the safety ropes must be 800 N !
- ▶ Have damaged safety ropes **1** or anchor points **3** replaced immediately by trained expert personnel!



**Note**

Document the inspections in writing!

- ▶ The scope and results of tests should be documented to permit reproducibility. This documentation forms part of the crane records and should be safely stored during the entire service life of the crane.

### 5.1 Checking of rope pretension on telescopic booms, illustration 1

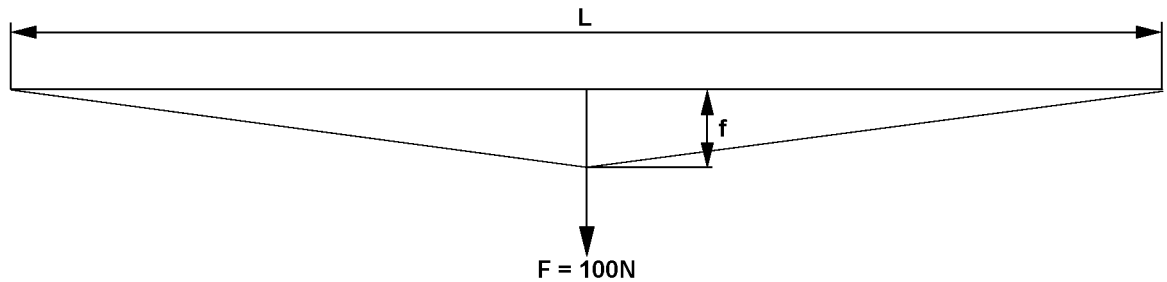


Fig.112738

The rope pretension must be 800 N. This can be checked with the aid of a spring balance, which is pulled centered on the safety rope. If the specified deflection (f) depending on the rope length (L) according to the following charts results for the raised load F = 100 N then the rope pretension of 800 N is set correctly.

Rope pretension is 800 N if:					
Rope length (L)	1.0 m	1.5 m	2.0 m	2.5 m	3.5 m
Deflection (f)	15 mm	25 mm	30 mm	40 mm	55 mm

Rope pretension is 800 N if:					
Rope length (L)	5.5 m	7.5 m	9.5 m	11.5 m	13.5 m
Deflection (f)	85 mm	115 mm	145 mm	180 mm	215 mm

### 5.2 Inspecting the rope pretension on lattice sections, illustration 2

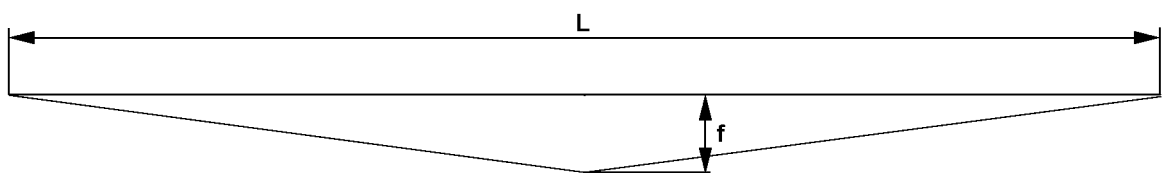


Fig.117747

The rope pretension is 800 N , if a sag (f) according to the chart is present on the safety rope according to the rope length (L).

Rope pretension is 800 N if:					
Rope length (L)	1.0 m	1.5 m	2.0 m	2.5 m	3.5 m
Deflection (f)	0	1 mm	2 mm	3 mm	6 mm

LWE/LTR 1220-003/24204-02-02/en

Rope pretension is 800 N if:					
Rope length (L)	5.5 m	7.5 m	9.5 m	11.5 m	13.5 m
Deflection (f)	15 mm	28 mm	45 mm	66 mm	90 mm

## 6 Inspecting the load handling equipment and assembly aids



### WARNING

Load handling equipment and / or assembly aids **not** inspected!

Death, severe bodily injuries, property damage.

- ▶ Inspect load handling equipment and / or assembly aids at least once a year.

The recurring inspection of the load handling equipment and / or assembly aids must be carried out once a year.

The inspections of load handling equipment and / or assembly aids must be recorded.

The welding seams must be subjected to a visual inspection.

Check load handling equipment and assembly aids for:

- Damage
- Wear
- Cracks

Replace damaged, worn or ripped load handling equipment and assembly aids immediately.

Repairs on load handling equipment and assembly aids may solely be made in consultation and under the instructions of the Customer Service at **Liebherr-Werk Ehingen GmbH** by authorized and trained expert personnel.



### Note

- ▶ Document the scope of the inspection and the results in writing and comprehensibly.
- ▶ Save the documentation as a part of the crane records for the entire service life of the crane.

## 7 Inspecting of fastening equipment



### WARNING

Fastening equipment **not** inspected!

Death, severe bodily injuries, property damage.

- ▶ Check the fastening equipment at least once a year.

The inspections of the fastening equipment must be recorded.

The welding seams must be subjected to a visual inspection.

Inspect the fastening equipment according to the specifications of the corresponding regulations and standards.

Replace damaged, worn or ripped fastening equipment immediately.



### Note

- ▶ Document the scope of the inspection and the results in writing and comprehensibly.
- ▶ Save the documentation as a part of the crane records for the entire service life of the crane.

## 7.1 Grommets and cable laid fastening rope

Observe and comply with the manufacturer's operating instructions.



### WARNING

Damaged grommets and cable laid fastening rope used!

The fastening ropes can fail. The load can fall down.

- ▶ Do **not** use grommets and cable laid fastening rope with a corresponding number of wire breaks.
- ▶ Do **not** use grommets and cable laid fastening rope with a corresponding amount of damage.

Do **not** use grommets and cable laid fastening rope if there is one of the following numbers of wire breaks:

- Wire breaks of more than 10 wires along a length of 3D
- Wire breaks of more than 15 wires along a length of 6D
- Wire breaks of more than 40 wires along a length of 30D

Do **not** use grommets and cable laid fastening rope in the case of the following damage:

- Strong rope distortion
- Rotary distortion
- Kinks, bends, basket formation
- Corrosion
- Corrosion of the zinc coating
- Opening of the splice
- Loosening or opening of the rope bond
- Displacement of the rope bond from its original position
- Lack of identification

## 8 Inspecting the diaphragm reservoir



### Note

- ▶ The national regulations for pressurized container inspection must be observed!

The inspection of the diaphragm reservoir for specified gas pressure must be carried out by an **authorized inspector**, see chapter 7.04 and chapter 7.05.

## 9 Inspecting the relapse cylinders



### WARNING

Fatal accidents due to defective relapse cylinders!

Loss of oil or corrosion can damage the relapse cylinders!

Safe crane operation is no longer ensured!

- ▶ Crane operation with defective relapse cylinders is prohibited!

### 9.1 Pressure testing the relapse cylinders

The relapse cylinders must be inspected annually by an **authorized inspector**. The purpose of the inspections is to avoid accidents by detecting deficiencies early on.

## 9.2 Checking the gas pressure and oil fill before start up



### WARNING

Fatal accidents due to defective relapse cylinders!  
Loss of oil or corrosion can damage the relapse cylinders!  
Safe crane operation is no longer ensured!

- ▶ Before every start up: Carry out a visual inspection for leaks, damage and corrosion on the relapse cylinders.
- ▶ If any defects are found, the relapse cylinders must be inspected by the cylinder manufacturer!

The gas pressure and the oil fill must be checked by an **authorized inspector** for pressure containers.

## 9.3 Inspecting the safety controls on the relapse cylinders

Inspecting the interlocking system or limit switches on the relapse cylinders and the boom A-frames, see chapter 8.12.

# 10 Inspecting the rope pulleys

## 10.1 Checking for damage and cracks



### DANGER

Danger of accident in case of damage or cracks!

- ▶ Replace rope pulley immediately!

Check the entire rope pulley assemblies for damage and cracks once a year.

If rope pulleys are subjected to any impacts (e.g., with buildings) or are otherwise overloaded, they must be visually inspected for damage or cracks immediately.

## 10.2 Checking the groove diameter

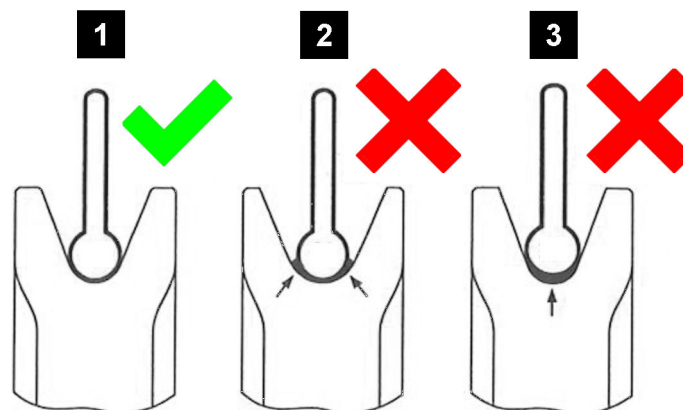


Fig.154258: Checking the groove diameter

- |   |                                     |
|---|-------------------------------------|
| <p>1 Groove diameter ok</p> <p>2 Groove diameter too wide</p> | <p>3 Groove diameter too narrow</p> |
|---|-------------------------------------|

### NOTICE

Worn rope pulleys!

The functionality and service life of the rope is reduced. Damage on rope.

- ▶ Before placing the rope, check the groove diameter of rope pulleys.

Visible wear on rope pulleys:

- Reduced groove diameter
- Negative impressions of the rope profile in the groove

Make sure that the following tools are available:

- Groove caliper

Make sure that the following prerequisites are met:

- All components to be inspected are cleaned.
- The rope does **not** obstruct the inspection of the components.



#### Note

- ▶ The actual groove diameter **must** be larger than the actual diameter of the rope!

The groove diameter of rope pulleys and winches must be at least 6 % larger than the nominal rope diameter.

Check the rope pulleys with a groove caliper for wear. When wear exists on the rope grooves: Repair or replace the rope pulleys.

## 11 Inspecting the carrier rollers

### 11.1 Performing a visual inspection



#### DANGER

Damaged carrier rollers!

Breakage and falling components. Death, severe bodily injuries, property damage.

- ▶ Carry out a visual inspection according to the maintenance intervals.
- ▶ Replace the carrier roller immediately.

The visual inspection must be carried out according to the following criteria:

- Wear
- Damage
- Cracks

Visible wear on carrier rollers:

- Negative imprints of the rope profile on the circumference of the carrier rollers
- Lead-in tracks

### 11.2 Checking the depth of the lead-in tracks



#### DANGER

Worn carrier rollers!

Breakage and falling components. Damage to ropes. Death, severe bodily injuries, property damage.

- ▶ Check the depth of the lead-in tracks.
- ▶ Replace worn carrier rollers immediately.

Make sure that the following prerequisites are met:

- All components to be inspected are cleaned.
- The rope does **not** obstruct the inspection of the components.

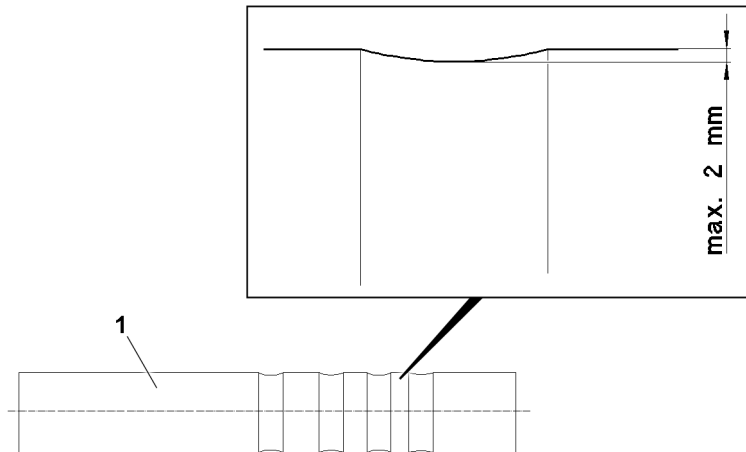


Fig.124864: Permissible depth of the lead-in tracks

1 Carrier roller

The depth of the lead-in tracks may be maximum 2 mm.

### 11.3 Checking the bearings for easy movement

Stiff or blocked carrier rollers wear unevenly and cause serious rope abrasion.

Ineffective carrier rollers can lead to irregular rope tension.

Tasks to check the carrier rollers:

- Check the carrier rollers for proper movement in their bearings.
- When carrier rollers are **not** easily moveable in their bearings: Fix the bearings.

### 11.4 Checking the tightening torque

The tightening torque of screws must be checked according to maintenance interval.

## 12 Inspecting the extension conditions of sliding beams

The extension conditions of the sliding beams must be inspected annually by an **authorized inspector**.

Check the extension conditions on every sliding beam:

- Check if the position 0 % of the LICCON display matches the actual condition of the sliding beam.
- Check if the position 100 % of the LICCON display matches the actual condition of the sliding beam.

## 13 Inspecting the function of the overload protection

Position the longest boom at minimum and maximum radius: Check the load indicator, using the hook block as a test load.

The display reading may not deviate by more than 10 % off the true load value at these two extreme positions.

Measure the indicated radius for the longest boom at its minimum radius and at a boom angle of 45°.



The display readings may not deviate more than 10 % from the measured boom radius.

## 14 Inspecting the pin connections



### WARNING

Pin connections **not** inspected!  
 Death, severe bodily injuries, property damage.  
 ▶ Check the pin connections at least once a year.

The periodic inspection of all pin connections must be carried out once a year.

The inspections of the pin connection must be recorded.

Check the pin connections for:

- Properly secured pin connections
- Damage to the pins and / or connector elements
- Damage to the retaining elements

Replace damaged pins immediately.

Immediately replace damaged, bent or broken retaining elements.

Only replace damaged pins with identical pins.

Only replace damaged retaining elements with identical retaining elements.



### Note

- ▶ Document the scope of the inspection and the results in writing and comprehensibly.
- ▶ Save the documentation as a part of the crane records for the entire service life of the crane.

## 15 Inspecting the slewing ring connection

### 15.1 Checking the tilt play

The wear of the slewing ring connection is determined by measuring the tilt play with the ring installed.

The permissible tilt play depends on the type of slewing ring connection.



### WARNING

The tilt play of the slewing ring connection is too large!  
 If the permissible tilt play is exceeded, then safe crane operation is **no** longer possible.  
 Death, severe bodily injuries, property damage.

When the permissible tilt play is exceeded:

- ▶ Replace the slewing ring connection.

The determination of the tilt play must be carried out according to the **test instructions** of **Liebherr-Werk Ehingen GmbH**.

Request the test instructions and permissible tilt play: Contact Liebherr Service.

## 16 Inspecting the mounting of the load bearing equipment

### 16.1 Checking the tightness of the mounting screws

The mounting screws must be checked for a tight fit during the annual crane inspection.

The mounting screws are pre-stressed at the factory, so that no loosening of the screw connections will occur during normal crane operation.

The screw connection may become overloaded and the mounting screws may be permanently stretched if the crane is overloaded or if the load is pulled free. The mounting screws must be checked immediately for a tight fit after an overload.

Check the tightening torque of the mounting screws of load bearing equipment for a tight fit:

- Slewing ring connection
- Winches
- Slewing gears
- Transmission
- Trailer coupling

If a mounting screw can be tightened, then the mounting screw is loose. Follow the instructions in section „Checking the mounting screws for damage“.

### 16.2 Checking the mounting screws for damage

Completely unscrew the loose mounting screws and check in detail for damage.

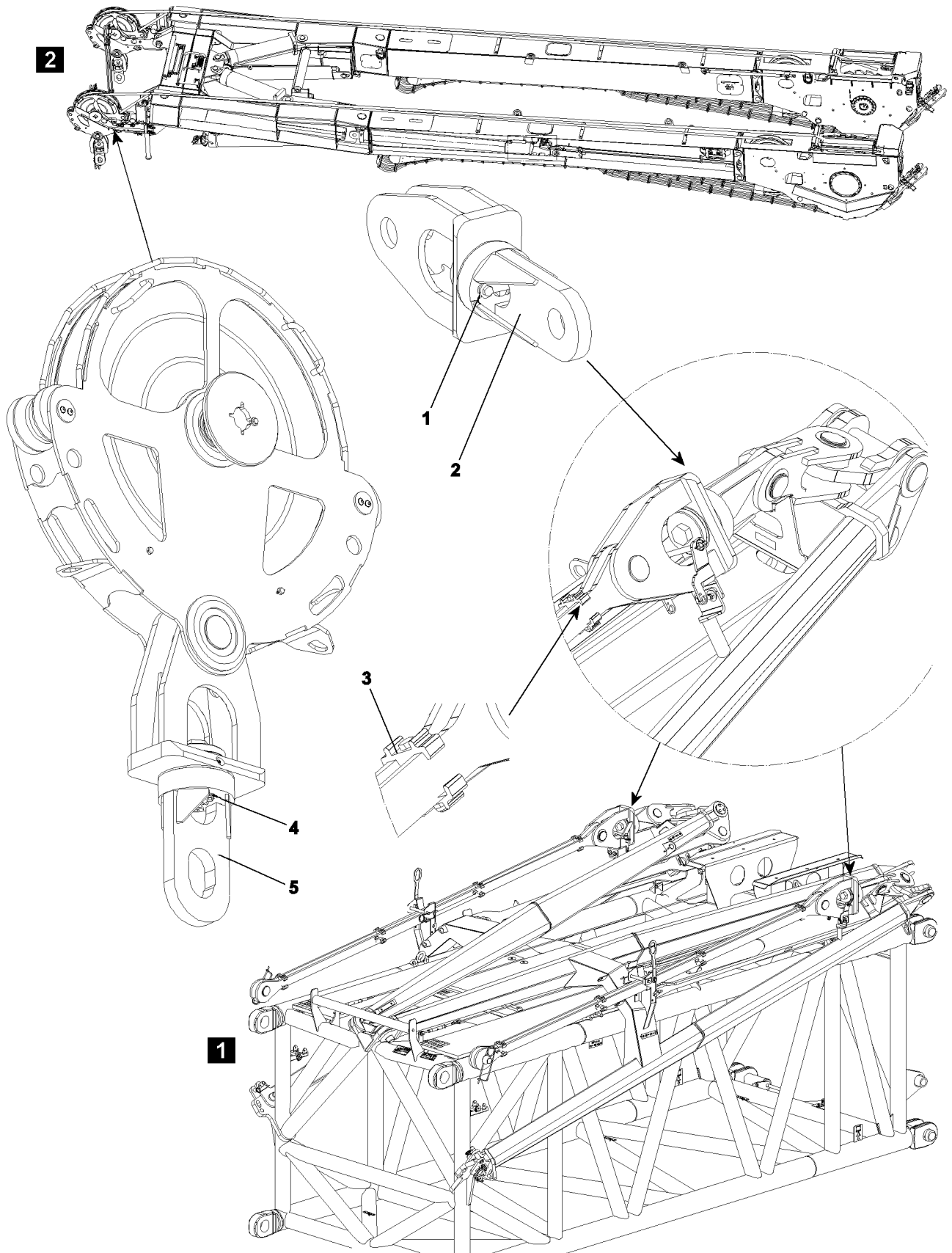
Completely unscrew the adjacent mounting screws and check in detail for damage.

Replace the mounting screw if any of the following damage is present:

- The mounting screw is stretched by more than 2 % (in relation to its original length).
- Cracks, permanent deformation or other damage is visible on the mounting screw.
- The mounting screw is uneven.
- There is pitting.
- The thread is hard to move.

If there is **no** damage, reuse the checked mounting screws (expansion screws) a maximum of two times.

# 17 Inspecting the tele extension with eccentric, illustration 1



LWE/LTR 1220-003/24204-02-02/en

Fig. 109096

- Inspection of anti-rotation device **1** for damage and loose screw connection.
- Inspection of swivel **2** for easy turnability.
- Inspection of all clamps **3** for damage and function.

## 18 Inspecting the change over pulleys, illustration 2

- Inspection of anti-rotation device **4** for damage and loose screw connection.
- Inspection of swivel **5** for easy turnability.

## 19 Inspecting the oil and fuel tanks

Visually check the oil and fuel tanks at least once a year for leaks and safe mounting.

Repairs may only be carried out by authorized and trained specialists.

Improper repairs; e.g., welding, hard or soft soldering is not permitted, particularly if the Service department at Liebherr-Werk Ehingen GmbH has not been consulted!

## 8.03 Inspecting of winches

1	Inspecting the hoist and retracting winches	3
2	Inspection of the auxiliary reeving winch, recovery winch and spare wheel winch	5
3	Monitoring the winches	5

*Fig.195219*

LWE/LTR 1220-003/24204-02-02/en

# 1 Inspecting the hoist and retracting winches

The hoist and retracting winches are designed in sealed planetary gear version. These gears are sized for long service life and the drive shafts and gears are designed for endurance.

Even though the hoist and retracting winches are designed for long life, an external visual inspection is not adequate, since their life can be significantly affected by bad maintenance (insufficient oil), using oil that does not meet specification requirements, defective seals, improper operation or overloading.

The annual inspection must therefore be carried out by an **expert** in accordance with the following specification.

The winches must be inspected by an **authorized inspector** every four years after the initial license.

Within the territorial validity of the BGV D6, after the 10th year in operation, counted from the first day of initial license, when the theoretical service life is not over, the winches must be checked annually by an **authorized inspector**.

## 1.1 Checking the groove diameter



### WARNING

Worn winches!

Damage of flanged disks, high rope wear, operational problems. Broken rope, falling load.

- ▶ Before placing the rope, check the groove diameter of winches.

Visible wear on winches:

- Reduced groove diameter.
- Mechanical damage, for example scrub marks or scouring on flanged disks

Make sure that the following tools are available:

- Groove caliber

Make sure that the following prerequisites are met:

- All components to be inspected are cleaned.
- The rope does **not** obstruct the inspection of the components.



### Note

- ▶ The groove radius may **not** be smaller than the actual diameter of the rope.

The groove diameter of rope pulleys and winches must be at least 6 % larger than the nominal rope diameter.

Check winches with a groove caliber for wear. When wear is present: Fix the winch or replace.

## 1.2 Inspection intervals

At least once a year, see Crane operating instructions, chapter 7.03.

## 1.3 Checking the oil level

Check the oil level with the dipstick.

For hoist and retracting winches **without** a dipstick, we recommend that the oil is drained and the amount compared to the specified oil quantity.

## 1.4 Evaluating oil color

Assume that the oil has been overheated if it is black and / or a burnt oil smell is detected. Change the oil.

## 1.5 Checking for solid foreign substances

In general, the oil must be analyzed by a qualified laboratory.

For simple testing, the following procedure can be used:

- Drip the used oil on a specified filter fleece.
- Visual inspection with a magnifying glass may reveal coarse particles.
- If coarse particles are found: Have the components of the oil analyzed by a qualified laboratory.

---

### NOTICE

Danger of property damage!

- ▶ Repairs may only be carried out by an authorized and trained expert personnel.
  - ▶ Replace damaged parts and change the gear oil.
- 

## 1.6 Visual inspection for leaks

The gears must be checked for leaks, since oil losses - in addition to polluting the environment - can lead to gear failure.

## 1.7 Checking the gear brakes

Check the brakes each time the gears are inspected.



### WARNING

Condition of gear and brakes incorrectly transmission evaluated!

The load can fall down, death, property damage.

- ▶ Only qualified personnel with specialized knowledge may be used to evaluate gears and brakes.
- 

In order to do so, proceed as follows:

- Make sure that the hoist rope is sufficiently pretensioned, in particular in the lower layer of the winch. See chapter 4.08.
- Attach a load, which creates the maximum rope pull in the uppermost layer of the coil with 1 strand, and raise it just off the ground by luffing it up.
- Block the winch brake:
  - For cranes with LICCON 1: „Release the winch brake“ by unplugging the valve plug from the valve.
  - For cranes with LICCON 2: By activating the setting program for blocking the winch brake.
- Activate the winch in the lowering direction.

The brake may **not** slip during the test, which means that the winch may **not** turn.



### WARNING

The brake slips and the winch turns!

The load can fall down, death, property damage.

- ▶ Stop crane operation.
  - ▶ Contact Customer Service at Liebherr-Werk Ehingen GmbH.
- 

## 1.8 Documenting the completed inspection

The results of the annual inspections and maintenance work, including the steps taken, must be documented by the competent or authorized inspector, including attachments from the inspection labs and qualified service companies if applicable.

This documentation must be filed in the crane inspection log under the heading "Periodic inspections".



## 2 Inspection of the auxiliary reeving winch, recovery winch and spare wheel winch

The inspection of the auxiliary reeving winch, recovery winch and spare wheel winch regarding scope and content is made according to the manufacturer's instructions.

- Check the auxiliary reeving winch, recovery winch and spare wheel winch according to the manufacturer's instructions.
- Request data about the service life of the auxiliary reeving winch, recovery winch and spare wheel winch from the respective manufacturer.

## 3 Monitoring the winches

### 3.1 Theoretical service life

The designer of your crane used a theoretical total operating time when designing and sizing the winches. This resulted in the theoretical service life of the equipment.

The winches of your crane are classified according to ISO 4301/1 as follows:

Winches	Classification
Power train group:	M3
Load spectrum:	L1
Load spectrum factor Km:	0.125
Theoretical service life D:	3200 h



#### Note

- ▶ The „theoretic service life“ is not equal to the real (true) service life of a winch!

The actual service life of the winch is affected by many additional outside factors; for example:

- Overloads caused by unapproved use of the crane.
- Inadequate maintenance: Oil is not changed in a timely manner
- Improper operation:
  - Extreme acceleration or deceleration of the load
  - Load falling into the ropes
- Maintenance errors:
  - Using the wrong type of oil
  - Too much or too little oil
  - Contamination during oil change
- Assembly errors during repair and maintenance
- **Undetected** leaks
- Incorrectly set safety equipment
- Hidden damage from accidents
- Extreme environmental conditions:
  - Low or high temperatures
  - Aggressive atmosphere
  - Dust and dirt

### 3.2 Used proportion of the theoretical service life

The crane operator is obligated to carry out an inspection of the crane at least once a year.

At this time, the actually used part of the theoretical service life must also be calculated. If necessary, the crane operator must contract an authorized inspector.

For the determination of the used part of the theoretical service life, the actual operating conditions (load spectrum) and the hoist gear operating hours for each inspection interval are to be determined. The operator is responsible for the documentation in the crane inspection log.

### 3.2.1 Determining the operating conditions (load spectrum)

The load spectrum of the crane is divided into groups, please refer to ISO 4301/1.

Select one of the following load spectrums and record it in the crane inspection log for the respective inspection interval based on the actual operating conditions. A more precise determination of the load spectrum is permissible.

#### Load spectrum class: Light L1

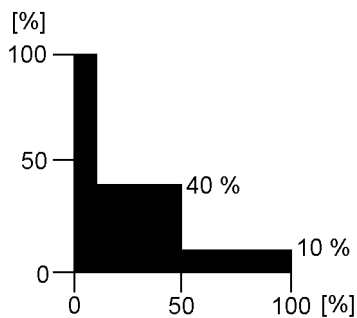


Fig.195234: Graphic illustration Load spectrum L1

#### Definition:

Power train or parts thereof are subjected to maximum stress only in exceptional cases, but normally only operate at very light loads.

#### Operating time rates:

- 10 % of the time at maximum load (dead load and 1/1 working load)
- 40 % of the time with dead load and 1/3 working load
- 50 % of the time only with dead load

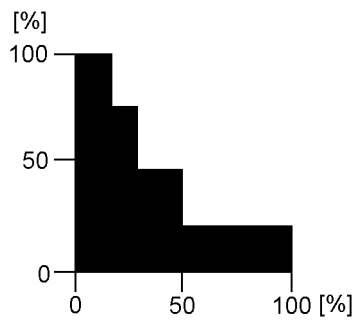
#### Factor of load spectrum:

$K_m = 0.125$



#### Note

- Load spectrum L1 with load spectrum factor  $K_m = 0.125$  is normally applied to cranes used for assembly operations!

**Load spectrum class: Medium L2***Fig.195235: Graphic illustration Load spectrum L2***Definition:**

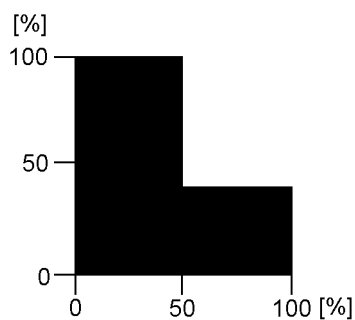
Power train or parts thereof are subjected to maximum load relatively often, but normally only operate at light load.

**Operating time rates:**

- 1/6 of the time at maximum load (dead load and 1/1 working load)
- 1/6 of the time with dead load and 2/3 working load
- 1/6 of the time with dead load and 1/3 working load
- 50 % of the time only with dead load

**Factor of load spectrum:**

$$K_m = 0.25$$

**Load spectrum class: Heavy L3***Fig.195236: Graphic illustration Load spectrum L3***Definition:**

Power train or parts thereof are frequently subjected to maximum load and normally operate at medium load.

**Operating time rates:**

- 50 % of the time at maximum load (dead load and 1/1 working load)
- 50 % of the time only with dead load

**Factor of load spectrum:**

$$K_m = 0.5$$

### Load spectrum class: Very heavy L4

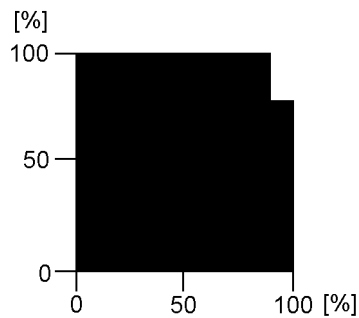


Fig.195237: Graphic illustration Load spectrum L4

#### Definition:

Power train or parts thereof are regularly subjected to near maximum loads.

#### Operating time rates:

- 90 % of the time at maximum load (dead load and 1/1 working load)
- 10 % of the time only with dead load

#### Factor of load spectrum:

$K_m = 1$

### 3.2.2 Determining the effective operating hours $T_i$

The effective operating hours calculated as follows must be entered into the crane inspection log for the respective inspection interval.

There are four different scenarios:

1. Operating hour meter installed on every winch.  
If an operating hour meter is installed on every winch in your crane, the effective operating hours  $T_i$  can be read directly during each inspection.
2. Operating hour meter installed for the overall crane drive.  
The winch proportion of the total superstructure operating hours must be estimated.  
For cranes used in assembly operations, the operating time for the hoist winches can be estimated generally at 20 % of the total operating hours of the superstructure.
3. One operating hour meter is used for both the crane engine and the crane drive.  
The winch proportion of the total crane operating hours must be estimated.  
For cranes used in assembly operations, the operating time for the superstructure can be estimated at 60 % of the total operating hours of the crane. If the hoist winch proportion is estimated at 20 % of the superstructure operating hours (see previous item), then the result in relation to the **total** operating hours of the crane is: 12 %.
4. No operating hour meter is available.  
In this case, the operator must estimate and document the actual operating hours of the winch.  
The approximate percentages stated above normally apply to main hoist winches. For auxiliary hoist winches or boom control winches, the proportion of the total operating hours can be significantly less and should therefore be estimated by the operator.

### 3.2.3 Determining the used proportion of the theoretical service life

For an inspection interval  $i$  (max. 1 year), the actually used proportion  $S_i$  of the theoretical Service life is derived from the formula:

$$S_i = \frac{K_{m_i}}{K_m} \times T_i$$

Fig.195230

Abbreviation	Explanation
$S_i$	Used proportion of the theoretical service life.
$K_m$	Load spectrum factor that was used to calculate the winch rates. This factor is provided in the Operating instructions.
$K_{m_i}$	Load spectrum factor for inspection interval $i$ according to section „Determining the operating conditions“.
$T_i$	Effective operating hours for inspection interval $i$ according to section „Determining the effective operating hours $T_i$ “.

The actually used proportion is subtracted from the remaining theoretical service life  $D_i$  after each inspection interval (see example).

If the remaining theoretical service life is not long enough to cover the next projected operating period, a general overhaul of the winch is required.

If the theoretical service life  $D$  has been reached (see section on „Theoretical service life“), then the winch may only be operated after conducting a general overhaul.

**A general overhaul of the winch is required not later than 10 years after start up.**

The general overhaul must be arranged by the operator and carried out by the manufacturer or the manufacturer's authorized representatives and must be documented in the inspection log. After the general overhaul, the manufacturer or the manufacturer's authorized representative will define a new theoretical service life  $D$ .

When the design life has not been reached after 10 years, continued operation of the winch without a general overhaul is acceptable, when the crane's authorized inspector has confirmed the accuracy of the actual service life calculation by signing the crane inspection log at each authorized inspection interval.

In such a case, the authorized crane inspector must thoroughly inspect the winch. This comprises at least:

- External visual inspection (leaks damage, deformation, etc.).
- Oil check, especially for metal residues.
- Load test at minimum and maximum rope pull and at maximum possible speed in both cases. At least one layer must be spooled up. Pay particular attention to any unusual noises during this load test.

The authorized crane inspector must confirm this inspection in the crane inspection log and must make a statement regarding suitability of the winch for continued operation. The next inspection must take place before the end of the 12th operating year and annually thereafter.

### 3.3 Example

According to the manufacturer's operating instructions, a crane with a separate operating hour meter for the travel drive and the crane drive is classified as follows:

- Power train group: M3
- Load spectrum: Light L1
- Factor of load spectrum:  $K_m = 0.125$
- Theoretical service life:  $D = 3200$  h

Actual usage proportion  $S$  of the theoretical service life is calculated using the individual inspection intervals as follows:

### 3.3.1 First inspection (first year)

The crane was used for assembly work during the past year:

Load spectrum L1, in other words  $Km_1 = 0.125$ .

The superstructure operating hour meter indicates 800 h. The winch was operated about 20 % of the time; i.e.  $T_1 = 160$  h.

The actual usage proportion  $S$  of the theoretical service life at the time of the first inspection is therefore:

$$S_1 = \frac{0,125}{0,125} \times 160 \text{ h} = 160 \text{ h}$$

*Fig.195231*

Remaining theoretical service life:

$$D_1 = 3200 \text{ h} - 160 \text{ h} = 3040 \text{ h}$$

The above values are recorded in the crane inspection log.

### 3.3.2 Second inspection (second year)

The crane was used at a harbor for unloading work:

Load spectrum L3, in other words  $Km_2 = 0.5$ .

The superstructure operating hour meter indicates 2000 h ; i.e., this means that during this period: 2000 h – 800 h = 1200 h ( 800 h were used during the first year of operation)

The winch was operated about 40 % of the time; i.e.  $T_2 = 480$  h.

The actual usage proportion  $S_2$  of the theoretical service life at the time of the second inspection is therefore:

$$S_2 = \frac{0,5}{0,125} \times 480 \text{ h} = 1920 \text{ h}$$

*Fig.195232*

Remaining theoretical service life:

$$D_2 = 3040 \text{ h} - 1920 \text{ h} = 1120 \text{ h}$$

### 3.3.3 Third inspection (third year)

The crane was used for assembly work and occasionally at a harbor for unloading work:

Load spectrum L2, in other words  $Km_3 = 0.25$ .

The superstructure operating hour meter indicates 3000 h ; i.e., this means that during this period: 3000 h – 2000 h = 1000 h ( 2000 h were used during the first two years of operation)

The winch was operated about 30 % of the time; i.e.  $T_3 = 300$  h.

The actual usage proportion  $S_3$  of the theoretical service life at the time of the third inspection is therefore:

$$S_3 = \frac{0,25}{0,125} \times 300 \text{ h} = 600 \text{ h}$$

*Fig.195233*

Remaining theoretical service life:

$$D_3 = 1120 \text{ h} - 600 \text{ h} = 520 \text{ h}$$

### 3.4 Chart for determining the theoretically remaining service life

Chart 1 includes an example.

The remaining theoretical service life is to be documented in chart 2.

**Chart to determine the remaining theoretical service life of winch No. 1 (Main hoist winch)**

Crane type: LTM 1050  
 Fabrication No.: 0010 540 08  
 Put in service: 12345  
 Serial number of winch according to data tag: 0815  
 Last general overhaul performed on: .....  
 Configuration data of winch (see Operating Manual):  
 Drive gear group: M 3  
 Load collective: L 1  
 Factor of load collective Km: 0.125  
 Theoretical service life D: 3200 hrs.

$S_i$  = Used part of theoretical service life since last inspection  
 $D_i$  = Remaining theoretical service life  
 $D_{i-1}$  = Remaining theoretical service life after previous inspection  
 $Km$  = Factor of load collective, which was taken for calculation of winch.  
 $Km_i$  = Factor of load collective in inspection interval  $i$   
 $T_i$  = Effective operating hours in inspection interval  $i$

(\*) In the following pages, carry over the last line from the previous page.

Inspection interval No. (max. annually)	Date of initial service data of inspection	Operating conditions since last inspection (load collective)	Factor of load collective	Total crane operating hours	Operating hours of super-structure	Operating hours of super-structure since last inspection	Operating hours of winch	Operating hours of winch since last inspection $T_i$	Used part of theoretical service life $D_i = \frac{S_i}{Km_i} \times T_i$	Remaining theoretical service life $D_i = D_{i-1} - S_i$	Name of inspector	Signature	Remarks	Name of expert	Signature
(*) 0	10.06.90	-	-	-	0	0	0	0	0	3200					
1	05.06.91	L1	0,125	-	800	800	-	160 (20% of 800)	160	3040	Müller				
2	20.05.92	L3	0,5	-	2000	1200	-	480 (40% of 1200)	1920	1120	Huber				
3	18.05.93	L2	0,25	-	3000	1000	-	300 (30% of 1000)	600	520	Maier				
4															

**CAUTION: Perform general overhaul at least once every 10 years!** In case of deviation, see guidelines in this chapter.  
 General overhaul last performed on : .....



LWE/TR 1220-003/24204-02-02/en

**Chart to determine the remaining theoretical service life of winch No. ....**

- Crane type: .....
  - Fabrication No.: .....
  - Put in service: .....
  - Serial number of winch according to data tag: .....
  - Last general overhaul performed on: .....
  - Configuration data of winch (see Operating Manual): M.....
  - Drive gear group: L.....
  - Load collective: .....
  - Factor of load collective Km: .....
  - Theoretical service life D: .....
- $S_i$  = Used part of theoretical service life since last inspection  
 $D_i$  = Remaining theoretical service life  
 $D_{i-1}$  = Remaining theoretical service life after previous inspection  
 $Km$  = Factor of load collective, which was taken for calculation of winch.  
 This factor is to be taken from the Operating Manual  
 $Km_i$  = Factor of load collective in inspection interval i  
 $T_i$  = Effective operating hours in inspection interval i
- \*) In the following pages, carry over the last line from the previous page.

Inspection interval No. (max. annually)	Date of initial service data of inspection	Operating conditions since last inspection (load collective)	Factor of load collective	Total crane operating hours	Operating hours of super-structure	Operating hours of super-structure since last inspection	Operating hours of winch	Operating hours of winch since last inspection $T_i$	Used part of theoretical service life $D_i$ : $\frac{Km_i}{Km} \times T_i$	Remaining theoretical service life $D_i = D_{i-1} - S_i$	Name of inspector	Signature	Remarks	Name of expert	Signature
i			$Km_i$	[h]	[h]	[h]	[h]	[h]	[h]	[h]					
(*)															

**CAUTION:** Perform general overhaul at least once every 10 years! In case of deviation, see guidelines in this chapter.

General overhaul last performed on : .....

Fig.121552-en: Table 2



## 8.04 Inspection of crane wire ropes

1	Crane ropes	3
2	Importance of inspection	3
3	Personal protective equipment	3
4	Qualification Inspection personnel	3
5	Unscheduled inspection	3
6	Intervals	4
7	Areas	4
8	Documenting inspection results	5
9	Wire ropes and rope end connections	5
10	Degree of severity	8
11	Abbreviations Rope diameter	8
12	Distortions and mechanical damage	8
13	Removal criteria Overview	8
14	Checking for broken strands	10
15	Determining the number of broken wires	10
16	Checking the rope end connection	15
17	Checking of rope diameter	15
18	Corrosion	18
19	Corkscrew-like distortion	20
20	Basket formation	21
21	Protruding, distorted insert or strand	22
22	Loop formation	23
23	Kinking or rope loops pulled closed	24
24	Buckles	25
25	Effects of heat, arcs	26
26	Combined degree of severity	26
27	Flattenings	26
28	Current checklist	29

*Fig.195219*

LWE/LTR 1220-003/24204-02-02/en

# 1 Crane ropes

This chapter applies, for example, for the following crane ropes:

- Hoist ropes
- Control ropes for the boom system
- Control ropes of the telescopic boom with rope mechanism: Pull-out ropes and return ropes
- Guy ropes for boom system

## 2 Importance of inspection

**Rope removal criteria:** If severe damage reduces the operational safety, then the rope has reached the removal criteria.

The importance of regular inspections is demonstrated by:

- Evaluation of operational safety of ropes
- Determination of rope removal criteria
- Determination of next inspection

## 3 Personal protective equipment



### WARNING

Wires and lubricant!

Severe injury and skin irritation.

- ▶ When working with ropes, always wear work gloves.



### WARNING

Protective equipment **not** worn!

Severe injuries.

- ▶ Wear hard hat, safety shoes and safety glasses.

## 4 Qualification Inspection personnel

Make sure that the following prerequisites are met:

- Inspection personnel are **expert personnel for crane rope inspection**.
- **Expert personnel for crane rope inspection:**
  - Are trained in the inspection of crane ropes according to **DIN ISO 4309** and have practical experience in the evaluation of rope removal criteria.
  - Have practical experience in the evaluation of rope removal criteria according to **DIN ISO 4309**.
- The inspection personnel is assigned (authorized) for the maintenance by the crane operator.

## 5 Unscheduled inspection

In the following situations the rope must be inspected:

- After unusual strain
- If non visible damage is suspected
- When a rope or the rope end connection is damaged
- When the rope has been placed again after disassembly
- When the rope has been out of service for longer than three months

## 6 Intervals

Intervals for crane inspection:

- according to determination by **expert personnel for crane rope inspection**
- or **at least once a year**



### Note

- ▶ Shortening the inspection interval: The older a rope is the more frequently will wire breaks occur.

Determining factors for determination of inspection intervals are:

- Legal regulations in the country where the crane is operated
- Climate conditions under which the rope drive is utilized
- Power train group
- Results of previous inspections on current or comparable machine and under comparable operating conditions
- Frequency and type of use of a rope
- Service life of rope

## 7 Areas



### WARNING

Broken wires and distortions on ropes in cross over areas!

Rope performance can be greatly reduced. Rope breakage. Death, severe injuries, property damage.

- ▶ Check rope cross over areas especially diligently.

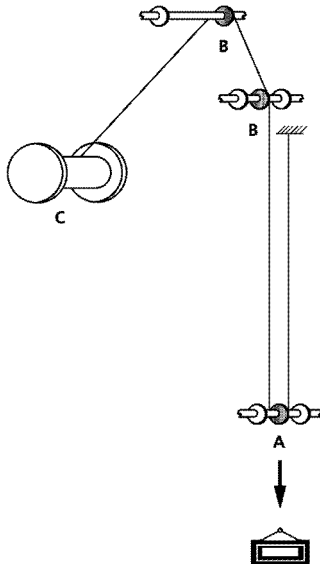


Fig.120969: Important inspection areas for multi layer spooled up ropes

- |  |   |
|--|---|
| <p><b>A</b> Rope sections, which run in the area of the load rise into the lower rope pulleys (the load is raised here).</p> <p><b>B</b> Rope intake on the first rope pulley in the area of the load rise</p> | <p><b>C</b> Rope sections, which are subjected in the cross over areas to the strongest effects (maximum deflection angle).</p> |
|--|---|

The rope must be checked over the entire length.

The following areas must be checked with special care:

- Rope end connections
- Safety coils and fixed point on the winch
- Areas of the rope which run through the hook block.
- Areas of the rope that run over the rope pulleys or lay on the rope pulleys.
- Areas of the rope that are spooled on the winch, especially cross over areas.
- Areas of the rope which are laying above the compensation pulleys.
- Areas of the rope which are subjected to abrasion due to external components.
- All areas of the rope that are subjected to temperatures above 60 °C.

## 8 Documenting inspection results



### Note

- ▶ Document the results of the inspections in an inspection checklist.
- ▶ Form for an inspection checklist, see section „Current checklist“.

## 9 Wire ropes and rope end connections



### WARNING

Wire rope with impermissible rope end connection!

The wire rope can fail. The load can fall down.

Death, severe bodily injuries, property damage.

- ▶ Select the permissible rope type for the respective application.
- ▶ Select the permissible rope end connection for the respective rope type.
- ▶ Observe and adhere to the warning display on the lock.

Wire rope application	Rope type
Hoist rope	Rotation-resistant rope
Guy rope or control rope	Non-rotation resistant rope
Auxiliary rope or assembly rope	Non-rotation resistant rope

*Rope type depending on the application*

The type of rope that is selected determines the corresponding rope end connections.

### 9.1 Rotation-resistant ropes with rope end connections

Use rotation-resistant ropes as **hoist ropes**.

Rotation-resistant ropes are special ropes that produce extremely little torque and twisting at the rope end connection when they are under strain.

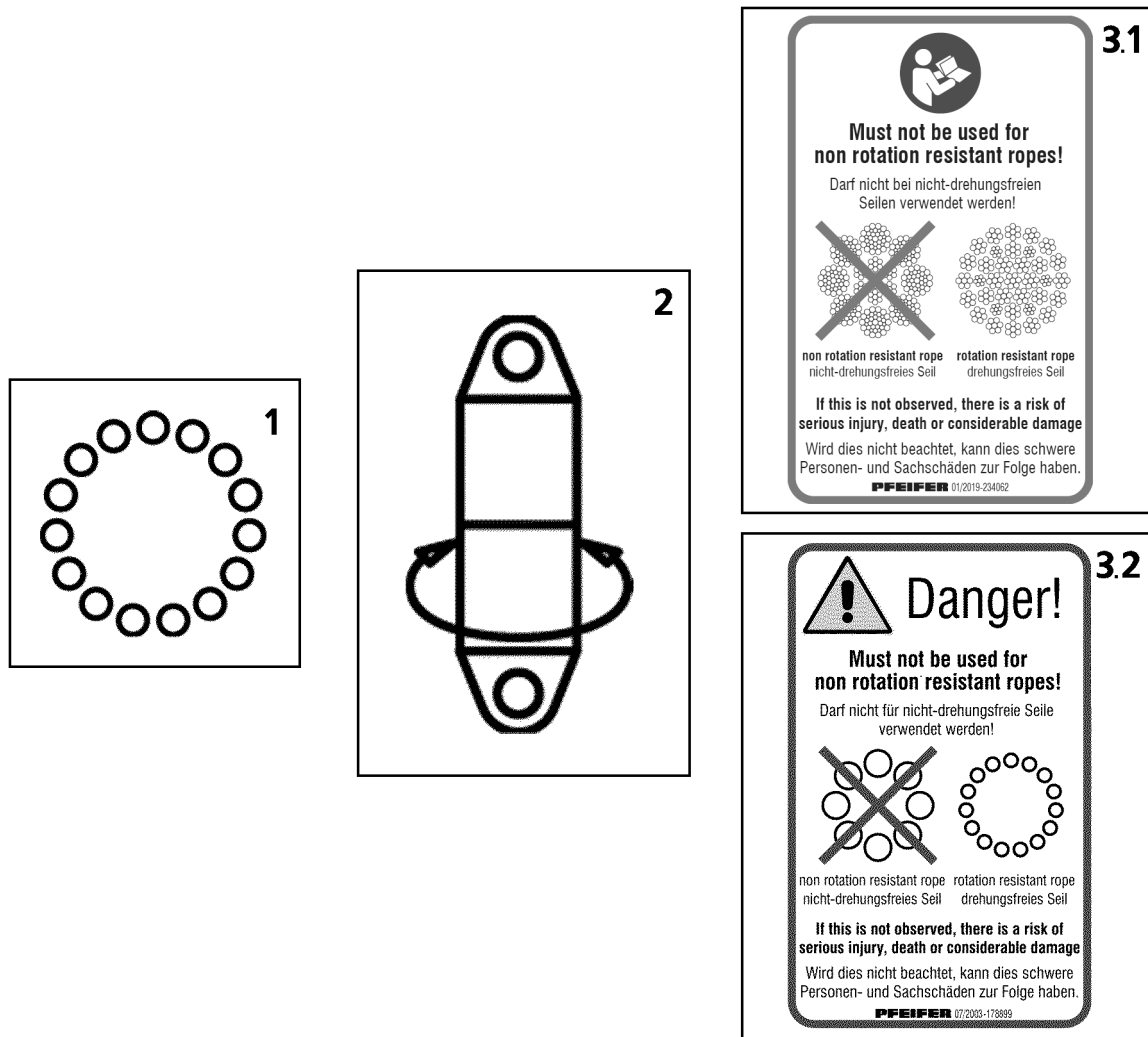


Fig.154083: Symbols for rotation-resistant ropes with rope end connections

- |   |                                     |     |  |
|---|-------------------------------------|-----|--|
| 1 | Rotation-resistant rope symbol      | 3.1 | Variation 1: Warning display on the PFEIFER lock |
| 2 | Rotating rope end connection symbol | 3.2 | Variation 2: Warning display on the PFEIFER lock |

Typical rotation-resistant rope structures are wire ropes with 15 to 18 outer strands. Rotation-resistant ropes are symbolically depicted with 15 outer strands (circles), see illustration 1.

### 9.1.1 Non-rotating rope end connection



#### Note

- ▶ In the case of a rotation-resistant ropes, Liebherr recommends the use of a lock **without** a swivel or a wedge lock. This can reduce the stress on the hoist ropes.

### 9.1.2 Rotating rope end connection



#### Note

- ▶ In the case of rotation-resistant ropes, Liebherr recommends **not** using a lock **with** a swivel and **not** to use a twist compensator / swivel.

To reduce a problematic turning behavior, the following rope end connections can be used in an individual case and after consultation with Liebherr customer service:

- Lock **with** swivel



- Twist compensator / swivel

## 9.2 Non-twisting ropes with rope end connections



### WARNING

Wire rope with impermissible rope end connection!

The wire rope can fail. The load can fall down.

Death, severe bodily injuries, property damage.

- ▶ Use a lock **without** a swivel or a wedge lock.
- ▶ **Never** use a lock **with** a swivel with non-twisting rope.
- ▶ **Never** use a twist compensator / swivel with a non-twisting rope.

Use non-twisting ropes as **guy ropes** or **control ropes**, **auxiliary ropes** or **assembly ropes**.

Non-twisting ropes generate high torque levels on the rope end connection under strain. For this reason, the rope ends must be protected from twisting using an appropriate rope end connection to prevent the wire rope from unscrewing under strain.

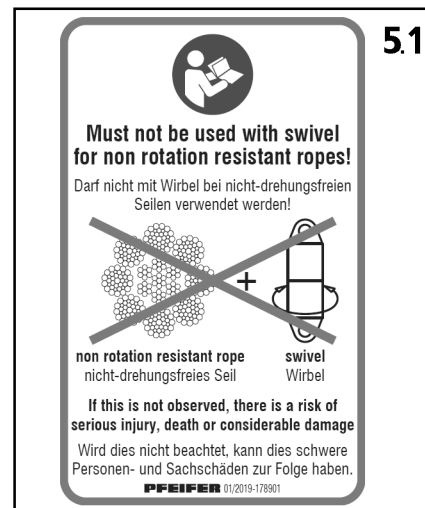
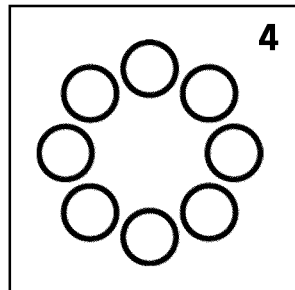


Fig.154084: Symbols for non-twisting ropes with rope end connections

4 Non-twisting rope symbol

5.2 Variation 2: Warning display on the PFEIFER lock / wedge lock

5.1 Variation 1: Warning display on the PFEIFER lock / wedge lock

Typical non-twisting rope structures are wire ropes with eight or ten outer strands. Non-twisting ropes are symbolically depicted with eight outer strands (circles), see illustration 4.

Only use non-twisting ropes with the following **non-twisting** rope end connections:

- Lock **without** swivel
- Wedge lock

A non-rotating rope end connection is also the mounting of the rope on the fixed point of the winch drum.

## 10 Degree of severity

The deciding factor for the removal criteria is which removal criteria are present and to which degree they occur.

When various removal criteria are **not** present to a full degree, then the removal criteria must be evaluated as a total entity. For every individual removal criteria a degree of severity must be determined (percentage value).

For a certain rope section the sum of individual degrees of severity results in a **combined degree of severity**, see section „Combined degree of severity“.

When the combined degree of severity is more than 100 %, then the rope must be taken down.

## 11 Abbreviations Rope diameter

Abbreviations	Description
Rope nominal diameter <b>d</b>	Rope diameter, identification of rope
Reference diameter <b>d<sub>ref</sub></b>	Measured rope diameter of a straight rope section, directly after placing the rope
6d	Length of 6-fold rope nominal diameter
30d	Length of 30-fold rope nominal diameter

*Abbreviations Rope diameter*

## 12 Distortions and mechanical damage



### WARNING

Distortions and mechanical damage!

Operational safety significantly disturbed, uneven load distribution within the rope.

- ▶ Have the manufacturer check if the distorted and damaged area can be severed.

Visible form changes often occur localized or in short rope sections.

When a safe operation of the rope is ensured, a distorted and damaged area can be severed.

## 13 Removal criteria Overview

The following chart provides an overview between removal criteria and the respective method for inspection. The degree is described, when the removal criteria is reached.

The removal criteria is described in detail in the subsequent sections.

**Note**

When the rope for parallel operation has reached the removal criteria:

- ▶ Often, both ropes must be replaced. The new rope has a larger diameter and other elongation characteristics.

Removal criteria	Degree for removal criteria	Inspection method
Broken strands	One strand is broken	Visual check
Broken wires on ropes, which run over rope pulleys and are spooled in multiple layers	Maximum number of broken wires reached, see Section Determining the number of broken wires	Count
Broken wire in the strand valleys	Two or more broken wires in strand valleys, on the contact points of two neighboring strands within an angular length (corresponds approx. to 6d)	Count
Broken wires in the area of the rope end connection	Two or more broken wires, according to decision of <b>expert personnel for crane rope inspection</b>	Visual inspection, test with marlin spike
Broken wire nests	On occurrence	Visual check
Reduction rope diameter at even diameter reduction	Maximum reduction of rope diameter reached	Measurement, calculation
Localized increase of rope diameter	Maximum increase of rope diameter reached	Measurement
Significant corrosion	Surface of rope is significantly affected or rust film emerges, according to decision of <b>expert personnel for crane rope inspection</b>	Visual check
Corkscrew-like distortion	Maximum permissible distortion reached	Measurement, calculation
Basket formation	On occurrence	Visual check
Wires or bunches of wires protruding from the rope	On occurrence, if more than one wire protrudes from the rope	Visual check
Flattenings	Larger than half of the diameter of the outer strand, according to decision of <b>expert personnel for crane rope inspection</b>	Visual check
Loop formation	Loops on several wires	Visual check
Kinking or remaining distortion	On occurrence	Visual check
Buckles or contusions	On occurrence, according to decision of <b>expert personnel for crane rope inspection</b>	Visual check

Removal criteria	Degree for removal criteria	Inspection method
Heat influence, electric voltage	Bluish discoloration, broken or melted wires	Visual check
Damage on rope end connections: Material cracks, deformation, wear, corrosion, traces of slipping between the locking clamp and rope	According to decision of <b>expert personnel for crane rope inspection</b>	Visual inspection
Combined degree of severity	Degree of severity 100 % or above, according to decision of <b>expert personnel for crane rope inspection</b>	Calculation of individual degrees of severity

*Removal criteria Overview*

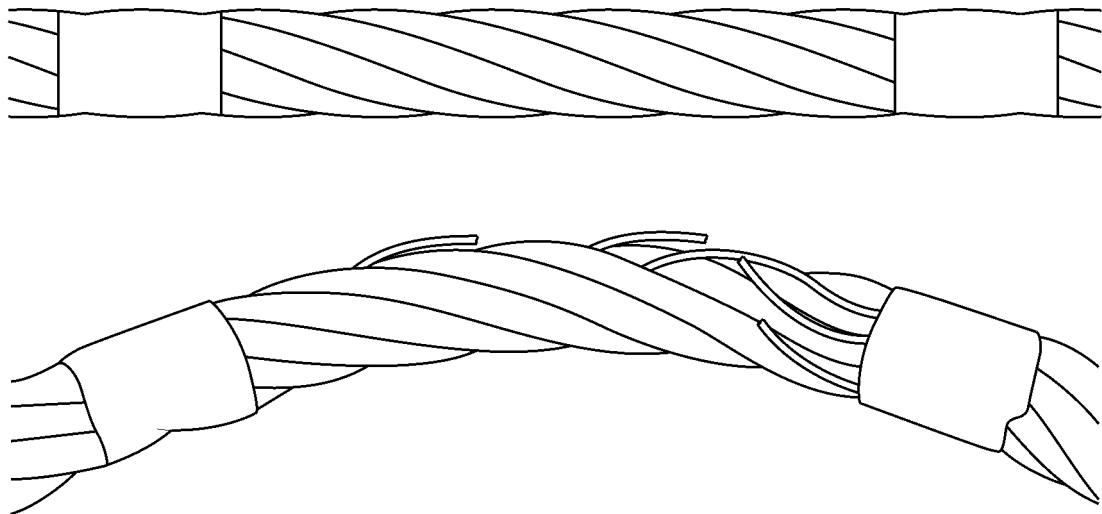
## 14 Checking for broken strands

A strand consists of several individual wires.

If a complete strand is broken:

- ▶ Take the rope down.

## 15 Determining the number of broken wires



*Fig.120980: Determine broken wires by bending*

By bending the rope, broken wires can be recognized better.

Make sure that the following prerequisites are met:

- The rope is clean.
- Inspection checklist is on hand.

### 15.1 Scattered occurring broken wires

The following different rope types each have their own chart for the permissible number of broken wires:

- Single layer and parallel roped ropes

- Rotation resistant ropes

The charts in this section are valid exclusively for **scattered occurring broken wires**.

### 15.1.1 Wire break increase rate

The wire break increase rate is an increase of broken wires, which can skyrocket with increasing use of the rope.

- ▶ Include the inspection checklists for the previous inspection and use it to draw a conclusion for the wire break rate increase.

### 15.1.2 Single layer and parallel roped ropes

Rope category number RCN	Total number of load carrying wires in the outer strand layer of rope <sup>1</sup>  n	Number of visible outer wire breaks <sup>2</sup>					
		Rope sections, which run over steel pulleys and / or wind up on a single layer spooling drum  (coincidental distribution of broken wires)				Rope sections, which wind up on a multi layer drum <sup>3</sup>	
		Class M1 to M4, or class unknown <sup>4</sup>				All classes	
		Lang lay		Even lay		Lang lay and even lay	
		Over a length of 6d <sup>5</sup>	Over a length of 30d <sup>5</sup>	Over a length of 6d <sup>5</sup>	Over a length of 30d <sup>5</sup>	Over a length of 6d <sup>5</sup>	Over a length of 30d <sup>5</sup>
01	$n \leq 50$	2	4	1	2	4	8
02	$51 \leq n \leq 75$	3	6	2	3	6	12
03	$76 \leq n \leq 100$	4	8	2	4	8	16
04	$101 \leq n \leq 120$	5	10	2	5	10	20
05	$121 \leq n \leq 140$	6	11	3	6	12	22
06	$141 \leq n \leq 160$	6	13	3	6	12	26
07	$161 \leq n \leq 180$	7	14	4	7	14	28
08	$181 \leq n \leq 200$	8	16	4	8	16	32
09	$201 \leq n \leq 220$	9	18	4	9	18	36
10	$221 \leq n \leq 240$	10	19	5	10	20	38
11	$241 \leq n \leq 260$	10	21	5	10	20	42
12	$261 \leq n \leq 280$	11	22	6	11	22	44

Rope category number RCN	Total number of load carrying wires in the outer strand layer of rope <sup>1</sup>  n	Number of visible outer wire breaks <sup>2</sup>					
		Rope sections, which run over steel pulleys and / or wind up on a single layer spooling drum  (coincidental distribution of broken wires)				Rope sections, which wind up on a multi layer drum <sup>3</sup>	
		Class M1 to M4, or class unknown <sup>4</sup>				All classes	
		Lang lay		Even lay		Lang lay and even lay	
		Over a length of 6d <sup>5</sup>	Over a length of 30d <sup>5</sup>	Over a length of 6d <sup>5</sup>	Over a length of 30d <sup>5</sup>	Over a length of 6d <sup>5</sup>	Over a length of 30d <sup>5</sup>
13	281 ≤ n ≤ 300	12	24	6	12	24	48
	n > 300	0.04 x n	0.08 x n	0.02 x n	0.04 x n	0.08 x n	0.16 x n

**Note:** Ropes with outer strands in the Seale type, number of wires per strand 19 or less (for example 6 × 19 Seale), are classified in this chart as two lines over the line, which would be defined due to the number of load carrying wires in the outer strands.

Number of visible broken wires (reached or exceeded) for removal criteria is reached, for **single-layer** and **parallel roped ropes** according to **DIN ISO 4309**

1) For the purpose of this international standard, fill wires are not considered to be load carrying wires and are not included in the value for n.

2) A broken wire has two ends (counted as one wire).

3) The values apply for damage in the cross over areas and the layers of coils due to deflection angles (not for rope sections, which run only over rope pulleys and do not spool up on the winch).

4) For ropes on drive gears of groups M5 to M8 twice the number of broken wires listed can be used.

5) d = Rope nominal diameter

- ▶ Check the rope over the entire length for visible broken wires.

When visible broken wires are scattered present:

- ▶ On the point of a broken wire, mark the rope sections on a length of 30d in both directions.
- ▶ Count visible broken wires in the marked rope sections and record them.
- ▶ Take the RCN (Rope category number) from the manufacturer's documentation of the rope.

When the make for single layer and parallel roped ropes is **not** listed in the chart:

- ▶ Determine the total number of load carrying wires in the rope: Add all wires in the strands of the outer layer, do **not** count fill wires.
- ▶ Compare the number of broken wires of each marked rope section 30d with the number of broken wires in the chart.

When the number of visible broken wires is smaller than listed in the chart:

- ▶ Within the rope section with the most broken wires: Mark the rope section with the most broken wires on a length of 6d.
- ▶ Count visible broken wires in the marked rope sections 6d and record them.
- ▶ Compare the number of broken wires of the marked rope section with the number of broken wires in the chart.

When the number of visible broken wires is equal to or larger than that listed in the chart:

- ▶ Take the rope down.
- ▶ Enter the results in the inspection checklist.

### 15.1.3 Rotation resistant ropes

Rope category number RCN	Total number of load carrying wires in the outer strands of rope <sup>1</sup>  n	Number of visible outer wire breaks <sup>2</sup>			
		Rope sections, which run over steel pulleys and / or wind up on a single layer spooling drum  (coincidental distribution of broken wires)		Rope sections, which wind up on a multi layer drum <sup>3</sup>	
		Over a length of 6d <sup>4</sup>	Over a length of 30d <sup>4</sup>	Over a length of 6d <sup>4</sup>	Over a length of 30d <sup>4</sup>
21	4 strands n ≤ 100	2	4	2	4
22	3 or 4 strands n ≥ 100	2	4	4	8
	At least 11 strands in the outer layer				
23-1	71 ≤ n ≤ 100	2	4	4	8
23-2	101 ≤ n ≤ 120	3	5	5	10
23-3	121 ≤ n ≤ 140	3	5	6	11
24	141 ≤ n ≤ 160	3	6	6	13
25	161 ≤ n ≤ 180	4	7	7	14
26	181 ≤ n ≤ 200	4	8	8	16
27	201 ≤ n ≤ 220	4	9	9	18
28	221 ≤ n ≤ 240	5	10	10	19
29	241 ≤ n ≤ 260	5	10	10	21
30	261 ≤ n ≤ 280	6	11	11	22
31	281 ≤ n ≤ 300	6	12	12	24
	n > 300	6	12	12	24

**Note:** Ropes with outer strands in Seale type, number of wires in each strand 19 or less (for example 18 × 19 Seale - WSC), are classified in this chart as two lines over the line, which would be defined due to the number of load carrying wires in the outer strands.

*Number of visible broken wires (reached or exceeded) is achieved in the rope removal criteria, for **rotation-resistant** ropes according to **DIN ISO 4309***

- 1) For the purpose of this international standard, fill wires are not considered to be load carrying wires and are not included in the value for n.
- 2) A broken wire has two ends (counted as one wire).
- 3) The values apply for damage in the cross over areas and the layers of coils due to deflection angles (not for rope sections, which run only over rope pulleys and do not spool up on the drum).
- 4) d = Rope nominal diameter

- ▶ Check the rope over the entire length for visible broken wires.

When visible broken wires are scattered present:

- ▶ On the point of a broken wire, mark the rope sections on a length of 30d in both directions.
- ▶ Count visible broken wires in the marked rope sections and record them.
- ▶ Take the RCN (Rope category number) from the manufacturer's documentation of the rope.

When the make for rotation-resistant ropes is **not** listed in the chart:

- ▶ Determine the total number of load carrying wires in the rope: Add all wires in the strands of the outer layer, do **not** count fill wires.

- ▶ Compare the number of broken wires of each marked rope section 30d with the number of broken wires in the chart.

When the number of visible broken wires is smaller than listed in the chart:

- ▶ Within the rope section with the most broken wires: Mark the rope section with the most broken wires on a length of 6d.
- ▶ Count visible broken wires in the marked rope sections 6d and record them.
- ▶ Compare the number of broken wires of the marked rope section with the number of broken wires in the chart.

When the number of visible broken wires is equal to or larger than that listed in the chart:

- ▶ Take the rope down.
- ▶ Enter the results in the inspection checklist.

## 15.2 Broken wire in the strand valleys

The broken wires in these areas point to the fact that the condition in the inside of the rope is deteriorating.

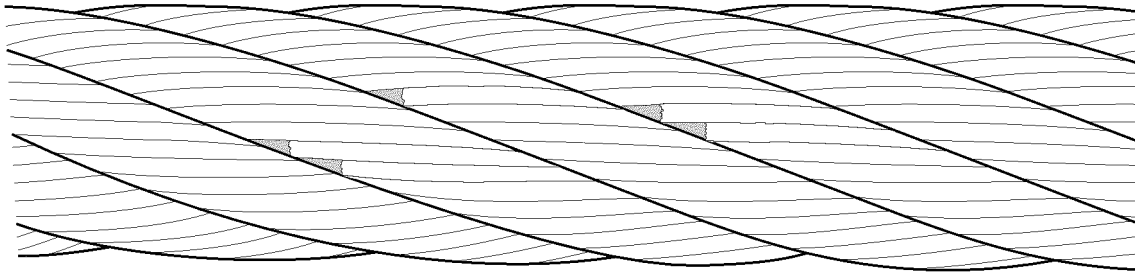


Fig.121005: Broken wire in the strand valleys

When two or more broken wires occur within a 6d long rope section:

- ▶ Take the rope down.

## 15.3 Broken wires on rope end connections

- ▶ Check the area near the rope end connections and carefully check for broken wires.

Loose wires are a sign of broken wires in the rope end connection.

- ▶ Use a marlin spike to check for loose wires.

When broken wires are near a rope end connection and two or more wires are affected:

- ▶ Take the rope down.

**or**

When the remaining rope lengths fulfil the minimum number of remaining coils in all operating positions:

Shorten the rope, see chapter 7.05.50.

- ▶ Attach the rope end connection.

## 15.4 Broken wires in rope sections, which are not spooled up on the winch

When the broken wires are concentrated on one or two strands, the removal criteria can be present at fewer broken wires as noted in the chart (rope section in the length of 6d).

- ▶ Have the rope removal criteria determined by **expert personnel for crane rope inspection**.



## 15.5 Broken wire nests

When broken wires are very close to each other or when the broken wires are concentrated on one strand, then the rope must be taken down, even at fewer broken wires than noted in the chart (rope section 6d).

- ▶ Have the rope removal criteria determined by **expert personnel for crane rope inspection**.

## 16 Checking the rope end connection

The removal criteria are evaluated by the **expert personnel for crane rope inspection**.

Check for broken wires, see section „Broken wires on rope end connections“.

### 16.1 Pressed rope end connection

Example of a pressed rope end connection: Locking clamp.

- ▶ Check the rope end connections for signs of possible slipping between the locking clamp and the wire rope.
- ▶ Check the rope end connections for material cracks.
- ▶ Check rope end connections for corrosion, deformation and wear.

### 16.2 Enlarged rope end connection

Example of an enlarged rope end connection: Locking cast sleeve.

- ▶ If present: Remove the beam.
- ▶ Check rope end connections for corrosion, deformation and wear.

If the rope connection is on a flat rope:

- ▶ Check the cone setting, see chapter 8.04.10.

### 16.3 Detachable rope end connection

Example of a detachable rope end connection: Wedge lock.

- ▶ Check that the rope end connections are fit tightly and correctly installed.
- ▶ Check the wire rope inside and at the outlet of the rope end connection. Check the rope according to the removal criteria in this chapter.

## 17 Checking of rope diameter

### 17.1 Even reduction of rope diameter



#### WARNING

Spooling problems due to reduced rope diameter!

- ▶ Take the rope down even when the removal criteria according to **DIN ISO 4309** has not yet been reached.

The values in this section do **not** apply for rope sections, which were damaged in cross over areas due to multi layer spooling on a winch.

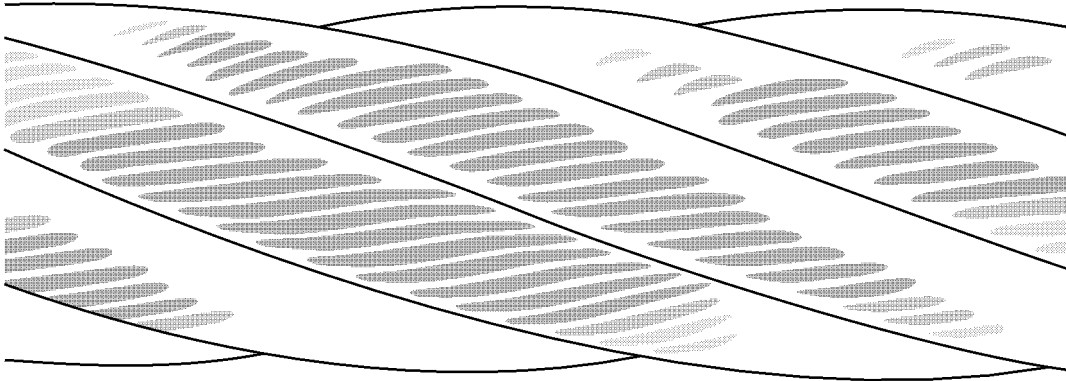


Fig.121001: External abrasion on the rope

The rope diameter changes due to abrasion, settling and external influences.

Abrasion of cover wires of outer strands of rope due to frictional contact. Especially in those areas where ropes are in contact with the rope pulleys during start up or slow down of the load.

Wear is increased by lack of or incorrect lubrication and the effect of dust.

Abrasion reduces the tensile strength of steel ropes because the cross section of the steel is reduced.

Additional possible causes for reduction of rope diameter:

- Wear in the inside of the rope
- Wear of fiber insert
- Breakage of a steel insert
- Broken inner strands

This section is valid solely for the following ropes:

- Ropes, which wind up on single layer winches
- Ropes, which run through a steel rope pulley

$$d_v = \frac{d_{\text{ref}} - d_m}{d} \times 100 \%$$

Fig.121372: Formula Reduction of rope diameter

$d_v$  = even reduction of rope diameter

$d_{\text{ref}}$  = rope diameter, which was determined before placement

$d_m$  = measured rope diameter

$d$  = rope nominal diameter: Take value from inspection checklist

The following chart applies exclusively for ropes, which wind up on single layer winches and / or run through a steel rope pulley.

Rope type	Even reduction of diameter $d_v$ (in percentages of rope nominal diameter $d$ )	Classification of degree of severity	
		Description	%
	Less than 6 %	—	0
Single layer rope with fiber insert	6 % and above, but less than 7 %	Light	20
	7 % and above, but less than 8 %	Medium	40
	8 % and above, but less than 9 %	High	60
	9 % and above, but less than 10 %	Very high	80
	<b>10 % and above</b>	<b>Rope removal criteria</b>	<b>100</b>

Rope type	Even reduction of diameter $d_v$ (in percentages of rope nominal diameter $d$ )	Classification of degree of severity	
		Description	%
Single layer rope with steel insert or parallel roped rope	Less than 3.5 %	—	0
	3.5 % and above, but less than 4.5 %	Light	20
	4.5 % and above, but less than 5.5 %	Medium	40
	5.5 % and above, but less than 6.5 %	High	60
	6.5 % and above, but less than 7.5 %	Very high	80
	<b>7.5 % and above</b>	<b>Rope removal criteria</b>	<b>100</b>
Rotation-resistant rope	Less than 1 %	—	0
	1 % and above, but less than 2 %	Light	20
	2 % and above, but less than 3 %	Medium	40
	3 % and above, but less than 4 %	High	60
	4 % and above, but less than 5 %	Very high	80
	<b>5 % and above</b>	<b>Rope removal criteria</b>	<b>100</b>

*Degree of severity and removal criteria depending on rope type and even diameter reduction according to DIN ISO 4309*

The medium value from the smallest and the largest measured diameter results in the value for  $d_m$ .

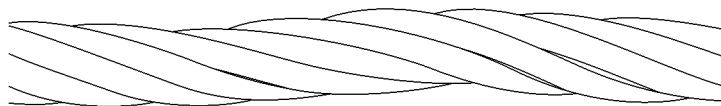
- ▶ Measure rope diameter on several locations and calculate measured diameter  $d_m$ .
- ▶ Calculate even reduction  $d_v$  of rope diameter with formula.
- ▶ Read the degree of severity in the chart, depending on the rope type.
- ▶ Document the degree of severity in the inspection checklist.

When the degree of severity has reached 100 %:

- ▶ Take the rope down.

## 17.2 Localized reduction of rope diameter

Localized reductions of rope diameter point to the fact that a rope insert may have failed, for example.



*Fig. 120983: Localized reduction of rope diameter*

- ▶ Check the rope for localized reduction of rope diameter.

When a localized reduction of the rope diameter is found:

- ▶ Take the rope down.

## 17.3 Localized increases of rope diameter

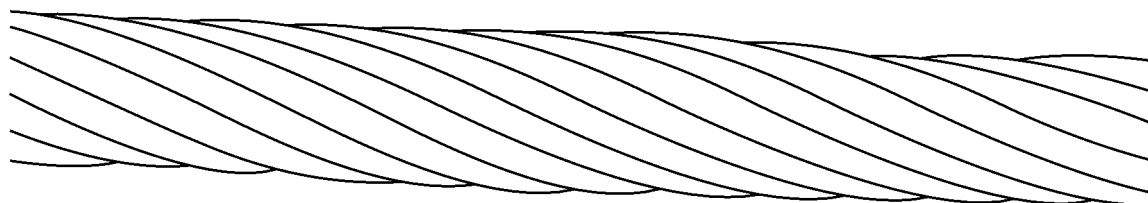


Fig. 120992: Localized increase of rope diameter

An increase over a longer area of the rope can be caused by absorption of moisture in the fiber insert or due to corrosion in the inside of the rope.

Rope insert	Maximum increase of rope diameter during operation
Steel	5 %
Fiber	10 %

- ▶ Check the rope for increases in rope diameter.

When the increases exceed the maximum values:

- ▶ Take the rope down.

## 18 Corrosion

Corrosion occurs due to insufficient lubrication, in maritime climates and in an atmosphere polluted by industrial fumes.

External corrosion is indicated by a rough wire surface. A superficial rust film can be wiped off.

Significant corrosion reduces the strength and elasticity of the rope due to the reduction of the rope diameter.

Inner corrosion is hard to detect.

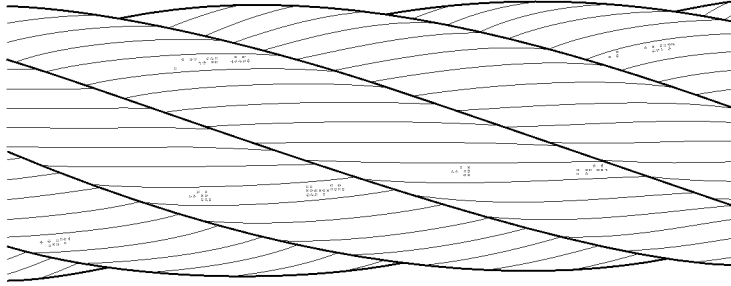
Do **not** use solvents to clean the rope.

Make sure that the following prerequisite is met:

- Rope is cleaned (wiped and brushed).

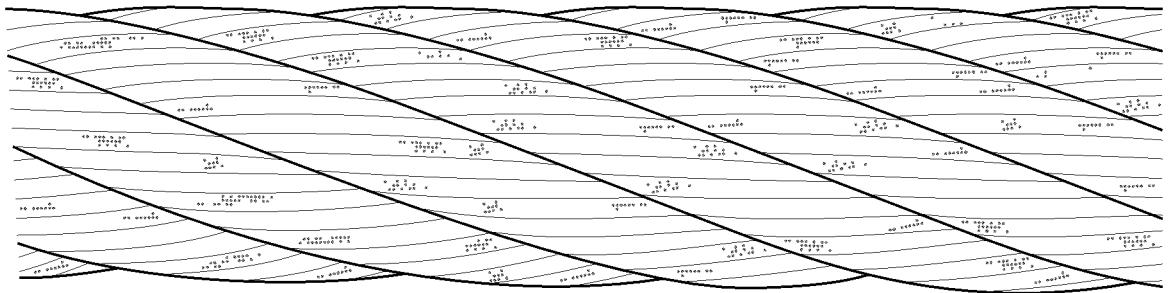
### 18.1 External corrosion

The various types of corrosion are classified and noted with the classification for removal criteria in percentages:

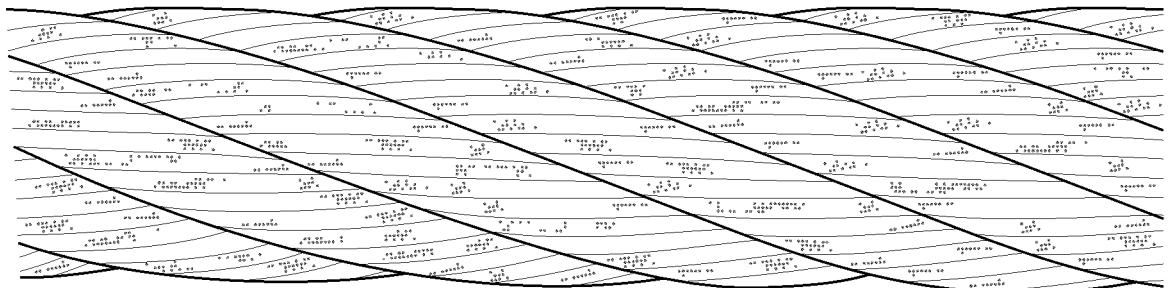


*Fig.120984: Surface light corrosion: Classification 0 % of removal criteria*

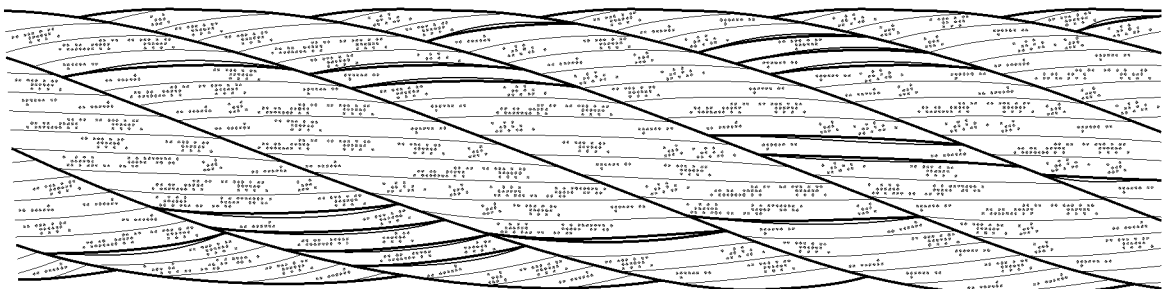
Superficial light corrosion (rust film) can be wiped off.



*Fig.120985: Surface feels rough: Classification 20 % of removal criteria*



*Fig.120986: Surface feels very rough: Classification 60 % of removal criteria*



*Fig.120987: Surface very decayed, spaces between individual wires can be easily recognized: Classification 100 % of removal criteria*

When 100 % of removal criteria is reached:

- ▶ Take the rope down.

## 18.2 Internal corrosion

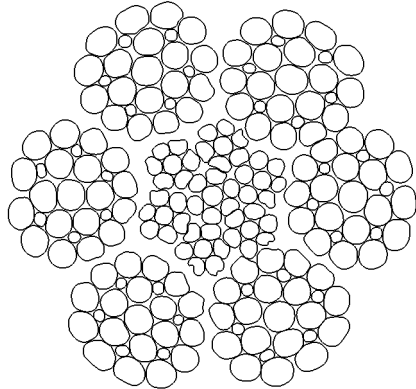


Fig.120982: Corrosion in the inside of the rope

Internal corrosion is present when clearly visible corrosion particles migrate between the valleys of the outer strands: Classification 100 % removal criteria.

When internal corrosion is found:

- ▶ Have the rope removal criteria evaluated by **expert personnel for crane rope inspection** or take the rope down.

## 18.3 Friction corrosion

Friction corrosion occurs as a type of brown powder, which migrates from the inside of the rope to the outside: Classification 100 % of removal criteria.

- ▶ Check the rope diligently for friction corrosion.

If friction corrosion is found:

- ▶ Have the rope removal criteria evaluated by **expert personnel for crane rope inspection** or take the rope down.

## 19 Corkscrew-like distortion



Fig.120988: Corkscrew-like distortion

Distortion where the rope is in the form of a corkscrew along its longitudinal axis.

Effects of corkscrew-like distortion:

- Irregular rope drive
- Rope wear
- Broken wire
- Bearing damage on rope pulleys

If the distortion is very pronounced, then other components can be affected in their function when the affected rope section runs through in crane operation.

- ▶ Check the entire rope for corkscrew-like distortion.

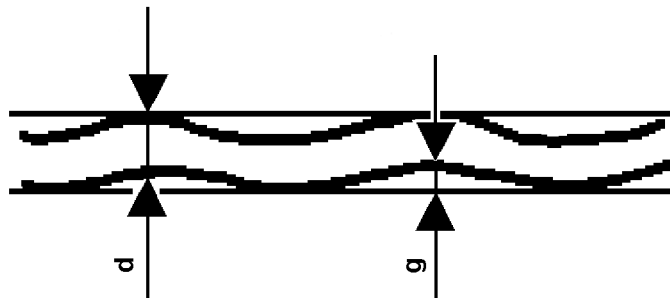


Fig.123988: Example for corkscrew-type distortion

**d** Rope nominal diameter    **g** Distance

Rope section	Conditions for removal criteria, formula
Straight rope section, which does <b>not</b> run through or around a rope pulley or spool up on a winch	$g \geq \frac{1}{3} \times d$
Straight rope section, which runs through or around a rope pulley or spools up on a winch	$g \geq \frac{1}{10} \times d$

When corkscrew-like distortion is present:

- ▶ Determine the rope nominal diameter **d** and distance **g** on the rope.
- ▶ Check the removal criteria with the formula.

When the removal criteria is reached:

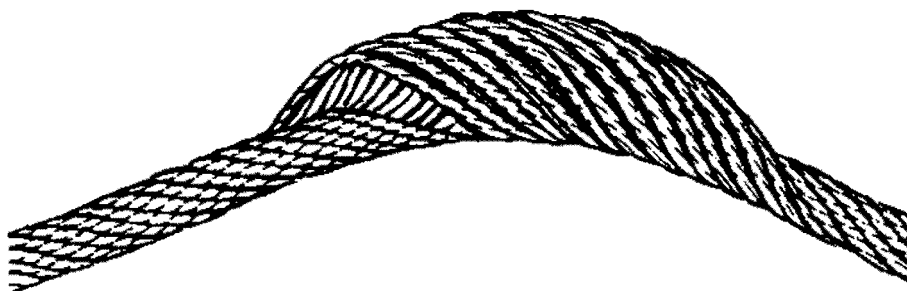
- ▶ Take the rope down.

## 20 Basket formation

This distortion occurs due to different layers between the outer strand layers and the inside of the rope.

Causes for basket formation are high angular pull angles during the run over the rope pulleys and run-in rope pulleys. Even load distribution over the entire cross section is not possible.

LWE/LTR 1220-003/24204-02-02/en



*Fig.120989: Basket formation*

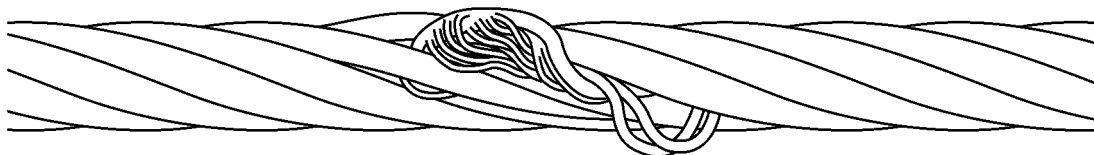
- ▶ Check the entire rope for basket formation.

When basket formation is present:

- ▶ Take the rope down.

## 21 Protruding, distorted insert or strand

This distortion is a special form of basket formation. The insert or the core of the rope protrudes between the outer strands or an outer strand protrudes from the rope banding.

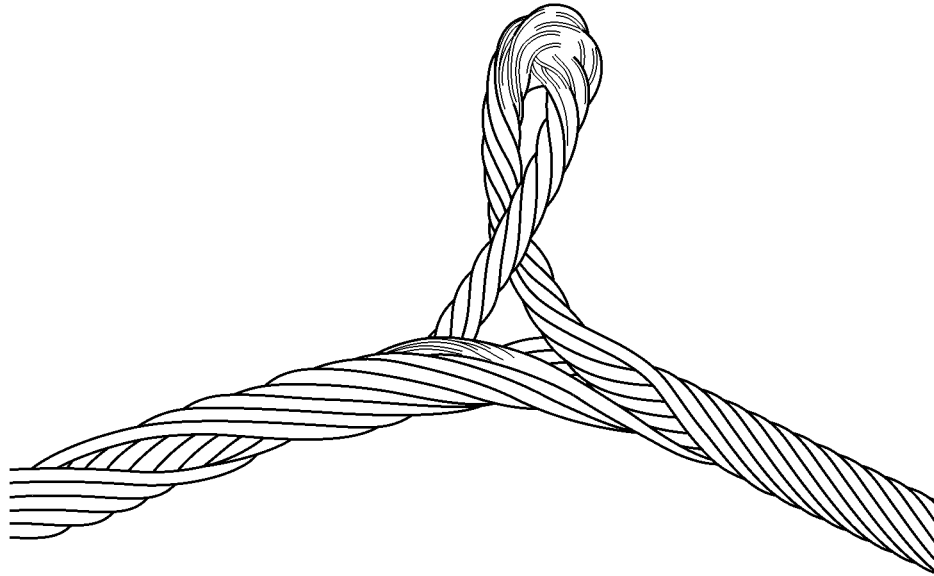


*Fig.120990: Protrusion of an insert (rope single layer)*



*Fig.120991: Distorted or protruding strand*





*Fig.121373: Protrusion of rope insert on rotation-resistant rope*

When the insert or a strand protrudes or is distorted, take the rope down. Have authorized inspector for crane rope inspection check if the rope area with the distortion can be removed.

- ▶ Check the entire rope for protruding, distorted insert or strand.

When protruding, distorted insert or braid is present:

- ▶ Take the rope down.
- ▶ Have **expert personnel for crane rope inspection** check if the rope area with the distortion can be removed.

## 22 Loop formation

At loop formation individual or several wires protrude from the rope and bulge upward (bird-caging).

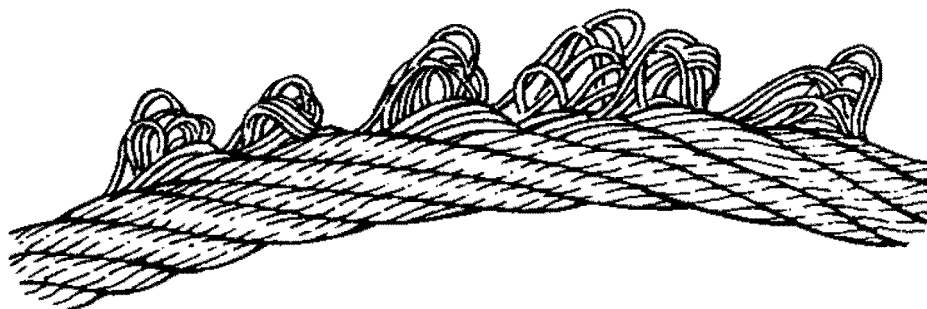
These areas are most often on the opposite side of the rope pulley groove.

Make sure that the following prerequisite is met:

- There are **no** broken wire ends present.

If only a core wire of the rope insert protrudes through the outer strands, then the rope does not have to be taken down when:

- The wire can be removed.
- The wire does not disturb other elements of the rope drive.



*Fig.120993: Emergence of individual wires*

- ▶ Check rope for loop formation.

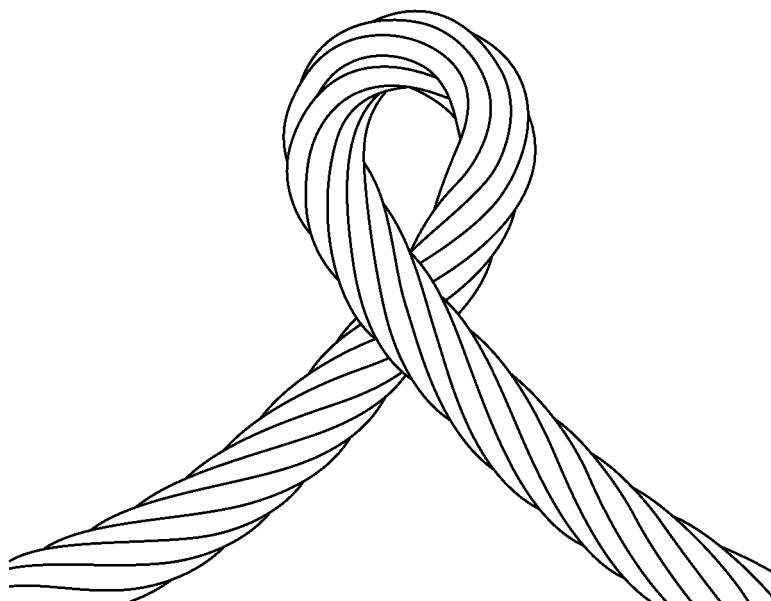
When solely a core wire protrudes:

- ▶ Remove the core wire.

When several wires are affected from the loop formation:

- ▶ Take the rope down.

## 23 Kinking or rope loops pulled closed



*Fig.121007: Kinking or rope loop pulled closed*

At this deformation a loop has formed in the rope, without the possibility to rotate around its own axis during a load. The rope is subjected to significant wear.

The rope is significantly distorted. The strength remains only in part.

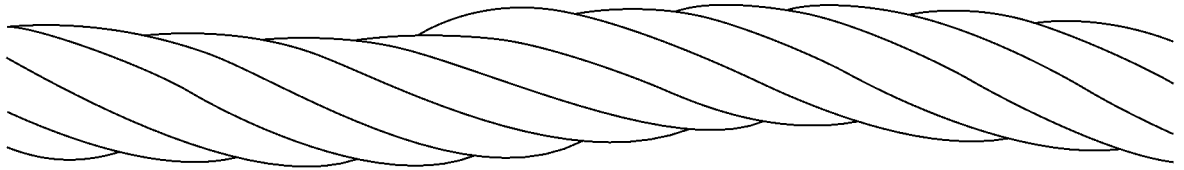


Fig.121002: Positive Kinking

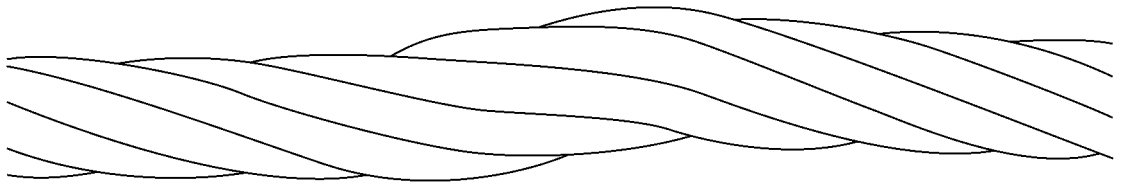


Fig.121003: Negative Kinking

- ▶ Check the rope for kinking or rope loops pulled closed.

When kinking or rope loops pulled closed occur:

- ▶ Take the rope down.

## 24 Buckles

Buckles are angular deformations. The rope was damaged due to external influences. Strong deformations of the rope cause stronger wear.

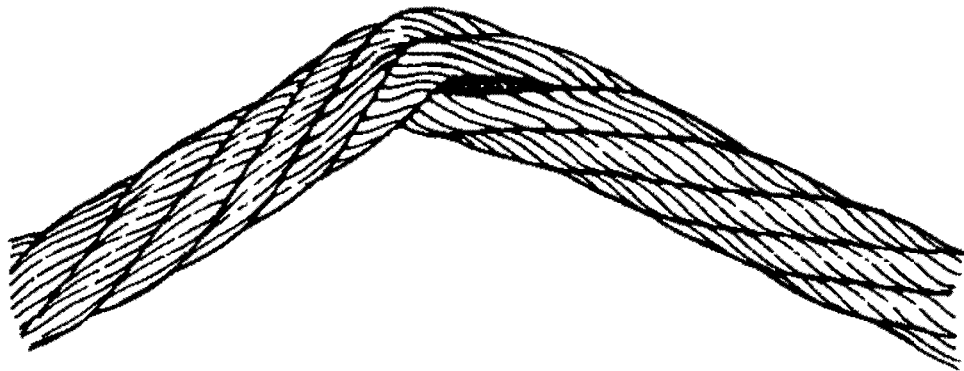


Fig.120999: Severe buckle

A buckle is a serious matter if a fold is visible on the underside of the rope.

When buckles are present:

- ▶ Have the rope inspected by **expert personnel for crane rope inspection**.

When a distortion and degree of severity permits further operation:

- ▶ Shorten the inspection interval.

When the removal criteria is reached:

- ▶ Take the rope down.

## 25 Effects of heat, arcs

Damage caused to the rope by welding work, for example.

Exceptional thermal effect is visible through tempering colors, the loss of lubricant and by localized melting of wires.

When thermal effect has occurred on the rope:

- ▶ Take the rope down.

## 26 Combined degree of severity



### Note

- ▶ For a method to determine the effect of a combined degree of severity and damage to the rope, see **DIN ISO 4309**.

When the condition of the rope deteriorates, then often a combination of various causes occurs.

To determine the degree of severity, the **expert personnel for crane rope inspection** must:

- take different damage within a rope section into account
- evaluate the entire effect of the damage and the distortions
- decide about the operational safety of the rope
- evaluate if inspection intervals must be adjusted
- decide if the rope must be taken down

**When the combined degree of severity is more than 100 %, then the rope must be taken down.**

## 27 Flattenings

Effects of flattenings on the rope:

- Rope sections with flattenings, which move **over the rope pulleys** tend to higher wear and a higher number of broken wires.
- Rope pulleys can be damaged.
- Flattenings on **stationary ropes** (guy ropes boom) promote quicker corrosion, especially in the areas where the outer strands have opened.

Flattened rope sections must be checked in shorter intervals for broken wires and corrosion.

### 27.1 Shorting the intervals

- ▶ Check the entire rope for flattenings.

When flattenings are present on stationary ropes:

- ▶ Shorten the intervals for rope inspection.

When it is **not** possible to shorten the intervals for the rope inspection:

- ▶ Take the rope down.

### 27.2 Improper mechanical damage

An improper mechanical damage occurs, for example, when the rope is trapped.

- ▶ Take the rope down immediately or shorten it, see chapter 7.05.50.

## 27.3 Operational transverse pressure

Operational transverse pressure causes flattenings, for example in the incline range of multi layer spooling.

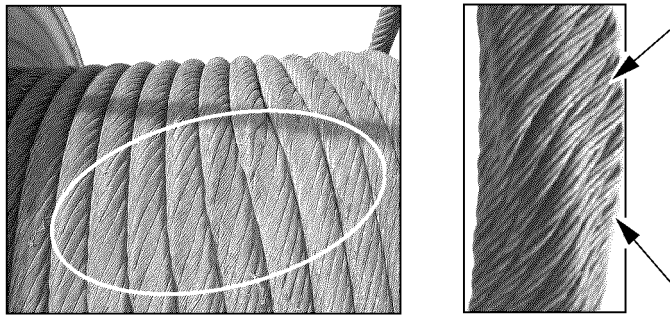


Fig.114002: Flattenings

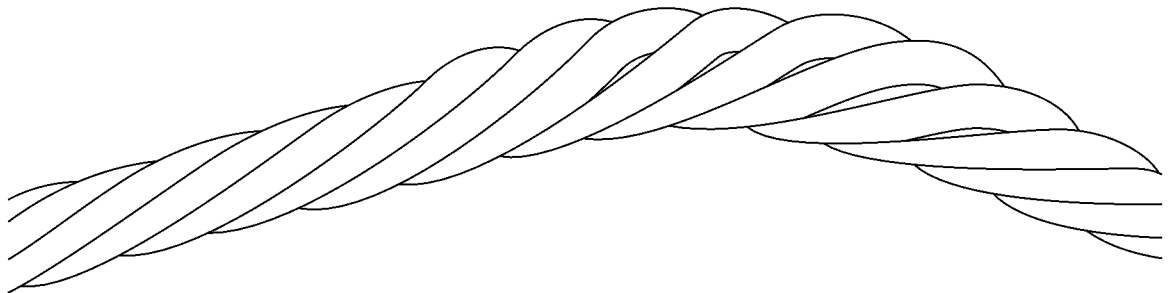


Fig.120996: Flattenings on multi layer windings

- ▶ Check the first rope layer of the winches for crushed areas and distortions.

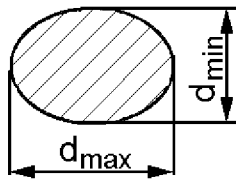


Fig.121006: Largest and smallest diameter on the distortion area

$$V = \frac{d_{\max} - d_{\min}}{d} \times 100 \%$$

Fig.121374: Formula to calculate the distortion

**V** Rope distortion in percentages

**d<sub>max</sub>** Largest diameter of distortion area

**d** Rope nominal diameter

**x**

**d<sub>min</sub>** Smallest diameter of distortion area

**n**

When distortions are present:

- ▶ Determine the number of broken wires See section „Determining the number of broken wires“.

When the number of permissible broken wires is exceeded:

- ▶ Take the rope down.
- ▶ Calculate the distortion  $V$  with the formula and document it in the inspection checklist.

When distortion  $V$  is larger than 5 %:

- ▶ Check the rope before every assembly and erection procedure.

When distortion  $V$  is larger than 10 %:

- ▶ Document the degree of severity of 50 % in the inspection checklist.

When distortion  $V$  is larger than 20 %:

- ▶ The degree of severity of 100 % is reached: Take the rope down.

# 28 Current checklist

LWE/LTR 1220-003/24204-02-02/en

<b>Crane and use:</b>																					
Rope application:			RCN <sup>3)</sup> :			Installation date:															
Brand name:			Nominal diameter:			Take-down date:															
Make <sup>1)</sup> :			<input type="radio"/> Right hand <input type="radio"/> Lang's lay <input type="radio"/> IWRC <input type="radio"/> Bare			Minimum tensile strength															
Direction of lay <sup>1)</sup> :			<input type="radio"/> Ordinary lay <input type="radio"/> FC <input type="radio"/> Galvanized			Permissible number of visible external broken wires															
Intermediate layer <sup>1)</sup> :			<input type="radio"/> WSC <input type="radio"/> Bare			Datum diameter															
Wire surface <sup>1)</sup> :						Permissible diameter reduction:			6d: 30d:												
Rope end connections:																					
Date	Visible external broken wires				Diameter				Corrosion		Damage, deformation		Severity level <sup>2)</sup>	Position in the rope	Severity level <sup>2)</sup>	Combined severity level <sup>2)</sup>	Name of expert for the wire rope	Signature			
	Number in length of	Position in the rope	Actual reduction to datum diameter	Position in the rope	Severity level <sup>2)</sup>	Position in the rope	Severity level <sup>2)</sup>	Position in the rope	Severity level <sup>2)</sup>	Position in the rope	Severity level <sup>2)</sup>										
JJ/MM/TT	6d	30d	6d	30d	6d	30d	6d	30d	6d	30d	6d	30d	6d	30d	6d	30d	6d	30d	6d	30d	

<sup>1)</sup> Check where applicable.  
<sup>2)</sup> State extent of damage; slight or 20%; medium or 40%; high or 60%; very high or 80%; take-down or 100%  
<sup>3)</sup> RCN = Rope Category Number

Fig.121370-en: Form for current checklist





## 8.05 Inspection of load hooks

1	Safety instructions	3
2	Inspection intervals	3
3	Checking the load hook	3

*Fig.195219*

LWE/LTR 1220-003/24204-02-02/en

# 1 Safety instructions

**WARNING**

The load hook did **not** pass the inspection!  
The load hook can rip. The fastened load can fall down.  
Death, severe bodily injuries, property damage.

If the load hook did **not** pass the inspection:

- ▶ Replace the load hook with the hook nut.
- ▶ Contact Customer Service at Liebherr-Werk Ehingen GmbH.

**WARNING**

**Incorrect** remedy of defects!

The load hook can rip. The fastened load can fall down.  
Death, severe bodily injuries, property damage.

- ▶ Have defects remedied by authorized, trained expert personnel.

**WARNING**

Welds on the load hook!

The load hook can rip. The fastened load can fall down.  
Death, severe bodily injuries, property damage.

- ▶ Do **not** weld the load hook, to repair defects, for example.

## 2 Inspection intervals

To detect defects in time and avoid accidents, observe the following instructions:

- Have the load hook checked as required, however **at least once a year** by an authorized inspector.
- Observe the national regulations concerning the inspection of load hooks.

## 3 Checking the load hook

The following points must be documented in the crane inspection log:

- Performance of the inspections
- Defects and damage
- Measures for remedying the defects and damage

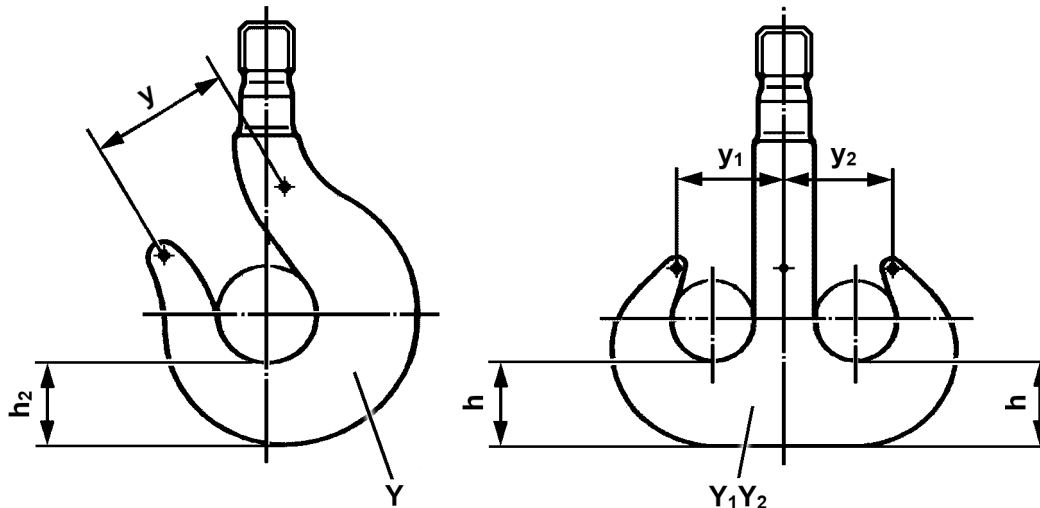


Fig.149076: Description of measured distances on the load hook

## 3.1 Checking the load hook for distortion

### 3.1.1 Hook shaft

If a distortion is visible on the hook shaft:

- ▶ Replace the load hook with the hook nut.

### 3.1.2 Hook mouth

The expansion of the hook jaw may be maximum 10 % in reference to the respective initial dimension.

The initial dimensions are indicated on the load hook, see chapter 2.05.10:

- Single hook: Initial dimension  $Y$
- Double hook: Initial dimension  $Y_1Y_2$

- ▶ Single hook: Distance  $y$  between the punch marks.
- ▶ Double hook: Measure the distance  $y_1$  and distance  $y_2$  between the punch marks.

When the expansion of the hook jaw is 10 % greater than the initial dimensions:

- ▶ Replace the load hook with the hook nut.

When the expansion of the hook jaw less than or equal to 10% of the initial dimensions:

- ▶ Follow the instructions in section „Checking the load hook for surface cracks“.

## 3.2 Checking the load hook for surface cracks

Make sure that the following prerequisites are met:

- Distortion is present.

Inspection is required in all points where distortion is present, mainly on the hook jaw.

If it is **not** possible to check the installed load hook:

- ▶ Remove the load hook: Contact Customer Service at Liebherr-Werk Ehingen GmbH.
- ▶ Prior to the inspection: Put the surfaces into a state in which surface cracks can be detected correctly.
- ▶ Check the load hook for surface cracks using a suitable procedure.

An authorized inspector must decide if the surface cracks can be repaired.

When the surface cracks have been repaired:

- ▶ Check if the load hook dimensions lie within the permissible tolerances. Contact Customer Service at Liebherr-Werk Ehingen GmbH.

When the surface cracks are **not** permissible:

- ▶ Replace the load hook with the hook nut.

### 3.3 Checking the hook body for wear

#### 3.3.1 Hook base

The wear on the hook base may be maximum 5 % in reference to the respective initial dimension:

- Single hook: Initial dimension  $h_2$
- Double hook: Initial dimensions  $h$

The respective initial dimensions are provided in the following chart:

Hook number	Single hook $h_2$ [mm]	Double hook $h$ [mm]
4	67	—
5	75	—
6	85	75
8	95	85
10	106	95
12	118	106
16	132	118
20	150	132
25	170	150
32	—	170
40	—	190
50	—	212
63	—	236
80	—	265
100	—	300
125	—	335
160	—	375
200	—	425
250	—	475
320	—	530
400	—	600

Initial dimensions for wear on the hook base, single hooks and double hooks

- ▶ Single hook: Measure the initial dimension  $h_2$ .
- ▶ Double hook: Measure the initial dimensions  $h$ .

When the wear on the hook base is 5 % greater than the initial dimension:

- ▶ Replace the load hook with the hook nut.

#### 3.3.2 Surfaces

Surfaces with wear must be connected smoothly with the adjacent surfaces.

- ▶ Check surfaces with wear for sharp edges, grooves or other surface errors.

An authorized inspector must decide if the surface errors can be repaired.

When the surface errors have been repaired:

- ▶ Check if the load hook dimensions lie within the permissible tolerances. Contact Customer Service at Liebherr-Werk Ehingen GmbH.

When the wear is **not** permissible:

- ▶ Replace the load hook with the hook nut.

### 3.4 Checking the double hook for damage

Visible damage indicate **improper** fastening of the load.

Relevant areas for the inspection:

- Lower area on the hook shaft
- On every hook: Transition area from the hook shaft to the hook jaw

- ▶ Check the load hook for visual damage.

An authorized inspector must decide if the damage can be repaired.

When the damage has been repaired:

- ▶ Check if the load hook dimensions lie within the permissible tolerances. Contact Customer Service at Liebherr-Werk Ehingen GmbH.

When the damage is **not** permissible:

- ▶ Replace the load hook with the hook nut.

### 3.5 Checking the load hook for corrosion

Depending on the overall condition of the load hook, an inspection expert must decide if the hook thread must be checked for corrosion nicks.

If the hook thread must be checked:

- ▶ Determine the Liebherr ID no. and manufacturer of the load hook, see chapter 2.05.10.
- ▶ Request the assembly instructions for the load hook: Contact Customer Service at Liebherr-Werk Ehingen GmbH.
- ▶ Remove the load hook: Contact Customer Service at Liebherr-Werk Ehingen GmbH.
- ▶ Disassemble the hook nut according to the manufacturer's assembly instructions.
- ▶ Check the hook thread, hook nut and machines surfaces on the hook shaft for corrosion.

An inspection expert must decide if the corrosion nicks can be repaired.

When the corrosion nicks have been repaired:

- ▶ Check if the dimensions of the hook thread and the hook shaft lie within the permissible tolerances. Contact Customer Service at Liebherr-Werk Ehingen GmbH.

If an **impermissible** axial play is suspected on the hook nut:

- ▶ Contact Customer Service at Liebherr-Werk Ehingen GmbH.

When the corrosion is **not** permissible:

- ▶ Replace the load hook with the hook nut.

If the load hook passed the inspection:

- ▶ Follow the instructions in the section „Assembling the hook nut“.

### 3.6 Assembling the hook nut

Make sure that the following prerequisites are met:

- The hook shaft, hook thread and hook nut fulfill all test criteria.
- The axial bearing is free of damage and turns easily.

If the axial bearing does **not** turn easily:

- ▶ Clean the axial bearing and replace the lubricant.
- or**
- ▶ Replace the axial bearing.

If the axial bearing is damaged:

- ▶ Replace the axial bearing.

Before the assembly of the hook nut: Corrosion protection must be applied between the thread sides.

- ▶ Grease the threads of the hook nut.
- ▶ Assemble the hook nut according to the manufacturer's assembly instructions.

The type of sealing after assembly must correspond to equivalent to the sealing before the inspection.

- ▶ Seal the transition between the hook thread and the hook nut thread.
- ▶ Install the load hook.

### 3.7 Checking the retaining elements

- ▶ Check if the twist guard of the hook nut (axle retainer) is tightened.
- ▶ Check if the twist guard of the hook nut functions.
- ▶ Check the function of the hook guard.

If the retaining element did **not** pass the inspection:

- ▶ Contact Customer Service at Liebherr-Werk Ehingen GmbH.

---

Empty page!

LWE/LTR 1220-003/24204-02-02/en



## 8.06 Inspection of hydraulic hose lines

1	Safety guidelines	3
2	Inspection intervals	3
3	Checking the end of the service life	3
4	Inspecting the hydraulic hose lines for damage	4
5	Inspecting the hydraulic hose lines for leaks	5
6	Documenting the inspection	5
7	Replacing hydraulic hose lines	5

*Fig.195219*

LWE/LTR 1220-003/24204-02-02/en

# 1 Safety guidelines



## WARNING

Damaged and leaky hydraulic hose lines!  
Fire, accidents, death, severe injury, property damage.

If leaky areas are found:

- ▶ Have these leaky areas inspected immediately by authorized and trained expert personnel and remedied.

If damage is found:

- ▶ Have the hydraulic hose lines replaced exclusively by authorized and trained expert personnel.

If it is determined that the service life is over:

- ▶ Have the hydraulic hose lines replaced exclusively by authorized and trained expert personnel.

Make sure that the following prerequisite is met:

- A **competent person for hydraulic hose lines** inspects the hydraulic hose lines.

A **competent person for hydraulic hose lines** has the following knowledge:

- Knowledge and experience in hydraulic and mechanics
- Knowledge of all requirements regarding valid standards:
  - ISO 8331
  - ISO 2230
  - ISO 1402
  - ISO/TR
  - EN 853 to EN 857
  - National regulations
- **or:** Knowledge of all requirements regarding the valid German standards, for example:
  - DIN 20066:202-10
  - BGR 237 Feb 2008, BG-Regulation

## 2 Inspection intervals

The inspection of hydraulic hose lines must be carried out in the following intervals:

- when the crane is **up to 10 years** old, at least one inspection every twelve months
- when the crane is **older than 10 years**, at least one inspection every six months

## 3 Checking the end of the service life

Hydraulic hose lines have a limited service life.

When hydraulic hose lines are properly stored, installed and used, then the manufacturer guarantees a service life of at least 10 years.

The life expectancy of hydraulic hose lines can deviate significantly from the noted service life of hydraulic hose lines.



### Note

Special case: Active rear axle steering!

- ▶ The life expectancy of hydraulic hose lines is six years, including a storage period of maximum two years.

The life expectancy of a hydraulic hose line depends on various factors:

- Environmental influences, for example: Temperature, humidity, corrosive air
- Use

- Working cycles
- Number of bending cycles
- Friction
- Fluid

The following factors reduce the life expectancy significantly:

- Heat
- Repeated bending under pressure

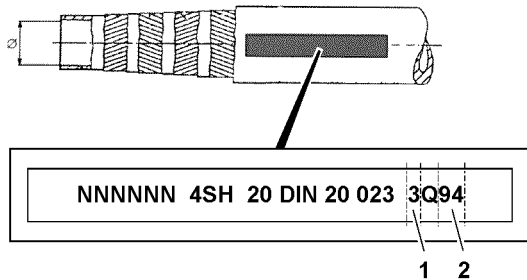


Fig.120159: Example for identification of hydraulic hose lines

The manufacturing date is marked on the fixtures or fittings.

- ▶ Read the quarter **1** of manufacture.
- ▶ Read the year **2** of manufacture.

When the life expectancy of a hydraulic hose line has been exceeded, then a **competent person** can decide **not** to replace the hydraulic hose line. Document the decisions, see section „Documenting the inspection“.

When the end of the service life is determined:

- ▶ Have the hydraulic hose lines replaced exclusively by authorized and trained expert personnel.

## 4 Inspecting the hydraulic hose lines for damage

Hydraulic hose lines must be replaced when one of the following damage is present:

- Damage on outer surface, such as chafe marks, cuts and cracks
- Brittleness due to aging of outer layer (cracks)
- Distortion, such as splitting of hose layers, bubbles, crushed areas, kinks, rotational stress
- Leakages
- Damage or distortion of hose fixtures or hose fitting (seal is endangered)
- Movement between hose and hose line, hose working itself loose from the fixture or the fitting
- Requirements for installation **not** observed
- Corrosion of fixture or fitting (solidness or function of fitting is endangered)

When the hydraulic hose line is **not** completely accessible:

- ▶ Remove the hydraulic hose line.

When the hydraulic hose line is protected with a protective hose:

- ▶ Check the hose protection for abrasion. Abrasion on a hose protective hose can indicate abrasion on the hydraulic hose line.
- ▶ Check hydraulic hose lines for distortion in pressureless and pressurized status and during bending.

When the hydraulic hose line is slightly damaged, then a **competent person** can decide **not** to replace the hydraulic hose line. Document the decisions, see section „Documenting the inspection“.

If damage is found:

- ▶ Have the hydraulic hose lines replaced exclusively by authorized and trained expert personnel.

## 5 Inspecting the hydraulic hose lines for leaks

- ▶ Check the crane for escaped hydraulic oil.
- ▶ Check the crane for leaks by visually checking the ground under the crane.

When the hydraulic system leaks:

- ▶ Have these leaks inspected immediately by authorized and trained expert personnel and remedied.  
**or**  
Contact Liebherr Service.

## 6 Documenting the inspection

Make sure that the following prerequisite is met:

- A **competent person for hydraulic hose lines** documents noticeable observations.

The following data about hydraulic hose lines is documented:

- Installation location
- Condition
- Date
- Time
- ▶ Document noticeable observations comprehensibly.

When the life expectancy of a hydraulic hose line has been exceeded or if the hydraulic hose line is slightly damaged, then a **competent person** can decide **not** to replace the hydraulic hose line.

When the hydraulic hose line is **not** replaced:

- ▶ Document decisions and replacements comprehensibly.
- ▶ Document the date for the next inspection comprehensibly.

## 7 Replacing hydraulic hose lines

To ensure maximum safety, sealing and service life, the following guidelines apply for replacement of hydraulic hose lines.



### WARNING

Impermissible spare parts!

Death, severe injury, property damage.

- ▶ Do **not** use repaired or used hydraulic hose lines.
- ▶ Use exclusively Original Liebherr spare parts.
- ▶ Use exclusively hydraulic hose lines according to manufacturer's specification (including fixtures, rubber piece goods and manufacturing process).

### NOTICE

Routing of hydraulic hose lines changed!

Abrasion. Incorrect bending radius. Stress. Shortened service life.

- ▶ Keep the routing of hydraulic hose lines.
- ▶ Inspect the hydraulic hose lines according to intervals.

- ▶ Adhere to the hose bending radii according to the manufacturer's specifications.
- ▶ Ensure the routing of hydraulic hose lines according to manufacturer's specifications (pressureless and pressurized condition).
- ▶ Ensure the distance between lines and structures.

If necessary:

- ▶ Check moving parts in the area of hydraulic hose lines.

When the hydraulic hose line is installed in straight direction:

- ▶ Ensure a sag of the hose.
- ▶ Avoid mechanical tension and twisting of the hose during installation.
- ▶ Fasten the hydraulic hose line according to manufacturer's specification.
- ▶ Do not cross hydraulic hose lines for high pressure and low pressure.
- ▶ Keep hydraulic hose lines away from hot components.

When hydraulic hose lines are in a surrounding with high temperatures:

- ▶ Install protective insulation according to manufacturer's specifications.

## 8.17 Inspection of ladders

1	Safety instructions	3
2	Inspection intervals	3
3	Inspecting the ladders	3
4	Inspection sheet and check list	3

*Fig.195219*

LWE/LTR 1220-003/24204-02-02/en



# 1 Safety instructions



## WARNING

Damaged ladders!  
Accident. Death, severe injury, property damage.

If damage is found:

- ▶ Have ladders repaired by authorized and trained expert personnel.

If it is determined that the ladder cannot be repaired:

- ▶ Scrap the ladder immediately.

Make sure that the following prerequisite is met:

- **Authorized and trained expert personnel** inspects the ladders.

The authorized and trained expert personnel has the following expertise:

- Knowledge, experience and abilities in repairing ladders
- Is familiar with the necessary prerequisites as determined by the contractor for the inspection of ladders
- Has the knowledge about the type, scope and intervals for the required inspections as determined by the contractor

## 2 Inspection intervals

The inspection of ladders must be carried out in the following intervals:

- The contractor determines the **required** intervals
- But there must be at least one inspection every **12 months**

Intervals depend on:

- Operating conditions
- Frequency of use
- Operational demands during use
- Frequency and severity of defects found during previous inspections

## 3 Inspecting the ladders

Make sure that the following prerequisites are met:

- Ladder inspection sheets are on hand. For blank form, see section „Inspection form for the inspection of ladders and steps“.
- Check lists are on hand. For a blank form, see section „Check list for the inspection of ladders and steps“.
- ▶ For every ladder and every step: Enter the data in the ladder inspection form.  
**or**  
Get the ladder inspection form for ladders or steps.
- ▶ Check the ladders and steps according to the check list and document the results.
- ▶ Collect the ladder inspection forms and check lists in the crane documentation.

## 4 Inspection sheet and check list

A sample inspection form and check list for the inspection of ladders and steps are shown below.

## 4.1 Inspection form for the inspection of ladders and steps

Ladder inspection form	
Inventory no. of the ladder / step	
Location / installation location	
Ladder type	Multi-purpose ladder
	Stepladder
	Leaning ladder
	Leaning ladder with transition
	Vertical ladder
	Vertical ladder with transition aid
	Platform ladder
	Step
	Other
Ladder material	Aluminum
	Plastic
	Steel
	Stainless steel
Number of rungs / steps	
Ladder length / ladder shortened to	
Manufacturer / dealer	
Article / type number	
Date of purchase	
Date of selection	
Name of authorized inspector	
Next inspection	

*Inspection form for the inspection of ladders and steps*

*Fig.151627-en*

## 4.2 Check list for the inspection of ladders and steps

Ensure the recording of the systematic inspection of ladders and steps:

- Summarize the following checklist for an inspection book.

LWE/TR 1220-003/24204-02-02/en

Inspection criteria	1. Inspection		2. Inspection		3. Inspection		4. Inspection		5. Inspection	
	Yes	No	Yes	No	Yes	No	Yes	No	Yes	No
<b>1. Operating instructions</b> (decal on the ladder) Present and legible	<input type="checkbox"/>	<input type="checkbox"/>	<input type="checkbox"/>	<input type="checkbox"/>	<input type="checkbox"/>	<input type="checkbox"/>	<input type="checkbox"/>	<input type="checkbox"/>	<input type="checkbox"/>	<input type="checkbox"/>
<b>2. Beams and rungs / stringers and steps</b> Loose connections Damage, cracks, breaks, wear Dents, kinks Exposed fibers of glass-fiber reinforced plastic Paint / glaze significantly damaged (if applicable) Tie rod loose or damaged (if applicable) Platform loose or damaged (if applicable)	<input type="checkbox"/>	<input type="checkbox"/>	<input type="checkbox"/>	<input type="checkbox"/>	<input type="checkbox"/>	<input type="checkbox"/>	<input type="checkbox"/>	<input type="checkbox"/>	<input type="checkbox"/>	<input type="checkbox"/>
<b>3. Ladder locks (if applicable)</b> Belts, chains, bracing damaged Hinge spreader damaged	<input type="checkbox"/>	<input type="checkbox"/>	<input type="checkbox"/>	<input type="checkbox"/>	<input type="checkbox"/>	<input type="checkbox"/>	<input type="checkbox"/>	<input type="checkbox"/>	<input type="checkbox"/>	<input type="checkbox"/>
<b>4. Fixtures</b> Hinges, articulations, locks damaged or loose Sliding parts are well lubricated Locking elements do not engage	<input type="checkbox"/>	<input type="checkbox"/>	<input type="checkbox"/>	<input type="checkbox"/>	<input type="checkbox"/>	<input type="checkbox"/>	<input type="checkbox"/>	<input type="checkbox"/>	<input type="checkbox"/>	<input type="checkbox"/>
<b>5. Feet and accessories</b> Feet, tips, caps missing or damaged Cross beam, feet extension defective	<input type="checkbox"/>	<input type="checkbox"/>	<input type="checkbox"/>	<input type="checkbox"/>	<input type="checkbox"/>	<input type="checkbox"/>	<input type="checkbox"/>	<input type="checkbox"/>	<input type="checkbox"/>	<input type="checkbox"/>
<b>6. Other defects</b>	<input type="checkbox"/>	<input type="checkbox"/>	<input type="checkbox"/>	<input type="checkbox"/>	<input type="checkbox"/>	<input type="checkbox"/>	<input type="checkbox"/>	<input type="checkbox"/>	<input type="checkbox"/>	<input type="checkbox"/>
<b>Result of the inspection</b> The ladder is OK and can be used The ladder may only be used after it is repaired The ladder must be replaced DATE, SIGNATURE	<input type="checkbox"/>	<input type="checkbox"/>	<input type="checkbox"/>	<input type="checkbox"/>	<input type="checkbox"/>	<input type="checkbox"/>	<input type="checkbox"/>	<input type="checkbox"/>	<input type="checkbox"/>	<input type="checkbox"/>
<b>Sent for repair to:</b> DATE, SIGNATURE										
<b>Repair / ladder replaced:</b> DATE, SIGNATURE										

Fig.14994-en



## 8.90 Inspection chart for cranes

1 Inspection chart for recurring inspections of Liebherr cranes

---

3

LWE/LTR 1220-003/24204-02-02/en

*Fig.195219*

LWE/LTR 1220-003/24204-02-02/en

# 1 Inspection chart for recurring inspections of Liebherr cranes

The following is a checklist to assist the inspector during the periodic inspections of Liebherr mobile and crawler cranes.

<b>Company:</b>	<b>Inspector:</b>
<b>Crane manufacturer: Liebherr</b>	<b>Crane type:</b>
<b>Serial number:</b>	<b>Stock number:</b>
<b>Year of construction:</b>	<b>Date:</b>
<b>Inspector's signature for No. 1 to 22:</b>	

1. inspection category: Crane document						
Component to be inspected	A	B	C	D	E	Comments
Crane inspection log						
Operating and installation instructions						
Crane control log						
Load chart manual						
Job planner						

2. inspection category: Signs / identification						
Component to be inspected	A	B	C	D	E	Comments
Factory tag						
Load data						
Operating instruction label						
Prohibition and command signs						
Other safety signs						

3. inspection category: Travel gear <sup>1</sup>						
Component to be inspected	A	B	C	D	E	Comments
Frame <sup>2</sup>						
Supports <sup>3</sup>						
Axles						
Wheels						
Tires						
Storage						
Transmission						
Universal drive shaft						
Leaf springs / springs						
Shock absorbers						

LWE/LTR 1220-003/24204-02-02/en

3. inspection category: Travel gear <sup>1</sup>						
Component to be inspected	A	B	C	D	E	Comments
Steering						
Brakes						
Hydraulic axle suspension						

4. inspection category: Chassis <sup>1</sup>						
Component to be inspected	A	B	C	D	E	Comments
Coverings						
Accessible surfaces						
Counterweight holders <sup>2</sup>						
Towing devices						
Accesses, ladders						
Holding devices, handles						
Platforms, railings						
Retainer for hook block <sup>2</sup>						
Boom support <sup>2</sup>						

5. inspection category: Chassis - driver's cab <sup>1</sup>						
Component to be inspected	A	B	C	D	E	Comments
Doors						
Windows / windshields						
Window wiper						
Mirrors						
Seat						
Heater						
Ventilation						
Sound absorber						
Trip recorder						
First aid kit						
Spare bulbs						
Hazard warning triangle						
Safety vest						

6. inspection category: Chassis - drive <sup>1</sup>						
Component to be inspected	A	B	C	D	E	Comments
Combustion engine						
Exhaust system						
Fuel tank						



6. inspection category: Chassis - drive <sup>1</sup>						
Component to be inspected	A	B	C	D	E	Comments
Urea tank						
Fuel container						
Filter						
Sound absorber						
Engine mount						
Oil levels						
Fuel lines						
Urea lines						
Fuel lines						

7. inspection category: Chassis - hydraulics <sup>1</sup>						
Component to be inspected	A	B	C	D	E	Comments
Oil container						
Filter with maintenance indicator						
Pumps						
Motors						
Valves						
Lines						
Hoses						
Cylinders						
Pressure limiting valves						

8. inspection category: Chassis - compressed air system <sup>1</sup>						
Component to be inspected	A	B	C	D	E	Comments
Compressor						
Filter						
Air tanks						
Valves						
Lines						
Hoses						
Cylinders						

9. inspection category: Chassis - electrical system <sup>1</sup>						
Component to be inspected	A	B	C	D	E	Comments
Motors						
Generators						
Battery						

LWE/LTR 1220-003/24204-02-02/en

9. inspection category: Chassis - electrical system <sup>1</sup>						
Component to be inspected	A	B	C	D	E	Comments
Switches / buttons						
Lines						
Fuses						
Resistors						
Lighting						
Brake lights						
Blinkers						
Tail lights						
Working lights						
Signaling systems						
Indicator lights						
Battery switch						
Limit switches: Transmission, steering, drive train						
Support pressure indicator <sup>2</sup>						

10. inspection category: Chassis - control systems <sup>1</sup>						
Component to be inspected	A	B	C	D	E	Comments
Engine regulation						
Transmission						
Couplings						
Circuits						
Brakes						
Steering						
Control displays						
Engine shut off line						
Control of supports <sup>2</sup>						
Axle suspension						
Crane leveling						
Rear axle steering						

11. inspection category: Superstructure						
Component to be inspected	A	B	C	D	E	Comments
Frame						
Coverings						
Treads						
Storage						

11. inspection category: Superstructure						
Component to be inspected	A	B	C	D	E	Comments
Counterweights						
Relapse retainer						
Slewing ring connection: Tilt play						
Slewing ring connection: Mounting screws						
Slewing ring connection: Gears						
Slewing gear: Mounting screws						
Slewing gear: Gears						

12. inspection category: Superstructure - crane operator's cab						
Component to be inspected	A	B	C	D	E	Comments
Doors						
Windows / windshields						
Window wiper						
Mirrors						
Seat						
Heater						
Ventilation						
Muffler						
Joystick for working functions						
Gear shifts						
Retainer: Crushing / shear locations						

13. inspection category: Superstructure - Retaining and protection devices						
Component to be inspected	A	B	C	D	E	Comments
Accesses, ladders						
Handles						
Coverings						
Covers						
Hatches						
Treads						

14. inspection category: Superstructure - drive train						
Component to be inspected	A	B	C	D	E	Comments
Combustion engine						
Exhaust system						
Fuel tank						
Urea tank						

LWE/LTR 1220-003/24204-02-02/en

14. inspection category: Superstructure - drive train						
Component to be inspected	A	B	C	D	E	Comments
Fuel container						
Filter						
Sound absorber						
Engine mount						
Fuel lines						
Urea lines						
Fuel lines						

15. inspection category: Superstructure - hydraulic system						
Component to be inspected	A	B	C	D	E	Comments
Oil container						
Filter						
Pumps						
Motors						
Valves						
Lines						
Hoses						
Cylinders						
Pressure limiting valves						
Lowering brake valves						
Brake control: Hoist gear						
Brake control: Slewing gear						

16. inspection category: Superstructure - electrical system						
Component to be inspected	A	B	C	D	E	Comments
Motors						
Generators						
Batteries						
Switches / buttons						
Lines						
Fuses						
Resistors						
Lighting						
Signal lights						

17. inspection category: Superstructure - control systems						
Component to be inspected	A	B	C	D	E	Comments
Engine regulation						
Transmission						
Flexible couplings						
Circuits						
Engine shut off line						
Control displays						

18. inspection category: Superstructure - rope drives						
Component to be inspected	A	B	C	D	E	Comments
Winch 1 <sup>3</sup>						
Winch 2 <sup>3</sup>						
Winch 3 <sup>3</sup>						
Winch 4 <sup>3</sup>						
Winch 5 <sup>3</sup>						
Winch 6C <sup>3</sup>						
Winch 6 <sup>3</sup>						
Assembly winches <sup>3</sup>						
Rope pulleys						
Rope end connection						
Rope for winch 1						
Rope for winch 2						
Rope for winch 3						
Rope for winch 4						
Rope for winch 5						
Rope for winch 6C						
Rope for winch 6						
Rope for assembly winches						
Guy ropes						

19. inspection category: Superstructure - hook						
Component to be inspected	A	B	C	D	E	Comments
Pulleys						
Rope guards on pulleys						
Axle support						
Load hook						
Load hook mounting						
Hook retention						

LWE/LTR 1220-003/24204-02-02/en

20. inspection category: Superstructure - safety and switch systems						
Component to be inspected	A	B	C	D	E	Comments
Hoist emergency limit switch I						
Hoist emergency limit switch II						
Lowering emergency limit switch I						
Lowering emergency limit switch II						
Boom emergency limit switch I						
Boom emergency limit switch II						
Luffing jib: Boom limit switch I						
Luffing jib: Boom limit switch II						
Load torque limiter						
Angle indicator: Boom						
Angle indicator: Luffing jib						
Angle indicator: Slewing gear						
Safety equipment: Control						
Working range limitation						
Pressure sensor						
Speed sensor						
Wind sensor						
Sliding beam monitoring						
Support pressure indicator						
Incline indicator						
Length indicator: Boom radius, boom length						
Emergency off system						
Engine stop						

21. inspection category: Boom						
Component to be inspected	A	B	C	D	E	Comments
Weld structure						
Rope pulleys						
Change over pulleys feed mechanism						
Luffing cylinder						
Telescoping cylinder						
Boom extension ropes						
Boom retraction ropes						
Boom bearings						
Boom pinning						
Guy rods						
Guy ropes						

21. inspection category: Boom						
Component to be inspected	A	B	C	D	E	Comments
Control ropes						
Guide ropes						
Safety ropes						
Relapse cylinders						
Pin connections						

22. inspection category: Equipment						
Component to be inspected	A	B	C	D	E	Comments
Weld structure						
Rope pulleys						
Relapse cylinder						
Relapse support						
Oscillation guard						
A-frame bearings						
Pinning of components						
Guy rods with pinning						
Rods with guide rail on A-frame 2 and A-frame 3						
All limit switches with switch mechanism						
Pin connections						

*Inspection chart for periodic inspections of Liebherr mobile and crawler cranes*

**Inspection criteria:**

- A = Present / complete
- B = Condition / maintenance
- C = Function
- D = Repair / replace
- E = Re-inspection required

**Evaluation:**

- Satisfactory = x
- Unsatisfactory = -
- Not required = 0

**Comments:**

- <sup>1</sup> Inspection of the crane carrier vehicle road worthiness is also fulfilled if it has already been certified by the road traffic department certification authority. For cranes that are not certified for use on public roads, an expert or authorized inspector must conduct the required tests to validate the vehicle's road worthiness.
- <sup>2</sup> These inspections must be carried out by an authorized inspector even if it has passed the road traffic department test and is certified.
- <sup>3</sup> Inspection of the winches with respect to the actually used proportion of their service life.

---

Empty page!

LWE/LTR 1220-003/24204-02-02/en



---

## 90 Appendix

LWE/LTR 1220-003/24204-02-02/en

---

LWE/LTR 1220-003/24204-02-02/en

# 90.01 Preface to the appendix

1 Foreword

---

3

LWE/LTR 1220-003/24204-02-02/en

*Fig.195219*

LWE/LTR 1220-003/24204-02-02/en

# 1 Foreword

This crane may only be used in a flawless technical condition and according to its mission as well as with constant awareness of safety and dangers. Any problems, which could affect safety, must be fixed immediately.



## Note

- ▶ Modifications on the crane may only be made with written approval by Liebherr-Werk Ehingen GmbH.

## 1.1 Change to the operating instructions

Changes to the operating instructions are received in the form of chapters. The chapter to be replaced must be removed from the operating instructions and replaced with the new chapter in the same location.

When you receive a change to the operating instructions:

- ▶ Remove the chapter to be replaced from the operating instructions.
- ▶ File the new chapter in the same location in the operating instructions.
- ▶ Destroy the replaced chapter.
- ▶ Fill out the change confirmation form in chapter 90.05 of the operating instructions.

## 1.2 Update to the operating instructions

Updates to the operating instructions, which you receive in the circular as Customer information, must be filed in the operating instructions in chapter 90.05.



Fig. 113870: Customer information decal

When you receive an update to the operating instructions:

- ▶ Attach the decals **1**, which are enclosed in the customer information to the footer of the respective chapter. See the following example.



## Note

Example: Update to the operating instructions!

If there is an update that concerns the operating instructions, chapter 2.04:

- ▶ Attach the decal **1** in the footer of chapter 2.04.
- ▶ File the update in chapter 90.05 of the operating instructions.
- ▶ Fill out the update confirmation form in chapter 90.05 of the operating instructions.

---

Empty page!

LWE/LTR 1220-003/24204-02-02/en

## 90.05 Update confirmation

1	Change confirmation form	3
2	Update confirmation	3
3	Customer information	4

*Fig.195219*

LWE/LTR 1220-003/24204-02-02/en



# 1 Change confirmation form

Chapter	Change	Completed	
		on	by

# 2 Update confirmation

Chapter	Update	Completed	
		on	by

LWE/LTR 1220-003/24204-02-02/en

## 3 Customer information

---

# Index

## 1

11952500 – California Proposition 65 Label **2.05 - 2**

## 3

3-piece folding jib, see illustration 3 **5.02 - 5**  
3-point support **2.04.10 - 25**

## 4

4-piece folding jib, see illustration 4 **5.02 - 5**

## 7

7725039 – Warning of high voltage **2.05 - 2**  
772564008 – Slewing range **2.05 - 3**  
772580408 – Limitation of maximum travel speed **2.05 - 3**

## 9

9402377 – Fastening point / lifting point **2.05 - 10**  
9412158 – Reading the operating instructions **2.05 - 6**  
97001802 – Falling platform **2.05 - 40**  
97003109 – Accessing the step ladder **2.05 - 16**  
97003110 – Folding the step ladder in and out **2.05 - 17**  
97003112 – Maximum suspended load **2.05 - 23**  
97004046 – Safety harness, maximum two persons **2.05 - 6**  
97006167 – Identifying the support base **2.05 - 17, 2.05 - 17**  
97008514 – Warning of head injuries **2.05 - 18**  
97009799 – Data logger **2.05 - 18**  
97011336 - Transport weights of the components **2.05 - 40**  
97011689 – Danger of crushing **2.05 - 20**  
97011690 – Overload of cab is prohibited **2.05 - 20**  
97012095 – Maximum load **2.05 - 19**  
97012737 – Danger of accident **2.05 - 22**  
97012949 – Maximum load **2.05 - 18**  
97016304 – Refueling **2.05 - 21**  
97016392 – Crushing danger for feet **2.05 - 22**  
97016911 – Danger of collision **2.05 - 35**  
97017585 – Falling telescopic boom during disassembly / assembly **2.05 - 7**  
97018351 – Falling telescopic boom during transport! **2.05 - 7**  
97018564 – Falling telescopic boom during transport! **2.05 - 7**  
97023034 – Disassembling **2.05 - 22**  
97027147 – Overloading of the combi box is prohibited **2.05 - 8**

97033982 – Assembling / disassembling the Derrick pivot section **2.05 - 28**  
97036732 – Access via 3-point support **2.05 - 23**  
97036733 – Fastening point **2.05 - 8**  
97036734 – Rigging point **2.05 - 38**  
97036735 – Fastening point for lattice section **2.05 - 12**  
97036736 – Fastening point for lattice sections **2.05 - 12**  
97036917 – Maximum suspended load **2.05 - 24**  
97037383 – Urea **2.05 - 24**  
97037625 – Suspended load Fastening points / rigging points **2.05 - 10**  
97037871 – Fastening points for lattice sections **2.05 - 13**  
97037952 – Warning of fatal electric shock **2.05 - 24**  
97038442 – Fastening point for lattice section **2.05 - 12**  
97038452 – Fastening point for lattice sections **2.05 - 13**  
97038454 – Fastening point for lattice sections **2.05 - 13**  
97039035 – Suspended load Assembly unit **2.05 - 15**  
97039753 – Danger of stumbling **2.05 - 34**  
97041305 – Overload of components **2.05 - 26**  
97042730 – Falling luffing cylinder **2.05 - 25**  
97042797 – Overload of components **2.05 - 25**  
97046488 – Corrosion inhibitor - antifreeze fluids **2.05 - 21**  
97047810 – Pinning brackets **2.05 - 25**  
97053409 – Entanglement hazard during winch operation **2.05 - 20**  
97053410 – Fastening equipment **2.05 - 14**  
97057097 – Fastening point to turn the component **2.05 - 15**  
97057524 – Fastening point for assembly of lattice sections **2.05 - 14**  
97057767 – Fastening points for lattice sections **2.05 - 14**  
97059339 – Suspended load Derrick pivot section **2.05 - 15**  
97068370 – Closing the cab door **2.05 - 19**  
97068839 - Transport weights of the components / fastening length of the fastening equipment **2.05 - 41**  
97069053 – Storage boxes open **2.05 - 19**  
97070905 – Removing the auxiliary jib (boom nose) **2.05 - 26**  
9707704 – Driving with the outrigger pad **2.05 - 27**  
97077304 – Positioning the outrigger pad **2.05 - 27**  
97094940 – Spark catcher **2.05 - 39**  
97095312 – Suspended load and fastening points for counterweight frame **2.05 - 16**  
97096132 – Fastening points for N-assembly unit **2.05 - 11**  
97097951 – Counterweight **2.05 - 29**  
97106824 – Installing the N-assembly unit **2.05 - 11**  
97107101 – Unlocking the telescopic boom locking pin **2.05 - 30**

97107199 – Do not unlock the telescopic boom locking pin **2.05 - 31**  
 97124295 – Load stop **2.05 - 4**  
 97127242 – Assembly aid **2.05 - 5**  
 97128894 – Counterweight and counterweight radius **2.05 - 31**  
 97131530 – Reduced crawler crane track width **2.05 - 32**  
 97137170 – Luffing cylinder and counterweight collision **2.05 - 4**  
 971494208 – Limitation of maximum travel speed **2.05 - 32**  
 971539808 – Warning notice for unpinning the auxiliary boom on the pulley head **2.05 - 33**  
 971539908 – Warning notice for unlocking the auxiliary boom **2.05 - 33**  
 973974408 - Transport weights of the components **2.05 - 40**  
 973974608 - Transport weights of the components **2.05 - 40**  
 976624808 – Fastening the load **2.05 - 42**  
 977055908 – Fastening point for swingable sliding beam **2.05 - 32**  
 978673908 – Warning of suspended load **2.05 - 34**  
 978674008 – Access for unauthorized personnel prohibited **2.05 - 34**  
 978674108 – Warning of crushing danger **2.05 - 35**  
 978674308 – Radio remote control **2.05 - 35**  
 978674408 – Danger of burns to hands **2.05 - 36**  
 978674508 – Warning of rotating parts **2.05 - 36**  
 978674608 – Crushing danger for hands **2.05 - 36**  
 978674808 – Personal protective equipment **2.05 - 37**  
 978674908 – Accessing the area is prohibited **2.05 - 37**  
 978675008 – Access prohibited **2.05 - 37**  
 978687408 – Rigging point **2.05 - 38**  
 978867108 – Warning of fatal electric shock **2.05 - 38**  
 979383308 – Oil change **2.05 - 39**  
 979561108 – Counterweight **2.05 - 39**

## A

Abbreviations Rope diameter **8.04 - 8**  
 Accelerating, changing the load **2.04 - 27**  
 Accepting the set up configuration **4.03 - 29**  
 Accesses to the crane **2.07 - 1**  
 Accessible crane chassis walking surfaces and stepping surfaces **2.07 - 8**  
 Accessing the crane cab via the ladder on the crane chassis **2.04 - 19**  
 Accessing the lattice sections or booms **2.04 - 16**  
 Acoustic / visual warnings outside the crane operator's cab **4.20 - 15**  
 Acoustic / visual warnings within the crane operator's cab **4.20 - 13**  
 Acoustic and optical warning devices **4.04 - 11**  
 Acoustic and optical warning signals **4.02 - 3**

Acoustic warnings on the LICCON monitor **4.02 - 28**  
 Activating / deactivating winch 1 **4.05 - 13**  
 Activating / deactivating winch 2 \* **4.05 - 16**  
 Activating the bypass at assembly and disassembly **5.01 - 27**  
 Activating the bypass at crawler assembly and crawler disassembly **5.01 - 26**  
 Activating the Unpin the cross carrier icon **4.03.50 - 20, 4.03.50 - 23, 4.03.50 - 26**  
 Activating „Unpin the cross carrier“ **3.80 - 19**  
 Actual load **4.02 - 3**  
 Actual load (current load) / net load **4.02 - 17**  
 Actual load display **4.08 - 15**  
 Actuating the hoist limit switch mechanically, illustration 1 **5.12 - 19**  
 Actuation of winch and / or crane movements during assembly / disassembly **5.01 - 28**  
 Adding diesel fuel **7.05 - 12**  
 Adding fuel **7.05 - 45, 7.05 - 49**  
 Adding urea solution **7.05 - 21**  
 Additional controls for certain crawler cranes **5.01 - 6**  
 Additional controls for cranes on tires on the front and supported on the rear **5.01 - 5**  
 Additional controls for cranes supported on the front and on tires on the rear **5.01 - 5**  
 Additional controls for cranes with a derrick boom **5.01 - 6**  
 Additional controls for cranes with crane support **5.01 - 5**  
 Additional controls for cranes with luffing auxiliary boom / accessories **5.01 - 6**  
 Additional controls for freestanding crane operation (on tires) **5.01 - 5**  
 Additional emergency operating modes **4.02 - 32**  
 Additional notes **0.01 - 3**  
 Additional risks **2.04 - 80**  
 Adjusting the brightness level of the BTT display **5.31 - 17**  
 Adjusting the contrast of the BTT display **5.31 - 17**  
 Adjusting the control helm **4.03 - 20**  
 Adjusting the fan stage **6.02 - 11**  
 Adjusting the folding jib angle hydraulically \* **5.02 - 75**  
 Adjusting the reeving **4.08 - 14**  
 Adjusting the temperature **6.02 - 8, 6.02 - 11**  
 Adjusting the track width from the crane cab **4.03.50 - 18**  
 Adjusting the track width while driving **4.03.50 - 16**  
 Adjusting the track width with the BTT **4.03.50 - 23**  
 Adjusting the track width with the radio remote control \* **4.03.50 - 26**  
 Adjustment of the track width **4.03.50 - 1**  
 After replacement of components **7.01 - 6**  
 Aids for work at a height **2.04 - 14**  
 Air distribution **6.02 - 12**  
 Air distribution for floorboard area **4.01 - 44**  
 Air distribution for head area **4.01 - 44**  
 Air filter system **7.05 - 10**  
 Air heater \* **4.01 - 40, 6.02 - 16**

- Air supply **6.02 - 14**
- Alarm functions **4.02 - 22, 4.02 - 67**
- Aligning the BTT with the crane **5.31 - 19**
- Aligning the crane **2.04 - 43**
- Aligning the crane cab horizontally **4.03 - 24**
- Aligning the moveable back pulley **4.06 - 6**
- Alpha -  $\alpha$  angle **5.70 - 30**
- Ambient temperature **0.01 - 9**
- Angle adjustment on the fixed lattice jib with mechanical adjustment **5.01 - 37**
- Angle guide values **5.70 - 32**
- Angle indicator for the folding jib **5.02 - 75**
- Angle sensor \* **5.02 - 70**
- Angle setting 22.5° **5.02 - 51, 5.02 - 53**
- Angle setting 45° **5.02 - 51, 5.02 - 53**
- Angular pull **4.08 - 11**
- Applying the parking brake **4.05 - 20**
- Areas **7.05.50 - 13, 8.04 - 4**
- Armrests **4.03 - 21**
- Ascending and descending the counterweight frame **2.07 - 6**
- Ascending and descending the crane chassis **2.07 - 3**
- Ascending and descending the crane superstructure **2.07 - 5**
- Ascending and descending the turntable **2.07 - 6**
- Assembling / disassembling **5.01 - 22**
- Assembling / disassembling of boom systems for supporting on ascending terrain (assembly / disassembly schematic) **5.01 - 61**
- Assembling / disassembling of boom systems for supporting on descending terrain (assembly / disassembly schematic) **5.01 - 64**
- Assembling / disassembling of electrical lines **5.01 - 24**
- Assembling / disassembling of hydraulic lines **5.01 - 25**
- Assembling / disassembling of lattice sections for lattice mast cranes **5.01 - 51**
- Assembling / disassembling the booms **5.01 - 29**
- Assembling / disassembling the counterweight **5.01 - 29**
- Assembling / disassembling the crane components **2.08 - 6**
- Assembling / disassembling the lattice sections on telescopic cranes with a luffing lattice jib **5.01 - 39**
- Assembling / disassembling the lattice sections on telescopic cranes with an auxiliary boom, with an auxiliary crane **5.01 - 43**
- Assembling / disassembling the lattice sections on telescopic cranes with an auxiliary boom, without an auxiliary crane **5.01 - 47**
- Assembling hoist gear 2 \* **4.07 - 15**
- Assembling lattice sections **5.01 - 51**
- Assembling the 3-piece folding jib **5.02 - 31**
- Assembling the 4-piece folding jib **5.02 - 35**
- Assembling the boom systems on ascending terrain **5.01 - 61**
- Assembling the boom systems on descending terrain **5.01 - 64**
- Assembling the cable drum on the auxiliary boom **5.70 - 9**
- Assembling the cable drum on the fixed jib **5.70 - 10**
- Assembling the cable drum on the luffing lattice jib **5.70 - 10**
- Assembling the cable drum on the telescopic boom **5.70 - 8**
- Assembling the camera on the auxiliary boom **5.70 - 10**
- Assembling the camera on the fixed jib **5.70 - 14**
- Assembling the camera on the luffing lattice jib **5.70 - 18**
- Assembling the camera on the telescopic boom **5.70 - 6**
- Assembling the central ballast **3.03 - 5**
- Assembling the central ballast block on the front **3.03 - 13**
- Assembling the central ballast block on the rear **3.03 - 9**
- Assembling the counterweight **4.07 - 11**
- Assembling the crawler carrier **3.01 - 3, 3.01 - 45, 3.03 - 15**
- Assembling the cross beam without wheels **2.04.10 - 16**
- Assembling the cross beam with wheels **2.04.10 - 16**
- Assembling the cross carrier on the crawler center section **3.01.20 - 1**
- Assembling the cross carrier with installed extension cylinder **3.01.20 - 15**
- Assembling the double cone pins horizontally **5.01 - 13**
- Assembling the double cone pins vertically **5.01 - 13**
- Assembling the double folding jib carried on the crane **5.02 - 25**
- Assembling the end section **5.02 - 29**
- Assembling the fixed lattice jib on the TF-adapter **5.01 - 34**
- Assembling the floodlight **5.80 - 2**
- Assembling the floodlight without pull relief **5.80 - 2**
- Assembling the floodlight with pull relief **5.80 - 3**
- Assembling the folding jib **5.02 - 13**
- Assembling the hook nut **8.05 - 6**
- Assembling the hose couplings in operating position (illustration 1) **5.02 - 57**
- Assembling the hose couplings in resting position (illustration 2) **5.02 - 57**
- Assembling the hydraulic folding jib \* **5.31 - 53**
- Assembling the jib boom **5.12 - 5**
- Assembling the jib boom carried on the crane **5.12 - 9**
- Assembling the ladder **2.04.10 - 14**
- Assembling the lattice sections on a luffing lattice jib **5.01 - 39**
- Assembling the lattice sections on an auxiliary boom with an auxiliary crane **5.01 - 43**
- Assembling the lattice sections on an auxiliary boom without an auxiliary crane **5.01 - 47**

Assembling the load hook **4.06 - 18**  
Assembling the platform ladder **2.04.10 - 16**  
Assembling the reducer, part 1 **5.02 - 25**  
Assembling the reducer, part 2 **5.02 - 29**  
Assembling the retaining pipes in the transport position **2.06 - 19**  
Assembling the retaining pipes in the working position **2.06 - 19**  
Assembling the separately transported folding jib for crane operating position **5.02 - 39**  
Assembling the separately transported folding jib for the transport position **5.02 - 41**  
Assembling the separately transported folding jib on the crane **5.02 - 39**  
Assembling the separately transported jib boom **5.12 - 15**  
Assembling the single folding jib carried on the crane **5.02 - 19**  
Assembling the sliding platform in the operating position **2.06 - 13**  
Assembling the sliding platforms **2.06 - 12**  
Assembling the stairs **2.06 - 10**  
Assembling the stairs and sliding platforms **2.07 - 3**  
Assembling the stairs with a medium track width **2.06 - 11**  
Assembling the stairs with a small track width **2.06 - 11**  
Assembling the stairs with a wide track width **2.06 - 12**  
Assembling the support plates **3.80 - 24**  
Assembling the swing platform in the transport position **2.06 - 16**  
Assembling the wind speed sensor in the transport position **5.75 - 14**  
Assembling winch 2 \* **5.09 - 5, 5.09 - 11**  
Assembling winch 2 without the auxiliary crane **5.09 - 5**  
Assembling winch 2 with the auxiliary crane **5.09 - 11**  
Assembly **5.10 - 5, 5.25 - 5**  
Assembly / disassembly procedures **4.20 - 4**  
Assembly aid **2.05 - 5**  
Assembly Cross carrier with installed extension cylinder **3.01.20 - 14**  
Assembly drawings **5.01 - 24**  
Assembly functions menu **5.31 - 49**  
Assembly of cross carrier with bracket **3.01.20 - 8**  
Assembly on the auxiliary boom **5.75 - 9**  
Assembly on the N-assembly unit. **5.75 - 11**  
Assembly on the telescopic boom **5.75 - 7**  
Assembly position **5.75 - 6**  
Assembly procedure **5.25 - 5**  
Assembly procedure, part 1 **5.02 - 19**  
Assembly procedure, part 2 **5.02 - 23**  
Assignment of the crane superstructure to the travel direction **4.10 - 27**  
Assignment of working direction and crawler carrier **4.03.50 - 19, 4.03.50 - 23, 4.03.50 - 26**  
Asymmetric track width adjustment **4.03.50 - 3**

Attaching the hoist limit switch weight **4.06 - 21, 4.06 - 24**  
Attaching the hook block **4.03 - 40**  
Authorized and trained service technician **7.01 - 2**  
Automatic operation **6.02 - 8**  
Automatic regeneration of the diesel particle filter **4.03 - 7**  
Automatic support \* **5.31 - 47**  
Auxiliary boom **1.01 - 7, 2.06 - 7, 4.12 - 3**  
Auxiliary boom luffing range **5.70 - 25**  
Auxiliary counterweight **1.02 - 4**  
Auxiliary equipment **1.02 - 4, 2.08 - 2**  
Auxiliary guying **5.01 - 9**  
Auxiliary heater / engine preheating \* **4.01 - 45**  
Auxiliary jib **1.02 - 4, 4.12 - 4**  
Auxiliary jib on the fixed lattice jib **4.12 - 21**  
Auxiliary jib on the luffing lattice jib **4.12 - 24**  
Auxiliary jib on the telescopic boom **4.12 - 14**  
Auxiliary pulley \* **4.06 - 28**

## **B**

Backrest adjustment **4.03 - 13, 4.03 - 18**  
Ballasting / turntable lock **5.31 - 55**  
Ballasting the counterweight plates **4.07 - 17**  
Ballast monitoring **4.07 - 21**  
Ballast weighing via the ballasting procedure **4.07 - 23**  
Ball locking pin **5.01 - 20**  
Ball valve positions during emergency operation **6.05 - 3**  
Basic machine **3.80 - 6, 3.80 - 10**  
Basic principles and procedure **8.01 - 4**  
Basket formation **7.05.50 - 10, 8.04 - 21**  
Batteries **7.01 - 15, 7.05 - 59**  
Battery voltage individual control display **4.02 - 45**  
Before starting to work **2.04 - 68**  
Beta -  $\beta$  angle **5.70 - 31**  
Bleeding by separate actuation of the grease pump **7.04 - 25**  
Bleeding by simulating crawler operation **7.04 - 23**  
Bleeding repaired lubrication lines **7.04 - 25**  
Bleeding the central lubrication system **7.04 - 23, 7.05 - 31**  
Bleeding the fuel line **7.05 - 47, 7.05 - 51**  
Block position of the relapse cylinders when setting down the load **5.01 - 6**  
Bluetooth Terminal (BTT) **5.31 - 1**  
Bluetooth Terminal (BTT) operating element **4.07 - 37**  
Boom limitations **4.02 - 23**  
Boom nose on lattice jib **4.12 - 4**  
Boom nose on telescopic boom **4.12 - 3, 4.12 - 13**  
Boom nose on the fixed lattice jib **4.12 - 19**  
Boom nose on the luffing lattice jib **4.12 - 23**  
Boom nose - telescopic boom **5.10 - 1**  
Boom radius **4.02 - 19**  
Breaking away fixed loads **4.08 - 13**  
Brief description **4.08 - 21**

Bringing the cable drum to the assembly height **5.70 - 5**  
 Bringing the camera to the assembly height **5.70 - 5**  
 Bringing the cross beam into the operating position **2.04.10 - 15**  
 Bringing the cross beam into the transport position **2.04.10 - 15**  
 Bringing the leaning ladder into the transport position **2.04.10 - 19**  
 Bringing the stepladder into the transport position **2.04.10 - 20**  
 Broken strands **7.05.50 - 7**  
 Broken wire **7.05.50 - 7**  
 Broken wire in the strand valleys **8.04 - 14**  
 Broken wire nests **8.04 - 15**  
 Broken wires in rope sections, which are not spooled up on the winch **8.04 - 14**  
 Broken wires on rope end connections **8.04 - 14**  
 BTT operation **5.31 - 69**  
 Buckles **7.05.50 - 12, 8.04 - 25**  
 Bulbs and fuses **7.05 - 59**  
 Burning-off the burner **7.05 - 47, 7.05 - 51**  
 Bypassing at assembly / disassembly **5.01 - 27**  
 Bypassing at assembly and disassembly **5.01 - 28**  
 Bypassing at crawler assembly / disassembly **5.01 - 26**  
 Bypassing the hoist top shut-off **4.20 - 45, 5.01 - 11**  
 Bypassing the LICCON overload protection **5.01 - 10**  
 Bypassing the overload protection **4.04 - 5, 5.01 - 9**  
 Bypassing the overload protection: Emergency situation (according to EN 13000:2010) **4.04 - 6**  
 Bypassing the overload protection: Failure of overload protection (according to EN 13000:2010) **4.04 - 5**  
 Bypassing the overload protection: Failure of the overload protection **4.04 - 5**  
 Bypassing the PAT overload protection **5.01 - 11**  
 Bypassing the radio connection **5.31 - 73**  
 Bypassing the seat contact button **4.05 - 4**  
 Bypassing track width monitoring **4.02 - 87**  
 Bypass of hoist limit switch **4.02 - 32**

## C

Cab auxiliary heater \* **7.05 - 45**  
 Cable drum **5.70 - 27**  
 Cable holding device **5.70 - 27**  
 Calculating the required length of transfers on uphill and downhill slopes **4.03.50 - 14**  
 Calculating the required length of transitions on uphill / downhill slopes **4.10 - 4**  
 Calculation example **4.10 - 5**  
 Calculation examples **2.04 - 38**  
 California Proposition 65 **0.01 - 1**  
 Calling up / closing the system screen **5.31 - 17**  
 Calling up / masking the crane operation monitoring functions **4.02 - 36**  
 Calling up the diesel particle filter load condition **4.03 - 6**

Calling up the service system **7.01.10 - 2**  
 Calling up the Working range limitation program **4.02 - 74**  
 Camera **5.70 - 1, 5.70 - 27**  
 Camera on the auxiliary boom - one cable drum **5.70 - 23**  
 Camera on the auxiliary boom - one cable drum and one cable holding device **5.70 - 25**  
 Camera on the auxiliary boom - two cable drums **5.70 - 23**  
 Camera on the telescopic boom **5.70 - 22**  
 Carrying out an intermediate lubrication **7.05 - 30**  
 Carrying out erection procedures **4.20 - 51**  
 Carrying out take down procedures **4.20 - 53**  
 Carrying out the assembly procedures **4.20 - 55**  
 Carrying out the erection / take down procedures **4.20 - 49**  
 Carrying the setting out **4.02 - 83**  
 Catch bar **4.04 - 18**  
 CE marking **0.01 - 5**  
 Center of gravity display on the LICCON monitor **4.10 - 7**  
 Center of gravity of the counterweight **2.05 - 43**  
 Central ballast **1.02 - 2, 3.03 - 1**  
 Central ballast 10t **1.03 - 8**  
 Central ballast combinations **3.03 - 3**  
 Central ballast during start up **3.03 - 3**  
 Central lubrication system **4.03 - 3, 7.05 - 28**  
 Chain bushing **7.04 - 16**  
 Chain link **7.04 - 15**  
 Chain pitch **7.04 - 16**  
 Change confirmation form **90.05 - 3**  
 Change to the operating instructions **90.01 - 3**  
 Changing oil on the planetary gear **7.04 - 7**  
 Changing over the mechanical folding jib from 0° to 22.5° or 45° **5.02 - 45**  
 Changing over the mechanical folding jib from 22.5° or 45° to 0° **5.02 - 77**  
 Changing the angle with the folding jib supported **5.02 - 53**  
 Changing the angle with the hoist rope **5.02 - 51, 5.02 - 81**  
 Changing the coolant **7.05 - 7**  
 Changing the diesel particle filter (DPF / filter module) for cleaning **7.05 - 24**  
 Changing the engine oil **7.05 - 5**  
 Changing the folding jib by supporting it **5.02 - 53, 5.02 - 83**  
 Changing the folding jib with the hoist rope **5.02 - 47, 5.02 - 77**  
 Changing the gear oil **7.05 - 27, 7.05 - 35**  
 Changing the master switch assignment **4.05 - 11**  
 Changing the oil **7.05 - 39, 7.05 - 41**  
 Changing the set up configuration **4.03 - 29**  
 Charge air temperature individual control display **4.02 - 45**  
 Charging a battery with the Liebherr charger \* **7.05 - 62**  
 Charging the batteries externally **7.05 - 63**

Charging the battery when installed **7.05 - 62**  
 Charging the battery while removed **7.05 - 62**  
 Charging the battery with an external charger **7.05 - 62**  
 Chart for determining the theoretically remaining service life **8.03 - 11**  
 Checking and replacing the return filter **7.05 - 56**  
 Checking bearings for easy movement **7.05.50 - 6**  
 Checking for broken strands **8.04 - 10**  
 Checking for corrosion **7.05.50 - 14**  
 Checking for damage and cracks **8.01 - 86**  
 Checking for flattenings **7.05.50 - 14**  
 Checking for leaks **7.04 - 5**  
 Checking for mechanical damage **7.05.50 - 5**  
 Checking for solid foreign substances **8.03 - 4**  
 Checking for wear and distortion **7.05.50 - 13**  
 Checking of rope diameter **8.04 - 15**  
 Checking of rope pretension on telescopic booms, illustration 1 **8.01 - 83**  
 Checking pretension pressure for the diaphragm reservoir **7.05 - 57**  
 Checking the air heater \* **7.05 - 48**  
 Checking the batteries **7.05 - 61**  
 Checking the bearings for easy movement **8.01 - 88**  
 Checking the central ballast blocks **3.03 - 6**  
 Checking the concentration of the antifreeze in the coolant **7.05 - 7**  
 Checking the condition of the belt drive **7.05 - 5**  
 Checking the connection type **5.31 - 17**  
 Checking the control rope for distortions **7.05.50 - 15**  
 Checking the coolant level **7.05 - 6**  
 Checking the depth of the lead-in tracks **8.01 - 87**  
 Checking the double hook for damage **8.05 - 6**  
 Checking the electrical connections **5.70 - 33, 5.75 - 12, 5.80 - 4**  
 Checking the end of the service life **8.06 - 3**  
 Checking the exhaust system for leaks and damage **7.05 - 24**  
 Checking the fill level of the fuel container **7.05 - 45, 7.05 - 49**  
 Checking the fill level of the fuel container \* **6.02 - 17**  
 Checking the fuel preliminary filter **7.05 - 15**  
 Checking the function **7.05 - 30, 7.05 - 47, 7.05 - 51**  
 Checking the gas pressure and oil fill before start up **8.01 - 86**  
 Checking the gear brakes **8.03 - 4**  
 Checking the groove diameter **8.01 - 86, 8.03 - 3**  
 Checking the heat flange **7.05 - 5**  
 Checking the hook body for wear **8.05 - 5**  
 Checking the labeling **5.01 - 2**  
 Checking the load hook **8.05 - 3**  
 Checking the load hook for corrosion **8.05 - 6**  
 Checking the load hook for distortion **8.05 - 4**  
 Checking the load hook for surface cracks **8.05 - 4**  
 Checking the lubrication **7.05.50 - 13**  
 Checking the maintenance status **7.01.10 - 6**  
 Checking the mounting screws for damage **8.01 - 90**  
 Checking the oil level in the crane cab **7.05 - 2**  
 Checking the oil level with the dipstick **7.05 - 3**

Checking the position **7.05.50 - 14**  
 Checking the profile clamps **7.05 - 24**  
 Checking the retaining elements **5.01 - 14, 8.05 - 7**  
 Checking the rope drive for spooling problems **7.05.50 - 14**  
 Checking the rope end connection **8.04 - 15**  
 Checking the ropes **7.05.50 - 12**  
 Checking the safety measures **2.04 - 44**  
 Checking the safety ropes and anchor points **8.01 - 82**  
 Checking the steel structures **5.01 - 2**  
 Checking the tightening torque **8.01 - 88**  
 Checking the tightness of the mounting screws **8.01 - 90**  
 Checking the tilt play **8.01 - 89**  
 Checking the valve clearance **7.05 - 5**  
 Checking the vent filter / breather filter **7.05 - 55**  
 Checking the water heater **7.05 - 47, 7.05 - 51**  
 Checking the wind speed sensor **5.75 - 12**  
 Check list for the inspection of ladders and steps **8.17 - 4**  
 Checks before starting to work with the crane **4.08 - 4**  
 Chemicals **2.04 - 3**  
 Cleaning the dust discharge valve **7.05 - 10**  
 Cleaning the water manifold **7.05 - 19**  
 Climate control **4.01 - 41, 4.03 - 26, 6.02 - 4**  
 Climate control button **4.01 - 42**  
 Climate control systems **6.02 - 3**  
 Closing the end section **5.01 - 31**  
 Closing the fixed lattice jib **5.01 - 36**  
 Closing the settings window **4.02 - 82**  
 Closing the side window pane **2.04 - 24**  
 Code calibration **5.31 - 7**  
 Combined degree of severity **8.04 - 26**  
 Comparison **4.02 - 3**  
 Complete crawler, 2-grouser pads 1000mm **1.03 - 6**  
 Complete machine with crawler carrier **3.80 - 14**  
 Complete machine without crawler carrier **3.80 - 15**  
 Completing emergency control **6.05 - 5**  
 Component description **3.01.20 - 3**  
 Component overview **5.09 - 3, 5.12 - 3**  
 Components **7.04 - 15**  
 Compressed air system \* **7.05 - 58**  
 Connecting the BTB and the BTT **5.31 - 7**  
 Connecting the leaning ladder to the ladder retainer and ascending **2.04.10 - 31**  
 Connecting the supply lines **5.09 - 8, 5.09 - 11**  
 Connector pins for erection rack / guy rods 97100629 **2.05 - 30**  
 Control **1.02 - 3**  
 Control elements **4.01 - 41**  
 Control elements in the set up program **4.02 - 14**  
 Control floodlight \* **5.31 - 63**  
 Control floodlight menu **5.31 - 61**  
 Control floodlight menu function keys **5.31 - 62**  
 Control measures before crane operation **5.01 - 4**  
 Control platform **4.03 - 19**  
 Control release **4.04 - 17**



Conversion chart **0.01 - 11**  
 Conversion chart for wind force **2.04 - 51**  
 Coolant **4.03 - 3**  
 Coolant system **7.06 - 3**  
 Coolant temperature individual control display **4.02 - 45**  
 Cooling system **7.05 - 5**  
 Corkscrew-like distortion **7.05.50 - 10, 8.04 - 20**  
 Corrosion **7.05.50 - 8, 8.04 - 18**  
 Cotter pin **5.01 - 16**  
 Counterweight **1.02 - 4, 4.07 - 1**  
 Counterweight and / or ballast **2.04 - 71**  
 Counterweight combinations **4.07 - 5**  
 Counterweight error message **4.07 - 24**  
 Counterweight frame **2.06 - 20**  
 Counterweight plate **1.03 - 8**  
 Crane **2.04 - 80, 3.80 - 3, 7.01 - 12**  
 Crane and crane components **2.04 - 25**  
 Crane and crane component transport **3.80 - 1**  
 Crane cab **2.04 - 18, 4.03 - 23**  
 Crane cab access on the crane chassis **2.04 - 20**  
 Crane cab access with a turned crane superstructure **2.04 - 21**  
 Crane cab with incline adjustment **2.04 - 23**  
 Crane chassis **2.06 - 10**  
 Crane chassis diesel engine maintenance status **7.01.10 - 4**  
 Crane components **1.01 - 3**  
 Crane condition **4.03 - 5**  
 Crane documentation **0.01 - 3**  
 Crane drive **1.02 - 3**  
 Crane driver's cab **1.02 - 3**  
 Crane driver's seat Version 1 **4.03 - 12**  
 Crane driver's seat Version 2 **4.03 - 17**  
 Crane engine maintenance status (engine 1) **7.01.10 - 5**  
 Crane engine maintenance status (engine 2) **7.01.10 - 6**  
 Crane floodlight menu **5.31 - 64**  
 Crane geometry and load information **4.02 - 16**  
 Crane geometry quick test **4.04 - 3**  
 Crane incline **4.02 - 52**  
 Crane in operation **2.04 - 5**  
 Crane movement with danger of tipping to the rear shut-off **4.20 - 26**  
 Crane on floating body **2.25 - 1**  
 Crane operation **2.04 - 68, 2.08 - 7, 4.05 - 1, 4.08 - 18**  
 Crane operation in case of thunderstorms **2.04 - 48**  
 Crane operation monitoring functions **4.02 - 33**  
 Crane operation program **4.02 - 15**  
 Crane operation with a load **2.04 - 69**  
 Crane operation with auxiliary pulley \* **4.06 - 28**  
 Crane operator's cab heater / engine preheating / air conditioning system **6.02 - 1**  
 Crane operator responsibilities **2.04 - 28**  
 Crane out of service **2.04 - 6**  
 Crane rope pretension **4.08 - 20**  
 Crane ropes **7.05.50 - 6, 8.04 - 3**

Crane speeds **1.03 - 4**  
 Crane superstructure **1.01 - 5, 1.02 - 2, 2.06 - 19**  
 Crane superstructure diesel engine maintenance status **7.01.10 - 5**  
 Cranes with a telescopic boom **2.08 - 6, 2.08 - 7**  
 Cranes with cam limit switch **5.01 - 3**  
 Cranes with lattice mast boom **2.08 - 5, 2.08 - 7**  
 Cranes with winch speed sensor **5.01 - 3**  
 Crane transport on floating devices **2.25 - 4**  
 Crawler carrier **3.80 - 9**  
 Crawler carrier assembly **3.01 - 1**  
 Crawler carrier in an incorrect position **4.02 - 84, 4.02 - 86**  
 Crawler center section **1.03 - 5, 1.03 - 6**  
 Crawler crane **1.03 - 4**  
 Crawler crane in crawler operation **4.03.50 - 15, 4.10 - 20**  
 Crawler travel  
 gear **1.01 - 3, 1.02 - 2, 4.02 - 54, 7.04 - 9**  
 Crawler travel gear menu **5.31 - 21**  
 Creeper gear or very slow movement **2.04 - 59**  
 Cross beams for platform ladder **2.04.10 - 15**  
 Cross carrier pinning cylinder **4.03.50 - 5**  
 Current checklist **8.04 - 29**  
 Customer information **90.05 - 4**  
 Cylinders **7.01 - 13**

## D

Damage to the rope **7.05.50 - 7**  
 Danger of crushing **4.08 - 18**  
 Danger of falling **4.08 - 19**  
 Dangers on the crane **2.04 - 3**  
 Danger zone of crane **2.04 - 5**  
 Data logger **0.01 - 2**  
 Deactivating the bypass at crawler assembly and crawler disassembly **5.01 - 26**  
 Decommissioning **7.01 - 14**  
 Defect during track width monitoring **4.02 - 85, 4.02 - 86**  
 Definition of directional data for crawler cranes **0.01 - 10**  
 Definition of directional data for mobile cranes **0.01 - 10**  
 Defrosting the window **6.02 - 13**  
 Degree of severity **8.04 - 8**  
 Derrick ballast - suspended ballast **2.04 - 72**  
 Descending from lattice sections or booms **2.04 - 17**  
 Description **1.03.10 - 2, 4.05 - 2, 5.75 - 3, 7.01.10 - 2**  
 Description of acoustic / visual warnings **4.20 - 11**  
 Description of intervals and tasks **7.01 - 3**  
 Description of the function **7.05 - 29**  
 Description using the example LR 1600-2, SL3F **4.08 - 22**  
 Destined use **2.25 - 3**  
 Detachable rope end connection **8.04 - 15**  
 Detaching / attaching the hook block on the fastening point **5.31 - 61**  
 Detaching the stairs **2.06 - 10**

Detent pin **5.01 - 18**  
 Determining the effective operating hours Ti **8.03 - 8**  
 Determining the exact charge condition of the rechargeable battery **5.31 - 17**  
 Determining the number of broken wires **8.04 - 10**  
 Determining the operating conditions (load spectrum) **8.03 - 6**  
 Determining the used proportion of the theoretical service life **8.03 - 8**  
 Diagnostics and troubleshooting **7.05 - 31**  
 Did an error message appear? **5.31 - 71**  
 Diesel engine **7.05 - 2, 7.06 - 3**  
 Diesel engine exhaust emissions **2.04 - 3**  
 Diesel particle filter (DPF) \* **4.03 - 6**  
 Diesel particle filter individual control display **4.02 - 44**  
 Dimensions **1.03 - 3**  
 Dimensions and weights **3.80 - 10**  
 Disabling automatic regeneration of the diesel particle filter **4.03 - 8**  
 Disassembling boom systems on ascending terrain **5.01 - 62**  
 Disassembling boom systems on descending terrain **5.01 - 65**  
 Disassembling lattice sections **5.01 - 53**  
 Disassembling the 3-piece folding jib **5.02 - 103**  
 Disassembling the 4-piece folding jib **5.02 - 107**  
 Disassembling the cable drum **5.70 - 35**  
 Disassembling the camera **5.70 - 34**  
 Disassembling the central ballast **3.01 - 67, 3.03 - 17**  
 Disassembling the central ballast block on the front **3.03 - 21**  
 Disassembling the central ballast block on the rear **3.03 - 25**  
 Disassembling the counterweight **4.07 - 27**  
 Disassembling the crawler carriers **3.01 - 53, 3.01 - 65**  
 Disassembling the cross carrier with installed extension cylinder **3.01.20 - 12**  
 Disassembling the double folding jib carried on the crane **5.02 - 97**  
 Disassembling the end section **5.02 - 97**  
 Disassembling the floodlight **5.80 - 4**  
 Disassembling the folding jib **5.02 - 87**  
 Disassembling the hydraulic hose drum **5.02 - 59**  
 Disassembling the jib boom **5.12 - 29**  
 Disassembling the jib boom carried on the crane **5.12 - 31**  
 Disassembling the lattice sections on a luffing lattice jib **5.01 - 41**  
 Disassembling the lattice sections on an auxiliary boom with an auxiliary crane **5.01 - 45**  
 Disassembling the lattice sections on an auxiliary boom without an auxiliary crane **5.01 - 49**  
 Disassembling the load hook **4.06 - 19**  
 Disassembling the reducer, part 1 **5.02 - 99**  
 Disassembling the reducer, part 2 **5.02 - 101**  
 Disassembling the separately transported auxiliary jib **5.12 - 35**  
 Disassembling the separately transported folding jib **5.02 - 111**  
 Disassembling the single folding jib carried on the crane, part 1 **5.02 - 93**  
 Disassembling the single folding jib carried on the crane, part 2 **5.02 - 95**  
 Disassembling the sliding platforms **2.06 - 15**  
 Disassembling the stairs **2.06 - 18**  
 Disassembling the wind speed sensor **5.75 - 12**  
 Disassembling the wind speed sensor in the transport position **5.75 - 4**  
 Disassembling winch 2 **5.09 - 13**  
 Disassembling winch 2 \* **5.09 - 19**  
 Disassembling winch 2 without the auxiliary crane **5.09 - 13**  
 Disassembling winch 2 with the auxiliary crane **5.09 - 19**  
 Disassembly **5.10 - 11, 5.25 - 9**  
 Disassembly Cross carrier with installed extension cylinder **3.01.20 - 11**  
 Disassembly of cross carrier with bracket **3.01.20 - 5**  
 Disassembly procedure **5.25 - 11**  
 Disconnecting the connections of the central lubrication system to the crawler carrier **3.01 - 63**  
 Disconnecting the connections to the crawler carrier **3.01 - 63**  
 Disconnecting the electrical connections **5.70 - 33**  
 Disconnecting the electrical connections to the crawler carrier **3.01 - 63**  
 Disconnecting the hook block **4.03 - 38**  
 Disconnecting the hydraulic connections to the crawler carrier **3.01 - 63**  
 Disengage the coupling control **4.03 - 31**  
 Disengaging / engaging the coupling control on the pump distributor gear **4.03 - 30**  
 Dismantling the platform ladder **2.04.10 - 18**  
 Display / operating element BTT **5.31 - 3**  
 Display \* **4.01 - 43**  
 Display areas in the Set up program **4.02 - 8**  
 Display areas in the Telescoping program **4.02 - 66**  
 Display areas of load chart values **4.02 - 9**  
 Display for surface pressure and inclination on the LICCON monitor **4.10 - 8**  
 Display for the inclination on the LICCON monitor **4.10 - 9**  
 Displaying the diesel particle filter load condition (DPF) **4.03 - 4**  
 Displaying the engine oil level **4.03 - 4**  
 Displaying the fuel reserve **4.03 - 3**  
 Displaying the hydraulic oil temperature **4.03 - 26**  
 Displaying the lubricants, operating fluids and fill levels on the LICCON monitor **4.03 - 3**  
 Displaying the set limit values **4.02 - 62**  
 Displaying the settings window **4.02 - 81, 4.02 - 91**  
 Displaying the urea reserve **4.03 - 4**  
 Displays **4.01 - 43**  
 Displays ECO-Mode in settings window **4.02 - 89**  
 Displays for center of gravity, surface pressure and incline on the LICCON monitor **4.03.50 - 15, 4.10 - 6**

Displays on control element **7.05 - 29**  
 Disposing of the machine **7.01 - 15**  
 Disposing of the oil **7.05 - 41**  
 Distortions and mechanical damage **8.04 - 8**  
 Distribution of the surface pressure **4.10 - 13**  
 Documentation of rope condition **7.05.50 - 13**  
 Documenting inspection results **8.04 - 5**  
 Documenting the completed inspection **8.03 - 4**  
 Documenting the inspection **8.06 - 5**  
 Double folding jib, see illustration 10 **5.02 - 11**  
 Double folding jib, see illustration 2 **5.02 - 3**  
 Double folding jib, see illustration 7 **5.02 - 9**  
 Double folding jib, see illustration 8 **5.02 - 9**  
 Draining the coolant **7.05 - 8**  
 Draining the fuel preliminary filter **7.05 - 16**  
 Draining the sediments in the fuel tank **7.05 - 20**  
 Driver's cab and crane cab **7.01 - 11**  
 Driving / swinging in the specified direction **2.04 - 61**  
 Driving forward **4.10 - 33, 4.10 - 39**  
 Driving from the crane cab **4.10 - 1**  
 Driving in curves forward to the left **4.10 - 35, 4.10 - 41**  
 Driving in curves forward to the right **4.10 - 35, 4.10 - 41**  
 Driving in curves in reverse to the left **4.10 - 35, 4.10 - 41**  
 Driving in curves in reverse to the right **4.10 - 35, 4.10 - 43**  
 Driving in reverse **4.10 - 33, 4.10 - 39**  
 Driving the crane: Load chart available **4.10 - 15**  
 Driving the crane: No load chart is available **4.10 - 17**  
 Driving the crawler crane in normal travel **4.10 - 33**  
 Driving the crawler crane in parallel travel **4.10 - 39**  
 Driving the outrigger pad in the cross direction over a cavity with a crawler crane **1.03.10 - 22**  
 Driving the outrigger pad in the cross direction with a crawler crane **1.03.10 - 18, 1.03.10 - 21**  
 Driving the transport vehicle out **3.01 - 43, 3.80 - 30**  
 Driving uphill / downhill **4.10 - 18**  
 Driving uphill / downhill by adjusting the angle of the boom system **4.10 - 19**  
 Driving with a load on the hook **4.10 - 16**  
 Driving with an extremely reduced load **2.04 - 67**  
 Driving with a reduced load **2.04 - 67**  
 Driving with a trailer **2.04 - 67**  
 Driving without a load on the hook **4.10 - 17**

## E

ECO-Mode **4.02 - 88**  
 ECO-Mode inactive **4.02 - 93**  
 ECO-Mode in crane operating screen displays **4.02 - 90**  
 Editing the speed reduction **4.02 - 81**  
 Effects of heat, arcs **7.05.50 - 12, 8.04 - 26**  
 Electrical connection **5.75 - 12, 5.80 - 3**  
 Electrical connections **5.02 - 63, 5.12 - 19**  
 Electrical connections on jib boom **5.12 - 19**  
 Electrical system **1.02 - 4, 7.05 - 59**

Emergency control **6.05 - 3, 6.05 - 5**  
 Emergency crane cab exit **2.04 - 8**  
 Emergency exit **2.04 - 7**  
 Emergency exit - driver's cab **2.04 - 7**  
 Emergency exit through front window **2.04 - 8**  
 Emergency exit through the roof window **2.04 - 8**  
 Emergency exit with EMERGENCY hammer \* **2.04 - 9**  
 Emergency operation LICCON overload protection (EN 13000:2010 active) **4.02 - 31**  
 Emergency operation unit **6.05 - 5**  
 Emergency operation with emergency operation unit **6.05 - 5**  
 Emergency situations **4.20 - 5**  
 Emergency stop (quick stop) **2.04 - 59**  
 EMERGENCY STOP switch / EMERGENCY OFF switch **4.04 - 17**  
 EMERGENCY STOP switch / EMERGENCY OFF switch quick test **4.04 - 17**  
 Emergency take down **6.05 - 1**  
 Endangering air traffic **2.04 - 6**  
 Ending crane operation **2.04 - 76**  
 Ending operation, no longer follow my instructions **2.04 - 59**  
 Engaging the coupling control **4.03 - 31**  
 Engaging the rapid gear **4.05 - 7**  
 Engine **1.02 - 2, 4.03 - 2**  
 Engine monitoring functions **5.31 - 33**  
 Engine oil level individual control display **4.02 - 43**  
 Engine oil pressure individual control display **4.02 - 46**  
 Engine operation menu **5.31 - 29**  
 Engine preheating **2.08 - 4**  
 Engine preheating auxiliary heater \* **7.05 - 49**  
 Engine regulation **4.10 - 23**  
 Engine rpm **4.05 - 8**  
 Engine type D 944 A7-03 **1.02 - 3**  
 Engine type D 944 A7-04 **1.02 - 3**  
 Engine type D 944 A7-05 **1.02 - 2**  
 Engine type D 944 A7-50 **1.02 - 3**  
 Enlarged rope end connection **8.04 - 15**  
 Entering and exiting the crane cab **2.07 - 4**  
 Entering the maximum permissible surface pressure **4.10 - 9**  
 Environmental / component temperature below -20°C **2.08 - 3**  
 Equipment **5.01 - 2**  
 Equipment and spare parts **0.01 - 9**  
 Erecting **5.02 - 73, 5.12 - 25**  
 Erecting / taking-down **5.01 - 67**  
 Erecting / taking down with crawler cranes **5.01 - 69**  
 Erecting / taking down with mobile cranes **5.01 - 68**  
 Erection **5.25 - 7**  
 Erection procedure **5.02 - 73, 5.12 - 25**  
 Error messages **4.02 - 3**  
 Establishing an electrical connection for ballast monitoring \* **3.03 - 14**  
 Establishing the connections of the central lubrication system to the crawler carrier **3.01 - 49**

Establishing the connection to the crawler carrier **3.01 - 49**  
Establishing the electrical / hydraulic connections **5.25 - 7**  
Establishing the electrical connection **5.25 - 7, 5.75 - 12, 5.80 - 4**  
Establishing the electrical connection for ballast monitoring to the central ballast blocks **4.07 - 22**  
Establishing the electrical connections **5.70 - 22**  
Establishing the electrical connections on the double folding jib **5.02 - 65**  
Establishing the electrical connections on the single folding jib **5.02 - 63**  
Establishing the electrical connections to the crawler carrier **3.01 - 49**  
Establishing the electrical connection to the hoist limit switch **5.02 - 63, 5.02 - 65**  
Establishing the electrical connection to the LED continuous light \* or flashing beacon \* **5.02 - 63, 5.02 - 65, 5.12 - 19, 5.12 - 21**  
Establishing the electrical connection to the wind speed sensor \* **5.02 - 63, 5.02 - 65, 5.12 - 19, 5.12 - 21**  
Establishing the electrical connection to winch 2 **5.09 - 7**  
Establishing the hydraulic connection **5.25 - 7**  
Establishing the hydraulic connections **5.02 - 57**  
Establishing the hydraulic connections to the crawler carrier **3.01 - 49**  
EU Declaration of Conformity **0.01 - 5**  
Evaluating oil color **8.03 - 3**  
Even reduction of rope diameter **8.04 - 15**  
Example **8.03 - 9**  
Example of crane on crawler with derrick boom, suspended ballast and long (main) boom system **2.04 - 40**  
Example of crane on crawler with derrick boom, suspended ballast and short (main) boom system **2.04 - 40**  
Example of crane on supports **2.04 - 41**  
Examples for the distribution of surface pressure **4.10 - 13**  
Examples of test points **8.01 - 7**  
Examples of the load bearing capacity of the ground **2.04 - 38**  
Exceeding the shut off limits of the LICCON overload protection **4.02 - 31**  
Exhaust system **7.01 - 11**  
Exhaust system \* **7.05 - 24**  
Exhaust system cleaning procedure **4.03 - 11**  
Extendible step \* for cranes on tires **2.04 - 18**  
Extendible step \* for LTR cranes **2.04 - 21**  
Extendible step for LTR 1060 and LTR 1100 **2.04 - 22**  
Extendible step for LTR 1220 **2.04 - 23**  
Extending / retracting the crawler carrier **4.03.50 - 21, 4.03.50 - 24, 4.03.50 - 27, 5.31 - 25**  
Extending / retracting the crawler carrier **4.01 - 35**

Extending / retracting the piston rod with the BTT **3.80 - 25, 3.80 - 35**  
Extending the boom **2.04 - 65**  
Extending the cross carriers **3.01 - 9, 3.01 - 10, 3.01 - 14, 3.01 - 18, 3.80 - 20, 3.80 - 20**  
Extending the cross carriers from the crane operator's cab **3.01 - 13, 3.01 - 91**  
Extending the cross carriers with the radio remote control \* **3.01 - 17**  
Extending the cross carrier with the BlueTooth™ Terminal **3.01 - 9**  
Extending the cross carrier with the BTT **3.80 - 18**  
Extending the piston rod from the crane operator's cab **3.01 - 27, 3.01 - 75**  
Extending the piston rod with the BlueTooth™ Terminal **3.01 - 25, 3.01 - 71**  
Extending the piston rod with the radio remote control \* **3.01 - 29, 3.01 - 77**  
Extending the support cylinders **3.80 - 26, 3.80 - 30, 3.80 - 33, 3.80 - 36**  
Extension ladder **2.04.10 - 24**  
External corrosion **8.04 - 18**

## F

Failure of components **4.20 - 5**  
Failure of sensor / limit switch **4.02 - 24**  
Failure of the overload protection **4.04 - 5**  
Fall protection equipment on the crane **2.06 - 1**  
Fan \* **4.03 - 18**  
Fan stage **4.01 - 43**  
Fastening **2.04 - 27**  
Fastening device **2.04 - 80**  
Fastening point **5.10 - 3, 5.12 - 3**  
Fastening point for end section **2.05 - 16**  
Fastening points **3.01.20 - 4, 5.09 - 3**  
Fastening points „folding jib complete“ **5.02 - 7**  
Fastening points „separated folding jib“ **5.02 - 11**  
Fastening positions for assembly / disassembly of the lattice jib **5.01 - 30**  
Fastening the central ballast blocks **3.03 - 7, 3.03 - 18**  
Fastening the counterweight plate **4.07 - 7**  
Fastening the counterweight plates **4.07 - 7**  
Fastening the counterweight plates and receptacle plate **4.07 - 7**  
Fastening the counterweight with a cross beam **4.07 - 9**  
Fastening the hook block **5.31 - 59**  
Fastening the load **4.08 - 7**  
Fastening the outrigger pad **1.03.10 - 5, 1.03.10 - 5**  
Fiber guy ropes **2.04 - 26, 5.01 - 3**  
Filling the grease container **7.04 - 21, 7.05 - 30**  
Filling the lubrication lines **7.05 - 31**  
Filling up the coolant **7.05 - 9**  
Fill quantities **7.06 - 3**  
Fill quantities, lubrication chart **7.06 - 1**  
First aid measures after rescue **2.04 - 18**

First inspection (first year) **8.03 - 10**  
 Fixed lattice jib **4.12 - 6, 4.12 - 18**  
 Flattening **7.05.50 - 9**  
 Flattenings **8.04 - 26**  
 Floating device **2.25 - 3**  
 Floating device, not supported **2.25 - 4**  
 Floating device, supported **2.25 - 4**  
 Floodlight **5.80 - 1**  
 Flying assembly / disassembly of lattice sections **5.01 - 55**  
 Flying assembly of lattice sections **5.01 - 55**  
 Flying disassembly of lattice sections **5.01 - 57**  
 Folding cross beam **2.04.10 - 15**  
 Folding jib **1.02 - 4, 2.06 - 8, 4.12 - 5, 4.12 - 15**  
 Folding jib (TK) \* **1.01 - 7**  
 Folding jib extension, see illustration 11 **5.02 - 11**  
 Folding jib hook points **2.06 - 9**  
 Folding jib - TK **5.02 - 1**  
 Folding jib variations **5.02 - 3**  
 Folding jib with angle sensor **5.02 - 70**  
 Folding jib with extension (TVK) \* **1.01 - 7**  
 Folding jib with hydraulic \* angle adjustment **5.02 - 75**  
 Folding jib without angle sensor **5.02 - 70**  
 Folding the boom nose into operating position, illustrations 3 and 4 **5.10 - 7**  
 Folding the boom nose into transport position, illustrations 5 and 6 **5.10 - 11**  
 Folding the control helm **4.03 - 19**  
 Folding the end section into operating position **5.12 - 13**  
 Folding the end section into the transport position **5.12 - 31**  
 Folding the front and rear cross-platforms **2.06 - 15**  
 For ambient temperatures of -18°C and lower **4.03 - 33**  
 For an ambient temperature above -18°C **4.03 - 33**  
 For cranes with pneumatic boom locking system **8.01 - 79**  
 For cranes with the Telematik telescopic boom system **8.01 - 80**  
 Foreword **90.01 - 3**  
 Forms of transport **3.80 - 2**  
 Frame **1.02 - 2, 1.02 - 2**  
 Friction corrosion **8.04 - 20**  
 Front crawler travel gear, definition **4.03.50 - 6**  
 Fuel reserve individual control display **4.02 - 42**  
 Fuel system **7.05 - 12**  
 Function  
 check **5.02 - 67, 5.02 - 69, 5.10 - 9, 5.12 - 23**  
 Function key line: Manual telescoping **4.02 - 71**  
 Function key line: Telescoping automatic operation **4.02 - 70**  
 Function key line (crane operation) **4.02 - 59**  
 Function key line (Set up) **4.02 - 11**  
 Function key line (working range limitation) **4.02 - 77**  
 Function key line (working range limitation) for variation V1 **4.02 - 77**

Function key line (working range limitation) for variation V2 **4.02 - 78**  
 Function keys in the Crane floodlight menu **5.31 - 65**  
 Function keys in the crawler travel gear menu **5.31 - 23**  
 Function keys in the support menu **5.31 - 43**  
 Function keys in the „Test system“ menu **5.31 - 67**

## G

Gamma -  $\gamma$  angle **5.70 - 32**  
 General controls before crane operation **5.01 - 4**  
 General information **8.01 - 2**  
 General information line **4.02 - 8**  
 General information regarding the BTT **5.31 - 9**  
 General notes regarding the acoustic / optical warnings to the surrounding crane area **4.20 - 9**  
 Giving a warning signal **4.05 - 4**  
 Gravity actuated relapse retainer **4.04 - 19**  
 Grommets and cable laid fastening rope **5.01 - 29, 8.01 - 85**  
 Ground connection **1.01 - 8**  
 Grounding **2.04 - 45**  
 Grounding the crane **2.04 - 45**  
 Grounding the load **2.04 - 46**  
 Guiding crane structures, lattice sections or crane components **5.01 - 24**  
 Guiding the load **4.08 - 18**  
 Guying the pivot section in flying mode with the derrick boom **5.01 - 59**  
 Guying the pivot section in flying mode with the SA-frame **5.01 - 57**  
 Guy rods **5.01 - 8**  
 Guy rods for telescopic cranes with luffing lattice jib **5.01 - 8**

## H

Handling of hook blocks **5.19 - 5**  
 Hand signals **2.04 - 58**  
 Hand signals for guidance **2.04 - 58**  
 Hard hat **2.04 - 13**  
 Hearing protection **2.04 - 14**  
 Heated crane components **2.04 - 5, 2.04 - 27**  
 Heater / climate control **4.03 - 16, 4.03 - 16**  
 Heater / climate control indicator light **4.03 - 16**  
 Heater / fan stages **4.03 - 16**  
 Heater control unit operating elements **6.02 - 5**  
 Heating-air conditioning device **7.05 - 41**  
 Height adjustment **4.03 - 15, 4.03 - 18**  
 Height dependant wind speed **2.04 - 52**  
 Height rescue system **2.04 - 12**  
 High pressure cleaner **7.01 - 9**  
 Hinged ladders **2.04.10 - 19**  
 Hoist gear **1.02 - 3, 7.05 - 39**  
 Hoist gear, hoist rope **2.04 - 73**  
 Hoist gear(s) **7.05 - 39**  
 Hoist gear 2 **5.09 - 1**  
 Hoist gear 2 with rope **1.03 - 9**

Hoist gear brake **7.05 - 41**  
Hoist limit  
switch **4.02 - 25, 5.02 - 67, 5.02 - 69, 5.10 - 9, 5.12 - 23**  
Hoist limit switch quick test **4.04 - 11**  
Hoist rope **4.06 - 7**  
Hoist rope guide for telescopic boom operation **4.06 - 3**  
Hoist rope length **4.08 - 15**  
Hoist rope lug \* **4.06 - 3**  
Hoist rope routing Folding jib / fixed lattice jib **4.06 - 4**  
Hoist rope routing for operation with luffing lattice jib **4.06 - 5**  
Hoist rope routing with one hoist rope **4.06 - 4**  
Hoist rope routing with two hoist ropes **4.06 - 4**  
Hoist top shut-off **4.20 - 26**  
Holding the luffing lattice jib **5.01 - 34**  
Hook base **8.05 - 5**  
Hook block **4.03 - 36, 4.06 - 14**  
Hook block overview **5.19 - 5**  
Hook blocks **1.03 - 11, 5.19 - 1**  
Hooking the hoist rope on the rope lock **4.06 - 15**  
Hook mouth **8.05 - 4**  
Hook operation **4.12 - 7**  
Hook operation depending on the load **4.12 - 9**  
Hook  
points **2.06 - 2, 2.06 - 6, 2.06 - 7, 2.06 - 19, 2.06 - 20**  
Hook shaft **8.05 - 4**  
Horizontal adjustment **4.03 - 12, 4.03 - 17**  
Horizontal movements **2.04 - 61**  
Horn **4.03 - 25**  
Horn warning sound **4.02 - 29**  
Hydraulically adjustable auxiliary boom **2.04 - 73**  
Hydraulically adjustable folding jib (TNZK) \* **1.01 - 7**  
Hydraulically adjustable folding jib with extension (TVNZK) \* **1.01 - 7**  
Hydraulic connections **5.02 - 57**  
Hydraulic hose lines **7.04 - 27, 7.05 - 58**  
Hydraulic oil, diesel fuel, operating fluids **2.04 - 5**  
Hydraulic oil level individual control display **4.02 - 44**  
Hydraulic oil preheating \* **4.03 - 26**  
Hydraulic oil temperature individual control display **4.02 - 46**  
Hydraulic safety valves **4.04 - 18**  
Hydraulic system **7.05 - 53, 7.06 - 4**  
Hydraulic tank **4.03 - 2**  
Hydraulic track width adjustment **1.02 - 2**

Icon explanation in assembly function menu **5.31 - 49**  
Icon explanation in engine operation menu **5.31 - 29**  
Icon explanation in the crawler travel gear menu **5.31 - 21**  
Icon explanation in the support menu **5.31 - 41**  
Icon explanation Start screen BTT **5.31 - 11**  
Icons for setting the slewing gear operating mode **4.02 - 83**

Icons in the Control floodlight \* menu **5.31 - 62**  
Icons in the crane floodlight menu **5.31 - 64**  
Identification of sliding beam **2.05 - 41**  
Identifications on auxiliary weights **2.05.10 - 5**  
Identifications on auxiliary weights at delivery **2.05.10 - 5**  
Identifications on auxiliary weights for re-order **2.05.10 - 6**  
Identifications on single hook or double hook **2.05.10 - 4**  
Identifications on the hook block or load hook **2.05.10 - 3**  
Identification Track width retracted **2.05 - 42**  
Idler **7.04 - 17**  
Impact protection **5.01 - 14**  
Importance of inspection **8.04 - 3**  
Important check before swinging out the hydraulic folding jibs (TNZK operation) **5.02 - 17**  
Important information about the BTT **5.31 - 5**  
Improper mechanical damage **8.04 - 26**  
Incline adjustment **4.03 - 14, 4.03 - 17**  
Increased corrosion **2.25 - 5**  
Increasing air distribution in the foot area **6.02 - 13**  
Increasing air distribution in the head area **6.02 - 12**  
Increasing the hook block weight **2.08 - 7, 4.08 - 24**  
Increasing the reeving number **4.08 - 24**  
Indicator lights **4.03 - 35**  
Indicator lights on the BKE „652“ **4.01 - 47**  
Individual control display of the hydraulic oil temperature, hydraulic circuit 1 **4.02 - 46**  
Individual control display of the hydraulic oil temperature, hydraulic circuit 2 **4.02 - 46**  
Individual control display of the torque converter temperature **4.02 - 47**  
Individual control display of the transmission temperature **4.02 - 45**  
Inspecting before start up **2.04 - 78**  
Inspecting load bearing crane structures, especially steel structures **8.01 - 4**  
Inspecting of fastening equipment **8.01 - 84**  
Inspecting of winches **8.03 - 1**  
Inspecting the carrier rollers **8.01 - 87**  
Inspecting the change over pulleys, illustration 2 **8.01 - 92**  
Inspecting the diaphragm reservoir **8.01 - 85**  
Inspecting the extension conditions of sliding beams **8.01 - 88**  
Inspecting the function of the overload protection **8.01 - 88**  
Inspecting the hoist and retracting winches **8.03 - 3**  
Inspecting the hydraulic hose lines for damage **7.04 - 28, 8.06 - 4**  
Inspecting the hydraulic hose lines for leaks **7.04 - 28, 8.06 - 5**  
Inspecting the ladders **8.17 - 3**  
Inspecting the lattice sections **8.01 - 78**  
Inspecting the load handling equipment and assembly aids **8.01 - 84**

Inspecting the locking system of the telescopic boom **8.01 - 79**  
 Inspecting the mounting of the load bearing equipment **8.01 - 90**  
 Inspecting the oil and fuel tanks **8.01 - 92**  
 Inspecting the pin connections **8.01 - 89**  
 Inspecting the relapse cylinders **8.01 - 85**  
 Inspecting the rope pretension on lattice sections, illustration 2 **8.01 - 83**  
 Inspecting the rope pulleys **8.01 - 86**  
 Inspecting the safety controls on the relapse cylinders **8.01 - 86**  
 Inspecting the slewing ring connection **8.01 - 89**  
 Inspecting the tele extension with eccentric, illustration 1 **8.01 - 91**  
 Inspection chart for cranes **8.90 - 1**  
 Inspection chart for recurring inspections of Liebherr cranes **8.90 - 3**  
 Inspection form for the inspection of ladders and steps **8.17 - 4**  
 Inspection intervals **8.03 - 3, 8.05 - 3, 8.06 - 3, 8.17 - 3**  
 Inspection of crane wire ropes **8.04 - 1**  
 Inspection of hydraulic hose lines **8.06 - 1**  
 Inspection of ladders **8.17 - 1**  
 Inspection of load hooks **8.05 - 1**  
 Inspection of the auxiliary reeving winch, recovery winch and spare wheel winch **8.03 - 5**  
 Inspection of the screws in the adjustment plates **8.01 - 81**  
 Inspections **4.03 - 2**  
 Inspection sheet and check list **8.17 - 3**  
 Installation of the track pads **7.04 - 17**  
 Installing the auxiliary weights **5.19 - 9**  
 Installing the batteries **7.05 - 63**  
 Installing the boom nose on the telescopic boom **5.10 - 5**  
 Installing the central ballast **3.01 - 45**  
 Installing the cross carrier **3.01.20 - 9**  
 Installing the diesel particle filter (DPF / filter module) after cleaning **7.05 - 25**  
 Installing the hook device on the ladder **2.06 - 4**  
 Installing the hose couplings in the operating or neutral position **5.02 - 57**  
 Installing the hydraulic hose drum **5.02 - 61**  
 Installing the single blocks **5.19 - 9**  
 Installing the support plates **3.01 - 23**  
 Installing the wedge lock **4.06 - 27**  
 Installing the wind speed sensor **5.75 - 4**  
 Instructions for resuming crane movement **4.20 - 19**  
 Integrated pneumatic system (IPS) **4.03 - 13**  
 Intended use **0.01 - 7, 2.04 - 76, 2.04 - 78, 2.04.10 - 2**  
 Intermediate lubrication of crawler carriers **7.04 - 25**  
 Intermediate section **1.02 - 4**  
 Internal corrosion **8.04 - 20**  
 Interrupting crane operation **2.04 - 73**  
 Intervals **7.05.50 - 13, 8.04 - 4**  
 Is the radio connection faulty? **5.31 - 72**

## J

Jib boom **5.12 - 1**  
 Jib boom (THK) \* **1.01 - 7**  
 Job planning **2.03 - 1**

## K

Kinking, rope loops (grommets) pulled closed **7.05.50 - 11**  
 Kinking or rope loops pulled closed **8.04 - 24**

## L

Labeling of the load carriers **2.05.10 - 1**  
 Ladder access **2.04.10 - 25**  
 Ladder categories **2.04.10 - 2**  
 Ladder inspection **2.04.10 - 12**  
 Ladders **2.04.10 - 1, 7.01 - 11, 7.04 - 28, 7.05 - 63**  
 Ladder safeguards **2.04.10 - 25**  
 Latch **5.01 - 19**  
 Lattice sections **2.04 - 25**  
 Lead and lead compounds **2.04 - 4**  
 Legal prerequisites **2.04 - 77**  
 Leveling instrument in the BTT **4.04 - 9**  
 Leveling instrument quick test **4.04 - 9**  
 Leveling instruments **4.04 - 9**  
 Leveling instruments in the LICCON monitor **4.04 - 9**  
 LICCON computer system **4.02 - 1, 4.03 - 27, 4.04 - 3**  
 LICCON job planner **2.04 - 39**  
 LICCON monitor at system start **4.02 - 4**  
 LICCON overload protection **4.04 - 3**  
 LICCON overload protection emergency operation (EN 13000:2010 not active) **4.02 - 32**  
 Liebherr Customer Service **7.01 - 7**  
 Lifting / lowering **4.05 - 13**  
 Lifting / lowering a load with even speed **2.04 - 60**  
 Lifting / lowering the hydraulic folding jib \* **5.31 - 57**  
 Lifting / lowering with winch 1 **4.05 - 14**  
 Lifting / lowering with winch 2 \* **4.05 - 16**  
 Lifting a joint load **4.12 - 26**  
 Lifting a joint load solely with the auxiliary boom **4.12 - 26**  
 Lifting a joint load with two booms **4.12 - 28**  
 Lifting a load with two cranes **2.04 - 55**  
 Lifting heights **1.03 - 12**  
 Lifting of personnel **2.04 - 76**  
 Lifting slowly **2.04 - 60**  
 Lifting the boom **2.04 - 64**  
 Lifting the boom and lower the load at the same time **2.04 - 66**  
 Lifting the counterweight from the central ballast **4.07 - 35**  
 Lifting the load **4.08 - 11, 4.08 - 16**  
 Lifting with auxiliary winch **2.04 - 64**  
 Lifting with main winch **2.04 - 64**  
 Light and / or heavy work **2.04.10 - 25**  
 Limiting engine rpm in ECO-Mode **4.02 - 92**

Limit sign auxiliary boom / accessory **4.02 - 24**  
Limit signs main boom **4.02 - 23**  
Limit switch Boom system **4.04 - 18**  
Linch pin **5.01 - 17**  
Lines **7.05 - 59**  
LMB emergency operation for crane control „EN 13000:2010 active“ **4.01 - 8**  
LMB emergency operation operating elements **4.01 - 8**  
Load bearing crane structures **2.08 - 7**  
Load burdens on the ground on cranes on crawlers **2.04 - 37**  
Load burdens on the ground on cranes on supports **2.04 - 37**  
Load hook **1.03 - 10, 4.06 - 18**  
Loading the crane onto the transport vehicle **3.01 - 69, 3.03 - 25**  
Loading the preassembled lattice jib **5.01 - 37**  
Loading without an auxiliary crane **3.80 - 31**  
Loads on the ground **1.03.10 - 3**  
Loads on the ground due to crane operation **2.04 - 37**  
Load spectrum class: Heavy L3 **8.03 - 7**  
Load spectrum class: Light L1 **8.03 - 6**  
Load spectrum class: Medium L2 **8.03 - 7**  
Load spectrum class: Very heavy L4 **8.03 - 8**  
Load weighing **4.08 - 14**  
Load weighing and load display **4.08 - 13**  
Localized increase of rope diameter **7.05.50 - 8**  
Localized increases of rope diameter **8.04 - 18**  
Localized reduction of rope diameter **8.04 - 17**  
Locking the engine rpm **4.05 - 8**  
Loop formation **7.05.50 - 11, 8.04 - 23**  
Lowering slowly **2.04 - 61**  
Lowering the boom **2.04 - 65**  
Lowering the boom and lift the load at the same time **2.04 - 66**  
Lowering the crane **3.01 - 51, 3.01 - 69, 3.80 - 33**  
Lowering the hoist gear **6.05 - 3**  
Lowering the hook block **5.19 - 3**  
Lowering the hook block if slack rope forms **5.19 - 3**  
Lowering the load **4.08 - 17**  
Lowering the load while stationary **2.04 - 61**  
Lubricating ladders **7.04 - 29**  
Lubricating the bearings **7.05.50 - 6**  
Lubricating the gear ring and the slewing gear pinion **7.05 - 33**  
Lubricating the inner gliding surfaces **7.05.50 - 3**  
Lubricating the locking pin **7.05.50 - 5**  
Lubricating the outer gliding surfaces **7.05.50 - 2**  
Lubricating the rope **7.05.50 - 15**  
Lubricating the slewing ring connection **7.05 - 32**  
Lubrication cycle **7.05 - 30**  
Lubrication schedule **7.06 - 4**  
Luffing **4.05 - 11**  
Luffing accessories limit switch **4.04 - 18**  
Luffing gear **1.02 - 3**  
Luffing in with a suspended load **4.20 - 35**  
Luffing lattice jib **4.12 - 7, 4.12 - 22**

Luffing the auxiliary boom / accessory up / down shut-off **4.20 - 22**  
Luffing the boom down **5.19 - 3**  
Luffing the hydraulic auxiliary boom \* **4.05 - 12**  
Luffing the telescopic boom **4.05 - 11**  
Luffing the telescopic boom down **3.80 - 42**  
Luffing the telescopic boom up **3.80 - 28**  
Luffing the telescopic boom up / down shut-off **4.20 - 21**  
Luffing with „hydraulic angle adjustment“ **5.02 - 75**  
Luff the telescopic boom down **6.05 - 3**  
Luff the telescopic boom up **6.05 - 3**

## M

Machine related movements **2.04 - 64**  
Main boom length **4.02 - 20**  
Maintaining the battery charge **4.03 - 33**  
Maintenance **2.08 - 7, 7.01 - 14**  
Maintenance and inspection schedule **7.02 - 2, 7.03 - 2, 7.03.50 - 2**  
Maintenance and service - General **7.01 - 1**  
Maintenance instructions - Crane boom **7.05.50 - 1**  
Maintenance instructions - Crane chassis **7.04 - 1**  
Maintenance instructions - Crane superstructure **7.05 - 1**  
Maintenance intervals **7.01 - 3**  
Maintenance intervals - Crane boom **7.03.50 - 1**  
Maintenance intervals - Crane superstructure **7.03 - 1**  
Maintenance intervals - Crawler chassis **7.02 - 1**  
Maintenance status **7.01.10 - 4**  
Maintenance technician **7.01 - 2**  
Manual operation **6.02 - 9**  
Manual rope winches **5.01 - 7**  
Manual support **5.31 - 45**  
Manufacturer **0.01 - 1**  
Master switch **4.05 - 3**  
Master switch assignment **4.05 - 10**  
Master switch assignment for machines with one winch **4.01 - 13**  
Master switch assignment for machines with two winches **4.01 - 19**  
Maximum climbing ability **4.10 - 18**  
Maximum load **4.02 - 17**  
Maximum load according to load chart and reeving **4.02 - 3**  
Maximum permissible temperatures on the travel gear **4.03.50 - 14**  
Maximum slewing speed **4.05 - 18**  
Maximum sound power level **2.05 - 29**  
Maximum surface pressure **1.03 - 3**  
Maximum value F-load display shut-off **4.20 - 27**  
Maximum values of F-load display reached **4.20 - 57**  
Measurement of wind speed **2.04 - 50**  
Measures in case of problems **5.31 - 71**  
Mechanically actuating the hoist limit switch, illustration X **5.02 - 63**  
Minimum rope coils **5.01 - 3**



Minimum rope reeving / minimum hook block weight **2.05 - 44**  
 Mobile cranes **2.04 - 26**  
 Monitored auxiliary functions **4.02 - 51**  
 Monitoring functions **4.03 - 5**  
 Monitoring the surface pressure and center of gravity **4.02 - 47**  
 Monitoring the turning range **4.05 - 18**  
 Monitoring the winches **8.03 - 5**  
 Moveable back pulley \* **4.06 - 6**  
 Movement on the crane **2.04 - 7**  
 Moving away from me **2.04 - 62**  
 Moving both track chains **2.04 - 62**  
 Moving one crawler chain **2.04 - 63**  
 Moving the transport vehicle in **3.01 - 69**  
 Moving toward me **2.04 - 62**  
 Multi-purpose ladder with height adjustment **2.04.10 - 21**

## N

Negative longitudinal inclination **4.10 - 19**  
 Noise emission **1.03 - 3**  
 No load chart is available **4.02 - 31**  
 Non-accessible surfaces **2.07 - 8**  
 Non-destined use **0.01 - 8, 2.25 - 3**  
 Non-rotating rope end connection **8.04 - 6**  
 Non-twisting ropes with rope end connections **8.04 - 7**  
 Note Weight sliding beams **2.05 - 43**

## O

Obligations of the crane operator **2.04 - 29**  
 Occurrence of an advance warning **4.02 - 26**  
 Occurrence of a shut-off in the working range limitation **4.02 - 78**  
 One-part hoist limit switch weight **4.06 - 23**  
 Only available for a diesel engine: Determining the total operating hours for the diesel engine **7.01.10 - 4**  
 Opening / closing the front window of the crane cab **4.03 - 24**  
 Opening / closing the roof window **4.03 - 25**  
 Opening the end section **5.01 - 33**  
 Operating and control instruments **4.01 - 3**  
 Operating and monitoring instruments on the crane superstructure **4.01 - 1**  
 Operating buttons on the BKE for release actuations „654“ **4.01 - 51**  
 Operating buttons on the BKE „653“ **4.01 - 47**  
 Operating condition of crane **4.20 - 6**  
 Operating conditions **2.25 - 3**  
 Operating console **4.01 - 46**  
 Operating ECOMode **4.02 - 91**  
 Operating elements, General **4.01 - 5, 4.01 - 39**  
 Operating elements at speed reduction of master switches **4.02 - 79**  
 Operating elements for seat adjustment **4.01 - 3**

Operating elements for special cases for operation of the LICCON overload protection **4.20 - 3**  
 Operating elements for the crawler operation **4.10 - 23**  
 Operating elements in ECO-Mode **4.02 - 89**  
 Operating elements in the Crane operation program **4.02 - 60**  
 Operating elements of the LICCON computer system **4.02 - 5**  
 Operating elements on the control panels **4.01 - 11**  
 Operating elements on the control platform **4.01 - 3**  
 Operating elements on the operating and control unit (BKE) **4.01 - 46**  
 Operating fluids and lubricants **7.07 - 1**  
 Operating instructions **6.02 - 3**  
 Operating interface **4.02 - 67**  
 Operating interface in ECO-Mode **4.02 - 89**  
 Operating interface in the settings window for speed reduction of master switches **4.02 - 80**  
 Operating interface Working range limitation program **4.02 - 75**  
 Operating the step from the crane cab **4.03 - 22**  
 Operating the test system **5.31 - 67**  
 Operating the timer **6.02 - 14**  
 Operating with telescopic boom and auxiliary boom **4.08 - 4**  
 Operational transverse pressure **8.04 - 27**  
 Optimizing measures for the travel route **4.03.50 - 14, 4.10 - 4**  
 Optional equipment and functions **0.01 - 10**  
 Ordering the diesel particle filter (DPF / filter module) **7.05 - 24**  
 Order of the displays in the crane operation monitoring functions **4.02 - 34**  
 Outtrigger pad LWE ID number 914618608 **1.03.10 - 13**  
 Outtrigger pad LWE ID number 914786508 **1.03.10 - 6**  
 Outtrigger pad LWE ID number 914786808 **1.03.10 - 8**  
 Outtrigger pad LWE ID number 914861908 **1.03.10 - 7**  
 Outtrigger pad LWE ID number 915236308 **1.03.10 - 9**  
 Outtrigger pad LWE ID number 915236408/915464608 **1.03.10 - 10**  
 Outtrigger pad LWE ID number 915696408 **1.03.10 - 14**  
 Outtrigger pad LWE ID number 918339808 **1.03.10 - 16**  
 Outtrigger pad LWE ID number 919427108 **1.03.10 - 19**  
 Outtrigger pads **1.03 - 7, 1.03.10 - 1**  
 Overflow container **7.05 - 41**  
 Overlapping of working ranges of several cranes **2.04 - 57**  
 Overload protection **4.02 - 2**  
 Overload protection quick test **4.04 - 3**  
 Overview Load chart **4.20 - 19**

Overview of acoustic / optical warnings **4.20 - 9**  
Overview of counterweight **4.07 - 3**  
Overview of icons for monitoring functions **4.02 - 37**  
Overview of the individual control displays **4.02 - 42**  
Overview of the retaining elements **5.01 - 15**

## **P**

Packing the diesel particle filter (DPF / filter module) for transport **7.05 - 25**  
Pairing process **5.31 - 7**  
Parking brake slewing gear **4.05 - 19**  
Pedal carrier **4.10 - 23**  
Pedal operating elements **4.01 - 7**  
Performing a visual inspection **8.01 - 87**  
Periodic crane inspections **8.01 - 1**  
Permissible load configurations **1.03.10 - 3**  
Permissible support pressures on the outrigger pad [A-B-C] **2.05 - 28**  
Permissible support pressures on the outrigger pad [A-B-C-D] **2.05 - 28**  
Personal protective equipment **2.04 - 9, 7.05.50 - 6, 8.04 - 3**  
Personnel **7.01 - 2**  
Personnel and qualification **2.04 - 79**  
Picking up and lowering overhead loads **4.08 - 23**  
Picking up the counterweight with the ballasting device **4.07 - 17**  
Picking up the fastening equipment **4.08 - 21**  
Pin connections **5.01 - 12**  
Pinning / unpinning the cross carriers **4.01 - 35**  
Pinning the assembly device with the crawler carrier **3.01 - 45, 3.01 - 65**  
Pinning the ballasting device **4.07 - 21**  
Pinning the collar pin **5.01 - 12**  
Pinning the crane superstructure **4.05 - 9, 4.05 - 9**  
Pinning the crawler carrier **3.01 - 47**  
Pinning the support cylinders **3.01 - 33, 3.01 - 78, 3.80 - 28, 3.80 - 36**  
Pinning the turntable with the BTT **4.07 - 37**  
Placement width **1.03.10 - 3**  
Placing a shorter crane rope **4.08 - 21**  
Placing the hoist rope or the control rope **5.01 - 2**  
Planning Crane operation **2.03 - 3**  
Platform ladder **2.04.10 - 16**  
Pneumatic springs **5.01 - 6**  
Positioning the folding jib **5.02 - 51, 5.02 - 55**  
Positioning the support cylinders in operating position **3.01 - 33, 3.80 - 27**  
Positioning the support cylinders in transport position **3.01 - 71, 3.80 - 34**  
Positioning the support plate off-center on the outrigger pad **1.03.10 - 10, 1.03.10 - 12, 1.03.10 - 14, 1.03.10 - 17, 1.03.10 - 20**  
Positive longitudinal incline **4.10 - 19**  
Possible weighing errors **4.08 - 14**  
Power-Save mode **4.02 - 94**

Power-save mode and Stand-by mode in the LIC-CON computer system **4.02 - 94**  
Preface **0.01 - 1**  
Preface to the appendix **90.01 - 1**  
Preheating the hydraulic oil **2.08 - 4**  
Preheating time **2.08 - 3**  
Preparatory work **5.02 - 47, 5.02 - 53, 5.02 - 73, 5.02 - 79, 5.12 - 25**  
Preparatory work before swinging in hydraulic folding jibs **5.02 - 89**  
Preparing for crane driving **4.03.50 - 15, 4.10 - 13**  
Preparing the assembly device **3.01 - 45, 3.01 - 65**  
Preparing the crane for emergency operation **6.05 - 5**  
Preparing the hook block **4.06 - 15**  
Preparing the hook block for crane operation **5.19 - 11**  
Preparing the hook block for removal **5.19 - 13**  
Preparing the ladder **2.06 - 3**  
Preparing the pin pulling device **3.01 - 47**  
Preparing the support plates for assembly **3.01 - 23, 3.80 - 25**  
Prerequisite for assembly **5.02 - 15**  
Prerequisite for disassembly **5.02 - 89**  
Prerequisites **2.04 - 79**  
Prerequisites for adjusting the track width while driving **4.03.50 - 12**  
Prerequisites for crane equipment and accessories **2.04 - 77**  
Prerequisites for crane operation **4.05 - 3**  
Prerequisites for driving the crane (crawler operation) **4.10 - 2**  
Prerequisites for driving uphill / downhill without adjusting the angle of the boom system **4.10 - 20**  
Prerequisites for lifting of personnel **2.04 - 77**  
Prerequisites for operation with crane LTM 1220 **5.02 - 15, 5.02 - 91**  
Prerequisites for operation with crane LTR 1220 **5.02 - 15, 5.02 - 91**  
Prerequisites for operation with lifting cage (cherry picker) **2.04 - 78**  
Pressed rope end connection **8.04 - 15**  
Pressure testing the relapse cylinders **8.01 - 85**  
Pretensioning the hoist rope with pretensioning ballast with two hook operation **4.08 - 24**  
Preventing fires **7.01 - 4**  
Prevention of improper machine use **7.01 - 15**  
Priority acoustic signal **4.02 - 29**  
Prior to track width adjustment **4.03.50 - 4**  
Problem signals on control element **7.05 - 31**  
Problems on central lubrication system **7.05 - 31**  
Procedure **4.02 - 81**  
Procedure for shut-off of crane movement **4.20 - 1**  
Procedure for special cases at operation of the LIC-CON overload protection **4.20 - 31**  
Procedure in case of slack rope **5.19 - 3**  
Product description **1.02 - 1**  
Programming the timer **6.02 - 14**

Protecting against burns **7.01 - 5**  
Protecting against the hazards of service fluids **7.01 - 6**  
Protecting from scalding **7.01 - 5**  
Protecting the crane against corrosion **7.01 - 12**  
Protecting the crane against corrosion for shut-down **7.01 - 14**  
Protecting the crane against corrosion for storage **7.01 - 13**  
Protective gloves **2.04 - 14**  
Protruding, distorted inlay, braiding **7.05.50 - 11**  
Protruding, distorted insert or strand **8.04 - 22**  
PSAgA, rescue equipment and tools **2.04 - 79**  
Pulley head height **4.02 - 21**  
Pump distributor gear **7.05 - 26**  
Putting the fuel system in operation **7.05 - 19**

## Q

Qualification Inspection personnel **8.04 - 3**  
Qualification Maintenance personnel **7.05.50 - 7**

## R

Radio connection **5.70 - 29**  
Rail transport **3.80 - 12**  
Raising the hoist gear **6.05 - 3**  
Ram work or pulling sheet piles **4.08 - 19**  
Rapid gear **4.02 - 33, 4.05 - 7**  
Receptacle plate **1.03 - 7**  
Recommendation for safe disposal **7.01 - 15**  
Reducing rope pull **2.08 - 6**  
Reducing rope unwinding **4.08 - 21**  
Reducing the maximum load **2.08 - 7**  
Reducing the maximum permissible wind speed \* **4.02 - 54**  
Reduction of rope diameter **7.05.50 - 8**  
Reeving in the hoist rope **5.10 - 9**  
Reeving in the hoist rope with the assembly winch \* **4.06 - 11**  
Reeving in the hoist rope with the auxiliary reeving rope **4.06 - 7**  
Reeving out the hoist rope on the telescopic boom head **5.02 - 17, 5.12 - 7**  
Reeving the hoist rope in **5.02 - 43, 5.02 - 43, 5.12 - 17**  
Reeving the hoist rope out **4.06 - 12, 5.02 - 85, 5.12 - 27, 5.12 - 27**  
Reeving the hook block in **4.06 - 14**  
Reeving the hook block out **4.06 - 16**  
Regenerating at a standstill of the diesel particle filter **4.03 - 9**  
Relapse cylinders **5.01 - 6**  
Release procedure **7.04 - 13**  
Releasing the button block on the BTT **5.31 - 5**  
Releasing the crane cab **7.05 - 44**  
Releasing the engine rpm lock **4.05 - 9**  
Releasing the parking brake **4.05 - 19**

Releasing the supply lines **5.09 - 13, 5.09 - 19, 5.09 - 19**  
Releasing the turntable lock **4.07 - 21, 4.07 - 33**  
Relieving the track chain **7.04 - 13**  
Removal criteria Overview **8.04 - 8**  
Removing broken wires **7.05.50 - 16**  
Removing hoist gear 2 \* **4.07 - 27**  
Removing the auxiliary weights **5.19 - 13**  
Removing the batteries **7.05 - 63**  
Removing the boom nose on the telescopic boom **5.10 - 15**  
Removing the cross carrier **3.01.20 - 6**  
Removing the diesel particle filter (DPF / filter module) **7.05 - 25**  
Removing the hoist limit switch weight **4.06 - 22, 4.06 - 25**  
Removing the rigging device **3.80 - 17**  
Removing the single blocks **5.19 - 13**  
Removing the support plates **3.01 - 81, 3.80 - 36**  
Removing the wedge lock **4.06 - 27**  
Renewing the pretension of hoist ropes **7.05.50 - 18**  
Repair welding **8.01 - 6**  
Replacing damaged crane components **7.01 - 6**  
Replacing hydraulic hose lines **8.06 - 5**  
Replacing the diesel particle filter **7.05 - 24**  
Replacing the dry air filter main element **7.05 - 10**  
Replacing the dry air filter safety element **7.05 - 11**  
Replacing the filter **7.05 - 52**  
Replacing the filter insert **7.05 - 18, 7.05 - 41, 7.05 - 43**  
Replacing the filter strainer **7.05 - 22**  
Replacing the fuel fine filter **7.05 - 20**  
Replacing the granular cartridge of the air dryer **7.05 - 58**  
Replacing the heat flange **7.05 - 5**  
Replacing the oil filter **7.05 - 5**  
Replacing the oil separator filter insert **7.05 - 5**  
Replacing the pressure filter elements **7.05 - 57**  
Rescue **2.04 - 80**  
Rescuing the assembly personnel **2.04 - 17**  
Resetting a problem **7.05 - 32**  
Resetting the diesel particle filter maintenance status **7.01.10 - 7**  
Resetting the engine oil maintenance status **7.01.10 - 7**  
Resetting the maintenance interval for the diesel particle filter (DPF / filter module) **7.05 - 25**  
Resetting the maintenance status **7.01.10 - 7**  
Respiratory protection **2.04 - 14**  
Restoring hoist rope pretension **4.08 - 21**  
Resuming crane operation **2.04 - 76**  
Retaining clips **5.01 - 21**  
Retaining elements **5.01 - 14**  
Retaining pins for erection rack 97100047 **2.05 - 29**  
Retracting / extending the ballast cylinder with the BTT **4.07 - 37**  
Retracting the boom **2.04 - 65**

Retracting the cross carriers **3.01 - 85, 3.01 - 88, 3.01 - 92, 3.01 - 96, 3.80 - 20, 3.80 - 41**  
 Retracting the cross carriers with the radio remote control \* **3.01 - 95**  
 Retracting the cross carrier with the BlueTooth™ Terminal **3.01 - 87**  
 Retracting the cross carrier with the BTT **3.80 - 39**  
 Retracting the support cylinders **3.01 - 33, 3.80 - 26, 3.80 - 28, 3.80 - 30, 3.80 - 33, 3.80 - 35**  
 Retracting the transport vehicle **3.80 - 31**  
 Retrofitting old ladders **2.04.10 - 3**  
 Returning to service **7.01 - 14**  
 Rigging **3.80 - 42**  
 Rigging device **3.80 - 3**  
 Rigging plans **3.80 - 2, 3.80 - 3, 3.80 - 9**  
 Rigging points **3.80 - 2**  
 Rigging points and fastening points **8.01 - 77**  
 Rigging the crane on the transport vehicle **3.01 - 99**  
 Rigging the guy rods on lattice booms on placed down boom system **5.01 - 69**  
 Road transport **3.80 - 10**  
 Roof instrument panel operating elements **4.01 - 39**  
 Rope end connections **4.06 - 2**  
 Rope pulleys **5.01 - 2**  
 Rope pulleys and guide pulleys **7.05.50 - 5**  
 Rope pulleys and hydraulic cylinders **2.08 - 8**  
 Rope reeving **4.06 - 1, 4.06 - 29**  
 Ropes **1.03 - 4, 5.01 - 2**  
 Rotating parts **7.01 - 6**  
 Rotating rope end connection **8.04 - 6**  
 Rotation resistant ropes **8.04 - 13**  
 Rotation-resistant ropes with rope end connections **8.04 - 5**

## S

Safe and problem-free operation **7.05.50 - 6**  
 Safety and warning display **0.01 - 2**  
 Safety equipment **0.01 - 9, 1.02 - 4, 4.04 - 1**  
 Safety equipment on the crane **4.04 - 9**  
 Safety goggles **2.04 - 14**  
 Safety guidelines **8.06 - 3**  
 Safety harness with height safety equipment **2.04 - 10**  
 Safety instructions in case of an external power supply **2.04 - 45**  
 Safety locking pin **5.01 - 16**  
 Safety shoes **2.04 - 14**  
 Safety signs **2.04.10 - 3**  
 Scattered occurring broken wires **8.04 - 10**  
 Seat cushion adjustment **4.03 - 15, 4.03 - 18**  
 Seat heater / seat climate control \* **4.03 - 18**  
 Second inspection (second year) **8.03 - 10**  
 Securing **3.80 - 43**  
 Securing against falls **7.01 - 4**  
 Securing against start up **7.01 - 3**  
 Securing bracket **2.04 - 24**

Securing personnel on shut off crane **2.04 - 78**  
 Securing persons to prevent them from falling **2.04 - 16**  
 Securing the cable **5.70 - 26**  
 Securing the crane cab for maintenance work **7.05 - 43**  
 Securing the ladder **2.06 - 5, 2.06 - 8, 2.06 - 20**  
 Securing the ladder in the transport position **2.06 - 21**  
 Securing the wind speed sensor in the transport position **5.75 - 14**  
 Selecting / deselecting icons on the touch display **4.03.50 - 19**  
 Selecting the crawler carrier **4.03.50 - 20, 4.03.50 - 24, 4.03.50 - 27**  
 Selecting the hoist winch **5.31 - 59**  
 Selecting the location **2.04 - 30**  
 Selecting the support automatic **3.80 - 29, 3.80 - 32**  
 Selecting the support cylinder **3.80 - 25, 3.80 - 35**  
 Selecting the telescoping target **4.05 - 29**  
 Selecting the telescoping target in the Set up program **4.05 - 29**  
 Selecting the telescoping target with the Telescoping program **4.05 - 30**  
 Service fluids and lubricants **7.01 - 15**  
 Service system **7.01.10 - 1**  
 Service system function key line **7.01.10 - 6**  
 Service system operating interface **7.01.10 - 3**  
 Servicing the central lubrication system of the crawler carrier **7.04 - 21**  
 Servicing the fuel preliminary filter **7.05 - 16**  
 Servicing the ladders **7.05 - 63**  
 Servicing the travel gear **7.04 - 3**  
 Setting down the counterweight with the ballasting device **4.07 - 29**  
 Settings and status displays on the BTT **5.31 - 17**  
 Setting the crawler carrier to the target track width **4.03.50 - 8, 4.03.50 - 11, 4.03.50 - 18**  
 Setting the limit value **4.02 - 63**  
 Setting the limit values for the load torque limiter for advance warning and shut-off **4.02 - 61**  
 Setting the operating elements for operating mode of the slewing gear **4.02 - 83**  
 Setting the operating mode and set up configuration **4.02 - 7**  
 Setting the operating mode and set up configuration via the function keys **4.02 - 7**  
 Setting the operating mode and set up configuration with the short code **4.02 - 7**  
 Setting the operating mode of the slewing gear **4.02 - 82**  
 Setting the set up configuration **4.03.50 - 6, 4.03.50 - 10, 4.03.50 - 16**  
 Setting up for boom nose on telescopic boom **4.12 - 13**  
 Setting up for operation with a boom nose on the fixed lattice jib **4.12 - 20**  
 Setting up for operation with a boom nose on the luffing lattice jib **4.12 - 24**

- Setting up for operation with a fixed lattice jib **4.12 - 19**
- Setting up for operation with an auxiliary jib on the fixed lattice jib **4.12 - 22**
- Setting up for operation with an auxiliary jib on the luffing lattice jib **4.12 - 25**
- Setting up for operation with a strong lattice jib **4.12 - 18**
- Setting up for operation with folding jib **4.12 - 16**
- Setting up for operation with the luffing lattice jib **4.12 - 23**
- Setting up for the auxiliary jib on the telescopic boom **4.12 - 15**
- Short description - „Assembling the crane“ **3.01 - 5**
- Shortening the rope **7.05.50 - 18**
- Short horn warning sound **4.02 - 29**
- Shorting the intervals **8.04 - 26**
- Showing the horizontal distance **2.04 - 63**
- Showing the vertical distance **2.04 - 60**
- Shut-off due to error message **4.20 - 28**
- Shut-off of crane movement **4.20 - 19**
- Shut-off of overload **4.20 - 20**
- Shutting off the crane movement **4.02 - 27**
- Side panel **4.01 - 40**
- Side support \* **4.03 - 19**
- Signs **2.05 - 2**
- Signs on the crane **2.05 - 1**
- Single folding jib, see illustration 1 **5.02 - 3**
- Single folding jib, see illustration 5 **5.02 - 9**
- Single folding jib, see illustration 6 **5.02 - 9**
- Single folding jib, see illustration 9 **5.02 - 11**
- Single hook operation **4.12 - 8, 5.10 - 9, 5.12 - 19**
- Single layer and parallel roped ropes **8.04 - 11**
- Single strand height safety equipment **2.04 - 12**
- Slewing gear **1.02 - 3**
- Slewing gear(s) **7.05 - 34**
- Slewing gear brake **4.05 - 18, 4.10 - 25**
- Slewing range **4.02 - 55**
- Slewing ring connection **7.05 - 32**
- Sliding the protective plate on the cross carrier into assembly position **3.01 - 47, 3.01 - 63**
- Sliding the protective plate on the cross carrier into operating position **3.01 - 49**
- Slip-resistant mats **7.01 - 11**
- Slopes and excavations **2.04 - 34**
- Sound insulation mats **7.01 - 11**
- Special cases for operation of the LICCON overload protection **4.20 - 3**
- Special functions **4.02 - 29**
- Special functions LICCON overload protection **4.02 - 30**
- Special jib boom **1.03 - 10**
- Special operating conditions **4.20 - 4**
- Specified service fluids and lubricants for Liebherr cranes **7.07 - 3**
- Speed reduction master switch **4.02 - 78**
- Speeds **1.03 - 3**
- Spinning out by turning out the hook block **7.05.50 - 17**
- Spinning out with single strand reeving **7.05.50 - 17**
- Split pin **5.01 - 15**
- Spooling the winch up / out shut-off **4.20 - 25**
- Spooling up loose hoist rope **5.19 - 3**
- Spring retainer **5.01 - 18**
- Stand-by mode **4.02 - 95**
- Starting operation, follow my instructions **2.04 - 58**
- Starting procedure **4.03 - 32**
- Starting the engine **4.03 - 32**
- Starting the slewing movement with a strong side wind **4.05 - 19**
- Starting the Telescoping program **4.02 - 67**
- Starting to drive **2.04 - 66**
- Starting up the LICCON Computer system and the touch displays **4.01 - 11**
- Start menu of the BTT **5.31 - 12**
- Start screen BTT **5.31 - 11**
- Start up and shut down of crane **4.03 - 1**
- Stationary stability **2.04.10 - 3**
- Steering ability **4.10 - 15**
- Step **4.03 - 21**
- Steps and folding brackets **4.03.50 - 4**
- Stop (normal stop) **2.04 - 58**
- Stopping the mobile crane **2.04 - 67**
- Stopping the slewing movement with a strong side wind **4.05 - 19**
- Storage **7.01 - 14**
- Storage conditions **7.01 - 14**
- Strong lattice jib **4.12 - 6, 4.12 - 17**
- Substructure **3.80 - 3**
- Suitable distribution of the surface pressure **4.10 - 15**
- Supplied cross beam **2.04.10 - 14**
- Supplied fall arrest system **2.04 - 9**
- Supplied fire extinguisher **2.04 - 15**
- Support **2.04 - 41**
- Supporting the crane **2.04 - 42, 2.08 - 4, 3.01 - 35, 3.01 - 55, 3.80 - 30**
- Supporting the crane from the crane operator's cab **3.01 - 39, 3.01 - 59**
- Supporting the crane with a variable support **2.04 - 42**
- Supporting the crane with the Bluetooth™ Terminal **3.01 - 37, 3.01 - 57**
- Supporting the crane with the BTT **3.80 - 28, 3.80 - 31**
- Supporting the crane with the radio remote control \* **3.01 - 41, 3.01 - 61**
- Support menu **5.31 - 39**
- Support plates **2.04 - 41**
- Surfaces **8.05 - 5**
- Suspended load fastening point **2.05 - 9, 2.05 - 9, 2.05 - 10**
- Swinging the boom nose into operating position, illustrations 1 and 2 **5.10 - 5**
- Swinging the boom nose into transport position, illustrations 7 and 8 **5.10 - 13**
- Swinging the folding brackets in **3.01 - 83, 3.80 - 37**
- Swinging the folding brackets out **3.01 - 21, 3.80 - 22**

Swinging the jib boom into the operating position **5.12 - 9**  
Swinging the jib boom into the transport position **5.12 - 33**  
Swinging the rope guide pulley into the operating position **5.02 - 43**  
Swinging the rope guide pulley into the transport position **5.02 - 85**  
Swinging the transmitter and receiver into the operating position **5.70 - 4**  
Swinging the transmitter and receiver into the transport position **5.70 - 33**  
Switching between automatic operation and manual operation **6.02 - 7**  
Switching on crane control from the crane superstructure **4.03 - 37**  
Switching the slewing gear to freewheeling **4.05 - 21**  
Symbols from 2018 **2.04.10 - 9**  
Symbols until the end of 2017 **2.04.10 - 4**  
Symmetric track width adjustment **4.03.50 - 3**  
System start **4.03 - 28**  
System start of the LICCON computer system **4.02 - 4**

## T

Taking an oil sample **7.01 - 8**  
Taking care of the crane **7.01 - 8**  
Taking on a load **4.08 - 7**  
Taking on a load with cross beam **4.08 - 9**  
Taking the counterweight down as an assembly with the cross beam on the central ballast **4.07 - 15**  
Taking the counterweight down with the crane **4.07 - 13**  
Taking the counterweight plates down on the central ballast **4.07 - 15, 4.07 - 31**  
Taking the fuel system out of service **7.05 - 17**  
Taking the lattice jib down into the roller cart **5.01 - 31**  
Taking the receptacle plate down on the central ballast **4.07 - 13**  
Technical data **1.03 - 1**  
Technical outrigger pad data for cranes with a lattice mast boom **1.03.10 - 13**  
Technical outrigger pad data for cranes with a telescopic boom **1.03.10 - 6**  
Technical safety instructions **2.04 - 1, 7.05 - 29**  
Technical safety instructions for assembly and disassembly **5.01 - 1**  
Tele extension 7m **1.03 - 9**  
TELEMATIK emergency operation (EN 13000:2010 active) **4.02 - 73**  
TELEMATIK emergency operation (EN 13000:2010 not active) **4.02 - 72**  
TELEMATIK emergency operation special function **4.02 - 72**  
Telematik system **4.05 - 28**  
Telescopic load **4.02 - 56**

Telescopic boom **1.02 - 4, 2.06 - 5, 4.08 - 21, 7.05.50 - 2**  
Telescopic boom (T) **1.01 - 5**  
Telescopic boom distortion because of sunshine on one side **4.08 - 5**  
Telescopic boom extension **1.02 - 4, 5.25 - 1**  
Telescopic boom extension fastening points **5.25 - 3**  
Telescopic boom limit switch **4.04 - 18**  
Telescoping **4.05 - 22**  
Telescoping crane movement **4.08 - 5**  
Telescoping cylinder (pressure too high) shut-off **4.20 - 28**  
Telescoping in automatic operation **4.05 - 38**  
Telescoping in automatic operation and manual operation **4.05 - 39**  
Telescoping in the Crane operation program **4.05 - 31**  
Telescoping in the Telescoping program **4.05 - 32**  
Telescoping screen **4.02 - 68**  
Telescoping the telescopic boom in shut-off **4.20 - 25**  
Telescoping the telescopic boom manually **4.05 - 32**  
Telescoping the telescopic boom out shut-off (limit length) **4.20 - 24**  
Telescoping to the telescoping target **4.05 - 31**  
Telescoping under load **4.05 - 37**  
Telescoping with master switch MS1 **4.05 - 26**  
Telescoping with master switch MS2 **4.05 - 25**  
Telescoping with master switch MSY **4.05 - 27**  
Temperature display **4.01 - 44**  
Temperature operating limits **7.05.50 - 7**  
Tensioning procedure **7.04 - 11**  
Tensioning the track chain **7.04 - 9**  
Terminology **1.01 - 1**  
Terms and abbreviations **2.04 - 78**  
Test system menu **5.31 - 67**  
The displays remain dark? **5.31 - 72**  
The function key line (Telescoping program) **4.02 - 70**  
The function keys **5.31 - 31**  
The function keys in the assembly functions menu **5.31 - 49**  
The menus (operating functions) **4.01 - 27**  
Theoretical service life **8.03 - 5**  
The set up program **4.02 - 7**  
The Telescoping program **4.02 - 65**  
The touch displays **4.01 - 11**  
The working range limitation program \* **4.02 - 74**  
The „floodlight“ menu \* (left touch display) **4.01 - 37**  
The „Hydraulic oil preheating / telescopic boom disassembly“ menu \* (left touch display) **4.01 - 39**  
The „Master switch configuration“ menu (left touch display) **4.01 - 17, 4.01 - 23**  
The „Master switch configuration“ menu (right touch display) **4.01 - 13, 4.01 - 19**  
The „Support“ menu (right touch display) **4.01 - 27**  
The „Track width adjustment“ menu (right touch display) **4.01 - 33**  
Third inspection (third year) **8.03 - 10**  
Three hook operation **4.12 - 9**

Three-part multi-purpose ladder **2.04.10 - 21**  
 Tilting the crane cab **4.03 - 23**  
 Tilting the crane cab upward **4.03 - 23, 7.05 - 41**  
 Time **4.01 - 44**  
 Timer **4.01 - 44**  
 Tire size **7.01 - 7**  
 To exceed the maximum permissible load moment **4.20 - 37**  
 To exceed the maximum value of the F-load display in crane operation. **4.20 - 41**  
 Total operating hours **7.01.10 - 3**  
 Track **1.02 - 2**  
 Track pad **7.04 - 16**  
 Track roller **7.04 - 17**  
 Track width adjustment operation **4.03.50 - 18**  
 Track width monitoring without shut-off of crane movement **4.02 - 84**  
 Track width monitoring with shut off of crane movement \* **4.02 - 85**  
 Track widths and extension conditions **4.03.50 - 2**  
 Track width set up configuration **4.03.50 - 2**  
 Traffic endangerment and environmental damage **2.04 - 6**  
 Transfer (between two cranes or two hooks) **2.04 - 63**  
 Transmission **7.06 - 4**  
 Transport **2.04 - 25**  
 Transport company **3.80 - 2**  
 Transporting the camera **5.70 - 36**  
 Transporting the hook block **4.08 - 9**  
 Transporting the hook block / load hook **5.19 - 7**  
 Transporting the hook block / load hook with the crane **5.19 - 7**  
 Transporting the hook block / load hook with the forklift **5.19 - 7**  
 Transporting the ladder **2.06 - 21**  
 Transporting the wind speed sensor **5.75 - 15**  
 Transport position on the N-assembly unit. **5.75 - 15**  
 Transport vehicle **3.80 - 2**  
 Travel drive **1.02 - 2**  
 Travel gear / hydraulic motors / track rollers **4.10 - 5**  
 Travel operation **2.04 - 66**  
 Travel route **4.03.50 - 13, 4.10 - 3**  
 Travel speeds **1.03 - 3**  
 Troubleshooting on the central lubrication system of the crawler carrier **7.04 - 27**  
 Turning **4.05 - 17**  
 Turning / driving in reverse **2.04 - 67**  
 Turning an extremely rotation-resistant hoist rope out **7.05.50 - 16**  
 Turning backward to the left **4.10 - 37, 4.10 - 45**  
 Turning backward to the right **4.10 - 37, 4.10 - 45**  
 Turning crawler operating modes on / off **4.10 - 29**  
 Turning ECO-Mode off **4.02 - 92**  
 Turning ECO-Mode on **4.02 - 91**  
 Turning forward to the left **4.10 - 37, 4.10 - 43**  
 Turning forward to the right **4.10 - 37, 4.10 - 43**  
 Turning manual operation on **6.02 - 7**

Turning normal travel crawler operation on / off **4.10 - 29**  
 Turning off procedure **4.03 - 34**  
 Turning off the engine in case of danger **4.03 - 34**  
 Turning on automatic operation **6.02 - 7**  
 Turning on the spot to the left (counterclockwise direction) **4.10 - 37**  
 Turning on the spot to the right (clockwise) **4.10 - 37**  
 Turning parallel travel crawler operation on / off **4.10 - 29**  
 Turning recirculating air off **6.02 - 14**  
 Turning recirculating air on **6.02 - 14**  
 Turning the air heater \* off **6.02 - 17**  
 Turning the air heater \* on **6.02 - 16**  
 Turning the auxiliary heater off **6.02 - 9**  
 Turning the auxiliary heater on **6.02 - 9**  
 Turning the auxiliary heater on and off **6.02 - 9**  
 Turning the BTT on using the ignition switch **5.31 - 69**  
 Turning the BTT on using the ON / OFF button **5.31 - 69**  
 Turning the climate control system off **6.02 - 10**  
 Turning the climate control system on **6.02 - 10**  
 Turning the climate control system on and off **6.02 - 10**  
 Turning the crane superstructure **4.05 - 22**  
 Turning the defrost window function off **6.02 - 13**  
 Turning the defrost window function on **6.02 - 13**  
 Turning the engine off **4.03 - 33**  
 Turning the engine off with the engine stop button **4.03 - 34**  
 Turning the Floodlight \* on / off **5.31 - 65**  
 Turning the heater control unit off **6.02 - 6**  
 Turning the heater control unit on **6.02 - 6**  
 Turning the heater control unit on and off **6.02 - 6**  
 Turning the heater control unit on and off manually **6.02 - 6**  
 Turning the heater control unit on and off via the ignition **6.02 - 6**  
 Turning the hydraulic oil preheating \* on **4.03 - 27**  
 Turning the hydraulic oil preheating on **2.08 - 4**  
 Turning the rapid gear off **4.05 - 7**  
 Turning the rapid gear on / off **4.10 - 31**  
 Turning the turntable to the left **6.05 - 3**  
 Turning the turntable to the right **6.05 - 3**  
 Turning the vibration sensor on / off **4.05 - 5**  
 Turning the warning sound off **4.02 - 29**  
 Turning the window wiper off **4.03 - 36**  
 Turning the window wiper on **4.03 - 35**  
 Two hook operation **4.12 - 1, 4.12 - 8, 5.10 - 9, 5.12 - 21**  
 Two hook operation monitored **4.12 - 11**  
 Two hook operation monitored / Two hook operation not monitored **4.12 - 10**  
 Two hook operation not monitored **4.12 - 11**  
 Two hook operation on individual loads **4.12 - 10**  
 Two hook operation on joint load **4.12 - 9**  
 Two-part hoist limit switch weight **4.06 - 20**  
 Two strand height safety equipment **2.04 - 12**

## U

Unloading and loading with the auxiliary crane **3.80 - 13**  
Unloading without an auxiliary crane **3.80 - 16**  
Unpinning / pinning the rope retaining pin **5.02 - 85**  
Unpinning the ballasting device **4.07 - 17, 4.07 - 29**  
Unpinning the crane superstructure **4.05 - 10**  
Unpinning the crawler carrier **3.01 - 67**  
Unpinning the lattice components **5.01 - 61**  
Unpinning the support cylinders **3.01 - 33, 3.01 - 71, 3.80 - 28, 3.80 - 35**  
Unscheduled inspection **8.04 - 3**  
Update confirmation **90.05 - 1, 90.05 - 3**  
Update to the operating instructions **90.01 - 3**  
Upper lumbar area support \* **4.03 - 18**  
Urea system \* **7.05 - 21**  
Urea tank individual control displays **4.02 - 43**  
Used proportion of the theoretical service life **8.03 - 5**  
Use of insertion plates into the track chains **4.03.50 - 14**  
User guidelines **2.04.10 - 12**  
Using a hinged ladder as a leaning ladder **2.04.10 - 19**  
Using a hinged ladders as a stepladder **2.04.10 - 20**  
Using insertion plates in the crawler chains **4.10 - 6**  
Using permissible service fluids **7.01 - 6**  
Using the Leaning ladder **2.04.10 - 28**  
Using the leaning ladder as a transition **2.04.10 - 33**  
Using the leaning ladder without the conical end section **2.04.10 - 29**  
Using the platform ladder **2.04.10 - 35**  
Using the stepladder **2.04.10 - 26**  
Using the three-part multi-purpose ladder as a leaning ladder **2.04.10 - 22**  
Using the three-part multi-purpose ladder as a stepladder **2.04.10 - 23**  
Using the vertical ladder with transition aid **2.04.10 - 34**  
Utilization bar diagram (dynamic utilization bar display) **4.02 - 18**

## V

Variation A: Track width adjustment with the superstructure turned, one-side **4.03.50 - 6**  
Variation B: Track width adjustment without counterweight **4.03.50 - 10**  
Variation C: Adjusting the track width while driving **4.03.50 - 12**  
Vehicle height **2.05 - 3**  
Ventilation **7.05 - 52**  
Vertical movements **2.04 - 60**  
Vibrations **1.03 - 3**  
Visual check for damage **4.08 - 4**  
Visual inspection for leaks **8.03 - 4**

## W

Walking on a boom component **5.01 - 71**  
Walking on lattice sections or booms **2.04 - 17**  
Walking on the telescopic boom **2.04 - 16**  
Walking surfaces and stepping surfaces **2.07 - 7**  
Warning apparel **2.04 - 14**  
Warranty and coverage **7.01 - 7**  
Washing the crane **7.01 - 8**  
Wear data for crawler travel gear **7.04 - 15**  
Wedge lock **4.06 - 26**  
Weight **3.01.20 - 3**  
Weights **1.03 - 4, 5.01 - 7**  
Welding work on the load **2.04 - 80**  
While working with the crane **2.04 - 68**  
Winch 1 **4.05 - 6**  
Winch 2 **1.02 - 4**  
Winch 2 or slewing gear **4.05 - 6**  
Winch display **4.02 - 57**  
Winch limit switch quick test **4.04 - 15**  
Winch spooled out limit switch **4.04 - 13**  
Wind influences **2.04 - 49**  
Wind influences during crane operation **2.04 - 54**  
Wind influences during erection and take-down **2.04 - 53**  
Wind influences for „Crane out of operation“ **2.04 - 55**  
Windows **4.03 - 24**  
Window washer fluid **4.03 - 3**  
Window washer system **4.03 - 36**  
Window wiper / window washer system **4.03 - 35**  
Wind sensor **5.02 - 69, 5.12 - 23**  
Wind speed **4.02 - 53**  
Wind speed, wind gust speed and wind direction **2.04 - 50**  
Wind speed charts for a variable support **2.04 - 50**  
Wind speed sensor **4.04 - 13**  
Wind speed sensor / airplane warning light **5.75 - 1**  
Wind speed sensor quick test **4.04 - 13**  
Winter operation **2.08 - 3**  
Wire break increase rate **8.04 - 11**  
Wire ropes **4.06 - 2**  
Wire ropes and rope end connections **4.06 - 2, 8.04 - 5**  
Working in low temperatures **2.08 - 1**  
Working in the vicinity of electricity transmission lines **4.08 - 19**  
Working in the vicinity of transmitters **2.04 - 47**  
Working on lattice sections or booms **2.04 - 17**  
Working on the crane superstructure or boom **2.04 - 29**  
Working on the telescopic boom head and / or auxiliary boom **2.04 - 16**  
Working with a high rope pull **4.08 - 21**  
Working with a load **4.08 - 1**

”

„Hoist top“ hoist limit switch **4.04 - 11**  
„Lower“ lumbar area support **4.03 - 13**  
„Upper“ lumbar area support **4.03 - 14**



---

LWE/LTR 1220-003/24204-02-02/en